

PowerTel 720 Assure +



PowerTel

7 SERIES

PowerTel 720 Assure + Twin



PowerTel 725 Reliant +



Important Safety Instructions	4	Making Calls from a Handset	31
Getting Started.....	6	Menu Options – Cordless Phone	34
Base Phone Guide.....	7	Phone Book – Cordless Phone.....	39
Cordless Handset and Charger Base.....	8	Caller List – Cordless Phone.....	43
Cordless Phone Handset Display Icons	9	Wrist Shaker.....	45
Set Up.....	10	Using the Wrist Shaker	50
Phone Menu and Display Guide.....	11	Help and Support.....	51
Using the Answering Machine.....	12	Troubleshooting Guide	51
Use on a Private Branch Exchange.....	21	Technical Details.....	54
Calling Functions	24	Default Settings	55
Adding a Handset	29	Maintenance And Warranty	56
Index.....	58		

FCC Compliance

The FCC requires that you will be advised of certain requirements involving the use of this telephone.

1. This equipment complies with Part 68 of the FCC rules. A label on the base unit of this equipment contains, among other information, the ACTA Registration Number (US:AAAEQ##TXXXX) and the Ringer Equivalence Number (REN) for this equipment. You must, upon request, provide this information to your telephone company.
 2. An applicable certification jacks Universal Service Order Codes (USOC) for the equipment is provided (i.e., RJ11C) in the packaging with each piece of approved terminal equipment.
 3. A plug and jack used to connect this equipment to the premises wiring and telephone network must comply with the applicable FCC Part 68 rules and requirements adopted by the ACTA. A compliant telephone cord and modular plug is provided with this product. It is designed to be connected to a compatible modular jack that is also compliant. See installation instructions for details.
 4. The REN is useful to determine the quantity of devices you may connect to your telephone line and still have all of those devices ring when your number is called. In most, but not all areas, the sum of the REN of all devices should not exceed five (5.0). To be certain of the number of devices you may connect to your line, as determined by the REN, you should call your local telephone company to determine the maximum REN for your calling area.
- NOTICE: If your home has specially wired alarm equipment connected to the telephone line, ensure the installation of this equipment does not disable your alarm equipment. If you have questions about what will disable alarm equipment, consult your telephone company or a qualified installer.
5. If your telephone causes harm to the telephone network, the telephone company may discontinue your service temporarily. If possible, they will notify you in advance. But if advance notice is not practical, you will be notified as soon as possible. You will be advised of your right to file a complaint with the FCC.
 6. Your telephone company may make changes to its facilities, equipment, operations or procedures that could affect the proper operation of your equipment. If they do, you will be given advance notice so as to give you an opportunity to maintain uninterrupted service.
 7. If you experience trouble with the telephone, please contact the Amplicom Service Center at 1-866-AMPLICOM (267-5426) for repair/warranty information. The telephone company may ask you to disconnect this equipment from the network until the problem have been corrected or you are sure that the equipment is not malfunctioning.
 8. This equipment may not be used on coin service provided by the telephone company. Connection to party lines is subject to state tariffs. (Contact your state public utility commission or corporation commission for information.)
- This device complies with Part 15 of the FCC Rules. Operation is subject to the following two conditions: (1) This device may not cause harmful interference, and (2) this device must accept any interference received, including interference that may cause undesired operation. Privacy of communications may not be ensured when using this phone. Changes or modifications not expressly approved in writing by Amplicom may void the user's authority to operate this equipment.
- Some cordless phones operate at frequencies that may cause interference to nearby TVs and VCRs; to minimize or prevent such interference, the base of the cordless phone should not be placed near or on top of a TV or VCR; and, if interference is experienced, moving the cordless telephone farther away from the TV or VCR will often reduce or eliminate the interference.
9. This product is equipped with a cordless handset, it is hearing aid compatible.
 10. Connection to party line service is subject to state tariffs. Contact the state public utility commission, public service commission or corporation commission for information.

FCC RF Radiation Exposure Statement:

This equipment complies with FCC RF radiation exposure limits set forth for an uncontrolled environment. For Handset unit it has been tested and meets the FCC RF exposure Guidelines, For base unit it should be installed and operated with a minimum distance of 20 centimeters between the radiator and your body.

Important Safety Instructions

When using your telephone equipment, basic safety precautions should always be followed to reduce the risk of fire, electric shock and injury to persons, including the following:

1. Do not use this product near water, for example, near a bath tub, wash bowl, kitchen sink or laundry tub, in a wet basement or near a swimming pool.
2. Do not use the telephone to report a gas leak in the vicinity of the leak.
3. Use only the power cord and batteries indicated in this manual. Do not dispose of batteries in a fire. They may explode. Check with local codes for possible special disposal instructions. Save these instructions for future use.

SAVE THESE INSTRUCTIONS

Avoid using a Telephone (other than a cordless type) during an electrical storm. There may be a remote risk of electrical shock from lightning.

Intended use

This phone is suitable for use on a public telephone network. Any other use is considered unintended use. Unauthorized modification or reconstruction is not permitted. **Do not** open the device and attempt any repair work yourself.

Phone location

Locate the base, corded phone, and wrist-shaker base:

- On a dry, flat and stable surface
- Where the power cable will not be a trip hazard

- Where it is not obstructed by furniture
- At least three feet from other electrical appliances
- Away from smoke, dust, vibration, chemicals, moisture, heat or direct sunlight.

Power failure – What to do

Power failure can affect your phone and equipment. Only the corded phone will work if there is a power failure.

Medical equipment

Do not use the phone near emergency or intensive care medical equipment, or during an electrical storm. If you have a pacemaker check with a medical expert before using this product.

Hearing aid compatibility

This phone works with most popular hearing aids. However, given the wide range of hearing aids available, the phone may not function fully with every hearing aid. Telephones identified with this logo have reduced noise and interference when used with most T-coil equipped hearing aids and cochlear implants. The TIA-1083 Compliant Logo is a trademark of the Telecommunications Industry Association. Used under license.

The charger unit is charging only for handset PowerTel 700 Assure, PowerTel 701 Extender, PowerTel 711 Extender Voice, PowerTel 720 Assure +, PowerTel 730 Assure Voice +, PowerTel 780 Assure, PowerTel 785 Assure Responder, and so on.

Handset unit: Use only the supplied adapter.



Caution: The phone will produce high volume when Boost is switched on.

Getting Started — Included Equipment

PowerTel 720 Assure + - Amplified Cordless Phone with Answering Machine

- 1 base unit with integrated Answering Machine)
- 1 cordless handset
- 1 rechargeable battery pack 3AAA 3.6V NiMH
- 1 power adapter
- 1 telephone cable

PowerTel 725 Reliant + - Amplified Cordless Phone with Answering Machine and Wrist Shaker

As PowerTel 720 Assure + and includes:

- 1 Wrist Shaker with Strap
- 1 Charger unit for Wrist Shaker (with Power Adapter Plug attached)

PowerTel 720 Assure + Twin - Amplified Cordless Phone with Answering Machine, and Additional Cordless Accessory Handset

- 1 base unit with integrated Answering Machine
- 2 cordless Handsets
- 2 Rechargeable Battery Packs & 3 AAA 3.6V NiMH
- 1 charger base for cordless handset(with Power Adapter Plug Attached)
- 1 power adapter
- 1 telephone cable

PowerTel 720 Assure + Phone Base

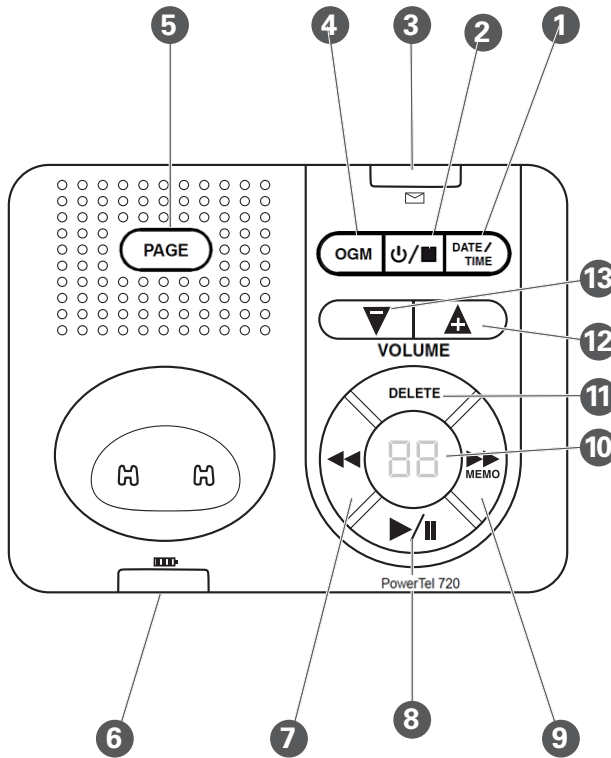

- 1 Date/Time
- 2 Answer on/off/Stop/
Answer mode
- 3 Indicator light for new answer
machine messages received
- 4 Outgoing message
- 5 Find handset/Registration
- 6 Incoming call/Charging/
Line in use
- 7 Rewind/Set language
- 8 Play/Pause/OK
- 9 Fast forward/Memo
- 10 Answer machine message
counter/Status display
- 11 Delete
- 12 Volume up
- 13 Volume down

PowerTel 701 Extender Handset and Charger Base

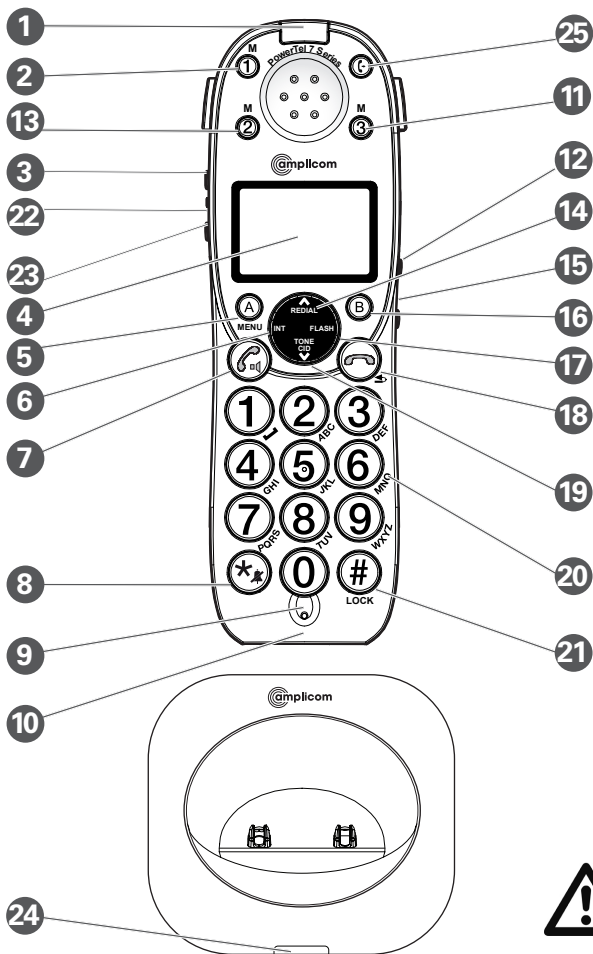

- 1 Incoming call
- 2 Memory 1
- 3 Boost
- 4 Display
- 5 Enter Menu/Mute/Delete
- 6 Internal call
- 7 External call/Handsfree
- 8 * /Ringer on/off
- 9 Pause (long press 0)
- 10 Microphone
- 11 Memory 3
- 12 Volume up/down
- 13 Memory 2
- 14 Up/Redial
- 15 Headset socket (Headset not included)
- 16 Phone book/Save/OK
- 17 Recall
- 18 End call
- 19 Down/Calls list/Equalizer
- 20 Keypad
- 21 #/Keylock
- 22 Red Light Boost Indicator
- 23 Select Profile (P)
- 24 Charging
- 25 Transfer call



Warning: This Handset has been specially designed for individuals who are hard of hearing and has a normal volume which is louder than a standard phone. Use of the Boost feature can cause hearing damage to individuals who are not experiencing hearing loss.

Optional (May not be included)

Cordless Phone Handset Display Icons

The following icons can appear in the LCD display:



Phone book mode



Play messages fast forward



More information to view up



Boost receiver volume is on



More information to view down

(Icon will flash)



Battery status



Mute handset microphone



Ringer off



New calls



Keylock is on



Answering machine is on



Handsfree mode



Answering machine is off



Call in progress



When steady— handset is in range



Internal call in progress (if additional handsets are installed)



When flashing — handset out of range

Set Up

Note: The Amplicom customer service toll free number has been pre-installed in the phone book of every telephone and cannot be edited or removed.

1. Connect the base

- i. Plug the power adapter into the base unit and the other end into a wall socket. The unit should power on and the display will light up.
- ii. Plug the telephone cable into the base unit

WARNING: Do not connect phone line to the phone socket yet.

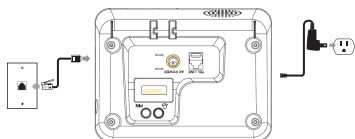

2. Connect the cordless phone charger base (Optional if included)

Plug the other power adapter that is already attached to charger base into the wall socket and switch the power on.

3. Install the battery pack

Insert the rechargeable battery pack into the handset as shown.

Dispose of battery pack properly. Do not allow battery pack to come into contact with fire or water.

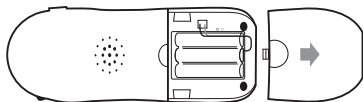

4. Charge the handset

Place the handset on its base to charge for a minimum of 16 hours before use.

5. Connect telephone cable



After initial charge, plug the telephone cable into the telephone wall socket.

YOUR POWERTEL PHONE IS NOW READY TO USE!



Phone Menu and Display Guide



The phone menu display allows access to the full phone functionality.

Open main menu: Press  .

Browse sub menu: Open the main menu and then press  or  .

Select sub menu item: Scroll using  or  until the menu item desired highlighted and press  or OK .

Browse a function: Open the sub menu and press  or  .

Select a function: Scroll using  or  until the required function is highlighted and press  or OK .

Enter digits or letters: Use the keypad.

Confirm or save an entry or action: Press  or SAVE .

Cancel and return to standby: press  .

Note: After 20 seconds, the phone will go into standby mode unless a button is pressed.

Using the answering machine

After setting up the phone system, use the following steps to set up and use the answering machine.

Switch answering machine on or off

Press  to turn the answering machine off and on.

The current answer mode will be announced.



When new messages are received, the message counter on the base and the base indicator light flash. The message counter also indicates the number of messages.

Set the language

Choose the answering machine voice prompt language: English, Spanish or French.

1. Press and hold  on the base for 10 seconds until two letters appear in the message counter display: En = English, Fr = French and Sp = Spanish.
2. Repeat the above procedure until the desired language code is displayed.



Adjust the base loudspeaker volume

Increase or decrease the base loudspeaker volume using  and .

The volume level is displayed on the base message counter, e.g. LI-5.

Set the answer mode

Choose the answer mode: Answer & Record, Answer only or Answer off. With the machine in Answer only mode callers will not be able to leave a message.



1. Press  to switch the answering machine on.
2. To change the mode between **Answer & Record**, **Answer Only** or **Answer Off**, press and hold  for two seconds.

Check the outgoing message

Press  to hear the current outgoing message.

Record an outgoing message





The outgoing message must be less than two minutes long. To change the default answering message:

1. Press and hold  on the base for two seconds. Record the new message after the beep. The base message counter will display 05 during recording.
2. To stop recording, press . The new message will be played back, and the base message counter will display 01.









Note: to return to the default message, press and hold  while the outgoing message is playing.

Set the answer delay

Choose the number of times the phone will ring before the answering machine answers an incoming call. Or, choose Time Saver, if no one will be available to answer the phone. Time Saver is useful if someone will be calling in from a different phone to listen to messages: if the machine answers after 2 rings, there are new messages to listen to. If it answers after 5 rings, there are no new messages. This feature gives the option of hanging up after 3 rings (because there are no new messages) to save time and avoid being charged for the call.

1. Press and hold  (located underneath the base) for two seconds. The current ring delay setting will be announced and will also be displayed on the message counter e.g. r2-9 or t5 (for Time Saver).
2. Use  and  to select either the number of rings (2 - 9) or Time Saver. Press  to confirm.

Set the day and time

1. Press and hold  for two seconds.
2. Choose a day of the week using  or . Press  to confirm.
3. Choose the hour using  or . The digits will also appear on the base message counter. Press  to confirm.
4. Choose the minutes using the  or  buttons, the digits will also be shown



on the base message counter. Press  to confirm.

Check the day and time

1. Press . The current day and time are announced.

Record a memo





Memo messages can be played back like normal messages.

1. Press and hold  for two seconds.
2. After the beep, record the memo. The message counter will show -- while recording.
3. Press  to stop recording. The base indicator light and the message counter will flash, and the counter will increase by one digit, e.g. 01.



Listen to messages or memos using the base buttons

Messages and memos are played in reverse order, with newer messages played first. The time and date of each message or memo is announced before playback.



Use the following buttons to control message playback:

- To play or pause, press 
- To stop, press 
- To rewind, press 
- To fast forward, press 

Delete a single message or memo

1. Press  to play a message or memo.
2. To delete it, press and hold  for two seconds while the message or memo is playing. The message counter will display dL while deletion is taking place.

Delete all messages and memos

1. Press and hold  for two seconds when no messages are being played.
2. Press  again, to confirm the deletions. The message counter will show dL to indicate that deletion is taking place.

Memory full





When the memory is full, the answering machine announces that fact, automatically stops taking more messages, and switches to **Answer Only** mode. Some existing messages or memos must be deleted before any new messages can be recorded.

Access the answering machine from a remote location

Messages on the answering machine can be listened to from other phones, including mobile phones.

A PIN (Personal Identification Number) code is required to access the answering machine. The default code is **000**. Change the PIN code to keep messages secure.

Change PIN

1. Press and hold **PIN**  (located underneath the base) for two seconds. The current 3 digit PIN will be announced and the first new digit requested. Enter a digit between 0 and 9.
2. Select the new first digit using  or , the digits will also be shown on the base message counter. Press  to confirm.
3. Repeat the above procedure for the 2nd and 3rd new digits.
4. After the 3rd digit has been confirmed, the new PIN will be announced.

Press  at any time to exit the Change PIN code mode and return to standby. The PIN code will remain unchanged.

Call in to check messages

1. Dial the system's phone number from a remote phone and wait until the answering machine picks up the call.
2. Press  twice, then enter the 3 digit PIN after the voice prompt.
3. Refer to the next section, "Manage messages from another phone" for additional instructions.

Manage messages using another phone

Use these numbers to manage messages from a remote location.

Press...

1 to **Rewind**

2 to **Play** or **Pause** your messages

3 to **Fast Forward** through your messages

4 to **Hear** the **outgoing message**

5 to **Record outgoing message** (**6** to **stop** recording)

6 to **Stop** messages

7 to **Delete current message** **8** to **Turn OFF** answering machine

8 to **Turn OFF** answering machine



9 to **Turn ON** answering machine

to **Record** a **memo** (**6** to **stop** recording)

Use the cordless handset

1. Open the answering machine menu by pressing **A** or **MENU**.







2. When **Ans Machine** is displayed, press **B** or **OK**.

3. Scroll using  **REDIAL** or  **TONES** **CID** to display desired function

Play Msgs, Ans On/Off, Record Memo, Outgoing Msg, Ans Settings, then press

B or **OK**.

If Play msg you will be given further choice to Play New Msgs or Play All Msgs. Ans On/Off turns Answering Machine ON or OFF. Outgoing Msg will give you the option to either Record Message or Play Message. Ans Settings will give you the option to setup your Answering Machine. AnswerMode - Answer Only or Answer and record, Answer Delay - (2-15 rings) or Time Saver, Security Code - option to set a new pin code is for remote access Language - English French or Spanish.

4. Press  to return to standby.3. The display will confirm action.
5. Using the keypad, enter a name for this stored number and press .
6. Edit the number for this name, if needed, and press .
7. Scroll using  REDIAL or  TONE CID to choose the ringer for this entry and press .

Use on a Private Branch Exchange

If the phone is on an exchange (e.g. dial 9 to get an outside line), calls can be transferred or called back by using the ^{FLASH} button. Check with the system administrator for system set-up and instructions. Private exchanges are normally used in a business-setting.

Set the recall time using the cordless handset

1. Open the menu by pressing A or ^{MENU}, then scroll using ^{REDIAL} or ^{FLASH} until **Base settings** is highlighted and press B or OK.
2. Scroll using ^{REDIAL} or ^{FLASH} until **Recall** is highlighted and press B or OK.
3. The current recall timing setting (e.g. **Short**) will be displayed.

4. Choose the desired recall timing setting (Short or Long) using ^{REDIAL} or ^{FLASH} and press B or SAVE.

Insert a dialing pause

Insert a pause before the dial tone if the system requires an outside line which takes awhile to connect.







To insert a dialling pause using your cordless handset, enter the number to reach the outside line and then press **0** for two seconds. A **P** on the display will show dialling pause is active.

Note: A dialing pause can be used with a phone number in the phone book.

Set the dial mode

There is a choice of two dialing modes: tone and pulse. The default setting is TONE and this is the correct setting for use within the United States.

Change the dial mode using the cordless handset

1. Open the menu by pressing A or **MENU**, scroll using  or  until **Base settings** is highlighted and press B or OK.
2. Scroll using  or  until **Dial Mode** is highlighted and press B or OK.
3. The current dial mode setting (e.g. **Tone**) is displayed.
4. Choose the dial mode setting required (Tone or Pulse) using  or  and press B or Save.

Reset to default settings

Important: Resetting to default will NOT delete phone book entries.

Reset to default settings on the cordless handset

1. Press **FLASH**  for 10 seconds.
2. Confirm or cancel the reset to default settings by pressing B or OK or A or NO.

Calling Functions

Make a call using the cordless phone

1. Enter the phone number.
2. Press A or DEL to delete a mistaken entry.
3. Dial the number by pressing .

End a call

press  on the cordless handset.





Answer a call

For the cordless handset, press  and then speak into the phone.

Redial a number using the cordless handset



The phone stores the last 10 numbers dialed.

Note: Each phone number will be announced from the redial list provided the Read Number feature is enabled.

1. Open the redial list by pressing  REDIAL .
2. Scroll through the redial list using  REDIAL or  TONE CID until the desired number is highlighted and then press  to dial the number.





Call back a previous caller

The phone stores the last 30 incoming phone numbers.





1. Open the incoming calls list by pressing  .
2. Scroll to find the desired number using  or  , to dial press

 on the cordless handset.

Dial a number in the phone book

1. Open the phone book by pressing  .
2. Scroll to find the desired number using  or  press  on the cordless handset.

Dial a number using the speed dial buttons

1. Choose a speed dial number by pressing   or  on the cordless handset.
2.  on the cordless handset to dial the number.

Adjust the handset earpiece volume

Note: The handset earpiece volume is louder than a standard phone.

To adjust the volume during a call, push the button on the side of the handset



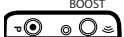

Boost the handset earpiece volume

To boost the handset earpiece volume during a call, press  and boost button will light red (cordless phone). An image of an ear will flash in the display the red boost indicator will light on the left side of the handset will be lit to show that boost is on.

Handsfree feature

Use the handsfree feature to talk to the caller without holding the handset or to let other people in the room listen to the conversation.

Cordless Phone:

1. Switch on handsfree mode during a call by pressing the  key a second time.
2. Exit handsfree mode by pressing .
3. To adjust the handsfree volume, use the  on right side of handset.

Note: Boost volume using  is not available during handsfree calling.

Use a headset (not included) with the cordless phone

Plug your headset into the headset socket marked  on the right side of the handset.

Mute the phone

Muting the phone during a call will silence the mouthpiece on the phone so it does not transmit any noise to parties on the other end of the line.

Cordless Phone:

To switch off the mouthpiece, press A or MUTE. **Mute On** will be displayed.



To switch it on again, press A or MUTE . The display will show **Off**.

Switch the cordless handset ringer on and off

To switch the ringer on and off, press and hold  for five seconds.

Lock and unlock the cordless handset keypad

Calls can still be answered as usual when the keypad is locked.

1. To lock the keypad, press and hold  for 2 seconds. The  icon will be displayed.
2. To unlock, press and release A or MENU then immediately, press and hold  until unlock confirmed.

Find a handset

A missing handset can be located from the base.

1. Press  on the base. The handset(s) will beep.
2. Press any button on the handset to stop the handset(s) beeping.

Answer call waiting on cordless handsets

1. When incoming call beep is heard, another call is incoming.
2. To answer call waiting Press FLASH.
3. To go back simply repeat step 1 and 2.

PowerTel 701 Cordless handset and charger base

Adding a Handset – Cordless Phone

Register a handset

Only register a handset if it has become de-registered from the base or if it was purchased separately.

Important: make sure any handset is fully charged before registering.

At the handset:



1. Press and hold **MENU** for approx 10 seconds until the display shows **Press and hold Page key**.



At the base:

2. Press and hold  for at least 10 seconds until the display shows **Register**.





De-register a handset

De-register a handset if too many are currently registered on the phone system.



1. Open the menu by pressing **MENU**, then scroll using  or  until **Handset** is highlighted and press **B** or **OK**.

2. Scroll using  or  until **Registration** is highlighted and press B.
Then scroll  to highlight **De-register** and press B.
3. Enter the PIN code (default PIN 0000) and press B.
4. Enter the handset's internal number (e.g. **1**) and press B to confirm.

Change a handset name

1. Open the menu by pressing MENU, then scroll using  or  until **Handset** is highlighted and press B.
2. Scroll using  or  until **Handset name** is highlighted and press B.
3. Edit or delete current name by pressing A to Delete or pressing INT or Flash to move cursor then press B or OK to save.

Transfer an external call internally

1. During an external call, press and hold  until a short beep is heard, then enter the internal call number of the name and number (1, 2, 3, or 4) to transfer the call to.
2. To accept the call on the receiving handset, press  or simply lift the handset off the base of the unit or press the Talk button on the handset.



Note: If no one picks up the call being transferred, re-answer the call at the current phone by pressing  .

Making Calls from a Handset



Note: One external line conference call can be made with multiple handsets internally by pressing  twice or simply lifting the base handset.

Make an internal call

If two or more handsets are registered to the base internal calls between handsets can be made. Each handset will have been allocated a handset number when registered, e.g. **HS1**, **HS2** etc. These calls are free of charge.

1. Press and hold **INT**. The display will show **Handset?** Enter the internal call number of the handset desired. The corded base unit is always 0
2. To accept the call on the receiving handset, press .
3. End the call by pressing .

Make a conference call





1. During an external call, press and hold **INT** until a short beep is heard, then enter the internal call number of the handset to transfer to.
2. To accept the call on the receiving handset, press .
3. Once the call has been received on the other handset, activate the conference call by pressing and releasing the B or Conf. button.
4. Place the external call on hold by pressing **INT** (if necessary).
5. The conference call will end when  is pressed.

Copy phone book entries to another registered handset







Note: Phone books can only be copied to another handset if that handset is registered on the same phone system.

- A single entry (Copy entry)
- Entries not already on the handset being copying to (Copy append)
- All entries (Copy all)





Important: When “copy all” is selected, all existing entries on the handset being copied to will be deleted. To prevent this from happening use “Copy append.”

1. Open the phone book by pressing B.
2. Scroll using  or  to find the entry or entries to copy and press B.
3. Scroll  to either **Copy entry**, **Copy append**, or **Copy all** and press B.
4. Scroll  or  to highlight the handset number and or base to copy to and press B.
5. Pick up the handset where copying entries to and press B or PB . The display will confirm Phone book entry received..

Copy a profile

1. Open the menu by pressing **MENU**, then scroll using  or  until **Profile** is highlighted and press B.
2. Scroll using  or  until **Profile 1, 2, or 3** is highlighted and press B.
3. Scroll using  or  until **Copy** is highlighted and press B.
4. Scroll using **INT** or **FLASH** until the handset (e.g. **2, 3** or **4**) to copy the profile to is highlighted, and press B.
5. On the copy-to handset, press B to confirm or **MENU** to cancel.

Setting or changing the System PIN code

1. Open the menu by pressing **MENU**, then scroll using  or  until **Base settings** is highlighted and press B.
2. Scroll using  or  until **System PIN** is highlighted and press B.
3. Enter the old PIN code (default PIN is 0000) and press B.
4. The phone will prompt for a new 4 digit PIN code (entered twice), press B.

Important: Do not change or reset the PIN code unless instructed by customer service.

Menu Options – Cordless Phone







Priority/Default setting

Any changed settings in the menu will be saved as default. The phone also allows for 2 separate user profiles.







User profiles

The phone can store 2 different user profiles with different settings for the Volume, Boost, and Equalizer features. Each Profile can be given a personalized name.

Add or edit a profile name

1. Open the menu by pressing A or ^{MENU}, scroll using  REDIAL or  TONE CID until **Profile** is highlighted and press B or OK.
2. Scroll using  REDIAL or  TONE CID until **Profile 1 or 2** is highlighted and press B or OK.
3. Scroll using  REDIAL or  TONE CID until **Name** is highlighted and press B or OK.
4. Delete the current name by pressing A or ^{MENU}.
5. Enter a new name (up to ten letters) and press B or OK.

Change a profile's handset volume or equalizer

1. Open the menu by pressing **MENU**, then scroll using  **REDIAL** or  **TONE CID** until you highlight **Profile** and press **B** or **OK**.
2. Scroll using  **REDIAL** or **_** until **Profile 1** or **2** is highlighted, press **B** or **OK**.
3. Scroll using  **REDIAL** or  **TONE CID** until the desired setting is highlighted, press **B** or **OK**.
4. The current setting will be displayed.
5. Change the appropriate setting using  **REDIAL** or  **TONE CID** and press **B** or **OK**.

Note: Press  to exit the menu and return the handset to standby.

Choose a profile to use

Note: Handset must be used to choose a profile for a call – a profile cannot be chosen using handsfree.

1. Before or after answering an incoming call, press the **PROFILE** button on the left side of the handset to select either profile **M1** or **M2** or **Profile OFF**.
2. The display will confirm your choice.



Note: Once a profile has been selected to use when making a call, the phone will return to the default settings after 30 seconds.

Changing Menu Settings

Handset ringer melody — There are ten ringer melodies. Default setting is 7.

Handset ringer volume — There are five volume levels plus **OFF**.

Tone (“Equalizer”) setting — There are three tone settings, LOW/MID/HIGH. Default is MID.

Note: To adjust tone while making a call, press the  button to access the equalizer setting, press the  or  button to adjust the setting. One can also use + VOL or - VOL on right side of handset to reach preferred equalizer / TONE setting.

Switch keypad beep on or off — Turns on or off the keypad beep.





Change contrast — There are five normal (BLACK ON AMBER) screen contrast levels and five negative (AMBER ON BLACK).

Switch “auto talk” on or off — The phone will automatically answer a call when the handset is removed from its base when Auto Talk is **ON**. This is the default setting. If Auto talk is **OFF**, press the  button to answer any calls.

Change backlight timer — Choose between 10, 20, 30 or 40 seconds until the backlight timer switches off.

Switch confirmation beep on or off — There is a beep confirmation when a setting is changed. This can be switched on or off.

Change language — There are three display languages available on the handset: **English**, **French**, and **Spanish**.



1. Open the menu by pressing MENU, then scroll  or  until **Handset** is highlighted and press B or OK.
2. Scroll  until the desired menu setting (see options above) is highlighted and press B or OK.
3. The current setting will be displayed.
4. Change the setting using  or  and press B or OK.

Changing Clock Settings

Change date/time — Enter the Date and Time settings.



Change clock to 12- or 24-hour format — Choose between a standard 12-hour format clock or a 24-hour format (military time). The default setting is 12 hour clock.

Set alarm — Set an alarm date, time, melody, and reoccurrence or off.

1. Open the menu by pressing **MENU**, then scroll  or  until **TIME, Select SET ALARM** by pressing **B AGAIN** is highlighted and press B or OK.
2. Scroll  to set reoccurrence (**Once, Every Day, Mon to Fri, or OFF**) and B or OK.
3. The current setting will be displayed.
4. Enter the desired date and/or time setting required (the handset has a 24-hour clock) B or OK.
5. Select the desired alarm melody and confirm by pressing B. The display will show the alarm has been set.





Changing Base Settings

Change base ringer melody — There are ten base ringer melodies.

1. Open the menu by pressing **MENU**, then scroll  or  until **Base settings** is highlighted and B or OK.
2. **Ring tone** is highlighted, B or OK.
3. The ringer melody setting (e.g. **8**) will be displayed.

4. Change the ringer melody using  REDIAL or  TONE CID and B or OK.

Change base ringer volume — There are five volume levels plus Off.

1. Open the menu by pressing MENU, then scroll using  REDIAL or  TONE CID until **Base settings** is highlighted and B or OK.
2. Scroll  TONE CID until **Ringer volume** is highlighted and B or OK.
3. The current base ringer volume level (e.g. **5**) will be displayed.
4. Change the base ringer volume using  REDIAL or  TONE CID and B or OK.

Phone Book – Cordless Phone

Up to 200 names with phone numbers can be alphabetically stored in the phone book. To quickly find a phone book entry, simply enter the first letter of the stored name.

Note: The Amplicom customer service toll free number has been pre-installed in the phone book of every telephone and cannot be edited or removed.



Note: Each phone book entry allows for up to 16 letters for any name and up to 24 digits for any phone number.

Important: Enter the area code for each phone number stored.

Keypad use for phone book





The keypad contains alpha-numeric keys. Pressing one key multiple times will scroll through the available letters and numbers which that key represents.

Other useful keys:





- press  for a space
- press  to delete a number or letter entered
- press  to change from upper case (e.g. ABC) to lower case (e.g. abc)

Note: To enter the same letter twice, enter the letter and then pause until the cursor moves to the next space before entering it again.



Enter a new name and number in the phone book

1. Open the phone book by pressing B.
2. Press B. The display will offer you the choice to edit entry, or you can scroll  or  to choose new entry, press B again.
3. Enter the name to store and press B.
4. Enter the phone number to store and press B.
5. Scroll using  or  to choose a ringer for this entry and press B.

Show details, copy entry, copy append, or copy all for a phone book entry

1. Open the phone book by pressing B.
2. Scroll using  REDIAL or  TONE CID to find the entry to show details, copy entry, copy append, or copy all and press B.
3. Scroll  TONE CID to display **Show details, copy entry, copy append, or copy all** and press B.
4. Press MENU to delete characters, use the keypad to enter new ones, press B.
5. Press MENU to delete digits, use the keypad to enter new ones, press B.
6. Scroll using  REDIAL or  TONE CID to choose a ringer for this entry and press B.

Delete a phone book entry or all entries

1. Open your phone book by pressing B.
2. Scroll using  REDIAL or  TONE CID to find the entry to delete or highlight any entry to delete all entries.
3. Press  TONE CID to display either **Delete entry** or **Delete all** and press B.
4. Press B to confirm or MENU to cancel.

Using speed dial memory buttons

One name (max. 16 characters) and one telephone number (max. 24 digits) can be stored under each of the quick dial memory buttons: ^M①, ^M②, and ^M③.

1. Press the ^M①, ^M②, or ^M③ speed dial button.
2. Press B. The display will show **New entry**, press B again.
3. Enter the name to store using the keypad and press B.
4. Enter the phone number to store and press B. **Saved** will be displayed.

Edit a speed dial entry

1. Choose the speed dial entry to edit by pressing either ^M①, ^M②, or ^M③.
2. Press B. The display will show **Edit entry**, press B again.
3. Press ^{MENU} to delete characters, use the keypad to enter new ones, press B.
4. Press ^{MENU} to delete digits, use the keypad to enter new ones, then press B. The display will show **Saved**.

Delete a speed dial entry





1. Choose the speed dial entry to delete by pressing either ^M①, ^M②, or ^M③.
2. Press B. Scroll  to **Delete entry** and press B.
3. Display will show **Delete entry?** Press B to confirm or ^{MENU} to cancel.



Incoming Calls - Cordless Phone



Note: You must subscribe to your phone service provider's Caller Display/ Caller ID service for this feature to work.

Incoming call telephone numbers will appear in the calls list. If the caller's number is stored in the phone book, the name will be displayed instead. A total of 30 incoming calls can be stored in the calls list (16 letters per name and 24 digits per number). The number of new calls received will be shown in the display with the flashing  icon. If the number does not appear, this is because the caller's identification (Call Line ID) has been withheld by the caller.



Open the calls list by pressing the  button. Scroll through the calls list by pressing  or . To display more information including the date and time of the call, press . Other displayed information:

- **WITHHELD NUMBER** – withheld number, or ID information isn't available
- **INTERNATIONAL** – call is from another country or using an internet service
- **PAYPHONE** – caller is calling from a public payphone





Store numbers from the calls list to the phone book

1. Press  to open the calls list at the most recent entry. Scroll until you reach the desired number you wish to add then press B or Options.
2. Scroll using  or  to save a number, save to M1, save to M2, or save to



M3. You must confirm to store by pressing B or OK.

3. The display will confirm action.
4. Using the keypad, enter a name for this stored number and press B.
5. Edit the number for this name, if needed, and press B.
6. Scroll using  REDIAL or  TONE CID to choose the ringer for this entry and press B.

Delete a single entry

1. Press  TONE CID to open the calls list at the most recent entry. Scroll until you reach the desired number you wish to add then press B or Options.
2. Scroll using  REDIAL or  TONE CID to find the listed to Delete and press B.
3. Scroll  TONE CID until **Delete** is highlighted and press B.

Delete all call list entries

1. Press  TONE CID to open the calls list and at the most recent entry press B.
2. Scroll  TONE CID until **Delete all** is highlighted and press B.
3. The display will show **Delete all Calls?** Press B to confirm or MENU to cancel.

Wrist Shaker

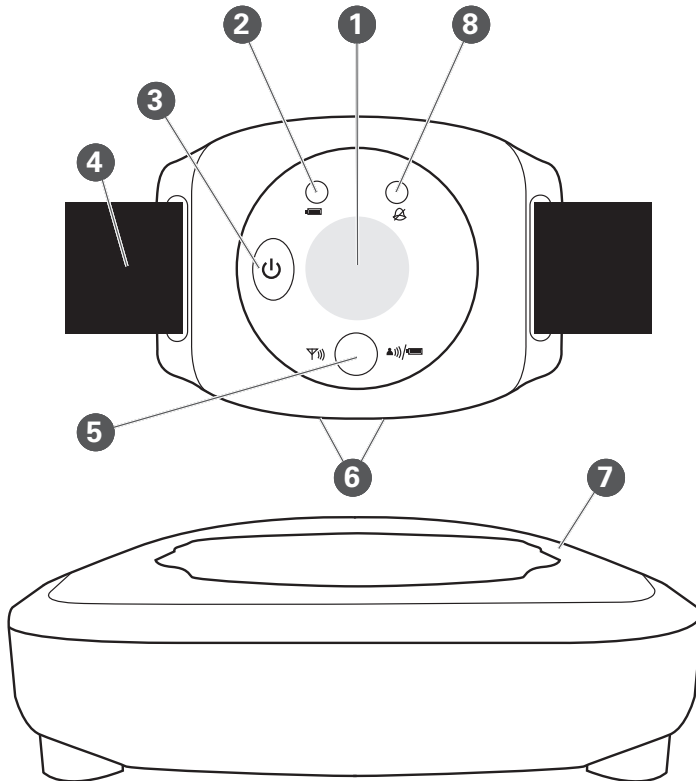

- 1 Stop Vibration / Page
- 2 Battery charging red light
- 3 Power on/off
- 4 Wrist strap
- 5 Registration mode/
Out of range/Low battery
2 color green or red light
- 6 Charging contacts
- 7 Charging unit
- 8 Incoming call green light

Connect and charge wrist shaker (Optional and may be included)

Important: Use only the power adapter supplied, otherwise wrist shaker may not work.

1. Plug in the charger unit

Plug the charger unit into the wall socket.

2. Place the wrist shaker in the charger unit

Place wrist shaker on its charger unit, with the two connection points facing down. A red light on the wrist shaker indicates it is charging properly. Charge the wrist shaker for 10 hours before use.

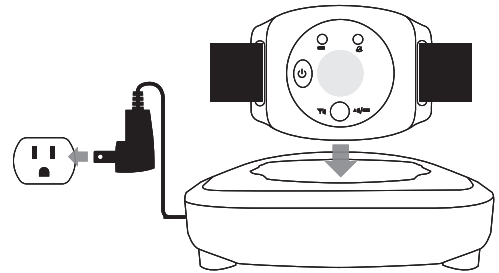



Note: When fully charged, the wrist shaker's battery will last five days. The larger red light will flash slowly when the battery is low and needs to charge for 10 hours.

3. Switch wrist shaker on/off

Press and hold  for five seconds, until the green light with the warning triangle comes on.

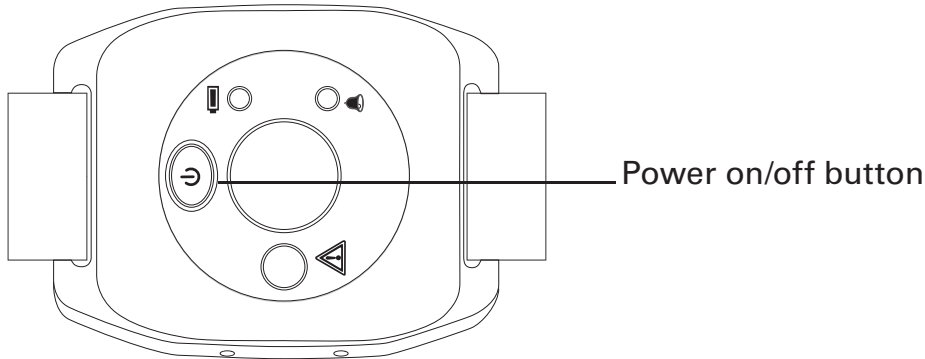

Note: The light flashes green then red if the wrist shaker is not registered or is out of range. Bring it closer to the PowerTel telephone to ensure it is within range. If the light still flashes, see page 49 for registration instructions.



Off: Press and hold  for about five seconds, until the green light goes off.

4. Turn on SOS Motor feature

The SOS Motor feature causes the wrist shaker to vibrate when a call comes in.

- i. At the corded phone base: Press ^{MENU} (under the display).
- ii. Use  _{REDIAL/P} to scroll to **SOS Motor**. Press ^{MENU} again.
- iii. Use  _{REDIAL/P} or ^{CID/FLASH}  to scroll to **On**. Press ^{MENU} again. **Saved** is displayed.

Attach the wrist strap

The wrist strap allows the wrist shaker to be worn like a watch. To attach or adjust the wrist strap:



1. Thread it from the back through one of the slots.
2. Slide the strap across the back of the wrist shaker.
3. Thread it back to front through the other slot.
4. Place the strap around the wrist and connect the velcro fasteners.

The telephones and wrist shaker are now ready for use!

Register the wrist shaker

Important: It is necessary to register the wrist shaker if it has become de-registered from the telephone or if a new wrist shaker needs to be registered.

At the wrist shaker:

1. Turn on the wrist shaker by pressing and holding  for about five seconds.
2. After the wrist shaker is On, press and hold  again for about 12 seconds, until the registration light flashes green. The wrist shaker will be in registration for about 1 minute.

At the corded phone base:

3. Press and hold  for at least 10 seconds, until **Register** is displayed (for about 10 seconds).

Note: To located the registration key , see the At a Glance section for the corded phone base at the beginning of this guide.

4. The registration light unit glows a steady green when the wrist shaker is registered (i.e. it isn't flashing).

Note: The registration light will flash green and red if the wrist shaker either isn't registered or is out of range.

Using the Wrist Shaker

Switch on

Press and hold  for five seconds. The green light with the warning triangle will come on.

Switch off

Press and hold  for five seconds, until the green light goes off.

Incoming calls

When you receive an incoming call, the green light will flash and the wrist shaker will vibrate.

Paging

You are able to page the wearer of the wrist strap by pressing . To stop the alert press the  (red center button).

Help and Support

Some issues may simply be resolved by disconnecting the power to the unit. In such instances the power to the main base station should be switched off and battery pack in the handset should also be removed for about 20 minutes. After 20 minutes, replace the battery pack and reconnect everything to determine if this has resolved the issue.

Troubleshooting Guide

I can't make phone calls

1. Make sure the phone cable is connected properly. Make sure you are using the phone cable that came with your phone.
2. Make sure the base is plugged in, switched on and working.
3. If you're using the cordless handset, make sure you are not located too far from the base (the phone should work up to 325 yards outdoors and up to 53 yards indoors).
4. Test the phone line and socket by using another phone.

I keep losing my connection on the cordless handset

1. Make sure you aren't too far from the base (in ideal conditions, it should work up to 325 yards outdoors and up to 53 yards indoors).
2. The base may not be in an ideal location – see Safety Information.

My handset keeps switching off

1. It may need recharging. So it can charge fully, place your handset on its charger base for at least 15 hours with the charger base plugged in and working.
2. Replace the rechargeable battery pack. Any replacement battery packs should be the same type as those provided.

The phone system isn't responding

You may need to reset to default settings. Please see page 39.

Answering machine won't record messages or memos

1. Check that the answering machine is connected and switched on.
2. Answering memory may be full. See page 32.

Caller's identification (Call Line ID) isn't working

1. Check you have this service on your phone line. Please call your network provider.
2. The caller may have withheld their phone number.

My handset or base doesn't ring

Check that the ringer is on.

I've got a buzzing noise on my radio, TV, or computer

We suggest you use your cordless handset at least 3 feet away from electrical equipment and mobile phones.

There is interference in the earpiece and/or the internet connection is very slow when using the phone

You must plug the phone into the wall socket via an ADSL filter if you have broadband internet on your phone line.

The white light on the base is constantly flashing

You have new answering machine message(s). Press  to listen to them and the flashing will stop. My answering machine won't record messages or memos

1. Check that your answering machine is connected and switched on.
2. Answering memory may be full. See page 17.

My remote access isn't working

1. Check you're using the correct PIN. See page 17 and 18.
2. Make sure you're using a touchtone phone.

Energy efficient power adapter

The included power adapter meets the eco-design requirements of the European Union (Directive 2005/32/EG).



Disposal

The  symbol on this product indicates that electrical and electronic apparatus and battery pack must be disposed of **separately** from domestic waste at suitable collection points provided by the public waste authorities.

Technical Details

Standard	DECT ¹ GAP ²
Power supply (base station)	Input: 100-240V ~50/60Hz 0.15A Output: 6VDC 800mA
Range	Outdoors Approx 325 yards/300m Indoors Approx 53 yards/50m
Standby	Up to 100hrs
Maximum Talk Time	Up to 10hrs
Rechargeable battery pack	AAA 3.6V 750mAh NiMH in handset unit.
Dialling mode	Tone (DTMF) Pulse
Optimum ambient temperature	32°F to 113°F (0°C to 45°C)
Optimum relative humidity	20% to 80%
Recall	300, 600 ms

¹ DECT: Digital Enhanced Cordless Telecommunication

² GAP: Generic Access Profile = standard for the operation of handsets and base stations from different manufacturers.

Default Settings

Cordless handset

Language	English
Handset name	PowerTel
Handset ringing melody (external)	7
Handset ringing melody (internal)	9
Handset ringing volume	5
Base ringing melody	8
Base ringing volume	5
Keypad beep	On
Auto talk	On
Contrast	3
Backlight time	10s
Boost memory	Off
Recall time	600ms
Dialing mode	Tone
PIN code	0000

Telephone answering machine

Language	English
Answer mode	Answer and record
PIN code for remote access	000
Answer delay	3
Time format	12 hour

Maintenance and Warranty

Maintenance

- Please clean your equipment's surfaces with a soft, lint-free cloth.
- Never use cleaning agents or solvents.

Warranty

AMPLICOM equipment is produced and tested according to the latest production methods. The implementation of carefully chosen materials and highly developed technologies ensure trouble free functioning and a long service life. The terms of the warranty do not apply where the cause of the equipment malfunction is the fault of the telephone network operator or any interposed private branch extension system. The terms of the warranty do not apply to the rechargeable battery pack or power packs used in the products. The period of warranty is 24 months from the date of purchase.

All deficiencies resulting from material of production faults which occur during the period of warranty will be eliminated free of charge. Rights to claims under the terms of warranty are annulled following intervention by the purchaser or third parties. Damage caused as a result of improper handling or operation, incorrect positioning or storing, improper connection or installation, Acts of God or other external influence are not covered by the terms of warranty.

In the case of complaints, we reserve the right to repair or replace defect parts or provide a replacement device. Replacement parts or devices become

our property.

Rights to compensation in the case of damage are excluded where there is no evidence of intent or gross negligence by the manufacturer.

If your equipment shows signs of defect during the period of warranty, please return to the sales outlet in which you purchased the AMPLICOM equipment together with the purchase receipt. All rights to claims under the terms of warranty in accordance with this agreement must be asserted exclusively with regard to your sales outlet.

Two years after the purchase of our products, claims under the terms of warranty can no longer be asserted.

Declaration of conformity

The ETL Listed Mark is an alternative to the CSA and UL marks. ETL Testing Laboratories owned by Intertek Testing Services (ITS) is recognized by OSHA as a Nationally Recognized Testing Laboratory (NRTL). ITS tests products according to nearly 200 safety and performance standards. The ETL Listed Mark is accepted throughout the United States when denoting compliance with nationally recognized standards such as ANSI, IEC, UL, and CSA.



This certification mark indicates that the product has been tested to and has met the minimum requirements of a widely recognized (consensus) U.S. product safety standard, that the manufacturing site has been audited, and that the applicant has agreed to a program of periodic factory follow-up inspections to verify continued conformance.

A

- Adjusting the handsfree volume 26
- Adjusting the earpiece volume 25
- Alarm 38
- Answering machine 12
- Auto talk 36

B

- Backlight timer 36
- Base ringer melody 38
- Base ringer volume 39
- Base settings 38
- Boosting the earpiece volume 26

C

- Changing the system's PIN code 33
- Change case 40
- Charging the battery pack 10
- Checking messages 13, 16
- Conference calls 31
- Connecting the base and charger 10
- Contrast 36

D

- Date/time 14, 37
- Default settings 55
- De-register a handset 29
- Dial mode 22
- Dialing pause 22
- Dialing from the phone book 25
- Dialing from a speed dial button 25
- Display icons 9

E

- Earpiece volume 24
- End a call 24
- Entering names in the phone book 40
- Equalizer 36

F

- Find a handset 28

H

Handset name 30
Handset ringer melody 36
Handset ringer on/off 27
Handset ringer volume 36
Handsfree 26
Headset use 27

I

Internal calls 31

K

Keypad lock 28
Keypad beep on/off 36

L

Language 12,37

M

Making a call 24
Making internal calls 31
Memory full 17
Mute 27

P

Phone book 39,43

R

Record outgoing message 13,19
Redial 24
Register a handset 29
Remotely checking messages 18
Reset to default settings 23

S

Speed dial 25

T

Tone control 35,36

U

Using a headset 27
Using the menu 11

This page intentionally left blank.