

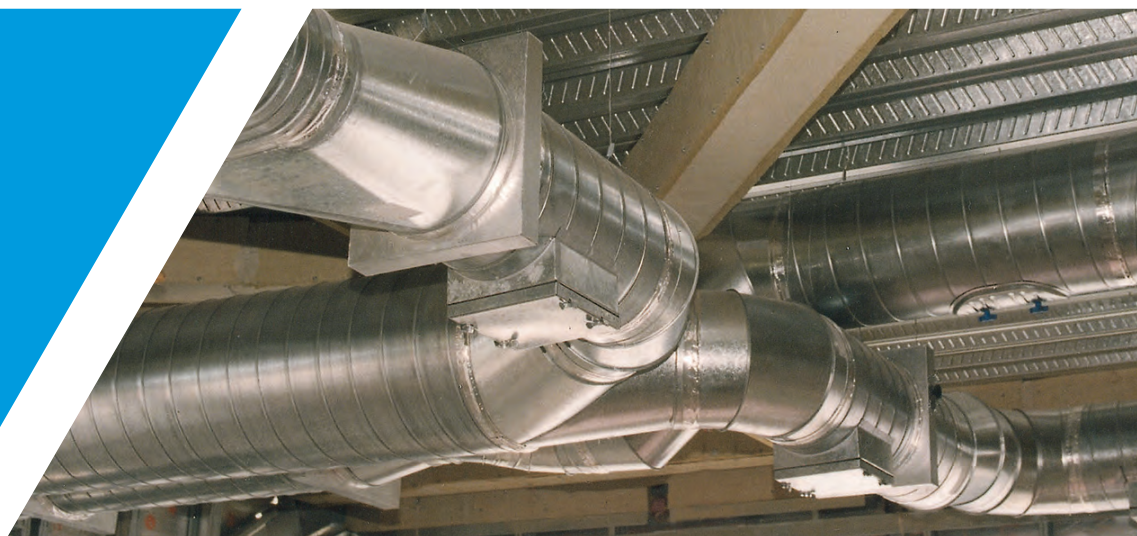

Hanger Systems

For suspending M&E services, HVAC and signage

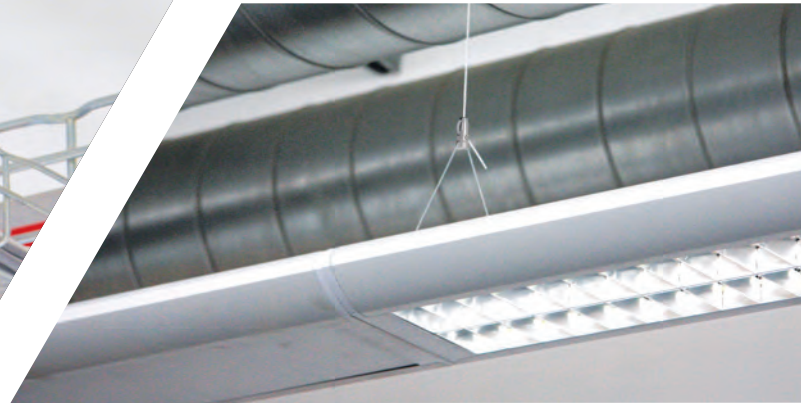

Introduction

What is a Gripple® hanger?

The Gripple hanger is supplied as part of a complete suspension kit, comprising the hanger and a high-tensile wire rope with a choice of fixing attached to it. The Gripple hanger incorporates a patented self-locking fastener mechanism that not only secures the wire rope, but also allows adjustment of the installation height.

The Gripple hanger is specifically designed to enable quick and easy installation of a variety of MEP (mechanical, electrical and plumbing) services and is a proven replacement to traditional threaded rod and chain solutions.

Gripple hangers are manufactured in a range of five standard sizes, all with an individual safe working load (from 10 kg up to 325 kg) and a safety factor of 5:1.

How does it work?

When the wire rope is inserted into the Gripple hanger channel and pulled through the other side, it's held in place by a spring-loaded high precision serrated wedge, allowing the wire to go one way, but not the other. The wire rope is then looped through the identical channel on the opposite side, providing a means of suspension. The Gripple hanger allows full adjustment to position the object being suspended.

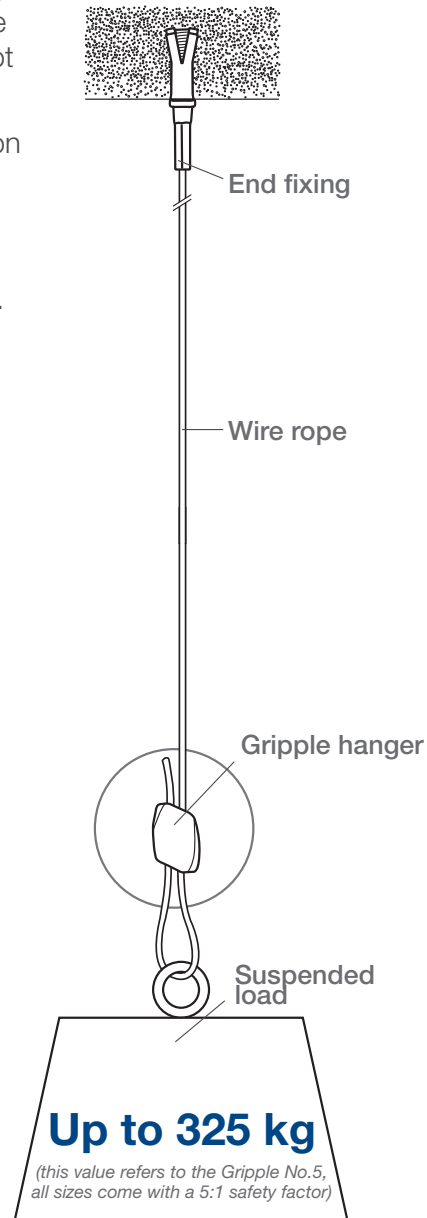
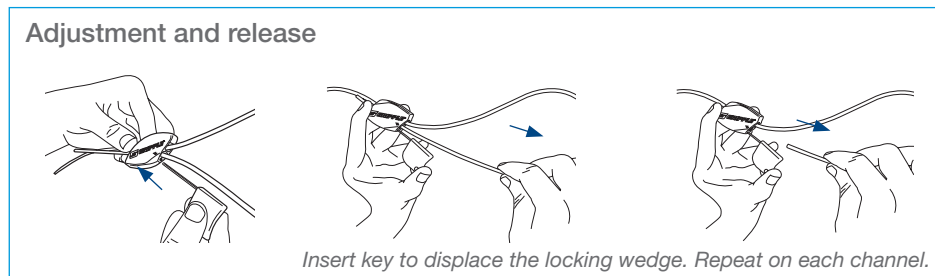
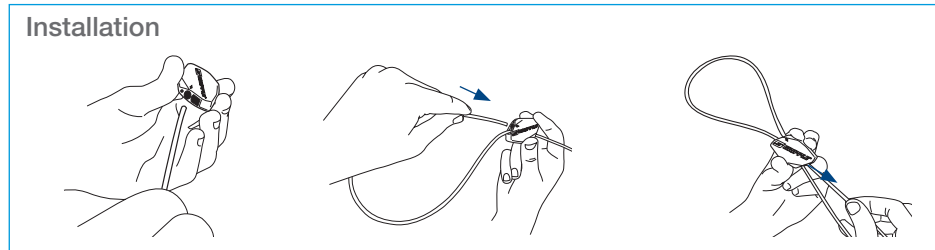

What are the benefits of using Gripple hangers?

- Saves time and money - Up to six times faster to install than traditional threaded rod.
- Lightweight and aesthetically pleasing - Discreet and lightweight, the Gripple hanger delivers a solution which is aesthetically pleasing and is also easier to handle, improving site safety.
- Strong and versatile - Gripple hangers are available in 5 load rated sizes (see Table 1 on Page 3), each designed to carry a specific weight range and designated safe working load (SWL). Gripple hangers can be installed vertically or at an angle to the suspended object (see Table 2 on Page 3).
- Environmentally friendly - By replacing a typical threaded rod installation with the Gripple hanger system, steel consumption is reduced by up to 95%, and vehicle movements are also reduced, lowering carbon emissions.
- Supplied in ready-to-use kits - The Gripple hanger is supplied as part of a complete suspension kit, comprising the hanger and a high-tensile wire rope with a choice of fixing attached to it. A setting key is also provided for unlocking and adjusting the Gripple hanger.

Technical information

Load ratings

Gripple hangers are available in 5 load rated sizes. Each size is designed to carry a specific weight range and has a designated safe working load (SWL). The SWL gives a minimum 5:1 safety factor in a vertical plane and applies to all lengths and end fixings, unless stated otherwise.

Table 1

Wire rope size	Weight Range	Safe Working Load
No.1	0 - 10 kg	10 kg
No.2	11 - 45 kg	45 kg
No.3	46 - 90 kg	90 kg
No.4	91 - 225 kg	225 kg
No.5	226 - 325 kg	325 kg

Hanging at angles

The load rating for a Gripple hanger is based on the suspension being hung vertically. If the wire rope is suspended at an angle, an additional sideways load is applied which reduces the load capacity of the overall suspension. The net effect is shown in the table below.

Table 2

Hanger size	Maximum load (kg) at an angle from vertical				
	0°	15°	30°	45°	60°
No.1	10	9.6	8.6	7	5
No.2	45	43	39	32	22
No.3	90	87	78	64	45
No.4	225	217	195	159	113
No.5	325	314	281	230	163
Load %	100	96	86	70	50

No Gripple hanger should be hung at an angle in excess of 60° from vertical

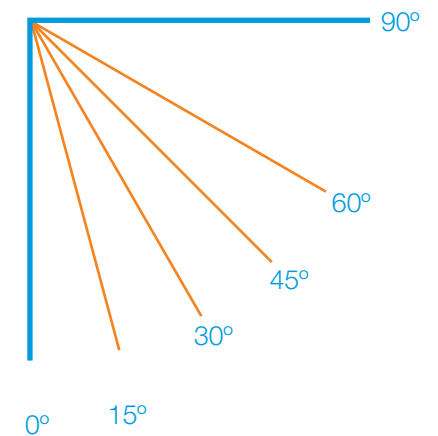

Quality and approvals

Quality is everything to Gripple; not just in the products we make and the manufacturing process we employ, but the way we do business. Our compliance to BS EN ISO9001 at our Sheffield manufacturing plant is the backbone of our own quality management system achieved under the auspices of the reputable LRQA.



Gripple's policy is one of continuous development and innovation. We therefore reserve the right to alter specifications, etc. without notice.

Applications- HVAC: Ventilation

Rectangular ducting, spiral ducting, oval ducting and PI foam ducting



Spiral ducting

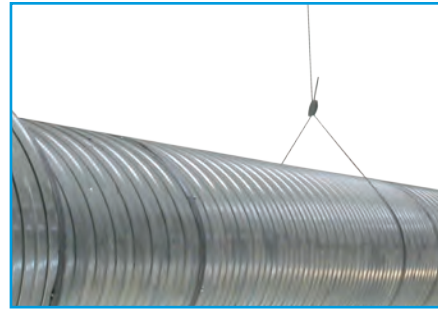

Spiral ducting



Oval ducting

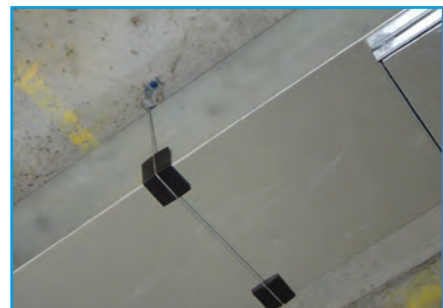
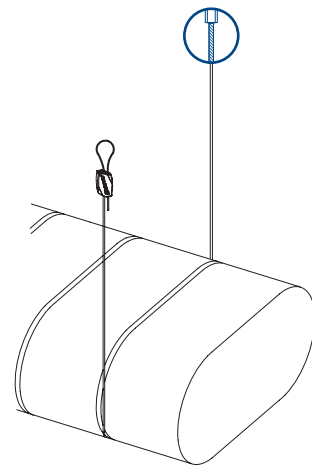
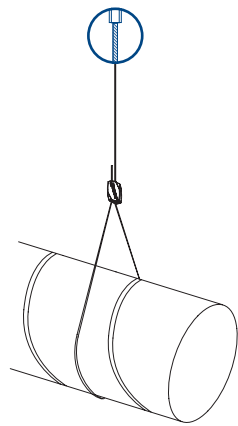
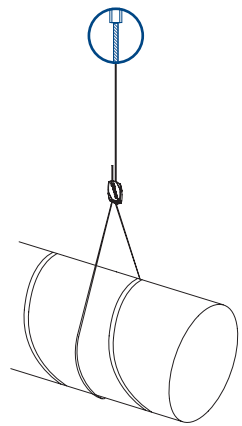

Rectangular ducting

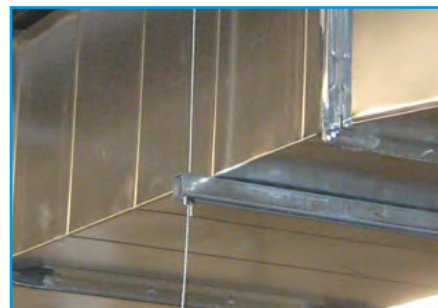

Rectangular ducting



PI foam ducting

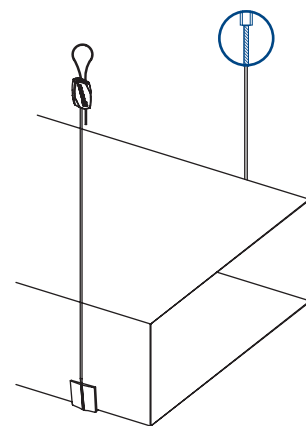
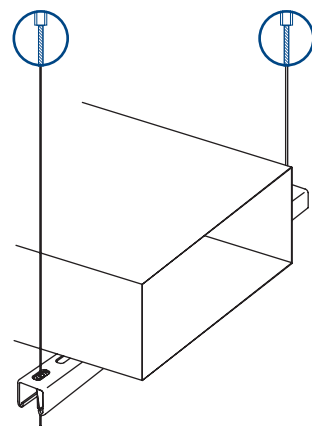
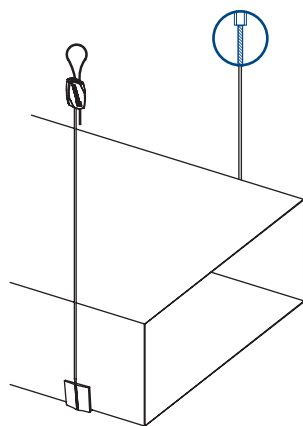

HVAC: Air Conditioning

Fabric ducting, swirl diffuser, plenum boxes, air conditioning units, refrigerant pipes and condensate pipes



Fabric ducting



Swirl diffuser



Plenum boxes

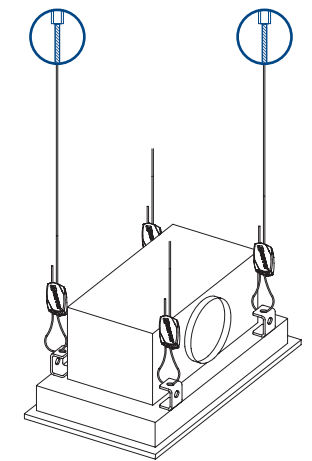
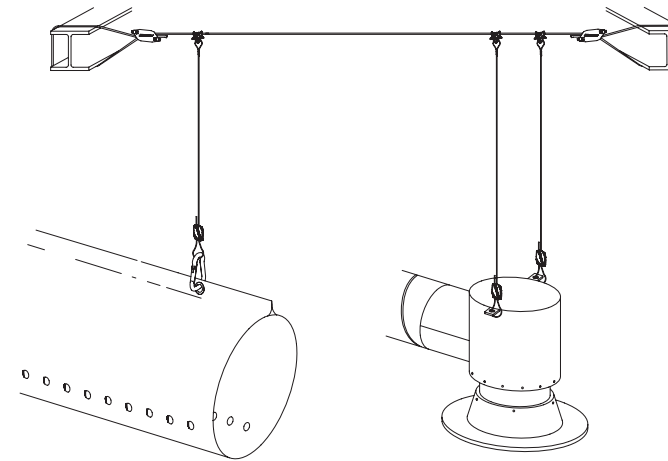

Air conditioning units



Refrigerant pipes



Condensate pipes

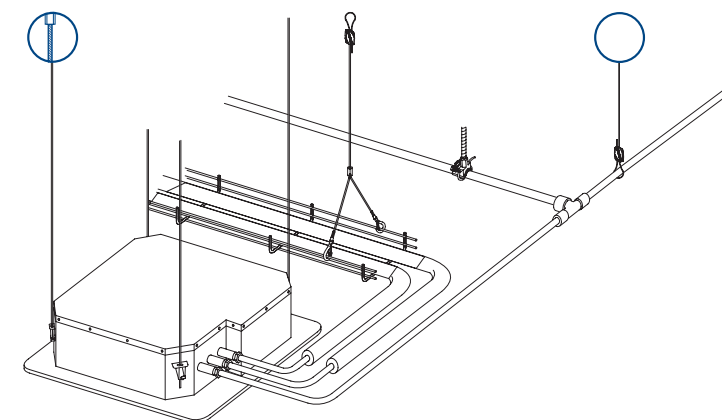

Mechanical

Copper pipes, steel pipes, intermediary supports, bracing and pipe rack



Copper pipes

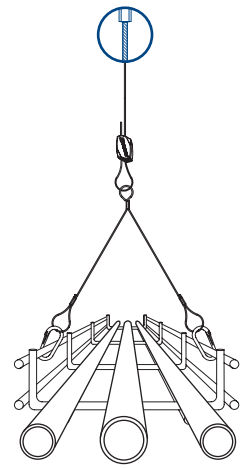

Steel pipes

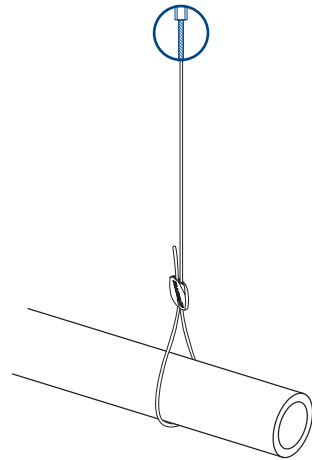

Plastic pipes

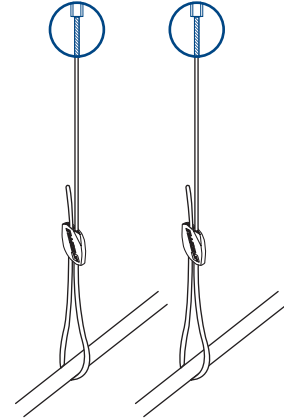

Intermediary supports for steel pipes

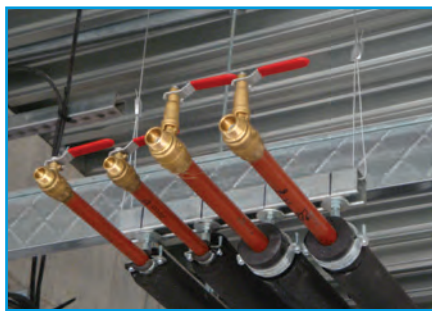
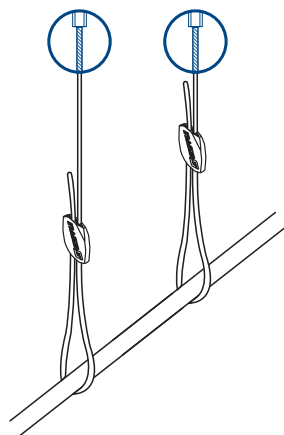

Steel pipes

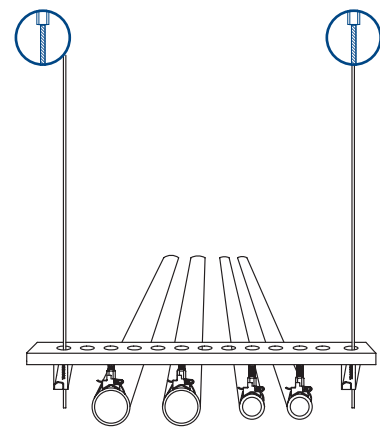

Bracing for steel pipes

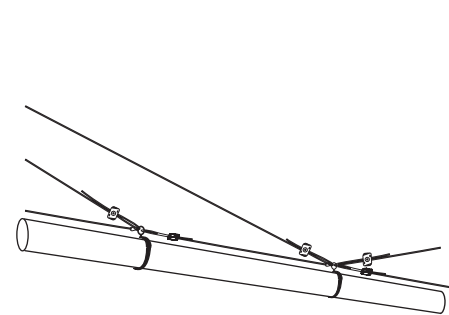

Electrical: Cable Containment

All types of cable containment on basket or tray



Cable basket

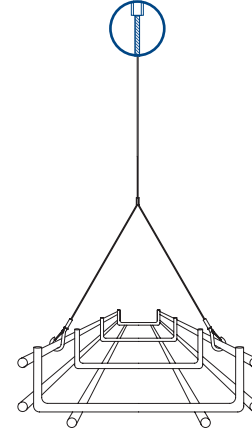

Cable basket

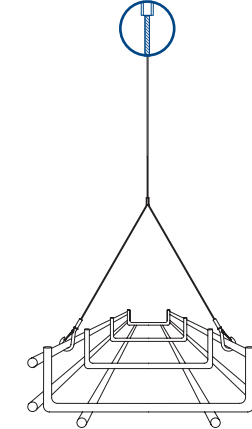

Perforated cable tray on channel

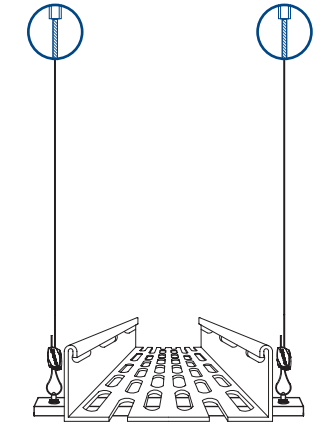

Multi-tiered cable basket on Trapeze

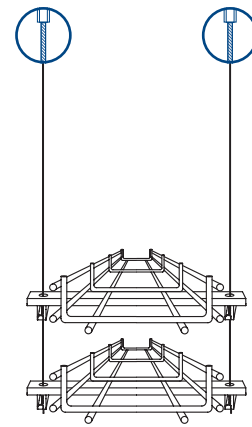

Ladder

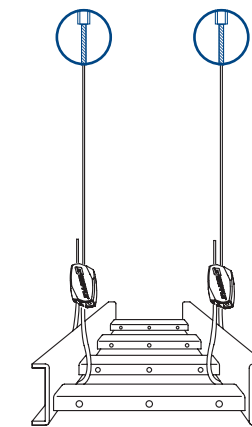

Multiple cable trays on single channel

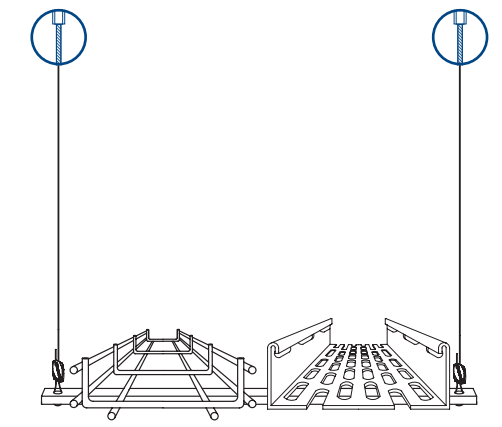

Electrical: Lighting

All types of hanging solutions for lighting



Industrial high bay

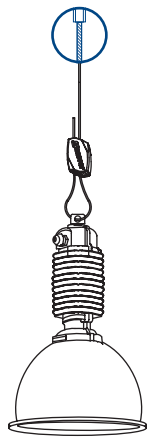

Strip lighting

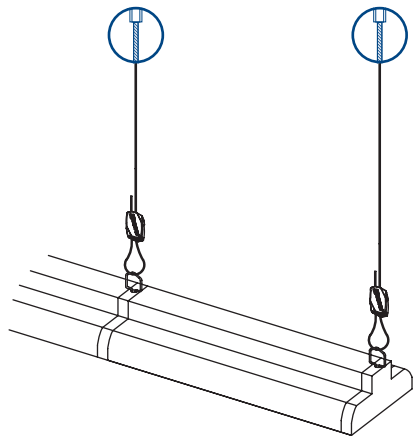

Panel lighting

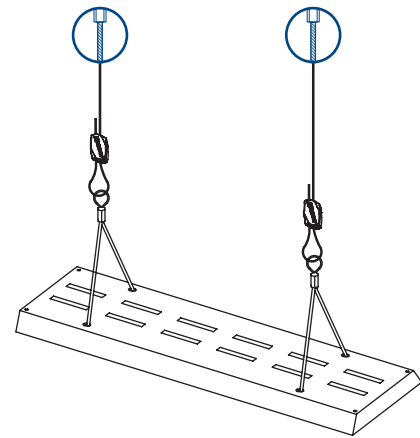

Busbar

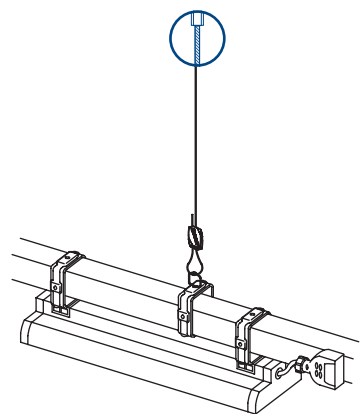

Lighting and Camera on Catenary

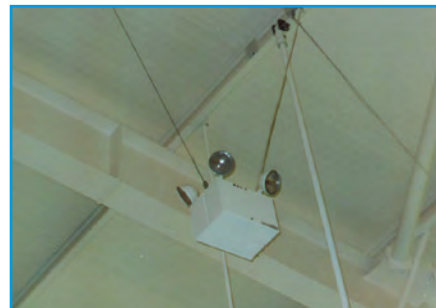
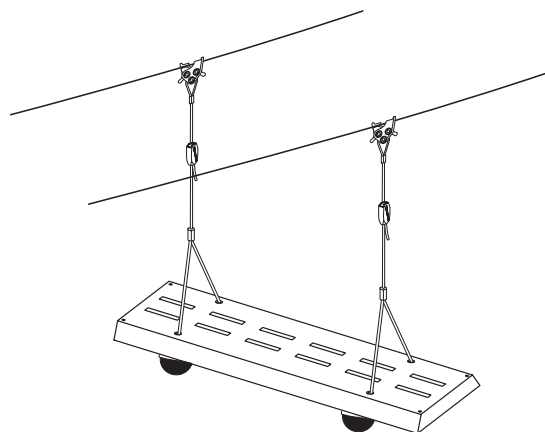

Emergency Lighting

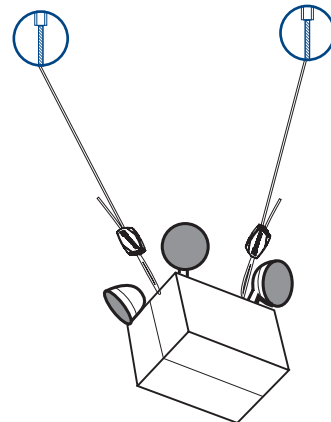

Electrical: Lighting

Architectural lighting suspensions when aesthetics are important



Angel

A variety of feet for suspending all types of lighting, signage and acoustic panels



From left to right: Y-Fit, Integrated Side Hook, Side Exit - Female, Side Exit - Male, Central Exit, Signage, Swivel, Signage Rail, Disc

Signage



In store signs

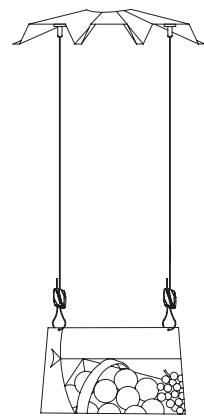

Information signs

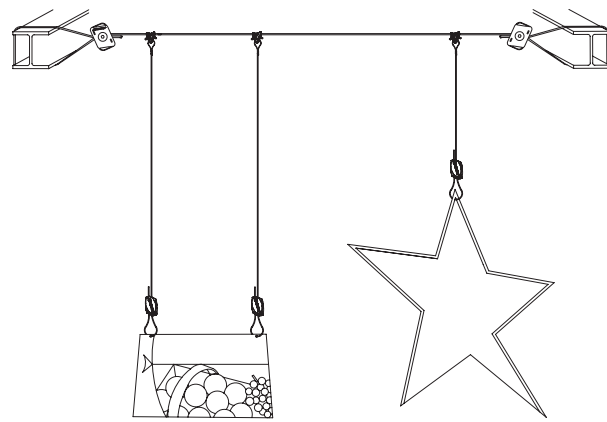

In store decorations

Cold Rooms

For positive and negative temperatures



Sandwich panel



Under panel lighting



Under panel evaporator

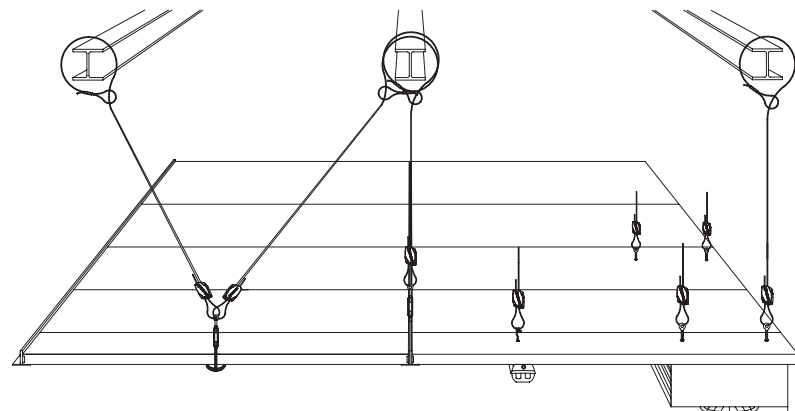

Suspended Ceilings

Suspended ceilings, acoustic baffles and decorative panels



Acoustic baffles

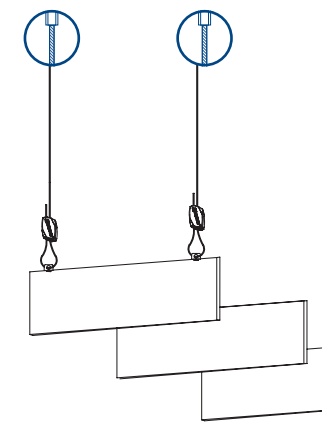

Suspended raft ceilings

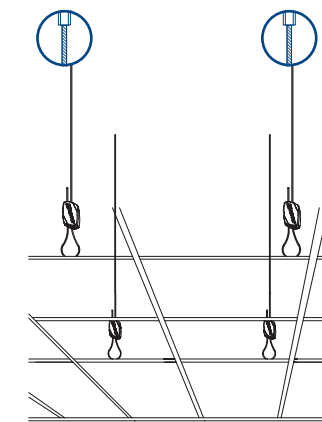

Contoured raft ceilings

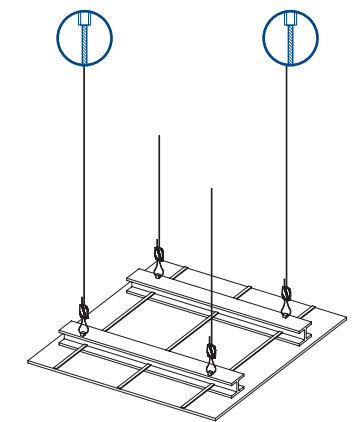

Decorative ceiling panels



Catenaries

Horizontal wire rope solution



Busbar and Lighting



Spiral ducting



Cable tray

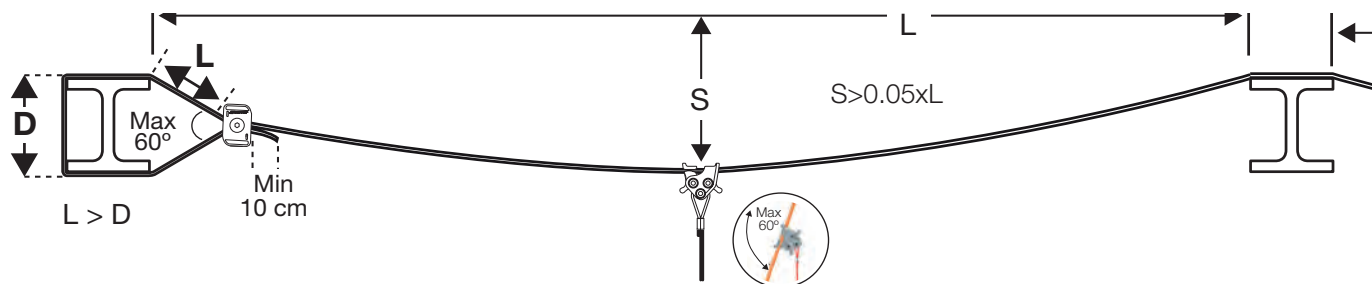
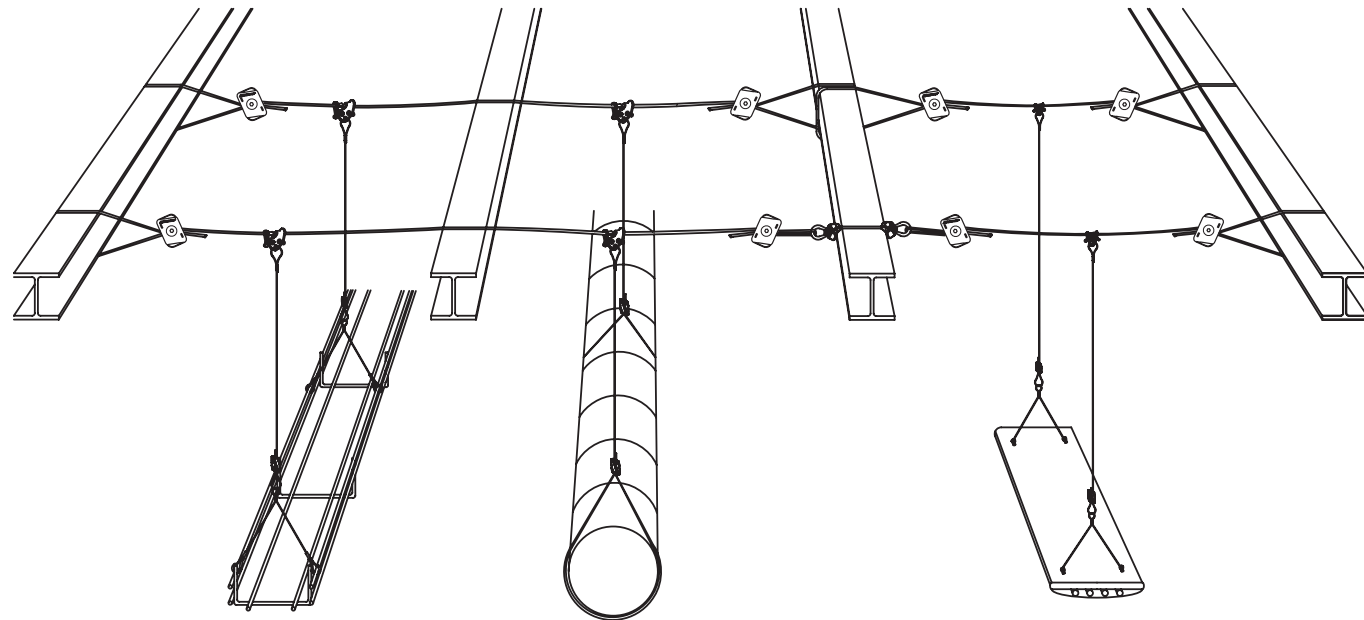

Other Applications

Fan coil units, chilled beams, decorations, loud speakers, diffuser kit & radiant panels



Decorations

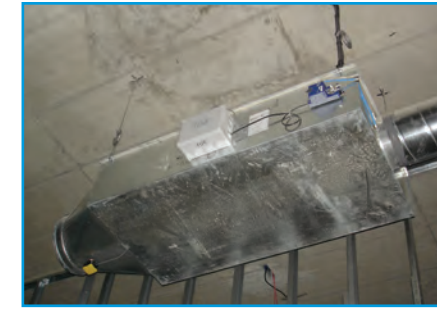

Fan coil units



Chilled beams

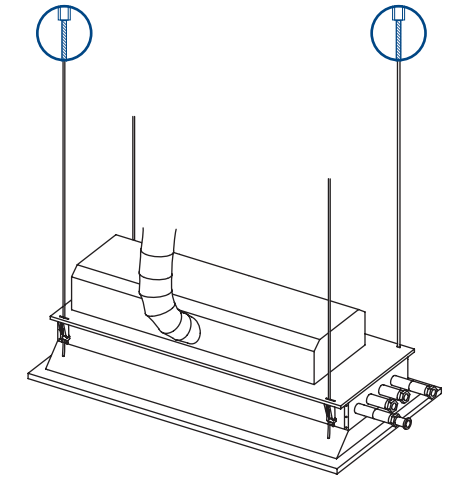
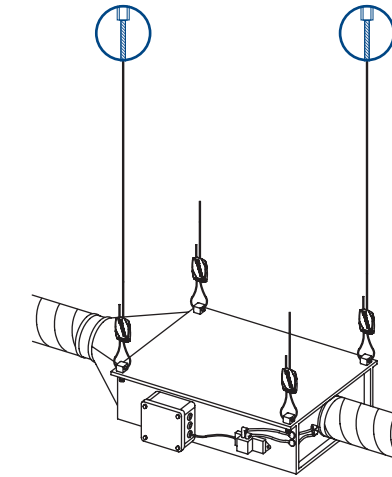
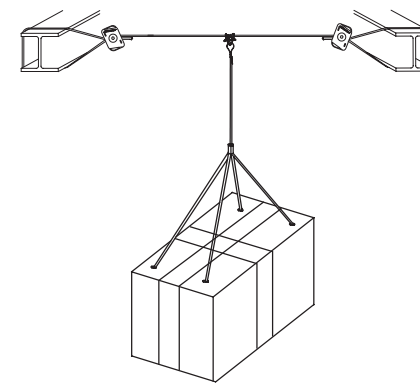

Loudspeakers



Diffuser kit



Radiant panels

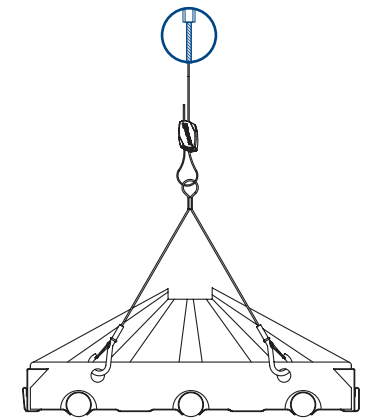
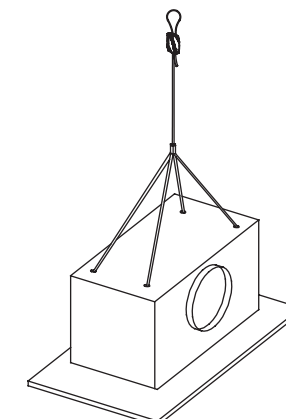
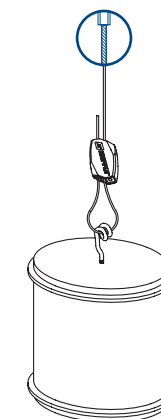

Seismic Bracing Solutions

A complete kit offering secure bracing in active seismic locations

Gripple Ltd. is a leading provider of seismic bracing and blast protection systems.

In contrast to standard wire bracing, Gripple's seismic system is fully tested and approved to OSHPD OPA-2123-10 and UL NEBS GR 63 Core Certification and has SMACNA verification, recognised as the most demanding requirement in the world.



Gripple Seismic Wire Bracing Systems

Gripple® Seismic Wire Bracing Solutions are pre-engineered systems that are up to 10 times faster to install, and can be used to brace new or retrofit nonstructural equipment or components. They require no tools to install, and no field swaging of wires. There are four wire bracing kit sizes, each with its own selection of wire lengths, end fittings, and brackets:

- GS10 Seismic Bracing Kit - Design Strength (LRFD*): 158 kg
- GS12 Seismic Bracing Kit - Design Strength (LRFD*): 476 kg
- GS19 Seismic Bracing Kit - Design Strength (LRFD*): 952 kg
- GS25 Seismic Bracing Kit - Design Strength (LRFD*): 1,746 kg

* Load Resistance Factor Design

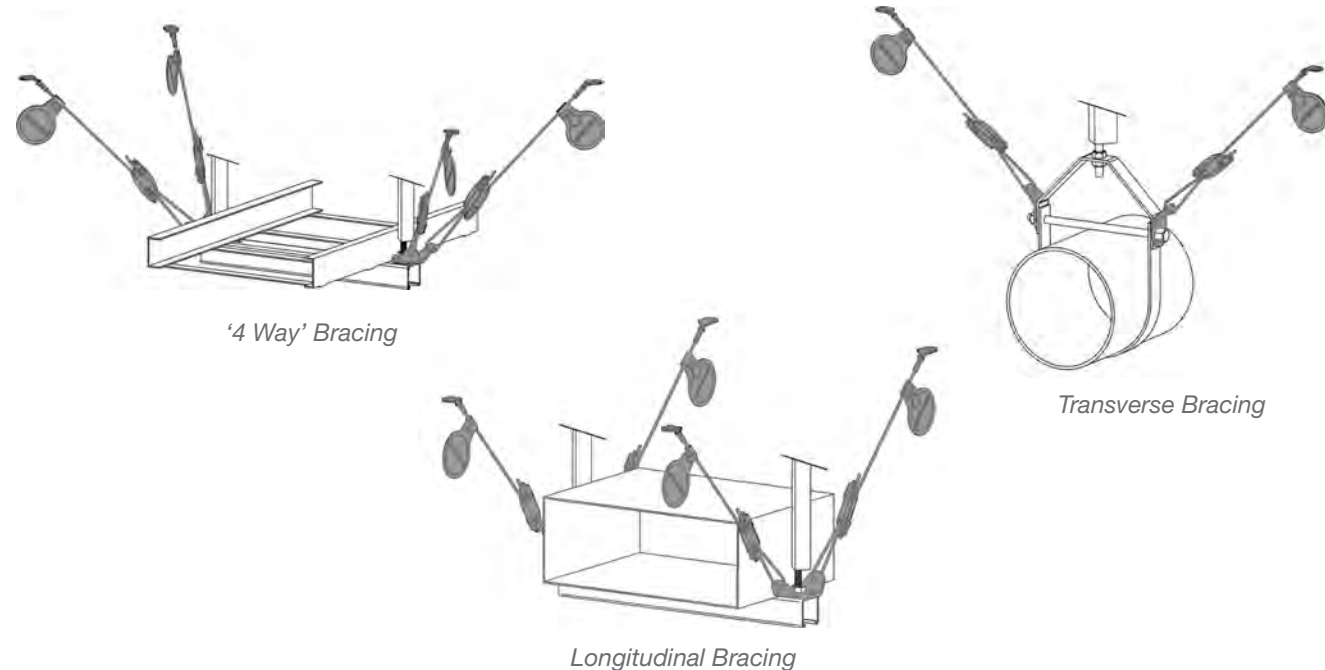

'4 Way' Bracing

Transverse Bracing

Longitudinal Bracing

Engineering Services

The complex and technical nature of seismic bracing requirements, industry regulations, and life-safety issues necessitates a partner like Gripple who can offer you complete beginning-to-end engineering services, such as:

- PE Stamped Drawings
 - Engineered seismic bracing calculations based on design category, occupancy, importance and relevant site specific seismic specifications.
 - Detailed engineer's sealed drawings (electronic format) prepared in AutoCAD or .pdf files (submitted by the consultant/contractor) indicating the location of seismic bracing points and bracket type.
- Coordination and Site Reviews - with Structural Engineer and Gripple to ensure proper installation of products.
- Gripple on-site training on seismic product installation.
- Budget Estimating - Our project quote for engineering services and products is all-inclusive and will not increase after signed off on. We do not add additional charges or fees once the project quote has been agreed upon.
- Products - And finally, we'll provide you with the appropriate quantity of complete Gripple Seismic Wire Brace Assembly Kits and/or vibration isolation products per Engineer's calculations for the required services.

Gripple has a wealth of experience, talents, and resources with which to provide you a complete Seismic Solution. Contact your local Gripple Territory Manager for assistance or information regarding any of the Engineering services we provide, and to ensure that your seismic bracing job is up to spec.

Approvals and Certificates

OSHPD OPA Pre-Approval

Following extensive testing and qualifications, Gripple® Seismic Wire Bracing Systems GS10, GS12, and GS19 have been assigned OPA-2123-10 for Fixed Equipment Anchorage by the California Office of Statewide Health Planning & Development (OSHPD).

SMACNA Verification

The Sheet Metal and Air Conditioning Contractors National Association (SMACNA) has deemed Gripple® Seismic an acceptable alternative for seismic hanger bracing in strict accordance with the ANSI / SMACNA Seismic Restraint Manual – Guidelines for Mechanical Systems.

UL NEBS GR 63 Core Certification

UL has awarded Gripple® Seismic the UL NEBS GR 63 Core Certification based on surpassing extensive shaker table testing requirements. Gripple® Seismic is the only seismic bracing company to hold this certification.

Additional Approvals

In addition, Gripple® Seismic has undergone all of the proper qualifications and extensive strength testing to meet any seismic design code requirements including: International Building Code, California State Building Code, National Fire Protection Association, and American Society of Civil Engineers.



'4 Way' Bracing



Longitudinal Bracing



Transverse Bracing

Gripple Strut and Rigid Support System

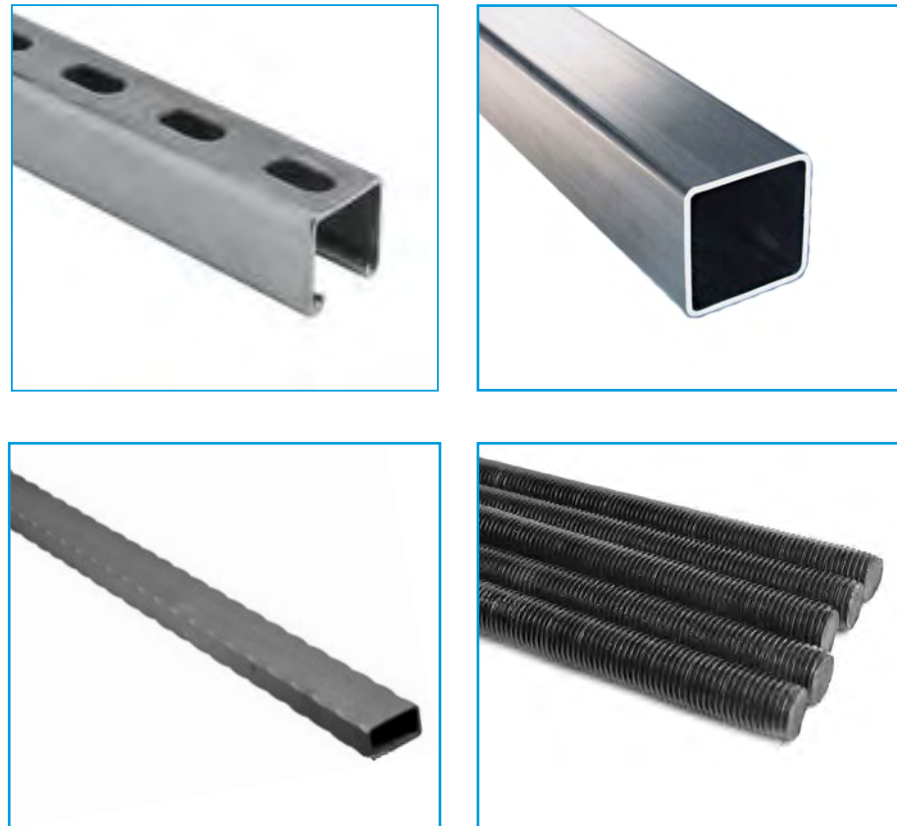

Technical Support

In situations where heavy loads need to be suspended such as heavy piping, Gripple will include a strut and rigid support system as part of the solution design. This is fixed at incremental lengths to provide additional support to the wire hanging system.

- Stress analysis

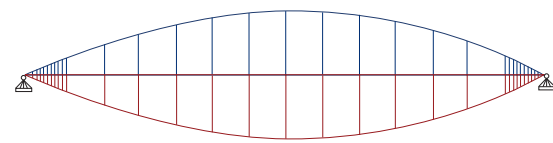

- Bespoke design as per application

- Deflection and shear analysis

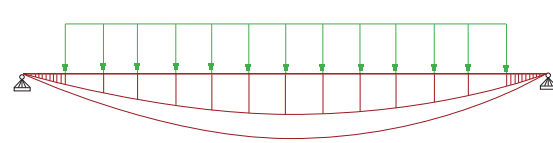

- Complete technical back-up

Strut Support System

GCS412125

Gripple strut support system are accurately and carefully cold formed to size from low-carbon strip steel. The design is customised to be used with Gripple Clamping System. Customised profiles are available.

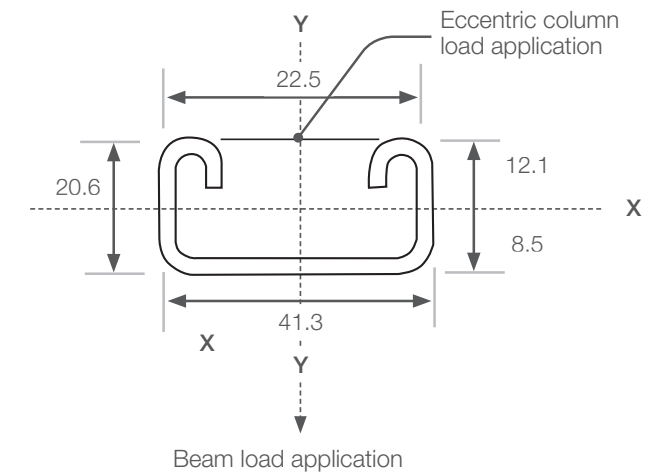

Section Properties

For use with static loads only

Area	Weight	Ixx	Zxx	Zxx	rxx	Iyy	Zyy	ryy
cm ²	kg/m	cm ⁴	(top)	(bottom)	cm	cm ⁴	cm ³	cm
2.35	1.85	1.2	1	1.43	0.72	5.44	2.63	1.5

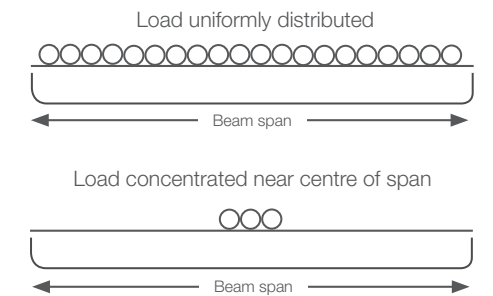

Safe Working Load Table

Length (m)	Safe Working Load (kg) Uniform		Def. limit span/200 (kg)	Def. limit span/360 (kg)	Safe Working Loads (kg) concentrated		Def. limit span/200 (kg)	Def. limit span/360 (kg)	Safe column loads kg at Centre	Safe column loads kg at Face
	(kg) Load	(mm) Def.			(kg) Load	(mm) Def.				
0.6	242	2.64	242	155	123	2.11	123	98	2988	904
0.7	208	3.59	203	115	106	2.87	106	74	2481	831
0.8	182	4.68	156	89	94	3.75	94	58	2029	757
0.9	163	5.94	125	71	84	4.75	80	47	1667	687
1.0	147	7.33	102	59	76	5.86	66	39	1385	623
1.1	134	8.87	85	49	70	7.09	55	33	1166	566
1.2	123	10.55	72	42	64	8.44	47	28	994	515
1.3	114	12.38	62	37	60	9.91	41	25		
1.4	106	14.36	54	32	56	11.49	36	22		
1.5	100	16.49	48	29	52	13.18	32	20		
1.6	91	18.76	40	23	46	15.00	26	15		
1.7	86	21.18	36	21	44	16.95	23	14		
1.8	81	23.74	32	19	41	19.00	21	12		
1.9	77	26.45	29	17	39	21.16	19	11		
2.0	73	29.31	26	15	37	23.45	17	10		
2.1	70	32.31	24	14	36	25.86	16	10		
2.2	67	35.46	22	13	34	28.38	15	9		
2.3	64	38.76	20	12	33	31.01	13	8		
2.4	61	42.2	19	11	32	33.77	13	8		
2.5	59	45.8	18	11	30	36.63	12	7		
2.6	57	49.53	16	10	29	39.63	11	7		
2.7	55	53.42	15	9	28	42.74	10	7		
2.8	53	57.45	14	9	27	45.95	10	6		
2.9	51	61.62	14	8	26	49.29	9	6		
3.0	49	65.95	13	8	26	52.76	9	6		

$$\frac{\alpha Le}{r_{xx}} > 180$$

Strut Support System

GCS414125

Gripple strut support system are accurately and carefully cold formed to size from low-carbon strip steel. The design is customised to be used with Gripple Clamping System. Customised profiles are available.

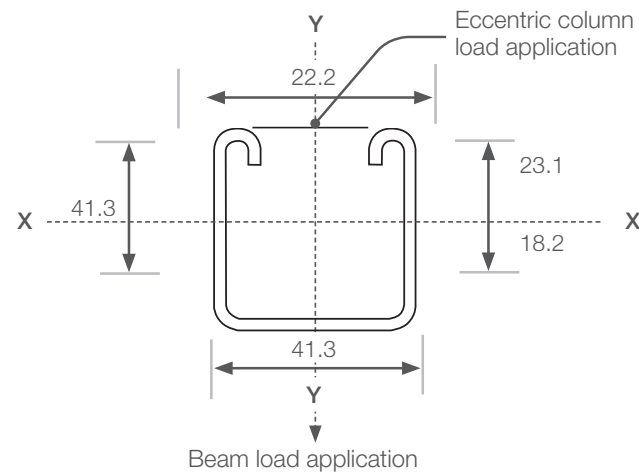

Section Properties

For use with static loads only

Area	Weight	Ixx	Zxx	Zxx	rxx	Iyy	Zyy	ryy
cm ²	kg/m	cm ⁴	(top)	(bottom)	cm	cm ⁴	cm ³	cm
3.39	2.67	7.32	3.17	4.03	1.5	9.34	4.5	1.66

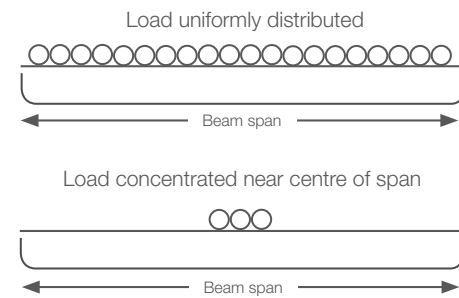

Safe Working Load Table

Length (m)	Safe Working Load (kg) Uniform		Def. limit span/200 (kg)	Def. limit span/360 (kg)	Safe Working Loads (kg) concentrated		Def. limit span/200 (kg)	Def. limit span/360 (kg)	Safe column loads kg at Centre	Safe column loads kg at Face
	(kg) Load	(mm) Def.			(kg) Load	(mm) Def.				
0.6	759	1.39	759	759	382	1.11	382	382	5186	1567
0.7	651	1.88	651	651	329	1.51	329	329	4828	1506
0.8	571	2.46	571	571	288	1.98	288	288	4381	1434
0.9	508	3.11	508	408	257	2.5	257	257	3938	1361
1.0	457	3.85	457	332	231	3.08	231	209	3522	1290
1.1	416	4.66	416	275	211	3.72	211	174	3156	1221
1.2	382	5.54	382	232	194	4.43	194	147	2811	1152
1.3	353	6.51	353	198	180	5.21	180	126	2551	1094
1.4	329	7.54	305	172	167	6.04	167	109	2333	1043
1.5	306	8.66	266	150	156	6.92	156	96	2122	990
1.6	284	9.86	232	130	143	7.88	143	82	1971	949
1.7	269	11.12	205	115	135	8.91	129	73	1817	905
1.8	253	12.47	183	103	127	9.98	115	65	1685	865
1.9	241	13.89	165	93	122	11.11	104	59	1596	837
2.0	228	15.39	149	84	115	12.31	94	53	1496	805
2.1	217	16.97	135	76	110	13.58	85	48	1388	768
2.2	208	18.63	123	70	105	14.9	78	44	1314	741
2.3	199	20.36	113	64	101	16.28	71	41	1249	717
2.4	190	22.16	104	59	96	17.73	66	37		
2.5	183	24.06	96	54	93	19.25	61	35		
2.6	176	26.02	89	51	89	20.81	56	32		
2.7	170	28.06	83	47	86	22.45	52	30		
2.8	163	30.17	77	44	83	24.14	49	28		
2.9	158	32.37	72	41	80	25.89	46	26		
3.0	153	34.63	67	39	78	27.71	43	25		

Strut Support System

GCHS414125

Gripple strut support system are accurately and carefully cold formed to size from low-carbon strip steel. The design is customised to be used with Gripple Clamping System. Customised profiles are available.

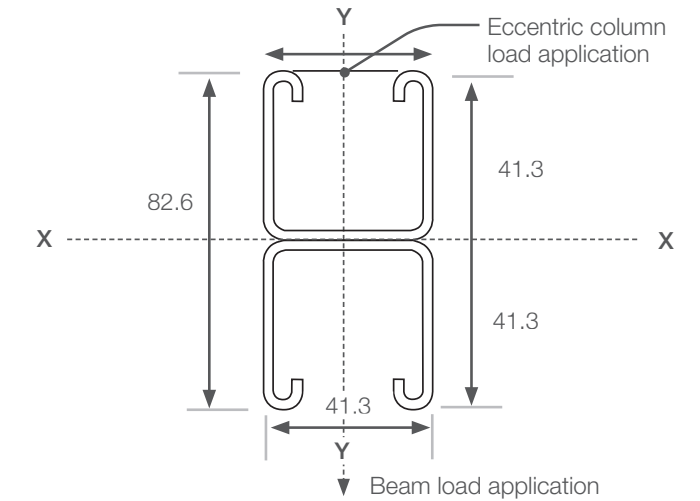

Section Properties

For use with static loads only

Area	Weight	Ixx	Zxx	Zxx	rxx	Iyy	Zyy	ryy
cm ²	kg/m	cm ⁴	(top)	(bottom)	cm	cm ⁴	cm ³	cm
6.78	5.34	37.2	9.01	9.01	2.3	18.68	9.1	1.66

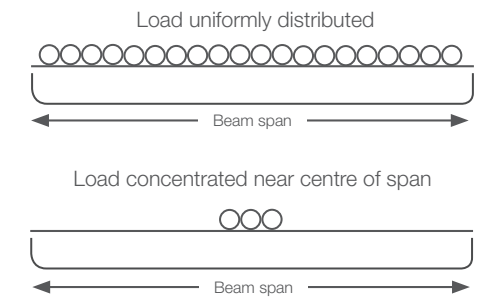

Safe Working Load Table

Length (m)	Safe Working Load (kg) Uniform		Def. limit span/200 (kg)	Def. limit span/360 (kg)	Safe Working Loads (kg) concentrated		Def. limit span/200 (kg)	Def. limit span/360 (kg)	Safe column loads kg at Centre	Safe column loads kg at Face
	(kg) Load	(mm) Def.			(kg) Load	(mm) Def.				
0.6	2148	0.77	2148	2148	1077	0.61	1077	1077	11646	2896
0.7	1842	1.05	1842	1842	923	0.84	923	923	11441	2873
0.8	1612	1.38	1612	1612	809	1.1	809	809	11203	2846
0.9	1434	1.75	1434	1434	719	1.4	719	719	10922	2815
1.0	1291	2.15	1291	1291	648	1.72	648	648	10584	2779
1.1	1174	2.61	1174	1174	589	2.09	589	589	10178	2736
1.2	1077	3.1	1077	1077	541	2.48	541	541	9695	2685
1.3	994	3.64	934	986	500	2.92	500	500	9139	2626
1.4	923	4.22	923	851	464	3.38	464	464	8528	2559
1.5	862	4.85	862	742	434	3.88	434	434	7892	2486
1.6	806	5.51	806	650	404	4.4	404	404	7263	2407
1.7	758	6.23	758	576	380	4.98	380	361	6663	2326
1.8	716	6.98	716	514	359	5.58	359	322	6106	2243
1.9	679	7.77	679	461	340	6.22	340	289	5598	2161
2.0	645	8.61	645	417	323	6.89	323	261	5139	2080
2.1	614	9.5	614	378	308	7.6	308	237	4727	2001
2.2	586	10.43	586	345	284	8.35	284	216	4357	1925
2.3	561	11.39	561	316	282	9.11	282	198	4026	1850
2.4	538	12.4	520	290	270	9.92	270	182		
2.5	516	13.46	480	267	259	10.76	259	168		
2.6	497	14.56	444	247	249	11.65	249	155		
2.7	478	15.7	412	230	240	12.56	240	144		
2.8	461	16.88	383	214	232	13.5	232	134		
2.9	445	18.11	357	199	224	14.49	224	125		
3.0	431	19.38	334	186	216	15.5	209	117		

End Fixings

Each ready-to-use kit comes with an end fixing of your choice, ranging from the popular and versatile Loop, to more bespoke fixings designed for specific applications. We aim to provide a solution whatever the substrate as presented in our full range below, followed by detailed information on our most popular end fixings.



Loop

- Ideal for looping around purlins, beams, roof trusses and other suitable building features
- Available up to 325 kg SWL, with a 5:1 safety factor
- Comes as a ready-to-use kit with wire rope and a Gripple hanger
- Available in lengths from 1 m to 10 m
- Other lengths are available on request
- Available in Stainless steel

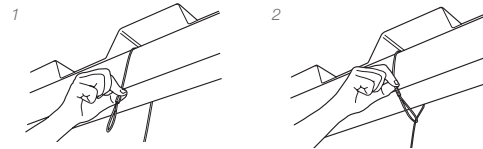

Stud

- Ideal for anchoring into concrete ceilings, metal decking and channel nuts
- Available in M6, M8 and M10, up to 225 kg SWL, with a 5:1 safety factor
- Supplied with drop-in anchors (as standard) or nuts as required
- Comes as a ready-to-use kit with wire rope and a Gripple hanger
- Available in lengths from 1 m to 10 m
- Other lengths are available on request
- Available in Stainless steel

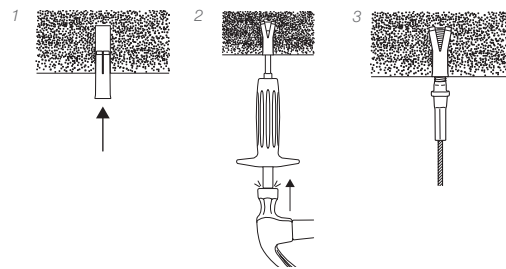

Toggle

- Ideal for roof cladding, light fittings, luminaires and other cavities
- Available up to 90 kg SWL, with a 5:1 safety factor
- Comes as a ready-to-use kit with wire rope and a Gripple hanger
- Available in lengths from 1 m to 10 m
- Other lengths are available on request
- Available in Stainless steel

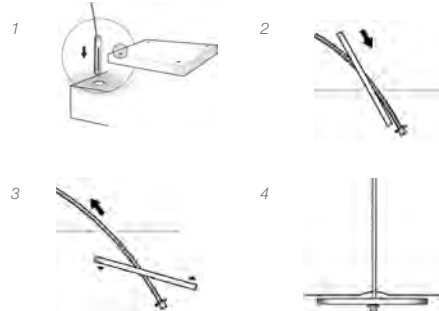

Snap hook

- Quick and easy attachment to cable basket, purlin clips and light fittings
- Available up to 90 kg SWL, with a 5:1 safety factor
- Comes as a ready-to-use kit with wire rope and a Gripple hanger
- Available in lengths from 1 m to 10 m
- Other lengths are available on request

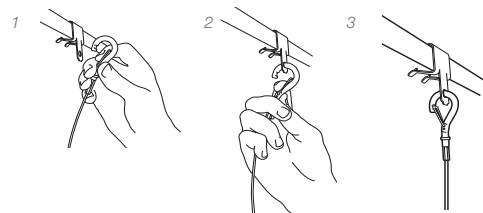

45° Eyelet

- Ideal for use in bracing applications
- Available up to 90 kg SWL, with a 5:1 safety factor
- Comes as a ready-to-use kit with wire rope and a Gripple hanger

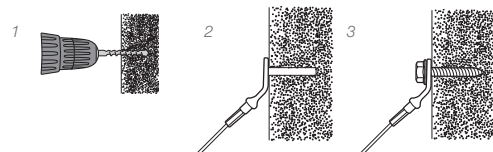

TR60 Wedge

Designed for use with Structural Metal Decks TR60+ and TR80+



Features & Benefits

- Adjustable and removable, no need for specialist tools or skills
- Available up to 100 kg SWL, with a 3:1 safety factor
- Comes as a complete kit with wire, Gripple fastener and setting key

Installation

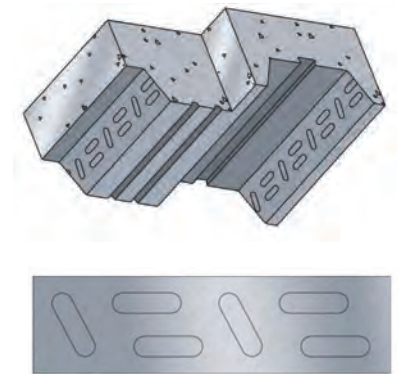
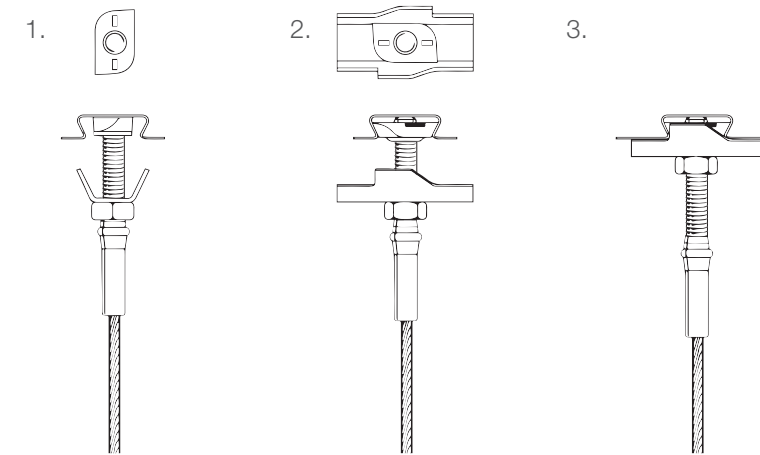

Specification

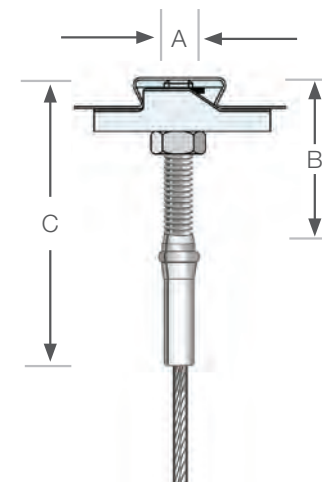

Dimension	mm
A	M8 / M10
B	45
C	70

Submission Information

Safe Working Load:

Up to 100 kg with a 3:1 safety factor

Swivel Clamp

Strong and versatile multi-directional beam clamp for suspension of light components to pitched beams without welding or drilling

Features & Benefits

- Solid fixing to steel construction without the need for welding or drilling
- Multidirectional clamp
- Designed for suspension of light components to pitched beams without welding or drilling
- For use with flange thickness up to 24 mm
- Articulation to 30° sideways, 45° forwards

Installation

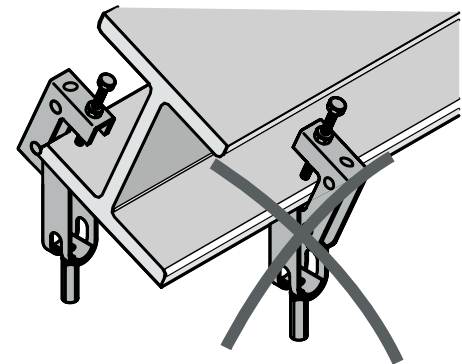

1. Adjust screw to allow space to position onto beam
2. Tighten the screw (M10) to lock in position

When attaching to pitched beams adhere to the recommended safe working load table.

Specification

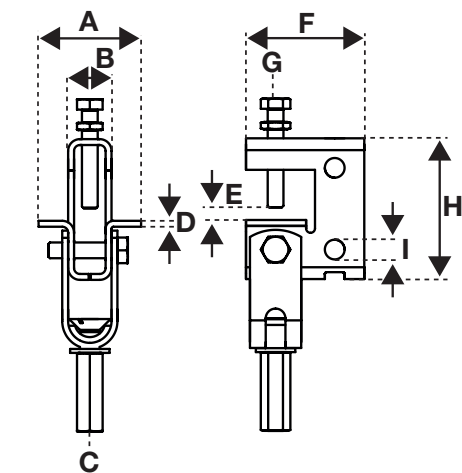

Dimensions (mm)								
A	B	C	D	E	F	G	H	I
52	22	M10	3	24 max.	60	13	72	10



Safe working load table.
Based on 1.4:1 Safety Factor.

2,500 N	1,100 N	2,500 N
2,800 N	2,800 N	900 N

Submission Information

Safe Working Load:

Up to 285 kg
Use with a No.1, No.2, No.3 or No.4 Gripple hanger

Material:

Steel
Finish - Dacromet

Beam Clamp

Strong and versatile fixing to steel construction, suitable for flange between 2 - 17 mm without the need for welding or drilling.

Features & Benefits

- Solid fixing to steel construction without the need for welding or drilling
- For use with vertical wire ropes and threaded rod only
- M6 connector
- Suitable for flange between 2 - 17 mm

Installation

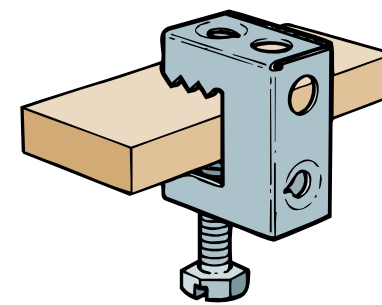

1. Adjust screw to allow space for your required flange
2. Slide into position ensuring the flange is fully inside the clamp
3. Tighten the screw (M6) to lock in position

Specification

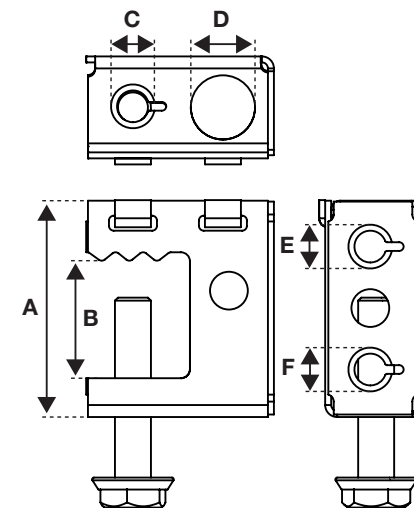

Dimensions (mm)					
A	B	C	D	E	F
35	2 - 17	M6	6.5	6	5.5



Submission Information

Safe Working Load:

Up to 68 kg at 1.4:1 safety factor or 32 kg at 3:1 safety factor*
Use with a No.1 or No.2 Gripple hanger

Material:

Spring Steel CS70
Finish - Delta-Tone 9000 (480 hours)

For use with static loads only

* Gripple has a policy of ensuring that all of our systems have safe working loads. Please discuss your project requirements with your local Gripple representative who will advise on the technical requirements

Purlin Clip

Designed for fixing to purlins to allow fast suspension with wire using a Gripple Stud end fixing.

Features & Benefits

- Holds fast at 90°
- For fixing to purlins
- M6 connector
- With holder (M6 - M10) for fast suspension using Gripple stud end fixing (adjustable by screwing)

Installation

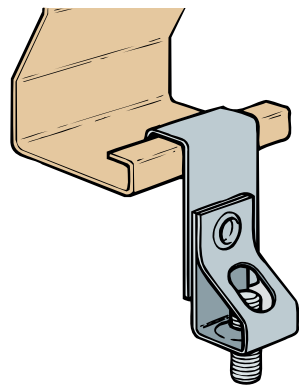

1. Position on purlin and clip into place
2. Insert stud end fixing into holder
3. Adjust by screwing to preferred height

Specification

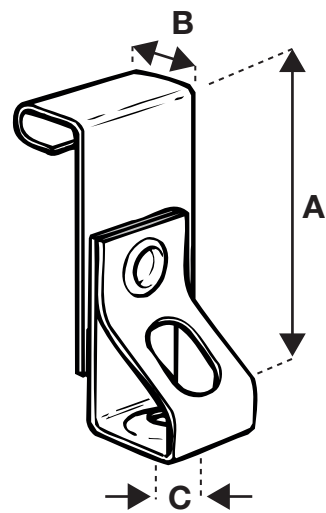

Dimensions (mm)		
A	B	C
68	15	M6, M8 or M10

Submittal Information

Safe Working Load:

Up to 20 kg at 1.4:1 safety factor or 9.5 kg at 3:1 safety factor*

Use with a No.1 Gripple hanger

Material:

Spring Steel CS70

Finish - Delta-Tone 9000 (480 hours)

For use with static loads only

* Gripple has a policy of ensuring that all of our systems have safe working loads. Please discuss your project requirements with your local Gripple representative who will advise on the technical requirements



Accessories

A wide variety of accessories are available, which are specifically designed to suit different substrates on-site.

Concrete

- 1) Drop-in anchor
- 2) Concrete ceiling anchor
- 3) Cracked concrete ring anchor



Beams and purlins

- 1) Tiger clip
- 2) Vertical flange clip
- 3) Purlin clip
- 4) Z purlin clip
- 5) Beam clip
- 6) GF Bracket



Adaptors

- 1) LSK Clip
- 2) V-Bracket (side)
- 3) V-Bracket (front)
- 4) Spring clip
- 5) M6 and M8 Adaptor
- 6) M8 Decking adaptor
- 7) Turnbuckle
- 8) Eyebolt



Brackets and attachments

- 1) G-Bracket
- 2) Trapeze
- 3) Trapeze washer
- 4) Link hook
- 5) Karabiner
- 6) U clamp
- 7) Straight connector
- 8) 90 degree connector
- 9) H bracket
- 10) V bracket
- 11) Straight connector



Tools

- 1) Torq tensioning tool
- 2) Adjustment key (small)
- 3) Adjustment key (large)
- 4) Wire cutters (small)
- 5) Wire cutters (large)
- 6) Drop-in anchor punch
- 7) Mechanical setting tool (Drop-in anchor)
- 8) Driver bit

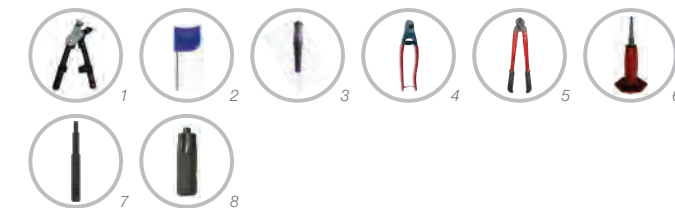

Finishing accessories

- 1) Ceiling fixing kit
- 2) Decor cover
- 3) Corner saddle
- 4) Twister
- 5) Protective sleeving

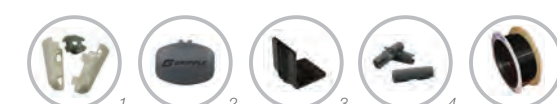

About Gripple

An introduction

Gripple introduced emphatic change to the building services market in the late 1990s, with a fresh and alternative means of suspension. When the original Gripple device was conceived, as a solution for joining and tensioning fence wires, no-one could have predicted that this would lead to the radical approach of using wire rope hangers, which have fast become the benchmark, for quick and easy methods of hanging mechanical, electrical, HVAC and plumbing services.

As a result of this revolution, Gripple introduced an entirely new way of working to the industrial sector; load-rated hanger kits quickly proved perfect for ducting, cable containment, lighting, piping, false ceilings, signage and much, much more. Driven by a problem-solving attitude and determination to innovate, the product range has expanded to thousands, offering customers a vast array of revolutionary suspension methods.

Not only have Gripple's versatile products brought speed, improved site safety and best practice efficiency savings to the installation process, the company also prides itself on providing bespoke hanging solutions and next day site delivery. Furthermore, personal consultations are always available, and Gripple strives continually to provide the best resolutions for specific needs. As a consequence, the company's capabilities are now recognised, admired and trusted worldwide.



Inside the Old West Gun Works



Improved Gripple housings

“...the company's capabilities are now recognised, admired and trusted worldwide.”

Sustainable development

A commitment to the environment

Gripple has always appreciated the importance of sustainability, pledging in an environmental policy statement to identify risks, prevent pollution, comply with the relevant legislation and improve its environmental performance overall. Customers can be confident that the company has minimised, as far as possible, its environmental impact during product design and manufacture, and believe that they and their applications can play a fundamental part in achieving their own sustainability objectives.

Gripple products have reduced significantly the quantity of steel used on a given project. By replacing traditional threaded rod installations with Gripple hangers, steel consumption is reduced by up to 95%. In other words, for each tonne of rod used, Gripple wire rope hangers can achieve the same results, but potentially weigh as little as 50 kg. Moreover, fewer vehicle movements mean lower transportation costs and emissions and, because they are lighter and easier to carry, accidents during handling and installation are also reduced.

As a manufacturer, Gripple recognises its responsibility to minimise the company's impact on the planet. Therefore, we constantly maximise our energy efficiency, decrease electricity use, reduce landfill / incinerated waste, increase recycling, conserve our raw materials' use and minimise packaging. We also integrate sustainability into our design process, which is epitomised by the impressive fact that a Gripple hanger today uses 30% less zinc than the original design, without compromising its strength or functionality.

A global family

From Sheffield to the wider world

An extensive range of innovative products is produced in state-of-the-art facilities in Sheffield, a city with a rich manufacturing history. On sites in the city's Don Valley - The Old West Gun Works, a former gun barrel plant, and the modern, purpose-built Riverside - this tradition is maintained to reflect the strong heritage that characterises the city.

The company's enviable growth has also demanded the establishment of other company 'homes'. Gripple Europe's base nestles in the Alsace region of France, the US division, Gripple Inc, operates out of Chicago and Gripple India in New Delhi. Firm relationships are maintained with many distributors, to whom Gripple products are supplied to ship to construction sites around the world.

Gripple's core ethos and values permeate each of the company's employees, who work as a team to ensure that the highest quality goods are delivered to all destinations, at all times. A spirit of creativity and innovation has allowed Gripple to reach where it is today and, by keeping this alive, game-changing solutions will continue to be provided far into the future.



The Old West Gun Works, Sheffield, UK



Gripple Europe SARL, Obernai, France



Gripple Inc, Aurora, USA

Awards



Hugh Facey Gripple's owner receiving the Queen's Award for Enterprise - International Business from the Lord Lieutenant of South Yorkshire



- 2016 - Queen's Award for International Trade
- 2015 - Employee Owned Business of the Year
- 2014 - "Made in Sheffield" - The Investment in People Award
- 2013 - "Made in Sheffield" - Overall Winner
- 2013 - "Make it in Great Britain" - One of the top 25 UK innovative companies as selected by the UK Government
- 2012 - Queen's Award for Enterprise - Innovation
- 2010 - Queen's Award for Sustainable Development
- 2009 - BFA - Innovation Award
- 2009 - BFA - Best Small Company Award
- 2009 - BFA - Best Engineering Plant Award
- 2009 - IMechE - Best Small / Medium Enterprise
- 2008 - Queen's Award for Enterprise - International Business
- 2007 - British Chambers of Commerce - Achievement in International Business
- 2007 - EEF - Annual Environmental Award
- 2006 - The Manufacturer - Manufacturer of the Year Award
- 2004 - IMechE - Best Small / Medium Enterprise
- 2004 - IMechE - Best Factory Award - Overall Winner
- 2004 - National Community Mark Standard
- 2003 - Management Today Awards for Manufacturing - Best Small Plant
- 2003 - Management Today Awards for Manufacturing - Best Innovation for R&D
- 2003 - IMechE - Best Product Innovation
- 2002 - British Chambers of Commerce - Export Excellence Award
- 2001 - National Language for Export - Regional Winner (Trade Partners UK)
- 2000 - Queen's Award for Enterprise - Innovation
- 1995 - Export Times - Corporate Exporter of the Year
- 1991 - The Prince of Wales Award for Innovation
- 1990 - Grand Prix du President de la République (France)
- 1990 - Concours Lepine Gold Medal (France)

National and global projects

India

Pharmaceutical Projects

- Abbots - Bharuch
- Torrent - Baddi
- Torrent - Gujarat
- Teva - Gujarat
- Nitin Life Sciences - Paunta Sahib
- Dr. Reddy's - Ghaziabad
- Dr. Reddy's - Hyderabad
- Sun Pharma - Halol
- Intas - Gujarat
- Ranbaxy - Baddi
- ACG - Gujarat
- Apotex - Bangalore
- Rexum Pharma - Bangalore
- Biocon - Bangalore

Textile Projects

- Trident - Bhopal
- Trident - Budhni
- Seeds - Vizag
- Quantum Clothing - Vizag
- Shahi Exports - Faridabad
- SRF - Chennai

- Ocean India - Vizag
- Brandix - Vizag
- Winsome Textiles - Baddi
- Arvind Mills - Santej
- Garg Acrylics - Bathinda
- Welspun - Vapi

Hotel Projects

- MB Hotel - Faridabad
- Ritz Carlton - Bangalore
- Ibis Hotel - Chennai
- Park Plaza - Zirakhpur
- Hyatt - Manesar
- Bharti Hotel, Aerocity - New Delhi
- Pride Hotel, Aerocity - New Delhi
- Duet Hotel - Chennai
- JRRCL - Jaipur
- Marriott - Guwahati
- Marriott - Shillong

- Royal Plaza - Chennai
- The Claridges - New Delhi
- Taj Palace - New Delhi

Commercial & Residential Projects

- DLF Capital Greens - Delhi
- GYS Vision - Gurgaon
- Ireo Rise - Mohali
- Emaar MGF Palm Drive - Gurgaon
- MGF Da Villas - Gurgaon
- DLF Mall of India - Noida
- Adobe - Noida
- SAP Lab - Gurgaon
- Infosys - Various Locations
- DLF Crest - Gurgaon
- DLF Camellias - Gurgaon
- NBCC Kidvai Nagar - Delhi

- HCL - Chennai
- HP - Bangalore
- World Bank - New Delhi
- Sun TV - Chennai
- EIL - Gurgaon
- NIIT - Neemrana
- American Express - Gurgaon
- Shiv Nadar University - Dadri
- Success Tower - Gurgaon
- Convergys - Gurgaon
- QAI - Noida
- ONGC - New Delhi
- CISCO - Bangalore
- Deloitte - Mumbai

Industrial Projects

- Knorr Bremse - Palwal
- Maruti-Suzuki - Gurgaon, Manesar
- Yamaha - Greater Noida
- Denso - Jhajjar
- Mann-Hummel - Bawal
- TVS WABCO - Chennai
- Ford - Chennai, Sanand
- Parker Hannifin - Mumbai
- SRF - Chennai
- Fiat - Pune
- Motherson Sumi - Lucknow, Pathredi
- TATA Lockheed Martin Aerostructures - Hyderabad
- Apollo Tyres - Chennai, Vadodara
- MRF Tyres - Chennai
- Pepsi Neelamangala - Satariya
- Coca Cola, Bangalore - Koshi
- SKF - Haridwar, Ahmedabad
- Parker Hannifin - Mumbai
- Volkswagen - Chennai
- BMW - Chennai
- Daimler - Chennai
- JCB - Jaipur
- FKIL - Pune
- Hero Moto Corp - Neemrana, Haridwar Jaipur
- Honda Motors - Tapukara
- Rexam - Chennai
- Honeywell - Pune
- Volvo - Indore
- Tata Cummins, Phaltan - Pune
- ITC - Haridwar, Nepal, Ranjangaon, Kidderpore, Malur

- TBK - Mysore
- ACG - Pitampur
- Panasonic - Jhajjar
- AISIN - Rohtak
- Nokia - Chennai

Other Projects

- Terminal 3 - Delhi International Airport
- Mumbai Airport - Mumbai
- L&T Hanger Bay, Boeing Hanger Facility - Nagpur
- Siri Fort Stadium - New Delhi
- Manekshaw Centre - New Delhi
- Appu Ghar - Gurgaon
- Lady Hardinge Hospital - New Delhi
- MCD Civic Centre - New Delhi
- Shoppers Stop - Various Locations
- Bharti-Walmart - Various Locations
- Metro Cash & Carry - Various Locations
- Amazon - Various Locations
- Vadodara Airport - Vadodara
- Coimbatore Airport - Coimbatore
- Flipkart - Various Locations
- Myntra - Bilaspur

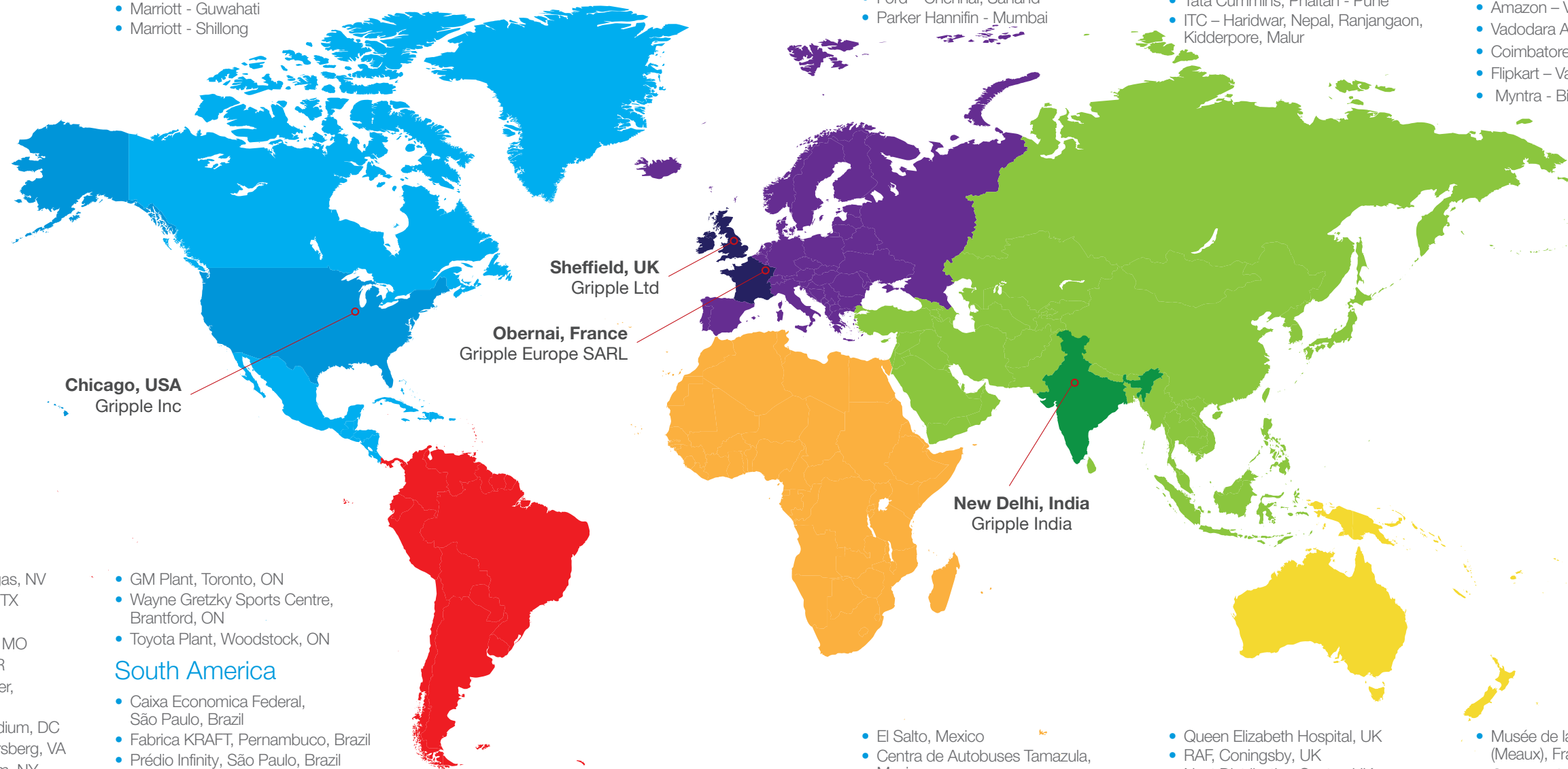

North America

- MGM City Center, Las Vegas, NV
- Dallas Cowboys Stadium, TX
- Trump Tower, Chicago, IL
- Busch Stadium, St. Louis, MO
- Facebook Data Center, OR
- Walter Reed Medical Center, Washington DC
- Washington Nationals Stadium, DC
- Fort Lee Army Base, Petersburg, VA
- New York Yankees Stadium, NY
- Nestle Plant, Anderson, IN
- Golden Nugget Hotel Casino, Las Vegas, NV
- Calgary Airport, Calgary, AB
- Niagara Regional Hospital, St. Catharines, ON
- Department of Natural Defense, Ottawa, ON

- GM Plant, Toronto, ON
- Wayne Gretzky Sports Centre, Brantford, ON
- Toyota Plant, Woodstock, ON

South America

- Caixa Economica Federal, São Paulo, Brazil
- Fabrica KRAFT, Pernambuco, Brazil
- Prédio Infinity, São Paulo, Brazil
- Lojas Besni, Mogi das Cruzes, São Paulo, Brazil
- ExpoCenter Transamerica, São Paulo, Brazil
- Hyundai CAO, Ribeirão Preto, Brazil
- Shopping Rio Mar, Recife, Brazil
- Loja TAM, Londrina, Brazil
- Hewlett Packard, Guadalajara, Mexico

- Expo Guadalajara, Guadalajara, Mexico
- Soriana Supermarket, Mexico
- Aeropuerto Benito Juarez, Mexico City, Mexico
- Nextel Maintenance Centre, Mexico City, Mexico
- Acero Sueco Palme - Centro de Distribución, c

- El Salto, Mexico
- Centra de Autobuses Tamazula, Mexico
- Convermex, Monterrey, Mexico
- Vega Monumental, Concepción, Chile
- Centro de Distribución Mannheim, Ciudad de los Valles, Chile

Europe

- Wembley Stadium, London, UK
- Swiss Re, London, UK

- Queen Elizabeth Hospital, UK
- RAF, Coningsby, UK
- Next Distribution Centre, UK
- Centre Pompidou (Paris et Metz), France
- Ikea, Auchan, Carrefour, Décathlon, France
- Usines assemblage Airbus A380 & A350 (Toulouse), France
- Direction Générale de la Gendarmerie Nationale (Issy-les-Moulineaux), France

- Musée de la Grande Guerre (Meaux), France
- Commerzbank Arena Frankfurt, Germany
- BMW, Audi, Daimler, Germany
- American Express Verwaltung, Germany
- Deutsche Post Verteilerzentren, Germany
- Netto, Metro, Germany
- Stadler Hannover, Germany

Key Recommendations

Failure to comply with these recommendations may result in product malfunction and possible damage to property or person and will invalidate the Gripple guarantee. Gripple products are guaranteed to be free from defects in materials and workmanship in accordance with our terms and conditions. No other warranty, whether express or implied, including any warranty of merchantability or fitness for purpose shall exist in connection with the sale or use of any Gripple product.

Full technical information and installation instructions should be obtained directly from Gripple Limited, Gripple Europe or Gripple Inc., any regional Gripple office, or via the website www.gripple.com.

Please adhere to the following key recommendations:



Loads

Always operate the product within its stated safe working load range.



Lifting

Do not use for lifting, either by crane or as part of a pulley system. Suspend static loads only.



Installation

Do not walk or stand on the Gripple product installation unless expressly designed for this purpose.



Painting

Do not paint the hanger prior to installation. Ensure that the hanger is in its final position prior to applying any paint to the wire rope assembly. Do not move the fastener after painting.



Lubrication

Do not apply oil or any other lubricant to the hanger or any other part of the assembly.



Joining

Never join two ends together in-line.



Wire Rope

Always use the fastener supplied and specified wire rope. Never use on coated wire rope or other rope. Trim any damaged filaments with the wire cutter before use.



Environment

Do not use in chlorinated or chemically corrosive atmospheres. Standard hangers are for use in dry and air conditioned environments only. Stainless steel hangers should be considered for high to saturated humid environments after validation by a competent person. Not suitable for Swimming pools.



Impact

If there is potential for impact on the wire rope suspension or suspended services, seek advice from Gripple Ltd. Technical Services prior to installation.



Hanging at an Angle to Vertical

Ensure that the load calculation considers the effect of 'side load'. For example, at an angle of 60° to vertical the SWL is effectively reduced by 50%



Ducting: When installing included angle teardrop hangers on round/spiral ducting or pipes, the final included angle of the assembly should not exceed 60°.



Y-Fit: Legs on Y-Fit not to be installed greater than 60°.



Visual inspection



Visual quality checks in place



Shadowgraph wedge inspection

Notes

www.gripple.com

info@gripple.com



Gripple Ltd (Headquarters)

The Old West Gun Works
Savile Street East
Sheffield S4 7UQ
UK

T | +44 (0) 800 018 4264

F | +44 (0)114 275 1155

E | info@gripple.com

Gripple Inc

1611 Emily Lane
Aurora
IL 60502
USA

T | +1 866 474 7753

F | +1 800 654 0689

E | usinfo@gripple.com

Gripple Europe SARL

1, rue du commerce
BP 37
67211 Obernai Cedex
France

T | +33 (0)3 88 95 44 95

F | +33 (0)3 88 95 08 78

E | frinfo@gripple.com

Gripple India

B 95/2
Naraina Industrial Area
Phase I
New Delhi-110028

T | +91 98103 00574

E | ininfo@gripple.com



A GLIDE company

