

2012 Edition

# Carloviana

Carlow Historical and Archaeological Society

*Cumann Staire agus Seandálaíochta Cheatharloch*



Winter Lecture Series.  
El Greco and the Carlow Nexus.  
History of Killeshin Parish.  
Development and Demise  
of the Carlow Burgess.  
Lewis's Carlow contd.  
Father John Dempsey and  
Carlow Town Commission.  
Role of the Irish in World War II.  
The Ancient Order of Hibernians  
in Graiguenamanagh.  
Drumphaea - The Coming of Christianity.  
Jonathan Swift's Carlow Connections.  
The Remarkable Haughtons  
of Carlow and Kildare.  
Eagle Hill, Hacketstown,  
its Environs and Characters.  
Cultural life in Carlow.  
The Origin of Carlow's Name.  
Ballyhacket, Hacketstown and the  
Micro-History of Anglo-Norman  
Colonists in Northeast Co. Carlow.  
National Schools History Prize.

Garlic is good, but give me Scallions.  
History of the RTC & ITC contd.  
Gate Lodges of Co. Carlow.  
Building on a Legacy - the Archaeological  
collection of Carlow County Museum.  
The Archaeology of Ballon Hill:  
A Review and Proposal.  
A Museum is Born.  
Vallancey's Military Surveys of 1776-1777  
& 1796 as relating to County Carlow and  
its Immediate Environs.  
A History of Brigidine Foundations in  
Roscrea, Ireland and Kenosha and  
Titusville, America.  
Clonmore, Co. Carlow. Its Antiquities.  
Carlow County Museum -  
Ireland's Newest Museum Opens.  
The 'Slashing Parson' of 1798: The Life  
and Death of Robert Rochfort of  
Clogrennane, Co. Carlow, 1775-1811.  
Kavanagh Castles of Co. Carlow.  
Observations on a Flint Leaf-Shaped Arrow  
head from Ballintemple, Co. Carlow and

some related finds from the County.  
Going to the Pictures.  
Dictionary of Irish Biography.  
Carlow's Olympic Connections.  
The Wastegrass and its Mass Rock.  
The Tithe War in North-East Carlow.  
The History Festival of Ireland.  
The Rowing Bunburys of Lisnavagh.  
The "Shemus" Cartoons in the  
Freeman's Journal.  
Letters from Clonburrin 1880-1930.

€10



**FRONT COVER**  
*Ruins of Clogrennane House*  
 Photograph courtesy of:  
 Shay Kinsellaa.



# CARLOVIANA

December 2012

No. 61

I.S.S.N. 0790 - 0813



## Regular Features

Editorial .....	2
Message from the President .....	3
Winter Lecture Series .....	4
National Schools History Prize .....	67
Obituaries .....	80
Officers .....	197
Members .....	198



**FRONT COVER PICTURE**

### *Ruins of Clogrennane House*

Photograph courtesy of:  
Shay Kinsellaa.



**BACK COVER PICTURE**

### *Costello Memorial Chapel*

Photograph courtesy of:  
Bertie Watchorn.

## Articles

El Greco and the Carlow Nexus .....	5
History of Killeshin Parish .....	6
Development and Demise of the Carlow Burgess .....	12
Lewis's Carlow contd .....	15
Father John Dempsey and Carlow Town Commission .....	18
Role of the Irish in World War II .....	21
The Ancient Order of Hibernians in Graiguenamanagh .....	24
Drumpea - The Coming of Christianity .....	29
Jonathan Swift's Carlow Connections .....	32
The Remarkable Haughtons of Carlow and Kildare .....	42
Eagle Hill, Hacketstown, its Environs and Characters .....	55
Cultural Life in Carlow .....	60
The Origin of Carlow's Name .....	62
Ballyhacket, Hacketstown and the Micro-History of Anglo-Norman Colonists in Northeast Co. Carlow .....	63
Garlic is good, but give me Scallions .....	68
History of the RTC & ITC contd .....	72
Gate Lodges of Co. Carlow .....	75
Building on a Legacy - the Archaeological collection of Carlow County Museum .....	77
The Archaeology of Ballon Hill: A Review and Proposal .....	81
A Museum is Born .....	89
Vallancey's Military Surveys of 1776-1777 & 1796 as relating to County Carlow and its Immediate Environs .....	90
A History of Brigidine Foundations in Roscrea, Ireland and Kenosha and Titusville, America .....	94
Clonmore, Co. Carlow. Its Antiquities .....	105
Carlow County Museum - Ireland's Newest Museum Opens .....	110
The 'Slashing Parson' of 1798: The Life and Death of Robert Rochfort of Clogrennane, Co. Carlow, 1775-1811 .....	117
Kavanagh Castles of Co. Carlow .....	140
Going to the Pictures .....	141
Observations on a Flint Leaf-Shaped Arrowhead from Ballintemple, Co. Carlow and some related finds from the County .....	144
Dictionary of Irish Biography .....	150
Carlow's Olympic Connections .....	153
The Wastegrass and its Mass Rock .....	155
The Tithe War in North-East Carlow .....	160
The History Festival of Ireland .....	166
The Rowing Bunburys of Lisnavagh .....	168
The "Shemus" Cartoons in the <i>Freeman's Journal</i> .....	177
Letters from Clonburrin 1880-1930 .....	180





**BACK COVER**

***Costello Memorial Chapel***

*Photograph courtesy of:  
Bertie Watchorn.*

**CARLOVIANA**

**December 2012**

**No. 61**

**I.S.S.N. 0790 - 0813**



**Editor: Jim Shannon**

**Editorial Committee:**

Martin Nevin  
Jimmy O'Toole  
Ann Power  
Nial O'Neill  
Pat O'Neill  
Padraig Dooley

**Published by:**

Carlow Historical &  
Archaeological Society,  
P.O. Box 162,  
Carlow.

**Email:**

[carlowhistorical@gmail.com](mailto:carlowhistorical@gmail.com)

**Website:**

[www.carlowhistorical.com](http://www.carlowhistorical.com)

Carlow Historical & Archaeological Society is affiliated to the Federation of Local History Societies.

All articles in this journal are the copyright of the Carlow Historical & Archaeological Society and may not be reproduced in any form without the permission of the editor.

Views and opinions expressed in this journal are not those of the editor or of the Carlow Historical & Archaeological Society.

**Printed by:**

Carlow Advertiser & Printing,  
Strawhall Industrial Estate,  
Carlow.

***Editorial***

At last we have a County Museum. After all the delays, disappointments and postponements the project that this Society began so many years ago has finally become a reality and the facility is open to the public. The Town Council provided the finance, the Society provided the bulk of the artefacts, the Curator and his staff provide the professional expertise, and numerous volunteers provide generously of their free time to help staff it. This museum will be a great asset to the area and we as a Society can feel justifiably proud of our part in its creation. Let us ensure that we use wisely our three seats on the Board of the Museum to make certain that it will continue into the future the work that our members began, and that Carlow will have a first-rate museum.

It is good to see that the National Museum has made available the artefacts discovered in the course of the dig on the route of the new motorway. The display in our County Museum really brings home to the visitor just how long human settlement goes back in this area – much further than history records.

This edition of "Carloviana" features several articles by authors new to us. This is a very welcome development. It is very good that people continue to come forward with interesting contributions on various topics, and we would indeed welcome even more such articles for future editions. It is particularly gratifying to see some young contributors coming forward and we hope they will continue to submit their work to us in the years ahead. Well done to all of you and we are well aware that without your work this Journal would be a much poorer affair.

Finally, we remind readers that the Society can be reached via email at [carlowhistorical@gmail.com](mailto:carlowhistorical@gmail.com) for further information regarding our lectures, outings, publications, or anything else about us that the enquirer may wish to know.

## Message from the President

The year started on a very sad note when our secretary, Thomas Brennan died suddenly in early December last. Thomas was in his second year as our secretary and will be missed for the quiet, courteous and efficient manner in which he handled everything and everyone with whom he came in contact. We extend our sincere condolences to his sisters Phyllis and Sheila.

The ambitions of our founder members and other early members of our society were finally realized on the 11<sup>th</sup> April when our new Carlow County Museum was officially opened by Phil Hogan T.D., Minister for the Environment. We are justifiably proud of our involvement in this project which is outlined in great depth in two articles in this issue. We must now use this marvellous facility—to visit it, to learn from it, perhaps to contribute artefacts but always to engage with it. On a lighter and optimistic note the activities of some of the non invited guests at the official opening at least ensured that many more people in the country now know that we have a museum than would otherwise have been the case.

It is nice to see that retirement has not slackened the pen of one of our busiest members and former president of our society, Michael Conry. At a function in the Royal Irish Academy in May Olivia O'Leary launched his latest ( and seventh ) book— which deals with the history and culture of Ireland including his adopted county. *Picking Bilberries, Fraochans & Whorts in Ireland—The Human Story* captures the stories of perhaps the last generation of our country people who engaged in this aspect of rural living which goes back to pre Christian times.

At the end of May we visited the Titanic Centre in Belfast. We extend our thanks to Bertie and Irene Watchorn whose organizational skills ensured a very enjoyable trip.

Over the weekend of the 15<sup>th</sup>/17<sup>th</sup> June members from the other CHAS—the Cork Historical and Archaeological Society visited Carlow and we were delighted to be able to guide them around our town and county.

In conjunction with Carlow Tourism we presented a Heritage Week exhibition at the Shaw Visual Centre. Photographs of Carlow Sugar Factory from 1926 to the 1960s together with other photographs of Carlow town and county from the early 20<sup>th</sup> century were displayed. The exhibition was organized by Martin Nevin and launched by Turtle Bunbury. Carlow Tourism has also produced a calendar for 2013 featuring several photographs from this collection.

Our Heritage Week mini lectures drew our largest ever audience when three of our members gave lectures on local businesses that have ceased trading and are now only memories. The lecturers were : Paul Lyons on the Sugar Company : Dan Carbery on the Governey Boot Factory and Corcoran's Mineral Waters : Pat O'Neill on the Carlow Blade Factory. The lectures were held in the Cobden Hall, St.Patrick's College.

In September Bertie & Irene organized a four day autumn outing to counties Roscommon, Longford, Leitrim and Fermanagh taking in several venues from Strokestown House to Beleek. Strangely enough the highlight seemed to be a visit to Tullamore Dew on the way home and the very tasty samples provided.

We hope to be in a position early next year to communicate with our members by email or through text messages. To this end we are requesting email addresses and mobile phone numbers from our members and if you have not provided these already perhaps you might contact any of our committee members.

Finally I want to thank all the members of our committee and sub committees for the work

they put in during the year. I also wish to thank the editorial board of Carloviana and our many contributors for another excellent publication.

Pat O'Neill



*The exhibit on Carlow's lost sugarmaking industry in the new Carlow County Museum - the Society's partnership with the local authority enabling us at last to realise our long-held ambition to provide a Museum for Carlow.*

*Photograph; Courtesy of Carlow County Museum*

## Winter Lecture Series

We got through our 2011/12 series of winter lectures with only one deviation from the planned schedule. Pat Comerford was unable to deliver the December lecture on Oak Park but society member Cathleen Delaney stepped into the breach giving a very informative lecture, from her own researches, on the Bruen family and Oak Park. Two of the lectures given in the 2011/12 season have appeared as articles in this journal--- Tom Joyce's lecture on Lady Harriet Kavanagh's journeys through Europe appeared in Carloviana 2011 and Dr. Colman Etchingham's lecture on the Norman colonists in north east Carlow is included in this issue. Our sixty fifth series of lectures starts off on the 10th October and the full schedule is given below. Starting time for each lecture is at 8.00 pm. Our lectures are free and open to members and the general public and we look forward to seeing as many as possible attend at the various venues.

### CARLOW HISTORICAL & ARCHAEOLOGICAL SOCIETY

#### LECTURES YEAR 2012-2013

Date	Lecturer	Topic	Venue	Time
10th October 2012	Felix Larkin	The "Shemus" cartoons in the Freeman's Journal	Talbot Hotel, Carlow	8 p.m.
21st November 2012	Louise Nugent	Medieval Pilgrimages	Ramada Hotel, Killerig	8 p.m.
12th December 2012	Paul Curran/ Fintan O'Neill	The Fire Brigade Service in County Carlow	Seven Oaks Hotel, Carlow	8 p.m.
16th January 2013	Frank Clarke	Catholic Priests and the Penal Laws, 1691 to 1760	Leighlinbridge Parish Centre	8 p.m.
20th February 2013	Michael Leonard	Austin Waldron: Carlow RTC The story of its establishment	Seven Oaks Hotel, Carlow	8 p.m.
20th March 2013	Mrs. Frankie Cole	Ballybar Races	Mount Wolseley Hotel, Tullow	8 p.m.

## EL GRECO AND THE CARLOW NEXUS

John Schwatschke

The construction of a satisfactory picture depends largely on balance. The figures or objects need not be equidistant, but the imaginary weight of the subjects should balance, as if held on a weighing scale. El Greco's painting of *The Adoration of the Shepherds* is a good example of balance in operation. While there may seem a heavier weight of figures on the left side, the balance is taken up on the right by the large mass of blue sky. It is not something that one would immediately notice, but imagine the painting without the sky, and a dark background instead. Then there would be an obvious weight of figures on the left.

As a personal view, I suggest that the artist began with great enthusiasm in painting a good image of the central Madonna. A good portrait is often the result of excited enthusiasm and creativity, whether by simple brushwork or dedicated hours, and oblivious to everything else. Even before this face was complete, the artist may have realised that it was not perfectly central, and so the other figures were introduced at various heights and colours to make a balance.

This painting (122x80cms) may have been the original version of *The Adoration of the Shepherds*, from which the larger one in *The Prado* (319x180cms) was painted to fit in its special place above the altar of the artist's burial chapel in Toledo. In the Prado picture, El Greco's own portrait appears as a shepherd, whether a self portrait or by his students. A student at a later time remembered that El Greco was present. But the smaller painting has the better portrait of the Madonna.

Perhaps it may now be said, that it was a visionary experience, of how such an exceptional masterpiece came to be in Carlow. A painting of such high quality that it rivaled any work by El Greco at *The National Gallery of Ireland*, and how it was exhibited with Picasso and Modigliani in a phantom art museum, *Le Musee Schwatschke* on Leighlin Road. While the opening by the Austrian Ambassador and art dealer, Susanne Macdougald gained some press coverage, an entire art museum existed (1976-1994) and then vanished without trace or recognition.

Admittedly the project had been established in France to exhibit my own paintings, being later transferred to Carlow. By then there were two important additions to the collection, Picasso's "Artist and Model" (deaccessioned from *The Museum of Modern Art, New York*) and Modigliani's *Portrait de Jean Cocteau*. The third exceptional masterpiece by El Greco became the centrepiece of the collection.

The astounding story of the acquisition of *The Adoration of the*



*The adoration of the Shepherds*

*Shepherds* is as bizarre as the mirage of the phantom art museum on Leighlin Road. Collecting old oil paintings at auctions was a hobby, and a challenge to appreciate good paintings. One of my finds was an old torn canvas at a sale in Baltinglass, reputed to have originated from Kilkee Castle. It was a version of "The Moneychangers" by Van Reymerswaele 1539. Research on this picture proved it to be older than the others because of a pounce box depicted on a table, for drying ink. This proved its age.

But the El Greco find was the best of all, and it started in 1985 in Montecito, California where I had my studio. Americans have an arrangement with the Internal Revenue Service whereby they can get tax deductions for donating art to US museums. This painting was one such donation. I had heard about it because someone had exchanged it for a Modigliani portrait from the previous owner. Then the El Greco was said to be only a copy, and was eventually donated to *The Salvation Army Charity shop* as a religious picture. It was there that I came across it, not knowing what it was, but the age of the canvas and old frame took my interest. I negotiated a part cash and part exchange deal, and left for Europe to collect my best painting by William Shayer Snr. with Christies valuation, and did the deal in California. For two months it was examined and x-rayed in laboratories until the canvas age was established as roughly 16th. century weave. This was progress, but Christies expert who had flown from New York to spend an hour examining it in storage, would not commit himself. On the other hand I observed that he couldn't eat his lunch with excitement.

I decided to leave for Europe, sending the frame by freight, and foolishly bringing the canvas wrapped as luggage. It was the first time I felt nervous about its possible value when I saw my package disappear over the conveyor belt into aircraft luggage. All went well, however, and I showed it to Christies London office who promptly told me it was a copy. I was on the street when they called me back so that the Directors could have a look at it. Their remark was that they didn't think "another one" existed. While no value was discussed, the painting came to Carlow for exhibition. The Spanish Ambassador was one of the first to visit and view the extraordinary find, which had originated in Toledo in the 16th. century. *Le Musee Schwatschke* closed in 1994.

# HISTORY OF KILLESHIN PARISH

Written and compiled by W. H. Fennell, Everton, Carlow, January, 1953

The ancient parochial districts of Killeshin and Sletty which compose the present Parish are intimately connected with the earliest period of Irish Church history. People sometimes ask why our Church is called Killeshin when it is at least two miles from that townland; the answer is simple. The old ruined Church at Killeshin was our Parish Church, and when it fell into decay the parishioners decided to build a new one, our present Parish Church, which retained the old name.

I think it would be of interest if I gave you briefly the history of old Killeshin. The name is derived from Uisean the Bard; it was a place of great importance. Sir Charles Coote in his statistical account of the Queen's County written towards the end of the last century makes mention of a town having stood at Killeshin in comparatively modern times; this place is remarkable for having once been the chief town in the county, though there is not a stone building standing except the ruins of the Church. Here were the County Gaol and the Court House where the Assizes were held, and the Governor's Mansion, which was a fine building, also a fort and public buildings of which there is now no trace. The stone stocks and gallows stood the wreck of time the longest. These sites were pointed out by the old people in whose recollection they were. When the present Roman Catholic Church, the Church of the Holy Cross, was being erected, it was necessary to remove the remains of the stocks and gallows as the site was on Gallows Hill. A Monastery was founded at Glen Uisean at the commencement of the sixth century by St. Diarmid who was its first Abbot. St. Lazarian of Leighlin was educated here

in this monastery. In the Annals of the Four Masters it is stated that Aedhen of Glen Uisean died 843 A.D. We also read that Glen Uisean Church with its famous yew trees was burned in 1077. In the year 1551 Henry Davells was granted part of the lands of Killeshin by Elizabeth I. Two ladies, the last descendants of Davells, died in great poverty in a hut at Lambstown, early in the last century; Lambstown is part of the farm now in the possession of George Ovington.

The existing early remains of the Church of Killeshin were the work of a period soon after the destruction of the old building in 1077. The beautiful doorway at the West end is sometimes erroneously called Norman; it is, in fact, one of the most striking examples of Hiberno Romanesque architecture. The Church was remodelled at three different periods. When the roof fell in, about the year 1726, about 40 feet of the Eastern portion was retained for Services. Before I leave old Killeshin, I would like to mention the Round Tower and Belfry.

In a fly leaf of a copy of the "Irish Statues" printed in the year 1720 (kindly lent by Mrs. Browne-Clayton, late of Browne's Hill) the following manuscript entry respecting the destruction of the Tower occurs.<sup>1</sup>

- " Monday ye 8th thy of March, 1723, that day the Steeple undermined
- Old English spelling.

and flung down by one Bambrick employed by Capt. Wolsley, in three days worke, at three of ye clock in ye afternoon, ye Steeple fell to the ground, being measured it was 105 feet high. Not a stone came out of it as it fell in " Miss Stokes in "Christian Inscriptions" says that it was the only one of its kind in Ire-

land; none other has been found built on pillars. An old Elizabethan map shows Killeshin with a large Church and Round Tower, and Old Derrig as a little village. So much for old Killeshin, we now come to the new.

In the year 1823 the old Church had fallen into a bad state of repair, the roof was leaking, and the place had become too small to accommodate the parishioners. A meeting was held in the ruins of the Church on the 14th October, 1823. It was decided to build a new Church. Some of the parishioners wanted it built on the same site, but it was pointed out to them that owing to the graves in the Graveyard there would not be room to build a bigger one, and the present Church would not hold half the parishioners. It was decided to accept the kind offer of Mr. William Clayton Browne of Browne's Hill of a site in his immediate possession near the Turnpike Gate, close to the town of Graigue. It may be of interest to give the names of those present at that meeting:—

Rev. Joseph Jameson, Officiating Clergyman; Robert M. Fishboume and J. Wilson, Churchwardens. J. Browne, W. Massey, J. Herring, W. Parsons, W. Fishbourne, W. Boyce, H. Deacon. R. Maher, R. Jackson, R. Wright, R. Byrne, A. Boyce, W. McCullagh, W. Wilson, R. Holies, J. Williams, James Young, H. McCoom, R. Shaw, W. Bambrick, H. Walker, R. Jackson, G. Wilson, H. Murray, J. Booth, W. Carr, E. Thorpe, W. Jackson, T. Booth, J. Valentine, R. Smyth, W. Reynor, M. Coombs, R. McDonnell.

It was almost a year after this meeting before the building commenced. There was a lot of correspondence and interviews with the Ecclesiastical Commissioners, sometimes called Board of First Fruits, before the required amount of £1,000 was raised. It was finished in the year 1825 and consecrated in 1826. The pews were allotted in that year. Some of the front seats were sold for as much as £10 each. It was not until 1825 that the Churchyard wall was built, and the iron entrance gate erected.

In the year 1841, Rev. Roland O'Connor died; he seems to have been a very popular Curate; there is a Tablet erected to his memory by the parishioners on the

## HISTORY OF KILLESHIN PARISH

North Wall of the Church, near the Organ. I shall have something more to say about this at a later stage.

At a Vestry Meeting in April of the year 1843, it was decided to buy a pair of strong iron hinges for the outside door, which was blown in during the terrific storm of the previous February. This storm was referred to for over a century afterwards as the "night of the Big Wind." This door faced west.

At a Vestry Meeting, held on Monday, 28th March, 1842, the following resolution was passed:- "That in consequence of the very great danger that persons attending Divine Service are liable to from there being no separate or distinct pathway for foot passengers, and from the frequent dangerous collisions that take place at present, that the South pathway be left entirely for carriages and other vehicles, and that the North pathway be for foot passengers alone, and that this resolution be the better observed, that stone pillars be erected at the East and West extremities of the North path". At this stage I came to a full stop when I read the following cutting from the "Carlow Sentinel" dated 28th March, 1846, so I had to begin all over again.

#### Killeshin Church

"On Thursday last, 26th inst., this very handsome structure, which has been lately erected in Graigue, at the Queen's County side of the river, and adjoining this town, was consecrated by the Lord Bishop of Ossory and Leighlin. A numerous body of Clergy were in attendance, and assisted in the ceremony. Amongst those we noticed the Reverends Harpur, Jameson, Jacob, Hare, Fitzgerald, Elliott, Brandon, Fishbourne, Harpur, Berry, Meaze, Barnier, Atkinson. The Hon. Archdeacon Stopford assisted as the Bishop's Chaplain. Morning prayers were read by the Rev. D. Massey, Curate of Killeshin, and an eloquent sermon from Deuteronomy IV, 7, 8, 9, was preached by the Rev. J. Beresford Johnstone, Rector of Tullow, and a collection made in support of the Scriptural Schools of the Parish. The Church was densely crowded by the parishioners and gentry of the neighbourhood. Col. Bruen, M.P., Major H. Cooper and R. Clayton Browne, Esq., acted as collectors. The whole ceremony was of an imposing and impressive char-

acter. The solemn and effective manner in which the Bishop pronounced the various parts of the Consecration Service made its way to the hearts of all present, and seemed to fill their minds with a deep sense of the beauty and propriety of the services of our Church. The new organ was used on this occasion for the first time, and the old 100th and the 118th Psalms were sung. The service concluded by the administration of the Sacrament of the Lord's Supper, of which all the clergy and many of the laity partook."

As already mentioned, I had discovered in the old Minute Book that the Church was built in 1825/26, pews allotted, Consecrated, and Services held in it. This is what happened: on going deeper into the matter and with much difficulty deciphering the old writing I discovered the following:- "April 1843, at a meeting of the Vestry it was brought to the notice of the parishioners that the Church was in a very dangerous condition, the arch having a large crack from end to end in it; it was resolved that the Rector communicate with the Ecclesiastical Authorities so as to have it inspected by a competent person, also that the present Church does not offer sufficient accommodation for the Parishioners."

The foundation might have been weak-



*Killeshin Church of Ireland*

Carloviana 2012

ened by a large trench dug close to the Church the previous year, June 1843. The Church was condemned by the Architect who said that a considerable portion of it would have to be taken down. In fact it was completely taken down and a larger one built. It was found that the foundation was only 18" deep, the mortar had not sufficient lime in it and the bricks crumbled away by touch.

They made no mistake the second time; they got that very competent Architect, Cobden, whose works have stood the test of time and include the Roman Catholic Cathedral, the spire on St. Mary's, Killeshin Roman Catholic Church, Staplestown Church, Braganza. entrance gateway to Duckett's Grove and House and "Thornville," Palatine.

The Rector stated that in the year 1825 when the Church was built the number of Protestants in the Parish was only 270 and that allowing for a probable increase, the Church should be such as would afford ample accommodation for at least 300, but instead of which, either from a change of plan, or the novel manner in which it was built, it was barely sufficient for 210, and that with pews only 2' 6" wide, much too narrow for two people to pass. Its entire extent being 64' long by 22' 6" wide, including chancel, pulpit, reading desk, aisle, etc. Since the above mentioned period the Protestant population has increased nearly 50%, and now our flock amounts to 394, and is still likely to increase considerably in consequence of having the commercial town of Graigue within the Parish, and the navigable River Barrow carrying on an extensive trade with Dublin, Cork, Waterford and New Ross.

There seems to have been great difficulty in obtaining a loan from the Ecclesiastical Commissioners for building another Church inside 20 years. Capt. Fitzmaurice, R.N., Old Derrig, interviewed them in Dublin and put the case of the Parishioners before them so forcibly that the money was granted. The first Church cost £1,000 and the second £750, the reduction in price being accounted for by using the materials in the first one. Of course the Parishioners had to put up a large portion of this money-£134-1-0d. The Church was insured for £500; premium £1-2-6 per annum.



**Items of Interest**

The Organ or Harmonium was brought from the old Parish Church, Killeshin, and erected on the Gallery; a new one was purchased in 1846 for use in the second Church; it was also erected on the Gallery where the choir sat in those days. It was used for the first time at the Consecration Service. The present Organ was purchased in Archdeacon Jameson's time in 1879 and erected in its present position. The Church was first heated by two

*Organ*

large stoves, burning coal. The two pipe or chimney outlets are still to be seen in the roof; they were in the centre of the aisle. They were replaced in 1902 by the steam pipe heating system, which was in use until 1952, when the present electric storage heaters were installed.

**The Bell**

Our Bell has a very interesting history. In the Very Rev. Canon Carrigan's history of Antiquities of the Diocese of Ossory, Vol. 2, page 323, appears the following:- "In the Parish of Lisdowney, district of Rathbeag, Co. Kilkenny, the Roman Catholic Parish Church, dedicated to St. Catherine, Virgin and Martyr, was thrown down about the year 1700 and a Protestant Church erected on its foundation. The latter Church had been deserted

and roofless for at least a century and a half, and it is a tradition of the people that though it was built for Protestant service yet no service was ever held within it. There was a Monastery here, but the period in which it flourished must have preceded the Anglo-Norman Invasion. The bell of the old Roman Catholic Church of Rathbeagh was found in a sand pit at the North side of the Graveyard on the lands of Caufield Best of Clone, a local magnate, who presented it to the Protestant Church Killeshin, Queen's County, where it is still in use." According to this account, the bell must be well over 300 years old; it has been erected on four different Churches. It was to the first Church at Killeshin that Mr. Best presented it. In 1955 it had to be taken down and sent to Dublin to have a small portion of it recast, as the tongue fell out of it, from constant friction. It had worn itself out. When it was re-erected it was set to be rung by electricity under the supervision of Mr. Albert Fennell.

This Mr. Best afterwards came to live at Bestfield, Carlow. The ruins of his mansion are still to be seen close to the Athy Road. It is believed that he inherited this property on the death of a relative.

*Bell & Door*

Carloviana 2012

It should make us feel ashamed of ourselves when we think of all the grumbling and complaining we had about the awful summer and bad harvest we have experienced in 1958. Our forefathers had some terrible trials to face, as we see from the following:- "Tuesday, January 15th, 1833; at a Vestry held this day, for the purpose of assessing the Parish, for a sum of money to relieve the distress of those who are suffering under the melancholy effects of that awful disease Cholera, and to relieve the wants of those who may be visited by it; the Rev. Roland O'Connor in the Chair." About a third of the Parishioners would be wiped out by this dreaded disease. Another visitation of it came in 14 years afterwards, in 1847, following the famine. Mention of the famine compels me to insert the following extract from a letter of the Vicar, the Rev. Dawson Massy, to the "Carlow Sentinel," 1847: "When I heard that three children were found starved to death, in one house in our Parish caused me to commence distributing food, and so much was it required, that a poor girl actually forced her attenuated body under the iron gate of the Churchyard and made her way into the School, where she fainted, and was with great difficulty preserved alive."

**1889**

Mrs. Young, Sextoness, resigned office; the Vestry granted her 6d. per week for life, so you can see her future was assured! Mrs. Whittaker was appointed in her place and remained in the position until the Rev. E. Bradshaw's time in 1911.

The Parish has several links with that famous man, Admiral Lord Nelson. In the graveyard lies buried the Hon. Charlotte Rochfort, wife of Horace Rochfort of Clogrennan; she was a grand niece of Lord Nelson's. Also interred there is Capt. James Fitzmaurice, R.N., of Old Derrig, who fought under Nelson either at the battle of Trafalgar or Copenhagen, and was wounded; he was then a Lieutenant.

The present Communion Plate was purchased in 1826 for the first Church at a cost of £3-0-0d. The names of the then Church-wardens are inscribed on them-William Fishbourne, James Wilson. It has been in regular use for the past 133 years.

## HISTORY OF KILLESHIN PARISH

The Church has been enriched down the years by some beautiful memorials. I think it would be fitting to mention them. The first is a tablet erected by the Parishioners to the memory of Rev. Roland O'Connor, Curate of Killeshin, and Rector of Sletty and Shrule. It is remarkable that although this memorial is in the present Church that Rev. Roland O'Connor was never inside it—he died in 1841—five years before it was built. He officiated in the first Church for 17 years, almost the full period of its existence. This must be without parallel in Church history.

The stained glass window on the South wall in Memory of Major Edward Haughton, late the Princess of Wales Regiment, erected by his brother officers.

The Reading Desk is in Memory of Rev. William Cooper Duke, A.B., T.C.D., who, for twenty-five years, was a faithful Minister of the Church in the Diocese. He was not Rector or Curate of Killeshin at any time.

The Communion Rails and Tiling in the Chancel to the Memory of the Ven. Archdeacon Jameson and his wife Emma, presented by their children.

The Font was presented by Mr. Henry Cole in memory of his wife Mary Conyers.

The Pulpit was presented by the late Mrs. Fitzmaurice of Everton in Memory of her husband, Mr. Edward Fitzmaurice.

The Lectern was erected to the Memory of Mr. Patrick Dudley Shackleton, by his wife.

Mrs. Macdonald of Hollymount presented the Tablet and Reredos in the Chancel, also the embroidered cloth on the Holy Table, in Memory of her husband, Major Donald Ramsey Macdonald, D.S.O., M.C., Royal Artillery, and her sons, Major John Robert Somerlead Macdonald, Royal Fusiliers, killed at the Battle of Sidi Barani, and Lieut. Roderick William Macdonald, R.N., who failed to return to H.M.S. *Courageous*, West of Alexandria, Mediterranean.

The Prie-dieu (the little Prayer-desk) was presented by the Parishioners of Killeshin in Memory of the Ven. Samuel Ridgeway, M.A., Archdeacon of Leighlin.



*Stained Glass Window*

The beautiful stained glass East Window was presented by Major A. J. W. Fitzmaurice and his brother, Capt. R. M. Fitzmaurice, in memory of their Father and Mother, Mr. and Mrs. William Fitzmaurice, formerly of Laurel Lodge and Kelvin Grove.

The two chairs in the Chancel were presented by Mrs. Wynne of Shrule, in Memory of her husband, William, and her children, Elizabeth, May, Victor Leslie, Frederick Philip, Violet Emily and Eileen Frances and William Robert. There is a Tablet on the left inside the Church door in Memory of Mr. William Treacy who was Sexton for 41 years, erected by the Parishioners of Killeshin. The beautiful Alms Dish was presented by Mrs. Nelson in Memory of her father, the Rev. Godfrey Haughton Jameson and her mother, Constance Jameson.

The Brass Flower Vases on the Holy Table were presented by Mr. David and Miss Eileen Sheridan of Bromley, Kent, in Memory of their father, David, and their mother, Annie (nee Fennell), and their sister, Hilda.

I now come to the families who have long connection with Killeshin.

The McMahon family of Hollymount is

the oldest in the Parish; I found that where the Elizabethan Grants are mentioned, that a Colonel St. Leger was granted three townlands in Killeshin Parish, Leagh, Ballyneskin, by Queen Elizabeth 1st, in 1551, and another which I cannot decipher. Mrs. Macdonald very kindly gave me the family history which linked up her family with the St. Legers and the Fishbournes. One of the St. Legers became 1st Viscount Doneraile; they are also connected with the Eustace family of Newtown, Tullow.

The Watters family comes second; in the year 1828 a Richard Watters was a Churchwarden.

The Fennell family comes third; my great grandfather, Richard Fennell, is mentioned in 1832.

The latter two families were in the Parish at the end of the 18th century but were not on the Vestry until the dates mentioned. It is a remarkable fact that for more than a century at least one member, of these three families attended every Vestry Meeting held.

The FitzMaurice family came to these parts from Kerry in 1620 and settled down at Raheendoran. The first mention in the Books of this family is in 1843. The reason they do not come into the Books earlier is that at that time Carlow Parish extended as far as Old Derrig, and when the second Church was built the River Barrow was fixed as the boundary; they had been in Carlow Parish until that time. Various members of the family resided in Killeshin Parish from then to the present time: Gamaliel FitzMaurice, at Laurel Lodge, and Ballyhide House, Major Harmon FitzMaurice different times at Castle-view, Crossleigh and Springhill House; he served with the Queen's County Regiment and was mobilized for the Crimea War; Arthur FitzMaurice, late of Johnstown, son of Arthur FitzMaurice of Kelvin Grove, lived at one time in Fruithill; his brother lived at Laurel Lodge, before going to Kelvin Grove; his son, Major A. J. W. FitzMaurice, now lives at Laurel Lodge.

The Jameson family had long associations with Killeshin Parish; the Rev. Joseph Jameson was a Curate in old Killeshin; as already mentioned he presided at the

## HISTORY OF KILLESHIN PARISH

meeting in 1823, which decided to build a new Church. He was afterwards Rector of Carlow. The beautiful stained glass East Window in St. Mary's, Carlow, was erected to his Memory. His son, the Rev. James Jameson, afterwards Archdeacon of Leighlin, came to Killeshin in 1867, and was Rector until the year of his death in 1889, 32 years in the Parish. He was succeeded by his son, the Rev. Godfrey Haughton Jameson, who remained in Killeshin until the year 1910, when he went to Tullow as Rector. His daughter is Mrs. Nelson of Urgan Glebe.

The Haughtons and Shackletons were Parishioners for nearly a century. They were descendants of the families who founded the Quaker Settlement and School at Ballytore in 1726. Sir Ernest Shackleton, the world-famous Antarctic explorer, who was born at Ballytore, often visited his relations in Graigue as a young man, and attended Divine Service in Killeshin on several occasions. They were Flour Millers and Corn Merchants. They played a very important part in the commercial life of the town of Carlow for a couple of centuries. Another very famous member of the Shackleton family was Mary, afterwards Mary Leadbeater; she wrote amongst other works the famous book, "The Annals of Ballytore." Capt. Paget Butler was church warden in 1865; he was a nephew of the Marquis of Ormond: he lived in Springhill House; also Church-warden in 1865 was Harmon Faulkner, Springhill Cottage; he was a grandson of Dr. Faulkner who was the Rev. Joseph Jameson's predecessor as Rector of Carlow in 1780. The last of the Faulkner family, Danny, died a few years ago in Carlow County Home, a broken-down Knight of the Road.



The farm now occupied by Mr. Nat Minion was the home of the Young family; they were in Killeshin Parish for over a century. They originally came from Slyguff, Bagenalstown.

Mr. Henry Cole was Superintendent of the Barrow Navigation Company. His name appears for many years in the Vestry books. The broken pillar tombstone, in Killeshin Graveyard (symbolic of a life cut away in its prime) was erected to the Memory of Brevet Major Henry Cole, East Suffolk Regiment, who died of sunstroke in New Zealand and was buried there.

The Lafarelle family resided for many years at Springhill House. James Lafarelle was Churchwarden in 1869. The family went to India in 1886. A Captain Knipe afterwards lived in Springhill House; he was Churchwarden on several occasions. His wife was an Indian Princess, a very wealthy lady, and was 28 stone in weight.

Also two other very old families who lived in Graigue were the Whittakers and Jamess. Mrs. Lewis of Dublin Street is a member of the Whittaker family, and George James, who died about 13 years ago, was the last of the family in the Parish.

#### The School House

I think I should give you a few interesting facts about the School House. The first mention of it was a letter addressed to Mr. Robert Fishbourne, Churchwarden of Killeshin in the year 1824, from the Rev. William Fishbourne, Rector of Ferns: "Dear Sir, a large tree, having been cut on the lands at Killenane, near Leighlin Bridge, in the possession of Mr. Groome, I am directed by the Lord Bishop of Ferns to acquaint you, that he gives that tree to the Parish of Killeshin, to be used in fitting up the new school house in that Parish. I have written Mr. Groome on the subject, Mr. John Payne of Leighlin-bridge will assist you in getting it." All the carting was done by Parishioners' horses. There seems to have been a lot of friction between the teachers, both male and female, and the Rector, and Inspection Committee. We read that in October 1826 a charge was preferred against Mrs. West, the School Mistress, for irritability of temper, and intemperance of language, and want of proper respect to the ladies

superintending the female school; she was dismissed from her position as teacher. Her husband was the boys' teacher. A Miss Jackson was appointed in her place. We read at a later date that Mr. West was also dismissed as his wife assaulted the new teacher-she beat her up in the School Yard !

At that time the attendance was 95. 40 Roman Catholics and 55 Protestants. There was a bitter controversy in the local papers between the Rector, the Rev. Dawson Massy, and the Parish Priest in Graigue, the Rev. J. Maher, in consequence of these children attending a Protestant School.

Copies of the letters in the " Carlow Post " and " Carlow Sentinel " are still in existence.

We read later of a lady teacher who seems to have been a nice, kindly, gentle creature; she tried to instil knowledge into her pupils with the aid of the leg of a small desk. Some of the children bore the marks for life. So much for the School.

#### Clergy

The first mention of a Rector was on 24th July, 1551, when Queen Elizabeth 1st gave a grant of English Liberty to Donnag Mora, Vicar of the Parish " Kil-



*The Venerable Samuel Ridgeway M.A.*

HISTORY OF KILLESHIN PARISH

lessyn," in Co. Carlow. There does not appear to be any continuity of names of Clergy until the Rev. Joseph Jameson is mentioned.

Oliver Keating is given as Vicar in 1615.

In 1690 Thomas Underwood, Minister.

1796 to 1823, Rev. Joseph Jameson, Curate.

1826, Rev. James Langrishe, Archdeacon, and Rev. Roland O'Connor, Curate.

1842 to 1846, Rev. John William Williamson, Rector; Rev. David Scott, Curate.

1847, Rev. Dawson Massy, Rector; Rev. P. C. Pounall, 1857, Curate.

1867, Ven. Archdeacon James Jameson.

1899, Rev. Godfrey Naughton Jameson, Rector.

1911, Rev. Edward Bradshaw, Rector.

1912, Rev. Samuel Ridgeway, Rector.

His curates were:- Rev. R. Hazley; Rev. R. Ridgeway; Rev. R. J. Charters; Rev. W. Packham; Rev. T. V. Perry; Rev. R. B. Thompson; Rev. Neville Phair; Rev. W. Daunt; Rev. W. W. Stanley; Rev. A. P. Fisher, Rev. R. W. Reynolds.

I now come to our present worthy Rector, Rev. J. G. Gash, and Rev. W. S. Baird, Curate.

Killeshin has been noted for its outstanding Clergymen down the centuries, and Mr. Gash and Mr. Baird have always upheld that great tradition. Our Parish is lucky in having two Clergymen of such outstanding ability here at the same time. I feel sure that every Parishioner will heartily agree with this statement, and our prayers should be - "Long may they remain with us."



Carlovians at the launch of Dr Michael Conry's latest book

Back: Dan Carbury, Owen Doyle, Martin Nevin, Dr Maurice Manning  
Front: Pat O'Neill Mgt. Minchin, Dr Michael Conry, Olivia O'Leary & Pat Comerford.

Carloviana 2012



## DEVELOPMENT AND DEMISE OF THE CARLOW BURGESS

Sean O'Shea

Apart from the conquest of Ireland, military honour and glory, the Normans, particularly the Norman Knights, had other motives when invading Ireland in 1169. They were particularly interested in making profit from the newly acquired land. To strengthen their hold on their property, castles were erected in strategic locations throughout the country, similar to a policy employed by them in England, after the conquest of that country in the previous century. A timber fortress/castle was erected by Hugh De Lacy, at the Barrow river in Carlow, for John De Clahull, a vassal of Strongbow, which survived for at least three decades. The building was subsequently replaced with a stone and masonry castle, by William Marshall, Earl of Pembroke. Its ruin stands to-day. To consolidate their holdings further, the Normans earmarked certain areas of land, called Burgage Land, and encouraged English and Welsh tenants to occupy this land by conferring (under statute), a considerable number of privileges on them, not afforded to other tenants, i.e. a Gaelic unfree tenant known as Bothach. The statute known as the Law of Breteuil, granted tenants of Burgage land, the status of Burgess, with the right to lease other land from the Lord, sell their interest in their property, and leave when they wished.

Ryan refers to the "yearly rent of twelve pence out of every Burgage".

Another important privilege granted to the Burgesses was the right to own their own Hundred Court, which allowed them to hold court confined to their own peers, and was entirely outside the jurisdiction of the Manor Court.

However, on leaving Burgess property, the tenant's title of Burgess ceased to

exist, as the title applied only to the occupier of Burgess land and dwelling house. In later years the title of Burgess had different connotations and meanings. The holding of a Burgess, consisted of a narrow street frontage, with a long narrow garden behind the house, and land adjacent to or near the settlement. Towns created in this manner were known as Boroughs. A number of Boroughs did not develop or survive as settlements, and ceased to exist - such as Dunleckney. Not all places with Burgesses were regarded as towns.

The Burgesses of Carlow were privileged, and their position was strengthened, when William, Earl Marshal, and Earl of Pembroke, granted the first charter to the town of Carlow, during the reign of King John (1199 -- 1216). Ryan states in his "History of Antiquities of County Carlow": "There can be no doubt the charter was granted about the time Marshal received the Marshalship of Ireland in 1208". However, the charter was not enrolled until 1296 (24th year of the reign of Edward 1).

Charters were granted by the Monarch of England, but in a few instances, a high ranking Lord, was favoured with the honour i.e. William Marshal, Earl of Pembroke and Walter de Lacey, Lord of Meath.

The Catherlach Charter records "Be it known to all men now and hereafter, that I, William Marshal, Earl of Pembroke, have granted to my Burgesses of Catherlach, all such liberties as Burgesses ought to have, and as it is lawful for me to confer, to be held and enjoyed forever of me and my heirs by them and their heirs" etc. The Charter contained the privileges already mentioned, and also states "It shall be lawful for the said Burgesses to have

a Guild of Merchants and other Guilds". However, there is no provision in the Charter for the appointment of a Portreeve, or the granting of Corporation status to the Burgesses, or authority enabling them to return members to Parliament. The Charter would have been modelled, like many granted in Ireland, on the franchises of free-laws of Bristol. A borough also evolved at this time at Old Leighlin, probably by way of prescription and custom, when Herlewin allowed burgage holdings to be provided on land, the property of the see (somewhat similar to a borough formed at Cashel during the bishopric of Donat). Old Leighlin Borough was managed and controlled by the Bishop, and was known as a Bishop Borough, of which a number existed:- Cashel, Clogher and Armagh.

Many of the Boroughs claiming corporate status did not develop into proper towns, (it has been calculated that only one in four Boroughs developed into towns). Some were villages, others eventually depopulated and disappeared. By the time of James 1, it was recorded that in Ireland there were forty four towns in which Municipal Corporations were supposed to have existed by prescription, or in which there were traces of Municipal bodies.

James' policy in Ireland, was to establish his own authority over the country's people, whether native or Anglo-Saxon, and in return, to treat all as his subjects. He therefore proposed that the first parliament that he summoned should be represented by members of the Irish race. To fulfil his wishes, James appointed a Commission, to inquire as to the existing state of Boroughs in Ireland. This Commission of Inquiry was under the guidance and control of Arthur, Lord Chichester of Belfast. Lord Chichester,

## DEVELOPMENT AND DEMISE OF THE CARLOW TOWN BURGESS

in correspondence at the time, set out the following criteria adopted by him, "To make such towns only, as we think fit and behoveful for the service (incorporation), and to omit such as are likely to be against us". In his submission to the King, he reported in relation to Catherlach, "none in whole county, there being no town fit." Notwithstanding Chichester's recommendation James bestowed a Royal Charter of Incorporation on the town of Catherlach on the 19th April 1613.

James' first parliament of Ireland, consisted of 226 members, of which 101 were Roman Catholic. Two members were elected from each of the following electoral areas:-

Cities and towns that were counties	9
Shires that sent Knights to parliament	33
Old Boroughs	31
New Boroughs	39
The University of Dublin	1

John Bere, Sergeant at Law and Sir Robert Jacob, Solicitor General, members of the newly formed Corporation of Carlow, represented the town in James' parliament of 1613.

The Charter granted by James "Ordained and decreed that within the said Borough of Carlow, there be one Body Corporate and Politique, consisting of one Portrieve, twelve free Burgesses and commonalty," and he further ordered "that the Portrieve and free Burgesses of the Borough and their successors for ever, may have full power and authority to elect and return two discreet and proper men, to serve and attend in every parliament in the Kingdom of Ireland hereafter to be held."

John Kerton was named "the first and modern Portrieve of the Borough" in the Charter, with the following twelve free Burgesses: John Bere, Sir Robert Jacob, Sir Adam Loftus, Anthony St. Ledger, Peter Wright, William Greatrake, Nicholas Harman, John Bromfield, John Ely, Robert Whitacre, Robert Sutton and Richard Keating.

Burgesses held office during their natural life, unless dismissed in the meantime for misconduct or ill government. The Portrieve was elected annually, and vacancies when they occurred, were filled by a majority of the members of the Corpo-

ration. Thus the status of the Burgess was expanded to include membership of Municipal Corporations, who possessed important privileges in relation to the election of parliamentary representatives.

Charters of Incorporation granted by James 1st were unpopular, as they were contrary to the original intention of all ancient incorporations, and repugnant to the corporate laws known in Ireland for the previous four centuries. In almost every instance, individuals who were to be first portrieve, burgesses and sheriffs of the town, were named in the charter and not infrequently also the Recorder and Town Clerk. All were required to take the oath of supremacy. The manner of election of members to parliament was also questionable, as it gave James a majority in the parliament of 1613. In fact the charters legally separated the members of the corporation class from the inhabitants of the town charters, including James I to the town of Catherlach, were subsequently terminated by Charles 2nd in 1672. Following a petition from Robert Brown late portrieve, free burgesses and community of Catherlach, a second royal charter was granted by Charles on the 24th December 1676. This charter outlived the King.

"Many of the charters of the several cities and towns formerly corporate in our kingdom of Ireland, have been by reason of several miscarriages and misdemeanours of the said cities and towns, during the time of the late horrid rebellion, forfeited unto us and others of said corporations, are dissolved or otherwise determined".

In relation to the petition made the charter continues:-

"Robert Brown Esq., late portrieve, the burgesses and community of the town of Catherlach have humbly petitioned us, we would be graciously pleased to grant unto them a new charter for the said borough, and to incorporate them by the names of sovereign, free burgesses and community of the said town and borough of Catherlach, with such franchises, liberties, privileges and advantages as they formerly held, under such restrictions and limitations as we should think fit".

The body corporate formed comprised one sovereign and twelve burgesses, namely:- Sir John Povey, Sir William

Temple, John Nicholas, Henry Berkeley, Edward Reynolds, John Warren, Robert Curtis, Michael Heade, Samuel Blackshaw, Sir Thomas Butler, Sir John Danalier and John Tench. Robert Brown was the first sovereign

On the 24th February 1689, James 11 granted the borough of Catherlach its last royal charter, which was short lived. This charter did not materially differ in its provisions from the charter of Charles 11. The corporation created under this charter comprised one sovereign, Garret Quigley, twenty four free burgesses and community of Catherlach. The corporation was also empowered to send two members to parliament.

Following the ascension of William 111 to the throne, all the charters of James 11 including his charter to the town of Catherlach were declared void under an Act of William in 1695. (An Act declaring all attainders and all other acts made in the late pretended parliament to be void). Catherlach Corporation, accordingly reverted to being governed by the former charter granted by Charles 11. Catholics however, were excluded from corporation membership by law from 1695, and the franchise remained exclusively Protestant until 1793.

Following the many changes and disturbances, confusion was caused in the management of corporations, eventually descending into corruption, resulting in political intrigues. In the process of time, the majority of corporations became the property of the aristocracy, and they in turn ensured their own aggrandisement by bestowing the representation of those to their sons and supporters. After this, corporations were regularly bought and sold. While the Sovereign and Burgesses constituted the ruling body, they were all persons connected with or in the immediate interest of the owner (known as patron), thus leaving the management of the corporation entirely in his hands. Catherlach Corporation became the property of the Burtons of Burton Hall, and like the majority of corporations was a closed corporation, which allowed parliamentary representation to be determined and controlled by the patron.

In 1796, William Burton, due to financial difficulties, disposed of his interest in the

## DEVELOPMENT AND DEMISE OF THE CARLOW TOWN BURGESS

corporation of Catherlagh to Charles William Bury, Earl of Charleville, Tullamore, for the sum of £15,000. Lord Charleville, the new owner and patron, at once replaced all the existing burgesses and appointed in their stead his own supporters, none of whom with the exception of two had any connection with the Catherlagh area: namely William Brown of Brownhill and James Butler of the town of Catherlagh. This procedure was completely contrary to the spirit of the charter and showed the aristocracy's illegal usurpation of the people's rights. The action of the Earl of Charleville condemned by the inhabitants of the town but to no avail.

As a consequence of the Rebellion of 1798, the Irish Parliament was prorogued on the 2nd August 1800, and did not again assemble in Ireland. The Act of Union was passed into law, which reduced the number of Irish parliamentary representation from three hundred to one hundred, who were now required to attend at the House of Commons in London. Catherlagh Borough's parliamentary representation was reduced to one member. Old Leighlin Corporation was disfranchised as a borough, and having lost its political usefulness, was permitted to fall into decay.

The introduction of the Reform Act of 1832 by the Liberal party, disfranchised corporations, thereby further reducing their political value. Parliamentary representation was then determined by way of the middle class vote, i.e., households with property of £10 valuation or over. At that particular time Lord Charleville's son represented the Borough of Catherlagh in the House of Commons.

A caustic profile of the burgesses that year in the Carlow Morning Post telling them to "pack up, ye rascals and begone (Dryden), gives some indication of their unpopularity, and lists them as follows:- "1. Edward Butler, Sovereign; and who barring a vow which he made to be true to you (lord Charleville), would have long ago withdrawn from the dirty job.

2. William Fishbourne - the running of a second coach would not indemnify poor Bill for his nice pickings, which he is about to lose.

3. William Browne, of the hill, who has been faithful to neither side. He has betrayed his patron by lately signing the Requisition of Reform and the interests of the country, by being so long a party to borough corruption and monopoly.

4. Robert Clayton Browne, son of the above William Browne. To give the devil his due, Robert is a worthy corporator, though more consistent than his Dad!, for Bob refused to convene his bailiwick lest, of course, he should in any way forward the wicked work of Reform, or comply with the well known wish of William the fourth, whose representative he was. Bye the by, master Bob is captain of the Carlow corps of yeomanry, who have lately distinguished themselves so highly at the interment of Voss the Nailor, when they paraded the streets of Carlow to the great edification of Orangemen and bigots, playing the tune of " Protestant Boys". Such is the triple capacity of Bob-

Corporator, Sheriff, Captain of Yeomen. The man of God, the Rev. Frederick Eyre Trench. The name of Trench speaks volumes. Curry, what relation is Fred to the Rev. Doctor Trench, who prosecuted Aeneas McDonnell?

6. Thomas Sterling Berry, Attorney, Clerk of the Pipe, Law-agent and confidential adviser to Lord Charleville, and residing in Hume Street, Dublin.

7. Malborough P. Berry, brother of the above, and Land-agent etc. etc. to Lord Charleville.

8. Francis Berry, brother of the two foregoing, and equal to either of them in devotion to his patron's interests. Three Berrys! The Lord preserve us, one of them would be quite enough.

9. Another man of God, the Rev. John Lever. God bless the Parsons, they always figure amongst the corruptionists. Master Lever is besides domestic chaplain to Lord Charleville.

10. William Wallace, not him of Bannock-burn, but he of Tullamore, Apothecary to Lord Charleville. Bravo, monsieur Purgon!

11. The Honourable Francis Aldborough Pretty. Pretty and Aldborough

don't sound well together.

12. Another Trench! oh! oh! oh!

13. Lord Charleville. Be it remembered, that in the year 1796, and in the month of February of said year, and on the nineteenth day of said month, you, Charles William Bury of Charleville forest, were admitted to the freedom of this borough — that on the tenth day of March following, you were made a Burgess of said borough; and that within sixteen days after, with a hop-step-and-a-leap, you became proprietor of said borough for the sum of £15,000 sterling, paid down on the nail, to one William Burton, of Burton Hall, in this county, sending all the then Burgesses a packing, as we by these presents, intend packing you and yours".

With the privilege of returning members to parliament being removed from the patron and burgesses, their end was in sight. The Municipal Corporations (Ireland) Act 1840 (3rd and 4th Victoria Cap 108) abolished fifty eight corporations, including Carlow Corporation, which was replaced with a Town Commission, thus bringing to an end the Corporation of Carlow and the demise of the Carlow Burgess.

The Carlow Burgess had survived over a period of six centuries, changing from tenant farmer to politician, with the privilege of election to parliamentary representation, though somewhat diluted in later years. Nevertheless the burgesses played an imposing and important role in the development of the town of Carlow and its environs, thereby recording a place for themselves in our heritage and history.

**References:-**

*Medieval Ireland* Tadhg O'Keeffe  
*Byrne's Dictionary of Irish Local History*  
Brophy Papers  
*Carlow Morning Post*  
*Sentinal*  
Gale's Account of Municipal Corporation  
*Parliamentary Gazetteer of Ireland*  
*Vol II Oxford English Dictionary*  
*History of Antiquities of County Carlow.*

Samuel Lewis was the editor and publisher of topographical dictionaries and maps of the United Kingdom and Ireland. The aim of the texts was to give in 'a condensed form', a faithful and impartial description of each place. The firm of Samuel Lewis and Co. was based in London. Samuel Lewis died in 1865.

A Topographical Dictionary of Ireland was first published in 1837 in two volumes, with an accompanying atlas; it marked a new and significantly higher standard in such accounts of Ireland. The first edition is available online. A second edition was published in 1842.

In the 1837 preface, the editor noted that: The numerous county histories, and local descriptions of cities, towns, and districts of England and Wales, rendered the publication of their former works, in comparison with the present, an easy task. The extreme paucity of such works, in relation to Ireland, imposed the necessity of greater assiduity in the personal survey, and proportionately increased the expense.

Lewis relied on the information provided by local contributors and on the earlier works published such as Coote's Statistical Survey (1801), Taylor and Skinner's Maps of the Roads of Ireland (1777), Pigot's Trade Directory (1824) and other sources. He also used the various parliamentary reports and in particular the census of 1831 and the education returns of the 1820s and early 1830s. Local contributors were given the proof sheets for final comment and revision. The names of places are those in use prior to the publication of the Ordnance Survey Atlas in 1838. Distances are in Irish miles (the statute mile is 0.62 of an Irish mile).

The dictionary gives a unique picture of Ireland before the Great Famine.

**Tankardstown, Templepeter  
Tinahinch, Tullowcrine  
Tullowmagrinagh or Thumagurna**

**Tullow or Tullowphelim,  
Urglin or Ruthland, Ullard and Wells**

#### Tankardstown

a parish, in the barony of Rathvilly, county of Carlow, and province of Leinster, 17 $\frac{1}{8}$  miles (N.W.N.) from Tullow; containing 1101 inhabitants. It is situated on the rivers Dereen and Slaney, the former of which separates it from the county of Wicklow and bounds it on the east, and the latter bounds it on the west. About seven-tenths of its surface consists of meadow and pasture; the remainder is arable, with a small portion of wood. Within its limits are the small hamlet called from its situation Tankardstown Cross roads, and Cappagh House, the residence of Wm. Young, Esq. In ecclesiastical concerns it is not known as a parish, but constitutes part of the rectory of Tullow, in the diocese of Leighlin; and in the R.C. divisions also it is part of the union or district of Tullow. About 170 children are educated in two private schools. At Capnagh is the ruins of an old castle.

#### Templepeter

a parish, in the barony of Forth, county of Carlow, and province of Leinster, 5 miles (S.E. by S.) from Carlow, on the road to Fennagh, and on the river Burrin; containing 349 inhabitants. Granite is plentiful, and the state of agriculture is improving. The living is a rectory, in the diocese of Leighlin, and in the patronage of the Bishop: the tithes amount to £64. 10. The protestant inhabitants attend divine service in the parish church of Dunleckney. In the R.C. divisions it is part of the union or district of Dunleckney. There is a private school, in which about 100 children are instructed. The ruins of the old church remain.

#### Tinnahinch

a village, in the barony of St. Mullin's, county of Carlow, and the province of Leinster, forming a suburb of the town of Graigue, in the county of Kilkenny, with which it is connected by a good stone bridge over the river Barrow: the population is returned with the parish.

#### Tullowcrine

a parish, in the barony of Idrone West, county of Carlow, and province of Leinster, 5 $\frac{1}{8}$  miles (S.W.) from Carlow, on the road from Leighlin-

**Lewis's Topographical Dictionary is now out of copyright. So it is the intention of the *Carlow Historical and Archaeological Society* to publish the full extent of the text relating to Carlow over a number of issues of its journal, *Carloviana*, under the title 'Lewis's Carlow'**

Bridge to Castlecomer, and on the river Barrow; containing 1348 inhabitants. It is an inappropriate cure, in the diocese of Leighlin, forming part of the union of Old Leighlin: the rectory is appropriate to the dean and chapter. The tithes amount to £300. In the R.C. divisions it forms part of the union or district of Leighlin-Bridge

#### Tullowmagrinagh or Thumagurna

a parish, in the barony and county of Carlow, and province of Leinster, 4 miles (S.E. by S.) from Carlow, on the road from Leighlin-Bridge to Tullow; containing 1109 inhabitants. It comprises 5913 statute acres, as apportioned under the tithe act, chiefly under an improved system of tillage. The seats are Castletown, the residence of---- Faulkner, Esq.; Racroge, W. Elliott, Esq.; and Kilballyhue, of --- Nolan, Esq. It is a rectory, in the diocese of Leighlin, forming the corps of the prebend of Tullowmagrinagh, in the cathedral of Leighlin, and part of the union of Ballinacarrig or Staplestown: the tithes amount to £320. 15. In the R.C. divisions it is the head of a district, also called Tinriland, comprising also the parishes Ballinacarrig, Ballycroogue, and Bennykerri, and containing the chapels of Tinriland and Bennekerry, the former in this parish. At Tinriland is a national school, in which about 340 children are educated. Mr. Haughton, a translator of some of Fenelon's works, lived in the parish.

#### Tullow or Tullowphelim

a market and post-town, and a parish, in the barony of Rathvilly, county of Carlow, and province of Leinster, 7 $\frac{3}{8}$  miles (E.S.E.) from Carlow, and 46 $\frac{1}{2}$  (S.S.W.) from Dublin, on the road from Carlow to Newtownbarry; containing 2587 inhabitants, of which number, 1929 are in the town. This place, which is situated on the river Slaney, over which is a bridge of five arches, built, according to an inscription on it, in the year 1767, is supposed to have been originally an appendage to a castle erected here by some of the first English settlers under directions of Hugh de Lacy, and to monastery founded here in 1315 for



Augustinian friars by Simon Lombard and Hugh Tallon, whose grant was confirmed, in 1331, by Edw. III. At the dissolution its temporalities were granted to the Earl of Ormonde. The castle was defended by Col. Butler in 1650 against the parliamentary army, but after a stubborn resistance it was taken by Cols. Hewson and Reynolds. There are no vestiges of it now in existence, and the only relic of the abbey is a mutilated stone cross in a burial-ground on the south side of the river. It is said that the building was taken down in the reign of Queen Anne, to supply materials for the erection of a barrack, on a site now occupied by the court-house. The town comprises two main streets and a few lanes, in which are 305 houses, mostly of inferior description: its outlets extends into two adjoining parishes of Ardristan and Killerrig. It obtained a patent for holding a market Saturday and another again on Tuesday: the market is now held on Saturday, and is the best corn market in the county. Fairs are held on April 21st, July 10th, Oct 29th, and Nov. 21st. The extensive flour-mill of Messrs. Doyle and Pim grinds about 10,000 barrells of wheat belonging to Mr. Carter and Mr. Roche. General sessions of the peace are held in the town in January, April, June, and October; petty sessions are also held here: the business of both is transacted in a small court-house. The town is a chief constabulary police station.

The parish contains 5837 statute acres, as apportioned under the tithe act: about one-half of it is meadow and pasture, and the remainder under tillage, with the exception of a small portion of wood. Two of its townlands are locally situated in the adjoining county of Wicklow. The Dereen river flows along its south-eastern and southern boundaries, and at its southern extremity joins the Slaney near the church of Aghade. The principal seats are Newtown, the residence of R. Eustace, Esq.; Rathglass, of Pilsworth Whelan, Esq.;-----, of R. Doyne,



*Mass Rock at Mr Garrett Moore's  
of Wastegrass, Tullow*

Esq.; Castlemore, the seat of the Eustace family; Rathrush, a seat of Viscount Frankfort de Montmorency: and Ballynunnery, of ---Swift, Esq.; the residence of W. Carter, Esq., is in the town. The living is a rectory, in the diocese of Leighlin, and in the patronage of the Marquess of Ormonde: the tithes amount to £600. There is a glebe-house, with a glebe near the church; the latter is a new building, erected in 1831 in the Gothic style. In the R.C. divisions the parish is the head of a union or district, comprising the parishes of Tullow and Tankardstown, and part of those of Ardristan. Pubbledrum and Urglin. In the union there are three chapels; that of Tullow is a spacious building with three galleries, to which has been lately added a very fine tower or spire. There is a monastery in the town, the friars of which, ten in number, superintend a classical school, and also a national school, to which the Board of National Education allows £20 per annum for an

additional master. The ladies of a convent superintend two schools, one for the daughters of the gentry, the other a free school for the education of the poorer classes; the latter of these also receives aid from the National Board. A number of orphan children are sent from Dublin to the monastery and convent schools for instruction. There is in the town a school for boys and girls, supported by subscriptions, and an infant's school, maintained by Chas. Doyne, Esq. There are also two private schools, in which are about 60 boys and 20 girls. Some distance south of the town there is the ruins of Castle Grace, erected by one of the ancient family of Grace, descended from Raymond le Gros. The title of Viscount Tullowphelim was evolved successively by two branches of the Butler Family, both of which have been years extinct.

#### **Urglin or Rutland**

a parish, in the barony and county of **Carlow**, and province of **Leinster**, 2 miles (E.N.E.) from Carlow, on the road from that town to Castledermot; containing 977 inhabitants. This parish comprises 3080 statute acres, as apportioned under the tithe act, and valued at £2715 per annum: the greater part of the land is in small holdings, and system of agriculture is improving. The seats are at Burton Hall, the residence of W. F. Burton, Esq., pleasantly situated on a rising ground in a finely planted demesne, approached by a long and wide avenue of trees; Rutland House, of - Mosse, Esq.; Rutland Lodge, of E. Burton, Esq.; Johnstown, of T. Elliott, Esq.; Benekerry Lodge, of E. Gorman, Esq.; Mount Sion, B. Colclough, Esq.; and Bennekerry House, of Mrs. Newton. At Palletinetown there is a constabulary station, and a fair is held there on the 26th of March. The living is a rectory, in the diocese of Leighlin, united in 1713 to the rectory of Grangeford, and by act of council, in 1803, to the impropriate cure of Kilerick, and in the patronage of the Bishop: the tithes amount to £250, and of the union to £542. 19. 2. The church is a neat plain building with a spire, erected in 1821 by aid of a loan of £700 from the late Board of First Fruits. In R.C. divisions the parish is partly in the union or district of Tullow, and partly in that of Tinryland, and contains a chapel belonging to the latter division, situated at Bennekerry. About 50 children are taught in a public school, and 110 in two private school.

#### **Ullard**

Ullard a parish, partly in the barony of St. Mullins, county of **Carlow**, and partly in the barony of Gowran, county **Kilkenny**, and province of **Leinster**, 2 miles from Graig, on the road from Carlow to New Ross; containing 2139 inhabitants. This parish is situated on both sides of the river Barrow, and comprises of 4989 statute acres, as apportioned under the tithe act. The living is a rectory, in the diocese of Leighlin, being the corps of the prebend thereof in the cathedral of Leighlin, and in the patronage of the Bishop; the tithes amount to £258. 9. 2 and the gross income of the prebend to £285. 9. There is a glebe-house, with a glebe of 30 acres. In the R.C. divisions it is part of the union or district of Graig. The remains of the church with an ornamental cross in the churchyard, appear to be of some antiquity.

#### **Wells**

**WELLS**, a parish, partly in the barony of **GOWRAN**, county of **KILKENNY**, but chiefly in that of **IDRONE WEST**, county of **CARLOW**, and province of **LEINSTER**, 2 miles (S. by W.) from Leighlin-bridge, on the road to Gowran; containing 1554 inhabitants. This parish is situated upon the south side of the river Barrow, and comprises 2633 statute acres, as apportioned under the tithe act, the whole of which is in a highly improved state of cultivation. Here is a slate quarry. Fairs for general farming stock are held on Ascension-day and Sept. 11th. The seats are Ravindon, the residence of the Rev. S. T. Roberts; Bur-



*Doorway at Ullard Church*

gage, of the Rev. T. Vigors; and the Deanery-house, of the Hon. and Very Rev. Dean Bernard. The living is a rectory, in the diocese of Leighlin, constituting, with the chapelry of Ballyknocken, the corps of the deanery of Leighlin, and in the patronage of the Crown: the tithes amount to £392. 6. 2., and the gross income of the deanery to £448. 4. 1.; there are several small glebes, comprising 21 acres. The church, which formerly

stood near the village of Royal Oak, was by act of council in 1807 removed to the site of the ancient chapel of Ballyknocken, now a townland in the parish: it is a plain building in an elevated situation overlooking the Barrow, erected in 1810 by aid of a gift of £500 and a loan of £200 from the late Board of First Fruits; the Ecclesiastical Commissioners have recently granted £956 for its repair. In the R. C. divisions the parish is part of the union or district of Leighlin-bridge: the chapel is a large building. The parochial school-house was built by aid of £60 from the incumbent: a female school is maintained by subscription, and there are two private schools, attended by about 140 children. The ruins of the former church at the Royal Oak are still visible; and near Ballyknocken is a rath of considerable extent, called by the peasantry "the Maudlin Moat."



*Wells Church*

This concludes the series 'Lewis's Carlow'

## Gate Lodges of Co Carlow

*Some have gone, some have faded*



*Browne's Hill Gate Lodge*

Carloviana 2012



## FATHER JOHN DEMPSEY AND CARLOW TOWN COMMISSION

Sean O'Shea

In the history of Local Government in Carlow County, I consider the most progressive and forward looking local authority, was the second Carlow Town Commission (1855-99), established under the Towns Improvement (Ireland) Act of 1854.

The measure of any corporate body is generally determined by its legacy to posterity and in this respect the Town Commission of that period is noteworthy, particularly in the latter half of its existence. Hereunder I mention some of the works undertaken by the Commissioners during their tenure of office, some of which are still with us today.

From the inception of the Town Commission in 1855, the formulation and adoption of a scheme to supply piped water for the town was under consideration. The majority of the citizens of the town were served only by way of street pumps, with the exception of large houses, licensed premises, etc which were in a position to obtain water from private wells on their property. However, it was only in the early eighteen nineties that practical steps were taken, following an inquiry regarding the quality and quantity of supply needed. Plans submitted by Mr. White C.E., Laois County surveyor, for a supply of water from Killeshin stream were recommended by Consulting Engineer Mr. Strype C.E. Dublin. A tender subsequently received from Mr. Dixon C.E., Anglesea Street, Dublin to carry out the scheme was accepted on the 5th September 1894; the Chairman of the Town Commission Mr. Michael Governey laid the foundation stone at Killeshin water works. Water from Killeshin supplied the town for the next ninety years and some of the pipes laid at that time are still in use today.

The Carlow Town Hall, which replaced the Municipal offices at Burrin Street, was opened in March 1886. William Hague, Dawson Street, Dublin was the architect and the contractor was Messrs Connolly, Upper Dominic Street Dublin. James Byrne Borough Surveyor agreed to oversee the contract as clerk of works for a sum of fifty pounds. The total cost including the market area amounted to approximately £4000

Today the Town Hall incorporates the building which adjoined it, and complements the character of the original structure. It stands as a monument to the foresight of the town fathers and continues to operate for municipal purposes today.

Another achievement of the Town Commission was the provision of St. Mary's cemetery, which has been in use by the residents of Carlow to bury their deceased members for well in excess of one hundred years. It is still in use today, although becoming somewhat over crowded.

Having reached agreement on the suitability of a site for a new cemetery, a committee of the Town Commission approached the owner Mr. Bruen of Oak Park and following negotiations an agreement was reached in March 1892 to lease the area required (7 statute acres) at a rent of fifteen pounds per year for a tenure of 900 years, payable half-yearly. The commissioners undertook to provide fencing between the new cemetery and adjoining land and to erect a wall around the proposed cemetery with suitable gates. A caretaker's house was also built. When works were completed the new cemetery was opened by John Hammond M.P. chairman of the Commission. William Whelan, Cox's Lane was appointed caretaker in April 1894 and on



*Fr John Dempsey plaque on the east side of St Laserian's Church, Leighlinbridge.*

*Erected by the people of Carlow.*

the 27th of May The Right Rev Dr. Comerford, Coadjutor Bishop of Kildare and Leighlin consecrated the new cemetery.

Carlow Town Commission was to the forefront in the country when it came to street lighting. This was a major responsibility for Town Commissioners contained in the establishing Act.

On the 18th November 1890, a proposal to light the town by electricity was considered by the Town Commissioners. At that time the cost of lighting the town with 104 oil lamps was £100. Street lighting with electricity would cost £170. Following negotiations with J.H. Gorden and Co. Ltd, Dublin, it was agreed at meeting of the 13th January 1891 to proceed with electric street lighting in the town. The contractors obtained a lease of Milford Mill and installed a turbine or turbines from which power was transmitted on poles along the Barrow towpath to a building on the quays opposite John Street. The work proceeded without delay and on the 24th June 1891, Carlow

## FATHER DEMPSEY AND CARLOW TOWN COMMISSION

town had electric public lighting for the first time.

On Monday 13th July 1891 a banquet was given in the Town Hall by Messrs Gorden and Co. Mr Gorden president of the company had this to say in the course of his address: "the little town of Carlow with only about six thousand inhabitants had through its Town Commission and general inhabitants put larger towns in the background. It is the first inland town in the whole of Great Britain and Ireland to be lighted throughout with electricity". The foregoing projects refer mainly to the last two decades of the Town Commission's existence. Credit is due to the commissioners of the day, including two outstanding chairmen, John Hammond M.P. and Michael Governey for their advancement and management of the town's public services at that time.

The decision to establish a Town Commission under the Towns Improvement (Ireland) Act 1854, was not without controversy. At that time there existed in the town a Commission created under the 9th of George IV (Lighting of Towns Act 1828), When the Bill proposing to replace that Commission was considered, by the members at their meeting of the 4th April 1854, concern was expressed and the bill was referred to a sub-committee for consideration. A number of meetings ensued without progress and in the meantime the Bill became an Act.

On the 22nd September a public meeting was held in the Court House to afford the Inhabitants of the town an opportunity to decide on the adoption of the Towns Improvement Act and if agreed memorialising the Lord Lieutenant. (Memorial: A request to the Lord Lieutenant to authorise the carrying into execution in the borough, the Towns Improvement Act 1854 and to give the necessary orders and directions of the purpose accordingly).

At the request of the chairman of the Town Commission the meeting was chaired by Thomas Whelan M.T.C. Numerous matters were discussed including the cost of abandoning the old Commission and establishing a new one; other issues of concern were the lighting of the town, voting rights, fairs and markets and the position regarding the status of Graigue. There were many objections in-

cluding a resolution to postpone the meeting to allow for a further inquiry into the provisions of the Act. Mr Haughton proposed an amendment to the resolution "that the meeting do adopt the memorial to the Lord Lieutenant" Mr. O'Shea M.T.C. seconded the amendment. The amendment was then put to the meeting by the chairman and following a show of hands was declared carried.

In the meantime the residents of Graigue opposed the introduction of the Act, particularly in relation to expected increases in rates and taxes. The local newspaper was also opposed to the adoption of the Act quoting "Let our fellow townsmen pause before they commit and act so suicidal to their own interests".

On the 10th November an order was issued by the Lord Lieutenant directing Charles Tucker and Arthur Fitzmaurice, Justices of the Peace to convene a meeting for the purpose of considering the adoption or rejection of the Towns Improvement Act 1854. This meeting was held in the Courthouse on the 1st December 1854. The opponents were arranged on one side and the advocates on the other. The conduct of the meeting was anything but harmonious. All objections were again considered, with complete disagreement continuing between the parties. Finally Mr. Tucker firmly called for a show of hands and declared the majority in favour of the Act. A poll was then demanded and the following day was fixed as the time for receiving votes. The resulting poll showed 114 in favour of adopting the Act and 75 against. Nearly 100 ratepayers abstained. The Lord Lieutenant was duly advised of the outcome. On the 4th January 1855 the Lord Lieutenant approved the establishment of a Town Commission in the town and directed the Justices of the Peace to arrange for the election of eighteen commissioners (Carlow 15, Graigue 3) to carry into execution the said Act.

Supporters of the Act held a meeting in Nolan's public house Tullow Street on Monday, 15th January 1855, to consider nominating fifteen commissioners for the Carlow Ward. Thaddeus O'Shea M.T.C. chaired the meeting and submitted a list of 15 ratepayers excluding opponents of the Act for consideration.

Disagreement followed with suggestions for additions to and omissions from the list, while many declined to accept office. Following a lengthy debate agreement could not be reached and when a large number of people left the room, it was agreed to adjourn the meeting.

A second meeting, in Nolan's public house, held on the 20th January, was chaired by J.H. Haughton. On this occasion Father Dempsey a local curate, opened the proceedings by reading out a list of names of proposed commissioners. Mr. Paul Cullen followed with an alternative list. The meeting was again bedevilled with lengthy arguments but a list could still not be agreed on. Eventually Mr. Matt Byrne proposed that "Mr. Haughton leave the chair and Mr. Laurence Kelly be called thereto". Mr. Haughton duly complied and left the room. Parties opposed to the Act were then asked to leave the room. Those remaining formed themselves into a committee and after a short recess a list was agreed and the proceedings concluded.

The list approved consisted of the following: Thomas Ellis, A. Coffey, Martin Mangan, Laurence Kelly, Thomas Tynan, Robert Dillon, Robert Lawler, Thomas Kelly, Thaddeus O'Shea, Thomas C. Butler, Patrick Kinsella, Mathew Byrne, Robert Farrell, Dr. Porter and J. Hancock Haughton.

At the time there seemed to be no record as to how agreement was finally resolved so quickly, but forty years later in the Sentinel a local historian gives his account of the happenings on that fateful night, when commissioners were nominated for the 1855 Town commission. The account related that: "Fr. Dempsey stood up from his chair and taking off his clerical cloak, a garment much in vogue then among the clergy, he slowly folded it up and hung it on the back of his chair; this done he turned up the cuffs of his coat sleeves and slowly and methodically as he had folded his cloak. During these movements he was viewed with much curiosity by the spectators and some individuals were heard to mutter, he must be going to fight somebody. Father Dempsey was a big man and it was known he sprang from a warlike Irish Sept, the O'Dempsey's of Clanmalier, so that the belief that he meant to fight pervaded the



## FATHER DEMPSEY AND CARLOWTOWN COMMISSION

meeting. He then said addressing the parties at the table who had made out the lists "you have named a good many gentlemen to act as commissioners, now I'll name fifteen and let me see who among them will refuse to act". He then named fifteen persons, pointing his finger at each and to everybody's surprise not a man of them entered a protest against taking office as a Commissioner. Decidedly the acquiescence arose from the elaborate preparations he had made, as if he meant to fight, and so nobody cared to face him by a refusal to accept office"

At the election held on the 27th January, 1855 the fifteen above-mentioned were duly elected without opposition. Three further commissioners were elected from the Graigue Ward — Adam Jackson, T.F. Gale and James Kelly.

Time the analyser of all things proved that Father Dempsey's involvement was the deciding factor and correct action and but for his intervention Carlow may never have had a second Town Commission.

The historian further recalls "I remember him (Fr. Dempsey) well: A popular man as a cleric, somewhat eccentric; great force of character with a keen sense of humour in his composition. His preaching was very effective, albeit he had a habit of

using vernacular words and phrases in his sermons which left him open to the criticism of the most critical and criticising congregations in Ireland. Although he might be told that people were smiling at his use of the vernacular word "forninst" yet, he used it again and cared not one jot what smiles it evoked"

In the historian's account he spells the name Dempsey, while on the plaque it reads Dempsey.

Fr John Dempsey was a native of Leighlin. He was born in 1811, educated for the priesthood at St Patrick's College, Carlow (1831-1838) and was ordained in 1838 for the Diocese of Kildare and Leighlin. Following his ordination he served as curate in Clonmore (1838-39), Clonegal (1839-44), Abbeyleix (1844-45) and Carlow (1845-55). He died as curate in Leighlin on 10th December, 1855 in his 44th year.

The plaque on Leighlin Church reads:

OF YOUR CHARITY  
PRAY FOR THE SOUL OF  
THE REV JOHN DEMPSEY C.C. LEIGHLIN  
WHO DIED ON THE 10TH DECEMBER 1855  
IN THE 44TH YEAR OF HIS AGE  
AND THE 19th OF HIS PRIESTHOOD.

THE PEOPLE OF CARLOW TO WHOM HE  
MINISTERED FOR 10 YEARS HAVE  
ERECTED THIS MONUMENT TO  
COMMEMORATE HIS AMICABILITY OF  
DISPOSITION HIS LOVE OF THE POOR  
AND HIS DEVOTION TO THE  
INTEREST OF THE PEOPLE

## Gate Lodges of Co Carlow

*Some have gone some have faded*



*Killinane House Gate Lodge*

Carloviana 2012

## ROLE OF THE IRISH IN WWII

Con McGrath

**T**HOUGH EDUCATED at Eton, and spending a good proportion of his early life in England, Tim Vigors always considered himself an Irishman. Vigors, who would begin the stages whereby Coolmore Stud in Fethard, Co Tipperary, would become the world's largest breeding operation of thoroughbred racehorses, flew into battle with his country's tricolour painted on the nose of his Spitfire.

Following many of his flying sorties, his plane was serviced by another Fethard man, Christy Matthews of Kerry Street. Christy served in the RAF ground forces during the war and often described Tim Vigors plane as returning, "riddled with bullet holes."

Timothy Ashmead Vigors was born at Hatfield, Hertfordshire, on March 22, 1921. His father was originally a stockbroker, but the family had been landowners in Co. Carlow for centuries.

Tim was brought up near Melton Mowbray in Leicestershire and his childhood was full of horse-riding, and fox hunts.

After leaving Eton, Tim enrolled as a cadet at RAF Cranwell in January 1939 - his godmother, an air enthusiast, had taken him flying, and he had immediately caught the bug. In February, 1940, he joined 222 Squadron at Duxford, flying Spitfires.

In his autobiography "Life's Too Short To Cry", published 2008, Vigors gives an honest, warts and all, account of what it

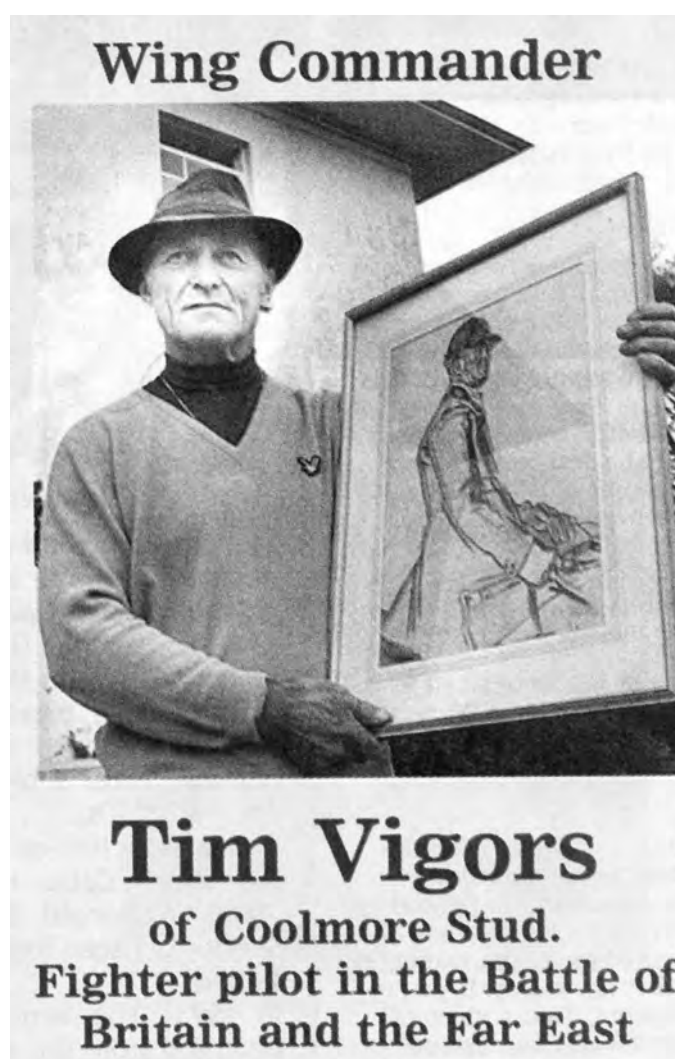

meant to be a raw, young pilot during the Battle of Britain. Like how, at 4 am on May 29, 1940, he accompanied 10 other pilots to receive instructions from their commander, Squadron Leader 'Tubby' Mermagen, who told them that they were to head for Dunkirk.

"I walked over to my aircraft to make sure everything was in order. My mouth was dry and for the first time in my life I understood the meaning of the expression 'taste of fear'. I suddenly realised that the moment had arrived . . . Within an hour I

could be battling for my life... Up until now it had all somehow been a game, like a Biggles book where the heroes always survived the battles and it was generally only the baddies who got the chop. I knew I had somehow to control this fear and not show it to my fellow pilots."

When he reached the coast of France, and came under fire from a German Me 109, his first reaction was "extreme fear which temporarily froze my ability to think. This was quickly replaced by an over-whelming desire for self-preservation."

He survived the encounter, and the next day shot down an Me 109. Two days later, also over Dunkirk, he shot down his first Heinkel 111.

ON THE night of June 19, 1940, Vigors returned from a night out somewhat the worse for wear for drink, and retired to bed at his base at Kirton in Lindsey, Lincolnshire. When a message called for a volunteer to intercept

German aircraft which had crossed the coast, Vigors took to the air wearing his scarlet pyjamas under a green silk dressing-gown. Despite his outfit he shot down another Heinkel.

Flying from Hornchurch, Essex, Squadron 222 suffered heavy casualties during the summer of 1940 and Vigors was twice forced to crash land his damaged Spitfire. But his successes over the Thames Estuary mounted, and, by the end of September, he had destroyed at least six enemy aircraft with a further six

ROLE OF THE IRISH IN WWII

probables. In October, 1940, he was awarded the Distinguished Flying Cross.

On October 30, Vigors destroyed two Me 109s over Kent, but any satisfaction was dissipated by the loss, in the same action, of his fellow pilot and close friend, Hilary Edridge. "A wave of misery swept over me," Vigors recalled. "I just couldn't get my mind to accept it . . . I started to cry"

Two months later he was posted to Singapore, joining 243 Squadron as a flight commander. A year later, he took temporary command of 453 (RAAF) Squadron, and immediately became involved in one of the most distressing events of his RAF career

On the afternoon of December 8, 1941, the Royal Navy's Force Z -which included the battleships Repulse and Prince of Wales - sailed north from Singapore to provide support against possible Japanese landings at Singora.

453 had been designated the Fleet Defence Squadron, and Vigors had established radio procedures with Prince of Wales. Like this, Admiral Phillips, like the commander of Force Z, maintained radio silence and did not call for support. On hearing of Japanese landings at Kuantan, Phillips changed his plan and, still main-

taining radio silence, altered course. In the meantime, Japanese reconnaissance aircraft had located Force Z.

When an attack against the ships appeared imminent, Phillips broke radio silence on December 10, and Vigors finally got the order to scramble his 11 Buffaloes. But it was too late: when he arrived, Repulse had gone down, Prince of Wales was sinking, and there was no sign of Japanese aircraft.

All Vigors could do was to fly over the survivors in the water and provide support for the rescuing destroyers. In this disaster, 840 sailors were lost, 513 in Repulse and 327 in Prince Of Wales. Vigors always felt bitter about the failure of the naval forces to call for his assistance.



The drama by no means ended now. Vigors was repeatedly attacked by Japanese aircraft as he swung below his parachute, fortunately he managed to land in the mountains near Penang. His position was not promising - he was severely burned and a bullet had passed through his left thigh-but he was found by two Malays, who carried him down the mountain to safety.

AFTER BEING evacuated to India, where he recovered, Vigors subsequently assumed command roles in India, until he returned to England in 1945. He took part in the fly-past for the anniversary of the Battle of Britain on September 15 and retired from the RAF in November 1946 as a wing commander.

Shortly before the war, Vigors's father had returned to Ireland, buying a farm in Co. Tipperary called Coolmore in 1945, where he trained race-horses. After inheriting Coolmore, Tim Vigors moved there in 1968, and it was he who began building it into the famous stud farm which it is today.

An old friend of Vincent O'Brien, Vigors sold two thirds of Coolmore to O'Brien and John Magnier in the mid-1970s, con-

After this, he led his squadron to northern Malaya. On December 13, 1941, he had just landed at Butterworth when Japanese aircraft arrived to attack the airfield, and he ordered his six pilots to take off immediately to intercept the bombers.

He attacked a large formation, and some reports claimed that Vigors hit three bombers in the melee. Eventually, his Buffalo was hit in the petrol tank and he was forced to bale out.

LEFT: Tim Vigors D.F.C. pictured on the cover of his autobiography "Life's Too short To Cry".

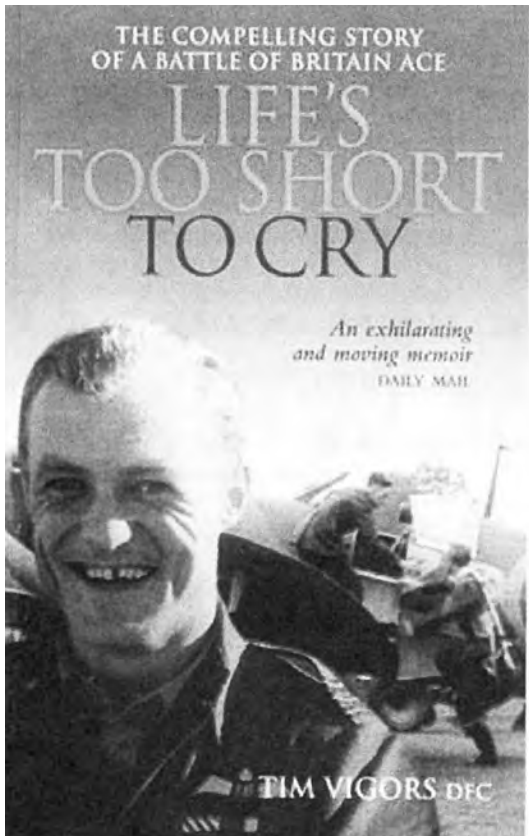



ROLE OF THE IRISH IN WWII

tinuing to work in partnership with them and with Robert Sangster. Later, having sold his remaining interest to Magnier and O'Brien, Vigors went to live in Spain, although he continued to work in the blood-stock business.

Despite being born in England, Tim Vigors always considered himself to be Irish and had a tricolour painted on the nose of his Spitfire. He returned to Newmarket, remaining there for 20 years before his death on November 14, 2003. He was survived by his children and wife Diana.

ON THE Battle of Britain Monument in London, the name of Tim Vigors appears listed as British.

Edward McManus who was involved with this memorial recalled for this writer Tim's views on his nationality, "The late Timothy Vigors was adamant that he was (Southern) Irish, but was born in Hertfordshire and went to Eton (the latter is irrelevant I know). His will specified that he was to be buried in the Republic."

However, because he was technically

born in Britain, he appears listed as British. McManus concluded, "I think his Irishness was a spiritual thing; in his book: "Life's Too Short To Cry", he devotes a lot of time to his thoughts on this." ■

Reproduced here with the permission of the author and Editor of "Ireland's Own"

# Gate Lodges of Co Carlow

Some have gone, some have faded



*'The Iron House' Gate Lodge of Duckett's Grove*

# THE ANCIENT ORDER OF HIBERNIANS IN GRAIGUENAMANAGH

John Joyce

In writing of the Ancient Order of Hibernians in Graiguenamanagh, it is appropriate that the background, against which that organisation operated during the seven and a half odd years of its existence in the area, should be considered. The early 1900s, the period about which we are dealing, might be said to be a bad time – not of course for everyone – but almost unimaginably so, by today's standards, for the poor – and there were many of them. For many people housing was dreadful; thatched and tin-roofed cabins; no water; no sanitation; often enough little or no food. Disease of all kinds was rampant, while public health standards, when compared with those about which we sometimes complain today, were abysmal.

Apart from a meagre Old Age Pension of 1/- to 5/- a week, which was introduced in 1908, and a limited and restricted system of insurance against illness and unemployment which was introduced in 1911, there were virtually no social welfare benefits. For most, if you were out of work, sick – or incapacitated, your problem was one of survival. All this, of course, was against the terrible background of The Great War; the Rising of 1916 and its aftermath; the Great Flu of 1918/19 and the closure of the Barrow Starch Works at Tinnahinch in the spring of 1919 with the disastrous loss of 60 jobs. And so, having painted, very briefly, that gloomy picture of the period, we can deal with the subject of this article.

It seems certain that, in the summer of 2010, few – if indeed anyone living in Graiguenamanagh or probably in all of Ireland at that time – was aware of the fact that a “Division” – for that is what

their branches were called – of the Ancient Order of Hibernians – had existed in Graiguenamanagh just about a hundred years prior to that date. The existence of the Order which had, in the early 1900s, involved itself deeply in community affairs and in the social, religious and political life of the town and the surrounding districts, had simply faded from the folk memory and, of course, all members of the Order in the area had long since passed on.

It was only after the death of Francie Murphy in April 2010 that tangible reminders of the existence in Graiguenamanagh of the AOH, as the Ancient Order of Hibernians was commonly known, came to light again. Francie was



*Sash of the  
Ancient Order of Hibernians*

a quiet, decent, man who lived, unmarried and alone, for the greater part of his life, in a small house at Upper Main Street. When his mother died while he was very young, he came to live with his cousins, Edward Ryan and his sister Mary, in their house at Upper Main Street. After their deaths in the early 1960s, Francie continued to live on in the house for the remainder of his life.

Edward Ryan, Francie's cousin, had been the last Secretary of the Graiguenamanagh Division of the AOH and, as such, he had been the custodian of the



*The Ancient Order of Hibernians reached its peak before the First World War*

## THE ANCIENT ORDER OF HIBERNIANS IN GRAIGUENAMANAGH

Order's Minute Book and what remained of its records and regalia. After Francie's death, his relatives very generously donated these mementos of the Order to the Graiguenamanagh Historical Society and they are now displayed in Graiguenamanagh Library. Following its final meeting on 23rd July 1920, at which it had been decided that the Graigue Division be dissolved, Edward Ryan brought these artefacts home and, having put them aside, it would seem that they did not see the light of day again until after the death of his cousin, Francie, some ninety years later, when his effects were being gathered together.

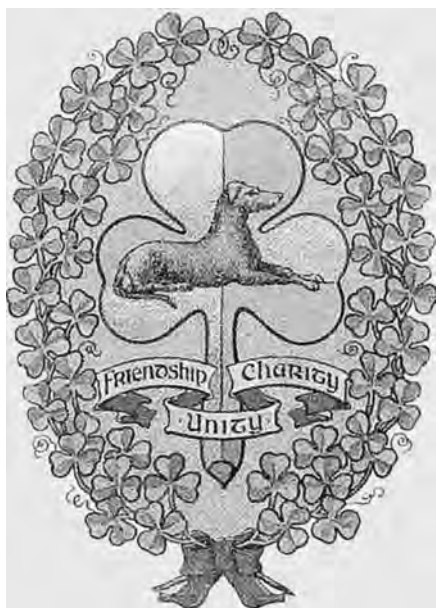

AOH Laurel

Graiguenamanagh Division was No.1161 of the Ancient Order of Hibernians. It adopted as its name "St. Fiacre's Division".<sup>1</sup> The Division was established on Sunday, 23rd February 1913 when three members of the Waterford Division, attended a meeting at Graigue and initiated those present into the Order. From that date up to July 1920, two hundred and fifteen men from Graiguenamanagh and the surrounding districts, drawn from all classes - town and country - are recorded as having been initiated into the Order, and one hundred and fifty seven meetings of the Division - that is an average of almost one meeting per fortnight, - were held.

To the questions "What was the AOH?" - and "What was it all about?", the answer is that the Ancient Order of Hiber-

nians was - and still is - a Catholic Fraternal Organisation, a male body, organised in Ireland for the purpose of defending Gaelic values and protecting the Church and clergy at a time when harsh penal laws made some such defence necessary. The precise date of the Order's foundation is uncertain but at the end of the 1800s it was reorganised in Ulster. From there, it expanded and became a nation-wide organisation which could be said to be the successor to or, at least, a significant link between the secret societies of old, such as the Whiteboys, Defenders and Ribbonmen of the eighteenth and earlier centuries and a newly developing nationalism.

The Order had as its motto the Latin words "pro fide et patria" ("for faith and fatherland"). An anti-English, anti-Protestant sentiment prevailed in its ranks into the 20th century, by which time it had developed into a lay-Catholic mass movement. It was vigorous in its support of the Irish Parliamentary Party, which sought self government for the entire island of Ireland. After 1905 the Order was controlled to a great extent by Joseph Devlin, the Belfast-based M.P., its leader and president from 1905 until his death in 1934. By 1914 the AOH had expanded over the entire island. It repudiated the right of the British Government to govern any part of Ireland but, mainly because of its total and constantly-stated renunciation of physical force, it was disliked by the militant young revolutionaries of the Irish Republication Brotherhood (IRB).

Today, the AOH is very different to that of the early 1900s, for its greatest strength is in America where it remains vibrant and active, with numerous branches and with some 80,000 members in 49 states.<sup>2</sup> It is the oldest Catholic lay institution in America, having been formed there after they had received authority from the organisation's headquarters in Ireland to form the first American branch in New York in 1836. It remains interested in all Irish affairs and seeks to promote Irish Cultural heritage in America. The Order also exists in Canada, Scotland and Ireland. However, while these organizations share a common thread, the American organisation is a separate and a vastly greater organisation than any of the others.

In Ireland it would appear that the Order is now, only a shadow of its former self. Within Northern Ireland, it remains a visible but somewhat marginal part of the Catholic community. It parades infrequently there, mainly on St. Patrick's Day, at Easter, on the Feast of the Assumption and a few other times a year. And, while anecdotal evidence claiming its current existence in one or two places in the Republic has been put forward, no authoritative evidence has been forthcoming to support this.

In its heyday, however, the AOH in Ireland was, as has been said, a highly organised, formidable, nationwide institution, run subject to 317 rules which were set out in detail in its 217 page Rule Book. In Graiguenamanagh, as in other Divisions, the order had the usual officers and Man-



AOH Masthead



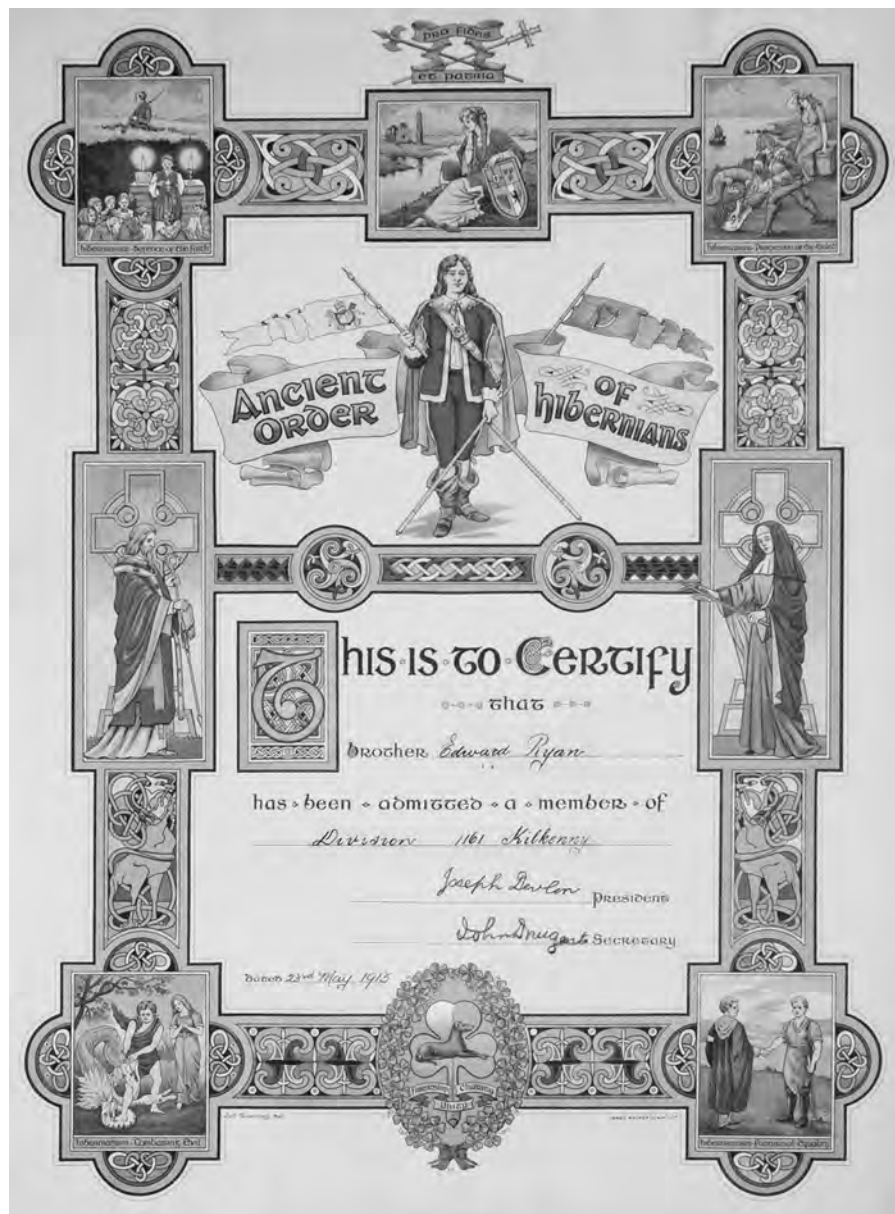

AOH Certificate

agement Committee. It also had a Vigilance Committee, which vetted applicants' suitability for membership; an Arbitration Committee, which dealt with members' complaints, - and trustees. There were committees for the concerts and dances which the Order frequently ran, while marshals were appointed to supervise excursions and to take charge of parades and other events which were part of the Order's activities.<sup>3</sup> Its parades, incidentally, which became part of its tradition, were colourful and peaceful, with none of the menace and triumphalism associated with Orange Parades.

To become a member, a candidate had first to be formally proposed and voted on. The names of the successful candi-

dates were then submitted to the Vigilance Committee which, after due consideration, reported on the applicants' suitability or otherwise. Only if the Vigilance Committee signified its approval was the applicant admitted into the Order. New members paid an initiation fee. All members were required to pay a weekly subscription of 3d and were cautioned against speaking of anything that had transpired at meetings to anyone other than to members who were in good standing. Meetings were usually held in The Club Rooms at High Street, which were specially enlarged to accommodate them.<sup>4</sup> Delegates from St. Fiacre's Division regularly attended the County Board meetings at Kilkenny and represented the Division at National Demonstrations and

at Conventions of the Order in Dublin and Belfast.

By 1914, the AOH had expanded and had saturated the entire island and, up to 1916, it was probably the dominant popular political organisation in the country, its political structure, in combination with the role which it developed as a patronage, brokerage and recreational organisation, having brought about its great expansion.

Under the heading of Patronage, a resolution in the Division's minute book reading "that members support and assist all Roman Catholics and give them all business possible" might be seen as typical. This "support each other" ethic was an elementary principle of the Order. More importantly, however, in the brokerage area, the Division endeavoured to bring about by negotiation and mediation - and by political influence - settlements and conditions which affected the entire community. From 1914 onwards, it concerned itself with school attendance - a problem about which repeated discussions took place. Although compulsory school attendance was in force, considerable difficulties were being experienced in respect of many families whose children continued to absent themselves from school. Motions were sent to each member of the Co. Council and to Thomastown District Council pressing for the enforcement of compulsory attendance at the schools of the parish and Fr. Mooney was deputed to lobby local Councillors about the matter. It took time, but eventually that situation was largely rectified. The Co. Council was also lobbied about the unsanitary conditions of the houses of the poor, particularly at High Street, many of which were wretched, and council members were pressurized regarding the erection of a new cottage scheme which - though many years afterwards - was built there.<sup>5</sup>

The Division also involved itself actively in charitable activities and at a time when poverty was rife and dole and other social benefits from the state were restricted, limited and meagre, help for members who were in need came very much to the fore as, under the National Insurance Act 1913, the AOH became a recognised Friendly Society and involved itself in a range of insurance schemes for its members. On 1st December 1916, St Fiacre's

## THE ANCIENT ORDER OF HIBERNIANS IN GRAIGUENAMANAGH

Division joined one of these schemes called 'The Centralised Benefit Fund'. As the fund was partially financed by members' subscriptions, its benefits were confined to those who were in a position to contribute the quarterly fee of 2/6. The arrangement appears to have been successful, for a vote of thanks was passed at a later stage, complimenting Head Office on the prompt manner in which claims made by those affected by the Great Flu of 1918/19 - which had decimated the town and district - were attended to. The records show that between 1916 and 1919, in excess of 700 cash payments were made to members in respect of sickness, maternity and other benefits

St. Fiacre's Division also endeavoured to have members who could not afford the insurance fee looked after under a health insurance plan which would enable them to qualify for lesser benefits. Arrangements were also made with Dr. Walshe, the local G.P., to attend to the needs of these members - and, during the flu epidemic, a committee for visiting the sick was set up. At that time also, arrangements were made for the poor to get potatoes at cost price, while members of the Order made their horses and carts available to till and prepare a field donated by Fr. Mooney into allotments which were made available to needy persons for growing potatoes.

In its recreational role, St. Fiacre's Division played a leading part in organising the concerts which were such an important element in the social life of the period. It also organised excursions by boats and brakes to places such as Woodstock, Dunmore East, Duncannon, St Mullins and Goresbridge. The Graiguenamanagh Temperance Band often accompanied these excursions, and on their way to Tramore the Division was met and welcomed at Waterford by the Barrack St. Brass and Reed Band and - if the usual procedures were carried out on that occasion - paraded with them from the main Waterford station to the Tramore Station at the other side of the city.

It is surprising to find that the names of those who attended meetings are not recorded in the minutes, most of which merely noted the names of those that were being proposed for membership, those passed by the Vigilance Committee and

those who were being initiated at the meetings. While some minor matters other than those mentioned are recorded in the minutes, they are dealt with very briefly.

In the Minute Book, there is little mention of political matters. In 1912, subscriptions were made to the "Belfast Indemnity Fund" to help defray expenses incurred in a libel action taken by the Order against the "Belfast Evening Telegraph" in respect of an article relating to thousands of Catholic workers who had been expelled from work in the shipyards. In 1914, a motion was passed condemning the shooting down of innocent people in Dublin. In July 1918, when four members of the local company of the I.R.A. were arrested, an excursion planned to go to Carlow was abandoned as a protest against their imprisonment. Lectures were given on Passive Resistance, on Proportional Representation and on the Manchester Martyrs. The major political item dealt with was the British Parliament's proposal to extend conscription to Ireland. That proposal provoked intense anti-conscription feelings. Resolutions were passed condemning conscription and it was decided that the Graiguenamanagh Division would support the national effort and oppose it "to the bitter end". A donation was made to the Parish Conscription Defence Fund. The Division also launched its own anti-conscription fund to which all members were expected to contribute and the proceeds of which were duly sent to the AOH Head Office. As all shades of Nationalist opinion were opposed to Conscription that project was eventually dropped.

Because there is so very little mention of political affairs in the minutes it is necessary, if the story of the AOH at Graiguenamanagh is to be completed, to switch briefly here from St. Fiacre's Division to the political background in Ireland against which it operated. In January 1913, the Ulster Volunteers were formed in Belfast to oppose Home Rule and, in November 1913, the Irish Volunteers were formed in Dublin to support it. The following year, 1914, saw the outbreak of the Great War and with it came the suspension, until the end of the war, of the Home Rule Act which the British Parliament had passed and which was awaiting royal assent. When, later that year, John Redmond, leader of the Irish Party - in the interest of making sure that the Home Rule Act would be put into ef-

fect - encouraged the Irish Volunteers to support the British and Allied War effort, the Irish Volunteers split into two groups. The great majority (175,000) under John Redmond, took the name The National Volunteers and supported involvement in the war. A minority (13,500) - later to come under the control of the Irish Republican Brotherhood (IRB) - retained the Irish Volunteers name and opposed Ireland's involvement in the war.

When the war ended, the British Parliament was dissolved and an election was called for December 1918. In Ireland, in that election, there was a dramatic upheaval in political allegiance as Sinn Fein swept to an overwhelming victory at the expense of the Irish Party, with that party being virtually wiped out and Unionist influence being felt mainly in the north. This sensational result had come about by reason of the frustration brought about by the delay in finding a resolution to the Home Rule issue, exaggerated by the Conscription crisis and Sinn Fein's association, in the mind of the public, with the 1916 rising. These factors had all contributed to the change as large numbers who had been members of The National Volunteers switched their loyalty and became members and supporters of the Irish Volunteers. That switch in allegiance was echoed in the Hibernian ranks, as young men, who were often AOH and pro-war in politics, after the rising became anti-war and joined Sinn Fein. And so, after the 1916 Rising, the AOH gradually melted away outside of Ulster and a great number of its members were absorbed into Sinn Fein and the Irish Republican Army. To aggravate its problems, the Order lost any residual strength it had when welfare systems of a more elaborate type developed and made its role as a friendly society superfluous. In National terms, by the 1930s, the AOH had ceased to be in any way significant.

An overall look at the St. Fiacre's Division minute book reveals that, although new members continued to be initiated up to November 1919, resignations - or perhaps, more accurately, defections - had been occurring. The minutes refer to members being dismissed shortly after the split; to members being suspended for six months and to members being removed from the roll. Only in the minute of 19th December 1919, however, is

## THE ANCIENT ORDER OF HIBERNIANS IN GRAIGUENAMANAGH

there any reference to difficulties being experienced by the Division. At that meeting, a resolution was passed complementing the President and Vice-president on their unceasing loyalty to the duties of their office and stating that were it not for the energy and courage shown by these officers in facing the difficulties that they had to undergo, the division would have been dissolved long ago. Only in that minute do we get a clear indication that problems existed. However, meetings continued to be held up to 11th June 1920 when a proposed visit to Woodstock Gardens was discussed. At the following meeting, two weeks later, the agenda was very different, as a letter was read from the I.R.A., East Battalion, Kilkenny. The minute of that meeting, as quoted hereunder, left little room for misunderstanding. It reads:

“A letter was read from the I.R.A., East Battalion, Kilkenny, stating that we, the AOH in Graig, were using an opposing influence on the present movement for an Irish Independence, and asking us to cancel

our Excursion to Woodstock. If not, steps were to be taken. Our worthy President suggested that owing to that letter we consider the dissolving of this Branch, as the Republican Army say that we are standing in the way of an Irish Independence”.

That was all. The meeting agreed that the President's suggestion be adopted, but that the matter should be deferred for a month and that all members be served with notice for the next meeting to be held on Friday 23rd July 1920. That meeting was held as scheduled and at it the proposition “that we dissolve this branch of the AOH” was passed unanimously.

That night, Edward Ryan, the Secretary, brought the Minute Book and the officers' regalia to his home and wrote up his final minute. The Ancient Order of Hibernians at Graiguenamanagh had ceased to exist.

## Endnotes

<sup>1</sup> Named for St. Fiacre of nearby Ullard.

<sup>2</sup> The order in America is dealt with extensively on the internet.

<sup>3</sup> Two businessmen, James P. Hughes and James Nolan, were initially elected as President and Vice-Chairman respectively of the Division. At a later stage Fr. Joseph Mooney P.P., as Chaplain, and Edward Ryan, as Secretary, were appointed. Unlike other officeholders, who held positions for limited periods, the four above-named were re-elected to their offices until the Division was dissolved.

<sup>4</sup> In 2012 this is a fast food restaurant

<sup>5</sup> This reference is in respect of the terrace of single-storeyed houses that are situated on right hand side as one goes up High Street.

<sup>6</sup> Brakes - the predecessors to busses - were large open-air waggonettes drawn by two or more horses,

## Gate Lodges of Co Carlow

*Some have gone, some have faded*



Holonden Gate Lodge, Royal Oak

Carloviana 2012

There were Christians in Ireland before Patrick. The new faith had spread through the Roman Empire like wildfire following the edict of Milan when Constantine decreed that henceforth Christianity would be a State religion. Constantine was a shrewd politician. He realised that the persecutions instigated by previous emperor's had only served to add fuel to the fire of evangelism.

The new adherents were becoming so numerous that it made no sense to have one half of your citizens in conflict with the other. Henceforth the new religion could spread with impunity. It became fashionable and indeed desirable for people in high places throughout the empire to become Christians. Indeed the Emperors own mother was known to be a believer.

In Roman-Celtic Britain, no less than everywhere else, Christianity became dominant. There was a common belief among early Christians in the Priesthood of all believers and it was common practice for ordinary people going about their business to spread the gospel at every opportunity.

There was trade between Britain and the east coast of Ireland.

In spite of Irish raiding parties pillaging for slaves merchants still regularly traded back and forth and it is probable that these merchants either shared the Gospel themselves, or facilitated missionary activity.

By the beginning of the fifth century Pope Celestine became aware of missionary activity by British Christians in Ireland.

By this time the office of the Bishop of Rome had morphed into a position of assumed supreme leadership throughout the empire - another of Constantine's political manoeuvres. The office of Supreme Pontiff existed in the Pagan priesthood, so it was politically expedient that the same be true of the new religion..

If something was going on in the Western Island, then it should be brought under the control of Rome. A bishop was appointed to go to Ireland and oversee the growth of these scattered Christian communities. His name was Palladius. Whether by disease or violence he died

shortly after coming here circa 431 AD. Very little is known about the life of Palladius and no account of his activities in Ireland survives.

It is probable that missionary activities by other evangelists went on apace as the new religion gained a foothold.

Then around 432 a remarkable man appeared on the Irish scene.

What set Patrick apart from the beginning was his knowledge of the Irish language, way of thinking and belief system. He had been abducted by Irish raiders as a youth of 15 and sold into slavery to a minor chieftain in the North East of Ireland. In the six years of his captivity, he would have learned Irish ways.

A person sold into slavery had two choices. Either retreat into a mental cocoon and slowly lose their mind and will to live, or embrace every opportunity to have contact with and learn from their captors. This would keep their intellects sharp and their minds active. Instead of languishing Patrick obviously chose the latter path.

When he returned as a missionary Patrick's preaching emphasised one difference above all others between the two belief systems. The gods of the old religion were not much more than larger than life versions of humans. They were

thought of as fearful beings which you cross at your peril. Religious ceremonies were mainly based on appeasement. Human sacrifice was practiced and after battle victorious warriors decapitated their victims and hung the heads outside their doors.

Whereas the Celtic gods were cruel and heartless the God of Patrick was loving and merciful. Instead of a Pantheon of tricksters who treated human beings as fodder for cruel twists of fate, here was a God who was kind and eager to do them good.

Celtic mythology holds out no hope of a pleasant afterlife unless you proved to be a superhuman warrior. Christianity on the other hand offered the free gift of eternal happiness in the afterlife to all, paid for by God's own Son. In the Celt's eyes, life was cheap and dignity only belonged to the fortunate and privileged few, whereas The God of Patrick offered dignity to the lowest of the low.

The question is, why did the Irish stop and listen to this foreigner with the strange beliefs? Patrick had one important attribute which above all others fascinated the Irish; Courage. He looked them in the eye and never showed fear. He had absolute conviction in the truth of his message, and unshakable faith in the protecting hand of God. No wonder this race of hero worshipping warriors were

# DRUMPHEA -

## THE COMING OF CHRISTIANITY

Liam O'Neill

touched to the centre of their souls.

By the time Patrick's ministry came to an end large areas of Ireland, particularly the North and East were well evangelised. It probably took many years for the message to penetrate the whole Island, but the new religion had such a firm grip that Ireland was changed forever.

One profound change was that slavery was drastically reduced and inter tribal warfare was lessened considerably. The Irish had truly passed from darkness into the light.

#### Two Christian Foundations.

Two types of Christian Pastor evolved in tandem. You had the one type who ministered to a local flock under the aegis of the local Chieftain. The other was the anchorite or hermit who sought solitude and the presence of God alone in a desert place.

As Christianity was established in the first hundred years after Patrick a proto-monastic movement swept the Christian Church.

Irish Christianity never suffered the persecutions which were often the lot of their European and Mediterranean Brethren. Instead of the "Red" Martyrdom of blood they invented their own "green" Martyrdom in which one would cut themselves off from the world and live in deserted places. It was a symbolic giving of one's life to God. If one could not go direct to God's presence through the "Red" Martyrdom, one could at least seek his presence in a lonely glen.

In his book "How the Irish Saved Civilisation" Thomas Cahill quoted a beautiful poem:

*Grant me sweet Christ the grace to find  
Son of the Living God  
A small but in a lonesome spot  
To make it my abode*

*A little pool but very clear  
To stand beside the place  
Where all men's sins are washed away  
By sanctifying Grace*

*A pleasant woodland all about  
To shield it (the hut) from the wind*

*And make a home for singing birds  
Before it and behind.*

*A southern aspect for the heat  
A stream along its foot  
A smooth green lawn with rich top soil  
propitious to all fruit.*

*Near to Drumphea in the woods at the  
foot of the mountains such a hermit found  
his perfect site.*

The above poem describes the place exactly as it would have been then. The place was Killoughternane and his name was Fortchern.

Local traditions have it that he was a blacksmith and even shod St. Patrick's own horse. He had a British name and probably came to Ireland as a missionary. There is precious little information on him but certainly missionary activity in Ireland by British Christians would have been carried on by men, and possibly women, following in Patrick's footsteps. The beliefs and worship style of the two Island Churches retained their own Celtic style, and intercourse between the two can be historically documented

Around this time, in the fifth century, the Roman legions finally left Britain and as Continental Europe began its descent into the chaos of the dark ages. It would only be natural that British Christianity would look to its neighbour in the west for fellowship and support. It would also only be natural that churchmen would have travelled back and forth across the Irish Sea. Fortchern may even have been an English or Saxon name.

The Colonisation of Britain by the Germanic tribes was not achieved in one push. It was a gradual process of pressure westward by the newcomers as the fractured tribal divisions of the natives weakened their resistance. The newcomers began to be converted to Christianity as they came into contact with and intermarried the older inhabitants. A fresh crop of eager missionaries would have appeared on the scene. A Saxon churchman would have been as accepted in Ireland as his Celtic brother.

Kiloughternane developed into a minor monastic settlement. St Finian is the first Irish name associated with the site.

The name of the place in English is the Upper Church of Finian. Whether this is the famous

Finian of Clonard or not we cannot be sure. The founding hermit would have found himself joined by other like minded men. St Manchan's poem continues:

*My choice of men to live with me  
And pray to God as well  
Quiet men of humble mind  
Their number I shall tell.*

*Four files of three or three of four  
To give the Psalter forth  
Six to pray by the south church wall  
And six along the north.*

*Two by two my dozen friends  
To tell the number right  
Praying with me to move the King  
Who gives the sun its light.*

The early Irish Hermits soon realised that they would never be really left alone, and that adherents were turning up and attaching to them in increasing numbers. They began to adapt primitive monastic rules to govern their little foundations. Because of the significance of the number twelve in Scripture: twelve Apostles, Twelve Patriarchs etc, they saw this as an ideal number for a congregation.

Each man would have his own cell in which to live. Beehive shaped structures of corbelled stone were common in some areas, but similar structures were constructed of Wattle and Daub. A framework of branches would be inserted in the ground in a circle and bent over and tied together at the top. Smaller branches would be wound in and out between them until you had in effect a large up-turned basket. This would be plastered over with mud which when dry provided a cosy windproof covering.

The earliest churches were constructed in similar fashion, but were rectangular in shape. A similar building would serve as a common room for all to eat meals together as well as other community functions.

*A lovely Church, A home for God  
Bedecked with linen fine  
Where over the white Gospel page  
The Gospel candles shine.  
A little house where all may dwell*

## DRUMPHEA - THE COMING OF CHRISTIANITY

*And body's care be sought  
Where none shows lust or arrogance  
None thinks an evil thought.*

So we can picture this little community in the woods of Killoughernane. Behind them the gently rounded hill cloaked in Oak woods sloped gradually upwards. Before them lay the marshy valley floor with its patches of open bogland interspersed with clumps of hazel and Willow. A little stream ran nosily down on its way to the Barrow river, and beside it a well of sweet water which slaked the thirst. The surrounding uplands were thickly wooded except for the top of Slieve Bawn which stretched northward in the right hand side.

A few yards up the slope stood the little Church and the community room, surrounded by the Beehive huts of the Monks. Patches of land were enclosed with post and wattle fences to keep animals in or out. Some were used as vegetable patches, or to grow oats for bread or barley for beer. A flock of sheep perhaps and some cows for milk and butter. A herd of pigs would have grazed the Oak woods for acorns and beech mast in the fall of the year. Beehives for honey and poultry for eggs and meat.

Various manufacturing or rural crafts would have been carried on, with different monastic sites having their own speciality. Earlier we referred to the legend of Fortchern being a blacksmith. He may in fact have spent his day working in farm implements and harness fastenings, as horseshoes were not used until later centuries.

#### St Munchans poem concludes;

*All I ask for housekeeping  
I get and pay no fees  
Leeks from the garden, poultry, game,  
Salmon and trout and bees.*

*My share of clothing and of food  
From the King of fairest face  
And I to sit at times alone  
And pray in every place.*

The one craft which all ecclesiastical sites practised was writing. The Holy Scriptures were vital to the work of spreading the Gospel and for ongoing devotions. Vellum was used instead of paper and each book was copied by hand. Vellum was made from the skins of

calves and lasted for hundreds of years. It kept its whiteness far longer than other materials. Even though it took many calf skins to make up one book it was considered worth the sacrifice.

The most common books were those of the basic four Gospels, with other sections of Scripture added depending on the resources of the monastery. In the early days the Monks were just concerned with getting the words down on the page. The more elaborate works developed later as monasteries grew rich and the writers had more time.

It was very probable that smaller local Churches such as Drumphea had Religious writings supplied from Killoughernane.

#### The Local Church in Drumphea.

Apart from the monastic settlement, each local chief of a tuath or extended family group had a small Church built in his area.

There was no parish system in existence. The first Church in Drumphea would have been built of Wattle and Daub with a thatched roof. It would have served the small community living in ring forts from Knockinadrane to Milltown. We cannot know with any certainty when Christianity came the area, but it could have been the case that Killoughernane had a Christian community long before the locals were converted. The idea that Patrick spread Christianity through every valley and hill during his lifetime was incorrect. It probably took generations for the new religion to take hold.

There is evidence that Drumphea was a centre of worship of the old pagan religion. It is situated on a hill which stands out from the surrounding landscape and overlooks a large expanse of countryside. Until the new school was built there was a large stone jutting out of the old stone wall at the top of the site which had three distinct man made hollows. It probably originally sat in a designated worship area where the old medieval church ruins are. In the old pagan celtic worship system a lot of things were done in threes. The hollows could have held three kinds of offering to the gods, or held three small symbolic fires. When a local chieftain accepted christ and gave a plot of

ground for a church the new clergy had a policy of building on the old pagan sites. This discouraged dual worship and symbolised the complete obliteration of the old faith. The old ceremonial paraphernalia would have been destroyed or rolled off the site.

The hierarchy of the new religion was not based on a system of dioceses as we know them today. Local leadership in a lot of areas was provided by the Abbot of the nearest monastery. The Clergy of Drumphea, Ballinree and other local Churches would have looked to the Abbot of Killoughernane as their spiritual head. It is also possible that each Cleric served more than one local Church; after all the population was very small. Of course a lot depended on local politics. If the tuath chiefs were on friendly terms with each other sharing a Cleric would have been no problem, if however they hated each others guts the division carried over into religious affairs.

Drumphea is situated in the barony of Idrone which corresponds to the clan territory of the Ui Drona tribe. When surnames evolved the tribe became Ui Riain or Ryan in modern usage. This tribe were in situ long before and long after the coming of christianity. Their clan territory would have been sub-divided between strong family or clan groups who would have occupied 3 or 4 townlands. The subsequent presence of church ruins would suggest that Drumphea was at the centre of one families area of influence and Ballinree was in another.

The stronger farmers and minor lords would have occupied ringforts at this time, but the slaves and landless labourers would have lived in more humble dwellings made of wattle and daub and grouped around the church. In a future article I hope to look at the social implications of the coming of Christianity.

#### Bibliography

*The Irish ringfort* by Matthew Stout  
*How the Irish saved civilization* by Thomas Cahill



# JONATHAN SWIFT'S CARLOW CONNECTIONS.

Mary Stratton Ryan

**“Vision is the Art of seeing things Invisible.”  
(Thoughts on Various Subjects by J.Swift 1726.)**

Jonathan Swift (1667-1745) was born on 30th November at no 7 Hoey's Court, Dublin. He was the only son of Jonathan Swift (1640-1667) Stewart of Kings Inns and Abigail Erick [Herrick] (1640-1710) of Wigston Magna, Leicestershire, daughter of Rev James Erick, Vicar of Thornton and his wife Elizabeth Imins. Abigail Swift was sister of the Rev Thomas Errick Vicar of Frisby and sister in law to the Rev John Kendall. The Swift Family have a long tradition in the Anglican Church and in the profession of Law. Jonathan's branch descended from the younger family of Swifts in Yorkshire. Jonathan's great grandfather the Rev Thomas Swift,(1535-1592) was Rector of St. Andrews, Canterbury, for 22 years and a Prebendary and Rector of Bridstow in Herefordshire; he died on 12th June aged 57 in 1592. His eldest son William succeeded him as Rector of St Andrews for 33 years and also was Rector of Harbal Down. His second son was Jonathan Swift's Grandfather; he was the Rev Thomas Swift, Vicar of Goodridge, Herefordshire who died in 1658, leaving six sons and five daughters. His sons were Godwin, William, Thomas, Adam and Jonathan and Drydan. His daughters were Mary who died young and Emely, Elizabeth, Sarah and Katherine. His sons all became lawyers except Thomas who joined the church. His eldest son Godwin (1627-1695) studied at Gray's Inn; at this time there was a great shortage of lawyers, in Ireland so Godwin, William, Adam and Jonathan emigrated to Ireland. Drydan had died young. Godwin was appointed Attorney- general of the Palatinate of Tipperary, under the Duke of Ormond; he had first married Catherine Webster of London (1630 - 1672).<sup>1</sup>

The Swift family had Swift cousins living in Frisby, Leicestershire during the 17th and 18th century; it was here that Jonathan Swift senior possibly met the seventeen year old Abigail Erick, who had a sober devout upbringing by a father who was a persecuted nonconformist minister. Abigail and Jonathan married two years after her brother's instution to a living in Frisby.<sup>2</sup>

They settled in Ireland where Jonathan was appointed steward of Kings Inns , Dublin on 25th January 1665. A daughter Jane was born to them on the 1st May 1666. Jonathan Swift senior died in early April 1667 [prior to the 15th] seven months before Jonathan's birth; this left his pregnant widow with an eighteen month old daughter, no home and an annuity of 20 pounds. Abigail remained in Hoey Court until Jonathan's birth; he was then placed in the care of a wet nurse which was a usual practise at



*Dean Swift from a copperplate engraving by Pierre Fourdrinier after a painting by Charles Jervas*



JONATHAN SWIFT'S CARLOW CONNECTIONS

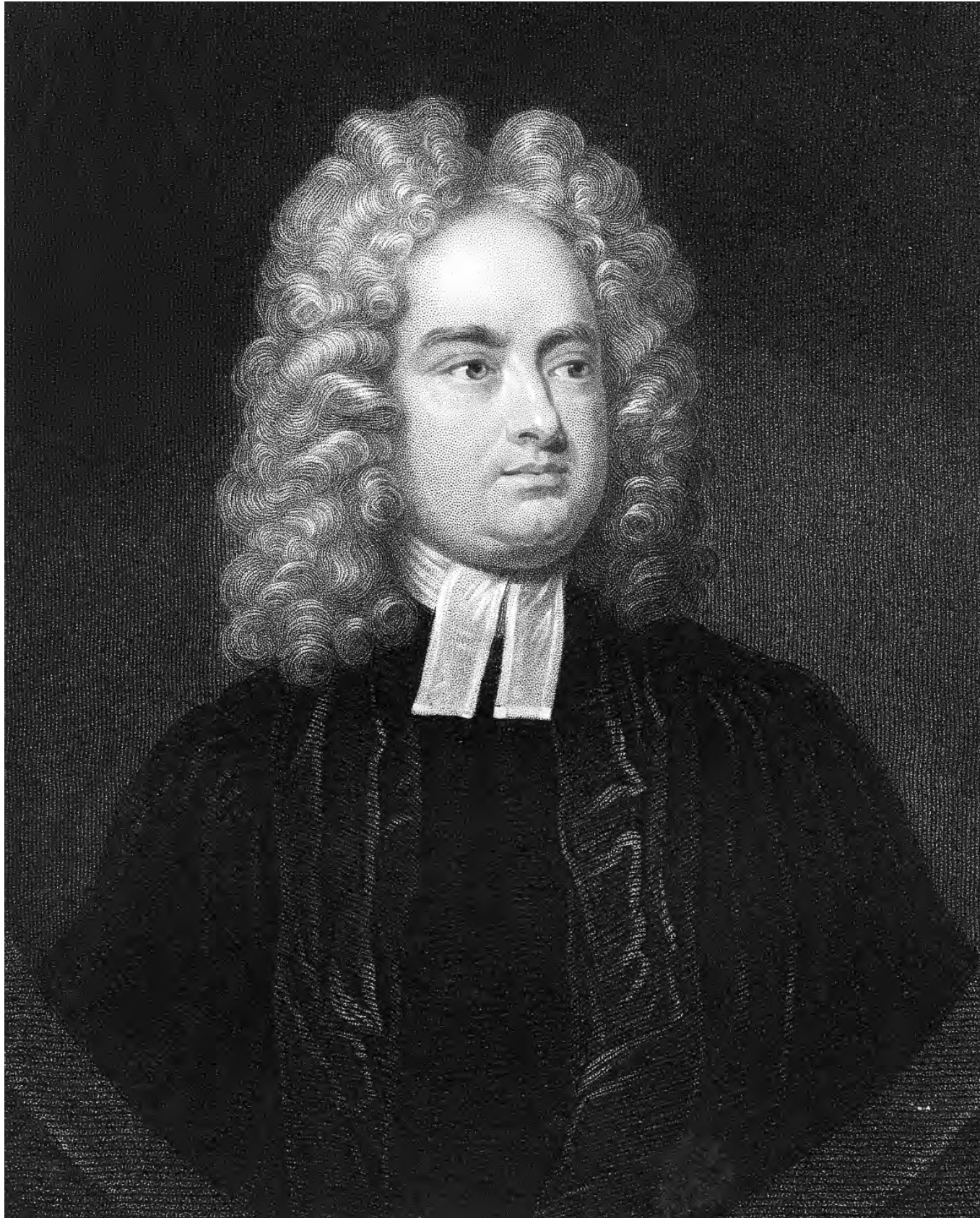

Steel engraving of Swift after portrait by Jervas in the Bodleian Library at Oxford

Carloviana 2012



the period. Later his Uncle Godwin of Swiftsheath, Co Kilkenny took him into his household and gave him an education. At an early age, sometimes recorded as 6 years of age, whereas students usually joined Kilkenny College aged 9, so most likely aged 9, Jonathan went to this excellent grammar school, founded by the Ormond family, who were related through marriage to Godwin.

Jonathan was joined by his English cousin Thomas son of Godwin's deceased brother the Rev Thomas Swift of Thope Mandeville in Northamptonshire and his wife Mary Davenant (daughter of Sir William Davenant poet and dramatist) who had died on 29th June 1667 at the age of 36.<sup>3</sup> Thomas was a year older than Jonathan; they both became part of his Uncle Godwin's household of fourteen cousins, off spring of Godwin and his four consecutive wives. He continued his education aged fourteen at Trinity College, Dublin, which he entered as a pensioner, under Sir George Ashe on the 24th of April, 1682 and studied there for the next seven years. Due to the war between James II and William, Prince of Orange, Jonathan left Trinity College and set sail for England. Here he spent a few months in Leicestershire with his Mother. On her advice, he introduced himself to a family friend Sir William Temple, at Moore Park where his sister Jane was already in the service of the Temple family.

#### **The Temple Family of *The Turrets*, Staplestown, Co Carlow.**

For three generations the Temple Family were involved in Irish affairs. Sir William Temple's (1628-1699) grandfather also Sir William (1553-1627) had been the most important of the early Provosts of Trinity College, Dublin. He gave the College its organization and character; his second son was Rev Dr. Thomas Temple also Provost at Trinity College. Sir William Temple's father Sir John (1600-1677) was born in Ireland and spent his life here, as Master of the Rolls. Sir John Temple had acquired a large estate in Co. Carlow of 1,500 acres following the Irish rebellion of 1641. He was elected M.P. for Co Meath being described as of Ballycrath, Co Carlow. His property in Carlow was excellent fertile agricultural land within an easy coach journey of Dublin. The estate was enhanced by two rivers, the Barrow and its tributary the Burren. This was the estate to which his son Sir William Temple and his wife Dorothy Osborne came to live in on their arrival in Ireland in 1656, Dorothy had just given birth to their first child John. It was here in Staplestown also known as Ballinacarrig that William and Dorothy lived in a beautiful house called *The Turrets*, for the next five years. During this time Sir William settled into farming and designed and planted an elaborate garden. His modern horticultural experiment's some based on Dutch and French influence occupied much of his time. He cultivated fruit trees and many species of trees and plants were introduced by him. He had a particular interest in the wool trade and various breeds of sheep and cattle were also introduced into the Carlow landscape. When not busy with his various farming enterprises he was reading and writing. His staff in Staplestown were of mixed religious beliefs and he wrote prayers which covered all denominations, a service for family and servants was held regularly in the Turrets lasting for up to an hour, introducing the very first Ecumenical service ever recorded in Carlow. Dorothy shared her husband's interests and the trials of their long courtship was one of the greatest ro-



*Sir William Temple*

Engraved by R.A. Muller from an engraving in the British Museum, after a painting by Sir Peter Lely

matic stories of the seventeenth century.<sup>4</sup>

In his memoirs Sir William Temple wrote that *he ow'd the greatest part of what he knew both of Phylosophy and Story to ye five years he pass'd when in Ireland. (Carlow)*. Sir William was elected an Irish M.P and as Carlow representative he attended a convention of estates in Dublin to discuss the restoration of the old Irish Parliament that predated the rebellion of 164; this was held on 7th February, 1660. The Temples idyllic existence in Carlow was not without sorrow as Dorothy lost five children, at birth or in early infancy. Sir William writes about this grief in his memoirs; it was a painful burden for them both. Reluctantly in 1663 they left their Carlow paradise, their gardens and library and returned to England where Sir William, now a member of the House of Commons, once more became involved in the political dramas of the century. His brother Sir John, Solicitor-General for Ireland was returned for the borough of Carlow, in Sir William's absence. However Sir William Temple did not forget his allegiance to Ireland; among the committees he was appointed to was one in which he became an active member for the promotion of Trade in Ireland. This committee's recommendations were a *Navigation Act* and the *Free Exportation of Wool*. He became Ambassador to the Hague, negotiated the Triple Alliance between England, Holland and Sweden and helped to arrange the marriage of William of Orange and Mary Stuart, daughter of James II.<sup>5</sup>

#### **Sir William Temple at Moore Park.**

When Jonathan Swift first met Sir William Temple in 1689 he had retired to Moore Park, near Farnham in Surrey. Swift became his secretary and amanuensis, writing, reading aloud and keeping accounts. In addition for the next twenty years he translated, edited and saw through to press virtually all Temple's literary works. Apart from two long breaks he lived for a decade in Temple's house at Moore Park, and his patron became friend

## JONATHAN SWIFT'S CARLOW CONNECTIONS

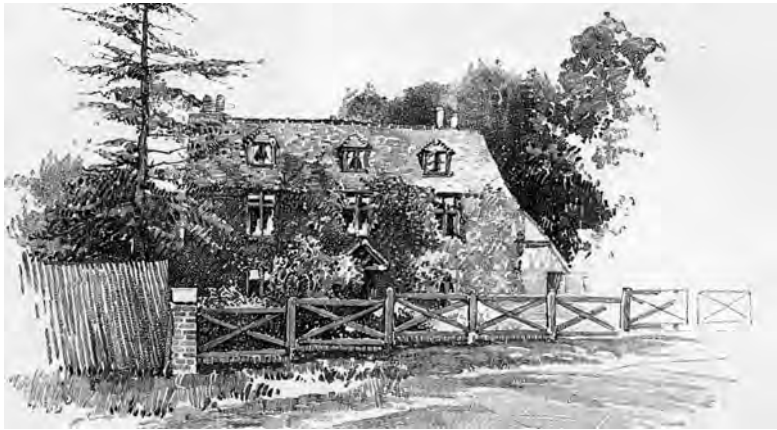

*Hester (Stella) Johnston's family cottage on the boundary of Moore Park estate. Drawn by Charles H. Woodbury, engraved by S Davis.*

and father figure to him. Swift had arrived in Temple's employment following the tragic death of Temple's only surviving son John (1655-1689) who had been Secretary for War. His son had taken his own life after what he perceived as a failed mission, in his duty for his King. It was therefore understandable that the young Jonathan Swift should develop a close relationship with the heart broken Temples.

A similar case may be found in the earlier arrival of Ester Johnson (Hetty) know later as Stella, aged eight at the time Swift first met her in Moore Park. It must be noted that the Johnson family<sup>6</sup> which consisted of the widowed Bridget Johnson, her daughters Ester and Anne and a son Edward did not live in Moore Park house but occupied a cottage of their own on the boundary of the estate (see sketch).

Dorothy Temple had lost two more infant children after leaving Ireland and only her eldest son John affectionately known as the *Little Creeper* had survived to manhood. A beautiful daughter Diana (1665-1679) whom they idolised, had died of smallpox aged fourteen.<sup>7</sup> The now childless Temples, having lost nine offspring, fostered a natural interest in the education and future of these two fatherless young people who had joined their household staff. In addition Hetty Johnson was a companion for and close in age to their two granddaughters, Elizabeth aged 9 and Dorothy aged 7, the children of their deceased son John and his French wife Marie du Plessis, Rambouillet, who lived spending time between Moore Park and London. The Temple Family were kind and generous; needless to say when Hetty Johnson appeared in the local village wearing fine clothes outgrown by the Temple children and speaking French it ignited a great deal of tavern talk and gossip, "placing her above her station".

Many untruths have been invented over the centuries concerning the relationships between Swift and Temple, Swift and Stella, and Stella and Temple. There is no mystery here except that which has been fabricated and fuelled by the collective imagination. Jonathan Swift was a Swift and neither Sir John

nor Sir William Temple's son, and Ester Johnson was the natural born daughter of Edward and Bridget Johnston, born on the 13th March, and baptised at Richmond, on the 20th March, 1681; her fathers people were from Nottinghamshire. Ester Johnston (Stella) was not a Temple.

On June 14th 1692 with funding from his Uncle William, Jonathan followed his Uncle the Rev Thomas's and his cousin Thomas's path to Oxford where he studied for an M.A at Hart Hall.<sup>8</sup>

In May 1694 Swift returned to Ireland to take Holy Orders; he was ordained by the Rev William Moreton, Bishop of Kildare in Christ Church Cathedral, Dublin on 13th January 1695.

#### From First to Last a Clergyman.

Installed as Dean of St. Patrick's Cathedral on the 13th June 1713 aged 45 Jonathan Swift had been in orders for 18 years. He rose from being an unknown cleric to a dignitary of great renown and continued as an active churchman until the last three years when physical illness left him no longer able to perform his duties. Swift was from first to last a clergyman for 50 years. During those years he was at times in intense involvement in the political scene, in defence of the Anglican Establishment which was in an impoverished position in Ireland in the 18th century.

Swift played the role of a powerful statesman and in this position he could perform certain services for his Church more valuable by being at the centre of politics in London than by remaining in



*St Patrick's Cathedral, Dublin, drawn by Harold Fenn, engraved by C.A.Powell*

his dioceses, for example, his work in gaining, the remission of The First Fruits, a traditional tax levied upon the Irish Church by the Crown – specifically upon the small income of his fellow clergymen. He became one of the most effective and brilliant Deans in the history of St Patrick's Cathedral.





Moore Park, residence of Sir William Temple and of Swift.  
Drawn by Charles H. Woodbury and engraved by R. Varley

*I look upon myself in the capacity of a clergyman; to be one appointed by providence for defending a post assigned me, and for gaining over as many enemies as I can. (Prose Works, ix. 262.)*

This statement by Swift shows that he was a man with a sense of purpose. Swift used his creativity as a writer, to hold up to humanity a mirror in which to see ourselves more clearly. Swift had a vision and he did not hesitate to set down what he saw. At times like all good clergymen he found it necessary to step into the mud of humanity to reach his straying flock. Swift worked throughout his life time with great energy and deliberateness. He was concerned to make humanity look at those timeless things which are



Sir William Temple's House and garden at Moore Park 1690.  
(by permission of Mr Basil Bacon)

the root cause of our ongoing problems. These he felt were *man's pride and self-deception, and the prevalence of hypocrisy and injustice*. Now he could not succeed in doing this with serious sermons alone, for he would not have been listened to and so he employed satire which was perfectly suited to his purpose.

#### The Essence of Swift.

The profundity of Sir William Temple's influence upon Jonathan Swift has always been underestimated. Although Swift's early odes met with a lack of success, he wrote three

prose works while at Moore Park: *The Battle of the Books*, *The Mechanical Operation of the Spirit* and *A Tale of a Tub*. His essay, *A Full and True Account of the Battle fought last Friday between the Ancient and the Modern books in Saint James's Library*, was written between 1697-8 and was certainly inspired in defence of an essay of Sir William Temple's published in 1692 on *Ancient and Modern Learning*. In true Swiftian style the result of the pitched battle was unknown, since the Advertisement tells us that; *the manuscript ... by the injury of fortune, or weather; being in several places imperfect, we cannot learn to which side the victory fell* (I,139)

This was a little ploy often used by Swift to keep the reader guessing.!

The essence of Swift is to be found in his most widely read and popular works, his masterpiece *Gulliver's Travels* and the *Drapier Letters*. His Poems show him to be a sensitive observant man who recorded realistically the world in which he lived. Swift could write on any subject, in *A Meditation upon a Broom-Stick*, he writes; *a broom-stick is an emblem of a tree standing on its head; and pray what is man but a topsyturvy creature, his animal faculties perpetually mounted on his rational, his head where his heels should be, grovelling on the earth.!*

Swift's famous long poem *Cadenus and Vanessa* is a recital of intellectual love, and is often misinterpreted. In Swift's own words we find the truth about how the poem came to be written; *It was a task performed on a frolic among some ladies, and she it was addressed to died some years ago in Dublin.....I forget what is in it, but believe it to be only a cavalier business..... I never saw it since I writ it. Neither if I had, would I use shift or arts, let people think of me as they please.* (letter to Knightley Chetwode) The poem had been written in Windsor fourteen years before it was published without Swift's permission. It is this author's opinion that the poem is the work of more than one pen and that Vanessa and some other ladies contributed to its composition. Writing poetry, puns and rhymes was a usual form of company entertainment at this period, *a dramatic poem* created on perhaps a long winter's evening in the drawing room by a group of intimate friends—a frolic among ladies.

His *Journal to Stella* was addressed to two people, to Ester Johnson, and her chaperone/companion Rebecca Dingley only later was the name *Stella* included as it was not in Swift's original letters. The Journal was in fact part of a collection of letters written to amuse and entertain the ladies, recording his life in London, this Journal gives us great insight into the compassionate, tender, generous and kind hearted side of Swift. He later retrieved these letters to use as a resource for the book he wrote on a *History of Queen Anne*. Since Stella's and Dingley's letters in reply to these have not survived half the story here is missing and therefore open to misinterpretation.

## JONATHAN SWIFT'S CARLOW CONNECTIONS

Swift originally published all of his work under a pseudonym such as Lemuel Gulliver, Isaac Bickerstaff and M.B. Drapier or anonymously. He was unwilling to allow himself to appear as the author of his work, yet whatever he wrote was the creation of a very individual genius with his unique character deeply engrained upon it. He would later say *that what he writ was all his own*. The only work he was ever paid for was 500 pounds for his book *Gulliver's Travels* and with this he set up a small loans fund to help his parishioners, who were mainly struggling craftsmen in the Liberties.

### The Dean's Garden.

Moore Park with its wonderful gardens and well stocked library provided Swift with perfect surroundings for the development of his creative ideas. Apart from Sir William Temple's guidance in Literature, Politics, and Religion, Jonathan Swift developed a love of gardening and of outdoor exercise, swimming walking, fishing and horse riding. Swift was an expert horseman, he always kept dogs, but was not too fond of cats; he was rather relieved when on first arriving to take up residence in the Dean-

ery that the previous occupant Dr John Stearne, came back after a few months to retrieve his tom cat who stank the house and upset his dogs.

It was at Moore Park that the terrible affliction of Menieres Disease, resulting in acute giddiness, sickness and deafness from a disturbance in the inner ear, first attacked him. He described it *as if he had the noise of a thousand wind mills in his ear*. He was to suffer all his life from it; the only relief he obtained was through intense physical exercise.

Sir William Temple had first explored his gardening theories in *The Turrets*, Staplestown, Carlow with his plantings and later on a larger scale at Moore Park with the Dutch style of garden design. In his book *Upon the Gardens of Epicurus* or of Gardening in the year 1685 he sets down many of his theories and his practical advice which is still popular today.

Temple sowed the seeds for modern garden design, when he introduced the world to *Sharawadgi* signifying a *careless grace* emulating the beauty of a more natural form of gardening found

in ancient Chinese gardens.<sup>9</sup> Swift like Temple found his tranquillity of mind in the garden, and followed several designs from Temple's gardens with canals stocked with fish and lined with Willows. He planted a garden of cherry, holly and apple trees on his little glebe at Laracor; and again in Naboth's Vineyard outside the Deanery of St. Patrick's. Swift also encouraged his Irish friends to plant gardens, for example at Sheridan house in Cavan and the Delany's at Delgany, and Vanessa at Marley Abbey.

Swift, Lord and Lady Orrery, Dr and Mrs Delaney and Dr Samuel Madden are credited with being the chief precursors of the *romantic-poetic garden* in Ireland.<sup>10</sup>

Less well known is the extent of Swift's specific debt to Temple's published works in the field of politics. Two essays of Temple's are particularly important in this regard, *An Essay upon the Origin and Nature of Government 1670-73* and also *Of Popular Discontents*, 1681. (see ref. to Harvard Studies in book list.)

Sir William Temple died on 26th January 1698 and Swift wrote at the time that with him *died all that was good and amiable among mankind*.

Swift brought bountiful ideas and ideals back to Ireland with him from Moore Park as well as a young ward Hester Johnson (Stella) and her companion, Rebecca Dingley who were his life long friend's.

### The Swifts of Ballynunnery, Carlow.

In 1681 Thomas Dineley Esq, an English travel writer, visited Ireland; in his Journal *Observations in his Voyage through the Kingdom of Ireland*, one of the places he visited was Staplestown, Co Carlow; at this period the estate had changed from the Temple family to the ownership of John Tench, M.P. of Lincoln's Inns. Dine-

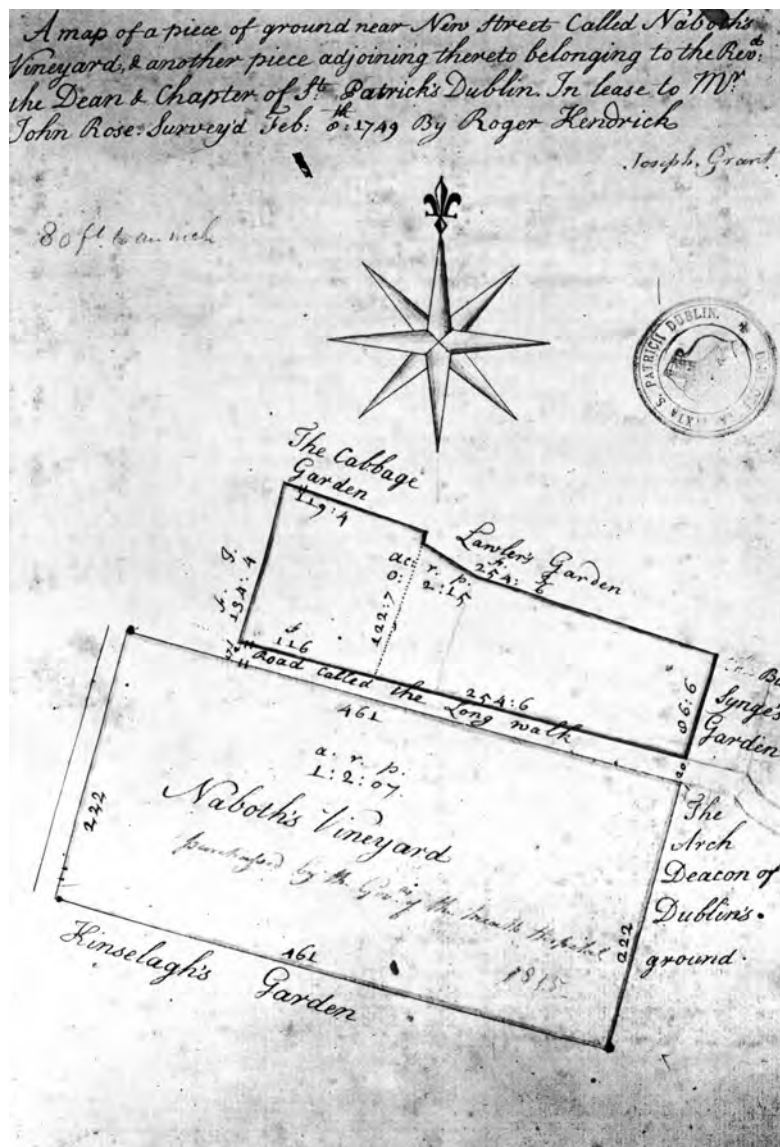

Naboth's Vineyard, St Patrick's Liberties, Dublin.  
Dean Swift's garden. Plan designed by Roger Kendrick 1749



ley describes the village of Staplestown and *The Turrets* in detail in his Journal and includes an imaginative pictorial-map. He also visited Ballynunnery, in the parish of Gilbertstown, Barony of Forth. It consisted of a Castle part of the estate of the Earl of Arran, son of the Earl of Ormond and was owned by Jonathan Swift's first cousin, Godwin Swift's son, Godwin Mead Swift of Swift's Heath, Co Kilkenny, who assumed the title of Viscount Carlingford.

According to Thomas Dineley; *The Castle at Ballynunnery is situated up on a rising Hill among good Gardens, Orchard's and Meadows; at the foot of the Hill and to one side of the Garden, near the Castle runneth a pleasant river. The River (Burren) abounds in Trout. There is also found a quantity of good Pearle not unlike the Scottish Pearle, which the Lady of the house likes to showeth.*<sup>11</sup>

Dineley also wrote about the excellent quality of wool, with the annual *Sheeps Grey Prize* awarded to the best wool in Carlow, Carlow weavers were counted amongst the finest in Ireland, and were praised also for the finest of linen weaving of a special Damask.<sup>12</sup> much sought after for its very elaborate designs, sold through Kilkenny merchants to Europe. There is every possibility that Jonathan Swift visited both The Turrets Staplestown and also Ballynunnery Castle when he visited Carlow. In travelling from Carlow to Kilkenny he would certainly have visited the most ancient 12th century St Lazerian's Cathedral of Old Leighlin. However, this has not been recorded although correspondence exists on matters of Choral issues between Swift and the Rector of Leighlin.

On 3rd June, 1723 Swift had departed Dublin on horseback which is the way he always travelled; he had planned a visit to the South and West of Ireland for some years, first mentioned in a letter to his friend Chetwode as far back as March 1715. In May 1723 three weeks before his friend Esther (Vanessa) Van Homrigh's death, he had corresponded with Robert Cope telling him of his plan for his tour South.<sup>12</sup> He had postponed setting out on his journey on this occasion, awaiting the arrival of Dr Henry Jenny a clergyman from Mullaghbrack, outside Loughgall, Co Armagh, a friend of Cope's, who was to travel with him, but in the end could not join him. It was therefore a planned journey and not an impetuous one.

He set off with one servant on his tour; he was staying with the Rector, Rev Samuel Morland in Carlow town, in mid June. The Carlow Church of Saint Mary's Abbey had been founded in 634 and the Parish still holds the oldest Vestry Book in Ireland. The Minute book dates from 1669 and is complete to the present day. While staying in the Vicarage which was then on the corner of Haymarket, Rev Samuel Morland took him on a tour of Carlow.

According to Sir William Wild in his memoir of Jonathan Swift this is where on being shown the rather impoverished condition of St Mary's church, he wrote the couplet;

**"Poor Town, proud people.  
High Church and low steeple".**

It is possible that Swift's visit South may have been to assess the building of new churches, later called Churches of the First Fruits; it is significant that some time after Swift's Visit to Carlow that the

Right Rev Josiah Hort, Lord Bishop of Ferns and Leighlin presided over a Vestry meeting in Carlow with plans and funds ready to build a new St. Mary's Church, in Carlow town.<sup>13</sup>

Swift's journey for these three months, is sparsely documented as no journal or correspondence has survived. However, we find several local references about it, some facts and lots of fiction. Part of his route encompassed Carlow, Kilkenny, Cashel, Cork, Bandon and Ross Carbery and back through Clonfert where he had an appointment with the Bishop Theophilus Bolton.

While visiting Myross, Swift stayed with Rev. Philip Somerville, the local vicar. This was later recorded by Edith Somerville and Martin Ross in their *Irish Memories* (1917) Swift also stayed with cousins of the Somervilles at Castletownshend, the estate of Colonel Bryan Townshend. What is certain is that from this trip he learned more about the Irish people and the Irish landscape. This knowledge was most fruitful when on his return from London in 1727, he met a series of catastrophic harvests. In a land where so many lived on the edge of famine, these crop failures brought death and starvation to thousands of impoverished Irish families. Swift was driven to his most *explosive indignation* over the cruel treatment of human beings, many treated like slaves. In defence of the Irish People he penned some of his finest essays from the *Drapier*, a year after this Southern Tour. (1724-25) showing that he identified himself with his suffering people.<sup>14</sup> Swift was always a very practical man not content just to write about something but to do something about it for example in the Wood's coinage debate.<sup>15</sup>

Jonathan Swift endeared himself to the people of Ireland and became a symbol of Liberty.

#### **The Myth of Madness, Swift was not Insane.**

Jonathan Swift was elected a Governor of the Bethlehem Hospital (Bedlam) London in 1714; this experience made Swift acutely aware of the painful plight of individuals who suffered from mental illness. In Swift's time there were only two such hospitals in Europe. Swift was horrified at the treatment and the practise of the parading of human suffering. It was his long term plan which he worked towards for fifteen years to save the funds to build a more humane hospital in Dublin, where people would be cared for with dignity. Swift's philanthropy and his great vision came to fruition in the founding of St Patrick's Hospital to which he left his whole fortune, and detailed instructions on how it was to be governed.<sup>16</sup>

The myth of madness is false in Swift's case, Swift was not insane. There is clear evidence that Swift was not ill when he wrote his will. It is also clear and with well documented proof that only in his last three years and then only as a result of a physical illness did Swift lose the power to communicate with others and to manage his affairs.

Before this event he foresaw his own situation and among the last words he wrote were the following;

*My resolution is to preserve the dignity of my station, and the*

## JONATHAN SWIFT'S CARLOW CONNECTIONS

*honour of my Chapter; and gentlemen, it is incumbent upon you to aid me, and show who and what the Dean and Chapter of Saint Patrick's are.*

Medical knowledge at the time lacked understanding of Swift's lifelong disability. It was not until 1862 that Prosper Meniere identified the sudden attacks of dizziness, nausea, coldness of stomach and deafness which now bear the name of Meniere disease. What a brave and courageously spirited man Swift was to do so much afflicted with such a life-long burden. *The Irish Journal of Medical Science* published an article which gives a graphic description of Swift's last illness.<sup>17</sup> Swift suffered a "stroke" which left him with the ability to understand but unable to communicate, a brilliant mind, a genius imprisoned; how frustrating and soul destroying for such a man e greatest joy was to be found in "Words". It was only at this point that a Committee of Guardians was appointed to manage his affairs. On the 19th October 1745 when Swift died in his Deanery of St Patrick's, Dublin he left nothing undone; he had even carefully penned his own *Epitaph*.

#### The Ladies in Swift's life.

Swift was passionately in favour of equal education for women, and as Tutor and Mentor he encouraged the ladies in his care to read and develop their minds.

Jonathan Swift never married or had an heir although volumes have been written and will continue to be written on his relationship with two women Stella and Vanessa. There were many women in Swift's life. Most notable is the fact that women who were dear to him remain somewhat protected in the shadows. They are his Mother, his sister Jane and his four paternal aunts, Emily spelt Emely, Elizabeth, Sarah and Katherine, his Mother's sisters and his endless female cousins, amongst a long list of admirers not least his ladies from the Liberties who idolised him. While staying with his Mother aged 21, Swift fell in love with Elizabeth Jones, who was not quite his pox faced mistress but was his Mother's cousin and the charming and respectable daughter of the Rev John Jones, Vicar of Wanslip, Leicestershire. His Mother was so concerned that he would make an imprudent marriage that she implored her brother-in-law the Rev John Kendall, who was now in her father's position as Vicar of Thornton, to write to him a stern letter asking him what his intentions were. His reply was a very long and mature letter dated 11th February 1691 in which he gives us his first indication that he intends to join the Church and has no intention of marriage *not yet, that I am so difficult to please, I may even put it off to the other world!*

The only proposal of marriage recorded was as a result of Swift's passionate feelings for Jane Waring whom he called Varina, daughter of the Archdeacon of Dromore, Ireland; he proposed to her and she rejected him; there is only so much rejection the human heart can endure, especially for such a very proud man; Swift was not to place himself again in this situation. Four years later his Uncle Adam wrote to ask what his intentions were to Jane Waring as the matter was not resolved and perhaps the lady entertained the idea of renewing their relationship. Swift's letter to Jane was the retort of a wounded person

striking back with one of the most poisonous letters ever penned by him, indicative of his deep hurt .Jane died unmarried in 1720. Swift was cared for in his final years by his devoted first cousin Martha Whiteway, daughter of his Uncle Adam.

When one looks at Swift's portraits by Charles Jervas and Francis Bindon it maybe difficult to imagine a smiling or a laughing Swift, although he has been described thus;

*In person Swift was tall, well made and in his youth esteemed handsome, his eyes were azure blue ,his nose aquiline, mouth small although his lips were rather fleshy; he had large bushy black eye-brows; his countenance had something noble in it, which impressed awe upon beholders. His features were often illuminated with a smile, although never by violent laughter. In society his manners were free, engaging and polite.*<sup>18</sup>

Swift's friend Joseph Addison (1672-1719 ) poet, essayist, and statesman dedicated a book he wrote on Italy to Swift inscribed *To Dr Swift the most agreeable companion, the truest friend and the greatest genius of the age.*

To the people of Ireland Dean Jonathan Swift is a Champion of Liberty and A Giant in our Lilliput for all time.

#### One final Carlow Connection.

In addition to Jonathan Swift's connection with the Temple family of 'The Turrets' Staplestown, Carlow and with his cousins, the Swifts of Ballynunnery Castle, Carlow there is one further Carlow connection; the Carlovian author of this article has family links with Jonathan Swift. Mary Stratton Ryan's great aunt Annie Louise Stratton (1892-1985) daughter of Henry John Stratton and his wife Ellen Turner of Cattistock, Dorset, married The Right Reverend Godwin Swift (1872-1944) of Epsom, Surrey later Vicar of All Saints Sudbury, Suffolk. Rev Godwin Swift was a direct descendant of Godwin Swift of Swiftsheath, Co Kilkenny, Jonathan Swift's Uncle. They had one son Godwin born in 1929.

This article is therefore dedicated to the author's father John W.G. Stratton, his cousin Godwin Swift and in memory of Godwin and Hazel's only son Godwin William Dean Swift (Bill) Lawyer (1961-1999)

#### Endnotes:

<sup>1</sup> The Rev. Godwin Swift's Family papers. Priv.coll.

<sup>2</sup> The Parish Registers of Frisby-on-the Wreake, Co. Leicestershire. Information researched with the kind assistance of Archivist & Historian Mr John Billings, Frisby on the Wreake.

<sup>3</sup> Rev, Thomas Swift - Swift Family Papers. Priv.coll.

<sup>4</sup> Read my Heart ,Dorothy Osborne and Sir William Temple, A Love Story in the "Age of Revolution" by Jane Dunn. pub. Harper Press, London 2008.

<sup>5</sup> "Memoirs of the Life, Work and Correspondence of Sir William Temple Bart". Vol 1.Pub. by Longmans of London 1836. Vol 1 & Vol 2.

<sup>6</sup> "Cadenus and Swift's most valuable friend", by Sybil le Brocquy p24 pub by *The Lilliput Press*, Dublin 2003.



*Gulliver illustration by T. Morten in Gulliver's Travels by Dean Swift, pub. by Cassell, Peter and Galpin, London, Paris, New York.*



## JONATHAN SWIFT'S CARLOW CONNECTIONS

- <sup>7</sup> Ref. a Painting of Diana Temple (1665-1679) and her aunt Martha Temple by artist Gaspar Netscher.
- <sup>8</sup> Swift Family Papers, ref to Rev Thomas Swift. 3rd son of Thomas Swift, brother of Jonathan Swift senior. He was a fellow and lecturer in Logic Oxford, in 1660, and was appointed rector of Thorpe Mandeville, Northamptonshire. In 1666 he was preferred to the rectory of St Edmunds, Lombard Street, London. On arriving in London to take up his post he found it was destroyed by the Great Fire of London. The British Museum holds two of his letters 1667. His address was London House, Aldersgate Street; he died of small pox on 29th June, 1667, leaving his wife Mary and only son Thomas who became companion to his Irish cousin, Jonathan Swift.
- <sup>9</sup> Sir William Temple's Book on Gardening; "Upon the Gardens of Epicurus" or "Of Gardening in the Year 1685" First published in 1685. reprinted Pallas Ed, 2004 London.
- <sup>10</sup> Lost Demesnes ,Irish Landscape Gardening.1660-1845 by Edward Malins & The Knight of Glin, pub Barrie & Jenkins Ltd. London 1976 pp31-52.
- <sup>11</sup> Thomas Dineley esq., "Observations in his Voyage through the Kingdom of Ireland In the Year 1681". reprint Dublin 1870. N.L.I. pp 42-43.
- <sup>12</sup> "Carloviana" year 1986, Damask Weavers (Moran) p20.
- <sup>13</sup> "The Vestry Book Carlow 1669" entry dated 18th July, 1726.
- <sup>14</sup> Drapier's Letters' was a series of 7 pamphlet's written between 1724-25 by Swift.
- <sup>15</sup> 'Woods', A Letter concerning the Brass Half-Pence by M.B.Drapier.1724.
- <sup>16</sup> "Swifts Philanthropy" by J.N.P. Moore of St Particks Hospital, Dublin, VIII pp 137-156. "A Dublin Tercentenary Tribute 1667-1967". Pub. By The Dolmen Press ,Dublin 1967.
- <sup>17</sup> 'The Illness of Dean Swift'. Irish Journal of Medical Science, Aug-Sept. 1952, pp.337-46
- <sup>18</sup> "The History and antiquities of the Collegiate and Cathedral Church of St. Patrick's". By William Monks Mason 1820. Book 11. p 412.
- Further reading**
- Jonathan Swift . The Oxford Authors, a critical edition of The Major Works. Pub. Oxford University Press 1984. UK.
- "Life of Jonathan Swift by Henry Craik" vol.1&11. pub London, Macmillan & Co.1894.
- "Memoirs of Jonathan Swift, D.D. Dean of St. Patrick's Dublin", by Sir Walter Scott, Bart. Pub by Robert Cadell, Edinburgh 1834.
- "Prose Works of Jonathan Swift". 14 vols. ed. Herbert Davis pub Oxford ,1939-69.
- "Jonathan Swift ; A Critical Introduction". By Denis Donoghue, pub Cambridge 1969.
- "Swift; The Man , His Work, and the Age", by Irvin Ehrenpreis. 3 vol. London 1983.
- "The Personality of Jonathan Swift". by Irvin Ehrenpreis.pub. Methuen & Co London 1958.
- "The Life of Jonathdan Swift", vol 1. by John Forster. London 1875.
- "In Search of Swift" by Denis Johnston. Pub Dublin 1959.
- Jonathan Swift ; The Irish Identity. by Robert Mahony pub New Haven and London,1995.
- Jonathan's Travels; Swift and Ireland by Joseph McMinn. Pub. Belfast and New York 1994.
- "Jonathan Swift"; A Hypocrite Reversed. by David Nokes pub. Oxford 1985.
- "Jonathan Swift; Journal to Stella. 2vols.ed by Harold Williams pub Oxford 1948.
- The Poems of Jonathan Swift. 3 vols ed by Harold Williams 2nd ed Oxford 1958.
- Fair Liberty Was All His Cry. ed. by A.Norman Jeffares A Tercentenary Tribute to Jonathan Swift 1667-1745.pub Macmillan London & St Martins Press New York 1967.
- "The Life and Friendships of Dean Swift". by Stephen Gwynn pub Henry Holt & Co.U.S.A. Oct 1933
- "Jonathan Swift Major Prophet". by A.L. Rowse. pub. Thames & Hudson. 1975.
- The Conjured Spirit. by Evelyn Hardy. Pub. The Hogart Press London 1949.
- The Skull of Swift. by Shane Leslie pub .Chatto & Windus London 1928.
- Jonathan Swift. A Critical Biography by J.Middleton Murry pub Oxford at Alden Press 1954.
- Jonathan Swift A Dublin Tercentenary Tribute. ed by Roger McHugh & Philip Edwards 1667-1967 pub *The Dolmen Press*.1967.
- "Locating Swift", a collection of essays on the 250 th Anniversary of the death of Jonathan Swift editors Aileen Douglas, Patrick Kelly, & Ian Campbell Ross. Pub.Four Courts Press Ltd.1998. Dublin.
- "The Legacy of Swift" a Bi-Centenary Record of St Patricks Hospital, Dublin with a Catalogue of the Exhibition pub for The Governors at the Sign of the Three Candles 1948.Dublin.
- "Swift's Earliest Political Tract and Sir William Temple's Essay's" by Robert J. Allen. "Harvard Studies" vol. XIX Cambridge Harvard University Press 1937
- 'Jonathan Swift' a portrait by Victoria Glendinning pub. Henry Holt & Co New York 1998 .
- "Jonathan Swift and Popular Culture. Myth, Media, and the Man". by Ann Cline Kelly. pub . Palgrave Macmillan 2008.
- "Swift An Illustrated Life" by Bruce Arnold pub .The Lilliput Press, Dublin 1999.
- "Jonathan Swift and The Church of Ireland". 1710-1724. by Christopher J.Fauske, pub. Irish Academic Press 2002
- "Jonathan Swift, The Enigma of a Genius". by William Kean Seymore, pub. by Moore Park College, Farnham, Surry 1967.U.K.

*The  
Remarkable  
Haughtons  
of Carlow  
and Kildare*

Introduction:  
Dr Norman MacMillan

The Haughton family archive is kept by Major Christopher Haughton who has kindly allowed *Carloviana* to reproduce the family short biographies. Next year a selection of additional material will be published and the second part of the family tree will be included. The editors are grateful to Major Haughton for this help in delivering such a unique and remarkable series of biographical details and providing an accurate family tree."



*Major Christopher Haughton*

Born in Falmouth, Cornwall in November 1935 and he was educated at Lucton School Herefordshire from where he joined the Army.

He was commissioned into the Royal Artillery from the Royal Military Academy, Sandhurst in 1956.

He married Jane ( nee Pickering ) in 1961 and has three children a son and two daughters.

During his career he served in Cyprus, Malaysia, Germany, France, The Netherlands and the UK.

He retired to Devon in 1991 and spent the next few years instructing yacht cruising and examining candidates for their yachting qualifications in South West England.

A keen sportsman he represented his regiment at rugby, hockey, swimming, basketball, boxing, sailing and orienteering during his service.

He is related to Professor Samuel Haughton through his Great Great Grandfather Samuel Pierson Haughton.

A national plaque (National Committee for Commemorative Plaques in Science & Technology) was erected on the Haughton family home on Burrin Bridge for Rev Samuel Haughton FRS (1821-1897). He is buried in Killeshin Church in Graiguecullen in an unmarked grave Quaker style next to that of his son. There is currently a proposal to award a national plaque to James 'Vegetable' Haughton (1795-1873) who is shown now in his correct family relationship to Samuel in the accurate family tree provided by Christopher Haughton.

The importance of the Haughton family for Carlow and its environs is one that is of some real significance. The campaign from the 1970s by McMillan in Carloviana to undertake new research into Haughton has been of importance in that it developed new scholarship on this Carlow polymath Samuel to built on the work of Joe D. Burchfield. Burchfield's 'Lord Kelvin and the Age of the Earth' (New York, 1975) despite the misleading title actually centred on Haughton's contribution to the age of the earth. Both McMillan and Martin Nevin worked with Burchfield to develop the local knowledge of Samuel and this work sparked considerable renewed interests in the Carlowman Trinity including researches by the present Provost Paddy Prendergast and most notably that of the other editor of this material Miguel DeArce. DeArce's researches has significantly extended scholarship on Samuel Haughton and that of his lifetime collaborator James Galbraith (1818-1890). Joe Haughton, Professor of Geography in Trinity was at that time in the late 1970s working in the Museum Building in Trinity College in an office perhaps previously occupied by Samuel. Joe Haughton was able to help with details on a Haughton family tree published at the time in Carloviana. In several recent biographic entries on Samuel it is incorrectly stated that James 'Vegetable' Haughton was his father. It is therefore clear that to obtain from Christopher such verified and detailed family records is a great breakthrough for local history. This important Leinster family owned mills in both Carlow and Athy but these biographies are also of importance to the burgeoning Haughton scholarship.

The biography of Christopher Haughton is included at the head of this article which will be seen as very much in the tradition of the family. Haughtons were Quakers or in the case of veritable 'Vegetable' a Unitarian. The Haughton's recorded family history shows the connections with the Shackleton Quaker family and detail the linked preoccupation of both families with education. James Haughton indeed worked with JKL Bishop James of Kildare and Leighlin to help establish the National School system in 1831 which was launched in Leinster but spread in time to every corner of the British Empire.

Samuel Haughton and James Galbraith produced a series of internationally important textbooks that were of inestimable importance to university education in the late 19th century as they ranged over so many subjects. These books helped technically train and educate officers for the Empire. Importantly, these cram books provided concise information specially designed for passing examinations. The conundrum here is both these Trinity dons were with Isaac Butt founders of Home Rule Party and thereby fathers of Irish independence and the Republic. Galbraith remarkably while a Trinity don even visited Parnell when he was a prisoner in Kilmainham and incurred the odium

of many powerful figures in college including the Provost. It will be noted from these biographies published below that many of the Haughtons served in the British army and interestingly these family biographies illuminate family connections to the great Imperialist Rudyard Kipling (1865-1935) and the school Westward Ho. This school was established for purposes of providing manpower for the Empire.

The importance of understanding the nuances of the complex relationships of this outstanding Anglo-Irish family with the region is today recognised. Historically how important this is can be underlined for Carlow when it is remembered that county always returned Unionist MPs when it was under British Rule until the late 19th century when MPs like limbless Unionist Arthur MacMurrough Kavanagh (1831-1889) in Borris was sensationally defeated by a Home Rule candidate. The Vegetable Haughton was importantly a firm early supporter of Irish independence as espoused by O'Connell and The Liberator's mentor JKL who initiated the very first civil disobedience campaigns against British rule with the campaign in Graiguecullen to refuse to pay the tithes to the Established Church. James Haughton stood for Catholic Emancipation and very much stood with 'The men of 98' who are buried in the Croppy Grave in Graiguecullen. The conundrum of the Haughtons with their radical nationalist family traditions in a family studied with such a long and distinguished service to the British military is not unusual by any means in many important Anglo-Irish families!

Carlow is indebted to Christopher for allowing the publication of these family biographical details that so graphically highlight stark divergent tendencies and sculpt a family tradition that was nevertheless one the Haughtons are collectively proud of despite such obvious divergent tendencies. The details in themselves are a very 'good read' but throughout flag interesting historical relationships and detail. They constitute in themselves a very important historic record. Christopher being an British army man through and through is very much part of the Haughton tradition being paradoxically very proud of his relative's contributions to severing the links of Ireland with Britain.





THE REMARKABLE HAUGHTONS OF CARLOW AND KILDARE

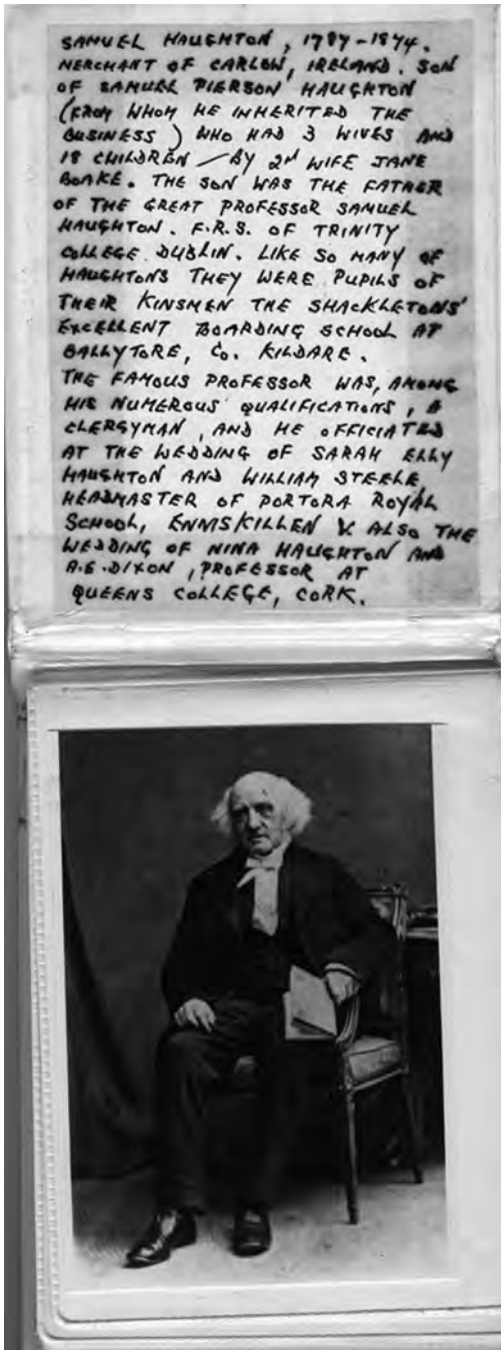
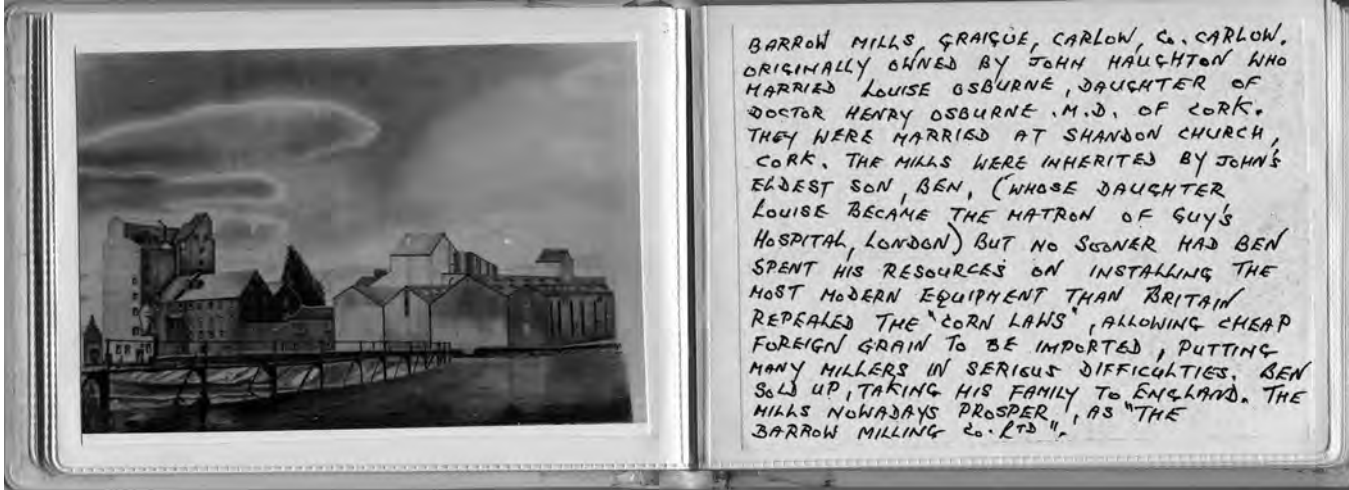

The Haughton grave in Killeshin Churchyard, Graiguecullen, Carlow

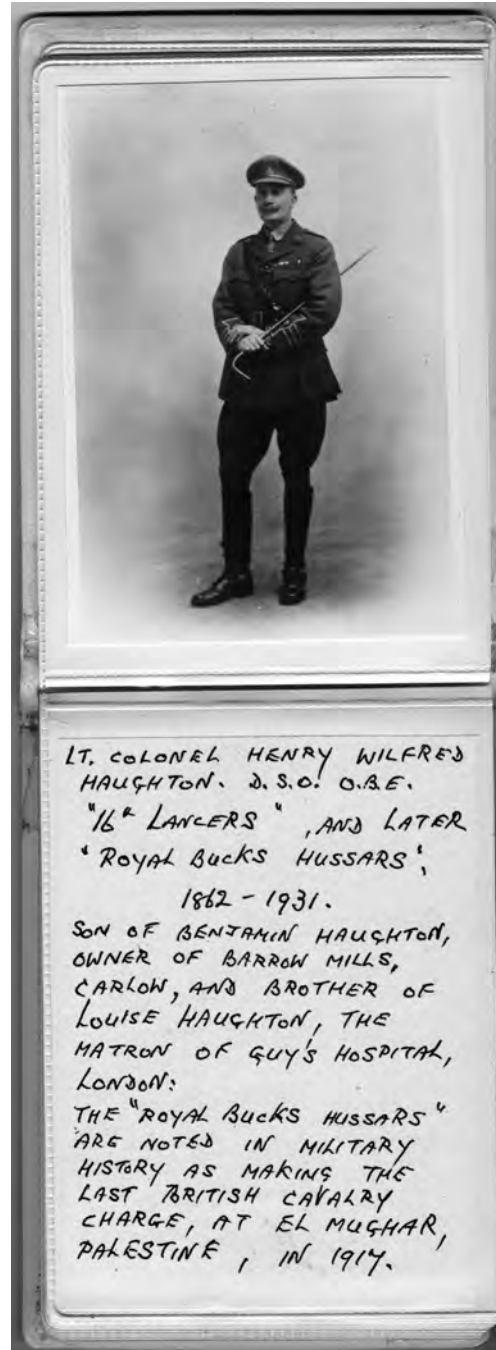

*Haughton Diaries*



THE REMARKABLE HAUGHTONS OF CARLOW AND KILDARE

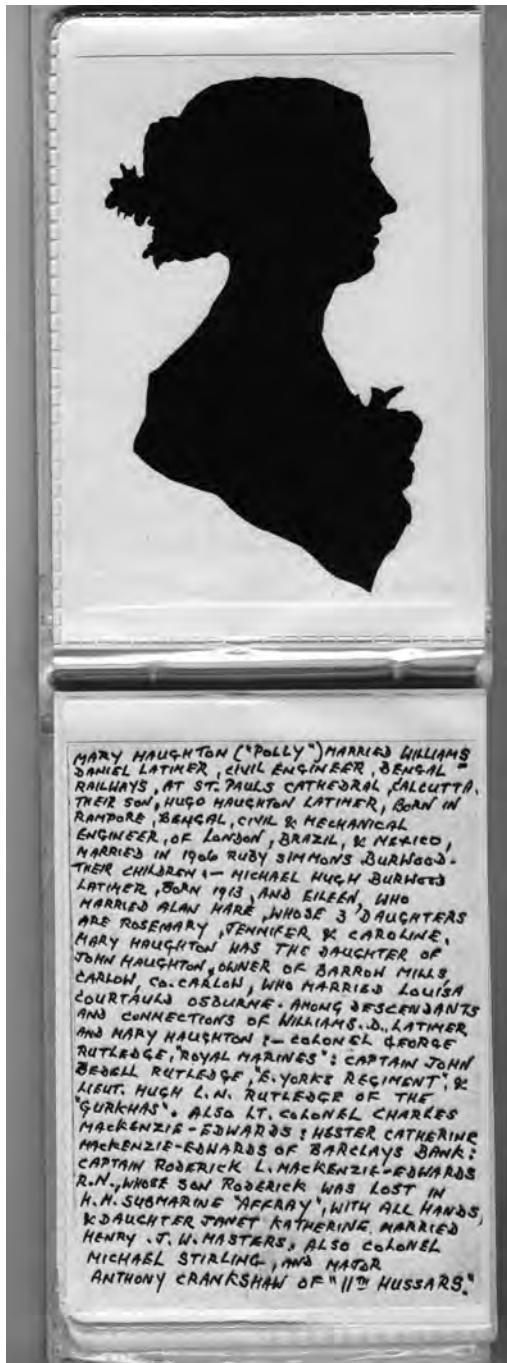

MARY HAUGHTON ("POLLY") MARRIED WILLIAMS DANIEL LATIMER, CIVIL ENGINEER, BENGAL RAILWAYS, AT ST. PAULS CATHEDRAL, CALCUTTA. THEIR SON, HUGO HAUGHTON LATIMER, BORN IN RANPORE, BENGAL, CIVIL & MECHANICAL ENGINEER, OF LONDON, BRAZIL, & MEXICO, MARRIED IN 1906 RUBY SIMMONS BURKHOOPTER CHILDREN - MICHAEL HUGH BURKHOOPTER LATIMER, BORN 1913, AND EILEEN, WHO MARRIED ALAN HARE, WHOSE 3 DAUGHTERS ARE ROSEMARY, JENNIFER, & CAROLINE. MARY HAUGHTON WAS THE DAUGHTER OF JOHN HAUGHTON, OWNER OF BARRON MILLS, CARLOW, CO. CARLOW, WHO MARRIED LOUISA COURTAULD OSBURN. AMONG DESCENDANTS AND CONNECTIONS OF WILLIAMS D. LATIMER AND MARY HAUGHTON - COLONEL GEORGE RUTLEDGE, "ROYAL MARINES"; CAPTAIN JOHN BEDELL RUTLEDGE, "6. YORKE REGIMENT"; & LIEUT. HUGH L. N. RUTLEDGE OF THE "GURKHAS". ALSO LT. COLONEL CHARLES MACKENZIE-EDWARDS; HESTER CATHERINE MACKENZIE-EDWARDS OF BARCLAYS BANK; CAPTAIN RODERICK L. MACKENZIE-EDWARDS R.N., WHOSE SON RODERICK WAS LOST IN H.M. SUBMARINE "AFFRAY", WITH ALL HANDS, & DAUGHTER JANE KATHERINE, MARRIED HENRY J. W. MASTERS, ALSO COLONEL MICHAEL STIRLING, AND MAJOR ANTHONY CRANKSHAW OF "11<sup>TH</sup> HUSSARS".

*Haughton Diaries*

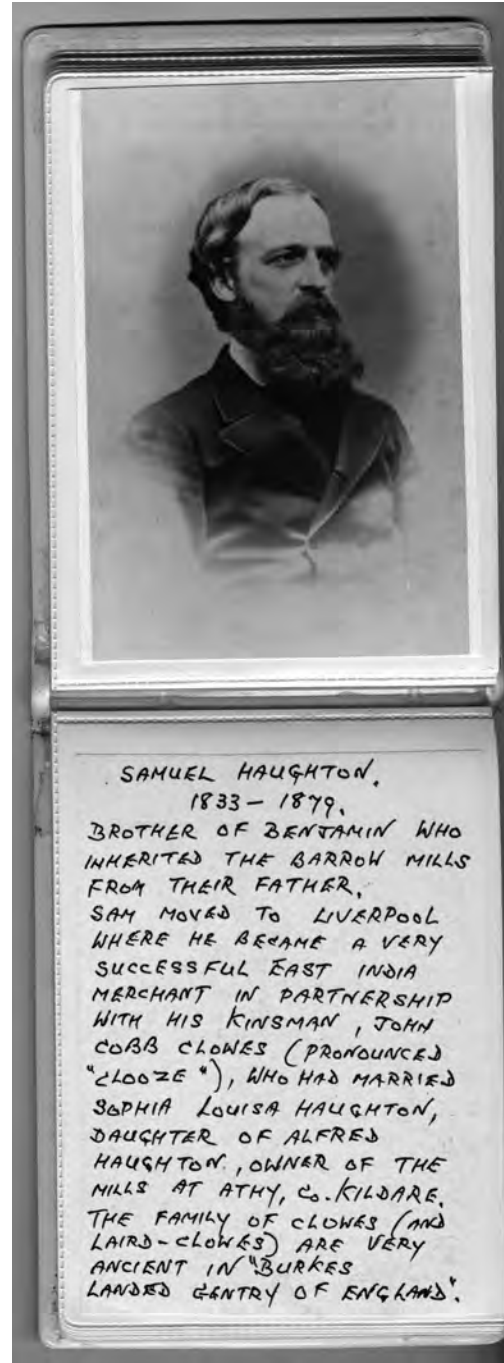

SAMUEL HAUGHTON, 1833 - 1879. BROTHER OF BENJAMIN WHO INHERITED THE BARRON MILLS FROM THEIR FATHER. SAM MOVED TO LIVERPOOL WHERE HE BECAME A VERY SUCCESSFUL EAST INDIA MERCHANT IN PARTNERSHIP WITH HIS KINSMAN, JOHN COBB CLOWES (PRONOUNCED "CLOOZE"), WHO HAD MARRIED SOPHIA LOUISA HAUGHTON, DAUGHTER OF ALFRED HAUGHTON, OWNER OF THE MILLS AT ATHY, CO. KILDARE. THE FAMILY OF CLOWES (AND LAIRD-CLOWES) ARE VERY ANCIENT IN "BURKES LANDED GENTRY OF ENGLAND".



THE COL. HAUGHTON IN THE CENTRE IS LT. COLONEL JOHN HAUGHTON, COLONEL OF THE REGIMENT. THE PHOTO WAS TAKEN NOT LONG BEFORE HE WAS KILLED IN ACTION, MEMORIALS TO HIM BEING ERECTED, BY HIS BROTHER OFFICERS, IN THE SCHOOL CHAPEL AT LIPPINGHAM, AND DESHANUR CEMETERY ON THE N.W. FRONTIER OF INDIA. IT WILL BE SEEN THAT SWORDS WERE STILL AN ESSENTIAL, ESPECIALLY IN COMBAT WITH HIGHLY-SKILLED SWORDSMEN AMONG THE TOUGH, RUTHLESS, FRONTIER TRIBESMEN, WITH WHOM THE INDIAN ARMY WAS CONSTANTLY AT WAR. HIGH SKILL WAS ALSO NEEDED IN OVERCOMING THE COMPLEX PROBLEMS OF MOUNTAIN WARFARE.





THE REMARKABLE HAUGHTONS OF CARLOW AND KILDARE

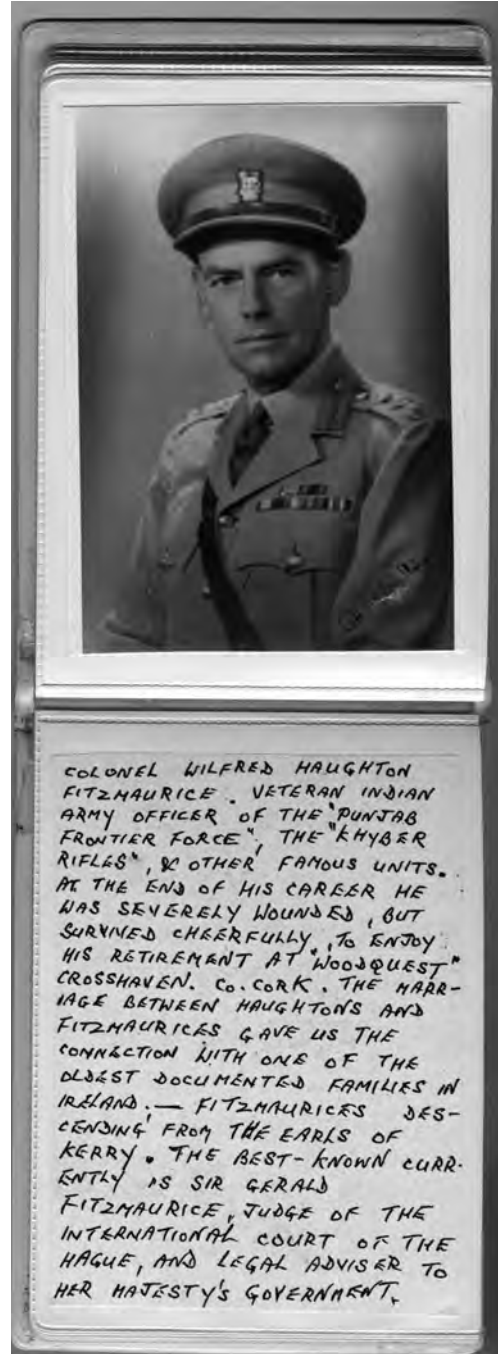
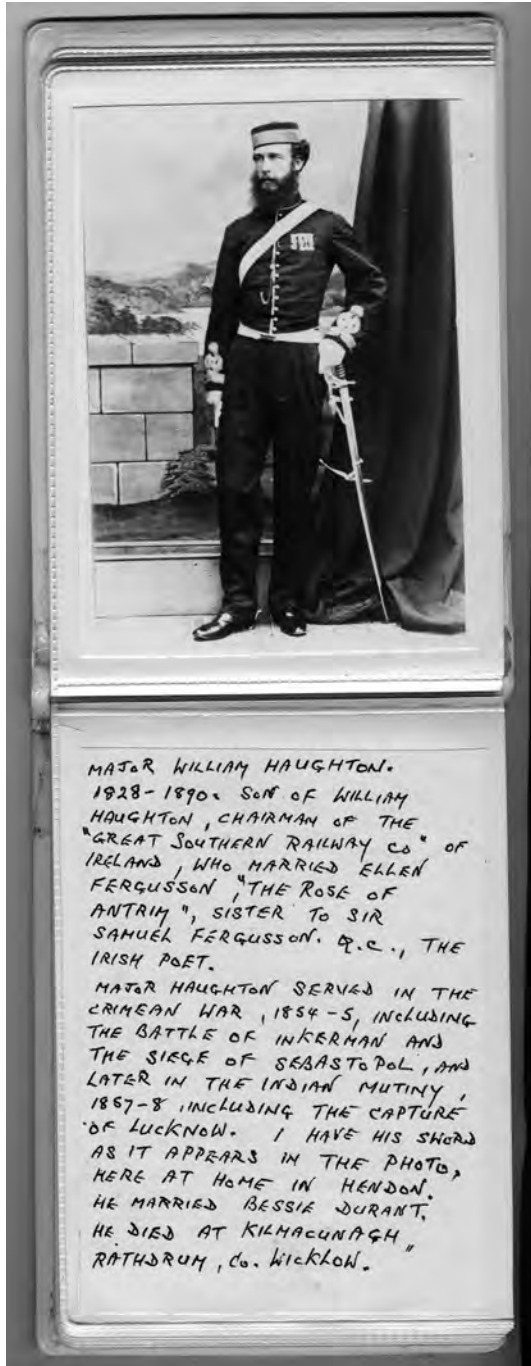

*Haughton Diaries*

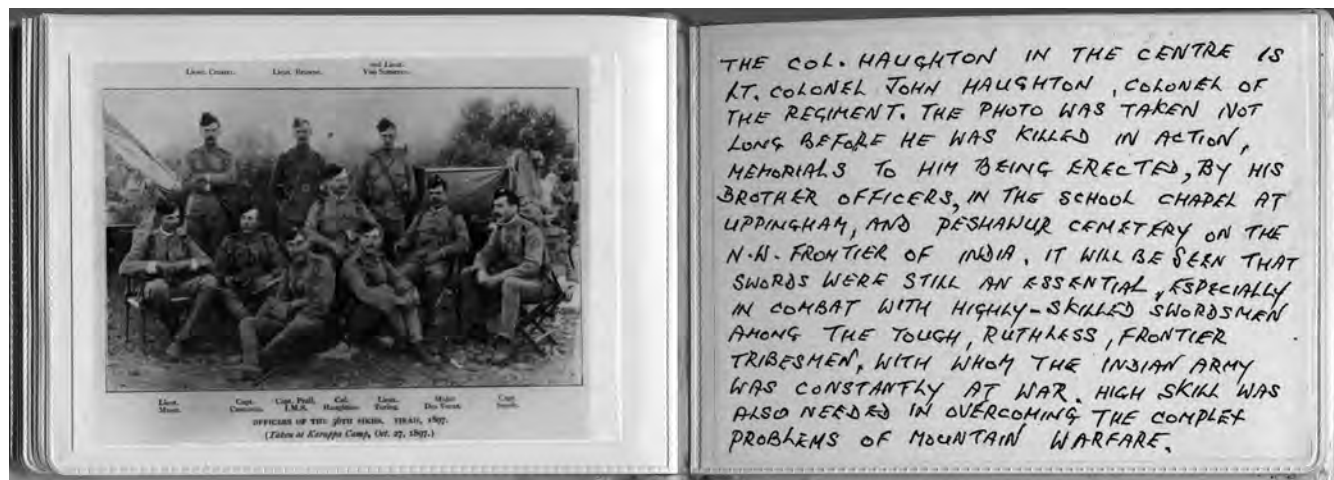



THE REMARKABLE HAUGHTONS OF CARLOW AND KILDARE

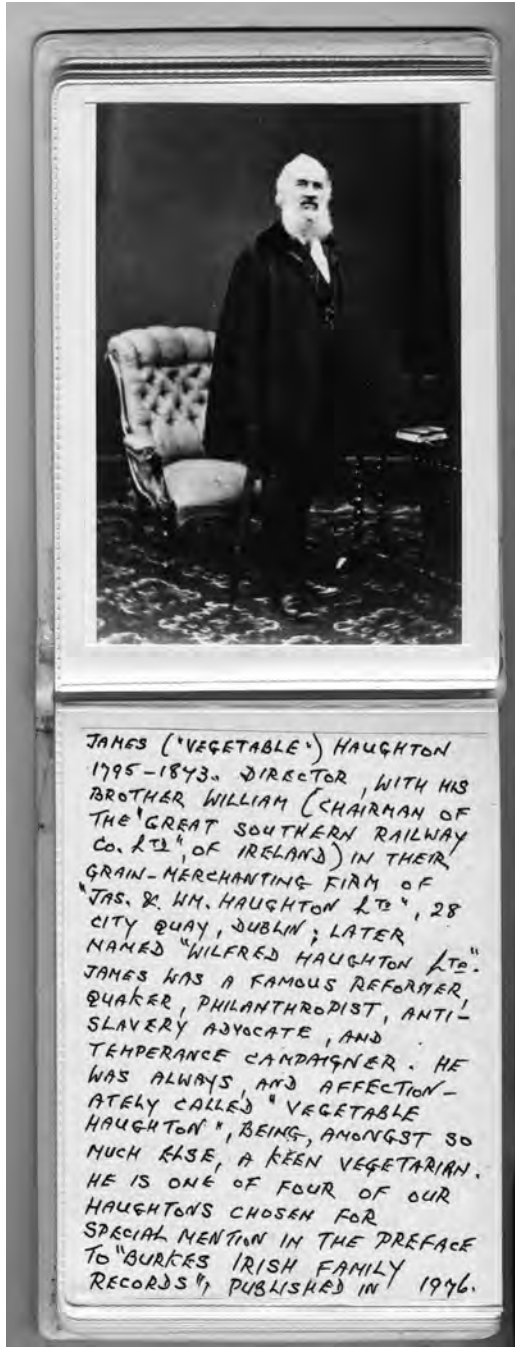

*Haughton Diaries*

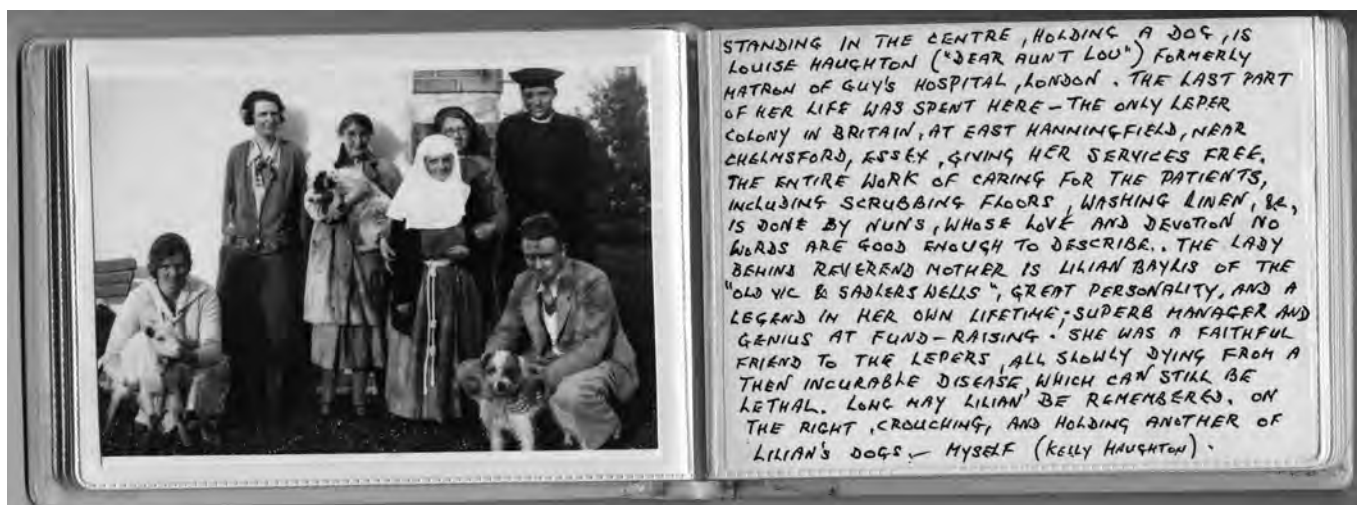
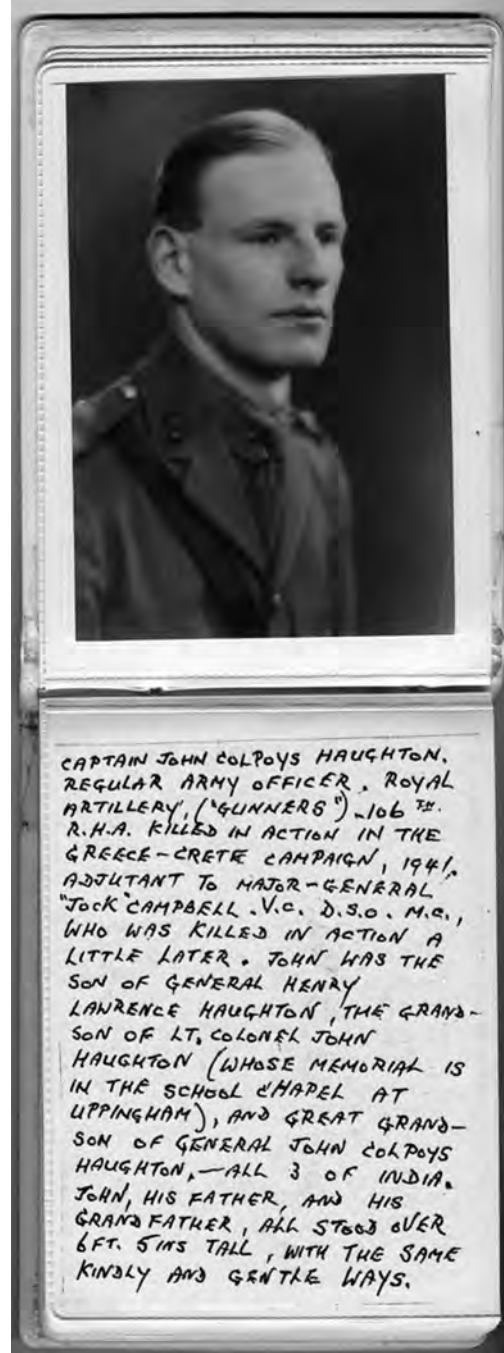



THE REMARKABLE HAUGHTONS OF CARLOW AND KILDARE

*Haughton Diaries*

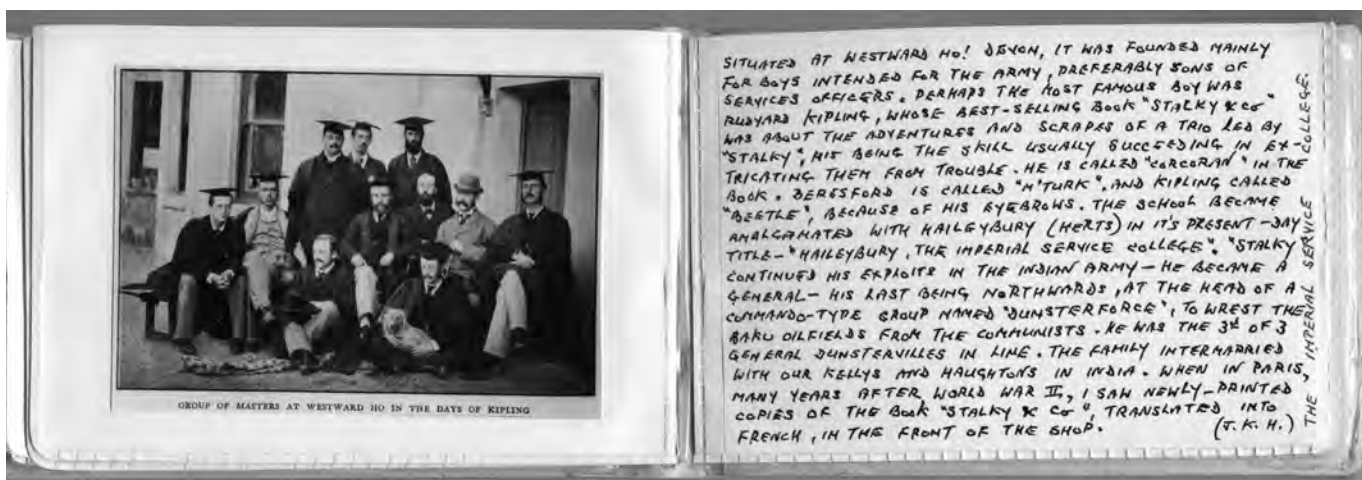
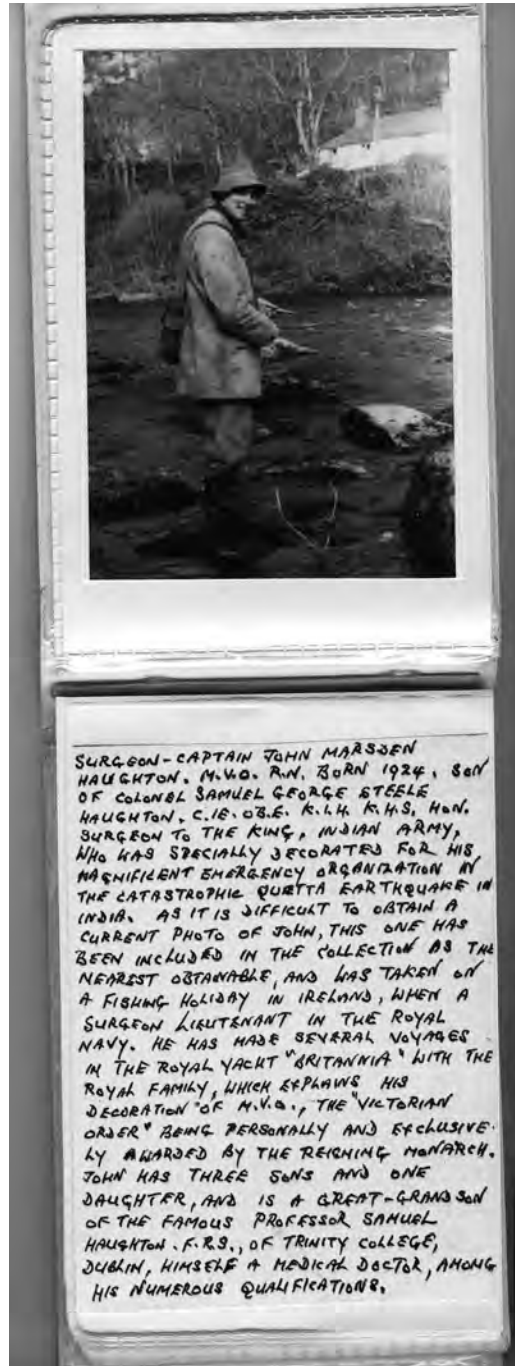
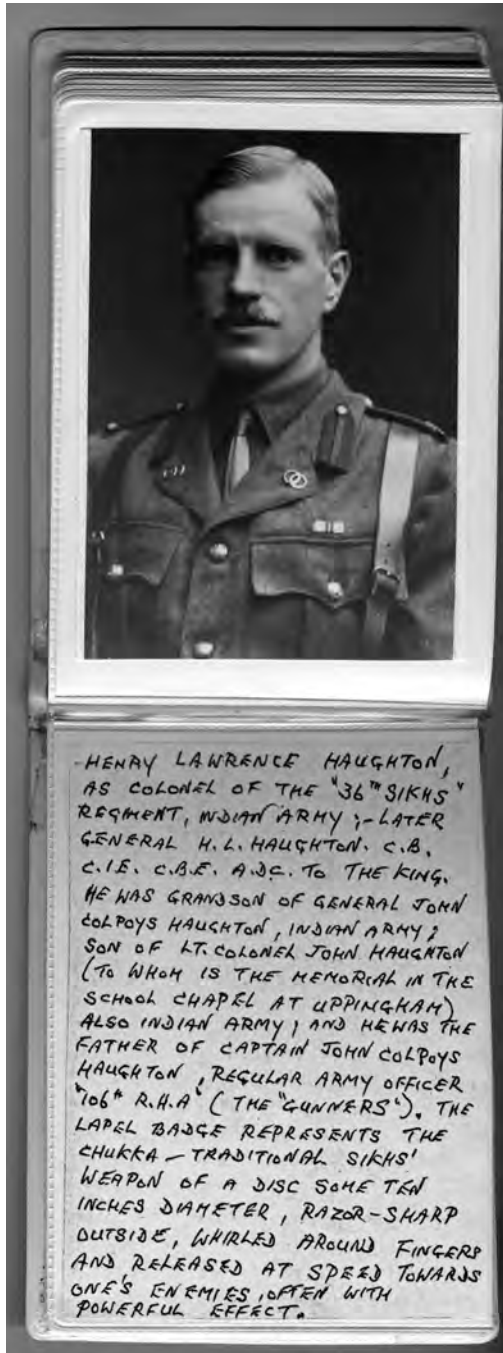



THE REMARKABLE HAUGHTONS OF CARLOW AND KILDARE



DOCTOR JOHN NELBY HAUGHTON ("NELBY")  
1866-1955. IN CONTINUAL PRACTICE IN  
FALMOUTH, CORNWALL TILL 1939, WHEN, AT  
THE AGE OF 73 HE JOINED THE MERCHANT  
NAVY AS SHIP'S SURGEON, BEING FAR TOO  
OLD FOR ACCEPTANCE BY THE ROYAL NAVY.  
SAILED THROUGHOUT THE WAR ON MERCHANT  
SHIPS, DEEPLY INVOLVED IN THEIR BATTERED  
EXISTANCE OF TORPEDOES, MINES, BOMBS,  
AND SAVAGE DESTRUCTION BY GERMAN  
BATTLESHIPS AS SITTING DUCKS. NO  
ROUTE WAS IN ANY SENSE FREE OF ALL  
THESE MENACES. WITH NELBY IS HIS WIFE  
FLORENCE MAUD AUDREY, DAUGHTER OF  
LT. COLONEL HERBERT SHOUBRIDGE OF THE  
INDIAN ARMY. NELBY'S FATHER, MAJOR-  
GENERAL JOHN HAUGHTON, MARRIED PENEL-  
OPE NELBY - "BURKES PEERAGE AND  
BARONETAGE", NELBY OF BENTON MANOR  
GRANTHAM, LINES. NELBY'S DAUGHTER,  
JOANNE ASTER, MARRIED THOMAS C. ANGUS,  
SON OF CAPTAIN ANGUS, MARINE SUPER-  
INTENDENT, P & O SHIPPING LINES.  
NELBY'S SON LT. COMMANDER JOHN  
WILFRED HAUGHTON. R.N.R. ("WILFRED")  
TWICE WON THE "DISTINGUISHED SERVICE  
CROSS", IN WORLD WAR II.

*Haughton Diaries*

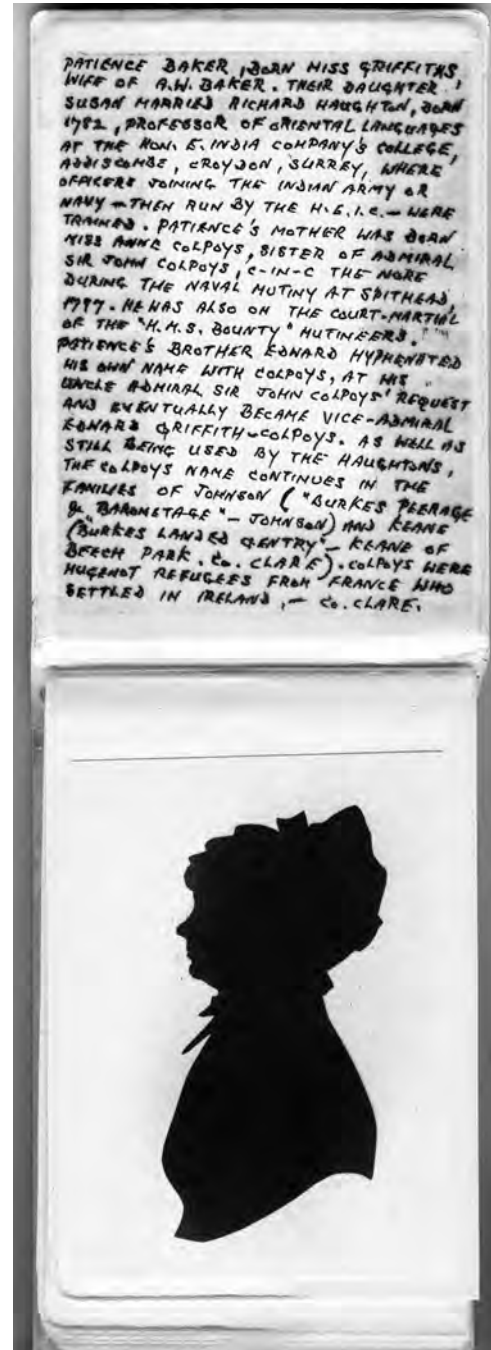

PATIENCE BAKER, JOAN MISS GRIFFITHS  
WIFE OF A.W. BAKER. THEIR DAUGHTER,  
SUSAN MARRIED RICHARD HAUGHTON, BORN  
1782, PROFESSOR OF ORIENTAL LANGUAGES  
AT THE HON. E. INDIA COMPANY'S COLLEGE,  
ADDISCOMBE, CROYDON, SURREY, WHERE  
OFFICERS JOINING THE INDIAN ARMY OR  
NAVY - THEN RUN BY THE H.E.I.C. - WERE  
TRAINED. PATIENCE'S MOTHER WAS DEAN  
MISS ANNE COLPOYS, SISTER OF ADMIRAL  
SIR JOHN COLPOYS, C-IN-C THE NAVAL  
DURING THE NAVAL MUTINY AT SPITHEAD,  
1797. HE HAS ALSO ON THE COURT-MARTIAL  
OF THE "H.M.S. BOUNTY" MUTINEERS.  
PATIENCE'S BROTHER EDWARD HYDRATED  
HIS OWN NAME WITH COLPOYS, AT HIS  
EARLY ADMIRAL SIR JOHN COLPOYS' REQUEST  
AND EVENTUALLY BECAME VICE-ADMIRAL  
EDWARD GRIFFITH-COLPOYS. AS WELL AS  
STILL BEING USED BY THE HAUGHTONS,  
THE COLPOYS NAME CONTINUES IN THE  
FAMILIES OF JOHNSON ("BURKES PEERAGE  
& BARONETAGE" - JOHNSON) AND KEANE  
("BURKES LANDED GENTRY" - KEANE OF  
BEECH PARK, Co. CLARE). COLPOYS WERE  
HUGENOT REFUGEES FROM FRANCE WHO  
SETTLED IN IRELAND, - Co. CLARE.

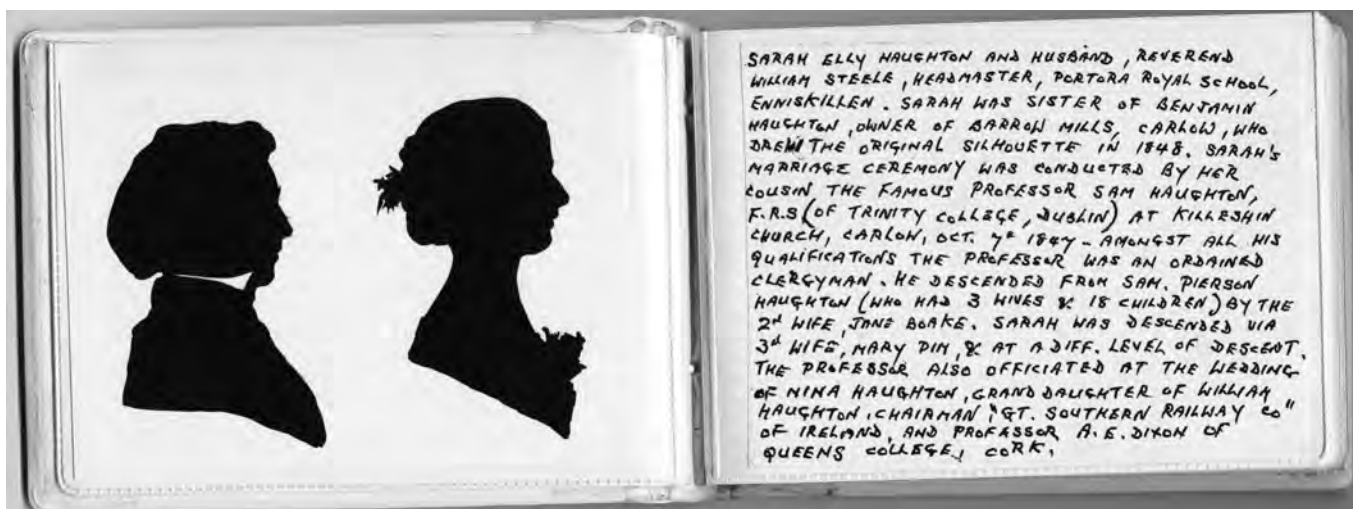

SARAH ELLY HAUGHTON AND HUSBAND, REVEREND  
WILLIAM STEELE, HEADMASTER, PORTORA ROYAL SCHOOL,  
ENNISKILLEN. SARAH WAS SISTER OF BENJAMIN  
HAUGHTON, OWNER OF BARRON MILLS, CARLOW, WHO  
DREW THE ORIGINAL SILHOUETTE IN 1848. SARAH'S  
MARRIAGE CEREMONY WAS CONDUCTED BY HER  
COUSIN THE FAMOUS PROFESSOR SAM HAUGHTON,  
F.R.S (OF TRINITY COLLEGE, DUBLIN) AT KILKESHIN  
CHURCH, CARLOW, OCT. 7<sup>th</sup> 1847. AMONGST ALL HIS  
QUALIFICATIONS THE PROFESSOR WAS AN ORDAINED  
CLERGYMAN. HE DESCENDED FROM SAM. PIERSON  
HAUGHTON (WHO HAD 3 WIVES & 15 CHILDREN) BY THE  
2<sup>nd</sup> WIFE JANE BOAKE. SARAH WAS DESCENDED VIA  
3<sup>rd</sup> WIFE, MARY DIN, & AT A DIFF. LEVEL OF DESCENT,  
THE PROFESSOR ALSO OFFICIATED AT THE WEDDING  
OF NINA HAUGHTON, GRAND DAUGHTER OF WILLIAM  
HAUGHTON, CHAIRMAN 1<sup>st</sup> GT. SOUTHERN RAILWAY Co.  
OF IRELAND, AND PROFESSOR A.E. DIXON OF  
QUEENS COLLEGE, CORK.







THE REMARKABLE HAUGHTONS OF CARLOW AND KILDARE

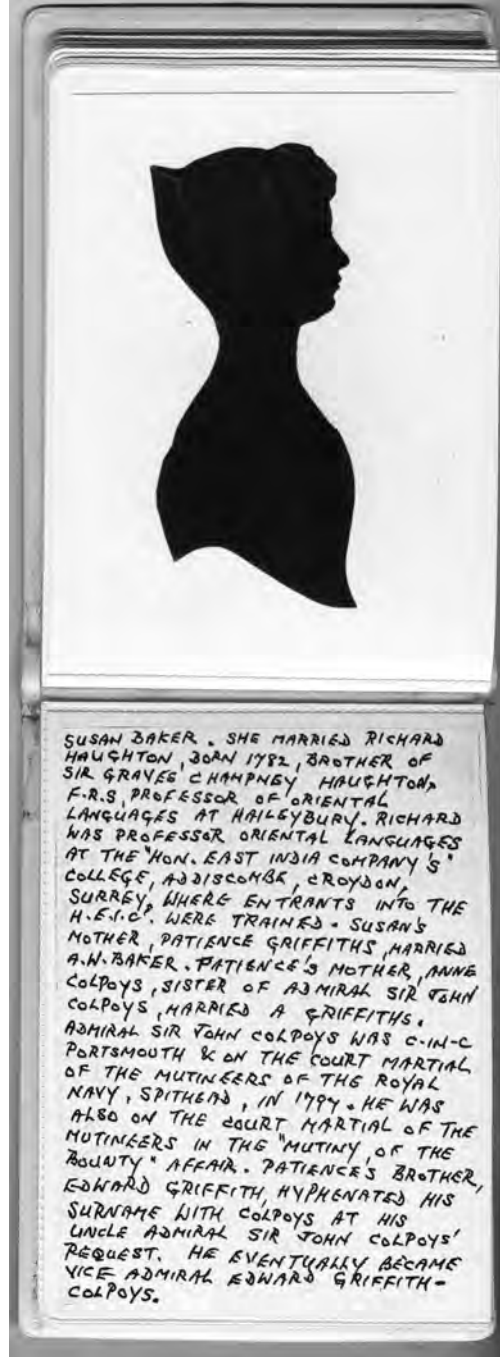
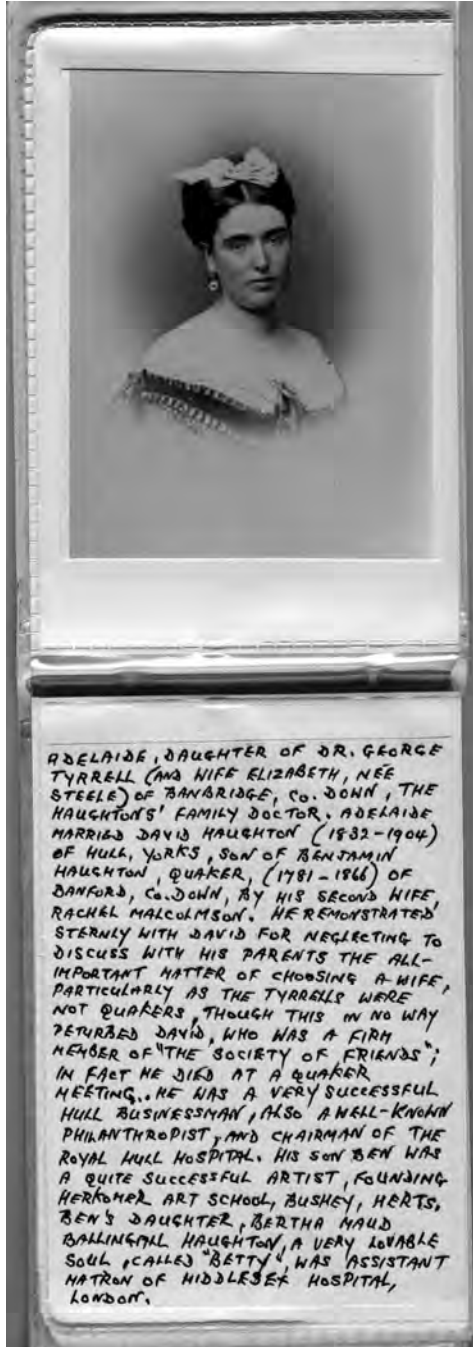

*Haughton Diaries*

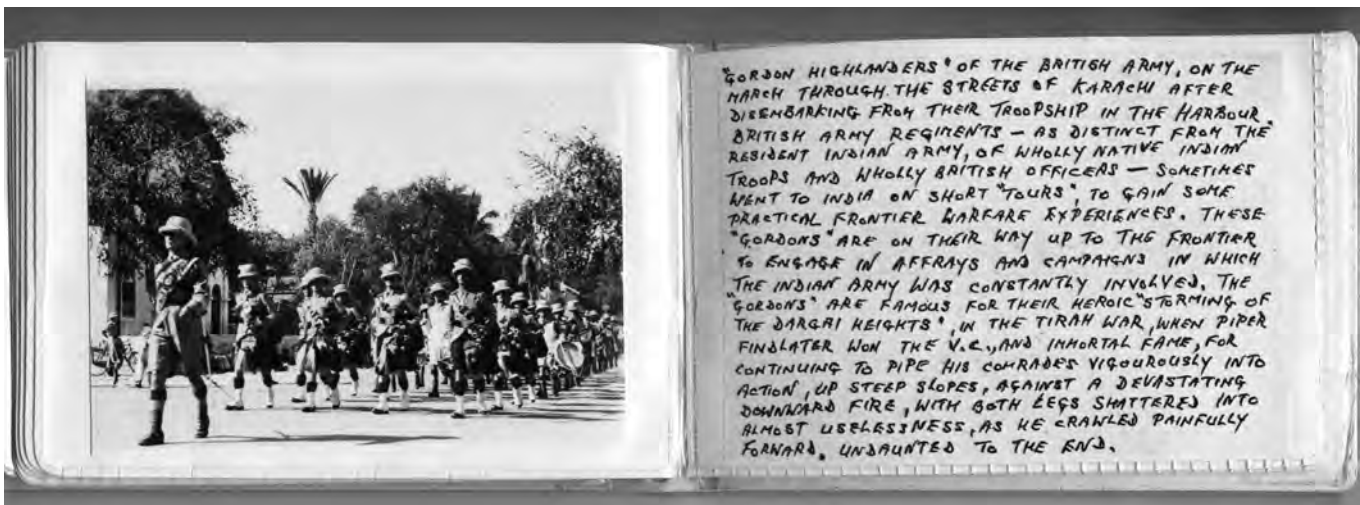



THE REMARKABLE HAUGHTONS OF CARLOW AND KILDARE

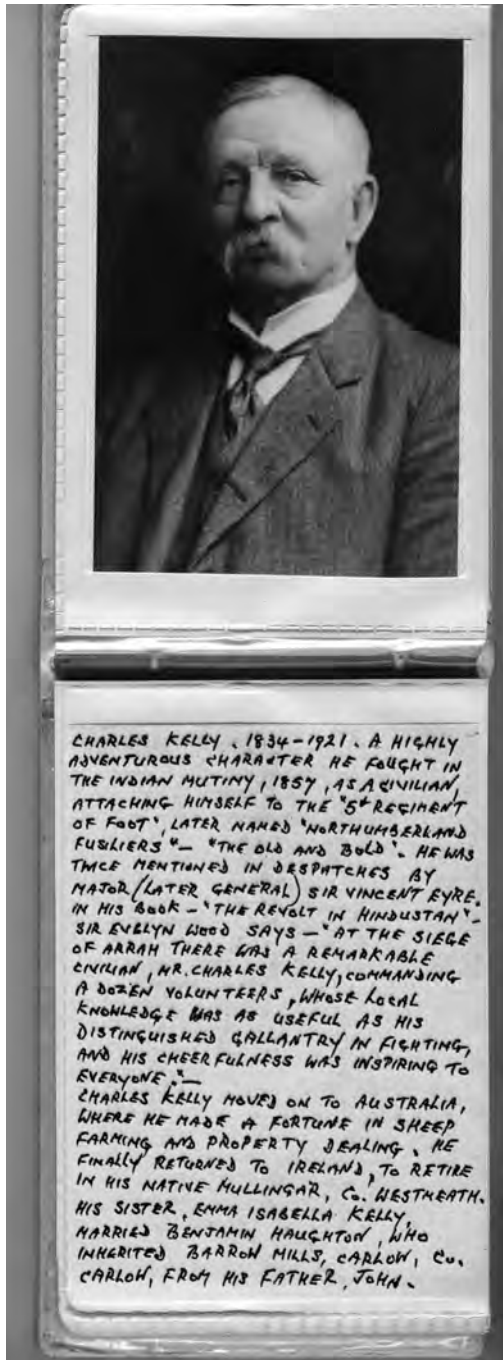

*Houghton Diaries*

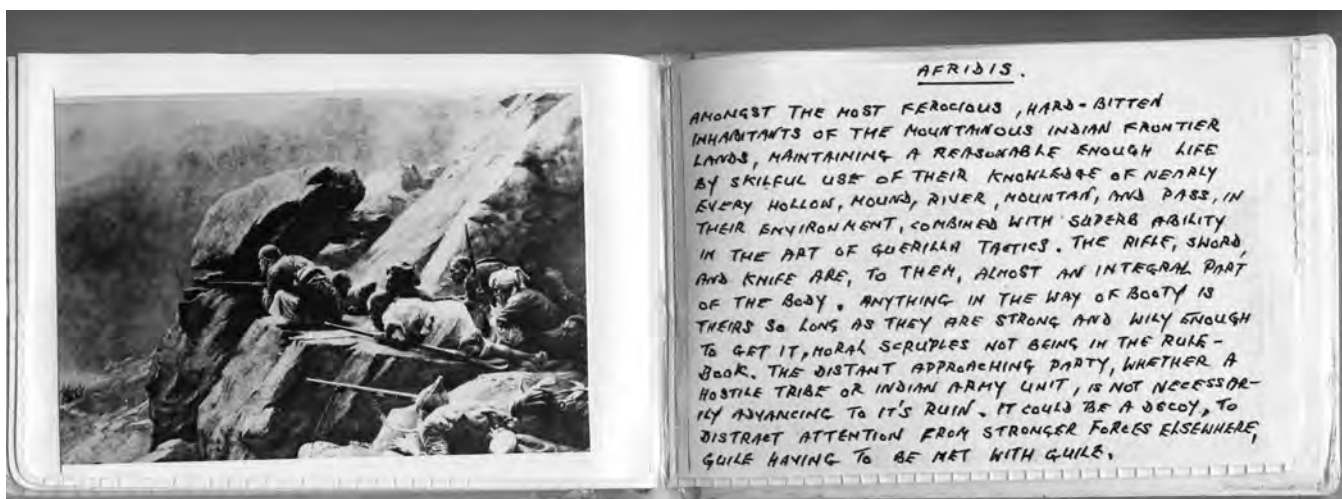

THE REMARKABLE HAUGHTONS OF CARLOW AND KILDARE

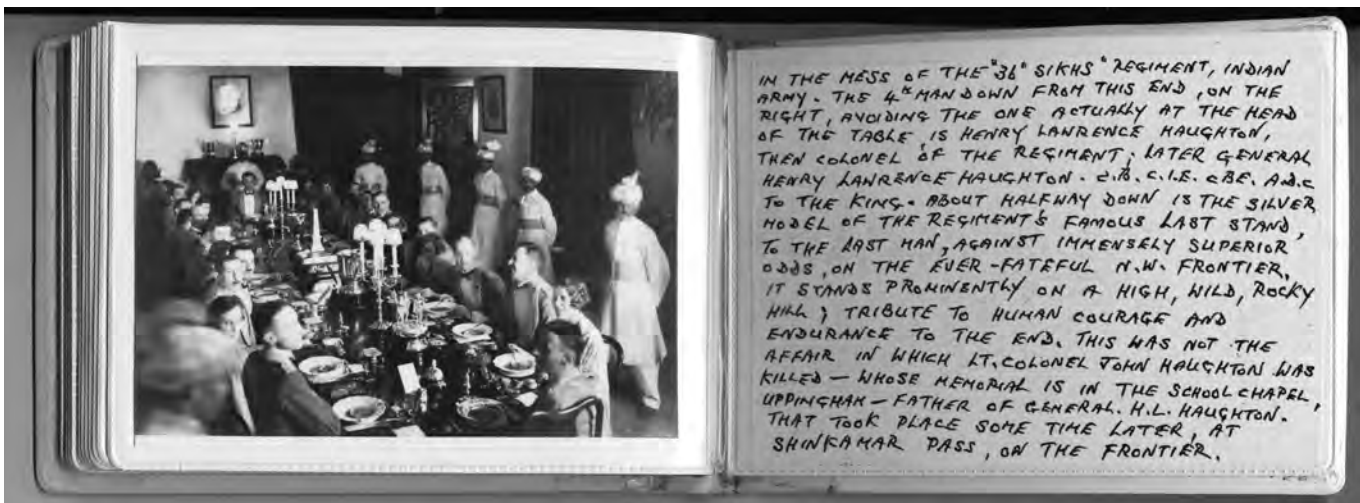
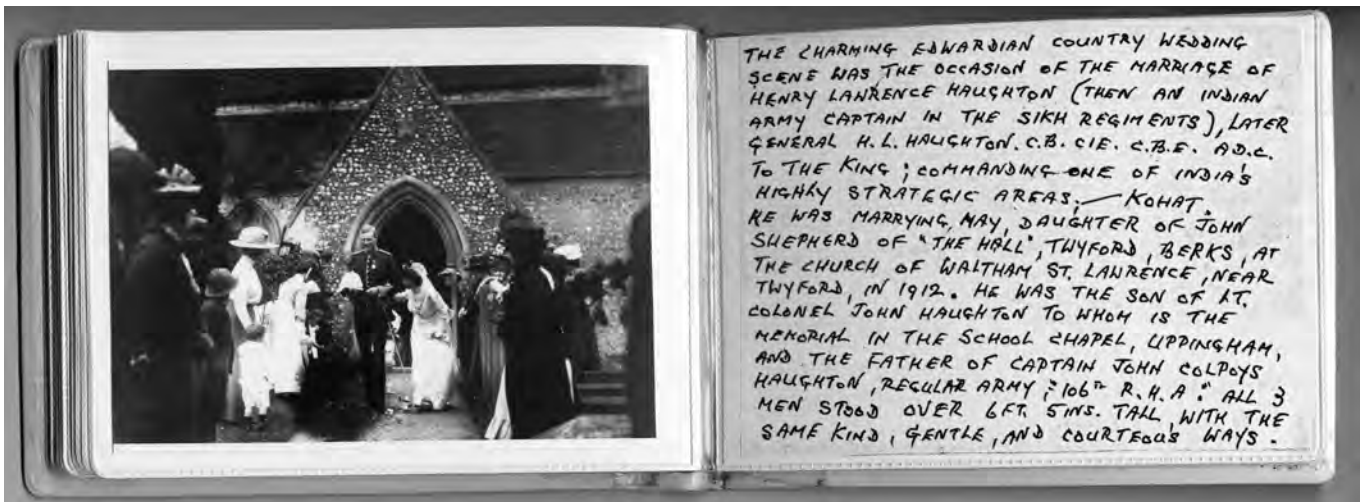
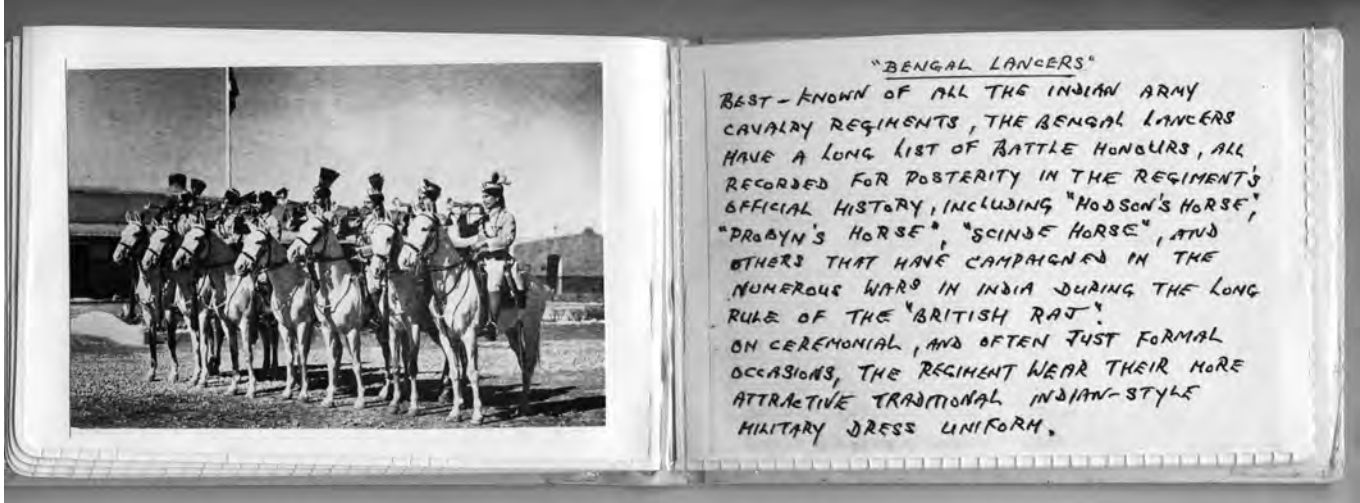



THE REMARKABLE HAUGHTONS OF CARLOW AND KILDARE

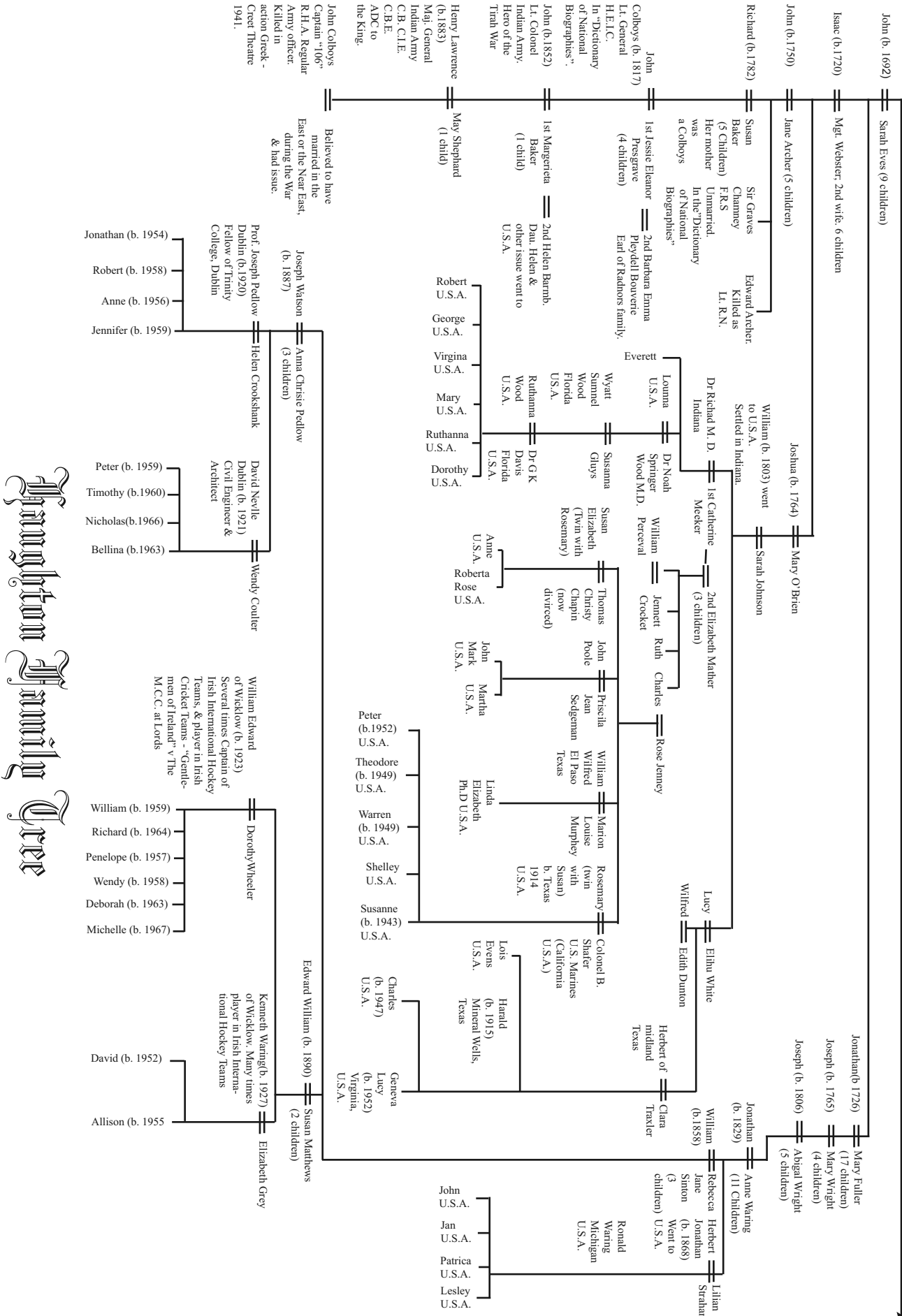

Haughton Family Tree



THE REMARKABLE HAUGHTONS OF CARLOW AND KILDARE

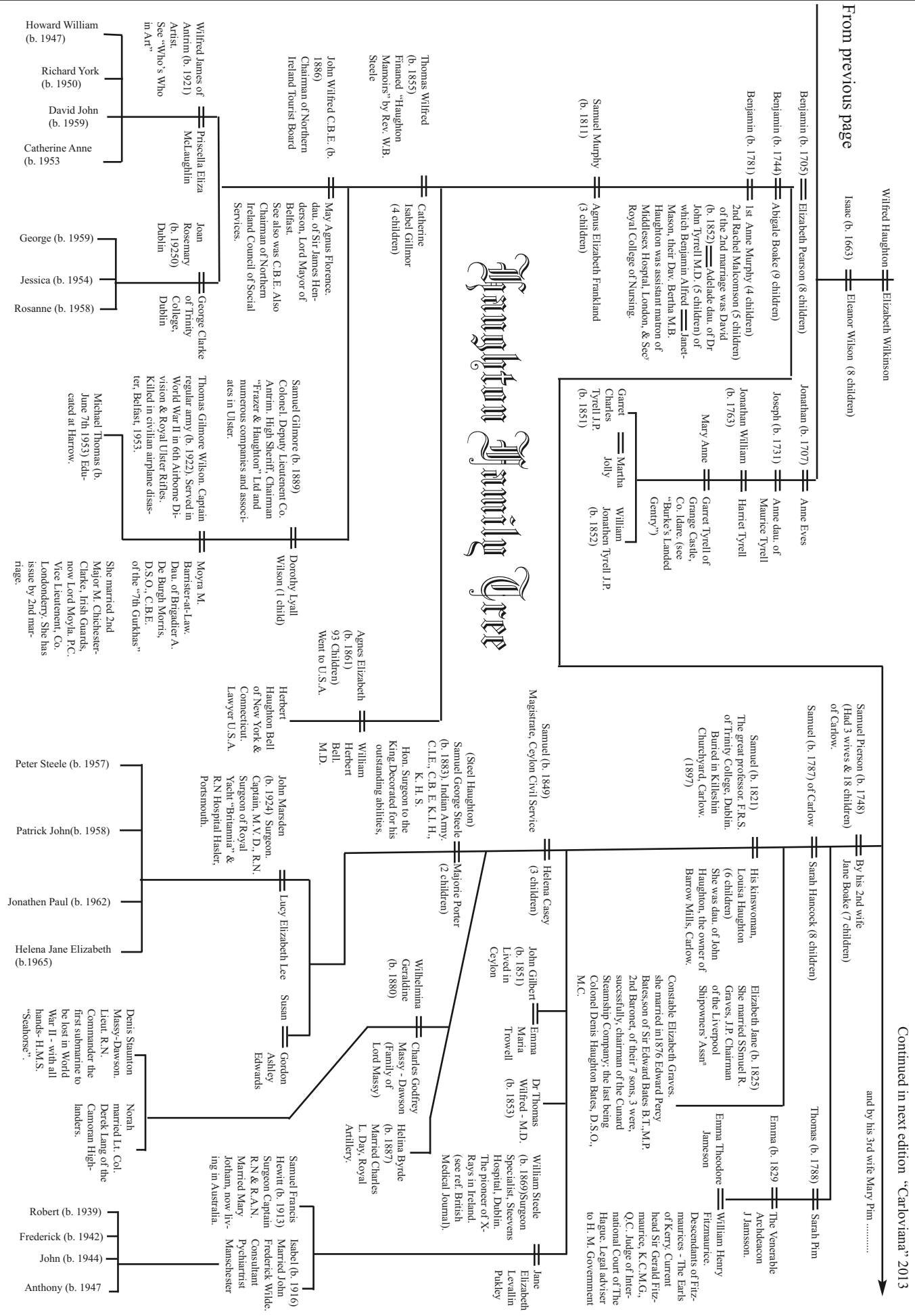

## Eagle Hill, Hacketstown - its environs and characters.

Patrick M. Byrne

In the northeast corner of County Carlow, on the southwest side of Hacketstown, stands Eagle Hill. It dominates its entire surroundings in all directions for at least 2 ½ to 3 miles from its base, including the town itself that nestles in its shadow. The hill stands on its own on what is called the Granite Belt, between Lugnaquilla and the Leinster Range. The hill's major axis runs northwest to southeast and because of its prominent peak it is easily recognised, and can be easily seen from the top of Lugnaquilla. Although not visible from the surrounding countryside, if you walk to the top of the hill you will notice three minor rocky peaks, known as the "Three Sisters," and on the most south-easterly of these there is a rock into which has been carved a bird bath, with the name "Doyle" chiselled around its edge. James Doyle, the last of the old stonecutters from Hacketstown, who died in the mid 1950s, did this.

According to local oral tradition there was to be found around the hill in the 1850s a shop that sold mostly snuff, tobacco, and very strong locally made poitín. There was also a bakery and 8 to 10 small thatched cabins, as well as a row of houses in Cronaskeagh called "Beggars' Row" which was said to be a very unsafe area to pass through at night. The most infamous area around the hill was at Eagle Hill House near Bully's corner, which is still standing. Into this house in 1830 came Dr. Barker and his brother to set up a doctor's surgery, and between 1830 and 1860 they carried out hundreds of abortions using the crude methods and implements of the time, and so the house became known as the "Abortion House." The older generation always said it was haunted by the ghosts of women who died there. Old men and women who walked those roads late at night would tell stories of how on certain nights of the year you could hear the ghostly sounds of women sobbing and crying pitifully around the house.

What were considered to be the most important houses around the base of the hill in those days were known as the principal seats of the local gentlemen. They were Woodside House, the residence of S. Jones, Esq., Ballykillane House, the residence of J. Brownrigg, Esq., and Ballasallagh House, the residence of J. Hosier, Esq., Capt.

In 1837 there were 16 families occupying houses and small farms in the townland of Eagle Hill and their names were as follows: - Sheppard Jones, Charles Kavanagh, John Kealy, John Kearney, John Kennedy, Matthew King, Thomas Lambe, John Leonard, James Reilly, John Reilly, Thomas Reilly, Margaret Ryan, Revd. Wm. Scott, Michael Ward and of course the infamous Barker brothers.

To the above named John Reilly and his wife Mary Whelan on the 23<sup>rd</sup> September 1841 was born a son and he was given the name Gerald. In later life he would become a very important person. Gerald Reilly spent his formative years in Hacketstown attending the new school in the Chapel-yard, (now St. John's day care Centre) and working on his parents' small farm on Eagle Hill. Later on as a young man he left home and went to work in Dublin, where he got married and raised a family and also became very interested in politics. In 1908 he became the first County Carlow man to be elected Lord Mayor of Dublin. The following is an extract taken from a paper at the time of his election: -

Dublin's Carlow Mayor  
29<sup>th</sup> August 1908

"For the first time in the history of the Dublin Corporation a Co. Carlow man has been elected to the position of Lord Mayor of Dublin. "True we have had members of Parliament for Carlow who occupied that high position," says the Carlow Nationalist, "but they were not Carlow men, viz. E.D. Gray and Charles Dawson." The new Lord Mayor is Gerald O'Reilly who hails from Eagle Hill in Hacketstown, Co. Carlow, though he was claimed by one of his ardent supporters

at his recent election as being a Co. Wicklow man and very nearly a chieftain of the O'Reilly clan. But no, the Lord Mayor is proud of the fact that he is a Carlow man from Eagle Hill in Hacketstown and has no claim on Wicklow further than that he was born within a few miles of its border."

Gerald O'Reilly enjoyed his term in office and was very well liked by the people of Dublin. He lived six years after his time as Lord Mayor and he passed away peacefully at his residence, Riversdale, Stillorgan, Co. Dublin on 19<sup>th</sup> March 1915. Gerald O'Reilly, "the Man from Eagle Hill," is buried in Glasnevin Cemetery in plot no. 499.

There was a baby born in Rathnafishogue in 1868 who in later life would go on to become world famous under an assumed name, and the following is a compilation of two articles that were printed in "Ireland's Own" many years ago and written by a man called Leo Bowes in answer to questions about this man, Little Johnny Connors, who was professional Flyweight Boxing Champion of the World from 1894 to 1900. His real name was Johnny Kennedy. He was born in Rathnafishogue, Hacketstown, Co. Carlow in 1868. His father, Martin Kennedy, lived in Rathnafishogue about 1 1/2 miles from Hacketstown, and he married a girl named Annie Kelly from Eagle Hill. They had ten children in the family and six of them were born in Rathnafishogue, including Johnny. While Johnny was still only going to school the family were evicted from their little farm and Martin Kennedy went on his own to America to look for work. He later sent for his wife and children. The family left the area and went via Hacketstown, Carnew and Bunclody to the ship at New Ross. When Johnny reached the age of seventeen in America he ran away from home to take up a hotel job in Missouri. When he was in St. Louis he had studied boxing and self-defence and it often proved beneficial in his job when dealing with unruly customers.



Bare-knuckle fighting was forbidden in those days but contests took place regularly at chosen venues. This was partly why the Irish youth changed his name from Kennedy to Connors, and partly because he did not want his parents to know of his whereabouts in case they would bring him back home. When the ban on fighting was lifted in 1892 Johnny set up a large training establishment. Here some of the best boxers in the world were involved, greats like Bob Fitzsimmons, Jim Jeffries, Jack Johnson and many others. Jack Johnson went on to become the greatest heavyweight champion of all time as a result of the attention paid to him by the man from Hacketstown.

In a report in the "Kansas City Journal" dated 17<sup>th</sup> March 1898 we read the following: "Johnny Connors, the Springfield Bantam, who is to meet Jimmy Barry arrived in Chicago tonight, and tomorrow a delegation of Springfield will come on to back their local celebrity. Word was received from Connors that he is six pounds under weight, tipping the scales at 104 lbs., and will enter the ring at that weight or near it. Barry's friends predict that he will make short work of the Springfield man. He is taking no chances of a surprise however, and he will be ready to put up a stiff fight."

Johnny Connors – Kennedy whose mother came from Eagle Hill lived in Springfield, Illinois, where he was known as the "Father of the City," and he passed away there one year before his hundredth birthday.

There is a story told of an incident that is supposed to have happened on the peak of Eagle Hill during the Battle of Hacketstown on 25<sup>th</sup> June 1798, and which in my opinion has, to say the least, been exaggerated. If we pick up the book "98 in Carlow" published in 1974 and turn to page 192 we will find an account of the incident, and it reads as follows: "When Kelly arrived at the Green of Hacketstown for the second time he found a group of four or five men from Rathbawn district outside a building of sod walls and thatched roof with no furniture, which did duty in those days for a Catholic Chapel. The men were watching an attack on the barracks when they noticed a redcoat riding round the moat or motty on Eagle Hill. Cullen of Corn-dog, one of the group, said as he rested his gun on the sod ditch that surrounded the chapel, "I'll leave that fellow's head

lower before he's much older." Just then at the crack of Cullen's gun the redcoat fell to the ground. He was a scout of Sergeant Nixon who with his contingent was only then approaching the town from Gould. On hearing the firing he had sent one of his cavalry to Eagle Hill to report conditions in the town. On seeing his scout fall Nixon and his party returned home, but before doing so they wreaked vengeance on poor unfortunate people by shooting them as they reaped their corn in the fields."

I will now give my reasons for claiming that this incident is highly exaggerated: Cullen would have been using a musket and muskets did not have sighting systems in place in those days.

The distance from the old chapel on the Green to the peak on Eagle Hill is approximately one mile.

At this distance and against the summer skyline Cullen could not have known if the man on horseback was a redcoat or not.

All 18<sup>th</sup> and early 19<sup>th</sup> century muskets were really only large smoothbore shotguns. The real problem with them was the poor quality of the black powder that they used to propel a large lead ball weighing one ounce through a build-up of black residue and gunge in the barrel, that after a very short time clogged up the touch-hole and coated the lock with a sticky black slime. To cope with this the lead ball was made between 4 and 6 hundredths of an inch smaller than the bore size, which was .75 calibre and so the ball was on average .71 in calibre. When the musket was fired the undersized ball skidded and bounced up the barrel and proceeded in a direction determined by its last contact with the musket's bore. Modern day tests have proven that beyond sixty yards the ball would lose its ability to hit a man-sized target and its range was approximately 250 yards. From this we can safely say that from a mile away on the Green you might as well try to shoot the moon as try to shoot a redcoat off his horse on Eagle Hill using a smoothbore musket.

Hacketstown itself sits at the very base of Eagle Hill and part of Mof-fett Street and Slate Row are in the townland of Eagle Hill North. From "Pigott's Provincial Directory" we get some idea of what the town was like and who the clergy, gentry, tradesmen and shopkeepers were in

the year 1824. It tells us that the population was exactly 1000 people. There was a post office and the postmaster was Mr. Boyd. The mail was conveyed by horse to Baltinglass on Sundays, Wednesdays and Fridays at 2 p.m. and returned on the same days at 40 minutes past 8 p.m. The post office was open from seven till eleven.

The gentry mentioned were John Brownrigg Esq., Thomas Furlong Esq., James Hosier Esq., Wm. Vanston Esq., and Edward Westby Esq. The clergy were Rev. Patrick Dolan P.P., Rev. Thomas Dooley, Rev. Dawson, and Rev. James Poe. Next in line come the shopkeepers and tradesmen: - Philip Boe, Tailor; Edward Boyd, Post Office and Innkeeper; John Brady, Apothecary; Matthew Broham, Baker; James Condel, Grocer; Pat Doyle, Publican and Baker; Ed. Furlong, Apothecary; Thos. Furlong, Tobacco Manufacturer and Grocer; Peter Jackson, Grocer; Francis Jones, Cloth Dealer; Thos. Kelly, Publican; Thos. Lambe, Shoemaker; Wm. Lambe, Leather Cutter; Lawrence Neil, Publican; Wm. Nicholson, Leather Cutter; Thomas Noblet, Hotel Keeper and Grocer; Sam Norton, Grocer; Michael Reilly, Tailor; Robert Stewart, Shoemaker; Wm. Strahan, Carpenter; Thos. Toole, Publican and John White, Tanner.

A few years later there was a topographical survey undertaken and completed by Lieutenant J.N. Rimington of the Royal Engineers and his team of surveyors, who were mapping and describing the parish of Hacketstown. Part of his report states that "There is a penny post to Baltinglass, and there is a dispensary in the town, which is open on Mondays, Wednesdays and Fridays from 10 to 11 a.m. Hacketstown now has a police station. A Loan Fund has been established, which grants loans not greater than £10 nor less than £1 at 6% interest. The market day in town is Thursday."

Lieutenant Rimington also discovered three corn mills all within two miles of Eagle Hill. In Sketch Map 13, which describes the townland of Ballasalla Lower we find this entry, "In the east of this townland there is

## EAGLE HILL, HACKETSTOWN, ITS ENVIRONS AND CHARACTERS

a small thatched mill for grinding oats, with overshot wheel ten feet in diameter and twenty inches broad. It has water for eight to nine months of the year, and is capable of grinding two to two and a half tons in twenty-four hours. It is occasionally employed by the farmers of the vicinity and sometimes by the owner. The mill and kiln are under the one roof. This mill is located on Ballasalla Brook close to the road between Ballasalla and Rathbawn”

Sketch Map 21 deals with Rathnafishogue and gives the surveyor’s description:

“It is nearly all cultivated, with a small portion of bog on the eastern side. The surface is hilly. It is pretty well cut up with roads. The River Derreen bounds the townland on the western side. In the southwestern portion, on a small stream flowing from the bog, is an old thatched mill for grinding oats, with overshot wheel eleven feet in diameter and twenty-two inches broad. The mill and kiln are out of repair, and have been out of use for the past ten years.”

We now move on to Sketch Map 37, which gives details of mill no.3:

“In the Borough townland there is an area called Mill Park, so called from the mill therein. Mr. Thomas Hobson is the owner of the mill, which grinds oats. The kiln and mill are thatched. There is an overshot wheel two feet ten inches broad, with a diameter of eleven feet. In all seasons it is well supplied with water, and is capable of grinding two tons in twenty-four hours. It is partly employed by the country people and partly by the owner. The produce of the owner is sold at the mill and in its vicinity.”

When Eagle Hill Quarry was in full production in the late 1800s and early 1900s it supplied stone for the making and repair of roads and laneways all around this area of Co. Carlow and beyond. To get this stone out of the quarry they built a small road, which is still in existence as a lane opposite the G.A.A. pitch. There was no machinery at all used in the early days, so all the stones were worked by hand, using lump hammers, sledges, crowbars and



Eagle Hill

chisels, and, needless to say, health and safety regulations were non-existent, so injuries to the eyes and face were a regular occurrence. This work on the quarry face was done by men known in this locality as “stone splitters”, who worked in groups or gangs of four or five men. Each man was expected to provide his own tools, and these would include chisel-edged iron jumpers, sledgehammers, bars and shovels. Each gang was assigned its own section of rock face and the gang was responsible for the excavation of the rock, for breaking it and gathering the broken rock in piles, ready for removal from the quarry. This was back-breaking and dangerous work, apart from the fact that the jagged edges of the freshly broken quartz rock were often razor sharp and could inflict a serious injury. My own grandfather, James Byrne, who worked there for a while, used to say, “the stones in the quarry on that hill would split you like a doctor’s lancet.” The broken stone was drawn away in four-wheeled wagons, using two horses to draw a ton, which was measured out by the cubic yard in a large steel-mesh cage. Working hours in the quarry were from 8 in the morning until 4.30 in the evening during the winter months, and 8 a.m. until 6 p.m. during the spring and summer for no extra pay. Men employed in the quarry would be working under constant scrutiny, and would be willing

to do anything the boss or foreman wanted. Life for most workers in those days and especially for quarrymen was filled with extremely hard and strenuous work that didn’t offer any future, and only barely kept food on the table, and they would be stuck in the same job for the rest of their lives. These men worked outdoors in all seasons and conditions, exposed to rain, hail, heat and frost for six days a week, and if they complained they would be told in no uncertain terms that they were lucky to have a good job. An old rhyme about the quarry went like this:

“On Eagle Hill the days were tall,  
(long)

The work was hard,  
And the pay was small.”

Up until the late 1950s most farmers around Eagle Hill would have kept a horse or two to work the farm, as tractors in those days were quite uncommon, so to keep the horses strong and healthy during the winter months they were fed on oats. It was also given to turkeys and hens, so most farmers in the area sowed a field or two of good quality oats, which in time was harvested and tied in sheaves, stoked and then stacked and left in the field for a short period to dry before being drawn into the haggard to be threshed about the middle of October.

Many of the entrances and lanes to the farms and fields in the vicinity of Eagle Hill in the 1930s, ‘40s and ‘50s were not constructed with a



Threshing 1933

tractor and threshing mill in mind, to say nothing of steam engines, so the problem had to be sorted out on the spot. However there were always plenty of eager hands willing to help, so trees would be trimmed and low-hanging boughs cut down, and sometimes the mill would be pulled and pushed manually into its proper position. During the threshing season all the farmers and men willing to help would turn up to lend a hand on the appointed day in that area, as well as women who could cook and help out in the kitchen, looking after ten or twelve hungry men and sometimes even more, not to mention young boys off school getting up to all kinds of mischief. It was a day when the local farming community helped each other out and many of the local characters turned up to give a hand with the work in exchange for a free feed. Old men who worked at threshing would always say that it was hard work but very enjoyable as every day had the makings of a pantomime because of the various characters who followed the mill from farm to farm. Most or all of these men had nicknames because of something they said or did or because of how they looked. In the days of steam, in the '20s and '30s, you would find in the threshing haggard men like the "ould Gouger" who had his own unique method of killing rats as they ran from the stacks of oats. He had taken an old well-worn two-pronged fork to the local blacksmith, where he had the prongs straightened and shortened to a length of six inches, and he then got the blacksmith to add another prong in the middle and this new

addition was barbed. The old two-pronged hayfork had now become a fearsome looking trident. According to local oral tradition the "ould Gouger" could throw this weapon with unerring aim, pinning the rat to the ground, and it was said that on average he would kill eight out of every ten rats that made a run for it. In November every year the trident was put to work again, only this time the Gouger used it to spear spawning salmon in the Derreen River.

Next on the scene at most threshings would be "Black Billy," who was so called not because of the colour of his hair, but because of his total aversion to H<sub>2</sub>O. He was also thin and lanky and it used to be said that he would have to pass by the same spot twice to make a shadow. Billy's favourite prank at the threshings was slipping live frogs into mugs of porter, as well as into the drinking water barrel. But apart from this Billy was a good workman and would do whatever was assigned to him, and do it well.

Another man most likely to be in the haggard was "Fitz," and it could be said that he was the clown prince of the group, and he was nearly always first to stir things up, especially at the dinner table. Fitz always boasted that he could tell how good the grub would be, and how well the house was kept, by looking at the way the oats was stacked and the turf was clamped in the haggard. One day however he turned up to a threshing on a farm near Hacketstown that he had never visited before. On arrival he noticed that everything was clean and tidy and seemed to be in good shape, and so he allowed that the

dinner would be good that day. But Fitz read the signs wrong this time. What he didn't know was that the farmer here was a very tidy man, whereas his wife was the direct opposite. One o'clock came and all hands were called to dinner, which on that day consisted of potatoes, salt, mugs of buttermilk and something that started off as cabbage and ended up as a slimy green mush. Fitz had been delayed at the straw rick and was about five minutes late going in. On entering the kitchen he found no space left at the big rough table, but help was at hand, as the lady of the house arrived on the scene and put him sitting upon a half bag of bran just inside the back door. She then disappeared into a room she called the parlour, and after a few minutes banging about in there she emerged, pulling an old empty tea-chest behind her, which she placed on the floor in front of Fitz and on this she placed a cracked and chipped plate, two forks and a large mug filled with buttermilk. She told him she was sorry that there were no more knives left, but perhaps he could use his penknife to peel his spuds and cut his meat. She then went and got him some potatoes and a bowl of the mushy green cabbage and told him to make a start and that the meat would follow as soon as she had served the men at the table. Fitz was not at all happy with this situation and was about to leave when her ladyship arrived back with at least a pound of fat hairy bacon with only a thin sliver of lean at the bottom, and told him to eat heartily as threshing was hungry work. The men sitting at the table were watching this scene being played out, and they swore that Fitz's face turned the same colour as the cabbage. Fitz usually passed the first remark and got the laughter going at the table, but on this occasion his thunder was about to be stolen. The lady of the house had left the kitchen to feed the hens and Long Johnny, who was seated at the rickety table just across from Fitz, had been gazing sternly at the large blob of semi-liquefied lard posing as bacon on his plate that wobbled and quivered when anyone moved at the table. While Fitz was

## EAGLE HILL, HACKETSTOWN, ITS ENVIRONS AND CHARACTERS

still contemplating what to do, Johnny got to his feet, cleared his throat, bent down and with his face about a foot from the plate, he said in a loud voice, "Ya can stop shivering now; I'm not going to ate ya!" Clever Tim, who was seated next to Long Johnny, now decided to add his tuppenceworth to the laughter at the table, saying, "Begob, boys, a man would have to be a glutton to call for a second helping of that." At this stage Fitz had heard enough, so, not to be outdone at raising laughs, he rose to his feet behind the tea-chest, slowly removed his cap, joined his hands, and with mock solemnity he looked up to Heaven and said,

"Oh Lord so high  
Up in the sky,  
Take pity on us now,  
And give us mate,  
That we can ate,  
And take away the sow!"

The good lady, who at this point was just coming in the back door, is said to have restrained a smile.

There were two other characters who frequented the streets of Hacketstown between the years 1910 and 1935. One of them was "the Thin-skinned Man," whose first name was Miley. It seems his skin had a translucent look to it, making it appear, as the old people who knew him said, as if he hadn't a drop of blood in his body. They also said he was as sharp as a breadknife and he would cut the ground from under anyone he disliked. He was also cantankerous and very argumentative and his favourite pastime was hunting rabbits on Eagle Hill with three dogs of doubtful pedigree. As an example of what Miley was like I will relate a little story that was told about him. He was standing at the corner one night with three or four other lads when one of them said, "I am going over to the shop to get a box of matches. I'll be back in a minute." As he was walking across the street Miley shouted after him, "Ya won't get anything in there." The lad turned round and foolishly asked why not. "Because," says Miley at the top of his voice so that everyone on the street could hear, "Ya already have a bill in there that's the length of a curlew's", and with that the



Guard Smith & Wife at Tombeigh Bridge

"thin-skinned man" winked at the grinning onlookers and said, "That soon put him back in his box."

The other character in town at that time was a fellow called "Handlebars Wass," whose first name was Joe. He had acquired both nicknames because of certain expressions he constantly used when speaking, e.g. he would say, "wass that for?" or, "Wass he going to do with that?" He would then almost always finish by saying, "Begob, boys, wouldn't that be a powerful yoke if it had handlebars on it?" Joe was an easygoing sort of fellow except at weekends, when he usually had drink taken, and then he was best avoided. He wore large wire-framed glasses with lenses described as being "as thick as the bottoms of jam jars," but despite this he seemed to be able to see fairly well. In the latter days of the R.I.C. he often spent a night in the cell sobering up, and he used to say that he had a room booked in the R.I.C. Hotel in Eagle Hill Street. The police barracks was building no. 1 in Eagle Hill Lane. On the changeover from the R.I.C. to the then Civic Guards Joe fared no better, except he was treated with a little more compassion. There was Guard named Smith in Hacketstown at the time, who was stationed here circa 1929 to 1935, and instead of putting "Handlebars" in the cell he would take him home and wait while Joe's wife put him to bed. One very wet Saturday night Joe was acting the maggot as usual again the Big Guard, as he was

known, brought him home and, to try to impress upon Joe to behave himself in future, Smith took his police baton off his belt and laid it on the table in front of Joe and said to him, "If you cause me any more trouble at weekends I'll hop that baton off your head!" Joe looked down at the shiny rosewood baton for a few minutes, and then he asked if he could take it up and look more closely at it. Guard Smith, thinking he was finally getting through to Joe, agreed. Joe picked up the baton and examined it from top to bottom and all around, and then looking up at the Big Guard, Joe uttered the immortal words, "Begob Sir, wouldn't that be a powerful yoke if it had handlebars on it?" It was said that Smith had to step outside Joe's door to laugh.

Guard Smith travelled the highways and byways around Hacketstown on a motorbike with a sidecar attached and he was usually accompanied by his wife.

And so for the time being we say a fond farewell to Eagle Hill and its stories and characters, like the "Ould Gouger" who was to rats what Clint Eastwood was to bandits, and men like Joe whose pronouncement on the baton came true in the 1980s, about 45 years after his death, when police forces around the world were issued with batons with a side appendage or handlebar on them. So let us hope that when Joe arrived at the Pearly Gates and was ushered into Heaven that they presented him with a large harp with handlebars on it.

## Cultural Life in Carlow

Liam D. Bergin

For some reason of which I am not aware, and which has little justification today, Carlow was once called the Athens of Leinster.

Only the Grecian facade of the Courts of Justice give any architectural clue, and there the similarity ends.

Academically speaking, however, Carlow can justly claim, in terms of the post penal law period, the oldest ecclesiastical colleges in Ireland. The minds of some very eminent churchmen have been formed there and from St Patrick's each year a good complement of priests goes out to the ends of the earth to teach all nations.

Culturally speaking this is Carlow's greatest pride.

The town itself and the people in it hardly differ from other provincial towns. Industrial employment is high, business is good and the surrounding countryside contains many large farms and rich farmers.

It would be far from true to say that among the people is Carlow cultural pursuits are highly regarded or that there is spontaneous attraction to the finer arts.

A public meeting called to promote a cultural venture may draw 40 or 50 who by no stretch of the imagination can be described as a representative cross-section of the community. You can be certain that only the prime movers will express their views, but most of the people will prefer to say nothing. Carlow people are very self-conscious in public. They are endowed with the conservative consciousness of a business fraternity and they are mortally afraid - and reasonably so - of the criticism that may follow if they open their mouths to express their minds.

In the light of this I can look forward to plenty of adverse criticism of what I say tonight. I haven't volunteered my views,

and I have been asked to give them without frills or flattery.

You will understand me then when I say that in one sense the strongest form of art in Carlow is the art of criticism, scathing criticism that stifles spontaneity and is readily sensed by strangers coming into the town who are frequently possessed of a more uninhibited enthusiasm.

In spite of this tendency, however, Carlow is not without her social and cultural activities. Most of them are run by the same set of people, and when we examine their personnel we find that the most active movers are drawn from the town's floating population.

Several people join local cultural societies possessed of ideas, but when it comes to putting these into practice they are inclined to take a back seat and let a few more willing workers do the spade-work

The best example of this was an effort made a few years ago to establish a sound branch of the Gaelic League. The townspeople at first expressed interest. They were all for a Gaelic League, but one that did not speak Irish. There wasn't too much desire to cultivate the language. A few members bore the brunt of organisation. The co-operation was difficult, the project eventually fell through, and now any semblance of a Gaelic League has vanished. The position of the Irish language is no credit to Carlow. The night Irish class at the Technical School has only eight pupils out of a possible 50.

Four years ago the Old Carlow Society was formed to examine the social history of the district. The founders were conscious of the importance of this work. From the beginning the society has maintained a fair membership. A good percentage of the members are not Carlow people by birth. In many ways this society has adhered to its objects, but most members fight shy of contributing ac-

tively to the work. The society has failed to make its journal a financial success, though that is no cultural criterion. The first volume went well, but the succeeding two have been hard to sell in a town of 8000 people even at the price of a shilling or two.

Most of the society's papers - one is read monthly - have been written by non-natives. On the whole, the average member prefers light entertaining material and anything academic usually gets a cold reception

The Little Theatre Society, founded a few years ago, continues an activity for which Carlow people have always had a soft spot. The Society was started to promote the drama, but it has always suffered the drawback of being without a home of its own. That indeed is one of Carlow's chief needs, and it seems a pity that with some goodwill that nothing can be done to establish a social centre where all cultural activities could have a pied de terre.

The lack of a civic centre is quite apparent. We need a comfortable auditorium with adjoining rooms. Even travelling theatrical companies have to compete with hard chairs against the plush cinema seats, and Carlow posteriors are not prepared to suffer discomfort even in the best of causes.

A couple of years ago a society was established for subscription concerts. About 200 members were enlisted. Most of them had to be personally approached. The subscription was ten shillings for four concerts, and the artists included names like Charles Lynch, Isobel Baillie, Ida O'Reilly, Terry O'Connor and others. But for Radio Eireann's broadcast free the venture would have resulted in a loss. It lasted for two seasons and then had to be abandoned for lack of public support. Some of the concerts were held in the cinema and 250 was the largest attendance in a house with a capacity of six or seven hundred. And spontaneous attendance by the non-subscribing public was negligible.

Exhibitions of pictures by Irish artists have been sponsored by the education authorities from time to time and have attracted interest, especially among the



## CULTURAL LIFE IN CARLOW

younger people. There is no class of painting, design or sculpture in the town as of now and the Vocational Committee has not seen its way to renew this form of instruction, which had some popularity a few years ago. Perhaps something could be done to revive a greater interest in the subject.

I am told by older people that the taste of Carlovians has receded in the past 50 years. The cinema is in some way responsible and the great bulk of the population prefers to pay for synthetic amusement as opposed to presentations with a living cultural value.

The thrill-a-minute Western film draws an unfailing audience. Carlow filmgoers plump for action and coloured musicals, and given these conditions the fans are not particular what they see seven nights out of the week. Religious films like *Song of Bernadette* will fill the houses for a full week, and most charity concerts with a strong, comedy element are a draw. A glance at the newspaper will tell anyone that there must be money in cheap dances.

Carlow in my own generation has produced no noteworthy writers or playwrights, no outstanding musicians. I say this with all deference to those who, out of an excess of local patriotism, may claim otherwise. Judging by either national or international standards there appears no distinguished name in the realm of the arts. But Carlow finds a certain reflected glory in the fact that her Technical School building – now inadequate for the demand for this type of education – was presented to her by its former owner George Bernard Shaw.

A few years ago Shaw also made a gift to the town of the income on his other local property, provided the money would not be used to relieve the rates. Shaw intended the money to be used in any cultural cause or for general improvement. His wishes demanded a special Act of the Dáil so that the Urban Council could accept his or any other gift under the Shavian conditions. As far as I am aware nobody has yet been able to say how the money can be used.

Carlow has several choirs and singing

combinations and a small instrumental ensemble. Two of these choirs – both under the direction of Karl Seeldrayers, organist and professor of Church music, and a graduate of the Lemmens Institute of Malines – confine themselves to church music and follow closely the precepts of the papal *Motu Proprio*. They comprise the fine students' choir of St. Patrick's College and the Cathedral Choir, composed of townsmen and boys.

Last year the two combined to present a formidable sacred concert in aid of Maynooth. Sorry to say, the attendance was a poor reflection on the standard of the performance, which consisted of a fine balance of ancient and modern music.

St. Cecilia's – a new choir of men and ladies – has just been auspiciously started. In Graiguecullen parish, across the River Barrow, Mr. Murray marshalled the St. Fiach's singers into a creditable combination, but they have now become relatively inactive.

Incidentally, the term "in aid of" reminds me that a great deal of musical and dramatic endeavour is conceived in towns for this ulterior motive, and, while I don't deprecate anything done in a good cause, I think that a number of cultural endeavours are born and die in the charitable urge of the moment.

Still running, in its fifth season, is the Carlow Gramophone Society, with about eighty members and an average attendance at the fortnightly concerts of about thirty. This is a cultural society, formed for lovers of good music. It must have had a considerable effect in improving the musical appreciation of its members and at least a limited influence on musical taste.

One of the most useful and, I dare say, fruitful, advances in the town's cultural history has been the establishment of what is popularly known as The Workers' College. This extension university course in social and economic science caters for nearly thirty students. Its moving spirits are Father Prendergast, Professor of Sociology at St. Patrick's, Mr. Bernard O'Neill, CEO of the Vocational Education Scheme, and Mr. Crotty, Headmas-

ter.

The College may well create a desire for extension courses in other subjects, and the university authorities have promised their favourable reaction to any further demands for higher education. Perhaps we can hope for a more serious approach from the younger generation to the things of life that are more enduring and more valuable.

Continuation education can help train our young people to think more in terms of the finer pursuits of life. In this way they may be taught a better discretion before their semi-developed minds have to face a world of sensations in which so much cynicism abounds.

In Carlow there is evident a demand for craft education, which cannot be supplied owing to lack of premises. Can we hope that there may be more adult or adolescent education on a higher intellectual level beyond the bare limits of that effected by the primary and secondary schools? It is alarming to think that young people will continue to be satisfied to spend their leisure in useless and often demoralising amusement.

I would like to make one observation about cultural pursuits in general. Our traditional cultural life, harassed and perverted by many agents, and in no small way by the misfortunes of a history best forgotten, has withered. This applies to every Irish town I know.

Our language barely influences our lives. Intellectual and social pursuits, which should stem spontaneously from a virile Gaelic civilisation, are absent. The vacuum is filled by a surfeit of facile and shallow amusements. What can be done about it?

The home should be the fountainhead of all cultural inspiration. But when our language is ignored in our homes, even when the rising generation can speak it, it must be counted as all but dead.

Folk music, folklore and domestic cultural activities which continue to be significant – in Spain for instance – and are created even today, have become museum relics in Ireland. A cheap imported

culture (God bless the mark) spreads its superficial thralldom. From our cultural heritage only a mess of pottage remains.

In this respect Carlow is no worse than any other provincial town or city in Ireland. But something might be done.

Can we not begin to regard music and art as worthy to be taught as a subject in our schools? We are not going to advance culturally in terms of children rasping fiddles before they know what music is, or securing first-class honours in piano examinations through a proficiency achieved by soul-less and uninspiring repetition. If we continue to fool ourselves that this is music or that it tends towards musical appreciation then we can throw our hats at culture.

The present generation does not give much inspiration and displays a very limited amount of aesthetic taste. The picture of Carlow town as far as cultural pursuits go is not terribly inspiring even at its best. Only a fraction of 8,000 people take an intelligent interest in the arts. I see two proximate causes for this. People who might encourage and patronise cultural movements are too preoccupied with material matters. Then there is a spirit of criticism, which tends to frighten and in-

hibit any serious endeavour. I always feel, rightly or wrongly, that in Carlow intellectual pursuits are measured off in terms of commercial welfare. There is a marked refusal of people to take responsibility for fear others may accuse them of seeking dividends in prestige.

It is hard to imagine how cultural activities can be born or survive in face of the attitude that anyone who has the temerity to advance his opinions is making a fool of himself.

Idealism in such an atmosphere cannot be said to flourish very freely. An altruist will rapidly despair in an environment where so many – like Oscar Wilde's cynic – know the price of everything and the value of nothing. In the end every place gets the cultural life it deserves.

After the shutters go up in Carlow there is certain activity among the groups I have mentioned. One cannot say that the activity is pure culture. It is a mixture of gregariousness with a cultural condiment.

Most Carlovians, preoccupied with business during the day, are apparently satisfied to sit by the fireside after the day's work. Sport occupies the leisure hours of the most active; but for all the cinema is the great repository for boredom.

If people are intellectually minded in the town – and a good many must be – their intellectual aspirations more than likely find an outlet in the privacy of their homes. They are certainly not apparent in public.

These are the facts as I see them. The picture, as I have painted it, is not very flattering, but not conceived in any spirit of perversity. Great praise is due to many individuals in small groups in the town for the efforts they have made to provide leisure of a constructive and serious nature. The criticisms that I have made have no personal application, because criticism of the state of things is not directed at individuals, in spite of the widespread tendency to accept it as such.

I hope that those who are doing good work to promote the arts in general will continue to do so, and perhaps one day the public of Carlow will turn a more cooperative ear to their endeavours.

The arts have seldom survived in adversity and of their very nature they demand a certain amount of patronage and good will.

[Broadcast by Radio Éireann, 1950]

## The origin of Carlow's name

Dave Barron

The name of Ceatharlach is generally interpreted as 'Four Lakes'; I suggest another possibility, Catherlough, 'fortified dwelling on the lake'. 'Four lakes' would be 'ceithre loch'. Geographically there is no evidence of four lakes in the Carlow area. However, the site of Carlow Castle is a raised piece of land in the middle of what was once an expanse of marshy, wet ground through which the river Barrow rambled before it was channelled by its current banks; until very recently the whole area was prone to flooding. This piece of high ground was key to control over the shallow part of the river, which was undoubtedly used for crossing before the construction of a bridge. It is more than likely that some ancient Celtic chieftain built his wooden fortress on the site that eventually was used by the Normans to build the stone castle whose ruins now stand. William Nolan quotes from a mid 17<sup>th</sup> century source (Carlow History and Society, p. 363) about the position of the site: 'upon a rising ground neer the river of Barrow and the Burren Water doe meet the castle on the west side of the said town upon a hill where the two aforesaid rivers doe unite, being naturally very strong and might by art be made impregnable'. So, geographically, the name 'fort on the lake' is plausible.

The celtic name for a lake or watery place was and is 'loch' or 'lach'. Hence the Welsh 'lough', the Scottish 'loch', the Manx 'lough' and the Irish 'loch' all have the same meaning, 'lake' or 'lough'. The present Irish word for city, 'cathair' originally meant 'fortified place' or 'citadel'. The celtic languages all have similar words for 'fort': Manx has 'caaghyr', Welsh has 'caer' (Caernarfon) and 'cadair' for 'stronghold', French has 'Car' (Carcassonne, 'walled city').

Therefore, a case can be made both from the language and from the geography to argue that the correct meaning of Ceatharlach is more likely to be 'the fort on the lake' than to be 'the four lakes'.

## Ballyhacket, Hacketstown and the micro-history of Anglo-Norman colonists in northeast Co. Carlow

Dr. Colman Etchingham

The first aim of this article is to investigate the origin of two Co. Carlow place-names: Hacketstown, and the less well-known Ballyhacket, which is preserved in the two modern townlands of Ballyhacket Upper and Lower. These lie about four-to-five kilometres southwest of Rathvilly. About thirteen kilometres east of Ballyhacket lies Hacketstown, the origin of which place-name is uncertain. Ballyhacket, as we will see, takes its name from Haket de Ridelesford, whose family were allied with Strongbow, a leading figure in the Norman invasion of Ireland in the late 1160s and early 1170s. The Normans were military adventurers hired to re-instate Dermot MacMurrough as king of Leinster and their arrival marked the beginning of the centuries-long English presence in Ireland.

Investigating the origins of Hacketstown and Ballyhacket highlights the importance of place-names as sources for history, the second and more general purpose of this article. Place-names are really antiquities, just like buildings and other field monuments, such as castles, old houses, burial places and gravestones. Like such material antiquities, place-names are equally precious relics of our history. They are often preserved in written form, but minor place-names such as field names usually survive only in oral tradition. The vast majority of our place-names are originally Gaelic, and we use and transmit them generally without reflecting on their original meaning. When we reflect on meaning or origin, we can sometimes be misled by assumptions.

Hacketstown is a good example.

It might be assumed that the

Gaelic form on road signs, ‘Baile Haicéid’, is original and was later merely translated to English Hacketstown. This is not so, however, for the earliest documented reference in 1540 is to *Haketston in Clonemor* (Mon. Poss.). A roughly contemporary Gaelic source, the poem-book of the O’Byrne’s known as the *Leabhar Branach*, refers about 1575 to *Hagastún* (Leabhar Bran., p. 68). Here

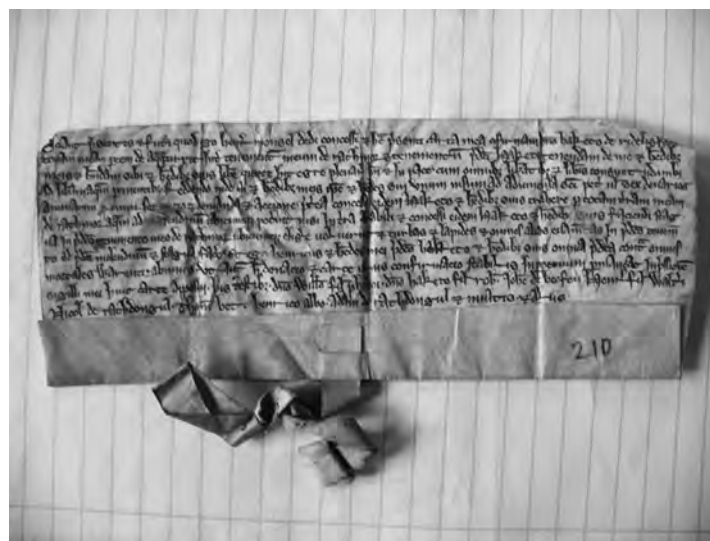

The Haket Charter (Courtesy The National Library of Ireland)

we have an originally English place-name transmitted in an Irish text, with the English name rendered in Gaelic spelling. The *-tún* reflects the pronunciation of the Middle English word *tūn* (a settlement, later a town). Hacketstown is definitely an English place-name that certainly goes back to long before the 16<sup>th</sup> century. Alongside our old Gaelic names, we should also treasure as part of our heritage old names of other origin, whether English, French or Norse. The meaning and origin of a place-name are often not as obvious as they might seem and can only be established by documenting all the recorded examples. Hacketstown and Ballyhacket are especially fascinating for, as we will see, both were originally English place-names and both also acquired Gaelic forms before the 16<sup>th</sup> century — in Hacketstown’s case, two different Gaelic forms.

This paper originated when our editor, Jim Shannon, drew my attention to an original, almost 800-year-old document, datable to about 1238, which he came across in the National Library, Dublin. The existence of this document has been noticed before in print, for example by Liam Price (*Place-names*, p. 104), and a brief summary has been published (COD I, p. 41). The full text has not been published or discussed, how-

ever. It is in Latin, so it needed to be translated, but first the script needed to be deciphered and the document transcribed. Transcribing the scribe’s handwritten text presented the bigger challenge for me, since I am not an expert in the Norman script of this period. The second task, translating the Latin, was not so difficult, since Medieval Latin is largely straightforward. Therefore, although a few minor points remain uncertain — as indicated below by gaps and question-marks — the gist of the document is quite clear. Here is my translation, reproducing the spelling of names exactly as they appear in the original:

Let all present and future know that I, Henry Monsel, gave, granted and by this my present charter confirmed to Sir Haket de Ridelisford all my portion of the water that flows between my tenement of Rathmor and the tenement of the aforesaid Haket, to be held of me and my heirs ... (?) by him and his heirs, freely, quietly, wholly, fully ... (?) and in peace, with all liberties and free customs pertaining to free water; he and his heirs rendering thence to me and my heirs a hawk at Saint Peter’s Chains [Lammas Day, 1<sup>st</sup>

August], otherwise six pence annually for every service and claim and action henceforth granted to the same Haket and his heirs to draw through all my land of Rathmor water to the mill wheresoever he shall be able, except in arable land; and I granted to the same Haket and his heirs that ponds be made in my aforesaid tenement of Rathmor wheresoever he shall wish to choose, and turfs and rocks and all other easements in the aforesaid tenement for the aforesaid mill and ponds ... (?); I Henry and my heirs will guarantee to the aforesaid Haket and his heirs all the aforesaid against all mortals, so that, therefore by ... (?) and this (?) charter confirmed, so that it remain valid in perpetuity, I affixed the impression of my seal upon this charter; these being witnesses: Sir William son of Phillip, Sir Haket son of Robert, John de Beofou, Henry son of Walter, Nicholas of Rathdongul, Thomas Bet, Henry White, Adam of Rathdongul and many others.

The document, then, concerns Sir Haket de Ridelesford, to whom one Henry Monsel makes a grant, specifically a grant of water rights: 'all my part of the water that flows between my tenement' — identified as Rathmore, 'tenement' in medieval legal jargon meaning a property holding — and that of Haket de Ridelesford. Haket is granted the 'liberties and free customs pertaining to free water', perhaps including fishing rights, all in return for an annual rent of a hawk or six pence. The grant also permits Haket to draw water for a mill through Henry's holding of Rathmore, but not through his arable land. It also permits construction of ponds and a mill in Rathmore. Rathmore is represented by the modern townland directly east of the townlands of Ballyhacket Upper and Lower.

A medieval watermill could be powered by a millstream, an artificial channel that drew water from a natural source, such as a river or lake, to a millpond, from where the water was conducted to the mill by a millrace. A less elaborate method was to channel water along an artificial canal directly to the millwheel and back into the river. The

grant in fact refers to ponds, so it seems the more elaborate method was used at Rathmore in the thirteenth century. Here the River Slaney seems the only feasible source of sufficient water for a millstream. However, the Slaney does not flow 'between' the modern townlands of Ballyhacket and Rathmore, but forms the south-eastern boundary of both. Accordingly, 'the water that flows between my tenement of Rathmor and the tenement of the aforesaid Haket' seems to be the little stream, a tributary of the Slaney, which forms the boundary between the townlands of Ballyhacket and Rathmore (see OS six-inch maps for Co. Carlow, sheet 3).

In Haket's holding, the townlands of Ballyhacket, the ground rises slightly from the Slaney, and a millstream obviously could not draw water uphill. The section of the Slaney that abuts Henry's land of Rathmore is evidently more suitable, for there the river flows quickly and the riverbank is quite low and flat. This would facilitate drawing off water in a millstream to a millpond, and there was, in fact, a corn mill still in existence at this point in the 1830s, about 200 metres inside the townland of Rathmore (OS six-inch map). Still to be seen here are substantial remains of an 18<sup>th</sup>-century mill, which was powered by a direct channel from the Slaney. Although the method of conducting water to this mill differs from that apparently used here in the thirteenth century, is this material relic a descendant of Haket de Ridelesford's mill of about 1238?

The grant of about 1238 clearly concerns Ballyhacket beside Rathmore (and not the modern village of Hacketstown), as is further suggested by the identity of two of the witnesses: Nicholas and Adam of Rathdongul. These were evidently neighbours of Haket and Henry, as Rathdongul seems to reflect Gaelic *Ráith Dúngail*, which is likely represented by the townland of Rathdaniel, east of Ballyhacket and north of Rathmore.

Henry Maunsel and Sir Haket de Ridelesford were evidently well-to-do gentry under the Norman dispensation, holding their lands as 'free tenants' in perpetuity. A watermill for grinding corn would have been a major asset for Haket's own household, but also potentially lucrative: medieval owners of a mill could charge their sub-tenants for use of

the mill. Yet only a nominal rent of a hawk or six pence was demanded of Haket by Henry. This was apparently a standard nominal rent, since a hawk or six pence also appears in an unrelated early 13<sup>th</sup>-century record I have come across where land was exchanged. We can only guess at what lies behind Henry's generosity to Haket. Henry himself had arable land, through which Haket was not allowed to have his millstream dug. Did Henry not have a mill of his own? There is no explicit suggestion that he could have use of Haket's mill, which perhaps we might expect if this was part of the deal. Presumably some corresponding benefit accrued to Henry from Haket that is not specified in the grant, but which explains its generous terms for Haket.

Let us fill in what we can of Haket de Ridelesford's background. The grant is dated around 1238, but Haket is first mentioned thirty years before in documents of 1207. These are papal and royal confirmations of a privilege granted by Haket de Ridelesford, obviously before 1207, to the nunnery of Graney, Co. Kildare, less than three kilometres northwest of Ballyhacket. The nunnery was granted the right to appoint a clergyman to the church of Kinneagh, Co. Carlow, Haket's local church (Brooks, 1951, p. 126; 1952, p. 55). This shows that Haket was an adult and controlled the Ballyhacket area before 1207, though in what capacity is unclear. Haket was clearly a younger relative, perhaps a son, of Walter de Ridelesford, the leading late twelfth-century member of a northern English family with roots in Yorkshire or Lincolnshire (Brooks, 1951, pp 115-6). Walter was a close aid of Richard Fitzgilbert de Clare, better known as Strongbow, in his expedition to Ireland in 1170 (Orpen, 1911, pp 226, 369). Walter was rewarded by Strongbow with two substantial land grants, one at Bray and the adjacent region, the other being a vast tract of land in the south of modern Co. Kildare, the southwest of modern Co. Wicklow (especially the Glen of Imaal) and the north of modern Co. Carlow. (It is a curious coincidence that the de Ridelesfords should be connected both with my place of upbringing, the Bray area, and my present place of residence in northeast Carlow).

The second of Walter's land grants from Strongbow comprised the pre-Norman Gaelic mini-kingdom or

## ANGLO-NORMAN COLONISTS IN NORTHEAST CARLOW

lordship of Uí Muiredaig (Brooks, 1951, p. 124), whose ruling family by the 12<sup>th</sup> century bore the surname Ua Túathail (O'Toole). The centre of Walter's manor in this region was at Castledermot and Kilkea, Co Kildare, the latter represented today by Kilkea Castle hotel and golf course. Here there survives a typical large Norman motte castle, an earthwork mound, possibly the castle built by the royal agent Hugh de Lacy for Walter de Ridelesford in 1181, according to the Norman chronicler of the invasion of Ireland, Gerald the Welshman, writing in the 1180s (*Expugnatio*, pp 194-5, 339-40). Walter de Ridelesford died about 1200 and was succeeded by his son, also Walter. Walter de Ridelesford II died about 1238 and various legal documents of his are witnessed by Hacket de Ridelesford, between the early 1200s and the 1230s (Brooks, 1951, pp 130-4). Was Hacket another son of Walter I and brother of Walter II, as supposed by previous writers on the de Ridelesfords (e.g. Brooks, 1951, p. 130)? If we return for a moment to the witness list of our 1238

document, however, we find these include one 'Haket son of Robert'. If this is Hacket de Ridelesford himself — and witnesses to grants could also be beneficiaries — this would suggest that Hacket was probably a nephew and obviously not a son of Walter I. In any event, it is clear that Hacket was a junior member of the family, holding Kinneagh and Ballyhacket by 1207 as a sub-tenant of Walter II, and perhaps previously of Walter I. Walter de Ridelesford II had no sons, so the main line of the family died out. The vast manor of Castledermot and Kilkea, occupying parts of three modern counties, was divided between heiresses and their husbands (Brooks, 1951, pp 137-8; 1952, p. 45).

However, de Ridelesfords still held Kinneagh and Ballyhacket throughout the Middle Ages and into the 16<sup>th</sup> century. These were clearly descendants of Hacket de Ridelesford specifically, since they used 'Hacket alias Ridelesford' as a surname. In 1545 *John Hacket alias Ridelesford* held *Hackettistown and Kyneth*, including the *mill of Hackettistown and the water called Hascket's lake* (COD IV, p. 277). This refers to the mill



*The ruins of the mill at Rathmore*

and associated waterworks provided for in Henry Maunsel's grant, three hundred years earlier. The association with the church of Kinneagh shows that this is not a reference to the modern village of Hacketstown. Rather, it shows that the modern townlands that bear the name Ballyhacket were, like the modern village, originally called 'Hacketstown' — *Hackettistown* in 1545, representing *Haket his tūn* in the Middle English of the twelfth and thirteenth-century settlers.

By the 15<sup>th</sup> and 16<sup>th</sup> centuries much of Anglo-Norman Ireland had been re-conquered by Gaelic speakers, while many settlers 'went native' and became, famously, 'more Irish than the Irish themselves'. Thus originally English place-

names were gaelicised. Ballyhacket is evidently an example: *tūn* became *baile*, but the 'Hacket' element was retained. Probably *Hackettistown* was still the official English name in 1545, co-existing with Gaelic *Baile Haicéid*, which only later was itself anglicised to give the modern English version of the townland name Ballyhacket. John Hacket, an Old English settler dwelling in 1545 in a region where the Gaelic Irish had gained much ground, almost certainly spoke Irish as well as English. The violent impact of the Gaelic resurgence in northeast Carlow is to be seen in one of the sources already mentioned. The *Leabhar Branach*, the poem book of the O'Byrnes, refers to the modern village of Hacketstown as *Hagastún*. The poem in question celebrates an extensive raiding campaign against colonial centres in Leinster by Aodh mac Sheáin Ua Broin. He was father of the better-known late sixteenth-century O'Byrne chieftain, Fiach mac Aodha (MacHugh) Ua Broin.

So much for Ballyhacket. All this leaves us none the wiser as to the origins of the name of the modern village of Hacketstown itself, lying about thirteen kilometres east of Ballyhacket. Modern

Hacketstown is certainly not within the boundaries of the lands originally granted Walter de Ridelesford, and a remnant of which was retained by the descendants of Hacket de Ridelesford until the 16<sup>th</sup> century. We must look at another major Anglo-Norman landholder in Carlow east of the River Slaney. This was Theobald Walter, ancestor of the famous later medieval colonial family, the Butlers. Theobald Walter was granted lands, in or before 1192, in the northeast of modern Co. Carlow and the southwest of modern Co. Wicklow (RBO, p. 9; Flanagan, 1981, pp 8-11). These lands, including Tullow and Clonmore, again comprised a pre-existing Gaelic lordship, this time that of the Uí Felmeda. The ruling fami-



lies of the Uí Felmeda in the 12<sup>th</sup> century, who were cousins of the Uí Cheinselaig (Kinsella) kings of pre-Norman Leinster, of whom Dermot MacMurrrough was the last, bore the surnames Mac Dalbaig (MacDalvey?) and Úa Domnaill (O'Donnell) (Flanagan, 1981). Many Butler documents supply valuable evidence for the history and place-names of Co. Carlow, for example an 'extent' or survey of Butler lands in northeast Carlow and southwest Wicklow in 1303 (RBO, pp 2-7), which sheds fascinating light on the history and place-names of the Tullow-Clonmore-Rathvilly region in the early 14<sup>th</sup> century.

The Butler 'extent' of 1303 may suggest how the Hackets alias de Ridelesfords of Ballyhacket might have been linked to Hacketstown. 'Adam Mauncel' is reported holding land in Rathmore from the Butlers (RBO, p. 5). He must be a direct or collateral descendant of Henry Maunsel, whose grant to his neighbour Hacket de Ridelesford, about 65 years earlier, was the starting point for this article. Another Butler tenant in 1303 was 'Almoricius de Beaufo' (RBO, p. 2), the location of whose substantial holding is as yet unclear to me but who, like Adam Maunsel, also 'swore' i.e. witnessed the 'extent' (RBO, p. 7). One Adam de Beaufo was another Butler tenant in 1303 (RBO, p. 7), whose holding was perhaps at Butlersgrange, now a townland about 2 kilometres north-east of Tullow and about 5 kilometres south-east of Ballyhacket. These two presumably represent later generations of the family of 'John de Beofou', who witnessed Henry Maunsel's grant to Hacket de Ridelesford about 1238. There is also an early 13<sup>th</sup>-century Butler land-grant at Tullow, located near the 'road that leads towards Rathmore', which was witnessed by 'Adam de Rathdonegill' (RBO, p. 10), who also witnessed Maunsel's grant to Hacket about 1238. It seems, then, that several of Hacket de Ridelesford's neighbours back in the early 13<sup>th</sup> century were Butler tenants, including Henry Maunsel at Rathmore. Since the Butler lordship included Clonmore, and Clonmore included Hacketstown, perhaps Hacket de Ridelesford or one of his descendants had an unrecorded interest in Hacketstown, perhaps as 13<sup>th</sup> century tenants of the Butlers.

Easily the biggest Butler tenant in 1303 was John Wogan, whose holdings

included Clonmore (which in turn included Hacketstown) (RBO, p. 2). Wogan was a major figure in the colonial elite in the late 13<sup>th</sup> and early 14<sup>th</sup> centuries, and from 1295 to 1313 was Justiciar, the office later known as Lord Deputy, Lord Lieutenant or Viceroy, that is, the English king's governor of Ireland. Between 1305 and 1317 Wogan consolidated his acquisition of the former de Ridelesford manor of Castledermot and Kilkea, partly through marrying a de Ridelesford heiress (Brooks, 1952, pp 53-5). The manor had been dispersed, it may be recalled, after Walter de Ridelesford II's death without male heir about 1238. Thus Wogan became immediate lord of the descendants of Hacket de Ridelesford, still the sub-tenants of Ballyhacket and Kinneagh, as shown by late-13<sup>th</sup>-to-early-14<sup>th</sup> century records (Brooks, 1952, pp 56-7). Perhaps in the era of Wogan the descendants of Hacket de Ridelesford also became sub-tenants of Wogan's at Hacketstown.

How Hacketstown acquired its name remains a matter of conjecture, therefore, whereas the situation is perfectly clear in the case of Ballyhacket. On the evidence that has come to light so far, it is presumed that Hacketstown too was somehow connected with the Hackets alias de Ridelesfords. The rarity of the name Hacket is asserted by previous commentators (Brooks, 1951, p. 115) and it is found among the de Ridelesfords of Ireland and also of Lincolnshire. A possible spanner in the works is a book, published in London in 1830, by one William Lynch. It is entitled *A view of the legal institutions, honorary hereditary offices, and feudal baronies, established in Ireland during the reign of Henry the Second*. Lynch asserts (p. 255) that the Hackets of Hacketstown descended from a certain Paganus Hacket, someone with no connection to the de Ridelesfords but who came to Ireland with Henry II in 1171. In Lynch's favour is the fact that, writing when he did, he had access to records later destroyed in the Civil War when the Custom House was burned in 1922. On the other hand, as one writer put it diplomatically: 'it is difficult ... to adjust his [Lynch's] account to other record evidence' (Brooks, 1952, p. 56). Less politely, we can state that Lynch is plainly wrong or confused about some matters. Yet his comments are intriguing, given the absence of any certain evidence

that would link the Hackets alias de Ridelesfords with Hacketstown.

We have seen that Ballyhacket originally bore the medieval English name *Haket his tūn*, only becoming Ballyhacket through being gaelicised at some point in the later Middle Ages. On the other hand we have seen that what has become the modern village of Hacketstown was so called both in English (*Haketston*, also derived from Middle English *Haket his tūn*) and Irish (*Hagastún*) in the 16<sup>th</sup> century. Here we see one strategy of the Gaelic Irish of the time when confronted with a purely English place-name: simply apply to it the rules of Gaelic spelling and make no attempt to translate the meaning of the name. This is the mirror image of the strategy adopted by English speaking modern Ireland towards the vast bulk of our inherited Gaelic place-names: simply apply English spelling rules and make no attempt to translate the meaning. Thus, for example, Clúain Mór ('Big Meadow') becomes simply Clonmore.

However, we also see another strategy adopted by Gaelic speakers in northeast Carlow in or before the 16<sup>th</sup> century, which produced an alternative name for *Haketston / Hagastún* (to denote our modern village of Hacketstown). The evidence is in another English-language 16<sup>th</sup> century document, from the Butler records known as the Ormond Deeds. In 1575 the Earl of Ormond granted the manor of 'Clonmore' to Hugh Geankagh of 'Portrushin' (modern townlands of Portrushen Upper and Lower along the Kiltegan road) (COD V, p. 261). The record includes mention of several places identifiable with modern townlands in the vicinity of Hacketstown, as well as 'Ballyhacket', where this clearly denotes Hacketstown, and not Ballyhacket thirteen kilometres west by the bank of the Slaney. It seems the Gaelic Irish of the 16<sup>th</sup> century knew the originally English-named place Hacketstown (that is our modern village) by two names: either in Irish translation as *Baile Haicéid* (the existence of which is indicated by the English 'Ballyhacket' in the Ormond Deeds), or by rendering the English name phonetically as *Hagastún*. Faced with the fascinating light that place-name evidence sheds on cultural interaction between Irish and English in northeast Carlow in the Middle Ages, we might well ask, what's in a name?

## ANGLO-NORMAN COLONISTS IN NORTHEAST CARLOW

**Conclusion: a place-names project for County Carlow?**

I would like to conclude with a more general thought. Place-name studies are comparatively underdeveloped in the Republic of Ireland. A county-by-county data-base and analysis is needed. This is work not currently being undertaken (or likely to be undertaken) by universities or the Ordnance Survey Place-names Office, which are pre-occupied by other worthwhile projects. Like so much else in this country, we have an opportunity to do it for ourselves. The only county in the Republic that has a published data-base and analysis of the kind I have in mind is Wicklow. This was the result of the private scholarship of the late District Justice Liam Price, who did the work in his spare time between the 1940s and 1960s. What is required is the scholarly study of documents, combined with fieldwork that could be undertaken by local people, to recover minor names (like field names) that only survive in oral tradition. I have heard rumours of a field-name collection project in Co. Louth, and last year RTE's Damian O'Reilly reported that the Meath Society and the IFA were collaborating on a field-name collection project. The Carlow Society might be interested in playing a role in such a project, perhaps in collaboration with such organisations as the IFA, Macra and local schools. The completion of such a project is very

achievable in a compact county such as ours, which contains only seven baronies. By way of comparison, I have recently supervised a PhD thesis on the place-names of two Co. Meath baronies, which was successfully completed within a few years by the student concerned. I would be willing to play a part in such a project in Carlow, should there be wider interest.

## References

- Brooks, 1951, 1952 Eric St. John  
Brooks, 'The de Ridelesfords', *Journal of the Royal Society of Antiquaries of Ireland* 81 (1951), pp 115-138; 82 (1952), pp 45-61.
- COD I Calendar of Ormond Deeds I, ed. Edmund Curtis (Dublin, 1932).
- COD IV Calendar of Ormond Deeds IV, ed. Edmund Curtis (Dublin, 1939).
- COD V Calendar of Ormond Deeds V, ed. Edmund Curtis (Dublin, 1941).
- Expugnatio Expugnatio Hibernica: the Conquest of Ireland by Giraldus Cambrensis, ed. A. B. Scott and F. X. Martin (Dublin, 1978)
- Flanagan, 1981 Marie Therese Flanagan, 'Mac Dalbaig, a Leinster chieftain', *Journal of the Royal Society of Antiquaries of Ireland* 111 (1981), pp 5-13.
- Leabhar Bran. Leabhar Branach: the Book of the O'Byrnes, ed. Seán Mac Airt (Dublin, 1944).
- Mon. Poss. Extent of Irish Monastic Possessions, ed. Newport B. White (Dublin, 1943).
- Orpen, 1911 G. H. Orpen, *Ireland under the Normans*, (4 vols, Dublin, 1911), I.
- OS Ordnance Survey County Carlow (Dublin, 1840).
- Price, Placenames Liam Price, *The place-names of Co. Wicklow* (Dublin, 1945-67).
- RBO The Red Book of Ormond, ed. Newport B. White (Dublin, 1932)

---

## National Schools' History Prize

---

Our annual History Prize competition for National Schools was once again a great success, attracting over a hundred entries from seventeen schools. As in previous years, the judges commented on the very high standard achieved by many of the young entrants. This is greatly to the credit of the children and their teachers, and the Society expresses its thanks and congratulations to all concerned.

This year's prizewinners, all of them pupils of Scoil Náisiúnta Naomh Peadar is Pól, Ballon, were:  
1st Prize (€100) : Órla Kenny, "Kavanagh Castles of County Carlow" which we publish elsewhere in this journal.  
2nd Prize (€50) : Raena Maye McElwee, "St. Mullins Motte and Bailey."  
3rd Prize (€50) : David Lalor, "St. Fortiarnan's Holy Well and the White Church."

Next year's competition will begin immediately after Christmas when entry forms and information about the contest will sent to the schools. We hope that pupils and teachers will continue to show interest and that pupils will benefit by discovering more about the local history of their area.

The committee has also decided that the presentation of prizes will be a stand alone ceremony on this occasion, rather than holding it after one of our winter lectures as we did in the past.

# Garlic is good, but give me Scallions

Fergus Moran

It was Dan Carbery, a friend since childhood who asked me a month or so ago to put down on paper some early memories of growing up in Carlow. He seemed to think it could be of interest to or ring a bell with old-time Carloviana readers. Dan's stated reason for this is that my memories may be a wee bit less clouded - according to him - due to my having been away for so much of the last half-century. Dan reckons his memories and those of our schoolboy pals have become opaque and over-layed by the changes of time as, with time, the town and its environs has continued to change. A previously somnolent and somewhat typical provincial market town has morphed from what it had been during the impecunious forties and fifties to one of noisy economic vibrancy and diverse pursuits today.

The farming and marketing core, the town's *raison d'être*, with its attendant sights, smells and rhythms has over the years been pushed further afield. The working farms that prospered close in when we were boys (within such urban areas as Hanover Road, the Blackbog and Green Roads, Rathnapish and Askea as examples) are no more. Gone with them also the manure chips and dung patties then prevalent on the

roads; the horse drawn drays, soft-tyred and low-slung, the back of which we loved to leap aboard, where we could be hidden from sight behind the haycock (a hay cock which had been ratcheted up with a capstan bar and situated more or less precisely over the single axle) and if we were small enough and light enough and few enough (no more than three very skinny ones) balance could be retained and the shafts would not rise up to give us away.

However the top of the hit parade for us boys in those days was the mighty steamroller. For its ponderous, implacable, crunching enormity of purpose as it trundled down the road majestically rattling its chain gear, spinning its flywheel and gushing steam from orifices high and low, well there just was nothing in the world like it to stir the blood. Perhaps youngsters today get something of a similar feeling from George Lucas' robots in Star Wars but even he cannot duplicate the reality of touch, sound and smell we got from a Corporation steamroller. (I could tell you stories about how three pre-teens fired it up one summer weekend from where it was parked temporarily in Carpenter's yard and trundled out onto Barrack St. and into the Fair Green - but, who would believe that?).

Well, anyway, no question but that the town has evolved and grown into an important regional hub both in academics and industry, attracting skills and students to say nothing of the bedroom commuting commuters from, once considered, faraway Dublin.

But, yet ...

Crashing his bloody pain dispensing golf-stick on the nearest desk, I can hear Chesty Murray bellow: *"Don't do that; a sentence does not begin with a conjunctive! Seeldrayers, spell them conjunctive."*

*(Ah, yes - you were just what we needed at eight years old after the nuns at St. Josephs, Chesty. Quick on your dancing feet you were and delighted in keeping us all hopping. May God keep you and may you be tall enough to leap and not have to scabble up to the window sill in heaven's classroom at 10 minutes to 2 o'clock of a summer afternoon and may Brother MacInerney continue to turn a blind eye on your tardiness.)*

God rest Brother MacInerney too, he was the CBS grammar school principal during the Forties and what a holy terror that man was!

Holy Sufferin'...

Br. Mac had the leather in his soutane pocket always coiled ready for action. He was very accurate with it, even from the far wall between the rows - and the back of the head of the petrified statue at the blackboard would tingle with anticipa-

GARLIC IS GOOD, BUT GIVE ME SCALLIONS

tion of his deadly aim and while struck dumb with the fearful certainty of it would be relieved at the rescue by the sudden slap of the unfurling strap.

Still .. (*Ha! Look at that, a preposition, not entirely bad, yet not entirely acceptable to our old secondary English teacher, Mr. Donnelly, better known to decades of classes as Snaky John for his evil way of using thumb and forefinger to lift you out of the desk by the temple hairs.*)

Still and all, while there can be no doubt the town has grown in national importance over the years I may tell you it was not without its eccentricities, its characters, its lively interests all those years ago in our own ruminatory time. No, not by a long chalk.

**Eccentricities and Characters:**

Well, there is a plethora to choose from but I will offer just a couple.

How about a people's park where pram strolling mothers mingled with tig playing toddlers being positioned between an asylum and a cemetery and an evil-smelling gasworks? It never seemed to strike anyone as being incongruous; I doubt if many gave it much of a thought. As for characters (best to play it safe here so I will just go with one. One that all the other characters regarded as the real McCoy).

Now, there was a day for Tom McDonald(Kinsella?), better known by Carlow children as 'Nick Nock' (because of a nasal intonation to his voice due to the poor man's cleft palate) when he was at

the door to Shevlin's pub on Tullow St. and wasn't he pulled up short by the voice of Father Kennedy reproving: "*Tom, now Tom, you go in there with the Devil beside you*".

And without faltering a step Nick Nock shot back with his nasal lisp: "*Bedad, Father, he had better stay out ... I only have the price of one pint!*"

We all thought that was good stuff!

Then there was another time again I heard when Mr. MacDonald (Kinsella?) was stopped by another one of the priests of the parish, not sure which, it sounds like Waldron but would have been before his time so perhaps it was Crowley.

"*MacDonald!(Kinsella?)*" says he: "*If you continue into that public house your immortal soul will be damned to hell so it will.*"

Wearing hand-me-down black trousers given to him that day by the kind Father Miller, he shouldered on in, lisping triumphantly: "*And so it might but bejaysus me arse'll be in Heaven*"!

Laugh! The whole town laughed at that one.

There are screeds of similar stories and a slew of Carlovians to tell them. The town was smaller and the tom-toms ever active. We had no shortage of characters (plus a few real boyos) among our neighbours. Townspeople whose foibles and eccentricities would today surely be considered actionable and likely to be viewed as an intolerable threat to the lockstep order of the community. But you know, in our less enlightened times, be-

fore the Seven Deadly Sins took hold and spread across the land like Bridget's cloak, people out of step with society were tolerated and accepted for the most part, cut a little slack as you might say; even for someone such as the town's roguish Clark Gable: "The Digger", caught at being light-fingered again and disappearing for another standard six months of government-paid holiday. Even then most all - except only perhaps a small clique in the sodality or a junta of sage pharisees whispering behind their pints in "The Sheaf o' Wheat" - most in fact were more bemused than bothered and prone to let it go with a bob of the head and an "*Arrah musha..!*" Eccentricities were considered as normal expressions of a person's make-up even to the point of extreme, whereat someone might observe with little or no malice: "*Wouldn't you say that one's a bit natural, now?*"

Boyhood memories ... well, as for that, I do know we were never short of things to do. Indeed the town was chock full of boyish interests, there to be enjoyed by any youngster with a bit o' jizz in him.

There was some furtive soccer and good rugby both of which were frowned upon by the G.A.A. The school supported football and hurling, naturally, with Br. O'-Connor, 'The Black Ace', and his powerful whistle all over the pitch each Wednesday afternoon. A fine Kerryman was "Blackie" and he died blowing that final whistle. God rest him.

Many of us have fond memories of whistling down Cox's Lane, flying past

Prendergast's and the Bank Field to the swimming club and the great galas held there in the Barrow, where Jimmy O'Neill taught a few and charmed the rest with his two-and-a-halves and his half-gaynors. Jimmy had diving prowess to be sure and won many provincial championships, both for Leinster and Munster. The finishing line for the Rowing Club's racing regattas was at the same spot (33yds. across at the diving board) and the senior crew of the day did Carlow proud: Maurice Dowling, Harry Griffiths, Eamonn Stafford and Mick Bolger were peerless in the clinker fours cox'd by the diminutive Joe Fenton.

Or down the lane by Corcoran's bottling plant at the Graigue Bridge to the Boat House where every summer at least a dozen four-oared wherrys were kept out of the sun under the arch of the bridge, ever at the ready and varnished bright by 'Skipper' Hennessy.

On weekends they would all be out, loaded to the gunnels with ministering mothers and ecstatic young ones and men, stripped to shirt sleeves and the odd waistcoat, rowing all the way up to the weir at Knockbeg for a day's picnic outing. Hours later the return trip, with the help of the slow current and the foremost triangle of duckboards standing up against the bow on each boat like a Polynesian sail to catch the evening breeze. Oh boy, what a sight to see, one in front of the other, gliding with little effort down the stretch past "the Bishop's"... one behind the other, like the amble of Brown's cows.

**Interests:**

There was gymnastics and boxing too at the clapboard one-storey gym on Burrin St. owned by Nolans the Carrier and started by Paddy Nolan and Terry Moran with Des Early and others (forgive me now, I was too young to know all the principals) not long after the War. We youngsters fought bouts of three x 3 minute rounds in Portlaoise and Muine Bheag and at a carnival in the Bank Field one year too, as I remember. A pity the Boxing Club folded too soon, foundering on hard times around 1952 or so.

The local troop of Boy Scouts was very active at that time and although yours truly got kicked out of the Cubs' Curlew Patrol for lack of adequate attendance (too much time on the river) I have not forgotten the times we had camping by the Slaney during Easter with Martin Doogue and the Brophy brothers providing supervision, sleeping in bell tents, feet to the pole and wrapped in a blanket - no 'mála codhladta' then, Miss O'Hara dear - and the fright in the night listening to Martin Brophy's older brother tell ghost stories. It took real fortitude to answer a call of nature in the small hours after that; to brave the trees as they moved in the moonlight with the frost crackling underfoot and your fearful eyes boxing the compass on your 11 year old neck. That kind of thing stays with you, and if you don't mind me saying so, had an owl done a woo at the moment of the wee everything would have stopped and frozen solid... there and then... sure as shooting.

Fishing for trout, roach, perch and pike

in the River; close by the beet factory's manifolds was a sweet spot. I would be remiss not to mention the daily fighting we boys did too. Games and playground rough-housing were always physical, wrestling could turn to blows with limited verbal warning; tempers flared, fists flew, noses bled and honour was restored in less time than it takes to tell. Rarely did it end with lasting grudges but it did tend to establish a pecking order that some might consider immutable. The War was not long over and Ireland was broke ... we were brought up hard and hardy and to be quick about it.

On those rainy, misty sort of days when ye might be at a loose end, 'hanging out' likely meant exploring any orchard within a mile or two radius of Duggan's the Cross. Mitching was dangerous and infrequent but apples and pears made a grand repast, especially when augmented with an uprooted scallion and a scraped carrot or a green curly cabbage leaf. Best of all, a potato or two tossed on the coals of a tucked-away fire pulled out with a stick, hot and black and just perfect. Gloriously so, if someone had remembered to bring a pad of butter in his pocket.

But, also (ah, Mr. Donnelly! please ...), depending on the season there could be fun to be had with conkers and catapults, or marbles and - with milk bottle caps - pitch and toss; whipping tops and bird's nests; hayrides, Pursers the Farrier and the blacksmith's forge (especially the one on the Accommodation Road) and - if you minded your manners - a split bottle of Corcoran's lemonade for the asking at



GARLIC IS GOOD, BUT GIVE ME SCALLIONS

the door of the bottling plant. The tang of Mr. Brannigan's saddlery near the foot of Tullow Street on a rainy day (to say nothing of the briny smell of hides from Oliver's Tannery down the bottom of the Haymarket); and noses pressed against the glass sniggering at the pig's head profile in Lipton's – or was it Good's - shop window. The wondrous and dark coolness in the back of Sutton's general emporium.

Learning to swim in the Old Burrin up beyond the Mill Race across the tracks and over the hill to the sandy shoals. Seven years old on an endless summer's day and miles from home with not a bother on us; shoes or boots hanging by the laces around your neck was 'cool' before anybody knew what cool was. Or up the Barrow track to cross at Hickson's lock and over the weir to join the boaters picnicking. And (ouch) that's not the half of it. There was more stuff and adventure for a youngster to do than there were hours in the day. Rain or shine we roamed and ranged, free and wild without fear or hindrance. It was blessed!

Carlow then was very much a market town and on the first Monday and Tuesday of every month the hustle and bustle of drovers and jobbers with the attendant sounds and smells of the varying livestock being driven through town on those Fair Days stays caught in my nostrils still.

The valley land is arable (probably more so now that it is well rested) and the bisecting river was an all important com-

mercial as well as social venue, with barges carrying refined sugar from the Beet Factory.

Watching the loading of a barge was a delightful sight for a boy. Each bag weighed about 300lb and was delivered to the waterside from above by a wooden chute made smooth and shiny by the weight of the speeding burlap. At the bottom each man shouldered the weight and walked it over a plank laid 'thwartship across the open hold. With a twitch and a dip of the weighted shoulder the bag fell – *thuwmp!* – almost always lining up perfectly exact with its neighbour. A thousand bags and more and not a one needed to be lifted from below the knees.

Think of that.

Thoughts swirl in the downstream of memory and faraway flickering impressions. Some are imbued with chalk-dust and chilblains, but the knowledge in me remains that, above all, the introspective inquisitiveness, the curiosity of Carlow people is what gave the town its quiet air of singularity, of being sturdy and grounded. I sense it still each time I return 'home'.

*Postscript:*

*It's a funny thing... Dan asked me to write a bit about my memories of Ballinabranagh and spending summers there on Jimmy Delaney's farm.*

*I wanted to do that too but here it is and I never got to it.*

*Ah, well, perhaps another time ... God*

*willing...)*

T. Fergus Moran  
Sausalito, Calif.

Winter, 2011. 2011

Fergus Moran a Master Mariner **F.G.** is the eldest of three sons (Fergus, Nial and Rory) of Terry and Nancy O'-Morain. He was reared in Barrack Street Carlow.

He completed his secondary education at the Christian Brothers School Carlow in 1954. He followed a career at sea with the Merchant Navy 1954 through 1968 serving on various type vessels.

He married Sheila O Rourke of 51 Dublin Street Carlow in 1962 and they have one son Terence Breffni.

In his youth he was a prominent member of both Carlow Swimming and Rowing Clubs and earlier the Boxing Club in Burrin Street.

From 1968 to 2003 he continued his maritime career with stevedoring companies in the San Francisco Bay Area. Upon retiring he continued to work as a senior consultant for various ocean terminal development and green field projects around the world.

In retirement Fergus and Sheila reside in Sausalito across the Golden Gate Bridge from San Francisco but pays regular visits back to Ireland. His son Terry is a CMDR in the U.S. Navy.





This is part 8 of the 'Carlow Regional Technical College - Institute of Technology Carlow History' with previous material published since 2003 in *Carloviana*. The material in this and previous parts of this series are those of the various named authors or interviewees and do not constitute official view of the Institute.

## HISTORY OF THE RTC & ITC CONTINUED (PART 8)

*Edited by Norman McMillan & Martin Nevin*

### Mathematics Colm Kelly

When I first arrived in Carlow in September 1972, the Maths was a service subject that was supplied from what was then known as the Science department. The Maths group consisted of only four people: Pat O'Connor, Mary O'Brien (shortly to become Mrs O'Connor) and Michael Hegarty and Pat Walsh. Pat although an electronic engineer, had a good practical approach to teaching Maths. Mary's background was more pure Maths while Michael's background was in statistics. Pat Walsh serviced apprentice maths hours. This proved to be a good marriage of talents and was reflected in sound academic but practical syllabuses.

I was appointed as a Class 3 teacher and I was quickly to discover that this was a fitting title. My contract had no weekly maximum number of teaching hours. There was an annual limit of 900 hours which when divided over the 35 week teaching year, meant that an average weekly load in excess of 26 hours. Typically at the time, a lecturer could be working in all three of the College's departments. Night classes were included in this and the union cry at the time was "ban three nights". In my own case, my first timetable had 29 hours spread over the three departments of the college. I worked three night classes. My Monday timetable started at 9.00am and finished at 10.00pm with an hour lunch break and a tea break from 5.00 to 7.00 i.e. ten hours of lectures. In addition to all this, I was assigned a number of apprentice classes whose year ran to the middle of July.

Timetabling was of course not comput-

erised and each department worked independently so for the first few weeks bi-location was a mandatory requirement of all lecturers as timetable clashes occurred. We didn't ask each other how many classes a person had but rather how many clashes. Despite this apparent chaos, I was impressed by how much development work had already been done by the lecturers who had arrived in the first two years of the college. Where they found the time to develop courses in such a full timetable I do not know. In any case, in all the new courses assigned to me there were well developed, appropriate syllabuses. There was to some extent a sharing between colleges and indeed some courses were nationally accredited. Still, it required a huge commitment on the part of the early pioneers to ensure that courses were up and running efficiently.

In 1973, Michael Heaton, now sadly deceased, joined as a part-time lecturer but was quickly promoted to full-time lecturing status. Michael was a champion chess player and on several occasions played simultaneous chess against ten opponents winning almost all matches. In 1976, Pat Murphy, Marion Murphy and Ray Jordan joined the Maths lecturing staff. Pat's background was in statistics while Ray's

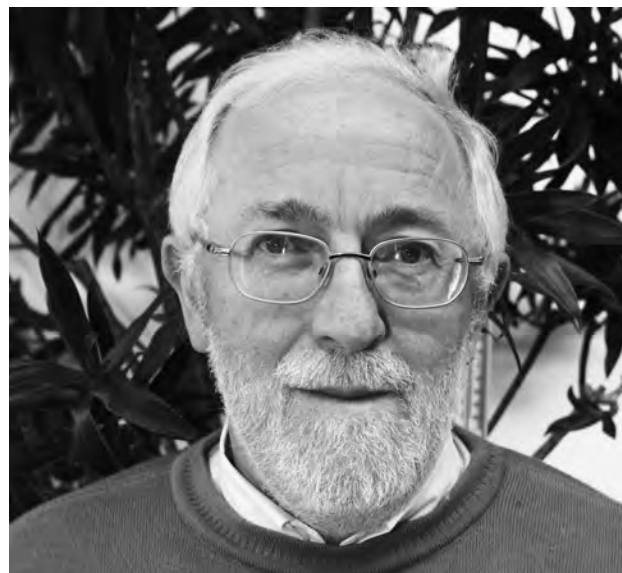

*Colm Kelly*

was more mainstream. Gradually, individual staff were allocated to different departments and although ostensibly still domiciled in Science, the early team spirit and collaboration between lecturers diminished. In 1980, Michael Wall (now sadly deceased) and Eugene Kernan joined the Engineering department directly as Maths lecturers. This heralded the eventual allocation of Maths staff to particular departments.

The increasing importance of computers saw a number of staff convert over to this emerging area. Maths lecturers were natural candidates for such conversion, myself included. This development along with the migration of Maths lecturers to individual departments had the unfortunate effect of having the status of Maths reduced. Individual staff had to fight lonely battles to maintain a leading role

## HISTORY OF THE RTC CONTINUED



*Ray Jordan was born in Dublin on 31 December 1952. He attended St. Paul's College, Raheny, Dublin from September 1965 to June 1970. He studied Mathematical Science at UCD from September 1970 to September 1975 and graduated with M.Sc. (1st Hons.) in Mathematical Science.*

*He was employed by New Ireland Insurance Co. as an Actuarial Student from January 1976 to September 1977.*

*The next year was spent lecturing in Mathematics at the University of Jos, Nigeria. He then took up employment here in Carlow as Assistant Lecturer in Mathematics.*

*He is brother of the writer, Neil Jordan.*

for Maths in individual courses. This trend was not unique to Carlow and unfortunately failure to see the central importance of Maths is now recognised as a major national drawback.

During the 1980s and 1990s additional mathematics staff were recruited including Sharon McDonald, Damien Raftery, Joe Bennett and Esther Brett.

#### Soccer

When I arrived in Carlow in 1972, Paul Kinsella "looked after" the college soccer team. Note that I didn't use a phrase like "coached or managed the soccer team". Looking after any team at that time involved such tasks as washing gear after matches, lining pitches, setting up nets and corner flags, sourcing and paying for referees, arranging buses for travel to matches, paying all expenses usually out of one's own pocket (hoping to get it back by some means or other at a future date). There was no money available from the Student's Union and so regular discos had to be arranged and supervised at the college in order to raise funds to pay for all expenses. If the team qualified for the fi-



*Patrick Murphy, M.Sc. Diploma in Computer Simulation and Mathematical Modelling, T.C.D.*

*Patrick Murphy was educated at Colaiste Christ Ri, Cork. He entered UCC with Keliher and College entrance scholarships in 1971 and obtained a B.Sc. in Mathematical Science in 1975. He was teaching assistant in Mathematics at the NIHE, Limerick in 1975/76. He spent three months in the Central Statistics Office in Dublin and left to take up a research post with An Foras Taluntais in Sandymount Avenue, Dublin and Oak Park, Carlow. He was then appointed Assistant Lecturer in Mathematics at Carlow*

nals weekend, there was further financial pressure. Oh yes, I forgot to mention, looking after the team also involved training and coaching the team.

At the beginning of 1973, Paul approached me to take over the soccer team. At the time, I thought that Paul had conducted a great head-hunting exercise culminating in me as the choice for "manager" of the team. I thought Paul saw some rare footballing genius in me that would bring great success to the team. With the benefit of hindsight, I think he saw sucker written on my forehead. Not knowing what "looking after" the team meant, I was delighted to take on the task.

Apart from the logistical problems associated with looking after the soccer team, I soon discovered that the competition was of very high standard. Carlow RTC had a student population of a few hundred students at the time and were competing with colleges such as Kevin Street and Bolton Street whose student population exceeded 5,000. In our first year we reached the semi-finals and were lucky to avoid both Kevin Street and Bolton Street in the semi-final. The finals were held in Let-



*Michael Wall, was native of Castledermot, Co. Kildare. His secondary education was gained at Castledermot and Athy Vocational Schools. He graduated with a B.Sc. (Hons.) from St. Patrick's College, Maynooth.*

terkenny and luckily for us, we were narrowly beaten by Letterkenny in the semi-final. I say "luckily", because Letterkenny were outclassed in the final by a Kevin Street team that included a teenage Brian Kerr. The entire Kevin Street team were playing football at either League of Ireland or Leinster Senior League. I resolved there and then that if we ever qualified again that we would have a team capable of competing at this level.

In order to put together a team of a high standard, it was vital that every potential player attending the college was checked to ensure that no talent was overlooked. This included looking at Gaelic players who could be converted to fill a role. In 1976, we again reached the semi-finals, this time playing Bolton Street who had overrun all opposition to date. In a very exciting match, Carlow lost 4-3 against a team that Joey Malone (then best friend of Paul McGrath and a team-mate with St Patrick's Athletic) and Pat who later gained a full International cap for Ireland. The rest of the team was made up of players with League of Ireland experience. Carlow had 4 players who had either played or would shortly play League of Ireland soccer including Niall O'Donnell of Athy Town who later played in a Cup Final for St Patricks Athletic. The outstanding player on the field that day was an outstanding Laois Gaelic player Kieran Whelan who could have played soccer at any level had he chosen to pursue such a career

Despite putting up a good show against Bolton Street that day, I could see that we still needed to improve if we were ever to

HISTORY OF THE RTC CONTINUED

win out the colleges' soccer. In 19878, I felt, at last that I had a team that could win the competition. However, the league section of the competition started badly, as we lost to Rathmines College 1-0 in our first match. This defeat proved a blessing in disguise as it revealed some weaknesses that weren't apparent beforehand. A trawl of college talent produced a few extra players of substance and the team captained by Niall O'Donnell won their next seven games to finally win the Technical

but didn't select a Carlow player. At the presentation, he remarked on this apparent omission and said that the Carlow performance was so team-oriented that no one player stood out and that if he selected a Carlow player, he would have to select the entire team.

Although the Universities had their own competition, the combined Technical colleges under Brian Kerr and assisted by myself, played the combined Universities

of course went on to win European titles with under-age teams and had the ultimate honour of managing the Irish soccer team. If he had been given more support and time by John Delaney FAI Chief Executive, I believe that Ireland would have achieved a lot more than it did.

In 1982, Carlow again won the college's cup captained by Kildare Town's Alan Egan with a team spearheaded by local players Dinny Ryan, Kevin Madden.



*Presentation photo of team members winners of the Irish Technical Colleges'. In front J.J. Gallagher, Colm Kelly, captain Niall O'Donnell and Andy Callinan holding the Senior trophy won by the team.*

There was also a good representation once again from Athy Town with Pat Troute and match winner Charlie Hughes. Carlow disposed of Kevin Street 4-3 in the semi-final with Aldo Marini of Athy Town grabbing a hat-trick. Unfortunately Aldo was injured for the final and his replacement David Bonus despite making an impressive start also picked up an injury after 15 minutes. This required a re-organisation of the team with our main scoring threat eliminated. However, an early goal by was defended with great resolution to the end. Again, the Bolton Street team was littered with players with League of Ireland experience. This time, Brian Kerr selected Carlow's Billy Manning as player of the tournament.

At the end of 1983, I "retired" as the college's soccer "looker-after". In the 10 years of my stewardship, a period in which more than 60 matches were played, Carlow lost a total of 10 matches usually losing to the eventual winners. Carlow held the proud record of never losing a home game during that time. It would take almost 30 years before Carlow again won the College's cup.

Colleges Cup. Athy Town always provided quality players for the college team and in 19878 there were three Athy Town players: Niall O'Donnell, Dom Brennan and "Bobo" Whelan who was top goalscorer in the competition. Brian Kerr was deputed to select player of the tournament

each year and always got at least a draw from these matches. This was Brian Kerr's first major experience managing at a reasonably high level although he had managed under-age teams since he was thirteen. He gave up playing at a relatively young age in order to manage teams. He

Lost painting of the "Platform Spellbinder" a Portrait of George Bernard Shaw by Artist Bertha Newcombe, has been found at an Oxford college and was handed back to the original owner, the Labour Party. It was long thought that the painting was destroyed in the London bombing of WW II but it now appears to have been moved from the Labour Party Headquarters in London during the War, to Oxford. The work was officially identified by Professor Audrey Mullender, principal of Ruskin College.

The portrait is 5ft high and 3ft 2in wide and was handed back to Mr Andrew Smith, Labour M.P for Oxford East

The portrait "Platform Spellbinder" is now hanging in the new headquarters in Westminster.

Ref. BBC News Oxford. 22nd June, 2012.

The article "The Platform Spellbinder" was published in 2011 edition of "Carloviana" Mary Stratton Ryan.



G. B. S., PLATFORM SPELLBINDER  
Portrait by Bertha Newcombe, unframed.



Some have gone, some have faded

# Gate Lodges of Co Carlow

*Martin Nevin*



Rathvinden Gate Lodge



Strawhall Gate Lodge



St Dympna's Gate Lodge



Park Gate Lodge





Sion Cross Gate Lodge

Some have gone, some have faded

# Gate Lodges of Co Carlow

*Martin Nevin*



Castletown Gate Lodge



Busherstown Gate Lodge



Milford Gate Lodge



Kilgraney Gate Lodge



## Building on a legacy - the archaeological collection of Carlow County Museum

Sinéad Marshall

One of Ireland's newest cultural institutions, Carlow County Museum (CCM), opened its doors to the public in April 2012. It manages a varied collection of over 5,000 objects connected to Carlow's heritage including geology, archaeology, folklife and social history. This article focuses on the archaeological collection, giving a brief overview of some of its highlights and publishing a complete catalogue for the first time. 'Journeys in Time – the archaeology of the M9 Carlow By-pass', the Museum's first temporary exhibition, is also discussed.

### Developing a County Museum in Carlow

As far back as 1892 the people of Carlow were considering setting up a Museum to display the rich array of artefacts found here, many of which were stored in local gentry's houses (Brophy). However the first publicly accessible Museum here dates back to 1973 when Carlow Historical & Archaeological Society (CHAS) founded one run by volunteers in the Old Academy on College Street. Carlow Town Council kindly gave the Museum a new home in the old Town Hall Theatre in 1979. By 2002 the Council had appointed a professional curator to formally take over operation of the Museum. In the following year the institution was designated to collect and display archaeological objects from the county on behalf of the National Museum of Ireland.

This entire process culminated in the creation of an official County Museum, housed in the beautifully restored Presentation Convent, back where it all began on College Street. Four exhibition galleries are spread across three floors; the two largest showcase the permanent collection with two smaller galleries for temporary exhibitions.

### Archaeological artefacts in the permanent collection

Carlow's new Museum is home to geological, archaeological, folklife and more recent items donated by curious Carlovians over the decades. Much of the permanent archaeological collection (Table 1) is on display on the ground floor.

Interesting artefacts include stone axeheads, which are contemporary with Neolithic portal tombs (dolmens) such as Browneshill. Made by early farmers to chop down trees and clear space for farmland these were very useful tools when set into a wooden handle. One of the largest axeheads was found in a field close to Kilgraney Portal Tomb.

A Bronze Age cemetery on Ballon Hill was investigated by antiquarian Richard Smith in the 19th century. Many burials and artefacts were found and it is still regarded as one of the most extensive and significant cemeteries of its time (O'Neill). A presentation case specially made to fit finds from a bronze spear or razor and two polished stones is an artefact in itself. A Bronze Age burial urn on display was found in a triple cist grave of this date at Royal Oak by another antiquarian P. D. Vigors. Bronze swords, a socketed spearhead and an axehead called a palstave show the development of wealthy elite groups at this time. Recent donations to the Museum include a beautiful bronze looped and socketed axehead dating to 1000 – 750 BC (Waddell).

A bronze tripod pot, used for cooking on open fires, and two stone lamps are from medieval times. Similar pots found in Fermanagh are thought to have been used in well-off households with poorer houses using pottery vessels for cooking (Williams and Gormley). Medieval houses, whether of stone or wood, were quite dark. The 10th – 12th century stone lamps cast a dull light by filling the hollow with fat or oil and

draping a burning wick over the side. One of our lamps was evidently well used as it is cracked and soot stained around the edges.

### The Jackson family

Many visitors will enjoy seeing rare objects collected by a 19th century family of antiquarians from Carlow. The Jackson collection of manuscripts, coins, weapons and 'antiquities' was a legacy bequeathed to the people of Carlow in 1859. This collection had been stored in various locations, occasionally being shown to the public, until the Urban District Council became its custodians in the 1960's. Its remnants, housed in the County Museum today, form the core of the archaeological collection including impressive artefacts such as the Bronze Age weapons described above. Recording provenance was not seen as important in the 19th century and records of where these artefacts were found are not known to exist, although much of the collection is thought to be from County Carlow.

A beautiful Viking Age gilt-silver drinking horn mount dates to the 11th century. Its elaborate design was influenced by a mixture of Irish and Scandinavian styles. You can just imagine a Viking sitting around a fire at night showing off by quaffing ale from his decorated drinking horn – one of the status symbols of its day.

### Journeys in Time

The Museum's first temporary exhibition is also of archaeological interest - 'Journeys in Time, the archaeology of the M9 Carlow By-pass'. It has been developed by Carlow County Museum in association with the National Roads Authority (NRA), the National Museum of Ireland and Rubicon Heritage Services, who carried out the excavations. Archaeologists and Museum Assistants Deirdre Kearney and the au-



thor, Sinéad Marshall, worked on the research, design and co-ordination of this exhibition with Curator Dermot Mulligan. It will run for one year until April 2013.

Aspects of over sixty archaeological sites and a selection of the artefacts found are on view. All artefacts have been assessed by the archaeological consultants on the scheme, Rubicon Heritage Services, and some have been the subject of professional specialist reports. The catalogue below (Table 2) lists the type, date, find location (provenance) and artefact number of each archaeological object in the Museum's collection at present. A number of artefact types, such as scrapers, were in use over many years and may not be tied down to one particular period e.g. Neolithic or Bronze Age. Where the specialist reports have not indicated a precise date they have been recorded as 'Prehistoric' as none were assigned a medieval or later date. Other artefact types such as hone stones for sharpening knives could be prehistoric or medieval in date. Where finds are unstratified or of uncertain date they are listed as of 'Unknown' date.

Significant sites include Carlow's oldest houses – the first Neolithic houses ever discovered in the county from Busherstown and Russellstown (O'Connell and O'Neill). These 5,700 year old rectangular houses were built of wood and thatched. Inside the house would have been smoky as no holes in the roof or chimneys are thought to have existed to let the smoke out from the fire. Since it was used for cooking the family's food as well as for heating the fire was probably on the go all the time. It is only in our recent history that fires were allowed to go out at night as it was thought to be bad luck.

Intricate workmanship is reflected in so many artefacts. Materials such as bone, stone, metal and glass were used to make tools and decorative items. The oldest man-made items in the whole Museum, two Mesolithic hunter-gatherers tools called Bann flakes, may be seen in this exhibition. These worked stones were the multi-tools of their time, called on for many jobs from use as a spearhead while hunting to butchering meat for making dinner.

Stone axeheads have been found in the county before but one particular example on display here traveled from Northern Ireland thousands of years ago. Neolithic quarries in pockets of the unusual Porcellanite stone have been found in Antrim and on Rathlin Island. We can now tell that trade in this precious stone extended to Carlow. Clearly certain tools were worth waiting for.

Daily tasks such as cooking the dinner are brought home to us by pieces of cooking pots belonging to Ireland's first farming families. Carinated bowls were round bottomed pots used for cooking in an open fire over 5,000 years ago. We can still see the black soot burnt onto the outside of these sherds.

One tiny Iron Age blue-green glass bead is the Museum's smallest object at less than 2mm in diameter. The mind boggles at how it was made by winding molten glass around a thin metal rod. An unusual medieval ring-brooch or buckle was discovered in a corn-drying kiln. Ring-brooch specialist and NRA archaeologist Mary Deevy examined this delicate piece of 800 year old jewellery before it went on display.

All artefacts on display in this exhibition are officially 'On Loan' from the National Museum of Ireland. As noted above Carlow County Museum is designated by the National Museum of Ireland to collect and display archaeological finds from Carlow in their own county (National Cultural Institutions Act).

#### **New clues to our past**

'New' finds are steadily making their way into the Museum; many have lain in a drawer or cabinet for years; others are newly discovered. New material often poses more questions than it answers initially. How was this made? How was it used? How did it come to be found here? Is it near an archaeological site? Who did it belong to?

Carlow's landscape has shaped how people lived, worked and were laid to rest. Its natural resources influenced patterns of settlement, industrial and burial activity. Artefacts may be beautiful or fascinating to look at but one of the more important considerations from an archaeological viewpoint is where they came from and what that can tell

us. Context is paramount. Was this Neolithic axehead dropped in the forest or buried in a pit in the floor of a house? Scatters of stone tools may indicate a tool-making or settlement site nearby. Their relationship to one another on the ground could even tell you where the tool maker sat while working. The tiny glass bead was found in a burial, helping to date it accurately. It is impossible to divorce the artefact from its original function, the location it was found and the society that created it. If you do happen across an artefact Carlow's new County Museum may be your first port of call, helping to record important details about the find.

#### **Research material**

Publications on the county's monuments (Brindley and Kilfeather) and the results of archaeological excavations are no longer a rarity. Information on the county's material culture is more difficult to access. A catalogue of all artefacts found in Carlow and housed in the National Museum of Ireland was commissioned by Carlow County Museum in 2005 (Gibbons), covering objects from the Irish Antiquities, Art and Industrial and Folklife divisions. Archaeological artefacts are listed by 'townland' and by 'find type' for ease of use and references to published sources are given where appropriate. Appendices are provided on The Jackson Collection, as it stood in 1946, as well as a full list of slides and photographs of Carlow artefacts and monuments held by the Irish Antiquities division of the National Museum of Ireland. While this is an unpublished internal report it is available for reference.

Carlow County Museum's collection of artefacts, catalogues, original materials and publications is a valuable resource for researchers with potential for focused artefact research and comparative studies on regional and national levels. It is hoped publication of this brief overview with catalogues of will also be of assistance (Tables 1 + 2). One example of its potential is our current liaison with researchers from the Discovery Programme's Late Iron Age and Roman Ireland (LIARI) Project to document any artefacts of this date in the collection.

While further analysis and assessment of the whole collection would

BUILDING ON A LEGACY

be required significant raw data exists as the basis for publications dedicated to Carlow's archaeological artefacts alone. Williams' and Gormley's 'Archaeological Objects from County Fermanagh' is a good model although in the ten years since it was published on-line publication has become a more cost effective and respectable alternative.

**A resource to cherish**

Delicate beads, pottery and tools and all played important roles in people's daily lives, connecting us directly to thousands of years of human occupation in the county. Carlow County Museum's role in preserving and caring for these archaeological gems ensures their survival for future generations. I wonder what they'll make of them.

**Note:** I wish to thank all the staff of Carlow County Museum for their kind assistance with this article.

**Bibliography**

Brophy, M. 11/6/1892 The Proposed Museum for Carlow, the Collection of Antiquities and Curiosities at Browne's Hill. The Nationalist and Leinster Times.

Brindley, A. and Kilfeather, A. 1993 Archaeological Inventory of County Carlow. Dublin.

Gibbons, E.K. 2005 Objects from Carlow County Museum in the National Museum of Ireland, Vols I + II. Unpublished report.

O'Neill, P. 2006 Ballon Hill and the Lecky Collection. Carloviana.

O'Connell, T.J. and O'Neill, N. A fixed abode: Neolithic houses in County Carlow, in Stanley, M., Danaher, E. and Eogan, J. Eds. 2009 Dining and Dwelling, NRA Monograph Series No. 6. Dublin.

Prendergast, E. 1946 Catalogue of the Jackson Collection, in the Town Hall, Carlow. Unpublished report.

Waddell, J. 2010 edition. The Prehistoric Archaeology of Ireland. Dublin.

Williams, B. and Gormley, S. 2002 Archaeological Objects from County Fermanagh. Belfast.

Table 1: Carlow County Museum permanent collection catalogue.

Artefact type	Date	Provenance	Museum Ref. - CCM
Stone axehead	Neolithic		
Clowater	82/10		
Stone axehead	Neolithic		
Clonmore	82/37		
Stone axehead	Neolithic	Car-	
low	83/106		
Stone axehead	Neolithic	Car-	
low	02/193		
Stone axehead	Neolithic	Car-	
low	02/194		
Stone axehead	Neolithic	Car-	
low	02/1422		
Stone axehead	Neolithic	Car-	
low	02/02390		
Stone axehead	Prehistoric	Bal-	
lygowan NMF	04/05		
Stone axehead	Prehistoric	Bal-	
laghaclay	NMF 07/01		
Possible stone axehead	Unknown		
Carlow	83/77		
Burial urn	Bronze Age		
Royal Oak	02/177		
Bronze palstave axehead	Bronze Age		
Carlow	80/57		
Bronze sword	Bronze Age	Car-	
low	83/105/1		
Bronze sword	Bronze Age	Car-	
low	83/105/2		
Bronze sword	Bronze Age	Car-	
low	83/105/3		
Bronze sword	Bronze Age	Car-	
low	83/105/4		
Bronze sword	Bronze Age	Car-	
low	02/1513		
Bronze spearhead	Bronze Age	Car-	
low	02/1512		
Metal spearhead	Bronze Age	Car-	
low	83/107		
Ballon Hill presentation case with bronze razor / spear & 2 polished stones	Bronze Age		Ballon Hill 07/85 A-D
Looped and socketed axehead	Bronze Age		Carlow NMF 12/02
Quern - top stone, decorated	Medieval		Carlow 02/02637
Granite quern - top stone	Iron Age / Medieval		Carlow 02/02638
Granite pot quern - base stone -	Iron Age / Medieval		Carlow 02/02640
Stone weight - loom / net weight	Un-		

known	Carlow	02/02641	
Quern stone, decorated	Medieval		
Ballyfeanan / Ballywhinnin			
NMF	12/01		
Mill Stone	Unknown		Car-
low	02/02642		
Carved stone head	Iron Age / Medieval		
Carlow	02/241		
Glass jar labelled "Carbonised cereal grains excavated at Wood Quay 1980, dating from Viking period"	Medieval		Dublin 02/02480
Gilt-silver drinking horn mount	Medieval - Viking age		Carlow 83/108
Stone lamp	Medieval		Car-
low	80/34		
Stone lamp	Medieval		
Knockevagh	82/12		
Bronze tripod pot	Medieval / post-medieval		Carlow 73/216
Spindle whorl	Unknown		Bal-
lygowan NMF	04/05		
Spindle whorl / weight	Unknown		Carlow 83/109/10

Table 2: Catalogue of artefacts recently excavated in Carlow - 'On Loan' from the National Museum of Ireland for the exhibition 'Journeys in Time'.

Artefact type	Date	Provenance	Museum Ref. - NMI
Bann flake	Late Mesolithic		
Johnstown	E2757:003:001		
Miniature arrowhead	Bronze Age		
Ballybar Lower	E2622:024:002		
Faience bead	Bronze Age		
Moyle Big	E2598:7010:001		
Carinated bowl pottery	Neolithic		
Ballybannon	E2613:421:006		
Carinated bowl pottery	Neolithic		
Ballybannon	E2613:421:014		
Food vessel pottery	Bronze Age		
Tinryland	E2589:001:002		
Quartz crystal	Bronze Age		
Ballybar Upper	E2588:026:001		
Barbed & tanged arrowhead	Bronze Age		
Ballybannon	E2610:048:004		
Hollow-based arrowhead	Neolithic		
Ballybar Lower	E2618:251:001		
Flint scraper	Neolithic		
Burtonhall Demesne	E2570:1032:121		
Flint scraper	Neolithic		
Burtonhall Demesne	E2570:1040:200		
Flint scraper	Prehistoric		



BUILDING ON A LEGACY

Prumplestown Lower E2626:026:025		ryland E2589:078:004		Porcellanite axe Neolithic
Stone flake Prehistoric		Ring brooch / buckle Medieval		Russellstown E 2571:246:001
Ballybannon E2610:144:003		Ballybannon E2617:082:001		Flint scraper Neolithic
Butt-trimmed form Late		Antler pick Prehistoric		Russellstown E2571:172:002
Mesolithic Ballybar Lower E2618:001:002		Ballybar Lower E2618:150:006		Flint scraper Neolithic
Chert blade Prehistoric Tin-		Possible weaving shuttle Medieval?		Russellstown E2571:293:004
ryland E2589:002:001		Ballybar Lower E2618:140:001		Chert scraper Prehistoric
Chert blade Late Mesolithic Tin-		Grinding stone Unknown		Russellstown E2572:1000:035
ryland E2598:098:001		Rathcrogue E2591:254:006		Grooved ware pottery Late Ne-
Flint knife blade Late Mesolithic Tin-		Anvil stone Bronze Age		olithic – Early Bronze Age
ryland E2589:028:001		Ballyburn Lower E2566:032:001		Russellstown E2571:041:003
Flint knife Prehistoric		Hone stone Bronze Age		Grooved ware pottery Late Ne-
Powerstown E2601:001:001		Ballyburn Lower E2566:038:001		olithic – Early Bronze Age
Chert blade Late Mesolithic Tin-		Hone stone Unknown		Russellstown E2571:041:029
ryland E2589:098:002		Ballybannon E2612:4175:029		Carinated bowl pottery Neolithic
Convex stone scraper Prehistoric		Hone stone Unknown Tin-		Russellstown E2571:089:005
Tinryland E2598:003:008		ryland E2589:078:005		Grooved ware Granite quern stone frag-
Chert object Prehistoric		Carinated bowl pottery Neolithic		ment Late Neolithic – Early Bronze
Prumplestown Lower		Russellstown E2571:098:005		Age Russellstown
E2626:044:072		Carinated bowl pottery Neolithic		E2571:092:002
Flint knife Prehistoric		Russellstown E2571:098:022		Grooved ware pottery Late Ne-
Ballybar Lower E2618:4237:042		Carinated bowl pottery Neolithic		olithic – Early Bronze Age
Flint scraper Prehistoric		Russellstown E2571:098:037		Russellstown E2571:092:019
Ballybannon E2610:036:006		Flint arrowhead Prehistoric		Grooved ware pottery Late Ne-
Bone pin fragment Medieval		Russellstown E2571:122:001		olithic – Early Bronze Age
Ballybar Lower E2618:150:008		Chert axe Neolithic		Russellstown E2571:092:032
Pottery Medieval		Russellstown E2571:153:001		Grooved ware pottery Late Ne-
E2618:183:002		Chert Bann flake Late Mesolithic		olithic – Early Bronze Age
Stone axe / plough share Prehistoric		Russellstown E2571:12002:010		Russellstown E2571:092:153
Moyle Big E2595:002:115		Copper alloy button Post-me-		
Pottery Medieval Moyle Big		dieval Busherstown		
E2595:077:639		E2581:1015:003		
Pottery Medieval Moyle Big		Blue-green glass bead Iron Age		
E2595:077:640		Busherstown E2581:5151:291		
Stone axehead Neolithic		Bowl pottery Bronze Age		
Burtonhall Demesne		Busherstown E2583:008:002		
E2570:1040:038		Flint flake Prehistoric		
Copper disk Post-medieval		Busherstown E2581:3007:014		
Cloghrystick E2623:4001:035		Flint scraper Prehistoric		
Pottery Post-medieval Tinryland		Busherstown E2583:002:005		
E2590:062:002		Hone stone Unknown		
Pottery Post-medieval Powerstown		Russellstown E2571:105:001		
E2601:012:011		Chert blade Prehistoric		
Pottery Post-medieval Powerstown		Russellstown E2571:309:001		
E2601:012:012		Flint scraper Prehistoric		
Hammer stone Unknown		Russellstown E2571:360:037		
Prumplestown Lower		Grinding stone Prehistoric		
E2625:066:006		Russellstown E2571:360:041		
Grinding stone Unknown Tin-		Carinated bowl pottery Neolithic		
ryland E2589:002:009		Russellstown E2571:105:008		
Quarrying wedge Post-medieval		Carinated bowl pottery Neolithic		
Burtonhall Demesne		Russellstown E2571:105:009		
E2568:1001:003		Carinated bowl pottery Neolithic		
Hammer stone Unknown Tin-		Russellstown E2571:105:012		
ryland E2589:208:001		Carinated bowl pottery Neolithic		
Pottery Post-medieval Prum-		Russellstown E2571:105:019		
plestown Lower E2628:001:004		Carinated bowl pottery Neolithic		
Glass bottle neck 18 <sup>th</sup> century Tin-		Russellstown E2571:105:022		
		Carinated bowl pottery Neolithic		
		Russellstown E2571:360:014		

Carloviana 2012

## Obituaries

Since our last issue the following long serving members of our society have passed away:

Thomas Brennan

Dr. Edward Gavin

Edward Kennedy

Fr. Thomas McDonnell

James Murphy

Thomas Dunne

## The archaeology of Ballon Hill, Co. Carlow: A review and proposal

Nial O'Neill

*Situated to the immediate west of Ballon village, Co. Carlow, Ballon Hill has an incredible history of yielding pottery, human remains and other artefacts of archaeological interest. Unfortunately, all the archaeological objects recovered to date where found either as stray finds or as a result of what can only be described as 19<sup>th</sup> century treasure hunting. Here we clearly have a burial ground of regional, if not national, importance dating to 2500-4500 years ago. With all the disturbance the hill has experienced (including quarry works) it appears as though an unknown proportion of the archaeological remains have already been damaged. Our present knowledge of the extent of archaeological remains here can only be described as minimal at best. However, with the application of modern and professional archaeological investigative procedures, we can gain a much clearer understanding of the archaeology present. We may be able to demonstrate that Ballon Hill, Co. Carlow was a site of great importance in Bronze Age Ireland. This article then has a two-fold purpose, to review what we know to date about the archaeology here and to propose some initial steps to further that knowledge.*

Ballon Hill is a low rise 3.5km west of the River Slaney and, although low, commands good views of the surrounding countryside. The regional setting is one

bounded by the Blackstairs Mountains to the south, Castlecomer plateau to the west and the Wicklow mountains to the northeast. The Douglas River, a tributary of the Slaney, is located less than 1km to the east. The land surrounding the hill itself is well-drained fertile land used for both pasture and crop cultivation. The hill is oval-shaped, with its longest axis running northwest/southeast. Two earthworks are recorded on the hill in the Sites and Monuments Record (SMR), the first

site of the old rath' and the second (SMR CW013-068) was described as 'large and curious entrenchments, locally known as "the walls of Troy"' (Graves 1853, 296). Reference is also made to a possible stone circle on or near the hill (Graves 1867, 10). A third site appears in the SMR records; this is a flat cemetery (SMR CW013-065) to the north of the hill. The 3<sup>rd</sup> edition ordnance survey (OS) map (1907) marks this spot as 'Urns found AD 1853' (see OS map no. CW013-14/15). This reference to 'urns found' relates to work carried out by J. Richardson Smith in the second half of the 19<sup>th</sup> century. Accounts of these works were published by James Graves in 1853, 1855 and 1867.

Writing in 1853 regarding exploration works carried out here, James Graves informs us that 'pans' or 'crocks' have been found all over Ballon Hill and were often broken 'when the usual incantations did not change the bones into gold' (Graves 1853, 296-7). The pans or crocks referred to here are pottery vessels dating to the Bronze Age (circa. 2500-500 BC) and more often than not accompanied burials (Kavanagh 1976; Ó Riordáin and Waddell 1993). The vast majority of these pottery vessels fall into four main sub-types; bowls (Figure 1), vases (Figures 2 and 3), collared urns (Figure 4) and cordoned urns (Figure 5). These could contain the cremated bone of one or more individuals or they could accompany either

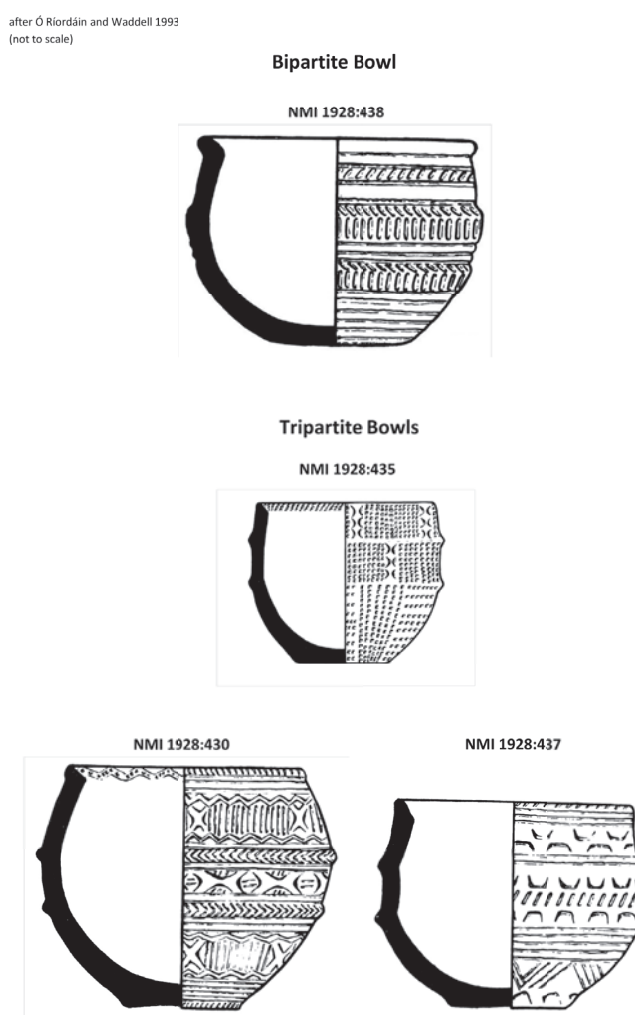

(SMR CW013-067) was reportedly 'the

cremated bone or unburnt bone (referred to as an inhumation burial). All these pottery and burial types may be found in either cist (small stone-lined burials) or in simple pits.

Irish Bronze Age burial is one characterised by the continued use of megalithic tombs in Wedge Tombs and the reuse of Neolithic burial monuments as was seen at Baunogenasraid, Co. Carlow (Raftery 1974), but also by the appearance and development of an entirely new burial custom. This was the burial of individuals in either cists (stone-lined graves) or simple pits and sometimes accompanied by pottery vessels. What is clear is that this burial custom became a funerary tradition associated with our Bronze Age (2500-500 BC). Examples of these burials appear nationwide.

The published accounts of exploration works on Ballon Hill in the 1850s and 1860s are incredible to read from a present day perspective (also see O'Neill 2006, 36-40). The volume of pottery recovered, the sheer extent of deposits of archaeological significance coupled with the number of burials uncovered indicates one of the largest known cemeteries of the Irish Bronze Age. However, as well intended as the explorations may

After Ó Riordáin and Waddell 1993  
(not to scale)

Bipartite vases

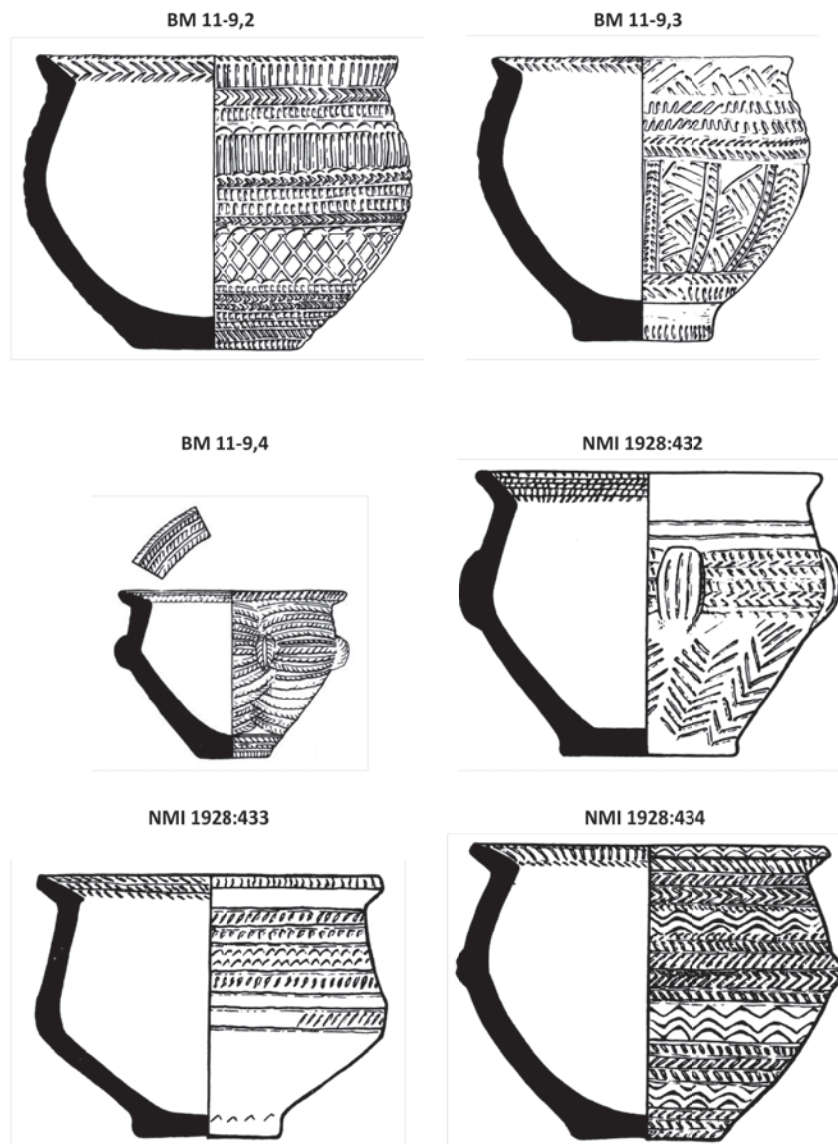

have been, the published accounts tell of a complete disregard for archaeological remains beyond the retrieval of the finest pottery vessels. Many references are made to beds of charcoal, cists with bone and charcoal but without pottery and small to large pits containing only burnt material. All of these were then clearly disturbed to check for the presence of pottery and other artefacts. Unlike today, retrieval of artefacts was often the only way to explain or understand archaeological remains. Today, however, we can analyse even the smallest fragments of cremated bone potentially telling us the age, sex, height, and general health of an individual. Evidence of disease and trauma suffered by the buried individual

may also be revealed.

Analysis of charcoal and other organic material accompanying artefacts can also provide very useful information on the local environment, crop cultivation, weather patterns, and food sources. Investigations into what food people ate, how they obtained it how and where they stored and processed it may also be undertaken. Advances in the analysis of both human bone and other organic materials can often provide us with far more information than can be

gleaned from high status artefacts.

Finally and significantly, radiocarbon dates may be obtained for the death and burial of these individuals from undisturbed charcoal or other organic materials retrieved from burials.

**The 19<sup>th</sup> Century works**

The exploration works carried out during 1853-4 were surmised and published by James Graves, although J. Richardson Smith oversaw the works. Brief accounts of later works carried out on Ballon Hill were published in 1855 and 1867.





ARCHAEOLOGY OF BALLON HILL

*Cloghan-na-marbhan*

We are told that the works began at the so-called Cloghan-na-marbhan or the stone of the dead. Three human skeletons were found underneath this ‘huddled together in a small space’. At a further depth four large granite blocks were overturned to reveal a ‘bed of charcoal’ and broken urns of ‘four distinctive patterns’.

After Ó Riordáin and Waddell 1993  
(not to scale)

*The ‘top of the hill’*

The works next moved to the top of the hill. Here, we are told, a ‘large bed of charred wood and burned bones was struck on, two feet under the sod’.

*The ‘neighbouring quarry’*

Then in the ‘neighbouring quarry search was made in spots where the “bearing” had remained undisturbed’ and that a highly decorated urn was found embedded in sand here.

*The ‘site of the old rath’*

After this, works moved to the ‘site of the old rath’. He curiously remarks that ‘here digging proved most difficult, as it was paved with great blocks of stone, set on end, and fitting close together’. We are told large quantities of bone and charcoal was observed between the stones and underneath the ‘pavement’ where half an urn and fragments of two others were also found. Still on the site of the old rath, ‘a great layer of burnt bones and charcoal’ was revealed. A cist approximately 0.6m in length and 0.3m in width and orientated north/south was soon discovered. This cist was noted as containing an urn of very elaborate pattern. Also unearthed here was another urn (ref. No. NMI 1928:444) (Figure 5) found in an inverted position with sod or earth placed in its mouth to prevent the bone within from falling out.

According to Graves (1853), a five-sided

chamber was next discovered. However, he states that this was in the course of further investigation and is unclear as to whether this was at ‘the site of the old rath’ or not. The chamber was filled with sand and held, near its base, 3 pebbles arranged in a triangle and surrounded by burnt bone. Above these was a large in-

In December 1853 works were resumed at ‘the north side of the rath where most of the urns were found in June and July last’. However, with what he felt to be ‘negative’ results here Smith now ‘tried the west, or upper side of the rath’. Here he found traces of ‘great fires, and two very deep pits’. He also uncovered an urn ‘seven inches high, of a curious pattern, and ornamented by six raised hoops’ (possibly NMI 1928:442) (Figure 4). He continues over the next few days finding ‘deep beds of charcoal’, ‘many more pits’ and portions of pottery vessels.

On the 9<sup>th</sup> of January 1854 we are told a large cist was found on the ‘upper side of the rath’. With the cist containing only bone and charcoal, the covering stone was replaced.

He goes on to remark that a great number of the cists and pits he recovered contained only animal and bird bones and no human remains. A small number of other vessels are found by ‘the men’ working ‘by themselves’ in the ‘rath’.

In 1855 J. Richardson Smith sent details of further works on the hill that were published in the *Proceedings and Transactions of the Kilkenny and South-East of Ireland Archaeological Society* Vol. 3, No. 2, pp374-75. Here he recounts explorations at the ‘south side of the rath, on the top of the hill’ then ‘the west side’ followed by ‘near the top of the hill’ where he ‘tried many places’. He goes on to tell us that at about ‘ten yards from the masonry at the top of the hill’ discovery was made of a skeleton lying west/east, that is with the feet located at the eastern end. No skull was present and he remarks that the

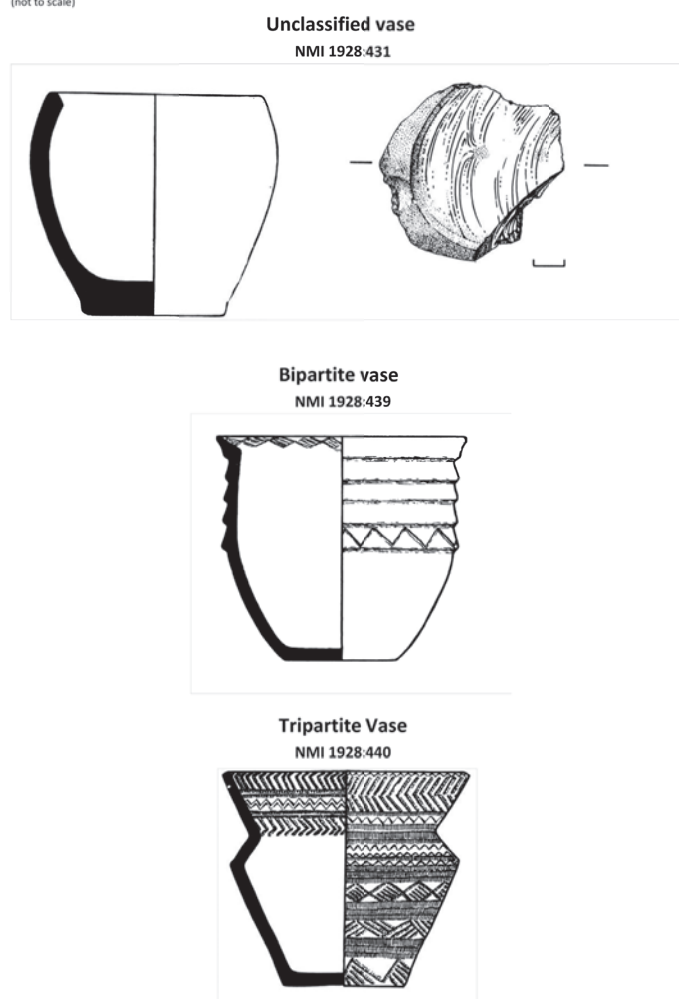

verted pot and over this was a small vase (ref no BM 11-9, 4) (Figure 2). A small portion of a bronze blade was uncovered near to the top of the burial chamber.

Digging was continued ‘by the rath’ and here two large cists were discovered. One contained an inverted urn more than 0.33m in height and almost completely full of bone. A third cist was also found, this example was recorded as 0.97m long, 0.71m wide and 0.46m deep. Works were stopped at this point for a number of months.





body must have been interred without the head as 'the shoulder joints coming close to an upright quarry stone; the collar bones were in their places, and unbroken; the body was stretched out'. He tells us that there was an 'up-cut' on the inside left femur (or thigh bone) and that he removed the remains and preserved them with gelatine. We are told he went on to check the 'on each side of the place where the skeleton was found, but discovered little to interest'.

#### Trails on other spots

We are told that many 'beds of bones and charcoal only' were found through 'trails on other spots'.

Also that, 'in one spot' a circular stone-lined pit contained, amongst other bone, a 'remarkably large human jawbone'. The pit measured 0.91m in diameter and 1.52m in depth.

In 1867 a Mr. Leaky sent a letter that was published as part of a short piece by James Graves, again in the *Proceedings and Transactions of the Kilkenny and South-East of Ireland Archaeological Society* in New Series, Vol. 6, No. 1, pp209-10. Here, we are told that new works were carried out on Ballon Hill and that several cists were uncovered. These were smaller than those previously found and contained burnt bone and no pottery. No indication is given as to where on the hill these works were carried out. He tells us that these cists were irregular in shape—approaching circular to oval and were 0.46-0.61m in diameter. He also found 'sunken pits' understood to be where the bodies were burnt.

In this letter he also tells us that he has had two of the cists reconstructed near Ballykealy House and 'fixed in the same position in which they were on the hill'. A third cist 'in which was found two urns' was restored 'exactly as it was, and in the same spot' on the hill.

#### **Discussion**

As a result of hearing accounts that large

numbers of vessels had been destroyed on Ballon Hill from the planting of trees and from quarry works, J. Richardson Smith undertook his own physical investigations or 'diggings' to try to recover some of these pottery vessels. On reading the accounts of his works, it is clear that he was primarily interested in recovering the most ornate pottery vessels. However, for us to fully understand what archaeological monuments are actually on or near Ballon Hill, what exactly was unearthed here and what archaeology may still remain, we might start by assessing the descriptions of works published in the 19<sup>th</sup> century. These descriptions indicate several large monuments, numerous burials containing human bone, animal bone, pottery and grave goods in the form of a probable bronze blade and 3 small stones.

#### *The large monuments*

Three possible large monuments or enclosures/defined or bounded spaces are mentioned in the 19<sup>th</sup> century accounts. These were the 'old rath', entrenchments known locally as 'the walls of troy' and a possible stone circle.

The accounts tell us it was the 'old rath' where the best pottery was unearthed. Here, a pavement 'with great blocks of stone' set on end, and fitting close together' was uncovered. We are told that the excavation continued to a depth of six feet 'bones being still found at that depth'. He carried on finding several cists and 'great layers of burned bones and charcoal' here. It immediately comes to mind to wonder if he is actually excavating into a burial mound? In a study of the burials of the Bronze Age in southeast Ireland (Mount 1999) it was found that 73% of graves were less than 0.74m in depth. So with bones still being found at six feet, we can be in no doubt that in 1853 Smith was digging into a mound of material placed above the burials. From the description given it is difficult to ascertain the structure of this mound as clearly the focus was on retrieving pottery vessels. It appears as though a pave-

ment covered an area containing burials and archaeological deposits. If some of this pavement remains today further archaeological investigation would be required to understand its extent and purpose or function.

The probability that the 'old rath' was in fact an enclosure around, and perhaps contemporary with, this burial mound appears highly likely. It seems, therefore, that the term 'old rath' refers to the previous existence of an enclosing element around this part of the hill and so suggesting this may have been an enclosed burial mound. Mount (1999) remarks that 'apparently flat' cemeteries (or cemeteries that were unenclosed and without burial mounds) may also have been marked or bounded by some features. A number of such sites in Ireland, notably Urbaireagh, Co. Antrim (Waterman 1968), and Ballyveelish, Co. Tipperary (Doody 1987), have been found upon excavation to have been surrounded by circular ditches and may in fact have been barrows' (p.152). It may also be the case that the entire hill was enclosed by a fosse and/or bank; however, geophysical survey, and possibly targeted archaeological testing, would be required to ascertain this.

Several clues as to the location of the 'old rath' are found throughout the accounts. On the 20<sup>th</sup> of December 1853 it is stated that works commenced 'at the north side of the rath, where most of the urns were found in June and July last'. This seems then, to be suggesting that the north side of the rath is also to the north of the hill as the 3rd edition Ordnance Survey (OS) map has a mark on it 'Urns found 1853 AD' which is very much to the north of the hill. We are then told on the 23<sup>rd</sup> of December, 3 days later, 'tried the west, or upper side of the rath' and on the July 21st, 1855 'commenced digging on the south side of the rath, on the top of the hill'. From these references it appears as though the 'rath' was located on the northern or north-eastern portion, of Ballon Hill, perhaps extending north beyond



ARCHAEOLOGY OF BALLON HILL

the hill.

Whilst bearing in mind that reference is made to the 'south side of the rath, on the top of the hill' (that the southern portion of the enclosing element of the 'old rath' may have been located near to or on top of the hill) we are also told in the opening paragraphs of the 1853 account of works that 'On the summit... were formally large and curious entrenchments, locally known as "the walls of Troy" (p296). From this it appears possible that the site of the 'old rath' and the entrenchments (the walls of troy) are

either one and the same, concentric enclosures or at least in very close proximity to each other.

Reference is made (Graves 1867) to 'a circle of stones... upright, and in a large circle' being 'on the part of the Hill which their tradition marks out for this, have been found the best cists and the best urns'. This appears to tell us that a stone circle may have been located around the spot marked on the 3<sup>rd</sup> edition OS map as mark 'Urns found 1853 AD'. Stone circles are known to be associated with burials such as at Drombeg, Co. Cork (Fahy 1959) and Newgrange, Co. Meath. It is entirely conceivable that a stone circle may have existed on or near Ballon Hill and possibly to the immediate north of the 'old rath'; however, without further information we cannot be sure. Only a geophysical survey of this area could possibly tell if this may be true.

It is interesting that the term 'walls of Troy' was used for the enclosing elements around/on the hill. The term is often used to indicate an impenetrable fortress or concentric enclosing elements. Was there then a multivallate enclosure around the hill? Or northern portion of the hill?

*The human remains*

From the descriptions given, it is difficult to ascertain the number of cist and pit

burials that were uncovered. It appears that it was at a minimum of 8 cists (six mentioned in the 1853 account and 'several' in the 1867 account taken as a minimum of two), although it was, without doubt, many more than this. Throughout the accounts given there are numerous references to deposits and pits of charcoal and burnt and unburnt bone. With this it

is impossible to ascertain the number of Bronze Age burial pits. Are at least some of the 'beds of charcoal' and pits of varying sizes mentioned throughout these accounts simple Bronze Age burials? He also uncovered at least 5 inhumation burials (3 found near the so-called Stone of the Dead, one in a circular stone-lined pit and another 'decapitated' example found near the top of the hill). By the accounts given, it seems that these were all adult skeletons.

The human remains held by the national museum under the Leaky Collection includes 8 groupings of unburnt bone (NMI 1928:459-466) and 12 groupings of cremated bone (NMI 1928:467-478). These are referred to as 'groupings' as it is unclear, without further study, whether each individual number equates to one or more burials or portions of burials.

Charles Mount (1999), in a comprehensive study of Bronze Age burials in the southeast of Ireland, provides a figure of 442 recorded burials of Bronze Age date known at that time. Of this 226 are cist burials; with these numbers in mind it is clear that Ballon Hill constitutes an important burial site in Bronze Age Ireland. Mount assesses the cists and pits under

numerous criteria such as size, orientation and contents, however, refers very little to Ballon Hill as little reliable information exists on the archaeology here.

*Animal bone*

There is also reference made to animal bone throughout the accounts, from possible large mammals such as deer to bird bones and some of this mixed in with de-

posits found in cists. Animal bone is known from prehistoric burials in Ireland (see McCormick 1985/86) and may have been placed in burial monuments as part of a burial rite. Mount (1999, 142) provides examples of sites where animal bone was uncovered such as at Halverstown, Co. Kildare (Raftery 1940, 57-61).

*Pottery*

The pottery uncovered is certainly a wonderful array of the funerary pottery of the Irish Bronze Age. Anne Brindley (2007) in 'The dating of food vessels and urns in Ireland' has provided us with date ranges for the different types of Irish Bronze Age funerary pottery. This was achieved through the radiocarbon dating of dozens of secure, undisturbed deposits from burials containing pottery of these types. She found that the Bowl vessels generally date to 2200-1800 BC, Vases to 2150-1700 BC, Cordoned Urns to 1730-1500 BC and Collared Urns of a similar date to Cordoned Urns. Many of the pottery vessels from Ballon Hill have been assessed as part of larger research works by Ó Ríordáin and Waddell (1993) and Kavanagh (1973) and to these we are grateful for their descriptions (see Table 1). We are also grateful to Brendán Ó

After Kavanagh 1976  
(Not to scale)

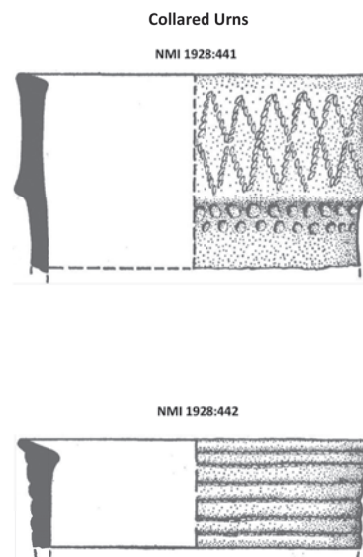

Ríordáin (1959) for recognising three vessels in the British Museum as being from Ballon Hill.

From these descriptions it seems as though the small vase catalogued BM 11,9-4 (see Figure 2) is the small pottery vessel referred to as being found with the bronze blade and 3 small stones or possible amulets in a '5-sided chamber' (the possible blade and 2 of the 3 small stones are now on display in Carlow County Museum). This vessel, and therefore this burial, dates to sometime around 200 years of 1925 BC (after Brindley 2007). The vessel found on the 23<sup>rd</sup> June 1853 that was recorded as having had sod or 'sraugh' in the mouth of the vessel which still contained cremated bone is that catalogued as cordoned urn NMI 1928:444 (see Figure 5). After Brindley (2007) this vessel/burial dates to 100 years or so around 1615 BC. It also seems likely that the pottery vessel found on the 23<sup>rd</sup> of December 1853 at the west, or upper side of the rath is that catalogued as collared urn NMI 1928:442 (see Figure 4). These examples serve to show that with some information and the application of modern archaeological techniques we begin to be able to piece together the archaeological activity on Ballon Hill. However, this is just the tip of the iceberg and much more investigation needs to be undertaken.

#### Understanding Ballon Hill

What can be done to enhance our understanding of Ballon Hill, its archaeology, its significance and the people interred there?

##### Geophysical survey

It is entirely possible that the location of the 'old rath' may be confirmed by a geophysical survey of the hill itself. This may be conducted either over a large area or targeted at the most likely locations of the 'old rath' based on our present knowl-

edge.

The presence or otherwise of a stone circle may also be assessed by geophysical survey, perhaps focusing on the area around the spot marked as 'Urns found in 1853' on the 3<sup>rd</sup> edition OS map.

##### Assessment of the human remains

In the 1867 account we are told of the reconstructions of 3 cist graves 'I have had the bones and charcoal found in each carefully re-deposited in them' suggesting some care was taken with the bone from cists. Also, writing in 1930, the then Director of the National Museum Adolf Mahr, tells us that human remains from Ballon Hill were submitted to the museum (Mahr 1930, 73-4). The Leaky collection in the national museum includes both unburnt bone (NMI 1928:459-466) and cremated bone (NMI 1928:467-478). The possibility then exists for a modern assessment of these remains.

It is clear that with a full assessment of the human bone by an osteo-archaeologist much could be learned. The assessment of human remains yields concrete information about individuals, information which would otherwise simply be unobtainable. To begin with, a human bone assessment can tell us generally about the bones recovered such as the quantity, nature and condition of remains. In addition, it can also determine age, sex, stature, and any pathological conditions from which the individuals may have suffered. These can include disease, trauma, congenital disorders, dietary deficiencies, occupational markers and, sometimes, cause of death. This information; the demographic profile of any community, the health of the individuals within it and even their physical characteristics are all inextricably linked to the social and physical environments they inhabited (O'Sullivan et al, 2002).

##### Assessment of the artefacts

A full assessment of all the artefacts held by the National Museum of Ireland needs to be carried out. This can further help to date activity on Ballon Hill. The artefacts and human remains also need to be looked at in relation to their findspot, was there any information provided to the national museum on where the artefacts and human remains were found (particular cists/pits)? Can any of the artefacts or human remains be related to particular pottery vessels as documented in the 19<sup>th</sup> century published accounts? And to particular grave sites?

##### In summary...

While much of the pottery has already been assessed (Ó Ríordáin and Waddell 1993; Kavanagh 1976 and Brindley 2007), detailed studies of the human bone, animal bone, artefacts and with a geophysical survey we can start to put all this information into context. We may be able to relate human bone to the pottery and to particular cist or pit burials. We could find out:

when the burials took place,

the demographics of who was buried here,

the development of the hill as a burial ground over time,

any other uses, besides for burial, the hill may have had

and reveal the true extent of the importance of Ballon Hill *circa* 2500-4500 years ago.



ARCHAEOLOGY OF BALLON HILL

References:

- Brindley, A.L. 2007. *The dating of food vessels and urns in Ireland*. Bronze Age Studies 7. Dept. of Archaeology, NUI Galway
- Doody, M.G. 1987. Early Bronze Age burials, Ballyveelish 3, Co. Tipperary. In R.M. Cleary et al. (Eds), *Archaeological excavations on the Cork-Dublin gas pipeline (1981-2)*. Cork Archaeological Studies no. 1. University College Cork.
- Fahy, E.M. 1959. A recumbent stone circle at Drombeg, Co. Cork. *Journal of the Cork Archaeological Society* 64, 1-27.
- Graves, J. 1853. The pagan cemetery at Ballon Hill, Co. Carlow. *Transactions of the Kilkenny Archaeology Society* 2(2), 295-303.
- Graves, J. 1855. Proceedings and Transactions. *Proceedings and transactions of the Kilkenny and South-East of Ireland Archaeological Society* 3(2), 374-5.
- Graves, J. 1867. Proceedings and Papers. *The Journal of the Kilkenny and South-East of Ireland Archaeological Society, New Series*, 6(1), 209-210.
- Kavanagh, R. 1976. Collared and Cordoned cinerary urns in Ireland. *Proceedings of the Royal Irish Academy* 76C, 293-403.
- Mahr, A. 1930. Recent acquisitions of archaeological finds made by the National Museum, Dublin. *Journal of the Royal Society of Antiquities of Ireland* 60, 73-78.
- McCormick, F. 1985/86. Faunal remains from prehistoric Irish burials. *Journal of Irish Archaeology* 3, 37-48.
- Mount, C. 1999. Early Bronze Age burial in the south-east of Ireland in the light of recent research. *Proceedings of the Royal Irish Academy* 97C, 101-193.

After Kavanagh 1976  
(Not to scale)

Cordoned Urns

NMI 1928:444

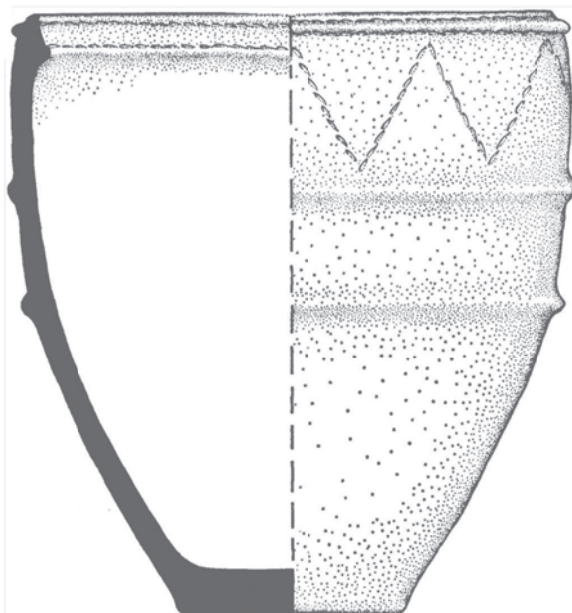

NMI 1928:445

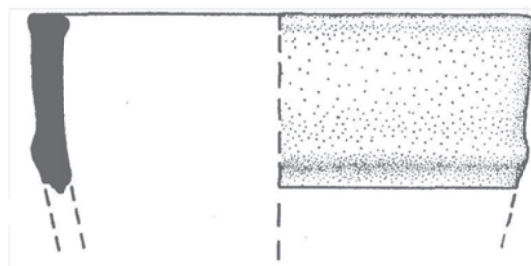

Carloviana 2012



O'Neill, P. 2006. Ballon Hill and the Leaky collection. *Carloviana* 55, 36-40.

Ó Ríordáin, B. 1959. Bronze Age Pottery from Ballon Hill in the British Museum. *Journal of the Royal Society of Antiquaries of Ireland* 89, 31-33.

Ó Ríordáin, B. and Waddell, J. 1993. *The funerary bowls and vases of the Irish Bronze Age*. Galway University Press.

O'Sullivan, J., Hallissey, M. & Roberts, J. 2002. *Human Remains in Irish Archaeology: legal, scientific, planning and ethical implications*. The Heritage Council: GUARD.

Raftery, B. 1974. A prehistoric burial mound at Baunogenasraid, Co. Carlow. *Proceedings of the Royal Irish Academy* 74C, 277-312.

Raftery, J. 1940. Bronze Age burials at Halverstown, Co. Kildare. *Journal of the Royal Society of Antiquaries of Ireland* 70, 57-61.

Waterman, D. 1968. Cordoned urn burials and ring-ditch at Urbalreagh, Co. Antrim. *Ulster Journal of Archaeology* 31, 25-32

Table 1

**Pottery vessels from Ballon Hill**

Abbreviations

NMI-National Museum of Ireland

BM-British Museum

**Reference No. Pottery Vessel Type**

**Description Descriptive reference  
Approx. Date ranges after  
Brindley 2007**

NMI 1928:430 Bowl Almost complete but in fragments. Decorated with incised horizontal lines and false relief. Comb impressions occur on the rim bevel and some of the short lines of the exte-

rior, seemingly impressed, contain faint comb marks. Impressed or incised ornament occurs on the base. Ó Ríordáin and Waddell 1993 2200-1800 BC

NMI 1928:431 ? Plain Anomalous vessel, plain; buff-coloured with thick, heavy fabric. Ó Ríordáin and Waddell 1993 ?

NMI 1928:432 Vase Small vessel with five imperforate lugs. Decorated with incised ornament. Ó Ríordáin and Waddell 1993 2150-1700 BC

NMI 1928:433 Vase Decorated with impressed or incised ornament. Rough triangular impressions occur near the base. Ó Ríordáin and Waddell 1993 2150-1700 BC

NMI 1928:434 Vase Decorated with incised lines and false relief, a raised rib emphasises the shoulder. Ó Ríordáin and Waddell 1993 2150-1700 BC

NMI 1928:435 Bowl Decorated with false relief and comb impressions Ó Ríordáin and Waddell 1993 2200-1800 BC

NMI 1928:436 Vase Decorated with incised lines. Ó Ríordáin and Waddell 1993 2150-1700 BC

NMI 1928:437 Bowl Decorated with incised or impressed ornament Ó Ríordáin and Waddell 1993 2200-1800 BC

NMI 1928:438 Bowl Decorated with lightly grooved or impressed short lines and incised horizontal lines. Ó Ríordáin and Waddell 1993 2200-1800 BC

NMI 1928:439 Vase Anomalous vase, ribbed with some incised ornament. Ó Ríordáin and Waddell 1993

Carloviana 2012

2150-1700 BC

NMI 1928:440 Vase Finely decorated with false relief, horizontal whipped cord impressions and comb impressions on the interior of the neck, the exterior bears comb-impressed lines, triangular impressions (executed with a wooden implement- the grain of the wood being visible) and whipped cord forming horizontal lines. Ó Ríordáin and Waddell 1993 2150-1700 BC

NMI 1928:441 Collared Urn Only the collar and 5cm below survive from this vessel. The collar is deep, measuring 8cm. The rim is slightly bevelled and decorated with three rows of cord impressions. Below the collar are two rows of possible bird-bone impressions. The ware is coarse but well smoothed over. It is buff in colour with large sections blackened. Kavanagh 1976 1730-1500 BC

NMI 1928:442 Collared Urn Portions of the collar only survive from this vessel. The collar measures 8cm and decoration consists of six rows of cord impressions arranged about 1cm apart. The ware is coarse with large grits and buff coloured. Kavanagh 1976 1730-1500 BC

NMI 1928:443 ? Pottery vessel None Unknown

NMI 1928:444 Cordoned Urn This is a large vessel with two thick applied cordons. The rim has a deep internal bevel the lower edge of which is moulded into a slight cordon. Two lines of horizontal cord are used to decorate this area. There is also an external bevel on the rim at the lower edge of which there is also a slight moulding. One line of cord is impressed under it. Immediately below this raised ridge is a further fine of cord. The first cordon is applied a distance of 10.6cm from the rim. Within this area a broad chevron motif is impressed in twisted cord. The second cordon occurs

## ARCHAEOLOGY OF BALLON HILL

<p>about mid-way down the vessel. The ware is extremely coarse with large grits, but is well smoothed over. It is pink in colour. Kavanagh 1976 1730-1500 BC</p>	<p>NMI 1928:446 ? Pottery vessel None Unknown</p>	<p>BM 1920,11-9,3 Vase Incised decoration with a drum-shaped base. Vessel was restored. Ó Riordáin; Ó Riordáin and Waddell 1993 1959 2150-1700 BC</p>
<p>NMI 1928:445 Cordoned Urn Only the upper portion of this vessel survives. One cordon is all that is now visible. The rim is flat and undecorated as is the rest of the pot. The cordon occurs at c. 7cm below the rim. The ware is gritty but compact and is buff in colour. Kavanagh 1976 1730-1500 BC</p>	<p>NMI 1928:447 Vase (probably) Numerous small fragments of a probable vase bearing incised ornament. Ó Riordáin and Waddell 1993 2150-1700 BC?</p>	<p>BM 1920,11-9,4 Vase Miniature vase with finely incised ornament and five imperforate lugs. Ó Riordáin 1959; Ó Riordáin and Waddell 1993 2150-1700 BC</p>
	<p>BM 1920,11-9,2 Vase Decorated with incised lines and incised or impressed short lines. Suffered damage during World War II Ó Riordáin 1959; Ó Riordáin and Waddell 1993 2150-1700 BC</p>	

## A Museum is Born

Jake Duggan

The story of County Carlow Military Museum is quite interesting. We have all heard the stories of Carlow and the First World War and Carlow and the 1798 Rebellion, but we have little knowledge of the history of the places that display these facts. Carlow can say with pride that it is one of an exclusive few counties that have their very own designated military museum and this is how it happened :

County Carlow Military Museum all began with one man , Donal “Donie” Cunningham. He was a member of D company in the FCÁ in Carlow from the early 1980s up until 1985.

In 1985 Donie joined the United States army. He had kept in close contact with his friends in the FCÁ . After completing his helicopter pilot training , he served in the Gulf War. He served through Desert Storm and Desert Shield.

Donie was tragically killed in a helicopter crash off the coast of Cyprus.

When the members of D company found out what had happened they debated what to do about the friend that they had lost. They came to the conclusion that a case with his uniform on display would be the best way to commemorate their friend and on December the 8<sup>th</sup> 1995 an open night was held, which was attended by Donie’s family and representatives of the United States Army , for the unveiling of the case with his uniform.

With this the first step towards a County Military Museum was taken. The people of Carlow rallied when they heard that military artefacts were present and soon more items and stories were dusted off and soon the original items became far out weighed by everything and anything that fell into the golden criteria of being both Carlow and military related.

Another case was made to house this fledgling collection , and by this point more and more people had gotten involved. This collection was now getting too big for the FCÁ hut and was in dire need of relocation to “a place of its own”.

So in the late 1990s negotiations were afoot to find a permanent home for what was to be a dubbed “The Military Museum”. There was a premises acquired , the “Old Church” in the grounds of St. Dymphna’s Hospital, and the County Carlow Military Museum was formally opened in the year 2001 , six years after the original case containing Donie’s uniform.

The museum has gone from strength to strength since 1995 and houses the life stories and adventures of Carlovians in uniform. It has given people a place to hang their uniforms with pride after years of service , to intrigue and captivate imaginations of the old and the young , no matter what country they served with.

You can still see Donie’s uniform on display in the County’s Military Museum. It might serve as a gentle reminder that from small beginnings great things can come to be.



## Vallancey's military surveys of 1776-1777 & 1796 as relating to County Carlow and its immediate environs.

Edward J Law

The British Library holds manuscript material, originally part of the topographical collection of King George III of England, relating to military surveys of Ireland undertaken from 1776 to 1782 by Charles Vallancey.<sup>1</sup>

Lieutenant-Colonel Charles Vallancey was born c1725 in Flanders, of a Huguenot family, and educated at Eton and the Royal Military Academy, Woolwich, England, before joining the army. In 1750 he came to Ireland with his regiment, where he spent the remainder of his life as a career soldier pursuing military surveying and engineering. In this he received encouragement from Viscount Townshend, Lord Lieutenant of Ireland 1767-72, who had been a contemporary at Eton College.<sup>2</sup>

The origin of the surveys are set out in Vallancey's introduction to his survey of 1776:

To His Majesty.

May it please your Majesty.

In obedience to your Majesty's commands, I have commenced a military survey of that part of Ireland, being south of the bays of Dublin and Galway, comprehending the harbours of Dublin, Wexford, Waterford, Dungarvan, Youghal, Corke,<sup>3</sup> Kinsale, Bantry, Kenmare and Galway, the coast adjoining said harbours, the roads leading from each of these parts to Dublin, and the cross-roads leading from each to the other. The Execution of this survey, I humbly propose to

divide into five parts.

The survey covers much of southern Ireland with material in particular on counties Carlow, Cork, Kilkenny, Tipperary, Waterford and Wexford. The material is presented not primarily for its military interest but for the topographical descriptions it gives in support of the strategies and tactics being promoted, in which it has much to interest the local historian.

The extracts presented here relate to County Carlow, and it is hoped to publish papers relating to the other counties elsewhere. In addition to the survey of 1776-7 Vallancey also undertook a similar survey in 1796, with updates in 1797, which he named the military itinerary, a manuscript version of which is held in the British national archives.<sup>4</sup> This later account incorporates much of the material from 1776-7, but updated with regard to subsequent events particularly the war between France and Britain which broke out in 1793, and the French expedition to Bantry Bay in December 1796. This article, which deals fully with the former surveys, incorporates, as footnotes, extracts of updated and new material from that of 1796.

Although Vallancey informed the King that he would present the survey in five parts it appears that only three of the five were completed, and only two of those three divisions are relevant to this paper:

The first to extend from Arklow, eastward along the sea coast to Wexford and Waterford harbours, up the eastern side of Waterford harbour, to the conflux of the rivers Sure and Barro; up the eastern

side of the Barro, to Leighlin-bridge, distant from Dublin 44 miles, and to express all the chief roads and military objects contained in this surround. The second, to extend from Leighlin-bridge along the western side of the River Barro to Waterford and Passage; along the sea coast to Tramore, Dungarvon and Youghal; up the river Blackwater (by Youghal) to Cappoquin; and from thence across the mountains to Clonmel, up the river Suir, from the conflux of the rivers Sure and Barro to Clonmel, Cahir, Thurles and Roscrea; from thence across the country to Maryborough distant from Dublin 39 miles.

...

Each division or survey to be contained in a separate report, and when finished, the whole to be blended in one survey.

The object of the survey was to provide strategies and tactics to oppose an enemy either before disembarking in Ireland or after an invasion. Vallancey noted that if an enemy intended to invade the island with a force sufficient to take possession of it for some time he would need to assemble 20 or 30,000 troops on the coasts of France or Spain, and amass transports in proportion, and a fleet to convey them. Preparations of that order could not be effected without coming to the attention of the British who would be able to prepare to meet them at sea, or certainly on the coast of Ireland.

## VALLANCEY'S MILITARY SURVEYS

With this expression of confidence he moved on to his survey of the routes which an enemy might take if he were able to land any force on the south east coast. He made a concise summary of the navigable rivers and their crossings. The Barrow was navigable to Leighlin Bridge, and for small boats to Carlow, and the tide flowed to Saint Mullins within a mile and a half of Graignamanagh. The Suir was navigable to Clonmel, twelve miles above Waterford, and the tide flowed near to Carrick, seven miles above Waterford. The Slaney was navigable to Enniscorthy, with the tide flowing near to that town. On the Nore the tide flowed to Inistiogue and was navigable to Thomastown. The first bridges over the rivers were at Graignamanagh on the Barrow; at Carrick on the Suir; on the Slaney it was at Enniscorthy; and on the Nore at Inistiogue. Vallancey records that 'these rivers being not fordable from the sea to the above bridges, or near them, consequently they form so many obstacles to an enemy, moving from any part of the sea coast contained between the harbours of Waterford and Wexford.'

Duncannon fort is discounted as 'a very trifling defence' and he allows that an enemy well acquainted with the rivers Barrow, Nore and Suir, taking advantage of the half flood, could convey his troops, cannon and baggage to Waterford, Ross and Inistiogue, if not to Graignamanagh, on the one tide.

Writing in general of the country in the survey he notes that it

is well inhabited, well cultivated and inclosed, the tops of some mountains excepted. The inclosures are small, and fenced with a double ditch, and a hedge of furze, which grows to a great height, and is the common fuel in a country which has so little bog-turf, these fences render it very difficult for cavalry to pass anywhere out of the high roads. The land abounds with grain, black cattle and sheep: the cattle are driven to the mountains during the summer season, a circum-

stance much in our favour in a country where nine tenths of the inhabitants would meet an enemy with open arms. The roads in general are good.

Vallancey's trained military observation is informative on the sizes of towns and villages, the nature of housing, shipping, waterborne trade, local roads and landscape, farming and crops. The following is extracted from the notes accompanying plate 3 of his survey:

Of the Rivers Barro, Nore & Sure; and of the roads leading from the mouth of Waterford Harbour to Dublin, by Ross, Graignamanagh and Leighlin Bridge.

The conflux of the rivers Barro & Sure forms the harbour of Waterford, this conflux is called parting water; it is 12 miles distant from the harbours mouth, and 4½ miles from Duncannon Fort; at this conflux the river Barro departs from the Sure in a direction to the North East.

10 miles above this conflux the River Nore discharges into the Barro on the western side.

Eight miles above parting water, and on the eastern banks of the Barro, stands the town of Ross, and 12 miles above Ross is the village of Graignamanagh, at which place is the first bridge over the river Barro, next the harbours mouth.

Seven miles above Graignamanagh is Gores Bridge, the 2<sup>nd</sup> pass over this river; from thence to Bagnels Bridge, or Royal Oak, is four miles and a quarter, and 2¾ miles above this is Leighlin Bridge, the 4<sup>th</sup> pass over the Barro—these distances are taken by water.

The Barro rises in the bog of Allen, is navigable

at all seasons for boats carrying 8 tons, from the sea to Carlow, for boats of 5 tons burthen to the town of Athy, and so little fall has this river, that in time of floods, and in winter, it is navigable for boats of like burthen to the town of Munstereven, distant from Dublin only 30 miles.

The tide-water flows to St Mullins, 10 miles above Ross; from St Mullins to Graignamanagh the navigation is continued by means of 3 small canals, the rest is a river navigation. From Graignamanagh to Leighlin Bridge and Carlow, the passage is not so easily performed on account of some sharps. The boats are towed over these by force of men; the usual allowance is one man to each ton burthen, besides the boats crew, which consists of 5 others.

#### *Boats on the Barro*

These boats are 45 feet long, 8 feet wide, and draw about 22 inches water when loaded<sup>s</sup>: there are 70 boats belonging to Graignamanagh, about 20 to the Nore, and as many between Graignamanagh and Leighlin Bridge which are constantly employed in transporting coals from the pits near Athy to Ross, where the coals are shipped for Dublin and other towns on the coast.

#### *Are fit for ponton bridges.*

As these boats will conveniently carry 40 men each, and are convenient either for passing these rivers or for transporting baggage and artillery, they become a great military object in time of war, especially if an invasion is expected; and the construction of these boats being very uniform, they are preferable to pontons

for a bridge. Each boat is furnished with a mast and sail, and by taking advantage of the tide they run from Graignamannagh to parting-water in one tide.

The heading *Towns and villages of the Barro described* encompasses, Ross, Graignamannagh and Goresbridge as well as the Carlow towns:

Bagnells Bridge consists of one good public inn, known by the name of the Royal Oak, and about 20 cabbins.

Leighlin Bridge is the great pass over the river Barro from Dublin to all parts of Munster, the village consists of one large inn, about 30 stone built houses, 2 large breweries, and about 150 cabbins; it is situated on each side of the river, and would canton 500 infantry and 200 cavalry.

His notes accompanying 'plate 4' commence:

Of the road from Graignamannagh to Leighlin Bridge, being a continuation of the road from Ross to Dublin through Polemonte.

The enemy finding it impossible to force Graignamannagh bridge, will hasten to pass through the defile formed by the river Barro and the Black mountains, and will push on the eastern side of the Barro, through Burris towards Leighlin Bridge.

In this movement of the enemy we must not omit to take advantage of the Scallagh pass, through which our troops from Enniscorthy, Wexford, Tullough etc. will have a fair opportunity of falling on his flank; and by means of this pass, we might take the like advantage over his rear, during his attack on

Graignamannagh bridge.

Should the enemy have passed Burris, we may reap the same advantage, by turning round the mountain by the road to Dunlackney etc. instead of passing by Rathgarran towards Graignamannagh. Detachments should likewise be sent from Bunclowdy and Clonegall to pass round mountain Leinster, to fall into the great road to Dublin; but it must be observed, that when the enemy has passed the village of Burris, the country opens, and he can no longer be said to be in a Defilee.

From Burris (a very inconsiderable village) there are two good roads to Leighlin Bridge; one runs nearly parallel to the river Barro, the other branches off to the right, opposite the angle of the Park wall of Burris, this leads round the hills of Knockmahon, Killgrany and Killcarig, which are well situated to command both these roads, and do at the same time secure the passes over the Barro at Goresbridge and Bagnells Bridge.

Should the enemy find so much opposition, as to attempt the pass of the Scallagh, in order to penetrate on the eastern side of that great range of mountains, he will be much embarrassed. To explain this more, a particular survey of the Scallagh pass, and of the roads from thence towards Dublin, is annexed to this report in Plate 7.

The country from Graignamannagh to Leighlin Bridge, particularly from Gorebridge, is much inclosed and cultivated. The roads are numerous and good; the villages too

small to become an object for the cantonment of an army, or for yielding subsistence. Provisions, in this and every other improved part of Ireland are scattered up and down in farmers houses, yet when collected, become plentiful. For this reason large flower mills with extensive granaries, have of late years been erected in every county, and in this track are two, one at Bagnells bridge, whose granary will contain 1000 barrels of wheat; and another at Leighlin bridge, where are likewise several smaller mills, whose produce may be together estimated equal to the former.

In a concluding statement to his description of the first division he clarifies his statements on the numbers capable of being billeted or cantoned in the various towns and villages and makes pre-emptive excuses for any omissions he may have made:

Wherever I have mentioned the number of Troops each Town or Village will canton, I beg leave to be understood, that every building which can protect a Soldier or a Horse from the inclemency of the weather, is on such emergency turned to that use. On every other occasion, as assembling Troops for Exercise, or on a march through the Country in time of Peace, two thirds of these numbers must be deducted, that neither the Troops or the Inhabitants may be distressed.

In a work of so extensive a nature as this Survey, executed without the least Assistance, I humbly conceive some omissions may be expected in the Field. Excess of fatigue, bad accommodations in the Coun-



VALLANCEY'S MILITARY SURVEYS

try, and new objects arising each moment to view, are apt to lead from the original Plan of the work; and the deliberate reflections of the Closet may point out objects of importance, which did not strike in the Field.

In drawing up this Report from my Field Notes, it occurs, the River Slaney, from the Town of Ennis-corthy to the Harbours mouth, and the road on its bank from that Town to Wexford, should have been contained in this Survey. I humbly propose to blend the succeeding Survey with this, and to add the Plans omitted.

a l l  
which is humbly submitted.

Charles Vallancey Lieut:  
Colonel and

Director of Engineers.

The second division of his survey was presented to George III in 1777 when he wrote

In obedience to your Majesty's Commands I have completed the second division of the Military Survey of Ireland, extending coastways from the Harbour of Waterford to the Harbour of Youghal, and in-land to the Towns of Cashell and Kilkenny, containing about 1200 square miles; and in obedience to your Majesty's special command, I have also surveyed the Harbours of Corke and Kinsale, the Environs and Coast adjacent, which Surveys I have now the honour of laying before Your Majesty together with the following observations.

In my Report of the first division of this Survey, the

Enemy was supposed to have landed on the Eastern shore of Waterford Harbour, and to have pressed forward towards Dublin; the opposition, may be made to the Enemy in that Route, has been fully explained in that Report.

The Enemy is here supposed to enter the same Harbour with intention, to fall on the Town of Waterford; to push to the Town of Kilkenny; to attempt the pass over the River Suire at Carrick; and lastly to make good a junction with another body of his Troops, landed at Corke.

The following are extracts of his observations and strategies in relation to the movements which an enemy could make having gained possession of Waterford city, insofar as they relate to Carlow.

We will now suppose the Enemy in possession of Waterford, Ross and Carrick meditating to move Northwards to fall on Kilkenny, or Westwards along the Suire towards Limerick, or Southwards towards Corke; these are the only movements he can possibly make from Waterford.

*Boats on the Suire, Nore and Barro. Should be seized when a descent is expected.*

On the rivers Suire, Nore and Barro, between Carrick, Ennistearg and Graignamanna, there are about 200 flatbottomed boats, of 8 and 10 tons burthen, constantly employed; The greater part commonly remain at the Quays of Waterford waiting for Cargoes. Should these be assembled in the Harbour, they might give such assistance to the Enemy, as to enable him to reach the bridges of Carrick, Ennis-

teague and Graig, with the same tide of flood which brings him in, and the next day be Master of Kilkenny, Carlo etc.

<sup>1</sup> British Library, maps: 51 Top L1 31-2 6 Tab 35 The harbours of Cork & Kinsale, the environs & coast adjacent, 1778; 51 Top L1 31-2 6 Tab 36 Report on the 1<sup>st</sup> part of the survey, 1776.

<sup>2</sup> Many articles have been written about Vallancey, among the most important are:

J. H. Andrews, 'Charles Vallancey and the map of Ireland', *Geographical Journal*, 132 (1966), 48-61  
Monica Nevin, General Charles Vallancey 1725-1812, *Journal of the Royal Society of Antiquaries of Ireland*, Vol. 123, 1993, pp19-58.

Monica Nevin, The defence of the southern part of Ireland by General Vallancey, Chief Engineer, *Journal of the Royal Society of Antiquaries of Ireland*, Vol. 125, 1995, pp 5-9.

William O'Reilly, Charles Vallancey and the *Military Itinerary* of Ireland, in Proceedings of the Royal Irish Academy, Vol. 106C, pp 125-217

Norman Vance, 'Vallancey, Charles (c.1726-1812)', *Oxford Dictionary of National Biography*, Oxford University Press, 2004; online edn, Jan 2008

[<http://www.oxforddnb.com/view/article/28051>]

<sup>3</sup> The original spelling of the manuscript has been retained in quotations therefrom.

<sup>4</sup> The National Archives, Kew, WO 30/63.

<sup>5</sup> 1796. Records the same dimensions whilst noting that they drew only 20 inches of water and could hold 50 men. It also notes that there were about 500 canoes, called cots, which contain three men each and 'are used only during the fishing season for salmon and remain in the ditches and meadows the remainder of the year'.

Historic Howler

A second year Junior Cert pupil writing about nineteenth-century fashions stated, "Women wore corsets so tightly laced that they were unable to breed(sic) in them."

The teacher returned the work with the comment, "This is probably accurate, but I doubt if it's what you meant to say."

[ Name and address of perpetrator with editor, who can vouch for the truth of the above, since he was the teacher in question.]



## A History of Brigidine Foundations in Roscrea, Ireland and Kenosha and Titusville, America

Anne Power

Founded in Tullow, Co. Carlow in 1807 by Daniel Delany, Bishop of Kildare and Leighlin the Brigidine sisters were the second indigenous religious congregation, after the Presentation sisters, to be established in Ireland. While there is documentary evidence on the foundation of the houses in the diocese—Tullow (1807), Mountrath (1809), Abbeyleix (1842) and Goresbridge (1858)—there is little material on the foundations made outside the diocese—Roscrea (1823), Cashel (1827) and Castlecomer (?-1829). It frustratingly illustrates that possibly nuns then did not take the occasion and their experience sufficiently seriously to bother to write it down in any detail or ‘worse’, as Lavinia Byrne proposes, ‘they kept silent out of a warped desire to avoid vainglory’.<sup>i</sup> This same silence is applicable to the establishment in 1851 of the first Brigidine institute in America at Kenosha, Wisconsin. Mystery surrounds this venture and lack of documentary material makes it all the more tantalisingly so.

### Roscrea (1823-42)

Within seven years of Bishop Delany’s death there was a Brigidine foundation in Roscrea in the diocese of Killaloe. Strangely, neither the Tullow nor Mountrath annals make any mention of this 1823 foundation. There is however, a rather pointed reference in the Mountrath annals to the dismissal in 1823 of two nuns, Sisters Gertrude (Kate) and Magdalen (Brigid) Delany who ‘were sent out of the convent for insubordination by Doctor Doyle’. The profession book also has the same addendum to their names that they were ‘dismissed by Doctor Doyle for insubordination’.<sup>ii</sup> These two-brief references are rather strange given

that the two Delanys, blood sisters from Ballyfin, were experienced nuns having entered in Tullow in 1808. Transferred to Mountrath convent in 1810 they were among the first group of Mountrath nuns to make their perpetual vows in 1822 to Bishop Doyle. Some enlightenment is thrown on the mystery of their ‘dismissal’ by the discovery in 1997 of a manuscript among the papers of Father Edmund Dobson of Saffron Walden parish, England.<sup>iii</sup> The manuscript stated that Sisters Gertrude (Kate) and Magdalen (Brigid) Delany established a Brigidine congregation in Roscrea in 1823. Father Dobson had previously lived in the Cistercian monastery at Roscrea. It seems a reasonable inference to make that the setting up of the Roscrea foundation was forgotten (such a foundation would be an independent house and in a different diocese) and that insubordination was used in the later annals and profession book as an explanation for their disappearance from the convent records.

This may have been the understanding of the fate of Sisters Magdalen and Gertrude Delany but a recent discovery by the author provides a totally different picture and appears to show that they were not guilty of insubordination but rather had Bishop Doyle’s permission for the foundation in Roscrea. There is an enlightening reference to ‘Magdalen and Gertrude leaving the house’ in the accounts book for 1823 accompanied by what appears to be a list of articles needed to furnish a new foundation.<sup>iv</sup> Included in the list are: two beds, two pairs of blankets, two quilts, three pairs of sheets, twenty-nine yards of stuff, three yards of flannel, four gowns, four cloaks, a lock and key.<sup>v</sup> Sister Magdalen was also given cash to the value of £1 while Sister Gertrude was given 2s.6d for her visit to

Tullow convent. We are not given any explanation as to why she visited Tullow but the journey there and back cost £1.6s.7d. The total outlay by the Mountrath convent for the two nuns was £7.19s.5d. It can be assumed, if this expense can be taken as referring to the Roscrea foundation, that they had Bishop Doyle’s permission for the venture as he ‘examined and approved’ and signed the account book on his visitation shortly afterwards.<sup>vi</sup> It is hardly credible that Bishop O’Shaughnessy of Killaloe would accept into his diocese two nuns dismissed by such a noted bishop as Doyle to set up a foundation from a house from which they had been dismissed. Although there are two letters in the diocesan archives from O’Shaughnessy to Doyle, they contain no reference to the Brigidines.

Ignatius Murphy in his book *The Diocese of Killaloe* and A. McAndrew in her article the ‘History of the National school, Roscrea’ both state that James O’Shaughnessy (d.1838), parish priest of Roscrea (1810-38) went to the Brigidine convent in Mountrath to persuade the sisters to establish a convent school in his parish.<sup>vii</sup> O’Shaughnessy had been promoted to this key parish by his uncle Bishop James O’Shaughnessy, who with his strong sense of family had no qualms about promoting his nephews and grandnephews to the key parishes in the diocese.<sup>viii</sup> In opening a convent school, O’Shaughnessy wished to combat the proselytising influence of the six Protestant schools in his parish.<sup>ix</sup> Among the six schools, there was an Erasmus Smith school which had twenty-eight Catholic children and a ‘notorious’ charter school in Dunkerrin parish.<sup>x</sup> In all there were ninety-four Catholic children attending Protestant schools.<sup>xi</sup> The two

## BRIGIDINES IN ROSCREA AND AMERICA

Delanys answered the call to become the founding members of a new religious house in Roscrea.<sup>xiii</sup> With ten years experience of convent life, theirs was the first convent for women in Killaloe diocese since the Reformation.<sup>xiiii</sup> The nuns arrival in Roscrea was the beginning of a new era of an active apostolate in the diocese of Killaloe but in this they were continuing their experience already established in the diocese of Kildare and Leighlin,

No particulars of the foundation survive except that O'Shaughnessy gave them a house in Rosemary St where they held school.<sup>xiv</sup> Whether O'Shaughnessy continued to fund the project is unknown, but in a short time increasing numbers necessitated a move to a house in Abbey St near the ruined Franciscan friary.<sup>xv</sup> They were forced to move a third time this time to larger premises in Limerick St where they began to keep boarders as well as continuing their work among the poor children. The success of their work and the need for more postulants was recognised by Father Bannon who sought aspirants in Dublin.<sup>xvi</sup> One such was Anne Marie MacMahon (1791-1866) who, because of her devotion to the Sacred Heart, wished to become a nun of the Visitation order.<sup>xvii</sup> There was no house of the order in Ireland and on being told of the Brigidine devotion to the Sacred Heart, the 36-year-old agreed to join the community in Roscrea.

While this devotion brought her to the Brigidines it would also impact on their later history. In 1862 Mother Adele Delvaux heard the story of the beginning of this devotion from Mother Teresa MacMahon (Anne Marie) then in her seventies. She explained that as a young girl she had an extraordinary experience while at prayer after mass in the Jesuit church in Dublin. The congregation had left when suddenly a priest, vested for mass, appeared from the sacristy. He signed her to come near, which she did, supposing that he wished her to answer his mass. When she knelt down, however, he placed his hands on her head and said 'You must have great devotion to the Sa-

cred Heart and through you the devotion will spread in Ireland'. Then he taught her a prayer which she was to recite daily. After many repetitions the words were so stamped in her memory that she never had the least trouble afterwards in saying it by heart. When she raised her head the priest had disappeared and though she often visited the church she never saw him again. She knew this prayer afterwards as the act of Reparation composed by St Margaret Mary. It was this promise to spread devotion to the Sacred Heart which, when told by Father Bannon that Bishop Delany had made this devotion an important feature of his institute, inclined her to the Brigidines.

She entered Roscrea convent in 1826 three years after its establishment. Within six years this most remarkable woman, in religion Mother Teresa, was superior and in 1832 was responsible for the move of thirty boarders and a hundred day pupils to the impressive Air Hill House with its beautiful grounds within five minutes walk of the town.<sup>xviii</sup> Teresa MacMahon had quietly entered into negotiations with its owner a local Protestant named Smith who had got into financial difficulties.<sup>xix</sup> According to Margaret Gibbons, Smith hoped to get a good price from interested Protestants but that pressure was put on Smith to sell to the sisters by a Mr Scroope, his Catholic friend, by 'other men of weight and influence' and by Lord Portarlington, who had large interests in the town.<sup>xx</sup> Against all expectations he sold the property to her and, significantly, she renamed it Mount St Joseph acknowledging the historical link to Mountrath. Murphy states that the Roscrea community was well established at this juncture and had a plentiful supply of vocations.<sup>xxi</sup>

The community seems to have attracted the well educated more middle class girls that Delany desired as the report of a Brigidine reception ceremony of the 6 August 1838 in the *Clare Journal* shows. Two sisters made their profession while three young women, one of them a niece of Bishop Kennedy, were received

into the order. The reception ceremony, held in the parish chapel, was considered such a noteworthy event that it was reported on in detail:

Immediately after last mass, at which the excellent choir of Roscrea chapel performed some choice and splendid pieces of sacred music, a procession of young ladies bearing wax tapers in their hands, and dressed in beautiful garbs of virgin white, proceeded from the sacristy, while in the rear, followed the lovely young lady about to be received, decorated in all the splendour which taste and fashion could desire. She knelt at the foot of the altar, and in a firm and audible voice, in answer to the Reverend Mr Blake, the officiating clergyman, bid adieu, forever, to the wiles and vanities of this transitory world, and nobly took up the cross to follow in the footsteps of the divine Redeemer. To those who have never witnessed the sublime and soul-stirring rites of the Roman Catholic church, this would have been of intense interest.<sup>xxii</sup>

By 1842 the paper noted the 'the increasing and marked success' of the Brigidine convent in Roscrea. In 1842 the *Catholic Directory* carried a more detailed advertisement for the Brigidine boarding school than had appeared in the 1838 advertisement—Tullow and Mountrath had only got permission to establish boarding schools in 1837.<sup>xxiii</sup> It cost £18 per annum for girls under 12-years of age and £20 per annum for those over 12-years. Its syllabus offered English and French, history, geography, grammar, writing, arithmetic, the use of globes, drawing, needlework, both plain and ornamental. The sisters also continued their work among the poor. Their work drew this comment from the *Limerick Reporter* of



18 February 1842: 'It is impossible to estimate the benefits conferred on the poor children of this district by the benevolent and untiring exertions of the ladies of this community'.<sup>xxiv</sup> At this time there were eight professed sisters, seven novices, and one lay sister in the community.<sup>xxv</sup> But the community suffered a devastating loss in 1841 with the sudden death of Carlow native Agnes Hughes, a gifted French mistress and 'the life and soul of the school, the greatest support in the community'.<sup>xxvi</sup> Her death, which made the need to find a replacement French teacher an imperative, would have unforeseen consequences for the Brigidine convent.

While the convents were independent of each other, there is no record of Teresa MacMahon attempting to seek help from either Mountrath or Tullow convents or of any correspondence whatsoever between the convents as would have been Delany's wish. Instead, at her request the parish priest wrote to his friend Doctor O'Halloran, Rector of the Irish College, Paris, seeking a French girl who would come to Roscrea on an au pair basis to teach French in the school.<sup>xxvii</sup> O'Halloran who regularly said mass at the convent of the Sacred Heart, Rue de Varennes, consulted Mother Charlotte Goold (1804-49), who was French-born of Irish parentage on the matter.<sup>xxviii</sup> This meeting was the prelude to momentous change for the Roscrea Brigidines. It coincided with the desire of the founder of the Society of the Sacred Heart, Madeleine Sophie Barat, to establish foundations in England and Ireland.<sup>xxix</sup> The practical reasons for the foundations were firstly that they would provide English-speaking members for the society, who in time would help the foundations in America and Australia and secondly Ireland was seen as a way into Protestant England which was both a challenge and mission for Barat.<sup>xxx</sup> She wrote on 19 February 1842:

Of the two locations offered the [English] one would be the more acceptable than that in Ire-

land as far as pupils are concerned. As for postulants, we would attract many more in Ireland! Also, it would be a true work of Providence to catch both. So may the little mother [Eugénie de Gramont] give good instructions to Mother Croft, whom she is sending there, so that these two fish fall into the nets of the Sacred Heart.<sup>xxxi</sup>

It wasn't just England's enemies who saw Ireland as the backdoor of England. Goold who knew of Barat's intention is said to have proposed a Brigidine affiliation to O'Halloran who submitted the proposal to a surprised Teresa MacMahon and her community.<sup>xxxii</sup> Events moved rapidly on the transfer of the Brigidines. On 7 March 1842 Teresa MacMahon wrote to Eugénie de Gramont, the provincial of the Sacred Heart order in Paris:

It gives me great pleasure to perceive that the proposal has been favourably received by your community and I trust that nothing will occur to prevent its being carried into effect. Although I am fully confident that there is nothing in the rules of your order which would render it unsuitable to the circumstances of our community, yet I am desirous of having a copy of those rules, previously to our making any further arrangements, in order that each sister of the community may have a close knowledge of the duties and obligations of the order previously to her entering it. With regard to the pecuniary circumstances of our convent, we are not rich, but we are however independent and our prospects are most favourable. I am confident that our affiliation to the order of the Sacred Heart, the very name of which is much venerated in Ireland, would be of great advantage to our establishment....<sup>xxxiii</sup>

Bishop Kennedy visited the convent in Paris on his way back from Rome. There he formed a favourable impression of the community and on his return to Roscrea, Kennedy wrote to Paris in April stating that the project had his 'entire and hearty approbation'.<sup>xxxiv</sup> On 14 May 1842, two French representatives, Charlotte Goold and Elisa Croft arrived in Roscrea from England where they had been engaged in plans for a foundation at Berrymead and outlined the details of the proposed amalgamation.<sup>xxxv</sup> After two days the representatives left to give the community space to consider the amalgamation. Croft stayed at the Ursuline convent in Cork while Goold returned to France. In response to Goold's appraisal of conditions in Roscrea, Barat wrote that 'the details you give me are not very satisfactory still, if Jesus wills that the society begin in a Bethlehem, may the will of Jesus be done'.<sup>xxxvi</sup> Not all in Roscrea were in favour of the change including the parish priest Dr Blake, some of the nuns and some parents of the boarding school children.<sup>xxxvii</sup> Dr Blake, however, seeing the change as the will of God gave his consent as did the parents who were reassured that the boarding school would continue. With ample resources of its own, the Sacred Heart congregation could afford the large capital outlay for the continued upkeep of the boarding school.<sup>xxxviii</sup>

On the 23 June 1842 Elisa Croft returned to Roscrea to initiate the changes necessary for the transfer and by August 1842 all the arrangements were completed.<sup>xxxix</sup> She was appointed superior of the first Sacred Heart foundation in Ireland while Teresa MacMahon gave over her authority to her new superior and became a novice again at 52-years of age all the while both assisting Croft in every way and helping her former charges to adapt to the new rules and customs.<sup>xl</sup> On 21 November 1842 fifteen former Brigidines received the habit of the Society of the Sacred Heart thus ending a successful nineteen year Brigidine pres-

ence in Roscrea.<sup>xii</sup> This most unusual transfer of an entire community from one congregation to another was facilitated by the fact that the Brigidines had as yet not received papal approbation and that the Roscrea community was an independent unit in a different diocese under the direction of Bishop Kennedy and had no links with Tullow and Mountrath other than the common rule of life given by Bishop Doyle in 1828 and the remembered experience of Bishop Delany brought to Roscrea by the two pioneers, Sisters Gertrude and Magadalen Delany. Mystery surrounds their further history as there is no record of them in the Society of the Sacred Heart's archives. Murphy suggests that by 1832 with the convent well established that they returned to Mountrath while McAndrew says that when the Mountrath sisters were recalled, Teresa MacMahon was made superior. However the two did not return to Mountrath and it seems reasonable to suggest that were among a number of the Brigidine sisters buried in the parish graveyard, the wooden crosses marking their graves having disappeared before they were reinterred in the Sacred Heart convent graveyard.<sup>xliii</sup>

The success of the two Delany sisters in establishing a Brigidine convent, parish and boarding schools in the very heart of a Protestant locality ought not to be forgotten but celebrated as a proud Brigidine achievement.

#### **First Brigidine foundation in America (1851-1869)**

an ill-starred and somewhat uncanonical group<sup>xliiii</sup>

According to a brief reference in the Mountrath annals two professed sisters Angela McKay, a choir sister, and Mary Anne Foran, a lay-sister left the convent to make a foundation in America.<sup>xliiv</sup> It is intimated that this was at the behest of Angela McKay's brother who was believed to be a priest. This reference, however, is not corroborated by Maureen Funk in her history *Kenosha's Irish Ex-*

*perience 1839-1890.*<sup>xlv</sup> In her essay she states that Father Michael McFaul, pastor of St Mark's parish, Kenosha funded the two nuns to come out to America. Peter Leo Johnson in his 'The American Odyssey of the Irish Brigidines' also names McFaul as the 'promoter and helper of their migration'.<sup>xlvi</sup> In the period 1851-61 McFaul was one of the many priests in Wisconsin who received Irish immigrants sponsored by philanthropist Vere Foster.<sup>xlvii</sup> On his visit to America in 1850 Vere Foster (1819-1900), discovered the demand for labour in America and Canada.<sup>xlviii</sup> Being acutely aware of conditions in Ireland he 'considered that it was as natural and desirable for young people to emigrate as it is for young bees to swarm'.<sup>xlix</sup> Accordingly he set up his scheme of assisted passage for those for whom a good recommendation was forthcoming. The immigrants were mainly girls who went to America to work as servants on farms and in town houses.<sup>l</sup> The influx of female immigration of the 1850s was due to the sharply declining opportunities for women's wage earning due in part to 'the continued deindustrialization of the Irish countryside and because economic pressures and demographic change caused major shifts from subsistence to commercial agriculture and from tillage to pasture farming'.<sup>li</sup> There was a pressing need for religious to provide a Catholic education for the families of the immigrants. However, the problem of when and where McFaul made contact with the Brigidine sisters remains. It is also possible, but most unlikely, that Bishop John Martin Henni of Milwaukee called on the convent when he visited Ireland in 1849.<sup>lii</sup>

McKay and Foran's intrepid venture was affected by Bishop Haly's unwillingness to consent to a Brigidine establishment outside the diocese of Kildare and Leighlin. This is understandable and was prudent on his part as, over forty years after their establishment they had not gained approbation from Rome. In fact Bishop Haly, with the help of Moth-

ers Catherine McAuliffe and Joseph Fitzpatrick, was then in the process of trying to gain this approbation. Bishop Haly, nevertheless, relented and gave them permission to go to America but only on certain conditions. He forbade the superior, Mother Peter Stein, to give them the Brigidine habit and Rule book to take to America.<sup>liii</sup>

The venture must have created some difficulties within the Mountrath community. We can argue this from the document that Foran—professed before Bishop Nolan on 21 Sept 1837—signed stating that she was leaving the convent of her own free will. While it was usual for lay sisters to sign such a document when leaving the convent, in this case we can infer some difficulty, as unusually, the document was witnessed by two senior priests, Patrick Fitzpatrick, P.P. of Mountrath and Daniel Nolan, Administrator of Ballyfin, rather than the superior as would be the norm. There is no archival material to suggest that Bishop Haly insisted that Foran sign the document before the two priests.<sup>li</sup> Neither is there evidence to show that the 52-year-old McKay—professed before Bishop Doyle on 10 March 1829—signed such a document.

The middle-aged Angela McKay had twenty-two years experience of religious life and the younger Mary Ann Foran had fourteen years when they set out on their long journey to St Mark's parish, Kenosha, Wisconsin. Kenosha situated fifty-five miles north of Chicago and twenty-five miles south of Milwaukee was the most southern port on Lake Michigan in Wisconsin state.<sup>liv</sup> On their arrival, the sisters faced the danger of disembarkation at Kenosha's notoriously unsafe harbour. The year before their arrival, a whole family, probably Irish drowned when a steamer overturned in rough water.<sup>lvi</sup>

Kenosha, formerly the small village of Southport, was incorporated as a city in 1850 with a population of 6,000 in 1851.<sup>lvii</sup> The Brigidine sisters arrived at

the time of heaviest Irish immigration to the state (1850-60). Their mission was to the city's Irish who formed nearly half (533) of the city's foreign population of 1,162.<sup>lviii</sup> One other Irish immigrant was a young girl, Mary Delany who was believed to have been taken to Kenosha by McKay and Foran.<sup>lix</sup> Neither Funk or Johnson mention her, though a notice in the Catholic *Almanac* mentions the infant community, its two professed sisters and one postulant and Sister Angela as superior.<sup>lx</sup> There was also a substantial Catholic German population among Kenosha's 244 German immigrants.<sup>lxi</sup>

McKay and Foran arrived in Kenosha six years after the passage of Colonel Michael Frank's school act on 16 June 1845, when the first free public school in Wisconsin opened in the basement of the Irish parish church of St Mark's.<sup>lxii</sup> It was stipulated that no religious instruction be given during school hours. Unusually in the matter of the control of Catholic education, St Mark's pastor, the Swiss born Father Kundig was instrumental in having the school act passed into law.<sup>lxiii</sup> Many of the Irish immigrants, because of their economic circumstances, voted in favour of the act. School, however, continued to be held in the basement until a new school was built in 1849.

On his arrival as parish priest of St Mark's parish, Michael McFaul set about establishing church controlled parochial schools with the help of the two Brigidine nuns who were lodged in a convent named for St Brigid.<sup>lxiv</sup> They quickly established St Mark's Female school. The following notice appeared in the Catholic *Almanac*:

This religious congregation, named after St Bridget, the holy virgin and abbess of Kildare, and patroness of Ireland, was founded in the town of Tullow by the Rt. Rev. Dr. Delany, Bishop of Kildare and Leighlin, and especially protected by his successor, Rt. Rev. Dr. Doyle.

The great aim of this congregation of sisters is the instruction of female children, as expressed in the first chapter of its supplementary rule and constitutions; which place, moreover, the congregation under the immediate jurisdiction and authority of the diocesan bishop. This infant community has been established here but recently. There are two professed sisters and one postulant [Brigid Delany?]. Sister Angela superior.<sup>lxv</sup>

Other than the last two sentences, this notice is taken word for word from the 1828 rule and constitution written by Bishop Doyle.<sup>lxvi</sup> Its appearance in the Catholic *Almanac*—which depended on episcopal channels for its information—shows that either McKay or Foran, it must be assumed, defied Bishop Haly's restriction on taking the rule to America and begs the question whether the notice was placed deliberately or accidentally with the intention to deceive church authorities.<sup>lxv</sup>

Given their recognition in the Catholic *Almanac*, it appears that the little community had official approval from their arrival in Kenosha. Another report showed that in 1851 the school had 'a good number of female pay scholars, whilst others were taught gratis by the sisters'.<sup>lxviii</sup> In this they were following their Irish Brigidine experience. The sisters clearly impressed a reporter on the *Wahrheitsfreund* who stated that their work in the parish was 'incalculable'.<sup>lxix</sup> The reporter was not the only person to be impressed for the *Almanac* carried the notice in 1852 that the convent housed three professed sisters and several novices and that the school was ready to receive boarders at moderate terms.<sup>lxx</sup> Surprisingly Mary Anne Foran was listed as the superior though the following year Angela McKay is again named as superior.

Moreover, in 1852 the Swiss born Bishop Henni (1805-81) recognised the value of their work declaring that they

did well in instructing large numbers of the poor children of the parish.<sup>lxxi</sup> He was, however, so concerned about their financial state that on two occasions he wrote to the Society for the Propagation of the Faith in Lyon, France pleading for financial assistance. In his letter of 19 January 1852 he pointed to his need for \$1,800 for an establishment for the Brigidines in Kenosha.<sup>lxxii</sup> Just over a year later on 28 February 1853, he described their circumstances and the efforts that he had made to give them a permanent base and declared:

The Sisters of St Bridget, who arrived here so exceedingly poor from Ireland, as I stated in my last year's report, but who do now very well in teaching a large school of poor children. They have as yet scarcely a home of their own, because of want means which I expected in vain from Europe. Yet, in order to have them located permanently I had again (necessarily) contracted debts of \$600.<sup>lxxiii</sup>

The bishop stresses the urgency of his need for the money. Although there is a letter from Bishop Henni in the Delany diocesan archives it makes no reference to the American Brigidines.<sup>lxxiv</sup>

Despite the sisters best efforts to put parochial education on a permanent footing and the bishop's efforts to settle them financially, the sisters for some unknown reason withdrew from Kenosha in 1855. There are several possible explanations for their departure. Had their status as being uncanonical been discovered? While the Catholic *Almanac* carried the notice of their rule from 1851-53 it did not do so in 1854 only listing St Mark's day school as under the care of the Sisters of St Bridget.<sup>lxxv</sup> This is conceivably the main reason and would explain to Bishop Henni why the sisters received no funding or moral support from Ireland. Again may be they found it hard to compete with the already established free school and that not enough parents had sufficient

## BRIGIDINES IN ROSCREA AND AMERICA

means to pay private day school and boarders' fees. Funk gives some other explanations for their exodus. One reason she suggests is their failure to expand beyond one school in the parish and another likely and influential cause of the community's instability was a pastorate that changed hands three times during the period of their stay in Kenosha.<sup>lxxvi</sup> Priests seemed to move from parish to parish almost on an annual basis. McFaul was in St Michael's Church, Porter, Rock County in 1856 and in the few years previous to his coming to Kenosha he served briefly in, for example, Janesville and Beloit.

After their departure, the Brigidines were replaced by the School Sisters of Notre Dame who had been invited to the diocese of Milwaukee by Bishop Henni in 1855.<sup>lxxvii</sup> The order founded by Mother Theresa of Jesus Gerhardinger in Bavaria in 1833 came to America expressly to meet the educational needs of Wisconsin's large German immigrant population.<sup>lxxviii</sup> The Notre Dame Sisters would have been aware of the work of the Brigidines through their chaplain, the Rev. Anthony Urbanek who referred to it in a letter to Archbishop Milde of Vienna.<sup>lxxix</sup>

At this period, according to Revd Robert McNamara, Bishop John Timon of Buffalo pleaded for teaching congregations to make foundations in the twelve counties of his diocese.<sup>lxxx</sup> After their withdrawal from Kenosha, Sister Angela and her Brigidines were one of the many congregations who answered his plea. However, their sojourn teaching at St Mary's Rochester was for a very brief period from 1855 to 1856 but within this time frame Bishop Timon presided at a Brigidine profession on 1 February 1856.<sup>lxxxi</sup> We know, however, that five months later the little Brigidine group were established in St Bridget's, Buffalo, New York.<sup>lxxxii</sup> A notice in the *Buffalo Catholic Sentinel* of 12 July 1856 announced a sacred concert on 13 July for the benefit of the school house and the

sisters' dwelling. On 18 October 1856 the same paper reported on a fair at Townsend hall which realised \$650 for the school fund for which Sister Angela offered her 'warmest thanks to ladies and gentlemen for their presence and purses'. It was also inferred that she was a very energetic person. The new school a large brick building was almost complete on 25 April 1857.

Just two months previously in February, Bishop Timon officiated at the public reception of two postulants, who had 'undergone preparation for some time and were well instructed in their new obligations'. On 23 May 1857 Johanna and Honora Delehunty received the white veil from Bishop Timon when the 'attendance of the clergy and the significant dress of the sisters and the two ladies [...] attracted the attention of all present'. They were called in religion Sister Mary Joseph and Sister Frances. It is not stated if they were the two postulants mentioned in February. Nevertheless, with everything apparently going so well, within nine months they were on the move again. What happened the Brigidines? Did they leave of their own accord or did the bishop transfer them? And if so why? It cannot have been their uncanonical status because Bishop Timon did not deny them the right to receive candidates. Was it easier to deal with them because they had no obligations to a mother house? A brief reference in the bishop's diary of 9 February 1858 states 'send M. Farrell with Brigidines to Medina'. In early January he was in the Convent of Mercy looking for a 'colony' of sisters for St Bridget's parish. By February they had replaced the Brigidines but the four Mercy sisters found no household furnishings when they arrived. Pierce writes that 'Whatever comforts the Brigidines had possessed they took with them' adding somewhat tetchily, 'no doubt they purchased them'.

Isaac S. Signor states that in the winter of 1858 Sisters Angela McKay and Bridget Delany of the Brigidine

order accompanied by a young woman Miss Magin came to teach school in St Mary's parish, Medina, Orleans County, New York.<sup>lxxxiii</sup> He makes no mention of Mary Anne Foran. The nuns were under the supervision of the pastor Fr Nicholas Byrnes (1855-1859), 'a dignified and warm-hearted priest'.<sup>lxxxiv</sup> Fr Thomas Brady succeeded Byrnes as pastor. In 1860, however, he went to St Andrew's parish, Grand Rapids and must have taken McKay, Delany and the two white novices with him.<sup>lxxxv</sup> Again there is no mention of Mary Anne Foran. Unfortunately for the little group of sisters in either 1861 or 1862 Brady joined the 15<sup>th</sup> Michigan or 'Mulligan Regiment' of the Union army as chaplain during the Civil War.<sup>lxxxvi</sup> As a result of Brady leaving to become chaplain, the two white novices returned to their homes.<sup>lxxxvii</sup> Nevertheless throughout the 'turbulent years' of the Civil War, Mother Angela continued to teach in the parish school, assisted by a secular lady.<sup>lxxxviii</sup>

In April 1862, the twenty-year-old Miss Ellen Eardly of Grand Rapids joined the two sisters taking Mary Agnes as her name in religion.<sup>lxxxix</sup> She was in all probability the first religious vocation from the Grand Rapid region.<sup>xc</sup> With the entrance of Agnes Eardly, Mother Angela opened a select school for girls where both women taught school until May 1866. Sister Agnes (b.1842) and her younger sister Mary (b.1846), who later joined Mother Angela, were from Co Wicklow but the whole family had emigrated to America in the 1850s.<sup>xci</sup> There is a tradition in the Convent of Mercy, Erie that one of the Eardly sisters had serious eye trouble before leaving Ireland. Her mother brought her to the Mercy foundress, Mother Catherine McAuley who blessed her with a ring and she was cured of the eye ailment.<sup>xcii</sup>

The little community also cared for twenty orphan children continuing a Brigidine tradition. Unlike in Milwaukee, they do not appear to have had episcopal sanction with no reference to them ap-

pearing in Detroit's Catholic *Almanac*.<sup>xciii</sup> According to Eardly, Bishop Peter Paul Lefebre of Detroit, seen as a 'careful and conservative prelate' advised Mother Angela to return to her convent in Ireland. He would not allow her to receive candidates, and advised Eardly to enter another order.<sup>xciv</sup> The Rev. John W. McGee holds that it was their non-recognition by the order in Ireland that eventually caused their dismissal by the bishop. He states that:

None of the standard histories of Grand Rapids so much as mentions the period of the Brigidine sisters. [...] The work the sisters did is important from the standpoint of its being the first beginnings of Catholic education in the city and, indeed, in this section of the state. Here in Grand Rapids they left a mark which the years have almost erased, but their courage and heroism ought never to be left to oblivion.<sup>xcv</sup>

Undaunted Mother Angela pleaded her case for a place to Bishop Josue Young of the diocese of Erie. Young, a convert to Catholicism and of an old Puritan New England family, appointed Mother Angela to Titusville, Pa. and, unlike Lefebre, was eager to see the order flourish.<sup>xcvi</sup> The diocese and its people were benefiting from the discovery of oil in Oil Creek on 29 August 1859. The sisters arrived in Titusville on 4 May 1866 to a five-room dwelling with a schoolroom large enough to hold sixty children.<sup>xcvii</sup> According to Eardly the bishop gave instructions for additions to be made to the school. The *Titusville Herald* of 6 July 1866 throws light on the community involvement in moving the former Catholic church building from Nellstown to Titusville that made the extension to the school house possible.

The building was removed from Nellstown to its present site some three weeks ago. It was used for a Catholic church at

Nellstown until the land was sold for oil purposes since which time it has been unoccupied. Thirty-five volunteer teams were procured, and free passes being issued by Colonel Keese for transportation over the Titusville and Pithole plank road, Fr Mignault and his company proceeded to Nellstown took down the church and brought it on wheels to Titusville. The procession on its return extended half a mile along the road and excited much curiosity among spectators who inquired if Pithole was being moved to Titusville. The building now forms the wing of the convent, and the work of the addition being mostly gratuitous the whole cost of reconstruction will not exceed \$300. Four sisters have arrived at the convent, who will devote their time to the education of pupils. Two large bells to cost \$1200 will soon be placed in the tower of the church. The bishop of Erie is expected to consecrate them on which occasion two sisters will take the vows of nuns and one young lady will take the veil.<sup>xcviii</sup>

Misfortune overtook the sisters when 'their good friend' Bishop Young died suddenly on 6 September 1866. It was nearly two years before his successor the Irish born Tobias Mullen was consecrated bishop of Erie on 2 August 1868.<sup>xcix</sup> In the meantime the sisters established a motherhouse, started an academy and taught in the parish school of St Titus.<sup>c</sup> Within a short time they were teaching about three hundred children and depended on what they received for music lessons and on the fees from fifteen or eighteen girl boarders to survive.<sup>ci</sup> On 4 July 1866, Sister Agnes Eardly made her final profession while her sister received the white veil and the name Mary Joseph.<sup>cii</sup> Six girls joined the convent in the beginning of 1867. Four received the white veil after six months trial and the other two returned to their homes. Adversity struck the community once again with the sudden death in bed

of the 75-year-old Mother Angela on 18 January 1867.<sup>ciii</sup> The *Titusville Evening Journal* reported her death as being from heart disease. It led with a ten line poem in her honour and, in the following brief summary, noted that the 'dear departed nun' was a 'model of piety whose conversation was always a great source of edification'.<sup>civ</sup>

The funeral procession took place on the 21<sup>st</sup> instant. On that day there was a solemn high mass of *Requiem* with deacon and subdeacon, at St Titus's church, the Rev N. Mignault acting as high priest, and the Rev J. L. Finucane, of Petroleum Centre, serving as deacon, and the Rev Arthur Mignault as sub-deacon. The church was draped in deep mourning, the walls and ceiling were festooned with streamers of black, and the altar and tabernacle were draped with black and trimmed with white fringe. The choir sang most beautifully, and during the service Mr P. Cronin sang beautiful verses of Spirit Rest.

In the central aisle, the corpse during the service rested on a catafalque, which was festooned and draped in black, trimmed with white, and illuminated with numerous candles. The procession was headed by Brown's brass band, immediately followed by the hearse and the sisters of the convent, then the day-school children, the Catholic Literacy Society, the ladies of the Sodality and Rosary, miscellaneous persons, sleighs, etc. The entire procession was over half a mile in length. It was the largest funeral procession that has taken place in this city, numbering over 1,000 persons. The church paid her last tribute, her grand

solemn honours to the child of God, which is the greatest gift that mortal remains can receive.<sup>cv</sup>

The *Catholic* of Pittsburg also reported on her death noting that she was in the thirty-ninth year of her profession.<sup>cv</sup>

The reports show the regard in which Mother Angela McKay was held. Eardly and the other sisters continued to teach and the *Catholic Almanac* shows that the superior was Sister Mary Agnes Eardly while Sister Mary Josephine was principal of the academy. They continued to accept new entrants to the convent, two of whom, Miss Fanny M. Cleary, in religion, Sister Mary Rose, and Miss Louisa Bunning, in religion, Sister Mary Aloysius received the white veil of novice in July 1868 from Fr Joseph Edouard Napoleon Mignault, pastor of Titusville.<sup>cvii</sup> One other report noted that Fr Mignault always conducted the ceremonies in the parish church with great solemnity and to the edification of the people who attended.<sup>cviii</sup> On this occasion he was assisted by his brother Revd A. Mignault and Revd J. Dunn. On 24 July 1868 the *Catholic* gave a glowing report of the activities of the convent community:

The community is in a flourishing condition, and have an excellent academy connected with the mother house. The exhibition of the pupils of this female seminary, given on the 12<sup>th</sup> inst., in the largest hall of this city, was one of the most brilliant affairs of the kind ever witnessed, and would do honour to the most renowned academies in the country. The tragedy of Esther was beautifully rendered by the young ladies in full costume, and elicited the most flattering praises from press and audience.

Bishop Mullen made a visitation of the convent on 26 September 1868.<sup>cix</sup> For both the years 1867 and 1868 the atten-

dance in St Titus's school was 250.<sup>cx</sup>

In 1868 neither of the Eardly sisters were in posts of responsibility. The *Catholic Almanac* names Sister Mary Anne Foran as superior and Sister Mary Francis as principal.<sup>cx</sup> According to Eardly, Mary Anne Foran appeared on the scene in October 1868. Apparently Foran applied to the Mignault for permission to join the community.<sup>cxii</sup> It is possible that he could have known Mary Anne Foran as he ministered in the diocese of Milwaukee when they were in Kenosha.<sup>cxiii</sup> It is difficult to understand why Mignault gave his consent to her coming, and even more so that he appointed her superior within a few weeks of her arrival—she was a lay sister, had abandoned Mother Angela McKay, and had no contact with the community for many years. Other than Brigid Delany none of the sisters would have known her. His decision must have created dissatisfaction within the community. There is no evidence as to when or if Foran was ever professed a choir sister.

Misfortune struck the convent once more, when on 14 January 1869, all of their buildings were burned to the ground but amazingly nearly all the furnishing was saved.<sup>cxiv</sup> The thermometer on that eventful night marked 30 degrees below zero.<sup>cxv</sup> On the 16 January 1869 Fr Mignault wrote of the disaster:

My poor St Bridget's Mother House, Novitiate, and schools are in ruins. The building was 145 feet in length, and had been considerably improved last Fall, and the last cent paid on it the day before the sad calamity. This sad catastrophe throws the whole community, orphans, etc into the street.<sup>cxvi</sup>

Seventeen orphans besides other boarders and nuns were made homeless.<sup>cxvii</sup> The *Catholic* reported that

One short hour sufficed to re-

duce to ashes the result of years of solicitude, of privations, and of constant labours. In the midst of the rigors of winter, his [Fr Mignault] poor devoted sisters are deprived of shelter, their young and delicate novices are forced from their loved asylum, and the hundreds of children the objects on which these holy ladies lavished their time and strength, and minds, and heart's affection, are without a school in which to learn the since of God as well as merely human knowledge.<sup>cxviii</sup>

Fr Mignault appealed to the people of Titusville for help:

My good people of Titusville, appealed to yesterday, for the rebuilding of our convent, testified to their proverbial generosity. During the appeal they were all willing to give. Though taxed and retaxed for four years past to the amount of \$70,000, they showed their sympathy for the sisters and orphans by subscribing the magnificent sum of \$2,500. However this proof of their sympathy would be useless—for what is \$2,500 to build a mother house, novitiate, orphan asylum and schools—that sympathy would be powerless unless assistance comes from abroad, through a generous public. Never was greater assistance required in order to preserve a much needed establishment, the only one in the oil regions and for the protection of the devoted sisters, novices, and orphans.

For God's sake, dear and good Mr Porter, use all the influence of your worthy organ, to prevent a still sadder catastrophe, I mean the disbandment of my poor though good and will-



ing, community of sisters, and the deprivation of my children and orphans of the blessings of education. I am now hurriedly engaged in erecting a shed by the road side, for the purpose of furnishing the community with a shelter from the inclemency of the weather, until a generous public, understanding my painful position, feel that my relief can no longer be considered as intrusive.<sup>cxix</sup>

From that night they lived in the temporary shelter until 18 April 1869 when disaster struck again and this time all they possessed was burnt. It was suggested that this was probably the work of an incendiary.<sup>cxx</sup> Within two days, on 20 April 1869 Mignault promptly removed the sisters from the parish and brought the professed to Erie where they were lodged with the Sisters of St Joseph and he took the three novices to Mother Elizabeth Bruyère, foundress of the Grey Nuns in Ottawa, Canada. Writing to Mignault in September 1869, she hopes that the three 'will persevere' in their vocation.<sup>cxxi</sup> The sisters remained with the Sisters of St Joseph until the Bishop Mullen returned from the 10<sup>th</sup> Provincial Council of Baltimore (1869). Although the Sisters of St Joseph had given the sisters lodgings they were not able, according to their rule, to receive them into their community.<sup>cxxii</sup> As a consequence of a suggestion of Bishop Mullen, the two Eardly sisters entered the Benedictine convent in Erie. They made their novitiate again and in a change of religious names became Sister Gabriella Eardly, O.S.B.—the correspondent—and her sister became Sister Gregoria Eardly, O.S.B. Over a forty-one-year period they made an important educational contribution to the Benedictines in Erie.<sup>cxx</sup> The other professed sisters went to Rochester and to the Sisters of Charity in Troy, N.Y.<sup>cxxiv</sup> Following on the disaster, the parish was left with no one to administer the school. In 1870, Bishop Mullen invited the Sisters of Mercy to start a foun-

ation which they did with seven sisters and were quickly teaching 400 pupils while in 1871 they opened St Joseph's Academy, a private school for girls..<sup>cxxv</sup>

Sister Gabriella does not place the blame for the demise of the Brigidines on Bishop Mullen but squarely on Mary Anne Foran and Fr Mignault. McGee states that Mignault and Foran discussed the matter and that it was they who decided that the community should disband and the sisters seek life in other convents as happened.<sup>cxxvi</sup> It is possible that a combination of lack of finance and Mignault's own debilitating ill-health made him take such a serious step. Before and throughout his priestly life Mignault suffered from serious bouts of illness.<sup>cxxvii</sup> Shortly after this event he was advised by his bishop to change to a different field. Instead he retired and toured Europe including Ireland. There is no record in the annals that he visited Mountrath or any of the other convents but there is a record that on the 10 May 1869 the sisters of Tullow convent sent £20 to Fr Mignault for the Titusville convent – £10 of this was from Sister Aloysius O'Kelly.<sup>cxxviii</sup> Frustratingly, neither is there a record as to who informed the Tullow nuns of the situation in Titusville. Possibly Mignault had solicited help from them after the first fire. Sister Gabriella does not make any reference to this money in her letter of June 1927. Many years earlier, as a Benedictine sister, she sent a photograph of Fr Mignault to Tullow convent. In an undated inscription, she asks the convent, 'to pray for me my dear sisters, this is the third of his pictures I sent you but I know you never got them as the letters were never sent.'<sup>cxix</sup>

Nothing further is known of the life of Sister Mary Ann Foran. She is said to have left the convent of the Sisters of St Joseph with Sister Brigid Delany to visit friends in Rochester, N.Y.<sup>cxx</sup> Neither sisters returned to the convent in Erie but Brigid Delany returned to Titusville where she lived with charitable friends for a few months.<sup>cxxxi</sup> She accepted a

home given her by her niece, the superior of the Sisters of Charity, Troy, New York. She was old and enfeebled by a fall on ice coming out of church yet she journeyed back to Ireland to reach Tullow convent c.1873 late on a stormy night.<sup>cxxxii</sup> She was given shelter in the convent but Bishop Lynch would not allow her to stay probably because of her uncanonical status. She was given refuge, however, in the South Presentation Convent, Cork where she lived out the remaining years of her life dying in 1883. Her headstone recognises her as a Sister of St Brigid, professed for thirty years. How this was arranged is unknown.

The indomitable pioneering spirit, courage and fortitude of Sister Angela McKay and her sisters on the American mission was emulated by other Mountrath convent sisters when they began their mission to Australasia in 1883, coincidentally the same year that Sister Brigid Delany died.

<sup>i</sup> Lavinia Byrne, *Woman at the Altar: The Ordination of Women in the Roman Catholic Church* (London, 1994), p.48.

<sup>ii</sup> Mountrath Annals, DA/BC/AIr/326.

<sup>iii</sup> MS, The coming of the Brigidines to Roscrea, DA/BC/BGA/810.01; O'Riordan, *Pathfinders: The Mountrath Story*, ii (1997), p.11.

<sup>iv</sup> Mountrath Receipts and Expenditure 1823-49, DA/BC/AIr/403.

<sup>v</sup> Ibid. Also included on the list were: 9 petticoats, 14 handkerchiefs 4 towels, 1 pr shoes, 12 caps, 2 boxes, 7 pairs of stockings, 6 shifts, 4 flannel waistcoats, a cloak for Sr Magdalen.

<sup>vi</sup> Ibid.

<sup>vii</sup> Ignatius Murphy, *The Diocese of Killaloe 1800-1850* (Dublin, 1992), p.149; A. McAndrew, 'History of the National School, Roscrea' in DA/BC/AIr/306.

<sup>viii</sup> Murphy, *The Diocese of Killaloe*, p.50.

<sup>ix</sup> McAndrew, 'Roscrea' in DA/BC/AIr/306.

<sup>x</sup> Ibid.

- <sup>xi</sup> Ibid.
- <sup>xii</sup> Tom Prior, 'Early Years' in Tom Prior & George Cunningham (eds), *Convent of the Sacred Heart Roscrea, 1842-1992* (Roscrea, 1992), p.23; McAndrew, 'Roscrea'.
- <sup>xiii</sup> Murphy, *The Diocese of Killaloe*, p.149.
- <sup>xiv</sup> McAndrew, 'Roscrea'; Murphy, *The Diocese of Killaloe*, p.149.
- <sup>xv</sup> McAndrew, 'Roscrea'.
- <sup>xvi</sup> Ibid.
- <sup>xvii</sup> 'Roscrea Connection' in *Convergence Brigidine Newsletter* December, 1980, DA/BC/AIr/364
- <sup>xviii</sup> Roscrea Connection; Murphy, *The Diocese of Killaloe*, p.149; McAndrew, 'Roscrea'; newspaper cutting, DA/BC/BGA/810.01.
- <sup>xix</sup> McAndrew, 'Roscrea'.
- <sup>xx</sup> Margaret Gibbons, *Glimpses of Catholic Ireland in the eighteenth century, restoration of the daughters of St Brigid by Most Rev. Dr Delany* (Dublin, 1932), p.375.
- <sup>xxi</sup> Murphy, *The Diocese of Killaloe*, pp149-50.
- <sup>xxii</sup> Ibid., p.150.
- <sup>xxiii</sup> Ibid., p.149.
- <sup>xxiv</sup> Ibid. p.150.
- <sup>xxv</sup> Ibid.
- <sup>xxvi</sup> McAndrew, 'Roscrea'; Murphy, *The Diocese of Killaloe*, p.151; Gibbons, *Glimpses*, p.375.
- <sup>xxvii</sup> Roscrea Connection.
- <sup>xxviii</sup> Murphy, *The Diocese of Killaloe*, p.151; Kilroy, *Madeline Sophie Barat*, p.386; Roscrea Connection.
- <sup>xxix</sup> Kilroy, *Madeline Sophie Barat*, p.343.
- <sup>xxx</sup> Ibid.
- <sup>xxxi</sup> Madeline Sophie Barat to Aimée d'Avenas, Rome, 19 Feb. 1842 in Kilroy, *Madeline Sophie Barat*, p.343.
- <sup>xxxii</sup> McAndrew, 'Roscrea'.
- <sup>xxxiii</sup> Ibid.; Murphy, *The Diocese of Killaloe*, p.151; Gibbons, *Glimpses*, p.375; Roscrea Connection.
- <sup>xxxiv</sup> Murphy, *The Diocese of Killaloe*, p.151.
- <sup>xxxv</sup> Kilroy, *Madeline Sophie Barat*, p.343; Prior, 'Early Years', p.24.
- <sup>xxxvi</sup> Roscrea Connection.
- <sup>xxxvii</sup> McAndrew, 'Roscrea'.
- <sup>xxxviii</sup> Caitriona Clear, *Nuns in nineteenth-century Ireland*, (Dublin, 1987), p.43.
- <sup>xxxix</sup> Murphy, *The Diocese of Killaloe*, p.151.
- <sup>xl</sup> Roscrea Connection.
- <sup>xli</sup> Roscrea Connection; McAndrew, 'National School, Roscrea'.
- <sup>xlii</sup> Prior, 'Early Years', p.33.
- <sup>xliiii</sup> Mary Teresa Cullen, *The Early American Brigidine Story*, DA/BC/BGA/820.2.
- <sup>xliiv</sup> Mountrath Annals, DA/BC/AIr/324.
- <sup>xli v</sup> Maureen Funk, *Kenosha's Irish Experience 1839-1890*, [www.freepages.genealogy.rootweb.ancestry.com/.../maureen\\_funk.htm](http://www.freepages.genealogy.rootweb.ancestry.com/.../maureen_funk.htm) accessed 29 June 2012.
- <sup>xli vi</sup> Rev. Peter Leo Johnson, 'The American Odyssey of the Irish Brigidines' in *The Salesianum*, 39:2 (April, 1944), 61-67 at 61. McFaul ministered in the diocese of Milwaukee until 1858 when he moved to the milder climate of Missouri. In 1875, he resigned because of ill-health and died in 1910, p.63.
- <sup>xli vii</sup> Vere Foster leaflet, [www.proni.gov.uk/index/exhibitions\\_talks\\_and\\_events/19th\\_century\\_emigration/](http://www.proni.gov.uk/index/exhibitions_talks_and_events/19th_century_emigration/) accessed 29 June 2012.
- <sup>xli viii</sup> *A Short Biographical Study of Vere Foster First president* (INTO, Bangor Congress Committee, 1956), p.7. Vere Foster worked in the UK diplomatic service before giving this up to concentrate on his emigration scheme. He was a distant cousin of John Foster the last Speaker of the Irish Commons and became the first president of the INTO.
- <sup>xli ix</sup> *A Short Biographical Study of Vere Foster*, p.7.
- <sup>l</sup> Vere Foster leaflet, [www.proni.gov.uk/index/exhibitions\\_talks\\_and\\_events/19th\\_century\\_emigration/](http://www.proni.gov.uk/index/exhibitions_talks_and_events/19th_century_emigration/) accessed 29 June 2012.
- <sup>li</sup> Patrick O'Sullivan, (ed.) *The Irish World Wide History, Heritage, Identity* vol.4 Irish Women and Migration (London, 1995), p.42.
- <sup>lii</sup> Johnson, 'The American Odyssey', p.67.
- <sup>liii</sup> Mountrath Annals, DA/BC/AIr/324.
- <sup>li v</sup> Foran
- <sup>li v i</sup> Funk, *Kenosha*.
- <sup>li v i i</sup> Ibid.
- <sup>li v i i i</sup> Ibid; Johnson, 'The American Odyssey', p.62.
- <sup>li v i i i i</sup> Funk, *Kenosha*.
- <sup>li x</sup> Mountrath Annals, DA/BC/AIr/324.
- <sup>li x i</sup> *Catholic Almanac* (1852) in Johnson, 'The American Odyssey', p.63.
- <sup>li x i i</sup> Funk, *Kenosha*.
- <sup>li x i i i</sup> Ibid.
- <sup>li x i i i i</sup> Ibid.
- <sup>li x i v</sup> Ibid.; Johnson, 'The American Odyssey', p.63
- <sup>li x v</sup> *Catholic Almanac* (1852), in Johnson, 'The American Odyssey', p.63.
- <sup>li x v i</sup> Brigidine Rule and Constitution 1828, DA/BC/AIr/359.
- <sup>li x v i i</sup> *Catholic Almanac* (1852), in Johnson, 'The American Odyssey', p.64.
- <sup>li x v i i i</sup> Ibid., p.63
- <sup>li x i x</sup> *Wahrheitsfreund* 18 Sept.1851 in Johnson, 'The American Odyssey', p.65; *Wahrheitsfreund*, the first German Catholic newspaper in America was founded in Fr John Martin Henni in 1837, *Catholic Encyclopaedia*, [www.newadvent.org/cathen/10319a.htm](http://www.newadvent.org/cathen/10319a.htm) accessed 14 July 2012.
- <sup>li x x</sup> *Catholic Almanac* (1852), Johnson, 'The American Odyssey', p.63.
- <sup>li x x i</sup> Johnson, 'The American Odyssey', p.64.
- <sup>li x x i i</sup> *Salesianum* 25 (July, 1930), pp 37-42, p.42 received from [kfrymark@sfs.edu](mailto:kfrymark@sfs.edu)
- <sup>li x x i i i</sup> Ibid., p.37.
- <sup>li x x i v</sup> Bishop J.M. Henni to Bishop James Walshe, Milwaukee, 24 July 1866, DA/BP/12/JW/1867/08.
- <sup>li x x v</sup> Johnson, 'The American Odyssey', p.64.
- <sup>li x x v i</sup> Funk, *Kenosha*.
- <sup>li x x v i i</sup> Johnson, 'The American Odyssey', p.64; Rainer, 'Milwaukee', accessed 14 July 2012.
- <sup>li x x v i i i</sup> Johnson, 'The American Odyssey', p.64;
- <sup>li x x i x</sup> *Berichte der Leopoldinen-Stiftun* 25 (1853) (Wein, 1831) in Johnson, 'The American Odyssey', p.64.
- <sup>li x x x</sup> Robert McNamara, *The diocese of Rochester* p.64, DA/BC/BGA/820.2.
- <sup>li x x x i</sup> Diary of Bishop Timon, McNamara, *The diocese of Rochester* p.64.
- <sup>li x x x i i</sup> Mary Gerald Pierce, RSM, *Unto All — His Mercy: the First Hundred Years of the Sisters of Mercy in the Diocese of Buffalo 1858-1958* (Buffalo, N.Y., n.d.), p.21, DA/BC/BGA/820.1.
- <sup>li x x x i i i</sup> Isaac S. Signor, *Landmarks of Orleans County, New York*, (n.d.), pp39-115, [www.ebooksread.com/authors-eng/isaac](http://www.ebooksread.com/authors-eng/isaac) accessed 30 June 2012.
- <sup>li x x x i v</sup> Signor, *Landmarks of Orleans County*, pp39-115.
- <sup>li x x x v</sup> Sr Gabriella Eardly, O.S.B. to Mother Josephine, St Benedict's Convent, Erie, Pa., 23 June 1927, DA/BC/AIr/406 temporary reference; Gibbons *Glimpses* p.360; Signor, *Landmarks of Orleans County*, pp.39-115.
- <sup>li x x x v i</sup> He died after falling ill from exposure on his way home from the war,

www.findagrave.com

<sup>lxxxvii</sup> Eardly to Mother Josephine, 23 June 1927, DA/BC/AIr/406 temporary reference.

<sup>lxxxviii</sup> Ibid..

<sup>lxxxix</sup> Ibid..

<sup>xc</sup> John W. McGee, *The Catholic Church in the Grand River Valley* (1950), p.166. Booklet sent to me by Sr Janet Staab, OSB, archivist, Benedictine Sisters, Mount St Benedict Archives, Erie, Pennsylvania 16511, USA.

<sup>xc1</sup> The file records of the Benedictine Sisters, show that Ellen & Mary Eardly's surname is given as Early. Their father was Patrick Early and their mother's maiden name was Margaret Leigh.

<sup>xcii</sup> Sr Eustace, RSM to Mary Teresa Cullen, CSB, 30 Aug. 1978, Cullen, *The Early American Brigidine Story*, DA/BC/BGA/820.2.

<sup>xciii</sup> Johnson, 'The American Odyssey', p.66.

<sup>xciv</sup> Eardly to Mother Josephine, 23 June 1927; Thomas Meehan, 'Detroit' in *The Catholic Encyclopaedia*, [www.newadvent.org/cathen/04758b.htm](http://www.newadvent.org/cathen/04758b.htm) accessed 30 June 2012.

<sup>xcv</sup> McGee, *The Catholic Church in the Grand River Valley*, p.165.

<sup>xcvi</sup> James Dunn, 'Erie' in *The Catholic Encyclopaedia*, [www.newadvent.org/cathen/05518b.htm](http://www.newadvent.org/cathen/05518b.htm) accessed 30 June 2012.

<sup>xcvii</sup> Eardly to Mother Josephine, 23 June

1927. According to Eardly, Bishop Young visited one of the Brigidine convents when he visited Europe.

<sup>xcviii</sup> Titusville Herald 6 July 1866, DA/BC/BGA/820.2

<sup>xcix</sup> Dunn, 'Erie', accessed 30 June 2012. <sup>c</sup> *Titusville Herald*, 3 July 1991, p.3.

<sup>ci</sup> Eardly to Mother Josephine, 23 June 1927.

<sup>cii</sup> Ibid.

<sup>ciii</sup> Ibid.

<sup>civ</sup> *Titusville Evening Herald*, DA/BC/AIr/832.

<sup>cv</sup> Ibid.

<sup>cvi</sup> Copy of notice in *The Catholic*, Pittsburgh, 23 (19 Jan. 1867), p.405. The mercy annals record that Sr Angela and eight Mercy sisters were reinterred in the new St Catherine's cemetery between 5-8 Dec. 1900, in Cullen, *The Early American Brigidine Story*.

<sup>cvi1</sup> Copy of notice in *The Catholic*, Titusville, 25 (24 July 1868), p.189.

<sup>cvi11</sup> Copy of report in *A century of progress: Diocese of Erie: 1853-1953* supplement to the *Lake Shore Visitor* (4 Dec.1953)

<sup>cix</sup> Copy of notice in *The Catholic*, Titusville, 25 (26 Sept.1868), p.4-5.

<sup>cx</sup> *Catholic Almanac* (1868-69), Johnson, 'The American Odyssey', p.66.

<sup>cx1</sup> Ibid..

<sup>cxii</sup> Eardly to Mother Josephine, 23 June 1927.

<sup>cxiii</sup> Francis Newton Thorpe, *History of Crawford County, Pennsylvania* (n.d.)

[www.ebooksread.com/authors-eng/france](http://www.ebooksread.com/authors-eng/france) <sup>cxiv</sup> Eardly to Mother Josephine, 23 June 1927; *Titusville Herald*, 3 July 1991, p.3 & 26 Feb.1993, p.64.

<sup>cxv</sup> Eardly to Mother Josephine, 23 June 1927.

<sup>cxvi</sup> Copy of report in *The Catholic*, Titusville, 25 (23 Jan. 1869), p.380.

<sup>cxvii</sup> Sisters of St Joseph Order Community Date Book 14 Jan. 1869 sent to me by Sr Janet Staab, OSB, archivist.

<sup>cxviii</sup> Copy of report in *The Catholic*, Titusville, 25 (23 Jan. 1869), p.380.

<sup>cxix</sup> Ibid., (25 Jan. 1869), p.389.

<sup>cx</sup> Sisters of St Joseph Order Community Date Book, 18 April 1869.

<sup>cxxi</sup> Sister Jeanne d'Arc Lortie, SCC to Sr M. Lawrence Franklin, Sisters of Mercy, Erie, 14 Nov.1974 in Cullen, *The Early American Brigidine Story*.

<sup>cxxi1</sup> Sisters of St Joseph Order Community Date Book, 20 June 1869.

<sup>cxxi11</sup> The Benedictine Sisters records recognise both sisters as Brigidine sisters located in Titusville before their disbandment. The records show that both sisters entered on 20 June 1869 and pronounced their perpetual vows before Bishop Tobias Mullen & Mother Scholastica Burkhardt, Prioress of the Erie Benedictine Sisters on 15 August 1873. Sr Gabriella celebrated her diamond jubilee in 1933 and d. 26 Dec 1934. She taught elementary and secondary school for 41 years. Sr Gregoria also taught elementary and secondary school for 41 years and d, 21 Feb. 1916.

<sup>cxxi111</sup> Sisters of St Joseph Order Community Date Book, 20 June 1869; 'Do you know that' leaflet, DA/BC/BGA/Congregational research, Box 225a.

<sup>cxxi1111</sup> *Titusville Herald*, 26 Feb.1993, p.64.

<sup>cxxi11111</sup> McGee, *The Catholic Church in the Grand River Valley*, p.167.

<sup>cxxi111111</sup> [www.ebooksread.com/authors-eng/france](http://www.ebooksread.com/authors-eng/france)

<sup>cxxi1111111</sup> Tullow Receipts & Expenditure Book (Jan.1858-70) in DA/BC/AIr/543.

<sup>cxxi11111111</sup> Photo of Fr N. Mignault., DA/P/B/2/272

<sup>cxxi111111111</sup> Eardly to Mother Josephine, 23 June 1927.

<sup>cxxi1111111111</sup> Eardly to Mother Josephine, 23 June 1927.

<sup>cxxi11111111111</sup> Eardly to Mother Josephine, 23 June 1927; Gibbons, *Glimpses*, p.363.



Gate Lodge at Woodside House, Hacketstown, formerly owned by the Jones family

Carloviana 2012

## Clonmore, Co. Carlow. Its Antiquities

Lord Walter Fitzgerald

[First published in the "Carlow Nationalist", March 29<sup>th</sup> 1913, as the text of a paper read "at a recent meeting of the County Kildare Archaeological Society."]

The name of Clonmore means "the large meadow." There are thirty townlands bearing this name scattered throughout Ireland, and four parishes; the latter are situated in the following counties:-

In the County Kilkenny; the patron saint of this Parish Church is St. Kenny, who is venerated on the 11<sup>th</sup> October.

In the County Wexford, founded by St. Aidan, alias Mogue, whose festival occurs on the 31<sup>st</sup> January.

In the County Louth; the church is dedicated to St. Columbkil, venerated on the 9<sup>th</sup> June.

In the County Carlow, the Clonmore with which we are about to deal.

Clonmore lies six and a half miles as the crow flies to the south-east of Rathvilly. To distinguish it from other places of the name it was called in ancient times "Cluain- Mór- Maedhóg" (pronounced Clonmore Mogue) after its patron saint. This saint was originally called Aedh (pronounced Ay), but by endearing the name with the prefix Mo and the affix oge, the name became Mo-Aedh-oge (i.e. my young Ay), hence Maedhog or Mogue. This St. Mogue's festival falls on the 11<sup>th</sup> April, and he should not be confused with his famous namesake, St. Mogue, the patron saint of the Diocese of Ferns, who is venerated on the 31<sup>st</sup> January; they were, too, the sons of entirely different parents. St. Mogue of Clonmore is stated to have been a half-brother (by the mother) of Aedh mac Ainmire, Monarch of Ireland from A.D. 568 to 594<sup>1</sup>. At the time of the Anglo-Norman invasion of Ireland towards the close of the twelfth century, the

district in which Clonmore Mogue lay was called Hy Felimy Tuagh, that is "the northern Ofelimy," occupied by the septs of O'Honchon (now unknown) and O'Garvey; there was another Ofelimy, called Hy Felimy Deas, or "the southern Ofelimy," which was situated in the County Wexford, and was the territory of the sept of the O'Murchoe (pronounced O'Murroo), now known as Murphy. Ofelimy Tuagh comprised the present County Carlow baronies of Carlow and Rathvilly: the name is now obsolete except in the parish name of Tullowphelim, the old name of the town Tullow. Ofelimy Tuagh itself was a sub-district in the great territory of Hy Kinsellagh, belonging to the Mac Murrough sept; the latter comprised the whole of the County Wexford, the County Carlow, and the district of Shillelagh, and Ofelimy Tuagh. Mac-Murrough, as a surname, is now obsolete, and it is represented in our day by Kavanagh and Kinsella.<sup>ii</sup>

Clonmore is a place of exceptional interest on account of its antiquarian remains, which consist of:-

A Pagan sepulchral Moat.

The ancient churchyard, and a plain cross-shaft in it.

An unsculptured granite high cross.

A Blessed Well (St. Mogue's), and a boulder Font.

A Bullaun stone

The castle ruins of large dimensions.

When it was that St. Mogue founded a religious establishment at Clonmore is not known for certain, but it was towards the close of the sixth century. Several saints, besides St. Mogue himself, were buried in its cemetery; a list of them is to be found in Bishop Comerford's "History of the Diocese of Leighlin." References to this place in the Annals of the Four Masters are given under the following dates; the title "Abbot," which occurs amongst them, must be taken as meaning the head of the religious community:-

A.D. 771. Maccoigeadh, Abbot of Cluain-mór-Maedhóg died.<sup>iii</sup>

774 Clonmore-Mogue and Kildalkey were burned.

834 The plundering of Ferns, Clonmore-Mogue, and Dromin (Co. Meath) by the foreigners (i.e. the Danes).

835 Clonmore-Mogue was burned on Christmas night by the foreigners, and a great number were slain by them, and

many prisoners were carried off.

877 Ferghil, Abbot of Clonmore-Mogue, died.

886 Seachnasach, son of Focarta, Abbot of Clonmore-Mogue, died.

918 Meraighe of Clonmore-Mogue died.

919 Flaithbheartach, son of Muircheartach, Abbot of Clonmore, died.

920 Ailell, son of Flaithim, Abbot of Clonmore-Mogue, died.

972 Caibre, son of Echtighern, Coarb (i.e. successor of St. Mogue) of Clonmore-Mogue died.

1040 Moone-Columbkil (Moone), Disert Diarmad (now Castledermot),

Moghna-Moshenoc (now Dunmanoge, Co. Kildare), and Clonmore-Mogue were plundered by Dermot, son of Donough Mael-na-bó (MacMurrough) Lord of Hy-Kinsellagh, and he carried many prisoners from the oratories.

1052 Art, son of Muireadhach, of Clonmore-Mogue, the glory of Leinster, died.

From this period there is no further mention of the place by the Annalists. We will now describe the antiquarian remains, which extend for half a mile in a line due east and west, in the order they lie in, commencing with the moat on the east and finishing with the castle on the west.

### The Moat

The moat is a high conical mound surrounded by a deep trench, out of which it was formed. On its east side is a small square earthwork, separated from the moat by the trench; the earthwork may, or may not, be ancient; it forms a small paddock, which, judging by the old-fashioned tillage ridges, was used as a potato garden. There is no trace of a rampart either round the summit or the base of the moat. Some archaeologists hold the view that these moats, or "mottes" as they call them, were erected by the Anglo-Normans, on which a wooden tower was erected for defence, during the building of the stone castle. In my opinion a moat situated near a churchyard of Celtic foundation is a Pagan sepulchral mound, covering a "kist" or slab-lined chamber containing the skeleton, or calcined bones in an urn, of the king or chief thus commemorated. As Clonmore-Mogue was founded in the sixth century, the



*The Moat (courtesy Eddie McDonald)*

moat, I conclude, is a Pagan sepulchral mound. Tradition states that an underground passage runs from the moat to the castle, half a mile off.

The Churchyard

A public road encroaches on the churchyard on its northern side, and possibly runs over the site of the ancient church, as there are no traces of any ecclesiastical building within the present precincts of the burial ground; and it is not usual to find interments on the north side of the church ruins in an Irish churchyard. On the opposite side of this road stands a small Protestant church, built early in the nineteenth century, in the exceedingly plain style then in vogue. At the north side of the church, and close to the boundary wall, there is an undressed granite boulder (4 feet long by 2 feet 4 inches in breadth), deeply sunk in the ground; it contains a rectangular basin occupying most of the space, and is now a receptacle for rainwater and miscellaneous rubbish. This trough is a primitive font. An almost identically similar trough, both in size and shape, is now placed at the base of the tall unsculptured cross (closely resembling the one at Clonmore) in the churchyard at Aghowle, which lies 4 ½ miles away, as the crow flies, to the south. About the middle of the churchyard stands the broken shaft of a high cross standing on a square base. The shaft is neither ornamented nor divided into panels; in its present state it stands 6 feet 2 inches in height, with faces measuring 18 inches and 12 inches.

About a perch from it, to the south, lies the head, embedded in the ground on its side. The head and arms are ringed, but not perforated, in a similar fashion to “St. Mogue’s Cross,” described further on, which, however, is not so massive. There are several granite boulders and slabs, some recumbent, others upright, dotted over the churchyard, which belong to an early period, and bear on them in relief either a plain or a ringed cross. One large slab in the southeast corner, near a sycamore tree, is remarkable in having an oblong hole (9 inches by 6 inches) cut through it. This slab is sunk in the earth on its side, and measures 4 feet in length, with an average thickness of 7 inches. It is puzzling to understand the object of the square perforation, unless it served for a socket in which a cross-shaft originally stood. There are no lettered tombstones of a date earlier than the eighteenth century; one of the earliest that I could discover is a Byrne slab, now lying in a badly fractured condition near a fallen in vault at the west end of the churchyard; the inscription on it reads: -

This stone was erected by Mr. Charles Byrne of Sleat[y in the ] Queen’s County<sup>iv</sup> May 1745. H[ere lyeth] the Body of Mr Charles By[rne of .....] in the Queen’s County who dep[arted this life] the 21<sup>st</sup> July 1768 ..... Mr Edmund Byrne ..... tomb.

At the top of the stone is cut in relief a peculiar coat-of-arms, which in no way resembles the Byrne or O’Byrne Arms given by Burke in his “General Armory.”<sup>v</sup>

The Arms on the slab may be described as: -

A chevron between two stars and a ..... above and three hands (below) ; on a chief three lions rampant.

The crest is chipped away, and the motto on a scroll is illegible. Ryan in his “History of the County Carlow” (p.336) states that “the following inscription, somewhat mutilated, appears on a stone in the churchyard”:-

“Here : lyeth : the : body : of Mr : McHugh : Gaunkagh<sup>vi</sup> : Byrn : and : his : three : children : Murtagh : Ion : and : Ann : he : was : ye : great : great : grandson : of : Phelim : Buoy : —ug : deceased : Octr 20<sup>th</sup> : 1737 : aged \_\_\_\_\_”

After a very careful search I failed to find any trace of this slab. In 1579 a Hugh O’Byrn, alias “Hugh ganekagh mac Phelim,” of Clonmore, was a juror on a County Carlow Inquisition.

Standing side by side, on the west side of the churchyard are two headstones, erected to the memory of priests, with the inscriptions facing the west. One commemorates the Rev. Patrick Rosseter (? C.C.) who died on the 9<sup>th</sup> August 1771, aged fifty-two; and the other the Rev. Nicholas Doogan (C.C.) who died on the 28<sup>th</sup> January 1767, aged forty, the cause of whose death is said to have been a fall from his horse (see the Journal, vol.v. p.327).

“St. Mogue’s Cross”

“St. Mogue’s Cross” stands to the west of the Protestant church, on the same side of the road and close to the road-ditch. It is



CLODMORE, CO. CARLOW. ITS ANTIQUITIES

set on a square base. The shaft and head are composed of a single piece of granite, 7 feet 3 inches high, and 4 feet 3 inches across the arms. The faces of the shaft are 15 ½ inches and 10 ½ inches in width, and not divided into panels. The head is ringed, though not perforated. This cross being less massive than that in the churchyard was probably also not so tall.

St. Mogue's Well

This Blessed Well is situated near "St. Mogue's Cross," and by the side of the little stream that flows under the road a little further on; the stump of a large mountain ash (or quicken tree) stands over it. The well, which is a very small one, is now sadly neglected. There is no sign of the rigs and other votive offerings usually to be met with at a Blessed Well, though in former times it was resorted to for cures. There is a curious little granite boulder, 25 inches long and 13 inches broad at its widest end, lying on the right-hand side of the well, with a hollow in it near the upper end, from which runs a groove down its length. Formerly a person resorting to the Well for a cure drew some water from it and poured it into the hollow of the boulder before applying it to the affected part.

It is a strange fact that "the Pattern" which was formerly held at the Well took place, according to Father Shearman<sup>vii</sup>, on the 31<sup>st</sup> day of January, the festival day of St. Mogue, Patron Saint of the Diocese of Ferns, whereas St. Mogue of Clonmore was venerated on the 11<sup>th</sup> of April, as stated in the "Martyrology of Donegal," thus: -

"Maedhog of Cluain-mór Maedhog, in Leinster. Aedh was his name. He was of the race of Cathaoir Mór. And Aedh, son of Ainmire, Monarch of Erin, had the same mother."

The Bullaun Stone

There is a granite boulder lying a short distance out in the field on the south side of the road leading to Clonmore Castle, and near the wooden gate leading into the field. The boulder is level with the ground, and would be difficult to find without a guide. It measures close on 6 feet in length, and about 33 inches in width. In it there are three large "bullauns," or artificial hollows, from 13 to 11 inches in diameter, and from 8 to 10 inches in depth. Two of the "bullauns"



(courtesy Eddie McDonald)

are very close to one another. What object they served is a puzzle to archaeologists, though some consider that they were used to pound grain in. No name or tradition appears to be connected with this "bullaun stone" in the locality.

The Castle of Clonmore.

It is strange that a place of such size and importance as the existing ruins of this castle prove it to have been should be mentioned so little in the Irish Annals, and that previous to the sixteenth century it is not mentioned at all in the printed calendars of Documents and State Papers relating to Ireland (so far as they have been edited)<sup>viii</sup>.

Nor does Clonmore appear among the County Carlow lordships which fell to the share of Matilda le Marshal (wife of William, Earl of Warren, and widow of Hugh Bigod, Earl of Norfolk) when she and her four sisters succeeded to the Lordship of Leinster on the death of the last of their five brothers in 1245. This would tend to show that it did not acquire importance till later. As far as can be judged from the widely scattered scraps of information which are given below, Clonmore appears to have been a royal castle, that is one belonging to the Crown, by whom it was placed in the custody of, or leased to, powerful barons and constables, to hold it against the onslaughts of the O'Tooles, the O'Byrnes, and the Kavanaghs; and we may be sure that its garrison had far from an easy

time, though no records either of assaults or sieges have been preserved. As will be proved further on, a castle, badly in need of repairs existed here in 1332, but when and by whom it was erected we have no evidence; the existing ruins show additions which are not "bonded" into the walls they are built against, proving that in the course of the centuries the castle was from time to time enlarged. The references to this place, lamentably few and far between, as far as they can be gathered, are as follows: -

The earliest mention of Clonmore appears in Thady Dowling's "Annals of Ireland," where it is stated that Sir Edmund Butler, Deputy to Sir John Wogan, the Justiciary of Ireland, in the month of September 1313, proceeded against the O'Tooles and O'Byrnes, and subdued them; he then marched from Arklow to "Clonemoore," and thence to Carlow. As the crow flies Clonmore is seventeen miles from Arklow, and fifteen from Carlow. Breaking the march at Clonmore would prove the then existence of a castle in which the Deputy took shelter.

The next notice of this place is in 1332. Friar Clyn, in his "Annals of Ireland," relates that about the Feast of the Holy Trinity, in this year, Sir Anthony de Lucy, the Justiciary, carried out extensive repairs to the "Castrum de Clonmore," after which he did the same to the Castle of Arklow. In 1334 Thomas de Wogan was constable of the Castle. In 1355 the Treasurer of Ireland was ordered to pay



ten marks to Simon Ruly de Walterstown, custodian of the castle for its defence; and in the same year James Archibold is named as its constable. In 1356 Peter le Boteller was appointed constable.<sup>ix</sup>

We now come to the first reference of the Castle and Manor of Clonmore being in the possession of one of the Anglo-Irish barons – Sir David Wogan, Kt., of Rathcoffy, in the County Kildare. On the 24<sup>th</sup> February 1417 Sir David's widow, Anastacia, daughter of Sir John Staunton, lord of the Barony of "Otymy" (i.e. Clane, Co. Kildare), was assigned her dower<sup>x</sup>, which consisted of one third of the manors of Rathcoffy and of Kilkea, and "further there is assigned to the said Anastacia the third part of the Castle or Manor of Clonmore, in the east part, with free entry and exit to the parcels aforesaid; further the third part of the Manor of Kylpype and Kypole<sup>xi</sup>, in the west part," etc.

For how long the Wogan family were in possession of Clonmore is not known, but probably they had obtained a lease for twenty-one years.

More than another century elapses before we again hear of Clonmore; Silken Thomas, the 10<sup>th</sup> Earl of Kildare's Rebellion had just been suppressed, and to reward Pierce, 8<sup>th</sup> Earl of Ormond, for his activity on behalf of the Crown, Letters Patent, dated the 23<sup>rd</sup> October 1537, were signed, granting him and his eldest son, James Butler, Treasurer of Ireland, the Castles and Manors of Rathvilly, Clonmore, Tullagh-Offelym alias Tullow, Killasno (Kellistown, formerly Killosna)<sup>xii</sup>, Powerstown, and Leighlin, all in the County Carlow, and also the Manor of Arklow, to hold to them and their heirs by Knight's service.<sup>xiii</sup>

In 1583, amongst other persons living in the neighbourhood of Clonmore, pardons (for what is not stated) were granted by the Crown to a family of O'Byrne, probably tenants of the Earl of Ormond; they were: - Hugh "ganagah" (i.e. the snub-nosed) mac Phelim O'Byrne of Clonmore; Margaret Grace, his wife; and their sons, Phelim mac Hugh, Garrett mac Hugh, James mac Hugh, William mac Hugh, and Robert mac Hugh, all of Clonmore, horsemen.<sup>xiv</sup>



Clonmore Castle (courtesy Eddie McDonald)

In January 1600 the County Carlow is stated to be "for the most part in revolt; the Castles of Carlow and Laughlin, being kept by wards for her Majesty, do stand; and likewise the Castles of Arklow, Ravilly, Clonmore, Tully, Cloughgreny (Clogrennan), and Shrough Boe (Straboe, Barony of Rathvilly), belonging to the Earl of Ormonde and kept at his lordship's charge, are held still, but all the lands are laid waste about them."<sup>xv</sup>

According to an Inquisition taken in Carlow on the 18<sup>th</sup> January 1636, James, Earl of Ormond (created a Duke in 1642), was in possession of the Castle of Clonmore, 200 messuages, 200 cottages, 500 garden-plots, an orchard, 3,000 acres of tillage, 2,000 acres of grazing land, 2,000 acres of wood, 500 acres of furze and heather, and 500 acres of bog in Clonmore and the following townlands belonging to the manor: -<sup>xvi</sup>

- Killmacarton (Kilmacart, 4)<sup>xvii</sup>
- Hackettstown (Hacketstown, )
- Ballynafunshogue alias Constable's hill (Constable Hill, 4)
- Ballycullane (Ballynakillane, 4)
- Croneskeagh (Croneskeagh, 9)
- Ballygallduffe (Ballykilduff, 9)
- Ballynekilly (Ballynakill, 9)
- Ballyduffe (Ballyduff, 9)
- Killongford (Killalongford, 9)
- Raheene (Raheen, 9)
- Crewcrim (Cry-crin, 9)
- Tombeigh (Tombeagh, 4)
- Dromgoine (Drumguin, 4)
- Coollemanagh (Coolmanagh, 4)

During the rebellion of 1641 Clonmore, like so many other castles in Leinster, changed hands more than once; and was eventually, it is said, rendered indefensible by the Cromwellian leaders, Colonels

Hewson and Reynolds, in 1650.

From the possession of the Ormonde family, the Manor and Castle of Clonmore passed to the Howard family, probably about 1697, when Ralph Howard of Dublin acquired from the Duke of Ormonde the estate of North Arklow, in which Shelton is situated. His descendant, the Rt. Hon. Ralph Howard, P.C., was in 1776 created Baron of Clonmore, of Clonmore Castle, in the County Carlow, and in 1785 Viscount Wicklow; in 1793 his son Robert was created Earl of Wicklow. Clonmore is now in the possession of the Stopford family, Earls of Courtown.

The existing ruins of the castle show that it was built on the plan of a hollow square, the sides by a wide fosse, now filled in, but which can still be clearly traced on the north side.

There is no keep or central tower, as the principal residence occupied all the east side. The whole of the south side is level with the ground; this is to be regretted, as it contained the gate-tower (the only entrance into the bawn or courtyard) with its portcullis and drawbridge. The walls surrounding the bawn are very high, and have projecting towers at the northwest and southwest corners, thus adding to the defence of the walls on the outside. The tower at the northwest angle, known as the Maiden's Tower, fell in 1848. the bawn contained the dwellings of the retainers and garrison, the stables, the bakehouse, the brewhouse, etc. The buildings on the east side contain rooms, great and small, narrow passages, and vaulted chambers, all in a very ruinous

CLONMORE, CO. CARLOW. ITS ANTIQUITIES



Window and "Pooka head" (courtesy E. McDonald)

condition; they are lit on the bawn side by narrow slits, or windows of two lights with lancet-shaped heads; on the outside, at the upper floor, the windows are also of two lights with ornamental ogee-shaped heads of cut stone; but many of them are now shapeless gaps in the walls. That additions took place in ancient times to these buildings is clearly seen by the fact that the newer work is not bonded to the older walls, and in one place a splay is made so that the newer wall should not block up a window in the older building. The vaulted work was turned on boards, the impression of them being clearly visible in the mortar. There is a slender eight-sided turret at the northeast end, and a semi-circular slender turret surmounts the southeast end of these buildings. Facing the public road (which runs where the southern portion of the fosse lay) there is a peculiar long cross-shaped

arrow-slit, nearly above which is a gargoyle bearing a grotesque human face, which the peasants call a "pooka-head."

As stated above, the buildings at the east are in a very ruinous condition, and it is astonishing on what slight support huge masses of masonry still remain in position. Ivy covers a considerable portion of the walls, and their present ruinous condition may be largely attributed to its growth. Formerly a couple of cabins stood in the bawn, but they were thrown down some years ago, and now the interior is used as a potato plot. There is a tradition, so common with most castles, that an underground passage runs from the castle to the pagan sepulchral moat half a mile away eastwards; its entrance is still pointed out in one of the vaulted chambers.

A short account of Clonmore is given in Bishop Comerford's "History of the Dioceses of Kildare and Leighlin" (vol. Iii, pp. 178-184). In 1862 John McCall published a pamphlet on "The Antiquities and History of Clonmore in the County Carlow," a little work long out of print; it was printed by J.M. O'Toole and Son, of 6 and 7 Great Brunswick Street, Dublin. Two views of the eastern portion of the castle ruins, interior and exterior, are given in Francis Grose's "Antiquities of Ireland," vol.i, from drawings by Lieutenant Daniel Grose, sketched in 1792; they show the ruins to be in very much the same condition as they are at present (1912).

<sup>i</sup> Annals of the Four Masters, 1881, note m. Book of Rights ,p.208

<sup>ii</sup> Orpen's "Song of Dermot and the Earl," p.327

<sup>iii</sup> In the succeeding notices the place-names will be given in their English form

<sup>iv</sup> Sleaty lies a mile to the north of Carlow-Graigue

<sup>v</sup> The O'Byrne Arms, given therein, are - Grules, a chevron between three dexter hands argent, Crest, a mermaid with a comb and a mirror. Motto: Certavi et vici.

<sup>vi</sup> I.e., of the snub nose.

<sup>vii</sup> "Loca Patriciana." Note on p.186.

<sup>viii</sup> There is a large gap in this series, extending from 1307 to 1509.

<sup>ix</sup> These four references to Clonmore are to be found on pages 44, 57b, 59 and 63 of Rot. Hib. Canc. Cal.

<sup>x</sup> Rot. Canc. Hib., p.223b.

<sup>xi</sup> In the County Wicklow.

<sup>xii</sup> The Irish form of the name was "Cill Osnaidh," and more anciently still "Ceann Loseada," ; see "Annals of the Four Masters" vol. I, p.152.

<sup>xiii</sup> Calendar of Carew Manuscripts, 1515-74, p.128.

<sup>xiv</sup> Elizabeth Fiants, No. 2739 and 4163.

<sup>xv</sup> Calendar of State Papers, Ire., 1599-1600, p.438.

<sup>xvi</sup> Co. Carlow Chancery Inquisition, No. 56 of Charles I.

<sup>xvii</sup> The number following the townland name is that of the 6-inch Ordnance Survey Map on which it occurs.

## Carlow County Museum – Ireland’s Newest Museum Opens

Dermot Mulligan, Museum Curator

On Thursday April 11<sup>th</sup> last the new Carlow County Museum on College Street in Carlow Town was opened by Minister Phil Hogan, TD, Minister for Environment, Community & Local Government and Cllr. Tom O’Neill, Cathaoirleach of Carlow Town Council. The Museum has been developed by Carlow Town Council in partnership with the Carlow Historical & Archaeological Society (CHAS). The Museum is entered through Carlow Tourist Office and admission to the Museum is free. Speaking at the opening Minister Phil Hogan, TD, said “that the existing building is in a very good location and the renovation, extension and conversion didn’t happen by accident and I want to thank the people and community for making sure that this particular part of our history is now a living part of the community in Carlow County Museum.”

The Carlow Historical & Archaeological Society (CHAS) founded and opened the Museum in 1973. In 1979 it was relocated to the former Theatre of the Town Hall, a space provided by Carlow Town Council. The Society managed the Museum on a voluntary basis with employment assistance from FAS. In 2002 Carlow Town Council took over the operation of the Museum and has worked in partnership with CHAS to undertake the redevelopment. Pat O’Neill, President of CHAS speaking at the opening ceremony said “We have realised in this marvellous facility the ambitions of the founder members of our society, and if any museum deserves the description of a community museum this is it. The collection came from the community through the efforts and energies of our society members, and the local authorities accommodated our ambitions through the provision of this beautiful and historic setting.”

To further this partnership a Board of

Carlow County Museum was established in 2005. The Board consists of seven members, three Members of Carlow Town Council, three representatives of the Carlow Historical & Archaeological Society (CHAS) and a County Manager’s nominee. The Museum Curator acts as Secretary to the Board. The position of Chairperson of the Board alternates on an annual basis between the Members of the Town Council and the CHAS representatives. The Museum Board oversees strategic development and devises the County Museum’s policies. The Museum Board has issued five annual reports, starting in 2007, and these can be viewed on the Museum’s website. The present Board members are Carlow Town Council Members Cllr. John Cassin, Cllr. Rody Kelly & Cllr. Walter Lacey; Carlow Historical & Archaeological Society Members: Mr. Seamus Murphy, Mr. Martin Nevin & Mrs Noreen Whelan with Mr. Michael Brennan, Town Clerk as the County Manager’s Nominee. Mr. Martin Nevin was the Chairperson of the Board at the time of the Museum opening. Cllr

Society for having the vision to establish the Museum. They should be proud of what they achieved and that heritage of the county is all the better for their foresight.” Martin Nevin, Chairman of the Board of Carlow County Museum spoke about the pioneering members of CHAS who established the Museum saying that “following a number of visits to museums such as Enniscorthy, Cork, Limerick and Drogheda the project was set in train. A public meeting was convened in the Forester’s Hall..... By unanimous agreement it was decided to launch the project and a museum committee was set-up to look into the availability of a suitable premises.”

The building in which the Museum is now housed is a landmark building within the centre of Carlow town. Until 1989 it was home to the Presentation Sisters. From here generations of Carlow girls were educated and the Sisters legacy thrives in the town through both Scoil Mhuire Gan Smál primary school and Presentation College secondary school.



Tom O’Neill, Cathaoirleach of Carlow Town Council speaking at the opening ceremony said “I would like to thank the

In January 2011 to mark the bicentenary of the Presentation Sisters’ arrival to Carlow town they presented Carlow Town

CARLOW COUNTY MUSEUM

Council with their 1811 Carlow foundation chalice for display in the new Museum. The new Museum occupies the College Street end of the former Convent. The front of the building, facing Tullow Street, was renovated in 1998 to house the Carlow Library & Archive. In 2000 a Fáilte Ireland Tourist Office was opened in the building. The Museum occupies the rest of the building which has four exhibition rooms; the two largest house the Museum's permanent collection while the two smaller rooms are used for temporary exhibitions. The Museum is accessed through the Tourist Office.

Externally the Tullow Street facade of the Convent has a number of architectural features to ensure the building stands out on the town's main street. Probably due to the narrowness of College Street coupled with the height of the building its external appearance is quite plain. As a result a series of red banners have been erected along College Street to lift the building and highlight its location to visitors. But what the building may lack in features on the outside it more than makes up for on the inside.

The Museum's ground floor was used as the Convent's primary school until 1960. Originally there were three classrooms separated by partition walls with access provided by a corridor on the College Street side of the building. Since 1989 these rooms had been used for a variety of community and voluntary organisational purposes. As a result alterations were made to a number of these internal spaces.

To provide the Museum with a flexible display gallery it was decided to open up the ground floor as one large display space. To allow the building dry out from a potentially serious rising damp problem the plaster was stripped off the walls. Not only did the walls dry out (the new floor has a damp proof course installed) but a series of archways and alcoves in the walls were revealed for the first time in decades. It was decided not to replaster over the walls but to retain the features and cover the walls instead with Hydi – a strong anti-damp course that looks like a whitewash. This prevents dampness entering through the walls and yet allows the rubble walls to



*Pulpit and banner. (Courtesy Carlow County Museum)*

breathe outwards. An original fireplace backing onto the Tourist Office has been retained in its original position.

Below the original stairwell a window that was originally a door was reinstated as an opening for access to the Museum's extension. At the foot of the stairs an opening was punched through into the Museum extension to provide a door into the new ladies' toilets. The large north window above the stairs had all its broken panes of glass replaced while a new teak base was installed to replace the rotten timbers. Through this leaded window a framed view of the Cathedral steeple can be enjoyed. To retain this view and yet prevent natural daylight from entering the building, which would damage the artefacts, it was decided to build a new internal wall at the first floor landing all the way to the first floor ceiling. This stairwell was previously used by pupils as well as the public to access the Convent's first floor Chapel to attend services. The half landing has a limestone holy water font which now displays the Convent's 1811 chalice and is surrounded by a collage of Convent photographs.

At the top of the stairs one enters into what was the Convent's former Chapel. This is now arguably the most impressive room within all of Carlow Local Authorities public buildings. Considering the many architectural features in this room particular care and attention was given to the care and restoration of this

room. Apart from the exhibitions that have been installed here the former Chapel is an exhibit in its own right.

The main part of the Chapel ceiling has fifty panels and each panel was gilded during the nineteenth century. Unfortunately sometime during the 1960s the ceiling was painted over. Over the years some of the panels paint began to flake re-revealing parts of the original gild. The gild is so thin it is virtually impossible to strip back the paint without also stripping off the gild. However, just enough flaking occurred to reveal the impression of the patterns that were originally gilded onto the ceiling. When the main construction works were completed and prior to the installation of the exhibitions all fifty panels were skillfully re-gilded. Careful scrutiny of the ceiling by a curious visitor will reveal that the centre of one of the panels still contains the hook from which the Chapel's sanctuary light once hung.

The altar, along with the stalls, organ, wall memorials and Stations of the Cross were removed in 1989 but the two wooden and plaster blind archways along with the organ screen were retained along with the reredos (back of the altar). The wooden reredos which is located in one of the blind archways contains Victorian glass and along many of its edges contained gilding. This was extensively cleaned and re-gilded.

The Chapel has two types of floor boards,

At the pulpit end of the Chapel are possibly the original floor boards of pitch pine. These are rough, worn, and contain protruding knots, and lack tongue and groove joining. The main Chapel floor contains tongue and grooved white deal floor boards. Although not the original floor boards they are still of an age to be considered of suitable vintage that they are an important feature of the former Chapel.

For some time mystery surrounded the dedication of the six stained glass windows. The dedication reads "Pray for the repose of the soul of Mr. P. Hanlon, RIP". Following the publication of an article in the Carlow People newspaper requesting information about the stained glass windows Mr. John Murphy of Killinure, Tullo contacted the Museum suggesting that this might be Patrick Hanlon from Grange who died in 1928 and is buried in the graveyard adjoining St. Patrick's Church in Rathoe, Co. Carlow.

According to Patrick Hanlon's obituary, published in the Nationalist & Leinster Times on June 27<sup>th</sup> 1928, he died on October 17<sup>th</sup> and his death "removes a prominent figure in the public life of County Carlow ... He was closely identified with every movement for the welfare of the country. He was a staunch supporter of the tenant farmers in their fight against Landlordism and was a loyal and enthusiastic Nationalist of the old school of Irish politics... For many years he was a most attentive and capable member of the old Carlow Board of Guardians... Deceased was returned a member of the first County Council, and of the Rural District Council, in 1899... The late Mr. Hanlon was a successful and progressive farmer, and his interest in agriculture was shown at the meetings of the County Carlow Committee for Agriculture..."

These details were forwarded to Sister Marie Therese King, Presentation Sisters Provincial Archivist who manually searched the Carlow Convent's Annals for this period. It has transpired that Patrick Hanlon of Grange is indeed the P Hanlon to whom the windows are dedicated. His connection to the Convent was through his sister, Mary Lucy, who according to Convent records entered the

Carlow Convent in 1855 at twenty one years of age taking the name Sister Catherine. Unfortunately she died in 1870 aged just thirty six years and is interred in the Convent's graveyard which adjoins Carlow Cathedral. In his last will and testament he left 'One thousand pounds to Reverend Mother Superior for the time being of the Presentation Convent Carlow, in trust for the benefit of the Community of said Convent.' It appears that all of this money was used in the Convent's Chapel as the Annals state in September 1931 that "the inseting of six stained glass windows in our little Chapel was completed to-day. The gift of P. Hanlon, Grange Co. Carlow." In May 1933 the Annals further state "Today saw the completion in our little Chapel of the triple magnificent gift of Mr. P Hanlon, Grange ... in the form of six stained glass windows, set of stalls and Stations of the Cross - all of which so enhance the beauty of our little sanctuary."

The Chapel houses the Museum's largest object - the magnificent hand carved nineteenth century pulpit from the next door Cathedral of the Assumption. The pulpit, made in Bruges in Belgium, was controversially removed as part of the mid 1990s reordering of the Cathedral. When the pulpit was removed from the Cathedral it was brought into the former Chapel area and re-erected. It wasn't until some years later that the Museum was allocated the building and the pulpit is now, along with the Chapel, central to its new religious display.

Directly behind the Chapel and at first and second floor levels directly above the Tourist Office are the Museum's two temporary exhibition galleries. This area was previously the Sacristy and the Sister's cells (bedrooms). In 2000 as part of the Tourist Office fit out these two floors were developed into exhibition galleries. They were used on a number of



*The Fourth Station of the Cross (Courtesy Carlow county Museum)*

The six windows in Carlow County Museum are Mary with St. Anne her Mother; the Sacred Heart of Jesus with St. Margaret Mary; the birth of Jesus; the Fourth Station of the Cross; Our Lady with St. Bernadette at Lourdes; the Annunciation. The beautiful windows were crafted by Earley & Company of Camden Street, Dublin and their work is considered as good as Harry Clarke's studio works. Two of the windows are on view as part of the Museum's religious display. The other four windows are covered with removable panels to keep daylight out.

occasions to house exhibitions organised by the Museum, the Arts Office, Eigse and the Carlow County Development Partnership. Alterations were made to this area including the removal of the existing stairwell so as to gain extra exhibition wall space. A new staircase was installed in the void between the floors along with the addition of a lift, thus making the entire Museum building fully accessible to those with physical disabilities. The installation of the stairs and lift was one of the trickier onsite construction jobs and the space is quite tight; in fact

## CARLOW COUNTY MUSEUM

several design options were considered before the present installation was agreed upon. At the end of the tour visitors egress the Museum and return to the ground floor via the beautiful original main Convent staircase.

It was decided early on in the design process that the existing convent building would be maximised as the Museum's new exhibition galleries. Therefore to accommodate the ancillary facilities such as offices, toilets, onsite storage and canteen an extension would be required. The extension is located to the north and north east of the building, described by Michael O'Boyle, Bluett & O'Donoghue Architects as a 'bookend'. The first floor portion of the extension is respectful of the Convent's leaded windows, with the installation of a flat roof below the large north window and a balcony in front of the first window on the east side. The extension is clad in cut Carlow limestone to complement the existing convent building which was built of mainly limestone rubble. To achieve some onsite storage a basement was constructed as part of the extension. One of the most crucial times during the entire construction was the excavation of the foundations and basement as its location beside a nineteenth century building could have been problematic. It was important to have good weather during this time to avoid the deep foundations becoming water logged. The existing convent foundations proved to be substantial and there was very little rain during this period. The basement was constructed with ease and from there the block work and limestone cladding were easily erected. The Museum building is fully accessible and this is something not always possible or easy to achieve in a nineteenth century building.

The exhibition design and installation was led in house by the Museum staff. It was decided to lay out the exhibitions thematically and not chronologically. Major themes of Carlow's history were identified and this was compared to the Museum's collection. Due to constraints of space the Museum can only display a snapshot of the county's entire history at any one time. This is no different to the former Museum in the Town Hall and to the vast majority of long established Museums. The Museum has an off site stor-

age unit that houses the reserve collection. It is planned over time to display more artefacts from the reserve collection as well as incorporating new items that are added to the collection. Through the temporary exhibition galleries a topic can be expanded and explained in more depth than may be possible in the permanent galleries due to constraints of space.

The majority of the artefacts were moved from the Museum store in portable boxes and containers but some required more planning and the use of lifting equipment. The former Nationalist & Leinster Times printing press was certainly one of the most interesting pieces to move. Firstly it was located in the former Museum premises in the former Town Hall theatre, complicated by the fact it was located at first floor level. Using a pallet truck the printer was moved to the car park side of the Town Hall. Temporarily one of the sash windows was removed and Walls Engineering supplied a crane which lifted the printer out through the window. It was transported by a truck to the Museum and the crane lifted the printer through the Museum's ground floor fire exit onto the pallet truck which along with other lifting equipment positioned the printer in its new display location. The culm crusher, after being washed, was transported with the aid of a JCB and a pallet truck while the Thompson Engineering manufactured World War 1 aeroplane wing was moved by both careful manual handling and a large flat bed trailer. The professionally made nineteenth century banner 'Tinryland and Bennekerry Irish National League', although light to lift, provided its own display challenge. Firstly it was conserved by Rachel Phelan Textile Conservation, Dublin who surface cleaned the banner; fibres and tassels were restitched and realigned and the painted images were conserved. Through consultations between Museum staff, Seamus Proctor Carpentry and the conservator a bespoke double sided MDF and perspex display unit was constructed.

Among the new displays are exhibitions dealing with:

John Tyndall, Carlow's prolific 19<sup>th</sup> century scientist whose discoveries still have an impact to this day; he is arguably the Father of Fibre Optics, discovered the greenhouse effect and was a renowned

mountaineer. Captain Myles Keogh was in the 7<sup>th</sup> US Calvary and killed in the Battle of Little Big Horn along with General Custer. Kevin Barry, a medical student from Co. Carlow was executed in 1920 in Mountjoy Gaol at the age of 18 for his role in the War of Independence. For centuries during the Bronze Age Dinn Ríg was the seat of the Kings of the Province of Leinster and from where the name Leinster came from. Carlow Sugar Factory, Ireland's first and largest sugar factory, was in 1925 the first public pri-



*First floor exhibition gallery  
(Courtesy Carlow County Museum)*

vate partnership in the history of the State and an innovative agricultural business. The former convent Chapel exhibition gallery houses the Museum's largest object – the magnificently hand carved 19<sup>th</sup> century pulpit from the Cathedral of the Assumption. It is considered one of the finest pulpits in Ireland. The Museum collection contains rare archaeological specimens of axes, swords, Bronze Age food vessels and an exquisite eleventh century piece of Irish silver which is part of the Jackson collection. The ground floor contains a display of trades and commercial life such as the forge, shop, bar, Boot Factory, plumber, carpenter, barber and a kitchen. The law and order section displays the original trap door from the gallows of Carlow Gaol, possibly the only one on display in a Museum in Ireland. All of the exhibitions will be added to and enhanced over the coming years.

The majority of the project costs were met from within Carlow Town Council's own resources but have received grant assistance from the Heritage Council, the Department of Tourism, Culture & Sport, Carlow County Development Partnership and Fáilte Ireland.



The renovation, extension and conversion of the building into a museum must also be viewed in the overall context of its setting in Carlow's Cultural Quarter. The Carlow 800 plan published in 2000 is a master plan for the town, presenting a civic vision of Carlow for the twenty first century. It identified a number of quarters for the town including Cultural Quarter that has now come to fruition. The cultural quarter runs from Tullow Street along College Street to the Old Dublin Road encompassing the County Library, Archive, Tourist Office, the Cathedral of the Assumption, Carlow College, the Visual Centre for Contemporary Art & The George Bernard Shaw Theatre and the magnificent early nineteenth century Carlow Courthouse. The Quarter is also home to Carlow Tourism, Eigse – the Carlow Arts Festival & Glór Ceatharlach. Two years ago as part of this Cultural Quarter plan realignment works were undertaken to College Street, onto which the Museum is facing, with the provision of new pavements and the opening up of boundary walls of Carlow College. The Museum is the last part of the Cultural Quarter to be opened. Cllr Tom O'Neill, Cathaoirleach of Carlow Town Council speaking at the opening ceremony stated that "like the Museum, many of these sites are free and together they provide an important cluster of visitor attractions in the heart of our town."

Nationally there are twelve official County/City Museums in Ireland. A County/City Museum is one that is operated by a Local Authority. Carlow is now the second County/City Museum in Leinster, the other being in Co. Louth. The Museum is the third County/City Museum in the south east region with Waterford Treasurers and South Tipperary County Museum being the other two. All the County/City Museums work closely with the National Museum of Ireland, particularly in the area of Archaeological Finds. Under the National Monuments Act 1930 and its amendments all archaeological objects found with no known owner are the property of the Irish State. Over the years the National Museum has been collecting artefacts from every county in the country and obviously not all artefacts can be displayed. Significantly through the Designation Status the National Museum empowers the

County/City Museums to collect and display archaeological material found in their respective counties on its behalf. Prior to tendering for the main contractor Museum staff met with the National Museum to discuss the overall plans for the building and any advice given was incorporated. Post the construction works and prior to the installation of the main exhibitions National Museum staff thoroughly inspected the building. This inspection was to ensure that the Museum met the criteria of a Designated Museum and that the Museum was suitable to display objects from the national collection. The National Museum staff were extremely pleased with the building and its facilities and in fact most of what they saw exceeded their expectations.

The new Museum's two temporary exhibition galleries will accommodate both travelling exhibitions and those created in house. Making full use of these galleries and the designation status the Museum decided that the first temporary exhibition would be 'Journeys in Time – the Archaeology of the M9 Carlow Bypass'. It has been developed by Carlow County Museum in association with the National Roads Authority (NRA), the National Museum of Ireland and Rubicon Heritage Services, who carried out the excavation work. Speaking at the Museum opening archaeologist with the NRA Noel Dunne said that "Extensive archaeological research and investigations were undertaken between 2001 and 2006 along the route of the Carlow Bypass in advance of road construction - through constraint, route selection and environmental impact assessment phases, followed by archaeological test-trenching and finally excavation of discovered sites. In all, 64 sites were excavated and the results have contributed greatly to our understanding of Carlow's past – quite significant findings that will form a tremendous resource into the future, in terms of education, tourism and local historical awareness."

Significant sites include Carlow's oldest houses at Russellstown & Busherstown, the first Neolithic (4,000 - 2,500BC) houses ever discovered in the county.

Many Mesolithic (7,000 – 4,000BC) objects were found including Bann flakes and stone blades. An unusual medieval ring-brooch or buckle is believed to be first of its kind found in County Carlow. Other finds range from a porcellanite stone axe originally from Co. Antrim, a number of grave goods, a red deer antler pick, pottery of different types and shapes, stone axes, stone scrapers, a medieval bone pin, different types of arrowheads and an iron quarry wedge. One Iron Age blue-green glass bead is the Museum's smallest object at less than 2mm in diameter. All artefacts on display in this exhibition are on loan from the National Museum of Ireland. The importance of these excavation results for Carlow is acknowledged by the fact that 'Journeys in Time' is the very first temporary exhibition to be held in Carlow County Museum and it will run until April 2013.



*Archaeology Exhibition  
(Courtesy Carlow County Museum)*

There are two full time staff employed by Carlow Local Authorities, Dermot Mulligan, Museum Curator and John McDarby, Staff Officer. Presently there are two people engaged through Jobbridge, the national internship scheme, two through the TUS programme coordinated by the Carlow County Development Partnership Ltd. The Tourist Office is operated by Carlow Tourism on behalf of Fáilte Ireland. To ensure the Museum can function on a day to day basis there is a team of volunteers who since the Museum opening have given selflessly of their time and indeed the Museum is very grateful to them for this.

Over the last ten years while the new Museum premises were in the process of being developed the Museum engaged in a variety of community projects, exhibitions, walks and talks. Although being a County Museum allows for a wide scope

## CARLOW COUNTY MUSEUM

of displays and exhibitions to be undertaken, it is only possible to provide a snapshot of the County's wide history and heritage within the display galleries. Through these outreach projects the Museum recognises that many other aspects of the County's heritage can be accessed and focused on. Some of the projects the Museum undertook or were involved in included: The Interreg 111: the Cultural Exchange project with the Museum Service, Pembrokeshire, Wales; the Carlow Town Heritage Trail; the Leighlinbridge Historic Town Trail; the Carlow – Trails of the Saints; the Borris House Geo-Physical Survey; the Carlow Folklore Exhibition; the Clonegal Commemorative Plaques; the Carlow GAA 125<sup>th</sup> Anniversary Exhibition 2009; the Geological Survey of Ireland geology walks in the Blackstairs, 2004 – 2007 and a special walk to Carlow's Volcano in 2008; the Heritage Boat Association National Rally in Carlow Town 2005; the Carlow Cathedral Heritage Week Exhibition, 2010; the Michael O'Hanrahan 1916 90<sup>th</sup> Anniversary Commemoration, 2006; the Royal Society of Antiquaries "Rubbing Shoulders with the Dead" exhibition and is the national Heritage Week coordinator for County Carlow since 2005.

The Museum is conscious that it is displaying a variety of artefacts from around the County and that where possible visitors should be encouraged to explore further into the County. To this end the exhibition panels make references to other places to visit, trails and drives to follow as well as websites to view for more information.

Check out [www.carlowcountymuseum.ie](http://www.carlowcountymuseum.ie) or join in on [www.facebook.com/carlow-countymuseum](http://www.facebook.com/carlow-countymuseum) and [twitter.com/carlow-countymus](https://twitter.com/carlow-countymus)

Carlow County Museum Opening Hours:  
Monday - Saturday  
10.00am - 4.30pm September - May  
Monday - Saturday  
10.00am - 5.00pm June - August  
Sundays & Banks Holidays  
2.00pm - 4.30pm June - August

Admission to Carlow County Museum is free and is self guided. Guided tours can be provided for groups (pre booked),

schools can enjoy the special fun quiz while families can undertake their own investigations with our junior detective quiz.

#### Appendix 1 Carlow County Museum Opening Ceremony Details for Wednesday April 11<sup>th</sup> 2012

##### 4.15pm to 5.15pm:

Minister Phil Hogan, TD, Minister for the Environment, Community & Local Government was given a tour of Carlow County Museum.

Following the tour Minister Hogan and Cllr. Tom O'Neill, Cathaoirleach of Carlow Town Council unveiled the commemorative plaque in the Museum's entrance hallway.

##### 5.15pm

Opening speeches hosted next door in the Cathedral of the Assumption\*

Cllr. Tom O'Neill, Cathaoirleach of Carlow Town Council

Martin Nevin, Chairperson of the Board of Carlow County Museum

Pat O'Neill, President of the Carlow Historical & Archaeological Society

Noel Dunne, Archaeologist, National Roads Authority

Blessing of the new County Museum led by Monsignor Brendan Byrne

Minister Phil Hogan, TD, Minister for the Environment, Community & Local Government speech and officially declared Carlow County Museum opened.

MC – Dermot Mulligan, Museum Curator

Cllr. Tom O'Neill, Cathaoirleach of Carlow Town Council made a presentation of a framed Browneshill Dolmen artwork to Minister Phil Hogan TD on behalf of Carlow Town Council and the Museum Board.

##### 6.00pm

Reception hosted in the Visual Centre for Contemporary Art.

#### Appendix 2

##### Carlow County Museum Project Credits/ Details

###### Board of Carlow County Museum:

Martin Nevin, Chairman; Michael Brennan, Town Clerk, Cllr. John Cassin, Cllr.

Rody Kelly, Cllr. Walter Lacey, Seamus Murphy & Noreen Whelan.

###### Carlow County Museum Design Team:

Architect Michael O'Boyle, Bluett & O'Donoghue Architects, Dublin

Design Team Leader & Structural Engineer Ivor Bowe, Bowe Consulting Engineers, Carlow

Quantity Surveyor Andy Quinn of McCullagh Lupton Quinn, Kilkenny

Structural Engineer Tom Gleeson (R.I.P), Carlow

Mechanical & Electrical Engineer Eddie Doyle, Doyle Environmental, Ullard

Michael Brennan, Town Clerk, Carlow Town Council;

Tim Madden, Clerk of Works, Carlow County Council

Overall Project Coordinator & Exhibition Design Leader Dermot Mulligan, Museum Curator, Carlow County Museum.

###### Carlow County Museum Contractors:

Main Contractor: Bam Building Ltd, Kill, Co. Kildare

Electrical Contractor: Seamus Byrne Electrical Ltd., Carlow

Mechanical Contractor: Murphy & Kelly, Thomastown, Co. Kilkenny

Lift Contractor: Kone Ireland Ltd., Dublin

Leaded Windows Contractor: Irish Stained Glass, Dublin

Gilding Contractor: Naomi McBride & Associates, Co. Sligo

Oil Painting Contractor: Naomi McBride & Associates, Co. Sligo

Display Cases: Armour Systems Ltd, Milton Keynes, England; Click Netherfield, Scotland

Conservators: Liz D'Arcy, Studio for Paper Conservation, Co. Wicklow; Susannah Kelly Archaeological Conservator, Dublin; Rachel Phelan Textile Conservation, Dublin; On the Edge Ltd, Co. Wicklow.

Picture Framing: Fine Framers, Carlow Town

Moulding: Old Mould Company, Co. Wicklow.

Historical Researcher: Dr. Margaret Murphy, Co. Carlow.

Irish Translation: Máire Uí Iarnáin, Co. na Gaillimhe

Graphic Design & Printing: Lightning Print & Design, Carlow; Carlow Graphics.

Environmental Monitoring: Instrument Technology, Co. Meath

Contractors:

Gerrie Dunne Building Contractors; Edwards Engineering, Tullow, Co. Carlow; James J Farrell, Carlow Town; Paul Hoey Decorator, Carlow Town; Thomas O'Neill & Sons, Carlow Town; Proctory Carpentry, Carlow Town; Walls Engineering, Carlow & Xenon Security, Carlow.

Museum Staff:

Dermot Mulligan, Museum Curator; John McDarby, Staff Officer; Martin O'Rourke, Building Maintenance Superintendent; Museum Assistants - Deirdre Kearney, Sinéad Marshall, Shannon Basso Gaule, Tom Roche, David Halpin & Jake Duggan. Thanks to all our volunteers who have and are assisting in the running of the Museum.

Grant Aid & Specific Funding Received from:

Department of Arts, Heritage and the Gaeltacht  
 Carlow County Development Partnership  
 European Regional Development Fund Interreg 111A Programme  
 Fáilte Ireland  
 The Heritage Council  
 The National Roads Authority

Thanks for help, support, guidance to the following organisations, societies, groups & individuals:

Cllr. Tom O'Neill, Cathaoirleach of Carlow Town Council, Members of Carlow Town Council - Cllrs Michael Abbey, Anne Ahern, Eileen Brophy, John Cassin, Des Hurley, Roddy Kelly, Walter Lacey, Jennifer Murnane O'Connor.  
 Cathaoirleach and Members of Carlow County Council; Cathaoirleach and Members of Muinebheag Town Council.

Tom Barry, County Manager; Michael Brennan, Town Clerk and the Carlow Local Authorities Management Team. The Board of Carlow County Museum. To all the staff of Carlow Town Council. Josephine Coyne, County Librarian and the staff of Carlow County Library. To the staff of Carlow Local Authorities. To the staff of Carlow Town Amenity Trust.

The President, former Presidents, committees and members of the Carlow Historical & Archaeological Society and

Museum Committees for their vision, foresight, enthusiasm and pioneering spirit in founding and operating Carlow County Museum since 1973.

Director and staff of the National Museum of Ireland including Dr. Patrick Wallace, Ragnall Ó Floinn, Ned Kelly, Paul Doyle, Anthony Read, Gregory Kelly, Isabella Mulhall, Nessa O'Connor, Mary Cahill, Maeve Sikora, Carol Smith, Christopher Harbidge, Pádraig Clancy, Andy Halpin and Mathew Parkes.

Michael Murphy, Chairman and the Board of Carlow Tourism, Eileen O'Rourke CEO and the staff of Carlow Tourism - Gwen Brennan, Lorraine Brennan, Kay Farrell, Alison Fitzharris, Alberto Urbina and Carolyn Wilkinson.

Rónán Swan, Acting Head of Archaeology & Noel Dunne, Archaeologist, National Roads Authority (NRA)

To the Chairperson, Festival Directors and staff of Eigse, Carlow Arts Festival for their help and support over the years.

To the Presentation Sisters for their invaluable information, support and eternal encouragement to all associated with this project.

The Staff of Bam Building Ltd including Leo Harmon, Derek O'Connor, Kieran Brophy, Tavin Broaders; The Local Authorities Museums' Association (LAMA); Carlow - Kilkenny Energy Agency; Former County Managers: Matt O'Connor, Tom Dowling & Joe Crockett; Mary Walsh and staff of Carlow County Development Partnership; Michael Starrett and the staff of the Heritage Council; Sergeant Mary Corcoran, Crime Prevention Unit; Carlow Gardai; Carlow Civil Defence; Chris Corlett, Archaeologist Department of Environment, Community & Local Government; Fr. John Cummins, Fr. Rory Nolan, Bernard Gerraghty and the Cathedral Parish; Monsignor Caoimhín Ó Néill, Dr. Thomas McGrath, staff and students of Carlow College; Jarlath Judge and the staff of CRISP Carlow; Mark Thomas and the staff of the Pembrokeshire Museum Service, Wales; Judith Martin and the National Council for the Blind; Emma Whitmore, Glór Cheatharlach; Grace Marshall, Office of

Public Works; Staff of Visual and the George Bernard Shaw Theatre; Fiona Cunnane and the staff of Carlow Volunteer Centre; FAS; Jobbridge - National Internship Scheme; Dr. Gillian Barrett; Alan Cashin, Tom Clowry; Ger Deering; Therese Jackman; Matt Kelly; Dr. Peadar McArdle; Hugh Maguire; Paddy Matthews, Declan O'Connor; Mary O'Neill, Bobby, Mary & Gemma Quinn, Lorcan Scott, Joe Watters, Town Clerk (retired); Pat Mealey, John Kavanagh, Bill Flemming & the residents of Presentation Close;

To all the people who since 1973 have presented the Museum with artefacts and objects for display. Together these objects give us a greater understanding of our rich past.

\* With the potential for several hundred people to gather for the opening it was decided that the Museum could not accommodate such a crowd inside the exhibition galleries. It was planned to hold the opening ceremony in what was the former Presentation Convent garden, now Presentation Close car park. According to the Presentation Sisters there was a tradition of having a party in the gardens following the Communion and Confirmation of their pupils in the Cathedral. It was decided that weather permitting the Museum would have its own version of a garden party in honour of this tradition. Unfortunately in the hour or so leading up to the ceremony the weather broke. Several weeks prior to the opening the Cathedral of the Assumption agreed to host the ceremony if the weather wasn't favourable. They did this both as a neighbourly gesture and in honour of their close ties over the years with the Presentation Sisters. As a point of clarification the speeches in the Cathedral were given from the side of the altar using a music stand as a lectern and not from the pulpit as widely reported in the media. Speaking from the pulpit in the Cathedral is a practical impossibility since the mid 1990s when the pulpit was removed as part of the renovations of the Cathedral. It is estimated that between five hundred and seven hundred people attended the opening.

## The 'Slashing Parson' of 1798: The Life & Death of Rev. Robert Rochfort of Clogrennane, Co. Carlow, 1775-1811.

By Shay Kinsella

### Introduction

The ruins of Clogrennane House court mystery. Built in 1815 to replace their earlier home, Clogrennane Lodge, its walls are the main physical reminder of the Rochfort family's presence in the county Carlow townland of Clogrennane. However, with its back towards the public road, facing the steep incline of Clogrennane Hill, it seems resigned to obscurity, the climbing ivy camouflaging it even further into the green landscape. The correct spelling of the townland is itself characteristic of the confusion and uncertainty surrounding the Rochfort historiography: is it Clogrennane, Cloughrenan or Clogrinan, as all variations occur in the sources? Much of the family history is uncharted and lies as damaged and brittle as the small holding of Rochfort papers in the National Library.<sup>i</sup> In turn, the details of where and how these papers were acquired is a similar story of uncertainty, the only note in the Library's accession records being a comment on the soiled and damaged state of the documents.<sup>ii</sup> At least three myths exist in folklore describing the family's origins in Carlow, and are symbolic of the ambiguity and invention surrounding their history.<sup>iii</sup> Much recovery remains to be done before their story disappears like the original Rochfort home or the towers of Clogrennane Castle.

In his masterly survey of the Carlow gentry, Jimmy O' Toole claims the Rochfort name is remembered in Carlow for two diverse reasons: Horace Rochfort's role in promoting the development of cricket, polo and rugby in the county in the nine-

teenth century, and for his father's role in the prosecution of the 1798 rebellion in Carlow.<sup>iv</sup> In allocating a pivotal role to Col. John Staunton Rochfort (1764-1844) in that regard, O' Toole and others base their evidence on his considerable corre-

However, no historical account to date has assessed the arguably more significant, provocative and dramatic role played by his younger brother, the Reverend Robert Rochfort. The story of his life and early death is dominated by alle-



*Ruins of Clogrennane House, completed 1815. The Rochforts left in 1923.  
Photo; Shay Kinsella*

spondence with the Dublin administration in the Rebellion Papers of the National Archives, the account of his encounter with William Farrell in his *Carlow in '98*, and the writings of fellow Orangeman John Ryan in his *History and antiquities of county Carlow* (1833). In her thesis, Maura Duggan outlines his activities in great detail, and the existing historiography of the period rightly grants him a central role in the turbulent affairs of that year, sharing the limelight of notoriety with Robert Cornwall of Myshall Lodge. Similarly, L.M. Cullen claims that Rochfort was 'so influential', both within and outside Carlow in 1798.<sup>v</sup>

gations of brutality and cruelty in 1798 that make him Carlow's answer to pitch-capping Captain Swaine. Thirty years after the rebellion, his reputation had been demonised to an unparalleled degree in the county. Accused of sectarian butchery and the remorseless and unauthorised execution of United Irish prisoners without trial, the exploits of 'the slashing parson' as he came to be labelled, were recalled and elaborated on,<sup>vi</sup> ranking him just below Robert Cornwall in terms of violence and brutality. He cuts an intriguing figure in the imagination by his fusion of religious and military concerns - striking in his clerical

garb, bible in one hand and cat-o'-nine-tails in the other, unapologetic to the last in his preaching of an omnipotent Protestant Ascendancy. For decades, indeed, until the Rochforts finally left Ireland in 1923, the legacy of Robert Rochfort's activities in '98 hung over the family like a spectre, destroying their electoral chances (John Staunton Rochfort was the last of the Clogrennane branch to have a seat in parliament) and tainting their entitlement to a good name in subsequent decades.

His story is engaging in its savagery and drama, his premature death at the age of thirty-six locking him into a legend he could never change, unlike his brother John Staunton who mellowed considerably with time, age and hindsight. In addition, the story is appealing in the dichotomy of Robert's character. On the one hand he was charismatic, handsome, popular with the eligible women of Carlow, charming in the vigour of youth, an intelligent preacher with excellent prospects who was always immaculately presented. On the other, he was bloodthirsty, vengeful, inherently sectarian, obsessive, paranoid, and at worst, murderous. His death in 1811 was celebrated with delight in the *Irish Magazine* by Watty Cox, the most vitriolic critic of the political *status quo* of his day. Rochfort was granted the lengthiest and most detailed mock-obituary of several 1798 demons, in a publication where details of the rebellion in Carlow were given significant coverage, and where the county received attention for the sectarian nature of events there. Rochfort's death-notice was full of sardonic quips and devastating in its allegations.<sup>vii</sup> In his own eyes, the Reverend felt his actions in the suppression of the rebellion were a righteous defence of his Protestant inheritances. The nation of the Protestant élite was the one he had in mind when he ordered William Farrell to 'serve your country' by informing on his comrades.<sup>viii</sup> However, to Cox and the United Irishmen, Rochfort had in fact betrayed his

nation by perpetuating English rule in Ireland and was in fact, 'the assassin of his country'.<sup>ix</sup> It can indeed be argued that the activities of the Rochfort brothers and their promotion of Orange sympathies in Carlow were the key factor in the defeat of the United Irishmen in the county that year. It was Robert, however, who appeared to revel in the bloodshed. In this light, his story is highly worthy of study and is crucial to a description and understanding of the 1798 rebellion in a Carlow context.

#### His father, John Rochfort: 1735-1812.

Although Cox claimed he was born into 'the dregs of Ascendancy', Robert Rochfort (of the 17<sup>th</sup> generation from the original De Rochefort settlers in Ireland in the early fourteenth century) was born into a family with an impressive pedigree in the Anglo-Irish élite.<sup>x</sup> His great-grandfather, the Hon. Robert Rochfort, had been the Speaker of the Irish House of Commons, and his grandfather, a notable Tory, had sat in the Irish parliament for 47 years.<sup>xi</sup> The primary influence, however, on Robert's burgeoning political and social awareness was undoubtedly his father.

Forty years old at the time of Robert's birth, John Rochfort (1735-1812) was at the head of a considerable estate and was a renowned upholder of Protestant interests across several counties. As the son of an MP, and grandson of the Speaker, John Rochfort grew up enjoying the power and privileges of the landed élite and appreciating a need for their protection. Heir to the entailed estate at Clogrennane, he served as High Sheriff for Carlow in 1758 at the age of twenty-three.<sup>xii</sup> Two years later, in February 1760, he married Dorothea (Dora) Burgh,

daughter of Thomas Burgh of Bert House, Co. Kildare in a valuable connection for the family. The Burghs, although far from affluent, were 'a family of splendid lineage' according to A.P.W. Malcolmson, and one worthy of Rochfort interests. Dora's elder sister Margaretta (Peggy) had already married John Foster, who would later become the last Speaker of the Irish House of Commons and subsequently, Chancellor of the Irish Exchequer and Lord Oriel. As 'uncle' to John Rochfort's children, Foster was to prove an invaluable patron and stepping-stone to promotion and societal elevation.<sup>xiii</sup>

John Rochfort succeeded to his father's estate on the latter's death in December 1771.<sup>xiv</sup> As the only surviving son, John inherited the entirety of his father's property which included the lands of Newpark in Dublin, estates in Co. Westmeath and Wexford, as well as their primary seat at Clogrennane in Carlow which included the lands of Raheendoran. For convenience during their trips to the capital, the Rochforts had a residence in Jervis St. and another on Ormond Quay as well as a residence on Dublin St. in Carlow town. John Rochfort extended the family's landed portfolio by leasing an estate at Clonskee, Co. Galway and acquiring the lands of Adamstown and Milltown in Dublin.<sup>xv</sup> By 1812, Edward Wakefield estimated that the Rochforts enjoyed an annual income of between £5,000 - £7,000.<sup>xvi</sup> Despite the vicissitudes of the following century and a notable decline in their fortunes, the family still owned 3,392 acres in 1883, across three counties.<sup>xvii</sup> However, in the 1770s, the Rochfort holdings were even more extensive, and their concomitant social, economic and political powers were at their zenith.

John Rochfort's ascent in political circles was impressive and largely self-engineered. His ambition was matched by ability, and a persuasive and confident manner of address. Although he con-

ceded he did not have the largest estate in Carlow in 1772, he wrote to the Lord Lieutenant of Ireland, Lord Townshend, and made an impassioned application for the Governorship of the county, stressing his qualifications and accomplishments.<sup>xviii</sup> His fervour was rewarded in the following month when he was personally appointed as Governor of Carlow by Lord Townshend.<sup>xix</sup> By the time of Robert Rochfort's birth in 1775, John Rochfort's position of leadership and power in the county was assured. One of his most significant – and indeed symbolic – duties was the administration of the Test Oath to Catholics, by order of an act of Parliament in 1774. The oath demanded a profession of loyalty to the Crown and an acknowledgement of the limitations of papal authority. It was a 'test' to ascertain whether or not a Catholic was likely to acquiesce with, or resist the status quo of Protestant Ascendancy in Ireland. The rewards for Catholics taking the oath included the franchise and the right to hold their estates. As Edward Wakefield commented in 1812, 'those who do not make this declaration, are still subject to the whole vengeance of the penal code'.<sup>xx</sup> The fact that Rochfort was the primary administrator of the oath in the county says much about his status in contemporary Carlow.

His name was a byword for loyalty and he was known as an active prosecutor of disaffection and public unrest. He wrote assertively to Dr James Keefe, Roman Catholic Bishop of Kildare & Leighlin in late 1775, questioning why he and his clergy had yet to take the oath, undoubtedly stressing the whiff of resistance which such a stance implied. Dr Keefe was eager to assure Rochfort of the loyalty and cooperation of his clergy, and in November of 1775, he responded with a 'promise' to John Rochfort that 'before it was very long, I expected I should have the pleasure of appearing before him with as many as I could conveniently assemble of my clergy to convince him and mankind, by the most solemn Test we are

capable of giving, that we maintained none of those pernicious doctrines imputed to us'.<sup>xxi</sup> Accordingly, Borris (the seat of the most prominent Catholic gentry family in the county of Carlow, the Kavanaghs) was chosen as the point of rendezvous, and on 4 December 1775, Rochfort and a fellow Justice of the Peace travelled there to administer the oath to Thomas Kavanagh in his own home, as well as to Dr Keefe, and thirty of the Roman Catholic clergy and laity of the neighbourhood.<sup>xxii</sup> Dr Keefe had privately told Kavanagh of his reluctance to take the oath and seems to have been one of the first prelates in the country to do so. However, he conceded it was inevitable that he should take it and he would have been aware that a promise to John Rochfort could not be broken without suffering the consequences.<sup>xxiii</sup>

As well as an upholder of religious supremacy, Rochfort was also very proactive in prosecuting any threats to his caste's political or financial interests. He was especially notable in countering agrarian attacks by Whiteboys in Carlow in the mid-1770s. The Whiteboys were localised, oath-bound societies determined to eliminate injustices relating to landholding, such as high rents, tithes and the imposition of fines when renewing leases, such as those imposed on Lord Donegall's estate in Antrim where the 'Hearts of Steel' had conducted a violent campaign of attacking cattle, breaking fences, raiding for arms and intimidating opponents. John Rochfort had imposed similar fines on his tenants in Galway, and it is likely he did so across all his estates, including that in Carlow.<sup>xxiv</sup> There was certainly a significant amount of Whiteboy activity in Co. Carlow, with one report claiming the county was 'infested' with a great number of such malefactors.<sup>xxv</sup> Rochfort's brother-in-law, William Burgh complained to him of the abuse done to his estate at Aghade, near Tullow.<sup>xxvi</sup> This was probably done with a view to engaging Rochfort's support, for he had a formidable reputation for

suppressing agrarian disturbances. In October of 1775, the *Morning Post and Daily Advertiser* newspaper in London claimed that 'great numbers' of Whiteboys were active in Carlow and that informers in their midst were giving up many of them to the authorities: 'the gaols of Carlow and Maryborough are daily crowding with them, who have so long been a terror to peaceable subjects'.<sup>xxvii</sup> John Rochfort was active in pursuing the Whiteboys and had been personally responsible for apprehending 'no less than six of that lawless banditti' and committing them to Carlow Gaol on 19 October 1775. Six months later, in April of 1776, the High Sheriff and Grand Jury of the county saw fit to assemble for the specific purpose of thanking Rochfort and William Paul Butler 'for their active and spirited conduct, and unwearied diligence, in pursuing, apprehending and bringing to justice, a great number of those deluded people called White Boys, that have infested this county'.<sup>xxviii</sup> This report portrays Rochfort as a persistent, aggressive, and determined prosecutor – a man with no sympathy for those who chose to disrupt the *status quo*. For the Carlow gentry, Rochfort had come to epitomise an assertive and omnipotent Ascendancy. Such was the primary male influence on Robert Rochfort.

It is therefore hardly surprising that John Rochfort was central to the formation of the Volunteer movement in the county on the 1780s. Stemming from fears engendered by the American Revolution and a desire to protect national interests and prepare against possible invasion, the Volunteers were localised, largely Protestant, armed units who would step into the breach left by the withdrawal of military forces to the war. By 1780, the county was drawn into the Movement with the formation of eight Volunteer Corps, and the vast majority of the principal gentry were involved – including Thomas Kavanagh and his Catholic Corps, the Borris Rangers.<sup>xxix</sup> 'Colonel J. Rochfort' was credited as the head of the 'County of



Carlow Legion' corps, which was associated on 1 September 1779, with some sources claiming that Henry Bunbury was co-founder.<sup>xxx</sup> With this Carlow corps to the north of Clogrennane, Rochfort also established the Leighlin & Leighlinbridge Volunteers to the south in 1779.<sup>xxxi</sup>



*Banner of Carlow Legion of Volunteers founded by Col. John Rochfort, father of Rev. Robert Rochford  
Image courtesy James Adams & Sons*

The Carlow Legion quickly created an identity for itself with its representative insignia. The design of its oval flag (which was recently put up for auction in Adams' of Dublin's '800 Years of Irish History' sale) would certainly have embodied Rochfort's ideologies. It depicts Hibernia holding a flag and staff in one hand and a leafy sprig in the other.<sup>xxxii</sup> A distinctively Irish aura is created by the harp on which Hibernia lies and the external border of shamrocks surrounding the motto 'Be True to yourselves'. In this case, being true to oneself meant embracing a proud triumphal Protestantism defending the *status quo* and perpetuating an Anglo-Irishness which placed the majority of power in the hands of a minority. The flag, measuring 71 x 66 cm, remained on a bracket in St. Mary's Church of Ireland, Carlow until a refurbishment in 1975.<sup>xxxiii</sup> The Volunteers fulfilled a significant public and social as well as a military role in Co. Carlow, boosting the self-esteem of the local gentry and their

underlings with its pomp and ceremonies, allowing for the impressive display of arms, uniforms, parades and soirées. The new Volunteers added an exciting new element to the annual Protestant celebrations in July of the Williamite victory at Aughrim in the town.<sup>xxxiv</sup> William Farrell remembered the enthusiasm and positive atmosphere of the Volunteers' early days: 'in Carlow in particular there was one of the handsomest dressed corps and best appointed in every respect that could be found [...] There was scarcely any man, even in the most trifling business, but could afford to buy his own clothing and not only that but could afford his time to go to drills and parades and at times to go a long distance to reviews and pay all expenses himself'.<sup>xxxv</sup>

British successes in the American war were celebrated with gusto in Carlow. When Admiral Rodney won his important victory over a Spanish Squadron at the Battle of Cape St. Vincent in January 1780, John Rochfort embraced the opportunity to celebrate the apparent invincibility of British military might and right. On 15 March he led the 'Old-Leighlin Volunteers' on a celebratory march from Leighlinbridge to his home at Clogrennane Lodge, where they fired a *feu-de-joye* (rifle salute) in honour of Rodney's recent victory. The corps was 'afterwards elegantly entertained by the Colonel'.<sup>xxxvi</sup> The deep impression such a host made on a five-year-old Robert Rochfort, under his own roof, should not be underestimated, nor the sight of his father in his new scarlet uniform with lemon facings, with its powerful connotations of confidence, fortitude and supremacy.<sup>xxxvii</sup>

By 1782, Rochfort had advanced to become one of the aides-de-camp of the Volunteers' reviewing general, the Duke of Leinster, William Fitzgerald. His status as the face of the Volunteers in the county reached a head with the selection of Carlow as the venue for the Third Provincial Review of the Volunteers. On 11 August 1782, the Duke arrived in the

county town and was received by Rochfort's Carlow Legion under arms, 'amidst the joyful acclamations of numberless spectators'.<sup>xxxviii</sup> The following day, despite torrential rain, three thousand troops marched to Pollerton in ceremonial procession. Rochfort (with the other three aides-de-camp) accompanied the Duke and Duchess (in her ornamental carriage with decorated ponies) there at four o'clock where the various Corps paraded before them, 'and were politely dismissed by his Grace, he finding it impossible for the troops to fire with any propriety, as the rain descended in torrents, to the disappointment of the greatest number of spectators we ever remember to have seen assembled on such an occasion'.<sup>xxxix</sup> Nevertheless, a dinner was held that night, 'where a number of patriotic and loyal toasts were drank' followed by a ball 'which was crowded with a number of the most beautiful women perhaps in the world'.<sup>xl</sup>

Rochfort's popularity induced him to seek election for Carlow County in 1783, where he pledged to abide by 'independent principles'.<sup>xli</sup> He polled a respectable 337 votes compared to the 508 votes and 351 votes respectively for the ultimate victors William Burton and Sir Richard Butler. However, support for Rochfort was signalled by the fact that 107 of his votes were 'plumpers' where the voter had decided to vote for Rochfort alone, declining their right to nominate a second candidate.<sup>xlii</sup>

#### Robert's Early Life:

John and Dora Rochfort's first child was a daughter, Anne, born c. 1760 (who was to live to the grand age of 102, dying in November 1862).<sup>xliii</sup> Their eldest son, John Staunton Rochfort was born on 25 October 1764, and he was to have only one brother.<sup>xliiv</sup> The exact date of Robert's birth is unclear, but can be lim-



REV. ROBERT ROCHFORD

ited to some date in 1775.<sup>xlv</sup> With a younger sister, Dorothea, the four Rochfort children grew up in Clogrennane Lodge on the Rochfort estate in Carlow, which extended into Queen's County over the Fishogue river which ran through their demesne.

A map of the Rochfort demesne in Carlow by Thomas Ivers in the year preced-

in 1774 from Carlow to Leighlinbridge did not run in front of the ruin of Clogrennane Castle along the Barrow's banks. This did not happen until early in the following century, just before the completion of Clogrennane House in 1815 - a new mansion built by John Staunton Rochfort to replace Clogrennane Lodge, on a site higher up in the demesne.<sup>xlvii</sup> At that stage, the Castle was

turned south, passing in front of the Lodge and its gardens, before proceeding towards Ballygowan (known locally as Aughnagash) and the Ballinabranna road. Iver's map provides the only known (albeit crude) representation of the earlier Rochfort seat, and Robert Rochfort's home - he was dead for some years before his brother finished Clogrennane House. It shows a modest two and three-storeyed building (facing Clogrennane hill, its back to the Barrow, on a site to the right of the current avenue still known as the 'Castle Lawn'), with a number of tall chimneys on a hipped roof. The illustration shows little sign of ornamentation apart from what appears to be a narrow, protruding central block with a triangular pediment. To the south of the house, however, was a considerable ornamental garden with decorative flowerbeds and walkways. A modest lodge was situated on the public road, from which visitors ascended a short flight of steps to the Rochfort home. To the rear of Clogrennane Lodge lay a field, the Castle lawn, which terminated at Clogrennane Castle, a building which was used only for the old coach-house in its vicinity.



Part of Rochfort estate in 1774 from Ivers' map in National Library of Ireland. From West (top) to East (bottom) note the Barrow, Clogrennane Castle at "2" and Clogrennane Lodge at "3". Courtesy National Library of Ireland.

ing Robert's birth shows the contemporary layout of roads, fields and Clogrennan Lodge and Castle.<sup>xlvi</sup> Unlike the existing modern road, its counterpart

incorporated to serve as a gatehouse entrance into the remodelled demesne. In 1774 however, the public road did not turn in front of the castle but continued west towards the Killeshin hills and

An inventory of Clogrennane Lodge dated October 1794 shows the degree of comfort, and indeed luxury, enjoyed by the Rochforts.<sup>xlviii</sup> The house had three reception rooms, leading off from a grand entrance hall with its eight-day clock and glass globe. It had at least five bedrooms, the principals of which had separate and adjoining dressing rooms. Clogrennane Lodge had a library which held almost seven thousand volumes, large and small. The catering and storage facilities of the house were impressive with a large kitchen, cotton storage room, a housemaid's closet, pantry (with separate cook's larder), a room for Mrs. Rochfort's maid-in-chief, as well as the various out-buildings including a greenhouse, the steward's office and coach-house. The accent and understanding of the domestic who undertook the inven-



tory comes across in the spelling and appellations attributed to some of the items, such as the 'brickfast parlor' downstairs. The library was simply the 'book room' which held Mr. Rochfort's standing and marine 'tennisscopes', the first floor had all the 'bedrooms', and the 'Min's room' was next door to the Maids' room.

Some of the bedrooms in the Rochfort home were named by the theme of their décor, such as the Chinese Room, the Cotton Room and the Yellow Bed Chamber. This latter appears to have been Robert Rochfort's bedroom but it had recently undergone a renovation after his departure in 1794 -for by this stage (1794), Robert was a student in Trinity College, Dublin. The inventory tells us that 'Master Robert's bid' is 'Gone to D[ublin].' The only other mention of him in the inventory is the fact that '1 small white quilt for Master Robert' was awaiting his return in the store room.

#### Chaplain in Dublin Castle, 1796.

By the age of fifteen, Robert had begun to consider his academic studies and future career. Ten years younger than his elder brother, Robert watched John Staunton's progress in the academic and civic worlds with interest. John Staunton Rochfort graduated from Trinity College Dublin with a law degree in 1784 (the year after his father's failed election attempt) and was called to the Irish Bar in 1786 and pursued his legal career as a barrister in Dublin from this date. However, he was always aware of his inevitable inheritance of Clogrennane estate and was secure, to some degree, in this fact. It was a different story for Robert, and his counterparts among the younger sons of the landed gentry. The career choices of such young men were far more significant and pressing, and to a large degree determined their future prosperity or otherwise. It was very com-

mon for such younger sons to take Holy Orders and become Reverend gentlemen of the Established Church. It is unclear whether Robert would have pursued such a course by natural inclination, but he was hugely influenced by his mother in this regard. It was Dora Rochfort who strongly impressed on her younger son the wisdom and propriety of pursuing a clerical degree, and Robert followed her directions.<sup>xlix</sup> He entered Trinity College Dublin on 8 July 1791, at fifteen years of age, where he enjoyed the privilege of private tutoring in his chosen field. He graduated with a B.A. in the spring of 1796.<sup>l</sup> The next task was to find a lucrative or prestigious posting, and Rochfort appears to have achieved the latter objective when he was appointed as one of the Chaplains-in-Ordinary of the Lord Lieutenant, Lord Camden, in Dublin Castle.<sup>li</sup> The influence of his father as a member of the Grand Jury for Dublin was probably at play here. Although the role was largely insignificant and left little room for personal distinction (there may have

In Dublin Castle, Rochfort associated with the leading figures at the heart of the British administration in Ireland, who bolstered his views of Protestant right and a determination to check any attempts to undermine it. His superior in his new role was the Rev. Alexander Staples, who had been First Chaplain in the Castle since 1764.<sup>liii</sup> Staples was himself a younger son of the gentry from an estate at Lissan, Co. Tyrone, whose eldest brother, the Rt. Hon. John Staples, was an MP in the Irish Parliament, and the brother-in-law of Thomas Conolly of Castletown House.<sup>liv</sup> John Staples would play a very active role in the suppression of the 1798 rebellion in his own locality of Tyrone and Derry and his activities were brought to the attention of Chief Secretary Pelham.<sup>lv</sup> Like Staples, Robert's older brother was also an MP at this stage, John Staunton representing Coleraine from 1796-7, and Fore from 1798-1800.<sup>lvi</sup>

It was probably at this stage that Rochfort also made the acquaintance of Robert Cornwall, an MP for Enniscorthy, an attorney based at Stephen's Green who had landed interests in Myshall, Co. Carlow. Cornwall, undoubtedly the leading figure in the prosecution of the 1798 rebellion in Carlow, served as Second Chamberlain in the Lord Lieutenant's household and would almost certainly have made contact with a fellow Carlowman in his lordship's employ.<sup>lvii</sup> Twenty years Rochfort's senior, it is likely he took the young clergyman under his wing in the daunting corridors of power in the capital, possibly imparting his views that violence was the best way to deal with the wild Irish peasantry: in 1790, he claimed a raucous fair in Myshall 'went off very well, and only a few heads broken, which I assisted in making, by way of preserving the peace'.<sup>lviii</sup>

Whether through personal connections, or through oratorical skill (in which he appears to have had some talent, as we shall see), Robert Rochfort secured his



*Belt plate from the Infantry Unit of Carlow Yeomanry. Rev. Robert Rochfort was captain of this unit in 1803. Courtesy James Adams & Sons*

been as many as 21 chaplains in total), the real significance of the posting lay in the huge influence played by the personalities he met and interacted with, their political convictions crystallizing his own inherited sentiments about how to 'be true to yourself'.<sup>liii</sup>

greatest coup at this time by gaining the attentions of Lord Camden himself, the Lord Lieutenant- a notorious opponent to Catholic emancipation. The young cleric made his acquaintance to the extent that Lord Camden made a promise to provide an independent living for Rochfort in the church.<sup>lx</sup> Advancement and financial security seemed assured but was interrupted, to Rochfort's fury, by the outbreak of rebellion in 1798, and Camden's hasty resignation and departure from the country in June of that year. For Rochfort, retribution was to be swift and savage.

#### Carlow in 1798

The savagery of the 1798 rebellion in Carlow is all the more evident when one considers the excellent relations which appear to have existed between Catholics and Protestants during the early 1780s. According to Farrell, 'there was no part of Ireland where a better feeling of friendship existed between both Catholics and Protestants, nor no part where greater numbers of both were blood relations'.<sup>lx</sup> That the Catholic population was in the majority in the county was clear, perhaps in as great a ratio as 10:1.<sup>lxi</sup> With the outbreak of the French revolution, the establishment of a Catholic college in Carlow town and concessions to the Catholics granted by Langrishe's relief bill of 1792, Protestant equanimity was unsettled in Carlow which proved the genesis of what Duggan, in her remarkable study of the period, terms 'a garrison mentality'- what we have we will hold.<sup>lxii</sup> The thought that Catholics might receive the franchise - a measure conceded in 1793- was an extremely worrying notion. Popular unrest and a Catholic sense of frustration which followed in the wake of Earl Fitzwilliam's withdrawal as viceroy (a man with renowned Catholic sympathies) engendered further paranoia and a decided defensiveness amongst the gentry.

The Rochforts were keenly aware and perturbed by such developments. As early as September 1792, John Staunton Rochfort sat on a committee of Carlow gentlemen in September 1792 to take Catholic 'mistrust and jealousy' into consideration, 'where none ought in reason or justice to exist'.<sup>lxiii</sup> The aggressive attitude and growing fears of the Rochfort family (and many of the Carlow gentry) can be seen in the committee's most significant resolution:

That we will resist by every means in our power any measure that shall directly or indirectly tend to give the Roman Catholics any influence over the Legislative Body, as we are fully convinced was any share whatever of the elective franchise to be imparted to them, the Protestant establishment in Church and State would be totally subverted.

Rochfort was also alarmed by raids for arms on the homes of gentlemen in the vicinity of Clogrennane Lodge. His neighbours, John Alexander of Milford and Nicholas Roche of Fonthill had been targeted in 1793.<sup>lxiv</sup> Although never approached, the Rochforts had extensive firearms at Clogrennane Lodge with 28 pieces, including a case of 12 pistols, 9 rifles and 5 blunderbusses.<sup>lxv</sup> Such a quantity may suggest a purpose for the firearms beyond the leisurely pursuit of hunting. With the outbreak of war with France in 1793, the gentry gladly accepted the idea of forming local Militias, as a successor to the Volunteer movement. Such a force would serve not only to strengthen national defences but could also be used to check local disorder. In addition, subservient Yeomanry units (volunteer corps of farmers officered by the local gentry) were to be established to buttress local defence. The Cloydagh & Killeshin Yeomanry was established as early as 31 October 1796, led by Captain (later Colonel) John Staunton Rochfort.<sup>lxvi</sup> The unit comprised of infantry and a cavalry corps headed by Captain Robert Rochfort, his military

title becoming as symbolic of his interests as his ecclesiastical one.<sup>lxvii</sup>

Although it is likely that Farrell exaggerated when he claimed the United Irishmen 'spread in every direction like wild-fire', the organisation had certainly taken a firm, if not omnipresent hold in the county.<sup>lxviii</sup> One of its chief attractions was the camaraderie which members seemed to enjoy, along with a sense of purpose and activity. However, seditious papers, clandestine meetings and a changed attitude amongst the people did not go unnoticed by the gentry. John Staunton Rochfort was hugely disturbed when details of the conspiracy began to emerge. In his later life, he would admit with grudging admiration that he felt the machinery of the United Irishmen and their scheme of rebellion 'was always pretty perfect'.<sup>lxix</sup> By late 1797, confrontation seemed inevitable and Walter Kavanagh spoke for many of the Protestant interest in Carlow when he wrote to Chief Secretary Thomas Pelham in Dublin Castle: 'I beg on this trying occasion to assure his Excellency of my exertions and allegiance and that it is my determination, with the assistance of government to quell the insurrection here or perish in the attempt'.<sup>lxx</sup> Such stoicism was shared by Robert Rochfort, with the notable qualification that the notion of defeat would never have been considered by him, let alone entertained.

The United Irishmen were making definite strides close to Robert's home territory of Clogrennane. Robert Cornwall estimated that there were 'not less than four hundred' sworn United Irishmen - 'these deluded people' - in the area between Leighlinbridge and his home in Myshall.<sup>lxxi</sup> Just six miles from the Rochfort home, the town of Leighlinbridge was a hotbed of united Irish activity, according to Kevin Whelan.<sup>lxxii</sup> Croppy haircuts were common, late-night meetings by the Barrow were noticed, as were sprigs of trees in the windows of homes in the area - a symbol of solidarity

with the United Irishmen.<sup>lxxiii</sup> By later 1797 / early 1798, according to David ‘Hibernicus’ Byrne, Leighlinbridge was ‘a very disturbed neighbourhood, where patrols of the soldiery and parties of armed peasantry, not as yet denominated *rebels*, alternately prowled by night, doing so much mischief that the friends of each party suffered in turn. Murders, house-burning, imprisonment, whipping, carrying-off cattle and other property became so frequent [...]’.<sup>lxxiv</sup> The murder of William Bennett (a critic, if not opponent of United Irish schemes) in Leighlinbridge in October 1796 seems to have fired the Rochforts and Cornwall into more decisive, defensive and aggressive action. Up until that point, Cornwall argued he ‘stood singly in opposing the infamous disturbers of the peace’. He was now joined by John Staunton and Robert Rochfort in prosecuting the rebels. Their role would be crucial. With Cornwall, the Rochforts contributed the largest block of correspondence from Leinster to Dublin Castle in 1798, and their promotion of Orangeism (as we shall see) certainly contributed to Carlow’s unique status as the only Leinster county to be proclaimed in its entirety during that year.<sup>lxxv</sup> Indeed, it could be argued that the aggressive actions of the Rochfort brothers in the area between Clogrennane and Leighlinbridge played a fundamental, antagonistic role in fanning rebel flames in the vicinity and catapulting affairs towards a violent crescendo the following year. Thirty years after the rebellion, a local newspaper would describe Leighlinbridge as ‘a place so frequently converted in “former times” to the orgies of Brunswickism’.<sup>lxxvi</sup>

#### Robert Rochfort’s activities, 1797-8.

It appears Robert Rochfort took advantage of leave from his duties in Dublin Castle and returned home to Clogrennane as often as he could where he proved far more zealous and impetuous in his actions than his older brother. The differ-

ence in their ages is a certain factor here: John Staunton was thirty-three at the time of the rebellion, while Robert was twenty-two. However, too much should not be made of Robert’s youth in explaining or qualifying his fervour, for many of the principal insurgents in the United Irish ranks were of a similar age, e.g. Mick Heydon, the principal rebel leader in the Battle of Carlow, was the same age as Robert Rochfort.<sup>lxxvii</sup> While both brothers were committed to the defence and perpetuation of their Ascendancy, the Rochfort family motto seems to neatly summarise the dichotomy in their *modus operandi* at this juncture: ‘*Vi Vel suavitate*’ – by Violence or by mildness.<sup>lxxviii</sup>

After the rebellion, in William Farrell’s account, John Staunton claimed: ‘I clearly foresaw from the beginning how all this would end and I did all in my power to prevent the people under me from having anything to do with so foolish a business [...] I acquitted myself in using my best endeavours to prevent them joining what I knew would be their ruin, and if they have not done so, they must only blame themselves’.<sup>lxxix</sup> His correspondence shows how he feared the possibility of open rebellion and worked to avoid it, but Robert foresaw it as an opportunity to prove his metal and worked to provoke it. While John Staunton wrote alarmist and pleading letters to the officials in Dublin Castle, Robert was wont to take matters into his own hands and sought to imitate the aggressive activities of Robert Cornwall, his colleague from the Castle, in nearby Myshall. Cornwall was renowned for his nightly patrols, sometimes over a radius of twenty miles, raiding homes, searching for arms and pikes and gathering seditious material. Robert attempted to do the same in the Clogrennane area and beyond. Riding at the head of his cavalry corps, he tried to locate meetings, identify suspects and arrest recalcitrants. He quickly made a name for himself among what Cornwall termed ‘the lower orders in this county’, as well as the ruling powers and com-

mentators of the county and country.<sup>lxxx</sup> His patrols were dreaded and were so effective as to merit mention in Sir Richard Musgrave’s famous *Memoirs of the different rebellions in Ireland* in 1802. This account, despite its limiting bias, gives an insight into possible factors which propelled Rochfort into such assertive action. Musgrave alleges that a weakening deference to Protestant might was observed in the county in 1797, ‘the insolent looks and haughty demeanour of the peasants, who would not formerly approach a gentleman but with the greatest humility, now challenged his attention with a broad stare, often followed by a sardonic grin’.<sup>lxxxi</sup> Such a situation was intolerable for the twenty-two year old. Having grown up admiring the spectacle of the Volunteers, soaked in the pride and power of his caste and religion during his Trinity education, and with a nascent sense that he was playing his part in the grand scheme of things with the chief players in Dublin Castle, Robert Rochfort returned to Carlow incredulous that his social and political inferiors would have the gall or nerve to rock his boat. Here was an opportunity to emulate his father’s fierce loyalist reputation, and armed with the fearlessness, impetuosity and courage of youth, his objective was to be unmistakably assertive. In his ideal operation, violence was to be the first resort. Accordingly, the United Irishmen worked hard in ‘avoiding the patrols [sic] of Mr. Robert Rochfort of Clogrennan [sic], and of Mr Cornwall of Myshall-lodge, who much to their honour never ceased to harass those miscreants by night, at the head of their respective yeomen corps’.<sup>lxxxii</sup> Based on the fact that there were only two loyalist claimants for compensation in the aftermath of the rebellion from the Clogrennane/Leighlinbridge area, it would seem that the Rochfort yeomanry ruled with an effective iron fist, seriously impeding the United forces.<sup>lxxxiii</sup> The close relationship between Robert and Cornwall – that of mentor and protégé – is confirmed by the fact that Cornwall himself supplied

these details to Musgrave when he was researching his book, and he made certain the author highlighted the importance and vigour of Robert's actions.<sup>lxxxiv</sup> Thus Musgrave alleges in relation to the two men: 'I have been assured that the county of Carlow would have been as much desolated as the county of Wexford, but that these gentlemen, by unabated exertions and the most undaunted courage, struck terror into them [United Irishmen], by surprising and arresting them, in their most secret haunts and recesses'.<sup>lxxxv</sup>

Efforts of a different, diplomatic kind were being made by Robert's brother. In November of 1797, John Staunton Rochfort as a magistrate of the county informed Pelham of his fears, that 'danger' was imminent from 'those deluded men stiled [sic] United Irishmen', and estimating that there were three thousand men in their ranks in the county. He petitioned that extra troops be sent immediately to Leighlinbridge or 'that part of the county Carlow on the west side of the River Barrow will be [...] freed to join the United Men'.<sup>lxxxvi</sup> Pelham adhered to his request but resisted Rochfort's request to proclaim the county. His plan of an amnesty for those who chose to surrender their arms and take an oath of allegiance was welcomed, but the failure to proclaim the county would be misinterpreted by the rebellious elements as weakness on the Government's part, according to Rochfort.<sup>lxxxvii</sup> A month later, after the insignificant surrender of some guns, pikes and other weapons, Rochfort reminded Pelham that the situation had not changed. He had heard rumours of a letter from Lord Edward Fitzgerald claiming that French assistance was imminent, which was apparently doing the rounds of the county, bolstering United Irish morale, and government troops continued to be fired at by persons unknown.<sup>lxxxviii</sup>

By January of 1798, fear and paranoia were palpable, and the vicinity of Clogrennane Lodge resembled a battle

ground, where only one side had taken the field. The Rochforts utilised the Cloydagh & Killeshin Yeomanry like a private defence force, and had some of them on active guard duty after dark outside their demesne, while the remainder presumably accompanied Robert on his patrols. A regiment of the Ninth Dragoons from Carlow town was also regularly assigned to guard duty at Clogrennane.<sup>lxxxix</sup> Such apparently exorbitant defensive measures were not entirely unwarranted. Indeed, in November of 1797, a man named Patrick Irwin, who had been arrested in Old Leighlin by Cornet Lowther of the Ninth Dragoons, informed his captors that Clogrennane was linked with Carlow as one of the three United Irish regiments in the local area, consisting of thirty men each.<sup>xc</sup> Also, on 19 January 1798, John Staunton informed government that 'a yeoman of mine' was shot at on the road between Leighlinbridge and Milford when he was on his way to guard at Clogrennane between five and six o' clock in the evening. The first bullet missed its target, but a second hit his horse in the neck which caused it to throw its rider.<sup>xci</sup> However alarming the incident, the following months would show an increase in confidence on the loyalist side with the arrest of some Clogrennane farmers charged with membership of the United Irishmen and unlawful armed assembly at the Carlow Spring Assizes in March 1798.<sup>xcii</sup> By this stage, the Rochforts had become a lot more self-assured because of their involvement in the greatest threat to United Irish activity in the county: the Orange order.

#### The Orange Order & Sectarianism in Carlow

It was the Rochfort involvement in the Orange Order and their leading role in its propagation in Carlow that brings them great notoriety in the story of the 1798 rebellion. It brought a notable and vicious sectarianism in its wake and can be said

to have inspired Robert Rochfort in much of the savage violence he perpetrated that summer. As Maura Duggan has argued, the arrival of the Orange factor into Carlow's volatile crucible proved a catalyst which brought the disgruntled elements of society into open rebellion from fear of apparently imminent Orange brutality.<sup>xciii</sup> In this regard, as chief organisers of the movement, the Rochfort brothers must be placed at the cynosure of events in Carlow in 1798. In L.M. Cullen's estimation, the suppression of the rebellion in Carlow was gentry-driven, with the Rochforts in the vanguard of an Orange surge.<sup>xciv</sup> He claims a powerful Carlow interest emerged which was capable of influencing other counties and which implies 'a hidden agenda in the Irish politics of the day'.<sup>xcv</sup>

Captain Robert Rochfort and Lieutenant Colonel John Staunton Rochfort were intimately involved in the earliest creation of Orange Grand Lodges at county level. John Staunton was proposed for membership of Lodge 176 on 13 February 1798 (the first to be established in the capital) and became a member the following week.<sup>xcvi</sup> Robert Cornwall joined the same lodge later in the month.<sup>xcvii</sup> One commentator contends that Lodge 176 was 'the most powerful club in Dublin and the nucleus of a national Orange movement'.<sup>xcviii</sup> Records claim that on 8 March 1798, 'Lt. Col. Rochfort' attended a meeting in Dublin, and agreed to plans for 'organizing the Orange men of Ireland, and rendering them more effective in their support of their King and glorious constitution'.<sup>xcix</sup> The Grand Lodge Register for 1798 shows that on the same date, a warrant for Lodge 414 (seemingly based in the Clogrennane/Leighlinbridge district) was granted to Robert Rochfort.<sup>c</sup> Indeed, Maura Duggan argues that it was possibly Robert himself who attended the March meeting in Dublin and not his older brother, for John Staunton was a member of another Lodge, as we have seen.<sup>ci</sup> If such was the case, it seems Robert was Master of Lodge 414.<sup>cii</sup> Be-



cause his name does not appear with that of other Carlow gentlemen in the membership of Lodge 176, Duggan has suggested that this means he was evidently occupied with the position of Grand Master of the County.<sup>ciii</sup> Whatever the exact details, both brothers were actively involved at the highest level, with John Staunton attending the inaugural meeting of the Grand Orange Lodge of Ireland in Dublin on 9 April that year.<sup>civ</sup>

They moved immediately to bring the organisation to life in Carlow. Thirty years later, polemicist and Tory John Ryan claimed the county was indebted to John Staunton 'for the introduction (in 1798) of that bond of loyalty, the Orange system, within its limits'<sup>cv</sup> and Duggan is unequivocal in her claim that the Rochforts were 'the most prominent family in the Orange association in Carlow'.<sup>cvi</sup> Ryan implies that the existing yeomanry corps was used as the basis for recruitment into the Orange ranks. If one concurs with Duggan's assertion that 'the Rochfort corps must have been almost entirely Protestant in composition', (highly likely given the Rochforts' religious prejudices) its members undoubtedly joined the Orange movement, as Robert would have been an audacious and unforgiving recruiting agent. Watty Cox alleged that membership of the Orange movement, or at least Orange sympathies, was expected of members in the Rochfort corps, and while there *were* some Catholics members, Robert tackled this by producing 'a neat pocket volume, bound in Orange; shewing that a Catholic may retain his situation in the Carlow yeomen, merely by avoiding the superstitious practice of going to Mass; wreathing his temples with Orange in the shooting season and [...] tamely listening to Cromwell's Coblers abusing the religion of his forefathers.'<sup>cvi</sup> Indeed, in later life, John Stanton Rochfort would admit that the Yeomanry was essentially a Protestant institution and that 'I think they [the yeomanry] have always been afraid of the Catholics'.<sup>cvi</sup>

The Lodge where Robert was Master had a membership of 241, and the entire body of yeomanry in Carlow was estimated to amount to 653 in 1798.<sup>cix</sup> Given the overlap between Orangeism and the yeomanry, and the fact that the Rochforts were dominant in two different lodges, Duggan may be correct in her assertion that 'half, if not more' of the yeomanry body in the county was controlled by the brothers.<sup>cx</sup> The association of the Orange Lodges with the yeomanry served only to intensify religious divisions and suspicions. In a very short space of time, Orangeism, Protestantism and Oppression became synonymous concepts in the county in the minds of Catholic population. Captured United Irish leader Laurence Griffin claimed 'the people in Carlow think all Protestants Orangemen',<sup>cx</sup> and Duggan has traced how fears of Orange massacres were used as spurs to encourage enrolment into the United Irish ranks.<sup>cxii</sup> In the spring of 1798, it is clear that the reputation of Orange brutality in Carlow was as powerful as its actual occurrence. Fear was indeed a palpable commodity in the county, and rumours of Orange violence were rife. In January of 1798, the Governor of Carlow Gaol told government that residents in a village to the north-east of the county were made delirious by reports from 'two well-dressed men' who claimed that 'the Orange men, Army & Protestants from Carlow were all coming to burn their houses & to murder them'. Claiming that the priests were nursing such rumours, he concluded 'it is truly astonishing to perceive how eagerly they are received and tenaciously credited'.<sup>cxiii</sup> Orange confidence was at its height by late Spring, with Farrell recalling the provocative, taunting demeanour of the army in Carlow, displaying 'their Orange ribbons and their fifes and drums in every direction, playing "Croppies Lie Down" and every other tune that would insult or annoy the people most'.<sup>cxiv</sup>

As the main propagators of Orangeism in the county, the issue of Rochfort sectari-

anism needs to be addressed here. The potential of the Orange order as a militant Protestant force to counteract the growing strength of the United Irishmen was immediately embraced by John Staunton and Robert Rochfort. To them, their religion was a key facet of their identity and inheritances, as much a part of their world-view as their politics; in fact, politics and religion were inextricably linked. Thirty years after the rebellion, John Staunton Rochfort would argue that the hostility between the two contending sects in Ireland had always been an inherently religious issue, 'a continuation of the old grudge, carried down from the Saxon or English inhabitants of the country, down to the Catholics and Protestants'.<sup>cxv</sup> To his understanding, the religious divide was central to all other issues. The Catholic peasant conceives himself, and his religion, indigenous to the land, that he is one of the original inhabitants, and he identifies all Protestants, whether of English or of Irish descent, with the English, and with the English religion; he conceives that they are usurpers on the land, that have deprived him or the Catholics at large, of their inheritance, and that neither the Protestant nor his religion, belong to the soil, but to another country.<sup>cxvi</sup>

Although his political convictions had mellowed at this juncture with time and reflection, in 1798, Rochfort and his younger brother viewed the United Irish movement as an embodiment of strictly Catholic grievances that posed a significant threat which needed to be eliminated.

In 1792 as we have already seen, John Staunton Rochfort manifested a decided suspicion and distrust of Catholicism in all its forms and institutions, and resisted moves towards Catholic relief. In this he was influenced and supported by his aunt's husband (and his patron), John Foster, Speaker in the Irish house of Commons who was part of a notable group 'in the government who were pre-

## REV. ROBERT ROCHFORD

pared to encourage strong protestant feeling as far as their positions as office-holders would permit', according to Hereward Senior.<sup>cxvii</sup> As the years progressed and matters became more intense, Rochford increasingly read the issues along denominational lines. The United Irish movement was, in essence, a Catholic conspiracy, he alleged in a letter to Pelham in October of 1797, where he worked hard to build a case associating the tenets of the United Irish movement with 'the articles of the Church of Rome, as taught in the Catholick [sic] college or school of Carlow, which I procured with great difficulty and with some address & expense'.<sup>cxviii</sup> To support his claim, he attached a seditious ballad he had confiscated in Carlow, and drew attention 'not only to the concordance of the sentiments contained in it to the articles of the Church of Rome, but even to the very words being the same'. He also believed the priests in his vicinity were advising their flocks not to take the oath of allegiance, 'that any oath taken under the influence of fear is not to be kept'.

The Orange Order provided John Staunton Rochford with a much-needed sense of security. On 1 April 1798, he reported confidently that his yeomanry would 'willingly parade every Sunday and attend upon any emergency, and be a very powerful addition to the forces of the country upon any sudden rising. If the gentlemen in every other county conducted themselves as they have done in this county, rebellion would soon be stifled'.<sup>cxix</sup> While he employed informers where he could,<sup>cxx</sup> he was aware that Loyalism's greatest weapon was the common fear of Orangeism and all its religious bigotry. Indeed, in early June, the under-secretary William Elliot lamented to his superior Thomas Pelham that the rebellion in Leinster 'has certainly assumed a strong religious spirit and I cannot help suspecting that the Orange associations, which, you will recollect, were formed and promoted by Colonel Rochford and some other gentlemen in

the counties of Wexford and Carlow, operated very mischievously'.<sup>cxxi</sup> Not surprisingly, John Staunton 'was looked on as a deadly enemy' by the United Irishmen and was the subject of an assassination plot, according to Farrell.<sup>cxviii</sup> Cornwall was under a similar threat, and the likelihood is that Robert was also in their ranks.<sup>cxviii</sup> One intercepted paper from Rathvilly, apparently written by and for United Irishmen stated that 'the lives of all gentlemen who have worked against [us] are lost'.<sup>cxvii</sup>

As an ordained clerk of Holy Orders, and representative of the established church, Robert Rochford was actuated by a more primal sense of his responsibilities as defender of the faith and his inheritances, than his brother. Watty Cox defined him sardonically as a 'this Corinthian pillar of the church and state', and ironically, this is exactly what Robert aspired to be.<sup>cxv</sup> The combination of his occupation, his Orangeism and his militant pursuit of the disaffected quickly created a reputation for him as the embodiment of what Pakenham calls 'the bogeyman of Catholic fancy'.<sup>cxvii</sup> His very clothes and hair were carefully constructed to constitute and advertise his beliefs – in contrast to the croppy hairstyle, 'the Loyalists all wearing real or artificial queues [pigtailed]' according to *Hibernicus*.<sup>cxvii</sup> In the thick of the trials in Leighlinbridge that summer, Robert made certain to have his hair dressed immaculately.

In the spring of 1798, his prosecuting mind led him to question the loyalty and political persuasion of those within the hallowed ranks of his cavalry corps in the Cloydagh Yeomanry. Robert's suspicions fell on Corporal Charles Brennan from Clonmore, Queen's county. Rochford disapproved of 'the general conduct of said Brennan' – was he giving the insolent looks and haughty manner *à la* Musgrave, perhaps? – the company he kept and the houses he frequented. It is more than likely that all of these involved Brennan in communication with the

Catholic population, which led Rochford to label him as a 'seditious person'. Brennan was probably a Catholic himself, given his surname and the fact that a Protestant was highly unlikely to be disloyal in the ranks of the county's most confident, sectarian and diligent centre of activity, led by the Rochford brothers. Unsurprisingly, Robert summarily dismissed Brennan from the corps on Sunday 1 April 1798.<sup>cxviii</sup> That night at half past ten, he rode to Brennan's house (with a loyal retinue) to raid it for incriminating material or arms. On arrival, he discovered that Brennan was not at home and proceeded to search the house for evidence. His endeavours were rewarded handsomely. In a hidden drawer in Brennan's desk, Robert Rochford discovered the oath and constitution of the United Irishmen, and a statement claiming that a fleet of 170 Frenchmen was en route to Ireland, amongst other seditious papers. On continuing his search, Robert found an unregistered musket and some ball cartridges, 'none of which belonged to yeomanry'. He concluded that Brennan had stolen these articles from a soldier of the Ninth dragoons when on guard at Clogrennane. The following day, Robert made a sworn statement to a Justice of the Peace (in this case, conveniently, his brother) and forwarded all the documentation he had intercepted to Dublin. By believing to have discovered a United Irishman in his ranks, Rochford's sense of purpose was confirmed. His suspicions and growing frustrations had been justified. Such incidents boosted the Rochfords' morale significantly, and their confidence peaked. With an active and Orange yeomanry at their disposal, rebellion would be easily quashed. The Brennan case is important in that it marks the consolidation of Robert Rochford's dangerous perception of the invincibility of his cause, that he had a natural ability to detect disaffection, and that to eradicate disloyalty he had only to act on his instinct. He was determined to act decisively and ruthlessly and in the conviction that he was right. In the com-

ing months, he not only personified, but legitimised Catholic fears of the Orange spectre.

#### The Aftermath of the Battle of Carlow

With such fears whipping the demoralised United Irishmen into a frenzy, they launched an ill-fated, and easily-quashed attack on Carlow town on the night of 23 May 1798, where 630 people were said to have been killed.<sup>cxxxix</sup> The Rochforts played no part in the affairs of that night but were central to the prosecution of United Irish suspects in Leighlinbridge in the weeks after the battle. Colonel John Staunton Rochfort, as the local magistrate, set up his headquarters as President of the Court in Hackett's Inn, in the Market Square of the town. According to William Farrell, who was transported there after his arrest, 'the most death-like silence prevailed and all nature seemed petrified with terror' on the road to Leighlinbridge.<sup>cxxx</sup> The village was like a ghost-town, the terrified inhabitants remaining indoors, aghast at the instruments of justice outside the door of Hackett's inn: 'the whole apparatus of death or torture, as the case might be, viz.: a triangle, rope and cat-o'-nine tails appended to it, for it was in the public street before the men and women, old and young, that prisoners were stripped naked and executed'.<sup>cxxxi</sup> The inn itself was full of officers and yeomen, 'Major' Robert Cornwall conspicuous in their number, who made to draw a pistol on Farrell when he proved uncooperative.<sup>cxxxii</sup> Threats of violence against the prisoners were carried into terrifying actuality in Farrell's presence. Over this chaotic scene of hasty court-martials followed by summary punishment and execution, Colonel John Staunton Rochfort commanded, held in fearful awe by locals and prisoners alike. When Farrell proved reticent to approach him he declared:

"Come on, come on [...] come up to me. Oh, my God, if one of thy creatures can inspire such awe, what apprehensions must we be under, when Thy thunder rolls, and Thy trumpet calls us to come to trial before thyself in all Thy awful majesty".<sup>cxxxiii</sup>

Robert would have been delighted with this speech, his objective to subvert the haughty manner and irreverence of the peasantry now achieved. Having missed the ignition of the rebellion in Carlow town, he was determined to see it quenched and acquired accommodation in the home of Mrs Finemore in the village, the wife of a Dublin merchant, and future mother-in-law of David 'Hibernicus' Byrne.<sup>cxxxiv</sup> The issue of enforced free-quartering of troops on the civilian population was so contentious in Carlow that Thomas Addis Emmet believed it was of the primary causes of the rebellion in Carlow and elsewhere.<sup>cxxxv</sup> In the aftermath of the rebellion, troops from the regular army were billeted forcibly on the local population and Mrs Finemore was obliged to accommodate some officers, 'who took up their abode with her, eating of her meat, and drinking of her cup, which often sparkled with generous wine'.<sup>cxxxvi</sup> While polite and hospitable, she was ill at ease during their stay. It was here that Robert Rochfort decided to accommodate himself in the first week of July 1798, to be in the thick of the action, rather than return each night to his home in Clogrennane a short distance away.<sup>cxxxvii</sup> His stay in Leighlinbridge was to make him infamous.

Firstly, he was resident in the house when 'ruffians' from Mrs Finemore's household decided to lay a beam from her drawing-room window to a corresponding window in the adjoining house in imitation of a gallows, declaring 'it would be a snug corner to hang the *croppies* in'.<sup>cxxxviii</sup> Mrs Finemore was appalled but summoned the courage to address these 'gentlemen', saying: 'You are masters of my house and of such ac-

commodation, as I can afford you, but I beg you to desist, for if you do not I shall go away and leave the house to yourselves'.<sup>cxxxix</sup> If Rochfort was not directly involved in the construction of the gallows, he certainly made no move to dismantle it. Over the coming days, his reputation as 'the slashing parson' was made as he inflicted summary justice on the prisoners who arrived for court-martial. Farrell places Robert Rochfort in Leighlinbridge market-square during the hanging of a prisoner named Lannan, a sentence executed by Cornet Lowther of the ninth Dragoons, an associate of the family. Rochfort was present when the death sentence was pronounced on Farrell, and he was noted busying himself, liaising with officers, passing on information he had extracted from prisoners.<sup>cxl</sup>

His sensational obituary in the *Irish Magazine* portrays him as rabid and vengeful at this time. He is said to have personally used a taws (leather whip) and a sword on prisoners, and clapped his hands in time 'to the music of the Triangles' as prisoners were tortured.<sup>cxli</sup> A pitiable sectarianism is construed in the claim that he held a Bible in his hands during many of these activities. Elsewhere, Cox continued on the theme of Rochfort's sectarianism and alleged acts by claiming that 'to make the best rascal in Ireland [...] take an Orangeman from Carlow, initiate him in all the Purple mysteries, under any of the B—d's, V—r's, or R[ochfor]t's; let him preside at floggings and torture and hanging without trial; let him shoot some half score peasants on their knees; let him burn houses and let him be sure to burn all the inhabitants therein'.<sup>cxlii</sup> While the veracity of Watty Cox's claims is hugely debatable, such violence was possible given Robert Rochfort's obsession with pursuing his foes. The rebellion had vindicated his hatred of the insurgents and violence was seen as deserved retribution. As one member of the Militia shouted to Farrell and his comrades, imprisoned in the guard-house behind Hackett's inn: "Ah, you croppy

## REV. ROBERT ROCHFORD

vagabonds, it's a fine time for you to be praying! You are praying now but you didn't pray in time! What is the reason of allowing light to such rebels? Let it be put out immediately."<sup>cxliii</sup> This was the mood that dominated in the village. Orangeism and Protestant militancy were at their most triumphant in the wake of the United Irish defeat, and Rochford would certainly have been on a high, his sense of righteousness and superiority indomitable. That such emotions could easily have strayed into violent excess is not too far a supposition. In support of this contention, evidence of his excesses can be found outside Cox's diatribes, in other more trustworthy sources.

The most serious charge of savagery against Rochford is found in the account of David Byrne, who was informed of the facts by his mother-in-law, Mrs Finemore.<sup>cxliv</sup> Before his breakfast, Robert Rochford was known to employ a barber in his lodgings to shave him and powder his hair in the necessary style. On one particular morning, he borrowed his hostess's dressing-gown to wear as he underwent the procedures. Before the task was completed, word was brought to him that a certain prisoner had just arrived in the town and had been lodged in the stables behind Hackett's inn. According to Byrne, 'so blood thirsty was he that on hearing that a prisoner had arrived, he started up, leaving his toilet unfinished, took a pistol, went to the guard-house, and shot the man'. This account provides us with the ultimate, and supremely pathetic image of Robert Rochford in the events of 1798: that of a hysterical clergyman in woman's clothing, racing to murder a prisoner without trial, before breakfast, and returning home to have his hair done. To her immense credit, Mrs Finemore was (characteristically) the only person to express her horror, telling him: 'I did not think, sir, that so handsome a young man as you could commit such a cruel murder; as for my dressing gown, you may keep it, for it shall never go on my back'. Such acts led Cox to

create a 'New Glossary' whereby the phrase '*a loyal man*' was to be newly defined as 'a Protestant from Carlow' or 'any fellow who has distinguished himself in 1798, by some acts in support of the constitution, for which he would be hanged at the present day'.<sup>cxlv</sup>

Rochford also encountered William Farrell and the latter's account provides further evidence of Rochford's detestation of 'rebel' ways. The conversation they had clearly establishes Rochford's anger and disbelief that some of the prisoners were still unprepared to cooperate even when the game was up. He attempted to induce Farrell to inform with promises that 'you should be protected at the Castle or sent abroad to any place you wish' – itself an indication of the powers Rochford had, or perceived himself to have in his place of employment and with the authorities there.<sup>cxlvi</sup> His anger is palpable in the following exchange:

"Now, Farrell", said he, "you have only a few minutes to live and I would recommend it to you to give whatever information is in your power to put a stop to this unfortunate rebellion you were engaged in; it is the only atonement you can make to your country for all the blood that has been spilled and you should do it to the utmost extent in your power, as it may be a means of stopping it altogether, preventing more bloodshed and restoring peace."

"I wish it was in my power to stop it, sir", said I; "when I was at liberty I done my best to stop it and would do it again if I could, but I could give no information now that would be of the least use".

"That is very strange", said he, turning away [...]

"It is not in my power, sir", said I, "to give information against anyone".

"Impossible", said he, staring at me.

In total, Rochford approached Farrell three times in an effort to extract infor-

mation, believing it 'impossible' that his efforts would be obstructed by a mere rebel. Farrell was probably spared Robert's ire by the knowledge that his case had already been tried by his elder brother.

In direct contrast to 'blood thirsty' Robert, John Staunton Rochford was displaying his complete distaste for prosecuting the rebellion, and was loath to leave Hackett's Inn to attend executions whenever the drums rolled to collect soldiers for that purpose. However, when duty called, he would not be found wanting. "It is a melancholy business but I must attend it", he told Farrell. On his return shortly afterwards, he 'seemed very much agitated and distressed at what he was after witnessing and made some severe observations on the punishment the men were after suffering who were far less implicated than I was'.<sup>cxlvii</sup> The great likelihood is that Farrell took advantage of Rochford's depression, and cooperated in some way, in return for the Colonel's assistance in securing his release.

When the grisly proceedings concluded in Leighlinbridge, John Staunton was only too happy to return to the comforts of Clogrennane lodge, but Robert's zeal persisted. At a 'great luncheon' held there shortly afterwards, a visitor informed his hosts that he believed Captain Andy Farrell of nearby Crossneen – a United Irishman and survivor of Vinegar Hill – had returned to his homeplace and was in hiding in the locality.<sup>cxlviii</sup> Col. Rochford showed little relish for pursuing him, claiming 'he has escaped so far; we shouldn't interfere with him'. Typically, his younger brother insisted 'No, [...] we must proceed against him'. Amazingly, the story claims that the Rochfords' butler was sympathetic to the United Irish cause and informed the like-minded coachman, Pat MacDonald, to 'Go and warn Farrell if he is in the neighbourhood and take this bottle of whiskey'. The source of this story claims that MacDonald was either

(understandably) afraid, or got drunk and Farrell was not warned. Accordingly, he was captured the following Sunday. These two servants were not the only Rochfort staff who failed to share their employers' political views. The overseer of the Clogrennane estate, Dick Heydon, although a member of the Carlow Yeoman Infantry was executed in Carlow Gaol for his membership of the United Irish movement.<sup>cxlix</sup>

As the years moved on, Robert Rochfort's role in the suppression of disaffection assumed a great notoriety. By 1811, a local author calling himself 'A Carlow Friend' suggested that 'Rev. R—R—' ranked fourth in the entire county (behind Arundel Best, Sir Richard Butler and Robert Cornwall respectively) in terms of the intensity and severity with which Orangemen prosecuted the rebellion.<sup>cl</sup> A persistent fear of persecution meant the author could only print his initials, but his description as 'Captain of yeomanry and Justice of the Peace !!!' makes his identity unmistakable. The three exclamation marks apparently register shock at the apparent ease with which Rochfort reconciled ostensibly contradictory religious and military functions, which appeared to others as uneasy bedmates. A later acquaintance, the diarist Elizabeth Ham was also struck that 'he held the seemingly anomalous professions of Captain of a Troop of Yeomanry, and Clergyman'.<sup>cli</sup> There is also evidence to suggest that he preferred his military rather than his clerical title.<sup>clii</sup> However, for Rochfort, the two roles shared the same objective and were in many ways one and the same thing. He was not exceptional in this regard. His acquaintance and colleague, Rev. John Whitty of Ballickmoyler (a noted Orange enclave according to Duggan, and only a few miles from Clogrennane) was active as a Captain in the local yeomanry.<sup>cliii</sup> When his house was attacked by rebels retreating from the Battle of Carlow, it is

claimed he and his household held out for three hours, sending word to the Rochforts for assistance and extra ammunition.<sup>cliv</sup> His house was destroyed and he received compensation in the amount of £175.6.9.<sup>clv</sup> Both he and Rev. Rochfort were rewarded with commissions as Justices of the Peace for Co. Carlow in 1800.<sup>clvi</sup> However, there the similarities end. While their beliefs may have been the same, John Whitty's actions appear defensive and retaliatory as opposed to Rochfort's decided aggression. In addition, the younger man was not limited in his actions by consideration for a wife and young family as Whitty was. In time, the latter's role appeared minor, while Rochfort's was singled out for its controversy. In national terms, Rochfort's notoriety is eclipsed by such pitch-capping clerical magistrates as Cope and Owen in Wexford (where five Protestant clergymen were killed during the rising), but he forms part of a significant minority of Protestant clerics who took up arms against the United Irish movement, and in this regard his legacy is unique in Carlow.<sup>clvii</sup> No other clergyman, of whatever persuasion, played so decisive and significant a role in the events of 1798 in the county.

#### Rev. Rochfort: Post 1798

In the years after the rebellion, Robert's expectations for glorious life in a newly loyal nation were to be sorely disappointed. His hopes for reward in light of the zeal he had shown in punishing the enemies of the state were never realised. Indeed, it is likely the controversy attached to his efforts proved counter-productive to his elevation. In July of 1800, we find him active as a magistrate, ever watchful of crimes with a seditious element. In taking a sworn statement about an armed robbery in Ballinabranna, Rochfort noted the assailants had pretended to be loyalists to gain admission,

demanding of cooper James Neal: 'Open the door you rascal until I search your house for rebels'.<sup>clviii</sup> Lord Camden's offer of clerical patronage had evaporated in the heat of the rebellion, and Robert struggled to find a parish. His name does not appear in any of Canon Leslie's biographical lists of Church of Ireland clergy and their parishes in the library of the Representative Church Body. It does appear in an addendum to one volume, in a list of those who 'do not appear in any list of Incumbents or Curates'.<sup>clix</sup> This ledger's claim that he was ordained a Deacon of Killala in 1804 is incorrect. In that year, despite the fact that he received his Master's from Trinity, he was still living at Clogrennane Lodge without having secured a parish. He felt like he was being left behind, the reputation he had constructed for himself unappreciated by the authorities.

By contrast, John Staunton Rochfort's career was blossoming and in that year, through his uncle John Foster's influence, he was appointed to the prestigious position of Chairman of the Enquiry Board into Public Accounts, based in Sackville St. Dublin.<sup>clx</sup> He had also married in 1801 and his son Horace was born in 1805. Robert remained single, despite his popularity with the local female population. Watty Cox claimed that he was not only partial to 'the soft tender, amorous amusements of the Divine' as provided by the fairer sex, but that he 'prostrated himself at the feet of Venus, to whose witching charms he became a wasting prey'.<sup>clxi</sup> His lack of prospects may have left the notoriously picky Protestant girls, as Wakefield saw them, cold. Incidentally, the author claimed that the unmarried yeomen of Ireland were invariably Protestants.<sup>clxii</sup> Robert Rochfort remained among their number.

His spirits picked up temporarily with the plan to build a new Anglican church at Cloydagh, just outside Clogrennane demesne. The nearest Protestant church was in Carlow town, and to remedy the

## REV. ROBERT ROCHFORD

situation, the Board of First Fruits made a gift of £500 in 1803 for its erection.<sup>clxiii</sup> It is unclear whether Rochfort was the instigation behind the project, but one contemporary visitor to the church-in-progress was led to believe that the 'new church had been built for him'.<sup>clxiv</sup>



*Cloydagh Anglican church, just outside the former Rochfort demesne in Clogrennane. Apparently "built" for Rev. Robert Rochfort in 1804.  
Photo: Shay Kinsella*

Elizabeth Ham, daughter of an Englishman who was temporarily managing a brewery in the county, visited Carlow in 1804 and made a tour, even to viewing the grisly remains of Sir Edward Crosbie's head and that of four other rebels on a spike outside Carlow Gaol.<sup>clxv</sup> Over the course of her stay she made many friends, and noted how the ladies spoke very highly of Robert Rochfort; indeed, she commented that the Reverend 'was a great favourite with the Ladies I have mentioned'.<sup>clxvi</sup> One Miss Burn was especially enamoured with him and/or his sermons, and persuaded Elizabeth Ham

to accompany her to hear Captain Rochfort – 'as he was always called' – preach. On arrival at Cloydagh church, she noticed 'it had a very unfinished appearance, standing alone on a large common'. On entering the church "what was our dismay to see nothing but blocks of wood, Carpenter's benches, chips and shavings. There were three or four ladies at the east end, and Capt. Rochford [sic] in his surplice. Here a small space had been swept, and at a word from the Clergyman, a Labourer brought another form on which we seated ourselves whilst the service went on, one of the Ladies reading the responses".

Despite the disorder and frugal appointments (brothers of Miss Burns even joked about hurrying to get 'the best seats'), one can sense Rochfort's sense of pride in the church, that he had a calling to fulfil and now had a house to contain it, however simple. The building would perpetuate Protestant Carlow,

and there is evidence that decorative stones from the ancient ruined church of Clody in Clogrennan demesne were incorporated into its construction.<sup>clxvii</sup>

His contentment was short-lived however. He was never officially appointed as vicar to the parish; instead, Rev. Bartholomew Thomas held that position until 1826.<sup>clxviii</sup> Instead, financial exigencies meant he was obliged to take a retrograde step, and return to his position as a Chaplain-in-ordinary at Dublin Castle. Even though he was personally appointed by the new lord Lieutenant of Ireland, the

Duke of Richmond, Charles Lennox in April 1807, Robert and his family understood that in terms of financial and social advancement, 'being a Chaplain to the Lord Lieu't we know from the experience of others to be no reliance'.<sup>clxix</sup> Chaplains were so badly paid that even Robert's superior, the Rev. Alexander Staples was eager to leave the Castle, and begged his brother (Hon. John Staples MP), as early as 1797, to acquire for him a position in Christ Church Cathedral which paid £150.<sup>clxx</sup> The only extra position of some financial consequence Robert was able to secure was that of Treasurer of Carlow County Infirmary, which came with a small stipend.<sup>clxxi</sup> Indeed, there appears to be some irregularity in the accounts in his favour. Between the spring and summer assizes, the remuneration he was awarded as Treasurer increased from £28.6.0 to a remarkable £100 – by far the greatest item of expenditure in that presentment. The fact that Rochfort was personally named in the former document, and only as 'Treasurer' in the latter, attaches a suspicion to the payments and suggests that perhaps discreet efforts were being made, at a local level to compensate Robert for his troubles and send some public money his way.<sup>clxxii</sup>

By June of 1807, however, his spirits had hit rock bottom, and his mother despaired on hearing him 'reflecting on his own age, now past 30, dropping sentences expressive of great disappointm't, & marking that his spirits are becoming habitually depressed'.<sup>clxxiii</sup> This was noticed by all members of his family, but especially Dora Rochfort who spent all of her later life feeling the anxiety and guilt of having suggested a religious career for her younger son. She wrote to her brother-in-law, John Foster, hoping that he might be able to assist 'the dear Robert' in the same way he had helped her eldest son. She expressed her worries:

"knowing how strongly I have urged him to that choice, & feeling from that a sort



of responsibility toward him, it deeply affects me to hear him, when, you cannot wonder that I languish to snatch him from this state of mind & see him properly apply'd; but I am indeed so far happy as to be able to assert that he will never disgrace your recommendation of him."

She asked about the possibility of the Lord Lieutenant himself acting in Robert's interest, given that he had recently appointed him to his household, and assured Foster that the wishes of any cooperative Bishop would be adhered to. It seems the family were moved to act *en force* to assist him at this time. John Rochfort snr. also wrote to Foster about Robert's promotion – 'I shall commit the arrangement relative to him, to my *cara sposa* - & yourself.'<sup>clxxxiv</sup> Similarly, John Staunton Rochfort was active on his brother's behalf, writing to no less an individual than the Hon. Sir Arthur Wellesley, MP (future Duke of Wellington) who had some Carlow connections, petitioning him to secure the living of Feighcullen in Co. Kildare worth £70 a year, for Robert.<sup>clxxxv</sup>

By June of the following year, all these efforts had come to nothing, which brings into question his qualification and suitability to fulfil a clerical role. His mother, with typical faith, believed that a church calling was eminently suited to Robert 'whose demeanour has indeed been, ever since he determined for the Church, most perfectly exemplary; he has dedicated much time to qualifying himself for, & to the duties of his profession'.<sup>clxxxvi</sup> His talents for sermons were appreciated by the ladies of Carlow, but also in Dublin, where the directors of St. Andrew's Parish invited 'the Rev. Robert Rochfort, MA, Chaplain to his Grace the Lord Lieutenant of Ireland' to give a sermon on the occasion of the first playing of their new organ in May 1807, and advertised the same in the national press.<sup>clxxxvii</sup> The following week, a meeting of the parishioners 'unanimously resolved that

our thanks are justly due, and are hereby given to the Rev. Robert Rochfort [...] for his very eloquent sermon so admirably suited to the occasion, although undertaken at a very short notice.'<sup>clxxxviii</sup> Robert's only surviving letter, however, betrays an awkward, unpunctuated and convoluted diction. In describing his brother's recovery from a serious illness in 1810, Robert attempted to assure John Foster that

"there is very little doubt but that it has been a most resolute effort of nature to throw out superficially whatever has been amiss with [his] Constitution, & there is every degree of probability that a renewal of the Constitution will take place in consequence of the incessant & heavy discharge with which his astonishing bodily patience & submissiveness has been afflicted with."<sup>clxxxix</sup>

However, a verdict on his habitual style can certainly not be made on the basis of one letter. So what was the real obstacle to the advancement of this well-connected, intelligent and capable young man?

In 1810, John Staunton confessed his doubts of Robert 'getting anything in the church' and confessed his desire to see his brother with a new sense of purpose: 'I am anxious about it, as to give him some active duty [...] and give him the opportunity of marking that he embraced the profession from liking it.'<sup>clxxx</sup> Was this John Staunton acknowledging that Robert's militant behaviour had created the impression that doctrinal ministrations were less significant and appealing to him than the political and social powers enjoyed by Anglican clergymen? Was this, in fact, the obstacle to his advancement, or had tales of his violence grown wings and flown to the authorities, eager to hush rumours of military excess? His apparent friendlessness at this point can, in all probability, be read as a tacit acknowledgement from his friends, colleagues and relations that he had gone too far in the summer of 1798, that his stock

had been damaged, and that they could not or would not risk tainting themselves by association with him.

While post-rebellion Carlow remained a deferent place to its Protestant rulers, Wakefield observed in 1809 that the Carlow gentry were largely 'ignorant and conceited' and prone to unwarranted and inexcusable violence towards their social inferiors.<sup>clxxxxi</sup> He also commented on how the ordinary people were proud to tell their tales of the cruelties suffered in 1798.<sup>clxxxii</sup> The extremes of Robert Rochfort's world-view were becoming less acceptable, as Wakefield, *The Irish Magazine* and others were publicising. The heights of Protestant triumphalism were waning as efforts increased to secure Catholic emancipation and Protestant militancy was coming under attack. In 1803, he was still an active yeoman, one of two captains in the Carlow Infantry Corps, in charge of 150 men, part of an organisation whose very existence retarded the healing of social wounds.<sup>clxxxiii</sup> Wakefield was extremely critical of the yeomanry as a divisive, provocative force in Irish life. In his view, the force served only

"to establish a line of separation between two classes of men, who ought to be taught to consider themselves as one. So marked a privilege, conferred on the minority, generally intoxicates them with an idea of their pre-eminence, causes them ignorantly to conceive, that they are authorized to domineer over the majority, and creates in the bosoms of those people jealousy and will-will".<sup>clxxxiv</sup>

The author, who visited Clogrennane in 1809 and met Robert Rochfort in the course of writing his account, says much about contemporary distaste for political and military extremism in the decade after the rebellion.<sup>clxxxv</sup> The reputation of the Rochfort yeomanry continued to decline after Robert Rochfort's death, with one commentator complaining in 1831 about their raucous behaviour, claiming its members were mainly poor, landless

and former inmates of the Carlow's foundling hospital.<sup>clxxxvi</sup> That same year, Carlow MP, Walter Blackney told the House of Commons that the yeomanry had been the great cause of disaffection in the county.<sup>clxxxvii</sup>

It seemed, as all family efforts to help Rochfort failed, that he was destined for disappointment. It must have been hugely demoralising for him to realise that the sum of his authority consisted of overseeing the construction of walls and roads at the behest of the Grand Jury, on which his elder brother and Robert Cornwall sat.<sup>clxxxviii</sup> Dora Rochfort increasingly clung at straws, claiming that 'any hope that we could hold out to him that seemed not too distant, would vivify his spirits & show him that he was neith'r forgotten, nor undervalued by his friends & relations'.<sup>clxxxix</sup> However, this is apparently how Robert Rochfort felt as his efforts and actions of 1798, in the name of Church and State came to nothing.

#### The death and legacy of Robert Rochfort

Left with no other choice, Robert took over the management of Clogrennane Lodge's home farm. He had always taken an interest in horticulture, and appears to have been an improving and progressive farmer. In March 1801, he acted as chairman of the first meeting of Carlow Farming Society at the Bear Inn.<sup>cxc</sup> There is also evidence that he wanted to maintain Clogrennane's reputation for impressive woodlands and one source claims that he wrote a treatise entitled 'Stimula to Industry', 'in which he forcibly proves the necessity of putting ground to its full value, thereby preventing that idleness which is so manifest in the bloated countenance of the peasantry of Ireland'.<sup>cxcii</sup> He also undertook a detailed mapping of the family demesne

and old Clody parish – 'in which is delineated, every little nook' according to Watty Cox.<sup>cxciii</sup> While this was patently undertaken to allow Rochfort greater insight into his family estate to enable its more efficient management, to Cox, it merely confirmed that Robert was 'truly of the Cromwellian order, for, he took care that no part of it should fall into the hands of a mere Irishman'. He sought to improve husbandry on the estate, introducing new crops and exploiting the lime-kilns which his brother had established in nearby Raheendoran. By 1809, Rochfort was using sixty barrels of lime to an acre of land.<sup>cxciii</sup> Edward Wakefield visited Clogrennane in the summer of that year and Robert supplied him with impressive figures detailing the previous year's crops. The phenomenal success of the mills at Milford, co-owned and directed by a family friend, John Alexander, patently accounts for the dominance of grain crops on Rochfort's farm, which produced seven barrels of wheat, twelve barrels of barley (destined for the gargantuan malt-house in Milford, the largest in Ireland at that time) and sixteen barrels of oats. The potato, however, was the major crop with seventy barrels being harvested in the autumn of 1808.<sup>cxciv</sup>

At this time, his father, John Rochfort Snr. happily informed John Foster that Robert had found some peace at Clogrennane, 'enjoying a country life'.<sup>cxcv</sup> His favourite of the traditional pursuits of the gentry was game-shooting and his love of poultry was suggested as one of the contributory factors to his death by Cox.<sup>cxcvi</sup> Ever keen to impress that his actions in the rebellion had forever damaged Ireland, Cox further alleged that in his 'ruling passion', Robert was frustrated by a lack of birds: 'that species, which was his favourite amusement, having become so timid since the thunder of '98, that all the efforts of this son of the chace [sic] could not make them break covert or tempt them to the field'.<sup>cxcvii</sup>

But time was running out for Robert and

a series of deaths brought a cloud over Clogrennane Lodge. Following his wife's premature death (from consumption) in October 1808, John Staunton Rochfort was himself taken ill with a curious and lingering disease in his leg. Robert accompanied him on a trip to Cheltenham in June 1810, on the advice of a doctor to bathe in the healing waters there. To his uncle Foster, Robert confessed his alarm at 'this strange eruptive disease to which no medical man here can positively give a name'.<sup>cxcviii</sup> As John Staunton recuperated, their mother, Dora Rochfort, declined in old age. Ever anxious about Robert, she enjoyed some peace of mind when he directed his energies into farming. However, she would never know that as she approached her end, her beloved younger son was also dangerously ill. In early 1811, Robert himself manifested signs of a corruptive and unknown disease. By March, John Staunton informed his uncle that the symptoms of his brother's illness, advancing at an alarming rate, resembled those of pleurisy and sciatica.<sup>cxcix</sup> Although he had youth on his side, his doctors were extremely worried, and it soon looked as if Robert could not recover. In March 1811, John Staunton reported that the illness 'has turned into a sore abscess in his hip, which has burst, & the physicians who attend are afraid that the quantity of the discharge will bring on a hectic fever, which may be fatal'.<sup>cc</sup>

John Staunton Rochfort and his two sisters, Anne and Dorothea, were at their mother's bedside in Bath when she died peacefully on 23 March 1811, blissfully unaware that Robert lay on his own deathbed in Clogrennane at the same time. According to her eldest son, 'she was in the full possession of her intellects to the last & spoke intelligibly within half an hour of her death. She had the satisfaction of having three of her children about her without the drawback of knowing the dangerous state that Robert is in'.<sup>ccii</sup> Having lost his wife and mother, and just recovering from his own trials,

John Staunton now turned to face Robert's illness. By the end of May, he journeyed to Ireland, although his own foot was not fully healed yet, when he realised that Robert's time was up: 'The accounts I have lately received of my Brother have been so unfavourable that I mean to go by Waterford to see him as soon as possible.'<sup>ccii</sup> The end came for Rev. Robert Rochfort at Clogrennane Lodge on 30 June 1811 at the age of thirty-six. His place of burial is unknown; it could possibly be in the Rochfort plot in St. Audoen's Church in Dublin, or in the vicinity of St. Mary's Church in Carlow where his death was registered.<sup>cciii</sup> It was a heavy blow for his brother who was comforted by his uncle who invited him to stay. 'My dear Rochfort,' wrote Foster, 'I received your account of your loss of Robert with sincere sorrow – had not you better come to us here – you may be as retired as you choose - & Cloghrehnan [sic] must be too dismal a monster of late misfortunes to allow you to revive your cheerful spirits.'<sup>cciv</sup>

It was a sudden, painful and unexpected end, typical of the disappointment and frustration of Robert's later years, and in death his reputation was to become even more controversial. As the news spread, old wounds were recalled and the hand of vengeance was seen in his demise. Stories of his wasting illness were dispersed, describing a plague of parasites which allowed those victimised by the Reverend some satisfaction, a taste of revenge with a smack of divine retribution. In David Byrne's version, Rochfort had died 'like the wicked King Antiochus, of the *morbus pedicularis*, or lousy disease, the vermin swarming on every part of his body in such numbers, that a servant with a brush, could not in appearance diminish their quantity, though constantly employed in brushing them off'.<sup>ccv</sup> In Cox's version, Rochfort had died 'after a putrid, loathsome, lingering illness, [...] interrupted by the foul wrinkled hag, Disease: whose beaver tooth knawed every fibre of the constitution, and produced the pre-

mature fall'.<sup>ccvi</sup> Cox gives a triumphal role to Rochfort's victims in his demise, painting an apocalyptic scene of battle at his deathbed. In it, vengeful and organised locals gathered around Clogrennane Lodge to sneer at Rochfort's misery, being forcibly driven away by a faithful domestic. This latter, Cox claims, 'had daily to resist the united [a pun on United Irishmen?] efforts of the embattled squadrons of prey, which screamed round the windows of his dying master'. The downtrodden had assumed the upper hand; in this battle, Rochfort would be the one to perish.

It was a common practice in the popular imagination to attach pain and suffering deaths to the death notices of the demons of 1798. It soothed the popular imagination that injustice would not go unpunished and allowed some sense of justice to prevail. Robert Cornwall's death later that year was also attributed to a 'loathsome disease'.<sup>ccvii</sup> According to *Hibernicus*, Cornet Lowther, the notorious torturer of the Ninth Dragoons stationed in Carlow, 'was attacked by a disease, in which the flesh rotted off the bones; and he fell to pieces'.<sup>ccviii</sup> However, the invective and apparent rejoicing which greeted Rochfort's death was remarkable. In his scalding obituaries, Cox saw fit to make Rochfort's as least three times longer than that of Cornwall. Indeed, Cox's magazine contains hints that Cornwall may have mellowed to some degree in his old age and expressed regret about his violent role in 1798. In imagining a painting of an Adonis shooting a satyr, Cox claims 'this inimitable painting, we are informed, was done from Bob C—, of Carlow, shooting Byrne, the rebel, on his knees. It is but justice to say that Mr C—

has repented of that morning's work, and has turned Methodist. "Oh, the still small voice of Conscience!"'<sup>ccix</sup> On the other hand, Cox claimed Rochfort had remained immovable in his beliefs to the end, even when his preferred militancy had gone out of fashion, alleging that Robert had been encouraging John Scrigg, the Catholic schoolmaster in Cloydagh to convert and proselytise the children in his care.<sup>ccx</sup> Cox was also unforgiving in dismissing the apparent generosity of Rochfort to his servants in his will, and claims 'charity covers a multi-



Grave of Robert's brother, Colonel John Staunton Rochfort of Clogrennane (1764-1844) in Rochfort plot in St. Audoen's Church, Dublin.  
Photo: Shay Kinsella

tude of sins'.<sup>ccxi</sup>

Whatever the truth about Robert Cornwall's conversion, the details of a change of thinking in John Stanton Rochfort's mind in the first three decades of the nineteenth century is confirmed by his own words. As Duggan has concluded, the legacy of 1798 in Carlow was a deep and ingrained sectarianism on both sides, and 'the Protestant gentry regressed a

## REV. ROBERT ROCHFORD

century or more in their attitude towards the Catholics.<sup>ccxii</sup> John Staunton had never been an advocate of violence, and had no stomach for brutality, and with time, he began to disassociate himself from the passions of that period. By 1825, he was trying to distance himself from what he called 'an Orange feeling', advocating new, more liberal and paternal politics, while admitting that 'my early prejudices lay the other way.'<sup>ccxiii</sup> Remaining an implacable defendant of the Ascendancy's privileges, he lost his fears of a Catholic threat, and came to believe that relief measures would be beneficial for all parties in Ireland. In fact, he welcomed Catholic Emancipation as a means of ensuring the perpetuity of Protestant authority: 'it would have a beneficial effect upon the peace of the country [...] for if the hostility to the Protestant establishment is done away with entirely, or reduced or diminished in any degree, the Protestant establishment must be the safer [...] it would remove the hostile feelings that are now entertained by the Roman Catholics'.<sup>ccxiv</sup> In relation to tithes, he claimed that 'it is very unfair that one religion should support the establishment of another'.<sup>ccxv</sup> He praised the good nature and intelligence of the common people, claiming that the 'benevolence is a very strong ingredient in the Irish peasant'.<sup>ccxvi</sup> Such a change in attitude was probably influenced by his close friendship with John Alexander of Milford House, a liberal thinker whose own father in Belfast, was an associate of William Drennan's – one of the founders of the United Irishmen. Rochfort also claimed that by reading and corresponding on Catholic issues, by interviewing, observing and even visiting the homes of 'the very lowest peasants', he developed a sympathetic understanding of Catholic grievances and became determined to address them.<sup>ccxvii</sup>

In surviving his brother, John Staunton's reputation was given time to recover and change, a process denied to Robert by his premature death, and his legacy solidified

into that of a vengeful tyrant. With his charitable donations and efforts to improve industry and agriculture in the county, John Staunton Rochfort appears to have been forgiven for his sins in the years before Emancipation. With their noted feudal tendencies, the Carlow tenantry and peasantry seemed glad to welcome back a remorseful gentleman, which allowed them to resume their traditional allegiances free from pangs of conscience. They gladly welcomed his emphatic declarations of paternalism, that 'he would support the public views and interests of the inhabitants of Carlow, while he had life'.<sup>ccxviii</sup> Only seven years after Robert's death, the *Carlow Morning Post* records the county's selective amnesia in John Staunton's favour as it declared effusively: 'We have never yet been deceived in you'.<sup>ccxix</sup> Another article that year claimed 'the people of Carlow are fully sensible of their obligations to Col. Rochfort,' in light of his efforts to prevent famine.<sup>ccxx</sup> Even Thomas Finn, the likely writer of the 'Slaughter in Carlow' articles for the *Irish Magazine* in which Robert Rochfort was vilified, was gushing in his praise of John Staunton Rochfort in 1818, claiming that 'it was a theme upon which all classes were equally eloquent in this town', even concurring that some public gesture should be made to thank Rochfort for his efforts on behalf of the poor and his leniency at the assizes.<sup>ccxxi</sup> As John Staunton made good, Robert's crimes went unmentioned, but were neither forgiven nor forgotten as subsequent events

proved.

The improvement in the Rochfort reputation continued as the new heir, Horace came of age in 1827 and sought election on a liberal ticket for Carlow county in 1830.<sup>ccxxii</sup> After his mother's death in 1808, he was reared by his maternal aunt and her husband, Sir Robert Heron MP, an influential Whig politician. Horace's upbringing was far more enlightened and liberal than that of his father and uncle, and while they were alarmed by the



Horace Rochfort of Clogrennane (1807-1891) as a young man. Nephew of Rev. Robert Rochfort. Oak Park Photo Collection

events in France in 1789, Horace grew up (under Sir Robert's influence), 'rejoicing in the French Revolution as the downfall of bigotry'.<sup>ccxxiii</sup> By 1830, the Carlow gentry was a divided and contending group, and the powers of the Ascendancy were being challenged from within. Horace Rochfort believed the stranglehold on the county's parliamentary representation, as exercised by Henry Bruen and his father-in-law Thomas Kavanagh was

'one of the most disgraceful coalitions that ever yet was formed to put down the free sense of any body of electors'.<sup>ccxxiv</sup> He became the poster-boy of Carlow Liberal interests, lauded by the *Carlow Morning Post* and supported by such no-

people. But lo! At the end of ten months, our once popular candidate throws himself into the arms of the oligarchy'.<sup>ccxxv</sup> Inevitably, perhaps, all the old prejudices against the Rochforts were dusted down as they returned to historical form. All

thirty five years before seeking election again, and on those two further occasions, he failed to secure the votes. Ninety years after the rebellion, author Michael Brophy queried the family's lack of electoral success, claiming it 'was



*Clogrennane Castle and Clogrennane House c.1830. A painting in private hands. Courtesy Patrick and Julie Rochfort*

strange that no member of the old and popular family of Rochfort had been elected'.<sup>ccxxvii</sup> The ghost of Robert Rochfort had a considerable amount to do with this. His actions were alive in the imagination of the conscientious elector for decades, impacting negatively on the Rochforts' chances of becoming MPs. As one voter, Garret Cullen, put it in 1834, he could not bring himself to vote for Horace Rochfort because 'he could not remove from his mind certain feelings engendered towards the Rochfort family, in consequence of certain conduct of some of that family in the year 1798'. The

tables as Henry Parnell and Lord Milton in England. Although he lost the election in 1830, he was given another chance the following year.

However, Horace Rochfort was a true liberal and believed in fairness for all sides. He saw no good in the total overthrow of the existing political and social systems, and sought to improve the political infrastructure of the nation rather than overhaul it. In expressing some – as he saw it legitimate – reservations with the extent of the reforms proposed in the 1831 Relief bill, Rochfort's liberal supporters in Carlow felt hugely betrayed and rejected him as a turn-coat. Their attacks knew no mercy, and the *Carlow Morning Post* wrote: 'This young stripling, this political weathercock, is of all political creeds, just as his interest guides him. He started last year on the popular interest; he was then the humble servant of the

the efforts of John Staunton Rochfort and his son were dismissed, as the editor claimed Horace bore 'an ill-omened name'. With even greater bitterness, the ghost of Rev. Robert Rochfort was held up as the true representative of the family's politics. The correspondent claimed that Horace was

"as hostile to the present bill of Reform, as was his uncle, the slashing parson, to the unfortunate Papists of 1798. But as Mr Rochfort is only accountable for his own conduct, we shall say nothing more of the parson."<sup>ccxxvi</sup>

Horace, mortified and bruised by the whole experience, retreated from politics as did his father, and played no significant role in the turbulent election crises of that decade. Although a hugely popular landlord and sportsman until his death in 1891, Horace Rochfort would wait

magnitude of the issue is confirmed by Cullen's closing statement that 'he was not singular in this regard, many other good and patriotic individuals having kept aloof on the same principle'.<sup>ccxxviii</sup>

The story of Robert Rochfort is of a man who acted in extremes, initially connived at by a supportive following. Its real significance lies in his embodiment of overtly aggressive Orangeism but also as a case study of the speed with which such militancy fell out of favour. Capable, resourceful and confident, his role in 1798 left him disillusioned, isolated and adrift in later life as his resumé worked against him. In death his legend was confirmed. Tales of his savagery came out of hiding, his italicised denomination in the *Irish Magazine* was rounded out and his bru-

talities multiplied. In investigating the myth and the man, one comes face to face with the arrogant belief system which propelled him into action and one meets a remarkable figure in Carlow's history. Even his obituarist admitted he was 'gifted with abilities to move in the first circles', and warned his readers not to underestimate him: 'Reader, do not imagine that his genius was of an ordinary kind, no, no, as fortune sometimes wraps in ermine the assassin of his country, so, nature is often lavish, where she might be frugal'.<sup>ccxxix</sup> His story may have died in Carlow's popular memory, but in assessing his legacy, the last word can be left to Cox in perhaps his only irrefutable claim that, on Rochfort's death,

"every child of ascendancy mourned his departed friend, but, though all should prove ungrateful, and forget the services of this man, his name shall be remembered, while the town of Leighlin Bridge shall mark the map of Ireland; or the year 98 tinge her calamitous history."<sup>ccxxx</sup>

*Shay Kinsella wishes to thank Sr Maura Duggan for reading a draft of this paper and for her advice. Also to Patrick and Julie Rochfort of Gloucestershire for their encouragement and assistance.*

*Shay Kinsella is currently pursuing his PhD on the Alexander family of Milford, and would welcome any information, anecdotes, photographs etc. on the family and the area, from associates, former employees etc. He can be contacted at Cloughna, Milford, Co. Carlow, or at shaycarlow@yahoo.ie.*

#### Notes

National Library of Ireland, Rochfort of Clogrennane Papers, Ms. 8682.

<sup>ii</sup> Thanks to Frances Clarke, Manuscripts Department, National Library for this information.

<sup>iii</sup> For Rochfort origin myths, see Irish Schools Folklore Collections,

Ballinkillen N.S., Co. Carlow; Any Monahan, *The Praying Angel*, Faulkner Papers, Public Record Office of Northern Ireland, p.217; and N.D. McMillan, *One hundred and fifty years of cricket and sport in county Carlow* (Carlow, 1983), p. 4.

<sup>iv</sup> Jimmy O'Toole, *the Carlow gentry* (Carlow, 1993), p. 173.

<sup>v</sup> L.M. Cullen, 'Politics and rebellion: Wicklow in the 1790s' in *Wicklow: history and society* (Dublin, 1994), pp. 411-501, at p. 425.

<sup>vi</sup> *Carlow Morning Post*, 9 May 1831.

<sup>vii</sup> Robert Rochfort's obituary in the *Irish Magazine*, August 1811, pp. 383-4, hereinafter Obituary.

<sup>viii</sup> William Farrell, *Voice of rebellion: Carlow in 98*, edited by Roger McHugh with an introduction by Patrick Bergin (Dublin, 1998), p. 204.

<sup>ix</sup> Obituary.

<sup>x</sup> Obituary.

<sup>xi</sup> Edith Mary Johnston-Liik, *History of the Irish Parliament* (Belfast, 2002), Vol. VI, p. 178.

<sup>xii</sup> *Burke's Landed gentry of Ireland* (London, 1912), p. 601.

<sup>xiii</sup> A.P.W. Malcomson, *John Foster; the politics of the Anglo-Irish ascendancy* (Oxford, 1978), p. 26.

<sup>xiv</sup> *Finn's Leinster Journal*, 2 Feb. 1771.

<sup>xv</sup> Public Record Office of Northern Ireland (hereinafter PRONI), D562/251, 'Statement of the Affairs of John Rochfort the Younger on his marriage settlement with Dora Burgh of February 28 1760'.

<sup>xvi</sup> Edward Wakefield, *An Account of Ireland, statistical and political* (London, 1812), Vol. I, p. 247.

<sup>xvii</sup> In Dublin, Queen's County and Carlow; John Bateman, *The great landowners of Great Britain and Ireland* (London, 1883), p. 383.

<sup>xviii</sup> Edith Johnston-Liik, *History of the Irish Parliament* (Belfast, 2002), Vol. VI, p. 179.

<sup>xix</sup> *Freeman's Journal*, 12 Nov. 1772.

<sup>xx</sup> Edward Wakefield, Vol. II, p. 513.

<sup>xxi</sup> PRONI, T3331/10. 20 Nov. 1775.

<sup>xxii</sup> *Freeman's Journal*, 7 Dec. 1775.

<sup>xxiii</sup> Ibid.

<sup>xxiv</sup> PRONI, D562/251.

<sup>xxv</sup> *Finn's Leinster Journal*, 10 Apr. 1776.

<sup>xxvi</sup> PRONI, T2519/4/266.

<sup>xxvii</sup> *Morning Post and Daily Advertiser*, 26 Oct. 1775.

<sup>xxviii</sup> *Finn's Leinster Journal*, 10 Apr. 1776.

<sup>xxix</sup> Maura Duggan, *County Carlow, 1791-1801: a study in an era of revolution*. Unpublished M.A. Thesis, U.C.D. (December, 1969), p. 38 and Appendix G, p. xxviii.

<sup>xxx</sup> Ibid, p. xxviii.

<sup>xxxi</sup> Pádraig Ó Snodaigh, 'Ceatharlach i 1798 – nua amharc ar na staraíthe' in *Carlow: history and society*, edited by Thomas McGrath (Dublin, 2008), p. 593.

<sup>xxxii</sup> See [www.adams.ie](http://www.adams.ie). Lot 631, Independence sale, 18 Apr. 2012.

<sup>xxxiii</sup> See [www.rootsweb.ancestry.com](http://www.rootsweb.ancestry.com): 'Colonel J. Rochford [sic] and Major Henry Bunbury'. Accessed 15/8/2012.

<sup>xxxiv</sup> Duggan, *County Carlow*, p. 38.

<sup>xxxv</sup> Farrell, *Carlow in 98*, p. 23-4.

<sup>xxxvi</sup> *Gazetteer and New Daily Advertiser*, 28 Mar. 1780.

<sup>xxxvii</sup> The uniform of the County of Carlow Legion corps is described in [http://en.wikipedia.org/wiki/List\\_of\\_Irish\\_Volunteers\\_Corps](http://en.wikipedia.org/wiki/List_of_Irish_Volunteers_Corps). Accessed 15/8/2012.

<sup>xxxviii</sup> *Finn's Leinster Journal*, 21 Aug. 1782.

<sup>xxxix</sup> *Freeman's Journal*, 15 Aug. 1782.

<sup>xl</sup> *Finn's Leinster Journal*, 21 Aug. 1782.

<sup>xli</sup> Ibid. 2 Aug. 1783.

<sup>xlii</sup> Robert Malcomson, *The Carlow Parliamentary Roll* (Dublin, 1872), p. 25.

<sup>xliiii</sup> *Burke's Landed gentry of Ireland*, p. 601.

<sup>xliv</sup> *Freeman's Journal*, 27 Oct. 1764.

<sup>xliv</sup> Only two dates can be found in Robert's timeline, one of which is likely to be inaccurate: his entry into Trinity College on 8 July 1791 aged 15 years, and his death on 30 June 1811 aged 36 years.

<sup>xlvi</sup> National Library of Ireland (hereinafter NLI), Longfield Maps, 21 F 32 (10), 'A survey and pan of the demesne of Clogrennan situate in the Queen's county and county of Carlow, the estate of John Rochfort 1774, parish of Cloydagh, Barony of Idrone West', by Thos. Ivers.

<sup>xlvii</sup> NLI, Rochfort Papers, Ms. 8682, J.S. Rochfort to Mary Rochfort, 26 May 1815.

<sup>xlviii</sup> NLI Ms. 8682 (3), 'An Inventory of the furniture of Clogrenan Lodge & of all moveables in the offices, farming utensils [sic] & c.'



- xlix PRONI, D207/34/166. Dora Burgh to John Foster, June 1807.
- <sup>1</sup> *Alumni Dublinenses 1593-1860* (Bristol, 2001), Vol. II, reprinted from the 1935 edition, p. 712.
- li PRONI T2727/3/2/135. John Staunton Rochfort to Hon. Sir Arthur Wellesley MP, 22 May 1807. Robert's posting is also referred to in *Hibernicus, or Memoirs of an Irishman now in America* (Pittsburgh, 1828), p. 68.
- lii *Gentleman and Citizen's Almanack by John Watson*, (Dublin, 1818), p. 125. By 1818, the lord Lieutenant had a Clerical household totalling 26 staff including 21 Chaplains-in-Ordinary.
- liii His appointment is mentioned in *Freeman's Journal*, 15 Sep. 1764.
- liv <http://en.wikipedia.org/wiki/John-Staples> Accessed on 15/8/2012.
- lv National Archives of Ireland, Rebellion Papers (hereinafter NAI RP) 620/28/13.
- lvi Edith Mary Johnston-Liik, *History of the Irish parliament*, Vol. VI, p. 179.
- lvii *Ibid*, Vol. III, p. 509.
- lviii NLI Faulkner Papers, Cornwall to Samuel Faulkner, 5 Jul. 1790.
- lix PRONI T2627/3/2/135.
- lx Farrell, *Carlow in 98*, p. 49.
- lxi Wakefield, Vol. II, p. 599.
- lxii Duggan, *County Carlow*, p. 44.
- lxiii *Freeman's Journal*, 27 Sep. 1792.
- lxiv Duggan, *County Carlow*, p. 62.
- lxv NLI, Rochfort Papers, Ms 8682.
- lxvi Duggan, *County Carlow*, appendix O, p. xxxvii.
- lxvii NAI RP 620/36/224.
- lxviii Farrell, *Carlow in 98*, p. 30.
- lxix John Staunton Rochfort's evidence in the *Report from the select committee on the state of Ireland* (1831-2) (677), p. 75.
- lxx NAI, RP 620/33/3.
- lxxi NAI RP 620/34/23.
- lxxii Quoted by Fidelma Whelan, 'United Irishmen in Carlow in the 1790's', in *Carloviana* (2005), p. 33.
- lxxiii Martin Nevin, *The sprig in the window: 1798 in the Leighlin area* (Carlow, 1998), p. v and p.2.
- lxxiv *Hibernicus, or memoirs of an Irishman now in America* (Pittsburgh, 1828), p. 38. The identity of the author as David Byrne of Leighlinbridge, Co. Carlow, has been conclusively established by Edward J. O'Day, in 'From Carlow royalist to Kentucky republican: the emigration odyssey of David Byrne, 1797-1827' in *Carloviana* (1996), pp. 31-35.
- lxxv Cullen, *op. Cit.*, p. 445.
- lxxvi *Carlow Morning Post*, 6 Jun. 1831.
- lxxvii Farrell, *Carlow in 98*, p. 113.
- lxxviii *Burke's landed gentry of Ireland*, p. 602.
- lxxix Farrell, *Carlow in 98*, p. 145-6.
- lxxx NAI RP 620/34/24.
- lxxxi Sir Richard Musgrave, *Memoirs of the different rebellions in Ireland* (Dublin, 1802), Vol. II, p. 244.
- lxxxii *Ibid*, pp. 245-6.
- lxxxiii See Tommy Clarke, 'Carlow claimants for compensation in 1798', *Carloviana* (1998), p. 60.
- lxxxiv James Kelly, *Sir Richard Musgrave, 1746-1818: ultra-Protestant ideology* (Dublin, 2009), p. 97.
- lxxxv Musgrave, *Memoirs*, Vol. II, p. 246.
- lxxxvi NAI RP 620/33/8 and 620/33/29.
- lxxxvii NAI RP 620/33/39.
- lxxxviii NAI 620/33/93.
- lxxxix NAI 620/36/224.
- xc Quoted by Conor Murphy in Mick Kinsella, Conor Murphy & Edward N. Moran, *Kilcumney '98: its origins, aftermath & legacy* (Kilkenny, 1998), p. 29.
- xcii NAI RP 620/35/51.
- xciii For the arrests of Patrick and John Hughes of Clogrennane, see *Kilcumney '98*, op cit. p. 32.
- xciv Duggan, *county Carlow*, see Chapter VI and p. 231.
- xcv Cullen, *op. Cit.*, p. 413.
- xcvi *Ibid*, p. 432.
- xcvii Duggan, *County Carlow*, p. 134.
- xcviii *Ibid*.
- xcix Hereward Senior, *Orangeism in Ireland and Britain 1795-1836* (London, 1966), p. 76.
- cl Ogle Robert Gowan, *Orangeism: its origin and history* (Toronto, 1859), p. 196.
- cl Duggan, *County Carlow*, p. 136.
- cli *Ibid*, p. 130-1; Gowan, *Orangeism*, p. 189.
- clii Gowan, *Orangeism*, p. 196.
- cliii Duggan, *County Carlow*, p. 135.
- cliv Gowan, *Orangeism*, p.198.
- clv John Ryan, *The history and antiquities of the county of Carlow* (Dublin, 1833), p. 322-3.
- clvi Duggan, *County Carlow*, p. 130.
- clvii Obituary, 1811.
- clviii John Staunton Rochfort's evidence in the *Report of the Select Committee on the state of Ireland* (1825), p. 442.
- clix *Ibid*, p. 138. Unfortunately, Duggan bases some of her assertions for the strength of the Rochfort yeomanry in 1798 on figures from 1803 (p. 139) when the situation had changed significantly. By that time, Robert had moved from the head of Cloydagh's cavalry corps into Carlow town's infantry unit.
- clx *Ibid*.
- clxi NAI RP 620/36/9A No. 11.
- clxii See Duggan, *County Carlow*, Chapter VI, pp. 125-143.
- clxiii NAI RP 620/35/11.
- clxiv Farrell, *Carlow in 98*, p. 68.
- clxv John Staunton Rochfort's evidence in the *Report from the select committee on the state of Ireland* (1831-2) (677), p.74.
- clxvi John Staunton Rochfort's's evidence in the *report from the select committee on the state of Ireland* (1825)(129), p. 440.
- clxvii Hereward Senior, *Orangeism in Ireland and Britain, 1795-1836* (London, 1966), p. 23.
- clxviii NAI RP 620/33/93.
- clxix NAI RP 620/36/110A.
- clxx See John Staunton Rochfort's payment of £20 on 1 May 1798 to Mr Hobbs of Carlow in the Account of Secret Service Money, Ireland, 1798 in John T. Gilbert, *Documents relating to Ireland, 1795-1804* (Dublin, 1893), p. 14.
- clxxi Gregory to Pelham, 3 June 1798, in *Ibid*, p. 125-6.
- clxxii Farrell, *Carlow in 98*, p. 146.
- clxxiii For the threat against Cornwall, see Duggan, *County Carlow*, p. 81, and *Kilcumney '98*, p. 36.
- clxxiv Quoted by Duggan, *County Carlow*, p. 115.
- clxxv *Irish Magazine*, August 1811, p. 384.
- clxxvi Thomas Pakenham, *The year of liberty* (London, 1969), p. 169.
- clxxvii *Hibernicus*, *Op. Cit.*, p. 42.
- clxxviii All the information on this case is given in NAI RP 620/36/224.
- clxxix Duggan, *County Carlow*, p. 151.
- clxxx Farrell, *Carlow in '98*, p. 133.
- clxxxi *Ibid*, p. 134.
- clxxxii *Ibid*, p. 137.
- clxxxiii *Ibid*, p. 145.
- clxxxiv See Edward J. O'Day, *Op. Cit.*, p. 35, n. 18.
- clxxxv *Document relating to Ireland*, op.cit, p. 180.
- clxxxvi *Hibernicus*, *Op. Cit.*, p. 69.

- exxxvii For date, see letter quoted from Jackson Collection, J.S. Rochfort to Keeper of Carlow Gaol, re: Farrell, in Sean O'Shea, 'The Jackson Museum', *Carloviana* (2004), p. 54.
- exxxviii Ibid.
- exxxix Ibid.
- exl Ibid, p. 204.
- exli *Irish Magazine*, August 1811, p. 383-4.
- exlii *Irish Magazine*, July 1810, p. 307.
- exliiii Farrell, *Carlow in 98*, p. 139.
- exliv The following details are taken from *Hibernicus*, op. Cit, pp. 68-9.
- exlv *Irish Magazine*, April 1810, p. 192.
- exlvi Farrell, *Carlow in '98*, p. 204.
- exlvii Ibid, p. 146-7.
- exlviii The following information is taken from the recollections of Miss Annie Cummins of Castletown, given in 1949, in Peadar MacSuibhne, *Parish of Killeshin / Graigcullen* (Carlow, 1975), pp. 78-9.
- exlix Farrell, *Carlow in 98*, p. 164-5.
- cl *Irish Magazine*, April 1811, p. 175.
- cli Eric Gillet (ed.), *Elizabeth Ham by herself* (London, 1945), p. 79.
- clii Ibid. Ham claims he was always called 'Captain' rather than 'Reverend'.
- cliii Duggan, *County Carlow*, p. 152.
- cliv Rev. Dermot McKenna, 'The clergy in Carlow during the 1798 rebellion' in *Carloviana* (1998), pp. 65-6. Rev. Robert Rochfort does not feature in this article.
- clv Tommy Clarke, 'Carlow claimants for compensation in 1798', in *Carloviana* (1998), p. 60.
- clvi For a petition for Whitty's appointment see NAI RP 620/52/87.
- clvii See Patrick Comerford, 'Church of Ireland clergy and the 1798 rising' in Liam Swords (ed.), *Protestant, Catholic and Dissenter: the clergy and 1798* (Dublin, 1997), p. 232.
- clviii 'The examination of James Neal of Ballinabranagh [...] by Robert Rochfort Esquire' in Pat Purcell Papers on [http://www.rootsweb.ancestry.com/~irl-car2/PPP\\_Doc\\_1800\\_1.htm](http://www.rootsweb.ancestry.com/~irl-car2/PPP_Doc_1800_1.htm). Accessed 15/8/2012.
- clix Canon Leslie, Biographical index Church of Ireland Clergy, P-Y, p. xix.
- clx See Malcomson, *John Foster*, op.cit, Table three and p. 278.
- clxi *Irish Magazine*, August 1811, p. 384.
- clxii Wakefield, *Account of Ireland*, Vol. II, p 578.
- clxiii Lewis, *Topographical dictionary of Ireland* (London, 1840), Vol. I, p. 381.
- clxiv *Elizabeth Ham by herself*, p. 79.
- clxv Ibid, p. 16.
- clxvi The following anecdotes are taken from Ibid, pp. 79-80.
- clxvii Canon D.W.T. Crooks & Reverend Iain J.E. Knox (eds.), *Clergy of Cashel and Emly, Clergy of Leighlin, compiled by the Canon J.B. Leslie, Biographical succession lists* (Ulster, 2012), p.230.
- clxviii Ibid.
- clxix PRONI D207/34/166, Dora Rochfort to John Foster, Jun. 1807.
- clxx NAI RP 620/28/160.
- clxxi *Accounts presented to the house of commons of the presentments passed by the grand juries of Ireland, at the spring and summer assizes, in the year 1807* (1808), p. 29.
- clxxii Ibid, p. 29 and p. 36.
- clxxiii PRONI D207/34/166.
- clxxiv PRONI D207/34/167.
- clxxv PRONI T2627/3/2/135. John Staunton Rochfort to Wellesley, 22 May 1807.
- clxxvi PRONI D207/34/166.
- clxxvii *Freeman's Journal*, 8 May 1807.
- clxxviii Ibid, 15 May 1807.
- clxxix PRONI D207/34/130.
- clxxx PRONI D207/33/99. 22 Jun. 1808.
- clxxxi Wakefield, op.cit. Vol. II, p. 773.
- clxxxii Ibid, p. 374.
- clxxxiii Duggan, *County Carlow*, p. 139.
- clxxxiv Wakefield, op. Cit. Vol. II, p.373.
- clxxxv Ibid, Vol. I, pp. 420-5.
- clxxxvi *Carlow Morning Post*, 6 May 1831.
- clxxxvii *Hansard*, 7 Sep. 1831.
- clxxxviii Grand Jury presentments 1807, Op cit, p. 29-30, p.37.
- clxxxix PRONI D207/34/166.
- exc Quoted from John Murphy's contemporary diary, in *Kilcumney '98*, p. 213.
- exci On forestry, see 'Co. Carlow: Planting of trees, 1795-1808', signed by Robert Rochfort & others, Lot 466, 29 Jul. 2010, on [www.mealys.com](http://www.mealys.com), accessed on 15/8/12; Obituary, 1811.
- excii Ibid.
- exciii Wakefield, op.cit., Vol. I, p. 420.
- exciv Ibid, pp. 420-5.
- excv PRONI D207/34/86, 28 Jul. 1809.
- excvi Obituary.
- excvii Ibid.
- excviii PRONI D207/34/130, 30 Jun. 1810.
- excix PRONI D207/34/149, 11 Mar. 1811.
- cc Ibid.
- cei PRONI D207/34/150, 24 Mar. 1811.
- ceii PRONI D207/34/157, 29 May, 1811.
- ceiii Church of Ireland records online, Carlow parish at <http://churchrecords.irishgenealogy.ie>, accessed 15/8/12.
- ceiv PRONI D207/34/158, 2 Jul. 1811.
- cev *Hibernicus*, op.cit, p. 68.
- cevi Obituary, 1811.
- cevii *Irish Magazine*, November 1811, p. 328.
- ceviii *Hibernicus*, p. 68.
- ceix *Irish Magazine*, Feb. 1811, p. 81.
- cex Obituary.
- cexi Ibid.
- cexii Duggan, *County Carlow*, p. 232.
- cexiii Rochfort's 1825 evidence, op. cit. p. 441 and p. 452.
- cexiv Rochfort's 1825 evidence, op. Cit. p. 434.
- ce xv Rochfort's 1832 evidence, op. Cit. p. 79.
- ce xvi Ibid, p. 453.
- ce xvii Ibid, p. 453.
- ce xviii *Carlow Morning Post*, 9 Nov. 1818.
- ce xix Ibid, 16 Feb. 1818.
- ce xx Ibid, 11 May 1818.
- ce xxi Ibid.
- ce xxii Horace William Noel Rochfort was born on 5 November 1805. All other sources date it to 1807. However, confusion about his date of birth is resolved by an article in the *Carlow Morning Post* of 13 Nov. 1828, which describes his twenty-first birthday celebrations in Clogrennane House.
- ce xxiii NLI MS 41146/29, Farnham Papers, Horace Rochfort to Lord Farnham, 19 Sep. 1830.
- ce xxiv Sheffield Archives, Wentworth Woodhouse Muniments, WWM/G2/30, Horace Rochfort to lord Milton 23 Aug. 1830.
- ce xxv *Carlow Morning Post*, 9 May 1831.
- ce xxvi Ibid.
- ce xxvii Brophy, *Carlow: past and present* (Carlow, 1888), p. 33.
- ce xxviii *Carlow Morning Post*, 17 May 1834.
- ce xxix Obituary.
- ce xxx Ibid.

## Kavanagh Castles of Co. Carlow

Órla Kenny

For my history project this year I decided to do a tour of some castles owned by the Kavanagh family in County Carlow. A number of these castles are quite close to where I live. The Kavanagh family occupied a lot of castles in Co. Carlow.

On a bright Sunday afternoon in early February along with my Mam and Dad we took to the road with a map and some books about Carlow castles from Carlow library. We drove to a number of the sites, to Graiguenaspidogue, Ballyloo, Castletown, Ballymoon, Garryhill and Rathnageeragh to see what remains today.

### Graiguenaspidogue Castle

We stopped just down the road from my house close to the Fighting Cocks public house and opposite the old petrol station. We entered a field now owned by Mr. James Reddy. My Grandad had told me where to go as he had been told all about this castle years ago. In the field you can still see some granite boulders, evidence of a castle, and similar to the granite at Ballyloo Castle. The castle was a Kavanagh home in the 1400s. My Grandad also told me that years ago after the castle had been demolished music, laughter and singing could be heard at night at the site.

### Ballyloo Castle

For the next castle we drove the short distance to Ballyloo, which is just off the main Carlow/Wexford road. Again my Grandad knew this site as it was just across the field from his birthplace in Ballyloo. This castle is on land now owned by Mrs. Bradley and formerly by Mr. Jack Little. The remains are up along driveway. Art Óg Kavanagh built the castle in the 1400s. It was four stories high with a lovely view of the country. It was a granite building. The castle ruins are now nearly covered in bushes and hedging.

### Castletown Castle

We drove next to Castletown Castle, which is on the main Carlow/Wexford road. The walls of the castle are still standing. Arthur Kavanagh acquired the castle in 1631. The castle was renovated and extended by the Monaghan family. A large tillage farm surrounds this castle.

### Leighlinbridge Castle

Next we drove to the picturesque village of Leighlinbridge. On the banks of the River Barrow is Leighlinbridge Castle, also known as the Black Castle. This was one of Ireland's earliest Norman castles and was built by Sir Edward Bellingham. A fifty-foot tall broken tower can be seen today. During the 14<sup>th</sup> century the Kavanaghs recaptured most of heir land in the area, including the castle.

### Rathnageeragh Castle

Next we took the road towards Garryhill, the centre of Kavanagh country, and on towards Drumpea before coming to signposts for Rathnageeragh Castle. We travelled along a narrow road under the foot of Mount Leinster before we found the castle. This looked to be a castle of great strength, towering high into the sky. A courtyard is visible. Horses graze happily in the fields surrounding the castle. The Kavanagh family built this castle as an outfort. In the last century a set of manacles was found in the castle walls.

### Ballyloughan Castle

Next we travelled back through Garryhill



Rathnageeragh Castle Photo: Órla Kenny

and towards Bagenalstown and found the impressive remains of Ballyloughan Castle. This castle stands in the middle of a large grass field. It is about fifty feet high. The Normans built it around 1300 but the Kavanaghs occupied it during most of its history. It is a beautiful castle with a gatehouse in the centre and two large towers are also visible. A plaque at the

Carloviana 2012

field gate said that archaeological excavations took place in 1955 and a silver finger ring of the 14<sup>th</sup> century was found.

### Ballymoon Castle

Another Kavanagh castle is at Ballymoon which is outside Bagenalstown on the Fenagh road. Its ruins date to the 14<sup>th</sup> century. It is a very striking building. I enjoyed walking around and exploring this castle. Some beautiful granite stone walls can be seen. Square towers can be seen on three sides of the castle. A small timber footbridge from the main road gives you access to the castle. Ballymoon Castle is now a tourist attraction for visitors to Carlow.

I enjoyed the trip from Fenagh southwards towards Garryhill, which leads to Borris and St. Mullins, which is the heart of Kavanagh Country. While on the road we also stopped to look for Garryhill Castle, where Art Óg Kavanagh lived as King of Leinster during the 14<sup>th</sup> century. My Great-Great-Uncle, Mr. John Ryan, who lives in Garryhill, told me the castle was burnt by the English in the late 1300s. He said it was a wooden building

with a thatched roof.

The Kavanagh family occupied many castles in Carlow and I hope you enjoy reading about my trip to a selection of them and the photographs.

## GOING TO THE PICTURES

DAN CARBERY

It must be difficult if not impossible for the young people of today to understand the pleasure and excitement of going to the cinema in 1940s and 1950s. Saturation television, DVDs and all the other modern technologies are now taken for granted.

In my youth we did not go to the cinema or the movies, we said we were “going to the pictures”. This was the most popular leisure activity at the time. We looked forward to every visit to the Ritz or Coliseum, both on Tullow Street, Carlow.

My father, a great man for the “pictures” himself, was very strict with his children. We had definite rules about how often we could go. It was every two weeks. We would push this a little and when requesting permission to go he would ask how long it has been since you last attended.

We would say it will be two weeks on Friday and not one week last Friday. This was more likely to bring a positive response from him.

If a religious film came we would be

given permission to go but on our condition that it would not effect our atten

dance at normal films. Children can be very astute in handling parents.

We kept in touch with what films were coming by observing the “stills” which were photos on display outside the cinema. The programmes for the current week were displayed but there was also a special place for coming attractions. Posters were also printed each week giv-

published in the Nationalist and Leinster Times, our local newspaper. Most films were in black and white, but there would

be special mention of a coming colour film being in glorious Technicolor.

The times of showing in the Ritz Carlow were generally as follows: Sunday a matinee at 3pm with first house at 6pm, and second house at 9pm. Monday, Wednesday and Friday had two houses 6.30pm and 9pm. Tuesday and Thursday



*The earlier cinema on the site of the present Post Office*

ing the week’s programme. These were distributed to shops for display in the window. Free passes were given to the shopkeeper and some of my school friends were fortunate to have access to these. The programme of films was also

had one house 8.30pm.

The Ritz opened in 1938. There had been a cinema, owned by Slaters, in Burren Street on the site of the current Post Office. It was, however, destroyed by a fire.

There was also a much earlier cinema on the same site which is illustrated on page 25 of Carloviana 1971. There were three different admission prices. The cheapest seats were at the front close to the screen with entry from the side of the cinema in Charlotte Street. Then the stalls were at the back further from the screen. The most expensive seats were on the balcony upstairs. I am afraid there was a certain amount of class distinction at the time even when "going to the pictures".

There were regular changes of programme so you could go every night of the week to see a different film by alternating between the Ritz and the Coliseum. The Sunday programme was stand alone. Monday and Tuesday was the same film and then a change for Wednesday and Thursday with a further change for Friday and Saturday. This meant four different programmes in the week. The foreman in our family building firm of D & J Carbery was Tommy Corcoran, a great man for the pictures. He went almost each night to the earlier showing and then adjourned to his club "The Workman's" in Browne Street for some relaxation after a hard day's work on the building sites.

If a particularly good film came it might show for the full week without a change of programme. You could pre-book tickets to make sure that you got in. Saturday night was very popular and a long queue often formed along the footpath from the Ritz at the corner of Charlotte Street, towards the old Garda Barracks.

The normal programme had the main feature film but there was also a support film. The show opened with advertisements for national and local businesses. These were followed by trailers showing extracts from future films or coming attractions. Next came the support film and an interval to allow for a toilet break and, of course, if you had the money, to buy a tub of ice cream. This was always a special treat when "going to the pictures". I remember we had Pathe or Movietone News also at times. This was pre-television days and it was wonderful to see some of the major news items on film, including extracts from All Ireland Football and Hurling Finals as well as International Rugby from Lansdowne Road and other grounds. I can recall the spe-

cial edition of news showing the coronation of Queen Elizabeth in 1952 which, although short, brought people to the Ritz, including my aunt Melba Governey. On Sunday there was also an episode of a serial that always ended in drama such as the hero being pushed over a cliff and falling to his death. You had to go the following Sunday to find out what happened. He had either fallen onto a ledge or managed to grab hold of a projecting bush to save his life. My father's rule of only allowing us to go every two weeks prevented us from following the serials. At the end of the programme the National Anthem was played and the majority of those attending stood until it was complete.

As already mentioned the local newspaper The Nationalist published the programmes of films at the various cinemas in the region. I have the copy of Saturday 23<sup>rd</sup> January 1937 that my mother kept as it records the death of her eldest brother Michael Governey who died at the age of 28. This edition includes advertisements for Carlow Cinema, which was located in Burrin Street opposite the Deighton Hall on the site of the present Post Office. The Sunday programme was Two Black Sheep starring Otto Kruger and is described as "a pathos drama with touches of light comedy blended in a gripping play of strong human appeal". The support film was Joe E. Brown in Alibi Ike. Entry prices were Balcony 1/8 Stalls 1/- Pit 4d. Other cinemas listed were Athy Picture Palace and Palace Cinema Bagenalstown (The Perfect Talkie Cinema). The importance of the cinema at the time is shown by the Carlow and District notes giving a full review of all the films for the week at Carlow Cinema. The Muinebeag Notes did likewise for the Palace Cinema.

I also have a copy of The Nationalist dated July 5<sup>th</sup> 1958, which is the edition recording my father's obituary. On the same page there are advertisements for the Ritz Super-Cinema Carlow and the Coliseum Carlow as well as the Astor Cinema Muinebeag (Bagenalstown), the Grand Central Cinema Tullow, and Myshall Parish Hall Cinema. The Coliseum was showing "Rooney" all week Monday to Saturday. I well recall this comedy film made in Ireland about a hurler. The main character Rooney was

played by John Gregson and also starred Barry Fitzgerald and I think Noel Purcell. The director needed a scene showing a hurling final complete with packed stadium, a band and parade of players before the game. In September 1957, Kilkenny were playing Waterford in the All Ireland Hurling Final at Croke Park. I attended the game and saw John Gregson parade with the Kilkenny team around the park with the crowd cheering him. This footage was included in the film, the World Premiere of which I attended at the Savoy Cinema in O'Connell Street Dublin on Thursday 13<sup>th</sup> March 1958.

When watching the pictures all those years ago we gave little thought to those responsible for showing it from the projection box or room. That was until it broke down and the screen went blank. The audience went wild with whistles of protest until the showing restarted.

To get some idea on the running of a cinema I spoke to Carlow native Val Slater a former manager of the Ritz Cinema in Tullow Street Carlow. Val is a well-known driving instructor, but he spent much of his earlier working life in many cinemas across the country. He started in the Coliseum Carlow, then worked in the Ritz and, after years in various cinemas in Ballina, Athlone, Sligo and elsewhere, he returned to manage the Ritz. The cinema was owned by Amalgamated Cinemas Ireland Ltd the Elliman Brothers Company and had various local directors such as Des Early the solicitor and Carmel McDonnell (nee Duggan) both well known. Many people worked in the Ritz over the years and included Joe Carter and his son Brendan who worked as projectionists. The Kavanagh sisters of Browne Street were ticket sellers and attendants. Hogans also worked there.

The decision on what films were shown was made in Dublin. When films were released in Ireland the major Dublin Cinemas got them first and, sometime later, they came to Carlow and to the smaller cinemas around the country. The film reels came to Carlow Rail Station packed in steel boxes. I can recall seeing the man from the Ritz wheeling a hand truck up Dublin Road with the previous night's films for dispatch to their next destination and of course collecting the new films for

## GOING TO THE PICTURES

that night's showing.

The Coliseum Cinema Tullow Street Carlow opened on 16<sup>th</sup> September 1941. It was situated on the site of nos. 59-61 Tullow Street and had seating for 750. The first film shown was "Bachelor Mother" starring Ginger Rogers and David Niven.

I spoke to Paul Delaney who worked in the Cinema from 1958 until it closed in 1994. He started on December 8<sup>th</sup> 1958 employed as a rewind boy and, over the years, progressed until he was manager. In the earlier days, films were collected at Carlow Railway Station. They had to be wound onto special reels and spliced together for showing. When Paul started, 10 people were working there including Robert Fleming and John Fitzpatrick. Two of Robert's sons Aidan and Gregory also worked in the Cinema as did Harry Hogan known as 'Buster Crabbe' who was charged with controlling the young patrons. Working with Paul when the Coliseum closed were Joan Collins, Edel Byrne and Nan Brown. The Coliseum was demolished to make way for the present entrance road into the Carlow Shopping Centre from Tullow Street.

In preparing this article I asked some friends to recount their memories of "Going to the Pictures" in their youth. Fr. Tom Little included the following in his reply:

"On being asked to write this article on "Going to the Pictures" it brings back such happy memories of a time long gone, when as children with friends we went to see the latest story in town.

One of the highlights of the month when we were young was the day we were allowed to go to the pictures. The week beforehand we had to be so good to our Mam. Our pocket money was saved up. Promises were made that we would be good at the pictures and on the way home. At that time we had to travel on bicycles and if it were at night then we had to have our bicycle lights in good order for fear of meeting the Garda.

The name of the picture was posted up outside of the church, which could not fail to attract your attention as the adults chatted after mass. Friday night was the first showing but it could also be seen on

Sunday at the matinee.

The great actors and actresses such as Charlie Chaplin, Laurel and Hardy, Charlton Heston, Shirley Temple, Marilyn Monroe, Yul Brynner, Bing Crosby, Deborah Kerr and Bob Hope were all names to look forward to, with John Wayne proving to be the best cowboy of them all.

The picture hall in Borris was in the centre of the town, which really was the Town Hall. At that time, to gain entry, you had to pay by giving your money to the lady who looked out through a little window. She told you to keep your ticket and "there is no going in and out" were the famous last words. As you stepped towards the double door past a well positioned sweet stand you knew that you entered a totally new world. Finding your seat with the help of a well directed flash lamp that was held by one of the stewards was the next big hurdle. At the front of the hall there were wooden benches known as forms and the rest of the hall was filled with chairs arranged in rows. The front seating cost less as it was nearer the screen than the chairs and was affectionately known as the pit. The machine for showing the picture was situated at the back of the hall. It had two big reels on either end. The man showing the picture always seemed to smoke and when the shaft of light from the machine lit up the white screen his smoke turned a distinct blue colour.

There were always advertisements of great things in Graiguenamanagh, Bagenalstown, Tullow and Carlow, shown at the beginning. It was not until you saw the two big shells opening that you knew you were in for a great treat of being at the pictures.

It was at the pictures that one learned that it was nice to sit beside a girl for the first time. I never forget one time when there was a break in the picture everyone stood up leaving myself and the girl I was sitting beside on the edge of the form to "see saw" to the floor causing an enormous thud. When the lights came on we were the object of everyone's laughter.

Graiguenamanagh Hall owned by Joyces was more up market. It was a real Picture Hall with seats, which sprung up when you stood up. It also had a curtain which

opened up and closed when the picture opened and at the end. At the end of a matinee one always seemed to come out of the hall dazzled by the bright light of the day which had continued at its own pace as you had stepped off for a few hours."

Mrs. Margaret Haughney of Leighlinbridge recalls going to The Astor Cinema, Borris Road, Bagenalstown. This was owned by Brownes. "The price to get into the Cinema was 4d into the pit. The first film I ever saw was Going My Way with Bing Crosby in it. We would have walked into Bagenalstown for the 6pm showing. We started going to the pictures at 14 years of age and there would have been 5 or 6 of us walking in together. We would have gone to the cinema about every 3 or 4 weeks. The Usher Ginger Clarke was very strict; if there was any talking during the film or messing he would put you out straight away."

To conclude those of us who grew up in the pre television age will each have their own happy memories of "going to the pictures". I only have to pause and think back to the excitement and wonder of it all to a young boy growing up in Carlow long ago. I can recall so many of the films and the stars. Our favourites were of course the Westerns. First we had a Roy Rogers, Gene Autry (who actually visited the Ritz in 1939) with their horses Trigger and Champion. We knew the name of every cowboy's horse. Later we had Randolph Scott and my favourite John Wayne who also played in many war films. The comedies were Laurel and Hardy, Abbot and Costello together with The Marx Brothers and many others. My favourite channel for T.V. films is TCM where I can record and view the old black and white films at my leisure.

With all the modern special effects and multi-million budgets available to films today they produce magnificent spectacles but I doubt if they give anything like the excitement and entertainment we got as youngsters "Going to the Pictures".

## THE END



## Observations on a flint leaf-shaped arrowhead from Ballintemple, Co. Carlow and some related finds from the county

Isabella Mulhall

On 29<sup>th</sup> November 2011, a flint leaf-shaped arrowhead (Fig.1) was discovered just off the L2021, close to the River Slaney, around 3.5km south of the village of Ardattin in the townland of Ballintemple, Co. Carlow. It was a surface find, made in Coillte's Ballintemple Nursery during the course of a routine plant health inspection being carried out by Cathal Ryan, an inspector with the Forestry Service. The discovery was reported by the finder to the present writer at the National Museum of Ireland, in line with the National Monuments Acts 1930 to 2004. On behalf of the State, and under Section 68 (2) of the National Cultural Institutions Act (1997), the arrowhead was then acquired, on 4<sup>th</sup> April 2012, by Carlow County Museum, where it is currently on display.

The presence of the arrowhead at Ballintemple raises a number of challenging questions, with implications that reach to the heart of prehistoric Carlovian life. How old is it? Who made it? How was it made? What was it used for? And how did come to rest, finally, in Ballintemple? These are the questions that will be addressed here in this article. Doubtless, the artefact has many secrets it can unveil to us about life in Ballintemple and the surrounding areas in prehistoric times. When considered alongside comparable arrowhead discoveries, from a variety of contexts within Carlow and further afield, it presents a range of fresh insights into the rich and diverse nature of this county's prehistoric past.

### Date and description of object

The Ballintemple arrowhead measures approximately 4cm long x 3cm wide and has a maximum thickness of 0.5cm. It has bi-facial invasive flaking where flakes from both faces are

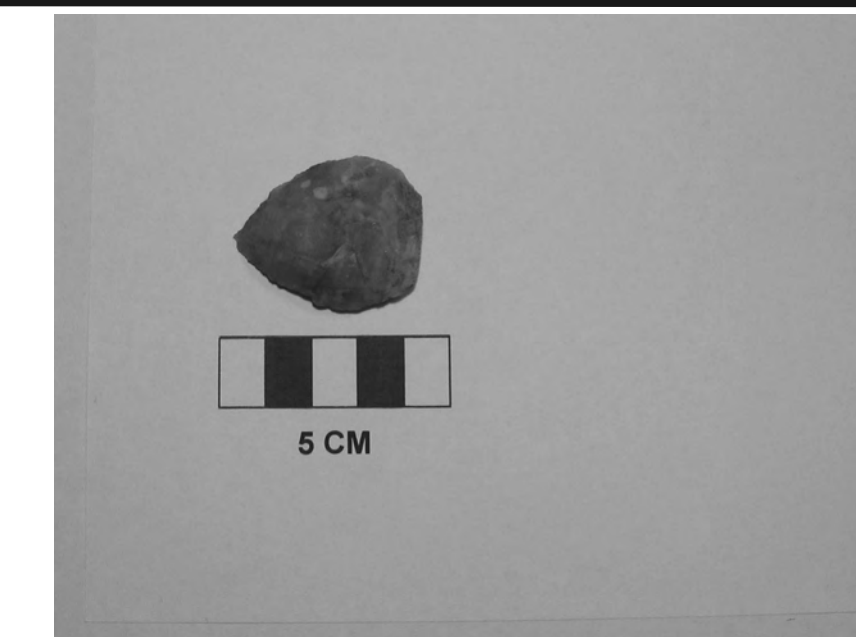

Fig.1 The Ballintemple arrowhead Photo:courtesy of Carlow County Museum

removed, and has a small amount of cortex or exterior chalky surface at the base. It has very light patination, that is to say, has very little surface weathering<sup>i</sup>.

The artefact can be classified as a broad leaf-shaped arrowhead<sup>ii</sup>. Leaf-shaped arrowheads are so-called because they lack the projecting tangs associated



Fig.2 Barbed and tanged arrowhead from Ballyglass West, Co. Mayo Photo: Jonathan Hession, courtesy of the National Roads Authority

## BALLINTEMPLE ARROWHEAD

with the later barbed and tanged arrowheads (Fig. 2). They were manufactured by pressure flaking; the original blank piece of flint was shaped by removing flakes from the surface and worked to a sharp point. This technique allowed for the production of finely crafted tools, such as piercing arrowheads<sup>iii</sup>. Leaf-shaped arrowheads are primarily known from the early Neolithic (c. 4000-3200BC), a period that witnessed the introduction of farming to Ireland and a corresponding move towards a more sedentary way of life. It was also marked by new developments such as pottery production, in addition to advances in stone working techniques. A diverse range of lithic (stone) technologies is associated with a range of artefacts from this period which also includes lozenge-shaped arrowheads, javelin or spearheads, convex scrapers, plano-convex knives and polished stone axes.

Broad leaf-shaped arrowheads such as the one from Ballintemple, possess a flat base and are not very widely known from the archaeological record<sup>iv</sup> with leaf-lozenge shaped arrowheads and elongated leaf-shaped arrowheads being more commonly found<sup>v</sup>.

The arrowhead is a striking early example of the technical and aesthetic expertise of stone craftsmanship in prehistory. In particular, it demonstrates a preference for the use of good quality flint with excellent fracture properties (*i.e.* the ease with which it can be flaked during the course of manufacture). It has been argued elsewhere that skilled flint knapping played a crucial role in ensuring the success rate of arrowhead production<sup>vi</sup>. The Ballintemple arrowhead has all the hallmarks of having been manufactured by one such skilled flint knapper, and would undoubtedly have been a valuable possession to whoever owned it.

#### Raw materials used in the manufacture of arrowheads

That the Ballintemple arrowhead was an isolated or "stray" find raises some important questions. Was it manufactured locally using raw materials available in the Ballintemple area or could the materials have been sourced

further afield? Could it have been introduced into the area as a finished product or even as an arrowhead pre-form<sup>vii</sup> as a result of trade contacts with neighbouring communities? Explaining the arrowhead's apparent isolation demands a wider understanding of flint exploitation practices and trade patterns in the area in the early Neolithic period.

Flint was the best-known and most ubiquitous of the stone sources used in the past<sup>viii</sup>.<sup>ix</sup> However, given that there are no bedrock flint sources (*in situ* deposits) known in County Carlow, secondary sources of flint would have been exploited. These would most likely have arisen as a result of recurrent glaciations which would have eroded flint out of the bedrock in County Antrim (primary source), and transported it in a southerly direction where it was eventually redistributed<sup>x</sup>. It seems most likely that the context from which the flint was procured for the Ballintemple arrowhead would have been either the river deposits or glacial tills in County Carlow, or the beach deposits found along the eastern seaboard (research is still ongoing in this regard).

It is important to note that in the history of the nursery at Ballintemple, no topsoil was ever introduced into the area from outside<sup>xi</sup>. This suggests that the arrowhead was not inadvertently brought into the area from outside in recent times, which in turn strengthens the argument that Ballintemple and surrounding areas were inhabited since at least the early Neolithic period. The discovery in the 1970s of three Neolithic polished stone axeheads in the neighbouring townland of Carrickslaney further testifies to a Neolithic presence in the wider area<sup>xii</sup>. Determining the exact nature and extent of this presence would however, be difficult in light of the limited evidence available. Furthermore, it would be impossible to establish whether the inhabitants of the area were arrowhead manufacturers or whether they were simply arrowhead consumers who sourced their supplies elsewhere. The River Slaney would doubtlessly have served as a navigation channel, opening up endless possibilities for the communities along its banks, and creating wide-ranging trading opportunities for them. Indeed, log boats

are well attested from this period and would have played a pivotal role in the transportation of raw materials or finished products. No examples of Neolithic log boats have so far come to light in County Carlow, but a recently discovered log boat from Greyabbey Bay, Co. Down dating from the late fourth millennium BC<sup>xiii</sup> clearly illustrates the range and complexity of the technological skills known from the period.

#### Function of arrowheads

Functioning as single piece projectile points, arrowheads would have been very diverse tools, but would primarily have been used for hunting smaller animals. They would most likely have been affixed to their shafts using some sort of adhesive such as resin, sometimes reinforced by twine or animal sinew<sup>xiv</sup>. An example of a chert arrowhead from the stone tool assemblage excavated at the site of an enclosed early Neolithic settlement complex at Tullahedy, Co. Tipperary clearly demonstrates how arrowheads were hafted in grooved wooden shafts; in this instance, the outline of the shaft was left on the actual arrowhead<sup>xv</sup>. Closer to home, a leaf-shaped arrowhead was found at a depth of about 3m in bog at Clonaddadoran, south of Port Laoise, with part of the birch shaft still attached<sup>xvi</sup>. This find is an exceptional firsthand demonstration of the intricacies of the hafting process.

Abundant evidence of arrowheads in the archaeological record reflects the importance of archery in both hunting and warfare in Neolithic times<sup>xvii</sup>. At the Neolithic site of Hambledon Hill in Dorset, England, an adult male was uncovered with a leaf-shaped arrowhead embedded in the vertebrae of his upper thoracic cavity<sup>xviii</sup>. At Poul nabrone Dolmen, on the Burren in County Clare, the tip of a flint or chert arrowhead was found lodged in the hip bone of an adult male. There was no trace of infection or healing, indicating that this was a perimortem wound - one which occurred at or around the time of death<sup>xix</sup>.

Arrowheads may also have had a ceremonial or ritual function, as I will go on to explain, given that they have come to light as grave goods accompanying burials in megalithic tombs and single burials of the period.



BALLINTEMPLE ARROWHEAD



Fig.3 Leaf-shaped arrowhead from Ballybar Lower, Co. Carlow.  
Photograph: Studiolab, courtesy of the National Roads Authority

**Contexts from which arrowheads have been recovered**

One of the mysteries of the Ballintemple arrowhead is its isolation. While leaf-shaped arrowheads have most commonly been recovered in apparent contexts, such as in habitation sites or sepulchres, the Ballintemple arrowhead, as a stray find, was not found in association with any archaeological site, monument or object. As I have hinted above, it is unclear at present why the Ballintemple arrowhead ended up where it did- far removed from any related settlement evidence. What is clear from the archaeological record, however, is that leaf-shaped arrowheads were associated with both the living and the dead in the early Neolithic period. They have been recovered from a wide range of contexts that show their use in hunting, warfare, as part of the house-building process, as grave goods accompanying burials and in ceremonial gatherings.

*Isolated discoveries*

Stray or chance discoveries of single arrowheads commonly feature in the archaeological record. While there are no other projectile points known from the townland of Ballintemple, a well-finished flint leaf-shaped arrowhead was unearthed by chance in 1969 in a “newly ploughed bog” in the neighbouring townland of Monaughrim, located to the

south east of Ballintemple. This arrowhead has a marked point and fine secondary working on both faces but, unlike the Ballintemple arrowhead, has a rounded butt<sup>xx</sup>. It was also a stray find that did not come from a clear archaeological context, in contrast with other examples known from the county. Like the arrowhead from Ballintemple, its isolated context remains an enigma.

*Habitation sites*

Leaf-shaped arrowheads have been recovered from a substantial number of the early Neolithic habitation sites excavated to date in Ireland. At Ballybar Lower, Co. Carlow a leaf-shaped arrowhead was recovered during the excavation of a localised series of twelve pits (Fig. 3) ahead of the N9/N10 Carlow Bypass<sup>xxi</sup>. However, unlike the arrowhead from Ballintemple, it is a small leaf-lozenge shaped arrowhead that was unfinished due to a knapping error. It was found in a pit together with two flakes and a blade, all which can be dated to the early Neolithic period on technological and typological grounds<sup>xxii</sup>.

A small flint leaf-shaped arrowhead came to light along with flint débitage and pottery sherds in an area of post- and stake-holes

during the excavation of an early Neolithic structure at Oakpark/Painestown, Co. Carlow<sup>xxiii</sup>. The deposition of arrowheads in post-holes and slot-trenches may have been for ritual purposes and may indicate a ceremonial element to the house-building process. Parallels for such depositions are numerous in the Irish archaeological record. A rock-crystal leaf-shaped arrowhead was recovered from a posthole during excavations of a Neolithic house structure at Ballyglass, Co. Mayo<sup>xxiv</sup>. The latter appears to be the only example of a quartz projectile in the Irish archaeological record<sup>xxv</sup>

At Knowth, Co. Meath, a finely executed leaf-shaped arrowhead was brought to light along with small fragments of Neolithic pottery in the stone-lined trench of a sub-rectangular Neolithic house. The house was uncovered in the area adjacent to the Eastern entrance of the Knowth Passage Tomb<sup>xxvi</sup>.

Finally, a broken leaf-shaped arrowhead was recovered from the wall-slot of Neolithic house at Ballintaggert/Lisnagonnell, Co. Down<sup>xxvii</sup> whilst at Corbally, Co. Kildare, an unfinished leaf-shaped arrowhead was unearthed in the packing material of a rectangular Neolithic house<sup>xxviii</sup>. It has been suggested by many commentators that the deposition of broken pottery and



Fig.4 Court tomb at Creevykeel, Co. Sligo  
Photo: National Monuments Service of the Dept. of Arts, Heritage and the Gaeltacht



## BALLINTEMPLE ARROWHEAD

stone implements (including arrowheads, stone axeheads and quernstones) in the foundation trenches or postholes of Neolithic houses was for ritual purposes. This is a pattern that is known across the island of Ireland and has been observed in a considerable number of the eighty or so Neolithic houses that have been excavated to date in the country.

#### Burial sites

In addition to their recovery from settlement sites, leaf-shaped arrowheads are also commonly found in burial tombs of the period, most notably court tombs. A court tomb consists of a long cairn of approximately rectangular or trapezoidal shape with an unroofed court giving access to a longitudinally placed gallery of one or more chambers<sup>xxxix</sup>. There are no examples of court tombs known from County Carlow but examples from elsewhere in Ireland include Bavan Court Tomb, Co. Donegal<sup>xxx</sup> and Creevykeel, Co. Sligo<sup>xxxi</sup> (Fig. 4), both of which produced well-executed leaf-shaped arrowheads in addition to other lithic material including lozenge-shaped arrowheads, hollow scrapers, end scrapers and plano-convex knives. The appearance of arrowheads in this context seems to denote that they were used as grave goods to accompany the dead. However, their presence in the tombs may also be explained by the possibility that they were originally embedded in the actual remains of the dead, and therefore do not constitute gravegoods *per se*. In other words, they were used to lethal effect and entered the tomb “in” the remains, rather than “with” them.

Dolmens, or portal tombs as they are also known, have likewise yielded arrowheads during the course of archaeological investigations. Excavations at Poul nabrone Dolmen, County Clare, referred to above, produced several arrowheads in addition to a triangular bone pendant, two stone beads, part of a mushroom headed bone pin, a polished stone axe, several other flint and chert implements and over sixty sherds of plain coarse pottery<sup>xxxii</sup>. The likelihood exists, of course, that leaf-shaped arrowheads and other associated early Neolithic grave goods would have also featured as an integral part of the burial rite in the portal tombs of County Carlow. Some of the most impressive and well-preserved portal tombs in the

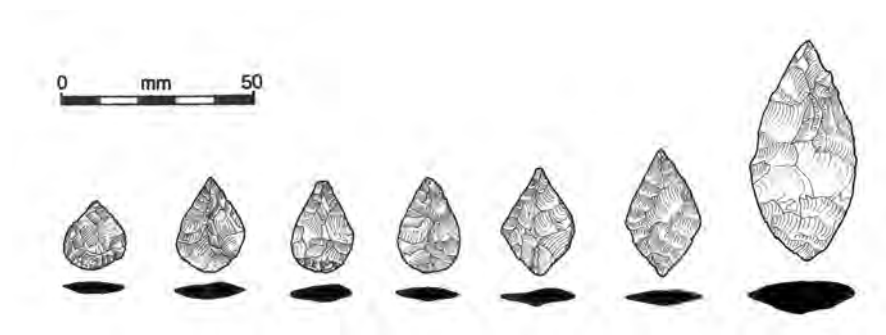

Fig 5. Miniature leaf-shaped arrowheads from Tullahedy, Co. Tipperary  
Drawing by Patsi Bates, courtesy of the National Roads Authority

country, are located at Brownshill, in the townland of Kernanstown, and Haroldstown, where remarkable examples of megalithic engineering are undoubtedly in evidence. Neither of these tombs has been scientifically investigated to date and therefore nothing is known of the remains contained therein or their associated gravegoods. Future excavations at these sites may indeed reveal a fuller picture of the socially complex nature of the society in which the megalith builders of County Carlow lived.

#### Causewayed enclosures

Leaf-shaped arrowheads have also been recovered from Neolithic causewayed enclosures such as the one excavated in Magheraboy, Co. Sligo<sup>xxxiii</sup>. This large multi-functional early Neolithic earthwork was radiocarbon dated to between 3900 and 3600BC and partially enclosed circa five acres of hilltop. Causewayed enclosures have invariably been interpreted as settlement sites, ceremonial or ritual centres, trading centres, communal meeting places, mortuary sites and even cattle compounds. Given the diverse range of uses attributed to these sites it is unsurprising that finds of arrowheads broadly similar to the one from Ballintemple are not uncommon.

Archaeological finds from the site at Magheraboy also included a broken porcellanite axe, scrapers, a javelin head fragment, quartz crystals and early Neolithic pottery<sup>xxxiv</sup>, testimony again to the extensive trade-networks that existed throughout the island of Ireland in Neolithic times.

#### Lithic scatters

Finally, in addition to the contexts outlined above, leaf-shaped arrowheads have also come to light as part of lithic scatters such as the one excavated at Glenulra, Co. Mayo, situated 2.5km southeast of the Céide Fields (Neolithic Field System). This site produced artefacts of flint, chert and quartz/rock-crystal including one broken leaf-shaped arrowhead. The arrowhead in this instance was manufactured from chert. Findings such as these imply an area of stone tool production where artefacts of all levels of completeness were found in addition to manufacturing lithic waste or *débitage*<sup>xxxv</sup>.

Excavations of the enclosed settlement complex at Tullahedy, Co. Tipperary, referred to above, revealed evidence of intense on-site stone tool production<sup>xxxvi</sup>. However, unlike the Ballintemple example, arrowheads from this site included nine miniature chert leaf-shaped arrowheads (Fig. 5). In

addition to these, an array of other stone implements including scrapers, complete and fragmentary polished stone axes and simple blades and flakes came to light. Recent analysis of the lithic finds from the site has also shown that the majority of arrowheads recovered there were unfinished examples which appear to have been produced by novice knappers, or which broke during the course of manufacture. It has also been demonstrated at that site that some examples were never completed as they may have been considered too small and/or too thick for manufacture, whilst others were rejected because they were not fully symmetrical or because their size ratio was problematic<sup>xxxvii</sup>. By contrast, the Ballintemple arrowhead, as I have mentioned, demonstrates high quality craftsmanship by a very experienced flint knapper.

**Concluding remarks: the archaeological significance of the Ballintemple area**

Although there are no other archaeological objects dating from the Neolithic period recorded from the townland of Ballintemple, several archaeological sites are known from Ballintemple and may quite possibly be prehistoric in date.

The Archaeological Inventory of County Carlow lists three oval enclosures<sup>xxxviii</sup> which showed up as faint and indistinct cropmarks during aerial photography of the area<sup>xxxix</sup>. Subsequent to the publication of this inventory, aerial reconnaissance carried out in 1996 revealed two sub-rectangular shaped cropmarks<sup>xl</sup>. There is a distinct possibility that some of these cropmarks, particularly the latter two, may represent the remains of Neolithic settlements such as those uncovered at Corbally, Co. Kildare or Knowth, Co. Meath referred to above. These would provide a framework for the Ballintemple arrowhead and would enable us to gain a better understanding of the complex nature of prehistoric settlement in the Slaney hinterland. Without recourse to archaeological investigation however, the precise nature, function and date of these enclosures remain unknown.

The Ballintemple arrowhead has undoubtedly something to tell us about life in Ballintemple and

surrounding areas in the early Neolithic period almost six thousand years ago. It speaks to us perhaps of a community that had access to flint and possessed expertise in lithic technology, or perhaps who fished in the nearby River Slaney and hunted small animals or, indeed, engaged in warfare. Does it speak to us of a community that may have had contact with the tomb-builders from Haroldstown and Brownhill who firmly left their mark on Carlow's rich landscape? Can we dare to imagine a thriving community who felled their trees with "Carrickslaney-type" stone axes and farmed the surrounding lands?

Future finds of archaeological significance will undoubtedly shed further light on this area. Indeed, there is every reason to believe that further evidence of the Neolithic lies hidden beneath the rich agricultural lands of Ballintemple and surrounding areas. The deep tantalising secrets of this enigmatic arrowhead may some day be revealed to us in full.

**Acknowledgements:**

Cathal Ryan, Forestry Inspector, Forest Service, Dept. of Agriculture, Food and the Marine: for reporting the find to the National Museum of Ireland and for his assistance at the time of discovery.

Dermot Mulligan, Curator, Carlow County Museum: for providing permission to describe the arrowhead from Ballintemple here and for providing photographs of same.

Claire Anderson, Irish Antiquities Division, National Museum of Ireland; for her comments on the manufacture of the arrowhead from Ballintemple.

Matthew Parkes, Natural History Division, National Museum of Ireland: for his comments on the sources of flint in prehistoric Ireland.

Noel Dunne, National Roads Authority: for providing images (from Studiolab) and information on the finds from the Carlow Bypass excavations.

Pat Doody, Coillte, Ballintemple, Co. Carlow: for providing information on Ballintemple Nursery, Co. Carlow.

Graeme Warren, School of Archaeology, University College Dublin: for providing information on the Ballyglass, Co. Mayo rock-crystal arrowhead ahead of publication.

Killian O'Driscoll: for providing access to this unpublished thesis - *Understanding quartz technology in prehistoric Ireland*- University College Dublin.

Michael Stanley, National Roads Authority: for providing the illustration of the Tullahedy miniature leaf-shaped arrowheads (drawn by Patsi Bates) and the image of the barbed and tanged arrowhead from Ballyglass West, Co. Mayo (by Jonathan Hession).

Jimmy and Frankie Quinlan, Ardattin Cottage Museum, Co. Carlow: for local historical information on the area.

Tony Roche, National Monuments Service: for providing the image of Creevykeel Court Tomb, Co. Sligo.

Colleagues and friends, especially Peter Jones and Kim Briggs, for their insightful comments on the text.

**Bibliography:**

Anderson, E. (1994) *Flint and stone tools*. In M. Ryan (ed.) *Irish Archaeology Illustrated*, 35-8. Dublin.

Brindley, A. and Kilfeather, A. (1993) *Archaeological Inventory of County Carlow*. Dublin.

Byrne, G., Walsh, P., Warren, G., McIlreavey, D. and Rathbone, S. (2009) *Archaeological excavations at Glenulra Scatter (92E140). Stratigraphic Report*. Irish National Strategic Archaeological Research Fund 2009. Dublin.

Cleary, R. and Kelleher, H. (2011) *Archaeological finds at Tullahedy, Co. Tipperary: Neolithic settlement in North Munster*. Cork.

Danaher, E. (2004) Symbolic enclosure: a tantalising Neolithic space in the north-west. *Archaeology Ireland* 18, No. 4, 18-21.

## BALLINTEMPLE ARROWHEAD

- Driscoll, K. (2010) Understanding quartz technology in prehistoric Ireland. Retrieved 21/08/2012 from, [http://www.lithicsireland.ie/PhD\\_Quartz\\_lithic\\_technology\\_Bibliography.html](http://www.lithicsireland.ie/PhD_Quartz_lithic_technology_Bibliography.html)
- Dunne, N. (2009) An exciting array of finds from the Carlow Bypass. *Seanda* NRA Archaeology Magazine 2007 Issue 2, 64-66.
- Eogan, G. and Roche, H. (1991) Knowth. Multi-period. Retrieved 05/08/2012 from, <http://www.excavations.ie/Pages/Details.php?Year=&County=Meath&id=3799>
- Forsythe, W. and Gregory, N. (2007) A Neolithic log boat from Greyabbey, Co. Down. *Ulster Journal of Archaeology* (Third Series) 66, 6-13
- Gillespie, R. (2009) A treasury in time around Charlestown, Co. Mayo. *Seanda* NRA Archaeology Magazine 2009, Issue 4, 8-11.
- Green, S. (1980) *The Flint Arrowheads of the British Isles* (Parts I and II). BAR British Series 75 (i), Oxford.
- Hackett, L. (2006) Ballybar Lower, Co. Carlow: Prehistoric Activity. Retrieved 05/08/2012 from, <http://www.excavations.ie/Pages/Details.php?Year=&County=Carlow&id=1495>
- Herity, M. (1987) The Finds from Irish Court Tombs. *Proceedings of the Royal Irish Academy* 87C, 103-281.
- Large, S. (2004) Ballintaggert/Lisnagonnell, Co. Down. Neolithic and Bronze Age. Retrieved 05/08/2012 from, <http://www.excavations.ie/Pages/Details.php?Year=&County=Down&id=11346>
- Lynch, A. (1988) Poul nabrone- a stone in time. *Archaeology Ireland* 2, 105-7.
- Mercer, R. (1980) *Hambledon Hill: A Neolithic Landscape*. Edinburgh.
- Monteith, J. (2008) *IDA Business Park, Carlow: Archaeological Resolution (for Valerie J. Keeley Limited). Oakpark or Painestown, Co. Carlow*. Retrieved 05/08/2012 <http://www.excavations.ie/Pages/Details.php?Year=&County=Carlow&id=1916>
- O'Neill Hencken, H. (1939) A Long Cairn at Creevykeel, Co. Sligo. *Journal of the Royal Society of Antiquaries of Ireland* 9, 53-98.
- Purcell, A. (2002) Excavation of three Neolithic houses at Corbally, Kildare, Co. Kildare. *Journal of Irish Archaeology* 11, 31-75.
- Sheridan, A. (1994) *The First Farmers*. In M. Ryan (ed.) *Irish Archaeology Illustrated*, 47-52. Dublin.
- Sternke, F. (2009) Appendix 8- Lithics Finds Report for E2620 Ballybar Lower, Co. Carlow. In L. Hackett and R. Hanbridge *N9/N10 Kilcullen to Waterford Scheme: Kilcullen to Powerstown. Final report on archaeological investigations at Site E2620, in the townland of Ballybar Lower, Co. Carlow*.
- Sternke, F. (2011) The Stone Tools. In R. Cleary and H. Kelleher *Archaeological finds at Tullahedy, Co. Tipperary: Neolithic settlement in North Munster*. Cork.
- Sternke, F. (2012) What lies beneath. *Seanda* NRA Archaeology Magazine 2012, Issue 7, 10-11.
- Waddell, J. (1998) *The Prehistoric Archaeology of Ireland*. Galway.
- Warren, G.M. (forthcoming) The Chipped Stone. In S. Ó Nualláin, S. Greene and K. Rice (eds.), *Excavation of the Centre Court Tomb and Underlying House Site at Ballyglass, Co. Mayo*. Dublin.
- Woodman, P., Finlay, N. and Anderson, E. (2006) *The Archaeology of a Collection: The Keiller-Knowles Collection of the National Museum of Ireland*. Dublin.
- Websites accessed:  
National Monuments Service, Archaeological Survey of Ireland ([www.archaeology.ie](http://www.archaeology.ie))  
Searchable Database of Irish excavation reports ([www.excavations.ie](http://www.excavations.ie))
- <sup>i</sup> Claire Anderson, *pers. comm.*  
<sup>ii</sup> *Ibid.*  
<sup>iii</sup> Anderson 1994, 37  
<sup>iv</sup> Claire Anderson, *pers. comm.*  
<sup>v</sup> Woodman *et al.* 2006, 128  
<sup>vi</sup> Green 1980, 2  
<sup>vii</sup> *i.e.* an unfinished arrowhead  
<sup>viii</sup> Woodman *et al.* 2006, 81  
<sup>ix</sup> Although flint dominates the archaeological lithic record in Neolithic times both in County Carlow and further afield, chert was also used extensively in the production of arrowheads. A wide range of other lithic resources was also available and was exploited in the Neolithic, though not to the same extent as flint or chert. Siltstone was used at Ballyglass West, Co. Mayo for the production of a barbed and tanged arrowhead (Fig. 2) found adjacent to a spread of burnt stone and charcoal dated to the Middle Neolithic period (Gillespie 2009, 8).  
<sup>x</sup> Matthew Parkes, *pers. comm.*  
<sup>xi</sup> Pat Doody, *pers. comm.*  
<sup>xii</sup> Topographical Files, National Museum of Ireland  
<sup>xiii</sup> Forsythe and Gregory 2007, 6  
<sup>xiv</sup> Sheridan 1994, 49; Sternke 2012, 11  
<sup>xv</sup> Sternke 2012, 10-11  
<sup>xvi</sup> Waddell 1998, 49  
<sup>xvii</sup> Waddell 1998, 49  
<sup>xviii</sup> Mercer 1980  
<sup>xix</sup> Lynch 1988, 106  
<sup>xx</sup> Topographical Files, National Museum of Ireland  
<sup>xxi</sup> Hackett 2006; Dunne 2007, 66  
<sup>xxii</sup> Sternke 2009, Appendix 8  
<sup>xxiii</sup> Monteith 2008  
<sup>xxiv</sup> Warren forthcoming  
<sup>xxv</sup> Driscoll 2010  
<sup>xxvi</sup> Eogan and Roche 1991  
<sup>xxvii</sup> Large 2004  
<sup>xxviii</sup> Purcell 2002, 39-41  
<sup>xxix</sup> Waddell 1998, 78  
<sup>xxx</sup> Herity 1987, 198-200  
<sup>xxxi</sup> O'Neill Hencken 1939, 84-5  
<sup>xxxii</sup> Lynch 1988, 107  
<sup>xxxiii</sup> Danaher 2004, 20  
<sup>xxxiv</sup> *Ibid.*  
<sup>xxxv</sup> Byrne *et al.* 2009, 6  
<sup>xxxvi</sup> Cleary and Kelleher, 2011  
<sup>xxxvii</sup> Sternke 2011, 241  
<sup>xxxviii</sup> CW018-002001; CW018-002002 and CW018-002003  
<sup>xxxix</sup> Brindley and Kilfeather 1993, 28  
<sup>xl</sup> CW017-056 and CW017-057. National Monuments Service, Archaeological Survey of Ireland



## Dictionary of Irish Biography

Reviewed by Jimmy O'Toole

Both nationally and internationally the publication in 2009 of the Dictionary of Irish Biography (DIB) was greeted by a very favourable media reaction while the book critics were equally enthusiastic, with few criticisms of any consequence being penned. Statistically the nine volume work had just about everything – covering 2,000 years, it includes 9,700 biographies written by 700 contributors. The articles range from 200 to 15,000 words with an impressive eight million word content. On the international stage the Dictionary won the 2009 American Publishers Award for Professional and Scholarly excellence (prose) for best multi-volume work in the Humanities and Social sciences.

The DIB was a collaborative project between Cambridge University Press and the Royal Irish Academy and the editors were James McGuire of University College Dublin and James Quinn of the Royal Irish Academy. Typical of the glowing tributes from critics was this line from the *Sunday Tribune* "...all 7,000 pages of it has just been published to the sound of dropping jaws, purring appreciation and universal acclaim". The historian and academic Diarmuid Ferriter had no reservations either – "It is an indispensable reference work, as well as reflecting a wide definition of what constitutes an historically significant character."

These words may be all very well when the nine volumes are looked at from a national perspective but the acid test of their value, sense of fairness to those deserving mention, and their much talked about "comprehensive nature", can only be properly accessed when analysed on a county by county basis. In Co. Carlow, at least, these tests would leave the DIB coming up short in several of the subject headings set by the editorial team – artists, scientists, lawyers, actors, musicians, writers, politicians, criminals and saints.

The most glaring omission must surely

be that of Pierce Butler (1744-1822) born at the family seat Ballintemple, near Tullow, Co. Carlow, elected to the U.S. senate and architect and signatory of the American Constitution. Butler has been written about extensively on both sides of the Atlantic, and one would have thought a mention in the DIB would have been merited. The nine volumes contain countless lesser known political figures, who would fall far short of Butler's standing on the international stage. Another Carlow-born politician who enjoyed political success out of Ireland was Tom Reid (1881-1963) who was elected a Labour MP for Swindon in Wiltshire in 1945, a seat he held for eight years. Reid was born at Mount View, Grange, Tullow and was one of a family of seven sons. He enjoyed a distinguished career in the British Colonial Civil Service holding several posts in Ceylon (now Sri Lanka). He spent 26 years serving as Mayor and Chief Executive Officer of the capital Colombo and as a member of the Ceylon Legislature in charge of labour affairs. He was primarily responsible for drafting a new constitution under which the island, re-named Sri Lanka, won its independence. He was the last white member of Government and in Colombo a city street – Reid Avenue – is named after him, and he is also remembered on a plaque in Government House. James Wynne (1841-1908) from Slyguff, Bagenalstown, was mayor of Port Elizabeth, South Africa and later held a seat in parliament for the city's North End constituency.

It is difficult to get to grips with the terms of reference set for individual inclusion. For example the way in which Carlow parliamentarians are listed is little short of haphazard. Of the sixteen elected to the House of Commons (3) and Dail Eireann (13) during the 20<sup>th</sup> century, only four are listed. Walter McMurrough Kavanagh, elected unopposed to the House of Commons in a by-election in 1908; James Lennon was in prison when he was elected in 1918 – was re-elected in 1921

and defeated in 1922. In a constituency carve up in the 1930s Carlow was joined with Kildare, Wicklow, and Wexford and in 1938 Paddy Cogan, who lived at Ballykillduff, Tobinstown, was elected for Wicklow and he was re-elected in four subsequent elections before his eventual defeat in 1954. The only other political entry is Tom Nolan, T.D. who was elected for Carlow/Kilkenny on five occasions between 1965 and 1981. He was appointed Minister for Labour in 1980 – the only elected representative from Co. Carlow to hold ministerial office during the 20<sup>th</sup> century.

John O'Donovan's splendid book *Members and Messengers* (Carlow 2003) provides a comprehensive listing of every parliamentarian elected for Carlow during the 20<sup>th</sup> Century. Those, inexplicably excluded from the DIB, were - John Hammond, MP, The Elms, Athy Road, Carlow, elected 1891; 1892, 1895, 1900 and 1906; Michael Molloy, MP, Grange, elected 1910 (Jan and Dec). He was the last MP to represent Co. Carlow in the British House of Commons; Gearoid O'Sullivan, TD, a native of Cork who lived in Dublin, elected 1921 and 1922 for Carlow/Kilkenny and on five subsequent occasions for South Dublin; Patrick Gaffney, TD, Tullow St., Carlow, elected 1922; Ned Doyle, TD, Laragh, Ballon, elected 1923, 1927 (June and September); Thomas Bolger, TD, Downings, Tullow, elected 1925 by-election; Francis Humphreys, TD, Shangarry, Myshall, elected 1932, 1937, 1938, 1943, 1944, 1951 and 1957; James Hughes, TD, Kellistown, elected 1938, 1943, and 1944; Joseph Hughes, TD, Kildrenagh, Bagenalstown, elected 1948, 1951, 1954 and 1957; Desmond Governey, TD, Kilkenny Road, Carlow, elected 1961, 1965, 1969, 1973, 1981 and 1982; M.J. Nolan, TD, Athy Road, Carlow, elected 1982, 1987, 1989, 1992, and 2002; John Browne, TD, Ballinacarrig, Carlow, elected 1989, 1992, and 1997.

From the world of academia the exclusion of Prof. Denis Donoghue is difficult

DICTIONARY OF IRISH BIOGRAPHY

to understand. He was born in Tullow in 1928 and brought up in Warrenpoint, Co. Down where his father served in the RUC. Educated at UCD, he later became Professor of English and American Literature, before taking up the Henry James Chair of English and American Letters in New York University. He has published several books including *Warrenpoint* (1991) a memoir in which he recounted his memories of Tullow. A father of eight, his youngest daughter Emma's book *Room* was one of the works shortlisted for the 2010 Man Booker prize for literature. The omission of Nicholas Aylward Vigors (1785–1840) is another surprise. The Old Leighlin born zoologist and politician was a co-founder of the Zoological Society of London in 1826 and its first secretary until 1833. He succeeded to his father's estate in 1828 and was M.P. for the borough of Carlow from 1832 until 1835. He later served between 1837 to 1840.

Perusal of D. J. O'Donoghue's book *The Geographical Distribution of Irish Ability* (1906) touches briefly on the success stories of several Carlow born talents, some featured in the DIB but many oth-



John Tyndall, FRS

ers now largely forgotten. Among them are Samuel Downing, renowned engineer, John McCall and W.J. Onahan, a notable Irishman in Chicago, who did much for Irish literature. Notable military careerists William Brereton, General Sir Dudley St. Leger Hill and Captain Edwin

Richards, also missed the cut.

Carlow's Hollywood connection is ignored. The murder of top Paramount film director William Desmond Taylor on February 1st, 1922, led to the discovery that the victim's real name was William Cunningham Deane Tanner, who was born at The Elms, Athy Road, Carlow on April 26, 1872. The actor/director appeared in several movies and the shooting that led to his death was never solved. Other names that might have been included were the novelist James Murphy (1839-1921), from Glynn; Edward Murphy (1818-1896) was a native of Ballyellin and was elected to the Canadian Parliament. Mary O'Toole (1874-1957), was a women's rights activist in America and was the first woman to be appointed a judge in the District of Columbia Municipal Court.

Inclusions in the Carlow listing that could cause a raised eyebrow or two include the footballer Tommy Murphy (1921-92) whose address is actually given as Graiguecullen, Co. Laois; William Dargan, railway engineer, believed by many to have been born in Laois; on the other side of the county Charles Guilfoyle Doran (1835-1909) is given a Carlow address but his birthplace at Ardnaboy, Knockananna, is in Co. Wicklow. But there is some good news for those who were omitted. According to Dr. Kevin Whelan in a review of the Dictionary the 9,700 selections were made from a wider database of 60,000 and in his words "...the website will eventually list the unfortunate 50,000 who missed out". One can only hope that some very deserving Carlow names, many more than mentioned in this review, will be favoured with a little space.

Biographical details of the following people linked to Co. Carlow by birth, career or who died in the county are published in the Dictionary of Irish Biography -

Bagenal, Beauchamp (c.1735-1802), landowner and MP born Dunleckney Manor.



Beauchamp Bagenal

Bagwell, Phillippa Jocelyn (c1853 - 1937), philanthropist, and promoter of local industry.

Baillie, William (1723-1810), printmaker and art dealer, native of Kilbride.

Bergin, Liam D (1913-94), newspaper proprietor and editor, born Carlow town.

Bergin, Patrick (1913-1991), trade unionist and republican, born Carlow town.

Brownrigg, Abraham (1836-1928), catholic bishop of Ossory, born Ballypierce, Clonegal.

Byrne, Edmund (c1655/6-1723/4), alias Edward Hamson, Archbishop of Dublin, born Ballybrack, Co. Carlow.

Butler, Richard (1761-1802), 7<sup>th</sup> baronet, MP, was born, probably at Garyhunden, Co. Carlow.

Cloney, Thomas (1774-1850), insurgent leader, and catholic activist, probably born at Ballybeg, near St. Mullins.

Cogan, Patrick (1902-1977), politician, was born at Ballykillduff, Tobinstown

Collier, Peter Fenelon (1849-1909), publisher, and newspaper proprietor, born in Myshall.

Commins, Andrew (1832-1916), barrister and politician, born at Ballybeg, Co. Carlow.



Crosbie, Edward William (1755?-1798), 5<sup>th</sup> baronet, victim of a miscarriage of justice, Viewmount, Carlow.

Dargan, William (1799-1867), engineer, was born in Co. Carlow.

Delany, William (1835-1924), Jesuit and president of UCD was born in Leighlinbridge.

Donovan, Robert (1862-1934) journalist and professor, born in Leighlinbridge.

Doran, Charles Guilfoyle (1835-1909), civil engineer, Fenian, and bibliophile was born Ardnaboy, Knockananna.

Doyne, William Thomas ((1832-77), railway engineer, born Old Leighlin.

Farrell, Michael James (1899-1962), writer, was born in Carlow town.

Haughton, James (1795-1873), social reformer and philanthropist born in Carlow town.

Haughton, Samuel (1821-97), geologist, physiologist, and mathematician was born in Carlow town.

Kavanagh, Arthur McMurrough (1831-89), landlord and politician, born in Borris House.

Kavanagh, Walter McMurrough (1856-1922), landlord, politician and financial

expert, born Borris House.

Keogh, Myles Walter (1840-76), soldier, born at Orchard House, Leighlinbridge.

Kerney, Leopold Harding (1881-1958), diplomat, was born in Carlow.

Lawlor, Edward (1939-99), property developer and philanthropist, born in Tullow.

Lennon, James (1880-1958), republican and advocate of credit reform was born in Borris.

MacDonagh, Oliver Ormond Gerard (1924-2002) historian, born in Carlow town.

McGrath, Joseph (1858-1923) first registrar of the NUI.

Maguire, Nicholas (c1460-1512) bishop of Leighlin and Historian, born Tullamaguinna..

Maher, Anne (Mary Columba) (1777-1855), Dominican prioress.

Maher, Michael (1860-1918), Jesuit priest, philosopher, and psychologist.

May, George Augustus Chichester (1816-92), lawyer, and lord chief Justice of Ireland.

Murphy, John (1753-1798), catholic priest and insurgent leader, executed in Tullow.

Moran, Patrick Francis (1830-1911), cardinal, born in Leighlinbridge.

Nolan, John (Amnesty Nolan) (1846 – 87), nationalist and amnesty activist, born in Ballon.

Nolan, Thomas (1921-1992), politician and businessman, born Cappawater, Myshall.

O'Donohoe, Patrick (1808-54), Young Irishman, was born in Clonegal.

O'Kelly, Denis (Count) (1728-1787), adventurer, professional gambler, racehorse owner and breeder.

O'Meara, Frank (1853-88), landscape painter, was born in Carlow town.

O'Neill, Thomas Patrick (1921-1996),

historian, born in Ballon.

O'Toole, Rose (d.c. 1629), politically significant member of the O'Toole family.

Swayne, Sean (1933-1996), catholic priest and liturgist, born in Julia Creek.

Tyndall, John (1820-93), scientist and mountaineer, born in Leighlinbridge.

Sources - *Members and Messengers*, John O'Donovan, 2003; *The Geographical Distribution of Irish Ability*, D.J. O'Donoghue, 1906; *Carlow's International Achievers*, Jimmy O'Toole, 1999.



## Carlow's Olympic Connections

Jimmy O'Toole

In the four decades since the Munich Olympics sports fans in Co. Carlow will have had more than a passing interest in the fortunes of competitors in track and field, rowing and swimming and for very diverse reasons. The 1972 games saw Carlow's first ever Olympian Sean Drea, from Bagenalstown compete in the single sculls rowing. In 1988 in Seoul T.J. Kearns from Rathvilly carried Carlow hopes in the 110m hurdles, while in the swimming pool that same year his second cousin Gary O'Toole, from Bray, was competing for Ireland. It was in the Seoul Olympics that another name would emerge and whose success as a world famous trainer would continue to endure right up to the London Olympics 2012. That athletics trainer is Bro. Colm O'Connell, a Cork born Patrician Brother, who received his secondary school education at St. Patrick's Monastery in Tullow.

Sean Drea, was born at Wells near Bagenalstown, on March 3<sup>rd</sup>, 1947, and was educated at the local St. Josephs Academy. During an illustrious rowing career in Ireland, specialising in single sculls, he went on to represent his country in world championships and the Olympics. In the Munich games in 1972 he put in a strong performance with a 7<sup>th</sup> place finish. In 1973 he won 1st place at the Henley Regatta, repeating the victory in 1974 and 1975. A record speed he set at Henley was not broken until the 1990s. He brought rowing performances in Ireland to new highs when he won silver in the World Championships in 1975 where he finished second to Peter Michael Kolbe. In 1974 he won the U.S. national championships and he was favourite for the World Championships in Rostee, but had to withdraw to undergo emergency surgery to have a kidney stone removed.

At the 1976 Olympics in Montreal Sean Drea broke the 2,000m world record in



*Seán Drea*

the semi-final with a time of 6:52.46. However he missed out on a medal position, finishing fourth, after a disappointing third quarter performance in the final. Later he spent many years in Philadelphia as a coach with the Fairmount Rowing Association, and one of the highlights of his career there was the coaching of John Riley of the U.S. at the World Championships in 1989 and 1991. He rowed in the Heads of the River Race in 1997 with a veteran Schuylkill Navy Crew.

Today Sean is engaged in farming near

Greystones, Co. Wicklow, and is a regular visitor to the family farm at Wells and is a frequent guest of Carlow Rowing Club, where he is an honorary member. His son Jack is a keen rower and rowed for Oxford Brookes University at Henley in 2004.

T.J Kearns was born in the village of Rathvilly on June 2<sup>nd</sup> 1966, to Jim Kearns and his wife Pauline (nee Bolger, a native of Tullow). After winning a succession of county titles in the 110m hurdles, he repeated these successes at national level, securing sufficient points to represent Ireland at Olympic, European and world championship competitions. Growing up, sport played an important part in the lives of the Kearns family. T.J.'s brother Linus was a key player with the local G.A.A. senior football team, and played for many years on the Co. Carlow senior football championship team .

T.J.'s first appearance in Olympic games was in Seoul in 1988. Four years later in Barcelona he achieved much improved times with a 7<sup>th</sup> placing in the quarter finals. Again in Atlanta in 1996, Kearns secured a third placing in the first round with a time of 13.67. His personal best time of 13.55 was achieved in 1996 - an Irish record he held until his time was overtaken by Peter Coughlan. Apart from his three Olympic appearances T.J.

Kearns represented Ireland at European and World Championships - in the latter event in Tokyo in 1991, he achieved 7<sup>th</sup> position in the semi-finals. Three years later in the European Championships he came in third in the qualifying heats, dropping to sixth in heat two. Now living in Blackrock , Co. Dublin with his wife Emma and four children, he is engaged in property sales valuations and travels extensively in the Middle East.

CARLOW'S OLYMPIC CONNECTION

In the parish of Tullow there was a second interest in the Seoul and Barcelona Olympic Games where Bray swimmer Gary O'Toole represented Ireland. Gary's grandmother was May Kealy, from Crosslow and her sister Anne Kealy was T.J.'s grandmother. Gary's parents Aidan and Kay lived at Charnwood, off Killarney Road, in Bray and it was in the nearby Presentation College Pool that Gary developed his early interest in swimming.

While studying at University College, Dublin, he won a 200m breaststroke silver medal at the 1989 European Long Course Championships in Bonn. He also won a gold medal at the World University Championships in 1991 when representing University College Dublin. He helped break five national relay records, including short course and long course. Since his retirement from competitive swimming Gary has been a practising orthopaedic surgeon with specialist interest in cancer and sports knee surgery, and continues to provide expert analysis for RTE sports programmes. He is married to Sorcha, and have twin daughters Libby and Robyn and the family live in Donnybrook, Dublin.

Bro. Colm O'Connell's teaching career took him to Kenya where the Patrician Order, with its worldwide headquarters in Tullow, open a school at Iten on the rim of the Great Rift Valley in 1961. For the order is was just another of its many schools around the world. But St. Patricks High School, a struggling outpost of education in this vast country, is no ordinary school. It produces more international and Olympic athletes than

other school in the world and much of the credit for that goes to Bro. O'Connell. He is a former headmaster of the school, and continues in the role of athletics coach.

A farmer's son, Colm O'Connell was born in Caherduggan, Co. Cork on 16<sup>th</sup> August, 1948, the second of five children. He entered the Patrician Juniorate at Mount St. Joseph, Tullow in September 1962, and made his first profession at Our Lady of Lourdes, Ballykealy, in August 1965. He sat his Leaving Certificate at St. Patrick's Monastery, Tullow, in 1968 and following his university education in Galway and Maynooth, he was on the teaching staff at Ballyfin College, County Laois and St. Patrick's Secondary School, Newbridge, before he was appointed to Iten in 1976.

The list of international successes by former St. Patrick's boys is impressive. Ninety-five per cent of Kenya's national team come from the area. The country has shone at middle and long distance track events ever since, newly independent, it sent its first team to the Tokyo Olympics in 1964, winning bronze in the 800m. After the Kenyans boycott of the 1976 and 1980 Olympics, it was their dazzling resurgence at the 1988 where they won four gold, two silver, and a bronze that turned the spotlight on their athletics training and in particular the man responsible. That was the year of the drugs scandal involving Ben Johnson of Canada, who was stripped of his gold medal in the 100m. In the months afterwards visiting journalists seeking out the secret of the Kenyans success were told by Bro. O'Connell "Suddenly the Kenyans seemed like a breath of fresh air,

the nice face of athletics. They ran naturally, were very relaxed, and their talent had nothing to do with drugs and steroids. People clutched at that. Suddenly everyone wanted to know Kenya's secret - where the athletes came from how they trained. So it was around that time that reports and cameramen started turning up". Training facilities are still basic at St. Patricks but on the plus side Bro. O'Connell admits the altitude is an advantage, there are no distractions in this remote region, the climate is dry and mild and the boys enjoy a healthy, high protein diet of maize and beans.

At London 2012 another St. Patrick's athlete David Rudisha took gold in the 800m, and set a new world record in the process. The influence of the Kenyan methods is spreading. Mo Farah the Somali born British runner who won gold in the 5000m and 10,000m events in London spent several months training in Eastern Kenya. Since 1976 twenty five world champions and four Olympic gold medallists have come through St. Patricks making Bro. Colm O'Connell the most successful running coach in history. Unique in one other way - he has never been to an Olympic games, watching events instead on a television in a hotel in the nearby village.

Mount St. Joseph, was purchased from the Patrician Order by the Morrissey family in 1994 and has since been developed as prestigious hotel, country club and golf course, with an international visitor clientele. Bro O'Connell was a guest of the Morrisseys on one occasion.



CHAS outing, summer 2012 - Titanic Exhibition, Belfast

## The Wastegrass and its Mass Rock

Christopher P. McQuinn

Situated on a side road off the Tullow to Ardattin road lies the townland known as Crosslow. Here is found a farm called The Wastegrass, which is now owned by Mrs. Mary Moore. On this farm lies an example of one of Ireland's many Mass rocks. The story of this Mass Rock, and that of the Moore family, provides an example of the emergence and development of Irish Catholic culture in Tullow, in the diocese of Kildare and Leighlin, and even in far off Australia.

### Eucharistic Congresses

June 2012 saw the 50<sup>th</sup> International Eucharistic Congress take place in Dublin. Eighty years earlier a similar event took place, just ten years after the trauma of the foundation of the state. The 1932 Eucharistic Congress provided a platform on a national and on a local level to celebrate religious and national identity. In Tullow, on both occasions, a Mass Rock was transported from its home at The Wastegrass (where the Moore and Doyle families have acted as its custodians for



*Mass Rock was displayed in Church of Most Holy Rosary, Tullow, June 2012.*

centuries) to the town. In 1932 the Mass Rock was placed in the Square beside an altar used for Benediction. Three years earlier, in 1929, it was also placed in the Square to mark the centenary of Catholic Emancipation, an event attended by an estimated 10,000 people<sup>1</sup>. In 2012 the Mass Rock was displayed for the duration of the Congress in Tullow's Church of the Most Holy Rosary. The Wastegrass Mass Rock provided a connecting link between the present and the past.

### Historical Background

A Mass Rock (*Carraig an Aifrinn* in Irish) was a stone used in mid-seventeenth century Ireland as a location for Catholic worship. These stones were generally located in isolated places, due to the difficulty and danger involved arising from Cromwell's campaign against the Irish, and the Penal Laws of 1695. Bishops were banished and priests had to register to preach under the 1704 Registration Act. Priest hunters were employed to arrest unregistered priests and Presbyterian preachers under an Act of 1709.

These penal laws were aimed at the elimination of Catholicism as a political force<sup>2</sup>. Papal recognition of the Catholic Stuarts claim to the throne of England resulted in these measures against Catholics, who were regarded as having divided allegiance<sup>3</sup>.

In many instances a stone to serve as the Mass Rock would be taken from a church ruin. Because these services were illegal, they were not scheduled, and their occurrence was communicated by word of mouth between parishioners. Daire Keogh<sup>4</sup> quotes a report to Rome from Bishop Hugh MacMahon of Clogher (1660-1737): "To hear Mass these people must rise early and travel through frost and snow; some of them advanced in years, leave their homes the previous day to make sure they arrive in time and place where Mass is celebrated....Greater

danger, of course threatened the priests, as government persecuted them unceasingly and bitterly, with the result that priests have celebrated Mass with their faces veiled, lest they should be recognised by those present."

James Keeffe, Bishop of Kildare and Leighlin<sup>5</sup> (1702 – 1787) "preached the Word of God incessantly in glens and bogs, for chapels in his time were few and wretched<sup>6</sup>.



*Burial place of Bishop James Keeffe at "The Old Graves", Carlow; the inscription includes the following:*

*"HERE HE DESIRED THAT HIS REMAINS SHOULD BE LAID AMONG THE POOR FOR WHOM HE HAD LIVED AND WITH WHOM AFTER DEATH HE DESIRED TO BE ASSOCIATED"*

Photograph courtesy of Brendan Kealy

The practice of using Mass Rocks waned as the implementation of the penal laws lessened, and they began to be repealed, and as worship moved to thatched Mass houses. Similar stones, known as Mass Stones are found in Scotland.



THE WASTEGRASS AND ITS MASS ROCK



*Mr. Garret Moore points to original location of Mass Rock at "The Camel's Corner". There was a Mass Path stile here also.*

**The Wastegrass Mass Rock**

The Wastegrass Mass Rock was originally sited at The Camel's Corner which lies between three hills bordering The Wastegrass. These hills acted as look-out posts during Mass in penal times. The Camel's Corner is located at the junction of three farms: Moore's The Wastegrass, O'Toole's of Tullow Hill and Leybourne's, Mount Vernon.

The Mass Rock now stands on its end in the ditch of another field, with its top side facing out towards the field. Mr. Garret Moore says that it was placed there prior to his father's time. The top side has a number of carvings: a simple cross, surrounded by the letters "I H S"<sup>7</sup>, and a heart with a cross on top<sup>8</sup>. A square pocket has been chiselled out to contain relics<sup>9</sup>.

Garret Moore (b. 1927) remembers the Mass Rock being loaded, in 1932, onto a horse's cart, by four men using planks, to be transported to Tullow for the Corpus Christi celebration in the Square, as part of the Eucharistic Congress. The men involved were his father, Nicholas Moore and Tom Wheeler (father of Mrs. Lil Maxwell, Pairc Mhuire, Tullow and of Mrs. Mary Cullen, Dublin Road, Tullow) who worked on the farm, and two others.

The Mass Rock had previously been displayed in the Square in 1929 where ceremonies were held to mark the centenary of the Catholic Emancipation Act. The highlight was the Corpus Christi procession, in which an estimated 10,000 people took part. The Mass Rock was positioned on the left, outside the present Bank of Ireland. Garret is in possession of a small stone holy water font, associ-

ated with the Mass Rock. This was also used at the 1929 Centenary Celebrations in the Square; it appears in a photograph taken at the time. The photograph shows the font on the ground in front of the Mass Rock. Above the rock is a portrait of Bishop Daniel Delany<sup>10</sup> who was devoted to the Blessed Eucharist, and organised one of the first Corpus Christi processions in Ireland in 1784. To the left and right of the rock are busts, one of Bishop James Doyle (JKL)<sup>11</sup> and the other of Daniel O'Connell.



*Mass Rock in the Square, Tullow, 1929 for celebrations to mark the centenary of Catholic Emancipation.*



*Bishop Daniel Delany (1747-1814)*



*Bishop James Doyle (1786-1834)*

An t-Ath Peadar MacSuibhne (Fr. P. Swayne), the noted historian, visited The Wastegrass in 1940s with the Tullow Parish Administrator, Fr. James Mahon, a personal friend of Garret's father, Nicholas. On seeing the font, he pleaded to be given it for a museum in Knockbeg College, but without success.

Garret Moore remembers Mass being said at the Rock in his mother's time for the Crosslow people. He thinks it may have been said by one of his brothers, Fr. Nicholas Moore. Fr. Tom McDonnell, then Chaplain to Tullow Community School, said Mass at the Rock, on a number of occasions in the 1980s, for groups of his pupils.

**Doyles of "The Wastegrass"**

In the mid 1800s The Wastegrass was owned by a Mr. Peter Doyle. Three boys lived with the Doyle family, and from there attended the Patrician Monastery School in Tullow to prepare for studies for the priesthood. Peter Doyle promised a gold watch to the first of them to become a priest. The three became priests: Father J. Dawson, S.M., Dublin, Father Patrick Cosgrave, C.C., Ballyfin, who died in 1894, and Father Edward Kavanagh<sup>12</sup>, P.P., Monasterevin, who died in 1925. Fathers Cosgrave and Kavanagh were both from Clonegal and were nephews of Mrs. Doyle. The watch was won by Father Dawson<sup>13</sup>.

The Doyle couple had no family. A niece, Mary, also a Cosgrave, from Orchard, Clonegal, came to live with them. Her uncle, Peter Doyle, was closely re-

THE WASTEGRASS AND ITS MASS ROCK

lated to Bishop Michael Comerford<sup>14</sup>. Mary Cosgrave inherited the farm, and married a Garret Moore from Canon-squarter. They were the grandparents of Mr. Garret Moore, now living at The Wastegrass, Mr. Paddy Moore, Tullow Hill, Mrs. May Fox, Castlebar, Co. Mayo, Fr. Nicholas Moore P.P., Borris, Co. Carlow (d. 2004), Sr. Bernie Moore, Irish Sisters of Charity, Zambia (d. 2007, Dublin), Mrs. Rita Kearney, Kilconnor, Fenagh, Co. Carlow, and Fr. Eddie Moore, P.P., Allen, Co. Kildare. The Moore family were also closely related to Bishop Edward Nolan (1834-1837)<sup>15</sup>. Bishop Nolan's mother was named Mary Moore.



Bishop Edward Nolan (1793-1837)



Bishop Michael Comerford (1830-1895)

**Bishop Thomas Fox**

At Knocklow Bridge stand the ruins of a mill once owned by the Fox family. A stone in the gable wall facing the bridge bears the inscription "TF" – Thomas Fox. A member of the Fox family fell into debt and, on hearing that the bailiffs were on their way from Tullow to arrest him, escaped by foot across Dawson's field on the far side of the river, eventually making his way to Australia. A son of his, Thomas Martin Fox (1893-1967) was ordained a priest, and went on to become Bishop of the Diocese of Wilcannia-Forbes, near Sydney, Australia. His term of office was from 1931 to 1967. Bishop Fox made two visits to the Wastegrass, one in the 1940s, and one during the 1950 Holy Year. He was accompanied by a younger priest. Bishop Fox paid particular attention to the Mass Rock, marking out the inscriptions on it with chalk, before filming the rock.

**Sr. Gertrude (Bridie) Moore**

In September 1894, the not yet seventeen year old Bridie Moore from The Wastegrass set sail for Australia join the Brigidine Sisters. She had been born on 24 October 1877 to Garret Moore and Mary Cosgrave, and was baptised on 28 October by Fr. Patrick Cosgrave, sponsors being Patrick Cosgrave and Winifred Kelly.



Original Moore homestead is now a farm building.

Bridie was reared in the old thatched house, as was the present Garret Moore and his siblings<sup>16</sup>. This building is now used as a shed, but two of its windows and the outline of the house can be seen. It had a sitting room, a kitchen and two

bedrooms downstairs, as well one bedroom upstairs, and a loft for storing apples.

Bridie left Tullow on 5 September 1894 and reached Echuca on 19 October. Travelling with Bridie, were M.M. John (Synon), three professed Sisters: Teresa Flynn, Patrick Flynn and Vincent Crowe, and two other postulants: Norah Cooke and Maryanne Kenny. Bridie had a strong link with Echuca as her aunt, Mother Benedict Moore, was Superior. A second link was that another relative, Bridie Gaynor, was already in Echuca. Her name in religion was Sr. Ursula.

The group travelled first to England, and joined the ship, the *Austral*, at Tilbury, from where they sailed to Australia. Bridie kept a diary of her voyage in two notebooks, and sent them home to her family<sup>17</sup>. These writings give a fascinating account of life on board ship, such as daily Masses celebrated by Irish priests also bound for the Australian mission, the interaction of the nuns with the other passengers at concerts, talent shows and balls ("of course we were lookers on and did not take part in the dancing"<sup>18</sup>), disembarking and sight-seeing at ports of call, including Gibraltar, Naples, Pompeii, Port Said, Suez, Colombo, celebrations and sports (which she took part in) as the Equator was crossed, the birth of a baby girl on board, and the welcome to her new convent home.

Bridie's mother would become very upset when she received letters from her, and would spend the day in a small field near the house<sup>19</sup>.

The following is an extract from *The Brigidine Story Echuca*, which was produced in 1986 to coincide with celebrations to mark the centenary of Echuca's foundation: "Sr. Gertrude Moore was a young Irish girl who came from Tullow to Echuca in 1894 with the intention of entering the Convent. Being rather young she remained in the boarding school until she entered as a postulant in 1897. She was a niece of Sr. Benedict Moore, Echuca foundress. A gentle, lovable personality, she spent her life in Echuca, but died in Mentone in 1922 while convalescing. She had suffered

much from constant illness borne without complaint. Her great educational contribution lay in preparation of teachers for their work<sup>20</sup>.”

Sr. Gertrude Moore was Principal of St. Mary's School, Echuca in 1917, perhaps until 1920<sup>21</sup>. In 1922 she was on the Primary School staff, when owing to ill health she had to give up her duties and go to Melbourne for a complete rest. She had a heart attack while at Mentone, and died on 7 February. Sr. Gertrude is buried at Cheltenham cemetery in Melbourne<sup>22</sup>.

#### Mass Path<sup>23</sup>

A Mass path went through The Wastegrass, passing through Mount Vernon (Leybourne's farm), meeting the Blind Lane at a right angle bend where Jim Murphy's house now stands; one side of this bend goes to Mount Wolseley Village and the other side meets the Shrouhaun. The big field of Leybourne's, through which the Mass path went, was known as the Infirmary Field. If a farmer had an animal that was not thriving he would get permission from Mr. Leybourne to graze it in the field, which would lead to its recovery. In the corner of the Infirmary field was a brick pond where bricks were made in former times. The future Supreme Court Judge John O'Byrne<sup>24</sup> (1884 – 1954), as a young boy, walked daily to the Patrician Secondary School, Tullow, from Killabeg, beyond Coolkenno, over stepping stones across the River Dereen at Tomkin's farm, through Moore's farmyard, and along the same Mass Path.

#### The Journey

The Mass Rock at The Wastegrass has witnessed an important part of the journey of Irish Catholicism: its struggle for two centuries under the Penal Laws, its growth and development as a confident power, its challenges of recent times, its healing and reconciliation as we experience the theme of the 2012 International Eucharistic Congress – “Communion with Christ and with one another”. The

Doyle and Moore families have played their part in this story.

#### BIBLIOGRAPHY

Church of the Most Holy Rosary, Tullow (2005) *Tullow its Church & its People* Publication to commemorate bicentenary of dedication of parish church

Brigidine Post Primary School, Patrician Post Primary School, Tullow (1978) *A Commemorative Magazine*

Brigidine Sisters (1986) *The Brigidine Story Echuca*. Publication to commemorate the centenary of the arrival of the Brigidine Sisters in Echuca, Victoria, Australia

Byrne, E.A. (2012) *Political Corruption in Ireland, 1922-2012 A crooked harp?* Manchester and New York: Manchester University Press

Carlow Historical and Archaeological Society (1989) *Carloviana*

Comerford, M. (1886) *Collections relating to the Dioceses of Kildare and Leighlin Vol.1* Dublin: James Duffy and Sons

McEvoy, J. (1993) *Carlow College 1793-1993*. Carlow: The Carlovian Press

McGrath, T. (1999) *Politics, Interdenominational Relations and Education in the Public Ministry of Bishop James Doyle of Kildare and Leighlin, 1786-1834*. Dublin: Four Courts Press

Moore, B. (1894) *Diary of Bridie Moore, Tullow, Co. Carlow*. Delany Archive, Carlow. Transcript privately published

Nolan, W. and McGrath, T. (2006) *Kildare History & Society* Dublin: Geography Publications

Ryan, E. (1958) *Monasterevin Parish Co. Kildare, Some Historical Notes* Naas: Leinster Leader Ltd.

Ryan, S. and Leahy, B., Editors (2012) *Treasures of Irish Christianity* Dublin: Veritas Publications

#### WEBSITES

[www.delanyarchive.ie](http://www.delanyarchive.ie)

[www.wikipedia.org](http://www.wikipedia.org)

<sup>1</sup> Carloviana (1989), p.17.

<sup>2</sup> Salvador Ryan and Brendan Leahy (Editors), Article by Daire Keogh, *Treasures of Irish Christianity* p. 145

<sup>3</sup> William Nolan and Thomas McGrath (Editors), Article by Thomas McGrath, *Kildare History and Society* p.297

<sup>4</sup> Ryan and Leahy, op. cit., p.146

<sup>5</sup> **Bishop James Keeffe** took his Doctorate degree from the Sorbonne, Paris, and had been parish priest of Tullow, before being named bishop in 1752. (Comerford, *Collections Dioceses of Kildare and Leighlin Vol 1*, p. 83). He continued to reside in Aghade, Tullow. Keeping a low profile due to the penal laws banning bishops, Dr. Keeffe's letters from Rome to him were addressed: “Patrick Keeffe, Shopkeeper, Tullow” and his letters to Rome were signed “ex loco nostri refugii”, i.e. “from our place of refuge.” In his eighties he began the building of Carlow College.

<sup>6</sup> Comerford, *Collections Dioceses of Kildare and Leighlin Vol. 1*, p. 83, quoting Bishop James Doyle.

<sup>7</sup> **“IHS”**: *IHSOUS* (Greek: Jesus) from the first three letters in capitals of the name in Greek alphabet. It can also refer to the Latin: *IESUS HOMINUM SALVATOR* (Jesus Saviour of Mankind – see Wikipedia). Fearghus O Fearghail (Ryan & Leahy - op. cit. p. 140) gives the monogram as Greek, representing a profession of faith in Jesus (*IHSOUS*) as Son (*HUIOUS*) and Saviour (*SOTER*). The reverence and affection with which Christians regarded the Holy Name of Jesus reach back to the earliest days of Christianity. Many religious groups, e.g. the Jesuits, have also incorporated a cross with “IHS” as their emblem. The “IHS”, as on penal wooden crosses, is often accompanied by three nails – one for each hand and one for the feet – incised in a fan shape fashion and pointing to a date. (Ryan & Leahy, op. cit. p. 140). The carving on the Wastegrass Mass rock is very weathered, so there is no evidence of these symbols. But there is space for them.

<sup>8</sup> **The Sacred Heart** is often depicted in

## THE WASTEGRASS AND ITS MASS ROCK

Christian Art as a flaming heart shining with divine light, pierced by a lance-wound, encircled by a crown of thorns, surmounted by a cross, and bleeding. This symbol of devotion to Jesus' love for humanity spread rapidly after the reported visions of St. Margaret Mary Alacoque in France in the late 1600s. Again, the Jesuit order did much to propagate this image. (See Wikipedia).

<sup>9</sup> Traditionally in Catholic worship first class relics of at least two saints, at least one of which had to be a martyr were inserted in a cavity in the altar and sealed, a practice meant to recall the use of martyrs' tombs as places of Eucharistic celebration during the persecutions of the Church in the 1<sup>st</sup> to 4<sup>th</sup> centuries. (See Wikipedia).

<sup>10</sup> **Bishop Daniel Delany** (1747-1814) was born at Paddock, near Mountrath. He was educated in a local hedge school, moving to priestly studies in St. Omer College, France and in College of Lombards, Paris. He was ordained in 1770 in St. Omer, where he served for 7 years as Professor of Rhetoric. Returning to Ireland, he was appointed curate in Tullow and became Coadjutor to Bishop Keefe, whom he succeeded in 1788. Among his achievements were the completion of Carlow College in 1793, the building of Tullow Parish Church in 1805, and the founding in Tullow of the Brigidine Sisters and Patrician Brothers in 1807 and 1808 respectively.

<sup>11</sup> **Bishop James Warren Doyle** (1786-1834), known as JKL, was born close to New Ross. Following his joining the Augustinian Order in 1805, he studied for his Doctorate at Coimbra, Portugal (1806-1808). He served in the Portuguese and British forces opposing the French invasion of Iberia. He was ordained in 1809 in Enniscorthy. Dr. Doyle was Professor of Rhetoric and then of Theology in Carlow College from 1813-1819. In 1819, at age 33, he was consecrated Bishop of Kildare and Leighlin. He was politically assertive, and a prolific writer of books and pamphlets on pastoral, political, educational and interdenominational matters. Dr. Doyle was a powerful ally, and sometime critic, of Daniel O'Connell in the political campaign for Catholic Emancipation, appearing before parliamentary committees of the houses of Lords and Commons in 1825. He helped to establish the National

School system in 1831. In 1833 he completed the construction of Carlow Cathedral, and died the following year.

<sup>12</sup> **Fr. Edward Kavanagh** was ordained in Maynooth in 1873. Having served in various parishes, he was appointed parish priest of Ballon in 1894. During his three years there he added two porches to the Church of St. Peter and Paul, erected a marble High Altar and Reredos, and built National Schools in chiselled granite. He took a strong part in the anti-Parnellite campaign.

<sup>13</sup> Eileen Ryan, *Monasterevin Parish, Co. Kildare, Some Historical Notes*. p. 74-75.

<sup>14</sup> **Bishop Michael Comerford** (1830-1895) was born in Carlow Town. He became parish priest of Monasterevin in 1878 and was named Coadjutor Bishop of Kildare and Leighlin in 1888. He resided in Braganza, Carlow. He was outlived by the aged Bishop James Lynch, whom he had been appointed to succeed. Bishop Comerford published a large amount of material during his life, including the three volume work, *Collections relating to the Diocese of Kildare and Leighlin*, between 1883 and 1886. While Parish Priest of Monasterevin, Dr. Comerford had the Parish Church of Saints Peter and Paul completed, erected parochial residences and Christian Brothers' Schools. He had Carlow Cathedral embellished during his time as Coadjutor Bishop. He is buried in front of the high altar in the cathedral and is commemorated by the Flemish pulpit which was formerly in the cathedral, and which is at present in Carlow Museum.

<sup>15</sup> **Bishop Edward Nolan** was born in Tullow in 1793. His mother, Mary Moore, married James Nolan (b. 1758) in 1787. Dr. Comerford in *Collections, Diocese of Kildare and Leighlin vol.1* p.122 recounts, that while Mary Moore was still a girl, Dr. Keefe, the then Bishop (See note 4 above) gave her an episcopal ring, telling her to keep it for one of her sons who should be a bishop. Edward's mother kept the ring, not mentioning the matter except to her husband. When Bishop Keefe died she gave it to his successor, Bishop Delany, informing him of the circumstances of how it came into her possession. Dr. Delany accepted it, but only on trust, and returned it before his death in 1814. Edward Nolan was educated in Carlow College from an early

age (1804-1811) and in Maynooth, where he was ordained in 1819. He was on the

staff of Carlow College from 1819 to 1834. Dr. Comerford (ibid. p123) deals with his controversy with Bible Society in Carlow, 1824. Professor Nolan was vice-president of the college when Bishop James Doyle (JKL) died in 1834, and he succeeded Dr. Doyle as bishop. He died four years later, at the age of forty-four, a victim of typhus fever caught in the course of his ministry.

<sup>16</sup> Mr. Garret Moore, interview with present writer, June 2012.

<sup>17</sup> Diary of Bridie Moore, Tullow, Co. Carlow, 1894, formerly in the possession of the Moore family, and now housed in Delany Archive, Carlow

<sup>18</sup> Ibid., transcription p.9.

<sup>19</sup> Mr. Garret Moore, interview with present writer, June 2012.

<sup>20</sup> Brigidine Sisters, *The Brigidine Story Echuca*, p. 45

<sup>21</sup> Ibid. p.61.

<sup>22</sup> Ibid. p. 22.

<sup>23</sup> A **Mass path** is a pedestrian track or road connecting destinations frequently used by rural communities, most usually the destination of Sunday Mass. Mass paths typically included stretches crossing fields of neighbouring farmers, and were likely to contain stiles when crossing fences, or plank bridges when crossing ditches.

<sup>24</sup> **Justice John O'Byrne** was from Seskinn, Tinahely. Graduating from The Royal University in 1907 with first place and first class honours he joined the civil service, went on to study law, and was called to the Bar in 1911. He was Attorney General from 1924-1926, having previously been involved in drafting the constitution of The Irish Free State. He was appointed to the Supreme Court in 1940. Justice O'Byrne chaired two enquiries into alleged political corruption: The Ward Tribunal, 1946 and The Locke Tribunal, 1947.

## The Tithe War in north-east Carlow

James P. Shannon

Church tithes were a tax of one tenth of the profits from lands and the stock upon lands, used for the upkeep of the church. First introduced into Ireland during the reign of Henry II, they were not generally applied until the reign of Elizabeth I. There were two types of tithe: *great* or *rectorial*, on corn, hay and wood; and *small* or *vicarial*, on flax, garden produce and potatoes. Pasture land and its produce was exempted from tithes by an Act of the Irish Parliament in 1735.

This tax was extremely unpopular in Ireland for two main reasons. Firstly since the tithe proceeds went, at least nominally, to the upkeep of the Church of Ireland, the majority of the population, who did not belong to that Church, felt that it was an unjust imposition on them. It meant that they had voluntarily to support their own clergy and also by law to support the clergy of the Established Church. Secondly since pasture land was exempt the burden fell entirely on those who tilled their land. Landlords and large-scale graziers thus paid no tithe, while the small tillage farmer and the cottier found their meagre profits being assessed for the tax by the tithe proctor.

It is no wonder then that this tax was bitterly resented and that it was the cause of much complaint and ill feeling over many years. This finally erupted in what was known as the "Tithe War," which was fought between 1831 and 1838. The war started in Graiguenamanagh on 3rd March 1831, when the cattle of Fr. Martin Doyle were seized for tithe by the tithe proctor. Fr. Doyle protested about this and was backed by his bishop, James Doyle, the famous JKL, who issued a pamphlet advocating a policy of passive resistance to tithes.

The anti-tithe agitation soon spread throughout the country. Unfortunately the policy of passive resistance was not always followed and there were a number of bloody clashes. The first of these, at Castlepollard, Co. Westmeath, on May 31<sup>st</sup> 1831, resulted in seventeen deaths.

Then on June 18<sup>th</sup>, at Newtownbarry (now Bunclody), Co. Wexford, yeomen fired into a crowd, killing 17 and wounding 20. On 14<sup>th</sup> December the same year forty policemen clashed with 20,000 anti-tithe demonstrators at Carrigshock, Co. Kilkenny. The chief constable and 16 of his men were killed and seven more were seriously wounded.

The struggle continued throughout the country for the next several years and the north-east Carlow area was to play quite a significant part in it

A public meeting of "the Landowners and Tithe-Payers of the united Parishes of Clonmore, Kilquiggan and Knockballistine" was held on Sunday, April 29<sup>th</sup> 1832 at Killalongford. At least five thousand people attended. Edmond Burke of Liscolman, who chaired the meeting, gave a rousing speech in which he likened the country to "an overburdened and goaded ass obliged to bear two riders" "We must contribute," he said, "to the maintenance of the clergy of the Established Church and the clergy of the religion of the people."<sup>i</sup>

Cornelius Kelly of Clonmore proposed a resolution condemning the tithe system and gave a concrete example of the grievousness of the burden it imposed on the people. The living of Aghold, together with one third of the profits of Mullinacuff, Crecrin and Liscolman, called the vicarial tithe, belonged to the Rev. Mr. Mcgee. Rev. Mr. Morgan, who lived at New Ross, drew the other two thirds of the revenue of the said parishes, called the rectorial tithe. Mr. Morgan pocketed annually £450 from this source. Mr. McGee, by employing "two decent fat proctors", had raised the income from his share from about £350 to at least £650 per year. This meant that the two reverend gentlemen between them were extracting from the union at large a total of eleven hundred pounds a year. Thirty years earlier the total income had been only £500 a year.

A long list of resolutions opposing tithes and committing the people to peaceful means of protest were passed, and published in the following week's "Carlow Morning Post."<sup>ii</sup> One resolution, proposed by Rev. Mr. Healy and seconded by Mr. P. Byrne specifically condemned illegal associations and pledged themselves if such appeared in the area to "assist the constituted authorities in every way we can, to exterminate it from among us."

The following Sunday, May 6<sup>th</sup>, an even bigger meeting took place in the Chapel yard, Hacketstown. The report in the Carlow Morning Post estimated the crowd as "not less than twelve thousand persons." The reporter went on to say, "The utmost good order was observed, and it could not but have occurred to many of the spectators how happily that scene contrasted with the deplorable events which in the days of the rebellion took place on that very spot."<sup>iii</sup> (St. Brigid's Church is built on the site of the military barracks that was attacked in the Battle of Hacketstown. In earlier centuries this was the site of Hacketstown Castle.)

Mr. James Kenny of Kilmacart chaired this enormous meeting and Mr. Matthew Healy acted as Secretary.

The first speaker was the Parish Priest of Hacketstown, Rev. D. Lalor. He condemned the tithes as unjust and urged his people to refuse to pay them. He himself, he said, would do so and the government could seize his goods or put him in jail. If so, he expected that he would come out as good a man as ever. He referred to violent and bloody events in Skibbereen, Newtownbarry and Carrigshock, all caused by the tithe dispute. He urged people to resist the tithe system, but to do so legally. His native Queen's County was currently in a deplorable condition owing to illegal assocons. If any Whitefeet should come among them he advised the people to seize them and give them up to justice. "Go on legally and constitutionally," he said, "and there is no doubt

## TITHE WAR IN NORTH-EAST CARLOW

whatever but you will prosper.”<sup>iv</sup>

Rev. Mr. Molloy followed with advice in a similar vein. He expressed the opinion that if people’s property were seized and sold for tithes it would be a miserable wretch indeed who would bid for it. He referred to Lord Stanley’s Bill, then before Parliament, which would empower the Lord Lieutenant of Ireland to collect the tithes for the parsons. Would the noble marquess who fought so gallantly at Waterloo consent to become tithe-proctor-general? (Cries of “he will not.”) He instanced what had happened at Rathdrum where no one could be found to purchase the cattle seized but two magistrates. He also advised the people to shun illegal associations.

Fr. Lalor then proposed a set of resolutions to be sent to Parliament as “the petition of the Parishioners of Hacketstown, in the County Carlow.” These resolutions were unanimously adopted.

After that Messrs. Shea and Hayden addressed the meeting and “after giving three cheers for King William, three for Old Ireland, and three for O’Connell, the vast multitude dispersed in the most peaceable and orderly manner.”<sup>v</sup>

The Tithe War in the area heated up shortly after that when, on May 16<sup>th</sup>, the sheriff and his bailiffs seized fourteen head of cattle, the property of Mr. Philip Germaine of Lisneveagh, Rathvilly, for arrears of tithes. This was done at the suit of Rev. Mr. Whitty, the rector of Rathvilly. The officers of the law were protected in the execution of their duty by two troops of dragoons, two companies of infantry and twenty-three policemen, all under the command of Major Ryan. Such protection was probably necessary in view of the size of the crowd that assembled to watch the proceedings. As the Carlow Morning Post related, “At three o’clock in the morning fire blazed on every hill and horns were sounding throughout the entire district, extending twenty miles in every direction, and in the morning about twenty thousand persons were assembled.”<sup>vi</sup> Despite the vast numbers of people present no opposition was offered and no insult even was given. The people in vast numbers were adhering admirably to the non-violent policy advised by their leaders.

The sheriff offered the cattle for sale but nobody offered to buy. The sheriff and his numerous helpers and protectors then drove the cattle to Carlow, accompanied by “a tremendous crowd of people which accumulated at every step.”<sup>vii</sup> The cattle were lodged in the yard of Mr. McDowell, the governor of the jail, and the people, on the advice of several Catholic clergymen, went peaceably home.

A fact worth noting is that the cattle were valued at £8 a head, a total of £112, whereas the amount of tithe and expenses owing came to less than £35.

On the following Monday the sheriff again attempted to sell the cattle. The streets leading to the yard where the cattle were held were packed with people, many of whom were making a great deal of noise with tin horns and cows’ horns in order suitably to express their contempt for “the parsons and their armed followers.”

The sale was announced at twelve o’clock amid “the most tremendous and volcanic execrations ever witnessed or heard before.”<sup>viii</sup> At this stage the Sheriff ordered the two bailiffs to drive out the bullocks. There followed a most extraordinary scene, best described in the words of the “Carlow Morning Post”: “to his [the Sheriff’s] great astonishment, and to the utter and ineffable surprise of the whole multitude, Byrne, the senior bailiff refused, threw up his situation, and mixed with the people; the other bailiff could not be found..... When poor Byrne refused, the Sheriff, in a fit of Tory madness, ran at him, and thrusting a sharp stick at his belly, exclaimed in the elegant diction of aristocratic phraseology, “God damn your soul you rascal, go to the devil out of my sight.” All now was cheers, and shouts, and groans, and yells, and horns; Byrne was chaired forthwith, carried through the town, a collection made to reward his honesty, and he is now styled by the people, “the patriotic bailiff.”<sup>ix</sup>

For the rest of that day the crowds remained on the streets, at one time visiting the offices of the “Carlow Morning Post” and giving three cheers for that newspaper. Later Mr. John Reynolds addressed them and urged them to continue to act lawfully and constitutionally. He also

took the opportunity to condemn the activities of some Whitefeet who, he said, had been active in the area. He urged them to follow the advice of their great leader, O’Connell and have nothing to do with such illegal organisations. He also advised that they stay away from arms and from drink.

Monday night passed without incident and again on Tuesday morning the town was crowded by thousands of men. James Caulfield of Levinstown addressed them outside the gaol at eleven o’clock. After him came Rev. Mr. Gahan who urged them to be peaceable and not to attempt the slightest infraction of the law.

At twelve o’clock it was announced that the sale had been postponed until the following morning, whereupon the people dispersed with the intention of coming again in the morning. That night was again quiet.

Wednesday morning again saw enormous crowds of men from many miles around coming in to Carlow. At twelve o’clock the arrival of two thousand Kildaremen was greeted by enthusiastic cheering. At half past twelve Mr. Caulfield again spoke to the assembled masses, pointing out the injustice of the tithe system and also once again imploring them to conduct themselves peaceably and constitutionally.

At half past two the Sheriff sent for Mr. Caulfield and informed him that the bullocks would be either sold or released on the following day.

By ten o’clock on Thursday morning the streets were again crowded and when Mr. Caulfield arrived with his Kildare men around twelve o’clock the crowd was estimated to number twenty thousand. Once again the speeches, delivered on this occasion by Messrs. Lalor, Gahan and Walsh, called on the people to behave peaceably.

At noon the dragoons, military and police were led out to prepare for the sale. Mr. Caulfield and other gentlemen now arranged that the multitude of men would be well away from these, at least twenty perches. They were kept informed of what was happening by Mr. Caulfield and



some others who were continually galloping back and forth between the people and the military. About sixty “respectable and prudent farmers” were “stationed at the place of sale, in order to witness the transaction, and to see the man who would bid.”<sup>x</sup> Eleven magistrates were in attendance, including the two deputy lieutenants of the county.

Immediately before the sale commenced three yeomen were found sitting behind one of the houses in the street where the people were assembled and one of them, named Walker, had a loaded gun in his possession. They were brought before the magistrates, but Col. Bruen decided that no offence had been committed and they were released. The “Carlow Morning Post” commented acidly that “Colonel Bruen decided ..... there was no harm whatever in a yeoman and an orangeman sitting behind a house *privately*, with a loaded gun, in company with two others, and all this occurring during the excitation of a tithe sale. Verily, it looks like a Newtownbarry scheme; but yet we are informed that there has been no offence whatever, and thus Master Walker, the Orangeman, has been acquitted.”<sup>xi</sup>

The Sheriff now drove out one bullock and offered it for sale. There was no bidder and so “after a solemn pause and much writhing and gnashing of teeth among the shoneens, the poor bullock is remanded back again to prison, and the sale adjourned till Friday at one o’clock!”<sup>xii</sup> When Mr. Caulfield conveyed this news to the crowd a wild shout was raised by the vast crowd, and the people then dispersed peaceably, with the intention of attending again on the morrow.

By the time appointed for the auction on Friday the town was even more crowded. The multitude on this occasion was reckoned to number fifty thousand. Once again Mr. Caulfield and his assistants ensured that a wide space separated the people from the military and this time the additional precaution was taken of posting men behind the houses “to prevent any of the yeomen from firing among the military and thereby causing a riot and slaughter.”<sup>xiii</sup> Obviously the yeomen were not trusted. On the other hand the commander of the regular troops, Major Ryan, was praised by the “Carlow Morn-

ing Post” for “acting his part in a most impartial and honourable way; he seems to have nothing to do with the bullocks or the tithe party – he is merely in the capacity of commanding officer, and possesses fully the confidence of the people.”<sup>xiv</sup>

The same paper commented on the sobriety of the people, “not a glass of whiskey drunk in town as yet - .... The priests are doing their duty”

The cattle were now brought out. Again no bidder could be found. The sale was abandoned and Mr. Germaine was asked to drive home the bullocks.

At this point Major Ryan spoke to Mr. Caulfield, Mr. Germaine and other leaders and expressed a hope that the peaceable conduct of the last six days would continue; that there would be no exhibition or procession of bullocks through the town, and that no injury would be inflicted on the property or person of Mr. Whitty.

The bullocks were now freed and “the whole multitude accompanied them out of town without any exhibition save the triumphant acclaim which was raised by fifty thousand men as they went along. The bullocks were all *crowned* with laurels on leaving the town and followed home by ten thousand men from Rathvilly and the neighbourhood.”<sup>xv</sup>

Despite the remarkably peaceable behaviour of such vast crowds the authorities were evidently still fearful of some kind of violent revenge being attempted against Rev. Mr. Whitty. A brief item in the “Carlow Morning Post” of Thursday, May 31<sup>st</sup>, 1832, is worth quoting in full. Under the heading “Parson Whitty” the story ran: “This meek divine is now under the protection of six policemen: we should have said five, for one of these worthies being a papist, was removed, as being an unsafe guardian for the Reverend Apostolic Minister. Ha! Ha! Ha!”

A better proof of the baneful effect of the tithe system on inter-denominational relations could hardly be found.

The next major event in the Tithe War in the area occurred on the estate of the

wonderfully named William Wentworth Fitzwilliam Hume of Humewood, Kiltegan. There was a curious history to the tithes of Kiltegan parish. About forty years earlier the tithes of the parish had been rising and had reached a level considered by the people to be grievously oppressive. Accordingly a plan was worked out to prevent their future increase. The Mr. Hume of that time, landlord of the Humewood estate, was asked to purchase in his own name the legal right of collecting the tithes of the parish thenceforward. This he did, for the sum of fifty pounds per annum.<sup>xvi</sup> The tenants breathed a collective sigh of relief, confident that Mr. Hume would see them right and that there would be no further increases in the burden of tithe.

Alas for their hopes! Mr. Hume gave the right to collect the tithes as part of his daughter’s dowry to his son-in-law, a Protestant minister, who raised the sum collected annually to over £400. This son-in-law was now dead and the tithes had reverted to the current Mr. Hume, he of the many names, who now set out to exact from the recalcitrant tenants what he considered his due.

Mr. Hume was helped in his efforts by a body of cavalry that arrived in Baltin-glass on Sunday November 11<sup>th</sup> and also by “the police of the district, the infantry, previously stationed in the town, a body of rifles from Hacketstown, and some orange bums from Orange Donard.”<sup>xvii</sup> All of this help achieved very little. The entire day on Monday, November 12<sup>th</sup> “was spent in marching and just at nightfall an old horse and some four or five pigs were marched into Baltinglass in solemn procession and lodged in the pound by the very heroes, probably, who vanquished the immortal Bonaparte on the plains of Waterloo. The medals, however, were not worn on this occasion.”<sup>xviii</sup>

On the succeeding days Mr. Hume’s efforts continued. On the Tuesday the combined forces gathered a total of “one cow, one car and three sacks or bags.”<sup>xix</sup> And so the campaign went on. Failing to find sufficient livestock or other easily portable goods to seize, Mr. Hume was at last reduced to seizing the corn and hay in haggards.

## TITHE WAR IN NORTH-EAST CARLOW

After a fortnight of this he proceeded to sell the seized goods by auction on Monday November 26<sup>th</sup>. On that day eight pigs were sold, being bought back by their owner for the amount of his tithe, £4- 12s, plus costs of 7s 6d.

At this stage three floats, or carts arrived, sent from Dublin by Thomas Rhames, 12, Whitefriar St., to take away whatever of the seized property might be bought by the bum-bailiffs<sup>xx</sup>. When the drivers of these carts saw what was happening they attempted to withdraw, but were prevented by the police from removing the horses or floats. The drivers then refused to have any more to do with such activity and returned to Dublin by the coach, presumably at the cost of their jobs.

The auction continued on the Tuesday, when five sacks of oats belonging to William Donegan of Deansfort, valued at £5 16s were sold to one of the bailiffs for 5s. A cow belonging to James Whelan of Rathdangan, value £6 10s went to the same man for £1. The entire haggards of six farmers were purchased for the owners.

More than two thousand people attended this sale. The Roman Catholic clergy of the parish were there to ensure that no breach of the peace would occur and they were successful in their efforts. Everything went off quietly.

The "Morning Post" on Monday, December 3<sup>rd</sup> 1832 carried a long article on Mr. Hume's campaign in which he was cuttingly portrayed as "a champion of the militant church as by law established in Ireland." "The invaluable blessings resulting to a neighbourhood from a natural protector being resident on his estate," said the author, "is now being every day more manifest in the splendid achievements of this most just, and prudent, and philanthropic gentleman." The article went on sarcastically to make the point that Mr. Hume's tithe-gathering efforts were costing far more than was being gathered: "Here is a highly respectable, and as all his neighbours know, a most wealthy gentleman, undertaking a tithe campaign. In the short space of only three weeks, and with the assistance of about three hundred soldiers, he is able, by tithe seizures and auctions, to realise a sum

amply sufficient to cover fully, or nearly fully, one shilling in the pound of his expenses – having the honour and glory and popularity of his campaign as more than adequate compensation for the remaining nineteen."

On Saturday, December 1<sup>st</sup> the tithe collectors were at Rathdangan, where they found the people totally unwilling to bid for the seized corn. Two stacks of corn were purchased by the bum-bailiffs and then, after Mr. Hume had consulted with the Magistrate in attendance, it was decided to burn the corn. The bailiffs carried it outside the haggard and one Twamley ignited it. One of the bailiffs threw some of the burning corn at some of the women present. It was evident that the people were deeply outraged by the wanton destruction of the corn, but "Notwithstanding these provocations, the previous irony of the magistrate, and their own excited feelings, the people preserved their peaceful demeanour and loyal conduct."<sup>xxi</sup>

On the following Tuesday a haggard at Tynneclash, valued at £40 was sold to Hume for £2, another at Portrishen, valued at £70 went to Twamley for £1. 15s. After that the tithe collectors moved to Cornawn Hill where a large crowd awaited them. Four haggards were auctioned here and despite the size of the crowd and the smallness of the police escort on the occasion there was no trouble.

On Thursday December 13<sup>th</sup> the "Morning Post" went so far as to confer on Mr. Hume a new title, "Willy the Wisp." In doing so the paper announced, it was "impelled by an admiration of the grand and ample scenes we have witnessed these days past of military revolutions and conflagrations of corn haggards, in which our Captain acted a very conspicuous part; we have presumed to follow the example of our ancestors, in conferring a name that epitomises the history of the magnificent victory gained over the Idolatrous Papists of this neighbourhood." There had been an incident, the writer reported, when one of the military knocked down with his musket an offending countryman. This led to some agitation and the situation might well have got out of hand, "but the interference of the officers and the active exertions of the

Rev. D. Lalor, P.P. of Hacketstown, restored tranquillity."

The officers and Fr. Lalor were greatly helped in their endeavours by the appearance on the scene of "our County and Borough candidates, Messrs. Blackney, Wallace and Vigors, accompanied from Rathvilly by nearly one hundred freeholders on horseback and a vast number of the boys on foot, who unharnessed the horses and drew the coach into Hacketstown, amidst the most joyous acclamations." Each of the candidates addressed the assembled people, who then "returned home in the most peaceful and orderly manner, after drinking a few barrels of Carter's strong ale, ordered them by Mr. Vigors."

The policy of peaceful resistance was holding, but only just. One gets a definite impression that, but for luck, a very ugly incident might well have developed on this occasion

At Baltinglass fair on Saturday 8<sup>th</sup> December "some tithe pigs were discovered to be offered for sale; in a few minutes the fair business was abandoned, and all eyes were anxious to see these extraordinary animals, but in vain; they were run by themselves at a most furious rate, nearly a mile out of town."<sup>xxii</sup>

Agitation continued throughout Ireland and by 1833 arrears of tithes were calculated to amount to more than £1,000,000. The cost to the state of enforcing the payment of tithes was proving prohibitive; the cost of collecting £12,316 in arrears in the year 1831 had been £26,000. Clearly this was not sustainable, and the leaders of the anti-tithe campaign were hopeful that if the pressure could be kept up and violent action could be avoided that the sheer cost to government would eventually force a solution. By 1834 the government was ready to make a serious effort. In February of that year the Chief Secretary, Edward John Littleton, introduced a bill for the commutation of tithes into a land tax payable to the state. This would eliminate the hated tithe proctors and the tithe farmers, and was thus acceptable to Daniel O'Connell and the other leaders of the anti-tithe agitation. However the House of Lords defeated the bill and the government of Lord Grey resigned, to be replaced by a new adminis-

tration led by Lord Melbourne.

The rejection of the bill caused the Carlow "Morning Post" to prophecy that "tithes are now extinct in good earnest. The people will not pay, the government will not interfere, and thus through the unexampled folly of the hereditary legislators the unfortunate parsons will fall victims to starvation."<sup>xxiii</sup>

The Tithe war raged on throughout the country and this same year saw two notorious incidents. At Doon, Co. Limerick there was a riot when the local Church of Ireland rector seized for tithe, and offered for sale, the cow of a Catholic priest. At Rathcormack, Co. Cork, when the Archdeacon of Cloyne, Rev. William Ryder, entered the home of a widow, Mrs. Ryan, in pursuit of forty shillings in tithe there was a confrontation between local supporters of Mrs. Ryan and the troops of the Royal Irish Dragoons and the 29<sup>th</sup> Regiment. Nineteen people were killed and thirty-five injured. This "Massacre of Rathcormack" proved to be the last fatal incident in the Tithe War, but the dispute itself was much inflamed by the deaths and it was to take several more years before a solution was finally found.

Meanwhile much sectarian bitterness had been stirred up, and many regrettable, if non-fatal, consequences were to follow. In the year 1834 seventy-one people were evicted from their holdings in the townland of Ballybrack on the estate of Mr. Ralph Howard, M.P. for Co. Wicklow. They were listed in the "Morning Post" as: -

Widow Lyons, one son and one daughter.  
Widow Whelan, one daughter and four sons.

Another Widow Whelan, one son and three daughters.

Patrick Lyons and wife, one son and one daughter.

Thomas Boland and wife, and four sons.

Thomas Whelan and wife.

Thomas Neill and wife, three sons and three daughters.

James Whelan and wife, and five sons.

Michael Neill and wife, two sons and four daughters.

Joseph Farrell and wife, two daughters and one son.

Thomas Whelan and an aged aunt.

John Fitzgerald and wife, one son and one daughter.

Michael Heron and wife, one son and one daughter.

James Whelan and wife, two sons and five daughters.

A number of new tenants were installed, described by the "Leinster Independent" as "three or four orange tenants, who, ever since, for want of means, have been forced to let their new farms in *con-acres*, and to take in as grazing cattle the stock of the former tenants."<sup>xxiv</sup>

Colonel Howard's agent eventually reinstated some of the evicted families as tenants. This led to bad feeling between these families and those of the evicted who had not been so fortunate. On a Saturday night in early February 1835 a desperate quarrel occurred between the two groups and they beat each other severely on the road. On the Sunday morning one of them, "a man named Martin Whelan, was found with his head nearly cloven in two, it is supposed, from the blow of a spade."<sup>xxv</sup> The coroner's jury brought in a verdict of "found killed by some person or persons unknown."

Around the same time as the Ballybrack evictions, in the townland of Barraderry the following people were evicted by the Rev. Mr. Westby: -

Widow Farrell, two sons and two daughters.

Widow Farrell, four sons and three daughters.

Another Widow Farrell, three sons and one daughter.

Thomas Higginson and wife, three sons and three daughters.

William Haydon (a blind man) and wife, and three sons.

James Farrell and wife, one son and two daughters.

John and Henry Haydon, two brothers.

Joseph Bulger and wife, three sons, five daughters and one brother.

James Goss and wife, two sons and three daughters.

Mary Toole and her son, both persons of weak intellect.

There was also a report of evictions on the estate of Lady Elizabeth Strafford, daughter of the late Earl of Aldborough.<sup>xxvi</sup>

Partly as a response to these evictions and partly to advance the anti-tithe cause a large public meeting took place on Sunday December 14<sup>th</sup> 1834 on the Hill of Rathduffmore, about two miles from Hacketstown. The stated purpose of this gathering was to deliberate "on the propriety of addressing the King for the dismissal from his Majesty's councils of the Duke of Wellington, the enemy of every species of reform in Church and State, and taking to his councils the tried friends of the Throne and the people." Also "to petition the legislature for the total abolition of Tithes, and for the enactment of remedial measures to protect the people from the exterminating system which many of the Landlords of the country have lately adopted towards their tenantry."<sup>xxvii</sup>

Thomas Byrne chaired this meeting and Daniel Shea acted as Secretary. The meeting was very well attended; the ground on which the people stood was measured before the meeting broke up and found to measure 21,168 square feet. Allowing two square feet per person, the "Morning Post" calculated the attendance as 10,584,<sup>xxviii</sup> "all of whom conducted themselves in the most peaceable and orderly manner."

Prominent among the platform party were the parish priests of Hacketstown, Fr. Denis Lawler, and of Baltinglass, Fr. Daniel Lawlor, as well as Mr. Roach, Chief Constable of Police, whose conduct the "Morning Post" was pleased to report was "most gentlemanly." That paper also noted that there had been several policemen "in coloured (presumably plain) clothes" among the crowd. These also "conducted themselves very properly; they appeared rather spectators than otherwise."

The first speaker was Rev. Denis Lawler. The respect and esteem in which this man was held by his parishioners was evident in the hearty cheering that greeted his standing up to speak and continued at appropriate times during his remarks. He was indeed a very able man and earlier that year had been one of the three priests named on the terna by the pastors of the diocese for appointment as co-adjutor to JKL.

## TITHE WAR IN NORTH-EAST CARLOW

Fr. Lawler delivered a lengthy and very able speech in which he outlined the whole history of Tithes from the time of Charlemagne down. He condemned the present system of Tithes as an unjust and oppressive tax on the seven and a half million Catholic Irish who were compelled to pay the parsons for ministering to the other half million, and he went on to advocate that the meeting petition the Parliament to abolish Tithes altogether and that the King be petitioned to get rid of the Tory government.

Fr. Lawler was followed by Mr. M. Furlong who proposed to the meeting an address to the King in which was set forth the arguments against Tithes. Several other speakers followed, among them Rev. Daniel Lawlor, and Mr. Daniel Shea. The meeting passed a number of resolutions along the lines suggested by the organisers.

Rev. Denis Lawler again addressed the multitude before the end of the meeting. He highly praised the services of Daniel O'Connell and "proposed that they show their gratitude in some substantial manner. He would, he said, commence by his subscription of £1, and trusted the landholders of the parish would follow his example. He then proposed three cheers for the King, three for Daniel O'Connell, and three for the total and unqualified abolition of tithes. After which the meeting separated in the most orderly and peaceable manner."<sup>xxix</sup>

It was noticeable that the agitation was being led to a great extent by the Catholic clergy, as indeed was to be expected given the political and social conditions of the time, given also the fact that this entire anti-tithe protest had been started in the first place by the Graiguenamanagh priest with the support of his bishop, JKL.

It was also noticeable that the clergy were very concerned that the campaign should not be allowed to get out of hand and that the people should be careful to stay within the law. Thus we find in December 1835 when a large meeting of the people of the Kiltegan area assembled to protest at the enforcement of tithes, their parish priest, Rev. Fr. Cullen of Rathvilly urged them to be "scrupulously observant

of the law, and in no instance to allow their abhorrence of the [tithe] system to lead them to the commission of crime."<sup>xxx</sup>

That same month, December 1835 nearly two hundred Catholic tenants were evicted from the lands of Mr. Brewster at Haroldstown. A Protestant landowner, Mr. Myles Young of Ballykilduff, took pity on their destitution and in the words of the *Leinster Independent*, "invited them, one and all, to take possession of his out-offices, which were at once extensive and commodious; and here the poor people are welcome to remain until they can settle in some other domicile. Mr. Young has also offered such of them as choose to accept it, a rood of land to each family, at a moderate rent, to build a house; and to such as cannot pay rent, a spot for a house, without any charge."<sup>xxxi</sup> The paper highly praised this "act of benevolence and charity" as "humane and Christian conduct of a respectable Protestant landholder."

The year 1836 saw the foundation by Daniel O'Connell of the Reform Registry Association and once again the clergy were active in leading the formation of local clubs to further the aims of the new organisation and to raise funds for its support through the collection of the "Justice Rent". Fr. Lawler chaired a meeting for this purpose at Hacketstown on August 29<sup>th</sup>, and a public meeting on the subject was held on August 1<sup>st</sup>, Fr. Lawler again in the chair. This meeting was addressed by Mr. Mara from the Dublin headquarters of the Association, who went on the same day to address similar meetings in Rathvilly, Tullow and Myshall.

However that was practically Fr. Lawler's last act of leadership in Hacketstown, because he was transferred to Bagenalstown shortly thereafter. The parishioners of Hacketstown showed their esteem for him by inviting him back to a public dinner in his honour on Thursday November 17<sup>th</sup>.<sup>xxxii</sup>

Finally the government found a workable solution to the long running tithe conflict when they passed the Tithe Commutation Act in 1838. Under this act the tithe was reduced by a quarter and became a rent charge payable by the head landlord who

was allowed to pass the charge on to his immediate sub-tenants by way of an increase in the rent. This did not eliminate the hated charge entirely, but it did reduce it and it did get rid of the tithe proctor and the tithe-farmer and so a weary country was prepared to accept it as a tolerable compromise.

This outcome, although short of outright victory, must be seen as quite a triumph for O'Connell and his staunch allies the Catholic clergy. They had succeeded in harnessing the power of public opinion and using it to force the establishment to change an unjust system. Even more remarkably they had managed to persuade the people, in the face of galling provocation, to remain within the law (for the most part – there were acts of violence – see footnote).<sup>xxxiii</sup> To bring together crowds of such magnitude and to keep them peaceable and orderly despite the festering sense of grievance felt by so many was an outstanding feat of leadership. Their victory was not total, but it nevertheless was a real victory, and in the winning of it the people of north-east Carlow had played a valiant and honourable part.

<sup>i</sup> Carlow Morning Post, May 3, 1832

<sup>ii</sup> *ibid.*

<sup>iii</sup> Carlow Morning Post, May 10, 1832

<sup>iv</sup> *ibid.*

<sup>v</sup> *ibid.*

<sup>vi</sup> Carlow Morning Post, May 21, 1832

<sup>vii</sup> *ibid.*

<sup>viii</sup> Carlow Morning Post, May 24, 1832

<sup>ix</sup> *ibid.*

<sup>x</sup> Carlow Morning Post, May 28, 1832

<sup>xi</sup> *ibid.*

<sup>xii</sup> *ibid.*

<sup>xiii</sup> *ibid.*

<sup>xiv</sup> *ibid.*

<sup>xv</sup> *ibid.*

<sup>xvi</sup> Carlow Morning Post, November 15, 1832

<sup>xvii</sup> *ibid.*

<sup>xviii</sup> *ibid.*

<sup>xix</sup> Carlow Morning Post, November 29, 1832

<sup>xx</sup> *ibid.*

<sup>xxi</sup> Carlow Morning Post, December 10<sup>th</sup>, 1832

<sup>xxii</sup> Carlow Morning Post, December 13<sup>th</sup>, 1832

<sup>xxiii</sup> Carlow Morning Post, August 16<sup>th</sup>, 1834.

<sup>xxiv</sup> *Leinster Independent*, February 14<sup>th</sup>, 1835

<sup>xxv</sup> *ibid.*

<sup>xxvi</sup> Carlow Morning Post, November 1<sup>st</sup>, 1834

<sup>xxvii</sup> Carlow Morning Post, December 20<sup>th</sup>, 1834.

<sup>xxviii</sup> *Ibid.*

<sup>xxix</sup> *Ibid.*

<sup>xxx</sup> *Leinster Independent*, December 5<sup>th</sup>, 1835

<sup>xxxi</sup> *Leinster Independent*, December 18<sup>th</sup>, 1835

<sup>xxxii</sup> *Leinster Independent*, November 12<sup>th</sup>, 1836

<sup>xxxiii</sup> Lord Gort, speaking in the House of Lords, said that in 1832 alone there were 242 homicides, 1,179 robberies, 401 burglaries, 568 burnings, 280 cases of cattle-maiming, 161 assaults, 203 riots and 723 attacks on houses, all directly attributable to tithe-enforcement.

## The History Festival of Ireland

Turtle Bunbury

### PERSONAL THOUGHTS

My brother Andrew first fired the idea of a history festival at me in November 2012. I then span it over to Hugo Jellett, the incoming CEO and Artistic Director at the Eigse Carlow Arts Festival. And Hugo passed it right back to me and challenged me to get a show up and running.

Getting a good selection of speakers was all important so I was very fortunate indeed when people like Diarmaid Ferriter, Kevin Myers, Catriona Crowe and David Norris agreed to come on board. I also struck lucky when both Myles Dungan and Patrick Geoghegan, rival radio historians at RTE1 and Newstalk, gave the weekend the thumbs up.

By the time I had twelve good speakers on board, I felt able to relax. In the end, I think we had close to thirty speakers so there was a great diversity of minds, although not enough women speakers. There were some events where there were too many speakers, and other events where the speakers were effectively of the same opinion. I hope we've learned how to redress these conundrum and I'm confident that we get a date pinned down soon, we can get an equally good line up of historians, both Irish and international, pinned down for 2013.

There's no point hosting a festival if people don't know you're having it. As well as Facebook and Twitter, we garnered some key support from the media, which helped get the word out to historical enthusiasts across the country. By the time, the weekend finally came, the festival was already a household name for many people, thanks to some excellent coverage in the Carlow Nationalist, Carlow People, Irish Times, Examiner and Sunday Independent, as well as on local and national radio, and from Tommy Graham of *History Ireland* magazine.

The incessant rains looked set to be our greatest challenge and we were desperately worried that the lawns where

the marquee stood would become mud tracks. However, the Victorians who laid down the lawns at Lisnavagh knew all about drainage and despite the festival coming in one of the wettest weeks of the year, the water had virtually all drained away by the time the first guests arrived. And, as it happened, the sun shone for most of the weekend.

Maintaining a festive ambience was also a challenge because history has a habit of being desperately serious. However, I think we managed a reasonable balance and a strong sense of humour pervaded between matters stern and solemn. As curator of the event, I missed just about every talk apart from the two I

c/o [history@turtlebunbury.com](mailto:history@turtlebunbury.com) and for those who attended the 2012 event, I hope you enjoyed the show.

### THE HISTORY FESTIVAL WEEK-END

On the weekend of 9-10<sup>th</sup> June 2012, Lisnavagh House hosted the inaugural History Festival of Ireland. Blessed by one of the few sunny spells in an otherwise rain-lashed summer, upwards of 600 people arrived at the Victorian mansion to enjoy two days of non-stop historical entertainment – debates, presentations,



Lisnavagh House Photo: Greg Denieffe

was actively involved in. That was a downside for me personally, but it was terrific to watch everyone spilling out from the various talks looking satisfied, and clearly there was a wonderful ambience about the event, as evidenced by the incredible applause – see [http://www.turtlebunbury.com/historyfestival/2012/festival\\_intro.html](http://www.turtlebunbury.com/historyfestival/2012/festival_intro.html) - which concluded that the event was 'a roaring success'.

We'll aim to mirror that in 2013. We'll conjure up another raft of talks and debates, bringing in a little more audience participation. We will probably introduce a genealogical angle for 2013 also as family history is of such exceptional interest to people these days.

If anyone else has any suggestions, I'm always game on to hear them

readings and performances. There were two venues – the handsome oak-panelled library in Lisnavagh House, and an elegant canvas marquee on the lawn wherein the guests sat on church pews.

### SATURDAY

The first debate in the library considered the wisdom of the government's plan to stop history from being a compulsory subject on the junior curriculum from September 2014. The intended chair was Catriona Crowe of the National Archives. Unfortunately she and speaker Diarmaid Ferriter had a flat tyre and then got a little lost so, much to their disappointment, they missed most of the talk. As Diarmaid said when he finally took his seat,

## HISTORY FESTIVAL

'at least we weren't headed to the inaugural geography festival'. In their absence, Myles Dungan of RTE One's 'The History Show' took the chair, while travel writer and documentary maker Manchán Magan and art historian Robert O'Byrne debated the merits of learning history at school.

Meanwhile, events in the marquee kicked off with a presentation entitled 'Hidden Gems and Forgotten People' by Larry Breen of the Federation of Local History Societies ([www.localhistory.ie](http://www.localhistory.ie)) and Pat Devlin of the Federation for Ulster Local Studies ([www.fuls.org.uk](http://www.fuls.org.uk)). This focused on the extraordinary breadth and depth of local history across Ireland, and ways in which lesser-known stories could be brought to light.

The local history talk tapered neatly into a presentation by Marian Lyons, Professor of History at NUI Maynooth, about the upcoming year of the Gathering, a tourism initiative to bring the Irish diaspora from across the world back to Ireland in 2013.

Many of the Irish who emigrated to North America in the mid 19<sup>th</sup> century were invariably drafted into the opposing armies during the American Civil War. Their fate was the subject of a Hedge School, or round-table panel discussion, chaired by Tommy Graham of *History Ireland* magazine, and featuring Myles Dungan, Tom Bartlett, Lar Joye and Jack Burtchill.

Back in the library, the second debate was underway with Senator David Norris in the chair. The subject was the British Empire and whether it could have existed without the Irish contribution. The topic was hotly debated by the *Irish Independent*'s Kevin Myers, Professor Micheál Ó Siochrú, and Patrick Geoghegan from Newstalk's 'Talking History' radio show. The congregation also enjoyed a soliloquy from the chairman about his recent campaign to become 9<sup>th</sup> President of Ireland.

In the marquee, a series of readings and presentations got underway' lead off by British military historian Josh Levine who told the extraordinary story of 'Operation Fortitude', an Allied plan to confuse the Germans into thinking the D-Day landings would take place around Calais rather than Normandy. Former BBC correspondent Maurice Walsh then spoke about 'The News from Ireland', his project to examine how foreign corre-

spondents reported on the Irish War of Independence. Stuart Rosenblatt explained how the Irish Jewish Family History Database was compiled. And finally Ann Matthews gave a presentation on Cumann na mBan and the misuse of the International Red Cross insignia in 1916.

Did any of the villains of Irish history have any virtues? Or were there any virtuous Irish heroes who were really villains? Such was the challenge laid down to five historians who gave back-to-back 15-minute talks on 'Five People Who Put the Hiss into History'. The talks were by Patrick Geoghegan (Lord Castlereagh), Ruth Dudley-Edwards (Constance Markiewicz), Micheál Ó Siochrú (Oliver Cromwell), Tommy Graham (Francis Higgins aka 'the Sham Squire') and Martin Nevin (Dermot MacMurrough, King of Leinster), while the chair was ably filled by Paddy Cullivan, leader of 'The Late Late Show' House Band and resident Satirist with the Leviathan Political Cabaret.

Paddy Cullivan then went to the marquee to entertain guests with his Alternative History of Ireland, told through maps, slides and songs such as 'Going Forward' and 'She's a Model and she works in Spar'.

The fourth and final Saturday debate sparkled in the library with chairman Diarmaid Ferriter inviting Ruth Dudley-Edwards, Myles Dungan, Manchán Magan and the Daily Beast's Royal correspondent Tom Sykes to muse upon whether Queen Elizabeth II's visit to Ireland in 2011 was truly historic, or just an elaborate trade and public relations stunt?

## SUNDAY

Sunday morning in the marquee began with a focus on how to record and chronicle local and family history. Manchán Magan joined Ida Milne, Mary Muldowney and Regina Fitzpatrick of the Oral History Network Ireland as they explained the thinking behind their campaign 'Turning Talk into History'. Robert O'Byrne then interviewed festival curator Turtle Bunbury about the ongoing Vanishing Ireland project, and its companion piece, Vanishing Carlow, which was on exhibition at the GBS Visual Arts Centre in Carlow from 9<sup>th</sup> June until 26<sup>th</sup> August.

By midday, the Lisnavagh Library was fizzing along as Maurice Walsh steered Ruth Dudley-Edwards and Kevin Myers through a discussion called 'What has the Catholic Church ever done for us?', aided and abetted by some useful audience participation.

This was followed by another five back-to-back 15 minute presentations on some of the 'Unsung Heroines' of Irish history, chaired by Fiona Fitzsimon of Eneclann and featuring Catriona Crowe (Hilda Tweedy), Sr. Maura Duggan (the Dominicans of Bagenalstown), Maurice Walsh (Rosamund Jacob), Turtle Bunbury (Lola Montez) and Robert O'Byrne (Maria Edgeworth).

Over in the marquee, Tommy Graham ignited a second History Ireland Hedge School, this time focusing on ways in which the 1000<sup>th</sup> anniversary of Brian Boru's history over the Vikings at Clontarf might best be celebrated in 2014. He was joined by medieval historians Seán Duffy and Edel Breatnach, as well as Pat Wallace, former director of the National Museum of Ireland.

A series of diverse talks and readings followed. Michael Sheridan gave a talk called 'Murder in Monte Carlo' about a Wimbledon finalist from Co. Waterford who was involved in a grim murder story. This was followed by talks by Val Byrne on 'Feaghe mac Hugh and the Clonmore connection', Hugh Fitzgerald Ryan on the luckless Petronilla and Dame Alice Kytler, Marc-Ivan O'Gorman on the murder of Carlow-born Hollywood director William Deane Taylor, and Alison Maxwell on an iconic Dublin restaurant called Jammets.

By mid-afternoon, the Library was hosting a presentation by Kevin Myers on whether those who left the Irish Army to fight for Britain in World War Two deserved to be classed as deserters. Both Kevin – and Ruth Dudley-Myers who fielded audience questions alongside him – were firmly of the view that they should not have been so-classed.

The final event of the 2012 History Festival was a stunning performance by Jeananne Crowley in which she provided an introductory look at the life of Sydney Ownenson, Lady Morgan, one of the most remarkable hostesses of 19<sup>th</sup> century London, told through her childhood memories of Ireland and her rise through the ranks of the British hierarchy.



## The Rowing Bunburys of Lisnavagh

Greg Denieffe

### From “The Oarsman’s Farewell to his Oar”

Many oars have I had – lo! These cups are a token –

Since first a raw Freshman I splashed in a crew;

Their shafts may be warped and their blades may be broken,

But their staunchness lived on to be centered in you.

Lo! All these old oars that I lost with or won with

Return to remind me of failure or fame.

The traditions are yours of those blades I have done with;

The wood may have changed, but the soul is the same.

R. C. Lehman, 1901.

### Introduction

On the 25<sup>th</sup> August 2011, I visited Lisnavagh House, Rathvilly, County Carlow, Ireland and met the charming Turtle Bunbury, Great Great Grandson of the 2<sup>nd</sup> Lord Rathdonnell. The house that exists today is about one third of the original building but it still has the feel of a grand country house. The reason for my visit was to see first-hand the home of the rowing

Bunburys.

The family has a proud history of rowing achievement at Eton College and at Oxford [Brasenose College, Oxford University and Oxford Etonians]. Carlow Rowing Club has been the beneficiaries of the family on more than one occasion. However, very little was known by the members, of the wonderful rowing history that existed on their doorstep.

The previous evening I visited Carlow Rowing Club to view the seven commemorative pencil oars celebrating the family’s achievements at Henley Royal Regatta. These were donated to the Club in 2000 by Turtle’s father, the current and 5<sup>th</sup> Lord Rathdonnell. The oars were for many years hung in the stairwell of old Lisnavagh and then in the cellar following demolition in the 1950s of the main part of the house. They are now proudly displayed in the gym/function room of the Club.



Tom Bunbury (2nd Lord Rathdonnell) dressed in whites

Carloviana 2012

Tom Bunbury was the eldest son of Captain William and Pauline (nee Stronge) McClintock Bunbury. His father was born William McClintock and in 1846 he assumed the additional name of Bunbury, his mother’s maiden name. William was a Captain in the Royal Navy and sat as a Member of Parliament for County Carlow between 1846 and 1852 and again between 1853 and 1862. He was also the younger brother of John McClintock the 1<sup>st</sup> Lord Rathdonnell. Tom succeeded to the title on the death of his uncle in 1879. Tom’s father died in 1866 while he and his brother Jack were at Eton.

In January 1897 Baily’s Magazine of Sports & Pastimes published a five page review of Lord Rathdonnell’s life to that time. Tom and his Brother Jack’s exploits with the oar are given due mention as is William’s win at Henley in 1896, a win that he would repeat later that year.

### *An extract from Baily’s Magazine of Sports & Pastimes;*

“When a boy of ten years he was sent to Eton and educated under John Hawtry and Dr. Warre. He distinguished himself greatly by his love of sport and became an expert oarsman, winning the sculling in 1868, and the pairs twice, in 1867 with his cousin Mr. Calvert, and in 1868 with Mr. F. A. Currey. He rowed in the Eton eight at Henley in 1867 and 1868, winning the Ladies’ Plate on each

THE ROWING BUNBURYS OF LISNAVAGH

occasion, he being captain of the boats and rowing stroke (sic). He also played in the Wall and Field eleven at Football for two and three years; twice ran second in the School Hurdle Race, and one year was fifth in the school mile.

His brother, Jack Bunbury, who afterwards rowed for Oxford rowed with him in 1868, and stroked the Eton eight for the next two years, so that three years in succession there was a Bunbury at the stroke oar: his young son, bent on following his father's footsteps, pulled stroke in the Eton eight at Henley in 1896, when they won the Ladies Plate"

Dr Edmond Warre's contribution to Eton's success at Henley cannot be overstated and Tom and Jack were fortunate to be rowing under his tutelage.

Warre was born in 1837 and educated at Eton and Balliol College, Oxford, where he had a distinguished career, taking a double first (1856 and 1859). He was an outstanding oarsman and at Eton he won the School Pulling for coxed pairs in 1854. At Oxford, he went Head of the River with Balliol in 1855 and 1859, won the University Sculls and Pairs in 1855-56, the University Fours in 1856 and 1858, and was O.U.B.C. president in 1858. He rowed for Oxford in The Boat Race in 1857 and in 1858, winning the former. He also won the Silver Goblets at Henley Royal Regatta in 1857 partnering Arthur Lonsdale. Warre and Lonsdale were runners up in 1858 but Warre won Silver Goblets again in 1859 partnering John Arkell. There were also two wins in the Ladies' Plate in 1855 and 1858.



Dr. Warre by "Spy" in "Vanity Fair"

He returned to Eton in 1860 as a Housemaster, and in 1884 was elected Headmaster, a position which he retained until 1905. He took much interest in sport at Eton, and the high standard of rowing to which the Eton eights attained was due in a large measure to his coaching. His schoolboy crews won the Ladies' Plate eight times and reached the final of the Grand five times.<sup>[1]</sup>

Warre died at Eton at the age of 82. His son Felix Warre rowed at Henley with Tom's eldest son Billy in 1896 & 1897.

A wonderful collection of Dr Warre's rowing medals was included in the 'Marine Sale' held by Bonhams of New Bond Street, London on 22<sup>nd</sup> March 2011. Also included were medals won by crews trained by Dr Warre at Eton. These included the 1867 Eton College House Fours and 1867 and 1868 Ladies' Plate medals, crews that Tom Bunbury rowed in. Details and photographs can be found at this address <http://www.bonhams.co/eur/auctions/18783/lot/57/#>.

**1867 Blade Inscription**

**Grand Chall<sup>se</sup> Cup**

Carloviana 2012

Kingston R.C.

**Ladies Plate**

Radley

Bow. S. H. Woodhouse

2. A. G. P Lewis

3. W. R. L. Mirehouse

4. J. H. Ridley

5. J. Edwards Moss

6. T. K. M<sup>se</sup> Bunbury

7. W. C. Calvert

Str. W. D. Benson

Cox. F. E. H. Elliot

Eton College beat Radley College by three lengths in the final of the Ladies' Plate in a time of 7m. 55s. They also beat Kingston Rowing Club in a heat of the Grand Challenge Cup but withdrew from the next round.<sup>[2]</sup> According to Baily's, W. C. Calvert was Tom's cousin and they rowed together again the following year.

**1868 Blade Inscription**

**Grand Challenge**

University College

Kingston R.C.

**Ladies Plate**

University College

Pembroke College

Bow. W. Farrer

2. J. M<sup>se</sup> C. Bunbury

3. F. Johnstone

4. J. H. Goldie  
 5. J. Edwards Moss  
 6. F. H. Currey  
 7. W. C. Calvert  
 Str. T. K. M<sup>c</sup> C. Bunbury  
 Cox. F. E. H. Elliot

The Ladies' Plate final was a three boat affair with Eton College beating University College, Oxford and Pembroke College, Oxford in a record time of 7m. 18s. Eton College lost in the final of the Grand Challenge Cup to London Rowing Club but there is no mention of this race in the inscription on the oars used by Tom or Jack.<sup>[3]</sup>

The 1868 Eton crew had a young man in the four seat that would leave a lasting impression on the world of rowing. John Goldie only lived for forty seven years but is still remembered to this day. After leaving Eton he went to St. John's College, Cambridge. Goldie captained St. Ives Rowing Club in 1869 and won the Colquhoun Sculls in 1870. He stroked the Cambridge crew in the Boat Race in 1869, 1870, 1871 and 1872. Cambridge's victory in 1870 ended Oxford's nine consecutive years of victories and Cambridge won again in 1871 (Jack Bunbury was in the Oxford crew) and 1872. He captained Leander from 1873 to 1876 and stroked them when they won the Grand Challenge Cup in 1875. The second Cambridge boat is named "Goldie" after him and his name was given to the Goldie Boat-house, used by the University crews.

There was plenty of in-house racing at Eton and Tom was successful in the 'House Fours' for three years in succession, the 'School Pulling' twice and the 'School Sculling' in 1868 the year he won all three. Tom Bunbury left Eton in 1868 but according to 'Henley Royal Regatta, A celebration of 150 years' by Richard Burnell [1989], he represented Eton College again the following year when he and W. C. Calvert were beaten in the final of the Silver Goblets by London Rowing Club.

The Henley records for 1869 had this to say about the race; "A good race to Fawley, when Messrs. Long and Stout gradually drew away and won easily by 3 lengths. Time 9 min. 20s. Messrs. Finch and Goldie, Lady Margaret, Cambridge, entered but withdrew." Losing to Albert de Laude Long was no disgrace as his successes at Henley include five wins in the Grand, eight wins in the Stewards', four wins in the Goblets and a win in the Presentation Cup for four oars without Cox in 1872. A staggering eighteen wins between 1868 and 1877.

After leaving Eton, Tom received a commission in the Scots Greys. On his retirement from the army he was a captain in the Leicestershire Yeomanry and Hon. Colonel of the Sixth Battalion, Royal Irish Rifles. In 1918 he became president of the Royal Dublin Society and took a keen interest in the success of the annual horse show. He was a notable breeder of Short-horns and a frequent prize-winner at the Dublin Shows. He was also H.M. Lieutenant and High Sheriff for County Carlow. He married, in

1874, Katherine Anne Bruen [daughter of Henry Bruen, of Oak Park, Carlow]. She was a frequent prize giver at the local regatta run by Carlow Rowing Club on the River Barrow. In 1901 he presented a silver cup "The Rathdonnell Challenge Cup" to Carlow Rowing Club for competition by junior fours at the regatta. Lord Rathdonnell died in 1929.<sup>[4]</sup>

Jack was the younger and only brother of Tom Bunbury. Shortly before Jack's birth, his parents and elder brother moved to the new house at Lisnavagh, Rathvilly, County Carlow. Jack was an extremely talented and by far the most successful oarsman in the family. He began his rowing at St. Peter's College in Radley in the early 1860's and in September 1865 he joined his brother Tom in Dr Warre's House at Eton. His first success at Henley Royal Regatta was in the two seat of the Eton Crew that won the Ladies' Plate in 1868. The boat was stroked by Tom and for the next two years Jack would stroke the Eton eight to two more victories in the same event. There are two 1868 oars in the Carlow Rowing Club collection as each member of the crew would have received their own winning blade. He was also a good sculler winning the Eton Silver Sculls in 1870.<sup>[5]</sup>

#### 1869 Blade Inscription

#### Grand Challenge

Oxford Etonian Club

#### Ladies Plate

THE ROWING BUNBURYS OF LISNAVAGH

Radley  
 Lady Margaret, Cambridge

Bow. F. E. H. Elliot

2. F. G. Ricardo

3. M. C. Farrer

4. F. A. Currey

5. J. Edwards Moss

6. F. Johnstone

7. J. S. Follett

Str. J. W. M<sup>c</sup> C. Bunbury

Cox. W. C. Cartwright

The Eton eight for Henley in 1869 was unusual in that their bow man, F. E. H. Elliot rowing at exactly nine stone was the coxswain of the winning Ladies' crews of 1867 and 1868 when he weighed 7 stone 2 pounds and 7 stone 11 pounds respectively. Jack moved into the stroke seat replacing his brother and Eton won the Ladies' Plate rather easily beating Radley College in a heat and Lady Margaret Boat Club, Cambridge by four lengths in the final in a time of 7m. 58s. In the 'Grand', Eton lost their heat to their old boys, Oxford Etonian Club by  $\frac{3}{4}$  length, the winning time being 7m. 34s. Oxford beat London in the final.

**1870 Blade Inscription**

**Grand Chall<sup>ge</sup> Cup**  
 London R. C.

**Ladies Plate**

Radley Coll<sup>ge</sup> B. C.

Dublin Univ<sup>ty</sup> B. C.

Bow. A. C. Yarborough

2. R. E. L. Naylor

3. J. S. Follett

4. F. C. Ricardo

5. F. W. Currey

6. A. W. Mulholland

7. C. W. Benson

Str. J. W. M<sup>c</sup> C. Bunbury

Cox. W. C. Cartwright

Jack kept his place in the stroke seat of the Eton eight in 1870 and Eton won the Ladies' Plate for the fifth successive year. Radley College was beaten in the heats and Dublin University Boat Club rowing as Trinity College, Dublin was overcome in the final by two lengths in a time of 7m. 46s. In the Grand Challenge Cup, Eton lost to London Rowing Club in a heat and London lost yet again to the Oxford Etonian Club in the final.

The Eton old boys club had first won the Grand in 1844 and repeated that success in 1866, 1867, 1869 and 1870. They would win it for a final time in 1871 and Jack Bunbury would be in the four seat to enjoy his greatest sporting achievement. But before that there was the little matter of the most famous boat race in the world. The race between Cambridge University Boat Club and Oxford University Boat Club and simply

know as The Boat Race.

1870 was the first appearance of an Irish club at Henley Royal Regatta. Trinity College, Dublin became not only the first Irish entry but also the first from overseas, albeit at that time not a foreign entry. They entered for the Grand, Ladies', Stewards', Visitors', Wyfolds, Goblets and Diamonds but thinking better of it and having only nine men to man the boats they withdrew from the Stewards' and the Wyfolds. The crew that lined up in the final against Jack and his Eton eight were from the bow: J. O'G. Delmege, S. McIvor, W. Murray, D. H. Doran, C. B. Barrington, E. T. Kennedy, I. McIvor, F. E. Bird and P. S. Abraham (cox). At the end of racing they recorded Ireland's first win at the regatta by winning the Visitors' which at that time was a coxed fours event.<sup>[6]</sup>

Another Irish connection with the 1870 Eton crew was Andrew Walter Mulholland who rowed at six. He was the eldest son of John Mulholland, 1<sup>st</sup> Lord Dunleath of Ballywalter Park, County Down. You can read about John Mulholland and The Mulholland Cup [The rowing championship of the river Lagan and Belfast Lough 1867-1878] in my article dated 25<sup>th</sup> October 2011 on the 'Hear the Boat Sing' website at this address <http://hear-the-boat-sing.blogspot.com/2011/10/greg-deni-effe-on-mulholland-cup.html>.

John Mulholland was educated at the Belfast Academy but all three of his sons went to Eton College and then to Balliol College, Oxford.

Andrew was born in 1852 and was

at Eton from 1865 to 1871. According to The Eton Register, Part III, 1862-1868, Andrew was in the Eton VIII in 1870 and the Oxford VIII of 1877 (sic) and died at the age of 24 of typhoid fever on 2 June 1877.

Andrew had two brothers, Henry Lyle Mulholland [1854-1931] who succeeded his father as Lord Dunleath and Alfred J. Mulholland [1856-1938]. It was not Andrew but Alfred who was in the Oxford University Boat Club crew of 1877 and who took part in the most famous university boat race of all time. Gordon Ross sums up the race succinctly in his book 'The Boat Race' [1954], "Vanity, spice and all manner of things graced 1877. The race is historical, controversial . . . unbelievable . . . the result? . . . a dead heat!"

After finishing at Eton College in 1870 Jack went up to Oxford University where he quickly joined the Brasenose College Boat Club, the oldest collegiate boat club in the world. In his short stay at the university he won The Trial Eights [1870], The Silver Sculls [1871] and The Silver Challenge Oars for pairs [1871] for his college in the Oxford University rowing events.<sup>[7]</sup> See appendix 3 for a complete record of Jack's races for Brasenose. Jack was only at Oxford until December 1871 when he left to pursue a career in the army. As preparations for the annual University Boat Race between Oxford and Cambridge got underway, many wondered whether the 12-stone Jack Bunbury might be selected as the Oxford stroke. Oxford had enjoyed a run of nine consecutive victories

before Cambridge beat them in April 1870. The pressure was back on Oxford and, as such, much of it fell on their young stroke.

On 11 Feb 1871, The Graphic said Oxford was struggling to find a suitable stroke as 'it is said that Mr. Bunbury, who came from Eton with a great reputation, has not "last" enough for the place'. Nonetheless the mustachioed Jack was chosen as stroke. In the build up to the race, Cambridge were able to field 'a good stroke and a good No. 7' while Oxford, with five veterans from 1870's 'Dark Blue' crew, 'will have men who are untried to fill both those important places.' The Graphic predicted a victory for Cambridge.<sup>[8]</sup> They were soon out practicing on the water, displaying their prowess to a few riverside spectators, in a boat built by Messrs J and S Salter. Sometimes they were steered by Mr. W. Benson while Mr. E. G. Banks coached them by horse-back from the bank.<sup>[9]</sup>

On February 25, the Penny Illustrated stated that Jack had 'much improved on his trial-eight form . . . and if he can make the heavy men behind him row forty in an outrigger as well as he did the boys' crew forty-eight, he will be able to show an older on younger shoulders than is often seen'. But much doubt was still placed on Oxford having 'almost a boy for a stroke to a mammoth crew'. He weighed 8lb less than the average member of the Oxford team. On February 23, Oxford decided to swap Jack with the No. 7, R. Lesley. It seems to have worked better for them and by March 18, the Penny Illustrated favoured Oxford over Cambridge. On Saturday

April 1st, the two crews set off but it was Cambridge who, despite a last minute spurt by Lesley and the Oxford crew by the Mortlake brewery, won by a length in 23 minutes and 5 seconds ('with a foul wind from the north east').

The Oxford University Boat Club Crew 1871

Bow. S. H. Woodhouse (Eton & University Coll.)

2. E. Giles (Westminster & Christ Church)

3. T. S. Baker (Lancing & Queen's)

4. E. C. Malan (Sherborne & Worcester)

5. J. E. Edwards-Moss (Eton & Balliol)

6. F. E. Payne (Cheltenham G. S. & St. John's)

7. J. W. Mc Bunbury (Eton & Brasenose)

Str. R. Lesley (Radley & Pembroke)

Cox. F. H. Hall (King's School, Canterbury & Corpus Christi)

At Henley in July 1871, Jack was defeated by Mr. William Fawcus of the Tynemouth Rowing Club, shortly before Fawcus defeated Mr. Long, the Wingfield sculls winner. Jack also stroked (sic) the Eton boys to win the Grand for Oxford Etonians in 1871.<sup>[10]</sup>

This was the sixth and final time that the Eton old boys would win the premier event at the premier regatta in the country. It was Jack's finest hour in a boat and probably his last. The up-and-coming London Rowing Club was

THE ROWING BUNBURYS OF LISNAVAGH

beaten in the final by 1½ lengths in a time of 8m. 5s.

In fact the winning Oxford crew was stroked by F. E. Armitstead. The rest of the crew was as follows, F. E. H. Elliot (Bow), W. Farrer (2), M. A. Farrer (3), J. W. McClintock- Bunbury (4), J. Edwards-Moss (5), A. G. P Lewis (6), S. H. Wood-House (7) and E. E. Grubbe (Cox).

In December 1871 Jack purchased a commission in the 2nd Dragoons. He succeeded his brother Tom, to the office of High Sheriff for County Carlow in 1877 and the following year married Myra Watson. Four days after the wedding, Jack was made a Lieutenant in the Scots Greys. He was no stranger to trouble or misfortune; however in October 1882 he and Myra had a son, Geoffrey. Things got worst not better and in 1883 he was forced to sell his house at Moyle and a few years later he moved to England. There is some confusion over where Jack resided but according to Turtle Bunbury in his online history of the family, his principal residence was in Cheshire. On 2nd October 1892, Geoffrey died aged nine. A year later, on the 14th October 1893 Jack died. He was 42 and was laid to rest alongside his son in the graveyard at St. Helen's Church, Tarporley, Cheshire.[11]



Billy Bunbury  
1878-1900

William McClintock Bunbury was born at Lisnavagh in 1878, the eldest son of Thomas Kane (Tom) McClintock Bunbury, 2nd Baron Rathdonnell, and his wife, Lady Katherine Anne (Kate) Rathdonnell. Billy was educated at the Dragon School in Oxford and Eton College [April 1892 – December 1897] where he was in Rev S. A. Donaldson's House. Donaldson was successor to Rev Edmund Warre and like him an enthusiastic rowing coach. As was his father before him, Billy was captain of boats at Eton and stroked the winning Ladies' Plate crews of 1896 and 1897. The two blades used by Billy in these events are the only two in the collection bearing the Eton College crest. He joined the Scots Greys shortly after leaving Eton. He was posted to South Africa in December 1899 and died ten weeks later on the 17th February 1900 having been shot in both legs in a raid on a Boer position 8 miles outside Kimberley. According to a letter from Harry Scobell (Billy's immediate superior) to Lord Rathdonnell dated 19th February 1900, Billy was buried in the cemetery just outside Kimberley. He is not listed on the Kimberley Boer War Memorial at Kimberley Cemetery but there are 130 graves there containing unknown soldiers. He is however named on the Memorial to the Fallen Heroes of the Royal Scots Greys (2nd Dragoons) on Princess Street in Edinburgh which was unveiled in the presence of his parents on 16 November 1906.

1896 Blade Inscription

Ladies Plate

Carloviana 2012

- Jesus College, Oxford
- Trinity Hall, Cambridge
- Emmanuel College, Cambridge
- Henley [Eton Crest] 1896
- Balliol College, Oxford
- Trinity College, Dublin
- Bedford Grammar School
- Radley College Boat Club
  
- Bow. Hon. M. C. A. Drummond
- 2. C. M Black
- 3. F. Warre
- 4. E. L. Warre
- 5. J. L Philips
- 6. J. A. Tinne
- 7. W. Dudley Ward
  
- Str. Hon. W. McClintock Bunbury
- Cox. R. A. Blyth

At Henley the Eton crew beat Jesus College, Oxford in their first heat and Radley College in their second heat before beating Balliol College, Oxford by 2½ lengths in the final in a time of 8m. 6s.

In the Eton crew was Felix W. Warre, son of Dr Warre who was coach to Billy's father and uncle whilst they were at Eton. Felix was born at Eton and later went to Balliol College, Oxford. He rowed for Oxford in the successful 1898, 1899 and 1901 Boat Race crews. His Henley successes include two wins in the Grand in 1900 and 1903, the Stewards' in 1900, the



Silver Goblets with J. H. Hale in 1901, the Visitors' in 1899 and 1901 and his two wins in the Ladies' in 1896 and 1897.

Like his father, his rowing medals and other rowing memorabilia were offered for sale by Bonhams in March 2011. Details can be found at this address <http://www.bonhams.co./eur/auctions/18783/lot/59/>.

In the photographs of the Ladies' Plate medals, W. McClintock-Bunbury's name can be clearly seen on the name shields.



*William Dudley Ward*

Also in the '96 crew was one of the most successful rowers of that time, William Dudley Ward. He was so successful that he was depicted by "Spy" [Leslie Ward] in Vanity Fair on 29th March 1900. He rowed for Cambridge in the Boat Race in 1897 when Oxford won. As President of CUBC he rowed in the winning Cambridge crews in the 1899 and 1900 Boat Races. At Henley Royal Regatta he was runner up in Silver Goblets in 1900 partnering R Etherington-Smith. Rowing for Third Trinity, Cambridge he won the Stewards' Challenge Cup in 1901. In 1902 he won the Grand Challenge Cup, the Steward's Challenge Cup again, and the Silver Goblets part-

nering C W H Taylor. In 1903 his college crew won the Steward's and with Leander he won the Grand again.

1897 Blade Inscription

Ladies Plate

Emmanuel, Cam

Balliol, Ox

Trinity, Ox

Henley [Eton Crest] 1897

Christ Church, Ox

Kings College, Cam

Bedford Grammar School

Radley B. C.

Bow. W. H. Chapman

2. W. Astor
3. Hon. W. E. Guinness
4. H. J. Hale
5. Lord Vivian
6. F. W. Warre
7. J. L. Phillips

Str. Hon. W. McClintock Bunbury

Cox. G. A. Lloyd

Stroking the boat for the second year in succession, Billy and his Eton crew beat Radley College in their first heat and King's College, Cambridge in their second heat and Emmanuel College, Cambridge in the final by ½ length in

a time of 7m. 1s. The Grand Challenge Cup was won by New College, Oxford who beat Leander Club by 2 feet in a time of 6m. 51s.

Felix Warre also returned to win a second Ladies' but this time rowing on strokeside in the six seat having been on bowside the previous year.

Another returning member of the crew was John Lionel Philips. He was Captain of Boats in 1897[12] and he and Billy won the Eton School Pulling that year. After leaving Eton he went up to New College, Oxford and in his first year there won the OUBC Fours and raced in the Trial Eights but failed to make the Oxford University Blue boat. This is not surprising as New College were particularly strong having won the Grand at Henley earlier that year. His Eton, Henley and OUBC medals were offered for sale in January 2012 by Jordan's Antiques. Included were his Ladies' Plate Medals for 1896 and 1897 and the name shield for the 1896 crew with W. McClintock-Bunbury's name at stroke. For the record, I couldn't resist and after contacting the seller a successful deal was done!

Occupying the three seat was Walter Edward Guinness, 3rd son of Edward Guinness (1st Earl of Iveagh) and younger brother of Rupert Guinness. Walter was born in Dublin in 1880 and had a distinguished political career serving under Winston Churchill. He was created the 1st Baron Moyne in 1932 and was assassinated in Cairo in 1944 by the militant Jewish group Lehi for his role in British Palestinian policy.

THE ROWING BUNBURYS OF LISNAVAGH

His brother Rupert was a successful rower winning the Ladies' Plate with Eton in 1893 and the Diamond Challenge Sculls at Henley in 1895 and 1896 for Leander Club. Rupert succeeded his father in 1927 becoming the 2nd Earl of Iveagh and Chancellor of the University of Dublin (Trinity College). In 1939 he presented his Dublin residence, Iveagh House, St. Stephens Green to the Irish Government and the gardens to University College Dublin. He was president of Dublin University Boat Club between 1949 and 1967.

You will find more about Rupert Guinness and his rowing exploits on the 'Hear The Boat Sing' website. Firstly, there is Tim Koch's entry on 26 March 2010 "The Rowing English Gentleman" and then Göran Buckhorn's entry on 24 August 2010 "The Sculling Earl To Be".

Floret Etona

Eton's best-known holiday takes place on the so-called "Fourth of June", a celebration of the birthday of King George III. The day is celebrated with the Procession of Boats, in which the top rowing crews from the top four years row past in vintage wooden rowing boats. The "Fourth of June" is no longer celebrated on 4 June, but on the Wednesday before the first weekend of June. The first boat in the procession is the ten-oar Monarch pictured above. This is followed by the rest of the fleet in the following order and seniority of crew; Victory, Prince of Wales, Britannia, Thetis, Hibernia, St. George, Alexandra, Defiance and finally Dreadnought. There are two excellent articles on the procession on the 'Hear The Boat Sing' website. The entry dated the 11 May 2010 is called "Etonians and their Boaters" and that on the 5 June 2011 is called "Tim Koch On the 2011 Eton's Procession of Boats".

The above photograph originally appeared in Vivian Nickalls' autobiography "Oars, Wars and Horses" which was published in 1932. It reappeared on page fifty in Peter Mallory's epic 2,500 page "The Sport of Rowing" in 2011. Tom Bunbury (Lord Rathdonnell) is seated center, being the elder "Captain" with his son Billy standing on the right. Unfortunately there appears to be two errors in the caption both of which relate to the Bunburys. The Eton Registers published in 1901 & 1906 list Tom as Captain of the Boats in 1868 [not 1863] and J. L. Philips as Captain of the Boats in 1897 and not Billy. It is still a wonderful picture and I am very grateful to Peter for the scan of the photograph.

The Rathdonnell Cup

It is purely speculation, but I believe that William's death in 1900 led directly to Lord Rathdonnell [Tom Bunbury] reviewing the rowing exploits of the family and of his wish to mark his son's passing in some way. Carlow Rowing Club [founded 1859] has most of the hand written minutes since the founding of the club but unfortunately there is a gap from the late 1890's to the early 1900's. In any event Lord Rathdonnell presented a silver cup to the Club in 1901 for competition between junior [now Intermediate] fours.

Inscription

1901

PRESENTED TO THE



Eton 4th June, Procession of boats, 1889



THE ROWING BUNBURYS OF LISNAVAGH

CARLOW ROWING CLUB

BY

Lord Rathdonnell

TO BE COMPETED FOR ANNUALLY

BY JUNIOR OARSMEN

IN

FOUR OARED BOATS

I would like to thank everyone who has helped me in collating the rowing achievements of the McClintock-Bunbury family, especially author, historian and TV presenter Turtle Bunbury who has allowed me to use his website and photographs to add background and colour to the lives of Tom, Jack and Billy, the only three 'wet-bobs'[14] from County Carlow. For further information on the McClintock-Bunbury family please visit Turtle's website at [www.turtlebunbury.com](http://www.turtlebunbury.com).

\*\*\*\*\*

References.

[1]. In Retrospect 1839-1989 - An Exhibition Sponsored by Phillips at Stoner Park and HRR. Pub-

lished 1989.

[2]. The Eton Register, Part III, 1862-1868. Published 1906.

[3] Ibid.

[4] The Times, Obituaries 24 May 1929.

[5] The Eton Register, Part III, 1862-1868. Published 1906.

[6] In Black & White - A History of Rowing at Trinity College, Dublin. Raymond Blake, 1991; pgs 29-30, and Henley Royle Regatta - A celebration of 150 years, London, Richard Burnell, Published 1989; pg 104.

[7] Oxford Rowing - A History of Boat-Racing at Oxford from the Earliest Times, Rev. W. E. Sherwood, Published 1900; pgs 187-188, 227, 261, 291-292, 301 & 353.

[8] Sporting Notes - The Graphic (London, England), Saturday, February 11, 1871; Issue 63.

[9] University Boat-Race - Penny Illustrated Paper (London, England), Saturday, February 18, 1871; pg. 109; Issue 490.

[10] Baily's magazine of sports

and pastimes (Vinton, 1899).

[11] From the Burial Register at St. Helen's Church, Tarporley: Entry 219. Geoffrey McClintock Bunbury, abode Calveley, buried 4th October 1892, nine years of age. Ceremony performed by W.O. Hughes. Entry 259. John William McClintock Bunbury, abode Somerby, buried 17th October 1893, 41 years. Ceremony performed by E.W. Evans. Details and photograph supplied by Maurice Hunt, Hon. Archivist to the Parish of St. Helen's, Tarporley, Cheshire.

[12] The Eton Register, 1893-1899. Published 1901.

[13] J. L Philips' medals are as follows; Eton College Trial Eights, 1895 & 1896; Ladies' Challenge Plate, 1896 & 1897; Oxford University Boat Club Trial Eights 1897 and Oxford University Boat Club Four Oars 1897. Name shields for all but the 1897 Ladies' Plate are also included.

[14] According to Webster's Online Dictionary a wet-bob is a boy at Eton who goes in for boating, but a dry-bob is one who goes in for cricket.



Carloviana 2012



## The “Shemus” Cartoons in the *Freeman’s Journal*

Felix M. Larkin

‘Cartoons can say things that are perhaps less easy to say in a more straightforward journalistic context’ – that’s a quotation from Steve Bell, the *Guardian’s* brilliant cartoonist, in an interview published in the *Irish Times* on 21 August 2010. The essential truth of that statement is demonstrated by the impact earlier this year of the Doonesbury cartoon strips in focusing attention on controversial Texas anti-abortion legislation.<sup>1</sup> Several Martyn Turner cartoons have had a similar impact here in Ireland: one thinks, most obviously, of his cartoon in 1992 about the young girl in the so-called X case imprisoned within the confines of the Irish State behind barbed wire, like in an internment camp.<sup>2</sup> Another cartoonist who had that kind of impact was ‘Shemus’, whose work appeared in the *Freeman’s Journal* in the final years of that old and distinguished Irish newspaper.

The *Freeman* published some three hundred Shemus cartoons between 1920 and 1924. They are remarkably hard-hitting commentaries on the events of that turbulent period, and were aptly described in Dáil Éireann in 1923 as ‘artistic bombs’ by the prominent Labour Party deputy, Cathal O’Shannon.<sup>3</sup> During the War of Independence, their main target was the increasingly brutal nature of British rule in Ireland. Later, they attacked the new government of Northern Ireland and the anti-Treaty elements in the new Irish Free State with all the venom previously directed against the British authorities. This reflected the editorial policy of the *Freeman*; the Shemus cartoons were subject to the *Freeman’s* editorial policy, not independent of it.

The cartoonist was an English artist, Ernest Forbes (1879–1962) – afterwards well known in London and in his native Yorkshire for his landscapes and portraits, both drawings and oil paintings.

He used a number of pseudonyms during his long career, and even ‘Ernest Forbes’ was a contrivance: his full name was Ernest Forbes Holgate. He dropped the surname when signing his work; and in 1927, when he had returned to England after the *Freeman* closed down, he formally changed his name by deed poll to Ernest Forbes. The pseudonym ‘Shemus’ was exclusive to the *Freeman’s Journal*.<sup>4</sup>

When Forbes joined the *Freeman*, its principal proprietors were Martin Fitzgerald, a successful Dublin wine merchant, and Hamilton Edwards, a retired British journalist who had once worked with Lord Northcliffe in London but was now living in Ireland.<sup>5</sup> It is likely that Edwards, with his experience and connections in London, recruited Forbes to the *Freeman*. The Shemus cartoons are broadly similar in style to cartoons that were appearing at that time in London newspapers such as the *Daily Mirror* and the *Daily Mail*, both Northcliffe publications. Forbes



Carloviana 2012

remained essentially a British cartoonist in exile while in Ireland, at his best when treating his Irish subject matter from the perspective of British politics and focusing on British politicians. After the British left Ireland in 1922 and Forbes was thus deprived of a British context for his work, his cartoons became much less subtle and insightful – and he produced fewer of them.

The superb quality of Forbes' work at its best is evident in the cartoon entitled *It Means Nothing to Them*, published shortly after the occupation of the Four Courts in Dublin by armed anti-Treatyites in April 1922, the prelude to the outbreak of the civil war. Apart from the force of its message – the punch that it packs – it is a most accomplished and skilful piece of drawing. Its unambiguous message is that armed resistance to the Treaty, symbolised by the gunmen in the foreground, flouts majority opinion in Ireland. The building in the background is the Bank of Ireland in College Green, Dublin, the seat of the last Irish parliament before the Act of Union of 1800. The caption has one gunman asking 'What's all the noise?', to which the second replies 'Don't worry. It's only the voice of the unarmed people'.



Carloviana 2012

The most notorious of the Shemus cartoons depicts de Valera as the mouthpiece of Erskine Childers. Entitled *Giving Him His Lines*, it appeared on 10 February 1922 – shortly after the Treaty debates in the Dáil had concluded. The caption has Childers saying to Dev: 'That's fine. They fit you as well as ever – all except the cap, but that can't be helped. Now, don't forget to say it exactly as I told you.' The cap that doesn't fit de Valera is the French revolutionary 'Liberty Cap', the *bonnet rouge*. Childers was intellectually one of the most formidable opponents of the Treaty, and there was particular animosity towards him in the pro-Treaty camp. The *Freeman* faithfully reflected that animosity, and boosted it. An editorial also published on 10 February 1922 warned that de Valera was 'in danger from the Childers' medicine', a message reinforced in the cartoon by attributing Childers' influence to flattery. The demonization of Childers by the *Freeman* and others led to his execution by the Free State government in November 1922, after he had been found guilty by a military tribunal of little more than a technical infringement of the law.<sup>6</sup>

*Henry, The Ruthless* is another Shemus cartoon which attacks a specific individual unfairly. Published on 8 June 1922, the target on this occasion was Sir Henry Wilson, the former Chief of the Imperial General Staff in London who became Unionist MP for North Down at Westminster in February 1922. In March 1922 he was appointed advisor on security matters to the new government of Northern Ireland. He was strongly anti-nationalist, and the *Freeman* held him responsible for the spate of sectarian violence directed against the Catholic population of Belfast.

In this cartoon, the Grim Reaper reports back to Wilson – thereby suggesting in stark terms where blame for the atrocities in Belfast lay. It is a deeply troubling image in view of the fact that Wilson was himself

## THE "SHEMUS" CARTOONS IN THE FREEMANS JOURNAL

shot dead by two IRA men in London just a fortnight after the cartoon was published. Professor Keith Jeffrey's recent biography of Wilson indicates that he was, in fact, a relatively moderate voice within Ulster unionist circles.<sup>7</sup>



The *Freeman's* campaign against Wilson has a curious symmetry with its campaign against Erskine Childers. In both cases the *Freeman* was guilty of encouraging widely-held prejudices, which led to their deaths. The *Freeman* will not have changed anyone's opinion of Childers or Wilson, but its treatment of them shows how the press can shape the tone of political discourse. In these instances, it was a particularly nasty tone. The Shemus cartoons were an important ingredient in shaping that tone. The writer Desmond Ryan, who was on the *Freeman's* staff in the 1920s, recalls in his memoir *Remembering Sion* that the Childers cartoon so disgusted him that he resolved to leave the *Freeman* on account of it.<sup>8</sup> His reaction parallels that of some US newspapers which declined to use the recent *Doonesbury* strips. Commenting on the *Doonesbury* strips, Martyn Turner said this: 'Most cartoonists actually enjoy the thought that they might be upsetting the odd person through their drawings. Perversely we still see it as

our mission to "twist a few tails", as a former editor of the *Irish Times* was fond of saying.'<sup>9</sup> I feel sure that that is a sentiment which Shemus – Ernest Forbes – would have wholeheartedly endorsed.

**Felix M. Larkin is chairman of the Newspaper and Periodical History Forum of Ireland. His book, *Terror and Discord: the Shemus Cartoons in the Freeman's Journal, 1920–1924*, was published by A&A Farmar in 2009.**

<sup>1</sup> The cartoon strips appeared in the *Irish Times*, 12–17 March 2012.

<sup>2</sup> Illustration no. 30 in Mark O'Brien, *The Irish Times: a history* (Dublin: Four Courts Press, 2008), between pp 160–1.

<sup>3</sup> *Dáil Debates*, vol. 3, col. 2935, 26 June 1923.

<sup>4</sup> For further biographical information on Forbes, see Felix M. Larkin, *Terror and discord: the Shemus cartoons in the Freeman's Journal, 1920–1924* (Dublin: A. & A. Farmar, 2009), pp 13–24.

<sup>5</sup> For an account of the history of the *Freeman's Journal* newspaper, see Felix M. Larkin, 'A great daily organ: the *Freeman's Journal*, 1763–1924', in *History Ireland*, 14:3 (May/June 2006), pp 44–9.

<sup>6</sup> Andrew Boyle, *The Riddle of Erskine Childers* (London: Hutchinson, 1977), p. 319.

<sup>7</sup> Keith Jeffrey, *Field-Marshal Sir Henry Wilson: a political soldier* (Oxford: Oxford University Press, 2006), pp 279–80.

<sup>8</sup> Desmond Ryan, *Remembering Sion: a chronicle of storm and quiet* (London: Arthur Barker, 1934), p. 280.

<sup>9</sup> *Irish Times*, 15 March 2012.



## Letters from Clontburrin 1880-1930

Carmel McCarthy

Together with my siblings, I grew up in Clontburrin House, near the village of Fenagh, Co. Carlow. Our parents had bought the house and farm in 1945, as World War II was drawing to a close. My earliest memories go back to the harsh winter of 1947 when the river Burrin which bordered our land was flooded in a spectacular way. Now and again we children were reminded that another family had lived there before us, but normally that did not bother us as we swam in the river, climbed various trees, explored every nook and cranny of the farm, and played with a doctor's bag that we found in one of the unused rooms. We knew that, among previous owners, there had been a family called Fryer, and that one of them had been a doctor. There was a room in our house called the "dispensary" in which were assembled all kinds of empty medicine bottles, and once, while digging in the garden, my brother found an Indian coin – a rupee dated 1862. The hill sloping down towards the Blackford bridge was called Fryer's Hill. As children, that was as far as our knowledge of the previous occupants of Clontburrin House stretched. However, this was to change significantly, when a Google search pointed us to the Fryer Library in the University of Queensland. This library was named in honour of "John Denis Fryer, a graduate of the University, who served overseas in World War I and died in 1923 as a result of injuries received during his war service."<sup>2</sup> Among the extensive archival material donated to the University of Queensland by the family of John Fryer (aka Jack) are twenty-three letters, all of them linked to Clontburrin in one way or another, and written by various members of the Fryer family.<sup>3</sup> These letters are mainly addressed to Jack's father, Charlie, who had emigrated to Queensland from Clontburrin in 1880. Charlie was the oldest son of Dr William F. Fryer, the owner of the doctor's bag and medicine bottles that we had played with as children. Covering a period of over fifty years, these letters give us fascinating glimpses of family life in a rural setting

in Ireland in the latter part of the nineteenth century and the early decades of the twentieth.



*Jack Fryer*

Jack Fryer won a scholarship to the University of Queensland in 1915.<sup>4</sup> By the end of the first term, however, he abandoned his studies and, at the age of 20, volunteered for military service in the first Australian Imperial Force (AIF). He was commissioned in 1916, and sent to France where he was exposed to gas poisoning in early 1917. After a period of hospitalization in England, Jack returned to France in August 1918 for the Battle of Amiens, the turning point on the Western Front. There he was again wounded, this time by a stick bomb. Back home after the war, he re-enrolled in 1920 at the University of Queensland to complete his English degree studies. However his health began to fail, and on 7 February 1923, at the age of 27 he died. His death certificate gives the cause of death as pulmonary tuberculosis, an illness which may have been exacerbated by exposure to gas poisoning during the war, though this is not certain.<sup>5</sup>

The Fryer archive in Queensland University ultimately owes its existence to the fact that Charlie Fryer, Jack's father, emigrated from Clontburrin to Australia in 1880, aged 26. Having settled near Springsure in Central Queensland, he began work at Orion Downs, a sheep station owned by a Mr Wilson. The following year a young local girl aged sixteen, Rosina Richards, arrived in the station to care for Mr Wilson's four step-children. Rosina and Charlie married two years later (1883), and they had seven children, of whom Jack was the fifth.

The various letters related to Clontburrin in this Fryer archive give us first-hand entry into the everyday life of the Fryer family there from 1880-1930. In particular they highlight the sense of distance and separation caused by emigration, as they document how the family of Charlie and Rosina Fryer struggled to make ends meet in a distant land. The letters bear witness to how concerned the Clontburrin family was for their young son and his family in faraway Australia. They also illustrate the extent to which one particular family in rural Co Carlow was affected by events on the world stage, as well as by local issues, such as those linked to the Land League.<sup>6</sup> In order to understand the context of the letters more fully, a brief picture of the Fryer family in Clontburrin now follows, based on the letters and supplemented by other sources. The primary family consisted of William F. Fryer, his wife Elizabeth S. Fryer and their seven children.

William Francis Fryer (1829-1914) of Kinsale, Co Cork, was admitted to the Royal College of Surgeons on 12 October 1849,<sup>7</sup> and the following year passed a preliminary examination in Glasgow.<sup>8</sup> It is not clear when he graduated, or when exactly he and his family came to live in Clontburrin. The first letter from Clontburrin in the Queensland archive is dated 1880, while the Irish Valuation Office records William Fryer as living in Clontburrin in 1879. These records also specify that John Bath was resident in Clontburrin

## LETTERS FROM CLONBURRIN

in the 1850s-1870s, and before him, Francis Dillon, Resident Magistrate. Slater's Directory of Ireland (1894) indicates that William Fryer, M.D., was the "Dispensary Medical Officer and Registrar of Births, Marriage and Deaths for Myshall."

All we know of his wife, Elizabeth Stuart Cochrane (= Lizzie Fryer), is what can be gleaned from her letters to Charlie and Rosina in Queensland. She died in Clonburrin in 1894. William and Lizzie Fryer had seven children: Charles (1854-1944), Lily (1856?), Willie (1859?), Kitty (1861), Harry (1864-1936), Tom (1866?), and Maggie (1868-1929). The dates for Charlie come from the Fryer archive, while those for Kitty, Harry and Maggie come from the 1911 census of Ireland. The dates for the other four children in between are estimations. The letters and other records indicate that this family resided at Clonburrin from about 1875-1936.<sup>9</sup> They would have moved to Clonburrin some years earlier than 1880, but not before 1871, since the Valuation Office cites John Bath as resident there in that year. None of the Fryer children therefore could have been born in Clonburrin, given that Maggie, the youngest, was born in 1868. We know from the Fryer archive that Charlie was born in Oulart, Co Wexford, in 1854. In 1894, when Lizzie Fryer was dying in Clonburrin, their second son Willie, then aged about 35, had a medical practice in Ipswich, while Harry was farming in Clonburrin. William Fryer and three of his children – Kitty, Harry and Maggie – are listed in the 1901 and 1911 censuses as the only Fryers living in Clonburrin in the first decades of the twentieth century. Kitty, the last surviving member of the Fryer family in Clonburrin, moved to England in 1936 (aged 76), and the house was sold to Patrick Walsh, who in turn sold it to our parents in 1945.

Charlie Fryer, the oldest of the Fryer children, spent two years studying medicine, after which he worked for a short time in the National Bank (now the Bank of Ireland) in Enniscorthy.<sup>10</sup> As already mentioned, he emigrated to Queensland in 1880, and some three years later married Rosina Richards. Their first child was a daughter, Elizabeth Fryer (aka Lizzie 1884-1985).<sup>11</sup> She was followed by six

sons: William Thomas (1887-1949), Charles George (1889-1917, killed in action in France), Henry Hardy (1892-1980), John Denis (1895-1923), Richard Alexander (1899- ?), and Walter Pensonby (1906-1980). The older four of the six sons enlisted and fought in World War I. Henry visited Clonburrin in 1917 while recovering from war injuries.<sup>12</sup> Writing from there to his mother (Rosina) in Australia, he describes Clonburrin as "Dad's old home".

Lily, the second of the Fryer children, married a Belfast man, Sam McCurry, who worked in the GPO in Dublin. They lived first in Blackrock, Co Dublin, and then moved to 3 Spencer Villas, Kingstown (= Dun Laoghaire). One of their daughters, Ruth, married Horatio Mathews, and lived in London, while another daughter, Christabel, is mentioned in Lizzie Fryer's 1889 letter to her daughter-in-law, Rosina.

Willie Fryer, brother of Charlie, and son of William and Lizzie Fryer, took his final medical exams at Edinburgh in 1882, was a surgeon on a Clan Sinclair ship later in 1882, a medical assistant in London in 1884, and had a medical practice in Suffolk, and later in Ipswich in 1891. He married Linda about 1890.<sup>13</sup> It seems that the four young Australian Fryers developed close connections with their uncle Willie and aunt Linda in Ipswich, when recovering from war wounds or while having a break from active service.

Tom first tried for the Civil Service, but failed the entrance examinations in 1884. He then studied to gain employment in the Bank of Ireland and was stationed first in Clonakilty (1888), and later in Clonmel (1894). By 1930 he was retired and living in Cornwall. Harry, Kitty and Maggie continued to live in Clonburrin with their widower father. None of these three married, and on the death of their father in 1914, each inherited a third of the land and property. Maggie died in 1929, while Harry continued to farm in Clonburrin until his death in 1936 (aged 72). On Harry's death Kitty moved from Clonburrin to England, and Clonburrin was sold in 1937 to Patrick Walsh for £575. It was bought by Peadar and Kathleen McCarthy in 1945 for £1400.

In 1917 young Henry Fryer (son of Charlie and Rosina), brother of Jack, visited Clonburrin while on leave from military service. In 1919 Uncle Willie and Aunt Linda Fryer visited Clonburrin from Ipswich, and were received by Kitty and Maggie.

Rosina Fryer, Jack's mother, first worked as a child-minder at the Orion Downs sheep station where she met her future husband. She later qualified as a nurse and midwife – she is said to have delivered her first baby at the age of twelve! In 1895 she and Charlie worked as a married couple at the local hospital, she as matron and Charlie as wardsman. It was here that Jack was born later that year.

#### Extracts from the Letters (1880-1930)

Some preliminary comments on letter-writing in the nineteenth century may be helpful in appreciating the context and contents of this particular collection. One can reasonably presume that what we have in the extant Clonburrin letters in the John D. Fryer archive does not represent all the letters that were actually written by the Fryer family to Charlie. Instead what we have are those few that, for one reason or another, Charlie and his family members actually preserved. In a world that did not yet have access to phone, fax, text-messaging, or e-mails, correspondence by letter-writing played a far more vital part than it does today. It was a lifeline connecting families separated by thousands of miles from home, whether because of work or military service. Reading through the Fryer archive, we sense this separation and loss, and the attempts to close the gap through frequent letters. Small wonder that many of the letters implore Charlie to communicate more regularly.

A second preliminary comment concerns the one-sided nature of the correspondence. We do not know how regularly Charlie replied to these letters. When he did reply from time to time, one gets the impression that it was never often enough, especially when we read the poignant exhortation of Willie to Charlie in his letter of 1894:

Now dear Charlie, will you like a good fellow write home if you can manage it at

all. You perhaps think we don't care, but we do indeed, and have written to you several times. If you have not succeeded as you wished, don't think that that will make any difference, because you will always be my brother, no matter what, though we used to have our squabbles.

Even if what we now possess has been preserved somewhat randomly, and given that we do not know exactly what Charlie and Rosina may have written in reply, nevertheless we have an extraordinary first-hand window into the day-to-day concerns of a family trying to remain in communication with each other across continents and against the background of war and its tragic effects on family life.

We begin with the earliest letter in the archive, written by Tom (aged 14) to his brother Charlie (aged 26). The handwriting is that of a young person, and his interests are very local. He mentions a number of neighbours by name – some of these family names persist in the general locality to the present day. The date is May 1880, so it must have been just some months after Charlie had emigrated to Queensland. It is clear from Tom's letter that Charlie has already written to the family and described something of his new life, since Tom asks him how many horses he has, and whether he likes riding. When Tom speaks of riding to Nurney three times a week with his older brother (Harry, aged 16) to a Mr Weir, this is most likely a reference to some kind of schooling, as William Weir of Nurney is recorded as a Church of Ireland clergyman in 1880 ([irishgenealogy.com](http://irishgenealogy.com) website).

Clonburrin, Garryhill, May 1880

My dear Charlie,  
I was glad to hear from you and to know that you are quite well. I am going to tell what happened since you left us. Rourke has left us long ago and Farrell is in his place and Taylor in Reddy's place. Henry Dillon is dead and Tom James and Mr Vesey. John James has got

Mrs Ruddock's farm. The two Roses John and Willie are gone to America, and Frank Nolan he is married to Sarah Bow that was at Mr G. James. Tom Jenkinson has left the cottage and is in Mrs Burgess's farm and man by the name of Nolan has it now.

Harrie and I go over to Nurney three days in the week to Mr Weir. It's a good ride over. I ride the ass and Harrie the bay mare. The Butlers of Ballybar go too. The two asses are here still, the old one is as big a rogue as ever, but Bob is a very good ass; old Bill is alive still, he's twice as strong as when you left us. He is quite fat. Harrie hunted Gipsy this winter. She hunts well. George James is not in the land yet. I suppose out where you are their [sic] is no such thing as winter. Are you fond of riding? I suppose you ride a great deal. How many horses have you? Have you any young ones? John Nolan has made great improvements on his farm. He has squared our old field.

I take up this letter again as it was to [sic] late to go with the last letters so I take it up again. There is a great change in Fenagh since you left. I go every day to Nurney now. Harrie does not go now. As Harrie has told you all news, and I have not anything that would interest you, so I must say good bye.

I am dear Charlie, your loving brother, Tom.

Letter no. 2 in the Fryer archive comes from Kitty (aged 19). Written some two years later, her perspective includes family news, as well as local and political comment. She is concerned about various injuries – her father's ankle and Harry's finger. She records that her sister Lily has left the family nest, and is now working in Dublin, while staying with an aunt, and that Willie is studying hard for his medical exams. The references she makes to

a "Charlie Fryer and his brother Willie" are to cousins, sons of an Uncle Henry Fryer. Her journey to the Horse Show with Papa is by train. Most interesting from a political viewpoint are her references to the "Land Leaguers" and the social upheaval linked to their agitation.

Clonburrin, 25 Jan 1882<sup>14</sup>

My dear Charlie,  
We were indeed glad to get a letter from you again. We had been first saying the day before it was a long time since you wrote, and were wondering the cause of it. It was doubly good news to hear that you are quite well, except for the bruise to your finger, which I hope by this time is quite well. We are all quite well thank goodness, except Papa has been laid up with a sprained ankle for the past two months, and Harry got his second finger in his left hand broken by the little threshing machine, which you may remember Papa bought just before you went out, but thank God he is quite well now, and Papa is getting much better. Lily is in Dublin now; staying with Aunt Margaret. Willie has left Butlers and is living with Aunt now. He is studying very hard and I think expects to be going to Edinburgh in April next (DV). Lily went to Dublin last August on a visit to Mrs Wynn, Mrs Badham's sister, and then came home for Xmas with Willie. She returned with him again which makes it very pleasant for him.

Willie has grown I think very much since you left, but Harry has grown more than any. Maggie has grown very much. I am the smallest now of any of the family. Charlie Fryer is going to the Church. He is very soon to be ordained now. His brother Willie has a very good appointment now. He is second mate of the ship which he is in, and has 5/9d per day.

## LETTERS FROM CLONBURRIN

The last place he has been to was Calcutta.

I was up in Dublin for the first time last September. I went up for a week with Papa. There was an excursion train at the time, it was the time of the Horse Show. There have been a great many changes in Ireland owing to this Land question and a number of murders have been made, which was very sad indeed. Numbers of people have left Ireland. Nearly all the upper tiers [?] are reducing their households, doing with less servants. Lord Rathdonnell, Mr Pembury, Mr Bagnall are all gone to England for the hunting. John Watson has come from India. He is in England now. Mrs Gray is going to live [sic] us later. Gary has come of age. Mrs Desey has gone to live near Bagnalstown. A great number of people are gone to America. Three of Mrs Fenelon's children are gone. Mrs Butler's old house is knocked down.

This winter so far has been very mild. There is a new Dr. in Bagnalstown, which the Land Leaguers got. Dr. Allen seems to be getting a good deal to do now. Mr Henry Bath is dead, he died last Friday. He has left the little girl his wife had a very large fortune. Mr Gluer has taken agencies in Limerick. An agent now has not a very pleasant post. Old Spot is still alive. And old Rourke<sup>15</sup> looks out in his garden sometimes. He is a kind wonderful old man. He has the white hat still which you gave him.

I think I have told you all news. We would miss Harry so dreadfully, we do not like the idea of his going so far. He is now a great help to Papa. Farming is the only thing he likes. He is a very

quiet good boy.

And now, dear Charlie, I think it is time I should bring my letter to a close. All unite with me in fondest love to you, hoping to hear from you soon again,

Ever dear Charlie, your loving sister, Kitty.

P.S. I hope you will be able to make out my letter for it is frightfully written.  
K. F.

Letter no. 3 is from Charlie's father, and is difficult to decipher, as he overwrites part of the letter at right angles. It is the first of six extant letters from William to his son, almost all of which are characterized by a plea to write more often.

14 September 1882

My dear Charlie

Why do you not write? You ought to know that we are always anxious to hear from you, and as each week passes by we say, it is a wonder Charlie does not write. Many things have occurred since we last wrote. Among the first kind of news is that Lillie is going to be married next November to a McCurry. He is in the [?] offices of the G.P.O. Lillie met him when in Dublin.

Willie is going over to Edinburgh next week to sit for his exams. He is thinking of getting into the army. Harry is working away at the farm. He is very fond of farming. I do not know what Tommie will turn his mind to. H. B. is staying with us for the last fortnight. Did we mention to you that Mr Beresford<sup>16</sup> was dead? Old Rourke is still alive. He is a wonderful old man. Saw on the paper the other day that the Government are going to help emigration to Australia this year. Labour has gotten very scarce. It was very difficult to work lands this harvest. It was also very wet and a good deal of corn was damaged. All the

Greyburns are married with the exception of Maria. Bab has gone to Australia with his wife. He has a dairy farm and goes into town every day with his milk. Have you ever seen anything of Anthony Ralph? The old man is still alive and so is old Rourke. All your old friends ask constantly for you ... Charlie Fryer has been ordained for Church of England. All the family left when the father got married to his second wife. The girls are living in Dublin.

Did you have an opportunity of getting your photograph taken? Get it done and send one. ... I think Harrie is writing to you ... He has grown very much. Tommie and Maggie have also grown very much. Capt. Murray (who lived at Janeville) with his family have gone to America. He was smashed he says through the [?] and dishonesty of his agent. Do you ever see anything of Mrs Blackett's friends who got you to write last time to us. Write soon and tell us all particulars as to your position and how you are getting on.

God keep you and your family,

Your affectionate father,  
WF Fryer

Letter no. 4 is to Charlie, this time from his mother, Lizzie. She signs her name in full at the end of this, and all her letters (including those to Rosina, her daughter-in-law) as: "Your loving mother, Lizzie S. Fryer." Exhorting Charlie to write more regularly, her concerns in this letter relate mainly to family news, and to Charlie's religious practice.

Clonburrin 20 September [1882]<sup>17</sup>

My dear Charlie,

It is now a long long time since we have had a letter from you, but I trust you are well and happy. I suppose you are now quite naturalized to the "New Country"

and to its habits. Since last you wrote to us many changes have occurred and I am sure you are surprised at the news your father's letter contained regarding Lily getting married. The man she has chosen is indeed very nice and good.

You would not know Harrie now, he is grown so tall, much taller than Willie. The latter has left for Edinburgh to pass his examinations. I trust poor fellow he will be successful. We have all the horses still. Gypsy is as stubborn as ever and your father is anxious to get her sold, but cannot sell Pied Bob. ...

How are you off now for a place of worship? Is there no way you could have service every week? I trust dear Charlie you do not forget each day reading God's word. May it indeed be a "Lamp unto your feet, and a Light unto your path."

I hope dear Charlie you will write very soon and regularly to us, you know it gives us such pleasure to hear from you and know how you are getting on. I forgot to mention Isabelle Watson that lived in Ballinrane. She was a long time ailing and suffered very much before her death. She died very happy trusting in her Saviour.

Lily Smith and Maggie unite with me in much love to you and may God bless you and keep you in the narrow path for his dear Son's sake.

I am your loving mother,  
Lizzie S. Fryer

Letter no. 5 is from William (then aged 23) to his brother Charlie. This letter comes not from Clonburrin, but from the S.S. Clan Sinclair, a ship belonging to a company set up in 1869 to operate passenger routes between Britain and Bombay via the Suez Canal. A rather long letter, its interest lies in the description

Willie gives of how he secured his first medical appointment, the colourful details of his journey thousands of miles away from home, and a short account of the wedding in Fenagh Church of Lily, their sister.

S.S. Clan Sinclair  
Indian Ocean, Near  
Colombo  
20 December 1882

My dear Charlie,  
I am sure you will be rather surprised to get a letter from me from here. I hope that nothing is wrong with you as it is nearly a year now since we heard from you. I am now a fully fledged surgeon. I went over to Edinburgh as I told you in my break for a month before the exam and read up with a grinder there and passed successfully, and got this appointment, surgeon to this vessel, a steamer of nearly 3000 tons. The salary is only £4.0.0 a month, but we are fed well, so it is fully worth a hundred a year or even more than that on land, and I was fortunate in getting it so soon.

The way I did was this: one of the lodgers at the house where I stayed, a Mr. Stevenson, knew the manager of the firm in Glasgow, and so it was decided that if I were successful in my exam I should get it. The house that I lodged in was owned by Mrs Purves' sister, a Mrs Farquharson, a very nice woman. I was made very comfortable when there, and was shown the chief places about Edinburgh by her husband. Edinburgh is a very pretty city.

I heard at home that John Purves is about to leave Mrs Beresford and take a farm on his own responsibility. I suppose you have heard too, that Lily is married. She will live at Blackrock, her husband's name is Sam McCurry, a Belfast man. He has

Carloviana 2012

an appointment in the secretary's office GPO Dublin. The wedding passed off very well. It took place at Fenagh Church. This was on Nov. 8. I had to start from home on the 17<sup>th</sup> for Liverpool as it was there I joined the ship. I spent a night at a cousin's of the Purves, a Mr. Paxton, a solicitor, and I had a run down to Chester which is a very quaint old town. I had not time to see very much of Liverpool.

But I have seen now a good deal of things all in a heap. We passed Gibraltar, which is a fine rocky place, then called at Malta and saw the monastery where they have some twenty-six mummified bodies of monks, and the Cathedral which is a beautifully antique piece of architecture, containing some silver that the Knights of St John brought with them from Rhodes. The ceiling is painted very nicely, representing different scenes, the subjects of which I could not tell. Then the walls have beautiful carving, and the floor was formed of marble slabs bearing the armorial characters and inscriptions of the knights whose graves they covered, altogether forming a splendid mosaic. Then the Palace has an interesting old armory, and a cranial chamber, the walls of the latter are covered with most splendid tapestry I ever saw, representing at the top the knights' different battles with the Turks and lower down the continents of Asia, Africa, America.<sup>18</sup>

We stayed at Port Said for a few hours, nothing particular did I see there – a lot of native sellers came around the ship, but I did not buy anything as they were asking too high a price. We saw a good deal of flying fish in the Indian Ocean and

LETTERS FROM CLONBURRIN

had rather a rolling passage causing some of the passengers to feel sick.

I hope they will soon have a letter home from you, knowing that you are getting on well. A good deal of the people ask after you, and now hoping that you are quite well and praying God to bless you, through and for our Redeemer esp.

I am, Your affectionate brother, Willie

Letter no. 6 also comes from Willie (now 25) to his brother Charlie, this time written from London, where he has a new appointment. Once again there is a familiar and poignant pleading with Charlie to write home, because all of the family are anxious to have news of him.

Monkton House, Acton,  
London W.  
26 March 1884

My dear Charlie,  
You must think it strange my long silence, but as we have never heard from you, we are at our wits end thinking what has become of you. But Mr Wilson's secretary ... told me that you were Mail Contractor for the Government out there, so I hope it is a step upward for you. I have often wished to get a vessel going out to that quarter but the only ones that do are beyond the influence or interest that I can command at present.

I am a Medical Assistant here with a very nice man who has a family of three daughters. It is an indoor appointment so I am treated like one of the family. They are all well at home. ...

Now dear Charlie, will you like a good fellow write home if you can manage it at all. You perhaps think we don't care, but we do indeed, and have written to you several times. If you have not succeeded as you wished,

don't think that that will make any difference, because you will always be my brother, no matter what, though we used to have our squabbles.

Things go on just the same at Clonburrin. Harrie is the Steward now, and is the biggest of us. Tommie is in Dublin reading for the Civil Service and I hope he may be successful.

Now with love to you dear Charlie and asking you to excuse this short letter. But the next one will be more full. God bless you.

Your affectionate brother, Willie.

Letter no. 7 is the second letter from Charlie's father, William (now aged 55). He is responding to the news just received that Charlie has married Rosina the previous year (1883). One can sense the disappointment that Charlie has not been in contact personally to tell them his news.

20 May 1884

My dear Charlie,  
I was glad to hear that you had settled for a home life and trust that you and your wife will be a comfort and help for each other, but why my dear Charlie will you not write home to some of us? We all have written from time to time and you have never replied to any. Surely the letters do not miscarry, as Willie wrote from England to you by that friend of Mrs B. and it was through him that we learned of your marriage. Will you send a photograph of yourself and wife. Is she Australian or British? What are you doing now for a livelihood?

Harrie was disappointed you had never written to him. He is thinking of America. Purves recommends the Cape. Purves was speaking a short time ago that you had not written to him. Why have

you given up all your old friends? Willie is at present in London at Acton with a Dr Francis. He likes his place very well. Lillie is quite well, had a daughter last Xmas day. Tommie is reading in Dublin for C.S. examination [civil service]. ...

Mr O'Neill has got a farm from Mr Brien at Killoughernaune. He is doing very well. Geo Lacey is still the same. His nephew Geo had to go to the Lunatic Asylum. I hear however he is getting better. Garry Grey had to go to France for his health. You know his mother died of consumption also his sister Hettie. Did you ever get newspapers from us, as it's said that the newspapers are finally detained at the offices.

Mr and Mrs Bunbury (Miss Watson that was) are living in England. The Land League movement caused a great number of gentlemen to go to England for hunting. Will unfortunate Ireland ever have peace? Charlie Fryer is going to London next month for a curacy. None of your Uncle Henry's family are living with him since his marriage. The girls however go on visits. They are living in Dublin.

I will now bid you a fond adieu, praying that God will help you and direct you and her whom you have chosen for a helpmate, in all your ways through this world, and bring you to that better world above for Christ's sake.

All send their love,  
Your affectionate father,  
W.F. Fryer

Letter no 8, also from Charlie's father, is very moving as it expresses his joy, and that of the entire family on the receipt of the much longed-for letter from Charlie. It is touching for its deep faith.

Clonburrin  
Bagnalstown



12 June 1884

My dear Charlie

It was with great joy indeed that we received your letter yesterday containing your photo and your wife's. You will no doubt receive a letter I sent to you about a fortnight ago, asking you to write. You will give my love to your wife and I pray God that your marriage will be a blessing to you and to her. Oh, my dear boy, ask for God's blessing on all your doings, and if the prayer of faith, however weak, ascends, He will in His own good time give you a blessing. You will each of you I pray be a help to each other through this sinful world, and as He has promised this, He will never leave nor forsake any who call upon Him. May we all call upon Him hourly for all our supplies of comfort. When you write next give all the particulars of your doings. Oh often, dear Charlie, during your long silence we have said, What is the poor fellow doing? Is he happy and comfortable and increasing in worldly prosperity?

Lillie is most happy. She has got a Christian husband. Kittie is small but Maggie grown a nice graceful pretty girl. Harrie is more inclined for the Cape or Canada. He is speaking of going to the Cape and get [sic] into the Police for three years so as to be able to see what the country is.<sup>19</sup> He is a very clever fellow about the farm. He does everything for me (with Purves) in the buying and selling, and is able to hold a plough. He has a fine manly disposition.

We have had a very dry time for the last couple of months. Meadows and corn bad. We had a wet winter and early spring which kept work very backward.

Now be sure and write

soon and give an account of your present position.

God help you and Rosina,  
Your affectionate father, WF  
Fryer

Letter no. 9 is the first of four letters from Lizzie to her daughter-in-law, Rosina. No date is given, but its contents show that this letter came soon after Charlie's letter to his father (letter no. 8). It is a gentle letter, in which Lizzie welcomes Rosina (aged 19) into the family and assures the young couple of her prayers.

Clonburrin, 16 June [1884]

My dear Rosina,  
I felt truly glad when Charlie's letter arrived to his father, as I could not imagine what was the cause of his continued long silence. I am united in warm congratulations for you and Charlie by all at home, and pray God will bless you both spiritually and temporally, for His dear Son's sake, and enable you each day to "cast your care upon Him who careth for you." Your "photo" is very nice but I should not have known Charlie his face has gotten much thinner. Had you a large wedding? Charlie's sister Lily has one little daughter. Her husband is in the General Post Office. He is an excellent young man. She is very happy. I hope you will send me a long letter and tell me how you are getting on, as I shall always be glad to hear from you.

All unite with me in fond love for you and Charlie,

I am your fondly attached mother, Lizzie S.  
Fryer

The main theme of letter no. 10, written by Charlie's father in 1885, is yet again one of reproach that his son is not replying to their many letters. He gives some local news as well as details on the family. Harry is now running the farm at Clonburrin, while his father fears that he may emigrate to join the Cape Mounted Police.

Carloviana 2012

Clonburrin  
Bagnalstown  
29 October 1885

My dear Charles,

Once more again we write to you in hopes it may receive a reply from you. All your family ask constantly, "Have you heard from Australia? How is Master Charles?"

Now I may begin by asking you how you and your wife are getting on. Your mother each day is expecting to get a letter from her in answer to hers. I hope you are getting on in worldly matters successful, and above all things, in heavenly laying up a good store in heaven. Have you had any family, what has God sent?

We have Willie and Tom at home now. Tom was reading for CS Exams but failed. He is now reading at home for Bank of Ireland. Willie who is now writing to you, has left London, and is trying for Japan on board one of P&O Steamers. I hope he may succeed. We are all well thank God. Maggie was down in the south with the Swantons in the summer, and Kitty is now in Dublin with Lillie.

Your niece is a very nice child and good tempered. Harrie is still at home looking after the place, but intends (I think) to emigrate. Gary Gray went to Australia a short time ago. He was in delicate health. ... Your mother has just come in from driving. She says old Mrs Lawler was asking for you. So you will see you are not forgotten. Harrie wrote three times to you he says, and you did not reply to him. Be sure dear Charles, write and tell us everything about you. ...

I am trying to think of news but I cannot do so. All at home send their love.

God bless you, your af-

LETTERS FROM CLONBURRIN

fectionate W.F. Fryer.

Letter no. 11 is Willie's third letter to his brother Charlie. From it we see William, as yet unmarried, in a medical practice in Suffolk. His sister Kitty is with him, probably keeping house. Willie's letter is full of interesting details relating to Clonburrin and the neighbourhood.

Meadlerham, Straham  
Suffolk  
25 March 1888

My dear Charlie

At length after this long silence I feel I must drop you a line to let you know how we all are doing and indeed we would like very much to know how you are. Well here I am in a small room in a small cottage, with a nice little fire in the grate and with Kitty as my companion. I dare say you have not begun fires yet if you ever need to. We have had a very long spell of cold weather, snow and frost off and on since Xmas, the farmers in consequence very backward with their work. This is a great corn raising part of England, but the farmers are growling very much at the state of things and the prices. They are hard enough up and many of them have become bankrupt.

I am here since November 1887 working away on my own and at present can just keep my head above water. I have got a mare, Betsy, and trap and a kind of gig. Kit and I live here in a tiny cottage, there being no decent house available. I am not yet married, but hope before the year that I may be.

This is a very flat part of the country about 25 miles from the sea (German Ocean), and as there are no intervening mountains we get the pure and unadulterated N.E. sea breeze and a pretty cold one it is. It is a very quiet part too, very little hunting,

scarcely any society beyond the clergy. Suffolk does not boast of many resident gentry, but I expect in the summer there will be a good many tennis parties, and I imagine not much sickness, as the people are very long-lived and don't ail much.

There is another doctor of the name of Cuthbert here. This is a village of about 700 inhabitants, boasts a church, four public houses, one general shop, two butchers and about a half dozen smaller hucksters. I came here on the death of a man named Taylor who drank himself to death. I was lead [sic] to imagine that the practice was worth far more than it really is. This man Taylor had been an assistant with Cuthbert and they treated him very badly so he started on his own account and did very well for a time and then gave way to drink. The Cuthberts of course did not like him and don't care much about me. There are two, father and son, but the latter is not at all popular, being very rough in his manner. His father holds the parish appointment and being nearly past his work I think there would be a chance of my getting it if he resigned.

Now you will want to know how they all are at home. Father and mother are both well, father working away at the Fenagh dispensary still. Harry, who has grown a great big fellow, minding the bit of ground for him. The rent was reduced 30% last year, so that it has come down a good deal.

Only Harrie and Mag are at home. Tom has got into the Bank of Ireland and is stationed at Clonakilty at present. Beauchamp Brady is dead. Inglis came home after his military service. You knew I think that he had enlisted. He is now married to

Minnie Watson. It came off on 14 February of this year. Robbie Watson got promoted in the "Cape" police and is married. John is at home doing well as a horse dealer. He is the champion polo player of the world.<sup>20</sup> His father is still the M.F.H.

Mr Phillips is the clergyman of Fenagh now. Mrs Baddham is dead. And the daughters work as governesses. Matt Farrell works for Father. I don't know what has become of James Reddy. Rourke is still to the good. So is old Anty Nolan but she has been superannuated as dispensary hostess. And Fanny Tuthill née Ralph is dead.

I do not know of anything more to tell you. Purves has left Fenagh Lodge and has taken Richard Newland's farm at Newtown and I think is doing well He has got five children. Johnny Rose is dead.

I hope you and Rose are quite well and with love to you both in which Kit joins,

I am your affectionate brother, Will

Letter no. 12 is Lizzie's second to her daughter-in-law that has been preserved. The year is not given, but reference to her little granddaughter "Lizzie" (born 1884) and to "children" implies a date about 1887-1889, by which time the two oldest sons were born. We learn from this letter that the Australian grandchildren have been ill, as Lizzie attempts to console Rosina. True to character, she also expresses concern for the spiritual welfare of the family.

Clonburrin, 30 July [1887-1889]

My dear Rose

As Father wrote to Charlie, I thought I would put off writing to you for a little while. I suppose Charlie has gotten his father's letter with the one from Christabel. At this time I was very glad when I got your letter and dear little

Lizzie's "photo." She must be a fine little thing and a great companion for you. What an anxious time you must have during the children's long illness, but your Heavenly Father did not forget you through all, but sent kind friends to be a comfort. How truly can we say, "His tender mercies are over all his works." His promises are true and steadfast. Little Christabel [McCurry] is with us still, her father has left to see the Cumberland Lakes and to attend meetings in Ipswich. I am truly glad to learn from your letter both you and Charlie are so happy and love each other, as the old Proverb is "the wealth of the cottages is love." Are your father and mother still living? And have you any brothers and sisters? I was sorry to hear Charlie's latest employer made so many mispractices, but I trust the Lord will open something better for Charlie soon. ...

Have you good earnest ministers near you? And is there a branch of the Young Women Christians Association near you? A great many people are gone to America from this part, so that labourers have become very scarce. Tell Charlie Anthony Ralph never writes to his family. His sister does not know whether he is alive. His father is dead some time. ...

I hope, dear Rose, you will soon write again. With very much love, in which I am united by all for you and Charlie. Kisses for the dear children,

Your loving mother,  
Lizzie S. Fryer

Letter no. 13 is Lizzie's third to her daughter-in-law. In it she gives a summary of the family in Clonburrin, and is building up a picture of Rosina's in-laws in Ireland. She begs Rosina to get Charlie

to write, and underlines her request.

22 January 1891

My dear Rose,  
Your affectionate letter which I duly received on the 20th gave me very much pleasure. We all felt so glad hearing the good news of your and Charlie and the dear children. What a good child dear little Lizzie must be.

A friend of mine left us about four years ago for Brisbane and I begged of her to try and get me some news of poor Charlie. Miss Stephen's friend knew Mrs Gillespie and each day we were expecting to hear some news of Charlie and you.

Willie was married last November and is living in England. He is a doctor. Harrie is attending to the farm and Tom, Charlie's youngest brother, is in the Bank of Ireland. Lily, your eldest sister-in-law, is married eight years. She had four children, three of them are alive, two boys and two girls. She is settled near Dublin. Her husband has an appointment in the Post Office. The two other sisters are unmarried and living at home at present.

I shall always be so glad to hear from you when you have time and tell Charlie to take courage and write to us. It will give us such pleasure. I do love the dear little ones. Their dear grandfather, aunts and uncle Harrie unite with me in sending them a great many kisses.

How very different the weather is here, winter and a very severe one. Tell Charlie an old friend of his, the second Miss Gray of Upton is married to Mr Dawson. They are in Melbourne at present with Mr George Watson, and Charlie's old friend Forbes Watson was buried yesterday. He died of

Carloviana 2012

typhoid fever and his death was a happy one and he died trusting in his Saviour.

When you get this letter dear Rose do make Charlie write to us, and please God he will get a long letter from us all telling all the news. I am sure Willie will be delighted when he hears we had a letter from you, for Willie is so anxious to know about Charlie.

I trust dear Charlie has given his heart to the Lord. May your loving Father guide you both by his Holy Spirit each day. For his dear Son's sake ...

Where is Charlie working and are you near a Church? I hope Charlie is getting on well. Tell Charlie Mr Bates is living in Janeville. He has eight children. Robbie is quite a young man.

I hope this letter will reach you and that Charlie will take courage and write. Do make him dear Rose.

Grandfather, Aunts and Uncle unite with me in fondest love for you dear Rose, dear Charlie and many kisses for the darling children.

Believe me to be, your loving mother  
Lizzie S Fryer

Letter no. 14 comes from William, now aged 62, his fifth extant letter to his son Charlie. It is a rather lengthy letter, so what follows is slightly abbreviated. We learn that Charlie has been unemployed due to strikes. We also get an update on family news, as well as farming problems.

Clonburrin, Bagnalstown,  
26 September 1891

My dear Charlie,  
We were all so pleased getting your letter on 1<sup>st</sup> August and to learn that you, Rose and the children were all well, but sorry to know you were so long idle owing to

LETTERS FROM CLONBURRIN

the strikes, which I hope may soon pass away and that you may be able to get some appointment more congenial. Your mother is thank God quite well and has been with Lillie in Blackrock for the last 6 weeks. I expect her home next week. The stay will make her strong I hope for the winter. ... We had Tommie at home for his holidays a few weeks back. He is still in Clonmel. Willie and the wife are quite well when we heard a short time ago. Tell my little granddaughter I sent her letter to her cousin in Blackrock and she was very glad to get it. I suppose she will write her another. I suppose Rose got the letter your mother wrote to her, and I will wait till your mother comes home to send you this as the women-folk contrive to have more to write about than the men.

This has turned out a very long wet season with us, a large quantity of hay spoiled, and corn from being too ripe shelling a second growth. I had Kellett's field cut and ... they shook it out one fine day to tram, when suddenly a heavy shower of rain came, and for 6 weeks on and off we could do nothing with it. I fear it will not be much use as fodder. I hear a great many in the same way as sufferers. Mr Nolan had to cut one of his large fields with scythe and hooks...

John Watson has left the Army, he is now Master of the Meath Hounds, has a large salary for hunting them. I heard 2,900 a year. He is married to a Miss Booth of Co Wicklow. You may perhaps have seen her father at Ballydarton. Robbie Watson you are aware was in the Cape Mounted Police, and when he filled up his time, I believe he got a

commission out in Africa. Bow has come home from the ranches in Manitoba, and is now in London, having got some clerk work as secretary to some gentleman. ...

Letter no. 15 is from Charlie's mother, written in 1891, on her return from her visit to Lily and family. She appears refreshed by the change of air, and her mood is upbeat. Once again she urges her son to seek ways of having some kind of Sunday service. She includes various updates on the wider family and neighbours. Since the letter is quite lengthy with this kind of detail, it has been abbreviated here.

20 November 1891

My Dear Charlie,  
You will say it took a long time to finish this letter. I was in Dublin the time your letter arrived and did not return for some time. I was staying with Lily. Her eldest was delighted with the card. Her cousin Lizzie sends hers. Lily is going to live in Kingstown as she thinks the air is better than Blackrock. Her husband is a very good Christian man, he is so anxious to do good for his Master above. She has been most fortunate in getting such a good pious man.

I heard dear Charlie your prospects are getting better and brighter. It is very sad to think there is so little thought of in keeping the Sabbath. I have been thinking could you not manage to collect the nearest people to you and have a prayer meeting if there is no place of worship near you. I hope Rose and the children are quite well, living in the bush. How are you managing their education? ...

Willie has bought a practice in Ipswich. He has gotten some money with his wife, she is very nice and good. Her uncle, Mr Badham is very fond of Willie

and is a most generous man. Did I tell you the manager of the National Bank where you were in Enniscorthy turned out very badly and had to be dismissed. ...

I suppose when this reaches you it will be Xmas, and I am joined by all, dear Charlie, in wishing you, dear Rose, and all the children a very happy and bright Xmas and New Year. May the Lord indeed bless you both, guiding you both always by His Holy Spirit and leading in the narrow path ever keeping you in it. For His dear Cross's sake because all reach their finish. Love and kisses for the children.

Your loving mother,  
Lizzie S Fryer

Letter no. 16 is from William (now aged 65) to Charlie, and is very direct and quite firm. From it we learn that Charlie has asked for £100, which his father either cannot or does not wish to give him, and he explains why. One way of estimating the value of £100 then would be to compare it to the sale of Clonburrin House and land in 1937 for £575. The formulation of the letter gives the impression that William is under pressure, both because of the amount of errors it contains, and the difficulty of deciphering the handwriting.

Clonburren [sic]  
Bagnalstown, Ireland  
20 February 1894

My dear Charlie,  
We were indeed pleased getting a letter you [sic], after such a long silence, as your last was written in August 91. It disappointed us your having said nothing about your children, or as to your domestic concerns. It must be a great trial to you to have no work but would it not be wiser for you to stay with one employer than going about from one place to another?

And now Charlie, as to

LETTERS FROM CLONBURRIN

the £100 which you ask me for, just at present it is quite impossible. I could [sic] give it unless I borrowed it, which I do not wish to do. You know there are Kitty and Maggie as well as your mother to be provided for, and the only way I could do that was by insuring my life for a small sum, so that when it pleases God to summon me, they may have a few pounds to keep them, till they look about and see what is to be done. In your former letter you stated that land was going to the bad and several rich persons were being [?] so that they had to turn to labor, and being the case, would it be wise for you if I could manage about the money to invest? I will now give this paper to your mother, who will write to Rose.

God bless you and I hope you ask Him to guide you in the perfect way.

Your affectionately  
William F Fryer

Letter no. 17, from Lizzie to Rosina, is included with William's letter above. Although Lizzie makes no mention of Charlie's request for money, we get the impression that she is quite perturbed about their situation, and prays that all will be well. She would like to know how things really are for the family and children, but feels powerless. Her comment about this being "a stupid letter" possibly reflects her anxiety. It could also point to a deteriorating health situation, as she died six months later.

My dear Rose,  
As Father is writing to Charlie, I wish to send you a line, this same time. I have been expecting a letter from you, but I trust you and the dear children are well. Many changes have occurred here since I last wrote to you. Willie is settled in England and has two children. Charlie's sister Lily has five children.

I felt very much disappointed Charlie did not mention anything about you or the children, how you are getting on or where you are.

I feel this is such a stupid letter I have so little news to tell. I can thank God to write we are all well. All unite with me, dear Rose, in much love and praying the good Lord will bless you, Charlie and the dear children, and guide you by His Holy Spirit each day for his dear Son's sake.

Your loving Mother,  
Elizabeth S Fryer

Letter no 18 comes from Willie (aged 35) to tell his brother Charlie of the death of their mother. It recounts a brave ending to a brave life.

Clonburrin  
Bagnalstown  
22 August 1894

My dear Charlie,  
Our dear mother passed away early on Monday morning at 1.20 am. Her end was very peaceful, like a child falling asleep, and so patient she never murmured. I was home with her for a fortnight. She was in bed the whole time, and so weak that she could not sit up, had to be lifted from one side of the bed to the other. Harry was devoted in his nursing of her. She knew us all up to the last almost and seemed to be conscious of what was said though she was to [sic] weak to articulate clearly. She died trusting fully in her Saviour and his work for her.

Poor father is much cut up and I am fetching him over to Ipswich with me for a change for a month. It will do him good. I am writing this letter at Sandymount, at Uncle's on my way to Ipswich. So it accounts for the slight mourning paper. You would be much struck with the changes in Fenagh. It has

Carloviana 2012

become so depopulated and the gentry are dying out. Kilconnor empty. Three at Ballydarton. Three at Myshall. Inglis Brady going to the dogs drinking.

Tom is now in the Bank of Ireland at Clonmel. Harry farming at Clonburrin but it is not paying. I am at Ipswich where I have a good bit of hard work, but cannot complain of the way I get on. Henry Nolan and G. James are dead.

We buried mother at the end of Dr Carey's grave. They had great difficulty in sinking the grave as they came upon a rock, and consequently had to pick it away. Michael Nolan was very kind in getting everything he could done for us, and in helping in every way.

I hope you and Rosina and the children are well. I suppose the latter must be getting big now and be a help to you. All at Clonburrin join me in love to you all.

Your affectionate  
brother, Willie

Letter no. 19 was written by Charlie's son, Henry, to his mother Rosina. Reading between the lines, it would seem that he was on sick leave from military service in 1917, with at least an arm injury, if not more. It is interesting to read how this young Australian soldier viewed Clonburrin, where his father grew up, and also to read the list of people he gives who remembered his father Charlie.

Clonburrin  
31 July 1917

My dear Mother,  
As you will see by the address I am at Dad's old home, and a very pretty place it is too. Everything is looking lovely.

And the people about here are all very nice, and make you welcome. And the old people wish to be remembered to Dad. I expect Dad will tell you the names

LETTERS FROM CLONBURRIN

of them. There was a Mr and Mrs Purves, Pat Kinsella, Charlie Nolan and Tom Tuthill. So I expect Dad will remember them.

I am leaving here tomorrow for Ipswich to spend a few days there [with Willie and Linda]. Then from there I have to report at Weymouth. And from there I expect it will be to a Training Batt then on to France again. So you see I am having a good trip around.

I had a letter from T. Gillespie. He is on his furlough also. So we are running things pretty closely. Getting wounded the same afternoon. Then he left Dartford the morning after I arrived. And now we are on furlough together. So I expect we shall soon be back in France together again soon.

Well, Mother, I wish you could all have as good a trip around the old country as I have had. Especially now as everything is so green and looks so well. I have been haymaking with Uncle these last two days. So you see my arm is pretty well alright again.

Well, Mother, I shall have to knock off now hoping this will find you all in the best of health. I am your loving son, Henry

Letter no. 20 comes from Aunt Linda Fryer. Together with her husband Willie, she was taking a break in Clonburrin in 1919 after the death of their daughter Nan. She is writing to her niece-in-law, Lizzie Fryer in Queensland, the oldest child of Charlie and Rosina, now aged 35, to congratulate her on her recent engagement to James Gilmour. It is a long chatty letter, so what follows here is a shorter version. The Charlie she refers to is Lizzie's brother, the second son of Charlie and Rosina, lost in action in World War I.

Clonburrin  
Bagnalstown

19 October 1919

My dear Lizzie,  
I feel quite ashamed to write to you, having left your loving letter so long unanswered, and you unthanked for it, but for a long time I felt as if I could not write to anyone, except just to my own boys and girls, and then I had the servant difficulties, from which everyone seems to be suffering, and which kept me busy at other things besides letter-writing.

Yes, we do feel very sad and lonely without our darling Nan. The boys knew what a sweet, happy, unselfish girl she was, just the one everybody seemed to go to, but God knows best. Our dear child is happier with the Lord she loved and served, than we could ever make her.

Kathleen has had a lovely holiday this summer and is really better than she has been since the great shock and sorrow.

You will see from the above address that Uncle Willie and I are having a little holiday with Aunt Kitty and Aunt Maggie – he has not had a holiday for eight years, and I could not leave home this summer while Kathleen was away as we had nothing but a nice young housemaid who could not be left, so I have come too.

I know I ought to have written our hearty and loving congratulations to you long ago, but you will forgive me, won't you and accept them now. I was really pleased to hear of your engagement and no doubt in this you are married and I trust very, very happy. I do not know where your house is, but I expect this will reach you.

I cannot think what your old house will be like without you, the boys spoke as if

you were the centre of it all.

It was a great pleasure to us to get to know the boys, and we were so glad to be able to make a little bit of home for them. I always felt how I should appreciate anyone doing the same for my boys in case of need. I am very [sic] we never saw Charlie. I am sure you must have felt it very much when you got the others back and one short. But indeed you have much to be thankful for in getting the others back safe. I hope Will and Henry are still much recovered than when I saw them last. Please thank them for their letters, also Jack. We shall miss them this Christmas, especially as we shall have neither Will nor Douglas. The former is in the Ladybird,<sup>21</sup> one of the two monitors left in the Danube, and is now at Buda Pest. He is a bit lonely but is glad he went, it is such a unique experience. Douglas is surveying in the Mediterranean this last six months and has been between Alexandria and Port Said, but it is altogether a two years' job. He seems to like it very much. Dermot has just entered Cambridge, with a view to the medical.

I suppose it will be nearly Christmas time when this reaches you, so please accept our best wishes for a very happy one for you and yours. If you should ever find your way over to England, you know that you and your husband will have a warm welcome.

With our love for each,  
Your affectionate Aunt  
Linda Fryer

Letter no. 21 was also written by Aunt Linda Fryer in 1923 to Lizzie Gilmour (née Fryer), to express her condolences on the death of Lizzie's brother, Jack Fryer. Like the previous letter it was full of family news as well, so the paragraphs



LETTERS FROM CLONBURRIN

below have been abbreviated somewhat. Although no address is given as to where she was writing from, it was most likely from their home in Ipswich.

9 December 1923

My dear Lizzie,

It is a very long time since any communication has passed between us. I see your last letter was written in March to tell about Jack. I had just written to your mother when your letter arrived so I am afraid yours got left as I felt you would hear all news of us from it. Now I have as usual left my letter to [sic] late to arrive in time for Christmas but I hope the New Year will not be very old when this arrives to wish you all a happy New Year. ...

It was terribly sad about dear Jack, the future seemed all so bright before him, but God saw fit to take him to Himself. I wonder how his fiancé is and has she made up her mind to come to England... I wonder is Henry married yet? Are any of the older boys engaged?

Now I must close this very uninteresting letter, hoping you are all well, particularly your husband and little girl. I do hope your mother is stronger and getting over all her misery and her sorrow, at least as much as anyone can. Life can never be the same, but she has many dear ones left to her.

With my love and very best wishes for a happy New Year for each of your dear ones.

Your affectionate Aunt  
Linda

Letter no. 22 is the second last of the Clonburrin letters. It was written by Willie (aged 69), while visiting at Clonburrin in 1928, to his brother Charlie (now aged 74) in Queensland. He lists a number of interesting political and social changes. The "Kathleen" he refers to is

his daughter who visited Queensland. He also describes how weak his sister Maggie in Clonburrin is – she died four months later (4 March 1929).

At Clonburrin  
Fenagh, Bagnalstown  
30 October 1928

My dear Charlie,

It is ages since I sent a letter to you but you have heard a bit about us from Kathleen, who has spoken about all your kindness to her and for which I am very grateful. It does not seem so long since your boys were with us and yet it is. I was very glad to hear of all your doings.

I am here for my usual holiday until Friday next, 4<sup>th</sup> November when I return for my usual routine.

Maggie has had a nasty bout of illness and is still in bed, weak and thin. I believe she had influenza and after pneumonia and heart weakness. She apparently kept about too long before seeing a doctor. She has a damaged left lung, the result of a pleurisy in 1895. She is now fearfully emaciated and I fear will be a long time before she will be strong again.

Harry and Kitty are very well and are kept busy. Harry has acted as nurse and been most attentive. I believe he didn't have his clothes off for a full night.

The doctor too, O'Connor, a comparative newcomer to Bagnalstown, has also been very attentive and treated her very skillfully.

You would find many changes if you were here now. All the Watsons and Grays gone, Denny Beresford, now a widower, an occasional resident. Garryhill shut up, Myshall House burned during the troublesome times of Free Staters and Republicans. Michael Nolan and his sisters the only remains of the Nolan

Carloviana 2012

family. Malachy Ryan dead. William O'Neill still alive and living at Ballyloughin. Clonmore empty; a son, the only son, of Mr Letchford is living at a place called Hitcham about 20 miles from Ipswich. The Bates scattered over the world. Robbie married in Dublin, Sissy died recently in West Australia. Her sister Lottie married to a man named Phelp is living out there, with some government job connected with emigration. Georgie and Rachel are in South Africa married. Tom is [sic] Canada, Bertie dead. Kilconnor occupied by a lower class of farmer who does not keep it up as formerly. The previous occupier a Mr Steward was killed in the war and his widow and sister-in-law are living in England, near Chichester.

I dare say Kathleen has told you about all of our family. Like you I am a grandfather, of Will's two children, Patience 6 and Lena 4.

I was at the opening meet of the Carlow Hounds on Tuesday. The Master is a Mr Hall and the Huntsman Mr Grogan. His father lived at Slaney Park near Tullow. I wasn't mounted, Harry had to go into Carlow and stopped to see the meet. Harry hunts pretty respectably. I was not fit behind or I might have ridden his hunter to the meet, but as I have been only exercising the horse since arrival and had not been on a horse's back for two years, I was quite sore, and as one gets old one does not get over stiffness so easily.

Harry has got some land near Ballydarton<sup>22</sup> and is doing fairly well cattle dealing (selling) and some horse dealing. He got some good prices I believe for some hunters.

LETTERS FROM CLONBURRIN

J. Purves is still alive, over 80. Mrs. died early this year. He is living in R. Newland's farm, Boherduff. One of his sons is in America, the other in South Africa. Two daughters, Mela and Janice, are at home, the other, Sissie is married in Scotland.

I think this is all the news I have. With love to you and all your family,  
Your affectionate brother, Will

The last of the Clonburrin letters (no. 23) preserved in the Fryer Library comes from Henry (aka Harry), and is addressed to his brother Charlie. Harry, now aged 76, was the one who maintained the farm in Clonburrin from teenage years through to his death in 1936, even though at one period (1884) there were fears that he might go to join the Cape Police in South Africa. The update he gives Charlie mentions a number of people who can be still be remembered today by locals living within a radius of about five miles.

Clonburrin  
Bagnalstown  
19 October 1930

My dear Charlie  
It is a long time since a line passed between us, so I thought I would drop a line and wish you and yours all the compliments of the season. I hope you are all keeping well.

I don't know if you heard that poor Maggie has gone to rest. Willie told me that he would write to you and let you know, but I have not seen him for the last year and half. I don't know if he told you would see a great many changes in this place. Not a Watson in the whole neighbourhood, Ballydarton divided amongst ex soldiers, Kilconnor with one of the Nolans, Lumclone with Morrow, a retired school-teacher, Evergreen with a Miss Corrigan, Upton with a Nolan (one of

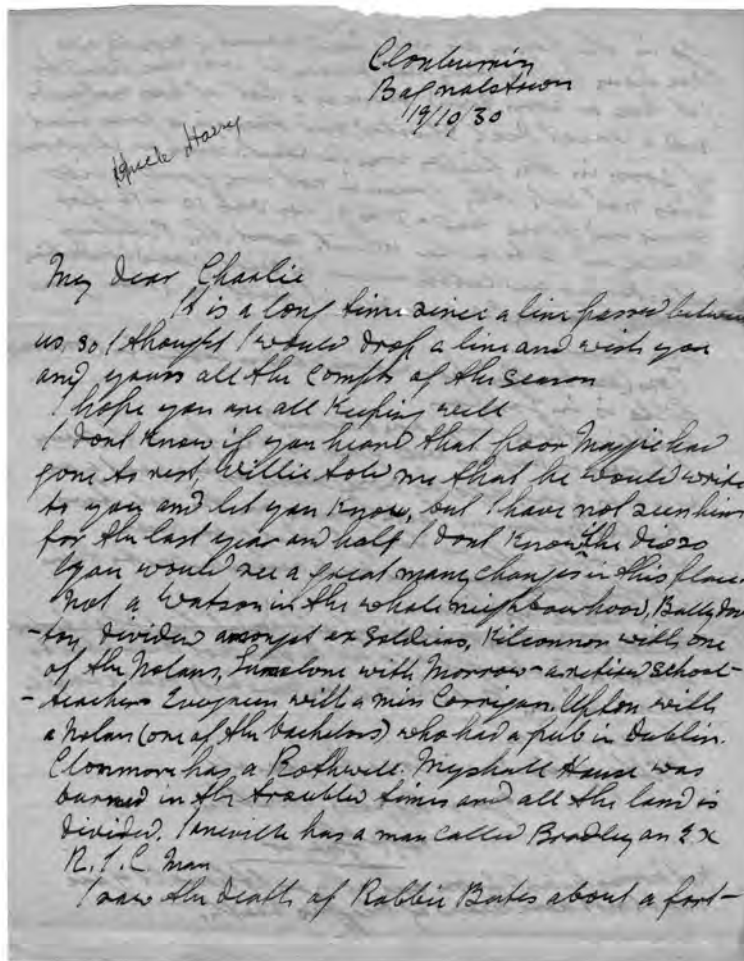

Letter no.23. Harry Fryer to his brother Charlie

the bachelors) who had a pub in Dublin. Clonmore has a Rothwell. Myshall House was burned in the troubled times and all the land is divided. Janeville has a man called Bradley, an ex R.I.C. man.

I saw the death of Robbie Bates about a fortnight ago in the paper, his wife died about a month ago. We have had a very wet season. It was very hard to get hay or corn saved. There is a lot of hay not saved and a great deal spoiled and there is a great deal of corn in the fields, some in sheafs, more in shoots and bits not cut. The grain is not very good, quite small and price bad - 7/- to 9/- for oats, 10/- to 14/- for barley and 12/- to

14/- for wheat. The potatoes blackening and cattle unless in very good condition selling badly. So you see it will be a bad year for farmers.

Tom (our brother) has retired and is living in Cornwall. Lillie is in London. Willie's three boys are married. Purves is keeping well, goes to the fairs the same as forty years ago. He sometimes asks about you. Bertie Nolan and Jack Lomax are the only two old people left in Fenagh that you knew.

I hope your boys are well. Remember me to them. Also Lexie McMillan.<sup>23</sup> Michael Nolan is laid up at present. He got a stroke about a fortnight ago and he has not been able to speak

since. Pat (the one you knew best) died a couple of years ago.

Kitty joins me in love to you all.

Your affectionate brother,  
HH Fryer.

I haven't heard from any of you. I thought you might not have heard of Maggie's death.

#### Concluding Comments

The focus in this article has been on the extant letters written by the Fryer family of Clonturrin to their oldest son Charlie who emigrated to Queensland in 1880, and also to certain other members of his family. In the nature of things it is a one-sided correspondence, with a certain random character as to how and why the extant Clonturrin letters survived. As already mentioned above, it is reasonable to suppose that Charlie and Rosina would have received other letters from Clonturrin that, for one reason or another, were not preserved. However, since the focus of the archive is on Jack, in whose memory the Fryer Library was named, it is understandable that the archive should contain many more letters apart from those related to Clonturrin. In addition to these latter, the material donated to the library by Jack's family contains several letters and postcards from Jack and his three older brothers, written from various war locations and other postings. It also contains letters written by various grandchildren of William and Lizzie Fryer to Charlie's children, as well as family birth, marriage and death certificates, school records, newspaper cuttings, photos, military insignia and other memorabilia.

If the contents of these other letters were added to those printed above we would have a richer portrayal of the various characters, particularly of Jack and his siblings. Nevertheless, the Clonturrin letters as they stand are absorbing at a number of levels. First, they are authentic letters, written out of love and concern for Charlie and his family. The authors of these letters could never have known that one day we would be privileged to read how they longed to hear more often from their emigrant son and brother, as they filled him in with minute details concerning the family, friends, and neighbours he had left behind. We can also be struck by

the concern that Charlie's parents, especially his mother, showed regarding reli-

have come from this voyage. It seems that in later years Lily and her family



Clonturrin House, 1901

gious values and practice. There is hardly a letter in which she does not pray for the spiritual wellbeing of Charlie and his family.

Second, these letters are particularly interesting for the insights they give regarding the neighbourhood of Clonturrin and the surrounding villages of Fenagh, Myshall, Garryhill, and Nurney, all within a radius of five miles. There are references also to the larger entities of Carlow, Bagenalstown, Tullow and Old Leighlin. Many of the family names mentioned in the letters can be linked to their twenty-first century descendants who still live in the general area.

Third, and perhaps most striking, is the world-wide network of connections emanating from this house in rural Co Carlow. William senior was born in Kinsale, Co Cork, trained in Glasgow, and practised as a country doctor in the Fenagh and Myshall district of Co Carlow, whereas his son Willie trained in Edinburgh, was a medical officer on a passenger ship travelling to India, had medical appointments in London and Suffolk, and finally settled in Ipswich, having bought a practice there. His description of passing through Gibraltar, Malta and Port Said is reminiscent of someone doing the Grand Tour – the rupee recently dug up from the garden in Clonturrin may well

moved to London. Tommie, on retirement from the Bank of Ireland, settled in Cornwall, and Kitty, on selling Clonturrin also moved to England. Only Maggie and Harrie, as well as their parents, died in Clonturrin. Finally, there is Charlie, who emigrated to Australia, and lived in the Springsure and Rockhampton districts of Queensland. It is ultimately thanks to him that we now have access directly and indirectly to the various "Letters from Clonturrin".

The narrative thread of the letters returns us from Australia to Europe as Charlie's four older sons find their way back to the "old country" and into the thick of World War I. After Jack's premature death he was honoured by his *alma mater* through the establishment of the Fryer Library, and the *Fryer Folios*, a journal which illustrates the range of special collections in the Fryer Library, and publishes scholarly research based on these sources. By way of conclusion, I wish to acknowledge the interest and enthusiasm of Laurie McNeice, Director of the Fryer Library of Queensland University, and to thank her for her generous help at every stage in researching these "Letters from Clonturrin."

<sup>1</sup> Permission to reproduce the Fryer let-

LETTERS FROM CLONTARRIN

ters and photos contained in this article was kindly granted by Laurie McNeice, Manager and Senior Librarian, Fryer Library, University of Queensland, Australia.

<sup>2</sup> Laurie McNeice, "John Denis Fryer: A Life Remembered," *Friar Folios* 3 (2008): 4.

<sup>3</sup> John D. Fryer Collection, University of Queensland, Australia (UQFL23).

<sup>4</sup> For an illustrated overview of Jack Friar's life, see Laurie McNeice, "John Denis Fryer: A Life Remembered," *Friar Folios* 3 (2008): 4-7.

<sup>5</sup> Jack Fryer's army records contain no mention of his having been exposed to poison gas during his war service, though his close friend P.R. Stephensen states this as a fact in his obituary of Fryer published in the UQ student magazine *Galmahra* in May of 1923 (P.R. Stephensen, "The Death of a Friend", *Galmahra*, May 1923: 28-31). In discussing new information concerning the origins of the Fryer Library, and the man for whom it was named, Mark Cryle, former Fryer Library Manager, questions the assumption that Jack's death was due to gas poisoning; see M. Cryle, "A Very Small Acorn", *Fryer Folios*, June 2010: 7-13. Noting the cause of death given on Fryer's death certificate, Cryle concludes: "How much, if at all, his war service contributed to his terminal disease cannot ever be known." (p. 9).

<sup>6</sup> Founded by Michael Davitt in 1879, the Land League's chief objective was to abolish "landlordism" in Ireland, and to enable tenant farmers to own the land they worked on. The period of its agitation is known as the "Land War." Kitty Fryer refers to the Land League in her letter of 1882 to her brother Charlie, as does her father in his letter of 1884.

<sup>7</sup> As recorded in 1849 in the journal *Medical Intelligence*, p. 615.

<sup>8</sup> The *British Medical Journal* of 8 Nov 1873, in a paragraph titled "Medical News," and a subtitle, "Apothecaries Hall, Dublin," mentions William Francis Fryer as one of "the following gentlemen [who] passed the preliminary examination in arts."

<sup>9</sup> William Fryer and his family, though not poor, would have been tenants of the landlord, Sir Frederick Ponsonby (1815-1895), Sixth Earl of Bessborough.

<sup>10</sup> His mother Lizzie in her letter of

1891 refers to the manager of the "National Bank where you were in Enniscorthy."

<sup>11</sup> Lizzie married James Gilmour in 1919, and they had a daughter Alexis (aka Lex). Lizzie qualified as a teacher, and was the author of a biographical account of her brother Jack. She oversaw the donation of the Fryer archive to the University of Queensland.

<sup>12</sup> Henry's grandson, Colin Thomas, lives in Springsure. His sister Beverly Bain kindly sent us a photo of a picture of Clontarrin, painted by Christabel McCurry, daughter of Lily McCurry (née Fryer), in 1901 for her cousin Lizzie Gilmour (née Fryer).

<sup>13</sup> Willie and Linda had seven children: Nan (who died in 1919), Douglas H. (Naval Commander), Will (Navy), Dermot (MD, Cambridge), Kathleen, Norah and Eileen. Douglas Fryer visited the McCarthy family in Clontarrin in July 1964.

<sup>14</sup> Not June, as currently listed in the UQFL23 archive; its contents point to winter.

<sup>15</sup> There are many references in the letters to "old Rourke" (a very near neighbour who lived in the small cottage very close to Clontarrin on the Raheenwood road).

<sup>16</sup> The Bunbury Papers ([www.rootsweb.ancestry.com](http://www.rootsweb.ancestry.com)) record the death of Capt. Denis Pack-Beresford on 28 December 1881 at his residence, Fenagh House, Carlow. "He had been suffering from an acute attack of gout which he appeared to have surmounted; but that dread enemy was only momentarily baffled, for, it returned on the morning of Wednesday last, and put a sudden termination to the life of this widely-known and popular gentleman."

<sup>17</sup> The year 1882 is deduced from contents (Lily's impending wedding; Willie's exams).

<sup>18</sup> The Tapestry Chamber in the Grand Master's Palace in Valetta contains the famous Gobelin Tapestries. Woven in France for Ramon Perelles Rocafal, the Spaniard who was Grand Master from 1697-1720, they were donated by him in 1710. Also known as the Indies Tapestries, they depict exotic scenes from South America, the Caribbean, India and Africa and are still in excellent condition.

<sup>19</sup> Founded in 1882, many Irish served in the Cape Mounted Police, which had its headquarters in Capetown – it ceased to exist in 1913.

<sup>20</sup> Sir John Watson came home from India in 1884. The first recorded polo match was played in Co Carlow in 1872.

<sup>21</sup> HMS Ladybird was an Insect class gunboat of the Royal Navy, launched in 1916. Originally built to patrol the River Danube during World War I, it was later shipped to China to serve on the Yangtze River.

<sup>22</sup> Situated about 45 metres down a lane on the Myshall road just after Fenagh Church, this field was later used by Fenagh GAA club.

<sup>23</sup> Mary Alexis McMillan was Jack Fryer's fiancée at the time of his death.

Faction Fighting

In his *Traits and Stories of the Irish Peasantry* William Carleton describes a faction fight as follows:

On the O'Hallaghans being driven to the churchyard, they were at a mighty inconvenience for weapons. Most of them hadd lost their sticks, it being the usage in fights of this kind to twist the cudgels from the grasp of the beaten men, to prevent them from rallying. They soon, however, furnished themselves with the best they could find, videlicet, the skull, leg, thigh, and arm bones which they found lying about the graveyard. This was a new species of weapon for which their adversaries were scarcely prepared. Out they sailed in a body - some with these, others with stones, and making fierce assault on their enemies, absolutely *druv* them back - not so much by the damage they were doing, as by the alarm and terror which these unexpected species of missiles excited.



A recently taken photograph of a manhole cover in Charlotte Street, Carlow.

It reads:

M Mc Hugh & Sons  
Foundry  
Carlow

The cover was spotted by the ever watchful Jimmy Donegan who would like to know more about the location of the foundry



Members of CHAS at the Glen View Folk Museum, Ballinamore, Co Leitrim September 2012.

---

**2012**  
**Officers and Members**  
**of the**  
**Carlow Historical and Archaeological Society**

---

**President**

Pat O'Neill

**Vice President**

Bertie Watchorn

**Secretary**

Deirdre Kearney

**Treasurer**

Catherine McGuill

**Public Relations Officer**

Noreen Whelan

**Editor**

Jim Shannon

**Committee**

Pat O'Neill, Bertie Watchorn, Deirdre Kearney, Catherine McGuill, Noreen Whelan, Jim Shannon,  
Martin Nevin, Dan Carbery, Joe Brennan, Seamus Murphy, Des O'Mahony, Richard Codd,  
Mrs.Margaret Minchin, Peadar Cullen, John Burke,

**Honorary Life Members**

Kevin Kennedy, Rose Murphy, Seamus Murphy, Martin Nevin, Willie White.

**Members**

Declan Alcock, 96 Pearse Road, Graiguecullen, Carlow	Ivor Bowe, Bowe Consulting, Strawhall Ind.Est. Carlow
Noel Alcock, 42 Staunton Avenue, Graiguecullen, Carlow	John & Bernadette Boyd, 8 Shaw Park, Athy Road, Carlow
Thomas Alcock, Oisín, Derrymoyle, Carlow	Dr.Geoffrey Bremble, Chapel House, 11 Cothill, Oxford
John Alexander, Milford, Co.Carlow	Joseph & Mary Brennan, 63 Green Road, Carlow
Bernie Atkinson, 56 The Downs, Pollerton Big, Carlow	Joseph & Deirdre Brennan, 1 Strawhall Villas, Carlow
Eric & Jean Atkinson, Coolnakisha, Leighlingridge,	Phyllis Brennan, 32 College Gardens, Granby Row, Carlow
Robert Aughney, Lumcloone Cross, Fenagh,Co. Carlow	Sheila Brennan, 32 College Gardens, Granby Row, Carlow
Margaret Baragry, 8 Larkfield, Carlow	Ms Brid Brett, Ballyhide, Carlow
James Bolger, 7 Henry Street, Graiguecullen, Carlow	Edward Brophy, 1 Sycamore Road, Rathnapish, Carlow
Michael Boyce, "Mulroy", 14 Braganza, Carlow	Gregory Brophy, Castlemore, Tullow, Co. Carlow
Ivor Bowe, Bowe Consulting, Strawhall Ind.Est. Carlow	

Carloviana 2012

## MEMBERS

Mrs. Brigid Brophy, Slieveveagh, Rathdangan, Co. Wicklow  
 John Burke, "Aghaboe", Knocknagee, Carlow  
 Fergal Browne, "Churchview", Rutland, Carlow  
 Turtle Bunbury, Old Fort, Tobinstown, Tullow, Co. Carlow  
 Msgr Brendan Byrne, The Shroughawn, Tullow, Co. Carlow  
 Rev. Gerald Byrne P.P., Graiguenamanagh, Co. Kilkenny  
 Margaret Byrne, 16 Sutton Grove, Sutton, Dublin 13  
 Joseph & Sarah Callinan, The Field, Pollerton Little, Carlow  
 Vincent Callanan, Cloneen, Nurney, Co. Carlow  
 Dan & Attracta Carbery, Glencarrig, Green Road, Carlow  
 Kay Carbery, 58 Monacurragh, Carlow  
 Eugene & Patricia Carbery, Mortarstown, Carlow  
 Michael Carbery, 1 Pembroke, Carlow  
 Sr. Mary Carmody, 4 Pinewood Avenue, Carlow  
 Mrs Claire Carroll, 7 Braganza, Athy Road, Carlow  
 Matthew Cleary, Erindale Lodge, Kilkenny Road, Carlow  
 Francis & Aine Coady, 43 Barrow Lock, Leighlinbridge  
 Richard Codd, Munny, Coolkenno, Tullow, Co. Carlow  
 Gerry Coen, Kilkenny Road, Carlow  
 Mrs. Frances Cole, "Ballybar," Carlow  
 Sr Eileen Comerford, Apt.7, Poachers Lock, Leighlinbridge  
 Paul & Noeline Connell, 11 The Glade, Oakpark Rd., Carlow  
 Ann Connolly, Red Mills, Goresbridge, Co. Kilkenny  
 Michael Conry, Avila, Tullow Road, Carlow  
 James & Brenda Conway, Coppengagh, Tullow, Co. Carlow  
 L.V. & Rita Conway, Straboe, Tullow, Co. Carlow  
 John Conway, Rathvinden, Leighlinbridge, Co. Carlow  
 John & Dawn Coogan, Castlemore, Tullow, Co. Carlow  
 Thomas Corrigan, Knockfield, Castledermot, Co. Kildare  
 Claire Cotter, 33 College Gardens, Granby Row, Carlow  
 Thomas & Kathleen Cox, Ballyknockan, Fenagh, Co. Carlow  
 Norman & Christine Cree, Ballyknockan, Leighlinbridge  
 Ken & Maureen Crowe, Derrymoyle, Carlow  
 Kathleen Cubberly, Ballycormack, Bagenalstown  
 Kathleen Cullen, Killamoat, Rathdangan, Co. Wicklow  
 Peadar Cullen, Killamoat, Rathdangan, Co. Wicklow  
 Kieran Cummins, Upper Tomard, Milford, Co. Carlow  
 Michael Daly, Caherea, Browneshill, Carlow  
 Pat & Eileen Darcy, Crossneen, Carlow  
 James & Marlene Davis, 2 Borlum Wood, Green Rd., Carlow  
 James Deane, The Shop, Tinryland, Co. Carlow  
 Cynthia Deane, Co. Carlow VEC, Athy Road, Carlow  
 Eamon & Cathleen Delaney, Tobacco Meadows, Carlow  
 Paul & Breda Delaney, 22 Heatherfield, Dublin Road, Carlow  
 James & Catherine Dempsey, Ballinacarrig, Carlow  
 Randall Dempsey, Hanover Cross, Carlow  
 Hugh Dolan, 35 Oakley Park, Tullow Road, Carlow  
 John & Mary Dollard, 8 Monacurragh, Carlow  
 James Donegan, St. Killian's Crescent, Carlow  
 Eddie Donohue, Rathvarrin, Ardattin, Co. Carlow  
 Margaret Donohue, 13 Sherwood, Hacketstown Rd., Carlow  
 Martin & Bernadette Doogue, Hillcrest, Baltinglass  
 Thomas & Mairead Doolan, Ballinacarrig, Carlow  
 Anthony & Phil Dooley, Barrowside, Carlow  
 Pdraig Dooley, 23 Dolmen Gardens, Carlow  
 Mrs. Michelle Doorley, Kilree Street, Bagenalstown  
 Michael Doran, Leighlinbridge, Co. Carlow  
 Leslie & Cora Dowley, Oak Park, Carlow  
 Anne E. Dowling, Kellistown, Carlow  
 John A. Dowling, Linkardstown, Carlow  
 James Downey Jnr, 20 Monacurragh, Carlow  
 Owen Doyle, Tinnaslee, Graiguenamangh, Co. Kilkenny  
 Mrs Lil Doyle, Ballycullane, Hacketstown, Co. Carlow  
 Mrs Marian Doyle, 3 Dolmen Gardens, Pollerton, Carlow  
 Thomas Doyle, Chapel Hill, Baltinglass, Co. Wicklow  
 Percy Drea, Wells, Bagenalstown, Co. Carlow  
 Margaret Dunny, 11 Braganza, Athy Road, Carlow  
 Dr Colmain Etchingham, Ballinguilky, Hacketstown  
 James Farrell, Grosvenor, Kilkenny Road, Carlow  
 Joseph Feeley, Moytura, Dunleckney, Bagenalstown  
 George Fitzgerald, 25 Riverside, Carlow  
 William Fitzgerald, 50 Sycamore Road, Rathnapish, Carlow  
 Dr Tom Foley, Leighlinbridge, Co. Carlow  
 Desmond & Jean Foot, Pound Lane, Borris, Co. Carlow  
 Tony & Olive Fortune, 16 Sharon Avenue, Brownhill Road  
 Andreas & Mary Froelich, Sandfield, Oakpark Road, Carlow  
 Sean Gavin, "Garryduff House," Paulstown, Co. Kilkenny  
 Thomas & Marian Geoghegan, Ballincarrig, Carlow  
 Bernard Geraghty, Oakpark, Carlow  
 Christopher & Mai Glancy, 16 Oak Grove, Royal Oak Road,  
 Bagenalstown, Co. Carlow  
 Mrs. Kathleen Goodwin, 7 Aylesbury, Dublin Road, Carlow  
 Robert & Betty Graham, Crossneen, Carlow  
 Mrs Jane Hancock, Corries, Bagenalstown, Co. Carlow  
 Mrs Donna Hannigan, 22 Barrow Lock, Leighlinbridge  
 Derek Hardy, Knocknagee, Carlow  
 Patrick Healy, Pollerton Castle, Carlow  
 Rory Healy, Pollerton Castle, Carlow  
 Mrs Muriel Hendy, Narraghmore Manor, Athy, Co. Kildare  
 Mrs. Anna Hennessy, Ballytiglea, Borris, Co. Carlow  
 Seamus & Mary Hogan, Rathrush, Rathoe, Co. Carlow  
 Paddy Holohan, Ballycarney, Blackbog Road, Carlow  
 Michael & Pauline Hosey, The Boulders, Tinryland  
 William & Kathleen Hosey, Castlemore, Tullow, Co. Carlow  
 Robert Gerald Howson, Carlow Road, Leighlinbridge  
 Mrs. Betty Hughes, Ballinabranna, Co. Carlow  
 John Hughes, Kildrenagh, Bagenalstown, Co. Carlow  
 Robin & Nora James, "The Dormer", Brownhill Rd., Carlow  
 Brigid A. Johnson, 36 Eastwood, Bagenalstown, Co. Carlow  
 Jim & Helen Jordan, Ratheadan House, Leighlinbridge  
 Mrs Pauline Jordan, Church Road, Bagenalstown, Co. Carlow  
 Thomas Joyce, Rathgorvan, Ballymurphy, Borris, Co. Carlow  
 Una Kane, Castledermot, Co. Kildare  
 Dan Kavanagh, Rathshanmore, Hacketstown, Co. Carlow  
 Larry Kavanagh, 17 Shillelagh Grove, Tullow, Co. Carlow  
 Darryl Kealy, Shroughan, Tullow, Co. Carlow  
 Paul Keane, Tullow Road, Carlow  
 Deirdre Kearney, "Ardmore", Brownhill Road, Carlow  
 Thomas Kehoe, 57 Dublin Street, Carlow  
 Edward Kelly, 118 St. Clare's Road, Graiguecullen, Carlow  
 Michael Kelly, 17 Ashdale Close, Kinsealy Court, Swords  
 George Kenny, 4 Frederick Avenue, Carlow  
 Arthur Kennedy, Cappagh, Ballon, Co. Carlow  
 William & Brigid Kepple, Rathrush, Rathoe, Co. Carlow  
 Thomas King, 7 Sycamore Road, Rathnapish, Carlow  
 Rita Lacey, Closh, Ballylinan, Athy, Co. Kildare  
 Michael Lawler, 14 The Elms, Athy Road, Carlow  
 Michael & Margaret Lawlor, 20 New Oak Estate, Carlow  
 Fr Andy Leahy C.C., 3 The Rise, Tullow, Co. Carlow  
 John Lohan, 33 Pairc Mhuire, Muinebheag, Co. Carlow



## MEMBERS

Martin J Lynch, 118 Beechwood Park, Pollerton, Carlow  
 Brian & Mary Lyons, Crossneen, Carlow  
 Paul & Carmel Lyons, Oakpark Road, Carlow  
 Tony Lyons, Boherbee, Paulstown, Co. Kilkenny  
 Jim & Bridget Mathews, 12 Luttrellstown Green,  
 Luttrellstown, Co. Dublin  
 Brendan May, Gardenfield, Tuam, Co. Galway  
 Mrs Pat Maye, "Atrium", Brownhill Road, Carlow  
 Kathleen McCarthy, Clonburrin House, Fenagh, Muine Bheag  
 Michael McCarthy, Clonburrin House, Fenagh, Muine Bheag  
 Cornelia McCarthy, Flanders Cross, Knocklonogad,  
 Bagenalstown Co. Carlow  
 Mel McDermott, 43 Friar's Green, Tullow Road, Carlow  
 Edward McDonald, Clonmore, Hacketstown, Co. Carlow  
 Jim McDonnell, Hillview, Brownhill, Carlow  
 James McDonnell, 17 Mirfield Road, Solihull, West Midlands  
 Joseph McDonald, 4 Heatherfield Court, Carlow  
 Tony McEvoy, Cheshire Home, Tullow, Co. Carlow  
 Rev. John McEvoy P.P., Paulstown, Co. Kilkenny  
 Mrs Catherine McGuill, Sandbrook Lodge, Blackbog Road,  
 Carlow  
 Barry McHugh, Mountain View House, Green Road, Carlow  
 Rev. Dermot McKenna, 20 Sherwood, Carlow  
 Christopher McQuinn, 18 Shillelagh Grove, Tullow  
 Fonsie Mealey, Georgian Mews, The Square, Castlecomer  
 Anne T Meaney, 3 Kilcarrig Street, Bagenalstown, Co. Carlow  
 Peter & Margaret Minchin, Coolnacuppogue, Bagenalstown  
 Michael & Mary Monahan, Johnsduffwood, Old Leighlin  
 Anne T. Mooney, 42 Bourlum Wood, Green Road, Carlow  
 Charles & Ann L Moore, Tullow Lodge, Tullow, Co. Carlow  
 Margaret Moran, 109 Beechwood Park, Pollerton, Carlow  
 Luke & Helen Morrissey, 30 Conway Park, Muinebheag  
 James Mulhall, Castlemore, Tullow, Co. Carlow  
 Dermot Mulligan, 19 Marble Court, Paulstown, Co. Kilkenny  
 Patrick & Joan Mulligan, Marian Ville, Tullow Rd, Carlow  
 Frank Mulvey, 44 Feltham Hall, Blackbog Road, Carlow  
 Anne Murphy, Pollerton Little, Carlow  
 Christopher Murphy, Barnagoole, Bagenalstown  
 Eileen Murphy, Drumpeha, Garryhill, Co. Carlow  
 Ger & Kathryn Murphy, "Duncar", Browneshill, Carlow  
 Kevin Murphy, Pollerton Little, Carlow  
 Michael Murphy, Seven Oaks Hotel, Carlow  
 Pdraig Murphy, 65 Blackheath Park, Clontarf, Dublin 3  
 Patricia Murphy, Killinure, Tullow, Co. Carlow  
 Patrick E. Murphy, Ratheadon, Bagenalstown, Co. Carlow  
 Patrick Murphy, 2 Oak Park Drive, Carlow  
 John Murphy, Coolkenno, Tullow, Co. Carlow  
 John Murphy, Killinure, Tullow, Co. Carlow  
 Rody Murphy, 4 Oak Park Road, Carlow  
 Matthew & Kathleen Murray, Ballyhide, Carlow  
 Martin & Rosaleen Nevin, Carlow Road, Leighlinbridge  
 Ann Nolan, Wayside, Station Rd, Bagenalstown, Co. Carlow  
 Breda Nolan, Station Road, Bagenalstown, Co. Carlow  
 Catherine Nolan, 6 Bagnal Court, Court Place, Carlow  
 Frank Nolan, "Sunnydale", Oak Park Road, Carlow  
 Liam & Sheila Nolan, Newtown, Bagenalstown, Co. Carlow  
 Eamonn A. Nolan, 90 Green Road, Carlow  
 Henry Nolan Snr, 7 Oaklawns, Dublin Road, Carlow  
 Patrick M. Nolan, College Road, Kilkenny  
 Kennedy & Bernie O'Brien, Tinryland, Carlow  
 Teddy O'Brien, 19 Ashgrove, Tullow Road, Carlow  
 Seamus O'Connor, Carlow County Council, Athy Rd, Carlow  
 Mrs Eileen O'Connor, Rosemount, Borris, Co. Carlow  
 John O'Donovan, Kilnock, Ballon, Co. Carlow  
 Peter O'Dowd, Shankhil, Paulstown, Co. Kilkenny  
 Anne O'Dwyer, The Forge, Castlemore, Tullow, Co. Carlow  
 Carmel O'Dwyer, 14 Sharon Avenue, Brownhill, Carlow  
 John O'Gorman Solicitors, Athy Road, Carlow  
 Mrs. Betty O'Gorman, 59 Dublin Street, Carlow  
 Anne O'Hara, 13 Frederick Avenue, Carlow  
 P J O'Hare, Glenamoy, Leighlinbridge, Co. Carlow  
 Des & Breda O'Mahony, "The Kerries", 22 Braganza, Carlow  
 Gerry O'Malley, 64 Green Road, Carlow  
 Eilish O'Neill, 22 Bagenal Court, Court Place, Carlow  
 Msgr Kevin O'Neill, St. Patrick's College, Carlow  
 Maurice O'Neill, Kilmurry, Ballon, Co. Carlow  
 Nial O'Neill, 43 Connolly Villas, Ennis, Co. Clare  
 Patrick O'Neill, 21 Bullock Park, Carlow  
 Paul O'Neill, Everton, Springhill, Carlow  
 Eileen O'Rourke, 35 Quinagh Green, Carlow  
 Hugh O'Rourke, St. Anthony's, Ballyhide, Carlow  
 Bernard O'Shea, 34 Bullock Park, Carlow  
 Fr Philip O'Shea P.P., Myshall, Co. Carlow  
 Jeremiah O'Sullivan, Geatagreine, Coill Sean Dubh,  
 Sean Leachlainn, Co. Ceartharlach  
 James & Carmel O'Toole, Borlum House, Kilkenny Rd, Carlow  
 Mrs. Helen Pender, Russellstown, Palatine, Carlow  
 Muriel Poole Downey, Ryle Belle, Ballinaboley,  
 Leighlinbridge, Co. Carlow  
 Ann Power, 42 Kilcarrig St, Bagenalstown, Co. Carlow  
 Mrs Marie Quirke, Newtown, Bagenalstown, Co. Carlow  
 Mrs. Eithne Reddy, 28 Borlum Wood, Green Road, Carlow  
 T.J.G. Redmond, Heywood, Oakpark, Carlow  
 Mrs Mena Rice, Main Street, Borris, Co. Carlow  
 Patrick Roche, Coolnakisha, Leighlinbridge, Co. Carlow  
 Michael Roche, 20 Tanner Hall, Athy Road, Carlow  
 Brid De Roiste, 15 Clarence Gate, Kilkenny Road, Carlow  
 Peter & Anne Rose, Spahill House, Borris, Co. Carlow  
 Oliver & Phillo Seery, Tinryland, Co. Carlow  
 Denis Shannon, Tinryland, Co. Carlow  
 James Shannon, "Lorien", Scotland, Hacketstown, Co. Carlow  
 Jack Sheehan, Dunleckney, Bagenalstown, Co. Carlow  
 Richard Sheehan, Dunleckney, Bagenalstown, Co. Carlow  
 John Sheil, Bohermore, Bagenalstown, Co. Carlow  
 Kae Slattery, "Windover", 15 Sycamore Rd, Rathnapish, Carlow  
 Seamus & Bridget Somers, Killinane, Bagenalstown  
 Derek Stacey, Brannockstown, Naas, Co. Kildare  
 George & Anne Stephenson, Elmdale, Knockfiled,  
 Castledermot, Co. Kildare  
 Jack Stratton, "Rockdale", Kilmeaney, Carlow  
 Valerie Stratton, "Rockdale", Kilmeaney, Carlow  
 Derek & Joan Treacy, 57 Highfield, Dublin Road, Carlow  
 Robert & Irene Watchorn, Ballinakill, Ballickmoyler, Carlow  
 Seosamh Watson, Glenview, Nurney, Co. Carlow  
 Oliver & Mary Whelan, 152 Seapark, Malahide, Co. Dublin  
 Mrs Noreen Whelan, 17 Sycamore Road, Rathnapish, Carlow  
 Fr Edward Whelan P.E., Ballon, Co. Carlow  
 Paul White, Oakpark, Carlow  
 Arthur Willis, Rathrush, Rathoe, Co. Carlow  
 Tony Wynne, 92 Jennings Lane, Atherton, California



*Carlow  
County  
Museum*

## See what you're missing

The Museum is located on College Street.  
Carlow County Museum opening hours as follows:

### June to August

Monday to Saturday  
10.am to 5.00pm  
Bank Holidays & Sundays  
2.00 pm to 4.30 pm

### September to May

Monday to Saturday  
10.00 am to 4.30 pm  
(Closed on Bank Holidays)

## Admission is Free

### Interested in Volunteering?

We are always looking for new volunteers. If you have an interest in history or would like to try something new you can contact us by email, telephone or just drop in to us.

Email: [museum@carlowcoco.ie](mailto:museum@carlowcoco.ie)  
Tel : (059) 913 1554

Web: [www.carlowcountymuseum.ie](http://www.carlowcountymuseum.ie)

Email: [museum@carlowcoco.ie](mailto:museum@carlowcoco.ie)

Tel: 059 913 1554

 [facebook.com/carlowcountymuseum](https://www.facebook.com/carlowcountymuseum)

 [@carlowcountymus](https://twitter.com/carlowcountymus)

CARLOW  
COUNTY COUNCIL

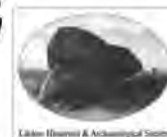



R Est 1892

1877  
COSTELLO  
MEMORIAL  
CHAPEL

Carrick on Shannon Heritage Group Ltd

**Costello Memorial Chapel**

A remarkable example of one man's deep love for his wife, this tiny R.C. chapel on Bridge Street in Carrick is the smallest in Ireland and reputedly the second smallest in the world. When Mary Josephine Costello died at the age of 47 on 6th of October 1877 her heart-broken husband, Edward Costello, had her body embalmed and placed in the care of the Marist Sisters in Carrick-on-Shannon. He immediately commissioned this beautiful Chapel in her memory and as a last resting place for them both.