

August 31, 2016

PHY 554 Lecture 2

V.N. Litvinenko

History of Accelerators

There are books and long articles written about the history of accelerators. Here we are recall some elements of the history as it fit the purpose of our course: without any attempt to follow neither the historical event nor the importance of the new inventions.

19th century

First man-made accelerators were naturally electrostatic and accelerated electrons— e.g. were both generated and accelerated by applying high voltage. First were cathode tubes, which generated so-called cathode rays (see more on http://www.brooklyn.cuny.edu/bc/ahp/LAD/C3/C3_Electrons.html). What is probably most remarkable that initially people used batteries for this experiments – AC current was not yet readily available.

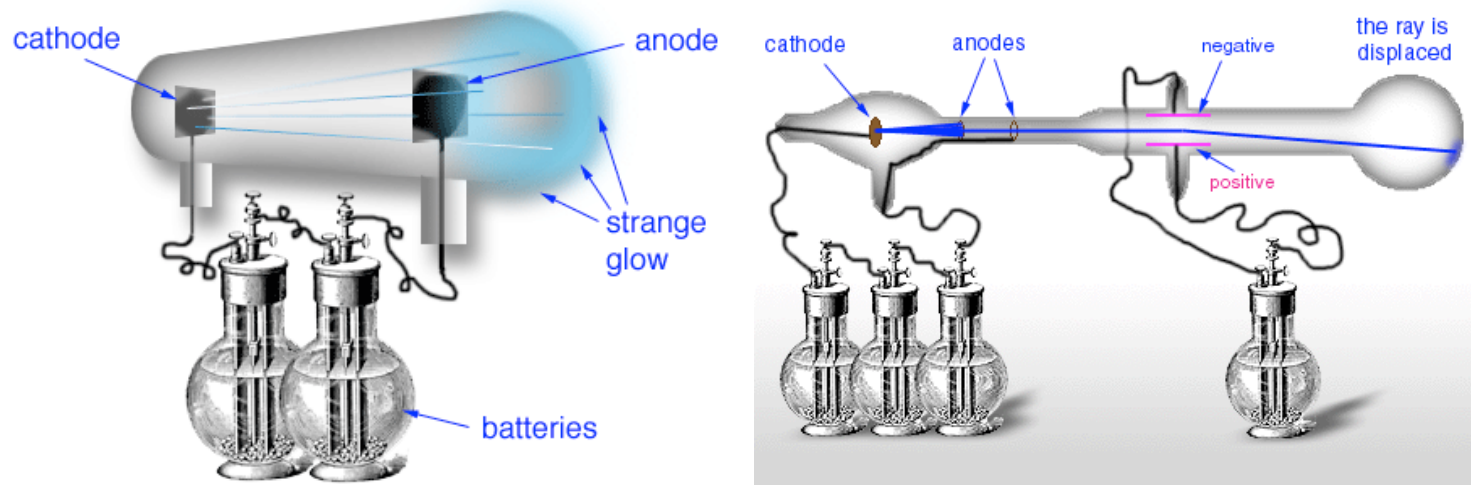

Fig. 2.1. German glass blower's - Heinrich Geissler - apparatus consisted of a glass tube in which an anode (the positive pole, or plate) was at one end, and the cathode (the negative pole, or plate) was at the other end. His superior vacuum pump removed all the air from the tube, and he connected the anode and the cathode to the appropriate ends of a powerful battery. At high enough voltages electricity certainly seemed to be able to leap across the vacuum between the oppositely charged plates, but that was not all. On the wall opposite to the negative cathode, the glass glowed a strange, greenish color.

William Crookes, among several others showed that **bringing a magnet next to the sides of the tube caused the cathode rays to bend** in a way that strongly suggested that they were made up of electrically charged particles - not waves. English physicist Joseph John Thomson carried out a series of experiments using tube that incorporated two small plates, between which the rays had to travel. By connecting these plates to a battery, an electric field was generated and the rays were bent! **In 1897 J.J. Thomson** announced that the cathode rays consisted of negatively charged particles (which he called "corpuscles") that were only less than 1/1000th of the mass of a hydrogen atom. This was something very new. **Thomson was awarded the Nobel Prize in 1906** for his "discovery" of the first sub-atomic particle; **the electron**. Thus, **19th century reached energies in accelerators ~ 10 KeV, e.g. ~1e4 eV**. Next century had to increase it to ~few TeV. e.g. > 1e12 eV, a 100,000,000 increase.

1st half-of-20th century: from electrostatic cans to synchrotrons

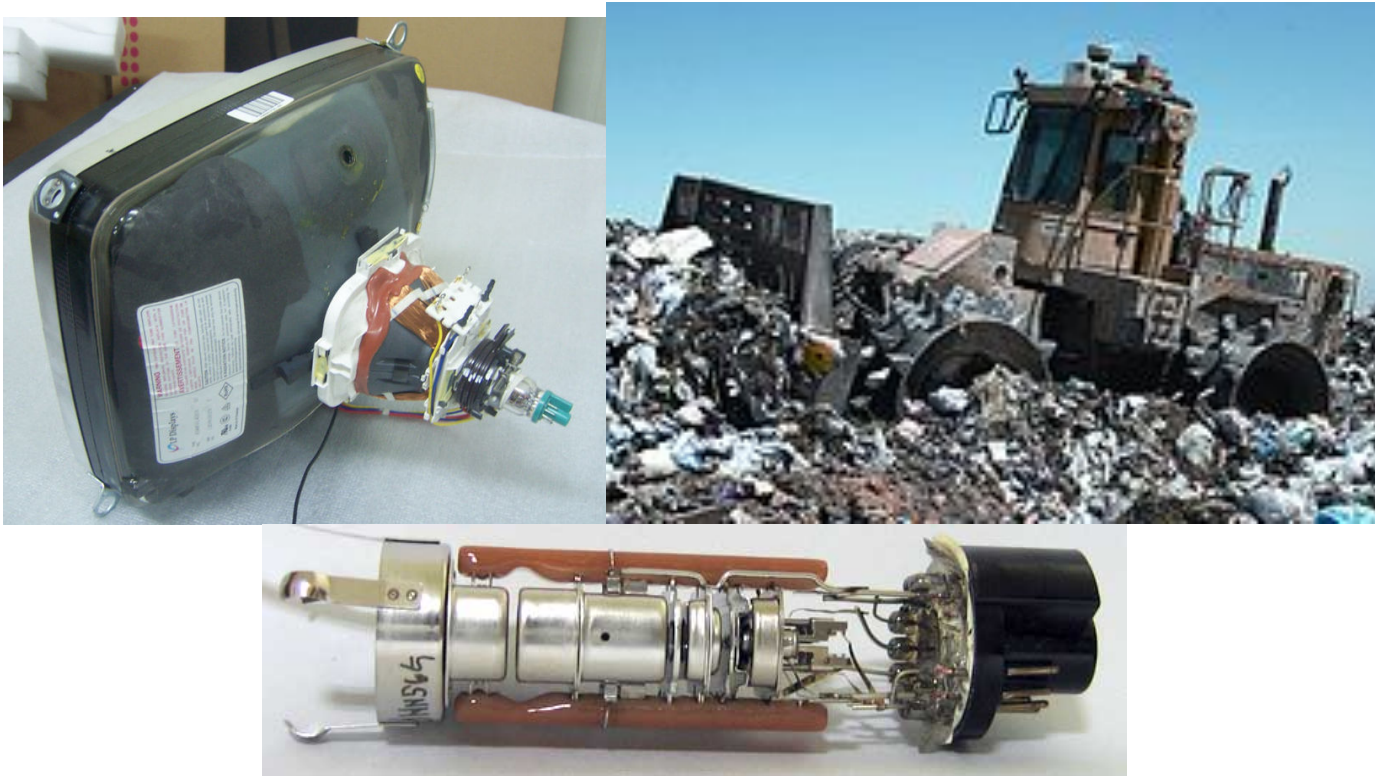
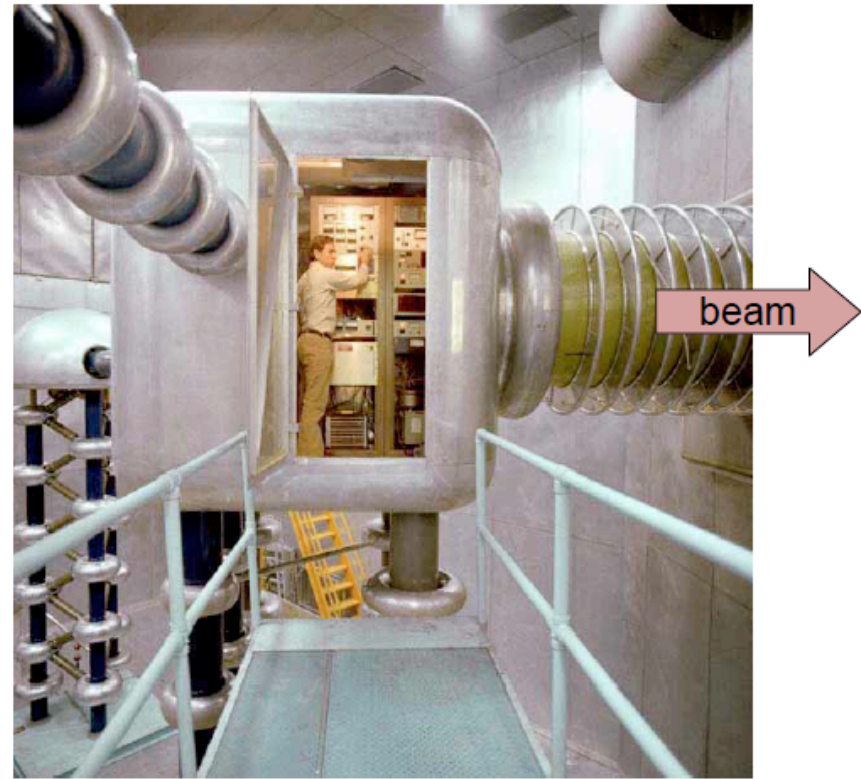
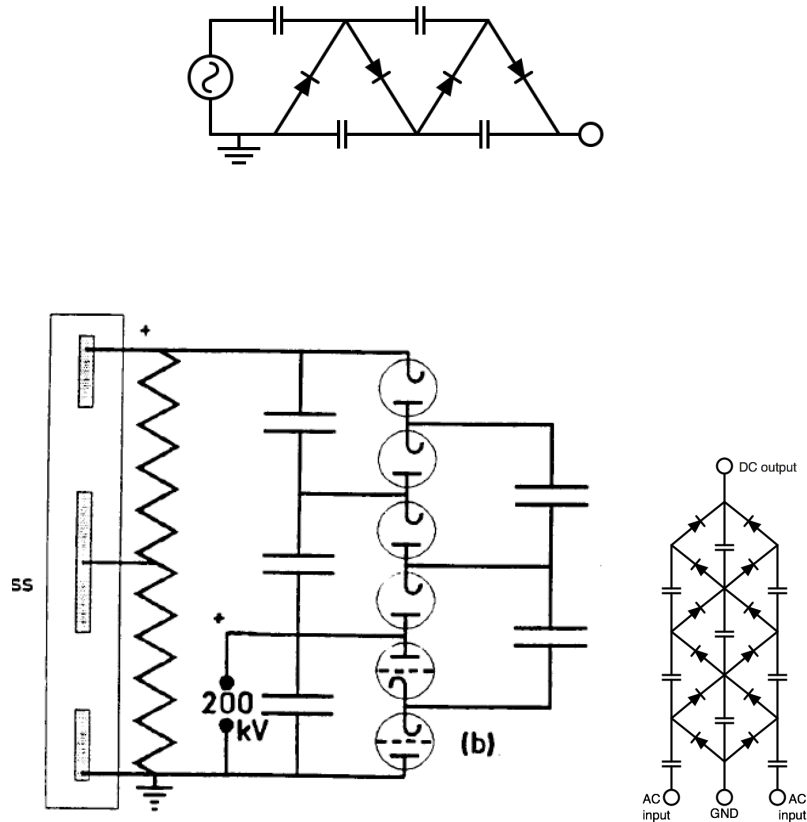

Fig. 2.2. Billions of these tubes were made in 20th century – now most of them are in the landfills...

Usually the development of accelerators is seen through a looking glass of their users – high-energy or nuclear physicists, synchrotron radiation users or material scientists. Here I present it from point of view of the accelerator science.

In 1928 Cockcroft & Walton propose a AC connected DC rectifier accelerator (see Fig. 2.3) which multiplied applied voltage (later wide use of AC current made it even simpler) and in 1932 reached voltage of 700 kV [2] where they accelerate protons and split Li atoms. At about the same time Van de Graaff invented an electrostatic generator, which reached a potential of 1.5 MV [3].



Crockroft-Walton at FNAL accelerates H⁻ to 750keV

Fig. 2.3. Idea (http://en.wikipedia.org/wiki/Cockcroft-Walton_generator) and one of late 20th century realization

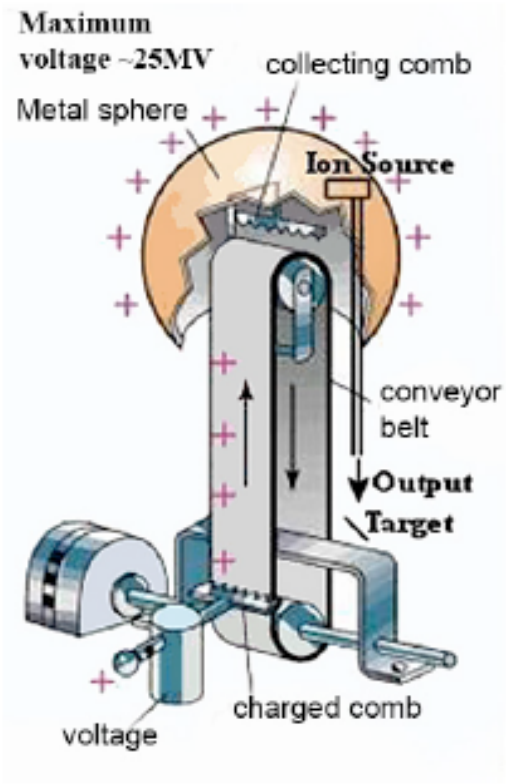
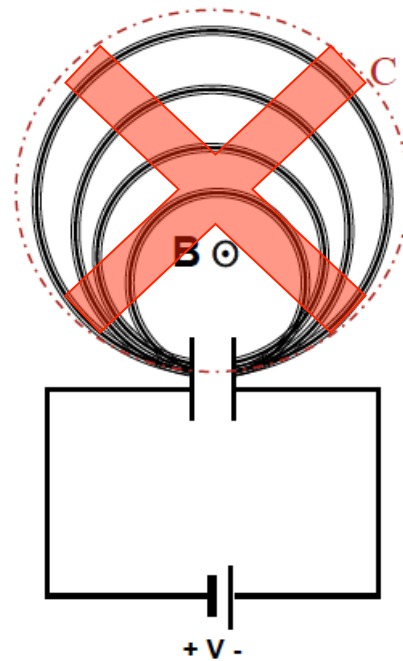

Fig. 2.4. Idea of the Van de Graaff invented an electrostatic generator and one of the biggest tandem accelerators at Daresbury (UK) with 42 m (14 stories high) 20 MV acceleration tube, placed vertically (Photo: CCLRC).

The limits of the electrostatic accelerator – otherwise very powerful and technologically simple – comes from a simple fact that one can not accelerate twice (or multiple times) a charged particle in the same DC accelerating gap – e.g. it requires to have full accelerating voltage applied to the terminal – thus the dimensions in all directions scale with the its voltage. Maximum electric field is usually limited by electric break-down ~ 10 kV/cm -e.g. 20 m for a 20 MeV accelerator.



In addition, one should just observe a lightning just one to understand how dangerous such devices could be for a decent conductors, like human bodies...

One unusual exception is idea of a tandem, which accelerate a negatively charge ions (like H^-) from the ground to the positively charged terminal, strip the electrons from the ions using a thin foil and accelerating positively charged ion (like H^+) to the twice the total voltage, just proved the rule. One of the simplest Maxwell equations forbids this option with a rigor close to the non-existence of Perpetuum mobile.

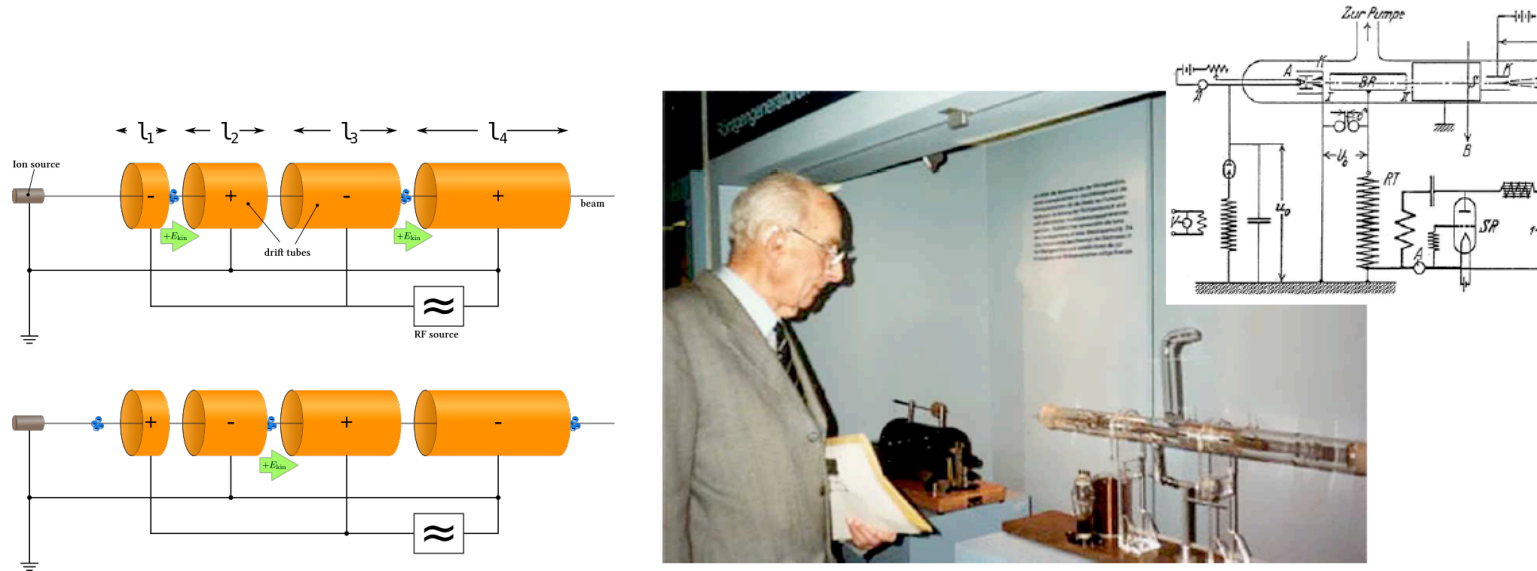

Fig. 2.5. Does not matter how much fun is electrostatic and how many good electrostatic “dinosaurs” are in basements of our universities, Maxwell equation prohibits multiple acceleration is DC electric field:

$$\Delta E = e \oint \vec{E} \cdot d\vec{l} = -\frac{e}{c} \frac{\partial}{\partial t} \left(\int \vec{H} \cdot d\vec{s} \right) \quad (2.1)$$

Naturally – as the history of accelerator science proves now and again – there are physicists who find a solution for accelerating particles without creating “total voltage problem”. What is also remarkable that these developments were parallel to that of electrostatic accelerators.

In 1924 Ising proposed using time-varying fields, which later got name of RF linacs (Radio Frequency linear accelerators). In 1928 Wideröe demonstrates first RF linac using a 1 MHz, 25 kV oscillator for 50 keV linac accelerating potassium ions.



Courtesy of W. Barletta

Fig. 2.6. Wideröe’s linac for slow particles – the particles are shielded from the reverse field by a conducting tubes (which are a part of the RF resonant circuit!) and see only accelerating voltage. Thus, with total “applied” voltage V per cell, particle get $N e V$ energy boost.

Alvarez followed up by suggesting linac with drift tubes, which were not grounded, and many more advanced schemes emerged later – needless to say all using the non-zero value of $\text{curl}\vec{E}$. The RF linac technology grew-up dramatically through 20th century - benefiting heavily from powerful RF transmitters developed for military radar applications - and modern pulse linear accelerator reaching accelerating gradient exceeding 100 MeV per meter.



This "resonant acceleration" becomes easier when particles getting to relativistic velocities, which happens in electron linacs. Many radiation treatments facilities in hospitals treating cancer patients have so-called medical linacs generating bremsstrahlung gamma-ray beam by slamming ~ 15 MeV electron beam into a metal target. In 1960th **SLAC built 2-mile linear accelerator (above)**, which reached energy up to 50 GeV in a single pass of electrons and positrons.

CW accelerators have more modest – but still impressive – accelerating gradients ~ 20 MeV per meter. Because of the energetics, such accelerators usually operate with Super-conducting RF (SRF) structures, which have very low losses (good super-conducting Ni has $\sim 1,000,000$ lower losses than a very good Cu). Two future X-ray FEL (free-electron laser) facilities will use SRF linacs as their drivers. (see next section about re-circulating accelerators where SRF even more popular)

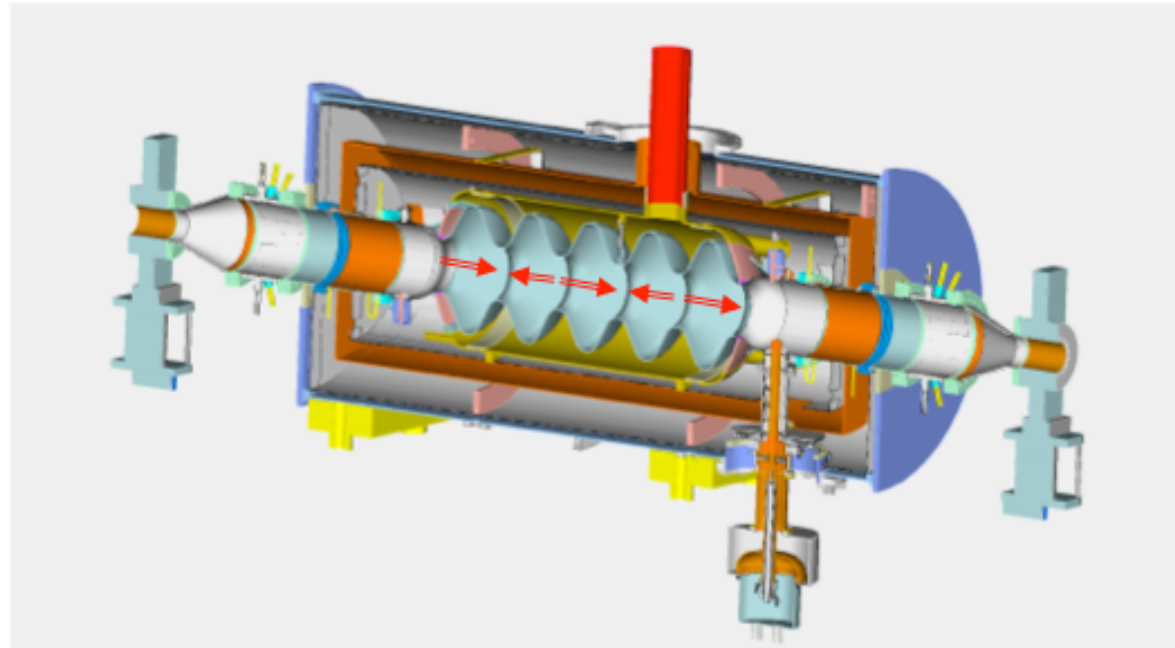
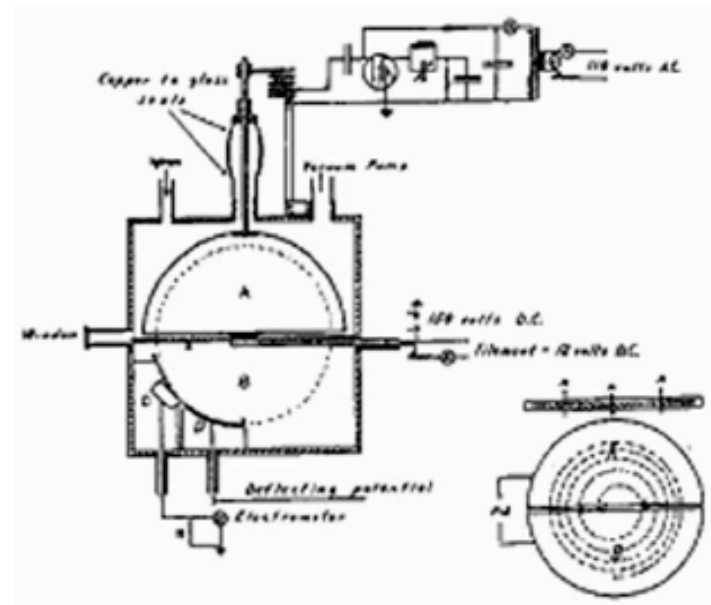
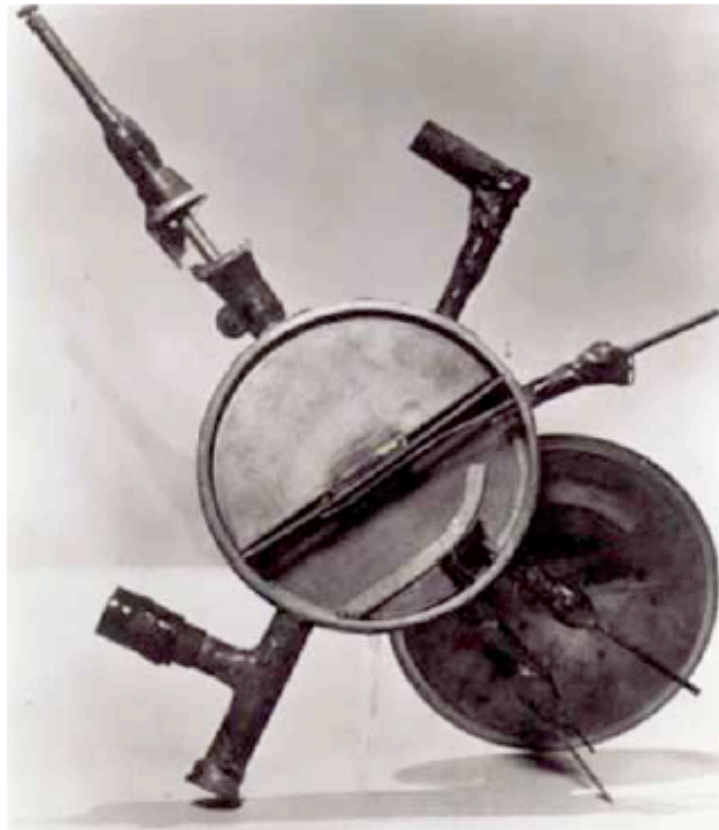

Fig. 2.7. A 20 MeV Super-conducting RF (SRF) linac at BNL R&D ERL facility. Electric field had a standing wave pattern oscillating with RF frequency– when electron propagates from one cell to another, electric field changes its direction and electron continues accelerating in each cell.

Protons and ions are much more stubborn – they are moving slowly for quite awhile and hadron linacs are much longer and more complicated than that for electrons (or positrons). Still, there is 1 GeV proton SRF linac was built at Oakridge National Laboratory for a neutron spallation source. You will learn a lot about linear accelerators in next few weeks – hence, the end of this introduction.

Success of Wideröe inspired Lawrence to conceive the cyclotron – a cyclic accelerator where particles are passing through the accelerating RF gap many-many times.



Lawrence, E.O. and Sloan, D.: Proc. Nat. Ac. Sc., 17, 64 (1931)

Lawrence, E.O. & Livingstone M.S.: Phys. Rev 37, 1707 (1931).

Fig. 2.8. First proof-of-principle cyclotron built by Lawrence and the hand-drawing of the machine.

Cyclotrons are resonant accelerators, initially designed for a non-relativistic particles: e.g. ions and protons at modest sub-GeV energies. The main idea of Lawrence was based on following – the Larmor precession frequency in an uniform magnetic field for non-relativistic limit does not depend on the particle velocity. Let's derive it for a relativistic particle and then use $\gamma^{-1} \ll 1$ limit.

$$\frac{d\vec{p}}{dt} \equiv [\vec{\omega} \times \vec{p}] = -\frac{e}{c} [\vec{v} \times \vec{B}]; \vec{p} = \gamma m \vec{v} \Rightarrow \vec{\omega} = \frac{e\vec{B}}{\gamma mc} \quad (2.2)$$

It is a good place to introduce beam rigidity frequently used in accelerator physics books and papers. From eq. (2.2) we can easily find the radius of the trajectory ρ ;

$$\omega = \frac{eB}{\gamma mc} = \frac{v}{\rho} \Leftrightarrow \rho = \frac{pc}{eB}; \quad p = \gamma mv, \quad (2.3)$$

and to define the easy-to-remember **beam (particle) rigidity**:

$$B\rho = \frac{pc}{e} \Leftrightarrow \left\{ \begin{array}{l} B\rho [kGs \cdot cm] = \frac{pc [MeV]}{0.299792458} \cong \frac{pc [MeV]}{0.3} \\ B\rho [T \cdot m] = \frac{pc [GeV]}{0.299792458} \cong \frac{pc [GeV]}{0.3} \\ B\rho [T \cdot km] = \frac{pc [TeV]}{0.299792458} \cong \frac{pc [TeV]}{0.3} \end{array} \right\} \quad (2.4)$$

Just to remind you, the energy measured in eV (SI units) is engineering preference – physicists will be very happy e Gs cm (SGS units) or even with Heaviside $\epsilon=m=c=1$, but eV are used and we can transferred into J ($=10^7$ erg) by remembering the charge of electron to be: $e= 1.60217657 \cdot 10^{-19}$ C and $1J=1C \cdot 1V$. Hence $1 \text{ eV } 1.60217657 \cdot 10^{-19}$ J. Two most important rest mass energies are:

$$\begin{aligned}
 m_e c^2 &= 0.511998910 \text{ MeV} \approx 0.511 \text{ MeV} \\
 m_p c^2 &= 938.272046 \text{ MeV} \approx 0.938 \text{ GeV} \\
 m_p / m_e &= 1836.1526
 \end{aligned}
 \tag{2.5}$$

One should note that the top (2.4) equation in the {} mixes units from SGS (Gs, cm, frequently preferred by physicists) and SI (Volt, preferred by engineers) system, while the middle has only SI units (T, m, V). The coefficient in the denominator is typical for using SI system where the speed of light ,

$$c = 2.99792458 \cdot 10^8 \text{ m/s}$$

is (artificially!) eliminated in the Lorentz force equations. $1 \text{ GeV} = 10^9 \text{ eV}$ puts 10^9 back into the ratios between the units, leaving us with $c/10^9 = 0.299792458$ hanging in the balance. Thus, the coefficient in equation (2.4) is easy to remember it is speed of the light measured in 10^9 m/s In any case, whatever trick you use, remember these practical units.

Now back to cyclotrons: For $\gamma=1$ the particles rotate with constant angular velocity. If one make the RF frequency $f_{RF} = \frac{\omega}{2\pi} = \frac{eB}{2\pi mc}$, the particles will go around and at each pass will pick-up RF voltage gap. This accelerating principle was very successful for heavy particles and with some modest modification serves some of most powerful hadron accelerators of today – an PSI (Swiss) 590 MeV cyclotron is one of the most powerful hadron accelerators in the world. Note here that for nonrelativistic or semi-relativistic particles it is conventional to quote particle's kinetic energy, which goes to zero at rest. For ultra-relativistic particles the total energy is a norm.

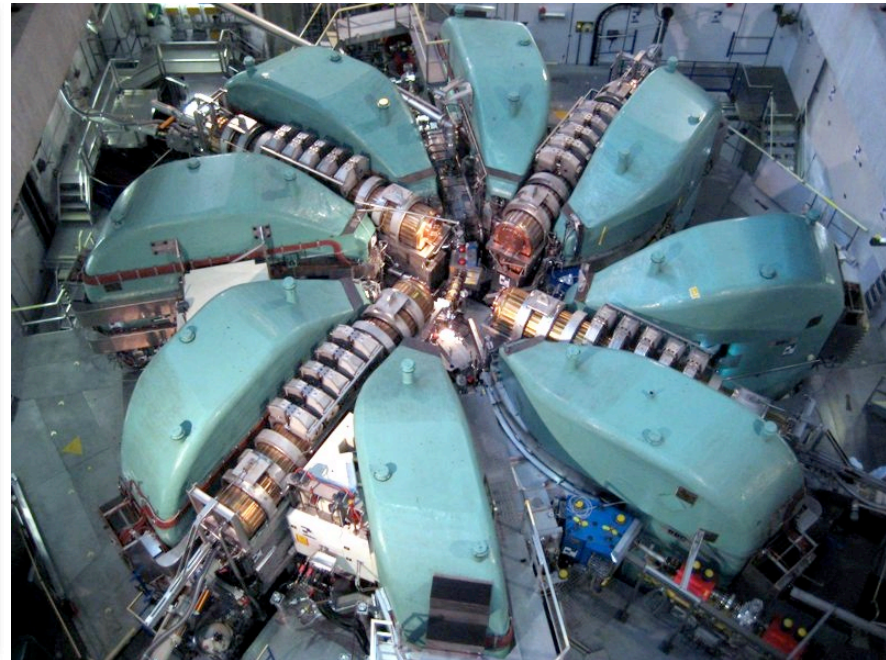
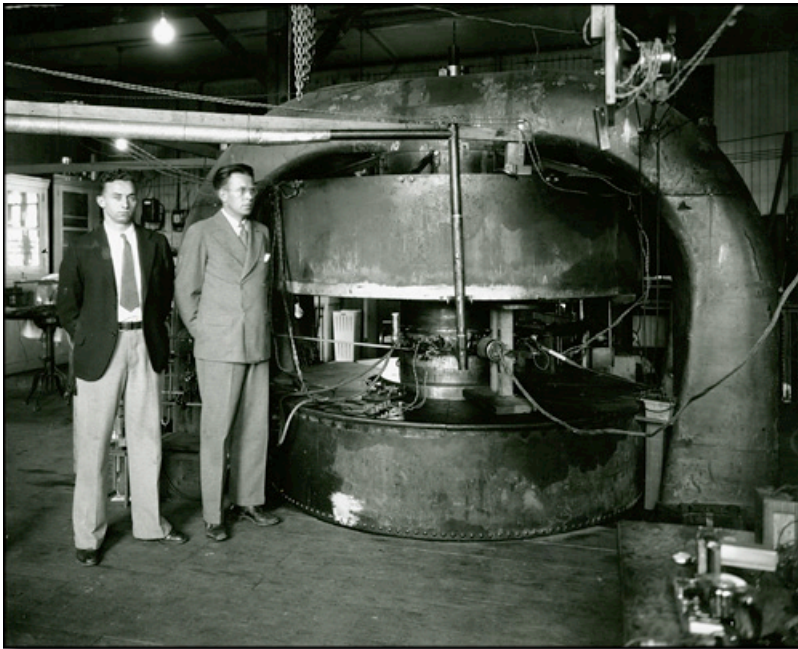

Fig. 2.9. Lawrence with 27" cyclotron in 1932 (left) and a powerful 590 MeV cyclotron built in early 1970s and still operating in Paul Scherrer Institute (Switzerland) which has a specially shape of magnets to correct for relativistic effects – particle in this cyclotron reach 78.9% of the speed of the light. The later accelerate particles from 72 MeV to 590 in 186 passes (revolutions) – each pass particles gain about 2.8 MeV.

Again, not surprisingly, there is a similar resonance scheme, which was created for relativistic electrons – it is called a **microtron**.

The resonance conditions are reached by the following:

$$T_{rev} = \frac{2\pi}{\omega} = \frac{2\pi\gamma_n mc}{eB} = \frac{n}{f_{RF}} \cdot k, \quad n, k \text{ are intergers} \quad (2.6)$$

i.e. the particles gains the energy per pas in the RF cavity which elongates the travel time by an integer number of the RF period – see fig below.

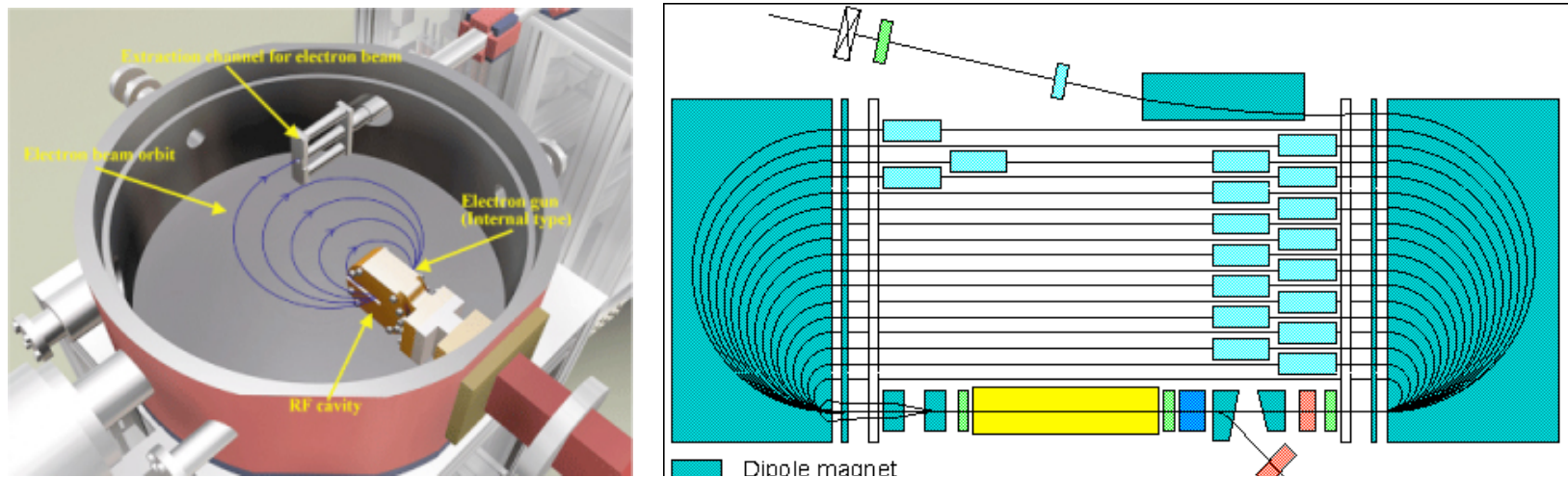

Fig. 2.10. A classical round (left) and race-track (right) microtrons.

Microtrons were predecessors of recirculating linacs. The largest SRF recirculating linac is undergoing an up-grade at Thomas Jefferson Accelerator Facility, which will accelerate polarized electron beam to 12 GeV by passing them 5- times through two SRF linear accelerators operating at RF frequency of 1.5 GHz.

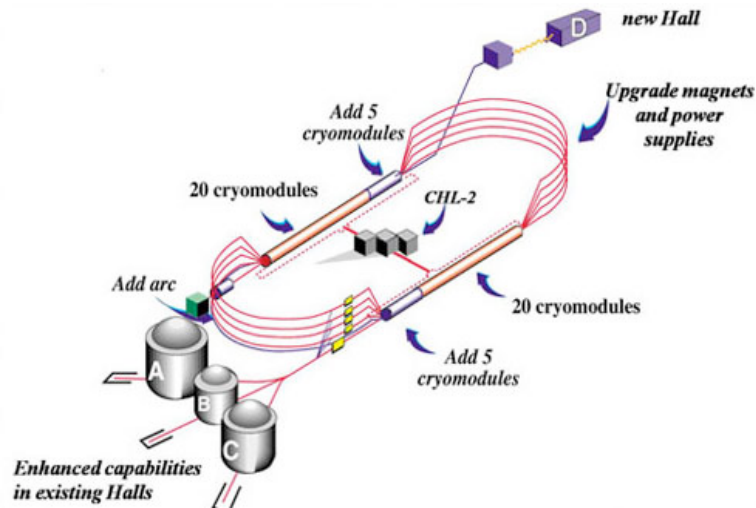

Fig. 2.11. CEBAF, a 12 GeV (was operating at 6 GeV) recirculating SRF linac at Thomas Jefferson Accelerator Facility. On the right – SRF accelerating modules. Upgrade to be finished by 2015.



Probably most unusual – green and energy efficient – extension of this concept are energy recovery linacs (ERL). The idea – which is very simple in principle, not in implementation! - was suggested by Tigner in 1965.

It is so simple – since the direction of electric field in linac reverses every half of the RF period, put the accelerated and used particles back into the linac but in the decelerating phase and take the beam energy back. With very low losses in SRF linacs it would turn them into apparent Perpetuum mobile.

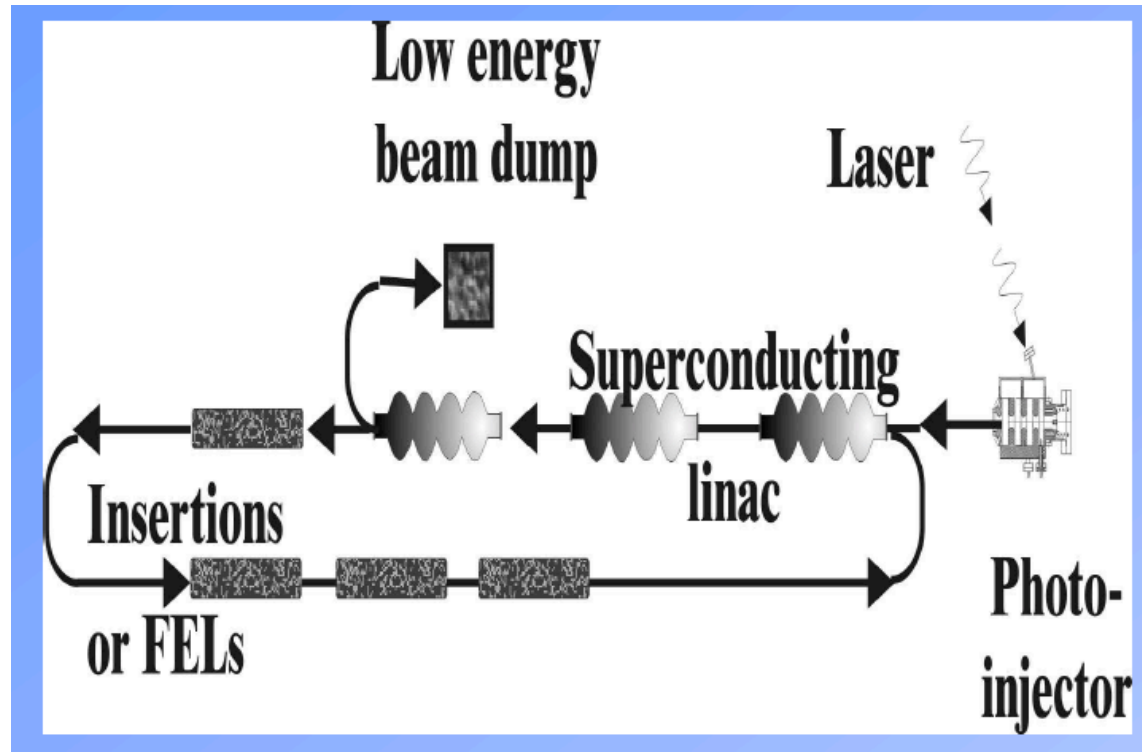
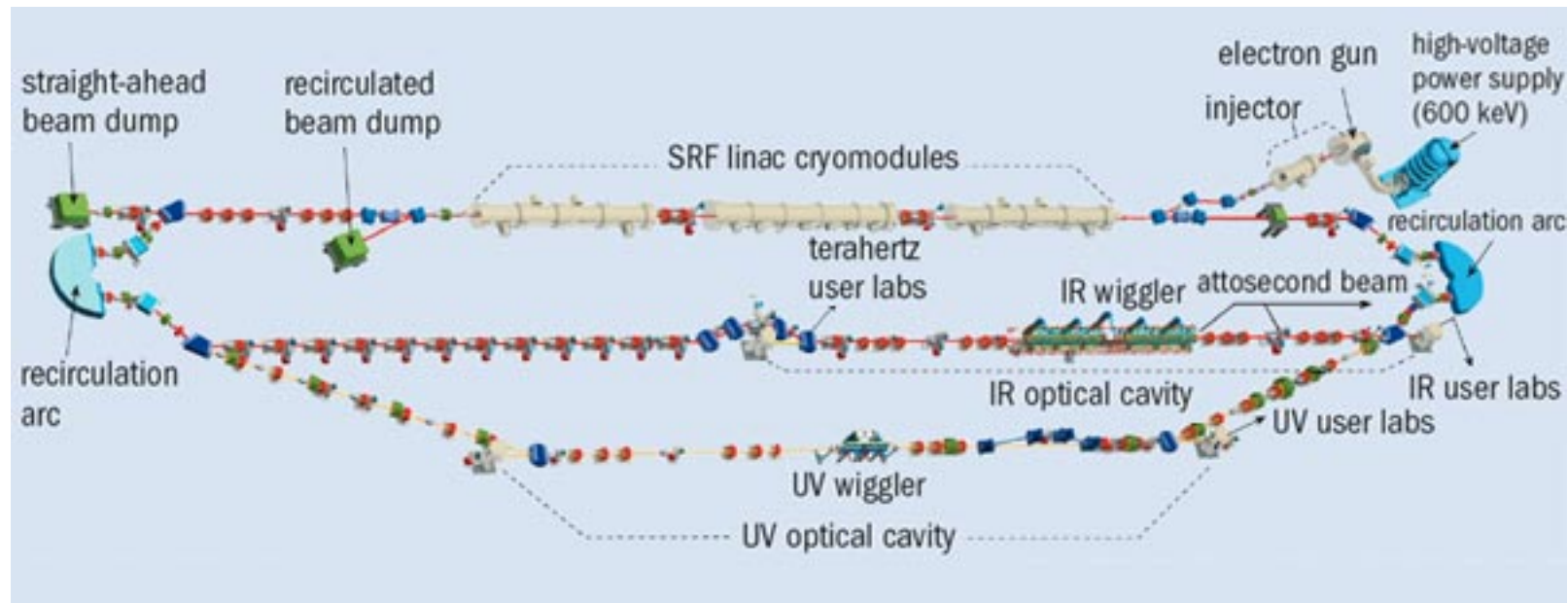

Fig. 2.12 One of traditional ERL schemes for FELs

It took more than 30 years actually to implement it in practice with a decent (10 mA) beam current – the problem was that SRF linacs have many high-Q modes which could cause beam instability.



Now we believe that we learned how to control them and are considering an 20 GeV ERL with 6 to 16 passes up in the energy and 16 passed down for eRHIC at BNL – I am sure that you would hear more about it in weeks ahead.

The biggest ERL conceived at the moment is 60 GeV 3-pass machine for LHeC – an electron-hadron collider at LHC. Both eRHIC and LHeC are projects waiting for approvals and funds to be realized.

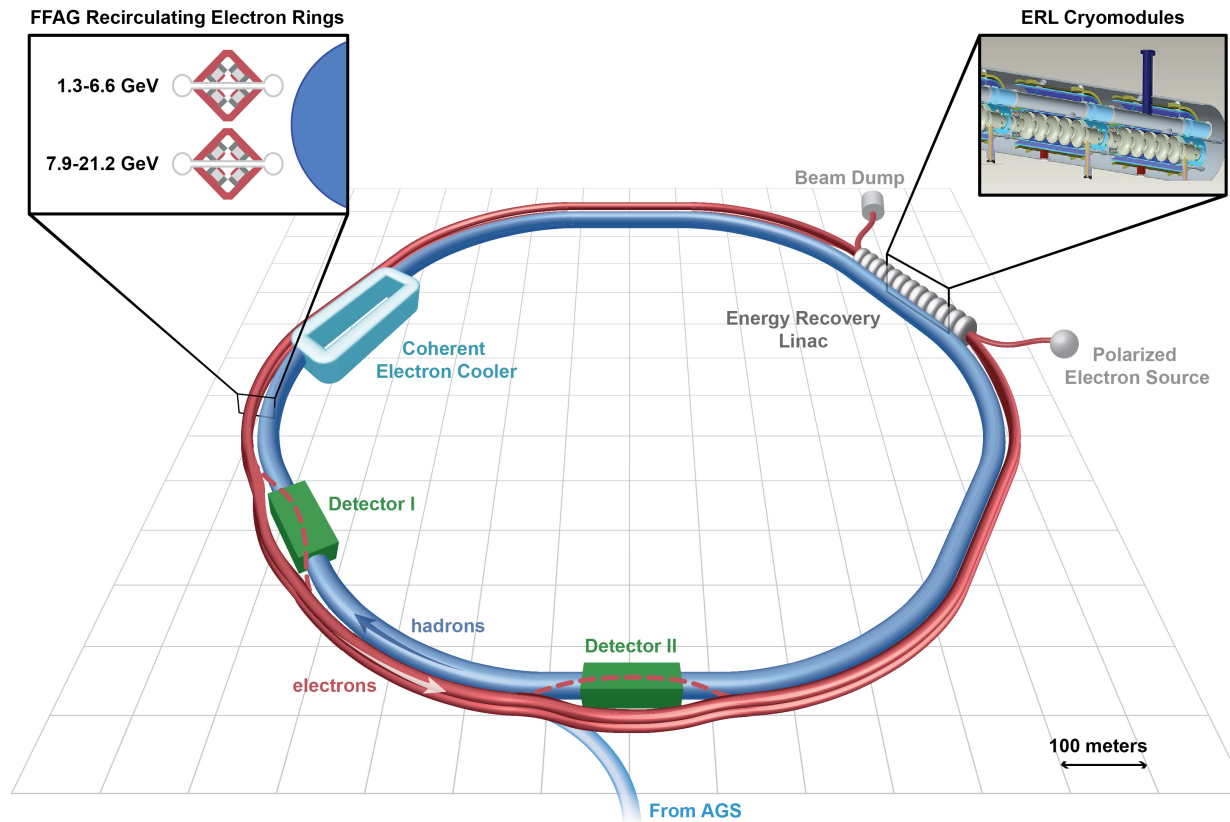
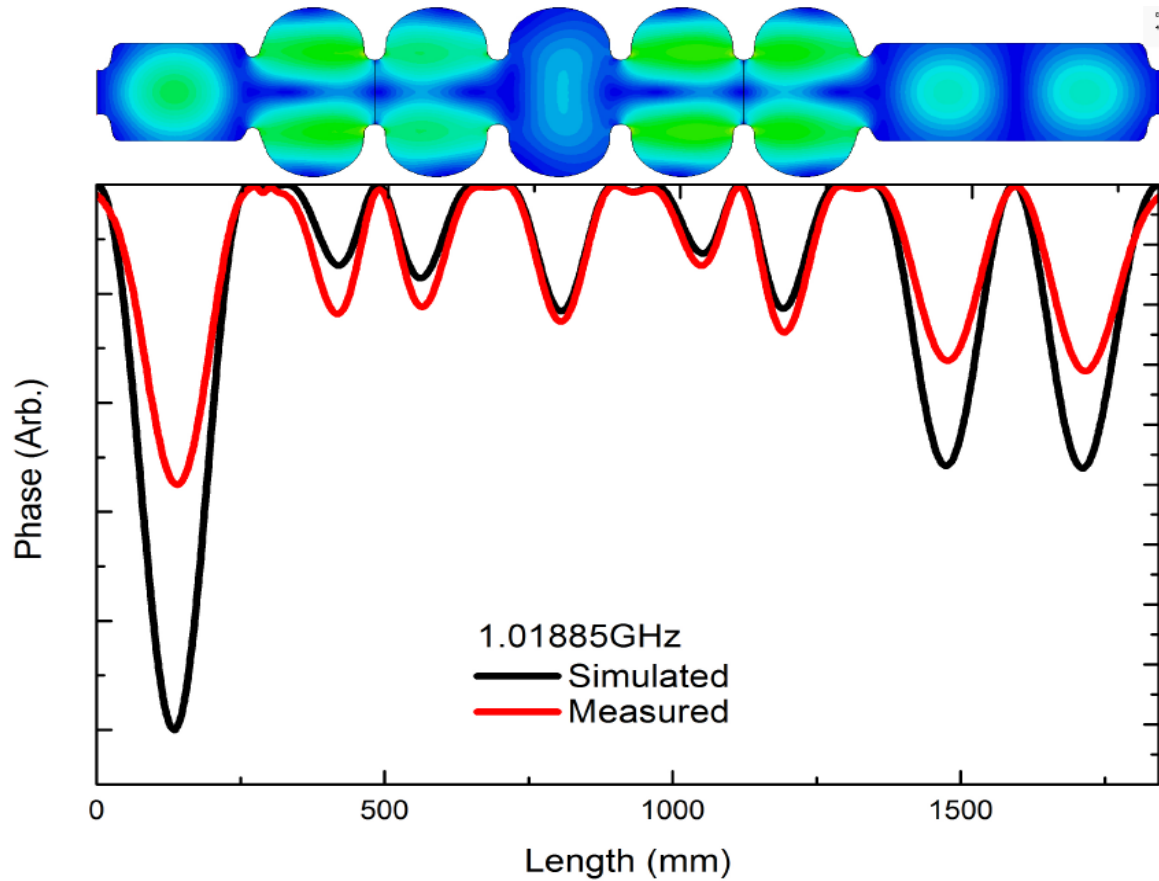

Fig. 2.13 Schematic of eRHIC – an electro-ion collider with 16-pass 21 GeV ERL.

Bottom line:

In RF cavities, as you will learn in detail in this course, the alternating electric and magnetic fields exist naturally in vacuum:

$$\frac{\partial \vec{E}}{c \partial t} = \text{curl} \vec{B}; \quad \frac{\partial \vec{B}}{c \partial t} = -\text{curl} \vec{E} \quad (2.7)$$



Betatrions. (please note that the name is deceptive and this type of accelerators should be called *induction accelerators*). There is another way of accelerating particles using induced by alternating magnetic field, e.g. Faraday law

$$e \oint \vec{E} \cdot d\vec{l} = -\frac{e}{c} \frac{d}{dt} \left(\int \vec{H} \cdot d\vec{s} \right)$$

The idea was written in his lab-book by a young Norwegian student, Wideröe, in 1923 but not published. It included 2:1 rule (see below). Later he added stability criterion. In 1927 he built a model of such betatron but it did not worked – and he turned to RF accelerators (see fig. 2.6) where he succeeded! **In 1940 Kernst** re-invented betatron and built a first working 2.2 MeV electron betatron. His largest betatron reached 300 MeV.

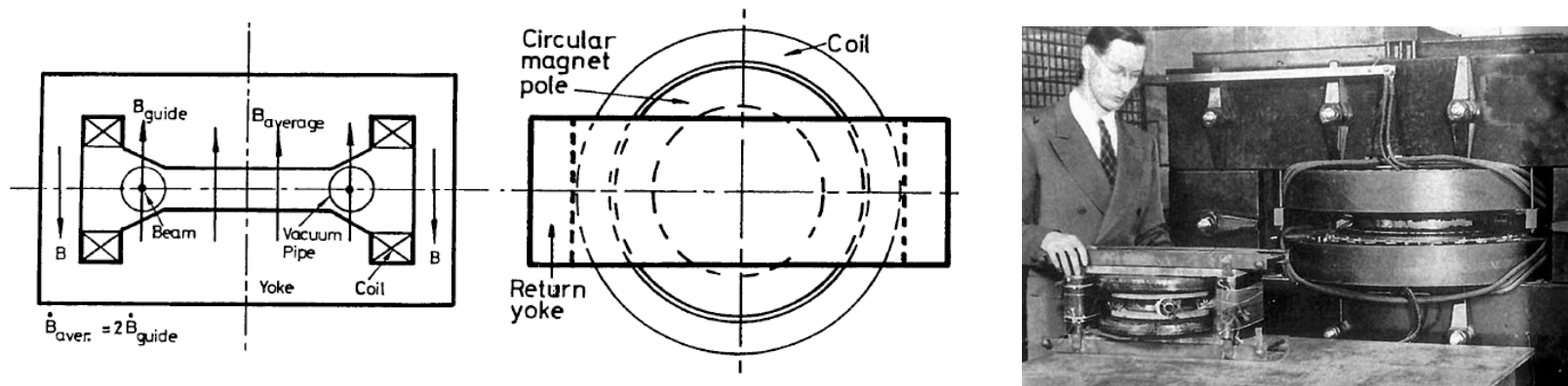

Fig. 2.14 Schematic of circular betatron (lest) and Kerst with his induction (betatron) accelerator (right)

For a axially symmetric system, the consideration for a constant radius of the particle's orbit are rather simple: an alternating magnetic field induces longitudinal electric field at an radius ρ :

$$dl = r d\theta; \quad ds = r dr d\theta; \quad \int d\theta = 2\pi$$

$$eE_{\theta}(\rho) = -\frac{1}{c\rho} \int_0^{\rho} \frac{dB(r)}{dt} \frac{dr^2}{2} = -\frac{\rho}{2c} \frac{d\bar{B}}{dt}; \quad (2.8)$$

$$\bar{B} = \frac{\int_0^{\rho} B(r)r dr}{\rho^2 / 2}$$

Then the change of the particle's momentum then

$$\frac{dp}{dt} = -eE_{\theta} = \frac{e\rho}{2c} \frac{d\bar{B}}{dt}. \quad (2.9)$$

Let's compare it with eq. (2.3) which we rewrite as

$$p = \frac{eB(\rho)\rho}{c} \quad (2.3')$$

to derive so-called **betatron ratio 2:1**:

$$\bar{B} = 2B \quad (2.10)$$

i.e. the average vertical magnetic field within encircled by the beam trajectory should be twice that on the beam orbit.

A short detour: Anybody who tried building room temperature magnets will learn right away that using soft magnetic steel (with permeability $\sim 1,000!$) is the way to go. We will discuss it again in the course. The steel has one important limitation – it saturates at about 2T (20 kGs) magnetic field. After that its permeability plummets and the usefulness of the magnetic steel vanishes. As you will see from the following problem, circular betatrons ramp energy gradually – the acceleration rate limited by the voltage induced in the magnet coils and their possible electric breakdown.

The etymology of many physics notation – and of course accelerator physics notations – have historic background.

One of these term you would hear and read again and again in accelerator physics talks and text: **betatron oscillations**. It would be natural to call these oscillations *transverse* since they occur in the directions transverse to the direction of the beam propagation.

But in spite of the logic they are called “*betatron oscillations*”. One of the main reasons for this name is the importance of **transverse beam stability in betatrons**, where particles accelerate slowly (again, you would show this in you home work!) for up to millions of turns.

One of the typical early errors in building betatrons, cyclotrons and microtrons was a desire to make **the vertical magnetic field near the orbit as homogeneous as possible**. Stability of transverse motion was not considered to be important and good engineers who build a nearly ideal magnets **saw that beam intensity dies off when beam propagates for more and more turns** – naturally in betatrons it was the most noticeable problem.

Post-factum it is easy to understand that a charged particle in ideal parallel vertical magnetic field will have **a helical trajectory and particles even with a small vertical momentum will fly away**, hit vacuum chamber and get lost.

In fact, in cyclotrons this effect was not very important and Livingston (at that time a student) shim the cyclotron magnet (see fig 2.15) in small steps to make beam propagating without loss....

To solve this problem – you will derive exact equations later in the course – a simple solution was found to slightly bend the magnetic field lines and introducing a component of focusing (returning) force for a particle, which wander off the plane of the magnet. As shown in the Fig. 2.15, the reducing magnetic field with the radius provides for the returning force in vertical direction.

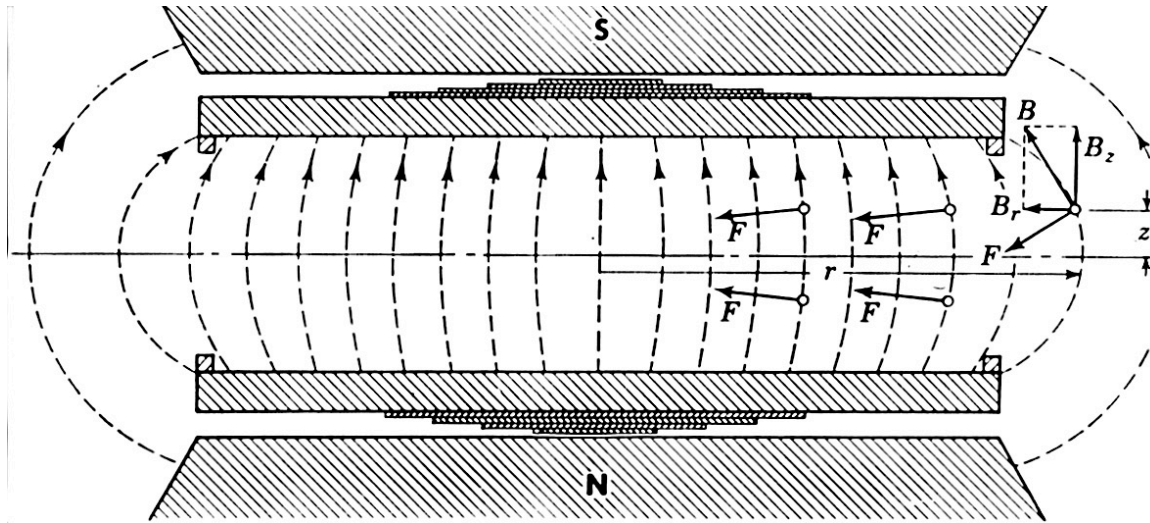

Fig. 2.15. Principle of vertical (weak focusing) using in cyclotrons.

Operating betatrons (see fig. 2.14) also used weak focusing forcing particles to execute stable vertical (and horizontal) oscillations about the ideal closed orbit. **These oscillations were most prominent and were studied in details in betatrons – hence, the name betatron oscillations stuck!**

A betatron accelerator can be “un-wrapped” into a linear accelerator. One of the version uses a set of toroidal ferromagnetic cores to generate a longitudinal field (see Fig. 2.15).

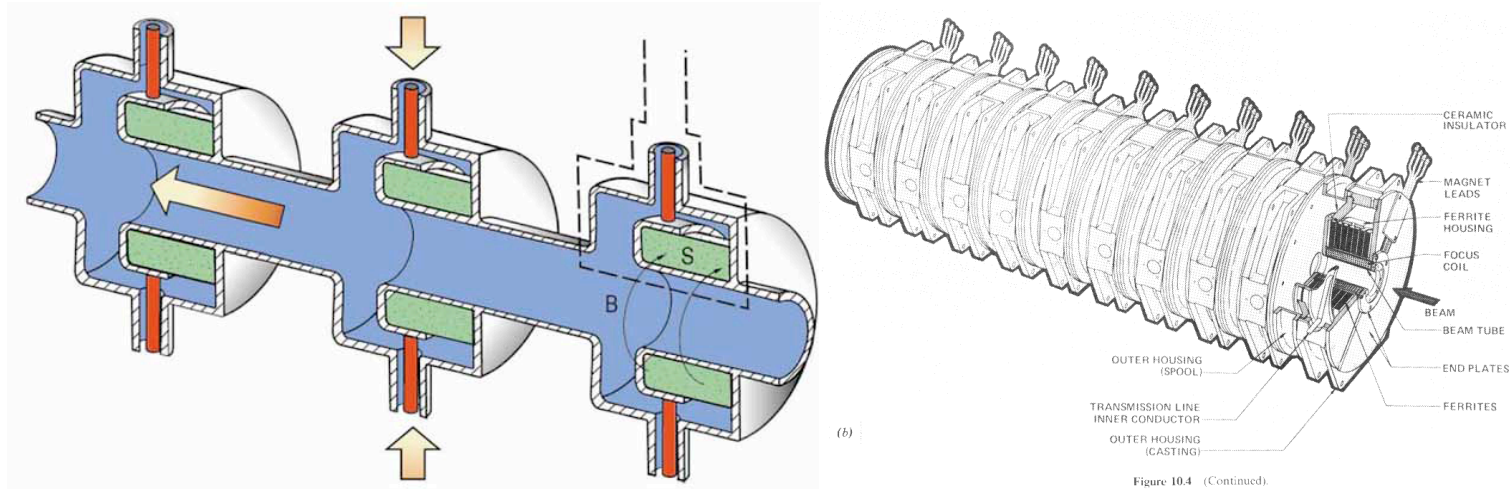

Fig. 2.16 Left: An operational principle of induction linac (-or a linear betatron) invented by Christofilos (also inventor of strong focusing) and (right) schematic of op operational induction linac [4].

Betatron were (and are still successful) simple pulsed accelerators, which operate with very high peak currents beams (kA!). But while successful, betatrons are limited in accelerating gradients and voltages by the voltage induced in the excitation coils.

References:

- [1] A BRIEF HISTORY AND REVIEW OF ACCELERATORS, P.J. Bryant, CERN, Geneva, Switzerland, <http://cds.cern.ch/record/261062/files/p1.pdf>
- [2] J.D. Cockcroft and E.T.S. Walton, "Experiments with high velocity ions", Proc. Royal Soc., Series A 136 (1932), 619–30.
- [3] R.J. Van de Graaff, "A 1,500,000 volt electrostatic generator", Phys. Rev., 387, (Nov.1931), 1919–20.
- [4] http://cdn.preterhuman.net/texts/science_and_technology/physics/ , Principles of Charged Particle Accelerators/chap10.pdf
- [5] www.werc.or.jp/english/reseadeve/activities/accelerator/accelerator/synchro/index.htm
- [6] E.M. McMillan, "The synchrotron - a proposed high-energy particle accelerator", Phys. Rev., Letter to the editor, 68 (Sept. 1945), 1434.
- [7] V. Veksler, J. of Phys, USSR, 9 (1945), 153–8.
- [8] E.D. Courant and H.S. Snyder, *Annals of Physics*, 3, 1, 1958
- [9] D.W. Kerst, "The acceleration of electrons by magnetic induction", Phys. Rev., 60 (July 1942), 47–53.
- [10] M.S. Livingston, "Particle accelerators: A brief history", Harvard University Press, Cambridge, Massachusetts (1969), 32.
- [13] E.D. Courant, M.S. Livingston and H.S. Snyder, "The strong-focusing synchrotron – a new high-energy accelerator", Phys. Rev., 88 (Dec. 1952), 1190-6, and
- [14] N.C. Christofilos, Unpublished report (1950), and U.S. Patent no. 2.736,799, filed March 10, 1950, issued February 28, 1956. Energy Accel., CERN, 1971 (CERN, Geneva, 1971), 501–4.