

Overview

The optional HP StorageWorks MSA SAN Switch 2/8 for the HP StorageWorks Modular Smart Array 1000 (MSA1000) is integrated into the MSA1000 chassis, requiring no additional rack space. This switch takes advantage of the MSA's high availability features and offers full 2 Gb full fabric performance at an attractive price. A second MSA SAN switch 2/8 can be installed for redundancy. There are seven pluggable ports available (four SFPs are included). The eighth port is directed internally to the controller.

The MSA SAN Switch 2/8 offers low price per port and full scalability, doing so while taking zero rack space, even in a redundant configuration. This second generation integrated switch option offers the customer more ports and is a full member of the HP StorageWorks SAN Switch family, assuring interoperability from the smallest to the largest SAN configuration.

The HP StorageWorks MSA SAN Switch 2/8 is used by true entry-level SAN configuration customers as an inexpensive switch based on cost per port. It is also attractive to mid-range SAN configuration customers who appreciate its rack saving characteristics, and need its interoperability with external HP StorageWorks SAN Switch products.

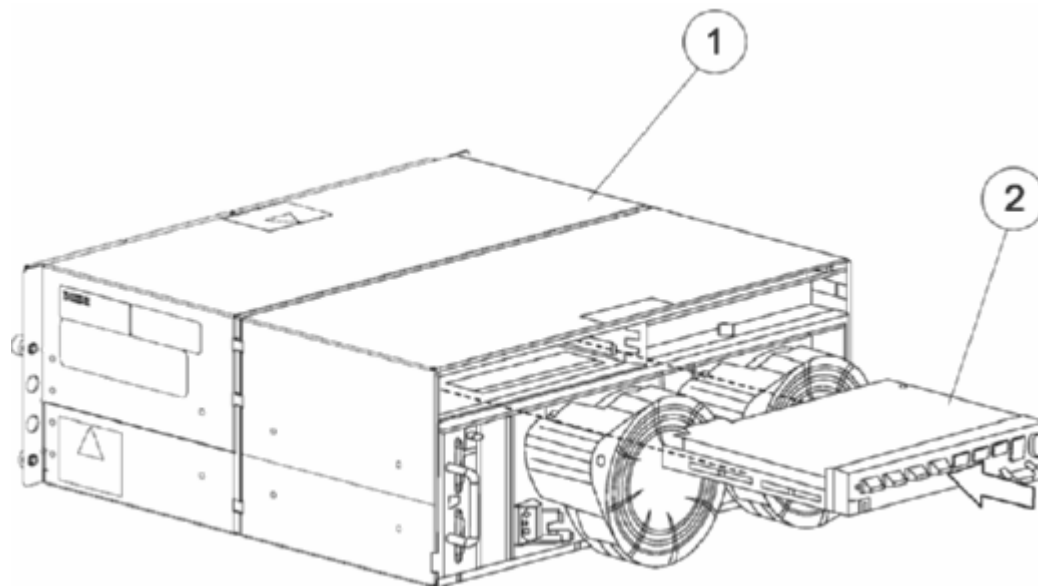

1.MSA1000

2.HP StorageWorks MSA SAN Switch 2/8

Overview

Key Features and Benefits

- **Reduced Total Cost of Ownership for SAN Infrastructure**
 - Enables storage consolidation, simplified management of data center SAN environment
- **Interoperability with the more than 1 MILLION port HP SAN Switch installed base**
- **Highest integration with HP Open View Storage Area Manager via:**
 - SAN Switch API
 - SAN Switch element managers
 - HP StorageWorks Fabric Manager (optional)
- **Broadest range of compatibility with SAN products**
 - Multi-vendor server and storage environment
 - Widest range of HP SAN solutions
 - Backward compatible with previously installed 1Gb SAN Switches
- **Flexible storage connectivity**
 - The only SAN solutions providing the complete HP SAN Switch functionality from Embedded to Enterprise. The HP SAN Switch value line products allows the capability to apply the complete SAN Switch functionality to an affordable entry level SAN deployment and then to grow that deployment to the largest SAN fabric solutions supported by HP.
- **2 Gb 8-port Fabric Switch integrated into the HP MSA1000 chassis**
 - 7-ports external, 1-port internal
 - 2 Gb / 1Gb frequency agile
- **Supports all HP Power Pack software features**
 - Includes WebTools and Advanced Zoning
- **Seven small form factor short wave (SFP) ports (ships with 4 SFPs included)**
- **Efficient, space saving design**

Models

HP StorageWorks MSA HP StorageWorks MSA SAN Switch 2/8
SAN Switch 2/8

288247-B21

Product Highlights

Configuration support Please visit: <http://h18000.www1.hp.com/products/storageworks/san/documentation.html>

Advanced Fabric Services

- ISL Trunking (optional)
 - Hardware Enforced Zoning
 - WebTools
 - Remote Switch (optional)
 - Fabric Watch (optional)
 - End-to-End Performance Analysis (optional)
 - Extended Fabric (optional)
-

Manageability

- WebTools
 - OpenView
 - API
 - IP
 - SNMP
-

Software Components, Standard

Frame Filtering

An ASIC based capability in the 2 Gb family of SAN switches that enables new applications and features. The switch has the ability to "view" the first 64-bytes of the Fibre Channel frame. At this time, Frame Filtering enables advanced capabilities such as Advanced Zoning and Advanced Performance Monitoring (optional).

Advanced Zoning

In the 2Gb generation of switches, WWN Zoning and Access Control **are enforced by hardware that provides the same simple administration previously enforced only with software.** Administrators can organize a physical fabric into logical groups and prevent unauthorized access by devices outside the Zone

WebTools

Enables organizations to monitor and manage single Fibre Channel switches and small SAN fabrics. Tasks can be performed through a Java-capable Web browser from a standard laptop, desktop PC or workstation from any location within the enterprise.

QuickLoop

QuickLoop enables Fibre Channel private-loop devices in legacy environments to migrate to a fully scalable Fabric to be used for a Storage Area Network (SAN). It supports Fibre Channel Arbitrated Loop (FC-AL) devices with a Fabric. This advanced service enables private-loop hosts and storage devices to attach to a Fabric without modifying host drivers.

Software Components, Optional

MSA SAN Switch 2/8 Power Pack Software Bundle

The MSA SAN Switch 2/8 Power Pack Software Bundle includes:

- ISL Trunking
 - Advanced Performance Monitor
 - Remote Switch
 - Extended Fabric
 - Fabric Watch
-

Product Highlights

ISL Trunking

For high performance enhanced Trunking, this optional license logically groups up to four E-ports to provide a high bandwidth trunk between two switches. Each 2 Gb switch needs its own license. The switch operating system views the trunk as a single, high bandwidth resource (up to 8 Gb) when routing connections between switches. Connections are load-balanced across the individual links, which comprise the logical trunk group. Each 8-port switch can have a total of two separate 4-port Trunk groups.

Remote Switch

Remote switch fabric functions with the aid of a bridging device or network bridge. The network bridge supports both Fibre Channel physical interfaces, as well as secondary non-Fibre Channel FCIP physical interface.

Fabric Watch

Fabric Watch enables each switch to monitor the SAN for potential faults-and automatically alert network managers to problems before they become failures. Fabric Watch tracks a variety of SAN fabric elements, events, and counters. Monitoring fabric-wide events, ports, SFPs, and environmental parameters permits early fault detection and isolation as well as performance measurement. Each switch in the SAN needs its own Fabric Watch license.

Advanced Performance Monitoring

This enabling technology helps administrators monitor and watch specific fabric metrics from a SID (Source ID) to a DID (Destination ID), so they can fine-tune and scale the fabric more efficiently. Plus, Advanced Performance Monitoring includes the ability for early warning detection of hot spots within the fabric, a powerful tool for maintaining overall balanced performance.

Extended Fabric

Extends all of the scalability, reliability, and performance benefits of Fibre Channel Storage Area Networks (SANs) beyond the native 10 km distance specified by the Fibre Channel standard.

Secure Fabric OS

Secure Fabric OS™ is available only on the B-Series platform and is the only solution that provides protection for both management access and switch-to-switch authentication. This comprehensive security solution for SAN fabrics provides policy-based security protection for more predictable change management, assured configuration integrity and reduced risk of downtime. Secure Fabric OS protects the network by using the strongest, enterprise-class security methods available, including digital certificates and digital signatures, multiple levels of password protection, strong password encryption and Public Key Infrastructure (PKI)-based authentication, and 128-bit encryption of the switch's private key used for digital signatures. With its flexible design, Secure Fabric OS enables organizations to customize SAN security to meet specific policy requirements. In addition, Secure Fabric OS works in conjunction with Advanced Zoning to further secure access to the SAN, simplify storage management, and reduce provisioning time.

Fabric Manager

Fabric Manager is a highly scalable, Java-based application that manages multiple switches and multiple fabrics (up to eight) in real time, helping SAN administrators with SAN configuration, monitoring, dynamic provisioning, and daily management. SAN administrators gain rapid access to critical SAN information across multiple personality fabrics, including both Fabric OS SANs and enhanced Secure Fabric OS SANs.

Service and Support, HP Care Pack, and Warranty Information

Warranty

(1-1-1) Hardware Warranty - One-year on-site warranty, 8x5, next business day response, installation not included.

NOTE: The hardware warranty covers firmware and embedded non-saleable software. Saleable software carries its own warranty, please see below.

Software Warranty: HP warrants only that the software media will be free of physical defects for a period of ninety (90) days from delivery.

EXCLUSIVE REMEDY: The entire liability of HP and its suppliers and your exclusive remedy for software that does not conform to this Limited Warranty shall be the repair or replacement of the defective media. This warranty and remedy are subject to your returning the defective media during the warranty period to HP in the country in which you obtained the software.

HP Service & Warranty Support

HP Service & Warranty Support Additional Warranty protection and/or HP Installation packages can be purchased.

NOTE: Certain restrictions and exclusions apply. Consult the Customer Support Center for details. HP provides a one-year, hardware limited warranty, fully supported by a worldwide network of resellers and service providers. The first year of Rights to New License Version and standard business day, standard business hours telephone support is included with the purchase of an HP Power Pack. In order to continue to receive telephone support and Rights to New License Version after the first year, the purchase of a software support contract or Care Pack is required.

In addition, available service offerings include a full range of HP Care Pack packaged hardware and software services:

- Installation
- Extended coverage hours and enhanced response times
- System management and performance services
- For more information on warranty and support options, please visit our Web site at: <http://www.hp.com/hps/tech/storage/supp/>.

Software Product Services

- Stand-alone telephone support
- Rights to new license version
- Media and documentation updates

Hardware Product Services

- Installation services
- On-site maintenance (includes warranty support)
- Response time upgrades during the warranty period
- Post-warranty coverage

HP Care Pack Services Warranty Upgrade Options

Service offerings include a full range of Customer HP Care Pack services for both hardware and software services:

- Response - Upgrade on-site response from next business day to same day 4-hours
- Coverage - Extend hours of coverage from 5 days x 9 hours to 7 days x 24 hours
- Duration - Select duration of coverage for a period of 1, 3, or 5 years

Additional Warranty protection and/or HP Installation packages can be purchased.

NOTE: Certain restrictions and exclusions apply. Consult the HP Customer Support Center for details.

Service and Support, HP Care Pack, and Warranty Information

HP Care Pack Information

HP Care Pack is defined as an upgrade to the product warranty attribute, available for a specific duration and hours of coverage.

- HP Care Pack is not available for less than the product's warranty duration.
- HP Care Pack is available for sale anytime during the warranty period for most products, but the commencement date will be the same as the Warranty Start Date (delivery date to end user customer). Proof of purchase may be required.
- HP Care Pack services are prepaid.

For additional HP Care Pack (hardware & software) information, as well as orderable part numbers, please refer to the URL listed below:

<http://h18005.www1.hp.com/services/carepaq/index.html>

Additional Services

Implementation service, SAN Architecture service. For more information on service options, please visit our Web site at: <http://www.hp.com/go/san>.

Family Information

Features	4/8 SAN Switch Base and 4/8 SAN Switch	4/16 SAN Switch and 4/16 SAN Switch Power Pack	SAN Switch 4/32 and SAN Switch 4/32 Power Pack	4/64 SAN Switch and 4/64 SAN Switch Power Pack	SAN Director 2/128 and Director 2/128 Power Pack	4/256 SAN Director and 4/256 Power Pack
Targeted Environment	Workgroups, Departments	Workgroups, Departments	Workgroups, Departments	Workgroups, Departments	Data Centers	Data Centers
Port Bandwidth	4Gbit/sec	4Gbit/sec	4Gbit/sec	4Gbit/sec	2 Gbit/sec	Up to 4Gbit/sec
Aggregate device bandwidth	64 Gbit/sec end-to-end	128 Gbit/sec end-to-end	128-256 Gbit/sec end-to-end	256 Gbit/sec end-to-end	512 Gbit/sec end-to-end	2.176Tbit/sec
OS Support	NOTE: Please Refer to SAN Design Guide pointer http://www.hp.com/go/SANdesign or http://www.hp.com/go/SANdesignguide					
Storage system support	MA8000 EMA12000/ EMA16000 EVA, XP, VA, MSA	MA8000 EMA12000/ EMA16000 EVA, XP, VA, MSA	MA8000 EMA12000/ EMA16000 EVA, XP, VA, MSA	MA8000 EMA12000/ EMA16000 EVA, XP, VA, MSA	MA8000 EMA12000/ EMA16000 EVA, XP, VA, MSA	MA8000 EMA12000/ EMA16000 EVA , XP, VA, MSA
Ports	16 SFP	16 SFP	32 SFP	32 SFP Base 64 Total	32 SFP Base 128 Total	256 Total
Cascading support	Yes	Yes	Yes	Yes	Yes	Yes
Advanced Trunking	Optional Upgrade	Included with Power Pack or Optional Upgrade	Included with Power Pack or Optional Upgrade	Included with Power Pack or Optional Upgrade	Included with Power Pack or Optional Upgrade	Included with Power Pack or Optional Upgrade
Form factor	1U	1U	1U	2U	14U	14U
Zoning Software	Yes (Included)	Yes (Included)	Yes (Included)	Yes (Included)	Yes (Included)	Yes (Included)
Hot plug, redundant power supplies	No	No	Yes	Yes	Yes	Yes
Hot plug fans	No	No	Yes	Yes	Yes	Yes
Enterprise Backup Solution (EBS) support	Yes	Yes	Yes	Yes	Yes	Yes

Family Information

Features	Brocade 4Gb SAN Switch for HP p-Class BladeSystem	Brocade 4Gb SAN Switch for HP c-Class BladeSystem	MSA SAN Switch 2/8 (embedded switch)	HP 400 Multi-protocol Router	B-Series Multi-protocol Router Blade
Targeted Environment	Workgroups, Departments	Workgroups, Departments	Workgroups, Departments	Workgroups, Departments	Data Centers
Port Bandwidth	4 Gbit/sec	4 Gbit/sec	2 Gbit/sec	4 Gbit/sec Ethernet: 1 Gbit/sec	4 Gbit/sec Ethernet: 1 Gbit/sec
Aggregate device bandwidth	48 Gbit/sec end-to-end	192 Gbit/sec end-to-end	32 Gbit/sec end-to-end	128 Gbit/sec	N/A
OS Support	NOTE: Please Refer to SAN Design Guide pointer http://www.hp.com/go/SANdesign or http://www.hp.com/go/SANdesignguide				
Storage system support	MSA, EVA, XP	MSA, EVA, XP	MSA 1000	MSA, EVA, XP	MSA, EVA, XP
Ports	4 external / 8 internal	4 or 8 external / 8 or 16 internal	7 external / 1 internal	18 ports: 16 FC and 2 Gigabit Ethernet	18 ports: 16 FC and 2 Gigabit Ethernet
Cascading support	Yes	Yes	Yes	Yes	Yes
Advanced Trunking	Optional Upgrade	Optional Upgrade	Optional Upgrade	Optional Upgrade	Optional Upgrade to chassis
Form factor	Embedded	Embedded	Embedded	1U	Blade in Director
Zoning Software	Yes (Included)	Yes (Included)	Yes (Included)	Yes (Included)	Yes (Included)
Hot plug, redundant power supplies	Yes, in BladeSystem Enclosure	Yes, in BladeSystem Enclosure	No	No	Yes, in director chassis
Hot plug fans	Yes, in BladeSystem Enclosure	Yes, in BladeSystem Enclosure	No	No	Yes, in director chassis
Enterprise Backup Solution (EBS) support	Yes	Yes	Yes	Yes	Yes

Configuration Information

Step 1 – Base Configuration

Select one:

Model Name	Model Description	Part Number
HP StorageWorks MSA SAN Switch 2/8	(1) MSA SAN Switch 2/8; four (4) SFPs installed; WebTools license; Zoning license; documentation	288247-B21

Step 2 – Additional Options

Optical Transceivers (SFP)	Short Wave,(1)	A7446B
----------------------------	----------------	--------

2-Gb optical cables	LC-LC for between two 2-Gb devices	
	2 m LC-LC Multi-Mode Fibre Channel Cable	221692-B21
	5 m LC-LC Multi-Mode Fibre Channel Cable	221692-B22
	15 m LC-LC Multi-Mode Fibre Channel Cable	221692-B23
	30 m LC-LC Multi-Mode Fibre Channel Cable	221692-B26
	50 m LC-LC Multi-Mode Fibre Channel Cable	221692-B27
	LC-SC for between a 1-Gb and a 2-Gb device	
	2 m LC-SC Multi-Mode Fibre Channel Cable	221691-B21
	5 m LC-SC Multi-Mode Fibre Channel Cable	221691-B22
	15 m LC-SC Multi-Mode Fibre Channel Cable	221691-B23
	30 m LC-SC Multi-Mode Fibre Channel Cable	221691-B26
	50 m LC-SC Multi-Mode Fibre Channel Cable	221691-B27

Step 3– Optional Software

Optional Software	Fabric Watch	324504-B21
	NOTE: For 8 and 16-port switches.	
	ISL Trunking Kit	324506-B21
	NOTE: For 8 and 16-port switches.	
	Advanced Performance Monitor	324507-B21
	NOTE: For 8 and 16-port switches.	
	QuickLoop	324508-B21
	NOTE: For 8 and 16-port switches.	
	Remote Switch	325891-B21
	NOTE: For 8 and 16-port switches.	
Extended Fabric		324505-B21
	NOTE: For 8 and 16-port switches.	
	Power Pack Software Bundle	325892-B21
NOTE: The PowerPak Software Bundle includes the following options - ISL Trunking Remote Switch, Fabric Watch, and Extended Fabric.		

Fibre Channel Standards And Revisions	FC-FG Rev 3.5	FC-AL Rev. 4.5	FC-FLA Rev 2.7	FC-PLDA Rev 2.1	FC-VI Rev 1.5
	FC-PH-2 Rev 7.4	FC-GS-2 Rev 5.3	FC-PH-3 Rev 9.4	FC-SW Rev 3.3	IPFC RFC 2625
	FC-AL-2 Rev. 7.0	FC-PH Rev 4.3			

Technical Specifications

Fibre Channel ports	8 universal ports (1 internal, 7 external; ships with 4 SFPs installed, standard)		
Scalability	Full fabric architecture: http://h18006.www1.hp.com/products/storageworks/san/documentation.html		
Performance	2.125 GB/sec line speed, full duplex		
Certified maximum	20 switches, 7 hops; larger fabrics certified as required		
Interoperability	SAN Switch 8, SAN Switch 16, SAN Switch 8-EL, SAN Switch 16-EL, SAN Switch 2/8v, SAN Switch 2/16v, SAN Switch 2/16N, SAN Switch 2/16, SAN Switch 2/1-EL, Core Switch 2/64, SAN Switch 2/32, SAN Director 2/128; 4/256 SAN Director; 4/64 SAN Switch ;SAN Switch 4/32; 4/8 SAN Switch; 4/16 SAN Switch; Brocade 4Gb SAN Switch for HP p-Class BladeSystem; Brocade 4Gb SAN Switch for HP c-Class BladeSystem; MSA SAN Switch 2/8'; HP 400 MP-Router; and HP MP-Router		
Switch core	Non-blocking		
Fabric latency	<2 µ sec. with no contention, cut-through routing		
Maximum frame size	2112-byte payload		
Classes of service	Class 2, Class 3, Class F (inter-switch frames)		
Port types	FL_Port, F_Port, and E_Port; self-discovery based on switch type (U_Port)		
Data traffic types	Fabric switches support unicast, multicast (256 groups), and broadcast		
Media types	Small Form-Factor Pluggable (SFP)		
Laser	Short-wave up to 500 m (1,640 ft); long-wave up to 10 km (6.2 mi) when available		
Fabric services	Simple Name Server, Registered State Change Notification (RSN), Alias Server multicast); and Zoning, WebTools, optional QuickLoop™, Fabric Watch, Extended Fabrics™, and Remote Switch™		
Options	SFP media		
Supported software	Telnet, SNMP, WebTools, Brocade Zoning, SES (optional), Fabric Watch, Extended Fabrics, Remote Switch		
Management access	10/100 Ethernet (RJ-45), serial port		
Diagnostics	POST and embedded online/offline diagnostics		
Dimensions	Width	12.50 in (31.75 cm)	
	Height	7.75 in (19.70 cm)	
	Depth	17.00 in (43.20 cm)	
	Weight	2.72 lb (1.233 kg)	
Environment	Temperature	Operating	32° to 104° F (0° to 40 C°)
		Non-operating	-31° to 147° F (-25° to 70° C)
	Vibration	Operating	0.5 G, p-p 5-500-5 Hz
		Non-operating	2.0 G p-p, 5-500Hz

© Copyright 2007 Hewlett-Packard Development Company, L.P.

The information contained herein is subject to change without notice.

The only warranties for HP products and services are set forth in the express warranty statements accompanying such products and services. Nothing herein should be construed as constituting an additional warranty. HP shall not be liable for technical or editorial errors or omissions contained herein.