

Intel® Server System SR2600UR

Technical Product Specification

Intel order number E45274-004



Revision 1.1

October 2009

Enterprise Platforms and Services Division

Revision History

Date	Revision Number	Modifications
March 2009	1.0	Initial release.
October 2009	1.1	Updated section 7.3 - Control Panel Connectors

Disclaimers

Information in this document is provided in connection with Intel® products. No license, express or implied, by estoppel or otherwise, to any intellectual property rights is granted by this document. Except as provided in Intel's Terms and Conditions of Sale for such products, Intel assumes no liability whatsoever, and Intel disclaims any express or implied warranty, relating to sale and/or use of Intel products including liability or warranties relating to fitness for a particular purpose, merchantability, or infringement of any patent, copyright or other intellectual property right. Intel products are not intended for use in medical, life saving, or life sustaining applications. Intel may make changes to specifications and product descriptions at any time, without notice.

Designers must not rely on the absence or characteristics of any features or instructions marked "reserved" or "undefined." Intel reserves these for future definition and shall have no responsibility whatsoever for conflicts or incompatibilities arising from future changes to them.

The Intel® Server System SR2600UR may contain design defects or errors known as errata which may cause the product to deviate from published specifications. Current characterized errata are available on request.

This document and the software described in it are furnished under license and may only be used or copied in accordance with the terms of the license. The information in this manual is furnished for informational use only, is subject to change without notice, and should not be construed as a commitment by Intel Corporation. Intel Corporation assumes no responsibility or liability for any errors or inaccuracies that may appear in this document or any software that may be provided in association with this document.

Except as permitted by such license, no part of this document may be reproduced, stored in a retrieval system, or transmitted in any form or by any means without the express written consent of Intel Corporation.

Intel, Pentium, Itanium, and Xeon are trademarks or registered trademarks of Intel Corporation.

*Other brands and names may be claimed as the property of others.

Copyright © Intel Corporation 2008-2009.

Table of Contents

1. Introduction	9
1.1 Chapter Outline.....	9
1.2 Server Board Use Disclaimer	10
2. Product Overview.....	11
2.1.1 Processor Support.....	13
2.2 System Overview	15
2.3 System Dimensions	15
2.4 System Components	16
2.5 Hard Drive and Peripheral Bays	17
2.6 System Board Overview	18
2.7 Front Bezel Features	22
2.8 Rack and Cabinet Mounting Options	23
3. Power Subsystem	24
3.1 Mechanical Overview.....	24
3.2 Single Power Supply Module Population.....	26
3.3 Handle and Retention Mechanism.....	26
3.4 Hot-swap Support.....	26
3.5 Airflow	27
3.6 AC Power Cord Specification Requirements	27
3.7 Output Cable Harness	27
3.7.1 P1 – Server Board Power Connector	28
3.7.2 P2 – Processor Power Connector	28
3.7.3 P3 – Power Signal Connector.....	29
3.7.4 P4 – Backplane Power Connector.....	29
3.7.5 P5 – Midplane Power Connector	29
3.8 AC Input Requirements	30
3.8.1 Efficiency	30
3.8.2 AC Input Voltage Specification	30
3.8.3 AC Line Dropout / Holdup.....	31
3.8.4 AC Line 5 VSB Holdup	31
3.8.5 AC Inrush.....	31
3.9 Protection Circuits.....	31

3.9.1	Over-current Protection (OCP)	31
3.9.2	Over-voltage Protection (OVP)	32
3.9.3	Over-temperature Protection (OTP).....	32
3.10	DC Output Specification	33
3.10.1	Output Power / Currents	33
3.10.2	Standby Output / Standby Mode.....	33
3.11	Power Supply Status LED	33
4.	Cooling Subsystem.....	34
4.1	Non-redundant Fan Module	35
4.2	Redundant Fan Module	38
4.3	Airflow Support	40
4.3.1	Power Supply Zone	40
4.3.2	Full-height Riser Zone	41
4.3.3	CPU / Memory / Low-profile PCI Zone.....	41
4.4	Drive Bay Population	42
4.5	Memory Slot Population.....	42
5.	System Board Interconnects.....	43
5.1	Midplane	43
5.2	Bridge Board.....	50
5.3	Hot-swap SAS/SATA Backplane	51
6.	Peripheral and Hard Drive Subsystem	59
6.1	Slimline Drive Bay.....	59
6.2	Hard Drive Bays.....	61
6.2.1	Hot-swap Drive Carriers	61
6.3	Optional Tape Drive or Additional Hard Drive Flex Bay	62
6.4	Midplane Options.....	63
6.4.1	Passive Midplane.....	64
6.4.2	Active Midplane with SAS/SATA RAID Support	64
6.5	Hot-swap SAS/SATA Backplane	67
6.5.1	SAS/SATA Backplane Layout.....	68
6.5.2	SAS/SATA Backplane Functional Architecture.....	70
6.6	Enclosure Management Cabling for Passive Midplane	72
7.	Standard Control Panel	73
7.1	Control Panel Buttons.....	73
7.2	Control Panel LED Indicators	74

7.2.1	Power / Sleep LED	76
7.2.2	System Status LED.....	76
7.2.3	Drive Activity LED	77
7.2.4	System Identification LED.....	77
7.3	Control Panel Connectors.....	78
7.4	Internal Control Panel Interconnect	79
8.	Intel® Local Control Panel.....	81
8.1	LED Functionality.....	82
8.1.1	Power / Sleep LED	83
8.1.2	System Status LED.....	83
8.1.3	Drive Activity LED	84
8.1.4	System Identification LED.....	84
8.2	Intel® Local Control Panel Interconnects	85
9.	PCI Riser Cards and Assembly	87
9.1	Riser Card Options	89
9.2	PCI Riser Card Mechanical Drawings	90
10.	Environmental Specifications	94
10.1	System Level Environmental Limits.....	94
10.2	Serviceability and Availability.....	94
10.3	Replacing the Backup Battery	95
11.	Regulatory and Certification Information.....	96
11.1	Product Regulatory Compliance	96
11.1.1	Product Safety Compliance	96
11.1.2	Product EMC Compliance – Class A Compliance	97
11.1.3	Product Ecology Compliance.....	97
11.1.4	Certifications / Registrations / Declarations	97
11.2	Product Regulatory Compliance Markings	98
11.3	Rack Mount Installation Guidelines	100
11.4	Power Cord Usage Guidelines	102
11.5	Electromagnetic Compatibility Notices	102
11.5.1	FCC Verification Statement (USA)	102
11.5.2	ICES-003 (Canada)	103
11.5.3	Europe (CE Declaration of Conformity)	103
11.5.4	VCCI (Japan)	103
11.5.5	BSMI (Taiwan)	104

11.5.6 KCC (Korea) 104

11.6 Regulated Specified Components 105

Appendix A: Integration and Usage Tips..... 106

Appendix B: POST Code Diagnostic LED Decoder 107

Appendix C: POST Code Errors 111

Glossary..... 116

Reference Documents 118

List of Figures

Figure 1. Top Down View – Passive System SKU Shown.....	15
Figure 2. Major System Components	16
Figure 3. Drive Bay Overview	17
Figure 4. Intel® Server Board S5520UR.....	18
Figure 5 Intel® Server Board S5520UR Components	19
Figure 6. Back Panel Feature Overview	20
Figure 7. Intel® Light-Guided Diagnostic LEDs - Server Board.....	21
Figure 8. Optional Front Bezel.....	22
Figure 9. Front Bezel Supporting Standard Control Panel.....	23
Figure 10. Front Bezel Supporting Intel® Local Control Panel	23
Figure 11. Mechanical Drawing for Power Supply Module	24
Figure 12. Mechanical Drawing for Power Distribution Module	25
Figure 13. Power Supply Blank.....	26
Figure 14. Non-redundant Fan Module.....	35
Figure 15. Non-redundant Fan Header Assignments on Midplane.....	37
Figure 16. Fan Module Assembly	38
Figure 17. Redundant Fan Header Assignments on Midplane	39
Figure 18. CPU Air Duct with Air Baffle	41
Figure 19. 3.5-inch Drive Blank.....	42
Figure 20. DIMM Blank	42
Figure 21. Passive Midplane Board	43
Figure 22. Active SAS/SATA RAID Midplane Board.....	44
Figure 23. Bridge Board.....	50
Figure 24. 3.5-inch Hot-swap SAS/SATA Backplane (Front Side View).....	51
Figure 25. 3.5-inch Hot-swap SAS/SATA Backplane (Back Side View)	52
Figure 26. Optional Sixth Hard Drive (Front View).....	59
Figure 27. Slimline Optical Drive Assembly for 3.5-inch drive System	60
Figure 28 Connector to Slimline Optical Device	60
Figure 29. 3.5-inch Hard Drive Tray Assembly	61
Figure 30. Flex Bay.....	62
Figure 31. Optional Sixth Hard Drive (Front View).....	62
Figure 32. Optional Tape Drive (Front View)	63

Figure 33. Passive Midplane Board	64
Figure 34. Active Midplane with SAS/SATA RAID Support	65
Figure 35. Architecture Overview.....	66
Figure 36. Hot-swap SAS/SATA Backplane (Front Side View)	68
Figure 37. Hot-swap SAS/SATA Backplane (Back Side View).....	69
Figure 38. SAS/SATA Backplane Functional Block Diagram	70
Figure 39. Standard Control Panel Assembly Module	73
Figure 40. Control Panel Buttons.....	73
Figure 41. Control Panel LEDs	74
Figure 42. Standard Control Panel PCB	79
Figure 43. Intel® Local Control Panel Assembly Module.....	81
Figure 44. Intel® Local Control Panel Overview	81
Figure 45. 2U Riser Assembly	87
Figure 46. 2U PCI Express* Passive Riser	88
Figure 47. 2U PCI Express* Passive Riser – Primary Side	90
Figure 48. 2U PCI Express* Passive Riser – Secondary Side	91
Figure 49. 2U Butterfly PCI-X/PCI Express* Active Riser – Primary Side	91
Figure 50. 2U Butterfly PCI-X/PCI Express* Active Riser – Secondary Side.....	92
Figure 51. 2U Butterfly PCI Express* Active Riser – Primary Side	92
Figure 52. 2U Butterfly PCI Express* Active Riser – Secondary Side	93
Figure 53. Diagnostic LED Placement Diagram	107

List of Tables

Table 1. System Feature Set	11
Table 2. Mixed Processor Configurations	14
Table 3. System Dimensions	15
Table 4. Drive Overview.....	17
Table 5. Major Board Components	20
Table 6. AC Power Cord Specifications.....	27
Table 7. Power Harness Cable Definitions	27
Table 8. P1 Main Power Connector	28
Table 9. P2 Processor Power Connector.....	28
Table 10. P3 Power Signal Connector.....	29
Table 11. P4 Backplane Power Connector	29
Table 12. P5 Midplane Power Connector	29
Table 13. Efficiency.....	30
Table 14. AC Input Rating.....	30
Table 15. Over-current Protection Limits / 240 VA Protection	32
Table 16. Over-voltage Protection (OVP) Limits.....	32
Table 17. Output Power and Current Ratings.....	33
Table 18. LED Indicators	33
Table 19. Non-redundant Cooling Zones.....	35
Table 20. Non-redundant Fan Connector Pin Assingment	36
Table 21. Non-redundant Fan Header Assignment	37
Table 22. Redundant Cooling Zones	38
Table 23. Redundant Fan Connector Pin Assingment.....	39
Table 24. Redundant Fan Header Assignment.....	40
Table 25. 120-pin Server Board-to-Midplane Bridge Board Connector Pin-out.....	44
Table 26. Midplane Fan Header Pin-outs	46
Table 27. Midplane Power Connector Pin-out	46
Table 28. Midplane-to-Backplane Card Edge Connector #1 Pin-out.....	47
Table 29. Midplane-to-Backplane Card Edge Connector #2 Pin-out.....	48
Table 30. Active Midplane SAS RAID Battery Backup Connector Pin-out.....	48
Table 31. Passive Midplane SATA/SAS Connector Pin-outs	49
Table 32. 2x4 SAS/SATA Backplane Power Connector Pin-out (J7L2)	52

Table 33. 1x7 Sixth HDD / Tape Drive Option Power Connector Pin-out (J2M1)	53
Table 34. Sixth HDD Option SATA/SAS I/O Connector Pin-out (J4L1)	53
Table 35. Slimline Optical Drive Slot Connector (J1A1)	54
Table 36. I ² C Connector (J6L3)	54
Table 37. PCI Express* X4 Slot Connector from Midplane (J4N1)	55
Table 38. PCI Express* X4 Slot Connector from Midplane (J6N1)	56
Table 39. USB Floppy Drive Connector (J2A1)	56
Table 40. Intel® Local Control Panel (LCP) Connector (J9A1).....	57
Table 41. Control Panel Slot Connector (J9B1).....	57
Table 42. SAS/SATA Hard Drive Connector Pin-outs (J2C3, J2B1, J4C1, J4B1, J7C1).....	58
Table 43. J1L1 Connector to Slimline Optical Device.....	60
Table 44. Hard Drive LED Function Definitions	71
Table 45. Hard Drive Activity LED Functionality	71
Table 46. Control Button and Intrusion Switch Functions	74
Table 47. Control Panel LED Functions.....	75
Table 48. SSI Power LED Operation	76
Table 49. Control Panel LED Operation	76
Table 50. External USB Connectors (J1B1)	78
Table 51. Video Connector (J1A1).....	78
Table 52. 64-pin Control Panel Connector (J6B1).....	80
Table 53. Control Panel LED Functions.....	82
Table 54. SSI Power LED Operation	83
Table 55. Control Panel LED Operation	83
Table 56. 50-pin Control Panel Connector.....	85
Table 57. Internal USB Header.....	86
Table 58. Riser Card Options	89
Table 59. System Environmental Limits Summary	94
Table 60. Time Estimate for System Maintenance Procedures.....	94
Table 61. POST Progress Code LED Example	107
Table 62. Diagnostic LED POST Code Decoder	108
Table 63. POST Error Messages and Handling.....	111
Table 64. POST Error Beep Codes	114
Table 65. Integrated BMC Beep Codes	115

1. Introduction

This Technical Product Specification (TPS) provides system-specific information detailing the features, functionality, and high-level architecture of the Intel® Server System SR2600UR. The *Intel® Server Board S5520UR Technical Product Specification* should also be referenced to obtain greater detail of functionality and architecture specific to the integrated server board, but which are also supported on this server system.

In addition, design-level information for specific subsystems can be obtained by ordering the External Product Specifications (EPS) or External Design Specifications (EDS) for a given subsystem. EPS and EDS documents are not publicly available. They are only made available under NDA with Intel and must be ordered through your local Intel representative. See the Reference Documents section at the end of this document for a complete list of available documents.

The Intel® Server System SR2600UR may contain design defects or errors known as errata, which may cause the product to deviate from published specifications. Refer to the *Intel® Server Board S5520UR/Intel® Server System SR2600UR Specification Update* for published errata.

1.1 Chapter Outline

This document is divided into the following chapters:

- Chapter 1 – Introduction
- Chapter 2 – Product Overview
- Chapter 3 – Power Subsystem
- Chapter 4 – Cooling Subsystem
- Chapter 5 – System Board Interconnects
- Chapter 6 – Peripheral and Hard Drive Subsystem
- Chapter 7 – Standard Control Panel
- Chapter 8 – Intel® Local Control Panel
- Chapter 9 – PCI Riser Cards and Assembly
- Chapter 10 – Environmental Specifications
- Chapter 11 – Regulatory and Certification Information
- Appendix A – Integration and Usage Tips
- Appendix B – POST Code Diagnostic LED Decoder
- Appendix C – Post Code Errors
- Glossary
- Reference Documents

1.2 Server Board Use Disclaimer

Intel Corporation server boards support add-in peripherals and contain a number of high-density VLSI and power delivery components that need adequate airflow to cool. Intel ensures through its own system development and testing that when Intel server building blocks are used together, the fully integrated system will meet the intended thermal requirements of these components. It is the responsibility of the system integrator who chooses not to use Intel-developed server building blocks to consult vendor datasheets and operating parameters to determine the amount of air flow required for their specific application and environmental conditions. Intel Corporation cannot be held responsible if components fail or the server board does not operate correctly when used outside any of their published operating or non-operating limits.

2. Product Overview

The Intel® Server System SR2600UR is a rack mount 2U server system with features that are designed to support the high-density high performance computing server market. The system is integrated with an Intel® Server Board S5520UR and is offered in two different system configurations:

- Configuration 1: System integrated with an active SAS/SATA midplane, a redundant fan module, and a 5 slot PCI-E Riser (SR2600URLX)
- Configuration 2: System integrated with a passive midplane, a non-redundant fan module, and a 3 slot PCI-E Riser (SR2600URBRP)

This chapter provides a high-level overview of the system features. Greater detail for each major system component or feature is provided in the following chapters.

Table 1. System Feature Set

Feature	Description
Peripheral Interfaces	<p>External connections:</p> <ul style="list-style-type: none"> ▪ DB-15 video connector (back) ▪ RJ-45 serial Port A connector ▪ Two RJ-45 10/100/1000 Mb network connections ▪ Four USB 2.0 connectors (back) ▪ One USB 2.0 connector (front) <p>Internal connections:</p> <ul style="list-style-type: none"> ▪ One USB 2x5 pin header, which supports two USB 2.0 ports ▪ One low-profile USB 2x5 pin header to support low-profile USB Solid State drives ▪ One DH-10 Serial Port B header ▪ Six Serial ATA (SATA) II connectors ▪ Two I/O module connectors ▪ One RMM3/GCM4 connector to support optional Intel® Remote Management Module 3 ▪ SATA Software 5 Activation Key connector ▪ One SSI-EEB compliant front panel header ▪ One SSI-EEB compliant 24-pin main power connector ▪ One SSI-compliant 8-pin CPU power connector ▪ One SSI-compliant auxiliary power connector
Video	<p>On-board ServerEngines* LLC Pilot II Controller</p> <ul style="list-style-type: none"> ▪ Integrated 2D Video Controller ▪ 32 MB DDR2 Memory
LAN	Two 10/100/1000 Intel® 82575 PHYs

Feature	Description
Expansion Capabilities	<p>The following riser card options are available:</p> <ul style="list-style-type: none"> ▪ Three full-height PCI Express* slots (passive) ▪ Two full-height PCI-X slots with an on-board PXH bridge chip and one full-height and two low-profile PCI Express* slots ▪ Five full-height PCI Express* slots
Hard Drive Options	<ul style="list-style-type: none"> ▪ Five 3.5-inch hot-swap SATA / SAS hard drives ▪ Flex bay for sixth 3.5-inch hot-swap SATA / SAS hard drive or a 3.5-inch tape drive or two fixed 2.5-inch hard drives
Peripherals	<ul style="list-style-type: none"> ▪ Slimline bay for slimline SATA optical drive ▪ PCI riser card bracket
Control Panel	<ul style="list-style-type: none"> ▪ Standard control panel ▪ Intel® Local Control Panel
LEDs and displays	<p>With standard control panel:</p> <ul style="list-style-type: none"> ▪ NIC1 Activity ▪ NIC2 Activity ▪ Power / Sleep ▪ System Status ▪ System Identification ▪ Hard Drive Activity <p>Intel® Light-Guided diagnostics:</p> <ul style="list-style-type: none"> ▪ Fan Fault ▪ DIMM Fault ▪ CPU Fault ▪ 5V-STBY ▪ System Status ▪ System Identification ▪ POST Code Diagnostics
Power Supply	Up to two 750-W power supply modules
Fans	<p>Intel® Server System SR2600URBRP:</p> <ul style="list-style-type: none"> ▪ Non-redundant fan option containing three system fans ▪ Two non-redundant fans in power supply <p>Intel® Server System SR2600URLX:</p> <ul style="list-style-type: none"> ▪ Redundant fan option containing six system fans ▪ Two non-redundant fans in power supply
System Management	<p>On-board ServerEngines* LLC Pilot II Controller</p> <ul style="list-style-type: none"> ▪ Integrated Baseboard Management Controller (Integrated BMC), IPMI 2.0 compliant ▪ Integrated Super I/O on LPC interface <p>Support for Intel® System Management Software 3.1</p>

2.1.1 Processor Support

The server board supports the following processors:

- One or two Intel® Xeon® Processors 5500 Series in FC-LGA 1366 socket B package with 4.8 GT/s, 5.86 GT/s or 6.4 GT/s Intel® QuickPath Interconnect.
- Up to 95-W Thermal Design Power (TDP); processors having higher Thermal Design Power are not supported.

Previous generations of the Intel® Xeon® processors are not supported on the server board.

2.1.1.1 Processor Population Rules

Note: Although the server board does support dual-processor configurations consisting of different processors that meet the defined criteria below, Intel does not perform validation testing of this configuration. For optimal system performance in dual-processor configurations, Intel recommends that identical processors be installed.

When using a single processor configuration, the processor must be installed into the processor socket labeled CPU1. A terminator is not required in the second processor socket when using a single processor configuration.

When two processors are installed, the following population rules apply:

- Both processors must be of the same processor family.
- Both processors must have the same front-side bus speed.
- Both processors must have the same cache size.
- Processors with different speeds can be mixed in a system, given the prior rules are met. If this condition is detected, all processor speeds are set to the lowest common denominator (highest common speed) and an error is reported.
- Processor stepping within a common processor family can be mixed as long as it is listed in the processor specification updates published by Intel Corporation.

The following table describes mixed processor conditions and recommended actions for all Intel® server boards and systems that use the Intel® 5520 Chipset. The errors fall into one of the following two categories:

- **Fatal:** If the system can boot, it goes directly to the error manager, regardless of whether the “Post Error Pause” setup option is enabled or disabled.
- **Major:** If the “Post Error Pause” setup option is enabled, system goes directly to the error manager. Otherwise, the system continues to boot and no prompt is given for the error. The error is logged to the error manager.

Table 2. Mixed Processor Configurations

Error	Severity	System Action
Processor family not identical	Fatal	<p>The BIOS detects the error condition and responds as follows:</p> <ul style="list-style-type: none"> ▪ Logs the error into the system event log (SEL). ▪ Alerts the Integrated BMC of the configuration error with an IPMI command. ▪ Does not disable the processor. ▪ Displays “0194: Processor family mismatch detected” message in the error manager. ▪ Halts the system.
Processor cache not identical	Fatal	<p>The BIOS detects the error condition and responds as follows:</p> <ul style="list-style-type: none"> ▪ Logs the error into the SEL. ▪ Alerts the Integrated BMC of the configuration error with an IPMI command. ▪ Does not disable the processor. ▪ Displays “0192: Cache size mismatch detected” message in the error manager. ▪ Halts the system.
Processor frequency (speed) not identical	Major	<p>The BIOS detects the error condition and responds as follows:</p> <ul style="list-style-type: none"> ▪ Adjusts all processor frequencies to lowest common denominator. ▪ Continues to boot the system successfully. <p>If the frequencies for all processors cannot be adjusted to be the same, then the BIOS:</p> <ul style="list-style-type: none"> ▪ Logs the error into the SEL. ▪ Displays “0197: Processor speeds mismatched” message in the error manager. ▪ Halts the system.
Processor microcode missing	Fatal	<p>The BIOS detects the error condition and responds as follows:</p> <ul style="list-style-type: none"> ▪ Logs the error into the SEL. ▪ Alerts the Integrated BMC of the configuration error with an IPMI command. ▪ Does not disable processor. ▪ Displays “816x: Processor 0x unable to apply microcode update” message in the error manager. ▪ Pauses the system for user intervention.
Processor Intel® QuickPath Interconnect speeds not identical	Halt	<p>The BIOS detects the error condition and responds as follows:</p> <ul style="list-style-type: none"> ▪ Logs the error into the system event log (SEL). ▪ Alerts the Integrated BMC of the configuration error with an IPMI command. ▪ Does not disable the processor. ▪ Displays “0195: Processor Front Side Bus speed mismatch detected” message in the error manager. ▪ Halts the system.

2.2 System Overview

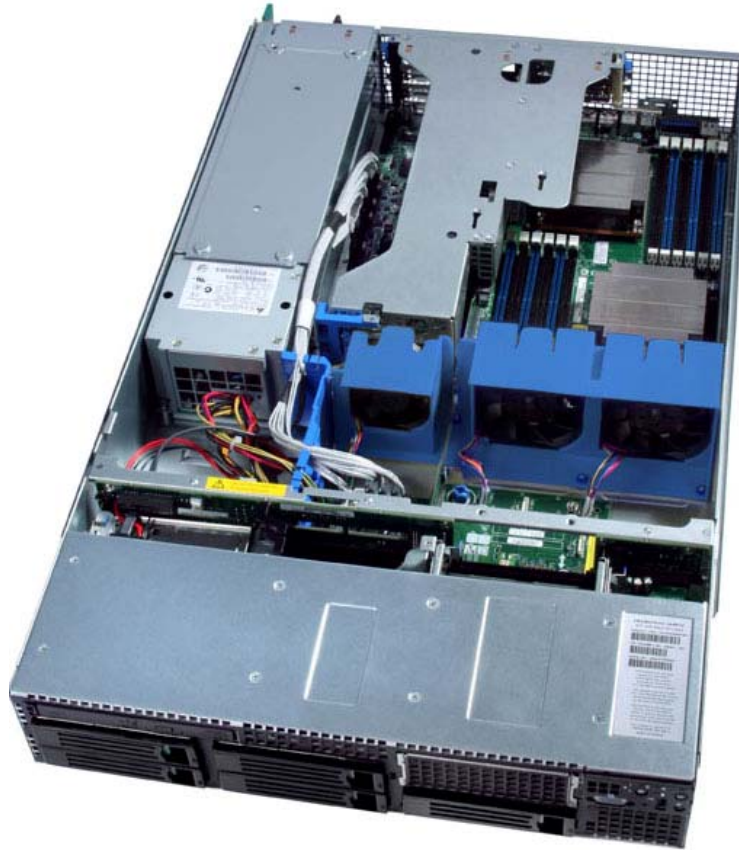

Figure 1. Top Down View – Passive System SKU Shown

2.3 System Dimensions

Table 3. System Dimensions

Height	87.30 mm	3.44 in
Width without rails	430 mm	16.93 in
Width with rails	451.3 mm	17.77 in
Depth without CMA	704.8 mm	27.75 in
Depth with CMA	838.2 mm	33.0 in
Maximum Weight	29.5 kg	65 lbs

2.4 System Components

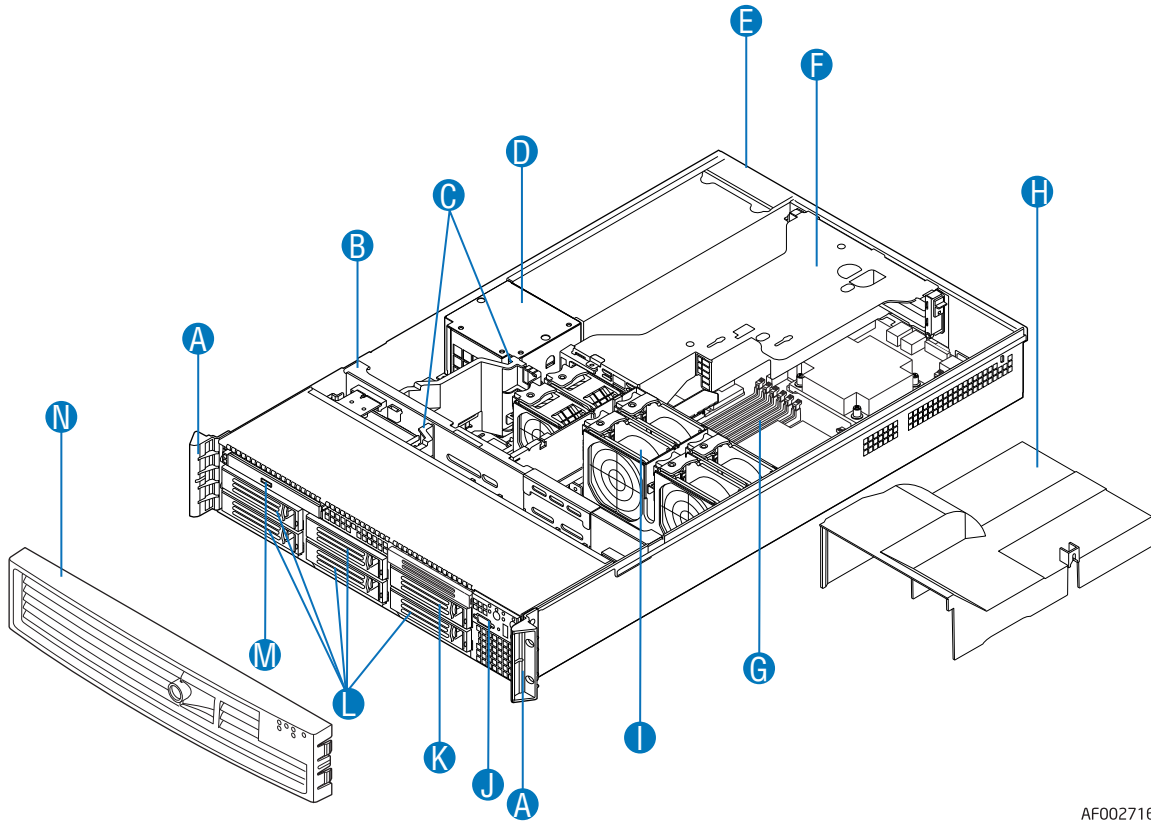

AF002716

A.	Rack Handles	H.	CPU Air Duct
B.	SAS/SATA Backplane	I.	System Fan Assembly
C.	Air Baffles	J.	Standard Control Panel
D.	Power Distribution Module	K.	Flex Bay – Sixth HDD or Tape or two 2.5-inch HDDs (Optional)
E.	Power Supply Modules	L.	Hard Drive Bays
F.	Riser Card Assembly	M.	Slimline Optical Drive Bay
G.	System Memory	N.	Front Bezel (Optional)

Figure 2. Major System Components

2.5 Hard Drive and Peripheral Bays

The system is designed to support several different hard drive and peripheral configurations. The system includes a hot-swap backplane capable of supporting either SAS or SATA drives. The sixth bay (see letter “B” in the following figure) can optionally be configured to support a sixth 3.5-inch hard drive, a 3.5-inch tape drive, or two additional fixed 2.5-inch hard drives.

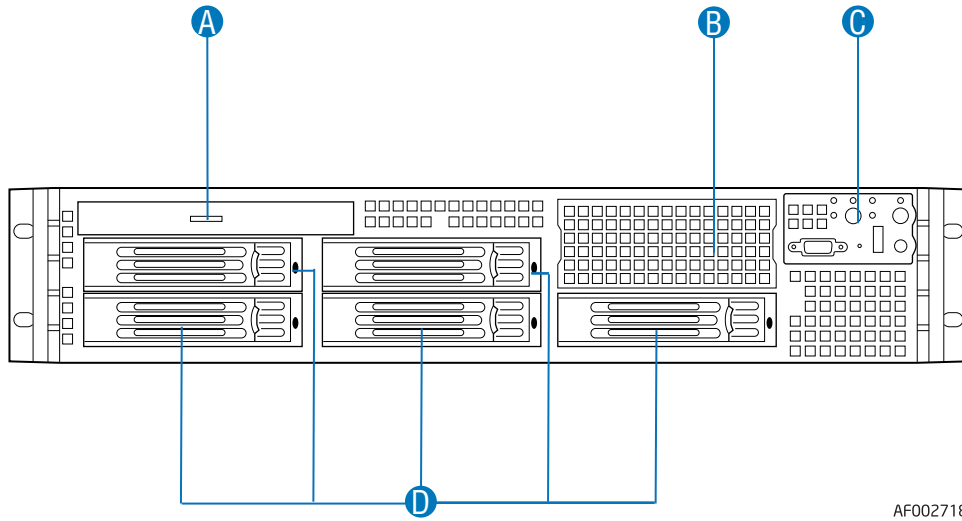

AF002718

A.	Slimline Optical Drive Bay
B.	Flex Bay - Sixth Hard Drive, Tape Drive, or two fixed 2.5-inch Hard Drives (Optional)
C.	System Control Panel
D.	3.5-inch Hard Drive Bays (5)

Figure 3. Drive Bay Overview

Table 4. Drive Overview

	Active System Product Code – SR2600URLX	Passive System Product Code – SR2600URBRP
Slimline SATA Optical Drive	Supported	Supported
Slimline USB Floppy Drive	Not Supported	Not Supported
SATA Drives	Up to six 3.5-inch drives	Up to six 3.5-inch drives
SAS Drives	Up to six 3.5-inch drives	Up to six 3.5-inch drives

2.6 System Board Overview



Figure 4. Intel® Server Board S5520UR

The following figure shows the board layout of the server board. Each connector and major component is identified by a number or letter, and a description is given below the figure.

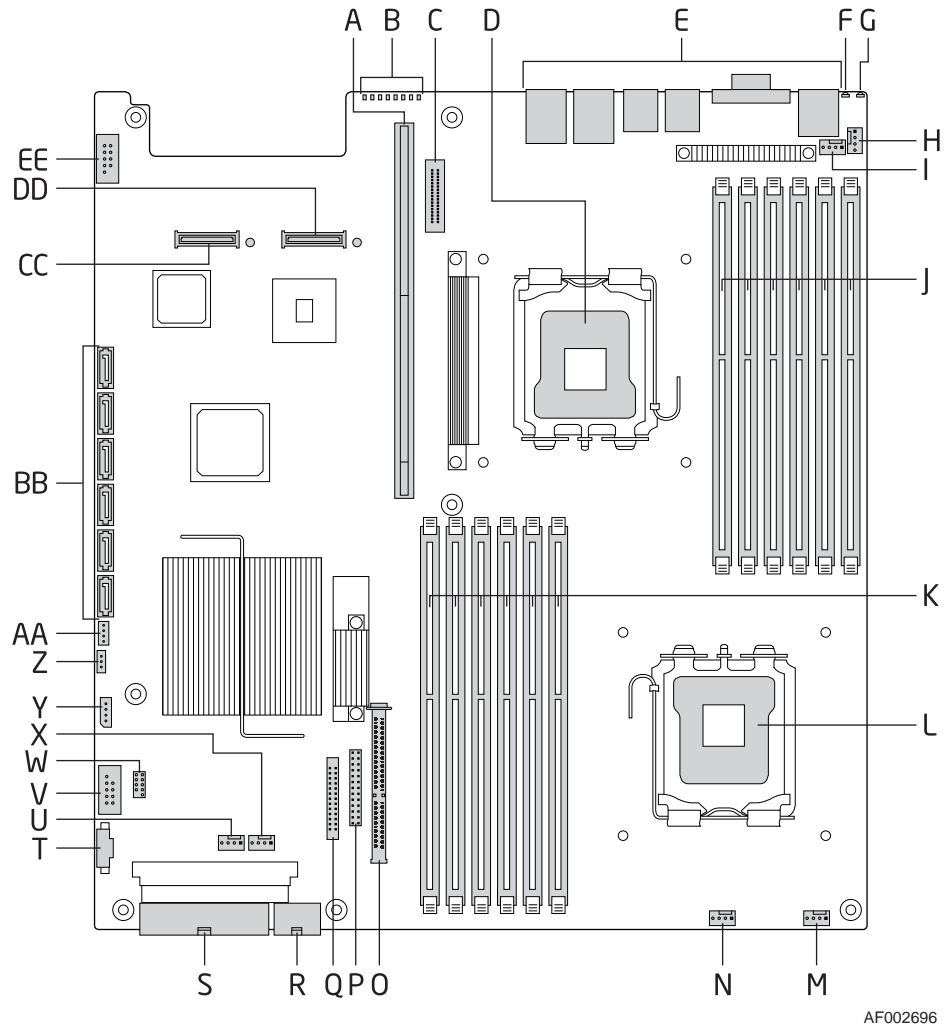
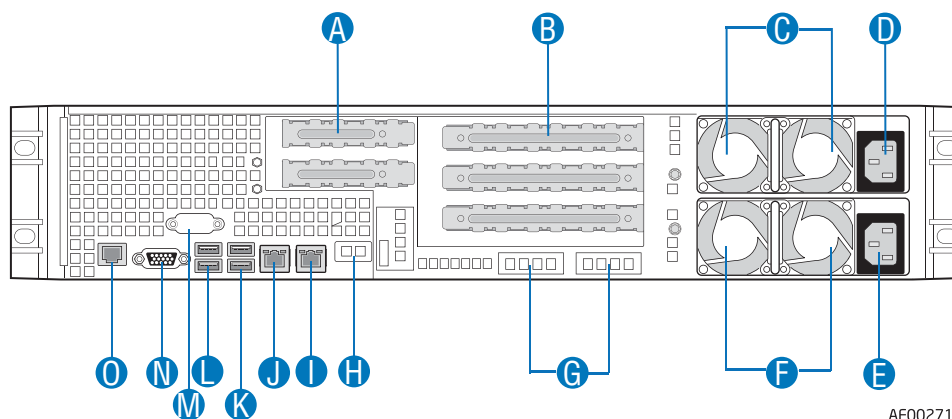

Figure 5 Intel® Server Board S5520UR Components

Table 5. Major Board Components

	Description		Description
A	280-pin Intel® Adaptive Riser Card Slot	Q	Fan Board Connector (Intel® Server Chassis)
B	POST Code LEDs	R	2x4 Power Connector
C	Intel® RMM3 Header	S	Main Power Connector
D	Processor 1	T	Power Supply SMBus Connector
E	Back Panel I/O	U	Fan Header
F	ID LED	V	USB Header
G	System Status LED	W	Low-profile USB Solid State Driver Header
H	Fan Header	X	Fan Header
I	Fan Header	Y	LCP IPMB Header
J	Processor 1 DIMM Slots	Z	SATA RAID 5 Key Header
K	Processor 2 DIMM Slots	AA	SGPIO Header
L	Processor 2	BB	SATA Connectors
M	Fan Header	CC	I/O Module Mezzanine Connector 2
N	Fan Header	DD	I/O Module Mezzanine Connector 1
O	Bridge Board Connector (Intel® Server Chassis)	EE	Serial Port B Header
P	Front Panel Connector		



AF002717

A.	Low-profile PCIe* Add-in Card Slots	I.	NIC 1
B.	Full-height PCI Add-in Card Slots	J.	NIC 2
C.	Upper Power Supply Module Fans	K.	USB
D.	Upper Power Receptacle	L.	USB
E.	Lower Power Receptacle	M.	DB-9 Serial B Connector
F.	Lower Power Supply Module Fans	N.	Video
G.	Intel® I/O Expansion Module (Optional)	O.	RJ-45 Serial A Connector
H.	Intel® Remote Management Module 3 NIC (Optional)		

Figure 6. Back Panel Feature Overview

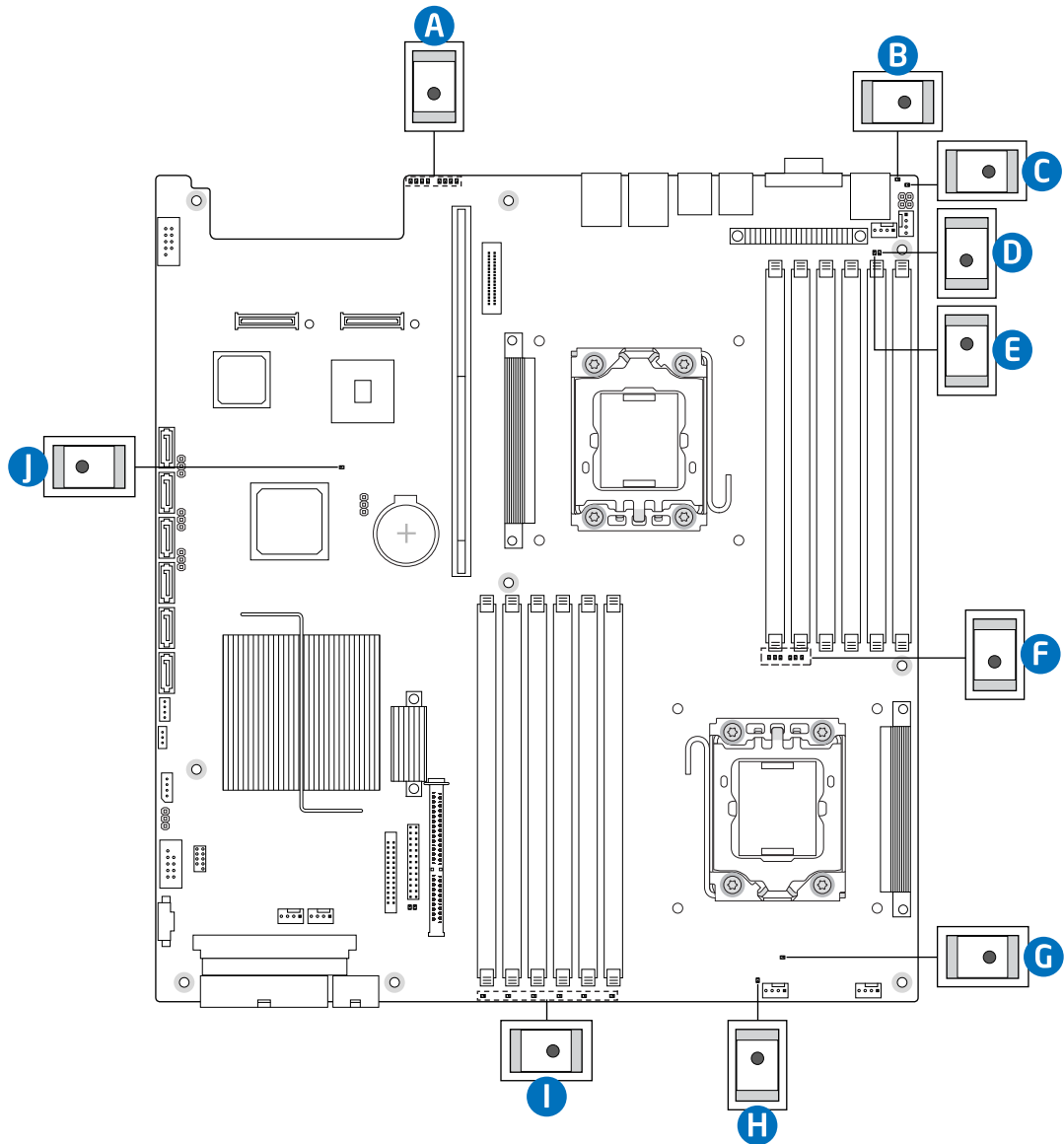

AF002833

A	POST Code Diagnostic LEDs	F	CPU 1 DIMM Fault LEDs
B	System Identification LED	G	CPU 2 Fan Fault LED
C	Status LED	H	Memory 2 Fan Fault LED
D	Memory 1 Fan Fault LED	I	CPU 2 DIMM Fault LEDs
E	CPU 1 Fan Fault LED	J	5V Standby LED

Figure 7. Intel® Light-Guided Diagnostic LEDs - Server Board

2.7 Front Bezel Features

The optional front bezel is made of molded plastic and uses a snap-on design. When installed, its design allows for maximum airflow to maintain system cooling requirements.

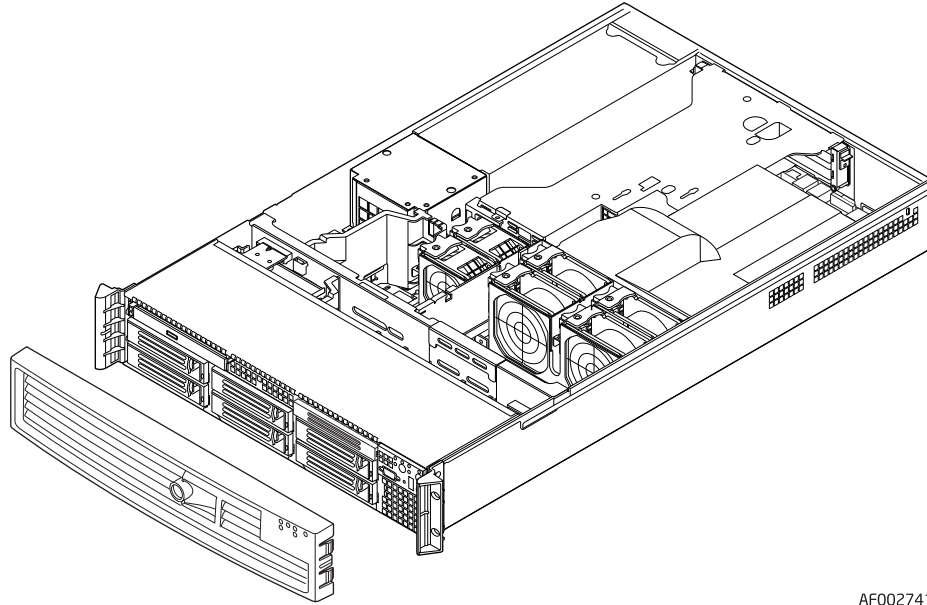

AF002741

Figure 8. Optional Front Bezel

Separate front bezels are available to support systems that use either a standard control panel or the Intel® Local Control Panel with LCD support.

When the standard control panel is used, light pipes on the backside of the front bezel allow the system status LEDs to be monitored with the front bezel in the closed position. The front bezel lock is provided to prevent unauthorized access to hard drives, peripheral devices and the control panel.

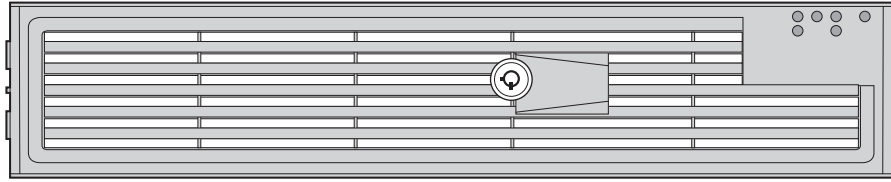

TP02101

Figure 9. Front Bezel Supporting Standard Control Panel

When the local control panel is used, the control panel module can be adjusted to extend further out from the chassis face to allow the LCD panel to protrude from the front bezel.

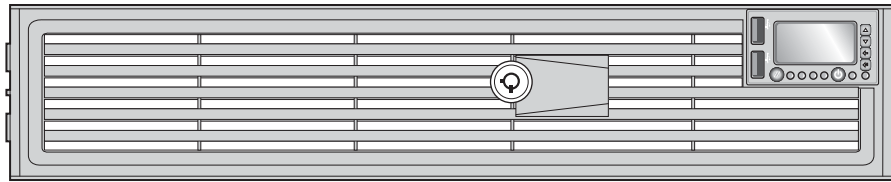

AF000054

Figure 10. Front Bezel Supporting Intel® Local Control Panel

2.8 Rack and Cabinet Mounting Options

The system is designed to support 19 inches wide by up to 30 inches deep server cabinets. The system supports three rack mount options:

- A fixed mount relay rack / cabinet mount kit (Product Order Code - AXXBRACKETS) which can be configured to mount the system into either a 2-post rack or 4-post cabinet.
- A tool-less full extracting slide rail kit (Product Order Code – AXXHERAIL2) designed to support an optional cable management arm (Product Order Code – AXXRACKCARM2).
- A basic slide rail kit (Product Order Code – AXXBASRAIL13) designed to mount the system into a standard (19 inches by up to 30 inches deep) EIA-310D compatible server cabinet.

3. Power Subsystem

The power subsystem of the system consists of an integrated Power Distribution Module (PDM), a power module enclosure, and support for up to two 750-Watt power supply modules. The power subsystem can be configured to support a single module in a 1+0 non-redundant configuration, or dual modules in a 1+1 redundant power configuration. In a 1+1 configuration, a single failed power module can be hot-swapped with the system running. Either configuration supports up to a maximum of 750 Watts of power.

This chapter provides technical details on the operation of the power supply module and power subsystem. For additional information, refer to the *Intel® Server System SR2600 AC Power Supply Specification* and the *Intel® Server System SR2600 Power Distribution Module Specification*.

3.1 Mechanical Overview

The following figures display the Power Distribution Module and the Power Supply Module dimensions.

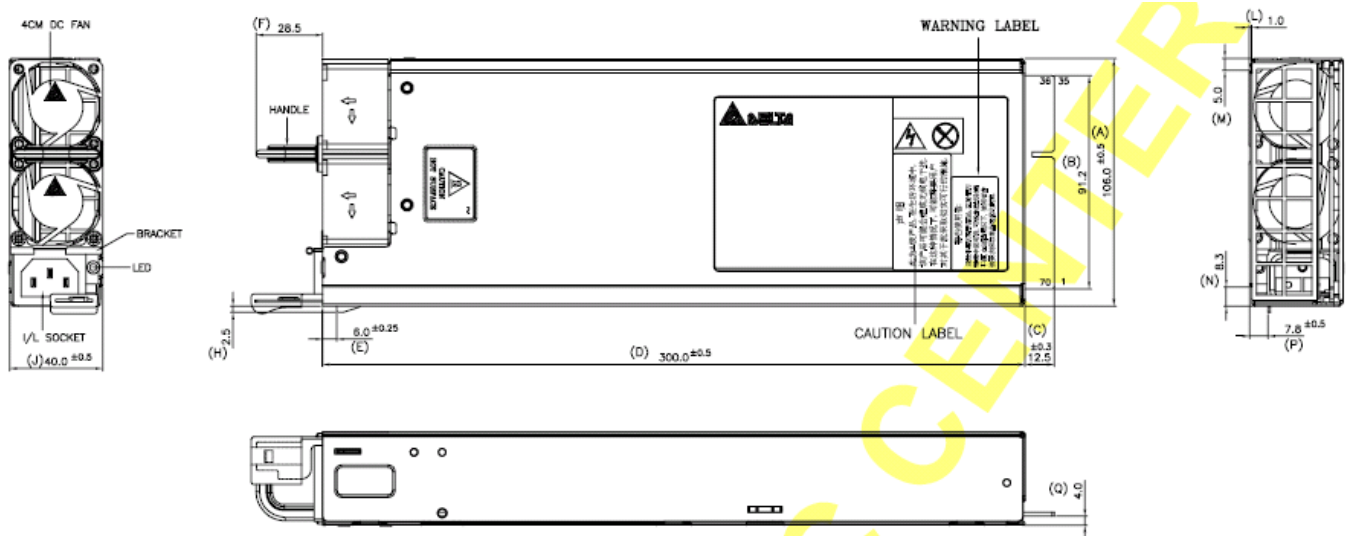

Figure 11. Mechanical Drawing for Power Supply Module

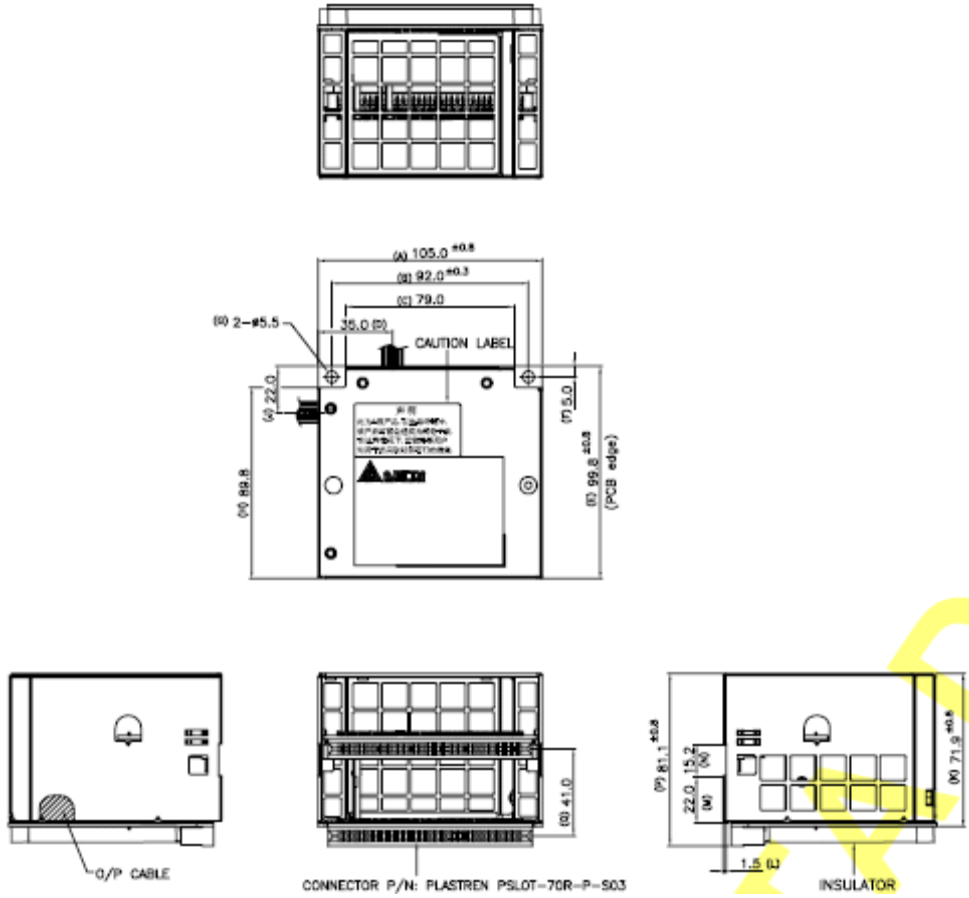

Figure 12. Mechanical Drawing for Power Distribution Module

3.2 Single Power Supply Module Population

In single power module configurations, server management firmware requires that the power supply module be populated in the top power module slot. The non-operating slot must have the power supply blank installed.

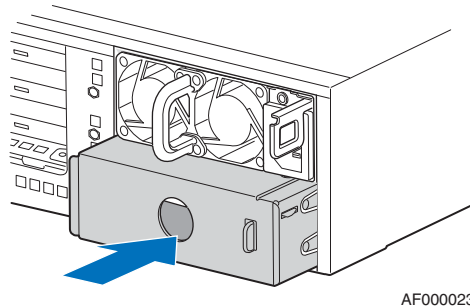

Figure 13. Power Supply Blank

Configuring a single power supply module in the bottom location causes the server management firmware and BIOS to generate a system error during POST and the error is reported to the System Event Log (SEL).

3.3 Handle and Retention Mechanism

Each power supply module includes a handle for module insertion to or removal from the module enclosure. Each module has a simple retention mechanism to hold the power module in place once it is inserted. This mechanism withstands the specified platform mechanical shock and vibration requirements. The tab on the retention mechanism is colored green to indicate it is a hot-swap touch point. The latch mechanism is designed to prevent insertion or removal of the module when the power cord is plugged in. This aids the hot-swapping procedure.

3.4 Hot-swap Support

Hot-swapping a power supply module is the process of extracting and re-inserting a power supply module from an operating power system. During this process, the output voltages remain within specified limits. Up to two power supply modules may be on a single AC line. The power supply module can be hot-swapped using the following procedure:

- **Extraction:** To remove the power supply, unplug the power cord first, and then remove the power module. This can be done in standby mode or power-on mode.
- **Insertion:** Insert the module first, and then plug in the power cord. If the system is powered off, the system and the power supply will power on into standby mode or power-on mode.

3.5 Airflow

Each power supply module incorporates two non-redundant 40-mm fans for self cooling and partial system cooling. The fans provide at least 10 CFM airflow through the power supply when installed in the system and operating at maximum fan speed. The cooling air enters the power module from the PDB side (pre-heated air from the system).

3.6 AC Power Cord Specification Requirements

The AC power cord used must meet the specification requirements listed in the following table.

Table 6. AC Power Cord Specifications

Cable Type	SJT
Wire Size	16 AWG
Temperature Rating	105°C
Amperage Rating	13 A
Voltage Rating	125 V

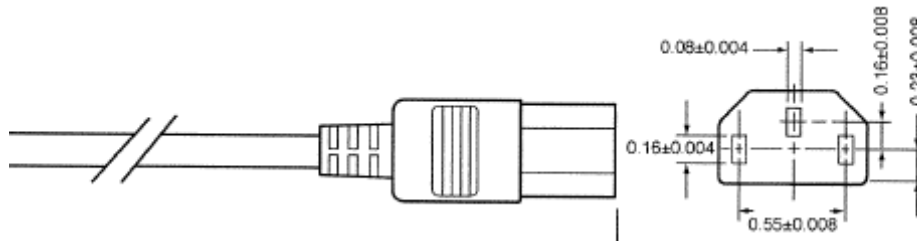

3.7 Output Cable Harness

The power distribution board provides a cable harness providing connectors to the various system boards. The harness size, connectors, and pin outs are shown below. Listed or recognized component appliance wiring material (AVLV2), CN, rated 105°C minimum, 300 VDC minimum is used for all output wiring.

Table 7. Power Harness Cable Definitions

Length mm	To Connector #	No of Pins	Description
95	P1	2x12	Main Power Connector, 90° angle
110	P2	2x4	Processor Power Connector, 90° angle
100	P3	1x5	Server Board Signal Connector
150	P4	2x4	Backplane Power Connector
220	P5	2x5	Midplane Power Connector

3.7.1 P1 – Server Board Power Connector

Connector housing: 24-pin Molex* Mini-Fit Jr. 39-01-2245 or equivalent

Contact: Molex Mini-Fit, HCS, Female, Crimp 44476 or equivalent

Table 8. P1 Main Power Connector

Pin	Signals	18 AWG Color	Pin	Signal	18 AWG Colors
1	+3.3 VDC	Orange	13	+3.3 VDC	Orange
2	+3.3 VDC	Orange	14	-12 VDC	Blue
3	COM (GND)	Black	15	COM	Black
4	5 VDC	Red	16	PS_ON#	Green
	5 V RS	Red (24 AWG)	17	COM	Black
5	COM	Black	18	COM	Black
6	+5 VDC	Red	19	COM	Black
7	COM	Black	20	Reserved (-5 V in ATX)	N.C.
8	PWR OK	Gray	21	+5 VDC	Red
9	5 VSB	Purple	22	+5 VDC	Red
10	+12 V3	Yellow/Blue	23	+5 VDC	Red
11	+12 V3	Yellow/Blue	24	COM	Black
12	+3.3 VDC	Orange			

3.7.2 P2 – Processor Power Connector

Connector housing: 8-pin Molex* 39-01-2085 or equivalent

Contact: Molex 45750-1112 or equivalent

Table 9. P2 Processor Power Connector

Pin	Signal	16 AWG Colors	Pin	Signal	16 AWG Colors
1	COM	Black	5	+12 V1	Yellow
2	COM	Black	6	+12 V1	Yellow
3	COM	Black	7	+12 V2	Yellow/Black
4	COM	Black	8	+12 V2	Yellow/Black

3.7.3 P3 – Power Signal Connector

Connector housing: 5-pin Molex* 50-57-9705 or equivalent

Contact: Molex 16-02-0087 or equivalent

Table 10. P3 Power Signal Connector

PIN	Signal	24 AWG Colors
1	I ² C Clock (SCL)	White/Green
2	I ² C Data (SDL)	White/Yellow
3	SMBAlert#	White
4	ReturnS	White/Black
5	3.3RS	White/Orange

3.7.4 P4 – Backplane Power Connector

Connector housing: 8-pin Molex* Mini-Fit Jr. PN# 39-01-2285 or equivalent

Contact: Molex Mini-Fit, HCS, Female, Crimp 44476 or equivalent

Table 11. P4 Backplane Power Connector

Pin	Signal	18 AWG Colors	Pin	Signal	18 AWG Colors
1	COM	Black	5	+12 V4	Yellow/Green
2	COM	Black	6	+12 V4	Yellow/Green
3	+5 V	Red	7	+5 VSB	Purple
4	+5 V	Red	8	+3.3 V	Orange

3.7.5 P5 – Midplane Power Connector

Connector housing: 10-pin Molex* Mini-Fit Jr. 43025-1000 or equivalent

Contact: Molex Mini-Fit, HCS, Female, Crimp 43030-0007 or equivalent

Table 12. P5 Midplane Power Connector

Pin	Signal	20 AWG Colors	Pin	Signal	20 AWG Colors
1	COM	Black	6	+12 V3	Yellow/Blue
2	COM	Black	7	+12 V3	Yellow/Blue
3	+5 V	Red	8	+12 V3	Yellow/Blue
4	+3.3 V	Orange	9	+12 V3	Yellow/Blue
5	COM	Black	10	+5 VSB	Purple

3.8 AC Input Requirements

The power supply module incorporates universal power input with active power factor correction, which reduces line harmonics in accordance with the EN61000-3-2 and JEIDA MITI standards.

3.8.1 Efficiency

The following table provides the required minimum efficiency level at various loading conditions. These are provided at three different load levels: 100%, 50% and 20%. Efficiency is tested only at 230 VAC.

Table 13. Efficiency

Loading	100% of Maximum	50% of Maximum	20% of Maximum
Recommended Efficiency	85%	89%	85%

3.8.2 AC Input Voltage Specification

The power supply must operate within all specified limits over the input voltage range shown in the following table.

Table 14. AC Input Rating

Parameter	Minimum	Rated	Maximum	Startup VAC	Power-off VAC	Maximum Input AC Current	Maximum Rated Input AC Current
Line Voltage (110)	90 V _{rms}	100 - 127 V _{rms}	140 V _{rms}	85 VAC ± 4 VAC	75 VAC ± 5 VAC	12 A _{rms} ^{1,3}	11.0 A _{rms} ⁴
Line Voltage (220)	180 V _{rms}	200 - 240 V _{rms}	264 V _{rms}	-	-	6.0 A _{rms} ^{2,3}	5.5 A _{rms} ⁴
Frequency	47 Hz	50/60 Hz	63 Hz				

Notes:

1. Maximum input current at low input voltage range is measured at 90 VAC, at maximum load.
2. Maximum input current at high input voltage range is measured at 180 VAC, at maximum load.
3. This is not to be used for determining agency input current markings.
4. Maximum rated input current is measured at 100 VAC and 200 VAC.

Harmonic distortion of up to 10% of the rated AC input voltage must not cause the power supply to go out of specified limits. The power supply powers off at or below 75 VAC ± 5 VAC. The power supply starts up at or above 85 VAC ± 4 VAC. Application of an input voltage below 85 VAC does not cause damage to the power supply or blow a fuse.

3.8.3 AC Line Dropout / Holdup

An AC line dropout is defined to be when the AC input drops to 0 VAC at any phase of the AC line for any length of time. During an AC dropout of one cycle or less, the power supply must meet dynamic voltage regulation requirements over the rated load. If the AC dropout lasts longer than one cycle, the power supply should recover and meet all turn-on requirements. The power supply must meet the AC dropout requirement over rated AC voltages, frequencies, and output loading conditions. Any dropout of the AC line does not cause damage to the power supply.

- **20 ms** minimum when tested under the following conditions: Maximum combined load = 562.5 W
- **12 ms** minimum when tested under the following conditions: Maximum combined load = 750 W

3.8.4 AC Line 5 VSB Holdup

The 5 VSB output voltage should stay in regulation under its full load (static or dynamic) during an AC dropout of 70 ms minimum (= 5 VSB holdup time) whether the power supply is in ON or OFF state (PSON asserted or de-asserted).

3.8.5 AC Inrush

AC line inrush current should not exceed 40 A peak for up to one-quarter of the AC cycle, after which the input current should be no more than the specified maximum input current. The peak inrush current should be less than the ratings of its critical components (including input fuse, bulk rectifiers, and surge limiting device).

The power supply must meet the inrush requirements for any rated AC voltage, during turn on at any phase of AC voltage, during a single cycle AC dropout condition as well as upon recovery after AC dropout of any duration, and over the specified temperature range (T_{op}). It is acceptable that AC line inrush current may reach up to 60 A peak for up to 1 millisecond.

3.9 Protection Circuits

Protection circuits inside the PDB and the power supply cause the power supply's main +12 V output to shut down, or cause a shutdown of any of the three outputs on the PDB. Any one of these shutdowns results in shutting down the entire power supply / PDB combination. If the power supply latches off due to a protection circuit tripping, an AC cycle OFF for 15 seconds resets the power supply and the PDB.

3.9.1 Over-current Protection (OCP)

Each DC/DC converter output on the PDB has individual OCP protection circuits. The power supply and power distribution board (PS and PDB) shut down and latch off after an over-current condition occurs. This latch is cleared by toggling the PSON# signal or by an AC power interruption. The over-current limits are measured at the PDB harness connectors.

The DC/DC converters are not damaged from repeated power cycling in this condition. The +12 V output from the power supply is divided on the PDB into four channels and each is limited to 240 VA of power. Current sensors and limit circuits shut down the entire PS and PDB if the limit is exceeded. The limits are listed in the following table.

Table 15. Over-current Protection Limits / 240 VA Protection

Output Voltage	Minimum OCP Trip Limits	Maximum OCP Trip Limits
+3.3 V	110% min (= 26.4 A min)	150% max (= 36 A max)
+5 V	110% min (= 33 A min)	150% max (= 45 A max)
-12 V	125% min (= 0.625 A min)	400% max (= 2.0 A max)
+12 V1	26.0 A min	32 A max
+12 V2	26.0 A min	32 A max
+12 V3	112.5% min (= 18.0 A min)	20 A max
+12 V4	112.5% min (= 18.0 A min)	20 A max

3.9.2 Over-voltage Protection (OVP)

Each DC/DC converter output on the PDB has individual OVP circuits built in and they are locally sensed. The PS and PDB shut down and latch off after an over-voltage condition occurs. This latch is cleared by toggling the PSON# signal or by an AC power interruption. The over-voltage limits are measured at the PDB harness connectors. The voltage never exceeds the maximum levels when measured at the power pins of the output harness connector during any single point of fail. The voltage never trips any lower than the minimum levels when measured at the power pins of the PDB connector.

Table 16. Over-voltage Protection (OVP) Limits

Output Voltage	OVP Minimum (V)	OVP Maximum (V)
+3.3 V	3.9	4.5
+5 V	5.7	6.5
+5 VSB	5.7	6.5
-12 V	-13.3	-14.5
+12 V1/2/3/4	13.0	14.5

3.9.3 Over-temperature Protection (OTP)

The power supply is protected against over-temperature conditions caused by loss of fan cooling or excessive ambient temperature. In an OTP condition, the power supply shuts down. When the power supply temperature drops to within specified limits, the power supply restores power automatically, while the 5 VSB remains constantly on. The OTP trip level has a minimum of 4°C of ambient temperature hysteresis, so that the power supply does not oscillate on and off due to a temperature recovery condition. The power supply alerts the system of the OTP condition via the power supply FAIL signal and the PWR LED.

3.10 DC Output Specification

3.10.1 Output Power / Currents

The following table defines power and current ratings for this 750 W continuous (860 W pk) power supply in 1+0 or 1+1 redundant configuration. The combined output power of both outputs does not exceed the rated output power. The power supply must meet both static and dynamic voltage regulation requirements for the minimum loading conditions. Also, the power supply is able to supply the listed peak currents and power for a minimum of 10 seconds. Outputs are not required to be peak loaded simultaneously.

Table 17. Output Power and Current Ratings

	+12 V	+5 VSB
Maximum Load	62.0 A	3.0 A
Minimum Dynamic Load	3.0 A	0.1 A
Minimum Static Load	0.0 A	0.1 A
Peak Load	70.0 A (12 seconds minimum)	5.0A (0.5 seconds minimum @ turn-on)
Maximum Output Power (continuous)	12 V x 62 A = 744 W maximum	5 V x 3 A = 15 W maximum
Peak Output Power	12 V x 70 A = 840 W pk	5 V x 5 A = 25 W pk

3.10.2 Standby Output / Standby Mode

The 5 VSB output is present when an AC input greater than the power supply turn-on AC voltage is applied. Applying an external 5.25 V to 5 VSB does not cause the power supply to shut down or exceed operating limits. When the external voltage is removed, the voltage returns to the power supplies' operating voltage without exceeding the dynamic voltage limits.

3.11 Power Supply Status LED

Each power supply module has a single bi-color LED to indicate power supply status. The LED operation is defined in the following table.

Table 18. LED Indicators

Power Supply Condition	Bi-Color LED
No AC power to all power supplies	Off
No AC power to this PSU only (for 1+1 configuration) or Power supply critical event causing a shutdown: failure, fuse blown (1+1 only), OCP, OVP, fan failed	Amber
Power supply warning events where the power supply continues to operate: high temp, high power, high current, slow fan.	1 Hz Blink Amber
AC present / Only 5 VSB on (PS Off)	1 Hz Blink Green
Output ON and OK	Green

The LED is visible on the rear panel of each installed power supply module.

4. Cooling Subsystem

Several components and configuration requirements make up the cooling subsystem of the system. These include the system fan module, the power supply fans, air baffles, CPU air duct, and drive bay population. All are necessary to provide and regulate the airflow and air pressure needed to maintain the system's thermals when operating at or below maximum specified thermal limits.

Two system fan assembly options are available for this system:

- The first option is a non-redundant three fan solution providing sufficient airflow to maintain internal system thermal requirements when the external ambient temperature remains within specified limits.
- The second option is a redundant fan solution. Three parallel sets of fans are arranged in series to provide redundant cooling in the event of a single fan failure. Each cooling option utilizes two fan types: a 60-mm variable-speed fan and an 80-mm variable-speed fan.

The system uses a variable fan speed control engine to provide adequate cooling for the system at various ambient temperature conditions, under various server workloads, and with the least amount of acoustic noise possible. To minimize acoustics, the fans operate at the lowest speed for any given condition.

The Integrated Baseboard Management Controller (Integrated BMC) on the Intel® Server Board S5520UR is used for the variable fan speed control function. The Integrated BMC monitors selective component temperatures, the ambient temperature, and each fan's RPM to determine the necessary airflow. The Integrated BMC sets the fan speeds to the appropriate RPM to maintain proper cooling. The Integrated BMC also logs errors into the System Event Log (SEL) when temperature sensors exceed their safe operating ranges, or if any of the fans fail to operate at safe airflow speeds.

If a fan fails, the Integrated BMC boosts the remaining fans to compensate for the lost airflow. A system with redundant fans can continue to operate in this degraded condition while the non-redundant system may not. If the cooling is not sufficient under a failed fan condition, the system eventually shuts down to protect its primary components from thermal damage.

4.1 Non-redundant Fan Module

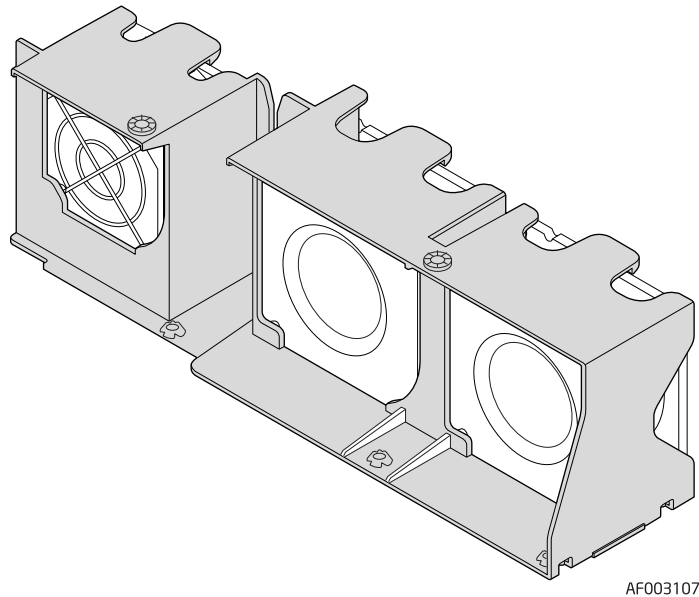

Figure 14. Non-redundant Fan Module

This option provides the primary airflow for system configurations that do not require redundant cooling.

Table 19. Non-redundant Cooling Zones

Fan	Cooling Zone	Description of greatest cooling influence
System Fan #1	CPU2	Primary cooling for CPU 2 and Memory 1
System Fan #2	CPU1	Primary cooling for hard drives 4 and 5, CPU 1, and Memory 2
System Fan #3	PCI	Primary cooling for hard drives 2 and 3, full-height PCI cards, and the Intel® 5520 Chipset IOH
Power Supply Fans - 2 fans per module	Power Supply	Primary cooling for hard drives 0 and 1, and the power supply module(s)

The system fan module is designed for ease of use and supports several management features that can be utilized by the Integrated Baseboard Management Controller.

- The fan module houses two different fan sizes: System fans 1 and 2 use an 80-mm fan; System fan 3 uses a 60-mm fan.
- Each fan is designed for tool-less insertion to or removal from the fan module housing. For instructions on installing or removing a fan module, see the *Intel® Server System SR2600UR/SR2625UR Service Guide*.

Note: The fans are NOT hot-swappable. The system must be turned off in order to replace a failed fan.

- Each fan within the module is capable of supporting multiple speeds. If the external ambient temperature of the system exceeds the value programmed into the thermal sensor data record (SDR), the Integrated BMC firmware increases the speed for all the fans within the fan module.
- Each fan is responsible for cooling a specific zone of the system. If the components in the zone begin to exceed a safe operating temperature as programmed by the SDR, the Integrated BMC firmware increases the speed for the fans tied to that zone.
- Each fan connector within the module supplies a tachometer signal that allows the Integrated BMC to monitor the status of each fan. If one of the fans fails, the remaining fans increase their rotation and attempt to maintain the thermal requirements of the system.
- Each fan has an associated fault LED on the midplane located next to the fan header. If a fan fails, system management illuminates the fault LED for the failing fan.

Table 20. Non-redundant Fan Connector Pin Assingment

Pin	Signal Name	Description
1	Tachometer B	Reserved, unused by the non-redundant fan
2	PWM	Fan speed control signal
3	12 V	Power for fan
4	12 V	Power for fan
5	Tachometer A	Fan RPM sensor output Two pulse per revolution for the 80-mm fan Four pulses per revolution for the 60-mm fan
6	Return	Return path to ground
7	Return	Return path to ground
8	Fan Presence	Reserved, unused by the non-redundant fan
9	LED Cathode	Loopback signal to pin 10
10	LED Anode	Loopback signal to pin 9

The system fans plug into headers on the midplane board as shown in the following figure.

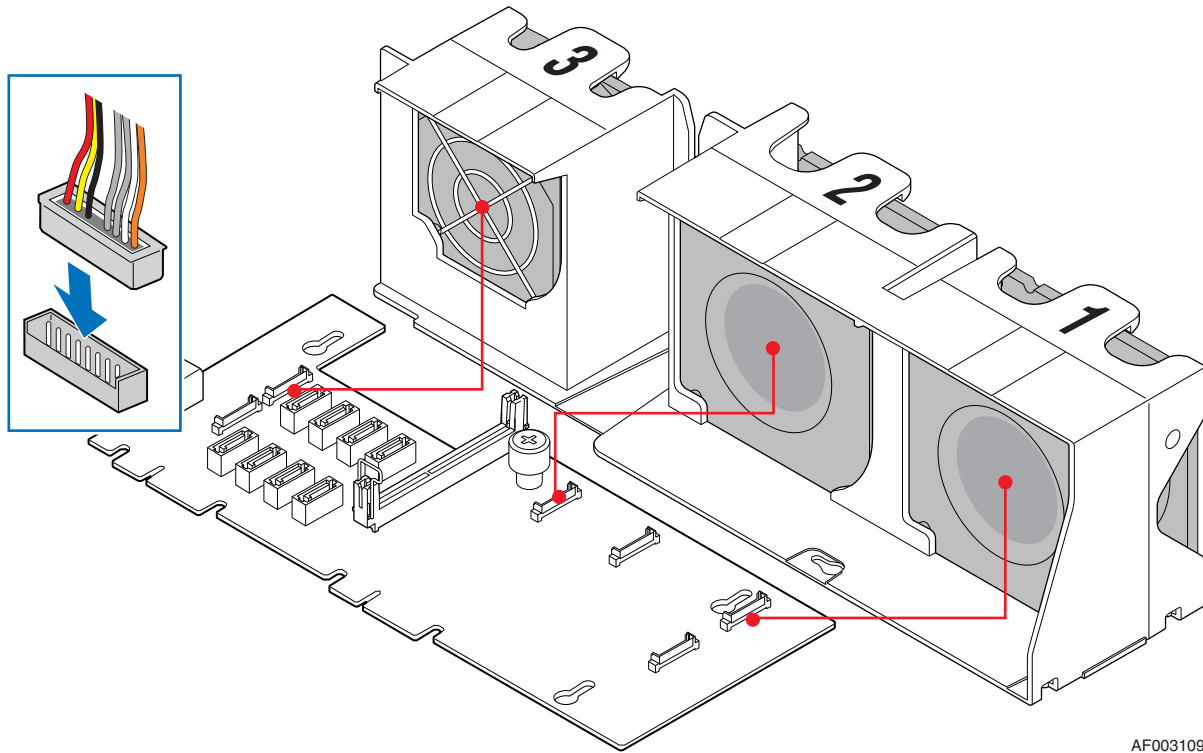

AF003109

Figure 15. Non-redundant Fan Header Assignments on Midplane

Table 21. Non-redundant Fan Header Assignment

Fan ID	Midplane Fan Header Name
Fan #1 - CPU1 cooling	FAN_2
Fan #2 - CPU2 cooling	FAN_4
Fan #3 - PCI cooling	FAN_5

4.2 Redundant Fan Module

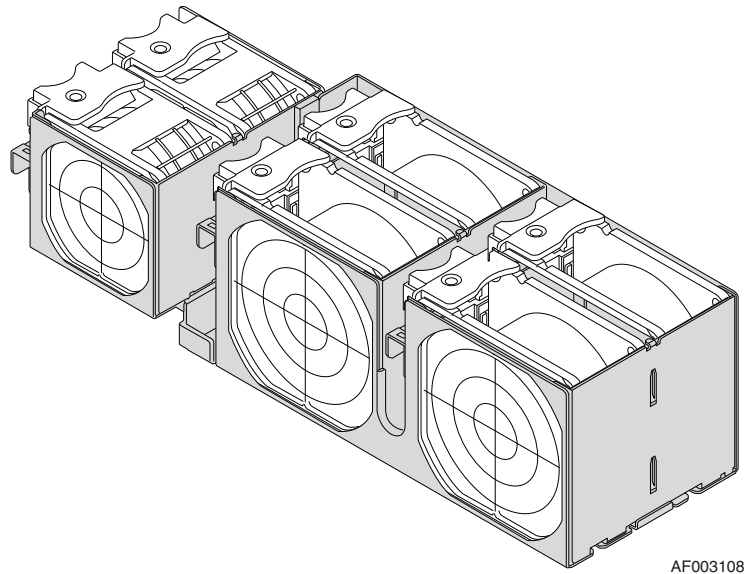

Figure 16. Fan Module Assembly

Table 22. Redundant Cooling Zones

Fan	Cooling Zone	Description of Greatest Cooling Influence
System Fan #1 & #2	CPU2	Primary cooling for CPU 2 and Memory 1
System Fan #2 & #3	CPU1	Primary cooling for hard drives 4 and 5, CPU 1, memory 2, and the low-profile PCI cards
System Fan #5 & #6	PCI	Primary cooling for hard drives 2 and 3, Full-height PCI cards, Intel® 5520 Chipset IOH
Power Supply Fans 2 fans per module	Power Supply	Primary cooling for hard drives 0 and 1, and the power supply module(s)

Each 10-pin fan connector provides power and ground, PWM control, tachometer output, a fan present detection signal, and a fault LED signal allowing it to be monitored independently by server management software. The following table provides the pin-out and description for the connectors on each fan.

Table 23. Redundant Fan Connector Pin Assingment

Pin	Signal Name	Description
1	Tachometer B	Reserved, unused by redundant fan
2	PWM	Fan speed control signal
3	12 V	Power for fan
4	12 V	Power for fan
5	Tachometer A	Fan RPM sensor output Two pulses per revolution for the 80-mm fan Four pulses per revolution for the 60-mm fan
6	Return	Return path to ground
7	Return	Return path to ground
8	Fan Presence	Detection if fan is installed in system
9	LED Cathode	LED in fan
10	LED Anode	Reserved, unused by the redundant fan

The system fans are hot-pluggable and do not have any cable connections. They mate directly to the fan module. The system fan module plugs into headers on the midplane board as shown in the following figure.

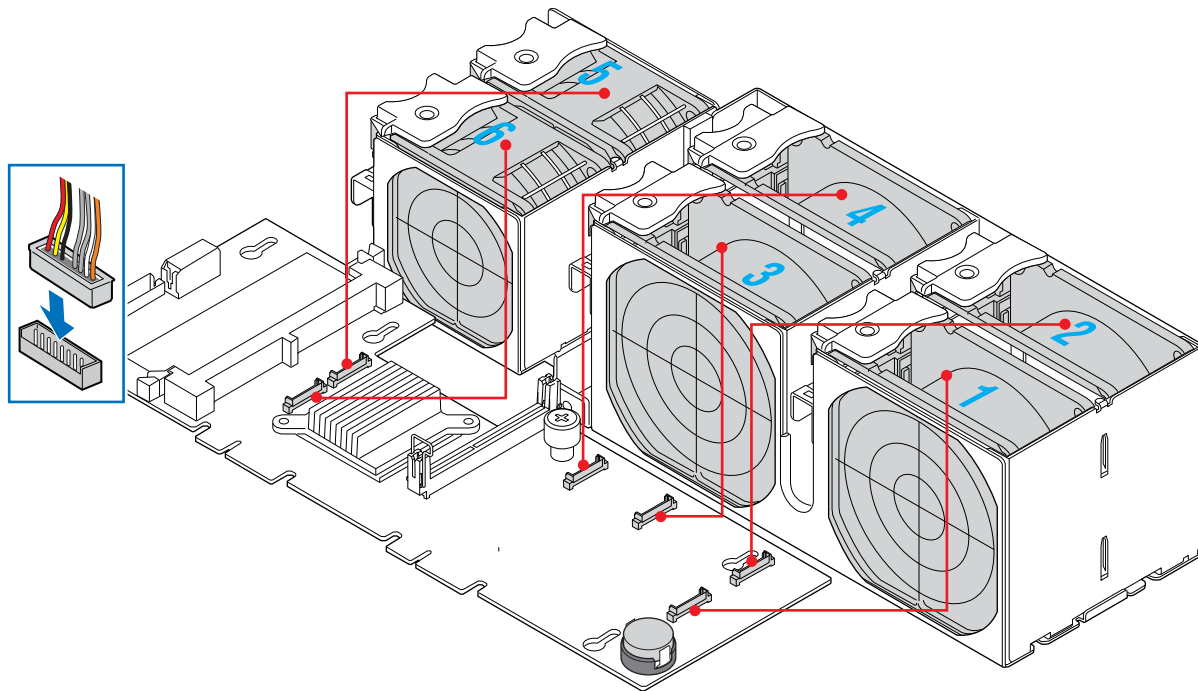

AF002994

Figure 17. Redundant Fan Header Assignments on Midplane

Table 24. Redundant Fan Header Assignment

Fan ID	Midplane Fan Header Name
Fan #1 - CPU1 Cooling	FAN_1
Fan #2 - CPU1 Cooling	FAN_2
Fan #3 - CPU2 Cooling	FAN_3
Fan #4 - CPU2 Cooling	FAN_4
Fan #5 - PCI Cooling	FAN_5
Fan #6 - PCI Cooling	FAN_6

The system fan module is designed for ease of use and supports several management features that can be utilized by the Integrated Baseboard Management Controller.

- The fan module houses two different fan sizes: System fans 1, 2, 3 and 4 use an 80-mm fan; System fans 5 and 6 use a 60-mm fan.
- Each fan is designed for tool-less insertion to or removal from the fan module and can be hot-swapped in the event of failure.
- Each fan within the module is equipped with a failure LED. In a fan fails, server management illuminates the fault LED on the failing fan.
- Each fan within the module is capable of supporting multiple speeds. If the external ambient temperature of the system exceeds the value programmed into the thermal sensor data record (SDR), the Integrated BMC firmware increases the speed for all the fans within the fan module.
- Each fan is responsible for cooling a specific zone of the system. If the components in the zone begin to exceed a safe operating temperature as programmed by the SDR, the Integrated BMC firmware increases the speed for the fans tied to that zone.
- Each fan connector within the module supplies a tachometer signal that allows the Integrated BMC to monitor the status of each fan. If one of the fans fails, the remaining fans increase their rotation and attempt to maintain the thermal requirements of the system.

4.3 Airflow Support

To control airflow within the system, the system uses an air baffle and a CPU air duct to isolate and direct airflow to three critical zones: the power supply zone, the full-height PCI riser zone, and the CPU/memory/low-profile PCI riser zone.

4.3.1 Power Supply Zone

An air baffle is used to isolate the airflow of the main system board zones from the zone directly in front of the power supply. As the power supply fans pull pre-heated air through the power supply from inside the system, the zone in front of it must remain as cool as possible by drawing air from the leftmost drive bays only.

4.3.2 Full-height Riser Zone

The full-height riser zone is the area between the power supply assembly and the full-height riser card of the riser assembly. The airflow through this area is generated by system fan 3 of the fan module in a non-redundant fan configuration. In a redundant fan configuration, the airflow for this zone is provided by system fans 5 and 6. Air is drawn from the drive bay area through the fan and pushed out of the system through ventilation holes at the back of the system.

4.3.3 CPU / Memory / Low-profile PCI Zone

The CPU / memory / low-profile PCI zone is the area between the low-profile riser card of the riser assembly and the right chassis wall. In a non-redundant fan configuration, the airflow for this zone is generated by system fans 1 and 2 of the fan module. In a redundant fan configuration, the airflow for this zone is provided by system fans 1, 2, 3 and 4. Air is drawn from the drive bay area, through the fans, directed through the CPU air duct, and out through ventilation holes on both the back wall and rear side wall of the system.

The CPU air duct combined with the DIMM blanks is used to direct airflow through the processor heatsinks and memory areas for both single and dual processor configurations.

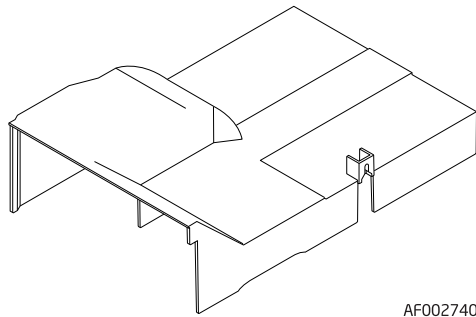

AF002740

Figure 18. CPU Air Duct with Air Baffle

4.4 Drive Bay Population

To maintain proper air pressure within the system, all hard drive bays must be populated with either a hard drive or drive blank.

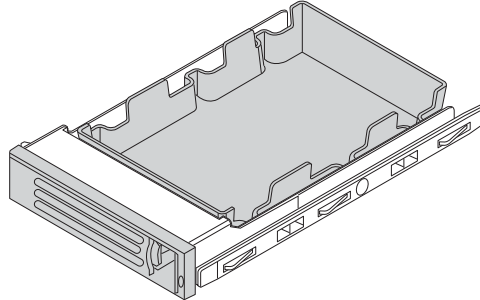

TP02104

Figure 19. 3.5-inch Drive Blank

4.5 Memory Slot Population

To maintain proper airflow over the DIMMs and CPUs, DIMMs or DIMM blanks must be populated. The requirements are as follows:

- One CPU installed – All CPU 1 DIMM slots must either have a DIMM or DIMM blank installed. You may leave the CPU 2 DIMM slots empty or store extra DIMM blanks in the blue DIMM slots.
- Two CPUs installed – All blue DIMM slots in CPU 1 and CPU 2 must either have a DIMM or DIMM blank installed. You may store extra DIMM blanks in any unused CPU1 DIMM slots.

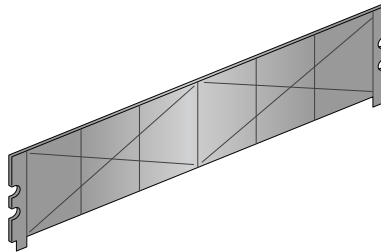

Figure 20. DIMM Blank

5. System Board Interconnects

System boards within the system include the midplane, bridge board, hot-swap backplane, and control panel. This chapter describes the interconnect features of each, and defines the pin-outs for each connector. Functional details of each system board are described in later chapters.

5.1 Midplane

The midplane is designed and used, along with that of the bridge board and hot-swap backplane, to improve cable routing within the system. The midplane is the key system board of the system. It serves as the primary interface between the server board, hot-swap backplane, and control panel. Two midplanes are offered for this system: a passive SATA/SAS, and an active SAS/SATA RAID.

The passive midplane is a simple pass-through from the backplane to the SATA connectors on the server board or SAS/SATA connectors on an add-in card.

The following figure shows the location for each connector found on the passive midplane board.

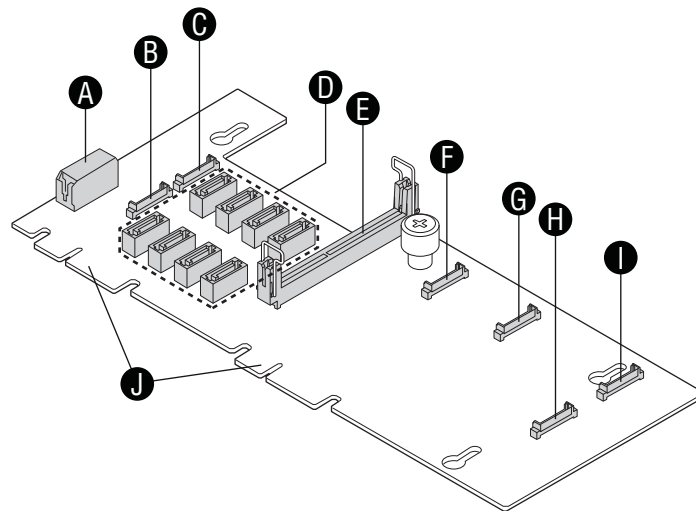

AF000047

A.	Power Connector	F.	Fan 4 Connector
B.	Fan 6 Connector	G.	Fan 3 Connector
C.	Fan 5 Connector	H.	Fan 1 Connector
D.	SAS/SATA Connectors	I.	Fan 2 Connector
E.	Bridge Board Connector	J.	Backplane Connector

Figure 21. Passive Midplane Board

The system also supports an active SAS/SATA RAID midplane. This system board incorporates an LSI LSISAS1078 SAS controller onto the board. For information about SAS/SATA RAID support, see Chapter 6. The following figure shows the location for each connector found on this board.

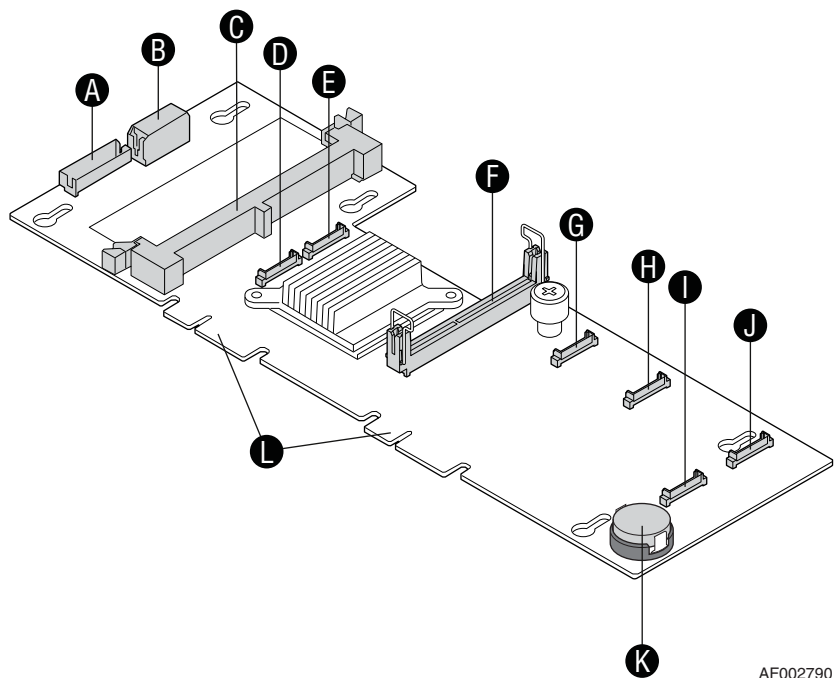

AF002790

A.	Optional RAID Cache Battery Backup Connection	G.	Fan 4 Connector
B.	Power Connector	H.	Fan 3 Connector
C.	Mini-DIMM Connector	I.	Fan 1 Connector
D.	Fan 6 Connector	J.	Fan 2 Connector
E.	Fan 5 Connector	K.	RAID Activation Key Connector
F.	Bridge Board Connector	L.	Backplane Connectors

Figure 22. Active SAS/SATA RAID Midplane Board

The following tables define the connector pin-outs for both midplane boards.

Table 25. 120-pin Server Board-to-Midplane Bridge Board Connector Pin-out

Pin	Signal Name	Pin	Signal Name
1	GND	61	SMB_SENSOR_3V3SB_CLK_BUF
2	PE1_ESB_TX_DN3	62	SMB_SENSOR_3V3SB_DAT_BUF
3	PE1_ESB_TX_DP3	63	FM_BRIDGE_PRSNT_N
4	GND	64	GND
5	PE_WAKE_N	65	PE1_ESB_RX_DN_C3
6	GND	66	PE1_ESB_RX_DP_C3
7	PE1_ESB_TX_DN2	67	GND
8	PE1_ESB_TX_DP2	68	FAN_PRSNT6_N
9	GND	69	GND

Pin	Signal Name	Pin	Signal Name
10	FAN_PRSNT5_N	70	PE1_ESB_RX_DN_C2
11	GND	71	PE1_ESB_RX_DP_C2
12	PE1_ESB_TX_DN1	72	GND
13	PE1_ESB_TX_DP1	73	FAN_PRSNT4_N
14	GND	74	GND
15	RST_PS_PWRGD	75	PE1_ESB_RX_DN_C1
16	GND	76	PE1_ESB_RX_DP_C1
17	PE1_ESB_TX_DN0	77	GND
18	PE1_ESB_TX_DP0	78	RAID_KEY_PRES
19	GND	79	GND
20	FM_RAID_MODE	80	PE1_ESB_RX_DN_C0
21	GND	81	PE1_ESB_RX_DP_C0
22	CLK_IOP_DN	82	GND
23	CLK_IOP_DP	83	FAN_PRSNT1_N
24	GND	84	FAN_PRSNT3_N
25	SGPIO_DATAOUT1	85	FAN_PRSNT2_N
26	SGPIO_DATAOUT0	86	GND
27	SGPIO_LOAD	87	USB1_ESB_DP
28	SGPIO_CLOCK	88	USB1_ESB_DN
29	GND	89	GND
30	USB2_ESB_DP	90	USB1_ESB_OC_N
31	USB2_ESB_DN	91	USB0_ESB_OC_N
32	GND	92	GND
33	USB2_ESB_OC_N	93	USB0_ESB_DP
34	NIC1_LINK_LED_N	94	USB0_ESB_DN
35	NIC1_ACT_LED_N	95	GND
36	LED_STATUS_AMBER_R1	96	FP_NMI_BTN_N
37	NIC2_LINK_LED_N	97	BMC_RST_BTN_N
38	NIC2_ACT_LED_N	98	FP_PWR_BTN_N
39	LED_STATUS_GREEN_BUF_R1	99	FP_ID_SW_L
40	GND	100	GND
41	SMB_PBI_5VSB_DAT	101	SMB_IPMB_5VSB_DAT
42	SMB_PBI_5VSB_CLK	102	SMB_IPMB_5VSB_CLK
43	GND	103	GND
44	V_IO_HSYNC2_BUF_FP	104	LED_HDD_ACTIVITY_N
45	V_IO_VSYNC2_BUF_FP	105	LED_HDD_5V_A
46	GND	106	FP_PWR_LED_R_N
47	V_IO_BLUE_CONN_FP	107	FP_PWR_LED_3VSB
48	V_IO_GREEN_CONN_FP	108	FP_ID_LED_R1_N
49	V_IO_RED_CONN_FP	109	FM_SIO_TEMP_SENSOR
50	GND	110	LED_FAN3_FAULT
51	LED_FAN6_FAULT	111	LED_FAN2_FAULT
52	LED_FAN5_FAULT	112	LED_FAN1_FAULT
53	LED_FAN4_FAULT	113	FAN_PWM_CPU1
54	FAN_PWM3	114	GND
55	GND	115	FAN_PWM_CPU2
56	PCI_FAN_TACH10	116	PCI_FAN_TACH9
57	FAN_TACH8	117	FAN_TACH7

Pin	Signal Name	Pin	Signal Name
58	FAN_TACH6	118	FAN_TACH5
59	FAN_TACH4_H7	119	FAN_TACH3_H7
60	FAN_TACH2_H7	120	FAN_TACH1_H7

Table 26. Midplane Fan Header Pin-outs

J2B1 - FAN_1		J2B3 - FAN_3		J7B1 - FAN_5	
Pin	Signal Name	Pin	Signal Name	Pin	Signal Name
1	FAN_TACH5	1	FAN_TACH7	1	FAN_TACH10
2	FAN_PWM_CPU1	2	FAN_PWM_CPU2	2	FAN_PWM3
3	P12V	3	P12V	3	P12V
4	P12V	4	P12V	4	P12V
5	FAN_TACH1_H7	5	FAN_TACH3_H7	5	FAN_TACH9
6	GND	6	GND	6	GND
7	GND	7	GND	7	GND
8	FAN_PRSNT1_N	8	FAN_PRSNT3_N	8	FAN_PRSNT5_N
9	LED_FAN1_FAULT	9	LED_FAN3_FAULT	9	LED_FAN5_FAULT
10	LED_FAN1	10	LED_FAN3	10	LED_FAN5

J2B2 - FAN_2		J3B1 - FAN_4		J7B2 - FAN_6	
Pin	Signal Name	Pin	Signal Name	Pin	Signal Name
1	FAN_TACH6	1	FAN_TACH8	1	UNUSED
2	FAN_PWM_CPU1	2	FAN_PWM_CPU2	2	FAN_PWM3
3	P12V	3	P12V	3	P12V
4	P12V	4	P12V	4	P12V
5	FAN_TACH2_H7	5	FAN_TACH4_H7	5	FAN_TACH10
6	GND	6	GND	6	GND
7	GND	7	GND	7	GND
8	FAN_PRSNT2_N	8	FAN_PRSNT4_N	8	FAN_PRSNT6_N
9	LED_FAN2_FAULT	9	LED_FAN4_FAULT	9	LED_FAN6_FAULT
10	LED_FAN2	10	LED_FAN4	10	LED_FAN6

Table 27. Midplane Power Connector Pin-out

Pin	Signal Description
1	GND
2	GND
3	P5V
4	P3V3
5	GND
6	P12V
7	P12V
8	P12V
9	P12V
10	P5V_STBY

Table 28. Midplane-to-Backplane Card Edge Connector #1 Pin-out

J7A1 - HSBP#1 I/F			
Pin	Signal Name	Pin	Signal Name
A1	RST_PS_PWRGD	B1	GND
A2	GND	B2	SATA0_RX_N
A3	GND	B3	SATA0_RX_P
A4	SATA1_RX_N	B4	GND
A5	SATA1_RX_P	B5	GND
A6	GND	B6	SATA0_TX_N
A7	GND	B7	SATA0_TX_P
A8	SATA1_TX_P	B8	GND
A9	SATA1_TX_N	B9	GND
A10	GND	B10	USB2_ESB_DN
A11	GND	B11	USB2_ESB_DP
A12	USB2_ESB_OC_N	B12	GND
A13	GND	B13	SATA2_RX_N
A14	GND	B14	SATA2_RX_P
A15	SATA3_RX_N	B15	GND
A16	SATA3_RX_P	B16	NC_RESERVEDB16
A17	GND	B17	SMB_SAS_EDGE_DAT
A18	GND	B18	NC_RESERVEDB18
A19	GND	B19	SMB_SAS_EDGE_CLK
A20	SATA3_TX_P	B20	NC_RESERVEDB20
A21	SATA3_TX_N	B21	GND
A22	GND	B22	SATA2_TX_P
A23	GND	B23	SATA2_TX_N
A24	SATA5_RX_N	B24	GND
A25	SATA5_RX_P	B25	GND
A26	GND	B26	SATA4_RX_N
A27	GND	B27	SATA4_RX_P
A28	SATA5_TX_P	B28	GND
A29	SATA5_TX_N	B29	GND
A30	GND	B30	SATA4_TX_P
A31	GND	B31	SATA4_TX_N
A32	P5V_STBY	B32	GND

Table 29. Midplane-to-Backplane Card Edge Connector #2 Pin-out

J4A1 - HSBP#2 I/F			
Pin	Signal Name	Pin	Signal Name
A1	SGPIO_DATAOUT0	B1	SGPIO_CLOCK
A2	SGPIO_DATAOUT1	B2	GND
A3	GND	B3	SATA_ADDIN1_RX_N
A4	GND	B4	SATA_ADDIN1_RX_P
A5	SATA_ADDIN2_RX_N	B5	GND
A6	SATA_ADDIN2_RX_P	B6	GND
A7	GND	B7	SATA_ADDIN1_TX_N
A8	GND	B8	SATA_ADDIN1_TX_P
A9	SATA_ADDIN2_TX_P	B9	GND
A10	SATA_ADDIN2_TX_N	B10	GND
A11	GND	B11	SGPIO_LOAD
A12	SMB_PBI_3VSB_DAT	B12	SMB_IPMB_5VSB_DAT
A13	SMB_PBI_3VSB_CLK	B13	SMB_IPMB_5VSB_CLK
A14	USB0_ESB_OC_N	B14	GND
A15	GND	B15	USB1_ESB_DP
A16	GND	B16	USB1_ESB_DN
A17	USB0_ESB_DP	B17	GND
A18	USB0_ESB_DN	B18	GND
A19	GND	B19	USB1_ESB_OC_N
A20	LED_NIC1_ACT_N	B20	LED_HDD_ACTIVITY_N
A21	LED_NIC1_LINK_N	B21	LED_HDD_5V_A
A22	FM_SIO_TEMP_SENSOR	B22	FP_ID_SW_L
A23	LED_NIC2_LINK_N	B23	BMC_RST_BTN_N
A24	LED_NIC2_ACT_N	B24	FP_PWR_BTN_N
A25	GND	B25	FP_NMI_BTN_N
A26	V_BLUE_CONN_FP	B26	FP_PWR_LED_3VSB
A27	V_GREEN_CONN_FP	B27	FP_PWR_LED_R_N
A28	V_RED_CONN_FP	B28	FP_ID_LED_R1_N
A29	GND	B29	GND
A30	V_HSYNC2_BUF_FP	B30	LED_STATUS_AMBER_R1
A31	V_VSYNC2_BUF_FP	B31	LED_STATUS_GREEN_BUF_R1
A32	GND	B32	FP_LED

Table 30. Active Midplane SAS RAID Battery Backup Connector Pin-out

Pin	Signal Description
1	P12V
2	GND
3	NC_P5V_MONITOR
4	GND
5	P1V8_VBAT_RAID
6	GND
7	PWRGD_P3V3_STBY
8	GND
9	P1V8_VBAT_RAID

Pin	Signal Description
10	GND
11	PX_RESET_N
12	GND
13	SMB_CLK_P3V3
14	GND
15	SMB_DAT_P3V3
16	BBU_PFAIL_N
17	BBU_DDR_SEL
18	BBU_BBE
19	BBU_BBSTROBE
20	BBU_BBSTATUS

Table 31. Passive Midplane SATA/SAS Connector Pin-outs

J5A2 - SAS_7		J6A1 - SAS_6		J5B1 - SAS_4		J6B1 - SAS_2	
Pin	Signal Name	Pin	Signal Name	Pin	Signal Name	Pin	Signal Name
1	GND	1	GND	1	GND	1	GND
2	SATA_ADDIN1_TX_P	2	SATA5_TX_P	2	SATA3_TX_P	2	SATA1_TX_P
3	SATA_ADDIN1_TX_N	3	SATA5_TX_N	3	SATA3_TX_N	3	SATA1_TX_N
4	GND	4	GND	4	GND	4	GND
5	SATA_ADDIN1_RX_N	5	SATA5_RX_N	5	SATA3_RX_N	5	SATA1_RX_N
6	SATA_ADDIN1_RX_P	6	SATA5_RX_P	6	SATA3_RX_P	6	SATA1_RX_P
7	GND	7	GND	7	GND	7	GND

J5A1- SAS_8		J6A2 - SAS_5		J5B2 - SAS_3		J6B2 - SAS_1	
Pin	Signal Name	Pin	Signal Name	Pin	Signal Name	Pin	Signal Name
1	GND	1	GND	1	GND	1	GND
2	SATA_ADDIN2_TX_P	2	SATA4_TX_P	2	SATA2_TX_P	2	SATA0_TX_P
3	SATA_ADDIN2_TX_N	3	SATA4_TX_N	3	SATA2_TX_N	3	SATA0_TX_N
4	GND	4	GND	4	GND	4	GND
5	SATA_ADDIN2_RX_N	5	SATA4_RX_N	5	SATA2_RX_N	5	SATA0_RX_N
6	SATA_ADDIN2_RX_P	6	SATA4_RX_P	6	SATA2_RX_P	6	SATA0_RX_P
7	GND	7	GND	7	GND	7	GND

5.2 Bridge Board

The system utilizes a bridge board to route signals from the server board to the midplane board. The bridge board carries signals for three USB ports, SSI front panel control signals, video, various I²C buses, fan control signals, and a PCI Express* x4 bus for SAS controller function. For details, see Table 25.

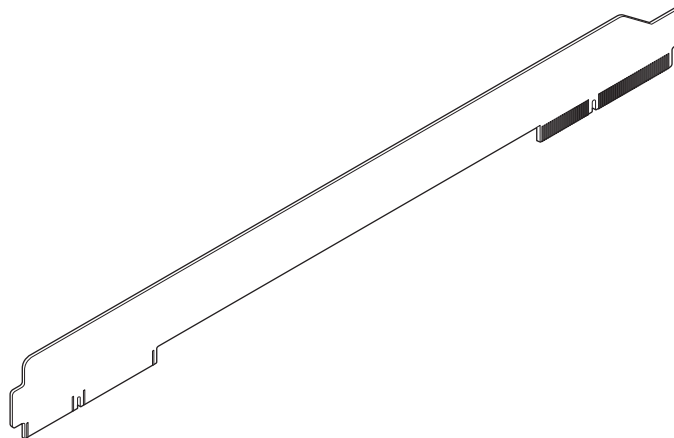

AF000037

Figure 23. Bridge Board

5.3 Hot-swap SAS/SATA Backplane

The hot-swap backplane provides support for both SAS and SATA hard drives. There are no hard drive cables that connect to the backplane. All hard drive control signals are routed from the midplane board, which plugs directly into the backplane.

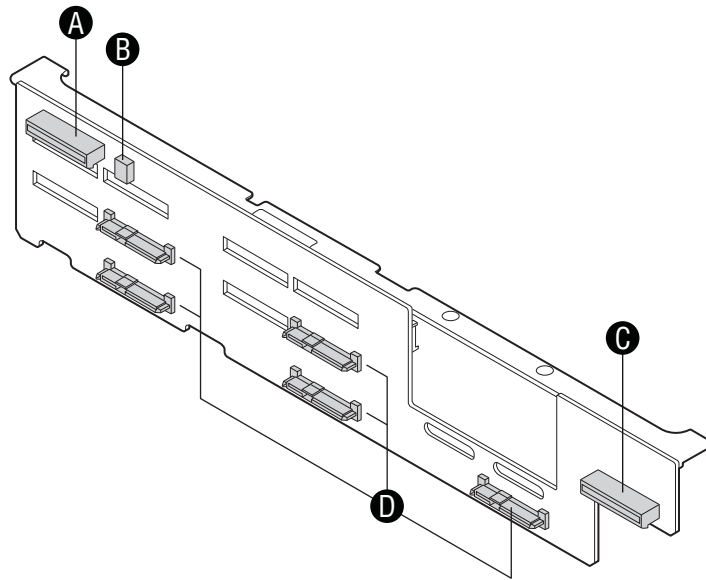

AF000045

A.	Slimline Interposer Card Connector	C.	Control Panel Connector
B.	USB Floppy Connector	D.	SAS/SATA hot-swap Connectors

Figure 24. 3.5-inch Hot-swap SAS/SATA Backplane (Front Side View)

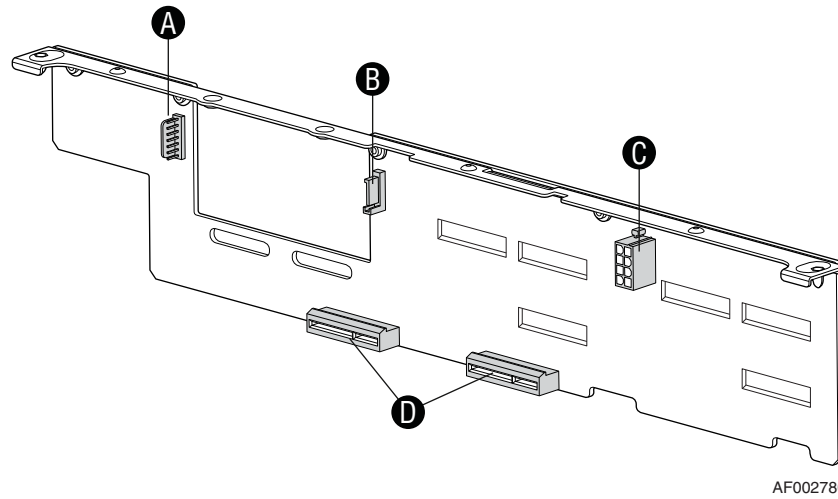

A.	Power Connector (for Sixth Hard Drive or SATA Tape Drive)	C.	Power Connector
B.	SAS/SATA Connector (for Sixth Hard Drive or SATA Tape Drive)	D.	Midplane Connector

Figure 25. 3.5-inch Hot-swap SAS/SATA Backplane (Back Side View)

Table 32. 2x4 SAS/SATA Backplane Power Connector Pin-out (J7L2)

Pin #	Signal Name
1	Ground
2	Ground
3	P5V
4	P5V
5	P12V
6	P12V
7	P5V_STBY
8	P3V3

Table 33. 1x7 Sixth HDD / Tape Drive Option Power Connector Pin-out (J2M1)

Pin #	Signal Name
1	P12V
2	Ground
3	Ground
4	P5V
5	SASS_PRSTNT_L
6	LED_SASS_ACT_L
7	P3V3

Table 34. Sixth HDD Option SATA/SAS I/O Connector Pin-out (J4L1)

Pin #	Signal Name
1	Ground
2	SASS_TX_DP
3	SASS_TX_DN
4	Ground
5	SASS_RX_DN
6	SASS_RX_DP
7	Ground

Table 35. Slimline Optical Drive Slot Connector (J1A1)

Pin #	Signal Name	Pin #	Signal Name
A1	P5V	B1	GND
A2	P5V	B2	SATA_TXP
A3	P5V	B3	SATA_TXN
A4	P5V	B4	GND
A5	P5V	B5	GND
A6	P5V	B6	SATA_RXN
A7	P5V	B7	SATA_RXP
A8	P5V	B8	GND
A9	P5V	B9	GND
A10	P5V	B10	GND
A11	P5V	B11	GND
KEY		KEY	
A12	P5V	B12	GND
A13	P5V	B13	GND
A14	P5V	B14	GND
A15	P5V	B15	GND
A16	P5V	B16	GND
A17	P5V	B17	GND
A18	P5V	B18	GND

Table 36. I²C Connector (J6L3)

Pin #	Signal Description
1	SMB_VSC_12C_DAT0
2	GROUND
3	SMB_VSC_12C_CLK0
4	Not Used

Table 37. PCI Express* X4 Slot Connector from Midplane (J4N1)

Pin #	Signal Name	Pin #	Signal Name
A1	SGPIO_DATA0	B1	SGPIO_CLOCK
A2	SGPIO_DATA1	B2	Ground
A3	Ground	B3	SAS6_RX_DN
A4	Ground	B4	SAS6_RX_DP
A5	SAS7_RX_DN	B5	Ground
A6	SAS7_RX_DP	B6	Ground
A7	Ground	B7	SAS6_TX_DN
A8	Ground	B8	SAS6_TX_DP
A9	SAS7_TX_DP	B9	Ground
A10	SAS7_TX_DN	B10	Ground
A11	Ground	B11	SGPIO_LOAD
A12	SMB_PB1_5VSB_DAT	B12	SMB_IPMB_5VSB_DAT
A13	SMB_PB1_5VSB_CLK	B13	SMB_IPMB_5VSB_CLK
A14	USB_OC1_N	B14	Ground
A15	Ground	B15	USB_P2P
A16	Ground	B16	USB_P2N
A17	USB_P1P	B17	Ground
A18	USB_P1N	B18	Ground
A19	Ground	B19	USB_OC2_N
A20	LED_NIC1_ACT_L	B20	LED_HDD_ACT_R_L
A21	LED_NIC1_LINK_R_L	B21	PV_HDD_LED_3V_A
A22	FP_THERM_SENSOR	B22	FP_ID_SW_L
A23	LED_NIC2_LINK_R_L	B23	RST_FP_BTN_L
A24	LED_NIC2_ACT_L	B24	FP_PWR_BTN_L
A25	Ground	B25	FP_NMI_BTN_L
A26	V_IO_BLUE_CONN_FP	B26	FP_PWR_LED_5VSB
A27	V_IO_GREEN_CONN_FP	B27	LED_FP_PWR_R_L
A28	V_IO_RED_CONN_FP	B28	LED_FP_ID_R_L
A29	Ground	B29	Ground
A30	V_IO_HSYNC_BUFF_FP_L	B30	LED_FP_SYS_FLT1_R_L
A31	V_IO_VSYNC_BUFF_FP_L	B31	LED_FP_SYS_FLT2_R_L
A32	Ground	B32	FP_FLT_LED_5VSB

Table 38. PCI Express* X4 Slot Connector from Midplane (J6N1)

Pin #	Signal Name	Pin #	Signal Name
A1	RST_PWRGD_PS	B1	Ground
A2	Ground	B2	SAS0_RX_DN
A3	Ground	B3	SAS0_RX_DP
A4	SAS1_RX_DN	B4	Ground
A5	SAS1_RX_DP	B5	Ground
A6	Ground	B6	SAS0_TX_DN
A7	Ground	B7	SAS0_TX_DP
A8	SAS1_TX_DP	B8	Ground
A9	SAS1_TX_DN	B9	Ground
A10	Ground	B10	USB_P3N
A11	Ground	B11	USB_P3P
A12	USB_OC3_N	B12	Ground
A13	Ground	B13	SAS2_RX_DN
A14	Ground	B14	SAS2_RX_DP
A15	SAS3_RX_DN	B15	Ground
A16	SAS3_RX_DP	B16	Not Used
A17	Ground	B17	SMB_SAS_3V3_SDA
A18	Ground	B18	Not Used
A19	Ground	B19	SMB_SAS_3V3_SCL
A20	SAS3_TX_DP	B20	Not Used
A21	SAS3_RT_DN	B21	Ground
A22	Ground	B22	SAS2_TX_DP
A23	Ground	B23	SAS2_TX_DN
A24	SAS5_RX_DN	B24	Ground
A25	SAS5_RX_DP	B25	Ground
A26	Ground	B26	SAS4_RX_DN
A27	Ground	B27	SAS4_RX_DP
A28	SAS5_TX_DP	B28	Ground
A29	SAS5_TX_DN	B29	Ground
A30	Ground	B30	SAS4_TX_DP
A31	Ground	B31	SAS4_TX_DN
A32	P5V_STBY	B32	Ground

Table 39. USB Floppy Drive Connector (J2A1)

Pin #	Signal Description
1	P5V_USB_PWR
2	USB_ICH_P7N
3	USB_ICH_P7P
4	Ground

Table 40. Intel® Local Control Panel (LCP) Connector (J9A1)

Pin #	Signal Description
1	SMB_IPMB_5VSB_DAT
2	Ground
3	SMB_IPMB_5VSB_CLK
4	P5V_STBY_R

Table 41. Control Panel Slot Connector (J9B1)

Pin #	Signal Name	Pin #	Signal Name
B1	FP_THERM_SENSOR	A1	GND
B2	P5V	A2	V_IO_VSYNCH_BUF_FP
B3	P5V	A3	GND
B4	P5V	A4	V_IO_HSYNCH_BUF_FP
B5	N/C	A5	GND
B6	GND	A6	V_IO_BLUE_CONN_FP
B7	P5V_STBY	A7	GND
B8	GND	A8	V_IO_GREEN_CONN_FP
B9	FP_SLT)LED_3VSB	A9	GND
B10	GND	A10	V_IO_RED_CONN_FP
B11	LED_FP_SYS_FLT1_N	A11	GND
KEY		KEY	
B12	FP_ID_BTN_N	A12	GND
B13	LED_FP_ID_N	A13	FP_RST_BTN_N
B14	SMB_IPMB_5VSB_DAT	A14	GND
B15	SMB_IPMB_5VSB_CLK	A15	N/C
B16	GND	A16	GND
B17	LED_NIC1_ACT_N	A17	SMB_SEN_3VSB_DAT
B18	LED_NIC1_LINK_N	A18	SMB_SEN_3VSB_CLK
B19	FP_PWR_BTN_N	A19	GND
B20	FP_PWR_LED_3VSB	A20	FP_NMI_BTN_N
B21	PV_LED_HDD_3V3_A	A21	GND
B22	GND	A22	USB_HUB_DOWN_P2P
B23	GND	A23	USB_HUB_DOWN_P2N
B24	LED_NIC2_ACT_N	A24	GND
B25	LED_NIC2_LINK_N	A25	GND
B26	N/C	A26	P5V_USB_HUB_P2
B27	LED_HDD_ACT_N	A27	P5V_USB_HUB_P1
B28	LED_FP_PWR_N	A28	GND
B29	LED_FP_SYS_FLT2_N	A29	GND
B30	GND	A30	USB_HUB_DOWN_P1P
B31	GND	A31	USB_HUB_DOWN_P1N
B32	RST_PWRGD_PS	A32	GND

Table 42. SAS/SATA Hard Drive Connector Pin-outs (J2C3, J2B1, J4C1, J4B1, J7C1)

Pin #	Signal Description
SI	Ground
S2	SAS#_TX_DP (# = 0...4)
S3	SAS#_TX_DN (# = 0...4)
S4	Ground
S5	SAS#_RX_DN (# = 0...4)
S6	SAS#_RX_DP (# = 0...4)
S7	Ground
S8	Not Used
S9	Not Used
S10	Not Used
S11	Not Used
S12	Not Used
S13	Not Used
S14	Not Used
P1	Not Used
P2	Not Used
P3	Not Used
P4	Ground
P5	Ground
P6	P3V3
P7	P5V
P8	P5V
P9	P5V
P10	Ground
P11	LED_SAS#_ACT_L (# = 0...4)
P12	Ground
P13	P12V
P14	P12V
P15	P12V
PTH0	Ground
PTY1	Ground

6. Peripheral and Hard Drive Subsystem

The system can be configured to support several different hard drive and peripheral configurations. The peripheral/hard drive subsystem consists of a drive bay supporting a slimline optical drive, hard drives, and a flex bay; a midplane; and a hot-swap backplane. This chapter describes the details for each subsystem component.

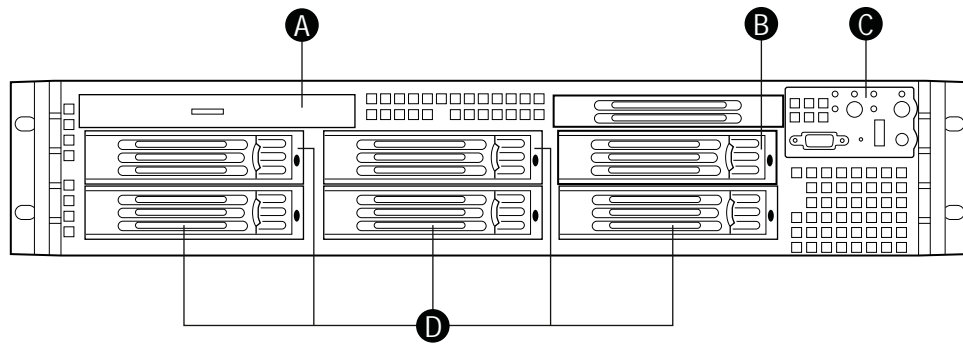

TP02108

A.	Slimline SATA Optical Drive Bay
B.	Flex Bay - Sixth Hard Drive (shown), Tape Drive, or two fixed 2.5-inch Hard Drives (Optional)
C.	System Control Panel
D.	3.5-inch Hard Drive Bays (5)

Figure 26. Optional Sixth Hard Drive (Front View)

6.1 Slimline Drive Bay

The system provides a slimline drive bay that is designed to support a single slimline SATA optical drive or USB Floppy Drive. For a list of supported drives, use the *Server Configurator Tool* available at <http://serverconfigurator.intel.com/default.aspx>.

Either drive type is mounted to a tool-less tray that allows for easy installation into and removal from the system. Once inserted into the system, the assembly locks into place. It is not hot-swappable. For removal, the system must be powered down, the system top cover removed and the locking latch disengaged. For additional details, see the *Intel® Server System SR2600UR/SR2625UR Service Guide*.

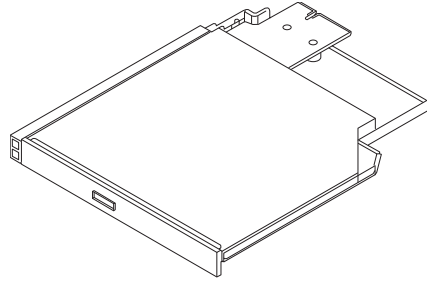

AF000043

Figure 27. Slimline Optical Drive Assembly for 3.5-inch drive System

The SATA Optical drive assembly includes an interposer board which plugs into the back of the optical drive. The interposer board is a card-edge type card that eliminates the need for cable connections. As the drive assembly is inserted into the drive bay, the edge connector is blind mated to a slot connector on the backplane.

The interposer board has two connectors. The first connector is the industry standard 13-pin SATA interface used by all slimline optical devices. The second connector is the card edge used to connect directly to the hot-swap backplane board.

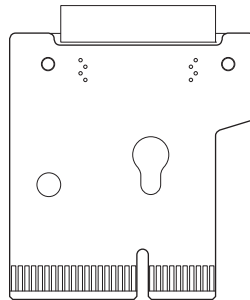

AF000042

Figure 28 Connector to Slimline Optical Device

Table 43. J1L1 Connector to Slimline Optical Device

Pin #	Signal Name	Pin #	Signal Name
A1	P5V	B1	GND
A2	P5V	B2	SATA_TXP
A3	P5V	B3	SATA_TXN
A4	P5V	B4	GND
A5	P5V	B5	GND
A6	P5V	B6	SATA_RXN
A7	P5V	B7	SATA_RXP
A8	P5V	B8	GND
A9	P5V	B9	GND
A10	P5V	B10	GND

Pin #	Signal Name	Pin #	Signal Name
A11	P5V	B11	GND
KEY		KEY	
A12	P5V	B12	GND
A13	P5V	B13	GND
A14	P5V	B14	GND
A15	P5V	B15	GND
A16	P5V	B16	GND
A17	P5V	B17	GND
A18	P5V	B18	GND

6.2 Hard Drive Bays

The system can be configured to support up to six¹ hot-swap 3.5-inch SAS or SATA hard disk drives. Hard drives are mounted to hot-swap drive trays for easy insertion to or extraction from the drive bay.

6.2.1 Hot-swap Drive Carriers

Each hard drive must be mounted to a hot-swap drive carrier, making insertion and extraction of the drive from the system very simple. Each drive carrier has its own dual-purpose latching mechanism, which is used to both insert/extract drives from the system and lock the carrier in place. Each drive tray supports a light pipe that provides a drive status indicator. The light pipe is located on the backplane and can be viewed from the front of the system.

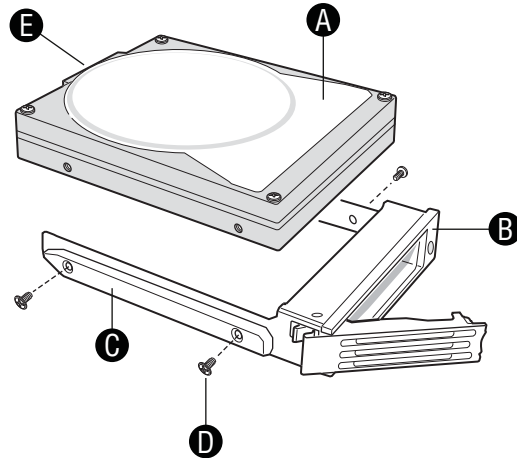

TP02106

A.	Hard Drive
B.	Drive Carrier
C.	Side Rail
D.	Mounting Screw
E.	Hard Drive Connector

Figure 29. 3.5-inch Hard Drive Tray Assembly

¹ Default Five Hard Drives + one optional Sixth Hard Drive using Flex Bay

6.3 Optional Tape Drive or Additional Hard Drive Flex Bay

For system configurations that require either a Tape Drive, a sixth 3.5-inch hard disk drive, or two additional fixed 2.5-inch drives, a multi-purpose drive bay is provided. By default, this drive bay is covered by one face plate. The bay is located next to the control panel.

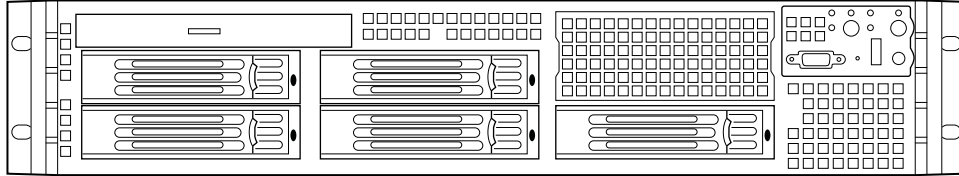

AF002730

Figure 30. Flex Bay

To configure two additional fixed 2.5-inch hard drives, a drive cage is installed in the default filler panel (Product Order Code – ASR2600FIXDRV). The kit includes one cage supporting two fixed 2.5-inch drives, four vibration isolators, power and SATA cables, and all required hardware.

Note: The 2.5-inch drives are not hot-swappable and must be cabled to either the server board or an add-in controller card.

To configure a sixth hard drive, the filler panel is removed and the sixth hard drive accessory kit is installed (Product Order Code – ASR2500SIXDRV). This kit includes a backplane board insert, power cable, drive carrier, and upper filler panel.

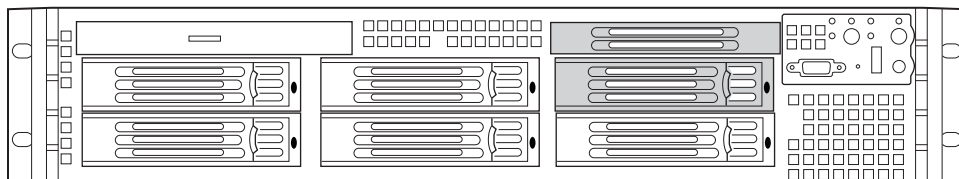

TP02108

Figure 31. Optional Sixth Hard Drive (Front View)

To install a 3.5-inch tape drive, the filler panel is removed and the optional tape drive kit is installed (Product Order Codes – ASR2500SATAPE or ADRTAPEKIT). Both tape drive kits include tape drive mounting tray and necessary cables.

Note: To remove the tape drive tray from the system, a spring latch located inside the system on the back right side of the carrier must be released to allow the drive tray to slide free. Do not attempt to pull out the drive tray without first releasing the spring latch. Doing so may damage the plastic faceplate.

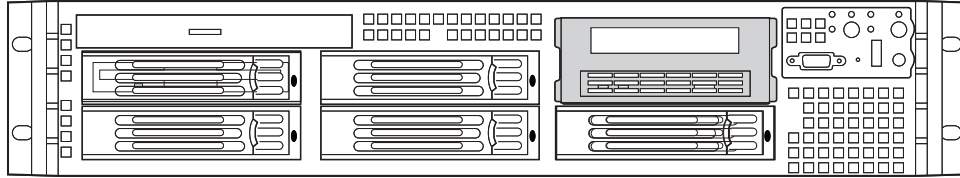

TP02008

Figure 32. Optional Tape Drive (Front View)

6.4 Midplane Options

The midplane is the interconnect between the server board and both the hot-swap backplane and control panel. It is also used to determine which hard drive technology is to be supported. Two different midplane options are available for this platform: 1) a passive midplane capable of supporting SATA ports from the server board or SAS using ports from an add-in card; 2) an active SAS/SATA RAID midplane.

This section describes the hard drive interface support of each of the midplane boards.

6.4.1 Passive Midplane

The passive midplane is used as an interconnect, routing drive control signals from either the on-board SATA ports of the server board or SAS/SATA ports from an add-in card to the hot-swap backplane. The hard drive controller signals are cabled to the midplane, which then routes the signals to the hot-swap backplane through two edge connectors that plug directly into it. For details, see Table 28 and Table 29.

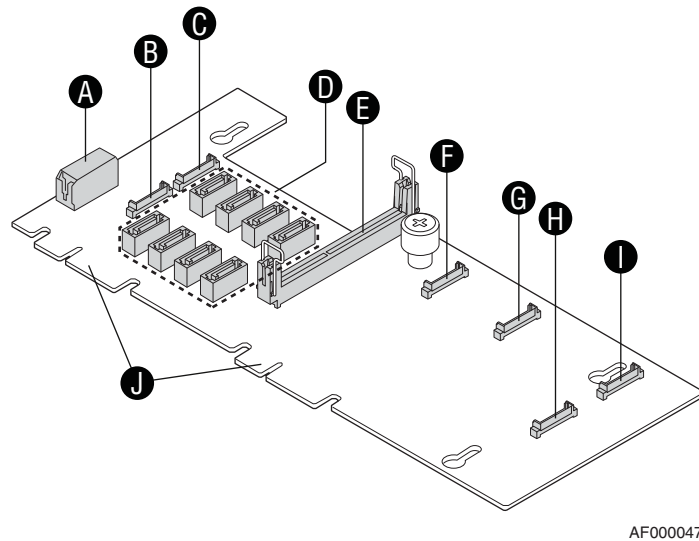

AF000047

A.	Power Connector	F.	Fan 4 Connector
B.	Fan 6 Connector	G.	Fan 3 Connector
C.	Fan 5 Connector	H.	Fan 1 Connector
D.	SAS/SATA Connectors	I.	Fan 2 Connector
E.	Bridge Board Connector	J.	Backplane Connector

Figure 33. Passive Midplane Board

6.4.2 Active Midplane with SAS/SATA RAID Support

The active midplane is used to provide SAS/SATA RAID support. It has an integrated LSI LSISAS1078 3 Gb/s RAID On-a-Chip (ROC) device. It provides support for up to six SAS drives in this system. By default, this midplane option provides software RAID levels 0, 1, and 10 and utilizes Intel® Embedded RAID Technology II. With the installation of optional RAID enablement devices, the midplane can support hardware RAID levels 0, 1, 5, 6, 10, 50 and 60. The midplane attaches to the hot-swap backplane by two card edge connectors, which eliminates the need for any hard drive cables. The following sub-sections describe the board-level SAS/SATA RAID functionality.

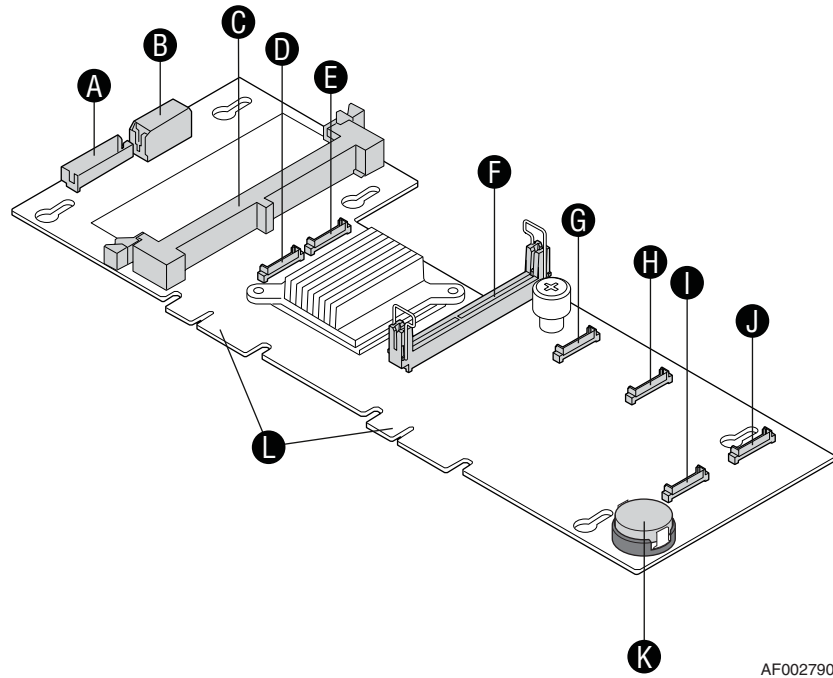

AF002790

A.	RAID Battery Backup Unit Connector	G.	Fan 4 Connector
B.	Power Connector	H.	Fan 3 Connector
C.	Mini-DIMM Connector	I.	Fan 1 Connector
D.	Fan 6 Connector	J.	Fan 2 Connector
E.	Fan 5 Connector	K.	RAID Activation Key Connector
F.	Bridge Board Connector	L.	Backplane Connector

Figure 34. Active Midplane with SAS/SATA RAID Support

6.4.2.1 Architectural Overview

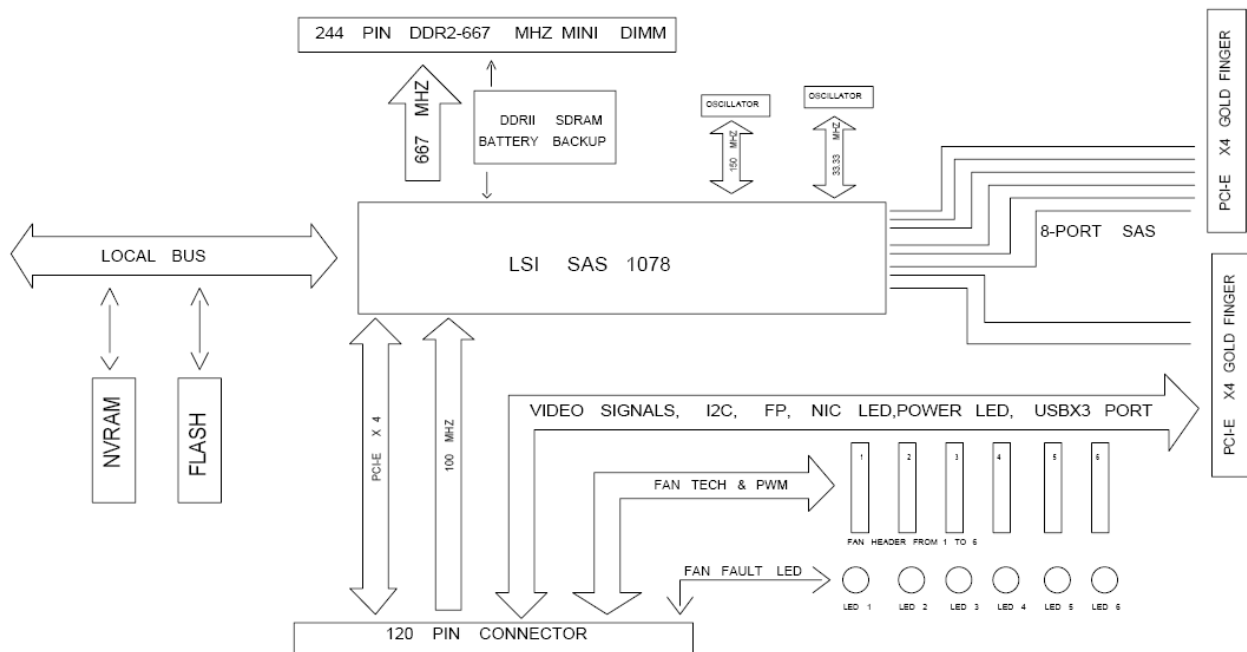

Figure 35. Architecture Overview

6.4.2.2 x4 PCI Express* Card Edge Interfaces

Two x4 PCI Express* card edges are used to connect the active midplane to the hot-swap backplane. For details, see Table 28 and Table 29. The use of card edge connectors to the backplane eliminates all hard drive cabling.

6.4.2.3 LSI LSISAS1078 ROC

The LSI LSISAS1078 ROC supports transfer rates of up to 3 GB/s on each SAS port. It integrates a high-speed DDR/DDR2 SDRAM interface for Hardware RAID cache. It utilizes a PCI Express* interface to provide transmission and reception rates of up to 10 GB/s over a x4 link.

6.4.2.4 Optional Hardware RAID Support

The active midplane supports options to provide full hardware RAID support. Options required to enable hardware RAID support include an Intel® RAID Activation Key (Product Order Code – AXXRAKSAS2) and installation of a Mini-DIMM for Intel® RAID Cache support. To protect from data loss during an unexpected power loss event, an Intel® RAID Smart Battery Backup module (AXXRSBBU3) is also supported. Hardware RAID levels supported include 0, 1, 5, 10, and 50.

6.4.2.4.1 Intel® RAID Activation Key

The Intel® RAID Activation Key enables the full intelligent SAS Hardware RAID solution. The activation key plugs directly into a connector (J1A10) on the midplane board. With no RAID activation key installed, only SAS Software RAID levels 0, 1, and 10 are supported.

6.4.2.4.2 Intel® RAID Cache support

To further enable support for hardware RAID, the active midplane provides a 244-pin mini-DIMM connector (J8C1), supporting a single registered ECC non-parity DDR2-400 MHz Mini-DIMM to provide Intel® RAID cache. Supported mini-DIMM capacities range from 128 MB to 1 GB.

Note: For a list of Intel validated mini-DIMMs, use the *Server Configurator Tool* available at <http://serverconfigurator.intel.com/default.aspx>.

6.4.2.4.3 Intel® RAID Smart Battery Backup Module

With an Intel® RAID Smart Battery Backup module installed, data loss is prevented when data is still present in the RAID Cache Module and power is unexpectedly lost. Depending on the cache module capacity used, the battery backup unit can provide 48 to 72 hours of battery backup power to allow data stored in the RAID cache to be processed. A 2x10 connector (J9A2) is used to attach the battery backup unit to the midplane. For details, see Table 30.

6.5 Hot-swap SAS/SATA Backplane

The SR2600 system supports its own multifunctional SAS/SATA backplane with the following features:

- Vitesse VSC410 enclosure management controller
 - External non-volatile Flash ROM
 - Four I²C interfaces
 - Compliance with SCSI Accessed Fault Tolerant Enclosures (SAF-TE) specification
 - Compliance with Intelligent Platform Management Interface (IPMI)
- Five 3.5-inch compatible hot-swap hard drive connectors
- Designed to support an optional sixth hard drive
- Power for an optional tape drive or two additional 2.5-inch SAS/SATA hard drives
- Hard Drive Status and Fault LEDs for each hard drive connector
- Card edge connectors for most interconnects, including:

- Midplane
- Control Panel
- Slimline SATA Optical Drive
- Temperature Sensor
- FRU EEPROM
- One 2x4-pin Power Connector

6.5.1 SAS/SATA Backplane Layout

The hot-swap backplane installs on the back side of the hot-swap drive bay inside the system. Alignment features on the system and backplane assembly make for easy tool-less installation. For instructions on installing and removing the backplane, see the *Intel® Server System SR2600UR/SR2625UR Service Guide*. The following diagram shows the layout of components and connectors found on the board.

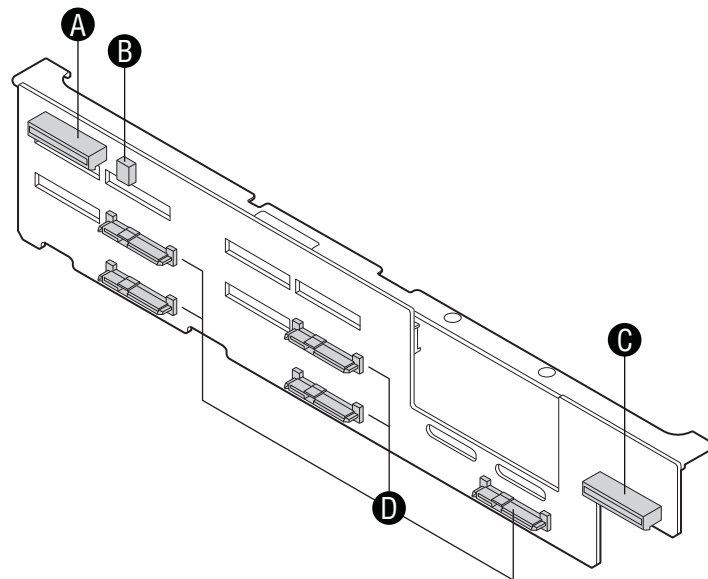

AF000045

A.	Slimline interposer Card Connector	C.	Control Panel Connector
B.	Slimline USB Floppy Connector	D.	SAS/SATA Hot-swap Connectors

Figure 36. Hot-swap SAS/SATA Backplane (Front Side View)

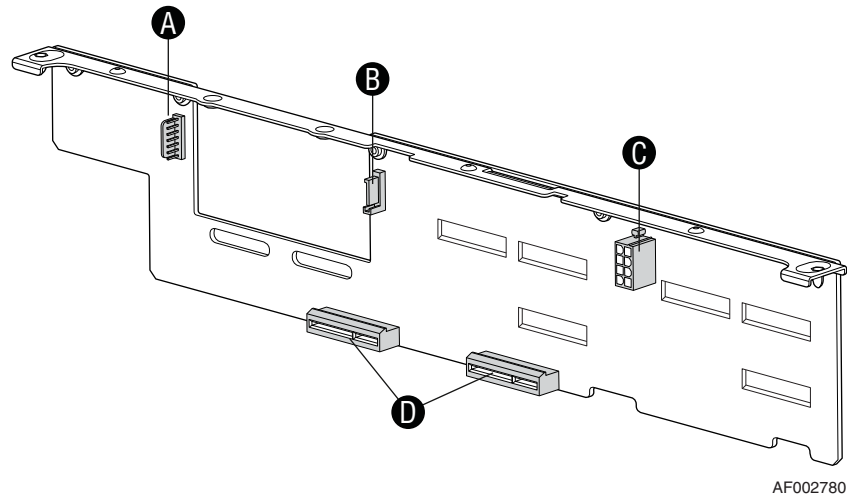

A.	Power Connector (for sixth Hard Drive or Tape Drive or 2.5-inch fixed drives)	C.	Power Connector
B.	SAS/SATA Connector (for sixth Hard Drive or SATA Tape Drive)	D.	Midplane Connectors

Figure 37. Hot-swap SAS/SATA Backplane (Back Side View)

Note: To prevent the backplane from flexing when installing or removing hard drives from the drive bay, make sure the midplane is securely fastened and the system top cover is in place.

Make sure all system boards, peripherals, and cables are detached from the backplane before removing the backplane from the system. Failure to detach components from the backplane before removal may result in component damage.

6.5.2 SAS/SATA Backplane Functional Architecture

The following figure shows the functional blocks of the SAS/SATA backplane.

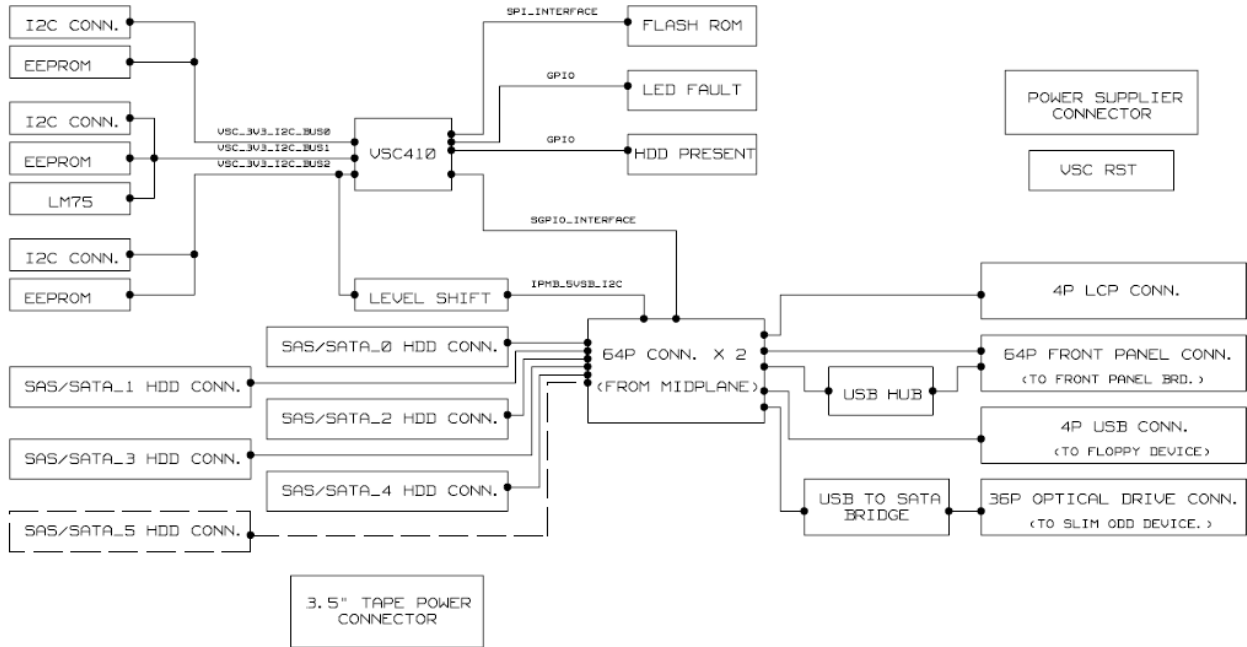

Figure 38. SAS/SATA Backplane Functional Block Diagram

6.5.2.1 Enclosure Management Controller

The backplane utilizes the features of the Vitesse VSC410 to implement several enclosure management functions. The chip provides in-band SAF-TE and SES management, and utilizes the following four I²C interfaces:

1. I²C bus 0 is connected to an EEPROM, which stores configuration and FRU data.
2. I²C bus 1 is connected to an LM75 temperature sensor.
3. I²C bus 2 is connected to an IPMB bus from the server board.
4. I²C bus 3 is connected to an active midplane SAS controller.

6.5.2.2 Hard Drive Activity and Fault LEDs

The backplanes support an activity/fault LED for each of the hard drive connectors. The LED illuminates green for activity or amber for a drive fault. The green activity LED is driven by the SAS/SATA hard disk drive directly. The amber fault LED is driven by the VSC410 management controller whenever a fault condition is detected. When the drive is used in a RAID configuration, the RAID controller has control over the fault LED and it may exhibit different behavior.

Table 44. Hard Drive LED Function Definitions

Status LED	Definition
Green	HDD Activity
Amber	HDD Fail

The activity LED functionality is controlled directly by the hard drives. This causes the LED to function differently between SAS and SATA drives. The expected operation is outlined in the following table.

Table 45. Hard Drive Activity LED Functionality

Condition	Drive Type	Behavior
Power on with no drive activity	SAS	Ready LED stays on
	SATA	Ready LED stays off
Power on with drive activity	SAS	Ready LED blinks off when processing a command
	SATA	Ready LED blinks on when processing a command
Power on and drive spun down	SAS	Ready LED stays off
	SATA	Ready LED stays off
Power on and drive spinning up	SAS	Ready LED blinks
	SATA	Ready LED stays off

6.5.2.3 Optional Sixth Hard Drive

The SR2600 is capable of supporting a sixth hot-swap SAS/SATA hard drive with the addition of an optionally installed backplane add-in board. The sixth drive add-in board assembly consists of a PCB with power and interface connectors, and a mounting bracket. This allows the add-in card to slide into a fitted cutout on the existing backplane.

6.5.2.4 Optional Two 2.5-inch Hard Drives

The SR2600 is capable of supporting two additional 2.5-inch non-hot-swap SAS/SATA hard drives with the addition of an optionally installed drive cage and cables. The 2.5-inch fixed drive assembly is installed in the default filler panel and consists of a hard drive cage, all required mounting hardware, and all required cabling.

6.6 Enclosure Management Cabling for Passive Midplane

When using a rack-optimized system with a passive backplane or midplane and an add-in RAID card, you must install an additional 3-pin cable between the RAID card and the backplane or midplane to enable fault LED control. The cable is included with your integrated system or the backplane or midplane kit.

In Intel® Server System SR2600URBRP, the 3-pin white HBA CONN connector on the passive midplane should be used.

IMPORTANT: No cable is required for fault LED control when using the on-board SAS or SATA RAID controller. No cable is required for fault LED control when using an active backplane or midplane. In these configurations, connecting a 3-pin I²C cable to the backplane or midplane may cause unexpected system behavior.

7. Standard Control Panel

The standard control panel supports several push buttons, status LEDs, USB and video ports to centralize system control, monitoring, and accessibility within a common compact design.

The control panel assembly comes pre-assembled and is modular in design. The control panel assembly module slides into a slot on the front of the system and is blind mated with a slot connector on the backplane. It is not hot-swappable.

Control panels from previous server generations are not compatible with the SR2600 system.

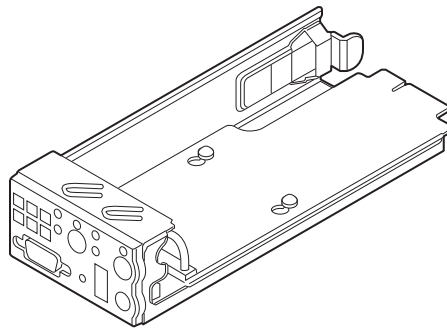

TP02110

Figure 39. Standard Control Panel Assembly Module

7.1 Control Panel Buttons

The standard control panel assembly houses several system control buttons. The function of each control button is listed in the following table.

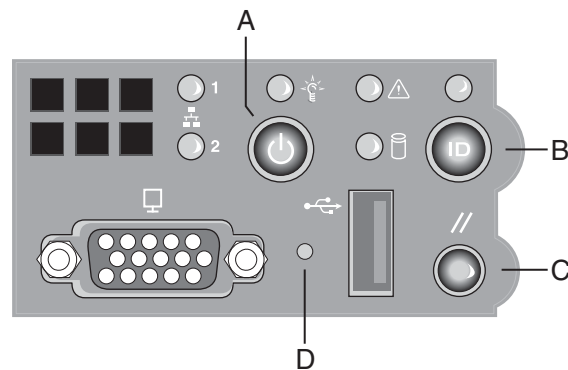

TP02111

Figure 40. Control Panel Buttons

Table 46. Control Button and Intrusion Switch Functions

Reference	Feature	Function
A	Power / Sleep Button	Toggles the system power on/off. This button also functions as a Sleep Button if enabled by an ACPI-compliant operating system.
B	ID Button	Toggles the front panel ID LED and the server board ID LED on/off. The server board ID LED is visible through the rear of the system and allows for server identification and location when working behind a rack of servers.
C	Reset Button	Reboots and initializes the system.
D	NMI Button	When the NMI button is pressed with a paper clip or pin, it puts the server in a halt state for diagnostic purposes and allows the issuance of a non-maskable interrupt. After issuing the interrupt, a memory download can be performed to determine the cause of the problem.

7.2 Control Panel LED Indicators

The control panel houses six LEDs to display the system's operating state. The LEDs are visible with or without the front bezel.

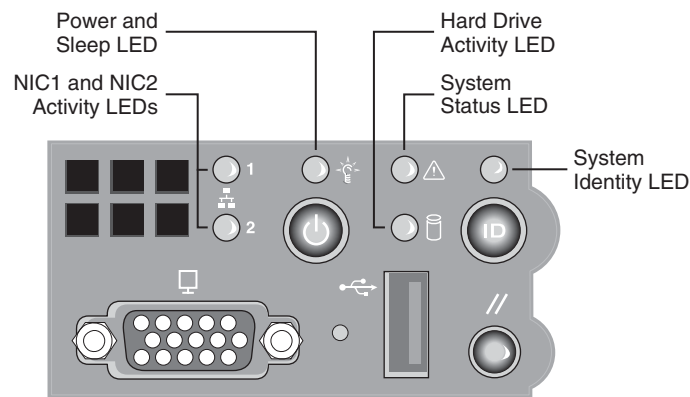

TP02112

Figure 41. Control Panel LEDs

The following table identifies each LED and describes its functionality.

Table 47. Control Panel LED Functions

LED	Color	State	Description
NIC1 / NIC2 Activity	Green	On	NIC Link
		Blink	NIC Activity
Power / Sleep (on standby power)	Green	On	Legacy power-on / ACPI S0 state
		Blink ^{1,4}	Sleep / ACPI S1 state
	Off	Off	Power-off / ACPI S4 or S5 state
System Status (on standby power)	Green	On	Running / normal operation
		Blink ^{1,2}	Degraded
	Amber	On	Critical or non-recoverable condition.
		Blink ^{1,2}	Non-critical condition.
Off	Off	POST / system stop.	
Disk Activity	Green	Random blink	Provides an indicator for disk activity.
	Off	Off ³	No hard disk activity
System Identification	Blue	On	Identify active via command or button.
	Off	Off	No Identification.

Notes:

1. Blink rate is ~1 Hz at 50% duty cycle.
2. The amber status takes precedence over the green status. When the amber LED is on or blinking, the green LED is off.
3. Off when the system is powered off (S4/S5) or in a sleep state (S1).
4. The power LED sleep indication is maintained on standby by the chipset. If the system is powered down without going through the BIOS, the LED state that is in effect at the time of power-off is restored when the system is powered on until the BIOS clears it. If the system is not powered down normally, it is possible that the Power LED is blinking while the system status LED is off. This is due to a failure or configuration change that prevents the BIOS from running.

The current limiting resistors for the power LED, the system fault LED, and the NIC LEDs are located on the server board.

7.2.1 Power / Sleep LED

Table 48. SSI Power LED Operation

State	Power Mode	LED	Description
Power-off	Non-ACPI	Off	System power is off, and the BIOS has not initialized the chipset.
Power-on	Non-ACPI	On	System power is on, but the BIOS has not yet initialized the chipset.
S5	ACPI	Off	Mechanical is off, and the operating system has not saved any context to the hard disk.
S4	ACPI	Off	Mechanical is off. The operating system has saved context to the hard disk.
S3-S1	ACPI	Slow blink ¹	DC power is still on. The operating system has saved context and gone into a level of low-power state.
S0	ACPI	Steady on	System and the operating system are up and running.

Note:

1. Blink rate is ~ 1Hz at 50% duty cycle.

7.2.2 System Status LED

Table 49. Control Panel LED Operation

Color	State	Criticality	Description
Off	N/A	Not ready	AC power off
Green	Solid on	Ok	System booted and ready
Green	Blink	Degraded	System degraded Including, but not limited to: <ul style="list-style-type: none"> ▪ Unable to use all of the installed memory (more than one DIMM installed). ▪ Correctable errors over a threshold of 10 and migrating to a spare DIMM (memory sparing). This indicates that the user no longer has spare DIMMs specifying a redundancy lost condition. The corresponding DIMM LED should light up. ▪ In a mirrored configuration, when memory mirroring takes place and system loses memory redundancy. This is not covered by the second bullet above. ▪ Redundancy loss such as power supply or fan. This does not apply to non-redundant subsystems. ▪ PCI Express* link errors ▪ CPU failure / disabled – if there are two processors and one of them fails ▪ Fan alarm – Fan failure. Number of operational fans should be more than the minimum number needed to cool the system ▪ Non-critical threshold crossed – temperature and voltage

Color	State	Criticality	Description
Amber	Blink	Non-critical	<p>Non-fatal alarm – system is likely to fail</p> <p>Including, but not limited to:</p> <ul style="list-style-type: none"> ▪ Critical voltage threshold crossed ▪ VRD hot asserted ▪ Minimum number of fans to cool the system are not present or have failed ▪ In non-sparing and non-mirroring mode if the threshold of ten correctable errors is crossed within the window
Amber	Solid on	Critical, non-recoverable	<p>Fatal alarm – system has failed or shut down</p> <p>Including, but not limited to:</p> <ul style="list-style-type: none"> ▪ DIMM failure when there is one DIMM present and no good memory is present ▪ Run-time memory uncorrectable error in non-redundant mode ▪ IERR signal asserted ▪ Processor 1 missing ▪ Temperature (e.g., CPU ThermTrip, memory TempHi, critical threshold crossed) ▪ No power good – power fault ▪ Processor configuration error (e.g., processor stepping mismatch)

7.2.3 Drive Activity LED

The drive activity LED on the front panel indicates drive activity from the on-board hard disk controllers. The Intel® Server Board S5520UR also provides a header giving access to this LED for add-in controllers.

7.2.4 System Identification LED

The blue system identification LED is used to help identify a system for servicing. This is especially useful when the system is installed in a high-density rack or cabinet that is populated with several similar systems.

The blue system ID LED can be illuminated using one of the following mechanisms:

- By pressing the system ID button on the system control panel, the ID LED displays a solid blue color until the button is pressed again.
- By issuing the appropriate hex IPMI system identify value, the ID LED either blinks blue for 15 seconds and turns off or blinks indefinitely until the appropriate hex IPMI system identify value is issued to turn it off.

7.3 Control Panel Connectors

The control panel has two external I/O connectors:

- One USB port
- One VGA video port

The following tables provide the pin-outs for each connector.

Table 50. External USB Connectors (J1B1)

Pin #	Description
1	PWR_FP_USB2
2	USB_DN2_FP_R
3	USB_DP2_FP_R
4	GND
5	GND
6	GND
7	GND

Table 51. Video Connector (J1A1)

Description	Pin #	Pin #	Description
VGA_RED	1	9	GND
VGA_GREEN	2	10	GND
VGA_BLUE	3	11	Unused
Unused	4	12	VGA_DDCCDAT
GND	5	13	VGA_HSYNC_L
GND	6	14	VGA_VSYNC_L
VGA_INUSE_L	7	15	VGA_DDCCCLK
GND	8	16	GND
		17	GND

If a monitor is connected to the control panel video connector, the rear video port on the server board is disabled and the control panel video is enabled. The video source is the same for both connectors and is switched between the two, with the rear video having priority over the control panel. This provides easy front access to the server.

7.4 Internal Control Panel Interconnect

All control panel signals are directed through a single 64-pin card edge connector eliminating the need for any cables. When installed into the system control panel bay, the control panel card edge connector is blind mated with a slot connector on the backplane.

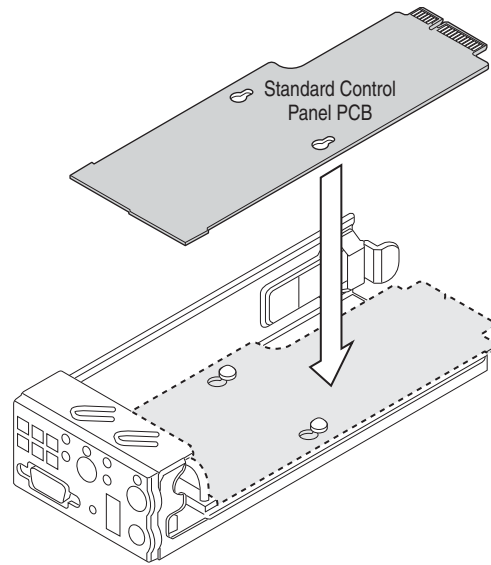

AF000039

Figure 42. Standard Control Panel PCB

The following table defines the pin-out for the 64-pin edge connector.

Table 52. 64-pin Control Panel Connector (J6B1)

Pin	Signal Name	Pin	Signal Name
A1	GND	B1	1_WIRE_BUS
A2	VGA_VSYNC_FP_L	B2	P5V
A3	GND	B3	P5V
A4	VGA_HSYNC_FP_L	B4	P5V
A5	GND	B5	VGA_INUSE_L
A6	VGA_BLUE_FP	B6	GND
A7	GND	B7	P5V_STBY
A8	VGA_GREEN_FP	B8	GND
A9	GND	B9	FAULT_LED_5VSB
A10	VGA_RED_FP	B10	GND
A11	GND	B11	FP_SYS_FLT_LED1_R_L
A12	GND	B12	FP_ID_SW_L
A13	FP_RST_BTN_L	B13	FP_ID_LED_R_L
A14	GND	B14	NC_IPMB_5VSB_SDA
A15	NC_FP_CHASSIS_L	B15	NC_IPMB_5VSB_SCL
A16	GND	B16	GND
A17	BP_I2C_5V_SDA	B17	NIC1_ACT_LED_L
A18	BP_I2C_5V_SCL	B18	NIC1_LINK_LED_R_L
A19	GND	B19	FP_PWR_BTN_L
A20	FP_NMI_BTN_L	B20	PWR_LED_5VSB
A21	GND	B21	HDD_LED_P3V3_A
A22	USB_DP2_FP	B22	GND
A23	USB_DN2_FP	B23	GND
A24	GND	B24	NIC2_ACT_LED_L
A25	GND	B25	NIC2_LINK_LED_R_L
A26	PWR_FP_USB2	B26	HDD_FAULT_LED_R_L
A27	PWR_FP_USB3	B27	HDD_LED_ACT_R_L
A28	GND	B28	FP_PWR_LED_R_L
A29	GND	B29	FP_SYS_FLT_LED2_R_L
A30	USB_DP3_FP	B30	GND
A31	USB_DN3_FP	B31	GND
A32	GND	B32	NC_RST_P6_PWRGOOD

8. Intel® Local Control Panel

The Intel® Local Control Panel utilizes a combination of control buttons, LEDs, and LCD display to provide system accessibility, monitoring, and control functions. The pre-assembled module slides into a slot on the front of the system where a card edge connector is blind mated to a matching slot edge connector on the backplane eliminating any cable attachments. The Intel® Local Control Panel module is designed so that it can be adjusted for use with or without an outer front bezel.

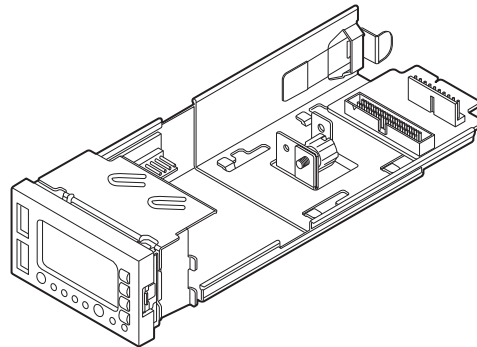

TP02113

Figure 43. Intel® Local Control Panel Assembly Module

The following diagram provides an overview of the control panel features.

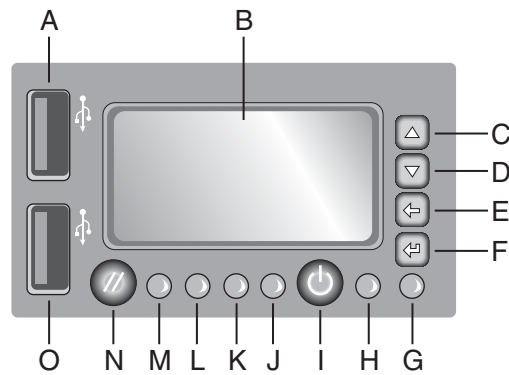

TP02099

A.	USB 1.1 Port	I.	System Power Button
B.	LCD Display	J.	System Status LED
C.	LCD Menu Control Button – Up	K.	NIC 2 Activity LED
D.	LCD Menu Control Button – Down	L.	NIC 1 Activity LED
E.	LCD Menu Control Button – Previous Option	M.	Hard Drive Activity LED
F.	LCD Menu Control Button – Enter	N.	System Reset Button
G.	ID LED	O.	USB 1.1 Port
H.	Power LED		

Figure 44. Intel® Local Control Panel Overview

8.1 LED Functionality

The following table identifies each LED and describes its functionality.

Table 53. Control Panel LED Functions

LED	Color	State	Description
NIC1 / NIC2 Activity	Green	On	NIC Link
	Green	Blink	NIC Activity
Power / Sleep (on standby power)	Green	On	Legacy power-on / ACPI S0 state
		Blink ^{1,4}	Sleep / ACPI S1 state
	Off	Off	Power-off / ACPI S4 or S5 state
System Status (on standby power)	Green	On	Running / normal operation
		Blink ^{1,2}	Degraded
	Amber	On	Critical or non-recoverable condition.
		Blink ^{1,2}	Non-critical condition.
	Off	Off	POST / system stop.
Disk Activity	Green	Random blink	Provides an indicator for disk activity.
	Off	Off ³	No hard disk activity
System Identification	Blue	On	Identify active via command or button.
	Off	Off	No Identification.

Notes:

1. Blink rate is ~1 Hz at 50% duty cycle.
2. The amber status takes precedence over the green status. When the amber LED is on or blinking, the green LED is off.
3. Off when the system is powered off (S4/S5) or in a sleep state (S1).
4. The power LED sleep indication is maintained on standby by the chipset. If the system is powered down without going through the BIOS, the LED state that is in effect at the time of power-off is restored when the system is powered on until the BIOS clears it. If the system is not powered down normally, it is possible that the Power LED is blinking while the system status LED is off. This is due to a failure or configuration change that prevents the BIOS from running.

The current limiting resistors for the power LED, the system fault LED, and the NIC LEDs are located on the Intel® Server Board S5520UR.

8.1.1 Power / Sleep LED

Table 54. SSI Power LED Operation

State	Power Mode	LED	Description
Power-off	Non-ACPI	Off	System power is off, and the BIOS has not initialized the chipset.
Power-on	Non-ACPI	On	System power is on, but the BIOS has not yet initialized the chipset.
S5	ACPI	Off	Mechanical is off, and the operating system has not saved any context to the hard disk.
S4	ACPI	Off	Mechanical is off, and the operating system has saved context to the hard disk.
S3-S1	ACPI	Slow blink ¹	DC power is still on, and the operating system has saved context and gone into a level of low-power state.
S0	ACPI	Steady on	System and the operating system are up and running.

Note:

1. Blink rate is ~ 1Hz at 50% duty cycle.

8.1.2 System Status LED

Table 55. Control Panel LED Operation

Color	State	Criticality	Description
Off	Not applicable	Not ready	AC power off
Green	Solid on	Ok	System booted and ready
Green	Blink	Degraded	<p>System degraded Including, but not limited to:</p> <ul style="list-style-type: none"> ▪ Unable to use all of the installed memory (more than one DIMM installed). ▪ Correctable errors over a threshold of 10 and migrating to a spare DIMM (memory sparing). This indicates that the user no longer has spare DIMMs indicating a redundancy lost condition. Corresponding DIMM LED should light up. ▪ In a mirrored configuration, when memory mirroring takes place and system loses memory redundancy. This is not covered by the second bullet above. ▪ Redundancy loss such as power supply or fan. This does not apply to non-redundant subsystems. ▪ PCI Express* link errors ▪ CPU failure / disabled – if there are two processors and one of them fails ▪ Fan alarm – Fan failure. Number of operational fans should be more than the minimum number needed to cool the system ▪ Non-critical threshold crossed – temperature and voltage

Color	State	Criticality	Description
Amber	Blink	Non-critical	Non-fatal alarm – system is likely to fail Including, but not limited to: <ul style="list-style-type: none"> ▪ Critical voltage threshold crossed ▪ VRD hot asserted ▪ Minimum number of fans necessary to cool the system are not present or have failed ▪ In non-sparing and non-mirroring mode if the threshold of ten correctable errors is crossed within the window
Amber	Solid on	Critical, non-recoverable	Fatal alarm – system has failed or shut down Including, but not limited to: <ul style="list-style-type: none"> ▪ DIMM failure when there is one DIMM present, no good memory present ▪ Run-time memory uncorrectable error in non-redundant mode ▪ IERR signal asserted ▪ Processor 1 missing ▪ Temperature (e.g., CPU ThermTrip, memory TempHi, critical threshold crossed) ▪ No power good – power fault ▪ Processor configuration error (e.g., processor stepping mismatch)

8.1.3 Drive Activity LED

The drive activity LED on the front panel indicates drive activity from the on-board hard disk controllers. The Intel® Server Board S5520UR also provides a header giving access to this LED for add-in controllers.

8.1.4 System Identification LED

The blue system identification LED is used to help identify a system for servicing. This is especially useful when the system is installed in a high-density rack or cabinet that is populated with several similar systems.

The blue system ID LED can be illuminated using one of the following mechanisms:

- By pressing the system ID button on the system control panel, the ID LED displays a solid blue color until the button is pressed again.
- By issuing the appropriate hex IPMI system identify value, the ID LED either blinks blue for 15 seconds and turns off or blinks indefinitely until the appropriate hex IPMI system identify value is issued to turn it off.

8.2 Intel® Local Control Panel Interconnects

The Intel® Local Control Panel module includes the control panel interface board and an interposer board. Connectors on the control panel interface board are cabled to matching connectors on the interposer board. When the pre-assembled control panel module is installed into the system, a card edge connector on the interposer card is blind mated with a slot edge connector on the backplane. This section defines the pin-out for each connector and header found on both the control panel interface board and interposer board.

- A 64-pin card edge connector on the interposer board is used to route signals to/from the backplane to the control panel interface board. The backplane is used as a conduit for communication to the server board.
- Signals from the card edge connector are routed to the control panel interface board through matching 50-pin connectors on the interposer board and control panel interface board. The 50-pin connectors are attached using a small 50-pin flat cable.
- USB signals from the card edge connector are routed to the control panel interface board through matching 10-pin connectors on the interposer board and control panel interface board. The 10-pin connectors are attached using a small 10-pin round cable.
- A 4-pin IPMI header (not used).
- A 4-pin NMI/Temp Sensor header.

The following tables provide the pin-outs for each connector.

Table 56. 50-pin Control Panel Connector

Pin	Signal Name	Pin	Signal Name
A1	GND	B1	1_WIRE_BUS
A2	VGA_VSYNC_FP_L	B2	P5V
A3	GND	B3	P5V
A4	VGA_HSYNC_FP_L	B4	P5V
A5	GND	B5	VGA_INUSE_L
A6	VGA_BLUE_FP	B6	GND
A7	GND	B7	P5V_STBY
A8	VGA_GREEN_FP	B8	GND
A9	GND	B9	FAULT_LED_5VSB
A10	VGA_RED_FP	B10	GND
A11	GND	B11	FP_SYS_FLT_LED1_R_L
A12	GND	B12	FP_ID_SW_L
A13	FP_RST_BTN_L	B13	FP_ID_LED_R_L
A14	GND	B14	NC_IPMB_5VSB_SDA
A15	NC_FP_CHASSIS_L	B15	NC_IPMB_5VSB_SCL
A16	GND	B16	GND
A17	BP_I2C_5V_SDA	B17	NIC1_ACT_LED_L
A18	BP_I2C_5V_SCL	B18	NIC1_LINK_LED_R_L
A19	GND	B19	FP_PWR_BTN_L
A20	FP_NMI_BTN_L	B20	PWR_LED_5VSB
A21	GND	B21	HDD_LED_P3V3_A
A22	USB_DP2_FP	B22	GND
A23	USB_DN2_FP	B23	GND

Pin	Signal Name	Pin	Signal Name
A24	GND	B24	NIC2_ACT_LED_L
A25	GND	B25	NIC2_LINK_LED_R_L
A26	PWR_FP_USB2	B26	HDD_FAULT_LED_R_L
A27	PWR_FP_USB3	B27	HDD_LED_ACT_R_L
A28	GND	B28	FP_PWR_LED_R_L
A29	GND	B29	FP_SYS_FLT_LED2_R_L
A30	USB_DP3_FP	B30	GND
A31	USB_DN3_FP	B31	GND
A32	GND	B32	NC_RST_P6_PWRGOOD

Table 57. Internal USB Header

Pin #	Description
1	PWR_FP_USB2
2	PWR_FP_USB3
3	USB_DP2_FP
4	USB_DN2_FP
5	USB_DP3_FP
6	USB_DN3_FP
7	GND
8	GND
9	TP_USB0_P9
10	TP_USB0_P10

9. PCI Riser Cards and Assembly

The system supports different riser card options depending on the add-in card configuration desired. The riser assembly for the system is tool-less. Standoffs on the bracket allow the riser cards to slide onto the assembly where a latching mechanism secures each riser in place. Holding down the latch releases the risers for easy removal.

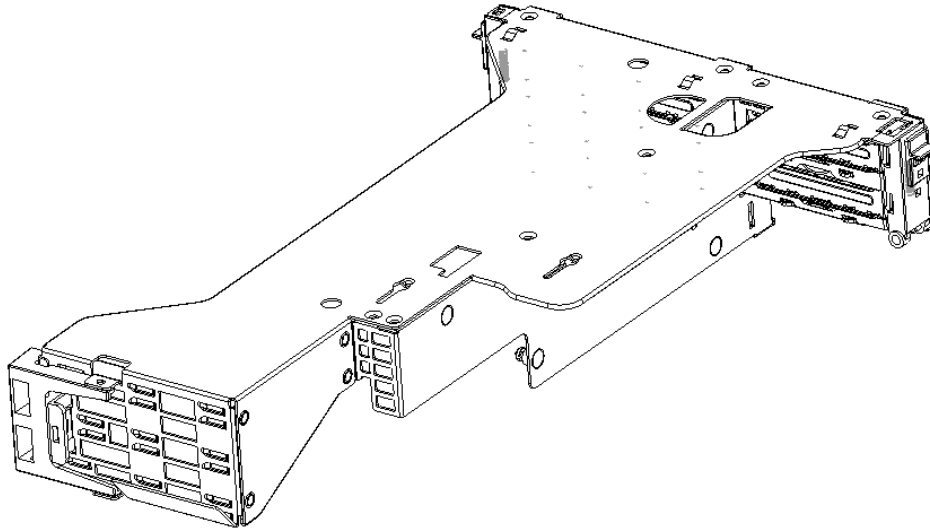

Figure 45. 2U Riser Assembly

When re-inserting the riser assembly into the system, tabs on the back of the assembly should be aligned with slots on the back edge of the system. The tabs fit into the slots securing the riser assembly to the system when the top cover is in place. For additional information, see the *Intel® Server System SR2600UR/SR2625UR Service Guide*.

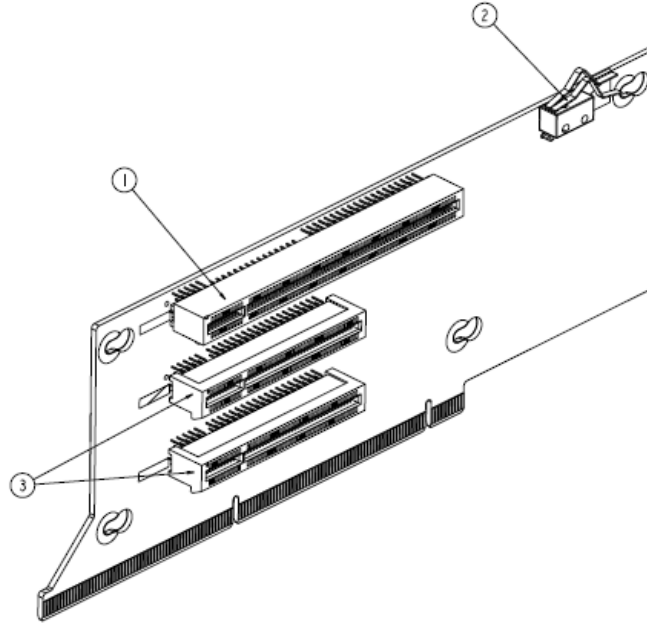

Figure 46. 2U PCI Express* Passive Riser

9.1 Riser Card Options

The Intel® Server Board S5520UR has one riser slot capable of supporting riser cards for both 1U and 2U system configurations. The riser slot (J4E1) implements Intel® Adaptive Slot Technology. This 280-pin connector is capable of supporting riser cards that meet either the PCI-X or PCI Express* technology specifications. Some risers can support both full-height and low-profile add-in cards by using a 'butterfly' configuration.

The following table identifies the card configurations and the connector types used.

Table 58. Riser Card Options

Riser Card Option	Slot Configuration
2U PCI Express* Passive Riser (Product Order Code – ASR26XXFHR)	Three full-height PCI Express* connectors
2U Butterfly PCI Express*/PCI-X Active Riser (Product Order Code – ASR26XXFHXR)	Two full-height PCI-X 133 connectors One full-height PCI Express* connector Two low-profile PCI Express* connectors
2U Butterfly PCI Express* Active Riser (Product Order Code – ASR26XXFHLPR)	Three full-height PCI Express* connectors Two low-profile PCI Express* connectors
2U PCI-X Active Riser (Product Order Code – ASR26XX____)	One Full Height PCI-X 133Mhz connector Two Full Height PCI-X 100Mhz connectors

Note: All PCI Express* add-in cards run at x8 speeds independent of population. The PCI Express* x16 connectors utilize a x8 electrical connection.

9.2 PCI Riser Card Mechanical Drawings

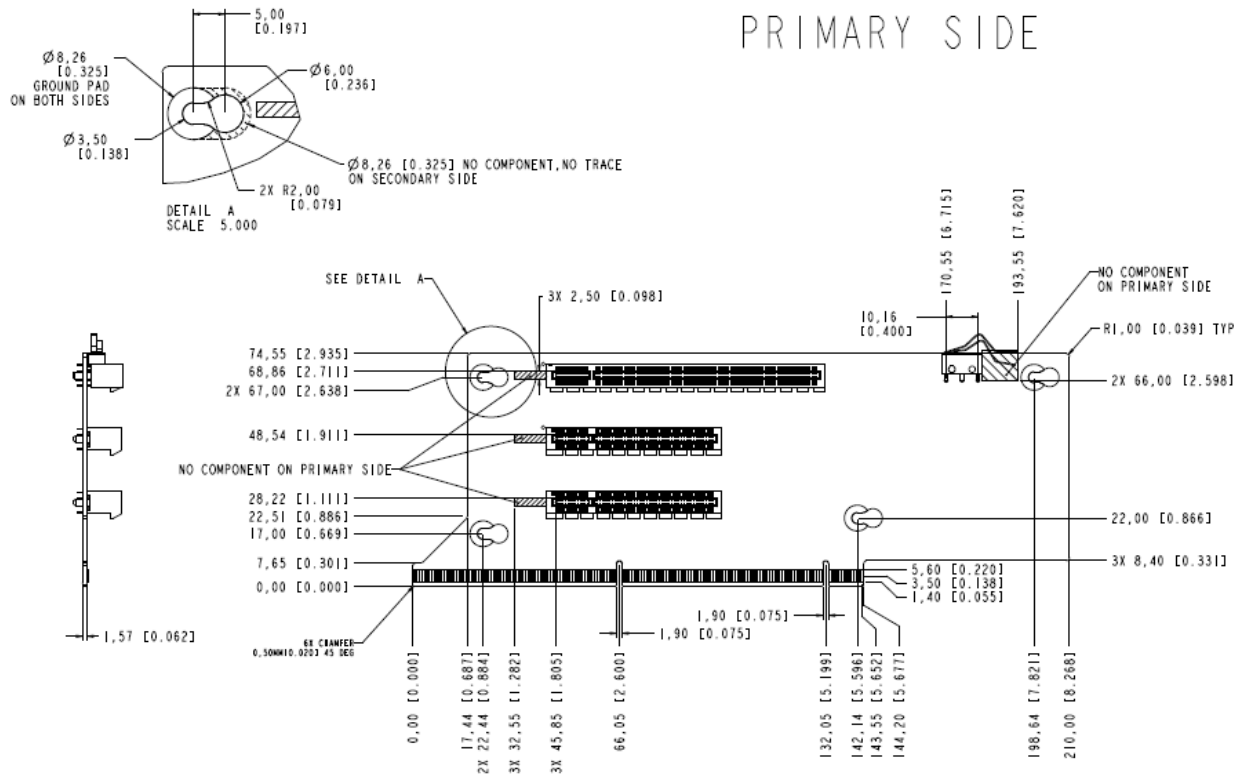

Figure 47. 2U PCI Express* Passive Riser – Primary Side

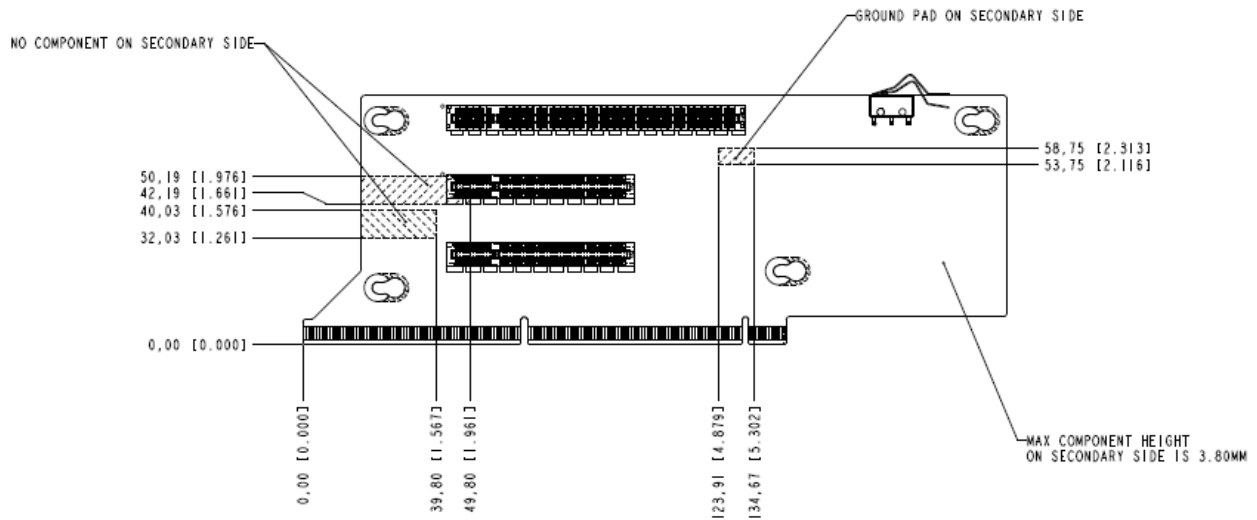

Figure 48. 2U PCI Express* Passive Riser – Secondary Side

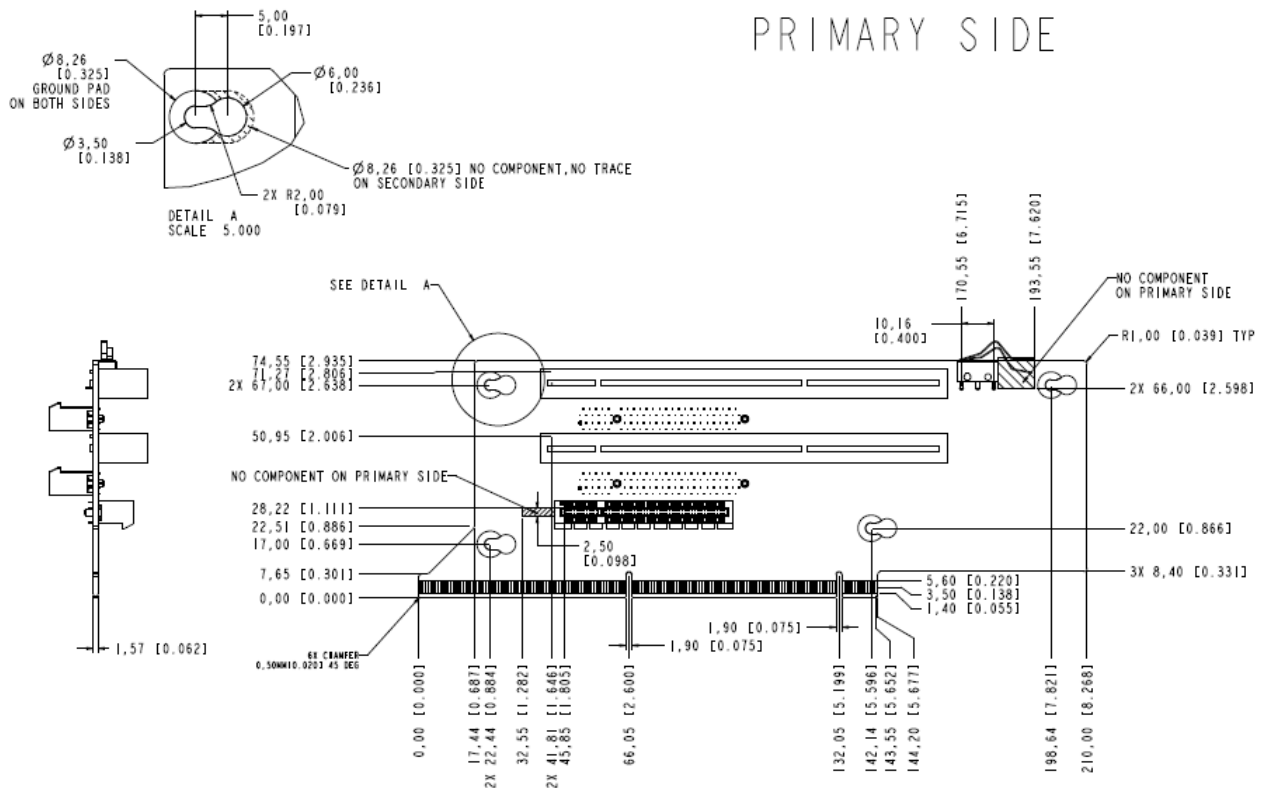

Figure 49. 2U Butterfly PCI-X/PCI Express* Active Riser – Primary Side

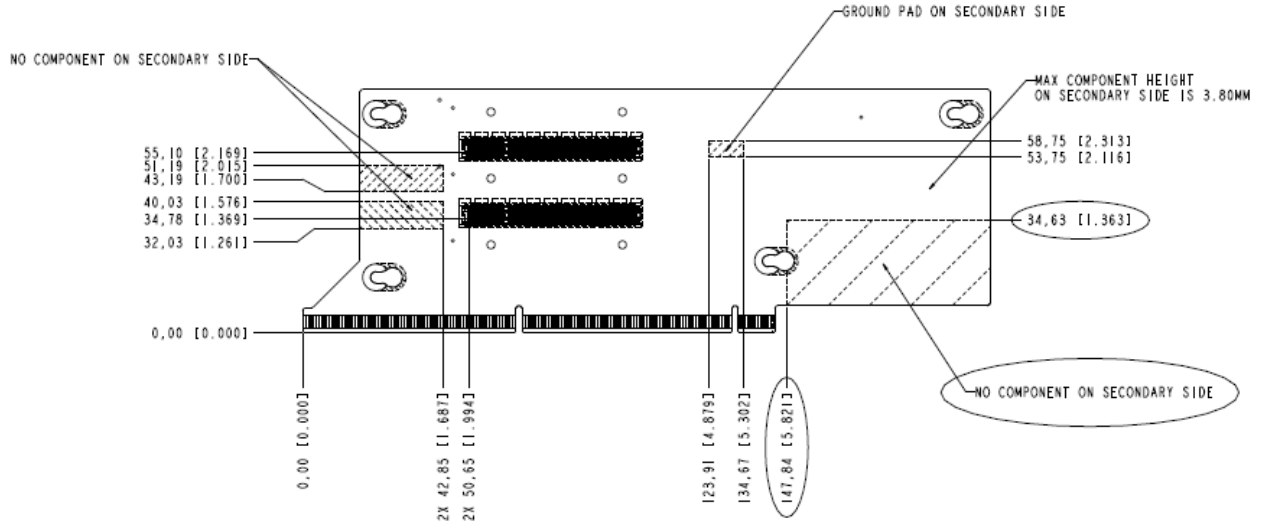

Figure 50. 2U Butterfly PCI-X/PCI Express* Active Riser – Secondary Side

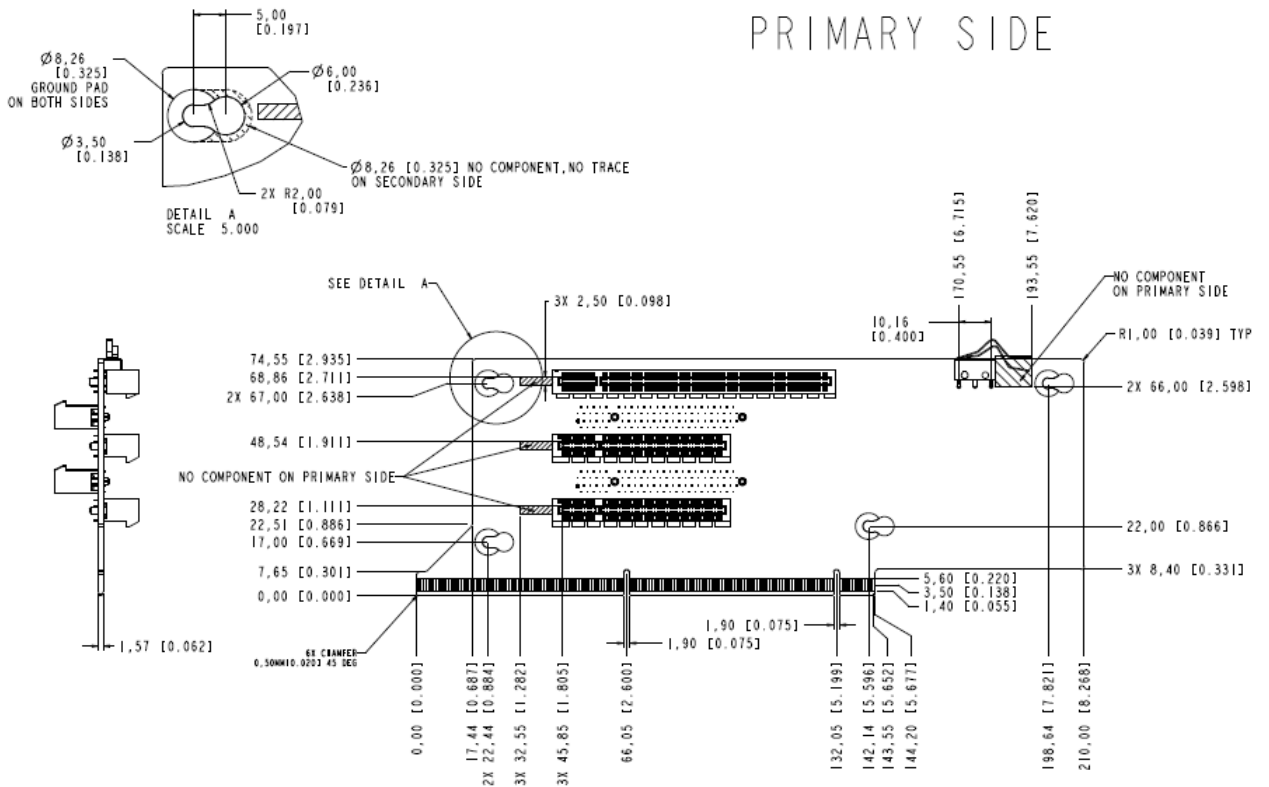

Figure 51. 2U Butterfly PCI Express* Active Riser – Primary Side

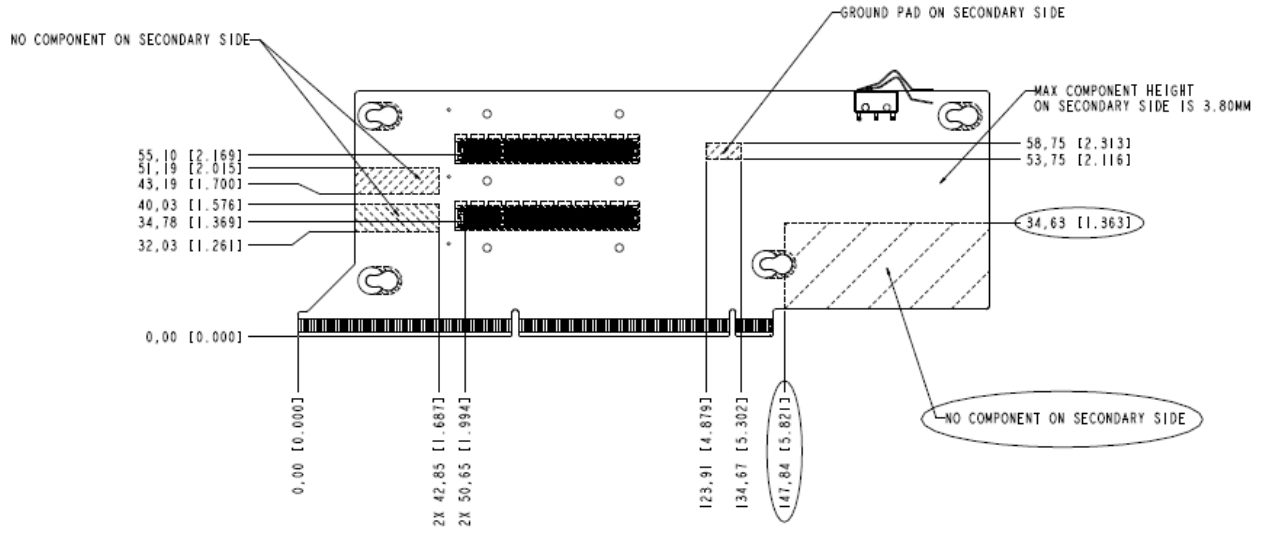

Figure 52. 2U Butterfly PCI Express* Active Riser – Secondary Side

10. Environmental Specifications

10.1 System Level Environmental Limits

The following table defines the system level operating and non-operating environmental limits.

Table 59. System Environmental Limits Summary

Parameter	Limits
Operating Temperature	+10°C to +35°C with the maximum rate of change not to exceed 10°C per hour
Non-Operating Temperature	-40°C to +70°C
Non-Operating Humidity	90%, non-condensing at 35°C
Acoustic noise	Sound power: 7.0 BA in an idle state at typical office ambient temperature. (23 +/- 2 degrees C)
Shock, operating	Half sine, 2 g peak, 11 milliseconds
Shock, unpackaged	Trapezoidal, 25 g, velocity change 136 inches/second (≥ 40 lbs to < 80 lbs)
Shock, packaged	Non-palletized free fall in height 24 inches (≥ 40 lbs to < 80 lbs)
Vibration, unpackaged	5 Hz to 500 Hz, 2.20 g RMS random
Shock, operating	Half sine, 2 g peak, 11 milliseconds
ESD	+/- 15 KV except I/O port +/- 8 KV per Intel® Environmental test specification
System Cooling Requirement in BTU/Hr	2550 BTU/hour

10.2 Serviceability and Availability

The system is designed to be serviced by qualified technical personnel only.

The desired Mean Time To Repair (MTTR) of the system is 30 minutes, including diagnosis of the system problem. To meet this goal, the system enclosure and hardware have been designed to minimize the MTTR.

The following table defines the maximum time needed by a trained field service technician to perform the listed system maintenance procedures, after diagnosing the system and identifying the failed component.

Table 60. Time Estimate for System Maintenance Procedures

Activity	Time Estimate
Remove cover	1 min
Remove and replace hard disk drive	2 min
Remove and replace power supply module	1 min
Remove and replace system fan	2 min
Remove and replace backplane board	6 min
Remove and replace control panel module	1 min
Remove and replace server board	8 min

10.3 Replacing the Backup Battery

The lithium battery on the server board powers the real time clock (RTC) for up to 10 years in the absence of power. When the battery starts to weaken, it loses voltage, and the server settings stored in CMOS RAM in the RTC (e.g., the date and time) may be wrong. Contact your customer service representative or dealer for a list of approved devices.



WARNING

Danger of explosion if battery is incorrectly replaced. Replace only with the same or equivalent type recommended by the equipment manufacturer. Discard used batteries according to manufacturer's instructions.



ADVARSEL!

Lithiumbatteri - Eksplosionsfare ved fejlagtig håndtering. Udskiftning må kun ske med batteri af samme fabrikat og type. Levér det brugte batteri tilbage til leverandøren.



ADVARSEL

Lithiumbatteri - Eksplosjonsfare. Ved utskifting benyttes kun batteri som anbefalt av apparatfabrikanten. Brukt batteri returneres apparatleverandøren.



WARNING

Explosionsfara vid felaktigt batteribyte. Använd samma batterityp eller en ekvivalent typ som rekommenderas av apparattillverkaren. Kassera använt batteri enligt fabrikantens instruktion.



VAROITUS

Paristo voi räjähtää, jos se on virheellisesti asennettu. Vaihda paristo ainoastaan laitevalmistajan suosittelemaan tyyppiin. Hävitä käytetty paristo valmistajan ohjeiden mukaisesti.

11. Regulatory and Certification Information



WARNING

To ensure regulatory compliance, you must adhere to the assembly instructions in this document to ensure and maintain compliance with existing product certifications and approvals. Use only the described, regulated components specified in this document. Use of other products / components will void the UL listing and other regulatory approvals of the product and will most likely result in noncompliance with product regulations in the region(s) in which the product is sold.

To help ensure EMC compliance with your local regional rules and regulations, before computer integration, make sure that the chassis, power supply, and other modules have passed EMC testing using a server board with a microprocessor from the same family (or higher) and operating at the same (or higher) speed as the microprocessor used on this server board. The final configuration of your end system product may require additional EMC compliance testing. For more information please contact your local Intel Representative.

This is an FCC Class A device. Integration of it into a Class B chassis does not result in a Class B device.

11.1 Product Regulatory Compliance

The server chassis product, when correctly integrated per this document, complies with the following safety and electromagnetic compatibility (EMC) regulations.

Intended Application – This product was evaluated as Information Technology Equipment (ITE), which may be installed in offices, schools, computer rooms, and similar commercial type locations. The suitability of this product for other product categories and environments (such as medical, industrial, telecommunications, NEBS, residential, alarm systems, test equipment, etc.), other than an ITE application, may require further evaluation.

11.1.1 Product Safety Compliance

- UL60950 – CSA 60950(USA / Canada)
- EN60950 (Europe)
- IEC60950 (International)
- CB Certificate & Report, IEC60950 (report to include all country national deviations)
- GS Certification (Germany)
- GOST R 50377-92 - Certification (Russia)
- Belarus Certification (Belarus)
- Ukraine Certification (Ukraine)
- CE - Low Voltage Directive 73/23/EEE (Europe)
- IRAM Certification (Argentina)
- GB4943- CNCA Certification (China)

11.1.2 Product EMC Compliance – Class A Compliance

- FCC /ICES-003 - Emissions (USA/Canada) Verification
- CISPR 22 – Emissions (International)
- EN55022 - Emissions (Europe)
- EN55024 - Immunity (Europe)
- EN61000-3-2 - Harmonics (Europe)
- EN61000-3-3 - Voltage Flicker (Europe)
- CE – EMC Directive 89/336/EEC (Europe)
- VCCI Emissions (Japan)
- AS/NZS 3548 Emissions (Australia / New Zealand)
- BSMI CNS13438 Emissions (Taiwan)
- GOST R 29216-91 Emissions (Russia)
- GOST R 50628-95 Immunity (Russia)
- Belarus Certification (Belarus)
- Ukraine Certification (Ukraine)
- KCC Certification (EMI) (Korea)
- GB 9254 - CNCA Certification (China)
- GB 17625 - (Harmonics) CNCA Certification (China)

11.1.3 Product Ecology Compliance

Intel has a system in place to restrict the use of banned substances in accordance with world wide regulatory requirements. A Material Declaration Data Sheet is available for Intel products. For more reference on material restrictions and compliance you can view Intel's Environmental Product Content Specification at <http://supplier.intel.com/ehs/environmental.htm>.

- Europe - European Directive 2002/95/EC - Restriction of Hazardous Substances (RoHS) Threshold limits and banned substances are noted below.
Quantity limit of 0.1% by mass (1000 PPM) for:
Lead, Mercury, Hexavalent Chromium, Polybrominated Biphenyls Diphenyl Ethers (PBB/PBDE)
Quantity limit of 0.01% by mass (100 PPM) for:
Cadmium
- California Code of Regulations, Title 22, Division 4.5, Chapter 33: Best Management Practices for Perchlorate Materials
- China – Restriction of Hazardous Substances (China RoHS)
- WEEE Directive (Europe)
- Packaging Directive (Europe)





11.1.4 Certifications / Registrations / Declarations











- NRTL Certification (US/Canada)
- CE Declaration of Conformity (CENELEC Europe)
- FCC/ICES-003 Class A Attestation (USA/Canada)
- VCCI Certification (Japan)

- C-Tick Declaration of Conformity (Australia)
- MED Declaration of Conformity (New Zealand)
- BSMI Certification (Taiwan)
- GOST R Certification / Certification (Russia)
- Belarus Certification / Certification (Belarus)
- KCC Certification (Korea)
- IRAM Certification (Argentina)
- CNCA CCC Certification (China)
- Ecology Declaration (International)
- China RoHS Environmental Friendly Use Period
- Packaging & Product Recycling Marks

11.2 Product Regulatory Compliance Markings

This Intel Server Chassis product is provided with the following regulatory and safety markings. In the event there is no room for a marking(s) on the chassis, the information is provided here in this document.

Regulatory Compliance	Country	Marking
cULus Listing Marks	USA/Canada	
GS Mark	Germany	
CE Mark	Europe	
FCC Marking (Class A)	USA	This device complies with Part 15 of the FCC Rules. Operation of this device is subject to the following two conditions: (1) This device may not cause harmful interference, and (2) This device must accept any interference received, including interference that may cause undesired operation. Manufactured by Intel Corporation
EMC Marking (Class A)	Canada	CANADA ICES-003 CLASS A CANADA NMB-003 CLASSE A
VCCI Marking (Class A)	Japan	この装置は、クラス A 情報技術装置です。この装置を家庭環境で使用すると電波妨害を引き起こすことがあります。この場合には使用者が適切な対策を講ずるよう要求されることがあります。VCCI-A
BSMI Certification Number & Class A Warning	Taiwan	

Regulatory Compliance	Country	Marking	
		<div style="border: 1px solid black; padding: 5px;"> <p>警告使用者： 這是甲類的資訊產品，在居住的環境中使用時，可能會造成射頻干擾，在這種情況下，使用者會被要求採取某些適當的對策</p> </div>	
GOST R Marking	Russia		
KCC Mark (Korean Communications Comission)	Korea		
China Compulsory Certification Mark	China		
Belarus Safety Compliance Mark	Belarus		
Waste of Electronic and Electrical Equipment Recycling Mark	Europe		
China Restriction of Hazardous Substance Environmental Friendly Use Period Mark	China		
China Recycling Mark	China		
Recycling Marks	International		
Battery Perchlorate Warning Information	California	<p>Perchlorate Material – Special handling may apply. See www.dtsc.ca.gov/hazardouswaste/perchlorate This notice is required by California Code of Regulations, Title 22, Division 4.5, and Chapter 33: Best Management Practices for Perchlorate Materials. This product may include a battery which contains Perchlorate material.</p>	
Safety	Multiple Power Cord Marking	 <p>This unit has more than one power supply cord. To reduce the risk</p>	

Regulatory Compliance	Country	Marking
		<p>of electrical shock, disconnect (2) two power supply cords before servicing.</p> <p>Simplified Chinese: 注意： 本设备包括多条电源系统电缆。为避免遭受电击，在进行维修之前应断开两（2）条电源系统电缆。</p> <p>Traditional Chinese: 注意： 本設備包括多條電源系統電纜。為避免遭受電擊，在進行維修之前應斷開兩（2）條電源系統電纜。</p> <p>German: Dieses Geräte hat mehr als ein Stromkabel. Um eine Gefahr des elektrischen Schlages zu verringern trennen sie beide (2) Stromkabeln bevor Instandhaltung.</p>
Nordic Countries	Connection to Proper Ground Outlet	<p>“WARNING:” “Apparaten skall anslutas till jordat uttag, när den ansluts till ett nätverk.” “Laite on liitettävä suojamaadoituskoskettimilla varustettuun pistorasiaan.” “Connect only to a properly earth grounded outlet.”</p>
Safety	Stand-by power	

11.3 Rack Mount Installation Guidelines

Anchor the equipment rack: The equipment rack must be anchored to an unmovable support to prevent it from falling over when one or more servers are extended in front of the rack on slides. You must also consider the weight of any other device installed in the rack. A crush hazard exists should the rack tilt forward which could cause serious injury.

Temperature: The temperature, in which the server operates when installed in an equipment rack, must not go below 5 °C (41 °F) or rise above 40 °C (104 °F). Extreme fluctuations in temperature can cause a variety of problems in your server.

Ventilation: The equipment rack must provide sufficient airflow to the front of the server to maintain proper cooling. The rack must also include ventilation sufficient to exhaust a maximum of 1023 BTU's (British Thermal Units) per hour for the server. The rack selected and the ventilation provided must be suitable to the environment in which the server will be used.

If AC power supplies are installed:

Mains AC power disconnection: The AC power cord(s) is considered the mains disconnect for the server and must be readily accessible when installed. If the individual server power cord(s) will not be readily accessible for disconnection then you are responsible for installing an AC power disconnect for the entire rack unit. This main disconnect must be readily accessible, and it must be labeled as controlling power to the entire rack, not just to the server(s).

Grounding the rack installation: To avoid the potential for an electrical shock hazard, you must include a third wire safety ground conductor with the rack installation. If the server power cord is plugged into an AC outlet that is part of the rack, then you must provide proper grounding for the rack itself. If the server power cord is plugged into a wall AC outlet, the safety ground conductor in the power cord provides proper grounding only for the server. You must provide additional, proper grounding for the rack and other devices installed in it.

Overcurrent protection: The server is designed for an AC line voltage source with up to 20 amperes of overcurrent protection per cord feed. If the power system for the equipment rack is installed on a branch circuit with more than 20 amperes of protection, you must provide supplemental protection for the server.

If DC power supplies are installed:

Connection with a DC (Direct Current) source should only be performed by trained service personnel. The server with DC input is to be installed in a Restricted Access Location in accordance with articles 110-16, 110-17, and 110-18 of the National Electric Code, ANSI/NFPA 70. The DC source must be electrically isolated by double or reinforced insulation from any hazardous AC source.

Main DC power disconnect: You are responsible for installing a properly rated DC power disconnect for the server system. This mains disconnect must be readily accessible, and it must be labeled as controlling power to the server. The circuit breaker of a centralized DC power system may be used as a disconnect device when easily accessible and should be rated no more than 10 amps.

Grounding the server: To avoid the potential for an electrical shock hazard, you must reliably connect an earth grounding conductor to the server. The earth grounding conductor must be a minimum 18AWG connected to the earth ground stud(s) on the rear of the server. The safety ground conductor should be connected to the chassis stud with a Listed closed two-hole crimp terminal having 5/8 inch pitch. The nuts on the chassis earth ground studs should be installed with a 10 in/lbs torque. The safety ground conductor provides proper grounding only for the server. You must provide additional, proper grounding for the rack and other devices installed in it.

Overcurrent protection: Overcurrent protection circuit breakers must be provided as part of each host equipment rack and must be incorporated in the field wiring between the DC source and the server. The branch circuit protection shall be rated minimum 75Vdc, 10 A maximum per feed pair. If the DC power system for the equipment rack is installed with more than 10 amperes of protection, you must provide supplemental protection for the server.

11.4 Power Cord Usage Guidelines



WARNING

Do not attempt to modify or use an AC power cord set that is not the exact type required. You must use a power cord set that meets the following criteria:

- Rating: In the U.S. and Canada, cords must be UL (Underwriters Laboratories, Inc.) Listed/CSA (Canadian Standards Organization) Certified type SJT, 18-3 AWG (American Wire Gauge). Outside of the U.S. and Canada, cords must be flexible harmonized (<HAR>) or VDE (Verband Deutscher Elektrotechniker, German Institute of Electrical Engineers) certified cord with 3 x 0.75 mm conductors rated 250 VAC (Volts Alternating Current).
- Connector, wall outlet end: Cords must be terminated in grounding-type male plug designed for use in your region. The connector must have certification marks showing certification by an agency acceptable in your region and for U.S. must be Listed and rated 125% of overall current rating of the server.
- Connector, server end: The connectors that plug into the AC receptacle on the server must be an approved IEC (International Electrotechnical Commission) 320, sheet C13, type female connector.
- Cord length and flexibility: Cords must be less than 4.5 meters (14.76 feet) long.

11.5 Electromagnetic Compatibility Notices

11.5.1 FCC Verification Statement (USA)

This device complies with Part 15 of the FCC Rules. Operation is subject to the following two conditions: (1) This device may not cause harmful interference, and (2) this device must accept any interference received, including interference that may cause undesired operation.

*Intel Corporation
5200 N.E. Elam Young Parkway
Hillsboro, OR 97124-6497
1-800-628-8686*

This equipment has been tested and found to comply with the limits for a Class A digital device, pursuant to Part 15 of the FCC Rules. These limits are designed to provide reasonable protection against harmful interference in a residential installation. This equipment generates, uses, and can radiate radio frequency energy and, if not installed and used in accordance with the instructions, may cause harmful interference to radio communications. However, there is no guarantee that interference will not occur in a particular installation. If this equipment does cause harmful interference to radio or television reception, which can be determined by turning the equipment off and on, the user is encouraged to try to correct the interference by one or more of the following measures:

- Reorient or relocate the receiving antenna.
- Increase the separation between the equipment and the receiver.
- Connect the equipment into an outlet on a circuit different from that to which the receiver is connected.
- Consult the dealer or an experienced radio/TV technician for help.

Any changes or modifications not expressly approved by the grantee of this device could void the user's authority to operate the equipment. The customer is responsible for ensuring compliance of the modified product.

Only peripherals (computer input/output devices, terminals, printers, etc.) that comply with FCC Class A or B limits may be attached to this computer product. Operation with noncompliant peripherals is likely to result in interference to radio and TV reception.

All cables used to connect to peripherals must be shielded and grounded. Operation with cables, connected to peripherals that are not shielded and grounded may result in interference to radio and TV reception.

11.5.2 ICES-003 (Canada)

Cet appareil numérique respecte les limites bruits radioélectriques applicables aux appareils numériques de Classe Aprescrites dans la norme sur le matériel brouilleur: "Appareils Numériques", NMB-003 édictée par le Ministre Canadian des Communications.

English translation of the notice above:

This digital apparatus does not exceed the Class A limits for radio noise emissions from digital apparatus set out in the interference-causing equipment standard entitled "Digital Apparatus," ICES-003 of the Canadian Department of Communications.

11.5.3 Europe (CE Declaration of Conformity)

This product has been tested in accordance too, and complies with the Low Voltage Directive (73/23/EEC) and EMC Directive (89/336/EEC). The product has been marked with the CE Mark to illustrate its compliance.

11.5.4 VCCI (Japan)

この装置は、情報処理装置等電波障害自主規制協議会（VCCI）の基準に基づくクラス A 情報技術装置です。この装置を家庭環境で使用すると電波妨害を引き起こすことがあります。この場合には使用者が適切な対策を講ずるよう要求されることがあります。

English translation of the notice above:

This is a Class A product based on the standard of the Voluntary Control Council for Interference (VCCI) from Information Technology Equipment. If this is used near a radio or television receiver in a domestic environment, it may cause radio interference. Install and use the equipment according to the instruction manual.

11.5.5 BSMI (Taiwan)

The BSMI Certification Marking and EMC warning is located on the outside rear area of the product.

警告使用者：
 這是甲類的資訊產品，在居住的環境中使用時，可能會造成射頻干擾，在這種情況下，使用者會被要求採取某些適當的對策

11.5.6 KCC (Korea)

Following is the KCC certification information for Korea.



1. 기기의 명칭(모델명) :
2. 인증번호 :
3. 인증받은 자의 상호 :
4. 제조년월일 :
5. 제조자/제조국가 :

English translation of the notice above:

1. Type of Equipment (Model Name): On Certification and Product
2. Certification No.: On KCC certificate. Obtain certificate from local Intel representative
3. Name of Certification Recipient: Intel Corporation
4. Date of Manufacturer: Refer to date code on product
5. Manufacturer/Nation: Intel Corporation/Refer to country of origin marked on product

11.6 Regulated Specified Components

To maintain the UL listing and compliance to other regulatory certifications and/or declarations, the following regulated components must be used and conditions adhered to. Interchanging or use of other component will void the UL listing and other product certifications and approvals.

Updated product information for configurations can be found on the Intel Server Builder Web site at the following URL:

<http://channel.intel.com/go/serverbuilder>

If you do not have access to Intel's Web address, please contact your local Intel representative.

- **Server chassis** (base chassis is provided with power supply and fans) — UL listed.
- **Server board** — you must use an Intel server board — UL recognized.
- **Add-in boards** — must have a printed wiring board flammability rating of minimum UL94V-1. Add-in boards containing external power connectors and/or lithium batteries must be UL recognized or UL listed. Any add-in board containing modem telecommunication circuitry must be UL listed. In addition, the modem must have the appropriate telecommunications, safety, and EMC approvals for the region in which it is sold.
- **Peripheral Storage Devices** — must be UL recognized or UL listed accessory and TUV or VDE licensed. Maximum power rating of any one device or combination of devices cannot exceed manufacturer's specifications. Total server configuration is not to exceed the maximum loading conditions of the power supply.

Appendix A: Integration and Usage Tips

This section provides a list of useful information that is unique to the Intel® Server System SR2600UR and should be kept in mind while integrating and configuring your Intel® Server Board S5520UR.

- Only low-profile (1.2 in or 30.48 mm) DIMMs can be used in the server system.
- Processor fans are not supported and are not needed in the server system. The system fan module and power supply fans provide the necessary cooling needed for the system. Using a processor fan in this system may cause Intel® System Management Software to incorrectly monitor the system fans.
- The CPU air duct and air baffle must be used to maintain system thermals.
- To maintain system thermals, all hard drive bays must be populated with either a hard drive or drive blank.
- System fans are not hot-swappable
- Use of the screw found on the front edge of the top cover is required when the unit is installed in a user accessible environment.
- A USB Floppy support kit (Product Order Code – AXXUSBFLOPPY) is available for installing a slimline USB floppy drive in either the slimline bay or in the first 3.5-inch hard drive bay.
- The FRUSDR utility must be run to load the proper Sensor Data Records for the server chassis onto the server board.
- Make sure the latest system software is loaded on the server. This includes system BIOS, FRUSDR, Integrated BMC firmware, and hot-swap controller firmware. The latest system software can be downloaded from <http://support.intel.com/support/motherboards/server/s5520ur/>

Appendix B: POST Code Diagnostic LED Decoder

During the system boot process, the BIOS executes a number of platform configuration processes, each of which is assigned a specific hex POST code number. As each configuration routine is started, the BIOS displays the POST code to the POST Code Diagnostic LEDs on the back edge of the server board. To assist in troubleshooting a system hang during the POST process, the Diagnostic LEDs can be used to identify the last POST process that was executed.

Each POST code is represented by eight amber Diagnostic LEDs. The POST codes are divided into two nibbles, an upper nibble and a lower nibble. The upper nibble bits are represented by Diagnostic LEDs #4, #5, #6, #7. The lower nibble bits are represented by Diagnostics LEDs #0, #1, #2 and #3. If the bit is set in the upper and lower nibbles, the corresponding LED is lit. If the bit is clear, the corresponding LED is off.

The Diagnostic LED #7 is labeled as “MSB”, and the Diagnostic LED #0 is labeled as “LSB”.

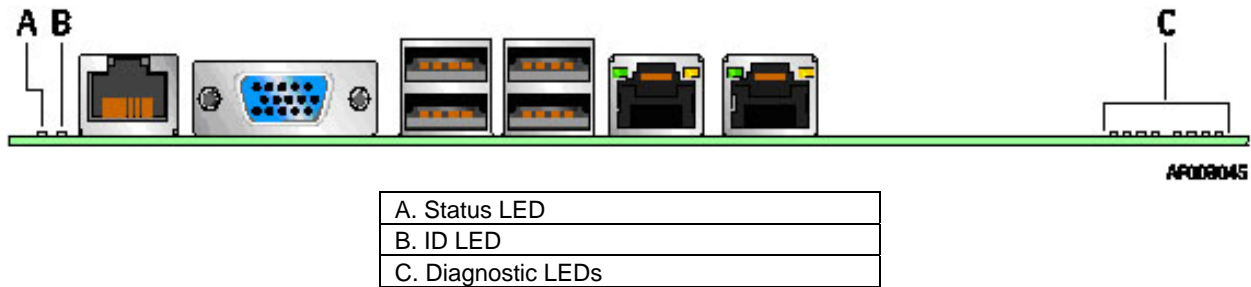

Figure 53. Diagnostic LED Placement Diagram

In the following example, the BIOS sends a value of ACh to the diagnostic LED decoder. The LEDs are decoded as follows:

Table 61. POST Progress Code LED Example

LEDs	Upper Nibble LEDs				Lower Nibble LEDs			
	MSB							LSB
	LED #7	LED #6	LED #5	LED #4	LED #3	LED #2	LED #1	LED #0
	8h	4h	2h	1h	8h	4h	2h	1h
Status	ON	OFF	ON	OFF	ON	OFF	ON	OFF
Results	1	0	1	0	1	1	0	0
	Ah				Ch			

- Upper nibble bits = 1010b = Ah; Lower nibble bits = 1100b = Ch; the two are concatenated as ACh.

Table 62. Diagnostic LED POST Code Decoder

Checkpoint	Diagnostic LED Decoder								Description
	O = On, X=Off								
	Upper Nibble				Lower Nibble				
	MSB							LSB	
LED	8h	4h	2h	1h	8h	4h	2h	1h	
	#7	#6	#5	#4	#3	#2	#1	#0	
Multi-use code (This POST Code is used in different contexts)									
0xF2h	O	O	O	O	X	X	O	X	Seen at the start of Memory Reference Code (MRC) Start of the very early platform initialization code Very late in POST, it is the signal that the OS has switched to virtual memory mode
Memory Error Codes (Accompanied by a beep code)									
0xE8h	O	O	O	X	O	X	X	X	No Usable Memory Error: No memory in the system, or SPD bad so no memory could be detected
0xEAh	O	O	O	X	O	X	O	X	Channel Training Error: DQ/DQS training failed on a channel during memory channel initialization.
0xEBh	O	O	O	X	O	X	O	O	Memory Test Error: memory failed Hardware BIST.
0xEDh	O	O	O	X	O	O	X	O	Population Error: RDIMMs and UDIMMs cannot be mixed in the system
0xEEh	O	O	O	X	O	O	O	X	Mismatch Error: more than 2 Quad Ranked DIMMS in a channel.
Memory Reference Code Progress Codes (Not accompanied by a beep code)									
0xB0h	O	X	O	O	X	X	X	X	Chipset Initialization Phase
0xB1h	O	X	O	O	X	X	X	O	Reset Phase
0xB2h	O	X	O	O	X	X	O	X	DIMM Detection Phase
0xB3h	O	X	O	O	X	X	O	O	Clock Initialization Phase
0xB4h	O	X	O	O	X	O	X	X	SPD Data Collection Phase
0xB6h	O	X	O	O	X	O	O	X	Rank Formation Phase
0xB8h	O	X	O	O	O	X	X	X	Channel Training Phase
0xB9h	O	X	O	O	O	X	X	O	Memory Test Phase
0xBAh	O	X	O	O	O	X	O	X	Memory Map Creation Phase
0xBBh	O	X	O	O	O	X	O	O	RAS Initialization Phase
0xBFh	O	X	O	O	O	O	O	O	MRC Complete
Host Processor									
0x04h	X	X	X	X	X	O	X	X	Early processor initialization where system BSP is selected
0x10h	X	X	X	O	X	X	X	X	Power-on initialization of the host processor (bootstrap processor)
0x11h	X	X	X	O	X	X	X	O	Host processor cache initialization (including AP)
0x12h	X	X	X	O	X	X	O	X	Starting application processor initialization
0x13h	X	X	X	O	X	X	O	O	SMM initialization
Chipset									
0x21h	X	X	O	X	X	X	X	O	Initializing a chipset component
Memory									
0x22h	X	X	O	X	X	X	O	X	Reading configuration data from memory (SPD on DIMM)
0x23h	X	X	O	X	X	X	O	O	Detecting presence of memory
0x24h	X	X	O	X	X	O	X	X	Programming timing parameters in the memory controller
0x25h	X	X	O	X	X	O	X	O	Configuring memory parameters in the memory controller
0x26h	X	X	O	X	X	O	O	X	Optimizing memory controller settings
0x27h	X	X	O	X	X	O	O	O	Initializing memory, such as ECC init
0x28h	X	X	O	X	O	X	X	X	Testing memory
PCI Bus									
0x50h	X	O	X	O	X	X	X	X	Enumerating PCI busses
0x51h	X	O	X	O	X	X	X	O	Allocating resources to PCI busses
0x52h	X	O	X	O	X	X	O	X	Hot Plug PCI controller initialization
0x53h	X	O	X	O	X	X	O	O	Reserved for PCI bus
0x54h	X	O	X	O	X	O	X	X	Reserved for PCI bus
0x55h	X	O	X	O	X	O	X	O	Reserved for PCI bus

Checkpoint	Diagnostic LED Decoder								Description
	O = On, X=Off								
	Upper Nibble				Lower Nibble				
	MSB							LSB	
LED	8h	4h	2h	1h	8h	4h	2h	1h	
	#7	#6	#5	#4	#3	#2	#1	#0	
0x56h	X	O	X	O	X	O	O	X	Reserved for PCI bus
0x57h	X	O	X	O	X	O	O	O	Reserved for PCI bus
USB									
0x58h	X	O	X	O	O	X	X	X	Resetting USB bus
0x59h	X	O	X	O	O	X	X	O	Reserved for USB devices
ATA/ATAPI/SATA									
0x5Ah	X	O	X	O	O	X	O	X	Resetting SATA bus and all devices
0x5Bh	X	O	X	O	O	X	O	O	Reserved for ATA
SMBUS									
0x5Ch	X	O	X	O	O	O	X	X	Resetting SMBUS
0x5Dh	X	O	X	O	O	O	X	O	Reserved for SMBUS
Local Console									
0x70h	X	O	O	O	X	X	X	X	Resetting the video controller (VGA)
0x71h	X	O	O	O	X	X	X	O	Disabling the video controller (VGA)
0x72h	X	O	O	O	X	X	O	X	Enabling the video controller (VGA)
Remote Console									
0x78h	X	O	O	O	O	X	X	X	Resetting the console controller
0x79h	X	O	O	O	O	X	X	O	Disabling the console controller
0x7Ah	X	O	O	O	O	X	O	X	Enabling the console controller
Keyboard (only USB)									
0x90h	O	X	X	O	X	X	X	X	Resetting the keyboard
0x91h	O	X	X	O	X	X	X	O	Disabling the keyboard
0x92h	O	X	X	O	X	X	O	X	Detecting the presence of the keyboard
0x93h	O	X	X	O	X	X	O	O	Enabling the keyboard
0x94h	O	X	X	O	X	O	X	X	Clearing keyboard input buffer
0x95h	O	X	X	O	X	O	X	O	Instructing keyboard controller to run Self Test (PS2 only)
Mouse (only USB)									
0x98h	O	X	X	O	O	X	X	X	Resetting the mouse
0x99h	O	X	X	O	O	X	X	O	Detecting the mouse
0x9Ah	O	X	X	O	O	X	O	X	Detecting the presence of mouse
0x9Bh	O	X	X	O	O	X	O	O	Enabling the mouse
Fixed Media									
0xB0h	O	X	O	O	X	X	X	X	Resetting fixed media device
0xB1h	O	X	O	O	X	X	X	O	Disabling fixed media device
0xB2h	O	X	O	O	X	X	O	X	Detecting presence of a fixed media device (hard drive detection, etc.)
0xB3h	O	X	O	O	X	X	O	O	Enabling / configuring a fixed media device
Removable Media									
0xB8h	O	X	O	O	O	X	X	X	Resetting removable media device
0xB9h	O	X	O	O	O	X	X	O	Disabling removable media device
0xBAh	O	X	O	O	O	X	O	X	Detecting presence of a removable media device (CDROM detection, etc.)
0xBCh	O	X	O	O	O	O	X	X	Enabling / configuring a removable media device
Boot Device Selection (BDS)									
0xD0	O	O	X	O	X	X	X	X	Trying to boot device selection 0
0xD1	O	O	X	O	X	X	X	O	Trying to boot device selection 1
0xD2	O	O	X	O	X	X	O	X	Trying to boot device selection 2
0xD3	O	O	X	O	X	X	O	O	Trying to boot device selection 3
0xD4	O	O	X	O	X	O	X	X	Trying to boot device selection 4
0xD5	O	O	X	O	X	O	X	O	Trying to boot device selection 5
0xD6	O	O	X	O	X	O	O	X	Trying to boot device selection 6
0xD7	O	O	X	O	X	O	O	O	Trying to boot device selection 7

Checkpoint	Diagnostic LED Decoder								Description
	O = On, X=Off								
	Upper Nibble				Lower Nibble				
	MSB							LSB	
LED	8h	4h	2h	1h	8h	4h	2h	1h	
	#7	#6	#5	#4	#3	#2	#1	#0	
0xD8	O	O	X	O	O	X	X	X	Trying to boot device selection 8
0xD9	O	O	X	O	O	X	X	O	Trying to boot device selection 9
0xDA	O	O	X	O	O	X	O	X	Trying to boot device selection A
0xDB	O	O	X	O	O	X	O	O	Trying to boot device selection B
0xDC	O	O	X	O	O	O	X	X	Trying to boot device selection C
0xDD	O	O	X	O	O	O	X	O	Trying to boot device selection D
0xDE	O	O	X	O	O	O	O	X	Trying to boot device selection E
0xDF	O	O	X	O	O	O	O	O	Trying to boot device selection F
Pre-EFI Initialization (PEI) Core									
0xE0h	O	O	O	X	X	X	X	X	Started dispatching early initialization modules (PEIM)
0xE1h	O	O	O	X	X	X	X	O	Reserved for initialization module use (PEIM)
0xE2h	O	O	O	X	X	X	O	X	Initial memory found, configured, and installed correctly
0xE3h	O	O	O	X	X	X	O	O	Reserved for initialization module use (PEIM)
Driver eXecution Environment (DXE) Core (not accompanied by a beep code)									
0xE4h	O	O	O	X	X	O	X	X	Entered EFI driver execution phase (DXE)
0xE5h	O	O	O	X	X	O	X	O	Started dispatching drivers
0xE6h	O	O	O	X	X	O	O	X	Started connecting drivers
DXE Drivers									
0xE7h	O	O	O	X	O	O	X	O	Waiting for user input
0xE8h	O	O	O	X	O	X	X	X	Checking password
0xE9h	O	O	O	X	O	X	X	O	Entering BIOS setup
0xEAh	O	O	O	X	O	X	O	X	Flash Update
0xEEh	O	O	O	X	O	O	O	X	Calling Int 19. One beep unless silent boot is enabled.
0xEFh	O	O	O	X	O	O	O	O	Unrecoverable boot failure
Runtime Phase / EFI Operating System Boot									
0xF2h	O	O	O	O	X	X	O	X	Signal that the OS has switched to virtual memory mode
0xF4h	O	O	O	O	X	O	X	X	Entering Sleep state
0xF5h	O	O	O	O	X	O	X	O	Exiting Sleep state
0xF8h	O	O	O	O	O	X	X	X	OS has requested EFI to close boot services (ExitBootServices () Has been called)
0xF9h	O	O	O	O	O	X	X	O	OS has switched to virtual address mode (SetVirtualAddressMap () Has been called)
0xFAh	O	O	O	O	O	X	O	X	OS has requested the system to reset (ResetSystem () has been called)
Pre-EFI Initialization Module (PEIM) / Recovery									
0x30h	X	X	O	O	X	X	X	X	Crisis recovery has been initiated because of a user request
0x31h	X	X	O	O	X	X	X	O	Crisis recovery has been initiated by software (corrupt flash)
0x34h	X	X	O	O	X	O	X	X	Loading crisis recovery capsule
0x35h	X	X	O	O	X	O	X	O	Handing off control to the crisis recovery capsule
0x3Fh	X	X	O	O	O	O	O	O	Unable to complete crisis recovery capsule

Appendix C: POST Code Errors

Whenever possible, the BIOS outputs the current boot progress codes on the video screen. Progress codes are 32-bit quantities plus optional data. The 32-bit numbers include class, subclass, and operation information. The class and subclass fields point to the type of hardware that is being initialized. The operation field represents the specific initialization activity. Based on the data bit availability to display progress codes, a progress code can be customized to fit the data width. The higher the data bit, the higher the granularity of information that can be sent on the progress port. The progress codes may be reported by the system BIOS or option ROMs.

The Response section in the following table is divided into three types:

- **No Pause:** The message is displayed on the screen during POST or in the Error Manager. The system continues booting with a degraded state. The user may want to replace the erroneous unit. The setup POST error Pause setting does not have any effect with this error.
- **Pause:** The message is displayed on the Error Manager screen, and an error is logged to the SEL. The setup POST error Pause setting determines whether the system pauses to the Error Manager for this type of error, where the user can take immediate corrective action or choose to continue booting.
- **Halt:** The message is displayed on the Error Manager screen, an error is logged to the SEL, and the system cannot boot unless the error is resolved. The user needs to replace the faulty part and restart the system. The setup POST error Pause setting does not have any effect with this error.

Table 63. POST Error Messages and Handling

Error Code	Error Message	Response
0012	CMOS date / time not set	Pause
0048	Password check failed	Halt
0108	Keyboard component encountered a locked error.	No Pause
0109	Keyboard component encountered a stuck key error.	No Pause
0113	Fixed Media The SAS RAID firmware cannot run properly. The user should attempt to reflash the firmware.	Pause
0140	PCI component encountered a PERR error.	Pause
0141	PCI resource conflict	Pause
0146	PCI out of resources error	Pause
0192	L3 cache size mismatch	Halt
0194	CPUID, processor family are different	Halt
0195	Front side bus mismatch	Pause
0196	Processor Model mismatch	Pause
0197	Processor speeds mismatched	Pause
0198	Processor family is unsupported.	Pause
019F	Processor and chipset stepping configuration is unsupported.	Pause
5220	CMOS/NVRAM Configuration Cleared	Pause
5221	Passwords cleared by jumper	Pause
5224	Password clear Jumper is Set.	Pause
8110	Processor 01 internal error (IERR) on last boot	Pause
8111	Processor 02 internal error (IERR) on last boot	Pause
8120	Processor 01 thermal trip error on last boot	Pause
8121	Processor 02 thermal trip error on last boot	Pause
8130	Processor 01 disabled	Pause
8131	Processor 02 disabled	Pause

Error Code	Error Message	Response
8140	Processor 01 Failed FRB-3 Timer.	No Pause
8141	Processor 02 Failed FRB-3 Timer.	No Pause
8160	Processor 01 unable to apply BIOS update	Pause
8161	Processor 02 unable to apply BIOS update	Pause
8170	Processor 01 failed Self Test (BIST).	Pause
8171	Processor 02 failed Self Test (BIST).	Pause
8180	Processor 01 BIOS does not support the current stepping for processor	No Pause
8181	Processor 02 BIOS does not support the current stepping for processor	No Pause
8190	Watchdog timer failed on last boot	Pause
8198	Operating system boot watchdog timer expired on last boot	Pause
8300	Integrated Baseboard Management Controller failed self-test	Pause
84F2	Integrated Baseboard Management Controller failed to respond	Pause
84F3	Integrated Baseboard Management Controller in update mode	Pause
84F4	Sensor data record empty	Pause
84FF	System event log full	No Pause
8500	Memory component could not be configured in the selected RAS mode.	Pause
8520	DIMM_A1 failed Self Test (BIST).	Pause
8521	DIMM_A2 failed Self Test (BIST).	Pause
8522	DIMM_A3 failed Self Test (BIST).	Pause
8523	DIMM_A4 failed Self Test (BIST).	Pause
8524	DIMM_B1 failed Self Test (BIST).	Pause
8525	DIMM_B2 failed Self Test (BIST).	Pause
8526	DIMM_B3 failed Self Test (BIST).	Pause
8527	DIMM_B4 failed Self Test (BIST).	Pause
8528	DIMM_C1 failed Self Test (BIST).	Pause
8529	DIMM_C2 failed Self Test (BIST).	Pause
852A	DIMM_C3 failed Self Test (BIST).	Pause
852B	DIMM_C4 failed Self Test (BIST).	Pause
852C	DIMM_D1 failed Self Test (BIST).	Pause
852D	DIMM_D2 failed Self Test (BIST).	Pause
852E	DIMM_D3 failed Self Test (BIST).	Pause
852F	DIMM_D4 failed Self Test (BIST).	Pause
8540	DIMM_A1 Disabled.	Pause
8541	DIMM_A2 Disabled.	Pause
8542	DIMM_A3 Disabled.	Pause
8543	DIMM_A4 Disabled.	Pause
8544	DIMM_B1 Disabled.	Pause
8545	DIMM_B2 Disabled.	Pause
8546	DIMM_B3 Disabled.	Pause
8547	DIMM_B4 Disabled.	Pause
8548	DIMM_C1 Disabled.	Pause
8549	DIMM_C2 Disabled.	Pause
854A	DIMM_C3 Disabled.	Pause
854B	DIMM_C4 Disabled.	Pause
854C	DIMM_D1 Disabled.	Pause
854D	DIMM_D2 Disabled.	Pause
854E	DIMM_D3 Disabled.	Pause
854F	DIMM_D4 Disabled.	Pause
8560	DIMM_A1 Component encountered a Serial Presence Detection (SPD) fail error.	Pause
8561	DIMM_A2 Component encountered a Serial Presence Detection (SPD) fail error.	Pause
8562	DIMM_A3 Component encountered a Serial Presence Detection (SPD) fail error.	Pause
8563	DIMM_A4 Component encountered a Serial Presence Detection (SPD) fail error.	Pause
8564	DIMM_B1 Component encountered a Serial Presence Detection (SPD) fail error.	Pause
8565	DIMM_B2 Component encountered a Serial Presence Detection (SPD) fail error.	Pause
8566	DIMM_B3 Component encountered a Serial Presence Detection (SPD) fail error.	Pause
8567	DIMM_B4 Component encountered a Serial Presence Detection (SPD) fail error.	Pause

Error Code	Error Message	Response
8568	DIMM_C1 Component encountered a Serial Presence Detection (SPD) fail error.	Pause
8569	DIMM_C2 Component encountered a Serial Presence Detection (SPD) fail error.	Pause
856A	DIMM_C3 Component encountered a Serial Presence Detection (SPD) fail error.	Pause
856B	DIMM_C4 Component encountered a Serial Presence Detection (SPD) fail error.	Pause
856C	DIMM_D1 Component encountered a Serial Presence Detection (SPD) fail error.	Pause
856D	DIMM_D2 Component encountered a Serial Presence Detection (SPD) fail error.	Pause
856E	DIMM_D3 Component encountered a Serial Presence Detection (SPD) fail error.	Pause
856F	DIMM_D4 Component encountered a Serial Presence Detection (SPD) fail error.	Pause
8580	DIMM_A1 Correctable ECC error encountered.	Pause after 10 Occurrence
8581	DIMM_A2 Correctable ECC error encountered.	Pause after 10 Occurrence
8582	DIMM_A3 Correctable ECC error encountered.	Pause after 10 Occurrence
8583	DIMM_A4 Correctable ECC error encountered.	Pause after 10 Occurrence
8584	DIMM_B1 Correctable ECC error encountered.	Pause after 10 Occurrence
8585	DIMM_B2 Correctable ECC error encountered.	Pause after 10 Occurrence
8586	DIMM_B3 Correctable ECC error encountered.	Pause after 10 Occurrence
8587	DIMM_B4 Correctable ECC error encountered.	Pause after 10 Occurrence
8588	DIMM_C1 Correctable ECC error encountered.	Pause after 10 Occurrence
8589	DIMM_C2 Correctable ECC error encountered.	Pause after 10 Occurrence
858A	DIMM_C3 Correctable ECC error encountered.	Pause after 10 Occurrence
858B	DIMM_C4 Correctable ECC error encountered.	Pause after 10 Occurrence
858C	DIMM_D1 Correctable ECC error encountered.	Pause after 10 Occurrence
858D	DIMM_D2 Correctable ECC error encountered.	Pause after 10 Occurrence
858E	DIMM_D3 Correctable ECC error encountered.	Pause after 10 Occurrence
858F	DIMM_D4 Correctable ECC error encountered.	Pause after 10 Occurrence
85A0	DIMM_A1 Uncorrectable ECC error encountered.	Pause
85A1	DIMM_A2 Uncorrectable ECC error encountered.	Pause
85A2	DIMM_A3 Uncorrectable ECC error encountered.	Pause
85A3	DIMM_A4 Uncorrectable ECC error encountered.	Pause
85A4	DIMM_B1 Uncorrectable ECC error encountered.	Pause
85A5	DIMM_B2 Uncorrectable ECC error encountered.	Pause
85A6	DIMM_B3 Uncorrectable ECC error encountered.	Pause
85A7	DIMM_B4 Uncorrectable ECC error encountered.	Pause
85A8	DIMM_C1 Uncorrectable ECC error encountered.	Pause
85A9	DIMM_C2 Uncorrectable ECC error encountered.	Pause
85AA	DIMM_C3 Uncorrectable ECC error encountered.	Pause
85AB	DIMM_C4 Uncorrectable ECC error encountered.	Pause
85AC	DIMM_D1 Uncorrectable ECC error encountered.	Pause
85AD	DIMM_D2 Uncorrectable ECC error encountered.	Pause
85AE	DIMM_D3 Uncorrectable ECC error encountered.	Pause
85AF	DIMM_D4 Uncorrectable ECC error encountered.	Pause
8601	Override jumper is set to force boot from lower alternate BIOS bank of flash ROM	No Pause
8602	WatchDog timer expired (secondary BIOS may be bad!)	No Pause
8603	Secondary BIOS checksum fail	No Pause
8604	Chipset Reclaim of non critical variables complete.	No Pause
9000	Unspecified processor component has encountered a non specific error.	Pause
9223	Keyboard component was not detected.	No Pause
9226	Keyboard component encountered a controller error.	No Pause
9243	Mouse component was not detected.	No Pause
9246	Mouse component encountered a controller error.	No Pause
9266	Local Console component encountered a controller error.	No Pause
9268	Local Console component encountered an output error.	No Pause
9269	Local Console component encountered a resource conflict error.	No Pause
9286	Remote Console component encountered a controller error.	No Pause
9287	Remote Console component encountered an input error.	No Pause
9288	Remote Console component encountered an output error.	No Pause
92A3	Serial port component was not detected	Pause

Error Code	Error Message	Response
92A9	Serial port component encountered a resource conflict error	Pause
92C6	Serial Port controller error	No Pause
92C7	Serial Port component encountered an input error.	No Pause
92C8	Serial Port component encountered an output error.	No Pause
94C6	LPC component encountered a controller error.	No Pause
94C9	LPC component encountered a resource conflict error.	Pause
9506	ATA/ATPI component encountered a controller error.	No Pause
95A6	PCI component encountered a controller error.	No Pause
95A7	PCI component encountered a read error.	No Pause
95A8	PCI component encountered a write error.	No Pause
9609	Unspecified software component encountered a start error.	No Pause
9641	PEI Core component encountered a load error.	No Pause
9667	PEI module component encountered an illegal software state error.	Halt
9687	DXE core component encountered an illegal software state error.	Halt
96A7	DXE boot services driver component encountered an illegal software state error.	Halt
96AB	DXE boot services driver component encountered invalid configuration.	No Pause
96E7	SMM driver component encountered an illegal software state error.	Halt
0xA022	Processor component encountered a mismatch error.	Pause
0xA027	Processor component encountered a low voltage error.	No Pause
0xA028	Processor component encountered a high voltage error.	No Pause
0xA421	PCI component encountered a SERR error.	Halt
0xA500	ATA/ATPI ATA bus SMART not supported.	No Pause
0xA501	ATA/ATPI ATA SMART is disabled.	No Pause
0xA5A0	PCI Express* component encountered a PERR error.	No Pause
0xA5A1	PCI Express* component encountered a SERR error.	Halt
0xA5A4	PCI Express* IBIST error.	Pause
0xA6A0	DXE boot services driver Not enough memory available to shadow a legacy option ROM.	No Pause

POST Error Beep Codes

The following table lists the POST error beep codes. Prior to system video initialization, the BIOS uses these beep codes to inform users on error conditions. The beep code is followed by a user-visible code on the POST Progress LEDs. For complete details, refer to the *Intel® S5500/S5520 Server Board Family BIOS External Product Specification*.

Table 64. POST Error Beep Codes

Beeps	Error Message	POST Progress Code	Description
3	Memory error	0xE8, 0xEB, 0xED, 0xEE	System halted because a fatal error related to the memory was detected.

The Integrated BMC may generate beep codes upon detection of failure conditions. Beep codes are sounded each time the problem is discovered, such as on each power-up attempt, but are not sounded continuously. Codes that are common across all Intel server boards and systems that use same generation chipset are listed in the following table. Each digit in the code is represented by a sequence of beeps whose count is equal to the digit. For complete details, refer to the *Intel® Server System Integrated Baseboard Management Controller Core External Product Specification*.

Table 65. Integrated BMC Beep Codes

Code	Reason for Beep	Associated Sensors	Supported
1-5-2-1	No CPUs installed or first CPU socket is empty.	CPU Missing Sensor	Yes
1-5-4-2	Power fault: DC power unexpectedly lost (power good dropout).	Power unit – power unit failure offset.	Yes
1-5-4-4	Power control fault (power good assertion timeout).	Power unit – soft power control failure offset.	Yes

Glossary

Word / Acronym	Definition
ACA	Australian Communication Authority
ACPI	Advanced Configuration and Power Interface
ANSI	American National Standards Institute
ATA	Advanced Technology Attachment
BMC	Baseboard Management Controller
BIOS	Basic Input/Output System
CMOS	Complementary Metal-oxide-semiconductor
D2D	DC-to-DC
EMC	Electromagnetic Compatibility
EMP	Emergency Management Port
ESD	Electrostatic Discharge
FP	Front Panel
FRB	Fault Resilient Boot
FRU	Field Replaceable Unit
I ² C	Inter-integrated Circuit bus
IPMI	Intelligent Platform Management Interface
LCD	Liquid Crystal Display
LPC	Low-pin Count
LSB	Least Significant Bit
MSB	Most Significant Bit
MTBF	Mean Time Between Failure
MTTR	Mean Time to Repair
NIC	Network Interface Card
NMI	Non-maskable Interrupt
OTP	Over-temperature Protection
OVP	Over-voltage Protection
PCI	Peripheral Component Interconnect
PCB	Printed Circuit Board
PCIe*	Peripheral Component Interconnect Express*
PCI-X	Peripheral Component Interconnect Extended
PFC	Power Factor Correction
POST	Power-on Self Test
PSU	Power Supply Unit
RAID	Redundant Array of Independent (or Inexpensive) Disks
RAM	Random Access Memory
RI	Ring Indicate
SATA	Serial Advanced Technology Attachment
SCA	Single Connector Attachment
SDR	Sensor Data Record
SE	Single-Ended
SMBus	System Management Bus
THD	Total Harmonic Distortion

Word / Acronym	Definition
UART	Universal Asynchronous Receiver Transmitter
USB	Universal Serial Bus
VCCI	Voluntary Control Council for Interference
VRD	Voltage Regulator Down
VSB	Voltage Standby

Reference Documents

See the following documents for additional information:

- *Intel® Server Board S5520UR Technical Product Specification*
- *Intel® Server System SR2600UR AC Power Supply Module Specification*
- *Intel® Server Board S5520UR/Intel® Server System SR2600UR Spares/Parts List and Configuration Guide*
- *Intel® Server System SR2600UR/SR2625UR Service Guide*
- *Intel® S5500/S5520 Server Board Family BIOS External Product Specification*
- *Intel® Server System Integrated Baseboard Management Controller Core External Product Specification*