

Chapter 3

Anterior Pituitary & The Endocrine Hypothalamus

Nam Deuk Kim, Ph.D.

Structure-function of the Endocrine Hypothalamus and Pituitary Gland

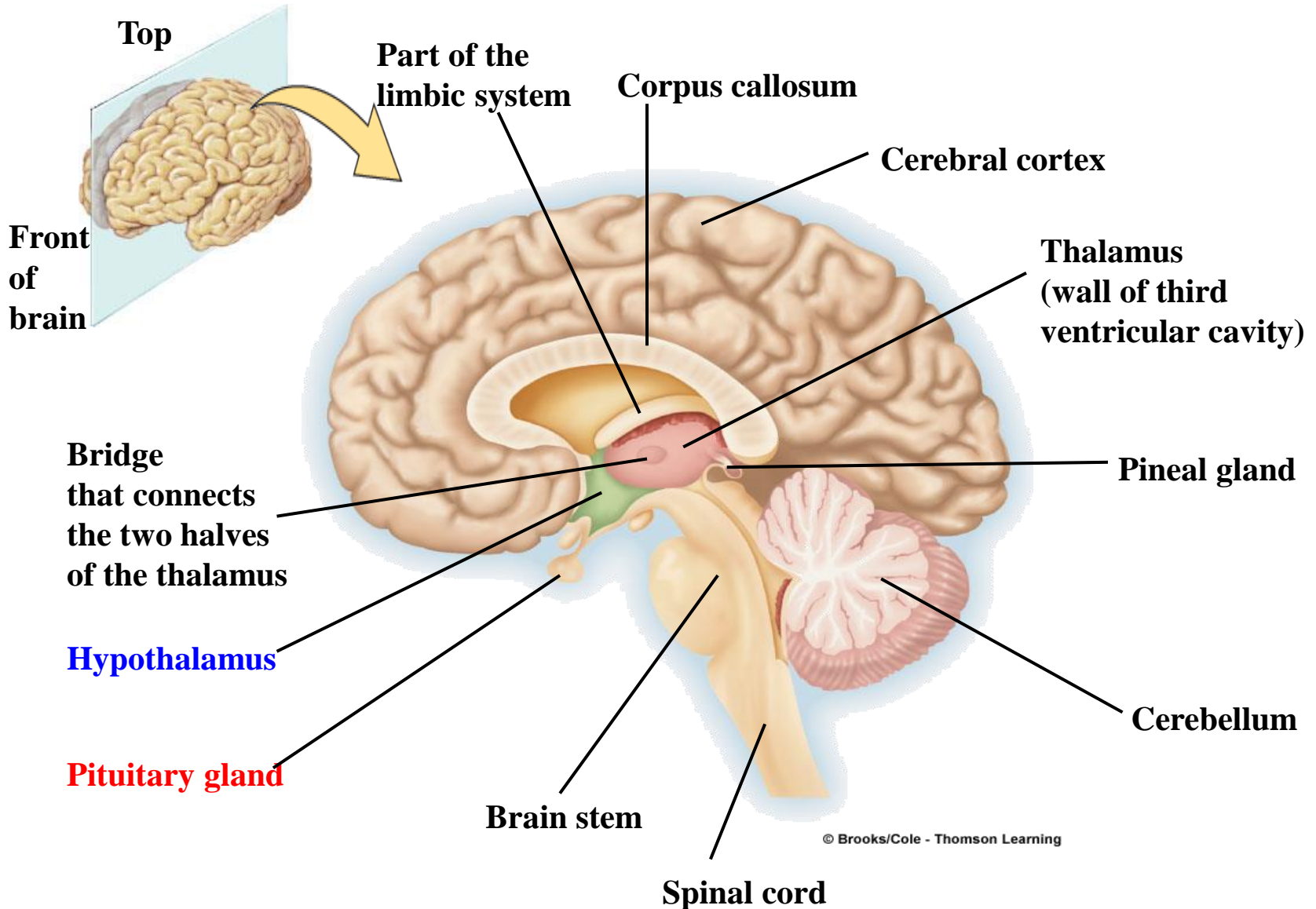

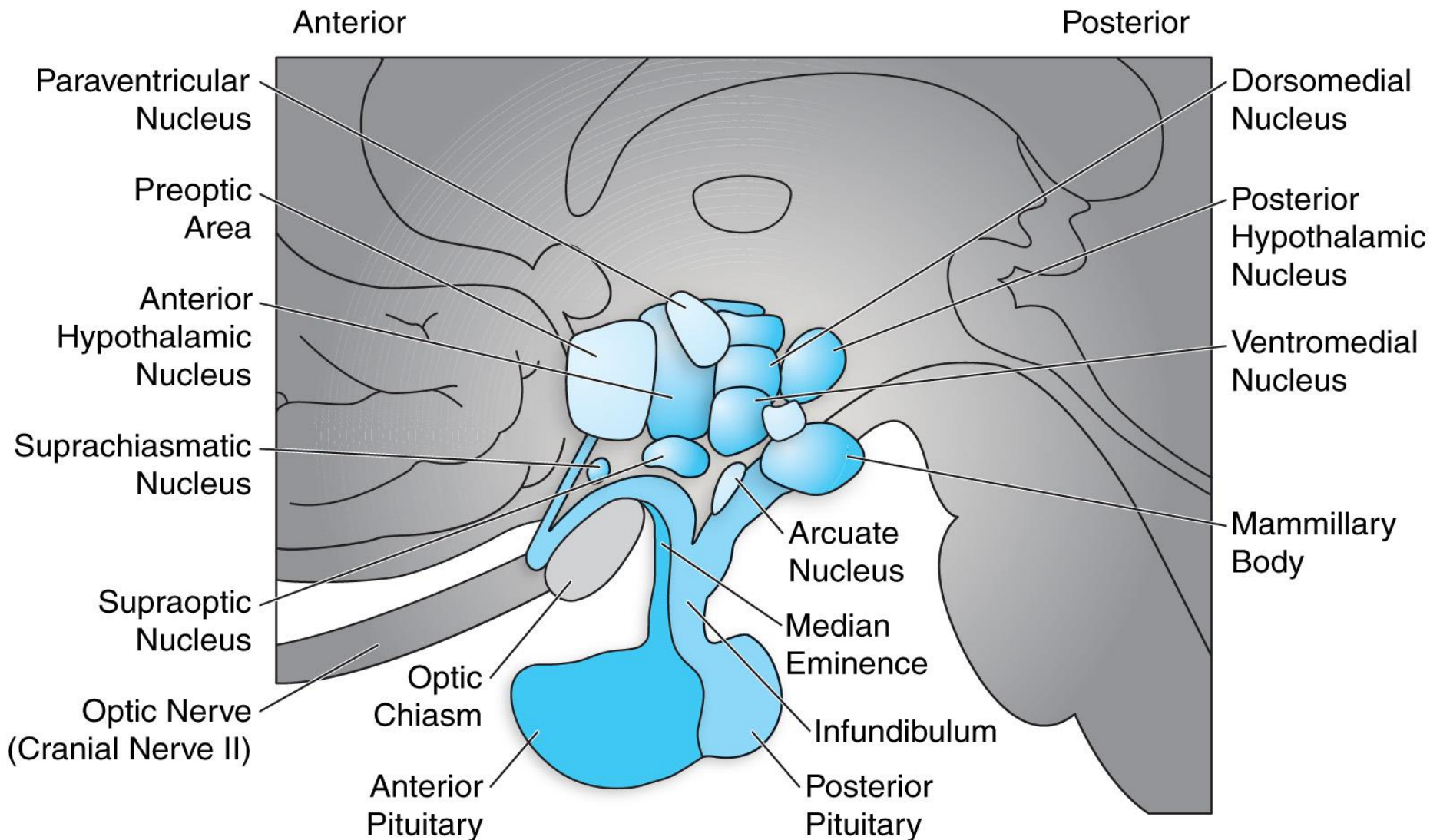

Fig. 6-1: Frontal section through the cerebral hemispheres of the human brain; the principal **hypothalamic nuclei** present within the plane of transect are indicated.

Medial Basal Hypothalamus

- Hypophysiotropic
- Median eminence to suprachiasmatic region
- Parvocellular neurosecretory system
 - CNS input via synaptic contact
 - Synthesis of hypophysiotropic factors
 - Release → hypophysial portal system
 - Via neuronal impingement
- **Secrete peptide hormones**
- **Nonhypophysiotropic functions of hypothalamus**
 - Thirst
 - Hunger/satiety
 - Thermo-regulation
 - Regulatory systems of emotions (behavior)
 - Sex hormones associated

▲ **TABLE 18-3**

Major Hypophysiotropic Hormones

HORMONE	EFFECT ON THE ANTERIOR PITUITARY
Thyrotropin-Releasing Hormone (TRH)	Stimulates release of TSH (thyrotropin) and prolactin
Corticotropin-Releasing Hormone (CRH)	Stimulates release of ACTH (corticotropin)
Gonadotropin-Releasing Hormone (GnRH)	Stimulates release of FSH and LH (gonadotropins)
Growth Hormone–Releasing Hormone (GHRH)	Stimulates release of growth hormone
Growth Hormone–Inhibiting Hormone (GHIH)	Inhibits release of growth hormone and TSH
Prolactin-Releasing Hormone (PRH)	Stimulates release of prolactin
Prolactin-Inhibiting Hormone (PIH)	Inhibits release of prolactin

Hierarchic chain of command and negative feedback in endocrine control

The general pathway involved in the hierarchic chain of command among the hypothalamus, anterior pituitary, and peripheral target endocrine gland is depicted on the left. The pathway on the right leading to cortisol secretion provides a specific example of this endocrine chain of command. The hormone ultimately secreted by the target endocrine gland, such as cortisol, acts in negative-feedback fashion to reduce secretion of the regulatory hormones higher in the chain of command.

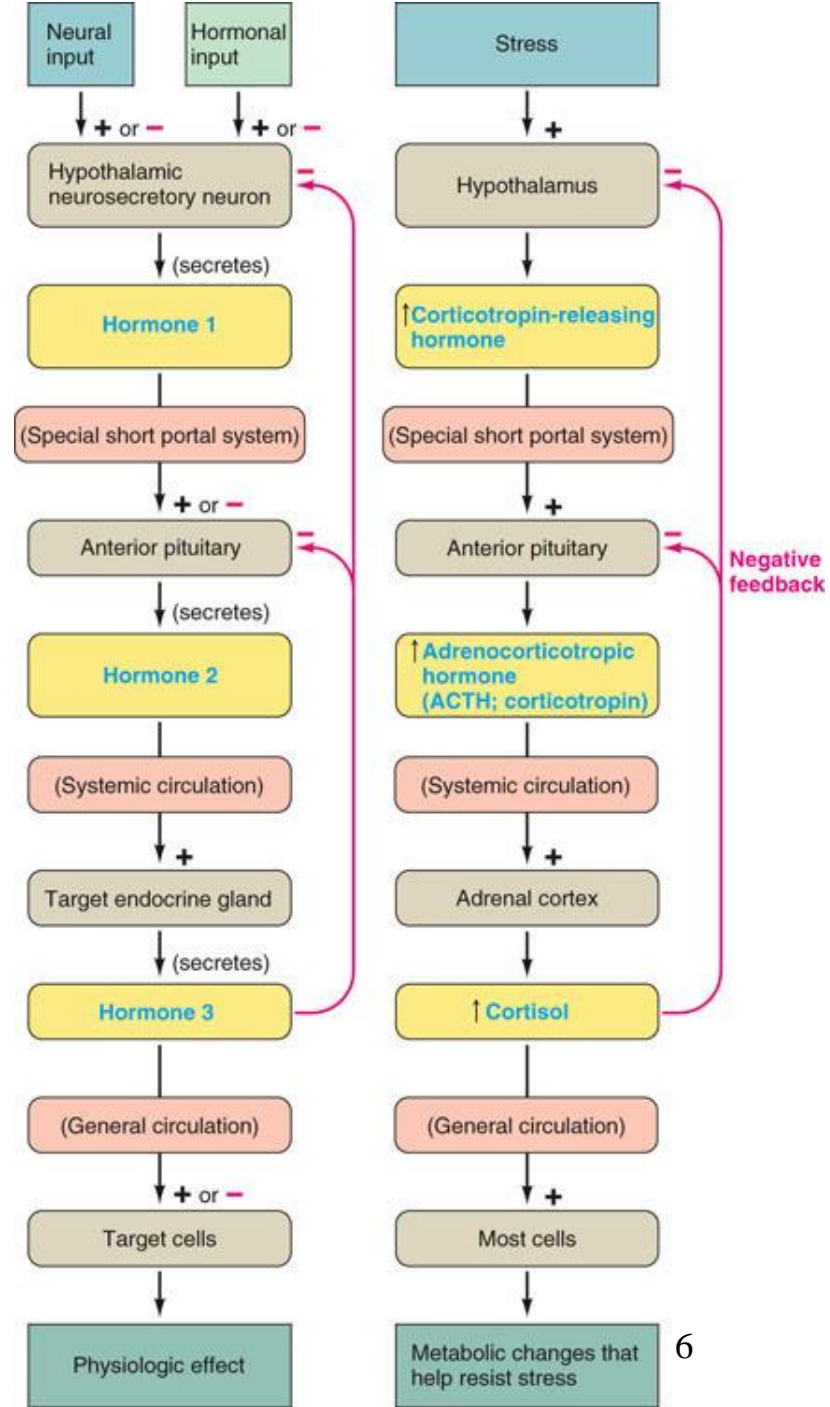

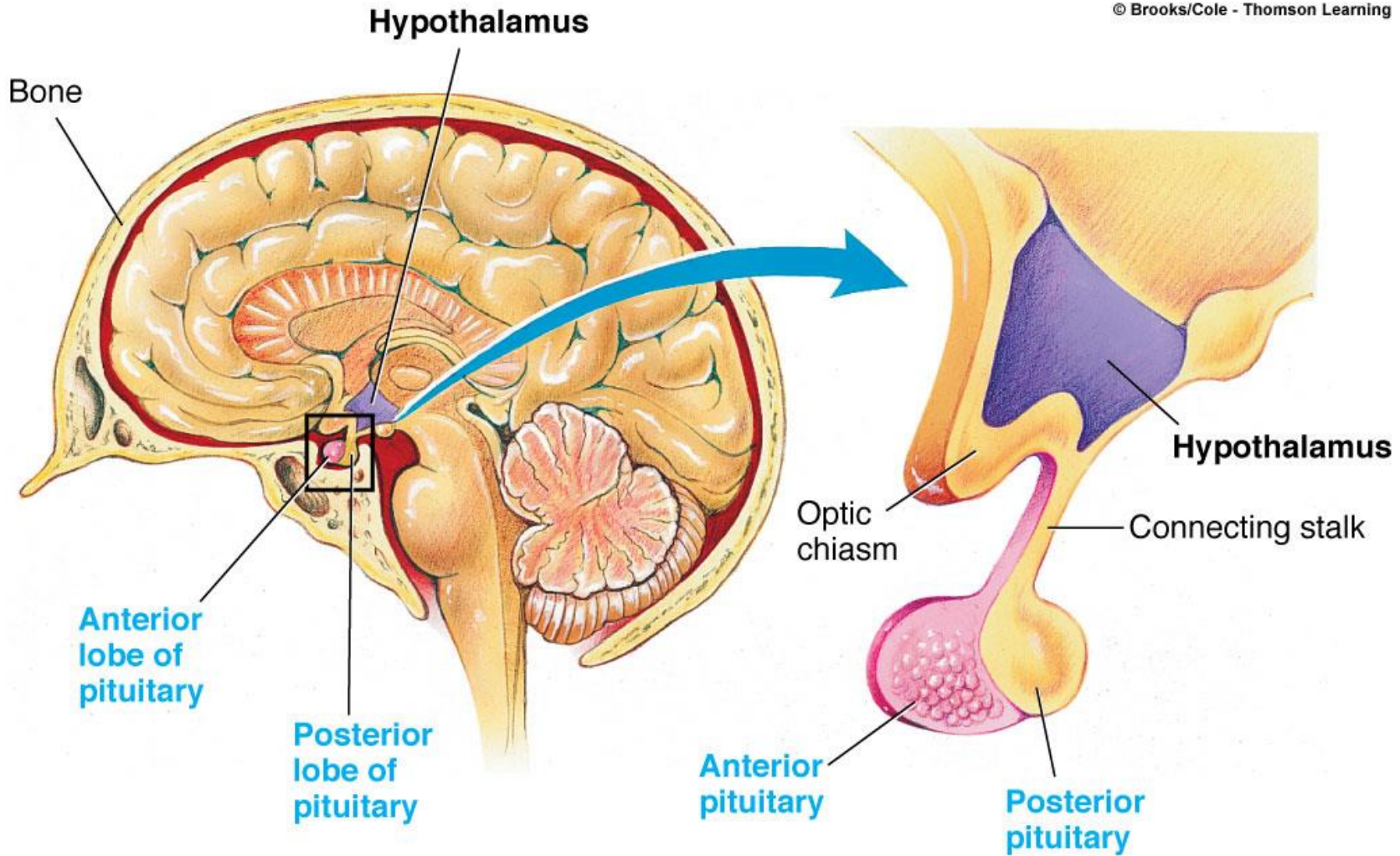

※ **Pituitary gland**: smaller than the tip of the little finger; 0.5~1.0 g

E. Endocrine System The hypophysis (pituitary)

2 major parts

1) Adenohypophysis, anterior pituitary

7 different hormones are made and secreted here.

2) Neurohypophysis, posterior pituitary (Pars nervosa)

Hormones secreted here are made in the hypothalamus..

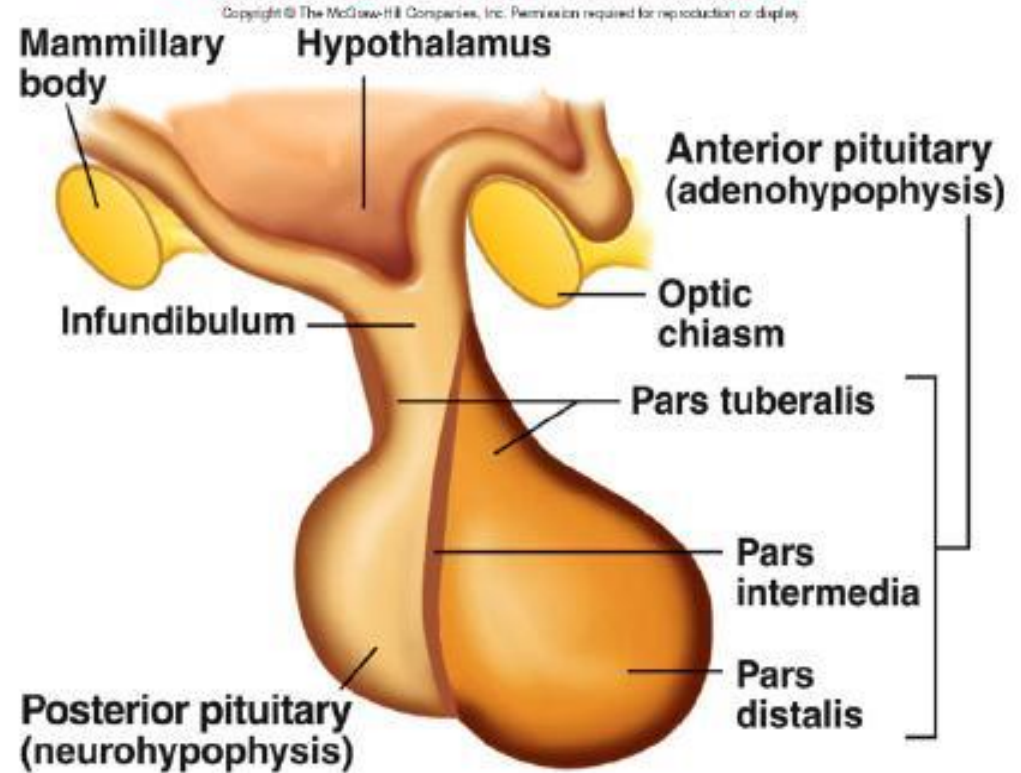

Pituitary Gland (Hypophysis)

Adenohypophysis

Pars Distalis

Pars Tuberalis

Pars Intermedia

Anterior Lobe

Intermediate Lobe

Neurohypophysis

Pars Nervosa

Infundibulum

Posterior Lobe

Neurointermediate Lobe

Fig. 5.1. Anatomical components of the pituitary gland.

Pituitary Gland

- Hypophysis (Pituitary Gland)
- Small gland located in bony cavity just below **hypothalamus**
 - Thin stalk connects pituitary gland to hypothalamus
- Consists of two anatomically and functionally distinct lobes
 - **Posterior pituitary (neurohypophysis)**
 - Composed of nervous tissue
 - **Anterior pituitary (adenohypophysis)**
 - Consists of glandular epithelial tissue

Pituitary Gland

- **Anterior pituitary**
 - Secretes six different peptide hormones that it produces itself
 - **Tropic hormones**
 - **Thyroid-stimulating hormone (TSH)**
 - » Stimulates secretion of thyroid hormone
 - **Adrenocorticotrophic hormone (ACTH)**
 - » Stimulates secretion of cortisol by adrenal cortex
 - **Follicle-stimulating hormone (FSH)**
 - » In females, stimulates growth and development of ovarian follicles; promotes secretion of estrogen by ovaries
 - » In males, required for sperm production
 - **Luteinizing hormone (LH)**
 - » In females, responsible for ovulation and luteinization; regulates ovarian secretion of female sex hormones
 - » In males, stimulates testosterone secretion
 - **Growth hormone (GH)**
 - » Primary hormone responsible for regulating overall body growth; important in intermediary metabolism
 - **Not a tropic hormone**
 - **Prolactin (PRL)**
 - » Enhances breast development and milk production in females

Pituitary Gland

- Release of hormones from both anterior and posterior pituitary is controlled by **hypothalamus**
- **Posterior pituitary**
 - Along with hypothalamus forms **neuroendocrine system**
 - Does not actually produce any hormones
 - Stores and releases two small peptide hormones
 - **Vasopressin**
 - Conserves water during urine formation
 - **Oxytocin**
 - Stimulates uterine contraction during childbirth and milk ejection during breast-feeding

Relationship of the Hypothalamus and Posterior Pituitary

1. The **paraventricular and supraoptic nuclei** both contain neurons that produce **vasopressin** and **oxytocin**. The hormone, either vasopressin or oxytocin depending on the neuron, is synthesized in the neuronal cell body in the hypothalamus.
2. The hormone travels down **the axon** to be stored in the neuronal terminals **within the posterior pituitary**.
3. On excitation of the neuron, the stored hormone is released from these terminals into the systemic blood for distribution throughout the body.

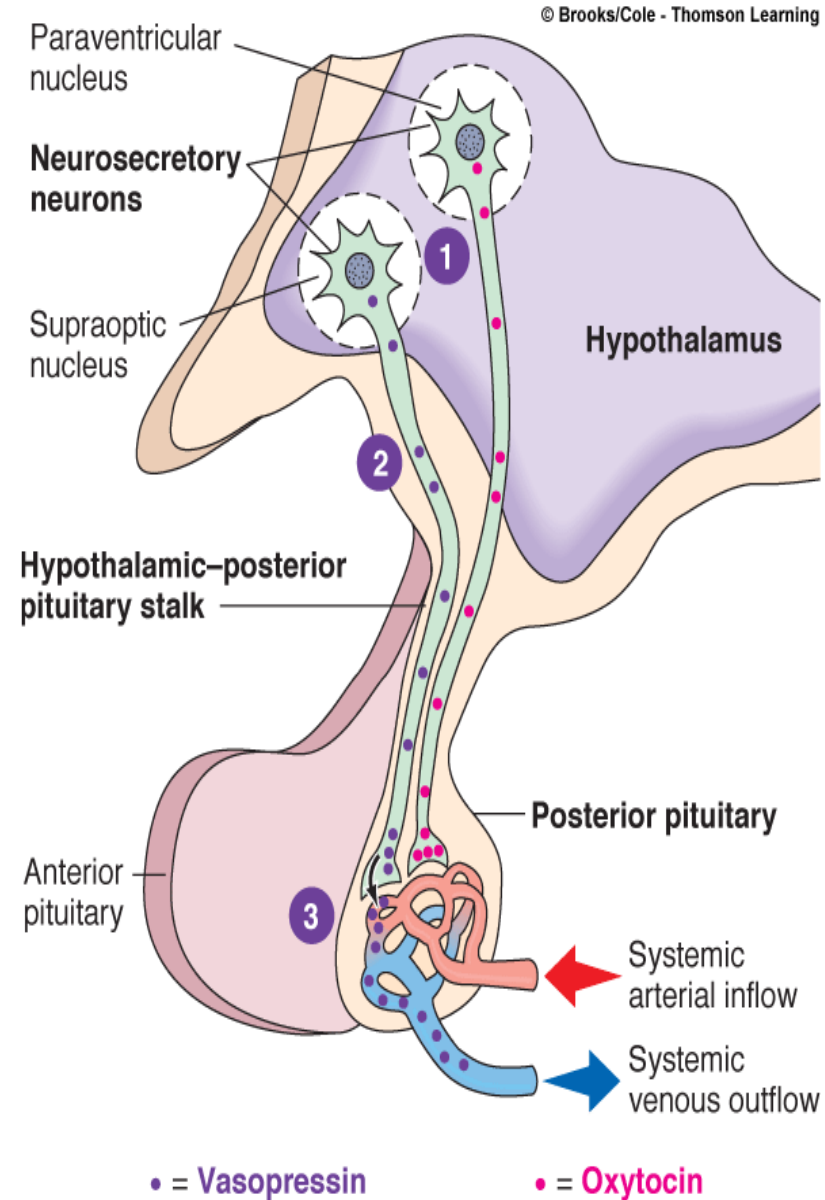

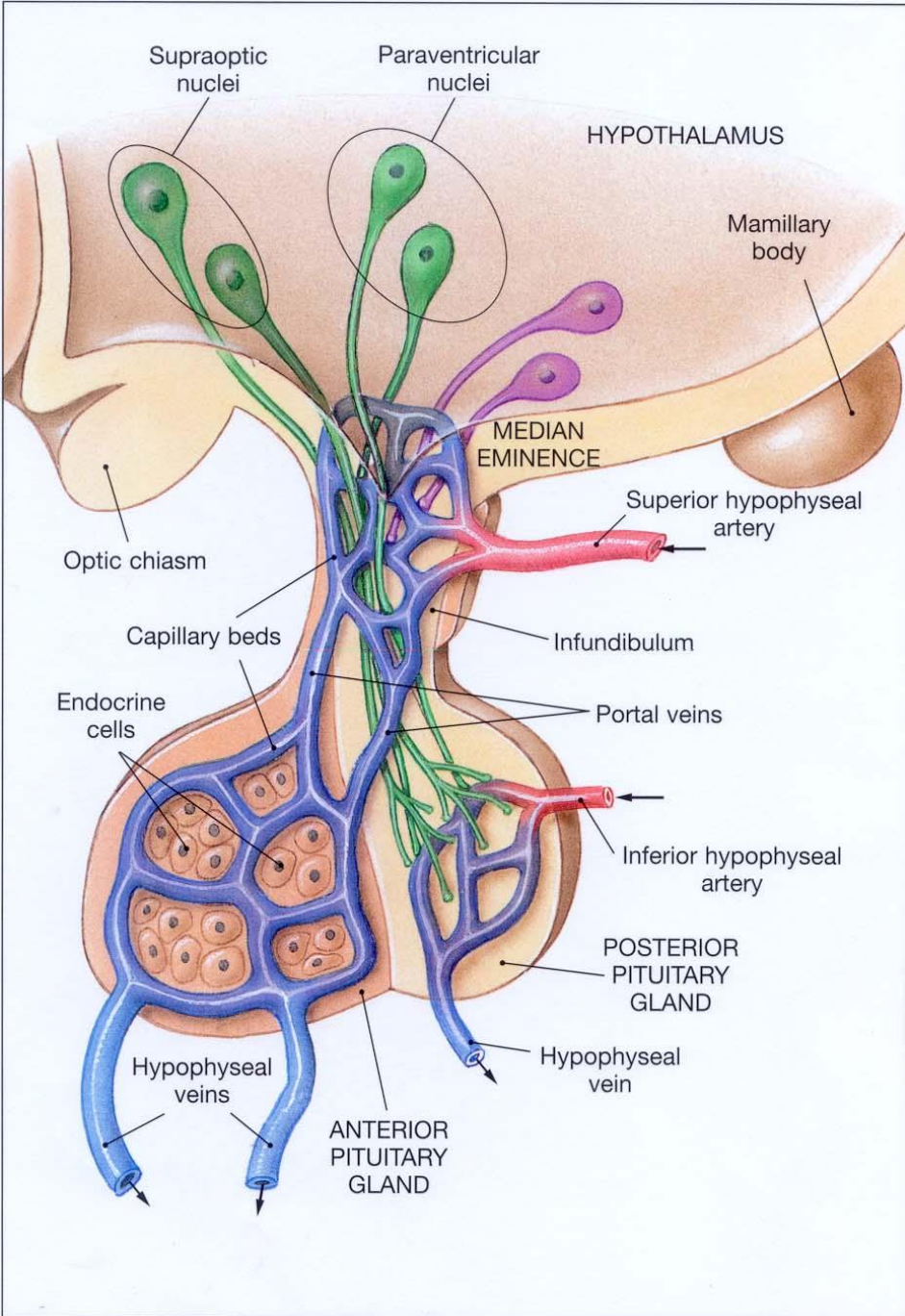

Hypothalamus secretes releasing hormones and inhibiting hormones that control anterior pituitary. Also synthesizes vasopressin and oxytocin, which travel to posterior pituitary.

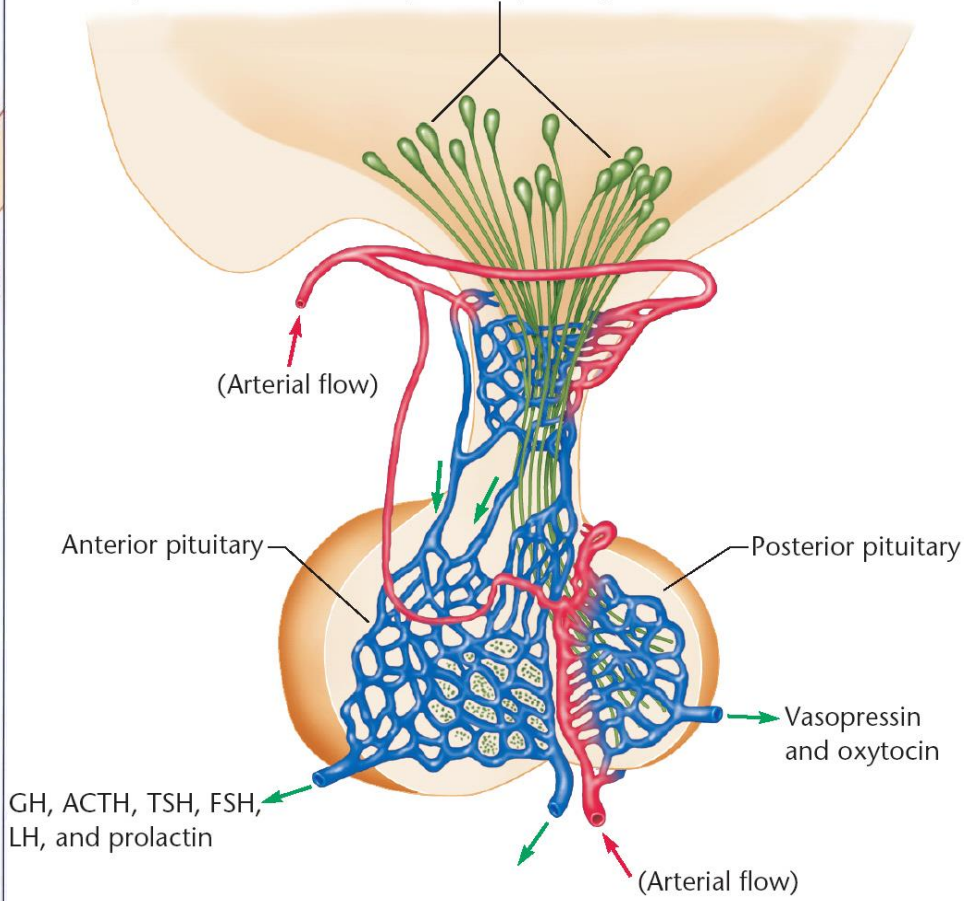

Vascular Link Between the Hypothalamus and Anterior Pituitary

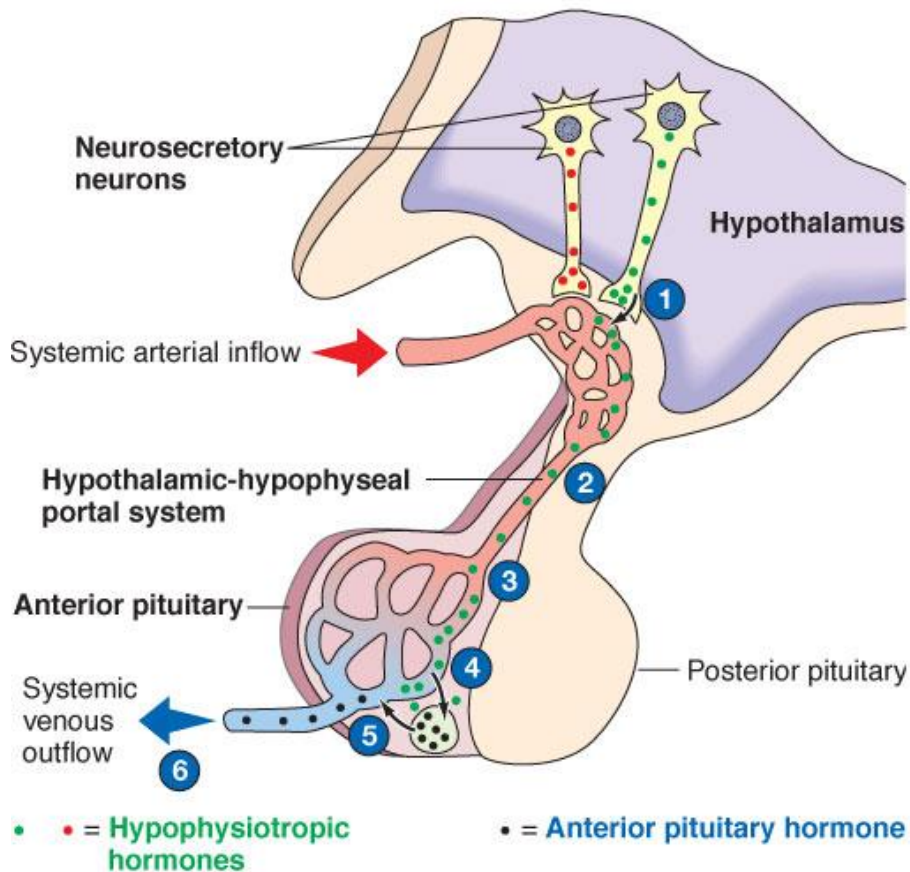

- 1 Hypophysiotropic hormones (releasing hormones and inhibiting hormones) produced by neurons in the hypothalamus enter the hypothalamic capillaries.
- 2 These hypothalamic capillaries rejoin to form the hypothalamic-hypophyseal portal system. This vascular link passes to the anterior pituitary.
- 3 Here it branches into the anterior pituitary capillaries.
- 4 The hypophysiotropic hormones leave the blood across the anterior pituitary capillaries and control the release of anterior pituitary hormones.
- 5 On stimulation by the appropriate hypothalamic releasing hormone, a given anterior pituitary hormone is secreted into these capillaries.
- 6 The anterior pituitary capillaries rejoin to form a vein, through which the anterior pituitary hormones leave for ultimate distribution throughout the body by the systemic circulation.

© Brooks/Cole - Thomson Learning

Hypothalamus & Pituitary Gland

- Hypothalamic releasing and inhibiting hormones help regulate anterior pituitary hormone secretion
- **Two most important factors** that regulate anterior pituitary hormone secretion
 - Hypothalamic hormones
 - Feedback by target-gland hormones

► Control of the Anterior and Posterior Pituitary by the Hypothalamus

- 1** Releasing and inhibiting hormones are released from hypothalamic neurons into the hypothalamo-pituitary portal system.
- 2** Hypothalamic-releasing and hypothalamic-inhibiting hormones are carried down the pituitary stalk by the hypothalamopituitary portal system.
- 3** Hypothalamic-releasing and hypothalamic-inhibiting hormones increase or decrease, respectively, the release of anterior pituitary hormones into general circulation.

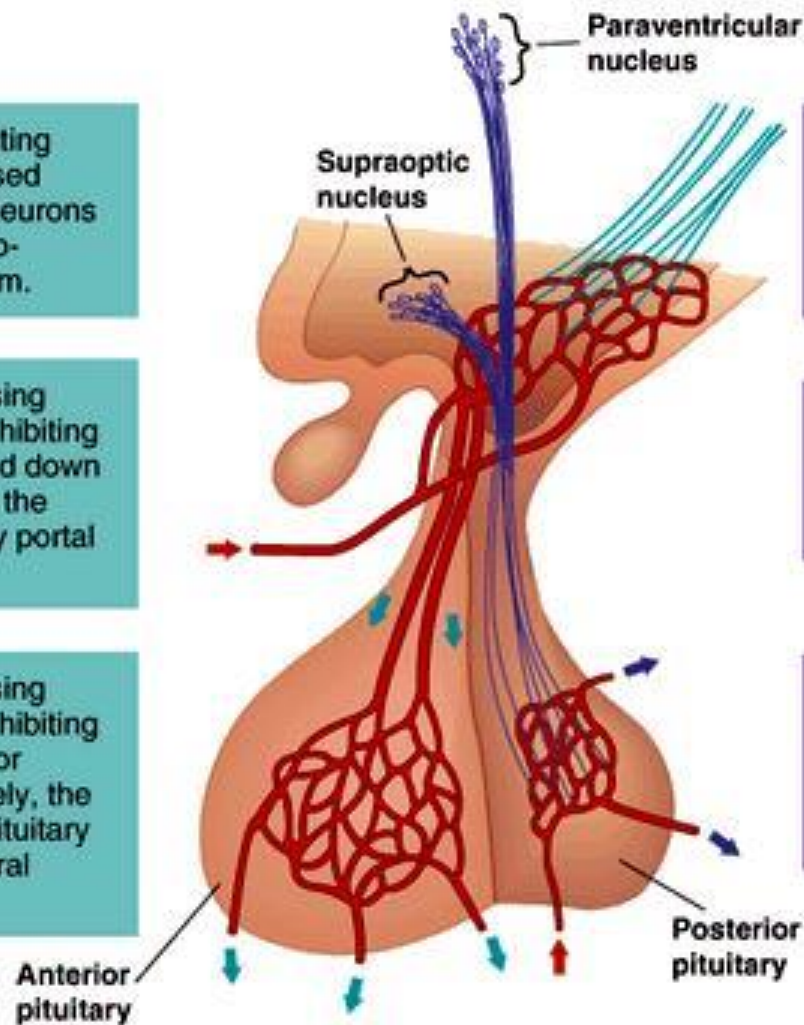

- 1** Oxytocin and vasopressin are synthesized in the paraventricular and supraoptic nuclei of the hypothalamus.
- 2** Oxytocin and vasopressin are carried by axonal transport down the pituitary stalk.
- 3** Oxytocin and vasopressin are released into general circulation from terminal buttons in the posterior pituitary.

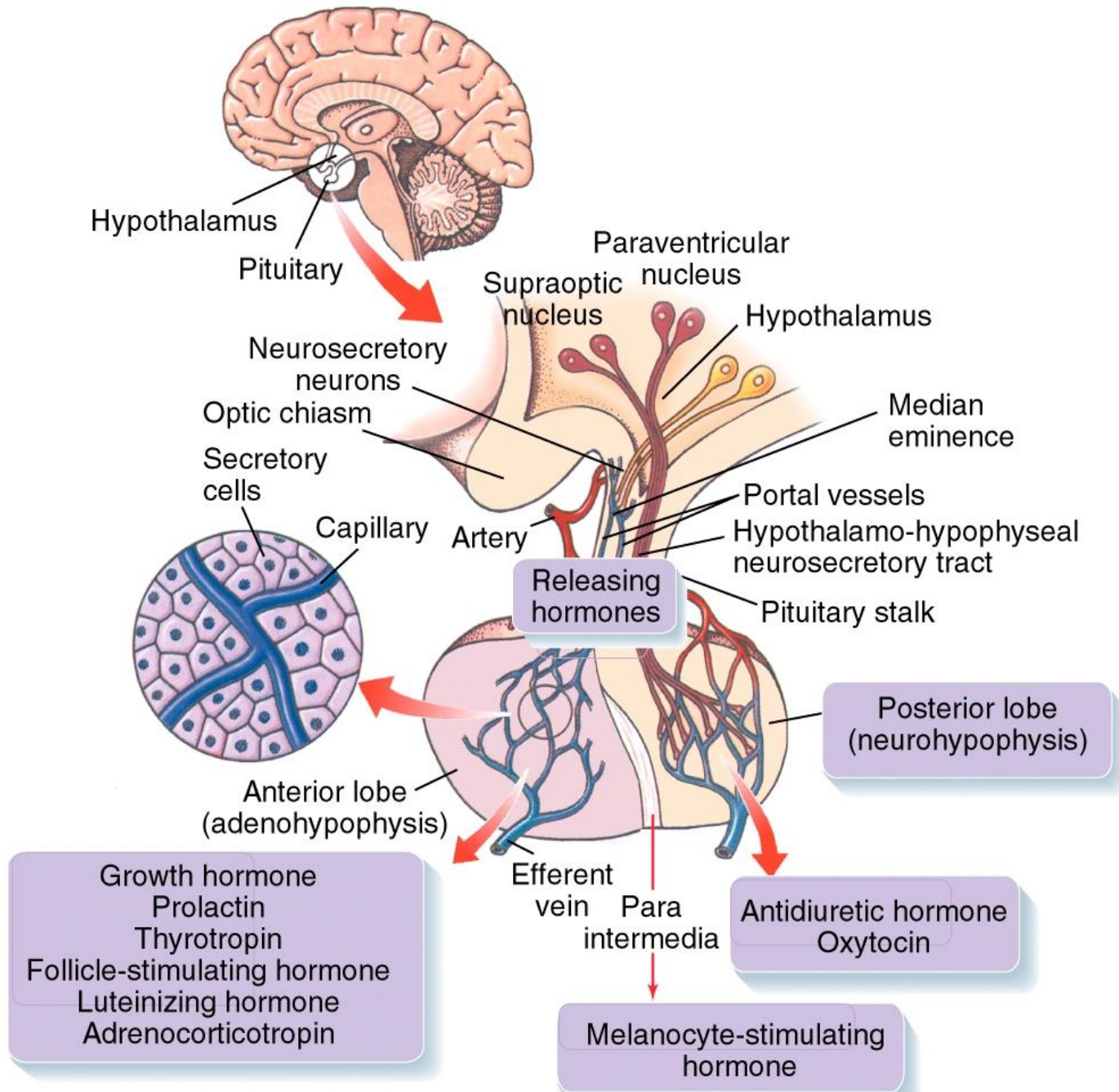

Pituitary Hormones

- Hypophysiotropic hormones from hypothalamus
 - GHRH, SST (GHIH), TRH, PIH, GnRH, CRH
- Three main families of anterior pituitary hormones
 - Somatomammotropic (lactogenic): GH, PRL
 - Glycoproteins sharing common α subunit: TSH, FSH, LH
 - Proopiomelanocortin (POMC) \rightarrow ACTH, MSH
- Two neurohypophysial hormones (posterior pituitary hormones): oxytocin & vasopressin

Overview of anterior pituitary hormone functions

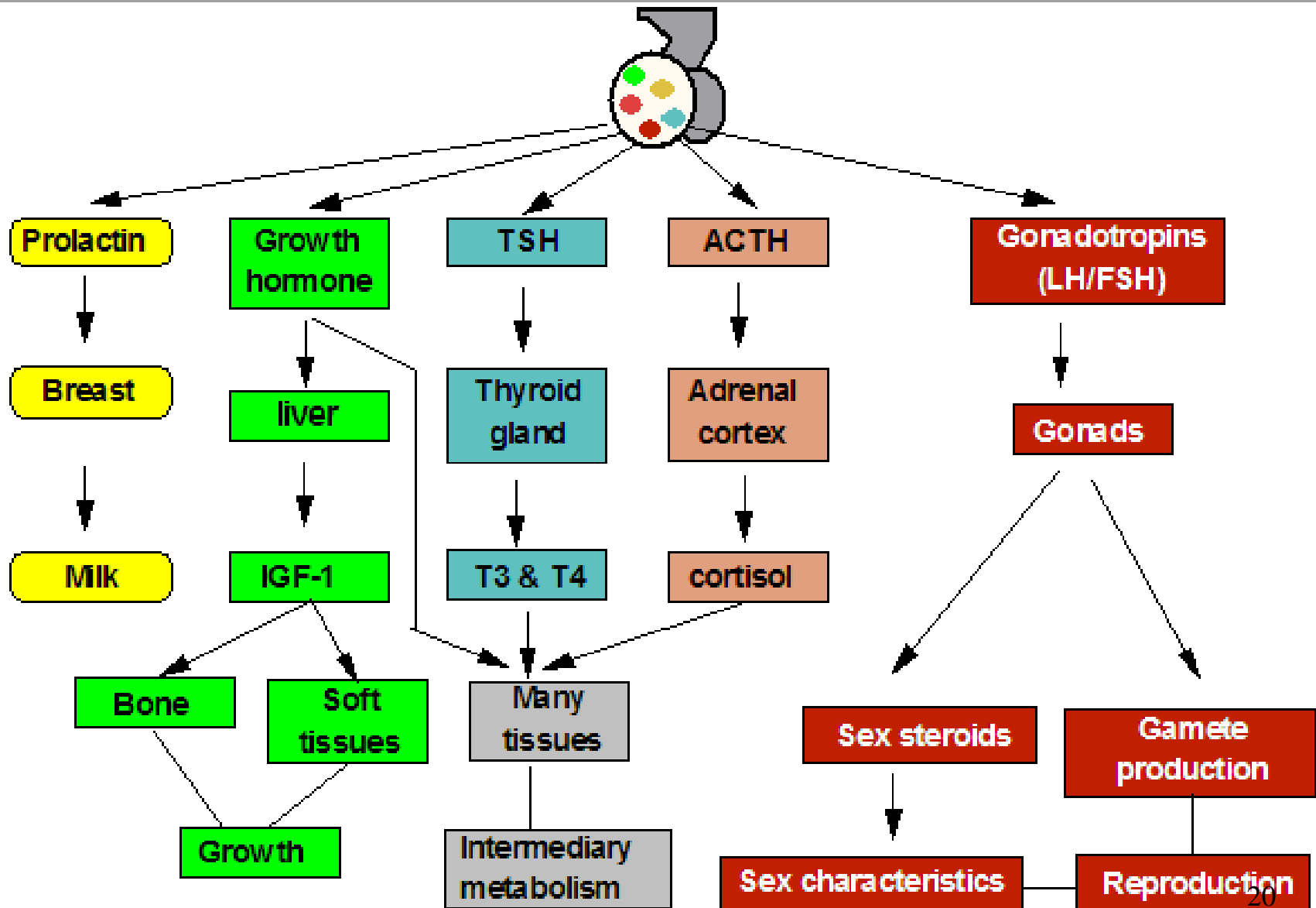

TABLE 5.1 Histochemical classification of pituitary pars distalis cells

Cell Type	Hormone		Staining Characteristic
Corticotroph ^a	Corticotropin	(ACTH)	Basophil
Thyrotroph	Thyrotropin	(TSH)	Basophil
Gonadotroph			
FSH-gonadotroph	Follitropin	(FSH)	Basophil
LH-gonadotroph	Lutropin	(LH)	Basophil
Lactotroph (mammotroph)	Prolactin	(PRL)	Acidophil
Somatotroph	Growth hormone	(GH)	Acidophil

^aCytological classification uses either the suffix -troph or -trope (e.g., corticotrope).

Copyright © 2007 Pearson Prentice Hall, Inc.

Functions of the anterior pituitary hormones

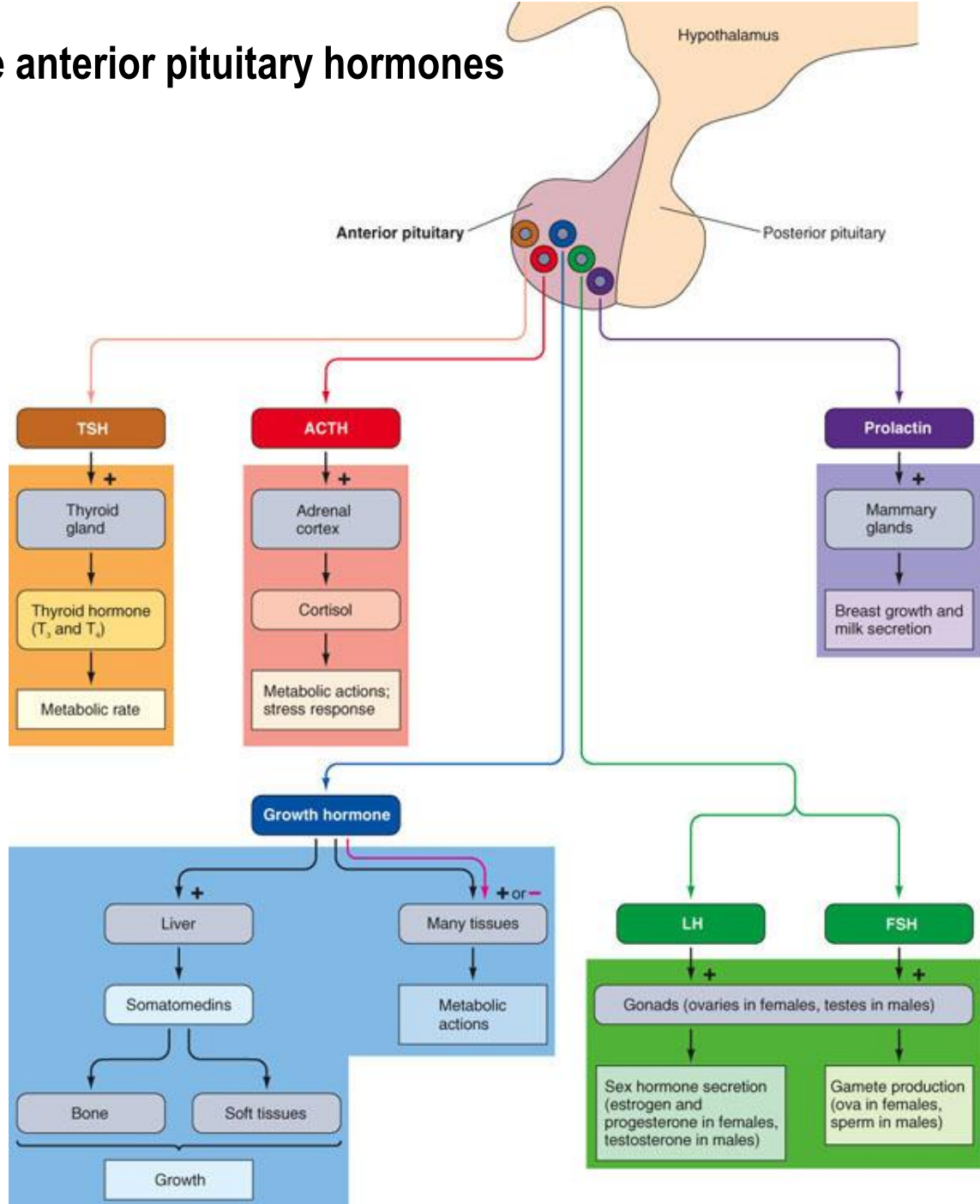

Peripheral hormone exert feedback actions in the hypothalamus

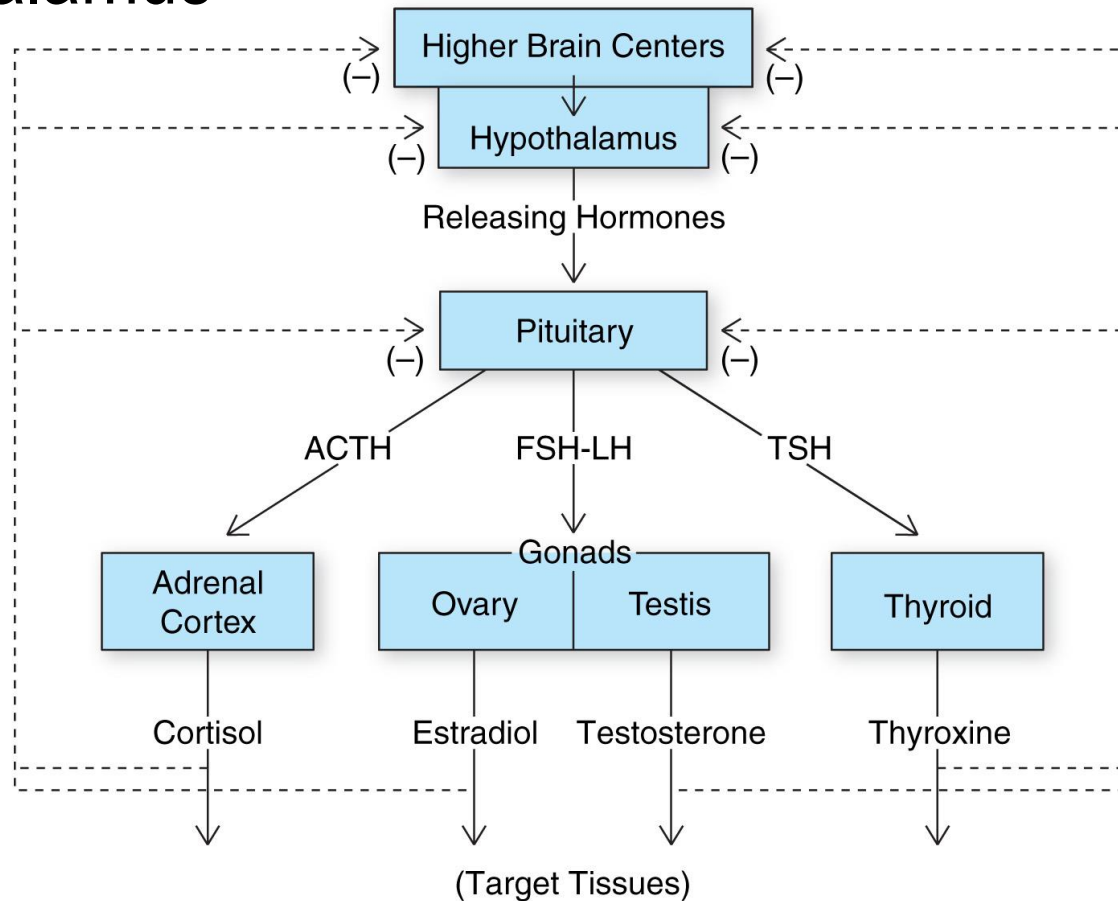

Fig. 6-16: Feedback control of pituitary hormone secretion.

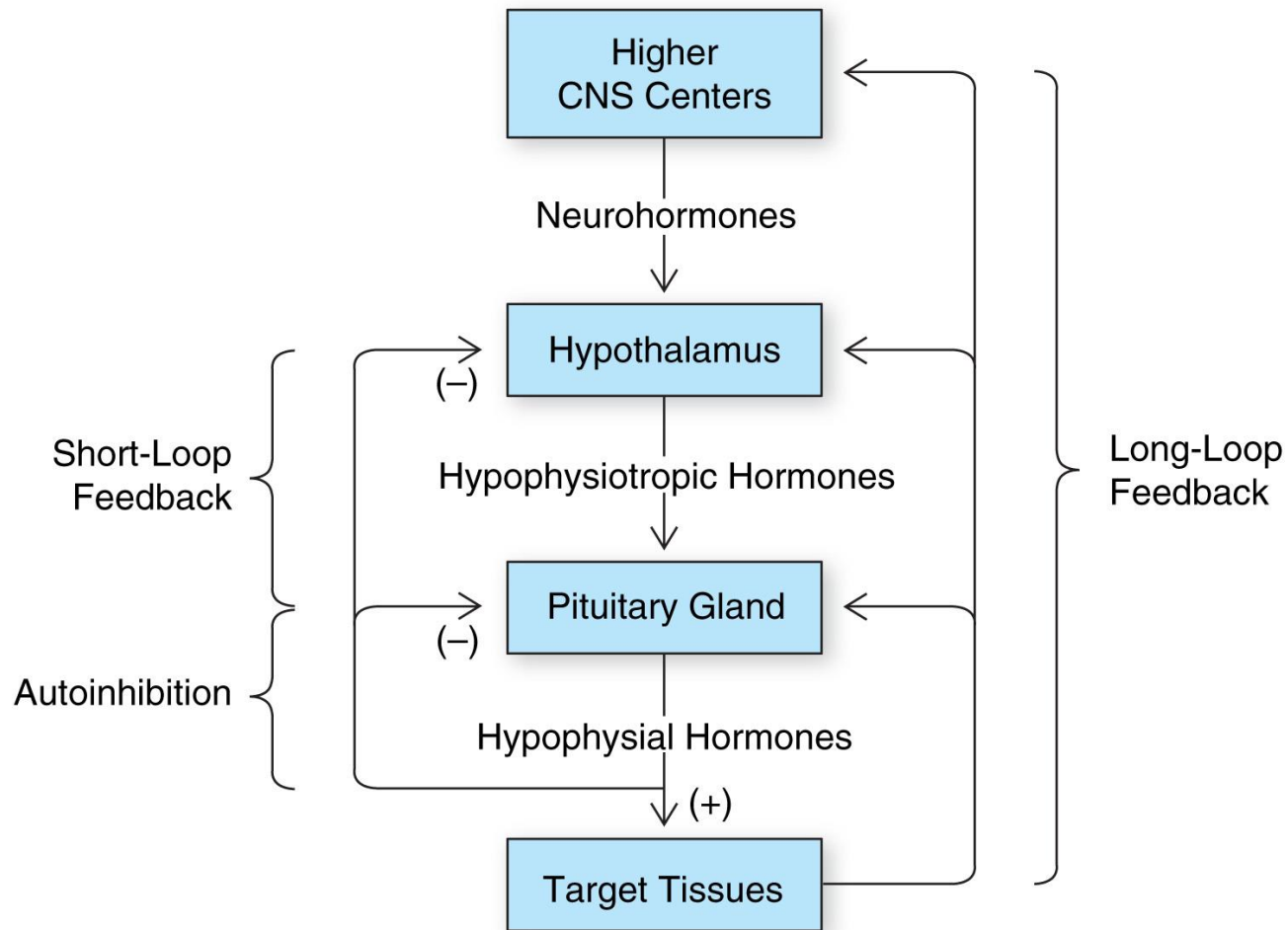
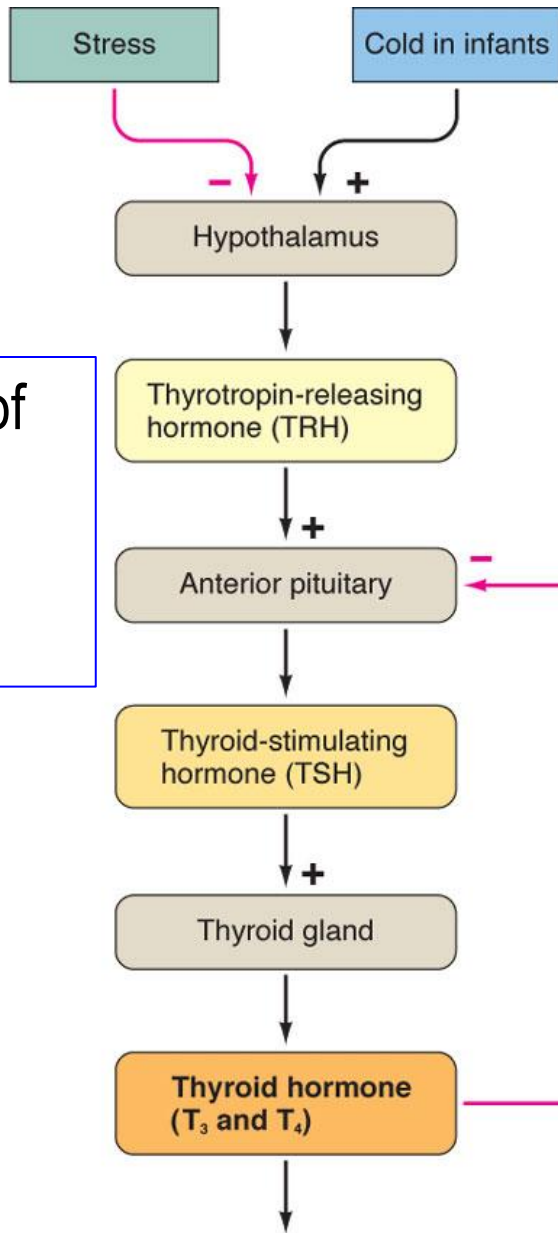
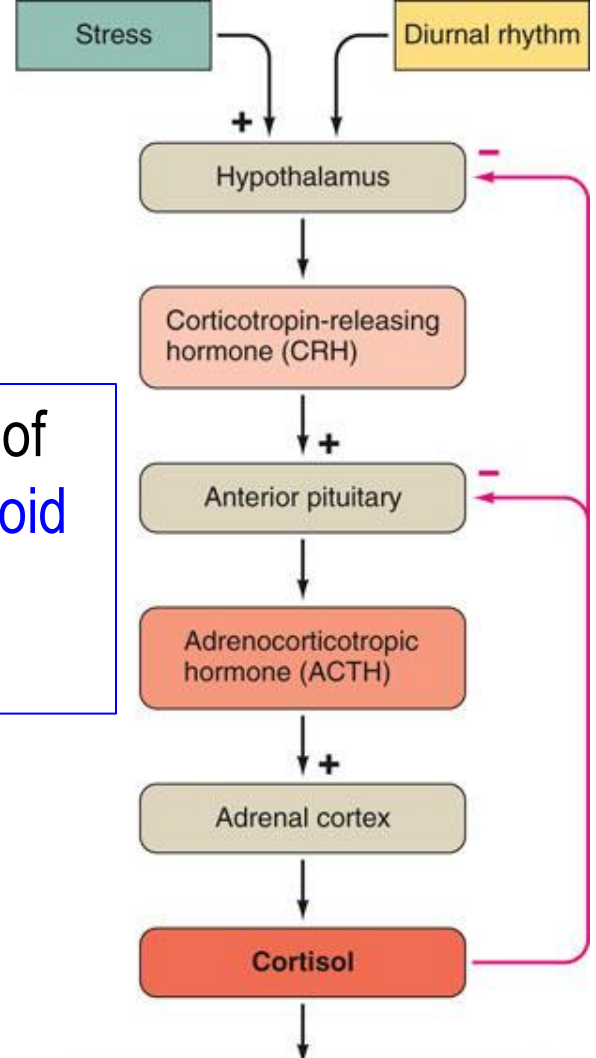

Fig. 6-17: Model of long-loop and short-loop mechanisms and autoregulation of pituitary hormone secretion.



↑ Metabolic rate and heat production; enhancement of growth and CNS development; enhancement of sympathetic activity

Regulation of Thyroid Hormone Secretion



Regulation of Glucocorticoid Hormone Secretion

Metabolic fuels and building blocks available to help resist stress

- ↑ Blood glucose (by stimulating gluconeogenesis and inhibiting glucose uptake)
- ↑ Blood amino acids (by stimulating protein degradation)
- ↑ Blood fatty acids (by stimulating lipolysis)

1. Control of Growth Hormone Secretion

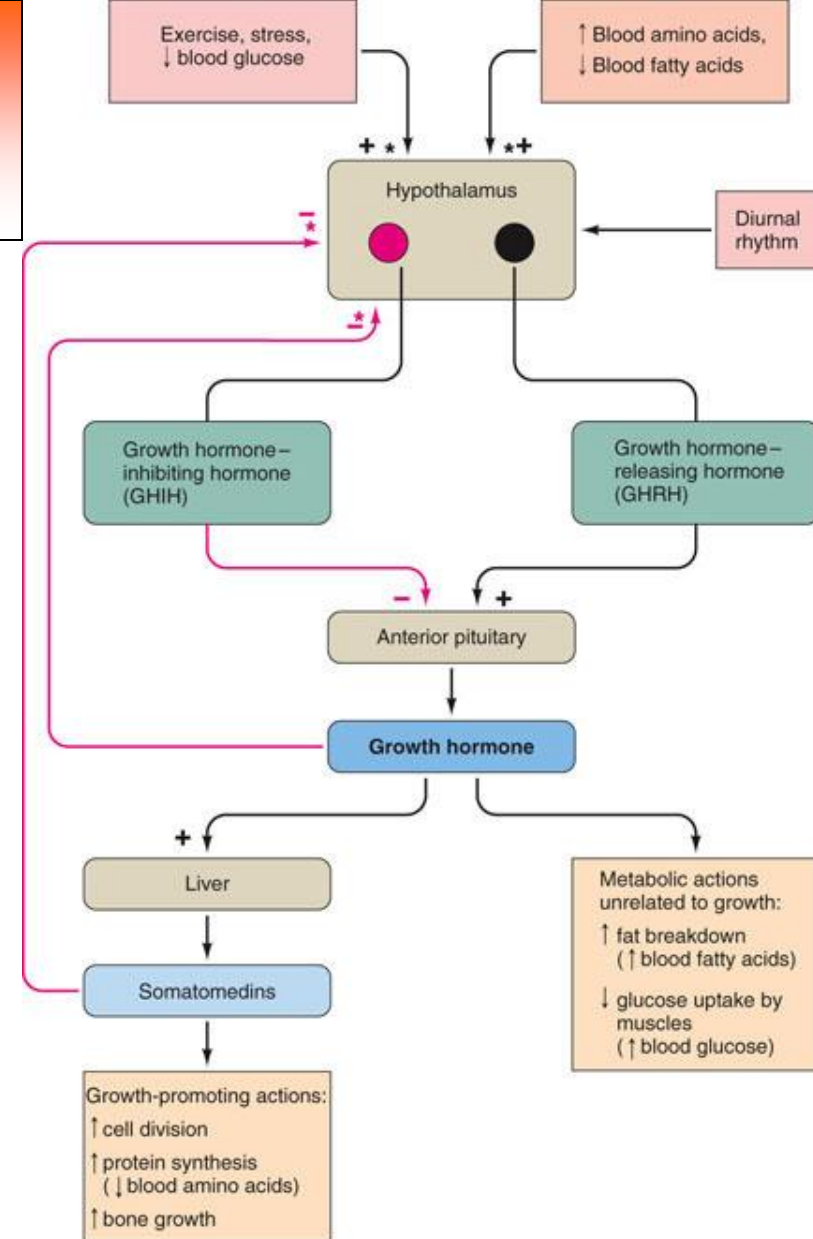

*These factors all increase growth hormone secretion, but it is unclear whether they do so by stimulating GHRH or inhibiting GHIH, or both.

*These factors inhibit growth hormone secretion in negative-feedback fashion, but it is unclear whether they do so by stimulating GHIH or inhibiting GHRH or inhibiting the anterior pituitary itself.

Growth Hormone Releasing Hormone

- GHRH: 44 aa, simple peptide
 - First 29 residues highly conserved
 - Expressed in arcuate and ventromedial nuclei
- Target cells: ant. pit. somatotrophs
 - Heptahelical G-protein coupled receptor
 - Stimulating adenylyl cyclase
 - PKA through activating plasma Ca^{2+} channels
 - PLC through IP_3 , increased intracell Ca^{2+}
 - Synth. GH + discharge stored GH
 - Cortisol, thyroid hormones required

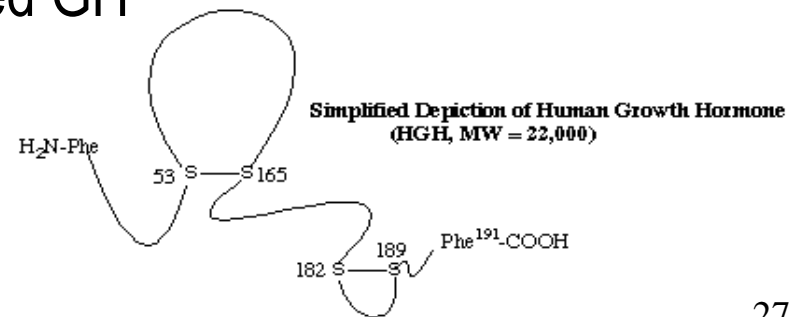

- GH-releasing hormone (GHRH) and Ghrelin stimulate GH secretion
- A 44-amino-acid peptide was isolated from a human pancreatic tumor that specifically stimulated GH secretion, both in vitro and in vivo, from the rat pituitary gland.

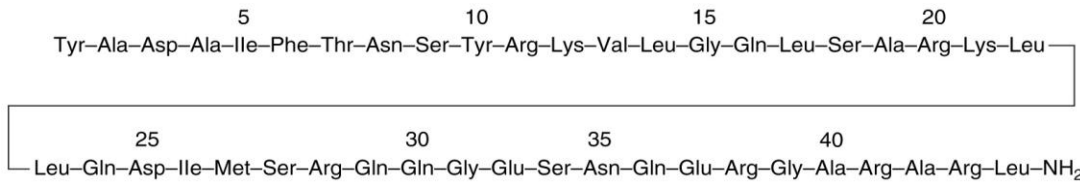
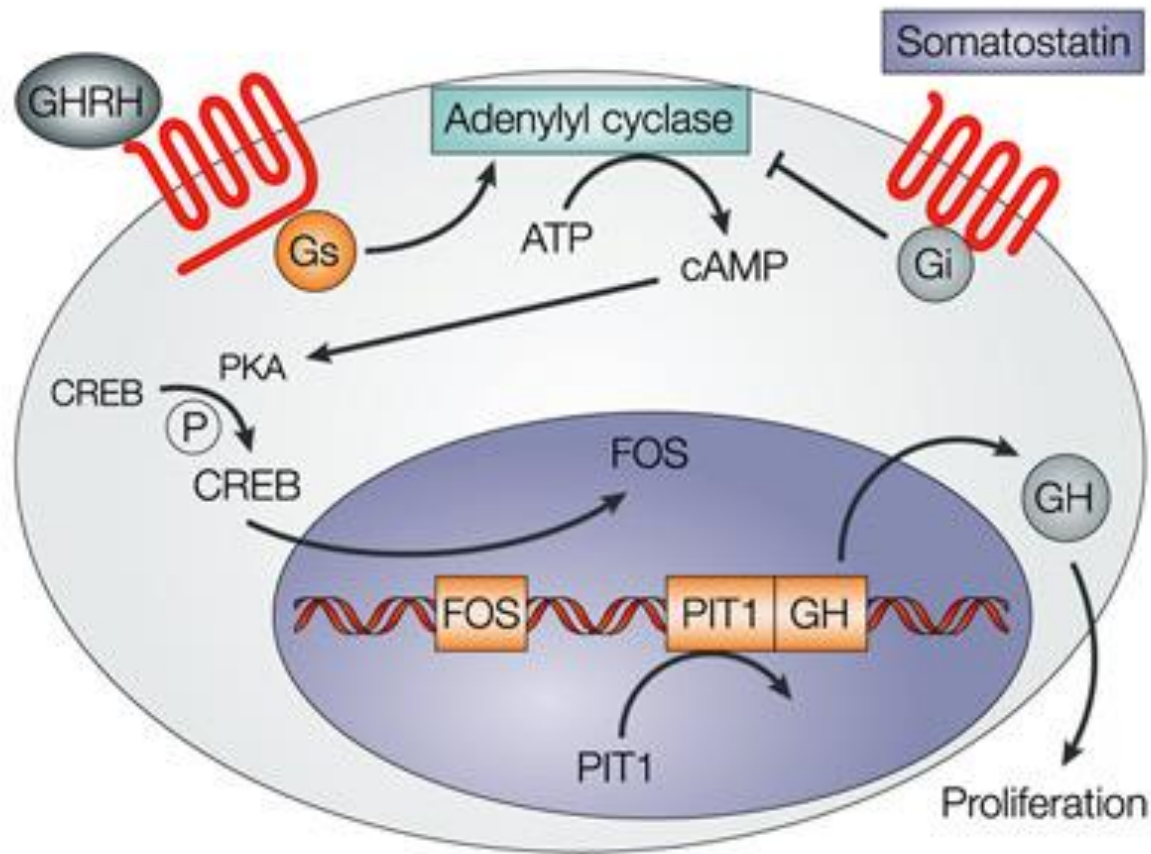

Fig. 6-9: Primary structure of a growth hormone-releasing hormone (GHRH).

	1	2	3	4	5	6	7	8	9	10
Mammal	pGlu	His	Trp	Ser	Tyr	Gly	Leu	Arg	Pro	Gly-NH ₂
Chicken I	pGlu	His	Trp	Ser	Tyr	Gly	Leu	Gln	Pro	Gly-NH ₂
Catfish	pGlu	His	Trp	Ser	His	Gly	Leu	Asn	Pro	Gly-NH ₂
Chicken II	pGlu	His	Trp	Ser	His	Gly	Trp	Tyr	Pro	Gly-NH ₂
Dogfish	pGlu	His	Trp	Ser	His	Gly	Trp	Leu	Pro	Gly-NH ₂
Salmon	pGlu	His	Trp	Ser	Tyr	Gly	Trp	Leu	Pro	Gly-NH ₂
Lamprey	pGlu	His	Tyr	Ser	Leu	Glu	Trp	Lys	Pro	Gly-NH ₂

Fig. 6-11: The primary structures of some known forms of GnRH [22]. The amino acid residues that differ from the mammal appear enclosed here.



CRE=Cyclic AMP Response Element

CREB=Cyclic AMP Response Element Binding Protein

FOS=protein that regulates several genes

PIT1=Pituitary specific transcription factor

Nature Reviews | **Cancer**

- Amount of GH discharged depends on:
 - Amount of GHRH
 - Somatotroph GHRH receptor status
 - Amount stored GH
- Episodic GHRH → episodic GH release
- Termination GH burst w/ negative feedback on brain neurons
 - Neurons prod SST
 - Somatotrophs have SST receptors
- Cortisol → GHRH receptor expression + GH expression

Growth Hormone (somatotropin)

- GH accounts for 4% to 10% of the wet weight of the ant. pit. in the human adult (5 mg to 10 mg per gland).
- GH is polypeptide of 191 a.a. made by somatotrophs and contains two disulfide bonds. It is very similar to Prl and is identical in 161 a.a.
- GH is made as a prohormone and is cleaved to GH by proteolysis.
- GH circulates in the plasma bound to one or more binding proteins.
- Circulating levels of GH decrease 2-3 wks after birth and reach basal levels characteristic of adulthood.

Growth Hormone

- GH remains constant during accelerated growth in early childhood but there is an increase during the maximal growth period around puberty.
- In all mammals studied so far, spontaneous episodes of GH occur several times over a 24 h period and **most during the first 90 minutes of nocturnal sleep.**
- **GHRH** from the hypothalamus and somatostatin control **GH** secretion.

Growth Hormone

- GH is anabolic and enhances amino acid incorporation into muscle protein and stimulates collagen deposition and produces a concomitant decrease in blood urea nitrogen and amino acid levels.
- Effects of GH are mediated by somatomedins (insulin-like growth factors, IGF's) released from the liver in response to GH.
- They stimulate cellular growth in a number of organs and tissues.

Growth Hormone

- **Acromegalics** may display increased BMR and lipolytic actions of GH combined with anti-insulin actions on other tissues, may result in hyperglycemia as a symptom of developing **diabetes mellitus**.
- In young animals the epiphyses of long bones are separated from the shaft of bones by an epiphyseal cartilaginous plate. **Chondrogenesis** is accelerated by GH which results in widening of the **epiphyseal plates** as more **chondroitin sulfate** is made and released by chondrocytes. This is also used as a bioassay for GH.

Somatostatin (SST)

- Somatostatin (SST) [also known as growth hormone-inhibiting hormone (GHIH) or somatotropin release-inhibiting factor (SRIF)]
- SST: inhibition of GH
- 14 aa's; 2 cys → intrachain disulfide bond cyclization
- SRIF gene on chromosome 3 → 116 aa preproSRIF
- Convertase → 14 aa brain peptide
 - also pancreas, GI tract SST's

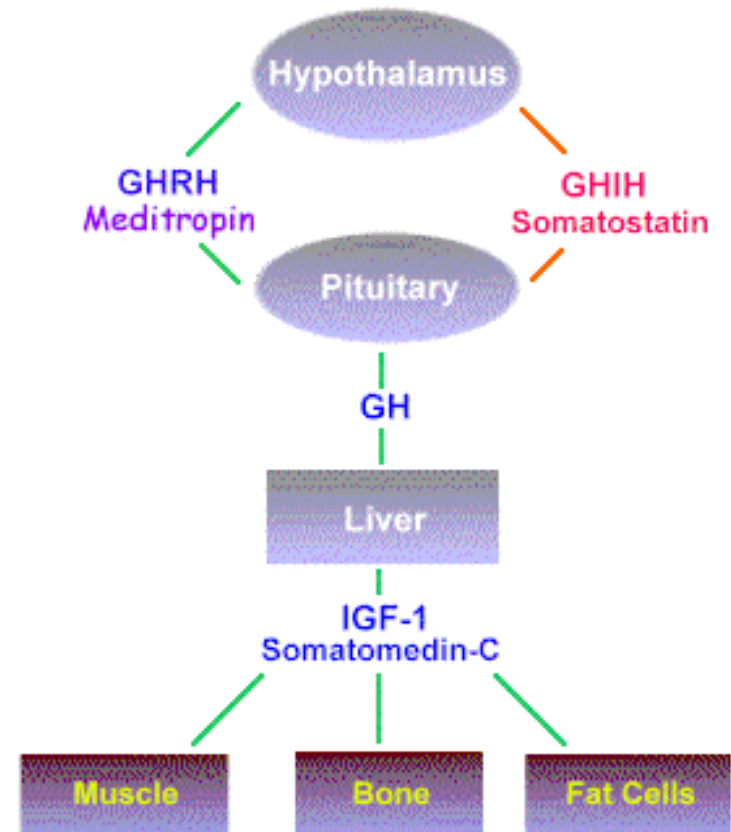

copyright © 1998 Los Gatos Longevity Institute

- Somatostatin (SST) inhibits GH secretion from somatotrophs
 - A tetradecapeptides
 - The oxidized form (ring) and the reduced (linear) forms of the peptide both have full biological activity in vitro and in vivo.

Ala-Gly-Cys-Lys-Asn-Phe-Phe-Trp-Lys-Thr-Phe-Thr-Ser-Cys

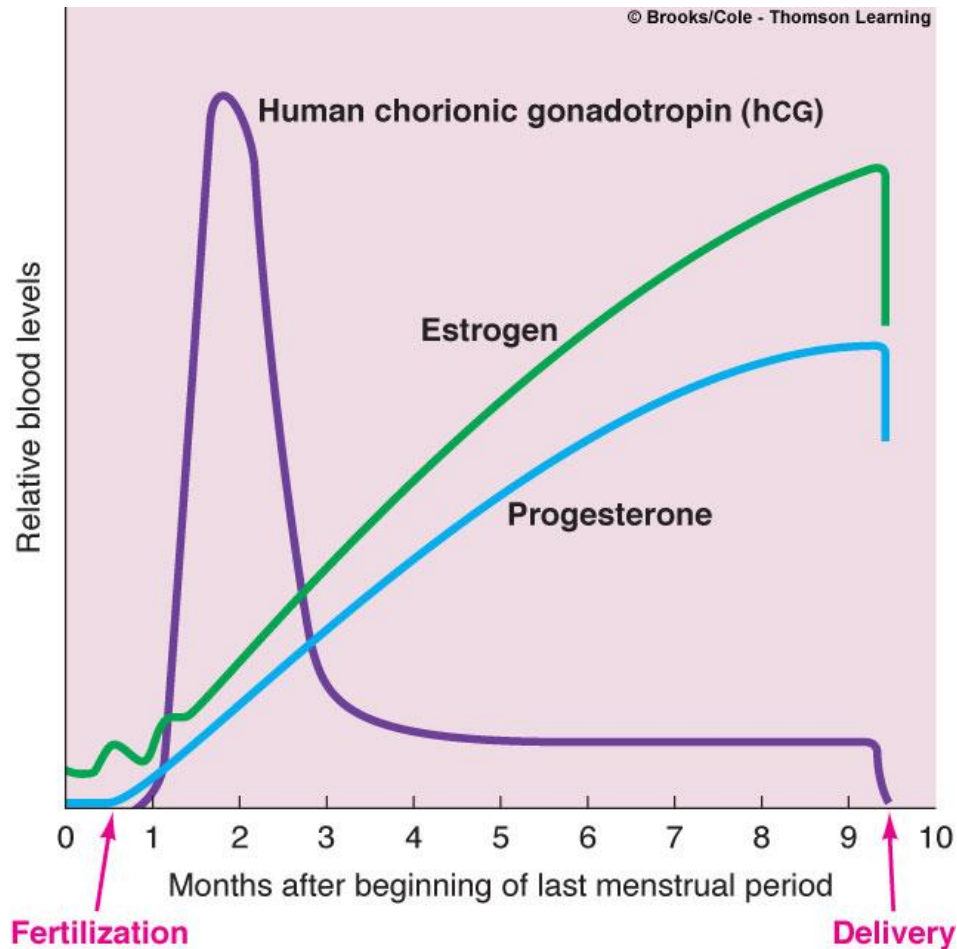

Fig. 6-7: Primary structure of mammalian somatostatin.

- **SRIF's** (somatotropin release-inhibiting factor)
 - Heptahelical receptors
 - G-protein coupled
 - Inhibit adenylate cyclase
- **Somatotrophs**: turn off GH secretion
- **Widespread effects**
 - Inhibits calcitonin, PTH, renin, gastric HCl, ACh, adrenergic neurotransmitters
 - Lowers serum [glucose]
 - TRH antagonist
 - Antagonizes messengers important to cell proliferation

2. Control of Prolactin Secretion

Secretion Rates of Placental Hormones



Sucking Reflexes

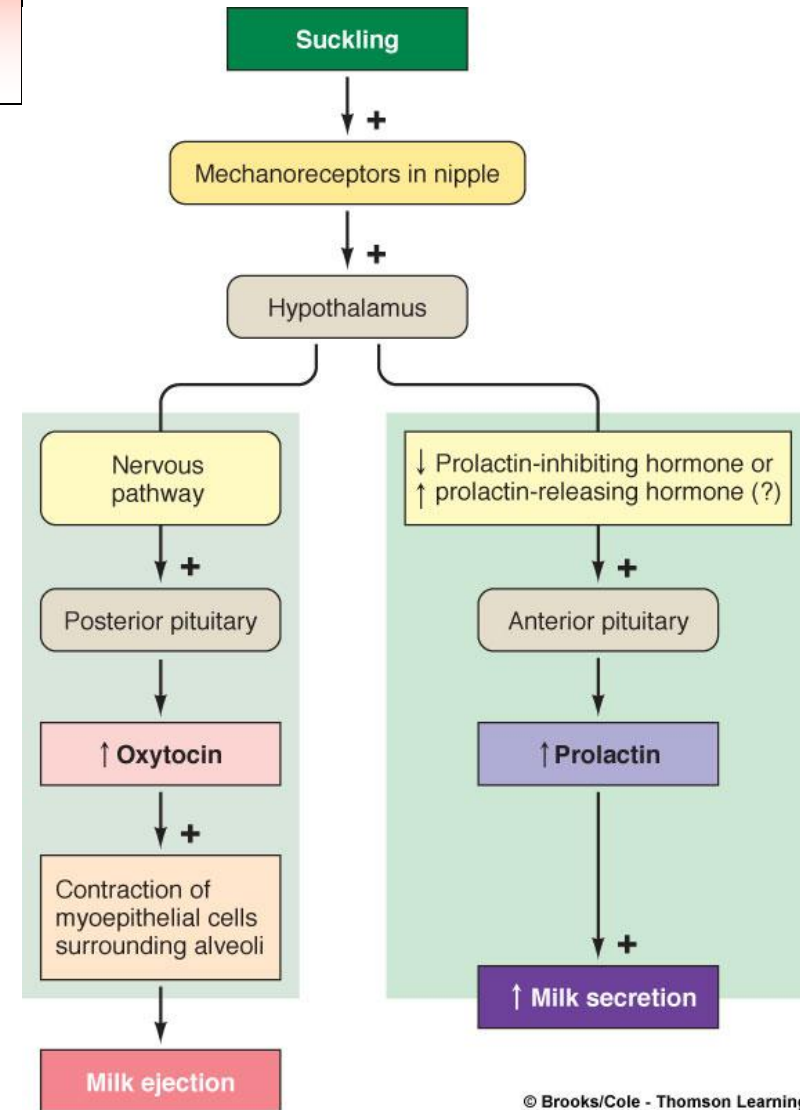

© Brooks/Cole - Thomson Learning

Prolactin (Prl)

- Prl is a **single chain polypeptide** ~ 23 kDa with 3 disulfide bonds.
- Structural variants of Prl arise from differential splicing and CHO moieties vary among species.
- Serum Prl increases at puberty but only modestly compared to the rise in FSH/LH.
- **E₂ stimulates Prl secretion.**
- Prl increases during pregnancy and reaches maximal values at parturition.

Prolactin

- Production and secretion of Prl by lactotrophs is stimulated by E_2 . E_2 increases mitotic activity and cell number of pituitary lactotrophs.
- Prl levels decrease by 3 wks in mothers that do not nurse. Concentrations of Prl in amniotic fluid exceed that found in serum.
- Mammatrophic action of Prl requires participation of E_2 , P_4 , insulin, glucocorticoids and GH. In ovx (ovaryectomized) rabbits given E_2 and P_4 to induce lobuloalveolar growth, Prl was able to induce milk production.

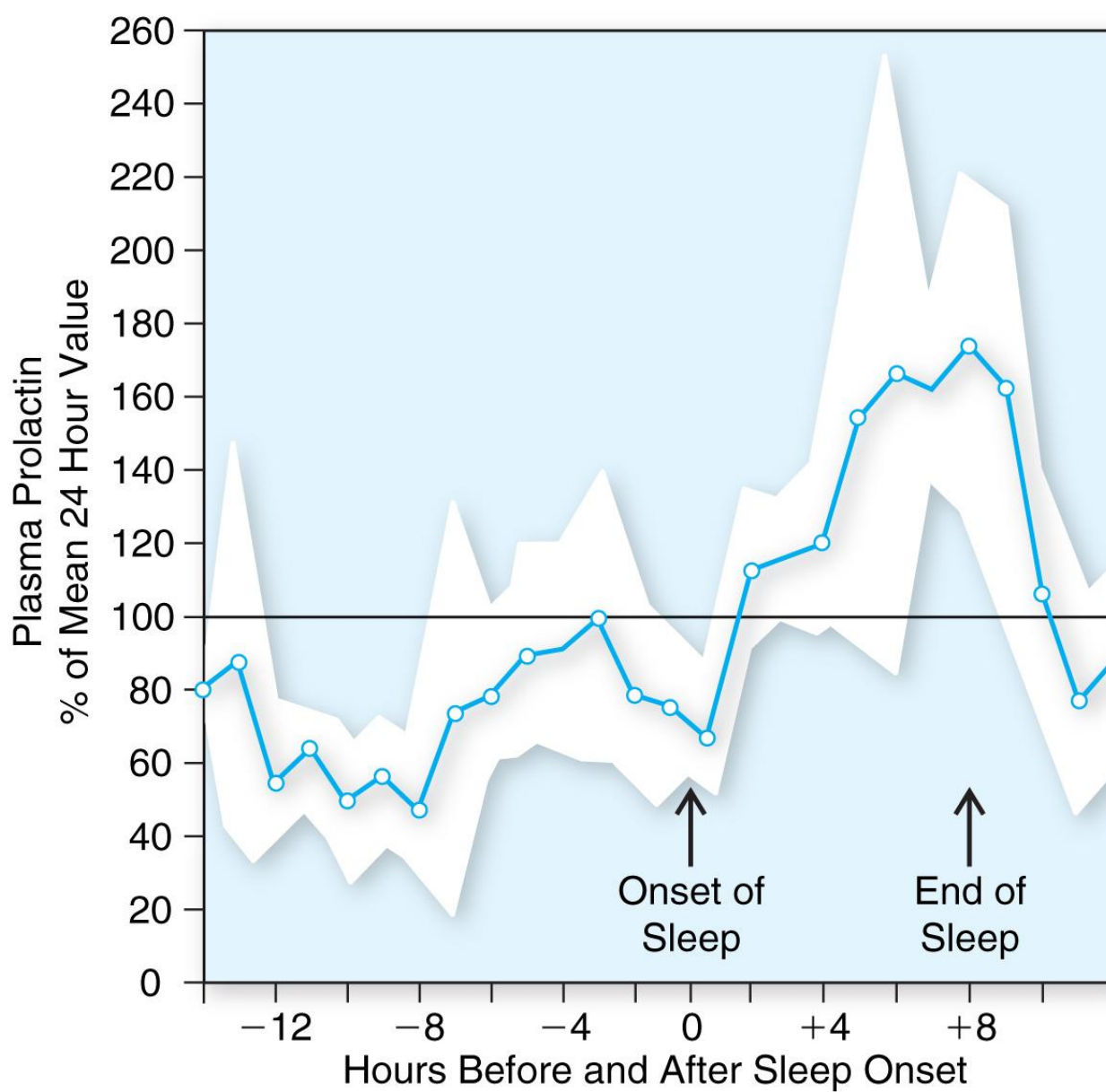

Fig. 5.6. Human plasma levels of PRL during a 24-hour period.

Prolactin

- Prl is luteotrophic in some mammals and may act in concert with LH and FSH on the CL to stimulate P_4 biosynthesis and secretion.
- Prl has profound effects on the growth, differentiation and function of hair, sebaceous glands, and brood patch feathers.
- In pigeons and doves Prl controls the production of so-called crop sac “milk”. Epithelium of the walls of the crop thicken and cells accumulate lipid and begin to degenerate and form crop milk.

Prolactin Inhibiting Hormone (PIH)

- Basal PRL release unless interrupted w/ hypothalamus signal
- PIH=dopamine
 - Also produced by tuberoinfundibular, tuberohypophyseal dopamine neurons
- Dopamine receptor (D2)

Signals to Advance PRL Synthesis

- Estrogens stimulate PRL gene expression
 - Inhibit tuberohypophyseal DA neurons
 - Induce lactotroph hyperplasia
- TRH stimulates PRL secretion
 - Not physiological release factor during lactation
- Oxytocin stimulates PRL secretion (?)
- Angiotensin II stimulates PRL secretion

- Prolactin Releasing Hormone??
 - VIP (from GHRH family) stim's PRL secr'n in vitro
 - Acts through adenylate cyclase
 - Produced by lactotrophs (autocrine?)
- Serotonin & adrenaline stimulate PRL secretion
- Histamine may inhibit PRL via H2 receptors

Luteinizing Hormone, Follicle-Stimulating Hormone, and Thyrotropin are Glycoprotein Hormones

- Three hormones of the anterior pituitary are glycoproteins, containing up to 33% carbohydrate by weight.
- LH, FSH, and TSH contain covalently bound carbohydrate moieties at one or more positions within their structures.
- Composed of two chains, so called α and β subunits.
- α subunit: identical to each other; 92 aa's.
- β subunit: 110-111 aa's for LHs; 112-118 aa's for TSHs, 117-121 aa's for LHs; 145 aa's for human chorionic gonadotropin (hCG)

Luteinizing Hormone
(LH)

Thyrotropin
(TSH)

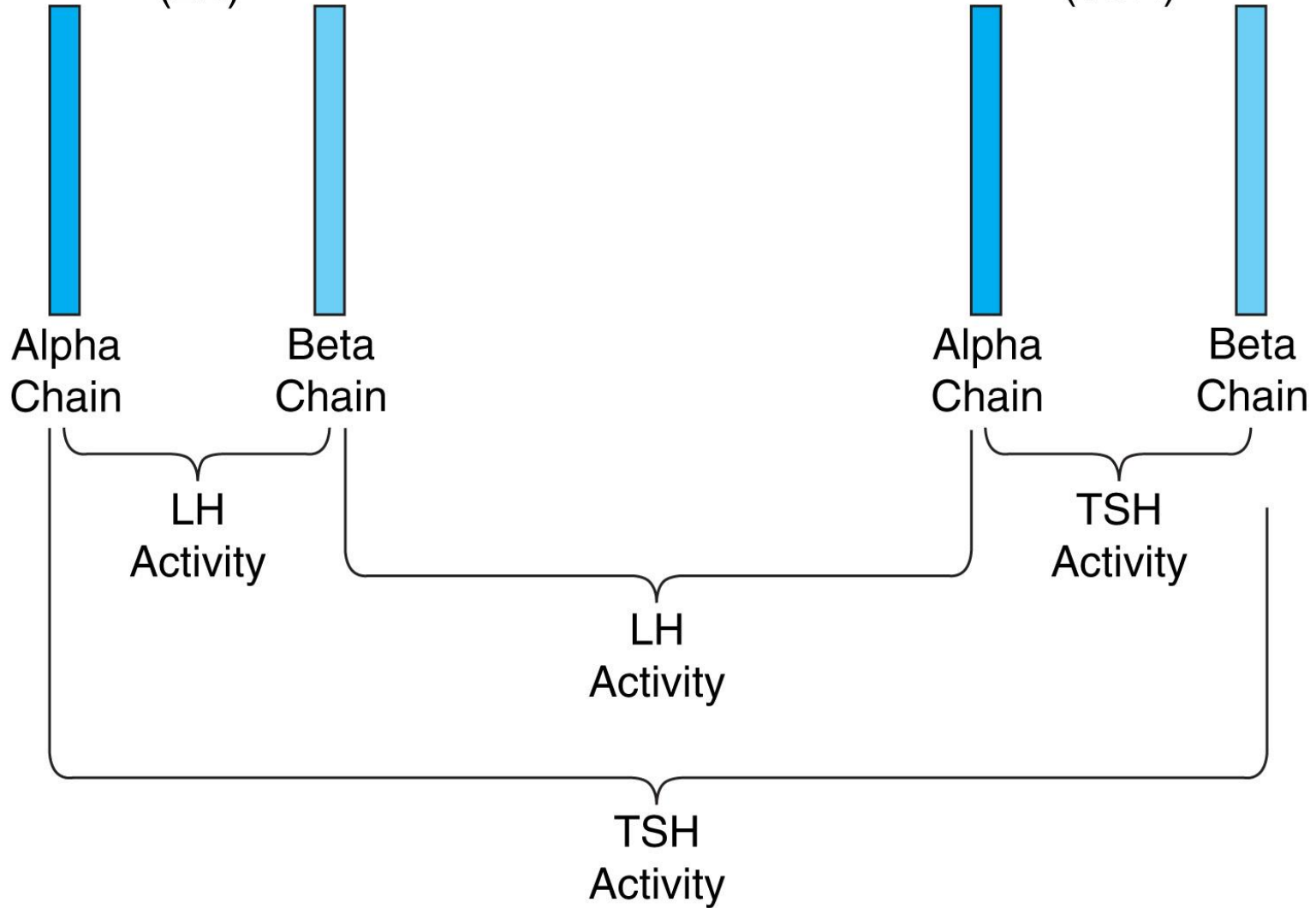
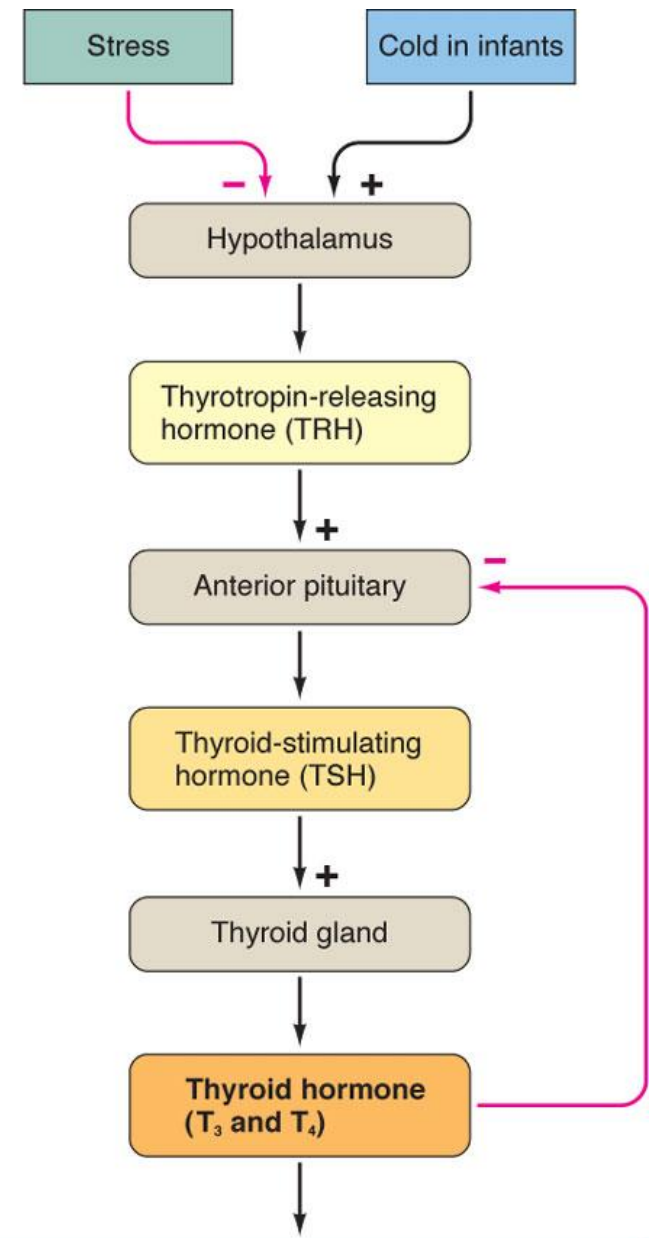

Fig. 5.7. Glycoprotein subunit hybridization studies.

3. Regulation of Thyroid Hormone Secretion

© Brooks/Cole - Thomson Learning



↑ Metabolic rate and heat production; enhancement of growth and CNS development; enhancement of sympathetic activity

Thyrotropin Releasing Hormone (TRH) → Thyroid Stimulating Hormone (TSH)

- Gene for TRH on chromosome 3
 - Inhibit expression by glucocorticoids
- Precursor protein; post-translational cleavage
 - 255 aa's
 - TRH tripeptide duplicated 5 times in sequence
- Most important regulator of synthesis of TRH=thyroid hormones (T3 > T4)
 - Long-loop negative feedback

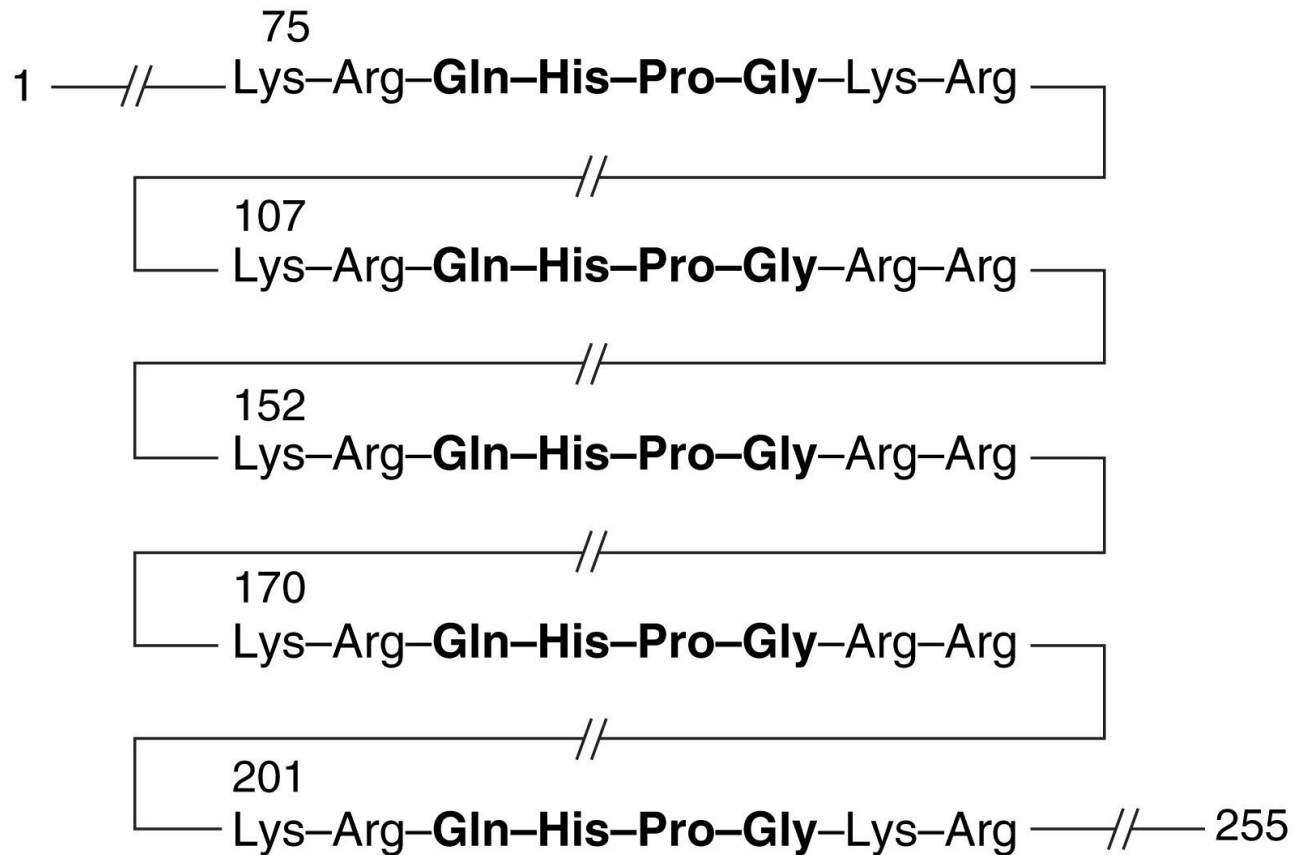

Fig. 6-6: The cDNA sequence of the **TRH precursor encodes a protein of 255 amino acids**. The sequence **Gln-His-Pro-Gly** occurs five times and each tetrapeptide is flanked by paired basic residues (Lys Arg or Arg Arg). Thus, the prohormone generates five TRH molecules from each precursor protein.

- **Thyrotropin-releasing hormone (TRH)** stimulates synthesis and secretion of TSH
 - From about 25,000 ovine and porcine hypothalamic fragments, about 1 mg of TRH was obtained.

NH₂–His–Pro–Glu–OH

NH₂–Pro–Glu–His–OH

NH₂–Pro–His–Glu–OH

NH₂–His–Glu–Pro–OH

NH₂–Glu–Pro–His–OH

NH₂–Glu–His–Pro–OH

(pyro)–Glu–His–Pro–NH₂

Copyright © 2007 Pearson Prentice Hall, Inc.

Fig. 6-4: Six synthetic peptides related to thyrotropin-releasing hormone (TRH).

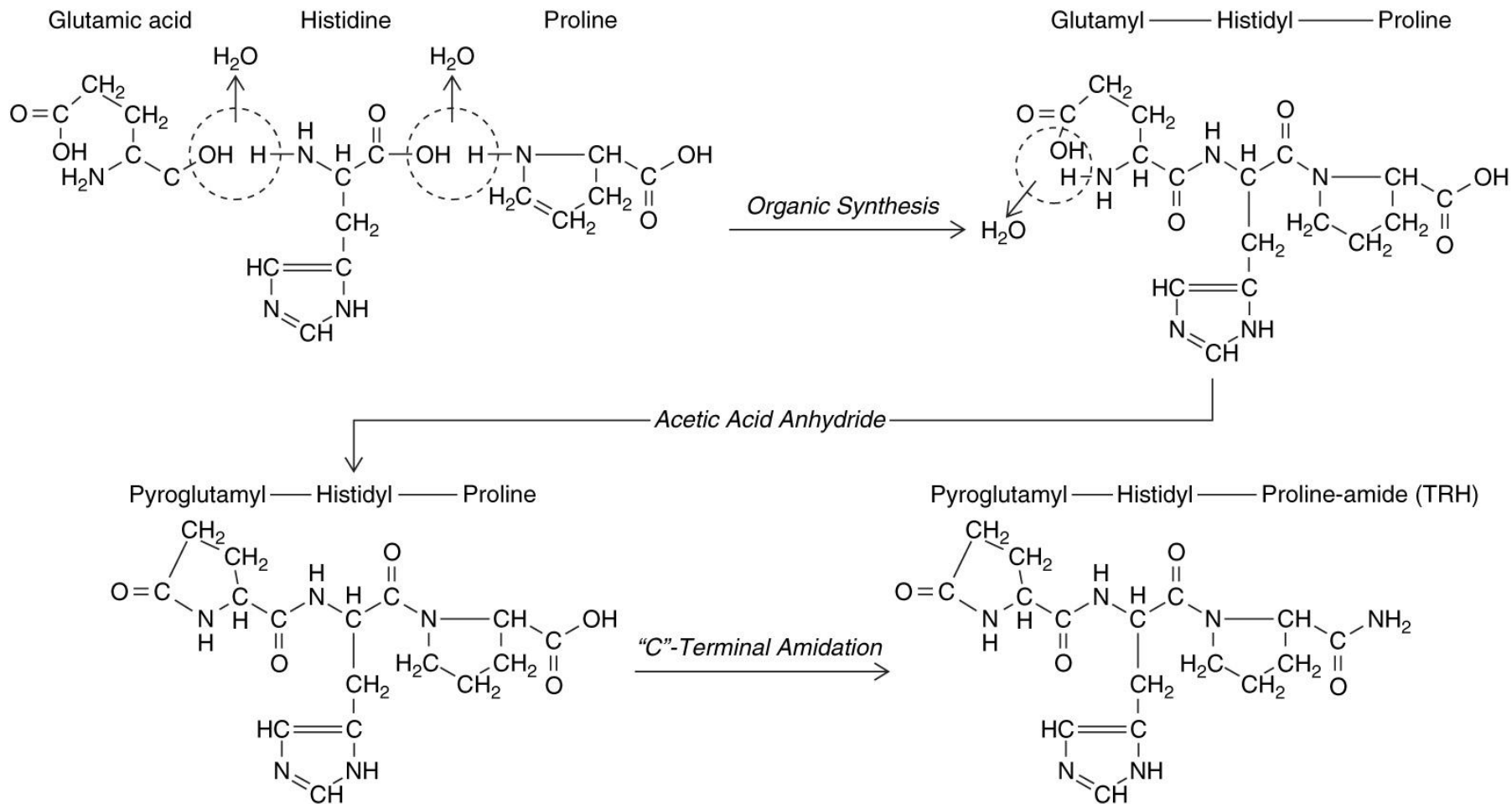

Fig. 6-5: Synthesis of thyrotropin-releasing hormone (TRH).

- **Episodic secretion** → portal system
 - Circadian rhythm of TSH secretion
 - Stimulated by a adrenergic receptor agonists
 - Inhibited by dopamine agonists, endorphins, SST
- **Target cells: anterior pituitary thyrotrophs**
 - Heptahelical receptor
 - Coupled to G protein
 - Activates IP_3 pathway
 - PLC and PKC activity
 - Synthesis and secretion of TSH
- Gene for TRH receptor on chromosome 8

- Control of TRH secretion
 - **Noradrenergic neurons** stimulate TSH secretion by a stimulatory action on TRH-secreting neurons.
 - **Glucocorticoid** excess inhibits thyroid function at a suprapituitary level

4. Regulation of FSH & LH Hormone Secretion

Correlation between hormonal levels and cyclic ovarian and uterine changes

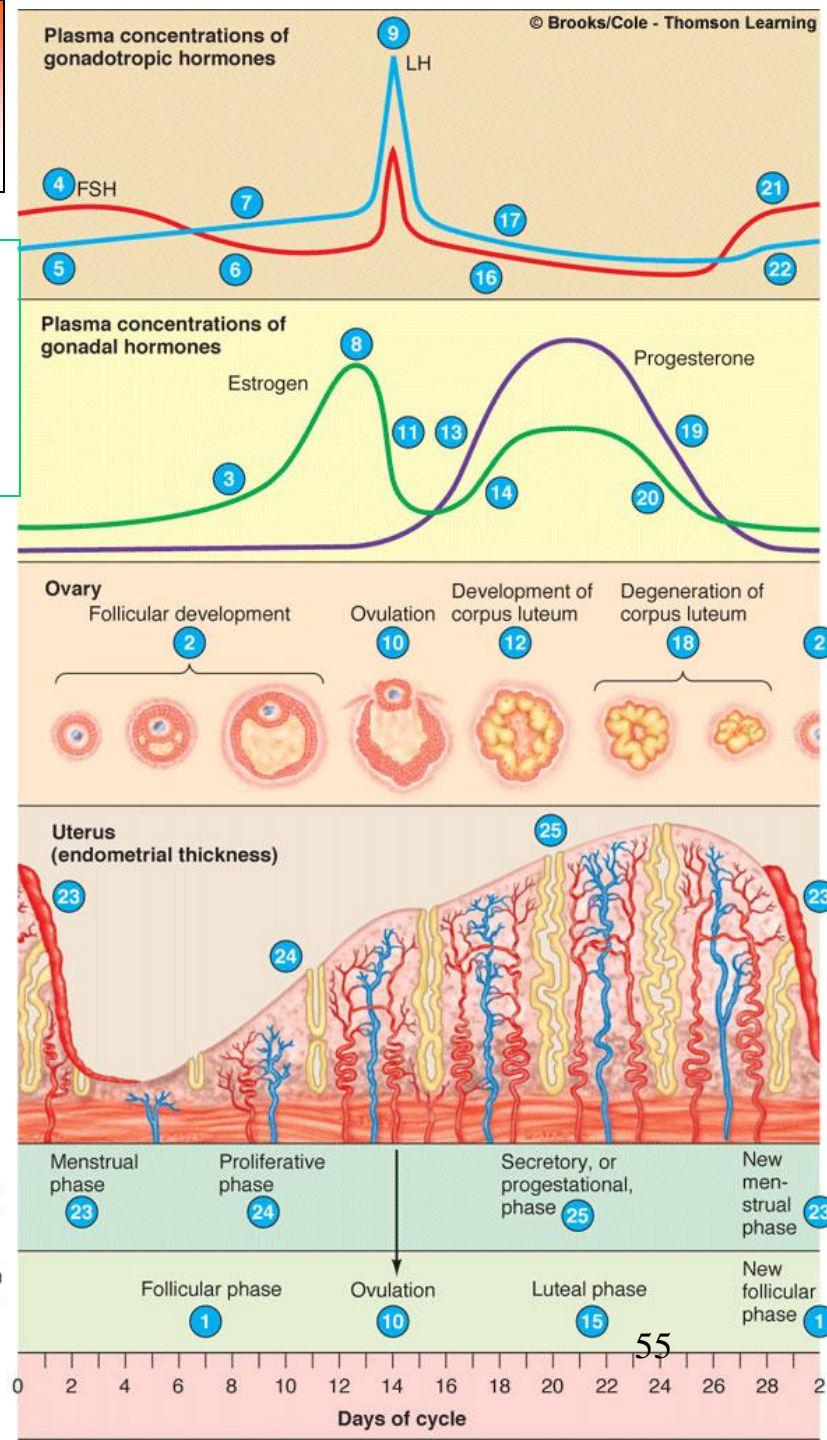

Feedback control of FSH and tonic LH secretion during the follicular phase

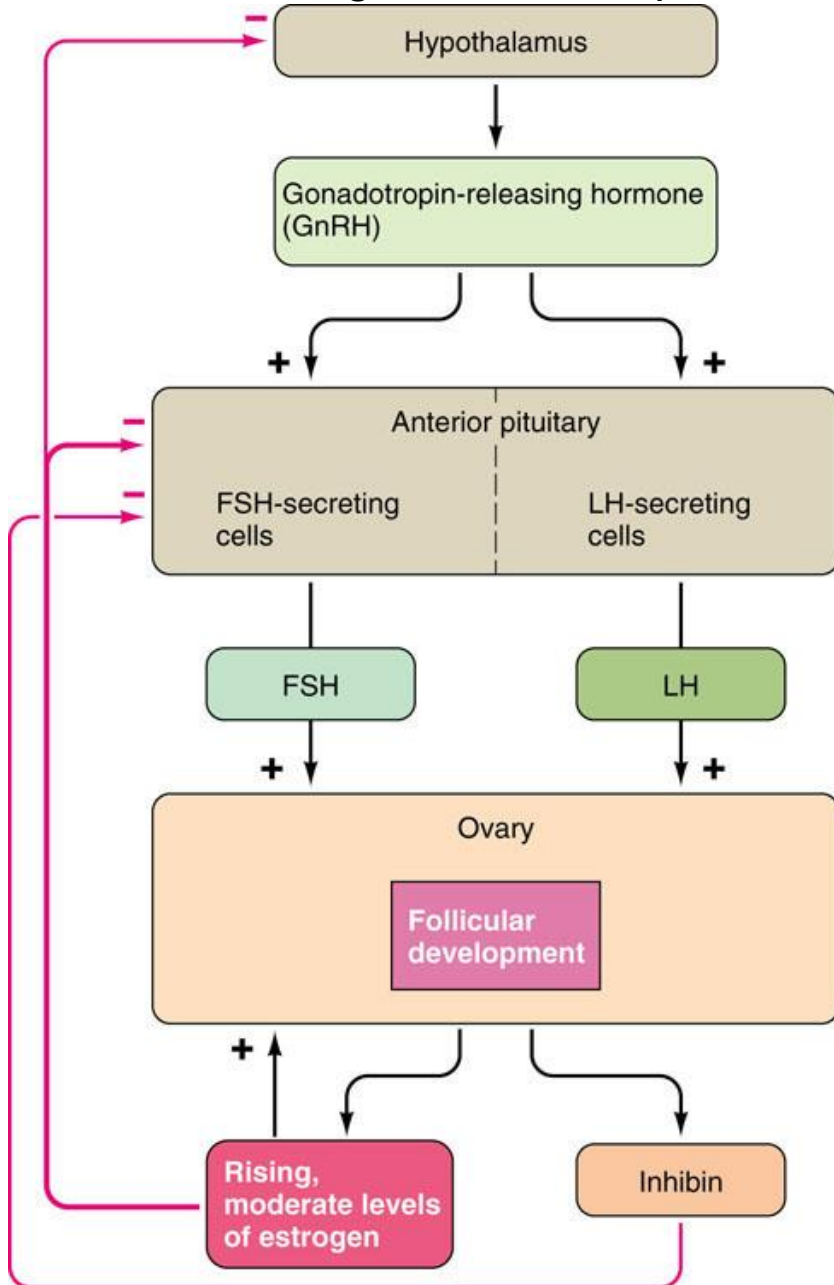

Control of the LH surge at ovulation

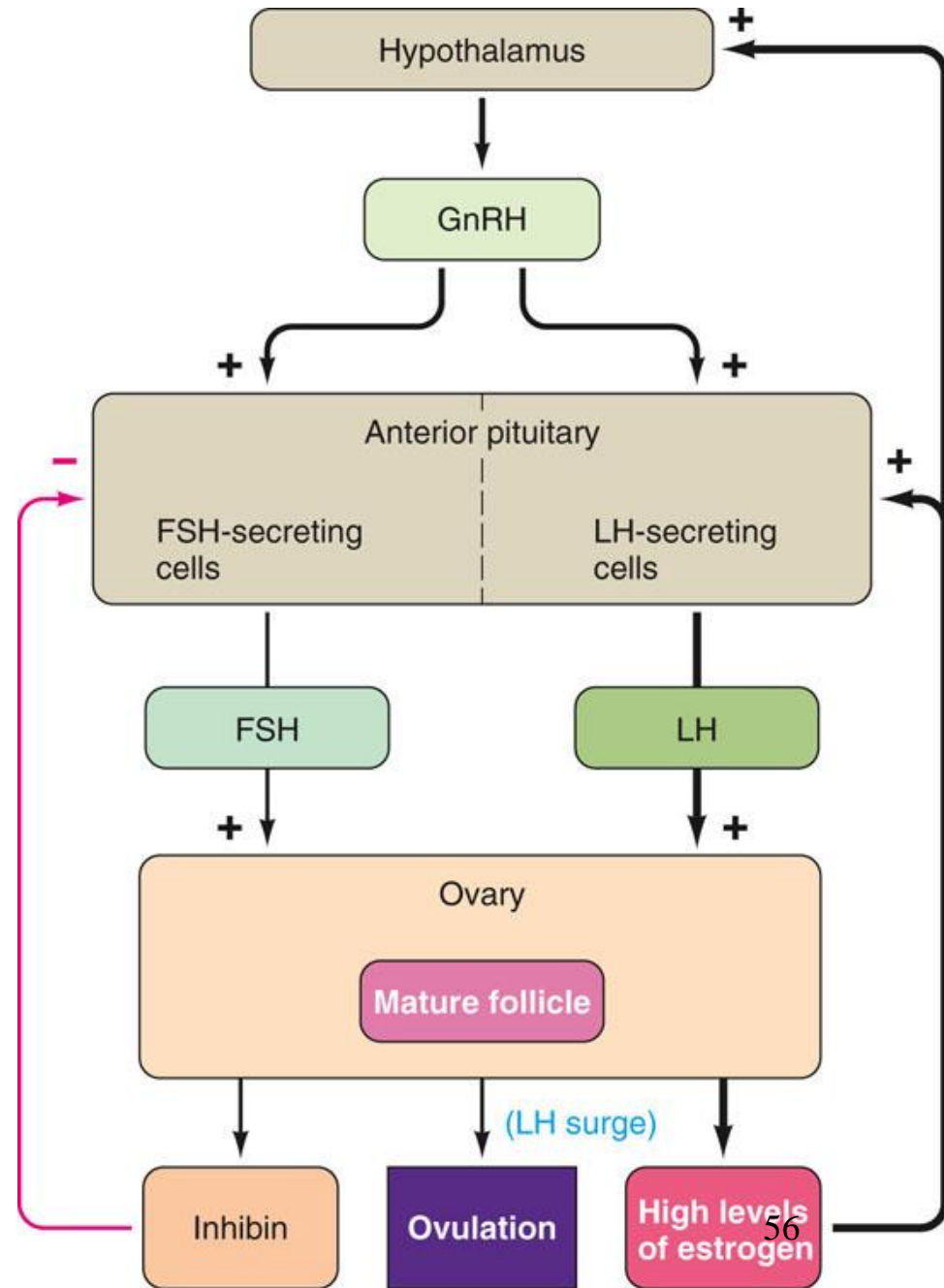

Gonadotropin Releasing Hormone → FSH, LH

- Mammalian **decapeptide**; well conserved
 - Chromosome 8p21-8p11.2
- GnRH neurons
 - Human development in **olfactory placode**
 - Migrate via olfactory bulb guided by **anosmin** (neural cell adhesion molecule)
 - Anosmin also reg's migration olfactory epithelium (including those from vomeronasal organ)
 - **Anosmin-1** is a secreted, EM associated glycoprotein found in humans and other organisms responsible for normal development, which is expressed in the brain, spinal cord and kidney. Absence or damage to the protein results in Kallmann syndrome in humans, which is characterized by loss of olfactory bulbs and GnRH secretion leading to anosmia and hypothalamic hypogonadotropic hypogonadism. Anosmin-1 is coded by the KAL-1 gene, which is found on the X chromosome; 100 kDa; and is expressed on the outside of cells.

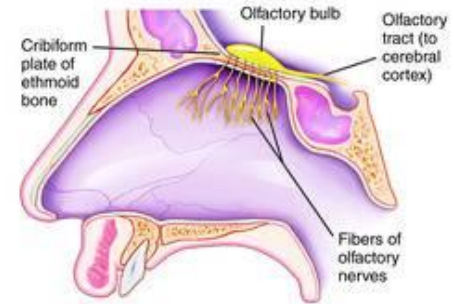

- Gonadotropin-releasing hormone (GnRH) stimulates LH and FSH secretion from gonadotrophs

- A **decapeptide hormone**

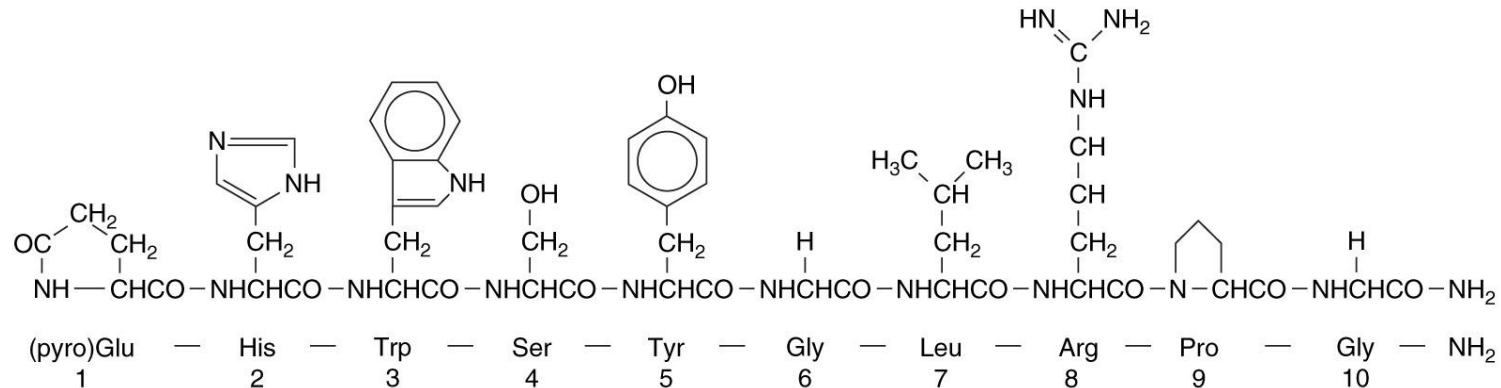

Fig. 6-10: Primary structure of mammalian gonadotropin-releasing hormone (GnRH).

- GnRH neurons (cont'd)
 - Intrinsic rhythmic activity → pulsatile release
 - Stimulating input via
 - Neuropeptide Y
 - Noradrenergic neurons @ alpha-1 adrenergic receptors
 - Inhib. input via
 - GABAergic neurons (important prior to puberty)
 - Some NPY neurons
 - β -endorphin neurons
 - Implicated in stress; negative feedback of androgens, progesterone
 - Dopaminergic neurons

- GnRH target cells: **gonadotrophs**
- GnRH receptors
 - Encoded by chromosome 4q13.2-13.3
 - Contains response elements that regulate its expression
 - For glucocorticoid, progesterone, thyroid hormones, CREB
 - G-protein linked heptahelical transmembrane
 - Gαq → PLC pathway
 - IP₃-Ca²⁺, DAG-PKC-MAP kinase
 - expression of a subunit common to FSH/LH

- GnRH receptors (cont'd)
 - Also → opening of voltage gated Ca^{2+} channels → Ca^{2+} influx
 - Important to release gonadotropins
 - selective expression LH- β subunit
 - Downregulated when continuous (not pulsatile) GnRH
 - Upregulated w/ high pulses GnRH
- FSH, LH
 - Glycoprotein similar to TSH, hCG
 - Share common α subunit
 - Hormone specific β subunits

- FSH/LH α subunit
 - Chromosome 6
 - Required for receptor binding
 - Expression controlled by several hormones
 - Coordinated w/ expression β subunit genes
 - In gonadotrophs, stimulated by
 - GnRH via DAG-PKC-MAP kinase pathway
 - Inhibited by
 - Estrogens
 - Unaffected by thyroid hormones

• FSH β subunit

- Chromosome 11
- Required for receptor specificity
- Highest when low freq GnRH pulses received by gonadotrophs
 - GnRH pulses @ higher frequency \rightarrow suppression FSH β subunit
 - Continuous GnRH \rightarrow absolute inhibiting FSH β subunit
- Activins (similar to inhibins) \rightarrow increased FSH β mRNA (autocrine)
 - High GnRH pulses \rightarrow producing follistatin within pituitary gl.
 - Follistatin binds activins \rightarrow prevent FSH-stimulating activity

- LH β subunit
 - Chromosome 19 (homologous w/ hCG β subunit genes)
 - Required for receptor specificity
 - Stimulated w/
 - GnRH applied @ higher frequency, amplification
 - Suppressed w/
 - Androgens (male), progesterone (female) inhib freq GnRH pulses
 - Estrogens (directly @ pit)
 - Testosterone \rightarrow estradiol in pit (via aromatase)

- FSH/LH β subunit reg'n
 - Higher GnRH pulses \rightarrow upregulating GnRH receptors \rightarrow favors LH β prod'n
 - Sertoli cell inhibin B \rightarrow inhibiting FSH β @ gonadotrophs
 - Inhibin B stimulated by FSH
 - Testosterone/DHT suppress FSH β
 - Via gonadotroph androgen receptors
- FSH/LH secretion pulsatile
 - LH high amplified fluctuations
 - FSH relatively stable amplifications

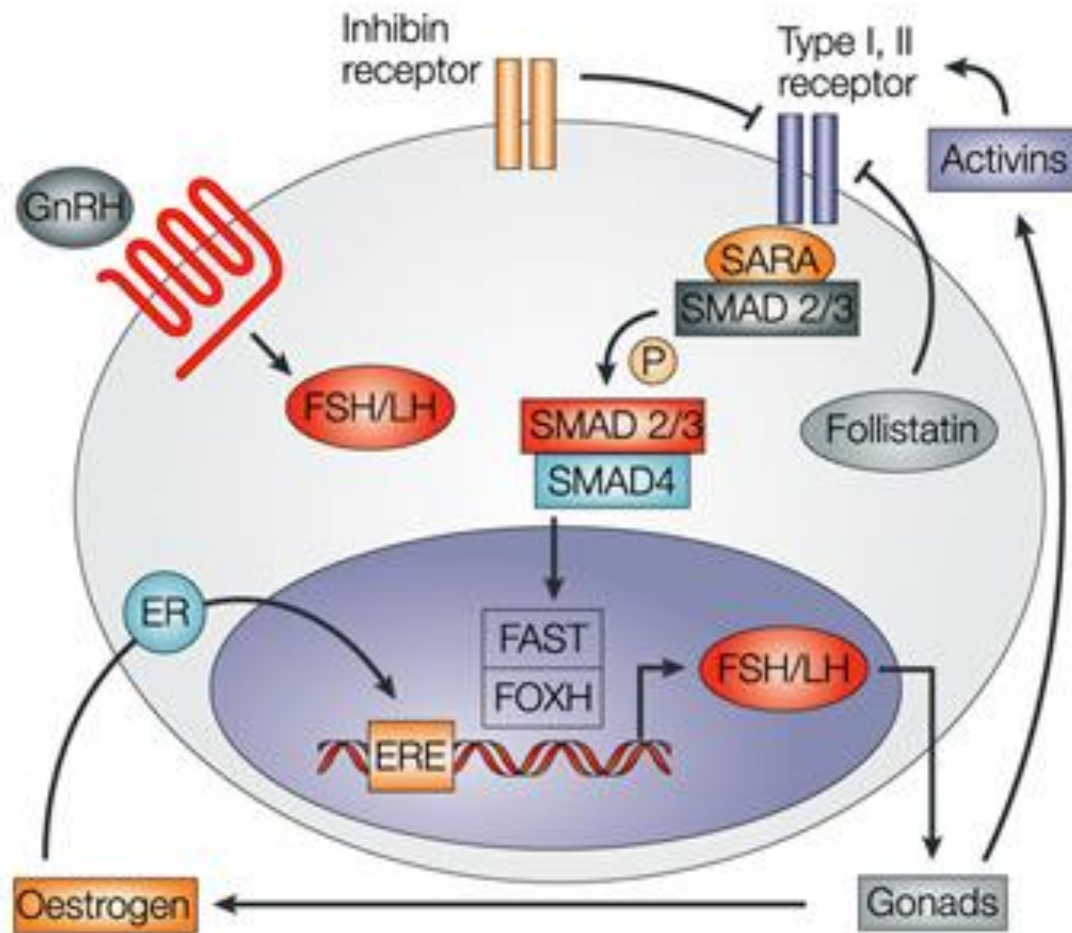

Nature Reviews | Cancer

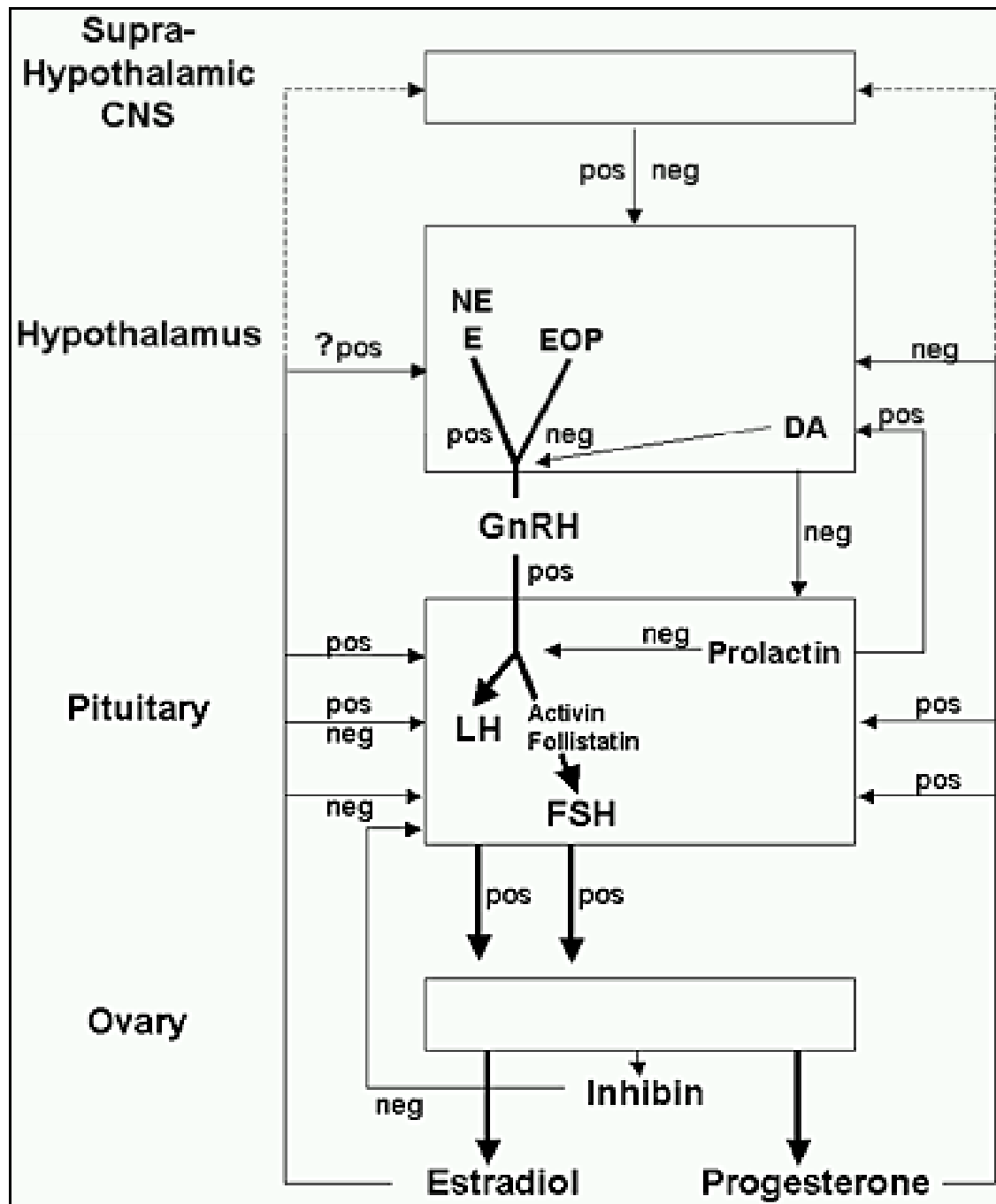

5. Control of Cortisol Secretion

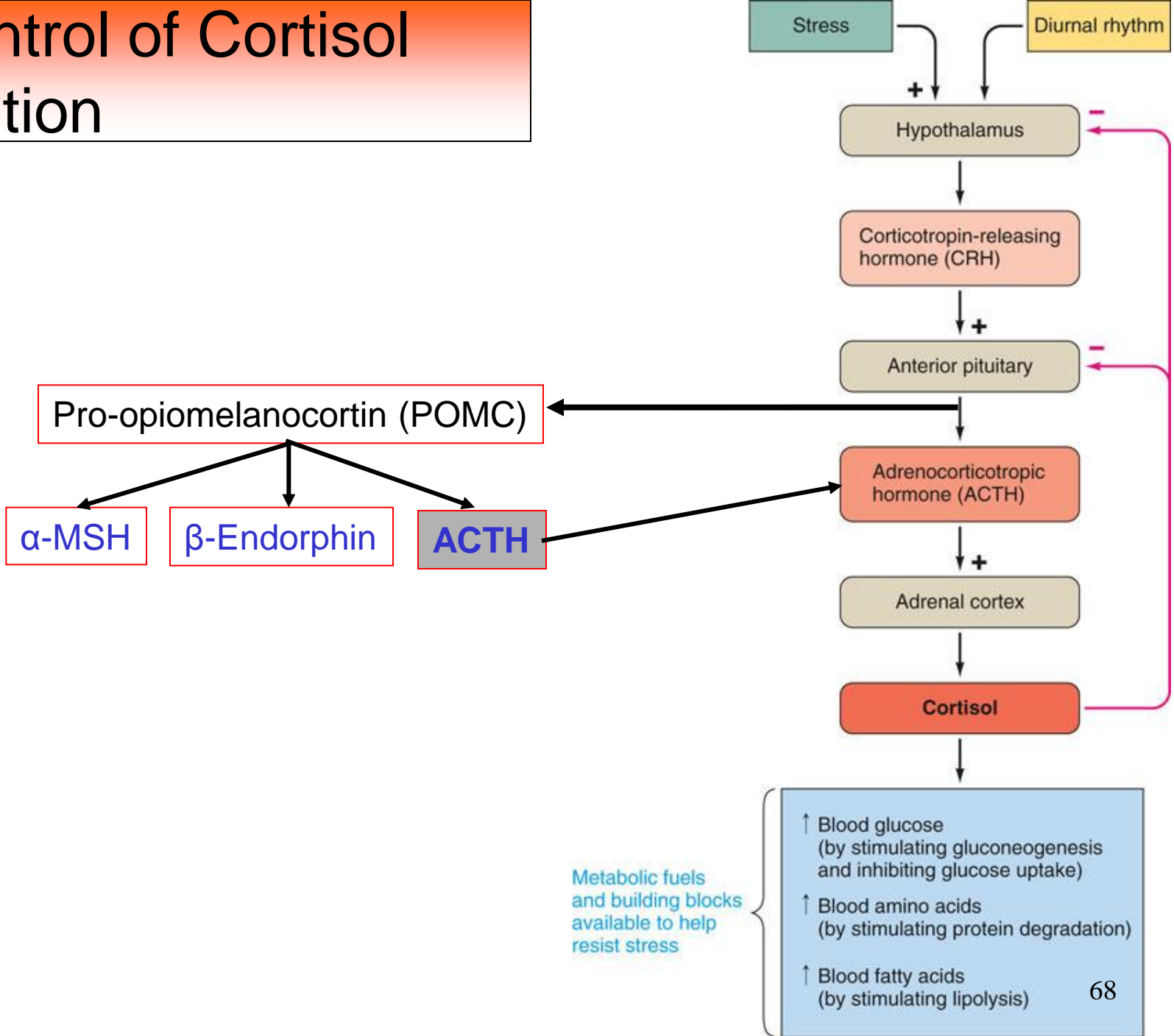

Corticotropin Releasing Hormone (CRH) → ACTH

- **41 aa's; highly conserved**
- **Synthesized in parvocellular region of paraventricular nucleus in hypothalamus**
 - Sensitive to glucocorticoids (negative feedback)
 - Co-express AVP
- **Widely expressed in CNS**
 - Mediate stress-related psychological anxiety
 - Overproducing or increased CRH
 - In CSF correlates w/ major depression, anorexia nervosa
 - Mediates sleep/appetite disturbances of depression

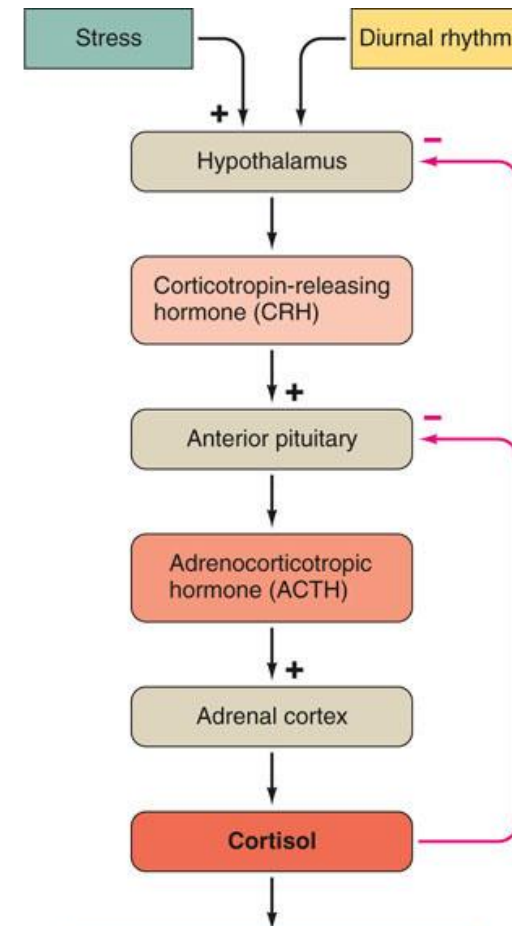

Metabolic fuels and building blocks available to help resist stress

- ↑ Blood glucose (by stimulating gluconeogenesis and inhibiting glucose uptake)
- ↑ Blood amino acids (by stimulating protein degradation)
- ↑ Blood fatty acids (by stimulating lipolysis)

- Corticotropin-releasing hormone (CRH) stimulates **ACTH** secretion from corticotrophs
 - 41-residue peptide

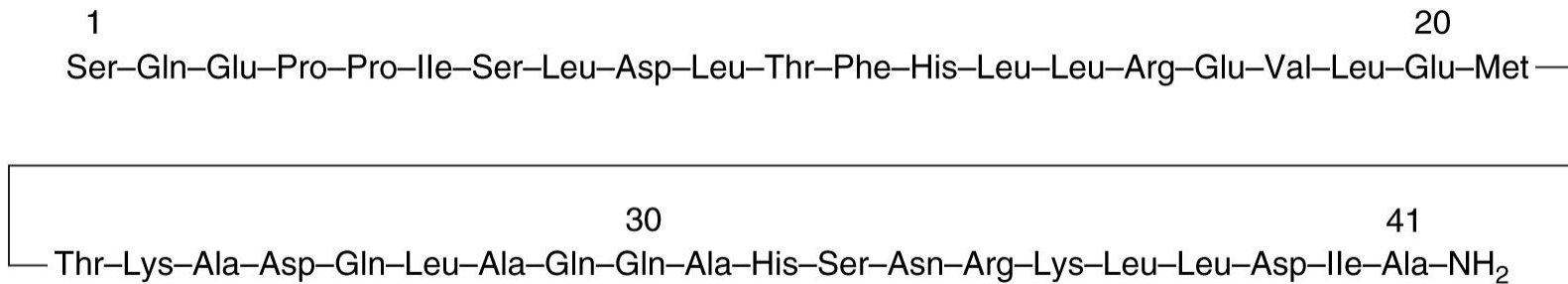
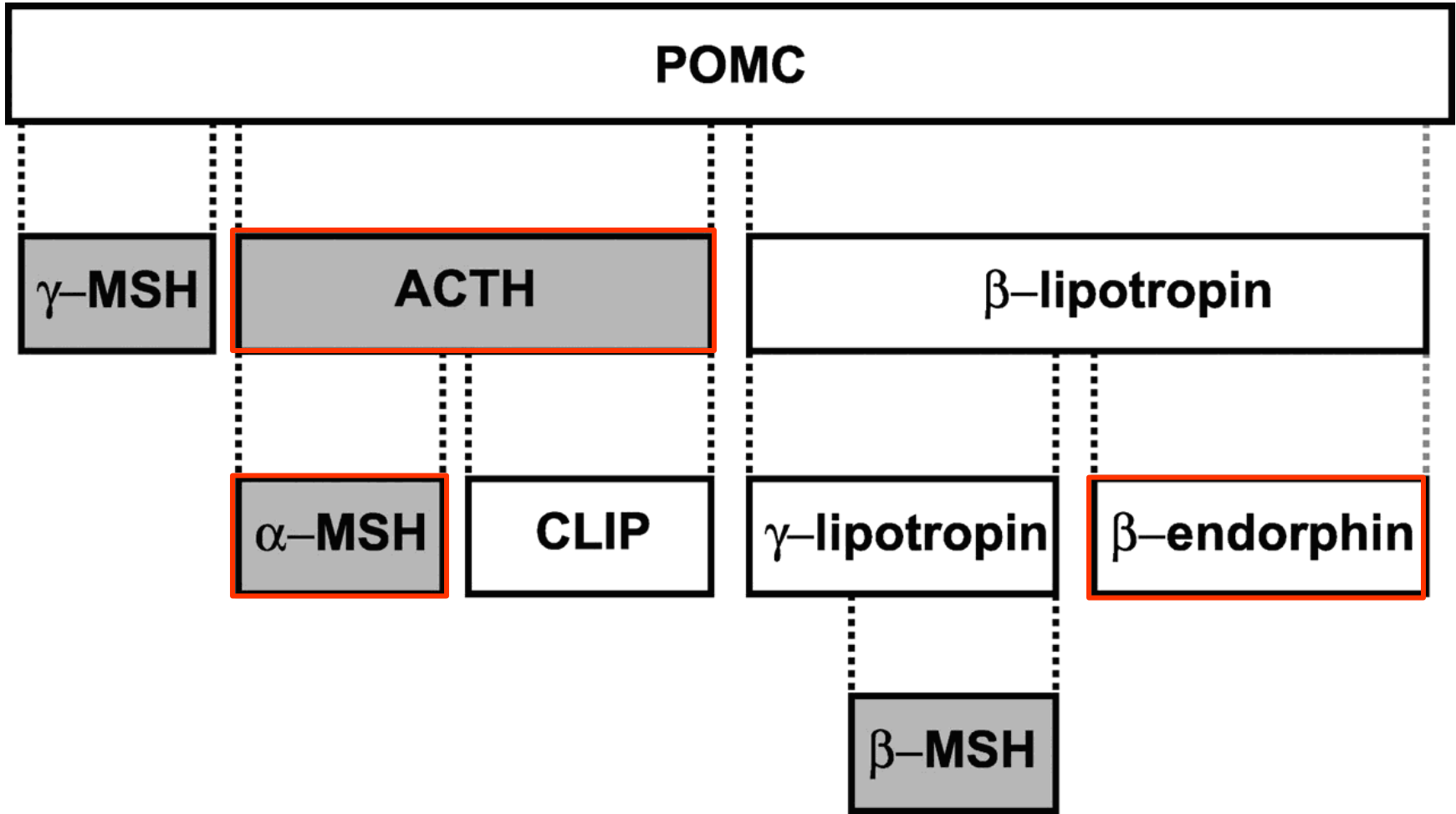

Fig. 6-12. Primary structure of a corticotropin-releasing hormone (CRH).

- CRH outside CNS
 - May be proinflammatory signal
 - Stimulating synthesis of PG's
 - From placenta, parturition initiation
- Induction release w/ central catecholamines into portal cap. plexus
 - Probably w/ stress
 - **Stress → ACTH release (through CRH)**
 - Emotional; hypoxia; hypercapnea
 - Decreased blood pressure; depleting ECF volume
 - Infections (w/ increased IL-1 β)
 - Environmental temperature changes; fever
 - Ethanol consumption

- CRH has **binding protein (CRH-BP)**
 - CRH “sink”
 - Assoc'd w/ membr's near CRH brain target cells
 - Another form secreted by liver, placenta
- Target cells: corticotrophs in ant. pit. gland
- Two CRH receptors (CRH ligand of CRH1R)
 - G-protein coupled heptahelical receptors
 - Binding → ad cyclase → → synth. & release ACTH
 - Negative feedback controlled by cortisol
 - Glucocorticoids suppress CRH1R mRNA

- ACTH (corticotropin)
 - Synthesized in pars distalis
 - Precursor = POMC (proopiomelanocortin)
 - 241 aa's
 - Holds ACTH, β -LPH (lipotropin), β -MSH (melanocyte-stimulating hormone)
 - β -MSH not physiologically active
 - w/ β -LPH: β -endorphin, met-enkephalin (neurohormones)
 - Proprotein convertase 3 catalyzes POMC \rightarrow ACTH + β -LPH
 - Cleaved \rightarrow α -MSH in pars distalis
 - Similar sequence
 - ACTH melanotropic activity
 - Circadian adrenocortical rhythm



- ACTH (cont'd)

- Smallest ant. pit. peptide hormone

- 39 aa chain; highly conserved

- Bio activity in invariant 1-24 aa N-terminal sequence

- Synthesis & secretion were stimulated

- CRH

- ADH (AVP)

- CCK (sometimes)

- ACh → CNS cholinergic structures → ACTH release

- Suppressed by

- Glucocorticoids

- » Hypothalamus membrane receptor non-genomic mech, then @ ant. pit.

- CRH-BP

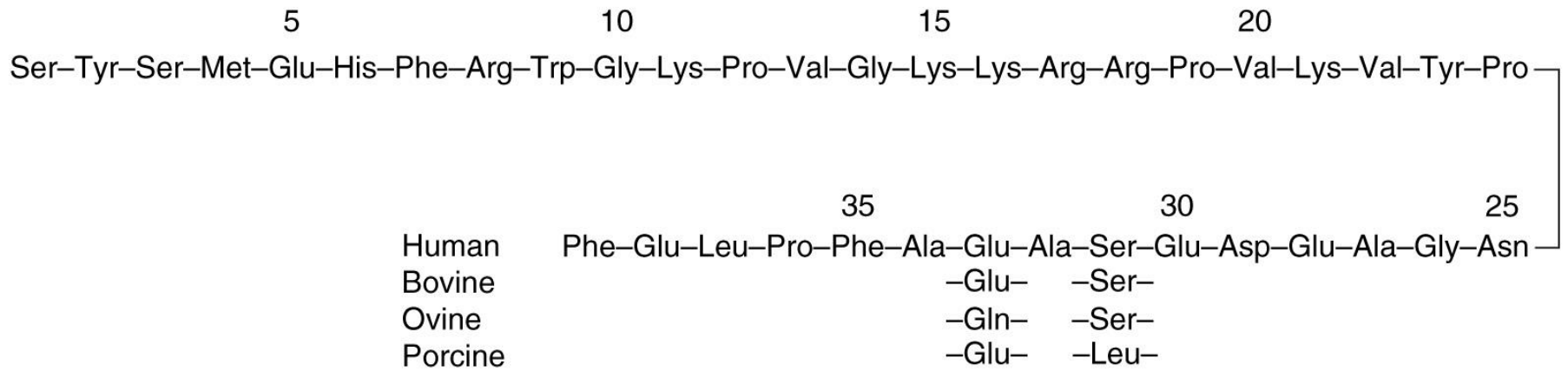

Fig. 5.8. Comparative primary structures of some corticotropins

- **ACTH** (cont'd)
 - Target = adrenal steroidogenic tissue
 - Stimulates glucocorticoid biosynthesis
 - Cortisol, corticosterone
 - Important in carbohydrate metabolism
 - Glucocorticoid feedback inhibit @ hypothal. & ant. pit.
- **α -MSH** produced in
 - Human intermed. ant. pit. in fetal life
 - 13 aa's
 - Skin keratinocytes w/ UVB → eumelanin
 - Monocytes – anti-inflammatory
 - Some neurons – appetite suppressing, decrease body temp.

Pituitary Pathophysiology

TABLE 5.2 Some examples of pituitary pathophysiology

Hormone	Etiology	Symptom
All hormones	No pituitary hormones (empty sella syndrome)	Panhypopituitarism
Growth hormone (GH)	Deficiency (childhood)	Short stature
	Excess child	Gigantism
	adult	Acromegaly
Prolactin (PRL)	Deficiency	No disease states reported
	Excess	Hyperprolactinemia: galactorrhea–amenorrhea syndrome
Thyrotropin (TSH)	Deficiency child	Hypothyroidism (cretinism)
	adult	Hypothyroidism (myxedema)
	Excess	Hyperthyroidism (thyrotoxicosis, Graves' disease)
Follitropin (FSH)	Deficiency	Hypogonadism: failure of germ cell maturation
	Excess	No information available
Lutropin (LH)	Deficiency	Hypogonadism: failure of sexual maturation
	Excess	No information available
Corticotropin (ACTH)	Deficiency	Addison's disease
	Excess	Cushing's disease/syndrome (hypercortisolism)
Oxytocin	Deficiency	No information available (necessary for milk secretion)
	Excess	No disease states reported
Vasopressin (AVP, ADH)	Deficiency	Diabetes insipidus (excessive water loss, dehydration)
	Excess	Syndrome of inappropriate ADH secretion (hypertension)

Pathophysiology of Hypothalamic Dysfunction

- Related to defects in hypophysiotropic hormone synthesis and secretion or to altered activity of the neuronal inputs to hypophysiotropin neurons
- Overproduction or underproduction of dopamine within CNS neurons, for example, is believed responsible for the etiology of schizophrenia and Parkinson's disease, respectively.
- Some tumors may secrete hypothalamic hormones.
 - a. Ectopic secretion of a CRH-like peptide for certain cases of Cushing's disease
 - b. PRL-secreting tumor

TABLE 6.1 Experimental evidence supporting a hypothalamic control of pituitary hormone secretion

1. Pituitary stalk section or placement of a mechanical barrier between the hypothalamus and the pituitary gland leads to diminished or enhanced secretion of certain pituitary hormones.
2. Ectopic transplantation of the pituitary gland leads to decreased or increased secretion of pituitary hormones.
3. Replantation of ectopically transplanted pituitaries under the hypothalamus leads to reactivation of pituitary hormone secretion (e.g., reestablishment of ovulatory cycles).
4. Specifically placed discrete lesions in the hypothalamus lead to diminished or enhanced secretion of specific hypophysial hormones.
5. Electrode stimulation of discrete hypothalamic sites leads to inhibition or release of certain pituitary hormones.
6. Pituitary hormone secretion is inhibited by implantation of target organ tissues or their hormones into discrete sites within the hypothalamus.
7. Hypothalamic extracts injected into intact animals or added to pituitary glands incubated in vitro enhance or inhibit pituitary secretions.
8. Ectopic pituitary grafts are reactivated (after partial atrophy) by local infusions of extracts of the median eminence.
9. Fragments of the pituitary gland transplanted within a specific site (hypophysiotropic area) of the hypothalamus remain functionally active.
10. Administration of pharmaceutical agents that enhance or inhibit neurotransmitter production by hypothalamic neurons leads to enhanced or inhibited pituitary hormone secretion.
11. Synthetic peptides identical in structure to the putative hypophysiotropic hormones mimic the activity of the hypothalamic peptides on pituitary hormone secretion.
12. Pituitary hypophysiotropic hormones are found in the hypophysial portal blood in greater concentration than in the systemic circulation.
13. Radiolabeled gonadal steroids localize to hypothalamic sites known to control pituitary gonadotropin secretion.
14. Electrode stimulation of hypothalamic tissue in vitro leads to a Ca^{2+} -dependent release of putative hypophysiotropins.
15. Electrical stimulation of the hypothalamus elevates plasma levels of hypophysiotropins.
16. Adrenalectomy, gonadectomy, and thyroidectomy, procedures which alter levels of pituitary hormone secretion, also alter hypothalamic levels of hypophysiotropins.
17. Immunocytochemical techniques localize hypophysiotropins to specific hypothalamic neurons.
18. Administration of antisera to hypophysiotropic hormones leads to enhanced or inhibited pituitary hormone secretion.