

RAiO

RA8816N

144x65 Character / Graphic LCD Driver Specification

Version 1.2

June 02, 2011

Update History		
Version	Date	Description
1.0	January 03, 2011	Preliminary edition
1.1	May 17, 2011	1. Revise REG[12h] of Table 5-1 and relative descriptions. 2. Add Section 6-2 : N-line Inversion.
1.2	May 23, 2011	1. Add the description of REG[19h]. 2. Remove IIC relative descriptions.
	June 2, 2011	1. Add maximum sleep mode current in Table 9-2.

Chapter	Contents	Page
1.	General Description	5
2.	Feature	5
3.	Block Diagram.....	6
4.	Pin Definition	7
4-1	MPU Interface	7
4-2	Clock and Power	8
4-3	LCD Panel Interface	8
4-4	Misc.	9
5.	Registers Description	10
5-1	Register Table.....	10
5-2	Register Contents	11
6.	Function Description.....	24
6-1	MPU Interface	24
6-1-1	Parallel Interface.....	24
6-1-2	Serial Interface.....	25
6-1-3	Register Read/Write	27
6-1-4	Memory Read/Write.....	29
6-2	N-Line Inversion	31
6-3	Memory	32
6-4	System Clock.....	33
6-5	LCD Driver and Power Circuit	33
6-5-1	Booster Circuit	34
6-5-2	Voltage Regulator	35
6-5-3	Voltage Follower	36
6-5-4	LCD Driver	37
6-6	Interrupt	37
6-7	Key-Scan	38
6-8	I/O Port	39
6-9	ASCII Block	39
6-10	Power Control.....	40
7.	Display Functions	41
7-1	Text Mode	41
7-2	Graphic Mode	41
7-3	Cursor Setting	42
7-3-1	Cursor Position and Shift.....	42
7-3-2	Cursor Display and Blink	42
7-3-3	Cursor Height.....	43
7-4	Display Window.....	43
7-5	Horizontal Scroll.....	44
7-6	Vertical Scroll	45
8.	Pin Diagram	47
8-1	COG Pad	47
8-2	Pad X/Y Coordinate	49

9. Electrical Characteristic	54
9-1 Absolute Maximum Ratings	54
9-2 DC Characteristic	54
9-3 Timing Characteristic	55
9-3-1 Parallel Interface.....	55
9-3-2 Serial Interface.....	57
9-3-3 Reset Interface	60
Appendix A. COG Technical Parameter	61
Appendix B. BIG-5 Font Code Table	66
Appendix C. GB Font Code Table	73
Appendix D. S-JIS Font Code Table	95

1. General Description

The RA8816N is a Dot-Matrix LCD Driver that supports both character and graphic modes. It has a built-in 256K bytes character ROM and 1170 bytes display RAM. The embedded ROM consists of Chinese (or Japanese for –J product), English and ASCII fonts, and the embedded display RAM supports up to 144x65 dots LCD panel. The RA8816N also provides a scrolling buffer memory for scrolling functions. It supports vertical and horizontal scrolling features, and all of these functions are executed by hardware.

In character mode, the RA8816N supports Traditional Chinese (BIG5), Simplified Chinese (GB) and Japanese (S-JIS) code. The system (MPU) does not need to take a lot of time to show the Chinese or Japanese font in this mode. It also provides small ASCII (8x8) and big ASCII (8x16) fonts for English, Japanese, European and Latin character. The RA8816N also integrates much powerful hardware that includes contrast adjustment, 4x5 Key-Scan and eight General Purpose I/Os.

The RA8816N is a highly integrated chip of LCD controller and driver. It reduces a lot of time for system development, and saves much cost for hardware system that due to it provides many features for related LCD display applications.

2. Feature

- Support both Character and Graphic Mode
- Support 8080 / 6800, 8 / 4-bit Parallel Interface, 3-Wire / 4-Wire Serial Interface
- Built-in 256KB Font ROM: Chinese, S-JIS, English, ASCII, Japanese, Latin, Latin-ext A, Latin-ext B
- Support ASCII 8x8 / 8x16 Half Size Font, 16x16 Full Size Chinese Font
- Support Maximum 144 SEG x 65 COM LCD Panel. 4 x 9 Chinese Fonts (16x16), or 8 x 18 English Fonts (8x8)
- Built-in 256 bytes SRAM for Create Font
- Built-in 1170 bytes Display RAM and 450 bytes Scrolling Buffer
- Support 1/65 Duty, 1/9~1/5 Bias Panel
- Built-in 2X~4X (Voltage Booster), Voltage Regulator, Voltage Follower
- Eight General Purpose I/Os (GPIO)
- Built-in 4x5 Key-scan Circuit
- Support Horizontal / Vertical Scrolling Functions
- Provide 32-Steps Contrast Adjuster
- Build-in RC Oscillator
- Voltage Operation: VDD → 2.7~3.6V
- Package: Gold Bump Die

Table 2-1 : Ordering Information

Parts Number	Package and Font Type
RA8816N-T	Au-Bump Die, Traditional Chinese (BIG5)
RA8816N-S	Au-Bump Die, Simplified Chinese (GB2312)
RA8816N-J	Au-Bump Die, Japanese (S-JIS)

3. Block Diagram

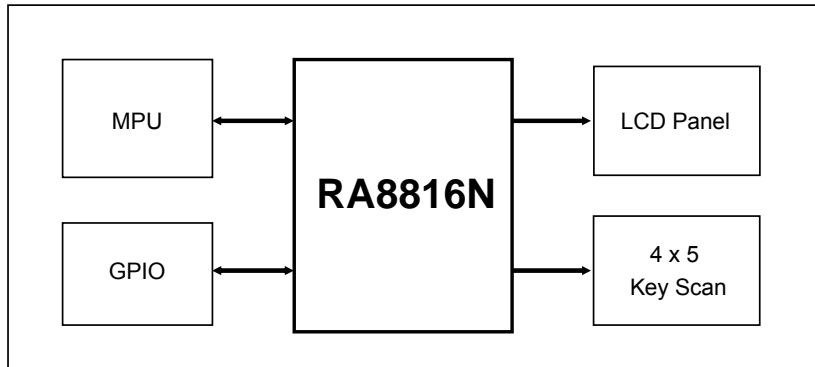

Figure 3-1 : System Block

The RA8816N is consisted of Display RAM, 256KB Font ROM, Command Registers, LCD Controller, LCD Driver, Voltage Booster, Voltage Regulator, MPU Interface and Key-Scan circuit.

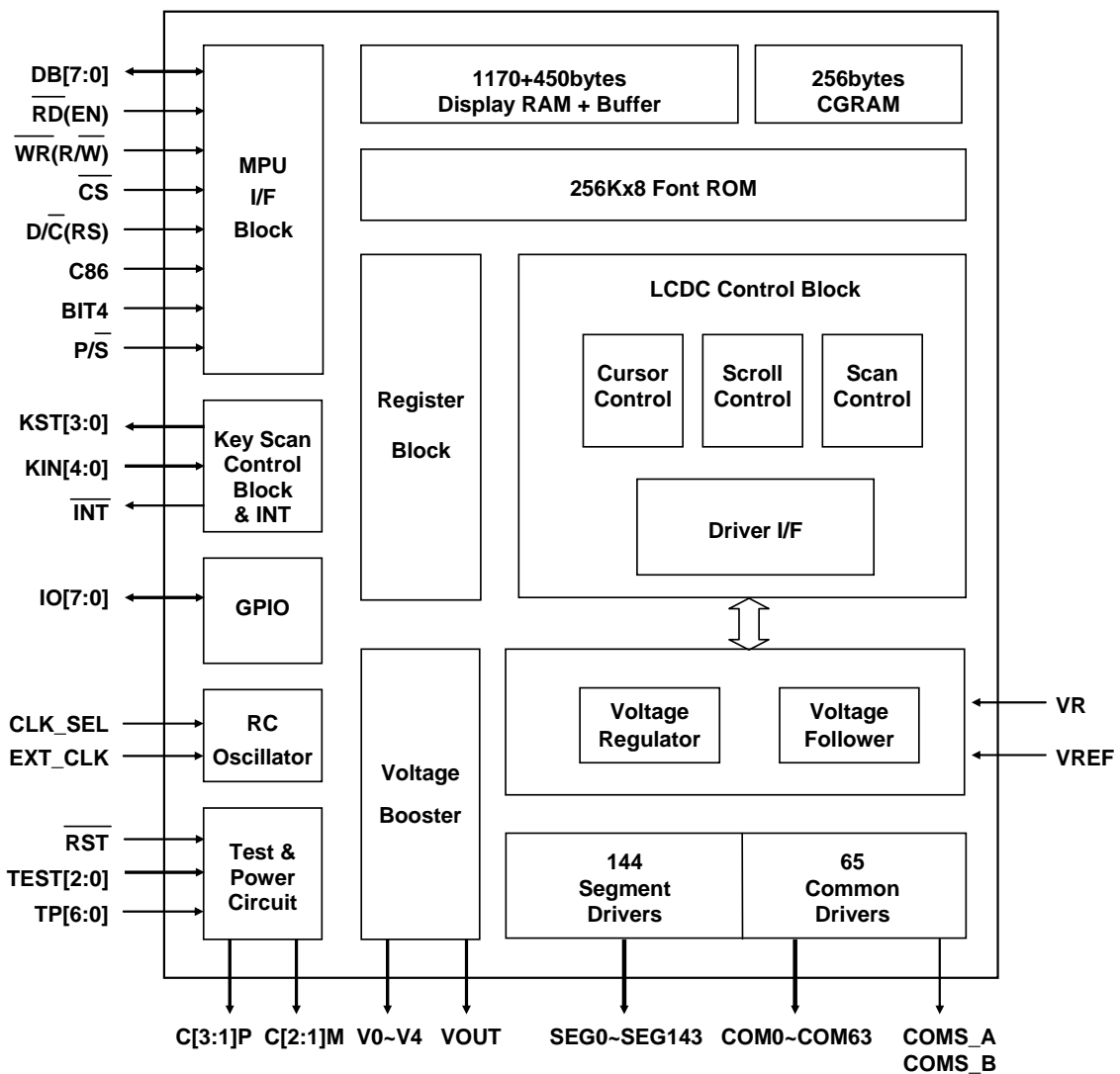

Figure 3-2 : Internal Block

4. Pin Definition

4-1 MPU Interface

Table 4-1

Pin Name	I/O	Description										
DB[7:0] DB0: SCK DB1: SDA/SDO DB2: RS/SDI DB3: \overline{CS} DB[7:6]: SMOD	I/O	<p>Data Bus</p> <p>When MPU uses parallel mode and 8-bit interface then all of the DB[7:0] are valid. When uses 4-bit interface then only DB[3:0] are valid, and DB[7:4] have to be kept floating.</p> <p>When P/\overline{S} is "0", then the interface between MPU and RA8816N is Serial Mode. The pins DB[7:6] (SMOD[1:0]) are used to select which serial mode:</p> <table border="1"> <thead> <tr> <th>SMOD :</th> <th>Serial Mode</th> </tr> </thead> <tbody> <tr> <td>0 0</td> <td>: Reserved.</td> </tr> <tr> <td>0 1</td> <td>: 3-Wire, SCK, SDA, \overline{CS} are used.</td> </tr> <tr> <td>1 0</td> <td>: 4-Wire, SCK, SDA, RS, \overline{CS} are used.</td> </tr> <tr> <td>1 1</td> <td>: 4-Wire, SCK, SDO, SDI, \overline{CS} are used.</td> </tr> </tbody> </table> <p>In serial mode, all of the related signals are defined by DB[3:0]:</p> <p>SCK (DB0) : Serial Clock. SDA (DB1) : Bi-direction Mode Serial Data. SDO (DB1) : Data Out. RS (DB2) : Memory/Register Cycle Select. SDI (DB2) : Serial Data In. \overline{CS} (DB3) : Chip Select, active low.</p>	SMOD :	Serial Mode	0 0	: Reserved.	0 1	: 3-Wire, SCK, SDA, \overline{CS} are used.	1 0	: 4-Wire, SCK, SDA, RS, \overline{CS} are used.	1 1	: 4-Wire, SCK, SDO, SDI, \overline{CS} are used.
SMOD :	Serial Mode											
0 0	: Reserved.											
0 1	: 3-Wire, SCK, SDA, \overline{CS} are used.											
1 0	: 4-Wire, SCK, SDA, RS, \overline{CS} are used.											
1 1	: 4-Wire, SCK, SDO, SDI, \overline{CS} are used.											
\overline{RD} EN	I	<p>Read Control or Enable</p> <p>When use 8080 series interface, \overline{RD} is the read signal and active low. When use 6800 series interface, EN is the Enable signal and active high. This pin must be kept high for 3 or 4-wires serial mode.</p>										
\overline{WR} R/W	I	<p>Write Control or Read-Write Control</p> <p>When use 8080 series interface, \overline{WR} is the write signal and active low. When use 6800 series interface, this pin is R/\overline{W}, active high for read cycle and active low for write cycle. This pin must be kept high for 3 or 4-wires serial mode.</p>										
D/ \overline{C} RS	I	<p>Data/Command Select or Register Select</p> <p>When use 8080 series interface, this is Data or Command signal. When D/\overline{C} is "0", means Register Cycle (or Command Cycle). When D/\overline{C} is "1", means Data Access Cycle (Data Cycle). When use 6800 series interface, this is the RS signal. When RS is "0", means Register Cycle and "1" means Data Access Cycle. This pin must be kept high for serial mode.</p>										
\overline{CS}	I	<p>Chip Select</p> <p>This is chip enable for RA8816N. This pin must be kept high for serial mode.</p>										
\overline{INT}	O	<p>Interrupt Signal</p> <p>This is an interrupt output for MPU. Active low ◦</p>										
C86	I	<p>MPU Select</p> <p>C86 = 0 → The MPU interface is 8080 series. C86 = 1 → The MPU interface is 6800 series (Default). This pin must be kept high for serial mode.</p>										

BIT4	I	Data Bit Select BIT4 = 0 → The parallel mode is use 8-bit data bus. BIT4 = 1 → The parallel mode is use 4-bit data bus (Default). This pin must be kept high for serial mode.
P/ \bar{S}	I	Parallel/Serial Select $P/\bar{S} = 0$ → The MPU interface is serial mode (Default). See the setting of DB[7:6]. $P/\bar{S} = 1$ → The MPU interface is parallel mode.

4-2 Clock and Power

Table 4-2

Pin Name	I/O	Description
V0~V4	O	Voltage Source of LCD Driver The relationship of the power is $V_{OUT} > V_0 \geq V_1 \geq V_2 \geq V_3 \geq V_4 \geq V_{SS}$
C[3:1]P, C[2:1]N	I	Capacitor Input These are used to connect capacitors for internal Booster.
VOUT	O	Booster Output
VREF	I	Reference Voltage Input This is the external reference voltage input when the internal one is disabled.
VR	I	Voltage Adjustment Applies voltage between V0 and VSS by connecting a resistor divider.
CLK_SEL	I	Clock Select This pin is used to select the clock source. When CLK_SEL is "1", the clock is generated by internal RC oscillator. When CLK_SEL is "0", the system clock is driven by external pin - EXT_CLK.
EXT_CLK	I	External Clock When CLK_SEL is "0", this pin is the external clock input. When CLK_SEL is "1", this pin is not used and has to be connected to VDD or GND.
VDD VDDP	P	Power
GND GNDP	P	Ground

4-3 LCD Panel Interface

Table 4-3

Pin Name	I/O	Description
SEG0 ~ SEG143	O	Segment Signals for Panel
COM0 ~ COM63	O	Common Signals for Panel
COMS_A COMS_B	O	Icon Common Signals for Panel
DUMY[5:0]	O	Dummy PAD

4-4 Misc.

Table 4-4

Pin Name	I/O	Description
KST[3:0]	O	Key Strobe Output
KIN[4:0]	I	Key Data Input For pins that are not used, please connect them to VDD.
IO[7:0]	I/O	General Purpose I/O
$\overline{\text{RST}}$	I	Reset RST=0, RA8816N will be reset. RST=1, Normal condition, there is an embedded Pull-High resistor in it.
TEST[2:0]	I	Test Pins These pins must be connected to GND in normal mode.
TP[6:0]	I	Test Pins These pins must be kept NC for normal mode.

Table 4-5 : Pin Definition of Parallel / Serial Mode of MPU

Pin Name	I/O	Parallel Mode				Serial Mode		
		8080		6800		3-Wire	4-Wire (A-Type)	4-Wire (B-Type)
		8Bit	4Bit	8Bit	4Bit			
DB7	I/O	DB7	--* ¹	0	--	0	1	1
DB6	I/O	DB6	--	1	--	2	0	1
DB5	I/O	DB5	--	--	--	--	--	--
DB4	I/O	DB4	--	--	--	--	--	--
DB3	I/O	DB3	DB3	DB3	DB3	$\overline{\text{CS}}$	$\overline{\text{CS}}$	$\overline{\text{CS}}$
DB2	I/O	DB2	DB2	DB2	DB2	--	RS	SDI
DB1	I/O	DB1	DB1	DB1	DB1	SDA	SDA	SDO
DB0	I/O	DB0	DB0	DB0	DB0	SCK	SCK	SCK
$\overline{\text{RD}}$, EN	I	$\overline{\text{RD}}$	$\overline{\text{RD}}$	EN	EN	1* ²	1* ²	1* ²
$\overline{\text{WR}}$, R/W	I	$\overline{\text{WR}}$	$\overline{\text{WR}}$	R/W	R/W	1* ²	1* ²	1* ²
D/C, RS	I	D/C	D/C	RS	RS	1* ²	1* ²	1* ²
$\overline{\text{CS}}$	I	$\overline{\text{CS}}$	$\overline{\text{CS}}$	$\overline{\text{CS}}$	$\overline{\text{CS}}$	1	1	1
C86	I	0	0	1	1	1	1	1
BIT4	I	0	1	0	1	1	1	1
P/S	I	1	1	1	1	0	0	0

Note1 : "--" means the pin is not used and kept floating (NC).

Note2 : In serial mode, the unused parallel pins have to be connected to high (VDD).

5. Registers Description

5-1 Register Table

Table 5-1 : Register Table

ID	Name	D7	D6	D5	D4	D3	D2	D1	D0	Description
0	DWFR	B/C	--	NW5	NW4	NW3	NW2	NW1	NW0	Wave Form Select
1	PWRR	SRST	MCLR	--	IO_IEN	KWK	IOWK	DOFF_Z	SLP	Power Control
2	SYSR	LS3	LS2	LS1	LS0	FONT1	FONT0	RS1	RS0	System Setting
3	MWMR	BMOD1	BMOD0	BIEN	ASCS	BOLD	INV	MD1	MD0	Memory Mode
4	CURCR	H3	H2	H1	H0	--	BLK	CR	CUR_EN	Cursor Control
5	X-CUR	--	--	X5	X4	X3	X2	X1	X0	Cursor X Position
6	Y-CUR	--	Y6	Y5	Y4	Y3	Y2	Y1	Y0	Cursor Y Position
7	KEYR	KSB	KDB1	KDB0	KSTB_SEL	K_AUTO	IRE	KF1/KSTB1	KF0/KSTB0	Key-scan Control
	KSDR	SIRQ	KSTB1	KSTB0	KSD4	KSD3	KSD2	KSD1	KSD0	Key-scan Data
8	SWSXR	--	--	--	SSX4	SSX3	SSX2	SSX1	SSX0	X-Scroll Start
9	SWSYR	--	--	SSY5	SSY4	SSY3	SSY2	SSY1	SSY0	Y-Scroll Start
A	SWRXR	--	--	--	SRX4	SRX3	SRX2	SRX1	SRX0	X-Scroll Range
B	SWRYR	PINV	--	SRY5	SRY4	SRY3	SRY2	SRY1	SRY0	Y-Scroll Range
C	SCOR	SL7	SL6	SL5/SR5	SL4/SR4	SL3/SR3	SL2/SR2	SL1/SR1	SL0/SR0	Scroll Unit
D	ASCR	SPD3	SPD2	SPD1	SPD0	STP3	STP2	STP1	STP0	Auto Scroll Control
E	SCCR	SCR_IMD1	SCR_IMD0	SCR_MD	SBUF	SCR_DIR1	SCR_DIR0	SCR_INTEN	AUTO_SCROLL	Scroll Control
F	ISR	BF	--	--	--	IO_I	SCR_I	KI	BI	Interrupt Status
10	CSTR	BR2	BR1	BR0	CT4	CT3	CT2	CT1	CT0	Contrast
11	DRCR_A	BOFF	EN_R	EN_G	ROFF	IDIR	--	CDIR	SDIR	Driver Control
12	DRCR_B	CK_BS1	CK_BS0	RR2	RR1	RR0	IRS	--	--	Driver Control
13	BLTR	BLK_EN	PBK_EN	--	INV	BLT3	BLT2	BLT1	BLT0	Blink Setting
14	IODR	OE7	OE6	OE5	OE4	OE3	OE2	OE1	OE0	I/O Port Direction
15	IODAR	IOD7	IOD6	IOD5	IOD4	IOD3	IOD2	IOD1	IOD0	I/O Port Data
17	CGMI	--	--	--	--	--	UMI2	UMI1	UMI0	Create Font Select
18	CGMD	CGMD7	CGMD6	CGMD5	CGMD4	CGMD3	CGMD2	CGMD1	CGMD0	Create Font Data
19	MISR	--	--	--	--	--	--	--	EOR	Misc Register

5-2 Register Contents

The RA8816N accepts two Command Cycle from MPU. One is Register Cycle (RS = 0) and the other one is Memory Cycle (RS = 1). MPU has to assign the register number of RA8816N before accesses these registers. Therefore, the first byte that MPU passes to RA8816N will be stored into Index Register and RA8816N will assume the next byte is read from or write into the register assigned by Index Register.

IR (Index Register)

RW	RS	DB7	DB6	DB5	DB4	DB3	DB2	DB1	DB0
0	0	0	0	0	ID4	ID3	ID2	ID1	ID0

ID[4:0]: These bits are used to store the register number that MPU wants to access on next cycle.

The ID[[4:0] provide 32 register numbers (00h~1Fh). But currently RA8816N only uses 25 registers (00h~18h). All of these registers are initialed to be "00h" after RESET.

Memory Data (RAMD)

RW	RS	DB7	DB6	DB5	DB4	DB3	DB2	DB1	DB0
0/1	1	D7	D6	D5	D4	D3	D2	D1	D0

If RS is "1", it means MPU executes the Memory Cycle for the RA8816N. When RW is "0", MPU will write data to Display or ICON RAM that according to the setting of MD[1:0] (bit1-0 of REG[03h]). For example, MPU writes Big5 / GB / ASCII code to memory in Text Mode, or write bitmap data to display memory in Graphic mode. When RW is "1", the MPU reads data from different paths of RA8816N. It depends on the operation mode as following:

- 1.Full Size Text Mode: From up to down of left side (16 bytes), and then up to down of Right side (16 bytes), total are 32 bytes.
- 2.Half Size Text Mode: From up to down, total 16 bytes data.
- 3.Small ASCII Text Mode: From up to down, total 8 bytes data.
- 4.Graphics Mode: From left to right, each reading is one byte (8 Pixels).

[00h] Driver Waveform Register (DWFR)

RW	DB7	DB6	DB5	DB4	DB3	DB2	DB1	DB0
0	B/C	--	NW5	NW4	NW3	NW2	NW1	NW0

B/C: Select driver waveform type.

0 → B-Type waveform. AC drive waveform alternates in every frame.

1 → C-Type waveform. AC drive waveform is generated and alternates (n-line reversed AC drive) in each lines specified by NW5–NW0

NW[5:0]: These bits are used to assign the Common (Line) number that internal frame signal changes state. The number n is set as NW + 1 for C-type function. For example, NW= 4, the AC drive will alternate each 5 commons. This function is only supported when B/C is "1" (C-Type wave form). About the relative information, please refer to EOR description (REG[19h] Bit 0) and Section 6-2 for detail description.

[01h] Power Control Register (PWRR)

RW	DB7	DB6	DB5	DB4	DB3	DB2	DB1	DB0
0	SRST	MCLR	--	IO_IEN	KWK	IOWK	DOFF_Z	SLP

SRST: S/W reset.

0 → No action.

1 → All of the registers will be initialed again except the display memory. Once this bit is set to 1 then RA8816N has to take 50us for operation and cannot accept any new command from MCU.

MCLR: Memory clear.

0 → No action.

1 → Clear the Display RAM data to "00h". Once this bit is set to 1 then RA8816N has to spend 20ms for operation and cannot accept any new command from MCU. It is not allowed that both MCLR and SRST are set to "1" or MCLR will be no effect.

IO_IEN : I/O port interrupt setting.

0 → Disable.

1 → Enable.

KWK: Key-scan wakes up setting.

0 → Disable.

1 → Enable.

IOWK: I/O port wakes up setting.

0 → Disable.

1 → Enable.

DOFF_Z: Display off.

0 → LCD driver and display off.

1 → LCD driver and display on.

SLP: Sleep mode setting.

0 → RA8816N wakes up.

1 → Enter sleep mode, and disable the clock. This bit will be cleared to "0" when wake up signal is from I/O port or Key-scan.

[02h] System Register (SYSR)

RW	DB7	DB6	DB5	DB4	DB3	DB2	DB1	DB0
0	LS3	LS2	LS1	LS0	FONT1	FONT0	RS1	RS0

LS[3:0]: Set the segment number. The maximum segment of RA8816N is 144.

Table 5-2

LS3	LS2	LS1	LS0	Line No.
0	0	0	0	16
0	0	0	1	32
0	0	1	0	48
0	0	1	1	64
0	1	0	0	80
0	1	0	1	96
0	1	1	0	112
0	1	1	1	128
1	0	0	0	144
⋮				Reserved
1	1	1	1	Reserved

FONT[1:0]: Set font code mapping.

00 → BIG-5, 10 → GB2312, X1 → S-JIS.

RS[1:0]: Set the common number. The maximum common of RA8816N is 64 (Not including Icon).

Table 5-3

Duty	RS1	RS0	Status	Common Output Pads								
				COM [0-15]	COM [16-23]	COM [24-26]	COM [27-36]	COM [37-39]	COM [40-47]	COM [48-63]	COMS	
1/33	0	0	Normal	COM [0-15]	NC					COM [16-31]	COMS	
			Reverse	COM [31-16]	NC					COM [15-0]		
1/49	0	1	Normal	COM[0-23]		NC			COM[24-47]		COMS	
			Reverse	COM[47-24]		NC			COM[23-0]			
1/55	1	0	Normal	COM[0-26]			NC	COM[27-53]			COMS	
			Reverse	COM[53-27]			NC	COM[26-0]				
1/65	1	1	Normal	COM[0-63]								COMS
			Reverse	COM[63-0]								

[03h] Memory Write Mode Register (MWMR)

RW	DB7	DB6	DB5	DB4	DB3	DB2	DB1	DB0
0	BMOD1	BMOD0	BIEN	ASCS	BOLD	INV	MD1	MD0

BMOD[1:0]: Set the range for memory written.

Table 5-4

BMOD1	BMOD0	Memory Range of Write
0	0	Normal Display Range
0	1	Display Range + Scroll-Buffer
1	x	Scroll-Buffer

BIEN: Busy interrupt control.

0 → Disable.

1 → Enable (After write data to memory).

ASCS: Select BIG ASCII Table.

0 → Select ASCII Table-1.

1 → Select ASCII Table-2. (Refer to Ch. 6-9)

BOLD: Select Bold Font to write into Display RAM.

0 → Normal font.

1 → Bold font.

INV: Select inverse font to write into Display RAM.

0 → Normal font.

1 → Inverse font.

MD[1:0]: Select operation mode for Display RAM.

Table 5-5

MD1	MD0	Operation Mode
0	0	Graphic Mode
0	1	Small ASCII (8X8)
1	0	Big ASCII (8X16)
1	1	Full Size (16X16)

In Full-Size mode (MD[1:0] = 11), if the first byte data is less than 80h, the RA8816N will assume it is an ASCII code and show the Big ASCII font. But if want to show the Big ASCII font that code is larger than 80h, then the operation mode has to be changed to Big ASCII mode (MD[1:0] = 10).

[04h] Cursor Control Register (CURCR)

RW	DB7	DB6	DB5	DB4	DB3	DB2	DB1	DB0
0	H3	H2	H1	H0	--	BLK	CR	CUR_EN

H[3:0]: Set the cursor height.

Table 5-6

H3	H2	H1	H0	Height (Pixel)
0	0	0	0	1
0	0	0	1	2
0	0	1	0	3
0	0	1	1	4
0	1	0	0	5
0	1	0	1	6
0	1	1	0	7
0	1	1	1	8
1	0	0	0	9
1	0	0	1	10
1	0	1	0	11
1	0	1	1	12
1	1	0	0	13
1	1	0	1	14
1	1	1	0	15
1	1	1	1	16

In Small ASCII mode (8X8), the H3 is reserved. The setting of cursor height is only form 1~8 pixels (H[3:0] = x000b ~ x111b).

BLK: Cursor blink select.

- 0 → No blinking.
- 1 → Cursor blinking.

CR: Cursor return.

- 0 → No action.
- 1 → Cursor return. Cursor will return to the left of panel.

CUR_EN: Cursor display select.

- 0 → Cursor hides.
- 1 → Cursor displays.

[05h] Cursor Position Register of X (X-CUR)

RW	DB7	DB6	DB5	DB4	DB3	DB2	DB1	DB0
0	--	--	X5	X4	X3	X2	X1	X0

X[5:0]: Set the cursor position on segment. The unit is 8 pixels. Because the maximum segment of the RA8816N is 144-pixels, therefore the range of X[5:0] is 0~11h. When the X[5:0] is 20h or 21h, then the cursor position is assign to horizontal scroll buffer.

[06h] Cursor Position Register of Y (Y-CUR)

RW	DB7	DB6	DB5	DB4	DB3	DB2	DB1	DB0
0	--	Y6	Y5	Y4	Y3	Y2	Y1	Y0

Y[6:0]: Set the cursor position on common. The unit is 1 pixel. Because the maximum common of the RA8816N is 64-pixels, therefore the range of Y[6:0] is 0~3Fh. When the Y[6:0] is 40h~4Fh, then the cursor position is assign to vertical scroll buffer. When it is 50h then the cursor is located at COMS (Icon).

[07h] Key-scan Control Register (KEYR) (Write Only)

RW	DB7	DB6	DB5	DB4	DB3	DB2	DB1	DB0
0	KSB	KDB1	KDB0	KSTB_SEL L	K_AUTO	IRE	KF1/ KSTB1	KF0/ KSTB0

KSB: Key-scan control.

0 → Disable key-scan.

1 → Enable key-scan.

KDB[1:0]: Set the de-bounce time of key-scan in auto mode. The one time means one loop of key-scan.

Table 5-7

KDB1	KDB0	Times
0	0	8
0	1	16
1	0	32
1	1	64

KSTB_SEL: In manual mode,

0 → The DB[1:0] are defined as KF[1:0].

1 → The DB[1:0] are defined as KSTB[1:0]. In auto mode, the DB[1:0] is also defined as KF[1:0].

K_AUTO: Set the scan mode.

0 → Manual Mode. The RA8816N will not store the code into AKD[6:0]. MPU has to read data from KSTB[1:0] and KSD[4:0] to make sure which key is pressed. Of course, MPU could know if not only one key is pressed at the same time in manual mode.

1 → Auto Mode. The RA8816N will auto detect the key-pressed event and store the code into AKD[6:0] for MPU reading.

IRE: Set the interrupt of key-scan.

0 → Hardware interrupt is disabled while key is pressed.

1 → Generate hardware interrupt while key is pressed.

KF[1:0]: Set the frequency of Key-scan.

Table 5-8

KF1	KF0	Pulse Width	Key-scan Cycle Time (4x5)
0	0	256us	1.024ms
0	1	512us	2.048ms
1	0	1.024ms	4.096ms
1	1	2.048ms	9.182ms

KSTB[1:0]: In manual mode, These two bits are used to set the strobe for the Row of key matrix. If key-pressed event is occurred, MPU can read data from KSTB[1:0] and KSD[4:0] to make sure which key is pressed. The strobe data are also readable from Bit[6:5] of register KSDR.

[07h] Key-scan Data Register (KSDR) (Read Only)

If **K_AUTO = 0:**

RW	DB7	DB6	DB5	DB4	DB3	DB2	DB1	DB0
1	SIRQ	KSTB1	KSTB0	KSD4	KSD3	KSD2	KSD1	KSD0

SIRQ: Indicate the interrupt of key-scan. This bit is cleared when bit 1 of REG[0Fh] is written "0".

KSTB[1:0]: These two bits show which pin of KST[3:0] is active.

KSD[4:0]: KIN return data. These bits are used in manual mode. MPU can read data from KSTB[1:0] and KSD[4:0] to make sure which key is pressed.

If **K_AUTO = 1:**

RW	DB7	DB6	DB5	DB4	DB3	DB2	DB1	DB0
1	SIRQ	AKD6	AKD5	AKD4	AKD3	AKD2	AKD1	AKD0

SIRQ: Indicate the interrupt of key-scan. This bit is cleared when bit 1 of REG[0Fh] is written "0".

AKD[6:0]: Scan Data (Code). In auto mode, MPU reads data from this register to know the status of key matrix. The RA8816N supports 4x5 key matrix -- total 20 keys. The BCD number of 00h~09h and 10h~19h are mapping to these keys.

Table 5-9

AKD[6:0]	Scan Data
00h~19h	Key No. Input
20h~39h	Long Key No. Input
42h	Key Release
Other	Reserved

[08h] Scroll Window Start X Register (SWSXR)

RW	DB7	DB6	DB5	DB4	DB3	DB2	DB1	DB0
0	--	--	--	SSX4	SSX3	SSX2	SSX1	SSX0

SSX[4:0]: Set Segment (X) start point of scroll window. The unit is half size width (8 pixels).

[09h] Scroll Window Start Y Register (SWSYR)

RW	DB7	DB6	DB5	DB4	DB3	DB2	DB1	DB0
0	--	--	SSY5	SSY4	SSY3	SSY2	SSY1	SSY0

SSY[5:0]: Set the Common (Y) start point of scroll window. The unit is one pixel.

[0Ah] Scroll Window Range X Register (SWRXR)

RW	DB7	DB6	DB5	DB4	DB3	DB2	DB1	DB0
0	--	--	--	SRX4	SRX3	SRX2	SRX1	SRX0

SRX[4:0]: Set Segment (X) offset of scroll window. The unit is half size width (8 pixels).

[0Bh] Scroll Window Range Y Register (SWRYR)

RW	DB7	DB6	DB5	DB4	DB3	DB2	DB1	DB0
0	PINV	--	SRY5	SRY4	SRY3	SRY2	SRY1	SRY0

PINV : Inverse area select.

0 → Whole screen inverse.

1 → Partial screen inverse.

The function should be considered with bit 4 of BLTR (REG[13h]).

SRY[5:0]: Set the Common (Y) offset of scroll window. The unit is one pixel.

[0Ch] Scroll Offset Register (SCOR)

RW	DB7	DB6	DB5	DB4	DB3	DB2	DB1	DB0
0	SL7	SL6	SL5/SR5	SL4/SR4	SL3/SR3	SL2/SR2	SL1/SR1	SL0/SR0

SL[7:0]: Set the shifted unit of horizontal scroll. The unit is one pixel and active when register SCR_MD (bit 5 of REG[0Eh]) is cleared to "0".

SR[5:0]: Set the shifted unit of vertical scroll. The unit is one pixel and active when register SCR_MD (bit 5 of REG[0Eh]) is set to "1".

In auto scroll mode, this register is also used to set the Common or Segment start position of scroll. In manual scroll mode, the shifted unit of this register cannot over the range of scroll area defined in REG[08h~0Bh].

[0Dh] Auto-Scroll Control Register (ASCR)

RW	DB7	DB6	DB5	DB4	DB3	DB2	DB1	DB0
0	SPD3	SPD2	SPD1	SPD0	STP3	STP2	STP1	STP0

SPD[3:0]: Set the speed of auto scroll.

Table 5-10

SPD3	SPD2	SPD1	SPD0	Scroll Time
0	0	0	0	1 Unit
0	0	0	1	3 Units
0	0	1	0	5 Units
0	0	1	1	7 Units
0	1	0	0	17 Units
0	1	0	1	19 Units
0	1	1	0	21 Units
0	1	1	1	23 Units
1	0	0	0	129 Units
1	0	0	1	131 Units
1	0	1	0	133 Units
1	0	1	1	135 Units
1	1	0	0	145 Units
1	1	0	1	147 Units
1	1	1	0	149 Units
1	1	1	1	151 Units

1 Unit = 1 Frame Cycle

STP[3:0]: Set the shifted unit on auto scroll mode.

Table 5-11

STP3	STP2	STP1	STP0	Shift Pixel
0	0	0	0	1
0	0	0	1	2
0	0	1	0	3
0	0	1	1	4
0	1	0	0	5
0	1	0	1	6
0	1	1	0	7
0	1	1	1	8
1	0	0	0	9
1	0	0	1	10
1	0	1	0	11
1	0	1	1	12
1	1	0	0	13
1	1	0	1	14
1	1	1	0	15
1	1	1	1	16

[0Eh] Scroll Control Register (SCCR)

RW	DB7	DB6	DB5	DB4	DB3	DB2	DB1	DB0
0	SCR_IM D1	SCR_IM D0	SCR_MD	SBUF	SCR_DIR 1	SCR_DI R0	SCR_INT EN	AUTO_S CR

SCR_IMD[1:0]: The definition is as following and they are available in auto scroll mode.

0X: Set 1 pixel shift to caused interrupt (SCR_INTEN must be 1).

10: Set 8 pixels shift to caused interrupt (SCR_INTEN must be 1)

11: Set 16 pixels shift to caused interrupt (SCR_INTEN must be 1)

SCR_MD: Scroll mode select.

0 → Manual scroll, the scroll offset is cleared to "0".

1 → Auto scroll mode.

SBUF: Scroll-Buffer Control.

0 → Disable scroll buffer. The scroll area does not include the scroll buffer, only for display area.

1 → Enable scroll buffer. The scroll area includes the display area and scroll buffer.

SCR_DIR[1:0]: Select the direction of scroll.

Table 5-12

SCR_DIR1	SCR_DIR0	Direction of Scroll
0	0	Left to Right (Horizontal)
0	1	Right to Left (Horizontal)
1	0	Up to Down (Vertical)
1	1	Down to Up (Vertical)

SCR_INTEN: Set the scroll interrupt.

0 → Disable scroll interrupt.

1 → In auto scroll mode, when scrolling 1, 8 or 16 pixels generate an interrupt to MPU.

AUTO_SCR: Auto-Scroll control.

0 → Stop the Auto-Scroll. If want to stop the auto scroll mode or display new data on the screen, then the bit5 of SCR_MD must be cleared to 0 first.

1 → Auto-Scroll is enabled.

[0Fh] Interrupt Status Register (ISR)

RW	DB7	DB6	DB5	DB4	DB3	DB2	DB1	DB0
1	BF	--	--	--	IO_I	SCR_I	KI	BI

BF: Busy flag.

0 → Display RAM is idle (Write complete).

1 → Display RAM is in busy (Data Write).

IO_I: I/O port interrupt.

0 → No I/O port interrupt.

1 → Interrupt for I/O port.

SCR_I: Scroll interrupt.

0 → No scroll Interrupt.

1 → Interrupt for scroll is completed

KI: Key-scan interrupt.

0 → No key pressed Interrupt.

1 → Interrupt for key pressed.

BI: Busy interrupt.

0 → No busy Interrupt

1 → Interrupt for the event of writing data to display RAM is completed.

[10h] Contrast Adjust Register (CSTR)

RW	DB7	DB6	DB5	DB4	DB3	DB2	DB1	DB0
0	BR2	BR1	BR0	CT4	CT3	CT2	CT1	CT0

BR[2:0]: Set the LCD Bias(Base on 144x65).

Table 5-13

BR2	BR1	BR0	Bias
0	0	0	1/5
0	0	1	1/6
0	1	0	1/7
0	1	1	1/8
1	0	0	1/9
1	0	1	1/9
1	1	0	1/9
1	1	1	1/9

CT[4:0]: Set the Contrast (32 Levels). Normally it depends on the liquid crystal, power and panel size to adjust the best display quality.

Table 5-14

CT4	CT3	CT2	CT1	CT0	Contrast
0	0	0	0	0	Light
0	0	0	0	1	↓
⋮					
1	1	1	1	1	

[11h] Driver Control Register1 (DRCR_A)

RW	DB7	DB6	DB5	DB4	DB3	DB2	DB1	DB0
0	BOFF	EN_R	EN_G	ROFF	IDIR	--	CDIR	SDIR

BOFF: Booster control.

- 0 → Disable internal booster and use the external voltage.
- 1 → Enable internal booster.

EN_R: Reference voltage control.

- 0 → Disable the internal reference voltage circuit and the regulator uses external one.
- 1 → Enable internal reference voltage circuit for regulator using.

EN_G: Regulator control.

- 0 → Use external power for V0. EN_R and BOFF have to be cleared to "0" (Off) to reduce power consumption.
- 1 → The LCD bias V0 is generated by internal regulator.

ROFF: Voltage Follower control.

- 0 → Disable internal Voltage Follower, and use external voltage to generate LCD Bias voltage. If use external Voltage Follower, then EN_G, EN_R and BOFF have to be cleared to "0" (Off) to reduce power consumption.
- 1 → Internal Voltage Follower is enabled for LCD Bias voltage.

IDIR : Icon sequence select.

- 0 → Icon sequence is fixed.
- 1 → Icon sequence follow the setting of CDIR / SDIR.

CDIR: Common sequence select.

- 0 → Pins COM0~63 are mapping to Common 0~63.
- 1 → Pins COM0~63 are mapping to Common 63~0.

SDIR: Segment sequence select.

- 0 → Pins SEG0~143 are mapping to Segment 0~143.
- 1 → Pins SEG0~143 are mapping to Segment 143~0.

[12h] Driver Control Register (DRCR_B)

RW	DB7	DB6	DB5	DB4	DB3	DB2	DB1	DB0
0	CK_BS1	CK_BS0	RR2	RR1	RR0	IRS	--	--

CK_BS[1:0]: Select the clock of Booster. Assume that the RC oscillator clock is 100KHz.

Table 5-15

CK_BS1	CK_BS0	Clock of Booster
0	0	SYS_CLK/2 → 50KHz
0	1	SYS_CLK/4 → 25KHz
1	0	SYS_CLK/6 → 16.7KHz
1	1	SYS_CLK/8 → 12.5KHz

RR[2:0]: Set the Resistor Ratio of Regulator. The ratio is $V_0 : V_{REF}$. Please refer to Ch. 6-5-2.

Table 5-16

RR2	RR1	RR0	Resistor Ratio
0	0	0	X3
0	0	1	X3.5
0	1	0	X4
0	1	1	X4.5
1	0	0	X5
1	0	1	X5.5
1	1	0	X6
1	1	1	X6.4

IRS: Select the resistors for the V0 voltage level adjustment.

- 0 → Do not use the internal resistors. The V0 voltage level is regulated by an external resistor voltage divider that is attached to the VR signal.
- 1 → Use the internal resistors.

[13h] Blink Timer Register (BLTR)

RW	DB7	DB6	DB5	DB4	DB3	DB2	DB1	DB0
0	BLK_EN	PBK_EN	--	INV	BLT3	BLT2	BLT1	BLT0

BLK_EN: Blinking function.

- 0 → Off.
- 1 → On.

PBK_EN: Whole or partial screen blinking selection.

- 0 → Whole screen.
- 1 → Partial screen. The blinking area depends on the scroll window. It means the partial area is set by register SWSXR, SWSYR, SWRXR and SWRYR. When the partial blinking is off, the above four registers had better to be cleared to 0. Note, only BLK_EN is set to "1" when blink is active.

INV: Set display inversely.

- 0 → Normal display.
- 1 → Display inversely. The inverse area depends on the bit7 (PINV) of register SWRYR.

BLT[3:0]: Set blinking time.

Table 5-17

BLT3	BLT2	BLT1	BLT0	Blink Time (Unit: Frames)
0	0	0	0	8
0	0	0	1	16
0	0	1	0	24
0	0	1	1	32
0	1	0	0	40
0	1	0	1	48
0	1	1	0	56
0	1	1	1	64
1	0	0	0	72
1	0	0	1	80
1	0	1	0	88
1	0	1	1	96
1	1	0	0	104
1	1	0	1	112
1	1	1	0	120
1	1	1	1	128

[14h] I/O Direction Control Register (IODR)

RW	DB7	DB6	DB5	DB4	DB3	DB2	DB1	DB0
0	OE7	OE6	OE5	OE4	OE3	OE2	OE1	OE0

OE[7:0]: Select the I/O port direction.
 0 → Input.
 1 → Output.

[15h] I/O Data Register (IODAR)

RW	DB7	DB6	DB5	DB4	DB3	DB2	DB1	DB0
0	IOD7	IOD6	IOD5	IOD4	IOD3	IOD2	IOD1	IOD0

IOD[7:0]: This register stores the input / output data of I/O port when it is in input / output mode.

[17h] CGRAM Register (CGMI)

RW	DB7	DB6	DB5	DB4	DB3	DB2	DB1	DB0
0	--	--	--	--	--	UMI2	UMI1	UMI0

UMI[2:0]: Select the create font number. The RA8816N allows user to create eight 16x16 full size fonts. The mapping font code is FFF0h~FFF7h.

Table 5-18

UMI2	UMI1	UMI0	Font Code
.0	0	0	FFF0h
0	0	1	FFF1h
0	1	0	FFF2h
0	1	1	FFF3h
1	0	0	FFF4h
1	0	1	FFF5h
1	1	0	FFF6h
1	1	1	FFF7h

[18h] CGRAM Data Register (CGMD)

RW	DB7	DB6	DB5	DB4	DB3	DB2	DB1	DB0
0	CGMD7	CGMD6	CGMD5	CGMD4	CGMD3	CGMD2	CGMD1	CGMD0

CGMD[7:0]: This register is write-only and is used to transfer the data of 16x16 full size font. MPU writes continuous 32 bytes data of bit-map of 16x16 full size font into this register that after program REG[17h]. If user wants to show the self-created font, just writes the two bytes font code to RA8816N.

[19h] MISC. Register (MISR)

RW	DB7	DB6	DB5	DB4	DB3	DB2	DB1	DB0
0	--	--	--	--	--	--	--	EOR

EOR: EOR is used when the C-type LCD waveform is not alternated by combining the set values of NW and the duty ratio of the LCD. It is active with C-type waveform only and no function when B-type waveform is set.

- 0 → The N-line inversion signals are driven directly. The N-line inversion signal does not repeat for each frame.
- 1 → The odd / even frame-select signals and the N-line inversion signals are EORed for alternating drive. Besides, the N-line inversion signal waveform will repeat for each frame.

6. Function Description

6-1 MPU Interface

6-1-1 Parallel Interface

MPU interface of the RA8816N supports both 8080 and 6800 series with 4-bit or 8-bit data bus. If "C86" is connected to GND / VDD, then the interface is defined as 8080 / 6800 type. Refer to the Figure 6-1 and Figure 6-2.

If "BIT4" is connected to GND / VDD, then the data bus width of MPU interface is 8 / 4-bit. And only the DB[3:0] of data bus are available in 4-bit mode.

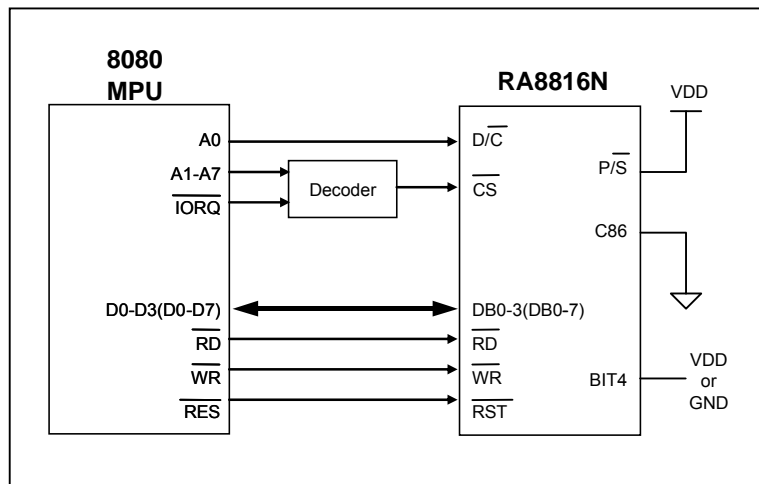

Figure 6-1 : 8080 (4/8-Bit) MPU Interface

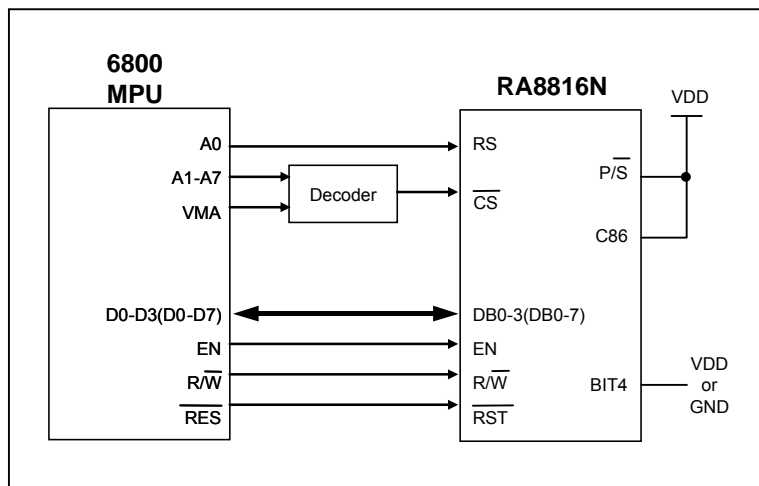

Figure 6-2 : 6800 (4/8-Bit) MPU Interface

6-1-2 Serial Interface

The RA8816N also supports three types serial interface that are 3-Wires and 4-Wires (A-Type, B-Type) respectively. This feature is controlled by pin “P/S” and DB[7:6]. Please refer to Table 4-1 and Table 6-1, in serial mode, DB[7:6] are used as SMOD[1:0] to select the different serial mode. Please also refer to Table 6-1. Figure 6-3 to Figure 6-4 are the interface diagrams of MPU and RA8816N which is in serial mode.

Table 6-1

SMOD	Serial Interface Mode
0 1	3-Wires. Use signals SCK, SDA and \overline{CS} .
1 0	4-Wires (A-Type). Use signals SCK, SDA, RS and \overline{CS} .
1 1	4-Wires (B-Type). Use signals SCK, SDO, SDI and \overline{CS} .

The SPI interface connection diagrams for are listed below. It must be noted that in the 4-wire B-Type serial mode, the SCK signal has to be added an external pull-high resistor as Figure 6-5.

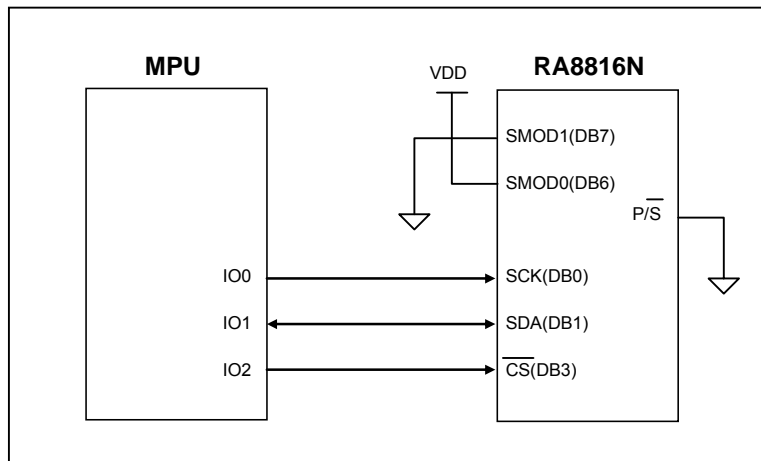

Figure 6-3 : 3-Wires MPU Interface

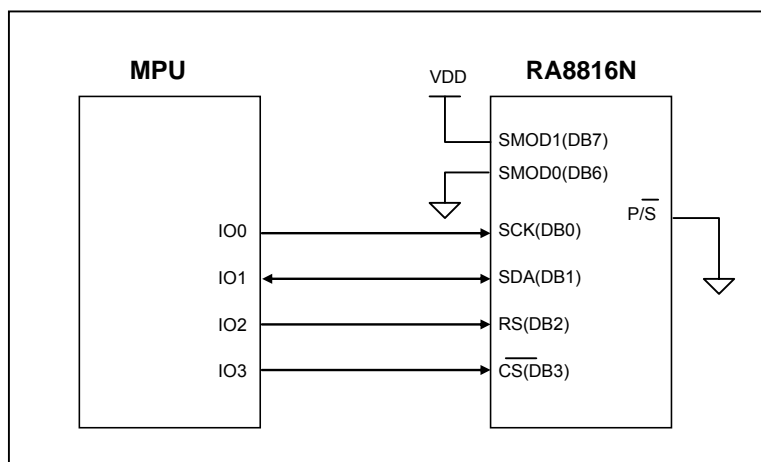

Figure 6-4 : 4-Wires (A-Type) MPU Interface

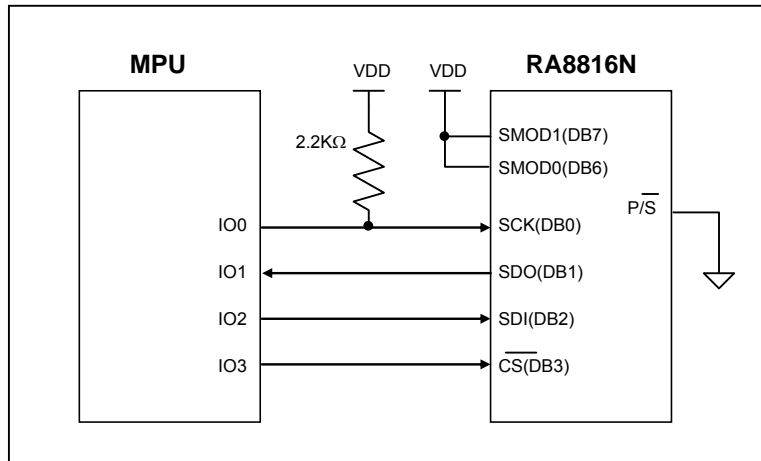

Figure 6-5 : 4-Wires (B-Type) MPU Interface

6-1-3 Register Read/Write

The RA8816N accepts two access cycles from MPU. One is read / write cycle from / to register and the other one is from / to memory. As description of Ch. 5-2, MPU must tell RA8816N that which register will be accessed. Therefore the first data that is written to RA8816N is used to select the register number, and the second one is the exact data that is written into or read from this register.

Because of the features of the RA8816N are controlled by the contents of internal registers. So if we write data to register is like to give a command to RA8816N, therefore we can say that the Register Access Cycle and Command Cycle are the same.

Figure 6-6 and Figure 6-7 show the register access timing of 8080 MPU (8-bit) interface with RA8816N, and 6800 MPU (8-bit) interface in Figure 6-8 and Figure 6-9. Figure 6-10 to Figure 6-12 show the register access timing of serial interface.

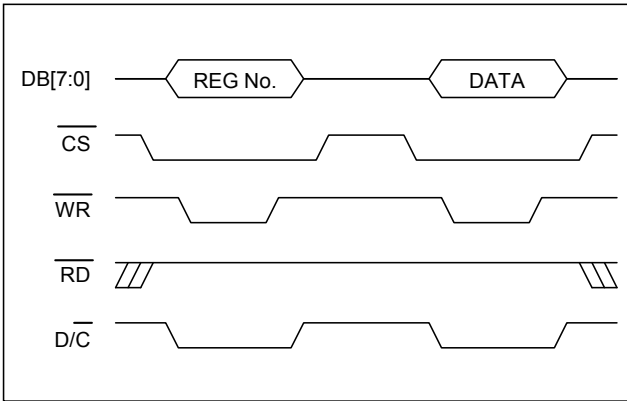

Figure 6-6 : Register Write on 8080 (8-bit) I/F

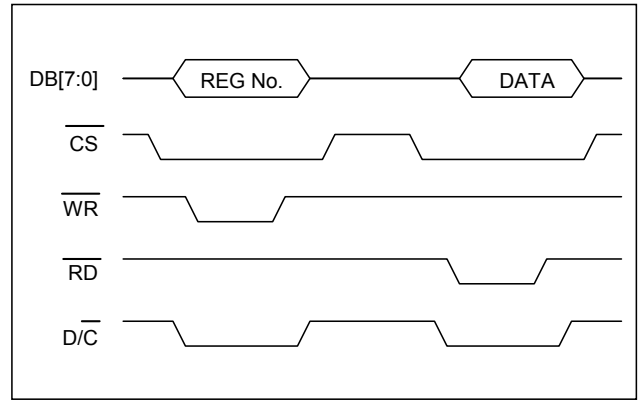

Figure 6-7 : Register Read on 8080 (8-bit) I/F

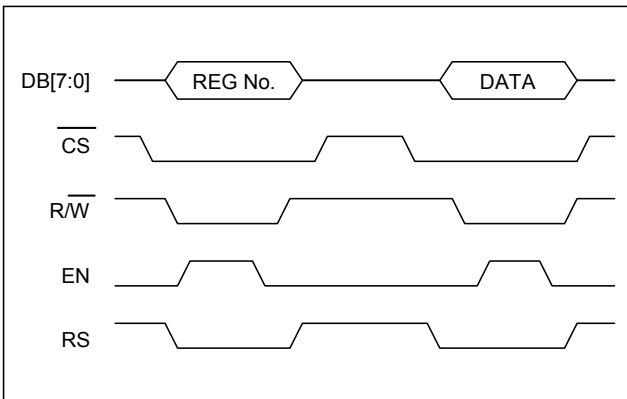

Figure 6-8 : Register Write on 6800 (8-bit) I/F

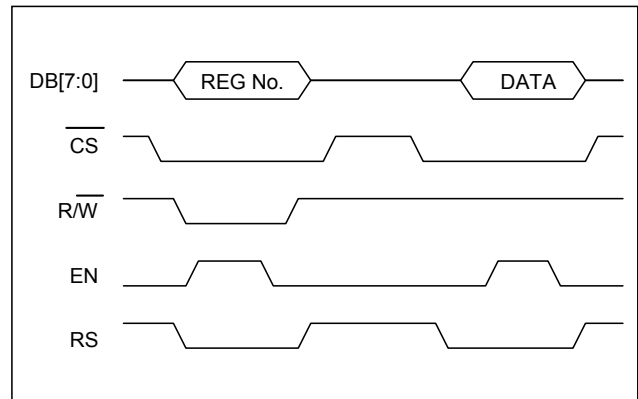

Figure 6-9 : Register Read on 6800 (8-bit) I/F

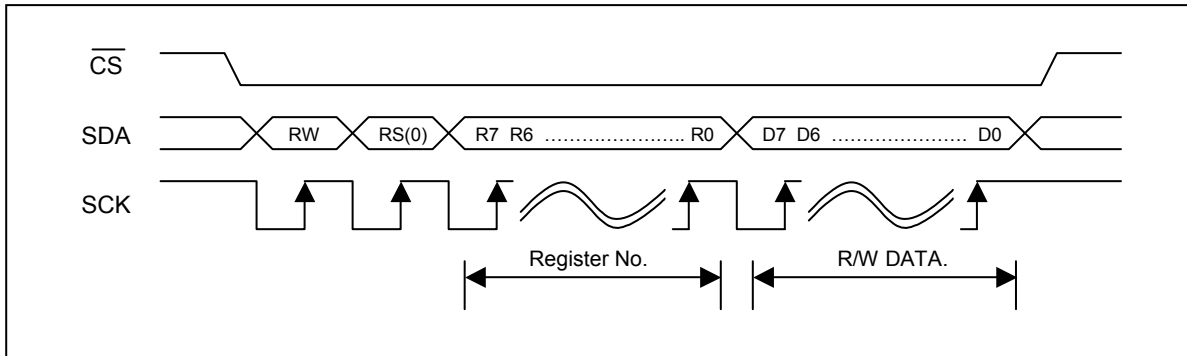

Figure 6-10 : Register Read / Write Access on 3-Wires I/F

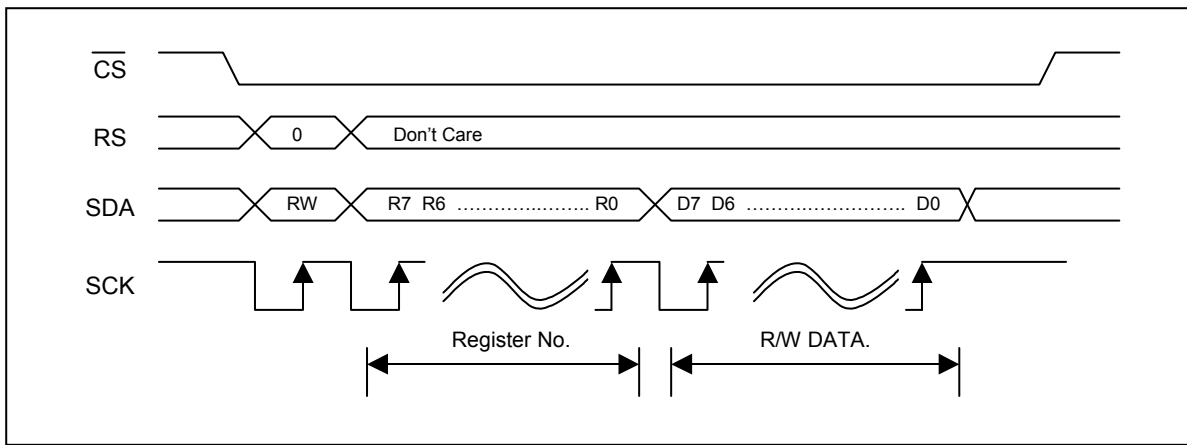

Figure 6-11 : Register Read / Write Access on 4-Wires (A-Type) I/F

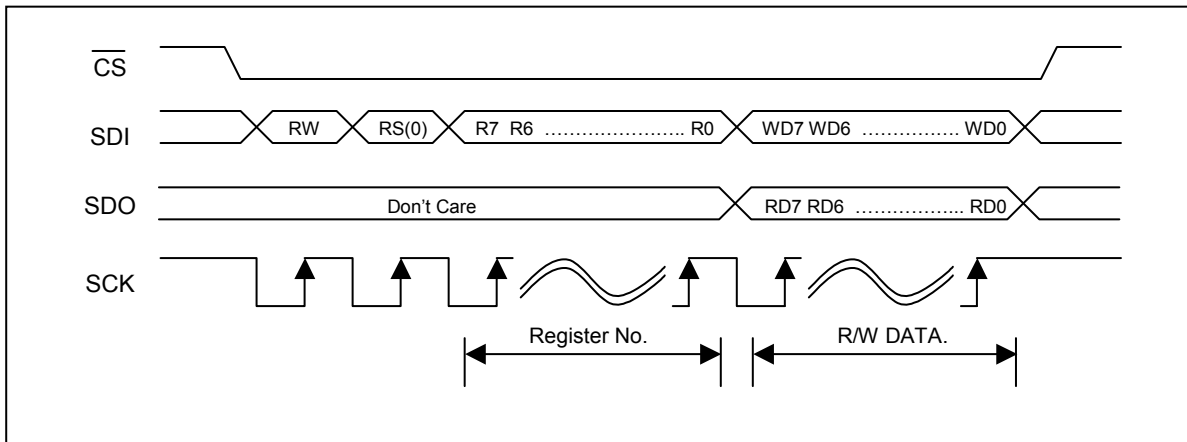

Figure 6-12 : Register Read / Write Access on 4-Wires (B-Type) I/F

6-1-4 Memory Read/Write

Another cycle for MPU to RA8816N is memory Read / Write cycle. Normally it is used to show information on LCD screen. Memory writing means to write data into the mapping address that cursor is located in the memory. After the action is completed, the cursor address will auto increase and the data of next memory write will be filled into the new memory address that new cursor position locates. Because all of the memory read / write cycles transfer the display data, so we can abbreviate the name of Memory Access Cycle to Data Cycle.

Figure 6-13 to Figure 6-16 show the 8-bit memory access timing of 8080 and 6800 MPU interface with RA8816N respectively. Figure 6-17 to Figure 6-19 show the memory access timing of serial interface.

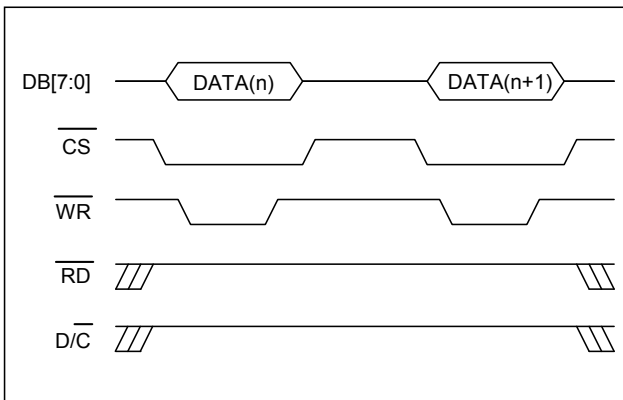

Figure 6-13 : Memory Write on 8080 (8-bit) I/F

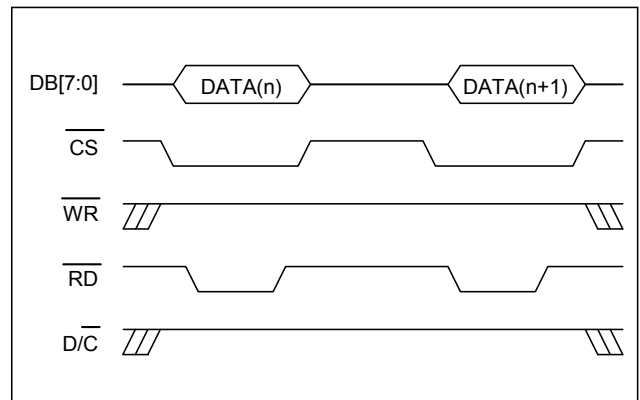

Figure 6-14 : Memory Read on 8080 (8-bit) I/F

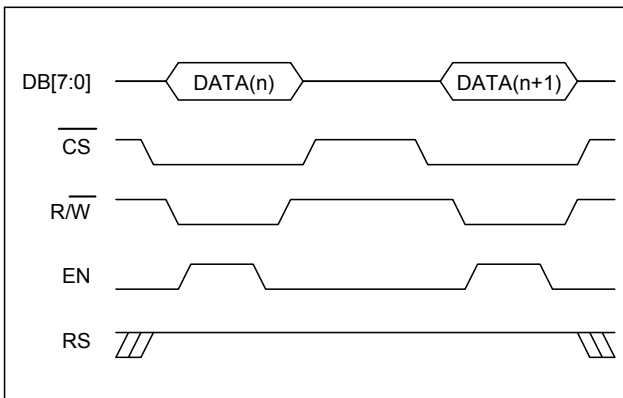

Figure 6-15 : Memory Write on 6800 (8-bit) I/F

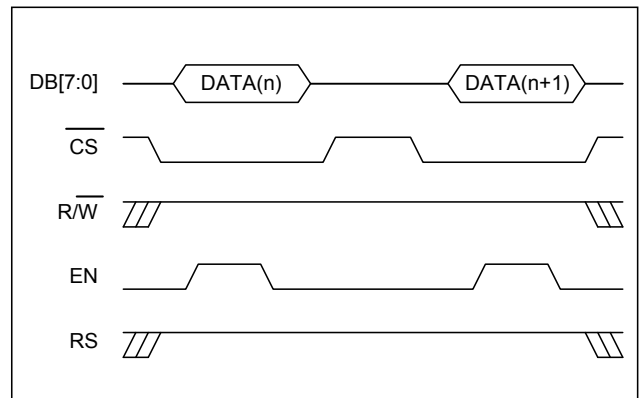

Figure 6-16: Memory Read on 6800 (8-bit) I/F

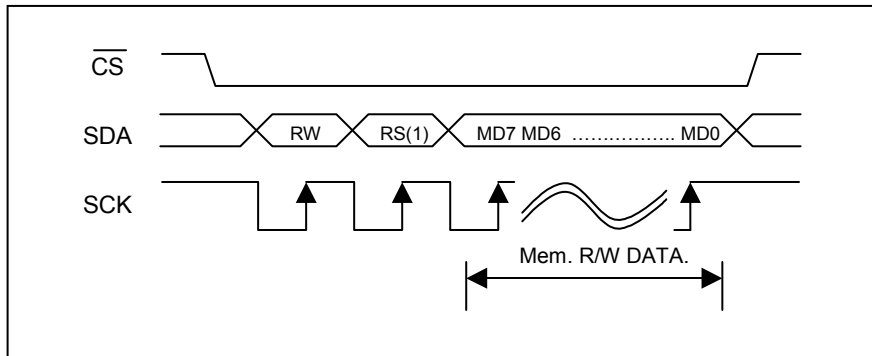

Figure 6-17 : Memory Read / Write Access on 3-Wires I/F

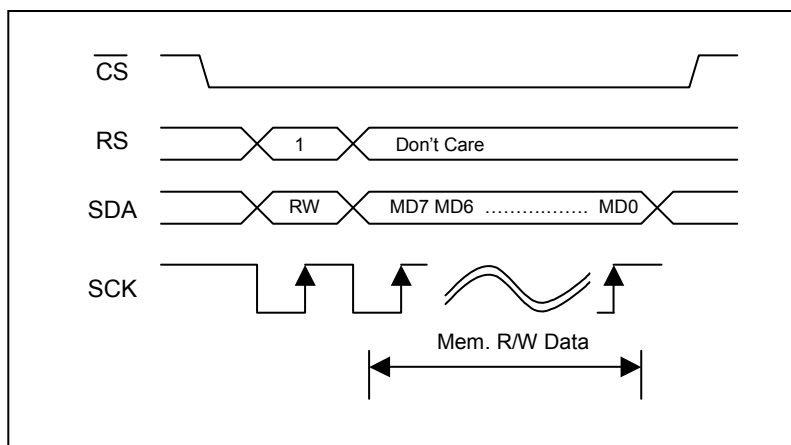

Figure 6-18 : Memory Read / Write Access on 4-Wires (A-Type) I/F

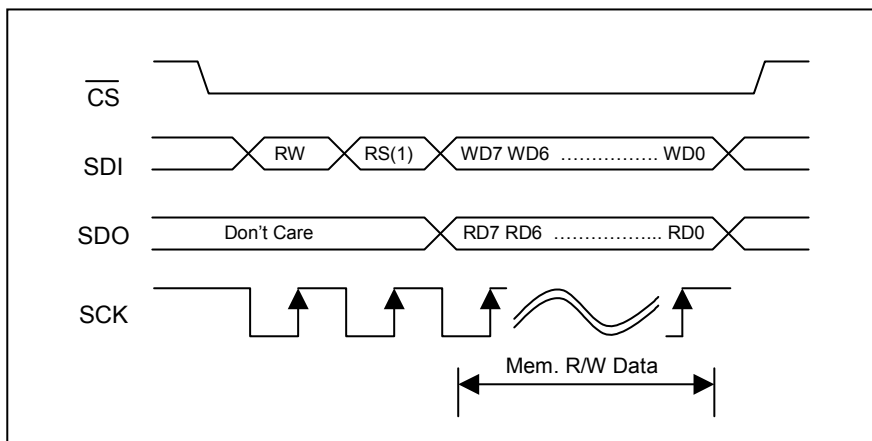

Figure 6-19 : Memory Read / Write Access on 4-Wires (B-Type) I/F

6-2 N-Line Inversion

The RA8816N supports not only the LCD reversed AC drive in a one-frame unit (B-type waveform) but also the n-line reversed AC drive which alternates in an n-line unit from 1 to 64 lines (C-type waveform). When a problem affecting display quality occurs, such as crosstalk at high duty driving, the n-line inversion AC drive waveform (C-type waveform) can improve the quality. Determine the number of the n (NW bit set value + 1) for alternating after confirmation of the display quality with the actual LCD panel. EOR bit (REG[19h] bit 0) can be used when LCD is not alternated in some NW / duty ratio setting. However, if the number of n is reduced, the LCD alternating frequency becomes high and the current consumption is increased.

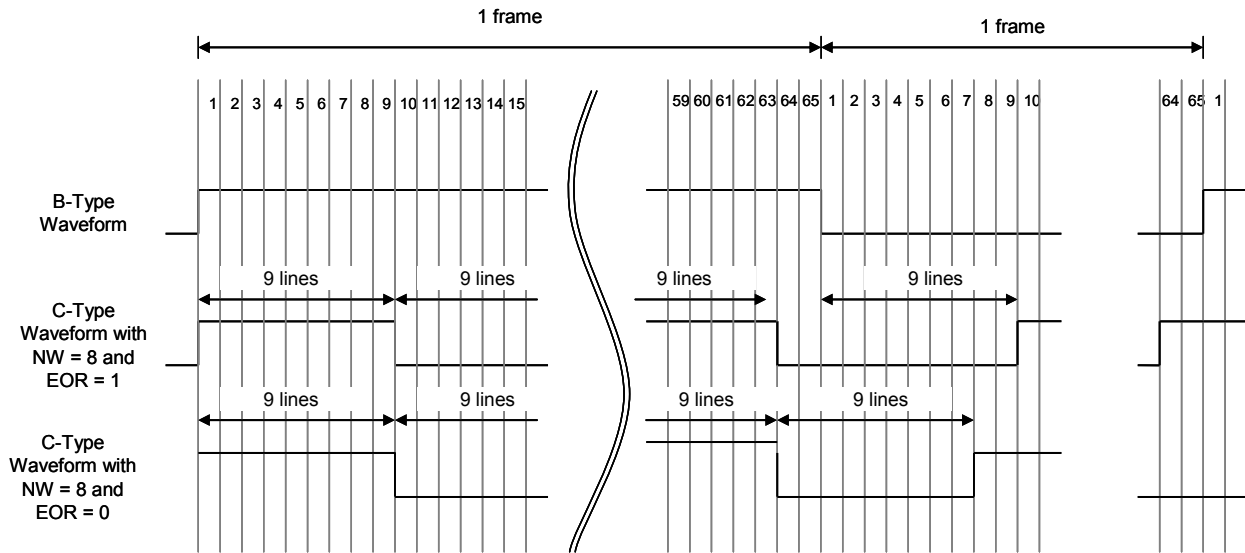

Figure 6-20 : N-Line Inversion Internal AC-drive Waveform

6-3 Memory

The RA8816N is embedded three memories:

1. 256K bytes Font ROM
2. 1170 bytes Display RAM
3. Character Generator RAM (CGRAM)

The 256K bytes Font ROM stores bit map data of Chinese or Japanese font. It also includes English, Japanese, European, Latin (Latin-ext A, Latin-ext B) ASCII table. In text mode, RA8816N will read the bit map data from Font ROM and pass to display RAM when the RA8816N receives the standard code from MPU. The LCD control circuit will read data from display RAM continuously and send to driver circuit. So the text will be shown on the LCD screen. Therefore, MPU will save a lot of time to calculate the position of cursor and read next bit map data from font ROM then write to display RAM. It will raise display efficiency to process Chinese text display and reduce system developing time.

Table 6-2 : Contents of 256KB Font ROM

Part Number	Embedded Font		
RA8816N-T	Traditional Chinese (BIG-5 Code), 16x16 Font Size	8x8 ASCII	8x16 ASCII
RA8816N-S	Simplified Chinese (GB2312 Code), 16x16 Font Size	8x8 ASCII	8x16 ASCII
RA8816N-J	Japanese (S-JIS Code), 16x16 Font Size	8x8 ASCII	8x16 ASCII

The display range of RA8816N is 144x65 dots. So it needs 1170 bytes (144*65/8) display RAM. In addition, a built-in scroll buffer provides the scrolling and shifting functions also.

The Character Generator RAM (CGRAM) is used for user to create special fonts. There are eight space of full size font reserved for user. Their codes are fixed from FFF0h to FFF7h. MPU can write the mapping code to the RA8816N and show the bit map font on screen that after the user font (writing 32 bytes to CGRAM) is created.

6-4 System Clock

The clock of the RA8816N is generated by the internal circuit. Normally the clock frequency is around 100KHz. When the bit0 (SLP) of register PWRR is set to “1”, then the clock will be stopped.

When the input pin “CLK_SEL” is set to “0”, then system clock could be input also from external clock through pin “EXT_CLK”.

6-5 LCD Driver and Power Circuit

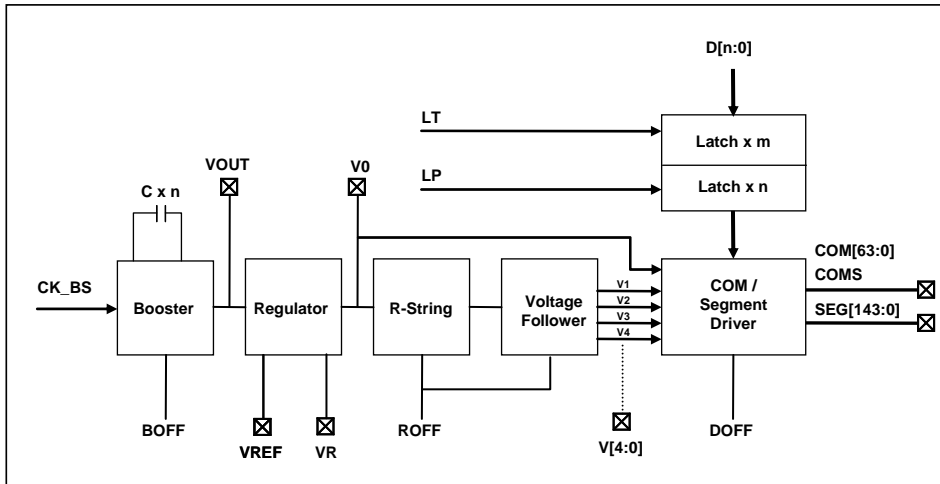

Figure 6-21 : LCD Driver and Power Supply Circuit Block

The driver circuit of RA8816N is a low power design. The power supply circuit is consisted of Booster, Voltage Regulator and Voltage Follower. For different requirements of power, the Driver Control Register (REG[11h]) is used to enable or disable related circuits.

User can use the setting of register REG[11h] to select the internal or external power. Please refer to the following of Table 6-3.

Table 6-3 : Setting Table of Power Circuit

Driver Control Register (DRCR_A) D7 D6 D5 D4	Booster	Voltage Regulator	Reference Voltage(VREF) of Voltage Regulator	Voltage Follower	External Power
1 1 1 1	ON	ON	Internal	ON	VDD
0 1 1 1	OFF	ON	Internal	ON	VOUT, VDD
1 0 1 1	ON	ON	External	ON	VREF, VDD
0 0 1 1	OFF	ON	External	ON	VOUT, VREF, VDD
0 0 0 1	OFF	OFF	Don't Need	ON	V0, VDD
0 0 0 0	OFF	OFF	Don't Need	OFF	V0~V4, VDD

6-5-1 Booster Circuit

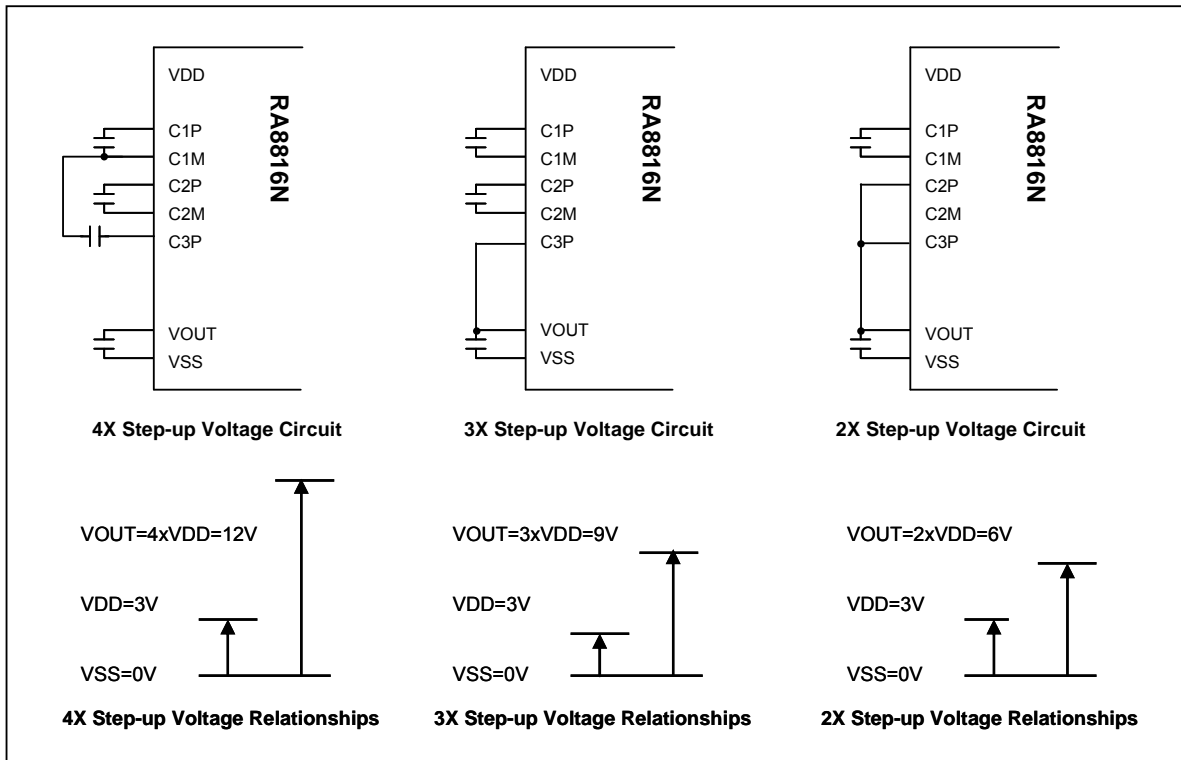

Figure 6-22 : Application Circuit of Booster

RA8816N has a built-in Booster that can generate 2~4 times of “ $V_{DD}-V_{SS}$ ” voltage which is called “VOUT”. It supplies higher voltage power for next stage circuits – Voltage Regulator and internal driver circuit. If user want to get VOUT equal to $2 \times V_{DD}$, a capacitor C1 needs to be connected between C1P and C1M. $3 \times V_{DD}$ could be got if an additional capacitor C1 is added between C2P and C2M. And $4 \times V_{DD}$ could be got also if one more capacitor C1 is added between C3P and C1M.

When the circuit operates in 2x or 3x mode, the unused positive capacitor pins (CxP) must be connected to VOUT in short circuit and negative pins (CxN) are kept floating. The detail application circuit is shown above as Figure 6-22.

The clock source of Booster is also controlled by register DRCCR_B. Please refer to the description of REG[12h] in Chapter 5-2. Normally, if use the internal driver power, then the application circuit is shown as Figure 6-23. If use external VOUT, that means do not use the internal Booster, then the connection is shown as Figure 6-24.

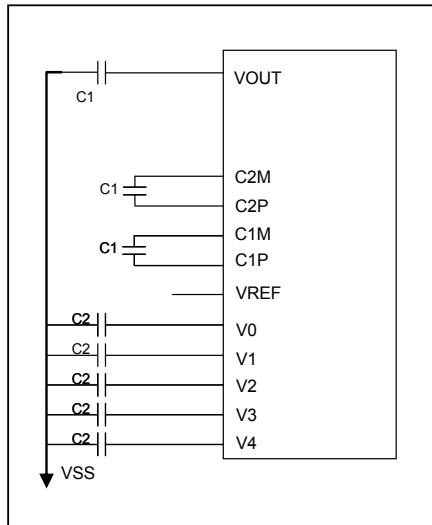

Figure 6-23 : Internal VOUT (3*VDD)

Note: The capacitor value of C1 is 1uF and C2 is 1uF.

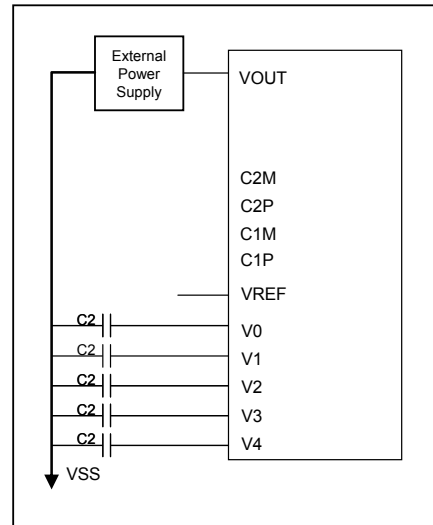

Figure 6-24 : External VOUT

6-5-2 Voltage Regulator

The Voltage Regulator is consisted of Band-Gap reference circuit and OP-Amp. The purpose is to generate a stable power - V_0 to supply Voltage Follower. RA8816N also has a built-in 32-level adjustment circuit and a fixed voltage - V_{IREF} to generate a reference voltage V_{REF} which is the reference voltage to generate V_0 . The basic formula is derived as following:

$$V_0 = (1+R1/R2) * V_{REF} = (1+R1/R2) * (1-(62-2\alpha)/162) * V_{IREF}$$

The α is the setting of CT[4:0] of Register CSTR. When CT[4:0]=1Fh then $V_{REF}=V_{IREF}$.

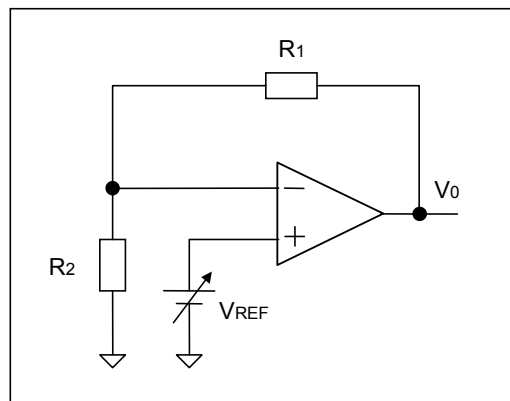

Figure 6-25 : Voltage Regulator

The resistor ratio (V_0 / V_{REF}) of Voltage Regulator is adjustable by register DRCR_B. There are total eight cases - 3 / 3.5 / 4 / 4.5 / 5 / 5.5 / 6 / 6.4. Refer to the description of bit[5:3] of register RCR_B on Ch. 5-2. If want to use external resistor divisor then refer to the bit2 of register DRCR_B and Figure 6-26.

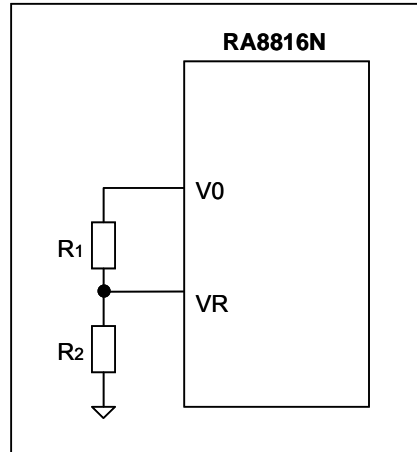

Figure 6-26 : Use External Resistor Divisor

The VREF of the RA8816N is supplied from internal circuit or external VREF Pin. Please refer to Table 6-4 :

Table 6-4 : Select V_{REF}

V _{REF} Type	DRCR-A Bit6 (EN_R)	DRCR-A Bit5 (EN_G)	Temperature Gradient	Unit	V _{REF}
Internal V _{REF}	1	1	-0.1	%/°C	$(1-(62-2\alpha)/162)*V_{IREF}$
External V _{REF}	0	1	-	-	V _{REF} Pin
	X	0	-	-	

Normally, the internal VIREF value is 2.1V. When Voltage Regulator Circuit is disabled (EN_G=0), then the Reference Voltage Circuit is disabled too. The Voltage Regulator also provides -0.1%/°C auto adjustment for temperature compensation.

6-5-3 Voltage Follower

The internal Voltage Follower provides V0~V4 power for LCD driver circuit. Of course, user can select internal or external Voltage Follower. The relationship of V0~V4 and VOUT is as following:

$$VOUT > V0 > V1 > V2 > V3 > V4 > GND$$

The LCD bias of RA8816N is adjustable by register CSTR that from 1/5 to 1/9. User can also adjust the display quality from this register. Meanwhile, the driving current is also adjustable by register DRCR_B that in order to fit different panel demand. Figure 6-27 shows the circuit of using internal Voltage Follower. For external V0~V4, the connection is shown as Figure 6-28.

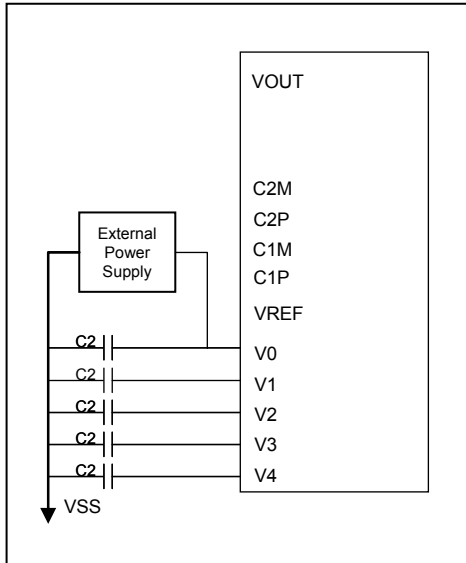

Figure 6-27 : Use Internal Voltage Follower

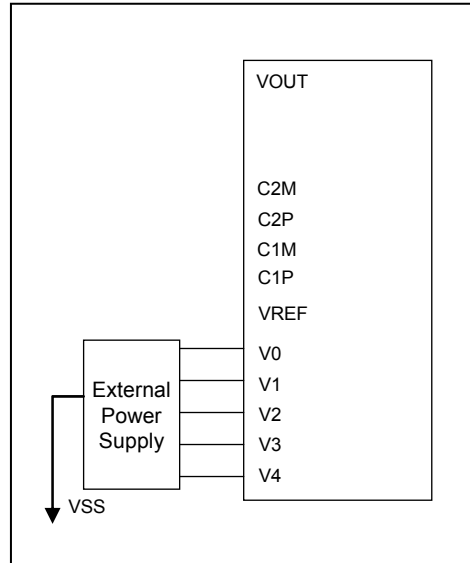

Figure 6-28 : Use External Voltage Follower

6-5-4 LCD Driver

The Segment / Common driver of RA8816N is used to latch the data of pre-stage, then send to level shifter for combination. The combined data will follow the timing generator to control the switches then pass the V0~V4 to Common and Segment.

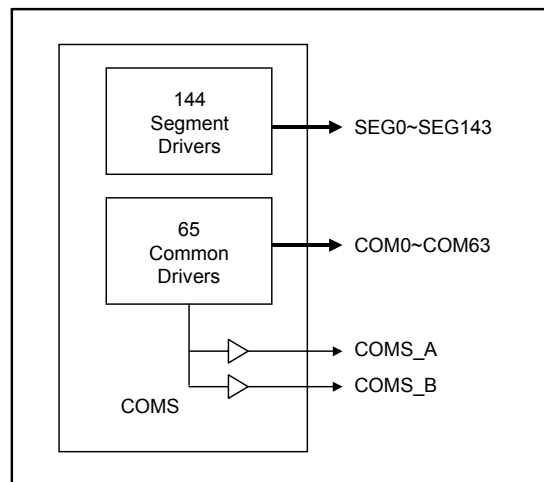

Figure 6-29 : The Segment and Common Driver

The DOFF_Z of register PWRR is used to control on / off of LCD panel. When DOFF_Z is set to "0" then the LCD driver is disabled. At this state, the driver output signals COM0~COM63, SEG0~SEG143, COMS_A and COMS_B are GND, and the screen of LCD panel is turned off.

6-6 Interrupt

The RA8816N provides an interrupt signal (\overline{INT}) to response three possible interrupt:

1. Busy Interrupt– When the action that data are written to display RAM is completed.
2. Scroll Interrupt - When the scroll window shifted 1, 8 or 16 pixels.
3. Key-scan Interrupt - When a key was pressed.

The interrupt of above could be enabled or disabled by register setting. MPU can read the interrupt message form interrupt status register. The $\overline{\text{INT}}$ is low active, so when MPU detect that the interrupt happens then must clear interrupt status so that $\overline{\text{INT}}$ returns to high. If user do not use the hardware interrupt ($\overline{\text{INT}}$), then MPU can get the interrupt message by reading the status register.

6-7 Key-Scan

The RA8816N has a built-in 4x5 key-scan circuit for extra key board function to assist user to integrate a key matrix application. In auto mode, MPU can read the key code from register to realize the key event is short pressed, long pressed or released. User can also adjust the cycle time of key-scan. Figure 6-30 is a simple application curcuit. Table 6-5 is the mapping keyboard code of key matrix as Figure 6-30. So MPU realizes which key is pressed by reading register KSDR.

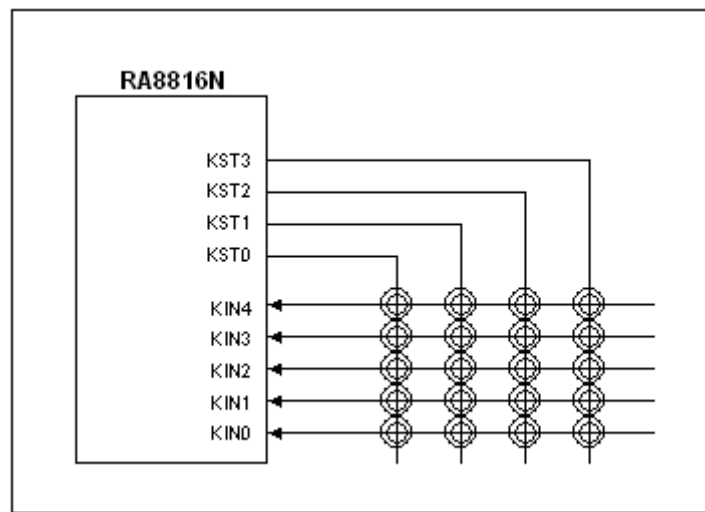

Figure 6-30 : 4x5 Key Matrix Curcuit

Table 6-5 : Keyboard Code (BCD Code) of Auto-Mode

	Short-Press				Long-Press			
	KST3	KST2	KST1	KST0	KST3	KST2	KST1	KST0
KIN0	15	10	05	00	35	30	25	20
KIN1	16	11	06	01	36	31	26	21
KIN2	17	12	07	02	37	32	27	22
KIN3	18	13	08	03	38	33	28	23
KIN4	19	14	09	04	39	34	29	24

In auto mode, if a key is pressed over one second, then RA8816N will issue 2nd interrupt and change the data of register – KSDR to a long pressed code. Therefore MPU realizes which key is pressed over one second.

6-8 I/O Port

The RA8816N provides eight general purpose I/O pins. Each I/O pin is easy to set as input or output. They can be used to drive LED, wakeup RA8816N or provide information for whole system.

6-9 ASCII Block

The RA8816N has built-in three ASCII blocks which contains ASCII and special symbols for user to show on display in text mode directly. Actually these three ASCII blocks are stored in 256K bytes Font ROM (see Chapter 6-3). As Figure 6-31~Figure 6-33, the left of each table is high nibble, and the right is low nibble. These blocks are selected by MD0 and MD1 of register MWMR. If user needs special symbols or graphs, the customized ROM code is possible.

Figure 6-31 is the table of small ASCII. Each character size is 8x8 dots. Therefore if the LCD panel size is 144 SEG x 65 COM then it can show eight rows, and each row has 18 samll ASCII fonts. Figure 6-32 and Figure 6-33 are the tables of big ASCII. For the same panel size, it can show four rows, and each row has 18 characters.

	0	1	2	3	4	5	6	7	8	9	A	B	C	D	E	F
0	☉	☼	☽	☿	♁	♂	♃	♅	♁	♂	♃	♅	♁	♂	♃	♅
1	▶	◀	◀	▶	◀	▶	◀	▶	◀	▶	◀	▶	◀	▶	◀	▶
2	!	"	#	\$	%	&	'	()	*	+	,	-	.	/	
3	0	1	2	3	4	5	6	7	8	9	:	;	<	=	>	?
4	@	A	B	C	D	E	F	G	H	I	J	K	L	M	N	O
5	P	Q	R	S	T	U	V	W	X	Y	Z	[\]	^	_
6	'	a	b	c	d	e	f	g	h	i	j	k	l	m	n	o
7	p	q	r	s	t	u	v	w	x	y	z	{		}	~	
8	Š	š	Ÿ	ÿ	Š	š	Ÿ	ÿ	Š	š	Ÿ	ÿ	Š	š	Ÿ	ÿ
9	É	é	Æ	æ	Ö	ö	Ü	ü	Û	û	Œ	œ	Œ	œ	Œ	œ
A	á	à	í	î	ó	ô	ñ	ä	å	Å	Ä	Å	Ä	Å	Ä	Å
B	ì	ï	ò	õ	ö	ù	û	ü	ý	ÿ	Œ	œ	Œ	œ	Œ	œ
C	ø	å	ä	å	ä	å	ä	å	ä	å	ä	å	ä	å	ä	å
D	—	—	—	—	—	—	—	—	—	—	—	—	—	—	—	—
E	ø	å	ä	å	ä	å	ä	å	ä	å	ä	å	ä	å	ä	å
F	É	é	Æ	æ	Ö	ö	Ü	ü	Û	û	Œ	œ	Œ	œ	Œ	œ

Figure 6-31 : Small ASCII (Table 0)

	0	1	2	3	4	5	6	7	8	9	A	B	C	D	E	F			
0	☉	☼	☽	☿	♁	♂	♃	♅	♁	♂	♃	♅	♁	♂	♃	♅			
1	▶	◀	◀	▶	◀	▶	◀	▶	◀	▶	◀	▶	◀	▶	◀	▶			
2	!	"	#	\$	%	&	'	()	*	+	,	-	.	/				
3	0	1	2	3	4	5	6	7	8	9	:	;	<	=	>	?			
4	@	A	B	C	D	E	F	G	H	I	J	K	L	M	N	O			
5	P	Q	R	S	T	U	V	W	X	Y	Z	[\]	^	_			
6	'	a	b	c	d	e	f	g	h	i	j	k	l	m	n	o			
7	p	q	r	s	t	u	v	w	x	y	z	{		}	~				
8	đ	À	á	â	ã	ä	å	Ā	ā	Ă	ă	Ą	ą	Ć	ć	Č	č		
9	Č	č	Ď	ď	Ě	ě	Ǽ	ǽ	Ǿ	ǿ	Ǻ	ǻ	Ǿ	ǿ	Ǻ	ǻ	Ǿ	ǿ	
A	ā	à	á	â	ã	ä	å	Ā	ā	Ă	ă	Ą	ą	Ć	ć	Č	č		
B	°	±	²	³	¼	½	¾	¸	¹	º	»	œ	ÿ	ı					
C	À	Á	Â	Ã	Ä	Å	Ā	ā	Ă	ă	Ą	ą	Ć	ć	Č	č			
D	Đ	đ	Ě	ě	Ǽ	ǽ	Ǿ	ǿ	Ǻ	ǻ	Ǿ	ǿ	Ǻ	ǻ	Ǿ	ǿ			
E	ā	à	á	â	ã	ä	å	Ā	ā	Ă	ă	Ą	ą	Ć	ć	Č	č		
F	č	ć	ď	đ	ě	ǽ	ǿ	Ǻ	ǻ	Ǿ	ǿ	Ǻ	ǻ	Ǿ	ǿ	Ǻ	ǻ	Ǿ	ǿ

Figure 6-32 : Big ASCII (Table 1)

	0	1	2	3	4	5	6	7	8	9	A	B	C	D	E	F			
0	☉	☼	☽	☿	♁	♂	♃	♅	♁	♂	♃	♅	♁	♂	♃	♅			
1	▶	◀	◀	▶	◀	▶	◀	▶	◀	▶	◀	▶	◀	▶	◀	▶			
2	!	"	#	\$	%	&	'	()	*	+	,	-	.	/				
3	0	1	2	3	4	5	6	7	8	9	:	;	<	=	>	?			
4	@	A	B	C	D	E	F	G	H	I	J	K	L	M	N	O			
5	P	Q	R	S	T	U	V	W	X	Y	Z	[\]	^	_			
6	'	a	b	c	d	e	f	g	h	i	j	k	l	m	n	o			
7	p	q	r	s	t	u	v	w	x	y	z	{		}	~				
8	Ÿ	ÿ	Š	š	Ÿ	ÿ	Š	š	Ÿ	ÿ	Š	š	Ÿ	ÿ	Š	š	Ÿ	ÿ	
9	◀	◀	◀	◀	◀	◀	◀	◀	◀	◀	◀	◀	◀	◀	◀	◀	◀	◀	◀
A	Ё	ё	Ђ	ђ	Є	є	І	і	Ј	ј	Љ	љ	Њ	њ	Ћ	ћ	Ў	ў	
B	А	Б	В	Г	Д	Е	Ж	З	И	Й	К	Л	М	Н	О	П			
C	Р	С	Т	У	Ф	Х	Ц	Ч	Ш	Щ	Ъ	Ы	Ь	Э	Ю	Я			
D	а	б	в	г	д	е	ж	з	и	й	к	л	м	н	о	п			
E	р	с	т	у	ф	х	ц	ч	ш	щ	ъ	ы	ь	э	ю	я			
F	ѐ	ё	ђ	ѓ	є	є	і	і	ј	ј	љ	љ	њ	њ	ћ	ћ	ў	ў	

Figure 6-33 : Big ASCII (Table 2)

6-10 Power Control

The RA8816N supports normal and sleep mode for operation. If writes "1" to bit 0 of register PWRR, then RA8816N will enter sleep mode. The functions of LCD display and driver will be stopped. All of the signals of COM and SEG will keep low, Key Strobe signals will keep high, and I/Os keep the original state. Because the system clock is stopped also, the power consumption is very low.

The RA8816N provides three ways to wake up the system:

1. Write "0" to bit0 of register PWRR.
2. Key-scan to wake up
3. I/O wake up

In wake up phase, RA8816N will wake up the RC oscillator first then RA8816N is enabled to accept commands from MPU and LCD driver is waked up also for activity. At the same time, the power block will recover status before system enter sleep mode. If all internal circuius are used, the recovery time will take around 250ms.

7. Display Functions

7-1 Text Mode

The embedded 256KB Font ROM includes Traditional Chinese or Simplified Chinese or S-JIS Japanese, and English, Japanese, European and Latin (Latin-ext A, Latin-ext B) ASCII. In text mode, it supports full size (Chinese, English and S-JIS Japanese) or half size (English) font display. The full size font is consisted of 16x16 bit map and the half size font is consisted of 8x16 or 8x8. Please refer to the following Figure 7-1:

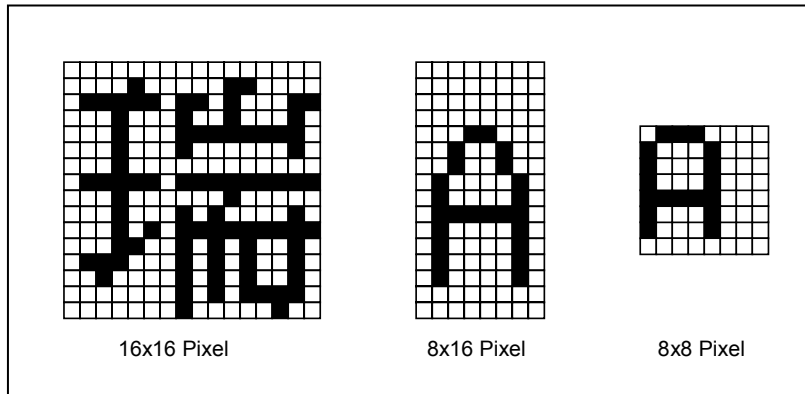

Figure 7-1 : Full Size and Half Size Font

The font display is operated with text mode. Full size font code includes two bytes data therefore MPU has to send twice that are high byte and low byte. For half size font, only one byte is needed. So if RA8816N receives one or two codes then the mapped font will be shown on the cursor position. Based on the maximum supported panel size that is described above, it can display 9x4 full size characters or 18x4 half size characters.

The register MWMR is used to set the font size for display. User can also select the different display mode such as bold, inverse or normal in this register.

7-2 Graphic Mode

In the graphics mode, the RA8816N fills the bit map data into display memory directly. So if the MD[1:0] of register MWMR is set "00" (Graphics Mode), then write the data into memory and will be shown on the screen that cursor points.

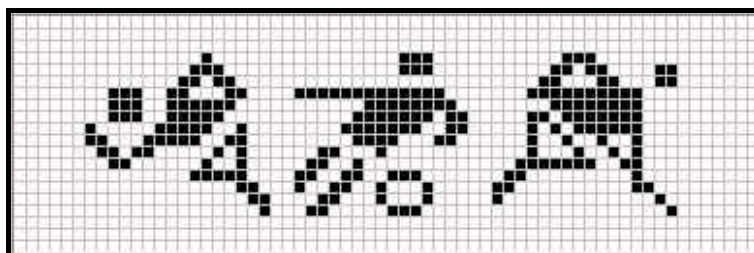

Figure 7-2 : Graphics Mode Display

The display RAM size of the RA8816N is 1170 bytes (144*65/8). Each memory bit is mapped to LCD panel. If the data is "1" then the mapped dot is turn on. Please refer to Figure 7-3.

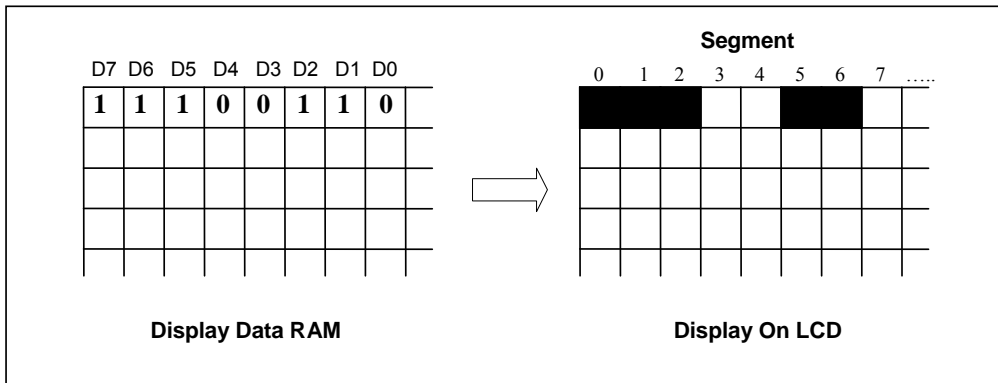

Figure 7-3 : Display Data Mapping to the Screen

The RA8816N also provides a clean feature to clear all of the display RAM. If the “MCLR” of register PWRR is set “1”, then all of contents of Display RAM will be cleared to “0”. In graphics mode, user can select blinking or inverse through register BLTR. The blinking region is assigned by the size of Scroll Window.

7-3 Cursor Setting

7-3-1 Cursor Position and Shift

The unit of Segment Address is 8 bit, Common is 1 bit. For example, if user want to show a font “制” on the third position (full-size) of top, then the register X-CUR and Y-CUR have to be set 04h and 00h. If the second row want to show “器” as Figure 7-4, then the X-CUR and Y-CUR are set 00h and 10h.

Both of text and graphic modes, the cursor position are designated by the same register X-CUR and Y-CUR. If fill data to display RAM or show a Chinese font on screen, the cursor will auto increases and the boundary is the display window.

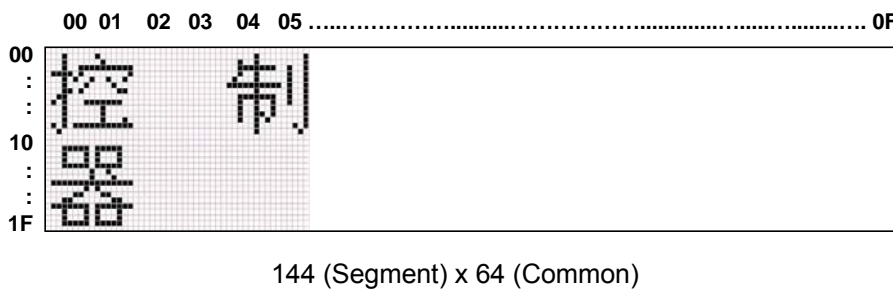

Figure 7-4 : An Example for Cursor Setting

7-3-2 Cursor Display and Blink

The RA8816N provides cursor on / off and blinking features. These functions are controlled by register CURCR. The cycle time of blinking depends on the setting of register BLTR. The range is from 8 to 128 frames.

7-3-3 Cursor Height

The cursor height is also set by register CURCR. For full size mode the cursor height is adjustable from 1 to 16 pixels, and half size is form 1 to 8 pixels. Please refer to Figure 7-5.

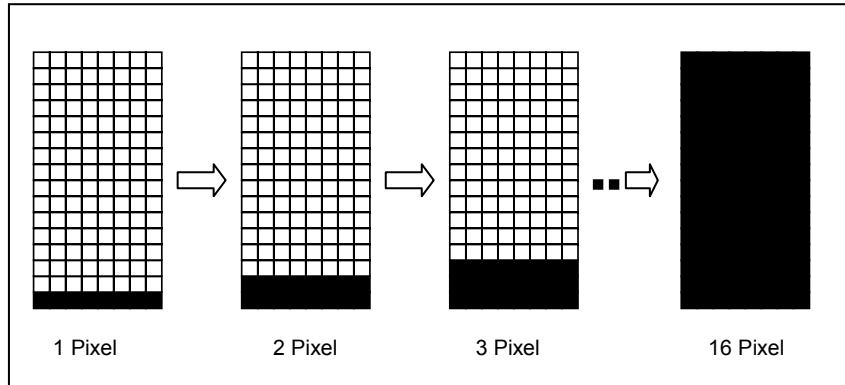

Figure 7-5 : Cursor Height

7-4 Display Window

Normally, the Display Window size is the same as LCD panel. It's set by register SYSR. The maximum range is 144 (Segment) x 64 (Common). RA8816N provides an extra Common (COM-S) as the selection of Icon so there are total 144 Icons for using. Before access the COM-S, the register Y-CUR has to be set 50h, then program the X-CUR to select Icon.

RA8816N provides two positions for the panel layout of COM-S. It's convenient for user to design the position of Icon for application. Refer to Figure 7-6.

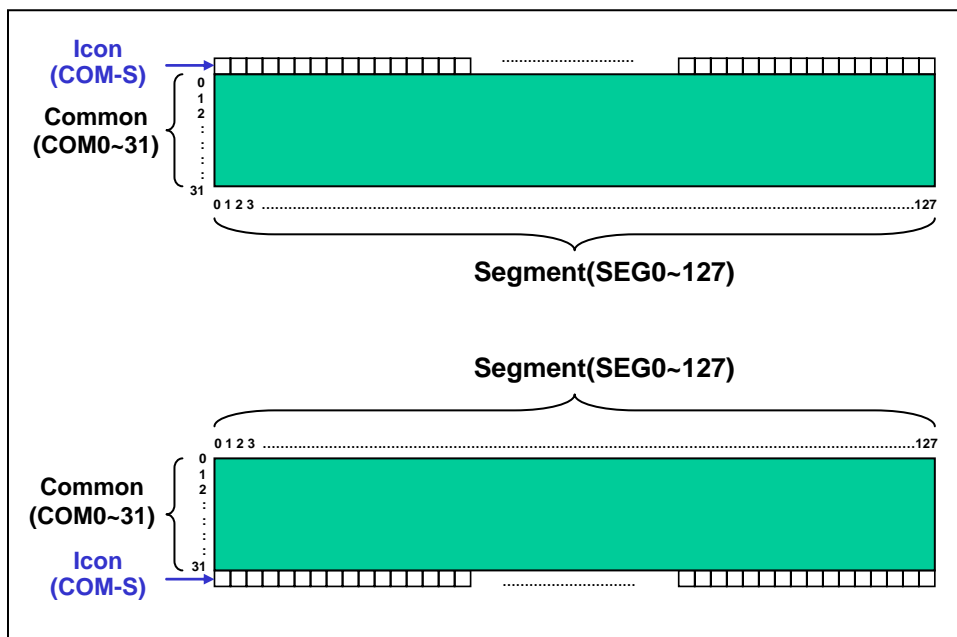

Figure 7-6 : Display Window and Icon

7-5 Horizontal Scroll

The RA8816N provides horizontal scroll feature. User can assign the range of scrolling, scroll unit and speed. Refer to the following example as Figure 7-7. The scroll unit is set to 2 pixels.

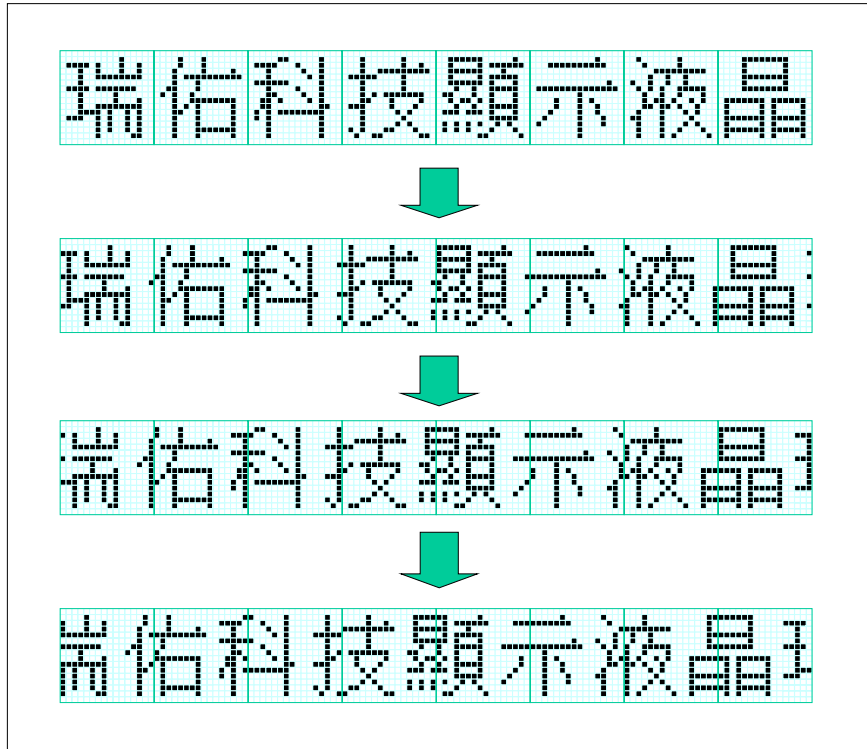

Figure 7-7 : Horizontal Scroll

The RA8816N allows to scroll or shift horizontally (leftward or rightward). User can use the scrolling buffer to show the function. For example, store the data or text on the horizontal scroll buffer first, then fill the new data / text into the buffer that after the screen shift 16 pixels. User can repeat these actions and find the screen shifts like caption of advertisement. Figure 7-8 is an example to show the horizontal shift. The shifted unit is 8 pixels and the gray area is the scroll buffer that will not be shown on screen.

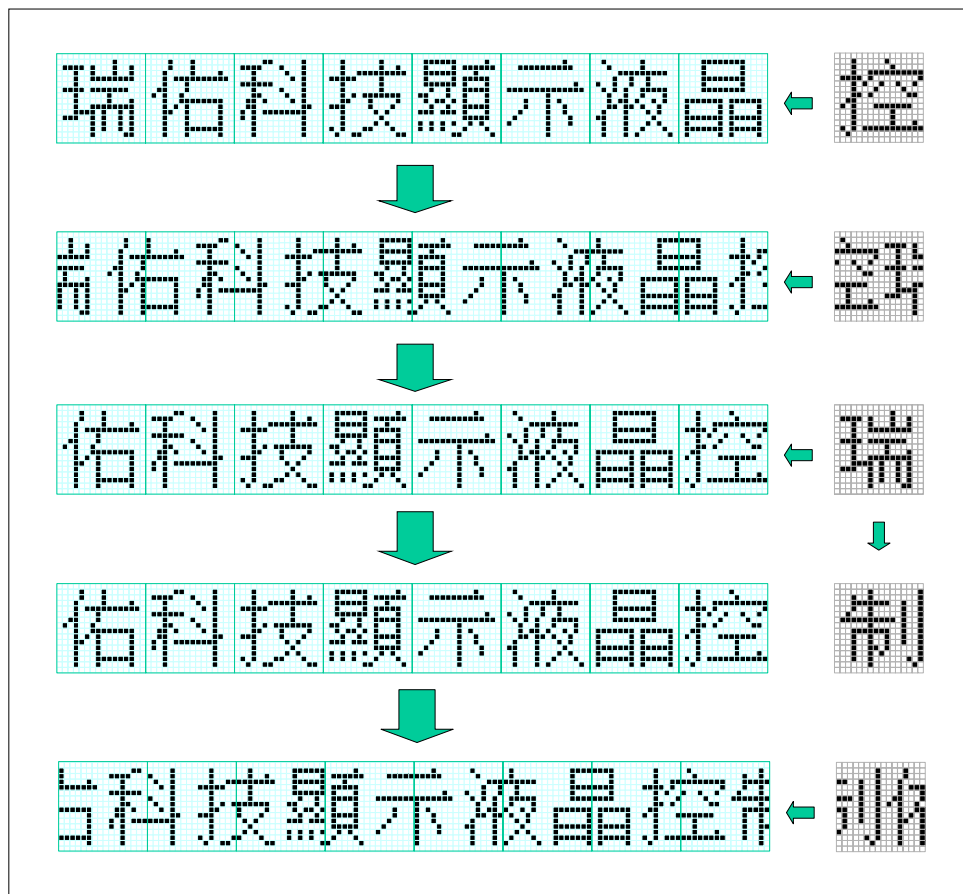

Figure 7-8 : Horizontal Shift

7-6 Vertical Scroll

The RA8816N also provides vertical (upward or downward) scroll and shift features that like horizontal function. User can use the scrolling buffer to show the function. For example, store the data or text on the vertical scroll buffer first, then fill the new data / text into the buffer that after the screen shift 16 pixels. The same with horizontal function, user can repeat these actions and find the screen shifts like caption of advertisement. Please refer to the following example as Figure 7-9. The vertical scroll unit is set to 2 pixels.

Please refer to application note for the related vertical scroll features.

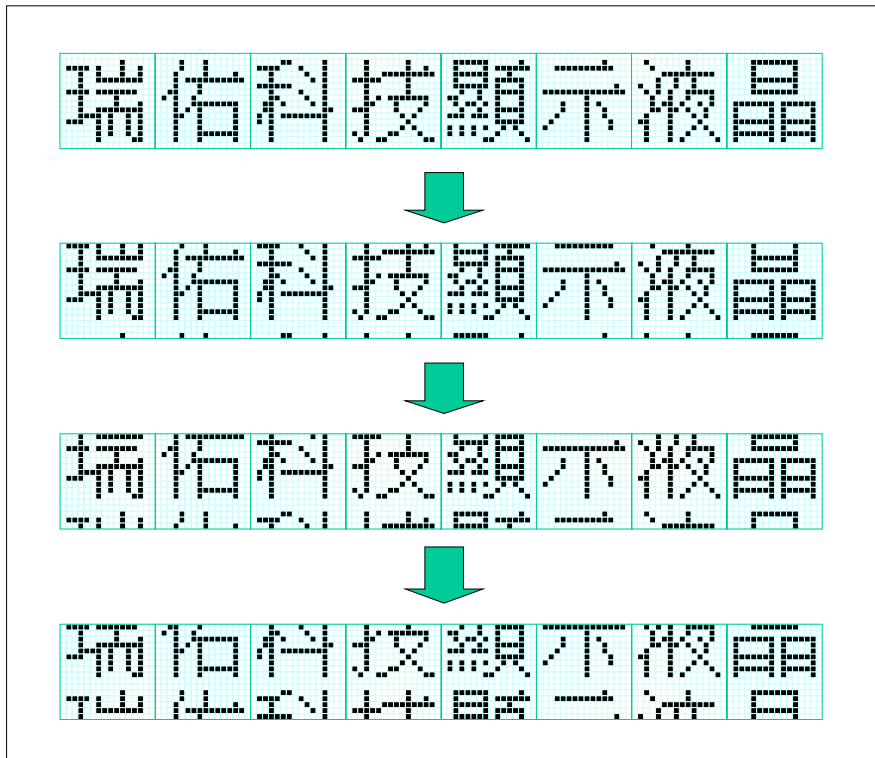

Figure 7-9 : Vertical Scroll

8. Pin Diagram

8-1 COG Pad

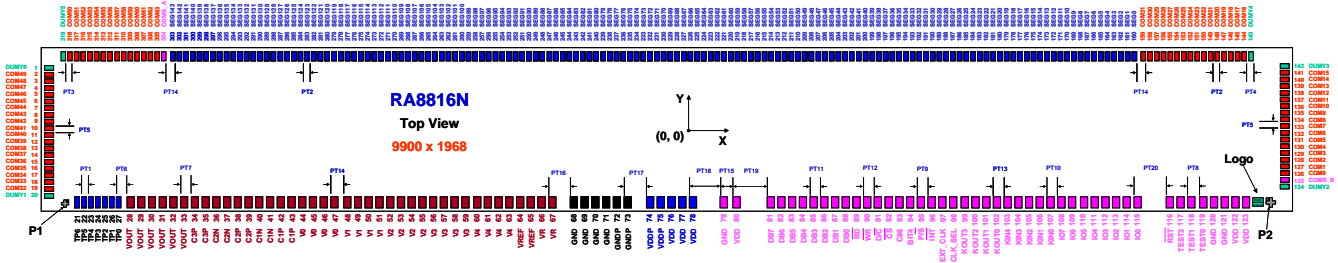

Figure 8-1 : Pin Diagram

Table 8-1 : Bump Size and Pitch

Chip Size	9900μm x 1968μm	
Chip Thickness	482.6μm (19mil)	
Bump Size	PAD 1~20, PAD 124~142 (COM / SEG Pads)	74μm x 30μm
	PAD 143~319 (COM / SEG Pads)	30μm x 74μm
	PAD 21~27 (NC)	38μm x 74μm
	PAD 28~123 (MCU/PWR Pads)	60μm x 84μm
Bump Pitch	PT1: PAD 21~27	46μm
	PT2: PAD 144~159, PAD 160~303, PAD 304~318	50μm
	PT3: PAD 318~319	50.79μm
	PT4: PAD 143~144	59.51μm
	PT5: PAD 1~20, PAD 124~142	60μm
	PT6: PAD 27~28	66μm
	PT7: PAD 28~47, PAD 48~67, PAD 68~73, PAD 74~78, PAD 119~123	80μm
	PT8: PAD 118~119	88.28μm
	PT9: PAD 95~96, PAD 98~99	88.44μm
	PT10: PAD 107~108	88.45μm
	PT11: PAD 81~83, PAD 84~87, PAD 89~90, PAD 91~93, PAD 94~95, PAD 99~100, PAD 101~102, PAD 104~107, PAD 108~110, PAD 111~113, PAD 114~115, PAD 116~118	88.51μm
	PT12: PAD 83~84, PAD 87~88, PAD 90~91, PAD 93~94, PAD 97~98, PAD 100~101, PAD 103~104, PAD 110~111, PAD 113~114	88.52μm
	PT13: PAD 88~89, PAD 96~97, PAD 102~103	88.58μm
	PT14: PAD 47~48, PAD 159~160, PAD 303~304	90μm
	PT15: PAD 79~80	95.76μm
	PT16: PAD 67~68	130μm
PT17: PAD 73~74	150μm	
PT18: PAD 78~79	220μm	
PT19: PAD 80~81	257.89μm	
PT20: PAD 115~116	265.61μm	
Bump Height	15 ± 3μm	

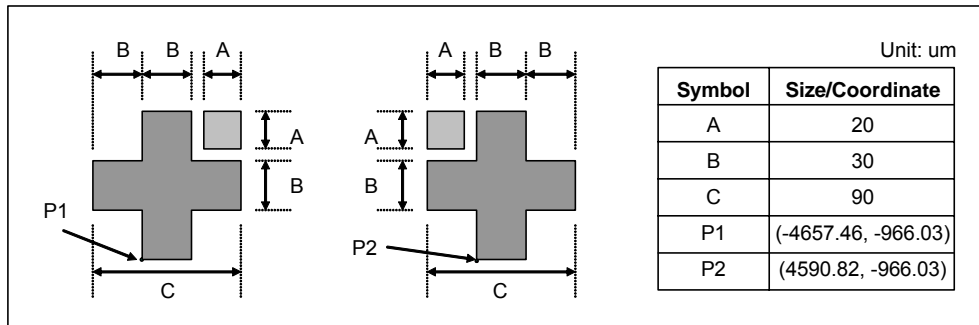

Figure 8-2 : Fixed Point Dimension

8-2 Pad X/Y Coordinate

PAD	PAD Name	X	Y
1	DUMY0	-4883.61	471.47
2	COM49	-4883.61	411.47
3	COM48	-4883.61	351.47
4	COM47	-4883.61	291.47
5	COM46	-4883.61	231.47
6	COM45	-4883.61	171.47
7	COM44	-4883.61	111.47
8	COM43	-4883.61	51.47
9	COM42	-4883.61	-8.53
10	COM41	-4883.61	-68.53
11	COM40	-4883.61	-128.53
12	COM39	-4883.61	-188.53
13	COM38	-4883.61	-248.53
14	COM37	-4883.61	-308.53
15	COM36	-4883.61	-368.53
16	COM35	-4883.61	-428.53
17	COM34	-4883.61	-488.53
18	COM33	-4883.61	-548.53
19	COM32	-4883.61	-608.53
20	DUMY1	-4883.61	-668.53
21	TP6	-4520.61	-922.78
22	TP5	-4474.61	-922.78
23	TP4	-4428.61	-922.78
24	TP3	-4382.61	-922.78
25	TP2	-4336.61	-922.78
26	TP1	-4290.61	-922.78
27	TP0	-4244.61	-922.78
28	VOUT	-4178.61	-917.78
29	VOUT	-4098.61	-917.78
30	VOUT	-4018.61	-917.78
31	VOUT	-3938.61	-917.78
32	VOUT	-3858.61	-917.78

PAD	PAD Name	X	Y
33	VOUT	-3778.61	-917.78
34	C3P	-3698.61	-917.78
35	C3P	-3618.61	-917.78
36	C2M	-3538.61	-917.78
37	C2M	-3458.61	-917.78
38	C2P	-3378.61	-917.78
39	C2P	-3298.61	-917.78
40	C1M	-3218.61	-917.78
41	C1M	-3138.61	-917.78
42	C1P	-3058.61	-917.78
43	C1P	-2978.61	-917.78
44	V0	-2898.61	-917.78
45	V0	-2818.61	-917.78
46	V0	-2738.61	-917.78
47	V0	-2658.61	-917.78
48	V1	-2568.61	-917.78
49	V1	-2488.61	-917.78
50	V1	-2408.61	-917.78
51	V1	-2328.61	-917.78
52	V2	-2248.61	-917.78
53	V2	-2168.61	-917.78
54	V2	-2088.61	-917.78
55	V2	-2008.61	-917.78
56	V3	-1928.61	-917.78
57	V3	-1848.61	-917.78
58	V3	-1768.61	-917.78
59	V3	-1688.61	-917.78
60	V4	-1608.61	-917.78
61	V4	-1528.61	-917.78
62	V4	-1448.61	-917.78
63	V4	-1368.61	-917.78
64	VREF	-1288.61	-917.78

PAD	PAD Name	X	Y
65	VREF	-1208.61	-917.78
66	VR	-1128.61	-917.78
67	VR	-1048.61	-917.78
68	GND	-918.61	-917.78
69	GND	-838.61	-917.78
70	GND	-758.61	-917.78
71	GND	-678.61	-917.78
72	GNDP	-598.61	-917.78
73	GNDP	-518.61	-917.78
74	VDDP	-368.61	-917.78
75	VDDP	-288.61	-917.78
76	VDD	-208.61	-917.78
77	VDD	-128.61	-917.78
78	VDD	-48.61	-917.78
79	GND	171.39	-917.78
80	VDD	267.15	-917.78
81	DB7	525.04	-917.78
82	DB6	613.55	-917.78
83	DB5	702.06	-917.78
84	DB4	790.58	-917.78
85	DB3	879.09	-917.78
86	DB2	967.6	-917.78
87	DB1	1056.11	-917.78
88	DB0	1144.63	-917.78
89	\overline{RD}	1233.21	-917.78
90	\overline{WR}	1321.72	-917.78
91	D/\overline{C}	1410.24	-917.78
92	\overline{CS}	1498.75	-917.78
93	C86	1587.26	-917.78
94	BIT4	1675.78	-917.78
95	P/\overline{S}	1764.29	-917.78
96	\overline{INT}	1852.73	-917.78

PAD	PAD Name	X	Y
97	EXT_CLK	1941.31	-917.78
98	CLK_SEL	2029.83	-917.78
99	KOUT3	2118.27	-917.78
100	KOUT2	2206.78	-917.78
101	KOUT1	2295.3	-917.78
102	KOUT0	2383.81	-917.78
103	KIN4	2472.39	-917.78
104	KIN3	2560.91	-917.78
105	KIN2	2649.42	-917.78
106	KIN1	2737.93	-917.78
107	KIN0	2826.44	-917.78
108	IO7	2914.89	-917.78
109	IO6	3003.4	-917.78
110	IO5	3091.91	-917.78
111	IO4	3180.43	-917.78
112	IO3	3268.94	-917.78
113	IO2	3357.45	-917.78
114	IO1	3445.97	-917.78
115	IO0	3534.48	-917.78
116	\overline{RST}	3800.09	-917.78
117	TEST2	3888.6	-917.78
118	TEST1	3977.11	-917.78
119	TEST0	4065.39	-917.78
120	GND	4145.39	-917.78
121	GND	4225.39	-917.78
122	VDD	4305.39	-917.78
123	VDD	4385.39	-917.78
124	DUMY2	4883.61	-657.03
125	COMS_B	4883.61	-597.03
126	COM0	4883.61	-537.03
127	COM1	4883.61	-477.03
128	COM2	4883.61	-417.03

PAD	PAD Name	X	Y
129	COM3	4883.61	-357.03
130	COM4	4883.61	-297.03
131	COM5	4883.61	-237.03
132	COM6	4883.61	-177.03
133	COM7	4883.61	-117.03
134	COM8	4883.61	-57.03
135	COM9	4883.61	2.97
136	COM10	4883.61	62.97
137	COM11	4883.61	122.97
138	COM12	4883.61	182.97
139	COM13	4883.61	242.97
140	COM14	4883.61	302.97
141	COM15	4883.61	362.97
142	DUMY3	4883.61	422.97
143	DUMY4	4445.15	917.78
144	COM16	4385.64	917.78
145	COM17	4335.64	917.78
146	COM18	4285.64	917.78
147	COM19	4235.64	917.78
148	COM20	4185.64	917.78
149	COM21	4135.64	917.78
150	COM22	4085.64	917.78
151	COM23	4035.64	917.78
152	COM24	3985.64	917.78
153	COM25	3935.64	917.78
154	COM26	3885.64	917.78
155	COM27	3835.64	917.78
156	COM28	3785.64	917.78
157	COM29	3735.64	917.78
158	COM30	3685.64	917.78
159	COM31	3635.64	917.78
160	SEG0	3545.64	917.78

PAD	PAD Name	X	Y
161	SEG1	3495.64	917.78
162	SEG2	3445.64	917.78
163	SEG3	3395.64	917.78
164	SEG4	3345.64	917.78
165	SEG5	3295.64	917.78
166	SEG6	3245.64	917.78
167	SEG7	3195.64	917.78
168	SEG8	3145.64	917.78
169	SEG9	3095.64	917.78
170	SEG10	3045.64	917.78
171	SEG11	2995.64	917.78
172	SEG12	2945.64	917.78
173	SEG13	2895.64	917.78
174	SEG14	2845.64	917.78
175	SEG15	2795.64	917.78
176	SEG16	2745.64	917.78
177	SEG17	2695.64	917.78
178	SEG18	2645.64	917.78
179	SEG19	2595.64	917.78
180	SEG20	2545.64	917.78
181	SEG21	2495.64	917.78
182	SEG22	2445.64	917.78
183	SEG23	2395.64	917.78
184	SEG24	2345.64	917.78
185	SEG25	2295.64	917.78
186	SEG26	2245.64	917.78
187	SEG27	2195.64	917.78
188	SEG28	2145.64	917.78
189	SEG29	2095.64	917.78
190	SEG30	2045.64	917.78
191	SEG31	1995.64	917.78
192	SEG32	1945.64	917.78

PAD	PAD Name	X	Y
193	SEG33	1895.64	917.78
194	SEG34	1845.64	917.78
195	SEG35	1795.64	917.78
196	SEG36	1745.64	917.78
197	SEG37	1695.64	917.78
198	SEG38	1645.64	917.78
199	SEG39	1595.64	917.78
200	SEG40	1545.64	917.78
201	SEG41	1495.64	917.78
202	SEG42	1445.64	917.78
203	SEG43	1395.64	917.78
204	SEG44	1345.64	917.78
205	SEG45	1295.64	917.78
206	SEG46	1245.64	917.78
207	SEG47	1195.64	917.78
208	SEG48	1145.64	917.78
209	SEG49	1095.64	917.78
210	SEG50	1045.64	917.78
211	SEG51	995.64	917.78
212	SEG52	945.64	917.78
213	SEG53	895.64	917.78
214	SEG54	845.64	917.78
215	SEG55	795.64	917.78
216	SEG56	745.64	917.78
217	SEG57	695.64	917.78
218	SEG58	645.64	917.78
219	SEG59	595.64	917.78
220	SEG60	545.64	917.78
221	SEG61	495.64	917.78
222	SEG62	445.64	917.78
223	SEG63	395.64	917.78
224	SEG64	345.64	917.78

PAD	PAD Name	X	Y
225	SEG65	295.64	917.78
226	SEG66	245.64	917.78
227	SEG67	195.64	917.78
228	SEG68	145.64	917.78
229	SEG69	95.64	917.78
230	SEG70	45.64	917.78
231	SEG71	-4.36	917.78
232	SEG72	-54.36	917.78
233	SEG73	-104.36	917.78
234	SEG74	-154.36	917.78
235	SEG75	-204.36	917.78
236	SEG76	-254.36	917.78
237	SEG77	-304.36	917.78
238	SEG78	-354.36	917.78
239	SEG79	-404.36	917.78
240	SEG80	-454.36	917.78
241	SEG81	-504.36	917.78
242	SEG82	-554.36	917.78
243	SEG83	-604.36	917.78
244	SEG84	-654.36	917.78
245	SEG85	-704.36	917.78
246	SEG86	-754.36	917.78
247	SEG87	-804.36	917.78
248	SEG88	-854.36	917.78
249	SEG89	-904.36	917.78
250	SEG90	-954.36	917.78
251	SEG91	-1004.36	917.78
252	SEG92	-1054.36	917.78
253	SEG93	-1104.36	917.78
254	SEG94	-1154.36	917.78
255	SEG95	-1204.36	917.78
256	SEG96	-1254.36	917.78

PAD	PAD Name	X	Y
257	SEG97	-1304.36	917.78
258	SEG98	-1354.36	917.78
259	SEG99	-1404.36	917.78
260	SEG100	-1454.36	917.78
261	SEG101	-1504.36	917.78
262	SEG102	-1554.36	917.78
263	SEG103	-1604.36	917.78
264	SEG104	-1654.36	917.78
265	SEG105	-1704.36	917.78
266	SEG106	-1754.36	917.78
267	SEG107	-1804.36	917.78
268	SEG108	-1854.36	917.78
269	SEG109	-1904.36	917.78
270	SEG110	-1954.36	917.78
271	SEG111	-2004.36	917.78
272	SEG112	-2054.36	917.78
273	SEG113	-2104.36	917.78
274	SEG114	-2154.36	917.78
275	SEG115	-2204.36	917.78
276	SEG116	-2254.36	917.78
277	SEG117	-2304.36	917.78
278	SEG118	-2354.36	917.78
279	SEG119	-2404.36	917.78
280	SEG120	-2454.36	917.78
281	SEG121	-2504.36	917.78
282	SEG122	-2554.36	917.78
283	SEG123	-2604.36	917.78
284	SEG124	-2654.36	917.78
285	SEG125	-2704.36	917.78
286	SEG126	-2754.36	917.78
287	SEG127	-2804.36	917.78
288	SEG128	-2854.36	917.78

PAD	PAD Name	X	Y
289	SEG129	-2904.36	917.78
290	SEG130	-2954.36	917.78
291	SEG131	-3004.36	917.78
292	SEG132	-3054.36	917.78
293	SEG133	-3104.36	917.78
294	SEG134	-3154.36	917.78
295	SEG135	-3204.36	917.78
296	SEG136	-3254.36	917.78
297	SEG137	-3304.36	917.78
298	SEG138	-3354.36	917.78
299	SEG139	-3404.36	917.78
300	SEG140	-3454.36	917.78
301	SEG141	-3504.36	917.78
302	SEG142	-3554.36	917.78
303	SEG143	-3604.36	917.78
304	COMS_A	-3694.36	917.78
305	COM63	-3744.36	917.78
306	COM62	-3794.36	917.78
307	COM61	-3844.36	917.78
308	COM60	-3894.36	917.78
309	COM59	-3944.36	917.78
310	COM58	-3994.36	917.78
311	COM57	-4044.36	917.78
312	COM56	-4094.36	917.78
313	COM55	-4144.36	917.78
314	COM54	-4194.36	917.78
315	COM53	-4244.36	917.78
316	COM52	-4294.36	917.78
317	COM51	-4344.36	917.78
318	COM50	-4394.36	917.78
319	DUMY5	-4445.15	917.78

9. Electrical Characteristic

9-1 Absolute Maximum Ratings

Table 9-1

Parameter	Symbol	Rating	Unit
Supply Voltage Range	V_{DD}	-0.3 to 4.0	V
Input Voltage Range	V_{IN}	-0.3 to 7.0	V
External VOUT Voltage Range	VOUT	-0.3 to 14	V
Operation Temperature Range	T_{OPR}	-40 to 85	°C
Storage Temperature Range	T_{ST}	-55 to 125	°C

Note: Stresses above those listed under "Absolute Maximum Ratings" may cause permanent damage to this device. These are stress ratings only. Functional operation of this device under these or any other conditions above those indicated in the operational sections of this specification is not implied or intended. Exposure to the absolute maximum rating conditions for extended periods may affect device reliability.

9-2 DC Characteristic

Table 9-2

Parameter	Symbol	Min.	Typ.	Max.	Unit	Condition
Operating Voltage	V_{DD}	2.7	3.3	3.6	V	
VOUT Voltage	VOUT	6	--	13.2	V	
Input High Voltage	V_{IH}	$0.8 \times V_{DD}$	--	V_{DD}	V	
Input Low Voltage	V_{IL}	0	--	$0.2 \times V_{DD}$	V	
Output High Voltage	V_{OH}	$0.8 \times V_{DD}$	--	V_{DD}	V	
Output Low Voltage	V_{OL}	0	--	$0.2 \times V_{DD}$	V	
Built-in Reference Voltage	V_{IREF}	2.08	2.1	2.12	V	Test by C/P tester
Input Leakage Current	I_{IL}	-1	--	+1	μA	$V_{IN} = V_{SS} \sim V_{DD}$
Oscillator Frequency	F_{CL}	80	100	120	KHz	
Operating Mode Current (Normal Mode Current)	I_{DD}	0.2	--	1.1	mA	Min.:*1 Max.:*2
Sleep Mode Current	I_{SLP}	--	0.2	3	μA	

1: No access, $T_A=25^\circ\text{C}$, $V_{DD}=3.3\text{V}$, built-in boost power supply off, display on

2: No access, $T_A=25^\circ\text{C}$, $V_{DD}=3.3\text{V}$, built-in boost setting: $V_{OUT}=4 \times V_{DD}$, display on

9-3 Timing Characteristic

9-3-1 Parallel Interface

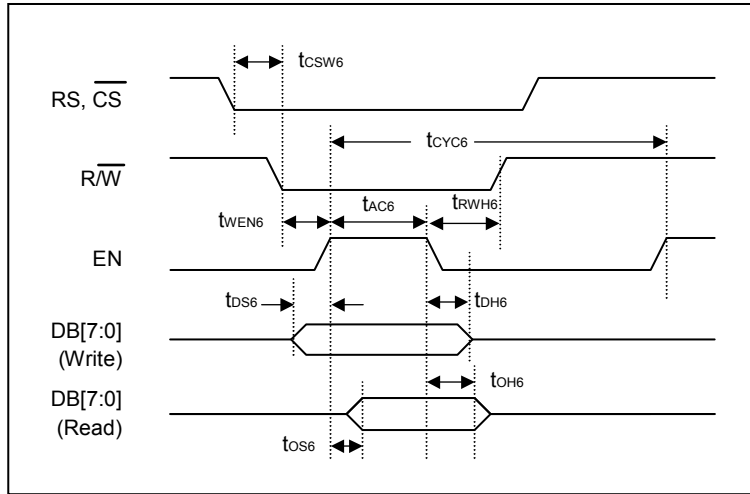

Figure 9-1 : 6800 MPU Timing

6800 MPU Interface

Table 9-3

Item	Signal	Symbol	Condition	Rating		Unit
				Min.	Max.	
Address Setup Time	RS, \overline{CS}	t_{CSW6}		0	--	ns
Read/Write Setup Time	R/ \overline{W}	t_{WEN6}		10	--	
Read/Write Hold Time		t_{RWH6}		10	--	
Enable Access Time	EN	t_{AC6}		90	--	
Access Cycle Time		t_{CYC6}	Command Cycle	200	--	
			Data Cycle	400	--	
Write Data Setup Time	DB[7:0]	t_{DS6}		10	--	
Write Data Hold Time		t_{DH6}		10	--	
Read Data Access Time		t_{OS6}		30	50	
Read Data Hold Time		t_{OH6}		10	--	

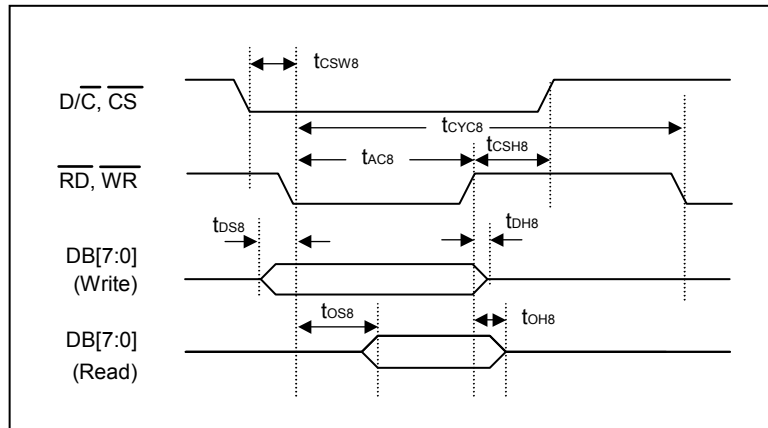

Figure 9-2 : 8080 MPU Timing

8080 MPU Interface

Table 9-4

Item	Signal	Symbol	Condition	Rating		Unit
				Min.	Max.	
Address Setup Time	RS, \overline{CS}	t_{CSW8}		10	--	ns
Address Hold Time		t_{CSH8}		10	--	
Read/Write Access Time	\overline{RD} , \overline{WR}	t_{AC8}		90	--	
Access Cycle Time		t_{CYC8}	Command Cycle	200	--	
			Data Cycle	400	--	
Write Data Setup Time	DB[7:0]	t_{DS8}		10	--	
Write Data Hold Time		t_{DH8}		10	--	
Read Data Setup Time		t_{OS8}		30	50	
Read Data Hold Time		t_{OH8}		10	--	

9-3-2 Serial Interface

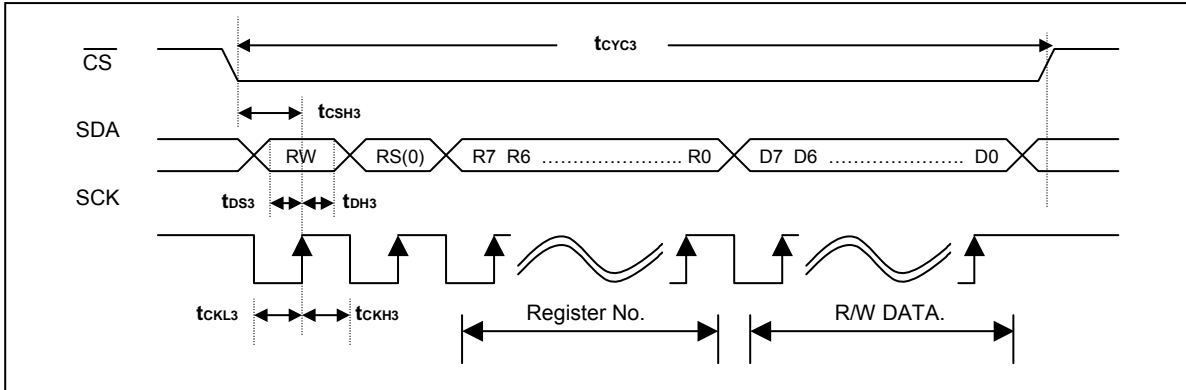

Figure 9-3 : 3-Wire Timing

3-Wire Serial Interface

Table 9-5

Item	Signal	Symbol	Condition	Rating		Unit
				Min.	Max.	
Access Time	\overline{CS}	t_{cyc3}		3.6	--	μs
\overline{CS} Setup Time		t_{csh3}		20	--	ns
Clock Low Pulse Width	SCK	t_{ckl3}		100	--	
Clock High Pulse Width		t_{ckh3}		100	--	
Data Setup Time	SDA	t_{ds3}		20	--	
Data Hold Time		t_{dh3}		10	--	

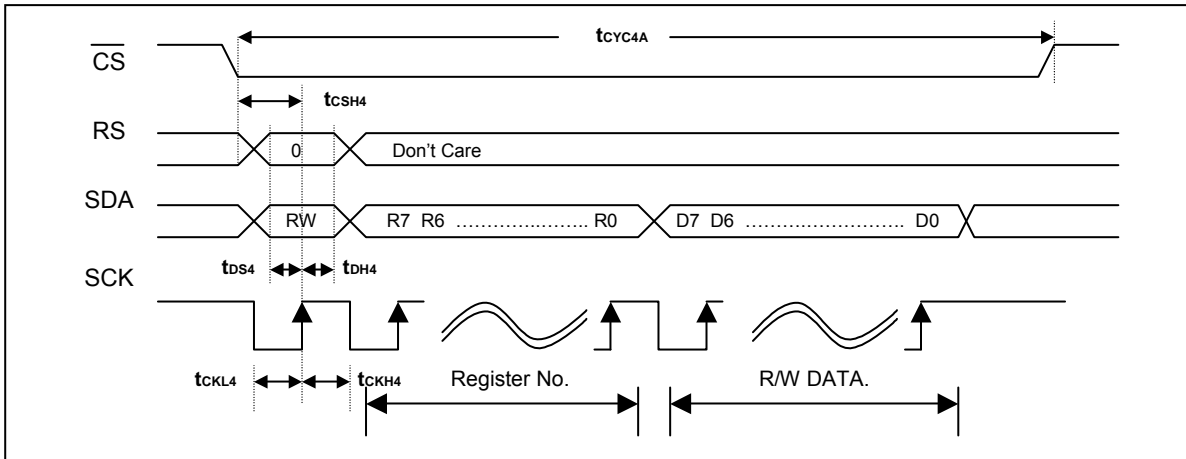

Figure 9-4 : 4-Wire (A-Type) Timing

4-Wire (A-Type) Serial Interface

Table 9-6

Item	Signal	Symbol	Condition	Rating		Unit
				Min.	Max.	
Access Time	\overline{CS}	t_{CYC4A}		3.4	--	μs
\overline{CS} Setup Time		t_{CSH4}		20	--	ns
Clock Low Pulse Width	SCK	t_{CKL4}		100	--	
Clock High Pulse Width		t_{CKH4}		100	--	
Data Setup Time	SDA, RS	t_{DS4}		20	--	
Data Hold Time		t_{DH4}		10	--	

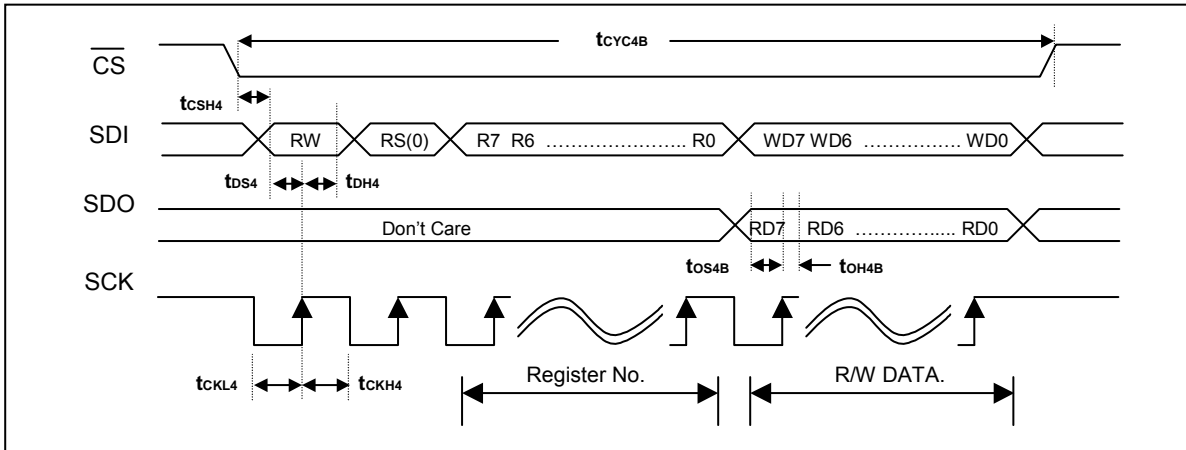

Figure 9-5 : 4-Wire (B Type) Timing

4-Wire (B-Type) Serial Interface

Table 9-7

Item	Signal	Symbol	Condition	Rating		Unit
				Min.	Max.	
Access Time	\overline{CS}	t_{CYC4B}		3.6	--	μs
\overline{CS} Setup Time		t_{CSH4}		20	--	ns
Clock Low Pulse Width	SCK	t_{CKL4}		100	--	
Clock High Pulse Width		t_{CKH4}		100	--	
Data Write Setup Time	SDI	t_{DS4}		20	--	
Data Write Hold Time		t_{DH4}		10	--	
Data Read Setup Time	SDO	t_{OS4B}		20	--	
Data Read Hold Time		t_{OH4B}		10	--	

9-3-3 Reset Interface

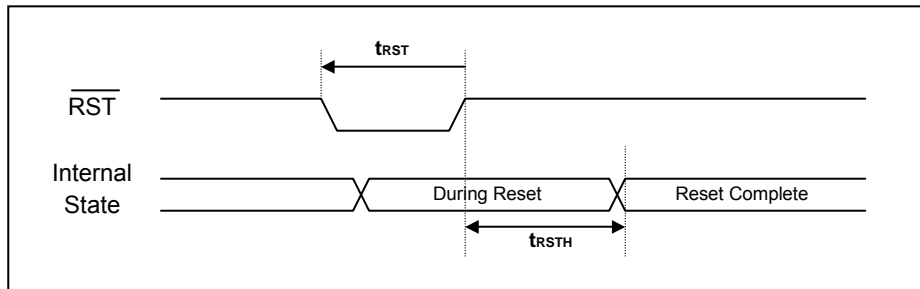

Figure 9-6 : Reset Timing

Table 9-8

Item	Signal	Symbol	Condition	Rating		Unit
				Min.	Max.	
Reset Pulse Width	$\overline{\text{RST}}$	t_{RST}		5	--	ms
Reset Complete Hold Time	$\overline{\text{RST}}$	t_{RSTH}	$F_{\text{CL}} = 100\text{KHz}$ (Internal RC Oscillator)	5	--	ms

Appendix A. COG Technical Parameter

A-1 COG Application

A-1-1 Basic Connection of Serial I/F

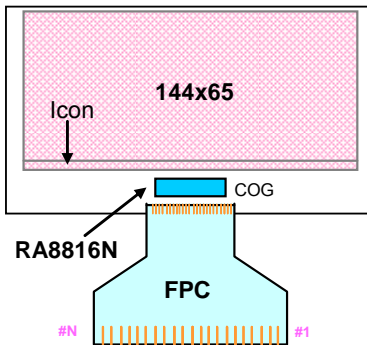

Figure A-1 : COG Module

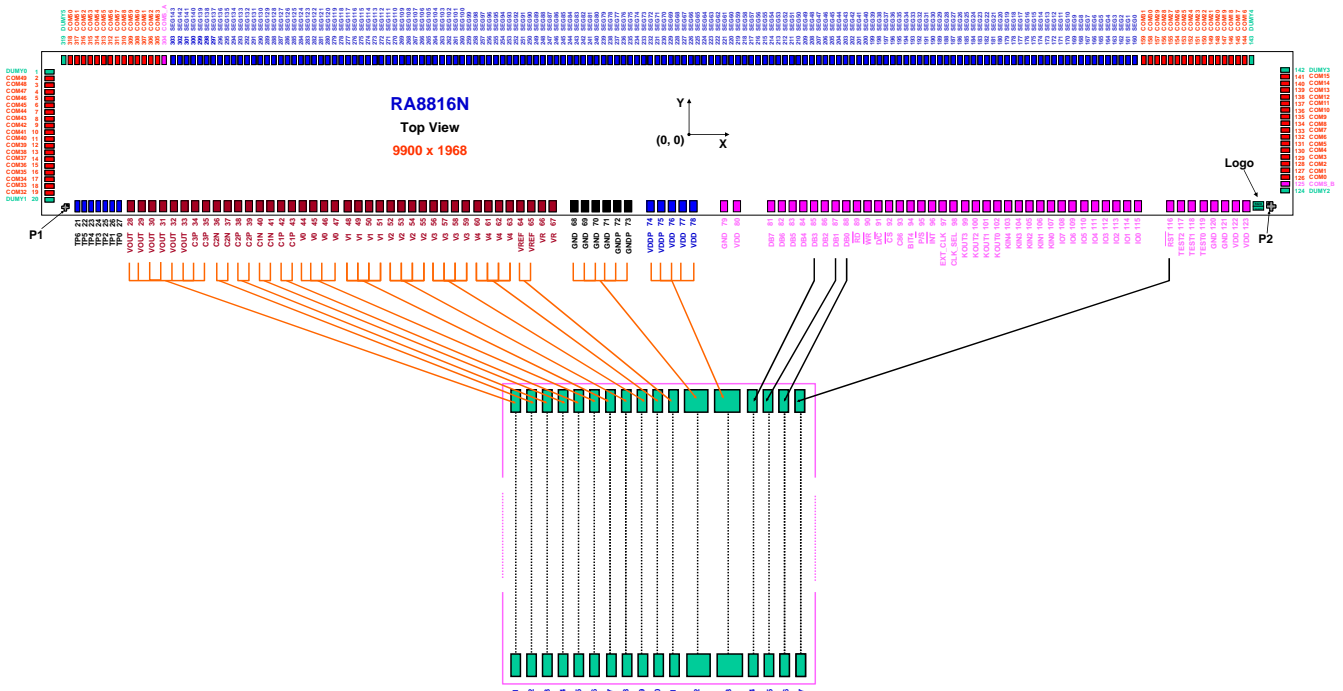

Figure A-2 : Example (A) of Basic Connection of Serial (3-Wires) I/F

The RA8816N provides many interfaces for MPU that including parallel, 3-wire serial, 4-wire serial, and some useful I/O interface like GPIO and Key-scan. Therefore there are many options for user to connect COG die to FPC. Figure A-1 is an example of COG module and Figure A-2 is RA8816N COG die that connects to FPC for basic 3-wire interface. Please note that the unused parallel signals of MPU have to connect to VDD.

A-1-2 Basic Connection of Parallel I/F

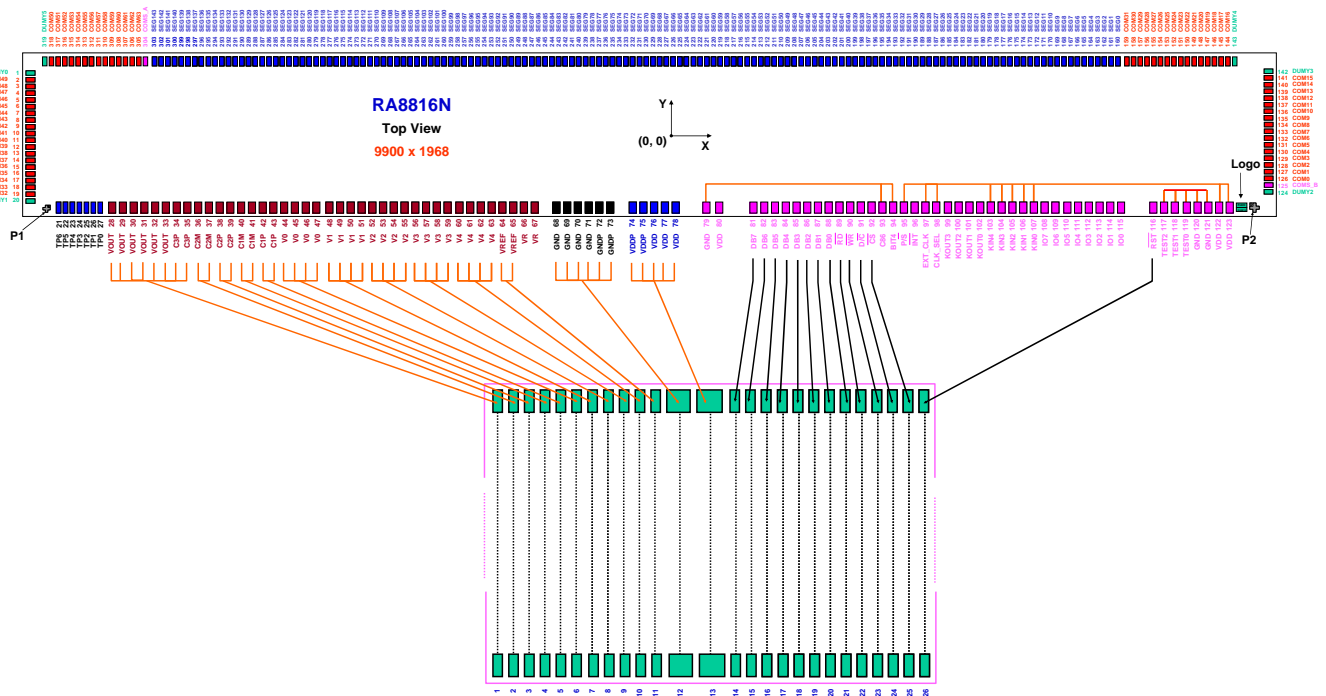

Figure A-3 : Example (A) of Basic Connection of Parallel I/F

Figure A- 3 is an example for RA8816N COG die that connects to FPC for basic parallel interface.

A-1-3 Other Application for FPC

Figure A- 4 is another example that uses 3-wires MPU I/F, 3-times VDD, 2 I/O signals and 2x2 Key-scan. In this case, the FPC only uses 23 pins. Some setting pins are connected to VDD or GND through ITO route, like C86, BIT4, P/S, CLK_SEL and EXT_CLK. The pad number 75, 76, 120 ~ 123 are VDD or GND used by these setting pins and need not to be connected to FPC. The unused parallel signals of MPU and KIN have to be tied to VDD.

The RA8816N also provides two common outputs for Icon that makes panel layout easier to meet their application.

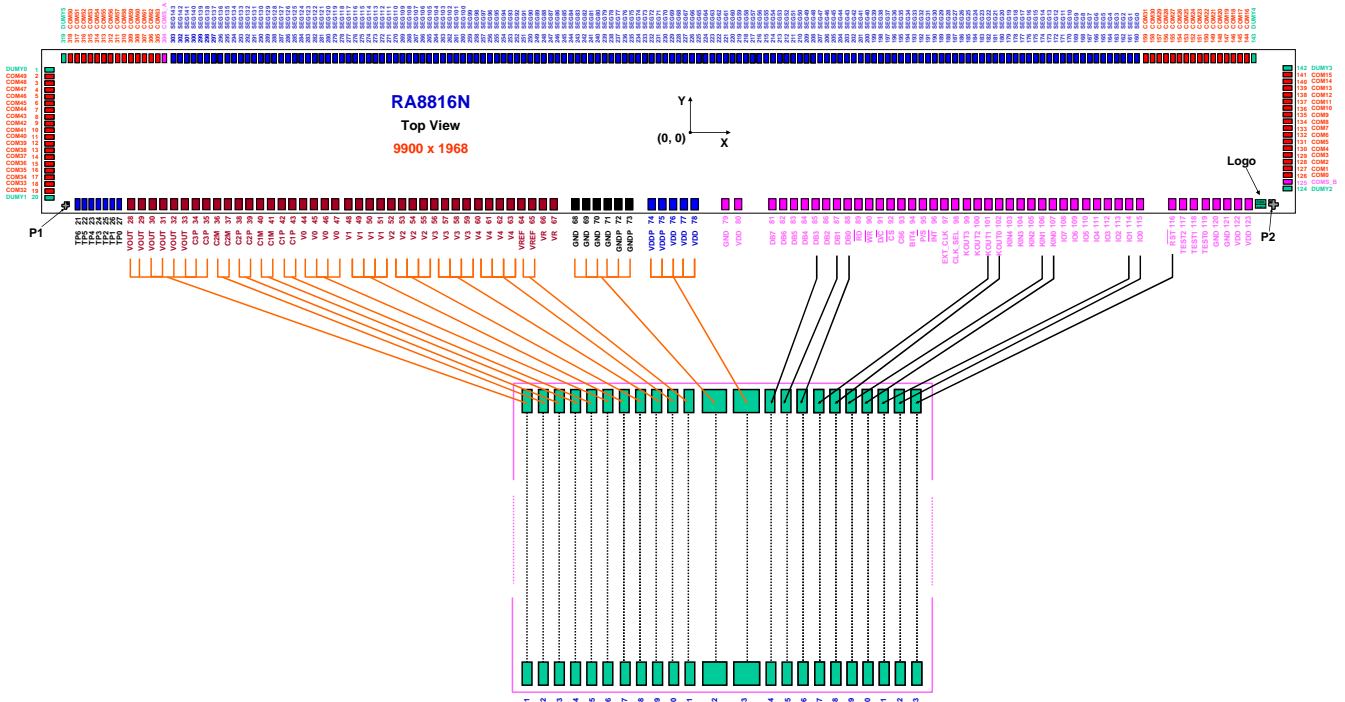

Figure A- 4 : Example of COG Module

The Figure A- 5 is an example for 144x65 LCD panel.

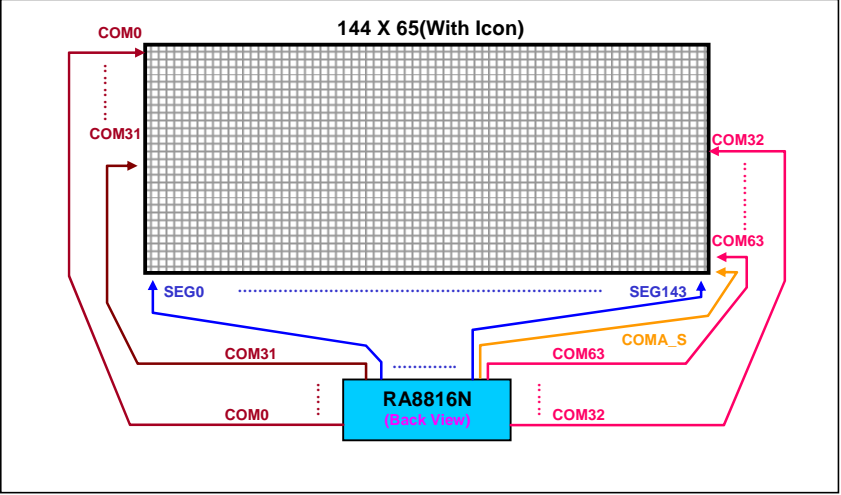

Figure A- 5 : The Connection of RA8816N with LCD Panel (144x65)

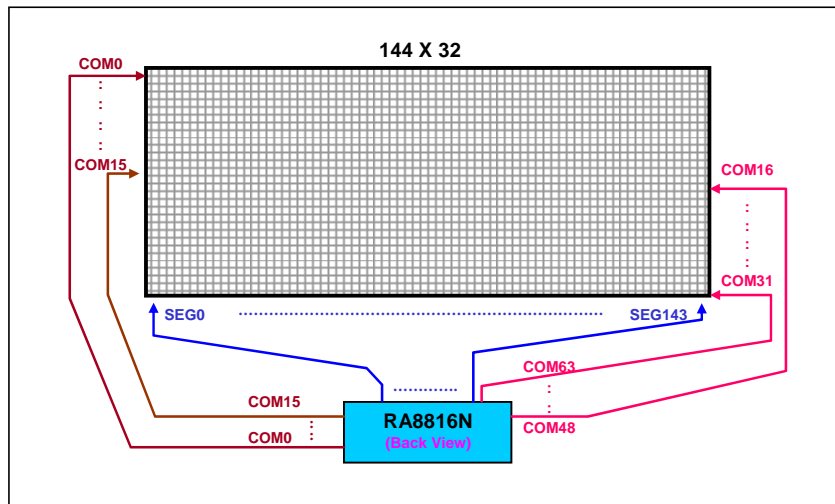

Figure A- 6 : The Connection of RA8816N with LCD Panel (144x32)

Figure A- 6 is an example of connection that uses 144x32 panel. In this case, it supports two rows for full size (16x16) or four rows for half-size (8x8) fonts. Please refer to Table 5-3 for the Common signals connection

A-2 ITO

Table A- 1 : ITO Resistance of COG

PAD Name	ITO(Ohm)	PAD Name	ITO(Ohm)	PAD Name	ITO(Ohm)
VDD , VDDP	100	C1M	100	BIT4	600
GND , GNDP	100	C2P	100	P/ \bar{S}	600
VREF	150	C2M	100	CLK_SEL	600
VOUT	100	C3P	100	EXT_CLK	600
VR	150	DB[7:0]	600	KST[3:0]	600
V4	100	\bar{RD} , EN	600	KIN[4:0]	600
V3	100	\bar{WR} , R/ \bar{W}	600	IO[7:0]	600
V2	100	D/ \bar{C} , RS	600	\bar{RST}	600
V1	100	\bar{CS}	600	TEST[2:0]	600
V0	100	\bar{INT}	600		
C1P	100	C86	600		

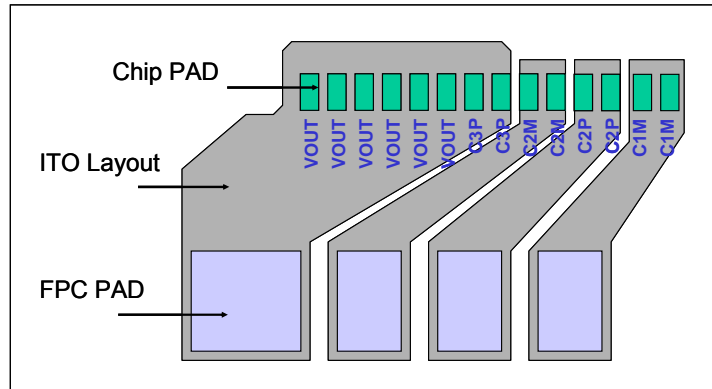

Figure A- 7 : ITO Layout Example - VOUT

The RA8816N power signals (such as VDD, GND, VOUT, V[4:0], C[1:3]P, C[1:2]M) have to be kept smaller ITO resistance (less than 100Ω is better). So the width of ITO layout must be kept as wide as possible to reduce the wire resistance. Figure A- 7 is an example for VOUT layout of panel. Because the RA8816N provides six pads for VOUT, user has to connect these pads to FPC with a wide wire. In this case, the VOUT is three times of VDD, so the C3P have to be connected to VOUT.

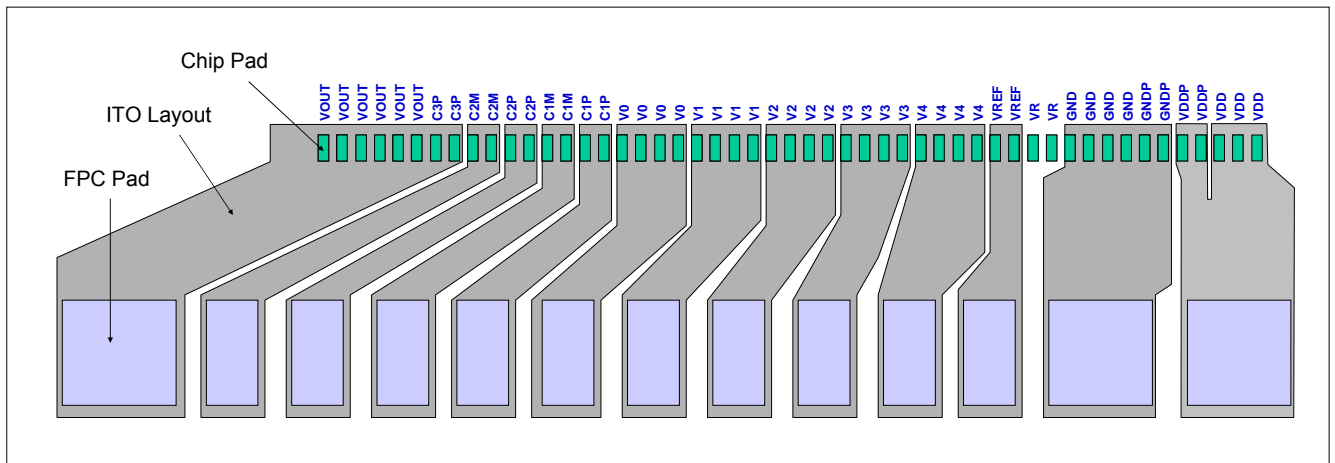

Figure A- 8 : ITO Layout Example

Figure A- 8 is a layout example of RA8816N to FPC on COG module. The RA8816N provides several VDD / GND pads, user also has to connect these pads to FPC with a wide wire.

The distance of FPC and VDD / GND of RA8816N should be as close as possible. For FPC design, layout of power signals needs to be kept as wide as possible also to reduce resistance. It is better if VDD / GND wire width is double than other signals.

On the other hand, for panel with 128x64 resolution, use 4x VDD and Vop less than 9.5V is better.

Appendix B. BIG-5 Font Code Table

A1	0	1	2	3	4	5	6	7	8	9	A	B	C	D	E	F
4		,	、	。	•	•	;	:	?	!	:	,	、	.
5	.	:	:	?	!		-		-		{	~	()	^	
6	~	{	}	~	~	[]	~	~	【	】	~	~	《	》	^
7	~	<	>	^	~	「	」	~	~	『	』	~	~	()	?
A	?	{	}	[]	“	”	“	”	“	”	“	”	#	&	*
B	※	§	”	○	●	△	▲	◎	☆	★	◇	◆	□	■	▽	▼
C	⊕	%	-	-	-	-	-	-	-	-	~	~	#	&	*	+
D	-	x	÷	±	√	<	>	=	≤	≥	≠	∞	≡	+	-	
E	<	>	=	~	∩	∪	⊥	∠	∟	∠	log	ln	∫	§	·	·
F	♀	♂	⊕	⊙	↑	↓	←	→	↖	↗	↘	↙			/	?

A4	0	1	2	3	4	5	6	7	8	9	A	B	C	D	E	F
4	一	乙	丁	七	乃	九	了	二	人	儿	入	八	几	刀	刁	力
5	匕	十	卜	又	三	下	丈	上	丫	丸	凡	久	么	也	乞	于
6	亡	兀	刃	勾	千	叉	口	土	土	夕	大	女	子	子	彳	寸
7	小	尢	尸	山	川	工	己	己	巳	巾	干	升	弋	弓	才	?
A	?	丑	丐	不	中	丰	丹	之	尹	予	云	井	互	五	亢	仁
B	什	什	仆	仇	仍	今	介	仄	元	允	丙	六	兮	公	冗	凶
C	分	切	刈	勾	勾	勿	化	匹	午	升	卅	卞	卮	友	及	反
D	壬	天	夫	太	夭	孔	少	尤	尺	屯	巴	幻	甘	弔	引	心
E	戈	户	手	扎	支	文	斗	斤	方	日	日	月	木	欠	止	歹
F	毋	比	毛	氏	水	火	爪	父	爻	片	牙	牛	犬	王	丙	?

A2	0	1	2	3	4	5	6	7	8	9	A	B	C	D	E	F
4	\	/	\	\$	¥	₹	¢	£	%	@	°	°	°	°	°	mil
5	mm	cm	km	KM	m	mg	kg	cc	°	尅	尅	尅	尅	尅	尅	尅
6	疋	糲	—	—	—	—	—	—	—	—	—	—	—	—	—	—
7	■	+	+	+	+	+	+	+	+	+	+	+	+	+	+	?
A	?	~	~	~	~	~	~	~	~	~	~	~	~	~	~	0
B	I	2	3	4	5	6	7	8	9	I	II	III	IV	V	VI	VII
C	VIII	IX	X	I	II	III	Ⅳ	Ⅴ	Ⅵ	Ⅶ	Ⅷ	Ⅷ	文	十	卅	卅
D	B	C	D	E	F	G	H	I	J	K	L	M	N	O	P	Q
E	R	S	T	U	V	W	X	Y	Z	a	b	c	d	e	f	g
F	h	i	j	k	l	m	n	o	p	q	r	s	t	u	v	?

A5	0	1	2	3	4	5	6	7	8	9	A	B	C	D	E	F
4	世	丕	且	丘	主	乍	乏	乎	以	付	仔	仕	他	仗	代	令
5	仙	仞	充	兄	冉	冊	冬	凹	出	凸	刊	加	功	包	匆	北
6	匝	仞	半	卉	卡	占	卯	卮	去	可	古	右	召	叮	叩	叨
7	叨	司	叵	叫	另	只	史	叱	台	句	叭	叻	四	囚	外	?
A	央	失	奴	奶	孕	它	尼	巨	巧	左	市	布	平	幼	弁	
B	弘	弗	必	戊	打	扔	扒	扒	斥	旦	朮	本	未	未	札	正
C	母	民	氏	永	汁	汀	汜	犯	玄	玉	瓜	瓦	甘	生	用	甩
D	田	由	甲	申	疋	白	皮	皿	目	矛	矢	石	示	禾	穴	立
E	丞	丢	兵	兵	乱	互	交	亦	亥	仿	伉	伙	伊	伙	伍	伐
F	休	伏	仲	件	任	仰	佻	份	企	佞	光	兕	兆	先	全	?

A3	0	1	2	3	4	5	6	7	8	9	A	B	C	D	E	F
4	w	x	y	z	A	B	Γ	Δ	E	Z	H	Θ	I	K	Λ	M
5	N	Ξ	O	Π	P	Σ	T	Υ	Φ	X	Ψ	Ω	α	β	γ	δ
6	ε	ζ	η	θ	ι	κ	λ	μ	ν	ξ	ο	π	ρ	σ	τ	υ
7	φ	χ	ψ	ω	ς	ζ	η	θ	ι	κ	λ	μ	ν	ξ	ο	π
A	?	ㄣ	ㄨ	ㄊ	ㄎ	ㄎ	ㄎ	ㄎ	ㄎ	ㄎ	ㄎ	ㄎ	ㄎ	ㄎ	ㄎ	ㄎ
B	ㄨ	ㄨ	ㄨ	ㄨ	ㄨ	ㄨ	ㄨ	ㄨ	ㄨ	ㄨ	ㄨ	ㄨ	ㄨ	ㄨ	ㄨ	ㄨ
C																
D																
E																
F																

A6	0	1	2	3	4	5	6	7	8	9	A	B	C	D	E	F
4	共	再	冰	列	刑	划	刎	刎	劣	匈	匡	匠	印	危	吉	吏
5	同	吊	吐	吁	吋	各	向	名	合	吃	后	咄	吒	因	回	囿
6	圳	地	在	圭	圪	圪	圪	夙	多	夷	夸	妄	奸	妃	好	她
7	如	妲	字	存	宇	守	宅	安	寺	尖	屹	州	帆	并	年	?
A	?	式	弛	忙	付	戎	戎	戎	戎	扣	扛	托	收	早	旨	旬
B	旭	曲	曳	有	朽	朴	朱	朵	次	此	死	氛	汝	汗	汗	江
C	池	汐	汕	污	汛	汛	灰	牵	牝	百	竹	米	糸	缶	羊	
D	羽	老	考	而	柔	耳	聿	肉	肋	肌	臣	自	至	白	舌	舛
E	舟	艮	色	艾	虫	血	行	衣	西	阡	串	亨	位	住	佇	佗
F	佞	伴	佛	何	估	佐	佑	伽	伺	伸	佃	估	似	但	佣	?

A7	0	1	2	3	4	5	6	7	8	9	A	B	C	D	E	F
4	作	你	伯	低	伶	余	佯	佈	佚	兌	克	免	兵	洽	洽	別
5	判	利	刪	創	劫	助	努	劬	匡	即	卵	吝	吭	吞	吾	否
6	呎	吧	呆	呃	吳	呈	呂	君	吩	告	吹	吻	吸	吮	吵	啞
7	吠	吼	呀	吱	含	吟	听	囟	困	囹	囿	坊	坑	址	坍	?
A	?	均	坎	圾	坐	坏	圻	壯	夾	妝	妒	妨	妞	媼	妙	妖
B	妍	妤	妓	妊	妥	孝	孜	孚	孛	完	宋	宏	尅	局	屁	尿
C	尾	岐	岑	岔	岌	巫	希	序	庇	床	廷	弄	弟	彤	彤	衍
D	役	忘	忌	志	忍	忱	快	忸	忪	戒	我	抄	抗	抖	技	扶
E	抉	扭	把	扼	找	批	扳	抒	扯	折	扮	投	抓	抑	技	改
F	攻	攸	早	更	東	李	杏	材	村	杜	杖	杞	杉	杆	杠	?

AA	0	1	2	3	4	5	6	7	8	9	A	B	C	D	E	F
4	昇	服	朋	杭	枋	枕	東	果	杳	杷	枇	枝	林	杯	杰	板
5	枉	松	析	杵	枚	料	杼	杪	杲	欣	武	歧	歿	氓	氛	泣
6	注	泳	沱	泌	泥	河	沾	沿	沼	波	沫	法	泓	沸	泄	油
7	況	沮	泗	泗	決	沿	治	泡	泛	泊	沫	混	泚	泖	泔	?
A	?	炕	炎	炒	炊	炙	爬	爭	爸	版	牧	物	狀	狎	狙	狗
B	狐	玩	玳	玳	玫	玳	玳	玳	疔	疔	疾	的	孟	盲	直	知
C	社	祀	祁	秉	稊	空	穹	竺	糾	罔	羌	芊	者	肺	肥	肢
D	肱	股	肫	肩	肴	肪	肯	臥	與	舍	芳	芝	芙	芭	芽	芰
E	芹	花	芬	芥	苾	芸	芩	芰	芴	芷	虎	虱	初	表	軋	迎
F	返	近	邵	邱	邱	邨	采	金	長	門	阜	陀	阿	阻	附	?

A8	0	1	2	3	4	5	6	7	8	9	A	B	C	D	E	F
4	杓	棠	步	每	求	汞	沙	沁	沈	沉	沅	沛	汪	決	沐	汰
5	沌	汨	沖	沒	汽	沃	汲	汾	汙	沅	沔	沔	沔	泚	沂	灶
6	灼	災	灸	牢	牡	牠	狄	狂	玖	甫	甫	男	甸	皂	盯	矣
7	私	秀	禿	究	系	罕	肖	肱	肝	肘	肱	肚	育	良	芒	?
A	?	芋	芍	見	角	言	谷	豆	豕	貝	赤	走	足	身	車	辛
B	辰	迂	迪	迅	迄	巡	邑	邢	邪	邦	那	西	采	里	防	阮
C	阱	阪	阮	並	乖	乳	事	些	亞	享	京	佯	依	侍	佳	使
D	佬	供	例	來	侃	佰	併	侈	佩	佻	侖	侖	侖	侖	侖	兔
E	兒	兕	兩	具	其	典	冽	函	刻	券	刷	刺	到	刮	制	剝
F	効	勵	卒	協	卓	卑	卦	卷	卸	卹	取	叔	受	味	呵	?

AB	0	1	2	3	4	5	6	7	8	9	A	B	C	D	E	F
4	陂	佳	雨	青	非	亟	亭	亮	信	侵	侯	便	俠	備	俏	保
5	促	侶	俘	俟	俊	俗	侮	俐	俄	係	俚	俚	俚	侷	兗	冒
6	靑	冠	剎	剎	削	前	刺	剋	則	勇	勉	勃	勁	匍	南	卻
7	厚	叛	咬	哀	咨	哎	哉	咸	噴	咳	哇	晒	咽	咪	品	?
A	?	哄	哈	咯	咫	咱	咻	咻	咧	咧	囿	垂	型	垠	垣	垢
B	城	垮	垓	奕	契	奏	奎	奧	姜	姘	姿	姣	姨	娃	姥	姪
C	姚	姦	威	姻	孩	宣	宦	室	客	宥	封	屎	屏	屍	屋	峙
D	峒	巷	帝	帥	帟	幽	庠	度	建	弈	弭	彥	很	待	徊	律
E	徇	後	徻	怒	思	怠	急	急	怨	恍	恰	恨	恢	恆	恃	恬
F	恫	恪	恤	扁	拜	挖	按	拼	拭	持	拮	拽	指	拱	拷	?

A9	0	1	2	3	4	5	6	7	8	9	A	B	C	D	E	F
4	咖	呷	咕	咀	呻	呷	咄	咒	咆	呼	咐	呱	呱	和	咚	呢
5	周	咋	命	咎	固	垃	珂	坪	坩	坡	坦	坤	坼	夜	奉	奇
6	奈	奄	奔	妾	妻	委	妹	妮	姑	姆	姐	姍	始	姓	姊	妯
7	妳	姍	姍	孟	孤	季	宗	定	官	宜	宙	宛	尙	屈	居	?
A	?	屨	岷	岡	岸	岩	岫	岱	岳	帘	帚	帖	帕	帛	帛	幸
B	庚	店	府	底	庖	延	弦	弧	弩	往	征	佛	彼	忝	忠	忽
C	念	忿	快	怔	怯	恍	怖	怪	怕	怡	性	惘	佛	但	或	戕
D	房	戾	所	承	拉	拌	拄	抵	拂	抹	拒	招	披	拓	拔	拋
E	拈	揆	抽	押	拐	拙	拇	拍	抵	拚	抱	拘	拖	拗	拆	抬
F	拎	放	斧	於	旺	昔	易	昌	昆	昂	明	昀	昏	听	昊	?

AC	0	1	2	3	4	5	6	7	8	9	A	B	C	D	E	F
4	拯	括	拾	挫	挑	挂	政	故	斫	施	既	春	昭	映	昧	是
5	星	昨	昱	吟	曷	柿	梁	柱	柔	某	柬	架	枯	柵	柵	柯
6	柄	柑	枊	柚	查	枸	柏	柞	柳	桤	桤	柢	柢	渠	歪	殃
7	殆	段	毒	毗	氟	泉	洋	洲	洪	流	津	洌	洌	洞	洗	?
A	?	活	洽	派	淘	洛	泵	涸	清	洗	洩	洩	洩	洩	洩	炫
B	爲	炳	烜	烜	炭	炸	炮	炤	爰	牲	牯	牯	狩	狼	狡	玷
C	珊	玻	玲	珍	珀	玳	甚	甬	畏	界	吠	吠	疫	疤	疥	疥
D	疣	癸	皆	皇	皈	盈	盆	盃	盃	盃	省	甦	相	眉	看	盾
E	眇	矜	矜	矜	矜	矜	矜	矜	矜	矜	矜	矜	矜	矜	矜	矜
F	突	竿	竿	籽	紂	紅	紅	紅	紅	紅	紅	紅	紅	紅	紅	紅

AD	0	1	2	3	4	5	6	7	8	9	A	B	C	D	E	F
4	耐	耍	崑	耶	胖	胥	胚	胃	背	胡	胛	胎	胞	胤	胝	
5	致	舳	苧	范	茅	苜	苛	苦	茄	若	茂	茱	苗	英	茁	
6	苜	苔	苑	苞	苓	苟	茛	虢	虹	虻	虺	衍	衫	要	劬	
7	計	訂	訃	貞	負	赴	越	臥	軍	軌	述	迦	迢	迪	迴	?
A	?	迭	迫	迨	迨	郊	郎	郁	郤	曾	酊	重	門	限	陋	陌
B	降	面	革	韋	非	音	頁	風	飛	食	首	香	乘	毫	倌	倍
C	傲	俯	倦	控	俸	倩	倅	倆	值	借	倚	倒	們	俺	偃	偏
D	倨	俱	倡	個	候	倘	俳	修	倭	倪	俾	倫	倉	兼	冤	冥
E	豕	凍	凌	淮	凋	剖	剗	剔	剛	剝	匪	卿	原	厝	叟	哨
F	唐	唱	嗜	吟	哥	哲	唆	哺	唔	哩	哭	員	唉	哮	哪	?

B0	0	1	2	3	4	5	6	7	8	9	A	B	C	D	E	F	
4	虔	蚊	蚪	蚪	蚤	蚩	蚌	蚣	蚱	衰	衷	衷	袂	衽	祇	記	
5	訐	討	訐	訐	訐	訐	訐	訐	訐	訐	訐	訐	訐	訐	訐	訐	
6	躬	軒	軻	軻	軻	軻	軻	軻	軻	軻	軻	軻	軻	軻	軻	軻	
7	郡	郝	郢	酒	配	酌	釘	針	釧	釜	針	閃	院	陣	陡	?	
A	?	陞	陝	除	陞	陞	隻	飢	馬	骨	高	門	隔	鬼	乾	僭	
B	僞	停	假	偃	偃	偃	健	偶	偃	偃	偃	偵	側	偷	偏	倏	
C	儗	儗	晃	晃	晃	晃	剪	副	勒	務	勸	動	匍	匏	匙	匿	區
D	匾	參	曼	商	啪	啦	啞	啞	啡	啡	啡	啡	啡	啡	啡	啡	啡
E	啤	唸	售	啜	啜	啜	啜	啜	啜	啜	啜	啜	啜	啜	啜	啜	啜
F	埠	埠	基	堂	堵	執	培	夠	奢	娶	婁	婉	婦	焚	炯	?	

AE	0	1	2	3	4	5	6	7	8	9	A	B	C	D	E	F
4	哦	啣	唇	哽	唏	圃	圃	埂	埔	埋	埃	埠	夏	套	奘	奚
5	娑	娘	娜	娟	娛	妮	姬	娉	婉	娥	婁	娉	孫	冠	幸	
6	害	家	宴	宮	宵	容	宸	射	脣	展	屐	峭	峽	峻	峪	峨
7	峰	島	埃	峴	差	席	師	庫	庭	座	弱	徒	徑	徐	恙	?
A	?	恣	恥	恐	怨	恭	恩	息	悄	悟	悚	悍	悔	悌	悅	悖
B	扇	拳	擊	拿	捎	挾	振	捕	捋	捆	捏	捉	挺	捐	挽	挪
C	挫	挨	捍	捌	效	枚	料	旁	旅	時	晉	晏	晃	晒	响	暄
D	晁	書	朔	朕	朗	校	核	案	框	桓	根	桂	桔	栩	梳	栗
E	桌	桑	栽	柴	桐	架	格	桃	株	桅	桤	桁	殊	殉	殷	
F	氣	氧	氨	氮	氫	泰	浪	涕	消	涇	浦	浸	海	浙	涓	?

B1	0	1	2	3	4	5	6	7	8	9	A	B	C	D	E	F
4	娼	婢	婚	婆	姨	孰	寇	寅	寄	寂	宿	密	尉	專	將	屠
5	屨	罪	崇	崕	崎	嶺	崑	崩	崔	崑	崑	崑	崑	崑	崑	崑
6	常	帶	帳	帷	康	庸	庶	庵	庾	張	強	彗	彬	彩	彫	得
7	徒	從	徠	徠	徠	徠	徠	徠	徠	徠	徠	徠	徠	徠	徠	徠
A	?	情	悖	悖	悖	悖	悖	悖	悖	悖	悖	悖	悖	悖	悖	悖
B	掠	控	捲	掖	探	接	捷	捧	掘	措	捱	掩	掉	掃	掛	捫
C	推	掄	授	掙	採	掬	排	掏	掀	捻	捩	捨	捺	敵	敖	救
D	教	敗	啓	敏	敘	敕	敵	斜	斛	斬	族	旋	旌	旌	晝	晚
E	晤	晨	晦	晞	曹	昂	望	梁	梯	槽	梓	梵	樺	桶	樞	梧
F	梗	械	槌	棄	梭	柳	梅	樞	條	梨	梟	梟	梟	梟	梟	梟

AF	0	1	2	3	4	5	6	7	8	9	A	B	C	D	E	F
4	涅	涉	浮	浚	浴	浩	涌	忍	浹	涅	渴	涇	烜	烘	烤	烙
5	烈	烏	參	特	狼	狹	狽	狽	玃	玃	玃	玃	玃	玃	玃	玃
6	畔	畝	畜	畜	留	疾	病	症	痲	痲	痲	痲	痲	痲	痲	痲
7	匏	益	盃	盃	眩	真	眠	眨	矩	砗	砗	砗	砗	砗	砗	砗
A	?	砥	砥	砥	砥	砥	砥	砥	砥	砥	砥	砥	砥	砥	砥	砥
B	秣	秧	租	秦	秩	秘	窄	窈	站	筓	笑	粉	紡	紗	紋	紊
C	素	索	純	紐	紕	級	紕	納	紙	紛	缺	罟	羔	翹	翁	耆
D	耘	耕	耙	耗	耽	耽	耽	耽	耽	耽	耽	耽	耽	耽	耽	耽
E	能	脊	胼	胼	臭	臭	臭	臭	臭	臭	臭	臭	臭	臭	臭	臭
F	荆	茸	荐	草	茵	茵	茵	茵	茵	茵	茵	茵	茵	茵	茵	茵

B2	0	1	2	3	4	5	6	7	8	9	A	B	C	D	E	F
4	毫	毳	氫	涎	涼	淳	涼	液	淡	洵	淤	添	淺	清	淇	淋
5	涯	淑	澗	澗	澗	澗	澗	澗	澗	澗	澗	澗	澗	澗	澗	澗
6	深	淮	淨	淆	溜	涪	涪	涪	涪	涪	涪	涪	涪	涪	涪	涪
7	犁	猜	猛	猖	獯	獯	獯	獯	獯	獯	獯	獯	獯	獯	獯	獯
A	?	盜	甜	產	略	哇	畢	異	疏	痔	痕	疵	痊	痲	咬	盃
B	盒	盛	眷	眾	眼	睚	睚	睚	睚	睚	睚	睚	睚	睚	睚	睚
C	窳	筮	笨	笛	第	符	笙	管	管	粒	粗	粗	粗	粗	粗	粗
D	紹	縛	紕	細	紳	組	累	終	繼	絨	絨	絨	絨	絨	絨	絨
E	耜	聊	聆	脯	脖	脣	脣	脣	脣	脣	脣	脣	脣	脣	脣	脣
F	莞	莘	莘	莖	莖	莖	莖	莖	莖	莖	莖	莖	莖	莖	莖	莖

B3	0	1	2	3	4	5	6	7	8	9	A	B	C	D	E	F
4	莆	菟	處	彪	蛇	蛙	蚶	蚪	蚪	蚪	蚪	蚪	蚪	蚪	蚪	蚪
5	袈	被	袒	袖	袍	袋	覓	規	訪	訝	訣	訥	許	設	訟	訛
6	訖	豉	豚	販	責	貫	貨	貪	貧	赧	赦	趾	跌	軛	軟	這
7	逍	通	逗	連	速	逝	逐	逕	逞	造	透	逢	遯	逛	途	?
A	?	部	郭	都	酌	野	釵	釧	鈞	釧	釧	閉	陪	陵	陳	
B	陸	陰	陴	陶	陷	陬	雀	雪	零	章	竟	頂	頃	魚	鳥	鹵
C	鹿	麥	麻	傢	傍	傅	備	傑	傀	儉	傘	傲	最	凱	割	割
D	創	剩	勞	勝	助	博	厥	畜	喀	喧	啼	喊	喝	喘	喂	喜
E	喪	啞	喇	喋	喃	喳	單	喟	唾	啣	喚	喻	喬	哩	啾	喉
F	嚙	喙	圍	堯	堪	場	堤	堰	報	堡	塢	埃	壹	壺	奠	?

B6	0	1	2	3	4	5	6	7	8	9	A	B	C	D	E	F
4	詔	詛	詐	詆	訴	診	訶	詖	象	貂	貯	貼	貳	貽	賁	費
5	賀	貴	買	貶	賀	貸	越	超	趁	跬	距	跋	跚	跑	跌	跛
6	跽	軻	軻	軻	軻	軻	軻	軻	軻	軻	軻	軻	軻	軻	軻	軻
7	酥	量	鈔	鈕	鈣	鈉	鈞	鈣	鈣	鈣	鈣	鈣	鈣	鈣	鈣	鈣
A	?	間	閒	閱	隊	階	隋	陽	隅	隆	隍	陞	隄	雁	雅	雄
B	集	雇	雲	雲	韌	項	順	須	殮	飪	飯	飽	飲	飭	馮	馭
C	黃	黍	黑	亂	備	債	傲	傳	僅	傾	催	傷	傻	德	修	剿
D	剷	剷	募	勦	勤	勢	勦	匯	嗟	晦	噪	唳	嗎	嗜	齧	噓
E	嗣	嗤	噁	噁	噁	噁	噁	噁	噁	噁	噁	噁	噁	噁	噁	噁
F	塔	墳	塌	塢	塊	塢	塢	塢	塢	塢	塢	塢	塢	塢	塢	塢

B4	0	1	2	3	4	5	6	7	8	9	A	B	C	D	E	F
4	婷	媚	媚	媒	媛	媧	孳	孳	寒	富	寓	寐	尊	尋	就	嵌
5	嵐	巖	嵇	巽	幅	帽	幘	幘	幾	廊	廁	廂	殿	弼	彭	復
6	循	徨	惑	惡	悲	悶	惠	愜	悞	悞	悞	悞	悞	悞	悞	悞
7	復	惶	愉	愀	愀	戟	扉	擊	掌	描	揀	揩	揉	揆	揆	?
A	?	插	揣	提	握	揖	揭	揮	捶	援	揪	換	摒	揚	措	敞
B	敦	敢	散	斑	斐	斯	普	晰	晴	晶	景	暑	智	晾	晷	曾
C	替	期	朝	棺	棕	棠	棘	棗	椅	棟	棵	森	棧	棹	棒	棲
D	棣	棋	棍	植	椒	椎	棉	棚	楮	菜	款	欺	欽	殘	殖	殼
E	毯	氦	氦	氦	港	游	游	游	游	游	游	游	游	游	游	游
F	湘	渤	湖	溼	渭	渦	湯	渴	湍	渺	測	湃	淪	渾	滋	?

B7	0	1	2	3	4	5	6	7	8	9	A	B	C	D	E	F
4	媳	嫂	嬈	嵩	崆	峴	幹	廉	廈	弒	彙	傍	微	愚	意	慈
5	感	想	愛	惹	愁	愈	慎	慌	慄	慄	慄	慄	慄	慄	慄	慄
6	戡	戡	搓	搾	搞	搪	搭	搽	搬	搏	搜	搔	損	搶	搖	搗
7	構	敬	斟	新	暗	暉	暇	暈	暖	暄	暄	暄	暄	暄	暄	暄
A	?	楚	楷	楠	楔	極	椰	概	楊	慎	楫	楞	楓	楹	榆	棟
B	楣	桔	歇	歲	毀	殿	毓	礎	溢	溯	滓	溶	滂	源	溝	滇
C	滅	溥	溥	溥	溥	溥	溥	溥	溥	溥	溥	溥	溥	溥	溥	溥
D	煩	煤	煉	照	煜	煬	煦	煌	煥	煥	煥	煥	煥	煥	煥	煥
E	獅	猿	猓	瑯	瑯	瑯	瑯	瑯	瑯	瑯	瑯	瑯	瑯	瑯	瑯	瑯
F	痰	瘁	痲	痲	痲	痲	痲	痲	痲	痲	痲	痲	痲	痲	痲	痲

B5	0	1	2	3	4	5	6	7	8	9	A	B	C	D	E	F
4	漑	渙	灑	潛	涓	涓	涓	涓	涓	涓	涓	涓	涓	涓	涓	涓
5	牌	椅	犀	猶	猥	猴	猩	珙	琪	琳	琢	琥	琵琶	琴	瑄	
6	琛	琦	琨	甥	甦	畫	番	痢	痛	痣	瘰	痘	痞	痲	登	發
7	皖	皓	皴	盜	困	短	硝	硬	硯	稍	稈	程	稅	稀	窘	?
A	?	窗	窘	童	竣	等	策	筆	筐	筒	答	筍	筋	筏	筑	粟
B	粥	絞	結	絨	絕	紫	絮	絲	絡	給	絢	經	絳	善	翔	翕
C	盞	聒	肅	腕	腔	腋	腑	腎	脹	腆	脾	臑	腓	腓	舒	舜
D	菩	萃	菸	萍	菠	菅	萋	菁	華	菱	菴	著	萊	菰	萌	菌
E	菽	菲	菊	莢	萎	萄	菜	萇	菴	菴	菴	菴	菴	菴	菴	菴
F	蛤	蚶	蚶	街	裁	裂	袂	覃	視	註	詠	評	詞	証	詰	?

B8	0	1	2	3	4	5	6	7	8	9	A	B	C	D	E	F
4	睹	睪	睬	睜	睜	睜	睜	矮	碎	碰	碗	碗	碗	碗	碗	碗
5	確	確	祺	祿	禁	萬	禽	稜	稚	稠	稔	稔	稔	稔	稔	稔
6	節	筠	筮	筮	梁	粳	粳	粳	粳	粳	粳	粳	粳	粳	粳	粳
7	署	義	羨	群	聖	聘	肆	肆	肆	肆	肆	肆	肆	肆	肆	肆
A	?	腹	腺	腦	鼻	艇	蒂	葷	落	萱	葵	葦	葫	葉	葬	葛
B	萼	萼	萼	萼	萼	萼	萼	萼	萼	萼	萼	萼	萼	萼	萼	萼
C	蛻	蜂	蜃	蜃	蜃	蜃	蜃	蜃	蜃	蜃	蜃	蜃	蜃	蜃	蜃	蜃
D	規	解	訛	該	詳	試	詩	詰	誇	詼	詼	詼	詼	詼	詼	詼
E	詮	詬	詹	詬	訾	訾	訾	訾	訾	訾	訾	訾	訾	訾	訾	訾
F	賅	跡	跟	跨	路	跳	跳	跳	跳	跳	跳	跳	跳	跳	跳	跳

B9	0	1	2	3	4	5	6	7	8	9	A	B	C	D	E	F
4	辟	農	運	遊	道	遂	達	逼	違	遐	遇	過	過	遍	遑	逾
5	遁	鄒	鄒	酬	酪	酪	粘	鉗	鉗	鉗	鉗	鉗	鉗	鉗	鉗	鉗
6	鉗	鉗	鉗	鉗	鉗	鉗	鉗	鉗	鉗	鉗	鉗	鉗	鉗	鉗	鉗	鉗
7	雷	電	電	零	靖	靴	靴	預	頑	頑	頑	頑	頑	頑	頑	頑
A	?	飽	飾	馳	馱	馱	髡	鳩	禿	鼎	鼓	鼠	僧	僮	僂	僂
B	僂	僚	僕	像	僑	僱	僱	僱	僱	僱	僱	僱	僱	僱	僱	僱
C	嘛	嘗	嗽	嘔	嘆	嘉	嘍	嘍	嘍	嘍	嘍	嘍	嘍	嘍	嘍	嘍
D	塵	塾	境	墓	塾	塾	塾	塾	塾	塾	塾	塾	塾	塾	塾	塾
E	嫩	嫗	嫗	嫗	嫗	嫗	嫗	嫗	嫗	嫗	嫗	嫗	嫗	嫗	嫗	嫗
F	屢	屢	屢	屢	屢	屢	屢	屢	屢	屢	屢	屢	屢	屢	屢	屢

BC	0	1	2	3	4	5	6	7	8	9	A	B	C	D	E	F
4	劇	劈	劉	劍	創	麗	厲	嘖	嘖	嘖	嘖	嘖	嘖	嘖	嘖	嘖
5	嘖	嘖	嘖	嘖	嘖	嘖	嘖	嘖	嘖	嘖	嘖	嘖	嘖	嘖	嘖	嘖
6	嬋	嫵	嬌	嬌	寮	寬	審	寫	層	履	履	履	履	履	履	履
7	廚	廟	廝	廣	廠	彈	影	德	徵	慶	慧	慮	慮	慮	慮	慮
A	?	感	慰	懲	懲	懲	懲	懲	懲	懲	懲	懲	懲	懲	懲	懲
B	摯	摹	撞	撲	撈	撐	撐	撐	撐	撐	撐	撐	撐	撐	撐	撐
C	搗	搗	搗	搗	搗	搗	搗	搗	搗	搗	搗	搗	搗	搗	搗	搗
D	標	槽	模	樓	樊	樂	樂	樂	樂	樂	樂	樂	樂	樂	樂	樂
E	潼	澄	潑	潑	潑	潑	潑	潑	潑	潑	潑	潑	潑	潑	潑	潑
F	滕	濤	濕	濕	濕	濕	濕	濕	濕	濕	濕	濕	濕	濕	濕	濕

BA	0	1	2	3	4	5	6	7	8	9	A	B	C	D	E	F
4	愿	態	慷	慢	慣	慟	慟	慘	慵	截	撇	摘	摔	撒	摸	樓
5	摺	摺	摺	摺	摺	摺	摺	摺	摺	摺	摺	摺	摺	摺	摺	摺
6	槁	榮	槓	構	榛	樵	樵	樵	樵	樵	樵	樵	樵	樵	樵	樵
7	歉	歌	氳	漳	演	滾	漓	滴	漩	漾	漠	漬	漏	漂	漢	?
A	?	滿	滯	漆	漱	漸	漲	漣	漣	漫	潔	澈	漪	滬	漁	滲
B	滌	滷	熔	熙	煽	熊	熄	炎	爾	犒	犖	獄	獐	瑤	瑣	瑪
C	瑰	瑤	甄	疑	瘡	瘍	瘋	瘡	瘡	瘡	瘡	瘡	瘡	瘡	瘡	瘡
D	碟	碧	碳	碩	碩	福	禍	種	稱	窪	窩	竭	端	管	箕	?
E	箋	筵	算	箝	箝	箝	箝	箝	箝	箝	箝	箝	箝	箝	箝	箝
F	綾	綠	緊	綴	網	網	綺	綢	綿	綵	綸	維	緒	緇	綬	?

BD	0	1	2	3	4	5	6	7	8	9	A	B	C	D	E	F
4	瑾	瑾	畿	瘡	瘡	瘡	瘡	瘡	瘡	瘡	瘡	瘡	瘡	瘡	瘡	瘡
5	瞋	瞋	磋	磅	確	磊	碾	礪	碼	磬	稿	稼	穀	稽	稷	稻
6	窳	窮	箭	箱	箴	箴	箴	箴	箴	箴	箴	箴	箴	箴	箴	箴
7	緘	緘	緘	緘	緘	緘	緘	緘	緘	緘	緘	緘	緘	緘	緘	緘
A	?	翩	耦	膜	膝	膠	膚	腓	蔗	蔽	蔚	蓮	蔬	蔭	蔓	?
B	蔑	蔣	蔡	葡	蓬	蔥	菘	蔞	螂	蝟	蝶	蝠	蝦	蝸	蝨	編
C	蝗	蝻	蝻	衛	衝	褐	複	襖	褸	褸	褸	褸	褸	褸	褸	褸
D	請	諸	課	詭	詔	調	誰	論	評	誹	諛	誼	諒	談	諄	誕
E	賞	賦	賤	賤	賤	賤	賤	賤	賤	賤	賤	賤	賤	賤	賤	賤
F	踢	踏	踩	踮	踮	踮	踮	踮	踮	踮	踮	踮	踮	踮	踮	踮

BB	0	1	2	3	4	5	6	7	8	9	A	B	C	D	E	F
4	罰	翠	翡	翟	聞	聚	肇	腐	膀	膏	膈	膊	腿	脅	臧	臺
5	與	舔	舞	鯁	蓉	蒿	蓆	蓄	蒙	蒞	蒲	蒜	蓋	蒸	蓀	蓆
6	蒐	蒼	蓑	蓑	蜿	蜜	蜻	蝻	蝻	蝻	蝻	蝻	蝻	蝻	蝻	蝻
7	裘	裹	裸	製	裨	褚	綢	誦	誌	語	誣	認	誠	誓	誤	?
A	?	說	誥	誨	誘	誑	誑	誑	誑	誑	誑	誑	誑	誑	誑	誑
B	趕	踴	輔	輒	輕	輓	辣	遠	邁	遜	遣	遙	遞	遞	遞	遞
C	鄙	鄙	鄙	醉	酸	酷	餘	鉸	銀	銅	銘	銖	銖	銖	銖	銖
D	鉸	銖	閏	閏	閏	閏	閏	閏	閏	閏	閏	閏	閏	閏	閏	閏
E	韶	頗	頷	颯	颯	餃	餅	餌	餉	駁	駁	駁	駁	駁	駁	駁
F	鳶	鳳	麼	鼻	齊	億	儀	僻	僵	價	儂	儂	儂	儂	儂	儂

BE	0	1	2	3	4	5	6	7	8	9	A	B	C	D	E	F
4	輓	適	遮	遨	遭	遷	鄰	鄭	鄧	鄧	醇	醉	醋	醃	銜	銜
5	銷	鋪	銑	鋤	鋤	銳	銑	銑	銑	銑	銑	銑	銑	銑	銑	銑
6	霉	靠	鞍	鞋	鞏	頤	頤	頤	頤	頤	頤	頤	頤	頤	頤	頤
7	駛	駕	駕	駒	駙	骷	髻	髻	髻	髻	髻	髻	髻	髻	髻	髻
A	?	馱	馱	馱	馱	馱	馱	馱	馱	馱	馱	馱	馱	馱	馱	馱
B	剿	勳	噲	噲	噲	噲	噲	噲	噲	噲	噲	噲	噲	噲	噲	噲
C	壁	壘	壇	壘	壘	壘	壘	壘	壘	壘	壘	壘	壘	壘	壘	壘
D	憶	憾	懊	懈	戰	擅	擁	擋	撻	撻	撻	撻	撻	撻	撻	撻
E	擒	擔	搗	整	曆	曉	暹	暹	暹	暹	暹	暹	暹	暹	暹	暹
F	樹	橄	橢	橡	橋	橋	橋	橋	橋	橋	橋	橋	橋	橋	橋	橋

BF	0	1	2	3	4	5	6	7	8	9	A	B	C	D	E	F
4	濃	澤	濁	澧	澳	激	澹	澶	澗	澠	熾	熾	熾	熾	熾	燈
5	燕	熹	燎	燙	焜	燃	燄	獨	璜	璣	璘	璒	璓	瓠	甌	甍
6	瘴	癘	痛	盧	盪	瞞	瞞	瞞	瞞	瞞	瞞	瞞	瞞	瞞	瞞	穎
7	穆	穌	穆	窺	筍	筍	筍	筍	筍	筍	筍	筍	筍	筍	筍	?
A	?	縑	縑	縑	縑	縑	縑	縑	縑	縑	縑	縑	縑	縑	縑	膳
B	膩	膨	臻	興	艘	艙	蕊	蕙	蕙	蕙	蕙	蕙	蕙	蕙	蕙	蕙
C	螃	螟	螞	螢	融	衡	褪	裨	裨	裨	裨	裨	裨	裨	裨	諫
D	諱	謀	諜	諧	詔	諾	謁	謂	諷	諭	諳	諛	諛	諛	諛	貓
E	賴	蹄	跛	踴	蹂	踴	輻	輻	輻	輻	輻	輻	輻	輻	輻	選
F	遲	遼	遺	鄴	醒	錠	錶	鋸	鋸	鋸	鋸	鋸	鋸	鋸	鋸	?

C2	0	1	2	3	4	5	6	7	8	9	A	B	C	D	E	F
4	駿	鮮	鮫	鮪	鮭	鴻	鵠	粟	黏	黏	黏	黏	黏	黏	黏	叢
5	嚙	嚙	壙	壙	壙	壙	壙	壙	壙	壙	壙	壙	壙	壙	壙	斷
6	曜	朦	檠	檠	檠	檠	檠	檠	檠	檠	檠	檠	檠	檠	檠	瀟
7	瀆	濺	瀑	瀏	燠	燠	燠	燠	燠	燠	燠	燠	燠	燠	燠	?
A	?	癒	瞽	瞽	瞽	瞽	瞽	瞽	瞽	瞽	瞽	瞽	瞽	瞽	瞽	簪
B	篔	篔	篔	篔	篔	篔	篔	篔	篔	篔	篔	篔	篔	篔	篔	聶
C	臍	臍	臍	臍	臍	臍	臍	臍	臍	臍	臍	臍	臍	臍	臍	蟠
D	覆	覲	觴	謨	謹	諤	諤	諤	諤	諤	諤	諤	諤	諤	諤	軀
E	轉	輒	邈	邃	邈	醫	醫	醫	醫	醫	醫	醫	醫	醫	醫	鎰
F	鏞	鉞	鎗	鎗	鎗	鎗	鎗	鎗	鎗	鎗	鎗	鎗	鎗	鎗	鎗	?

C0	0	1	2	3	4	5	6	7	8	9	A	B	C	D	E	F
4	錐	錚	錚	錚	錚	錚	錚	錚	錚	錚	錚	錚	錚	錚	錚	寬
5	霏	靛	靜	靛	靛	靛	靛	靛	靛	靛	靛	靛	靛	靛	靛	餽
6	飴	飴	駭	駭	駭	駭	駭	駭	駭	駭	駭	駭	駭	駭	駭	鴿
7	駕	默	黔	龍	龜	優	償	備	儲	勵	嚙	嚙	嚙	嚙	嚙	?
A	?	噫	壕	壓	壑	壑	嬰	嬪	嬪	孺	廬	履	嶼	嶼	嶼	嶼
B	幫	彌	徽	應	懂	懇	懦	慙	戲	戴	擊	擊	擊	擊	擊	擦
C	擬	摺	擢	獲	斂	斂	曙	曖	檀	檔	檄	檢	檜	檜	檜	燥
D	槩	檐	槩	歌	殮	龜	氈	濼	濱	濟	濠	濠	濠	濠	濠	澀
E	濬	濡	溲	濕	溲	漣	燧	營	燧	燧	燧	燧	燧	燧	燧	爵
F	牆	寧	獲	璩	環	璩	璩	瘳	瘳	瘳	瘳	瘳	瘳	瘳	瘳	?

C3	0	1	2	3	4	5	6	7	8	9	A	B	C	D	E	F
4	鞭	靛	顏	顏	題	顛	颯	餽	餽	餽	餽	餽	餽	餽	餽	鬃
5	鬆	魏	魍	魍	鯨	鯨	鯨	鯨	鯨	鯨	鯨	鯨	鯨	鯨	鯨	儂
6	燕	壞	壘	壘	寵	龐	盧	懲	懷	懶	懶	懶	懶	懶	懶	樹
7	櫛	櫛	櫛	瀛	瀛	瀛	瀛	瀛	瀛	瀛	瀛	瀛	瀛	瀛	瀛	獸
A	?	獺	璽	瓊	瓣	疇	疆	癩	癩	癩	癩	癩	癩	癩	癩	簿
B	箴	箴	箴	箴	擊	繭	繭	繭	繭	繭	繭	繭	繭	繭	繭	藩
C	藝	藪	藕	藤	藥	諸	蟻	蠅	蠅	蟹	蟾	襠	襠	襠	襠	譚
D	譜	識	證	譚	譚	譚	譚	譚	譚	譚	譚	譚	譚	譚	譚	蹊
E	蹴	麟	轎	辭	邊	邈	醜	醜	鏡	鏡	鏡	鏡	鏡	鏡	鏡	鏗
F	鏢	鏢	鏢	鏢	鏢	鏢	鏢	鏢	鏢	鏢	鏢	鏢	鏢	鏢	鏢	鏗

C1	0	1	2	3	4	5	6	7	8	9	A	B	C	D	E	F
4	瞧	瞭	矯	磷	磷	磷	磷	磷	磷	磷	稔	隆	簇	篋	篋	篷
5	簌	簌	糠	糜	糞	糞	糞	糞	糞	糞	縮	績	縷	縷	縷	縫
6	總	縱	縷	繁	縷	縷	縷	縷	縷	縷	縷	縷	縷	縷	縷	聰
7	聯	聳	臆	臆	臆	臆	臆	臆	臆	臆	臆	臆	臆	臆	臆	?
A	?	薄	蓄	薛	薑	蓄	薯	薛	薇	薨	薨	薨	薨	薨	薨	蟬
B	蟆	螻	螻	螺	蝸	蟋	蟀	褶	襄	襖	製	覬	謎	謗	謙	講
C	謊	謊	謝	膳	謔	謔	豁	豁	豁	賺	賽	購	賸	賸	賸	踢
D	蹈	蹊	轄	輾	輾	輾	輾	輾	輾	輾	還	邁	邁	邁	邁	醞
E	醜	鍍	鎂	鎂	鎂	鎂	鎂	鎂	鎂	鎂	鎂	鎂	鎂	鎂	鎂	閻
F	閻	閻	閻	閻	閻	閻	閻	閻	閻	閻	閻	閻	閻	閻	閻	?

C4	0	1	2	3	4	5	6	7	8	9	A	B	C	D	E	F
4	願	顛	颯	餽	餽	鯨	鯨	鯨	鯨	鯨	鯨	鯨	鯨	鯨	鯨	鯨
5	鵬	麒	麗	麓	翹	勸	嚙	嚙	嚙	嚙	嚙	嚙	嚙	嚙	嚙	寶
6	嶼	懸	餓	攘	攔	攔	攔	攔	攔	攔	攔	攔	攔	攔	攔	癢
7	瘳	礦	礦	礬	礬	寶	競	籌	籃	籍	糯	糲	糲	糲	糲	繼
A	?	纂	畧	耀	臚	艦	藻	藹	磨	磨	蘆	蘋	蘇	蘊	蠓	蠕
B	檻	覺	觸	議	譬	警	譯	諳	諳	贏	瞻	躄	躄	躄	躄	體
C	釋	鐘	鏡	鏞	闖	霰	飄	饒	饒	饒	饒	饒	饒	饒	饒	鯁
D	鹹	麵	黨	颯	颯	齡	儷	儷	儷	儷	儷	儷	儷	儷	儷	懼
E	攝	攝	攜	攜	攜	櫻	欄	欄	欄	欄	欄	欄	欄	欄	欄	欄
F	籐	纏	纏	纏	纏	蘭	薜	蘭	薜	蘭	薜	蘭	薜	蘭	薜	?

C5	0	1	2	3	4	5	6	7	8	9	A	B	C	D	E	F
4	護	譽	賊	躡	躍	躋	轟	辯	醜	鑣	鑊	鐵	鎗	鐸	錫	鎬
5	闢	霸	霹	露	響	顧	顛	饗	驅	騾	騫	騾	體	魔	魑	鱗
6	鰥	鶯	鶴	鷓	鴉	鸞	駮	鞞	齧	齧	儼	儼	嚙	嚙	嚙	囉
7	學	嶺	巒	鸞	懿	攤	權	歡	灑	灘	濯	瓢	疊	癩	癩	?
A	?	襪	籠	籟	聾	聽	臟	襲	視	艘	讀	贖	價	躑	躑	轡
B	酈	鑄	鑑	鑿	霽	靄	韃	韃	顛	饗	驕	驕	髒	鬚	鬚	鯁
C	鰥	鰥	鷓	鷓	鷓	鷓	鷓	鷓	鷓	鷓	鷓	鷓	鷓	鷓	鷓	鷓
D	瓊	竊	籤	簡	籟	纓	織	纒	贖	蘸	蘿	蟲	變	邏	邏	鏢
E	鑲	錄	壓	顯	廢	驚	驛	驗	髓	體	髒	鱗	鱗	鱗	鱗	鱗
F	儼	囑	壩	攪	潮	癩	癩	癩	癩	癩	癩	癩	癩	癩	癩	?

C6	0	1	2	3	4	5	6	7	8	9	A	B	C	D	E	F
4	識	艷	贛	釀	鑪	靈	靈	靈	靈	靈	靈	靈	靈	靈	靈	靈
5	鹼	鹽	龍	齧	齧	齧	齧	齧	齧	齧	齧	齧	齧	齧	齧	齧
6	顧	饒	腕	鬚	鬚	灑	灑	灑	灑	灑	灑	灑	灑	灑	灑	灑
7	鑽	鑿	鑿	鑿	鑿	鑿	鑿	鑿	鑿	鑿	鑿	鑿	鑿	鑿	鑿	?
A	?															
B																、
C	ノ	ノ	ノ	ノ	ノ	ノ	ノ	ノ	ノ	ノ	ノ	ノ	ノ	ノ	ノ	ノ
D	ヨ	シ	支	无	无	无	无	无	无	无	无	无	无	无	无	全
E	々	メ	〇	一	〔	〕	*	あ	あ	い	い	う	う	え	え	お
F	お	か	が	き	ぎ	く	ぐ	け	げ	こ	ご	さ	ざ	し	じ	?

C7	0	1	2	3	4	5	6	7	8	9	A	B	C	D	E	F
4	ず	せ	ぜ	そ	ぞ	た	だ	ち	ぢ	つ	つ	づ	て	で	と	
5	ど	な	に	ぬ	ね	の	は	ば	び	び	び	ふ	ぶ	ぶ	へ	
6	べ	へ	ほ	ぼ	ま	み	む	め	も	や	や	ゆ	ゆ	よ	よ	
7	ら	り	る	れ	ろ	わ	わ	る	る	を	ん	ア	ア	イ	イ	?
A	?	ウ	ウ	エ	エ	オ	オ	カ	カ	キ	キ	ク	ク	ケ	ケ	コ
B	ゴ	サ	ザ	シ	ジ	ス	ズ	セ	ゼ	ソ	ゾ	タ	ダ	チ	ヂ	ツ
C	ツ	ツ	テ	デ	ト	ド	ナ	ニ	ヌ	ネ	ノ	ハ	バ	パ	ヒ	ビ
D	ピ	フ	ブ	ブ	ヘ	ベ	ペ	ホ	ボ	ポ	マ	ミ	ム	メ	モ	ヤ
E	ヤ	ユ	ユ	ヨ	ヨ	ラ	リ	ル	レ	ロ	ワ	ワ	キ	エ	ヲ	ン
F	ヴ	カ	ケ													?

Appendix C. GB Font Code Table

A1	0	1	2	3	4	5	6	7	8	9	A	B	C	D	E	F
A			、	。	・	-	√	∴	”	々	—	~	∥	…	‘	’
B	“	”	[]	<	>	《	》	「	」	『	』	【	】	【	】
C	±	×	÷	:	∧	∨	Σ	∏	∩	∪	∞	∴	√	⊥	#	∠
D	^	⊙	∫	∂	≡	≠	≈	∞	∞	≠	≠	≠	≠	≠	∞	∴
E	∴	δ	♀	°	’	^	℃	\$	⊙	∅	£	%	§	№	☆	★
F	○	●	◎	◇	◆	□	■	△	▲	※	→	←	↑	↓	■	

A2	0	1	2	3	4	5	6	7	8	9	A	B	C	D	E	F
A		i	ii	iii	iv	v	vi	vii	viii	ix	x					
B		1.	2.	3.	4.	5.	6.	7.	8.	9.	10.	11.	12.	13.	14.	15.
C	16.	17.	18.	19.	20.	(1)	(2)	(3)	(4)	(5)	(6)	(7)	(8)	(9)	(10)	(11)
D	(12)	(13)	(14)	(15)	(16)	(17)	(18)	(19)	(20)	①	②	③	④	⑤	⑥	⑦
E	⑧	⑨	⑩			(←)	(→)	(⇄)	(↻)	(↻)	(↻)	(↻)	(↻)	(↻)	(↻)	
F		I	II	III	IV	V	VI	VII	VIII	IX	X	XI	XII			

A3	0	1	2	3	4	5	6	7	8	9	A	B	C	D	E	F
A		!	"	#	¥	%	&	'	()	*	+	,	-	.	/
B	0	1	2	3	4	5	6	7	8	9	:	;	<	=	>	?
C	@	A	B	C	D	E	F	G	H	I	J	K	L	M	N	O
D	P	Q	R	S	T	U	V	W	X	Y	Z	[\]	^	_
E	`	a	b	c	d	e	f	g	h	i	j	k	l	m	n	o
F	p	q	r	s	t	u	v	w	x	y	z	{		}	—	

A4	0	1	2	3	4	5	6	7	8	9	A	B	C	D	E	F
A		あ	あ	い	い	う	う	え	え	お	お	か	が	き	ぎ	く
B	ぐ	け	げ	こ	ご	さ	ざ	し	じ	す	ず	せ	ぜ	そ	ぞ	た
C	だ	ち	ち	っ	っ	づ	て	で	と	と	な	に	ぬ	ね	の	は
D	ば	ば	ひ	び	び	ふ	ぶ	ぶ	へ	べ	べ	ほ	ぼ	ぼ	ま	み
E	む	め	も	や	や	ゆ	ゆ	よ	よ	ら	り	る	れ	ろ	わ	わ
F	あ	え	き	ん												

A5	0	1	2	3	4	5	6	7	8	9	A	B	C	D	E	F
A		ア	ァ	イ	ィ	ウ	ゥ	エ	ヱ	オ	ォ	カ	ガ	キ	ギ	ク
B	グ	ケ	ゲ	コ	ゴ	サ	ザ	シ	ジ	ス	ズ	セ	ゼ	ソ	ゾ	タ
C	ダ	チ	ヂ	ツ	ヅ	テ	ヂ	ト	ド	ナ	ニ	ヌ	ネ	ノ	ハ	
D	バ	バ	ヒ	ビ	ピ	フ	ブ	ヰ	ヱ	ベ	ホ	ボ	ポ	マ	ミ	
E	ム	メ	モ	ヤ	ヤ	ユ	ユ	ヨ	ヨ	ラ	リ	ル	レ	ロ	ワ	ヅ
F	キ	エ	ヲ	ン	ヴ	カ	ケ									

A6	0	1	2	3	4	5	6	7	8	9	A	B	C	D	E	F
A		A	B	Γ	Δ	E	Z	H	Θ	I	K	Λ	M	N	E	O
B	Π	P	Σ	T	Τ	Φ	X	Ψ	Ω							
C		α	β	γ	δ	ε	ζ	η	θ	ι	κ	λ	μ	ν	ξ	ο
D	π	ρ	σ	τ	υ	φ	χ	ψ	ω							
E	ˆ	˘	˙	˚	˛	˜	˝	˞	˟	ˠ	ˡ	ˢ			ˣ	ˤ
F	ˆ	˘														

A7	0	1	2	3	4	5	6	7	8	9	A	B	C	D	E	F
A		A	B	B	Г	Д	E	Ё	Ж	З	И	Й	К	Л	М	Н
B	О	П	Р	С	Т	У	Ф	Х	Ц	Ч	Ш	Щ	Ъ	Ы	Ь	Э
C	Ю	Я														
D		а	б	в	г	д	е	ё	ж	з	и	й	к	л	м	н
E	о	п	р	с	т	у	ф	х	ц	ч	ш	щ	ъ	ы	ь	э
F	ю	я														

A8	0	1	2	3	4	5	6	7	8	9	A	B	C	D	E	F
A		ō	ó	ô	ò	ē	é	è	è	ī	í	ì	ì	ō	ó	ò
B	ò	ū	ú	û	ù	û	û	ü	û	ü	ê	á	â	ã	ä	å
C	g				ウ	ウ	ウ	ウ	ウ	ウ	ウ	ウ	ウ	ウ	ウ	ウ
D	ウ	ウ	ウ	ウ	ウ	ウ	ウ	ウ	ウ	ウ	ウ	ウ	ウ	ウ	ウ	ウ
E	ウ	ウ	ウ	ウ	ウ	ウ	ウ	ウ	ウ	ウ	ウ	ウ	ウ	ウ	ウ	ウ
F																

A9	0	1	2	3	4	5	6	7	8	9	A	B	C	D	E	F
A					—	—			---	---			---	---		
B	┌	┌	┌	┌	┐	┐	┐	┐	└	└	└	└	┘	┘	┘	┘
C	└	└	└	└	┘	┘	┘	┘	┌	┌	┌	┌	┐	┐	┐	┐
D	┘	┘	┘	┘	└	└	└	└	┌	┌	┌	┌	┐	┐	┐	┐
E	+	+	+	+	+	+	+	+	+	+	+	+	+	+	+	+
F																

AA	0	1	2	3	4	5	6	7	8	9	A	B	C	D	E	F
A																
B																
C																
D																
E																
F																

AB	0	1	2	3	4	5	6	7	8	9	A	B	C	D	E	F
A																
B																
C																
D																
E																
F																

AC	0	1	2	3	4	5	6	7	8	9	A	B	C	D	E	F
A																
B																
C																
D																
E																
F																

AD	0	1	2	3	4	5	6	7	8	9	A	B	C	D	E	F
A																
B																
C																
D																
E																
F																

AE	0	1	2	3	4	5	6	7	8	9	A	B	C	D	E	F
A																
B																
C																
D																
E																
F																

AF	0	1	2	3	4	5	6	7	8	9	A	B	C	D	E	F
A																
B																
C																
D																
E																
F																

B0	0	1	2	3	4	5	6	7	8	9	A	B	C	D	E	F
A		啊	阿	埃	挨	哎	唉	哀	皑	癌	藹	矮	艾	碍	爰	隘
B	鞍	氨	安	俺	按	暗	岸	胺	案	肮	昂	盎	凹	敖	熬	翱
C	袄	傲	奥	懊	澳	芭	捌	扒	叭	吧	芭	八	疤	巴	拔	跋
D	靶	把	耙	坝	霸	罢	爸	白	柏	百	摆	佰	败	拜	裨	斑
E	班	搬	扳	般	颁	板	版	扮	拌	伴	瓣	半	办	絆	邦	帮
F	梆	榜	膀	绑	棒	磅	蚌	镑	傍	谤	苞	胞	包	褒	剥	

B1	0	1	2	3	4	5	6	7	8	9	A	B	C	D	E	F
A		薄	雹	保	堡	饱	宝	抱	报	暴	豹	鲍	爆	杯	碑	悲
B	卑	北	辈	背	贝	钡	倍	狈	备	惫	焙	被	奔	苯	本	笨
C	崩	绷	甬	泵	蹦	迸	逼	鼻	比	鄙	笔	彼	碧	蓖	蔽	毕
D	毙	恣	币	庇	痹	闭	敝	弊	必	辟	壁	臂	避	陛	鞭	边
E	编	眨	扁	便	变	卞	辨	辩	辨	遍	标	彪	膘	表	鳖	憋
F	别	瘪	彬	斌	濒	滨	宾	摈	兵	冰	柄	丙	秉	饼	炳	

B2	0	1	2	3	4	5	6	7	8	9	A	B	C	D	E	F
A		病	并	玻	菠	播	拨	钵	波	博	勃	搏	铂	箔	伯	帛
B	舶	脖	膊	渤	泊	驳	捕	卜	哺	补	埠	不	布	步	簿	部
C	怖	擦	猜	裁	材	才	财	睬	睬	采	彩	菜	蔡	餐	参	蚕
D	残	惭	惨	灿	苍	舱	仓	沧	藏	操	糙	槽	曹	草	厕	策
E	侧	册	测	层	蹭	插	叉	茬	茶	查	碴	搽	察	岔	差	诧
F	拆	柴	豺	搀	掺	蝉	馋	谗	缠	铲	产	阐	颤	昌	猖	

B3	0	1	2	3	4	5	6	7	8	9	A	B	C	D	E	F
A		场	尝	常	长	偿	肠	厂	敞	畅	唱	倡	超	抄	钞	朝
B	嘲	潮	巢	吵	炒	车	扯	撤	掣	彻	澈	郴	臣	辰	尘	晨
C	忱	沉	陈	趁	衬	撑	称	城	橙	成	呈	乘	程	惩	澄	诚
D	承	逞	骋	秤	吃	痴	持	匙	池	迟	弛	驰	耻	齿	侈	尺
E	赤	翅	斥	炽	充	冲	虫	崇	宠	抽	酬	畴	踌	稠	愁	筹
F	仇	绸	瞅	丑	臭	初	出	橱	厨	躇	锄	雏	滁	除	楚	

B4	0	1	2	3	4	5	6	7	8	9	A	B	C	D	E	F
A		础	储	矗	搐	触	处	揣	川	穿	椽	传	船	喘	串	疮
B	窗	幢	床	闯	创	吹	炊	捶	锤	垂	春	椿	醇	唇	淳	纯
C	蠢	戮	绰	疵	茨	磁	雌	辞	慈	瓷	词	此	刺	赐	次	聪
D	葱	囱	匆	从	丛	凑	粗	醋	簇	促	蹕	篡	窜	摧	崔	催
E	脆	瘁	粹	淬	翠	村	存	寸	磋	撮	搓	措	挫	错	搭	达
F	答	瘩	打	大	呆	歹	傣	戴	带	殆	代	贷	袋	待	逮	

B5	0	1	2	3	4	5	6	7	8	9	A	B	C	D	E	F
A		怠	耽	担	丹	单	郸	掸	胆	旦	氦	但	惮	淡	诞	弹
B	蛋	当	挡	党	荡	档	刀	捣	蹈	倒	岛	祷	导	到	稻	悼
C	道	盗	德	得	的	蹬	灯	登	等	瞪	凳	邓	堤	低	滴	迪
D	敌	笛	狄	涤	翟	嫡	抵	底	地	蒂	第	帝	弟	递	缔	颠
E	掂	滇	碘	点	典	靛	垫	电	佃	甸	店	惦	奠	淀	殿	碉
F	刁	雕	凋	刁	掉	吊	钓	调	跌	爹	碟	蝶	迭	谍	叠	

B6	0	1	2	3	4	5	6	7	8	9	A	B	C	D	E	F
A		丁	盯	叮	钉	顶	鼎	锭	定	订	丢	东	冬	董	懂	动
B	栋	侗	恫	冻	洞	兜	抖	斗	陡	豆	逗	痘	都	督	毒	牍
C	独	读	堵	睹	赌	杜	镀	肚	度	渡	妒	端	短	锻	段	断
D	缎	堆	兑	队	对	墩	吨	蹲	敦	顿	囤	钝	盾	遁	掇	哆
E	多	夺	垛	躲	朵	蹉	舵	剥	惰	堕	蛾	峨	鹅	俄	额	讹
F	娥	恶	厄	扼	遏	鄂	饿	恩	而	儿	耳	尔	饵	洱	二	

B7	0	1	2	3	4	5	6	7	8	9	A	B	C	D	E	F
A		贰	发	罚	筏	伐	乏	阀	法	珐	藩	帆	番	翻	樊	矾
B	钒	繁	凡	烦	反	返	范	贩	犯	饭	泛	坊	芳	方	肪	房
C	防	妨	仿	访	纺	放	菲	非	啡	飞	肥	匪	诽	吠	肺	废
D	沸	费	芬	酚	吩	氛	分	纷	坟	焚	汾	粉	奋	份	忿	愤
E	粪	丰	封	枫	蜂	峰	锋	风	疯	烽	逢	冯	缝	讽	奉	凤
F	佛	否	夫	敷	肤	孵	扶	拂	福	幅	氟	符	伏	俘	服	

B8	0	1	2	3	4	5	6	7	8	9	A	B	C	D	E	F
A		浮	涪	福	袱	弗	甫	抚	辅	俯	釜	斧	脯	腑	府	腐
B	赴	副	覆	赋	复	傅	付	阜	父	腹	负	富	讣	附	妇	缚
C	咐	噶	嘎	该	改	概	钙	盖	溉	干	甘	杆	柑	竿	肝	赶
D	感	秆	敢	赣	冈	刚	钢	缸	肛	纲	岗	港	杠	篙	皋	高
E	膏	羔	糕	搞	搞	稿	告	哥	歌	搁	戈	鸽	酪	疙	割	革
F	葛	格	蛤	阁	隔	谿	个	各	给	根	跟	耕	更	庚	羹	

B9	0	1	2	3	4	5	6	7	8	9	A	B	C	D	E	F
A		埂	耿	梗	工	攻	功	恭	龚	供	躬	公	宫	弓	巩	汞
B	拱	贡	共	钩	勾	沟	苟	狗	垢	枸	购	够	辜	菇	咕	箍
C	估	沽	孤	姑	鼓	古	蛊	骨	谷	股	故	顾	固	雇	刮	瓜
D	刚	寡	挂	褂	乖	拐	怪	棺	关	官	冠	观	管	馆	罐	惯
E	灌	贯	光	广	逛	瑰	规	圭	硅	归	龟	闺	轨	鬼	诡	癸
F	桂	柜	跪	贵	刽	辊	滚	棍	锅	郭	国	果	裹	过	哈	

BA	0	1	2	3	4	5	6	7	8	9	A	B	C	D	E	F
A		骸	孩	海	氦	亥	害	骇	酣	憨	邯	韩	含	涵	寒	函
B	喊	罕	翰	撼	捍	旱	憾	悍	焊	汗	汉	夯	杭	航	壕	嚎
C	豪	毫	郝	好	耗	号	浩	呵	喝	荷	菏	核	禾	和	何	合
D	盒	貉	阍	河	洵	赫	褐	鹤	贺	嘿	黑	痕	很	狠	恨	哼
E	亨	横	衡	恒	轰	哄	烘	虹	鸿	洪	宏	弘	红	喉	侯	猴
F	吼	厚	候	后	呼	乎	忽	瑚	壶	葫	胡	蝴	狐	糊	湖	

BB	0	1	2	3	4	5	6	7	8	9	A	B	C	D	E	F
A		弧	虎	唬	护	互	沪	户	花	哗	华	猾	滑	画	划	化
B	话	槐	徊	怀	淮	坏	欢	环	桓	还	缓	换	患	唤	痪	蒙
C	焕	涣	宦	幻	荒	慌	黄	磺	蝗	簧	皇	凰	惶	煌	晃	幌
D	恍	谎	灰	挥	辉	恢	徊	回	毁	悔	慧	卉	惠	晦	贿	陪
E	秽	会	烩	汇	讳	悔	绘	荤	昏	婚	魂	浑	混	豁	活	伙
F	火	获	或	惑	霍	货	祸	击	圾	基	机	畸	稽	积	箕	

BC	0	1	2	3	4	5	6	7	8	9	A	B	C	D	E	F
A		肌	饥	迹	激	讥	鸡	姬	绩	缉	吉	极	棘	辑	籍	集
B	及	急	疾	汲	即	嫉	级	挤	几	脊	己	薊	技	冀	季	伎
C	祭	剂	悻	济	寄	寂	计	记	既	忌	际	妓	继	纪	嘉	枷
D	夫	佳	家	加	荚	颊	贾	甲	钾	假	稼	价	架	驾	嫁	歼
E	监	坚	尖	笺	间	煎	兼	肩	艰	奸	緘	茧	检	柬	碱	硷
F	拣	捡	简	俭	剪	减	荐	槛	鉴	践	贱	见	键	箭	件	

BD	0	1	2	3	4	5	6	7	8	9	A	B	C	D	E	F
A		健	舰	剑	饫	渐	溅	涧	建	僵	姜	将	浆	江	疆	蒋
B	浆	奖	讲	匠	酱	降	蕉	椒	礁	焦	胶	交	郊	浇	骄	娇
C	嚼	搅	较	矫	侥	脚	狡	角	饺	缴	绞	剿	教	酵	轿	较
D	叫	窖	揭	接	皆	秸	街	阶	截	劫	节	桔	杰	捷	睫	竭
E	洁	结	解	姐	戒	藉	芥	界	借	介	疥	诫	届	巾	筋	斤
F	金	今	津	襟	紧	锦	仅	谨	进	靳	晋	禁	近	焮	浸	

BE	0	1	2	3	4	5	6	7	8	9	A	B	C	D	E	F
A		尽	劲	荆	兢	茎	睛	晶	鲸	京	惊	精	稷	经	井	警
B	景	颈	静	境	敬	镜	径	痉	靖	竟	竞	净	炯	窘	揪	究
C	纠	玖	韭	久	灸	九	酒	厥	救	旧	臼	舅	咎	就	疚	鞠
D	拘	狙	狙	居	驹	菊	局	咀	矩	举	沮	聚	拒	据	巨	具
E	距	踞	锯	俱	句	惧	炬	剧	捐	鹃	娟	倦	眷	卷	绢	掬
F	攫	抉	掘	倔	爵	觉	决	诀	绝	均	菌	钧	军	君	峻	

BF	0	1	2	3	4	5	6	7	8	9	A	B	C	D	E	F
A		俊	竣	浚	郡	骏	喀	咖	卡	咯	开	揩	楷	凯	慨	刊
B	堪	勘	坎	砍	看	康	慷	糠	扛	抗	亢	炕	考	拷	烤	靠
C	坷	苛	柯	棵	磕	颗	科	壳	咳	可	渴	克	刻	客	课	肯
D	哨	垦	恳	坑	吭	空	恐	孔	控	扼	口	扣	寇	枯	哭	窟
E	苦	酷	库	裤	夸	垮	垮	跨	胯	块	筷	俭	快	宽	款	匡
F	筐	狂	框	矿	眶	旷	况	亏	盍	岿	窥	葵	奎	魁	傀	

CO	0	1	2	3	4	5	6	7	8	9	A	B	C	D	E	F
A		馈	愧	溃	坤	昆	捆	困	括	扩	廓	阔	垃	拉	喇	蜡
B	腊	辣	啦	莱	来	赖	蓝	婪	栏	拦	篮	阑	兰	澜	澜	揽
C	览	懒	纛	烂	滥	琅	榔	狼	廊	郎	朗	浪	捞	劳	牢	老
D	佬	姥	酪	烙	涝	勒	乐	雷	镭	蕾	磊	累	偶	垒	擂	肋
E	类	泪	棱	楞	冷	厘	梨	犁	黎	篱	狸	离	漓	理	李	里
F	鲤	礼	莉	荔	吏	栗	丽	厉	励	砾	历	利	僿	例	俐	

C1	0	1	2	3	4	5	6	7	8	9	A	B	C	D	E	F
A		痢	立	粒	沥	隶	力	璃	哩	俩	联	莲	连	镰	廉	怜
B	漉	帘	敛	脸	链	恋	炼	练	粮	凉	梁	粱	良	两	辆	量
C	晾	亮	谅	撩	聊	僚	疗	燎	寥	辽	潦	了	摺	镣	廖	料
D	列	裂	烈	劣	猎	琳	林	磷	霖	临	邻	鳞	淋	凛	赁	吝
E	拎	玲	菱	零	龄	铃	伶	羚	凌	灵	陵	岭	领	另	令	溜
F	琉	榴	硫	馏	留	刘	瘤	流	柳	六	龙	葶	咙	笼	窿	

C2	0	1	2	3	4	5	6	7	8	9	A	B	C	D	E	F
A		隆	垄	拢	陇	楼	娄	楼	篓	漏	陋	芦	卢	颅	庐	炉
B	掳	卤	虐	鲁	麓	碌	露	路	赂	鹿	漭	禄	录	陆	戮	驴
C	吕	铝	侣	旅	履	屨	缕	虑	氯	律	率	滤	绿	恋	挛	率
D	溲	卵	乱	掠	略	抡	轮	伦	仑	论	纶	论	萝	螺	罗	逻
E	锣	箩	骡	裸	落	洛	骆	络	妈	麻	玛	码	蚂	马	骂	嘛
F	吗	埋	买	麦	卖	迈	脉	瞒	慢	蛮	满	蔓	曼	慢	漫	

C3	0	1	2	3	4	5	6	7	8	9	A	B	C	D	E	F
A		漫	芒	茫	盲	氓	忙	莽	猫	茅	锚	毛	矛	铆	卯	茂
B	冒	帽	貌	贸	么	玫	枚	梅	酶	霉	煤	没	眉	媒	镁	每
C	美	昧	寐	妹	媚	门	闷	们	萌	蒙	檬	盟	锰	猛	梦	孟
D	眯	醚	靡	糜	迷	谜	弥	米	秘	觅	泌	蜜	密	扉	棉	眠
E	绵	冕	免	勉	媵	緬	面	苗	描	瞄	藐	秒	渺	庙	妙	蔑
F	灭	民	抿	皿	敏	悯	闽	明	螟	鸣	铭	名	命	谬	摸	

C4	0	1	2	3	4	5	6	7	8	9	A	B	C	D	E	F
A		摹	蘑	模	膜	磨	摩	魔	抹	末	莫	墨	默	沫	漠	寞
B	陌	谋	牟	某	拇	牡	亩	姆	母	墓	暮	幕	募	慕	木	目
C	睦	牧	穆	拿	哪	呐	纳	那	娜	纳	氛	乃	奶	耐	奈	南
D	男	难	囊	挠	脑	恼	闹	淖	呢	馁	内	嫩	能	妮	霓	倪
E	泥	尼	拟	你	匿	膩	逆	溺	蕉	拈	年	碾	撵	捻	念	娘
F	酿	鸟	尿	捏	聂	孽	皓	镊	镍	涅	您	柠	犴	凝	宁	

C5	0	1	2	3	4	5	6	7	8	9	A	B	C	D	E	F
A		拧	泞	牛	扭	钮	纽	脓	浓	农	弄	奴	努	怒	女	暖
B	虐	疟	挪	懦	糯	诺	哦	欧	鸥	殴	藕	呕	偶	讴	啪	趴
C	爬	帕	怕	琶	拍	排	牌	徘	湃	派	攀	潘	盘	磐	盼	畔
D	判	叛	兵	庞	旁	榜	胖	抛	咆	刨	炮	袍	跑	泡	坯	胚
E	培	裴	赔	陪	配	佩	沛	喷	盆	砰	抨	烹	澎	彭	蓬	棚
F	硼	篷	膨	朋	鹏	捧	碰	坯	砒	霹	批	披	劈	琵琶	毗	

C6	0	1	2	3	4	5	6	7	8	9	A	B	C	D	E	F
A		啤	脾	疲	皮	匹	痞	僻	屁	譬	篇	偏	片	骗	瓢	漂
B	瓢	票	撇	瞥	拼	频	贫	品	聘	乒	坪	苹	萍	平	凭	瓶
C	评	屏	坡	泼	颇	婆	破	魄	迫	粕	剖	扑	铺	仆	莆	葡
D	菩	蒲	埔	朴	圃	普	浦	谱	曝	瀑	期	欺	栖	戚	妻	七
E	凄	漆	柒	沏	其	棋	奇	歧	畦	崎	脐	齐	旗	祈	祁	骑
F	起	岂	乞	企	启	契	砌	器	气	迄	弃	汽	泣	讫	掐	

C7	0	1	2	3	4	5	6	7	8	9	A	B	C	D	E	F
A		恰	洽	牵	扞	钎	铅	千	迁	签	仟	谦	乾	黔	钱	钳
B	前	潜	遣	浅	谴	堑	嵌	欠	歉	枪	呛	腔	羌	墙	蔷	强
C	抢	橇	锹	敲	悄	桥	瞧	乔	侨	巧	鞘	橐	翘	峭	俏	窍
D	切	茄	且	怯	窃	软	侵	亲	秦	琴	勤	芹	擒	禽	寝	沁
E	青	轻	氢	倾	卿	清	擎	晴	氛	情	顷	请	庆	琼	穷	秋
F	丘	邱	球	求	囚	酋	泗	趋	区	蛆	曲	躯	屈	驱	渠	

C8	0	1	2	3	4	5	6	7	8	9	A	B	C	D	E	F
A		取	娶	龇	趣	去	圉	颞	杈	醛	泉	全	痊	拳	犬	券
B	劝	缺	焯	瘸	却	鹊	榷	确	雀	裙	群	然	燃	冉	染	瓢
C	壤	攘	嚷	让	饶	扰	绕	惹	热	壬	仁	人	忍	韧	任	认
D	刃	妊	纫	扔	仍	日	戎	茸	蓉	荣	融	熔	溶	容	绒	冗
E	揉	柔	肉	茹	蠕	儒	孺	如	辱	乳	汝	入	褥	软	阮	蕊
F	瑞	锐	闰	润	若	弱	撒	洒	萨	腮	鳃	塞	赛	三	叁	

C9	0	1	2	3	4	5	6	7	8	9	A	B	C	D	E	F
A		伞	散	桑	噪	丧	搔	骚	扫	嫂	瑟	色	涩	森	僧	莎
B	砂	杀	刹	沙	纱	傻	啥	煞	筛	晒	珊	苦	杉	山	删	煽
C	衫	闪	陕	擅	赡	膳	善	汕	扇	缮	墒	伤	商	赏	晌	上
D	尚	裳	梢	稍	稍	烧	芍	勺	韶	少	哨	邵	绍	奢	赊	蛇
E	舌	舍	赦	摄	射	慑	涉	社	设	神	申	呻	伸	身	深	娠
F	绅	神	沈	审	婢	甚	肾	慎	渗	声	甥	甥	牲	升	绳	

CA	0	1	2	3	4	5	6	7	8	9	A	B	C	D	E	F
A		省	盛	剩	胜	圣	师	失	狮	施	湿	诗	尸	虱	十	石
B	拾	时	什	食	蚀	实	识	史	矢	使	屎	驶	始	式	示	士
C	世	柿	事	拭	誓	逝	势	是	嗜	噬	适	仕	侍	释	饰	氏
D	市	恃	室	视	试	收	手	首	守	寿	授	售	受	瘦	兽	蔬
E	枢	梳	殊	抒	输	叔	舒	淑	疏	书	赎	孰	熟	薯	暑	曙
F	署	蜀	黍	鼠	属	术	述	树	束	戍	竖	墅	庶	数	漱	

CB	0	1	2	3	4	5	6	7	8	9	A	B	C	D	E	F
A		恕	刷	耍	摔	衰	甩	帅	栓	拴	霜	双	爽	谁	水	睡
B	税	吮	瞬	顺	舜	说	硕	朔	烁	斯	撕	嘶	思	私	司	丝
C	死	肆	寺	嗣	四	伺	似	饲	巳	松	耸	忪	颂	送	宋	讼
D	诵	搜	艘	擞	嗽	苏	酥	俗	素	速	粟	僂	塑	溯	宿	诉
E	肃	酸	蒜	算	虽	隋	随	绥	髓	碎	岁	穗	遂	隧	祟	孙
F	损	笋	蓑	梭	唆	缩	琐	索	锁	所	塌	他	它	她	塔	

CC	0	1	2	3	4	5	6	7	8	9	A	B	C	D	E	F
A		濼	挞	踢	踏	胎	苔	抬	台	泰	猷	太	态	汰	坍	摊
B	贪	瘫	滩	坛	檀	痰	潭	谭	谈	坦	毯	袒	碳	探	叹	炭
C	汤	塘	糖	堂	棠	膛	唐	糖	倘	躺	淌	趟	烫	掏	涛	滔
D	绦	萄	桃	逃	淘	陶	讨	套	特	藤	腾	疼	誊	梯	剔	踢
E	绉	提	题	蹄	啼	体	替	嚏	惕	涕	剃	厝	天	添	填	田
F	甜	恬	舔	腆	挑	条	迢	眺	跳	贴	铁	帖	厅	听	炆	

CD	0	1	2	3	4	5	6	7	8	9	A	B	C	D	E	F
A		汀	廷	停	亭	庭	挺	艇	通	桐	酮	瞳	同	铜	彤	童
B	桶	捅	筒	统	痛	偷	投	头	透	凸	秃	突	图	徒	途	涂
C	属	土	吐	兔	湍	团	推	颓	腿	蜕	褪	退	吞	屯	臀	拖
D	托	脱	陀	驮	驼	橛	妥	拓	唾	挖	蛙	蛙	洼	娃	瓦	
E	袜	歪	外	腕	弯	湾	玩	顽	丸	烷	完	碗	挽	晚	皖	惋
F	宛	婉	万	腕	汪	王	亡	枉	网	往	旺	望	忘	妄	威	

CE	0	1	2	3	4	5	6	7	8	9	A	B	C	D	E	F
A		巍	微	危	韦	违	桅	围	唯	惟	为	潍	维	苇	萎	委
B	伟	伪	尾	纬	未	蔚	味	畏	胃	喂	魏	位	渭	谓	尉	慰
C	卫	瘟	温	蚊	文	闻	纹	吻	稳	紊	问	喻	翁	瓮	挝	蜗
D	祸	窝	我	斡	卧	握	沃	巫	呜	钨	乌	污	诬	屋	无	芜
E	梧	吾	吴	毋	武	五	梧	午	舞	伍	侮	坞	戊	雾	晤	物
F	勿	务	悟	误	昔	熙	析	西	晒	砂	晰	嘻	吸	锡	牺	

CF	0	1	2	3	4	5	6	7	8	9	A	B	C	D	E	F
A		稀	息	希	悉	膝	夕	惜	熄	烯	溪	沙	犀	橄	袭	席
B	习	媳	喜	铣	洗	系	隙	戏	细	瞎	虾	匣	霞	辖	暇	峡
C	侠	狭	下	厦	夏	吓	掀	掀	先	仙	鲜	纤	咸	贤	衔	舷
D	闲	涎	弦	嫌	显	险	现	献	县	腺	馅	羨	宪	陷	限	线
E	相	厢	镶	香	箱	襄	湘	乡	翔	祥	详	想	响	享	项	巷
F	橡	像	向	象	萧	硝	霄	削	哮	嚣	销	消	宵	淆	晓	

D0	0	1	2	3	4	5	6	7	8	9	A	B	C	D	E	F
A		小	孝	校	肖	啸	笑	效	楔	些	歇	蝎	鞋	协	挟	携
B	邪	斜	胁	谐	写	械	卸	蟹	懈	泄	泻	谢	屑	薪	芯	锌
C	欣	辛	新	忻	心	信	衅	腥	猩	惺	兴	刑	型	形	邢	
D	行	醒	幸	杏	性	姓	兄	凶	胸	匈	汹	雄	熊	休	修	羞
E	朽	嗅	锈	秀	袖	绣	墟	戌	需	虚	嘘	须	徐	许	蓄	酗
F	叙	旭	序	畜	恤	絮	婿	绪	续	轩	喧	宣	悬	旋	玄	

D1	0	1	2	3	4	5	6	7	8	9	A	B	C	D	E	F
A		选	癣	眩	绚	靴	薛	学	穴	雪	血	勋	熏	循	旬	询
B	寻	驯	巡	殉	汛	训	讯	逊	迅	压	押	鸦	鸭	呀	丫	芽
C	牙	蚜	崖	衙	涯	雅	哑	亚	讶	焉	咽	阍	烟	淹	盐	严
D	研	蜒	岩	延	言	颜	阎	炎	沿	奄	掩	眼	衍	演	艳	堰
E	燕	厌	砚	雁	唁	彦	焰	宴	谚	验	殃	央	鸯	秧	杨	扬
F	佯	疡	羊	洋	阳	氧	仰	痒	养	样	漾	邀	腰	妖	瑶	

D2	0	1	2	3	4	5	6	7	8	9	A	B	C	D	E	F
A		摇	尧	遥	窑	谣	姚	咬	舀	药	要	耀	椰	噎	耶	爷
B	野	冶	也	页	掖	业	叶	曳	腋	夜	液	一	壹	医	揖	铍
C	依	伊	衣	颐	夷	遗	移	仪	胰	疑	沂	宜	姨	彝	椅	蚁
D	倚	己	乙	矣	以	艺	抑	易	邑	屹	亿	役	臆	逸	肄	疫
E	亦	裔	意	毅	忆	义	益	溢	诣	议	谊	译	异	翼	翌	绎
F	茵	荫	因	殷	音	阴	姻	吟	银	淫	寅	饮	尹	引	隐	

D3	0	1	2	3	4	5	6	7	8	9	A	B	C	D	E	F
A		印	英	樱	婴	鹰	应	纓	莹	莹	营	荧	蝇	迎	赢	盈
B	影	颖	硬	映	哟	拥	佣	靡	痈	庸	雍	踊	蛹	咏	泳	涌
C	永	愚	勇	用	幽	优	悠	忧	尤	由	邮	铀	犹	油	游	酉
D	有	友	右	佑	釉	诱	又	幼	迂	淤	于	孟	榆	虞	愚	舆
E	余	俞	逾	鱼	愉	渝	渔	隅	予	娱	雨	与	屿	禹	宇	语
F	羽	玉	域	芋	郁	吁	遇	喻	峪	御	愈	欲	狱	育	誉	

D4	0	1	2	3	4	5	6	7	8	9	A	B	C	D	E	F
A		浴	寓	裕	预	豫	馭	鸳	渊	冤	元	垣	袁	原	援	辕
B	园	员	圆	猿	源	缘	远	苑	愿	怨	院	曰	约	越	跃	钥
C	岳	粤	月	悦	阅	耘	云	邗	匀	陨	允	运	蕴	酝	晕	韵
D	孕	匝	砸	杂	栽	哉	灾	宰	载	再	在	咱	攒	暂	赞	赃
E	脏	葬	遭	槽	凿	藻	枣	早	澡	蚤	躁	噪	造	皂	灶	燥
F	责	择	则	泽	贼	怎	增	憎	曾	赠	扎	喳	渣	札	轧	

D5	0	1	2	3	4	5	6	7	8	9	A	B	C	D	E	F
A		钢	闸	眨	栅	榨	咋	乍	炸	诈	摘	斋	宅	窄	债	寨
B	瞻	毡	詹	粘	沾	盏	斩	辗	崭	展	蘸	栈	占	战	站	湛
C	绽	樟	章	彰	漳	张	掌	涨	杖	丈	帐	账	仗	胀	瘴	障
D	招	昭	找	沼	赵	照	罩	兆	肇	召	遮	折	哲	蛰	辙	者
E	错	蔗	这	浙	珍	斟	真	甄	砧	臻	贞	针	侦	枕	疹	诊
F	震	振	镇	阵	蒸	挣	睁	征	净	争	怔	整	拯	正	政	

D6	0	1	2	3	4	5	6	7	8	9	A	B	C	D	E	F
A		帧	症	郑	证	芝	枝	支	吱	蜘	知	肢	脂	汁	之	织
B	职	直	植	殖	执	值	侄	址	指	止	趾	只	旨	纸	志	挚
C	掷	至	致	置	帜	峙	制	智	秩	稚	质	炙	痔	滞	治	窒
D	中	盅	忠	钟	衷	终	种	肿	重	仲	众	舟	周	州	洲	诒
E	粥	轴	肘	帚	咒	皱	宙	昼	骤	珠	株	蛛	朱	猪	诸	诛
F	逐	竹	烛	煮	拄	瞩	嘱	主	著	柱	助	蛀	贮	铸	筑	

D7	0	1	2	3	4	5	6	7	8	9	A	B	C	D	E	F
A		住	注	祝	驻	抓	爪	拽	专	砖	转	撰	赚	篆	桩	庄
B	装	妆	撞	壮	状	椎	锥	追	赘	坠	缀	諄	准	捉	拙	卓
C	桌	琢	茁	酌	啄	着	灼	浊	兹	咨	资	姿	滋	淄	孜	紫
D	仔	籽	滓	子	自	渍	字	髻	棕	踪	宗	综	总	纵	邹	走
E	奏	揍	租	足	卒	族	祖	诅	阻	组	钻	纂	嘴	醉	最	罪
F	尊	遵	昨	左	佐	柞	做	作	坐	座						

D8	0	1	2	3	4	5	6	7	8	9	A	B	C	D	E	F
A		亍	丌	兀	丐	廿	卅	丕	亘	丞	鬲	彝	罍	卮	禺	丌
B	匕	毛	夭	爻	危	氏	囟	胤	旭	毓	宰	黻	丿	亟	霰	乚
C	乚	亅	丰	李	耆	屮	厶	厶	厶	厶	厶	厶	厶	厶	厶	厶
D	匚	匚	匚	匚	匚	匚	匚	匚	匚	匚	匚	匚	匚	匚	匚	匚
E	剌	剌	剌	剌	剌	剌	剌	剌	剌	剌	剌	剌	剌	剌	剌	剌
F	仞	仞	仞	仞	仞	仞	仞	仞	仞	仞	仞	仞	仞	仞	仞	仞

D9	0	1	2	3	4	5	6	7	8	9	A	B	C	D	E	F
A		侏	佗	侏	伽	佶	佷	侑	侗	侃	侏	侑	佻	侑	佻	侑
B	侑	侑	伊	侑	侑	俚	俚	俚	侑	俚	俚	侑	侑	侑	侑	侑
C	侑	侑	侑	侑	侑	侑	侑	侑	侑	侑	侑	侑	侑	侑	侑	侑
D	侑	侑	侑	侑	侑	侑	侑	侑	侑	侑	侑	侑	侑	侑	侑	侑
E	侑	侑	侑	侑	侑	侑	侑	侑	侑	侑	侑	侑	侑	侑	侑	侑
F	侑	侑	侑	侑	侑	侑	侑	侑	侑	侑	侑	侑	侑	侑	侑	侑

DA	0	1	2	3	4	5	6	7	8	9	A	B	C	D	E	F
A		淞	冂	冂	冂	冂	冂	冂	冂	冂	冂	冂	冂	冂	冂	冂
B	讠	讠	讠	讠	讠	讠	讠	讠	讠	讠	讠	讠	讠	讠	讠	讠
C	讠	讠	讠	讠	讠	讠	讠	讠	讠	讠	讠	讠	讠	讠	讠	讠
D	讠	讠	讠	讠	讠	讠	讠	讠	讠	讠	讠	讠	讠	讠	讠	讠
E	冂	冂	冂	冂	冂	冂	冂	冂	冂	冂	冂	冂	冂	冂	冂	冂
F	冂	冂	冂	冂	冂	冂	冂	冂	冂	冂	冂	冂	冂	冂	冂	冂

DB	0	1	2	3	4	5	6	7	8	9	A	B	C	D	E	F
A		邨	邨	邨	邨	邨	邨	邨	邨	邨	邨	邨	邨	邨	邨	邨
B	邨	邨	邨	邨	邨	邨	邨	邨	邨	邨	邨	邨	邨	邨	邨	邨
C	邨	邨	邨	邨	邨	邨	邨	邨	邨	邨	邨	邨	邨	邨	邨	邨
D	邨	邨	邨	邨	邨	邨	邨	邨	邨	邨	邨	邨	邨	邨	邨	邨
E	邨	邨	邨	邨	邨	邨	邨	邨	邨	邨	邨	邨	邨	邨	邨	邨
F	邨	邨	邨	邨	邨	邨	邨	邨	邨	邨	邨	邨	邨	邨	邨	邨

DC	0	1	2	3	4	5	6	7	8	9	A	B	C	D	E	F
A		邨	邨	邨	邨	邨	邨	邨	邨	邨	邨	邨	邨	邨	邨	邨
B	邨	邨	邨	邨	邨	邨	邨	邨	邨	邨	邨	邨	邨	邨	邨	邨
C	邨	邨	邨	邨	邨	邨	邨	邨	邨	邨	邨	邨	邨	邨	邨	邨
D	邨	邨	邨	邨	邨	邨	邨	邨	邨	邨	邨	邨	邨	邨	邨	邨
E	邨	邨	邨	邨	邨	邨	邨	邨	邨	邨	邨	邨	邨	邨	邨	邨
F	邨	邨	邨	邨	邨	邨	邨	邨	邨	邨	邨	邨	邨	邨	邨	邨

DD	0	1	2	3	4	5	6	7	8	9	A	B	C	D	E	F
A		苐	苎	苏	苐	苑	苒	苓	苔	苕	苘	苒	苓	苔	苕	苖
B	苗	苘	苒	苓	苔	苕	苘	苒	苓	苔	苕	苘	苒	苓	苔	苕
C	苗	苘	苒	苓	苔	苕	苑	苒	苓	苔	苕	苑	苒	苓	苔	苕
D	苗	苘	苒	苓	苔	苕	苑	苒	苓	苔	苕	苑	苒	苓	苔	苕
E	苗	苘	苒	苓	苔	苕	苑	苒	苓	苔	苕	苑	苒	苓	苔	苕
F	苗	苘	苒	苓	苔	苕	苑	苒	苓	苔	苕	苑	苒	苓	苔	苕

DE	0	1	2	3	4	5	6	7	8	9	A	B	C	D	E	F
A		莧	莩	莪	莫	莬	莭	莮	莯	莰	莱	莲	莳	莴	莵	莶
B	获	莸	莹	莺	莻	莼	莽	莾	莿	莼	莽	莿	莼	莽	莿	莼
C	莿	莼	莽	莿	莼	莽	莿	莼	莽	莿	莼	莽	莿	莼	莽	莿
D	才	扌	扌	扌	扌	扌	扌	扌	扌	扌	扌	扌	扌	扌	扌	扌
E	扌	扌	扌	扌	扌	扌	扌	扌	扌	扌	扌	扌	扌	扌	扌	扌
F	扌	扌	扌	扌	扌	扌	扌	扌	扌	扌	扌	扌	扌	扌	扌	扌

DF	0	1	2	3	4	5	6	7	8	9	A	B	C	D	E	F
A		摺	摺	摺	摺	摺	摺	摺	摺	摺	摺	摺	摺	摺	弋	弋
B	弋	弋	弋	弋	弋	弋	弋	弋	弋	弋	弋	弋	弋	弋	弋	弋
C	呢	吡	吡	吡	吡	吡	吡	吡	吡	吡	吡	吡	吡	吡	吡	吡
D	啞	啞	啞	啞	啞	啞	啞	啞	啞	啞	啞	啞	啞	啞	啞	啞
E	啞	啞	啞	啞	啞	啞	啞	啞	啞	啞	啞	啞	啞	啞	啞	啞
F	啞	啞	啞	啞	啞	啞	啞	啞	啞	啞	啞	啞	啞	啞	啞	啞

EO	0	1	2	3	4	5	6	7	8	9	A	B	C	D	E	F
A		啞	啞	啞	啞	啞	啞	啞	啞	啞	啞	啞	啞	啞	啞	啞
B	啞	啞	啞	啞	啞	啞	啞	啞	啞	啞	啞	啞	啞	啞	啞	啞
C	啞	啞	啞	啞	啞	啞	啞	啞	啞	啞	啞	啞	啞	啞	啞	啞
D	啞	啞	啞	啞	啞	啞	啞	啞	啞	啞	啞	啞	啞	啞	啞	啞
E	啞	啞	啞	啞	啞	啞	啞	啞	啞	啞	啞	啞	啞	啞	啞	啞
F	啞	啞	啞	啞	啞	啞	啞	啞	啞	啞	啞	啞	啞	啞	啞	啞

E1	0	1	2	3	4	5	6	7	8	9	A	B	C	D	E	F
A		帷	幄	幔	幃	幙	幡	岌	岈	岙	岜	岝	岞	岠	岢	岑
B	岌	岍	岎	岏	岙	岜	岝	岞	岠	岢	岣	岤	岥	岧	岨	岫
C	岌	岍	岎	岏	岙	岜	岝	岞	岠	岢	岣	岤	岥	岧	岨	岫
D	岌	岍	岎	岏	岙	岜	岝	岞	岠	岢	岣	岤	岥	岧	岨	岫
E	徻	徼	徇	徙	徚	徛	徜	徝	從	徟	徠	徢	徣	徤	徥	徦
F	徻	徼	徇	徙	徚	徛	徜	徝	從	徟	徠	徢	徣	徤	徥	徦

E2	0	1	2	3	4	5	6	7	8	9	A	B	C	D	E	F
A		猓	猓	猓	猓	猓	猓	猓	猓	猓	猓	猓	猓	猓	猓	猓
B	猓	猓	猓	猓	猓	猓	猓	猓	猓	猓	猓	猓	猓	猓	猓	猓
C	猓	猓	猓	猓	猓	猓	猓	猓	猓	猓	猓	猓	猓	猓	猓	猓
D	猓	猓	猓	猓	猓	猓	猓	猓	猓	猓	猓	猓	猓	猓	猓	猓
E	猓	猓	猓	猓	猓	猓	猓	猓	猓	猓	猓	猓	猓	猓	猓	猓
F	猓	猓	猓	猓	猓	猓	猓	猓	猓	猓	猓	猓	猓	猓	猓	猓

E3	0	1	2	3	4	5	6	7	8	9	A	B	C	D	E	F
A		恹	恹	恹	恹	恹	恹	恹	恹	恹	恹	恹	恹	恹	恹	恹
B	恹	恹	恹	恹	恹	恹	恹	恹	恹	恹	恹	恹	恹	恹	恹	恹
C	恹	恹	恹	恹	恹	恹	恹	恹	恹	恹	恹	恹	恹	恹	恹	恹
D	恹	恹	恹	恹	恹	恹	恹	恹	恹	恹	恹	恹	恹	恹	恹	恹
E	恹	恹	恹	恹	恹	恹	恹	恹	恹	恹	恹	恹	恹	恹	恹	恹
F	恹	恹	恹	恹	恹	恹	恹	恹	恹	恹	恹	恹	恹	恹	恹	恹

E4	0	1	2	3	4	5	6	7	8	9	A	B	C	D	E	F
A		洄	洄	洄	洄	洄	洄	洄	洄	洄	洄	洄	洄	洄	洄	洄
B	洄	洄	洄	洄	洄	洄	洄	洄	洄	洄	洄	洄	洄	洄	洄	洄
C	洄	洄	洄	洄	洄	洄	洄	洄	洄	洄	洄	洄	洄	洄	洄	洄
D	洄	洄	洄	洄	洄	洄	洄	洄	洄	洄	洄	洄	洄	洄	洄	洄
E	洄	洄	洄	洄	洄	洄	洄	洄	洄	洄	洄	洄	洄	洄	洄	洄
F	洄	洄	洄	洄	洄	洄	洄	洄	洄	洄	洄	洄	洄	洄	洄	洄

E5	0	1	2	3	4	5	6	7	8	9	A	B	C	D	E	F
A		灑	灑	澹	澹	濂	濂	濂	濂	濂	灑	灑	灑	灑	灑	灑
B	灑	灑	宀	宀	宀	宀	宀	宀	宀	宀	寤	寤	寤	寤	寤	寤
C	寤	迨	迨	迨	迨	迨	迨	迨	迨	迨	迨	迨	迨	迨	迨	迨
D	迨	迨	迨	迨	迨	迨	迨	迨	迨	迨	迨	迨	迨	迨	迨	迨
E	迨	迨	迨	迨	迨	迨	迨	迨	迨	迨	迨	迨	迨	迨	迨	迨
F	迨	迨	迨	迨	迨	迨	迨	迨	迨	迨	迨	迨	迨	迨	迨	迨

E6	0	1	2	3	4	5	6	7	8	9	A	B	C	D	E	F
A		姪	姪	姪	姪	姪	姪	姪	姪	姪	姪	姪	姪	姪	姪	姪
B	姪	姪	姪	姪	姪	姪	姪	姪	姪	姪	姪	姪	姪	姪	姪	姪
C	姪	姪	姪	姪	姪	姪	姪	姪	姪	姪	姪	姪	姪	姪	姪	姪
D	姪	姪	姪	姪	姪	姪	姪	姪	姪	姪	姪	姪	姪	姪	姪	姪
E	姪	姪	姪	姪	姪	姪	姪	姪	姪	姪	姪	姪	姪	姪	姪	姪
F	姪	姪	姪	姪	姪	姪	姪	姪	姪	姪	姪	姪	姪	姪	姪	姪

E7	0	1	2	3	4	5	6	7	8	9	A	B	C	D	E	F
A		纒	纒	纒	纒	纒	纒	纒	纒	纒	纒	纒	纒	纒	纒	纒
B	纒	纒	纒	纒	纒	纒	纒	纒	纒	纒	纒	纒	纒	纒	纒	纒
C	纒	纒	纒	纒	纒	纒	纒	纒	纒	纒	纒	纒	纒	纒	纒	纒
D	纒	纒	纒	纒	纒	纒	纒	纒	纒	纒	纒	纒	纒	纒	纒	纒
E	玳	玳	玳	玳	玳	玳	玳	玳	玳	玳	玳	玳	玳	玳	玳	玳
F	玳	玳	玳	玳	玳	玳	玳	玳	玳	玳	玳	玳	玳	玳	玳	玳

E8	0	1	2	3	4	5	6	7	8	9	A	B	C	D	E	F
A		琛	琛	琛	琛	琛	琛	琛	琛	琛	琛	琛	琛	琛	琛	琛
B	琛	琛	琛	琛	琛	琛	琛	琛	琛	琛	琛	琛	琛	琛	琛	琛
C	楸	楸	楸	楸	楸	楸	楸	楸	楸	楸	楸	楸	楸	楸	楸	楸
D	楸	楸	楸	楸	楸	楸	楸	楸	楸	楸	楸	楸	楸	楸	楸	楸
E	楸	楸	楸	楸	楸	楸	楸	楸	楸	楸	楸	楸	楸	楸	楸	楸
F	楸	楸	楸	楸	楸	楸	楸	楸	楸	楸	楸	楸	楸	楸	楸	楸

E9	0	1	2	3	4	5	6	7	8	9	A	B	C	D	E	F
A		椶	椶	椶	椶	椶	椶	椶	椶	椶	椶	椶	椶	椶	椶	椶
B	渠	楸	楸	楸	楸	楸	楸	楸	楸	楸	楸	楸	楸	楸	楸	楸
C	楸	楸	楸	楸	楸	楸	楸	楸	楸	楸	楸	楸	楸	楸	楸	楸
D	楸	楸	楸	楸	楸	楸	楸	楸	楸	楸	楸	楸	楸	楸	楸	楸
E	猷	葵	殳	殳	殳	殳	殳	殳	殳	殳	殳	殳	殳	殳	殳	殳
F	軻	軻	軻	軻	軻	軻	軻	軻	軻	軻	軻	軻	軻	軻	軻	軻

EA	0	1	2	3	4	5	6	7	8	9	A	B	C	D	E	F
A		辶	辶	辶	辶	辶	辶	辶	辶	辶	辶	辶	辶	辶	辶	辶
B	臧	臧	臧	臧	臧	臧	臧	臧	臧	臧	臧	臧	臧	臧	臧	臧
C	臧	臧	臧	臧	臧	臧	臧	臧	臧	臧	臧	臧	臧	臧	臧	臧
D	臧	臧	臧	臧	臧	臧	臧	臧	臧	臧	臧	臧	臧	臧	臧	臧
E	臧	臧	臧	臧	臧	臧	臧	臧	臧	臧	臧	臧	臧	臧	臧	臧
F	臧	臧	臧	臧	臧	臧	臧	臧	臧	臧	臧	臧	臧	臧	臧	臧

EB	0	1	2	3	4	5	6	7	8	9	A	B	C	D	E	F
A		彳	彳	彳	彳	彳	彳	彳	彳	彳	彳	彳	彳	彳	彳	彳
B	彳	彳	彳	彳	彳	彳	彳	彳	彳	彳	彳	彳	彳	彳	彳	彳
C	彳	彳	彳	彳	彳	彳	彳	彳	彳	彳	彳	彳	彳	彳	彳	彳
D	彳	彳	彳	彳	彳	彳	彳	彳	彳	彳	彳	彳	彳	彳	彳	彳
E	彳	彳	彳	彳	彳	彳	彳	彳	彳	彳	彳	彳	彳	彳	彳	彳
F	彳	彳	彳	彳	彳	彳	彳	彳	彳	彳	彳	彳	彳	彳	彳	彳

EC	0	1	2	3	4	5	6	7	8	9	A	B	C	D	E	F
A		彳	彳	彳	彳	彳	彳	彳	彳	彳	彳	彳	彳	彳	彳	彳
B	彳	彳	彳	彳	彳	彳	彳	彳	彳	彳	彳	彳	彳	彳	彳	彳
C	彳	彳	彳	彳	彳	彳	彳	彳	彳	彳	彳	彳	彳	彳	彳	彳
D	彳	彳	彳	彳	彳	彳	彳	彳	彳	彳	彳	彳	彳	彳	彳	彳
E	彳	彳	彳	彳	彳	彳	彳	彳	彳	彳	彳	彳	彳	彳	彳	彳
F	彳	彳	彳	彳	彳	彳	彳	彳	彳	彳	彳	彳	彳	彳	彳	彳

ED	0	1	2	3	4	5	6	7	8	9	A	B	C	D	E	F
A		恣	恣	恚	恣	恣	恣	恣	恣	恣	恣	恣	恣	恣	恣	恣
B	瑟	聿	聿	聿	聿	聿	聿	聿	聿	聿	聿	聿	聿	聿	聿	聿
C	砧	砧	砧	砧	砧	砧	砧	砧	砧	砧	砧	砧	砧	砧	砧	砧
D	砧	砧	砧	砧	砧	砧	砧	砧	砧	砧	砧	砧	砧	砧	砧	砧
E	砧	砧	砧	砧	砧	砧	砧	砧	砧	砧	砧	砧	砧	砧	砧	砧
F	眇	眇	眇	眇	眇	眇	眇	眇	眇	眇	眇	眇	眇	眇	眇	眇

EE	0	1	2	3	4	5	6	7	8	9	A	B	C	D	E	F
A		睽	睽	睽	睽	睽	睽	睽	睽	睽	睽	睽	睽	睽	睽	睽
B	吠	吠	吠	吠	吠	吠	吠	吠	吠	吠	吠	吠	吠	吠	吠	吠
C	罍	罍	罍	罍	罍	罍	罍	罍	罍	罍	罍	罍	罍	罍	罍	罍
D	钗	钗	钗	钗	钗	钗	钗	钗	钗	钗	钗	钗	钗	钗	钗	钗
E	钗	钗	钗	钗	钗	钗	钗	钗	钗	钗	钗	钗	钗	钗	钗	钗
F	钗	钗	钗	钗	钗	钗	钗	钗	钗	钗	钗	钗	钗	钗	钗	钗

EF	0	1	2	3	4	5	6	7	8	9	A	B	C	D	E	F
A		铄	铄	铄	铄	铄	铄	铄	铄	铄	铄	铄	铄	铄	铄	铄
B	铄	铄	铄	铄	铄	铄	铄	铄	铄	铄	铄	铄	铄	铄	铄	铄
C	铄	铄	铄	铄	铄	铄	铄	铄	铄	铄	铄	铄	铄	铄	铄	铄
D	铄	铄	铄	铄	铄	铄	铄	铄	铄	铄	铄	铄	铄	铄	铄	铄
E	铄	铄	铄	铄	铄	铄	铄	铄	铄	铄	铄	铄	铄	铄	铄	铄
F	铄	铄	铄	铄	铄	铄	铄	铄	铄	铄	铄	铄	铄	铄	铄	铄

F0	0	1	2	3	4	5	6	7	8	9	A	B	C	D	E	F
A		稊	稊	稊	稊	稊	稊	稊	稊	稊	稊	稊	稊	稊	稊	稊
B	鸫	鸫	鸫	鸫	鸫	鸫	鸫	鸫	鸫	鸫	鸫	鸫	鸫	鸫	鸫	鸫
C	鸫	鸫	鸫	鸫	鸫	鸫	鸫	鸫	鸫	鸫	鸫	鸫	鸫	鸫	鸫	鸫
D	鸫	鸫	鸫	鸫	鸫	鸫	鸫	鸫	鸫	鸫	鸫	鸫	鸫	鸫	鸫	鸫
E	痲	痲	痲	痲	痲	痲	痲	痲	痲	痲	痲	痲	痲	痲	痲	痲
F	痧	痧	痧	痧	痧	痧	痧	痧	痧	痧	痧	痧	痧	痧	痧	痧

F1	0	1	2	3	4	5	6	7	8	9	A	B	C	D	E	F
A		瘵	瘵	瘵	瘵	瘵	瘵	瘵	瘵	瘵	瘵	瘵	瘵	瘵	瘵	瘵
B	瘵	瘵	瘵	瘵	瘵	瘵	瘵	瘵	瘵	瘵	瘵	瘵	瘵	瘵	瘵	瘵
C	褻	褻	褻	褻	褻	褻	褻	褻	褻	褻	褻	褻	褻	褻	褻	褻
D	褻	褻	褻	褻	褻	褻	褻	褻	褻	褻	褻	褻	褻	褻	褻	褻
E	褻	褻	褻	褻	褻	褻	褻	褻	褻	褻	褻	褻	褻	褻	褻	褻
F	褻	褻	褻	褻	褻	褻	褻	褻	褻	褻	褻	褻	褻	褻	褻	褻

F2	0	1	2	3	4	5	6	7	8	9	A	B	C	D	E	F
A		蛄	蛄	蛄	蛄	蛄	蛄	蛄	蛄	蛄	蛄	蛄	蛄	蛄	蛄	蛄
B	蛄	蛄	蛄	蛄	蛄	蛄	蛄	蛄	蛄	蛄	蛄	蛄	蛄	蛄	蛄	蛄
C	蛄	蛄	蛄	蛄	蛄	蛄	蛄	蛄	蛄	蛄	蛄	蛄	蛄	蛄	蛄	蛄
D	蛄	蛄	蛄	蛄	蛄	蛄	蛄	蛄	蛄	蛄	蛄	蛄	蛄	蛄	蛄	蛄
E	蛄	蛄	蛄	蛄	蛄	蛄	蛄	蛄	蛄	蛄	蛄	蛄	蛄	蛄	蛄	蛄
F	蛄	蛄	蛄	蛄	蛄	蛄	蛄	蛄	蛄	蛄	蛄	蛄	蛄	蛄	蛄	蛄

F3	0	1	2	3	4	5	6	7	8	9	A	B	C	D	E	F
A		蟻	蟻	蟻	蟻	蟻	蟻	蟻	蟻	蟻	蟻	蟻	蟻	蟻	蟻	蟻
B	蟻	蟻	蟻	蟻	蟻	蟻	蟻	蟻	蟻	蟻	蟻	蟻	蟻	蟻	蟻	蟻
C	蟻	蟻	蟻	蟻	蟻	蟻	蟻	蟻	蟻	蟻	蟻	蟻	蟻	蟻	蟻	蟻
D	蟻	蟻	蟻	蟻	蟻	蟻	蟻	蟻	蟻	蟻	蟻	蟻	蟻	蟻	蟻	蟻
E	蟻	蟻	蟻	蟻	蟻	蟻	蟻	蟻	蟻	蟻	蟻	蟻	蟻	蟻	蟻	蟻
F	蟻	蟻	蟻	蟻	蟻	蟻	蟻	蟻	蟻	蟻	蟻	蟻	蟻	蟻	蟻	蟻

F4	0	1	2	3	4	5	6	7	8	9	A	B	C	D	E	F
A		箆	箆	箆	箆	箆	箆	箆	箆	箆	箆	箆	箆	箆	箆	箆
B	箆	箆	箆	箆	箆	箆	箆	箆	箆	箆	箆	箆	箆	箆	箆	箆
C	箆	箆	箆	箆	箆	箆	箆	箆	箆	箆	箆	箆	箆	箆	箆	箆
D	箆	箆	箆	箆	箆	箆	箆	箆	箆	箆	箆	箆	箆	箆	箆	箆
E	箆	箆	箆	箆	箆	箆	箆	箆	箆	箆	箆	箆	箆	箆	箆	箆
F	箆	箆	箆	箆	箆	箆	箆	箆	箆	箆	箆	箆	箆	箆	箆	箆

F5	0	1	2	3	4	5	6	7	8	9	A	B	C	D	E	F
A		酢	醃	醜	醜	醜	醜	醜	醜	醜	醜	醜	醜	醜	醜	醜
B	醜	醜	醜	醜	醜	醜	醜	醜	醜	醜	醜	醜	醜	醜	醜	醜
C	躑	躑	躑	躑	躑	躑	躑	躑	躑	躑	躑	躑	躑	躑	躑	躑
D	躑	躑	躑	躑	躑	躑	躑	躑	躑	躑	躑	躑	躑	躑	躑	躑
E	躑	躑	躑	躑	躑	躑	躑	躑	躑	躑	躑	躑	躑	躑	躑	躑
F	躑	躑	躑	躑	躑	躑	躑	躑	躑	躑	躑	躑	躑	躑	躑	躑

F6	0	1	2	3	4	5	6	7	8	9	A	B	C	D	E	F
A		觥	觥	觥	觥	觥	觥	觥	觥	觥	觥	觥	觥	觥	觥	觥
B	觥	觥	觥	觥	觥	觥	觥	觥	觥	觥	觥	觥	觥	觥	觥	觥
C	觥	觥	觥	觥	觥	觥	觥	觥	觥	觥	觥	觥	觥	觥	觥	觥
D	觥	觥	觥	觥	觥	觥	觥	觥	觥	觥	觥	觥	觥	觥	觥	觥
E	觥	觥	觥	觥	觥	觥	觥	觥	觥	觥	觥	觥	觥	觥	觥	觥
F	觥	觥	觥	觥	觥	觥	觥	觥	觥	觥	觥	觥	觥	觥	觥	觥

F7	0	1	2	3	4	5	6	7	8	9	A	B	C	D	E	F
A		鯨	鯨	鯨	鯨	鯨	鯨	鯨	鯨	鯨	鯨	鯨	鯨	鯨	鯨	鯨
B	鯨	鯨	鯨	鯨	鯨	鯨	鯨	鯨	鯨	鯨	鯨	鯨	鯨	鯨	鯨	鯨
C	鯨	鯨	鯨	鯨	鯨	鯨	鯨	鯨	鯨	鯨	鯨	鯨	鯨	鯨	鯨	鯨
D	鯨	鯨	鯨	鯨	鯨	鯨	鯨	鯨	鯨	鯨	鯨	鯨	鯨	鯨	鯨	鯨
E	鯨	鯨	鯨	鯨	鯨	鯨	鯨	鯨	鯨	鯨	鯨	鯨	鯨	鯨	鯨	鯨
F	鯨	鯨	鯨	鯨	鯨	鯨	鯨	鯨	鯨	鯨	鯨	鯨	鯨	鯨	鯨	鯨

Appendix D. S-JIS Font Code Table

JIS	SJIS	字
2121	8140	
2122	8141	、
2123	8142	。
2124	8143	、
2125	8144	・
2126	8145	・
2127	8146	:
2128	8147	;
2129	8148	?
212A	8149	!
212B	814A	˘
212C	814B	°
212D	814C	´
212E	814D	‘
212F	814E	”
2130	814F	ˆ
2131	8150	—
2132	8151	—
2133	8152	˘
2134	8153	˘
2135	8154	˘
2136	8155	˘
2137	8156	//
2138	8157	全
2139	8158	々
213A	8159	↗
213B	815A	○
213C	815B	—
213D	815C	—
213E	815D	-
213F	815E	/
2140	815F	\
2141	8160	~
2142	8161	
2143	8162	
2144	8163	...

JIS	SJIS	字
2145	8164	..
2146	8165	‘
2147	8166	’
2148	8167	“
2149	8168	”
214A	8169	(
214B	816A)
214C	816B	[
214D	816C]
214E	816D	[
214F	816E]
2150	816F	{
2151	8170	}
2152	8171	<
2153	8172	>
2154	8173	《
2155	8174	》
2156	8175	「
2157	8176	」
2158	8177	『
2159	8178	』
215A	8179	【
215B	817A	】
215C	817B	+
215D	817C	-
215E	817D	±
215F	817E	×
2160	8180	÷
2161	8181	=
2162	8182	≠
2163	8183	<
2164	8184	>
2165	8185	≦
2166	8186	≧
2167	8187	∞
2168	8188	∴

JIS	SJIS	字
2169	8189	♂
216A	818A	♀
216B	818B	°
216C	818C	’
216D	818D	”
216E	818E	℃
216F	818F	¥
2170	8190	\$
2171	8191	¢
2172	8192	£
2173	8193	%
2174	8194	#
2175	8195	&
2176	8196	*
2177	8197	@
2178	8198	§
2179	8199	☆
217A	819A	★
217B	819B	◦
217C	819C	●
217D	819D	◎
217E	819E	◇
2221	819F	◆
2222	81A0	□
2223	81A1	■
2224	81A2	△
2225	81A3	▲
2226	81A4	▽
2227	81A5	▼
2228	81A6	※
2229	81A7	〒
222A	81A8	→
222B	81A9	←
222C	81AA	↑
222D	81AB	↓
222E	81AC	＝

JIS	SJIS	字
222F	81AD	
2230	81AE	
2231	81AF	
2232	81B0	
2233	81B1	
2234	81B2	
2235	81B3	
2236	81B4	
2237	81B5	
2238	81B6	
2239	81B7	
223A	81B8	€
223B	81B9	⇒
223C	81BA	⇐
223D	81BB	⇔
223E	81BC	↷
223F	81BD	↶
2240	81BE	∪
2241	81BF	∩
2242	81C0	
2243	81C1	
2244	81C2	
2245	81C3	
2246	81C4	
2247	81C5	
2248	81C6	
2249	81C7	
224A	81C8	↵
224B	81C9	↷
224C	81CA	↶
224D	81CB	⇒
224E	81CC	⇔
224F	81CD	↷
2250	81CE	⇔
2251	81CF	
2252	81D0	

JIS	SJIS	字
2253	81D1	
2254	81D2	
2255	81D3	
2256	81D4	
2257	81D5	
2258	81D6	
2259	81D7	
225A	81D8	
225B	81D9	
225C	81DA	∠
225D	81DB	⊥
225E	81DC	∩
225F	81DD	∅
2260	81DE	▽
2261	81DF	≡
2262	81E0	≡
2263	81E1	⏪
2264	81E2	⏩
2265	81E3	√
2266	81E4	∞
2267	81E5	∞
2268	81E6	∴
2269	81E7	∫
226A	81E8	∫
226B	81E9	
226C	81EA	
226D	81EB	
226E	81EC	
226F	81ED	
2270	81EE	
2271	81EF	
2272	81F0	Å
2273	81F1	‰
2274	81F2	#
2275	81F3	♭
2276	81F4	♪

JIS	SJIS	字
2277	81F5	†
2278	81F6	‡
2279	81F7	¶
227A	81F8	
227B	81F9	
227C	81FA	
227D	81FB	
227E	81FC	○
2321	8240	
2322	8241	
2323	8242	
2324	8243	
2325	8244	
2326	8245	
2327	8246	
2328	8247	
2329	8248	
232A	8249	
232B	824A	
232C	824B	
232D	824C	
232E	824D	
232F	824E	
2330	824F	0
2331	8250	1
2332	8251	2
2333	8252	3
2334	8253	4
2335	8254	5
2336	8255	6
2337	8256	7
2338	8257	8
2339	8258	9
233A	8259	
233B	825A	
233C	825B	

JIS	SJIS	字
233D	825C	
233E	825D	
233F	825E	
2340	825F	
2341	8260	A
2342	8261	B
2343	8262	C
2344	8263	D
2345	8264	E
2346	8265	F
2347	8266	G
2348	8267	H
2349	8268	I
234A	8269	J
234B	826A	K
234C	826B	L
234D	826C	M
234E	826D	N
234F	826E	O
2350	826F	P
2351	8270	Q
2352	8271	R
2353	8272	S
2354	8273	T
2355	8274	U
2356	8275	V
2357	8276	W
2358	8277	X
2359	8278	Y
235A	8279	Z
235B	827A	
235C	827B	
235D	827C	
235E	827D	
235F	827E	
2360	8280	

JIS	SJIS	字
2361	8281	a
2362	8282	b
2363	8283	c
2364	8284	d
2365	8285	e
2366	8286	f
2367	8287	g
2368	8288	h
2369	8289	i
236A	828A	j
236B	828B	k
236C	828C	l
236D	828D	m
236E	828E	n
236F	828F	o
2370	8290	p
2371	8291	q
2372	8292	r
2373	8293	s
2374	8294	t
2375	8295	u
2376	8296	v
2377	8297	w
2378	8298	x
2379	8299	y
237A	829A	z
237B	829B	
237C	829C	
237D	829D	
237E	829E	
2421	829F	あ
2422	82A0	あ
2423	82A1	い
2424	82A2	い
2425	82A3	う
2426	82A4	う

JIS	SJIS	字
2427	82A5	え
2428	82A6	え
2429	82A7	お
242A	82A8	お
242B	82A9	か
242C	82AA	が
242D	82AB	き
242E	82AC	ぎ
242F	82AD	く
2430	82AE	ぐ
2431	82AF	け
2432	82B0	げ
2433	82B1	こ
2434	82B2	ご
2435	82B3	さ
2436	82B4	ざ
2437	82B5	し
2438	82B6	じ
2439	82B7	す
243A	82B8	ず
243B	82B9	せ
243C	82BA	ぜ
243D	82BB	そ
243E	82BC	ぞ
243F	82BD	た
2440	82BE	だ
2441	82BF	ち
2442	82C0	ぢ
2443	82C1	っ
2444	82C2	っ
2445	82C3	づ
2446	82C4	て
2447	82C5	で
2448	82C6	と
2449	82C7	ど
244A	82C8	な

JIS	SJIS	字
244B	82C9	に
244C	82CA	ぬ
244D	82CB	ね
244E	82CC	の
244F	82CD	は
2450	82CE	ば
2451	82CF	ば
2452	82D0	ひ
2453	82D1	び
2454	82D2	び
2455	82D3	ふ
2456	82D4	ぶ
2457	82D5	ぷ
2458	82D6	へ
2459	82D7	べ
245A	82D8	ぺ
245B	82D9	ほ
245C	82DA	ぼ
245D	82DB	ぼ
245E	82DC	ま
245F	82DD	み
2460	82DE	む
2461	82DF	め
2462	82E0	も
2463	82E1	ゃ
2464	82E2	ゃ
2465	82E3	ゅ
2466	82E4	ゅ
2467	82E5	よ
2468	82E6	よ
2469	82E7	ら
246A	82E8	り
246B	82E9	る
246C	82EA	れ
246D	82EB	ろ
246E	82EC	わ

JIS	SJIS	字
246F	82ED	わ
2470	82EE	ゐ
2471	82EF	ゑ
2472	82F0	を
2473	82F1	ん
2474	82F2	
2475	82F3	
2476	82F4	
2477	82F5	
2478	82F6	
2479	82F7	
247A	82F8	
247B	82F9	
247C	82FA	
247D	82FB	
247E	82FC	
2521	8340	ア
2522	8341	ア
2523	8342	イ
2524	8343	イ
2525	8344	ウ
2526	8345	ウ
2527	8346	エ
2528	8347	エ
2529	8348	オ
252A	8349	オ
252B	834A	カ
252C	834B	ガ
252D	834C	キ
252E	834D	ギ
252F	834E	ク
2530	834F	グ
2531	8350	ケ
2532	8351	ゲ
2533	8352	コ
2534	8353	ゴ

JIS	SJIS	字
2535	8354	サ
2536	8355	ザ
2537	8356	シ
2538	8357	ジ
2539	8358	ス
253A	8359	ズ
253B	835A	セ
253C	835B	ゼ
253D	835C	ソ
253E	835D	ゾ
253F	835E	タ
2540	835F	ダ
2541	8360	チ
2542	8361	ヂ
2543	8362	ッ
2544	8363	ツ
2545	8364	ヅ
2546	8365	テ
2547	8366	デ
2548	8367	ト
2549	8368	ド
254A	8369	ナ
254B	836A	ニ
254C	836B	ヌ
254D	836C	ネ
254E	836D	ノ
254F	836E	ハ
2550	836F	バ
2551	8370	パ
2552	8371	ヒ
2553	8372	ビ
2554	8373	ピ
2555	8374	フ
2556	8375	ブ
2557	8376	プ
2558	8377	ヘ

JIS	SJIS	字
2559	8378	ベ
255A	8379	ペ
255B	837A	ホ
255C	837B	ボ
255D	837C	ポ
255E	837D	マ
255F	837E	ミ
2560	8380	ム
2561	8381	メ
2562	8382	モ
2563	8383	ヤ
2564	8384	ャ
2565	8385	ユ
2566	8386	ュ
2567	8387	ヨ
2568	8388	ョ
2569	8389	ラ
256A	838A	リ
256B	838B	ル
256C	838C	レ
256D	838D	ロ
256E	838E	ワ
256F	838F	ヰ
2570	8390	キ
2571	8391	ヱ
2572	8392	ヲ
2573	8393	ン
2574	8394	ヴ
2575	8395	カ
2576	8396	ケ
2577	8397	
2578	8398	
2579	8399	
257A	839A	
257B	839B	
257C	839C	

JIS	SJIS	字
257D	839D	
257E	839E	
2621	839F	A
2622	83A0	B
2623	83A1	Γ
2624	83A2	Δ
2625	83A3	E
2626	83A4	Z
2627	83A5	H
2628	83A6	Θ
2629	83A7	I
262A	83A8	K
262B	83A9	Λ
262C	83AA	M
262D	83AB	N
262E	83AC	Ξ
262F	83AD	O
2630	83AE	Π
2631	83AF	P
2632	83B0	Σ
2633	83B1	T
2634	83B2	Υ
2635	83B3	Φ
2636	83B4	X
2637	83B5	Ψ
2638	83B6	Ω
2639	83B7	
263A	83B8	
263B	83B9	
263C	83BA	
263D	83BB	
263E	83BC	
263F	83BD	
2640	83BE	
2641	83BF	α
2642	83C0	β

JIS	SJIS	字
2643	83C1	γ
2644	83C2	δ
2645	83C3	ε
2646	83C4	ζ
2647	83C5	η
2648	83C6	θ
2649	83C7	ι
264A	83C8	κ
264B	83C9	λ
264C	83CA	μ
264D	83CB	ν
264E	83CC	ξ
264F	83CD	ο
2650	83CE	π
2651	83CF	ρ
2652	83D0	σ
2653	83D1	τ
2654	83D2	υ
2655	83D3	φ
2656	83D4	χ
2657	83D5	ψ
2658	83D6	ω
2659	83D7	
265A	83D8	
265B	83D9	
265C	83DA	
265D	83DB	
265E	83DC	
265F	83DD	
2660	83DE	
2661	83DF	
2662	83E0	
2663	83E1	
2664	83E2	
2665	83E3	
2666	83E4	

JIS	SJIS	字
2667	83E5	
2668	83E6	
2669	83E7	
266A	83E8	
266B	83E9	
266C	83EA	
266D	83EB	
266E	83EC	
266F	83ED	
2670	83EE	
2671	83EF	
2672	83F0	
2673	83F1	
2674	83F2	
2675	83F3	
2676	83F4	
2677	83F5	
2678	83F6	
2679	83F7	
267A	83F8	
267B	83F9	
267C	83FA	
267D	83FB	
267E	83FC	
2721	8440	A
2722	8441	Б
2723	8442	B
2724	8443	Г
2725	8444	Д
2726	8445	E
2727	8446	Ё
2728	8447	Ж
2729	8448	З
272A	8449	И
272B	844A	Й
272C	844B	К

JIS	SJIS	字
272D	844C	Л
272E	844D	М
272F	844E	Н
2730	844F	О
2731	8450	П
2732	8451	Р
2733	8452	С
2734	8453	Т
2735	8454	У
2736	8455	Ф
2737	8456	Х
2738	8457	Ц
2739	8458	Ч
273A	8459	Ш
273B	845A	Щ
273C	845B	Ъ
273D	845C	Ы
273E	845D	Ь
273F	845E	Э
2740	845F	Ю
2741	8460	Я
2742	8461	
2743	8462	
2744	8463	
2745	8464	
2746	8465	
2747	8466	
2748	8467	
2749	8468	
274A	8469	
274B	846A	
274C	846B	
274D	846C	
274E	846D	
274F	846E	
2750	846F	

JIS	SJIS	字
2751	8470	а
2752	8471	б
2753	8472	в
2754	8473	г
2755	8474	д
2756	8475	е
2757	8476	ё
2758	8477	ж
2759	8478	з
275A	8479	и
275B	847A	й
275C	847B	к
275D	847C	л
275E	847D	м
275F	847E	н
2760	8480	о
2761	8481	п
2762	8482	р
2763	8483	с
2764	8484	т
2765	8485	у
2766	8486	ф
2767	8487	х
2768	8488	ц
2769	8489	ч
276A	848A	ш
276B	848B	щ
276C	848C	ъ
276D	848D	ы
276E	848E	ь
276F	848F	э
2770	8490	ю
2771	8491	я
2772	8492	
2773	8493	
2774	8494	

JIS	SJIS	字
2775	8495	
2776	8496	
2777	8497	
2778	8498	
2779	8499	
277A	849A	
277B	849B	
277C	849C	
277D	849D	
277E	849E	
2821	849F	—
2822	84A0	
2823	84A1	┌
2824	84A2	└
2825	84A3	┐
2826	84A4	┘
2827	84A5	┌
2828	84A6	└
2829	84A7	┐
282A	84A8	┘
282B	84A9	┌
282C	84AA	—
282D	84AB	
282E	84AC	┌
282F	84AD	└
2830	84AE	┐
2831	84AF	┘
2832	84B0	┌
2833	84B1	└
2834	84B2	┐
2835	84B3	┘
2836	84B4	┌
2837	84B5	└
2838	84B6	┐
2839	84B7	┘
283A	84B8	┌

JIS	SJIS	字
283B	84B9	┐
283C	84BA	┘
283D	84BB	└
283E	84BC	┌
283F	84BD	┘
2840	84BE	┌
2841	84BF	
2842	84C0	
2843	84C1	
2844	84C2	
2845	84C3	
2846	84C4	
2847	84C5	
2848	84C6	
2849	84C7	
284A	84C8	
284B	84C9	
284C	84CA	
284D	84CB	
284E	84CC	
284F	84CD	
2850	84CE	
2851	84CF	
2852	84D0	
2853	84D1	
2854	84D2	
2855	84D3	
2856	84D4	
2857	84D5	
2858	84D6	
2859	84D7	
285A	84D8	
285B	84D9	
285C	84DA	
285D	84DB	
285E	84DC	

JIS	SJIS	字
285F	84DD	
2860	84DE	
2861	84DF	
2862	84E0	
2863	84E1	
2864	84E2	
2865	84E3	
2866	84E4	
2867	84E5	
2868	84E6	
2869	84E7	
286A	84E8	
286B	84E9	
286C	84EA	
286D	84EB	
286E	84EC	
286F	84ED	
2870	84EE	
2871	84EF	
2872	84F0	
2873	84F1	
2874	84F2	
2875	84F3	
2876	84F4	
2877	84F5	
2878	84F6	
2879	84F7	
287A	84F8	
287B	84F9	
287C	84FA	
287D	84FB	
287E	84FC	
2921	8540	!
2922	8541	"
2923	8542	#
2924	8543	\$

JIS	SJIS	字
2925	8544	%
2926	8545	&
2927	8546	'
2928	8547	(
2929	8548)
292A	8549	*
292B	854A	+
292C	854B	,
292D	854C	-
292E	854D	.
292F	854E	/
2930	854F	0
2931	8550	1
2932	8551	2
2933	8552	3
2934	8553	4
2935	8554	5
2936	8555	6
2937	8556	7
2938	8557	8
2939	8558	9
293A	8559	:
293B	855A	;
293C	855B	<
293D	855C	=
293E	855D	>
293F	855E	?
2940	855F	@
2941	8560	A
2942	8561	B
2943	8562	C
2944	8563	D
2945	8564	E
2946	8565	F
2947	8566	G
2948	8567	H

JIS	SJIS	字
2949	8568	I
294A	8569	J
294B	856A	K
294C	856B	L
294D	856C	M
294E	856D	N
294F	856E	O
2950	856F	P
2951	8570	Q
2952	8571	R
2953	8572	S
2954	8573	T
2955	8574	U
2956	8575	V
2957	8576	W
2958	8577	X
2959	8578	Y
295A	8579	Z
295B	857A	[
295C	857B	¥
295D	857C]
295E	857D	^
295F	857E	_
2960	8580	`
2961	8581	a
2962	8582	b
2963	8583	c
2964	8584	d
2965	8585	e
2966	8586	f
2967	8587	g
2968	8588	h
2969	8589	i
296A	858A	j
296B	858B	k
296C	858C	l

JIS	SJIS	字
296D	858D	m
296E	858E	n
296F	858F	o
2970	8590	p
2971	8591	q
2972	8592	r
2973	8593	s
2974	8594	t
2975	8595	u
2976	8596	v
2977	8597	w
2978	8598	x
2979	8599	y
297A	859A	z
297B	859B	{
297C	859C	
297D	859D	}
297E	859E	~
2A21	859F	。
2A22	85A0	「
2A23	85A1	」
2A24	85A2	、
2A25	85A3	・
2A26	85A4	ヲ
2A27	85A5	ァ
2A28	85A6	ィ
2A29	85A7	ゥ
2A2A	85A8	ヱ
2A2B	85A9	ォ
2A2C	85AA	ャ
2A2D	85AB	ヰ
2A2E	85AC	ヨ
2A2F	85AD	ッ
2A30	85AE	ー
2A31	85AF	ヾ
2A32	85B0	ィ

JIS	SJIS	字
2A33	85B1	ウ
2A34	85B2	エ
2A35	85B3	オ
2A36	85B4	カ
2A37	85B5	キ
2A38	85B6	ク
2A39	85B7	ケ
2A3A	85B8	コ
2A3B	85B9	サ
2A3C	85BA	シ
2A3D	85BB	ス
2A3E	85BC	セ
2A3F	85BD	ソ
2A40	85BE	タ
2A41	85BF	チ
2A42	85C0	ツ
2A43	85C1	テ
2A44	85C2	ト
2A45	85C3	ナ
2A46	85C4	ニ
2A47	85C5	ヌ
2A48	85C6	ネ
2A49	85C7	ノ
2A4A	85C8	ハ
2A4B	85C9	ヒ
2A4C	85CA	フ
2A4D	85CB	ヘ
2A4E	85CC	ホ
2A4F	85CD	マ
2A50	85CE	ミ
2A51	85CF	ム
2A52	85D0	メ
2A53	85D1	モ
2A54	85D2	ヤ
2A55	85D3	ユ
2A56	85D4	ヨ

JIS	SJIS	字
2A57	85D5	ラ
2A58	85D6	リ
2A59	85D7	ル
2A5A	85D8	レ
2A5B	85D9	ロ
2A5C	85DA	ワ
2A5D	85DB	ン
2A5E	85DC	ゝ
2A5F	85DD	゜
2A60	85DE	キ
2A61	85DF	エ
2A62	85E0	ワ
2A63	85E1	カ
2A64	85E2	ケ
2A65	85E3	ヴ
2A66	85E4	ガ
2A67	85E5	ギ
2A68	85E6	グ
2A69	85E7	ゲ
2A6A	85E8	ゴ
2A6B	85E9	ザ
2A6C	85EA	ジ
2A6D	85EB	ズ
2A6E	85EC	ゼ
2A6F	85ED	ゾ
2A70	85EE	ダ
2A71	85EF	ヂ
2A72	85F0	ヅ
2A73	85F1	デ
2A74	85F2	ド
2A75	85F3	バ
2A76	85F4	パ
2A77	85F5	ピ
2A78	85F6	ピ
2A79	85F7	ブ
2A7A	85F8	ブ

JIS	SJIS	字
2A7B	85F9	ベ
2A7C	85FA	ペ
2A7D	85FB	ボ
2A7E	85FC	ポ
2D21	8740	①
2D22	8741	②
2D23	8742	③
2D24	8743	④
2D25	8744	⑤
2D26	8745	⑥
2D27	8746	⑦
2D28	8747	⑧
2D29	8748	⑨
2D2A	8749	⑩
2D2B	874A	⑪
2D2C	874B	⑫
2D2D	874C	⑬
2D2E	874D	⑭
2D2F	874E	⑮
2D30	874F	⑯
2D31	8750	⑰
2D32	8751	⑱
2D33	8752	⑲
2D34	8753	⑳
2D35	8754	I
2D36	8755	II
2D37	8756	III
2D38	8757	IV
2D39	8758	V
2D3A	8759	VI
2D3B	875A	VII
2D3C	875B	VIII
2D3D	875C	IX
2D3E	875D	X
2D3F	875E	・
2D40	875F	ミ

JIS	SJIS	字
2D41	8760	キ
2D42	8761	セン
2D43	8762	メル
2D44	8763	グラム
2D45	8764	トン
2D46	8765	アール
2D47	8766	ヘクタール
2D48	8767	リットル
2D49	8768	ワット
2D4A	8769	カリ
2D4B	876A	ドル
2D4C	876B	セント
2D4D	876C	パーセント
2D4E	876D	ミリバル
2D4F	876E	ページ
2D50	876F	mm
2D51	8770	cm
2D52	8771	km
2D53	8772	mg
2D54	8773	kg
2D55	8774	cc
2D56	8775	m ³
2D57	8776	
2D58	8777	
2D59	8778	
2D5A	8779	
2D5B	877A	
2D5C	877B	
2D5D	877C	
2D5E	877D	
2D5F	877E	平成
2D60	8780	々
2D61	8781	//
2D62	8782	№
2D63	8783	KK
2D64	8784	Tel

JIS	SJIS	字
2D65	8785	㊤
2D66	8786	㊦
2D67	8787	㊧
2D68	8788	㊨
2D69	8789	㊩
2D6A	878A	株
2D6B	878B	有
2D6C	878C	代
2D6D	878D	聯
2D6E	878E	証
2D6F	878F	聯
2D70	8790	≡
2D71	8791	≡
2D72	8792	∫
2D73	8793	ℳ
2D74	8794	Σ
2D75	8795	√
2D76	8796	⊥
2D77	8797	∠
2D78	8798	⊥
2D79	8799	△
2D7A	879A	∴
2D7B	879B	∩
2D7C	879C	∪
2D7D	879D	
2D7E	879E	
2E21	879F	!
2E22	87A0	"
2E23	87A1	#
2E24	87A2	\$
2E25	87A3	%
2E26	87A4	&
2E27	87A5	'
2E28	87A6	(
2E29	87A7)
2E2A	87A8	*

JIS	SJIS	字
2E2B	87A9	+
2E2C	87AA	,
2E2D	87AB	-
2E2E	87AC	.
2E2F	87AD	/
2E30	87AE	0
2E31	87AF	1
2E32	87B0	2
2E33	87B1	3
2E34	87B2	4
2E35	87B3	5
2E36	87B4	6
2E37	87B5	7
2E38	87B6	8
2E39	87B7	9
2E3A	87B8	:
2E3B	87B9	;
2E3C	87BA	<
2E3D	87BB	=
2E3E	87BC	>
2E3F	87BD	?
2E40	87BE	@
2E41	87BF	A
2E42	87C0	B
2E43	87C1	C
2E44	87C2	D
2E45	87C3	E
2E46	87C4	F
2E47	87C5	G
2E48	87C6	H
2E49	87C7	I
2E4A	87C8	J
2E4B	87C9	K
2E4C	87CA	L
2E4D	87CB	M
2E4E	87CC	N

JIS	SJIS	字
2E4F	87CD	O
2E50	87CE	P
2E51	87CF	Q
2E52	87D0	R
2E53	87D1	S
2E54	87D2	T
2E55	87D3	U
2E56	87D4	V
2E57	87D5	W
2E58	87D6	X
2E59	87D7	Y
2E5A	87D8	Z
2E5B	87D9	[
2E5C	87DA	¥
2E5D	87DB]
2E5E	87DC	^
2E5F	87DD	_
2E60	87DE	`
2E61	87DF	a
2E62	87E0	b
2E63	87E1	c
2E64	87E2	d
2E65	87E3	e
2E66	87E4	f
2E67	87E5	g
2E68	87E6	h
2E69	87E7	i
2E6A	87E8	j
2E6B	87E9	k
2E6C	87EA	l
2E6D	87EB	m
2E6E	87EC	n
2E6F	87ED	o
2E70	87EE	p
2E71	87EF	q
2E72	87F0	r

JIS	SJIS	字
2E73	87F1	S
2E74	87F2	T
2E75	87F3	U
2E76	87F4	V
2E77	87F5	W
2E78	87F6	X
2E79	87F7	Y
2E7A	87F8	Z
2E7B	87F9	{
2E7C	87FA	
2E7D	87FB	}
2E7E	87FC	-
2F21	8840	。
2F22	8841	「
2F23	8842	」
2F24	8843	、
2F25	8844	・
2F26	8845	フ
2F27	8846	ア
2F28	8847	イ
2F29	8848	ウ
2F2A	8849	エ
2F2B	884A	オ
2F2C	884B	カ
2F2D	884C	キ
2F2E	884D	ク
2F2F	884E	ケ
2F30	884F	コ
2F31	8850	カ
2F32	8851	キ
2F33	8852	ク
2F34	8853	ケ
2F35	8854	コ
2F36	8855	カ
2F37	8856	キ
2F38	8857	ク

JIS	SJIS	字
2F39	8858	ケ
2F3A	8859	コ
2F3B	885A	サ
2F3C	885B	シ
2F3D	885C	ス
2F3E	885D	セ
2F3F	885E	ソ
2F40	885F	タ
2F41	8860	チ
2F42	8861	ツ
2F43	8862	テ
2F44	8863	ト
2F45	8864	ナ
2F46	8865	ニ
2F47	8866	ヌ
2F48	8867	ネ
2F49	8868	ノ
2F4A	8869	ハ
2F4B	886A	ヒ
2F4C	886B	フ
2F4D	886C	ハ
2F4E	886D	ホ
2F4F	886E	マ
2F50	886F	ミ
2F51	8870	ム
2F52	8871	メ
2F53	8872	モ
2F54	8873	ヤ
2F55	8874	ユ
2F56	8875	ヨ
2F57	8876	ラ
2F58	8877	リ
2F59	8878	ル
2F5A	8879	レ
2F5B	887A	ロ
2F5C	887B	ワ

JIS	SJIS	字
2F5D	887C	ソ
2F5E	887D	ゝ
2F5F	887E	。
2F60	8880	キ
2F61	8881	エ
2F62	8882	ワ
2F63	8883	カ
2F64	8884	ケ
2F65	8885	ヴ
2F66	8886	ガ
2F67	8887	ギ
2F68	8888	グ
2F69	8889	ゲ
2F6A	888A	ゴ
2F6B	888B	ザ
2F6C	888C	ジ
2F6D	888D	ズ
2F6E	888E	ゼ
2F6F	888F	ゾ
2F70	8890	ダ
2F71	8891	ヂ
2F72	8892	ヅ
2F73	8893	デ
2F74	8894	ド
2F75	8895	バ
2F76	8896	パ
2F77	8897	ビ
2F78	8898	ピ
2F79	8899	ブ
2F7A	889A	プ
2F7B	889B	ベ
2F7C	889C	ペ
2F7D	889D	ボ
2F7E	889E	ボ
3021	889F	垂
3022	88A0	唾

JIS	SJIS	字
3023	88A1	娃
3024	88A2	阿
3025	88A3	哀
3026	88A4	愛
3027	88A5	挨
3028	88A6	始
3029	88A7	逢
302A	88A8	葵
302B	88A9	茜
302C	88AA	穉
302D	88AB	悪
302E	88AC	握
302F	88AD	渥
3030	88AE	旭
3031	88AF	葦
3032	88B0	芦
3033	88B1	鯨
3034	88B2	梓
3035	88B3	圧
3036	88B4	幹
3037	88B5	扱
3038	88B6	宛
3039	88B7	姐
303A	88B8	虻
303B	88B9	飴
303C	88BA	絢
303D	88BB	綾
303E	88BC	鮎
303F	88BD	或
3040	88BE	粟
3041	88BF	裕
3042	88C0	安
3043	88C1	庵
3044	88C2	按
3045	88C3	暗
3046	88C4	案

JIS	SJIS	字
3047	88C5	闇
3048	88C6	鞍
3049	88C7	杏
304A	88C8	以
304B	88C9	伊
304C	88CA	位
304D	88CB	依
304E	88CC	偉
304F	88CD	囿
3050	88CE	夷
3051	88CF	委
3052	88D0	威
3053	88D1	尉
3054	88D2	惟
3055	88D3	意
3056	88D4	慰
3057	88D5	易
3058	88D6	椅
3059	88D7	爲
305A	88D8	畏
305B	88D9	異
305C	88DA	移
305D	88DB	維
305E	88DC	緯
305F	88DD	胃
3060	88DE	萎
3061	88DF	衣
3062	88E0	謂
3063	88E1	違
3064	88E2	遺
3065	88E3	医
3066	88E4	井
3067	88E5	亥
3068	88E6	域
3069	88E7	育
306A	88E8	郁

JIS	SJIS	字
306B	88E9	磯
306C	88EA	一
306D	88EB	壹
306E	88EC	溢
306F	88ED	逸
3070	88EE	稻
3071	88EF	茨
3072	88F0	芋
3073	88F1	鱒
3074	88F2	允
3075	88F3	印
3076	88F4	咽
3077	88F5	員
3078	88F6	因
3079	88F7	姻
307A	88F8	引
307B	88F9	飲
307C	88FA	淫
307D	88FB	胤
307E	88FC	蔭
3121	8940	院
3122	8941	陰
3123	8942	隱
3124	8943	韻
3125	8944	吋
3126	8945	右
3127	8946	宇
3128	8947	烏
3129	8948	羽
312A	8949	迂
312B	894A	雨
312C	894B	卯
312D	894C	鵜
312E	894D	窺
312F	894E	丑
3130	894F	確

JIS	SJIS	字
3131	8950	白
3132	8951	渦
3133	8952	嘘
3134	8953	唄
3135	8954	鬱
3136	8955	蔚
3137	8956	鰻
3138	8957	姥
3139	8958	廐
313A	8959	浦
313B	895A	瓜
313C	895B	閏
313D	895C	嚙
313E	895D	云
313F	895E	運
3140	895F	雲
3141	8960	荏
3142	8961	餌
3143	8962	叡
3144	8963	營
3145	8964	嬰
3146	8965	影
3147	8966	映
3148	8967	曳
3149	8968	榮
314A	8969	永
314B	896A	泳
314C	896B	洩
314D	896C	瑛
314E	896D	盈
314F	896E	穎
3150	896F	穎
3151	8970	英
3152	8971	衛
3153	8972	詠
3154	8973	銳

JIS	SJIS	字
3155	8974	液
3156	8975	疫
3157	8976	益
3158	8977	駅
3159	8978	悅
315A	8979	謁
315B	897A	越
315C	897B	闕
315D	897C	榎
315E	897D	厭
315F	897E	円
3160	8980	園
3161	8981	堰
3162	8982	奄
3163	8983	宴
3164	8984	延
3165	8985	怨
3166	8986	掩
3167	8987	援
3168	8988	沿
3169	8989	演
316A	898A	炎
316B	898B	焰
316C	898C	煙
316D	898D	燕
316E	898E	猿
316F	898F	緣
3170	8990	艷
3171	8991	苑
3172	8992	菌
3173	8993	遠
3174	8994	鉛
3175	8995	鴛
3176	8996	塩
3177	8997	於
3178	8998	汚

JIS	SJIS	字
3179	8999	甥
317A	899A	凹
317B	899B	央
317C	899C	奧
317D	899D	往
317E	899E	応
3221	899F	押
3222	89A0	旺
3223	89A1	横
3224	89A2	欧
3225	89A3	殴
3226	89A4	王
3227	89A5	翁
3228	89A6	襖
3229	89A7	鶯
322A	89A8	鷓
322B	89A9	黄
322C	89AA	岡
322D	89AB	沖
322E	89AC	荻
322F	89AD	億
3230	89AE	屋
3231	89AF	億
3232	89B0	臆
3233	89B1	桶
3234	89B2	牡
3235	89B3	乙
3236	89B4	俺
3237	89B5	卸
3238	89B6	恩
3239	89B7	温
323A	89B8	穩
323B	89B9	音
323C	89BA	下
323D	89BB	化
323E	89BC	仮

JIS	SJIS	字
323F	89BD	何
3240	89BE	伽
3241	89BF	伽
3242	89C0	佳
3243	89C1	加
3244	89C2	可
3245	89C3	嘉
3246	89C4	夏
3247	89C5	嫁
3248	89C6	家
3249	89C7	寡
324A	89C8	科
324B	89C9	暇
324C	89CA	果
324D	89CB	架
324E	89CC	歌
324F	89CD	河
3250	89CE	火
3251	89CF	珂
3252	89D0	禍
3253	89D1	禾
3254	89D2	稼
3255	89D3	箇
3256	89D4	花
3257	89D5	苛
3258	89D6	茄
3259	89D7	荷
325A	89D8	華
325B	89D9	菓
325C	89DA	蝦
325D	89DB	課
325E	89DC	擘
325F	89DD	貨
3260	89DE	迦
3261	89DF	過
3262	89E0	霞

JIS	SJIS	字
3263	89E1	蚊
3264	89E2	俄
3265	89E3	峨
3266	89E4	我
3267	89E5	牙
3268	89E6	画
3269	89E7	臥
326A	89E8	芽
326B	89E9	蛾
326C	89EA	賀
326D	89EB	雅
326E	89EC	餓
326F	89ED	駕
3270	89EE	介
3271	89EF	会
3272	89F0	解
3273	89F1	回
3274	89F2	塊
3275	89F3	壞
3276	89F4	廻
3277	89F5	快
3278	89F6	怪
3279	89F7	悔
327A	89F8	恢
327B	89F9	懷
327C	89FA	戒
327D	89FB	拐
327E	89FC	改
3321	8A40	魁
3322	8A41	晦
3323	8A42	械
3324	8A43	海
3325	8A44	灰
3326	8A45	界
3327	8A46	皆
3328	8A47	繪

JIS	SJIS	字
3329	8A48	芥
332A	8A49	蟹
332B	8A4A	開
332C	8A4B	階
332D	8A4C	貝
332E	8A4D	凱
332F	8A4E	効
3330	8A4F	外
3331	8A50	咳
3332	8A51	害
3333	8A52	崖
3334	8A53	慨
3335	8A54	概
3336	8A55	涯
3337	8A56	碍
3338	8A57	蓋
3339	8A58	街
333A	8A59	該
333B	8A5A	鎧
333C	8A5B	骸
333D	8A5C	湮
333E	8A5D	馨
333F	8A5E	蛙
3340	8A5F	垣
3341	8A60	柿
3342	8A61	蛎
3343	8A62	鈎
3344	8A63	劃
3345	8A64	嚇
3346	8A65	各
3347	8A66	廓
3348	8A67	擴
3349	8A68	攪
334A	8A69	格
334B	8A6A	核
334C	8A6B	殼

JIS	SJIS	字
334D	8A6C	獲
334E	8A6D	確
334F	8A6E	穫
3350	8A6F	覺
3351	8A70	角
3352	8A71	赫
3353	8A72	較
3354	8A73	郭
3355	8A74	閣
3356	8A75	隔
3357	8A76	革
3358	8A77	学
3359	8A78	岳
335A	8A79	樂
335B	8A7A	額
335C	8A7B	顎
335D	8A7C	掛
335E	8A7D	笠
335F	8A7E	檜
3360	8A80	櫃
3361	8A81	梶
3362	8A82	鯁
3363	8A83	瀉
3364	8A84	割
3365	8A85	喝
3366	8A86	恰
3367	8A87	括
3368	8A88	活
3369	8A89	渴
336A	8A8A	滑
336B	8A8B	葛
336C	8A8C	褐
336D	8A8D	轄
336E	8A8E	且
336F	8A8F	鯉
3370	8A90	叶

JIS	SJIS	字
3371	8A91	椈
3372	8A92	樺
3373	8A93	鞆
3374	8A94	株
3375	8A95	兜
3376	8A96	竈
3377	8A97	蒲
3378	8A98	釜
3379	8A99	鎌
337A	8A9A	嚙
337B	8A9B	鴨
337C	8A9C	栢
337D	8A9D	茅
337E	8A9E	萱
3421	8A9F	粥
3422	8AA0	刈
3423	8AA1	苻
3424	8AA2	瓦
3425	8AA3	乾
3426	8AA4	侃
3427	8AA5	冠
3428	8AA6	寒
3429	8AA7	刊
342A	8AA8	勘
342B	8AA9	勸
342C	8AAA	卷
342D	8AAB	喚
342E	8AAC	堪
342F	8AAD	姦
3430	8AAE	完
3431	8AAF	官
3432	8AB0	寬
3433	8AB1	干
3434	8AB2	幹
3435	8AB3	患
3436	8AB4	感

JIS	SJIS	字
3437	8AB5	慣
3438	8AB6	憾
3439	8AB7	換
343A	8AB8	敢
343B	8AB9	柑
343C	8ABA	桓
343D	8ABB	棺
343E	8ABC	款
343F	8ABD	歡
3440	8ABE	汗
3441	8ABF	漢
3442	8AC0	澗
3443	8AC1	漣
3444	8AC2	環
3445	8AC3	甘
3446	8AC4	監
3447	8AC5	看
3448	8AC6	竿
3449	8AC7	管
344A	8AC8	簡
344B	8AC9	緩
344C	8ACA	缶
344D	8ACB	翰
344E	8ACC	肝
344F	8ACD	艦
3450	8ACE	莞
3451	8ACF	觀
3452	8AD0	諫
3453	8AD1	貫
3454	8AD2	還
3455	8AD3	鑑
3456	8AD4	問
3457	8AD5	閑
3458	8AD6	閔
3459	8AD7	陷
345A	8AD8	韓

JIS	SJIS	字
345B	8AD9	館
345C	8ADA	館
345D	8ADB	丸
345E	8ADC	含
345F	8ADD	岸
3460	8ADE	巖
3461	8ADF	玩
3462	8AE0	癌
3463	8AE1	眼
3464	8AE2	岩
3465	8AE3	翫
3466	8AE4	贗
3467	8AE5	雁
3468	8AE6	頑
3469	8AE7	顏
346A	8AE8	願
346B	8AE9	企
346C	8AEA	伎
346D	8AEB	危
346E	8AEC	喜
346F	8AED	器
3470	8AEE	基
3471	8AEF	奇
3472	8AF0	嬉
3473	8AF1	寄
3474	8AF2	岐
3475	8AF3	希
3476	8AF4	幾
3477	8AF5	忌
3478	8AF6	揮
3479	8AF7	机
347A	8AF8	旗
347B	8AF9	既
347C	8AFA	期
347D	8AFB	棋
347E	8AFC	棄

JIS	SJIS	字
3521	8B40	機
3522	8B41	婦
3523	8B42	毅
3524	8B43	氣
3525	8B44	汽
3526	8B45	畿
3527	8B46	祈
3528	8B47	季
3529	8B48	稀
352A	8B49	紀
352B	8B4A	徽
352C	8B4B	規
352D	8B4C	記
352E	8B4D	貴
352F	8B4E	起
3530	8B4F	軌
3531	8B50	輝
3532	8B51	飢
3533	8B52	騎
3534	8B53	鬼
3535	8B54	龜
3536	8B55	偽
3537	8B56	儀
3538	8B57	妓
3539	8B58	宜
353A	8B59	戲
353B	8B5A	技
353C	8B5B	擬
353D	8B5C	欺
353E	8B5D	犧
353F	8B5E	疑
3540	8B5F	祇
3541	8B60	義
3542	8B61	蟻
3543	8B62	誼
3544	8B63	議

JIS	SJIS	字
3545	8B64	掬
3546	8B65	菊
3547	8B66	鞠
3548	8B67	吉
3549	8B68	吃
354A	8B69	喫
354B	8B6A	桔
354C	8B6B	橘
354D	8B6C	詰
354E	8B6D	砧
354F	8B6E	杵
3550	8B6F	黍
3551	8B70	却
3552	8B71	客
3553	8B72	脚
3554	8B73	虐
3555	8B74	逆
3556	8B75	丘
3557	8B76	久
3558	8B77	仇
3559	8B78	休
355A	8B79	及
355B	8B7A	吸
355C	8B7B	宮
355D	8B7C	弓
355E	8B7D	急
355F	8B7E	救
3560	8B80	朽
3561	8B81	求
3562	8B82	汲
3563	8B83	泣
3564	8B84	灸
3565	8B85	球
3566	8B86	究
3567	8B87	窮
3568	8B88	笈

JIS	SJIS	字
3569	8B89	級
356A	8B8A	糾
356B	8B8B	給
356C	8B8C	旧
356D	8B8D	牛
356E	8B8E	去
356F	8B8F	居
3570	8B90	巨
3571	8B91	拒
3572	8B92	拋
3573	8B93	拳
3574	8B94	渠
3575	8B95	虛
3576	8B96	許
3577	8B97	距
3578	8B98	鋸
3579	8B99	漁
357A	8B9A	禦
357B	8B9B	魚
357C	8B9C	亨
357D	8B9D	享
357E	8B9E	京
3621	8B9F	供
3622	8BA0	俠
3623	8BA1	僑
3624	8BA2	兇
3625	8BA3	競
3626	8BA4	共
3627	8BA5	凶
3628	8BA6	協
3629	8BA7	匡
362A	8BA8	卿
362B	8BA9	叫
362C	8BAA	喬
362D	8BAB	境
362E	8BAC	峽

JIS	SJIS	字
362F	8BAD	強
3630	8BAE	疆
3631	8BAF	怯
3632	8BB0	恐
3633	8BB1	恭
3634	8BB2	挾
3635	8BB3	教
3636	8BB4	橋
3637	8BB5	況
3638	8BB6	狂
3639	8BB7	狹
363A	8BB8	矯
363B	8BB9	胸
363C	8BBA	脅
363D	8BBB	興
363E	8BBC	蕎
363F	8BBD	鄉
3640	8BBE	鏡
3641	8BBF	響
3642	8BC0	饗
3643	8BC1	驚
3644	8BC2	仰
3645	8BC3	凝
3646	8BC4	堯
3647	8BC5	曉
3648	8BC6	業
3649	8BC7	局
364A	8BC8	曲
364B	8BC9	極
364C	8BCA	玉
364D	8BCB	桐
364E	8BCC	籽
364F	8BCD	僅
3650	8BCE	勤
3651	8BCF	均
3652	8BD0	巾

JIS	SJIS	字
3653	8BD1	錦
3654	8BD2	斤
3655	8BD3	欣
3656	8BD4	欽
3657	8BD5	琴
3658	8BD6	禁
3659	8BD7	禽
365A	8BD8	筋
365B	8BD9	緊
365C	8BDA	芹
365D	8BDB	菌
365E	8BDC	衿
365F	8BDD	襟
3660	8BDE	謹
3661	8BDF	近
3662	8BE0	金
3663	8BE1	吟
3664	8BE2	銀
3665	8BE3	九
3666	8BE4	俱
3667	8BE5	句
3668	8BE6	区
3669	8BE7	狗
366A	8BE8	玖
366B	8BE9	矩
366C	8BEA	苦
366D	8BEB	軀
366E	8BEC	馭
366F	8BED	駟
3670	8BEE	駒
3671	8BEF	具
3672	8BF0	愚
3673	8BF1	虞
3674	8BF2	喰
3675	8BF3	空
3676	8BF4	偶

JIS	SJIS	字
3677	8BF5	寓
3678	8BF6	遇
3679	8BF7	隅
367A	8BF8	串
367B	8BF9	櫛
367C	8BFA	釧
367D	8BFB	屑
367E	8BFC	屈
3721	8C40	掘
3722	8C41	窟
3723	8C42	沓
3724	8C43	靴
3725	8C44	轡
3726	8C45	窪
3727	8C46	熊
3728	8C47	隈
3729	8C48	条
372A	8C49	栗
372B	8C4A	繰
372C	8C4B	桑
372D	8C4C	鋏
372E	8C4D	勲
372F	8C4E	君
3730	8C4F	薰
3731	8C50	訓
3732	8C51	群
3733	8C52	軍
3734	8C53	郡
3735	8C54	卦
3736	8C55	袈
3737	8C56	祁
3738	8C57	係
3739	8C58	傾
373A	8C59	刑
373B	8C5A	兄
373C	8C5B	啓

JIS	SJIS	字
373D	8C5C	圭
373E	8C5D	珪
373F	8C5E	型
3740	8C5F	契
3741	8C60	形
3742	8C61	徑
3743	8C62	惠
3744	8C63	慶
3745	8C64	慧
3746	8C65	憩
3747	8C66	揭
3748	8C67	携
3749	8C68	敬
374A	8C69	景
374B	8C6A	桂
374C	8C6B	溪
374D	8C6C	畦
374E	8C6D	稽
374F	8C6E	系
3750	8C6F	經
3751	8C70	繼
3752	8C71	繫
3753	8C72	罍
3754	8C73	莖
3755	8C74	荆
3756	8C75	蚩
3757	8C76	計
3758	8C77	詣
3759	8C78	警
375A	8C79	輕
375B	8C7A	頸
375C	8C7B	鷄
375D	8C7C	芸
375E	8C7D	迎
375F	8C7E	鯨
3760	8C80	劇

JIS	SJIS	字
3761	8C81	戟
3762	8C82	擊
3763	8C83	激
3764	8C84	隙
3765	8C85	桁
3766	8C86	傑
3767	8C87	欠
3768	8C88	決
3769	8C89	潔
376A	8C8A	穴
376B	8C8B	結
376C	8C8C	血
376D	8C8D	訣
376E	8C8E	月
376F	8C8F	件
3770	8C90	儉
3771	8C91	倦
3772	8C92	健
3773	8C93	兼
3774	8C94	券
3775	8C95	劍
3776	8C96	喧
3777	8C97	圈
3778	8C98	堅
3779	8C99	嫌
377A	8C9A	建
377B	8C9B	憲
377C	8C9C	懸
377D	8C9D	拳
377E	8C9E	捲
3821	8C9F	檢
3822	8CA0	權
3823	8CA1	牽
3824	8CA2	犬
3825	8CA3	獻
3826	8CA4	研

JIS	SJIS	字
3827	8CA5	硯
3828	8CA6	絹
3829	8CA7	梟
382A	8CA8	肩
382B	8CA9	見
382C	8CAA	謙
382D	8CAB	賢
382E	8CAC	軒
382F	8CAD	遣
3830	8CAE	鍵
3831	8CAF	險
3832	8CB0	蹟
3833	8CB1	驗
3834	8CB2	齟
3835	8CB3	元
3836	8CB4	原
3837	8CB5	敵
3838	8CB6	幻
3839	8CB7	弦
383A	8CB8	減
383B	8CB9	源
383C	8CBA	玄
383D	8CBB	現
383E	8CBC	絃
383F	8CBD	舷
3840	8CBE	言
3841	8CBF	諺
3842	8CC0	限
3843	8CC1	乎
3844	8CC2	個
3845	8CC3	古
3846	8CC4	呼
3847	8CC5	固
3848	8CC6	姑
3849	8CC7	孤
384A	8CC8	己

JIS	SJIS	字
384B	8CC9	庫
384C	8CCA	弧
384D	8CCB	戶
384E	8CCC	故
384F	8CCD	枯
3850	8CCE	湖
3851	8CCF	狐
3852	8CD0	糊
3853	8CD1	袴
3854	8CD2	股
3855	8CD3	胡
3856	8CD4	菰
3857	8CD5	虎
3858	8CD6	誇
3859	8CD7	跨
385A	8CD8	鈷
385B	8CD9	雇
385C	8CDA	顧
385D	8CDB	鼓
385E	8CDC	五
385F	8CDD	互
3860	8CDE	伍
3861	8CDF	午
3862	8CE0	吳
3863	8CE1	吾
3864	8CE2	娛
3865	8CE3	後
3866	8CE4	御
3867	8CE5	悟
3868	8CE6	梧
3869	8CE7	檣
386A	8CE8	瑚
386B	8CE9	碁
386C	8CEA	語
386D	8CEB	誤
386E	8CEC	護

JIS	SJIS	字
386F	8CED	酬
3870	8CEE	乞
3871	8CEF	鯉
3872	8CF0	交
3873	8CF1	佼
3874	8CF2	侯
3875	8CF3	候
3876	8CF4	倖
3877	8CF5	光
3878	8CF6	公
3879	8CF7	功
387A	8CF8	効
387B	8CF9	勾
387C	8CFA	厚
387D	8CFB	口
387E	8CFC	向
3921	8D40	后
3922	8D41	喉
3923	8D42	坑
3924	8D43	垢
3925	8D44	好
3926	8D45	孔
3927	8D46	孝
3928	8D47	宏
3929	8D48	工
392A	8D49	巧
392B	8D4A	巷
392C	8D4B	幸
392D	8D4C	広
392E	8D4D	庚
392F	8D4E	康
3930	8D4F	弘
3931	8D50	恒
3932	8D51	慌
3933	8D52	抗
3934	8D53	拘

JIS	SJIS	字
3935	8D54	控
3936	8D55	攻
3937	8D56	昂
3938	8D57	晃
3939	8D58	更
393A	8D59	杭
393B	8D5A	校
393C	8D5B	梗
393D	8D5C	構
393E	8D5D	江
393F	8D5E	洪
3940	8D5F	浩
3941	8D60	港
3942	8D61	溝
3943	8D62	甲
3944	8D63	皇
3945	8D64	硬
3946	8D65	稿
3947	8D66	糠
3948	8D67	紅
3949	8D68	紘
394A	8D69	絞
394B	8D6A	綱
394C	8D6B	耕
394D	8D6C	考
394E	8D6D	肯
394F	8D6E	肱
3950	8D6F	腔
3951	8D70	膏
3952	8D71	航
3953	8D72	荒
3954	8D73	行
3955	8D74	衡
3956	8D75	講
3957	8D76	貢
3958	8D77	購

JIS	SJIS	字
3959	8D78	郊
395A	8D79	酵
395B	8D7A	鉦
395C	8D7B	砧
395D	8D7C	鋼
395E	8D7D	閤
395F	8D7E	降
3960	8D80	項
3961	8D81	香
3962	8D82	高
3963	8D83	鴻
3964	8D84	剛
3965	8D85	劫
3966	8D86	号
3967	8D87	合
3968	8D88	壕
3969	8D89	拷
396A	8D8A	濠
396B	8D8B	豪
396C	8D8C	轟
396D	8D8D	翹
396E	8D8E	克
396F	8D8F	刻
3970	8D90	告
3971	8D91	国
3972	8D92	穀
3973	8D93	酷
3974	8D94	鵠
3975	8D95	黑
3976	8D96	獄
3977	8D97	漉
3978	8D98	腰
3979	8D99	甌
397A	8D9A	忽
397B	8D9B	惚
397C	8D9C	骨

JIS	SJIS	字
397D	8D9D	狛
397E	8D9E	込
3A21	8D9F	此
3A22	8DA0	頃
3A23	8DA1	今
3A24	8DA2	困
3A25	8DA3	坤
3A26	8DA4	墾
3A27	8DA5	婚
3A28	8DA6	恨
3A29	8DA7	懇
3A2A	8DA8	昏
3A2B	8DA9	昆
3A2C	8DAA	根
3A2D	8DAB	梱
3A2E	8DAC	混
3A2F	8DAD	痕
3A30	8DAE	紺
3A31	8DAF	良
3A32	8DB0	魂
3A33	8DB1	些
3A34	8DB2	佐
3A35	8DB3	又
3A36	8DB4	唆
3A37	8DB5	嵯
3A38	8DB6	左
3A39	8DB7	差
3A3A	8DB8	查
3A3B	8DB9	沙
3A3C	8DBA	磋
3A3D	8DBB	砂
3A3E	8DBC	詐
3A3F	8DBD	鎖
3A40	8DBE	裳
3A41	8DBF	坐
3A42	8DC0	座

JIS	SJIS	字
3A43	8DC1	挫
3A44	8DC2	債
3A45	8DC3	催
3A46	8DC4	再
3A47	8DC5	最
3A48	8DC6	哉
3A49	8DC7	塞
3A4A	8DC8	妻
3A4B	8DC9	宰
3A4C	8DCA	彩
3A4D	8DCB	才
3A4E	8DCC	採
3A4F	8DCD	裁
3A50	8DCE	歲
3A51	8DCF	濟
3A52	8DD0	災
3A53	8DD1	采
3A54	8DD2	犀
3A55	8DD3	碎
3A56	8DD4	砦
3A57	8DD5	祭
3A58	8DD6	齋
3A59	8DD7	細
3A5A	8DD8	菜
3A5B	8DD9	裁
3A5C	8DDA	載
3A5D	8ddb	際
3A5E	8DDC	劑
3A5F	8DDD	在
3A60	8DDE	材
3A61	8DDF	罪
3A62	8DE0	財
3A63	8DE1	冴
3A64	8DE2	坂
3A65	8DE3	阪
3A66	8DE4	堺

JIS	SJIS	字
3A67	8DE5	榊
3A68	8DE6	肴
3A69	8DE7	咲
3A6A	8DE8	崎
3A6B	8DE9	埼
3A6C	8DEA	碕
3A6D	8DEB	鷺
3A6E	8DEC	作
3A6F	8DED	削
3A70	8DEE	咋
3A71	8DEF	搾
3A72	8DF0	昨
3A73	8DF1	朔
3A74	8DF2	柵
3A75	8DF3	窄
3A76	8DF4	策
3A77	8DF5	索
3A78	8DF6	錯
3A79	8DF7	桜
3A7A	8DF8	鮭
3A7B	8DF9	笹
3A7C	8DFA	匙
3A7D	8DFB	冊
3A7E	8DFC	刷
3B21	8E40	察
3B22	8E41	拶
3B23	8E42	撮
3B24	8E43	擦
3B25	8E44	札
3B26	8E45	殺
3B27	8E46	薩
3B28	8E47	雜
3B29	8E48	臯
3B2A	8E49	鯖
3B2B	8E4A	捌
3B2C	8E4B	鑄

JIS	SJIS	字
3B2D	8E4C	鮫
3B2E	8E4D	皿
3B2F	8E4E	晒
3B30	8E4F	三
3B31	8E50	傘
3B32	8E51	參
3B33	8E52	山
3B34	8E53	慘
3B35	8E54	撒
3B36	8E55	散
3B37	8E56	棧
3B38	8E57	燦
3B39	8E58	珊
3B3A	8E59	產
3B3B	8E5A	算
3B3C	8E5B	纂
3B3D	8E5C	蚕
3B3E	8E5D	讚
3B3F	8E5E	贊
3B40	8E5F	酸
3B41	8E60	餐
3B42	8E61	斬
3B43	8E62	暫
3B44	8E63	殘
3B45	8E64	仕
3B46	8E65	仔
3B47	8E66	伺
3B48	8E67	使
3B49	8E68	刺
3B4A	8E69	司
3B4B	8E6A	史
3B4C	8E6B	嗣
3B4D	8E6C	四
3B4E	8E6D	士
3B4F	8E6E	始
3B50	8E6F	姉

JIS	SJIS	字
3B51	8E70	姿
3B52	8E71	子
3B53	8E72	屍
3B54	8E73	市
3B55	8E74	師
3B56	8E75	志
3B57	8E76	思
3B58	8E77	指
3B59	8E78	支
3B5A	8E79	孜
3B5B	8E7A	斯
3B5C	8E7B	施
3B5D	8E7C	旨
3B5E	8E7D	枝
3B5F	8E7E	止
3B60	8E80	死
3B61	8E81	氏
3B62	8E82	獅
3B63	8E83	社
3B64	8E84	私
3B65	8E85	糸
3B66	8E86	紙
3B67	8E87	紫
3B68	8E88	肢
3B69	8E89	脂
3B6A	8E8A	至
3B6B	8E8B	視
3B6C	8E8C	詞
3B6D	8E8D	詩
3B6E	8E8E	試
3B6F	8E8F	誌
3B70	8E90	諮
3B71	8E91	資
3B72	8E92	賜
3B73	8E93	雌
3B74	8E94	飼

JIS	SJIS	字
3B75	8E95	齒
3B76	8E96	事
3B77	8E97	似
3B78	8E98	侍
3B79	8E99	児
3B7A	8E9A	字
3B7B	8E9B	寺
3B7C	8E9C	慈
3B7D	8E9D	持
3B7E	8E9E	時
3C21	8E9F	次
3C22	8EA0	滋
3C23	8EA1	治
3C24	8EA2	爾
3C25	8EA3	璽
3C26	8EA4	痔
3C27	8EA5	磁
3C28	8EA6	示
3C29	8EA7	而
3C2A	8EA8	耳
3C2B	8EA9	自
3C2C	8EAA	蒔
3C2D	8EAB	辭
3C2E	8EAC	汐
3C2F	8EAD	鹿
3C30	8EAE	式
3C31	8EAF	識
3C32	8EB0	鳴
3C33	8EB1	竺
3C34	8EB2	軸
3C35	8EB3	穴
3C36	8EB4	雫
3C37	8EB5	七
3C38	8EB6	叱
3C39	8EB7	執
3C3A	8EB8	失

JIS	SJIS	字
3C3B	8EB9	嫉
3C3C	8EBA	室
3C3D	8EBB	悉
3C3E	8EBC	濕
3C3F	8EBD	漆
3C40	8EBE	疾
3C41	8EBF	質
3C42	8EC0	実
3C43	8EC1	葩
3C44	8EC2	篠
3C45	8EC3	僂
3C46	8EC4	柴
3C47	8EC5	芝
3C48	8EC6	屢
3C49	8EC7	蕊
3C4A	8EC8	縞
3C4B	8EC9	舍
3C4C	8ECA	写
3C4D	8ECB	射
3C4E	8ECC	捨
3C4F	8ECD	赦
3C50	8ECE	斜
3C51	8ECF	煮
3C52	8ED0	社
3C53	8ED1	紗
3C54	8ED2	者
3C55	8ED3	謝
3C56	8ED4	車
3C57	8ED5	遮
3C58	8ED6	蛇
3C59	8ED7	邪
3C5A	8ED8	借
3C5B	8ED9	勻
3C5C	8EDA	尺
3C5D	8EDB	杓
3C5E	8EDC	灼

JIS	SJIS	字
3C5F	8EDD	爵
3C60	8EDE	酌
3C61	8EDF	积
3C62	8EE0	錫
3C63	8EE1	若
3C64	8EE2	寂
3C65	8EE3	弱
3C66	8EE4	惹
3C67	8EE5	主
3C68	8EE6	取
3C69	8EE7	守
3C6A	8EE8	手
3C6B	8EE9	朱
3C6C	8EEA	殊
3C6D	8EEB	狩
3C6E	8EEC	珠
3C6F	8EED	種
3C70	8EEE	腫
3C71	8EEF	趣
3C72	8EF0	酒
3C73	8EF1	首
3C74	8EF2	儒
3C75	8EF3	受
3C76	8EF4	呪
3C77	8EF5	寿
3C78	8EF6	授
3C79	8EF7	樹
3C7A	8EF8	綬
3C7B	8EF9	需
3C7C	8EFA	囚
3C7D	8EFB	収
3C7E	8EFC	周
3D21	8F40	宗
3D22	8F41	就
3D23	8F42	州
3D24	8F43	修

JIS	SJIS	字
3D25	8F44	愁
3D26	8F45	拾
3D27	8F46	洲
3D28	8F47	秀
3D29	8F48	秋
3D2A	8F49	終
3D2B	8F4A	繡
3D2C	8F4B	習
3D2D	8F4C	臭
3D2E	8F4D	舟
3D2F	8F4E	蒐
3D30	8F4F	衆
3D31	8F50	襲
3D32	8F51	讐
3D33	8F52	蹴
3D34	8F53	輯
3D35	8F54	週
3D36	8F55	曾
3D37	8F56	酬
3D38	8F57	集
3D39	8F58	醜
3D3A	8F59	什
3D3B	8F5A	住
3D3C	8F5B	充
3D3D	8F5C	十
3D3E	8F5D	從
3D3F	8F5E	戎
3D40	8F5F	柔
3D41	8F60	汁
3D42	8F61	洪
3D43	8F62	獸
3D44	8F63	縱
3D45	8F64	重
3D46	8F65	銃
3D47	8F66	叔
3D48	8F67	夙

JIS	SJIS	字
3D49	8F68	宿
3D4A	8F69	淑
3D4B	8F6A	祝
3D4C	8F6B	縮
3D4D	8F6C	肅
3D4E	8F6D	塾
3D4F	8F6E	熟
3D50	8F6F	出
3D51	8F70	術
3D52	8F71	述
3D53	8F72	俊
3D54	8F73	峻
3D55	8F74	春
3D56	8F75	瞬
3D57	8F76	竣
3D58	8F77	舜
3D59	8F78	駿
3D5A	8F79	准
3D5B	8F7A	循
3D5C	8F7B	旬
3D5D	8F7C	楯
3D5E	8F7D	殉
3D5F	8F7E	淳
3D60	8F80	準
3D61	8F81	潤
3D62	8F82	盾
3D63	8F83	純
3D64	8F84	巡
3D65	8F85	遵
3D66	8F86	醇
3D67	8F87	順
3D68	8F88	処
3D69	8F89	初
3D6A	8F8A	所
3D6B	8F8B	暑
3D6C	8F8C	曙

JIS	SJIS	字
3D6D	8F8D	渚
3D6E	8F8E	庶
3D6F	8F8F	緒
3D70	8F90	署
3D71	8F91	書
3D72	8F92	薯
3D73	8F93	藹
3D74	8F94	諸
3D75	8F95	助
3D76	8F96	叙
3D77	8F97	女
3D78	8F98	序
3D79	8F99	徐
3D7A	8F9A	恕
3D7B	8F9B	鋤
3D7C	8F9C	除
3D7D	8F9D	傷
3D7E	8F9E	償
3E21	8F9F	勝
3E22	8FA0	匠
3E23	8FA1	升
3E24	8FA2	召
3E25	8FA3	哨
3E26	8FA4	商
3E27	8FA5	唱
3E28	8FA6	嘗
3E29	8FA7	獎
3E2A	8FA8	妾
3E2B	8FA9	娼
3E2C	8FAA	宵
3E2D	8FAB	將
3E2E	8FAC	小
3E2F	8FAD	少
3E30	8FAE	尙
3E31	8FAF	庄
3E32	8FB0	床

JIS	SJIS	字
3E33	8FB1	廠
3E34	8FB2	彰
3E35	8FB3	承
3E36	8FB4	抄
3E37	8FB5	招
3E38	8FB6	掌
3E39	8FB7	捷
3E3A	8FB8	昇
3E3B	8FB9	昌
3E3C	8FBA	昭
3E3D	8FBB	晶
3E3E	8FBC	松
3E3F	8FBD	梢
3E40	8FBE	樟
3E41	8FBF	樵
3E42	8FC0	沼
3E43	8FC1	消
3E44	8FC2	涉
3E45	8FC3	湘
3E46	8FC4	燒
3E47	8FC5	焦
3E48	8FC6	照
3E49	8FC7	症
3E4A	8FC8	省
3E4B	8FC9	硝
3E4C	8FCA	礁
3E4D	8FCB	祥
3E4E	8FCC	称
3E4F	8FCD	章
3E50	8FCE	笑
3E51	8FCF	粧
3E52	8FD0	紹
3E53	8FD1	肖
3E54	8FD2	菖
3E55	8FD3	蔣
3E56	8FD4	蕉

JIS	SJIS	字
3E57	8FD5	衝
3E58	8FD6	裳
3E59	8FD7	訟
3E5A	8FD8	証
3E5B	8FD9	詔
3E5C	8FDA	詳
3E5D	8FDB	象
3E5E	8FDC	賞
3E5F	8FDD	醬
3E60	8FDE	鉦
3E61	8FDF	鍾
3E62	8FE0	鐘
3E63	8FE1	障
3E64	8FE2	鞞
3E65	8FE3	上
3E66	8FE4	丈
3E67	8FE5	丞
3E68	8FE6	乘
3E69	8FE7	冗
3E6A	8FE8	剩
3E6B	8FE9	城
3E6C	8FEA	場
3E6D	8FEB	壤
3E6E	8FEC	孃
3E6F	8FED	常
3E70	8FEE	情
3E71	8FEF	擾
3E72	8FF0	条
3E73	8FF1	杖
3E74	8FF2	淨
3E75	8FF3	狀
3E76	8FF4	暈
3E77	8FF5	穰
3E78	8FF6	蒸
3E79	8FF7	讓
3E7A	8FF8	釀

JIS	SJIS	字
3E7B	8FF9	錠
3E7C	8FFA	囑
3E7D	8FFB	埴
3E7E	8FFC	飾
3F21	9040	拭
3F22	9041	植
3F23	9042	殖
3F24	9043	燭
3F25	9044	織
3F26	9045	職
3F27	9046	色
3F28	9047	觸
3F29	9048	食
3F2A	9049	蝕
3F2B	904A	辱
3F2C	904B	尻
3F2D	904C	伸
3F2E	904D	信
3F2F	904E	侵
3F30	904F	昏
3F31	9050	娠
3F32	9051	寢
3F33	9052	審
3F34	9053	心
3F35	9054	慎
3F36	9055	振
3F37	9056	新
3F38	9057	晉
3F39	9058	森
3F3A	9059	榛
3F3B	905A	浸
3F3C	905B	深
3F3D	905C	申
3F3E	905D	疹
3F3F	905E	真
3F40	905F	神

JIS	SJIS	字
3F41	9060	秦
3F42	9061	紳
3F43	9062	臣
3F44	9063	芯
3F45	9064	薪
3F46	9065	親
3F47	9066	診
3F48	9067	身
3F49	9068	辛
3F4A	9069	進
3F4B	906A	針
3F4C	906B	震
3F4D	906C	人
3F4E	906D	仁
3F4F	906E	刃
3F50	906F	塵
3F51	9070	壬
3F52	9071	尋
3F53	9072	甚
3F54	9073	尽
3F55	9074	腎
3F56	9075	訊
3F57	9076	迅
3F58	9077	陣
3F59	9078	韌
3F5A	9079	筭
3F5B	907A	誡
3F5C	907B	須
3F5D	907C	酢
3F5E	907D	囟
3F5F	907E	厨
3F60	9080	逗
3F61	9081	吹
3F62	9082	垂
3F63	9083	帥
3F64	9084	推

JIS	SJIS	字
3F65	9085	水
3F66	9086	炊
3F67	9087	睡
3F68	9088	粹
3F69	9089	翠
3F6A	908A	衰
3F6B	908B	遂
3F6C	908C	醉
3F6D	908D	錐
3F6E	908E	錘
3F6F	908F	隨
3F70	9090	瑞
3F71	9091	髓
3F72	9092	崇
3F73	9093	嵩
3F74	9094	數
3F75	9095	樞
3F76	9096	趨
3F77	9097	雛
3F78	9098	据
3F79	9099	杉
3F7A	909A	椳
3F7B	909B	菅
3F7C	909C	頗
3F7D	909D	雀
3F7E	909E	裾
4021	909F	澄
4022	90A0	摺
4023	90A1	寸
4024	90A2	世
4025	90A3	瀨
4026	90A4	畝
4027	90A5	是
4028	90A6	淒
4029	90A7	制
402A	90A8	勢

JIS	SJIS	字
402B	90A9	姓
402C	90AA	征
402D	90AB	性
402E	90AC	成
402F	90AD	政
4030	90AE	整
4031	90AF	星
4032	90B0	晴
4033	90B1	棲
4034	90B2	栖
4035	90B3	正
4036	90B4	清
4037	90B5	牲
4038	90B6	生
4039	90B7	盛
403A	90B8	精
403B	90B9	聖
403C	90BA	声
403D	90BB	製
403E	90BC	西
403F	90BD	誠
4040	90BE	誓
4041	90BF	請
4042	90C0	逝
4043	90C1	醒
4044	90C2	青
4045	90C3	静
4046	90C4	齊
4047	90C5	稅
4048	90C6	脆
4049	90C7	隻
404A	90C8	席
404B	90C9	惜
404C	90CA	戚
404D	90CB	斥
404E	90CC	昔

JIS	SJIS	字
404F	90CD	析
4050	90CE	石
4051	90CF	積
4052	90D0	籍
4053	90D1	績
4054	90D2	脊
4055	90D3	責
4056	90D4	赤
4057	90D5	跡
4058	90D6	蹟
4059	90D7	碩
405A	90D8	切
405B	90D9	拙
405C	90DA	接
405D	90DB	撰
405E	90DC	折
405F	90DD	設
4060	90DE	窃
4061	90DF	節
4062	90E0	說
4063	90E1	雪
4064	90E2	絕
4065	90E3	舌
4066	90E4	蝉
4067	90E5	仙
4068	90E6	先
4069	90E7	千
406A	90E8	占
406B	90E9	宣
406C	90EA	專
406D	90EB	尖
406E	90EC	川
406F	90ED	戰
4070	90EE	扇
4071	90EF	撰
4072	90F0	栓

JIS	SJIS	字
4073	90F1	梅
4074	90F2	泉
4075	90F3	淺
4076	90F4	洗
4077	90F5	染
4078	90F6	潛
4079	90F7	煎
407A	90F8	煽
407B	90F9	旋
407C	90FA	穿
407D	90FB	箭
407E	90FC	線
4121	9140	織
4122	9141	羨
4123	9142	腺
4124	9143	舛
4125	9144	船
4126	9145	薦
4127	9146	詮
4128	9147	賤
4129	9148	踐
412A	9149	選
412B	914A	遷
412C	914B	錢
412D	914C	銑
412E	914D	閃
412F	914E	鮮
4130	914F	前
4131	9150	善
4132	9151	漸
4133	9152	然
4134	9153	全
4135	9154	禪
4136	9155	繕
4137	9156	膳
4138	9157	糲

JIS	SJIS	字
4139	9158	噲
413A	9159	塑
413B	915A	岨
413C	915B	措
413D	915C	曾
413E	915D	曾
413F	915E	楚
4140	915F	狙
4141	9160	疏
4142	9161	疎
4143	9162	礎
4144	9163	祖
4145	9164	租
4146	9165	粗
4147	9166	素
4148	9167	組
4149	9168	蘇
414A	9169	訴
414B	916A	阻
414C	916B	遡
414D	916C	鼠
414E	916D	僧
414F	916E	創
4150	916F	双
4151	9170	叢
4152	9171	倉
4153	9172	喪
4154	9173	壯
4155	9174	奏
4156	9175	爽
4157	9176	宋
4158	9177	層
4159	9178	匝
415A	9179	惣
415B	917A	想
415C	917B	搜

JIS	SJIS	字
415D	917C	掃
415E	917D	插
415F	917E	搔
4160	9180	操
4161	9181	早
4162	9182	曹
4163	9183	巢
4164	9184	檜
4165	9185	槽
4166	9186	漕
4167	9187	燥
4168	9188	争
4169	9189	瘦
416A	918A	相
416B	918B	窓
416C	918C	糟
416D	918D	総
416E	918E	綜
416F	918F	聡
4170	9190	草
4171	9191	莊
4172	9192	葬
4173	9193	蒼
4174	9194	藻
4175	9195	装
4176	9196	走
4177	9197	送
4178	9198	遭
4179	9199	鎗
417A	919A	霜
417B	919B	騷
417C	919C	像
417D	919D	增
417E	919E	憎
4221	919F	臧
4222	91A0	蔵

JIS	SJIS	字
4223	91A1	贈
4224	91A2	造
4225	91A3	促
4226	91A4	側
4227	91A5	則
4228	91A6	即
4229	91A7	息
422A	91A8	捉
422B	91A9	束
422C	91AA	測
422D	91AB	足
422E	91AC	速
422F	91AD	俗
4230	91AE	属
4231	91AF	賊
4232	91B0	族
4233	91B1	続
4234	91B2	卒
4235	91B3	袖
4236	91B4	其
4237	91B5	揃
4238	91B6	存
4239	91B7	孫
423A	91B8	尊
423B	91B9	損
423C	91BA	村
423D	91BB	遜
423E	91BC	他
423F	91BD	多
4240	91BE	太
4241	91BF	汰
4242	91C0	訖
4243	91C1	唾
4244	91C2	墮
4245	91C3	妥
4246	91C4	惰

JIS	SJIS	字
4247	91C5	打
4248	91C6	柁
4249	91C7	舵
424A	91C8	梢
424B	91C9	陀
424C	91CA	駄
424D	91CB	驛
424E	91CC	体
424F	91CD	堆
4250	91CE	対
4251	91CF	耐
4252	91D0	岱
4253	91D1	帯
4254	91D2	待
4255	91D3	怠
4256	91D4	態
4257	91D5	戴
4258	91D6	替
4259	91D7	泰
425A	91D8	滯
425B	91D9	胎
425C	91DA	腿
425D	91DB	苔
425E	91DC	袋
425F	91DD	貸
4260	91DE	退
4261	91DF	逮
4262	91E0	隊
4263	91E1	黛
4264	91E2	鯛
4265	91E3	代
4266	91E4	台
4267	91E5	大
4268	91E6	第
4269	91E7	醜
426A	91E8	題

JIS	SJIS	字
426B	91E9	鷹
426C	91EA	滝
426D	91EB	瀧
426E	91EC	卓
426F	91ED	啄
4270	91EE	宅
4271	91EF	托
4272	91F0	扱
4273	91F1	拓
4274	91F2	沢
4275	91F3	濯
4276	91F4	琢
4277	91F5	託
4278	91F6	鐸
4279	91F7	濁
427A	91F8	諾
427B	91F9	茸
427C	91FA	凧
427D	91FB	蛸
427E	91FC	只
4321	9240	叩
4322	9241	但
4323	9242	達
4324	9243	辰
4325	9244	奪
4326	9245	脫
4327	9246	巽
4328	9247	豎
4329	9248	辿
432A	9249	棚
432B	924A	谷
432C	924B	狸
432D	924C	鱈
432E	924D	樽
432F	924E	誰
4330	924F	丹

JIS	SJIS	字
4331	9250	单
4332	9251	嘆
4333	9252	坦
4334	9253	担
4335	9254	探
4336	9255	旦
4337	9256	歎
4338	9257	淡
4339	9258	湛
433A	9259	炭
433B	925A	短
433C	925B	端
433D	925C	箏
433E	925D	綻
433F	925E	耽
4340	925F	胆
4341	9260	蛋
4342	9261	誕
4343	9262	鍛
4344	9263	团
4345	9264	壇
4346	9265	彈
4347	9266	断
4348	9267	暖
4349	9268	檀
434A	9269	段
434B	926A	男
434C	926B	談
434D	926C	值
434E	926D	知
434F	926E	地
4350	926F	弛
4351	9270	恥
4352	9271	智
4353	9272	池
4354	9273	痴

JIS	SJIS	字
4355	9274	稚
4356	9275	置
4357	9276	致
4358	9277	蜘
4359	9278	遲
435A	9279	馳
435B	927A	築
435C	927B	畜
435D	927C	竹
435E	927D	筑
435F	927E	蓄
4360	9280	逐
4361	9281	秩
4362	9282	窒
4363	9283	茶
4364	9284	嫡
4365	9285	着
4366	9286	中
4367	9287	仲
4368	9288	宙
4369	9289	忠
436A	928A	抽
436B	928B	昼
436C	928C	柱
436D	928D	注
436E	928E	虫
436F	928F	衷
4370	9290	註
4371	9291	耐
4372	9292	鑄
4373	9293	駐
4374	9294	樗
4375	9295	瀦
4376	9296	猪
4377	9297	苧
4378	9298	著

JIS	SJIS	字
4379	9299	貯
437A	929A	丁
437B	929B	兆
437C	929C	涸
437D	929D	喋
437E	929E	寵
4421	929F	帖
4422	92A0	帳
4423	92A1	庁
4424	92A2	弔
4425	92A3	張
4426	92A4	彫
4427	92A5	徵
4428	92A6	懲
4429	92A7	挑
442A	92A8	暢
442B	92A9	朝
442C	92AA	潮
442D	92AB	牒
442E	92AC	町
442F	92AD	眺
4430	92AE	聽
4431	92AF	脹
4432	92B0	腸
4433	92B1	蝶
4434	92B2	調
4435	92B3	諜
4436	92B4	超
4437	92B5	跳
4438	92B6	銚
4439	92B7	長
443A	92B8	頂
443B	92B9	鳥
443C	92BA	勅
443D	92BB	抄
443E	92BC	直

JIS	SJIS	字
443F	92BD	朕
4440	92BE	沈
4441	92BF	珍
4442	92C0	賃
4443	92C1	鎮
4444	92C2	陳
4445	92C3	津
4446	92C4	墜
4447	92C5	椎
4448	92C6	槌
4449	92C7	追
444A	92C8	鎚
444B	92C9	痛
444C	92CA	通
444D	92CB	塚
444E	92CC	母
444F	92CD	掴
4450	92CE	槻
4451	92CF	佃
4452	92D0	漬
4453	92D1	柘
4454	92D2	辻
4455	92D3	蔦
4456	92D4	綴
4457	92D5	鏢
4458	92D6	椿
4459	92D7	潰
445A	92D8	坪
445B	92D9	壺
445C	92DA	孀
445D	92DB	紬
445E	92DC	爪
445F	92DD	吊
4460	92DE	釣
4461	92DF	鶴
4462	92E0	亭

JIS	SJIS	字
4463	92E1	低
4464	92E2	停
4465	92E3	偵
4466	92E4	剃
4467	92E5	貞
4468	92E6	呈
4469	92E7	堤
446A	92E8	定
446B	92E9	帝
446C	92EA	底
446D	92EB	庭
446E	92EC	廷
446F	92ED	弟
4470	92EE	悌
4471	92EF	抵
4472	92F0	挺
4473	92F1	提
4474	92F2	梯
4475	92F3	汀
4476	92F4	碇
4477	92F5	禎
4478	92F6	程
4479	92F7	締
447A	92F8	艇
447B	92F9	訂
447C	92FA	諦
447D	92FB	蹄
447E	92FC	逋
4521	9340	邸
4522	9341	鄭
4523	9342	釘
4524	9343	鼎
4525	9344	泥
4526	9345	摘
4527	9346	擢
4528	9347	敵

JIS	SJIS	字
4529	9348	滴
452A	9349	的
452B	934A	笛
452C	934B	適
452D	934C	鎬
452E	934D	溺
452F	934E	哲
4530	934F	徹
4531	9350	撤
4532	9351	轍
4533	9352	迭
4534	9353	鉄
4535	9354	典
4536	9355	填
4537	9356	天
4538	9357	展
4539	9358	店
453A	9359	添
453B	935A	纏
453C	935B	甜
453D	935C	貼
453E	935D	轉
453F	935E	顛
4540	935F	点
4541	9360	伝
4542	9361	殿
4543	9362	澗
4544	9363	田
4545	9364	電
4546	9365	兔
4547	9366	吐
4548	9367	堵
4549	9368	塗
454A	9369	妬
454B	936A	屠
454C	936B	徒

JIS	SJIS	字
454D	936C	斗
454E	936D	杜
454F	936E	渡
4550	936F	登
4551	9370	菟
4552	9371	賭
4553	9372	途
4554	9373	都
4555	9374	鍍
4556	9375	砥
4557	9376	砺
4558	9377	努
4559	9378	度
455A	9379	土
455B	937A	奴
455C	937B	怒
455D	937C	倒
455E	937D	党
455F	937E	冬
4560	9380	凍
4561	9381	刀
4562	9382	唐
4563	9383	塔
4564	9384	塘
4565	9385	套
4566	9386	宕
4567	9387	島
4568	9388	嶋
4569	9389	悼
456A	938A	投
456B	938B	搭
456C	938C	東
456D	938D	桃
456E	938E	梲
456F	938F	棟
4570	9390	盜

JIS	SJIS	字
4571	9391	淘
4572	9392	湯
4573	9393	涛
4574	9394	灯
4575	9395	燈
4576	9396	当
4577	9397	痘
4578	9398	禱
4579	9399	等
457A	939A	答
457B	939B	筒
457C	939C	糖
457D	939D	統
457E	939E	到
4621	939F	董
4622	93A0	蕩
4623	93A1	藤
4624	93A2	討
4625	93A3	膳
4626	93A4	豆
4627	93A5	踏
4628	93A6	逃
4629	93A7	透
462A	93A8	鐙
462B	93A9	陶
462C	93AA	頭
462D	93AB	騰
462E	93AC	鬪
462F	93AD	働
4630	93AE	動
4631	93AF	同
4632	93B0	堂
4633	93B1	導
4634	93B2	懂
4635	93B3	撞
4636	93B4	洞

JIS	SJIS	字
4637	93B5	瞳
4638	93B6	童
4639	93B7	胴
463A	93B8	萄
463B	93B9	道
463C	93BA	銅
463D	93BB	峠
463E	93BC	鴿
463F	93BD	匿
4640	93BE	得
4641	93BF	德
4642	93C0	澆
4643	93C1	特
4644	93C2	督
4645	93C3	禿
4646	93C4	篤
4647	93C5	毒
4648	93C6	独
4649	93C7	読
464A	93C8	枋
464B	93C9	橡
464C	93CA	凸
464D	93CB	突
464E	93CC	椴
464F	93CD	届
4650	93CE	鳶
4651	93CF	苔
4652	93D0	寅
4653	93D1	酉
4654	93D2	澗
4655	93D3	噸
4656	93D4	屯
4657	93D5	惇
4658	93D6	敦
4659	93D7	沌
465A	93D8	豚

JIS	SJIS	字
465B	93D9	遁
465C	93DA	頓
465D	93DB	吞
465E	93DC	曇
465F	93DD	鈍
4660	93DE	奈
4661	93DF	那
4662	93E0	内
4663	93E1	乍
4664	93E2	凧
4665	93E3	薙
4666	93E4	謎
4667	93E5	灘
4668	93E6	捺
4669	93E7	鍋
466A	93E8	檣
466B	93E9	馴
466C	93EA	繩
466D	93EB	啜
466E	93EC	南
466F	93ED	楠
4670	93EE	軟
4671	93EF	難
4672	93F0	汝
4673	93F1	二
4674	93F2	尼
4675	93F3	弋
4676	93F4	迹
4677	93F5	匂
4678	93F6	賑
4679	93F7	肉
467A	93F8	虹
467B	93F9	廿
467C	93FA	日
467D	93FB	乳
467E	93FC	入

JIS	SJIS	字
4721	9440	如
4722	9441	尿
4723	9442	菲
4724	9443	任
4725	9444	妊
4726	9445	忍
4727	9446	認
4728	9447	濡
4729	9448	禰
472A	9449	祢
472B	944A	寧
472C	944B	葱
472D	944C	猫
472E	944D	熱
472F	944E	年
4730	944F	念
4731	9450	捻
4732	9451	撚
4733	9452	燃
4734	9453	粘
4735	9454	乃
4736	9455	廼
4737	9456	之
4738	9457	埜
4739	9458	囊
473A	9459	惱
473B	945A	濃
473C	945B	納
473D	945C	能
473E	945D	腦
473F	945E	膿
4740	945F	農
4741	9460	靦
4742	9461	蚤
4743	9462	巴
4744	9463	把

JIS	SJIS	字
4745	9464	播
4746	9465	霸
4747	9466	杷
4748	9467	波
4749	9468	派
474A	9469	琶
474B	946A	破
474C	946B	婆
474D	946C	罵
474E	946D	芭
474F	946E	馬
4750	946F	俳
4751	9470	廢
4752	9471	拌
4753	9472	排
4754	9473	敗
4755	9474	杯
4756	9475	盃
4757	9476	牌
4758	9477	背
4759	9478	肺
475A	9479	輩
475B	947A	配
475C	947B	倍
475D	947C	培
475E	947D	媒
475F	947E	梅
4760	9480	楳
4761	9481	煤
4762	9482	猥
4763	9483	買
4764	9484	壳
4765	9485	賠
4766	9486	陪
4767	9487	這
4768	9488	蠅

JIS	SJIS	字
4769	9489	秤
476A	948A	矧
476B	948B	萩
476C	948C	伯
476D	948D	剥
476E	948E	博
476F	948F	拍
4770	9490	柏
4771	9491	泊
4772	9492	白
4773	9493	箔
4774	9494	粕
4775	9495	舶
4776	9496	薄
4777	9497	迫
4778	9498	曝
4779	9499	漠
477A	949A	爆
477B	949B	縛
477C	949C	莫
477D	949D	駁
477E	949E	麦
4821	949F	函
4822	94A0	箱
4823	94A1	砧
4824	94A2	箸
4825	94A3	肇
4826	94A4	筭
4827	94A5	櫨
4828	94A6	幡
4829	94A7	肌
482A	94A8	畑
482B	94A9	畠
482C	94AA	八
482D	94AB	鉢
482E	94AC	澆

JIS	SJIS	字
482F	94AD	爨
4830	94AE	醜
4831	94AF	髮
4832	94B0	伐
4833	94B1	罰
4834	94B2	拔
4835	94B3	筏
4836	94B4	闊
4837	94B5	鳩
4838	94B6	嘶
4839	94B7	塙
483A	94B8	蛤
483B	94B9	隼
483C	94BA	伴
483D	94BB	判
483E	94BC	半
483F	94BD	反
4840	94BE	叛
4841	94BF	帆
4842	94C0	搬
4843	94C1	斑
4844	94C2	板
4845	94C3	汜
4846	94C4	汎
4847	94C5	版
4848	94C6	犯
4849	94C7	班
484A	94C8	畔
484B	94C9	繁
484C	94CA	般
484D	94CB	藩
484E	94CC	販
484F	94CD	範
4850	94CE	采
4851	94CF	煩
4852	94D0	頒

JIS	SJIS	字
4853	94D1	飯
4854	94D2	挽
4855	94D3	晚
4856	94D4	番
4857	94D5	盤
4858	94D6	磬
4859	94D7	蕃
485A	94D8	蛮
485B	94D9	匪
485C	94DA	卑
485D	94DB	否
485E	94DC	妃
485F	94DD	庇
4860	94DE	彼
4861	94DF	悲
4862	94E0	扉
4863	94E1	批
4864	94E2	披
4865	94E3	斐
4866	94E4	比
4867	94E5	泌
4868	94E6	疲
4869	94E7	皮
486A	94E8	碑
486B	94E9	秘
486C	94EA	緋
486D	94EB	罷
486E	94EC	肥
486F	94ED	被
4870	94EE	誹
4871	94EF	費
4872	94F0	避
4873	94F1	非
4874	94F2	飛
4875	94F3	樋
4876	94F4	簸

JIS	SJIS	字
4877	94F5	備
4878	94F6	尾
4879	94F7	微
487A	94F8	枇
487B	94F9	毘
487C	94FA	琵琶
487D	94FB	眉
487E	94FC	美
4921	9540	鼻
4922	9541	柊
4923	9542	稗
4924	9543	匹
4925	9544	疋
4926	9545	髭
4927	9546	彦
4928	9547	膝
4929	9548	菱
492A	9549	肘
492B	954A	粥
492C	954B	必
492D	954C	畢
492E	954D	筆
492F	954E	逼
4930	954F	桧
4931	9550	姬
4932	9551	媛
4933	9552	紐
4934	9553	百
4935	9554	謬
4936	9555	俵
4937	9556	彪
4938	9557	標
4939	9558	水
493A	9559	漂
493B	955A	瓢
493C	955B	票

JIS	SJIS	字
493D	955C	表
493E	955D	評
493F	955E	豹
4940	955F	廟
4941	9560	描
4942	9561	病
4943	9562	秒
4944	9563	苗
4945	9564	錨
4946	9565	鉦
4947	9566	蒜
4948	9567	蛭
4949	9568	鱸
494A	9569	品
494B	956A	彬
494C	956B	斌
494D	956C	浜
494E	956D	瀕
494F	956E	貧
4950	956F	賓
4951	9570	頻
4952	9571	敏
4953	9572	瓶
4954	9573	不
4955	9574	付
4956	9575	埠
4957	9576	夫
4958	9577	婦
4959	9578	富
495A	9579	富
495B	957A	布
495C	957B	府
495D	957C	佈
495E	957D	扶
495F	957E	敷
4960	9580	斧

JIS	SJIS	字
4961	9581	普
4962	9582	浮
4963	9583	父
4964	9584	符
4965	9585	腐
4966	9586	膚
4967	9587	芙
4968	9588	譜
4969	9589	負
496A	958A	賦
496B	958B	赴
496C	958C	阜
496D	958D	附
496E	958E	侮
496F	958F	撫
4970	9590	武
4971	9591	舞
4972	9592	葡
4973	9593	蕪
4974	9594	部
4975	9595	封
4976	9596	楓
4977	9597	風
4978	9598	葺
4979	9599	落
497A	959A	伏
497B	959B	副
497C	959C	復
497D	959D	幅
497E	959E	服
4A21	959F	福
4A22	95A0	腹
4A23	95A1	複
4A24	95A2	覆
4A25	95A3	淵
4A26	95A4	弗

JIS	SJIS	字
4A27	95A5	扌
4A28	95A6	沸
4A29	95A7	仏
4A2A	95A8	物
4A2B	95A9	鮒
4A2C	95AA	分
4A2D	95AB	吻
4A2E	95AC	噴
4A2F	95AD	墳
4A30	95AE	憤
4A31	95AF	扮
4A32	95B0	焚
4A33	95B1	奮
4A34	95B2	粉
4A35	95B3	糞
4A36	95B4	紛
4A37	95B5	雰
4A38	95B6	文
4A39	95B7	聞
4A3A	95B8	丙
4A3B	95B9	併
4A3C	95BA	兵
4A3D	95BB	塀
4A3E	95BC	幣
4A3F	95BD	平
4A40	95BE	弊
4A41	95BF	柄
4A42	95C0	並
4A43	95C1	蔽
4A44	95C2	閉
4A45	95C3	陛
4A46	95C4	米
4A47	95C5	頁
4A48	95C6	僻
4A49	95C7	壁
4A4A	95C8	癖

JIS	SJIS	字
4A4B	95C9	碧
4A4C	95CA	別
4A4D	95CB	瞥
4A4E	95CC	蔑
4A4F	95CD	篋
4A50	95CE	偏
4A51	95CF	變
4A52	95D0	片
4A53	95D1	篇
4A54	95D2	編
4A55	95D3	辺
4A56	95D4	返
4A57	95D5	遍
4A58	95D6	便
4A59	95D7	勉
4A5A	95D8	婉
4A5B	95D9	弁
4A5C	95DA	鞭
4A5D	95DB	保
4A5E	95DC	舖
4A5F	95DD	鋪
4A60	95DE	圃
4A61	95DF	捕
4A62	95E0	步
4A63	95E1	甫
4A64	95E2	補
4A65	95E3	輔
4A66	95E4	穗
4A67	95E5	募
4A68	95E6	墓
4A69	95E7	慕
4A6A	95E8	戊
4A6B	95E9	暮
4A6C	95EA	母
4A6D	95EB	簿
4A6E	95EC	菩

JIS	SJIS	字
4A6F	95ED	倣
4A70	95EE	倅
4A71	95EF	包
4A72	95F0	呆
4A73	95F1	報
4A74	95F2	奉
4A75	95F3	宝
4A76	95F4	峰
4A77	95F5	峯
4A78	95F6	崩
4A79	95F7	庖
4A7A	95F8	抱
4A7B	95F9	捧
4A7C	95FA	放
4A7D	95FB	方
4A7E	95FC	朋
4B21	9640	法
4B22	9641	泡
4B23	9642	烹
4B24	9643	砲
4B25	9644	縫
4B26	9645	胞
4B27	9646	芳
4B28	9647	萌
4B29	9648	蓬
4B2A	9649	蜂
4B2B	964A	褒
4B2C	964B	訪
4B2D	964C	豐
4B2E	964D	邦
4B2F	964E	鋒
4B30	964F	飽
4B31	9650	鳳
4B32	9651	鵬
4B33	9652	乏
4B34	9653	亡

JIS	SJIS	字
4B35	9654	傍
4B36	9655	剖
4B37	9656	坊
4B38	9657	妨
4B39	9658	帽
4B3A	9659	忘
4B3B	965A	忙
4B3C	965B	房
4B3D	965C	暴
4B3E	965D	望
4B3F	965E	某
4B40	965F	棒
4B41	9660	冒
4B42	9661	紡
4B43	9662	肪
4B44	9663	膨
4B45	9664	謀
4B46	9665	貌
4B47	9666	貿
4B48	9667	銖
4B49	9668	防
4B4A	9669	吠
4B4B	966A	頰
4B4C	966B	北
4B4D	966C	僕
4B4E	966D	卜
4B4F	966E	墨
4B50	966F	撲
4B51	9670	朴
4B52	9671	牧
4B53	9672	睦
4B54	9673	穆
4B55	9674	釦
4B56	9675	勃
4B57	9676	沒
4B58	9677	殆

JIS	SJIS	字
4B59	9678	堀
4B5A	9679	幌
4B5B	967A	奔
4B5C	967B	本
4B5D	967C	翻
4B5E	967D	凡
4B5F	967E	盆
4B60	9680	摩
4B61	9681	磨
4B62	9682	魔
4B63	9683	麻
4B64	9684	埋
4B65	9685	妹
4B66	9686	昧
4B67	9687	枚
4B68	9688	每
4B69	9689	哩
4B6A	968A	槓
4B6B	968B	幕
4B6C	968C	膜
4B6D	968D	枕
4B6E	968E	鮪
4B6F	968F	証
4B70	9690	鱒
4B71	9691	榘
4B72	9692	亦
4B73	9693	俣
4B74	9694	又
4B75	9695	抹
4B76	9696	末
4B77	9697	沫
4B78	9698	迄
4B79	9699	俥
4B7A	969A	繭
4B7B	969B	磨
4B7C	969C	万

JIS	SJIS	字
4B7D	969D	慢
4B7E	969E	滿
4C21	969F	漫
4C22	96A0	蔓
4C23	96A1	味
4C24	96A2	未
4C25	96A3	魅
4C26	96A4	巳
4C27	96A5	箕
4C28	96A6	岬
4C29	96A7	密
4C2A	96A8	蜜
4C2B	96A9	湊
4C2C	96AA	蓑
4C2D	96AB	稔
4C2E	96AC	脈
4C2F	96AD	妙
4C30	96AE	耗
4C31	96AF	民
4C32	96B0	眠
4C33	96B1	務
4C34	96B2	夢
4C35	96B3	無
4C36	96B4	牟
4C37	96B5	矛
4C38	96B6	霧
4C39	96B7	鷓
4C3A	96B8	椋
4C3B	96B9	婿
4C3C	96BA	娘
4C3D	96BB	冥
4C3E	96BC	名
4C3F	96BD	命
4C40	96BE	明
4C41	96BF	盟
4C42	96C0	迷

JIS	SJIS	字
4C43	96C1	銘
4C44	96C2	鳴
4C45	96C3	姪
4C46	96C4	牝
4C47	96C5	滅
4C48	96C6	免
4C49	96C7	棉
4C4A	96C8	綿
4C4B	96C9	緬
4C4C	96CA	面
4C4D	96CB	麵
4C4E	96CC	摸
4C4F	96CD	模
4C50	96CE	茂
4C51	96CF	妄
4C52	96D0	孟
4C53	96D1	毛
4C54	96D2	猛
4C55	96D3	盲
4C56	96D4	網
4C57	96D5	耗
4C58	96D6	蒙
4C59	96D7	儲
4C5A	96D8	木
4C5B	96D9	默
4C5C	96DA	目
4C5D	96DB	杳
4C5E	96DC	勿
4C5F	96DD	餅
4C60	96DE	尤
4C61	96DF	戾
4C62	96E0	粃
4C63	96E1	貰
4C64	96E2	問
4C65	96E3	悶
4C66	96E4	紋

JIS	SJIS	字
4C67	96E5	門
4C68	96E6	匆
4C69	96E7	也
4C6A	96E8	冶
4C6B	96E9	夜
4C6C	96EA	爺
4C6D	96EB	耶
4C6E	96EC	野
4C6F	96ED	弥
4C70	96EE	矢
4C71	96EF	厄
4C72	96F0	役
4C73	96F1	約
4C74	96F2	葉
4C75	96F3	訳
4C76	96F4	躍
4C77	96F5	靖
4C78	96F6	柳
4C79	96F7	薺
4C7A	96F8	鎗
4C7B	96F9	愉
4C7C	96FA	愈
4C7D	96FB	油
4C7E	96FC	癒
4D21	9740	諭
4D22	9741	輸
4D23	9742	唯
4D24	9743	佑
4D25	9744	優
4D26	9745	勇
4D27	9746	友
4D28	9747	宥
4D29	9748	幽
4D2A	9749	悠
4D2B	974A	憂
4D2C	974B	揖

JIS	SJIS	字
4D2D	974C	有
4D2E	974D	柚
4D2F	974E	湧
4D30	974F	涌
4D31	9750	猶
4D32	9751	猷
4D33	9752	由
4D34	9753	祐
4D35	9754	裕
4D36	9755	誘
4D37	9756	遊
4D38	9757	邑
4D39	9758	郵
4D3A	9759	雄
4D3B	975A	融
4D3C	975B	夕
4D3D	975C	予
4D3E	975D	余
4D3F	975E	与
4D40	975F	誉
4D41	9760	輿
4D42	9761	預
4D43	9762	備
4D44	9763	幼
4D45	9764	妖
4D46	9765	容
4D47	9766	庸
4D48	9767	揚
4D49	9768	搖
4D4A	9769	擁
4D4B	976A	曜
4D4C	976B	楊
4D4D	976C	樣
4D4E	976D	洋
4D4F	976E	溶
4D50	976F	熔

JIS	SJIS	字
4D51	9770	用
4D52	9771	窯
4D53	9772	羊
4D54	9773	耀
4D55	9774	葉
4D56	9775	蓉
4D57	9776	要
4D58	9777	謠
4D59	9778	踊
4D5A	9779	遙
4D5B	977A	陽
4D5C	977B	養
4D5D	977C	慾
4D5E	977D	抑
4D5F	977E	欲
4D60	9780	沃
4D61	9781	浴
4D62	9782	翌
4D63	9783	翼
4D64	9784	淀
4D65	9785	羅
4D66	9786	螺
4D67	9787	裸
4D68	9788	来
4D69	9789	莱
4D6A	978A	賴
4D6B	978B	雷
4D6C	978C	洛
4D6D	978D	絡
4D6E	978E	落
4D6F	978F	酪
4D70	9790	乱
4D71	9791	卵
4D72	9792	嵐
4D73	9793	欄
4D74	9794	濫

JIS	SJIS	字
4D75	9795	藍
4D76	9796	蘭
4D77	9797	覽
4D78	9798	利
4D79	9799	吏
4D7A	979A	履
4D7B	979B	李
4D7C	979C	梨
4D7D	979D	理
4D7E	979E	璃
4E21	979F	痢
4E22	97A0	裏
4E23	97A1	裡
4E24	97A2	里
4E25	97A3	離
4E26	97A4	陸
4E27	97A5	律
4E28	97A6	率
4E29	97A7	立
4E2A	97A8	葎
4E2B	97A9	掠
4E2C	97AA	略
4E2D	97AB	劉
4E2E	97AC	流
4E2F	97AD	溜
4E30	97AE	琉
4E31	97AF	留
4E32	97B0	硫
4E33	97B1	粒
4E34	97B2	隆
4E35	97B3	竜
4E36	97B4	龍
4E37	97B5	侶
4E38	97B6	慮
4E39	97B7	旅
4E3A	97B8	虜

JIS	SJIS	字
4E3B	97B9	了
4E3C	97BA	亮
4E3D	97BB	僚
4E3E	97BC	兩
4E3F	97BD	凌
4E40	97BE	寮
4E41	97BF	料
4E42	97C0	梁
4E43	97C1	涼
4E44	97C2	獵
4E45	97C3	療
4E46	97C4	瞭
4E47	97C5	稜
4E48	97C6	糧
4E49	97C7	良
4E4A	97C8	諒
4E4B	97C9	遼
4E4C	97CA	量
4E4D	97CB	陵
4E4E	97CC	領
4E4F	97CD	力
4E50	97CE	綠
4E51	97CF	倫
4E52	97D0	厘
4E53	97D1	林
4E54	97D2	淋
4E55	97D3	隣
4E56	97D4	琳
4E57	97D5	臨
4E58	97D6	輪
4E59	97D7	隣
4E5A	97D8	鱗
4E5B	97D9	麟
4E5C	97DA	溜
4E5D	97DB	罍
4E5E	97DC	淚

JIS	SJIS	字
4E5F	97DD	累
4E60	97DE	類
4E61	97DF	令
4E62	97E0	伶
4E63	97E1	例
4E64	97E2	冷
4E65	97E3	勵
4E66	97E4	嶺
4E67	97E5	伶
4E68	97E6	玲
4E69	97E7	礼
4E6A	97E8	苓
4E6B	97E9	鈴
4E6C	97EA	隸
4E6D	97EB	零
4E6E	97EC	靈
4E6F	97ED	麗
4E70	97EE	齡
4E71	97EF	曆
4E72	97F0	歷
4E73	97F1	列
4E74	97F2	劣
4E75	97F3	烈
4E76	97F4	裂
4E77	97F5	廉
4E78	97F6	恋
4E79	97F7	憐
4E7A	97F8	漣
4E7B	97F9	煉
4E7C	97FA	簾
4E7D	97FB	練
4E7E	97FC	聯
4F21	9840	蓮
4F22	9841	連
4F23	9842	鍊
4F24	9843	呂

JIS	SJIS	字
4F25	9844	魯
4F26	9845	櫓
4F27	9846	炉
4F28	9847	賂
4F29	9848	路
4F2A	9849	露
4F2B	984A	勞
4F2C	984B	婁
4F2D	984C	廊
4F2E	984D	弄
4F2F	984E	朗
4F30	984F	樓
4F31	9850	榔
4F32	9851	浪
4F33	9852	漏
4F34	9853	牢
4F35	9854	狼
4F36	9855	籠
4F37	9856	老
4F38	9857	聾
4F39	9858	蠟
4F3A	9859	郎
4F3B	985A	六
4F3C	985B	麓
4F3D	985C	祿
4F3E	985D	肋
4F3F	985E	錄
4F40	985F	論
4F41	9860	倭
4F42	9861	和
4F43	9862	話
4F44	9863	歪
4F45	9864	賄
4F46	9865	脇
4F47	9866	惑
4F48	9867	粹

JIS	SJIS	字
4F49	9868	鷲
4F4A	9869	互
4F4B	986A	亘
4F4C	986B	鰐
4F4D	986C	託
4F4E	986D	藁
4F4F	986E	蕨
4F50	986F	椀
4F51	9870	灣
4F52	9871	碗
4F53	9872	腕
4F54	9873	.
4F55	9874	.
4F56	9875	.
4F57	9876	.
4F58	9877	.
4F59	9878	.
4F5A	9879	.
4F5B	987A	.
4F5C	987B	.
4F5D	987C	.
4F5E	987D	.
4F5F	987E	.
4F60	9880	.
4F61	9881	.
4F62	9882	.
4F63	9883	.
4F64	9884	.
4F65	9885	.
4F66	9886	.
4F67	9887	.
4F68	9888	.
4F69	9889	.
4F6A	988A	.
4F6B	988B	.
4F6C	988C	.

JIS	SJIS	字
4F6D	988D	.
4F6E	988E	.
4F6F	988F	.
4F70	9890	.
4F71	9891	.
4F72	9892	.
4F73	9893	.
4F74	9894	.
4F75	9895	.
4F76	9896	.
4F77	9897	.
4F78	9898	.
4F79	9899	.
4F7A	989A	.
4F7B	989B	.
4F7C	989C	.
4F7D	989D	.
4F7E	989E	.
5021	989F	弑
5022	98A0	丐
5023	98A1	丕
5024	98A2	个
5025	98A3	卬
5026	98A4	、
5027	98A5	井
5028	98A6	丿
5029	98A7	乂
502A	98A8	乖
502B	98A9	乘
502C	98AA	亂
502D	98AB	丿
502E	98AC	豫
502F	98AD	事
5030	98AE	舒
5031	98AF	式
5032	98B0	于

JIS	SJIS	字
5033	98B1	亞
5034	98B2	亟
5035	98B3	亼
5036	98B4	亢
5037	98B5	京
5038	98B6	毫
5039	98B7	亶
503A	98B8	从
503B	98B9	仍
503C	98BA	仄
503D	98BB	仆
503E	98BC	仉
503F	98BD	仗
5040	98BE	仃
5041	98BF	仉
5042	98C0	仉
5043	98C1	价
5044	98C2	伉
5045	98C3	佚
5046	98C4	估
5047	98C5	佛
5048	98C6	佝
5049	98C7	佗
504A	98C8	佇
504B	98C9	佶
504C	98CA	侈
504D	98CB	侏
504E	98CC	侏
504F	98CD	佻
5050	98CE	佩
5051	98CF	佰
5052	98D0	侑
5053	98D1	佯
5054	98D2	來
5055	98D3	侖
5056	98D4	儘

JIS	SJIS	字
5057	98D5	俛
5058	98D6	俟
5059	98D7	俎
505A	98D8	俘
505B	98D9	俛
505C	98DA	俑
505D	98DB	俚
505E	98DC	俐
505F	98DD	弟
5060	98DE	俚
5061	98DF	倚
5062	98E0	倨
5063	98E1	倔
5064	98E2	倪
5065	98E3	倥
5066	98E4	倅
5067	98E5	倅
5068	98E6	倣
5069	98E7	倡
506A	98E8	倩
506B	98E9	倅
506C	98EA	倅
506D	98EB	俯
506E	98EC	們
506F	98ED	倆
5070	98EE	優
5071	98EF	假
5072	98F0	會
5073	98F1	偕
5074	98F2	修
5075	98F3	偈
5076	98F4	做
5077	98F5	偕
5078	98F6	惚
5079	98F7	偷
507A	98F8	傀

JIS	SJIS	字
507B	98F9	倣
507C	98FA	傅
507D	98FB	傴
507E	98FC	傲
5121	9940	僉
5122	9941	僊
5123	9942	傳
5124	9943	僂
5125	9944	僖
5126	9945	僞
5127	9946	僥
5128	9947	僦
5129	9948	僧
512A	9949	僨
512B	994A	價
512C	994B	僵
512D	994C	儉
512E	994D	僞
512F	994E	儂
5130	994F	儃
5131	9950	億
5132	9951	儅
5133	9952	儆
5134	9953	儇
5135	9954	儈
5136	9955	儉
5137	9956	儋
5138	9957	儅
5139	9958	儿
513A	9959	兀
513B	995A	兒
513C	995B	兌
513D	995C	兔
513E	995D	競
513F	995E	競
5140	995F	兩

JIS	SJIS	字
5141	9960	兪
5142	9961	兮
5143	9962	冀
5144	9963	冂
5145	9964	冂
5146	9965	冊
5147	9966	冉
5148	9967	冏
5149	9968	冑
514A	9969	冓
514B	996A	冕
514C	996B	冖
514D	996C	冤
514E	996D	寇
514F	996E	豕
5150	996F	寫
5151	9970	冪
5152	9971	冫
5153	9972	決
5154	9973	冫
5155	9974	冲
5156	9975	冰
5157	9976	冫
5158	9977	冽
5159	9978	冫
515A	9979	涼
515B	997A	凜
515C	997B	几
515D	997C	處
515E	997D	凧
515F	997E	凭
5160	9980	凰
5161	9981	凵
5162	9982	凵
5163	9983	刃
5164	9984	刊

JIS	SJIS	字
5165	9985	剗
5166	9986	剗
5167	9987	刵
5168	9988	刪
5169	9989	刮
516A	998A	剗
516B	998B	剗
516C	998C	剗
516D	998D	剗
516E	998E	剗
516F	998F	剗
5170	9990	剗
5171	9991	剗
5172	9992	剪
5173	9993	剗
5174	9994	剩
5175	9995	剗
5176	9996	剗
5177	9997	剗
5178	9998	劍
5179	9999	劍
517A	999A	劍
517B	999B	劍
517C	999C	劈
517D	999D	劑
517E	999E	辨
5221	999F	辦
5222	99A0	劬
5223	99A1	劬
5224	99A2	劬
5225	99A3	劬
5226	99A4	勁
5227	99A5	勅
5228	99A6	勗
5229	99A7	勞
522A	99A8	勗

JIS	SJIS	字
522B	99A9	勗
522C	99AA	飭
522D	99AB	勗
522E	99AC	勗
522F	99AD	勗
5230	99AE	勗
5231	99AF	勺
5232	99B0	匆
5233	99B1	匈
5234	99B2	甸
5235	99B3	甸
5236	99B4	甸
5237	99B5	匏
5238	99B6	匕
5239	99B7	匚
523A	99B8	匣
523B	99B9	匯
523C	99BA	匱
523D	99BB	匳
523E	99BC	匚
523F	99BD	區
5240	99BE	卅
5241	99BF	卅
5242	99C0	卅
5243	99C1	卉
5244	99C2	卅
5245	99C3	準
5246	99C4	卞
5247	99C5	卞
5248	99C6	卮
5249	99C7	卮
524A	99C8	卻
524B	99C9	卷
524C	99CA	厂
524D	99CB	厖
524E	99CC	厖

JIS	SJIS	字
524F	99CD	厦
5250	99CE	厥
5251	99CF	厮
5252	99D0	廠
5253	99D1	厶
5254	99D2	參
5255	99D3	篡
5256	99D4	雙
5257	99D5	叟
5258	99D6	曼
5259	99D7	變
525A	99D8	叮
525B	99D9	叨
525C	99DA	叭
525D	99DB	叭
525E	99DC	吁
525F	99DD	咩
5260	99DE	呀
5261	99DF	听
5262	99E0	吭
5263	99E1	吼
5264	99E2	吮
5265	99E3	呐
5266	99E4	吩
5267	99E5	咨
5268	99E6	呖
5269	99E7	咏
526A	99E8	呵
526B	99E9	咎
526C	99EA	炫
526D	99EB	呱
526E	99EC	呷
526F	99ED	咎
5270	99EE	咒
5271	99EF	呻
5272	99F0	咀

JIS	SJIS	字
5273	99F1	呶
5274	99F2	咄
5275	99F3	咐
5276	99F4	咆
5277	99F5	哇
5278	99F6	喙
5279	99F7	咸
527A	99F8	啞
527B	99F9	咬
527C	99FA	哄
527D	99FB	哈
527E	99FC	咨
5321	9A40	咫
5322	9A41	晒
5323	9A42	咤
5324	9A43	啗
5325	9A44	品
5326	9A45	咤
5327	9A46	哥
5328	9A47	哦
5329	9A48	唏
532A	9A49	唔
532B	9A4A	哽
532C	9A4B	哮
532D	9A4C	哭
532E	9A4D	哺
532F	9A4E	哧
5330	9A4F	啞
5331	9A50	哇
5332	9A51	啣
5333	9A52	啞
5334	9A53	售
5335	9A54	啜
5336	9A55	啖
5337	9A56	啖
5338	9A57	啗

JIS	SJIS	字
5339	9A58	唸
533A	9A59	唸
533B	9A5A	唸
533C	9A5B	喙
533D	9A5C	喀
533E	9A5D	咯
533F	9A5E	喊
5340	9A5F	喟
5341	9A60	畜
5342	9A61	啾
5343	9A62	喘
5344	9A63	唧
5345	9A64	單
5346	9A65	啼
5347	9A66	喃
5348	9A67	喻
5349	9A68	喇
534A	9A69	嘍
534B	9A6A	嗚
534C	9A6B	嗅
534D	9A6C	嗟
534E	9A6D	嘎
534F	9A6E	嗜
5350	9A6F	嗤
5351	9A70	嗔
5352	9A71	嘔
5353	9A72	嗽
5354	9A73	噴
5355	9A74	嗾
5356	9A75	嗽
5357	9A76	嘛
5358	9A77	噠
5359	9A78	噎
535A	9A79	噐
535B	9A7A	營
535C	9A7B	嘴

JIS	SJIS	字
535D	9A7C	嘶
535E	9A7D	嘲
535F	9A7E	嚙
5360	9A80	噫
5361	9A81	噤
5362	9A82	嘯
5363	9A83	噬
5364	9A84	噪
5365	9A85	嗜
5366	9A86	噤
5367	9A87	鼻
5368	9A88	嚙
5369	9A89	噎
536A	9A8A	噎
536B	9A8B	嚙
536C	9A8C	嚙
536D	9A8D	嚙
536E	9A8E	嚴
536F	9A8F	囁
5370	9A90	嚼
5371	9A91	嚼
5372	9A92	嚙
5373	9A93	轉
5374	9A94	嚙
5375	9A95	嚼
5376	9A96	嚼
5377	9A97	嚼
5378	9A98	口
5379	9A99	囁
537A	9A9A	囁
537B	9A9B	囁
537C	9A9C	囁
537D	9A9D	囁
537E	9A9E	囁
5421	9A9F	囁
5422	9AA0	國

JIS	SJIS	字
5423	9AA1	圍
5424	9AA2	圓
5425	9AA3	團
5426	9AA4	圖
5427	9AA5	奮
5428	9AA6	園
5429	9AA7	圪
542A	9AA8	圻
542B	9AA9	圯
542C	9AAA	坎
542D	9AAB	圪
542E	9AAC	址
542F	9AAD	坏
5430	9AAE	坩
5431	9AAF	垂
5432	9AB0	垩
5433	9AB1	坡
5434	9AB2	坩
5435	9AB3	坩
5436	9AB4	垓
5437	9AB5	垠
5438	9AB6	圻
5439	9AB7	垓
543A	9AB8	坩
543B	9AB9	坩
543C	9ABA	埃
543D	9ABB	坩
543E	9ABC	埔
543F	9ABD	埕
5440	9ABE	埕
5441	9ABF	壘
5442	9AC0	坩
5443	9AC1	埕
5444	9AC2	棚
5445	9AC3	埕
5446	9AC4	坩

JIS	SJIS	字
5447	9AC5	場
5448	9AC6	堡
5449	9AC7	塢
544A	9AC8	塢
544B	9AC9	塢
544C	9ACA	毀
544D	9ACB	塢
544E	9ACC	塢
544F	9ACD	塢
5450	9ACE	塢
5451	9ACF	塢
5452	9AD0	墟
5453	9AD1	塢
5454	9AD2	塢
5455	9AD3	壞
5456	9AD4	墻
5457	9AD5	堵
5458	9AD6	墮
5459	9AD7	壅
545A	9AD8	壓
545B	9AD9	壑
545C	9ADA	墟
545D	9ADB	壙
545E	9ADC	壘
545F	9ADD	壙
5460	9ADE	壙
5461	9ADF	壤
5462	9AE0	壘
5463	9AE1	壯
5464	9AE2	壺
5465	9AE3	壺
5466	9AE4	壙
5467	9AE5	壺
5468	9AE6	壽
5469	9AE7	夊
546A	9AE8	夊

JIS	SJIS	字
546B	9AE9	夊
546C	9AEA	夊
546D	9AEB	夢
546E	9AEC	夥
546F	9AED	夊
5470	9AEE	夭
5471	9AEF	夊
5472	9AF0	夸
5473	9AF1	夾
5474	9AF2	竒
5475	9AF3	奕
5476	9AF4	奂
5477	9AF5	奎
5478	9AF6	奚
5479	9AF7	奘
547A	9AF8	奢
547B	9AF9	奘
547C	9AFA	奧
547D	9AFB	奘
547E	9AFC	奘
5521	9B40	奸
5522	9B41	妁
5523	9B42	妝
5524	9B43	佞
5525	9B44	佞
5526	9B45	妣
5527	9B46	妣
5528	9B47	姆
5529	9B48	姨
552A	9B49	姜
552B	9B4A	妍
552C	9B4B	姪
552D	9B4C	姚
552E	9B4D	娥
552F	9B4E	娟
5530	9B4F	娑

JIS	SJIS	字
5531	9B50	娜
5532	9B51	娉
5533	9B52	娉
5534	9B53	婀
5535	9B54	姪
5536	9B55	婉
5537	9B56	嫩
5538	9B57	娶
5539	9B58	婢
553A	9B59	婪
553B	9B5A	媚
553C	9B5B	媪
553D	9B5C	媪
553E	9B5D	媪
553F	9B5E	媪
5540	9B5F	媽
5541	9B60	媽
5542	9B61	媪
5543	9B62	媪
5544	9B63	嫩
5545	9B64	嫖
5546	9B65	嫖
5547	9B66	嫖
5548	9B67	嬌
5549	9B68	嫖
554A	9B69	嫖
554B	9B6A	嫖
554C	9B6B	嫩
554D	9B6C	嫖
554E	9B6D	嫖
554F	9B6E	嫖
5550	9B6F	嫖
5551	9B70	嫖
5552	9B71	嫖
5553	9B72	子
5554	9B73	孕

JIS	SJIS	字
5555	9B74	孚
5556	9B75	亨
5557	9B76	孛
5558	9B77	孩
5559	9B78	孰
555A	9B79	孳
555B	9B7A	孳
555C	9B7B	學
555D	9B7C	孳
555E	9B7D	孺
555F	9B7E	宀
5560	9B80	它
5561	9B81	宦
5562	9B82	宸
5563	9B83	寃
5564	9B84	寇
5565	9B85	雀
5566	9B86	寔
5567	9B87	寐
5568	9B88	寤
5569	9B89	實
556A	9B8A	寢
556B	9B8B	寔
556C	9B8C	寥
556D	9B8D	寫
556E	9B8E	寔
556F	9B8F	寶
5570	9B90	寶
5571	9B91	尅
5572	9B92	將
5573	9B93	專
5574	9B94	對
5575	9B95	尔
5576	9B96	尠
5577	9B97	尢
5578	9B98	尫

JIS	SJIS	字
5579	9B99	尸
557A	9B9A	尹
557B	9B9B	屁
557C	9B9C	屈
557D	9B9D	屎
557E	9B9E	眞
5621	9B9F	屐
5622	9BA0	屛
5623	9BA1	屛
5624	9BA2	屬
5625	9BA3	屮
5626	9BA4	屮
5627	9BA5	屮
5628	9BA6	屹
5629	9BA7	岌
562A	9BA8	岑
562B	9BA9	岔
562C	9BAA	岌
562D	9BAB	岫
562E	9BAC	岷
562F	9BAD	岫
5630	9BAE	岫
5631	9BAF	岷
5632	9BB0	岷
5633	9BB1	岫
5634	9BB2	岷
5635	9BB3	峙
5636	9BB4	峩
5637	9BB5	峽
5638	9BB6	峩
5639	9BB7	峭
563A	9BB8	崑
563B	9BB9	峪
563C	9BBA	崑
563D	9BBB	崑
563E	9BBC	崗

JIS	SJIS	字
563F	9BBD	崑
5640	9BBE	崑
5641	9BBF	崑
5642	9BC0	崑
5643	9BC1	崑
5644	9BC2	崑
5645	9BC3	崑
5646	9BC4	崑
5647	9BC5	崑
5648	9BC6	崑
5649	9BC7	崑
564A	9BC8	崑
564B	9BC9	崑
564C	9BCA	崑
564D	9BCB	崑
564E	9BCC	崑
564F	9BCD	崑
5650	9BCE	崑
5651	9BCF	崑
5652	9BD0	崑
5653	9BD1	崑
5654	9BD2	崑
5655	9BD3	崑
5656	9BD4	崑
5657	9BD5	崑
5658	9BD6	崑
5659	9BD7	崑
565A	9BD8	崑
565B	9BD9	崑
565C	9BDA	崑
565D	9BDB	崑
565E	9BDC	崑
565F	9BDD	崑
5660	9BDE	崑
5661	9BDF	崑
5662	9BE0	崑

JIS	SJIS	字
5663	9BE1	崑
5664	9BE2	崑
5665	9BE3	崑
5666	9BE4	崑
5667	9BE5	崑
5668	9BE6	崑
5669	9BE7	崑
566A	9BE8	崑
566B	9BE9	崑
566C	9BEA	崑
566D	9BEB	崑
566E	9BEC	崑
566F	9BED	崑
5670	9BEE	崑
5671	9BEF	崑
5672	9BF0	崑
5673	9BF1	崑
5674	9BF2	崑
5675	9BF3	崑
5676	9BF4	崑
5677	9BF5	崑
5678	9BF6	崑
5679	9BF7	崑
567A	9BF8	崑
567B	9BF9	崑
567C	9BFA	崑
567D	9BFB	崑
567E	9BFC	崑
5721	9C40	崑
5722	9C41	崑
5723	9C42	崑
5724	9C43	崑
5725	9C44	崑
5726	9C45	崑
5727	9C46	崑
5728	9C47	崑

JIS	SJIS	字
5729	9C48	廩
572A	9C49	廬
572B	9C4A	廳
572C	9C4B	廳
572D	9C4C	廳
572E	9C4D	廸
572F	9C4E	廸
5730	9C4F	弁
5731	9C50	弁
5732	9C51	弁
5733	9C52	彘
5734	9C53	彘
5735	9C54	弋
5736	9C55	弋
5737	9C56	弓
5738	9C57	弩
5739	9C58	弭
573A	9C59	弭
573B	9C5A	弭
573C	9C5B	彈
573D	9C5C	彌
573E	9C5D	彎
573F	9C5E	彎
5740	9C5F	互
5741	9C60	彖
5742	9C61	彖
5743	9C62	彖
5744	9C63	彖
5745	9C64	彭
5746	9C65	彖
5747	9C66	徬
5748	9C67	徬
5749	9C68	徬
574A	9C69	徬
574B	9C6A	徬
574C	9C6B	徬

JIS	SJIS	字
574D	9C6C	徑
574E	9C6D	徇
574F	9C6E	徇
5750	9C6F	徇
5751	9C70	徇
5752	9C71	徇
5753	9C72	徇
5754	9C73	徇
5755	9C74	徇
5756	9C75	徇
5757	9C76	徇
5758	9C77	徇
5759	9C78	徇
575A	9C79	徇
575B	9C7A	徇
575C	9C7B	徇
575D	9C7C	徇
575E	9C7D	徇
575F	9C7E	徇
5760	9C80	怙
5761	9C81	恂
5762	9C82	恂
5763	9C83	恂
5764	9C84	忽
5765	9C85	怛
5766	9C86	怕
5767	9C87	怫
5768	9C88	怦
5769	9C89	怦
576A	9C8A	怦
576B	9C8B	恚
576C	9C8C	恚
576D	9C8D	恚
576E	9C8E	恚
576F	9C8F	恂
5770	9C90	協

JIS	SJIS	字
5771	9C91	恆
5772	9C92	恍
5773	9C93	恣
5774	9C94	恃
5775	9C95	恤
5776	9C96	恂
5777	9C97	恬
5778	9C98	恂
5779	9C99	恙
577A	9C9A	恂
577B	9C9B	悍
577C	9C9C	惧
577D	9C9D	恂
577E	9C9E	悚
5821	9C9F	恂
5822	9CA0	悛
5823	9CA1	悖
5824	9CA2	悖
5825	9CA3	悖
5826	9CA4	悖
5827	9CA5	悖
5828	9CA6	惡
5829	9CA7	悖
582A	9CA8	惠
582B	9CA9	倦
582C	9CAA	悴
582D	9CAB	悴
582E	9CAC	悽
582F	9CAD	惆
5830	9CAE	悵
5831	9CAF	悵
5832	9CB0	悵
5833	9CB1	悵
5834	9CB2	悵
5835	9CB3	悵
5836	9CB4	悵

JIS	SJIS	字
5837	9CB5	愀
5838	9CB6	愀
5839	9CB7	愀
583A	9CB8	愀
583B	9CB9	愀
583C	9CBA	愀
583D	9CBB	愀
583E	9CBC	愀
583F	9CBD	愀
5840	9CBE	愀
5841	9CBF	愀
5842	9CC0	愀
5843	9CC1	愧
5844	9CC2	慊
5845	9CC3	慊
5846	9CC4	愼
5847	9CC5	愆
5848	9CC6	愆
5849	9CC7	愆
584A	9CC8	愆
584B	9CC9	慄
584C	9CCA	慄
584D	9CCB	慄
584E	9CCC	慘
584F	9CCD	慙
5850	9CCE	慙
5851	9CCF	慙
5852	9CD0	慙
5853	9CD1	傷
5854	9CD2	慙
5855	9CD3	慙
5856	9CD4	慙
5857	9CD5	慙
5858	9CD6	慙
5859	9CD7	慙
585A	9CD8	慙

JIS	SJIS	字
585B	9CD9	愁
585C	9CDA	憇
585D	9CDB	憬
585E	9CDC	懔
585F	9CDD	憚
5860	9CDE	憊
5861	9CDF	憑
5862	9CE0	憫
5863	9CE1	憮
5864	9CE2	憐
5865	9CE3	懷
5866	9CE4	應
5867	9CE5	懷
5868	9CE6	懈
5869	9CE7	勲
586A	9CE8	慍
586B	9CE9	愴
586C	9CEA	懋
586D	9CEB	懼
586E	9CEC	慍
586F	9CED	儒
5870	9CEE	懣
5871	9CEF	懶
5872	9CF0	懣
5873	9CF1	懣
5874	9CF2	懿
5875	9CF3	懼
5876	9CF4	懼
5877	9CF5	懣
5878	9CF6	懣
5879	9CF7	戈
587A	9CF8	戍
587B	9CF9	戍
587C	9CFA	戍
587D	9CFB	戔
587E	9CFC	戔

JIS	SJIS	字
5921	9D40	憂
5922	9D41	戩
5923	9D42	截
5924	9D43	戮
5925	9D44	戰
5926	9D45	戲
5927	9D46	戩
5928	9D47	扁
5929	9D48	扎
592A	9D49	扞
592B	9D4A	扣
592C	9D4B	扛
592D	9D4C	扞
592E	9D4D	扞
592F	9D4E	扼
5930	9D4F	狂
5931	9D50	扶
5932	9D51	找
5933	9D52	抒
5934	9D53	抓
5935	9D54	抖
5936	9D55	拔
5937	9D56	扞
5938	9D57	扞
5939	9D58	拗
593A	9D59	拮
593B	9D5A	伸
593C	9D5B	拏
593D	9D5C	拿
593E	9D5D	拆
593F	9D5E	擔
5940	9D5F	拮
5941	9D60	拜
5942	9D61	拌
5943	9D62	拊
5944	9D63	拂

JIS	SJIS	字
5945	9D64	拇
5946	9D65	拋
5947	9D66	拉
5948	9D67	拈
5949	9D68	拈
594A	9D69	拱
594B	9D6A	拈
594C	9D6B	挂
594D	9D6C	拈
594E	9D6D	拯
594F	9D6E	拈
5950	9D6F	捐
5951	9D70	挾
5952	9D71	捍
5953	9D72	搜
5954	9D73	捏
5955	9D74	掖
5956	9D75	拈
5957	9D76	掀
5958	9D77	掀
5959	9D78	捶
595A	9D79	掣
595B	9D7A	掏
595C	9D7B	掉
595D	9D7C	掙
595E	9D7D	掙
595F	9D7E	捫
5960	9D80	捩
5961	9D81	掙
5962	9D82	揩
5963	9D83	揀
5964	9D84	揆
5965	9D85	揣
5966	9D86	揉
5967	9D87	插
5968	9D88	擲

JIS	SJIS	字
5969	9D89	掬
596A	9D8A	搖
596B	9D8B	拳
596C	9D8C	搆
596D	9D8D	搓
596E	9D8E	搦
596F	9D8F	搶
5970	9D90	攝
5971	9D91	搗
5972	9D92	搦
5973	9D93	搏
5974	9D94	摧
5975	9D95	摯
5976	9D96	搏
5977	9D97	摻
5978	9D98	攪
5979	9D99	撕
597A	9D9A	撓
597B	9D9B	撥
597C	9D9C	撩
597D	9D9D	撈
597E	9D9E	撼
5A21	9D9F	據
5A22	9DA0	擒
5A23	9DA1	擅
5A24	9DA2	擇
5A25	9DA3	撻
5A26	9DA4	擊
5A27	9DA5	搯
5A28	9DA6	攔
5A29	9DA7	舉
5A2A	9DA8	舉
5A2B	9DA9	擠
5A2C	9DAA	擡
5A2D	9DAB	抬
5A2E	9DAC	擣

JIS	SJIS	字
5A2F	9DAD	攢
5A30	9DAE	攬
5A31	9DAF	搯
5A32	9DB0	擴
5A33	9DB1	擲
5A34	9DB2	擺
5A35	9DB3	攀
5A36	9DB4	撥
5A37	9DB5	攘
5A38	9DB6	攜
5A39	9DB7	攢
5A3A	9DB8	攤
5A3B	9DB9	攀
5A3C	9DBA	攬
5A3D	9DBB	支
5A3E	9DBC	攵
5A3F	9DBD	攷
5A40	9DBE	攷
5A41	9DBF	攷
5A42	9DC0	攷
5A43	9DC1	攷
5A44	9DC2	攷
5A45	9DC3	攷
5A46	9DC4	攷
5A47	9DC5	攷
5A48	9DC6	攷
5A49	9DC7	攷
5A4A	9DC8	攷
5A4B	9DC9	攷
5A4C	9DCA	攷
5A4D	9DCB	攷
5A4E	9DCC	攷
5A4F	9DCD	攷
5A50	9DCE	攷
5A51	9DCF	攷
5A52	9DD0	攷

JIS	SJIS	字
5A53	9DD1	旃
5A54	9DD2	旃
5A55	9DD3	旃
5A56	9DD4	旃
5A57	9DD5	旃
5A58	9DD6	旃
5A59	9DD7	旃
5A5A	9DD8	旃
5A5B	9DD9	无
5A5C	9DDA	无
5A5D	9DDB	旱
5A5E	9DDC	杲
5A5F	9DDD	昊
5A60	9DDE	旻
5A61	9DDF	旻
5A62	9DE0	杳
5A63	9DE1	昵
5A64	9DE2	昶
5A65	9DE3	昴
5A66	9DE4	昴
5A67	9DE5	晏
5A68	9DE6	昞
5A69	9DE7	晉
5A6A	9DE8	晁
5A6B	9DE9	晞
5A6C	9DEA	晝
5A6D	9DEB	晤
5A6E	9DEC	皓
5A6F	9DED	晨
5A70	9DEE	晟
5A71	9DEF	晔
5A72	9DF0	晰
5A73	9DF1	晔
5A74	9DF2	暈
5A75	9DF3	暎
5A76	9DF4	暎

JIS	SJIS	字
5A77	9DF5	暎
5A78	9DF6	暎
5A79	9DF7	暎
5A7A	9DF8	暨
5A7B	9DF9	暎
5A7C	9DFA	曉
5A7D	9DFB	暎
5A7E	9DFC	瞥
5B21	9E40	曄
5B22	9E41	瞭
5B23	9E42	曖
5B24	9E43	矇
5B25	9E44	曠
5B26	9E45	眩
5B27	9E46	曦
5B28	9E47	曩
5B29	9E48	日
5B2A	9E49	曳
5B2B	9E4A	曷
5B2C	9E4B	肫
5B2D	9E4C	腺
5B2E	9E4D	朞
5B2F	9E4E	朦
5B30	9E4F	朧
5B31	9E50	霸
5B32	9E51	朮
5B33	9E52	朮
5B34	9E53	朮
5B35	9E54	朮
5B36	9E55	朮
5B37	9E56	朮
5B38	9E57	朮
5B39	9E58	朮
5B3A	9E59	朮
5B3B	9E5A	朮
5B3C	9E5B	朮

JIS	SJIS	字
5B3D	9E5C	枋
5B3E	9E5D	枋
5B3F	9E5E	杰
5B40	9E5F	杰
5B41	9E60	杼
5B42	9E61	杪
5B43	9E62	杪
5B44	9E63	枋
5B45	9E64	枋
5B46	9E65	枋
5B47	9E66	枋
5B48	9E67	枷
5B49	9E68	柯
5B4A	9E69	枋
5B4B	9E6A	束
5B4C	9E6B	枳
5B4D	9E6C	枳
5B4E	9E6D	枸
5B4F	9E6E	粗
5B50	9E6F	柞
5B51	9E70	柞
5B52	9E71	柞
5B53	9E72	柞
5B54	9E73	枹
5B55	9E74	枹
5B56	9E75	粒
5B57	9E76	枹
5B58	9E77	檜
5B59	9E78	桀
5B5A	9E79	框
5B5B	9E7A	栩
5B5C	9E7B	桀
5B5D	9E7C	桀
5B5E	9E7D	桀
5B5F	9E7E	桀
5B60	9E80	梳

JIS	SJIS	字
5B61	9E81	梲
5B62	9E82	梓
5B63	9E83	档
5B64	9E84	桷
5B65	9E85	桿
5B66	9E86	梟
5B67	9E87	桔
5B68	9E88	梭
5B69	9E89	梔
5B6A	9E8A	條
5B6B	9E8B	椰
5B6C	9E8C	梃
5B6D	9E8D	檣
5B6E	9E8E	枳
5B6F	9E8F	桴
5B70	9E90	梵
5B71	9E91	枊
5B72	9E92	桢
5B73	9E93	桲
5B74	9E94	梔
5B75	9E95	楮
5B76	9E96	桴
5B77	9E97	棊
5B78	9E98	榭
5B79	9E99	棘
5B7A	9E9A	榲
5B7B	9E9B	榜
5B7C	9E9C	桐
5B7D	9E9D	控
5B7E	9E9E	棍
5C21	9E9F	楫
5C22	9EA0	棧
5C23	9EA1	棕
5C24	9EA2	櫻
5C25	9EA3	椒
5C26	9EA4	接

JIS	SJIS	字
5C27	9EA5	棗
5C28	9EA6	棣
5C29	9EA7	榭
5C2A	9EA8	棹
5C2B	9EA9	棠
5C2C	9EAA	楨
5C2D	9EAB	榭
5C2E	9EAC	楹
5C2F	9EAD	櫛
5C30	9EAE	楨
5C31	9EAF	樹
5C32	9EB0	榆
5C33	9EB1	楹
5C34	9EB2	楷
5C35	9EB3	榭
5C36	9EB4	楸
5C37	9EB5	楫
5C38	9EB6	楔
5C39	9EB7	椋
5C3A	9EB8	楮
5C3B	9EB9	楸
5C3C	9EBA	楸
5C3D	9EBB	椋
5C3E	9EBC	楸
5C3F	9EBD	椰
5C40	9EBE	榆
5C41	9EBF	楞
5C42	9EC0	棟
5C43	9EC1	棧
5C44	9EC2	櫟
5C45	9EC3	楹
5C46	9EC4	榮
5C47	9EC5	槐
5C48	9EC6	檉
5C49	9EC7	槁
5C4A	9EC8	楨

JIS	SJIS	字
5C4B	9EC9	楸
5C4C	9ECA	槎
5C4D	9ECB	棗
5C4E	9ECC	槲
5C4F	9ECD	槁
5C50	9ECE	楸
5C51	9ECF	槲
5C52	9ED0	榧
5C53	9ED1	榧
5C54	9ED2	榧
5C55	9ED3	榧
5C56	9ED4	榜
5C57	9ED5	榕
5C58	9ED6	榴
5C59	9ED7	檉
5C5A	9ED8	榔
5C5B	9ED9	樂
5C5C	9EDA	穆
5C5D	9EDB	槿
5C5E	9EDC	權
5C5F	9EDD	槲
5C60	9EDE	榭
5C61	9EDF	槲
5C62	9EE0	縱
5C63	9EE1	榭
5C64	9EE2	榭
5C65	9EE3	榭
5C66	9EE4	榭
5C67	9EE5	榭
5C68	9EE6	榭
5C69	9EE7	榭
5C6A	9EE8	榭
5C6B	9EE9	榭
5C6C	9EEA	榭
5C6D	9EEB	榭
5C6E	9EEC	榭

JIS	SJIS	字
5C6F	9EED	榭
5C70	9EEE	榭
5C71	9EEF	榭
5C72	9EF0	榭
5C73	9EF1	榭
5C74	9EF2	橙
5C75	9EF3	槿
5C76	9EF4	榭
5C77	9EF5	榭
5C78	9EF6	榭
5C79	9EF7	榭
5C7A	9EF8	榭
5C7B	9EF9	槲
5C7C	9EFA	榭
5C7D	9EFB	檢
5C7E	9EFC	榭
5D21	9F40	槲
5D22	9F41	槲
5D23	9F42	槲
5D24	9F43	槲
5D25	9F44	榭
5D26	9F45	榭
5D27	9F46	槲
5D28	9F47	榭
5D29	9F48	榭
5D2A	9F49	槲
5D2B	9F4A	榭
5D2C	9F4B	榭
5D2D	9F4C	榭
5D2E	9F4D	榭
5D2F	9F4E	榭
5D30	9F4F	榭
5D31	9F50	槲
5D32	9F51	榭
5D33	9F52	槲
5D34	9F53	榭

JIS	SJIS	字
5D35	9F54	鬱
5D36	9F55	櫛
5D37	9F56	欵
5D38	9F57	欵
5D39	9F58	盜
5D3A	9F59	欵
5D3B	9F5A	飲
5D3C	9F5B	歎
5D3D	9F5C	敵
5D3E	9F5D	歎
5D3F	9F5E	歐
5D40	9F5F	歎
5D41	9F60	歎
5D42	9F61	歎
5D43	9F62	歎
5D44	9F63	歡
5D45	9F64	歸
5D46	9F65	歹
5D47	9F66	歎
5D48	9F67	歎
5D49	9F68	歎
5D4A	9F69	歎
5D4B	9F6A	歎
5D4C	9F6B	殘
5D4D	9F6C	殫
5D4E	9F6D	殫
5D4F	9F6E	殫
5D50	9F6F	殫
5D51	9F70	殫
5D52	9F71	殫
5D53	9F72	殫
5D54	9F73	殫
5D55	9F74	殫
5D56	9F75	殫
5D57	9F76	殫
5D58	9F77	殫

JIS	SJIS	字
5D59	9F78	毋
5D5A	9F79	毓
5D5B	9F7A	筆
5D5C	9F7B	毬
5D5D	9F7C	毫
5D5E	9F7D	毳
5D5F	9F7E	毳
5D60	9F80	麾
5D61	9F81	氈
5D62	9F82	氓
5D63	9F83	气
5D64	9F84	氛
5D65	9F85	氫
5D66	9F86	氣
5D67	9F87	汞
5D68	9F88	汕
5D69	9F89	汩
5D6A	9F8A	汪
5D6B	9F8B	沂
5D6C	9F8C	沔
5D6D	9F8D	沚
5D6E	9F8E	沁
5D6F	9F8F	沛
5D70	9F90	汾
5D71	9F91	汨
5D72	9F92	汨
5D73	9F93	沒
5D74	9F94	沐
5D75	9F95	泄
5D76	9F96	決
5D77	9F97	泓
5D78	9F98	沽
5D79	9F99	泗
5D7A	9F9A	泗
5D7B	9F9B	沂
5D7C	9F9C	沮

JIS	SJIS	字
5D7D	9F9D	沱
5D7E	9F9E	沾
5E21	9F9F	沱
5E22	9FA0	泛
5E23	9FA1	混
5E24	9FA2	汧
5E25	9FA3	泪
5E26	9FA4	洩
5E27	9FA5	衍
5E28	9FA6	洵
5E29	9FA7	洫
5E2A	9FA8	洽
5E2B	9FA9	洸
5E2C	9FAA	洙
5E2D	9FAB	洵
5E2E	9FAC	洳
5E2F	9FAD	洒
5E30	9FAE	洌
5E31	9FAF	浣
5E32	9FB0	涓
5E33	9FB1	浚
5E34	9FB2	浚
5E35	9FB3	浹
5E36	9FB4	浙
5E37	9FB5	涎
5E38	9FB6	涕
5E39	9FB7	濤
5E3A	9FB8	湍
5E3B	9FB9	淹
5E3C	9FBA	洩
5E3D	9FBB	淵
5E3E	9FBC	涵
5E3F	9FBD	淇
5E40	9FBE	滄
5E41	9FBF	溷
5E42	9FC0	滄

JIS	SJIS	字
5E43	9FC1	淬
5E44	9FC2	淞
5E45	9FC3	淌
5E46	9FC4	淨
5E47	9FC5	淒
5E48	9FC6	浙
5E49	9FC7	淺
5E4A	9FC8	淙
5E4B	9FC9	淤
5E4C	9FCA	漑
5E4D	9FCB	淪
5E4E	9FCC	淮
5E4F	9FCD	渭
5E50	9FCE	湮
5E51	9FCF	潯
5E52	9FD0	渙
5E53	9FD1	潏
5E54	9FD2	湟
5E55	9FD3	渾
5E56	9FD4	渣
5E57	9FD5	湫
5E58	9FD6	灑
5E59	9FD7	灑
5E5A	9FD8	湍
5E5B	9FD9	湍
5E5C	9FDA	湍
5E5D	9FDB	渺
5E5E	9FDC	湎
5E5F	9FDD	渤
5E60	9FDE	滿
5E61	9FDF	渝
5E62	9FE0	游
5E63	9FE1	漑
5E64	9FE2	溪
5E65	9FE3	澗
5E66	9FE4	混

JIS	SJIS	字
5E67	9FE5	溷
5E68	9FE6	滓
5E69	9FE7	溥
5E6A	9FE8	溂
5E6B	9FE9	滄
5E6C	9FEA	溲
5E6D	9FEB	滔
5E6E	9FEC	滕
5E6F	9FED	漭
5E70	9FEE	溥
5E71	9FEF	滂
5E72	9FF0	溟
5E73	9FF1	潁
5E74	9FF2	漑
5E75	9FF3	灌
5E76	9FF4	滄
5E77	9FF5	滸
5E78	9FF6	滾
5E79	9FF7	漿
5E7A	9FF8	滲
5E7B	9FF9	漱
5E7C	9FFA	滯
5E7D	9FFB	漲
5E7E	9FFC	滌
5F21	E040	漾
5F22	E041	漓
5F23	E042	滷
5F24	E043	澆
5F25	E044	滌
5F26	E045	潛
5F27	E046	澁
5F28	E047	澀
5F29	E048	澇
5F2A	E049	潛
5F2B	E04A	潛
5F2C	E04B	潭

JIS	SJIS	字
5F2D	E04C	激
5F2E	E04D	潼
5F2F	E04E	潘
5F30	E04F	澎
5F31	E050	漚
5F32	E051	濂
5F33	E052	潦
5F34	E053	澳
5F35	E054	澣
5F36	E055	澡
5F37	E056	澤
5F38	E057	澹
5F39	E058	瀆
5F3A	E059	滌
5F3B	E05A	濟
5F3C	E05B	濕
5F3D	E05C	濬
5F3E	E05D	灑
5F3F	E05E	濘
5F40	E05F	濱
5F41	E060	濮
5F42	E061	濛
5F43	E062	瀉
5F44	E063	瀟
5F45	E064	灑
5F46	E065	瀑
5F47	E066	澆
5F48	E067	瀏
5F49	E068	瀘
5F4A	E069	瀛
5F4B	E06A	瀚
5F4C	E06B	瀦
5F4D	E06C	瀝
5F4E	E06D	瀘
5F4F	E06E	瀟
5F50	E06F	灑

JIS	SJIS	字
5F51	E070	灑
5F52	E071	灑
5F53	E072	灑
5F54	E073	灣
5F55	E074	炙
5F56	E075	炒
5F57	E076	炯
5F58	E077	炯
5F59	E078	炬
5F5A	E079	炸
5F5B	E07A	炳
5F5C	E07B	炮
5F5D	E07C	烟
5F5E	E07D	倏
5F5F	E07E	烝
5F60	E080	烙
5F61	E081	焉
5F62	E082	烽
5F63	E083	焜
5F64	E084	焙
5F65	E085	煥
5F66	E086	熙
5F67	E087	熙
5F68	E088	煦
5F69	E089	熒
5F6A	E08A	煌
5F6B	E08B	煖
5F6C	E08C	煬
5F6D	E08D	熏
5F6E	E08E	燠
5F6F	E08F	熄
5F70	E090	煩
5F71	E091	熨
5F72	E092	熬
5F73	E093	爛
5F74	E094	熹

JIS	SJIS	字
5F75	E095	熾
5F76	E096	燒
5F77	E097	燉
5F78	E098	燔
5F79	E099	燎
5F7A	E09A	燠
5F7B	E09B	燬
5F7C	E09C	燧
5F7D	E09D	燧
5F7E	E09E	燼
6021	E09F	燹
6022	E0A0	耀
6023	E0A1	爍
6024	E0A2	爐
6025	E0A3	爛
6026	E0A4	爨
6027	E0A5	爭
6028	E0A6	爬
6029	E0A7	爰
602A	E0A8	爲
602B	E0A9	爻
602C	E0AA	俎
602D	E0AB	爿
602E	E0AC	牀
602F	E0AD	牆
6030	E0AE	牋
6031	E0AF	牘
6032	E0B0	牴
6033	E0B1	牾
6034	E0B2	犁
6035	E0B3	犁
6036	E0B4	犇
6037	E0B5	犒
6038	E0B6	犖
6039	E0B7	犗
603A	E0B8	犘

JIS	SJIS	字
603B	E0B9	犹
603C	E0BA	豺
603D	E0BB	狃
603E	E0BC	狃
603F	E0BD	狄
6040	E0BE	狎
6041	E0BF	狒
6042	E0C0	貉
6043	E0C1	狼
6044	E0C2	狡
6045	E0C3	狹
6046	E0C4	狷
6047	E0C5	倏
6048	E0C6	猗
6049	E0C7	猊
604A	E0C8	猜
604B	E0C9	猖
604C	E0CA	猝
604D	E0CB	猴
604E	E0CC	狴
604F	E0CD	猩
6050	E0CE	猥
6051	E0CF	猥
6052	E0D0	獒
6053	E0D1	猓
6054	E0D2	默
6055	E0D3	獬
6056	E0D4	獯
6057	E0D5	獨
6058	E0D6	獮
6059	E0D7	默
605A	E0D8	獵
605B	E0D9	獻
605C	E0DA	獺
605D	E0DB	珈
605E	E0DC	玳

JIS	SJIS	字
605F	E0DD	玳
6060	E0DE	玻
6061	E0DF	珀
6062	E0E0	珥
6063	E0E1	珮
6064	E0E2	珞
6065	E0E3	璫
6066	E0E4	琅
6067	E0E5	瑯
6068	E0E6	琥
6069	E0E7	瑁
606A	E0E8	琲
606B	E0E9	珉
606C	E0EA	瑕
606D	E0EB	璵
606E	E0EC	瑟
606F	E0ED	璫
6070	E0EE	璫
6071	E0EF	瑜
6072	E0F0	瑩
6073	E0F1	瑰
6074	E0F2	瑣
6075	E0F3	瑪
6076	E0F4	璠
6077	E0F5	瑾
6078	E0F6	璋
6079	E0F7	璞
607A	E0F8	璧
607B	E0F9	瓊
607C	E0FA	瓏
607D	E0FB	璣
607E	E0FC	琰
6121	E140	瓠
6122	E141	瓣
6123	E142	砮
6124	E143	砮

JIS	SJIS	字
6125	E144	瓮
6126	E145	甌
6127	E146	甌
6128	E147	甌
6129	E148	甌
612A	E149	瓷
612B	E14A	甄
612C	E14B	甃
612D	E14C	甌
612E	E14D	甌
612F	E14E	甌
6130	E14F	甌
6131	E150	甌
6132	E151	甌
6133	E152	甌
6134	E153	甌
6135	E154	甌
6136	E155	甌
6137	E156	甌
6138	E157	甌
6139	E158	甌
613A	E159	甌
613B	E15A	甌
613C	E15B	甌
613D	E15C	甌
613E	E15D	甌
613F	E15E	甌
6140	E15F	甌
6141	E160	畫
6142	E161	睺
6143	E162	畸
6144	E163	當
6145	E164	疆
6146	E165	疇
6147	E166	疇
6148	E167	疊

JIS	SJIS	字
6149	E168	疊
614A	E169	疊
614B	E16A	疔
614C	E16B	疚
614D	E16C	疝
614E	E16D	疥
614F	E16E	疣
6150	E16F	痂
6151	E170	疖
6152	E171	痄
6153	E172	疵
6154	E173	疽
6155	E174	疽
6156	E175	疹
6157	E176	疱
6158	E177	痍
6159	E178	痊
615A	E179	痒
615B	E17A	瘰
615C	E17B	痣
615D	E17C	瘡
615E	E17D	痲
615F	E17E	痿
6160	E180	痲
6161	E181	瘁
6162	E182	痰
6163	E183	痺
6164	E184	癩
6165	E185	癩
6166	E186	瘋
6167	E187	瘍
6168	E188	瘡
6169	E189	癩
616A	E18A	瘡
616B	E18B	瘡
616C	E18C	瘡

JIS	SJIS	字
616D	E18D	癩
616E	E18E	瘤
616F	E18F	瘡
6170	E190	瘰
6171	E191	瘰
6172	E192	癩
6173	E193	癩
6174	E194	癩
6175	E195	癩
6176	E196	癩
6177	E197	癩
6178	E198	癩
6179	E199	癩
617A	E19A	癩
617B	E19B	癩
617C	E19C	癩
617D	E19D	癩
617E	E19E	癩
6221	E19F	癩
6222	E1A0	癩
6223	E1A1	癩
6224	E1A2	癩
6225	E1A3	癩
6226	E1A4	癩
6227	E1A5	癩
6228	E1A6	癩
6229	E1A7	癩
622A	E1A8	癩
622B	E1A9	癩
622C	E1AA	癩
622D	E1AB	癩
622E	E1AC	癩
622F	E1AD	癩
6230	E1AE	癩
6231	E1AF	癩
6232	E1B0	癩

JIS	SJIS	字
6233	E1B1	盂
6234	E1B2	盂
6235	E1B3	盂
6236	E1B4	盂
6237	E1B5	盂
6238	E1B6	盂
6239	E1B7	盂
623A	E1B8	盂
623B	E1B9	盂
623C	E1BA	盂
623D	E1BB	盂
623E	E1BC	盂
623F	E1BD	盂
6240	E1BE	盂
6241	E1BF	盂
6242	E1C0	盂
6243	E1C1	盂
6244	E1C2	盂
6245	E1C3	盂
6246	E1C4	盂
6247	E1C5	盂
6248	E1C6	盂
6249	E1C7	盂
624A	E1C8	盂
624B	E1C9	盂
624C	E1CA	盂
624D	E1CB	盂
624E	E1CC	盂
624F	E1CD	盂
6250	E1CE	盂
6251	E1CF	盂
6252	E1D0	盂
6253	E1D1	盂
6254	E1D2	盂
6255	E1D3	盂
6256	E1D4	盂

JIS	SJIS	字
6257	E1D5	盂
6258	E1D6	盂
6259	E1D7	盂
625A	E1D8	盂
625B	E1D9	盂
625C	E1DA	盂
625D	E1DB	盂
625E	E1DC	盂
625F	E1DD	盂
6260	E1DE	盂
6261	E1DF	盂
6262	E1E0	盂
6263	E1E1	盂
6264	E1E2	盂
6265	E1E3	盂
6266	E1E4	盂
6267	E1E5	盂
6268	E1E6	盂
6269	E1E7	盂
626A	E1E8	盂
626B	E1E9	盂
626C	E1EA	盂
626D	E1EB	盂
626E	E1EC	盂
626F	E1ED	盂
6270	E1EE	盂
6271	E1EF	盂
6272	E1F0	盂
6273	E1F1	盂
6274	E1F2	盂
6275	E1F3	盂
6276	E1F4	盂
6277	E1F5	盂
6278	E1F6	盂
6279	E1F7	盂
627A	E1F8	盂

JIS	SJIS	字
627B	E1F9	碼
627C	E1FA	磅
627D	E1FB	磊
627E	E1FC	磬
6321	E240	磧
6322	E241	磚
6323	E242	礮
6324	E243	磴
6325	E244	礮
6326	E245	礮
6327	E246	礮
6328	E247	礮
6329	E248	礮
632A	E249	礮
632B	E24A	祀
632C	E24B	祠
632D	E24C	祇
632E	E24D	崇
632F	E24E	祚
6330	E24F	祕
6331	E250	祓
6332	E251	祺
6333	E252	祿
6334	E253	禊
6335	E254	禊
6336	E255	禱
6337	E256	齋
6338	E257	禪
6339	E258	禮
633A	E259	禳
633B	E25A	禹
633C	E25B	禹
633D	E25C	秉
633E	E25D	枇
633F	E25E	秧
6340	E25F	柜

JIS	SJIS	字
6341	E260	稊
6342	E261	秣
6343	E262	稈
6344	E263	稍
6345	E264	稗
6346	E265	植
6347	E266	稠
6348	E267	稟
6349	E268	稟
634A	E269	稱
634B	E26A	稻
634C	E26B	稟
634D	E26C	稷
634E	E26D	裕
634F	E26E	穗
6350	E26F	穉
6351	E270	穡
6352	E271	穢
6353	E272	穩
6354	E273	穉
6355	E274	穰
6356	E275	穹
6357	E276	穽
6358	E277	窈
6359	E278	窗
635A	E279	窈
635B	E27A	窈
635C	E27B	窈
635D	E27C	窈
635E	E27D	窈
635F	E27E	窈
6360	E280	窈
6361	E281	窈
6362	E282	窈
6363	E283	窈
6364	E284	窈

JIS	SJIS	字
6365	E285	竇
6366	E286	竊
6367	E287	竝
6368	E288	竝
6369	E289	竝
636A	E28A	竝
636B	E28B	竝
636C	E28C	竝
636D	E28D	竝
636E	E28E	竝
636F	E28F	竝
6370	E290	竝
6371	E291	竝
6372	E292	竝
6373	E293	竝
6374	E294	竝
6375	E295	竝
6376	E296	竝
6377	E297	竝
6378	E298	竝
6379	E299	竝
637A	E29A	竝
637B	E29B	竝
637C	E29C	竝
637D	E29D	竝
637E	E29E	竝
6421	E29F	竝
6422	E2A0	竝
6423	E2A1	竝
6424	E2A2	竝
6425	E2A3	竝
6426	E2A4	竝
6427	E2A5	竝
6428	E2A6	竝
6429	E2A7	竝
642A	E2A8	竝

JIS	SJIS	字
642B	E2A9	筴
642C	E2AA	筴
642D	E2AB	筴
642E	E2AC	筴
642F	E2AD	筴
6430	E2AE	筴
6431	E2AF	筴
6432	E2B0	筴
6433	E2B1	筴
6434	E2B2	筴
6435	E2B3	筴
6436	E2B4	筴
6437	E2B5	筴
6438	E2B6	筴
6439	E2B7	筴
643A	E2B8	筴
643B	E2B9	筴
643C	E2BA	筴
643D	E2BB	筴
643E	E2BC	筴
643F	E2BD	筴
6440	E2BE	筴
6441	E2BF	筴
6442	E2C0	筴
6443	E2C1	筴
6444	E2C2	筴
6445	E2C3	筴
6446	E2C4	筴
6447	E2C5	筴
6448	E2C6	筴
6449	E2C7	筴
644A	E2C8	筴
644B	E2C9	筴
644C	E2CA	筴
644D	E2CB	筴
644E	E2CC	筴

JIS	SJIS	字
644F	E2CD	筴
6450	E2CE	筴
6451	E2CF	筴
6452	E2D0	筴
6453	E2D1	筴
6454	E2D2	筴
6455	E2D3	筴
6456	E2D4	筴
6457	E2D5	筴
6458	E2D6	筴
6459	E2D7	筴
645A	E2D8	筴
645B	E2D9	筴
645C	E2DA	筴
645D	E2DB	筴
645E	E2DC	筴
645F	E2DD	筴
6460	E2DE	筴
6461	E2DF	筴
6462	E2E0	糗
6463	E2E1	糗
6464	E2E2	糗
6465	E2E3	粵
6466	E2E4	糗
6467	E2E5	粢
6468	E2E6	糗
6469	E2E7	糗
646A	E2E8	糗
646B	E2E9	粳
646C	E2EA	粢
646D	E2EB	梁
646E	E2EC	糧
646F	E2ED	粹
6470	E2EE	粽
6471	E2EF	糗
6472	E2F0	糗

JIS	SJIS	字
6473	E2F1	糗
6474	E2F2	糝
6475	E2F3	糞
6476	E2F4	糜
6477	E2F5	糝
6478	E2F6	糞
6479	E2F7	糞
647A	E2F8	糞
647B	E2F9	糞
647C	E2FA	糞
647D	E2FB	糞
647E	E2FC	糞
6521	E340	紂
6522	E341	紂
6523	E342	紂
6524	E343	紂
6525	E344	紂
6526	E345	紂
6527	E346	紂
6528	E347	紂
6529	E348	紂
652A	E349	紂
652B	E34A	紂
652C	E34B	紂
652D	E34C	紂
652E	E34D	紂
652F	E34E	紂
6530	E34F	紂
6531	E350	紂
6532	E351	紂
6533	E352	紂
6534	E353	紂
6535	E354	紂
6536	E355	紂
6537	E356	紂
6538	E357	紂

JIS	SJIS	字
6539	E358	紂
653A	E359	紂
653B	E35A	紂
653C	E35B	紂
653D	E35C	紂
653E	E35D	紂
653F	E35E	紂
6540	E35F	紂
6541	E360	紂
6542	E361	紂
6543	E362	紂
6544	E363	紂
6545	E364	紂
6546	E365	紂
6547	E366	紂
6548	E367	紂
6549	E368	紂
654A	E369	紂
654B	E36A	紂
654C	E36B	紂
654D	E36C	紂
654E	E36D	紂
654F	E36E	紂
6550	E36F	紂
6551	E370	紂
6552	E371	紂
6553	E372	紂
6554	E373	紂
6555	E374	紂
6556	E375	紂
6557	E376	紂
6558	E377	紂
6559	E378	紂
655A	E379	紂
655B	E37A	紂
655C	E37B	紂

JIS	SJIS	字
655D	E37C	縹
655E	E37D	縹
655F	E37E	縹
6560	E380	縹
6561	E381	縹
6562	E382	縹
6563	E383	縹
6564	E384	縹
6565	E385	縹
6566	E386	縹
6567	E387	縹
6568	E388	縹
6569	E389	縹
656A	E38A	縹
656B	E38B	縹
656C	E38C	縹
656D	E38D	縹
656E	E38E	縹
656F	E38F	縹
6570	E390	縹
6571	E391	縹
6572	E392	縹
6573	E393	縹
6574	E394	縹
6575	E395	縹
6576	E396	縹
6577	E397	縹
6578	E398	縹
6579	E399	縹
657A	E39A	縹
657B	E39B	縹
657C	E39C	縹
657D	E39D	缸
657E	E39E	缺
6621	E39F	罇
6622	E3A0	罇

JIS	SJIS	字
6623	E3A1	罇
6624	E3A2	罇
6625	E3A3	罇
6626	E3A4	罇
6627	E3A5	罇
6628	E3A6	罇
6629	E3A7	罇
662A	E3A8	罇
662B	E3A9	罇
662C	E3AA	罇
662D	E3AB	罇
662E	E3AC	罇
662F	E3AD	罇
6630	E3AE	罇
6631	E3AF	罇
6632	E3B0	罇
6633	E3B1	罇
6634	E3B2	罇
6635	E3B3	羌
6636	E3B4	羔
6637	E3B5	羞
6638	E3B6	羝
6639	E3B7	羝
663A	E3B8	羝
663B	E3B9	羝
663C	E3BA	羝
663D	E3BB	羝
663E	E3BC	羝
663F	E3BD	羝
6640	E3BE	羝
6641	E3BF	羝
6642	E3C0	翅
6643	E3C1	羝
6644	E3C2	翊
6645	E3C3	翊
6646	E3C4	翊

JIS	SJIS	字
6647	E3C5	翫
6648	E3C6	翦
6649	E3C7	翮
664A	E3C8	翳
664B	E3C9	翹
664C	E3CA	翹
664D	E3CB	耆
664E	E3CC	耄
664F	E3CD	耄
6650	E3CE	耑
6651	E3CF	耘
6652	E3D0	耙
6653	E3D1	耜
6654	E3D2	耒
6655	E3D3	耨
6656	E3D4	耿
6657	E3D5	耻
6658	E3D6	聊
6659	E3D7	聆
665A	E3D8	聒
665B	E3D9	聘
665C	E3DA	聚
665D	E3DB	聳
665E	E3DC	聒
665F	E3DD	聯
6660	E3DE	聳
6661	E3DF	聳
6662	E3E0	聰
6663	E3E1	聳
6664	E3E2	聳
6665	E3E3	聽
6666	E3E4	聳
6667	E3E5	肆
6668	E3E6	肆
6669	E3E7	肅
666A	E3E8	肛

JIS	SJIS	字
666B	E3E9	肅
666C	E3EA	肚
666D	E3EB	肅
666E	E3EC	胃
666F	E3ED	肅
6670	E3EE	肅
6671	E3EF	胥
6672	E3F0	胥
6673	E3F1	胥
6674	E3F2	胃
6675	E3F3	胚
6676	E3F4	肅
6677	E3F5	脉
6678	E3F6	肅
6679	E3F7	肅
667A	E3F8	脛
667B	E3F9	脛
667C	E3FA	脛
667D	E3FB	肅
667E	E3FC	脛
6721	E440	隋
6722	E441	腴
6723	E442	脾
6724	E443	腴
6725	E444	腑
6726	E445	腴
6727	E446	腴
6728	E447	腮
6729	E448	腥
672A	E449	腦
672B	E44A	腴
672C	E44B	膈
672D	E44C	膈
672E	E44D	膊
672F	E44E	膊
6730	E44F	膂

JIS	SJIS	字
6731	E450	膠
6732	E451	臑
6733	E452	臑
6734	E453	臑
6735	E454	臑
6736	E455	臑
6737	E456	臑
6738	E457	臑
6739	E458	臑
673A	E459	臑
673B	E45A	臑
673C	E45B	臑
673D	E45C	臑
673E	E45D	臑
673F	E45E	臑
6740	E45F	臑
6741	E460	臑
6742	E461	臑
6743	E462	臑
6744	E463	臑
6745	E464	臑
6746	E465	臑
6747	E466	臑
6748	E467	臑
6749	E468	臑
674A	E469	臑
674B	E46A	臑
674C	E46B	臑
674D	E46C	臑
674E	E46D	臑
674F	E46E	臑
6750	E46F	臑
6751	E470	臑
6752	E471	臑
6753	E472	臑
6754	E473	臑

JIS	SJIS	字
6755	E474	舩
6756	E475	舩
6757	E476	舩
6758	E477	舩
6759	E478	舩
675A	E479	舩
675B	E47A	舩
675C	E47B	舩
675D	E47C	舩
675E	E47D	舩
675F	E47E	舩
6760	E480	舩
6761	E481	舩
6762	E482	舩
6763	E483	舩
6764	E484	舩
6765	E485	艱
6766	E486	艷
6767	E487	艸
6768	E488	艾
6769	E489	芍
676A	E48A	芒
676B	E48B	芫
676C	E48C	芫
676D	E48D	芫
676E	E48E	芬
676F	E48F	苾
6770	E490	苾
6771	E491	苟
6772	E492	苻
6773	E493	苻
6774	E494	苻
6775	E495	苻
6776	E496	苻
6777	E497	苻
6778	E498	苻

JIS	SJIS	字
6779	E499	萃
677A	E49A	苞
677B	E49B	茆
677C	E49C	苜
677D	E49D	茱
677E	E49E	苙
6821	E49F	茵
6822	E4A0	茴
6823	E4A1	茗
6824	E4A2	苙
6825	E4A3	茱
6826	E4A4	荀
6827	E4A5	茹
6828	E4A6	荐
6829	E4A7	荅
682A	E4A8	茯
682B	E4A9	茫
682C	E4AA	茗
682D	E4AB	荔
682E	E4AC	莅
682F	E4AD	薤
6830	E4AE	莪
6831	E4AF	荅
6832	E4B0	莢
6833	E4B1	莖
6834	E4B2	莫
6835	E4B3	莎
6836	E4B4	蒻
6837	E4B5	莊
6838	E4B6	茶
6839	E4B7	菟
683A	E4B8	荳
683B	E4B9	葱
683C	E4BA	莠
683D	E4BB	莉
683E	E4BC	萁

JIS	SJIS	字
683F	E4BD	菴
6840	E4BE	萱
6841	E4BF	董
6842	E4C0	蕘
6843	E4C1	菽
6844	E4C2	萃
6845	E4C3	崧
6846	E4C4	萋
6847	E4C5	菁
6848	E4C6	蒂
6849	E4C7	萁
684A	E4C8	菠
684B	E4C9	菲
684C	E4CA	萍
684D	E4CB	泡
684E	E4CC	蒴
684F	E4CD	莽
6850	E4CE	萸
6851	E4CF	淺
6852	E4D0	赫
6853	E4D1	葭
6854	E4D2	葍
6855	E4D3	萼
6856	E4D4	萼
6857	E4D5	葍
6858	E4D6	葍
6859	E4D7	葫
685A	E4D8	葛
685B	E4D9	葭
685C	E4DA	蒂
685D	E4DB	葩
685E	E4DC	葆
685F	E4DD	萬
6860	E4DE	葍
6861	E4DF	蒨
6862	E4E0	蒿

JIS	SJIS	字
6863	E4E1	蒨
6864	E4E2	葢
6865	E4E3	蒹
6866	E4E4	蒿
6867	E4E5	蒟
6868	E4E6	蒞
6869	E4E7	蓍
686A	E4E8	蒟
686B	E4E9	蓐
686C	E4EA	蓐
686D	E4EB	蓐
686E	E4EC	蓐
686F	E4ED	蕘
6870	E4EE	莠
6871	E4EF	蔡
6872	E4F0	蓐
6873	E4F1	蓐
6874	E4F2	蔗
6875	E4F3	蓐
6876	E4F4	蔬
6877	E4F5	蒺
6878	E4F6	蓐
6879	E4F7	蓐
687A	E4F8	蓐
687B	E4F9	蒺
687C	E4FA	蓐
687D	E4FB	蕘
687E	E4FC	蕘
6921	E540	蓐
6922	E541	蓐
6923	E542	蒺
6924	E543	蒺
6925	E544	蒺
6926	E545	蒺
6927	E546	蓐
6928	E547	蕘

JIS	SJIS	字
6929	E548	蒺
692A	E549	蕘
692B	E54A	蕭
692C	E54B	蓐
692D	E54C	蓐
692E	E54D	蕘
692F	E54E	薇
6930	E54F	蓐
6931	E550	蕘
6932	E551	蓐
6933	E552	蓐
6934	E553	藉
6935	E554	薺
6936	E555	藏
6937	E556	臺
6938	E557	蕘
6939	E558	藕
693A	E559	藝
693B	E55A	藥
693C	E55B	藜
693D	E55C	藹
693E	E55D	藹
693F	E55E	藹
6940	E55F	藹
6941	E560	藹
6942	E561	藹
6943	E562	藹
6944	E563	藹
6945	E564	藹
6946	E565	藹
6947	E566	藹
6948	E567	虍
6949	E568	虍
694A	E569	虍
694B	E56A	虍
694C	E56B	虍

JIS	SJIS	字
694D	E56C	虱
694E	E56D	蚓
694F	E56E	蚣
6950	E56F	蚩
6951	E570	蚪
6952	E571	蚋
6953	E572	蚌
6954	E573	蚌
6955	E574	蚯
6956	E575	蛄
6957	E576	蛆
6958	E577	蚰
6959	E578	蛉
695A	E579	螭
695B	E57A	虬
695C	E57B	蚶
695D	E57C	蛞
695E	E57D	蛩
695F	E57E	蚕
6960	E580	蛟
6961	E581	蛛
6962	E582	蛭
6963	E583	蜒
6964	E584	蜆
6965	E585	蜈
6966	E586	蜀
6967	E587	蜃
6968	E588	蛻
6969	E589	蟹
696A	E58A	蟀
696B	E58B	蝓
696C	E58C	蛹
696D	E58D	蚋
696E	E58E	蜴
696F	E58F	蜿
6970	E590	蝮

JIS	SJIS	字
6971	E591	蜻
6972	E592	蜥
6973	E593	蝟
6974	E594	蜚
6975	E595	蝠
6976	E596	蝟
6977	E597	蝟
6978	E598	蝟
6979	E599	蝎
697A	E59A	蝴
697B	E59B	蝗
697C	E59C	蝨
697D	E59D	蝮
697E	E59E	蝙
6A21	E59F	蝮
6A22	E5A0	蝮
6A23	E5A1	蜴
6A24	E5A2	蠅
6A25	E5A3	螢
6A26	E5A4	螟
6A27	E5A5	螂
6A28	E5A6	蝮
6A29	E5A7	蟋
6A2A	E5A8	蝨
6A2B	E5A9	蟀
6A2C	E5AA	蝶
6A2D	E5AB	蝮
6A2E	E5AC	蝮
6A2F	E5AD	蝮
6A30	E5AE	蝗
6A31	E5AF	蝮
6A32	E5B0	蝮
6A33	E5B1	蝮
6A34	E5B2	蝮
6A35	E5B3	蝮
6A36	E5B4	蝮

JIS	SJIS	字
6A37	E5B5	蝮
6A38	E5B6	蝮
6A39	E5B7	蝮
6A3A	E5B8	蝮
6A3B	E5B9	蝮
6A3C	E5BA	蝮
6A3D	E5BB	蝮
6A3E	E5BC	蝮
6A3F	E5BD	蝮
6A40	E5BE	蝮
6A41	E5BF	蝮
6A42	E5C0	蝮
6A43	E5C1	蝮
6A44	E5C2	蝮
6A45	E5C3	蝮
6A46	E5C4	蝮
6A47	E5C5	蝮
6A48	E5C6	蝮
6A49	E5C7	蝮
6A4A	E5C8	蝮
6A4B	E5C9	蝮
6A4C	E5CA	蝮
6A4D	E5CB	蝮
6A4E	E5CC	衫
6A4F	E5CD	袁
6A50	E5CE	衾
6A51	E5CF	袞
6A52	E5D0	袂
6A53	E5D1	袂
6A54	E5D2	袂
6A55	E5D3	衲
6A56	E5D4	袂
6A57	E5D5	袂
6A58	E5D6	袂
6A59	E5D7	袂
6A5A	E5D8	袂

JIS	SJIS	字
6A5B	E5D9	袂
6A5C	E5DA	袍
6A5D	E5DB	裘
6A5E	E5DC	裘
6A5F	E5DD	袂
6A60	E5DE	袂
6A61	E5DF	袂
6A62	E5E0	衿
6A63	E5E1	裔
6A64	E5E2	裘
6A65	E5E3	裙
6A66	E5E4	裝
6A67	E5E5	裏
6A68	E5E6	褂
6A69	E5E7	襦
6A6A	E5E8	裘
6A6B	E5E9	裨
6A6C	E5EA	襦
6A6D	E5EB	襦
6A6E	E5EC	禪
6A6F	E5ED	褊
6A70	E5EE	褊
6A71	E5EF	褊
6A72	E5F0	褊
6A73	E5F1	褊
6A74	E5F2	褊
6A75	E5F3	褊
6A76	E5F4	褊
6A77	E5F5	裏
6A78	E5F6	褊
6A79	E5F7	褶
6A7A	E5F8	褊
6A7B	E5F9	禪
6A7C	E5FA	禪
6A7D	E5FB	褊
6A7E	E5FC	褊

JIS	SJIS	字
6B21	E640	襦
6B22	E641	襠
6B23	E642	襯
6B24	E643	襪
6B25	E644	襯
6B26	E645	襪
6B27	E646	襪
6B28	E647	冎
6B29	E648	覃
6B2A	E649	覈
6B2B	E64A	羈
6B2C	E64B	覓
6B2D	E64C	覘
6B2E	E64D	覘
6B2F	E64E	覘
6B30	E64F	覘
6B31	E650	覘
6B32	E651	覘
6B33	E652	覘
6B34	E653	覘
6B35	E654	覘
6B36	E655	覘
6B37	E656	覘
6B38	E657	觚
6B39	E658	觜
6B3A	E659	觚
6B3B	E65A	觚
6B3C	E65B	觚
6B3D	E65C	觚
6B3E	E65D	訃
6B3F	E65E	訖
6B40	E65F	訖
6B41	E660	訖
6B42	E661	訖
6B43	E662	訖
6B44	E663	訖

JIS	SJIS	字
6B45	E664	訖
6B46	E665	訖
6B47	E666	詛
6B48	E667	詒
6B49	E668	詆
6B4A	E669	詈
6B4B	E66A	詠
6B4C	E66B	詭
6B4D	E66C	詒
6B4E	E66D	詢
6B4F	E66E	誅
6B50	E66F	誅
6B51	E670	誅
6B52	E671	誨
6B53	E672	誡
6B54	E673	誑
6B55	E674	誥
6B56	E675	誦
6B57	E676	誚
6B58	E677	誣
6B59	E678	諄
6B5A	E679	諍
6B5B	E67A	詔
6B5C	E67B	詔
6B5D	E67C	諫
6B5E	E67D	諳
6B5F	E67E	諧
6B60	E680	諤
6B61	E681	諱
6B62	E682	諛
6B63	E683	誼
6B64	E684	誼
6B65	E685	諷
6B66	E686	諷
6B67	E687	諛
6B68	E688	訶

JIS	SJIS	字
6B69	E689	謗
6B6A	E68A	謚
6B6B	E68B	謚
6B6C	E68C	謬
6B6D	E68D	謚
6B6E	E68E	謗
6B6F	E68F	謠
6B70	E690	謳
6B71	E691	鞫
6B72	E692	警
6B73	E693	謫
6B74	E694	謾
6B75	E695	謨
6B76	E696	譁
6B77	E697	譏
6B78	E698	譏
6B79	E699	譎
6B7A	E69A	證
6B7B	E69B	譖
6B7C	E69C	譖
6B7D	E69D	譚
6B7E	E69E	譚
6C21	E69F	譟
6C22	E6A0	譬
6C23	E6A1	譯
6C24	E6A2	譴
6C25	E6A3	譽
6C26	E6A4	讀
6C27	E6A5	譙
6C28	E6A6	讎
6C29	E6A7	讒
6C2A	E6A8	讓
6C2B	E6A9	讖
6C2C	E6AA	讖
6C2D	E6AB	讚
6C2E	E6AC	訶

JIS	SJIS	字
6C2F	E6AD	谿
6C30	E6AE	谿
6C31	E6AF	豈
6C32	E6B0	詭
6C33	E6B1	豎
6C34	E6B2	豐
6C35	E6B3	豕
6C36	E6B4	豕
6C37	E6B5	豕
6C38	E6B6	豕
6C39	E6B7	豕
6C3A	E6B8	豕
6C3B	E6B9	豕
6C3C	E6BA	豕
6C3D	E6BB	豕
6C3E	E6BC	豕
6C3F	E6BD	豕
6C40	E6BE	豕
6C41	E6BF	豕
6C42	E6C0	豕
6C43	E6C1	賤
6C44	E6C2	賈
6C45	E6C3	貪
6C46	E6C4	賄
6C47	E6C5	賈
6C48	E6C6	貳
6C49	E6C7	貳
6C4A	E6C8	貶
6C4B	E6C9	賈
6C4C	E6CA	賈
6C4D	E6CB	賤
6C4E	E6CC	賈
6C4F	E6CD	賈
6C50	E6CE	賈
6C51	E6CF	賺
6C52	E6D0	賈

JIS	SJIS	字
6C53	E6D1	贊
6C54	E6D2	贊
6C55	E6D3	贊
6C56	E6D4	贊
6C57	E6D5	羸
6C58	E6D6	瞻
6C59	E6D7	贖
6C5A	E6D8	齋
6C5B	E6D9	贓
6C5C	E6DA	贓
6C5D	E6DB	鼻
6C5E	E6DC	贖
6C5F	E6DD	赧
6C60	E6DE	赭
6C61	E6DF	乏
6C62	E6E0	赳
6C63	E6E1	趁
6C64	E6E2	趙
6C65	E6E3	跂
6C66	E6E4	趾
6C67	E6E5	跌
6C68	E6E6	跏
6C69	E6E7	跚
6C6A	E6E8	跖
6C6B	E6E9	跌
6C6C	E6EA	跛
6C6D	E6EB	跋
6C6E	E6EC	跪
6C6F	E6ED	躋
6C70	E6EE	跟
6C71	E6EF	跣
6C72	E6F0	跣
6C73	E6F1	踈
6C74	E6F2	踉
6C75	E6F3	踉
6C76	E6F4	蹀

JIS	SJIS	字
6C77	E6F5	踞
6C78	E6F6	踐
6C79	E6F7	踞
6C7A	E6F8	蹂
6C7B	E6F9	踵
6C7C	E6FA	踰
6C7D	E6FB	踣
6C7E	E6FC	蹊
6D21	E740	蹇
6D22	E741	蹉
6D23	E742	蹌
6D24	E743	躋
6D25	E744	蹈
6D26	E745	蹙
6D27	E746	蹤
6D28	E747	蹠
6D29	E748	踪
6D2A	E749	躡
6D2B	E74A	躡
6D2C	E74B	蹶
6D2D	E74C	蹲
6D2E	E74D	蹶
6D2F	E74E	躁
6D30	E74F	躡
6D31	E750	躡
6D32	E751	蹶
6D33	E752	躋
6D34	E753	躡
6D35	E754	躡
6D36	E755	躡
6D37	E756	躡
6D38	E757	躡
6D39	E758	躡
6D3A	E759	躡
6D3B	E75A	躬
6D3C	E75B	躡

JIS	SJIS	字
6D3D	E75C	躡
6D3E	E75D	躡
6D3F	E75E	躡
6D40	E75F	躡
6D41	E760	躡
6D42	E761	軋
6D43	E762	軋
6D44	E763	軋
6D45	E764	軋
6D46	E765	軋
6D47	E766	軋
6D48	E767	軋
6D49	E768	軋
6D4A	E769	軋
6D4B	E76A	軋
6D4C	E76B	軋
6D4D	E76C	軋
6D4E	E76D	輓
6D4F	E76E	輓
6D50	E76F	輓
6D51	E770	輓
6D52	E771	輓
6D53	E772	輓
6D54	E773	輓
6D55	E774	輓
6D56	E775	輓
6D57	E776	輓
6D58	E777	輓
6D59	E778	輓
6D5A	E779	輓
6D5B	E77A	輓
6D5C	E77B	輓
6D5D	E77C	輓
6D5E	E77D	輓
6D5F	E77E	輓
6D60	E780	輓

JIS	SJIS	字
6D61	E781	輓
6D62	E782	輓
6D63	E783	輓
6D64	E784	輓
6D65	E785	輓
6D66	E786	輓
6D67	E787	輓
6D68	E788	迕
6D69	E789	迕
6D6A	E78A	迕
6D6B	E78B	迕
6D6C	E78C	迕
6D6D	E78D	迕
6D6E	E78E	迕
6D6F	E78F	迕
6D70	E790	迕
6D71	E791	迕
6D72	E792	迕
6D73	E793	迕
6D74	E794	迕
6D75	E795	迕
6D76	E796	迕
6D77	E797	迕
6D78	E798	迕
6D79	E799	迕
6D7A	E79A	迕
6D7B	E79B	迕
6D7C	E79C	迕
6D7D	E79D	迕
6D7E	E79E	迕
6E21	E79F	迕
6E22	E7A0	迕
6E23	E7A1	迕
6E24	E7A2	迕
6E25	E7A3	迕
6E26	E7A4	迕

JIS	SJIS	字
6E27	E7A5	逾
6E28	E7A6	適
6E29	E7A7	邁
6E2A	E7A8	遞
6E2B	E7A9	邀
6E2C	E7AA	遯
6E2D	E7AB	遶
6E2E	E7AC	隨
6E2F	E7AD	遲
6E30	E7AE	邂
6E31	E7AF	遽
6E32	E7B0	邁
6E33	E7B1	邀
6E34	E7B2	邊
6E35	E7B3	邊
6E36	E7B4	邏
6E37	E7B5	邨
6E38	E7B6	邨
6E39	E7B7	邱
6E3A	E7B8	邵
6E3B	E7B9	郢
6E3C	E7BA	郤
6E3D	E7BB	扈
6E3E	E7BC	郭
6E3F	E7BD	鄂
6E40	E7BE	鄒
6E41	E7BF	鄙
6E42	E7C0	郚
6E43	E7C1	鄰
6E44	E7C2	酏
6E45	E7C3	醜
6E46	E7C4	醜
6E47	E7C5	酣
6E48	E7C6	酥
6E49	E7C7	醕
6E4A	E7C8	醕

JIS	SJIS	字
6E4B	E7C9	醒
6E4C	E7CA	醋
6E4D	E7CB	醉
6E4E	E7CC	醞
6E4F	E7CD	醞
6E50	E7CE	醫
6E51	E7CF	醞
6E52	E7D0	醞
6E53	E7D1	醞
6E54	E7D2	醞
6E55	E7D3	醞
6E56	E7D4	釀
6E57	E7D5	釀
6E58	E7D6	釉
6E59	E7D7	釋
6E5A	E7D8	釐
6E5B	E7D9	釐
6E5C	E7DA	釐
6E5D	E7DB	釜
6E5E	E7DC	釐
6E5F	E7DD	釐
6E60	E7DE	釐
6E61	E7DF	鉈
6E62	E7E0	鈞
6E63	E7E1	鈞
6E64	E7E2	鈔
6E65	E7E3	鈔
6E66	E7E4	鈕
6E67	E7E5	鈔
6E68	E7E6	鈔
6E69	E7E7	鈔
6E6A	E7E8	鉅
6E6B	E7E9	鉉
6E6C	E7EA	鉤
6E6D	E7EB	鉈
6E6E	E7EC	鉈

JIS	SJIS	字
6E6F	E7ED	鈿
6E70	E7EE	鈿
6E71	E7EF	鈿
6E72	E7F0	銜
6E73	E7F1	銖
6E74	E7F2	銖
6E75	E7F3	銖
6E76	E7F4	鉚
6E77	E7F5	鉚
6E78	E7F6	銑
6E79	E7F7	銑
6E7A	E7F8	銑
6E7B	E7F9	銑
6E7C	E7FA	銑
6E7D	E7FB	銑
6E7E	E7FC	銑
6F21	E840	銑
6F22	E841	銑
6F23	E842	銑
6F24	E843	銑
6F25	E844	銑
6F26	E845	銑
6F27	E846	銑
6F28	E847	銑
6F29	E848	銑
6F2A	E849	銑
6F2B	E84A	銑
6F2C	E84B	銑
6F2D	E84C	銑
6F2E	E84D	銑
6F2F	E84E	銑
6F30	E84F	銑
6F31	E850	銑
6F32	E851	銑
6F33	E852	銑
6F34	E853	銑

JIS	SJIS	字
6F35	E854	銑
6F36	E855	銑
6F37	E856	銑
6F38	E857	銑
6F39	E858	銑
6F3A	E859	銑
6F3B	E85A	銑
6F3C	E85B	銑
6F3D	E85C	銑
6F3E	E85D	銑
6F3F	E85E	銑
6F40	E85F	銑
6F41	E860	銑
6F42	E861	銑
6F43	E862	銑
6F44	E863	銑
6F45	E864	銑
6F46	E865	銑
6F47	E866	銑
6F48	E867	銑
6F49	E868	銑
6F4A	E869	銑
6F4B	E86A	銑
6F4C	E86B	銑
6F4D	E86C	銑
6F4E	E86D	銑
6F4F	E86E	銑
6F50	E86F	銑
6F51	E870	銑
6F52	E871	銑
6F53	E872	銑
6F54	E873	銑
6F55	E874	銑
6F56	E875	銑
6F57	E876	銑
6F58	E877	銑

JIS	SJIS	字
6F59	E878	門
6F5A	E879	閉
6F5B	E87A	問
6F5C	E87B	閱
6F5D	E87C	閑
6F5E	E87D	聞
6F5F	E87E	鬧
6F60	E880	閨
6F61	E881	閨
6F62	E882	閨
6F63	E883	閨
6F64	E884	閨
6F65	E885	閨
6F66	E886	閨
6F67	E887	閨
6F68	E888	閨
6F69	E889	潤
6F6A	E88A	閨
6F6B	E88B	閨
6F6C	E88C	閨
6F6D	E88D	閨
6F6E	E88E	閨
6F6F	E88F	閨
6F70	E890	關
6F71	E891	關
6F72	E892	關
6F73	E893	關
6F74	E894	阡
6F75	E895	阨
6F76	E896	阮
6F77	E897	阨
6F78	E898	陂
6F79	E899	陌
6F7A	E89A	陌
6F7B	E89B	陋
6F7C	E89C	陷

JIS	SJIS	字
6F7D	E89D	陝
6F7E	E89E	陞
7021	E89F	陝
7022	E8A0	陟
7023	E8A1	陟
7024	E8A2	陞
7025	E8A3	陞
7026	E8A4	陞
7027	E8A5	陞
7028	E8A6	隕
7029	E8A7	隗
702A	E8A8	險
702B	E8A9	隧
702C	E8AA	隱
702D	E8AB	隴
702E	E8AC	隰
702F	E8AD	隴
7030	E8AE	隸
7031	E8AF	隸
7032	E8B0	隹
7033	E8B1	隹
7034	E8B2	雋
7035	E8B3	雋
7036	E8B4	雍
7037	E8B5	襍
7038	E8B6	雜
7039	E8B7	霍
703A	E8B8	雕
703B	E8B9	鸞
703C	E8BA	霄
703D	E8BB	霏
703E	E8BC	霏
703F	E8BD	霓
7040	E8BE	霽
7041	E8BF	霽
7042	E8C0	霽

JIS	SJIS	字
7043	E8C1	霖
7044	E8C2	霽
7045	E8C3	霽
7046	E8C4	霽
7047	E8C5	霽
7048	E8C6	霽
7049	E8C7	霽
704A	E8C8	霽
704B	E8C9	霽
704C	E8CA	霽
704D	E8CB	靈
704E	E8CC	靈
704F	E8CD	靈
7050	E8CE	靜
7051	E8CF	靠
7052	E8D0	砲
7053	E8D1	醜
7054	E8D2	靨
7055	E8D3	勒
7056	E8D4	鞞
7057	E8D5	鞞
7058	E8D6	鞞
7059	E8D7	鞞
705A	E8D8	鞞
705B	E8D9	鞞
705C	E8DA	鞞
705D	E8DB	鞞
705E	E8DC	鞋
705F	E8DD	鞞
7060	E8DE	鞞
7061	E8DF	鞞
7062	E8E0	鞞
7063	E8E1	鞞
7064	E8E2	鞞
7065	E8E3	鞞
7066	E8E4	鞞

JIS	SJIS	字
7067	E8E5	鞞
7068	E8E6	鞞
7069	E8E7	鞞
706A	E8E8	鞞
706B	E8E9	鞞
706C	E8EA	鞞
706D	E8EB	鞞
706E	E8EC	鞞
706F	E8ED	鞞
7070	E8EE	韶
7071	E8EF	韻
7072	E8F0	韻
7073	E8F1	韻
7074	E8F2	韻
7075	E8F3	韻
7076	E8F4	韻
7077	E8F5	韻
7078	E8F6	韻
7079	E8F7	韻
707A	E8F8	韻
707B	E8F9	韻
707C	E8FA	韻
707D	E8FB	顯
707E	E8FC	顯
7121	E940	顯
7122	E941	顯
7123	E942	顯
7124	E943	顯
7125	E944	顯
7126	E945	顯
7127	E946	顯
7128	E947	顯
7129	E948	顯
712A	E949	顯
712B	E94A	顯
712C	E94B	顯

JIS	SJIS	字
712D	E94C	餃
712E	E94D	餉
712F	E94E	餒
7130	E94F	餹
7131	E950	餘
7132	E951	餡
7133	E952	飭
7134	E953	餞
7135	E954	餵
7136	E955	餅
7137	E956	餈
7138	E957	饗
7139	E958	餽
713A	E959	餹
713B	E95A	饈
713C	E95B	饉
713D	E95C	饊
713E	E95D	饋
713F	E95E	饌
7140	E95F	饍
7141	E960	饎
7142	E961	饏
7143	E962	饚
7144	E963	馗
7145	E964	馐
7146	E965	馑
7147	E966	馓
7148	E967	馔
7149	E968	馕
714A	E969	馐
714B	E96A	馑
714C	E96B	馓
714D	E96C	馔
714E	E96D	馕
714F	E96E	馐
7150	E96F	馑

JIS	SJIS	字
7151	E970	駱
7152	E971	駟
7153	E972	駢
7154	E973	駢
7155	E974	駢
7156	E975	駢
7157	E976	駢
7158	E977	駢
7159	E978	駢
715A	E979	駢
715B	E97A	駢
715C	E97B	駢
715D	E97C	駢
715E	E97D	駢
715F	E97E	駢
7160	E980	駢
7161	E981	駢
7162	E982	駢
7163	E983	駢
7164	E984	駢
7165	E985	駢
7166	E986	駢
7167	E987	駢
7168	E988	駢
7169	E989	駢
716A	E98A	駢
716B	E98B	駢
716C	E98C	駢
716D	E98D	駢
716E	E98E	駢
716F	E98F	駢
7170	E990	駢
7171	E991	駢
7172	E992	駢
7173	E993	駢
7174	E994	駢

JIS	SJIS	字
7175	E995	髟
7176	E996	髟
7177	E997	髟
7178	E998	髟
7179	E999	髟
717A	E99A	髟
717B	E99B	髟
717C	E99C	髟
717D	E99D	髟
717E	E99E	髟
7221	E99F	髟
7222	E9A0	髟
7223	E9A1	髟
7224	E9A2	髟
7225	E9A3	髟
7226	E9A4	髟
7227	E9A5	髟
7228	E9A6	鬥
7229	E9A7	鬪
722A	E9A8	鬪
722B	E9A9	鬪
722C	E9AA	鬪
722D	E9AB	鬪
722E	E9AC	鬪
722F	E9AD	鬪
7230	E9AE	魄
7231	E9AF	魃
7232	E9B0	魏
7233	E9B1	魃
7234	E9B2	魃
7235	E9B3	魃
7236	E9B4	魃
7237	E9B5	魃
7238	E9B6	魃
7239	E9B7	魃
723A	E9B8	鮑

JIS	SJIS	字
723B	E9B9	鮑
723C	E9BA	鮑
723D	E9BB	鮑
723E	E9BC	鮑
723F	E9BD	鮑
7240	E9BE	鮑
7241	E9BF	鮑
7242	E9C0	鮑
7243	E9C1	鮑
7244	E9C2	鮑
7245	E9C3	鮑
7246	E9C4	鮑
7247	E9C5	鮑
7248	E9C6	鮑
7249	E9C7	鮑
724A	E9C8	鮑
724B	E9C9	鮑
724C	E9CA	鮑
724D	E9CB	鮑
724E	E9CC	鮑
724F	E9CD	鮑
7250	E9CE	鮑
7251	E9CF	鮑
7252	E9D0	鮑
7253	E9D1	鮑
7254	E9D2	鮑
7255	E9D3	鮑
7256	E9D4	鮑
7257	E9D5	鮑
7258	E9D6	鮑
7259	E9D7	鮑
725A	E9D8	鮑
725B	E9D9	鮑
725C	E9DA	鮑
725D	E9DB	鮑
725E	E9DC	鮑

JIS	SJIS	字
725F	E9DD	鰯
7260	E9DE	鰱
7261	E9DF	鰱
7262	E9E0	鰱
7263	E9E1	鰱
7264	E9E2	鰱
7265	E9E3	鰱
7266	E9E4	鰱
7267	E9E5	鰱
7268	E9E6	鰱
7269	E9E7	鰱
726A	E9E8	鳧
726B	E9E9	鳧
726C	E9EA	鳧
726D	E9EB	鳧
726E	E9EC	鳧
726F	E9ED	鳧
7270	E9EE	鵝
7271	E9EF	鵝
7272	E9F0	鵝
7273	E9F1	鵝
7274	E9F2	鵝
7275	E9F3	鵝
7276	E9F4	鵝
7277	E9F5	鵝
7278	E9F6	鵝
7279	E9F7	鵝
727A	E9F8	鵝
727B	E9F9	鵝
727C	E9FA	鵝
727D	E9FB	鵝
727E	E9FC	鵝
7321	EA40	鵝
7322	EA41	鵝
7323	EA42	鵝
7324	EA43	鵝

JIS	SJIS	字
7325	EA44	鵝
7326	EA45	鵝
7327	EA46	鵝
7328	EA47	鵝
7329	EA48	鵝
732A	EA49	鵝
732B	EA4A	鵝
732C	EA4B	鵝
732D	EA4C	鵝
732E	EA4D	鵝
732F	EA4E	鵝
7330	EA4F	鵝
7331	EA50	鵝
7332	EA51	鵝
7333	EA52	鵝
7334	EA53	鵝
7335	EA54	鵝
7336	EA55	鵝
7337	EA56	鵝
7338	EA57	鵝
7339	EA58	鵝
733A	EA59	鵝
733B	EA5A	鵝
733C	EA5B	鵝
733D	EA5C	鵝
733E	EA5D	鵝
733F	EA5E	鵝
7340	EA5F	鵝
7341	EA60	鵝
7342	EA61	鵝
7343	EA62	鹵
7344	EA63	鹵
7345	EA64	鹽
7346	EA65	麩
7347	EA66	麩
7348	EA67	麩

JIS	SJIS	字
7349	EA68	麩
734A	EA69	麩
734B	EA6A	麩
734C	EA6B	麩
734D	EA6C	麩
734E	EA6D	麩
734F	EA6E	麩
7350	EA6F	麩
7351	EA70	麩
7352	EA71	麩
7353	EA72	麩
7354	EA73	麩
7355	EA74	黎
7356	EA75	黏
7357	EA76	黏
7358	EA77	黔
7359	EA78	黠
735A	EA79	黠
735B	EA7A	黠
735C	EA7B	黠
735D	EA7C	黠
735E	EA7D	黨
735F	EA7E	黯
7360	EA80	黠
7361	EA81	黠
7362	EA82	黠
7363	EA83	黠
7364	EA84	黠
7365	EA85	黠
7366	EA86	黠
7367	EA87	鼈
7368	EA88	鼈
7369	EA89	鼈
736A	EA8A	蓼
736B	EA8B	兕
736C	EA8C	鼈

JIS	SJIS	字
736D	EA8D	鼈
736E	EA8E	齊
736F	EA8F	齒
7370	EA90	齧
7371	EA91	齧
7372	EA92	齧
7373	EA93	齧
7374	EA94	齧
7375	EA95	齧
7376	EA96	齧
7377	EA97	齧
7378	EA98	齧
7379	EA99	齧
737A	EA9A	齧
737B	EA9B	齧
737C	EA9C	龕
737D	EA9D	龕
737E	EA9E	龕
7421	EA9F	堯
7422	EAA0	楨
7423	EAA1	遙
7424	EAA2	瑤
7425	EAA3	凜
7426	EAA4	熙
7427	EAA5	
7428	EAA6	
7429	EAA7	
742A	EAA8	
742B	EAA9	
742C	EAAA	
742D	EAAB	
742E	EAAC	
742F	EAAD	
7430	EAAE	
7431	EAAF	
7432	EAB0	

JIS	SJIS	字
7433	EAB1	
7434	EAB2	
7435	EAB3	
7436	EAB4	
7437	EAB5	
7438	EAB6	
7439	EAB7	
743A	EAB8	
743B	EAB9	
743C	EABA	
743D	EABB	
743E	EABC	
743F	EABD	
7440	EABE	
7441	EABF	
7442	EAC0	
7443	EAC1	
7444	EAC2	
7445	EAC3	
7446	EAC4	
7447	EAC5	
7448	EAC6	
7449	EAC7	
744A	EAC8	
744B	EAC9	
744C	EACA	
744D	EACB	
744E	EACC	
744F	EACD	

JIS	SJIS	字
7450	EACE	
7451	EACF	
7452	EAD0	
7453	EAD1	
7454	EAD2	
7455	EAD3	
7456	EAD4	
7457	EAD5	
7458	EAD6	
7459	EAD7	
745A	EAD8	
745B	EAD9	
745C	EADA	
745D	EADB	
745E	EADC	
745F	EADD	
7460	EADE	
7461	EADF	
7462	EAE0	
7463	EAE1	
7464	EAE2	
7465	EAE3	
7466	EAE4	
7467	EAE5	
7468	EAE6	
7469	EAE7	
746A	EAE8	
746B	EAE9	
746C	EAEA	

JIS	SJIS	字
746D	EAEB	
746E	EAEC	
746F	EAED	
7470	EAE E	
7471	EAEF	
7472	EAF0	
7473	EAF1	
7474	EAF2	
7475	EAF3	
7476	EAF4	
7477	EAF5	
7478	EAF6	
7479	EAF7	
747A	EAF8	
747B	EAF9	
747C	EAFA	
747D	EAFB	
747E	E AFC	

JIS	SJIS	字