

adaptec®

SAS, SATA, and SCSI RAID Controllers **Installation and User's Guide**

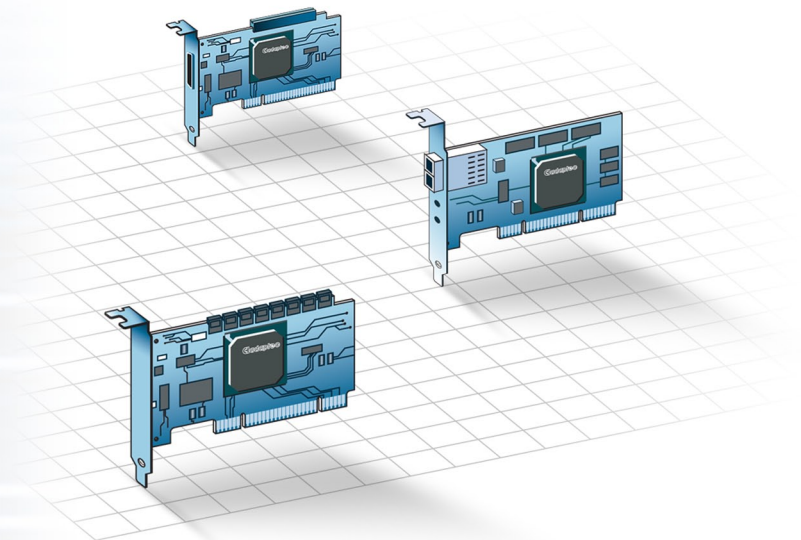

Copyright

©2005-2006 Adaptec, Inc. All rights reserved. No part of this publication may be reproduced, stored in a retrieval system, or transmitted in any form or by any means, electronic, mechanical, photocopying, recording or otherwise, without the prior written consent of Adaptec, Inc., 691 South Milpitas Blvd., Milpitas, CA 95035.

Trademarks

Adaptec, Adaptec Storage Manager, *SCSISelect*, *SATASelect*, and the Adaptec logo are trademarks of Adaptec, Inc., which may be registered in some jurisdictions.

Microsoft and Windows are trademarks of Microsoft Corporation in the US and other countries, used under license.

Red Hat is a trademark of Red Hat, Inc. in the US and other countries, used under license.

Novell and NetWare are trademarks of Novell, Inc. in the US and other countries, used under license.

All other trademarks are the property of their respective owners.

Changes

The material in this document is for information only and is subject to change without notice. While reasonable efforts have been made in the preparation of this document to assure its accuracy, Adaptec, Inc. assumes no liability resulting from errors or omissions in this document, or from the use of the information contained herein.

Adaptec reserves the right to make changes in the product design without reservation and without notification to its users.

Disclaimer

IF THIS PRODUCT DIRECTS YOU TO COPY MATERIALS, YOU MUST HAVE PERMISSION FROM THE COPYRIGHT OWNER OF THE MATERIALS TO AVOID VIOLATING THE LAW WHICH COULD RESULT IN DAMAGES OR OTHER REMEDIES.

Adaptec Customer Support

If you have questions about installing or using your Adaptec product, check this document first—you will find answers to most of your questions. If you need further assistance, use the support options listed below. To expedite your service, have your computer in front of you.

Technical Support Identification (TSID) Number

- Before contacting Technical Support, you need your unique 12-digit TSID number. The TSID number identifies your product and support status.
- The TSID number is included on a white, bar-coded label, like this example:

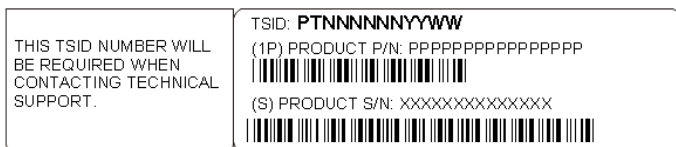

- Affix a copy of the TSID label to the CD jacket so that you don't lose it.

North America

- Visit our Web site at www.adaptec.com.
- Search the Adaptec Support Knowledgebase (ASK) at ask.adaptec.com for articles, troubleshooting tips, and frequently asked questions for your product.
- For information about Adaptec's support options, call +1 408-957-2550, 24 hours per day, 7 days per week. To speak with a Technical Support Specialist,
 - For **Hardware** products call +1 408-934-7274, Monday to Friday, 3:00 A.M. to 5:00 P.M., Pacific Time.
 - For **RAID and Fibre Channel** products call +1 321-207-2000, Monday to Friday, 3:00 A.M. to 5:00 P.M., Pacific Time.
- For support via e-mail, submit your question at ask.adaptec.com.
- You can order Adaptec products, including accessories and cables, by calling +1 408-957-7274. Or, you can order cables online at www.adaptec.com/buy-cables.

Europe

- Visit our Web site at www.adaptec-europe.com.
- **German:** Call +49 89 43 66 55 22, Monday to Friday, 9:00 to 17:00, CET. For support via e-mail, submit your question at ask-de.adaptec.com.
- **French:** Call +49 89 43 66 55 33, Monday to Friday, 9:00 to 17:00, CET. For support via e-mail, submit your question at ask-fr.adaptec.com.
- **English:** Call +49 89 43 66 55 44, Monday to Friday, 9:00 to 17:00, GMT. For support via e-mail, submit your question at ask.adaptec.com.
- You can order Adaptec cables online at www.adaptec.com/buy-cables.

Japan

- Visit our Web site at www.adaptec.co.jp.
- Call +81 3 5308 6120, Monday–Friday, 9:00 A.M. to 12:00 P.M. and 1:00 P.M. to 6:00 P.M.

Limited 3-Year Hardware Warranty

1. Adaptec, Inc. ("Adaptec") warrants to the purchaser of this product that it will be free from defects in material and workmanship for a period of three (3) years from the date of purchase. If the product should become defective within the warranty period, Adaptec, at its option, will repair or replace the product, or refund the purchaser's purchase price for the product, provided it is delivered at the purchaser's expense to an authorized Adaptec service facility or to Adaptec.
2. Repair or replacement parts or products will be furnished on an exchange basis and will either be new or reconditioned. All replaced parts or products shall become the property of Adaptec. This warranty shall not apply if the product has been damaged by accident, misuse, abuse or as a result of unauthorized service or parts.
3. Warranty service is available to the purchaser by delivering the product during the warranty period to an authorized Adaptec service facility or to Adaptec and providing proof of purchase price and date. The purchaser shall bear all shipping, packing and insurance costs and all other costs, excluding labor and parts, necessary to effectuate repair, replacement or refund under this warranty.
4. For more information on how to obtain warranty service, write or telephone Adaptec at 691 South Milpitas Boulevard, Milpitas, CA 95035, (800) 959-7274.
5. THIS LIMITED WARRANTY DOES NOT EXTEND TO ANY PRODUCT WHICH HAS BEEN DAMAGED AS A RESULT OF ACCIDENT, MISUSE, ABUSE, OR AS A RESULT OF UNAUTHORIZED SERVICE OR PARTS.
6. THIS WARRANTY IS IN LIEU OF ALL OTHER EXPRESS WARRANTIES WHICH NOW OR HEREAFTER MIGHT OTHERWISE ARISE RESPECT TO THIS PRODUCT. IMPLIED WARRANTIES, INCLUDING THOSE OF MERCHANTABILITY, FITNESS FOR A PARTICULAR PURPOSE AND NON-INFRINGEMENT SHALL (A) HAVE NO GREATER DURATION THAN 3 YEARS FROM THE DATE OF PURCHASE, (B) TERMINATE AUTOMATICALLY AT THE EXPIRATION OF SUCH PERIOD AND (C) TO THE EXTENT PERMITTED BY LAW BE EXCLUDED. IN THE EVENT THIS PRODUCT BECOMES DEFECTIVE DURING THE WARRANTY PERIOD, THE PURCHASER'S EXCLUSIVE REMEDY SHALL BE REPAIR, REPLACEMENT OR REFUND AS PROVIDED ABOVE. INCIDENTAL OR CONSEQUENTIAL DAMAGES, INCLUDING WITHOUT LIMITATION LOSS OF DATA, ARISING FROM BREACH OF ANY EXPRESS OR IMPLIED WARRANTY ARE NOT THE RESPONSIBILITY OF ADAPTEC AND, TO THE EXTENT PERMITTED BY LAW, ARE HEREBY EXCLUDED BOTH FOR PROPERTY DAMAGE, AND TO THE EXTENT NOT UNCONSCIONABLE, FOR PERSONAL INJURY DAMAGE.
7. SOME STATES DO NOT ALLOW THE EXCLUSION OR LIMITATION OF INCIDENTAL OR CONSEQUENTIAL DAMAGES FOR CONSUMER PRODUCTS, AND SOME STATES DO NOT ALLOW LIMITATIONS ON HOW LONG AN IMPLIED WARRANTY LASTS, SO THE ABOVE LIMITATION OR EXCLUSIONS MAY NOT APPLY TO YOU.
8. This warranty gives you specific legal rights, and you may also have other rights which vary from state to state.

Regulatory Compliance Statements

Federal Communications Commission Radio Frequency Interference Statement

WARNING: Changes or modifications to this unit not expressly approved by the party responsible for compliance could void the user's authority to operate the equipment.

This equipment has been tested and found to comply with the limits for a Class B digital device, pursuant to Part 15 of the FCC rules. These limits are designed to provide reasonable protection against harmful interference in a residential installation. This equipment generates, uses, and can radiate radio frequency energy, and if not installed and used in accordance with the instruction manual, may cause harmful interference to radio communications. However, there is no guarantee that interference will not occur in a particular installation. However, if this equipment does cause interference to radio or television equipment reception, which can be determined by turning the equipment off and on, the user is encouraged to try to correct the interference by one or more of the following measures:

- Reorient or relocate the receiving antenna.
- Increase the separation between equipment and receiver.
- Connect the equipment to an outlet on a circuit different from that to which the receiver is connected.
- Consult the dealer or an experienced radio/television technician for help.
- Use a shielded and properly grounded I/O cable and power cable to ensure compliance of this unit to the specified limits of the rules.

This device complies with part 15 of the FCC rules. Operation is subject to the following two conditions: (1) this device may not cause harmful interference and (2) this device must accept any interference received, including interference that may cause undesired operation.

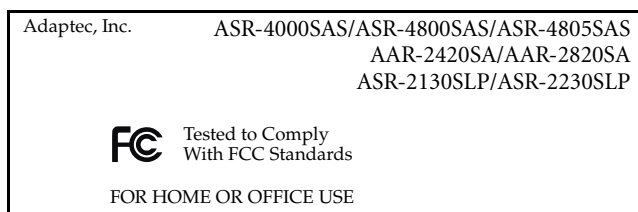

CE European Union Compliance Statement

This Information Technology Equipment has been tested and found to comply with EMC Directive 89/336/EEC, as amended by 92/31/EEC and 93/68/EEC, in accordance with:

- EN55022 (1998) Emissions
- EN55024 (1998) Immunity:
 - EN61000-4-2 (1998) Electrostatic discharge: ± 4 kV contact, ± 8 kV air
 - EN61000-4-3 (1998) Radiated immunity
 - EN61000-4-4 (1995) Electrical fast transients/burst: ± 1 kV AC, ± 0.5 kV I/O
 - EN61000-4-5 (1995) Surges ± 1 kV differential mode, ± 2 kV common mode
 - EN61000-4-6 (1996) Conducted immunity: 3 V
 - EN61000-4-11 (1994) Supply dips and variation: 30% and 100%

In addition, all equipment requiring U.L. listing has been found to comply with EMC Directive 73/23/EEC as amended by 93/68/EEC in accordance with EN60950 with amendments A1, A2, A3, A4, A11.

Australian/New Zealand Compliance Statement

This device has been tested and found to comply with the limits for a Class B digital device, pursuant to the Australian/New Zealand standard AS/NZS 3548 set out by the Spectrum Management Agency.

Canadian Compliance Statement

This Class B digital apparatus meets all requirements of the Canadian Interference-Causing Equipment Regulations.
Cet appareil numérique de la classe B respecte toutes les exigences du Règlement sur le matériel brouilleur du Canada.

VCCI Japanese Compliance (Voluntary Control Council Initiative)

This equipment complies to class B Information Technology equipment based on VCCI (Voluntary Control Council for Interface). This equipment is designed for home use but it may causes radio frequency interference problem if used too near to a television or radio. Please handle it correctly per this documentation.

Contents

About This Guide

What You Need to Know Before You Begin	12
Terminology Used in this Guide	12
How to Find More Information.....	12

Kit Contents and System Requirements

Kit Contents	14
System Requirements.....	14

About Your RAID Controller

Standard RAID Controller Features	17
Array-level Features	17
Advanced Data Protection Suite	17
Adding Enhanced Features.....	18
Using a Feature Key to Unlock Enhanced Features	18
Adding a Battery Backup Module	18
Upgrading the Controller Firmware.....	18
About the Adaptec 4000SAS.....	19
About the Adaptec 4800SAS.....	20
About the Adaptec 4805SAS.....	21
About the Adaptec 2420SA.....	22
About the Adaptec 2820SA.....	23
About the Adaptec 2130SLP	24
About the Adaptec 2230SLP	25

Getting Started

Choosing a RAID Level.....	27
Selecting Disk Drives	28
Disk Drives for SAS Controllers.....	28
Disk Drives for SATA Controllers	28
Disk Drives for SCSI Controllers	28
Selecting Cables	29
SAS Cables.....	29
SATA Cables.....	29
SCSI Cables	30
Installation Options	30
Basic Installation Steps.....	30
Installing with an Operating System.....	30
Installing on an Existing Operating System	30

Installing the Controller and Disk Drives

Before You Begin.....	32
Installing the Controller	32
Connecting Disk Drives to SAS RAID Controllers	33
Connecting Directly to the Controller.....	33
Connecting to a System Backplane.....	34
Connecting Disk Drives to SATA RAID Controllers	34
Connecting Disk Drives to SCSI RAID Controllers.....	35
Connecting External Devices.....	35
Next Steps.....	35

Creating a Bootable Array

Setting the Boot Controller	37
Creating an Array.....	37
Creating an Array with the ACU	37
Creating an Array with Adaptec Storage Manager	39
Making Your Array Bootable	40

Installing the Driver and an Operating System

Before You Begin.....	42
Creating a Driver Disk	42
Installing with Windows.....	43
Installing with Red Hat Linux	43
Installing with SuSE Linux	44
Installing with NetWare.....	44
Installing with OpenServer	45
Installing with UnixWare	45
Installing with FreeBSD	46

Installing the Driver on an Existing Operating System

Before You Begin.....	48
Creating a Driver Disk	48
Installing on Windows.....	49
Installing on Red Hat or SuSE Linux	49
Installing on NetWare.....	49
Installing on OpenServer	50
Installing on UnixWare	50
Installing on Solaris.....	51
Installing on FreeBSD	51

Managing Your Storage Space

About Adaptec Storage Manager	53
Installing Adaptec Storage Manager	53
About the Adaptec RAID Controller Configuration Utility.....	53
About the Adaptec RAID Controller Utility	54
About the Adaptec Flash Utility.....	54
Which Utility Should I Use?.....	54

Solving Problems

Troubleshooting Checklist	56
Silencing the Alarm.....	56
Recovering from a Disk Drive Failure	56
Failed Disk Drive Protected by a Hot Spare	57
Failed Disk Drive <i>Not</i> Protected by a Hot Spare.....	57
Failure in Multiple Arrays Simultaneously.....	57
Disk Drive Failure in a RAID 0 Array.....	57
Multiple Failures in the Same Array	58
Resetting the Controller.....	58

Introduction to Serial Attached SCSI (SAS)

Terminology Used in This Chapter	60
What is SAS?.....	60
How Do SAS Devices Communicate?.....	61
What's a Phy?	61
What's a SAS Port?	62
What's a SAS Address?.....	62
What's a SAS Connector?	62
What do SAS Cables Look Like?.....	63
How are Disk Drives Identified in SAS?	63
What are the SAS Connection Options?.....	63
Direct-attach Connections	63
Backplane Connections	64
SAS Expander Connections.....	64
How is SAS Different from Parallel SCSI?	65

Understanding RAID

Understanding Drive Segments	67
RAID 0 (Non-RAID Arrays)	67
RAID 1 Arrays	68
RAID 1 Enhanced Arrays.....	68
RAID 10 Arrays	69
RAID 5 Arrays	70
RAID 5EE Arrays.....	71
RAID 50 Arrays	72
RAID 6 Arrays	73
RAID 60 Arrays	73
Selecting the Best RAID Level	74

Using the Adaptec RAID Controller Utility

Introduction to the Adaptec RAID Controller Utility.....	76
Running the Adaptec RAID Controller Utility	76
Navigating the Adaptec RAID Controller Utility.....	76
Using the ACU to Create and Manage Arrays.....	76
Creating a New Array	76
Managing Existing Arrays	77
Initializing Disk Drives	77
Rescanning Disk Drives.....	77
Secure Erasing Disk Drives.....	78
Using the -Select Utility to Modify Controller Settings	78
Opening a -Select Utility	78
Applying Changes and Exiting.....	78
Modifying Your Controller's Configuration.....	79
General Controller Settings.....	79
SAS-specific Controller Settings	80
SATA-specific Controller Settings	80
SCSI-specific Controller Settings.....	81
Formatting and Verifying Disk Drives.....	82
Viewing the Event Log.....	82

Using the ACU for DOS

Getting Started	84
Working in the ACU Using Menus.....	84
Running the ACU Using Scripts	85
About Playback Mode	85
About Record Mode	86
Creating the Script File Manually	86
Array Definition Block Keywords.....	87
Channel Definition Block Keywords—SCSI only.....	90
ACU Error Codes.....	91
Sample Scripts.....	92

Using the Adaptec Flash Utility

System Requirements.....	95
Before You Begin.....	95
Obtaining the Firmware	95
Creating the Firmware Floppy Disks	96
Running the Menu-based AFU	96
Running the AFU from the Command Line	97
AFU Commands	97
Updating the Flash Using the AFU Command Line.....	100

Safety Information

Electrostatic Discharge (ESD)	101
-------------------------------------	-----

Technical Specifications

Environmental Specifications	103
DC Power Requirements	103
Current Requirements	103

Index

About This Guide

1

In this chapter...

What You Need to Know Before You Begin	12
Terminology Used in this Guide.....	12
How to Find More Information	12

This *Installation and User's Guide* explains how to install your Adaptec® RAID controller. It also describes the utilities included in your controller kit, and provides a basic overview of Serial Attached SCSI (SAS) and Redundant Array of Independent Disk (RAID) technology.

These RAID controller models are described in this *Guide*:

- Adaptec 4000SAS
- Adaptec 4800SAS
- Adaptec 4805SAS
- Adaptec 2420SA
- Adaptec 2820SA
- Adaptec 2130SLP
- Adaptec 2230SLP

What You Need to Know Before You Begin

You should be familiar with computer hardware, data storage, RAID technology, and the input/output (I/O) technology—Small Computer System Interface (SCSI), SAS, or Serial ATA (SATA)—used by your controller. (For an introduction to SAS, see [page 59](#).)

You should also be familiar with Direct Attached Storage (DAS) and Storage Area Network (SAN) concepts and technology.

Note: Because this *Guide* covers multiple Adaptec RAID products, some of the features and functions described may not be available for your controller. For more information, see [About Your RAID Controller on page 16](#).

Terminology Used in this Guide

Because you can use your Adaptec RAID controller to manage data storage in a variety of configurations from DAS to SAN, the generic term “storage space” is used to refer to controller(s) and disk drives being managed with Adaptec Storage Manager™ or the other utilities described in this *Guide*.

Many of the terms and concepts referred to in this *Guide* are known to computer users by multiple names. This *Guide* uses these terms:

- Controller (also known as adapter, board, or card)
- Disk drive (also known as hard disk, hard drive, or hard disk drive)
- Array (also known as a container or logical drive)

Note: The *Adaptec Storage Manager User's Guide* refers to arrays as logical drives. Why? Your RAID controller creates *arrays*, which your operating system (and Adaptec Storage Manager) recognizes as *logical drives*.

How to Find More Information

You can find more information about your Adaptec RAID controller and the software and utilities included with it by referring to these documents:

- *Readme.txt*—Includes updated product information and known issues; located on the RAID Installation CD.
- *Adaptec Storage Manager User's Guide*—Describes how to install and use the Adaptec Storage Manager software (see [page 53](#)); located on the Adaptec Storage Manager Installation CD.
- *Adaptec Storage Manager online Help*—Describes how to use the Adaptec Storage Manager software; accessible from the main window of Adaptec Storage Manager.
- *Command Line Utility User's Guide*—Describes how to use the command line utility (ARCCONF—see [page 53](#)) to perform basic array and configuration management functions; located on the Adaptec Storage Manager Installation CD.

Kit Contents and System Requirements

2

In this chapter...

Kit Contents..... 14

System Requirements..... 14

This chapter lists the contents of your Adaptec RAID controller kit and the system requirements that must be met for you to successfully install and use your controller.

Kit Contents

- Adaptec RAID controller
- RAID Installation CD (bootable), including controller drivers, and this *Guide*
- Adaptec Storage Manager Installation CD (not bootable), including user guides for Adaptec Storage Manager and the Adaptec RAID controller configuration command line utility (ARCCONF)
- Cables (type and quantity vary—for cable information about your controller, see [About Your RAID Controller on page 16](#))
- (*Selected models only*) Low-profile bracket
- *Adaptec RAID Controller Quick Start Guide*

System Requirements

- PC-compatible computer with Intel Pentium, or equivalent, processor
- Motherboard with these features:
 - Compliant with *PCI Local Bus Specification*, Revision 2.2 or later
 - Support for multifunction devices where one of the devices is a PCI bridge
 - Large memory-mapped address ranges

Refer to the Readme file on the RAID installation CD for additional motherboard compatibility information.

- One of these operating systems:
 - Microsoft® Windows® 2000, Windows Server 2003, Windows XP
 - Red Hat® Linux
 - SuSE Linux

Note: For the latest on Adaptec's support of Linux, or to download driver sources, visit the Support area of the Adaptec Web site at www.adaptec.com.

 - Novell® NetWare®
 - SCO® OpenServer® 6.0
 - UnixWare® 7.1.4
 - Sun® Solaris™ 10 (supports secondary controllers only, not boot controller; storage management must be done through the Adaptec Configuration Utility—see [page 76](#))
 - FreeBSD 5.4, 6.0 (driver support only; storage management must be done through the Adaptec Configuration Utility—see [page 76](#))

Note: For up-to-date operating system version support, refer to the Adaptec Web Site at www.adaptec.com.
- 128 MB (or more) of RAM

- Available compatible PCI/PCI-X/PCI-E slot (depending on your controller model—see the descriptions starting on [page 16](#))
- 20 MB of free disk drive space
- 16-bit SVGA color monitor with a resolution of at least 800 x 600
- CD drive

About Your RAID Controller

3

In this chapter...

Standard RAID Controller Features	17
Adding Enhanced Features	18
Adding a Battery Backup Module	18
Upgrading the Controller Firmware	18
About the Adaptec 4000SAS	19
About the Adaptec 4800SAS	20
About the Adaptec 4805SAS	21
About the Adaptec 2420SA	22
About the Adaptec 2820SA	23
About the Adaptec 2130SLP	24
About the Adaptec 2230SLP	25

This chapter provides an overview of standard Adaptec RAID controller features, and describes the unique features of your controller. It also explains how to upgrade your controller with enhanced features.

Standard RAID Controller Features

- Flash ROM for updates to controller firmware, BIOS, and the Adaptec RAID Configuration utility
- Disk drive hot-swapping
- Event logging and broadcasting including email and SNMP messages
- Multiple options for creating and managing RAID arrays—A full software application (Adaptec Storage Manager), a BIOS-based utility, a command line utility, and a DOS utility. See *Managing Your Storage Space* on page 52 for more information.
- (*SAS and SATA RAID controllers only*) Native command queuing (NCQ), which lets disk drives arrange commands into the most efficient order for optimum performance
- (*SAS and SCSI RAID controllers only*) Support for disk drive enclosures with SAF-TE enclosure management hardware
- (*SAS RAID controllers only*) Support for disk drive enclosures with SES2 enclosure management hardware

Some RAID controllers support a battery backup module (see page 18).

Array-level Features

Note: For more information, refer to the *Adaptec Storage Manager User's Guide* or online Help.

- Support for RAID 0, RAID 1, RAID 5, RAID 10, RAID 50¹, simple volumes, and spanned volumes
- Support for hot spares (global and dedicated)
- Support for automatic failover, so arrays are automatically rebuilt when a failed disk drive is replaced (applies to redundant arrays in SES2- or SAF-TE-enabled disk drive enclosures *only*)
- Optimized disk utilization, which ensures that the full capacity of all disk drives can be used, even if the disk drives vary in size
- Online capacity expansion, so you can increase the capacity of an array without recreating it
- Support for array migration from one RAID level to another

Advanced Data Protection Suite

- **Copyback Hot Spare**—You can use this feature to move data from a hot spare back to its original location after a failed disk drive is replaced.
- **Striped Mirror (RAID 1E)**—A RAID 1 Enhanced array is similar to a RAID 1 array except that data is both mirrored *and* striped, and more disk drives can be included.
- **Hot Space (RAID 5EE)**—A RAID 5EE array is similar to a RAID 5 array except that it includes a distributed spare and must be built from a minimum of four disk drives.
- **Dual Drive Failure Protection (RAID 6)**—A RAID 6 array is similar to a RAID 5 array except that it includes *two* independent sets of parity data instead of one.
- **Dual Drive Failure Protection (RAID 60¹)**—A RAID 60 array is similar to a RAID 50 array except that it includes *four* independent sets of parity data instead of two.

¹The Adaptec 2420SA RAID controller does not support RAID 50 or RAID 60.

Adding Enhanced Features

As your storage needs change, you can enhance data protection and improve performance by upgrading your Adaptec controller with extra features.

Currently, Adaptec offers the snapshot function as an upgrade feature which can be activated with a feature key (sold separately). A *snapshot* is a frozen image of a logical drive at a particular point in time. You can use this feature to back up your data to tape, clone a disk drive, or copy the data to multiple servers.

Note: Snapshots are supported by Windows and Linux operating systems only.

To purchase a feature key, contact your Adaptec Reseller or refer to the Adaptec Web site at www.adaptec.com. To unlock the enhanced features with a feature key, see [page 18](#).

Using a Feature Key to Unlock Enhanced Features

When you receive a feature key, use Adaptec Storage Manager to unlock the new features. For step-by-step instructions, follow the instructions in the online Help or the *Adaptec Storage Manager User's Guide* on the Adaptec Storage Manager Installation CD.

Adding a Battery Backup Module

This table shows the battery model supported by your Adaptec RAID controller.

RAID Controller	Battery Model
Adaptec 4800SAS / Adaptec 4805SAS	Adaptec Battery Module 600
Adaptec 2420SA / Adaptec 2820SA	Adaptec Battery Module 500
Adaptec 2130SLP / Adaptec 2230SLP	Adaptec Battery Module 400

To purchase a backup battery module, refer to the Adaptec Web site at www.adaptec.com.

Upgrading the Controller Firmware

To upgrade the firmware on your Adaptec RAID controller, follow the instructions in *Using the Adaptec Flash Utility* on [page 94](#).

About the Adaptec 4000SAS

The Adaptec 4000SAS is a low-profile SAS Zero Channel RAID controller with these features:

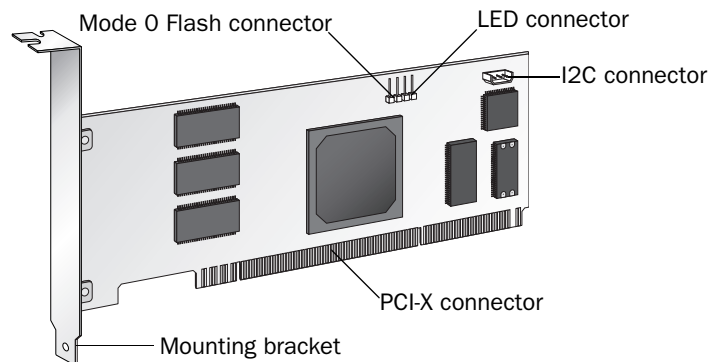

Bus compatibility	PCI-X
Maximum bus width	64-bit
Maximum bus speed	133 MHz
Standard cache	128 MB
Maximum number of disk drives	8
Audible alarm	No

About the Adaptec 4800SAS

The Adaptec 4800SAS is a SAS RAID controller with these features:

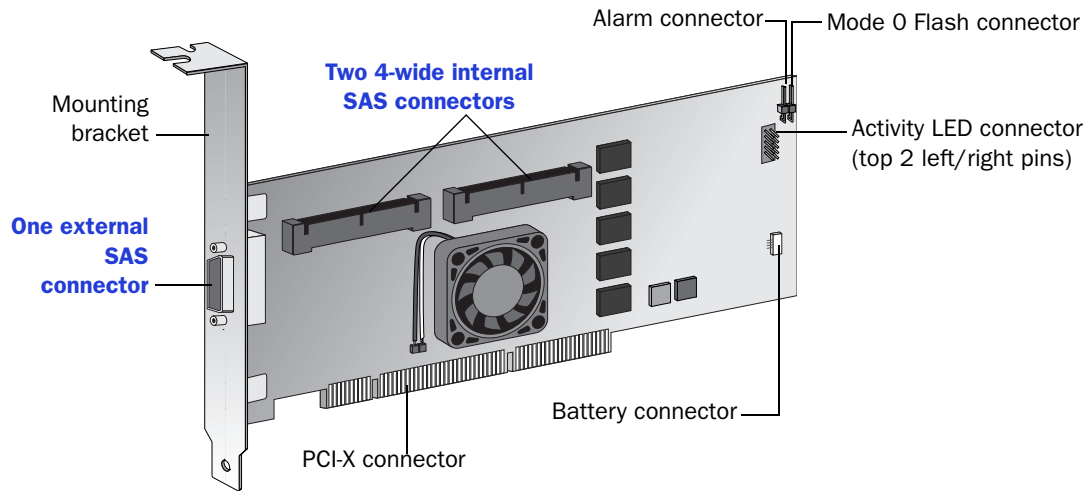

Bus compatibility	PCI-X
Maximum bus width	64-bit
Maximum bus speed	133 MHz
I/O processor clock frequency	500 MHz
Standard cache	128 MB DDR2 ¹
Maximum number of disk drives	8 (or up to 128 with expanders)
SAS cables included	2 (internal)
Battery backup module	Adaptec Battery Module 600 (sold separately—see page 18)
Audible alarm	Yes

¹ 256 MB also available

Note: Although this controller has an onboard speaker, you can connect it to an internal speaker with these specifications: 3.0 V, 90.0 mA. The internal speaker is not required, as the onboard speaker volume is appropriate for most environments.

About the Adaptec 4805SAS

The Adaptec 4805SAS is a SAS RAID controller with these features:

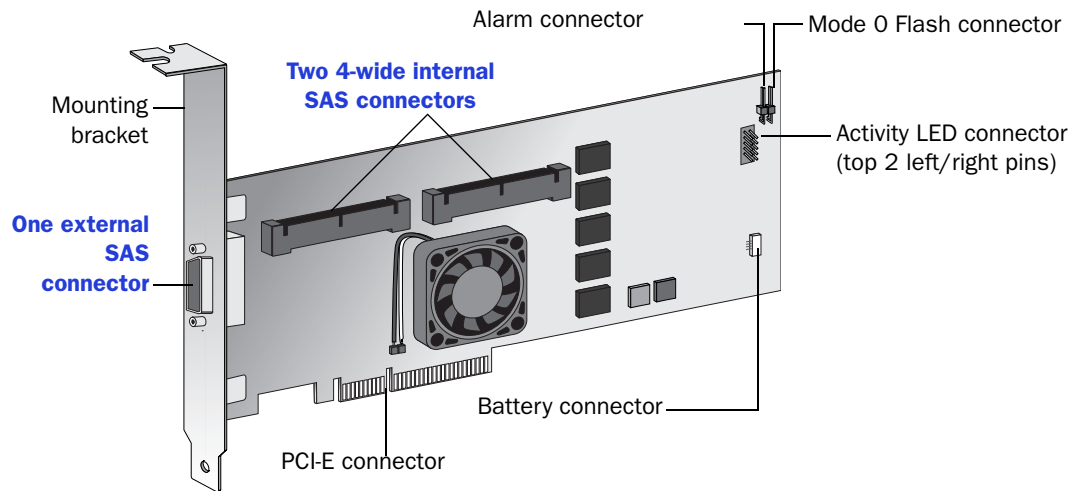

Bus compatibility	PCI-E x8
I/O processor clock frequency	500 MHz
Standard cache	128 MB DDR2 ¹
Maximum number of disk drives	8 (or up to 128 with expanders)
SAS cables included	2 (internal)
Battery backup module	Adaptec Battery Module 600 (sold separately—see page 18)
Audible alarm	Yes

¹ 256 MB also available

Note: Although this controller has an onboard speaker, you can connect it to an internal speaker with these specifications: 3.0 V, 90.0 mA. The internal speaker is not required, as the onboard speaker volume is appropriate for most environments.

About the Adaptec 2420SA

The Adaptec 2420SA is a SATA RAID controller with these features:

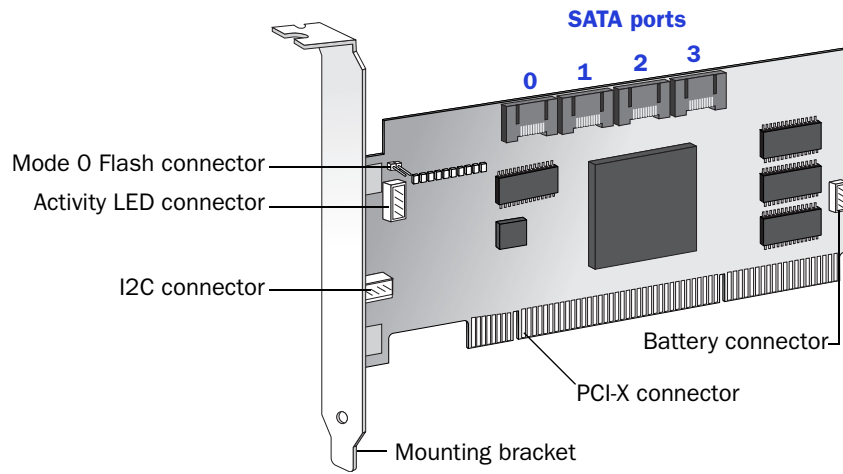

Bus compatibility	PCI-X, 3.3 V
Bus width	64-bit
Bus speed	133 MHz
Standard cache	128 MB ¹
Maximum number of disk drives	4
SATA cables included	4
Battery backup module	Adaptec Battery Module 500 (sold separately—see page 18)
Audible alarm	Yes

¹ 256 MB also available

Note: A low-profile bracket is included with this controller. However, this controller may not fit in all low-profile systems.

About the Adaptec 2820SA

The Adaptec 2820SA is a SATA RAID controller with these features:

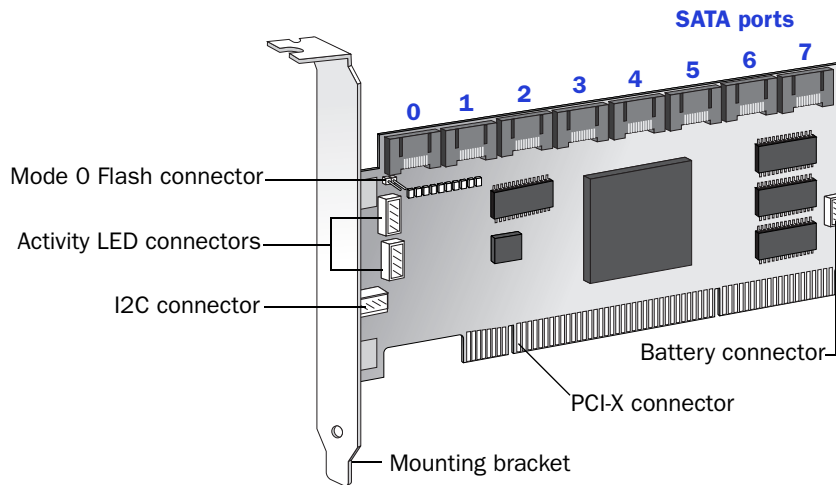

Bus compatibility	PCI-X, 3.3 V
Bus width	64-bit
Bus speed	133 MHz
Standard cache	128 MB ¹
Maximum number of disk drives	8
SATA cables included	8
Battery backup module	Adaptec Battery Module 500 (sold separately—see page 18)
Audible alarm	Yes

¹ 256 MB also available

Note: A low-profile bracket is included with this controller. However, this controller may not fit in all low-profile systems.

About the Adaptec 2130SLP

The Adaptec 2130SLP is a low-profile controller with these features:

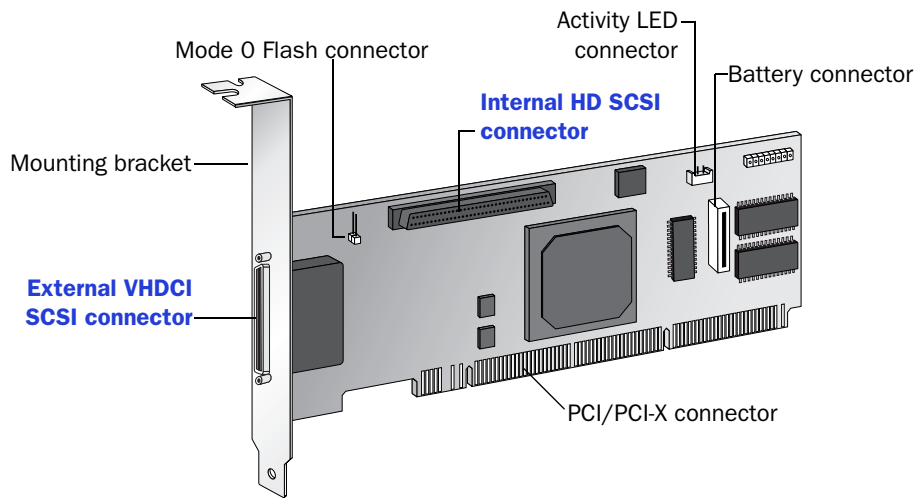

Bus compatibility	PCI / PCI-X, 3.3 V
Maximum bus width	64-bit
Maximum bus speed	133 MHz
Standard cache	128 MB or 256 MB (depending on your controller configuration)
Number of channels	1
Maximum number of disk drives	15
SCSI cables included	1 (internal)
Battery backup module	Adaptec Battery Module 400 (sold separately—see page 18)
Audible alarm	Yes

About the Adaptec 2230SLP

The Adaptec 2230SLP is a low-profile controller with these features:

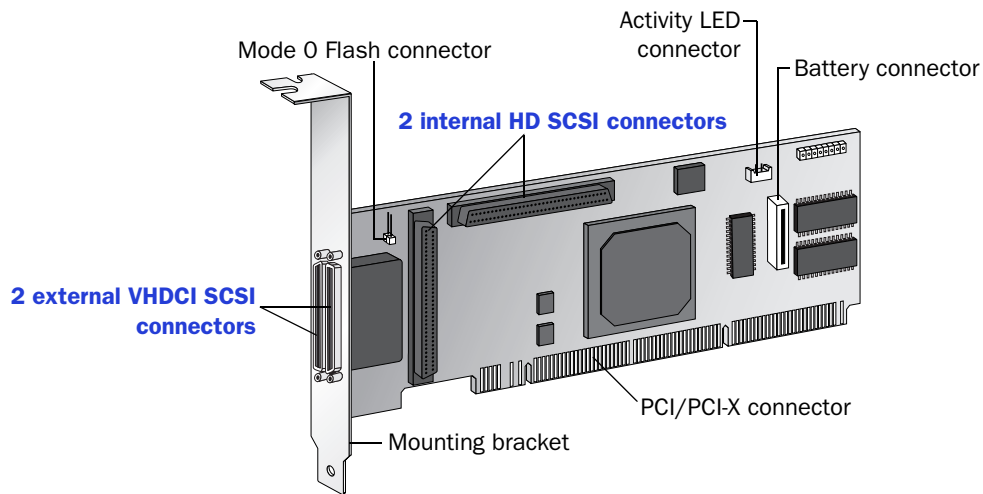

Bus compatibility	PCI / PCI-X, 3.3 V
Maximum bus width	64-bit
Maximum bus speed	133 MHz
Standard cache	128 MB or 256 MB (depending on your controller configuration)
Number of channels	2
Maximum number of disk drives	30 (15 per channel)
SCSI cables included	1 (internal)
Battery backup module	Adaptec Battery Module 400 (sold separately—see page 18)
Audible alarm	Yes

Getting Started

4

In this chapter...

Choosing a RAID Level.....	27
Selecting Disk Drives.....	28
Selecting Cables.....	29
Installation Options.....	30
Basic Installation Steps.....	30

This chapter provides the basic information you need to set up your disk drives and arrays the way you want them. It also describes the options you have for installing your Adaptec controller and disk drives, and creating arrays for data storage.

Note: Before you begin, familiarize yourself with your Adaptec controller's physical features and the RAID levels that it supports (see [About Your RAID Controller on page 16](#)).

Choosing a RAID Level

This section provides a brief overview of the RAID levels supported by your Adaptec RAID controller, including the minimum and maximum number of disk drives required by each.

- **RAID 0 (Non-redundant Array)**—Stripes data across multiple disk drives. Improved performance but no redundancy (see [page 67](#)).
- **RAID 1 Array**—Created from two disk drives where one disk drive is a *mirror* of the other (the same data is stored on each disk drive). Redundancy, but reduced capacity (see [page 68](#)).
- **RAID 1E Array**—Similar to a RAID 1 array except that data is mirrored *and* striped, and more disk drives can be included (see [page 68](#)).
- **RAID 5 Array**—Stripes data for improved performance and uses *parity* data to provide redundancy (see [page 70](#)).
- **RAID 5EE Array**—Similar to a RAID 5 array, but includes a distributed spare and must include a minimum of four disk drives (see [page 71](#)).
- **RAID 10 Array**—Built from two or more equal-sized RAID 1 arrays, stripes and mirrors data across multiple disk drives. Redundancy and improved performance (see [page 69](#)).
- **RAID 50¹ Array**—Built from multiple disk drives configured as two or more RAID 5 arrays, stripes stored data and parity data across all disk drives (see [page 72](#)).
- **RAID 6 Array**—Similar to a RAID 5 array except that it includes *two* independent sets of parity data instead of one (see [page 73](#)).
- **RAID 60* Array**—Similar to a RAID 50 array except that it includes *four* independent sets of parity data instead of two (see [page 73](#)).

Use the table on [page 74](#) to see how many disk drives you must connect to your RAID controller to support the RAID level you want.

¹ Because it supports four disk drives only, the Adaptec 2420SA RAID controller can't support RAID 50 or RAID 60.

Selecting Disk Drives

When selecting disk drives for your RAID array, ensure that all the disk drives have the same performance level. You can use different-sized disk drives in the array, but the array will be limited to the capacity of the smallest and slowest disk drive.

For more information, refer to the *Adaptec Storage Manager User's Guide* or online Help.

Disk Drives for SAS Controllers

Your SAS controller supports both SAS and SATA disk drives. For cable information, see [page 29](#).

Disk Drives for SATA Controllers

Your SATA controller supports SATA disk drives only. You need one SATA cable for each disk drive you are connecting to your SATA controller.

Disk Drives for SCSI Controllers

Your SCSI controller supports Ultra320 SCSI disk drives. It also supports Ultra2 or higher SCSI disk drives and peripherals, but at performance levels less than Ultra320. Adaptec does not recommend using SCSI disk drives or peripherals older than Ultra2.

Note: High-voltage Differential (HVD) disk drives are not supported and will damage your controller.

If you are mixing single-ended (SE) disk drives with Low-voltage Differential (LVD) disk drives:

- Ensure proper termination by using a cable (like the one included in the kit) with a built-in multimode terminator and proper adapters.
- Disable termination on all the SE disk drives.
- Put LVD and SE disk drives on separate channels for the best performance.

Note: If you mix SE and Ultra320 disk drives on the same channel, the performance of the Ultra320 disk drives is reduced to SE levels.

Selecting Cables

This section describes the cable options and requirements for your Adaptec controller:

- For SAS cables, see this page.
- SATA cables, see this page.
- SCSI cables, see [page 30](#).

SAS Cables

You need one SAS cable for each disk drive you are connecting to your Adaptec SAS RAID controller.

Depending on your requirements, you can use any of these cables:



Internal cable—Connects to a backplane.

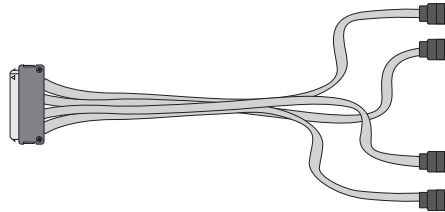

Internal fan-out cable—Connects to four internal SATA disk drives.
(SAS-to-SAS fan-out cables—not shown—are also available.)



External cable—Connects to an external SAS enclosure.

Cable connectors are keyed so that you can't insert them incorrectly.

Adaptec recommends using only Adaptec SAS cables. For more information or to purchase cables, visit the Adaptec Web site at www.adaptec.com.

SATA Cables

You need one SATA cable for each disk drive you are connecting to your Adaptec SATA RAID controller. SATA cables are included in the kit.

All SATA cables have the same connectors, as shown in the following figure, and the connectors are keyed so that you can't insert them incorrectly.



Adaptec recommends using only Adaptec SATA cables. For more information or to purchase cables, visit the Adaptec Web site at www.adaptec.com.

SCSI Cables

Depending on your requirements, you may need one or two internal cables. You may also need one external SCSI cable. Ensure that you have cables with the proper connectors for your RAID controller. One internal SCSI cable is included in the kit.

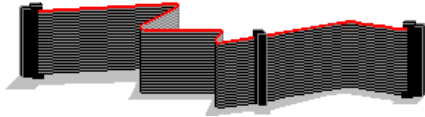

Internal SCSI cable—Connects to up to seven internal SCSI disk drives and devices.



External SCSI cable—Connects to an external SCSI disk drive or device.

Adaptec recommends using only high-quality Ultra320-rated cables with multimode terminators for all disk drives that share a channel with Ultra320 disk drives. Avoid poor quality cables, as they may degrade reliability. Do not use cables not rated for Ultra320 operation.

Adaptec recommends using only Adaptec SCSI cables. For more information or to purchase cables, visit the Adaptec Web site at www.adaptec.com.

Installation Options

When you install your Adaptec controller, you can choose to create a bootable array and then install your operating system and the controller driver on that array.

Alternatively, you can complete a standard installation, where the controller driver is installed on an existing operating system.

Basic Installation Steps

This section describes the installation process. Follow the steps for the installation option you've chosen.

Installing with an Operating System

- 1 Install and connect your controller and internal disk drives (see [page 31](#)).
If your controller has an external connector, you can connect external disk drives as well (or instead).
- 2 Set the boot controller (see [page 37](#)).
- 3 Create a bootable array (see [page 37](#)).
- 4 Install your operating system and the controller driver (see [page 41](#)).
- 5 Install Adaptec Storage Manager and begin to manage your data storage (see [page 52](#)).

Installing on an Existing Operating System

- 1 Install and connect your controller and internal disk drives (see [page 31](#)).
If your controller has an external connector, you can connect external disk drives as well (or instead).
- 2 Install the controller driver (see [page 47](#)).
- 3 Install Adaptec Storage Manager and begin to manage your data storage (see [page 52](#)).

Installing the Controller and Disk Drives

5

In this chapter...

Before You Begin	32
Installing the Controller.....	32
Connecting Disk Drives to SAS RAID Controllers.....	33
Connecting Disk Drives to SATA RAID Controllers.....	34
Connecting Disk Drives to SCSI RAID Controllers.....	35
Connecting External Devices.....	35

This chapter explains how to install your Adaptec RAID controller, and how to install and connect internal and external disk drives.

Before You Begin

- Read *Safety Information on page 101*.
- Familiarize yourself with your Adaptec RAID controller's physical features and the RAID levels that it supports (see [page 16](#)).
- Ensure you have the right quantity of disk drives for the RAID level you want to use for your arrays (see [page 28](#)).
- Ensure that you have the proper cables for your controller and disk drives (see [page 29](#)).
- If you are installing a low-profile RAID controller into a low-profile computer cabinet, replace the original full-height bracket with the low-profile bracket included in the kit.

 **Caution:** Handle the controller by its bracket or edges only.

Installing the Controller

This section describes how to install your Adaptec RAID controller into your computer cabinet.

- 1 Turn off your computer and disconnect the power cord. Open the cabinet, following the manufacturer's instructions.
- 2 Select an available PCI expansion slot that's compatible with your RAID controller and remove the PCI slot cover, as shown at right. (PCI bus compatibility is marked on the controller figures in [About Your RAID Controller on page 16](#).)

For the best performance, use the fastest available PCI slot that's compatible with your RAID controller.

 **Caution:** Touch a grounded metal object before handling the RAID controller.

- 3 As shown at right, insert the RAID controller into the PCI expansion slot and press down gently but firmly until it clicks into place. When installed properly, the RAID controller should appear level with the PCI expansion slot.
- 4 Secure the bracket in the PCI slot, using the retention device (for instance, a screw or lever) supplied with your computer.
- 5 Connect your computer's disk activity LED cable to the LED connector on the controller (marked on the figures in [About Your RAID Controller on page 16](#)).

Ensure that the positive lead of the LED cable (usually a red wire or a wire marked with a red stripe) is attached to pin 1.

Note: *Adaptec 4000SAS only*—Controller installation is complete. If you are installing the controller driver and an operating system on a bootable array, continue with [Creating a Bootable Array on page 36](#).

If you are completing a standard installation onto an existing operating system, continue with [Installing the Driver on an Existing Operating System on page 47](#).

- 6 *Optional*—Connect your RAID controller's I2C connector (not available on all models) to an I2C connector on an internal backplane or enclosure, using an I2C cable.

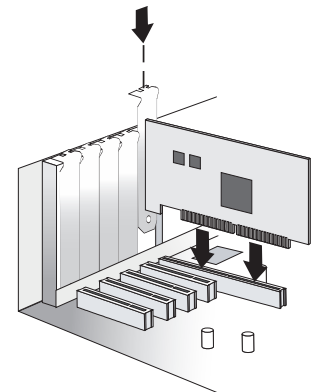
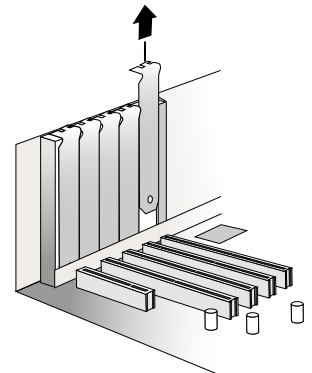

- 7 Prepare and install your internal disk drives, following the instructions for your type of controller:
 - For SAS RAID controllers, see [page 33](#).
 - For SATA RAID controllers, see [page 34](#).
 - For SCSI RAID controllers, see [page 35](#).

If you are not installing internal disk drives, close your computer cabinet, reattach the power cord, then continue with [Connecting External Devices on page 35](#).

Connecting Disk Drives to SAS RAID Controllers

You can connect SAS disk drives, SATA disk drives, or a combination of both to your SAS RAID controller. There are no jumpers or switches to set before installation.

If you plan to build a bootable array using internal disk drives, ensure you install at least the minimum number disk drives required to support the RAID level you want. See [page 27](#) for more information.

Note: Although you can connect both SAS and SATA disk drives to your SAS controller, Adaptec recommends that you *not* combine SAS and SATA disk drives within the same array or logical drive. See [page 60](#) for more information.

You have two connection options:

- To connect directly to the controller, see the following section.
- To connect to a backplane, see [page 34](#).

Connecting Directly to the Controller

In a direct-attach connection, SAS or SATA disk drives are connected directly to a SAS card with SAS cables. The number of direct-attached disk drives is limited to four per internal SAS connector. (For more information about direct-attach connections, see [page 63](#).)

- 1 Install your internal SAS or SATA disk drives, following the instructions in your system's documentation.
- 2 Use internal SAS cables to attach the disk drives to the controller. (SATA disk drives are shown in the following figure.)

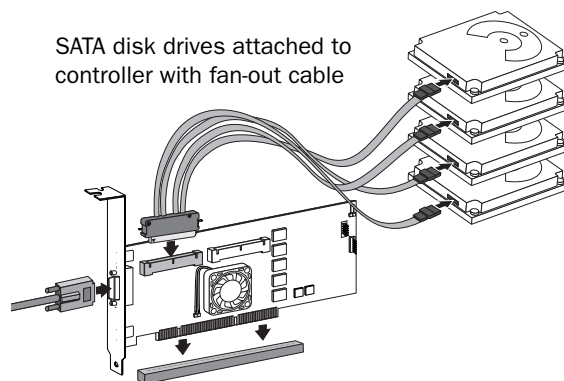

- 3 When all internal disk drives have been installed and attached to the controller, close your computer cabinet, reattach the power cord, then continue with [Connecting External Devices on page 35](#).

Connecting to a System Backplane

In a backplane connection, disk drives and SAS cards are attached to and communicate with each other through a system backplane.

The number of disk drives is limited to the number of slots available on the backplane. Some backplanes have embedded SAS expanders and can support up to 128 end devices. (For more information about backplane and expander connections, see [page 63](#).)

- 1 Connect one or more internal SAS or SATA disk drives to the backplane. (Refer to your system's documentation for more information.)
- 2 Use an internal SAS cable to connect the controller to the backplane.

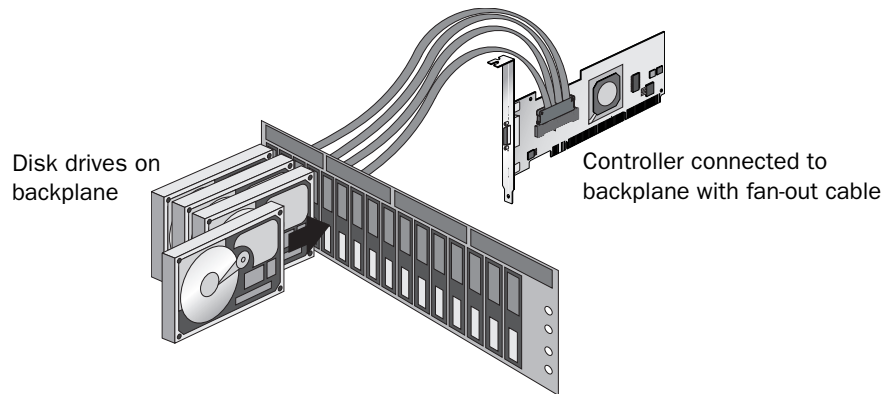

- 3 When all internal disk drives have been installed and connected, close your computer cabinet, reattach the power cord, then continue with [Connecting External Devices on page 35](#).

Connecting Disk Drives to SATA RAID Controllers

- 1 Install your SATA disk drives, following the instructions in your system's documentation. There are no jumpers or switches to set on the SATA controller or disk drives.
- 2 Use one SATA cable to connect each disk drive to a SATA port on the controller.
- 3 When all internal disk drives have been installed and connected, close your computer cabinet, and reattach the power cord.

Continue by either setting the boot controller (see [page 36](#)) or by installing the controller driver on an existing operating system (see [page 47](#)), depending on the type of installation you are completing.

Connecting Disk Drives to SCSI RAID Controllers

- 1 For each controller channel, set the SCSI ID of each disk drive to a unique number between 0 and 15.

The controller is set to ID 7 by default. Although not recommended, you can change the controller ID by using the Adaptec RAID Controller utility (see [page 75](#)).

Note: Do not change the controller ID unless absolutely necessary.

- 2 Install a terminator (or enable termination) on the disk drive at the end of each cable, or the end of the cable itself.

Remove any terminators (or disable termination) on disk drives between the ends of each cable.

Install your SCSI disk drives, following the instructions in your system's documentation.

- 3 If space inside your computer cabinet is limited, connect your disk drives to the SCSI cable *before* installing them. (For installation instructions, refer to your computer's documentation.)

 **Caution:** To avoid causing unstable operation, *do not* attach a cable to the controller unless the other end of the cable is attached to a least one disk drive.

Alternatively, install your disk drives, then connect them to the controller.

- 4 When all internal disk drives have been installed and connected, close your computer cabinet, reattach the power cord, then continue with [Connecting External Devices on page 35](#).

Connecting External Devices

Note: If you are not connecting any external devices, see the following section, [Next Steps](#).

- 1 (*SCSI controllers only*) Ensure that SCSI IDs and termination are set before completing the connections to external disk drives or devices. See [page 35](#).
- 2 Use high-quality cables to connect your controller to your external device(s), such as disk drives or disk drive enclosures.

Adaptec recommends using only Adaptec cables. For more information or to purchase cables, visit the Adaptec Web site at www.adaptec.com.

Next Steps

If you are installing the controller driver *and* an operating system onto a bootable array, continue with [Creating a Bootable Array on page 36](#).

If you are completing a standard installation onto an existing operating system, continue with [Installing the Driver on an Existing Operating System on page 47](#).

6

Creating a Bootable Array

In this chapter...

Setting the Boot Controller.....	37
Creating an Array	37
Making Your Array Bootable	40

This chapter explains how to set your Adaptec controller to be the boot controller, and how to create a bootable array.

Note: If you are completing a standard installation onto an existing operating system, you don't have to complete this task. Skip to [Installing the Driver on an Existing Operating System on page 47](#).

Setting the Boot Controller

Note: If your system won't contain more than one bootable controller, skip to the next section, [Creating an Array](#).

Your Adaptec RAID controller supports bootable disk drives and bootable arrays. To enable your system to boot from either a disk drive or an array connected to your controller:

- 1 Enter the system setup.
- 2 Navigate to the drive boot sequence.
- 3 Move the boot controller to the top of the list.

For more information, refer to your computer's documentation.

Creating an Array

This section explains how to create an array.

A RAID 5 array is created in the examples shown in this section because RAID 5 provides the most security and best performance with a minimum of three disk drives. However, you can choose to create an array with a different RAID level; you can also change array level later, after the operating system is installed.

You can create an array using either of these tools:

- **Array Configuration Utility**—BIOS-based menus and keyboard navigation (see the following section).
- **Adaptec Storage Manager**—Graphical software application (running from a bootable CD) that you can navigate with your mouse (see [page 53](#)).

You can use either tool, but the Adaptec RAID Controller utility is the quicker and easier tool for this task.

Note: Adaptec recommends that you *not* combine SAS and SATA disk drives within the same array. Adaptec Storage Manager generates a warning if you try to create a logical drive using a combination of SAS and SATA disk drives. See [page 60](#) for more information.

Creating an Array with the ACU

The ACU is menu-based and instructions for completing tasks appear on-screen. Menus can be navigated using the arrows, Enter, Esc, and other keys on your keyboard.

To create a RAID 5 array:

- 1 Power on your computer. When prompted, press **Ctrl+A** to enter the Adaptec RAID Controller utility.
- 2 If you have more than one controller of the same model or family in your computer, select your controller, then press **Enter**.
- 3 Select **Array Configuration Utility**, then press **Enter**.
- 4 Select **Initialize Drives**, then press **Enter**.

- 5 Select at least three disk drives for the array, press **Insert** for each selected disk drive, then press **Enter**.

 **Caution:** During initialization, all data is deleted from the disk. Before continuing, back up any data you want to keep.

- 6 Press **Y**, then press **Enter**.

The selected disk drives are initialized, then the Adaptec Configuration Utility screen appears.

- 7 Select **Create Array**, then press **Enter**.
- 8 Select the disk drives that were just initialized, press **Insert** for each selected disk drive, then press **Enter**.
- 9 When the Array Properties screen opens, follow the instructions in the following table:

Property Line	Entry or Selection
Array Type	Select RAID 5 , then press Enter .
Array Label	Type a name, then press Enter .
Array Size	Press Enter , then press Enter again to use the default granularity of GB.
Stripe Size	Press Enter to use the default (256KB).
Read Caching	Press Enter to use the default (Yes).
Write Caching	Press Enter to use the default (Enable always).
Create RAID via	Press Enter to use the default (Build/Verify).
[Done]	Press Enter .

- 10 When a cache warning message displays, type **Y**.
- 11 Once the array is created, a message displays telling you that the array can now be used. Press any key to return to the ACU Menu.

You can start using the array immediately. However, performance is reduced until the build process is complete.
- 12 Press **Esc** until the Exit Utility window appears.
- 13 Select **Yes**, then press **Enter**.

The computer restarts.
- 14 Continue with *Making Your Array Bootable* on page 40.

Creating an Array with Adaptec Storage Manager

This section describes how to use the Adaptec Storage Manager configuration wizard to build a RAID 5 array.

Note: You will need the RAID Installation CD to complete this task.

To create a RAID 5 array:

- 1 Insert the RAID Installation CD into your CD drive, then restart your computer.
- 2 When prompted, select the language you want, then press **Enter**.
- 3 Review the license information, then press **Enter**.

The main menu opens.

- 4 Click **Launch Configuration Utility**.

Adaptec Storage Manager opens.

- 5 Click **Create**.

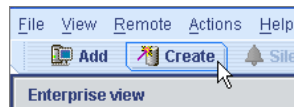

The Configuration wizard opens.

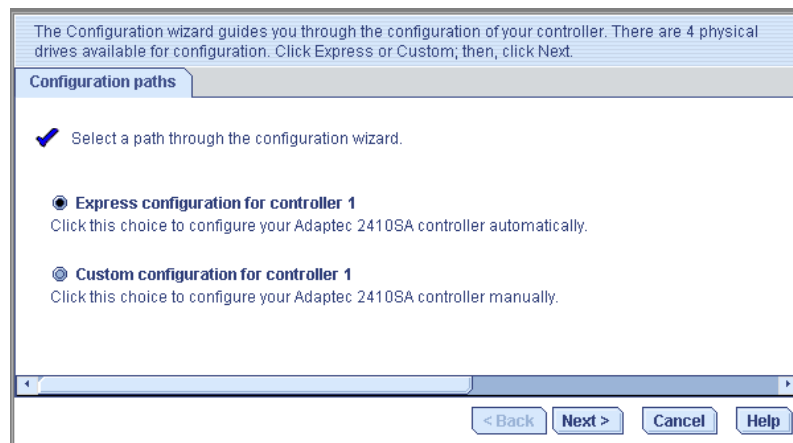

- 6 Select **Express configuration...**, then click **Next**.

- Review the information that is displayed.

Note: Adaptec Storage Manager uses the term *logical drives* when referring to *arrays* (see [page 12](#)).

In this example, Adaptec Storage Manager has used four equal-sized disk drives to automatically create one logical drive with RAID 5 and a hot spare.

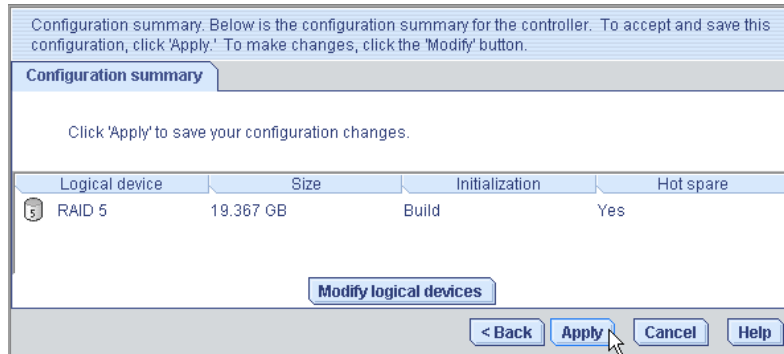

To specify a size for the logical drives, or to make other changes to the configuration, click **Modify logical devices**.

- Click **Apply**, then click **Yes** when prompted to confirm applying your new configuration.

Adaptec Storage Manager builds the logical drive(s).

The configuration is saved on the Adaptec controller (as an “array”, see [page 12](#)) and on the physical disk drives.

- Partition and format your logical drive.

The logical drive you created appears as a physical disk drive on your operating system. You *must* partition and format these logical drives before you can use them to store data.

- Close all windows, then click **Reboot** to restart your system.

- Remove the RAID Installation CD.

For information on installing and using Adaptec Storage Manager as a full software application, refer to the *Adaptec Storage Manager User's Guide* or online Help.

- Continue with [Making Your Array Bootable](#) on [page 40](#).

Making Your Array Bootable

Use the ACU to make the array bootable (see [Creating Bootable Arrays](#) on [page 77](#)).

Then continue with [Installing the Driver and an Operating System](#) on [page 41](#).

Installing the Driver and an Operating System

7

In this chapter...

Before You Begin	42
Creating a Driver Disk	42
Installing with Windows	43
Installing with Red Hat Linux	43
Installing with SuSE Linux.....	44
Installing with NetWare	44
Installing with OpenServer	45
Installing with UnixWare	45
Installing with FreeBSD	46

This chapter explains how to install your Adaptec RAID controller driver and an operating system onto a bootable array (see [page 36](#)).

Note: *Solaris users only*—You cannot use your Adaptec RAID controller as a boot controller. To install the driver on a computer with Solaris already installed, see [page 51](#).

To install the driver on an existing operating system, see [page 47](#).

Before You Begin

- Install and connect your Adaptec RAID controller and internal disk drives (see [page 31](#)).
- Create a bootable array (see [page 36](#)).
- Create a driver disk (see the following section).

Creating a Driver Disk

Note: You will need a floppy disk to complete this task.

To create a driver disk:

- 1 Set your system BIOS so that your computer boots from the CD drive. (For instructions, refer to your computer's documentation.)
- 2 Turn on your computer, then insert the RAID Installation CD included in your RAID controller kit.
- 3 Follow the on-screen instructions to get to the Adaptec Start Menu.
- 4 Click **Create Driver Disk**, then select your operating system.

Linux only—If prompted, select your operating system *and* the architecture:

- Intel 386 or 486 computers—Select **i386**.
 - Pentium I or II computers—Select **i586**.
 - Pentium III, IV, or AMD K-6 computers—Select **i686**.
 - AMD Athlon computers—Select **Athlon**.
- 5 Select your floppy disk drive letter, then select the format you want. (You need a full format only if your floppy disk has never been formatted or may have bad sectors.)
 - 6 Insert the floppy disk, then click **OK**.
- The system creates the driver disk.
- 7 Remove and label the driver disk.
 - 8 Continue with the instructions for your operating system:

- For Windows, see [page 43](#).
- For Red Hat Linux, see [page 43](#).
- For SuSE Linux, see [page 44](#).
- For NetWare, see [page 44](#).
- For OpenServer, see [page 45](#).
- For UnixWare, see [page 45](#).
- For FreeBSD, see [page 46](#).

Installing with Windows

Note: You will need your Windows installation CD to complete this task.

To install the Adaptec RAID controller driver while installing Windows:

- 1 Insert your Windows CD, then restart the computer.
- 2 Follow the on-screen instructions to begin the Windows installation.
- 3 When prompted to install a third-party driver, press F6.

Note: When F6 is active, a prompt appears at the bottom of the screen for only 5 seconds. If you miss your chance to press F6, restart your computer.

- 4 Insert the driver disk, then wait until you are prompted to install a driver.
- 5 Press S to specify that the driver is on a floppy disk, then press **Enter**.
The computer reads the disk.
- 6 When the Adaptec driver is found, press **Enter**.
- 7 Follow the on-screen instructions to complete the installation.
- 8 Continue with [Managing Your Storage Space on page 52](#).

Installing with Red Hat Linux

Note: You will need your Red Hat installation CD to complete this task.

To install the Adaptec RAID controller driver while installing Red Hat Linux:

- 1 Insert the first Red Hat installation CD.
 - 2 Restart your computer.
 - 3 When the Red Hat Welcome screen appears, type `linux dd` at the Boot: prompt.
 - 4 When prompted, insert the driver disk, then select **OK**.
 - 5 Follow the prompts to set up the environment you want.
 - 6 If you are installing other third-party devices, install them now. Otherwise, select **Done**.
 - 7 Complete the Linux installation, following the instructions included with your operating system.
 - 8 Continue with [Managing Your Storage Space on page 52](#).
-

Installing with SuSE Linux

To install the Adaptec RAID controller driver while installing SuSE Linux:

- 1 Insert the first SuSE installation CD.
- 2 Restart your computer.
- 3 When the SuSE installation selection screen appears, choose the type of installation you want, then press the **F6** key to indicate the use of a driver disk. (If **F6** is not shown on the screen, you may have an older version of SuSE; press the **Alt** key instead.)
- 4 When prompted, insert the driver disk, then press any key to continue.
- 5 Follow the prompts to set up the environment you want.
- 6 If you are installing other third-party devices, install them now. Otherwise, select **Back**.
- 7 Complete the Linux installation, following the instructions included with your operating system.
- 8 Continue with [Managing Your Storage Space on page 52](#).

Installing with NetWare

Note: You will need your NetWare installation CD to complete this task.

To install the driver when installing NetWare:

- 1 Restart your computer, then install NetWare. (For instructions, refer to your NetWare documentation.)

To be able to load additional drivers later, select **Manual** install mode during the first part of the installation.

To load additional drivers:

- a Select **Modify** when the storage adapters are displayed.
 - b Select **Storage adapters** and press the **Insert** key to add an unlisted driver from the floppy disk.
- 2 When the Device Types screen appears, check the **Storage adapters** list and select **Modify** to add another driver.
 - 3 Select **Storage adapters**, then press **Enter**.
All recognized controllers are displayed.
 - 4 If AACRAID is detected, delete it.
 - 5 Press **Insert** to add another driver.
The available drivers are displayed.
 - 6 Insert the driver floppy disk.
 - 7 Press the **Insert** key to scan the floppy disk drive.

Once the driver is selected, the Parameter screen is displayed.

- 8 From the lower window menu, select **Continue**, then press **Enter**.

If the driver installation process fails, the server console is displayed so you can see the cause of the failure.

To modify disk partitions, apply hot fixes, or perform volume maintenance, refer to your NetWare documentation.

- 9 Continue with [Managing Your Storage Space on page 52](#).

Installing with OpenServer

Note: You will need your OpenServer installation CD to complete this task.

To install the driver when installing OpenServer:

- 1 Insert the OpenServer installation CD.
- 2 Restart your computer.
- 3 Follow the on-screen instructions to begin the OpenServer installation.
- 4 When prompted to load more HBA drivers, insert the driver disk, then select **Yes**. (To load more HBA drivers, repeat this step.)
- 5 When all drivers have loaded, select **No**.
- 6 Complete the OpenServer installation, following the instructions included with your operating system.
- 7 Continue with [Managing Your Storage Space on page 52](#).

Installing with UnixWare

Note: You will need your UnixWare installation CD to complete this task.

To install the driver when installing UnixWare:

- 1 Insert the UnixWare installation CD.
 - 2 Restart your computer.
 - 3 Follow the on-screen instructions to begin the UnixWare installation.
 - 4 When prompted to load more HBA drivers, insert the driver disk, then select **Yes**. (To load more HBA drivers, repeat this step.)
 - 5 When all drivers have loaded, select **No**.
 - 6 Complete the UnixWare installation, following the instructions included with your operating system.
 - 7 Continue with [Managing Your Storage Space on page 52](#).
-

Installing with FreeBSD

Note: You will need your FreeBSD installation CD to complete this task.

To install the driver when installing FreeBSD:

- 1 Insert the FreeBSD installation CD.
- 2 Restart your computer.
- 3 When the FreeBSD start screen appears, select 6 to escape to loader prompt.
- 4 Type `load kernel`.
- 5 Type `load disk0:aacu.ko`.
If the driver fails to load, run `lsdev` and check for the floppy disk drive. Then, try again with the appropriate device.
- 6 Type `boot`.
- 7 Complete the FreeBSD installation, following the instructions included with your operating system.
- 8 Reboot your computer, then remove the driver disk.
- 9 Repeat Steps 3 through 6 the first time you boot the operating system boot to load the drivers again for the initial bootup.
- 10 Install the driver package permanently, following the instructions in [Installing on FreeBSD on page 51](#).
- 11 Continue with [Managing Your Storage Space on page 52](#).

Note: Currently, Adaptec Storage Manager is not supported on FreeBSD. To create and manage arrays, use the Adaptec RAID Controller Utility (ACU). See [page 54](#) for more information.

Installing the Driver on an Existing Operating System



In this chapter...

Before You Begin	48
Creating a Driver Disk	48
Installing on Windows	49
Installing on Red Hat or SuSE Linux	49
Installing on NetWare	49
Installing on OpenServer	50
Installing on UnixWare	50
Installing on Solaris.....	51
Installing on FreeBSD	51

This chapter explains how to install your Adaptec RAID controller driver.

Note: To install the driver while you're installing an operating system, see [page 41](#).

Before You Begin

Before you begin, install and connect your Adaptec RAID controller and internal disk drives (see [page 31](#)).

You must also create a driver disk (see [page 42](#)) before you begin installing the controller driver.

Creating a Driver Disk

Note: You will need a floppy disk to complete this task.

To create a driver disk:

- 1 Set your system BIOS so that your computer boots from the CD drive. (For instructions, refer to your computer's documentation.)
 - 2 Turn on your computer, then insert the RAID Installation CD included in your RAID controller kit.
 - 3 Follow the on-screen instructions to get to the Adaptec Start Menu.
 - 4 Click **Create Driver Disk**, then select your operating system.
Linux only—Select your operating system *and* the architecture:
 - Intel 386 or 486 computers—Select **i386**.
 - Pentium I or II computers—Select **i586**.
 - Pentium III, IV, or AMD K-6 computers—Select **i686**.
 - AMD Athlon computers—Select **Athlon**.
 - 5 Select your floppy disk drive letter, then select the format you want. (You need a full format only if your floppy disk has never been formatted or may have bad sectors.)
 - 6 Insert the floppy disk, then click **OK**. The system creates the driver disk.
 - 7 Remove and label the driver disk.
 - 8 Continue the driver installation for your operating system:
 - For Windows, see [page 49](#).
 - For Red Hat or SuSE Linux, see [page 49](#).
 - For NetWare, see [page 49](#).
 - For OpenServer, see [page 50](#).
 - For UnixWare, see [page 50](#).
 - For Solaris, see [page 51](#).
 - For FreeBSD, see [page 51](#).
-

Installing on Windows

To install the driver on Windows:

- 1 Start or restart Windows.
The Found New Hardware Wizard opens and searches for the driver.
- 2 Insert the driver disk, select **Floppy drive**, then click **Next**.
- 3 Click **Next**, then click **Next** again.
- 4 Follow the on-screen instructions to complete the driver installation.
- 5 Remove the driver disk and restart your computer.
- 6 Continue with [Managing Your Storage Space on page 52](#).

Installing on Red Hat or SuSE Linux

To install the module on Red Hat or SuSE Linux:

- 1 Insert and mount the RAID Installation CD:

Red Hat: `mount /dev/cdrom /mnt/cdrom`
SuSE: `mount /dev/cdrom /media/cdrom`
- 2 Install the module RPM:

`rpm -Uvh mount-point/xxx/yyy.rpm`

where `mount-point` is the specific mount point on the Linux system, `xxx` is the driver path, and `yyy.rpm` is the rpm file.
- 3 Reboot your computer to ensure the driver loaded correctly.
- 4 Run `fdisk`, `mkfs`, and create mount points for any new disk drives.
- 5 Continue with [Managing Your Storage Space on page 52](#).

Installing on NetWare

Note: Before you begin, ensure that your NetWare OS has been upgraded to the minimum patch level specified by Novell. Refer to the Novell Web site for more information.

To install the driver on NetWare:

- 1 Start your computer.
- 2 At the NetWare server console prompt, type `load hdetect`, then press **Enter** if it has not been loaded automatically.
- 3 At the Device types menu, select **Continue**, then press **Enter**.
- 4 At the Device type option, select **Modify**, then press **Enter**.
- 5 Select **Storage Adapters**, then press **Enter**.
- 6 At the Additional Driver Options menu, select **Modify**, then press **Enter**.
- 7 If `aacraid.ham` has already been detected, delete it.

- 8 At the Driver Name menu, press the **Insert** key.
- 9 Insert the driver disk, press the **Insert** key, then press **F3**.
- 10 At the `A:\` prompt, press **Enter**.
The driver installs.
- 11 At the Additional Driver Option menu, select **Return to driver summary**, then press **Enter**.
- 12 At the Driver type menu, select **Load on Additional Driver Options**.
- 13 After the driver loads, select **Continue**.
- 14 Continue with [Managing Your Storage Space on page 52](#).

Installing on OpenServer

To install the driver on OpenServer:

- 1 Start your computer, then insert the driver disk.
- 2 Begin the driver package installer:

```
pkgadd -d diskette1
```
- 3 At the installer prompt, type `go`.
- 4 Select **1** for the `aacraid` package.
- 5 When the installation is complete, select **q** to quit the installer.
- 6 Reboot your computer and remove the driver disk.
- 7 Continue with [Managing Your Storage Space on page 52](#).

Installing on UnixWare

To install the driver on UnixWare:

- 1 Start your computer, then insert the driver disk.
 - 2 Begin the driver package installer:

```
pkgadd -d diskette1
```
 - 3 At the installer prompt, type `go`.
 - 4 Select **1** for the `aacraid` package.
 - 5 When the installation is complete, select **q** to quit the installer.
 - 6 Reboot your computer and remove the driver disk.
 - 7 Continue with [Managing Your Storage Space on page 52](#).
-

Installing on Solaris

To install the driver on Solaris:

- 1 Start your computer.
- 2 Insert and mount the driver disk:

```
volcheck
```
- 3 Change to the driver installer directory:

```
cd /floppy/floppy0/DU/sol_210/i86pc/Tools
```
- 4 Start the driver installer:

```
./install.sh -i
```
- 5 Reboot your computer, then remove the driver disk.
- 6 Continue with *Managing Your Storage Space* on page 52.

Note: Currently, Adaptec Storage Manager is not supported on Solaris. To create and manage arrays, use the Adaptec RAID Controller Utility (ACU). See [page 54](#) for more information.

Installing on FreeBSD

To install the driver on FreeBSD:

- 1 Start your computer.
- 2 Insert and mount the driver disk:

```
mount -t msdos /dev/fd0 /mnt
```
- 3 Copy the driver package to the /tmp directory:

```
cp /mnt/aac-02.00.00-x.tgz /tmp
```
- 4 Install the driver package:

```
pkg_add aac-02.00.00-x.tgz
```
- 5 Reboot your computer, then remove the driver disk.
- 6 Continue with *Managing Your Storage Space* on page 52.

Note: Currently, Adaptec Storage Manager is not supported on FreeBSD. To create and manage arrays, use the Adaptec RAID Controller Utility (ACU). See [page 54](#) for more information.

Managing Your Storage Space

9

In this chapter...

About Adaptec Storage Manager	53
About the Adaptec RAID Controller Configuration Utility	53
About the Adaptec RAID Controller Utility	54
About the Adaptec Flash Utility	54
Which Utility Should I Use?	54

Once you have installed your Adaptec RAID controller, disk drives (or other devices), and device driver, you can begin to build and manage your storage space.

This chapter introduces Adaptec Storage Manager, and describes the other utilities included with your Adaptec RAID controller.

About Adaptec Storage Manager

Adaptec Storage Manager is a full-featured software application that helps you build a storage space for your online data, using Adaptec RAID controllers and disk drives.

With Adaptec Storage Manager, you can group disk drives into logical drives and build in redundancy to protect your data and improve system performance.

You can also use Adaptec Storage Manager to monitor and manage all the controllers and disk drives in your storage space from a single location.

When Adaptec Storage Manager is installed on a computer, the *Adaptec Storage Manager agent* is also installed automatically. The agent is like a service that keeps your storage space running. It's designed to run in the background, without user intervention, and its job is to monitor and manage system health, event notifications, task schedules, and other on-going processes on that system. It sends notices when tasks are completed successfully, and sounds an alarm when errors or failures occur on that system.

The agent uses less memory than the full application. If your storage space includes systems that won't be connected to monitors (and therefore won't require the user interface), you can choose to run the *agent only* on those systems instead of the full application. For more information, refer to the *Adaptec Storage Manager User's Guide* or online Help.

Installing Adaptec Storage Manager

Adaptec Storage Manager is included on the Adaptec Storage Manager Installation CD. For installation instructions, refer to the *Adaptec Storage Manager User's Guide*, also included on the Adaptec Storage Manager Installation CD.

About the Adaptec RAID Controller Configuration Utility

The Adaptec RAID Controller Configuration Utility (ARCCONF) is a command line utility that you can use to perform some basic array and configuration management functions.

With ARCCONF, you can:

- Create and delete logical drives
- Modify and copy configuration settings
- Recover from disk drive failures and troubleshoot

ARCCONF and the *Command Line Interface (CLI) User's Reference*, which describes how to use ARCCONF, are included on the Adaptec Storage Manager Installation CD.

Note: Adaptec recommends that only advanced users familiar with command line interfaces use ARCCONF.

About the Adaptec RAID Controller Utility

The Adaptec RAID Controller utility is a BIOS-based utility that you can use to create and manage controllers, disk drives and other devices, and arrays. The Adaptec RAID Controller utility comprises these tools:

- **Array Configuration Utility (ACU)**—For creating and managing arrays, and initializing and rescanning disk drives. (ACU for DOS is also available. See [page 83](#).)
- **A -Select utility**—SerialSelect, SATASelect®, or SCSISelect®, for modifying your controller and disk drive settings.
- **Disk Utilities**—For formatting or verifying disk drives.

The Adaptec RAID Controller utility is included in your controller's BIOS. For more information, see [Using the Adaptec RAID Controller Utility on page 75](#).

Note: The Adaptec RAID Controller utility is primarily intended for pre-operating system installation configuration.

About the Adaptec Flash Utility

The Adaptec Flash Utility (AFU) is a text-based DOS utility that you can use to update, save, or verify your RAID controller's firmware BIOS and Non-Volatile Random Access Memory (NVRAM).

 **Caution:** Although the AFU contains safeguards to prevent you from accidentally damaging your RAID controller's flash contents, it is still important to use the AFU carefully and correctly to avoid rendering your RAID controller inoperable. Adaptec recommends that only advanced users familiar with working in DOS use the AFU.

Which Utility Should I Use?

To create a bootable array, Adaptec recommends that you use the BIOS-based ACU (see [page 54](#)).

For all subsequent storage management tasks, Adaptec recommends that you install and use Adaptec Storage Manager (see [page 53](#)). As a full-featured software application with a graphical user interface, it is the easiest to use and offers the widest range of management functions.

Solving Problems

10

In this chapter...

Troubleshooting Checklist	56
Silencing the Alarm	56
Recovering from a Disk Drive Failure	56
Resetting the Controller	58

This chapter provides basic troubleshooting information and solutions for solving controller problems.

Troubleshooting Checklist

If you encounter difficulties installing or using your Adaptec RAID controller, check these items first:

- With your computer powered off, check the connections to each disk drive, to the power supply, to the LED connector, and so on.

Try disconnecting and reconnecting disk drives from the Adaptec RAID controller.

- Check that your Adaptec RAID controller installed in a compatible expansion slot (PCI, PCI-X, or PCI-E). To double-check the bus compatibility of your controller, see *About Your RAID Controller* on page 16.
- Ensure that your Adaptec RAID controller firmly seated and secured in the PCI/PCI-X/PCI-E expansion slot.
- If your Adaptec RAID controller is not detected during system boot, try installing it in a different compatible expansion slot. (See page 32 for instructions.)
- *SCSI RAID controllers only*—Ensure that each SCSI disk drive (or other device) on each SCSI bus assigned a unique SCSI ID.

Check that termination set correctly on each SCSI bus.

- Did the driver install correctly?
- If you have external disk drives (or other devices), are they powered on?

If you are still unable to resolve a problem, you can find additional troubleshooting information and direction on the Adaptec Web site at www.adaptec.com or the Support Knowledgebase at ask.adaptec.com.

Silencing the Alarm

If your Adaptec RAID controller includes an alarm, the alarm will sound when an error occurs. To silence the alarm, use Adaptec Storage Manager (see *Managing Your Storage Space* on page 52.)

Recovering from a Disk Drive Failure

This section explains how to recover when a disk drive fails:

- If the array was protected by a hot spare (see page 57).
- If the array was *not* protected by a hot spare (see page 57).
- If there is a disk drive failure in more than one array simultaneously (see page 57).
- If it is a RAID 0 array (see page 57).
- If multiple disk drives fail within the same array (see page 58).

Note: Adaptec Storage Manager uses the term *logical drives* when referring to *arrays* (see page 12).

Failed Disk Drive Protected by a Hot Spare

When an array is protected by a hot spare, if a disk drive in that array fails the hot spare is automatically incorporated into the array and takes over for the failed drive.

To recover from the failure:

- 1 Remove and replace the failed disk drive (following manufacturer's instructions).
- 2 *If copyback is not enabled*—In Adaptec Storage Manager, remove the 'hot spare' designation from the original hot spare (the disk drive that was built into the array). Then, designate a new hot spare to protect the arrays on that controller.

If copyback is enabled—Data is automatically moved back to its original location once the controller detects that the failed drive has been replaced. No action is required.

Failed Disk Drive Not Protected by a Hot Spare

When a array is not protected by a hot spare, if a disk drive in that array fails, remove and replace the failed disk drive. The controller detects the new disk drive and begins to rebuild the array.

If the controller fails to rebuild the array, check that the cables, disk drives, and controllers are properly installed and connected. Then, if necessary, use Adaptec Storage Manager to rebuild the array. For instructions, refer to the *Adaptec Storage Manager User's Guide* or online Help.

Failure in Multiple Arrays Simultaneously

If there's a disk drive failure in more than one array at the same time (one failure per array), and the arrays have hot spares protecting them, the controller rebuilds the arrays with these limitations:

- A hot spare must be of equal or greater size than the failed disk drive it's replacing.
- Failed disk drives are replaced with hot spares in the order in which they failed. (The array that includes the disk drive that failed first is rebuilt first, assuming an appropriate hot spare is available—see bullet above.)

If there are more disk drive failures than hot spares, see [Failed Disk Drive Not Protected by a Hot Spare](#) on page 57.

If copyback is enabled, data is moved back to its original location once the controller detects that the failed drive has been replaced.

Disk Drive Failure in a RAID 0 Array

Because RAID 0 volumes do not include redundancy, if a disk drive fails in a RAID 0 array, the data can't be recovered.

Correct the cause of the failure or replace the failed disk drives. Then, restore your data (if available).

Multiple Failures in the Same Array

Except in RAID 6 and RAID 60 arrays (see [page 66](#)), if more than one disk drive fails at the same time in the same array, the data can't be recovered.

Correct the cause of the failure or replace the failed disk drives. Then, restore your data (if available).

Note: In some instances, RAID 10 and RAID 50 arrays may survive multiple disk drive failures, depending on which disk drives fail. For more information, refer to the *Adaptec Storage Manager User's Guide* or online Help.

Resetting the Controller

This section explains how to reset (or *flash*) your Adaptec RAID controller. You may want to do this if the controller becomes inoperable, or if a firmware upgrade is unsuccessful.

To reset your Adaptec RAID controller:

- 1 Download the firmware version currently installed on your controller from www.adaptec.com
- 2 Extract the downloaded files to a folder on your local hard drive (for example, C:\Download\Drivers).
- 3 Create a bootable MS-DOS floppy disk and copy the AFU.exe file to it. Copy the first firmware image to the same floppy disk.
- 4 Create additional bootable MS-DOS floppy disks and copy each additional firmware image to its own floppy disk.
- 5 Power off your computer, disconnect the power cord, then open the cabinet following the manufacturer's instructions.
- 6 Disconnect all cables from the controller, then attach a shorting jumper to the Mode 0 flash connector. (To locate the Mode 0 flash connector on your Adaptec RAID controller, see the figures in [About Your RAID Controller on page 16.](#))
- 7 Reconnect the power cord, power on your computer, then boot to the floppy disk containing the AFU.exe file (see [Step 3](#)).
- 8 At the prompt, type `a:\afu update /c x`
where `x` is the controller number.
- 9 Insert the other floppy disks when prompted.
- 10 When the flash is complete, power off your computer, disconnect the power cord, then remove the jumper.
- 11 Close the computer cabinet, reconnect the power cord, then power on your computer.

The controller should boot correctly.

Introduction to Serial Attached SCSI (SAS)



In this appendix...

Terminology Used in This Chapter	60
What is SAS?	60
How Do SAS Devices Communicate?	61
What's a Phy?	61
What's a SAS Port?.....	62
What's a SAS Address?.....	62
What's a SAS Connector?	62
What do SAS Cables Look Like?	63
How are Disk Drives Identified in SAS?	63
What are the SAS Connection Options?	63
How is SAS Different from Parallel SCSI?.....	65

This section provides a basic overview of the main features of Serial Attached SCSI (SAS), introduces some common SAS terms, and explains how SAS differs from parallel SCSI.



Note: For technical articles and tutorials about SAS, refer to the SCSI Trade Association (STA™) Web site at www.scsita.org.

Terminology Used in This Chapter

For convenience, SAS HBAs and SAS RAID controllers are referred to generically in this chapter as *SAS cards*. HBAs, RAID controllers, disk drives, and external disk drive enclosures are referred to as *end devices* and expanders are referred to as *expander devices*.

For convenience, this chapter refers to end devices and expander devices collectively as *SAS devices*.

What is SAS?

Legacy parallel SCSI is an interface that lets devices such as computers and disk drives communicate with each other. Parallel SCSI moves multiple bits of data *in parallel* (at the same time), using the SCSI command set.

Serial Attached SCSI (SAS) is an evolution of parallel SCSI to a point-to-point serial interface. SAS also uses the SCSI command set, but moves multiple bits of data one at a time. SAS links end devices through direct-attach connections, or through expander devices.

SAS cards can typically support up to 128 end devices and can communicate with both SAS and SATA devices. (You can add 128 end devices—or even more—with the use of SAS expanders. See [page 64](#).)

Note: Although you can use both SAS and SATA disk drives in the same SAS *domain* (see [page 64](#)), Adaptec recommends that you not combine SAS and SATA disk drives within the same array or logical drive. The difference in performance between the two types of disk drives may adversely affect the performance of the array.

Data can move in both directions simultaneously across a SAS connection (called a *link*—see [page 61](#)). Link speed is 600 MB/sec in full-duplex mode. A SAS card with eight links has a maximum bandwidth of 4800 MB/sec in full-duplex mode.

Although they share the SCSI command set, SAS is conceptually different from parallel SCSI physically, and has its own types of connectors, cables, connection options, and terminology, as described in the rest of this chapter.

To compare SAS to parallel SCSI, see [How is SAS Different from Parallel SCSI?](#) on [page 65](#).

How Do SAS Devices Communicate?

SAS devices communicate with each other through links. A *link* is a physical connection between two phys.

As shown in the following figure, SAS devices contain ports (see [page 62](#)), ports contain *phys*, and each phy contains one transmitter and one receiver—one *transceiver*. A phy can belong to one port only.

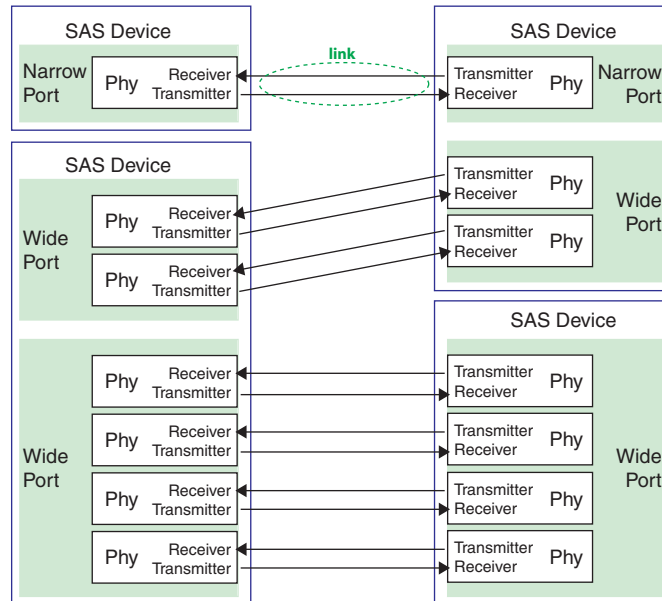

What's a Phy?

Phys are part of the physical communication connection between SAS devices. Each phy contains a transceiver that sends data back and forth between SAS devices.

When a connection is formed between two end devices, a link is established from a phy in one port to a phy in the other port. As shown in the figure above, a wide port can support multiple independent links simultaneously.

Phys are internal, within SAS connectors (see [page 62](#)).

SAS cables physically connect one or more phys on one SAS device to one or more phys on another SAS device.

What's a SAS Port?

Note: Because the physical link between SAS devices is from phy to phy, rather than port to port, a “port” is more of a virtual concept, different from what is normally considered a port on other types of RAID controllers and storage devices.

A *port* is one or more *phys*. A *narrow port* contains one *phy*. A *wide port* typically contains four *phys*.

Each port has its own unique SAS address (see [page 63](#)), and all the *phys* in a port share that same SAS address.

SAS card port options vary. A SAS card with four *phys* could be configured with one wide port, with two wide ports that comprise two *phys*, or with four narrow ports each containing one *phy*. (A wide port with four *phys* is referred to as a *4-wide* or *4x port*.)

What's a SAS Address?

Each SAS port is identified with a unique SAS address, which is shared by all *phys* on that port.

For example, a SAS disk drive might have two narrow ports. Each port has one unique SAS address. The single *phy* in each port uses its port's SAS address.

In another example, a SAS device might have one 4-wide port. That port has one SAS address, which is shared by all four *phys* in the port.

Unlike SCSI devices and SCSI IDs, SAS devices self-configure their SAS addresses. User intervention is not required to set SAS addresses, and SAS addresses cannot be modified.

What's a SAS Connector?

A SAS connector is the physical plug or receptacle that you see on a SAS device. It supports the power and signal line cable. It's what you plug a SAS cable into, or the end of the SAS cable that's being plugged in.

A connector is what forms physical links between *phys*.

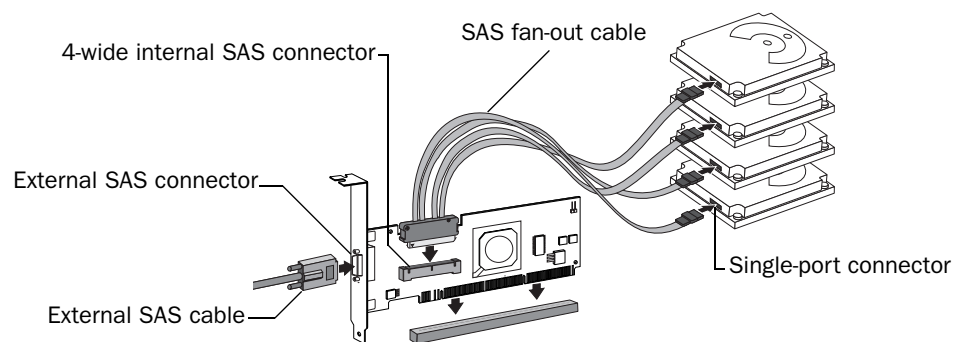

Some SAS connectors can support multiple links. The number of links a SAS connector can support is referred to as its *width*. *Narrow* connectors support a single link; *wide* connectors support up to four links.

A single SAS device may have one or more connectors. A single SAS connector may help form links between more than two SAS devices. (For instance, as shown in the figure above, the 4-wide internal SAS connector forms links with four independent disk drives.)

What do SAS Cables Look Like?

Internal SAS cables are narrower than internal parallel SCSI cables. The connectors vary in size depending on the number of links they support, from single link connectors to 4-wide (or larger) connectors. Internal fan-out cables (shown in the next figure) let you attach four disk drives to a single 4-wide connector.

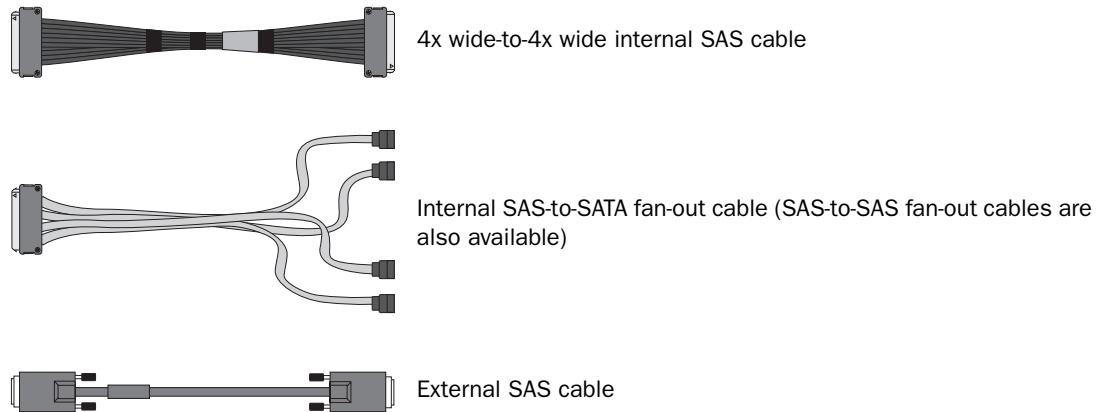

An example of some internal SAS cables and an external SAS cable are shown in the figure above.

How are Disk Drives Identified in SAS?

In the BIOS and in the management utilities (see [page 52](#)), disk drives are identified with numbers in this format:

XX:YY:ZZ

where XX is the disk drive count number, YY is the enclosure number, and ZZ is the slot number (within the enclosure). If the disk drive is not installed in an enclosure, a double dashes (--) appear instead of YY and ZZ (for instance, 01:--:--).

In parallel SCSI, XX is the disk drive's channel number, YY is the target number, and ZZ is the logical unit number (LUN).

What are the SAS Connection Options?

You can connect end devices to each other through direct cable connections and through backplane connections. When you use one or more expander devices (see [page 64](#)), you can create large configurations.

Direct-attach Connections

In a direct-attach connection, SAS or SATA disk drives are connected directly to a SAS card with SAS cables. One disk drive is attached to one SAS connector with one SAS cable (or multiple disk drives are attached to one SAS connector with one fan-out cable). The figure on [page 62](#) shows an example of direct-attach connections.

The number of direct-attached disk drives is limited to the number of *phys* supported by the SAS card. (Note that there may be multiple *phys* within a single connector. See [page 63](#).)

Backplane Connections

In a backplane connection, disk drives and SAS cards are attached to and communicate with each other through a system backplane.

The number of end devices is limited to the number of slots available on the backplane. For example, the Adaptec S50 enclosure, which contains an expander, is a backplane connection that supports up to 12 SAS or SATA disk drives.

Some backplanes support daisy-chain expansion to other backplanes. For example, you can daisy-chain (connect one to the next) up to nine Adaptec S50 enclosures to a single SAS card in a host system.

SAS Expander Connections

A SAS expander device literally expands the number of end devices that you can connect together. Expander devices, typically embedded into a system backplane (see [page 64](#)), support large configurations of SAS end devices, including SAS cards and SAS and SATA disk drives. With expander devices, you can build large and complex storage topologies.

There are two types of SAS expanders: *fanout expanders* and *edge expanders*. Each performs a different role in a storage system. (For more information about how SAS expanders work, refer to the STA Web site at www.scsita.org.)

You can connect up to 128 SAS ports to an edge expander. (A single edge expander can therefore support up to 128 SAS addresses.)

You can connect up to 128 edge expanders to a fanout expander.

You can use only one fanout expander in any single SAS *domain* (a topology of SAS—and possibly SATA—end devices and expander devices). A single SAS domain can therefore comprise up to 16,384 SAS ports (and therefore up to 16,384 SAS addresses).

The next figure illustrates (in very basic terms) a SAS domain and shows how SAS cards, SAS and SATA disk drives, and expander devices can fit together in a large data storage topology.

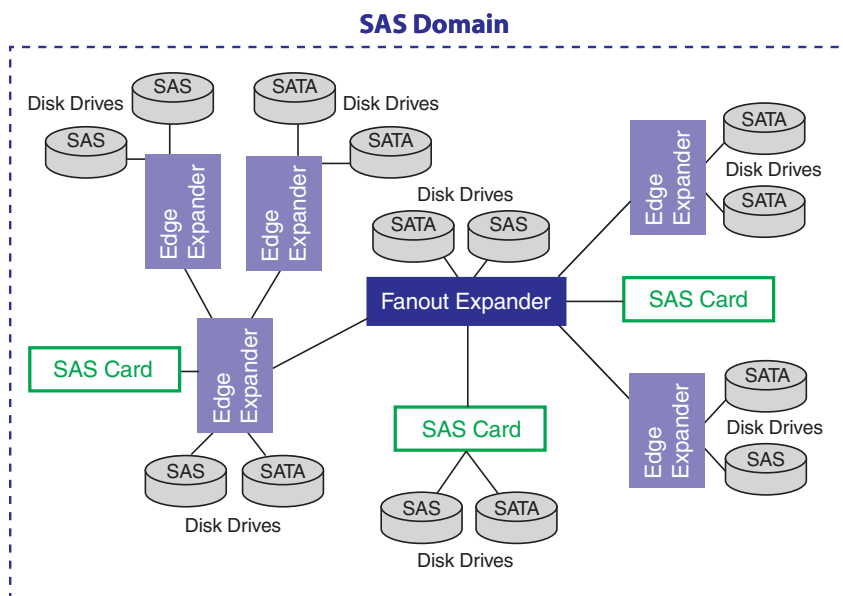

How is SAS Different from Parallel SCSI?

In summary, although SAS and parallel SCSI both use the SCSI command set, how they move data from one place to another is very different. To support point-to-point *serial* data transport, SAS introduces new types of connectors, cables, connection options, and terminology.

Generally speaking, SAS is faster and more flexible than parallel SCSI, and provides more options for building your storage space. SAS lets you mix SAS and SATA disk drives together, and lets you connect many, *many* more devices.

This table describes many of the main differences between the two interfaces.

Parallel SCSI	Serial Attached SCSI
Parallel interface	Serial interface
Maximum speed 320 MB/sec shared by all devices on the bus	Maximum speed 600 MB/sec per phy when in full-duplex mode
Supports SCSI devices only	Supports SATA and SAS disk drives simultaneously
Up to 16 devices per SCSI channel	More than 128 disk drives per SAS card, using an expander (see page 64)
Supports single-port devices only	Supports single- and dual-port devices
Uses SCSI IDs to differentiate between devices connected to the same adapter	Uses unique SAS addresses to differentiate between devices
User intervention required to set SCSI IDs	SAS addresses self-configured by SAS devices
Requires bus termination	Requires no bus termination
Standard SCSI connectors	SAS connectors (see page 63)

Understanding RAID

B

In this appendix...

Understanding Drive Segments.....	67
RAID 0 (Non-RAID Arrays).....	67
RAID 1 Arrays	68
RAID 1 Enhanced Arrays.....	68
RAID 10 Arrays	69
RAID 5 Arrays	70
RAID 5EE Arrays.....	71
RAID 50 Arrays	72
RAID 6 Arrays	73
RAID 60 Arrays	73
Selecting the Best RAID Level.....	74

When you create arrays (or logical drives), you can assign a RAID level to protect your data.

Each RAID level offers a unique combination of performance and redundancy. RAID levels also vary by the number of disk drives they support.

This appendix describes the RAID levels supported by your Adaptec RAID controller, and provides a basic overview of each to help you select the best level of protection for your data storage.

Understanding Drive Segments

A *drive segment* is a disk drive or portion of a disk drive that is used to create an array. A disk drive can include both *RAID segments* (segments that are part of an array) and available segments. Each segment can be part of only one logical device at a time. If a disk drive is not part of any logical device, the entire disk is an available segment.

RAID 0 (Non-RAID Arrays)

An array with RAID 0 includes two or more disk drives and provides data *striping*, where data is distributed evenly across the disk drives in equal-sized sections.

RAID 0 arrays do not maintain redundant data, so they offer no data protection. However, compared to an equal-sized group of independent disks, a RAID 0 array provides improved I/O performance.

Drive segment size is limited to the size of the smallest disk drive in the array. For instance, an array with two 250 GB disk drives and two 400 GB disk drives can create a RAID 0 drive segment of 250 GB, for a total of 1000 GB for the volume, as shown in this figure.

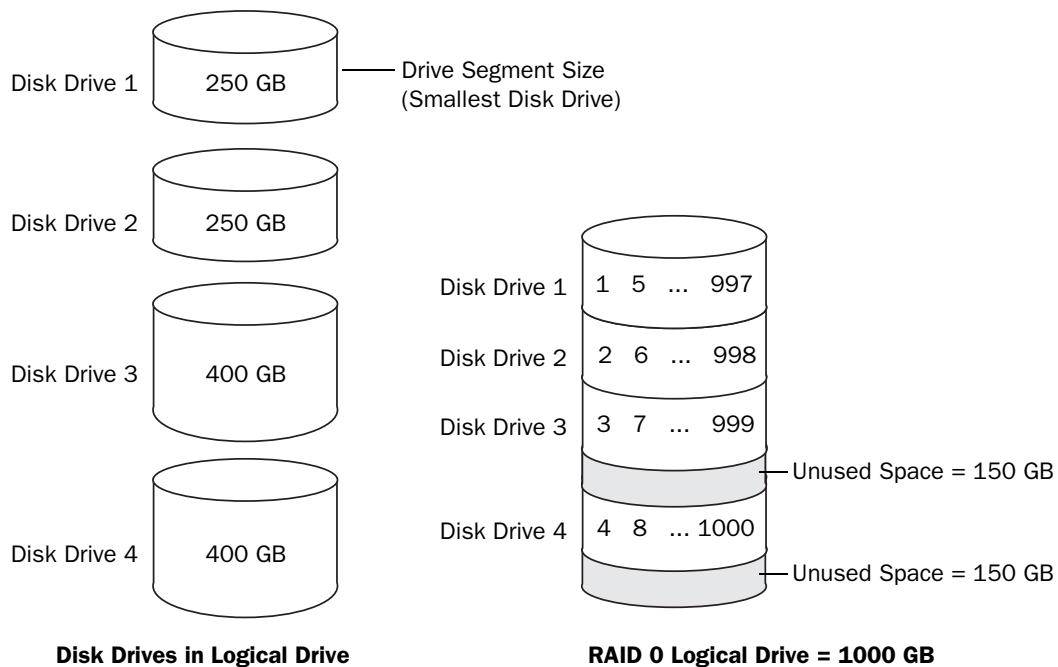

RAID 1 Arrays

A RAID 1 array is built from two disk drives, where one disk drive is a *mirror* of the other (the same data is stored on each disk drive). Compared to independent disk drives, RAID 1 arrays provide improved performance, with twice the read rate and an equal write rate of single disks. However, capacity is only 50 percent of independent disk drives.

If the RAID 1 array is built from different-sized disk drives, the free space, drive segment size is the size of the smaller disk drive, as shown in this figure.

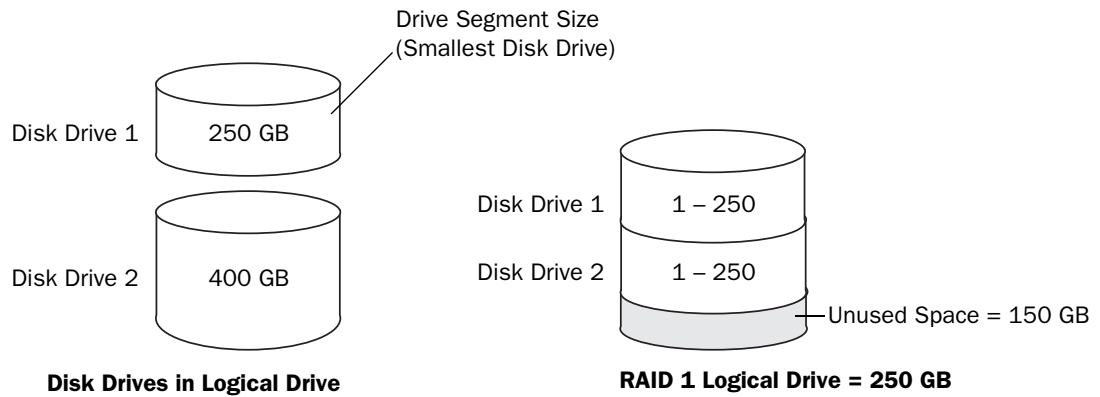

RAID 1 Enhanced Arrays

A RAID 1 Enhanced (RAID 1E) array—also known as a *striped mirror*—is similar to a RAID 1 array except that data is both mirrored *and* striped, and more disk drives can be included. A RAID 1E array can be built from three or more disk drives—depending on the stripe size, the maximum number of disk drives ranges from eight to sixteen.

In this example, the large bold numbers represent the striped data, and the smaller, non-bold numbers represent the mirrored data stripes.

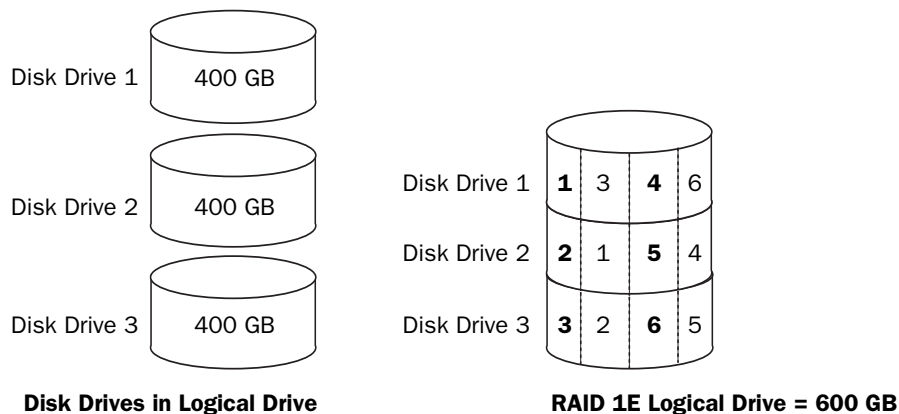

RAID 10 Arrays

A RAID 10 array is built from two or more equal-sized RAID 1 arrays. Adaptec RAID controllers support a maximum number of 128 disk drives in a RAID 10 array.

Data in a RAID 10 array is both striped and mirrored. Mirroring provides data protection, and striping improves performance.

Drive segment size is limited to the size of the smallest disk drive in the array. For instance, an array with two 250 GB disk drives and two 400 GB disk drives can create two mirrored drive segments of 250 GB, for a total of 500 GB for the array, as shown in this figure.

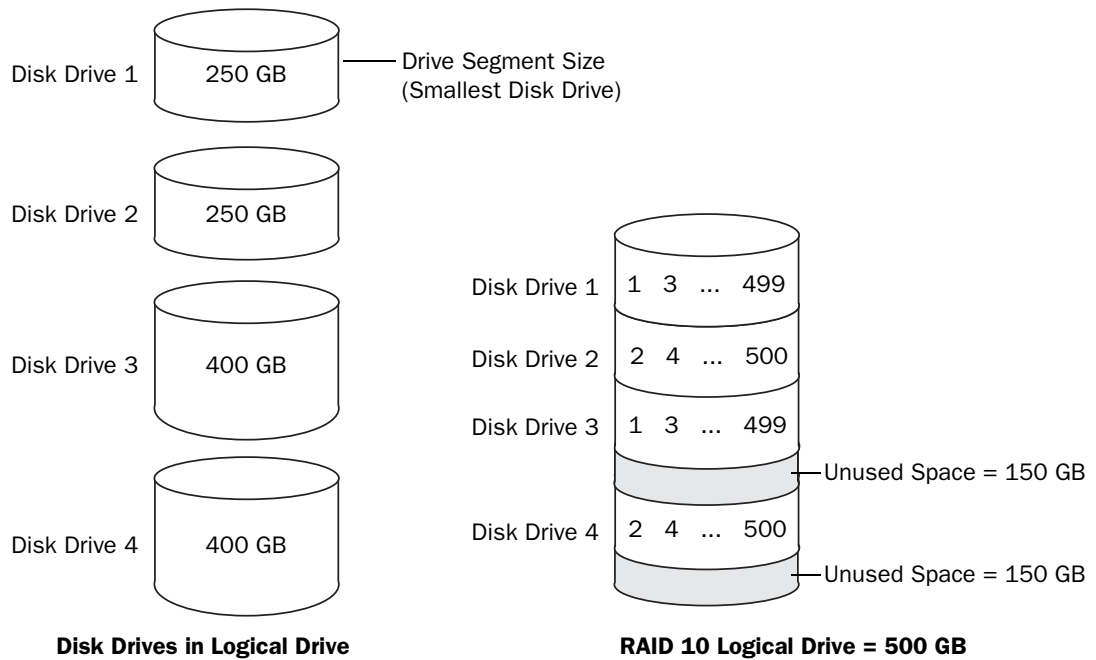

RAID 5 Arrays

A RAID 5 array is built from a minimum of three and a maximum of sixteen disk drives, and uses data striping and *parity* data to provide redundancy. Parity data provides data protection, and striping improves performance.

Parity data is an error-correcting redundancy that's used to re-create data if a disk drive fails. In RAID 5 arrays, parity data (represented by Ps in the next figure) is striped evenly across the disk drives with the stored data.

Drive segment size is limited to the size of the smallest disk drive in the array. For instance, an array with two 250 GB disk drives and two 400 GB disk drives can contain 750 GB of stored data and 250 GB of parity data, as shown in this figure.

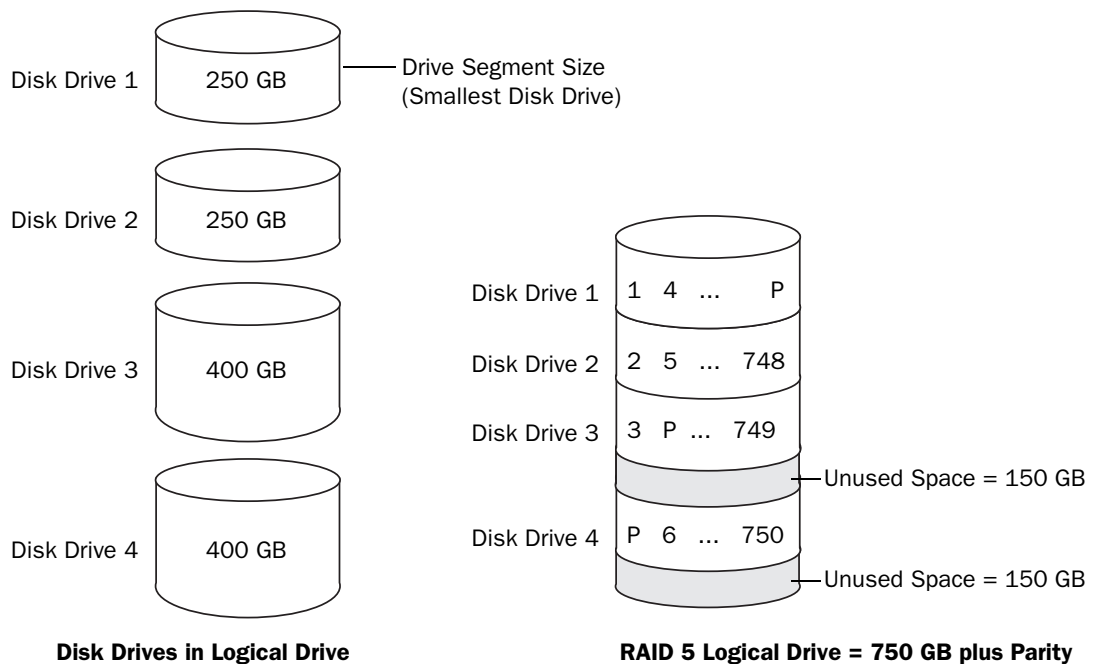

RAID 5EE Arrays

A RAID 5EE array—also known as a *hot space*—is similar to a RAID 5 array except that it includes a *distributed spare* drive and must be built from a minimum of four disk drives. The maximum number of disk drives is sixteen.

Unlike a hot spare, a distributed spare is striped evenly across the disk drives with the stored data and parity data, and can't be shared with other logical disk drives. A distributed spare improves the speed at which the array is rebuilt following a disk drive failure.

A RAID 5EE array protects your data and increases read and write speeds. However, capacity is reduced by two disk drives' worth of space, which is for parity data and spare data.

In this figure, S represents the distributed spare, P represents the distributed parity data.

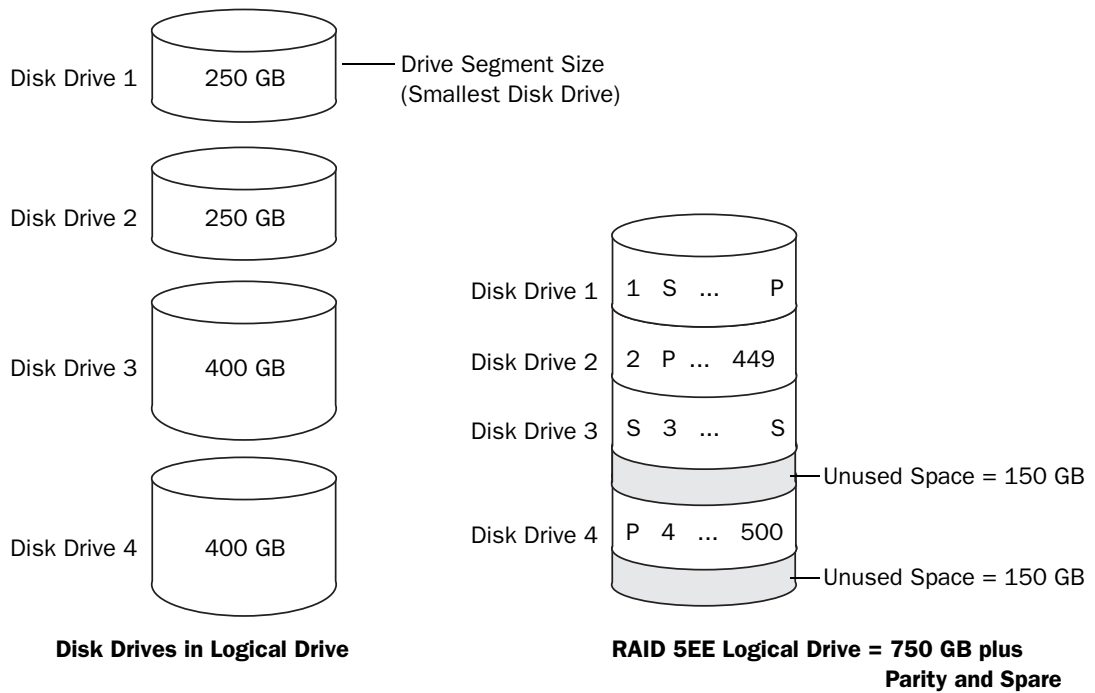

RAID 50 Arrays

A RAID 50 array is built from six to forty-eight disk drives configured as two or more RAID 5 arrays, and stripes stored data and parity data across all disk drives in both RAID 5 arrays. (For more information, see [RAID 5 Arrays on page 70](#).)

Note: Because the Adaptec 2420SA RAID controller doesn't support more than four disk drives, it doesn't support RAID 50 arrays.

The parity data provides data protection, and striping improves performance. RAID 50 arrays also provide high data transfer speeds.

Drive segment size is limited to the size of the smallest disk drive in the array. For example, three 250 GB disk drives and three 400 GB disk drives comprise two equal-sized RAID 5 arrays with 500 GB of stored data and 250 GB of parity data. The RAID 50 array can therefore contain 1000 GB (2 x 500 GB) of stored data and 500 GB of parity data.

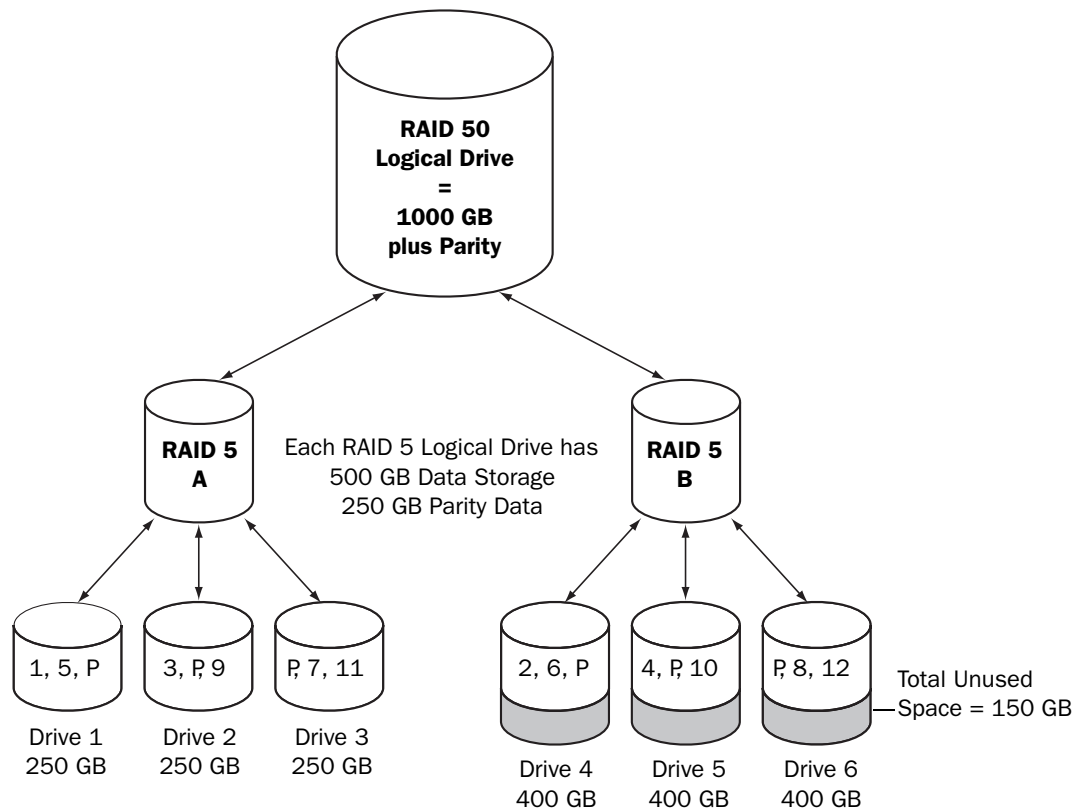

In the example above, P represents the distributed parity data.

RAID 6 Arrays

A RAID 6 array—also known as dual drive failure protection—is similar to a RAID 5 array because it uses data striping and parity data to provide redundancy. However, RAID 6 arrays include *two* independent sets of parity data instead of one. Both sets of parity data are striped separately across all disk drives in the array.

RAID 6 arrays provide extra protection for your data because they can recover from two simultaneous disk drive failures. However, the extra parity calculation slows performance (compared to RAID 5 arrays).

RAID 6 arrays must be built from four or more disk drives, to a maximum of sixteen. Maximum stripe size depends on the number of disk drives in the array.

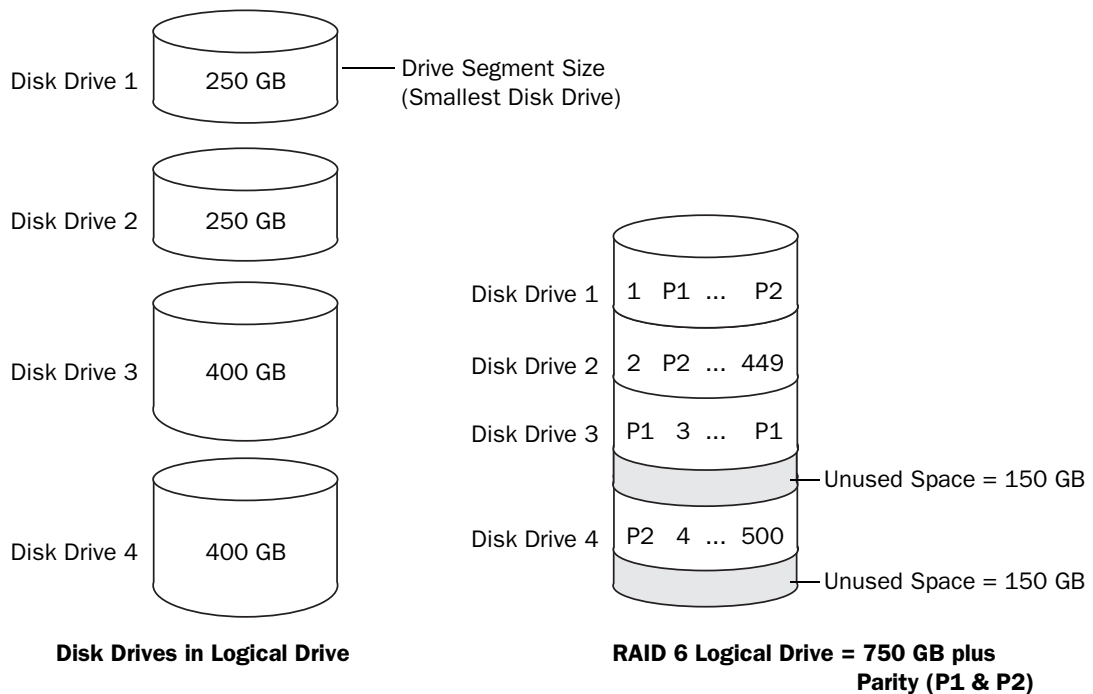

RAID 60 Arrays

Similar to a RAID 50 array (see [page 72](#)), a RAID 60 array—also known as dual drive failure protection—is built from eight disk drives configured as two or more RAID 6 arrays, and stripes stored data and two sets of parity data across all disk drives in both RAID 6 arrays.

Note: Because the Adaptec 2420SA RAID controller doesn't support more than four disk drives, it doesn't support RAID 60 arrays.

Two sets of parity data provide enhanced data protection, and striping improves performance. RAID 60 arrays also provide high data transfer speeds.

Selecting the Best RAID Level

Use this table to select the RAID levels that are most appropriate for the logical drives on your storage space, based on the number of available disk drives and your requirements for performance and reliability.

RAID level	Redundancy	Disk Drive Usage	Read Performance	Write Performance	Built-in Hot Spare	Minimum Disk Drives
RAID 0	No	100%	◆◆◆	◆◆◆	No	2
RAID 1	Yes	50%	◆◆	◆◆	No	2
RAID 1E	Yes	50%	◆◆	◆◆	No	3
RAID 10	Yes	50%	◆◆	◆◆	No	4
RAID 5	Yes	67 – 94%	◆◆◆	◆	No	3
RAID 5EE	Yes	50 – 88%	◆◆◆	◆	Yes	4
RAID 50 ¹	Yes	67 – 94%	◆◆◆	◆	No	6
RAID 6	Yes	50 – 88%	◆◆	◆	No	4
RAID 60*	Yes	50 – 88%	◆◆	◆	No	8

¹ Because it supports a maximum of four disk drives, the Adaptec 2420SA RAID controller can't support RAID 50 or RAID 60.

Disk drive usage, read performance, and write performance depend on the number of drives in the logical drive. In general, the more drives, the better the performance.

Using the Adaptec RAID Controller Utility



In this appendix...

Introduction to the Adaptec RAID Controller Utility	76
Running the Adaptec RAID Controller Utility	76
Using the ACU to Create and Manage Arrays	76
Using the -Select Utility to Modify Controller Settings	78
Formatting and Verifying Disk Drives	82
Viewing the Event Log	82

The Adaptec RAID Controller utility is a BIOS-based utility that you can use to create and manage controllers, disk drives and other devices, and arrays.

Note: Adaptec recommends that only advanced users familiar with working in a computer BIOS use the Adaptec RAID Controller utility tools. For more information, see [Managing Your Storage Space on page 52](#).

Introduction to the Adaptec RAID Controller Utility

The Adaptec RAID Controller utility comprises these tools:

- **The Array Configuration Utility (ACU)**—For creating and managing arrays, and initializing and rescanning disk drives (see [page 76](#)).
Note: Also available—ACU for DOS. See [page 83](#).
- **A -Select Utility**—*SerialSelect*, *SATASelect*, or *SCSISelect*, for modifying your controller and disk drive settings (see [page 78](#)).
- **Disk Utilities**—For formatting or verifying disk drives (see [page 82](#)).

Running the Adaptec RAID Controller Utility

If your Adaptec controller is connected to a RAID enclosure, power on your enclosure (or enclosures) before you power on your computer.

Start or restart your computer. When prompted, press Ctrl+A.

Note: The first time you power on your computer after you install a new controller, the BIOS may display a configuration that doesn't match your system's configuration. This is normal.

Navigating the Adaptec RAID Controller Utility

All the tools within the Adaptec RAID Controller utility are menu-based and instructions for completing tasks appear on-screen. Menus can be navigated using the arrows, Enter, Esc, and other keys on your keyboard.

Using the ACU to Create and Manage Arrays

To open the ACU, start the Adaptec RAID Controller utility (see [page 76](#)). If you have more than one controller, select your controller, then press **Enter**. Select **Array Configuration Utility**, then press **Enter**.

Follow the on-screen instructions to create and manage arrays, and initialize, rescan, and erase disk drives.

Creating a New Array

To begin creating an array, select **Create Arrays** from the main ACU menu.

Only disk drives that can be used in a new array are available for selection. (Disk drives must be initialized before they can be used in an array. See *Initializing Disk Drives on page 77* for more information.)

Use the **Array Properties** menu to modify the array's RAID level, size, name, stripe size, and caching settings.

Note: For more information about RAID levels and using disk drives to create arrays, see *Choosing a RAID Level on page 27*.

Managing Existing Arrays

To view or modify existing arrays, select **Manage Arrays** from the main ACU menu.

From the Manage Arrays menu, you can:

- View the properties of an array.

Note: Failed drives are displayed in a different text color.

- Make an array bootable (see [Creating Bootable Arrays on page 77](#)).
- Assign or remove hot spares.
- Delete an array.

 **Caution:** Before deleting an array, back up the data to avoid permanently losing it.

Creating Bootable Arrays

Note: You may need to change the system BIOS to modify the boot order. For more information, refer to your computer's documentation.

The controller always uses the lowest numbered array as its bootable array.

To make an array bootable:

- 1 Select **Manage Arrays** from the main ACU menu.
- 2 Select the array that you want to make bootable, then press **Ctrl+B**.

Note: You cannot make an array bootable while it's building, verifying, or rebuilding.

The array's number changes to Array 00, which makes this array the controller's boot array.

- 3 Restart your computer.

Initializing Disk Drives

If a disk drive appears grayed-out (unavailable for use in a new array), it may need to be initialized.

To begin initializing a disk drive, select **Initialize Drives** from the main ACU menu.

 **Caution:** Do not initialize a disk drive that is part of an array. Initializing a disk drive that's part of an array may make the array unusable.

Back up all data from your disk drive before you initialize it.

Rescanning Disk Drives

To begin rescanning a disk drive, select **Rescan Drives** from the main ACU menu.

Secure Erasing Disk Drives

When you perform a secure erase on a disk drive, all data on that disk drive is completely and irretrievably eradicated. Secure erase performs three distinct writing passes to the disk drive being erased—it does not just write zeros.

Performing a secure erase takes up to six times longer than clearing (or zeroing) a disk drive. You may want to perform a secure erase only on disk drives that contain confidential or classified information.

Note: To erase (or zero) a disk drive with non-classified information, you may choose to *format* it (see [page 82](#)) instead, or *clear* it using Adaptec Storage Manager—both options take much less time than the secure erase option.

To begin a secure erase, select **Secure Erase** from the main ACU menu, then select **Y** (yes). To return to the main ACU menu once the secure erase has begun, press **Esc**.

The selected disk drive(s) cannot be used until the erase is complete.

Stopping a Secure Erase

To stop a secure erase in progress:

- 1 In the main ACU window, select **Secure Erase**.
- 2 Select the disk drive being secure erased, then press **Ctrl+Q**.

The secure erase stops and the ACU returns to its main window.

Using the -Select Utility to Modify Controller Settings

Included in the Adaptec RAID Controller utility is a tool for modifying the settings of your controller and the disk drives connected to it. This utility is called *SerialSelect*, *SATASelect*, or *SCSISelect*, depending on what type of controller you have.

Opening a -Select Utility

To open a -Select utility, start the Adaptec RAID Controller utility (see [page 76](#)), select the -Select utility, then press **Enter**.

Follow the on-screen instructions to modify the settings of your controller and connected disk drives as required.

Applying Changes and Exiting

- 1 To exit a -Select utility, press **Esc** until you are prompted to exit.

If you modified any settings, you are prompted to save the changes before you exit.

- 2 Select **Yes** to exit, then press any key to restart your computer.

Any changes you made take effect after the computer restarts.

Modifying Your Controller's Configuration

Note: Default controller settings are suitable for most computers. Adaptec recommends that you *do not* change the default setting.

To modify your controller's settings, select **Controller Configuration** from the main *-Select* utility menu.

The table on [page 79](#) lists controller configuration options. Some options may not be available for your controller. Additional, controller-specific options are also available:

- For SAS controller-specific settings, see [page 80](#).
- For SATA controller-specific settings, see [page 80](#).
- For SCSI controller-specific settings, see [page 81](#).

General Controller Settings

Note: Default settings are shown in **bold** type.

Option	Description
Drive's Write Cache	When enabled, write cache is enabled on the disk drive. When disabled, write cache is not used on the disk drive. Default is the disk drive's setting . Caution —When write cache is enabled, there is a slight possibility of data loss or corruption during a power failure.
Runtime BIOS	When enabled , the controller BIOS allows the controller to act as a bootable device. Disabling the BIOS allows another controller to act as a bootable device.
Automatic Failover	When enabled , the controller automatically rebuilds an array when a failed disk drive is replaced. When disabled, the array must be rebuilt manually.
Array Background Consistency Check	When enabled, the controller constantly verifies a redundant array. Note that there may be a significant performance reduction. Default is disabled .
BBS Support	When enabled in systems that support BBS, the RAID controller is presented as a bootable device in the BIOS.
Array-based BBS Support	When enabled in systems that support BBS, the controller presents attached bootable devices up to the BIOS for boot device selection. This is relevant for logical arrays. Default is disabled .
Physical Drives Display During POST	When enabled, connected disk drives are displayed during system Power On Self Test (POST). Displaying the disk drives adds a few seconds to the overall POST time. Default is disabled .
CD-ROM Boot Support	When enabled , the system can be booted from a bootable CD. (This setting is not available on all RAID controller models.) Note —CD-ROMs are not supported by current software.
Removable Media Devices Boot Support	When enabled , removable media devices, such as CD drives, are supported. (This setting is not available on all RAID controller models.)
Alarm Control	When enabled, the alarm sounds. Default is enabled .

SAS-specific Controller Settings

In addition to the general settings listed on [page 79](#), your Adaptec SAS controller has SAS-specific settings that can be modified if required. (For more information about SAS, see [page 59](#).)

To modify SAS-specific settings, select **PHY Configuration** from the *SerialSelect* main menu.

Note: Default settings are shown in **bold** type.

Option	Description
PHY Rate	The data transfer rate between the controller and devices. The default setting is Auto , which allows the SAS card to adjust the data transfer rate as required.
CRC Checking	When enabled, determines whether the controller verifies the accuracy of data transfer on the serial bus. Default setting is Yes (enabled). Set to No (disabled) <i>only</i> if the controller is connected to a device that does not support CRC Checking.
SAS Address	In a situation where you want each phy on a controller to be in a different SAS domain, this setting specifies a unique world-wide name for each phy. Default is 0 . Note: This setting is for SAS address conflict resolution only and should otherwise remain at its default value.

SATA-specific Controller Settings

In addition to the general settings listed on [page 79](#), your Adaptec SATA controller has a SATA-specific setting that can be modified if required.

Option	Description
Write Cache	When enabled, the controller's write cache is enabled. Default is Yes (enabled). Caution —When enabled, there is a potential for data loss or corruption during a power failure.

SCSI-specific Controller Settings

In addition to the general settings listed on [page 79](#), your Adaptec SCSI controller has SCSI-specific settings that can be modified if required.

To modify SCSI-specific settings, select **SCSI Configuration** from the *SCSISelect* main menu.

SCSI Device Settings

You can use *SCSISelect* to modify some of the settings on the SCSI devices connected to your SCSI controller.

To modify SCSI device settings, select **SCSI Configuration** from the *SCSISelect* main menu, then select **Additional Options**. Devices are listed by SCSI ID. (To find the SCSI ID for a specific device, see [Formatting and Verifying Disk Drives on page 82](#).)

For the best device performance, don't change the default settings.

Note: Default settings are shown in **bold** type.

Option	Description
Maximum Transfer Rate	Shows the maximum data transfer rate that the SCSI channel supports.
Enable Disconnection	When enabled, the SCSI device can disconnect from the SCSI channel. Default is Yes (enabled).
Initiate Wide Negotiation	When enabled, the SCSI channel attempts 16-bit data transfer instead of 8-bit data transfer. Default is Yes (enabled).
QAS	When enabled, QAS (Quick Arbitration and Selection) is used to eliminate overhead and speed up data transfers on the SCSI bus. Default is No (disabled). Note —Adaptec recommends that you do not enable QAS if you are using an enclosure that supports Ultra320 expanders.
Packetized	When enabled, SCSI packetization (encapsulation) is used to reduce overhead and speed data transfer. Default is Yes (enabled).

SCSI Channel Interface Settings

Note: Default settings are shown in **bold** type.

Option	Description
Controller SCSI Channel ID	Sets the controller's SCSI ID. Adaptec recommends that you leave the controller set to the default (7), which gives it the highest priority on the SCSI channel.
SCSI Parity Checking	When enabled, the controller verifies the accuracy of data transfer on the SCSI channel. Disable only if the controller is connected to any SCSI device that does not support SCSI parity. Default is enabled .
Controller SCSI Channel Termination	Sets termination on the controller. Adaptec recommends that you retain the default setting (auto mode).

Formatting and Verifying Disk Drives

You can use the disk utilities to low-level format or verify your disk drives. (New disk drives are low-level formatted at the factory and do not need to be low-level formatted again.)

 **Caution:** Before you format a disk drive, back up all data. Formatting destroys all data on a disk drive.

To format or verify a disk drive:

- 1 Start the Adaptec RAID Controller utility (see [page 76](#)).
- 2 Select the controller you want, press **Enter**.
- 3 Select **Disk Utilities**.
- 4 Select the disk drive you want, then press **Enter**.
- 5 Select **Format Disk** or **Verify Disk Media**.

Viewing the Event Log

The BIOS-based event log records all firmware events, such as configuration changes, array creation, and boot activity.

Some events are not stored indefinitely—the event log is cleared of any non-persistent events each time you restart your computer; additionally, once the log is full, new events overwrite old events.

To view the event log:

- 1 Start the Adaptec RAID Controller utility (see [page 76](#)).
- 2 Select the controller you want, press **Enter**.
- 3 When the Adaptec RAID Controller utility menu appears, press **Ctrl+P**.
- 4 Select **Controller Log Information**, then press **Enter**.

The current event log opens.

Using the ACU for DOS



In this appendix...

Getting Started	84
Working in the ACU Using Menus.....	84
Running the ACU Using Scripts.....	85

This chapter describes the Array Configuration Utility (ACU) for DOS, a text-based utility that you can use to create, configure, and manage arrays. (A BIOS-based ACU is also available. See [page 76](#).)

Note: Adaptec recommends that only advanced users familiar with working in DOS use the ACU for DOS utility. For more information, see *Managing Your Storage Space* [on page 52](#).

Getting Started

Note: You need a bootable floppy disk to complete this task.

The ACU for DOS runs from a floppy disk which you can create using the RAID Installation CD that came in your Adaptec RAID controller kit.

To create the ACU floppy disk:

- 1 Insert your RAID Installation CD into the CD drive, then browse to this file:
`packages/firmware/controllermodel/acu.exe`

Where *controllermodel* is the model number of your Adaptec RAID controller.

- 2 Insert a bootable floppy disk and copy the `acu.exe` file to it.
- 3 Continue either of these two ways:
 - Work in the ACU using menus (see the following section)
 - Run the ACU using scripts (see [page 85](#))

Working in the ACU Using Menus

To work in the ACU using menus:

- 1 Insert the ACU floppy disk (see [Getting Started](#) above), then start or restart your computer.

The computer boots to the DOS command line.

- 2 Type `ACU` on the command line, then press `Enter`.

The ACU is menu-based and instructions for completing tasks appear on-screen. Menus can be navigated using the arrow, `Enter`, `Esc`, and other keys on your keyboard.

For more information about completing tasks, see *Using the ACU to Create and Manage Arrays* on [page 76](#).

Running the ACU Using Scripts

To work in the ACU using scripts:

- 1 Insert the ACU floppy disk (see [page 84](#)), then start or restart your computer.

The computer boots to the DOS command line.

- 2 Type ACU on the command line, specify a script file, and specify *either* the /P or /R switches listed in the following table. (Don't specify both.)

You may also add one or both of the optional switches.

Note: Command line syntax is *not* case sensitive.

Switch	Description
/P <file>	Playback Mode —The ACU reads the contents of the specified script file and creates arrays and configures channel settings based on the keywords defined in the script. See page 85 .
/R <file>	Record Mode —The ACU writes a RAID controller's existing array configuration to a specified script file, which lets you create the same configuration by running the ACU in playback mode (/P switch) with the resulting script. See page 86 .
/L <file>	(Optional) Log Filename Switch —If you include this switch, the ACU records its activity and any errors it encounters in the log file. If you do not include this switch, the ACU displays activity and errors on the screen. The <i>file</i> is a standard MS-DOS file, which can include a drive, directory, filename, and extension. Only the filename and extension (.log) are required. If no drive or directory is specified, the file is placed in the same location as the ACU executable.
/C <number>	(Optional) Controller Number Switch —In systems with more than one controller, this switch specifies which controller to change, where <i>number</i> is the controller number. The default controller number is 0 . Note —The number assigned to a particular controller depends on the controller's physical PCI slot and the order in which your system scans its PCI slots.

About Playback Mode

In this mode, the ACU reads the contents of the specified script file and creates arrays based on the keywords specified in the script.

The syntax is ACU /P <file> where *file* is the name of the script file. The file parameter can include a drive, directory, filename, and extension. If no drive or directory is specified, the file is placed in the same location as the ACU executable.

Note: The script file syntax allows only one hot spare to be assigned to an array. Therefore, when recording a RAID 10, the ACU can't map hot spares assigned to the individual mirror sets in the resulting script file. Instead, the ACU creates a single list for all hot spares assigned to the RAID 10. For more information, see *Method Keyword* [on page 89](#).

About Record Mode

Note: You can also create a script file manually (see [page 86](#)).

In Record Mode, the ACU writes a RAID controller's existing array configuration to a specified script file, which lets you create the same configuration by running the ACU in Playback Mode (/P switch) with the resulting script.

You can only record one RAID controller at a time with Record Mode. Record multiple RAID controllers separately using separate script files.

The syntax is `ACU /R <file>` where *file* is the name of the script file. The file parameter can include a drive, directory, filename, and extension, but only the filename and extension are required. If no drive or directory is specified, the file is placed in the same location as the ACU executable.

The ACU supports only a subset of available array types. If it encounters an array it can't create, a warning displays (or is recorded in the log file, if the /L switch is used); no keywords for that array are recorded in its script file.

When recording an array, the ACU always uses the default Wait setting (equivalent to Wait=Yes) unless you edit the script file and include Wait=No in the array's definition block. For more information, see *Wait Keyword* on [page 90](#).

Creating the Script File Manually

Script files contain blocks:

- Array definition block keywords (see [page 87](#))
- *Optional*—ACU error codes (see [page 91](#))

The syntax rules are:

- Each keyword must start its own line.
- Syntax is *not* case sensitive.

Entering Comments in the Script File

To enter a comment in the script file, start with a pound character (#). You can start anywhere on a line. For a sample script that includes comments, see *Sample Scripts* on [page 92](#).

Array Definition Block Keywords

The array definition block always begins with the keyword `Array` and ends with the keyword `End`. The other *required* array definition keywords are `Drives` and `Type`.

Array definition keywords and descriptions are listed in this table.

Keyword	Required?	Description
<code>Array</code>	Yes	Indicates the start of an array definition block. No default. See page 87 .
<code>Drives</code>	Yes	Specifies the disk drives used in creating the array. No default. See page 87 .
<code>End</code>	Yes	Indicates the end of an array definition block. No default. See page 88 .
<code>HotspareDrives</code>	No	Specifies hot spares to assign to the array. No default. See page 88 .
<code>InitializeAll</code>	No	Indicates whether to initialize all the drives connected to the controller. Default is No . See page 88 .
<code>Method</code>	Yes	Indicates the method (Build/Verify, Clear, or Quick Init) to use when creating a redundant array. Default is Build . See page 89 .
<code>ReadCache</code>	No	Indicates whether read caching is enabled for this array. Default is Yes . See page 89 .
<code>Size</code>	No	Specifies the size of the array. Default is Maximum . See page 89 .
<code>StripeSize</code>	No	Specifies size of contiguous I/O, in bytes. Default is 256 . See page 89 .
<code>Type</code>	Yes	Indicates the type of array to create. No default. See page 90 .
<code>Wait</code>	No	Indicates whether the ACU should wait for the new array's Build/Verify or Clear to complete before continuing. Default is Yes . See page 90 .
<code>WriteCache</code>	No	Indicates whether write caching is enabled for this array. Default is Yes . See page 90 .

Array Keyword

`Array` is a required keyword, indicating the start of an array definition block. The syntax is `Array=<label>`, where `label` is an optional alphanumeric string.

For example:

```
Array=MyData
```

Drives Keyword

`Drives` is a required keyword, specifying the devices to use in creating the array. There is no default value.

A disk drive is identified by its channel number, ID (target), and LUN, separated by colons; for example, `0:0:0` or `0:1:0`. Separate multiple disk drive identifiers with commas.

Prior to creating any new arrays, the ACU initializes any drives specified by the `Drives` keyword. If a disk drive is specified in more than one array definition block in a script, it is initialized only once.

 **Caution:** Any disk drive specified within the script file is initialized, which destroys any data on that disk drive.

For example:

```
Drives=0:0:0
```

```
Drives=0:0:0,0:1:0,0:2:0
```

End Keyword

End is a required keyword, indicating the end of the block.

HotspareDrives Keyword

HotspareDrives is an optional keyword, specifying the hot spares to assign to the array. The syntax for listing hot spares is the same as the *Drives Keyword on page 87*. If HotspareDrives is not specified, no hot spares are assigned to the array.

For example:

```
HotspareDrives=0:0:0,0:1:0
```

The same disk drive can be assigned to protect multiple arrays (as a pool spare). Once a pool spare is used by a failed disk drive, however, it is no longer available to protect the other arrays its assigned to.

This keyword does *not* verify that the available space on the specified hot spares is sufficient to serve as failover for the array.

When assigning hot spares to a multilevel array, HotspareDrives assigns all the hot spares in the list to *all* arrays within the multilevel array.

InitializeAll Keyword

If you want the ACU to initialize all drives connected to the controller and delete any existing arrays before any new arrays are created, even those that are not specified in any Drives keyword definition, specify InitializeAll=yes. Otherwise, the ACU initializes only those drives specified by the Drives keyword.

 **Caution:** Initializing a disk drive automatically deletes any existing arrays with that disk drive as their member.

Possible values:

- **Yes**—Initialize all drives.
- **No (default)**—Do not initialize all drives; only those drives specified with the Drives keyword are initialized.

For example:

```
Type=Volume
Type=RAID1
```

InitializeAll is a global keyword that you need to specify only once.

InitializeAll is always performed prior to array creation regardless of its position in the script.

If both InitializeAll=Yes and InitializeAll=No are specified in the same script file, InitializeAll=Yes is always the overriding value.

If an array is deleted during a Build/Verify process, the process is automatically terminated.

Method Keyword

Method is an optional keyword, indicating which method to use when creating a redundant (RAID 1, 5, and 10) array. Possible values:

- **Build** (the *default*)—Perform a Build/Verify process on the array. Takes longer than Clear, but allows you to begin using the array immediately.
- **Clear**—Clear the array. Faster than a Build/Verify process, but you have to wait for the operation to be completed before you can begin using the array.
- **Quick Init**—Makes the array available immediately, but does not accomplish a Build/Verify. Parity and mirror information is created as data is written to the disk drive (called full-stripe write mode), which reduces overall array performance. Maximum performance is achieved by starting and completing a Build/Verify.

For example:

```
Method=Build
```

ReadCache Keyword

ReadCache indicates whether the array uses read caching.

Possible values:

- **Yes** (*default*)—Enable read caching.
- **No**—Disable read caching.

For example:

```
ReadCache=Yes
```

Size Keyword

The Size keyword specifies the size of the array. Specify Maximum (the default) to create an array using the maximum available space, based on the array type and drives selected. Otherwise, specify the size as an integer or a decimal number, followed by the unit keyword MB (megabytes), GB (gigabytes), or TB (terabytes).

Note: A unit keyword is required with a numeric size value. If no unit keyword is specified, the ACU exits with an error.

For example:

```
Size=2.5GB
Size=300MB
Size=Maximum
```

StripeSize Keyword

The StripeSize keyword specifies the stripe size (in MB) written to each member of a striped array (RAID 0, RAID 5, or RAID 10).

The possible values for StripeSize are 16, 32, 64, 128, 256, 512 and 1024 KB. Default is 256.

For example:

```
StripeSize=256
```

Type Keyword

Type is a required keyword, indicating the array type. There is no default value. The possible values: Volume, RAID0, RAID1, RAID5, RAID10, or RAID50.

Depending on the RAID levels supported by your RAID controller, additional possible values are: RAID1E, RAID5EE, RAID6, RAID60.

Wait Keyword

Wait is an optional keyword that you can use to tell the ACU to allow the ACU to continue while the Build/Verify or Clear completes in the background; specify Wait=No. Otherwise, the ACU waits by default.

If the host is powered off before the Build/Verify or Clear process completes and is then restarted, the process resumes without any user intervention.

For example:

```
Wait=Yes
Wait=No
```

WriteCache Keyword

The WriteCache keyword indicates whether write caching is used for this array if write caching is supported for the system. Possible values are as follows:

- **Yes** (*default*)—Enable the write cache.
- **No**—Disable the write cache.

Setting an array's WriteCache keyword to Yes might result in data loss or corruption during a power failure.

For example:

```
WriteCache=Yes
```

Channel Definition Block Keywords—SCSI only

The channel definition block is optional. If used, it always begins with the keyword Channel and ends with the keyword End. The channel definition block keywords are listed in this table.

Keyword	Description
Channel	Used to identify the channel.
ControllerID	Changes the SCSI ID of the controller.
End	Indicates the end of a channel definition block.

Channel Keyword

Channel is an optional keyword that begins a channel definition block and specifies the channel number to which the channel keywords apply. Channels are numbered from zero to the maximum number of channels on the controller minus one.

You can include multiple channel definition blocks within a script file, each beginning with a channel keyword and value.

For example:

```
Channel=0
```

ControllerID Keyword

ControllerID is an optional keyword to change the SCSI ID of the controller. Normally, the SCSI controller is assigned SCSI ID 7 on each of its channels. You can specify any ID value between 0 and 7.

 **Caution:** Do not change the SCSI ID of the controller unless directed to do so by Adaptec Technical Support.

For example:

```
ControllerID=7
```

End Keyword

End is a required keyword, indicating the end of the block.

ACU Error Codes

When the ACU detects an error, it reports the error and exits immediately. If a log file is specified, the ACU writes the error code to the log file. Otherwise, it displays the error code on the screen.

The possible error messages returned by the ACU are listed in this table.

Code	Description
0	ACU ran without changes —ACU exited with no errors (success) and no report is required.
1	No controller found.
2	Syntax or logical error in the script file —The ACU encountered an invalid command or keyword in the specified script file.
3	Unable to open file.
4	Error in the command line parameters —You passed an invalid command-line switch to the ACU. (See <i>Running the ACU Using Scripts</i> on page 85 for a list of valid command-line switches.)
5	Unable to read system configuration —The ACU was unable to get the configuration information from the specified controller.
6	No drives detected.
7	Specified drive not found in system.
8	Specified array size too small —You specified an array size that is smaller than the minimum size allowed for this array.
9	Specified array size too big —You specified an array size that is larger than the maximum size allowed for this array.
10	Number of drives do not match the array type —The number of drives you selected is invalid for the type of array specified.
11	Unable to initialize drive.
12	Error occurred while creating array.
13	Too many spare drives assigned —You attempted to assign more than the maximum number of hot spares allowed for the specified array.
14	Insufficient memory to run the application.
15	Incorrect controller number.
16	Controller not responding.
17	Build/Verify/Clear failed.
100	You ran ACU and made changes —The ACU exited with no errors (success) and you must restart the computer.

Sample Scripts

This MS-DOS command invokes the ACU and creates arrays on controller 1 based on the array keywords defined in the script file A:\RAID.ACU. It also configures Channel 0 and saves a log of the operation in the log file C:\RAID.LOG:

```
A:\> ACU /P A:\RAID.ACU /L C:\RAID.LOG /C1
```

Sample Scripts for SCSI and SAS Controllers

Note: For a sample script for a SATA controller, see [page 93](#).

This sample script file is a sample RAID.ACU script as referred to in the ACU command above. This script creates these arrays—a 500 MB single-disk volume, and a 2-GB two-disk drive RAID 1 with a hot spare:

```
# Script to create volume, mirror, and RAID 5 arrays
# Create a 500MB volume labeled 'MySystem'
Array=MySystem
Type=Volume
Size=500MB
Drives=0:0:0
End

# Create a 2GB mirror labeled 'MyMirror'
Array=MyMirror
Type=RAID1
Size=2GB

# Use drives 1 and 2
Drives=0:1:0,0:2:0
# Disable write cache
WriteCache=No

# Assign 1 spare drive
HotspareDrives=0:3:0
End
```

This sample script file creates a maximum-size three-disk-drive RAID 5:

```
# Create a maximum size RAID 5 labeled 'MyData'
Array=MyData
Type=RAID5
Size=Maximum

# Use the maximum stripe size
StripeSize=256

# Clear the array (don't build/verify it)
Method=Clear

# Don't wait for clear to complete
Wait=No

# Use drives 0, 1, 2
Drives=0:0:0, 0:1:0, 0:2:0
End
```

Sample Script for SATA Controllers

This is a sample ACU file that will initialize all disk drives connected to the SATA controller and create a RAID 5 array with the disk drives on ports 0, 1, and 2.

```
Controller= 0,5:7:0
Controller Name=Adaptec Adaptec 2820SA
Subsystem ID=0x2A1
Firmware Version=V5.1-0[6792]
Total Ports=8
Port 0 = 0:0:0 Maxtor 279.479GB 279.395GB
Port 1 = 0:1:0 Maxtor 279.479GB 279.395GB
Port 2 = 0:2:0 Maxtor 279.479GB 279.395GB
Array=MyData2
Type=RAID5
Size=Maximum
InitializeAll=Yes
Method=Build/Verify
Wait=No
Drives=0:0:0, 0:1:0, 0:2:0
End
```

Using the Adaptec Flash Utility



In this appendix...

System Requirements	95
Before You Begin	95
Running the Menu-based AFU.....	96
Running the AFU from the Command Line.....	97
Updating the Flash Using the AFU Command Line	100

This chapter describes how to use the Adaptec Flash Utility (AFU), a text-based DOS utility that you can use to update, save, or verify the RAID controller's firmware BIOS and Non-Volatile Random Access Memory (NVRAM).

 **Caution:** Although the AFU contains safeguards to prevent you from accidentally damaging your RAID controller's flash contents, it is still important to use the AFU carefully and correctly to avoid rendering your RAID controller inoperable. Adaptec recommends that only advanced users familiar with working in DOS use the AFU. For more information, see [Managing Your Storage Space on page 52](#).

System Requirements

- MS-DOS version 5.0 or later.

Note: You can't run the AFU from a DOS command prompt window under any version of Windows.

- At least 8 MB of extended memory.

Compatibility Notes

- Supports HIMEM.SYS; compatible with other DOS drivers running under HIMEM.SYS (for example, SMARTDRV.SYS and SETVER.SYS).
- *Does not* support DOS extenders installed in memory, such as EMM386.SYS and DOS4GW.

Before You Begin

Before you begin:

- 1 Obtain the firmware (see the following section).
- 2 Create a firmware kit on floppy disks (see [page 96](#)).

There are two ways to run the AFU:

- Using the AFU menus (see [page 96](#))
- From the command line (see [page 97](#))

Obtaining the Firmware

To obtain RAID controller firmware, go to:

- **The RAID Installation CD**—Includes the AFU executable (AFU.exe) and a separate flash image. The flash image may comprise multiple User Flash Image (UFI) files.
- **The Adaptec Web site**—Download a new firmware file to get the most recent version of AFU.

See www.adaptec.com for more information.

Creating the Firmware Floppy Disks

Note: You will need at least two bootable MS-DOS floppy disks to complete this task. You can't create a bootable floppy disk using Windows 2000.

To create the firmware floppy disks:

- 1 Create a bootable MS-DOS floppy disk and copy these files to it:
 - AFU.exe
 - AAxxx01.ufi
 where xxx is the model number of your controller.
- 2 Create additional bootable MS-DOS floppy disks and copy each additional AAxxx0x.ufi file to a separate floppy disk. (Some RAID controllers have two UFI files; some have four. Each goes onto its own floppy disk.)
- 3 To use a menu-based AFU, see the following section.

To run the AFU from the command line, see [page 97](#).

Running the Menu-based AFU

Note: You can also run the AFU from the command line (see [page 97](#)).

To run the menu-based AFU:

- 1 Shut down your operating system and reboot to DOS from a bootable MS-DOS floppy disk or from a DOS partition on a bootable drive. (You can use a disk drive connected to the controller you are updating.)
- 2 At the DOS command prompt, type `AFU` with no arguments.
The AFU's main menu is displayed.
- 3 Select **Select Controllers**, then select the Adaptec RAID controller(s) to be flashed.
To update multiple RAID controllers in the same system, update the boot controller's flash first, restart the computer, then update the flash for the remaining controllers.
- 4 Select **Select an Operation**.
- 5 Choose the operation you want, then follow the on-screen instructions to complete the task:
 - **Update**—Updates all the flash components on a RAID controller with the flash image data from the UFI file.
 - **Save**—Reads the contents of a RAID controller's flash components and saves the data to a UFI file, which you can use to restore a RAID controller's flash if required.
 - **Verify**—Reads the contents of a RAID controller's flash components and compares it to the contents of the specified UFI file.
 - **Version**—Displays version information about a RAID controller's flash components.
 - **List**—Lists all supported RAID controllers detected on your system.
- 6 Complete the flash operation and restart your computer before trying to use the RAID controller again. (You can not use your RAID controller while you are updating its flash.)

Running the AFU from the Command Line

Note: You can also run a menu-based AFU (see [page 96](#)).

To run the AFU from the command line:

- 1 Power off your computer, insert the first AFU floppy disk, then power on your computer.
If your computer isn't set up to boot from the bootable floppy disk, enter the system setup utility to change the setting.
- 2 At the DOS command, type AFU followed by a command (see [page 97](#)) and any switches you want.

Note: To find a controller number, type AFU LIST, then press **Enter**.

The AFU processes the command, prompts you to insert additional floppy disks as needed, exits, and reports either success or an error message code.

To update a RAID controller's flash using the command line, see [page 100](#).

AFU Commands

This section lists the available AFU commands.

List

Displays the AFU-supported RAID controllers installed on your computer. Also displays the ID numbers assigned to each controller.

You don't have to restart the computer after completing this command.

This example shows a typical system response to a LIST command:

```
A:\> AFU LIST
Adaptec Flash Utility V4.0-0 B5749
(c)Adaptec Inc. 1999-2005. All Rights Reserved.
Controllers Detected and Recognized:
Controller #0 (03:05:00) Adaptec Adaptec 2230SLP
```

Save

Saves the contents of a RAID controller's flash in a UFI file. The name of the UFI file is based on the controller type and can't be changed.

You must restart the computer following a SAVE command.

The command syntax for the SAVE command is

```
AFU SAVE [/C<Controller ID>] [/D <UFI File Path>]
```

These switches are available:

- **/C <Controller ID>**—One or more RAID controller IDs representing the set of RAID controllers on which to perform the specified command. The default is 0; if the computer has multiple RAID controllers, the AFU defaults to controller 0 unless you specify otherwise.

For example:

To specify a single RAID controller ID: `/C 0`

To specify multiple IDs separated by commas: `/C 0,2`

To indicate all RAID controllers: `ALL`

If you are using multiple RAID controllers, you must specify the controller you want by using the `/C` switch; otherwise, the AFU displays an error message and exits.

- **/D <EFI File Path>**—Specifies the path where the EFI files are located. If you do not specify the `/D` switch, the AFU looks for (or creates) its EFI files in the default location.

You cannot specify the name of a EFI file, only its path. EFI filenames are predefined, based on the RAID controller type.

In this example, the AFU saves flash contents from RAID controller 0 to a EFI file in the current default drive and directory:

```
A:\> AFU SAVE /C 0
```

In this example, the AFU saves flash contents from Controller 1 to a EFI file in `C:\EFI_FILES`:

```
A:\> AFU SAVE /C 1 /D C:\EFI_FILES
```

Update

Updates the flash components of one or more RAID controllers on your computer from the flash image data in a EFI file. You must restart the computer following an update command.

The command syntax for the update command is:

```
AFU UPDATE [/C<Controller ID>] [/D <EFI File Path>]
```

You can also use the `/C` and `/D` switches (see [Save on page 97](#)).

This example shows a typical system response after an update.

```
A:\> AFU UPDATE /C 0
Adaptec Flash Utility V4.0-0 B5749
(c)Adaptec Inc. 1999-2005. All Rights Reserved.
Updating Controller 0 (Adaptec 2820)
Reading flash image file (Build 5749)
AFU is about to update firmware on controllers Adaptec Adaptec 2230SLP
***PLEASE DO NOT REBOOT THE SYSTEM DURING THE UPDATE***
This might take a few minutes.
Writing Adaptec Adaptec 2230SLP (4MB) Flash Image to controller 0...OK.
Verifying...OK
Please restart the computer to allow firmware changes to take effect.
```

Verify

Compares the contents of each of the flash components on a RAID controller to the corresponding image in a UFI file, and indicates whether they match. After using the verify command, you must restart the computer.

The command syntax for the VERIFY command is as follows:

```
AFU VERIFY [/C<Controller ID>] [/D <UFI File Path>]
```

You can also use the /C and /D switches. See [Save on page 97](#) for more information.

This example shows a typical system response after a verify command.

```
A:\> AFU VERIFY /C 0
Adaptec Flash Utility V4.0-0 B5749
(c)Adaptec Inc. 1999-2005. All Rights Reserved.
Reading flash image file (Build 5748)
Controller #0: Adaptec Adaptec 2820SA
ROM: Checksum: 797B [VALID] (Build 5748)
File: Checksum: 797B [VALID] (Build 5748)
      Image Compares Correctly
```

Version

Displays version information about the flash components on a RAID controller. After using the version command, restart your computer.

The command syntax for the version command is:

```
AFU VERSION [/C<Controller ID>]
```

You can also use the /C switch. See [Save on page 97](#) for more information.

This example displays version information about all supported RAID controllers.

```
A:\> AFU VERSION /C 0
Adaptec Flash Utility V4.0-0 B5749
(c)Adaptec Inc. 1999-2005. All Rights Reserved.
Version Information for Controller #0 (Adaptec Adaptec 2820SA)
ROM: Build 5748 [VALID] Fri Sep 27 13:28:40 EDT 2005
A:\> AFU VERSION /C ALL
```

Help

Displays a summary of AFU functions and command switches. For example:

```
A:\> AFU HELP
A:\> AFU /?
```

Updating the Flash Using the AFU Command Line

- 1 Create the firmware floppy disks (see [page 96](#)).
- 2 Power off your computer, insert the first AFU floppy disk, then power on your computer.
If your computer isn't set up to boot from the bootable floppy disk, enter the system setup utility to change the setting.
- 3 At the DOS command, if you have multiple controllers and you don't know the number of the controller you want to update, type `AFU LIST`, then press **Enter**. Otherwise, skip to the next step.
- 4 At the DOS command, type `AFU` followed by a command (see [page 97](#)) and any switches you want.
- 5 Update the flash using the instructions suitable for your requirements:
 - **To update a single RAID controller:**

```
AFU UPDATE /C <cont_number>
```

Where *<cont_number>* is the number of the RAID controller whose firmware you are updating. For example, to upgrade Controller 0, type `AFU UPDATE /C 0`
 - **To update multiple RAID controllers:**

```
AFU UPDATE /C <cont_number_a>,<cont_number_b>
```

Where *<controller_number_a>* and *<controller_number_b>* are the numbers of the Adaptec RAID controllers whose firmware you are updating. For example, to upgrade controllers 0, 2, and 3, type `AFU UPDATE /C 0, 2, 3`
 - **To update all RAID controllers simultaneously:**

```
AFU UPDATE /C all
```

Note: The UFI file identifies the RAID controllers, so you don't have to worry about flashing the wrong controller.
- 6 When prompted, insert the first firmware disk into your floppy disk drive.
The AFU reads the first disk.
- 7 When prompted, remove the first firmware disk and insert the second firmware disk into your floppy disk drive.
- 8 Repeat [Step 7](#) as required until the flash update is complete.

Safety Information



To ensure your personal safety and the safety of your equipment:

- Keep your work area and the computer clean and clear of debris.
- Before opening the system cabinet, unplug the power cord.

Electrostatic Discharge (ESD)

 **Caution:** ESD can damage electronic components when they are improperly handled, and can result in total or intermittent failures. Always follow ESD-prevention procedures when removing and replacing components.

To prevent ESD damage:

- Use an ESD wrist or ankle strap and ensure that it makes skin contact. Connect the equipment end of the strap to an unpainted metal surface on the chassis.

If a wrist strap is not available, ground yourself by touching the metal chassis before handling the controller or any other part of the computer.
- Avoid touching the controller against your clothing. The wrist strap protects components from ESD on the body only.
- Handle the controller by its bracket or edges only. Avoid touching the printed circuit board or the connectors.
- Put the controller down only on an antistatic surface such as the bag supplied in your kit.
- If you are returning the controller to Adaptec, put it back in its antistatic bag immediately.

Technical Specifications



In this appendix...

- Environmental Specifications..... 103
- DC Power Requirements..... 103
- Current Requirements..... 103

Environmental Specifications

Ambient temperature without battery backup module	0 °C to 50 °C
Relative humidity	10% to 90%, noncondensing
Altitude	Up to 3,000 meters

Note: Forced airflow is recommended, but not required.

DC Power Requirements

Ripple and noise	50 mV peak-to-peak (max)
DC Voltage	5 V \pm 5%, 3.3 V \pm 10%

Current Requirements

Adaptec Model	Maximum Current (A)
Adaptec 4000SAS	1.5 A @ 3.3 VDC; 0.75 A @ 5.0 VDC
Adaptec 4800SAS	1.4 A @ 3.3 VDC; 2.4 A @ 5.0 VDC
Adaptec 4805SAS	1.5 A @ 3.3 VDC; 1.3 A @ 12.0 VDC
Adaptec 2420SA	0.36 A @ 3.3 VDC; 2.4 A @ 5 VDC
Adaptec 2820SA	0.37 A @ 3.3 VDC; 2.4 A @ 5.0 VDC
Adaptec 2130SLP	2.5 A @ 3.3VDC; 2 A @ 5.0 VDC
Adaptec 2230SLP	2.5 A @ 3.3VDC; 2 A @ 5.0 VDC

A

ACU

- arrays [37](#)
- creating arrays [37, 76](#)
- creating bootable arrays [77](#)
- initializing disk drives [77](#)
- managing arrays [77](#)
- rescanning disk drives [77](#)
- secure erasing disk drives [78](#)
 - stopping a secure erase [78](#)

ACU for DOS [83 to 93](#)

- array definition block keywords [87](#)
- creating a floppy disk [84](#)
- menus [84](#)
- playback mode [85](#)
- record mode [86](#)
- sample scripts [92](#)
- script file syntax [86](#)
- scripts [85](#)
- switches [85](#)

Adaptec customer support [3](#)

Adaptec Flash Utility. *See* AFU

Adaptec RAID Controller Configuration utility. *See* ARCCONF

Adaptec RAID Controller utility [54, 75 to 82](#)

Adaptec Storage Manager [53](#)

- creating arrays [39](#)
- installing [53](#)

adapters. *See* controllers

advanced data protection [17](#)

AFU [54, 94 to 100](#)

Alarm Control setting [79](#)

ARCCONF [53](#)

Array Background Consistency Check setting [79](#)

Array Configuration Utility. *See* ACU

array definition block

- End keyword [88](#)
- HotspareDrives keyword [88](#)

array migration [17](#)

Array-based BBS Support setting [79](#)

arrays

- creating (ACU) [37, 76](#)
- creating (Adaptec Storage Manager) [39](#)
- creating bootable arrays [77](#)
- making an array bootable [40](#)
- managing with ACU [77](#)
- non-RAID [67](#)
- RAID 1 [68](#)
- RAID 10 [69](#)
- RAID 1E [68](#)
- RAID 5 [70](#)
- RAID 50 [72](#)
- RAID 5EE [71](#)
- RAID 6 [73](#)
- RAID 60 [73](#)

arrays (bootable) [36](#)

audible alarm [56](#)

automatic failover [17](#)

Automatic Failover setting [79](#)

B

backplane connections [34, 64](#)

battery backup module [18](#)

BBS Support setting [79](#)

BBU [18](#)

boards. *See* controllers

boot controller [37](#)

bootable arrays 40
 creating 36, 77

C

cables 29
 cards. *See* controllers
 CD-ROM Boot Support setting 79
 command line interface (flash utility) 97
 command line utility 53
 contents of controller kit 14
 Controller SCSI Channel ID setting 81
 Controller SCSI Channel Termination setting 81
 controllers
 Alarm Control setting 79
 Array Background Consistency Check setting 79
 Array-based BBS Support setting 79
 array-level features 17
 Automatic Failover setting 79
 BBS Support setting 79
 cables 29
 CD-ROM Boot Support setting 79
 connecting external devices 35
 data protection 17
 descriptions 16 to 25
 disk drives 28
 Drive's Write Cache setting 79
 enhanced features 18
 event log 82
 figures 16 to 25
 firmware 95
 flashing 58
 installation options 30
 installing 32
 keyed features 18
 modifying general settings 79
 modifying settings with *-Select* utilities 78
 Physical Drives Display During POST setting 79
 RAID levels 27
 Removable Media Devices Boot Support setting 79
 resetting 58
 Runtime BIOS setting 79
 setting boot controller 37
 specifications 102
 standard features
 troubleshooting 56
 updating firmware 95
 upgrading firmware 18
 copyback 17
 CRC Checking setting 80
 customer support 3

D

direct-attach connections 33, 63
 disk drives 28
 cables 29
 connecting to SAS controllers 33
 connecting to SATA controllers 34
 connecting to SCSI controllers 35
 external 35
 failure recovery
 multiple arrays 57
 multiple disk drives 58
 RAID 0 arrays 57
 with hot spare 57
 without hot spare 57
 formatting 82
 HVD 28
 initializing 77
 LVD 28
 recovering from failure 56
 rescanning 77
 SAS identifiers 63
 SE 28
 secure erasing 78
 stopping a secure erase 78
 verifying 82
 drive requirements 28
 Drive's Write Cache setting 79
 driver and operating system installation 41 to 46
 driver disk 42
 driver installation 47 to 51
 drivers
 installing on FreeBSD 51
 installing on Linux 49
 installing on NetWare 49
 installing on OpenServer 50
 installing on Solaris 51
 installing on UnixWare 50
 installing on Windows 49
 installing with FreeBSD 46
 installing with Linux 43, 44
 installing with NetWare 44
 installing with OpenServer 45
 installing with UnixWare 45
 installing with Windows 43

E

 electrostatic discharge 101
 Enable Disconnection setting 81
 end devices 60
 End property 88

enhanced features 18
 event log 82
 expander connections 64
 expander devices 60
 external devices 35

F

failed disk drives 56
 multiple arrays 57
 multiple disk drives 58
 RAID 0 arrays 57
 without hot spare 57
 feature keys 18
 firmware 95
 creating floppy disks 96
 firmware upgrades 18
 flashing controllers 58
 floppy disks for firmware update 96
 formatting disk drives 82
 FreeBSD
 driver installation 51
 OS installation 46

H

hard disk, hard disk drive, hard drive. *See* disk drive
 hot spares 17
 HotspareDrives keyword
 array definition block 88

I

initializing disk drives 77
 Initiate Wide Negotiation setting 81
 installation
 controllers 32
 creating a driver disk 42
 disk drives (SAS) 33
 disk drives (SATA) 34
 disk drives (SCSI) 35
 driver 47 to 51
 driver and FreeBSD 46
 driver and Linux 43, 44
 driver and NetWare 44
 driver and OpenServer 45
 driver and operating system 41 to 46
 driver and UnixWare 45
 driver and Windows 43
 existing operating system 30
 external devices 35
 installation options 30
 SAS backplane 34

installation, continued
 SAS direct-attach 33
 with operating system 30

K

keyed features 18
 kit contents 14

L

links (SAS) 61
 Linux
 driver installation 49
 OS installation 44
 Linux installation 43
 locked features 18

M

Managing 77
 Maximum Transfer Rate setting 81
 mirroring 27

N

NCQ 17
 NetWare
 driver installation 49
 OS installation 44
 non-RAID arrays 67

O

online expansion 17
 OpenServer
 driver installation 50
 OS installation 45
 operating system installation 41 to 46
 operating systems 14

P

Packetized setting 81
 parity 27
 Phy Rate setting 80
 phys 61
 Physical Drives Display During POST setting 79
 playback mode 85

Q

QAS setting 81

R

RAID

- RAID 0 67
- RAID 1 68
- RAID 10 69
- RAID 1E 68
- RAID 5 70
- RAID 50 72
- RAID 5EE 71
- RAID 6 73
- RAID 60 73
- RAID 1E 17
- RAID 5EE 17
- RAID 6 17
- RAID 60 17
- RAID controllers. *See* controllers
- RAID levels 27
- record mode 86
- recovering from disk drive failure 56
- Red Hat
 - driver installation 49
 - OS installation 43
- Redundant Array of Independent Disks. *See* RAID
- Removable Media Devices Boot Support setting 79
- replacing failed disk drives 56
- requirements 14
 - drive 28
- rescanning disk drives 77
- resetting controllers 58
- Runtime BIOS setting 79

S

safety information 101

SAS

- 4-wide ports 62
- backplane connections 34, 64
- cables 29, 63
- comparison to parallel SCSI 65
- connectors 62
- description 60
- direct-attach connections 33, 63
- disk drive identifiers 63
- disk drives 28
- edge expanders 64
- end devices 60
- expander connections 64
- expander devices 60
- fanout expanders 64
- link speed 60
- links 61

SAS, continued

- narrow connectors 62
- narrow ports 62
- phys 61
- ports 61, 62
- SAS address 62
- SAS cards 60
- SAS devices 60
- SAS domain 64
- terminology 60
- transceivers 61
- wide connectors 62
- wide ports 62
- SAS Address setting 80
- SAS controllers
 - cables 29
 - connecting disk drives 33
 - CRC Checking setting 80
 - disk drives 28
 - modifying with *-Select* utilities 80
 - Phy Rate setting 80
 - SAS Address setting 80
- SAS devices 60
- SATA
 - cables 29
 - disk drives 28
- SATA controllers
 - cables 29
 - connecting disk drives 34
 - disk drives 28
 - modifying with *-Select* utilities 80
 - Write Cache setting 80
- SATASelect 78
- scripts in ACU for DOS 92
- SCSI
 - cables 30
 - comparison to SAS 65
 - disk drives 28
- SCSI controllers
 - cables 30
 - connecting disk drives 35
 - Controller SCSI Channel ID setting 81
 - Controller SCSI Channel Termination setting 81
 - disk drives 28
 - Enable Disconnection setting 81
 - Initiate Wide Negotiation setting 81
 - Maximum Transfer Rate setting 81
 - modifying with *-Select* utilities 81
 - Packetized setting 81
 - QAS setting 81
 - SCSI Parity Checking setting 81

- SCSI Parity Checking setting 81
- SCSISelect 78
- secure erasing disk drives 78
 - stopping a secure erase 78
- Select utilities 78
 - applying changes 78
 - exiting 78
 - modifying controller settings 79
 - opening 78
- Serial ATA. *See* SATA
- Serial Attached SCSI. *See* SAS
- SerialSelect 78
- Small Computer System Interface. *See* SCSI
- snapshot 18
- software 53
- Solaris
 - driver installation 51
- specifications 102
- storage management
 - Adaptec RAID Controller utility 54
 - Adaptec Storage Manager 53
 - AFU 54
 - ARCCONF 53
- storage space 12
- support, customer 3
- SuSE
 - driver installation 49
- SuSE installation 44
- switches in ACU for DOS 85
- system requirements 14

T

- technical specifications 102
- technical support 3
- Technical Support Identification (TSID) number 3
- terminology 12
 - Adaptec Storage Manager 12
 - SAS 60

- tools
 - Adaptec RAID Controller utility 54
 - Adaptec Storage Manager 53
 - AFU 54
 - ARCCONF 53
- troubleshooting tips 55
- TSID Number
 - See* Technical Support Identification Number

U

- UnixWare
 - driver installation 50
 - OS installation 45
- updating firmware 95
- upgrading firmware 18
- utilities
 - Adaptec RAID Controller utility 54
 - AFU 54
 - ARCCONF 53

V

- verifying disk drives 82

W

- Windows
 - driver installation 49
 - OS installation 43
- Write Cache setting 80



Adaptec, Inc.
691 South Milpitas Boulevard
Milpitas, CA 95035 USA

©2005-06 Adaptec, Inc.
All rights reserved. Adaptec and the Adaptec logo are
trademarks of Adaptec, Inc. which may be
registered in some jurisdictions.

Part Number: CDP-00062-01-A, Rev. B
LB 03/06