

Multimedia: Making It Work

Eighth Edition

Tay Vaughan



New York Chicago San Francisco Lisbon London
Madrid Mexico City Milan New Delhi San Juan
Seoul Singapore Sydney Toronto

Contents

ACKNOWLEDGMENTS vii
ABOUT THIS BOOK x
INTRODUCTION xii

1 What Is Multimedia? 1

Definitions 1
Where to Use Multimedia 2
 Multimedia in Business 2
 Multimedia in Schools 3
 Multimedia at Home 5
 Multimedia in Public Places 7
 Virtual Reality 9
Delivering Multimedia 9
 CD-ROM, DVD, Flash Drives 10
 The Broadband Internet 10

2 Text 18

The Power of Meaning 20
 The Power and Irregularity of English 21
About Fonts and Faces 22
 Cases 24
 Serif vs. Sans Serif 24
Using Text in Multimedia 25
 Designing with Text 26
 Fields for Reading 36
 HTML Documents 39
Computers and Text 40
 The Font Wars Are Over 40
 Character Sets and Alphabets 42
 Mapping Text Across Platforms 45
 Languages in the World of Computers 46
Font Editing and Design Tools 50
 Fontlab 51
 Making Pretty Text 52
Hypermedia and Hypertext 53
 The Power of Hypertext 55
 Using Hypertext 56
 Searching for Words 57
 Hypermedia Structures 58
 Hypertext Tools 60

3 Images 68

Before You Start to Create 68
 Plan Your Approach 69
 Organize Your Tools 69
 Configure Your Computer Workspace 69
Making Still Images 70
 Bitmaps 71
 Vector Drawing 80
 Vector-Drawn Objects vs. Bitmaps 81
 3-D Drawing and Rendering 83
Color 88
 Understanding Natural Light and Color 88
 Computerized Color 91
 Color Palettes 94
Image File Formats 97

4 Sound 104

The Power of Sound 104
Digital Audio 106
 Making Digital Audio Files 108
MIDI Audio 113
MIDI vs. Digital Audio 118
Multimedia System Sounds 120
Audio File Formats 121
Vaughan's Law of Multimedia Minimums 123
Adding Sound to Your Multimedia Project 124
 Space Considerations 125
 Audio Recording 126
 Keeping Track of Your Sounds 128
 Audio CDs 128
 Sound for Your Mobile 129
 Sound for the Internet 130
 Testing and Evaluation 131
 Copyright Issues 131

5 Animation 140

The Power of Motion 140
Principles of Animation 141
Animation by Computer 142
 Animation Techniques 143
 Animation File Formats 149
Making Animations That Work 150
 A Rolling Ball 151
 A Bouncing Ball 152
 Creating an Animated Scene 155

6 Video 164

- Using Video 164
- How Video Works and Is Displayed 165
 - Analog Video* 166
 - Digital Video* 168
 - Displays* 170
- Digital Video Containers 173
 - Codecs* 174
 - Video Format Converters* 178
- Obtaining Video Clips 179
- Shooting and Editing Video 180
 - The Shooting Platform* 181
 - Storyboarding* 183
 - Lighting* 183
 - Chroma Keys* 184
 - Composition* 185
 - Titles and Text* 186
 - Nonlinear Editing (NLE)* 188

7 Making Multimedia 196

- The Stages of a Multimedia Project 196
- What You Need: The Intangibles 197
 - Creativity* 197
 - Organization* 198
 - Communication* 200
- What You Need: Hardware 200
 - Windows vs. Macintosh* 201
 - Connections* 203
 - Memory and Storage Devices* 205
 - Input Devices* 209
 - Output Devices* 210
- What You Need: Software 212
 - Text Editing and Word Processing Tools* 214
 - OCR Software* 215
 - Painting and Drawing Tools* 216
 - 3-D Modeling and Animation Tools* 218
 - Image-Editing Tools* 220
 - Sound-Editing Tools* 221
 - Animation, Video, and Digital Movie Tools* 221
 - Helpful Accessories* 222
- What You Need: Authoring Systems 222
 - Helpful Ways to Get Started* 223
 - Making Instant Multimedia* 224
 - Types of Authoring Tools* 227
 - Objects* 230
 - Choosing an Authoring Tool* 231

8 Multimedia Skills 240

- The Team 241
 - Project Manager* 241
 - Multimedia Designer* 243
 - Interface Designer* 245
 - Writer* 246
 - Video Specialist* 248
 - Audio Specialist* 250
 - Multimedia Programmer* 251
 - Producer of Multimedia for the Web* 253
- The Sum of Parts 254

9 Planning and Costing 260

- The Process of Making Multimedia 260
 - Idea Analysis* 262
 - Pretesting* 266
 - Task Planning* 266
 - Prototype Development* 268
 - Alpha Development* 271
 - Beta Development* 271
 - Delivery* 271
- Scheduling 273
- Estimating 274
 - Billing Rates* 277
- RFPs and Bid Proposals 280
 - The Cover and Package* 286
 - Table of Contents* 286
 - Needs Analysis and Description* 286
 - Target Audience* 287
 - Creative Strategy* 287
 - Project Implementation* 287
 - Budget* 287

10 Designing and Producing 294

- Designing 295
 - Designing the Structure* 296
 - Designing the User Interface* 308
 - A Multimedia Design Case History* 314
- Producing 318
 - Starting Up* 319
 - Working with Clients* 320
 - Tracking* 321
 - Copyrights* 321
 - Hazards and Annoyances* 322

11 Content and Talent 330

- Acquiring Content 331
 - Using Content Created by Others* 332
- Ownership of Content Created for a Project 343
- Acquiring Talent 347
 - Locating the Professionals You Need* 348
 - Working with Union Contracts* 349
 - Acquiring Releases* 351

12 The Internet and Multimedia 358

- Internet History 359
- Internetworking 360
 - Internet Addresses* 361
 - Connections* 365
 - The Bandwidth Bottleneck* 365
 - Internet Services* 367
 - MIME-Types* 369
 - The World Wide Web and HTML* 372
- Multimedia on the Web 374
 - Tools for the World Wide Web* 374
 - Web Servers* 375
 - Web Browsers* 376
 - Search Engines* 377
 - Web Page Makers and Site Builders* 377
 - Plug-ins and Delivery Vehicles* 381
 - Beyond HTML* 383

13 Designing for the World Wide Web 392

- Developing for the Web 392
 - HTML Is a Markup Language* 393
 - The Desktop Workspace* 396
 - The Small-Device Workspace* 396
 - Nibbling* 397
- Text for the Web 398
 - Making Columns of Text* 398
 - Flowing Text Around Images* 400

- Images for the Web 402
 - GIF and PNG Images* 402
 - JPEG Images* 403
 - Using Photoshop* 405
 - Backgrounds* 409
 - Clickable Buttons* 411
 - Client-Side Image Maps* 411
- Sound for the Web 413
- Animation for the Web 413
 - GIF89a* 413
- Video for the Web 414
 - Plug-ins and Players* 415

14 Delivering 422

- Testing 423
 - Alpha Testing* 423
 - Beta Testing* 423
 - Polishing to Gold* 425
- Preparing for Delivery 425
 - File Archives* 427
- Delivering on CD-ROM 429
 - Compact Disc Technology* 429
 - Compact Disc Standards* 431
- Delivering on DVD 434
 - DVD Standards* 436
- Wrapping It Up 436
- Delivering on the World Wide Web 438

Appendix 446

- System Requirements 446
- Installing and Running
 - CD Software and Features 448
- Help 449
- Removing MasterExam 449
- McGraw-Hill Technical Support 449
- LearnKey Technical Support 449
- Trial Software Technical Support 449

Index 450

Acknowledgments

This eighth edition of *Multimedia: Making It Work* includes the cumulated input and advice of many colleagues and friends over a twenty-year period. Each time I revise and update this book, I am pleased to see that the acknowledgments section grows. Indeed, it is difficult to delete people from this (huge) list because, like the stones of a medieval castle still occupied, new and revised material relies upon the older foundation. I will continue accumulating the names of the good people who have helped me build this edifice and list them here, at least until my publisher cries “Enough!” and provides substantial reason to press the DELETE key.

At McGraw-Hill, Meghan Riley was instrumental in producing this eighth edition. Molly Sharp from ContentWorks did the layout, Melinda Lytle oversaw graphic quality, and Bob Campbell and Paul Tyler copy-edited and proofread, respectively. As technical editor for this edition, Brad Borch helped to bring current the detailed descriptions of the many elements of multimedia that are discussed in the book.

In past editions, Tim Green, Jennifer Housh, Jody McKenzie, Julie Smith, Jimmie Young from Tolman Creek Design, Joe Silverthorn, Chris Johnson, Jennie Yates, John and Kathryn Ross, Madhu Prasher, Frank Zurbano, Judith Brown, Athena Honore, Roger Stewart, Alissa Larson, Cindy Wathen, Eileen Corcoran, Megg Bonar, Robin Small, Lyssa Wald, Scott Rogers, Stephane Thomas, Bob Myren, Heidi Poulin, Mark Karmendy, Joanne Cuthbertson, Bill Pollock, Jeff Pepper, Kathy Hashimoto, Marla Shelasky, Linda Medoff, Valerie Robbins, Cindy Brown, Larry Levitsky, Frances Stack, Jill Pisoni, Carol Henry, and Linda Beatty went out of their way to keep me on track. Chip Harris, Donna Booher, Takis Metaxas, Dan Hilgert, Helayne Waldman, Hank Duderstadt, Dina Medina, Joyce Edwards, Theo Posselt, Ann Stewart, Graham Arlen, Kathy Gardner, Steve Goeckler, Steve Peha, Christine Perey, Pam Sansbury, Terry Schussler, Alden Trull, Eric Butler, and Michael Allen have contributed to making the work more complete since its first edition.

Since the fifth edition, peer reviewers Sandi Watkins, Dana Bass, David Williams, Joseph Parente, Elaine Winston, Wes Baker, Celina Byers, Nancy Doubleday, Tom Duff, Chris Hand, Scott Herd, Kenneth Hoffman, Sherry Hutson, Judith Junger, Ari Kissiloff, Peter Korovessis, Sallie Kravetz, Jeff Kushner, Theresa McHugh, Ken Messersmith, Marianne Nilsson, Lyn Pemberton, Samuel Shiffman, and Dennis Woytek have added significant structure to the book’s foundation.

I would also like to acknowledge many friends in the computer and publishing industries who continue to make this book possible. They send me quotes and multimedia anecdotes to enliven the book; many arranged for me to review and test software and hardware; many have been there when I needed them. Some from editions past have changed companies or left the industry; my friend Dana Atchley, the well-known digital storyteller, has died. Whole companies in the list below have died, too, since the first edition of this book, but their discorporation is mourned differently from the heartfelt loss of the real people and real creators who launched the information age. I would like to thank them all for the time and courtesy they have afforded me on this long-legged project:

Grace Abbett, Adobe Systems
Jennifer Ackman, Edelman Worldwide
Eric Alderman, HyperMedia Group
Heather Alexander, Waggener Edstrom
Laura Ames, Elgin/Syferd PR
Kurt Andersen, Andersen Design
Ines Anderson, Claris
Travis Anton, BoxTop Software
David Antoniuk, Live Oak Multimedia
Yasemin Argun, Corel Systems
Cornelia Atchley, Comprehensive Technologies
Dana Atchley, Network Productions
Pamela Atkinson, Pioneer Software
Paul Babb, Maxon Computer

Ann Bagley, Asymetrix
Patricia Baird, *Hypermedia Journal*
Gary Baker, Technology Solutions
Richard Bangs, Mountain Travel-Sobek
Sean Barger, Equilibrium
Jon Barrett, Dycam
Kathryn Barrett, O’Reilly & Associates
Heinz Bartsch, The Search Firm
Bob Bauld, Bob Bauld Productions
Thomas Beinar, Add-On America/Rohm
Bob Bell, SFSU Multimedia Studies Program
George Bell, Ocron
Mike Bellefeuille, Corel Systems
Andrew Bergstein, Altec Lansing
Kathy Berlan, Borland International

Camarero Bernard, mFactory
Brian Berson, Diamondsoft
Bren Besser, Unlimited Access
Time Bigoness, Equilibrium
Ken Birge, Weber Shandwick
Nancy Blachman, Variable Symbols
Dana Blankenhorn, Have Modem Will Travel
Brian Blum, The Software Toolworks
Sharon Bodenschatz, International Typeface
Michele Boeding, ICOM Simulations
Donna Booher, Timestream
Gail Bower, TMS
Kellie Bowman, Adobe Systems
Susan Boyer, Blue Sky Software
Deborah Brown, Technology Solutions

Eric Brown, *NewMedia Magazine*
Russell Brown, Adobe Systems
Tiffany Brown, Network Associates
Stephanie Bryan, SuperMac
Ann Marie Buddrus, Digital Media Design
David Bunnell, *NewMedia Magazine*
Jeff Burger, Creative Technologies
Steven Burger, Ricoh
Bridget Burke, Gryphon Software
Dominique Busso, OpenMind
Ben Calica, Tools for the Mind
Doug Campbell, Spinnaker Software
Teri Campbell, MetaCreations
Doug Camplejohn, Apple Computer
Norman Cardella, Best-Seller
Tim Carrigan, Multimedia Magazine
Mike Childs, Global Mapper Software
Herman Chin, Computer Associates International
Curtis Christiansen, Deneba Software
Jane Chuey, Macromedia
Angie Ciaroni, Hayes
Kevin Clark, Strata
Cathy Clarke, DXM Productions
Regina Coffman, Smith Micro
Frank Colin, Equilibrium
David Collier, decode communications
Kelly Anne Connors, Alien Skin
David Conti, AimTech
Freda Cook, Aldus
Renee Cooper, Miramar Systems
Wendy Cornish, Vividus
Patrick Crisp, Caere
Michelle Cunningham, Symantec
Lee Curtis, CE Software
Eric Dahlinger, Newer Technology
Kirsten Davidson, Autodesk
John deLorimier, Kallisto Productions
John Derryberry, A&R Partners/Adobe Systems
Jeff Dewey, Luminaria
Jennifer Doettling, Delta Point
Sarah Duckett, Sonic Solutions
Hank Duderstadt, Timestream
Mike Duffy, The Software Toolworks
Eileen Ebner, McLean Public Relations
Dawn Echols, Oracle
Dorothy Eckel, Specular International
Joyce Edwards, Timestream
Kevin Edwards, c|net
Mark Edwards, Independent Multimedia Developer
Dan Elenbaas, Amaze!
Ellen Elias, O'Reilly & Associates
Shelly Ellison, Tektronix
Heidi Elmer, Sonic Foundry
Kathy Englar, RayDream

Jonathan Epstein, MPC World
Jeff Essex, Audio Synchrony
Sharron Evans, Graphic Directions
Kiko Fagan, Attorney at Law
Joe Fantuzzi, Macromedia
Lee Feldman, Voxware
Laura Finkelman, S & S Communications
Holly Fisher, MetaTools
Sean Flaherty, Nemetschek/VectorWorks
Terry Fleming, Timeworks
Patrick Ford, Microsoft
Marty Fortier, Prosonus
Robin Galipeau, Mutual/Hadwen Imaging
Kathy Gardner, Gardner Associates
Peter Garipey, Zedcor
Bill Gates, Microsoft
Petra Gerwin, Mathematica
John Geyer, Terran Interactive
Jonathan Gibson, Form and Function
Brittany Gidican, Edelman
Karen Giles, Borland
Amanda Goodenough, AmandaStories
Danny Goodman, Concentrics Technology
Howard Gordon, Xing Technology
Jessica Gould, Corel
Jonathan Graham, Iomega
Catherine Greene, LightSource
Fred Greguras, Fenwick & West
Maralyn Guarino, Blue Sky Software
Cari Gushiken, Copithorne & Bellows
Kim Haas, McLean Public Relations
Marc Hall, Deneba Software
Johan Hamberg, Timestream
Lynda Hardman, CWI - Netherlands
Tom Hargadon, Conference Communications
Chip Harris, InHouse Productions
Scott Harris, Chief Architect
Sue Hart, FileMaker
Robin Harwood, Maritime Energy
Trip Hawkins, 3DO/Electronic Arts
Randy Haykin, Apple Computer
Jodi Hazzan, SoftQuad
Ray Heizer, Heizer Software
Dave Heller, Salient Software
Josh Hendrix, CoSA
Maria Hermanussen, Gold Disk
Allan Hessenflow, HandMade Software
Lars Hidde, The HyperMedia Group
Erica Hill, Nuance
Dave Hobbs, LickThis
Petra Hodges, Mathematica
Kerry Hodgins, Corel
John Holder, John V. Holder Software
Elena Holland, Traveling Software
Mike Holm, Apple Computer
Robert Hone, Red Hill Studios

Kevin Howat, MacMillan Digital
Joy Hsu, Sonnet Technologies
Tom Hughes, PhotoDisc
Claudia Husemann, Cunningham Communications
Les Inanchy, Sony CD-ROM Division
Tom Inglesby, Manufacturing Systems
Carl Jaffe, Yale University School of Medicine
Farrah Jinha, Vertigo 3D
Cynthia Johnson, BoxTop Software
Scott Johnson, NTERGAID
JoAnn Johnston, Regis McKenna
Neele Johnston, Autodesk
Jedidah Karanja, Genealogy.com
Dave Kaufer, Waggener Edstrom
David Kazanjian, AFTRA Actor
Jenna Keller, Alexander Communications
Helen Kendrick, Software Publishing
Benita Kenn, Creative Labs
Duncan Kennedy, Tribeworks
Trudy Kerr, Alexander Communications
Gary Kevorkian, ULead Systems
Deirdre Kidd, Nemetschek
David Kleinberg, NetObjects
Jeff Kleindinst, Turtle Beach Systems
Kevin Klingler, Sonic Desktop Software
Sharon Klocek, Visual In-Seitz
Christina Knighton, Play Incorporated
Lewis Kraus, InfoUse
Katrina Krebs, Micrografx
Kevin Krejci, Pop Rocket
Bob Kremers, Waggoner Edstrom
Larry Kubo, Ocron
Jennifer Kuhl, Peppercom
Howard Kwak, Multimedia SourceBook
Irving Kwong, Waggener Edstrom
Craig LaGrow, *Morph's Outpost*
Lisa Lance, Vectorworks
Kimberly Larkin, Alexander Communications
Kevin LaRue, Allegiant Technologies
Mark Law, Extensis
Nicole Lazzaro, ONYX Productions
Dick Lehr, Boston University
Alan Levine, Maricopa Community Colleges
Bob LeVitus, LeVitus Productions
Steven Levy, *MacWorld*
Kitten Linderman, LaserSoft Imaging
Leigh-Ann Lindsey, Mathematica
Rob Lippincott, Lotus
Mark Lissick, C-Star Technology
Jason Lockhart, G3 Systems
Elliot Luber, Technology Solutions
David Ludwig, Interactive Learning Designs

Kirk Lyford, Vivid Details
 Jennifer Lyng, Aladdin Systems
 John MacLeod, FastForward
 Philip Malkin, Passport Designs
 Kevin Mallon, FileMaker
 Basil Maloney, Winalysis
 Kathy Mandle, Adobe Systems
 Audrey Mann, Technology Solutions
 Lisa Mann, O'Reilly & Associates
 Brent Marcus, Bender/Helper Impact
 Nicole Martin, Netopia/Farallon Division
 Jim Matthews, Fetch Software
 Robert May, Ikonic
 Georgia McCabe, Applied Graphics Technologies
 Rod McCall, Runtime Revolution
 Russ McCann, Ares Software
 Kevin McCarthy, Medius IV
 Charles McConathy, MicroNet Technology
 Carol McGarry, Schwartz Communications
 Peter McGill, Pilot and Photographer
 Laurie McLean, McLean Public Relations
 Amy McManus, Delta Point
 Bert Medley, *The NBC Today Show*
 Art Metz, Metz
 Steve Michel, Author
 Aline Mikaelian, Screenplay Systems
 Nancy Miller, Canto Software
 Doug Millison, Morph's Outpost
 Karen Milne, Insignia Solutions
 Brian Molyneaux, Heizer Software
 Molly Morelock, Macromedia
 Jeff Morgan, Radmedia
 Rob Morris, VGraph
 Glenn Morrissey, Asymetrix
 Terry Morse, Terry Morse Software
 Brendan Mullin, Peppercom
 Rachel Muñoz, Caere
 Philip Murray, Knowledge Management Associates
 Heather Nagey, LiveCode/RunRev
 Chuck Nakell, Inspiration Software
 Kee Nethery, Kagi Engineering
 Chris Newell, Musitek
 Mark Newman, Photographer
 Wendy Woods Newman, *Newsbytes*
 Terry Nizko, AimTech
 Glenn Ochsenreiter, MPC Marketing Council
 Maureen O'Connell, Apple Computer
 Jim O'Gara, Altsys
 Eric Olson, Virtus
 Karen Oppenheim, Cunningham Communications
 Kim Osborne, Symantec
 Nicole DeMeo Overson, GoLive Systems

Andy Parnig, PixoArts
 David Pawlan, Timestream
 Naomi Pearce, Bare Bones Software
 Susan Pearson, Waggener Edstrom
 Lorena Peer, Chroma Graphics
 Steve Peha, Music Technology Associates
 Sylvester Pesek, Optical Media International
 Christiane Petite, Symantec
 Paul Phelan, INESC (Portugal)
 Michael Pilmer, Alien Skin
 Scott Pink, Bronson
 Audrey Pobre, Quarterdeck
 Dave Pola, Equilibrium
 JB Popplewell, Alien Skin Software
 Melissa Rabin, Miramar
 Shirley Rafieetary, Medius IV
 Tom Randolph, FM Towns/Fujitsu
 Steven Rappaport, Interactive Records
 Ronelle Reed, Switzer Communications
 David Reid, Author
 Diane Reynolds, Graphsoft
 Laurie Robinson, Gold Disk
 Chuck Rogers, MacSpeech
 Connie Roloff, Software Products International
 John Rootenberg, Paceworks
 Amedeo Rosa, Alien Skin Software
 Upasana Nattoji Roy, SWITCH!
 Steve Rubenstein, *San Francisco Chronicle*
 Jill Ryan, McLean Public Relations
 Marie Salerno, AFTRA/SAG
 John Sammis, DataDescription
 Jay Sandom, Einstein & Sandom
 Pam Sansbury, Disc Manufacturing
 Richard Santalesa, R&D Technologies
 Anne Sauer, Fast Electronic U.S.
 Joe Scarano, DS Design
 Sonya Schaefer, Adobe Systems
 Rochelle Schiffman, Electronics for Imaging
 Rachel Schindler, Macromedia
 Melissa Scott, Window Painters
 Sandy Scott, Soft-Kat
 Brigid Sealy, INESC (Portugal)
 Karl Seppala, Gold Disk
 Chip Shabazian, Ocron
 Ashley Sharp, Virtus
 Philip Shaw, CodeStyle
 Elizabeth Siedow, Macromedia
 Adam Silver, Videologic
 Stephanie Simpson, Adaptex
 Marlene Sinicki, Designer
 Chris Smith, VideoLabs
 Brian Snook, Visual In-Seitz
 Kent Sokoloff, Timestream

Simone Souza, Roxio
 David Spitzer, Hewlett-Packard
 Chris Sprigman, King & Spalding
 Domenic Stansberry, Author
 Ann Stewart, Interactive Dimensions
 Polina Sukonik, Xaos Tools
 Lisa Sunaki, Autodesk
 Lee Swearingen, DXM Productions
 Joe Taglia, Insignia Solutions
 Meredith Taitz, Bare Bones Software
 Marty Taucher, Microsoft
 Bill Tchakirides, U-Design Type Foundry
 Toni Teator, NetObjects
 Amy Tenderich, Norton-Lambert
 Lori Ternacole, SoftQuad
 Dave Terran, WordPerfect
 Leo Thomas, Eastman Kodak
 Terry Thompson, Timestream
 Bill Thursby, Thursby Software Systems
 Alexandra Todd, McLean Public Relations
 Kim Tompkins, Micrografx
 Tom Toperczer, Imspace Systems
 Cara Ucci, Autodesk
 Ross Uchimura, GC3
 Jane Van Saun, Scansoft
 David Vasquez, SFU Multimedia Studies Program
 Sally von Barga, 21st Century Media
 Dan Wagner, Miramar Systems
 Helayne Waldman, SFU Multimedia Studies Program
 James J. Waldron, Visage
 Arnold Waldstein, Creative Labs
 Keri Walker, Apple Computer
 Brad Walter, Leister Productions
 Jon Ward, Tribeworks
 Stefan Wennik, Bitstream
 Chris Wheeler, TechSmith
 Tom White, Roland
 John Wilczak, HSC Software
 Darby Williams, Microsoft
 Laura Williams, Waggener Edstrom
 Mark Williams, Microsoft
 Shelly Williams, Prosonus
 Hal Wine, Programmer
 Sara Winge, O'Reilly & Associates
 Warren Witt, Thursby Software Systems
 Marcus Woehrmann, Handmade Software
 Sandy Wong, Fenwick & West
 Greg Wood, Corel
 Chris Yalonis, Passport Designs
 Alexandra Yessios, auto*des*sys
 Karl-Heinz Zahorsky, LaserSoft Imaging
 Barbara Zediker, Pioneer
 Frank Zellis, KyZen

ABOUT THIS BOOK

Important Multimedia Skills

Multimedia offers many career paths that can lead to occupations in such fields as graphic design, web design, animation, audio and video production, and project management. To become competent in any multimedia field, however, you need to learn the fundamental multimedia concepts first.

Multimedia: Making It Work builds a foundation for success in the discipline of multimedia by introducing you to the multimedia building blocks of text, images, sound, animation, and video while going one step further to develop an understanding of the process of making multimedia.

Learning Objectives set the goals of the chapter

Quote sidebars provide insight from experienced multimedia professionals

Notes, Tips and Warnings create a road map for success

Keywords, identified in red, point out important vocabulary and definitions you need to know

CHAPTER 4

Sound

In this chapter, you will learn how to:

- Describe the components and measurements of sound
- Use digital audio recording, processing, and editing software to understand its use
- Use MIDI to create and edit audio
- Compare and contrast the use of MIDI and digitized audio in a multimedia production
- List the important steps and considerations in recording and editing digital audio
- Determine which audio file formats are best used in a multimedia project
- Cite the considerations involved in managing audio files and integrating them into multimedia projects

The Power of Sound

When something vibrates in the air by moving back and forth (such as the cone of a loudspeaker), it creates waves of pressure. These waves spread like the ripples from a pebble tossed into a still pool, and when they reach your eardrums, you experience the changes of pressure, or vibrations, as sound. In air, the ripples propagate at about 750 miles per hour, or Mach 1 at sea level. Sound waves vary in sound pressure level (amplitude) and in frequency or pitch. Many sound waves mixed together form an audio sea of symphonic music, speech, or just plain noise.

Acoustics is the branch of physics that studies sound. When you quadruple the sound output power, there is only a 6 dB increase; when you make the sound 100 times more intense, the increase in dB is not hundredfold, but only 20 dB. A logarithmic scale (seen below) makes sense because humans perceive sound pressure levels over an extraordinarily broad dynamic range.

Sound pressure levels are measured in **decibels (dB)**; a decibel measurement is usually the ratio between a chosen reference point on a logarithmic scale and the level that is being measured. A logarithmic scale is also used for measuring the power of earthquakes (the Richter Scale) and stellar magnitudes (a first magnitude star is as bright as a second magnitude star is 100 times as bright).

Engaging and Motivational—The author explains technical concepts in a clear and interesting way using real-world examples.

78 Multimedia: Making It Work

transformations. Morphing (see Figure 3-6) allows you to smoothly blend two images so that one image seems to melt into the next, often producing some amusing results.

Figure 3-6 Morphing software was used to seamlessly transform the images of 16 youngsters. When a sound track of music and voices was added to the four-minute piece, it made a compelling video about how similar children are to each other.

Image-editing programs may, indeed, represent the single most significant advance in computer image processing during the late 1980s, bringing an amazing power to PC desktops. Such tools are indispensable for efficient multimedia production.

TIP When you start a color or gray-scale bitmap from the Macintosh to Windows, the colors seem darker and richer, even though they have precisely the same red, green, and blue (RGB) values. In some cases, this may improve the look of your images. In other cases you will want to first lighten (increase the brightness and contrast) of the Macintosh bitmap before bringing it to Windows.

Scanning Images After poring through countless clip art collections, you still haven't found the unusual background you want for a screen about gardening. Sometimes when you search for something too hard, you don't realize that it's right in front of you. Everyday objects can be scanned and manipulated using image-editing tools, such as those described in the preceding section, to create unusual, attention-getting effects. For example, to

We have to keep a keen eye on the details when doing our work, because we are actually using them. For instance, when doing our Halloween pages, we used a very cool pumpkin background that was beautifully saturated on the Mac side. On Windows, though, it was way too dark, and you couldn't read the overlying text. We had to lighten the GIF on the Mac side a few times before using it cross-platform.

Rich Santalea, Editor, *NorQuest Magazine*

Makes Learning Fun!—Rich, colorful text and artwork bring multimedia techniques and technologies to life.

Proven Learning Method Keeps You on Track

Multimedia: Making It Work is structured to give you a comprehensive understanding of multimedia tools, technologies, and techniques. The book's active learning methodology guides you beyond mere recall and through thought-provoking sidebars, essay topics, and lab projects. It is designed to foster your creativity and the development of critical-thinking and communication skills.

Effective Learning Tools

This feature-rich book is designed to make learning easy and enjoyable as you develop the skills and abilities that will aid you in your multimedia education and career. Woven directly into the text are the author's own personal insights gained

from more than 20 years in the multimedia industry. This expertise, combined with a personal and humorous style, makes learning interesting, motivational, and fun.

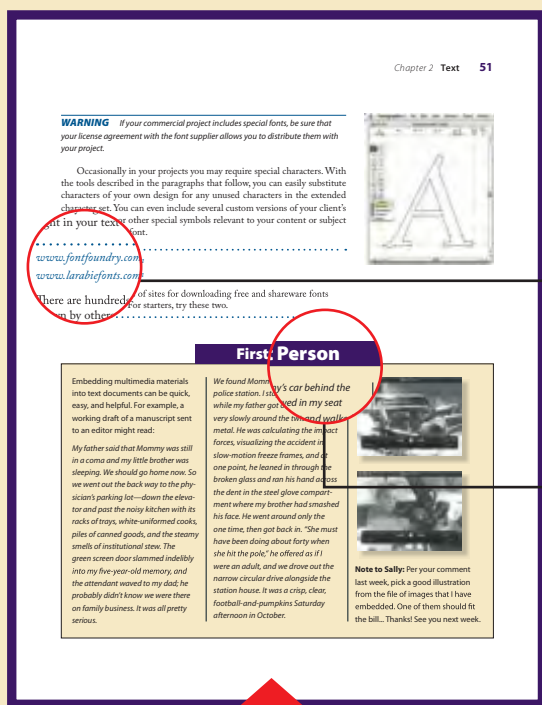

Provides Professional Insight— Quotes from experts in the field and notes from the author put key concepts into the context of real-world situations.

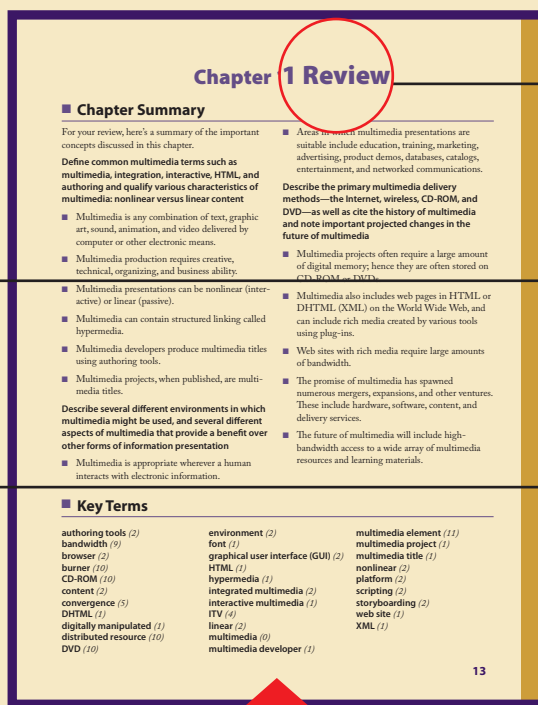

Robust Learning Tools— Summaries, key terms lists, quizzes, essay questions, and lab projects help you practice skills and measure progress.

Chapter Review sections provide concept summaries and key term lists, as well as questions and projects

Suggested Resources point to web sources to aid you in the creation and development of multimedia projects

First Person notes employ the author's personal experiences to emphasize key points

Each chapter includes:

- **Learning objectives** that set measurable goals for chapter-by-chapter progress
- Full-color **artwork** that provides step-by-step illustrations of techniques, making difficult concepts easy to visualize and understand
- Shared personal expertise from experts in the field in the form of **First Person** notes, sidebar **quotes**, **Vaughan's Laws** and **Vaughan's Rules**
- **Notes, Tips, and Warnings** that highlight important concepts and guide you through difficult areas
- **Highlighted Key Terms, Key Terms lists, and Chapter Summaries** that provide you with an easy way to review important concepts and vocabulary
- **Challenging End-of-Chapter Quizzes** that include vocabulary-building exercises, multiple-choice questions, essay questions, and on-the-job lab projects

Introduction

Since the first edition of this book in 1992, it has been necessary to update its content every few years. In writing this eighth edition, it has become clear that changes in multimedia tools, technologies, and delivery platforms are occurring at an increasingly rapid pace. Indeed, the rate of change itself seems exponential as new ideas and new applications of multimedia are born, gain traction, and then bear yet newer ideas in often unpredictable and immediate follow-ons. Overnight, words like “tweet” and “mashup” enter the lexicon and explode through the Internet into common usage. With cloud computing and ever-more powerful browsers, cross-platform difficulties among Windows, Mac, and Linux systems are diminished. With new mechanical designs, new tools are invented: “spudgers” are as necessary now as screwdrivers in the world of computer and electronic gear repair.

This “Black Stick” opens Apple iPhones and iPods, Mac Laptops and Desktops. Also used to open MP3/MP4 Players, Mobile Phones, Laptops, PCs, and any other Electronic Device. Will not scratch surfaces. Temperature resistant. Flat (screwdriver) end for spudging wire leads. Notch end for hooking and pulling wires or components. Pointed end used to form leads, probe, point, and hold objects for soldering. 6" long.



Spudger: Three Tools In One!

Happily for the longevity of this book, the fundamental concepts and techniques required to work with the elements of multimedia remain unchanged, and there are serious learning curves to climb before you can make your multimedia-capable computer stand up and dance!

This is a book about the basic parts of multimedia as much as about how to sew these parts together with current technology and tools. It is a book that shows you how to use text, images, sound, and video to deliver your messages and content in meaningful ways. It is about designing, organizing,

and producing multimedia projects of all kinds and avoiding technical and legal pitfalls along the way. Above all, it is a practical guide to making multimedia, complete with keywords, quizzes, exercises, tips, pointers, and answers.

The first part deals with the basic elements of multimedia and the skills required to work with them. Hardware and software tools are described in detail. You will learn about the importance of text and how to make characters look pretty, about making graphic art on your computer and how to choose colors, and about how to digitize sound and video segments. You will learn about human interaction and how to design a user-friendly computer interface. Then you will be introduced to the step-by-step creative and organizing process that results in a finished multimedia project. Today, the fastest moving wavefront in multimedia may be seen on the Internet, so I have updated and enlarged the chapters about designing, creating, and delivering multimedia for the Web and for Internet-connected multimedia devices such as mobile phones, e-books, and PDAs.

I have written this book for people who make or want to make multimedia, for people who gladly take up new challenges and are unafraid of intensely creative work. The words and ideas of this book are the harvest of many years in the computer industry and of hands-on experience deep in the factory where multimedia is being made. The book is intended to be, above all, useful.

I have made a great effort to include in this book references to as much multimedia software and hardware as I could, trying not to miss any players. But because the industry is fast paced and rapidly evolving, and because, while writing this book, I have rediscovered the finite limits of my own time, I am sure some have fallen into the bit bucket anyway. Immutable physical laws have prevented me from including the fine details of 40 or 50 hardware and software manuals and technical resources into the pages allowed for this book. The distillation presented here should, however, point you toward further information and study. I have also made a great effort to double-check my words and statements for accuracy; if errors have slipped past, they are mine alone.

Two decades ago, people’s experience on the information highway was a smooth ride paved with behavioral etiquette and with many kindnesses evolved from properly socialized dot-EDU users. Commerce was prohibited. Discourse and idea exchange through e-mail and newsgroups was encouraged. Language shortcuts such as IMHO (In My Humble Opinion) and smiley faces were de jure. RTFM was reserved for only the most surly.

Who could have predicted the impact of commerce, when the dot-com top-level-domain was opened for business? Well, Adam Smith's free hand of capitalism is at work, straining First Amendment rights to free speech and inciting road rage on the information highway. Now you can buy a million e-mail addresses, and if only half a percent of recipients respond to your body part enhancement, vitamin, or mortgage rate spam, you can make a fortune. Not only are computer platforms and multimedia implements changing, so is our notion of etiquette. With the tools described in this book, you will be able to shape the very nature of information and how it is accessed and presented, and you will invent the future. Remember to be polite: some people suggest that if you go flying back through time and you see somebody else flying forward into the future, it's probably best to avoid eye contact.

Some years ago, after completing a book about HyperCard, I swore never to write another. Writing a book is much like childbirth, I believe. In the beginning, it gestates slowly, usually over a few months. Then it ramps up inexorably and quickly toward deadline, until all attention is focused upon the delivery itself, and the pain and workload are great. Editors cry, "Push." Afterwards, you remember it was rough, but memories of the pain itself become diffused, and one is only too easily persuaded to do it again. I am glad to share my multimedia experiences with you, and hope that in reading this book you will become better at what you do.

Tay Vaughan
Appleton, Maine
November 2010

INSTRUCTOR AND STUDENT WEB SITE

For instructor and student resources, check out www.Vaughanmultimedia8e.com.

Additional Resources for Students

The Student Edition of the web site includes all of the textbook's learning objectives and multiple-choice questions by chapter. The multiple-choice questions can be taken electronically as quizzes, with the results submitted to the instructor.

Additional Resources for Instructors

Instructor support materials, organized the same way as the textbook, are provided on the Instructor Edition of the site. This edition of the site includes the following:

- Answer keys to the end-of-chapter activities in the textbook
- Instructor's Manual that contains learning objectives, classroom preparation notes, instructor tips, and a lecture outline for each chapter
- Engaging PowerPoint slides on the lecture topics with full-color artwork from the book
- Access to EZ Test online and test files that allow you to generate a wide array of tests (features automatic grading)
- EZ Test features hundreds of practice questions and a wide variety of question types and difficulty levels, enabling you to customize each test to maximize student progress
- LMS cartridges and other formats may also be available upon request; contact your sales representative

Contributors to the Instructor Resources

Brad Borch
President,
Activa Digital Media Design

Laura Osterweis
Assistant Professor,
Communication Arts Department,
Framingham State University

What Is Multimedia?

In this chapter, you will learn how to:

- Define common multimedia terms such as multimedia, integration, interactive, HTML, and authoring and qualify the characteristics of multimedia: nonlinear versus linear content
- Describe several different environments in which multimedia might be used, and several different aspects of multimedia that provide a benefit over other forms of information presentation
- Describe the primary multimedia delivery methods—the Internet, wireless, CD-ROM, and DVD—as well as cite the history of multimedia and note important projected changes in the future of multimedia

MULTIMEDIA is an eerie wail as two cat's eyes appear on a dark screen. It's the red rose that dissolves into a little girl's face when you press "Valentine's Day" on your iPhone. It's a small window of video laid onto a map of India, showing an old man recalling his dusty journey to meet a rajah there. It's an e-catalog of hybrid cars with a guide to help you buy one. It's a real-time video conference with colleagues in Paris, London, and Hong Kong, using whiteboards, microphones, and question techniques (see www.webtrain.com) on your office computer. At home, it's an interactive geometry lesson for a fifth-grader. At the arcade, it's goggle-faced kids flying fighter planes in sweaty, virtual reality. On a DVD, it's the interactive video sequence (or screen hot spots) that explain how the Harry Potter movie was made—all using your remote control.

Multimedia is any combination of text, art, sound, animation, and video delivered to you by computer or other electronic or digitally manipulated means. It is richly presented sensation. When you weave together the sensual elements of multimedia—dazzling pictures and animations, engaging sounds, compelling video clips, and raw textual information—you can electrify the thought and action centers of people's minds. When you give them interactive control of the process, they can be enchanted.

This book is about creating each of the elements of multimedia and about how you can weave them together for maximum effect. This book is for computer beginners as well as computer experts. It is for serious multimedia producers—and for their clients as well. It is for desktop publishers and video producers who may need a leg-up as they watch traditional methods for delivery of information and ideas evolve into new, technology-driven formats. This book is also for hobbyists, who want to make albums and family histories on the World Wide Web; for mainstream businesses, where word-processed documents and spreadsheets are illustrated with audio, video, and graphic animations; for public speakers, who use animation and sound on large monitors and auditorium projection systems to present ideas and information to an audience; for information managers, who organize and distribute digital images, sound, video, and text; and for educators and trainers, who design and present information for learning.

If you are new to multimedia and are facing a major investment in hardware, software, and the time you will need to learn each new tool, take a gradual approach to these challenges. Begin by studying each element of

multimedia and learning one or more tools for creating and editing that element. Get to know how to use text and **fonts**, how to make and edit colorful graphic images and animate them into movies, and how to record and edit digital sound. Browse the computer trade periodicals that contain the most up-to-date information. Your skills will be most valuable if you develop a broad foundation of knowledge about each of the basic elements of multimedia.

Producing a multimedia project or a **web site** requires more than creative skill and high technology. You need organizing and business talent as well. For example, issues of ownership and copyright will be attached to some elements that you wish to use, such as text from books, scanned images from magazines, or audio and video clips. The use of these resources often requires permission, and even payment of a fee to the owner. Indeed, the management and production infrastructure of a multimedia project may be as intense and complicated as the technology and creative skills you bring to bear in rendering it. Keys to successful development of a multimedia project are management of digital tools and skill sets, teamwork, general project management, documenting and archiving the process, and delivering the completed product on time and within budget.

Definitions

Multimedia is, as described previously, a woven combination of **digitally manipulated** text, photographs, graphic art, sound, animation, and video elements. When you allow an end user—also known as the viewer of a multimedia project—to control what and when the elements are delivered, it is called **interactive multimedia**. When you provide a structure of linked elements through which the user can navigate, interactive multimedia becomes **hypermedia**.

Although the definition of multimedia is a simple one, making it work can be complicated. Not only do you need to understand how to make each multimedia element stand up and dance, but you also need to know how to use multimedia computer tools and technologies to weave them together. The people who weave multimedia into meaningful tapestries are called **multimedia developers**.

The software vehicle, the messages, and the content presented on a computer, television screen, PDA (personal digital assistant), or mobile phone together constitute a **multimedia project**. If the project is to be shipped or sold to consumers or end users, typically delivered as a download on the Internet but also on a CD-ROM or DVD in a box or sleeve, with or without instructions, it is a **multimedia title**. Your project may also be a page or site on the World Wide Web, where you can weave the elements of multimedia into documents with **HTML** (Hypertext Markup Language) or **DHTML** (Dynamic Hypertext Markup Language) or **XML** (eXtensible Markup Language) and play rich media files created in such

The implementation of multimedia capabilities in computers is just the latest episode in a long series: cave painting, hand-crafted manuscripts, the printing press, radio, and television. . . . These advances reflect the innate desire of man to create outlets for creative expression, to use technology and imagination to gain empowerment and freedom for ideas.

Glenn Ochsenreiter, Director,
Multimedia PC Council

Multimedia is a very effective presentation and sales tool. If you're being driven somewhere in the back seat of a car, you may not remember how you got to your destination. If you had been driving the car yourself, chances are you could get there again. Studies indicate that if you're stimulated with audio, you will have about a 20 percent retention rate. With audio-visual, retention is up to 30 percent and in interactive multimedia presentations, where you are really involved, the retention rate is as high as 60 percent.

Jay Sandom,
Einstein & Sandom

For viewers presented with graphics and words, not just words alone, there was a 23 percent increase in retention (ability to remember information) and an 89 percent increase in transfer (ability to creatively apply information).

From: *Multimedia Learning* by
Richard E. Mayer, Cambridge
University Press, 2001

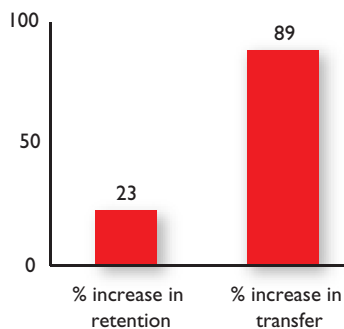

programs as Adobe's Flash, LiveMotion, or Apple's QuickTime by installing plug-ins into a **browser** application such as Internet Explorer, Safari, Google Chrome, or Firefox. Browsers are software programs or tools for viewing content on the Web. See Chapter 12 for more about plug-ins, multimedia, and the Web.

A multimedia project need not be interactive to be called multimedia: users can sit back and watch it just as they do a movie or the television. In such cases a project is **linear**, or starting at the beginning and running through to the end. When users are given navigational control and can wander through the content at will, multimedia becomes **nonlinear** and user interactive, and is a powerful personal gateway to information.

Determining how a user will interact with and navigate through the **content** of a project requires great attention to the message, the **scripting** or **storyboarding**, the artwork, and the programming. You can break an entire project with a badly designed interface. You can also lose the message in a project with inadequate or inaccurate content.

Multimedia elements are typically sewn together into a project using **authoring tools**. These software tools are designed to manage individual multimedia elements and provide user interaction. **Integrated multimedia** is the "weaving" part of the multimedia definition, where source documents such as montages, graphics, video cuts, and sounds merge into a final presentation. In addition to providing a method for users to interact with the project, most authoring tools also offer facilities for creating and editing text and images and controls for playing back separate audio and video files that have been created with editing tools designed for these media. The sum of what gets played back and how it is presented to the viewer on a monitor is the **graphical user interface**, or GUI (pronounced "goey"). The GUI is more than just the actual graphics on the screen—it also often provides the rules or structure for the user's input. The hardware and software that govern the limits of what can happen here are the multimedia **platform** or **environment**.

Where to Use Multimedia

Multimedia is appropriate whenever a human user is connected to electronic information of any kind, at the "human interface." Multimedia enhances minimalist, text-only computer interfaces and yields measurable benefit by gaining and holding attention and interest; in short, multimedia improves information retention. When it's properly constructed, multimedia can also be profoundly entertaining as well as useful.

Multimedia in Business

Business applications for multimedia include presentations, training, marketing, advertising, product demos, simulations, databases, catalogs,

instant messaging, and networked communications. Voice mail and video conferencing are provided on many local and wide area networks (LANs and WANs) using distributed networks and Internet protocols.

After a morning of mind-numbing overhead presentations delivered from the podium of a national sales conference, a multimedia presentation can make an audience come alive. Most presentation software packages let you make pretty text and add audio and video clips to the usual slide show of graphics and text material.

Multimedia is enjoying widespread use in training programs. Flight attendants learn to manage international terrorism and security through simulation. Drug enforcement agencies of the UN are trained using interactive videos and photographs to recognize likely hiding places on airplanes and ships. Medical doctors and veterinarians can practice surgery methods via simulation prior to actual surgery. Mechanics learn to repair engines. Salespeople learn about product lines and leave behind software to train their customers. Fighter pilots practice full-terrain sorties before spooling up for the real thing. Increasingly easy-to-use authoring programs and media production tools even let workers on assembly lines create their own training programs for use by their peers.

Multimedia around the office has also become more commonplace. Image capture hardware is used for building employee ID and badging databases, scanning medical insurance cards, for video annotation, and for real-time teleconferencing. Presentation documents attached to e-mail and video conferencing are widely available. Laptop computers and high-resolution projectors are commonplace for multimedia presentations on the road. Mobile phones and personal digital assistants (PDAs) utilizing Bluetooth and Wi-Fi communications technology make communication and the pursuit of business more efficient.

As companies and businesses catch on to the power of multimedia, the cost of installing multimedia capability decreases, meaning that more applications can be developed both in-house and by third parties, which allow businesses to run more smoothly and effectively. These advances are changing the very way business is transacted by affirming that the use of multimedia offers a significant contribution to the bottom line while also advertising the public image of the business as an investor in technology.

Multimedia in Schools

Schools are perhaps the destination most in need of multimedia. Many schools in the United States today are chronically underfunded and occasionally slow to adopt new technologies, and it is here that the power of multimedia can be maximized for the greatest long-term benefit to all.

The U.S. government has challenged the telecommunications industry to connect every classroom, library, clinic, and hospital in America to

History has proven that advances in the way we communicate can give rise to entirely new communication cultures. Much like the transition from radio to TV, the evolution from text messaging to multimedia messaging (MMS) marks a whole new era of mobile communications, combining images with sound and text.

.....
Jorma Ollila,
Chairman and CEO of Nokia

Here, in the country that invented the Internet, every child should have the chance to get online.

.....
Barack Obama,
President of the United States



Figure 1-1 Multimedia e-learning is a powerful, convenient, and cost-effective tool for both instructors and students. From *Tintinalli's Emergency Medicine: A Comprehensive Study Guide, 6e*, available online at www.accessmedicine.com.

the information superhighway. Funded by telephone surcharges (eRate), most schools and libraries in America are now connected. Steps have also been taken to provide governmental support for state-of-the-art technology in low-income rural and urban school districts. The National Grid for Learning (NGfL) has established similar aims for schools in the United Kingdom.

Multimedia will provoke radical changes in the teaching process during the coming decades, particularly as smart students discover they can go beyond the limits of traditional teaching methods. There is, indeed, a move away from the transmission or passive-learner model of learning to the experiential learning or active-learner model. In some instances, teachers may become more like guides and mentors, or facilitators of learning, leading students along a learning path, rather than the more traditional role of being the primary providers of information and understanding. The students, not teachers, become the core of the teaching and learning process. E-learning is a sensitive and highly politicized subject among educators, so educational software is often positioned as “enriching” the learning process, not as a potential substitute for traditional teacher-based methods.

Figure 1-1 shows a selection of instructional videos used for training emergency medicine specialists. Such online e-learning provides a cost-effective vehicle to learn clinical techniques outside of the hospital setting. From real-time echocardiographic images to explanations of the chemistry of synaptic transmission, multimedia is used as an effective teaching medium in medicine and other disciplines.

An interesting use of multimedia in schools involves the students themselves. Students can put together interactive magazines and newsletters, make original art using image-manipulation software tools, and interview students, townspeople, coaches, and teachers. They can even make video clips with cameras and mobile phones for local use or uploading to YouTube. They can also design and run web sites. As schools become more a part of the Internet, multimedia arrives by glass fiber and over a network

ITV (Interactive TV) is widely used among campuses to join students from different locations into one class with one teacher. Remote trucks containing computers, generators, and a satellite dish can be dispatched to areas where people want to learn but have no computers or schools near them. In the online version of school, students can enroll at schools all over the world and interact with particular teachers and other students—classes can be accessed at the convenience of the student’s lifestyle while the teacher may be relaxing on a beach and communicating via a wireless system. Washington On Line (www.waol.org), for

example, offers classes to students who do not wish to spend gas money, fight traffic, and compete for parking space; they even provide training to professors so they can learn how best to present their classes online.

Multimedia at Home

From gardening, cooking, home design, remodeling, and repair to genealogy software (see Figure 1-2), multimedia has entered the home. Eventually, most multimedia projects will reach the home via television sets or monitors with built-in interactive user inputs—either on old-fashioned color TVs or on new high-definition sets. The multimedia viewed on these sets will likely arrive on a pay-for-use basis along the data highway.

Today, home consumers of multimedia own either a computer with an attached CD-ROM or DVD drive or a set-top player that hooks up to the television, such as a Nintendo Wii, X-box, or Sony PlayStation machine. There is increasing **convergence** or melding of computer-based multimedia with entertainment and games-based media traditionally described as “shoot-em-up.” Nintendo alone has sold over 118 million game players worldwide along with more than 750 million games. Users with TiVo technology (www.tivo.com) can store 80 hours of television viewing and gaming on a stand-alone hard disk.



Figure 1-2 Genealogy software such as Reunion from Leister Productions lets families add text, images, sounds, and video clips as they build their family trees.

An interactive episode of *Wild Kingdom* might start out with normal narration. “We’re here in the Serengeti to learn about the animals.”

I see a lion on the screen and think, “I want to learn about the lion.” So I point at the lion, and it zooms up on the screen. The narration is now just about the lion. I say, “Well that’s really interesting, but I wonder how the lion hunts.” I point at a hunt icon. Now the lion is hunting, and the narrator tells me about how it hunts. I dream about being the lion. I select another icon and now see the world from the lion’s point of view, making the same kinds of decisions the lion has to make—with some hints as I go along. I’m told how I’m doing and how well I’m surviving. Kids could get very motivated from experiencing what it’s like to be a lion and from wanting to be a competent lion. Pretty soon they’d be digging deeper into the information resource, finding out about animals in different parts of the world, studying geography from maps displayed on the screen, learning which animals are endangered species. . . .

.....
 Trip Hawkins, Founder,
 Electronic Arts

First Person

From time to time during my childhood I would hear bits and pieces of family lore about my great-grandfather, Victor C. Vaughan, who had been, at least it seemed from snatches of occasional conversation, a Famous Person many years ago. Not until adulthood, though, did I come across his autobiography and have a chance to meet him as a real person. Today he comes to mind when we discuss “radical changes in the teaching process.” He was educated the old-fashioned way on a small farm in Missouri; I’ll let him tell you what it was like:

... I received the better part of my education at home. My wise mother did not pretend to dictate my instruction. She simply placed the books she desired me to read within my reach and supplied no others. I sat many a night into the wee small hours and absorbed, by the light of a sycamore ball floating in a cup of grease, the wonderful stories of Walter Scott. I knew every one of his characters in detail and sought their

prototypes among those about me. I clothed the farm and the neighboring hills and dales with romance. Rob Roy’s cave was a certainty. I discovered it in a high bluff on the creek. I read the works of Dickens and Thackeray with like avidity and recited the *Prisoner of Chillon* and the *Corsair*. These and books of like character filled my library shelves. There were also volumes of ancient history and I remember with what eagerness and enthusiasm I read the *Decline and Fall of the Roman Empire*. “Poor training,” a present-day educator would say, for one whose adult life was to be devoted to science. This may be true, but I am reciting facts. I cannot deny that my scientific work might have been more productive had my early training been different. However, I am not making a plea for a handicap, and I remain grateful to my mother for the books I read in childhood. They continue to be associated

with her hallowed memory. I never open one of these now ancient volumes without seeing her face, as with lighted candle she came to my room and gently urged me to go to bed.

Victor C. Vaughan continued to learn and apply eagerness and enthusiasm to every subject. Among his accomplishments, he became Dean of the Medical School at the University of Michigan and President of the American Medical Association. He was Surgeon General during the great Spanish Flu pandemic of 1918 and, it is said, he remained bitter to his last days that science, his great love, was unable to unravel the causes of that disaster.

It may be that today’s multimedia and interactive distance learning using video and audio delivered across broadband connections may not be sufficient to compete with the light of a sycamore ball floating in a cup of grease. It may be that the fundamental driver toward the success of any person’s education remains, simply and plainly, eagerness and enthusiasm.

Live Internet pay-for-play gaming with multiple players has also become popular, bringing multimedia to homes on the broadband Internet, often in combination with CD-ROMs or DVDs inserted into the user’s machine. Microsoft’s Internet Gaming Zone and Sony’s Station web site boast more than a million registered users each—Microsoft claims to

be the most successful, with tens of thousands of people logged on and playing every evening.

Multimedia in Public Places

In hotels, train stations, shopping malls, museums, libraries, and grocery stores, multimedia is already available at stand-alone terminals or kiosks, providing information and help for customers. Multimedia is piped to wireless devices such as cell phones and PDAs. Such installations reduce demand on traditional information booths and personnel, add value, and are available around the clock, even in the middle of the night, when live help is off duty. The way we live is changing as multimedia penetrates our day-to-day experience and our culture. Imagine a friend's bout of maudlin drunk dialing (DD) on a new iPhone, with the camera accidentally enabled.

Figure 1-3 shows a menu screen from a supermarket kiosk that provides services ranging from meal planning to coupons. Hotel kiosks list nearby restaurants, maps of the city, airline schedules, and provide guest services such as automated checkout. Printers are often attached so that users can walk away with a printed copy of the information. Museum kiosks are not only used to guide patrons through the exhibits, but when installed at each exhibit, provide great added depth, allowing visitors to browse through richly detailed information specific to that display.

My wife, the keeper of remotes, has rigged an entertainment system in our house that includes a remote controlled, ceiling mounted 96" x 96" drop-down screen, a 27" 16 x 9 format LCD screen, and an 1100 lumen Dell LCD projector connected to Wavecable, our Internet provider. We can watch our own CDs or Internet or Wavecable's TV/HDTV on our big screen while we track a sports show on the smaller screen off another Wavecable box. We have three cable boxes in our house.

Joe Silverthorn,
Interactive Media Professor,
Olympic College

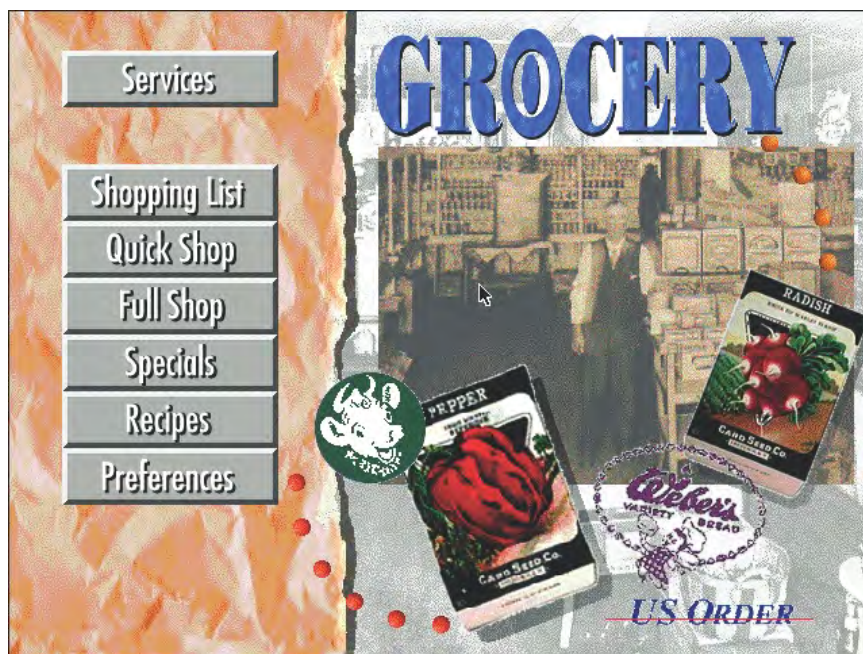

Figure 1-3 Kiosks in public places can make everyday life simpler.

The power of multimedia has been part of the human experience for many thousands of years, and the mystical chants of monks, cantors, and shamans accompanied by potent visual cues, raised icons, and persuasive text has long been known to produce effective responses in public places. Scriabin, the 19th-century Russian composer, used an orchestra, a piano, a chorus, and a special color organ to synthesize music and color in his Fifth Symphony, *Prometheus*. Probably suffering from synesthesia (a strange condition where a sensory stimulus, such as a color, evokes a false response, such as a smell), Scriabin talked of tactile symphonies with burning incense scored into the work. He also claimed that colors could be heard; Table 1-1 lists the colors of his color organ.

| Frequency (Hz) | Note | Scriabin's Color |
|----------------|------|-----------------------------------|
| 256 | C | Red |
| 277 | C# | Violet |
| 298 | D | Yellow |
| 319 | D# | Glint of steel |
| 341 | E | Pearly white shimmer of moonlight |
| 362 | F | Deep red |
| 383 | F# | Bright blue |
| 405 | G | Rosy orange |
| 426 | G# | Purple |
| 447 | A | Green |
| 469 | A# | Glint of steel |
| 490 | B | Pearly blue |

Table 1-1 Scriabin's Color Organ

Prometheus premiered before a live audience in Moscow in 1911, but the color organ had proved technologically too complicated and was eliminated from the program. Then Scriabin died suddenly of blood poisoning from a boil on his lip, so his ultimate multimedia vision, the *Mysterium*, remained unwritten. He would have reveled in today's world of MIDI synthesizers (see Chapter 4), rich computer colors, and video digitizers, and, though smell is not yet part of any multimedia standard, he would surely have researched that concept, too. The platforms for multimedia presentation have much improved since Scriabin's time. Today, multimedia is found in churches and places of worship as live video with attached song lyrics

shown on large screens using elaborate sound systems with special effects lighting and recording facilities. Scriabin would have loved this.

Virtual Reality

At the convergence of technology and creative invention in multimedia is virtual reality, or VR. Goggles, helmets, special gloves, and bizarre human interfaces attempt to place you “inside” a lifelike experience. Take a step forward, and the view gets closer; turn your head, and the view rotates. Reach out and grab an object; your hand moves in front of you. Maybe the object explodes in a 90-decibel crescendo as you wrap your fingers around it. Or it slips out from your grip, falls to the floor, and hurriedly escapes through a mouse hole at the bottom of the wall.

VR requires terrific computing horsepower to be realistic. In VR, your cyberspace is made up of many thousands of geometric objects plotted in three-dimensional space: the more objects and the more points that describe the objects, the higher the resolution and the more realistic your view. As you move about, each motion or action requires the computer to recalculate the position, angle, size, and shape of *all* the objects that make up your view, and many thousands of computations must occur as fast as 30 times per second to seem smooth.

On the World Wide Web, standards for transmitting virtual reality worlds or scenes in VRML (Virtual Reality Modeling Language) documents (with the filename extension .vrl) have been developed. Intel and software makers such as Adobe have announced support for new 3-D technologies.

Using high-speed dedicated computers, multi-million-dollar flight simulators built by Singer, RediFusion, and others have led the way in commercial application of VR. Pilots of F-16s, Boeing 777s, and Rockwell space shuttles have made many simulated dry runs before doing the real thing. At the Maine Maritime Academy and other merchant marine officer training schools, computer-controlled simulators teach the intricate loading and unloading of oil tankers and container ships.

Virtual reality (VR) is an extension of multimedia—and it uses the basic multimedia elements of imagery, sound, and animation. Because it requires instrumented feedback from a wired-up person, VR is perhaps interactive multimedia at its fullest extension.

Delivering Multimedia

Multimedia requires large amounts of digital memory when stored in an end user’s library, or large amounts of **bandwidth** when distributed over

People who work in VR do not see themselves as part of “multimedia.” VR deals with goggles and gloves and is still a research field where no authoring products are available, and you need a hell of a computer to develop the real-time 3-D graphics. Although there is a middle ground covered by such things as QuickTime VR and VRML that gives multimedia developers a “window” into VR, people often confuse multimedia and VR and want to create futuristic environments using multimedia-authoring tools not designed for that purpose.

.....
Takis Metaxis, Assistant
Professor of Computer Science,
Wellesley College

wires, glass fiber, or airwaves on a network. The greater the bandwidth, the bigger the pipeline, so more content can be delivered to end users quickly.

CD-ROM, DVD, Flash Drives

CD-ROM (compact disc read-only memory, see Chapter 7) discs can be mass-produced for pennies and can contain up to 80 minutes of full-screen video, images, or sound. The disc can also contain unique mixes of images, sounds, text, video, and animations controlled by an authoring system to provide unlimited user interaction.

Discs can be stamped out of polycarbonate plastic as fast as cookies on a baker's production line and just as cheaply. Virtually all personal computers sold today include at least a CD-ROM player, and the software that drives these computers is commonly delivered on a CD-ROM disc. Many systems also come with a DVD player combination that can read and burn CD-ROMs as well. Multilayered Digital Versatile Disc (**DVD**) technology increases the capacity and multimedia capability of CDs to 4.7GB on a single-sided, single-layered disc to as much as 17.08GB of storage on a double-sided, double-layered disc. CD and DVD **burners** are used for reading discs and for making them, too, in audio, video, and data formats. DVD authoring and integration software allows the creation of interactive front-end menus for both films and games.

In the very long term, however, CD-ROM and DVD discs are but interim memory technologies that will be replaced by new devices such as flash drives and thumb drives that do not require moving parts. As high-speed connections become more and more pervasive and users become better connected, copper wire, glass fiber, and radio/cellular technologies may prevail as the most common delivery means for interactive multimedia files, served across the broadband Internet or from dedicated computer farms and storage facilities.

The Broadband Internet

These days telecommunications networks are global, so when information providers and content owners determine the worth of their products and how to charge money for them, information elements will ultimately link up online as **distributed resources** on a data highway (actually more like a toll road), where you will pay to acquire and use multimedia-based information.

Curiously, the actual glass fiber cables that make up much of the physical backbone of the data highway are, in many cases, owned by railroads and pipeline companies who simply buried the cable on existing rights of way, where no special permits and environmental studies are necessary.

One railroad in the United States invested more than a million dollars in a special cable-laying trenching car; in the United Kingdom, fiber-optic cable runs in the towpaths of the decaying 19th-century canal and barge system. Bandwidth on these fiber-optic lines is leased to others, so competing retailers such as AT&T, Verizon, MCI, and Sprint may even share the same cable.

Full-text content from books and magazines is downloadable; feature movies are played at home; real-time news feeds from anywhere on earth are available; lectures from participating universities are monitored for education credits; street maps of cities are viewable—with recommendations for restaurants, in any language—and online travelogues include testimonials and video tracks. Just think—each of these interfaces or gateways to information is a multimedia project waiting to be developed!

.....
<http://earth.google.com>

<http://maps.google.com/help/maps/streetview>

www.moviefone.com

www.netflix.com

www.travelocity.com

www.nytimes.com

www.5pm.co.uk

Showtimes for many major cities, restaurants, vacation trips, and current news items are quickly available on the Web.

.....

Interactive multimedia is delivered to many homes throughout the world. Interest from a confluence of entertainment mega-corps, information publishers and providers, cable and telephone companies, and hardware and software manufacturers is driving this inevitable evolution, and profound changes in global communications strategy are on the drawing boards. What will be piped through this new system for entertainment, reference, and lifelong learning experiences are the very **multimedia elements** discussed in the chapters of this book, including text, graphics, animation, sound, and video.

The actual content provided, let us hope, will be excellent fare, generated by thinking and caring creative people using ideas that will propel all of us into a better world. Entertainment companies that own content easily converted to multimedia projects are teaming up with cable TV companies. Film studios are creating new divisions to produce interactive multimedia and wealthy talents have formed new companies to join in on

the action. Google is scanning millions of books and periodicals. Even without a clear business model with known profits, large media corporations are uniting to create huge conglomerates to control the content and delivery of tomorrow's information.

Some companies will own the routes for carrying data, other companies will own the hardware and software interfaces at the end of the line, at offices and homes. Some will knit it all together and provide supply-on-demand and billing services. Regardless of who owns the roadways and the hardware boxes, multimedia producers will create the new literature and the rich content sent along them. This is a fresh and exciting industry that is coming of age, but one that is still faced with many growing pains.

Chapter 1 Review

■ Chapter Summary

For your review, here's a summary of the important concepts discussed in this chapter.

Define common multimedia terms such as multimedia, integration, interactive, HTML, and authoring and qualify various characteristics of multimedia: nonlinear versus linear content

- Multimedia is any combination of text, graphic art, sound, animation, and video delivered by computer or other electronic means.
- Multimedia production requires creative, technical, organizing, and business ability.
- Multimedia presentations can be nonlinear (interactive) or linear (passive).
- Multimedia can contain structured linking called hypermedia.
- Multimedia developers produce multimedia titles using authoring tools.
- Multimedia projects, when published, are multimedia titles.

Describe several different environments in which multimedia might be used, and several different aspects of multimedia that provide a benefit over other forms of information presentation

- Multimedia is appropriate wherever a human interacts with electronic information.

- Areas in which multimedia presentations are suitable include education, training, marketing, advertising, product demos, databases, catalogs, entertainment, and networked communications.

Describe the primary multimedia delivery methods—the Internet, wireless, CD-ROM, and DVD—as well as cite the history of multimedia and note important projected changes in the future of multimedia

- Multimedia projects often require a large amount of digital memory; hence they are often stored on CD-ROM or DVDs.
- Multimedia also includes web pages in HTML or DHTML (XML) on the World Wide Web, and can include rich media created by various tools using plug-ins.
- Web sites with rich media require large amounts of bandwidth.
- The promise of multimedia has spawned numerous mergers, expansions, and other ventures. These include hardware, software, content, and delivery services.
- The future of multimedia will include high-bandwidth access to a wide array of multimedia resources and learning materials.

■ Key Terms

authoring tools (2)

bandwidth (9)

browser (2)

burner (10)

CD-ROM (10)

content (2)

convergence (5)

DHTML (1)

digitally manipulated (1)

distributed resource (10)

DVD (10)

environment (2)

font (1)

graphical user interface (GUI) (2)

HTML (1)

hypermedia (1)

integrated multimedia (2)

interactive multimedia (1)

ITV (4)

linear (2)

multimedia (0)

multimedia developer (1)

multimedia element (11)

multimedia project (1)

multimedia title (1)

nonlinear (2)

platform (2)

scripting (2)

storyboarding (2)

web site (1)

XML (1)

■ Key Term Quiz

1. _____ is any combination of text, graphic art, sound, animation, and video delivered to you by computer or other electronic means.
2. _____ allows an end user to control what and when the elements are delivered.
3. _____ is a structure of linked elements through which the user can navigate.
4. A _____ multimedia project allows users to sit back and watch it just as they do a movie or the television.
5. _____ tools are software tools designed to manage individual multimedia elements and provide user interaction.
6. The sum of what gets played back and how it is presented to the viewer on a monitor is the _____.
7. The hardware and software that govern the limits of what can happen are the multimedia _____.
8. The information that makes up a multimedia presentation is referred to as _____.
9. CD and DVD _____ are used for reading and making discs.
10. HTML and DHTML web pages or sites are generally viewed using a _____.

■ Multiple-Choice Quiz

1. LAN stands for:
 - a. logical access node
 - b. link/asset navigator
 - c. local area network
 - d. list authoring number
 - e. low-angle noise
2. A browser is used to view:
 - a. program code
 - b. storyboards
 - c. fonts
 - d. Web-based pages and documents
 - e. videodiscs
3. The “ROM” in “CD-ROM” stands for:
 - a. random-order memory
 - b. real-object memory
 - c. read-only memory
 - d. raster-output memory
 - e. red-orange memory
4. The software vehicle, the messages, and the content presented on a computer or television screen together make up:
 - a. a multimedia project
 - b. a CD-ROM
 - c. a web site
 - d. a multimedia title
 - e. an authoring tool
5. A project that is shipped or sold to consumers or end users, typically in a box or sleeve or on the Internet, with or without instructions, is:
 - a. a CD-ROM
 - b. an authoring tool
 - c. a multimedia project
 - d. a multimedia title
6. The 19th-century Russian composer who used an orchestra, a piano, a chorus, and a special color organ to synthesize music and color in his Fifth Symphony, *Prometheus* was:
 - a. Rachmaninoff
 - b. Tchaikovsky
 - c. Scriabin
 - d. Rimsky-Korsakoff
 - e. Shostakovich

7. Which one of the following *is not/are not* typically part of a multimedia specification?
- text
 - odors
 - sound
 - video
 - pictures
8. VR stands for:
- virtual reality
 - visual response
 - video raster
 - variable rate
 - valid registry
9. According to one source, in interactive multimedia presentations where you are really involved, the retention rate is as high as:
- 20 percent
 - 40 percent
 - 80 percent
 - 60 percent
 - 100 percent
10. Which of the following is displayable on a web page after installation of a browser plug-in?
- Windows 7
 - Adobe Flash
 - Mozilla
 - Internet Explorer
 - Firefox
11. PDA stands for:
- primary digital asset
 - processor digital application
 - personal digital assistant
 - practical digital accessory
 - portable digital armor
12. The glass fiber cables that make up much of the physical backbone of the data highway are, in many cases, owned by:
- local governments
 - Howard Johnson
 - television networks
 - railroads and pipeline companies
 - book publishers
13. DVD stands for:
- Digital Versatile Disc
 - Digital Video Disc
 - Duplicated Virtual Disc
 - Density-Variable Disc
 - Double-View Disc
14. Genealogy software is used to
- Study benthic sediments
 - Organize class reunions
 - Display family trees
 - Compute shortest routes for ambulances
 - Open e-mail
15. Which of the following is *not* a technology likely to prevail as a delivery means for interactive multimedia files?
- copper wire
 - glass fiber
 - radio/cellular
 - floppy disk
 - CD-ROM

■ Essay Quiz

- Briefly discuss the history and future of multimedia. How might multimedia be used to improve the lives of its users? How might it influence users in negative ways? What might be its shortcomings?
- You are a marketing director for a small telecommunications company. You are considering using multimedia to market your company's product. Put together an outline detailing the benefits and drawbacks of using a CD-ROM presentation, a multimedia web site, or a television advertisement.
- Multimedia is shifting from being localized (contained on a CD-ROM) to being distributed (available on the World Wide Web). What are some of the implications of this? Who will have access to the presentation? How will you keep it secure? How will you distribute it?

Lab Projects

■ Project 1.1

You have been given the task of creating an interactive Web presentation for marketing a new bicycle. Visit four different bicycle web sites using a suitable search tool. For each web site you visit, write in the table below the name of the site, its URL, and:

1. Describe each site in terms of its multimedia incorporation.
2. Discuss whether its multimedia content is appropriate and where and how additional media content might improve the site.
3. Describe what multimedia presentation formats it uses. Video? Virtual reality? 3-D animations?

| | |
|--|--|
| Site 1 | |
| URL (address): | |
| Describe the GUI. What navigational elements does it have? What colors does it use? Is it cluttered? | |
| Is the content relevant and appropriate? What additions/deletions of content might improve the site? | |
| Describe any multimedia presentations of specific products. What formats did they use? | |
| Site 2 | |
| URL (address): | |
| Describe the GUI. What navigational elements does it have? What colors does it use? Is it cluttered? | |
| Describe any multimedia presentations of specific products. What formats did they use? | |
| Site 3 | |
| URL (address): | |
| Describe the GUI. What navigational elements does it have? What colors does it use? Is it cluttered? | |
| Describe any multimedia presentations of specific products. What formats did they use? | |
| Site 4 | |
| URL (address): | |
| Describe the GUI. What navigational elements does it have? What colors does it use? Is it cluttered? | |
| Describe any multimedia presentations of specific products. What formats did they use? | |

■ Project 1.2

Review an educational multimedia CD-ROM title, and then fill out the table that follows.

| | |
|--|--|
| Title of CD | |
| Describe the GUI. What navigational elements does it have? What color scheme(s) does it use? Is it cluttered? | |
| Describe the educational content. Is it well organized? | |
| Would you be able to easily learn the subject matter using this package? | |
| Describe the product in terms of its multimedia incorporation. | |
| Discuss whether its multimedia content is appropriate and where and how additional media content might improve the site. | |

■ Project 1.3

Contact a local multimedia development company. Ask them what kinds of products they develop and whether they would describe two projects they have recently completed. Be sure that they provide you with enough information to answer each of the following questions.

Multimedia Project 1

1. Name of project.
2. Kind of product created.
3. What authoring tool(s) were used to create the project?
4. Who made up the development team for the project?
5. How did the production of the project develop?
6. How long did the project take to complete?
7. What problems were encountered?

Multimedia Project 2

1. Name of project.
2. Kind of product created.
3. What authoring tool(s) were used to create the project?
4. Who made up the development team for the project?
5. How did the production of the project develop?
6. How long did the project take to complete?
7. What problems were encountered?

■ Project 1.4

Visit a large public area such as a shopping mall, the downtown area of a city, or a museum. Locate a kiosk or other public multimedia installation. Spend 15 minutes observing who uses it and for how long.

1. Describe the installation. Where was it located? Is there a lot of foot traffic going past it? Is it conveniently located? Is it accessible to a wide range of users (tall, short, disabled, wheelchair, or vision impaired)?
2. Describe the usage pattern. Characterize the users. Were children attracted to it? Did users “play” with it?

Text

In this chapter, you will learn how to:

- Recognize the importance of word choice
- Describe the difference between a typeface and a font and list at least three attributes of a font, for example, upper/lowercase, serif/sans serif, PostScript/TrueType/OpenType
- Discuss the importance of text and the ways in which text can be leveraged in multimedia presentations
- Discuss the presentation of text on Windows and Macintosh platforms
- Find sources for free and shareware fonts
- Define hypermedia, hypertext, links, anchors, and nodes and be able to discuss both the potential and limitations of hypertext and hyperlinking systems

USING text and symbols for communication is a very recent human development that began about 6,000 years ago in the Mediterranean Fertile Crescent—Mesopotamia, Egypt, Sumeria, and Babylonia—when the first meaningful marks were scraped onto mud tablets and left to harden in the sun. Only members of the ruling classes and the priesthood were allowed to read and write the pictographic signs and cuneiforms. The earliest messages delivered in written words typically contained information vital to the management of people, politics, and taxes. Because this new medium did not require rote memorization by frail human gray matter, written messages became popular among the elite. Unlike their human counterparts, these new messages were less likely to perish due to dysentery or acts of God, or suffer from amnesia. Even if a message were intercepted by foes or competitors, it would still be indecipherable—except by those few who had acquired reading skills.

In fact, because those who could read probably attended the same private school or shared the same tutors, in those days reading, writing, and power politics were naturally intertwined. In some former eras it was a capital offense to read unless you belonged to the proper social class or possessed a patent granted to you by your rulers.



Today, text and the ability to read it are doorways to power and knowledge. Reading and writing are expected and necessary skills within most modern cultures. Now, depending upon your proficiency with words, you may be awarded a doctorate instead of the death penalty. And, as has been the case throughout history, text still delivers information that can have potent meaning.

Since the explosion of the Internet and the World Wide Web, text has become more important than ever. Indeed, the native language of the Web is HTML (Hypertext Markup Language), originally designed to display simple text documents on computer screens, with occasional graphic images thrown in as illustrations (see Chapter 12 for more history of the Internet). Academic papers, magazine articles, complex instruction manuals, and even the contents of entire books are now available for reading with a web browser. Add a built-in function that links, with a click of the mouse, selected words and phrases to other related and perhaps more-detailed material (the “hypertext” part of HTML, discussed later in this chapter), and you can surf the Net in a medium much richer than the paper pages of a book.

First Person

In the 15th century, when the Church was a strong power throughout Europe, Johann Gensfleisch zum Gutenberg, a trained goldsmith from Mainz, Germany, invented movable type for printing presses. He used this new invention for the task of producing religious literature, indulgence slips, and the Holy Bible. In the case of the Bible, he sold his copies to people who could read Latin and pay the equivalent of three years of a clerk’s wage to own a personal copy of this Great Work. Other printers, including the Estienne family in France and Aldus Manutius in Italy, soon entered the publishing marketplace to compete,

and they changed the fabric of society. The mass production of identical copies of text enabled an information-based paradigm shift that changed the human universe in a substantial way. Lots of scribes and illuminators were put out of business.

By way of pointing out that some elements of the human equation may be constant throughout history, I would remark that like many adventurers surfing the waves of today’s revolution, Gutenberg took on a financial investor, Johann Fust. Gutenberg, who was a visionary craftsman perhaps better suited to lab and shop work, defaulted on a

payment to Fust in 1455, was sued, and lost his press and all its profits. Toward the end of his life, it is said that he was granted a place as courtier to the archbishop of Mainz. This position had perhaps better remuneration than the diminishing social security plan rewarding today’s surfer who wipes out while hanging ten at the leading edge of the business world.

(From a speech by Tay Vaughan to the jointly held World Conference on Educational Multimedia and Hypermedia and World Conference on Educational Telecommunications, Freiburg, Germany, June 1998)

The social impact of this text-biased medium on the way people access and use information will be profound as the Web matures further. In contrast to today’s television medium, which consists of sound and images with a few text headlines “dumbed down” to the level of a perceived lowest common denominator of passive audience, the Web offers an active experience laden with enough choices to challenge even bright people

With its penchant for interactivity, multimedia too often ignores the power of narrative, of stories. There's really something to be said for documents with a beginning, middle, and end.

.....

Steven Levy, author of *Hackers*, *Artificial Life*, *Insanely Great*, *Unicorn's Secret*, and *Crypto*;
Senior Editor and chief technology writer for *Newsweek*

who can read. More than television, with its 50 or 100 or even 400 channels, the Web offers an explorer's paradise of billions of HTML documents. Yahoo! Search once claimed, "Our index now provides access to over 20 billion items. For those who are curious, this update includes just over 19.2 billion web documents, 1.6 billion images, and over 50 million audio and video files." Until 2009, the search engines displayed (bragged about) the total number of documents they indexed, in the billions. These huge numbers were very inaccurate, it turned out, and they have ceased making precise statements about quantity. A trick in the Google search engine is to type in "site:" and the name of a domain. Google will tell you how many pages from that domain are indexed:

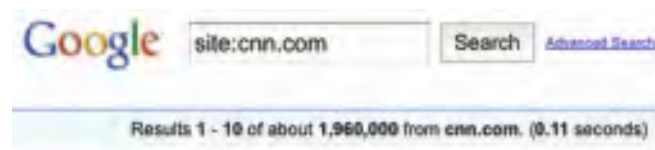

As bandwidth improves and more information is successfully embedded within these documents, developers of content will not escape the difficult design issues discussed in Chapter 10. Who is the audience? What words should I use? What typeface is best?

The Power of Meaning

Even a single word may be cloaked in many meanings, so as you begin working with text, it is important to cultivate accuracy and conciseness in the specific words you choose. In multimedia, these are the words that will appear in your titles, menus, and navigation aids as well as in your narrative or content.

Today's poets and songwriters concentrate text by distilling lengthy prose into few words heavy with meaning. Advertising wordsmiths render the meaning of entire product lines into an evocative single word, logo, or tag line. Multimedia authors weave words, symbols, sounds, and images, and then blend text into the mix to create integrated tools and interfaces for acquiring, displaying, and disseminating messages and data.

The words "Barbie," "green," and "lite" may each easily trigger a rush of different meanings. A piercing cry in the night, the sight of fire engines leaving your street as you steer your car into your neighborhood, the scent of drying kelp along the seashore, the feel of rough pine bark against your chest as you climb, fingernails on a chalkboard—all these raw sensory messages are important only because of what they mean to you. Indeed, you alone know the words that will stop you dead in your tracks with anger, or, better, soothe you seductively over a quiet dinner for two. These words have meaning.

I'd like to write something that comes from things the way wine comes from grapes.

.....

Walter Benjamin,
Philosopher/Writer

All of these examples demonstrate the following multimedia principle: it's important to design labels for title screens, menus, and buttons or tabs using words that have the most precise and powerful meanings to express what you need to say. Understand the subtle shadings. GO BACK! is more powerful than Previous; Quit is more powerful than Close. TERRIFIC! may work better than That Answer Was Correct. Experiment with the words you plan to use by letting others try them. If you have the budget, set up a focus group to have potential users experience your words. Watch them work. See if users flinch, balk, or click the Help button in confusion. See if they can even find the Help button.

Words and symbols in any form, spoken or written, are the most common system of communication. They deliver the most widely understood meaning to the greatest number of people—accurately and in detail. Because of this, they are vital elements of multimedia menus, navigation systems, keyword lists, and content. You will reward yourself and your users if you take the time to use excellent words. Let your poet loose!

TIP Browse through a thesaurus. You will be surprised at the number of synonyms and related words that are closely associated to the word you start with, and you will certainly find the one word that most perfectly fits your need. The majority of today's popular word processors ship with a bundled electronic thesaurus; many are also available for free on the Internet.

The Power and Irregularity of English

If you are reading this book in English, you might consider yourself lucky. A study by the British Council estimated that one billion people spoke English by the beginning of the second millennium as a first, second, or “foreign” language. English is the official or joint official language of more than 75 countries, and Algeria, when it dumped French in favor of English as the second language in schools, irritated a great many Parisian intellectuals. More than two-thirds of the world's scientists read English, and three-quarters of the world's mail is written in English. It is estimated that 80 percent of the world's information that is stored on computers is written in English. As Dutch-born Professor Boeree of Shippensburg University has said, “Unfortunately for learners of English, it still has several irregular verbs (e.g., to be and to have) and a large number of strong verbs (e.g. sing-sang-sung), plus a few irregular plurals (e.g. child-children, man-men...). Nevertheless, people around the world find English relatively easy, with one huge exception: English has the worst spelling of any language using the Latin alphabet!”

The most recent changes in English spelling have been driven by technology limits as SMS (Short Message Service) text messages commonly used by social networking sites such as Twitter and Facebook to

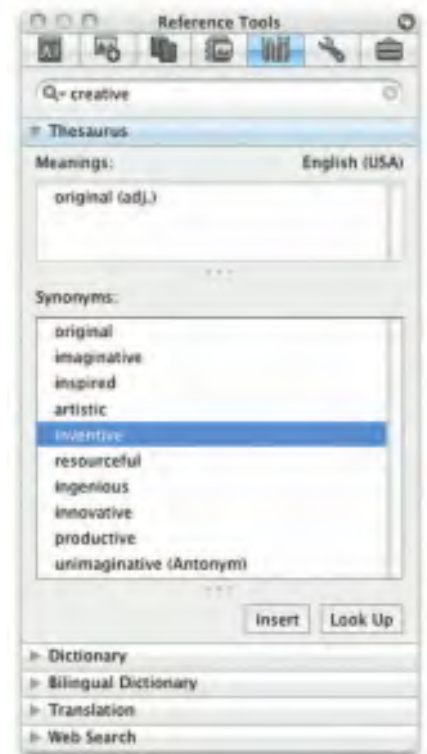

When we have a technical meeting with engineers coming from Germany, France, Spain, Sweden, Japan, and other countries, people say “Hello!” when they walk into the room; English is clearly the international common language of business and commerce and science. Sometimes the etiquette of polite speech is even more fascinating: when you have a room with a group of Germans talking to each other in German and suddenly a foreign visitor comes in, from one sentence to the other, they seamlessly switch to English.

.....
Dipl.-Ing. Roland Cuny
Karlsruhe, Germany

communicate and “tweet” allow only about 160 characters per message (140 bytes). As today’s most pervasive method of human-to-human data communication (more than three billion texters worldwide sending trillions of short text messages from phone to phone each year), users speaking many languages quickly developed word shortcuts to pack the most meaning into the fewest characters. NetLingo (www.netlingo.com) maintains a list of almost two thousand English acronyms and instant messaging jargon words such as XOXO (hugs & kisses), U (you), and NME (enemy). When assembled into a message, you might discover “were I a tear in ur eye i wood roll down onto ur lips. but if u were a tear in my eye i wood never cry as i wood be afraid 2 lose u!” With the arrival of MMS (Multimedia Messaging Service), which allows for 350,000-byte transmissions, perhaps these shortcut spellings will fade away. But perhaps not.

About Fonts and Faces

A **typeface** is a family of graphic characters that usually includes many type sizes and styles. A **font** is a collection of characters of a single size and style belonging to a particular typeface family. Typical font **styles** are boldface and italic. Your computer software may add other style **attributes**, such as underlining and outlining of characters. Type sizes are usually expressed in points; one **point** is 0.0138 inch, or about 1/72 of an inch. The font’s size is the distance from the top of the capital letters to the bottom of the descenders in letters such as *g* and *y*. Helvetica, Times, and Courier are typefaces; Times 12-point italic is a font. In the computer world, the term font is commonly used when typeface or face would be more correct.

A font’s size does not exactly describe the height or width of its characters. This is because the **x-height** (the height of the lowercase letter *x*) of two fonts may vary, while the height of the capital letters of those fonts may be the same (see Figure 2-1). Computer fonts automatically add space below the descender (and sometimes above) to provide appropriate line spacing, or **leading** (pronounced “ledding,” named for the thin strips of lead inserted between the lines by traditional typesetters).

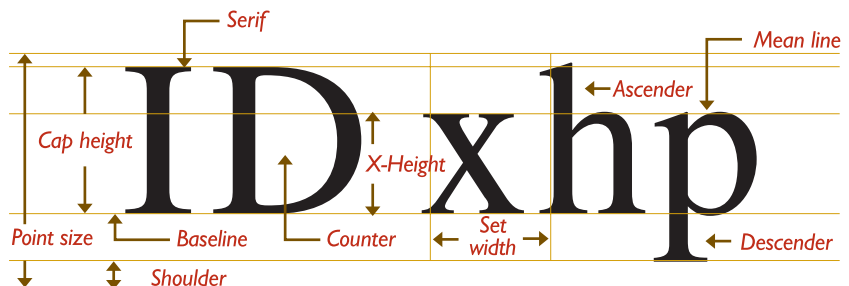

Figure 2-1 The measurement of type

Leading can be adjusted in most programs on both the Macintosh and the PC. Typically you will find this fine-tuning adjustment in the Text menu of image-editing programs or the Paragraph menu of word processing programs, though this is not an official standard. No matter where your application has placed the controls for leading, you will need to experiment with them to achieve the best result for your font. With a font editing program like Fontographer from Fontlab, Ltd. at www.fontlab.com (you'll see an example of it later in the chapter), adjustments can also be made along the horizontal axis of text. In this program the character metrics of each character and the kerning of character pairs can be altered. **Character metrics** are the general measurements applied to individual characters; **kerning** is the spacing between character pairs. When working with PostScript, TrueType, and Master fonts—but not bitmapped fonts—(see “Computers and Text” later in this chapter), the metrics of a font can be altered to create interesting effects. For example, you can adjust the body width of each character from regular to **condensed** to **expanded**, as displayed in this example using the Sabon font:

Regular
Condensed
Expanded

Or you can adjust the spacing between characters (**tracking**) and the kerning between pairs of characters:

| | | |
|---------------|-------------------|-------------------|
| Tighter Track | <i>A</i> <i>v</i> | <i>A</i> <i>v</i> |
| Looser Track | Kerned | Unkerned |

When it converts the letter *A* from a mathematical representation to a recognizable symbol displayed on the screen or in printed output (a process called **rasterizing**), the computer must know how to represent the letter using tiny square **pixels** (picture elements), or dots. It does this according to the hardware available and your specification, from a choice of available typefaces and fonts. Search for “free fonts.” High-resolution monitors and printers can make more attractive-looking and varied characters because there are more fine little squares or **dots per inch (dpi)**. And today's broad selection of software fonts makes it easier to find the right typeface and

font for your needs. The same letter can look very different when you use different fonts and faces:



Cases

In centuries when type was set by hand, the type for a single font was always stored in two trays, or *cases*; the upper tray held capital letters, and the lower tray held the small letters. Today, a capital letter is called **uppercase**, and a small letter is called **lowercase**.

TIP *Studies have shown that words and sentences with mixed upper- and lowercase letters are easier to read than words or sentences in all caps (uppercase). While uppercase can make your message appear important or urgent, use this sparingly; in online messaging it's known as "SHOUTING" or "YELLING" and can be annoying, if not offensive.*

In some situations, such as for passwords, a computer is **case sensitive**, meaning that the text's upper- and lowercase letters must match exactly to be recognized. But nowadays, in most situations requiring keyboard input, all computers recognize both the upper- and lowercase forms of a character to be the same. In that manner, the computer is said to be **case insensitive**.

WARNING *The directory names and filenames used in Uniform Resource Locator (URL) addresses on the Internet are case sensitive! Thus, <http://www.timestream.com/info/people/biotay/biotay1.html> points to a different directory and file than <http://www.timestream.com/info/people/bioTay/biotay1.html>. On the other hand, the record type (HTTP) and the domain name (www.timestream.com), and e-mail addresses (tay@timestream.com) as well, are usually case insensitive. Read more about addresses on the Internet in Chapter 12.*

Company and product names such as WordPerfect, OmniPage, Photo-Disc, FileMaker, and WebStar have become popular. Placing an uppercase letter in the middle of a word, called an **intercap**, is a trend that emerged from the computer programming community, where coders discovered they could better recognize the words they used for variables and commands when the words were lowercase but intercaptioned.

Serif vs. Sans Serif

Typefaces can be described in many ways, just as a home advertised by a realtor, a wine described by a food critic, or a political candidate's platform

can all be described in many ways. Type has been characterized as feminine, masculine, delicate, formal, capricious, witty, comic, happy, technical, newsy—you name it. But one approach for categorizing typefaces is universally understood, and it has less to do with the reader’s response to the type than it does with the type’s mechanical and historical properties. This approach uses the terms **serif** and **sans serif**.

Serif versus sans serif is the simplest way to categorize a typeface; the type either has a serif or it doesn’t (*sans* is French for “without”). The serif is the little decoration at the end of a letter stroke. Times, New Century Schoolbook, Bookman, and Palatino are examples of serif fonts. Helvetica, Verdana, Arial, Optima, and Avant Garde are sans serif. Notice the difference between serif (on the left) and sans serif:



On the printed page, serif fonts are traditionally used for body text because the serifs are said to help guide the reader’s eye along the line of text. Sans serif fonts, on the other hand, are used for headlines and bold statements. But the computer world of standard, 72 dpi monitor resolution is not the same as the print world, and it can be argued that sans serif fonts are far more legible and attractive when used in the small sizes of a text field on a screen. Indeed, careful selection of a sans serif font designed to be legible in the small sizes (such as Tahoma or Verdana) makes more sense when you are presenting a substantial amount of text on the screen. The Times font at 9-point size may look too busy and actually be difficult and tiring to read. And a large, bold serif font for a title or headline can deliver a message of elegance and character in your graphic layout. Use what is right for your delivery system, which may not necessarily be the same as what is right when you’re printing the material to paper. This is because when you’re printing out what you create on a computer monitor, **WYSIWYG** (What You See Is What You Get) is more of a goal than an absolute fact.

Using Text in Multimedia

Imagine designing a project that used no text at all. Its content could not be at all complex, and you would need to use many pictures and symbols to train your audience how to navigate through the project. Certainly voice and sound could guide the audience, but users would quickly tire of this because greater effort is required to pay attention to spoken words than to browse text with the eye.

A single item of menu text accompanied by a single action (a mouse click, keystroke, or finger pressed to the monitor) requires little training and is clean and immediate. Use text for titles and headlines (what it's all about), for menus (where to go), for navigation (how to get there), and for content (what you see when you get there).

TIP *In designing your navigation system, bring the user to a particular destination with as few actions and as short a wait as possible. If the user never needs the Help button to get there or never has to click the Back button when at a dead end, you're doing everything right!*

Designing with Text

Computer screens provide a very small workspace for developing complex ideas. At some time or another, you will need to deliver high-impact or concise text messages on the computer screen in as condensed a form as possible. From a design perspective, your choice of font size and the number of headlines you place on a particular screen must be related both to the complexity of your message and to its venue.

If your messages are part of an interactive project or web site where you know the user is seeking information, you can pack a great deal of text information onto the screen before it becomes overwhelmingly busy. Seekers want dense material, and while they travel along your navigational pathways, they will scroll through relevant text and study the details. Here is where you must strike a balance, however. Too little text on a screen requires annoying page turns and unnecessary mouse clicks and waits; too much text can make the screen seem overcrowded and unpleasant.

On the other hand, if you are creating presentation slides for public-speaking support, the text will be keyed to a live presentation where the text accents the main message. In this case, use bulleted points in large fonts and few words with lots of white space. Let the audience focus on the speaker at the podium, rather than spend its time reading fine points and subpoints projected on a screen.

TIP *A lengthy text document read by a web browser may scroll for hundreds of lines without annoying the user because it's expected. As a rule of thumb, however, try to make your web pages no longer than one-and-a-half to two screenfuls of text. On a 1024 × 768-pixel monitor, for example, you have about 600 pixels in height to work with before scrolling is necessary while viewing web content in a browser. Limit the width of your lines by using columns—reading a line of text across an entire 21-inch monitor screen is cumbersome, if not uncomfortable. For printing text documents, provide a separate link to a complete document in either*

plain text (.txt), rich text format (.rtf), word processor format (.doc, .odt, or .wpd), or Adobe PDF format (.pdf) instead of relying on a browser's print facilities. It is often more convenient to print and read a document than to scroll through many pages of text on a monitor.

Choosing Text Fonts

Picking the fonts to use in your multimedia presentation may be somewhat difficult from a design standpoint. Here again, you must be a poet, an advertising psychologist, and also a graphic designer. Try to intuit the potential reaction of the user to what is on the screen. Here are a few design suggestions that may help:

- For small type, use the most legible font available. Decorative fonts that cannot be read are useless, as shown at right.
- Use as few different faces as possible in the same work, but vary the weight and size of your typeface using italic and bold styles where they look good. Using too many fonts on the same page is called ransom-note typography. Visit <http://lifehacker.com/software/writing/faster-ransom-notes-for-busy-kidnappers-248692.php> to make your own ransom notes.
- In text blocks, adjust the leading for the most pleasing line spacing. Lines too tightly packed are difficult to read.
- Vary the size of a font in proportion to the importance of the message you are delivering.
- In large-size headlines, adjust the spacing between letters (kerning) so that the spacing feels right. Big gaps between large letters can turn your title into a toothless waif. You may need to kern by hand, using a bitmapped version of your text.
- To make your type stand out or be more legible, explore the effects of different colors and of placing the text on various backgrounds. Try reverse type for a stark, white-on-black message.
- Use anti-aliased text where you want a gentle and blended look for titles and headlines. This can give a more professional appearance. **Anti-aliasing** blends the colors along the edges of the letters (called **dithering**) to create a soft transition between the letter and its background.
- **T**ry drop caps (like the T to the left) and initial caps to accent your words. Most word processors and text editors will let you create drop caps and SMALL CAPS in your text. Adobe and others make initial caps (such as the one shown to the right from Adobe, called Gothic). The letters are actually carefully drawn artwork and are available in special libraries as encapsulated PostScript files (EPSF).

Can you read me?

Can you read me?



Why Me?



- Coding an initial cap for a web page is simple. Use CSS attributes:

```
p:first-letter { font-size: 200%; }
p:first-line { line-height: 100%; }
```

- If you are using centered type in a text block, keep the number of lines and their width to a minimum.
- For attention-grabbing results with single words or short phrases, try graphically altering and distorting your text and delivering the result as an image. Wrap your word onto a sphere, bend it into a wave, or splash it with rainbow colors.
- Experiment with drop shadows. Place a copy of the word on top of the original, and offset the original up and over a few pixels. Then color the original gray (or any other color). The word may become more legible and provide much greater impact. With web sites, shadowed text and graphics on a plain white background add depth to a page. Surround headlines with plenty of white space. **White space** is a designer's term for roomy blank areas, while programmers call the invisible character made by a space (ASCII 32) or a tab (ASCII 9) white space. Web designers use a nonbreaking space entity () to force spaces into lines of text in HTML documents.
- Pick the fonts that seem right to you for getting your message across, then double-check your choice against other opinions. Learn to accept criticism.
- Use meaningful words or phrases for links and menu items.
- Text links on web pages can accent your message: they normally stand out by color and underlining. Use link colors consistently throughout a site, and avoid iridescent green on red or purple on puce.
- Bold or emphasize text to highlight ideas or concepts, but do not make text look like a link or a button when it is not.
- On a web page, put vital text elements and menus in the top 320 pixels. Studies of surfer habits have discovered that only 10 to 15 percent of surfers *ever* scroll *any* page.

If you are older than eleven years, never *ever* use the Comic Sans face or the “fantasy” CSS attribute on a web page.

Brad Borch, Designer

NOTE Characters identified in a particular font (say, Garamond 10-point) do not always look the same on a Macintosh as they do on Windows display monitors. Typically, what is called 12-point on a Macintosh will be a 10- or 9-point size in Windows. And the actual shape of the characters may be different (see Figure 2-2). Take care to visually test the flow of your text on all platforms.

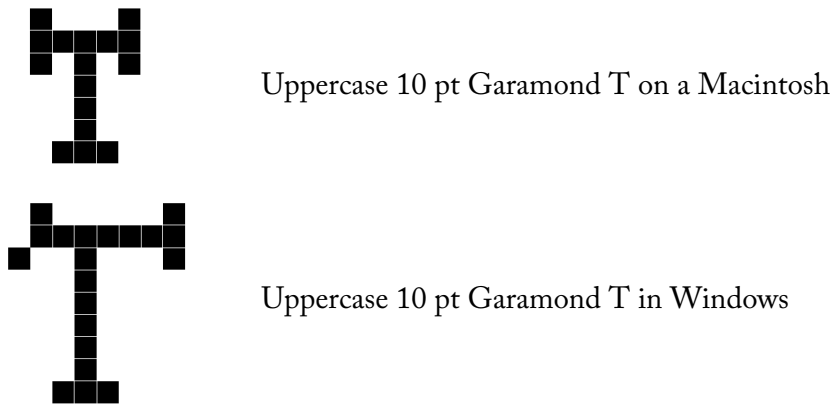

Figure 2-2 Examples of Garamond typeface displayed on a Macintosh (top) and in Windows

Installed Fonts Before you can use a font, it must be recognized by the computer’s operating system. If you want to use fonts other than those installed with your basic operating system, you will need to install them. When you install applications, fonts are often added to your collection.

Philip Shaw at www.codestyle.org maintains a useful list of the most commonly installed fonts for both Mac and Windows, shown in Figure 2-3. The most commonly reported fonts available on Windows computers are Tahoma, Microsoft Sans Serif, Verdana, and Courier New. On Macs expect Helvetica, Lucida Grande, and Courier.

My parents offered my brother and sister \$50 to teach me the alphabet, but that didn’t work. So I flunked second grade. I had the same nun again, and she was mean. She paddled me for two years, but I still didn’t learn the alphabet or how to read. By the time I was 15 or 16, I could get by in class with reading. But I could never spell. I was a woodshop major in high school, and my typical report card was two Cs, three Ds, and an F. I just got used to it. Though reading is still difficult for me, I do like readers. I like the written language because I like photocopying. I believe in double-spacing, since it helps my business!

.....
 Paul Orfalea,
 founder of Kinko’s,
 discussing his reading disability



Figure 2-3 The most commonly installed fonts on Windows, Macintosh, and Linux (March, 2010)

Use of **Cascading Style Sheets (CSS)**, preferred over the deprecated HTML tag, allows you to be quite precise about font faces, sizes, and other attributes (see Table 2-1).

| Property | Value | Description |
|-----------------|---|--|
| color | color | Sets the color of text |
| direction | ltr rtl | Sets the text direction. Use with Unicode-bidi property |
| line-height | normal number length % | Sets the distance between lines |
| letter-spacing | normal length | Increases or decreases space between characters |
| text-align | left right center justify | Aligns the text in an element |
| text-decoration | none underline overline line-through blink | Adds decoration to text |
| text-indent | length % | Indents the first line of text in an element |
| text-shadow | none color length | |
| text-transform | none capitalize uppercase lowercase | Controls the letters in an element |
| unicode-bidi | normal embed bidi-override inherit | Use for languages that run from left to right or both. Works with direction property |
| vertical-align | baseline sub super top text-top middle bottom text-bottom length % | Sets the vertical alignment of an element |

Table 2-1 Available Text Properties Using Cascading Style Sheets (CSS)

| Property | Value | Description |
|--------------|-------------------------|---|
| white-space | normal pre nowrap | Sets how white space inside an element is handled |
| word-spacing | normal length | Increases or decreases space between words |

Table 2-1 Available Text Properties Using Cascading Style Sheets (CSS) (Continued)

WARNING Although in HTML and using CSS you can specify a base font size, color, and other attributes for displaying text on a web page, you still have no guarantee that the font is installed in the user's system. If it is missing, a browser will attempt to substitute a similar font, but the look is not guaranteed to be the same as the one you have designed. In the font-family property you should add a generic catch-all such as "serif" or "sans serif" to cover an instance when your specified fonts are unavailable. If the right look is important to you, provide a way to download the font to the end user's computer. If the look is crucial, use a bitmap image of the text drawn in the selected font.

In a font-family list, you can include the names of both Windows and Macintosh fonts; if a font is not found on the local computer, the browser's preference-specified default font will be used.

```
h1 {font-family: Helvetica, Arial, Verdana, sans-serif;}
```

To address copyright and cross-platform font issues, Microsoft hired type designer Matthew Carter of Carter & Cone Type, Inc. ([http://new.myfonts.com/foundry/Carter_and_Cone_Type_Inc./](http://new.myfonts.com/foundry/Carter_and_Cone_Type_Inc/)) to design a serif font and a sans serif font that display well on a computer monitor. The two fonts Carter designed are Georgia (the serif font) and Verdana (the sans serif font), both of which Microsoft makes available for free. Since they are freely available and designed specifically for screen display, many designers recommend them as a "first choice" when specifying font faces for web pages.

Animating Text There are plenty of ways to retain a viewer's attention when displaying text. For example, you can animate bulleted text and have it "fly" onto the screen. You can "grow" a headline a character at a time. For public speakers, simply highlighting the important text works well as a pointing device. When there are several points to be made, you can stack keywords and flash them past the viewer in a timed automated sequence (as in the roadside Burma Shave ads—signs placed every half mile or so along the highway, each offering the motorist just a few more words toward a complete slogan). You might fly in some keywords, dissolve others, rotate or spin others, and so forth, until you have a dynamic bulleted list of words

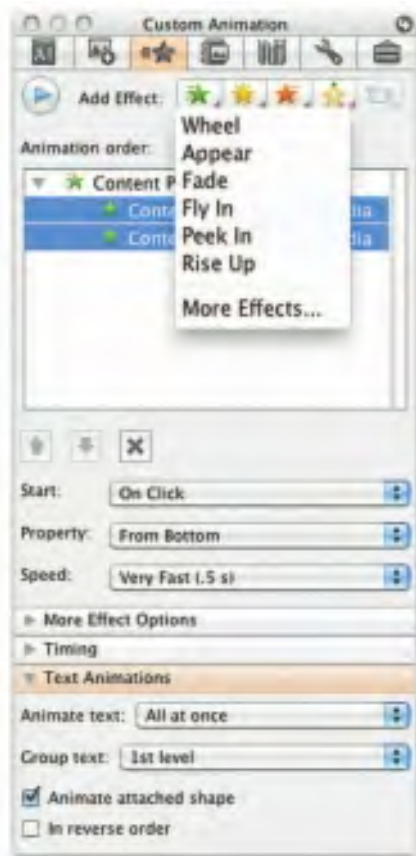

that is interesting to watch. But be careful—don't overdo the special effects, or they will become boring. For simple presentations, PowerPoint (see the custom Animation Palette at left) has bells and whistles to reveal a line of text one word or one letter at a time, or to animate an entire line.

Symbols and Icons

Symbols are concentrated text in the form of stand-alone graphic constructs. Symbols convey meaningful messages. The trash can symbol, for instance, tells you where to throw away old files; the hourglass cursor tells you to wait while the computer is processing. Though you may think of symbols as belonging strictly to the realm of graphic art, in multimedia you should treat them as text—or visual words—because they carry meaning. Symbols such as the familiar trash can and hourglass are more properly called **icons**: these are symbolic representations of objects and processes common to the graphical user interfaces of many computer operating systems.

Certainly text is more efficient than imagery and pictures for delivering a precise message to users. On the other hand, pictures, icons, moving images, and sounds are more easily recalled and remembered by viewers. With multimedia, you have the power to blend both text and icons (as well as colors, sounds, images, and motion video) to enhance the overall impact and value of your message.

Word meanings are shared by millions of people, but the special symbols you design for a multimedia project are not; these symbols must be learned before they can be useful message carriers. Some symbols are more widely used and understood than others, but readers of even these common symbols had to grow accustomed to their meanings. Learning a system of symbols can be as difficult as lessons in any foreign language.

WARNING Do not be seduced into creating your own language of symbols and icons.

Here are some symbols you may already know:

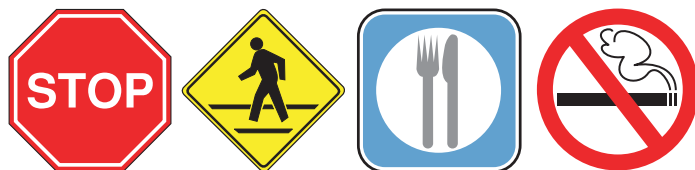

And here are some astronomer's symbols from the days of Kepler and Galileo that you may not have learned. Still in heavy use by astrologers, they represent the 12 constellations of the zodiac:

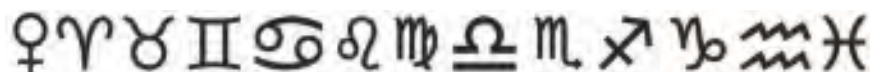

But why are there 13 icons in the preceding illustration? Or did you notice? Find the sign for the planet Venus among the constellations. Not easy if you are unfamiliar with the meaning of these symbols.

When early computers began to display bitmaps as well as lines of text, there was a flurry of creative attempts by graphic artists to create interesting navigational symbols to alleviate the need for text. The screens were pure graphic art and power—all lines and angles and stunning shadows. But many users were frustrated because they could not get to the data right away and had to first wade through help and guidance material to learn the symbols. In this context it is clearly safer, from a product design point of view, to combine symbols with text cues. This ensures the graphic impact of the symbols but allows prompting the user on their meaning. The Macintosh trash can icon, incidentally, also has a text label, “Trash,” just in case people don’t get the idea from the symbol. Indeed, long arguments occur among designers dealing with clarity of meaning and ambiguity: the Macintosh trash can is used to obliterate files but is also used to eject discs and mounted volumes, which are not “trashed” when ejected.

Nonetheless, a few symbols have emerged in the interactive multimedia world as an accepted lexicon of navigation cues that do not need text. These symbols are by no means universal, but Figure 2-4 shows some that have roots from the days of teletypewriters, others from early computer software and hardware development, and yet others from the consumer electronics world. Even for these “common symbols,” text labels are often added to the graphic icons to avoid uncertainty. Microsoft’s Word and Adobe’s Acrobat, for example, use an icon representing a 3.5" diskette to indicate “Save to Disk.” While this storage medium has been relegated to museums, the iconic meaning persists.

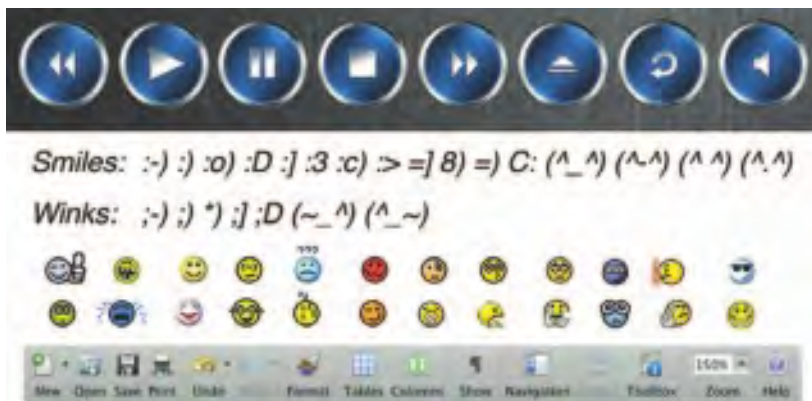

Figure 2-4 Some symbols, like Play, Pause, and Fast Forward, are easily recognized but may still be more precise with text titles. “Smiley” symbols, or emoticons, used in Internet conversation to express mood, once were made up entirely of text and punctuation characters. These have been replaced by both custom-made graphic symbols and official type characters as part of the international Unicode library (Block 1F600..1F64F). Indeed, sometimes it’s difficult to know what a smiley really *means!* ☺

Menus for Navigation

An interactive multimedia project or web site typically consists of a body of information, or content, through which a user navigates by pressing a key, clicking a mouse, or pressing a touch screen. The simplest menus consist of text lists of topics. Users choose a topic, click it, and go there. As multimedia and graphical user interfaces become pervasive in the computer community, certain intuitive actions are being widely learned.

For example, if there are three words on a computer screen, the typical response from the user, without prompting, is to click one of these words to evoke activity. Sometimes menu items are surrounded by boxes or made to look like push buttons. Or, to conserve space, text such as Throw Tomatoes, Play Video, and Press to Quit is often shortened to Tomatoes, Video, and Quit. Regardless, the user deduces the function.

Text is helpful to users to provide persistent cues about their location within the body of content. When users must click up and down through many layers of menus to reach their goal, they may not get lost, but they may feel transported to the winding and narrow streets of a medieval city where only the locals know the way. This is especially true if the user moves slowly from screen to screen en route to that goal. If Throw Tomatoes leads to Red or Green, then to California or Massachusetts, then to President or Vice President, then to Forehead or Chest, then to Arrested or Got Away, and so on, the user can end up tangled in the branches of a navigation tree without cues or a map. However, if an interactive textual or symbolic list of the branches taken (all the way from the beginning) is continuously displayed, the user can at any time skip intervening steps in a nonlinear manner or easily return to one of the previous locations in the list.

```

Tomatoes
  Red
    Massachusetts
      President
        Chest
          Arrested
  
```

The more locations included in the menu list, the more options available for navigation. On the Web, designers typically place on every page at least a Main Menu of links that offers the user a handhold and mechanism for returning to the beginning. Often they will also place a list, such as

[Home](#) > [Store](#) > [Home & Garden](#) > [Patio & Grilling](#) > [Gas Grills & Accessories](#) > [Gas Grills](#) > [Burners](#)

along the tops of storefronts to let shoppers know where they are currently located within the store. Inventive interface developers first referred to this

array of menu items as “breadcrumbs,” for they represent a map of the virtual forest and often the “trail” users have taken, like the edible markers so intelligently placed by Hänsel und Gretel along the way to the witch’s house in the Brother Grimms’ famous fairytale.

Navigation methodologies and navigation maps are discussed in greater detail in Chapter 13.

TIP *Avoid using more than a few levels of GO BACKs or RETURNs if you do not provide a map. Too much tunneling in and out with repetitive mouse clicks will frustrate users and discourage exploration. Display a perpetual menu of interactive text or symbolic cues so users can always extricate themselves from any place in the tunnel. In a web browser, this can be handled by a Back or Previous button containing a history of pages visited.*

Buttons for Interaction

In most modern cultures a doorbell is recognized by its context (next to the door itself, possibly lit); but if you grew up in a high-rise apartment, you may have seen 50 or more buttons at the entrance. Unless you knew that yours was the third from the top on the left, you could find your button only by reading the printed or scrawled name beside it. And certainly your Aunt Barbara needed this text cue to avoid having to push the Help button, which in this case rang in the building superintendent’s apartment.

In multimedia, **buttons** are the objects, such as blocks of text, a pretty blue triangle, or a photograph, that make things happen when they are clicked. They were invented for the sole purpose of being pushed or prodded with cursor, mouse, key, or finger—and to manifest properties such as highlighting or other visual or sound effects to indicate that you hit the target. On the Web, text and graphic art may be buttons. Buttons and the art of button design and human interaction are discussed in detail in Chapter 10. For now, remember that the rules for proper selection of text and fonts in your projects apply to buttons as well as headlines, bulleted items, and blocks of text.

The automatic button-making tools supplied with multimedia and HTML page authoring systems are useful, but in creating the text for you, they offer little opportunity to fine-tune the look of the text. Character- and word-wrap, highlighting, and inverting are automatically applied to your buttons, as needed, by the authoring system. These default buttons and styles may seem overused or trite, but by using common button styles, shapes, borders, and highlights, you increase the probability that users will know what to do with them—especially when they are also labeled.

Pick a font for buttons that is, above all, legible; then adjust the text size of the labels to provide adequate space between the button’s rim and



When I was four years old, a button was the little plastic knob mounted in brass next to the front door. When I pushed it, a muffled ringing sound worked its way through the house from the kitchen. Sometimes I would push the button a lot and somebody would always come to the door. As an adult, I’m still pushing buttons to make things happen.

.....

Ann Stewart, Multimedia Developer, Smyrna, Tennessee

the text. You can choose from many styles of buttons and several standard methodologies for highlighting. You will want to experiment to get the right combinations of font, spacing, and colors for just the right look.

In most authoring platforms, it is easy to make your own buttons from bitmaps or drawn objects. In a message-passing authoring system, where you can script activity when the mouse button is up or down over an object, you can quickly replace one bitmap with another highlighted or colored version of the bitmap to show that the button has been “pushed” or that the mouse is hovering over it. Making your own buttons from bitmaps or drawn objects gives you greater design power and creative freedom and also ensures against the missing font problem. On the other hand, this custom work may require a good deal more time. You can also implement these graphic image **rollovers** on web pages, using JavaScript to replace the image when there is a MouseOver or hover event; when a MouseUp event occurs on the image, the user can be directed to another page (see “Clickable Buttons” in Chapter 13). Typically the destination address (URL) is displayed in the status bar of the browser when the mouse is over a linked image or text element. So users know first if the mouse is over an active button and second, where that button will take them if they click.

Whether default or custom, treat the design and labeling of your buttons as an industrial art project: buttons are the part of your project the user touches.

Fields for Reading

You are already working uphill when you design text to be read on the screen. Experiments have shown that reading text on a computer screen is slower and more difficult than reading the same text in hard-copy or book form. Indeed, many users, it seems, would rather print out their reports and e-mail messages and read them on paper than page through screens of text. Reading hard copy is still more comfortable.

WARNING *Research has shown that when people read text on a computer screen they blink only 3 to 5 times per minute, but they blink 20 to 25 times per minute when reading text on paper. This reduced eye movement may cause dryness, fatigue, and possibly damage to the eyes. Research also suggests that monitors should be placed lower than eye level.*

Unless the very purpose of your multimedia project or web site is to display large blocks of text, try to present to the user only a few paragraphs of text per page. Use a font that is easy to read rather than a prettier font that is illegible. Try to display whole paragraphs on the screen, and avoid

breaks where users must go back and forth between pages to read an entire paragraph.

Portrait vs. Landscape

Traditional hard-copy and printed documents in the taller-than-wide orientation are simply not readable on a typical monitor with a wider-than-tall aspect ratio. The taller-than-wide orientation used for printed documents is called **portrait**; this is the 8.5-by-11-inch size unique to the United States or the internationally designated standard A4 size, 8.27 by 11.69 inches. The wider-than-tall orientation normal to monitors is called **landscape**. Shrinking an 11-inch-tall portrait page of text into your available monitor height usually yields illegible chicken tracks. There are four possible solutions if you are working with a block of text that is taller than what will fit:

- Put the text into a scrolling field. This is the solution used by web browsers.
- Put the text into a single field or graphic image in a project window, and let the user move the whole window up or down upon command. This is most appropriate when you need to present text with page breaks and formatting identical to the printed document. This is used by Adobe's popular Acrobat Reader for displaying PDF files.
- Break the text into fields that fit on monitor-sized pages, and design control buttons to flip through these pages.
- Design your multimedia project for a special monitor that is taller than it is wide (portrait) or a normal monitor rotated onto its side. Dedicated “page view” monitors are expensive; they are used for commercial print-based typesetting and layout. Video controllers can rotate the text display for you:



Electronic ink is a proprietary material that is processed into a film for integration into electronic displays. Although revolutionary in concept, electronic ink is a straightforward fusion of chemistry, physics and electronics to create this new material. The principal components of electronic ink are millions of tiny microcapsules, about the diameter of a human hair. In one incarnation, each microcapsule contains positively charged white particles and negatively charged black particles suspended in a clear fluid. When a negative electric field is applied, the white particles move to the top of the microcapsule where they become visible to the user. This makes the surface appear white at that spot. At the same time, an opposite electric field pulls the black particles to the bottom of the microcapsules where they are hidden. By reversing this process, the black particles appear at the top of the capsule, which now makes the surface appear dark at that spot. To form an E Ink electronic display, the ink is printed onto a sheet of plastic film that is laminated to a layer of circuitry. The circuitry forms a pattern of pixels that can then be controlled by a display driver. These microcapsules are suspended in a liquid “carrier medium” allowing them to be printed using existing screen printing processes onto virtually any surface, including glass, plastic, fabric, and even paper. Ultimately electronic ink will permit most any surface to become a display, bringing information out of the confines of traditional devices and into the world around us.

From E Ink Corporation
(www.eink.com)

eBooks, E-Readers, and Tablet Computers

eBooks are books digitized and formatted to be read using an eReader. eReaders display text, graphics, and multimedia—most using E Ink screens between five and ten inches diagonal, some with touch screens, some with wi-fi and 3G connectivity, and all with varying and sometimes non-standard input formats (see Table 2-2). Among eBook devices are the Apple iPad, Arrow, Astak EZ Reader, Barnes & Noble Nook, BeBook Neo, COOL-ER, Cybook, Foxit eSlick, iLiad, iRex Digital Reader, Jetbook, Kindle, and the Sony Reader.

| Format | Filename Extension |
|--------------------------|--------------------|
| Plain text | .txt |
| HTML | .html |
| PostScript | .ps |
| Portable Document Format | .pdf |
| DjVu | .djvu |
| EPUB | .epub |
| FictionBook | .fb2 |
| Mobipocket | .prc, .mobi |
| Kindle | .azw |
| eReader | .pdb |
| Broadband eBook | .lrf, .lrx |
| WOLF | .wol |
| Tome Raider | .tr2, .tr3 |
| ArghosReader | .aeh |
| Microsoft Reader | .lit |
| Multimedia eBook | .exe |

Table 2-2 E-Readers Can Read Many File Formats, Some Proprietary

The e-Ink screen is a technology for “electronic paper,” designed to imitate the appearance of ordinary ink on paper (see sidebar). e-Ink displays can be used in direct sunlight and boast a long battery life. But e-Ink is not required to read eBooks, which can be viewed on most computers and many Personal Digital Assistants (PDAs) and mobile phones using format converting/reading software such as Adobe Digital Editions.

HTML Documents

The standard document format used for displaying text pages on the Web is called Hypertext Markup Language (HTML). In an HTML document you can specify typefaces, sizes, colors, and other properties by “marking up” the text in the document with **tags**. The process of marking up documents or “styling” them is simple: Where you want text to be bold, surround it with the tags `` and `` or `` and ``; the text between the tags will then be displayed by your browser application in bold type. Where you have a header, surround it with `<H1>` and `</H1>`; for an ordered list of things (1, 2, 3, ... or a, b, c, ..., etc.), surround your list with `` and ``. There are many tags you can use to lay out a page. Cascading Style Sheets (CSS) work in conjunction with HTML and provide fine tuning and control of text and layout. How HTML and CSS work is discussed in greater detail in Chapters 12 and 13, and there are many good learning guides and references available on the Web.

.....
www.w3.org/TR/html4/

www.w3.org/MarkUp/Guide/

www.w3schools.com/html/default.asp

www.w3.org/Style/CSS/

Check out these web sites for more information about HTML

The remarkable growth of the Web is straining the “old” designs for displaying text on computers. Indeed, while marked-up text files (HTML documents) remain at the foundation of Web activity, when you visit a well-designed web site, you often discover graphic images, animations, and interactive work-arounds contrived to *avoid* displaying text. The neat paragraphs, indented lists, and formats for text documents for which HTML was originally intended are evolving into multimedia documents, not text documents, and the original HTML method and standard is consequently suffering great stress.

HTML Version 5 is a redesign that stretches into a multimedia delivery tool, making HTML no longer just a text display tool with assorted attachments and plugged-in objects. A new `<canvas>` element allows a box to be defined on a web page in which 2-D graphics can be drawn under program control. Video and audio (timed media) playback is supported. Still, HTML doesn't provide you with much flexibility to make pretty text elements, which are often done as graphical bitmaps placed within the HTML document's layout with image tags, ``, or incorporated into Flash animation files. Indeed, using plain HTML, you do not know what

font a reader will use to view your document—the default display font is a preference that can be set in the viewer’s browser, which knows it’s installed on that viewer’s machine. So some viewers may read your words in serif Times Roman, others in sans serif Helvetica or Arial.

Computers and Text

Very early in the development of the Macintosh computer’s monitor hardware, Apple chose to use a resolution of 72 pixels per inch. This matches the standard measurement of the printing industry (72 points per inch) and allows desktop publishers and designers to see on the monitor what their printed output will look like (WYSIWYG). In addition, Apple made each pixel square-shaped, providing even measurements in all directions. Until the Macintosh was invented, and the VGA video standard set for the PC (at 96 pixels per inch), pixels were typically taller than they were wide. The aspect ratio for a pixel on older EGA monitors, for example, is 1.33:1, taller than it is wide. VGA and SVGA monitor resolutions for both Macintosh and Windows display pixels at an aspect ratio of 1:1 (square).

The Font Wars Are Over

In 1985, the desktop publishing revolution was spearheaded by Apple and the Macintosh computer, in combination with word processing and page layout software products that enabled a high-resolution 300 dpi laser printer using special software to “draw” the shapes of characters as a cluster of square pixels computed from the geometry of the character. This special software was the **Adobe PostScript** page description and **outline font** language. It was licensed by Apple and included in the firmware of Apple’s LaserWriter laser printer.

PostScript is really a method of describing an image in terms of mathematical constructs (Bézier curves), so it is used not only to describe the individual characters of a font but also to describe entire illustrations and whole pages of text. Because each PostScript character is a mathematical formula, it can be easily scaled bigger or smaller so it looks right whether drawn at 24 points or 96 points, whether the printer is a 300 dpi LaserWriter or a high-resolution 1200, 2400, or even 3600 dpi image setter suitable for the finest print jobs. And the PostScript characters can be drawn much faster than in the old-fashioned way. Before PostScript, the printing software looked up the character’s shape in a bitmap table containing a representation of the pixels of every character in every size. PostScript quickly became the de facto industry font and printing standard for desktop publishing and played a significant role in the early success of Apple’s Macintosh computer.

There are two kinds of PostScript fonts: Type 3 and Type 1. Type 3 font technology is *older* than Type 1 and was developed for output to printers; it is rarely used by multimedia developers. There are currently over 6,000 different Type 1 typefaces available. Type 1 fonts also contain **hints**, which are special instructions for grid-fitting to help improve resolution. Hints can apply to a font in general or to specific characters at a particular resolution.

Other companies followed Adobe into the desktop publishing arena with their own proprietary and competitive systems for scalable outline fonts. In 1989, Apple and Microsoft announced a joint effort to develop a “better and faster” quadratic curves outline font methodology, called **TrueType**. In addition to printing smooth characters on printers, TrueType would draw characters to a low-resolution (72 dpi or 96 dpi) monitor. Furthermore, Apple and Microsoft would no longer need to license the PostScript technology from Adobe for their operating systems. Because TrueType was based on Apple technology, it was licensed to Microsoft. Adobe and Microsoft then developed a new and improved font management system incorporating the best features of both PostScript and TrueType, and by 2007, **OpenType** became a free, publicly available international standard. The font wars were over.

WARNING *TrueType, OpenType, and PostScript fonts do not display (or print) exactly the same, even though they may share the same name and size. The three technologies use different formulas. This means that word-wrapping in a text field may change. So if you build a field or a button that precisely fits text displayed with a PostScript font, be aware that if you then display it with the same font in TrueType or OpenType, the text may be truncated or wrapped, wrecking your layout.*

Font Foundries

Today collections of fonts are available through retail channels or directly from their manufacturers. Typefaces are created in a **foundry**, a term much like case, that has carried over from times when lead was poured into molds to make letter faces. There is also a special interest group (SIG) at America Online (go to Computing:Software Libraries:Desktop & Web Publishing Forum:Fonts) where people who enjoy designing and making interesting fonts post them for others to download—hundreds and hundreds of them with names like Evil of Frankenstein, CocaCola, Kerouac, LED, PonchoVia (sic), Spaghetti, TreeFrog, and Sassy. When you purchase some applications, such as CorelDraw or Adobe Illustrator, many extra fonts are included for free.

.....
www.typequarry.com/

www.oldfonts.com/

www.myfonts.com/

www.bitstream.com/

www.will-harris.com/

Commercial type foundries and font sites. These gateways lead to a discussion of fonts and where to find them. With *Esperfonto*, Will Harris provides an interesting tool for making font decisions: Casual or Formal, Body or Display, Friendly or Serious, Cool or Warm, Modern or Traditional.

WARNING *It is easy to spend hours and hours downloading neat and interesting fonts; they are like the midnight snack table on a Caribbean cruise liner—ice carvings and delectable goodies laid out as far as the eye can see.*

Character Sets and Alphabets

Knowing that there is a wide selection of characters available to you on your computer and understanding how you can create and use special and custom-made characters will broaden your creative range when you design and build multimedia projects.

The ASCII Character Set

The **American Standard Code for Information Interchange (ASCII)** is the 7-bit character coding system most commonly used by computer systems in the United States and abroad. ASCII assigns a number or value to 128 characters, including both lower- and uppercase letters, punctuation marks, Arabic numbers, and math symbols. Also included are 32 control characters used for device control messages, such as carriage return, line feed, tab, and form feed.

ASCII code numbers always represent a letter or symbol of the English alphabet, so that a computer or printer can work with the number that represents the letter, regardless of what the letter might actually look like on the screen or printout. To a computer working with the ASCII character set, the number 65, for example, always represents an uppercase letter *A*. Later, when displayed on a monitor or printed, the number is turned into the letter.

ASCII was invented and standardized for analog teletype communication early in the age of bits and bytes. The capabilities of the technology have now moved far beyond the original intent of the standard, but because millions of installed computers and printers use ASCII, it is difficult to set any new standards for text without the expense and effort of replacing existing hardware. At least, for these 128 characters, most computers and printers share the same values.

The Extended Character Set

A byte, which consists of eight bits, is the most commonly used building block for computer processing. ASCII uses only seven bits to code its 128 characters; the eighth bit of the byte is unused. This extra bit allows another 128 characters to be encoded before the byte is used up, and computer systems today use these extra 128 values for an extended character set. The extended character set is most commonly filled with ANSI (American National Standards Institute) standard characters, including often-used symbols, such as ¢ or ∞, and international diacritics or alphabet characters, such as ä or ñ. This fuller set of 255 characters is also known as the ISO-Latin-1 character set; it is used when programming the text of HTML web pages.

NOTE *The rules for encoding extended characters are not standardized. Thus ASCII value 165, for example, may be a bullet (•) character on the Macintosh or the character for Japanese yen (¥) in Windows (ANSI).*

Unicode

As the computer market has become more international, one of the resulting problems has been handling the various international language alphabets. It was at best difficult, and at times impossible, to translate the text portions of programs from one script to another. For example, the differences between the Latin script (also known as “Roman”) used by western European writers and the kanji script used by Japanese writers made it particularly challenging to transfer innovative programs from one market to another.

Since 1989, a concerted effort on the part of linguists, engineers, and information professionals from many well-known computer companies has been focused on a 16-bit architecture for multilingual text and character encoding. Called **Unicode**, the original standard accommodated up to about 65,000 characters to include the characters from all known languages and alphabets in the world.





Figure 2-5 Writing systems currently in use around the world. Unicode provides a consistent methodology for encoding the characters of any alphabet.

While 65,000 characters are sufficient for encoding most of the many thousands of characters used in major languages of the world, the Unicode standard and ISO/IEC 10646 now support three encoding forms that use a common repertoire of characters but allow for encoding as many as a million more characters. This is sufficient for all known character encoding requirements, including full coverage of all historic scripts of the world, as well as common notational systems.

Where several languages share a set of symbols that have a historically related derivation, the shared symbols of each language are unified into collections of symbols (called **scripts**). A single script can work for tens or even hundreds of languages (for example, the Latin script used for English and most European languages). Sometimes, however, only one script will work for a language (such as the Korean Hangul). Figure 2-5 shows a map of writing systems used in the world today.

The Unicode standard includes more than 18,000 Han characters (ideographs for Japanese, Chinese, and Korean) as well as obsolete alphabets such as cuneiform, hieroglyphs, and ancient Han characters. In addition, character space is reserved for users and publishers to create their own scripts, designed especially for their own applications. For example, a carpenter might develop a script that included a character meaning “half-inch Sheetrock,” another character meaning “three-quarter-inch plywood,” and so forth. HTML allows access to the Unicode characters by numeric reference. Thus `水` (in hexadecimal) represents the Chinese character for water:



The Unicode® Standard: A Technical Introduction
(www.unicode.org/unicode/standard/principles.html)

Mapping Text Across Platforms

If you build your multimedia project on a Windows platform and play it back on a Macintosh platform (or vice versa), there will be subtle (and sometimes not-so-subtle) differences. Fonts are perhaps the greatest cross-platform concern, because they must be mapped to the other machine. If a specified font doesn't exist on the target machine, a substitute must be provided that does exist on the target. This is **font substitution**. In many cross-platform-savvy applications, you can explicitly define the **font mapping**. Table 2-3 shows some typical mappings when crossing platforms.



| Mac→Win | Win→Mac |
|--|--|
| Mac:Chicago→Win:System | Win:Arial→Mac:Helvetica |
| Mac:Courier→Win:Courier New | Win:Courier→Mac:Courier |
| Mac:Geneva→Win:MS Sans Serif | Win:Courier New→Mac:Courier |
| Mac:Helvetica→Win:Arial | Win:MS Serif→Mac:New York |
| Mac:Monaco→Win:Terminal | Win:MS Sans Serif→Mac:Geneva |
| Mac:New York→Win:MS Serif | Win:Symbol→Mac:Symbol Map None |
| Mac:Symbol→Win:Symbol Map None | Win:System→Mac:Chicago |
| Mac:Times→Win:Times New Roman (sizes: 14→12, 18→14, 24→18, 30→24) | Win:Terminal→Mac:Monaco |
| Mac:Palatino→Win:Times New Roman | Win:Times New Roman→Mac:Times (sizes: 12→14, 14→18, 18→24, 24→30) |

Table 2-3 Typical Mappings for Common Macintosh and Windows Fonts

TIP Never assume that the fonts you have installed on your computer will also be installed on another person's computer. Pay attention to the way you include fonts in a project so that you never face the nightmare of your carefully picked fonts being replaced by an ill-suited default font like Courier (see the next "First Person"). If your work is being distributed to sites that may not have the fonts you are using, or if you do not license these fonts for distribution with your work, be sure to bitmap the special font text you use for titles, headlines, buttons, and so forth. For text to be entered by users, it is safest to stay with the installed Windows or Macintosh fonts, because you know they are universally available on that platform. In Windows, use the TrueType fonts installed during the Setup procedure.

First Person

We had a short break between sessions to install the software for a panel discussion about multimedia. Four of us brought media with discussion material. Our moderator installed her presentation first, and

we heard her wail, “Something’s wrong with my fonts!” We all looked at her ugly 48-point Courier and felt sorry for her; we knew her mistake. The beautiful fonts she had installed on her home system were

not installed in the system of the computer being used for the big-screen projector, and she had failed to bring the fonts along. By then, it was too late anyway.

Always be sure your fonts travel with your application when you are delivering software to run on a hardware platform other than the one you used to create the application. To avoid many font display problems, particularly for menus and headlines, you may wish to snap a picture of your text with a screen capture utility and use this image, or bitmap, instead of text that you type into a text field. (Chapter 3 describes bitmaps and how to capture and edit images.) This will ensure that the screen always looks right, regardless of what hardware platform you use or what fonts are installed.

It is not just fonts that are problematic; characters, too, must be mapped across platforms. Character mapping allows bullets, accented characters, and other curious characters that are part of the extended character set on one platform to appear correctly when text is moved to the other platform. Curly quotation marks, for example, rarely, if ever, map successfully across platforms.

Languages in the World of Computers

In modern Western languages, words are made up of symbols or letters strung together, representing as a whole the sounds of a spoken word. This is not so for Eastern languages such as Chinese, Japanese, and Korean (and the ancient languages of Sumeria, Egypt, and Mesopotamia). In these languages, an entire concept might be represented by a single word symbol that is unrelated to a specific phonetic sound.

The letters or symbols of a language are its alphabet. In English, the alphabet consists of 26 Roman or Latin letters; in Japanese, the kanji alphabet comprises more than 3,000 kanas, or whole words. The Russian alphabet, made up of Cyrillic characters based on the ancient Greek alphabet, has about the same number of letters as the Roman alphabet. All languages, from Navajo to Hebrew, have their own unique alphabets.

First Person

While we were in the early phases of producing my CD-ROM, *Multimedia: Working It Out!* I sold the rights to distribute it into Korea and Mainland China. Nobody on the production team had ever seen a computer that typed short-form Mandarin, and we knew that even when the English was localized, we would be hard pressed to recognize any of the text, much less edit or alter it in its new form.

So we devised a structured system of labels and names for *Multimedia: Working It Out!* and converted all the text in the project (about 600 “pages” of about a paragraph each) into 1-bit bitmaps in a Director movie. Donna Booher edited and formatted the text in Microsoft Word, Dan Hilgert bitmapped and screen-captured each page with Capture and Photoshop, and Peter Wolf imported the PICT files into Director (by the hundreds) as cast members. Each cast member had a unique (but systematic) name associated with a Director movie, a heading, and various icons. It took a while.

The localizers across the Pacific, then, would simply translate a page or a series of pages using their own native-language word processor, capture their own bitmaps, and we would substitute the new bitmaps

for the old using the unique identification labels. No language skills required!

When we started, Terry Thompson devised a color-coded master filing system and database so that all the word-processed text and the screen-captured bitmaps would remain neatly side by side and concurrent. This is called *version control*. By the time this project shipped, Donna’s computer was crashing four or five times a day and we had lost files, Dan had gone back to school, Peter and I were slapping miscellaneous text elements into the project without tracking where they came from, and we were changing labels and moving cast members around as we streamlined performance, debugged, and staggered toward a golden master and the Federal Express drop-off. We had converted Terry’s neatly organized system into chaos.

After the CD-ROMs were pressed, and there wasn’t anything anybody could change anymore anyway, we did a tricky thing with Lingo programming, DeBabelizer, and OmniPage Pro to convert the final project’s bitmapped text back into word processor text.

First we collected all the bitmapped text into a single Director movie (we

weren’t interested in pretty pictures, QuickTime, sounds, or other types of cast members, just text). Then we placed each page of bitmapped text into a movie frame (Cast to Time), neatly labeled that frame at the top with the identifying code of the image using a Lingo handler, and saved all of the frames as PICT images (an automatic command in Director’s Export menu). With DeBabelizer, we batch-converted these hundreds of PICT images from 72 dpi (screen capture resolution) to 300 dpi (printer resolution) and saved each as a 1-bit TIFF image. The process was automatic.

OmniPage Pro is a powerful optical character recognition (OCR) program that usually reads documents on a flatbed scanner and turns them into nicely formatted word processing documents. OmniPage (ah ha!) allows batch processing of TIFF (and more recently, PICT) images at 300 dpi, so we ran all of these TIFFs (automatically) through OmniPage, and bingo!, they came out as archival word processing files. Then we sent the word files to Guido Mozzi in Italy so that his team of translators could begin localizing there.

Some efforts are cyclical, we have discovered. The trick is to learn something and improve the process each time the task comes around!

The written Japanese language consists of three different types of character sets, namely: kanji, katakana, and hiragana. Kanji was originally taken from the Chinese language and is essentially a pictographic representation of the spoken word. Each kanji has two different readings, “on-yomi” and “kun-yomi,” respectively, the “Chinese rendering” and the “Japanese rendering.” Both are used depending on the conjugation of the kanji with other kanji.

Due to certain incompatibilities between the Japanese spoken word and kanji, two sets of kana or phonetic syllabary (alphabet) were developed. Katakana is the “square” kana and is used today for writing only foreign words or onomatopoeic expressions. Hiragana is the “cursive” kana and can be used alone to represent a certain word or combined with kanji to form other words and sentences. Romaji, a more recent addition to the alphabets of Japan, allows for the phonetic spelling of the Japanese language using the Roman characters familiar to the Western world.

.....
 Ross Uchimura, Executive Vice-President, GC3 Ltd., a cross-cultural expert

Most modern alphabets share one very important attribute: the graphic shapes and method for writing the Arabic numbers 0 1 2 3 4 5 6 7 8 9. This is a simple system for representing decimal numbers, which lends itself to easy reading, writing, manipulation, and calculation. Expressing and performing

$$16 + 32 = 48$$

is much easier in Arabic numbers than in Roman or Greek numerals:

$$XVI + XXXII = XLVIII$$

$$\iota\varsigma + \lambda\beta = \mu\eta$$

Use of Arabic notation has gradually spread across the world to supplant other systems, although Roman numerals are still used today in Western languages in certain forms and contexts.

Translating or designing multimedia (or any computer-based material) into a language other than the one in which it was originally written is called **localization**. This process deals with everything from the month/day/year order for expressing dates to providing special alphabetical characters on keyboards and printers. Even the many Western languages that share the Roman alphabet have their own peculiarities and often require special characters to represent special sounds. For example, German has its umlaut (¨); French its various accents (é), the cedilla (ç), and other diacritics; and Spanish its tilde (ñ). These characters are typically available in the extended character set of a font.

Special Characters in HTML

In HTML, **character entities** based upon the ISO-Latin-1 standard make up the alphabet that is recognized by browser software on the World Wide Web. All of the usual characters of an English keyboard are included (the 7-bit ASCII set is built in), but for the extended character set that includes tildes, umlauts, accents, and special symbols, you must use an escape sequence to represent them in an ISO-Latin-1 HTML document. A character entity is represented either by a number or by a word and is always prefixed by an ampersand (escape) and followed by a semicolon. For example, the name for the copyright symbol is “copy” and its number is 169. The symbol may be inserted into a document either as © or as ©—either way, the character © is generated by the browser. The list of character entities allowed in standard HTML is growing and will soon include mathematical symbols and even icons to represent things like trash cans, clocks, and disk drives. Word processors

First Person

When I was in Germany some years ago, I read a curious report in the *Frankfurter Allgemeine* about a fellow who was suing the local electric utility for not correcting the spelling of his name to its proper form in the German alphabet. His name had an umlaut in it (Wörm), but his bill always read Woerm. In German, the letter ö sounds different from the letter o, so I can't say I blamed him. At first he didn't pay his bill, claiming that he wasn't that person; then the

courts told him to pay anyway. So he initiated a civil suit to protect his name.

It seems the utility was using a legacy IBM system with a high-speed chain printer to produce the monthly bills, and none of the umlaut characters were available on the ASCII-based chain. By longstanding convention, when you are limited to the English alphabet, the letter e immediately follows any

umlautless vowel, to indicate that the umlaut should be there but isn't. Today, with high-speed laser printers and special fonts, the problem has probably gone away.

More recently, there are reports that the California Department of Motor Vehicles cannot handle blank spaces in the name fields of its massive database, so Rip Van Winkle's name was changed to Rip VanWinkle without his permission. Expect a lawsuit.

for languages other than English automatically insert the necessary character entities when a document is saved in HTML format or specify the character set to use.

.....
www.w3.org/TR/REC-html40/sgml/entities.html

An encyclopedic discussion and reference for HTML character entity references

Multilanguage Web Pages

When building a project in more than one language for the Web, consider translating the languages that use Roman fonts and displaying them as text in the browser in the normal way. Languages other than English may have many escaped characters, as you can see in Figure 2-6. If Chinese or Japanese or Arabic is desired, translate the Roman text onto a computer running an operating system using that native language. For the web page, the translator can then capture a screen image of the translated text, and you can embed that image into your web page. This process takes precise coordination among the designers, the content providers, and the translators, but it can be done smoothly with careful labeling of the bits and pieces.

```

<p>
What can this integrated network solution offer your business? Lower
costs, increased flexibility, and greater reliability by supporting all voice
and data requirements, including:</p>
<p>
O que esta solu&ccedil;&atilde;o de rede integrada pode oferecer a sua
empresa? Menores custos, elevada flexibilidade, e maior confiabilidade,
pelo suporte a todos os requisitos de voz e dados, incluindo:</p>
<p>
Qu&eacute; puede ofrecerle a su negocio esta soluci&oacute;n integrada
de redes? Menores costos, mayor flexibilidad y mayor fiabil-idad mediante
la compatibilidad con todos los requisitos para voz y datos, incluso:</p>
<p>

這種綜合性的網路產品能為您的公司企業帶來哪些好處呢？它能降低成本，提昇
服務的靈活性，以及具有更大的可靠性，因為它能支持各種話音與數據傳輸的要
求，包括：

</p>
<p>

この統合的ネットワークソリューションは、以下を含む音声、データ要件のすべてに対応し、費用
削減、フレキシビリティや信頼性の向上を実現させます。

求，包括：

</p>

```

Figure 2-6 Portion of a five-language web site using normal HTML code for the Roman languages and screen-captured graphic images to display the Chinese and Japanese translations

Font Editing and Design Tools

Special font editing tools can be used to make your own type, so you can communicate an idea or graphic feeling exactly. With these tools, professional typographers create distinct text and display faces. Graphic designers, publishers, and ad agencies can design instant variations of existing typefaces.

Typeface designs fall into the category of industrial design and have been determined by the courts in some cases to be protected by patent. For example, design patents have been issued for Bigelow & Holmes' Lucida, ITC Stone, and Adobe's Minion.

WARNING *If your commercial project includes special fonts, be sure that your license agreement with the font supplier allows you to distribute them with your project.*

Occasionally in your projects you may require special characters. With the tools described in the paragraphs that follow, you can easily substitute characters of your own design for any unused characters in the extended character set. You can even include several custom versions of your client's company logo or other special symbols relevant to your content or subject right in your text font.

.....
www.fontfoundry.com

www.larabiefonts.com

There are hundreds of sites for downloading free and shareware fonts drawn by others. For starters, try these two.

Fontlab

Fontlab, Ltd., located at www.fontlab.com, specializes in font editors for both Macintosh and Windows platforms. You can use this software to develop PostScript, TrueType, and OpenType fonts for Macintosh, Windows, and Sun workstations. Designers can also modify existing typefaces, incorporate PostScript artwork, automatically trace scanned images, and create designs from scratch. A sample of the Fontographer screen is shown in Figure 2-7.

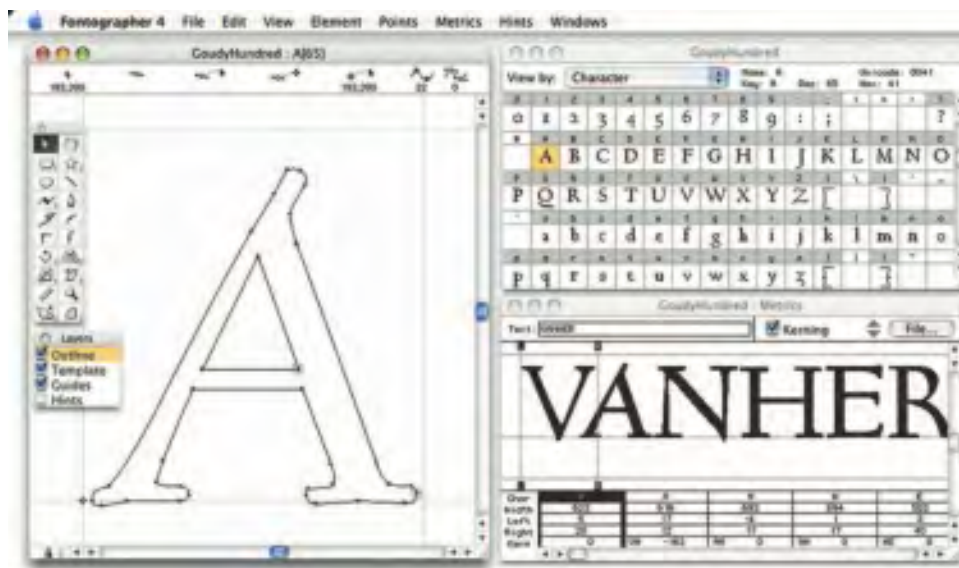

Figure 2-7 Fontographer is a powerful font editor for Macintosh and Windows.

Fontographer's features include a freehand drawing tool to create professional and precise inline and outline drawings of calligraphic and script characters, using either the mouse or alternative input methods (such as a pressure-sensitive pen system). Fontographer allows the creation of multiple font designs from two existing typefaces, and you can design lighter or heavier fonts by modifying the weight of an entire typeface.

Making Pretty Text

To make your text look pretty, you need a toolbox full of fonts and special graphics applications that can stretch, shade, shadow, color, and anti-alias

your words into real artwork. Pretty text is typically found in bitmapped drawings where characters have been tweaked, manipulated, and blended into a graphic image. Simply choosing the font is the first step. Most designers find it easier to make pretty type starting with ready-made fonts, but some will create their own custom fonts using font editing and design tools.

With the proper tools and a creative mind, you can create endless variations on plain-old type, and you not only choose but also customize the styles that will fit with your design needs.

Most image-editing and painting applications (see Figure 2-8 for a PowerPoint example) let you make text using the fonts available in your system. You can colorize the text, stretch, squeeze, and rotate it, and you can filter it through various plug-ins to generate wild graphic results.

As a multimedia developer, you may only need to be concerned about how your fonts look on monitors, not how they are printed to paper—unless, of course, you are printing perfect proposals, bids, storyboards, reports, and above all, invoices ☺. TrueType, OpenType, and PostScript outline fonts allow text to be drawn at any size on your computer screen without jaggies:



Figure 2-8 PowerPoint lets you manipulate text in many ways.

The Jaggies

Jaggies are avoided by anti-aliasing the edges of the text characters, making them seem smoother to the eye. Note the improved look of the anti-aliased letters in the bottom row of letters in Figure 2-9. Pasting an image that was anti-aliased against a light background onto a darker-colored background using transparency (so that the new, dark background is seen, instead of the old, light one) can be problematic: the blending pixels along the edge will show as a halo and may have to be edited pixel by pixel.

Macintosh and PCs handle anti-aliasing differently. Authoring programs such as Adobe Flash allow you to fine-tune anti-aliasing settings for text fields (see Figure 2-10), useful when you want a different look for text that will be static versus text that will be animated.



Figure 2-10 In some authoring programs, anti-aliasing can be fine-tuned.

Hypermedia and Hypertext

Multimedia—the combination of text, graphic, and audio elements into a single collection or presentation—becomes interactive multimedia when you give the user some control over what information is viewed and when it is viewed. Interactive multimedia becomes hypermedia when its designer provides a structure of linked elements through which a user can navigate and interact.

When a hypermedia project includes large amounts of text or symbolic content, this content can be indexed and its elements then linked



Figure 2-9 Anti-aliasing text and graphics creates “smooth” boundaries between colors. The top row of letters is not anti-aliased; the bottom row is.

When they first invented typesetting, there were variants cut of each character so that text would look as if it had been handwritten by a monk! Desktop designers have been fighting so hard to get their setting to look like it’s come from a Berthold system, that most of the new potential of desktop typography has been overlooked.

David Collier, Author of
*Collier’s Rules for Desktop Design
and Typography*

together to afford rapid electronic retrieval of the associated information. When words are keyed or indexed to other words, you have a **hypertext system**; the “text” part of this term represents the project’s content and meaning, rather than the graphical presentation of the text. Hypertext is what the World Wide Web is all about.

When text is stored in a computer instead of on printed pages, the computer’s powerful processing capabilities can be applied to make the text more accessible and meaningful. The text can then be called **hypertext**; because the words, sections, and thoughts are linked, the user can navigate through text in a nonlinear way, quickly and intuitively.

Using hypertext systems, you can electronically search through all the text of a computer-resident book, locate references to a certain word, and then immediately view the page where the word was found. Or you can create complicated Boolean searches (using terms such as AND, OR, NOT, and BOTH) to locate the occurrences of several related words, such as “Elwood,” “Gloria,” “mortgage,” and “happiness,” in a paragraph or on a page. Whole documents can be linked to other documents.

A word can be made hot, as can a button, thus leading the user from one reference to another. Click on the word “Elwood,” and you may find yourself reading a biography or resume; click on “mortgage,” and a calculator pops up. Some authoring systems incorporate a hypertext facility that allows you to identify words in a text field using a bold or colored style, then link them to other words, pages, or activities, such as playing a sound or video clip related to that hot word. You cannot do this kind of nonlinear and associative navigation in a sequentially organized book. But on a CD-ROM, where you might have more than 100,000 pages of text to investigate, search, and browse, hypertext is invaluable.

Because hypertext is the organized cross-linking of words not only to other words but also to associated images, video clips, sounds, and other exhibits, hypertext often becomes simply an additional feature within an overall multimedia design. The term “hyper” (from the Greek word “over” [ὑπερ]) has come to imply that user interaction is a critical part of the design, whether for text browsing or for the multimedia project as a whole. When interaction and cross-linking is then added to multimedia, and the navigation system is nonlinear, multimedia becomes hypermedia.

In 1945, Vannevar Bush wrote a seminal eight-page article, “As We May Think,” for the *Atlantic Monthly* (www.theatlantic.com/unbound/flashbks/computer/bushf.htm). This short treatise, in which he discusses the need for new methodologies for accessing information, has become the historic cornerstone of hypertext experimentation. Doug Englebart (inventor of the mouse) and Ted Nelson (who coined the term “hypertext” in 1965) have actively championed the research and innovations required of computer technology for implementing useful hypertext systems, and they have worked to combat the historic inertia of linear thought. Nelson

would claim that the very structure of thought is neither sequential nor linear and that computer-based hypertext systems will fundamentally alter the way humans approach literature and the expression of ideas during the coming decades.

The argument against this theory of associative thought is that people are, indeed, more comfortable with linear thinking and are easily overwhelmed by too much freedom, becoming quickly lost in the chaos of nonlinear gigabytes. As a practical reminder, it is important always to provide location markers, either text-and-symbol menus or illustrative maps, for users who travel the threads of nonlinear systems.

The Power of Hypertext

In a fully indexed hypertext system, all words can be found immediately. Suppose you search a large database for “boats,” and you come up with a whopping 1,623 references, or hits—among them, Noah’s Ark (open boat in water), television situation comedies (*The Love Boat*), political criticisms of cabinet members who challenged the status quo (rocked the boat), cabinet members who were stupid (missed the boat), and Christmas dinner trimmings (Grandmother’s gravy boat). So you narrow your search and look for “boats” and “water” when both words are mentioned on the same page; this time you get 286 hits. “Boats,” “water,” and “storms” gets you 37; “boats,” “water,” “storms,” and “San Francisco,” a single hit. With over a thousand hits, you are lost. With one hit, you have something! But you still may not find what you are looking for, as you can see in this fictional example:

The *storm* had come and gone quickly across the Colorado plains, but *water* was still puddled at the foot of the house-high bank of mud that had slid into town when the dam burst. In front of the general store, which had remained standing, four strong men carefully lifted a tiny *boat* onto the large dray wagon borrowed from the woodcutters. On a layer of blankets in the bilge of the *boat*, the undertaker had carefully laid out the remains of both the mayor and his paramour. The mayor had not drowned in the flood, but died of a heart attack in the midst of the panic. Children covered the *boat* with freshly cut pine boughs while horses were quickly harnessed to the wagon, and a strange procession began to move slowly down *San Francisco* Street toward the new cemetery. ...

The power of such search-and-retrieval systems provided by a computer for large volumes of data is immense, but clearly this power must be channeled in meaningful ways. Links among words or clusters of information need to be designed so that they make sense. Judgments must be made about relationships and the way information content is organized and made available to users. The lenses through which vast amounts of data

[Vannevar] Bush identified the problem—and the need to provide new ways to access information—but was he right about how the mind works? I suspect a purely associative model of human memory and mental processes is too simplistic.

Philip Murray, *From Ventura to Hypertext*, Knowledge Management Associates, Danvers, MA

The hype about hypertext may be justified. It can provide a computer-supported information environment which can add to our appreciation of the text, can go some way towards aping the mental agility of the human mind, can allow navigation along patterns of association, can provide a nonlinear information environment. But the problems of constructing nonlinear documents are not few and can prove to be very complex.

.....

Patricia Baird, Editor of *Hypermedia*, a scientific journal published in the United Kingdom

Hypermedia on its own simply functions as a reference tool. But when it is integrated within a goal-based activity, it becomes a powerful learning resource.

.....

Brigid Sealy and Paul Phelan, INESC, Porto, Portugal (conclusions from research funded by the European Commission's Human Capital and Mobility Program)

are viewed must necessarily be ground and shaped by those who design the access system.

The issue of who designs the lenses and how the designers maintain impartial focus is troubling to many scientists, archivists, and students of cognitive thinking. The scientists would remain “hermeneutically” neutral, they would balance freedom against authority and warn against the epistemological unknowns of this new intellectual technology. They are aware of the forces that allow advertising and marketing craftspeople to intuitively twist meanings and spin events to their own purposes, with actions that can affect the knowledge and views of many millions of people and thus history itself. But these forces remain poorly understood, are not easily controlled by authority, and will express themselves with immeasurably far-reaching, long-term impact on the shape of human culture.

The multimedia designer controls the filtering mechanisms and places the lenses within the multimedia project. A manufacturer, for instance, that presents its products using interactive multimedia can bring abundant information and selling power within reach of the user, including background information, collateral marketing material, pricing statistics, and technical data. The project design will be, of course, biased—to sell more of the manufacturer’s products and generate more profit; but this bias is assumed and understood in these circumstances. When the assumptions and understandings of inherent bias in any information base break down, when fiction or incomplete data is presented as full fact, these are the times when the powerful forces of multimedia and hypermedia can have their greatest deleterious effect.

WARNING *Bad multimedia projects will not alter the collective view of history; really bad projects might.*

Using Hypertext

Special programs for information management and hypertext have been designed to present electronic text, images, and other elements in a database fashion. Commercial systems have been used for large and complicated mixtures of text and images—for example, a detailed repair manual for a Boeing 747 aircraft, a parts catalog for Pratt & Whitney jet turbine engines, an instant reference to hazardous chemicals, and electronic reference libraries used in legal and library environments. Such searchable database engines are widely used on the Web, where **software robots** visit millions of web pages and index entire web sites. Hypertext databases rely upon proprietary indexing systems that carefully scan the entire body of text and create very fast cross-referencing indexes that point to

the location of specific words, documents, and images. Indeed, a hypertext index by itself can be as large as 50 percent to 100 percent the size of the original document. Indexes are essential for speedy performance. Google's search engine produces about 1,220,000,000 hits in less than a quarter of a second!

Commercial hypertext systems were developed historically to retrofit gigantic bodies of information. Licenses for use and distribution of these commercial systems are expensive, and the hypertext-based projects typically require the large mass-storage capability of one or many CD-ROMs and/or dedicated gigabyte hard disks. Simpler but effective hypertext indexing tools are available for both Macintosh and Windows, and they offer fairly elaborate features designed to work in concert with many multimedia authoring systems. Server-based hypertext and database engines designed for the Web are now widely available and competitively priced.

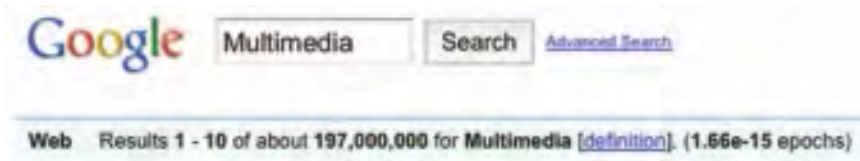

TIP Rather than designing an elaborate, fully cross-referenced hypertext system for your multimedia project, you can “hardwire” the links between the most salient words (highlight them in your text) so that a mouse click leads to a topic menu specific to the chosen word. Though this constrains the user’s movement through the text, the user will not perceive it as such, and you can thus maintain strict control over your navigation pathways and design.

Searching for Words

Although the designer of a hypermedia database makes assumptions, he or she also presents users with tools and a meaningful interface to exercise the assumptions. Employing this interface, users can tailor word searches to find very specific combinations. Following are typical methods for word searching in hypermedia systems:

- **Categories** Selecting or limiting the documents, pages, or fields of text within which to search for a word or words.
- **Word relationships** Searching for words according to their general proximity and order. For example, you might search for “party” and “beer” only when they occur on the same page or in the same paragraph.

- **Adjacency** Searching for words occurring next to one another, usually in phrases and proper names. For instance, find “widow” only when “black” is the preceding adjacent word.
- **Alternates** Applying an OR criterion to search for two or more words, such as “bacon” or “eggs.”
- **Association** Applying an AND criterion to search for two or more words, such as “skiff,” “tender,” “dinghy,” and “rowboat.”
- **Negation** Applying a NOT criterion to search exclusively for references to a word that are not associated with the word. For example, find all occurrences of “paste” when “library” is not present in the same sentence.
- **Truncation** Searching for a word with any of its possible suffixes. For example, to find all occurrences of “girl” and “girls,” you may need to specify something like **girl#**. Multiple character suffixes can be managed with another specifier, so **geo*** might yield “geo,” “geology,” and “geometry,” as well as “George.”
- **Intermediate words** Searching for words that occur between what might normally be adjacent words, such as a middle name or initial in a proper name.
- **Frequency** Searching for words based on how often they appear: the more times a term is mentioned in a document, the more relevant the document is to this term.

Hypermedia Structures

Two buzzwords used often in hypertext systems are link and node. **Links** are connections between the conceptual elements, that is, the **nodes**, which may consist of text, graphics, sounds, or related information in the knowledge base. Links connect Caesar Augustus with Rome, for example, and grapes with wine, and love with hate. The art of hypermedia design lies in the visualization of these nodes and their links so that they make sense, not nonsense, and can form the backbone of a knowledge access system. Along with the use of HTML for the World Wide Web, the term **anchor** is used for the reference from one document to another document, image, sound, or file on the Web (see Chapter 13).

Links are the navigation pathways and menus; nodes are accessible topics, documents, messages, and content elements. A **link anchor** is where you come from; a **link end** is the destination node linked to the anchor. Some hypertext systems provide unidirectional navigation and offer no return pathway; others are bidirectional.

The simplest way to navigate hypermedia structures is via buttons that let you access linked information (text, graphics, and sounds) that is contained at the nodes. When you’ve finished examining the information, you

return to your starting location. A typical navigation structure might look like the following:

Pages of text with hot words linked to InfoBites only

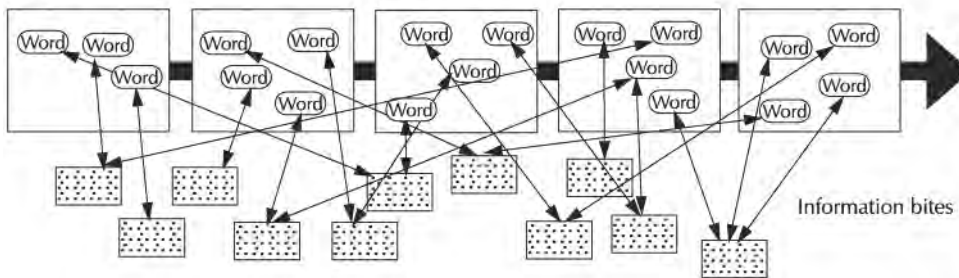

Navigation becomes more complicated when you add associative links that connect elements not directly in the hierarchy or sequence. These are the paths where users can begin to get lost if you do not provide location markers. A link can lead to a node that provides further links, as shown here:

Pages of text with hot words linked to InfoBites linked to pages and to other InfoBites

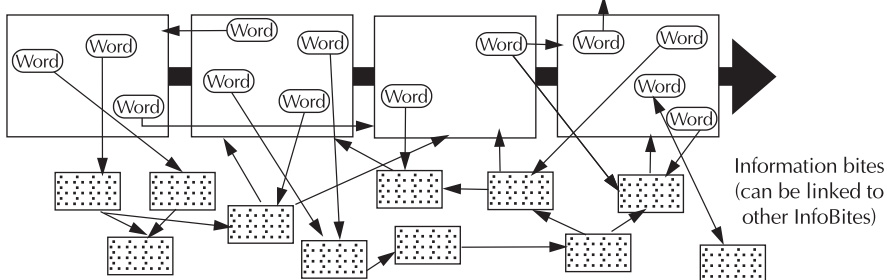

When you offer full-text search through an information base, there may be links between any number of items at your current node and any number of other nodes with items that meet your relationship criteria. When users are browsing freely through this system, and one page does not follow the next (as expected in the linear metaphor of books and literature), users can get lost in the associative maze of the designer's content:

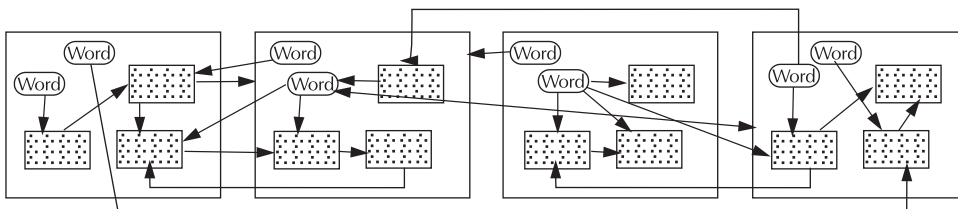

One publisher of hypermedia products claims that becoming lost in “hyperspace” may not be all that bad. The struggle to find your way back can be valuable in itself, and certainly a learning experience.

Hypermedia can take advantage of powerful capabilities that are becoming clearer as the new multimedia medium matures, giving us a greater choice in exploration, if not in outright plot definition, for example. From my experiences with “Playa Sirenas,” the real challenge facing storytellers in this new medium is allowing readers appropriate choices (some authorship of the story, really) while they navigate through the hypermedia experience, without destroying the successful and basic patterns that have been part of storytelling since people first gathered around campfires. There is something organic about these time-proven storytelling patterns. As an author in the new medium, you must first design the DNA or template of your story, then allow (and promote) mutation along evolutionary lines that you, as the author, have created as part of the template...

.....
 Hermann Steffen, hypermedia
 novelist, San Jose, Costa Rica

Hypertext Tools

Two functions are common to most hypermedia text management systems, and they are often provided as separate applications: building (or authoring) and reading. The builder creates the links, identifies nodes, and generates the all-important index of words. The index methodology and the search algorithms used to find and group words according to user search criteria are typically proprietary, and they represent an area where computers are carefully optimized for performance—finding search words among a list of many tens of thousands of words requires speed-demon programming.

Hypertext systems are currently used for electronic publishing and reference works, technical documentation, educational courseware, interactive kiosks, electronic catalogs, interactive fiction, and text and image databases. Today these tools are used extensively with information organized in a linear fashion; it still may be many years before the majority of multimedia project users become comfortable with fully nonlinear hypertext and hypermedia systems. When (and perhaps if) they do, the methodology of human thought and conceptual management—indeed, the way we think—will be forever changed.

Chapter 2 Review

■ Chapter Summary

For your review, here's a summary of the important concepts discussed in this chapter.

Recognize the importance of word choice

- With the recent explosion of the Internet and the World Wide Web, text has become more important than ever. Words and symbols in any form, spoken or written, are the most common system of communication. It's important to design labels for title screens, menus, and buttons using words that have the most precise and powerful meanings to express what you need to say. Experiment with the words you plan to use by letting others try them.

Describe the difference between a typeface and a font and list at least three attributes of a font, for example, upper/lowercase, serif/sans serif, PostScript/TrueType/OpenType

- A typeface is a family of graphic characters that usually includes many type sizes and styles.
- Serif versus sans serif is the simplest way to categorize a typeface.
- A font is a collection of characters of a single size and style belonging to a particular typeface family.
- Three common font styles are bold, italic, and underline, but there are several others; some, such as superscript, emboss, or strikethrough, have specialized uses.



- Type sizes are usually expressed in points (about 72 per inch).
- Leading is the space between lines.
- Kerning is the space between individual characters.
- Alignment can be left, right, centered, or justified.

Discuss the importance of text and ways text can be leveraged in multimedia presentations

- Size, color, background color, style, and leading are factors that affect the legibility of text.
- On the printed page, serif fonts are traditionally used for body text because the serifs are said to help guide the reader's eye along the line of text. Sans serif fonts, on the other hand, are used for headlines and bold statements. But sans serif fonts are far more legible and attractive when used in the small sizes of a text field on a screen.
- You must strike a balance between too little text on a screen and too much text.

Discuss the presentation of text on Windows and Macintosh platforms

- There will be subtle (and sometimes not-so-subtle) differences in how text looks on Windows and Macintosh platforms.

Find sources for free and shareware fonts

- Download free fonts and use shareware tools to modify fonts by adding special characters and even logos.

Define hypermedia, hypertext, links, anchors, and nodes and be able to discuss both the potential and limitations of hypertext and hyperlinking systems

- Multimedia—the combination of text, graphic, and audio elements into a single collection or presentation—becomes interactive multimedia when you give the user some control over what

information is viewed and when it is viewed. Interactive multimedia becomes hypermedia when its designer provides a structure of linked elements through which a user can navigate and interact.

- When a hypermedia project includes large amounts of text or symbolic content, this content can be indexed and its elements then linked together to afford rapid electronic retrieval of the associated information. When words are keyed or indexed to other words, you have a hypertext system; the “text” part of this term represents the project’s content and meaning, rather than the graphical presentation of the text. Hypertext is what the World Wide Web is all about.
- When text lives in a computer instead of on printed pages, the computer’s powerful processing capabilities can be applied to make the text more accessible and meaningful. The text can then be called hypertext; because the words, sections, and thoughts are linked, the user can navigate through text in a nonlinear way, quickly and intuitively. Because hypertext is the organized cross-linking of words not only to other words but also to associated images, video clips, sounds, and other exhibits, hypertext often becomes simply an additional feature within an overall multimedia design.
- Links are connections between the conceptual elements, that is, the nodes containing text, graphics, sounds, or related information in the knowledge base. The term anchor is formally used in HTML as the reference from one document to another document, image, sound, or file. Links are the navigation pathways and menus; nodes are accessible topics, documents, messages, and content elements. A link anchor is where you come from; a link end is the destination node linked to the anchor.

- The standard document format used for pages on the Web is called Hypertext Markup Language (HTML). In an HTML document you can specify typefaces, sizes, colors, and other properties by “marking up” the text in the document with tags. The remarkable growth of the Web is straining the “old” designs for displaying text on computers.

Dynamic HTML

uses Cascading Style Sheets (CSS) to define choices ranging from line height to margin width to font face. HTML character entities are represented either by a number or by a word and always prefixed by an ampersand (escape) and followed by a semicolon.

- You can search and view potentially billions of documents and files (information), but you can also become “lost in hyperspace.”



| Dec | Entity | Char |
|-----|----------|------|
| 34 | " | " |
| 38 | & | & |
| 60 | < | < |
| 62 | > | > |
| 160 | | |
| 161 | ! | ! |
| 162 | ¢ | ¢ |
| 163 | £ | £ |
| 164 | &curr; | ¤ |
| 165 | ¥ | ¥ |
| 166 | ¦ | ¦ |
| 167 | § | § |
| 168 | ¨ | ¨ |
| 169 | © | © |
| 170 | ª | ª |
| 171 | « | « |
| 172 | ¬ | ¬ |
| 173 | ­ | ­ |
| 174 | ® | ® |
| 175 | ¯ | ¯ |
| 176 | ° | ° |
| 177 | ± | ± |
| 178 | ² | ² |
| 179 | ³ | ³ |
| 180 | ´ | ´ |
| 181 | µ | µ |
| 182 | ¶ | ¶ |
| 183 | · | · |
| 184 | ¸ | ¸ |
| 185 | ¹ | ¹ |
| 186 | º | ª |
| 187 | » | » |
| 188 | ¼ | ¼ |
| 189 | ½ | ½ |
| 190 | ¾ | ¾ |
| 191 | ¿ | ¿ |
| 192 | À | À |
| 193 | Á | Á |
| 194 | Â | Â |
| 195 | Ã | Ã |
| 196 | Ä | Ä |
| 197 | Å | Å |
| 198 | Æ | Æ |
| 199 | Ç | Ç |
| 200 | È | È |
| 201 | É | É |
| 202 | Ê | Ê |
| 203 | Ë | Ë |
| 204 | ì | Ì |
| 205 | í | Í |

■ Key Terms

| | | |
|--|--|-----------------------------|
| Adobe PostScript (40) | font mapping (45) | outline font (40) |
| American Standard Code for Information Interchange (ASCII) (42) | font substitution (45) | pixel (23) |
| anchor (58) | foundry (41) | point (22) |
| anti-aliasing (27) | hint (for Type 1 PostScript fonts) (41) | portrait (37) |
| attribute (22) | hypertext (54) | rasterizing (23) |
| button (35) | hypertext system (54) | rollovers (36) |
| Cascading Style Sheets (CSS) (30) | icon (32) | sans serif (25) |
| case insensitive (24) | intercap (24) | scripts (44) |
| case sensitive (24) | jaggies (53) | serif (25) |
| character entity (48) | Kerning (23) | software robots (56) |
| character metrics (23) | landscape (37) | style (22) |
| condensed (23) | leading (22) | tag (39) |
| dithering (27) | link (58) | tracking (23) |
| dots per inch (dpi) (23) | link anchor (58) | TrueType (41) |
| Dynamic HTML (DHTML) (62) | link end (58) | typeface (22) |
| expanded (23) | localization (48) | Unicode (43) |
| font (22) | lowercase (24) | uppercase (24) |
| | node (58) | white space (28) |
| | OpenType (41) | WYSIWYG (25) |
| | | x-height (22) |

■ Key Term Quiz

1. Type sizes are usually expressed in _____.
2. When a password must be entered in upper- or lowercase in order to match the original password, it is said to be _____.
3. Symbolic representations of objects and processes common to the graphical user interfaces of many computer operating systems are called _____.
4. Special HTML characters, always prefixed by an ampersand (escape) and followed by a semicolon, are called _____.
5. “What you see is what you get” is spoken as _____.
6. Translating or designing multimedia (or any computer-based material) into a language other than the one in which it was originally written is called _____.
7. The little decoration at the end of a letter stroke is a _____.
8. Designers call roomy blank areas _____.
9. _____ blends the colors along the edges of the letters (called dithering) to create a soft transition between the letter and its background.
10. Conceptual elements consisting of text, graphics, sounds, or related information in the knowledge base are called _____.

■ Multiple-Choice Quiz

1. A family of graphic characters that usually includes many type sizes and styles is called a:
 - a. typeface
 - b. font
 - c. point
 - d. link
 - e. node
2. Which of the following is a term that applies to the spacing between characters of text?
 - a. leading
 - b. kerning
 - c. tracking
 - d. points
 - e. dithering
3. Intercapping, the practice of placing a capital in the middle of a word, is a trend that emerged from the computer programming community because:
 - a. it looks cool
 - b. they wanted to copy marketing practices in the electronics industry
 - c. they found they could see the words used for variables and commands better
 - d. one of the first computer programmers had a faulty SHIFT key on his keyboard
 - e. it increases security in case-sensitive passwords
4. Dynamic HTML uses _____ to define choices ranging from line height to margin width to font face.
 - a. Cascading Style Sheets
 - b. font mapping
 - c. font substitution
 - d. software robots
 - e. encapsulated PostScript
5. If a DHTML document includes a font face that is not installed on the user's computer, a browser will:
 - a. automatically download the correct font
 - b. refuse to load the page
 - c. leave a blank space where that text is
 - d. crash
 - e. try to substitute the font with a similar looking font
6. In the URL <http://www.timestream.com/info/people/biotay/biotay1.html>, which part is case sensitive?
 - a. the record type: "http://"
 - b. the domain name: "timestream.com"
 - c. the subdomain "www"
 - d. the document path: "info/people/biotay/biotay1.html"
 - e. all are case sensitive
7. Multimedia becomes interactive multimedia when:
 - a. the user has some control over what information is viewed and when it is viewed
 - b. the information is displayed by a computer with a touchscreen or other input device
 - c. the information is available on the Web—either the Internet or a local area network
 - d. quizzes and tests with evaluations and scoring are included
 - e. the user can change such attributes as volume and type size
8. Interactive multimedia becomes hypermedia when:
 - a. the information is available on the Web—either the Internet or a local area network
 - b. quizzes and tests with evaluations and scoring are included
 - c. it includes a structure of linked elements through which a user can navigate and interact

- d. the user can change such attributes as volume and type size
 - e. the content formatting complies with the American Standard Code for Information Interchange
9. Web pages are coded using:
- a. Unicode
 - b. American Standard Code for Information Interchange
 - c. File Transfer Protocol
 - d. Hypertext Markup Language
 - e. encapsulated PostScript
10. Which of the following provides a system for dynamically displaying a font?
- a. Apache
 - b. PostScript
 - c. HTTPD
 - d. serif
 - e. WYSIWYG
11. A printed page might be presented in which of these orientations?
- a. newsscape
 - b. portrait
 - c. flat-file
 - d. x-height
 - e. node
12. Which of the following is a character encoding system?
- a. FontTab
 - b. HTML
 - c. CSS
 - d. WYSIWYG
 - e. Unicode
13. The reference from one document to another document, image, sound, or file on the Web is a(n):
- a. sweetspot
 - b. anchor
 - c. node
 - d. tag
 - e. button
14. Which of the following is a problem that might apply to hypermedia?
- a. Users' eye movements affect their ability to link.
 - b. Users will be turned off by excessive animation.
 - c. Hypermedia software might create inappropriate links.
 - d. Current hyperlinking technology far exceeds what today's desktop computers can handle.
 - e. Search results generally are too granular to be useful.
15. Which of the following is a typical method for word searching in a hypermedia system?
- a. best fit
 - b. adjacency
 - c. popularity
 - d. tracking
 - e. localization

■ Essay Quiz

1. Describe what characteristics a block of text might have.
2. Describe what characteristics a typeface might have.
3. Discuss the problems encountered using text across computer platforms and in different languages.

4. Discuss the differences among multimedia, interactive multimedia, hypertext, and hypermedia.
5. Your boss wants you to create a hypermedia system for Web visitors to find technical support information about your company. What are some of the implications in creating this system? Should you hand-build the links or use an automatic indexing system? Why?

Lab Projects

■ Project 2.1

Visit a web site and print out a page. Visit the same page on another computer (preferably on another operating system), and print out the same page.

Compare the pages. Are the printouts different? Why?

■ Project 2.2

From three different publications, select a printed page. Circle the different blocks of text. Characterize the types of text used in each block by providing for each page:

- Publication name and page number.
- Which blocks are headlines? What type of font is used? Is it bold? serif? Characterize the text. How is it spaced?
- Which blocks are body text? What type of font is used? Is it bold? serif? Characterize the text. How is it spaced?

■ Project 2.3

Access a computer. Identify two programs that allow you to manipulate text. Write some text in varied styles and fonts. Print the results. For each, list:

- The program's name.
- The ways in which that program allows you to change text. Can you easily change the font? the color? the style? the spacing?

■ Project 2.4

Create a new document in a word processing application. Next, type in a line of text and copy the line five times. Now change each line into a different font. Recopy the entire set of lines three times. Finally, change the size of the first set to 10-point text, the second set to 18-point text, and the third set to 36-point text.

- Which of the smallest lines of text is most readable?
- Which line of text stands out the most?

■ Project 2.5

Review two different games or educational programs delivered on CD-ROM. Create a diagram that shows how the information in each is structured. For each, describe:

- How are the navigational structures similar in the two programs?
- What words are common to both programs (for example, “Quit,” “Home,” “Help,” etc.)?

Images

In this chapter, you will learn how to:

- Work out your graphical approach by planning your approach, organizing your tools, and configuring your computer workspace
- Differentiate among bitmap, vector, and 3-D images and describe the capabilities and limitations of all three
- Describe the use of colors and palettes in multimedia
- Cite the various image file types used in multimedia

MULTIMEDIA on a computer screen is a composite of elements: text, symbols, photograph-like bitmaps, vector-drawn graphics, three-dimensional renderings, distinctive buttons to click, and windows of motion video. Some parts of this image may even twitch or move so that the screen never seems still and tempts your eye. It may be a very colorful screen with gentle pastel washes of mauve and puce, or it may be brutally primary with splashes of Crayola red and blue and yellow and green. It might be stark black and white, full of sharp angles, or softened with gray-scale blends and anti-aliasing. It may be elegant or, by design, not. The computer screen is where the action is, and it contains much more than your message; it is also the viewer's primary connection to all of your project's content.

This chapter will help you understand the visual elements that make up a multimedia presentation. Graphic elements can usually be scaled to different sizes, colorized or patterned or made transparent, placed in front of or behind other objects, or be made visible or invisible on command. How you blend these elements, how you choose your colors and fonts, the tricks that you use to catch the eye, how adept you are at using your tools—these are the hallmarks of your skill, talent, knowledge, and creativity coalesced into the all-important visual connection to your viewers.

Before You Start to Create

At the beginning of a project, the screen is a blank canvas, ready for you, the multimedia designer, to express your craft. The screen will change again and again during the course of your project as you experiment, as you stretch and reshape elements, draw new objects and throw out old ones, and test various colors and effects—creating the vehicle for your message. Indeed, many multimedia designers are known to experience a mild shiver when they pull down the New menu and draw their first colors onto a fresh screen. Just so; this screen represents a powerful and seductive avenue for channeling creativity.

WARNING *Multimedia designers are regularly lured into agonizingly steep learning curves, long nights of cerebral problem solving, and the pursuit of performance perfection. If you are fundamentally creative, multimedia may become a calling, not a profession.*

Plan Your Approach

Whether you use templates and ready-made screens provided by your authoring system, clip art or objects crafted by others, or even if you simply clone the look and feel of another project—there will always be a starting point where your page is “clean.” But even before reaching this starting point, be sure you have given your project a good deal of thought and planning. Work out your graphic approach, either in your head or during creative sessions with your client or colleagues. There are strong arguments against drawing on a fresh screen without such foresight and preparation. To get a handle on any multimedia project, you start with pencil, eraser, and paper. Outline your project and your graphic ideas first: make a flow-chart; storyboard the project using stick figures; use three-by-five index cards and shuffle them until you get it right.

You may not “nail it” with the first design you submit to a client. Get a few examples from them or have them look at templates from a site such as www.templatemonster.com. When you have a clear idea what they want, submit a few variations—different visual designs, color palettes, and layouts.

Organize Your Tools

Most authoring systems provide the tools with which you can create the graphic objects of multimedia (text, interactive buttons, vector-drawn objects, and bitmaps) directly on your screen. If one of these tools is not included, the authoring system usually offers a mechanism for importing the object you need from another application. When you are working with animated objects or motion video, most authoring systems include a feature for activating these elements, such as a programming language or special functions for embedding them. Likely, too, your tools will offer a library of special effects—including zooms, wipes, and dissolves. Many multimedia designers do not limit their toolkits to the features of a single authoring platform, but employ a variety of applications and tools to accomplish many specialized tasks.

Configure Your Computer Workspace

When developing multimedia, it is helpful to have more than one monitor to provide lots of screen **real estate** (viewing area). In this way, you can

The organizing and creative process begins with drawings in pen or pencil on paper.

Too many times we are enthused about the color and the computer graphics tools, but they can overwhelm the creative design process.

.....

Dennis Woytek, Assistant Professor, Duquesne University

I like “do-overs,” where you make quick and dirty buttons now, or live text now, but go back later and replace those placeholders with more refined images or pretty bitmapped text. This do-over approach lets you work two ends against the middle—you can get right into designing navigation and animation, but know that you will put in the “good” images later.

.....

Sherry Hutson, Lecturer, University of Illinois at Springfield

display the full-screen working area of your project or presentation and still have space to put your tools and other menus. This is particularly important in an authoring system such as Flash or Director, where the edits and changes you make in one window are immediately visible in the presentation window—provided the presentation window is not obscured by your editing tool! During development there is a lot of cutting and pasting among windows and among various applications, and with an extra monitor, you can open many windows at once and spread them out. Both Macintosh and Windows operating systems support this extra hardware.

NOTE *A few weeks of having to repeatedly bring windows to the front, and then hide them again to see the results of your editing, will probably convince you to invest in a second monitor.*

TIP *Your operating system has keyboard shortcuts for moving among windows and applications, accessing your desktop, and for standard commands such as cut, copy, paste, and undo. Learning to use these commands—and using them consistently—will enable you to work efficiently.*

Making Still Images

Still images may be small or large, or even full screen. They may be colored, placed at random on the screen, evenly geometric, or oddly shaped. Still images may be a single tree on a wintry hillside; stacked boxes of text against a gray, tartan, or Italian marble background; an engineering drawing; a snapshot of your department manager's new BMW. Whatever their form, still images are generated by the computer in two ways: as **bitmaps** (or paint graphics) and as **vector-drawn** (or just plain “drawn”) graphics. Bitmaps may also be called “raster” images. Likewise, bitmap editors are sometimes called “painting” programs. And vector editors are sometimes called “drawing” programs.

Bitmaps are used for photo-realistic images and for complex drawings requiring fine detail. Vector-drawn objects are used for lines, boxes, circles, polygons, and other graphic shapes that can be mathematically expressed in angles, coordinates, and distances. A drawn object can be filled with color and patterns, and you can select it as a single object. The appearance of both types of images depends on the display resolution and capabilities of your computer's graphics hardware and monitor. Both types of images are stored in various file formats and can be translated from one application to another or from one computer platform to another. Typically, image files are compressed to save memory and disk space; many bitmap image

file formats already use compression within the file itself—for example, **GIF**, **JPEG**, and **PNG**.

Still images may be the most important element of your multimedia project or web site. If you are designing multimedia by yourself, put yourself in the role of graphic artist and layout designer. Take the time necessary to discover all the tricks you can learn about your drawing software. Competent, computer-literate skills in graphic art and design are vital to the success of your project. Remember—more than anything else, the user’s judgment of your work will be heavily influenced by the work’s visual impact.

Bitmaps

A **bit** is the simplest element in the digital world, an electronic digit that is either on or off, black or white, or true (1) or false (0). This is referred to as **binary**, since only two states (on or off) are available. A map is a two-dimensional matrix of these bits. A bitmap, then, is a simple matrix of the tiny dots that form an image and are displayed on a computer screen or printed.

First Person

A few years ago a large corporation asked us and one other multimedia developer to bid on a long-term contract for computer-based training. Though busy with other active projects, we didn’t want this possibly lucrative opportunity to slip by, so we spent a few days hastily putting together a demonstration of our technical skills for building nifty databases, designing tricky telecommunications systems, and integrating live video. We even “wire-framed” a bit of a working multimedia database with real data we got from the corporation.

We showed our demo to about a dozen management and training executives, in a fancy boardroom

that had a built-in projector and sound system with mixers and light dimmers—a place where we could knock the socks off anybody. But within 30 seconds, the disaster bells started tinkling: most of our presentation was going way over their heads. Afterward, there were one or two vague questions and some thank-you’s.

Our competitor’s presentation, on the other hand, provided a slick series of finely rendered bitmapped screen images and elegant visuals. It was heavy on pretty menu screens and very light on how-it-is-done technology. We later learned that one of their graphic artists had worked for two solid weeks on the color bitmaps for that demo. In the

follow-up phone call, we were told by our potential clients that the competition’s “incredible artwork” had won out over our “excellent technology demonstration.”

To cover our disappointment, we mumbled something to ourselves about not wanting to work with computer illiterates, anyway—people who could be taken to the cleaners by fresh paint. But we knew we’d missed a hefty piece of contract work because we hadn’t invested serious graphic art talent in our demonstration. We decided that’s why the real peas in the can are never the same bright green as the ones on the label. So we learned a marketing lesson.

A one-dimensional matrix (1-bit depth) is used to display monochrome images—a bitmap where each bit is most commonly set to black or white. Depending upon your software, any two colors that represent the on and off (1 or 0) states may be used. More information is required to describe shades of gray or the more than 16 million colors that each picture element might have in a color image, as illustrated in Figure 3-1. These picture elements (known as **pels** or, more commonly, **pixels**) can be either on or off, as in the 1-bit bitmap, or, by using more bits to describe them, can represent varying shades of color (4 bits for 16 colors; 8 bits for 256 colors; 15 bits for 32,768 colors; 16 bits for 65,536 colors; 24 bits for 16,772,216 colors). Thus, with 2 bits, for example, the available zeros and ones can be combined in only four possible ways and can, then, describe only four possible colors:

| Bit Depth | Number of Colors Possible | Available Binary Combinations for Describing a Color |
|-----------|---------------------------|--|
| 1-bit | 2 | 0, 1 |
| 2-bit | 4 | 00, 01, 10, 11 |
| 4-bit | 16 | 0000, 0001, 0011, 0111, 1111, 0010, 0100, 1000, 0110, 1100, 1010, 0101, 1110, 1101, 1001, 1011 |

Figure 3-1 A bitmap is a data matrix that describes the characteristics of all the pixels making up an image. Here, each cube represents the data required to display a 4 × 4-pixel image (the face of the cube) at various color depths (with each cube extending behind the face indicating the number of bits—zeros or ones—used to represent the color for that pixel).

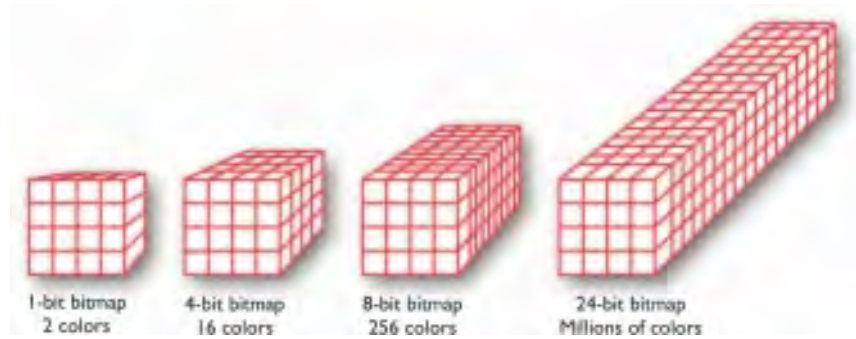

Together, the state of all the pixels on a computer screen make up the image seen by the viewer, whether in combinations of black and white or colored pixels in a line of text, a photograph-like picture, or a simple background pattern. Figure 3-2 demonstrates various color depths and compression formats. Image 1 is 24 bits deep (millions of colors); Image 2 is dithered to 8 bits using an adaptive palette (the best 256 colors to represent the image); Image 3 is also dithered to 8 bits, but uses the Macintosh system palette (an optimized standard mix of 256 colors). Image 4 is dithered to 4 bits (any 16 colors); Image 5 is dithered to 8-bit gray-scale (256 shades of gray); Image 6 is dithered to 4-bit gray-scale (16 shades of gray); and Image 7 is dithered to 1 bit (two colors—in this case, black and white).

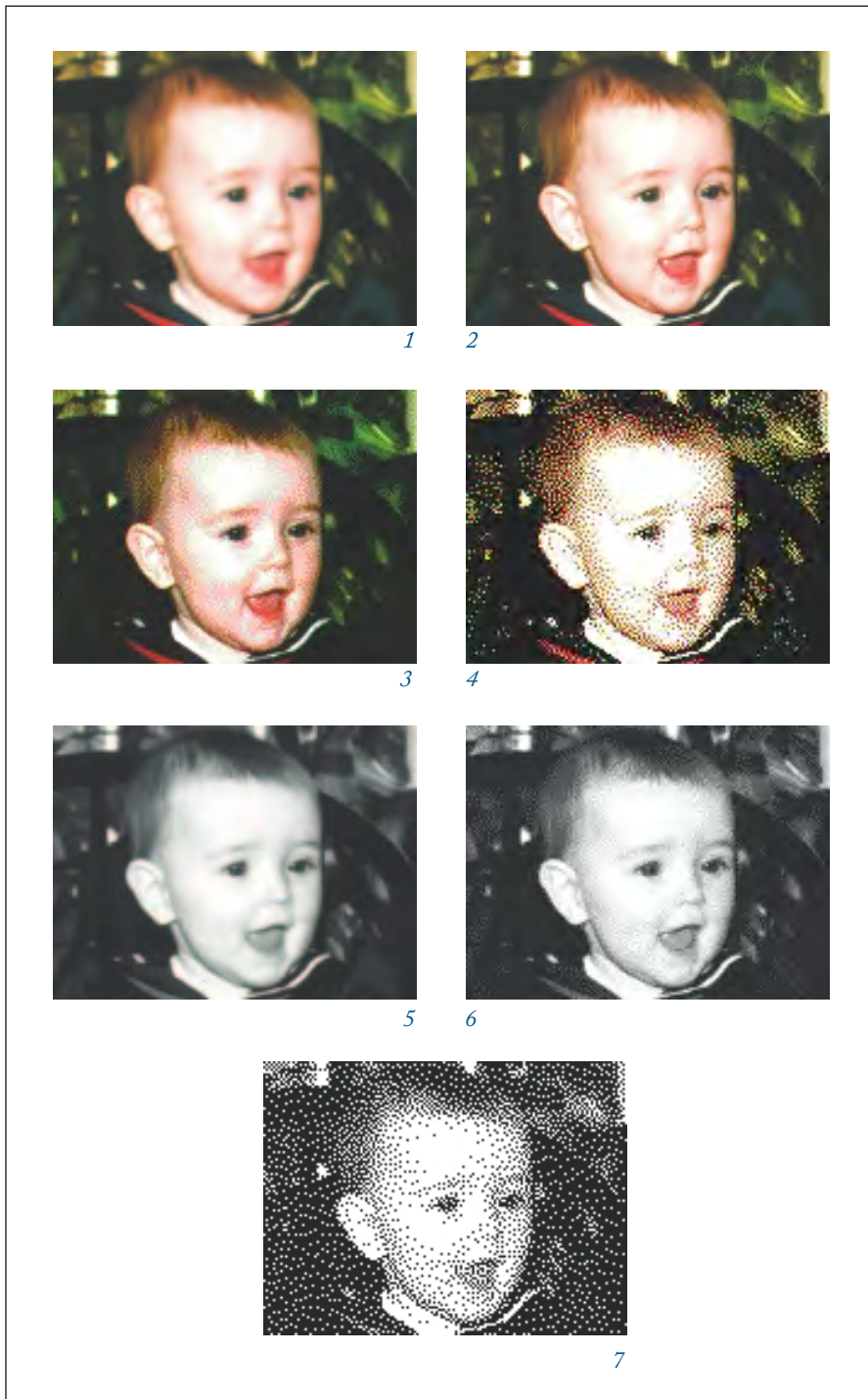

Figure 3-2 These images show the color depth of bitmaps as described in Figure 3-1. Note that Images 4 and 6 require the same memory (same file size), but the gray-scale image is superior. If file size (download time) is important, you can dither GIF bitmap files to the lowest color depth that will still provide an acceptable image.

Is there a colour scheme that will appear coloured or at least solid black for the colour-impaired? If you're gathering empirical evidence, I have something called red-green colour blindness (it is quite common in males). It doesn't mean that you don't know which traffic light is showing! What it means mainly is that the *tone* of red-type colours doesn't seem so different to the tone of greens—the obvious case is a poppy field. I can see the poppies as red OK if I look carefully or they are pointed out to me, but other people see them kind of exploding out of the green... For people like me, a vibrant yellow always works. I read somewhere that black on yellow is a reliable “strong” combination. Certainly it is used by one of the motoring organisations in the UK for special diversion notices and the like.

.....
 Graham Samuel, Educational Software Developer, The Living Fossil Co., London

Bitmap Sources

Where do bitmaps come from? How are they made? You can do the following:

- Make a bitmap from scratch with a paint or drawing program.
- Grab a bitmap from an active computer screen with a screen capture program, and then paste it into a paint program or your application.
- Capture a bitmap from a photo or other artwork using a scanner to digitize the image.
- Once made, a bitmap can be copied, altered, e-mailed, and otherwise used in many creative ways.

If you do not want to make your own, you can get bitmaps from suppliers of clip art, and from photograph suppliers who have already digitized the images for you. Libraries of clip art are available on CD-ROMs and downloadable through online services. Many graphics applications are shipped with clip art and useful graphics. A clip art collection may contain a random assortment of images, or it may contain a series of graphics, photographs, sound, and video related to a single topic. Some 3-D modeling programs incorporate libraries of pre-made 3-D models into the application, allowing you to drag and drop common objects into a scene.

You can also download an image bitmap from a web site: in most browsers right-click over the image to see a menu of options. Choose “Download image to disk,” “Copy Image,” or “Save picture as...” Regardless of the source of the image, you should be aware of who owns the copyright to the image you wish to use and what is required to reproduce the image legally.

WARNING *To avoid legal problems, always assume that an image on the Web is protected by copyright, even if there is no copyright notice shown. Just because you can easily download an image from a web site, doesn't mean that you can reuse that image in your own work without permission or paying a license fee. See Chapter 11 for more about copyright protection.*

Legal rights protecting use of images from clip libraries fall into three basic groupings. Public domain images were either never protected by a copyright or their copyright protection has ended. Generally these can be freely used without obtaining permission or paying a license fee, though there still may be an ownership issue for a particular work of art (such as a painting owned by an art gallery). Royalty-free images are purchased and then used without paying additional license fees. Rights-managed images require that you negotiate with the rights holder regarding terms for using the image and how much you will pay for that use.

Figure 3-3 shows a page of thumbnails describing a commercially available resource of royalty-free images called Photodisc, a part of Getty

Images (www.gettyimages.com). The Photodisc collections contain high-resolution bitmaps with a license for their “unlimited use.” But you should note that “unlimited use” often contains caveats: in many cases there is an upper limit to the number of “units” of your own product that you may distribute without paying more, so you need to read the fine print. These additional fees are usually reasonable, however, and affect only commercial multimedia publishers.



Figure 3-3 A page of thumbnails showing the content of various royalty-free Photodisc collections from Getty Images

Regardless of the source, once you have a bitmap, you can manipulate and adjust many of its properties (such as brightness, contrast, color depth, hue, and size). You can also cut and paste among many bitmaps using an image-editing program. If the clip art image is high resolution (aimed at 300 or 600 dpi printers, not 72 dpi monitors), you may discover that you can grab just a tiny portion of the high-res image—say, a sheep in the far corner of a farmyard or a car in a parking lot—and it will look great when displayed at monitor resolution.

Bitmap Software

The abilities and features of painting and image-editing programs range from simple to complex. The best programs are available in versions that work the same on both Windows and Mac platforms, and the graphics files you make can be saved in many formats, readable across platforms.

Macintosh computers do not ship with a painting tool, and Windows provides only a rudimentary Paint program, so you will need to acquire this very important software separately. Many multimedia authoring tools offer built-in bitmap editing features. Director, for example, includes a powerful image editor that provides advanced tools such as “onion-skinning” and image filtering using common plug-ins. Adobe’s Photoshop, however, remains the most widely used image-editing tool among designers worldwide; it is available without some bells and whistles in a less-expensive version, Photoshop Elements, which may have all the features you need for your projects.

Many designers also use a vector-based drawing program such as Adobe’s Illustrator, CorelDRAW, or InDesign to create curvy and complicated looks that they then convert to a bitmap. You can use your image-editing software to create original images, such as cartoons, symbols, buttons, bitmapped text, and abstract images that have a refined “graphic” look, but it is virtually impossible to create a realistic-looking photo from scratch using an image-editing program. The artistic painting tools offered by Corel’s Painter (www.corel.com/painter) include hundreds of brushes, sprays, watercolors, inks, and textures to mimic the output of natural media in a bitmap (see Figure 3-4). There are also many open source and free bitmap editors available—just type “graphics editors” in a search engine. Regardless of your program of choice, learning to use a high-powered paint program and image editor is a necessary investment in your multimedia future.



Figure 3-4 Painter is used for creating original artwork; for book, medical, and architectural illustration; to transform photographs into realistic-looking paintings; to build seamless patterns for fabrics; and for storyboarding scene concepts and costumes for movies and theater.

Capturing and Editing Images The image you see on your monitor is a digital bitmap stored in video memory, updated about every 1/60 of a second. As you assemble images for your multimedia project, you may often need to capture and store an image directly from your screen. The simplest way to capture what you see on the screen at any given moment is to press the proper keys on your computer keyboard. This causes a conversion from the screen buffer to a format that you can use.

- Both the Macintosh and Windows environments have a **clipboard**—an area of memory where data such as text and images is temporarily stored when you cut or copy them within an application. In Windows, when you press `PRINT SCREEN`, a copy of your screen's image goes to the clipboard. From the clipboard, you can then paste the captured bitmap into an application (such as Paint, which comes with Windows).
- On the Macintosh, the keystroke combination `COMMAND-SHIFT-3` creates a readable PNG-format file named Picture and places it on your desktop. You can then import this file's image into your multimedia authoring system or paint program. You can also press `COMMAND-CONTROL-SHIFT-4` to drag a rectangle on your screen and capture what is inside the rectangle onto the clipboard, ready for pasting.

The way to get more creative power when manipulating bitmaps is to use an image-editing program, likely one of the programs named previously. These are the king-of-the-mountain programs that let you not only retouch the blemishes and details of photo images, but also do tricks like placing an image of your own face at the helm of a square-rigger or right on the sideline at last year's Super Bowl. Figure 3-5 shows just such a composite image, made from two photographs. It was created by graphic artist Frank Zurbano and shows his fiancée, Brandy Rowell, chasing after wedding gifts on the lawn where they will be married. Isolating and extracting parts of an image is an essential skill in multimedia production. Most bitmap editors have “lasso” type tools that select areas by drawing a path. This selection can be “feathered,” or made to include partially transparent pixels outside the selected area.

In addition to letting you enhance and make composite images, image-editing tools allow you to alter and distort images. A color photograph of a red rose can be changed into a purple rose, or blue if you prefer. A small child standing next to her older brother can be “stretched” to tower over him. **Morphing** is another effect that can be used to manipulate still images or to create interesting and often bizarre animated



Figure 3-5 Image-editing programs let you add and delete elements in layers.

transformations. Morphing (see Figure 3-6) allows you to smoothly blend two images so that one image seems to melt into the next, often producing some amusing results.



Figure 3-6 Morphing software was used to seamlessly transform the images of 16 kindergartners. When a sound track of music and voices was added to the four-minute piece, it made a compelling video about how similar children are to each other.

We have to keep saturation in mind *all* the time when doing our web pages... viewing the graphics on both Macs and PCs before actually using them. For instance, when doing our Halloween pages, we used a very cool pumpkin background that was beautifully saturated on the Mac side. On Windows, though, it was way too dark, and you couldn't read the overlying text. We had to lighten the GIF on the Mac side a few times before using it cross-platform.

.....
Rich Santalesa, Editor,
NetGuide Magazine

Image-editing programs may, indeed, represent the single most significant advance in computer image processing during the late 1980s, bringing truly amazing power to PC desktops. Such tools are indispensable for excellent multimedia production.

NOTE When you import a color or gray-scale bitmap from the Macintosh to Windows, the colors will seem darker and richer, even though they have precisely the same red, green, and blue (RGB) values. In some cases, this may improve the look of your image, but in other cases you will want to first lighten (increase the brightness and possibly lower the contrast) of the Macintosh bitmap before bringing it into Windows.

Scanning Images After poring through countless clip art collections, you still haven't found the unusual background you want for a screen about gardening. Sometimes when you search for something too hard, you don't realize that it's right in front of you. Everyday objects can be scanned and manipulated using image-editing tools, such as those described in the preceding section, to create unusual, attention-getting effects. For example, to

enliven a screen with a gardening motif, scan a mixture of seeds, some fall foliage, or grass-stained garden gloves. Open the scan in an image-editing program and experiment with different filters, the contrast, and various special effects. Be creative, and don't be afraid to try strange combinations—sometimes mistakes yield the most intriguing results.

Another alternative to computer-generated graphics is to create artwork using traditional methods: watercolors, pastels, and even crayons. You can then scan the image, make necessary alterations, and tweak pixels on the computer. Too many designers have fallen into the trap of trying to draw detailed sketches using a mouse or drawing tablet, when a pencil or pen on paper would have produced better results quicker. In Chapter 10, Figure 10-7 shows a web page that uses a large image map of a seacoast village for navigation. The picture of the village was drawn on a large sheet of paper by artist Carolyn Brown using a fine pen. Then it was digitized in sections because the original drawing was too large for the scanner top. Four scans were stitched together into a single image using Photoshop layers, and the image was resized to fit the web page. Finally, it was colorized to look “old” and reduced in color depth to 4 bits so that it would load quickly on the Internet as a GIF.

Powerful filters and plug-ins are offered by most image-editing programs (see illustration to right) to manipulate bitmaps in many different ways. Experiment with your filters and plug-ins. Alien Skin's Exposure, for example, brings the creative tools of film photography to the world of digital editing with presets for many looks: discontinued films, dark-room tricks, lo-fi camera quirks like Holga and Lomo, vintage looks like Technicolor movie film and old Kodachrome that are distressed with dust, scratches, and lens blur, warped vignettes, and funky colors from cross-processing (see Figure 3-7).



Figure 3-7 Exposure from Alien Skin, offering photography effects, is one of hundreds of commercial plug-ins and filters available for manipulating bitmapped images. Here a digital color image has been processed to look like it came from a photographer's darkroom.

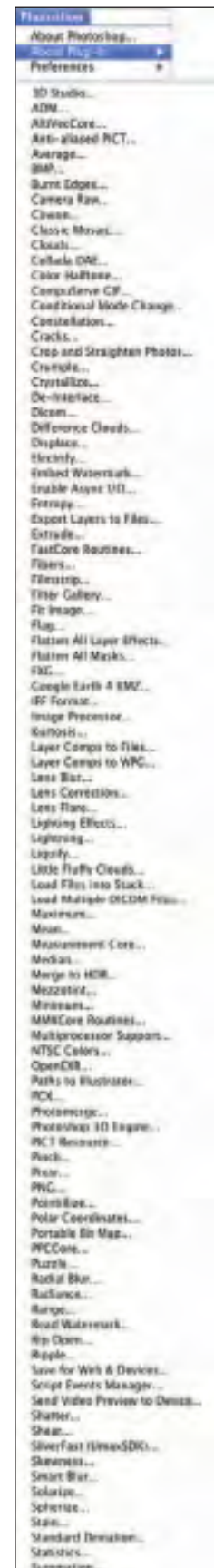

Vector Drawing

Most multimedia authoring systems provide for use of vector-drawn objects such as lines, rectangles, ovals, polygons, complex drawings created from those objects, and text.

- Computer-aided design (CAD) programs have traditionally used vector-drawn object systems for creating the highly complex and geometric renderings needed by architects and engineers.
- Graphic artists designing for print media use vector-drawn objects because the same mathematics that put a rectangle on your screen can also place that rectangle (or the fancy curves of a good line-art illustration) on paper without jaggies. This requires the higher resolution of the printer, using a page description format such as Portable Document Format (PDF).
- Programs for 3-D animation also use vector-drawn graphics. For example, the various changes of position, rotation, and shading of light required to spin an extruded corporate logo must be calculated mathematically. (Animation is discussed in Chapter 5.)

How Vector Drawing Works

A **vector** is a line that is described by the location of its two endpoints. Vector drawing uses **Cartesian coordinates** where a pair of numbers describes a point in two-dimensional space as the intersection of horizontal and vertical lines (the x and y axes). The numbers are always listed in the order x,y. In three-dimensional space, a third dimension—depth—is described by a z axis (x,y,z). This coordinate system is named for the French philosopher and mathematician, René Descartes. So a line might be simply

```
<line x1="0" y1="0" x2="200" y2="100">
```

where x1 and y1 define the starting point (in the upper-left corner of the viewing box) and x2 and y2 define the end point.

A simple rectangle is computed from starting point and size: your software will draw a rectangle (rect) starting at the upper-left corner of your viewing area (0,0) and going 200 pixels horizontally to the right and 100 pixels downward to mark the opposite corner. Add color information like

```
<rect x="0" y="0" width="200" height="100" fill="#FFFFFF" stroke="#FF0000"/>
```

and your software will draw the rectangle with a red boundary line and fill it with the color white. You can, of course, add other parameters to describe a fill pattern or the width of the boundary line. Circles are defined by a location and a radius:

```
<circle cx="50" cy="50" r="10" fill="none" stroke="#000000" />
```

Type the following code into a text editor and save it as plain text with a .svg extension. This is a **Scalable Vector Graphics** file. Open it in an HTML5-capable browser (File:Open File...) and you will see:

```
<svg xmlns="http://www.w3.org/2000/svg"
  xmlns:xlink="http://www.w3.org/1999/xlink"
  width="200"
  height="200"
  viewBox="-100 -100 300 300">
<rect x="0" y="0" fill="yellow" stroke="red" width="200" height="100"/>
<text transform="matrix(1 0 0 1 60 60)" font-family="'TimesNewRomanPS-BoldMT'" font-size="36">SVG</text>
</svg>
```



Because these SVG files can be saved in a small amount of memory and because they are scalable without distortion (try changing the width and height of the view box in the preceding code), SVG (Tiny) is supported by browsers on most mobile phones and PDAs. The SVG specification also includes time-based changes or animations that can be embedded within the image code (see www.w3.org/TR/SVG11/animate.html#AnimationElements). Figure 3-8 shows Adobe Illustrator saving a file in SVG format. Vector drawing tools use **Bézier** curves or paths to mathematically represent a curve. In practical terms, editing software shows you points on the path, each point having a “handle.” Changing the location of the handle changes the shape of the curve. Mastering Bézier curves is an important skill: these curves not only create graphic shapes but represent motion paths when creating animations.



Figure 3-8 Drawing software such as Adobe Illustrator can save vector graphics in SVG format.

Vector-Drawn Objects vs. Bitmaps

Vector-drawn objects are described and drawn to the computer screen using a fraction of the memory space required to describe and store the same object in bitmap form. The file containing the vector-drawn colored

rectangle described in the preceding section is less than 698 bytes of alphanumeric data (even less—468 bytes—when the description is tokenized or compressed as .svgz). On the other hand, the same rectangle saved as a .gif image with a 64-color palette takes 1,100 bytes.

Because of this file size advantage, web pages that use vector graphics as SVG files or in plug-ins such as Flash download faster and, when used for animation, draw faster than pages displaying bitmaps. It is only when you draw many hundreds of objects on your screen that you may experience a slowdown while you wait for the screen to be refreshed—the size, location, and other properties for each of the objects must be computed. Thus, a single image made up of 500 individual line and rectangle objects, for example, may take longer for the computer to process and place on the screen than an image consisting of just a few drawn circle objects.

A vector-drawn object is created “on the fly,” that is, the computer draws the image from the instructions it has been given, rather than displaying a precreated image. This means that vector objects are easily scalable without loss of resolution or image quality. A large drawn image can be shrunk to the size of a postage stamp, and while it may not look good on a computer monitor at 72 dpi, it may look great when printed at 300 dpi to a color printer. Resizing a bitmapped image requires either duplicating pixels (creating a blocky, jagged look called **pixelation**) or throwing pixels away (eliminating details). Because vector images are drawn from instructions on the fly, a rescaled image retains the quality of the original.

TIP *Using a single bitmap for a complicated image may give you faster screen-refresh performance than using a large number of vector-drawn objects to make that same screen.*

Converting Between Bitmaps and Drawn Images

Most drawing programs offer several file formats for saving your work, and, if you wish, you can convert a drawing that consists of several vector-drawn objects into a bitmap when you save the drawing. You can also grab a bitmapped screen image of your drawn objects with a screen capture program.

Converting bitmaps to drawn objects is more difficult. There are, however, programs and utilities that will compute the bounds of a bitmapped image or the shapes of colors within an image and then derive the polygon object that describes the image. This procedure is called **autotracing** and is available in vector drawing applications such as Illustrator or Freehand. Flash has a Trace Bitmap menu option that converts a bitmapped image into a vector image. Be cautious: the size of your Flash file may actually balloon because the bitmapped image is replaced by hundreds or even

thousands of tiny vector-drawn objects, leading to slow processing and display.

WARNING *Some bitmap applications allow vector images to be pasted into them. Be careful to save your vector drawing separately because you will not be able to edit the curves when they are bitmapped.*

3-D Drawing and Rendering

Drawing in perspective or in 3-D on a two-dimensional surface takes special skill and talent. Creating objects in three dimensions on a computer screen can be difficult for designers comfortable with squares, circles, and other x (width) and y (height) geometries on a two-dimensional screen. Dedicated software is available to help you render three-dimensional scenes, complete with directional lighting and special effects, but be prepared for late nights and steep learning curves as you become familiar with nurbs, deformations, mesh generations, and skinning! From making 3-D text to creating detailed walkthroughs of 3-D space, each application will demand study and practice before you are efficient and comfortable with its feature set and power.

The production values of multimedia projects have increased dramatically, and as the production bar has risen, end users' expectations have also ratcheted upward. The multimedia production bar moves like a high jump or pole vault contest—as each new project improves on the last, competitors must jump to meet the new, higher standard. Flat and colorless 2-D screens are no longer sufficient for a successful commercial multimedia project. 3-D-rendered graphic art and animation has become commonplace since the late 1980s, providing more lifelike substance and feel to projects. Luckily, in an arena where only high-powered workstations could supply the raw computing horsepower for effective 3-D designing, inexpensive desktop PCs and excellent software have made 3-D modeling attainable by most multimedia developers.

Today many products—including Daz3D (www.daz3d.com) and form•Z (www.formz.com)—are touted as essential tools for illustration, animation, and multimedia production. NewTek's Lightwave (www.newtek.com/lightwave) and Autodesk's Maya (www.autodesk.com/Maya) are industry-standard, high-end animation programs used for everything from multimedia programs and game designs to special effects in films and even feature-length movies. For experimenting with 3-D, Google's SketchUp (sketchup.google.com) provides a simple (and free) cross-platform tool. To delve deeply into 3-D, the open-source Blender (www.blender.org) is a powerful tool—but its complex interface presents a steep learning curve.

Form•Z, the 3-D form synthesizer, is above all a 3-D modeling program, even though it also includes drafting, rendering and animation. Additional photo-realistic rendering is offered by form•Z Render-Zone Plus. It combines solids and surface modeling. It also combines faceted (boundary) representations with parametric spline representations, NURBS, patches, and metaballs. This unique mixture of modeling personalities allows you to create any form, existing or imaginary, while working in a single package.

Marketing literature from
auto•des•sys, Inc.
(www.formz.com)

For 3-D, the depth (**z dimension**) of cubes and spheres must be calculated and displayed so that the perspective of the rendered object seems correct to the eye. As illustrated in Figure 3-9, most 3-D software packages provide adjustable views so that you can see your work from the top, bottom, or sides.

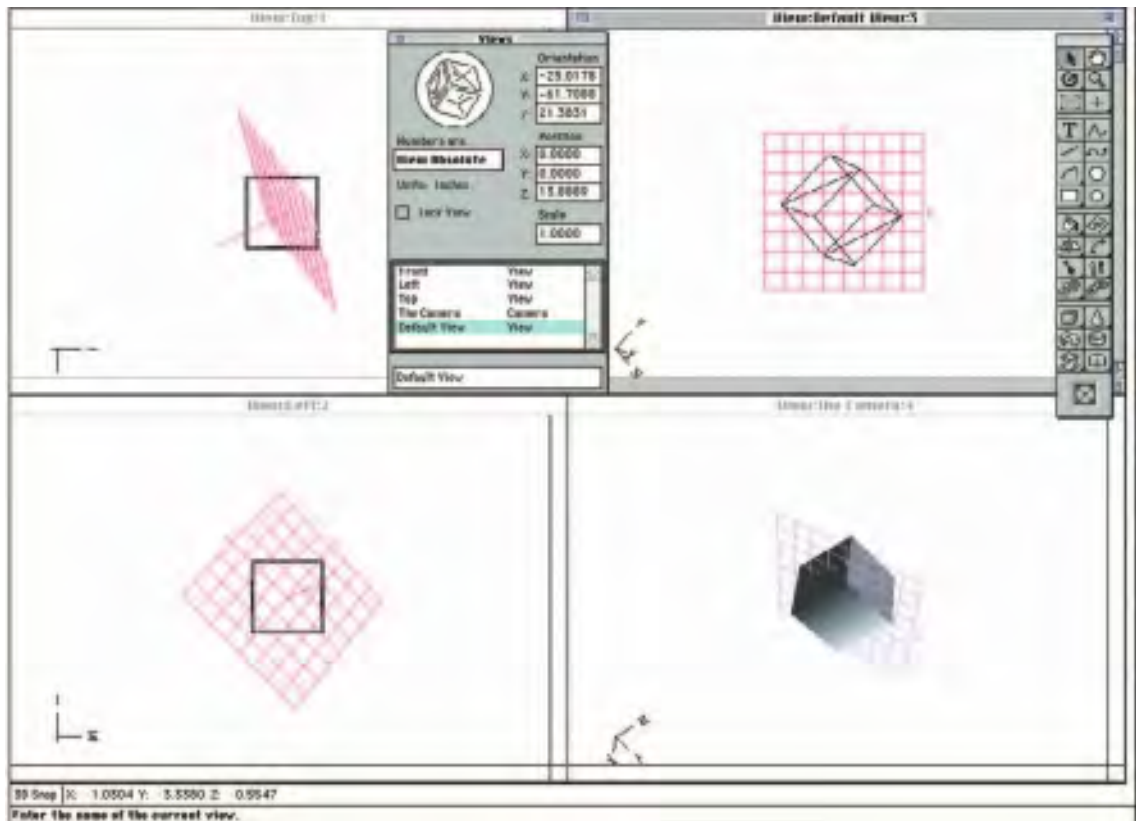

Figure 3-9 3-D applications provide x, y, and z axes and adjustable perspective views.

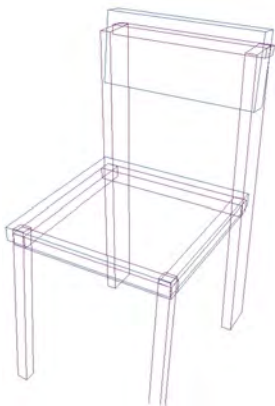

Figure 3-10 A chair modeled in 3-D is made up of various blocks and rectangles.

A great deal of information is needed to display a 3-D scene. **Scenes** consist of **objects** that in turn contain many small elements such as blocks, cylinders, spheres, or cones (described using mathematical constructs or formulas). The more elements contained in an object, the more complicated its structure will be and, usually, the finer its resolution and smoothness.

Objects and elements in 3-D space carry with them **properties** such as shape, color, texture, shading, and location. A scene contains many different objects. Imagine a scene with a table, chairs, and a background. Zoom into one of the objects—the chair, for example, in Figure 3-10. It has 11 objects made up of various blocks and rectangles. Objects are created by **modeling** them using a 3-D application.

To model an object that you want to place into your scene, you must start with a **shape**. You can create a shape from scratch, or you can import a previously made shape from a library of geometric shapes called **primitives**, typically blocks, cylinders, spheres, and cones. In most 3-D applications, you can create any 2-D shape with a drawing tool or place the outline of a letter, then extrude or lathe it into the third dimension along the z axis (see Figure 3-11). When you **extrude** a plane surface, its shape extends some distance, either perpendicular to the shape's outline or along a defined path. When you **lathe** a shape, a profile of the shape is **rotated** around a defined axis (you can set the direction) to create the 3-D object. Other methods for creating 3-D objects differ among the various software packages.

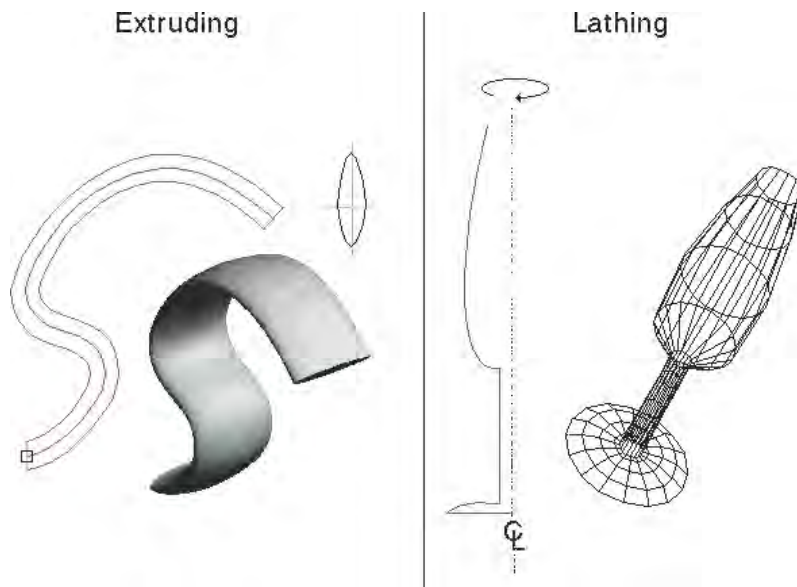

Figure 3-11 A free-form object created by extrusion and a wine flute created by lathing

Once you have created a 3-D object, you can apply **textures** and colors to it to make it seem more realistic, whether rough and coarse or shiny and smooth. You can also apply a color or pattern, or even a bitmapped picture, to texture your object. Thus you can build a table, apply an oak finish, and then stain it purple or blue or iridescent yellow. You can add coffee cup rings and spilled cheese dip with appropriate coloring and texturing.

To model a scene, you place all of your objects into 3-D space. Some complex scenes may contain hundreds (if not thousands) of elements. In modeling your scene, you can also set up one or more lights that will create diffuse or sharp shades and shadows on your objects and will also reflect, or **flare**, where the light is most intense. Then you can add a background and set a camera view, the location and angle from which you will view the final rendered scene.

Shading can usually be applied in several ways. As illustrated in Figure 3-12, flat shading (*b*) is the fastest for the computer to render and is most often used in preview mode. Gouraud shading (*a*), Phong shading (*d*), and ray tracing (*c*) take longer to render but provide photo-realistic images.

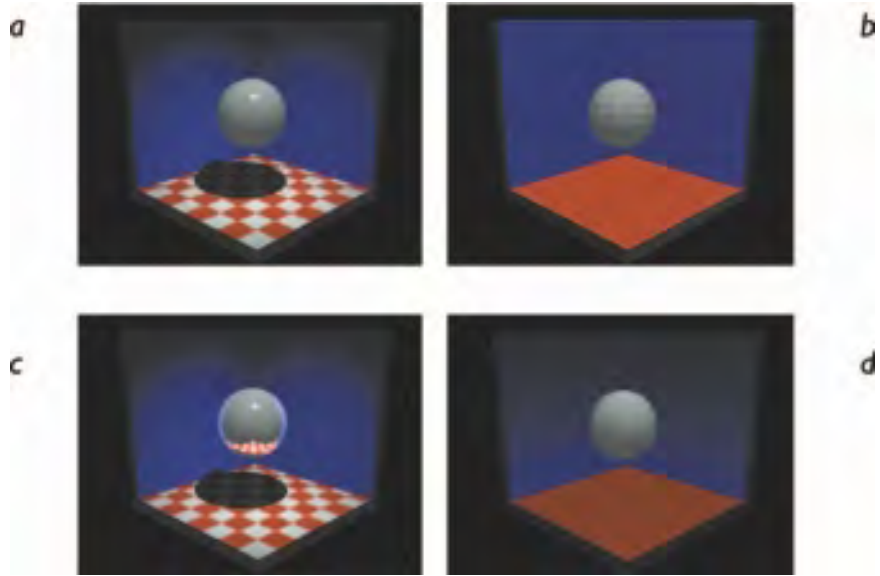

Figure 3-12 A scene rendered with four different methods of shading

When you have completed the modeling of your scene or an object in it, you then must render it for final output. **Rendering** is when the computer finally uses intricate algorithms to apply the effects you have specified on the objects you have created. Figure 3-13 shows a background, an object, and the rendered composite.

Rendering an image requires great computing muscle and often takes many hours for a single image, and you will feel the strength (or weakness) of your hardware. Indeed, some multimedia and animation companies dedicate certain computers solely for rendering. The final images for the classic animated movie *Toy Story* were rendered on a “farm” of 87 dual-processor and 30 quad-processor 100 MHz SPARCstation 20s. It took 46 days of continuous processing to render that film’s 110,000 frames at a rate of about one frame every one to three hours.

NOTE Farms of many computers hooked together may also be called “clusters of workstations,” or COWs. There is occasionally humorous contention regarding proper nomenclature: it seems that developers who live and work in cities tend to prefer the notion of computer farms; developers in rural communities already familiar with farms prefer to call these beasts COWs.

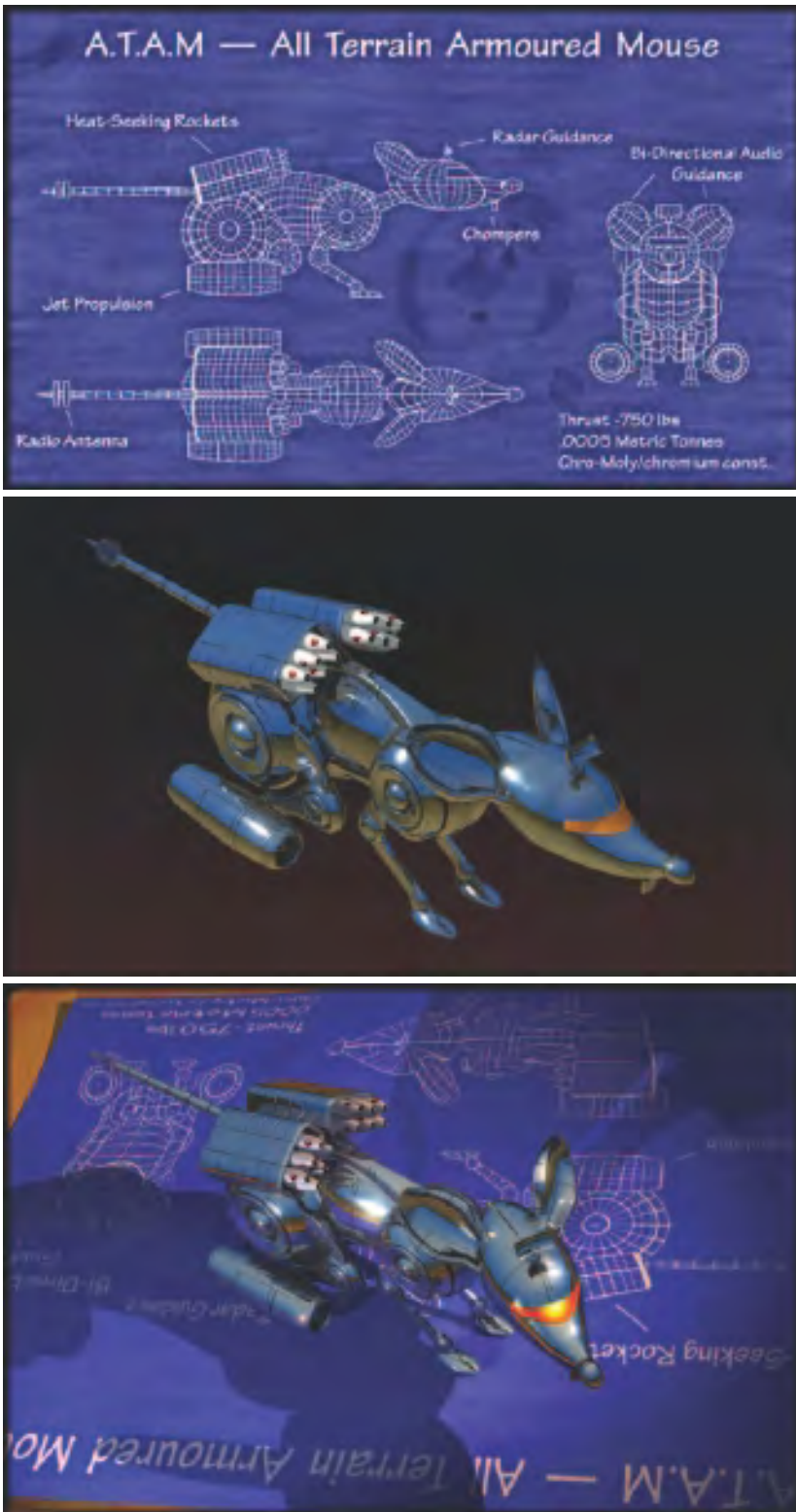

Figure 3-13 A background and object rendered into an image with shadows and lighting effects

Panoramas

Media players such as QuickTime and RealPlayer let you view a single surrounding image as if you were “inside” the picture and able to look up or down, turn, or zoom in on features. To make this work, you need to stitch together many images taken from different angles around a circle. Software such as ULead COOL 360 (www.ulead.com/cool360) or Panorama Factory (www.panoramafactory.com) works by importing a sequence of photos and letting you adjust them precisely into a single seamless bitmap, where the right edge attaches to the left edge and the color and lighting differences among the image are smoothed. You should allow some overlap when you take each photo for a 360-degree panorama, and you may need to adjust each photo’s contrast, brightness, hue, and saturation while stitching, if that feature is not provided by your software. Most programs also allow you to adjust perspective to compensate for different focal lengths or camera heights.

Color

Color is a vital component of multimedia. The next few sections explain where color comes from and how colors are displayed on a computer monitor. Management of color is both a subjective and a technical exercise. Picking the right colors and combinations of colors for your project can involve many tries until you feel the result is right. But the technical description of a color may be expressed in known physical values (humans, for example, perceive colors with wavelengths ranging from 400 to 600 nanometers on the electromagnetic spectrum), and several methods and models describe color space using mathematics and values (see Figure 3-14).

Understanding Natural Light and Color

Light comes from an atom when an electron passes from a higher to a lower energy level; thus each atom produces uniquely specific colors. This explanation of light, known as the **quantum theory**, was developed by physicist Max Planck in the late 19th century. Niels Bohr, another physicist, later showed that an excited atom that has absorbed energy and whose electrons have moved into higher orbits will throw off that energy in the form of quanta, or photons, when it reverts to a stable state. This is where light comes from.

Color is the frequency of a light wave within the narrow band of the electromagnetic spectrum to which the human eye responds. The letters of the mnemonic **ROY G. BIV**, learned by many of us to remember the colors of the rainbow, are the ascending frequencies of the visible light spectrum: red, orange, yellow, green, blue, indigo, and violet. Light that is infrared, or below the frequency of red light and not perceivable by the human eye, can

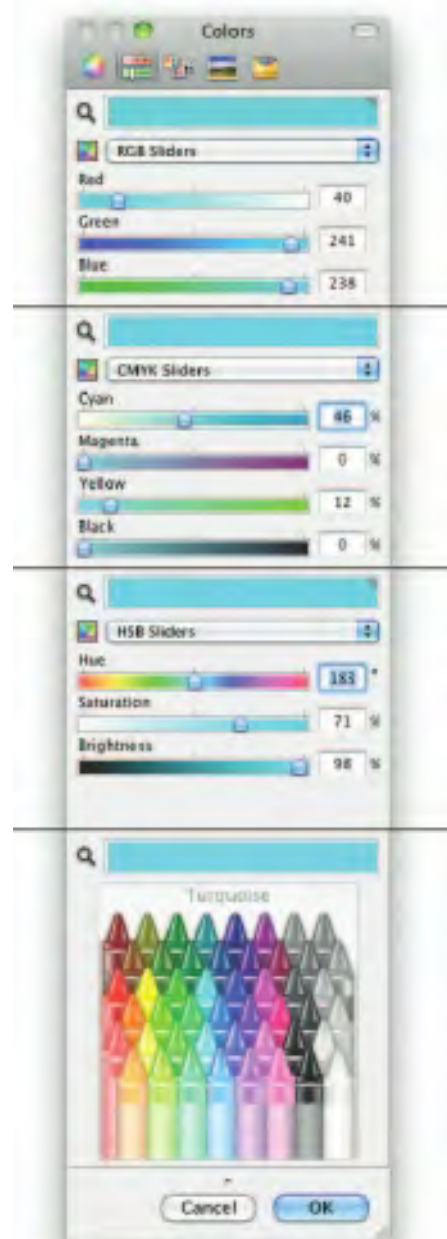
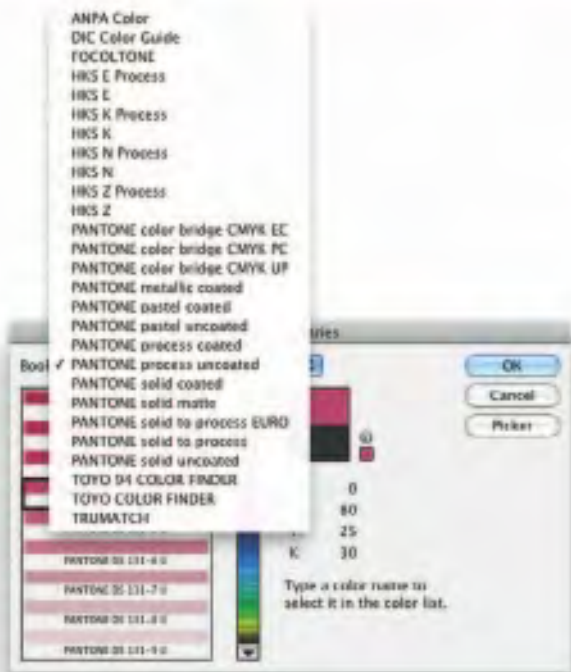
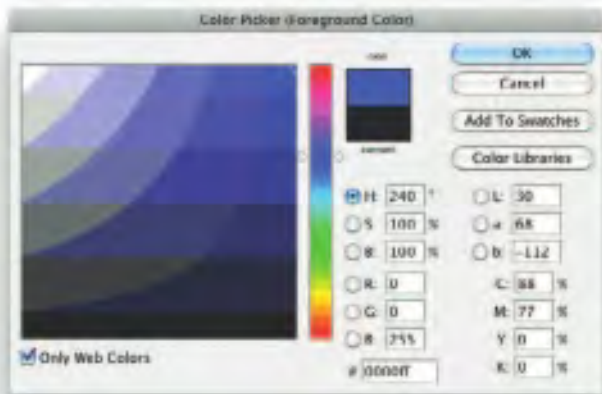
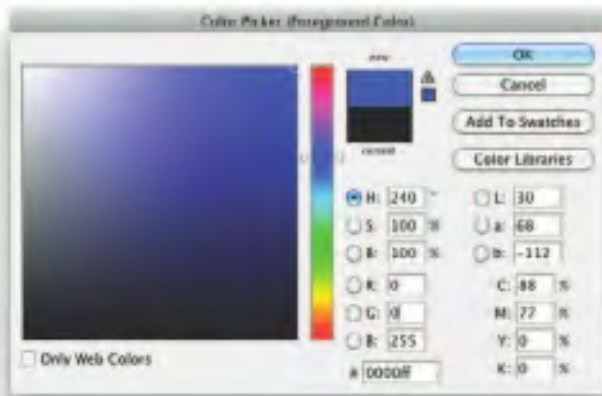

Figure 3-14 Color pickers allow you to select a color using one or more different models of color space.

be created and viewed by electronic diodes and sensors, and it is used for TV and VCR remote controls, for wireless communications among computers, and for night goggles used in the military. Infrared light is radiated heat. Ultraviolet light, on the other hand, is beyond the higher end of the visible spectrum and can be damaging to humans.

The color white is a noisy mixture of all the color frequencies in the visible spectrum. Sunlight and fluorescent tubes produce white light (though, technically, even they vary in color temperature—sunlight is affected by the angle at which the light is coming through the atmosphere, and fluorescent tubes provide spikes in the blue-green parts of the color spectrum); tungsten lamp filaments produce light with a yellowish cast; sodium vapor lamps, typically used for low-cost outdoor street lighting, produce an orange light characteristic of the sodium atom. These are the most common sources of light in the everyday (or every night) world. The light these sources produce typically reaches your eye as a reflection of that light into the lens of your eye.

The cornea of the eye acts as a lens to focus light rays onto the retina. The light rays stimulate many thousands of specialized nerves, called rods, which cover the surface of the retina. Receptors in the cones are sensitive to red, green, and blue light, and all the nerves together transmit the pattern of color information to the brain. The eye can differentiate among about 80,000 colors, or **hues**, consisting of combinations of red, green, and blue.

As color information is sent to the brain, other parts of the mind massage the data en route to its point of cognitive recognition. Human response to color is complicated by cultural and experiential filters that cause otherwise straightforward color frequencies to carry pleasant, unpleasant, soothing, depressing, and many other special meanings. In Western cultures, for example, red is the color of anger and danger; in Eastern cultures, red is the color of happiness. Red is the traditional color for Chinese restaurant motifs, to make them attractive and happy places; Western restaurants are often decorated in quieter pastels and earth tones. White, not black, is the color of funerals in Chinese culture.

Green, blue, yellow, orange, purple, pink, brown, black, gray, and white are the ten most common color-describing words used in all human languages and cultures. Komar and Melamid’s interesting tongue-in-cheek Internet study (www.diacenter.org/km/index.html) has determined that the favorite color in the world is blue.

See what an image looks like to someone with glaucoma, cataracts, macular degeneration, or a color deficit:

.....
www.vischeck.com/examples
www.webaim.org
.....

Computerized Color

Because the eye's receptors are sensitive to red, green, and blue light, by adjusting combinations of these three colors, the eye and brain will interpolate the combinations of colors in between. This is the psychology, not the physics, of color: what you perceive as orange on a computer monitor is a combination of two frequencies of green and red light, not the actual spectral frequency you see when you look at that namesake fruit, an orange, in sunlight. Various color models are illustrated in Figure 3-14. Although the eye perceives colors based upon red, green, and blue, there are actually two basic methods of making color: additive and subtractive.

Additive Color

In the **additive color** method, a color is created by combining colored light sources in three primary colors: red, green, and blue (**RGB**). This is the process used for cathode ray tube (CRT), liquid crystal (LCD), and plasma displays. On the back of the glass face of a CRT are thousands of phosphorescing chemical dots. These dots are each about 0.30mm or less in diameter (the **dot pitch**), and are positioned very carefully and very close together, arranged in triads of red, green, and blue. These dots are bombarded by electrons that “paint” the screen at high speeds (about 60 times a second). The red, green, and blue dots light up when hit by the electron beam. Your eye sees the combination of red, green, and blue light and interpolates it to create all other colors. Like CRTs, LCD and plasma screens utilize tiny red, green, and blue elements energized through tiny transparent conductors and organized in a Cartesian grid as illustrated by Marvin Raaijmakers and Angelo La Spina:

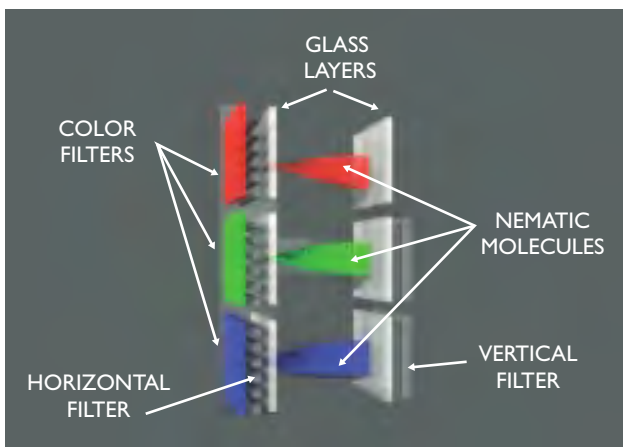

Subtractive Color

In the **subtractive color** method, color is created by combining colored media such as paints or ink that absorb (or subtract) some parts of the

color spectrum of light and reflect the others back to the eye. Subtractive color is the process used to create color in printing. The printed page is made up of tiny halftone dots of three primary colors: cyan, magenta, and yellow (designated as CMY). Four-color printing includes black (which is technically not a color but, rather, the absence of color). Since the letter B is already used for blue, black is designated with a K (so four-color printing is designated as **CMYK**). The color remaining in the reflected part of the light that reaches your eye from the printed page is the color you perceive.

All these factors make computerized color pretty tricky to manage. The fact that a paint program uses RGB to create the colors on your monitor, while your printer uses CMYK to print out your image, explains the problem of matching what you see on the screen with your printout. High-end image-editing programs such as Photoshop deal with this problem by allowing you to calibrate your monitor with your printer.

The following chart shows the three primary additive colors and how, when one of the primary colors is subtracted from this RGB mix, the subtractive primary color is perceived. The numbers in parentheses indicate the amount of red, green, and blue (in that order) used to create each of the colors in 24-bit color, which is described in the next section. A zero indicates a lack of that primary color, while 255 is the maximum amount of that color.

| RGB Combination (R,G,B) | Perceived Color |
|---|-----------------|
| Red only (255,0,0) | Red |
| Green only (0,255,0) | Green |
| Blue only (0,0,255) | Blue |
| Red and green (blue subtracted) (255,255,0) | Yellow |
| Red and blue (green subtracted) (255,0,255) | Magenta |
| Green and blue (red subtracted) (0,255,255) | Cyan |
| Red, green, and blue (255,255,255) | White |
| None (0,0,0) | Black |

Computer Color Models

Models or methodologies used to specify colors in computer terms are RGB, **HSB**, **HSL**, CMYK, **CIE**, and others. Using the 24-bit RGB (red, green, blue) model, you specify a color by setting each amount of red, green, and blue to a value in a range of 256 choices, from 0 to 255. Eight bits of memory are required to define those 256 possible choices, and that has to be done for each of the three primary colors; a total of 24 bits of memory ($8 + 8 + 8 = 24$) are therefore needed to describe the exact color, which is

one of “millions” ($256 \times 256 \times 256 = 16,777,216$). When web browsers were first developed, the software engineers chose to represent the color amounts for each color channel in a hexadecimal pair. Rather than using one number between 0 and 255, two **hexadecimal** numbers, written in a scale of 16 numbers and letters in the range “0123456789ABCDEF” represent the required 8 bits ($16 \times 16 = 256$) needed to specify the intensity of red, green, and blue. Thus, in HTML, you can specify pure green as #00FF00, where there is no red (first pair is #00), there is maximum green (second pair is #FF), and there is no blue (last pair is #00). The number sign (#) specifies the value as hexadecimal.

| Red | Green | Blue | Color |
|-----------|-----------|-----------|-------------------|
| 255 (#FF) | 255 (#FF) | 255 (#FF) | White (#FFFFFF) |
| 255 (#FF) | 255 (#FF) | 0 (#00) | Yellow (#FFFF00) |
| 255 (#FF) | 0 (#00) | 255 (#FF) | Magenta (#FF00FF) |
| 0 (#00) | 255 (#FF) | 255 (#FF) | Cyan (#00FFFF) |
| 255 (#FF) | 0 (#00) | 0 (#00) | Red (#FF0000) |
| 0 (#00) | 255 (#FF) | 0 (#00) | Green (#00FF00) |
| 0 (#00) | 0 (#00) | 255 (#FF) | Blue (#0000FF) |
| 0 (#00) | 0 (#00) | 0 (#00) | Black (#000000) |

In the HSB (hue, saturation, brightness) and HSL (hue, saturation, lightness) models, you specify hue or color as an angle from 0 to 360 degrees on a color wheel, and saturation, brightness, and lightness as percentages. Saturation is the intensity of a color. At 100 percent saturation a color is pure; at 0 percent saturation, the color is white, black, or gray. Lightness or brightness is the percentage of black or white that is mixed with a color. A lightness of 100 percent will yield a white color; 0 percent is black; the pure color has a 50 percent lightness.

The CMYK color model is less applicable to multimedia production. It is used primarily in the printing trade where cyan, magenta, yellow, and black are used to print process color separations.

| Color | Degrees |
|---------|---------|
| Red | 0° |
| Yellow | 60° |
| Green | 120° |
| Cyan | 180° |
| Blue | 240° |
| Magenta | 300° |

There are many valid color names for HTML and CSS listed by The World Wide Web Consortium (W3C) that can be used in place of #Hex values: for example, aqua, black, blue, fuchsia, gray, green, lime, maroon, navy, olive, purple, red, silver, teal, white, and yellow. Check out www.w3.org/TR/css3-color/#svg-color for a full list.

Other color models include CIE, **YIQ**, **YUV**, and **YCC**. CIE describes color values in terms of frequency, saturation, and illuminance (blue/yellow or red/green, which in turn corresponds to the color receptors in the cones of the eye). CIE more closely resembles how human beings perceive color, but certain devices such as scanners are unable to replicate the process.

YIQ and YUV were developed for broadcast TV (composite NTSC). They are based on luminance and chrominance expressed as the amplitude of a wave and the phase of the wave relative to some reference. Detail is carried by luminance (black and white), so reduction in color does not result in the loss of image definition detail. This analog process can be translated to a number value so that the computer can use a palette to assign a color to a pixel.

The Photo YCC model has been developed by Kodak to provide a definition that enables consistent representation of digital color images from negatives, slides, and other high-quality input. YCC is used for PhotoCD images.

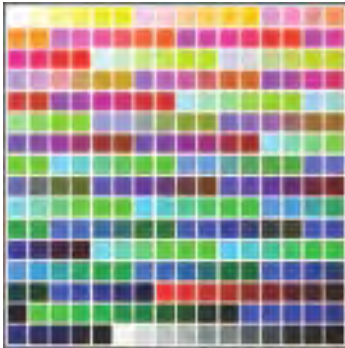

Macintosh System

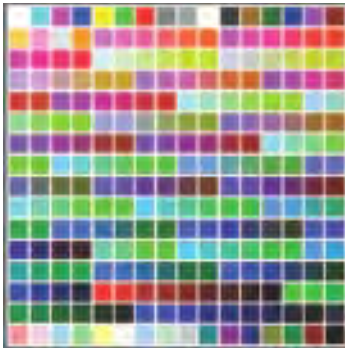

Windows System

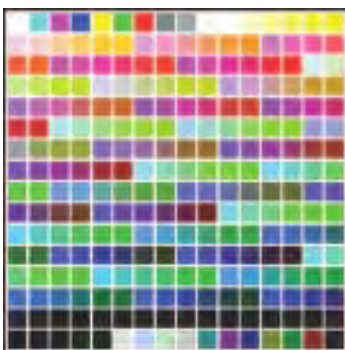

Web-Safe

Color Palettes

Palettes are mathematical tables that define the color of a pixel displayed on the screen. The most common palettes are 1, 4, 8, 16, and 24 bits deep:

| Color Depth | Colors Available |
|-------------|---|
| 1-bit | Black and white (or any two colors) |
| 4-bit | 16 colors |
| 8-bit | 256 colors (good enough for color images) |
| 16-bit | Thousands of colors (65,536; excellent for color images) |
| 24-bit | More than 16 million colors (16,777,216; totally photo-realistic) |

When color monitors became available for computers, managing the computations for displaying colors severely taxed the hardware and memory available at the time. 256-color, 8-bit images using a color lookup table or palette were the best a computer could do. 256 default system colors were statistically selected by Apple and Microsoft engineers (working independently) to be the colors and shades that are most “popular” in photographic images; their two system palettes are, of course, different. Web authorities also decided on a palette of 216 “web-safe” colors that would allow browsers to display images properly on both Macintosh and Windows computers.

GIF files using 256-color palettes are saved in a lossless format. The PNG format also uses palettes (24-bits or 32 bits if an “alpha” mask is included for transparency), and is lossless. It was developed for the Internet (it supports only the RGB color space) to expand GIF’s limited 256 colors to millions of colors.

In 24-bit color systems, your computer works with three channels of 256 discrete shades of each color (red, green, and blue) represented as the three axes of a cube. This allows a total of 16,777,216 colors ($256 \times 256 \times 256$). Just as the 44.1 kHz sampled-sound standard for CD music on compact discs that is discussed in Chapter 4 covers the range of human hearing, the color range offered by 24-bit systems covers what the human eye can sense.

Dithering

If you start out with a 24-bit scanned image that contains millions of colors and need to reduce it to an 8-bit, 256-color image, you get the best replication of the original image by **dithering** the colors in the image. Dithering is a process whereby the color value of each pixel is changed to the closest matching color value in the target palette, using a mathematical algorithm. Often the adjacent pixels are also examined, and patterns of different colors are created in the more limited palette to best represent the original colors. Since there are now only 256 colors available to represent the thousands or even millions of colors in the original image, pixels using the 256 remaining colors are intermixed and the eye perceives a color not in the palette, created by blending the colors mixed together. Thus any given pixel might not be mapped to its closest palette entry, but instead to the average over some area of the image; this average will be closer to the correct color than a substitute color would be. How well the dithered image renders a good approximation of the original depends upon the algorithm used and whether you allow the image-editing program to select the best set of 256 colors from the original image (called an adaptive palette) or force it to use a predetermined set of 256 colors (as, for example, with a System palette or the browser-safe web palette). Figure 3-15 compares the same scanned image dithered from millions of colors to 256 colors, 16 colors, 16 grays, and black and white.

Dithering concepts are important to understand when you are working with bitmaps derived from RGB information or based upon different palettes. The palette for the image of a rose, for example, may contain mostly shades of red with a number of greens thrown in for the stem and leaves. The image of your pretty Delft vase, into which you want to electronically place the rose, may be mostly blues and grays. Your software will

To generate a palette which is best for representing a particular image, we support Heckbert’s median cut algorithm. This algorithm first builds a three-dimensional table (a histogram cube) indicating how popular any given colour in the RGB cube is in the image being converted. It then proceeds to subdivide this histogram cube (by dividing boxes in half) until it has created as many boxes as there are palette entries.

The decision as to where to divide a box is based on the distribution of colours within the box. This algorithm attempts to create boxes which have approximately equal popularity in the image. Palette entries are then assigned to represent each box. There are other methods of generating a palette from an image, but Heckbert’s algorithm is generally regarded as the best trade-off between speed and quality.

.....
Allan Hessenflow of HandMade Software, makers of Image Alchemy, describing how an 8-bit palette is made

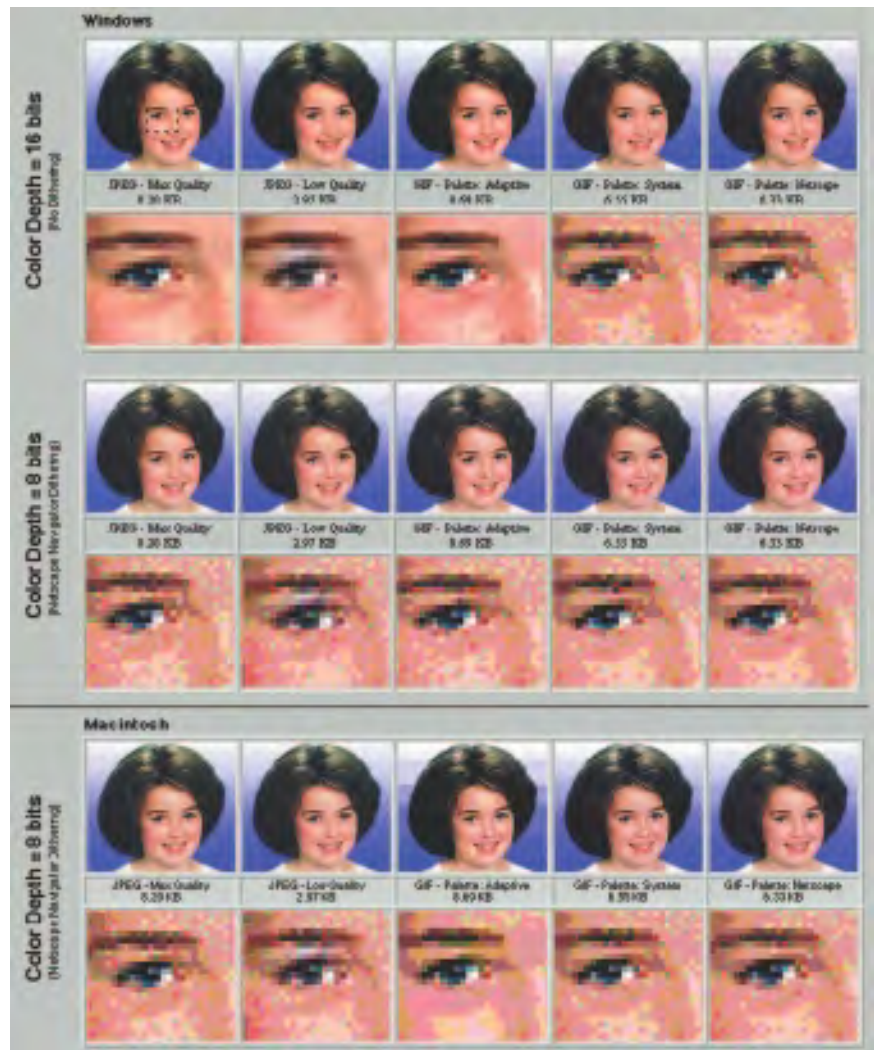

Figure 3-15 These images were dithered in Photoshop to best fit the 8-bit palettes of GIF files (Adaptive, System, or Custom 216 Netscape). Also shown are JPEG files compressed with highest and lowest quality and their actual file sizes. The files were then displayed using a browser at 16-bit and then 8-bit color depth. Note the subtle differences among palettes and systems, especially in the gradient blue background. Gradients do not usually dither well into 8-bit palettes.

Multimedia is just another way to transform ambiguity. There were so many ambiguous colors in this scan, I decided to make them unambiguous. How do you like the purple?

Lars Hidde, explaining why he dithered a perfectly fine 256-color image into a 16-color default palette

use a dithering algorithm to find the 256 color shades that best represent both images, generating a new palette in the process.

Dithering software is usually built into image-editing programs and is also available in many multimedia authoring systems as part of the application's palette management suite of tools.

Image File Formats

Most applications on any operating system can manage JPEG, GIF, PNG, and TIFF image formats. An older format used on the Macintosh, **PICT**, is a complicated but versatile format developed by Apple where both bitmaps and vector-drawn objects can live side by side. The **device-independent bitmap (DIB)**, also known as a **BMP**, is a common Windows palette-based image file format similar to PNG. **PCX** files were originally developed for use in Z-Soft MS-DOS paint packages; these files can be opened and saved by almost all MS-DOS paint software and desktop publishing software. **TIFF**, or Tagged Interchange File Format, was designed to be a universal bitmapped image format and is also used extensively in desktop publishing packages. Often, applications use a proprietary file format to store their images. Adobe creates a PSD file for Photoshop and an AI file for Illustrator; Corel creates a CDR file. **DXF** was developed by AutoDesk as an ASCII-based drawing interchange file for AutoCAD, but the format is used today by many computer-aided design applications. **IGS** (or **IGES**, for **Initial Graphics Exchange Standard**) was developed by an industry committee as a broader standard for transferring CAD drawings. These formats are also used in 3-D rendering and animation programs.

JPEG, PNG, and GIF images are the most common bitmap formats used on the Web and may be considered cross-platform, as all browsers will display them. Adobe's popular PDF (Portable Document File) file manages both bitmaps and drawn art (as well as text and other multimedia content), and is commonly used to deliver a "finished product" that contains multiple assets.

First Person

I needed to get about 40 bitmap files from the Macintosh to the Sun SPARCstation. "Piece of cake," I said. "Give me a few minutes." The network hadn't gone down in three days, and we were connected at broadband speeds. Well, the files had been saved in native Photoshop format on the Macintosh. So I launched Photoshop, opened each

file, and then saved it in PICT format. The translator program I wanted to use to convert Macintosh PICT files to Sun raster files was an MS-DOS application, so I renamed all the Macintosh files to fit the DOS eight-plus-three-character filename convention. Then I cranked up the PC, launched the translator, and batch-processed all of the files into RAS

files using the network. The 40 new files were now on the Macintosh, mixed in with the original PICTs. I collected the needed raster files into a single folder on the Macintosh and then sent the whole thing over to the Sun.

A few minutes? The process kept three chairs warm for about two hours.

Chapter 3 Review

■ Chapter Summary

For your review, here's a summary of the important concepts discussed in this chapter.

Work out your graphical approach by planning your approach, organizing your tools, and configuring your computer workspace

- What you see on a multimedia computer screen is the viewer's primary connection to all of your project's content.
- Work out your graphic approach before you begin, either in your head or during creative sessions with your client or colleagues.
- To get a handle on any multimedia project, start with pencil, eraser, and paper. Outline your project and your graphic ideas first: make a flowchart; storyboard the project using stick figures; use three-by-five index cards and shuffle them until you get it right.
- Most authoring systems provide simple tools for creating the graphic objects directly on your screen. Most can also import objects from other applications.
- Multimedia designers employ a variety of applications and tools to accomplish many specialized tasks.

Differentiate among bitmap, vector, and 3-D images and describe the capabilities and limitations of all three

- Bitmaps are an image type most appropriate for photo-realistic images and complex drawings requiring fine detail.
- Limitations of bitmapped images include large files sizes and the inability to scale or resize the image easily while maintaining quality.
- A bitmap is a simple information matrix describing the individual dots of an image, called pixels.

- The image's bit-depth determines the number of colors that can be displayed by an individual pixel.
- You can grab a bitmap image from a screen, scan it with a scanner, download it from a web site, or capture it from a video capture device.
- You can then manipulate and adjust many of its properties, and cut and paste among many bitmaps using specialized image-editing or "darkroom" programs.
- Vector images are most appropriate for lines, boxes, circles, polygons, and other graphic shapes that can be mathematically expressed in angles, coordinates, and distances.
- A vector object can be filled with color and patterns, and you can select it as a single object.
- Vector-drawn objects use a fraction of the memory space required to describe and store the same object in bitmap form.
- Most drawing programs can export a vector drawing as a bitmap.
- Converting bitmaps to vector-drawn objects is difficult; however, autotracing programs can compute the boundaries of shapes and colors in bitmapped images and then derive the polygon object that describes those bounds.
- For 3-D, the depth (z dimension) of cubes and spheres must be calculated and displayed so that the perspective of the rendered object seems correct to the eye.
- Objects and elements in 3-D space carry with them properties such as shape, color, texture, shading, and location.
- To model an object that you want to place into your scene, you must start with a shape.
- When you extrude a plane surface, it extends its shape some distance, either perpendicular to the shape's outline or along a defined path.

- When you lathe a shape, a profile of the shape is rotated around a defined axis (you can set the direction) to create the 3-D object.
- Rendering is when the computer finally uses intricate algorithms to apply the effects you have specified on the objects you have created.

Describe the use of colors and palettes in multimedia

- Color is the frequency of a light wave within the narrow band of the electromagnetic spectrum to which the human eye responds.
- Different cultures associate certain colors with different meanings.
- For 8-bit GIF images, the computer uses a palette of 256 colors to determine which colors to display.
- Dithering is a process whereby the color value of each pixel is changed to the closest matching color value in the target palette, using a mathematical algorithm.

- If you are using a specialized application to make bitmaps or drawings, make sure your multimedia authoring package can import the image files you produce, and that your application can export such a file.

Cite the various file types used in multimedia

- GIF and PNG images use palettes of colors.
- Windows uses device-independent bitmaps (DIBs) as its common image file format, usually written as BMP files.
- TIFF, or Tagged Interchange File Format, was designed to be a universal bitmapped image format and is also used extensively in desktop publishing packages.
- For handling drawn objects across many platforms, there are two common formats: DXF and IGS. JPEG and GIF images are the most common bitmap formats used on the Web and may be considered cross-platform, as all browsers will display them.

■ Key Terms

additive color (91)

autotracing (82)

Bézier (81)

binary (71)

bit (71)

bitmap (70)

BMP (97)

Cartesian coordinates (80)

CIE (92)

clipboard (77)

CMYK (92)

device-independent bitmap (DIB) (97)

dithering (95)

dot pitch (91)

DXF (97)

extrude (85)

flare (85)

GIF (71)

hexadecimal (93)

HSB (92)

HSL (92)

hue (90)

IGS or IGES (Initial Graphics Exchange Standard) (97)

JPEG (71)

lathe (85)

modeling (84)

morphing (77)

object (84)

palette (94)

PCX (97)

pel (72)

PICT (97)

pixel (72)

pixelation (82)

PNG (71)

primitive (85)

property (84)

quantum theory (88)

real estate (69)

rendering (86)

RGB (91)

rotated (85)

ROY G. BIV (88)

scene (84)

shading (86)

shape (85)

subtractive color (91)

SVG (Scalable Vector Graphics) (81)

texture (85)

TIFF (97)

vector (80)

vector-drawn (70)

YCC (94)

YIQ (94)

YUV (94)

z dimension (84)

■ Key Term Quiz

1. The working area of a computer display is sometimes called _____.
2. The type of image used for photo-realistic images and for complex drawings requiring fine detail is the _____.
3. The type of image used for lines, boxes, circles, polygons, and other graphic shapes that can be mathematically expressed in angles, coordinates, and distances is the _____.
4. The picture elements that make up a bitmap are called _____.
5. _____ allows you to smoothly blend two images so that one image seems to melt into the next.
6. The process that computes the bounds of the shapes of colors within a bitmap image and then derives the polygon object that describes that image is called _____.
7. _____ is when the computer uses intricate algorithms to apply the effects you have specified on the objects you have created for a final 3-D image.
8. _____ is the blocky, jagged look resulting from too little information in a bitmapped image.
9. A collection of color values available for display is called a _____.
10. _____ is a process whereby the color value of each pixel is changed to the closest matching color value in the target palette, using a mathematical algorithm.

■ Multiple-Choice Quiz

1. What is the best way to start creating your project's interface?
 - a. Start with pencil, eraser, and paper.
 - b. Outline your project and graphic ideas.
 - c. Storyboard using stick figures.
 - d. Use three-by-five index cards and shuffle them.
 - e. All of the above
2. Which image file type is best for photographs?
 - a. vector
 - b. encapsulated PostScript
 - c. bitmap
 - d. Shockwave
 - e. laser
3. A 24-bit image is capable of representing how many different colors?
 - a. 2
 - b. 16
 - c. 256
 - d. 65,536
 - e. 16,772,216
4. Vector-drawn objects are used for all of the following *except*:
 - a. lines
 - b. circles
 - c. polygons
 - d. photographs
 - e. boxes
5. "Unlimited use" of stock photography may actually impose a limitation on:
 - a. the number of units you can distribute without paying more.
 - b. the number of changes you can make to the image.
 - c. converting the image to another file format.
 - d. the filters you may use to alter the image.
 - e. the price you can charge for your product.
6. Name the area of memory where data such as text and images is temporarily stored when you cut or copy within an application.
 - a. scrapbook
 - b. notepad
 - c. junkyard
 - d. filedump
 - e. clipboard

7. Perhaps the single most significant advance in computer image processing during the late 1980s was the development of:
 - a. digital cameras
 - b. 3-D modeling programs
 - c. image-editing programs
 - d. scanners
 - e. electronic crayons
8. When an image created on a Macintosh is viewed on a PC:
 - a. it appears darker and richer because the values have changed
 - b. it appears lighter and less saturated because the values have changed
 - c. it appears darker and richer even though the values have not changed
 - d. it appears lighter and less saturated even though the values have not changed
 - e. it appears exactly the same
9. Graphic artists designing for print media use vector-drawn objects because:
 - a. they can contain more subtle variations in shading than bitmap graphics
 - b. printing inks respond better to them
 - c. they can be converted across platforms more easily
 - d. they can be scaled to print at any size
 - e. they can be viewed directly in Web browsers
10. The 3-D process of extending a plane surface some distance, either perpendicular to the shape's outline or along a defined path, is called:
 - a. lathing
 - b. rendering
 - c. modeling
 - d. extruding
 - e. skinning
11. A GIF image may contain:
 - a. 8 bits of color information per pixel
 - b. 16 bits of color information per pixel
 - c. 24 bits of color information per pixel
 - d. 32 bits of color information per pixel
 - e. 48 bits of color information per pixel
12. Which of these is the correct HTML hexadecimal representation of magenta (red + blue)?
 - a. 00GGHH
 - b. #FF00FF
 - c. 255,0,255
 - d. %R100-%G0-%B100
 - e. <color = "magenta">
13. Which of the following is *not* a color specification format?
 - a. RGB
 - b. HSB
 - c. GIF
 - d. CMYK
 - e. CIE
14. Which of the following is *not* a native Windows graphics file format?
 - a. BMP
 - b. RIFF
 - c. TIFF
 - d. PCX
 - e. PICT
15. TIFF stands for:
 - a. Transitional Image File Format
 - b. Total Inclusion File Format
 - c. Tagged Interchange File Format
 - d. Temporary Instruction File Format
 - e. Table Index File Format

■ Essay Quiz

1. Discuss the difference between bitmap and vector graphics. Describe five different graphic elements you might use in a project, for example, the background, buttons, icons, or text. Would you use a vector tool or a bitmap tool for each element? Why?
2. You are assigned to create an interface that will look good across platforms. What is the difference between images as shown on a Macintosh and PC? How would you deal with this problem?

3. List several simple geometric shapes. If you have a 3-D modeling program available, using these shapes, extrude or lathe them to create various objects, such as a teapot, a tree, a car, a table, or a lamp. Think of some other objects. How would you use the simple geometric shapes (called “primitives”) to create the 3-D object?
4. You are a designer given the task of creating a web site for a new division of your company. Start by defining the characteristics of the customers of the company and the kind of image the company wishes to present to its customers. Then specify a color palette to be used for the design of the site. Defend your color choices by discussing the associations people have with the colors and how they relate to your customers and the company’s image.

Lab Projects

■ Project 3.1

Select five different web pages, each from a different web site. Select pages that contain lots of colors and images, both photographs and graphics. View the five different pages on both a Macintosh and PC screen, preferably side by side, as well as on more than one computer on the same platform (for example, one Mac, two Windows computers). Note the differences in how each page appears across platforms and across screens. For each page, write a paragraph describing how they differ in terms of color tone, saturation, and any other characteristics that you notice.

■ Project 3.2

Using the capture tool built into the operating system or another dedicated tool, capture and save five different screens. Use the tools to save the entire screen, areas of the screen, the frontmost window, an image with a menu pulled down, and an image with the cursor (some capture programs may not be able to capture all these different types of images). Save the files and print them out.

■ Project 3.3

Download three different images from a web site. One should be photographic, one should be a graphic (solid colors or gradients), and one should be a mix. Convert the images to 256 colors. Use the tools available to use different dithering patterns and palettes. Print out the files before and after reducing to 256 colors. Write the file sizes on each one. Use an image-editing program to compare the effects of applying different palettes and compression methods to the original images.

■ Project 3.4

Visit different web sites. Describe the use of colors for each in subjective terms. Is each site vibrant? childish? muted? subtle? Why? What cultural or other factors determined the color selection? Print out a page from each site, and write a paragraph describing the colors and images used in each one.

■ Project 3.5

Open an image in an image-editing program capable of identifying colors. Select three different pixels in the image. Sample the color and write down its value in RGB, HSB, CMYK, and web (hexadecimal) color.

| Point | RGB | HSB | CMYK | Hexadecimal |
|-------|-----|-----|------|-------------|
| 1 | | | | |
| 2 | | | | |
| 3 | | | | |

Sound

In this chapter, you will learn how to:

- Describe the components and measurements of sound
- Use digital audio to record, process, and edit sound
- Use MIDI and understand its attributes, especially relative to digitized audio
- Compare and contrast the use of MIDI and digitized audio in a multimedia production
- List the important steps and considerations in recording and editing digital audio
- Determine which audio file formats are best used in a multimedia project
- Cite the considerations involved in managing audio files and integrating them into multimedia projects

SOUND is perhaps the most sensuous element of multimedia. It is meaningful “speech” in any language, from a whisper to a scream. It can provide the listening pleasure of music, the startling accent of special effects, or the ambience of a mood-setting background. Some feel-good music powerfully fills the heart, generating emotions of love or otherwise elevating listeners closer to heaven. How you use the power of sound can make the difference between an ordinary multimedia presentation and a professionally spectacular one. Misuse of sound, however, can wreck your project. Try testing all 56 of your ringtones on a crowded bus: your fellow passengers will soon wreck your day.

The Power of Sound

When something vibrates in the air by moving back and forth (such as the cone of a loudspeaker), it creates waves of pressure. These waves spread like the ripples from a pebble tossed into a still pool, and when they reach your eardrums, you experience the changes of pressure, or vibrations, as sound. In air, the ripples propagate at about 750 miles per hour, or Mach 1 at sea level. Sound waves vary in sound pressure level (amplitude) and in frequency or pitch. Many sound waves mixed together form an audio sea of symphonic music, speech, or just plain noise.

Acoustics is the branch of physics that studies sound. Sound pressure levels (loudness or volume) are measured in **decibels (dB)**; a decibel measurement is actually the ratio between a chosen reference point on a logarithmic scale and the level that is actually experienced. When you quadruple the sound output power, there is only a 6 dB increase; when you make the sound 100 times more intense, the increase in dB is not hundredfold, but only 20 dB. A logarithmic scale (seen below) makes sense because humans perceive sound pressure levels over an extraordinarily broad dynamic range.



A logarithmic scale is also used for measuring the power of earthquakes (the Richter Scale) and stellar magnitudes (a first magnitude star is

100 times as bright as a typical sixth magnitude star, which is at the limit of human visual perception—magnitude 31.5 is the faintest visible light object detectable by the Hubble Space Telescope). You can recognize logarithmic scales because they use divisions that are multipliers (1, 10, 100, 1000) instead of additions (1, 2, 3, 4).

The decibel scale, with some examples, is shown in Table 4-1; notice the relationship between power (measured in watts) and dB.

| dB | Watts | Example |
|-----|---------------|---|
| 195 | 25–40 million | Saturn rocket |
| 170 | 100,000 | Jet engine with afterburner |
| 160 | 10,000 | Turbojet engine at 7,000-pounds thrust |
| 150 | 1,000 | ALSETEX splinterless stun grenade |
| 140 | 100 | 2 JBL2226 speakers pulling 2,400 watts inside an automobile |
| 130 | 10 | 75-piece orchestra, at fortissimo |
| 120 | 1 | Large chipping hammer |
| 110 | 0.1 | Riveting machine |
| 100 | 0.01 | Automobile on highway |
| 90 | 0.001 | Subway train; a shouting voice |
| 80 | 0.0001 | Inside a 1952 Corvette at 60 mph |
| 70 | 0.00001 | Voice conversation; freight train 100 feet away |
| 60 | 0.000001 | Large department store |
| 50 | 0.0000001 | Average residence or small business office |
| 40 | 0.00000001 | Residential areas of Chicago at night |
| 30 | 0.000000001 | Very soft whisper |
| 20 | 0.0000000001 | Sound studio |

Table 4-1 Typical Sound Levels in Decibels (dB) and Watts

Sound is energy, just like the waves breaking on a sandy beach, and too much volume can permanently damage the delicate receiving mechanisms behind your eardrums, typically dulling your hearing in the 6 kHz range. In terms of volume, what you hear subjectively is not what you hear objectively. The perception of loudness is dependent upon the frequency or pitch of the sound: at low frequencies, more power is required to deliver the same perceived loudness as for a sound at the middle or higher frequency ranges. You may feel the sound more than hear it. For instance, when the ambient noise level is above 90 dB in the workplace, people are likely to make increased numbers of errors in susceptible tasks—especially when there is a high-frequency component to the noise. When the level is above

80 dB, it is quite impossible to use a telephone. Experiments by researchers in residential areas have shown that a sound generator at 45 dB produces no reaction from neighbors; at 45 to 55 dB, sporadic complaints; at 50 to 60 dB, widespread complaints; at 55 to 65 dB, threats of community action; and at more than 65 dB, vigorous community action, possibly more aggressive than when you tested your ringtones on the bus. This neighborhood research from the 1950s continues to provide helpful guidelines for practicing rock musicians and multimedia developers today.

Human hearing is less able to identify the location from which lower frequencies are generated. In surround sound systems, subwoofers can be placed wherever their energy is most efficiently radiated (often in a corner), but midrange speakers should be carefully placed.

There is a great deal more to acoustics than just volume and pitch. If you are interested, many texts will explain why middle C on a cello does not sound like middle C on a bassoon; or why a five-year-old can hear a 1,000 Hz tone played at 20 dB, while an older adult with presbycusis (loss of hearing sensitivity due to age) cannot. Your use of sound in multimedia projects will not likely require highly specialized knowledge of harmonics, intervals, sine waves, notation, octaves, or the physics of acoustics and vibration, but you do need to know how to record and edit sounds on your computer and incorporate them into your multimedia work.

Digital Audio

Digital audio is created when you represent the characteristics of a sound wave using numbers—a process referred to as digitizing. You can digitize sound from a microphone, a synthesizer, existing recordings, live radio and television broadcasts, and popular CD and DVDs. In fact, you can digitize sounds from any natural or prerecorded source.

Digitized sound is sampled sound. Every n th fraction of a second, a **sample** of sound is taken and stored as digital information in bits and bytes. The quality of this digital recording depends upon how often the samples are taken (**sampling rate** or frequency, measured in kilohertz, or thousands of samples per second) and how many numbers are used to represent the value of each sample (**bit depth, sample size**, resolution, or dynamic range). The more often you take a sample and the more data you store about that sample, the finer the resolution and quality of the captured sound when it is played back. Since the quality of your audio is based on the quality of your recording and not the device on which your end user will play the audio, digital audio is said to be **device independent**.

The three sampling rates most often used in multimedia are 44.1 kHz (**CD-quality**), 22.05 kHz, and 11.025 kHz. Sample sizes are either 8 bits or 16 bits. The larger the sample size, the more accurately the data will

describe the recorded sound. An 8-bit sample size provides 256 equal measurement units to describe the level and frequency of the sound in that slice of time. A 16-bit sample size, on the other hand, provides a staggering 65,536 equal units to describe the sound in that same slice of time. As you can see in Figure 4-1, slices of analog waveforms are sampled at various frequencies, and each discrete sample is then stored either as 8 bits or 16 bits (or more) of data.

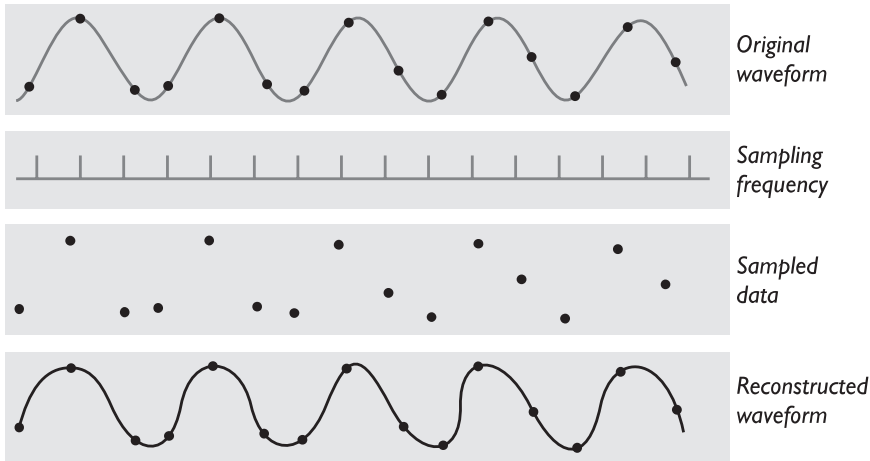

Figure 4-1 It is impossible to reconstruct the original waveform if the sampling frequency is too low.

The value of each sample is rounded off to the nearest integer (**quantization**), and if the amplitude is greater than the intervals available, clipping of the top and bottom of the wave occurs (see Figure 4-2). Quantization can produce an unwanted background hissing noise, and clipping may severely distort the sound.

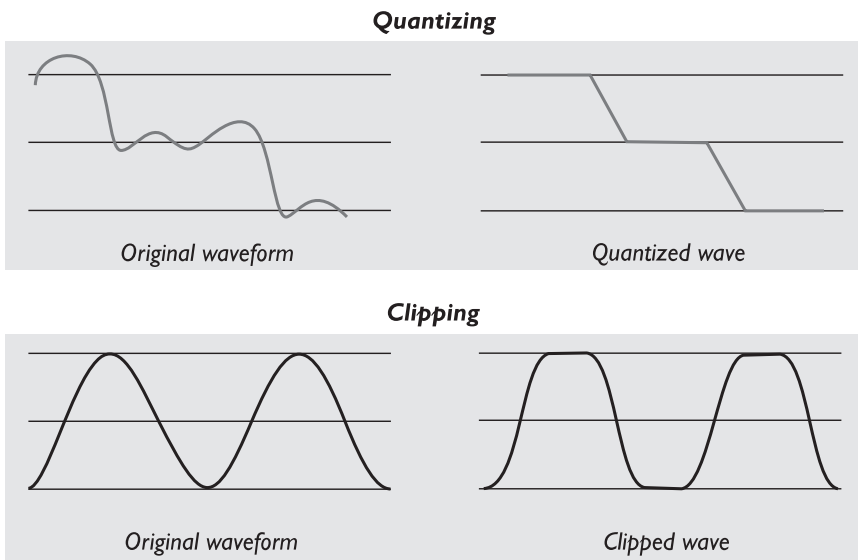

Figure 4-2 Examples of quantizing and clipping

I have a 20-second sample of a song which I play to my class at 8K, 22K, 44K, and 48K, and I have the students listen and compare quality. They comment that 8K does not sound all that bad *until* they hear the 44K and 48K.

They also see (hear) very little difference between 44K and 48K.

Dennis Woytek, Assistant Professor of Multimedia Technology, Duquesne University



Making Digital Audio Files

Making digital audio files is fairly straightforward on most computers. Plug a microphone into the microphone jack of your computer. If you want to digitize archived analog source materials—music or sound effects that you have saved on videotape, for example—simply plug the “Line-Out” or “Headphone” jack of the device into the “Line-In” jack on your computer. Then use audio digitizing software such as Audacity (see Figure 4-3), to do the work.

You should focus on two crucial aspects of preparing digital audio files:

- Balancing the need for sound quality against file size. Higher quality usually means larger files, requiring longer download times on the Internet and more storage space on a CD or DVD.
- Setting proper recording levels to get a good, clean recording.

Setting Proper Recording Levels

A distorted recording sounds terrible. If the signal you feed into your computer is too “hot” to handle, the result will be an unpleasant crackling or background ripping noise. Conversely, recordings that are made at too low a level are often unusable because the amount of sound recorded does not sufficiently exceed the residual noise levels of the recording process itself. The trick is to set the right levels when you record.

Any good piece of digital audio recording and editing software will display digital meters to let you know how loud your sound is. Watch the meters closely during recording, and you’ll never have a problem. Unlike analog meters that usually have a 0 setting somewhere in the middle and extend up into ranges like +5, +8, or even higher, digital meters peak out. To avoid distortion, do not cross over this limit. If this happens, lower your volume (either by lowering the input level of the recording device or the output level of your source) and try again. Try to keep peak levels between -3 and -10. Any time you go over the peak, whether you can hear it or not, you introduce distortion into the recording. In digital meter displays, if you see red, you are over the peak.

Editing Digital Recordings

Once a recording has been made, it will almost certainly need to be edited. Shown in Figure 4-3 with its special effects menu, Audacity is a free open-source sound editing application for Windows, Macintosh, and Linux (<http://audacity.sourceforge.net>). With such a tool you can create sound tracks and digital mixes. The basic sound editing operations that most multimedia producers need are described in the paragraphs that follow.

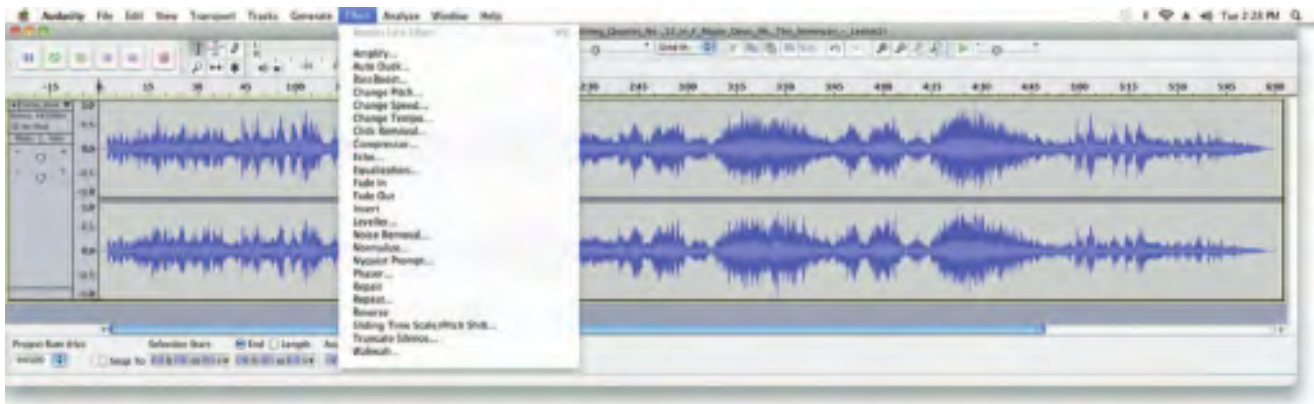

Figure 4-3 Audacity is an open-source, cross-platform editing tool for digitizing sound (<http://audacity.sourceforge.net/>).

Trimming Removing “dead air” or blank space from the front of a recording and any unnecessary extra time off the end is your first sound editing task. Trimming even a few seconds here and there might make a big difference in your file size. Trimming is typically accomplished by dragging the mouse cursor over a graphic representation of your recording and choosing a menu command such as Cut, Clear, Erase, or Silence.

Splicing and Assembly Using the same tools mentioned for trimming, you will probably want to remove the extraneous noises that inevitably creep into a recording. Even the most controlled studio voice-overs require touch-up. Also, you may need to assemble longer recordings by cutting and pasting together many shorter ones. In the old days, this was done by splicing and assembling actual pieces of magnetic tape.

Volume Adjustments If you are trying to assemble ten different recordings into a single sound track, there is little chance that all the segments will have the same volume. To provide a consistent volume level, select all the data in the file, and raise or lower the overall volume by a certain amount. Don’t increase the volume too much, or you may distort the file. It is best to use a sound editor to **normalize** the assembled audio file to a particular level, say 80 percent to 90 percent of maximum (without clipping), or about -16 dB. Without normalizing to this rule-of-thumb level, your final sound track might play too softly or too loudly. Even pros can leave out this important step. Sometimes an audio CD just doesn’t seem to have the same loudness as the last one you played, or it is too loud and you can hear clipping. Figure 4-4 shows the normalizing process at work in Adobe’s Soundbooth.

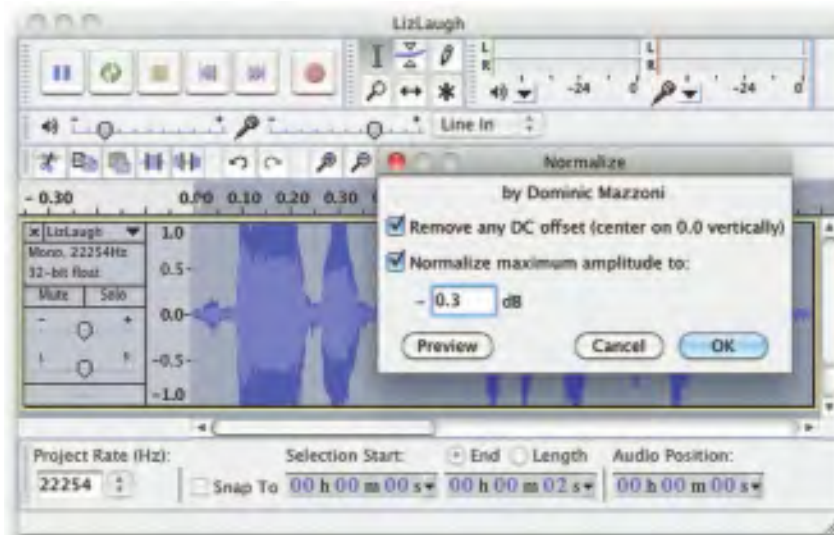

Figure 4-4 Normalizing evens out the sound level in an audio file.

Format Conversion In some cases, your digital audio editing software might read a format different from that read by your presentation or authoring program. Most sound editing software will save files in your choice of many formats, most of which can be read and imported by multimedia authoring systems. Data may be lost when converting formats. If, for example, you have a Digital Rights Management (DRM)–protected M4P file downloaded from the iTunes store and burn that file to an Audio CD track, the DRM data will be lost because the Audio CD format does not provide for DRM data. The now-unprotected tune on the CD can then be ripped into a playable **MP3** format.

Resampling or Downsampling If you have recorded and edited your sounds at 16-bit sampling rates but are using lower rates and resolutions in your project, you must **resample** or **downsample** the file. Your software will examine the existing digital recording and work through it to reduce the number of samples. This process may save considerable disk space.

Fade-ins and Fade-outs Most programs offer enveloping capability, useful for long sections that you wish to fade in or fade out gradually. This enveloping helps to smooth out the very beginning and the very end of a sound file.

Equalization Some programs offer **digital equalization (EQ)** capabilities that allow you to modify a recording's frequency content so that it sounds brighter (more high frequencies) or darker (low, ominous rumbles).

Time Stretching Advanced programs let you alter the length (in time) of a sound file without changing its pitch. This feature can be very useful, but watch out: most **time-stretching** algorithms will severely degrade the audio quality of the file if the length is altered more than a few percent in either direction.

Digital Signal Processing (DSP) Some programs allow you to process the signal with reverberation, multitap delay, chorus, flange, and other special effects using **digital signal processing (DSP)** routines.

Being able to process a sound source with effects can greatly add to a project. To create an environment by placing the sound inside a room, a hall, or even a cathedral can bring depth and dimension to a project. But a little can go a long way—do not overdo the sound effects!

TIP *Once a sound effect is processed and mixed onto a track, it cannot be further edited, so always save the original so that you can tweak it again if you are not happy.*

Reversing Sounds Another simple manipulation is to reverse all or a portion of a digital audio recording. Sounds, particularly spoken dialog, can produce a surreal, otherworldly effect when played backward.

Multiple Tracks Being able to edit and combine multiple tracks (for sound effects, voice-overs, music, etc.) and then merge the tracks and export them in a “final mix” to a single audio file is important.

File Size vs. Quality

Remember that the sampling rate determines the frequency at which samples will be taken for the recording. Sampling at higher rates (such as 44.1 kHz or 22.05 kHz) more accurately captures the high-frequency content of your sound. **Audio resolution** (such as 8- or 16-bit) determines the accuracy with which a sound can be digitized. Using more bits for the sample size yields a recording that sounds more like its original.

WARNING *The higher the sound quality, the larger your file will be.*

Stereo recordings are more lifelike and realistic because human beings have two ears. Mono recordings are fine but tend to sound a bit “flat” and uninteresting when compared with stereo recordings. Logically, to record stereo you need two microphones (left and right), and the sound file generated will require twice as much storage space as the mono file for the same length of play time.

Table 4-2 provides some commonly used sampling rates and resolutions, with resulting file sizes.

| Sampling Rate | Resolution | Stereo or Mono | Bytes Needed for 1 Minute | Comments |
|---------------|------------|----------------|---------------------------|--|
| 44.1 kHz | 16-bit | Stereo | 10.5MB | CD-quality recording; the recognized standard of audio quality. |
| 44.1 kHz | 16-bit | Mono | 5.25MB | A good trade-off for high-quality recordings of mono sources such as voice-overs. |
| 44.1 kHz | 8-bit | Stereo | 5.25MB | Achieves highest playback quality on low-end devices such as most of the sound cards in Windows PCs. |
| 44.1 kHz | 8-bit | Mono | 2.6MB | An appropriate trade-off for recording a mono source. |
| 22.05 kHz | 16-bit | Stereo | 5.25MB | Darker sounding than CD-quality recording because of the lower sampling rate, but still full and “present” because of high bit resolution and stereo. Preferred for CD-ROM projects. |
| 22.05 kHz | 16-bit | Mono | 2.5MB | Not a bad choice for speech, but better to trade some fidelity for a lot of disk space by dropping down to 8-bit. |
| 22.05 kHz | 8-bit | Stereo | 2.6MB | A popular choice for reasonable stereo recording where full bandwidth playback is not possible. |
| 22.05 kHz | 8-bit | Mono | 1.3MB | A thinner sound than the previous choice, but very usable. Any Macintosh or any MPC can play back this type of file. About as good as listening to your TV set. |
| 11 kHz | 8-bit | Stereo | 1.3MB | At this low a sampling rate, there are few advantages to using stereo. |
| 11 kHz | 8-bit | Mono | 650KB | In practice, probably as low as you can go and still get usable results; very dark and muffled. |
| 5.5 kHz | 8-bit | Stereo | 650KB | Stereo not effective. |
| 5.5 kHz | 8-bit | Mono | 325KB | About as good as a bad telephone connection. |

Table 4-2 One-Minute Digital Audio Recordings at Common Sampling Rates and Resolutions

TIP *The only reason to digitize audio at a higher specification than can be used by the target playback device is for archiving it. As playback technologies and bandwidth improve over time, you may wish (someday) for higher-quality original files when you upgrade a product. Save the originals!*

Consumer-grade audio compact discs provide stereo at a sampling rate of 44.1 kHz and 16-bit resolution. Sound studios using high-end equipment digitally record and edit performances at much higher sampling rates and depths than this target distribution platform, and the final mix is downsampled before mass replication.

Audiophiles (listeners seriously interested in perfect sound reproduction) have driven a small market for very high-end equipment that can play back SACD (Super Audio CD) or DVD-Audio formats written on special audio-only DVDs that require dedicated players and a system with as many as five full-frequency speakers and a subwoofer. This sound is typically sampled at a depth of 24 bits and frequency of 96 kHz. It is said by some that, while the limit of human hearing may be about 21 kHz, the unheard higher frequency harmonics (easily heard by dogs to 60 kHz, bats to 120 kHz, and dolphins to 150 kHz) “flood” the brain with pleasure-causing endorphins and lead to a fuller sensory experience.

Here are the formulas for determining the size (in bytes) of a digital recording. For a monophonic recording:

$$\text{sampling rate} * \text{duration of recording in seconds} * (\text{bit resolution} / 8) * 1$$

For a stereo recording:

$$\text{sampling rate} * \text{duration of recording in seconds} * (\text{bit resolution} / 8) * 2$$

(Remember, sampling rate is measured in kHz, or thousand samples per second, so to convert from kHz to a whole number, you must multiply by 1,000. Resolution is measured in bits per sample. Since there are 8 bits in a byte, you have to divide the bit resolution by 8.) Thus the formula for a 10-second recording at 22.05 kHz, 8-bit resolution would be

$$22050 * 10 * 8 / 8 * 1$$

which equals 220,500 bytes. A 10-second stereo recording at 44.1 kHz, 16-bit resolution (meeting the CD-quality Red Book Audio standards—an international recording standard discussed later in this chapter) would be

$$44100 * 10 * 16 / 8 * 2$$

which equals 1,764,000 bytes. A 40-second mono recording at 11 kHz, 8-bit resolution would be

$$11000 * 40 * 8 / 8 * 1$$

which equals 440,000 bytes.

Fortunately, for hard disk storage requirements at least, and for ring-tone files sent over a mobile phone, user expectations of audio quality are somewhat lower than for Grammy Award-winning recordings. (See Vaughan’s Law of Multimedia Minimums later in this chapter.)

MIDI Audio

MIDI (Musical Instrument Digital Interface) is a communications standard developed in the early 1980s for electronic musical instruments and

computers. It allows music and sound synthesizers from different manufacturers to communicate with each other by sending messages along cables connected to the devices. MIDI provides a protocol for passing detailed descriptions of a musical score, such as the notes, the sequences of notes, and the instrument that will play these notes. But MIDI data is not digitized sound; it is a shorthand representation of music stored in numeric form. Digital audio is a recording, MIDI is a score—the first depends on the capabilities of your sound system, the other on the quality of your musical instruments *and* the capabilities of your sound system.

A MIDI file is a list of time-stamped commands that are recordings of musical actions (the pressing down of a piano key or a sustain pedal, for example, or the movement of a control wheel or slider). When sent to a MIDI playback device, this results in sound. A concise MIDI message can cause a complex sound or sequence of sounds to play on an instrument or synthesizer; so MIDI files tend to be significantly smaller (per second of sound delivered to the user) than equivalent digitized waveform files.

Composing your own original score can be one of the most creative and rewarding aspects of building a multimedia project, and MIDI is the quickest, easiest, and most flexible tool for this task. Yet creating an original MIDI score is hard work. Knowing something about music, being able to play a keyboard, and having a lot of good ideas are just the prerequisites to building a good score; beyond that, it takes time and musical skill to work with MIDI.

Happily, you can always hire someone to do the job for you. In addition to the talented MIDI composers who charge substantial rates for their services, many young composers are also available who want to get into multimedia. With a little research, you can often find a MIDI musician to work for limited compensation. Remember, however, that you often get what you pay for.

The process of creating MIDI music is quite different from digitizing existing recorded audio. If you think of digitized audio as analogous to a bitmapped graphic image (both use sampling of the original analog medium to create a digital copy), then MIDI is analogous to structured or vector graphics (both involve instructions provided to software to be able to re-create the original on the fly). For digitized audio you simply play the audio through a computer or device that can digitally record the sound. To make MIDI scores, however, you will need **notation software** (see Figure 4-5), **sequencer software** (see Figure 4-6), and a **sound synthesizer** (typically built into the software of multimedia players in most computers and many handheld devices). A **MIDI keyboard** is also useful for simplifying the creation of musical scores.

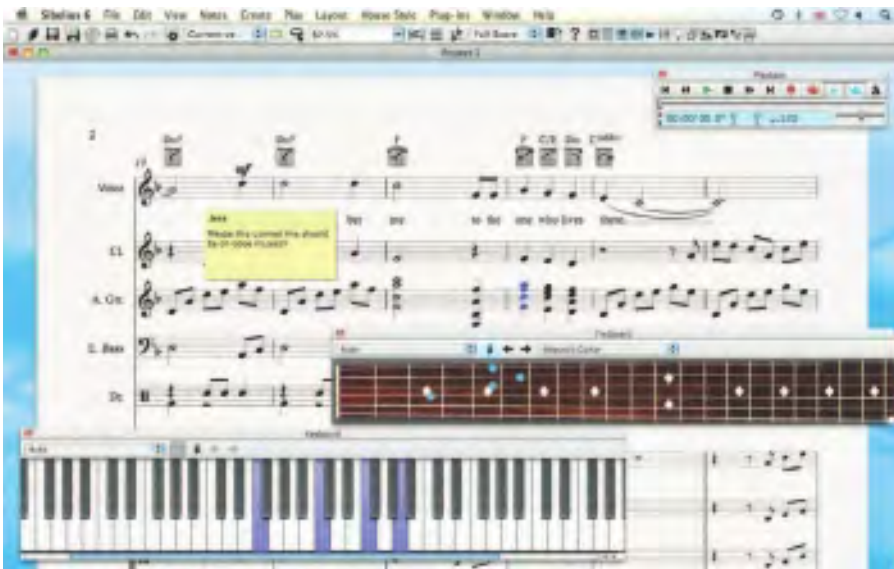

Figure 4-5 Notation and composition software such as Sibelius provides a way for composers and musicians to create and arrange scores using MIDI instruments.



Figure 4-6 Sequencer software such as Pro Tools allows you to record, edit, and save music generated from a MIDI keyboard or instruments and blend it with digital audio.

Rather than recording the sound of a note, MIDI software creates data about each note as it is played on a MIDI keyboard (or another MIDI device)—which note it is, how much pressure was used on the keyboard to play the note, how long it was sustained, and how long it takes for the note to decay or fade away, for example. This information, when played back through a MIDI device, allows the note to be reproduced exactly. Because the quality of the playback depends upon the end user's MIDI device rather than the recording, MIDI is **device dependent**. The sequencer software quantizes your score to adjust for timing inconsistencies (a great feature for those who can't keep the beat), and it may also print a neatly penned copy of your score to paper.

An advantage of structured data such as MIDI is the ease with which you can edit the data. Let's say you have a piece of music being played on a honky-tonk piano, but your client decides he wants the sound of a soprano saxophone instead. If you had the music in digitized audio, you would have to re-record and redigitize the music. When it is in MIDI data, however, there is a value that designates the instrument to be used for playing back the music. To change instruments, you just change that value. Instruments that you can synthesize are identified by a **General MIDI** numbering system that ranges from 0 to 127 (see Table 4-3). Until this system came along, there was always a risk that a MIDI file originally composed with, say, piano, electric guitar, and bass, might be played back with piccolo, tambourine, and glockenspiel if the ID numbers were not precisely mapped to match the original hardware setup. This was usually the case when you played a MIDI file on a MIDI configuration different from the one that recorded the file.

| ID | Sound | ID | Sound |
|----|-----------------------|----|-------------------------|
| 0 | Acoustic grand piano | 16 | Hammond organ |
| 1 | Bright acoustic piano | 17 | Percussive organ |
| 2 | Electric grand piano | 18 | Rock organ |
| 3 | Honky-tonk piano | 19 | Church organ |
| 4 | Rhodes piano | 20 | Reed organ |
| 5 | Chorused piano | 21 | Accordion |
| 6 | Harpsichord | 22 | Harmonica |
| 7 | Clarinet | 23 | Tango accordion |
| 8 | Celesta | 24 | Acoustic guitar (nylon) |
| 9 | Glockenspiel | 25 | Acoustic guitar (steel) |
| 10 | Music box | 26 | Electric guitar (jazz) |
| 11 | Vibraphone | 27 | Electric guitar (clean) |
| 12 | Marimba | 28 | Electric guitar (muted) |
| 13 | Xylophone | 29 | Overdriven guitar |
| 14 | Tubular bells | 30 | Distortion guitar |
| 15 | Dulcimer | 31 | Guitar harmonics |

Table 4-3 General MIDI Instrument Sounds

| ID | Sound | ID | Sound | ID | Sound |
|----|------------------------|-----|------------------------|------------------------|--------------------|
| 32 | Acoustic bass | 80 | Lead 1 (Square) | Percussion Keys | |
| 33 | Electric bass (finger) | 81 | Lead 2 (Sawtooth) | 35 | Acoustic bass drum |
| 34 | Electric bass (pick) | 82 | Lead 3 (Calliope lead) | 36 | Bass drum 1 |
| 35 | Fretless bass | 83 | Lead 4 (Chiff lead) | 37 | Side stick |
| 36 | Slap bass 1 | 84 | Lead 5 (Charang) | 38 | Acoustic snare |
| 37 | Slap bass 2 | 85 | Lead 6 (Voice) | 39 | Hand clap |
| 38 | Synth bass 1 | 86 | Lead 7 (Fifths) | 40 | Electric snare |
| 39 | Synth bass 2 | 87 | Lead 8 (Bass + lead) | 41 | Low-floor tom |
| 40 | Violin | 88 | Pad 1 (New Age) | 42 | Closed high-hat |
| 41 | Viola | 89 | Pad 2 (Warm) | 43 | High-floor tom |
| 42 | Cello | 90 | Pad 3 (Polysynth) | 44 | Pedal high-hat |
| 43 | Contrabass | 91 | Pad 4 (Choir) | 45 | Low tom |
| 44 | Tremolo strings | 92 | Pad 5 (Bowed) | 46 | Open high-hat |
| 45 | Pizzicato strings | 93 | Pad 6 (Metallic) | 47 | Low-mid tom |
| 46 | Orchestral harp | 94 | Pad 7 (Halo) | 48 | High-mid tom |
| 47 | Timpani | 95 | Pad 8 (Sweep) | 49 | Crash cymbal 1 |
| 48 | String ensemble 1 | 96 | FX 1 (Rain) | 50 | High tom |
| 49 | String ensemble 2 | 97 | FX 2 (Soundtrack) | 51 | Ride cymbal 1 |
| 50 | SynthStrings 1 | 98 | FX 3 (Crystal) | 52 | Chinese cymbal |
| 51 | SynthStrings 2 | 99 | FX 4 (Atmosphere) | 53 | Ride bell |
| 52 | Choir aahs | 100 | FX 5 (Brightness) | 54 | Tambourine |
| 53 | Voice oohs | 101 | FX 6 (Goblins) | 55 | Splash cymbal |
| 54 | Synth voice | 102 | FX 7 (Echoes) | 56 | Cowbell |
| 55 | Orchestra hit | 103 | FX 8 (Sci-Fi) | 57 | Crash cymbal 2 |
| 56 | Trumpet | 104 | Sitar | 58 | Vibraslap |
| 57 | Trombone | 105 | Banjo | 59 | Ride cymbal 2 |
| 58 | Tuba | 106 | Shamisen | 60 | High bongo |
| 59 | Muted trumpet | 107 | Koto | 61 | Low bongo |
| 60 | French horn | 108 | Kalimba | 62 | Mute high conga |
| 61 | Brass section | 109 | Bagpipe | 63 | Open high conga |
| 62 | Synth brass 1 | 110 | Fiddle | 64 | Low conga |
| 63 | Synth brass 2 | 111 | Shanai | 65 | High timbale |
| 64 | Soprano saxophone | 112 | Tinkle bell | 66 | Low timbale |
| 65 | Alto saxophone | 113 | Agogo | 67 | High agogo |
| 66 | Tenor saxophone | 114 | Steel drums | 68 | Low agogo |
| 67 | Baritone saxophone | 115 | Wood block | 69 | Cabasa |
| 68 | Oboe | 116 | Taiko drum | 70 | Maracas |
| 69 | English horn | 117 | Melodic tom | 71 | Short whistle |
| 70 | Bassoon | 118 | Synth drum | 72 | Long whistle |
| 71 | Clarinet | 119 | Reverse cymbal | 73 | Short guiro |
| 72 | Piccolo | 120 | Guitar fret noise | 74 | Long guiro |
| 73 | Flute | 121 | Breath noise | 75 | Claves |
| 74 | Recorder | 122 | Seashore | 76 | High wood block |
| 75 | Pan flute | 123 | Bird tweet | 77 | Low wood block |
| 76 | Bottle blow | 124 | Telephone ring | 78 | Mute cuica |
| 77 | Shakuhachi | 125 | Helicopter | 79 | Open cuica |
| 78 | Whistle | 126 | Applause | 80 | Mute triangle |
| 79 | Ocarina | 127 | Gunshot | 81 | Open triangle |

Table 4-3 General MIDI Instrument Sounds (Continued)

TIP *Making MIDI files is as complex as recording good sampled files; so it often pays to find someone already set up with the equipment and skills to create your score, rather than investing in the hardware, software, and the learning curve. Once you have gathered your audio material, you will need to edit it to precisely fit your multimedia project. As you edit, you will continue to make creative decisions. Because it is so easy to edit MIDI data, you can make many fine adjustments to your music as you go along.*

Since MIDI is device dependent and the quality of consumer MIDI playback hardware varies greatly, MIDI's true place in multimedia work may be as a production tool rather than a delivery medium. MIDI is by far the best way to create original music, so use MIDI to get the flexibility and creative control you want. Then, once your music is completed and fits your project, lock it down for delivery by turning it into digital audio data.

In addition to describing the instrument and the note, MIDI data can also describe the **envelope** of the sound: the **attack** (how quickly a sound's volume increases), the **sustain** (how long the sound continues), and the **decay** (how quickly the sound fades away).

TIP *Test your MIDI files thoroughly by playing them back on a variety of hardware devices or with different MIDI players before you incorporate them into your multimedia project. Windows Media Player and QuickTime will play MIDI on your computer.*

MIDI vs. Digital Audio

In contrast to MIDI data, digital audio data is the actual representation of a sound, stored in the form of thousands of individual numbers (*samples*). The digital data represents the instantaneous amplitude (or loudness) of a sound at discrete slices of time. MIDI data is to digital audio data what vector or drawn graphics are to bitmapped graphics. That is, MIDI data is device dependent; digital data is not. Just as the appearance of vector graphics differs depending on the printer device or display screen, the sounds produced by MIDI music files depend on the particular MIDI device used for playback. Similarly, a roll of perforated player-piano score played on a concert grand would sound different than if played on a honky-tonk piano. Digital data, on the other hand, produces sounds that are more or less identical regardless of the playback system. The MIDI standard lets instruments communicate in a well-understood language.

MIDI has several advantages over digital audio and two huge disadvantages. First, the advantages:

- MIDI files are much more compact than digital audio files, and the size of a MIDI file is completely independent of playback quality. In

general, MIDI files will be 200 to 1,000 times smaller than CD-quality digital audio files. Because MIDI files are small, they don't take up as much memory, disk space, or bandwidth.

- Because they are small, MIDI files embedded in web pages load and play more quickly than their digital equivalents.
- In some cases, if the MIDI sound source you are using is of high quality, MIDI files may sound better than digital audio files.
- You can change the length of a MIDI file (by varying its tempo) without changing the pitch of the music or degrading the audio quality. MIDI data is completely editable—right down to the level of an individual note. You can manipulate the smallest detail of a MIDI composition (often with submillisecond accuracy) in ways that are impossible with digital audio.
- Because they represent the pitch and length of notes, MIDI files can generally be converted to musical notation, and vice versa. This is useful when you need a printed score; in reverse, you can scan a printed score and convert it to MIDI for tweaking and editing.

Now for MIDI's disadvantages:

- Because MIDI data does not represent sound but musical instruments, you can be certain that playback will be accurate only if the MIDI playback device is identical to the device used for production. Imagine the emotional humming chorus from *Madame Butterfly* sung by a chorus of Budweiser frogs—same score, wrong instrument. Even with the General MIDI standard (see the General MIDI table of instrument sounds in Table 4-3), the sound of a MIDI instrument varies according to the electronics of the playback device and the sound generation method it uses.
- Also, MIDI cannot easily be used to play back spoken dialog, although expensive and technically tricky digital samplers are available.

In general, use MIDI in the following circumstances:

- Digital audio won't work because you don't have enough memory or bandwidth.
- You have a high-quality MIDI sound source.
- You have complete control over the machines on which your program will be delivered, so you know that your users will have high-quality MIDI playback hardware.
- You don't need spoken dialog.

The most important advantage of digital audio is its consistent playback quality, but this is where MIDI is the least reliable! With digital audio you can be more confident that the audio track for your multimedia project will sound as good in the end as it did in the beginning when you created it. For this reason, it's no surprise that digital audio is used far more frequently than MIDI data for multimedia sound delivery.

There are two additional and often more compelling reasons to work with digital audio:

- A wider selection of application software and system support for digital audio is available for both the Macintosh and Windows platforms.
- The preparation and programming required for creating digital audio do not demand knowledge of music theory, while working with MIDI data usually does require a modicum of familiarity with musical scores, keyboards, and notation, as well as audio production.

In general, use digital audio in the following circumstances:

- You don't have control over the playback hardware.
- You have the computing resources and bandwidth to handle digital files.
- You need spoken dialog.

Multimedia System Sounds

You can use sound right off the bat on your computer because beeps and warning sounds are available as soon as you install the operating system. Open the Sound Control Panel to listen to your system sounds, change them, or make a new, custom sound (see Figure 4-7).

In Windows, system sounds are WAV files, and they reside in the Windows\Media subdirectory. System event sounds include start.wav, chimes.wav, chord.wav, ding.wav, logoff.wav, notify.wav, recycle.wav, tada.wav, and the Microsoft sound.wav that typically plays when Windows starts up.

As you can see in Figure 4-7, you can assign these sounds to system events such as Windows startup, warnings from other applications, or clicks outside of an open dialog box (which causes the default beep in Windows). And you can create schemes of sounds and select a particular scheme according to your mood. You can also add your own sound files and install them so they play when system events occur: place the WAV sound files into your ~\Windows\Media directory and use the Sound Control Panel to select them.

In OS X on a Macintosh, you can only change your system alert sound. Put your custom sound file (in **AIF format**) into ~/System/Library/Sounds, then select it in the Sound preference pane.

TIP If you are new to computers, your first multimedia sound experience might be simply finding one of these system sounds in the Sound Control Panel and testing it.

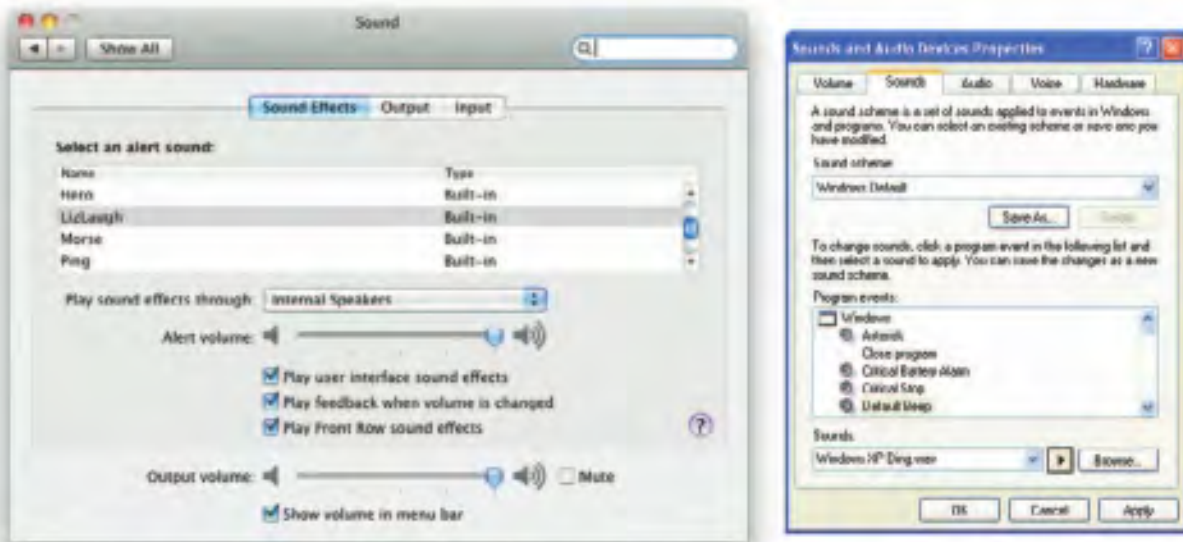

Figure 4-7 Sound Control Panels for Macintosh and Windows

Audio File Formats

When you create multimedia, it is likely that you will deal with file formats and translators for text, sounds, images, animations, or digital video clips. A sound file's format is simply a recognized methodology for organizing and (usually) compressing the digitized sound's data bits and bytes into a data file. The structure of the file must be known, of course, before the data can be saved or later loaded into a computer to be edited and/or played as sound. The file name extension identifies which method of storage is used.

There are many ways to store the bits and bytes that describe a sampled waveform sound. The method used for consumer-grade music CDs is **Linear Pulse Code Modulation (LPCM)**, often shortened to PCM. An audio CD provides up to 80 minutes of playing time, which is enough for a slow-tempo rendition of Beethoven's Ninth Symphony. Incidentally, being able to contain Beethoven's Ninth is reported to have been Philips's and Sony's actual size criterion during early research and development for determining the length of the sectors and ultimately the physical size of the compact disc format itself. The **CD-ROM/XA (extended architecture)** format for reading and writing CDs was developed later so you could put several recording sessions of music or data onto a single CD-R (recordable) disc. LPCM tracks from an audio CD are usually converted and stored on a computer in uncompressed **AIFF** (Audio Interchange File Format) or **wave format (WAV)** files when copied from the CD.

AIFF is historically used for Macintosh sound files. The WAV format was introduced by Microsoft when Windows was first released. Both formats contain uncompressed sound data. But there are huge numbers of sound file formats and “multimedia containers” that store sound data (more than three hundred different file name extensions are used for sound files), and often a converter is required to read or write sound files in the format you need. Hoo Technologies (www.hootech.com) offers MP3 to SWF, SWF/FLV to MP3, AIFF to MP3, MIDI to MP3, WMA to MP3, WAV to MP3, and OGG to MP3 converters. Their AIFF to MP3 converter will read the following formats: 3G2, 3GP, 3GP2, 3GPP, 4XM, AAC, AC3, ADX, AFC, AIF, AIFC, AIFF, ALAW, AMR, AMV, APE, ASF, AU, AVI, AWB, CAF, CDA, CDATA, DIF, DIVX, DTS, DV, DVD, DVR-MS, DXA, FLAC, FLC, FLI, FLIC, FLV, FLX, GSM, GXF, H261, H263, H263+, H264, IT, KAR, M1A, M1V, M2A, M2TS, M2V, M4A, M4B, M4V, MID, MIDI, MJ2, MJPEG, MJPG, MKA, MKV, MLP, MLV, MMF, MO3, MOD, MOV, MP+, MP1, MP2, MP3, MP4, MPA, MPC, MPE, MPEG, MPG, MPGA, MPP, MPV, MTM, MTS, MTV, MVI, MXF, NSA, NSV, NUT, NUV, OGA, OGG, OGM, OGV, OGX, OMA, PSP, PSX, PVA, QCP, QT, RA, RAM, RM, RMI, RMVB, ROQ, RPL, S3M, SDP, SHN, SMK, SND, SOL, SPX, STR, SWF, TS, TTA, UMX, VFW, VID, VMD, VOB, VOC, VQF, W64, WAV, WAVE64, WM, WMA, WMD, WMV, WV, XA, XM, XVID, XWMV, and YUV. And it will output to MP3, WAV, WMA, AAC, MP4, M4A (MPEG-4 Audio), M4B (MPEG-4 AudioBook), OGG, AMR, and AWB formats. But rest easy—you will likely only work with a handful of sound file types.

The MP3 format was developed by the Moving Picture Experts Group (**MPEG**) and evolved during the 1990s into the most common method for storing consumer audio. It incorporates a “**lossy**” compression algorithm to save space. An audio CD, for example, may hold an hour or so of uncompressed LPCM sound. That same CD, using MP3 compression, can store almost seven hours of the same music, but with a slight loss of quality. WMA (Windows Media Audio) is a proprietary Microsoft format developed to improve MP3. OGG was developed as an open-source and royalty-free “container” for sound compressed using Vorbis algorithms similar to MP3—because the Vorbis sound data resides within an Ogg container, these audio files are normally called “Ogg Vorbis.”

MP4 is a format based on Apple’s **QuickTime movie (.mov)** “container” model and is similar to the MOV format, which stores various types of media, particularly time-based streams such as audio and video. The mp4 extension is used when the file streams audio and video together. The m4a extension is used when the file contains only audio data. M4p files contain only audio, but are encrypted for Digital Rights Management (DRM). M4r files are used for ringtones on Apple’s iPhone. Other GSM

(Global System for Mobile Communications) mobile phones use 3gp files for their ringtones, a format also based on the MPG container model.

The AAC (Advanced Audio Coding) format, which is part of the MP4 model, was adopted by Apple's iTunes store, and many music files are commercially available in this format. ACC is the default format for iPod, iPhone, PlayStation, Wii, Dsi, and many mobile phones including Motorola, Nokia, Philips, Samsung, Siemens, and Sony Ericsson. The SWF format is a container for vector-based graphics and animations, text, video, and sound delivered over the Internet. Typically created using Adobe's Flash, SWF files require a plug-in or player be installed in the user's browser. Adobe claims that the Flash Player is installed in more than 98 percent of Web users' browsers and in more than 800 million handsets and mobile devices. Flash video files (FLV) contain both a video stream and an audio stream, and the FLV format has been adopted by YouTube, Google, Yahoo, Reuters.com, BBC.com, CNN.com, and other news providers for Internet delivery of content.

TIP *The most common sound formats you might use are wav, aif, aac, flv, mp3, mp4, mov, swf, wma, ogg, or for ringtones, m4r, aac, midi, mmf, 3g2, 3gp, 3gp2, and 3gpp. Be sure your audio software can read and write the formats you need.*

A **codec** (compressor-decompressor) is software that compresses a stream of audio or video data for storage or transmission, then decompresses it for playback. There are many codecs that do this with special attention to the quality of music or voice after decompression. Some are “lossy” and trade quality for significantly reduced file size and transmission speed; some are “lossless,” so original data is never altered. While editing your audio files, be sure to save your files using a lossless format or codec—with repetitive saves in a lossy format, you will notice a quality degradation each time. A container format such as MP4, MOV, or OGG may encapsulate data streams that use one of many codecs available in that container.

Vaughan's Law of Multimedia Minimums

A classic physical anthropology law (Liebig's Law of the Minimum) proposes that the evolution of eyesight, locomotor speed, sense of smell, or any other species trait will cease when that trait becomes sufficiently adequate to meet the survival requirements of the competitive environment. If the trait is good enough, the organism expends no more effort improving it. Thus, if consumer-grade electronics and

Vaughan's Law of Multimedia Minimums

There is an acceptable minimum level of adequacy that will satisfy the audience, even when that level may not be the best that technology, money, or time and effort can buy.

a handheld microphone are good enough for making your sound, and if you, your client, and your audience are all satisfied with the results, conserve your energy and money and avoid any more expenditure. And keep this Law of Minimums in mind when you make all your trade-off decisions involving other areas of high technology and multimedia, too.

Adding Sound to Your Multimedia Project

The original 128K Macintosh, released in January 1984, was technically a multimedia-capable machine. It displayed bitmapped graphics (albeit in black and white) and, more significantly, boasted 8-bit digital audio capability right on the motherboard. In fact, the very first Macintosh actually introduced itself by voice when it was unveiled by Steve Jobs.

Here's a little history: In order to use the Apple moniker, the original founders of Apple Computer, Inc., worked out an arrangement with the Beatles (yes, *those* Beatles). One part of that agreement stipulated that Apple Computer, Inc., would never venture into the music business. To Steve Jobs and Steve Wozniak, working out of their garage in the late 1970s on a machine that could barely manage a convincing system beep, that clause probably seemed a harmless one. Little did they know that years later their computer and the Apple itself would become the most popular provider of music in the world through its iTunes facility. The company did finally pay representatives of the Beatles about \$30 million to settle the issue once and for all.

Whether you're working on a Macintosh or in Windows, you will need to follow certain steps to bring an audio recording into your multimedia project. Here is a brief overview of the process:

1. Determine the file formats that are compatible with your multimedia authoring software and the delivery medium(s) you will be using (for file storage and bandwidth capacity).
2. Determine the sound playback capabilities (codecs and plug-ins) that the end user's system offers.
3. Decide what kind of sound is needed (such as background music, special sound effects, and spoken dialog). Decide where these audio events will occur in the flow of your project. Fit the sound cues into your storyboard (see Chapter 10), or make up a cue sheet.
4. Decide where and when you want to use either digital audio or MIDI data.
5. Acquire source material by creating it from scratch or purchasing it.

6. Edit the sounds to fit your project.
7. Test the sounds to be sure they are timed properly with the project's images. This may involve repeating steps 1 through 4 until everything is in sync.

When it's time to import your compiled and edited sounds into your project, you'll need to know how your particular multimedia software environment handles sound data. Each multimedia authoring program or web browser handles sound a bit differently, but the process is usually fairly straightforward: just tell your software which file you want to play and when to play it. This is usually handled by an importing or "linking" process during which you identify the files to play.

Scripting languages such as revTalk (RunRev), Lingo (Director), and ActionScript (Flash) provide a greater level of control over audio playback, but you'll need to know about the programming language and environment. In multimedia authoring environments, it is usually a simple matter to play a sound when the user clicks a button, but this may not be enough. If the user changes screens while a long file is playing, for example, you may need to program the sound to stop before leaving the current screen. If the file to be played cannot be found, you may need to code an entire section for error handling and file location. Sample code is generally provided in both printed and online documentation for software that includes sound playback. For web pages, you will need to embed a player and point to your sound file using HTML code.

Space Considerations

The substantial amount of digital information required for high-quality sound takes up a lot of storage space, especially when the quantity is doubled for two-channel stereo. It takes about 1.94MB to store 11 seconds of uncompressed stereo sound.

If monaural sound is adequate for your project, you can cut your storage space requirement in half or get double the playing time in the same memory space. With compression codecs, you might be able to store the sound in one-eighth the space, but you will lose some fidelity. Further, to conserve space you can downsample, or reduce the number of sample slices you take in a second. Many multimedia developers use 8-bit sample sizes at 22.05 kHz sampling rates because they consider the sound to be good enough (about the quality of AM radio), and they save immense amounts of digital real estate.

The following formula will help you estimate your storage needs. If you are using two channels for stereo, double the result.

$$(\text{sampling rate} * \text{bits per sample}) / 8 = \text{bytes per second}$$

If you prefer to solve for kilobytes (KB), not bytes, then try:

$$\text{sample rate} * \text{sample size} / 8 * \# \text{ seconds} * 2 \text{ (if stereo)} = \text{file size in KB}$$

For example, 60 seconds of stereo in Red Book Audio:

$$44.1 * 16 / 8 * 60 * 2 = 10,584\text{KB} \approx 10.59\text{MB}$$

This is an approximate result using 1000 instead of 1024 bytes per KB, but yielding the quick handy answer “...about ten and a half megabytes.”

You face important trade-offs when deciding how to manage digitized sound in your multimedia project. How much sound quality can you sacrifice in order to reduce storage? What compression techniques make sense? Will compressed sound work in your authoring platform? What is good enough but not amateurish? Can you get away with 8 bits at 11.025 kHz for voice mail, product testimonials, and voice-overs and then switch to higher sampling rates for music?

Many people feel that MP3s files sampled at 128 Kbps provide decent audio quality for music, especially when played through small speakers. For better quality, sample your music at 192 Kbps. Because the human voice does not use a wide range of frequencies, you can sample speech or voice at 96 Kbps or even 64 Kbps.

TIP *The sound of the human voice comes from one point (the mouth), so there is not much to gain by recording (or playing) it in stereo.*

Audio Recording

If your project requires CD-quality digitized sound at 44.1 kHz and 16 bits, you should hire a sound studio. High-fidelity sound recording is a specialized craft, a skill learned in great part by trial and error, much like photography. If you do decide to do it yourself at CD-quality levels, be prepared to invest in an acoustically treated room, high-end amplifiers and recording equipment, and expensive microphones.

As already stated, there are many trade-offs involved in making multimedia. For example, if you are satisfied with 22.05 kHz in your project or are constrained to this rate by storage considerations, any consumer-grade digital or analog recorder of reasonable quality will do fine. This, of course, also applies to conversations recorded from the telephone, where a sampling rate of 11.025 kHz is adequate. Noise reduction circuits and metal

With the collaboration of composer Dave Soldier, Komar & Melamid's Most Wanted Painting project (www.diacenter.org/km/index.html) was extended into the realm of music. A poll, written by Dave Soldier, was conducted on Dia's web site (www.diacenter.org). Approximately 500 visitors took the survey. Dave Soldier and Nina Mankin used the survey results to write music and lyrics for the Most Wanted and Most Unwanted songs.

A Note from the Composer

This survey confirms the hypothesis that popular music indeed provides an accurate estimate of the wishes of the vox populi. The most favored ensemble, determined from a rating by participants of their favorite instruments in combination, comprises a moderately sized group (three to ten instruments) consisting of guitar, piano, saxophone, bass, drums, violin, cello, synthesizer, with low male and female vocals singing in rock/r&b style. The favorite lyrics narrate a love story, and the favorite listening circumstance is at home. The only feature in lyric subjects that occurs in both most wanted and unwanted categories is "intellectual stimulation." Most participants desire music of moderate duration (approximately 5 minutes), moderate pitch range, moderate tempo, and moderate to loud volume, and display a profound dislike of the alternatives. If the survey provides an accurate analysis of these factors for the population, and assuming that the preference for each factor follows a Gaussian (bell-curve) distribution, the combination of these qualities, even to the point of sensory overload and stylistic dis cohesion, will result in a musical work that will be unavoidably and uncontrollably "liked" by 72 plus or minus 12 percent (standard deviation; Kolmogorov-Smirnov statistic) of listeners. The most unwanted music is over 25 minutes long, veers wildly between loud and quiet sections, between fast and slow tempos, and features timbres of extremely high and low pitch, with each dichotomy presented in abrupt transition. The most unwanted orchestra was determined to be large and features the accordion and bagpipe (which tie at 13 percent as the most unwanted instrument), banjo, flute, tuba, harp, organ, synthesizer (the only instrument that appears in both the most wanted and most unwanted ensembles). An operatic soprano raps and sings atonal music, advertising jingles, political slogans, and "elevator" music, and a children's choir sings jingles and holiday songs. The most unwanted subjects for lyrics are cowboys and holidays, and the most unwanted listening circumstances are involuntary exposure to commercials and elevator music. Therefore, it can be shown that if there is no covariance—someone who dislikes bagpipes is as likely to hate elevator music as someone who despises the organ, for example—fewer than 200 individuals of the world's total population would enjoy this piece.

Dave Soldier, composer and musician, who provides the Most Wanted Song and the Most Unwanted Song on a CD at www.diacenter.org/km/musiccd.html

tapes are helpful to remove hiss, but at a sampling rate of 22.05 kHz you are only going to be digitizing audio frequencies as high as about 11 kHz, anyway. Both the high and low ends of the audio hearing spectrum are therefore less important to you, and that is OK, because those areas are precisely the add-value focus of very elaborate and expensive consumer equipment.

Digital audio tape (DAT) systems provide a tape-based 44.1 kHz, 16-bit record and playback capability. You may, however, find that DAT is high-fidelity overkill for your needs, because the recordings are too accurate, precisely recording glitches, background noises, microphone pops, and coughs from the next room. A good editor can help reduce the impact of these noises, but at the cost of time and money.

Mobile phones can often record audio (and video), and applications and hardware attachments are available to manage external microphones and file transfer. USB and flash memory recorders range in quality, some suitable for voice only, some generating compressed MP3 files, and some recording in CD-quality stereo. Recordings can be directly downloaded as digital files using a USB cable or flash memory card reader.



Keeping Track of Your Sounds

In an elaborate project with many sounds, it is important to maintain a good database, keeping a physical track of your original material—just in case you need to revert to it when your disk drive crashes or you accidentally delete the work file. A database is particularly important because you may need to give your sound files such unhelpful names as `janesEyesOpenWide.aiff` or `Chapter11inSpanish03.wav`; these names contain some clues about the files' actual content, but you may need a more descriptive cross-reference. You don't want to have to load and play many sound files just to find the one you need.

Audio CDs

The method for digitally encoding the high-quality stereo of the consumer CD music market is an international standard, called ISO 10149. This is

also known as the **Red Book Audio** standard (derived simply from the color of the standard's book jacket). Developers of this standard claim that the digital audio sample size and sampling rate of Red Book Audio (16 bits at 44.1 kHz) allow accurate reproduction of all the sounds that humans can hear. Until recently, dedicated professional sound-studio equipment was used for this high-fidelity recording; today most off-the-shelf computers will record and play 16-bit sampled sound at 44.1 kHz and at 48 kHz. Converter and burning software such as Toast and CD-Creator from Roxio can translate the digital files of Red Book Audio found on consumer compact discs directly into a digital sound file formats such as MP3 or WAV.

Unlike DVDs, audio CDs do not contain information about artists, titles, or tracklists of songs. But player software such as Apple iTunes and AOL Winamp will automatically link to a database on the Internet when you insert a music CD. The precise length of your CD's Table of Contents (TOC) is then matched against the known TOC length for more than five million CDs containing more than 60 million songs. When it finds a match, the database service sends back what it knows about the CD you inserted. The database, formerly known as the Compact Disc Database or CDDDB, was built up over the years by fans from all over the world submitting information about their favorite CDs. The database is currently maintained by Gracenote Media Recognition Service (www.gracenote.com).

Sound for Your Mobile

Ringtones are perhaps the most widely- and often-heard sounds in today's world. Unlike plain old telephones, where a pulsating 90-volt signal is sent down copper wires to energize a hammer that clangs a bell, there is no bell in a digital mobile telephone. When the mobile receives a notice that someone is calling, the unit's software takes over and, depending on the programmed options, plays the user's choice of ringtone—either generated by internal MIDI software or played from a stored sound file. Ringtones play on a very small speaker and often compete in a noisy environment. Perhaps an urban myth, it is reported that an inventive sales executive recorded herself coughing and sent that awful sound to her phone as a ringtone. When she received an incoming call during a meeting, she would quickly cover her mouth, continue the cough, and excuse herself from the room in order to take the call. Ringtones aren't the end of it. Into the daily lexicon have entered answertones, ringbacktones, truetones, realtones, singtones, videotones, and “ringles.” Most are for sale from enterprising small and large businesses all over the world. MP3 files will play on most mobiles; check your phone's manual to be sure.

Sound for the Internet

There are several methods for playing digital or MIDI sound from a web page. The sound is actually not part of the web page but is a separate file with its own address on the Internet, which is “embedded” in the page. Web browsers associate files with applications and plug-ins: Figure 4-8 shows the Preferences panel from Firefox, which lets you specify what to do when the browser downloads a particular file type. The simplest way to embed a sound file in a web page is to call it from an inline HTML anchor:

```
<a href="mysound.wav"> Click here to play MySound! </a>
```

As an HTML anchor, the text “Click here to play MySound!” will usually be underlined, and when that link is clicked, the browser will find the file `mysound.wav` (in this case, in the same directory as the web page), will download it, and, depending on how the user has instructed the browser to manage WAV files, will open a player and play the sound.

Media players are designed to play files as soon as enough of the data is cached in your computer’s **buffer** (a place where data is stored temporarily). The downloading continues to fill the buffer faster than you empty it by playing the sound file, allowing the sound file to stream into your computer in the background, keeping ahead of what has already been played so the playback doesn’t pause or break up. **Streaming** files are dependent upon connection speed: you must wait longer (**streaming latency**) before the streamed sound begins to play when using a dial-up modem (low bandwidth) than when using a high-speed DSL connection (high bandwidth).

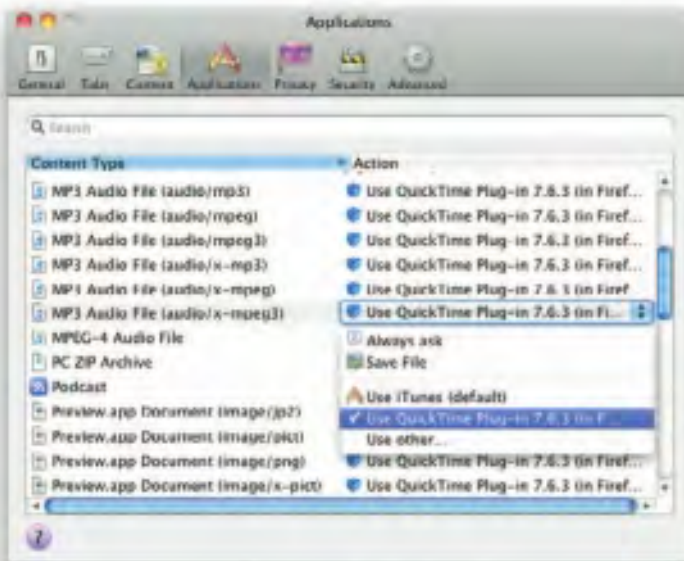

Figure 4-8 Web browsers must be told what to do when they download file types.

TIP See Chapter 13 for more about the HTML5 `<AUDIO>` tag, which can be used to play sound on a Web page without requiring a special player or helper application.

Adobe’s Flash allows you to integrate the sound tracks that you have made using a sound editor into a Web-based multimedia presentation, including both event sounds like button clicks and streaming sounds like background music. Because it can read and save MP3 files, Flash offers web designers serious and powerful options for solving the quality conundrum of high-quality (big) files and slow downloads versus low-quality (small) files and speedy delivery—with nice results. Because it must break

a sound into “frames” so it plays in sync with the timeline, Flash resamples the audio track if you ask it to “stream” in a movie clip; for the best quality, import an uncompressed audio clip into the Flash library and let Flash do the compression.

Testing and Evaluation

Putting everything together can be tough, but testing and evaluating what you’ve done can be even tougher—especially if your project involves a complicated live presentation, or if you’re shipping a commercial multimedia application. Unless you plan ahead, problems will not emerge until you begin testing.

TIP *During editing and authoring, regularly test the sound-and-image synchronization of your project. If you are delivering your sound on the Web, test it with different browsers and different connection speeds.*

Don’t forget to evaluate your sound storage medium. How much RAM does your project need to run effectively? Some authoring and delivery packages will stream sound directly off the hard disk or CD-ROM; others require the sound to be loaded into memory from the hard disk before they play. Sometimes you will need to break a sound or a music file into smaller parts. And MIDI files that sound terrific with expensive General MIDI during development will not have the same quality on a low-end FM-synthesis device at the end user’s site or on a handheld.

In the world of professional film and video production, sound is incorporated during **post-production**, or a **post-session**, after all the film and video footage has been assembled. Just so with multimedia—and don’t give it short shrift because of time or budget constraints. The sound track can make or break your project!

Copyright Issues

Ownership rights are significant issues for multimedia producers who would love to use a few bars of Beyonce’s latest hit or a nostalgic background of Bach suites played by Pablo Casals. Producers may rightfully fret about copyrights and permissions. Most developers play it safe by always making their own custom music from scratch in a sound studio, or with synthesizers, or by using sounds that have a clear and paid-for ownership and permission trail. Others simply take a risk and break the law.

WARNING *You are breaking the law if you record and use copyrighted material without first securing the appropriate rights from the owner or publisher of the material.*

As more and more multimedia is produced by more and more developers who are hungry for sound content, the copyright of sounds and images has become a major issue—not so much about who owns something, but how much of it they own. Because it is so easy to manipulate and edit a sound, just how much of someone’s original work do you have to change before it then becomes your own? There are separate licensing issues for use of a musical composition (even if you create a MIDI performance of it yourself) and for use of a particular recording of a musical composition (as when you make a copy of a song downloaded from iTunes). Different licensing arrangements may be required, depending upon exactly how you use the music in different types of multimedia programs—from a presentation you create for a client’s annual stockholders meeting, to a musical foundation beneath a commercial application. As this suggests, music licensing is a specialized and complicated area, so you should make sure you have cleared all the necessary rights before using any music in a product. The Harry Fox Agency (www.harryfox.com), for example, represents more than 27,000 music publishers and is the premier licensing resource for the mechanical use of music reproduced in all formats and media. Copyright issues and methods of securing permission for use (equally relevant for sounds, still images, and motion video) are discussed in more detail in Chapter 11.

A number of software vendors have entered the multimedia marketplace by selling digitized clip sounds with an unlimited-use, royalty-free license. Some of these products include musical clips, and some just include sound effects (doors closing, dogs barking, and water dripping). Other products have a mixture of both. But beware of sources claiming to be public domain that offer clips of Bella Swan and Edward in the Twilight Saga, or one-liners from Humphrey Bogart movies, because these sounds have likely been used without permission. Also, carefully read the licensing terms that come with any collection you purchase. Although the box may claim that the sounds are “unlimited-use, royalty free,” the fine print inside most likely limits their use to your personal machine and does not include the right to use them in any commercial use or republication in a form that would allow others to obtain them (such as using them on a web site).

WARNING *Taking a camera or tape or video recorder to some public events may be illegal without proper permission.*

Police Fight Cellphone Recordings

Witnesses taking audio of officers arrested, charged with illegal surveillance

Simon Glik, a lawyer, was walking down Tremont Street in Boston when he saw three police officers struggling to extract a plastic bag from a teenager's mouth. Thinking their force seemed excessive for a drug arrest, Glik pulled out his cellphone and began recording.

Within minutes, Glik said, he was in handcuffs.

"One of the officers asked me whether my phone had audio recording capabilities," Glik, 33, said recently of the incident, which took place in October 2007. Glik acknowledged that it did, and then, he said, "my phone was seized, and I was arrested."

The charge? Illegal electronic surveillance.

Jon Surmacz, 34, experienced a similar situation. Thinking that Boston police officers were unnecessarily rough while breaking up a holiday party in Brighton he was attending in December 2008, he took out his cellphone and began recording.

Police confronted Surmacz, a webmaster at Boston University. He was arrested and, like Glik, charged with illegal surveillance.

There are no hard statistics for video recording arrests. But the experiences of Surmacz and Glik highlight what civil libertarians call a troubling misuse of the state's wiretapping law to stifle the kind of street-level oversight that cellphone and video technology make possible.

In 1968, Massachusetts became a "two-party" consent state, one of 12 currently in the country. Two-party consent means that all parties to a conversation must agree to be recorded on a telephone or other audio device; otherwise, the recording of conversation is illegal. The law, intended to protect the privacy rights of individuals, appears to have been triggered by a series of high-profile cases involving private detectives who were recording people without their consent.

In arresting people such as Glik and Surmacz, police are saying that they have not consented to being recorded, that their privacy rights have therefore been violated, and that the citizen action was criminal.

It took five months for Surmacz, with the ACLU, to get the charges of illegal wiretapping and disorderly conduct dismissed. Surmacz said he would do it again.

"Because I didn't do anything wrong," he said. "Had I recorded an officer saving someone's life, I almost guarantee you that they wouldn't have come up to me and say, 'Hey, you just recorded me saving that person's life. You're under arrest.'"

Excerpted from http://necir-bu.org/wp/?page_id=1702 with permission. The New England Center for Investigative Reporting at Boston University is an investigative reporting collaborative. This story was done under the guidance of BU professors Dick Lehr and Mitchell Zuckoff.

Chapter 4 Review

■ Chapter Summary

For your review, here's a summary of the important concepts discussed in this chapter.

Describe the components and measurements of sound

- How you use the power of sound can make the difference between an ordinary multimedia presentation and a professionally spectacular one. Misuse of sound, however, can wreck your project.
- When something vibrates in the air by moving back and forth, it creates waves of pressure. These waves spread, and when they reach your eardrums, you experience the vibrations as sound.
- Acoustics is the branch of physics that studies sound.
- Sound pressure levels (loudness or volume) are measured in decibels (dB).

Use digital audio to record, process, and edit sound

- Digital audio data is the actual representation of a sound, stored in the form of thousands of individual samples that represent the amplitude (or loudness) of a sound at a discrete point in time.
- How often the samples are taken is the sampling rate.
- The three sampling frequencies most often used in multimedia are CD-quality 44.1 kHz (kilohertz), 22.05 kHz, and 11.025 kHz.
- Digital audio is not device dependent, and sounds the same every time it is played. For this reason digital audio is used far more frequently than MIDI data for multimedia sound tracks.
- You can digitize sounds from any source, live or prerecorded.
- The amount of information stored about each sample is the sample size and is determined by the

number of bits used to describe the amplitude of the sound wave when the sample is taken.

- Sample sizes are either 8 bits or 16 bits.
- The value of each sample is rounded off to the nearest integer (quantization).
- The preparation and programming required for creating digital audio do not demand knowledge of music theory.

Use MIDI and understand its attributes, especially relative to digitized audio

- MIDI data is not digitized sound; it is a shorthand representation of music stored in numeric form.
- MIDI files tend to be significantly smaller than equivalent digitized waveform files.
- MIDI data is device dependent; its playback depends on the capabilities of the end user's system.
- Because they are small, MIDI files embedded in web pages load and play more quickly than their digital equivalents.
- You can change the length of a MIDI file (by varying its tempo) without changing the pitch of the music or degrading the audio quality. MIDI data is completely editable.
- MIDI cannot easily be used to play back spoken dialog.
- Working with MIDI requires familiarity with musical scores, keyboards, and notation as well as audio production.

Compare and contrast the use of MIDI and digitized audio in a multimedia production

- MIDI is analogous to structured or vector graphics, while digitized audio is analogous to bitmapped images.

- MIDI is device dependent, meaning the quality of the playback is dependent upon the hardware installed on the user's machine, while digitized audio is device independent.
- Use MIDI only when you have control over the playback hardware and know your users will be using a high-quality MIDI device for playback.
- MIDI files are much smaller than digitized audio, so they may be used for delivery of music under the right circumstances.
- Use digitized audio for spoken dialog.

List the important steps and considerations in recording and editing digital audio

- The file size (in bytes) of a digital recording is $\text{sampling rate} * \text{duration of recording in seconds} * (\text{bit resolution} / 8) * \text{number of tracks}$ (1 for mono, 2 for stereo).
- Consumer-grade audio compact discs are recorded in stereo at a sampling rate of 44.1 kHz and a 16-bit resolution. Other sampling rates include 22.05 and 11 kHz, at either 16 or 8 bits.
- When recording (digitizing) audio, it's important to keep the recording level near the maximum without going over it.
- Important steps in digital sound editing include removing blank space from the start and end of a recording and normalizing the sound to bring all clips to approximately the same level.
- The native sound file formats for most Macintosh sound editing software are the **SND** and AIF formats, and most authoring systems will read these formats. In Windows, the native sound file format for most editing software is a WAV file.
- Many audio editors provide tools such as resampling, fade-ins and -outs, equalization, time stretching, various digital signal processing effects, and reversing sounds.

Determine which audio file formats are best used in a multimedia project

- MIDI scores require sequencer software and a sound synthesizer.

- The General MIDI format standardizes a set of MIDI instruments, ensuring that the MIDI sequence is played correctly.
- Streaming files begin playing when part of the file has been buffered into the computer's memory and are dependent upon connection speed.
- Adobe's Flash provides powerful tools for integrating and streaming sounds, including the MP3 format.
- Apple's QuickTime is a file format that, among other capabilities, enables digital audio to be interleaved with video information.

Cite the considerations involved in managing audio files and integrating them into multimedia projects

- Because sounds are time based, you may need to consider what happens to sounds that are playing in your project when the user goes to a different location.
- Appropriate use of sound requires technical considerations of disk space or bandwidth as well as the abilities of the authoring system to use various file formats and compression algorithms.
- Do not use equipment and standards that exceed what your project requires.
- Keep track of your audio files, and be sure to back them up.
- Regularly test the sound-and-image synchronization of your project.
- Evaluate your sound's RAM requirements as well as your users' playback setup.
- Be sure you understand the implications of using copyrighted material. You are breaking the law if you record and use copyrighted material without first securing the appropriate rights from the owner or publisher.
- You can purchase and use digitized clip sounds with an unlimited-use, royalty-free license.

■ Key Terms

| | | |
|--|--|-------------------------------------|
| acoustics (104) | digital equalization (EQ) (110) | quantization (107) |
| AIF format (120) | digital signal processing (DSP) (111) | QuickTime movie (.mov) (122) |
| AIFF (121) | downsample (110) | Red Book Audio (129) |
| attack (118) | envelope (118) | resample (110) |
| audio resolution (111) | General MIDI (116) | sample (106) |
| bit depth (106) | Linear Pulse Code Modulation (LPCM) (121) | sample size (106) |
| buffer (130) | lossy (122) | sampling rate (106) |
| CD-quality (106) | MIDI (113) | sequencer software (114) |
| CD-ROM/XA (extended architecture) (121) | MIDI keyboard (114) | SND (135) |
| codec (123) | MP3 (110) | sound synthesizer (114) |
| decay (118) | MPEG (122) | streaming (130) |
| decibels (dB) (104) | normalize (109) | streaming latency (130) |
| device dependent (116) | notation software (114) | sustain (118) |
| device independent (106) | post-production, post-session (131) | time stretching (111) |
| digital audio (106) | | wave format (WAV) (121) |
| digital audio tape (DAT) (128) | | |

■ Key Term Quiz

1. The branch of physics that studies sound is _____.
2. Sound pressure levels (loudness or volume) are measured in _____.
3. To adjust the level of a number of tracks to bring them all up to about the same level is to _____ them.
4. When audio is measured in order to be digitally stored, the value of each measurement is rounded off to the nearest integer in a process called _____.
5. Reducing the number of separate measurements of an audio file is called _____.
6. The standard file format for displaying digitized motion video on the Macintosh is _____.
7. The most common file format for editing sound on the Macintosh is _____.
8. The audio file format introduced by Microsoft and IBM with the introduction of Windows is the _____.
9. The process of playing a sound file while part of the file is still downloading is called _____.
10. Some software allows you to begin playing a downloading sound file as soon as enough of the sound is cached in your computer's _____.

■ Multiple-Choice Quiz

1. The file format that uses a shorthand representation of musical notes and durations stored in numeric form is:
 - a. AIFF
 - b. CD-ROM/XA
 - c. DSP
 - d. MIDI
 - e. QuickTime
2. Which of these statements regarding the MIDI audio format is *not* true?
 - a. The sound can easily be changed by changing instruments.
 - b. Spoken audio can easily be included.
 - c. Sound tracks can be created using sequencing software.
 - d. Files are generally smaller than the same digital audio sound.
 - e. Sounds can be stretched and timing changed with no distortion of the quality.
3. The primary benefit of the General MIDI over the previous MIDI specification is that:
 - a. the file sizes are much smaller due to the compression scheme
 - b. users can easily edit and adjust the data structures
 - c. it can be easily converted into the CD-ROM/XA format
 - d. MIDI files can be easily integrated into the computer's operating system as system sounds
 - e. the instruments are the same regardless of the playback source
4. What happens when an audio signal exceeds the recording device's maximum recording level?
 - a. The signal is compressed to an appropriate level.
 - b. "Clipping" of the signal occurs, introducing distortion.
 - c. The audio clip is extended to accommodate the extra data.
 - d. The entire clip's volume is reduced correspondingly.
 - e. The extra bits go into a buffer for later use.
5. As one story goes, the criterion used to set the length of the sectors and ultimately the physical size of the compact disc format was based on the length of:
 - a. the Beatles' "White Album"
 - b. Handel's *Messiah*
 - c. Beethoven's Ninth Symphony
 - d. Bach's *St. John's Passion*
 - e. Iron Butterfly's live rendition of "Innagaddadavida"
6. The process of recording a sound, stored in the form of thousands of individual measurements, each at a discrete point in time, is called:
 - a. sampling
 - b. synthesizing
 - c. sizing
 - d. quantizing
 - e. streaming
7. The file size of a five-second recording sampled at 22 kHz, 16-bit stereo (two tracks) would be about:
 - a. 110,000 bytes
 - b. 220,000 bytes
 - c. 440,000 bytes
 - d. 550,000 bytes
 - e. 880,000 bytes
8. Which of the following sound file characteristics does *not* directly affect the size of a digital audio file?
 - a. sample rate
 - b. sample size
 - c. tracks (stereo vs. mono)
 - d. volume
 - e. compression
9. Each individual measurement of a sound that is stored as digital information is called a:
 - a. buffer
 - b. stream
 - c. sample
 - d. capture
 - e. byte

10. Audio recorded at 44.1 kHz (kilohertz), 16-bit stereo is considered:
- phone-quality
 - voice-quality
 - FM-quality
 - CD-quality
 - AM-quality
11. Removing blank space or “dead air” at the beginning or end of a recording is sometimes called:
- quieting
 - pre-rolling
 - quantizing
 - trimming
 - flashing
12. DSP stands for:
- dynamic sound programming
 - data structuring parameters
 - direct splicing and partitioning
 - delayed streaming playback
 - digital signal processing
13. Sequencing software:
- places audio clips in order in a soundtrack
 - records and edits MIDI data
 - applies filters to digital audio clips in a predetermined order
 - manages a project by creating a timeline of events
 - helps synchronize images with a sound track
14. The slower a user’s connection, the longer he must wait for enough of the sound to download so that the entire file will have downloaded by the time the sound reaches the end. This effect is called:
- streaming latency
 - post-processing
 - compression
 - digital signal processing
 - multitap delay
15. The Red Book standard was so named because:
- the standard was pioneered in the former Soviet Union
 - red is an acronym for “Registered Electronic Data”
 - the standard’s book jacket was red
 - it was so expensive to produce CDs early on that most producers were “in the red”
 - the dye in the first recordable CDs had a reddish tint

■ Essay Quiz

- Discuss the implications of using audio in a production, focusing on the purpose of the audio, how to manage audio files, and copyright issues.
- List the four main sampling rates and the two sampling depths. Briefly describe what each is most useful for. How does mono versus stereo come into the equation?
- You have been assigned to design and produce the audio portions of a multimedia project. The program will be delivered on a CD-ROM, and video clips will take up most of the CD. You have only 50MB of storage space to store 20 one-minute clips of speech, 10 songs averaging three minutes long, and a background sound loop. What sampling rates and depths should you use for the speech, for the music, and for the background sound? Why? Roughly calculate the file size totals for these specifications, and be sure that you end up with less than the 50MB of storage space allotted. Discuss your reasoning.
- Describe what MIDI is, what its benefits are, and how it is best used in a multimedia project.
- List the steps you would go through to record, edit, and process a set of sound files for inclusion on a web site. How would you digitally process the files to ensure they are consistent, have minimum file size, and sound their best?

Lab Projects

■ Project 4.1

Go online and locate three sound editors (either from a shareware site or demo versions of commercial software). Document their capabilities. What file formats can they import from and export to? How many tracks can they handle? What DSP effects do they provide?

■ Project 4.2

Record two sounds using a simple recording device—a cassette recorder will work. One sound should be of speech, and one should be music. Connect the output from the recorder to a computer's audio input. Using a sound capture and editing tool, capture both clips in 44 kHz, 16-bit stereo (if you can't record in stereo, ignore the applicable directions). Capture the clips three times—once at a very low level, once at the correct level (just below peaking), and once at levels that are well over the maximum. Listen to the six clips. Note your observations regarding noise and distortion. Run all three clips through the editor's Normalize effect. Again, listen to the clips and note your observations.

■ Project 4.3

Down-convert the two normalized samples recorded at the correct level to 22.05, 11, and 5 kHz. Convert each of these eight (four sampling rates \times two files) to mono. You should now have 16 different files: 8 of the speech and 8 of music. Document the file size of each, and make a note of how each sounds (even better, enlist the aid of someone else who can listen while you play the sounds back, without telling them which you are playing). Which are acceptable? At what point does the lowered quality become unacceptable?

■ Project 4.4

Visit three web sites that use sound (you may need to find Flash-based web sites). Where, when, and how is sound used? Does the sound fit the mood of the site? Is there background sound? Can the sounds be turned on and off? Document your findings.

■ Project 4.5

Locate three web sites that offer “royalty-free” or “buyout” music. Such sites almost always allow visitors to listen to low-quality samples. What formats are the samples provided in? Listen to some of the samples. Try to identify which are synthesized and which are actual instruments playing the music. What are the license arrangements for using the music? Document your findings, noting the various lengths and formats the music is provided in.

■ Project 4.6

Visit the web site for the Harry Fox Agency and check the licensing terms for different uses of musical compositions and recordings of music. Briefly describe the terms for using music for which you have created a performance, for using a recording of a piece of music in a multimedia program, and for selling a product that contains music. Identify differences in rates for use of music in different types of media (for example, using as part of a one-time presentation to a limited audience, using in a multimedia product for commercial release, and using as part of a radio or TV broadcast).

Animation

In this chapter, you will learn how to:

- Define animation and describe how it can be used in multimedia
- Discuss the principles of animation
- Discuss the animation techniques of cel and computer animation and choose the correct file types for animations
- Create computer-generated animations from multiple still images

BY definition, **animation** makes static presentations come alive. It is visual change over time and can add great power to your multimedia projects and web pages. Many multimedia applications for both Macintosh and Windows provide animation tools.

The Power of Motion

You can animate your whole project, or you can animate here and there, accenting and adding spice. For a brief product demonstration with little user interaction, it might make sense to design the entire project as a video and keep the presentation always in motion. For speaker support, you can animate bulleted text or fly it onto the screen, or you can use charts with quantities that grow or dwindle; then, give the speaker control of these eye-catchers. In a parts-assembly training manual, you might show components exploding into an expanded view.

Visual effects such as wipes, fades, zooms, and dissolves are available in most multimedia authoring packages, and some of these can be used for primitive animation. For example, you can slide images onto the screen with a wipe, or you can make an object implode with an iris/close effect. Figure 5-1 shows examples of many transition effects that may be available in your editing software (in this case, an early version of Adobe's Premiere).

But animation is more than wipes, fades, and zooms. Animation is an object actually moving across or *into* or *out of* the screen; a spinning globe of our earth; a car driving along a line-art highway; a bug crawling out from under a stack of papers, with a screaming voice from the speaker telling you to "Shoot it, now!" Until video became more commonplace (see Chapter 6), animations were the primary source of dynamic action in multimedia presentations.

WARNING Overuse of animation and annoying visual effects can ruin a multimedia project. (Check out www.dack.com/web/flash_evil.html for a discussion of gratuitous use.)



Figure 5-1 Animation authoring applications typically offer many visual effects and transitions.

Principles of Animation

Animation is possible because of a biological phenomenon known as **persistence of vision** and a psychological phenomenon called **phi**. An object seen by the human eye remains chemically mapped on the eye's retina for a brief time after viewing. Combined with the human mind's need to conceptually complete a perceived action, this makes it possible for a series of images that are changed very slightly and very rapidly, one after the other, to seemingly blend together into a visual illusion of movement. The illustration shows a few cells, or frames, of a rotating logo. When the images are progressively and rapidly changed, the arrow of the compass is perceived to be spinning.



Digital television video builds 24, 30, or 60 entire frames or pictures every second, depending upon settings; the speed with which each frame is replaced by the next one makes the images appear to blend smoothly into movement. Movies on film are typically shot at a shutter rate of 24 frames per second, but using projection tricks (the projector's shutter flashes light through each image twice), the flicker rate is increased to 48 times per second, and the human eye thus sees a motion picture. On some film projectors, each frame is shown three times before the pull-down claw moves to the next frame, for a total of 72 flickers per second, which helps to eliminate the flicker effect: the more interruptions per second, the more continuous the beam of light appears. Quickly changing the viewed image is the principle of an animatic, a flip-book, or a zoetrope. To make an object travel across the screen while it changes its shape, just change the shape and also move, or **translate**, it a few pixels for each frame. Then, when you play the frames back at a faster speed, the changes blend together and you have motion and animation. It's the same magic as when the hand is quicker than the eye, and you don't see the pea moving in the blur of the gypsy's cups.

Animation by Computer

Using appropriate software and techniques, you can animate visual images in many ways. The simplest animations occur in two-dimensional (2-D) space; more complicated animations occur in an intermediate "2½-D" space (where shadowing, highlights, and forced perspective provide an illusion of depth, the third dimension); and the most realistic animations occur in three-dimensional (3-D) space.

In 2-D space, the visual changes that bring an image alive occur on the flat Cartesian x and y axes of the screen. A blinking word, a **color-cycling** logo (where the colors of an image are rapidly altered according to a formula), a cel animation (described more fully later on in this chapter), or a button or tab that changes state on mouse rollover to let a user know it is active are all examples of **2-D animations**. These are simple and static, not changing their position on the screen. **Path animation** in 2-D space increases the complexity of an animation and provides motion, changing the location of an image along a predetermined path (position) during a specified amount of time (speed). Authoring and presentation software such as Flash or PowerPoint provide user-friendly tools to compute position changes and redraw an image in a new location, allowing you to generate a bouncing ball or slide a corporate mascot onto the screen. Combining changes in an image with changes in its position allows you to "walk" your corporate mascot onto the stage. Changing its size from small to large as it walks onstage will give you a 3-D perception of distance.

In **2½-D animation**, an illusion of depth (the z axis) is added to an image through shadowing and highlighting, but the image itself still rests on the flat x and y axes in two dimensions. Embossing, shadowing, beveling, and highlighting provide a sense of depth by raising an image or cutting it into a background. Zaxwerks' 3D Invigorator (www.zaxwerks.com), for example, provides 3-D effects for text and images and, while calling itself "3D," works within the 2-D space of image editors and drawing programs such as Adobe Illustrator, Photoshop, Fireworks, and After Effects.

In **3-D animation**, software creates a virtual realm in three dimensions, and changes (motion) are calculated along all three axes (x, y, and z), allowing an image or object that itself is created with a front, back, sides, top, and bottom to move toward or away from the viewer, or, in this virtual space of light sources and points of view, allowing the viewer to wander around and get a look at all the object's parts from all angles. Such animations are typically rendered frame by frame by high-end 3-D animation programs such as NewTek's Lightwave or AutoDesk's Maya.

Today, computers have taken the handwork out of the animation and rendering process, and commercial films such as *Shrek*, *Coraline*, *Toy Story*, and *Avatar* have utilized the power of computers. (See Chapter 3 for an account of the historic "computer wall" of 117 Sun SPARCstations used to render the animated feature *Toy Story*.)

Animation Techniques

When you create an animation, organize its execution into a series of logical steps. First, gather up in your mind all the activities you wish to provide in the animation. If it is complicated, you may wish to create a written script with a list of activities and required objects and then create a storyboard to visualize the animation. Choose the animation tool best suited for the job, and then build and tweak your sequences. This may include creating objects, planning their movements, texturing their surfaces, adding lights, experimenting with lighting effects, and positioning the camera or point of view. Allow plenty of time for this phase when you are experimenting and testing. Finally, post-process your animation, doing any special renderings and adding sound effects.

Cel Animation

The animation techniques made famous by Disney use a series of progressively different graphics or cels on each frame of movie film (which plays at 24 frames per second). A minute of animation may thus require as many as 1,440 separate frames, and each frame may be composed of many layers of cels. The term **cel** derives from the clear celluloid sheets that were used for drawing each frame, which have been replaced today by layers of digital

I grew up using cel techniques and a huge animation crane to photograph with. I can tell you the static electricity caused hell with dust on the cels. Do you know why most 2-D animated characters in the past, like Mickey Mouse, wore white gloves? It was an inside joke... We all wore white gloves to protect the cels! And the reason most animated characters had only three fingers and a thumb inside their gloves was because it saved us time and money to drop that extra finger.

.....
 Joe Silverthorn, Integrated
 Multimedia Professor,
 Olympic College

imagery. Cels of famous animated cartoons have become sought-after, suitable-for-framing collector's items.

Cel animation artwork begins with **keyframes** (the first and last frame of an action). For example, when an animated figure of a woman walks across the screen, she balances the weight of her entire body on one foot and then the other in a series of falls and recoveries, with the opposite foot and leg catching up to support the body. Thus the first keyframe to portray a single step might be the woman pitching her body weight forward off the left foot and leg, while her center of gravity shifts forward; the feet are close together, and she appears to be falling. The last keyframe might be the right foot and leg catching the body's fall, with the center of gravity now centered between the outstretched stride and the left and right feet positioned far apart.

The series of frames in between the keyframes are drawn in a process called tweening. **Tweening** is an action that requires calculating the number of frames between keyframes and the path the action takes, and then actually sketching with pencil the series of progressively different outlines. As tweening progresses, the action sequence is checked by flipping through the frames. The penciled frames are assembled and then actually filmed as a **pencil test** to check smoothness, continuity, and timing.

When the pencil frames are satisfactory, they are permanently inked, photocopied onto cels, and given to artists who use acrylic colors to paint the details for each cel. Women were often preferred for this painstaking inking and painting work as they were deemed patient, neat, and had great eyes for detail. In the hands of a master, cel paint applied to the back of acetate can be simply flat and perfectly even, or it can produce beautiful and subtle effects, with feathered edges or smudges.

The cels for each frame of our example of a walking woman—which may consist of a text title, a background, foreground, characters (with perhaps separate cels for a left arm, a right arm, legs, shoes, a body, and facial features)—are carefully registered and stacked. It is this composite that becomes the final photographed single frame in an animated movie. To replicate natural motion, traditional cel animators often utilized “motion capture” by photographing a woman walking, a horse trotting, or a cat jumping to help visualize timings and movements. Today, animators use reflective sensors applied to a person, animal, or other object whose motion is to be captured. Cameras and computers convert the precise locations of the sensors into x,y,z coordinates and the data is rendered into 3-D surfaces moving over time.

TIP For experimenting with frame editing and timing, *Lunch Box DV* from *Animation Toolworks* (www.animationtoolworks.com) requires only a video camera and a monitor to get started.

Computer Animation

Computer animation programs typically employ the same logic and procedural concepts as cel animation and use the vocabulary of classic cel animation—terms such as layer, keyframe, and tweening. The primary difference among animation software programs is in how much must be drawn by the animator and how much is automatically generated by the software (see Figure 5-2). In path-based 2-D and 2½-D animation, an animator simply creates an object (or imports an object as clip art) and describes a path for the object to follow. The computer software then takes over, actually creating the animation on the fly as the program is being viewed by your user. In cel-based 2-D animation, each frame of an animation is provided by the animator, and the frames are then composited (usually with some tweening help available from the software) into a single file of images to be played in sequence. ULead's GIF Animator (www.ulead.com/ga) and Alchemy's GIF Construction Set Pro (www.mindworkshop.com) simply string together your collection of frames.

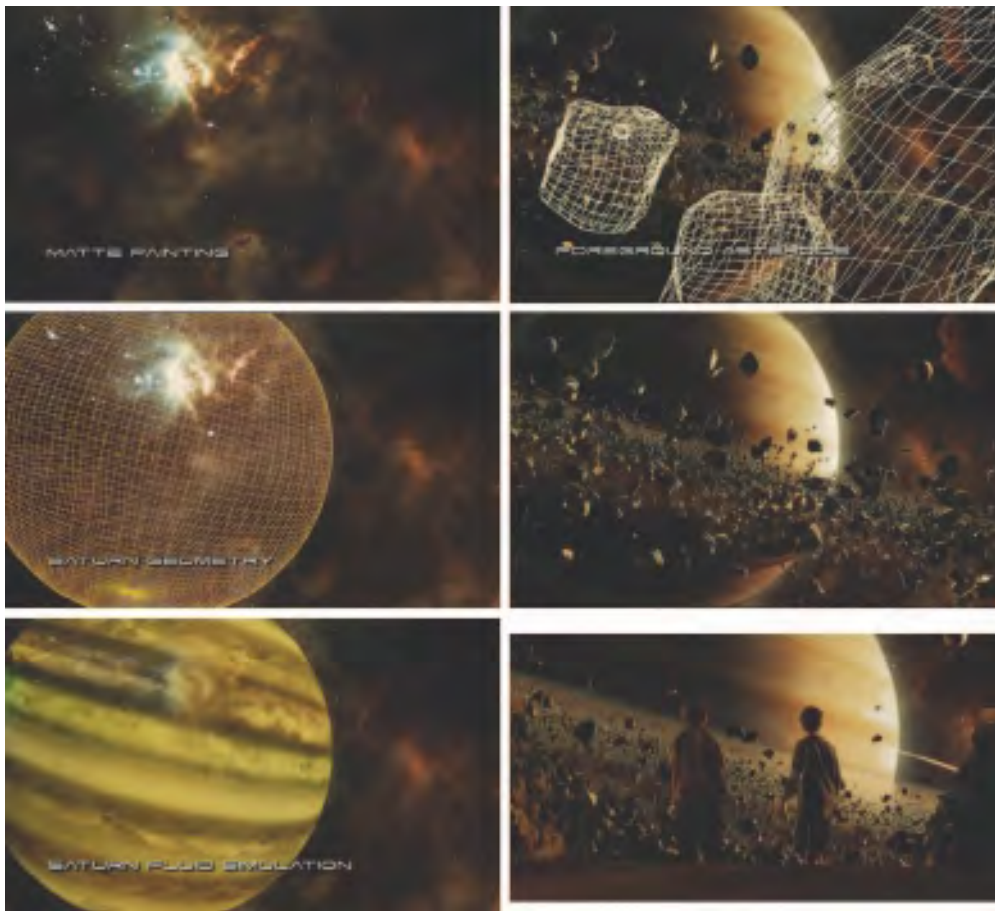

Figure 5-2 Several cels or digital image layers in a frame from the movie *Zathura* (Columbia Pictures/ Imageworks)

For 3-D animation, most of your effort may be spent in creating the models of individual objects and designing the characteristics of their shapes and surfaces. It is the software that then computes the movement of the objects within the 3-D space and renders each frame, in the end stitching them together in a digital output file or container such as an AVI or QuickTime movie.

On the computer, paint is most often filled or drawn with tools using features such as gradients and anti-aliasing. The word **inks**, in computer animation terminology, usually means special methods for computing color values, providing edge detection, and layering so that images can blend or otherwise mix their colors to produce special transparencies, inversions, and effects.

You can usually set your own frame rates on the computer. 2-D cel-based animated GIFs, for example, allow you to specify how long each frame is to be displayed and how many times the animation should loop before stopping. 3-D animations output as digital video files can be set to run at 15 or 24 or 30 frames per second. However, the rate at which changes are computed and screens are actually refreshed will depend on the speed and power of your user's display platform and hardware, especially for animations such as path animations that are being generated by the computer on the fly. Although your animations will probably never push the limits of a monitor's scan rate (about 60 to 70 frames per second), animation does put raw computing horsepower to task. If you cannot compute all your changes and display them as a new frame on your monitor within, say, 1/15th of a second, then the animation may appear jerky and slow. Luckily, when the files include audio, the software maintains the continuity of the audio at all cost, preferring to drop visual frames or hold a single frame for several seconds while the audio plays.

TIP *The smaller the object in path-based 2-D animation, the faster it can move. Bouncing a 10-pixel-diameter tennis ball on your screen provides far snappier motion than bouncing a 150-pixel-diameter beach ball.*

3-D animations are typically delivered as “pre-rendered” digital video clips. Software such as Flash or PowerPoint, however, render animations as they are being viewed, so the animation can be programmed to be interactive: touch or click on the jumping cat and it turns toward you snarling; touch the walking woman and...

Kinematics **Kinematics** is the study of the movement and motion of structures that have joints, such as a walking man. Animating a walking step is tricky: you need to calculate the position, rotation, velocity, and acceleration of all the joints and articulated parts involved—knees bend, hips flex, shoulders swing, and the head bobs. Smith Micro's Poser

(<http://my.smithmicro.com>), a 3-D modeling program, provides pre-assembled adjustable human models (male, female, infant, teenage, and superhero) in many poses, such as “walking” or “thinking.” As you can see in Figure 5-3, you can pose figures in 3-D and then scale and manipulate individual body parts. Surface textures can then be applied to create muscle-bound hulks or smooth chrome androids. **Inverse kinematics**, available in high-end 3-D programs such as Lightwave and Maya, is the process by which you link objects such as hands to arms and define their relationships and limits (for example, elbows cannot bend backward). Once those relationships and parameters have been set, you can then drag these parts around and let the computer calculate the result.

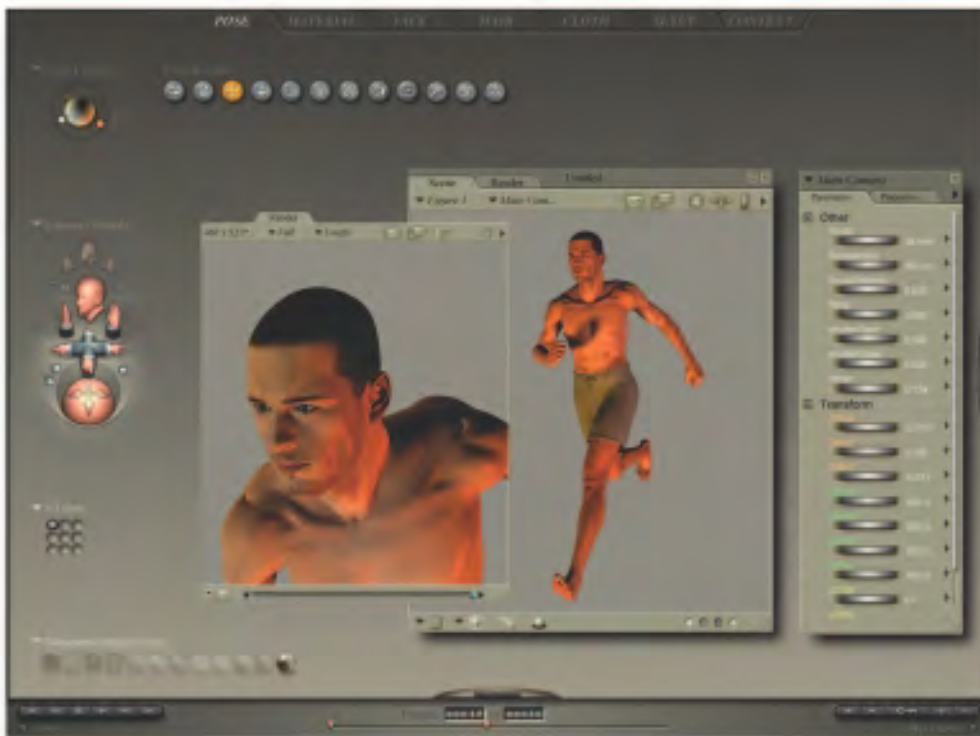

Figure 5-3 Smith Micro’s Poser understands human motion and inverse kinematics: move an arm, and the shoulders follow.

Morphing **Morphing** is a popular (if not overused) effect in which one image transforms into another. Morphing applications and other modeling tools that offer this effect can transition not only between still images but often between moving images as well. Some products that offer morphing features are Black Belt’s Easy Morph and WinImages (www.blackbeltsystems.com) and Human Software’s Squizz (www.humansoftware.com). Figure 5-4 illustrates part of a morph in which 16 kindergarten children are dissolved one into the other in a continuous, compelling motion video.

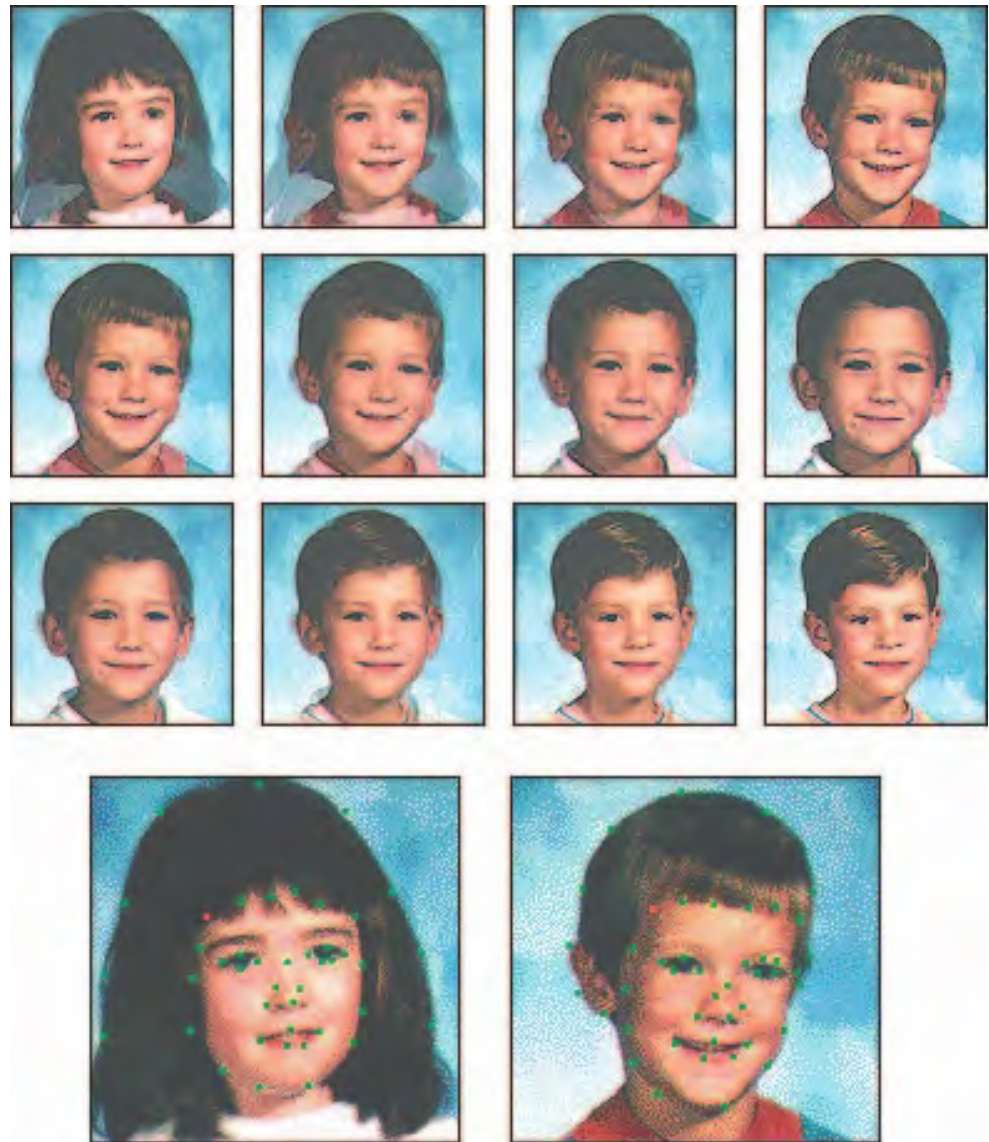

Figure 5-4 Morphing software was used to seamlessly transform the images of 16 kindergartners. When a sound track of music and voices was added to the four-minute piece, it made a compelling QuickTime video about how similar children are to each other. Matching key points (red) in the start and end image guide the morphing transition.

The morphed images were built at a rate of eight frames per second, with each transition taking a total of four seconds (32 separate images for each transition), and the number of key points was held to a minimum to shorten rendering time. Setting key points is crucial for a smooth transition between two images. The point you set in the start image will move to the corresponding point in the end image—this is important for things like eyes and noses, which you want to end up in about the same place

(even if they look different) after the transition. The more key points, the smoother the morph. In Figure 5-4, the red dot on each child's temple is a matching key point.

Animation File Formats

Some file formats are designed specifically to contain animations, so they can be ported among applications and platforms with the proper translators. Those formats include Director (.dir and .dcr), AnimatorPro (.fli and .flc), 3D Studio Max (.max), GIF89a (.gif), and Flash (.fla and .swf). Because file size is a critical factor when downloading animations to play on web pages, file compression is an essential part of preparing animation files for the Web. A Director's native movie file (.dir), for example, must be preprocessed and compressed into a proprietary Shockwave animation file (.dcr) for the Web. Compression for Director movies is as much as 75 percent or more with this tool, turning 100K files into 25K files and significantly speeding up download/display times on the Internet. Flash, widely used for web-based animation, makes extensive use of vector graphics (see Chapter 3) to keep the post-compression file size at absolute minimums. As with Director, its native .fla files must be converted to Shockwave Flash files (.swf) in order to play on the Web. To view these animations within a web page, special plug-ins or players are required (see Chapter 6).

In some cases, especially with 3-D animations, the individual rendered frames of an animation are put together into one of the standard digital video file containers, such as the Windows Audio Video Interleaved format (.avi), QuickTime (.qt, .mov), or Motion Picture Experts Group video (.mpeg or .mpg). These can be played using the media players shipped with computer operating systems.

New with HTML5 is animation built within a .svg (scalable vector graphics) file, where graphic elements can be programmed to change over time (www.w3.org/TR/SVG11/animate.html). In the following simple code, a patch of red expands within a rectangle, filling it in three seconds. Type this code into a text processor and save it as plain text with a .svg extension. Open the file with "File Open..." from a HTML5-compliant web browser to see it work. Change some parameters (duration, colors, location) and reload or refresh the file to see the effects of your changes.

```
<svg width="8cm" height="3cm" viewBox="0 0 800 300" xmlns="http://www.w3.org/2000/svg" version="1.1">
  <rect x="1" y="1" width="800" height="300" fill="none" stroke="rgb(255,0,255)" stroke-width="4" />
  <rect id="RectElement" x="300" y="100" width="300" height="100" fill="rgb(255,0,0)" >
    <animate attributeName="x" attributeType="XML" begin="0s" dur="3s" fill="freeze" from="300" to="0" />
    <animate attributeName="y" attributeType="XML" begin="0s" dur="3s" fill="freeze" from="100" to="0" />
    <animate attributeName="width" attributeType="XML" begin="0s" dur="3s" fill="freeze" from="300" to="800" />
    <animate attributeName="height" attributeType="XML" begin="0s" dur="3s" fill="freeze" from="100" to="300" />
  </rect>
</svg>
```

Making Animations That Work

Animation catches the eye and makes things noticeable. But, like sound, animation quickly becomes trite if it is improperly applied. Unless your project has a backbone of movie-like, animated imagery, use animation carefully (and sparingly) like spice to achieve the greatest impact. Your screens may otherwise become busy and “noisy.”

Multimedia authoring systems typically provide tools to simplify creating animations within that authoring system, and they often have a mechanism for playing the special animation files created by dedicated animation software. Today, the most widely used tool for creating multimedia animations for Macintosh and Windows environments and for the Web is Adobe’s Flash. Flash directly supports several 2½-D features, including z-axis positioning, automatic sizing and perspective adjustment, and kinematics. External libraries can extend Flash’s capabilities: open-source Papervision3D (<http://blog.papervision3d.org>) provides extensive support for true 3-D modeling and animation; Figure 5-5 shows GreenSock’s TweenMax (www.greensock.com/tweenmax) providing sophisticated tweening capabilities within Flash.

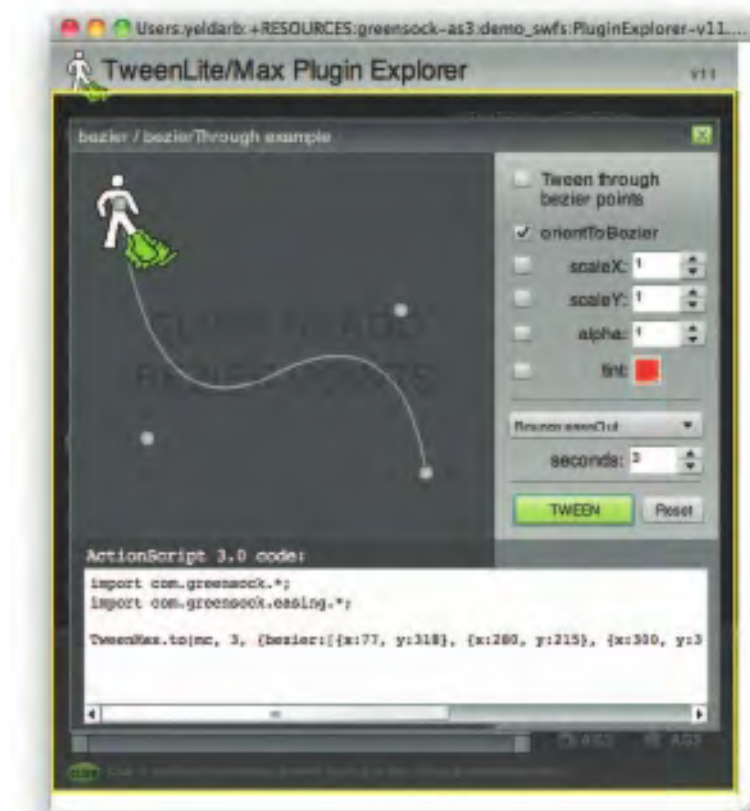

Figure 5-5 Plug-ins for Flash can make tweening easier.

A Rolling Ball

First, create a new, blank image file that is 100 × 100 pixels, and fill it with a sphere.

Create a new layer in Photoshop, and place some white text on this layer at the center of the image.



Make the text spherical using Photoshop's "Spherize" distortion filter, and save the result.

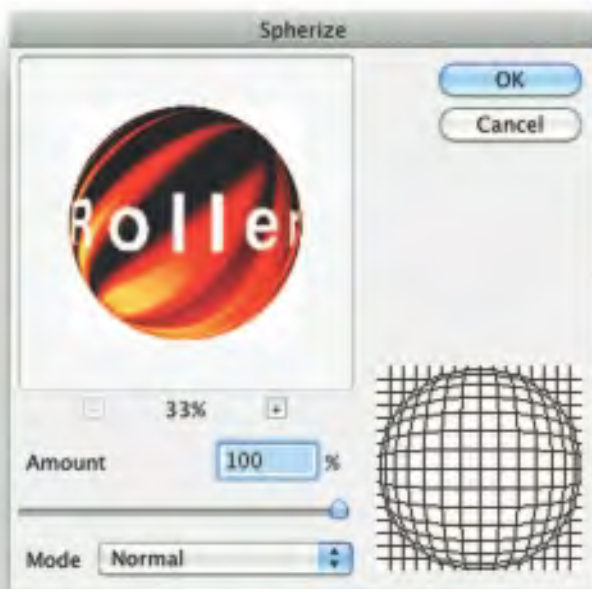

To animate the sphere by rolling it across the screen, you first need to make a number of rotated images of the sphere. Rotate the image in 45-degree increments to create a total of eight images, rotating a full circle

of 360 degrees. When each is displayed sequentially at the same location, the sphere spins:



For a realistic rolling effect, the circumference (calculated at pi times 100, or about 314 pixels) is divided by 8 (yielding about 40 pixels). As each image is successively displayed, the ball is moved 40 pixels along a line. Being where the rubber meets the road, this math applies when you roll any round object in a straight line perpendicular to your line of sight.

A Bouncing Ball

With the simplest tools, you can make a bouncing ball to animate your web site using GIF89a, an image format that allows multiple images to be put into a single file and then displayed as an animation in a web browser or presentation program that recognizes the format. The individual frames that make up the **animated GIF** can be created in any paint or image-processing program, but it takes a specialized program to put the frames together into a GIF89a animation. (Animating with GIF89a files is discussed in Chapter 13.) As with the rolling ball example, you simply need to flash a ball on the computer screen rapidly and in a different place each time to make it bounce up and down. And as with the rolling ball, where you should compute the circumference of the ball and divide by the number of images to determine how far it rolls each time it flashes, there are some commonsense computations to consider with a bouncing ball, too. In the formula, s equals distance, a equals acceleration due to gravity, and t equals time:

$$s = \frac{1}{2} at^2$$

Gravity makes your bouncing ball accelerate on its downward course and decelerate on its upward course (when it moves slower and slower until it actually stops and then accelerates downward again). As Galileo discovered while dropping feathers and rocks from the Leaning Tower of Pisa, a beach ball and a golf ball accelerate downward at the same rate until they hit the ground. But the real world of Italy is full of air, so the feather falls gently while the rock pounds dirt. It is in this real world that you should compose your animations, tempering them always with commonsense physics to give them the ring of truth.

Unless your animation requires precision, ignore the hard numbers you learned in high school (like 32 feet per second per second), and

simply figure that your ball will uniformly accelerate and decelerate up and down the pixels of your screen by the squares: 1, 4, 9, 16, 25, 36, 49, 64, 81, 100 are the squares of 1, 2, 3, 4, 5, 6, 7, 8, 9, and 10. This is illustrated in Figure 5-6. In the case of a perpetual-motion bouncing ball (even better than Silly Putty), it goes up the same way it comes down, forever, and this makes the job easy, because the up and down movements are symmetrical. You can use the same images for downward motion as you use for upward—as in frames 11 through 18 in Figure 5-5—by *reversing* them. You might also add a squash frame (not shown in Figure 5-6) when the ball hits the floor. The amount of squash would be determined by the type of ball—a steel ball or a balloon or a very soft rubber ball. The ball would squash when it hit and un-squash as it bounced up again. With a bit of programming, you might allow the user to choose the elasticity of the object, the amount of gravity, and the length of fall. Some animation software provides tools for this: it's called “**easing**.”

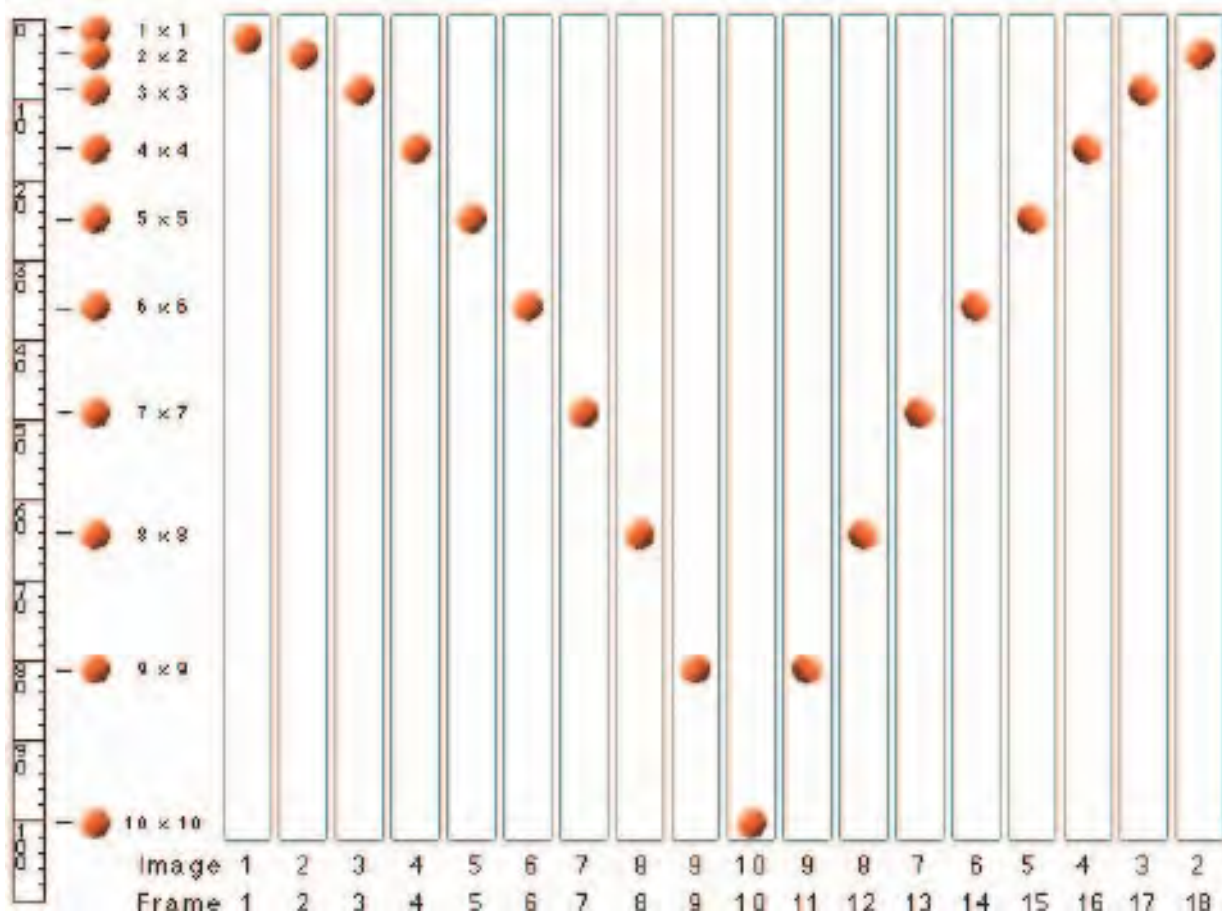
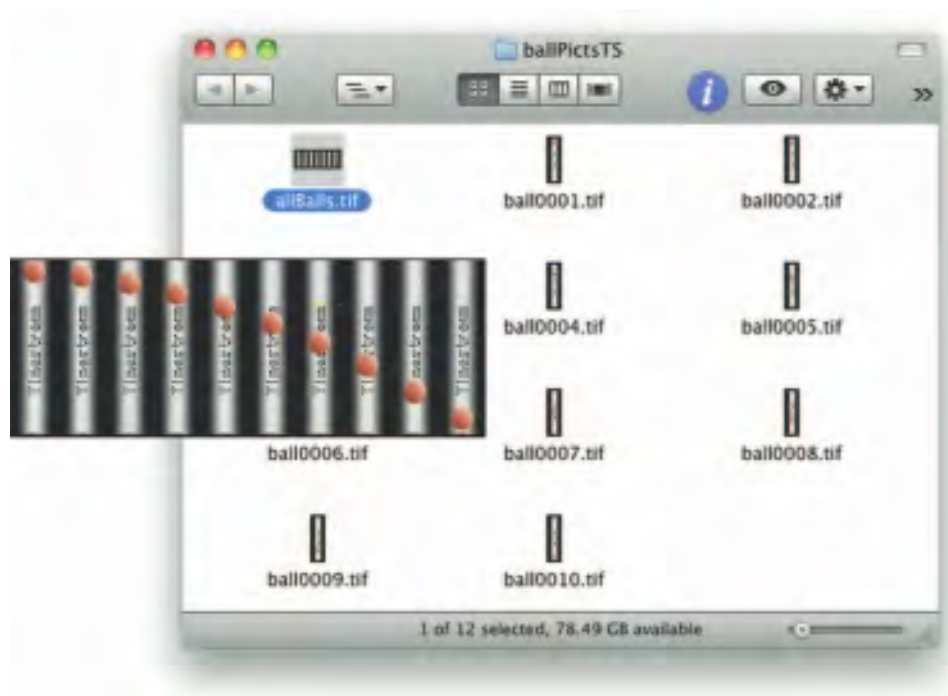

Figure 5-6 To make a bouncing ball seem natural, don't forget the acceleration effects of gravity. If you loop the 18 images shown here, the ball will bounce forever.

Open a graphics program and paint a ball about 15 pixels in diameter (if you have an odd-number diameter, there is a middle pixel that can be your center alignment point). If you wish to be fancy, make the ball with a 3-D graphics tool that will shade it as a sphere. Then duplicate the ball, placing each copy of it in a vertical line at the ten locations 1, 4, 9, 16, 25, 36, 49, 64, 81, and 100. The goal is to create a separate image file for each location of the ball, like the pages of a flip-book. With Photoshop, you can create a single file with ten layers to contain each ball at its proper location, and you can add an eleventh background layer, too. Then save each layer showing against the background as a separate file. (Use numbers in your filenames like ball01, ball02, and so on, to keep them organized.)



This is a construction process also easily managed with Director or Flash, in which you can place the same cast member or object (the ball) where you wish on the presentation stage.

You can also add a background and other art elements, and when you are done, you can export each frame as a graphics file using the export function. You will probably also wish to set the size of your stage to a small area just sufficient for your animation, say 32×120 pixels. The smaller the better if users will be downloading this animated GIF file into their web browsers.

To turn your collection of images into a GIF89a animation, you need an application like Stone Design's GIFfun (for Macintosh; see Figure 5-7) or ULead's GIF Animator (for Windows). These tools organize the sequence of images to be shown, set timing and transparency, and (most importantly) let you save the final GIF file in the proper format. See Chapter 13 for more details about animated GIF files and where to use them.

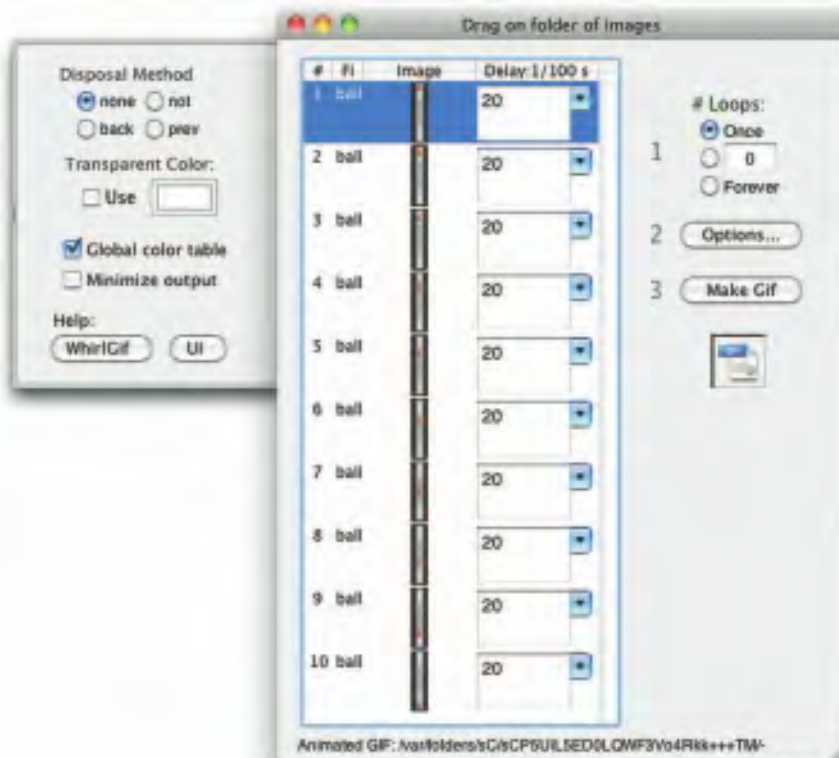

Figure 5-7 Many applications are available for Windows and Mac that will help build animated GIF files. Shown here is GIFfun for Mac, free from Stone Design (www.stone.com/GIFfun/), for organizing images and creating animations.

Creating an Animated Scene

A creative committee organized a brief storyboard of a gorilla chasing a man. From a stock library containing many images licensed for unlimited use, a photograph was chosen of Manhattan's Central Park where a bridge crossed a small river and high-rise apartments lined the horizon. The chase scene would occur across the bridge. To produce frames of the running man, a real actor was videotaped running in place against an Ultimatte

chroma-keyed blue background in a studio; a few frames of this were grabbed, and the blue background was made transparent in each image. The gorilla was difficult to find, so a toy model dinosaur about 25 centimeters tall was used; again, a few frames were captured and the background made transparent to form a composite. That was all that was required for image resources.

As illustrated in Figure 5-8*a*, the background was carefully cut in half along the edge of the bridge, so that the bridge railing could be placed in front of the runners. The running man was organized in a series of six frames that could be repeated many times across the screen to provide the pumping motions of running. The same was done for the dinosaur, to give him a lumbering, bulky look as he chased the little man across the bridge (see Figure 5-8*b*). The result, in Figure 5-8*c*, was simple and quickly achieved.

First Person

The animation storyboard called for a photo-realistic monster chasing a running man through a city park amid screams of terror. The man was already in Director, running in great strides across an arched footbridge in a woodsy scene with high-rises in the background; he even looked over his shoulder a few times in panic. We were scouting around for an effective Godzilla when a friend dropped by with a motorized, 12-inch Tyrannosaurus Rex from Toys'R'Us. It was perfect—opening

a toothy, gaping mouth every few steps as it lumbered along on C batteries.

I took the dinosaur and a video camera home to the delight and fascination of my three-year-old daughter, who helped rig a white sheet in front of the living room fireplace and a cardboard-box runway where Mr. TRex could strut his stuff before the camera. A couple of lamps gave him a sweaty sheen. We recorded about five minutes of video as my daughter happily retrieved Mr. TRex

each time he nosed off the “cliff” at the end of the stage.

I grabbed a still image about every fourth frame of the recording and imported the resulting files into Director as cast members. They needed a little cleanup and scaling, but the fellow looked really convincing when he was finally scored to run across the bridge. Next day, I mixed a bunch of sounds—singing birds, running footsteps, screams, roars, sirens, and gunshots—and it was done.

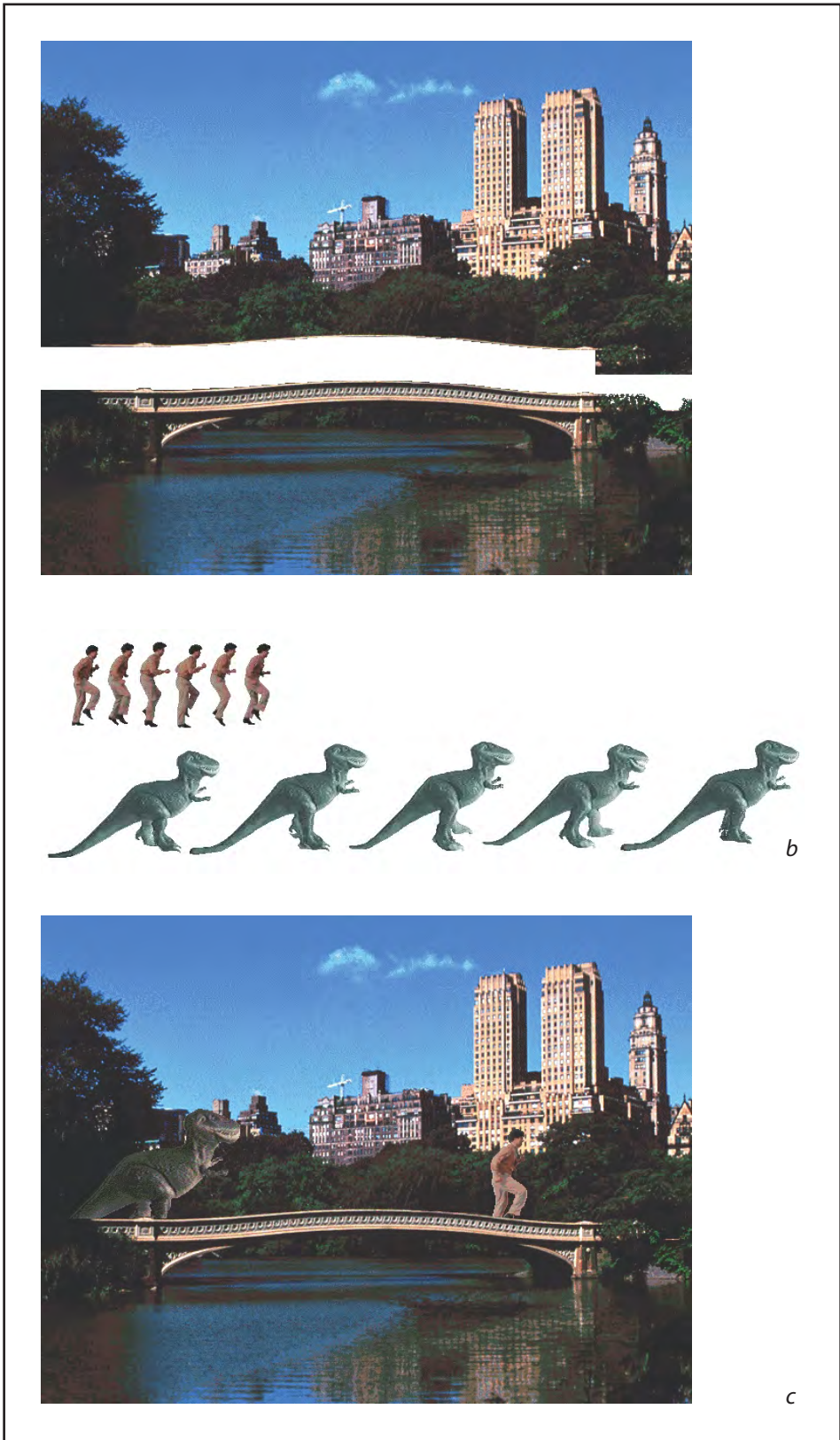

Figure 5-8 The upper portion of the photo was placed behind the runners (*b*) and the lower portion in front of them, to make them appear to run behind the bridge railing (*c*).

Chapter 5 Review

■ Chapter Summary

For your review, here's a summary of the important concepts discussed in this chapter.

Define animation and describe how it can be used in multimedia

- By definition, animation is the act of making something come alive.
- Depending on the size of the project, you can animate the whole thing or you can just animate parts of it.
- Visual effects such as wipes, fades, zooms, and dissolves, available in most authoring packages, are a simple form of animation.
- Animation is an object actually moving across, into, or out of the screen.

Discuss the principles of animation

- Animation is possible because of a biological phenomenon known as persistence of vision and a psychological phenomenon called phi.
- With animation, a series of images are changed very slightly and very rapidly, one after the other, seemingly blending together into a visual illusion of movement.
- Digital display video builds 24, 30, or 60 entire frames or pictures every second. Movies on film are typically shot at a shutter rate of 24 frames per second.

Discuss the animation techniques of cel and computer animation and choose the correct file types for animations

- Cel animation, an animation technique made famous by Disney, uses a series of progressively different graphics on each frame of movie film.

- Cel animation artwork begins with keyframes; these are the first and last frames of an action.
- Tweening is an action that involves creating the frames to depict the action that happens between keyframes.
- Computer animation programs typically employ the same logic and procedural concepts as cel animation.
- You can usually set your own frame rates on the computer, but the rate at which changes are computed and screens are actually refreshed will depend on the speed and power of your display platform and hardware.
- Kinematics is the study of the movement and motion of structures that have joints.
- Inverse kinematics is the process in which you link objects such as hands to arms and define their relationships and limits, then drag these parts around and let the computer calculate the result.
- Morphing is an effect in which one image transforms into another.
- Some file formats are designed specifically to contain animations, and they can be ported among applications and platforms with the proper translators.

Create computer-generated animations from multiple still images

- Multimedia authoring systems typically provide tools to simplify creating animations within that authoring system.

- The most widely used tool for creating multi-media animations for Macintosh and Windows environments is Adobe's Flash.
- With the simplest tools, you can make a bouncing ball to animate your web site using GIF89a.
- Making animations appear natural requires a basic understanding of the principles of physics. You should compose your animations using these principles, tempering them always with common-sense physics to give them the ring of truth.

■ Key Terms

animated GIF (152)

animation (140)

cel (143)

cel animation (144)

color cycling (142)

easing (153)

inks (146)

inverse kinematics (147)

keyframe (144)

kinematics (146)

morphing (147)

path animation (142)

pencil test (144)

persistence of vision (141)

phi (141)

3-D animation (143)

translate (142)

tweening (144)

2-D animation (142)

2½-D animation (143)

■ Key Term Quiz

1. An object seen by the human eye remains chemically mapped on the retina for a brief time after viewing. This phenomenon is called _____.
2. The human mind needs to conceptually complete a perceived action. This phenomenon is called _____.
3. To make an object travel across the screen while it changes its shape, just change the shape and also move or _____ it a few pixels for each frame.
4. The animation technique made famous by Disney involves showing a different image for each frame. This technique is called _____ animation.
5. The first and last frames of an action are called _____.
6. The series of frames in between the first and last frames in an action are drawn in a process called _____.
7. In computer animation terminology, _____ usually refers to special methods that allow images to blend or otherwise mix their colors to produce special transparencies, inversions, and effects.
8. The study of the movement and motion of structures that have joints is called _____.
9. The effect in which one image transforms into another is known as _____.

■ Multiple-Choice Quiz

1. Most authoring packages include visual effects such as:
 - a. panning, zooming, and tilting
 - b. wipes, fades, zooms, and dissolves
 - c. morphing
 - d. tweening
 - e. inverse kinematics
2. The term cel derives from:
 - a. the concept of each action in a sequence being a separate element or “cell”
 - b. the fact that the inks used in early animations were based on extracts from celery plants
 - c. an abbreviation of the phrase “composite element”
 - d. the fact that the first animations were the work of communist dissidents who were organized into cells
 - e. the clear celluloid sheets that were used for drawing each frame
3. Which of these is *not* a reason why animation is perceived as motion?
 - a. An image remains in the eye chemically for a brief time after viewing.
 - b. Our mind tries to “connect the dots” by completing perceived actions.
 - c. The use of darker colors for moving objects is interpreted by the mind as motion.
 - d. A sequence of images is read as continuous motion.
 - e. All of the above are valid reasons.
4. Movies on film are typically shot at a shutter rate of:
 - a. 15 frames per second
 - b. 24 frames per second
 - c. 29.97 frames per second
 - d. 30 frames per second
 - e. 48 frames per second
5. The clear sheets that were used for drawing each frame of animation have been replaced today by:
 - a. acetate or plastic
 - b. titanium
 - c. fiberglass
 - d. epoxy resin
 - e. digital paper
6. Today’s computer animation programs most closely resemble:
 - a. film “rotoscoping” techniques
 - b. the “phi” phenomenon described by Carl Jung
 - c. neuro-kinetics techniques pioneered by NASA
 - d. traditional cel animation
 - e. none of the above
7. The technical limitation you are likely to encounter in creating animations is:
 - a. the monitor’s refresh rate
 - b. the computer’s processing capability
 - c. the ability to accurately calculate physical actions
 - d. the “persistence of vision” phenomenon
 - e. the monitor’s color gamut
8. In general, the animation may appear jerky and slow if each frame is displayed for more than about:
 - a. 1/30 of a second
 - b. 1/15 of a second
 - c. 1/4 of a second
 - d. 1/2 of a second
 - e. 1 second

9. The process in which you link objects such as hands to arms and define their relationships and limits (for example, elbows cannot bend backward), then drag these parts around and let the computer calculate the result is called:
 - a. rotoscoping
 - b. de-morphing
 - c. meta-articulation
 - d. cyber-motion
 - e. inverse kinematics
10. To create a smooth transition between two images when morphing, it's important to set numerous:
 - a. layers
 - b. keyframes
 - c. key points
 - d. anchor tags
 - e. splines
11. The standard frame rate of computer animations is:
 - a. 10 frames per second
 - b. 15 frames per second
 - c. 24 frames per second
 - d. 30 frames per second
 - e. There is no standard; it depends on the file's settings.
12. Today, the most widely used tool for creating vector-based animations is:
 - a. Adobe's Flash
 - b. Adobe's GoLive
 - c. Corel's CorelDraw
 - d. Microsoft's KineMatix
 - e. Aactiva's InterStudio
13. The Director file format has which extension?
 - a. .dir and .dcr
 - b. .fli and .flc
 - c. .avi
 - d. .qt, .mov
 - e. .mpeg or .mpg
14. The file format that is most widely supported for web animations is:
 - a. PICT
 - b. .DCR
 - c. GIF89a
 - d. JPEG
 - e. AIFF
15. To keep the post-compression file size at absolute minimums, Flash makes extensive use of:
 - a. inverse kinematics
 - b. cel-type animation
 - c. vector graphics
 - d. inks
 - e. NURBS

■ Essay Quiz

1. Discuss the physical and psychological principles as to why animation works, as well as how it is usually presented.
2. Briefly discuss the origins of cel animation and the concepts that go into creating these animations. Be sure to include keyframes, tweening, and inks.

3. You need to create a simple animation of an animated logo. The logo depicts a planet orbiting the sun. Describe the motion in a storyboard. List the points in the action that would make good keyframes, and explain why. How would you need to manipulate the planet to make its motion look natural?
4. You need to create a simple animation of a man bowling, with the ball rolling down the alley and striking the pins. Describe the sequence of motions in a storyboard. Discuss the various techniques and principles you might employ to accurately represent the motion of the man moving, the ball rolling, and the pins falling.
5. Discuss where and how you might use animation in one of the following projects. Be creative. Where would animation be appropriate? Where would it be distracting? How could it best be used to visually illustrate a concept?
 - a. a web site for sports car enthusiasts
 - b. a presentation to shareholders of a financial report
 - c. a training CD on a printing press
 - d. a CD that depicts the history of a railroad

Lab Projects

■ Project 5.1

Use a search engine to search on the words “animation” and “definition.” Create a document that provides many different definitions of the term animation. Describe the differences among definitions. Which elements make the most difference among them—type of motion, process used for creation, method of playback, or something else? What do all (or, at least, most) of the definitions have in common?

■ Project 5.2

Locate a GIF animation at any web site. (Go to Google and do an image search using the term “animated GIF.” You may get as many as 6,460,000 hits!) Save the file of your choice to your computer’s hard drive. (On the Mac you can generally drag the image onto your desktop. On Windows, right-click and select “Save Picture (or Image) As”.) Using one of the shareware or freeware GIF animators available, open the file. Save the individual frames as separate files and print them out. Note how the GIF89a specification enables files to be saved so that only the differences between keyframes are saved.

■ Project 5.3

Pick an animation software package available for either the Macintosh or Windows that offers at least one form of animation (for example, 2-D cel animation, animated GIF, or 3-D animation). List its name and discuss its capabilities. Is the software capable of layers? Keyframes? Tweening? Morphing? Will it allow you to create cross-platform files for playback? Does it require a plug-in for viewing in a web browser?

■ Project 5.4

Conceptualize a brief animated sequence. Include a number of moving elements that move into and out of the frame. Consider where the keyframes should be. How do the elements move? Do they get bigger or smaller? Do they rotate? Do they “deform” (change shape)?

Create a storyboard with sketches showing at least ten of the keyframes.

Video

In this chapter, you will learn how to:

- Consider the implications of using digital video in multimedia
- Discuss video analog and digital technologies and displays
- Work with digital video containers and codecs to select the best video recording formats for multimedia projects
- Find and acquire video clips
- Shoot and edit video for use in multimedia

SINCE the first silent film movie flickered to life, people have been fascinated with “motion” pictures. To this day, motion video is the element of multimedia that can draw gasps from a crowd at a trade show or firmly hold a student’s interest in a computer-based learning project. Digital video is the most engaging of multimedia venues, and it is a powerful tool for bringing computer users closer to the real world. It is also an excellent method for delivering multimedia to an audience raised on television. With video elements in your project, you can effectively present your messages and reinforce your story, and viewers tend to retain more of what they see. But take care! Video that is not thought out or well produced can degrade your presentation.

Using Video

Carefully planned, well-executed video clips can make a dramatic difference in a multimedia project. A clip of John F. Kennedy proclaiming “Ich bin ein Berliner” in video and sound is more compelling than a scrolling text field containing that same speech. Before deciding whether to add video to your project, however, it is essential to have an understanding of the medium, its limitations, and its costs. This chapter provides a foundation to help you understand how video works, the different formats and standards for recording and playing video, and the differences between computer and television video. The equipment needed to shoot and edit video, as well as tips for adding video to your project, are also covered.

Video standards and formats are still being refined as transport, storage, compression, and display technologies take shape in laboratories and in the marketplace and while equipment and post-processing evolves from its analog beginnings to become fully digital, from capture to display. Working with multimedia video today can be like a Mojave Desert camping trip: you may pitch your tent on comfortable high ground and find that overnight the shifting sands have buried both your approach and your investment.

Of all the multimedia elements, video places the highest performance demand on your computer or device—and its memory and storage.

Consider that a high-quality color still image on a computer screen could require as much as a megabyte or more of storage memory. Multiply this by 30—the number of times per second that the picture is replaced to provide the appearance of motion—and you would need at least 30 megabytes of storage to play your video for one second, more than 1.8 gigabytes of storage for a minute, and 108 gigabytes or more for an hour. Just moving all this picture data from computer memory to the screen at that rate would challenge the processing capability of a supercomputer. Some of the hottest and most arcane multimedia technologies and research efforts have dealt with compressing digital video image data into manageable streams of information. Compression (and decompression), using special software called a **codec**, allows a massive amount of imagery to be squeezed into a comparatively small data file, which can still deliver a good viewing experience on the intended viewing platform during playback.

If you control the delivery platform for your multimedia project, you can specify special hardware and software enhancements that will allow you to work with high-definition, full-motion video, and sophisticated audio for high-quality surround sound. Or you can design a project to meet a specific compression standard, such as MPEG2 for **Digital Versatile Disc (DVD)** playback or MPEG4 for home video. You can install a superfast **RAID (Redundant Array of Independent Disks)** system that will support high-speed data transfer rates. You can include instructions in your authoring system that will spool video clips into RAM, ready for high-speed playback *before* they need to play. Having control of the playback platform is always good, but it is seldom available in the real world, so as you develop your video elements, you will need to make many choices and compromises based upon your assessment of the “lowest common denominator” playback platform where your project will be used.

How Video Works and Is Displayed

When light reflected from an object passes through a video camera lens, that light is converted into an electronic signal by a special sensor called a **charge-coupled device (CCD)**. Top-quality broadcast cameras and even camcorders may have as many as three CCDs (one for each color of red, green, and blue) to enhance the resolution of the camera and the quality of the image.

It’s important to understand the difference between analog and digital video. Analog video has a resolution measured in the number of horizontal scan lines (due to the nature of early cathode-tube cameras), but each of those lines represents continuous measurements of the color and brightness along the horizontal axis, in a linear signal that is analogous

Since multimedia gives you the ability to present information in a variety of ways, let the content drive the selection of media for each chunk of information to be presented. Use traditional text and graphics where appropriate; add animation when “still life” won’t get your message across; add audio when further explanation is required; resort to video only when all other methods pale by comparison.

David A. Ludwig, Interactive Learning Designs

to an audio signal. Digital video signals consist of a discrete color and brightness (RGB) value for each pixel. Digitizing analog video involves reading the analog signal and breaking it into separate data packets. This process is similar to digitizing audio, except that with video the vertical resolution is limited to the number of horizontal scan lines.

For some multimedia projects you may need to digitize legacy analog video. The following discussion will help you understand the differences between analog and digital video and the old and new standards for horizontal lines, aspect ratios, and interlacing.

Analog Video

In an analog system, the output of the CCD is processed by the camera into three channels of color information and synchronization pulses (sync) and the signals are recorded onto magnetic tape. There are several video standards for managing analog CCD output, each dealing with the amount of separation between the components—the more separation of the color information, the higher the quality of the image (and the more expensive the equipment). If each channel of color information is transmitted as a separate signal on its own conductor, the signal output is called **component** (separate red, green, and blue channels), which is the preferred method for higher-quality and professional video work. Lower in quality is the signal that makes up **Separate Video (S-Video)**, using two channels that carry luminance and chrominance information. The least separation (and thus the lowest quality for a video signal) is **composite**, when all the signals are mixed together and carried on a single cable as a composite of the three color channels and the sync signal. The composite signal yields less-precise color definition, which cannot be manipulated or color-corrected as much as S-Video or component signals.

The analog video and audio signals are written to tape by a spinning recording head that changes the local magnetic properties of the tape's surface in a series of long diagonal stripes. Because the head is canted or tilted at a slight angle compared with the path of the tape, it follows a helical (spiral) path, which is called **helical scan** recording. As illustrated in Figure 6-1, each stripe represents information for one field of a video frame. A single video frame is made up of two fields that are **interlaced** (described in detail later in the chapter). Audio is recorded on a separate straight-line track at the top of the videotape, although with some recording systems (notably for $\frac{3}{4}$ -inch tape and for $\frac{1}{2}$ -inch tape with high-fidelity audio), sound is recorded helically between the video tracks. At the bottom of the tape is a control track containing the pulses used to regulate speed. **Tracking** is the fine adjustment of the tape during playback so that the tracks are properly aligned as the tape moves across the playback

head. These are the signals your grandmother's VCR reads when you rent *Singing in the Rain* (on video cassette) for the weekend.

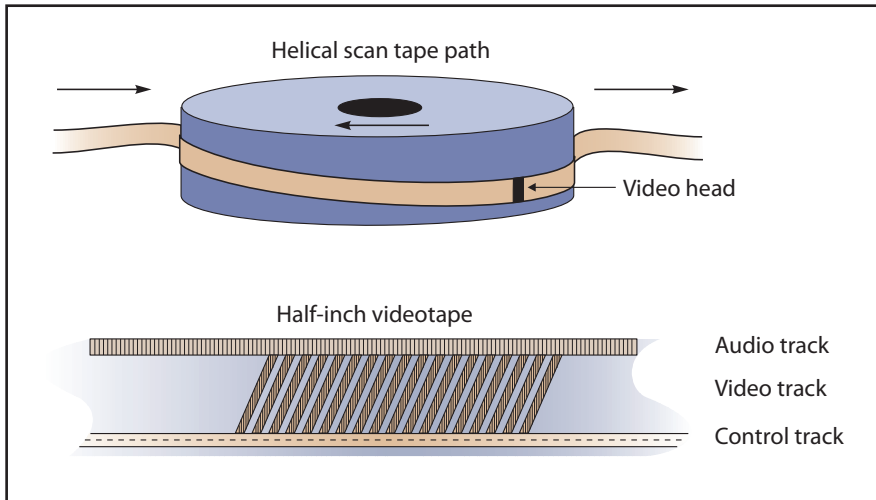

Figure 6-1 Diagram of tape path across the video head for analog recording

Many consumer set-top devices like **video cassette recorders (VCRs)** and satellite receivers add the video and sound signals to a sub-carrier and modulate them into a radio frequency (RF) in the FM broadcast band. This is the NTSC, PAL, or SECAM signal available at the Antenna Out connector of a VCR. Usually the signal is modulated on either Channel 3 or Channel 4, and the resulting signal is demodulated by the TV receiver and displayed on the selected channel. Many television sets today also provide a composite signal connector, a S-Video connector, and a **High-Definition Multimedia Interface (HDMI)** connector for purely digital input. Video displays for computers typically provide analog component (red, green, blue) input through a 15-pin **VGA connector** and also a purely digital **Digital Visual Interface (DVI)** and/or an HDMI connection.

Three analog broadcast video standards are commonly in use around the world: NTSC, PAL, and SECAM. In the United States, the NTSC standard has been phased out, replaced by the **ATSC Digital Television Standard**. Because these standards and formats are not easily interchangeable, it is important to know where your multimedia project will be used. A video cassette recorded in the United States (which uses NTSC) will not play on a television set in any European country (which uses either PAL or SECAM), even though the recording method and style of the cassette is “VHS.” Likewise, tapes recorded in European PAL or SECAM formats will not play back on an NTSC video cassette recorder. Each system is

Sometimes we define
“NTSC” as “Never The Same
Color.”

Richard Santalesa, R&D
Technologies

based on a different standard that defines the way information is encoded to produce the electronic signal that ultimately creates a television picture. Multiformat VCRs can play back all three standards but typically cannot dub from one standard to another. **Dubbing** between standards still requires high-end, specialized equipment.

NTSC

The United States, Canada, Mexico, Japan, and many other countries used a system for broadcasting and displaying video that is based upon the specifications set forth by the 1952 **National Television Standards Committee (NTSC)**. These standards defined a method for encoding information into the electronic signal that ultimately created a television picture. As specified by the NTSC standard, a single frame of video was made up of 525 horizontal scan lines drawn onto the inside face of a phosphor-coated picture tube every 1/30th of a second by a fast-moving electron beam. The drawing occurred so fast that your eye would perceive the image as stable. The electron beam actually made two passes as it drew a single video frame—first it laid down all the odd-numbered lines, and then all the even-numbered lines. Each of these passes (which happen at a rate of 60 per second, or 60 Hz) painted a field, and the two fields were then combined to create a single frame at a rate of 30 frames per second (fps). (Technically, the speed is actually 29.97 Hz.)

PAL

The **Phase Alternate Line (PAL)** system was used in the United Kingdom, Western Europe, Australia, South Africa, China, and South America. PAL increased the screen resolution to 625 horizontal lines, but slowed the scan rate to 25 frames per second. As with NTSC, the even and odd lines were interlaced, each field taking 1/50 of a second to draw (50 Hz).

SECAM

The **Sequential Color and Memory (SECAM)** (taken from the French name, reported variously as *Système Électronique pour Couleur Avec Mémoire* or *Séquentiel Couleur Avec Mémoire*) system was used in France, Eastern Europe, the former USSR, and a few other countries. Although SECAM is a 625-line, 50 Hz system, it differed greatly from both the NTSC and the PAL color systems in its basic technology and broadcast method. Often, however, TV sets sold in Europe utilized dual components and could handle both PAL and SECAM systems.

Digital Video

In digital systems, the output of the CCD is digitized by the camera into a sequence of single frames, and the video and audio data are compressed

before being written to a tape (see Figure 6-2) or digitally stored to disc or flash memory in one of several proprietary and competing formats. Digital video data formats, especially the codec used for compressing and decompressing video (and audio) data, are important; more about them later in this chapter.

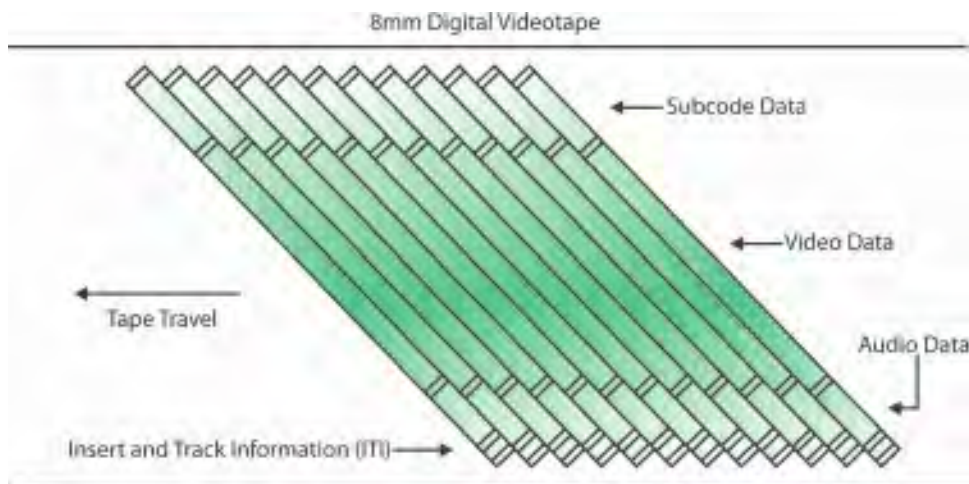

Figure 6-2 Diagram of tape path across the video head for digital recording

In 1995, Apple's FireWire technology was standardized as IEEE 1394, and Sony quickly adopted it for much of its digital camera line under the name i.Link. FireWire and i.Link (and USB 2) cable connections allow a completely digital process, from the camera's CCD to the hard disk of a computer; and camcorders store the video and sound data on an onboard digital tape, writable mini-DVD, mini-hard disk, or flash memory.

HDTV

What started as the **High Definition Television (HDTV)** initiative of the Federal Communications Commission in the 1980s changed first to the Advanced Television (ATV) initiative and then finished as the **Digital Television (DTV)** initiative by the time the FCC announced the change in 1996. This standard, which was slightly modified from both the Digital Television Standard (ATSC Doc. A/53) and the Digital Audio Compression Standard (ATSC Doc. A/52), moved U.S. television from an analog to a digital standard. It also provided TV stations with sufficient bandwidth to present four or five Standard Television (STV, providing the NTSC's resolution of 525 lines with a 3:4 aspect ratio, but in a digital signal) signals or one HDTV signal (providing 1,080 lines of resolution with a movie screen's 16:9 aspect ratio).

HDTV provides high resolution in a **16:9** aspect ratio (see Figure 6-3). This aspect ratio allows the viewing of Cinemascope and Panavision movies. There was contention between the broadcast and computer industries about whether to use interlacing or progressive-scan technologies. The broadcast industry promulgated an ultra-high-resolution, 1920×1080 interlaced format (1080i) to become the cornerstone of the new generation of high-end entertainment centers, but the computer industry wanted a 1280×720 progressive-scan system (720p) for HDTV. While the 1920×1080 format provides more pixels than the 1280×720 standard, the refresh rates are quite different. The higher-resolution interlaced format delivers only half the picture every $1/60$ of a second, and because of the interlacing, on highly detailed images there is a great deal of screen flicker at 30 Hz. The computer people argue that the picture quality at 1280×720 is superior and steady. Both formats have been included in the HDTV standard by the **Advanced Television Systems Committee (ATSC)**, found at www.atsc.org.

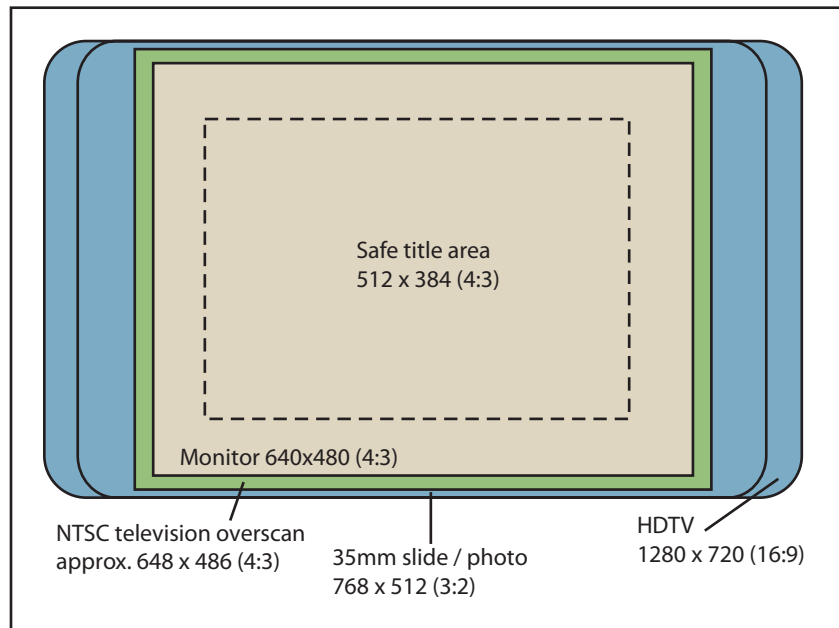

Figure 6-3 Here you can see the difference between VGA and HDTV aspect ratios.

Displays

Colored phosphors on a **cathode ray tube (CRT)** screen glow red, green, or blue when they are energized by an electron beam. Because the intensity of the beam varies as it moves across the screen, some colors glow brighter

than others. Finely tuned magnets around the picture tube aim the electrons precisely onto the phosphor screen, while the intensity of the beam is varied according to the video signal. This is why you needed to keep speakers (which have strong magnets in them) away from a CRT screen. A strong external magnetic field can skew the electron beam to one area of the screen and sometimes caused a permanent blotch that cannot be fixed by **degaussing**—an electronic process that readjusts the magnets that guide the electrons. If you had the misfortune to forget and wear a watch, the degausser might stop it permanently and then, if you are particularly unlucky, erase the magnetic strips on the credit cards in your wallet as well. If a computer displays a still image or words onto a CRT for a long time without changing, the phosphors will permanently change, and the image or words can become visible, even when the CRT is powered down. Screen savers were invented to prevent this from happening.

Flat screen displays are all-digital, using either **liquid crystal display (LCD)** or **plasma** technologies, and have supplanted CRTs for computer use. Some professional video producers and studios, however, prefer CRTs to flat screen displays, claiming colors are brighter and more accurately reproduced.

Full integration of digital video in cameras and on computers eliminates the analog television form of video, from both the multimedia production and the delivery platform. If your video camera generates a digital output signal, you can record your video direct-to-disk, where it is ready for editing. If a video clip is stored as data on a hard disk, CD-ROM, DVD, or other mass-storage device, that clip can be played back on a computer's monitor without special hardware.

Interlacing and Progressive Scan

The process of building a single frame from two fields is called interlacing, a technique that helps to prevent flicker on CRT screens. Computer monitors use a different **progressive-scan** technology, and draw the lines of an entire frame in a single pass, without interlacing them and without flicker. In television, the electron beam actually makes two passes on the screen as it draws a single video frame, first laying down all the odd-numbered lines, then all the even-numbered lines, as they are interlaced. On a computer monitor, lines are painted one-pixel thick and are not interlaced. Single-pixel lines displayed on a computer monitor look fine; on a television, these thin lines flicker brightly because they only appear in every other field. To prevent this flicker on CRTs, make sure your lines are greater than two pixels thick and that you avoid typefaces that are very thin or have elaborate serifs. If you are capturing images from a video signal, you can filter them through a de-interlacing filter provided by image-editing applications such as Photoshop and Fireworks. With typefaces, interlacing flicker

can often be avoided by anti-aliasing the type to slightly blur the edges of the characters. The term “interlacing” has a different meaning on the Web, where it describes the progressive display of lines of pixels as image data is downloaded, giving the impression that the image is coming from blurry into focus as increasingly more data arrives (see Chapter 13).

Most computers today provide video outputs to CRT, LCD, or plasma monitors at greater than 1024 × 768 resolution. Table 6-1 describes the various aspect ratios and width/heights in pixels used by computer displays since IBM’s VGA standard was adopted in 1987. The VGA’s once ubiquitous 640 × 480 screen resolution is again becoming common for handheld and mobile device displays.

| Acronym | Name | Aspect Ratio | Width (pixels) | Height (pixels) |
|---------|---|--------------|----------------|-----------------|
| VGA | Video Graphics Array | 4:3 | 640 | 480 |
| SVGA | Super Video Graphics Array | 4:3 | 800 | 600 |
| XGA | eXtended Graphics Array | 4:3 | 1024 | 768 |
| XGA+ | eXtended Graphics Array Plus | 4:3 | 1152 | 864 |
| WXGA | Widescreen eXtended Graphics Array | 5:3 | 1280 | 768 |
| WXGA | Widescreen eXtended Graphics Array | 8:5 (16:10) | 1280 | 800 |
| SXGA | Super eXtended Graphics Array | 4:3 | 1280 | 960 |
| SXGA | Super eXtended Graphics Array | 5:4 | 1280 | 1024 |
| HD | High Definition (Basic) | 16:9 | 1366 | 768 |
| WSXGA | Widescreen Super eXtended Graphics Array | 8:5 (16:10) | 1440 | 900 |
| HD+ | High Definiton (Plus) | 16:9 | 1600 | 900 |
| UXGA | Ultra eXtended Graphics Array | 4:3 | 1600 | 1200 |
| WSXGA+ | Widescreen Super eXtended Graphics Array Plus | 8:5 (16:10) | 1680 | 1050 |
| HD-1080 | Full High Definition | 16:9 | 1920 | 1080 |
| WUXGA | Widescreen Ultra eXtended Graphics Array | 8:5 (16:10) | 1920 | 1200 |

Table 6-1 Screen Resolutions for Computer Monitors

In the realm of digital television displays, Table 6-2 shows the most common screen resolutions. Note that the highest resolution, 1080p, does not include a 60-per-second frame refresh rate. When the ATSC standard was written in the early 1990s, that was simply too fast for the broadcast digital signal to keep up. Not shown is the 720 × 576 resolution used in PAL systems.

| Scan Lines from Top to Bottom | Pixels from Left to Right | Aspect Ratio | Display Rate in Frames per Second |
|-------------------------------|---------------------------|--------------|-----------------------------------|
| 1080p (progressive) | 1920 | 16:9 | 30, 24 |
| 1080i (interlaced) | 1920 | 16:9 | 30 |
| 720p (progressive) | 1280 | 16:9 | 60, 30, 24 |
| 480p (progressive) | 704 or 640 | 16:9 or 4:3 | 60, 30, 24 |
| 480i (interlaced) | 704 or 640 | 16:9 or 4:3 | 30 |

Table 6-2 Common Digital Television Resolutions

Overscan and the Safe Title Area

As illustrated earlier in Figure 6-3, it is common practice in the television industry to broadcast an image larger than will fit on a standard TV screen so that the “edge” of the image seen by a viewer is always bounded by the TV’s physical frame, or bezel. This is called **overscan**. In contrast, computer monitors display a smaller image on the monitor’s picture tube (**underscan**), leaving a black border inside the bezel. Consequently, when a digitized video image is displayed on a CRT, there is a border around the image; and, when a computer screen is converted to video, the outer edges of the image will not fit on a TV screen. Only about 360 of the 480 lines of the computer screen will be visible. Video editing software often will show you the safe areas while you are editing.

TIP Avoid using the outer 15 percent of the screen when producing computer-generated graphics and titles for use in television video. The **safe title area**, where your image will not be affected by overscanning, even in the worst conditions, is illustrated in Figure 6-3.

Digital Video Containers

A digital video architecture is made up of an algorithm for compressing and encoding video and audio, a container in which to put the compressed data, and a player that can recognize and play back those files. Common containers for video are Ogg (.ogg, Theora for video, Vorbis for audio), Flash Video (.flv), MPEG (.mp4), QuickTime (.mov), Windows Media Format (.wmv), WebM (.webm), and RealMedia (.rm). Containers may include data compressed by a choice of codecs, and media players may recognize and play back more than one video file container format.

Container formats may also include metadata—important information about the tracks contained in them—and even additional media

First Person

Captain's Log: We received some excellent design tips from Bernice T. Glenn:

As intermedia applications continue to proliferate, producers and designers need to know how to float between print and color pigment, digital color and RGB as viewed on a monitor, and analog color as viewed on a television screen. Color formulas for multimedia, especially when it is interactive, depend heavily on human factors. Contrast—or the degree of tonal difference between one color and another—is often more

important when working with color on a computer screen. A combination of pure yellow with pure violet, or blue and orange, for example, will vibrate when viewed in RGB. On video, disturbing flickers, extraneous colors, and other artifacts usually appear on the borders between pure complementary colors. On top of that, colors that look great on your computer monitor may not even show up when transferred to video. Important elements can be emphasized by using fully saturated colors against a neutral background, whose color

may complement as a grayed-down tint of the color.

When readability is important, contrast in color saturation and value between the type and its background really works, using almost any color combination.

Red or green may need to be avoided as cue colors [for menu buttons and icons] because eight percent of the population is color blind to some extent and cannot see reds or greens in their true color value.

From "Ask the Captain," a monthly column written by Tay Vaughan for NewMedia magazine

besides audio and video. The QuickTime container, for example, allows inclusion of text tracks, chapter markers, transitions, and even interactive sprites. Totally Hip's LiveStage Pro (www.totallyhip.com) is an authoring tool that can produce interactive multimedia self-contained within a single QuickTime .mov container.

Codecs

To digitize and store a 10-second clip of full-motion video in your computer requires the transfer of an enormous amount of data in a very short amount of time. Reproducing just one frame of digital video component video at 24 bits requires almost 1MB of computer data; 30 seconds of full-screen, uncompressed video will fill a gigabyte hard disk. Full-size, full-motion uncompressed video requires that the computer deliver data at about 30MB per second. This overwhelming technological bottleneck is overcome using digital video compression schemes or codecs (*coders/decoders*). A codec is the algorithm used to compress a video for delivery and then decode it in real time for fast playback. Different codecs are optimized for different methods of delivery (for example, from a hard drive, from a DVD, or over the Web). Codecs such as **Theora** and H.264 compress digital video information at rates that range from 50:1 to 200:1. Some codecs store only

the image data that changes from frame to frame instead of the data that makes up each and every individual frame. Other codecs use computation-intensive methods to predict what pixels will change from frame to frame and store the predictions to be deconstructed during playback. These are all lossy codecs where image quality is (somewhat) sacrificed to significantly reduce file size.

MPEG

The MPEG standards were developed by the **Moving Picture Experts Group (MPEG)**, (www.mpeg.org), a working group convened by the International Organization for Standardization (ISO) and the International Electro-technical Commission (IEC), which created standards for the digital representation of moving pictures as well as associated audio and other data. Using **MPEG-1** (specifications released in 1992), you could deliver 1.2 Mbps (megabits per second) of video and 250 Kbps (kilobits per second) of two-channel stereo audio using CD-ROM technology. **MPEG-2** (specifications released in 1994), a completely different system from MPEG-1, required higher data rates (3 to 15 Mbps) but also delivered higher image resolution, improved picture quality, interlaced video formats, multiresolution scalability, and multichannel audio features. MPEG-2 became the video compression standard required for digital television (DTV) and for making DVDs.

The MPEG specifications since MPEG-2 include elements beyond just the encoding of video. As a container, **MPEG-4** (specifications released in 1998 and 1999) provides a content-based method for assimilating multimedia elements. It offers indexing, hyperlinking, querying, browsing, uploading, downloading, and deleting functions, as well as “hybrid natural and synthetic data coding,” which will enable harmonious integration of natural and synthetic audiovisual objects. With MPEG-4, multiple views, layers, and multiple sound tracks of a scene, as well as stereoscopic and 3-D views, are available, making virtual reality workable. MPEG-4 can adjust to varied download speeds, making it an attractive option for delivery of video on the Web. The MPEG-4 AVC standard (Advanced Video Coding, Part 10) requires the H.264 codec for Blu-ray discs.

Because the software behind MPEG-4 is patented by more than two dozen companies, developers who build video editors and players that read and write MPEG-4 files must purchase licenses and make royalty payments.

The Codec Wars

The high bit rate requirements of video and the (relatively) low bit rates available from CD-ROMs, and later from the Web, have led to a long and occasionally confusing progression in the development of codecs.

My client had just completed a production run of 5,000 CDs containing my project for them. I was pretty proud of it: it had a 3D fly-in opening, integrated testing, Flash elements, customizable printing, the ability to save paths through the program. I thought I had thoroughly tested the golden master. But late in development I had changed the audio codec in three of the video clips and, sure enough, the audio wouldn't play on the Macintosh on those three clips. The client tossed the production run. I was a victim of the killer codec.

.....
Brad Borch, Activa Design

Generally, the greater the compression, the more processing “horsepower” (and waiting time) is needed to compress and decompress the video. So only relatively new computers are capable of decompressing highly compressed video at a rate that can keep up with the video data stream. Using the best or “latest” codecs in your project is a good idea, but it must be balanced by ensuring that the video will play on the widest range of computers.

Unencumbered by licensing and royalty fees, and supported by many but not all implementations of the HTML5 browsers' <VIDEO> tag (see Chapter 13), the Theora video codec and the Vorbis audio codec in an Ogg container is both platform independent and widely available, particularly within free and open-source video editing software. At one point in the development of the HTML5 specification, Ogg (using Theora and Vorbis codecs) was the video container required to be available in all compliant browsers, thus providing a single video format web developers could count on. But some manufacturers complained that their own favored (but proprietary and patented) codecs worked better and no container should be specified at all. To the consternation of the open-source and web developer community, midway through the evolution of the draft HTML5 spec the language was changed from effectively requiring all compliant browsers to support at minimum Ogg Theora video and Ogg Vorbis audio, as well as the Ogg container format, to simply *suggesting* that browsers support the same codecs, thus leaving standardization of the <VIDEO> containers and codecs in limbo (see Table 6-3).

The Flash video container, which uses the older VP6 and a newer H.263 codec (depending upon version), is used by YouTube and at many web sites but requires the Flash plug-in to be installed in the user's browser. For playing WMV containers, Macintosh computers require installing the Silverlight plug-in, a Microsoft development framework similar to Flash. The H.264 codec was developed by the Moving Picture Experts Group, is patented and proprietary, and is required on Blu-ray discs and used by YouTube, iTunes, and some broadcast services. Google's open-source VP8 codec works within the WebM container (www.webmproject.org), and was launched as an effort to replace Flash and H.264 on the Web. Google is re-encoding all its Flash holdings at YouTube to work with WebM and VP8 as well as with the H.264 codec.

Because of this codec and container war, for web developers wishing to place video elements onto their pages, programming with the HTML5 <VIDEO> tag (which was supposed to simplify and standardize inclusion of video at web sites) remains as complicated as ever (see Table 6-3). This is a constantly changing area of development, so check these browsers from time to time to see which codecs and containers are currently supported:

.....
 Chrome: www.chromium.org/

Safari: www.apple.com/safari/

Internet Explorer: ie.microsoft.com/testdrive/

Opera: www.opera.com/

Firefox: www.mozilla.com/

A discussion of the HTML5 <VIDEO> tag can be found in Chapter 13 along with snippets of code for launching your video using HTML5.

| | Internet Explorer 9 | Firefox 4.0+ | Safari 3.0+ | Chrome 6+ | Opera 11.0+ | Apple iPhone/iPad | Android Devices |
|---|---------------------|------------------|------------------|------------------|------------------|-------------------|-----------------|
| MP4 Container with H.264 video and ACC audio codecs | yes | | yes | yes | | yes | yes |
| MOV Container with H.264 video and ACC audio codecs | | | yes | | | yes | |
| OGG Container with Theora video and Vorbis audio codecs | | yes | | yes | yes | | |
| WebM Container with VP8 video and Vorbis audio codecs | yes | yes | | yes | yes | yes | yes |
| Flash FLV Container with VP6 video and MP3 audio codecs | plug-in required | plug-in required | plug-in required | plug-in required | plug-in required | | |
| Flash FLV Container with H.263 video and MP3 audio codecs | plug-in required | plug-in required | plug-in required | plug-in required | plug-in required | | |
| Flash MP4 Container with H.264 video and AAC audio codecs | plug-in required | plug-in required | plug-in required | plug-in required | plug-in required | | |

Table 6-3 Not All HTML5 Video Containers and Their Codecs Are Recognized as Playable by All Browsers

Video Format Converters

Be prepared to produce more than one version of your video (codecs in a container) to ensure that the video will play on all the devices and in all the browsers necessary for your project's distribution. DVD video uses MPEG-2 compression. Blu-ray video uses MPEG-4 AVC compression. These are known standards and few choices are necessary: simply click "Save for DVD" or "Save for Blu-ray." But if you need to prepare a video file that will run on an iPod, a Droid, and an Atom-based netbook, as well as in all web browsers, you will need to convert your material into multiple formats. There are many free, shareware, and inexpensive file format converters available for multiple platforms. Figure 6-4 shows a menu of video format selections and profiles available in the free converter Handbrake for Mac and Windows (<http://handbrake.fr>).



Figure 6-4
Working with many video formats (containers and codecs) is made simpler with conversion software.

Obtaining Video Clips

After you've decided that your project should and will include video, consider whether you should shoot new **“footage”** (a legacy term from the film and analog world) or acquire preexisting content for your video clips. There are many sources for film and video clips: a friend's home movies may suffice, or you can go to a “stock” footage house or a television station or movie studio. But acquiring footage that you do not own outright can be a nightmare—it is expensive, and licensing rights and permissions may be difficult, if not impossible, to obtain. Each second of video could cost \$50 to \$100 or more to license. Even material from a “public domain clip” from the National Archives must be researched:

Generally, materials produced by Federal agencies are in the public domain and may be reproduced without permission. However, not all materials appearing on this web site are in the public domain... Items found in our holdings may be copyrighted. Please note that it is your responsibility to identify the copyright owner and to obtain permission before making use of this material in any way.

NOTE *Many companies sell royalty-free video stock specifically for multi-media productions—these are lower resolution than broadcast quality and typically less than full-frame video.*

On some projects, you will have no choice but to pay the price for required footage. If it is absolutely essential that your project include a clip of Elvis Presley crooning “You Ain't Nothing But a Hound Dog,” and an Elvis impersonator just won't do, you will have to negotiate for rights to use the real thing. If your budget can't cover the cost of licensing a particular video clip, you may want to consider using other alternatives. You could try locating a less expensive archival video source, using a series of still images rather than video, or shooting your own video. If you shoot your own video for a project, make sure you have talent releases from all persons who appear or speak and permission to use the audio effects and music you weave into it. Licensing, permissions, and legal issues are discussed more fully in Chapter 11.

For projects that are focused on training, particularly training people to use software applications, video screen capture of mouse and key activity is widely used along with a voice-over sound track. Video screen capture tools for both PC and Macintosh systems will generate video files that can then be edited and integrated with audio. One eLearning

and courseware authoring program, Adobe's Captivate (www.adobe.com/products/captivate/), will not only capture your own screen activity but allow you to import video in a wide variety of formats (AVI, MOV, FLV, MPEG) and edit it into your final project.

TIP Before nonlinear video editing suites became commonplace in television studios, video was edited into a master using two tape decks (A and B). The A deck contained video of an event or the reporter doing an interview; the B deck contained ancillary and supporting material and scenery. "**B-roll**" is what editors call the collection of general footage that supports the main theme or narration. Locating and integrating B-roll, especially using royalty-free or public domain footage, can greatly enhance your project while keeping your costs down.

Shooting and Editing Video

Before you head out to the field with your camcorder in hand, it is important to understand at least the basics of video recording and editing, as well as the constraints of using video in a multimedia project.

Setting up a production environment for making digital video requires hardware that meets minimum specifications for processing speed, data transfer, and storage. There are many considerations to keep in mind when setting up your production environment, depending on the capabilities of your camcorder:

- Fast processor(s)
- Plenty of RAM
- Computer with FireWire (IEEE 1394 or i.Link) or USB connection and cables
- Fast and big hard disk(s)
- A second display to allow for more real estate for your editing software
- External speakers
- Nonlinear editing (NLE) software

Expensive professional video equipment and services may not yield proportionately greater benefits than if you used consumer-grade equipment and nonlinear editors. As with audio equipment, you need to make balancing decisions using Vaughan's Law of Multimedia Minimums (see Chapter 4). Most likely, your goal is to expend resources without diminishing returns—in other words, to produce multimedia that is adequate and does its job, but doesn't break your bank. If you can, experiment with

various combinations of video recording and playback devices hooked to your computer, and test the results using your multimedia-authoring platform. You can do a great deal of satisfactory work with consumer-grade video cameras and recording equipment if you understand the limitations of the technology.

The Shooting Platform

Never underestimate the value of a steady shooting platform. A classic symbol of amateur home movies is shaky camera work. Using a tripod or even placing the camera on a stable platform, such as a rolled-up sweater on the hood of a car, can improve a shot. With a little care, and careful adjustment of the lockdown screws, a sturdy conventional tripod can do wonders. If you must shoot handheld, try to use a camera with an electronic image stabilization feature for static shots, use a “steady-cam” balancing attachment, or use camera moves and a moving subject to mask your lack of steadiness. Even using a rolling office chair and sitting facing the back with the camera balanced on the chair-back makes a convenient, stable dolly. If you must shoot handheld, set the camera’s lens to the widest angle: at a wide angle, camera motion becomes smaller relative to the field of view and is thus less apparent.

And invest in an external microphone, like a Lavalier. It will give you better audio than the on-camera microphone during interviews, and you can easily hide it in the scene during general use. Or use a “shotgun” mic on a boom, with an operator who can “ride levels” by monitoring the recorded volume.

Most important, learn the features and controls of your camera—there are many tiny icons and menu selections! Study the manual. Experiment and practice. Stay organized—keep your extra batteries, spare memory cards and tapes, your charger and cables, and even your manual (in case you haven’t studied it hard enough) in a good camera bag. Learn how to connect the camera to your computer and how to access your video footage with nonlinear editing software. Learn how to use the editing software. If you are new to video, this is a steep learning curve with many small annoyances, but it is forgiving: if you mess up your video, there is often *something* from it that can be recovered and used.

Many digital camcorders will allow you to choose 4:3 or 16:9 aspect ratios for your recording, one or the other. Unfortunately, there is no easy way to convert between these aspect ratios, so you should decide up front which to use in your multimedia project. As shown in Figure 6-5, there are three ways to convert from a 4:3 aspect ratio for display on a 16:9 aspect ratio screen: you can *stretch* the 4:3 image to fill the 16:9 frame

(this distortion can make people look fat), you can zoom the width of the image to fit the 16:9 frame (you lose part of the top and bottom of the image), or you can place the image into the center of the 16:9 frame (leaving empty **pillars** right and left). There are two ways to convert from 16:9 to 4:3. The *Letterbox* or hard matte method produces blank bars at top and bottom, but leaves the original image untouched; *Pan and Scan*, on the other hand, loses both sides of the original image. When using the Pan and Scan method for conversion, editors will carefully pan across wide scenes to capture the best area to show. Videographers and wide-screen moviemakers often consider a 4:3 “safe frame” area when setting up their wide shots, knowing that their work will be converted to 4:3 for the DVD aftermarket. Some DVDs use an **anamorphic widescreen** coding system to squeeze 16:9 widescreen image data into a DVD’s standard 4:3 aspect ratio format; with a compatible player, these “Enhanced for Widescreen Televisions” discs will play the original video properly on a 16:9 screen.

Converting 16:9 to 4:3

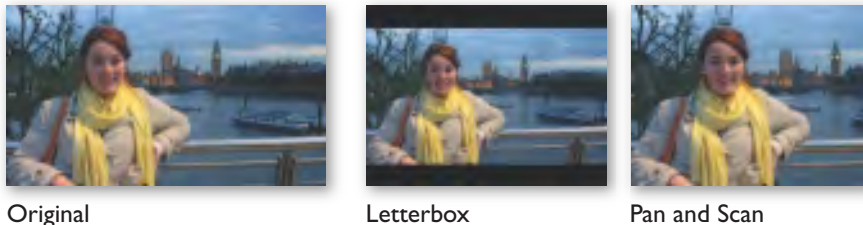

Original

Letterbox

Pan and Scan

Converting 4:3 to 16:9

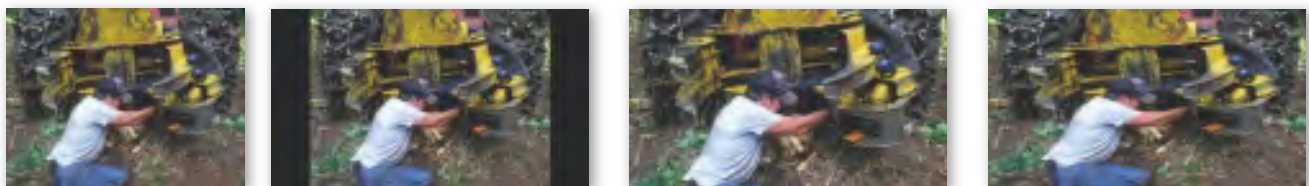

Original

Pillars

Zoom

Stretch

Figure 6-5 Methods for converting 4:3 and 16:9 aspect ratios in video production

TIP If your camera is HD-capable, it is a good idea to shoot your footage in HD. While it may be difficult to deploy HD video in your project due to bandwidth and memory constraints, you will have archived the footage at the highest resolution available to you. You can easily convert the high-definition

source video to standard definition, but you cannot convert the other way without enhancer software that attempts to increase the resolution and make the video “good looking.”

Storyboarding

Preplanning a video project is a factor that cannot be ignored without costing time loss, lots of unnecessary aggravation, and money that would be better spent elsewhere. Successful video production, of any sort, deserves the time it takes to make a plan to carry it out. It may take a little time at first, but you’ll find it to be very helpful in the long run. Storyboards are like any sequential comic you read daily. Every day there are three or four panels showing a progression of story or information. Take the time to structure your production by writing it down and then engineer a sequential group of drawings showing camera and scene, shooting angles, lighting, action, special effects, and how objects move through from start to finish. A storyboard can get everyone on one page quickly.

Lighting

Perhaps the greatest difference between professional camcorders and consumer camcorders is their ability to perform at low light levels. With proper lighting, however, it may be difficult for uninitiated viewers to differentiate between shots taken with an expensive studio-grade video camera and an inexpensive camcorder. Using a simple floodlight kit, or even just being sure that daylight illuminates the room, can improve your image. Onboard battery lights for camcorders can be useful, but only in conditions where the light acts as a “fill light” to illuminate the details of a subject’s face. As in photography, good lighting techniques separate amateurs from professionals in video shoots.

Illustrated in Figure 6-6 is a screen from *The Lighting Lab*. The standard lighting arrangement of a studio is displayed with fill, key, rim, and background lights. Changing any of these lights can make a dramatic difference in the shot. This project originally used a QuickTime container of several hundred single-frame images of the model as she is lighted by every permutation of lamp and intensity; clicking a light switch instantly shows the effect of that combination. If you are not convinced that lighting is critical to the success of a photo or video shoot, it will become immediately clear with this exercise! Try it at www.tayvaughan.com/multimedia/stuff/lightinglab.html.

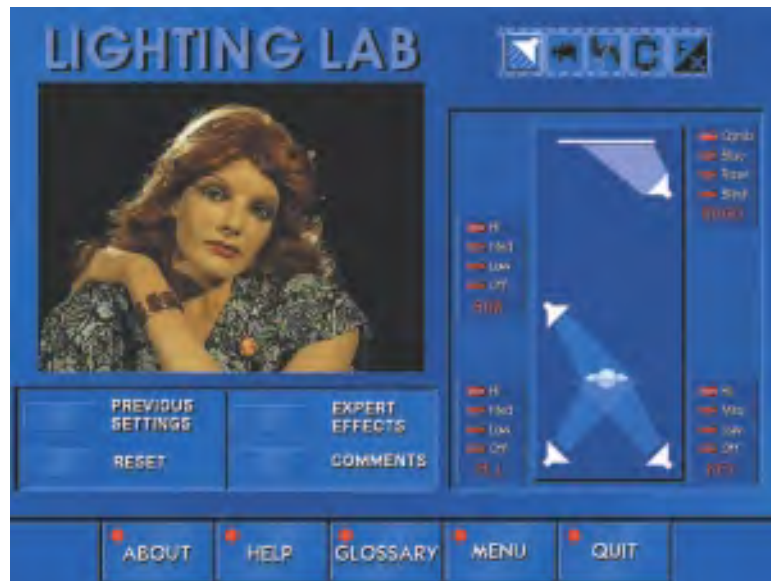

Figure 6-6 Good lighting is essential for quality video results.

When I worked in live video at KCAL in Los Angeles, one of our anchor women wore a blouse that was the same chroma-key blue that we could program into our Ultimatte. Actually, the anchor should have known better. We, being the naughty guys we were, keyed a closeup of two big eyes from one of the other anchors onto her blouse and fed it into the stage floor monitor and waited to see how long it would take before she noticed it. It was a couple of minutes, while everyone was trying to keep a straight face, before she saw what we had done. She threw her script at us, and we all broke up laughing.

Joe Silverthorn, Integrated Multimedia Professor, Olympic College

Chroma Keys

Chroma keys allow you to choose a color or range of colors that become transparent, allowing the video image to be seen “through” the computer image. This is the technology used by a newscast’s weather person, who is shot against a blue background that is made invisible when merged with the electronically generated image of the weather map. The weatherman controls the computer part of the display with a small handheld controller.

A useful tool easily implemented in most digital video editing applications is **blue screen, green screen, Ultimatte, or chroma key editing**. When Captain Picard of *Star Trek* fame walks on the surface of the moon, it is likely that he is actually walking on a studio set in front of a screen or wall painted blue. Actually placing Picard on the moon was, no doubt, beyond the budget of the shoot, but it could be faked using blue screen techniques. After shooting the video of Picard’s walk against a blue background and shooting another video consisting of the desired background moonscape, the two videos were mixed together: wherever there was blue in the Picard shot, it was replaced by the background image, frame by frame.

Blue screen is a popular technique for making multimedia titles because expensive sets are not required. Incredible backgrounds can be generated using 3-D modeling and graphic software, and one or more actors, vehicles, or other objects can be neatly layered onto that background. Video editing applications provide the tools for this.

When you are shooting blue screen, be sure that the lighting of the screen is absolutely even; fluctuations in intensity will make this “key”

appear choppy or broken. Shooting in daylight, and letting the sun illuminate the screen, will mitigate this problem. Also be careful about “color spill.” If your actors stand too close to the screen, the colored light reflecting off the screen will spill onto them, and parts of their body will key out. While adjustments in most applications can compensate for this, the adjustments are limited. Beware of fine detail, such as hair or smoke, that wisps over the screen; this does not key well.

Figure 6-7 shows frames taken from a video of an actor shot against blue screen. The blue background was removed from each frame, and the actor himself was turned into a photo-realistic animation that walked, jumped, pointed, and ran from a dinosaur.



Figure 6-7 This walking, jumping, and pointing actor was videotaped against a blue screen.

Composition

The general rules for shooting quality video for broadcast use also apply to multimedia. When shooting video for playback in a small window, it is best to avoid wide panoramic shots, as the sweeping majesty will be lost. Use close-ups and medium shots, head-and-shoulders or even tighter. Depending upon the compression algorithm used (see the discussion on

video codecs earlier in the chapter), consider also the amount of motion in the shot: the more a scene changes from frame to frame, the more “delta” information needs to be transferred from the computer’s memory to the screen. Keep the camera still instead of panning and zooming; let the subject add the motion to your shot, walking, turning, talking.

Beware of excessive backlighting—shooting with a window or a bright sky in the background—is a common error in amateur video production. Many cameras can be set to automatically compensate for backlighting. If you adjust for this, the background may be “blown out” (so bright the video signal peaks), but at least the foreground image you’re focusing on will be visible. Of course, the best choice in this situation is to light the foreground.

Non-professional cameras are set to always adjust the iris (the opening in the lens) to keep the image’s overall exposure at a constant level. When you go from a dark to light setting the camera will adjust, and you can often see this shift. Pro cameras allow the iris setting to be locked down to avoid this.

In different situations, white may not be white, depending on the color temperature (warmth or coolness) of the light source. **White balance** corrects for bluish, orange, or greenish color casts resulting from an uneven distribution of colors in the spectrum your eye tells you is white, but your less forgiving digital camera says is not quite white. Many cameras automatically set white balance with best guesses, but they also offer adjustable settings for daylight, shady, cloudy, tungsten, and fluorescent lighting conditions. Try to get the white balance correct when shooting; then you won’t be spending time with your editing software to remove the greenish tinge from your client’s white wedding dress.

Titles and Text

Titles and text are often used to introduce a video and its content. They may also finish off a project and provide credits accompanied by a sound track. Titles can be plain and simple, or they can be storyboarded and highly designed. For plain and simple, you can use templates (see Figure 6-8) in an image editor and then sequence those images into your video using your video editing software. Or you can create your own imagery or animations and sequence them. More elaborate titles, typical for feature films and commercial videos, can become multimedia projects in themselves. Upasana Nattoji Roy’s title design for Director Indrajit Nattoji’s “Aagey Se Right,” for example, began with creative ideas (see Chapter 10), transitioned into a detailed storyboard and animations (see Chapter 7), and was finally rendered using AfterEffects (see Figure 6-9).



Figure 6-8 Title templates are available for downloading. This template from “Westie” is at www.mediacollege.com/downloads/video/titles/.

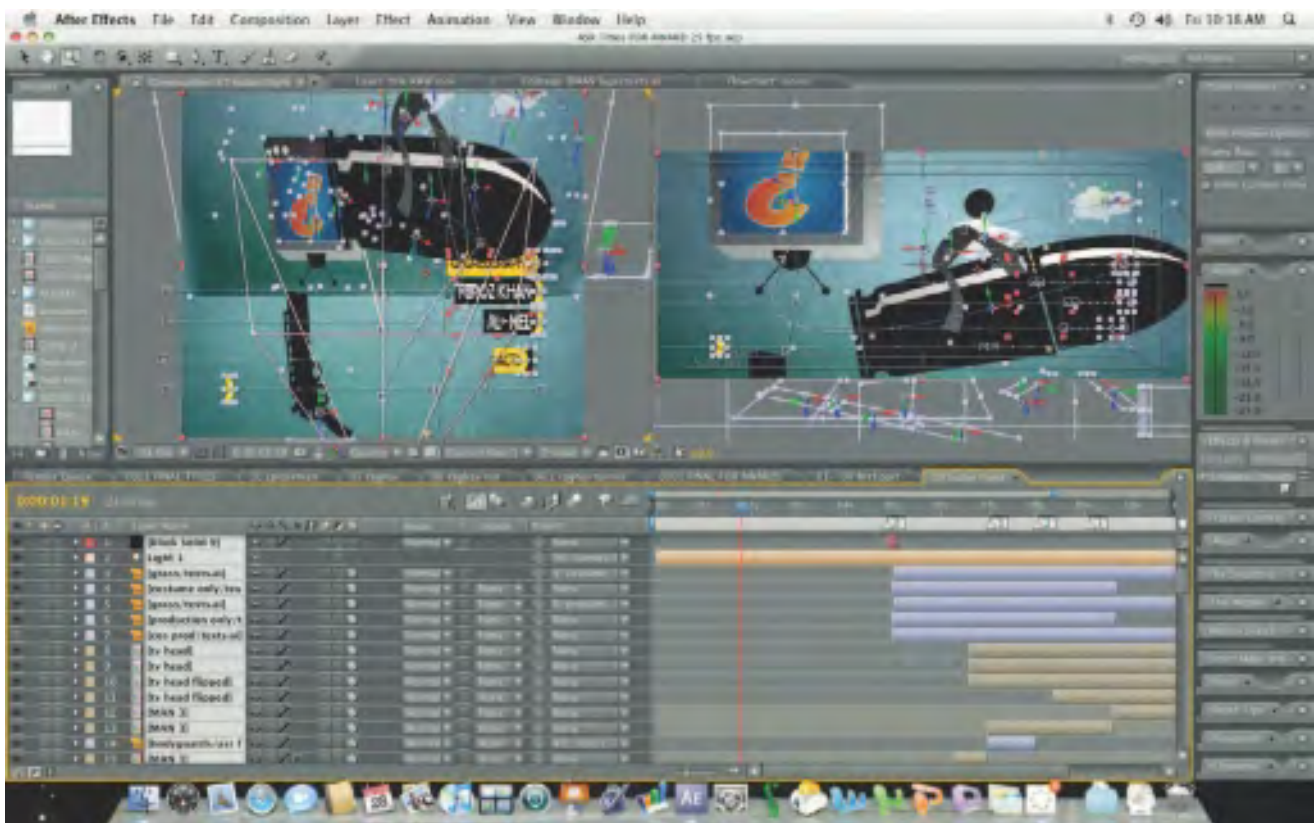

Figure 6-9 Elaborate titles are storyboarded, animated, and rendered to video using many multimedia tools. This title sequence was designed for a short film and stitched together using AfterEffects at Switch! Check out <http://theswitchsite.wordpress.com/> to view the finished title sequence.

If you make your own, here are some suggestions for creating good titles:

- Fonts for titles should be plain, sans serif, and bold enough to be easily read.
- When you are laying text onto a dark background, use white or a light color for the text.
- Use a drop shadow to help separate the text from the background image.
- Do not kern your letters too tightly.
- If you use underlining or drawn graphics, always make your lines at least two pixels wide. If you use a one-pixel-wide line (or a width measured in an odd number of pixels), the line may flicker when transferred to video due to interlacing.
- Use parallel lines, boxes, and tight concentric circles sparingly. When you use them, draw them large and with thick lines.
- Avoid colors like bright reds and magenta that are too “hot”; they might twinkle and buzz.
- Neighboring colors should be markedly different in intensity. For example, use a light blue and a dark red, but not a medium blue and a medium red.
- Keep your graphics and titles within the safe area of the screen. Remember that CRT televisions overscan (see the earlier section “Overscan and the Safe Title Area”).
- Bring titles on slowly, keep them on screen for a sufficient time, and then fade them out.
- Avoid making busy title screens; use more pages or a longer sequence instead.

Nonlinear Editing (NLE)

Top-of-the-line **nonlinear editing (NLE)** software includes Adobe’s Premiere, Apple’s Final Cut, and Avid’s Media Composer, the “A Team” of professional video editors. These are feature-packed and expensive packages designed to work hand-in-hand with fast and powerful computers (six gigabytes of RAM recommended) and dedicated file servers. Many hours of training and many days of experience are needed before users become proficient.

If your project involves simple cutting and editing of footage, with a few transitions and titles thrown in, then you may be satisfied with simpler software such as Microsoft’s Windows Live Movie Maker (see Figure 6-10) or Apple’s iMovie for Macs (see Figure 6-11) that come free with the operating system. Table 6-4 contains a list of free video editing software applications to choose from.

| Name | Platform | Download Address |
|--------------------------|-----------------------|---|
| Avidemux | Windows/Mac/BSD/Linux | www.avidemux.org |
| Cinelerra | Linux/Mac | www.heroinewarrior.com/cinelerra.php |
| iMovie | Mac | www.apple.com/ilife/imovie |
| Kdenlive | Linux/BSD/Mac | www.kdenlive.org |
| Kino | Linux/BSD | http://kinodv.org |
| LiVES | Linux/BSD/Mac | http://lives.sourceforge.net |
| OpenShot | Linux | www.openshotvideo.com |
| Pinnacle Videospin | Windows | www.videospin.com/Redesign |
| PiTiVi | Linux | www.pitivi.org |
| VideoLab | Windows | www.mitov.com/html/videolab.html |
| VideoThang TM | Windows | www.videothang.com |
| VirtualDub | Windows | www.virtualdub.org |
| Windows Live Movie Maker | Windows | http://explore.live.com/windows-live-movie-maker |

Table 6-4 Free Video Editing Software

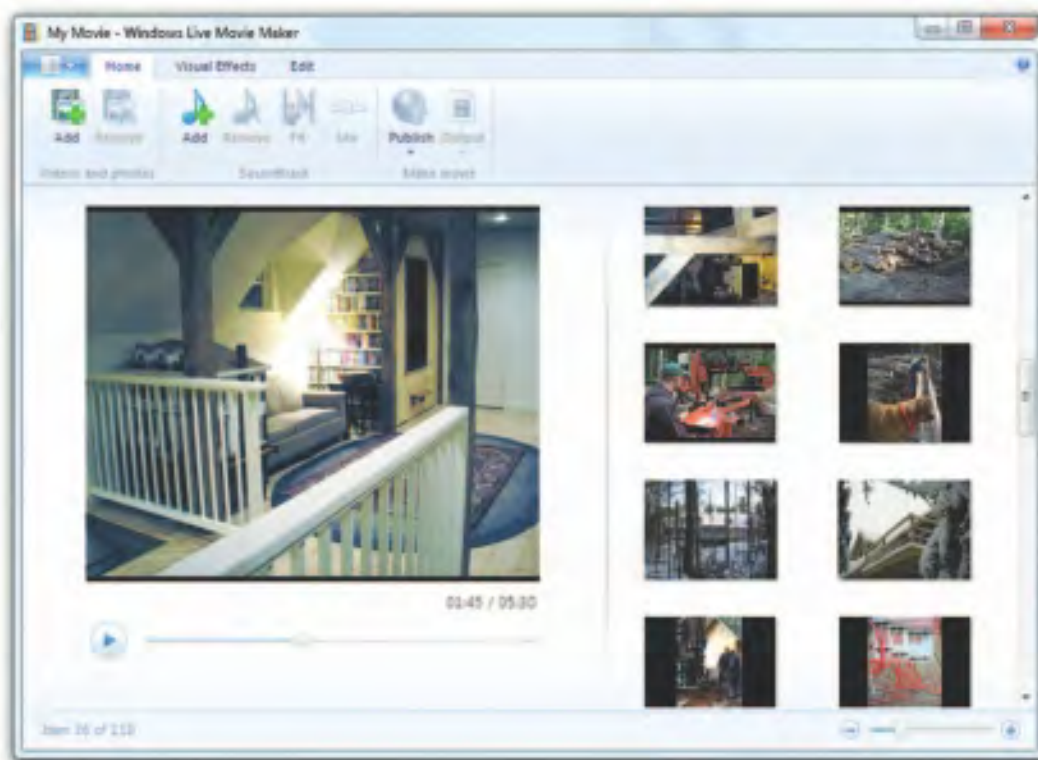

Figure 6-10 Windows Live Movie Maker comes free with Windows and can edit photos and videos, add special effects, and make DVDs and files for the Web.



Figure 6-11 iMovie is a robust video editor that comes free with Macintosh computers and provides full libraries of title templates, video effects, and transitions.

Remember not to edit and re-edit and re-edit again. The video codecs used are lossy, so each time you finalize a file, it will be less true than the original material—this is called **generation loss**. Because NLE software works with **EDLs (edit decision lists)** based upon the raw source video, be sure you have sufficient disk space to store your original footage.

Chapter 6 Review

■ Chapter Summary

For your review, here's a summary of the important concepts discussed in this chapter.

Consider the implications of using digital video in multimedia

- Video places the highest performance demand on any computer system.
- A massive amount of imagery must be squeezed into a comparatively small data file using compression (and decompression) software called a codec.
- You will need to make many choices and compromises based upon your assessment of the “lowest common denominator” playback platform where your project will be used.

Discuss video analog and digital technologies and displays

- A charge-coupled device (CCD) converts the light that has been reflected from an object through the camera's lens.
- Four broadcast and video standards and recording formats are commonly in use around the world: NTSC, PAL, SECAM, and HDTV.
- HDTV provides high resolution in a 16:9 aspect ratio.
- Flat screen displays are all-digital, using either liquid crystal display (LCD) or plasma technologies, and have supplanted CRTs for computer use.
- The process of building a single frame from two fields is called interlacing, a technique that helps to prevent flicker.
- Progressive-scan technology draws the lines of an entire video frame in a single pass, without interlacing them and without flicker.

- Don't place critical information such as text in the outer 15 percent of the screen. Keep it within the “safe title area.”

Work with digital video containers and codecs to select the best video recording formats for multimedia projects

- Codecs are digital video and audio compression schemes that compress a video into a container for delivery and then decode it during playback.
- Video containers may include data compressed by a choice of codecs, and media players may recognize and play back more than one video file container format.
- The MPEG standards were developed by the Moving Picture Experts Group.
- The HTML5 <VIDEO> tag was supposed to simplify and standardize inclusion of video at web sites, but it remains embroiled in a codec and container war.

Find and acquire video clips

- There are many sources for digital video, but getting the rights can be difficult, time-consuming, and expensive.
- eLearning projects often employ screen capture programs to record mouse and keyboard activities to teach about a software application.

Shoot and edit video for use in multimedia

- Always shoot using a steady shooting platform.
- Storyboards are a useful exercise when planning a shoot.
- Good, even lighting is extremely important.
- Expensive stages are not required when using blue screen or matte techniques.

- Avoid wide panoramic shots and camera motion when shooting for a small computer window on CD-ROM or the Web.
- Fonts for titles should be plain, sans serif, and bold enough to be easily read.
- Most editing is now being done on computers using nonlinear editing (NLE) software such as Avid, Premiere, and Final Cut.

■ Key Terms

- 16:9** (170)
- Advanced Television Systems Committee (ATSC)** (170)
- anamorphic widescreen** (182)
- ATSC Digital Television Standard** (167)
- B-roll** (180)
- blue screen** (184)
- cathode ray tube (CRT)** (170)
- charge-coupled device (CCD)** (165)
- chroma key** (184)
- chroma key editing** (184)
- codec** (165)
- component** (166)
- composite** (166)
- degaussing** (171)
- Digital Television (DTV)** (169)
- Digital Visual Interface (DVI)** (167)
- dubbing** (168)
- DVD (Digital Versatile Disc)** (165)
- EDL (edit decision list)** (190)
- footage** (179)
- generation loss** (190)
- green screen** (184)
- helical scan** (166)
- High Definition Television (HDTV)** (169)
- High-Definition Multimedia Interface (HDMI)** (167)
- interlacing** (166)
- liquid crystal display (LCD)** (171)
- Moving Picture Experts Group (MPEG)** (175)
- National Television Standards Committee (NTSC)** (168)
- MPEG-1** (175)
- MPEG-2** (175)
- MPEG-4** (175)
- nonlinear editing (NLE)** (188)
- overscan** (173)
- Phase Alternate Line (PAL)** (168)
- pillar** (182)
- plasma** (171)
- progressive-scan** (171)
- RAID (Redundant Array of Independent Disks)** (165)
- safe title area** (173)
- Separate Video (S-Video)** (166)
- Sequential Color and Memory (SECAM)** (168)
- Theora** (174)
- tracking** (166)
- Ultimatte** (184)
- underscan** (173)
- VGA connector** (167)
- video cassette recorder (VCR)** (167)
- white balance** (186)

■ Key Term Quiz

1. A redundant hard-disk system that will support high-speed data transfer rates is called a _____.
2. The television signal format used in the United States, Japan, and many other countries is known as _____.

3. Television screens use a process of building a single frame from two fields to help prevent flicker on CRTs in a technique called _____.
4. When creating graphics for conversion to video, do not place any critical information such as text in the outside 15 percent of the image. Instead, keep it within the _____ (three words).
5. High-Definition Television (HDTV) is displayed in a(n) _____ aspect ratio.
6. The television signal format used in France, Russia, and a few other countries is known as _____.
7. The digital video and audio compression schemes that compress a video for delivery and then decode it during playback are called _____.
8. When reformatting a 4:3 aspect ratio video to fit in the center of a HDTV screen, leaving the sides empty, the effect is called _____.
9. The video compression/decompression scheme used in an Ogg container is called _____.
10. MPEG is an acronym for _____.

■ Multiple-Choice Quiz

1. In a video camera, the sensor that picks up light is called a CCD. CCD stands for:
 - a. color-coding data
 - b. custom color descriptor
 - c. chroma-calculation daemon
 - d. charge-coupled device
 - e. carbon crystal digitizer
2. A computer's output on a CRT is calibrated to display an image:
 - a. smaller than the actual monitor's capability
 - b. larger than the actual monitor's capability
 - c. exactly the same size as the actual monitor's capability
 - d. that adjusts automatically to the monitor's capability
 - e. of a fixed size; whether it is larger or smaller than the monitor's capability depends on the monitor
3. Removing a residual magnetic field that distorts the colors on a television screen is called:
 - a. tracking
 - b. dubbing
 - c. streaming
 - d. flattening
 - e. degaussing
4. A video signal transmitted with all the signals mixed together and carried on a single cable is called:
 - a. RGB video
 - b. composite video
 - c. component video
 - d. multiformat video
 - e. chroma-key video
5. Which of the following is *not* a television signal format?
 - a. MPEG
 - b. NTSC
 - c. PAL
 - d. SECAM
 - e. HDTV
6. Computer displays draw the lines of an entire frame in a single pass; this technique is called:
 - a. streaming
 - b. progressive-scan
 - c. packing
 - d. flattening
 - e. overscan

7. The video technique that allows you to choose a color or range of colors that become transparent, allowing the video image to be visible behind those colors in the overlying image, is known by all of the following *except*:
- blue screen
 - Ultimatte
 - chroma key
 - interlacing
 - green screen
8. Which of the following is a multimedia container format?
- JPEG
 - DVD-RW
 - ComponentY
 - Hi-8
 - Ogg
9. Red or green should be avoided as cue colors because:
- they represent negative ideas in some cultures
 - they do not blend well with other colors
 - color-blind individuals cannot see them correctly
 - they are associated with “stop” and “go”
 - they remind people of Christmas
10. Which of the following is *not* a good idea when creating titles (text) to be used in video?
- Fonts for titles should be plain, sans serif, and bold enough to be easily read.
 - When you are laying text onto a dark background, use white or a light color for the text.
 - Do not kern your letters too tightly.
 - If you use underlining or drawn graphics, make sure your lines are only one pixel wide.
 - Use a drop shadow to help separate the text from the background.
11. Which of the following is *not* a typical studio light?
- rim light
 - fill light
 - key light
 - background light
 - focal light
12. Which of the following is *not* a codec?
- H.264
 - Theora
 - NTSC
 - VP6
 - VP8
13. Generation loss occurs when:
- an analog tape is copied to another analog tape
 - a digital file is copied to another hard disk
 - a digital file is copied to another hard drive
 - a digital file is compressed with a lossy codec
 - your teenage son gets his tongue pierced
14. MPEG stands for:
- Multiformat Processed-Event Graphics
 - Multi-Phase Element Grid
 - Meta-Program Environment Graph
 - Moving Picture Experts Group
 - Micro-Phase Electronic Guidance
15. Which of the following HTML5 tags is used in the display of multimedia video?
- <LOAD>
 - <ANIMATE>
 - <FORWARD>
 - <PLAY>
 - None of the above

■ Essay Quiz

1. List the steps involved in capturing video, compressing the video, and preparing it for DVD. Briefly discuss the decisions you need to make with each step regarding compromises on image quality and other limiting factors.
2. Discuss how the computer monitor image differs from a television image. List the limitations in creating images on the computer destined for a television screen.
3. Discuss several considerations in shooting and editing video for multimedia. What techniques would you use to produce the best possible video, at a reasonable cost? Which of these techniques apply to *all* video, and which apply specifically to multimedia?
4. Briefly discuss what defines the quality of a video signal. What factors affect this quality? How do the various analog television signal formats differ in quality? How does the recording format affect this quality? What about digital format? How can you ensure that your video is of the best possible quality? If the end result is going to be a postage-stamp-sized streaming video clip at 10 frames per second, why would quality matter?
5. Define codec and list an example of a codec.

Lab Projects

■ Project 6.1

Go to a local electronics superstore. What kinds of video cameras are available? What capabilities do the “prosumer” cameras have? What features do they have that would be useful in multimedia? Document your findings.

■ Project 6.2

Locate three web sites that include video clips. What format are they served in? Examine the HTML source code to discover what method of video delivery is used. Make a note of your findings. Some clips are available in a streaming format and are not easily downloadable. Others can be downloaded. Download the clips you can and open them in QuickTime or Windows Media Player. List the codecs that were used to compress the clips.

■ Project 6.3

Prepare five graphic images using a paint or drawing program. Be sure to include a variety of colors and contrasts. Add text to the images. Use small text, large text, text with serifs, bold text, and text in contrasting and similar colors. Add drop shadows. Add boxes and other shapes to the images, in various weights.

Locate a computer with video-out capabilities, and view the images on a digital display and on a CRT. Note your findings:

- Which color combinations worked well? Which did not?
- Were any colors distracting?
- What about the text and graphics? Which looked best?
- What about the safe title area? What percentage of the image was clipped? (Note that some computers have video outputs that underscan rather than overscan. Remember, such a setup does not accurately reflect the image size that would result from a computer-to-video conversion.)

Making Multimedia

In this chapter, you will learn how to:

- Describe the four primary stages in a multimedia project
- Discuss the intangible elements needed to make good multimedia: creativity, organization, and communication skill
- Discuss the hardware most often used in making multimedia and choose an appropriate platform for a project
- Understand common software programs used to handle text, graphics, audio, video, and animation in multimedia projects and discuss their capabilities
- Determine which multimedia authoring system is most appropriate for any given project

IN this chapter, you will be introduced to the workshop where multimedia is made, with guidance and suggestions for getting started, and you will learn about planning a project. In later chapters, you will learn about producing, managing, and designing a project; getting material and content; testing your work; and, ultimately, shipping it to end users or posting it to the Web.

The Stages of a Multimedia Project

Most multimedia and web projects must be undertaken in stages. Some stages should be completed before other stages begin, and some stages may be skipped or combined. Here are the four basic stages in a multimedia project:

- 1. Planning and costing** A project always begins with an idea or a need that you then refine by outlining its messages and objectives. Identify how you will make each message and objective work within your authoring system. Before you begin developing, plan out the writing skills, graphic art, music, video, and other multimedia expertise that you will require. Develop a creative “**look and feel**” (what a user sees on a screen and how he or she interacts with it), as well as a structure and a navigational system that will allow the viewer to visit the messages and content. Estimate the time you’ll need to do all the elements, and then prepare a budget. Work up a short **prototype** or **proof-of-concept**, a simple, working example to demonstrate whether or not your idea is feasible. The ease with which you can create materials with today’s production and authoring tools tempts new developers to immediately move into production—jumping in before planning. This often results in false starts and wasted time and, in the long run, higher development cost. The more time you spend getting a handle on your project by defining its content and structure in the beginning, the faster you can later build it, and the less reworking and rearranging will be required midstream. Think it through before you start! Your creative ideas and trials will grow into

screens and buttons (or the look and feel), and your proof-of-concept will help you test whether your ideas will work. You may discover that by breaking the rules, you can invent something terrific!

2. **Designing and producing** Perform each of the planned tasks to create a finished product. During this stage, there may be many feedback cycles with a client until the client is happy.
3. **Testing** Test your programs to make sure that they meet the objectives of your project, work properly on the intended delivery platforms, and meet the needs of your client or end user.
4. **Delivering** Package and deliver the project to the end user. Be prepared to follow up over time with tweaks, repairs, and upgrades.

What You Need: The Intangibles

You need hardware, software, and good ideas to make multimedia. To make *good* multimedia, you need talent and skill. You also need to stay organized, because as the construction work gets under way, all the little bits and pieces of multimedia content—the six audio recordings of Alaskan Eskimos, the Christmas-two-years-ago snapshot of your niece, the 41 articles still to scan with your optical character recognition (OCR) program—will get lost under growing piles of paper, CDs, videotapes, phone messages, permissions and releases, cookie crumbs, Xerox copies, and yesterday’s mail. Even in serious offices, where people sweep all flat surfaces clear of paperwork and rubber bands at five o’clock, there will be a mess.

You will need time and money (for consumable resources such as CD-R blanks and other memory or digital storage, for telephoning and postage, and possibly for paying for special services and time, yours included), and you will need to budget these precious commodities (see Chapter 9).

You may also need the help of other people. Multimedia development of any scale greater than the most basic level is inherently a team effort: artwork is performed by graphic artists, video shoots by video producers, sound editing by audio producers, and programming by programmers (see Chapter 8). You will certainly wish to provide plenty of coffee and snacks, whether working alone or as a team. Late nights are often involved in the making of multimedia.

Creativity

Before beginning a multimedia project, you must first develop a sense of its scope and content. Let the project take shape in your head as you think through the various methods available to get your message across to your viewers.

The most precious asset you can bring to the multimedia workshop is your creativity. It's what separates run-of-the-mill or underwhelming multimedia from compelling, engaging, and award-winning products, whether we're talking about a short sales presentation viewed solely by colleagues within your firm or provided for a fully immersive online game.

You have a lot of room for creative risk taking, because the rules for what works and what doesn't work are still being empirically discovered, and there are few known formulas for multimedia success. Indeed, companies that produce a terrific multimedia title are usually rewarded in the marketplace, but their success can be fleeting. This is because competitors often reverse-engineer the product, and then produce knockoffs using similar approaches and techniques, which appear on the market six months later. Good web site ideas and programming are easily cloned.

The evolution of multimedia is evident when you look at some of the first multimedia projects done on computers and compare them to today's titles. Taking inspiration from earlier experiments, developers modify and add their own creative touches for designing their own unique multimedia projects.

It is very difficult to learn creativity. Some people might say it's impossible—and that you have to be born with it. But, like traditional artists who work in paint, marble, or bronze, the better you know your medium, the better able you are to express your creativity. In the case of multimedia, this means you need to know your hardware and software first. Once you're proficient with the hardware and software tools, you might ask yourself, "What can I build that will look great, sound great, and knock the socks off the viewer?" This is a rhetorical question, and its answer is actually another question—which is simply, "How creative are you?"

WARNING *If you are managing a multimedia project, remember that creative talent is priceless, so be certain to reward it well. If you don't, you may find that your talent takes a job elsewhere, even at lower pay!*

Organization

It's essential that you develop an organized outline and a plan that rationally details the skills, time, budget, tools, and resources you will need for a project. These should be in place before you start to render graphics, sounds, and other components, and a protocol should be established for naming the files so you can organize them for quick retrieval when you need them. These files—called **assets**—should continue to be monitored throughout the project's execution. Chapter 9 provides planning and costing models for a multimedia project, while Chapter 10 discusses the details of multimedia project and asset management.

First Person

The Credit Alligator usually appears late in a multimedia project and has nothing to do with MasterCard or Visa. This gnarly animal typically lives unseen in the delicate fringes of workgroup politics, but can appear very suddenly, causing great distraction during beta testing, adding moments of personal tension, and occasionally destroying friendships and business relationships.

After hard cash, the most satisfying remuneration for your sweaty effort and creative, late-night contributions to a multimedia project is to see your name listed in the credits for a particular project. Indeed, getting visible credit is a special, high-value currency, in part because it can be added to your portfolio to help you land the next job. The more of this currency you have, the higher your potential wage and the more likely you will remain employed doing what you like to do. Start building defenses against this alligator up front. When you negotiate the original contract with whoever pays the multimedia bill, be sure to include wording such as: "We shall be allowed to include a production credit display on the closing screen or in another mutually agreeable position in the finished work." If you are an individual who is contracting to a producer, be sure it is understood that *if* there is a credit page, your name will be on it.

Not all clients will stand for a credit page. Large companies, for example, use many outside contractors to produce multimedia, but as a policy rarely allow contributors to be credited by name. Some contractors and frustrated employees develop ingenious workarounds for burying these important intellectual credits within their work.

The Credit Alligator raises its bumpy head over the little things, too, and there are often no appropriate defenses for it. For example, if your name begins with a letter that is toward the end of the alphabet, you may never appear first on the list of contributors, even if your contribution was major. Of course, if your name is Walsh or Young, you have endured this ordering system since first-grade lineups. Warning: reversing an alphabetic credit list from last to first will only create or heighten tension; to propose such a list is, in itself, ego-driven and self-serving. Learn to work around it.

The most treacherous place for the Credit Alligator to lurk is in the busy stretch of time during the finalizing of a CD-based project and the "going gold" process of producing a final master. If you are not participating in the final mastering but have contributed a piece or pieces to the project, you must trust the person doing the mastering to do it the right way. But, unfortunately it doesn't always happen the way you want it to.

One company recently consulted on a job where their work represented the second-greatest contribution from a group of about 15 contributors, all of whom had credit screens. Their contract required credit, but in the final version of the storyboard, they discovered their screen buried at the end of a four-minute linear sequence of all the other credits and advertisements. They asked the producer to move it up. "Sorry," said the producer, "it was an oversight." Then in the last-minute process of re-sequencing, the producer also switched the contracted company's custom music to his own company's credit screen, leaving our friend's screen attached to a pretty ugly leftover sound byte. Because the company was not included in the final feedback and approval loop, they discovered this "little mistake" only after mass replication. It's tough to change 50,000 shrink-wrapped CD-ROMs, so at that point there was nothing to say.

Crediting creative talent is sensitive stuff. Avoid recurring bouts with the Credit Alligator by publicizing your policy about credit screens. Talk about intellectual credit openly, not as a last-minute thing. Negotiate hard for inclusion of credit in all the projects you undertake for clients. Remember, multimedia doesn't spring from the bankrolls of investors and publishers—it's the result of the hard work of talented, real people.

Communication

Many multimedia applications are developed in workgroups comprising instructional designers, writers, graphic artists, programmers, and musicians located in the same office space or building. The workgroup members' computers are typically connected on a local area network (LAN). The client's computers, however, may be thousands of miles distant, requiring other methods for good communication.

Communication among workgroup members and with the client is essential to the efficient and accurate completion of your project. If your client and you are both connected to the Internet, a combination of Skype video and voice telephone, e-mail, and the **File Transfer Protocol (FTP)** may be the most cost-effective and efficient solution for both creative development and project management. In the workplace, use quality equipment and software for your communications setup. The cost—in both time and money—of stable and fast networking will be returned to you.

What You Need: Hardware

This book will help you understand the two most significant platforms for producing and delivering multimedia projects: the **Apple Macintosh operating system** (OS) and the **Microsoft Windows** OS, found running on most Intel-based PCs (including Intel-based Macintoshes). These computers, with their graphical user interfaces and huge installed base of many millions of users throughout the world, are the most commonly used platforms for the development and delivery of today's multimedia.

Certainly, detailed and animated multimedia is also created on specialized workstations from Silicon Graphics, Sun Microsystems, and even on mainframes, but the Macintosh and the Windows PC offer a compelling combination of affordability, software availability, and worldwide obtainability. Regardless of the delivery vehicle for your multimedia—whether it's destined to play on a computer, on a Wii, Xbox, or PlayStation game box, or as bits moving down the data highway—most multimedia will probably be made on a Macintosh or on a PC.

The basic principles for creating and editing multimedia elements are the same for all platforms. A graphic image is still a graphic image, and a digitized sound is still a digitized sound, regardless of the methods or tools used to make and display it or to play it back. Indeed, many software tools readily convert picture, sound, and other multimedia files (and even whole functioning projects) from Macintosh to Windows format, and vice versa, using known file formats or even **binary compatible** files that require no conversion at all. While there is a lot of talk about **platform-independent** delivery of multimedia on the Internet, with every new version of a browser there are still annoying failures on both platforms. These failures in **cross-platform** compatibility can consume great amounts of time as you prepare

for delivery by testing and developing workarounds and tweaks so your project performs properly in various target environments.

Selection of the proper platform for developing your multimedia project may be based on your personal preference of computer, your budget constraints, project delivery requirements, and the type of material and content in the project. Many developers believe that multimedia project development is smoother and easier on the Macintosh than in Windows, even though projects destined to run in Windows must then be ported and tested across platforms. Table 7-1 shows the penetration of operating systems.

| Windows | Mac | Other |
|---------|-------|-------|
| 90.76% | 4.32% | 4.92% |

Table 7-1 Worldwide Operating System Market Share in September, 2010 (Source: <http://marketshare.hitslink.com>)

Windows vs. Macintosh

A Windows computer is not a computer per se, but rather a collection of parts that are tied together by the requirements of the Windows operating system. Power supplies, processors, hard disks, CD-ROM and DVD players and burners, video and audio components, monitors, keyboards, mice, WiFi, and Bluetooth transceivers—it doesn't matter where they come from or who makes them. Made in Texas, Taiwan, Indonesia, India, Ireland, Mexico, or Malaysia by widely known or little-known manufacturers, these components

First Person

In November 1985, during the COMDEX trade show in Las Vegas, members of the computer press were invited to the birthing party for a new Microsoft product called Windows. A crowd of journalists and friends of Microsoft had gathered in a small, low-ceilinged hotel ballroom and were munching on hors d'oeuvres and sipping wine when the swinging doors to the pantry opened suddenly, and Bill Gates drove a golf cart onto the floor, towing a small trailer loaded down with hundreds of blue boxes

filled with the new product. A cheer went up, and the boxes disappeared into waiting hands. It was a fun party held in the time before Gates had become the richest man in the world and necessarily employed a personal security force, before his personal income would skew by two dollars the difference between the mean and median income of all Americans. He chatted with a few of us and proudly autographed some User Guides. Mine says "I hope you like the product; thanks for coming, Tay." Back in my office after the show,

I loaded the software onto my XT from the five 5.25-inch floppy disks in the box and ran it. Windows was a dog. Indeed, during the ensuing days and months, Windows had a very hard time in the "operating environment" popularity contest and dropped to low-visibility status. But Gates seemed to have a vision, and while we didn't hear too much about Windows during the next years, Gates and Microsoft worked on the product steadily and didn't give up. Windows 3.0, released many years later, changed the world.

are assembled and branded by Dell, HP, Sony, and others into computers that run Windows. If you are handy with a Phillips screwdriver and can read instructions, you can even order the parts and assemble your own computer “**clone**” to run Windows—at a considerable cost savings!

In the early days, Microsoft organized the major PC hardware manufacturers into the Multimedia PC Marketing Council, in order to develop a set of specifications that would allow Windows to deliver a dependable multimedia experience. Since then, the multimedia PC, or **MPC, specification** has evolved into “what a computer does.” And it does it all.

Unlike Microsoft, primarily a software company, Apple is a hardware manufacturing company that developed its own proprietary software to run the hardware. In 2006, Apple adopted Intel’s processor architecture, an engineering decision that allows Macintoshes to run natively with any x86 operating system, same as Windows. All recent models of Macintosh come with the latest Mac operating system, and using Boot Camp or Parallels software, Macs can also run the Windows operating system.

Networking Macintosh and Windows Computers

If you are working in a multimedia development environment consisting of a mixture of Macintosh and Windows computers, you will want them to communicate with each other. You will also wish to share other resources among them, such as printers.

Local area networks (LANs) and **wide area networks (WANs)** can connect the members of a workgroup. In a LAN, workstations are usually located within a short distance of one another, on the same floor of a building, for example. WANs are communication systems spanning greater distances, typically set up and managed by large corporations and institutions for their own use, or to share with other users.

LANs allow direct communication and sharing of peripheral resources such as file servers, printers, scanners, and network routers. They use a variety of proprietary technologies to perform the connections, most commonly **Ethernet** (using twisted-pair copper wires) and **WiFi** (using radio). If you are operating a cross-platform multimedia development shop, you should install a local Ethernet system so that your PCs and Macintoshes can talk to each other and to your network printers as well. This is many times more efficient than carrying removable media among your machines. Ethernet is only a *method* for wiring up computers, so you still will need **client/server software** to enable the computers to speak with each other and pass files back and forth. The Windows and Mac operating systems provide this networking software, but you may need expert help to set it up—it can be complicated!

Unless you are in a large business or part of government, your WAN is likely the Internet connected to you by an **Internet service provider (ISP)**; the Internet is worldwide and connects tens of millions of computers

and other devices! If you are working with people in various time zones (an artist in New York, a programmer in San Francisco, and a client in Singapore), all can communicate and share information with other locations at any time of day or night using the Internet network. Chapter 12 discusses the Internet in greater detail.

Connections

The equipment required for developing your multimedia project will depend on the content of the project as well as its design. You will certainly need as fast a computer as you can lay your hands on, with lots of RAM and disk storage space. Table 7-2 shows various device connection methodologies and their data transfer rates.

If you can find content such as sound effects, music, graphic art, clip animations, and video to use in your project, you may not need extra tools for making your own. Typically, however, multimedia developers have separate equipment for digitizing sound from tapes or microphone, for scanning photographs or other printed matter, and for making digital still or movie images.

| Connection | Transfer Rate |
|---------------------------|-----------------------|
| Serial port | 115 Kbps (0.115 Mbps) |
| Standard parallel port | 115 Kbps (0.115 Mbps) |
| USB (Original 1.0) | 12 Mbps (1.5 Mbps) |
| SCSI-2 (Fast SCSI) | 80 Mbps |
| SCSI (Wide SCSI) | 160 Mbps |
| Ultra2 SCSI | 320 Mbps |
| FireWire 400 (IEEE 1394) | 400 Mbps |
| USB (Hi-Speed 2.0) | 480 Mbps |
| SCSI (Wide Ultra2) | 640 Mbps |
| FireWire 800 (IEEE 1394) | 800 Mbps |
| SCSI (Wide Ultra3) | 1,280 Mbps |
| SATA 150 | 1,500 Mbps |
| SCSI (Ultra4) | 2,560 Mbps |
| SATA 300 | 3,000 Mbps |
| FireWire 3200 (IEEE 1394) | 3,144 Mbps |
| USB (Super-Speed 3.0) | 3,200 Mbps |
| SCSI (Ultra5) | 5,120 Mbps |
| SATA 600 | 6,000 Mbps |
| Fibre Channel (Optic) | 10,520 Mbps |

Table 7-2 Maximum Transfer Rates for Various Connections in Megabits Per Second

SCSI

The **Small Computer System Interface (SCSI)**—pronounced “scuzzy”—adds peripheral equipment such as disk drives, scanners, CD-ROM players, and other peripheral devices that conform to the SCSI standard. SCSI connections may connect *internal* devices such as hard drives that are inside the chassis of your computer and use the computer’s power supply, and *external* devices, which are outside the chassis, use their own power supply, and are plugged into the computer by cable.

The hardware and the drivers for SCSI have improved over the years to provide faster data transfers across wider buses. Unlike the less-expensive IDE scheme described next, a SCSI controller does not demand CPU time, and because it can support many devices, it is often preferred for real-time video editing, network servers, and situations in which writing simultaneously to two or more disks (**mirroring**) is required.

Vaughan’s One-Way Rule

Once you’ve tried it, you can’t go back.

Years ago, a few weeks after HyperCard was released by Apple, I went to work there, designing and building the guided tour for an information management tool used in-house by Apple. I said I didn’t know the software, but they said that’s okay, nobody else does, either. They gave me a cubicle with my name on it, a Macintosh Plus with a 20MB hard disk, and I was up and running. The Macintosh II had been shipping for a short while, and every department at Apple was attempting to get this latest and hottest color-enabled CPU—but most units were going to the retail channel. There were three Macintosh IIs among about 40 of us.

One afternoon, I sat at a Macintosh II and ran my software. I couldn’t believe it! The screen-to-screen dissolves and special effects I had carefully programmed on the old computer went by so fast I couldn’t see them. I had to reprogram everything, with a special test to check for CPU speed. If it was a fast machine, I programmed the visual effects to run slower; on a slow machine, faster. But the sad part was that I not only wanted this faster machine, I felt I *needed* it! I had the same experience moving from a dial-up modem to a DSL broadband Internet connection, and knew I’d never go back.

If the label on the cable on the table at your house says you hook up the camera simple as a mouse, but the packets burn a pocket on a socket on the port, then get your receipt and call them to abort.

.....
Tay Vaughan

IDE, EIDE, Ultra IDE, ATA, and Ultra ATA

Integrated Drive Electronics (IDE) connections, also known as **Advanced Technology Attachment (ATA)** connections, are typically only internal, and they connect hard disks, CD-ROM drives, and other peripherals mounted inside the PC. With IDE controllers, you can install a combination of hard disks, CD-ROM drives, or other devices in your PC. The circuitry for IDE is typically much less expensive than for SCSI, but comes with some limitations. For example, IDE requires time from the main processor chip, so only one drive in a master/slave pair can be active at once.

USB

A consortium of industry players including Compaq, Digital Equipment, IBM, Intel, Microsoft, NEC, and Northern Telecom was formed in 1995

to promote a **Universal Serial Bus (USB)** standard for connecting devices to a computer. These devices are automatically recognized (“**plug-and-play**”) and installed without users needing to install special cards or turn the computer off and on when making the connection (allowing “**hot-swapping**”). USB technology has improved in performance since its introduction (see Table 7-2) and has become the connection method of choice for many peripheral devices, from cameras to keyboards to scanners and printers. USB uses a single cable to connect as many as 127 USB peripherals to a single personal computer. Hubs can be used to “daisy-chain” many devices. USB connections are now common on video game consoles, cameras, GPS locators, cell phones, televisions, MP3 players, PDAs, and portable memory devices.

FireWire and i.LINK (IEEE 1394)

FireWire was introduced by Apple in the late 1980s, and in 1995 it became an industry standard (IEEE 1394) supporting high-bandwidth serial data transfer, particularly for digital video and mass storage. Like USB, the standard supports hot-swapping and plug-and-play, but it is faster, and while USB devices can only be attached to one computer at a time, FireWire can connect multiple computers and peripheral devices (peer-to-peer). Both the Mac OS and Windows offer IEEE 1394 support. Because the standard has been endorsed by the Electronics Industries Association and the Advanced Television Systems Committee (ATSC), it has become a common method for connecting and interconnecting professional digital video gear, from cameras to recorders and edit suites. Sony calls this standard i.LINK. FireWire has replaced Parallel SCSI in many applications because it’s cheaper and because it has a simpler, adaptive cabling system.

Memory and Storage Devices

As you add more memory and storage space to your computer, you can expect your computing needs and habits to keep pace, filling the new capacity. So enjoy the weeks that follow a memory storage upgrade or the addition of a gigabyte hard disk; the honeymoon will eventually end.

To estimate the memory requirements of a multimedia project—the space required on a hard disk, thumb drive, CD-ROM, or DVD, not the **random access memory (RAM)** used while your computer is running—you must have a sense of the project’s content and scope. Color images, text, sound bites, video clips, and the programming code that glues it all together require memory; if there are many of these elements, you will need even more. If you are *making* multimedia, you will also need to allocate memory for storing and archiving working files used during production, original audio and video clips, edited pieces, and final mixed pieces,

production paperwork and correspondence, and at least one backup of your project files, with a second backup stored at another location.

It is said that when John von Neumann, often called “the father of the computer,” was designing the ENIAC computer in 1945, there was an argument about how much memory this first computer should have. His colleagues appealed for more than the 2K Dr. von Neumann felt was sufficient. In the end, he capitulated and agreed to install 4K in the ENIAC, commenting “...but this is more memory than you will ever need.”

Random Access Memory (RAM)

If you are faced with budget constraints, you can certainly produce a multimedia project on a slower or limited-memory computer. On the other hand, it is profoundly frustrating to face memory (RAM) shortages time after time, when you’re attempting to keep multiple applications and files open simultaneously. It is also frustrating to wait the extra seconds required of each editing step when working with multimedia material on a slow processor.

In spite of all the marketing hype about processor speed, this speed is ineffective if not accompanied by sufficient RAM. A fast processor without enough RAM may waste processor cycles while it swaps needed portions of program code into and out of memory. In some cases, increasing available RAM may show more performance improvement on your system than upgrading the processor chip.

Read-Only Memory (ROM)

Unlike RAM, **read-only memory (ROM)** is not *volatile*. When you turn off the power to a ROM chip, it will not forget, or lose its memory. ROM is typically used in computers to hold the small BIOS program that initially boots up the computer, and it is used in printers to hold built-in fonts. **Programmable ROMs** (called **EPROMs**) allow changes to be made that are not forgotten when power is turned off.

Hard Disks

Adequate storage space for your production environment can be provided by large-capacity hard disks, server-mounted on a network. As multimedia has reached consumer desktops, makers of hard disks have built smaller-profile, larger-capacity, faster, and less-expensive hard disks. As network and Internet servers drive the demand for centralized data storage requiring **terabytes** (one trillion bytes), hard disks are often configured into fail-proof redundant arrays offering built-in protection against crashes.

Flash Memory or Thumb Drives

These flash memory data storage devices are about the size of a thin cigarette lighter and can be integrated with USB or FireWire interfaces to store from eight megabytes to several GB of data. They are available in every color of the rainbow, are extremely portable, and, because they have fewer moving parts, are more reliable than disk drives. Consisting of a small printed circuit board encased in a sturdy metal or plastic casing with a USB connector covered with a cap, the flash drive is trendy as a status symbol, and convenient to use. This same solid-state storage is used in digital cameras, cell phones, and audio recording devices, and for solid-state hard drives (no spinning platters or moving parts) that are found in some netbooks and other handheld devices.

CD-ROM Discs

Compact disc read-only memory (CD-ROM) players have become an integral part of the multimedia development workstation and are an important delivery vehicle for mass-produced projects. A wide variety of developer utilities, graphic backgrounds, stock photography and sounds, applications, games, reference texts, and educational software are available on this medium. CD-ROM players have typically been very slow to access and transmit data (150 KBps, which is the speed required of consumer Audio CDs), but developments have led to double-, triple-, quadruple-speed, 24x, 48x, and 56x drives designed specifically for computer (not Red Book Audio) use. These faster drives spool up like washing machines on the spin cycle and can be somewhat noisy, especially if the inserted compact disc is not evenly balanced. With a compact disc recorder, you can make your own CDs, using CD-recordable (CD-R) blank discs to create a CD in most formats of CD-ROM and CD-Audio (see Chapter 4). Software, such as Roxio's Toast and Easy CD Creator, lets you organize files on your hard disk(s) into a "virtual" structure, and then writes them to the CD in that order. CD-R discs are manufactured differently than normal CDs but can play in any CD-Audio or CD-ROM player. These write-once, enhanced CDs make excellent high-capacity file archives and are used extensively by multimedia developers for pre-mastering and testing CD-ROM projects and titles. Because they have become very inexpensive, they are also used for short-run distribution of finished multimedia projects and data backup. A CD-RW (read and write) recorder can rewrite 700MB of data to a CD-RW disc about 1,000 times.

Digital Versatile Discs (DVD)

In December 1995, nine major electronics companies (Toshiba, Matsushita, Sony, Philips, Time Warner, Pioneer, JVC, Hitachi, and Mitsubishi

Electric) agreed to promote a new optical disc technology for distribution of multimedia and feature-length movies called **Digital Versatile Disc (DVD)** (see Table 7-3). With a DVD capable not only of gigabyte storage capacity but also full-motion video (MPEG2) and high-quality audio in surround sound, this is an excellent medium for delivery of multimedia projects. Commercial multimedia projects will become more expensive to produce, however, as consumers' performance expectations rise. There are three types of DVD, including DVD-Read Write, **DVD-Video**, and **DVD-ROM**. These types reflect marketing channels, not the technology.

Blu-ray Discs

Driven by the implementation of **High Definition TV (HDTV)** and by the motion picture industry, a new technology was needed to increase storage capacity and throughput beyond DVD. Two competing and incompatible solutions were promoted and a war was fought in the marketplace between HD-DVD, backed by Toshiba, and **Blu-ray**, backed by Sony. By 2008, Toshiba had sold about one million HD-DVD players, but Sony had sold close to ten million Blu-ray players, which were also included in popular PlayStation game machines. Toshiba announced it was quitting.

Blu-ray is promoted not only for high definition television recording and high definition video distribution, but also for high definition camcorder archiving, mass data storage, and digital asset management and professional storage when used as a recording medium in BD-R format.

| DVD Feature | DVD Specification | Blu-ray Specification |
|----------------------------|--|--|
| Disc diameter | 120 mm (5 inches) | 120 mm (5 inches) |
| Disc thickness | 1.2 mm (0.6 mm thick disc × 2) | 1.2 mm (0.6 mm thick disc × 2) |
| Memory capacity | 4.7 gigabytes/single side | 25 gigabytes/single layer |
| Wave length of laser diode | 650 nanometer/635 nanometer (red) | 405 nanometer (blue-violet) |
| Data transfer rate 1x | Variable speed data transfer at an average rate of 4.69 Mbps for image and sound | Variable speed data transfer at an average rate of 36 Mbps for image and sound |
| Image compression | MPEG2 digital image compression | MPEG-2 Part 2, H.264/MPEG-4 AVC, and SMPTE VC-1 |
| Audio | Dolby AC-3 (5.1 ch), LPCM for NTSC and MPEG Audio, LPCM for PAL/SECAM (a maximum of 8 audio channels and 32 subtitle channels can be stored) | Dolby Digital (AC-3), DTS, and linear PCM |
| Running time (movies) | Single Layer (4.7GB): 133 minutes a side (at an average data rate of 4.69 Mbps for image and sound, including three audio channels and four subtitle channels) | Single Layer (25GB): Encoded using MPEG-2 video, about two hours of HD content; using VC-1 or MPEG-4 AVC codecs, about 4 hours of HD quality video and audio |

Table 7-3 DVD and Blu-ray Specifications

Input Devices

A great variety of input devices—from the familiar keyboard and handy mouse to touchscreens and voice recognition setups—can be used for the development and delivery of a multimedia project. If you are designing your project for a public kiosk, use a touchscreen. If your project is for a lecturing professor who likes to wander about the classroom, use a remote handheld mouse. If you create a great deal of original computer-rendered art, consider a pressure-sensitive stylus and a drawing tablet. Scanners enable you to use **optical character recognition (OCR)** software, such as OmniPage from ScanSoft, a division of Nuance Communications (see Figure 7-1), or Recore from Maxsoft-Ocron. With OCR software and a scanner, you can convert paper documents into a word processing document on your computer without retyping or rekeying.

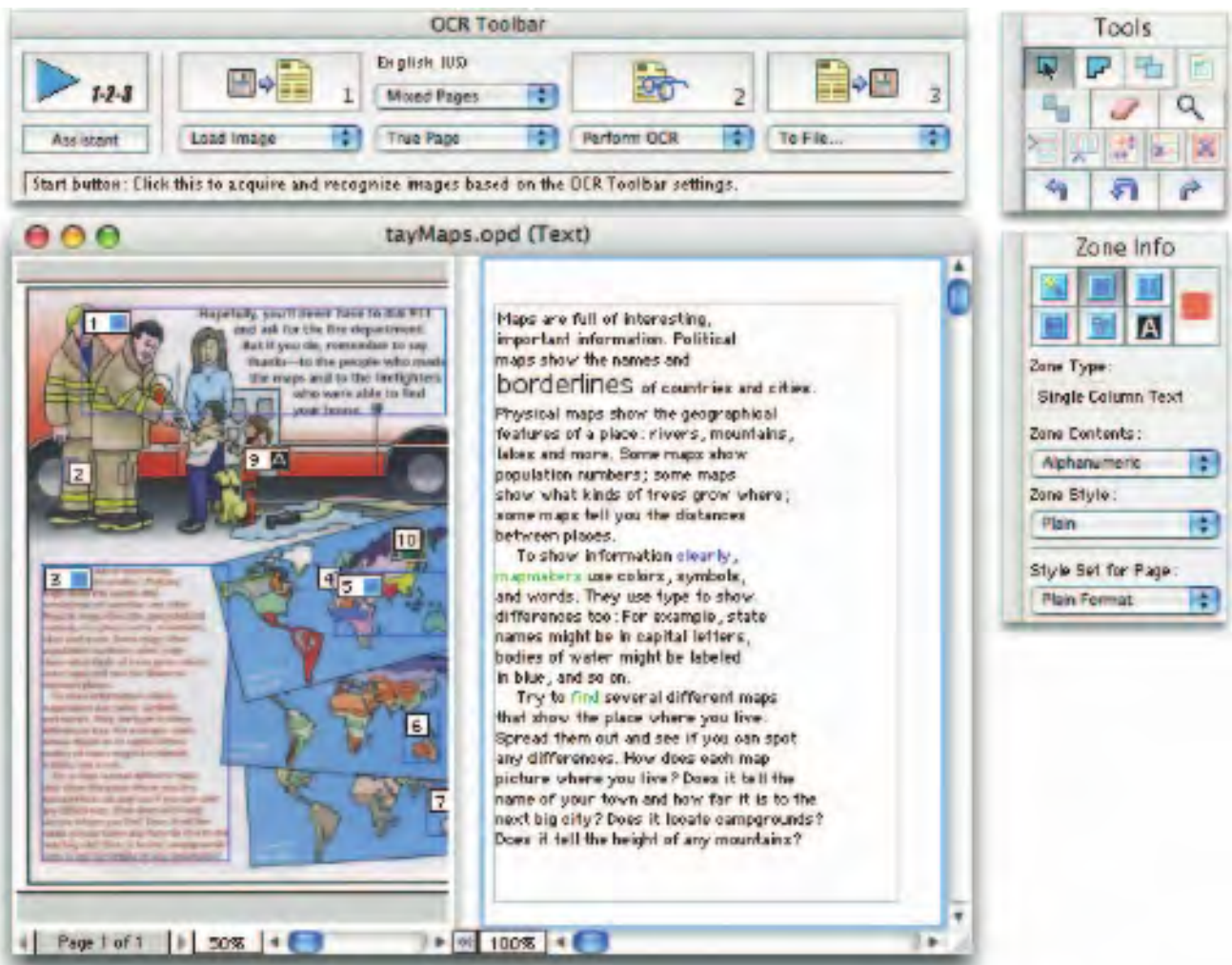

Figure 7-1 Working with a scanner, OCR software can save many hours of rekeying text.

Barcode readers are probably the most familiar optical character recognition devices in use today—mostly at markets, shops, and other point-of-purchase locations. Using photo cells and laser beams, barcode readers recognize the numeric characters of the **Universal Product Code** (UPC) that are printed in a pattern of parallel black bars on merchandise labels. With OCR, or **barcoding**, retailers can efficiently process goods in and out of their stores and maintain better inventory control.

An OCR terminal can be of use to a multimedia developer because it recognizes not only printed characters but also handwriting. This facility may be beneficial at a kiosk or in a general education environment where user friendliness is a goal, because there is growing demand for a more personal and less technical interface to data and information.

For hands-free interaction with your project, try **voice recognition systems**. These behavioral biometric systems usually provide a unidirectional cardioid, noise-canceling microphone that automatically filters out background noise and learns to recognize voiceprints. Most voice recognition systems currently available can trigger common menu events such as Save, Open, Quit, and Print, and you can teach the system to recognize other commands that are more specific to your application. Systems available for the Macintosh and Windows environments typically must be taught to recognize individual voices and then be programmed with the appropriate responses to the recognized word or phrase. Dragon's Naturally Speaking takes dictation, translates text to speech, and does command-to-click, a serious aid for people unable to use their hands.

The quality of your audio recordings is greatly affected by the caliber of your microphone and cables. A unidirectional microphone helps filter out external noise, and good cables help reduce noise emitted from surrounding electronic equipment.

Digital cameras use the same CCD technology as video cameras, described in Chapter 6. They capture still images of a given number of pixels (resolution), and the images are stored in the camera's memory to be uploaded later to a computer. The resolution of a digital camera is determined by the number of pixels on the CCD chip, and the higher the megapixel rating, the higher the resolution of the camera. Images are uploaded from the camera's memory using a serial, parallel, or USB cable, or, alternatively, the camera's memory card is inserted into a PCMCIA reader connected to the computer. Digital cameras are small enough to fit in a cell phone, and in a more complicated manner they can be used in a television studio or spy camera on an orbiting spacecraft.

Output Devices

Presentation of the audio and visual components of your multimedia project requires hardware that may or may not be included with the computer

itself, such as speakers, amplifiers, projectors, and motion video devices. It goes without saying that the better the equipment is, of course, the better the presentation. There is no greater test of the benefits of good output hardware than to feed the audio output of your computer into an external amplifier system: suddenly the bass sounds become deeper and richer, and even music sampled at low quality may sound acceptable.

TIP *Design your project to use many shorter-duration audio files rather than one long file. This simplifies the redaction of your project within your authoring system, and it may also improve performance because you will load shorter segments of sound into RAM at any one time.*

Often the speakers you use during a project's development will not be adequate for its presentation. Speakers with built-in amplifiers or attached to an external amplifier are important when your project will be presented to a large audience or in a noisy setting.

WARNING *Always use magnetically shielded speakers to prevent color distortion or damage to nearby CRT monitors.*

The monitor you need for development of multimedia projects depends on the type of multimedia application you are creating, as well as what computer you're using. A wide variety of monitors is available for both Macintoshes and PCs. High-end, large-screen graphics monitors and LCD panels are available for both, and they are expensive.

Serious multimedia developers will often attach more than one monitor to their computers because they can work with several open windows at a time. For example, you can dedicate one monitor to viewing the work you are creating or designing, and you can perform various editing tasks in windows on other monitors that do not block the view of your work.

No other contemporary message medium has the visual impact of video, but keep in mind that while good video greatly enhances your project, poor video will ruin it.

When you need to show your material to more viewers than can huddle around a computer monitor, you will need to project it onto a large screen or even a white-painted wall. **Cathode-ray tube (CRT)** projectors, liquid crystal display (LCD) panels, Digital Light Processing (DLP) projectors, and liquid crystal on silicon (LCOS) projectors, as well as (for larger projects) Grating-Light-Valve (GLV) technologies, are available. CRT projectors have been around for quite a while—they are the original “big-screen” televisions and use three separate projection tubes and lenses (red, green, and blue). The three color channels of light must “converge” accurately on the screen. Setup, focusing, and alignment are important for getting a clear

and crisp picture. CRT projectors are compatible with the output of most computers as well as televisions.

Graphic print designers often use special color-correction hardware to ensure that what they see on screen matches precisely what will be printed. Multimedia does not usually require the same level of precision—mostly because the multimedia will likely be presented on any number of monitors with widely varying color settings.

Hard-copy printed output has also entered the multimedia scene. From storyboards to presentations to production of collateral marketing material, printouts are an important part of the multimedia development environment. Color helps clarify concepts, improve understanding and retention of information, and organize complex data. As multimedia designers already know, intelligent use of color is critical to the success of a project.

What You Need: Software

Multimedia software tells the hardware what to do. Display the color red. Move that tiger three leaps to the left. Slide in the words “Now You’ve Done It!” from the right and blink them on and off. Play the sound of cymbals crashing. Run the digitized trailer for *Avatar*. Turn down the volume on that MP3 file!

The basic tool set for building multimedia projects contains one or more authoring systems and various editing applications for text, images, sounds, and motion video. A few additional applications are also useful for capturing images from the screen, translating file formats, and moving files among computers when you are part of a team—these are tools for the

Vaughan’s Rule for Keeping Up

Upgrade to proven products that lie in the calm water, slightly behind the leading edge of the wave.

housekeeping tasks that make your creative and production life easier.

The software in your multimedia toolkit—and your skill at using it—determines what kind of multimedia work you can do and how fine and fancy you can render it. Making good multimedia means picking a successful route through the software swamp. Alligators and learning curves can rise up out of this swamp to nip you in the knees.

You don’t have to be a programmer or a computer scientist to make multimedia work for you, but you do need some familiarity with terms and building blocks; as even the simplest multimedia tools require a modicum of knowledge to operate. If someone asks to borrow a metric 13 mm wrench,

you should know they are probably working with a nut or a bolt (and if you are an expert, you might know that a 1/2-inch wrench can usually be substituted). If someone sends you a file in Macintosh AIF format, you should know that you're getting *digitized* sound. Don't be afraid of the little things that so easily depress the uninformed. From plumbing to nuclear physics, learning is a matter of time and practice. You will be frustrated as you work your way up the learning curves of multimedia. There will be things you want to do, but you will not know how to work the tools. Take the time to learn the fundamentals of computers and multimedia taught in this book. Then, load up your tools and open the help files; your learning curve will be easier to manage because you have the bigger picture.

First Person

After getting my pilot's license for flying small, single-engine airplanes, I traveled from San Francisco to New York on a Boeing 747. Looking out the window at those perfectly circular irrigated farms in Nebraska and Iowa, my lazy thoughts drifted from corn to water to Chevys on levies to girls to football to rope swings splashing into sun-drenched rivers.

There was a small airport below. Would that make a good emergency field for a dead-stick Cessna? Mmmmm, I drifted. What if *this* plane had an emergency?

Mmmmm. What if the crew had been poisoned and we were on autopilot, and a flight attendant had just interrupted the movie to ask if there were a pilot on board? Mmmmm. I knew that if I had to sit in the pilot's seat of that 747

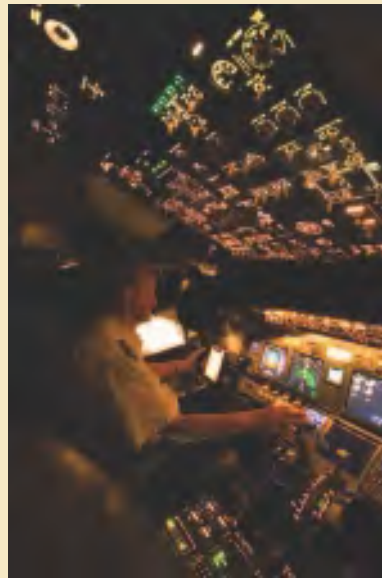

I wouldn't have a clue, and the plane would go down. Thousands of switches, glass screens, levers, pedals, blinking lights, and somewhere a radio, all waiting for me to do something with them. Hollywood's

version of this scenario, with the "tower" talking us down, would never work because I couldn't even turn on the radio.

It's like that when you learn multimedia. The same sinking feeling, frustration, and not knowing. But, because you have this book in hand, you're already in the pilot's seat and are on the way toward a successful landing. Relax. Step-by-step it will get easier. Manuals, online help systems, and instructors are your tower, and you have plenty of fuel. In the same way tens of thousands of pilots have learned to fly, you will learn to make multimedia!

(Photo by Pete McGill, who not only learned to fly heavies, but learned to make multimedia and shoots with a Canon 400D.)

TIP As you explore the workings of multimedia, you should know that web addresses are not guaranteed to be permanent but can abruptly disappear, just like the addresses for physical locations when the house burns down or floats away in a flood.

Microsoft.com, walmart.com, mcdonalds.com, and visa.com, however, represent such monoliths of business that it seems unlikely that they will float away, at least soon, in the river of time. If, when trying to connect to a URL, you receive a “404 – not found” error message, try stripping away the directories and subdirectories and filenames from the URL and then connect to the domain name itself. If you can connect to the domain name, you may find a menu that will then take you to the relocated document from another direction. If, for example, you are looking for a list of tools useful to web service providers at www.w3.org/hypertext/www/tools/ and the document is not there, try to connect to www.w3.org/, and then follow the hypertext menus provided. If none of these efforts brings you to your destination, you can try one of the search engines listed in Chapter 12.

Keep your tools sharp by upgrading them when new software and features become available, by thoroughly studying and learning each tool, by keeping an eye on the conversations and **FAQ (Frequently Asked Questions)** files online and in Internet blogs, and by observing the practices and products of other multimedia developers. Remember, each new tool has a learning curve.

TIP Always fill out the registration card for your new software and return it to the vendor, or register online. If the vendor pays attention to product marketing, you will frequently receive upgrade offers, special newsletters, and e-mails with helpful information.

The tools used for creating and editing multimedia elements on both Windows and Macintosh platforms do image processing and editing, drawing and illustration, 3-D and CAD, OCR and text editing, sound recording and editing, video and moviemaking, and various utilitarian housekeeping tasks.

Text Editing and Word Processing Tools

A **word processor** is usually the first software tool computer users learn. From letters, invoices, and storyboards to project content, your word processor may also be your most often used tool, as you design and build a multimedia project. The better your **keyboarding** or typing skills, the easier and more efficient your multimedia day-to-day life will be.

Typically, an office or workgroup will choose a single word processor to share documents in a standard format. And most often, that word processor comes bundled in an **office suite** that might include spreadsheet, database, e-mail, web browser, and presentation applications.

First Person

When I left graduate school, I joined the Carpenters Union and worked on highway bridges, apartment houses, and fine custom homes. The wholesale tool supply store that catered to the trade had one wall covered with more than a hundred different hammers—some for nailing big nails, some for tiny upholstery tacks, some for metal work, others with a hatchet on one side for shingles, or with a waffled striking head that would drive slick and wet nails under the roughest conditions. They all came in different weights

and handle lengths and shapes. I tested a few framing hammers and chose a 24-ounce waffle-head framing hammer that felt good. With it, I could drive big 16d nails in a single stroke. It had a wicked curved handle. It was a Vaughan hammer.

Next day at noon, the job boss took me aside and quietly told me that he limited hammer weight to 22 ounces, because the older guys on the crew couldn't keep up. My hammer was illegal, and if he saw it the next day, I'd be sent back to

the hiring hall. "Sorry," I said, "jeez, I didn't know." He let me leave early so I could get to the tool store before it closed.

In producing multimedia, no tool is illegal. You should use the best tools that fit your talent, needs, and budget.



Word processors such as Microsoft Word and WordPerfect are powerful applications that include spell checkers, table formatters, thesauruses, and prebuilt templates for letters, résumés, purchase orders, and other common documents.

Many developers have begun to use OpenOffice (www.openoffice.org) for word processing, spreadsheets, presentations, graphics, databases, and more. It can be downloaded and used completely free of charge for any purpose and is available in many languages. It can read and write files from other, more expensive, office packages. In many word processors, you can embed multimedia elements such as sounds, images, and video. Luckily, the population of single-finger typists is decreasing over time as children are taught keyboarding skills in conjunction with computer lab programs in their schools.

OCR Software

Often you will have printed matter and other text to incorporate into your project, but no electronic text file. With OCR software, a flatbed scanner, and your computer, you can save many hours of rekeying printed words, and get the job done faster and more accurately than a roomful of typists.

OCR software turns bitmapped characters into electronically recognizable ASCII text. A scanner is typically used to create the bitmap. Then the software breaks the bitmap into chunks according to whether



it contains text or graphics, by examining the texture and density of areas of the bitmap and by detecting edges. The text areas of the image are then converted to ASCII characters using probability and expert system algorithms. Most OCR applications claim about 99 percent accuracy when reading 8- to 36-point printed characters at 300 dpi and can reach processing speeds of about 150 characters per second. These programs do, however, have difficulty recognizing poor copies of originals where the edges of characters have bled; these and poorly received faxes in small print may yield more recognition errors than it is worthwhile to correct after the attempted recognition.

Painting and Drawing Tools

Painting and drawing tools, as well as 3-D modelers, are perhaps the most important items in your toolkit because, of all the multimedia elements, the graphical impact of your project will likely have the greatest influence on the end user. If your artwork is amateurish, or flat and uninteresting, both you and your users will be disappointed. Look in Chapters 10 and 13 for tips on designing effective graphical screens and in Chapter 3 for more about computer graphics.

Painting software, such as Photoshop, Fireworks, and Painter, is dedicated to producing crafted bitmap images. **Drawing software**, such as CorelDraw, FreeHand, Illustrator, Designer, and Canvas, is dedicated to producing vector-based line art easily printed to paper at high resolution.

Some software applications combine drawing and painting capabilities, but many authoring systems can import only bitmapped images. The differences between painting and drawing (that is, between bitmapped and drawn images) are described in Chapter 3. Typically, bitmapped images provide the greatest choice and power to the artist for rendering fine detail and effects, and today bitmaps are used in multimedia more often than drawn objects. Some vector-based packages such as Macromedia's Flash are aimed at reducing file download times on the Web and may contain both bitmaps and drawn art.

Look for these features in a drawing or painting package:

- An intuitive graphical user interface with pull-down menus, status bars, palette control, and dialog boxes for quick, logical selection
- Scalable dimensions, so that you can resize, stretch, and distort both large and small bitmaps
- Paint tools to create geometric shapes, from squares to circles and from curves to complex polygons
- The ability to pour a color, pattern, or gradient into any area
- The ability to paint with patterns and clip art
- Customizable pen and brush shapes and sizes
- An eyedropper tool that samples colors

- An autotrace tool that turns bitmap shapes into vector-based outlines
- Support for scalable text fonts and drop shadows
- Multiple undo capabilities, to let you try again
- A history function for redoing effects, drawings, and text
- A property inspector
- A screen capture facility
- Painting features such as smoothing coarse-edged objects into the background with anti-aliasing (see illustration); airbrushing in variable sizes, shapes, densities, and patterns; washing colors in gradients; blending; and masking.
- Support for third-party special-effect plug-ins
- Object and layering capabilities that allow you to treat separate elements independently
- Zooming, for magnified pixel editing
- All common color depths: 1-, 4-, 8-, and 16-, 24-, or 32-bit color, and gray-scale
- Good color management and dithering capability among color depths using various color models such as RGB, HSB, and CMYK
- Good palette management when in 8-bit mode
- Good file importing and exporting capability for image formats such as PIC, GIF, TGA, TIF, PNG, WMF, JPG, PCX, EPS, PTN, and BMP



If you are new to multimedia and to these tools, you should take time to examine more than one graphics software package. Find someone who is already familiar with graphics applications. You will spend many days learning to use your painting and drawing software, and if it does not fit you and your needs, you will be unhappy. Many artists learn to use a single, powerful tool well.

First Person

Years ago, I founded an accredited maritime school at Pier 66 in San Francisco, where we offered courses in everything from high-tech composite plastics and welding to Rules of the Road and celestial navigation. We also ran several marine trade certification programs. When I talked with Ford, General Motors,

Cummins, and Caterpillar about setting up a course for marine diesel mechanics, I was surprised at their competitive interest in supporting the program. It turned out that a widely publicized survey had shown that a mechanic trained to work on a particular brand of engine would stick with it for life, loyally

recommending and supporting that brand.

The same holds true for software. By the time you master an application, you have spent many hours on its learning curve. You will likely stay with that product and its upgrade path rather than change to another.

3-D Modeling and Animation Tools

3-D modeling software has increasingly entered the mainstream of graphic design as its ease of use improves. As a result, the graphic production values and expectations for multimedia projects have risen.

3-D is an abbreviation for “three dimensions.” While in a 2-D graphics program, images are painted in the “x” (horizontal or width) and “y” (vertical or height) axes, in 3-D depth is labeled as the “z” axis. Every program that layers objects on the screen must know each object’s “z” axis. Web browsers, for example, place objects on the screen using the CSS “z-index” attribute. Some software programs (such as Flash CS4 and ToonBoom Studio) can simulate depth by automatically scaling images based on a z-axis value to create a cartoonish or simulated 3-D effect. This differs from true 3-D modeling and rendering, where objects can be rotated and viewed from any direction or angle.

With 3-D modeling software, objects rendered in perspective appear more realistic; you can create stunning scenes and wander through them, choosing just the right lighting and perspective for your final rendered image. Powerful modeling packages such as VectorWorks (see Figure 7-2), AutoDesk’s Maya, Strata 3D, and Avid’s SoftImage are also bundled with assortments of prerendered 3-D clip art objects such as people, furniture, buildings, cars, airplanes, trees, and plants. Blender is a powerful (and free) cross-platform 3-D modeling program offering an extensive feature set. Google SketchUp is a free 3-D modeling program with limited capabilities, but with a large online library of components. Important for multimedia development, many 3-D modeling applications include export facilities for creating and saving a moving view or journey through a scene as a QuickTime or MPEG file.

Each rendered 3-D image takes from a few seconds to a few hours to complete, depending upon the complexity of the drawing and the number of drawn objects included in it. If you are making a complex walkthrough or flyby, plan to set aside many hours of rendering time on your computer.

TIP *If there are small errors or things you would like to change in a rendered movie sequence, it may take less time to edit each frame of the affected sequence by hand, using an image-editing program, rather than re-rendering the corrected original.*

A good 3-D modeling tool should include the following features:

- Multiple windows that allow you to view your model in each dimension, from the camera’s perspective, and in a rendered preview
- The ability to drag and drop primitive shapes into a scene
- The ability to create and sculpt organic objects from scratch
- Lathe and extrude features

- Color and texture mapping
- The ability to add realistic effects such as transparency, shadowing, and fog
- The ability to add spot, local, and global lights, to place them anywhere, and manipulate them for special lighting effects
- Unlimited cameras with focal length control
- The ability to draw spline-based paths for animation

WARNING *3-D imaging programs require speedy computers with lots of memory, and the learning curve is steep when you enter this world of nurbs, splines, and bump maps.*

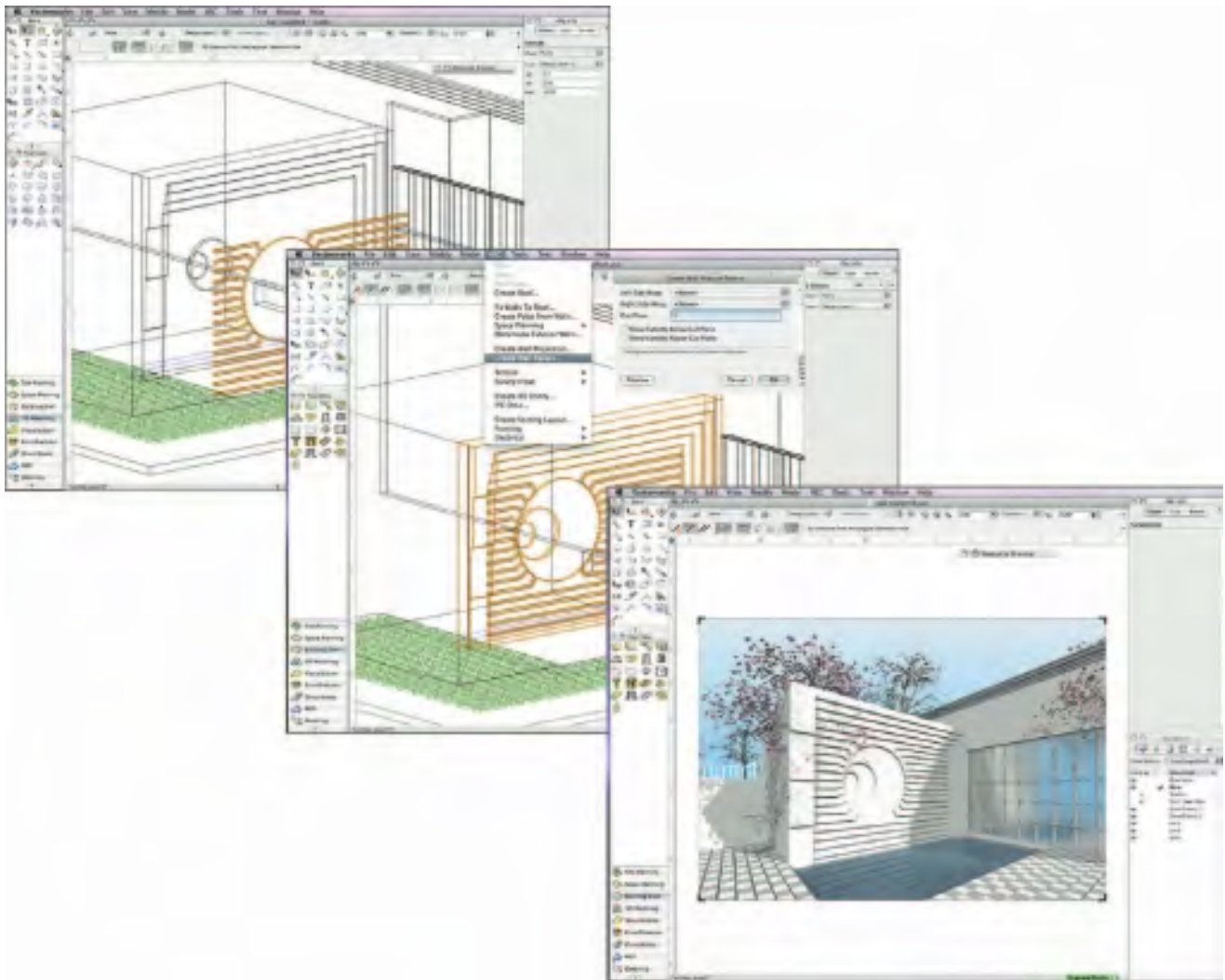

Figure 7-2 VectorWorks and other CAD applications can translate precise 2-D drawings into 3-D perspectives with lighting and shadows, but they can be complicated and very difficult to learn.

Image-Editing Tools

Image-editing applications are specialized and powerful tools for creating, enhancing, and retouching existing bitmapped images. These applications also provide many of the features and tools of painting and drawing programs and can be used to create images from scratch as well as images digitized from scanners, video frame-grabbers, digital cameras, clip art files, or original artwork files created with a painting or drawing package.

TIP *If you want to print an image to a 300 dpi printer for collateral reports and attractive print-matter icons, work with the image in the image-editing application at 300 dpi (every pixel will be a very fine laser printer dot). Then, save your work as a tiff or bmp file and import it into your word processor. The printed result is a finely detailed image at a high resolution.*

Here are some features typical of image-editing applications and of interest to multimedia developers:

- Multiple windows that provide views of more than one image at a time
- Conversion of major image-data types and industry-standard file formats
- Direct inputs of images from scanner and video sources
- Employment of a virtual memory scheme that uses hard disk space as RAM for images that require large amounts of memory
- Capable selection tools, such as rectangles, lassos, and magic wands, for selecting portions of a bitmap
- Image and balance controls for brightness, contrast, and color balance
- Good masking features
- Multiple undo and restore features
- Anti-aliasing capability, and sharpening and smoothing controls
- Color-mapping controls for precise adjustment of color balance
- Tools for retouching, blurring, sharpening, lightening, darkening, smudging, and tinting
- Geometric transformations such as flip, skew, rotate, and distort, and perspective changes
- The ability to resample and resize an image
- 24-bit color, 8- or 4-bit indexed color, 8-bit gray-scale, black-and-white, and customizable color palettes
- The ability to create images from scratch, using line, rectangle, square, circle, ellipse, polygon, airbrush, paintbrush, pencil, and eraser tools,

with customizable brush shapes and user-definable bucket and gradient fills

- Multiple typefaces, styles, and sizes, and type manipulation and masking routines
- **Filters** for special effects, such as crystallize, dry brush, emboss, facet, fresco, graphic pen, mosaic, pixelize, poster, ripple, smooth, splatter, stucco, swirl, watercolor, wave, and wind
- Support for third-party special-effect plug-ins
- The ability to design in layers that can be combined, hidden, and reordered

Sound-Editing Tools

Sound-editing tools for both digitized and MIDI sound let you see music as well as hear it. By drawing a representation of a sound in fine increments, whether a score or a waveform, you can cut, copy, paste, and otherwise edit segments of it with great precision—something impossible to do in real time (that is, with the music playing). The basics of computerized sound are discussed in Chapter 4.

Animation, Video, and Digital Movie Tools

Animations and digital video movies are sequences of bitmapped graphic scenes (**frames**), rapidly played back. But animations can also be made within the authoring system by rapidly changing the location of objects, or **sprites**, to generate an appearance of motion. Most authoring tools adopt either a frame- or object-oriented approach to animation, but rarely both.

To make movies from video, you may need special hardware to convert an analog video signal to digital data. Macs and PCs with FireWire (IEEE 1394) or USB ports can import digital video directly from digital camcorders. Moviemaking tools such as Premiere, Final Cut Pro, VideoShop, and MediaStudio Pro let you edit and assemble video clips captured from camera, tape, other digitized movie segments, animations, scanned images, and from digitized audio or MIDI files. The completed clip, often with added transition and visual effects, can then be played back—either stand-alone or windowed within your project.

WARNING *Digital video editing and playback requires an immense amount of free disk space, even when the video files are compressed.*

TIP Because digital movie data must stream rapidly and without interruption from your disk drive, be sure that you defragment and optimize your disk with a utility such as Norton's speed disk before recording and playing back your movie files. If your movie file is fragmented, the read head of the disk drive may need to pause sending data while it physically moves to wildly different locations on the disk; a defragmented file lets the head read sequentially from one adjoining sector to the next. Use disk optimizing utilities with caution, however: accidents have been known to happen, causing permanent data loss.

Helpful Accessories

No multimedia toolkit is complete without a few indispensable utilities for performing some odd, but oft-repeated, tasks. These are the comfortable and well-worn accessories that make your computer life easier.

On both the Macintosh and in Windows, a screen-grabber is essential. Because bitmapped images are so common in multimedia, it is important to have a tool for grabbing all or part of the screen display so that you can import it into your authoring system or copy it into an image-editing application for custom work. Screen-grabbing to the clipboard, for example, lets you move a bitmapped image from one application to another without the cumbersome steps of first exporting the image to a file and then importing it back into the destination application. In Windows, press the `PRINT SCREEN` key to place the contents of your screen onto the clipboard. On a Macintosh, press the `COMMAND` key, the `CONTROL` key, the `SHIFT` key, and the number 4 all at the same time, and then drag a rectangle across the screen. Whatever is in the rectangle is then placed on the clipboard, ready for pasting into an image-editing application. In Mac OS X, you can also use the Grab utility to capture the screen.

Format converters are additional indispensable tools for projects in which your source material may originate on Macintoshes, PCs, Unix workstations, or even mainframes. This is an issue particularly with video and audio files, because there are many formats and many compression schemes.

What You Need: Authoring Systems

Multimedia authoring tools provide the important framework you need for organizing and editing the elements of your multimedia project, including graphics, sounds, animations, and video clips. Authoring tools are used for designing interactivity and the user interface, for presenting your project on screen, and for assembling diverse multimedia elements into a single, cohesive product.

Authoring software provides an integrated environment for binding together the content and functions of your project, and typically includes everything you need to create, edit, and import specific types of data; assemble raw data into a playback sequence or cue sheet; and provide a structured method or language for responding to user input. With multimedia authoring software, you can make

- Video productions
- Animations
- Games
- Interactive web sites
- Demo disks and guided tours
- Presentations
- Kiosk applications
- Interactive training
- Simulations, prototypes, and technical visualizations

Helpful Ways to Get Started

Don't be overwhelmed when starting your multimedia project—there may be a lot of things to think about, but there are also a lot of things that have already been done for you. As the cliché goes, “There's no need to reinvent the wheel!” Consider the following tips for making your production work go smoothly:

- Use templates that people have already created to set up your production. These can include appropriate styles for all sorts of data, font sets, color arrangements, and particular page setups that will save you time.
- Use wizards when they are available—they may save you much time and pre-setup work.
- Use named styles, because if you take the time to create your own it will really slow you down. Unless your client specifically requests a particular style, you will save a great deal of time using something already created, usable, and legal.
- Create tables, which you can build with a few keystrokes in many programs, and it makes the production look credible.
- Help readers find information with tables of contents, running headers and footers, and indexes.
- Improve document appearance with bulleted and numbered lists and symbols.
- Allow for a quick-change replacement using the global change feature.

- Reduce grammatical errors by using the grammar and spell checker provided with the software. Do not rely on that feature, though, to set all things right—you still need to proofread everything.
- Include identifying information in the filename so you can find the file later.

Making Instant Multimedia

While this section discusses dedicated multimedia authoring systems, there is no reason to invest in such a package if your current software (or an inexpensive upgrade) can do the job. Indeed, not only can you save money by doing multimedia with tools that are familiar and already at hand, but you also save the time spent on the arduous and sometimes lengthy learning curves involved in mastering many of the dedicated authoring systems. Common desktop tools have become multimedia-powerful.

Some multimedia projects may be so simple that you can cram all the organizing, planning, rendering, and testing stages into a single effort, and make “instant” multimedia.

Here is an example: The topic at your weekly sales meeting is sales force performance. You want to display your usual spreadsheet so that the group can see real names and numbers for each member of the team, but then you want to add an animated, multicolored 3-D bar graph for visual impact. Preparing for your meeting, you annotate the cell containing the name of the most productive salesperson for the week, using sounds of applause found on the Web or a recording of your CEO saying “Good job!” or a colleague’s “Wait till next week, Pete!” At the appropriate time during the meeting, you click that cell and play the file. And that’s it—you have just made and used instant multimedia.

WARNING *You need special multimedia tools for digitizing your sounds and for creating animations and movies before you can attach these objects to your text, data, or presentation documents.*

You can use a voice annotation, picture, or video clip in many word processing applications (see Figure 7-3). You can also click a cell in a spreadsheet to enhance its content with graphic images, sounds, and animations (see Figure 7-4). If you like, your database can include pictures, audio clips, and movies (see Figure 7-5), and your presentation software can generate interesting titles, visual effects, and animated illustrations for your product demo (see Figure 7-6). With these multimedia-enhanced software packages, you get many more ways to effectively convey your message than just a slide show.



Figure 7-3 Most word processing programs allow you to include various image formats, movies, and digitized sounds (including voice annotations).

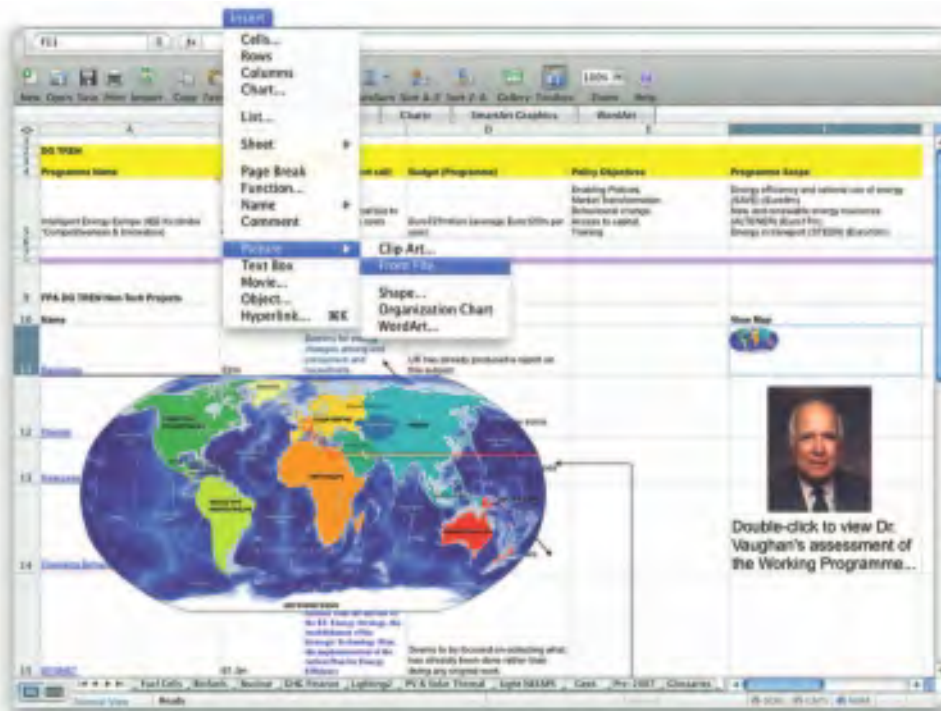

Figure 7-4 Spreadsheets can include embedded objects made with other applications.



Figure 7-5 A FileMaker Pro employee database can include image and sound resources.

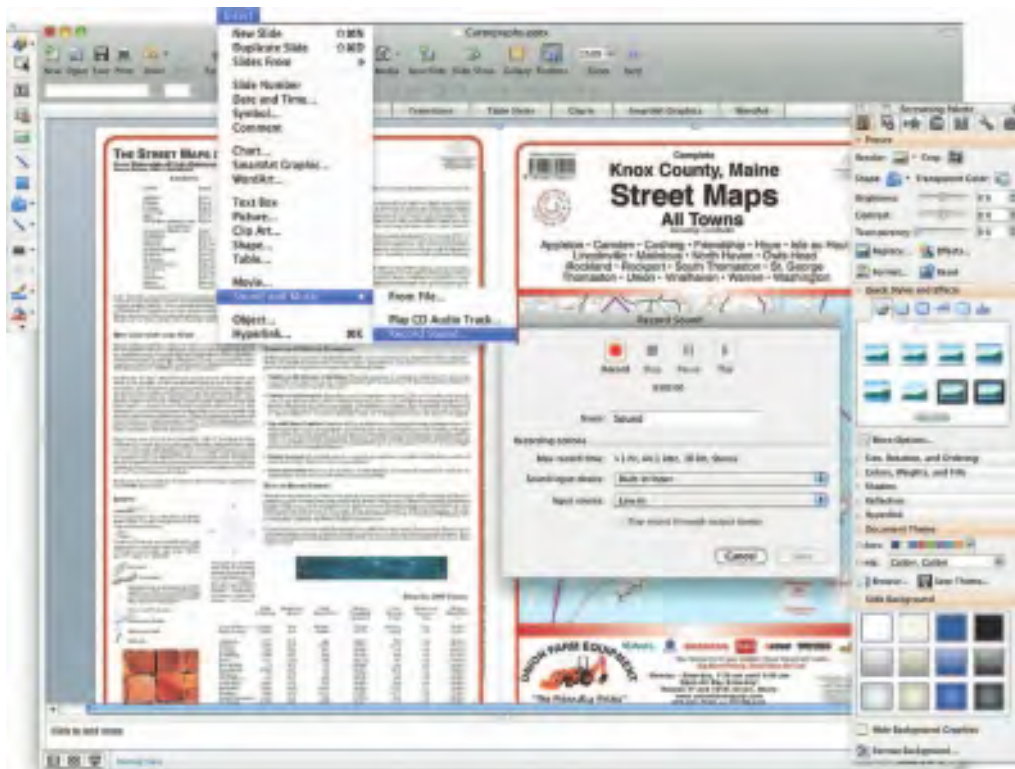

Figure 7-6 Microsoft PowerPoint provides multimedia linking and embedding features.

First Person

Embedding multimedia materials into text documents can be quick, easy, and helpful. For example, a working draft of a manuscript sent to an editor might read:

My father said that Mommy was still in a coma and my little brother was sleeping. We should go home now. So we went out the back way to the physician's parking lot—down the elevator and past the noisy kitchen with its racks of trays, white-uniformed cooks, piles of canned goods, and the steamy smells of institutional stew. The green screen door slammed indelibly into my five-year-old memory, and the attendant waved to my dad; he probably didn't know we were there on family business. It was all pretty serious.

We found Mommy's car behind the police station. I stayed in my seat while my father got out and walked very slowly around the twisted metal. He was calculating the impact forces, visualizing the accident in slow-motion freeze frames, and at one point, he leaned in through the broken glass and ran his hand across the dent in the steel glove compartment where my brother had smashed his face. He went around only the one time, then got back in. "She must have been doing about forty when she hit the pole," he offered as if I were an adult, and we drove out the narrow circular drive alongside the station house. It was a crisp, clear, football-and-pumpkins Saturday afternoon in October.



Note to Sally: Per your comment last week, pick a good illustration from the file of images that I have embedded. One of them should fit the bill... Thanks! See you next week.

Types of Authoring Tools

Each multimedia project you undertake will have its own underlying structure and purpose and will require different features and functions.

E-learning modules such as those seen on PDAs, MP3 players, and intra-college networks may include web-based teaching materials, multimedia CD-ROMs or web sites, discussion boards, collaborative software, wikis, simulations, games, electric voting systems, blogs, computer-aided assessment, simulations, animation, blogs, learning management software, and e-mail. This is also referred to as distance learning or blended learning, where online learning is mixed with face-to-face learning.

The various multimedia authoring tools can be categorized into three groups, based on the method used for sequencing or organizing multimedia elements and events:

- Card- or page-based tools
- Icon-based, event-driven multimedia and game-authoring tools
- Time-based tools



Card- and Page-Based Authoring Tools

Card-based or **page-based** tools are authoring systems, wherein the elements are organized as pages of a book or a stack of cards. Thousands of pages or cards may be available in the book or stack. These tools are best used when the bulk of your content consists of elements that can be viewed individually, letting the authoring system link these pages or cards into organized sequences. You can jump, on command, to any page you wish in the structured navigation pattern.

Page-based authoring systems such as LiveCode from Runtime Revolution (www.runrev.com) and ToolBook (www.toolbook.org) contain media objects: buttons, text fields, graphic objects, backgrounds, pages or cards, and even the project itself. The characteristics of objects are defined by properties (highlighted, bold, red, hidden, active, locked, and so on). Each object may contain a programming script, usually a property of that object, activated when an event (such as a mouse click) related to that object occurs. Events cause messages to pass along the hierarchy of objects in the project; for example, a mouse-clicked message could be sent from a button to the background, to the page, and then to the project itself. As the message traveled, it looks for handlers in the script of each object; if it finds a matching **handler**, the authoring system then executes the task specified by that handler.

Following are some typical messages that might pass along the object hierarchy of the LiveCode and ToolBook authoring systems:

| LiveCode Message | ToolBook Message |
|------------------|------------------|
| closeCard | leavePage |
| closeStack | leaveBook |
| idle | idle |
| mouseDown | buttonDown |
| mouseStillDown | buttonStillDown |
| mouseUp | buttonUp |
| newBackground | newBackground |
| openCard | enterPage |
| openStack | enterBook |

Now let's look at specific examples. To go to the next card or page when a button is clicked, place a message handler into the script of that button. An example in RunRev's LiveCode language would be:

```
on mouseUp
  go next card
end mouseUp
```

An example in ToolBook's OpenScript language would look like:

```
to handle buttonUp
  go next page
end buttonUp
```

The handler, if placed in the script of the card or page, executes its commands when it receives a “mouseUp” or “buttonUp” event message that occurs at any location on the card or page—not just while the cursor is within the bounds of a button.

Card- and page-based systems typically provide two separate layers on each card: a **background layer** that can be shared among many cards, and a foreground layer that is specific to a single card.

Icon- and Object-Based Authoring Tools

Icon- or object-based, event-driven tools are authoring systems, wherein multimedia elements and interaction cues (events) are organized as objects in a structural framework or process. Icon- or object-based, event-driven tools simplify the organization of your project and typically display flow diagrams of activities along branching paths. In complicated navigational structures, this charting is particularly useful during development.

Icon-based, event-driven tools provide a visual programming approach to organizing and presenting multimedia. First you build a structure or flowchart of events, tasks, and decisions, by dragging appropriate icons from a library. These icons can include menu choices, graphic images, sounds, and computations. The flowchart graphically depicts the project's logic. When the structure is built, you can add your content: text, graphics, animation, sounds, and video movies. Then, to refine your project, you edit your logical structure by rearranging and fine-tuning the icons and their properties.

With icon-based authoring tools, non-technical multimedia authors can build sophisticated applications without scripting. In Authorware from Adobe, by placing icons on a flow line, you can quickly sequence events and activities, including decisions and user interactions. These tools are useful for storyboarding, as you can change sequences, add options, and restructure interactions by simply dragging and dropping icons. You can print out your navigation map or flowchart, an annotated project index with or without associated icons, design and presentation windows, and a cross-reference table of variables.

Time-Based Authoring Tools

Time-based tools are authoring systems, wherein elements and events are organized along a timeline, with resolutions as high as or higher than 1/30 second. Time-based tools are best to use when you have a message

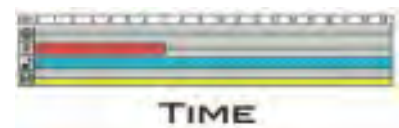

with a beginning and an end. Sequentially organized graphic frames are played back at a speed that you can set. Other elements (such as audio events) are triggered at a given time or location in the sequence of events. The more powerful time-based tools let you program jumps to any location in a sequence, thereby adding navigation and interactive control.

Each tool uses its own distinctive approach and user interface for managing events over time. Many use a visual timeline for sequencing the events of a multimedia presentation, often displaying layers of various media elements or events alongside the scale in increments as precise as one second. Others arrange long sequences of graphic frames and add the time component by adjusting each frame's duration of play.

Flash Flash is a time-based development environment. Flash, however, is also particularly focused on delivery of rich multimedia content to the Web. With the Flash Player plug-in installed in more than 95 percent of the world's browsers, Flash delivers far more than simple static HTML pages. ActionScript, the proprietary, under-the-hood scripting language of Flash, is based upon the international **ECMAScript** standard (www.ecma-international.org) derived from Netscape's original JavaScript.

Director Adobe's Director is a powerful and complex multimedia authoring tool with a broad set of features to create multimedia presentations, animations, and interactive multimedia applications. It requires a significant learning curve, but once mastered, it is among the most powerful of multimedia development tools. In Director, you assemble and sequence the elements of your project, called a "movie," using a Cast and a Score. The **Cast** is a multimedia database containing still images, sound files, text, palettes, QuickDraw shapes, programming scripts, QuickTime movies, Flash movies, and even other Director files. You tie these Cast members together using the **Score** facility, which is a sequencer for displaying, animating, and playing Cast members, and it is made up of frames that contain Cast members, tempo, a palette, timing, and sound information. Each frame is played back on a **stage** at a rate specified in the tempo channel. Director utilizes **Lingo**, a full-featured object-oriented scripting language, to enable interactivity and programmed control.

Objects

In multimedia authoring systems, multimedia elements and events are often treated as **objects** that live in a hierarchical order of **parent and child relationships**. Messages passed among these objects order them to *do* things according to the **properties** or **modifiers** assigned to them. In this way, for example, Teen-child (a teenager object) may be programmed to take out the trash every Friday evening, and does so when they get a

message from Dad. Spot, the puppy, may bark and jump up and down when the postman arrives, and is defined by barking and jumping modifiers. Objects typically take care of themselves. Send them a message and they do their thing without external procedures and programming. Objects are particularly useful for games, which contain many components with many “personalities,” all for simulating real-life situations, events, and their constituent properties.

Object-based authoring programs typically provide objects pre-programmed with sensible properties, messages, and functions. A video object, for example, will likely have a duration property (how long the video plays) and a source property (the location of the video file) and it will likely accept commands from the system such as “play” and “stop.”

Choosing an Authoring Tool

In the best case, you must be prepared to choose the tool that best fits the job; in the worst case, you must know which tools will at least “get the job done.” Authoring tools are constantly being improved by their makers, who add new features and increase performance with upgrade development cycles of six months to a year. It is important that you study the software product reviews in the blogs and computer trade journals, as well as talk with current users of these systems, before deciding on the best ones for your needs. Here’s what to look for:

Editing Features

The elements of multimedia—images, animations, text, digital audio and MIDI music, and video clips—need to be created, edited, and converted to standard file formats, using the specialized applications described in Chapters 2, 3, 4, 5, and 6, which provide these capabilities. Also, editing tools for these elements, particularly text and still images, are often included in your authoring system. The more editors your authoring system has, the fewer specialized tools you may need. In many cases, however, the editors that may come with an authoring system will offer only a subset of the substantial features found in dedicated tools. According to Vaughan’s Law of Multimedia Minimums (see Chapter 4), these features may very well be sufficient for what you need to do; on the other hand, if editors you need are missing from your authoring system, or if you require more power, it’s best to use one of the specialized, single-purpose tools.

Organizing Features

The organization, design, and production process for multimedia involves storyboarding and flowcharting. Some authoring tools provide a visual flowcharting system or overview facility for illustrating your project’s

structure at a macro level. Storyboards or navigation diagrams can also help organize a project and can help focus the overall project scope for all involved. Because designing the interactivity and navigation flow of your project often requires a great deal of planning and programming effort, your storyboard should describe not just the graphics of each screen, but the interactive elements as well. Features that help organize your material are a plus. Many web-authoring programs such as Dreamweaver include tools that create helpful diagrams and links among the pages of a web site. Planning ahead in an organized fashion may prevent countless moments of indecision, keep the client from changing her mind without periodic sign-offs on the materials included, and, in the long run, save you money.

Programming Features

Multimedia authoring systems offer one or more of the following approaches, as explained in the following paragraphs:

- Visual programming with cues, icons, and objects
- Programming with a scripting language
- Programming with traditional languages, such as Basic or C
- Document development tools

Visual programming with icons or objects is perhaps the simplest and easiest authoring process. If you want to play a sound or put a picture into your project, just drag the element's icon into the playlist—or drag it away to delete it.

Authoring tools that offer a **very high level language (VHLL)** or interpreted scripting environment for navigation control and for enabling user inputs or goal-oriented programming languages—such as Flash, LiveCode, Director, and ToolBook—are more powerful by definition. The more commands and functions provided in the **scripting language**, the more powerful the authoring system. Once you learn a scripting language, you will be able to learn other scripting languages relatively quickly; the principles are the same, regardless of the command syntax and keywords used.

As with traditional programming tools, look for an authoring package with good debugging facilities, robust text editing, and online syntax reference. Other scripting augmentation facilities are advantageous, as well. In complex projects, you may need to program custom extensions of the scripting language for direct access to the computer's operating system.

A powerful document reference and delivery system is a key component of some projects. Some authoring tools offer direct importing of preformatted text, indexing facilities, complex text search mechanisms, and hypertext linkage tools. These authoring systems are useful for development

of CD-ROM information products, online documentation and help systems, and sophisticated multimedia-enhanced publications.

With scripts, you can perform computational tasks; sense and respond to user input; create character, icon, and motion animations; launch other applications; and control external multimedia devices.

Interactivity Features

Interactivity empowers the end users of your project by letting them control the content and flow of information. Authoring tools should provide one or more levels of interactivity:

- **Simple branching**, which offers the ability to go to another section of the multimedia production (via an activity such as a keypress, mouse click, or expiration of a timer)
- **Conditional branching**, which supports a go-to based on the results of IF-THEN decisions or events
- A structured language that supports complex programming logic, such as nested IF-THENS, subroutines, event tracking, and message passing among objects and elements

Performance Tuning Features

Complex multimedia projects require exact synchronization of events—for example, the animation of an exploding balloon with its accompanying sound effect. Accomplishing synchronization is difficult because performance varies widely among the different computers used for multimedia development and delivery. Some authoring tools allow you to lock a production's playback speed to a specified computer platform, but others provide no ability whatsoever to control performance on various systems. In many cases, you will need to use the authoring tool's own scripting language or custom programming facility to specify timing and sequence on systems with different (faster or slower) processors. Be sure your authoring system allows precise timing of events.

Playback Features

As you build your multimedia project, you will be continually assembling elements and testing to see how the assembly looks and performs. Your authoring system should let you build a segment or part of your project and then quickly test it as if the user were actually using it. You should spend a great deal of time going back and forth between building and testing as you refine and smooth the content and timing of the project. You may even want to release the project to others who you trust to run it ragged and show you its weak points.

Why is programming fun? What delights may its practitioner expect as his reward?

First is the sheer joy of making things. As the child delights in his mud pie, so the adult enjoys building things, especially things of his own design. I think this delight must be an image of God's delight in making things, a delight shown in the distinctiveness of each leaf and each snowflake.

Second is the pleasure of making things that are useful to other people. Deep within, we want others to use our work and to find it helpful. In this respect the programming system is not essentially different from the child's first clay pencil holder "for Daddy's office."

Third is the fascination of fashioning complex puzzle-like objects of interlocking moving parts and watching them work in subtle cycles, playing out the consequences of principles built in from the beginning. The programmed computer has all the fascination of the pinball machine or the jukebox mechanism, carried to the ultimate.

Fourth is the joy of always learning, which springs from the non-repeating nature of the task. In one way or another the problem is ever new, and its solver learns something: sometimes practical, sometimes theoretical, and sometimes both.

Finally, there is the delight of working in such a tractable medium. The programmer, like the poet, works only slightly removed from pure thought-stuff. He builds his castles in the air, from air, creating by exertion of the imagination. Few media of creation are so flexible, so easy to polish and rework, so readily capable of realizing grand conceptual structures. (As we shall see later, this tractability has its own problems.) Yet the program construct, unlike the poet's words, is real in the sense that it moves and works, producing visible outputs separately from the construct itself. It prints results, draws pictures, produces sounds, moves arms. The magic of myth and legend has come true in our time. One types the correct incantation on a keyboard, and a display screen comes to life, showing things that never were nor could be.

Programming then is fun because it gratifies creative longings built deep within us and delights sensibilities we have in common with all men.

From *The Mythical Man-Month: Essays in Software Engineering*
by Frederick P. Brooks, Jr., Kenan Professor of Computer Science,
University of North Carolina at Chapel Hill

Delivery Features

Delivering your project may require building a run-time version of the project using the multimedia authoring software. A **run-time version** or **standalone** allows your project to play back without requiring the full authoring software and all its tools and editors. Often, the run-time version does not allow users to access or change the content, structure, and programming of the project. If you are going to distribute your project widely, you should distribute it in the run-time version. Make sure your authored project can be easily distributed.

Cross-Platform Features

It is also increasingly important to use tools that make transfer across platforms easy. For many developers, the Macintosh remains the multimedia authoring platform of choice, but 80 percent of that developer's target market may be Windows platforms. If you develop on a Macintosh, look for tools that provide a compatible authoring system for Windows or offer a run-time player for the other platform.

Internet Playability

Because the Web has become a significant delivery medium for multimedia, authoring systems typically provide a means to convert their output so that it can be delivered within the context of HTML or DHTML, either with special plug-ins or by embedding Java, JavaScript, or other code structures in the HTML document. Test your authoring software for Internet delivery before you build your project. Be sure it performs on the Web as you expect! Test it out for performance stability on as many platforms as you can.

Chapter 7 Review

■ Chapter Summary

For your review, here's a summary of the important concepts discussed in this chapter.

Describe the four primary stages in a multimedia project

- Planning and costing
- Designing and producing
- Testing
- Delivering

Discuss the intangible elements needed to make good multimedia

- Creativity
- Organization
- Communication skill

Discuss the hardware most often used in making multimedia and choose an appropriate platform for a project

- Windows and Macintosh are the two computer platforms most often used.
- Hardware elements such as hard disks and networked peripherals must be connected together.
- Memory and storage devices include hard drives, random access memory (RAM), read-only memory (ROM), flash memory and thumb drives, and CD-ROM, DVD, and Blu-ray discs.
- Input and output devices such as microphones, recorders, speakers, and monitors are required when working with multimedia elements.

Understand common software programs used to handle text, graphics, audio, video, and animation in multimedia projects and discuss their capabilities

- A word processor is a regularly used tool in designing and building a multimedia project.
- Image-editing software: bitmapped images provide the greatest choice and power to the artist for rendering fine detail and effects.
- Animations and digital video movies are sequences of bitmapped graphic scenes or frames, rapidly played back.
- With proper editing software, you can digitize video, edit, add special effects and titles, mix sound tracks, and save the clip.
- To master an application, you may have spent many hours learning it, and you will likely stay with that product rather than change to another.

Determine which multimedia authoring system is most appropriate for any given project

- Three metaphors are used by authoring tools that make multimedia: card- and page-based, icon- and object-based, and time-based.
- When choosing an authoring system, consider its editing, organizing, programming, interactivity, performance, playback, cross-platform, and delivery features.

■ Key Terms

- 3-D modeling software** (218)
- Advanced Technology Attachment (ATA)** (204)
- Apple Macintosh operating system (OS)** (200)
- assets** (198)
- background layer** (229)
- barcoding** (210)
- binary compatible** (200)
- Blu-ray** (208)
- card-based** (228)
- Cast** (230)
- cathode-ray tube (CRT)** (211)
- client/server software** (202)
- clone** (202)
- compact disc read-only memory (CD-ROM)** (207)
- conditional branching** (233)
- cross-platform** (200)
- Digital Versatile Disc (DVD)** (208)
- drawing software** (216)
- DVD-ROM** (208)
- DVD-Video** (208)
- ECMAScript** (230)
- Ethernet** (202)
- event-driven** (229)
- FAQ (Frequently Asked Questions)** (214)
- File Transfer Protocol (FTP)** (200)
- filter** (221)
- FireWire** (205)
- format converter** (222)
- frame** (221)
- handler** (228)
- High Definition TV (HDTV)** (208)
- hot-swapping** (205)
- icon- or object-based** (229)
- image-editing application** (220)
- Integrated Drive Electronics (IDE)** (204)
- Internet service provider (ISP)** (202)
- keyboarding** (214)
- Lingo** (230)
- local area network (LAN)** (202)
- look and feel** (196)
- Microsoft Windows** (200)
- mirroring** (204)
- modifier** (230)
- MPC specification** (202)
- object** (230)
- office suite** (214)
- optical character recognition (OCR)** (209)
- page-based** (228)
- painting software** (216)
- parent and child relationship** (230)
- platform-independent** (200)
- plug-and-play** (205)
- programmable ROM (EPROM)** (206)
- proof-of-concept** (196)
- property** (230)
- prototype** (196)
- random access memory (RAM)** (205)
- read-only memory (ROM)** (206)
- run-time version** (234)
- Score** (230)
- scripting language** (232)
- simple branching** (233)
- Small Computer System Interface (SCSI)** (204)
- sprite** (221)
- stage** (230)
- standalone** (234)
- terabyte** (206)
- time-based** (229)
- Universal Product Code (UPC)** (210)
- Universal Serial Bus (USB)** (205)
- very high level language (VHLL)** (232)
- visual programming** (232)
- voice recognition system** (210)
- wide area network (WAN)** (202)
- WiFi** (202)
- word processor** (214)

■ Key Term Quiz

1. A(n) _____ is a simple, working example that demonstrates whether or not an idea is feasible.
2. A(n) _____ file requires no cross-platform conversion.
3. FAQ stands for _____.
4. A package of software applications that might include a spreadsheet, database, e-mail, web browser, and presentation applications is called a(n) _____ (two words).
5. A program that changes an image from one type of graphics file to another is a(n) _____ (two words).

6. A network of workstations located within a short distance of one another that allows direct communication and sharing of peripheral resources such as file servers, printers, scanners, and network modems is called a(n) _____.
7. The type of memory used by a computer to run several programs at the same time is called _____.
8. The type of memory that is not erased when power is shut off to it is called _____.
9. Elements and events are organized along a timeline in a(n) _____ (two words) authoring system.
10. Each graphic scene in an animation is referred to as a(n) _____.

■ Multiple-Choice Quiz

1. As you design and build a multimedia project, your most often used tool may be your:
 - a. word processor
 - b. authoring system
 - c. image processor
 - d. drawing program
 - e. format converter
2. Of all the multimedia elements in a project, the one that will likely have the greatest influence on the end user is the:
 - a. video footage
 - b. sound effects
 - c. graphical impact
 - d. packaging
 - e. musical background
3. Painting software is dedicated to producing:
 - a. vector images
 - b. animations
 - c. 3-D images
 - d. bitmap images
 - e. video clips
4. DVD stands for:
 - a. Dynamically-Variable Disc
 - b. Distributed Video Disc
 - c. Data-Vision Disc
 - d. Double-Volume Disc
 - e. Digital Versatile Disc
5. When you turn off the power to this type of storage, any data stored in it is lost.
 - a. CD-ROM
 - b. ROM
 - c. OROM
 - d. EPROM
 - e. RAM
6. A barcode reader can:
 - a. scan graphics into a computer
 - b. read Universal Product Code patterns
 - c. provide pressure-sensitive input
 - d. recognize spoken words when trained
 - e. all of the above
7. Which of these is *not* a common platform for producing and delivering multimedia projects?
 - a. Macintosh OS X
 - b. Windows 98
 - c. Macintosh Classic
 - d. Windows XP
 - e. IBM VMS
8. A scripting language is considered:
 - a. a very low level language (VLLL)
 - b. an assembler language
 - c. a subset of HTML
 - d. a form of BASIC
 - e. a very high level language (VHLL)

9. For a project whose content consists of elements that can be viewed individually, this type of authoring system is particularly useful during development.
- card- or page-based tool
 - icon-based, event-driven tool
 - time-based tool
 - scripting language
 - All are equally useful.
10. Scripting languages operate by processing small blocks of code when certain events occur. Such a block of code is called:
- a function
 - a handler
 - a process
 - a script
 - a protocol
11. Most card-based programs have a layer that stays constant behind a layer above it that can be different on all other cards. This layer is called the:
- master layer
 - system layer
 - prime layer
 - background layer
 - static layer
12. In multimedia authoring systems, multimedia elements and events are often treated as objects that exist in a hierarchical relationship. This relationship is often called:
- servant and master
 - host and client
 - property and modifier
 - creator and creature
 - parent and child
13. Which of the following is *not* a stage of multimedia production?
- testing
 - planning and costing
 - designing and producing
 - marketing
 - delivering
14. Which of these is *not* a problem you might encounter in porting a program from a Mac to the PC (or from the PC to Mac)?
- Bitmapped images are larger on a PC.
 - Font sizes and shapes are slightly different.
 - Special characters are not the same.
 - Graphics with 256 colors show different colors.
 - All are potential problems.
15. The most precious asset you can bring to the multimedia workshop is your:
- creativity
 - programming skill
 - musical ability
 - film and video production talent
 - checking account

■ Essay Quiz

- You are a team leader who has been given six months to produce a multimedia title that will demonstrate your company's capabilities. Write a brief outline describing the timeline and the possible costs associated with the four stages of the project (you do not have to estimate actual amounts, just estimate percentage of budget). Justify your estimates.
- Consider your own skills, abilities, and goals. Where do you see yourself fitting into a multimedia production team? What abilities would you bring to a team now? What abilities do you need to work to

develop? What are your creative abilities? What is your level of mastery of multimedia tools (software and hardware)?

3. You have been assigned to develop a complex multimedia kiosk for an auto club that will allow users with an account to enter a start point and an ending point, and have a map printed out. What input devices could be used to identify the user? What input devices could be used to enter start and end locations? Could one device do both functions? What about printing out the maps?
4. List the various methods of connecting a computer with the “world,” and discuss the benefits and drawbacks of each.
5. Describe the problems you are likely to encounter in creating a cross-platform program, and list several ways to deal with these problems.

Lab Projects

■ Project 7.1

Create the credits for an imaginary multimedia production. Include several outside organizations, such as video production companies and audio mixing/post-production facilities. Don't forget to include copywriters and other content providers. It may be helpful to look at the credits for an actual production.

■ Project 7.2

Visit the web sites of three video-editing programs, and locate a page that summarizes the capabilities of each. List the formats each is able to import from and export or output to. How do they handle clips? Is there an easy, intuitive, “drop and drag” interface? How many audio and video tracks are included? How are transitions and filters included? What features do all of them have in common? What unique features does each one have? Document your findings.

■ Project 7.3

Diagram a network of three workstations; designate one a scanning workstation, one a graphics development workstation, and one a testing workstation. Include at least two input devices and two storage devices for each one, making logical choices (for example, backups, testing, etc.). Add a server for backup, a printer, and a connection to the Internet to your diagram.

■ Project 7.4

Locate three DVD-Videos. If possible, select DVDs of something besides feature films, making sure they include “bonus” materials. What extra materials are included? What materials are only available on a PC? Why are these materials not available on the television? Document your findings.

■ Project 7.5

You have been assigned to manage a major training project. This project is to include a complex simulation of a workplace task and a reference database of images. Create a hypothetical flow diagram that illustrates the relationship between the simulation and the database. Discuss how you might design and produce this project.

Multimedia Skills

In this chapter, you will learn how to:

- Identify the typical members of a multimedia project team and describe the skills that they need for their work
- Understand the importance of selecting and managing a team in order to produce successful multimedia projects

COMPUTER scientists, physicians, and firemen share highest honors as the most respected professions in the United States, according to a recent study of occupations. Are multimedia developers computer scientists? Or are they programmers, graphic artists, musicians, animators, storyboard craftspeople, information specialists, instructional designers, and/or Renaissance authors? However you define them, they come from all corners of the computer, art, literary, film, and audio worlds. Video producers become experts with computer-generated animations and MIDI controls for their edit suites. Architects become bored with two-dimensional drafting and create three-dimensional animated walk-throughs. Oil field engineers get tired of manipulating complex data sets and design mouse-driven human interfaces. Classical painters learn the electronic elements of red, green, and blue and create fantastic, computer-based artwork. A multimedia developer might be any or all of these and typically doesn't fit a traditional management information system (MIS) or computer science mold; many have never seen a line of C++ code or booted up a Linux server. Perhaps, in the broadest definition, multimedia developers might simply be called information technology workers.

Consider Leonardo da Vinci, the Renaissance man who was scientist, architect, builder, creative designer, craftsman, and poet folded into one. To produce good multimedia, you will need a similar diverse range of skills—detailed knowledge of computers, text, graphic arts, sound, and video. These skills, the **multimedia skill set**, may be available in a single individual or, more likely, in a composite of individuals working as a team. Complex multimedia projects are, indeed, often assembled by teams of artists and computer craftspeople, where tasks can be delegated to those most skilled in a particular discipline or craft. Many job titles and collaborative team roles for multimedia development are being adapted to pull from a mix of motion picture industry, radio and television broadcasting, and computer software industry experiences.



WARNING *A multimedia expert working alone will be hard-pressed to compete with a multidisciplinary team of experts and may be overwhelmed by the sheer amount of effort required to build a complex project single-handedly.*

The Team

A typical team for developing multimedia for DVD or the Web consists of people who bring various abilities to the table. Often, individual members of multimedia production teams wear several hats: graphic designers may also do interface design, scanning, and image processing. A project manager or producer may also be the video producer or scriptwriter. Depending upon the scope and content of your project and the mix of people required, according to Wes Baker, a professor at Cedarville University in Cedarville, Ohio, a multimedia production team may require as many as 18 discrete roles, including:

- Executive Producer
- Producer/Project Manager
- Creative Director/Multimedia Designer
- Art Director/Visual Designer
- Artist
- Interface Designer
- Game Designer
- Subject Matter Expert
- Instructional Designer/Training Specialist
- Scriptwriter
- Animator (2-D/3-D)
- Sound Producer
- Music Composer
- Video Producer
- Multimedia Programmer
- HTML Coder
- Lawyer/Media Acquisition
- Marketing Director

Project Manager

A project manager's role is at the center of the action. He or she is responsible for the overall development and implementation of a project as well as for day-to-day operations. Budgets, schedules, creative sessions, time sheets, illness, invoices, and team dynamics—the **project manager** is the glue that holds it together.

Mere possession of the equipment does not make one into a videographer, film editor, set designer, scriptwriter, audio engineer, animator, and programmer. Some people do possess all of the innate talents required to produce decent multimedia, but few have mastered all the skills required to bring a major project to fruition. More typically, world-class productions are realized through the teamwork of a variety of talented people with specialized experience.

Jeff Burger,
Contributing Editor,
NewMedia magazine

Mark Williams

Production of a CD-ROM reference guide at Microsoft involved a core team headed by project manager Mark Williams, along with additional specialists, technicians, and assistants, who were brought on board as needed.

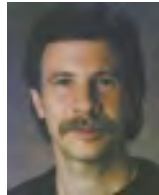

At Microsoft, project managers are called program managers, but it means exactly the same thing. The program manager has two major areas of responsibility: design and management. Design consists of devising a vision for the product, working out the complete functionality with the design team, and then putting it into a complete functional spec and adjusting it as necessary throughout the development of the product. The management side consists of scheduling and assigning tasks, running meetings, and managing milestones—essentially overseeing all aspects of product development from beginning to end.

Our core team consisted of a project manager (me), a **subject matter expert** (who is called an editor at Microsoft), a graphic designer, and a programmer (also called a software development engineer). Another important team member was the product manager—a marketing person who is responsible for representing the product to the outside world. We also found that it was very valuable to get early design input from the person who creates the online and printed help for the product and from the person who eventually manages the testing of the product.

In the production phase we brought in additional talent for scanning images, digitizing sound, proofreading, and other production tasks. We also worked with numerous specialists along the way, such as an audio producer for securing sound track material and, crucially, acquisitions specialists. The acquisitions folks were vital to the effort because we were trying to get a variety of media from people who really didn't understand what we were doing.

Specbing the right content and being able to acquire it was critical. Our pictures and content are all of the highest quality, and the design is clear and easy to use. Keeping a vision of the product in mind—and making sure that the design really meets the needs of the end user—is very important. Constant usability testing gives us a way to keep the end user involved in the design process.

A good project manager must completely understand the strengths and limitations of hardware and software so that he or she can make good decisions about what to do and what not to do. Aside from that I'd say the most important skills are people skills (keeping your team happy and motivated), organizational skills, and attention to all the myriad details of a

project. At the same time, it's critical to keep the big picture, the vision, in mind, so that everything that needs to get done does in fact *get* done.

Project Manager/Interface Expert

Multimedia company looking to immediately fill position working on interactive television project for major telecommunications company. Project manager needed to manage production and design efforts on large-scale, interactive television project for air in United States.

- Must be adept and experienced at managing complex projects, preferably with large corporate accounts.
- Must have solid understanding of interactivity and experience with interactive media in the broadcast television world.
- Must have several years of experience with interface design or have worked in management of an interface design group.
- Must have good design sensibilities.
- Communication skills a must; candidate must be an articulate and effective communicator, an excellent listener, and should be able to act as a conduit for the information passing between our team and the client's teams.
- Superior attention to detail and ability to coordinate large amounts of information a must.
- Prefer entertainment experience—ideally, television or video production.
- Solid computer or digital media experience and knowledge a must.
- Travel required for visiting focus groups and gathering consumer information.
- Must function well in fast-paced, team-oriented environment.
- Position must be filled immediately.

Multimedia Designer

The look and feel of a multimedia project should be pleasing and aesthetic, as well as inviting and engaging. Screens should present an appealing mix of color, shape, and type. The project should maintain visual consistency, using only those elements that support the overall message of the program. Navigation clues should be clear and consistent, icons should be meaningful, and screen elements should be simple and straightforward. If the project is instructional, its design should be sensitive to the needs and styles of its learner population, demonstrate sound instructional principles, and promote mastery of subject matter. But who puts it all together?

Graphic designers, illustrators, animators, and image processing specialists deal with the visuals. **Instructional designers** are specialists in education or training and make sure that the subject matter is clear and properly presented for the intended audience. **Interface designers** devise the navigation pathways and content maps. **Information designers**

structure content, determine user pathways and feedback, and select presentation media based on an awareness of the strengths of the many separate media that make up multimedia. All can be multimedia designers.

Kurt Andersen

Kurt Andersen is an instructional designer and was a senior designer at the George Lucas Educational Foundation, where he designed multimedia prototypes for middle school math and science curricula.

A **multimedia designer** often wears many hats, but most importantly he or she looks at the overall content of a project, creates a structure for the content, determines the design elements required to support that structure, and then decides which media are appropriate for presenting which pieces of content. In essence, the multimedia designer (sometimes called an information designer) prepares the blueprint for the entire project: content, media, and interaction.



From an interactive standpoint, many multimedia projects are too passive—you click and watch. The challenge is to get beyond what is appealing visually and design products that are activity-based. A multimedia project needs to be truly interactive, and this means that as a designer you have to have a clear picture of what goes on whenever the user interacts with the program.

Advances in technology are bringing us closer to this point. For example, one of the most interesting things going on is the development of *adaptive systems*, which accept user input and modify themselves based on this input. In training projects, they're called intelligent tutors. Right now, we're working on a medical application that will analyze a patient's history and background in order to present information that is personalized to that particular patient.

I was recently a member of two different teams that developed multimedia prototypes for middle school science and mathematics at the George Lucas Educational Foundation. Our approach was to develop prototypes that might be distributed as exemplars of rigorous, engaging, effective multimedia design using leading-edge technology. The real challenge was to create a program that presented mathematics so that users could play, explore, and develop their own conceptual schema around the concepts we were developing. We were also challenged to implement our ideas from a technological standpoint. For example, we wound up hooking up a high-end rendering machine so that we could do 3-D graphics on the fly.

Multimedia designers need a variety of skills. You need to be able to analyze content structurally and match it up with effective presentation

methods. You need to be an expert on different media types, and a capable media integrator, in order to create an overall vision. The ability to look at information from different points of view and a willingness to shift your own point of view to be empathetic with end users are absolutely essential. So are interpersonal skills, because you spend so much of your time interacting with other team members and with clients, as well as extracting information from subject matter experts. You must be able to “talk the talk” with all of them. Finally, you must understand the capabilities of your resources, both technological and human, and know when to push ahead and when to stop.

Multimedia Designer/Producer

Seeking an experienced, new-media professional who loves inventing the future and enjoys the challenge of integrating complex information and media systems.

Our ideal candidate has solid experience in interface design, product prototyping, and marketing communication. Knowledge of image manipulation is critical, as well as proven skills in Lingo scripting and the use of digital time-based authoring tools. We seek a team player with excellent communication skills and grace under pressure.

- Must have experience designing large information and/or entertainment systems.
- Must have experience creating system flows and program architectures.
- Must have solid organizational skills and attention to detail.

Interface Designer

Like a good film editor, an interface designer’s best work is never seen by the viewer—it’s “transparent.” In its simplest form, an interface provides control to the people who use it. It also provides access to the “media” part of multimedia, meaning the text, graphics, animation, audio, and video—without calling attention to itself. The elegant simplicity of a multimedia title screen, the ease with which a user can move about within a project, effective use of windows, backgrounds, icons, and control panels—these are the result of an interface designer’s work.

Nicole Lazzaro

Nicole Lazzaro is an award-winning interface designer with XEODesign in Oakland, California, and teaches interface design at San Francisco State University’s Multimedia Studies Program. She spends her days thinking of new ways to design multimedia interfaces that feel more like real life.

The role of an interface designer is to create a software device that organizes the multimedia content, lets the user access or modify that content, and presents the content on screen. These three areas—information

design, interactive design, and media design—are central to the creation of any interface, and of course they overlap.



In the real world, design responsibilities are often assigned differently depending on the project. An interface designer may also be the multimedia designer or the graphic designer. Sometimes all of the design is given to one person; sometimes it is divided among group members; and sometimes the interface springs from the group as a whole.

In the best of all worlds, everyone has input into the final vision, but realistically, everyone also has other responsibilities outside of interface design. The advantage of dedicating one team member experienced in a number of interface solutions to this particular task is to make sure the end user does not get left out of the equation. A good interface designer will create a product that rewards exploration and encourages use. You have to design the interface from the ground up, not just slap on some graphics and fancy icons after most of the programming is done.

A crucial skill is being familiar with a lot of multimedia interfaces so that you are able to visualize ideas as they are discussed. What is the best way to represent this function? Will this program look better using a hierarchical menu or a book metaphor? What will be the user's experience? Being familiar with film or video editing can be helpful, because telling a story with sounds and images is what most multimedia experiences are all about. From a visual perspective, cinematography and film editing are, I think, the closest parallels to what we would call interface design. These techniques can seamlessly change a point of view or tell a story more effectively, and they are being used by interface designers today. Knowing an authoring system is also crucial, so that you can develop your ideas in some interactive fashion and be able to present them to your design group. Having basic drawing skills also helps, because then you can describe how a screen looks using pencil and paper. Also, learn how to do user testing, and do lots of it!

Artist/Designer needed to create graphics for interactive multimedia titles aimed at children. Solid experience in graphic design, including knowledge of Adobe Photoshop and Adobe Premiere. Must have superior illustration ability. Must have experience in animation. Experience in video graphics and editing (Premiere, Avid, Media100, etc.) a plus.

Writer

Multimedia writers do everything writers of linear media do, and more. They create character, action, and point of view—a traditional **scriptwriter's**

tools of the trade—and they also create interactivity. They write proposals, they script voice-overs and actors' narrations, they write text screens to deliver messages, and they develop characters designed for an interactive environment.

Writers of text screens are sometimes referred to as content writers. They glean information from content experts, synthesize it, and then communicate it in a clear and concise manner. Scriptwriters write dialog, narration, and voice-overs. Both often get involved in overall design.

Domenic Stansberry

Domenic Stansberry is a writer/designer who has worked on interactive multimedia dramas for commercial products. He has also written for documentary film and published two books of fiction.

The role of the writer changes with each different project, depending on the people you're working with. But multimedia writing is always different from writing a film or video script. In a film or video, you're plotting a story the way a dramatist or novelist would. With multimedia, it can be more difficult: you're still thinking dramatically, but in smaller, more discrete units that have to interrelate to each other, and that have to be compiled into a puzzle of sorts.



In traditional drama there are characters and an inevitability about what happens to those characters. You build circumstances that have certain significance for your characters as they go on to meet their destiny. In multimedia, we plot out stories that can go many different ways. This is inherently contradictory to the way we've thought about dramatic structure. Intelligent writers are still work-

ing hard to invent interactive dramatic structures: we see some attempts in games, which are obstacle driven. The user needs to perform a task and is presented with an obstacle—and then a need to overcome the obstacle and move on. This is not unlike the position a character takes in a story or movie where characters are presented with physical or psychological obstacles and must find a way to get beyond them. It's really too bad that writers are not brought in on more game projects...the quality of the interaction would be much higher if they were.

I work best when I am involved at the conceptual level of a project, but in many projects, the flowcharts are generated first. Then as the writing process unfolds, you find that the flowchart doesn't work because the material isn't what the flowchart wants it to be. When you're working on a dramatic script, you have to make the characters and the drama work first, before you start doing flowcharts. So if the writer is invited into the process at Step 7 and handed a flowchart, you're going to run into a

problem. Another problem lies in working with people who are mainly from computer backgrounds. They are used to the writer as a writer of documentation—someone who comes in at the end of a project and writes a manual about how the product works. Computer people are often very uncomfortable with media people playing a role at the heart of the creative process. You need to develop a sense about where other team members are coming from when you are brought on to a project, and try to educate them if necessary.

But in the final analysis, the producer or project manager has to be the person to handle conflict in differing team members' visions. A good producer will get the most out of team members by getting them to work not against each other, but together toward their strengths. There are bound to be competing visions on a project, and in the best-case scenario, the team members will work out their differences through a consensus process. But if they can't, the producer has to have a guiding vision.

Multimedia Writer needed for multimedia kiosk in retail outlet. Must be familiar with interactive design and user interface issues. Background in marketing or copywriting a plus. Ability to work under tight deadlines in a team environment essential. Candidates will be asked to provide writing samples.

Video Specialist

Prior to the 2000s, producing video was extremely expensive, requiring a large crew and expensive equipment. Recently, however, the cost of the equipment and the size of the crew needed have dropped dramatically, and digital video presentation methods have combined increasingly capable hardware and software. The result is that video images delivered in a multimedia production have improved from postage-stamp-sized windows playing at low frame rates to full-screen (or nearly full-screen) windows playing at 30 frames per second. As shooting, editing, and preparing video has migrated to an all-digital format and become increasingly affordable to multimedia developers, video elements have become more and more part of the multimedia mix.

For high-quality productions, it may still be necessary for a **video specialist** to be responsible for an entire team of videographers, sound technicians, lighting designers, set designers, script supervisors, gaffers, grips, production assistants, and actors. However, for many modest projects, a video specialist may shoot and edit all of the footage without outside help.

Whether working individually or managing a large crew, a video specialist needs to understand how to shoot quality video, how to transfer the video footage to a computer, how to edit the footage down to the

final product using a digital nonlinear editing system (NLE), and how to prepare the completed video files for the most efficient delivery on DVD or the Web.

Oliver Streuli

Oliver Streuli has worked as a post-production editor on several Hollywood productions (*Silence of the Lambs*, *Family Man*, and *Rush Hour 2*). He currently works in Switzerland where he specializes in post-production of commercials, corporate marketing and educational videos, and broadcast programming.



Editing images into a creative and understandable flow is a rewarding career, although the actual work is generally done behind-the-scenes. Most people never notice good video editing, but practically everyone notices lousy work with sync problems and poor color correction. Post production includes mixing, adding titles, creating graphics and special effects, and tweaking audio. A working knowledge of tools like Adobe Photoshop, AfterEffects, and ProTools is immensely helpful, while extensive knowledge of nonlinear editing programs like Final Cut Pro or Avid is mandatory.

The workflow of a successful video project starts with good video and sound material—if the raw material is bad, there is only so much an editor can do to improve it. Editing a project can take anywhere from a few hours to a few months. For a 30-second commercial, you might have hours and hours of raw footage (also called dailies or rushes). The first edit is considered an “offline edit” and is done with compressed video and with titles and effects roughed in to save disk space. An Edit Decision List (EDL) is created during the offline editing process. This list of selected scenes becomes the “online edit,” which incorporates only footage specified in the EDL. Special effects, titles, graphics, and color corrections are then added. A sound studio will likely make an audio track of voiceovers, background music, and jingles that need to be mixed in, so a misstep during the offline editing process can trickle down and create plenty of problems later during online or audio sessions. Attention to detail and a willingness to ask questions goes a very long way towards a smooth project.

Video Specialist wanted for multimedia production. Must have strong background in video direction, nonlinear editing, and preparing digital video for efficient delivery. Good understanding of shooting for interactive programming required. A background working with Ultimatte green screens for compositing live video with computer-generated backgrounds a plus.

Audio Specialist

The quality of audio elements can make or break a multimedia project. **Audio specialists** are the wizards who make a multimedia program come alive, by designing and producing music, voice-over narrations, and sound effects. They perform a variety of functions on the multimedia team and may enlist help from one or many others, including composers, audio engineers, or recording technicians. Audio specialists may be responsible for locating and selecting suitable music and talent, scheduling recording sessions, and digitizing and editing recorded material into computer files (see Chapter 4).

Chip Harris

Chip Harris studied trumpet and electronic music composition at the Peabody Conservatory of Music, and he has worked with the noted composer Jean Eichelberger Ivy. He has recorded releases on major and independent labels, including Atlantic, RCA, and Warner Brothers, has composed music for CD-ROM titles for Virgin Games, Accolade, and E-greetings, and has created soundtracks for Clio and Joey award-winning spots.



An audio specialist working in multimedia should have a thorough understanding of the requirements involved in producing a successful sound track. Most often this person will be either an engineer, technician, composer, sound designer, or any combination of the above. On the rare occasion where all of these skills are requisite for employment, the position would most likely be for an audio department manager for a good-sized and well-funded multimedia company with in-house production facilities. However, even though positions such as these aren't plentiful, the skills and talents necessary for quality multimedia audio production are needed every day by companies who have opted to outsource their audio to independent contractors.

Whether it's recording voice-over talent for a business application, composing a musical score for a shoot-'em up game, or designing sound effects that reflect the particular feel of a product, the end result will rely on knowing the medium going in. By this I mean, for example, at what sampling rate will the audio be delivered? How much space is available for *all* audio combined? Can different sampling rates be applied to voice-over and music to save space and enhance overall quality? In composition will looping be required of individual pieces to provide a seamless score and to save valuable space? And who will do the looping, the composer or the engineer? Will some voice-over talents sound presentable

at higher sampling rates but not at lower? Will the producer understand the difference?

Of course, these are only a few examples of the questions and problems to be dealt with in multimedia audio production. But attention to detail, listening for a cohesive presentation, and quality recording techniques are the strong glue that successfully binds the diverse audio components together.

Multimedia Audio Specialist

Audio specialist needed for multimedia project.

Must have strong background in studio recording techniques—preferably with time spent in the trenches as an engineer in a commercial studio working on a wide range of projects. Must be comfortable working with computers and be open and able to learn new technology and make it work, with high-quality results. Familiarity with standard recording practices, knowledge of music production, and the ability to work with artists a definite plus. Requires fluency in MIDI; experience with sequencing software, patch librarians, and synth programming; and knowledge of sampling/samplers, hard disk recording, and editing. In addition to having a solid technical foundation, you must be able to survive long hours in the studio riding faders and pushing buttons.

Multimedia Programmer

A **multimedia programmer** or software engineer integrates all the multimedia elements of a project into a seamless whole using an authoring system or programming language. Multimedia programming functions range from coding simple displays of multimedia elements to controlling peripheral devices and managing complex timing, transitions, and record keeping. Creative multimedia programmers can coax extra (and sometimes unexpected) performance from multimedia-authoring and programming systems. Without programming talent, there can be no multimedia. Code, whether written in JavaScript, OpenScript, Lingo, RevTalk, PHP, Java, or C++, is the sheet music played by a well-orchestrated multimedia project.

Hal Wine

Hal Wine is a programmer familiar with both the Windows and Macintosh environments. In his many years of experience, he has worked in most of the important areas of computing and for many of the leading computing companies.

The programmer on a multimedia team is called on to perform a number of tasks, from assisting producers in organizing their code more effectively to enhancing the production and playback tools. The most important

skill a multimedia programmer can bring to a team is the ability to quickly learn and understand systems—and not just understand the various calls, but know *why* those calls are needed. In other words, you should be able to read between the lines of the technical manuals, so that your solutions are harmonious with the philosophy and intent of the system designers.



Multimedia products are displayed on a large variety of display systems, and the enhancement needed often requires going behind the normal system safeguards to meet the objective. Such programming requires a thorough understanding of the target operating system and the device capabilities needed to produce a robust solution.

While multimedia authoring tools are continually improving, they are also still evolving. Many times a producer will want to do something slightly beyond the built-in capabilities of the tools, and the programmer will build extensions to the authoring and presentation suite in order to add the desired capability or effect.

Many of the workers on a multimedia team have come to computing from a background in another discipline such as graphic art or journalism, and while they may have strong creative skills, most can benefit from learning more about computing techniques. Often, a multimedia programmer acts as a teacher and technical coach to the team. This implies having better than average communication and comprehension skills, both verbal and written, and the ability to listen!

I often come in to handle “emergencies” in multimedia projects, rather than participate in the whole project’s life cycle. This provides me with maximum variety in my own work, which really keeps me on my toes. Sometimes, I’ll be working for several clients simultaneously. The downside is that I miss out on a lot of the creative synergy; but even so, coming in on the spur of the moment, trying to understand the parameters of the problem, and producing robust solutions quickly leads to quite a bit of creativity, too. Knowing how to make your own latte is also useful.

Interactive Programmer (HTML, JavaScript, Flash, PHP, and C/C++) needed to work on multimedia prototyping and authoring tools for DVD and interactive web-based projects.

- Thorough knowledge of ActionScript, JavaScript, Flash, HTML5, PHP, and C/C++, Macintosh and Windows environments required.
- Must have working familiarity with digital media, particularly digital video.
- Must have a demonstrated track record of delivering quality programming on tight schedules.
- Must function well in fast-paced, team-oriented environment.
- Knowledge of AJAX methodologies desired.

Producer of Multimedia for the Web

Web site **producer** is a new occupation, but putting together a coordinated set of pages for the World Wide Web requires the same creative process, skill sets, and (often) teamwork as any kind of multimedia does. With a little effort, many of us could put up a simple web page with a few links, but this differs greatly from designing, implementing, and maintaining a complex site with many areas of content and many distinct messages. A web site should never be finished, but should remain dynamic, fluid, and alive. Unlike a DVD multimedia product replicated many times in permanent plastic, the work product at a web site is available for tweaking at any time.

Kevin Edwards

Kevin Edwards is Senior Multimedia Producer for CNET, a publicly traded media company that integrates television programming with a network of sites on the World Wide Web. In both types of media, CNET provides information about computers, the Internet, and future technology using engaging content and design. CNET has about two million members on the Internet, and its television programming—which airs on the USA Network, on the Sci-Fi Channel, and in national syndication—reaches an estimated weekly audience of more than eight million viewers.



Years ago I headed out to San Francisco to join CNET. I wore a lot of different hats at CNET, but my primary responsibility was with the company's online foray into multimedia. For example, early on we did a year-long project with Intel, where I was involved from original concept through implementation. The project merged hot media properties with cutting-edge technology to create a brand-new experience in web-based browsing, allowing users to become participants in the experience rather than just observers.

What helped me keep this project in focus was my well-rounded knowledge and ability to perform in all of the different roles required to produce the site—whether graphics, HTML, editorial, support, audio/video, or some other task. While it's a lot of fun to change hats and do many different tasks, it can be a lot of responsibility and pretty stressful. For me, building the original site meant that for a year and a half I was totally plugged into the Net, checking on our site, looking at stats, and analyzing what was going on in the entertainment/technology industries. This meant keeping Web profession hours rather than banker's hours, which meant it was pretty rare for me to take a day off, even on weekends, and my office became more of my living space than my apartment. To keep from burning out, you have to have a sense of ownership and a passion for what you're doing.

The best situation is when your team is composed of people who also turn into close friends. During this project we worked incredibly well together: each knew his or her particular field 100 percent and respected the other team members. We worked hard, played hard, and were able to really rock when put to the test. In fact, there were a couple of people who started the project with very little experience, but their eagerness and ability to learn, and the group's willingness to teach, made it happen.

Web Site Producer Excellent full-time opportunity with a large manufacturing firm. Responsible for developing Web projects from concept through implementation for internal and external clients. Interact with all levels of management, network teams, and development teams to provide efficient project solutions. Knowledge of HTML coding of tables, frames, and forms, knowledge of CGI scripting, and knowledge of Photoshop and Flash required. Exciting opportunity for a self-motivated individual looking for a career in new media. This new entry-level position in the firm's national marketing department requires a team player with creative ideas who is interested in gaining experience and knowledge in every aspect of web site development. Job responsibilities include maintaining/updating site content, managing documents, and developing new site features.

The Sum of Parts

Successful multimedia projects begin with selecting “team players.” But selection is only the beginning of a team-building process that must continue through a project's duration. **Team building** refers to activities that help a group and its members function at optimal levels of performance by creating a work culture that incorporates the styles of its members. You should encourage communication styles that are fluid and inclusive, and you should develop models for decision making that respect individual talents, expertise, and personalities. This isn't easy, but repeated studies have shown that workgroup managers with well-developed team skills are more successful than managers who dive headlong into projects without attention to team dynamics. Although it's usually a project manager who initiates team building, all team members should recognize their role; gentle collaboration is a key element of successful projects.

Currently, the Bureau of Labor Statistics does not have a category for jobs specific to multimedia. Some related areas listed by the bureau include

- Artists and related workers
- Multi-Media Artists
- Animators
- Designers
- Motion picture production and distribution

- Television, video, and motion picture camera operators and editors
- Writers and editors

You can also check out career information sites such as SkillsNet.net, Vault.com, and WetFeet.com for current information on careers in new media.

Graphic Designers

Graphic designers—or *graphic artists*—plan, analyze, and create visual solutions to communications problems. They find the most effective way to get messages across in print and electronic media using color, type, illustration, photography, animation, and various print and layout techniques. Graphic designers develop the overall layout and production design of magazines, newspapers, journals, corporate reports, and other publications. They also produce promotional displays, packaging, and marketing brochures for products and services, design distinctive logos for products and businesses, and develop signs and signage systems—called environmental graphics—for business and government. An increasing number of graphic designers also develop material for Internet Web pages, interactive media, and multimedia projects. Graphic designers also may produce the credits that appear before and after television programs and movies.

The first step in developing a new design is to determine the needs of the client, the message the design

should portray, and its appeal to customers or users. Graphic designers consider cognitive, cultural, physical, and social factors in planning and executing designs for the target audience. Designers gather relevant information by meeting with clients, creative or art directors, and by performing their own research. Identifying the needs of consumers is becoming increasingly important for graphic designers as they continue to develop corporate communication strategies in addition to creating designs and layouts.

Graphic designers prepare sketches or layouts—by hand or with the aid of a computer—to illustrate their vision for the design. They select colors, sound, artwork, photography, animation, style of type, and other visual elements for the design. Designers also select the size and arrangement of the different elements on the page or screen. They may create graphs and charts from data for use in publications, and they often consult with copywriters on any text that accompanies the design. Designers then present the completed design to their clients or

art or creative director for approval. In printing and publishing firms, graphic designers also may assist the printers by selecting the type of paper and ink for the publication and reviewing the mock-up design for errors before final publication.

Graphic designers use specialized computer software packages to help them create layouts and design elements and to program animated graphics.

Graphic designers sometimes supervise assistants who follow instructions to complete parts of the design process. Designers who run their own businesses also may devote a considerable time to developing new business contacts, choosing equipment, and performing administrative tasks, such as reviewing catalogues and ordering samples. The need for up-to-date computer and communications equipment is an ongoing consideration for graphic designers.

From The Occupational Outlook Handbook, U.S. Department of Labor, Bureau of Labor Statistics (<http://stats.bls.gov/oco/ocos090.htm>)

Chapter 8 Review

■ Chapter Summary

For your review, here's a summary of the important concepts discussed in this chapter.

Identify the typical members of a multimedia project team and describe the skills that they need for their work

- The project manager is responsible for the overall development and implementation of a project as well as for the day-to-day operations.
- Instructional designers make sure that the subject matter is clear and properly presented.
- Interface designers devise the navigation pathways and content maps on screen that let the user access or modify that content.
- Information designers structure content, determine user pathways and feedback, and select presentation media.
- Multimedia writers, sometimes called content writers, create characters, action, and point of view—and they also create interactivity.
- Multimedia video specialists must know the basics about shooting good video, and be thoroughly familiar with the tools and techniques used for digital editing on computers. They also must understand the potentials and limitations of the medium, including interactivity, how it will affect

the video, and how these limitations affect the video production itself.

- Audio specialists design and produce music, voice-over narrations, and sound effects. They may also be responsible for locating and selecting suitable music and talent, scheduling recording sessions, and digitizing and editing recorded material into computer files.
- A multimedia programmer or software engineer uses an authoring system or programming language to integrate the multimedia elements of a project into a seamless whole. Sometimes programmers need to build extensions to the authoring and presentation suite in order to extend the system's capabilities.
- Web site producers not only put together a coordinated set of pages for the World Wide Web but also constantly coordinate updates and changes.

Understand the importance of selecting and managing a team in order to produce successful multimedia projects

- In any project, including multimedia, team-building activities improve productivity by fostering communication and a work culture that helps its members work together.

■ Key Terms

audio specialist (250)

information designer (243)

instructional designer (243)

interface designer (243)

multimedia designer (244)

multimedia programmer (251)

multimedia skill set (240)

producer (253)

project manager (241)

scriptwriter (246)

subject matter expert (242)

team building (254)

video specialist (248)

■ Key Term Quiz

1. The diverse range of abilities needed to produce a new-media project is called the _____ (three words).
2. The person responsible for overall development and implementation of a project, as well as for day-to-day operations, is the _____ (two words).
3. The most appropriate title for the people whose job it is to look at the overall content of a project, create a structure, determine the design elements, and assign media to the content is the _____ (two words).
4. The work of a(n) _____ (two words) is best when it is “transparent”—as in never noticed by the user.
5. The most appropriate title for the person whose job it is to devise the navigation pathways and content maps is the _____ (two words).
6. The most appropriate title for the person whose job it is to structure content, determine user pathways and feedback, and select presentation media based on an awareness of the strengths of the many separate media that make up the total multimedia is the _____ (two words).
7. The most appropriate title for the person whose job it is to create characters, action, point of view, and interactivity, as well as write proposals, script voice-overs, actors’ narrations, and text screens, is the _____.
8. The most appropriate title for the person whose job it is to integrate all the multimedia elements of a project into a seamless whole using an authoring system or programming language is the _____ (two words).
9. Activities that help a group and its members function at optimal levels of performance by creating a work culture that incorporates the styles of its members is called _____ (two words).

■ Multiple-Choice Quiz

1. According to a recent study of occupations, which of these professions is *not* among the most respected professions in the United States?
 - a. computer scientists
 - b. physicians
 - c. lawyers
 - d. dentists
 - e. all are among those listed
2. At Microsoft Corporation, the product manager:
 - a. coordinates the project’s internal resources
 - b. represents the product to the outside world
 - c. oversees the entire team
 - d. acquires the assets used in the project
 - e. ensures the project does not go over budget
3. Which of these is *not* likely to be the responsibility of a project manager?
 - a. managing the overall development and implementation of a project
 - b. overseeing budgets, schedules, creative sessions, and team dynamics
 - c. acting as the “glue” that holds the project together
 - d. understanding the strengths and limitations of hardware and software
 - e. developing extensions to the authoring system

4. Which of these is *not* likely to be the responsibility of a multimedia designer?
 - a. creating interfaces
 - b. creating budgets and timelines for the project
 - c. ensuring the visual consistency of the project
 - d. structuring content
 - e. selecting media types for content
5. A multimedia designer might also be called:
 - a. a digital media engineer
 - b. a pixologist
 - c. an information designer
 - d. a meta-data designer
 - e. a media integrator
6. From an interactive standpoint, many multimedia projects are too:
 - a. interactive
 - b. fast-paced
 - c. game-like
 - d. passive
 - e. complex
7. An interface should:
 - a. be “transparent” to the user
 - b. provide control to the people who use it
 - c. allow the user to move about within the project
 - d. provide access to the “media” in the project
 - e. all of the above
8. From a visual perspective, interface design most closely parallels:
 - a. mapmaking
 - b. cinematography and film editing
 - c. technical writing
 - d. fine art
 - e. technical drawing and illustration
9. Interface designers should:
 - a. be familiar with film editing
 - b. know an authoring system
 - c. have basic drawing skills
 - d. know how to do user testing
 - e. all of the above
10. Multimedia writers are typically involved in writing all of the following *except*:
 - a. proposals
 - b. script voice-overs
 - c. actors’ narrations
 - d. authoring-language scripts
 - e. text screens to deliver messages
11. Writing for multimedia can be more difficult than writing for other media because:
 - a. character development is much more critical
 - b. the dramatic structures of multimedia are much more confined
 - c. multimedia development cycles are much shorter
 - d. writers must think in smaller, more discrete and interconnected units
 - e. all of the above
12. Which of these is *not* a necessary capability for a multimedia video specialist?
 - a. skill in managing all phases of video production
 - b. familiarity with the tools and techniques used for digital video editing on computers
 - c. ability to incorporate all the sophisticated video effects into a multimedia production
 - d. ability to make a video look larger than it really is
 - e. familiarity with interactivity and how it will affect the video
13. Which of the following is probably *not* a consideration of the multimedia audio specialist?
 - a. the sampling rate at which the audio will be delivered
 - b. how much space is available for all audio
 - c. which authoring system or programming language to use
 - d. locating and selecting suitable music and talent
 - e. digitizing and editing recorded material into computer files

14. The most important skill a multimedia programmer can bring to a team is the ability to:
 - a. quickly learn and understand systems
 - b. control peripheral devices such as laserdisc players
 - c. manage complex timing, transitions, and record keeping
 - d. coax extra performance from multimedia authoring and programming systems
 - e. act as a teacher and technical coach to the team
15. Producing multimedia for the Web is different from producing for DVD because:
 - a. the Web development industry is much more focused on sales and marketing
 - b. Web development is much better adapted to larger, longer media
 - c. Web design is much closer to print design; multimedia is more like film
 - d. Web interface design is much more complex than DVD interface design
 - e. a web site is never finished, but is always available for changes

■ Essay Quiz

1. Discuss why the multimedia skill set is different from other project skill sets.
2. List and define the skills in the multimedia skill set. Describe several ways of categorizing the skills; for example, how each skill is related to project management, to design, to media, and to programming.
3. Describe the skills related to organizing, structuring, and editing the information in a multimedia project. What are the various titles within this category, and what are the distinctions among these skills?
4. Define multimedia computer programming. How does the programmer fit into the team? Is he or she at the end of the process, simply putting all the parts together after everyone else is finished? How can the other skill sets benefit from understanding what the programmer does, and the authoring tools he or she uses?
5. Why are multimedia projects most frequently performed by teams? Whose responsibility is it to ensure that the team operates effectively? What can be done to promote team effectiveness?

Lab Projects

■ Project 8.1

Locate three multimedia projects and review the credits. How many members were on the team? What were their titles? How many team members performed more than one role? What tasks were “outsourced” (performed by outside companies)? Make a table that compares the titles for similar roles among the three projects. For each one, discuss how the team related to the product. (For example, if the product included original video footage, how large was the video production team?)

■ Project 8.2

Locate three web sites and locate the credits (sites should be large enough to have a professional web development team). How many members were on the team? What were their titles? How many team members performed more than one role? What tasks were “outsourced” (performed by outside companies)? Make a table that compares the titles for similar roles among the sites. For each one, discuss how the team related to the site.

■ Project 8.3

“Easter eggs” are small features hidden in web sites, games, and other software. They often include personal information about the development team that produced the project. Do a search for Easter eggs on the Web, and try to locate several. Describe what you find there. What do these hidden features say about the team that worked on the project?

Planning and Costing

In this chapter, you will learn how to:

- Determine the scope of a multimedia project
- Schedule the phases, tasks, and work items required to complete a project
- Estimate the cost, timeline, and tasks required to complete a project
- Write and structure the elements of a multimedia project proposal

BEFORE you begin a multimedia project, you must first develop a sense of its **scope** and content, letting the project take shape in your head as you think through the various methods available to get your message across to your viewers. Then you must develop an organized outline and a plan that is rational in terms of the skills, time, budget, tools, and resources you have at hand. Proper project planning is as important as planning the layout and content. Your plans should be in place before you start to render graphics, sounds, and other components, and you should refer to them throughout the project's execution.

First Person

When I was nine, my father told me about China. He brought the big spinning globe into the kitchen and used a fork to point out where we were and where China was. He explained that if we dug a hole deep enough in the backyard, eventually we would come out in a place called Peking. After school the next day, I began, unannounced, trenching a pit into the rocky soil of our New England backyard. The first layer was tough sod, then there was some topsoil and loam, and then a thick stratum of moist pea

gravel. I was knee-deep into the next layer— hard-packed clay— when my father discovered my work site when he came home at the end of the day. He was pleased I had missed the septic tank by several feet and sternly suggested that more study would be required before I dug any further. This was my first lesson in project planning, not to mention my first experience with project abandonment. Be sure you analyze the requirements of your multimedia project before you go to the toolshed.

The Process of Making Multimedia

Usually something will click in your mind or in the mind of a client that says, “Hey, wouldn’t it be neat if we could...” Your visions of sound and music, flashy images, and perhaps a video will solve a business need, provide

an attention-grabbing product demo, or yield a slick front end to an otherwise drab computer database. You might want to spark a little interest or a laugh in an otherwise dull meeting, build an interactive photo album for Christmas greetings to your family, or post your company's annual report in a new set of pages on the Web.

Plan for the entire process: beginning with your first ideas and ending with completion and delivery of a finished product. Think in the overview. The stepwise process of making multimedia is illustrated in Figure 9-1. Use this chart to help you get your arms around a new web site or DVD production! Note the feedback loops for revisions based upon testing and experiment. Note also the constant presence of an "evaluation committee" (who could be simply a project manager) to oversee the whole.

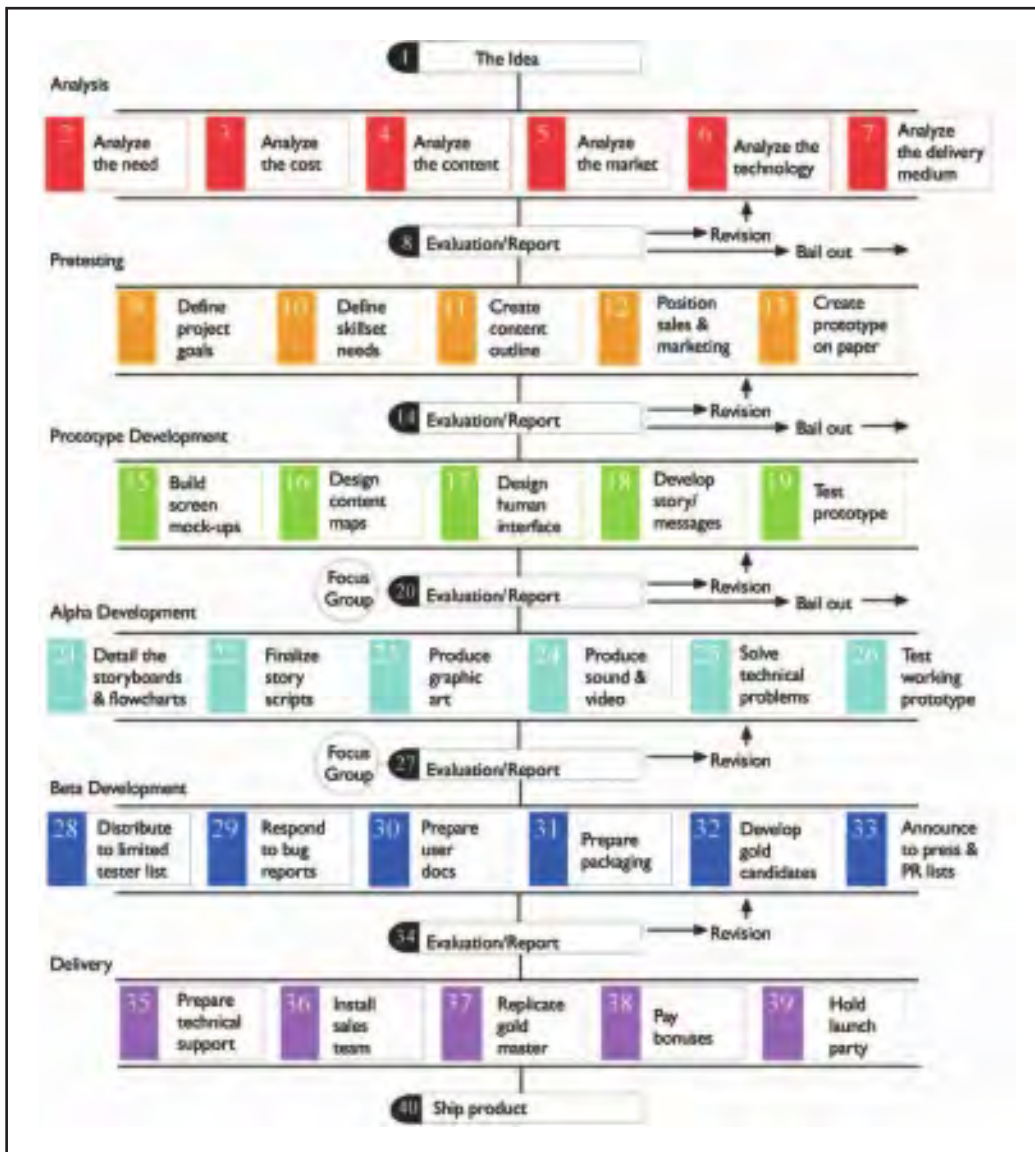

Figure 9-1
The process of making multimedia

We locked eight people in a room with pizza and out popped a design...

.....

Mike Duffy,
Chief Technical Officer,
Software Toolworks,
describing how the design
for the “20th Century
Almanac” was developed

It is, of course, easiest to plan a project using the experience you have accumulated in similar past projects. Over time, you can maintain and improve your multimedia-planning format, just like a batch of sourdough starter. Just keep adding a little rye and water every time you do a project, and the starter for your next job gets a bit more potent as your estimates become tempered by experience.

Idea Analysis

The important thing to keep in mind when you are toying with an idea is balance. As you think through your idea, you must continually weigh your purpose or goal against the feasibility and cost of production and delivery.

Use whiteboard, notepaper, and scratch pads as you flesh out your idea, or use a note-taking or outlining program on your computer. Start with broad brushstrokes, and then think through each constituent multimedia element. Ultimately, you will generate a plan of action that will become your road map for production. Who needs this project? Is it worthwhile? Do you have the materials at hand to build it? Do you have the skills to build it? Your idea will be in balance if you have considered and weighed the proper elements:

- What is the essence of what you want to do? What is your purpose and message?
- Who is your intended audience? Who will be your end users? What do they already know about the subject? Will they understand industry terms (jargon), and what information do they need your project to communicate to them? What will their multimedia playback platforms be, and what are the minimal technical capabilities of those platforms?
- Is there a client, and what does the client want?
- How can you organize your project?
- What multimedia elements (text, sounds, and visuals) will best deliver your message?
- Do you already have content material with which you can leverage your project, such as old videotapes or video files, music, documents, photographs, logos, advertisements, marketing packages, and other artwork?
- Will interactivity be required?
- Is your idea derived from an existing theme that can be enhanced with multimedia, or will you create something totally new?
- What hardware is available for development of your project? Is it enough?
- How much storage space do you have? How much do you need?
- What multimedia software is available to you?

- What are your capabilities and skills with both the software and the hardware?
- Can you do it alone? Who can help you?
- How much time do you have?
- How much money do you have?
- How will you distribute the final project?
- Will you need to update and/or support the final product?

You can maintain balance between purpose and feasibility by dynamically adding and subtracting multimedia elements as you stretch and shape your idea. You can start small and build from minimum capabilities toward a satisfactory result in an additive way. Or you can shoot the moon with a heavy list of features and desired multimedia results, and then discard items one by one because they are just not possible. Both additive and subtractive processes can work in concert and can yield very useful cost estimates and a production road map.

Consider the following scenario: You have a video clip with four head-and-shoulders testimonials that will be perfect for illustrating your message. So add motion video to your list. You will need to purchase digitizing software, so add that item and its cost to your list as well. But you want to make your product available at a web site frequented by rural students without high-speed connections who will wait minutes for the video to play. Subtract motion video, but add tiny framed still images of the four talking heads (captured with your new video software) using short, one-sentence voice-overs of the speakers (recorded from the video clip). Subtract one of the four testimonials because you discover that particular executive is no longer with the firm and you don't have a signed release. Add animation instead. Subtract. Add. Subtract. In this manner, you will flesh out your idea, adding and subtracting elements within the constraints of the hardware, software, and your budget of cost and expertise.

The time you spend defining your project in this way—reality-testing it against technology and your abilities—might be your most valuable investment, even before you boot up a computer. At any point, you can decide to go forward or bail out.

TIP *Treat your multimedia idea like a business venture. As you visualize in your mind's eye what you want to accomplish, balance the project's profit potential against the investment of effort and resources required to make it happen.*

Idea Management Software

Software such as dotProject, kForge, OpenProj, GanttProject (see Figure 9-2), outlining programs, and spreadsheets such as Excel can be useful for arranging your ideas and the many tasks, work items, employee

resources, and costs required of your multimedia project. Project management tools provide the added benefit of built-in analysis to help you stay within your schedule and budget during the rendering of the project itself.

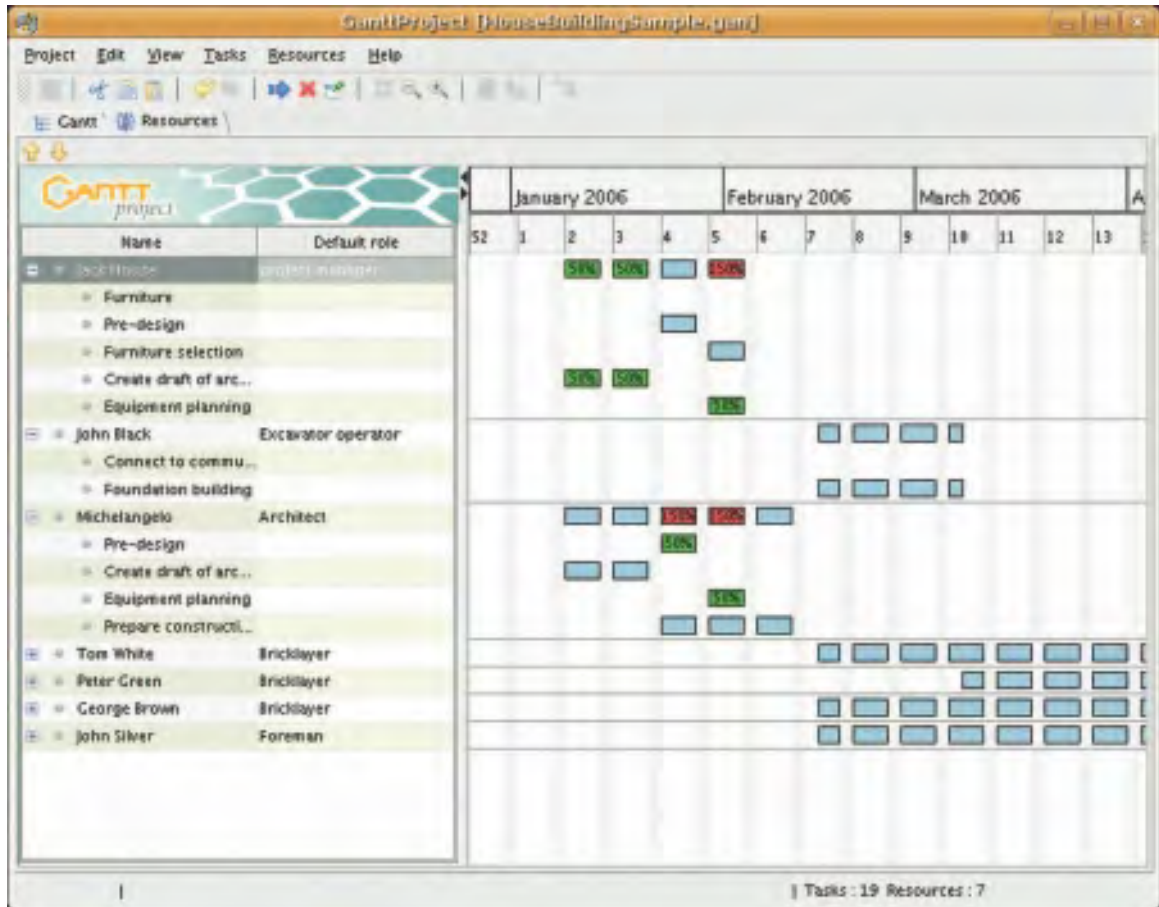

Figure 9-2 GanttProject, an open-source, web-based integrated project scheduling and management tool, generates helpful documents for instructional designers.

WARNING *Budget your time if you are new to project management software. It may be difficult to learn and to use effectively.*

Project management software typically provides **Critical Path Method (CPM)** scheduling functions to calculate the total duration of a project based upon each identified task, earmarking tasks that are critical and that, if lengthened, will result in a delay in project completion. **Program Evaluation Review Technique (PERT) charts** provide

graphic representations of task relationships, showing **prerequisites**, the tasks that must be completed before others can commence. **Gantt charts** depict all the tasks along a timeline.

.....
www.dotproject.net

www.ganttproject.biz

www.kforgeproject.com

<http://openproj.org>

The Paper Napkin

While not as high-tech as idea management software, any writing surface can serve as a repository for ideas when you have no other tools at hand. For example, the very early ideas of processing and preliminary planning can be sketched on a paper napkin (a real one is shown in Figure 9-3, which evolved into a complex multimedia project of many months' duration).

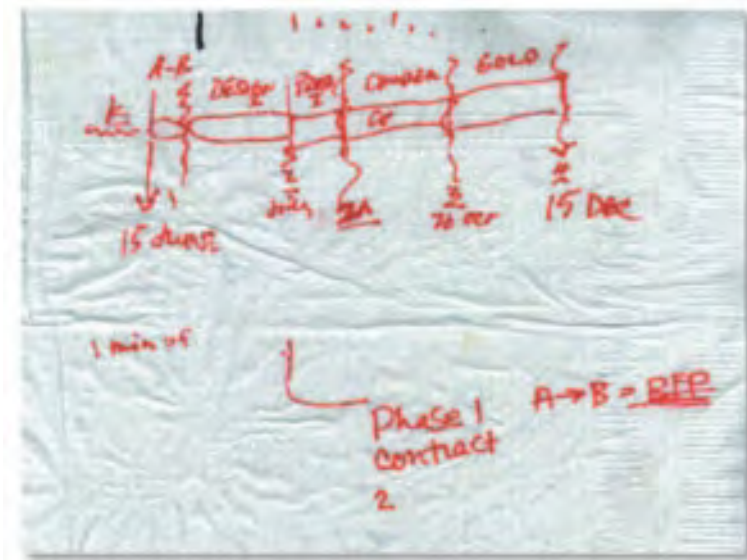

Figure 9-3 The ideas on this luncheon napkin evolved into an animated guided tour for Lotus's multimedia version of 1-2-3 in SmartSuite Millennium.

Around a lunch table, ideas were discussed, refined, and cultivated into a preliminary project plan. A prototype would be built, shown as the A-B portion of the napkin notes, which quite literally answered the question "How do we get from A to B with this idea?" The prototype would then be carefully examined in terms of projected work effort and the technology required for implementing a full-blown version. A more complete plan and cost estimate for full implementation would be developed, and the project would be launched in earnest.

First Person

Last time I took the red-eye home, the fat guy behind me was pretty ill—sneezing and hawking incessantly over my headrest on the full, hot plane. My glasses blurred with misty droplets, and I wiped the fog away with the damp cocktail napkin under my Coke. That trip cost me four days sick in bed, and I promised I would never fly night coach again to make a meeting, no matter how important.

Then I broke my promise and, after a sleepless night on the plane, found myself sitting in the muggy summer air on the bank of the Charles River, having lunch with Rob Lippincott and his multimedia team from Lotus. I pretended to be alert, but residual white noise from the plane ride beat in my ears, and my dry eyes wouldn't focus in the umbrella sunlight. Rob made intelligent notes with a ball-point pen on a paper napkin while my own input to the creative process

was reduced to grunts and short sentences. The smartest thing I did, though, was slip the paper napkin with its notes into my briefcase as we left the table. After some sleep, I was able to retrieve the napkin and craft those luncheon thoughts into the backbone of a rational project proposal and action plan. We launched the venture, and about ten months later it went gold, shipping with Lotus's new Multimedia product, Lotus SmartSuite Millennium 9.8.

Pretesting

If you decide that your idea has merit, take it to the next step. Define your project goals in greater detail and spell out what it will take in terms of skills, content, and money to meet these goals. If you envision a commercial product, sketch out how you will sell it. Work up a prototype of the project on paper, with an explanation of how it will work. All of these steps help you organize your idea and test it against the real world.

Task Planning

There may be many tasks in your multimedia project. Here is a checklist of action items for which you should plan ahead as you think through your project:

- | | | |
|---|---|---|
| <input type="checkbox"/> Design Instructional Framework | <input type="checkbox"/> Assemble Team | <input type="checkbox"/> Program and Author |
| <input type="checkbox"/> Hold Creative Idea Session(s) | <input type="checkbox"/> Build Prototype | <input type="checkbox"/> Test Functionality |
| <input type="checkbox"/> Determine Delivery Platform | <input type="checkbox"/> Conduct User Test | <input type="checkbox"/> Fix Bugs |
| <input type="checkbox"/> Determine Authoring Platform | <input type="checkbox"/> Revise Design | <input type="checkbox"/> Conduct Beta Test |
| <input type="checkbox"/> Assay Available Content | <input type="checkbox"/> Create Graphics | <input type="checkbox"/> Create Golden Master |
| <input type="checkbox"/> Draw Navigation Map | <input type="checkbox"/> Create Animations | <input type="checkbox"/> Replicate |
| <input type="checkbox"/> Create Storyboards | <input type="checkbox"/> Produce Audio | <input type="checkbox"/> Prepare Package |
| <input type="checkbox"/> Design Interface | <input type="checkbox"/> Produce Video | <input type="checkbox"/> Deliver or Install at Web Site |
| <input type="checkbox"/> Design Information Containers | <input type="checkbox"/> Digitize Audio and Video | <input type="checkbox"/> Award Bonuses |
| <input type="checkbox"/> Research/Gather Content | <input type="checkbox"/> Take Still Photographs | <input type="checkbox"/> Throw Party |

In a white paper about producing educational software, elearnity (www.elearnity.com) has allocated percentages of effort, as shown to the right:

Building a Team

Multimedia is an emerging technology requiring a set of skills so broad that multimedia itself remains poorly defined. Players in this technology come from all corners of the computer and art worlds as well as from a variety of other disciplines, so if you need to assemble a team, you need to know the people and skills it takes to make multimedia. (Refer to Chapter 8 for a description of the various skills and talents needed and how others have built successful teams.)

Building a matrix chart of required skills is often helpful to describe the makeup of your team. The skills and software capabilities available to you are not as limiting as your list of required hardware—you can always budget for new and more powerful software and for the learning curve (or consultant fees) required to make use of it. Indeed, authoring software is usually necessary only for development of the project, not its playback or delivery, and should be a cost or learning burden not directly passed to end users.

Figure 9-4 shows a skill matrix developed when four medium-sized multimedia development companies came together to bid on a single, large CD-ROM project. If you are building a complex web site, substitute Java/Ruby programmer, HTML/CSS programmer, and Server Specialist into the proper row.

Staying at the leading edge is important. If you remain knowledgeable about what's new and expected, you will be more valuable to your own endeavors, to your team, and to your employer or prospective clients. But be prepared for steep learning curves and difficult challenges in keeping your own skills (and those of your employees) current and in demand. And don't neglect team morale as hours grow long, deadlines slip, and tempers flare.

TIP If you are looking for multimedia talent, try placing a Help Wanted ad in one of the job-hunting/help wanted sites on the Internet. Or you can try one of the following web sites:

.....
www.careerbuilder.com

www.monster.com

www.hotjobs.com

| Task | Percentage of Effort |
|-----------------------------|----------------------|
| Analyze need | 3% |
| Draft mission statement | 1% |
| Create audience profile | 2% |
| Write objectives | 2% |
| Analyze and outline content | 6% |
| Lay out course map | 2% |
| Define treatment | 2% |
| Select learner activities | 2% |
| Storyboard the course | 19% |
| Author the course | 28% |
| Evaluate the course | 20% |
| Produce media | 13% |

In a business where success and failure often depends upon our ability to monitor and anticipate emerging technology, job recruiters see multimedia as very challenging. Not only does the fledgling multimedia industry incorporate some of the hottest computer technology tools, it draws on talent that comes from outside the traditional boundaries of data processing and MIS recruitment. The ill-defined but very technical skills needed for multimedia provide us, the industry recruiters, an exceptional opportunity for creativity. Our clients, too, need to be open-minded and flexible about the talent and skills required of multimedia developers.

.....
 Heinz Bartesch,
 Director of Sales and Marketing,
 The Search Firm (San Francisco)

www.jobbankusa.com
www.dice.com
<http://usajobs.opm.gov>
www.odesk.com
www.elance.com

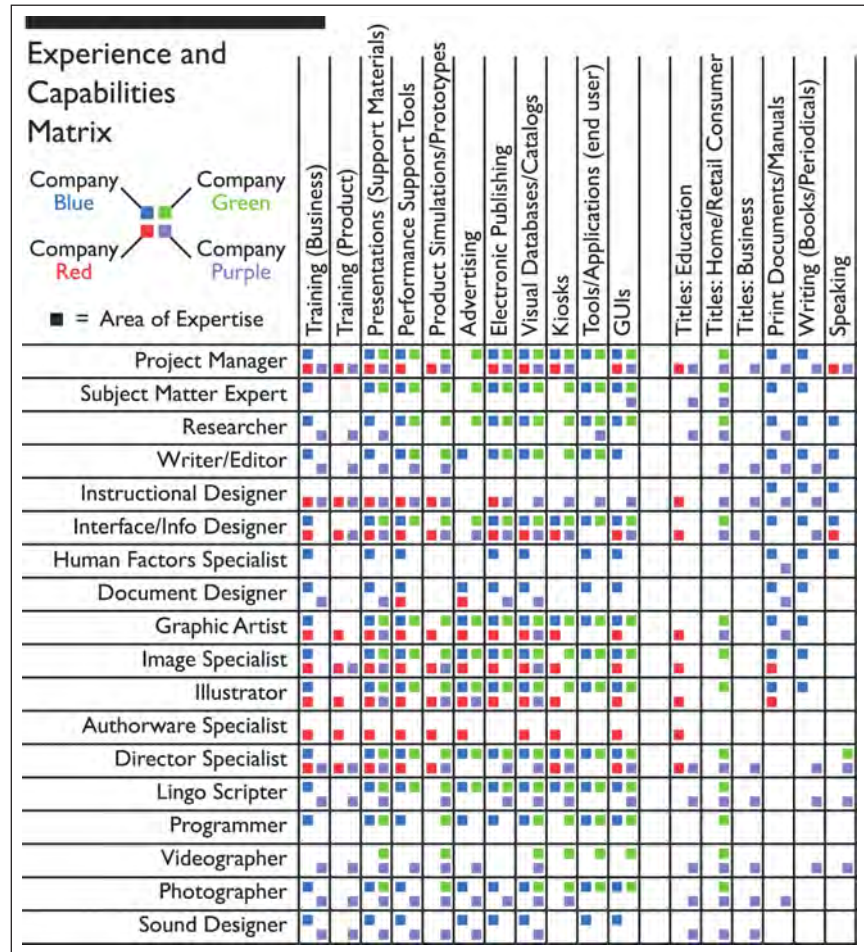

Figure 9-4 A matrix of available skills can assist you in planning for your project.

Prototype Development

Once you have decided that a project is worth doing, you should develop a working prototype. This is the point at which you begin serious work at the computer, building screen mock-ups and a human interface of menus and button clicks. Your messages and story lines will take shape as you

explore ways of presenting them. For the prototype, sometimes called a **proof-of-concept** or **feasibility study**, you might select only a small portion of a large project and get that part working as it would in the final product. Indeed, after trying many different approaches in the course of prototyping, you may end up with more than one viable candidate for the final product.

During this phase you can test ideas, mock up interfaces, exercise the hardware platform, and develop a sense about where the alligators live. These alligators are typically found in the swampy edges of your own expertise; in the dark recesses of software platforms that almost-but-not-quite perform as advertised and in your misjudgment of the effort required for various tasks. The alligators will appear unexpectedly behind you and nip at your knees, unless you explore the terrain a little before you start out.

Test your prototype along several fronts: technology (will it work on your proposed delivery platform or platforms?), cost (can you do this project within budget constraints?), market (can you sell it, or will it be properly used if it is an in-house project?), and human interface (is it intuitive and easy to use?). At this point you may wish to arrange a focus group, where you can watch potential end users experiment with your prototype and analyze their reactions. The purpose of any prototype is to test the initial implementation of your idea and improve on it based upon test results. So you should never feel committed or bound to any one option, and you should be ready and willing to change things!

Persuade the client to spend a small amount of money and effort up front to let you build a skeletal version of the project, including some artwork, interactive navigation, and performance checks. Indeed, there may be some very specific technology issues that need thorough examination and proof before you can provide a realistic estimate of the work and cost required. The focused experience of this proof will allow both you and the client to assess the project's goals and the means to achieve them.

Include your experimental pilot as the first phase of your project. At the pilot's conclusion, prepare a milestone report and a functional demo. You will be paid for the work so far, and the client will get real demonstration material that can be shown to bosses and managers. If your demo is good, it will be a persuasive argument within the client's management hierarchy for completing the full-scale project. Figure 9-5 is excerpted from trial calculations that were the result of a prototype five-language CD-ROM project. In the prototyping, office staff read the voice-over script as a "scratch track," like using a stand-in for the real thing; later, professional talent was used in the recording studio. As a result of building a prototype, accurate estimates of required storage space on the disc were possible.

Calculation Sheet

CD-ROM Project

Allocation of Disc Space

Note 1: The following trial calculations are based upon the file sizes yielded by an early voice rendering of the project’s English script.

Note 2: File sizes for low-resolution images (72dpi) of 640×480 and 768×512 pixel dimensions are estimated at 768KB each.

Note 3: File sizes for high-resolution images (300dpi) may range from 3.7MB to 4.5MB, depending upon image complexity and compression rates. The conservative figure of 4.5MB per high-resolution image is used in these estimates.

Note 4: More accurate real estate estimates will be available following finalization of the script and recording of the English version narration.

Note 5: Firm count of low-resolution images and their pixel dimensions will be calculated upon script freeze.

SUMMARY: There is adequate room on the disc for both sound and images if each language recording is limited to no more than 9 minutes.

Scratch Track File

| (English) | Duration | (English) | Duration |
|------------------|-----------------|---------------------------|-----------------|
| SNDE01A | 18.369 | SNDE10A | 5.658 |
| SNDE01B | 9.180 | SNDE11A | 23.856 |
| SNDE01C | 9.295 | SNDE12A | 14.314 |
| SNDE02A | 17.609 | SNDE13A | 14.193 |
| SNDE03A | 17.932 | SNDE14A | 7.487 |
| SNDE04A | 11.156 | SNDE15A | 16.172 |
| SNDE05A | 18.035 | SNDE16A | 19.450 |
| SNDE06A | 8.050 | SNDE17A | 5.830 |
| SNDE07A | 12.790 | SNDE18A | 21.443 |
| SNDE08A | 16.218 | SNDE19A | 12.295 |
| SNDE09A | 27.468 | Total | 306.800 Seconds |
| | | | 5.113 Minutes |
| | | plus Intro Fanfare | 30.0 Seconds |
| | | (Shared by all languages) | |

Figure 9-5 Trial calculations are possible after prototyping.

As part of your delivery at the end of the pilot phase, reassess your estimates of the tasks required as well as the cost. Prepare a written report and analysis of budgets and anticipated additional costs. This is also the proper time to develop a revised and detailed project plan for the client. It allows the client some flexibility and provides a reality check for you. At this point you can also finalize your budget and payment schedule for the continuation of the project, as well as ink a contract and determine overrun procedures.

Difficulties may arise if your client is disappointed in the quantity of material delivered or is otherwise not satisfied with your work. If you have kept good records of the time and effort spent during prototyping, you may be able to smooth the rough waters. Remember that developing multimedia is a “trying” experience—try this, try that, then try this again a bit differently—and the creative process soaks up a lot of hours and cost. Listen carefully to the client’s reaction to your prototype, because many problems can be quickly fixed, and all constructive comments can certainly be woven into the next phase of development.

Alpha Development

As you go forward, you should continually define the tasks ahead, because just as if you were navigating a supertanker, you should be aware of the reefs and passages that will appear along your course and prepare for them. With an **alpha** stage prototype in hand and a commitment to proceed, the investment of effort will increase and, at the same time, become more focused. More people may become involved as you begin to flesh out the project as a whole.

Beta Development

By the time your idea reaches the **beta** stage of development, you will have committed serious time, energy, and money, and it is likely too late to bail out. You have gone past the point of no return and should see it through. But by now you have a project that is looking great! Most of the features are working, and you are distributing it to a wider arena of testers. In fact, you are on the downhill slope now, and your concern should be simply successfully steering the project to its well-defined goal.

Delivery

By the time you reach the delivery stage, you are **going gold**—producing the final product. Your worries slide toward the marketplace: how will your project be received by its intended audience? You must also deal with a great many practical details, such as who will answer the support hotline

and run the live chat desk, or whether to co-locate a server or trust the current ISP to handle the predicted increased volume of hits. The alpha, beta, and final gold stages of project delivery for CD-ROM, DVD, and the Web are discussed in Chapter 14.

First Person

Not every prototype segues naturally into a full-blown project. Sometimes a project is shut down at this milestone due to reality shock: the client chokes on cost-to-completion estimates. Sometimes it's the Reorg Alligator: new managers with new agendas axe the project. Sometimes the client just plain doesn't like your work. Then sometimes a project simply disappears like a dream forgotten by mid-morning.

We were invited to prepare the prototype for a large and intricate intranet site behind a corporate firewall—potentially a two-year involvement. We proposed a first phase, an analysis and definition of the company's structure and information-gathering and dissemination needs so that we could lock down major content areas and the navigation design. We wanted to know how many buttons to put on the main menu and what they would say, before we spent long hours creating the bitmaps and animated GIFs of a neat interface. "No, no," they said, "our guys have put that together already."

So we negotiated for creation of artwork and HTML page styles that would provide a consistent look and feel throughout the site. We set a fixed price and provided a list of deliverables: (1) graphic style and GIF/JPEG elements for main home and subpages; (2) a complete site structure and map with navigationally functional "under construction" pages based on the organizational charts they would provide; and (3) working demo pages for two of the company's departments.

Then we had our first team meeting, and it soon became clear they needed hand-holding while their own Management Information System people transitioned from other tasks and got up to speed in their new jobs as in-house intranet team and webmasters. None had coded a page of HTML, although some had used editors and builders to get pages working. The database guy was stopped dead by an undefined Java error when accessing his massive SQL database. The server guy was still getting set up. The HTML guy was learning his authoring tools. There was neither a graphic

artist nor a handy pool of company graphic art from which our own contribution might spring. Okay, we thought, so they're on the learning curve. We can start from scratch. We took the group leader aside and quietly suggested that she consider bringing on a full-time graphics person to support her team.

During the next weeks, we developed a classy look and feel and theme. After a couple of feedback/change loops, they loved it. We worked up the more detailed bits and pieces of our deliverable and tightened up the organization of their proposed navigation map. By prototype deadline, we had spent all the hours we had estimated for the job, and they had the site up and working in test mode. We had gotten their motor running.

The last time we saw the SQL database programmer was on the afternoon we picked up our milestone check—he was removing shrink-wrap from a new copy of Photoshop, and the HTML guy was deep into Cold Fusion. We never heard from them again.

Scheduling

Once you have worked up a plan that encompasses the phases, tasks, and work items you feel will be required to complete your project, you need to lay out these elements along a timeline. This will usually include **milestones** at which certain **deliverables** are to be done. If you are working for a client, these are work products that are delivered to the client for approval. To create this schedule, you must estimate the total time required for each task and then allocate this time among the number of persons who will be asynchronously working on the project (see, for example, Figure 9-6). Again, the notion of balance is important: if you can distribute the required hours to perform a task among several workers, completion should take proportionally less time.

| Project Calc Sheet | | | | | | | | | | | | |
|--------------------|---------------------------|-----------|-------|------|---------|------|------|------|------|-------|------|------|
| c. 5 5 | | \$112,000 | | | | | | | | | | |
| Origination Fee | | Salary | March | | 1 April | | | | | 2 May | | |
| | | | 1 | 2 | 3 | 4 | 5 | 6 | 7 | 8 | 9 | 10 |
| 1 Content | | | | | | | | | | | | |
| | Director | 40 | 0.1 | 0.1 | 0.1 | 0.1 | 0.1 | 0.1 | 0.1 | 0.1 | 0.1 | 0.1 |
| | cost | | 0.22 | 0.22 | 0.22 | 0.22 | 0.22 | 0.22 | 0.22 | 0.22 | 0.22 | 0.22 |
| | Editor | 20 | | | | | 1 | 1 | | | | |
| | cost | | 0.00 | 0.00 | 0.00 | 0.00 | 1.12 | 1.12 | 0.00 | 0.00 | 0.00 | 0.00 |
| | Writer A | 40 | 1 | 1 | 1 | 1 | 1 | | | | | |
| | cost | | 2.24 | 2.24 | 2.24 | 2.24 | 2.24 | 0.00 | 0.00 | 0.00 | 0.00 | 0.00 |
| | Researcher | 16 | | | | | | | | | | |
| | cost | | 0.00 | 0.00 | 0.00 | 0.00 | 0.00 | 0.00 | 0.00 | 0.00 | 0.00 | 0.00 |
| | subtotal number personnel | | 1.1 | 1.1 | 1.1 | 1.1 | 2.1 | 1.1 | 1.1 | 0.1 | 0.1 | 0.1 |
| | cost | | 2.46 | 2.46 | 2.46 | 2.46 | 3.38 | 1.34 | 0.22 | 0.22 | 0.22 | 0.22 |
| 2 Art | | | | | | | | | | | | |
| | Director | 35 | 1 | 1 | 1 | 1 | 1 | 1 | 1 | 1 | 1 | 1 |
| | cost | | 1.40 | 1.40 | 1.40 | 1.40 | 1.40 | 1.40 | 1.40 | 1.40 | 1.40 | 1.40 |
| | Art 1 | 18 | | | | | | | | 1 | 1 | 1 |
| | cost | | 0.00 | 0.00 | 0.00 | 0.00 | 0.00 | 0.00 | 0.00 | 1.01 | 1.01 | 1.01 |
| | Art 2 | 13 | | | | | | | | | | |
| | cost | | 0.00 | 0.00 | 0.00 | 0.00 | 0.00 | 0.00 | 0.00 | 0.00 | 0.00 | 0.00 |
| | subtotal number personnel | | 1 | 1 | 1 | 1 | 1 | 1 | 1 | 2 | 2 | 2 |
| | cost | | 1.40 | 1.40 | 1.40 | 1.40 | 1.40 | 1.40 | 1.40 | 2.41 | 2.41 | 2.41 |
| 3 Technical | | | | | | | | | | | | |
| | Director | 35 | | | | | | | | 1 | 1 | 1 |
| | cost | | 0.00 | 0.00 | 0.00 | 0.00 | 0.00 | 0.00 | 0.00 | 1.40 | 1.40 | 1.40 |

Figure 9-6 Portion of a spreadsheet used to schedule manpower and project costs

WARNING Assigning twice as many people to work on a task may not cut the time for its completion precisely in half. Consider the administrative and management overhead of communication, networking, and necessary staff meetings required when additional staff is added.

Scheduling can be difficult for multimedia projects because so much of the making of multimedia is artistic trial and error. A recorded sound will need to be edited and perhaps altered many times. Animations need to be run again and again and adjusted so that they are smooth and properly placed. A QuickTime or MPEG movie may require many hours of editing and tweaking before it works in sync with other screen activities.

Scheduling multimedia projects is also difficult because the technology of computer hardware and software is in constant flux, and upgrades while your project is under way may drive you to new installations and concomitant learning curves. The general rule of thumb when working with computers and new technology under a deadline is that everything will take longer to do than you think it will.

In scheduling for a project that is to be rendered for a client, remember that the client will need to approve or sign off on your work at various stages. This approval process can wreak havoc with your schedule since it takes time and depends upon factors beyond your control. Perhaps more important, the client feedback may also require revision of your work. In order to protect yourself from a capricious client, you need to have points during the project for **client sign-off** on the work, meaning that he or she has approved the work to that point. If the client changes his or her mind later in the process, then any revisions of the previously approved materials would require a **change order**, meaning that the client agrees to pay the additional costs for making the changes, rather than your having to eat that unbudgeted cost out of your profit margin.

TIP *When you negotiate with your client, limit the number of revisions allowed (each revision costs time and money) before you rename the revisions as change orders and bill extra.*

Estimating

In production and manufacturing industries, it is a relatively simple matter to estimate costs and effort. To make chocolate chip cookies, for example, you need ingredients, such as flour and sugar, and equipment, such as mixers, ovens, and packaging machines. Once the process is running smoothly, you can turn out hundreds of cookies, each tasting the same and each made of the same stuff. You then control your costs by fine-tuning known expenses, like negotiating deals on flour and sugar in quantity, installing more efficient ovens, and hiring personnel at a

First Person

Many times we have heard about the Feedback Alligator. Its mottled skin boasts an Escher-like pattern of lines and marks, showing apparently clear definition along the head and neck, but converging to a brown muddled wash at the tail. When the tail wags this alligator, all hell breaks loose, and multimedia contracts can be severely strained or lost altogether.

Feedback Alligators can appear when you throw a client into the mix of creative people... when necessary-for-client-satisfaction approval cycles can turn your project into an anorexic nightmare of continuing rework, change, and consequently diminished profit. These alligators typically slink out from the damps *after* you have locked down a contract and scope of work, when the creative guys are already being well paid to ply their craft.

For client protection, multimedia creative artists should be hired with a cap on budget and time. They should be highly skilled, efficient, and have a clear understanding of what a project's goals are, and they should be allowed

to accomplish these goals with as much freedom as possible. But good multimedia artists should come close to the mark the first time.

They don't always. For example, you agree to compose background theme music to play whenever your client's logo shows on the screen. You master a sample file and pass it to the client. She doesn't quite like the sound but is not sure why. You go back to the MIDI sequencer and try again. The client still isn't sure that's it. Again, you make up a file and e-mail it to her for review. No, maybe it needs a little more Sgt. Pepper... this is our logo, remember?

The process of client feedback can go on and on forever in a resonance of desire-to-please and creative uncertainty unless you have developed rules for limiting these cycles. While your client might always be right, you will still go broke working unlimited changes on a fixed budget.

Projects can also suffer from "scope creep." If you don't clearly delineate the features and specifications of the project expected

by your client, you will be tempted to add features, enhancements, and improvements. Before long, the project's scope will exceed the original specifications, the budget, and your timeline.

So do two things to ward off the Feedback Alligator. First, make it clear up front (in your contract) that there will only be a certain number of review cycles before the client must pay for changes. Second, invite the client to the workstation or studio where the creative work is done. For sound, tickle the keyboard until the client says, "That's it!" Make 'em sign off on it. For artwork and animations, let the client spend an afternoon riding shotgun over the artist's shoulder, participating in color and design choices. Get the client involved.

If your client contact isn't empowered to make decisions but simply carries your work up to the bosses for "management approval," you are facing the unpleasant Son of Feedback Alligator. Demand a client contact who has budget and design authority.

more competitive wage. In contrast, making multimedia is not a repetitive manufacturing process. Rather, it is by nature a continuous research and development effort characterized by creative trial and error—a “trying” experience, as described previously. Each new project is somewhat different from the last, and each may require application of many different tools and solutions. Philosophers will counsel you that experience is something you get only after you need it!

TIP *To recoup learning-curve costs when you first perform a task, you must factor extra time into your budget; later you can increase your billing rate to reflect your improved skill level.*

In the area of professional services, let's consider some typical costs in the advertising community. Production of a storyboard for a 30-second commercial spot costs about \$50,000. Postproduction editing time in a professional video studio runs upwards of \$500 per hour. An hour of professional acting talent costs \$350 or more at union scale. The emerging multimedia industry, on the other hand, does not have a track record long enough to have produced “going rates” for its services. A self-guided tour distributed with a software product, for example, may cost \$15,000 for one client and \$150,000 for another, depending upon the tour's length and polish. A short original musical clip may cost \$50 or \$500, based on the talent used and the nature of the music. A graphical menu screen might take 2 or 20 hours to develop, depending on its complexity and the graphic art talent applied. Without available going rates for segments of work or entire projects, you must estimate the costs of your multimedia project by analyzing the tasks that it comprises and the people who build it.

Be sure you include the hidden costs of administration and management. It takes time to speak with clients on the telephone, to write progress reports, and to mail invoices. In addition, there may be many people in your workforce who represent specialized skills, for example, a graphic artist, musician, instructional designer, and writer. In this case, you'll need to include a little extra buffer of time and expense in your estimate to pay for these artists' participation in project meetings and creative sessions. Also, remember to include a line item in your budget for **contingencies**, as a little extra padding to cover the inevitable unexpected costs. Adding 10 percent to 15 percent of the total cost is a typical rule-of-thumb contingency amount.

As a general rule, there are three elements that can vary in project estimates: time, money, and people. As illustrated next, if you decrease any one of these elements, you'll generally need to increase one or both of the others. For example, if you have very little time to do a project (an aggressive

schedule), it will cost more money in overtime and premium sweat, and it may take more people. If you have a good number of people, the project should take less time. By increasing the money spent, you can actually decrease the number of people required by purchasing efficient (but costly) experts; this may also reduce the time required.

Do your best to estimate the amount of time it will take to perform each task in your plan. Multiply this estimate by your hourly billing rate. Sum the total costs for each task, and you now have an estimate of the project's total time and cost. Though this simple formula is easy, what is not so easy is diligently remaining within the budgeted time and money for each task. For this, you need good tracking and management oversight.

If you are working for an outside client, you will also need to determine a **payment schedule**. Payments are often divided into thirds: one-third up front upon the signing of a contract, one-third as work products are delivered and approved during the alpha and beta development phases, and one-third upon final approval of the completed production.



Billing Rates

Your billing rate should be set according to your cost of doing business plus a reasonable profit margin. Typical billing rates for multimedia production companies and web designers range from \$60 to \$150 an hour, depending upon the work being done and the person doing it. If consultants or specialists are employed on a project, the billing rate can go much higher. You can establish a rate that is the same for all tasks, or you can specify different rates according to the person assigned to a task. The Graphic Artists Guild (www.gag.org) provides its members a *Pricing & Ethical Guidelines* manual with pricing information based on real industry surveys. Pricing guides are also available at www.brennerbooks.com.

Everyone who contributes to a project should have two rates associated with their work: the employee's cost to the employer (including salary and benefits), and the employee's rate billed to the customer. The employee's cost, of course, is not included in your estimate, but you need to know

this as part of your estimate—because your profit margin is the difference between the rate you charge the client and the cost to your company, less a proportion of overhead expenses (rental or leasing of space, utilities, phones, shared secretarial and administrative services, and so on). If your profit margin is negative, you should reconsider both your project plan and your long-term business plan.

Multimedia production companies and web site builders with high billing rates claim their skill-sets and experience allow them to accomplish more work in a given amount of time, expertly, thus saving money, time, and enhancing the finished quality and reliability of a project. This is particularly the case with larger-scale, complex projects. Smaller and leaner companies that offer lower billing rates may claim to be more streamlined, hungry, and willing to perform extra services. Lower rates do not necessarily mean lower-quality work, but rather imply that the company either supports fewer overheads or is satisfied with a reduced profit margin. The business of making multimedia is a “low entry barrier” enterprise because all you need to get started is some (relatively) inexpensive computer hardware

First Person

Back when floppy disks were common, we were asked by a large institution to complete a project that had fallen on the floor. It was really worse than that—the project had actually slipped through the cracks in that floor. The single known copy of work—representing about \$30,000 in paid billings—had been copied to 19 high-density diskettes and stored in a file cabinet. Here, they had been discovered by the secretarial pool and formatted, to be used for WordPerfect documents. The secretaries remembered the whole thing because the stored backups contained protected files, so the disks were unusually difficult to erase! Luckily, bits and pieces of

the project were unearthed on the hard disk of a computer that had been disconnected and stored in the basement. We were able to reconstruct much of the artwork, but not the interactive links.

As we studied the leavings of the embarrassed progenitors, we discovered a trail of missteps and errors. It became clear that the institution made a bad decision in hiring a well-qualified engineering firm at great expense (standard billing rates) to construct a difficult multimedia presentation. CAD/CAM drawings and finite element analysis were the forte of these engineers—not animated icons and colorful bitmaps

with sound tracks. Furthermore, the engineering firm erred in selecting software that performed on the target hardware platform at about the speed of snails chasing a dog. Money had been spent, the product didn't work, and everyone involved was in gray limbo, slinking around, looking for a solution.

We determinedly pulled together the bits and pieces we could find, designed a snappy navigational structure we were proud of, and quickly fixed the big problem for a small fee (based upon our own standard billing rate). The institution, of course, was delighted and became a client of long standing.

and software, not a 70,000-square-foot factory or expensive tooling. You can make multimedia in a living room, basement, or garage. As more and more multimedia producers and web developers enter this marketplace, the competition is increasing and the free hand of supply and demand is driving prices (down).

Purchasers of multimedia services must, however, thoroughly examine the qualifications of a prospective contracting person or company to ensure that the work required can be accomplished on time and within budget. There is no more difficult business situation than a half-completed job and an exhausted budget.

Contractors and consultants can bring specialized skills such as graphic art, C and Java programming, database expertise, music composition, and video to your project. If you use these experts, be sure your billing rate is higher than theirs. Or, if you have a task the client has capped with a not-to-exceed cost, be sure your arrangement with the contractor is also capped. Contractors place no burden on your overhead and administration other than a few cups of coffee, and they should generate a generous profit margin for you during the course of your project. Be sure that contractors perform the majority of their work off-site, using their own equipment; otherwise, federal tax regulators may reclassify these freelancers as employees and require you to pay employee benefits. In 1998, in *Vizcaino v. Microsoft*, the U.S. Supreme Court required Microsoft Corporation to pay employee benefits to hundreds of workers that the court determined were regular employees rather than independent contractors. There are about 20 factors, according to the IRS, in determining whether a worker is an employee or an independent contractor for tax purposes, and companies may be liable for all employment benefits, including (as Microsoft discovered) stock option and stock sharing plans, if the work arrangement is not carefully constructed. However, when these outside workers are not classified as employees, then you run another risk—that they could retain ownership of the work they have created for you, limiting your right to use the material or restrict its use elsewhere. The best way to avoid this is to be sure that your contract with any outside workers clearly specifies the terms of ownership and rights of use of the product for which you are contracting. This “work for hire” issue is discussed in more detail in Chapter 11.

Example Cost Sheets

Figure 9-7 contains groups of expense categories for producing multimedia. If you use these in your own work, be sure to temper your guesses with experience; if you are new to multimedia production, get some qualified advice during this planning stage.

| | |
|--|---------------------------------------|
| PROJECT DEVELOPMENT COSTS | |
| Salaries | Video Production |
| Client meetings | Studio fees |
| Acquisition of content | Talent fees |
| Communications | Fees for licensing stock footage |
| Travel | Location fees |
| Research | Equipment rental |
| Proposal & contract prep | Digital capture & editing |
| Overhead | Authoring |
| | Salaries |
| | Hardware/software |
| | Consumables |
| PRODUCTION COSTS | |
| Management | |
| Salaries | |
| Communications | |
| Travel | |
| Consumables | |
| Content Acquisition | |
| Salaries | |
| Research services | |
| Fees for licensing content | |
| Content Creation | |
| All content categories | |
| Salaries | |
| Hardware/software | |
| Consumables | |
| Graphics Production | |
| Fees for licensing images or animation clips | |
| Audio Production | |
| Studio fees | |
| Talent fees | |
| Fees for licensing music rights | |
| Data storage | |
| | TESTING COSTS |
| | Salaries |
| | Focus groups |
| | Facility rental |
| | Printing costs |
| | Food and incentives |
| | Coop fees (payment for participation) |
| | Editing |
| | Beta program |
| | DISTRIBUTION COSTS |
| | Salaries |
| | Documentation |
| | Packaging |
| | Manufacturing |
| | Marketing |
| | Advertising |
| | Shipping |

Figure 9-7 There are many costs associated with producing multimedia.

RFPs and Bid Proposals

Often, potential clients don't have a clue about how to make multimedia, but they do have a vision or a mandate. You field a telephone call, a voice describes a need or a want, and you explain how you (and your company) can satisfy that need. Much of the talk may be instructional as you teach

First Person

I was downbound from Puget Sound to San Francisco, and the weather was up, with seas running heavy and winds gusting to 60 knots in our face. The Master and the First Mate were on the bridge, the old man sitting curled up in his upholstered high chair on the darkened starboard wing, the First pacing on the rubber mat behind the helmsman. The Third Mate was on watch, leaning over the radar screen and making fluorescent notes with a grease pencil. As I was a guest with no duties, I mostly hung out in the chart room while white water broke over the bows and the shuddering propeller came

out of the sea; wind screamed in the vents on the roof of the bridge. There wasn't much conversation that night, but the Master slowed us to five knots, concerned about the containers lashed to the forward deck. When the young Third Mate came into the chart room, I asked, "Where are we?" and he took a sharp pencil, made a fine point on the chart, and drew a tiny circle around the point. Then he smiled, proud to have good radar bearings. The First Mate came in about a half hour later, and when I asked the same question, he circled an area about the size of a walnut.

As the Master left the bridge for his cabin, I asked him, too, where we were. He took his thumb and rubbed it on the chart in a rough oval about the diameter of his fist, saying, "Somewhere in here," and grinned at me as the ship heaved suddenly and we grabbed for the handholds.

The more experience these professionals had, the larger the circle they drew, and the less they relied upon pinpoint navigation. You should be prudent when costing a multimedia production; precision estimating can wreck your project.

the client about the benefits and pitfalls of multimedia in all its forms. You seldom will glean enough information during this initial discussion to accurately estimate time or cost, so be prepared to answer these queries in vague terms while you present your available skill-sets and capabilities in the most favorable light. If the client is serious and your instruction well received, in short time you may be able to guide this client into good choices and reasonable decisions, working together to conceive and design an excellent product. Discussions will soon turn into design meetings. Somewhere along the way, you will sign a contract.

Occasionally you may encounter a more formal **Request for Proposal (RFP)**. These are typically detailed documents from large corporations that are "outsourcing" their multimedia development work. Figure 9-8 is an example of such a document that provides background information, scope of work, and information about the bidding process. Still, you should note that there is little "hard" information in this document; most bid proposals require contact with the client to fill in details prior to bidding.

**Smythe Industries
Request for Proposal**

Summary: The objective is to produce a family of materials which will develop a unique personality and visual image for the Smythe Campus in Vancouver, British Columbia, home of multiple Smythe subsidiaries and divisions.

As background, Smythe Industries was launched in 1995 following the acquisition of Wilson Aluminum Foundries, Ltd. (Canada) and Fenwick Rolling Mills, Inc. (U.S.A.) and is based in Vancouver. The site is also the headquarters for Global Aluminum Research, a research and development subsidiary. In addition, there are discussions concerning the establishment of a special alloy research institute at the Vancouver campus.

Each of the entities has unique personality traits, management structures, and business cultures which will need to be recognized and incorporated into the design process.

Audience & Message

Potential Employees – “employer of choice”

Business Development – “partner of choice”

Metals Companies

Academic Institutions

Government/Community officials – “good neighbor/citizen”

Smythe Employees – “credible/proud”

Scientific/Engineering Organizations – “credible research/scientifically advanced”

Tone & Manner

Innovative, scientifically advanced, sophisticated, credible

Colorful: jewel colors/crisp/high contrast

Energetic, modern, innovative, cutting edge

Geometric lines & shapes (vs. free form)

A human element: photography, illustration, etc.

Personable, warm, intellectually inviting

Electronic Communications RFP

Multimedia Presentation Capabilities

Summary: The objective is to create a set of tools which will deliver key messages while positioning Smythe Vancouver as an innovative user of technology for communication. There will be two components to this project: a presentation format and a library of images. We would like to develop a library, including still imagery, audio, and QuickTime movies, that can be contained on a set of CDs. Note: all images should be created with the goal of repurposing across different mediums and projects.

The key purpose is to make core messages and the corporate personality come alive by utilizing sound and motion. These multimedia assets will be used for recruiting purposes at career centers, job fairs, and in-house for visiting recruits. They will also serve as presentation support material at scientific and engineering forums.

Smythe will work with the multimedia design firm to create and identify existing television clips, video, and other material which can serve to reinforce key messages.

External Web Site

Summary: As the most visible element of Smythe’s Vancouver identity, the web site will set the stage for positioning the company in the research community as an employer of choice and a key player in esoteric alloy and metallurgical research. The web site will provide easy navigation for users to reach the areas of greatest interest to them, e.g. a particular business division, academic papers, employment opportunities, etc.

Figure 9-8 Some RFPs provide great detail.

The multimedia design firm will also be expected to create a library of images which can be utilized to update the site periodically. The design firm should also be prepared to provide input on ways to easily update and cost-effectively maintain the site. In addition, the web site should be created so that audio and live imagery can be incorporated and downloaded easily by users who have the appropriate equipment.

Internal Web Site

Summary: The internal web site is the primary medium for employee communication. It will be a useable, interesting tool for internal users and serve to reinforce corporate messages and the campus culture. Since the web site represents and includes different business entities on campus, this internal site will also introduce employees to activities in which other business units and groups are involved. The site will need to be designed with a template format so that it can be easily updated.

Production Elements for all Electronic Communications

Icons: Develop an illustrative style for a family of icons shared across the CD-ROM, internal web site, and external web site.

Interface Design: Develop an interface design that provides design parameters and a personality for the internal web site and external web site. (Note: Internal and external web sites should carry a similar look and feel; however, it must be easy to distinguish between the two.)

Visual Image: Produce a library of visual images. This will require the additional production of video clips and sound clips.

Photography: A photo shoot schedule and plan will be developed with Smythe to most effectively maximize time and resources in shooting photos which can be used in print, in the web sites, and in multimedia materials.

RFP Process

Quotations: Itemize quotes, e.g. project management, copy writing, editing, design, photography, illustrations, etc. Also provide 3 references.

Note: Smythe will write the HTML directives in-house and will also be posting to a server which is maintained in-house.

All quotes should be submitted to:

Suzanne Petruski
Project Manager
Smythe Industries
65 Silver Foil
Vancouver, BC, CANADA

Figure 9-8 Some RFPs provide great detail. (Continued)

A multimedia bid proposal will be passed through several levels of a company so that managers and directors can evaluate the project's quality and its price. The higher a bid proposal goes in the management hierarchy, the less chance it has of being read in detail. For this reason, you always want to provide an executive summary or overview as the first page of your proposal, briefly describing the project's goals, how the goals will be achieved, and the cost.

In the body of the proposal, include a section dealing with creative issues, and describe your method for conveying the client's message or

meeting the graphic and interactive goals of the project. Also incorporate a discussion of technical issues, in which you clearly define the target hardware platform. If necessary, identify the members of your staff who will work on the project, and list their roles and qualifications.

The backbone of the proposal is the estimate and project plan that you have created up to this point. It describes the scope of the work. If the project is complicated, prepare a brief synopsis of both the plan and the timetable; include this in the overview. If there are many phases, you can present each phase as a separate section of the proposal.

Cost estimates for each phase or deliverable milestone, as well as payment schedules, should follow the description of the work. If this section is lengthy, it should also include a summary.

TIP *Make the proposal look good—it should be attractive and easy to read. You might also wish to provide an unbound copy so that it can be easily photocopied. Include separate, relevant literature about your company and qualifications. A list of clients and brief descriptions of projects you have successfully completed are also useful for demonstrating your capabilities.*

Finally, include a list of your terms. Contract terms may become a legally binding document, so have your terms reviewed by legal counsel. An example is shown in Figure 9-9. Terms should include the following:

- A description of your billing rates and invoicing policy (for example, what percentage is to be paid up front, how much at certain milestones, and how much upon delivery).
- Your policy on client sign-offs and change order costs.
- Your policy for billing out-of-pocket expenses for travel, telephone, courier services, and so forth.
- Your policy regarding third-party licensing fees for run-time modules and special drivers (the client pays).
- Specific statements of who owns what upon completion of the project. You may wish to retain the rights to show parts of the work for your own promotional purposes and to reuse in other projects segments of code and algorithms that you develop.
- An assurance to the client that you will not disclose proprietary information.
- Your right to display your credits appropriately within the work.
- Your unlimited right to work for other clients.
- A disclaimer for liability and damages arising out of the work.

It is a significant task to write a project proposal that creatively sells a multimedia concept, accurately estimates the scope of work, and provides realistic budget costs. The proposal often becomes a melting pot, in that you develop the elements of your idea during early conversations

with a potential client and add the results of discussions on technique and approach with graphic artists and instructional designers. You blend what the client wants done with what you can actually do, given the client's budgetary constraints, and when the cauldron of compromise cools, your proposal is the result.

Sample Terms:

We will undertake this assignment on a time-and-expenses basis at our current hourly rate of \$___ per hour for ___job title___, \$___ per hour for ___job title___, \$___ per hour for ___job title___, plus applicable taxes and reimbursement of authorized out-of-pocket expenses. Reasonable travel, express, freight, courier and telecommunication expenses incurred in relation to the project, will be considered pre-authorized. [Client] will be responsible for all licensing fees of third-party products incorporated (with [Client]'s knowledge and approval) into the final product. We will invoice [Client] either upon [Client]'s acceptance of the specified deliverables for each work phase specified above, or monthly, whichever is more often. [Client]'s authorization, either written or verbal, to commence a work phase will constitute acceptance of the previous phase's deliverables. Invoices are due and payable upon presentation. To commence work, we require a retainer in the amount of \$_____, which will be deducted from the final invoice for the project.

Upon our receipt of final payment, [Client] shall own all rights, except those noted below, to the completed work delivered under this agreement, including graphics, written text, and program code. [Client] may at [Client]'s sole discretion copyright the work in [Client]'s name or assign rights to a third party. Ownership of material provided by third parties and incorporated in our work with [Client]'s knowledge and approval shall be as provided in any license or sale agreement governing said materials. We reserve the right to use in any of our future work for ourselves or any client all techniques, structures, designs and individual modules of program code we develop that are applicable to requirements outside those specified above. Further, our performance of this work for [Client] shall in no way limit us regarding assignments we may accept from any other clients now or at any time in the future.

We shall be allowed to show [Client]'s finished work, or any elements of it, to existing and prospective clients for demonstration purposes. If such demonstration showings would reveal information [Client] has identified to us as proprietary or confidential, we shall be allowed to create a special version for demonstrations which omits or disguises such information and/or [Client]'s identity as the client. We shall also be allowed to include a production credit display, e.g. "Produced by [Our Name]" or equivalent copy, on the closing screen or other mutually agreeable position in the finished work. Following [Client]'s acceptance of this proposal we shall also be allowed to identify [Client] as a client in our marketing communications materials.

In the event it is necessary in the course of this assignment for us to view or work with information of [Client]'s that [Client] identifies to us as proprietary and confidential (possibly including customer lists, supplier data, financial figures and the like), we agree not to disclose it except to our principals, associates and contractors having confidentiality agreements with us.

We make no warranty regarding this work, or its fitness for a particular purpose, once [Client] accepts it following any testing procedures of [Client]'s choice. In any event, our liability for any damages arising out of this work, expressly including consequential damages, shall not exceed the total amount of fees paid for this work.

Figure 9-9 Sample contract terms adapted from language developed by the HyperMedia Group, Inc. (do not use without appropriate legal counsel)

The Cover and Package

You have many options for designing the look and feel of your proposal. And though we are often warned to avoid judging a book by its cover, the reality is that it takes about two seconds for executives to assess the quality of the document they are holding. Sometimes, they decide before even touching it. Size up the people who will read your proposal and ferret out their expectations; tailor your proposal to these expectations.

If your client judges from the cover of your proposal that the document inside is amateurish rather than professional, you are already fighting an uphill battle. There are two strategies for avoiding this negative first impression:

1. Develop your own special style for a proposal cover and package, including custom fonts, cover art and graphics, illustrations and figures, unique section and paragraph styles, and a clean binding. Do your proposal first class.
2. Make the entire package plain and simple, yet businesslike. The plain part of the approach means not fussing with too many fonts and type styles. This austerity may be particularly successful for proposals to government agencies, where 12-point Times New Roman or 12-point Courier may be not just a de facto standard, but a required document format. If you must submit hardcopy documents in addition to PDF or DOC files, a stapled sheaf of papers is adequate. Don't try to dress up your plain presentation with Pee-Chee folders or cheap plastic covers; keep it lean and mean.

Table of Contents

Busy executives want to anticipate a document and grasp its content in short order. A table of contents or index is a straightforward way to present the elements of your proposal in condensed overview. In some situations, you may also wish to include an **executive summary**—a prelude containing no more than a few paragraphs of pithy description and budget totals. The summary should be on the cover page or immediately following. In an electronic submission, you can hotlink to the Table of Contents and to important sections.

Needs Analysis and Description

In many proposals, it is useful to describe in some detail the reason the project is being put forward. This **needs analysis** and description is particularly common in proposals that must move through a company's executive hierarchy in search of approval and funding.

Target Audience

All multimedia proposals should include a section that describes the target audience and target platform. When the end user's multimedia capabilities have a broad and uncertain range, it is crucial to describe the hardware and software delivery platform you intend to provide. For instance, if your project requires a special browser plug-in, you will need to adjust your multimedia strategy by revising the design or by requiring the end user to download the plug-in. Some clients will clearly control the delivery platform, so you may not need to provide detail regarding system components.

TIP *In your analysis, be sure to include a mention of platform assumptions and technical specifications. For example, "This program will function properly in Internet Explorer 6-9 and Firefox 3 in Windows, and in Safari 4 and Firefox 3 on the Macintosh. No guarantees are provided for functionality on other browsers or operating systems."*

Creative Strategy

A **creative strategy** section—a description of the look and feel of the project itself—can be important to your proposal, especially if the executives reviewing your proposal were not present for creative sessions or did not participate in preliminary discussions. If you have a library of completed projects that are similar to your proposed effort, it is helpful to include them with your proposal, pointing the client to techniques and presentation methods that may be relevant. If you have designed a prototype, describe it here, or create a separate heading and include graphics and diagrams.

Project Implementation

A proposal must describe the way a project will be organized and scheduled. Your estimate of costs and expenses will be based upon this description. The Project Implementation section of your proposal may contain a detailed calendar, PERT and Gantt project planning charts, and lists of specific tasks with associated completion dates, deliverables, and work hours. This information may be general or detailed, depending upon the demands of the client. The project implementation section is not just about how much work there is, but how the work will be managed and performed. You may not need to specify time estimates in work hours, but rather in the amount of calendar time required to complete each phase.

Budget

The budget relates directly to the scope of work you have laid out in the project implementation section. Distill your itemized costs from the project implementation description and consolidate the minute tasks of each project phase into categories of activity meaningful to the client.

Chapter 9 Review

■ Chapter Summary

For your review, here's a summary of the important concepts discussed in this chapter.

Determine the scope of a multimedia project

- Before beginning a project, develop a sense of its scope and content. Then develop an organized outline and a plan that considers the skills, time, budget, tools, and resources at hand.
- Plan for the entire process, beginning with your first ideas and ending with completion and delivery of a finished product.
- Maintain balance between purpose and feasibility by dynamically adding and subtracting multimedia elements as you stretch and shape your idea.
- Tasks are the building blocks of project management. Allocate an estimated amount of time to each task, and place each one along a calendar-based timeline. The end of each phase is a natural place to set a milestone.
- Project management software can be useful for arranging ideas and tasks; additionally, the software may include built-in analysis to help stay within schedule and budget.
- Build a matrix chart of required skills to help describe the makeup of your team.
- Because there are few concrete standards for multimedia and developers are constantly “pushing the envelope,” consider building a prototype to demonstrate that the idea is feasible and marketable.

Schedule the phases, tasks, and work items required to complete a project

- Lay out the phases, tasks, and work items along a timeline. Scheduling can be difficult to predict

due to artistic trial and error and because the technology of computer hardware and software is in constant flux. Include client approval time. Negotiate the number of review cycles to avoid endless reviews.

- Avoid the problem of cost run-ups by requiring clients to sign off at key stages in development and requiring change orders if a client changes specifications on you after signing off on them.

Estimate the cost, timeline, and tasks required to complete a project

- As a general rule, there are three elements that can vary in project estimates: time, money, and people.
- The budget is the total of estimated hours for each task times your hourly billing rate. There is no more difficult business situation than a half-completed job and an exhausted budget.
- Contractors and consultants can bring specialized skills to your project. Be sure they work off-site, using their own equipment, to avoid having them classified as employees.

Write and structure the elements of a multimedia project proposal

- Many projects come about from a phone call or less formal contact.
- Occasionally you may receive a more formal detailed document called a Request for Proposal (RFP), generally from large corporations that are “outsourcing” their multimedia development work.
- A multimedia bid proposal should include an executive summary or overview, a section dealing with creative issues, a description of how the project's goals will be met, and a discussion of technical issues.

- The backbone of the proposal is the estimate and project plan, followed by cost estimates for each phase or deliverable milestone, as well as payment schedules. Finally, include a list of your terms reviewed by legal counsel. Make sure the proposal looks professional.
- All multimedia proposals should include a section that describes the target audience and target platform.
- Your estimate of costs and expenses will be based upon the detailed description of your project.

■ Key Terms

alpha (271)

beta (271)

change order (274)

client sign-off (274)

contingencies (276)

creative strategy (287)

Critical Path Method (CPM) (264)

deliverable (273)

executive summary (286)

feasibility study (269)

Gantt chart (265)

going gold (271)

milestone (273)

needs analysis (286)

payment schedule (277)

prerequisites (265)

Program Evaluation Review

Technique (PERT) charts (264)

proof-of-concept (269)

Request for Proposal (RFP) (281)

scope (260)

■ Key Term Quiz

1. A prototype is sometimes called a proof-of-concept or _____.
2. When a project reaches the delivery stage, it is said to be _____.
3. In constructing a project timeline it is important to identify _____, important tasks that must be completed before others begin.
4. A marker that delineates a significant point in a project's timeline—time to deliver work-in-progress, to invoice based upon real work done, to assess or test progress, and/or to solicit and receive constructive feedback—is called a(n) _____.
5. A prototype in which most of the features are working, and you are distributing it to a wide arena of testers, is called a(n) _____.
6. A project management strategy that calculates the total duration of a project based upon each identified task, earmarking tasks that are critical, is called the _____.
7. _____ provide graphic representations of task relationships, showing what tasks must be completed before others can commence.
8. _____ depict all the tasks along a timeline.

9. A(n) _____ is a detailed document, generally from large corporations who are outsourcing their multimedia development work, asking for companies to suggest projects in response to a defined need.
10. A proposal should begin with the _____, a prelude containing no more than a few paragraphs of pithy description and budget totals.

■ Multiple-Choice Quiz

- The building blocks of project management are:
 - budgets
 - tasks
 - proposals
 - milestones
 - prerequisites
- The best point to do focus group testing is with the:
 - concept
 - prototype
 - beta
 - gold master
 - final version
- Which of the following is not an area that would need to be tested in a prototype?
 - technology (Will it work on your proposed delivery platform[s]?)
 - cost (Can you do this project within budget constraints?)
 - design (Will the colors and overall interface be attractive to potential users?)
 - market (Can you sell it, or will it be properly used if it is an in-house project?)
 - human interface (Is it intuitive and easy to use?)
- In determining the feasibility of a project, the most common limiting technological factor is:
 - the hardware on which the project is developed
 - the network delivering the project
 - the medium (CD-ROM, DVD, Internet) delivering the project
 - the end user's hardware
 - the telecommunications infrastructure
- A proof-of-concept or pilot project should probably include all of these except:
 - some artwork
 - interface design
 - packaging mock-ups
 - interactive navigation
 - performance checks
- In the referenced report on producing educational software, the task requiring the greatest percentage of effort was authoring, at 28 percent. The second most demanding task was:
 - analyze and outline content
 - lay out course map
 - select learner activities
 - evaluate the course
 - produce media
- Which of the following is *not* a method typically used by project management software?
 - Critical Path Method
 - Feasibility Assessment Review Technique
 - Program Evaluation Review Technique
 - Gantt charts
 - All of these are common methods.

8. Which of the following is *not* a reason why scheduling a multimedia project can be difficult?
 - a. Much of the making of multimedia is artistic trial and error.
 - b. Market forces may change the demand for the final product.
 - c. The technology of computer hardware and software is in constant flux.
 - d. Upgrades while your project is under way may add time to learn new hardware and software.
 - e. Client feedback loops depend upon factors beyond your control.
9. When calculating the budget for a project, you should use two rates for each employee working on the project: the employee's rate billed to the customer, and:
 - a. the employee's cost for tax purposes
 - b. the employee's rate for discounted/special clients
 - c. the employee's rate for rush/quick-turnaround projects
 - d. the employee's cost to the employer
 - e. the employee's rate for projects done on spec
10. Typical billing rates for multimedia production companies and web designers range from:
 - a. \$15 to \$30 an hour
 - b. \$30 to \$50 an hour
 - c. \$60 to \$150 an hour
 - d. \$150 to \$200 an hour
11. The business of making multimedia is a "low entry barrier" enterprise because:
 - a. those with disabilities can create multimedia
 - b. all you need to get started is some (relatively) inexpensive computer hardware and software
 - c. there are free or low-cost web hosting solutions available
 - d. lots of people can access web sites and DVDs
 - e. authoring systems make creating sophisticated projects fast and easy
12. Contractors and consultants should work off-site primarily because if they work on-site:
 - a. they may compromise the company's confidential information
 - b. they increase the wear on company equipment
 - c. providing space for them adds to overhead
 - d. they are generally less productive doing so
 - e. they may be legally considered employees
13. The first part of a proposal should be the:
 - a. executive summary
 - b. budget
 - c. timeline
 - d. project plan
 - e. terms and conditions
14. When the end user's multimedia capabilities have a broad and uncertain range, it is very important to describe:
 - a. the number of subcontractors working on the project
 - b. the authoring system that will be used on the project
 - c. the hardware and software platform intended for delivery
 - d. the creative strategy that will be used to create the media
 - e. the colors and fonts to be used in the interface
15. If the executives reviewing your proposal were not present for creative sessions or did not participate in preliminary discussions, it may be important to include a description of the look and feel of the project itself, called a(n):
 - a. creative strategy
 - b. executive summary
 - c. terms and conditions
 - d. needs analysis
 - e. table of contents

■ Essay Quiz

1. You have been given the task of finding a new project for a fictional multimedia development company to produce on spec. The project is an instructional game designed to teach learners how to program in JavaScript. Justify the project, discussing:
 - a. the market for the product,
 - b. the objectives of the project,
 - c. technical limitations, if any, and
 - d. a brief timeline.
2. List and briefly discuss the stages of a multimedia project. Be sure to define the milestones that mark the completion of the phase.
3. List at least ten primary tasks that go into producing a multimedia project. Place these steps in logical order. Comment on these steps with regard to whether they are critical to the timeline (which steps are dependent on the completion of an earlier step).
4. Discuss the factors that affect what a multimedia company might be able to charge for its work. Consider factors that affect overhead, factors related to experience and abilities, and factors related to the project itself.
5. Describe the various technical, management, and creative obstacles to accurately predict the time and resources needed to complete a multimedia project. How might the technical and creative problems be interrelated?

Lab Projects

■ Project 9.1

Select a project—perhaps a promotional DVD, a marketing web site, or a corporate intranet. Be creative, and specify the kind of organization you will be creating the project for. List the tasks required in developing the project. Specify how long each task will take.

■ Project 9.2

Based on the project specified in 9.1, create a team of at least three people for the project. Specify their titles, internal and external rates, and abilities. Write a one-paragraph bio explaining each team member's relevant experience and capabilities.

■ Project 9.3

Based on the project developed so far, assign the tasks to the team. Create a chart that clearly identifies the major tasks, which team member will be responsible for them, and when they will be done.

■ **Project 9.4**

Create a budget based on the task durations and rates for the project you have developed. Calculate both the internal cost (costs × hours) and the billing (rates × hours). Is the project profitable? Don't forget to include a reasonable amount for contingencies and overhead.

■ **Project 9.5**

Go online and locate an RFP for either a web site or multimedia DVD. Suitable RFPs should be fairly large in scope, at least \$25,000. Examine the RFP. How would you respond to it? Write an executive summary for an imaginary proposal you might write in response to the RFP.

Designing and Producing

In this chapter, you will learn how to:

- Design the structure and user interface for a multimedia project
- How to produce a successful multimedia project and work with clients

DESIGNING and building multimedia projects go hand in hand. For CD-ROM and DVD projects, design input is never over until the product is actually frozen and shipped. The best products are often the result of continuing feedback and modifications implemented throughout the production process; projects that freeze a design too early become brittle in the production workplace, losing the chances for incremental improvement. But there is a danger: too much feedback and too many changes can kill a project, draining it of time and money. Always balance proposed changes against their cost to avoid the “creeping features” syndrome.

For a project bound for a web site, the design may be completed and implemented, yet the site’s content may be regularly updated and changed, so the project may (by its very design) never be completely frozen. In such cases, it is especially important to set clear deadlines and milestones.

Just as the architect of a high-rise office tower must understand how to utilize the materials with which he or she works (lest the construction collapse on trusting clients), designers of multimedia projects must also understand the strengths and limitations of the elements that will go into their project. It makes no sense, for example, to design the audio elements of a multimedia project in memory-consuming 16-bit, 44.1 kHz stereo sound when the delivery medium will not have sufficient room for it; or to produce lengthy, full-screen, video clips to play at 30 frames per second over the Internet when targeted end users connect by dial-up modems; or to design lovely 1024 × 768 pixel graphics for elementary school laptops when that environment supports only 800 × 600 pixel screens. Architects don’t design inner city parking garages with 14-foot ceilings and wide turning radii for 18-wheel big rigs, and they don’t build them using wood or mud laid on a swampy foundation.

Designers must work closely with producers to ensure that their ideas can be properly realized, and producers need to confirm the results of their work with the designers. “These colors seem to work better—what do you think?” “It plays smoother now, but I had to change the animation sequence . . .” “Doing the index with highlighted lines slows it down—can we eliminate this feature?” Feedback loops and good communication between the design and production effort are critical to the success of a project.

The idea processing (described in Chapter 9) of your multimedia project will have resulted in a detailed and balanced plan of action, a production schedule, and a timetable. Now it's time for implementation!

Designing

The design part of your project is where your knowledge and skill with computers; your talent in graphic arts, video, and music; and your ability to conceptualize logical pathways through information are all focused to create the real thing. Design is thinking, choosing, making, and doing. It is shaping, smoothing, reworking, polishing, testing, and editing. When you design your project, your ideas and concepts are moved one step closer to reality. Competence in the design phase is what separates amateurs from professionals in the making of multimedia.

TIP *Never begin a multimedia project without first outlining its structure and content.*

Depending on the scope of your project and the size and style of your team, you can take two approaches to creating an original interactive multimedia design. You can spend great effort on the **storyboards**, or graphic outlines, describing the project in exact detail—using words and sketches for each and every screen image, sound, and navigational choice, right down to specific colors and shades, text content, attributes and fonts, button shapes, styles, responses, and voice inflections. (This approach is particularly well suited for teams that can build prototypes quickly and then rapidly convert them into finished goods.) Or you can use less-detailed storyboards as a rough schematic guide, allowing you to exert less design sweat up front and expend more effort actually rendering the product at a workstation.

The method you choose depends on whether the same people will do the whole thing (both the designing and the implementing) or whether implementation will be tasked or outsourced to a new team who will then need a detailed specification (that is, a detailed storyboard and sketches). Both approaches require the same thorough knowledge of the tools and capabilities of multimedia, and both demand a storyboard or a project outline. The first approach is often favored by clients who wish to tightly control the production process and labor costs. The second approach gets you more quickly into the nitty-gritty, hands-on tasks, but you may ultimately have to give back that time because more iterations and editing will be required to smooth the work in progress. In either case, the more planning on paper, the better and easier it will be to construct the project.

Designing the Structure

A multimedia project is no more than an arrangement of text, graphic, sound, and video elements (or *objects*). The way you compose these elements into interactive experiences is shaped by your purpose and messages.

How you organize your material for a project will have just as great an impact on the viewer as the content itself. Since the explosive growth of the World Wide Web and proliferation of millions and millions of multimedia-capable HTML documents that can be linked to millions of other similar documents in the cyberspace of the Web, your designs and inventions may actually contribute to the new media revolution: other creators may discover your work and build upon your ideas and methods.

On some projects, you may be both the designer and the programmer. This can work well because you will understand how the design features you choose will actually be implemented. Indeed, your design will be tempered, if not defined, by your programming and coding skills, and you will be less likely to specify features impossible or overly difficult to realize.

Navigation

Mapping the structure of your project is a task that should be started early in the planning phase, because navigation maps outline the connections or links among various areas of your content and help you organize your content and messages. A **navigation map** (or **site map**) provides you with a table of contents as well as a chart of the logical flow of the interactive interface. While with web sites a site map is typically a simple hierarchical table of contents with each heading linked to a page, as a more detailed design document your map may prove very useful to your project, listing your multimedia objects and describing what happens when the user interacts.

Just as eight story plots might account for 99 percent of all literature ever written (boy meets girl, protagonist versus antagonist, etc.), a few basic structures for multimedia projects will cover most cases: **linear navigation**, **hierarchical navigation**, **nonlinear navigation**, and **composite navigation**. Figure 10-1 illustrates the four fundamental organizing structures used in multimedia projects, often in combination:

- **Linear** Users navigate sequentially, from one frame or bite of information to another.
- **Hierarchical** Also called “linear with branching,” since users navigate along the branches of a tree structure that is shaped by the natural logic of the content.
- **Nonlinear** Users navigate freely through the content of the project, unbound by predetermined routes.

- Composite** Users may navigate freely (nonlinearly) but are occasionally constrained to linear presentations of movies or critical information and/or to data that is most logically organized in a hierarchy.

The method you provide to your viewers for navigating from one place to another in your project is part of the user interface. The success of the user interface depends not only upon its general design and graphic art implementations but also upon myriad engineering details—such as the position of interactive buttons or hot spots relative to the user’s current activity, whether these buttons “light up,” and whether you use standard Macintosh or Windows pull-down menus. A good user interface is critical to the overall success of your project.

The nature of your interface will vary depending on its purpose: browsing, database access, entertainment, information, instruction, reference, marketing, and gaming projects require different approaches and different navigation strategies.

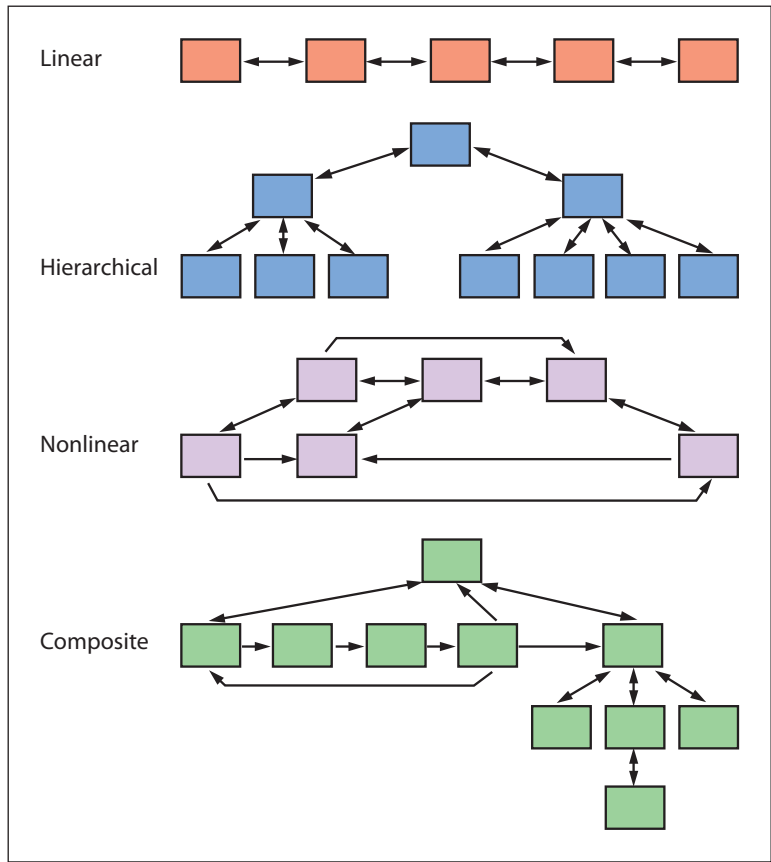
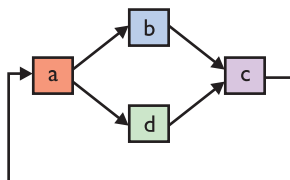

Figure 10-1 The four primary navigational structures used in multimedia

Structural Depth

Professor Judith Junger from the Open University of the Netherlands in Amsterdam suggests that when you design your multimedia product, you should work with two types of structure: depth structure and surface structure. **Depth structure** represents the complete navigation map and describes all the links between all the components of your project (see Figure 10-1). **Surface structure**, on the other hand, represents the structures actually realized by a user while navigating the depth structure. Thus the following depth structure



might be realized as the following surface structure:

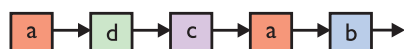

Some surface structures generated by users might look like this:

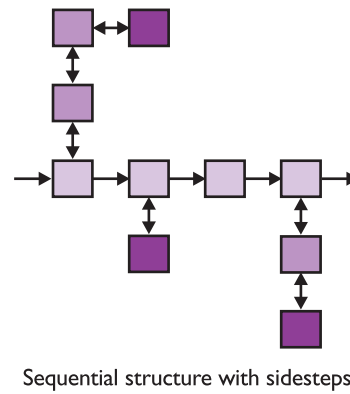
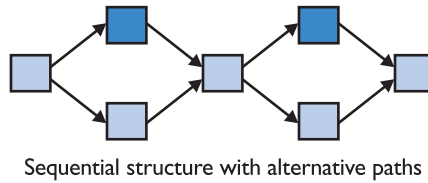
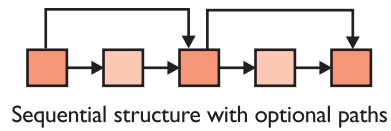

The following depth structure for a quiz thus consists of three possible surface structures:

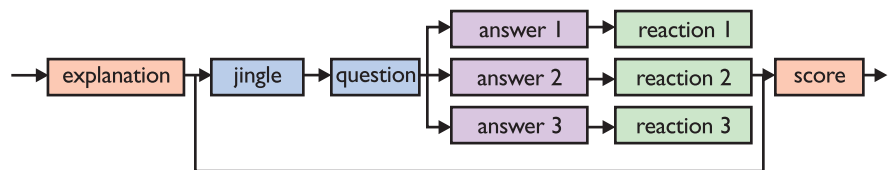

When you design your navigation map, it helps to think about surface structure—to view the product from a user’s perspective. Surface structures are of particular interest to marketing firms in tracking users’ routes through a web site to determine the effectiveness of the site’s design and to profile a user’s preferences. When a user’s preferences are known, a custom web site experience can be dynamically tailored and delivered to that user. Acquisition and management of such profiling data is a hot topic, with privacy advocates claiming the personal information revealed in these surface structures is akin to a person’s medical and health records.

Many navigation maps are essentially nonlinear. In these navigational systems, viewers are always free to jump to an index, a glossary, various

First Person

Dear Tay,

With regard to the creation of interactive fiction, what kinds of software engineering strategies would you recommend for creating stories that maintain a strong sense of cumulative action (otherwise known as plot) while still offering the audience a high frequency of interaction? In other words, how do you constrain the combinatoric explosion of the narrative pathways, while still maintaining the Aristotelian sense of a unity of plot?

—Patrick Dillon, Atlanta, GA

One and one-half T-shirts to Patrick Dillon! Would have been two for your invocation of a famous Greek philosopher, but then I couldn't find "combinatoric" in Webster's. Aristotle himself would have been pleased by the harmonious balance of your reward: you have asked a really good question.

As multimedia and the power of computers begin to change our approach to literature and storytelling, new engineering strategies do need to be implemented.

When fiction becomes nonlinear, and users can choose among alternative plot lines, the permutations can become staggering. To an author, this means each new plot pathway chosen by user interaction requires its own development, and one story may actually become several hundred or more. To constrain this fearsome explosion of narrative pathways, yet retain a high frequency of interaction, try designing your fiction around a single core

plot that provides the cumulative action, and use arrays of returning branches for detail and illustration. In this way you can entirely avoid the permutations of alternative universes and still offer the adventure of interactive exploration.

Dear Tay,

I just read your answer to Patrick Dillon's question about interactive fiction in your column. My response is difficult to contain: "Aaarrgggh-hhh!!!! You Ignorant Slut!" OK, perhaps I am overreacting, but you are refusing to let go of linearity. Why ever do you want to "constrain the combinatoric explosion of narrative pathways"? Good Lord, that's what makes the gametree bushy. This is exactly the kind of work that's well suited for a computer to perform—grinding out three billion story variations!

—Chris Crawford, San Jose, CA

Chris, I've been called a lot of things over the years (like Fay and Ray), and it's with a smile that I add your gift to my collection. Playing Jane Curtin to your Dan Aykroyd, I'll be happy to counter your counterpoint.

Your challenge represents a serious subject for multimedia designers today. I agree that interactive stories with too few branches are disappointingly flat and shallow. When a plot is broadly nonlinear, however, the permutations of events and possible outcomes become staggering, and the story as a whole becomes difficult to visualize and manage. Producing such work is also an

intellectual challenge and costly in time and effort.

A truly open-ended "hypermedia" navigation system for consumer consumption risks death by shock caused by open arterial branches and loss of story pressure, where plot lines become too diffuse and users founder in trivia. Most users may, indeed, *prefer* a structured, organized, and well-defined story environment.

The argument for simplicity is voiced by Steven Levy, the author of *Hackers* and *Artificial Life*, who says, "There's really something to be said for documents with a beginning, middle, and end."

The shape of this new literature made possible by multimedia computers and wide-bandwidth cable and telephone delivery systems is being born in the working designs of developers. The final test for successful multimedia design is the marketplace, where consumers will decide. Your interesting "algorithms for interpersonal behavior, personality models, artificial personality, languages of expression, and facial displays" represent, perhaps, a successful marriage of this computer power with literature containing malleable plots and seemingly endless variations. Indeed, your forthcoming epic game, *Le Morte D'Arthur*, will surely break new ground and quite possibly prove your point. Can't wait to get a copy!

From correspondence in "Ask the Captain," a monthly column by Tay Vaughan in NewMedia magazine.

Because all forms of information—including text, numbers, photos, video, and sound—can exist in a common digital format, they can be used simultaneously as people browse through an information stream, just as people use their various senses simultaneously to perceive the real world.

Bill Gates, Chairman,
Microsoft Corporation

menus, Help or About . . . sections, or even to a rendering of the map itself. It is often important to give viewers the sense that free choice is available; this empowers them within the context of the subject matter. Nonetheless, you should still provide consistent clues regarding importance, emphasis, and direction by varying typeface size and look, coloring, indenting, or using special icons.

The architectural drawings for your multimedia project are the storyboards and navigation maps. The storyboards are married to the navigation maps during the design process, and help to visualize the information architecture.

A simple navigation map is illustrated in Figure 10-2, where the subject matter of a small project to teach the basics of animation was organized schematically. The items in boxes are not only descriptions of content but also active buttons that can take users directly to that content. At any place in the project, users can call up this screen and then navigate directly to their chosen subject.

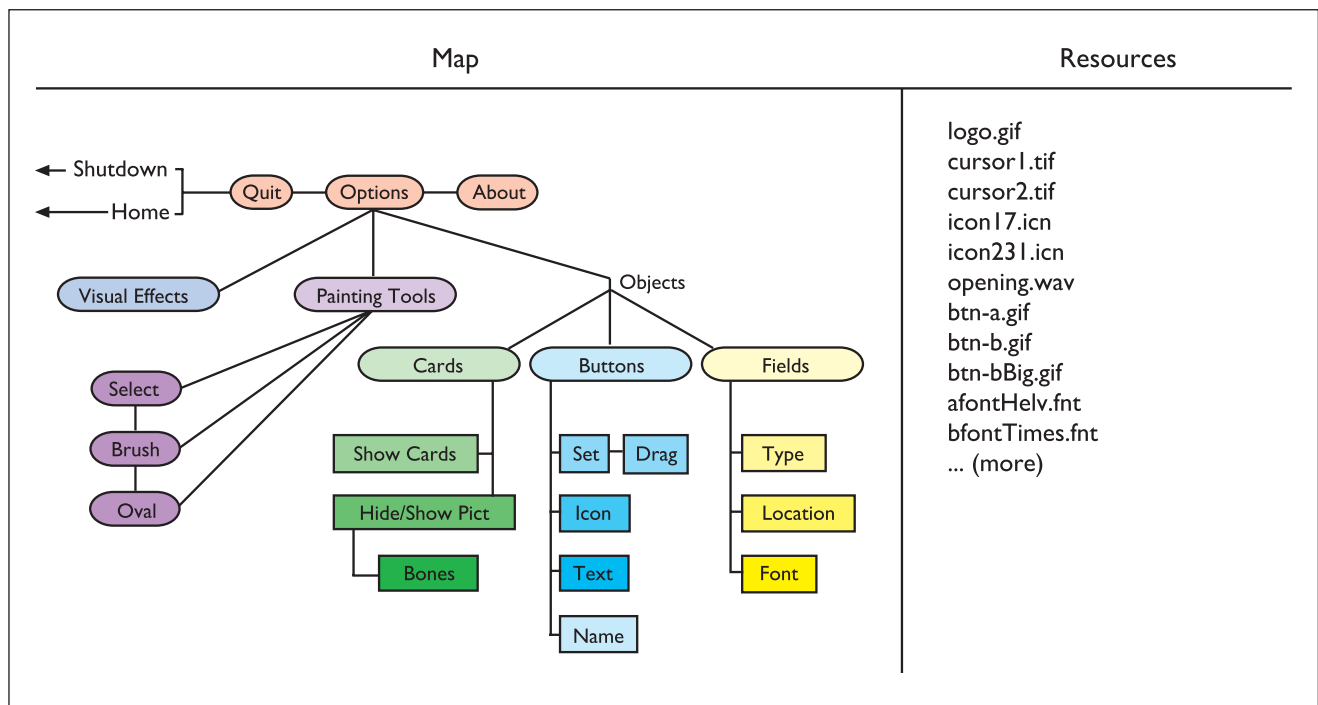

Figure 10-2 A simple navigation map

A storyboard for this same project, originally built for a small black-and-white low-resolution display, is organized sequentially, screen by screen, and each screen is sketched out with design notes and specifications before rendering. On the left, in Figure 10-3, are parts of the storyboard for this project; on the right are corresponding finished screens.

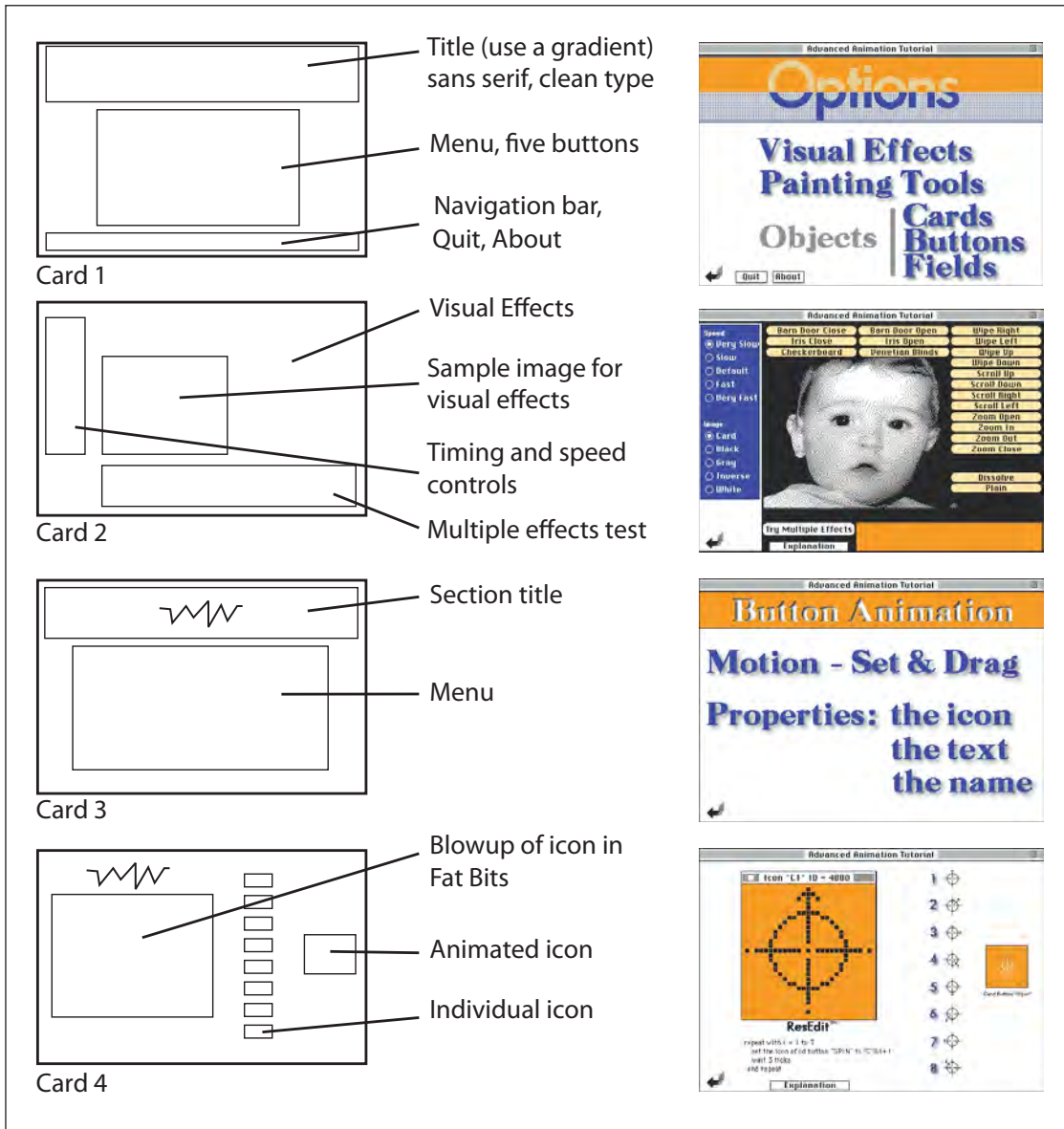

Figure 10-3 Storyboards on the left, with finished screens on the right

Really good software products should be simple, hot, and deep. People need to get into your software in about 20 seconds and get immediate positive feedback and reward; then they are smiling and having a good time and they want to go further. “Hot” means that you’ve got to be fully cooking the machine, with all its graphics and sound capabilities, conveying something dynamic and exciting that competes with what people are used to seeing in a movie or on TV. In terms of “deep,” it’s kind of like the ocean where there are people of all ages: some kids will just wade out in a foot of surf, other guys with scuba gear go way out and way deep. Make it possible for me to go as deep as I want, but don’t force it on me. Just let the depth of your product unfold to me in a very natural way.

Trip Hawkins, Founder,
Electronic Arts

Multimedia provides great power for jumping about within your project’s content. And though it is important to give users a sense of free choice, too much freedom can be disconcerting, and viewers may get lost. Try to keep your messages and content organized along a steady stream of the major subjects, letting users branch outward to explore details. Always provide a secure anchor, with buttons that lead to expected places, and build a familiar landscape to which users may return at any time.

Your content may not always be an assembly of discrete subjects as illustrated in Figure 10-2. If your material deals with a chronology of events occurring over time, for example, you may wish to design the structure as a linear sequence of events and then send users along that sequence, allowing them to jump directly to specific dates or time frames if desired (see Figure 10-4). A timeline will graphically show the positioning of your multimedia elements and can be helpful during the design phase: where there are overlapping events, you may wish to create cross-sectional paths or views for a “slice in time.”

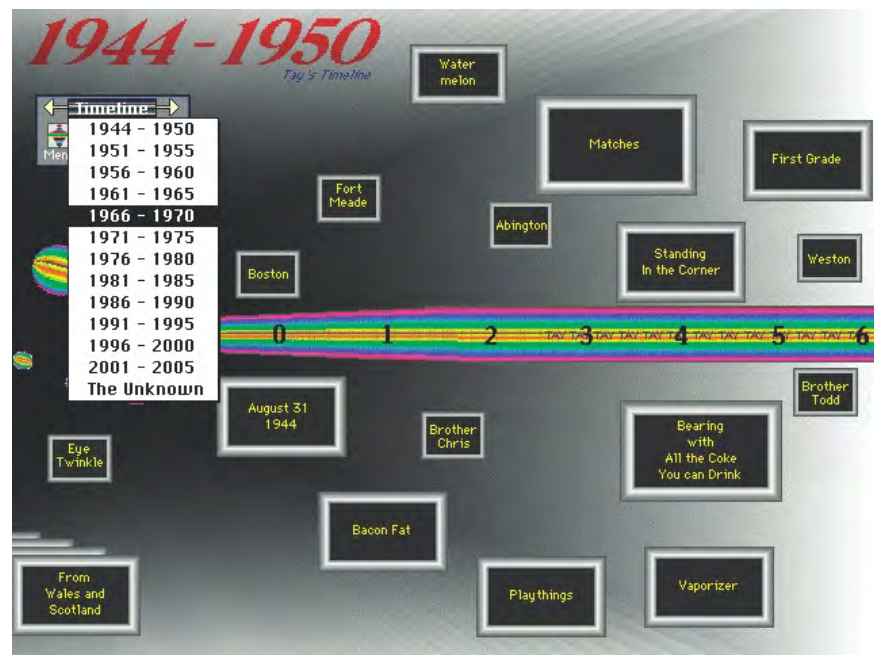

Figure 10-4 A chronological navigation map with active buttons

Even within a linear, time-based structure, you may still wish to sort events into categories regardless of when they occur. There is no reason you can’t do this and offer more than one method of navigating through your content. Figure 10-5, for instance, illustrates a navigation map that accesses the same events from the timeline form of Figure 10-4, but arranged here instead into meaningful groups of events.

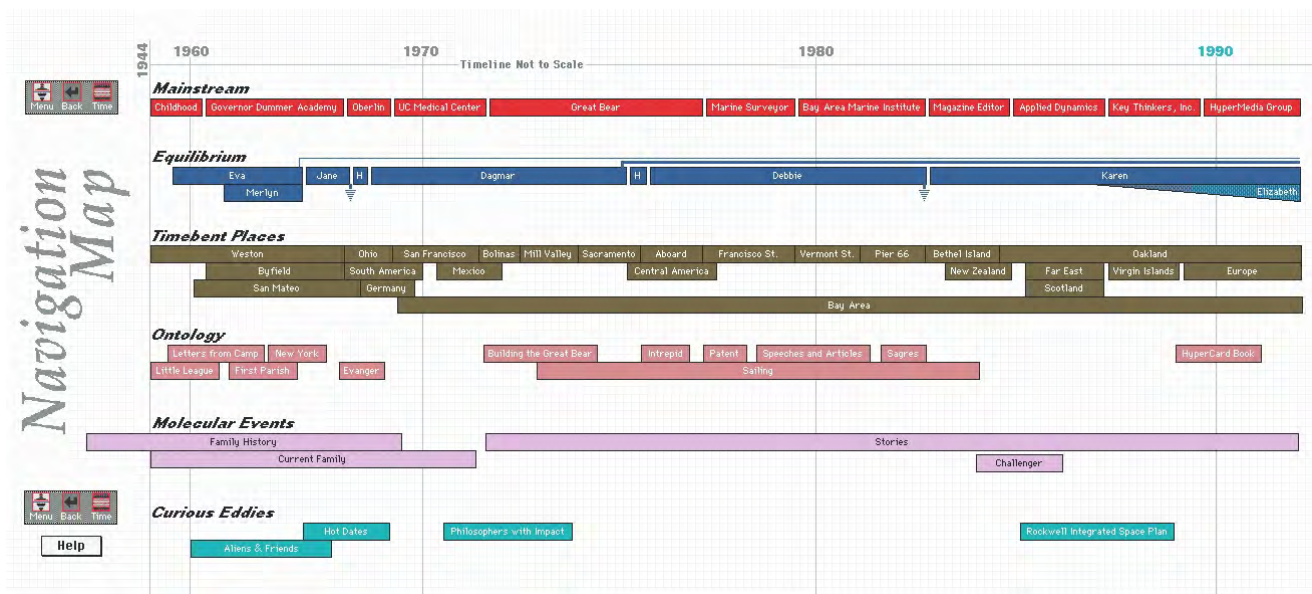

Figure 10-5 A navigation map based on events that are active buttons

Hot Spots, Hyperlinks, and Buttons

Most multimedia authoring systems allow you to make any part of the screen, or any object, into a **hot spot**. When users hover over or click a hot spot at that location, something happens, which makes multimedia not just interactive, but also exciting. Hot spots can be given more specific names based upon either their function or form. For example, if clicking the hot spot connects the user to another part of the document or program or to a different program or web site, it is referred to as a link or **hyperlink**. If the hot spot is a graphic image designed to look like a push button or toggle switch, it is called a **button**, more formally defined as a meaningful graphic image that you click or “touch” to make something happen.

Hot spots can be text or graphic images. Most authoring systems provide a tool for creating text buttons of various styles (radio buttons, check boxes, or labeled push buttons, for example), as well as graphic buttons.

TIP Designing a good navigation system and creating original buttons appropriate for your project are not trivial artistic tasks. Be sure you budget sufficient time in your design process for many trials, so you'll be able to get your buttons looking and acting just right.

Text buttons and their fonts and styles are described in Chapter 2. Graphic buttons can contain graphic images or even parts of images—for example, a map of the world with each country color coded, and a mouse click on a country yields further information. **Icons** are graphic objects

designed specifically to be meaningful as buttons and are usually small (although size is, in theory, not a determining factor). Icons are fundamental graphic objects symbolic of an activity or concept:



Once a style has been selected, you need to determine how your user will know that the button is active or is being selected. Highlighting a button or object, or changing its state, when the cursor rolls over it or the button is clicked, is the most common method of distinguishing it as the object of interest. Highlighting is usually accomplished by altering the object's colors and optionally moving the object a pixel or two or, if text, changing its size. Depending upon how you highlight, you can make a button appear off (not pressed) or on (pressed) as illustrated on the left.



Or you can use an animated GIF image that animates when the mouse hovers over it. The dove in the illustration begins flying when the mouse passes over the word "Habitat."

Your navigation design must provide buttons that make sense, so their actions will be intuitively understood by means of their icon or graphic representation, or via text cues. Do not force your viewers to learn many new or special icons; keep the learning curve to a minimum. It's also important to include buttons that perform basic housekeeping tasks, such as quitting the project at any given point, or canceling an activity.

Hot Spots in Web Pages HTML documents do not directly support interactive graphic buttons that follow the rules of good interface design—by highlighting or otherwise confirming a hover or mouse-down action. In most web browsers, you know you have clicked on a linked graphic (a button) only when the cursor changes while the browser seeks another document and loads it. But you *can* make plain and animated buttons for your HTML documents on the Web using plug-ins such as Flash or JavaScripts. A simple JavaScript or CSS `a:hover` in an HTML document can replace one image with another on mouseOver or hover. Other ways to

make interesting buttons and interactive graphical interfaces on the World Wide Web are described more fully in Chapter 13.

The simplest hot spots on the Web are the text anchors that link a document to other documents. This is because a browser usually indicates that some specific text is a hot link or anchor by coloring or underlining the text so it stands out from the body. Default colors for anchor text are a user-defined preference, though you can override the default in the <BODY> tag.

Using CSS in web site design, text can be easily colored and highlighted on hover and hyperlinked or anchored to other document URLs on clicking. Drop-down text menus (see Figure 10-6) allow for a dense hierarchy of menu choices to be displayed.



Figure 10-6 Drop-down menus at web sites are built using a combination of HTML, CSS, and JavaScript.

Other common buttons found on the Web consist of small JPEG or GIF graphic images that are themselves anchor links. Browsers indicate that an image is hot by drawing a border around it (you can remove this border by placing BORDER="0" into the tag). Larger images may be sectioned into hot areas with associated links; these are called **image maps**.

Figure 10-7 shows a graphic image of a village that has been programmed in HTML to have 32 hot spots with links (the document to open when clicked) and a JavaScript routine called "set" that will place an image into the frame at the left when the mouse rolls over that area. The code looks like this:

```
<AREA shape="rect" coords="180,85,230,135" href=" ../vendors/v25/index.html"
onmouseover="set(' ../vendors/v25/images/logomenu.gif ');">
```

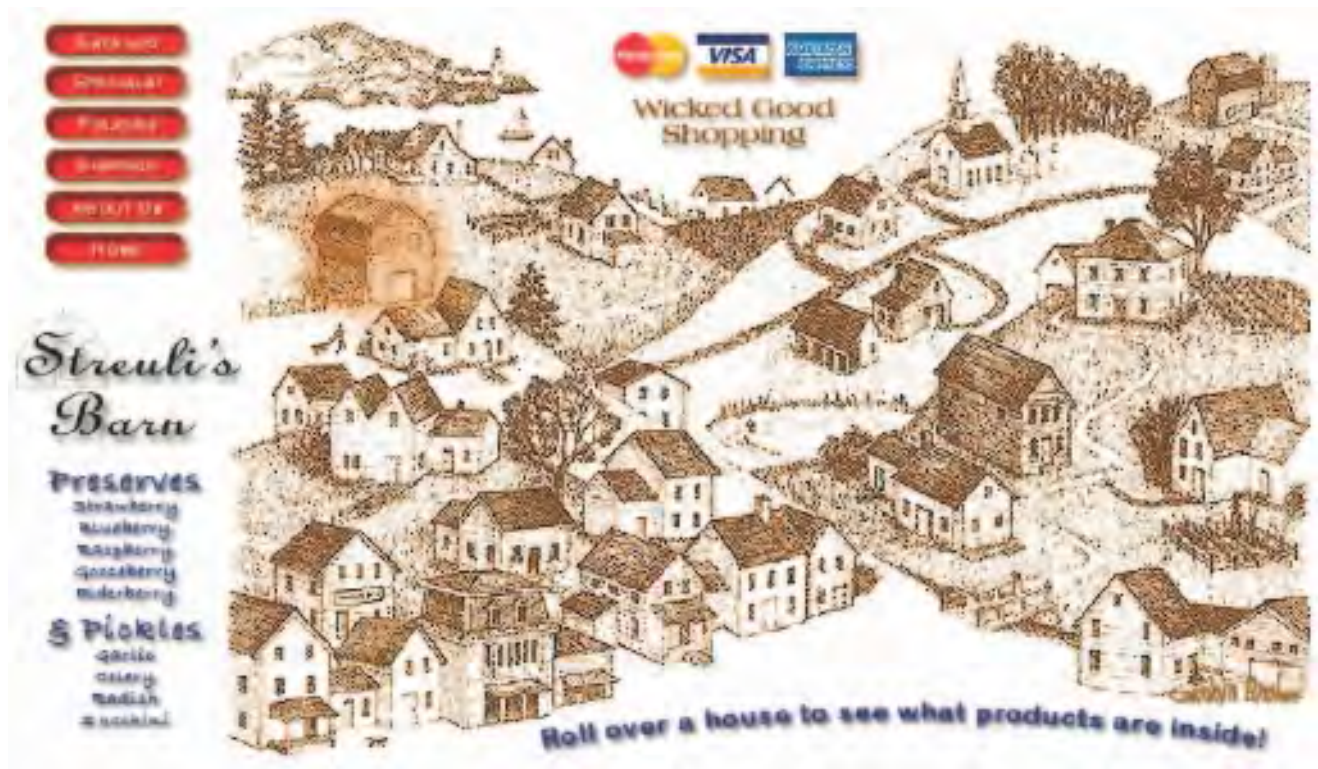

Figure 10-7 Using a large image map and JavaScript embedded in a normal HTML web page, when the mouse rolls over a house or barn, the content of that building is displayed as a separate graphic at the left. Users can actively explore this seaside village to discover what's hidden behind its doors.

Designers will build screens where there are tiny little things going on all over it at different places, and everything has momentous significance. And then the user is supposed to be able to find these momentous things. So people just glaze over. If you want them to hit a button, put a big button right in the middle of the screen.

.....
 Trip Hawkins, Chairman & CEO, 3DO Company

Icons

In Macintosh and Windows operating systems, icons have a special meaning, in that they constitute a suite of image resources that are linked to and identify an application, file, volume, or service.

On the Macintosh, icon image files (.icns) can contain one or more images of 16×16 , 32×32 , 48×48 , 128×128 , 256×256 , and 512×512 pixels as well as alpha channels for transparency masking. The Mac operating system automatically scales the image(s) to display at other sizes. To use your own icon for a file or folder, open the Get Info . . . dialog (COMMAND-I), click once on the icon shown at the top left of the Get Info panel to highlight it, and paste any 512×512 -pixel bitmap from the clipboard. The old icon is replaced with the new. You can also highlight an icon in the Get Info panel and copy it to the clipboard (COMMAND-C) for pasting into your image editor or directly into a project.

Windows 7 icons are 256×256 pixels and are scaled to Extra Large, Large, Medium, or Small sizes in the Views menu. To replace a folder or alias icon with your own, simply create a 256×256 pixel .png file and save it. Then go to a folder or shortcut and right-click it; select Properties.

Choose the Customize tab and select Change Icon. Browse to find your saved icon and click OK.

Building and saving icon files is simpler using an icon editor such as IcoFX (<http://icofx.ro/>) or the ICOformat plugin for Photoshop (www.telegraphics.com.au/sw/#icoformat). If you want to use a system icon within your project, it is often quickest to capture or grab it off the screen and place it directly into your project as a bitmap. Use caution, however, because the design of some icons (particularly those using corporate logos) may be protected by copyright or trademark.

Browsers automatically look for a tiny 16 × 16 pixel icon file named `favicon.ico` in the root of a web site, which they will display in one or more places in their “chrome” (the toolbars, status bars, sidebars, menus, and navigation elements surrounding the web page itself). In the following illustration, the Facebook icon is shown by the Firefox browser both in the URL address field and in the tab:

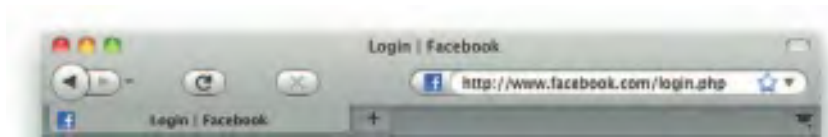

If you wish to identify your own web site with an icon, simply include a Windows-style `.ico` file (named `favicon.ico`) in the root folder of your site. It will be discovered by the browser and used for all pages at the site. Preferred, however, you can add a link tag in the `<HEAD>` element of your web page that identifies your icon image to the browser:

```
<link rel="icon" type="image/gif" href="http://www.yourwebsite.com/yourIcon.gif">
```

And with this method, you can use a `.gif`, `.jpg`, or `.png` image. Remember you can use transparency in a `.gif` or `.png` image when you don't want your icon to fill the 16 × 16 pixel box in the corners or edges. Use simple shapes, keep your lines sharp, and experiment in your image editor: it is very hard to make a decent image with only 16 × 16 pixels to work with.

Apple's handheld touch devices such as iPod(touch), iPhone, and iPad use a custom Safari browser to display web clips on a Home screen; they will display a custom icon for your web site if you include in the `<HEAD>` tag of your page a `<LINK>` tag to an appropriate image. Apple recommends a flat (not shiny) and simple 57 × 57 pixel image in `.png` format with sharp 90° corners. The display software will then render your icon with rounded corners, a drop shadow, and a reflective shine, as shown here.

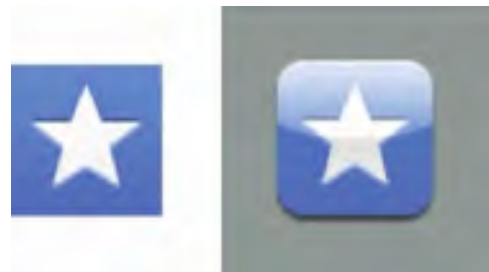

Put the following code into your HTML <HEAD> tag:

```
<link rel="apple-touch-icon" href="/somepath/image.png" />
```

or to force your icon not to be rendered,

```
<link rel="apple-touch-icon-precomposed.png" href="/somepath/image.png" />
```

Two readers didn't notice the screen had changed in different circumstances. This happened when the button they clicked on took them to a visually similar screen, and there was no visual effect as the screens changed. One reader was looking at the details of a hostel and clicked the left-hand Next arrow.

He arrived at a screen with details about another hostel, but he did not notice he was looking at a different screen.

He tried the right-hand Next arrow as well, and the screen changed back to the one he had been viewing initially, but again he did not notice the change and concluded the Next buttons did nothing. A visual effect or animation here would have provided a cue to make the screen changes more noticeable.

.....
Lynda Hardman of the Scottish HCI Centre, after focus group testing the "Glasgow Online" hypertext system

Designing the User Interface

The **user interface** of your multimedia product is a blend of its graphic elements and its navigation system. If your messages and content are disorganized and difficult to find, or if users become disoriented or bored, your project may fail. Poor graphics can cause boredom. Poor navigational aids can make viewers feel lost and unconnected to the content; or, worse, viewers may sail right off the edge and just give up and quit the program.

Novice/Expert Modes

Be aware that there are two types of end users: those who are computer literate and those who are not. Creating a user interface that will satisfy both types has been a design dilemma since the invention of computers. The simplest solution for handling varied levels of user expertise is to provide a **modal interface**, where the viewer can simply click a Novice/Expert button and change the approach of the whole interface—to be either more or less detailed or complex. Modal interfaces are common on bulletin boards, for example, allowing novices to read menus and select desired activities, while experts can altogether eliminate the time-consuming download and display of menus and simply type an activity code directly into an executable command line. Both novices and experts alike may quickly learn to click the mouse and skip the annoying ragtime piece you chose for background music.

Unfortunately, in multimedia projects, modal interfaces are not a good answer. It's best to avoid designing modal interfaces because they tend to confuse the user. Typically, only a minority of users are expert, and so the majority are caught in between and frustrated. The solution is to build your multimedia project to contain plenty of navigational power, providing access to content and tasks for users at all levels, as well as a help system to provide some hand-holding and reassurance. Present all this power in easy-to-understand structures and concepts, and use clear textual cues. Above all, keep the interface simple! Even experts will balk at a complex screen full of tiny buttons and arcane switches, and will appreciate having neat and clean doorways into your project's content.

GUIs

The Macintosh and Windows graphical user interfaces (GUI, pronounced “gooey”) are successful partly because their basic point-and-click style is simple, consistent, and quickly mastered. Both these GUIs offer built-in help systems, and both provide standard patterns of activity that produce standard expected results. The following actions, for example, are consistently performed by similar keystrokes when running most programs on the Macintosh or in Windows:

| Action | Macintosh Keystroke | Windows Keystroke |
|-----------|---------------------|-------------------|
| New file | ⌘-N | ALT-F-N OR CTRL-N |
| Open file | ⌘-O | ALT-F-O OR CTRL-O |
| Save file | ⌘-S | ALT-F-S OR CTRL-S |
| Quit | ⌘-Q | ALT-F-X OR CTRL-Q |
| Undo | ⌘-Z | ALT-E-U OR CTRL-Z |
| Cut | ⌘-X | ALT-E-T OR CTRL-X |
| Copy | ⌘-C | ALT-E-C OR CTRL-C |
| Paste | ⌘-V | ALT-E-R OR CTRL-V |

TIP Since *Cut*, *Copy*, and *Paste* are used so often, this mnemonic device may help you to remember their keyboard shortcuts: *X* looks like scissors and is to *Cut*. *C* is straightforward; *C* is for *Copy*. Think of *V* as an upside-down insertion caret (used to insert text when copy editing) and you will remember that it is for *Paste*.

For your multimedia interface to be successful, you, too, must be consistent in designing both the look and the behavior of your human interface. Multimedia authoring systems provide you with the tools to design and implement your own graphical user interface from scratch. Be prudent with all that flexibility, however. Unless your content and messages are bizarre or require special treatment, it’s best to stick with accepted conventions for button design and grouping, visual and audio feedback, and navigation structure.

Stick with real-world metaphors that will be understood by the widest selection of potential users. For example, consider using the well-known trash can for deleting files, a hand cursor for dragging objects, and a clock or an hourglass for pauses. If your material is time-oriented, develop metaphors

Vaughan’s General Rule for Interface Design

The best user interface demands the least learning effort.

Throw out your tried and true training or software development methodologies, and pretend that you're Spielberg or Lucas: think of what the viewer sees and hears and how the viewer interacts with the system you deliver. Create an "experience" for the viewer.

David A. Ludwig, Interactive Learning Designs

Computer graphics is more left- and right-brained—and not so spontaneous as doing it by hand. The ramp time is tedious; I am used to instant gratification with my fine artwork.

Cornelia Atchley, a fine artist creating multimedia art with computers, Washington, D.C.

for past, present, and future. If it is topic-oriented, choose metaphors related to the topics themselves. If it is polar (the pros and cons of an issue, for example), choose relevant contrasting images.

TIP *Most multimedia authoring systems include tutorials and instructions for creating and using buttons and navigation aids. Typically, they also supply templates or examples of attractive backgrounds and distinctive buttons that serve as an excellent starting place. In a large project, you might want to use a different metaphor as the backbone of each major section, to provide a helpful cue for users to orient themselves within your content. For the Travel section, for example, you could use icons that are sailing ships with various riggings; for the Finance section, buttons that are coins of different denominations; and for the buttons of the International Business section, you could use colorful flags from various countries.*

Users like to be in control, so avoid hidden commands and unusual keystroke/mouse click combinations. Design your interface with the goal that no instruction manual or special training will be required to move through your project. Users do not like to have to remember keywords or special codes, so always make the full range of options easily available as interactive buttons or menu items. And finally, users do make mistakes, so allow them a chance to escape from inadvertent or dangerous predicaments ("Do you really want to delete? Delete/Escape"). Keep your interface simple and friendly.

Graphical Approaches

Designing excellent computer screens requires a special set of fine art skills, and not every programmer or graduate in fine arts may be suited to creating computer graphics. Like programmers who must keep up with current operating systems and languages, computer graphic artists must also stay informed about the rapidly changing canvas of new features, techniques, applications, and creative tools.

The artist must make broad design choices: cartoon stick figures for a children's game, rendered illustrations for a medical reference, scanned bit-maps for a travel tour of Europe. The graphic artwork must be appropriate not only for the subject matter, but for the user as well. Once the approach is decided, the artist has to put real pixels onto a computer screen and do the work. A multimedia graphic artist must always play the role of the end user during the design and rendering process, choosing colors that look good, specifying text fonts that "speak," and designing buttons that are clearly marked for what they do.

Things That Work Here are some graphical approaches that get good results:

- Neatly executed contrasts: big/small, heavy/light, bright/dark, thin/thick, cheap/dear (see Figure 10-8)
- Simple and clean screens with lots of **white space** (see Figure 10-9)
- Eye-grabbers such as drop caps, or a single brightly colored object alone on a gray-scale screen
- Shadows and drop shadows in various shades
- Gradients
- Reversed graphics to emphasize important text or images
- Shaded objects and text in 2-D and 3-D



Figure 10-8 Contrasts attract the eye—Bud Knight, PGA Junior Champion at the turn of the century, was made thick by stretching him in an image-editing program.

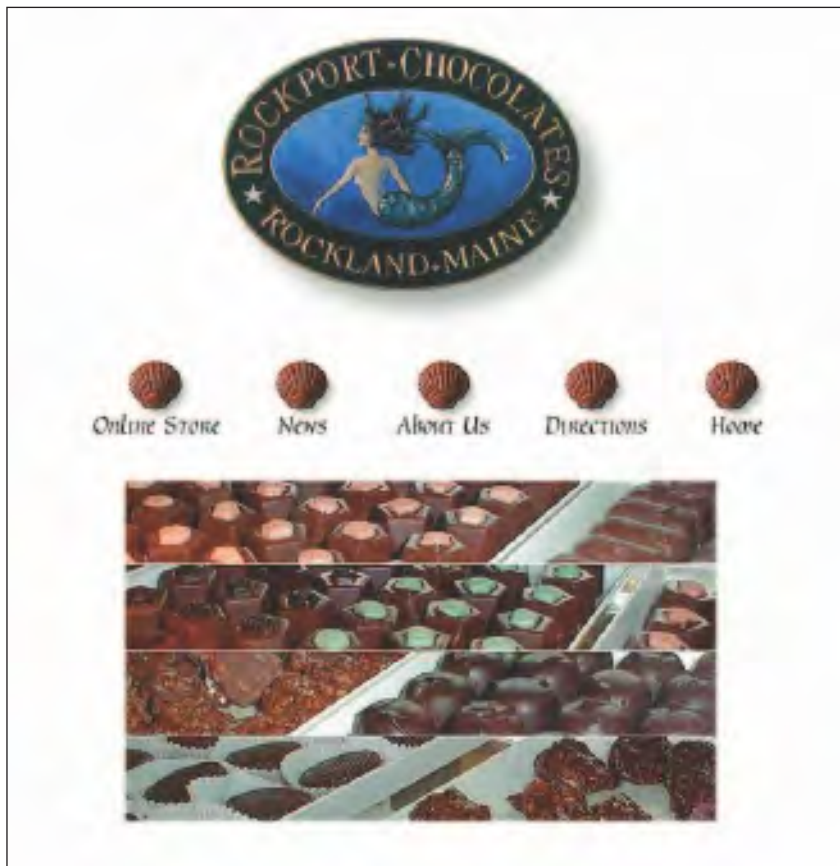

Figure 10-9 Use plenty of white space (“noninformation areas”) in your screens

Things to Avoid Here are some mistakes you will want to avoid in creating computer graphics:

- Clashes of color
- **Busy screens** (too much stuff)
- Using a picture with a lot of contrast in color or brightness as a background
- Trite humor in oft-repeated animations
- Clanging bells or squeaks when a button is clicked
- Frilly pattern borders
- Cute one-liners from famous movies
- Requiring more than two button clicks to quit
- Too many numbers (limit charts to about 25 numbers; if you can, just show totals)
- Too many words (don't crowd them; split your information into bite-sized chunks)
- Too many substantive elements presented too quickly

Most graphic artists will tell you that design is an “intuitive thing,” and they will be hard-pressed to describe the rules they follow in their everyday work. They know when colors are not “working” and will change them again and again until they're right, but they usually won't be able to explain why the colors work or don't work. A project with a good navigation design, though it may have been developed with good planning and storyboarding, is indeed more often the result of many hours of crafty finagling with buttons and editors. Visit <http://templatemonster.com> to see a huge number of web site templates, some of them Flash-based, and many with multimedia features such as animations, dynamic interfaces, and sound.

Audio Interfaces

A multimedia user interface may include important sound elements that reflect the rhythm of a project and may affect the attitude of your audience. Sounds can be background music, special effects for button clicks, voice-overs, effects synced to animation, or they may be buried in the audio track of a video clip. The tempo and style of background music can set the “tone” of a project. Vivaldi or Bach might be appropriate for a banking or investment annual report delivered on DVD. Comic laughs and screeching effects might be appropriate for a clothing web site aimed at preteens. Choose music that fits the content and the atmosphere you wish to create. In all cases, use special effects sparingly. Always provide a toggle switch to disable sound. (Many AOL users prefer to disable the “You've Got Mail!” voice, for example.) And always test a project that contains sound with potential users.

For more about design, visit:

.....
www.tsworldofdesign.com/tutorial/interface.htm

Developing web site navigation interfaces around usability

www.digital-web.com/features/feature_2002-12b.shtml

Digital Web magazine, “The Psychology of Navigation,” Jan 2003

<http://msdn.microsoft.com/en-us/library/ms993291.aspx>

Fitts’s UI Law applied to the Web

www.stcsig.org/usability/topics/articles/he-checklist.html

Heuristic evaluation: a system checklist (Xerox Corp.)

<http://developer.apple.com/mac/library/documentation/UserExperience/Conceptual/AppleHIGuidelines/XHIGIntro/XHIGIntro.html>

Apple human interface guidelines

<http://msdn.microsoft.com/library/default.asp?url=/library/en-us/dnui/html/iuiguideines.asp>

Microsoft inductive user interface guidelines

www.useit.com/

Jakob Nielsen’s guidelines for usability and Web design

www-01.ibm.com/software/ucd/ucd.html

User-centered design

www.useit.com/alertbox/20000514.html

Eye-tracking study of Web readers

www.useit.com/alertbox/20020707.html

User empowerment and the fun factor

www.useit.com/alertbox/20020609.html

Reduce redundancy: decrease duplicated design decisions

www.useit.com/alertbox/20011209.html

DVD menu design: the failures of Web design re-created yet again

www.useit.com/alertbox/20010121.html

Usability metrics

<http://desktoppub.about.com/cs/colorselection/p/index.htm>

Color symbolism

<http://desktoppub.about.com/od/howcolorworks/index.htm>

Color basics and theory

A Multimedia Design Case History

This section presents an example of the design process for a simple multimedia project about the construction and launch of a 31-foot ocean-going sailboat. This project was initially crafted in SuperCard (a Macintosh-only, page-based, authoring tool), but it was later ported to Adobe's Director (a time-based tool) so that it could be played on both Mac and Windows platforms (see Chapter 7 for details about authoring systems).

Storyboarding a Project

The source material (all that was available) practically sorted itself into logical groups: a pile of old photographs, a magazine article and newspaper clippings, engineering drawings, official documents, and some recorded sounds. The first storyboard was a simple hierarchical structure with branches to each subject area, as shown in Figure 10-10.

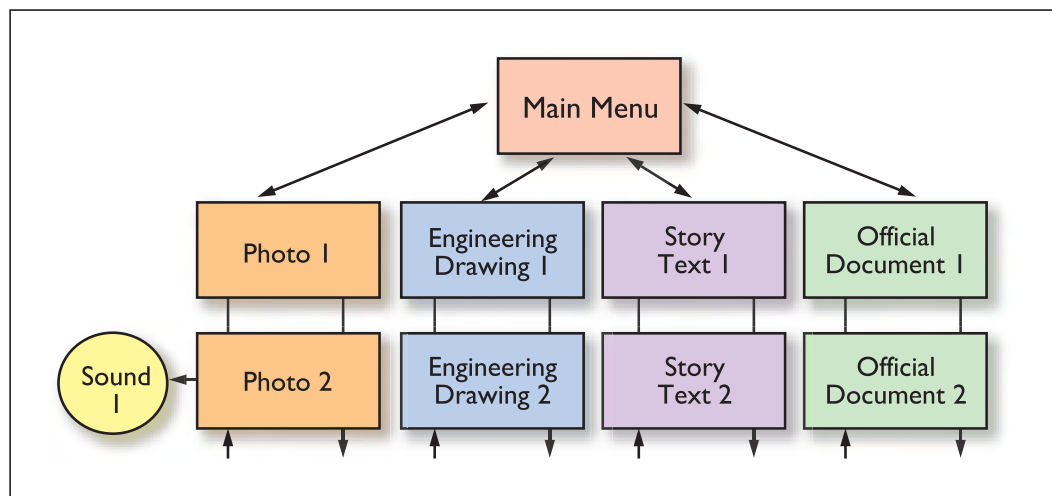

Figure 10-10 The first storyboard

Putting It Together

The most eye-catching photograph was chosen as a background for the main menu, and, as shown in Figure 10-11, the main menu was planned to contain clearly labeled buttons navigating to linear presentations of each topic area. From every screen in the project, users would be able to return to the main menu. Where sound bites were appropriate, clicking buttons on screens would play sounds. Adding a Quit button was necessary, also on the main menu, so that users would never be more than two button clicks from exiting the project (back to the main menu, and then quit).

The 50 or so 4 × 5 photographs were old color prints that offered poor contrast and faded colors (due to a saltwater dunking in a storm off the Central American coast-line). Digitized on a flatbed scanner in gray-scale, however, they worked fine, and Photoshop was available to improve contrast. All the prints were scanned, cropped to the same dimension, optimized, and stored as bitmapped objects within Director. While at the scanner, merchant marine licenses and documents were also digitized, and the magazine article was scanned using OCR software to bring it into ASCII format. The story text was imported into the project.

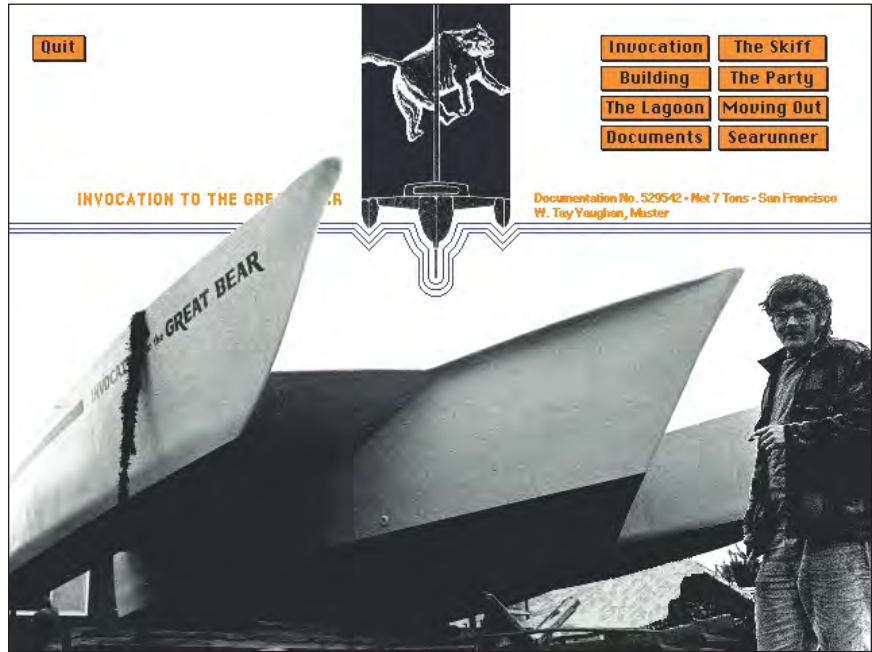

Figure 10-11 Main menu screen with relevant artwork as background

After all the content was in Director's Cast (see Chapter 11), and work on the navigation system was under way, several issues emerged. First, it is terrifically boring to read a 3,000-word story by scrolling a long text field. Second, the photos were too small to be placed alone on a single screen. So it made sense to combine the story line with the images, even though they were not directly related; the story about launching the boat would progress from beginning to end as the boat was slowly built in the pictures. The storyboard changed to that shown in Figure 10-12.

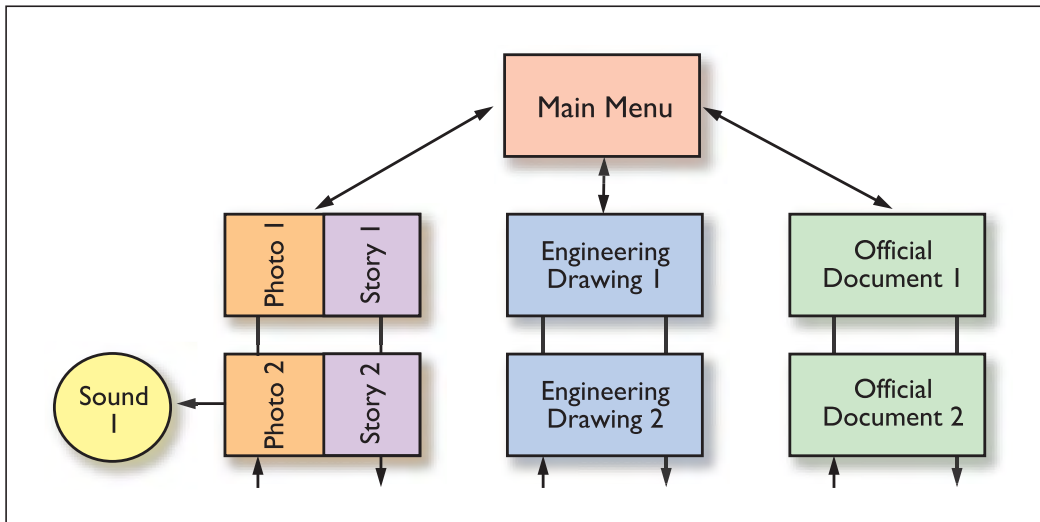

Figure 10-12 The second storyboard

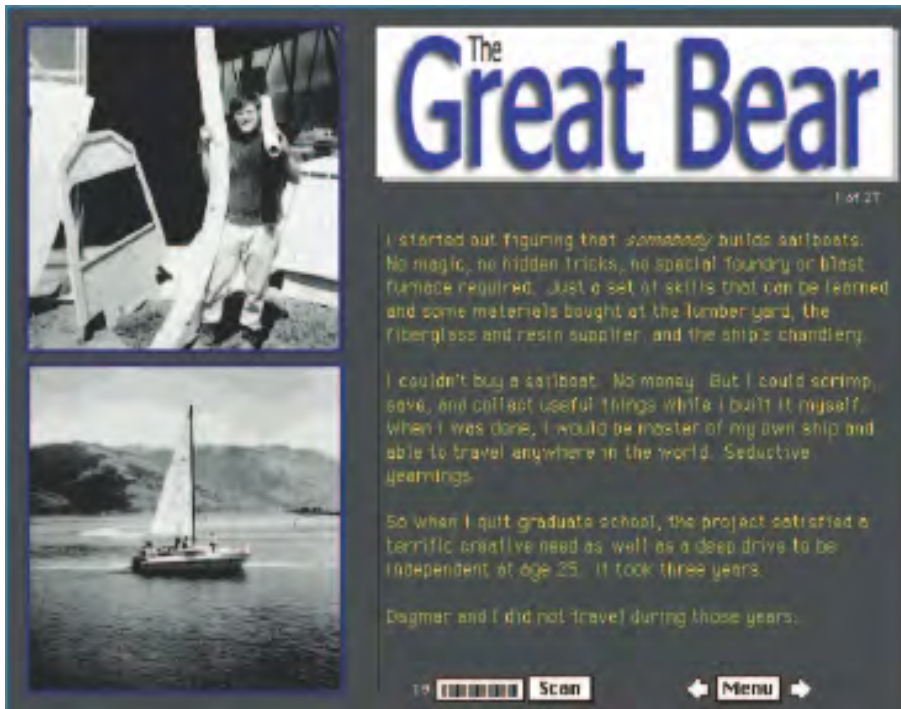

Figure 10-13 Snapshots are combined with text to form a 28-screen story line.

The photo-essay-and-story combination worked out to 28 screens. The photos were placed into the score, and the text was cut and pasted into fields (see Figure 10-13). It became clear that users might want to scan rapidly through the photographs to watch the boat being built, ignoring the text of the story. So a special button was programmed to scan through the images until the mouse was clicked.

Images that did not fit into the photo essay about building the boat—for instance, the launching party with its roast pig, the long haul to the beach by trailer, and setting the mooring—were withdrawn from the pile of construction

photographs; but because they were interesting, they were attached as separate branches accessible by button from the main menu. This was the third time the navigation changed, proving that you can continue to hang elements on a menu until the menu screen is too busy (and then you use submenus), or until you run out of material, as shown in Figure 10-14.

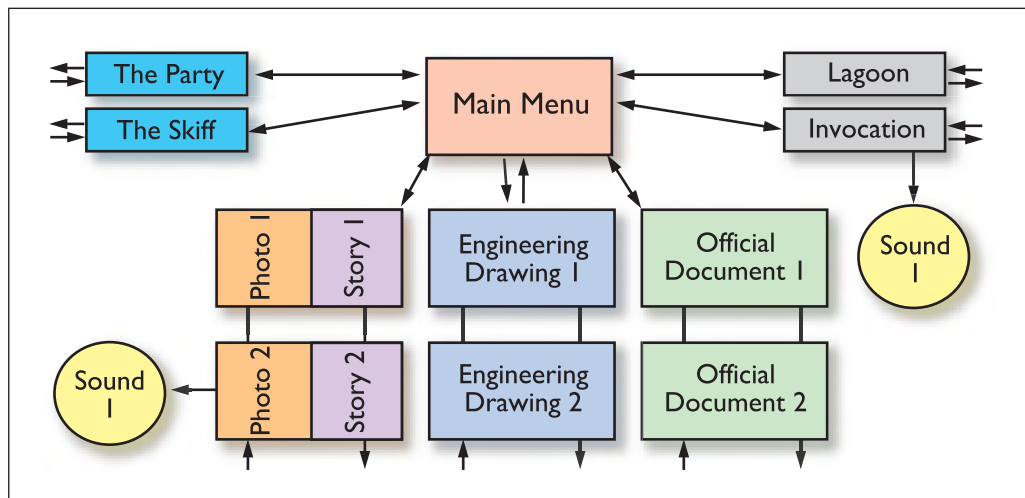

Figure 10-14 The third storyboard

Next, the sound bites were recorded, digitized, and added to the project. Figure 10-15, the screen where the sounds were to play, shows the special button installed to play sound bites. It's simply a picture of a loudspeaker.

The documents for the project included engineering drawings, highway permits, and licenses. The highway permit, for example, was 8.5 by 11 inches (portrait); but after some experimentation, once it was scaled to 480 pixels in height, it was (barely) readable and acceptable for this project. The licenses and drawings were in landscape orientation and fit more easily on a 640 × 480-pixel screen (see Figure 10-16).



Figure 10-15 Sound is played when the loudspeaker icon is clicked.

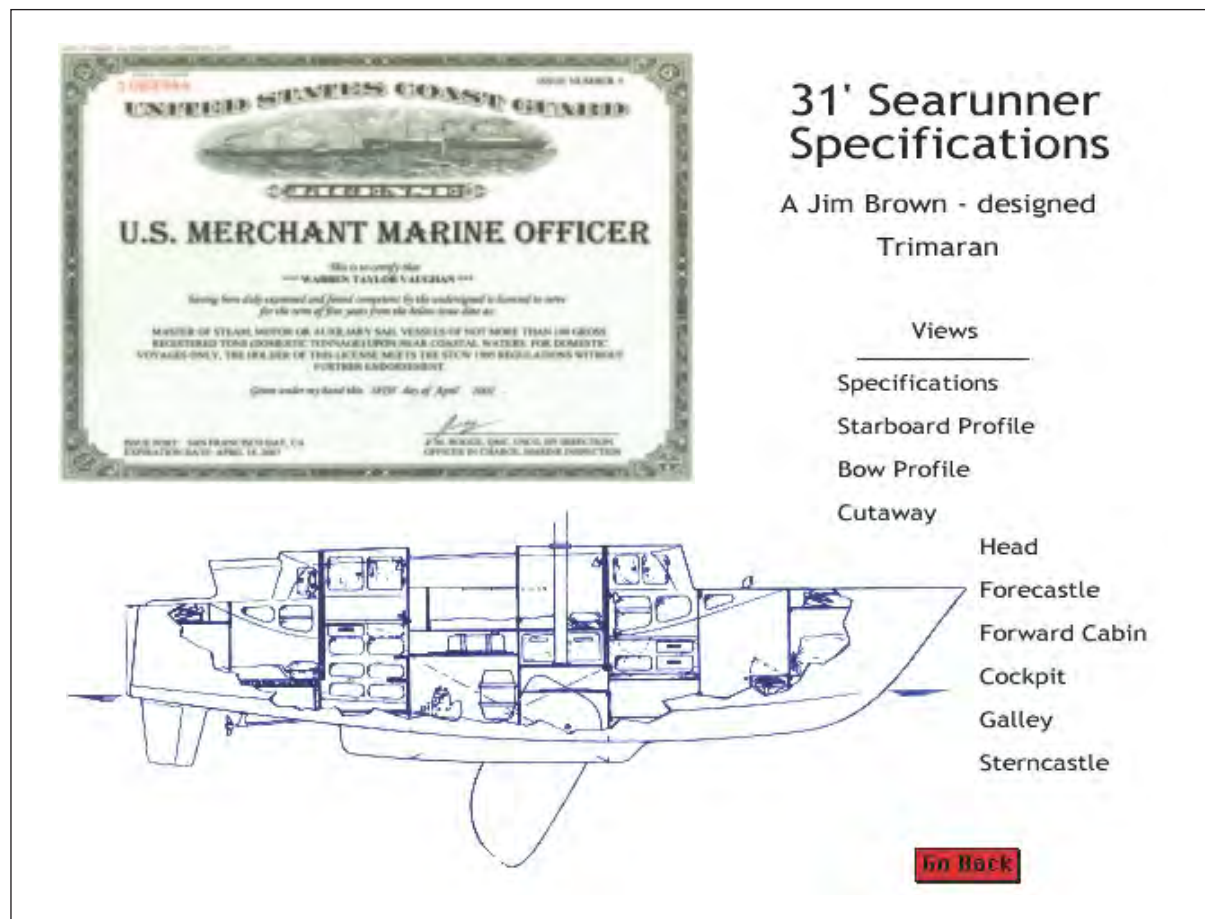

Figure 10-16 Larger fonts of some scanned documents can be read at 72 dpi resolution, and engineering drawings in landscape orientation can be resized to fit.

Developing multimedia can be like taking a joy ride in a washer/dryer. When it's all over you feel like you've been washed, rinsed, spun, and tumble-dried.

Kevin McCarthy,
Director of Business
Development, Medius IV

The buttons on the main menu were the wrong color, so they were changed a few times until the color worked. Helvetica title text wasn't fancy enough, so it was reworked and a drop shadow was laid in. A special slider button was built and programmed to allow the construction sequence to go immediately to any of the pictures in the sequence. The backgrounds were tweaked a little, and the order of images changed somewhat. A small red car was animated to drive along the edge of the lagoon.

The project described here was simple and straightforward. With the exception of designing a few custom buttons for auto-scanning through some of the images and designing the animations, the entire project was a progression of screens of information, with links activated by clicking buttons.

Producing

By the time you reach the development phases of your multimedia project and you start building, you should already have taken care to prepare your plan and to get organized. The project plan (see Chapter 9) now becomes your step-by-step instruction manual for building the product. For many multimedia developers, following this plan and actually doing the construction work—being down in the trenches of hands-on creation and production—is the fun part of any project.

Production is the phase when your multimedia project is actually rendered. During this phase you will contend with important and continuous organizing tasks. There will be times in a complex project when graphics files seem to disappear from the server, when you forget to send or cannot produce milestone progress reports, when your voice talent gets lost on the way to the recording studio, or when your hard disk crashes. So it's important to start out on the right foot, with good organization, and to maintain detailed management oversight during the entire construction process. This rule applies to projects large and small, projects for you or for a client, and projects with 1 or 20 people on staff. Above all, provide a good time-accounting system for everyone working on the project. At the end of the week, it's hard to remember how much time you spent on the tasks you did on Monday.

TIP *If your project is to be built by more than one person, establish a management structure in advance that includes specific milestones and the production expectations for each contributor.*

Starting Up

Before you begin your multimedia project, it's important to check your development hardware and software and review your organizational and administrative setup, even if you are working alone. This is a serious last-minute task. It prevents you from finding yourself halfway through the project with nowhere to put your graphics files and digitized movie segments when you're out of disk space, or stuck with an incompatible version of a critical software tool, or with a network that bogs down and quits every two days. Such incidents can take many days or weeks to resolve, so try to head off as many potential problems as you can before you begin. Here are some examples of things to think about.

- Desk and mind clear of obstructions?
- Best computers you can afford?
- Time-accounting and management system in place?
- Biggest (or most) monitors you can afford?
- Sufficient disk storage space for all work files?
- System for regular backup of critical files?
- Conventions or protocols for naming your working files and managing source documents?
- Latest version of your primary authoring software?
- Latest versions of software tools and accessories?
- Communication pathways open with client?
- Breathing room for administrative tasks?
- Financial arrangements secure (retainer in the bank)?
- Expertise lined up for all stages of the project?
- Kick-off meeting completed?

First Person

At 18, I used to hang around with people who drove fast cars, and once volunteered to help an acquaintance prepare his Ferrari Berlinetta for a race at Watkins Glen. My job was to set the valves while my friend went over the suspension, brakes, and later, the carburetor. The car boasted 12 cylinders and 24 valves, and adjusting the clearance between tappet and rocker arm seemed to me akin to

a jeweler's fine work. It required special wrenches and feeler gauges and an uncommon touch to rotate the high-compression engine so the cam was precisely at its highest point for each valve. I was blown away by the sheer quantity of moving parts under the Ferrari's long and shiny valve covers—my own fast car had only four cylinders and eight simple valves. It took me about seven exhausting hours

(including double-checking) to get it right. As the sun came up, though, the engine sounded great! Tuning up and preparing, I learned, is as important to the race as the race itself. My friend, however, learned a much tougher lesson: he spun out and rolled his Ferrari at the hairpin turn in the seventh lap. He crawled unhurt from the twisted wreckage, but all he was able to salvage from the car was the engine.

Working with Clients

Making multimedia for clients is a special case. Be sure that the organization of your project incorporates a system for good communication between you and the client as well as among the people actually building the project. Many projects have turned out unhappily because of communication breakdowns.

Client Approval Cycles

Provide good management oversight to avoid endless feedback loops—in this situation the client is somehow never quite happy, and you are forced to tweak and edit many times. Manage production so that your client is continually informed and formally approves by signing off on artwork and other elements as you build them. Occasionally, the technology will improve during development and you may be able to offer new features that will improve your project. Develop a scheme that specifies the number and duration of client approval cycles, and then provide a mechanism for change orders when changes are requested after sign-off. For change orders, remember that the client should pay extra and the changes should be costly.

First Person

We made up two sample musical tracks to play in the background and sent them off by overnight courier to the client. Four days later, the client phoned to say that both were good, but they were wondering if we couldn't make it sound a little more like Windham Hill. So we redid the music and sent two more samples. Five days later, the client said the samples were great, but the

boss wanted something with a Sergeant Pepper feel. So we sent a fifth creation, this time with a note that they would have to either settle on one of the five styles submitted, supply the music themselves, or pay us more money to keep up the creative composition work. They chose the music the boss liked, but we wound up more than two weeks behind schedule and had spent significantly

more money and effort on this task than originally budgeted.

Several months later, in the next job requiring original music composition, we specified a maximum of two review/feedback cycles and added a clause for cost overrun beyond that. The first sound we submitted to this new client was approved, and we stayed ahead of schedule and budget.

Data Storage Media and Transportation

It's important that the client be able to easily review your work. Remember that either you and the distant site need to have matching data transfer systems and media, or you need to provide a web or FTP site for your project. Organize your system before you begin work, as it may take some

time for both you and the client to agree on an appropriate system and on the method of transportation.

Because multimedia files are large, your means of transporting the project to distant clients is particularly important. Typically, both you and the client will have access to the Internet at high bandwidth. If not, the most cost- and time-effective method for transporting your files is on DVD-ROM by an overnight courier service (FedEx, DHL, or Postal Service Express Mail). Material completed in time for an afternoon pickup will usually be at the client's site by the next morning.

If you use the Internet to deliver your multimedia to the client, be sure that you set up rules and conventions for naming files placed at an FTP site, and use codes in the subject headers of your e-mail to describe the content of the message. After a project has been under way for a while, there will be many files and many communications, so these keywords and clues will make life easier. This is another place where planning ahead pays off!

Tracking

Organize a method for tracking the receipt of material that you will incorporate into your multimedia project. Even in small projects, you will be dealing with many digital bits and pieces.

Develop a **file-naming convention** specific to your project's structure. Store the files in directories or folders with logical names. **Version control** of your files (tracking editing changes) is critically important, too, especially in large projects. If more than one person is working on a group of files, be sure that you always know what version is the latest and who has the current version. If storage space allows, archive all file iterations, in case you change your mind about something and need to go back to a prior rendering.

Copyrights

Commonly used authoring platforms may allow access to the software programming code or script that drives a particular project. The source code of HTML pages on the Web may also be easily viewed.

In such an open-code environment, are you prepared to let others see your programming work? Is your code neat and commented? Perhaps your mother cautioned you to wear clean underclothing in case you were suddenly on a table among strangers in a hospital emergency room—well, apply this rule to your code. You can insert a copyright statement in your project that clearly (and legally) designates the code as your intellectual property (see Figure 10-17), but the code, tricks, and programming techniques remain accessible for study, learning, and tweaking by others.



Figure 10-17 Typical copyright and ownership statements embedded in <meta> tags at the top of an HTML page

Hazards and Annoyances

Even experienced producers and developers commonly run into at least some light chop and turbulence during the course of a project's development. The experts, however, never crash when their vehicle shudders or loses some altitude. You can expect the going to get rough at any number of stages—from trying to design the perfect interface, to endless testing, to problems with client sign-off or payment. Expect problems beyond your control, and be prepared to accept them and solve them.

Small annoyances, too, can become serious distractions that are counterproductive. The production stage is a time of great creativity, dynamic intercourse among all contributors, and, above all, hard work. Be prepared to deal with some common irritants, for example:

- Creative coworkers who don't take (or give) criticism well
- Clients who cannot or are not authorized to make decisions
- More than two all-nighters in a row
- Too many custom-coded routines
- Instant coffee and microwaved corn dogs
- Too many meetings; off-site meetings
- Missed deadlines
- Software and hardware upgrades that interrupt your normal operations

If your project is a team effort, then it is critical that everyone works well together—or can at least tolerate one another's differences—especially when the going gets tough. Pay attention to the mental health of all personnel involved in your project, and be aware of the dynamics of the group and whether people are being adversely affected by individual personalities. If problems arise, deal with them before they become hazardous; the mix of special creative talents required for multimedia can be volatile. If you stay organized and flexible throughout, you will complete your project successfully. See Chapter 14 for how to deliver it!

First Person

In 1975, I was hired to deliver a 41-foot cruising sailboat from Fort Lauderdale to the British Virgin Islands for the charter trade. In three days I assembled a crew of strangers, provisioned the boat, and checked all the equipment. Then we took off across the Gulf Stream and into the Bermuda Triangle.

After two days it was clear that the cook was a bad apple. It wasn't just that she couldn't cook—she whined about everything: the stove

wouldn't light, the boat heeled too much, her socks were wet, her sleeping bag tore on a cleat, her hair was tangled, she couldn't get her favorite radio station (now a few hundred miles astern). It was unending.

The whining began to envelop her in a smog-colored, onion-like layering, each new complaint accreting to the last one, like growing coral. By the fifth day, her unpleasant aura saturated the entire main cabin, and the rest of us had to

seek sanctuary in the cockpit or the small aft cabin. Efforts were made to solve this bizarre situation, but by then, nobody could get near her (or wanted to). When we pulled into tiny Caicos Island for water and fresh stores, I paid her off and arranged for a room at the quaint waterfront hotel, where she could wait three days for the weekly airplane back to Florida. Everyone felt bad about her disappointment and how it all turned out—for about an hour. The rest of the voyage was jubilant.

Chapter 10 Review

■ Chapter Summary

For your review, here's a summary of the important concepts discussed in this chapter.

Design the structure and user interface for a multimedia project

- The best products are often the result of continuing feedback and modifications implemented throughout the production process. However, too much feedback and too many changes can kill a project; always balance proposed changes against their cost.
- You can either describe the project in great detail before the production, or you can use rough storyboards and refine the design as you produce it.
- How you organize your material for a project will have just as great an impact on the viewer as the content itself.
- Start mapping the structure of your project early in the planning phase.
- Project designs are typically linear, hierarchical, nonlinear, or composite.
- The method you provide to your viewers for navigating from one place to another in your project is part of the user interface.
- Depth structure represents the complete navigation map and describes all the links between all the components of your project.
- Surface structure represents the structures actually realized by a user while navigating the depth structure.
- Hot spots can be text, graphic, and icon.

- Stick with accepted conventions for button design and grouping, visual and audio feedback, and navigation structure.

How to produce a successful multimedia project and work with clients

- Production is the phase when your multimedia project is actually rendered.
- Provide a time-accounting system for everyone working on the project.
- Check your development hardware and software and review your organizational and administrative setup.
- Have a system for communication between you, the client, and the people actually building the project in place.
- Provide management oversight and control the client review process to avoid endless feedback loops.
- Establish a process in which your client is continually informed and formally approves the project as you develop it.
- Organize a method for tracking the receipt of material that you will incorporate into your multimedia project.
- Develop a file-naming convention specific to your project's structure.
- Version control of your files (tracking editing changes) is critically important, especially in large projects.

■ Key Terms

busy screen (312)

button (303)

composite navigation (296)

depth structure (297)

file-naming convention (321)

hierarchical navigation (296)

hot spot (303)

hyperlink (303)

icon (303)

image map (305)

linear navigation (296)

modal interface (308)

navigation map (296)

nonlinear navigation (296)

production (318)

site map (296)

storyboard (295)

surface structure (297)

user interface (308)

version control (321)

white space (311)

■ Key Term Quiz

1. The graphic outlines that describe each page of a project in exact detail are called _____.
2. A multimedia structure in which users navigate sequentially, from one frame or bite of information to another, could be called _____.
3. A multimedia structure in which users navigate along the branches of a tree structure that is shaped by the natural logic of the content could be called _____.
4. A multimedia structure in which users navigate freely through the content of the project, unbound by predetermined routes, could be called _____.
5. A multimedia structure in which users may navigate freely, but are occasionally constrained to linear presentations, could be called _____.
6. The complete navigation map that describes all the links between all the components of your project is known as _____.
7. The structures actually realized by a user while navigating the project's content is known as _____.
8. Fundamental graphic objects that represent an activity or concept are called _____.
9. The standard that ensures that project files are given logical names and stored in folders with logical names is the _____.
10. Making sure that old files are archived and new versions are properly tracked is called _____.

■ Multiple-Choice Quiz

- Which of these is *not* an advantage of creating detailed storyboards before beginning production?
 - It will be better and easier to construct the project.
 - Less time is required in polishing the final product.
 - Getting to the production stage is faster.
 - It is better suited to separate design and production teams.
 - Clients who like to tightly control the production process prefer it.
- Which of these is *not* one of the listed types of organizational structures?
 - linear
 - hierarchical
 - nonlinear
 - composite
 - recursive
- The visual representation of a project that includes a table of contents as well as a chart of the logical flow of the interactive interface is often called:
 - a storyboard
 - a workflow diagram
 - a prototype
 - a navigation map
 - a master layout
- The method you provide to your viewers for navigating from one place to another in your project is part of the:
 - script
 - user interface
 - storyboards
 - depth structure
 - surface structure
- The generic term for any area of an image that can be clicked on is:
 - a hot spot
 - a storyboard
 - an image map
 - a rollover
 - an icon
- An interface in which a user can click a button and change the approach of the whole interface is called:
 - a prototype
 - a navigation map
 - a modal interface
 - a site map
 - a transitional GUI
- Having separate novice and expert interfaces for a multimedia program is generally not a good idea because:
 - it tends to take up too much disk space or bandwidth
 - novice users tend to get caught in the expert mode
 - only a minority of users are expert; most users are caught in between and are frustrated
 - most authoring systems are not capable of handling parallel structures
 - it makes developing documentation awkward and unwieldy
- GUI stands for:
 - General/Universal/Individual
 - General Utilization Instructions
 - Global Usage Image
 - Guidelines for Usability and Interaction
 - Graphical User Interface
- The Macintosh and Windows GUIs are successful partly because:
 - they enable cross-platform file structures
 - their basic point-and-click style is simple, consistent, and quickly mastered
 - they are highly customizable, allowing programmers to use program-specific keyboard shortcuts
 - they tend to make the computer run more efficiently
 - slick marketing efforts tricked gullible consumers

10. Noninformation areas left intentionally free from visual clutter are often referred to as:
- negative space
 - screen real estate
 - advanced organizers
 - white space
 - depth structure
11. The standards that ensure that project files are given logical names and stored in folders with logical names are the:
- usability guidelines
 - pattern-recognition algorithms
 - file-naming conventions
 - review-cycle management
 - project tracking protocols
12. Perhaps the most significant problem with creating a multimedia program that gives users complete free reign is that:
- such freedom is difficult to program
 - computers cannot yet process so many variables concurrently
 - too much freedom can be disconcerting to users
 - it is difficult to organize data into meaningful structures
 - such interfaces tend to be cluttered and unwieldy
13. Default colors for anchor text are found in which HTML tag?
- <HEAD>
 - <FRAME>
 - <LINK>
 - <COLOR>
 - <BODY>
14. Which of these is probably *not* a good step to take before starting the production process for a multimedia project?
- Lock in the design so there are no further changes to delay production.
 - Establish limits on client review cycles to reduce cost overruns.
 - Set up an FTP site for sending and receiving production files.
 - Establish clear file-naming and version control standards.
 - Check the state of your hardware and software to ensure reliability and capability, and integrate any upgrades.
15. An image on a web page can be sectioned in HTML into areas that are clickable links. This is called:
- a sweet spot
 - a site map
 - a rollover
 - a frameset
 - an image map

■ Essay Quiz

1. You are given the task of managing a design and production team to complete a multimedia web site for your own company. The site is to use the latest plug-ins for interactive 3-D presentation. The design team consists of a writer and a designer, and the production team includes two programmers. Would you make sure the design and storyboards were “nailed down” before beginning production, or would you start and allow the design to be changed during the production process? How would factors such as the client, the technology, and the relationship between the design and production teams affect your approach?

2. List the four different types of multimedia structures. Next, describe four hypothetical projects, one that might be appropriate for each of the four types. For each of these four projects, comment on why the project is best suited to that structure and why each of the three structures is less appropriate for that project.
3. Discuss the relationship between a program's content, its interface, and its usability. What is the best way to make the content accessible to users without unnecessary complexity? Where are modal interfaces useful? What are their drawbacks? Where are navigation or site maps useful? How might you use "themes" to identify different areas of a program or different approaches to the content's structure?
4. What are the steps you would take in "gearing up" for the production phase of a multimedia project? Organize your thoughts according to the infrastructure (hardware, software, networks, web/FTP site), team management, and client interaction.
5. Describe the tracking process you might use to control the project development process. Be sure to include a discussion of version control, file-naming convention, client review cycles, and team management.

Lab Projects

■ Project 10.1

Locate three different web sites: a news site, a shopping site, and a hobby or special interest site. Print out the home page for each site (the home page should include the primary navigation; it should not be a "splash page" that includes little navigation). Circle all the buttons on the interface. Note any buttons that are common to each site. Compare the layout and structure of the sites, ignoring aesthetic considerations. List the buttons that are different. Comment on why the buttons are laid out and grouped as they are. Is the site accessible? How are icons used? How are menus used? Write a report documenting your observations, and include the printouts.

■ Project 10.2

Locate three different web sites that have similar content and that include site maps. Print out each site's map. How are the structures similar? How are they different? How are the differences related to their content? How are the differences related to a different way of structuring the information? Write a report documenting your observations, and include the printouts.

■ Project 10.3

Create a site map for a hypothetical multimedia DVD project on the history of computers. Use the composite structure, and provide two means of navigating the content, one being a timeline. Be sure to include various options such as help, glossary, and so on. Trace the "surface" structures that three hypothetical users might take through the program: a novice user, an expert user, and someone looking for a particular fact about computer history. Explain why each user would take that particular path through the project.

■ **Project 10.4**

Using simple text blocks and icons, create a user interface for the project you developed in Project 10.3. Discuss what buttons are included, how they are logically grouped together, and why. What non-text interface elements might you include to provide navigational cues?

■ **Project 10.5**

Create five storyboards for the history of computers project. Storyboard a “splash screen,” the main menu, a submenu, and two different content screens.

Content and Talent

In this chapter, you will learn how to:

- Acquire content for a project and identify the benefits and drawbacks of various sources of content such as clip art, stock libraries, and public domain sources
- Discuss the concepts of copyright, public domain, licensing, and derivative works, and determine who owns the copyright for a work, depending on who contracted the work and for what purpose
- Discuss the process of identifying appropriate talent for a production, and issues in using talent, including union rules, contracts, and releases

EVERY multimedia project includes **content**. It is the “stuff” from which you fashion your messages. It is also the information and material that forms the heart of your project, and it is that which defines what your project is about.

Practically, content can be any and all of the elements of multimedia. You might use your collection of wedding photographs and videotapes to create a special multimedia newsletter for family and relatives. Or you might edit portions of the audio track from these videotapes and capture still images to build a multimedia database of aunts, uncles, and cousins. This material is your project’s content.

Content can have low and high **production value**. If you hire a team of professionals to shoot your wedding video, and then they digitize images and audio clips at broadcast quality, your content will have high production value. If you persuade Hillary Rodham Clinton to record the voice-over and Garry Trudeau, the “Doonesbury” artist, to retouch the images, it will have yet higher production value.

You must always balance the production value of your project against your budget and the desired result. For aerial photographs of the wedding reception, you would not likely commission the private launch of a spy satellite from Kennedy Space Center to achieve highest production value. Instead, you could rent a helicopter with paparazzi and still achieve good production value. Or you could photograph the wedding yourself from a neighboring rooftop and be satisfied with the lower production value. The production value of your project is a question of balance (see Vaughan’s Law of Multimedia Minimums in Chapter 4).

Content has to come from somewhere—either you make it or you acquire it. Whether you make it, borrow it, or buy it depends upon your project’s needs, your time constraints, and your pocketbook. Content that is destined for sale to the public is also wrapped up in numerous legal issues. Who owns the content? Do you have the proper rights to use it? Copyright laws, for example, establish rights for the creators or owners of literary works; musical works; dramatic works; pictorial, graphic, and sculptural works; motion pictures and other audiovisual works; and sound recordings. Do you have licenses for protected works and signed releases from anyone who appears in your project?

When the Vatican recently made a collection of artwork available on the World Wide Web, they made certain there was a digital “watermark” for each image; they would then know if the artwork was ripped off, without recourse to even higher laws. The Vatican is aware (as you should be) of the nature of the electronic revolution:

In accordance with international regulations on Intellectual Property and Author’s Rights, we inform our readers that the news items contained in the Vatican Information Service may be used in part or in their entirety, but only if the source (V.I.S., Vatican Information Service) is quoted. In the case of electronic retransmission (Internet, telematic networks, via PC-modem, fax, etc.), prior authorization from the Vatican Information Service is always required.

.....
www.vatican.va

www.christusrex.org

Collections of hundreds of classical images

This chapter discusses some of the legal issues surrounding content and the use of talent in multimedia projects. It provides examples of contract terms and introduces you to sources and providers of content and talent. Needless to say, always consult an attorney versed in intellectual property law when you negotiate the rights and ownership of content.

Acquiring Content

Content acquisition can be one of the most expensive and time-consuming tasks in organizing a multimedia project. You must plan ahead, allocating sufficient time (and money) for this task.

- If your project describes the use of a new piece of robotics machinery, for example, will you need to send a photographer to the factory for the pictures? Or can you digitize existing photographs?
- Suppose you are working with 100 graphs and charts about the future of petroleum exploration. Will you begin by collecting the raw data from reports and memos, or start with an existing spreadsheet or database? Perhaps you have charts that have already been generated from the data and stored as TIFF or JPEG files?
- You are developing an interactive guide to the trails in a national park, complete with video clips of the wildlife that hikers might encounter on the trails. Will you need to shoot original video footage, or are there existing tapes for you to edit?

This is how you do things on a shoestring. Years ago, we created a basketball product starring Dr. J and Larry Bird.

The first thing we knew we had to do was sign a contract with Dr. J. So we found a guy that knew his agent and we made a side deal with him to pay him to convince Julius to do it. And then we went to Julius and we made a deal where we gave him some stock in the company, rather than writing a huge check.

And we convinced him of the educational value of what we were doing, instead of just trying to get it to be an arms-length financial deal. So we were able to sign him up with an advance of only \$20,000. And he was quite easily the biggest name in basketball and one of the top two or three regarded professional athletes at the time. We got him for a royalty rate of 2 ½ percent (not what you hear today in a lot of cases), so you don't have to do things that have really high royalty rates and advances. By the way, he made a killing on the stock!

.....
 Trip Hawkins, Founder,
 Electronic Arts

TIP *Be sure to specify in your project plan the format and quality of content and data to be supplied to you by third parties. Format conversion and editing takes real time. Worse, if you have specified that images for a client's web site are to be 800 × 600 pixels, but the photo files you receive from your client's cousin are 320 × 240 pixels at 72 dpi, there will simply not be enough information in the image to enlarge it to the required resolution.*

Using Content Created by Others

When a work is created, certain rights, such as for the work's public display or performance, its use in a broadcast, or its reproduction, are granted to its creator. Among the rights most relevant to a multimedia producer are **electronic rights**—the rights to publish a work in a computer-based storage and delivery medium such as a CD-ROM or on the Web. Since the late 1980s, investors in the multimedia marketplace have been quietly purchasing electronic rights (the right to reproduce works in electronic form) to the basic building blocks of content—including films, videos, photographic collections, and textual information bases—knowing that in the future these elements can and perhaps will be converted from their traditional form to computer-based storage and delivery. This is smart, but not easy; the many union-supported contract restrictions and performer and producer rights are not only complicated and difficult to trace but also very expensive to acquire.

WARNING *If you negotiate ownership or rights to someone else's content, be sure to get the advice of a skilled copyright and contracts attorney.*

Obtaining the rights to content is not, however, a hopeless undertaking. For example, Amaze, Inc., acquired rights from several sources to produce a series of computer-based daily planners with a cartoon-a-day from Gary Larson's "The Far Side" or Cathy Guisewite's "Cathy," a word-a-day from Random House, or a question-a-day from the Trivial Pursuit game. Random House and Brøderbund's Living Books Division negotiated the rights to the Dr. Seuss books for multimedia use. Multimedia rights to Elvis Presley historical material, to the movie *Jurassic Park*, and to a myriad of other content have been acquired by multimedia developers and publishers.

Depending on the type and source of your content, the negotiations for usage rights can be simple and straightforward, or they may require complicated contracts and a stack of release forms. Each potential content provider you approach will likely have his or her own set of terms that you need to look at carefully, so that the terms are broad enough not to constrain the scope of your multimedia project.

Locating Preexisting Content

Preexisting content can come from a variety of sources, ranging from a trunk of old photographs in your neighbor's attic to a stock house or image bank offering hundreds of thousands of hours of film and video or still images, available for licensing for a fee.

If your needs are simple and fairly flexible, you may be able to use material from collections of **clip art**. Such collections of photographs, graphics, sounds, music, animation, and video are becoming widely available from many sources, for anywhere from fifty to several hundred dollars. Part of the value of many of these packages is that you are granted unlimited use, and you can be comfortable creating derivative versions tailored to your specific application. Carefully read the license agreement that comes with the collection before assuming you can use the material in any manner. In the six-point italicized type on the back of the agreement, you may discover that the licensor offers no guarantee that the contents of the collection are original works. Thus, the licensor bears no responsibility to indemnify you for inadvertently infringing on the copyrights of a third party. Even if the collection is described as allowing "free use," you may discover that the collection comes with severe restrictions on the way material can be used, or that a **royalty** is required for any use beyond wallpaper on your computer.

If your content needs are more specific or complex, a good place to start your search for material might be at a **still photo library**, a **sound library**, or a **stock footage** house. These "stock" resources may be public or private and may contain copyrighted works as well as materials that are in the public domain. **Public domain** means either that the work was never copyrighted in the first place or its copyright protection has expired over time and not been renewed; you can use public domain material without a license.

In addition to stock photos and videos clips, there are whole collections of flash animations and components, web site templates, sound effect libraries, and even 3-D models available for downloading and integration into multimedia projects. Many are not free, but stock material may save you many hours of effort.

.....
www.flashcomponents.net

www.templatemonster.com

www.sounddogs.com

<http://turbosquid.com>

Mickey Mouse Goes to Washington

Unless you earn your living as an intellectual property lawyer, you probably don't know that the Supreme Court has granted certiorari in *Eldred v. Ashcroft*, a case that will test the limits of Congress's power to extend the term of copyrights. But while copyright may not seem inherently compelling to nonspecialists, the issues at stake in *Eldred* are vitally important to anyone who watches movies, listens to music, or reads books. If that includes you, read on.

Back in 1998, representatives of the Walt Disney Company came to Washington looking for help. Disney's copyright on Mickey Mouse, who made his screen debut in the 1928 cartoon short "Steamboat Willie," was due to expire in 2003, and Disney's rights to Pluto, Goofy, and Donald Duck were to expire a few years later.

Rather than allow Mickey and friends to enter the public domain, Disney and its friends—a group of Hollywood studios, music labels, and

PACs representing content owners—told Congress that they wanted an extension bill passed.

Prompted perhaps by the Disney group's lavish donations of campaign cash—more than \$6.3 million in 1997–98, according to the nonprofit Center for Responsive Politics—Congress passed, and President Clinton signed, the Sonny Bono Copyright Term Extension Act.

The CTEA extended the term of protection by 20 years for works copyrighted after January 1, 1923. Works copyrighted by individuals since 1978 got "life plus 70" rather than the existing "life plus 50." Works made by or for corporations (referred to as "works made for hire") got 95 years. Works copyrighted before 1978 were shielded for 95 years, regardless of how they were produced.

In all, tens of thousands of works that had been poised to enter the public domain were maintained under private ownership until at least 2019.

So far so good—as far as Disney and its friends were concerned, at least. In 1999, a group of plaintiffs led by Eric Eldred, whose Eldritch Press offers free online access to public domain works, filed a challenge to the statute. Eldred argues that the CTEA is unconstitutional on two grounds: first, because the statute exceeds Congress's power under the Copyright Clause; and, second, because the statute runs afoul of the First Amendment by substantially burdening speech without advancing any important governmental interest.

Eldred lost before the district court and the D.C. Circuit. However, there is good reason to believe that he may yet prevail in the Supreme Court.

Chris Sprigman, Counsel to the Antitrust Group in the Washington, D.C. office of King & Spalding.

(Contrary to many predictions, on January 15, 2003, the United States Supreme Court upheld the Act in a 7–2 decision.)

Google claims that the full text of more than seven million books can now be searched and read online at Google Books (<http://books.google.com>) as part of an ongoing effort to scan and digitize entire libraries of books, magazines, journals, and articles from around the world. Certainly a noble idea, to make all known literature searchable and available on the Internet, but many are concerned that Google will, by the very nature of its vast collection, own a monopoly on much of the world's literature, particularly out-of-print "orphan" books, where copyrights are unknown or unclaimed. Lawsuits and haggling are underway involving copyright law, unfair competitive advantages, monetizing, and licensing rights of all kinds.

Google categorizes its holdings into three groups: in-copyright and in-print books, in-copyright but out-of-print books, and out-of-copyright books. For copyrighted and in-print material, users can search for the book, preview portions of it, and then purchase it through a bookseller like Amazon, Barnes & Noble, or Borders. In-copyright but out-of-print books can be previewed and purchased, opening an otherwise dry revenue stream to publishers and authors. Out-of-copyright books can be freely read, downloaded, and printed by the public. The mechanics of this system are being worked out in the courts; it's all about money and control.

The National Archives in Washington, D.C., is a rich source of content, both copyrighted and in the public domain. Other public sources include the Library of Congress, NASA, U.S. Information Agency, and the Smithsonian Institution, all in Washington, D.C. You cannot, however, safely assume that all material acquired from a public source is in the public domain. You remain responsible for ensuring that you do not infringe on a copyright.

In addition to public sources, there are many other repositories of content material. Commercial stock houses offer millions of images, video and film clips, and sound clips, and they often own the works outright—so, when they grant you a license for use of their work, you don't have to worry about possible copyright infringement of the rights of third parties. Some stock sources also specialize in certain subjects. For example, if you want a video clip of a shark, you might contact a stock footage house that specializes in underwater videos.

Copyrights

Copyright protection applies to “original works of authorship fixed in any tangible medium of expression.” The Copyright Act of 1976, as amended (17 U.S.C.A. §101 et. seq.) protects the legal rights of the creator of an original work. Consequently, before you can use someone else's work in your multimedia project, you must first obtain permission from the owner of the copyright. If you do not do this, you may find yourself being sued for **copyright infringement** (unauthorized use of copyrighted material).

Several changes in the law have created confusion over copyright protections. One change is that works now come under copyright protection as soon as they are created and presented in a fixed form. Prior to 1976, protection was only granted upon registration, but now works do not have to be registered with the U.S. Copyright Office to be protected. Because of this there is another crucial change: works no longer need a properly formatted statement of **copyright ownership** (for example, “Copyright © 2010 by Tay Vaughan”) to be protected. Many people assume, because of the pre-1976 rules, that if there is not a copyright statement, the work is available to be used. While that may be true for older works, you should start with the assumption that a work *is* protected, unless there is a specific statement that it is in the public domain. There are **fair use** exceptions in

Google's mission is to organize the world's information and make it universally accessible and useful. Today, together with the authors, publishers, and libraries, we have been able to make a great leap in this endeavor. While this agreement is a real win-win for all of us, the real victors are all the readers. The tremendous wealth of knowledge that lies within the books of the world will now be at their fingertips.

.....

Sergey Brin,
co-founder & president
of technology at Google,
October 28, 2008

which copyrighted material can be used without permission, but they are very limited and specific—primarily for educational and journalistic use and rarely for commercial use—so you should consult an attorney before assuming this exception applies to work you wish to use in a project.

Owning a copy of a work does not entitle you to reproduce the work, and you still need to obtain permission from the copyright owner to use it. If you buy a painting from an artist, the artist retains the copyright unless it is assigned to you. You do not have the right to reproduce the painting in any form, such as in postcards or a calendar, without permission.

For additional discussion about copyrights as they apply to original works created for a project, see “Ownership of Content Created for a Project” later in this chapter, and visit the U.S. Copyright Office at www.copyright.gov/.

Digital Rights Management (DRM) As rights and ownership are redefined for the information age, various rights management technologies are emerging and competing to become industry standard. Apple’s iTunes Store has sold more than six billion songs since going online in 2003. Songs downloaded from iTunes were protected with a DRM scheme called FairPlay, which works within Apple’s QuickTime container structure and limits the number of devices upon which the tune can be played (in 2009, Apple removed the DRM restriction for music tracks, but continues to protect movies and television shows). Microsoft Windows Media Rights Manager (Windows only) and the Windows Media Player 12 format incorporate extensive DRM capabilities. The Association of American Publishers is promoting DRM methodologies for protecting unauthorized copying of e-books. The Internet Streaming Media Alliance (ISMA) offers a content protection specification designed to provide a single, end-to-end encryption scheme for streaming media and file downloading that can be integrated with different key and rights management software and licensed content protection devices. A Digital Object Identifier (DOI), which has been proposed for identifying and exchanging intellectual property, provides a framework for managing intellectual content, linking customers with content suppliers, facilitating electronic commerce, and enabling automated copyright management for all types of media. The Digital Millennium Copyright Act of 1998 has set the rules. For an overview of this emerging battle, check out these URLs:

.....
www.copyright.gov/laws/

www.webopedia.com/TERM/D/DMCA.html

www.isma.tv/

www.doi.org/

www.current.tv/make/

First Person

Rights Management at Work

It is well known that professors and teachers who write textbooks do not get rich from the publisher's royalties. For all their hard work, they become famous perhaps, and they gain some bragging rights and add an important credit to their curriculum vitae as they strive toward tenure, but rich? Never.

So it was with some surprise that I received an e-mail from the Authors Registry in New York (www.authorsregistry.org), letting me know that I, as author of *Multimedia: Making It Work*, was owed some royalty monies collected by The Authors' Licensing and Collecting Society (ALCS) in the United Kingdom. For a five-percent fee, the Registry would take care of the paperwork and conversion from Pounds Sterling to U.S. Dollars and

mail me a check. Having in the past received more than one letter from Mr. Obutu in Nigeria offering me millions, I was skeptical.

It turns out that the ALCS (www.alcs.co.uk) is quite legitimate and collects a small fee on behalf of authors when their book (such as the one you are holding in your hands) is photocopied or scanned in schools, universities, businesses, public sector bodies or libraries or, according to Public Lending Right laws (www.plr.uk.com), each time their book is borrowed from a public library. In fact, the ALCS administers payments due to writers from the Austrian, Dutch, Belgian, French, Spanish, German, and Irish PLR schemes as well.

When the twice-yearly royalty check from the Authors Registry did finally arrive, less various commissions and

fees, it was sufficient to purchase a 25 kg bag of dry dog food for my Sophie. We both wish to thank those of you borrowing and copying readers from Britain and Europe who, most likely without knowing it, participated in a small but generous way in the formal management of writers' rights.

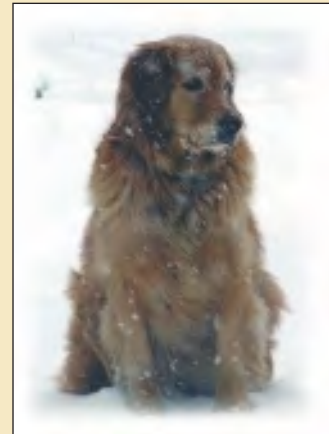

Obtaining Rights

You should license the rights to use copyrighted material before you develop a project around it. You may be able to negotiate outright ownership of copyrighted material. If the owner does not wish to give up or sell ownership rights, however, you may still be able to **license** the rights to use that material. Keep in mind, however, that different rights for the same copyrighted work (for example, rights for public performance, broadcast use, or publication) may be assigned to different parties. When you are negotiating a license make sure that the party you are dealing with has ownership of the appropriate rights.

There are few guidelines for negotiating content rights for use in multimedia products. If you are dealing with content providers who are

professionals familiar with electronic media, you may be given a standard **rate card** listing licensing fees for different uses, formats, and markets. Other content providers or owners may be less familiar with multimedia and electronic uses, and you will need to educate them.

Some **licensing agreements** may be as simple as a signed permission letter or release form describing how you may use the material. Other agreements will specify in minute detail how, where, when, and for what purpose the content may be used. Ideally, you would seek rights for **unlimited use**, which allows you to use the content anytime, anywhere, and in any way you choose; more likely, however, the final license would contain restrictions about how the material may be used. Try to retain the option to renegotiate terms in case you want to broaden the scope of use at a later date.

The following items are but a few of the issues you need to consider when negotiating for rights to use preexisting content:

- How will the content be delivered? If you limit yourself to CD-ROMs or DVDs, for example, you may not be able to distribute your product over the Internet without renegotiation.
- Is the license for a set period of time?
- Is the license exclusive or nonexclusive? (In an exclusive use arrangement, no one else would be able to use the material in the manner stipulated.)
- Where will your product be distributed? There may be different rates for domestic and international distribution.
- Do you intend to use the material in its entirety, or just a portion of it?
- What rights do you need? You need to be sure you have the right to reproduce and distribute the material. In addition, you may wish to use the material in promotions for your product.
- What kind of credit line or end-credits might the content owner require you to display?
- Does the content owner have the authority to assign rights to you? It is important to ensure you will not be held liable if a third party later sues for copyright infringement.
- Do you need to obtain any additional rights to use the content? For example, if you use a clip from a movie, do you need to get separate releases from actors appearing in the clip or from the director or producer of the movie?
- Will the copyright owner receive remuneration for the license? If so, what form will it take? A one-time fee? Royalty? Or a simple credit attribution?
- In what format do you wish to receive the content? Specifying formats is particularly important with video dubbed from a master.

Derivative Works Any text taken verbatim, or any image or music perfectly copied, clearly requires permission from its owner to incorporate it into your work. But there are some other, less clear-cut issues. For example, as a starter for your work, you may wish to incorporate but a tiny portion of an image owned by someone else, altering the image until the original is no longer recognizable. Is this legal? Indeed, how much of the original must you change before the product becomes yours or remains a **derivative work**? There are no simple answers to these tough questions.

Figure 11-1 shows an original photograph taken by Mark Newman, along with some artwork derived from it. Newman sold certain rights to 21st Century Media, which packages and sells assortments of stock photographs to computer graphics and multimedia developers on the Web and as CD-ROMs. The CD-ROM product contains these instructions:

You may make copies of the digitized images contained on the Product for use in advertisements, public or private presentations, business communications, multimedia presentations, and other uses as long as the images are not used to create a product for sale. For example, you may not use the images to create calendars, posters, greeting cards, or books of image collections for sale. You may not use, in whole or in part, or alter a digitized image in any manner for pornographic use.

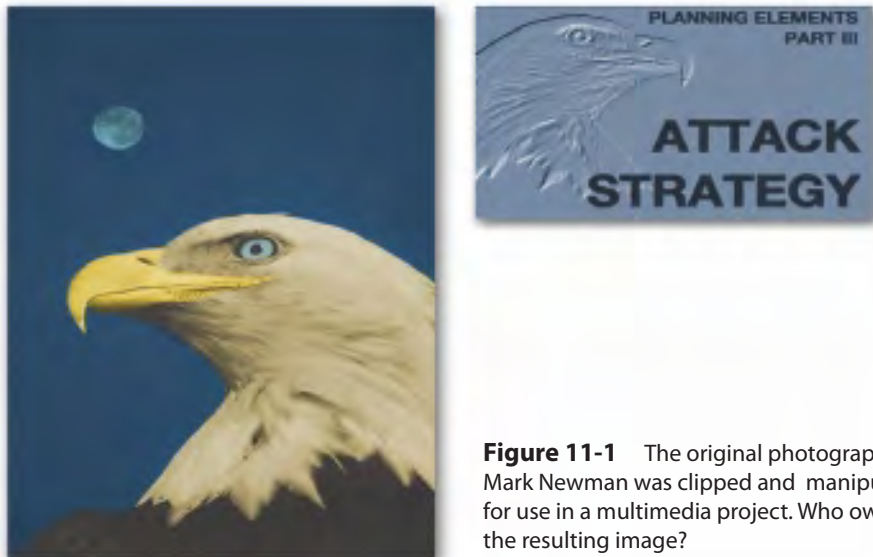

Figure 11-1 The original photograph by Mark Newman was clipped and manipulated for use in a multimedia project. Who owns the resulting image?

Suppose, however, that the image in Figure 11-1 were scanned from the pages of *National Geographic* or *Time*—what then? If you change 51 percent of the pixels, is the image yours? These questions of ownership will undoubtedly be resolved eventually in the courts.

There is a serious issue facing multimedia developers.

Now that they have tools to creatively modify things, how much of someone else's image, music, or video clip needs to be modified before ownership changes? This is up for grabs. There is a law called "fair use," which comes into play in a very limited way here. But I think there needs to be a law called "fair modification."

.....
Trip Hawkins, Founder,
Electronic Arts

Use of images, sounds, and other resources from stock houses such as PhotoDisc or Index Stock Photography is perhaps the safest way to go, because ownership and your rights to use the material are clearly stated.

WARNING Beware of clip media claiming to be public domain (where no copyrights apply) that include sounds from popular television shows or motion pictures.

Permissions Permission must also be obtained to use copyrighted text. Sample language follows for requesting permission to reprint copyrighted text material and sample terms that you might expect from the copyright owner. Such a request might look like:

Dear Sirs:

I am currently producing a computer-based multimedia presentation with a working title of (Title). My publisher is (Publisher, Publisher's Address). The anticipated completion date of the work is (Month/Year).

It will be used for (Use).

This letter is to request your permission to incorporate into this work a brief passage from: (Title, Author, Edition, ISBN, Page).

The text I wish to reproduce is: (Text).

Please process this request at your earliest convenience and use this letter or your own form to return your approval by mail or fax to: (Your Name/Address).

The undersigned, having full authority, hereby grants permission to (Your Name) to copy and reproduce the referenced text for use in the work cited above.

Signed: _____

Here are some typical terms you might expect to receive from a large publishing company:

1. To give full credit in every copy printed, on the copyright page or as a footnote on the page on which the quotation begins, or if in a magazine or a newspaper, on the first page of each quotation covered by the permission, exactly as "Reprinted with the permission of (Publisher) from (Title) by (Author). Copyright (Year) by (Publisher)."

2. To pay on publication of the work, or within 24 months of the date of granting the permission, whichever is earlier, a fee of: \$_____.
3. To forward one copy of the work and payment on publication to the Permissions Department of (Publisher).
4. To make no deletions from, additions to, or changes in the text, without the written approval of (Publisher).
5. That the permission hereby granted applies only to the edition of the work specified in this agreement.
6. That permission granted herein is nonexclusive and not transferable.
7. That this permission applies, unless otherwise stated, solely to publication of the above-cited work in the English language in the United States, its territories and dependencies and throughout the world. For translation rights, apply to the International Rights Department of (Publisher).
8. That unless the work is published within two years from the date of the applicant's signature (unless extended by written permission of (Publisher)) or, if published, it remains out of print for a period of six months, this permission shall automatically terminate.
9. This permission does not extend to any copyrighted material from other sources which may be incorporated in the books in question, nor to any illustrations or charts, nor to poetry, unless otherwise specified.
10. That the work containing our selection may be reproduced in Braille, large type, and sound recordings provided no charge is made to the visually handicapped.
11. That unless the agreement is signed and returned within six months from the date of issue, the permission shall automatically terminate.

Copyleft Antipodal to copyright is **copyleft**. While perhaps a cute play on words, copyleft represents a serious and growing worldwide effort to (as claimed in the preamble to the Free Art License) “grant the right to freely copy, distribute, and transform creative works without infringing the author’s rights.” Effectively, copyleft uses the copyright laws themselves to remove traditional copyright protections from a work and offer that work with legal and unlimited permission clearly granted to freely copy, modify, transform, or distribute the work.

In the software world, the GNU General Public License (GNU GPL) is “intended to guarantee your freedom to share and change all versions of



a program—to make sure it remains free software for all its users...“ From the preamble to the GNU GPL:

The licenses for most software and other practical works are designed to take away your freedom to share and change the works. By contrast, the GNU General Public License is intended to guarantee your freedom to share and change all versions of a program—to make sure it remains free software for all its users. We, the Free Software Foundation, use the GNU General Public License for most of our software; it applies also to any other work released this way by its authors. You can apply it to your programs, too.

When we speak of free software, we are referring to freedom, not price. Our General Public Licenses are designed to make sure that you have the freedom to distribute copies of free software (and charge for them if you wish), that you receive source code or can get it if you want it, that you can change the software or use pieces of it in new free programs, and that you know you can do these things.

To protect your rights, we need to prevent others from denying you these rights or asking you to surrender the rights. Therefore, you have certain responsibilities if you distribute copies of the software, or if you modify it: responsibilities to respect the freedom of others.

GNU GENERAL PUBLIC LICENSE

Version 3, 29 June 2007

Copyright © 2007 Free Software Foundation, Inc. <<http://fsf.org/>>

Responsibilities and provisos typically embedded in the copyleft material that you might want to use in a multimedia project include your obligation for “proper attribution of the work to its authors and access to previous versions of the work when possible.” The philosophical notion is of a “common work,” so if you change, improve, or modify someone else’s creative product, you should politely allow others to change, improve, or modify yours. Details of these copyleft licenses are available at:

.....
<http://artlibre.org/licence/lal/en>
www.gnu.org/copyleft/gpl.html
.....

Ownership of Content Created for a Project

In the process of developing your multimedia project, interfaces will be designed, text written, lines of code programmed, and original artwork illustrated with photographs, animations, musical scores, sound effects, and video footage. Each of these elements is an original work. If you are creating a project single-handedly for yourself, you own the copyright outright. If other persons who are not your employees also contribute to the final product, they may own copyright of the element created by them or may share joint ownership of the product unless they assign or license their ownership rights to you. Never rely on an oral agreement for assignment of rights. You should make it your practice in every project to get all assignments of rights or licensing terms in writing to protect everyone involved. You and your best friend may collaborate on a project today based on a handshake, but if there is a falling out that results in a dispute over ownership, having the terms in writing will save both of you from an expensive legal battle over who owns what.

The ownership of a project created by employees in the course of their employment belongs solely to the employer if the work fits the requirements of a “work made for hire.” To meet the definition of a work made for hire, several factors must be weighed to determine whether the individual is legally an employee or an independent contractor. Among these factors are where the work is done, the relationship between the parties, and who provides the tools and equipment.

If the individual contributing to a project is not an employee, the commissioned work must fall within one of the following “work made for hire” categories: a contribution to a collective work, a work that is part of a motion picture or other audiovisual work, a translation, a supplementary work, a compilation, an instructional text, a test, answer material for a test, or an atlas (1976 Copyright Act, 17 U.S.C. § 201(b)). Even if the work falls within one of these categories, be sure to get an agreement in writing from every individual contributing to the work that it is being created as a work for hire. Figures 11-2 and 11-3 offer sample contracts with employees and contractors to precisely specify ownership issues.

PROPRIETARY INFORMATION AND INVENTIONS AGREEMENT

NOTICE:

This agreement does not apply to an invention which qualifies fully under the provisions of Section 2870 of the Labor Code of California as an invention for which no equipment, supplies, facility, or trade secret information of (Company) was used and which was developed entirely on the employee's own time, and (a) which does not relate (1) to the business of (Company) or (2) to (Company's) actual or demonstrably anticipated research or development, or (b) which does not result from any work performed by the employee for (Company).

Employee's Name _____

Address _____

Date of Hire _____

In consideration of my employment by (Company) or any of its subsidiary or affiliated companies (all called "the Company") and the compensation paid me by the Company, I agree as follows:

1. I understand that my employment results in a confidential relationship between myself and the Company. It is expected that I will receive, during and for purposes of my employment, information about the Company's products, processes, business, plans, research programs, and like Company information (all called "the Company business"), which information is the property of the Company. I may also conceive of or develop ideas and inventions related to the Company business during or for purposes of my employment. The information received from the Company and information which I conceive or develop pertaining to the Company business are the sole property of the Company and are valuable trade secrets of the Company. I agree to preserve their value as Company property, by complying with the following requirements.

2. Except as required in the course of my employment, I shall not disclose to anyone or use at any time, either during or after my employment, any information about the Company business which is either received from the Company or conceived or developed by me, unless I have the prior written consent of the Company.

3. I agree to disclose promptly to the Company all inventions, ideas or conceptions, developments, and improvements (whether or not patentable or subject to copyright) which are made or conceived by me, either alone or together with others, during or as a result of my employment, provided that they pertain to the Company business. I will keep complete records of such matter and will and hereby do assign such matter to the Company, whether or not it has been tested or reduced to practice. Included are all data processing communications, computer software systems, programs, and procedures, which pertain to the Company business. All such records are and shall be the property of the Company alone.

4. Upon request of the Company, either during or after my employment, I will assist in applying for Letters Patent, or for copyright or Inventors Certificate or other appropriate legal form, on all such Inventions and Ideas, in this and in foreign countries, and will execute all papers necessary thereto, including assignments as may be requested by the Company, without further compensation to me. Such applications shall be filed at the expense of and under the control of the Company.

5. All unpublished data and information relating to the Company business, whether reduced to writing or not, are understood and agreed to be confidential and the sole property of the Company. This extends to all confidential information or data I may receive from or about any of the Company's licensees, customers, or others with whom the Company has a business relationship. I will maintain all such information in confidence and not use it other than as expressly requested by the Company, either during or after my employment with the Company, unless and until such information is published without fault on my part.

6. Upon termination of my employment, I will surrender all records and material relating to the Company business.

7. I am aware of no prior obligations which would prevent my compliance with the terms and spirit of this agreement.

8. This agreement shall be binding upon me and my heirs, executors, administrators, and assigns. The Company shall have the right to assign this agreement to any successor to the business in which I am employed.

Signed at _____, on _____, 20____

Employee (Signature)

Witness (Signature)

(Address of Witness)

Figure 11-2
Sample employer/
employee agree-
ment covering
intellectual prop-
erty and inventions;
consult an attorney
when preparing
your own legal
document.

Confidential

(Date) (Name and Address of Consultant)

Dear (Consultant): This document, when accepted and agreed to by you, will confirm our mutual understanding and agreement concerning your engagement as an independent contractor to render consulting services to (Employer Name).

You will be engaged as an independent contractor to provide such advice, consultation, and other assistance as may, from time to time, be requested by (Employer Name) in furtherance of (Employer Name)'s business in general and particularly for:

(General Statement of Scope of Work)

During the term of this Consulting Agreement, you agree to provide consulting services to (Employer Name), on the terms and conditions contained in Attachment A, "Description of Services and Reimbursement." Twice monthly you will submit a statement, in a form satisfactory to (Employer Name), setting forth the milestone reached and any authorized expenses incurred to be reimbursed by (Employer Name). Payment will be made according to the schedule in Attachment A.

The consulting services that you will provide are to be rendered at such times and at such places as are mutually agreed upon by (Employer Name) and you. You agree that (Employer Name) shall own all intellectual property rights, including but not limited to copyrights, patents, trade secrets, and trademarks in any and all products of your work within the scope of this Agreement. Said products will be copyrighted by (Employer Name) or in such other name as (Employer Name) may designate. You further agree that any work provided hereunder shall be considered "work made for hire" within the meaning of 17 U.S.C. 2201(b). However, (Employer Name) will give proper credit to you in a manner to be mutually agreed upon as appropriate to the creative direction of the work.

In the performance of the consulting services herein contemplated, you are, and shall be deemed to be for all purposes, an independent contractor (and not an employee or agent of (Employer Name)) under any and all laws, whether existing or future, including without limitation, Social Security laws, state unemployment insurance laws, withholding tax laws, and the payments and reports of any taxes and/or contributions under such laws. You will not be entitled to participate in any employee benefits accruing to employees of (Employer Name). You will not be authorized to make any material representation, contract, or commitment on behalf of (Employer Name).

You agree to comply with applicable laws, rules, and regulations in respect to self-employment, including without limitation, the payment of all taxes required, and you agree to furnish (Employer Name) evidence of the payment of such taxes if requested. In addition, you agree to defend, indemnify, and hold (Employer Name) harmless against all losses, liabilities, claims, demands, actions and/or proceedings, and all costs and expenses in connection therewith, including attorney's fees, arising out of your failure to comply with this paragraph. The term of this Consulting Agreement shall be for the period of time described in Attachment A, subject to the following limitations: Upon five (5) days written notice, either you or (Employer Name) may terminate this Consulting Agreement. Such termination shall be effective at the conclusion of said five-day period.

This Consulting Agreement shall terminate on your death.

Notwithstanding anything herein to the contrary, (Employer Name) may, without liability, terminate this Consulting Agreement for cause at any time, and without notice, and thereafter (Employer Name)'s obligations hereunder shall cease and terminate. The term "cause" shall mean, by way of example, but not by way of limitation:

Misappropriating funds or property of (Employer Name);

Attempting to obtain any personal profit from any transaction related to THIS consulting work which is adverse to the interest of (Employer Name);

Unreasonable neglect or refusal to perform the consulting services agreed to be performed by you under this Consulting Agreement;

Being convicted of a felony;

Being adjudicated a bankrupt; or

A breach of any of the other provisions of this Consulting Agreement.

Upon termination of this Consulting Agreement, for any reason, you will be paid your consulting fee on a pro rata basis, and you will be reimbursed for authorized expenses, to and including the effective date of such termination.

Figure 11-3

Sample employer/consultant agreement in the form of a letter; hire an attorney when preparing your own legal documents.

You agree to hold all Confidential Information in trust and confidence for (Employer Name), and except as may be authorized by (Employer Name) in writing, you shall not disclose to any person, and you shall take such reasonable precautions as may be necessary to prevent the disclosure of, any Confidential Information at all times during and after the term of this Consulting Agreement. For the purposes of this Consulting Agreement, "Confidential Information" shall mean all information obtained by you, or disclosed to you by (Employer Name), at any time before or during the term hereof, which relates to (Employer Name)'s or (Employer Name)'s clients' past, present, and future research, development, and business activities, and any other trade secrets, records, engineering notebooks, data, formulae, computer code, specifications, inventions, customer lists, and other proprietary information and data concerning (Employer Name) or any client, provided that Confidential Information shall not include information that becomes part of the public knowledge or literature (not as a result of any action or inaction on your part) either prior or subsequent to your receipt of such information.

Upon termination or expiration of this Consulting Agreement, you agree to return to (Employer Name) all written or descriptive matter, including but not limited to drawings, blueprints, descriptions, drafts, computer code, computer files, hardware, software, or other papers or documents that contain any Confidential Information.

(Employer Name) does not desire to receive information in confidence from you under this Consulting Agreement.

You represent and warrant that you are under no obligation or restriction nor will you assume any obligation or restriction which would in any way interfere or be inconsistent with the services to be furnished by you under this Consulting Agreement. In that regard, this Consulting Agreement will in no way restrict you from freely entering into other similar consulting agreements with other firms in the field as long as the provisions herein are honored.

(Employer Name) shall have sole discretion to make other consulting arrangements with other persons concerning any or all of the consulting services to be rendered by you under this Consulting Agreement.

(Employer Name) acknowledges and understands that he is the author of the work you are hired to consult on and that he is therefore responsible for its contents. In the event of a third party action against (Employer Name), (Employer Name) agrees to indemnify and hold you harmless if you are made a party to such action; provided however that (Employer Name) shall have no such responsibility to you if such suit arises due to your misconduct or gross negligence. You promise to provide (Employer Name) with all reasonable cooperation and assistance in any such action or proceedings.

If any action at law is necessary to enforce or interpret the terms of this Consulting Agreement, the prevailing party shall be entitled to reasonable attorneys' fees, costs, and necessary disbursements, in addition to any other relief to which such party shall be entitled.

This letter shall constitute the entire agreement between the parties hereto with respect to the subject matter hereof. In the event of any unresolved dispute in respect thereof, the matter shall be submitted to arbitration in accordance with the rules and regulations of the American Arbitration Association, and the decision of the arbitrator(s) shall be final and binding on both parties hereto.

The validity of this Consulting Agreement and any of its terms and conditions, as well as the rights and duties of the parties hereunder, shall be interpreted and construed pursuant to and in accordance with the laws of the State of California.

(Employer Name)

(Employer Signature)

Accepted and agreed to this ____ day of _____, 20__.

Consultant's Signature: _____

Consultant's Social Security Number or EIN: _____

Attachment A to the Consulting Agreement of (Date) between (Employer Name) and (Consultant)

Description of Services and Reimbursement

Figure 11-3
 Sample employer/
 consultant agree-
 ment in the form
 of a letter; hire an
 attorney when
 preparing your own
 legal documents.
 (Continued)

The copyright ownership of works created in whole or in part by persons who fall under the definition of **independent contractor** may belong to that contractor unless the work is specially ordered or commissioned for use and qualifies as a work made for hire, in which case the copyright belongs to the entity commissioning the work.

In late April 1997, Bruce Lehman, Commissioner of Patents and Trademarks, publicly stated that the Proposed Guidelines negotiated by CONFU participants had failed to achieve consensus support. In May 1997, at its third “final” meeting in Washington, D.C., CONFU participants concurred. None of the Proposed Guidelines would survive the comment and endorsement process that ended in May. [Ninety-three] organizations representing for profit and nonprofit publishers, the software industry, government agencies, scholars and scholarly societies, authors, artists, photographers and musicians, the movie industry, public television, licensing collectives, libraries, museums, universities and colleges spent untold amounts of money and more than two and a half years of their time and their energy to find agreement on the scope of fair use in various electronic contexts. Now it seems that not enough of their constituents and in some cases, not even the participants themselves, agreed with the result to qualify the Proposed Guidelines as consensus documents. Forgive the over-generalization, but users thought the Guidelines were over-restrictive, and copyright owners thought they were giving away too much.

.....
 From the web site of the Conference on Fair Use,
 an excellent resource and discussion area for gnarly copyright law issues:
www.utsystem.edu/ogc/intellectualproperty/confu.htm

A copyright can belong to a single individual or entity, or it may be shared jointly by several entities. Make sure that copyright ownership issues have been resolved, in writing, before people contribute to your project.

Acquiring Talent

After you have tested everybody you know and you still have vacant seats in your project, you may need to turn to professional talent. Getting the perfect actor, model, or narrator’s voice is critical. You don’t want to settle for a voice or an actor who is not quite polished or is ill suited to the part, or your whole project may have an amateurish feel.

Partnerships often finish in quarrels; but I was happy in this, that mine were all carried on and ended amicably, owing, I think, a good deal to the precaution of having very explicitly settled, in our articles, everything to be done by or expected from each partner, so that there was nothing to dispute, which precaution I would therefore recommend to all who enter into partnerships; for whatever esteem partners may have for, and confidence in each other at the time of the contract, little jealousies and disgusts may arise, with ideas of inequality in the care and burden of the business, etc., which are attended often with breach of friendship and of the connection, perhaps with lawsuits and other disagreeable consequences.

.....
 From the *Autobiography of Benjamin Franklin* (circa 1784)

Professional voice-over talents and actors in the United States usually belong to a union or guild, either **AFTRA (American Federation of Television and Radio Artists)** or **SAG (Screen Actors Guild)**. They are usually represented by a talent agent or agency that you can find in the yellow pages.

First Person

We put out a call for a multimedia acting job (male, mid-30s, credible voice, earnest smile), and 18 men showed up for tryouts at a local studio—17 were nonunion and 1 belonged to AFTRA. We videotaped each applicant as he read a prepared script, chatted with all of them, and asked them to walk around and jump up and down. The best choice by far, we thought at the end of a long day, was Dave Kazanjian, the union member.

“Oooh,” we said to ourselves, “real union talent! This is going to cost

us.” So we got together with the client and ran tapes of half a dozen of the better actors trying out, without saying which one was our favorite. The client’s choice was the same as ours, because Dave was very polished and professional and simply perfect for the part. Paying union-scale wages to the actor would double what we had estimated in our original budget, and we had naively assumed we could quickly and easily find the right talent from the nonunion pool. We ran the new numbers past the client, implying

that the second-choice actor was more affordable, even if he wasn’t quite perfect. Then we showed Dave’s clip next to the other guy, and repeated it a few times, until the difference was really apparent. The comparison was persuasive, and in the end, the client supported the extra cost.

We all learned again that you get what you pay for: Dave did a terrific job. In future proposals, we used union scale in estimating cost, whether we hired a union actor or not.

Locating the Professionals You Need

Before you can safely put a professional in front of a camera or a microphone, you have to find the talent first and then deal with hiring and union contracts.

Begin by calling a **talent agency** and explain what you need. The agency will probably suggest several clients who might fit your needs and send you to their web site for video or audio samples of the actors’ work. After reviewing the samples, you can arrange **auditions** of the best candidates, at your office or at a studio. You can also get in touch with several agencies and put out a **casting call** for screen or audio auditions. Furthermore, you are not limited to using union talent, and if your call is posted on bulletin boards in public places (in the theater department of a local university, for example), you may find yourself with many applicants, both union and nonunion, who are eager for the work.

TIP *If you run your own audition, be sure you are organized for it. You will need sign-up sheets for names and phone numbers, a sample script for applicants to read, a video camera or audio recorder, tracking sheets so that you can coordinate actors' names with their video or audio clips, and hospitable coffee and donuts.*

Working with Union Contracts

The two unions, AFTRA and SAG, have similar contracts and terms for minimum pay and benefits. AFTRA has approved an Interactive Media Agreement to cover on- and off-camera performers on all interactive media platforms. Figure 11-4 shows some AFTRA definitions related to interactive media.

DEFINITIONS

“Material”: includes all products (audio or visual) derived from the recordation of the live-action performances of performers, whether or not such performances are incorporated into the final version of the fully-edited Interactive Program produced hereunder by Producer.

“Interactive”: Interactive describes the attribute of products which enables the viewer to manipulate, affect or alter the presentation of the creative content of such product simultaneous with its use by the viewer.

“Interactive Media” means: any media on which interactive product operates and through which the user may interact with such product including but not limited to personal computers, games, machines, arcade games, all CD-interactive machines and any and all analogous, similar or dissimilar microprocessor-based units and the digitized, electronic or any other formats now known or hereinafter invented which may be utilized in connection therewith;

“Performers”: Persons whose performances are used as on or off-camera, including those who speak, act, sing, or in any other manner perform as talent in material for Interactive Media.

Figure 11-4 From the AFTRA Interactive Media Agreement (reprinted courtesy of AFTRA, 260 Madison Avenue, New York, NY 10016)

The AFTRA and SAG contracts are lengthy and detailed. Both share language and job descriptions (such as principal, voice-over performer, extra, singer, and dancer). Also, both unions have approximately the same wage scales for these jobs. Table 11-1 shows the Screen Actors Guild categories for interactive media work and rates. Of course, an actor can always negotiate more than minimum wage.

NOTE *With the advent of “new media,” some interesting words have entered the lexicon. “Webisodes” are short pieces of multimedia content distributed on the Internet. “Mobisodes” are short pieces (often TV shows) delivered to mobile phones. “Placeshifting” is watching or listening to multimedia at a place not originally intended. “Time-shifting” is watching or listening to content when the user wants, not when the broadcaster distributes it. “Snack-size media” involves a brief few minutes of content, not hours.*

| On-Camera Performers: | |
|--|------------|
| Day Performers (including solo/duo singers) | \$759.00 |
| 3-Day Performers (including solo/duo singers) | \$1,920.00 |
| Weekly Performers (including solo/duo singers) | \$2,634.00 |
| 6-Day Overnight Location | \$2,897.00 |
| Group Singers 3–8 (4-hour day) | \$720.00 |
| Group Singers 9+ (4-hour day) | \$628.00 |
| Dancers: | |
| Rehearsal Days Only | \$446.00 |
| Work Days (no rehearsal): Solo/Duo | \$759.00 |
| Work Days (no rehearsal): Group 3–8 | \$665.00 |
| Work Days (no rehearsal): Group 9+ | \$581.00 |
| Weekly Option (includes rehearsals): Solo/Duo | \$2,440.00 |
| Weekly Option (includes rehearsals): Group 3–8 | \$2,236.00 |
| Weekly Option (includes rehearsals): Group 9 + | \$2,034.00 |
| Off-Camera Performers: | |
| Day Performers (up to 3 voices/4-hour day) | \$759.00 |
| Additional Voices (one-third of Day Performer rate for each voice) | \$253.00 |
| Day Performer (1 voice/1 hour) | \$379.50 |
| Engaged for 6 to 10 Voices for a 6-hour day | \$1,518.00 |
| Singers (4-hour day): Solo/Duo | \$759.00 |
| Singers (4-hour day): Hourly Rate | \$379.50 |
| Singers (4-hour day): Group Singers 3–8 | \$402.00 |
| Singers (4-hour day): Group Singers 9+ | \$349.00 |
| Singers (4-hour day): Group Hourly Rate | \$225.00 |
| Background Actor Rates: | |
| General Background Actor | \$130.00 |
| Special Ability Actors and Stand-ins | \$163.00 |

Table 11-1 From the Screen Actors Guild, Interactive Media Rates 2008

If your talent needs are simple, you can usually get good contract advice directly from the union representative in your area or from the actors themselves. If your needs are elaborate or undefined, you may wish to consult an attorney or agent who specializes in this area and who can oversee the many required clauses and details of the contract.

Talent contracts are filled with quirky details and complicated formulas. Consider, for example, Article I.17.A.4(c)(i) of the AFTRA Interactive Media Agreement, which reads:

If a solo or duo is called upon to step out of a group to sing up to fifteen (15) cumulative bars during a session, the solo/duo shall be paid an adjustment of fifty percent (50%) of the solo/duo rate in addition to the appropriate group rate for that day.

Although the concept of “stepping out” may be more in keeping with an MTV video project than with your own multimedia work, you need to keep an eye out for buried clauses that do apply to your project.

WARNING *If you create a multimedia product that incorporates union talent under contract, you will be restricted to using the material only for its initial primary use. Later, if you wish to spin off bits and pieces for other purposes (such as a commercial or as part of a product for sale to the public), you must then renegotiate with the talent and the union and pay for this expanded and supplemental use.*

Acquiring Releases

A union talent contract explicitly states what rights you have to the still and motion images and voices you make and use. If, however, your talent is nonunion (a co-worker, perhaps, or a neighbor’s child, student actor, waitress, or tugboat captain), be sure to require the person to sign a **release form**. This form grants to you certain permissions and specifies the terms under which you can use the material you make during a recording session.

Figure 11-5 is a sample release form that covers most situations in a multimedia project and provides nearly perfect rights to the producer. Because such forms are legal documents, always consult an attorney to be sure that the specific language of your own release document meets your

Sometimes it is very difficult to do certain things because of previous rights that have been given out. For example, not too long ago I asked an executive from a media company if it would be possible to take some of his film footage and put it into a copyright library, to have something available for multimedia software developers to freely use in their interactive products? He said, “Well, we couldn’t use a single frame of any film that was ever shot by a director who was a member of the Directors Guild of America.” The bottom line is that there are so many rights attached to so many of these things, with so many different people involved, that it is very complicated even to figure out if you have the right to use it in any way, and again that’s too bad because again, that is just going to slow us down.

.....
 Trip Hawkins,
 Founder, Electronic Arts

requirements. For more about video and music releases and sample forms, check out www.current.tv/make/resources.

WARNING Do not include any images or voices of people in your multimedia project—even if you yourself recorded and edited the material—unless you have their written consent to use it; it is in the public domain; you are reporting it as news, commentary, or parody (fair use); or it is work unarguably made for hire.

Release Form

This is a release and authorization to use the name, voice, sounds, image and likeness, and writings of the undersigned ("Model"), as obtained in the photography / filming / video / audio session / creative session taking place

_____, at _____ ("the Session"), for commercial purposes by _____ and his respective successors and assigns (collectively, "Producer").

For valuable consideration, Model hereby authorizes the unlimited use in perpetuity by Producer of all recorded images, likenesses, voice and recorded sounds, and writings of Model obtained during the Session, and of Model's name in connection with such use. Model grants producer the rights to use such sounds, images, and likenesses in any and all media and forms now known or hereafter devised throughout the universe without limitation as to territory or term, including but not limited to advertising, literature, computer demonstrations, and packaging, whether in the form of photography, magnetic or electronic data storage, or any other form, both as obtained and as modified at Producer's sole discretion to suit business purposes of Producer. The compensation stated above shall be the sole compensation for all such use, and no further compensation, including but not limited to royalties, residuals, or use fees, shall be payable at any time.

Model further transfers and assigns all copyrights and all other rights in the recordings, sounds, images and likeness, and writings obtained at the Session to Producer. Producer shall have the right to register the copyright to these in the name of its choice and shall have the exclusive right to dispose of these in any manner whatsoever. This agreement constitutes the sole, complete, and exclusive agreement between Model and Producer.

Name: _____ SIGNATURE: _____

Address: _____ SOCIAL SECURITY NO.: _____

_____ DATE: _____

Phone: _____

Figure 11-5
Sample release form; consult an attorney when preparing your own legal document.

Chapter 11 Review

■ Chapter Summary

For your review, here's a summary of the important concepts discussed in this chapter.

Acquire content for a project and identify the benefits and drawbacks of various sources of content such as clip art, stock libraries, and public domain sources

- Content is the information and material that forms the heart of your project—or what your project is about. Content can have both low and high production value. You must always balance the production value of your project against your budget and the desired result.
- Content acquisition can be one of the most expensive and time-consuming tasks in organizing a multimedia project. Be sure to specify in your project plan the format and quality of content and data to be supplied to you by third parties. If you negotiate ownership or rights to someone else's content, be sure to get the advice of a skilled copyright and contracts attorney.
- Preexisting content can come from a variety of sources. Clip art collections of photographs, graphics, sounds, music, animation, and video are relatively inexpensive, and you are generally granted unlimited use. If your content needs are more specific or complex, a still photo library, a sound library, or a stock footage house is a good choice.

Discuss the concepts of copyright, public domain, licensing, and derivative works, and determine who owns the copyright for a work, depending on who contracted the work and for what purpose

- Some materials are in the public domain, meaning you can use the material without a license. But never assume a work is in the public domain, even if it bears no copyright notice.

- Always make sure you have permission to use copyrighted material, or you may find yourself being sued for copyright infringement. Works come under copyright protection as soon as they are created and presented in a fixed form. Owning a copy of a work does not automatically entitle you to reproduce the work. If the owner does not wish to give up or sell ownership rights, however, you may still be able to license the rights to use that material.
- Negotiating rights to use preexisting content involves many factors. In some cases you can use materials “derived” from another work, but this is a gray area of copyright law.
- In general, you own the copyright of works you create for yourself. You also own the copyright of works created by those whom you employ for the purpose of creating the work. If the contributor is not an employee, the work is not “work made for hire,” and he or she has not assigned ownership to you, then that contributor holds the copyright for the work.

Discuss the process of identifying appropriate talent for a production, and issues in using talent, including union rules, contracts, and releases

- Getting the perfect actor, model, or narrator's voice is critical. Professional talents and actors in the United States often belong to AFTRA or SAG and are represented by a talent agent or agency. The agency will probably suggest several clients who might fit your needs. Arrange auditions of the best candidates.
- Check out talent contracts carefully, and think about any limitations on future use. If your talent is nonunion, be sure to have the person sign a release form.

■ Key Terms

AFTRA (American Federation of Television and Radio Artists) (348)

audition (348)

casting call (348)

clip art (333)

content (330)

content acquisition (331)

copyleft (341)

copyright infringement (335)

copyright ownership (335)

copyright protection (335)

derivative work (339)

electronic rights (332)

fair use (335)

independent contractor (347)

license (337)

licensing agreement (338)

production value (330)

public domain (333)

rate card (338)

release form (351)

royalty (333)

SAG (Screen Actors Guild) (348)

sound library (333)

still photo library (333)

stock footage (333)

talent agency (348)

unlimited use (338)

■ Key Term Quiz

1. The information and material that forms the heart of your project—what your project is about—is _____.
2. Collections of media generally granted unlimited use are called _____.
3. If a work's copyright protection has expired and not been renewed, it is _____.
4. The term for unauthorized use of copyrighted material is _____.
5. Works come under _____ as soon as they are created and presented in a fixed form.
6. Even if the owner of a work does not wish to give up or sell ownership rights, you may still be able to _____ the rights to use that material.
7. A standard document that lists licensing fees for different uses, formats, and markets is called a(n) _____.
8. If an artist takes another person's work and creates a new work based on the original, such a work is said to be _____.
9. Professional talents and actors in the United States are usually represented by a(n) _____.
10. If your talent is nonunion, be sure to require the person to sign a(n) _____.

■ Multiple-Choice Quiz

1. Which of the following is not content?
 - a. photographs
 - b. animations
 - c. video clips
 - d. the graphical user interface
 - e. the program's programming code
2. The responsibility for ensuring that content included in a product does not infringe on a copyright belongs to:
 - a. the developer
 - b. the original creator
 - c. the product's purchaser
 - d. the U.S. Copyright Office
 - e. The Library of Congress

3. A source for free content in the public domain is:
 - a. a clip art collection
 - b. a stock photo/video library
 - c. a government agency
 - d. a publishing company
 - e. a television network
4. The legal privilege to publish a work in a computer-based storage and delivery medium is often called:
 - a. digital watermarks
 - b. electronic rights
 - c. computer publishing licenses
 - d. new media contracts
 - e. multimedia/Internet ownership
5. A disadvantage to using a clip art image from a stock library might be:
 - a. it is available in high-resolution
 - b. you are usually granted unlimited use
 - c. you can alter the image for derivative works
 - d. it is easily downloadable
 - e. you do not have exclusive rights
6. If a work is in the public domain:
 - a. you can secure a free license through the Public Domain Institute (PDI)
 - b. you can license it with a \$25 processing fee through the Library of Congress
 - c. you can use the material without a license or permission
 - d. you can use the material through the public domain contract, where some percentage of the profit is disbursed to nonprofit arts organizations
 - e. it is publicly owned and thus cannot be reproduced for any purpose
7. Which of the following issues might you consider when negotiating for rights to use preexisting content?
 - a. how the content will be delivered
 - b. the license's period of time
 - c. how the owner or artist will be credited
 - d. whether the copyright owner will receive remuneration for the license
 - e. all of the above
8. Works come under copyright protection:
 - a. as soon as they have been submitted to the U.S. Copyright Office
 - b. as soon as a notice is published in the legal notices of a local newspaper
 - c. as soon as they are notarized by a notary public
 - d. as soon as they are created and presented in a fixed form
 - e. as soon as the original idea, concept, drawing, draft, or intent is communicated to someone else
9. Owning a work entitles you to reproduce that work if:
 - a. you have purchased the work and possess a legal bill of sale
 - b. you have the permission of the copyright owner
 - c. the work is an original, unreproduced work that has not been previously copied
 - d. the work's value is less than \$100
 - e. you have a *really* good lawyer
10. Which of the following are included in the guidelines for creating a work derived in part from another person's work?
 - a. There are no clear-cut guidelines.
 - b. Less than 10 percent of the original work was used.
 - c. Using the work does not impact the sales or value of the original work.
 - d. The derivative work is not clearly recognizable as the original work.
 - e. The derivative work is in a different medium from the original.
11. In general, you may legally use a work in a project if:
 - a. it has a digital approval code
 - b. you paid someone to create it for you
 - c. the work contains no copyright information
 - d. it came from the school library
 - e. you got it off the Internet

12. Which of the following unions deals with acting and talent?
- AFTRA
 - IBEW
 - AFL-CIO
 - AFSCME
 - CIA
13. In general, if you create a multimedia product that incorporates union talent under contract, you:
- will have unlimited rights across all media
 - can use the material only in related media (such as Web/CD, newspaper/magazine, television/radio)
 - will be required to pay royalties
 - will have rights to the talent's firstborn children
 - will be able to use the material only for its initial primary use
14. If you use nonunion talent, you:
- probably don't need to worry about getting a release
 - should require the person to sign a release form
 - need to notify the local union representative
 - must state so plainly in the project's credits
 - must pay a surcharge to the local union
15. You do not need to worry about having someone's written consent to use his or her image or voice in your production if:
- it was already used in the *National Enquirer*
 - the subject is at least a first cousin
 - it is work product made for hire
 - the subject is younger than 18 years old
 - you are recording a public event

■ Essay Quiz

- List ten different kinds of content. Try to think of as many different variations as you can. List a high production value and low production value example of each.
- You are assigned to create a CD-ROM on white-water rafting for a company in West Virginia. The product is going to be sent to subscribers of *Outside* magazine. This magazine's readership has a high level of disposable income. Discuss the creative process you might go through to determine the content you will use in this project. Where will you get it? Will you use clip art? Public domain content? Will you produce new materials? What will the production values be? How will you justify the expense? What talent will you need for the project? Discuss how you will select the talent (on-screen versus voice-over, age, sex, ethnicity, etc.).
- You are assigned to create a web site for a town's nonprofit historical society. Discuss the creative process you might go through to determine the content you will use in this project. Where will you get it? Will you use clip art? Public domain content? Will you produce new materials? What will the production values be? How will you justify the expense?
- List five issues related to the rights to license and use someone else's work. Discuss how these issues affect the scope of your project. Will they affect the number of units you may distribute or where, when, and how you may distribute your project? Discuss the advantages and problems associated with hiring union, nonunion, and nonprofessional talent for a production. What factors would affect this decision?

Lab Projects

■ Project 11.1

Go online and locate three stock photo and video sources. Download comps of a photograph and a video clip from each of the sources. (Comps are small, low-resolution copies of the work that can be used for placement and testing.) Compare the cost, quality, and range of the offerings.

■ Project 11.2

Go online and locate three royalty-free music sources. Download two samples from each of the sources. Compare the cost, quality, and range of the offerings.

■ Project 11.3

Based on the research you did on the stock photo/video and royalty-free sources, estimate the total cost for content to develop a promotional presentation for a client. Assume you will use three 30-second video clips at about 320×240 -pixel size, ten stock photographs at about 800×600 at 72 dpi resolution, and one approximately three-minute audio clip to loop as background music. What are the high and low ranges for these projects?

■ Project 11.4

Contact a creative services agency or talent agency and ask to see the sourcebook. Most large markets have at least one creative sourcebook. These sourcebooks, among other things, often include a number of head shots, or pages with the face and vital statistics for agency talent in the area. Such sourcebooks also include illustrators, photographers, and other creative artists. Select a person to act as a spokesperson, as well as an illustrator, for a learning project. Photocopy the pages you select from the sourcebook. Justify your decision.

■ Project 11.5

Look at the credits of three DVDs. Copy the wording used in crediting various contributors. Look at several different web sites. Do they list credits? Why or why not?

The Internet and Multimedia

In this chapter, you will learn how to:

- Discuss the origins of the Internet
- Define what a computer network is and how Internet domains, addresses, and interconnections work
- Discuss the current state of multimedia on the Internet and tools for the World Wide Web

THE material covered in this chapter is designed to give you an overview of the Internet while describing particular features that may be useful to you as a developer of multimedia for the World Wide Web. URLs and other pointers are also included here to lead you to information for obtaining, installing, and using these applications and utilities.

This chapter does *not* provide details about technology for connecting and using the Internet, about setting up servers and hosts, about installing and using applications, or what to do when you discover that you pressed the wrong key and have broadcast the intimate details of last night's hot date to 532 friends.

Embarrassing yourself on the stage of the civilized world can be avoided by education. Visit your local bookstore, where, along with the work you are now reading, you may discover as many as a hundred helpful volumes about all the simple and arcane aspects of the Internet. Buy one or two of these and dig in. Or, if you are already connected to the Internet, much of the documentation you may require can be found by surfing the Net itself. Use a search engine such as those listed here. Look particularly for documents called **FAQs (Frequently Asked Questions)**, because they contain answers.

| | |
|----------------------|------------------------------|
| <i>AllTheWeb.com</i> | <i>www.alltheweb.com</i> |
| <i>AltaVista</i> | <i>www.altavista.com</i> |
| <i>AOL Search</i> | <i>http://search.aol.com</i> |
| <i>Ask</i> | <i>www.ask.com</i> |
| <i>Ask Jeeves</i> | <i>www.askjeeves.com</i> |
| <i>Bing</i> | <i>www.bing.com</i> |
| <i>Dogpile</i> | <i>www.dogpile.com</i> |
| <i>Gigablast</i> | <i>www.gigablast.com</i> |
| <i>Google</i> | <i>www.google.com</i> |
| <i>HotBot</i> | <i>www.hotbot.com</i> |

Lycos *www.lycos.com*
Open Directory *http://dmoz.org*
Yahoo *www.yahoo.com*

Search engines on the World Wide Web

.....

Internet History

The **Internet** began as a research network funded by the **Advanced Research Projects Agency (ARPA)** of the U.S. Defense Department, when the first node of the **ARPANET** was installed at the University of California at Los Angeles in September 1969. By the mid-1970s, the ARPANET “inter-network” embraced more than 30 universities, military sites, and government contractors, and its user base expanded to include the larger computer science research community. By 1983, the network still consisted of merely several hundred computers on only a few local area networks.

In 1985, the National Science Foundation (NSF) aligned with ARPA to support a collaboration of supercomputing centers and computer science researchers across the ARPANET. The NSF also funded a program for improving the backbone of the ARPANET, by increasing its bandwidth from 56 Kbps to T1 and then T3 (see “Connections” a little later in the chapter for more information) and branching out with links to international sites in Europe and the Far East.

In 1989, responsibility and management for the ARPANET was officially passed from military interests to the academically oriented NSF, and research organizations and universities (professors and students alike) became increasingly heavy users of this ever-growing “Internet.” Much of the Internet’s etiquette and rules for behavior (such as for sending e-mail and posting to newsgroups) was established during this time.

More and more private companies and organizations linked up to the Internet, and by the mid-1990s, the Internet included connections to more than 60 countries and more than 2 million host computers with more than 15 million users worldwide. Commercial and business use of the Internet was not permitted until 1992, but businesses have since become its driving force. By 2001 there were 109,574,429 domain hosts and 407.1 million users of the Internet, representing 6.71 percent of the world’s population. By the beginning of 2010 (see Table 12-1), about one out of every four people around the world (26.6 percent) had access to the Internet, and more than 51 million domain names had been registered as “dot coms.”

| World Regions | Population (2009 Est.) | Internet Users Dec. 31, 2000 | Internet Users Dec 31, 2009 | Penetration (% Population) | Growth 2000–2009 | Users% of Table |
|--------------------------|------------------------|------------------------------|-----------------------------|----------------------------|------------------|-----------------|
| Africa | 991,002,342 | 4,514,400 | 86,217,900 | 8.7% | 1,809.8% | 4.8% |
| Asia | 3,808,070,503 | 114,304,000 | 764,435,900 | 20.1% | 568.8% | 42.4% |
| Europe | 803,850,858 | 105,096,093 | 425,773,571 | 53.0% | 305.1% | 23.6% |
| Middle East | 202,687,005 | 3,284,800 | 58,309,546 | 28.8% | 1,675.1% | 3.2% |
| North America | 340,831,831 | 108,096,800 | 259,561,000 | 76.2% | 140.1% | 14.4% |
| Latin America/ Caribbean | 586,662,468 | 18,068,919 | 186,922,050 | 31.9% | 934.5% | 10.4% |
| Oceania/ Australia | 34,700,201 | 7,620,480 | 21,110,490 | 60.8% | 177.0% | 1.2% |
| WORLD TOTAL | 6,767,805,208 | 360,985,492 | 1,802,330,457 | 26.6% | 399.3% | 100.0% |

Table 12-1 World Internet Users and Population Stats (from www.internetworldstats.com)

First Person

When I was a kid, I took it for granted that you could see a million stars in the summer sky, and it wasn't until much later that I discovered the truth: only a paltry few thousand stars are actually visible to the naked eye from Earth. While "millions" is a perfect number

for a ten-year-old's perception of an infinite universe, the term needs definition. For example, what does "133 million users on the Internet" really mean? The following exercise might help: Start counting to a million, incrementing by one every second: (One) (Two) (Three) In

a minute, you will have counted to 60; in an hour, to 3,600. In 277.77 hours, you will reach a million—that's 11.57 24-hour days of nonstop counting, no pizza, no beer. You could try for the Guinness Book of Records, but you won't stay awake long enough!

Internetworking

In its simplest form, a **network** is a cluster of computers, with one computer acting as a **server** to provide network services such as file transfer, e-mail, and document printing to the **client** computers or users of that network. Using gateways and routers, a **local area network (LAN)** can be connected to other LANs to form a **wide area network (WAN)**. These LANs and WANs can also be connected to the Internet through a server that provides both the necessary software for the Internet and the physical data connection (usually a high-bandwidth telephone line, coaxial cable TV line, or wireless). Individual computers not permanently part of

a network (such as a home computer or a laptop) can connect to one of these Internet servers and, with proper identification and onboard client software, obtain an IP address on the Internet (see “IP Addresses and Data Packets” later in the chapter).

Internet Addresses

Let’s say you get into a taxi at the train station in Trento, Italy, explain in English or Spanish or German or French that you wish to go to the Mozzi Hotel, and half an hour later you are let out of the car in a suburban wood—you have an address problem. You will quickly discover, as you return to the city in the back of a bricklayer’s lorry to report your missing luggage and the cab driver, Mauro, who sped away in the rain, that you also have a serious language problem.

If you know how addresses work and understand the syntax or language of the Internet, you will likely not get lost and will save much time and expense during your adventures. You will also be able to employ short-cuts and workarounds.

Top-Level Domains

When the original ARPANET protocols for communicating among computers were remade into the current scheme of TCP/IP (Transmission Control Protocol/Internet Protocol) in 1983, the **Domain Name System (DNS)** was developed to rationally assign names and addresses to computers linked to the Internet. **Top-level domains (TLDs)** were established as categories to accommodate all users of the Internet:

| | |
|--------------------------|--|
| com | Commercial entities |
| edu | Degree-granting colleges and universities (other schools register in the country domain) |
| gov | U.S. federal government agencies (state and local agencies register in the country domain) |
| int | Organizations established by international treaties and international databases |
| mil | U.S. military |
| net | Computers belonging to network providers |
| org | Miscellaneous and non-government organizations |
| Two-letter country codes | More than 240 countries and territories |

In late 1998, the Internet Corporation for Assigned Names and Numbers (ICANN) was set up to oversee the technical coordination of the Domain Name System, which allows Internet addresses to be found

by easy-to-remember names instead of one of 4.3 billion individual IP numbers. In late 2000, ICANN approved seven additional TLDs:

| | |
|--------|--------------------------------------|
| aero | Air-transport industry |
| biz | Businesses |
| coop | Cooperatives |
| info | Unrestricted use |
| museum | Museums |
| name | For registration by individuals |
| pro | Accountants, lawyers, and physicians |

Concerns about “rights” and “ownership” of domains are inappropriate. It is appropriate to be concerned about “responsibilities” and “service” to the community.

J. Postel, from the Network Working Group RFC 1591, March 1994

As a particular domain name is built up from the top-level domain, it consists of different levels separated by a period (spoken as “dot”). Since we read left to right, we tend to think first.second.third, left to right, but domain name levels are numbered right to left. Companies such as Microsoft, Apple, and IBM have second-level domain addresses that read microsoft.com, apple.com, and ibm.com—they are commercial (.com) operations with their second-level domain to the left of the top-level “com” domain. Government (.gov) agencies such as the Federal Bureau of Investigation, the Internal Revenue Service (a branch of the U.S. Treasury Department), and the White House have addresses that read fbi.gov, irs.ustreas.gov (note that the irs constitutes a third-level address), and whitehouse.gov.

Second-Level Domains

Many second-level domains contain huge numbers of computers and user accounts representing local, regional, and even international branches as well as various internal business and management functions. So the

Internet addressing scheme provides for subdomains that can contain even more subdomains. Like a finely carved Russian matryoshka doll, individual workstations live at the epicenter of a cluster of domains.

Within the education (.edu) domain containing hundreds of universities and colleges, for example, is a second-level domain for Yale University called yale. At that university are many schools and departments (medicine, engineering, law, business, computer science, and so on), and each of these entities in turn

has departments and possibly subdepartments and many users. These departments operate one or even several servers for managing traffic to



and from the many computers in their group and to the outside world. At Yale, the server for the Computing and Information Systems Department is named *cis*. It manages about 11,000 departmental accounts—so many accounts that a cluster of three subsidiary servers was installed to deal efficiently with the demand. These subsidiary servers are named *minerva*, *morpheus*, and *mercury*. Thus, *minerva* lives in the *cis* domain, which lives in the *yale* domain, which lives in the *edu* domain. Real people's computers are networked to *minerva*. Other real people are connected to the *morpheus* and *mercury* servers. To make things easy (exactly what computers are for), the mail system database at Yale maintains a master list of all of its people. So, as far as the outside world is concerned, a professor's e-mail address can be simply *firstname.lastname@yale.edu*; the database knows he or she is really connected to *minerva* so the mail is forwarded to that correct final address. In detailed e-mail headers, you may see the complete destination address listed as well as names of the computers through which your mail message may have been routed.

E-mail accounts are said to be “at” a domain (written with the @ sign). There are never any blank spaces in an Internet e-mail address, and while addresses on the Internet are normally case insensitive, conventional use dictates using all lowercase: the Internet will find *tay@timestream.com*, *TAY@TIMESTREAM.COM*, and *Tay@Timestream.Com* to be the same address.

The US Domain and Country Codes

The two-letter top-level US domain is based on political boundaries and is used by federal, state, and local government agencies, high schools, technical/vocational schools, private schools, elementary schools, libraries, fire and police departments, and regular citizens. Any computer in the United States can be in the US domain. Some fictitious examples are as follows:

| | |
|------------------------------|--------------------------|
| <i>fs.fed.us</i> | Federal |
| <i>senate.state.pa.us</i> | State |
| <i>assembly.state.ny.us</i> | State |
| <i>mwra.state.ma.us</i> | State |
| <i>ci.wayland.mi.us</i> | City |
| <i>co.alameda.ca.us</i> | County |
| <i>ccsf.cc.ca.us</i> | Public community college |
| <i>appleton.lib.me.us</i> | Public library |
| <i>pps.k12.or.us</i> | Public school |
| <i>perkins.pvt.k12.ma.us</i> | Private school |

NOTE *The Internet RFC 1480, <http://rfc.net/rfc1480.html>, describes the hierarchical rules for addresses in the US domain.*

Two-letter country codes, based on the International Organization for Standardization (ISO) document ISO-3166, are used in the addresses of all computers located outside the United States. Each country has an administrator who is responsible for organizing the naming hierarchy within that country's domain. Some countries use categories similar to com, edu, and org. Others base their naming hierarchies on political boundaries, as in the US country code.

| | |
|----------------------------|---|
| schmidt@cage.rug.ac.be | Professor at University of Gent, Belgium |
| smythe@fiqus.unl.edu.ar | Student at L.C.S.A, Argentina |
| smith@iskratel.si | Commercial account, Slovenia |
| smith@laughs.co.uk | Commercial account, United Kingdom |
| smithe@idsc.gov.eg | Student at Cairo University, Egypt |
| smithy@udcf.gla.ac.uk | Researcher at University of Glasgow, Scotland |
| tsmith@library.usyd.edu.au | Scholar at University of Sydney, Australia |

TIP *For a list of all the two-letter country codes, see: www.iana.org/cctld/cctld-whois.htm.*

IP Addresses and Data Packets

When a stream of data is sent over the Internet by your computer, it is first broken down into packets by the Transmission Control Protocol (TCP). Each packet includes the address of the receiving computer, a sequence number (“this is packet #5”), error correction information, and a small piece of your data. After a packet is created by TCP, the Internet Protocol (IP) then takes over and actually sends the packet to its destination along a route that may include many other computers acting as forwarders. **TCP/IP** is two important Internet protocols working in concert.

The 32-bit address included in a **data packet**, the **IP address**, is the “real” Internet address. It is made up of four numbers separated by periods, for example, 140.174.162.10. Some of these numbers are assigned by Internet authorities, and some may be dynamically assigned by an **Internet service provider (ISP)** when a computer logs on using a subscriber's account. There are domain name servers throughout the Internet whose sole job is to quickly look up text-based domain name addresses in large distributed databases, convert them into real IP addresses, and then return

them to you for insertion into your data packets. Every time you connect to `http://www.google.com` or send mail to `president@whitehouse.gov`, the domain name server is consulted and the destination address is converted to numbers.

TIP IP addresses and domain names can be used interchangeably. Thus, `kona.midcoast.com` is the same Internet address as `69.39.100.10`. There are occasional problems with the Internet's DNS servers, and by using the IP address, you may get connected immediately. With a Ping utility, or using the "whois" function in Unix, you can discover a domain's IP address.

Connections

If your computer is connected to an existing network at an office or school, it is likely you are already connected to the Internet. If you are an individual working from home, you will need a telephone dial-up account or broadband cable, Digital Subscriber Line (DSL), or wireless equipment to connect to the **backbone** (the ultra-high-bandwidth underlying network operated by MCI, AT&T, Sprint, and other telecommunications companies) of the Internet through an Internet service provider (ISP).

The Bandwidth Bottleneck

Bandwidth is how much data, expressed in bits per second (bps), you can send from one computer to another in a given amount of time. The faster your transmissions (or the greater the bandwidth of your connection), the less time you will spend waiting for text, images, sounds, and animated illustrations to upload or download from computer to computer, and the more satisfaction you will have with your Internet experience. To think in bytes per second, divide the rate by eight. Table 12-2 lists the bandwidth of some common data transfer methods.

| Type of Connection | Bandwidth (in bits per second) Without Compression | Comment |
|--------------------|--|---|
| 56K modem | 56,000 | Maximum analog modem speed for copper wires, (Dial-Up) data compressed using V91 standard. Actual is about 48 Kbps. |
| ISDN | 56,000 to 128,000 | Integrated Services Digital Network basic services (128,000 bps if no voice mixed in). |
| Frame relay | 56,000 to 45,000,000 | Dedicated service offered by long-distance phone companies. |

Table 12-2 Bandwidth of Typical Internet and Computer Connections (For more information visit www.cis.eku.edu/loy/cis300/bandwidth.html.)

| Type of Connection | Bandwidth (in bits per second) Without Compression | Comment |
|-----------------------------|--|---|
| Ethernet-10 | 10,000,000 | Networking hardware and protocol, commonly uses two twisted pairs of copper wire. |
| T-1 (DS-1 in North America) | 1,544,000 | Equal to 24 leased lines at 56 Kbps. |
| E-1 (DS-1 in Europe) | 2,000,000 | European equivalent of a T-1 connection. |
| DSL | 1,500,000 to 9,000,000 | Digital Subscriber Line service available in various technologies (HDSL, SDSL, ADSL, VDSL, and RDSL) with differing data rates, operating distances, and ratios between downstream and upstream speeds. |
| Cable Modem | 3,000,000 upload; 7,000,000 download | Even though copper coaxial TV cable can be used in a bidirectional fashion, it was originally designed to carry limited signals in one direction. |
| Wireless (802.11) | 3,000,000 to 54,000,000 | Radio connection in the radio frequency (RF) bands of 2.4 GHz (WiFi) or 5.8 GHz. |
| T-3 (D-3 in North America) | 45,000,000 | Typical backbone speed of major ISPs in the United States (1996). |
| Fast Ethernet-100 | 100,000,000 | Networking hardware and protocol, commonly uses two twisted pairs of copper wire. |
| OC-3 | 155,000,000 | Upgrade for ISPs in the United States (1997). |
| Gigabit Ethernet | 1,000,000,000 | Used for local network backbones; standard in many computers. |
| OC-48 | 2,400,000,000 (2.4 gigabits per second) | Typical speed for intercity fiber-optic lines (called SONET or Synchronous Optical Network). |
| 10 Gigabit Ethernet | 10,000,000,000 (10 gigabits per second) | Used for local network backbones. |
| OC-255 | 13,210,000,000 (13.21 gigabits per second) | Really fast fiber-optic lines using SONET. |

Table 12-2 Bandwidth of Typical Internet and Computer Connections (For more information visit www.cis.eku.edu/loy/cis300/bandwidth.html.) (Continued)

The bottleneck at a typical user's low-bandwidth modem connection is the most serious impediment to sending multimedia across the Internet. At low bandwidth, a page of text (3,000 bytes) can take less than a second to send, but an uncompressed 640×480 , 8-bit/256-color image (about 300,000 bytes) can take a few minutes; an uncompressed 640×480 , 24-bit/16 million-color image (about 900,000 bytes) can take many minutes to send. Occasionally also, even though you may have a high-speed connection, the server delivering your requested file or content may be "throttled down" while it manages many requests at once, and yours must wait its turn.

To work within the constraints of bandwidth bottlenecks, multimedia developers on the Internet have but a few options:

- Compress data as tightly as possible (into ZIP or SIT or TAR files) before transmitting.
- Require users to download data only once; then store the data in a local hard disk cache (this is automatically managed by most browsers).
- Design each multimedia element to be efficiently compact—don't use a greater color depth than is absolutely necessary or leave extra space around the edges.
- Design alternate low-bandwidth and high-bandwidth navigation paths to accommodate all users.
- Implement streaming methods that allow data to be transferred and displayed incrementally as it comes in (without waiting for the entire data file to arrive).

Internet Services

To many users, the Internet means the World Wide Web. But the Web is only the latest and most popular of services available today on the Internet. E-mail; file transfer; discussion groups and newsgroups; real-time chatting by text, voice, and video; and the ability to log into remote computers are common as well. Internet services are shown here.

| Service | Purpose |
|---------|--|
| ftp | For transferring files between computers; can be anonymous or password protected (from File Transfer Protocol) |
| gopher | For menus of material available on the Internet (seldom used) |
| http | For posting and reading documents (from the Hypertext Transfer Protocol used by the World Wide Web) |
| https | For posting and reading encrypted (secure) documents |
| imap | For receiving electronic mail (from Internet Message Access Protocol) |
| irc | For real-time text messaging (from Internet Relay Chat) |
| mud | For real-time game playing (from MultiUser Dimension) |
| pop | For receiving electronic mail (from Post Office Protocol) |
| rtsp | For streaming media control (from Real Time Streaming Protocol) |
| telnet | For logging on and working from remote computers |
| smtp | For sending mail (Simple Mail Transport Protocol) |
| usenet | For participating in discussion groups (from USErs NETwork) |

Each Internet service is implemented on an Internet server by dedicated software known as a **daemon**. (Actually, daemons only exist on Unix/Linux systems—on other systems, such as Windows, the services may run as regular applications or background processes.) Daemons are

agent programs that run in the background, waiting to act on requests from the outside. In the case of the Internet, daemons support protocols such as the **Hypertext Transfer Protocol (HTTP)** for the World Wide Web, the **Post Office Protocol (POP)** for e-mail, or the **File Transfer Protocol (FTP)** for exchanging files. You have probably noticed that the first few letters of a **Uniform Resource Locator (URL)**—for example, `http://www.timestream.com/index.html`—notify a server as to which daemon to bring into play to satisfy a request. In many cases, the daemons for the Web, mail, news, and FTP may run on completely different servers, each isolated by a security firewall from other servers on a network.

FTP.ARL.MIL (Army Research Laboratory) Bandwidth Information

ARL has multiple high-speed connections to several significant networks, providing excellent performance for most document transfers:

- **DREN** This site is a primary node in the Defense Research and Engineering Network (DREN), which sports a variety of OC-12, OC-3, T-3, and T-1 communications links to other U.S. Government facilities.
- **The Internet Backbone** This site is connected to the Internet “backbone” at strategic locations via a “cloud” of OC-12 ATM paths provisioned over AT&T’s nationwide DISC ATM network: MAE-East in Washington, DC; FIX-West and MAE-West in San Francisco. The Sprint NAP in Pensauken, NJ. The NAP in Chicago, IL. The “Giga-pop” in Washington state.
- **NIPRNET (nee MILNET)** This site is gatewayed to a NIPRNET military Packet Switching Node that has multiple T-1 trunks.

Moving 1 MByte of data over an OC-3 link takes about 0.1 seconds, if your end is up to it.

Moving 1 MByte of data over a T-3 link takes about 1 second, if your end is up to it.

Moving 1 MByte of data over a T-1 link takes about 8 seconds.

Moving 1 MByte of data over a 56 Kbps link takes about 3 minutes.

Moving 1 MByte of data over a 28.8 Kbps modem takes about 5 minutes.

Naturally, no single file transfer ever gets the full bandwidth of these communications lines, as they are a shared resource. These figures should help you make a lower-bound estimate on how much time large file transfers might take.

You are free to transfer large files from this site at any time. Information seekers from all domains are welcome to view this data. It is important that our guests understand that this is an official U.S. Government System for unclassified use only. Use of this system constitutes consent to security testing and monitoring.

webmaster@arl.army.mil

MIME-Types

To work with multimedia on the Internet, you must work within the requirements of the appropriate protocol, using recognizable documents and formats. A voice attachment to an e-mail message, for example, must be identified by the Post Office daemon for what it is, and then be transmitted with the correct coding to the receiving computer. The receiver must have the proper software (and hardware) for decoding the information and playing it back. To identify the nature of the data transmitted and, by inference, the purpose of that data, the Internet uses a standard list of filename extensions called **Multipurpose Internet Mail Extensions (MIME-types)**. Most browsers allow you to define MIME-types and map “helper apps” to the type for decoding and playing. For example, with Netscape Navigator you can define Adobe’s Acrobat files (PDF files) as a MIME-type and select the Acrobat Reader as the player application.

These are not just used by the e-mail daemon but, by convention, by other Internet daemons, including the Web’s HTTP daemon. Perhaps the most widely installed HTTP software for managing web pages is the open-source application called Apache (www.apache.org). Table 12-3 shows a list of common MIME-types and their uses. (Note that many come from the Unix world, where the Internet was born.) You can also visit www.file-ext.com for more information.

| Extension | Type | Use |
|-----------|--------------------------|---------------------|
| ai | application/postscript | PostScript program |
| aif | audio/x-aiff | Audio |
| aifc | audio/x-aiff | Audio |
| AIFF | audio/x-aiff | Audio |
| aiff | audio/x-aiff | Audio |
| au | audio/basic | ULAW audio data |
| avi | video/x-msvideo | Microsoft video |
| bin | application/octet-stream | Binary executable |
| cpio | application/x-cpio | Unix CPIO archive |
| cs | application/x-csh | C shell program |
| dcr | application/director | Shockwave animation |
| dvi | application/x-dvi | TeX DVI data |
| eps | application/postscript | PostScript program |
| exe | application/octet-stream | Binary executable |

Table 12-3 Some Common MIME-Types Illustrate the Variety of Data Types and Formats Used on the Internet

| Extension | Type | Use |
|-----------|----------------------------------|---------------------------|
| fif | application/fractals | Fractal image format |
| flv | video/x-flv | Flash video |
| gif | image/gif | CompuServe image format |
| gtar | application/x-gtar | GNU tape archive |
| gz | encoding/x-gzip | GNU zip compressed data |
| hqx | application/mac-binhex40 | Macintosh BinHex archive |
| htm | text/html | Hypertext Markup Language |
| html | text/html | Hypertext Markup Language |
| ief | image/ief | Image |
| jpe | image/jpeg | JPEG image |
| jpeg | image/jpeg | JPEG image |
| jpg | image/jpeg | JPEG image |
| latex | application/x-latex | LaTeX document |
| kmz | application/vnd.google-earth.kmz | Google Earth document |
| man | application/x-troff-man | Unix manual page |
| me | application/x-troff-me | TROFF document |
| mov | video/quicktime | QuickTime video |
| movie | video/x-sgi-movie | SGI video |
| mpe | video/mpeg | MPEG video |
| mpeg | video/mpeg | MPEG video |
| mpg | video/mpeg | MPEG video |
| ms | application/x-troff-ms | TROFF document |
| pbm | image/x-portable-bitmap | PBM image |
| pgm | image/x-portable-graymap | PGM image |
| pnm | image/x-portable-anymap | PBM image |
| ppm | image/x-portable-pixmap | PPM image |
| ps | application/postscript | PostScript program |
| qt | video/quicktime | QuickTime video |
| ra | audio/x-pn-realaudio | RealAudio sound |
| ram | audio/x-pn-realaudio | RealAudio sound |
| ras | image/x-cmu-raster | CMU raster image |
| rgb | image/x-rgb | RGB image |
| roff | application/x-troff | TROFF document |
| rtf | application/rtf | Rich Text Format |

Table 12-3 Some Common MIME-Types Illustrate the Variety of Data Types and Formats Used on the Internet (*Continued*)

| Extension | Type | Use |
|-----------|-------------------------------|----------------------|
| sh | application/x-sh | Bourne shell program |
| shar | application/x-shar | Unix shell archive |
| sit | application/x-stuffit | Macintosh archive |
| snd | audio/basic | ULAW audio data |
| swf | application/x-shockwave-flash | Flash document |
| t | application/x-troff | TROFF document |
| tar | application/x-tar | Unix tape archive |
| tcl | application/x-tcl | TCL program |
| tex | application/x-tex | TeX document |
| texi | application/x-texinfo | GNU TeXinfo document |
| texinfo | application/x-texinfo | GNU TeXinfo document |
| text | text/plain | Plain text |
| tif | image/tiff | TIFF image |
| tiff | image/tiff | TIFF image |
| tr | application/x-troff | TROFF document |
| txt | text/plain | Plain text |
| vox | audio | VoxWare |
| wav | audio/x-wav | WAV audio |
| xbm | image/x-xbitmap | X bitmap |
| xpm | image/x-xpixmap | X pixmap |
| xwd | image/x-xwindowdump | X Window dump image |
| z | encoding/x-compress | Compressed data |
| zip | application/x-zip-compressed | Zip compressed data |

Table 12-3 Some Common MIME-Types Illustrate the Variety of Data Types and Formats Used on the Internet (Continued)

Multimedia elements are typically saved and transmitted on the Internet in the appropriate MIME-type format and are named with the proper extension for that type. For example, Shockwave Flash animation files end in .swf; image files end in .jpg, .jpeg, .gif, or .png; sound files end in .au, .wav, .aif, .mp3, or another conforming format; QuickTime and other video clips end in .qt, .mov, mp4, or avi.

WARNING Because some MIME-types for multimedia data are new or experimental, not all servers may recognize them. If you have problems with a multimedia file, check with your Internet service provider to be sure your server can serve “experimental” MIME-types. Some ISPs will not install the requisite, and often costly, server software for high-bandwidth streaming MIME-types.

The Semantic Web is an extension of the current Web in which information is given well-defined meaning, enabling computers and people to work in better cooperation. The W3C Semantic Web Activity, in collaboration with a large number of researchers and industrial partners, is tasked with defining standards and technologies that allow data on the Web to be defined and linked in a way that it can be used for more effective discovery, automation, integration, and reuse across applications. The Web will reach its full potential when it becomes an environment where data can be shared and processed by automated tools as well as by people.

.....
 Tim Berners-Lee
 and Eric Miller
 from *The Semantic Web Lifts Off*

The World Wide Web and HTML

The World Wide Web (www.w3.org/) started in 1989 at the European Particle Physics Laboratory (CERN) as a “distributed collaborative hypermedia information system.” It was designed by Tim Berners-Lee as a protocol for linking a multiplicity of documents located on computers anywhere within the Internet. This new Hypertext Transfer Protocol (HTTP) provided rules for a simple transaction between two computers on the Internet consisting of (1) establishing a connection, (2) requesting that a document be sent, (3) sending the document, and (4) closing the connection. It also required a simple document format called Hypertext Markup Language (HTML) for presenting structured text mixed with inline images.

An HTML document could contain hyperlinks or anchors that referred to other similar documents. With browser software, users could then click on designated areas of hot text in one document and jump to another, which itself might have more hot text pointing to yet other documents. Users could surf from document to document across the Web, with HTML as the underlying buoyant framework. Berners-Lee is currently developing the next evolution, the **Semantic Web**, which “provides a common framework that allows data to be shared and reused across application, enterprise, and community boundaries.” Visit www.w3.org/2001/sw/ for more.

Dynamic Web Pages and XML

HTML is fine for building and delivering uncomplicated *static* web pages. But you will need other tools and programming know-how to deliver *dynamic* pages that are built on the fly from text, graphics, animations, and information contained in databases or documents. JavaScript and programs written in Java may be inserted into HTML pages to perform special functions and tasks that go beyond the vanilla abilities of HTML—for mouse rollovers, window control, and custom animations.

Cold Fusion and PHP are applications running side by side with a web server like Apache; they scan an outgoing web page for special commands and directives, usually embedded in special tags. If they find a special tag in the page, the software will do what the tag tells it to do, like “get today’s date and put it into that table cell” or “search this database for all customers with balances greater than \$100 and, after alphabetizing, put that list into a table on the web page being served.” Working hand-in-hand with these application servers, Oracle, Sybase, and MySQL offer software to manage **Structured Query Language (SQL)** databases that may contain not only text but also graphics and multimedia resources like sounds and video clips. In concert with HTML, these tools provide

the power to do real work and perform real tasks within the context of the World Wide Web.

Flash animations, Director applications, and RunRev stacks can also be called from within HTML pages. These multimedia mini-applications, often programmed by Web developers, use a browser plug-in to display the action and perform tasks such as playing a sound, showing a video, or calculating a date. As with Cold Fusion and PHP, both use underlying programming languages. With the introduction of HTML5, browsers can play multimedia elements such as sound, animations, and video without requiring special plug-ins or software.

XML (Extensible Markup Language) goes beyond HTML—it is the next evolutionary step in the development of the Internet for formatting and delivering web pages using styles. Unlike HTML, you can create your own tags in XML to describe exactly what the data means, and you can get that data from anywhere on the Web. In XML, you can build a set of tags like

```
<fruit>
<type>Tomato</type>
<source>California</source>
<price>$.64</price>
</fruit>
```

and your XML document, according to your instructions, will find the information to put into the proper place on the web page in the formatting style you assign. For example, with XML styles, you can declare that all items within the `<price>` tag will be displayed in boldface Helvetica type.

TIP For more information about XML see:
www.xml.org
www.xml.com

In development as a technique to deliver more pleasing web experiences, AJAX (Asynchronous JavaScript and XML) uses a combination of XML, **CSS (Cascading Style Sheets)** for marking up and styling information), and JavaScript to generate dynamic displays and allow user interaction within a web browser.

Flash was created during the PC era—for PCs and mice. Flash is a successful business for Adobe, and we can understand why they want to push it beyond PCs. But the mobile era is about low power devices, touch interfaces and open web standards—all areas where Flash falls short.

The avalanche of media outlets offering their content for Apple's mobile devices demonstrates that Flash is no longer necessary to watch video or consume any kind of web content. And the 200,000 apps on Apple's App Store proves that Flash isn't necessary for tens of thousands of developers to create graphically rich applications, including games.

New open standards created in the mobile era, such as HTML5, will win on mobile devices (and PCs too). Perhaps Adobe should focus more on creating great HTML5 tools for the future, and less on criticizing Apple for leaving the past behind.

.....
 Steve Jobs,
 CEO Apple Computer, Inc.,
 April, 2010

The Web is becoming much more than a static library. Increasingly, users are accessing the Web for “web pages” that aren't actually on the shelves. Instead, the pages are generated dynamically from information available to the web server. That information can come from databases on the web server, from the site owner's enterprise databases, or even from other web sites.

.....
 Charles Goldfarb,
 who invented SGML
 (the parent language of HTML and XML)
 and coined the term “markup language”

Multimedia on the Web

During the coming years, most multimedia experiences on the Internet will occur on the World Wide Web, programmed within the constraints of HTML, then stretched by the enhanced capabilities provided by XML, Java, JavaScript, AJAX, and special plug-ins like Flash and QuickTime to enable browsers to exceed their limits. These tools are used to build “**Web 2.0**” sites where there is collaboration and information sharing such as seen in blogs, on wikis, and at social networking sites such as Facebook and Twitter.

To design and make effective multimedia for this environment, developers need to understand not only how to create and edit the elements of multimedia, but also how to deliver it for HTML browsers and plug-in/player vehicles. Well-crafted, professionally rendered sites on the Web include text, images, audio, and animation presented in a user-friendly interface that balances the bandwidth deficit against user patience.

Inside the event horizon of the amazing World Wide Web explosion are many uncertainties and unsolved challenges. The bandwidth deficit will certainly be met with technology solutions that will reach the last mile into homes and businesses. There is a terrific need for high-quality, compelling content; multimedia developers and entrepreneurs will fill this creative void.

Tools for the World Wide Web

In the late 1990s, multimedia plug-ins and commercial tools aimed at the Web entered the marketplace at a furious pace, each competing for visibility and developer/user mind share in an increasingly noisy venue. In the few years since the birth of the first line-driven HTTP daemon in Switzerland, millions of web surfers had become hungry for “cool” enhancements to entertaining sites. Web site and page developers needed creative tools to feed the surfers, while surfers needed browsers and the plug-ins and players to make these cool multimedia enhancements work.

A combination of the explosion of these tools and user demand for performance stresses the orderly development of the core HTML standard. Unable to evolve fast enough to satisfy the demand for features (there are committees, international meetings, rational debates, comment periods, and votes in the standards process), the HTML language is constantly being extended de facto by commercial interests. These companies regularly release new versions of web browsers containing **tags** (HTML formatting elements) and features not yet formally approved. By the time (measured in weeks!) millions of users have become dependent upon the features of the new browser versions, the more carefully considered official specification has no choice but to incorporate them. By the time features are “official,” of course—after more meetings, votes, and understated

demonstrations of power—still newer browser versions have been released with yet newer, unofficial features.

What keeps this cycle from being chaotic are the natural selection forces of the marketplace: developers strive toward a successful product that works better and satisfies more users without mutating so far from the core standard that there are no sales and the company collapses. Developers also complain about the contention among browser vendors because they must program workarounds that compensate for the performance differences among them, and they must test the performance of their site on all or as many as possible.

Browsers provide a method for third-party developers to “plug in” special tools that take over certain computational and display activities. They also support the **Java** and **JavaScript** languages by which programmers can create bits of programming script and Java **applets** to extend and customize a browser’s basic HTML capabilities, especially into the multimedia realm. Java and JavaScript are only related by name. Java is a programming language much like C++ that must be compiled into machine code to be executed by a computer’s operating system. JavaScript is a “scripting language” whose commands are executed at runtime by the browser itself. JavaScript code can be placed directly into HTML using `<script>` tags or referenced from a file with the “.js” extension.

Thus, while browsers provide the orchestrated foundation of HTML, third-party players and even nonprogrammers can create their own cadenzas to enhance browser performance or perform special tasks. It is often through these plug-ins and applets that multimedia reaches end users. Many of these tools are available as freeware and shareware while others, particularly server software packages, are expensive, though most any tool can be downloaded from the Internet in a trial version. Try it. If you like it or use it, buy it.

The stunning growth of the Internet as well as expansion of wireless mobile phone connectivity to the Internet has caused many multimedia developers to redirect their creative efforts toward providing software solutions for these arenas. This remains a new and lucrative frontier, and no developer wishes to be left behind.

Web Servers

The workings of the Web involve communication between two computers: a server and a client. The server delivers a file when a client asks for it. Because the playback or display performance of your multimedia content—particularly when it is a streaming MIME-type such as RealAudio or Shockwave/Flash or a QuickTime video—depends upon the speed and capabilities of the computer and software serving it (as well as the bandwidth and load factors of the Internet), you should know some basics.

A growing number of software vendors provide web servers of varying strength and capacity and for a variety of platforms, all of which meet the requirements of the Hypertext Transfer Protocol. A server is technically not the hardware, but the software—you should invest in server software that will stand up to your intended use and be supported by the vendor. Most vendors will also recommend hardware configurations. This combination of software and hardware is critical to your success and happiness if you wish to optimize response time (less than a second), your connections per second (as many as possible), and your throughput (plenty of room before your Internet connection is overwhelmed by traveling packets).

WARNING *If you do not develop growth predictions based upon sound business practices and install adequate server performance and load balancing, you may discover that those 6,000 hits you received in the hour after you and your brother held up the bedsheet boasting your company's URL during the Super Bowl are being served at 87 bytes per second or refused altogether. At least be sure your choice of server and its connection to the Internet backbone provide a sensible migration path for growth; people don't usually come back to an unsatisfying experience.*

Web Browsers

Your computer's performance is as important as the bandwidth of your connection to the Web. Web **browsers** are applications that run on a user's personal computer (on the client side on the Internet) to provide the interactive graphical interface for searching, finding, and viewing text documents, sounds, animations, and other multimedia resources on the Web. In 1996, as many as 50 browsers competed for market share, each boasting special or unique features, performance, and cost. Rich Santalesa, editor of *NetGuide* magazine, predicted even then that "the browser wars are over—it's a battle between Microsoft and Netscape, and everyone else is going to dry up and blow away." Indeed, by mid-2001, only two serious competitors remained: Netscape and Microsoft, and Netscape, despite more than 40 million registered users, was beginning a chameleon act. Purchased by AOL, then alloyed by a merger with Time Warner, Netscape was repositioned as a "media hub," not a software company, giving the new Netscape a chance to sell advertising across its many media properties and experiment with subscriptions rather than just free services within the AOL-Time Warner media empire (which includes properties such as *Fortune* and *Time* magazines and the 24-hour cable news network CNN). By 2006, Netscape was dead. From Netscape's ashes arose **Mozilla Firefox** as an open-source competitor to **Microsoft Internet Explorer**.

Despite the legal and financial seriousness of this competition, manifesting in very real congressional hearings and complicated multimillion-dollar antimonopoly lawsuits, some of those involved kept their sense of humor. Back in October 1997, late in the night after the gala announcement and rollout of Microsoft's new Explorer 4.0 in San Francisco, a group of Microsoft engineers drove 30 miles south to Netscape's headquarters and placed a truck-sized Explorer logo (the world-circling "e") on the front lawn of the competitor's headquarters, accented with a helium balloon saying "We Love You" and a greeting card with the message, "It's just not fair. Good people shouldn't have to feel bad. Best wishes, the IE team." By midmorning, Netscape's own engineers had crowned the Explorer logo with a giant dinosaur (their company mascot, named Mozilla), and nailed up a cardboard sign declaring, "Netscape 72, Microsoft 18" (the companies' market share at that time). Mozilla later spun out of Netscape in a free, open-source effort to standardize the browser's HTML engine.

Today, the majority of visitors to your web site will be using Microsoft's Internet Explorer, winner of the "browser wars" (see Table 12-4). In designing a web site, then, you should be certain that your documents and plug-ins work and look good using Internet Explorer.

| Internet Explorer | Firefox | Chrome | Safari | Opera | Unknown |
|-------------------|---------|--------|--------|-------|---------|
| 47% | 31% | 7% | 5% | 1% | 9% |

Table 12-4 Browser Market Penetration in 2010 (From www.w3counter.com)

Search Engines

You should become familiar with the operation of one or more search engines. They will ferret out information for you in seconds, information that would take months to find searching in a traditional library. Individualized personal search engines are available that can search the entire public Web, while enterprise search engines can search intranets, and mobile search engines can search PDAs and even cell phones.

Web Page Makers and Site Builders

To deliver multimedia on the Web today, you should know some HTML, meaning that you must place the proper tags and references into your documents to launch and control your multimedia. Many **HTML editors** and web page-making applications offer to shortcut your HTML learning curve and working effort. If you use one of these editors, enjoy its easing

your work effort, but do not shy away from learning the syntax and tags of the language. Often these “helpers” generate extremely complicated HTML code (described by some programmers as “garbage”) with the idea that if this code is hidden “under the hood,” who cares? As you yourself become more informed and better at HTML coding, you might discover that you are the person who cares!

HTML documents are simple ASCII text files saved to disk without any formatting at all—no bolding, underlining, special fonts, margins, or tabs. Professional web page developers often use only a word processor like BBEdit for the Mac (see Figure 12-1) or WordPad in Windows rather than a souped-up, drag-and-drop, HTML page builder, and they insert text and tags into their documents manually or with personalized shortcut keys and helper scripts. HTML currently includes about 50 tags, and once you understand their properties and uses, coding, or **marking up**, a document and saving it to your web site can be a straightforward process. Plain HTML may not be enough to create dynamic sites on the fly, sites based upon user preferences or that display “live” information pulled from databases or spreadsheets. To build these kinds of pages, you should be familiar with programming environments such as Microsoft’s Active Server Pages (.asp); Adobe’s ColdFusion (.cfm), which uses ColdFusion Markup Language (CFML); or the open-source and readily available PHP. For other powerful options beyond plain HTML, knowledge of Dynamic HTML (DHTML), **Extensible Markup Language (XML)**, and Cascading Style Sheets (CSS) will enhance your skill set.

Most web browsers allow you to read the HTML code behind the page you are viewing. In Firefox, click View:Page Source. The SeaMonkey browser, based on the Mozilla engine, includes a basic visual page editor, with several different modes, including a “Tag” mode, which visually shows the tags related to various elements on the page.

TIP For tools that add power to HTML pages see:

www.asp.net/

www.activeserverpage.org/

www.adobe.com/products/coldfusion/

www.php.net/

HTML translators are built into many word processing programs, so you can export a word-processed document with its text styles and layout converted to HTML tags for headers, bolding, underlining, indenting, and so on. Some are more powerful than others. These work well for simple text documents but tend to choke on powerful HTML features such as tables, forms, frames, and other extensions. Dedicated editors are



Figure 12-1 BBEdit is a professional programmer’s text editor with dedicated features for web page development.

usually **WYSIWYG (What You See Is What You Get)** word processors, and they provide more power and more features specifically geared to exploiting HTML. Microsoft Word, for example, automatically opens web pages in a WYSIWYG view. On the downside, these “helpful” features may cause a page with many embedded graphics to load into the word processor very slowly while it interprets and lays out the page as a browser would, instead of just loading the text of the page’s HTML code and letting you change a few tags or lines.

First Person

When I was 16, my grandmother loaned me \$500 so I could buy my first car. It was a lovely, previously owned, British racing green 1950 MG-TD, happiest doing about 45 miles per hour on tree-lined summer roads in New England. When you hinged up the hood sideways, everything inside was simple and well defined; there was plenty of room to tweak the twin SU carburetors, adjust the distributor, and replace simple parts like the electric fuel pump. I even took the tiny four-cylinder engine entirely out and replaced the shell bearings on the crankshaft. A decade later, with my previously owned 1960 Ford

pickup, it was the same—replacing the radiator or changing the starter motor was a piece of cake, and there was plenty of room to work on the engine. But then automobiles got complicated. It started with elaborate emission control systems, then electronic ignitions, then air conditioning, and finally, computers. Opening the hood of a car today, most of us can only stare dumbly at the myriad hoses and wires and color-coded containers for special fluids; and it's so compact a fit, you can't slip a screwdriver between the engine and the fire wall. When the "check engine" light comes on, an expert needs to "pull" the computer

codes with a special, expensive reader to see what's wrong.

Writing HTML for the Web today is still simple. But unless you are an expert, you might be staring dumbly at the complex source code created by a new generation of high-powered, special web tools that will deliver mind-boggling multimedia pages built—no muss, no fuss—with simple drag and drop. But like my car today, which is happiest at 70 miles per hour and could cruise at twice that, these HTML engines won't let you do much under the hood without special tools and knowledge.

Among the many tools in this emerging marketplace, SharePoint Designer from Microsoft links to Microsoft Office and provides not only WYSIWYG support for many of the latest HTML formatting extensions, but also extensive web site management support through its extensions. InDesign from Adobe saves pages as HTML documents and as **Adobe Acrobat PDF** files. Corel's XMetal imports and converts files created in Word, WordPerfect, Ami PRO, and other word processors. It has a point-and-click interface for inserting valid HTML tags and elements and provides an enhanced URL editor to manage references and calls to other documents and files. **Adobe Dreamweaver** is a WYSIWYG editor that lets you create and edit text pages, import images, and link to other documents, and offers enhanced integration with Acrobat PDF files. Dreamweaver has become the most popular WYSIWYG HTML editor today.

Managing and maintaining a web site is a serious undertaking when the site contains many thousands of text documents, images, and other resources. Software and expert system tools for automated web page development, document management, and site activity analysis are becoming widely available. Combined with page builders and multimedia editors,

these applications will evolve into the ubiquitous “word processors” of the new information age, essential to every home and office with outreach to the Web, and able to integrate and present all the elements of multimedia.

Content Management Systems (CMSs) combine the power and flexibility of a database with the dynamic capabilities of a programming language. Most CMSs are built on a combination of `mySQL`, an open-source database, and `PHP`, a programming language designed to be included directly in web pages. Here’s how it works: when a server receives a request for a web page, it looks through that page’s code to see if there are any `PHP` directives to retrieve data from a database. If it finds such a request, it opens the proper database, grabs the data, and inserts it into the web page as programmed.

CMSs offer prepackaged templates of pages with `PHP` code built in. Open-source Joomla, one of the most popular CMSs, is used in thousands of web sites, large and small. Drupal is another popular, powerful CMS. Concrete5 combines powerful `AJAX` technology to allow a more interactive experience. CMSs let non-technical computer users add and edit the content of the pages and manage the presentation and ordering of pages at a web site.

Plug-ins and Delivery Vehicles

Plug-ins add the power of multimedia to web browsers by allowing users to view and interact with new types of documents and images. **Helper applications**, or **players**, also provide multimedia power by displaying or running files downloaded from the Internet by your browser, but helpers are not seamlessly integrated into the operation of the browser itself. When an unrecognized embedded MIME-type that can’t be displayed within your browser is called from an HTML document (sounds, movies, unusual text or image files), most browsers will automatically launch a helper application (if it is specified in the browser’s preferences) to view or run it. However, this helper starts up and runs separately from the browser.

Many plug-ins are designed to perform special tasks not available without the plug-in installed. If you land on a web page containing embedded, compressed images, for example, and the proper plug-in to decompress those images is not installed, you will not be able to view the images.

Designers work around this problem by including hyperlinks in their pages, which direct the user to the site where the missing plug-in may be found. Users must then download and install the required plug-in, and then restart their browser. This is all a bit cumbersome. Until the marketplace determines which plug-ins will become de facto standards for the Web, however, developers have no alternative. Because downloading and installing plug-ins is perceived as a hassle for the end user, many tool

developers use the Java and JavaScript capabilities already built into today's web browsers. To offer a plug-in's functionality to visitors at your own web site, you may need the addition of MIME-type information to a special setup file on your server that many plug-ins require. If you do not control or operate your own server, you should let your service provider know the MIME-types that you need to have supported. Setting up servers for some of the multimedia plug-ins is not a trivial task, and many Internet service providers will not support high-bandwidth data streams for fear of overwhelming their Internet connection by serving your streaming voice or video to the world. Indeed, while a plug-in or a player may be free and readily available to anyone who wishes it, the software to actually build, compress, manipulate, and serve the special data (such as for compressed images, compressed audio, streaming video, animations, and VRML worlds) may be difficult and expensive, since the company makes money from the development tool, not the client software.

Text

Text and document plug-ins such as the popular **Adobe Acrobat Reader** get you past the display limitations of HTML and web browsers, where fonts are dependent on end users' preferences and page layout is primitive. In file formats provided by Adobe Acrobat, for example, special fonts and graphic images are embedded as data into the file and travel with it, so what you see when you view that file is precisely what the document's maker intended.

Images

Browsers enabled for HTML5 will read and display bitmapped JPEG, GIF, and PNG image files as well as **Scalable Vector Graphics (SVG)** files. Vector files are a mathematical description of the lines, curves, fills, and patterns needed to draw a picture, and while they typically do not provide the rich detail found in bitmaps, they are smaller and can be scaled without image degradation. Plug-ins to enable viewing of vector formats (such as Flash) are useful, particularly when some provide high-octane compression schemes to dramatically shrink file size and shorten the time spent downloading and displaying them. File size and compression sound a recurring theme on the Internet, where data-rich images, movies, and sounds may take many seconds, minutes, or even longer to reach the end user.

Vector graphics are also **device-independent**, in that the image is always displayed at the correct size and with the maximum number of colors supported by the computer. Unlike bitmapped files, a single vector file

can be downloaded, cached, and then displayed multiple times at different scaled sizes on the same or a different web page.

Sound

Sound over the Web is managed in a few different ways. Digitized sound files in various common formats such as MP3, WAV, AIF, or AU may be sent to your computer and then played, either as they are being received (**streaming** playback) or once they are fully downloaded (using a player). MIDI files may also be received and played; as discussed in Chapter 4, these files are more compact, but they depend upon your computer's MIDI setup for quality. Speech files can be specially encoded into a **token language** (a “shorthand” description of the speech components) and sent at great speed to another computer to be un-tokenized and played back in a variety of voices. Sounds may be embedded into QuickTime, Windows Media, and MPEG movie files. Some sounds can be **multicast** (using the multicast IP protocols for the Internet specified in RFC 1112), so multiple users can simultaneously listen to the same data streams without duplication of data across the Internet. Web-based (VoIP, or Voice over Internet Protocol) telephones also transmit data packets containing sound information.

Animation, Video, and Presentation

The most data-intensive multimedia elements to travel the Internet are **video streams** containing both images and synchronized sound, and commonly packaged as Apple's QuickTime, Microsoft's Video for Windows (AVI), and MPEG files. Also data rich are the files for proprietary formats such as Keynote, **Microsoft PowerPoint**, and other presentation applications. In all cases, the trade-offs between bandwidth and quality are constantly in your face when designing, developing, and delivering animations or motion video for the Web.

Beyond HTML

When an ingot of pure silicon is “pulled” from a furnace, the process begins with a “seed crystal,” around which the ingot forms. HTML is the seed crystal that is shaping and forming the nature of multimedia on the World Wide Web as it extrudes itself onto the Internet's data highway. Within the latticework of HTML servers and browsers, tags such as <OBJECT> (browser-specific for Internet Explorer) or <EMBED> (browser-specific for Firefox) enable text, sound, images, animations, and motion video across the Web. Hooks for powerful platform-independent Java applets and JavaScripts are built into most browsers, so you can design local interaction and activities without a lot of communication between client- and

server-based **Common Gateway Interface (CGI)** programming. CGI is a standard for interfacing external applications with information servers, such as HTTP or web servers, and CGI programs can be written in C/C++, Fortran, PERL, TCL, a Unix shell, Visual Basic, or even AppleScript, as long as the language is supported by the server platform.

The following is an example of the combined <OBJECT> and <EMBED> tags used to display a Flash movie in both the Internet Explorer and Firefox browsers. A browser will only act on a tag it understands, ignoring tags it does not recognize. (See www.adobe.com/cfusion/knowledgebase/index.cfm?id=tn_4150.)

```
<OBJECT classid="clsid:D27CDB6E-AE6D-11cf-96B8-444553540000"
codebase="http://download.macromedia.com/pub/shockwave/cabs/flash/swflash.cab#version=6,0,40,0"
WIDTH="550" HEIGHT="400" id="myMovieName">
<PARAM NAME=movie VALUE="myFlashMovie.swf">
<PARAM NAME=quality VALUE=high>
<PARAM NAME=bgcolor VALUE=#FFFFFF>
<EMBED href="/support/flash/ts/documents/myFlashMovie.swf" quality=high bgcolor=#FFFFFF
WIDTH="550" HEIGHT="400"
NAME="myMovieName" ALIGN="" TYPE="application/x-shockwave-flash"
PLUGINSOURCE="http://www.macromedia.com/go/getflashplayer">
</EMBED>
</OBJECT>
```

3-D Worlds

Three-dimensional environments and experiences on the Web are now possible with Intel's Internet 3-D Graphics Software using software such as Second Life, Papervision within Flash, Flash CS4, and **Adobe Director** for development and the Shockwave player for delivery. These have supplanted VRML (Virtual Reality Modeling Language) as an independent environment specifically designed to handle high-performance 3-D worlds containing 3-D text and images, textures, animations, morphs, multiple viewpoints, collision detection, gravity, sounds, and all the arcade elements associated with full-bore game action. With claims that well-executed interactive 3-D content can make nearly any web site more compelling and effective and can better attract, engage, and inform, Intel's algorithms and Adobe's delivery system allow 3-D content to be automatically scaled and tailored to each user's system and available bandwidth. Spinning off from a foundation of vector graphics and animation, 3-D renderings and creative whole worlds present only the latest of multimedia challenges and learning curves for web developers. As this 3-D technology becomes refined and end-user bandwidth increases during the coming years, the very shape of web pages will be altered forever.

TIP See the following sites for more information about 3-D tools and technology:

www.adobe.com/products/director/3d/3dservices

www.discreet.com

www.havok.com

www.maxon.net

www.newtek.com

www.nvidia.com

www.righthemisphere.com

www.softimage.com

First Person

When I received a press release from Alternate Realities Corporation, a small startup company spun out of a large research effort in North Carolina, I was intrigued. ARC's president, David Bennett, claimed, "We are redefining Virtual Reality!" He went on to describe "a new generation virtual environment that is a 3-D, immersive, full-color, interactive system enclosed in a 16-foot dome or sphere that can be either

portable (inflatable or interlocking) or permanent. The system includes a 360-degree projection system with a 180-degree field of view. Imagine a 16-foot helmet that fits over 15 people at the same time and is nonrestrictive! Larger units (in the 24-foot and up range) are in the early development stage."

I knew I had to have one for my experiments with VRML! The 5-meter

model, which fits in a 20 × 20-foot trade-show booth space, was available for \$280,000, and the 7-meter model, perfect for my backyard, was only slightly more, at \$340,000.



Chapter 12 Review

■ Chapter Summary

For your review, here is a summary of the important concepts discussed in this chapter.

Discuss the origins of the Internet

- The Internet began as a research network funded by the U.S. Defense Department in 1969.
- In 1989, the National Science Foundation took over its management, and research organizations and universities (professors and students alike) became increasingly heavy users of this ever-growing “Internet.”
- Commercial and business use of the Internet was not permitted until 1992, but businesses have since become its driving force.

Define what a computer network is and how Internet domains, addresses, and interconnections work

- A network is a cluster of computers, with one computer acting as a server to provide services such as file transfer, e-mail, and document printing to the client computers.
- Using gateways and routers, a local area network (LAN) can be connected to other LANs to form a wide area network (WAN). These LANs and WANs can also be connected to the Internet through a server that provides both the necessary software for the Internet and the physical data connection.
- The Domain Name System (DNS) manages the names and addresses of computers linked to the Internet.
- Computers on the Internet manage names in subdomains that are encapsulated so that visitors from outside the local network need not worry about the subdomain names.
- When a stream of data is sent over the Internet by your computer, it is first broken down into packets by the Transmission Control Protocol (TCP).

- The IP (Internet Protocol) address is made up of four numbers between 0 and 255 separated by periods.
- Bandwidth is how much data, expressed in bits per second (bps), you can send from one computer to another in a given amount of time. The bottleneck at a typical user’s low-bandwidth modem connection is the most serious impediment to sending multimedia across the Internet.
- When a server receives a request, it is handled by a specific application called a daemon that responds to the request based on the protocol.
- The first part of the URL (Uniform Resource Locator) identifies the protocol to use to handle the request.
- Multimedia elements are typically saved and transmitted on the Internet in the appropriate MIME-type (for Multipurpose Internet Mail Extensions) format and are named with the proper extension for that type.
- Hypertext Transfer Protocol (HTTP) provides rules for contacting, requesting, and sending documents encoded with the Hypertext Markup Language (HTML).
- HTML documents are simple ASCII text files. HTML currently includes about 50 tags.
- XML (Extensible Markup Language) allows you to create your own tags and import data from anywhere on the Web.

Discuss the current state of multimedia on the Internet and tools for the World Wide Web

- The explosion of tools and user demand for performance is stressing the orderly development of the core HTML standard. The marketplace keeps this cycle from being too chaotic.

- Interactions on the Web involve communication between two computers: a server and a client. The server delivers a file when a client asks for it.
- Browsers are the apps that run on a user's personal computer to provide the interface for downloading and viewing documents and multimedia.
- Professional web page developers often use only a word processor to edit their pages. Many HTML editors and web page-making applications offer to shortcut your HTML learning curve and working effort. Even if you use one of these editors, you should still understand the syntax and tags of the HTML language.
- Plug-ins allow users to view and interact with new types of documents and images. Requiring visitors to download plug-ins can be cumbersome, and servers must be set up to correctly handle requests for special data types.
- Web-enabled 3-D environments promise compelling and interactive multimedia experiences.

■ Key Terms

- Adobe Acrobat PDF** (380)
- Adobe Acrobat Reader** (382)
- Adobe Director** (384)
- Adobe Dreamweaver** (380)
- Advanced Research Projects Agency (ARPA)** (359)
- applet** (375)
- ARPANET** (359)
- backbone** (365)
- bandwidth** (365)
- browser** (376)
- Cascading Style Sheets (CSS)** (373)
- client** (360)
- Common Gateway Interface (CGI)** (384)
- daemon** (367)
- data packet** (364)
- device-independent** (382)
- Domain Name System (DNS)** (361)
- Extensible Markup Language (XML)** (373)
- FAQ (Frequently Asked Questions)** (358)
- File Transfer Protocol (FTP)** (368)
- helper application** (381)
- HTML editor** (377)
- HTML translator** (378)
- Hypertext Transfer Protocol (HTTP)** (368)
- Internet** (359)
- Internet service provider (ISP)** (364)
- IP address** (364)
- Java** (375)
- JavaScript** (375)
- local area network (LAN)** (360)
- marking up** (378)
- Microsoft Internet Explorer** (376)
- Microsoft PowerPoint** (383)
- Mozilla Firefox** (376)
- multicast** (383)
- Multipurpose Internet Mail Extensions (MIME-types)** (369)
- network** (360)
- player** (381)
- plug-in** (381)
- Post Office Protocol (POP)** (368)
- Scalable Vector Graphics (SVG)** (382)
- Semantic Web** (372)
- server** (360)
- streaming** (383)
- Structured Query Language (SQL)** (372)
- tag** (374)
- TCP/IP** (364)
- token language** (383)
- top-level domain (TLD)** (361)
- Uniform Resource Locator (URL)** (368)
- video stream** (383)
- Web 2.0** (374)
- wide area network (WAN)** (360)
- WYSIWYG (What You See Is What You Get)** (379)
- XML (Extensible Markup Language)** (373)

■ Key Term Quiz

1. Many web sites include pages that have answers to common inquiries. These pages are known as _____.
2. A cluster of computers tied together to share files and communications is a(n) _____.
3. The set of four numbers separated by periods that points to a domain is a(n) _____.
4. How much data, expressed in bits per second (bps), you can send from one computer to another in a given amount of time is called _____.
5. Each Internet service is implemented on an Internet server by dedicated software known as a(n) _____.
6. HTML formatting elements in HTML-encoded pages are called _____.
7. Bits of Java programming code used to extend and customize a browser's basic HTML capabilities are called _____.
8. The applications that run on a user's personal computer and provide the interactive graphical interface for viewing web pages are called _____.
9. Web page editors that visually show how a page looks as you are editing are often called _____ editors.
10. Media that is played as it is being received is said to be _____.

■ Multiple-Choice Quiz

1. DNS stands for:
 - a. Distributed Numbering System
 - b. Device Nomenclature System
 - c. Data Networking System
 - d. Domain Name System
 - e. Digital Neighborhood System
2. The levels of a domain name are separated by:
 - a. a period
 - b. the @ symbol
 - c. forward slashes
 - d. hyphens
 - e. spaces
3. Which of these is not a top-level domain?
 - a. com
 - b. edu
 - c. gov
 - d. mil
 - e. cis
 - f. home.html
4. Which of the following is a valid IP address?
 - a. 192.168.1.1
 - b. www.apple.com
 - c. activa@midcoast.com
 - d. http://www.pages.net/index.html
 - e. 12 Dreamcatcher Way, Hope, ME 04847
5. When a stream of data is sent over the Internet by your computer, it is first broken down into packets by the:
 - a. Transmission Control Protocol
 - b. Internet Protocol
 - c. Post Office Protocol
 - d. Simple Mail Transfer Protocol
 - e. File Transfer Protocol
6. Perhaps the most widely installed HTTP software for managing web pages is the open-source application called:
 - a. Apache
 - b. Daemon
 - c. ISP
 - d. Acrobat
 - e. Unix

7. Web pages are written in:
 - a. MPEG
 - b. HTML
 - c. QuickTime
 - d. TCP/IP
 - e. MIME
8. One of the greatest benefits of XML is that:
 - a. it allows you to create animated rollovers
 - b. it compresses audio and video files, allowing larger files to be sent
 - c. it connects local area networks with wide area networks
 - d. it allows you to create your own tags for data
 - e. it encapsulates data into packets for more reliable transmission
9. An IP address can be exchanged with a(n):
 - a. MIME-type
 - b. Point-to-Point Protocol
 - c. domain name
 - d. e-mail address
 - e. usenet group
10. HTTP stands for:
 - a. High-Technology Transmission Protocol
 - b. Help Text Translation Protocol
 - c. Hypertext Transfer Protocol
 - d. Hardware Testing Tool Protocol
 - e. How To Talk Protocol
11. The two most popular browsers in terms of number of users are Firefox and:
 - a. Acrobat
 - b. JavaScript
 - c. Shockwave
 - d. Internet Explorer
 - e. Yahoo!
12. Helper applications run:
 - a. on the client computer outside the browser
 - b. on the client computer within the browser
 - c. on the host computer outside the server
 - d. on the host computer within the server
 - e. on external devices such as an MP3 player or PDA
13. One criticism of visual page editors is that they:
 - a. encrypt the code, making later editing impossible
 - b. do not support features such as underlining and bold text
 - c. use nonstandard HTML tags
 - d. generate extremely complicated HTML code
 - e. require the use of plug-ins
14. Which of these tags would most likely be used in HTML to view a multimedia element on the Web?
 - a. <BLOCKQUOTE>
 - b. <OBJECT>
 - c. <OPEN>
 - d. <MM>
 - e. <FLASH>
15. Which audio file type's sound quality is dependent on the client's computer setup?
 - a. AIF
 - b. AU
 - c. MIDI
 - d. Shockwave
 - e. WAV

■ Essay Quiz

1. List the most common web protocols and their uses.
2. Describe what the different parts of the URL `http://www.secondLevel.topLevel/fileName.filetype` represent.
3. Briefly describe how a browser requests a URL, how the URL is handled, and how the server responds, in terms of the DNS system, encoding schemes, and data protocols.

4. Briefly describe the data rates of a 56K dial-up, ISDN, DSL, Cable Modem, and T1 connection. Roughly calculate how long it would take to download a web page consisting of a 5-kilobyte HTML page and 45 kilobytes of image files for each connection.
5. List the most common top-level domains, and describe what categories they are associated with.
6. You have been given the task of creating a new web site for your company. What tools will you use to create the pages? When might you use a word processor? When might you use a WYSIWYG tool? When might you use an HTML text editor? What are the strengths and weaknesses of each?

Lab Projects

■ Project 12.1

You are given the task of developing a new web site for a cooking magazine. Think about the capabilities of XML to allow you to define your own data tags. What data types would you include? How might you format them? What would be the benefits in this case of being able to define your own tags? Create an outline of how you might structure the data included in a recipe.

■ Project 12.2

Open a web browser. Locate the “helper applications” preferences panel in the browser. (Note: this option varies among browsers and operating systems, and may not be available for some.)

Find the following MIME-types: audio/x-aiff; application/postscript; application/x-gtar; text/html; image/jpeg; video/mpeg; image/tiff; video/quicktime; audio/x-pn-realaudio. List an application commonly used to read or edit each type.

■ Project 12.3

Open a word processor that exports to HTML. Create a page of formatted text. Be sure to use different text styles, numerous colors, indenting, tables, and other options. Print the page out from the word processing program.

Export the page to HTML, and then open the HTML page in a web browser. Print out the page from the browser. How does the browser-rendered page differ from the page in the word processor?

■ Project 12.4

View the source of the page you created in Project 12.4 in the browser. (Most browsers have a function that allows you to view the source HTML code of a web page.) Print out the source, either from the browser, or by copying the HTML code when you view the source, or by cutting and pasting. (Some browsers respond to the View Source command by automatically opening the HTML source in NotePad on the PC.)

Note how HTML treats various word processing features with its tags.

■ Project 12.5

Go online and compare web hosting packages from three different web hosts. Most hosting companies offer several options and prices. Select a basic, moderate, and advanced package from each host and describe that package's features and options. Do any of the host providers offer unique or unusual options?

Host: _____

| Package | Basic | Moderate | Advanced |
|-------------------------|-------|----------|----------|
| Storage space: | | | |
| Bandwidth: | | | |
| Streaming capabilities: | | | |
| Cost | | | |

Comments: _____

Host: _____

| Package | Basic | Moderate | Advanced |
|-------------------------|-------|----------|----------|
| Storage space: | | | |
| Bandwidth: | | | |
| Streaming capabilities: | | | |
| Cost | | | |

Comments: _____

Host: _____

| Package | Basic | Moderate | Advanced |
|-------------------------|-------|----------|----------|
| Storage space: | | | |
| Bandwidth: | | | |
| Streaming capabilities: | | | |
| Cost | | | |

Comments: _____

Designing for the World Wide Web

In this chapter, you will learn how to:

- Employ the basic methods for displaying elements of multimedia on a web page, including using HTML, CSS, and nibbling
- Manipulate the appearance of text on the Web
- Determine which graphics formats are best suited for different types of images and how they can be manipulated
- Play audio on a web page by embedding the sound within the site
- Include animation on a web page
- Include video on a web page with and without the use of plug-ins

LAUNCHED in 1989, the World Wide Web was not originally designed with multimedia in mind, but rather as a simple method for delivering text documents formatted in HTML, with occasional inline graphic illustrations and figures. By 1995, because it was operational, essentially free, and *good enough* to support traffic (see “Vaughan’s Law of Multimedia Minimums” in Chapter 4), the Web had become a full-bore information highway of words and pictures with tens of millions of users cruising along it. The Doppler back-draft of passing travelers has exposed the gristle of an overwhelming number of disappointing audio and visual experiences on the Web: “This is my home page; here is a list of my favorite places; this is me with my dog . . .” To fill this vacuum of content and presentation, inventive multimedia solutions and enhancements now compete for mind share, stretching the capabilities of HTML, web browsers, PCs, and the very fabric of the Internet in order to bring multimedia power to this environment. Plain text and pictures are no longer enough for this highway!

WARNING *Powerful multimedia tools can be used to create totally vacuous web pages.*

Developing for the Web

This chapter investigates and illustrates some methods for developing and presenting the basic elements of multimedia within the constraints of HTML, **Cascading Style Sheets (CSS)**, and the World Wide Web. This chapter is not intended to substitute for a more complete library of HTML, CSS, web design, and Internet how-to texts, but to present basic examples that will get you started. In 2001, there were more than 2,000 published books with the word “Internet” in their title. In 2003 there were more than 6,000. In 2006, there were more than 10,000. In 2010, a search at Amazon.com showed 43,196 books with the word “Internet” in their title!

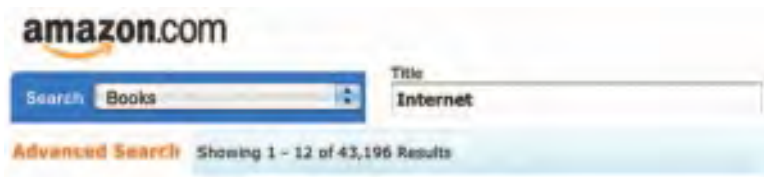

This chapter introduces you to basic ways you can put the elements of multimedia onto a web page. Learn how to use HTML tags with CSS styles rather than rely entirely on web page builders and WYSIWYG editors that never expect you to look under the hood.

All modern browsers allow you to examine the HTML code. Look for a menu item such as “View Source.” Use this feature to dig around in the source HTML code of web sites to see how the page is laid out. As you explore, you will discover that some code is neat and clear, some has plenty of embedded descriptive comments, and some is a mess of what programmers call “spaghetti” code.

HTML Is a Markup Language

You should have a basic understanding of HTML and CSS before you begin developing multimedia for the Web. HTML-coded documents, which are the fundamental vehicles for all types of information delivered on the World Wide Web, are explained in Chapter 12, but for this chapter you need to understand the basics of how HTML works.

HTML stands for Hypertext Markup Language. The “Markup Language” part of the name means that tags are used to do such things as format text and embed media. The tags are enclosed by angled brackets: `<>`. Some tags are bounding tags, requiring both an opening tag and a closing tag. The closing tag is indicated by a leading forward slash inside the angled brackets. This example for bolded text illustrates the use of the two tags:

```
<strong>This text is emphasized</strong>
```

Other tags, such as the tag for inserting an inline image, stand by themselves:

```
<IMG src="grey_ball.gif">
```

Note that the tags may be written in either upper- or lowercase; some HTML text-editing programs have a switch allowing you to select the case in which you want the tags written in your document.

Tags listed in Table 13-1 are used by **HTML5**. These simple tags along with CSS elements are used to build web pages. **Deprecated** tags such as `` and `<CENTER>` are no longer supported in the HTML standard, yet their use continues to be supported by most browsers.

| HTML Tag | Description | HTML Tag | Description |
|---------------|---|--------------|---|
| <!-- --> | Defines a comment | <footer>* | Defines a footer for a section or page |
| <!DOCTYPE> | Defines the document type | <form> | Defines a form |
| <a> | Defines a hyperlink | <h1> to <h6> | Defines header 1 to header 6 |
| <abbr> | Defines an abbreviation | <head> | Defines information about the document |
| <address> | Defines an address element | <header>* | Defines a header for a section or page |
| <area> | Defines an area inside an image map | <hgroup>* | Defines information about a section in a document |
| <article>* | Defines an article | <hr> | Defines a horizontal rule |
| <aside>* | Defines content aside from the page content | <html> | Defines an HTML document |
| <audio>* | Defines sound content | <i> | Defines italic text |
| | Defines bold text | <iframe> | Defines an inline subwindow (frame) |
| <base> | Defines a base URL for all the links in a page | | Defines an image |
| <bdo> | Defines the direction of text display | <input> | Defines an input field |
| <blockquote> | Defines a long quotation | <ins> | Defines inserted text |
| <body> | Defines the body element | <keygen>* | Defines a generated key in a form |
| | Inserts a single line break | <kbd> | Defines keyboard text |
| <button> | Defines a push button | <label> | Defines a label for a form control |
| <canvas>* | Defines graphics | <legend> | Defines a title in a fieldset |
| <caption> | Defines a table caption | | Defines a list item |
| <cite> | Defines a citation | <link> | Defines a resource reference |
| <code> | Defines computer code text | <map> | Defines an image map |
| <col> | Defines attributes for table columns | <mark>* | Defines marked text |
| <colgroup> | Defines groups of table columns | <menu> | Defines a menu list |
| <command>* | Defines a command button | <meta> | Defines meta information |
| <datalist>* | Defines a drop-down list | <meter>* | Defines measurement within a predefined range |
| <dd> | Defines a definition description | <nav>* | Defines navigation links |
| | Defines deleted text | <noscript> | Defines a noscript section |
| <details>* | Defines details of an element | <object> | Defines an embedded object |
| <dfn> | Defines a definition term | | Defines an ordered list |
| <div> | Defines a section in a document | <optgroup> | Defines an option group |
| <dl> | Defines a definition list | <option> | Defines an option in a drop-down list |
| <dt> | Defines a definition term | <output>* | Defines some types of output |
| | Defines emphasized text | <p> | Defines a paragraph |
| <embed>* | Defines external interactive content or plug-in | <param> | Defines a parameter for an object |
| <fieldset> | Defines a fieldset | <pre> | Defines preformatted text |
| <figcaption>* | Defines the caption of a figure element | <progress>* | Defines progress of a task of any kind |
| <figure>* | Defines a group of media content, and their caption | <q> | Defines a short quotation |

Table 13-1 Showing All HTML Tags Used for Building Web Pages. An Asterisk Marks Tags That Are New for HTML5 (see www.w3schools.com/html5/html5_reference.asp)

| HTML Tag | Description | HTML Tag | Description |
|------------|---|------------|----------------------------|
| <rp>* | Used in ruby annotations to define what to show browsers that do not support the ruby element | <sup> | Defines superscripted text |
| <rt>* | Defines explanation to ruby annotations | <table> | Defines a table |
| <ruby>* | Defines ruby annotations | <tbody> | Defines a table body |
| <samp> | Defines sample computer code | <td> | Defines a table cell |
| <script> | Defines a script | <textarea> | Defines a text area |
| <section>* | Defines a section | <tfoot> | Defines a table footer |
| <select> | Defines a selectable list | <th> | Defines a table header |
| <small> | Defines small text | <thead> | Defines a table header |
| <source>* | Defines media resources | <time>* | Defines a date/time |
| | Defines a section in a document | <title> | Defines the document title |
| | Defines strong text | <tr> | Defines a table row |
| <style> | Defines a style definition | | Defines an unordered list |
| <sub> | Defines subscripted text | <var> | Defines a variable |
| <summary>* | Defines the header of a "detail" element | <video>* | Defines a video |

Table 13-1 Showing All HTML Tags Used for Building Web Pages. An Asterisk Marks Tags That Are New for HTML5 (see www.w3schools.com/html5/html5_reference.asp) (Continued)

HTML and Multimedia

HTML provides tags for inserting media into HTML documents: the ** tag** for inline images; the **<AUDIO>** and **<VIDEO> tags** for multimedia; and the **<EMBED>** and **<OBJECT> tags** for compound document embedding used to insert a “nonstandard” item such as a Java applet or Flash animation into an HTML document.

But it is not as simple as it seems. There is a difference between the way various versions of browsers handle multimedia elements and the plug-ins that play them. Some browsers that understand the **<OBJECT>** tag ignore the **<EMBED>** tag, and some browsers that cannot read the **<OBJECT>** tag need the **<EMBED>** tag. The **Object/Embed method** places an **<EMBED>** tag within the **<OBJECT>** tag to ensure that multimedia elements will play in all browsers. Thus the HTML code to play a flash animation might look something like this:

```
<object classid="clsid:D27CDB6E-AE6D-11cf-96B8-444553540000" width="320" height="240" id="player1" name="player1">
  <param name="flashvars" value="file=playlist1.xml">
  <param name="movie" value="player.swf">
  <param name="allowfullscreen" value="true">
  <param name="allowsriptaccess" value="always">
  <embed id="player1"
    flashvars="file=playlist1.xml"
    name="player1"
```

```

        src="player.swf"
        width="320"
        height="240"
        allowscriptaccess="always"
        allowfullscreen="true"
    />
</object>

```

TIP *If you develop multimedia for the Internet, budget time and effort for keeping current in this rapidly changing environment—staying at the leading edge takes effort. It will be some years before multimedia delivery tools and techniques for the Web stabilize.*

The Desktop Workspace

Make your web pages look good on a 1024 × 768 display in true color (millions). Working at this resolution, you will satisfy more than 95 percent of all desktop viewers. Depending upon the browser and preferences set by the user, however, the area of the screen available for your web page, called the **viewport**, will always be less than the full display, and it is not controllable by the designer. Browser “**chrome**” (toolbars and other shiny stuff around the edges of your page’s viewport) can be either hidden or shown by the user. If you want to maximize the browser active window size, in Internet Explorer press F11 (function key 11) and go back to regular mode by clicking the mouse; other browsers offer Full Screen toggle switches in the “View” options. So design your web page for a 1,024-pixel-wide display by using tables and images that do not exceed about 1,000 pixels across the page, and you will have room for browser scroll bars. Many designers choose a viewport workspace 960 pixels wide; a number divisible by 3, 4, 5, 6, 8, 10, 12, 15, and 16. This makes many logical “grid systems” of columns possible.

The Small-Device Workspace

Under the hood of many browsers is a layout engine for rendering pages. Versions of those browser engines have been customized to run on small devices such as tablets, e-readers, netbooks, PDAs, and smartphones, and they follow known rules when laying out web pages for smaller viewports. Microsoft Internet Explorer uses the Trident engine; Firefox uses the Gecko engine; Opera uses the Presto engine; and Apple’s Safari and Google’s Chrome use the WebKit engine.

Smartphones use various operating systems: Android, iPhone OS, Linux, Maemo, Palm WebOS, RIM’s BlackBerry, Symbian OS, and Windows CE, with the most widely used being Symbian OS on handsets and devices manufactured by BenQ, Fujitsu, LG, Mitsubishi, Motorola, Nokia, Samsung, Sharp, and Sony Ericsson.

To deal with the multiplicity of viewport sizes in the small-device world (320 × 480, 240 × 320, 240 × 400, 854 × 480, etc.), the Android OS allows programmers to write one application that flexibly covers all display sizes by using virtual **density-independent pixels (dips)**:

The density-independent pixel is equivalent to one physical pixel on a 160 dpi screen, the baseline density assumed by the platform.... At run time, the platform transparently handles any scaling of the dip units needed, based on the actual density of the screen in use. The conversion of dip units to screen pixels is simple: `pixels = dips * (density / 160)`. For example, on a 240 dpi screen, 1 dip would equal 1.5 physical pixels. Using dip units to define your application's UI is highly recommended, as a way of ensuring proper display of your UI on different screens.

From the Android Developers Guide,
http://developer.android.com/guide/practices/screens_support.html

While HTML and CSS do not provide for device-independence, if you expect that your project will be widely viewed on small devices, consider designing at 960 pixels to allow the device's browser the most flexibility. More, you should keep in mind that input events on small devices are different from the clicks and drags of a computer with mouse or touchpad: a **Double Tap** makes the browser zoom in and center on a document; a **Touch and Hold** will display an information bubble; a **Drag** will move the viewport or pan; a **Flick** will scroll up or down; and a **Pinch Open** or **Pinch Closed** will zoom in or out. There are no mouseOver events without a mouse.

Nibbling

A principle you must always keep in mind when designing and making multimedia elements for the Web and particularly for handheld devices should be called “nibbling.” At a serious metal-working supply store you can buy a power tool called a nibbler—it devours the edges of sheet metal in an ear-damaging staccato of rapid tiny bites. You must apply this concept, for example, to the elegant bitmapped logo you created in Photoshop when you trim it from 24- to 8- to 4-bit color depth and resize it from 96 pixels square to 64 pixels square and create a transparent .png file. Nibble the audio clip of your client's theme song from 44.1 kHz to 11 kHz, and see if it's acceptable at an 8-bit sample size. Text as HTML is cheap: nibble your page design and throw away the pretty shadowed GIF graphic headers and image maps—re-create your text in HTML headers or emphasized text, and try coloring it. Put on your protective headgear—this compromising work is painful for you as the creator—and start nibbling, while

constantly seeking a balance between quality and the patience of a user who is downloading your material at 56 Kbps from home. Every choice you make should be tempered by bandwidth worry.

WARNING *For every image file referenced in an HTML document, a separate Internet HTTP connection must be made between your computer and that image's server before the image itself is downloaded; so using many different tiny images (such as various graphic images for bullets) may not be efficient. After a user has downloaded a file once, however, it should load more quickly from the user's local hard disk, where the browser stores them in a cache.*

Text for the Web

In addition to variations in the size of the viewport, viewers of your web site may not be displaying the same “preferred” font that you used to design your page because user preferences in the browser may alter the way text in your document looks and flows. To make the best of this uncertainty, many developers design their documents in Times Roman for the proportional serifed font, Verdana for proportional sans serif, and Courier as the mono-spaced font. These fonts readily move across platforms and are the default fonts users typically see if they do not set their own preferences. Although you can specify a font, and even alternate fonts, using CSS, browsers can only use a specified font if that font is installed on the end user's computer. Figure 2-3 in Chapter 2 shows a list of the most commonly installed fonts on Windows, Macintosh, and Linux computers.

NOTE *As with projects built for CD-ROM or DVD distribution using a multimedia authoring tool, if you wish to absolutely control the look of text on your web page, you must use a graphic bitmap rather than text in your HTML document. Adding images in place of text, however, increases the amount of time necessary to download your page. Embedding graphics into HTML documents is explained later in the chapter.*

You can tag text so that it is displayed as a header, strong, emphasized, or sub- or superscripted. Using CSS, you can specify your “preference” for font face and many text attributes (see Chapter 2), but the viewer's browser ultimately determines if and how these styles are displayed.

Making Columns of Text

The most powerful feature of HTML may be found in the **<TABLE> tag**. Study this tag and its attributes! To the right, you'll see how to organize your text into two columns, so it displays more like a newspaper or a magazine, using a table (see Figure 13-1).

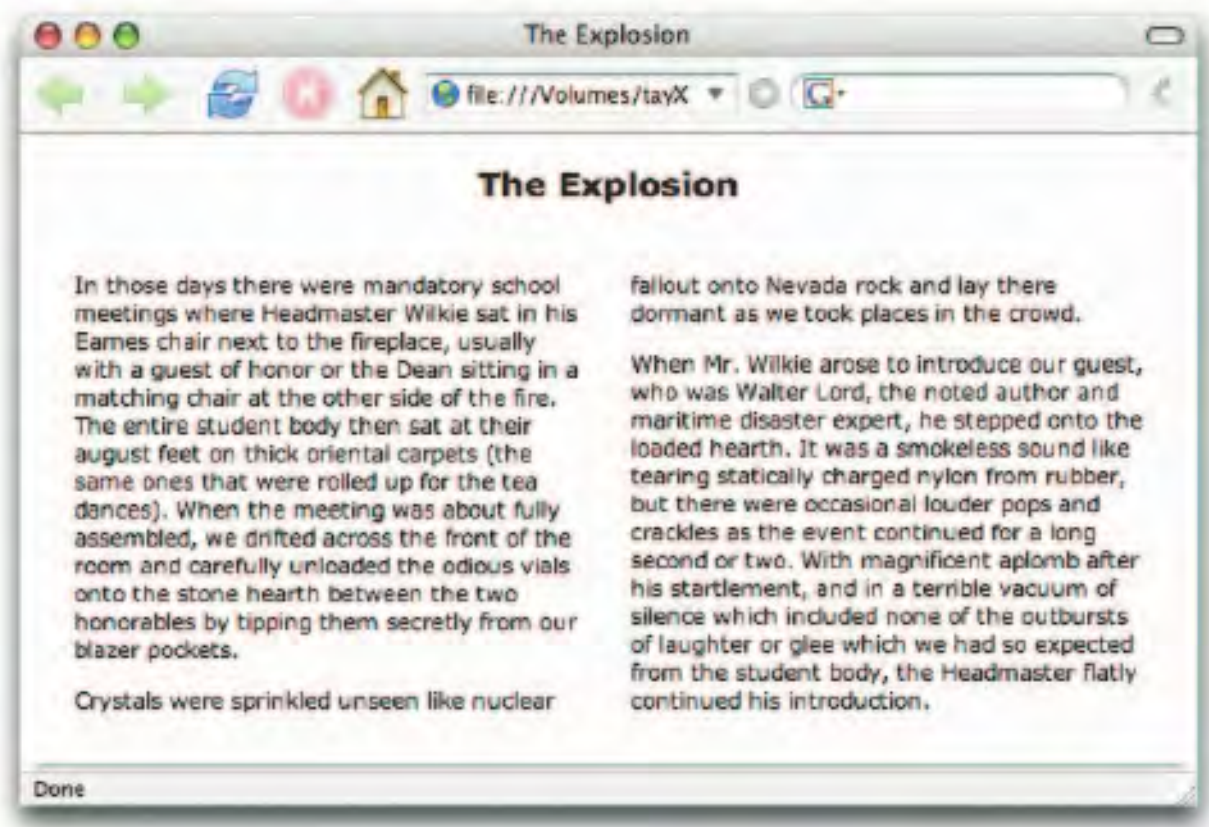

Figure 13-1 Using the <TABLE> tag, you can organize your text into columns.

```

<HTML>
<HEAD>
<TITLE>The Explosion</TITLE>
</HEAD>
<BODY>
<DIV ALIGN="center">
<H2>The Explosion</H2>
</DIV>
<TABLE BORDER="0" CELLSPACING="20">
<TR VALIGN="TOP">
<TD WIDTH="40%">
... text for Column 1 goes here ...
</TD>
<TD WIDTH="40%">
... text for Column 2 goes here ...
</TD>
</TR>
</TABLE>
<HR>
</BODY>
</HTML>

```

Flowing Text Around Images

As you can see in Figure 13-2, it is possible (and easy) to “flow” text around an image using the **ALIGN attribute** of the tag. This is a quick and simple method for mixing text and images in a pleasing layout. Add a <BR CLEAR="left"> tag at the end of your text paragraph, so that if there is not enough text to fill the entire vertical height of the image, your next paragraph will begin on a new line, left-justified, and below the image. To add space around your image so it doesn't butt right up against the text, use the Horizontal Space (**HSPACE**) and Vertical Space (**VSPACE**) attributes of the tag.



Figure 13-2 You can flow text around an image by using the ALIGN attribute of the tag.

```
<HTML>
<HEAD>
<TITLE>Sailing</TITLE>
</HEAD>
<BODY>
<IMG SRC="gbsky.gif" ALIGN="left" HSPACE="15" VSPACE="5">
<H2>Departure</H2>
... text goes here ...
<BR CLEAR="left">
<hr>
</BODY>
</HTML>
```

The following HTML and CSS code sets up a more complicated screen with flowing text (see Figure 13-3). It also includes a background image, a portrait image, and an image map that is used for navigation. (Background images and image maps are described later in this chapter.) This document also contains the foreign language special character *ä*, which is called out in the document using HTML's escape sequence for special characters, in this case, "ä". An **escape sequence** begins with an ampersand and ends with a semicolon. Also, note the link to a separate style sheet file holding the CSS code. A MIDI file is embedded in this page to provide background music.

```
<html>
<head>
<title>Annan Lapsuus</title>
<link rel="stylesheet" type="text/css" href="anna.css">
</head>
<body>
<table><tr>
<td width="20"></td> <!-- blank spacer column for indent -->
<td width="180" align="center" valign="top"> <!-- Column to hold image -->

</td>
<td width="400" align="left" valign="top"> <!-- Column to hold text and nav button -->
<h1>Annan Lapsuus</h1>
<p class="annaText">
Min&auml; sain oman huoneen. Sen sein&auml;t on maalattu vihreiksi. Ja yhdelle sein&auml;lle on
maalattu maisema. Mutta joelle ei maalattu joutsenia, koska min&auml; en halunnut. Niihin voi
kyll&auml;sty&auml;niin helposti.
<br><br>
Isi on tehnyt minulle kirjahyllyn. Min&auml; j&auml;rjest&auml;n siihen kaikki tavarat.
Kiiltokuva-albumit ja kirjan. Sen nimi on "Tiina saa suukon". Vaikka on minulla
muitakin kirjoja, mutta en min&auml; en&auml; sellaisia lastenkirjoja lue.
<br><br>
"T&auml;st&auml; l&auml;htien minun huoneeni on aina hyv&auml;ss&auml; j&auml;rjestyksess&auml;",
sanoin isille.
<br><br>

Isi hymyili.
</td></tr></table>
```



Figure 13-3 Images, text, and sound can be mixed in an HTML document. Note the use of escape sequences for special characters and an image map for navigation.

```

<!-- Use image map for click navigation -->
<map name="thispagemap">
<area shape="circle" coords="48,48,12" href="fhelp.htm">
<area shape="polygon" coords="50,50,0,0,100,0" href="fnavmap.htm">
<area shape="polygon" coords="50,50,0,100,100,100" href="f03.htm">
</map>
<!-- play MIDI file on this page -->
<EMBED SRC="03/pianobg.mid" width="0" height="2" autostart="true">
</body>
</html>

```

And the accompanying CSS code:

```

body {
    background-image: url(earth.jpg);
}
H1 {
    font-family: "Lucida Grande", "Trebuchet MS", Verdana, Helvetica, sans-serif;
    color: #FFFFFF;
    font-size : 24px;
    font-weight: bold;
}
p.annaText {
    font-family: "Lucida Grande", "Trebuchet MS", Verdana, Helvetica, sans-serif;
    color: #FFFFFF;
    font-size : 14px;
    font-weight : bold;
    line-height : 18px;
    text-align: left;
    padding-right: 20px;
}

```

Images for the Web

Theoretically, the Web can support any graphics format the client and server have in common. Practically, even though web standards do not specify a graphics format you must use, browsers recognize four image formats—GIF, PNG, JPEG, and SVG—without resorting to special plug-ins. These formats use built-in **compression algorithms** to reduce file size. (Graphic image formats are described in detail in Chapter 3.) For other graphics formats, such as CGM, CMX, DXF, and fractal- and wavelet-compressed images, special proprietary creation software and browser plug-ins may be required.

GIF and PNG Images

GIF images (Graphic Interchange File, also discussed in Chapter 3) are limited to 8 bits of color depth (256 colors). This is a commercial image format developed by CompuServe Information Services, an online

company once owned by Unisys and currently folded into America Online. In late 1994, Unisys announced a patent fee charge to all software developers who use the GIF format. In an angry, industry-wide response, **PNG** (for Portable Network Graphics Specification) was developed as a new “open” format (not requiring fees) to replace GIF. By allowing transparency by single pixel or by alpha channel mask and a 24-bit indexed palette, the PNG format is an improvement on the GIF format it was intended to replace. But it does not support animation. And because it only uses the RGB color model (not CMYK), PNG images may not print well.

First Person

A few years ago somebody told me about an interesting web survey: how does the world pronounce GIF? The results turned out about 50/50 on the hard/soft question, my colleague claimed. Then I spent considerable time using

that word (softly) in Europe before realizing everybody was being smirkingly polite about my outlandish pronunciation. In the San Francisco Bay Area, a world center for multimedia development, GIF has the soft “g” of “ginger,” “gin,” and

“gybe.” In New York, where little is soft, and in Europe, GIF has a more cutting, hard pronunciation, as in “giggling,” “gingham,” “girdled,” “guilty,” or “girls.” The real question is whether the written word requires a prefixed dot.

JPEG Images

JPEG (Joint Photographic Experts Group) images may contain 24 bits of color depth (millions of colors). JPEG uses a powerful but **lossy** compression method that produces files as much as ten times more compressed than GIF. Lossy means that information in the original image is lost in the compression process and cannot be retrieved. A **lossless** compression method does not irretrievably discard the original data.

WARNING Do not edit and reedit files that are in JPEG format. Every time you open a JPEG image and edit it, then recompress and save it as a compressed JPEG, the image degrades. After a few editing/saving cycles, you will be very disappointed. Edit and archive your images in a 24-bit lossless graphic format (such as TIFF, BMP, or PSD), then convert to JPEG (if you need to).

The JPEG compression scheme compresses about 20:1 before visible image degradation occurs. Test the amount of compression acceptable for your JPEG image; stay inside the “threshold of visible error.” To compress an image with JPEG, the image is divided into 8×8 -pixel blocks, and the resulting 64 pixels (called a “search range”) are mathematically described



Figure 13-4 Both images at the top were saved in the JPEG format, which compresses image data and trades image quality for small file size. The resulting compressed images at the bottom show the “lossy” and “blocky” nature of compressed JPEGs. The photo at top left is 71K in size when saved as a GIF (not shown) and only 27K saved as a JPEG (bottom left). The drawing at top right is 17K when saved as a GIF (not shown) and 46K as a JPEG (bottom right).

relative to the characteristic of the pixel in the upper-left corner. The binary description of this relationship requires far less than 64 pixels, so more information can be squeezed into less space. JPEG compresses slowly, about one to three seconds for a 1MB image, depending upon computer speed, but JPEG can compress images as much as 75:1, with loss.

GIF or JPEG?

Use JPEG for photo-realistic images containing many colors, and avoid using it for images already forced into a 256-color palette or for line drawings or 1-bit black-and-white images. GIF compresses drawings and cartoons that have only a few colors in them much better than JPEG, which may introduce visible defects—sharp edges and lines that blur—especially with small-size text. Figures 13-4 and 13-5 show the “blocky” and “lossy” nature of the compressed JPEG images. For the Web, use the JPEG format for photo-realistic images that are busy with color; use the GIF format for line art and drawings where there are large areas of the same color.

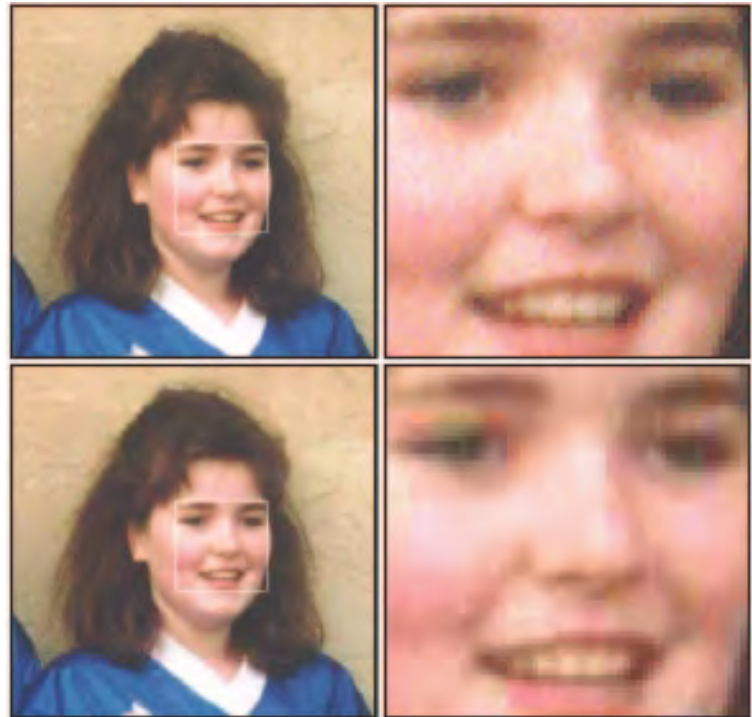

Figure 13-5 Lossy compression schemes save disk space but can also degrade an image. For the Web, line art is often better saved in GIF, PNG, or SVG format than in JPEG.

Using Photoshop

Adobe's Photoshop is the "tool of choice" for most graphic artists, so it is worth taking some time to provide a few suggestions for creating images for use on the World Wide Web. If you use a different image-editing application, follow the same logic and use the commands appropriate for that application. Always work in native Photoshop format using PSD files—these images are typically in RGB mode and use the maximum color depth. They are larger, but they contain more information that can be usefully processed when resizing and dithering, and you will get better final results. PSD files also contain layers, a very useful application feature. When creating images for display on a web page, use 72 pixels per inch resolution, which is the resolution of most monitors. When you convert a 24-bit RGB image to an 8-bit indexed image (change its mode), you lose huge amounts of color information that cannot be retrieved, meaning that the fine data is gone forever. So you should follow two practices in order to protect your original image. One is to save the original image in a 24-bit lossless image format (such as PSD, TIFF, or BMP). The other is to do all of your image manipulation (such as resizing, sharpening, and hue adjustments) in RGB mode. Next, save this source image in RGB mode as a PSD file, before reducing the color palette by saving it as a GIF or using a lossy compression like JPEG. By saving the high-quality original and saving the manipulated image in the program's native format, you can return to them if you need to make changes later.

TIP When you scan an image, the scanner will often default to print resolution of 300 dpi. When displayed on a 72 dpi resolution monitor, the picture will be displayed more than three times bigger than the original. Never fix this problem by changing the height and width attributes of the IMG tag. Even though this will display the image at the size you want, you still have a huge image file that will slow down the downloading and display of your page. Instead, use Photoshop or another image-editing program to resample the image at a 72 dpi resolution, and use that new image on your page.

When you are satisfied with your image and ready to save it as a GIF, PNG, or JPEG file, archive it as described earlier. If you make any mistakes while converting modes or saving, you will still have the original, complete with any layers you might have used. To be very safe, duplicate the original file and open the copy before saving to other formats.

Saving as JPEG Files

To save your image as a JPEG file, you do not need to change Photoshop's mode from RGB, but if you are using layers, you will need to "flatten" the image, merging all layers into a single bitmap. Once an image is flattened and you have edited or saved it, its layers cannot be remade without a great

deal of difficult cutting and pasting—so again, archive your original file! You must name your file with the extension .jpg or .jpeg if you will use it on the Web. Then click Save, and choose Maximum, High, Medium, or Low-quality compression in the dialog box that appears. Your file is ready for the Web.

Saving as GIF Files

To save a GIF file using Photoshop, you must first set the mode of your image to Indexed Color, converting it to the best 8-bit palette (256 colors) that will represent the image and be displayed well by web browsers. Note that the option of saving a Photoshop 24-bit RGB file in GIF format will not be available in Windows, and it will be grayed out on the Macintosh menu until you have converted your image to 8-bit mode: GIF is only for 8-bit images.

TIP Use GIF files for line art and images that contain large areas of the same color (that can be easily compressed). Use JPEG for photo-realistic images.

Palettes When you change the mode to Indexed Color, you must specify the color depth of the converted image, the color palette to be used, and whether the colors of your image should be dithered (Diffusion or Pattern) or not (None). Figure 13-6 shows the mode changing dialog box from Photoshop, where the custom Netscape Navigator palette for Windows has been selected.

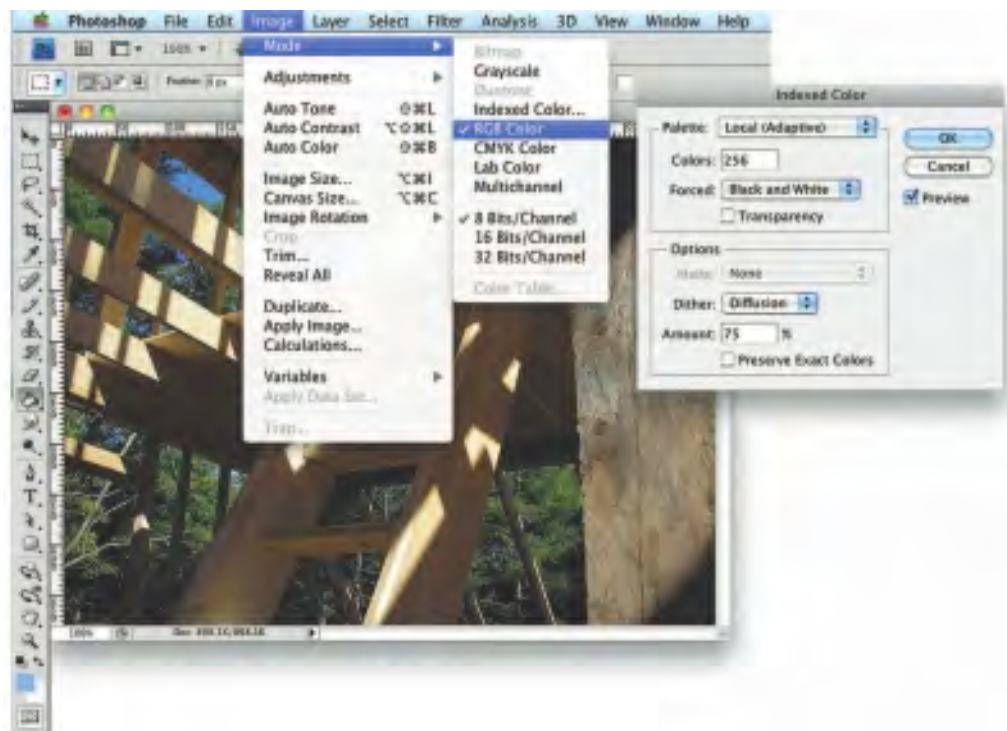

Figure 13-6

In Photoshop, changing the mode of your image from RGB Color to Indexed Color changes the color depth of your image.

Interlaced and Progressive Scans Both GIF and JPEG images can be saved so that when your browser displays the image as it is being downloaded, you can immediately see a chunky approximation of the final image, with resolution improving as more and more data comes in. While in baseline, or normal configuration, image data is stored as a single top-to-bottom scan; in **interlaced** GIF and **progressive** JPEG files, the data is organized in a different sequence within the file. An interlaced GIF file, for example, is arranged into a series of four passes:

Pass 1 : Every 8th row, starting with row 0

Pass 2 : Every 8th row, starting with row 4

Pass 3 : Every 4th row, starting with row 2

Pass 4 : Every 2nd row, starting with row 1

Figure 13-7 shows Photoshop's Save for Web & Devices dialog for saving an image as interlaced, and four increasingly resolved images.

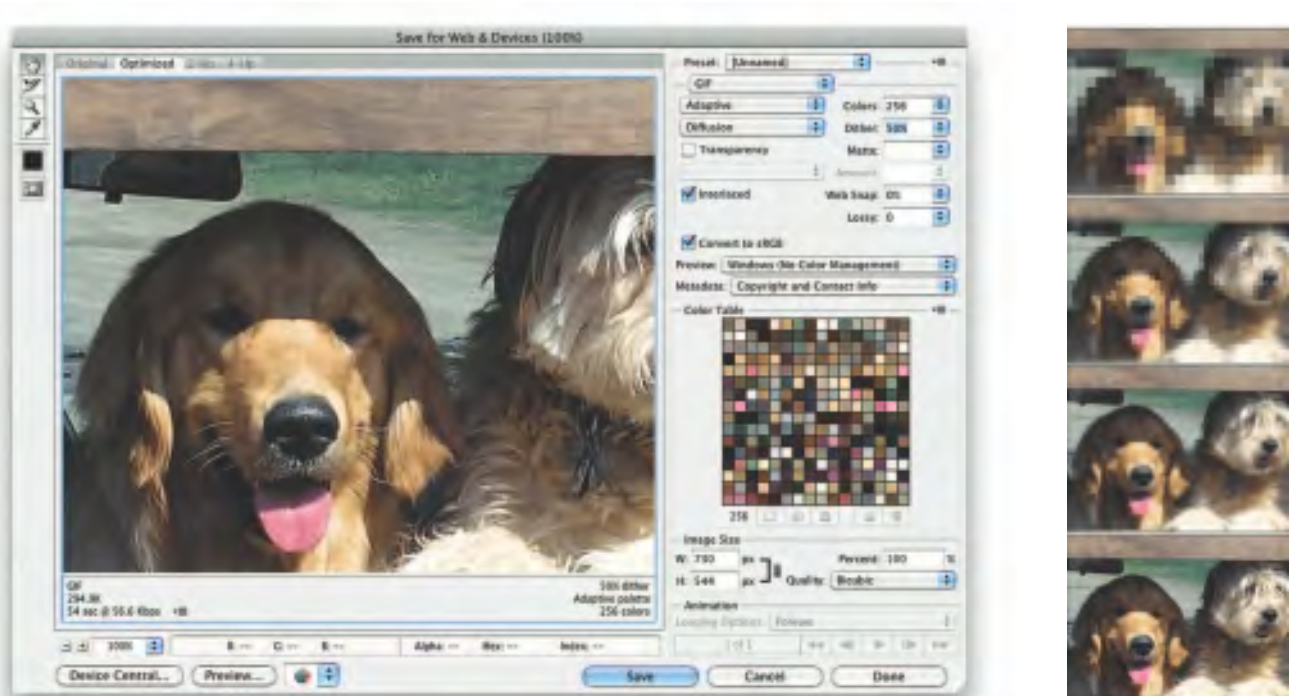

Figure 13-7 Interlacing settings when exporting a GIF89a file from Photoshop. With interlacing, the image incrementally improves its resolution as it downloads.

Transparency The GIF89a and PNG specifications allow for **transparency**: you can save your file with instructions to a browser to use a specific color or palette of colors (with PNG) as your selected

transparency color. In many cases, such as for company logos and inline illustrations, it is attractive to let an image float on top of the browser's background.

Images on web pages are displayed as rectangles. The area outside of the circle in Figure 13-8 is filled with a wash of color and would (without transparency) be displayed as a rectangle showing those colors to its edges. To make the part surrounding the circle transparent so that the circle floats on your web page, fill the area outside the circle with a single color, and then save the file, selecting that fill color to be transparent. While white is often used as the transparency color, in this example it would not work because there are white pixels inside of the circle that would also become transparent. Use a fill color not in the area you wish to show; in this case red works. Most image-editing tools provide a palette from which you can select the transparency index color. You cannot make a JPEG file transparent.

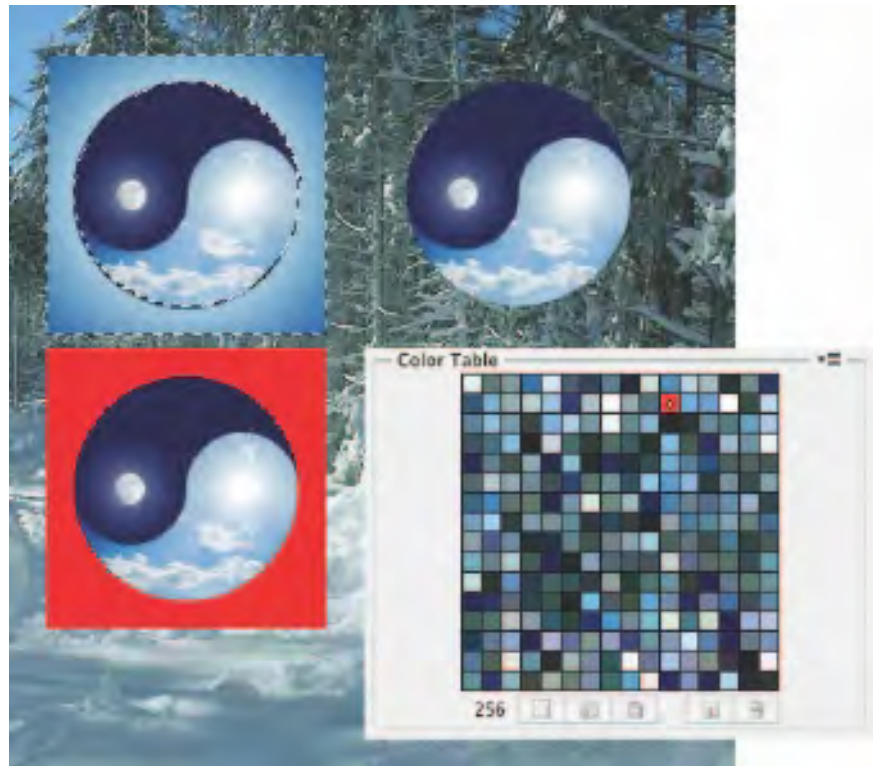

Figure 13-8 Use a transparent GIF or PNG to float a circle or other image on a web page: select the area outside of the circle (upper left), fill it with a single indexed color (red, lower left), choose that color to be transparent (lower right), and save the image as a GIF file. The circle will float on your page (upper right).

Backgrounds

Most browsers allow you to specify an image or color to place in the background of your page or into table cells. Text and images will float on top of this layer.

Background Coloring

You can choose colors for backgrounds, text, and anchors to URL links. Color controls for the entire page are attributes of the **<BODY> tag** and are set using CSS:

```
body {background-color: #0000FF;}
```

where “#0000FF” is a hexadecimal red-green-blue triplet used to specify the background color, in this case, blue. See Chapter 3 for an explanation of red-green-blue triplets.

Once you have chosen a background color, you will then want to set the color of your text and establish proper contrasts. Red on green shimmers, black on black is invisible. By setting styles in the **<BODY> tag**, you set default styles for the entire document. For white text on a blue background, the CSS code would be:

```
body {color: #FFFFFF;}
```

Background Images

Background images are by default tiled, or repeated, across and down the page until the page or page element is filled, so a randomly distributed “sandy” background image (see Figure 13-9) can easily be made from a very small source image.

Load a background image into a document by specifying its URL (if it is available somewhere on the Web) or its relative file path (if it is on the same server as the page) in the CSS attributes for the **<BODY> tag**, for example:

```
body {background-image: url('paper.gif');}
```

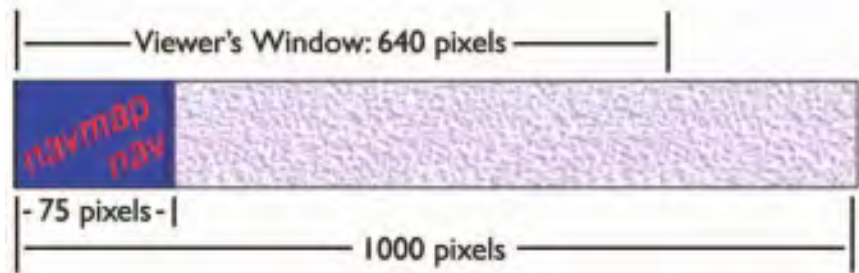

TIP It is a good idea to specify a background color similar to the prevailing color of the image being used for a background. If the user viewing your page has Image Loading turned off, or if your background image cannot be found for some reason, the page may still look close to the way you designed it. If the image you specify as a background has transparent areas, the background color will show through.



Figure 13-9 A simplified navigation map not only provides an overview of a multimedia project but also contains active links to documents using “hot” areas of the graphic. This is the navmap page from Navigare Necessse Est, a student-built love story.

Sidebars

In the navigation map shown in Figure 13-9, a commonly seen graphic layout was used: a vertical bar containing the word “navmap” is displayed at the left of the screen and in the background. When users scroll up or down, this bar remains stationary. Make the graphic bar at the left as wide as you wish (say 75 pixels); then set the full width of your image to 1,000 pixels. Fill the space to the right of your bar with plain color or a texture. When this background image repeats itself (tiles), it will repeat to the right only if the user widens the viewing window to more than 1,000 pixels; but the image will tile vertically in increments of its height until it reaches the bottom of the window. With CSS you can force the browser to repeat only vertically, only horizontally, or not at all. In this example, adding *background-repeat: repeat-y;* to your CSS code will allow repeats only vertically, even when the window is made wider than 1,000 pixels.

Clickable Buttons

To make a graphic image “clickable” so that it links to another document, simply include the image tag inside the bounding tags of an HTML anchor that points to that document’s URL:

```
<a href="documentToGoTo.html">

</a>
```

You can also use the **<A> tag** to provide a link to a larger graphic or even to a video clip from a small, thumbnail-sized image:

```
<a href="bigPicture.jpg"></a>
```

Be sure to include the **BORDER attribute** (border="0") in the **** tag if you wish to avoid showing a border around the button image (sometimes an ugly two blue pixels wide).



Client-Side Image Maps

Image maps are pictures with defined hot spots that link to other documents when a user clicks on them. Browsers support client-side image maps so that mouse coordinates and their associated document URLs can be included in an HTML document. This is managed by the **<MAP> tag** and the **USEMAP attribute** of the **** tag.

To make a client-side image map with USEMAP, you need three things: an image, a list of coordinates designating hot spots on the image, and the document URL associated with each hot spot. To program the image map into your HTML document, you use the USEMAP attribute

of the tag. Here is the HTML code for the navigation button in Figure 13-3 and detailed in Figure 13-10:

```

<MAP name="compass">
  <area shape="circle" coords="60,60,10" href="help.htm">
  <area shape="polygon" coords="60,60,0,0,120,0" href="back.htm">
  <area shape="polygon" coords="60,60,0,120,120,120" href="forward.htm">
  <area shape="polygon" coords="60,60,0,0,0,120" href="navmap.htm">
</map>
```

Compas.gif is the transparent image, the `hspace="5"` and `vspace="50"` attributes provide space between the image and the text around it, and the `border="0"` attribute makes the image borderless. The `usemap="#compass"` attribute points to the <map> extension tag that contains the coordinates and URLs. (The pound sign means the <MAP> tag is located in this same document.) A <MAP> segment may be placed anywhere in the body of the HTML document and is related to the correct image by the `name="xxxxxxx"` attribute of the <MAP> tag. You can have more than one image map in an HTML document, but they must have different names.

Within the <MAP> tag, the <AREA> tag defines the shape of the hot spot (as a circle, polygon, or rectangle) and anchors or links it to a URL. Areas are defined by x,y coordinates of the pixels in your bitmap: a circle by the x,y coordinates of its center location and radius (60,60,10), a polygon by a sequence of sets of x,y locations that close automatically (60,60,0,0,120,0 defines a triangle), or a rectangle (two x,y locations defining top left and bottom right).

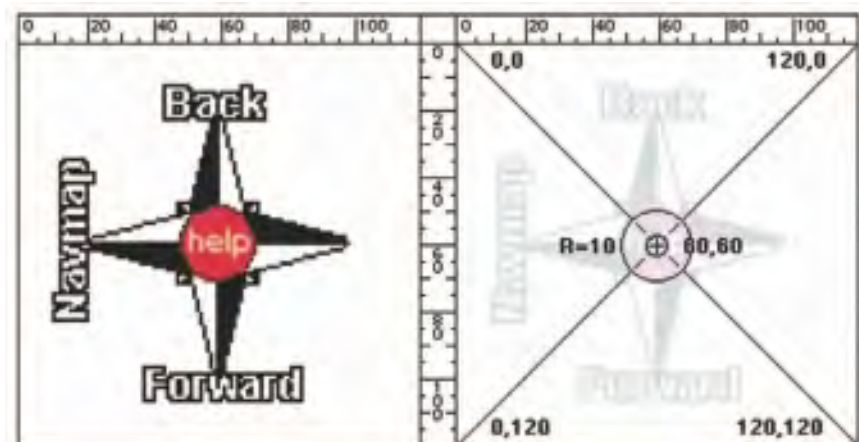

Figure 13-10 This enlarged image illustrates the coordinates used to define hot spots for image maps (the ruler is marked in pixels).

Sound for the Web

In the beginning, when the Internet was primarily a collection of Unix machines, sound files were sent from machine to machine in **AU format** and, when downloaded, were played back using a sound application. As the Web has developed, sound has become more important, and most browsers allow embedding of sounds into documents using the `<AUDIO>` tag. Inside this tag, the **autoplay** attribute, if present, starts the audio playing as soon as it is ready. If **controls** is present, a play/pause and other controls will be displayed. When **preload** is present, the audio will load when the page does and be ready to run. Text can be included in the tag that will be ignored unless the user's browser cannot understand the `<AUDIO>` tag:

```
<audio src="LizLaugh.aiff" preload autoplay controls loop>
Sorry, your browser does not support the HTML audio element.
</audio>
```

The `<A>` anchor tag and `<EMBED>` tag can also be used to play sound files:

```
Click <a href="LizLaugh.aiff">here</a> to play sound file.
<embed src="Mozart.mid" autostart="true" loop="false" width="120" height="50" hidden></embed>
```

Chapter 4 describes designing and making MIDI and digitized sound files in detail.

TIP Making sound for the Web requires the basic tools and techniques described in Chapter 4. Always nibble at your sound elements and reduce them to the lowest file sizes that will play acceptably. Remember, they will move across the Internet and may be downloaded or played on machines with low-bandwidth connections.

Animation for the Web

HTML makes no provision for animation, by itself delivering only a static page of text and graphics. Boring, many people said, and programmers went to work devising methods to liven up the view. JavaScript can dynamically change a web page without needing to reload it. JavaScript with XML features, combined into **Ajax** (Asynchronous JavaScript and XML), is used for powerful interactive applications such as Google's "Office." The Flash plug-in for browsers offers animation and interaction.

GIF89a

Browsers implement a little-known animation feature in the final 1989 revision "a" of the GIF file format specification. It is possible to make



simple animations by putting multiple images, or frames, into a single GIF89a file and display them with programmable delays (in 100ths of a second) between them.

When you use the tag to embed a GIF89a **multiframe image**, the browser downloads the file and stores it in the cache folder of your local hard disk. Once fully downloaded, the browser plays each frame of the image quickly and smoothly. Limit animated GIFs to small images, and use a more capable plug-in like Flash for animations over larger areas.

Read Chapter 5 to learn the basics of animation. Pick a tool or method and start creating. Lokki, the Shockwaved seagull, was created by a beginner and was flying in just a few hours:



Animation software includes Swish (www.swishzone.com), Flash, Director, After Effects, DHTML, and animated GIF files built using shareware and freeware. Designers must be careful how they use animation though: too much motion and too many flashy colors can cheapen a web site. Subtle animation, however, enhances a site's content and messages.

.....
<http://webstyleguide.com/wsg2/multimedia/animation.html>

http://website.needbeyond.com/templates2.html?flash_intro

www.animationtipsandtricks.com

www.compuphase.com/animtips.htm

For animation styles and tips

Video for the Web

In the past (and still today), playing video on a web page requires special plug-ins like Flash, QuickTime, RealVideo, Windows Media Player, or other proprietary software. These plug-ins use many different **codecs** (compressor/decompressors) and many different streaming and storage container file formats, each with its own interface and custom options, as shown here.



To reduce reliance on these plug-ins and offer a standard method for preparing and delivering video to the Web, the HTML5 specification provides a <VIDEO> tag, meaning that HTML5-capable browsers such as Internet Explorer

9, Firefox 3.5, Safari 4, Chrome, and Opera must contain within themselves the programming code required to recognize a video file, read and decompress both its audio and video components, and play that video on a screen—where and how you, as the designer, specify.

```
<video src="myVideo.mpg" preload autoplay controls width="320" height="240">
Sorry, your browser does not support the HTML video element.
</video>
```

There are more than 250 file formats that contain video elements (see www.fileinfo.com/filetypes/video), and there are more than 25 codecs from which to choose. And there are many methods and options to capture, compress, edit, store, and distribute video. Introduction of the HTML5 `<VIDEO>` tag is a push in the direction of a standardized few technologies and methodologies that will work for most everyone on the Internet.

The most commonly used codecs are H.264, Theora, and VP8 within MP4, Ogg, and WebM containers. Unfortunately, no one of these will necessarily play in every HTML5-compliant browser. To guarantee playability by all browsers, you may need to encode four separate versions of your video file, including a Flash .flv format as a fallback, and program your HTML `<VIDEO>` tag with all four. The browser will play the first file in the list that it can:

```
<video width="160" height="120" controls autoplay>
<source src="myVideo.mp4" type='video/mp4; codecs="avc1.42E01E, mp4a.40.2"'>
<source src="myVideo.webm" type='video/webm; codecs="vp8, vorbis"'>
<source src="myVideo.ogv" type='video/ogg; codecs="theora, vorbis"'>
<object type="application/x-shockwave-flash" width="160" height="120" wmode="transparent"
data="flvplayer.swf?file=myVideo.flv">
  <param name="movie" value="flvplayer.swf?file=myVideo.flv" />
  <param name="wmode" value="transparent" />
</object>
</video>
```

For more about making and editing video files, codecs, and distribution methods, see Chapter 6.

Plug-ins and Players

Prior to Adobe's acquisition, when Macromedia introduced Shockwave to allow the animation and interactivity of its flagship tool Director to be embedded into pages viewed, real animation and programmable power became available to web page developers. Later, they added Flash to their animation armory, which also uses Shockwave to create an .swf (Shockwave Flash) version of the native .fla file in order to make it displayable on a web page. **Players** and **plug-ins** became available for other multimedia tools with animation capabilities (for example, RunRev), and the

view came alive as long as the person viewing your page had installed the necessary plug-in on his or her machine. The QuickTime movie format includes the ability to create Virtual Reality (VR) files, also displayed on a web page via a player. Flash and proprietary viewers can be used to present panoramas. Figure 13-11 shows a real estate sales panorama—when you drag the mouse across this player’s window, the scene tracks and rotates in a 360-degree panorama. You can see adjacent rooms, too, by panning the image in a circle.

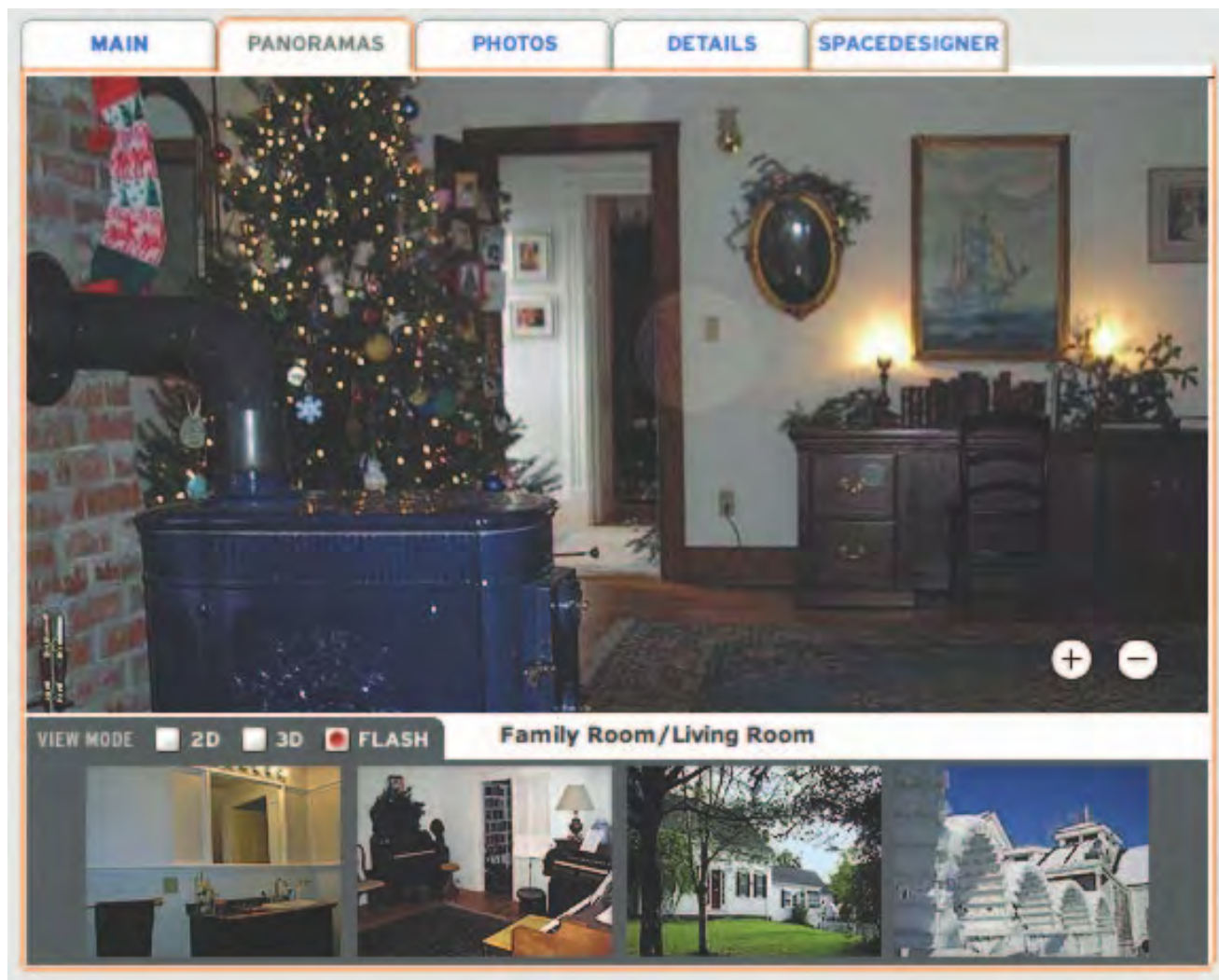

Figure 13-11 Useful multimedia tools can enhance commercial web sites.

Chapter 13 Review

■ Chapter Summary

For your review, here's a summary of the important concepts discussed in this chapter.

Employ the basic methods for displaying elements of multimedia on a web page, including using HTML, CSS, and nibbling

- The World Wide Web was designed as a simple method for delivering text and graphics.
- HTML provides tags for inserting media into HTML documents.
- Use the tag for inline images, the <AUDIO>, <VIDEO>, <OBJECT>, and <EMBED> tags for multimedia objects.
- Specify a font, and even alternates for it, using Cascading Style Sheets (CSS), but remember: browsers can only use fonts already on their computer.
- Use Cascading Style Sheets (CSS) to set text styles across the pages of your web site.
- Use a graphic bitmap if you wish to absolutely control the look of text in your HTML document.
- A viewport 960 pixels wide may be the most flexible choice.
- The overriding principle in designing web pages is to “nibble” away at the content in order to keep the size of the data as small as possible.

Manipulate the appearance of text on the Web

- Choose your fonts carefully: viewers may not have your special fonts installed on their computers.
- Use HTML tables to create columns of text.
- Flow text around images using the ALIGN attribute.

Determine which graphics formats are best suited for different types of images and how they can be manipulated

- Image formats, GIF, PNG, and JPEG, use built-in compression algorithms to reduce file size.
- GIF images are limited to 8 bits of color depth, or a palette of 256 colors while JPEG and PNG images may contain 24 bits of color depth.

- Use GIF files for line art and images that contain large areas of the same color. Use JPEG for photo-realistic images.
- The GIF89a specification allows for a selected transparency color. You cannot make a JPEG file transparent.
- JPEG and PNG use a powerful but lossy compression method that produces files as much as ten times more compressed than GIF.
- Most browsers allow you to specify an image or color to place in the background of your page in the <BODY> tag. Text and images will float on top of this layer.
- CSS is used to control the color of text in a document.
- Background images are automatically tiled, or repeated, across and down the page unless told not to using CSS.
- Placing an image inside an HTML anchor tag makes the graphic image clickable.
- Image maps are pictures with defined hot spots that link to other documents when a user clicks on them.

Play audio on a web page by embedding the sound within the site

- Audio play is provided by the <AUDIO> tag.
- Always nibble at your sound elements and reduce them to the lowest file sizes that will play acceptably.

Include animation on a web page

- Limit animated GIFs to small images, and use a more capable plug-in for animations over larger areas.
- Flash provides animation on the Web.

Include video on a web page with and without the use of plug-ins

- Play video using the <VIDEO> tag.

■ Key Terms

<A> tag (411)

Ajax (413)

ALIGN attribute (400)

<AUDIO> tag (395)

AU format (413)

autoplay (413)

<BODY> tag (409)

BORDER attribute (411)

Cascading Style Sheets (CSS) (392)

chrome (396)

codec (414)

compression algorithm (402)

controls (413)

density-independent pixels (DIPs) (397)

deprecated (393)

Double Tap (397)

Drag (397)

<EMBED> tag (395)

escape sequence (401)

Flick (397)

GIF (402)

HSPACE attribute (400)

HTML5 (393)

** tag** (395)

interlaced (407)

JPEG (403)

lossless (403)

lossy (403)

<MAP> tag (411)

multiframe image (414)

Object/Embed method (395)

<OBJECT> tag (395)

Pinch Open/Pinch Closed (397)

player (415)

plug-in (415)

PNG (403)

preload (413)

progressive (407)

<TABLE> tag (398)

Touch and Hold (397)

transparency (407)

USEMAP attribute (411)

<VIDEO> tag (395)

viewport (396)

VSPACE attribute (400)

■ Key Term Quiz

1. The tag used for inline images is the _____.
2. The attribute used to start a video playing when the page loads is _____.
3. An image that loads with increasing detail is _____.
4. Special characters on a web page may be shown using a(n) _____.
5. Tags no longer included in the most current version of the HTML standard but still recognized by browsers have been _____.
6. Perhaps the most powerful feature of HTML may be found in the _____ tag.
7. A(n) _____ is used to compress and decompress video files.
8. A new “open” format that was developed to replace GIF without requiring licensing fees is the _____ format.
9. The tag that defines hot spots on an image and the links associated with the hot spots is the _____ tag.
10. A graphic file format that allows for both transparency and animation is _____.

■ Multiple-Choice Quiz

1. The World Wide Web was originally designed to deliver:
 - a. high-quality multimedia
 - b. text documents with embedded graphics
 - c. data in many formats, including file transfers, chat, and e-mail
 - d. streaming media formats
 - e. top-secret military information
2. The VGA standard of a 640 × 480-pixel monitor showing 256 colors is:
 - a. the highest resolution and color depth currently available
 - b. the standard used by most browsers
 - c. still used by a small number of users
 - d. not used by a significant number of users
 - e. no longer considered a viable standard
3. Which of these is the *only* way to ensure that text appears exactly the same across platforms?
 - a. Create a bitmap image of the text.
 - b. Link to the font at a web site.
 - c. Include the font as a download on the server.
 - d. Specify the font using Cascading Style Sheets.
 - e. Embed the font into the HTML code itself.
4. One of the most important tags, useful for creating columns of information, is:
 - a. <BODY>
 - b. <BACKGROUND>
 - c. <EMBED>
 - d. <HEAD>
 - e. <TABLE>
5. Which of these statements about the GIF image specification is *false*?
 - a. It can be used to embed animations.
 - b. It can only include 256 colors.
 - c. It is best used for drawings and cartoons that have only a few colors in them.
 - d. It can be saved in an interlaced mode.
 - e. It was developed by Microsoft in 1982.
6. The tag that sets text attributes for an entire web page is:
 - a. <BODY>
 - b. <BACKGROUND>
 - c. <EMBED>
 - d. <HEAD>
 - e. <TABLE>
7. Which of these is *not* an attribute of the <VIDEO> tag?
 - a. Controls
 - b. Autoplay
 - c. Height
 - d. Preload
 - e. Background Color
8. You link a graphic image to another document or image by including the image tag inside which tag?
 - a. <A>
 - b. <URL>
 - c. <LINK>
 - d. <CLICK>
 - e. <GOTO>
9. What can the PNG image format *not* do?
 - a. Provide interlacing
 - b. Be transparent in some places
 - c. Show millions of colors
 - d. Be displayed by browsers
 - e. Include advertising animations
10. Which of these is *not* an image format supported by most browsers?
 - a. GIF
 - b. JPEG
 - c. PNG
 - d. DXF
 - e. All are supported by most browsers.
11. When you change an image's mode to Indexed Color, which of these is *not* a specification to be selected?
 - a. the color depth of the converted image
 - b. the compression level to be used
 - c. the color palette to be used
 - d. whether the colors of your image should be dithered or not
 - e. All of the above must be selected.

12. What is the most colors that can fit into a GIF palette?
 - a. 16
 - b. 40
 - c. 216
 - d. 254
 - e. 256
 - f. 512
13. When a background image is smaller than the viewport, by default the browser will:
 - a. simply ignore the background
 - b. display the background in the upper-left corner with the background color filling the rest of the window
 - c. tile the background image to fill the window
 - d. stretch the background image to fill the window
 - e. crash
14. The <AREA> tag within a <MAP> tag defines the shape of a hot spot as a:
 - a. circle
 - b. polygon
 - c. rectangle
 - d. All of the above
 - e. None of the above
15. When a browser downloads a file it cannot process itself, it can forward the file to an external application for processing. This external application is sometimes called a:
 - a. plug-in
 - b. helper application
 - c. CGI script
 - d. JavaScript
 - e. Java applet

■ Essay Quiz

1. How is the World Wide Web used today? How do you use it? What types of sites do you visit? How has it changed in your personal experience?
2. Bandwidth limitations impose serious limitations on presenting multimedia over the Web. What tools and strategies does a multimedia developer have to deal with the limitations of bandwidth?
3. HTML was never designed to include multimedia. What are the original design limitations of HTML? How has it been stretched to accommodate other media? How has the browser architecture been adapted to allow other media? What tools and strategies does a multimedia developer have to deal with these limitations?
4. List and describe the most important tags for multimedia in HTML.
5. What are the most common graphics file formats in use on the Web today? Discuss what each is best suited for, its limitations, and its capabilities.

Lab Projects

■ Project 13.1

Select three different web pages, each from a different site and with differing layouts. Print out the web pages. Examine them carefully.

Draw lines on the printout where you think the various cells of the tables were used to construct the pages.

■ Project 13.2

Again select three different web pages, each from a different site and with differing layouts. All browsers include the ability to view the source code of the web page. View the HTML source, and then print it out. Identify head, image, anchor, body, and table tags in the page by circling them.

(If you have access to a visual web page editor, import the source from the three pages in Lab Project 13.1 and note how the tables are laid out.)

■ Project 13.3

Select three different sites that present audio and three sites that present video, virtual reality, or animation. What data formats are used for the multimedia? Are different data rates offered? What plug-ins are required? Make a note of the URLs, media formats, data rates, and required plug-ins or helper applications.

■ Project 13.4

Again select three different web pages, each from a different site and with differing layouts. Reduce the size of the browser window. Does the layout contract past a certain point? Now widen the browser window. Does the layout expand beyond a certain point? Make notes of your findings, including the site's URL.

■ Project 13.5

Locate a site that uses Cascading Style Sheets. This may be visible in the HTML code itself within `<style>` tags, or else they may be referenced externally in a `<LINK>` tag. As in Project 13.4, print out the style sheet if it is linked. Circle any fonts, colors, sizes, and other style information.

■ Project 13.6

Take a digital photograph of yourself. Determine the coordinates for a circle around your right eye and a polygon around your nose. Create a `<MAP>` tag with shape attributes and using HTML code place the image onto a web page so that when you click on your right eye the browser sends you to www.facebook.com; when you click on your nose, you are sent to www.recipes.com.

Delivering

In this chapter, you will learn how to:

- List the steps a project should go through as part of the testing process, and describe their significance
- Determine what steps you need to take for preparing your project for delivery in the marketplace
- Discuss CD-ROM technology and standards as they apply to multimedia
- Discuss DVD standards and capacities as they apply to multimedia
- Determine the type of packaging needed for different multimedia projects
- Assess the technical considerations of project delivery on the World Wide Web

TEST it—and then test it again; that’s the unavoidable rule. You must test and review your project or web site to ensure that it is bug free, accurate, operationally and visually on target, and ready to meet the client’s requirements, even if that client is you.

Do this before the work is finalized and released for public or client consumption. A bad reputation earned by premature product release can destroy an otherwise excellent piece of work representing thousands of hours of effort. If you need to, delay the release of the work to be sure that it is as good as possible. It’s critical that you take the time to thoroughly exercise your project and fix both big and little problems; in the end, you will save yourself a great deal of agony!

One of the major difficulties you face in testing the operation of your multimedia project is that its performance may depend on specific hardware and system configurations and, in the case of the Internet, on end users’ connection speeds. If you cannot control the end user’s platform, or if the project is designed to be shown in many different environments, you must fully test your project on as many platforms as possible, including heavily loaded, complicated systems.

TIP Remember to budget for obtaining the hardware test platforms, as well as for the many hours of effort that testing will require. If you are working for a client, clearly specify the intended delivery platform as well as its hardware and software configuration, and provide a clause in your agreement or contract that you will test only to that platform.

Few computer configurations are identical. Even identical hardware configurations may be running dissimilar software that can interact with your program in unexpected ways. Because any element of a computer’s configuration may be the cause of a problem or a bug, you will spend a good portion of testing time configuring platforms, and additional time reproducing reported problems and curing them. It is not possible for even a well-equipped developer to test every possible configuration of computer, software, and third-party add-ons. Services are available to test your project for a fee. Such companies, for example uTest (www.utest.com), will run your project through its paces and try to identify all the bugs and problems they can wring out of it.

WARNING *Not everyone can test software. It takes a special personality to slog through this process. Every feature and function must be exercised, every button clicked. Then the same tests must be repeated again and again with different hardware and under various conditions.*

Testing

The terms alpha and beta are used by software developers to describe levels of product development when testing is done and feedback is sought. **Alpha releases** are typically for internal circulation only and are passed among a select group of mock users—often just the team working on the project. These versions of a product are often the first working drafts of your project, and you can expect them to have problems or to be incomplete. **Beta releases**, on the other hand, are sent to a wider but still select audience with the same caveat: this software may contain errors, bugs, and unknown alligators that slither out of the swamp at day's end to bite startled designers from behind. Because your product is now being shown and used outside the privacy of its birth nest, its reputation will begin to take form during beta phase. Thankfully though, beta-level bugs are typically less virulent than alpha bugs.

TIP *If your project is a web site, there are a number of online tools that will validate your code, and indicate where you need to make tweaks or repairs. Do a search for "HTML validation" or "CSS validation" tools.*

Alpha Testing

You should remain flexible and amenable to changes in both the design and the behavior of your project as you review the comments of your alpha testers. Beware of alpha testing groups made up of kindly friends who can provide positive criticism. Rather, you need to include aggressive people who will attack all aspects of your work. The meaner and nastier they are, the more likely they will sweat out errors or uncertainties in your product's design or navigation system. In the testing arena, learn to skillfully utilize friend and enemy alike. You will undoubtedly discover aspects of your work that, despite even the most insightful planning, you have overlooked.

Beta Testing

The beta testing group should be representative of real users and should not include persons who have been involved in the project's production. Beta testers must have no preconceived ideas. You want them to provide

From a letter with enclosed software, delivered by overnight courier to 240 testers around the world:

We had a bit of a scare on this Beta. Here is the replacement copy for the infected B5 program. For your info, the virus that got past me was a strain of nVir. It was dormant and fooled Virus Detective, Virex, and Interferon. Virex 1.1 listed it as a harmless "Stub" that was left over from a previous cleanup. It wasn't until late yesterday that we discovered that it was real. I must apologize for letting this slip past me and thank the people in our tech support department for their help in calling all the members of the Beta test team and alerting them to this problem. If they didn't get hold of you, it was certainly not for lack of trying.

Ben Calica, letter author and a product manager who claims this product shortened his life span by two years

commentary and reports in exchange for getting to play with the latest software and for recognition as part of this “inside” process.

Managing beta test feedback is critical. If you ignore or overlook testers’ comments, the testing effort is a waste. Ask your beta testers to include a detailed description of the hardware and software configuration at the time the problem occurred, and a step-by-step recounting of the problem, so that you can recreate it, analyze it, and repair it. You should also solicit general comments and suggestions. Figure 14-1 presents the search page from a web-based bug reporting system that is database driven and capable of managing thousands of reports about a complicated application in a meaningful way. (Apache is the most widely used HTTP daemon for serving web pages.)

The screenshot shows the ASP Bugzilla web interface. The browser address bar displays the URL: [https://www.apache.org/bugzilla/enter_bug.cgi?product=Apache httpd-2](https://www.apache.org/bugzilla/enter_bug.cgi?product=Apache+httpd-2). The page title is "ASP Bugzilla - enter Bug: Apache httpd-2". The navigation bar includes links for Home, Search, My Bugs, Find, Reports, My Votes, Preferences, Help, and Log out. A message at the top reads: "Before reporting a bug, please read the [bug writing guidelines](#), please look at the list of [most recently reported bugs](#), and please [search](#) for the bug." Below this is a "Show Advanced Fields" link. The form contains the following fields: Product (Apache httpd-2), Reporter (tay@timestream.com), Component (a dropdown menu with options: All, Build, Core, Documentation, Event MPM, mod_access, mod_auth), Version (a dropdown menu with options: 2.2.32, 2.2.33, 2.2.34, 2.2.35, 2.2-HWO), Severity (normal), Hardware (PC), and OS (Mac OS X 10.6). A message below the OS field says: "We've made a guess at your operating system and platform. Please check them and make any corrections if necessary." The Description field is highlighted with a red border and contains the text: "Do not provide patches or code fixes (see above for more)". Below the Description field are buttons for "Add an attachment" and "Cancel". The footer contains the text: "This is ASP Bugzilla: the Apache Software Foundation bug system. In case of problems with the functioning of ASP Bugzilla, please contact bugzilla-admin@apache.org. Please Note: this e-mail address is only for reporting problems with ASP Bugzilla. Mail about any other subject will be silently ignored." and navigation links: Home, Search, My Bugs, Find, Reports, My Votes, Preferences, Help, Log out, tay@timestream.com.

Figure 14-1

This page from a web-based bug reporting system seeks precise and reproducible descriptions of problems. In testing complex applications, thousands of bug reports may be received, and a dedicated quality control team may be tasked to deal with them.

TIP Look for testers from a broad range of users, novice to expert. You’ve been through the program hundreds of times, and you know what’s supposed to happen. A new or novice user may get stuck in a place where you thought all is clearly obvious.

Polishing to Gold

As you move through alpha and beta testing, and then through the debugging process toward a final release, you may want to use terms that indicate the current version status of your project. For example, **bronze** when you are close to being finished, gold when you have determined there is nothing left to change or correct and are ready to reproduce copies from your **golden master**. Some software developers also use the term **release candidate** (with a version number) as they continue to refine the product and approach a golden master. Going gold, or announcing that the job is finished, and then shipping, can be a scary thing. Indeed, if you examine the file creation time and date for many software programs, you will discover that many went gold at two o'clock in the morning.

Preparing for Delivery

If your completed multimedia project will be delivered to consumers or to a client who will install the project on many computers, you will need to prepare your files so they can be easily transferred from your media to the user's platform. Simply copying a project's files to the user's hard disk is often not enough for proper installation; frequently, you will also need to install special system and run-time files.

So that end users can easily and automatically set up your project or application on their own computers, you may need to provide a single program that acts as an **installer**.

WARNING *The task of writing a proper installation routine is not a trivial one. Be sure you set aside adequate time in your schedule and money in your programming budget for writing and testing the installation program for your project platforms.*

It is important to provide well-written documentation about the installation process so that users have a clear step-by-step procedure to follow. That documentation must include a discussion of potential problems and constraints related to the full range of your target platforms. Because you likely will not have control over the specification and configuration of the user's platform, it is critical that you include appropriate warnings in your installation document, like these examples:

- Must have at least 1GB of RAM
- Will not run unless QuickTime is installed
- 3MB available disk drive space
- Disable all screen savers before running
- Back up older versions before installing this update

First Person

We beat on the bronze version of the program right up to the last day, when we had to send a golden master to the duplicator by overnight courier. They were prepared to make 40,000 discs in a matter of hours and then hand-carry them directly to a trade show.

Like kids with sticks at a piñata birthday party, we did everything we could to make all the bugs tumble out of the program. Every time a bug appeared, we killed it. As we pounded and tested, fewer and fewer bugs fell out, until none appeared for about six hours straight, under every condition we could dream up. As the deadline for the courier's airport facility neared,

we were ready to apply the finishing touches to the product and stamp it gold. One of the guys waited in his car with engine running, ready for the sprint through commuter traffic to the airport.

We were saving the program every three minutes and nervously backing it up on different media about every ten minutes. We had built in a hidden software routine for debugging this project, and when the product manager clicked Save for the last time, he forgot to reset the program for normal use—we didn't know the master was flawed. Handling the disc like a uranium fuel rod traveling through heavy water, we packed it up and got it to

the waiting car. An hour later, our postpartum celebration was interrupted by a painful cry from down the hall—someone had discovered the flaw. By then the courier flight had departed.

We fixed it. Faced with the appalling possibility of 40,000 bad discs being invoiced to us instead of the client, we sent the exhausted product manager out on the midnight flight, without a chance even to go home and clean up. He had a golden master disc in his briefcase, one in his shirt pocket, one in his pants pocket, and one in a manila envelope that would never see an airport X-ray machine.

Often a file named **README.TXT** or **Read.Me** is a useful thing to include on the distribution disc of your project. This file can be a simple ASCII text file accessible by any text editor or word processing application. It should contain a description of changes or bugs reported since the documentation was printed and may also contain a detailed description of the installation process.

If your project will be deployed on the Web, provide special directions in a FAQ or Help page, where you can describe required plug-ins and browser compatibility and other issues. You can often do much dynamically using JavaScript “sniffer” routines to alert users when their browser is not compatible, and you can even serve a different version of your project tailored to that user's system or browser.

The clearer and more detailed your installation instructions are, the fewer frustrated queries you will receive from your project's users. If your project is designed for wide distribution, installation problems can cause you many headaches and a great deal of time and expense in providing answers and service over the telephone. Set up a product-related web site with pages for software registration, bug reporting, technical support, and program upgrades.

.....

From: Christopher Yavelow <Christopher@yav.com>

Subject: The case of the keyboardless kiosk

About ten days ago I posted an announcement to the list about our interactive kiosk installation at the new Netherlands Museum of Science and Technology.

Now I've discovered that science museums at this level are the target of bands of teenage hackers that try to crash all the exhibits. Our exhibit fell prey to such a band last Friday.

Although the software is running inside of a kiosk built into a larger "The Music is the Message" exhibit housing AND the museum visitor has only a trackball and single push button to operate the exhibit AND there is **no** way to quit the software without issuing a command-Q from a keyboard which is double-locked inside the guts of the exhibit housing, some kids were able to get back to the desktop and delete the 60 MB of files associated with the exhibit... and they did so in such a way that Norton Utils (3.5) could not find them for un-erasing (I had to bring over a CD-ROM version and re-install the entire exhibit).

How did they do it? Is there a way to get back to the desktop in such a scenario: a (for all practical purposes) keyboardless kiosk with only a trackball and single button interface and no on-screen option to quit the application? There are no menus, the menubar is hidden, there are no quit buttons, AllowInterrupts is set to false, etc., etc.

Christopher Yavelow
YAV Interactive Media
Brederodestraat 47
2042 BB Zandvoort
The Netherlands
eMail: Christopher@yav.com
wSite: <http://www.yav.com>

Scary message found at an Internet newsgroup for multimedia programmers

.....

File Archives

One or more of the files in your project can be compressed or "packed" into a single file, called an **archive**. When that archive is then decompressed, or the files are expanded or extracted, each file in the archive is "reconstituted." Figure 14-2 shows the menu of a zipped archive. Archives are

usually identified by filename **extensions** representing the compression software that was used, as shown in Table 14-1.

| Compression Software | Extension | Platform |
|----------------------|-----------|----------------|
| 7-Zip, WinZip | .zip | Windows |
| ARC | .arc | Windows |
| RAR | .rar | Windows |
| Windows Install | .cab | Windows |
| Macintosh Install | .dmg | Macintosh |
| Stuffit | .sit | Macintosh |
| Self-extracting | .exe | Windows |
| BinHex | .hqx | Internet |
| Tar | .tar | Internet, Unix |
| Gzip | .gz | Internet, Unix |

Table 14-1 Common Filename Extensions for Compressed File Archives



Figure 14-2
A file archive can contain many compressed files.

Self-extracting archives are useful for delivering projects in compressed form. On the Mac, these files typically carry the filename extension .sea. On Windows platforms, these archives are executable files with an .exe filename extender. With self-extracting archives, the user simply runs the executable archive, and the compressed files are automatically decompressed and placed into a folder on the hard disk.

TIP Keep a copy of your project archive off-site in case of fire or flood.

First Person

I recently discovered a group of computer scientists and programmers fully dedicated to exploring and improving the techniques and algorithms used for compression of digital data. These folks are from around the world and hang out on bulletin boards, where they have lengthy and arcane electronic conversations. Programmers and mathematicians such as Huffman,

Lempel, and Ziv have been made famous on these services.

The greatest contribution this group has made to computer technology may not be in the area of information condensation, but in the creative spin-off of peculiar new words such as freshen, pack, crunch, squash, shrink, crush, implode, distill, squeeze, stuff, and garble.

When you throw a few atoms and best guesses into this potpourri of words, the language of data compression joins that of modern physics, with its own quarks, gluons, and happy and sad particles. It's a creative and inventive place in the day-to-day forward motion of human endeavor, this place of strange and beautiful compression algorithms.

Delivering on CD-ROM

Many multimedia projects are delivered on CD-ROM or DVD. While the very first users of CD-ROMs were owners of large databases like library catalogs, reference systems, and parts lists, today most computers are shipped with a CD/DVD drive, and software that is not downloaded from the Internet is typically packaged on a disc.

Compact Disc Technology

A compact disc, or CD, is a thin wafer of clear polycarbonate plastic and metal measuring 4.75 inches (120 mm) in diameter, with a small hole, or hub, in its center. The metal layer is usually pure aluminum, sputtered onto the polycarbonate surface in a thickness measurable in molecules. As the disc spins in the CD player, the metal reflects light from a tiny infrared laser into a light-sensitive receiver diode. These reflections are transformed into an electrical signal and then further converted to meaningful bits and bytes for use in digital equipment.

Pits on the CD, where the information is stored, are 1 to 3 microns long, about 1/2 micron wide, and 1/10 micron deep. (By comparison, a human hair is about 18 microns in diameter.) A CD can contain as many as three miles of these tiny pits wound in a spiral pattern from the hub to the edge. A layer of lacquer is applied to protect the surface, and

artwork from the disc's author or publisher is usually silk-screened on the back side.

Compact discs are made in what is generally referred to as a **family process**. The glass master is made using the well-developed, photolithographic techniques created by the microchip industry: First an optically ground glass disc is coated with a layer of photo-resistant material 1/10 micron thick. A laser then exposes (writes) a pattern of pits onto the surface of the chemical layer of material. The disc is developed (the exposed areas are washed away) and is silvered, resulting in the actual pit structure of the finished master disc. The master is then electroplated with layers of nickel one molecule thick, one layer at a time, until the desired thickness is reached. The nickel layer is separated from the glass disc and forms a metal negative, or **father**.

In cases where low runs of just a few discs are required, the father is used to make the actual discs. Most projects, though, require several **mothers**, or positives, to be made by plating the surface of the father.

In a third plating stage, **sons**, or **stampers**, are made from the mother, and these are the parts that are used in the injection molding machines. Plastic pellets are heated and injected into the mold or stamper, forming the disc with the pits in it. The plastic disc is coated with a thin aluminum layer for reflectance and lacquer for protection, given a silk-screened label for marketing, and packaged for delivery. Most of these activities occur in a particle-free clean room, because one speck of dust larger than a pit can ruin many hours of work. The mastering process alone takes around 12 hours.

CD-R

CD-R (compact disc-recordable) is an excellent method for distributing multimedia projects. CD-R writers and blank CD-R discs are inexpensive, and for short runs of a product, it is more cost effective to **burn** your work onto CD-Rs and custom-label them with your own printer than to have the discs mastered and **pressed** using the expensive father and son method described previously. Many services with auto-loading equipment and 24-hour turnarounds can make short runs.

CD-R blanks that can hold as much as 84 minutes of Red Book sound (see the next section) or more than 700MB of data are made of a polycarbonate core coated with layers of reflective metals and special photosensitive organic dyes (see Figure 14-3). During the burning process, laser light hits the layer of dye, bakes it, and forms a pit. A 74-minute CD-R disc contains 333,000 sectors * 2048 bytes / sector for a capacity of 650.4MB. An 80-minute disc contains 360,000 sectors * 2048 bytes / sector for a data capacity of 703.1MB.

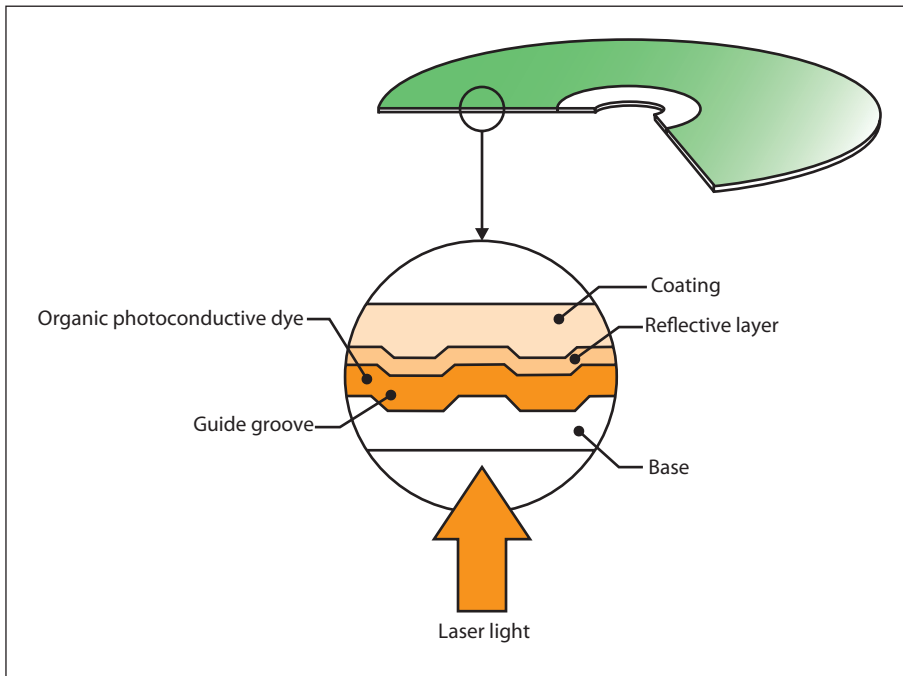

Figure 14-3

As a CD or DVD disc spins, laser light is beamed along a groove or track of lands (high points) and pits (low points). The difference in reflected light as the beam passes over these tiny spots is interpreted as binary data.

Compact Disc Standards

In 1979, Philips and Sony together launched CD technology as a digital method of delivering sound and music (audio) to consumers. This collaboration resulted in the **Red Book standard** (named for the color of the document's jacket), officially called the **Compact Disc Digital Audio Standard**. The Red Book standard defines the audio format for CDs available in music stores today; later, the Yellow Book covered CD-ROM; the Green Book covered **CD-I (Interactive)**; the Orange Book covered write-once, read-only (WORM) CD-ROMs; and the **White Book** covered **Video CD (Karaoke CD)**.

The Red Book

Red Book remains the basis for standards that define more elaborate digital data formats for computers and other digital devices. Audio CDs can provide up to 80 minutes of playing time, which is enough for a slow-tempo rendition of Beethoven's Ninth Symphony. This was reported to be Philips and Sony's actual criterion during research and development for determining the size of sectors and ultimately the physical size of the CD itself.

A CD may contain one or more **tracks**. These are areas normally allocated for storing a single song in the Red Book format. CDs also

contain lead-in information and a table of contents. Each track on the CD may use a different format; this allows you to create a mixed-mode disc that combines, for example, high-quality CD-Audio with Macintosh **Hierarchical File System (HFS)** CD-ROM or ISO 9660 data formats. Figure 14-4 illustrates the track layouts for Red Book, Yellow Book, Green Book, mixed mode, and for Kodak's **PhotoCD** Orange Book layout. Both Macintosh and Windows support commands to access both Red Book Audio and the data tracks on a CD, but you cannot access both at the same time.

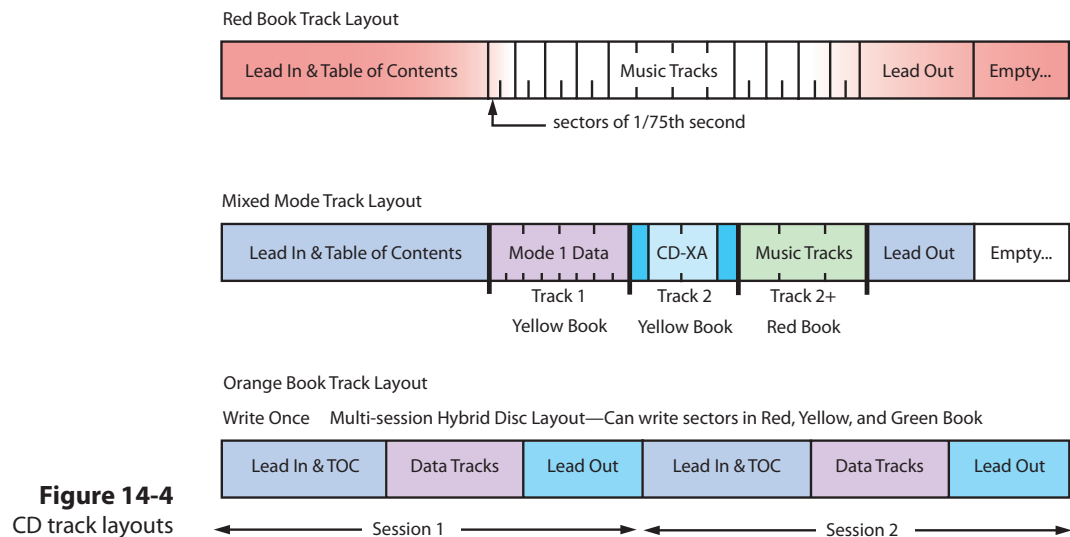

Though a CD contains tracks, the primary logical unit for data storage on a CD is a **sector**, which is 1/75 second in length. Each sector of a CD contains 2,352 bytes of data. After every sector are another 882 bytes consisting of two layers of error-detecting and error-correcting information (EDC and ECC) and timing control data. A CD actually requires, then, 3,234 bytes to store 2,352 bytes of data. EDC and ECC allow a scratched or dirty data sector to be reconstructed by software fast enough to avoid dropout of music. Timing codes are used to display song-playing time on an audio CD player.

TIP Because there is built-in error correction on CDs, small scratches may not affect playback, particularly when the scratch runs in a straight line from center to edge. To really wreck a CD, scratch it in an easy arc from the center to the rim; error correction won't keep up.

The disc spins at a constant linear velocity (CLV), so data can be read at a constant density and spacing. This means the rotational speed of the disc may vary from about 200 rpm when the read head is at the outer edge, to 530 rpm when it is reading near the hub. This translates to about 1.3 meters (51 inches) of travel along the data track each second. CD players use very sensitive motors so that no matter where the read head is on the disc, approximately the same amount of data is read in each second.

The CD's rotational speed and the density of the pits and lands on the CD allow data to be read at a sustained rate of 150 Kbps in a single-speed reader. This is sufficient for good audio, but it is very slow for large image files, motion video, and other multimedia resources, especially when compared to the high data-transfer rates of hard disk drives. New drives that spin many times faster when reading computer data, and slower for Red Book Audio, have been designed specifically for computers. In any case, CD access speed and transfer rate from CD-ROM is much slower than from a hard disk.

The Yellow, Green, Orange, and White Books

Philips and Sony developed the **Yellow Book** to provide an established standard for data storage and retrieval. The Yellow Book adds yet another layer of error checking to accommodate the greater reliability required of computer data, and it provides two modes: one for computer data and the other for compressed audio and video/picture data.

The most common standard currently used for CD-ROM production evolved from the Yellow Book, with Microsoft joining the collaboration, and it was approved by the International Standards Organization as **ISO 9660**.

WARNING *It is possible to damage your speakers if you play the digital track of a CD-ROM on your audio CD player. The digital data is decoded as full-volume noise by players that do not check for a data flag in the control field of the Q subchannel.*

Later, other standards were developed to deal with specific user requirements, such as synchronized interleaving of compressed audio and visual data in interactive digital movies (**Green Book**), and with formats for **write-once, read-only (WORM)** and magneto-optical CD technologies (**Orange Book**). A CD-R can have several separate images or **sessions** on it, each recorded at different times.

The Red, Yellow, Green, and Orange books describe the types of compact discs listed in Table 14-2.

| Name | Description | Comment |
|------------------------|-----------------------|--|
| CD-Audio or CD-DA | Digital audio | Consumer audio discs |
| CD-ROM High Sierra | Read-only memory | Vestigial standard, seldom used |
| CD-ROM ISO 9660 | Read-only memory | MS-DOS and Macintosh files |
| CD-ROM HFS | Read-only memory | Macintosh HFS files |
| CD-ROM/XA | Read-only memory | Extended Architecture |
| CD-I or CD-RTOS | Interactive | Philips Interactive motion video |
| CD-I Ready | Interactive/Ready | Audio CD with features for CD-I player |
| CD-Bridge | Bridge | Allows XA track to play on CD-I player |
| CD-MO | Magneto-optical | Premastered area readable on any CD player |
| CD-WO or CD-R | Write-once recordable | May use multiple sessions to fill disc |
| CD+G | Mixed mode | CD+Graphics—MTV on disc |
| CDTV | ISO 9660 variant | Commodore proprietary system |
| PhotoCD | Compressed images | Kodak multisession XA system |
| Video CD or Karaoke CD | Bridge | Karaoke full-motion MPEG video |

Table 14-2 Compact Disc Formats

Many multimedia developers place both Macintosh files and PC files on the same CD in a **hybrid format**, letting the user launch the proper applications for the appropriate platform. You can selectively hide the files of either platform when you create a hybrid so that Windows users will not be confused by odd-looking Macintosh files in their directories, and vice versa. Graphics, text, and data files written in common formats such as DOC, TIF, PIC, DBF, and WKS can be read from an ISO 9660 CD and imported into your application, whether the file was generated on a Macintosh or a PC.

Delivering on DVD

Digital Versatile Discs (DVDs) employ a different (multilayer, high-density) manufacturing process than audio and data CDs, and this technology provides as much as 15.9GB of storage on a single disc in the Double Sided, Dual-Layered format (DVD-18). More common and readily available are Single-Sided, Single-Layered discs offering 4.37GB of storage (DVD-5), often called “4.7GB Media.”

In December 1995, nine major electronics companies (Toshiba, Matsushita, Sony, Philips, Time Warner, Pioneer, JVC, Hitachi, and Mitsubishi Electric) agreed to promote a new optical disc technology for distribution of multimedia and feature-length movies called DVD.

With this medium capable not only of gigabyte storage capacity but also full-motion video (MPEG2) and high-quality audio in surround sound, the bar was raised for multimedia developers: commercial multimedia projects become more expensive to produce as consumers' performance expectations rise.

Is DVD+R/+RW a real DVD format?

DVD+R/+RW recorders are the only DVD recorders that use just one operating mode, which always creates DVD-Video compatible discs. Whereas other formats have different physical disc types or different logical formats (methods used to record video on a disc) to offer the user a flexible recording experience, DVD+R/+RW offers the user flexibility and a rich feature set, without sacrificing compatibility. With DVD+R/+RW, there is no need to buy expensive dedicated players to allow playback of recorded discs, as the recordings can be played on the majority of the 100s of millions of DVD-Video players and DVD-ROM drives available today. Furthermore, also on a physical level DVD+RW and DVD+R are closer to the DVD format than competing formats, as they do not need special "pre-pits" on the disc that could affect compatibility. All in all, DVD+R/+RW is the most real recordable DVD format around.

.....
From a DVD+RW Alliance FAQ

Is +RW a DVD Format?

+RW is not the DVD Format created and authorized by the DVD Forum. Likewise, although strikingly similar in appearance to the DVD-RW, there is no DVD Format called DVD+RW or +RW among the Formats created and authorized by the DVD Forum. There is No Verification Process for +RW or DVD+RW products authorized by the DVD Forum. There is No Verification Laboratory authorized by the DVD Forum to test +RW or DVD+RW products. There are No Test Specifications for +RW or DVD+RW products authorized by the DVD Forum and available at DVD FLLC. Also, there is no guarantee for compatibility between the products employing the DVD Forum-approved Formats and the products employing the +RW or DVD+RW technology.

.....
From a DVD Format/Logo Licensing Corporation FAQ

DVD Standards

Different formats are used to write DVD-video discs and DVD data storage discs. DVD-video discs use a variant of MPEG2 and were designed for set-top boxes connected to televisions. DVD-video is authored by mastering software that allows rudimentary scripting and branching for menu structures, chapter markers, and slide shows, but the format only allows for basic logic (and relies on a simple handheld remote control input device).

Using a DVD disc as a storage medium, you can create a complex multimedia title using any authoring or programming system, and distribute it on a DVD-ROM disc. Most computers can read or play both DVD-ROM and DVD-video discs. Set-top DVD players are limited to playing DVD-video.

There are three competing sets of standards for data recording on DVD: DVD-R/DVD-RW, DVD+R/DVD+RW, and DVD-RAM. The “R” and “RW” stand for recordable and rewritable respectively. DVD standards are supported by the DVD Forum (www.dvdforum.com). DVD+ standards are supported by the DVD+RW Alliance (www.dvdrw.com). DVD-RAM has better recording features but requires more specialized playback hardware. DVD-R/DVD-RW and DVD+R/DVD+RW are similar and can be played back on most DVD players and drives.

With Dolby AC-3 Digital Surround Sound as part of the DVD specifications, six discrete audio channels can be programmed for digital surround sound, and with a separate subwoofer channel, developers can program the low-frequency doom and gloom music popular with Hollywood. DVD also supports Dolby Pro-Logic Surround Sound, standard stereo, and mono audio. Users can randomly access any section of the disc and use the slow-motion and freeze-frame features during movies. Audio tracks can be programmed for as many as 8 different languages, with graphic subtitles in 32 languages. Some manufacturers such as Toshiba are providing parental control features in their players.

True to marketing principles, DVD manufacturers express DVD capacities in billion byte quantities where “billion” or “Giga” means the vernacular $1000 \times 1000 \times 1000$, not the more precise binary definition of $1024 \times 1024 \times 1024$ bytes used by your computer. This makes the advertised capacity of a DVD disc sound about seven percent bigger than it really is; you will not be able to record more than 4.37GB onto a blank disc!

Wrapping It Up

Packaging is an important area where sales and marketing issues extend the process of making multimedia into the real world of end users. Like the cover of a book, people will judge your work based upon the impression it makes.

If your project is for your own use, you may not need the pretty cover, cardboard box, and shrink-wrap that is required for over-the-counter software sold to consumers. If your project is for a client or for the Web, you may simply need to deliver it on any sufficient storage media or upload it to a server. But if your project is headed for wider distribution within a large company or organization or into retail channels, you will need to think about packaging.

If your project is destined to be sold into the consumer retail channel, then you have made a **title**. Software titles are most often distributed on CD-ROM or DVD. The software itself may, indeed, be only one item (the most important one) in a package that includes a user's manual, a registration card, quick reference guides, hardware adapters, and collateral marketing material from you or other parties with whom you have arrangements.

Retailers claim that consumers typically relate the finish of a package to quality and price of the product inside. The fancier, bigger, and heavier the package is, the higher its perceived value. Software manufacturers juggle the elements of this equation when they determine the cost of goods and shipping/freight add-ons and set the product's price point. Many big software boxes are shipped with plenty of sailboat fuel inside, and with cardboard or open-cell foam to hold the thin disc and manuals in place. In fact, the manuals may not be printed, but included on the distribution disc as .PDF files.

The art for your cover should reflect the content and function of the enclosed product; it should also follow normal rules for good design layout. Your company's logo should be prominent, and if this is one of a series of titles, the artwork should conform to the coordinated look or style you are using throughout that series or product line.

When your product reaches the retail channel, it may be displayed on shelves or racks, in kiosks, or it may be hung on brackets. You should be sure to put the name of your title on the front face and on the spine of the package. Use photo-quality images and high-caliber artwork for the front, because this is the most visible face of your package. Many packages are shrink-wrapped with thin plastic to protect them from fingerprints and pilferage at the retail outlet. Even after the shrink-wrap is on your package, there is room for additional artwork: bright stickers can be effective eye-catchers. And some vendors apply specially made holographic stickers to identify their product and to prevent unauthorized bootleg copies from reaching the marketplace.

Some vendors have developed unique or special solutions to make their product stand out. Authorware, for example, was once shipped in a custom-designed briefcase with carry handle. An expensive software package, this briefcase was easily absorbed in the purchase price. Fractal Design



Figure 14-5 Some software comes in interesting packages.

A few years ago I taught a student of mine about HTML, just before she went off to a summer internship working on a traditional book publisher's web site. She returned to school three months later and demonstrated to me how one might use the Web to generate profits—at a time when many doubted it was easy to do. Working for the publisher, she was assigned the job of marketing a book for college students. She did her research and discovered how advertising in the search engines works: by “buying” the word “college” on a few of them, she was able to place an ad on search results that were related to colleges; visitors who clicked on her ad were linked to the publisher's web site, where they could purchase the book online. While explaining the process, she checked the online sales of her book: over 5,000 copies had been sold online within a month of publication—eight of them during the last hour!

Panagiotis Takis Metaxas,
Associate Professor of Computer Science,
Wellesley College

Painter was at one time shipped in a metal paint can with a colorful paper wrapper, and Eye Candy special effects for After Effects came in a metal movie reel case (see Figure 14-5). But package size and shape options are, more often than not, limited by the common constraints of the floor and shelf space found in retailing outlets and by the expense of fabricating a nonstandard container.

Most industrial cities boast more than one packaging specialist with whom you can consult. These outfits can supply cardboard and plastic boxes, printing, cutting, folding, and wrapping services. Environmentally responsible packaging, especially for compact discs, is popular, and special sleeves and cardboard containers are available. Be sure to consider the weight and bulk of your package—an ounce of extra weight that pushes you over a zone or destination boundary might increase your shipping costs significantly. The outside wrap for shipping should be plain because pilferage, especially for international destinations and customs zones, can be a problem. Look for volume discounts and price breaks.

The current trend in software packaging is toward simplification. Indeed, as the information revolution takes hold, more software and documentation will be available for purchase and downloading directly from the Web, and today's boxes and bright packages will become quaint collector's items.

Delivering on the World Wide Web

Delivering multimedia projects built for the World Wide Web can be as simple as renaming a directory or transferring a group of files to a web server. Servers and networked systems are discussed in Chapter 7. On the face of it, the mechanics of actually putting a project on the Web are trivial, particularly because you have likely been designing, building, and testing within “web space” throughout the development of your project, anyway. But delivery of your project and **activation** of your pages by making them available to your intended audience on the Web, whether to the general public or to an intranet of select users behind a firewall, should be approached with caution. Here there are many technical considerations

that, while outside the topic of multimedia per se, should be understood if you want your project to be a success.

If you own or host the delivery web server yourself, you will have better security control, better integration of your project into your internal LAN or intranet, and you can fine-tune the server's configuration parameters and specify and install any special software you need. On the other hand, you will likely need a full-time webmaster, and you will pay for a high-bandwidth connection directly to the Internet. When you have control of the server, you can provide secure commerce services for credit card transactions, encryption and passwords, special databases, and custom CGI programming. For multimedia projects requiring streaming technologies such as RealAudio or video conferencing, you can purchase and install the necessary software on the server.

If your project will reside at a site hosted by an Internet service provider (ISP) or on a company's own internal intranet, you must discover during the planning phase of your project what the host's limitations might be and design your project within those limitations. It does no good to include PhotoCD image pacs, ToolVox meta voice files, or complex Java scripts in your web pages, only to find that your ISP does not or will not support the MIME-type or purchase and install the necessary server software for you.

Internet directories like Yahoo, and search engines like Google, are important components of the Web's "how-to-find-it" functionality and power: using meta tags, be sure your project will register with the search engines and can be easily found.

TIP *The following are informative URLs for web site promotion and search engine submission:*

www.allaboutyourownwebsite.com/web_site_promotion.php3

www.insideoutmarketing.com/index.php?p=pages&pid=4

Chapter 14 Review

■ Chapter Summary

For your review, here's a summary of the important concepts discussed in this chapter.

List the steps a project should go through as part of the testing process, and describe their significance

- Alpha releases are typically circulated among a select group of mock internal users for testing.
- Beta releases are sent to a wider but still select audience with the understanding that the software may contain errors or bugs.
- Beta testers should include a detailed description of the hardware and software configuration and a step-by-step recounting of the problem so that you can re-create it.
- Fully test your project on as many platforms as possible, including heavily loaded, highly expanded systems. Any element of a computer's configuration may be the cause of a problem or a bug, so plan to spend lots of time configuring and testing various platforms and reproducing and fixing bugs.
- Budget for obtaining the hardware test platforms, as well as for the many hours of effort that testing will require.
- Your contract should clearly specify the intended delivery platform and its hardware and software configuration, and provide a clause that you will test only to that platform.

Determine what steps you need to take for preparing your project for delivery in the marketplace

- You may need to provide a single program that acts as an installation routine, which is not a trivial task.
- Provide well-written documentation about the installation process so that users have a clear step-by-step procedure to follow.

- The clearer and more detailed your installation instructions are, the fewer frustrated users' queries you will receive.
- Use a shareware or commercial compression utility for creating program archives that can then be decompressed and "reconstituted" into the original file structure.
- Self-extracting files allow the user to run the executable archive; compressed files are automatically decompressed and placed on the hard disk.

Discuss CD-ROM technology and standards as they apply to multimedia

- The majority of multimedia products sold into retail and business channels are delivered on CD-ROM or DVD.
- CD-R writers and blank CD-R discs are an inexpensive way to distribute multimedia projects.
- For short runs of a product, it is cheaper to burn your work onto CD-Rs and custom-label them with your own printer.
- The Red Book standard defines the CD audio format; Yellow Book is for CD-ROM; Green Book is for CD-I (Interactive); Orange Book is for write-once, read-only (WORM) CD-ROMs; and White Book is for Video CD (Karaoke CD).
- A single-speed reader allows data to be read at a sustained rate of 150 Kbps, much slower than from a hard disk.
- Although you can access all files on the CD from either platform, a PC executable program will not run on a Macintosh, and vice versa.
- A hybrid format places both Macintosh files and PC files on the same CD, with both PC and Macintosh executable programs.

- The ISO 9660 standard is the most widely used digital data file format for CDs.
- ISO 9660 follows the MS-DOS file-naming conventions—directory names are limited to eight characters, and directories may not be nested more than eight deep.

Discuss DVD standards and capacities as they apply to multimedia

- Digital Versatile Discs (DVDs) are made with a multilayer, high-density manufacturing process that provides 4.7 gigabytes of storage.
- Set-top DVD players for movie viewing at home do not play data-formatted DVDs.

Determine the type of packaging needed for different multimedia projects

- Packaging is an important consideration in marketing your project. Although users often equate quality with large boxes, high-caliber artwork, and fancy packaging, the current trend in software packaging is toward simplification.

Assess the technical considerations of project delivery on the World Wide Web

- Delivering multimedia projects built for the World Wide Web can be as simple as renaming a directory or transferring a group of files to a web server. On the other hand, hosting your own server for delivering your project means tackling a variety of issues, including security, server-side configuration, and access.

■ Key Terms

activation (438)

alpha release (423)

archive (427)

beta release (423)

bronze (425)

burn (430)

CD-I (Interactive) (431)

CD-ROM/XA (Extended Architecture) (434)

Compact Disc Digital Audio Standard (431)

Digital Versatile Disc (DVD) (434)

extension (428)

family process (430)

father (430)

golden master (425)

Green Book (433)

Hierarchical File System (HFS) (432)

hybrid format (434)

installer (425)

ISO 9660 (433)

Karaoke CD (431)

mother (430)

Orange Book (433)

PhotoCD (432)

pressed (430)

README.TXT, Read.Me (426)

Red Book standard (431)

release candidate (425)

sector (432)

self-extracting archive (428)

session (433)

son, stamper (430)

title (437)

track (431)

Video CD (431)

White Book (431)

write-once, read-only (WORM) (433)

Yellow Book (433)

■ Key Term Quiz

1. The test release of a product that is typically for internal circulation only and is passed among a select group of mock users is the _____.
2. The test release of a product that is sent to a select group of external users with the understanding that the software may contain errors and bugs is the _____.
3. The final release of a product when there is nothing left to change or correct and it is ready to be reproduced is the _____.
4. The test release of a product with a version number as the developers continue to refine the product and approach a final version is called a(n) _____.
5. A program that saves all necessary run-time files to the user's hard drive is called a(n) _____.
6. Many projects include a plain-text file containing a description of changes or bugs reported since the documentation was printed and a detailed description of the installation process. This file is often named _____.
7. When several files are compressed into a single file, it is usually called a(n) _____.
8. Compressed files can be saved with the ability to automatically decompress themselves and place the files on the built-in hard disk. Such files are called _____.
9. A CD-ROM that contains both Macintosh files and PC files on the same CD is a(n) _____.
10. A CD-R can have several separate images on it, each recorded at different times. Each of these is called a(n) _____.

■ Multiple-Choice Quiz

1. When delivering a project, you should:
 - a. not bother testing; it'll probably work
 - b. test once on your development computer
 - c. test on a couple of other computers
 - d. test on several other computers at least once
 - e. test on as many different computers as many times as you can
2. The pre-OS X Macintosh environment is well known for its sensitivity to certain drivers and other parts of system software that conflict with some software applications. These are known as:
 - a. DLLs
 - b. plug-ins
 - c. sectors
 - d. extensions
 - e. headers
3. The files used by Windows to store configuration information and settings is called the:
 - a. settings file
 - b. parameters list
 - c. registry database
 - d. profile typesheet
 - e. system configuration file
4. The beta testing group is best composed of:
 - a. the internal development team
 - b. users typical of the target group for the software
 - c. a cross-section of the computer-using public
 - d. computer neophytes
 - e. other programmers who are familiar with the authoring system used

5. Which of the following is an extension for a Macintosh file compressed as a self-extracting archive?
 - a. .exe
 - b. .hqx
 - c. .zip
 - d. .sea
 - e. .sit
6. Which of the following is *not* an option for delivering a project?
 - a. Burn CD-Rs of the project.
 - b. Use a father disc to press CDs.
 - c. Use a mother disc to press CDs.
 - d. Use a son disc to press CDs.
 - e. Deliver the project via the Web.
7. Compact discs are manufactured by etching a negative master, then pressing a positive imprint of that master, and then using a third-generation negative imprint from the positive to stamp out production discs. This process is called the:
 - a. etching process
 - b. stamper process
 - c. milling process
 - d. positive-negative process
 - e. family process
8. Each sector of a CD contains 2,352 bytes of data. After every sector are another 882 bytes used for:
 - a. copyright information
 - b. encryption key storage
 - c. file directory indexing and linking
 - d. writing additional information
 - e. error detection and correction
9. What is the maximum amount of data that a CD-R (compact disc-recordable) can hold?
 - a. 44MB
 - b. 128MB
 - c. 256MB
 - d. 700MB
 - e. 4.7GB
10. The Compact Disc Digital Audio Standard used for consumer audio CDs available in music stores today is also known as the:
 - a. ISO 9660 standard
 - b. Red Book standard
 - c. Orange Book standard
 - d. High Sierra standard
 - e. CD-ROM/XA standard
11. The most widely used format for storing digital data in files on CDs is the:
 - a. ISO 9660 standard
 - b. Yellow Book standard
 - c. White Book standard
 - d. CD-ROM/XA standard
 - e. DVD-ROM standard
12. The compact disc standard that allows both computer data and compressed audio data and video/image information to be read and played back, apparently simultaneously, is called the:
 - a. Red Book standard
 - b. Yellow Book standard
 - c. Green Book standard
 - d. DVD-ROM standard
 - e. CD-ROM/XA standard
13. The CD-I (Interactive) standard is proprietary to:
 - a. Apple
 - b. High Sierra
 - c. JVC
 - d. Kodak
 - e. Philips
14. CD-ROM packages are shrink-wrapped with thin plastic:
 - a. to prevent outgassing of harmful chemicals used in the manufacturing process
 - b. to inhibit oxidation of the CD-ROM surface
 - c. to protect them from fingerprints and pilferage at the retail outlet
 - d. to reduce unauthorized bootleg copies
 - e. for a more professional look
15. Which of the following is *not* a benefit of hosting your own web server for product delivery site on the Web?
 - a. ability to specify and install any special software you need
 - b. better security control
 - c. ability to fine-tune the server's configuration parameters
 - d. easy access to technical support
 - e. ability to provide secure commerce services

■ Essay Quiz

1. List the testing stages involved in preparing a project for delivery. What type of testers should be part of each stage's testing team?
2. List the benefits and capabilities of file compression and archiving software.
3. Describe the two methods of copying CD-ROMs, and discuss the benefits and drawbacks of each method.
4. Cite the two primary methods for delivering a project, and discuss the benefits and drawbacks of each method.
5. List the various DVD formats and summarize their purposes and capabilities.

Lab Projects

■ Project 14.1

Visit the web sites of three CD duplication companies. Do they all offer both duplication (mastering) and replication (burning CD-Rs)? What quantities are available? What options for labeling are available? What options for packaging are included? Document your findings by creating a table that briefly compares prices and options.

■ Project 14.2

Create a form that beta testers can return after testing, and be sure to include information regarding the conditions surrounding bugs.

■ Project 14.3

Use a shareware or freeware compression utility to compress five files—for example, a text file, a JPEG image, an executable file (an application). What percentage compression can you achieve? Repeat the compression, saving the files as self-extracting archives. Document your findings by creating a table that compares original size, compressed, and size compressed as self-extracting file.

■ Project 14.4

Locate five computer systems and compare their configurations. Document your findings by creating a table with the following information:

- What operating system and version is installed?
- What is the processor and what is its speed?
- How much RAM is installed?
- How much hard-drive space is available?

- Is QuickTime installed?
- What is the CD-ROM drive's speed?
- What is the video card/monitor's resolution and color depth?
- What are the system's sound capabilities?

■ **Project 14.5**

Locate five CD-ROMs, DVDs, or downloaded programs that include “readme” files. Read each of the files, and observe what each one includes. Document your findings by summarizing the contents of each one.

About the CD-ROM

THE CD-ROM included with this book comes complete with MasterExam, trial versions of six different software tools, a digital sampler of seven multimedia-related McGraw-Hill titles, and the electronic version of the book. The MasterExam software is easy to install on any Windows 2000/XP/Vista/7 computer and must be installed to access the MasterExam features. The software trial versions must each be installed individually. You may, however, browse the digital sampler and electronic book directly from the CD without installation.

System Requirements

The digital sampler and electronic book require Adobe Reader. The MasterExam software requires Windows 2000 or higher and Internet Explorer 6.0 or above and 20 MB of hard disk space for full installation.

NOTE *All of the questions included in MasterExam are also included in PDF format as part of the electronic book.*

Each software trial version has different system requirements and many of these trials are available in different versions compatible with different operating systems. The CD includes many, but not all, of the available versions.

To download the versions not included on the CD, please visit the software vendors' respective web sites:

- For the Macintosh-compatible version of Exposure 3, please visit www.alienskin.com/downloads.
- For the Macintosh or Linux-compatible versions of LiveCode 4.5, please visit www.runrev.com/downloads.
- For the Macintosh-compatible version of Vectorworks Architect, please visit www.nemetschek.net/architect/index.php.

BBEdit 9.5 System Requirements

- Macintosh OS X 10.5 or later
- Universal application

Easy Gif Animator 5.1 System Requirements

- Windows 2000, 2003, XP, Vista, 7

Exposure 3 Host and System Requirements

Host Requirements

- Adobe Photoshop CS3 or later
- Adobe Lightroom 2 or later
- Adobe Photoshop Elements 7 or later
- Corel Paint Shop Pro Photo X3

System Requirements

- 1024 × 768 or greater monitor resolution
- Intel Pentium 4 processor (or compatible)
- Windows XP SP3 or later

iClone4 EX System and Additional Requirements

System Requirements

Minimum System Requirements

- Pentium4 2GHz
- 1GB RAM
- 2GB free hard disk space
- Display Resolution: 1024 × 768
- Color Depth: True Color (32-bit)
- Graphics Card: Support for DirectX 9.0c and Shader Model 3.0
- Video Memory: 256MB RAM

Recommended System Requirements

- Dual core CPU or higher
- 2GB RAM or higher recommended

- 2GB free hard disk space or higher recommended
- Display Resolution: 1024 × 768 or higher
- Graphics Card: NVIDIA GeForce 8 Series or higher / ATI HD 3000 Series or higher
- Video Memory: 512MB RAM or higher recommended
- Video card compatible with Pixel Shader 3.0 recommended for optimized visual performance

Operating System Requirements

- Windows XP (with Service Pack 2 or later), Vista, 7
- Support for 32-bit and 64-bit operating system

Additional Requirements

- Sound card
- Keyboard
- Speaker
- 3-button mouse
- DirectX 9 and WMEncoder 9 are required for WMV exporting
- Internet connection required for online activation

LiveCode 4.5 Supports

- Windows 2000 SP4
- Windows XP SP2 and above
- Windows Server 2003
- Windows Vista SP1 and above (both 32-bit and 64-bit)
- Windows 7 (both 32-bit and 64-bit)
- Windows Server 2008

Vectorworks Architect System Requirements

- Minimum of 2GB RAM
- Pentium 2 GHz or better processor
- Typically 4GB Windows XP SP3, Vista SP2, Windows 7

Installing and Running CD Software and Features

If your computer is running Windows and your CD-ROM drive is configured to autorun, the CD-ROM will automatically start up upon inserting the disk. If not, browse to the CD and click the LaunchTraining.exe icon. Macintosh users can browse the electronic book files, digital sampler files, and software trial versions from CD's root folder.

MasterExam

From the opening screen, Windows users may install MasterExam by clicking the MasterExam link. This will begin the installation process and create a program group named LearnKey. To run MasterExam, use Start | All Programs | LearnKey | MasterExam.

MasterExam provides you with additional chapter review questions in an electronic exam environment. You have the option to take an open book exam including references and answers, a closed book exam, or the timed MasterExam.

When you launch MasterExam, a digital clock display will appear in the bottom right-hand corner of your screen. The clock will continue to count down to zero unless you choose to end the exam before the time expires.

Trial Software

From the opening screen, Windows users can access the software trial versions by clicking the Trial Software link.

BBEdit 9.5

To install BBEEdit 9.5, click the Download EBBEdit 9.5 link. This will open a folder that contains the BBEEdit_9.5.1_Demo.dmg file. Save this file to your computer. Open the file and follow the instructions to install the demo.

Easy Gif Animator 5.1

To install Easy Gif Animator 5.1, click the Download Easy Gif Animator 5.1 link. This will open a folder that contains the egifan5.exe file. Save this file to your computer. Open the file and follow the instructions to install the demo.

Exposure 3

To install Exposure 3, click the Download Exposure 3 link. This will open a folder that contains the exposure-3.0.0.1049.exe file. Save this file to your computer. Open the file and follow the instructions to install the demo.

To watch a video on the features of Exposure 3, click the Launch "Exposure 3: Getting Started" Video link. You must have an internet connection to watch this video, as this link will open an Internet Explorer browser. This video and other video tutorials on Exposure 3 features can be found on the Alien Skin Software, LLC website, www.alienskin.com.

iClone4 EX

To install iClone4 EX, click the Download iClone4 EX link. This will open a folder that contains the iclone.exe file. Save this file to your computer. Open the file and follow the instructions to install the demo.

To watch a video on the features of iClone4 EX, click the Launch "iClone4 Product Quick Tour" Video link. You must have Adobe Media Player installed to watch this video. If you do not have Adobe Media Player, you can watch the video on the Reallusion Inc. web site, www.reallusion.com/iclone.

LiveCode 4.5

To install LiveCode 4.5, click the Download LiveCode 4.5 link. This will open a folder that contains the LiveCodeInstaller-4_5_0-Windows.zip file. This zip file contains LiveCode 4.5 release notes and the LiveCode 4.5 demo. Save the zip file to your computer and extract the contents. Open the LiveCodeInstaller-4_5_0-Windows.exe file and follow the instructions to install the demo.

To read the LiveCode 4.5 release notes, open the LiveCodeNotes-4_5_0.pdf file.

Vectorworks Architect

To install Vectorworks Architect, click the Download Vectorworks Architect link. This will open a folder that contains the Vectorworks-Architect-Overview.exe file. Save this file to your computer. Open the file and follow the instructions to install the demo.

To watch a video on the features of Vectorworks Architect, click the Launch “Vectorworks Architect” Video link. You must have Adobe Media Player installed to watch this video. If you do not have Adobe Media Player, you can watch the video on the Nemetschek Vectorworks, Inc. web site, www.nemetschek.net/architect/explore.php.

Digital Sampler

Seven different chapters from seven different multimedia-related McGraw-Hill titles are provided in PDF format. Adobe Reader has been included on the CD-ROM.

Electronic Book

The entire contents of the textbook, as well as the questions included in MasterExam, are provided in PDF format.

Help

A help file is provided through the help button on the main page in the lower left hand corner. An individual help feature is also available through MasterExam.

Removing MasterExam

MasterExam is installed to your hard drive. For best results removing MasterExam, use the Start | All Programs | LearnKey | Uninstall option.

McGraw-Hill Technical Support

For questions regarding the content of the electronic book or the MasterExam, please visit www.mhprofessional.com/techsupport/. For customers outside the 50 United States, e-mail international_cs@mcgraw-hill.com.

LearnKey Technical Support

For technical problems with the MasterExam software (installation, operation, removing installations), please visit www.learnkey.com, e-mail techsupport@learnkey.com, or call toll free at 1-800-482-8244.

Trial Software Technical Support

For questions or technical problems with the trial software please visit the website of the software vendor.

- BBEdit 9.5 www.barebones.com
- Easy GIF Animator 5.1 www.blumentals.net
- Exposure 3 www.alienskin.com
- iClone4 EX www.reallusion.com
- LiveCode 4.5 www.runrev.com
- Vectorworks Architect www.vectorworks.net

A

- <A> tag, HTML
 - creating clickable buttons, 411
 - creating sound for Web, 413
- AAC (Advanced Audio Coding) format, 123
- acoustics, 104–106
- acting talent, costs of professional, 276
- ActionScript, Flash, 230
- activation of web pages, 438–440
- active-learner model, for multimedia, 4
- Active Server Pages (ASP), building dynamic web pages, 378
- adaptive systems, development of, 244
- additive color method, 91
- addresses
 - Internet, 361–365
 - URL, 24, 212
- adjacency, word search method in hypermedia systems, 58
- administration, budgeting for hidden costs of, 276
- Adobe
 - Acrobat PDF files. See PDFs (Portable Document Files)
 - Acrobat Reader, 382
 - Captivate, 180
 - Cold Fusion, 372–373, 378
 - Director. See Director
 - Dreamweaver, 232, 380
 - Flash. See Flash
 - Illustrator. See Illustrator
 - InDesign, 76, 380
 - Photoshop. See Photoshop
 - PostScript page description, 40–41
- Advanced Audio Coding (AAC) format, 123
- Advanced Research Projects Agency (ARPA), 359
- Advanced Technology Attachment (ATA) connections, 204
- Advanced Television (ATV), 169
- Advanced Television Systems Committee (ATSC)
 - for analog broadcast video, 167
 - digital video formats in, 170
- After Effects animation software, 414
- AFTRA (American Federation of Television and Radio Artists), 348–351
- AI file format, 97
- AIF file format, 120
- AIFF (Audio Interchange File Format), 121–122
- AJAX (Asynchronous JavaScript and XML), 373, 413
- Alchemy's GIF Construction Set Pro, 145
- ALCS (Author's Licensing and Collecting Society), 336
- alert sound, changing on Macintosh, 120
- Alien Skin Exposure, 79
- ALIGN attribute of tag, flowing text around images, 400–402
- alpha releases, 423
- alpha testing, 271, 423
- alphabets
 - computers and, 42–44
 - unique in all languages, 46–47
- alternates, word search method in hypermedia systems, 58
- America Online, font foundries, 41
- American Federation of Television and Radio Artists (AFTRA), 348–351
- American National Standards Institute (ANSI), 42–43
- American Standard Code for Information Interchange (ASCII), 42–43, 48
- analog video
 - defined, 165–166
 - digitizing, 166
 - overview of, 166–168
- anamorphic widescreen, 182
- anchor, HTML, 58
- Andersen, Kurt (multimedia designer), 244–245
- Android OS, 396
- animated GIFs, 152–155
- animation
 - cel, 143–144
 - computer, 142–143, 145–149
 - creating bouncing ball, 152–155
 - creating rolling ball, 151–152
 - creating scene, 155–157
 - defined, 140
 - file formats, 149
 - overuse of, 140
 - PNG images not supporting, 403
 - power of motion, 140–141
 - principles of, 141–142
 - review, 158–163
 - text, 31–32, 221
 - tools for, 150, 221–222
 - with vector-drawn objects for 3-D, 80
 - for Web, 413–414
- AnimatorPro, .fli and .flc formats, 149
- annoyances, production stage, 322–324
- ANSI (American National Standards Institute), 42–43
- anti-aliasing
 - avoiding interlacing flicker on CRTs with, 171–172
 - avoiding jaggies with, 53
 - defined, 27
- AOL-Time Warner empire, 376
- Apple. See also Macintosh operating system (OS)
 - displaying icon for web site on handheld devices, 307–308
 - font wars, 40–41
 - history of aspect ratios for pixels, 40
 - iTunes. See iTunes Store
 - QuickTime. See QuickTime (.mov) format
- applets, Java, 375
- approval cycles, client, 320–321
- Arabic numbers, of most alphabets, 48
- archives
 - creating in delivery stage, 427–429
 - digital audio recording, 112
- ARL (Army Research Library), 368
- Army Research Library (ARL), 368
- ARPA (Advanced Research Projects Agency), 359
- ARPANET, 359
- artwork, scanning to create bitmaps, 79
- “As We May Think” (Bush), 54–55
- ASCII (American Standard Code for Information Interchange), 42–43, 48
- Ashcroft v. Eldred, 334
- ASP (Active Server Pages), building dynamic web pages, 378
- aspect ratio
 - common digital television resolutions, 172–173
 - converting in video production, 181–182
 - screen resolutions for computer monitors, 172
 - shooting video, 181–182
- assets, monitoring throughout project execution, 198
- Association of American Publishers, incorporating DRM, 336
- association, word search method in hypermedia systems, 58
- Asynchronous JavaScript and XML (AJAX), 373, 413
- ATA (Advanced Technology Attachment) connections, 204
- ATSC (Advanced Television Systems Committee)
 - for analog broadcast video, 167
 - digital video formats in, 170
- attack of sound, MIDI files, 118
- attributes, font style, 22
- ATV (Advanced Television), 169
- AU format, history of web sound, 413
- Audacity, sound digitization with, 108–109
- audio. See also sound CDs. See CD (compact disc) technology
 - designing project to use shorter-duration files, 211
 - file size vs. quality and resolution, 111–113
 - interface design, 312–313
 - specialists, 250–251
- Audio Interchange File Format (AIFF), 121–122
- Audio Video Interleaved (.avi) format, 3-D animation for Web, 149
- audio-visual stimulation, retention rate of, 2
- audiophiles, 113
- <AUDIO> tag, HTML, 395, 413
- auditions, locating professionals, 348–349
- authoring tools
 - adding sound to multimedia project, 125
 - animation, 140–141, 150–151
 - with bitmap editing features, 76

- choosing, 231–234
- defined, 2
- getting started, 223–224
- graphics, 69
- implementing GUI with, 309–310
- making instant multimedia, 224–227
- objects, 230–231
- overview of, 222–223
- types of, 227–230
- Author's Licensing and Collecting Society (ALCS), 336
- Autobiography of Benjamin Franklin (circa 1784), 347
- AutoDesk
 - DXF file format, 97
 - Maya, 83, 143
- autoplay attribute of <AUDIO> tag, 413
- autotracing, 82–83
- .avi (Windows Audio Video Interleaved) format, 3-D animation for Web, 149
- Avid's SoftImage 3-D modeling software, 218

B

- B-rolls, video clips from, 180
- backbone, connecting to Internet, 365
- background layer, 229
- backgrounds
 - avoiding excessive backlighting when shooting video, 186
 - choosing text font, 27
 - creating animated scene, 156–157
 - flowing text around images in, 401
 - rendering into image with shadows and lighting effects, 86–87
 - for Web, 405–408
- bandwidth
 - Internet and, 365–367
 - multimedia requirements, 9–10
- barcode readers, 210
- barcoding, 210
- Beatles, and Apple Computer, Inc., 124
- Beethoven's Ninth Symphony, audio CDs
 - playing length of, 121, 431
- Berners-Lee, Tim, 372
- beta releases, 423
- beta testing, 271, 423–424
- Bézier curves
 - PostScript characters and, 40
 - vector drawing tools using, 80
- bid proposals
 - budget, 287
 - cover and package for, 286
 - creative strategy for, 287
 - needs analysis in, 286
 - overview of, 281–285
 - project implementation, 287
 - sample terms for, 285
 - table of contents in, 286
 - target audience for, 287
- billing rates, 277–280
- binary compatible files, 200
- binary, defined, 71
- BIOS program, and ROM, 206
- bitmap editors, 76
- bitmaps
 - capturing and editing images, 77
 - controlling look of text on Web with graphic, 398
 - converting between drawn objects and, 82–83
 - file formats, 97
 - image-editing applications for, 220–221
 - making own buttons from, 36
 - mapping text across platforms, 46
 - overview of, 70–73
 - painting and drawing tools, 216–217
 - resizing, 82
 - software for, 76–79
 - sources of, 74–75
 - vs. vectors, 81–83
- bits
 - of common color palettes, 94
 - defined, 71
- Black Belt, morphing tool, 147
- Blender, 3-D modeling software, 83, 218
- Blu-ray video, 178, 208
- blue, as favorite color in world, 90
- blue screen, 184–185
- BMP, 97
- <BODY> tag, HTML, background color for Web, 409
- Bohr, Niels, 88
- Boolean searches, with hypertext systems, 54
- BORDER attribute of tag, clickable buttons, 411
- borders
 - creating hot spots on Web, 305
 - what to avoid in UI design, 312
- bouncing ball animation, 152–155
- breadcrumbs, menus for navigation, 35
- broadband Internet, 10
- bronze, delivery stage of project, 425
- browsers
 - defined, 2
 - development of, 376–377
 - HTML and multimedia issues, 395
 - identifying icon image to, 307–308
 - indicating image is hot, 305
 - reading HTML code, 378
 - recognizing HMTL5 video codecs and containers, 176–177
 - smaller viewports and, 395–396
 - sound for Internet and, 130
 - support for third-party plug-ins, 375
- budget
 - balancing production value of project against, 330
 - in bid proposals, 287
 - for hardware test platforms, 422

- buffer, Internet sound, 130
- burners, CD-ROM and DVD, 10
- burning, CD-R discs, 430
- business, multimedia applications for, 2–3
- busy screens, avoiding, 312
- buttons
 - clickable, for Web, 304–306, 411
 - creating hot spots with, 303–304
 - GUI design and, 310
 - interactive multimedia using, 35–36
 - positioning in UI design, 297
 - using 2-D to change state on mouse rollover, 142
 - what to avoid in UI design, 312

C

- CAD (computer-aided design) programs
 - IGS/IGES file format, 97
 - using vector-drawn objects, 80
- camera, stable shooting platforms, 181–182
- <CANVAS> tag, HTML, 38
- Captivate, Adobe, 180
- capture tools, for video clips, 179–180
- capturing images, 77
- card-based authoring tools, 228–229
- Cartesian coordinates
 - in 2-D animation, 142
 - in vector drawing, 80
- Cascading Style Sheets. See CSS (Cascading Style Sheets)
- case history, in multimedia design, 314–318
- case insensitivity
 - defined, 24
 - of HTML markup tags, 393
- case sensitivity
 - defined, 24
 - e-mail addresses, 363
 - fonts, 24
 - URL addresses, 24
- Cast, Director authoring tool, 230
- casting calls, 348
- categories, word search method in hypermedia systems, 57
- cathode ray tubes. See CRTs (cathode ray tubes)
- CCDs (charge-coupled devices)
 - in analog video, 166
 - in digital video, 168–169
 - how video works, 165
 - in video cameras, 210
- CD (compact disc) technology, 429–430, 431–433
- CD-I (Interactive), Green Book standard for, 431
- CD-R (compact disc-recordable) disks, 207, 430–431
- CD-ROM (compact disc read-only memory) discs
 - CD-R technology, 430–431
 - CD standards, 431–434

- CD technology, 429–430
 - delivering multimedia on, 10, 429
 - in multimedia workspace, 207
 - Orange Book standard for WORM, 431
 - Yellow Book standard for, 431, 433–434
- CD-ROM/XA (extended architecture) format, 121, 434
- CD-RW (CD-read and write) disks, 207
- CDD (Compact Disc Database), 129
- CDR file format, Corel, 97
- cel animation
 - techniques, 143–144, 158
 - using 2-D, 142
- cell phones. *See* mobile phones
- CGI (Common Gateway Interface), 384
- change order, scheduling project, 274
- character entities, HTML, 48
- character metrics, 23
- character sets
 - computers and, 42–44
 - languages in world of computers, 46–50
 - mapping across platforms, 46
 - special characters in HTML, 48–49
 - substituting characters of own design, 51–53
- charge-coupled devices. *See* CCDs (charge-coupled devices)
- chroma keys, shooting video, 184–185
- chrome, browser, 395
- CIE color model, 94
- clickable buttons, for Web, 411
- client computers, 360
- client/server software, 202
- client-side image maps, 411–412
- client sign-off, 274–275
- clients
 - approval cycles, 320–321
 - communication with, 200
 - data storage media and transportation, 320–321
 - in production stage, 320–321
 - project estimates for, 274–277
- clip art
 - as source of bitmaps, 74
 - using material from collections of, 335
- clipboards, 77
- clone, assembling own computer, 202
- clusters of workstations (COWs), 87
- CLV (constant linear velocity), of CDs, 433
- CMFML (Cold Fusion Markup Language), 378
- CMSs (Content Management Systems), 381
- CMYK (cyan, magenta, yellow, black) color model, 91–93
- codecs
 - compressing sound, 123–124
 - compressing video, 165
 - compressing video for Web, 415
 - shooting video, 186
 - video format converters, 178
- Cold Fusion
 - building dynamic web pages, 378
 - extending HTML on Web, 372–373
- Cold Fusion Markup Language (CMFML), 378
- color
 - for 3-D objects, 85
 - choosing web background, 409
 - for color-impaired, 73
 - computerized, 91–94
 - creating hot spots with text anchors, 305
 - designing for multimedia, 174
 - natural light and, 88–90
 - palettes, 94–96, 406
 - perception of, 88–89
 - for still images, 77
 - for text, 27–28
 - user interface design, 311, 312
 - vision loss and, 90
- color-cycling logo, 2-D animation, 142
- color depth
 - bitmaps, 72–73
 - GIF images, 402
 - JPEG images, 403
 - PSD files, 405
- color organ, Scriabin, 8
- color pickers, 89
- commercial applications of VR, 9
- commercial hypertext systems, 57
- Common Gateway Interface (CGI), 384
- communication
 - in multimedia projects, 200
 - working with clients, 320–321
- compact disc (CD) technology, 429–430, 431–433
- Compact Disc Database (CDD), 129
- Compact Disc Digital Audio Standard, 431
- compact disc read-only memory disks. *See* CD-ROM (compact disc read-only memory) discs
- compact disc-recordable (CD-R) disks, 207, 430–431
- component, analog video signal output, 166
- composite navigation, 296–297
- composite signals, analog video, 166
- composition, video, 185–186
- compression
 - JPEG lossy, 403–404
 - preparing animation files for Web, 149
 - video. *See* also codecs, 174–175
- CompuServe Information Services, and GIF images, 402–403
- computer-aided design (CAD) programs
 - IGS/IGES file format, 97
 - using vector-drawn objects, 80
- computer animation
 - kinematics, 146–147
 - morphing, 147–149
 - techniques, 145–146, 158
 - understanding, 142–143
- computerized color
 - additive method, 91
 - models, 92–94
 - overview of, 91
 - subtractive method, 91–92
- computers
 - configuring workspace for images, 69–70
 - displaying image using underscan, 173
 - HDTV standard for, 170
 - screen resolutions, 172
 - using progressive-scan technology, 171–172
 - working with farms of, 87
- computers, and text
 - character sets and alphabets, 42–44
 - font wars, 40–42
 - languages, 46–50
 - mapping text across platforms, 45–46
 - overview of, 40
- Concrete5, 381
- condensed characters, 23
- conditional branching, for interactivity, 233
- connections
 - analog video connectors, 167
 - FireWire and i.Link, 205
 - IDE (or ATA), 204
 - Internet, 365
 - overview of, 203–204
 - SCSI, 204
 - USB, 204–205
- constant linear velocity (CLV), of CDs, 433
- consultants, billing rates and, 279
- containers, digital video
 - codec wars, 175–177
 - codecs, 174–175
 - MPEG, 175
 - overview of, 173–174
 - video format converters, 178
- content
 - defined, 330
 - navigation of, 2
 - overview of, 330–331
- content acquisition
 - copyrights, 335–337
 - created by others, 332
 - locating preexisting, 333–335
 - obtaining rights to, 337–342
 - overview of, 331–332
 - ownership of created content, 344–347
 - review, 353–357
- Content Management Systems (CMSs), 381
- contingencies, budgeting for, 276
- contractors
 - billing rates and, 279
 - ownership of works and independent, 347
- contracts, union, 349–351
- contrasts, in user interface design, 311–312
- controls attribute of <AUDIO> tag, 413
- convergence, computer-based multimedia with entertainment media, 5

- conversion
 - of audio file formats, 110
 - between bitmaps and vector-drawn objects, 82–83
 - of video file formats, 178
 - copyleft, 342–343
 - copyright
 - Digital Rights Management, 336
 - Eldred v. Ashcroft, 334
 - images, 74
 - infringement, 335
 - inserting into your project, 321–322
 - obtaining rights. *See* rights
 - ownership, 335
 - ownership of works, 343–347
 - for preexisting content, 333–335
 - protection, 335
 - public domain material and, 333–334
 - sound, 131–132
 - Copyright Act of 1976, 335
 - Copyright Term Extension Act (CTEA), 334
 - Corel, CDR file format, 97
 - CorelDRAW, 76
 - cost sheets, 279–280
 - costing stage
 - billing rates, 277–280
 - estimating, 274–277
 - overview of, 196–197
 - country codes, in Internet addresses, 363–364
 - Courier font, for Web, 398
 - cover, developing proposal, 286
 - COWs (clusters of workstations), 87
 - CPM (Critical Path Method), project management software, 264
 - creative strategy, bid proposals, 287
 - creativity, in multimedia projects, 197–198
 - Credit Alligator, 199
 - crediting creative talent, 199
 - Critical Path Method (CPM), project management software, 264
 - criticism, learning to accept, 28
 - cross platform
 - choosing authoring tools, 234
 - designing text for Web, 398
 - encoding extended characters, 43
 - failures in compatibility, 200–201
 - mapping text, 45–46
 - saturation in images, 78
 - visualizing flow of text, 28–29
 - CRTs (cathode ray tubes)
 - overview of, 170–171
 - preventing flicker with interlacing, 171–172
 - projectors, 211–212
 - some professionals preferring, 171
 - using additive color method, 91
 - CSS (Cascading Style Sheets)
 - with AJAX, 373
 - defined, 62
 - dynamic web pages using, 378
 - flowing text around images using, 401–402
 - with HTML, 38
 - online tools for validation of, 423
 - text for Web using, 398
 - with text properties, 30–31
 - understanding before developing multimedia for Web, 393
 - CTEA (Copyright Term Extension Act), 334
 - cultural responses to color, 90
 - cyan, magenta, yellow, black (CMYK) color model, 91–93
- ## D
-
- da Vinci, Leonardo, 240
 - daemons
 - defined, 367–368
 - using MIME-types, 369–371
 - DAT (digital audio tape) systems, 128
 - data packets, IP addresses and, 364–365
 - database
 - embedding with image and sound, 224, 226
 - keeping track of your sounds with, 128
 - Daz3D tool, 3-D, 83
 - dB (decibels)
 - measuring sound pressure levels, 104–105
 - normalizing sound levels, 109–110
 - perception of loudness and, 104–106
 - .dcr format, animation, 149
 - de-interlacing filters, 171–172
 - debugging, choosing authoring tool, 232
 - decay of sound, MIDI files, 118
 - deep software products, 302
 - Defense Research and Engineering Network (DREN), 368
 - degaussing, and CRT screens, 171
 - deliverables, 273
 - delivery
 - on CD-ROM, 429–434
 - choosing authoring tool for, 232, 234
 - on DVD, 434–436
 - file archives for, 427–429
 - overview of, 9–12, 197, 422–423
 - preparing for, 425–427
 - process of making project, 271–272
 - review, 440–445
 - testing, 423–425
 - on Web, 438–439
 - wrapping it up, 436–438
 - delivery vehicles, Internet, 377–381
 - density-independent pixels (dips), Android OS, 396
 - depth structures, 297–298, 302
 - derivative works, negotiating content rights, 339–340
 - designing
 - buttons, 303–306
 - hot spots, 303–306
 - hyperlinks, 303–306
 - icons, 306–308
 - multimedia design case history, 314–318
 - navigation, 296–297
 - overview of, 296–297
 - review, 325–329
 - structural depth, 297–303
 - user interface, 308–313
 - for World Wide Web. *See* World Wide Web design
 - designing and producing stage
 - designing. *See* designing
 - overview of, 197, 294–295
 - producing. *See* production phase
 - desktop workspace, Web design, 396
 - device dependency, MIDI files, 116, 118–119
 - device-independent bitmap (DIB) files, 97
 - device-independent, vector graphics as, 382–383
 - DHTML (Dynamic Hypertext Markup Language)
 - animation with, 414
 - building dynamic web pages, 378
 - creating multimedia on Web, 1
 - dialog, and MIDI audio, 119–120
 - DIB (device-independent bitmap) files, 97
 - digital audio
 - adding to project, 124
 - editing recordings, 108–111
 - file size vs. quality, 111–113
 - managing over Web, 383
 - MIDI audio vs., 118–120
 - overview of, 106–107
 - playing from web page, 130
 - proper recording levels, 108
 - review, 134–135
 - sound-editing tools, 221
 - digital audio tape (DAT) systems, 128
 - digital cameras, 210
 - digital EQ (equalization), digital audio recordings, 110
 - Digital Light Processing (DLP) projectors, 211
 - Digital Millennium Copyright Act of 1998, 336
 - Digital Object Identifier (DOI), 336
 - Digital Rights Management. *See* DRM (Digital Rights Management)
 - digital signal processing (DSP), digital audio, 111
 - Digital Television (DTV), 169
 - Digital Versatile Discs. *See* DVDs (Digital Versatile Discs)
 - digital video
 - containers, 173–178
 - defined, 165–166
 - displays, 170–173
 - overview of, 168–173
 - television resolutions, 172–173
 - Digital Video Interface (DVI), analog video, 167
 - digitally manipulated elements, 1

- dips (density-independent pixels), Android OS, 396
 - .dir format, animation, 149
 - Director
 - animation file formats (.dir and .dcr), 149
 - animation software, 414
 - as authoring tool, 230
 - image editor, 76
 - distortion, of still images, 77–78
 - distributed resources, delivering through, 10
 - distribution costs, 280
 - dithering, 27, 95–96
 - DLP (Digital Light Processing) projectors, 211
 - DNS (Domain Name System), 361–362
 - documentation, project installation instructions, 425–427
 - DOI (Digital Object Identifier), 336
 - Dolby AC-d Digital Surround Sound, and DVDs, 436
 - Dolby Pro-Logic Surround Sound, and DVDs, 436
 - dolly, for stable shooting platform, 181
 - Domain Name System (DNS), 361–362
 - domain names, interchangeable with IP addresses, 365
 - dot pitch, 91
 - dots per inch (dpi), 23
 - Double Tap, on small devices, 396
 - downsampling, digital audio recordings, 110
 - Drag, on small devices, 396
 - Dragon's Naturally Speaking, 210
 - drawing software, 216–217
 - drawn objects, making own buttons from, 36
 - Dreamweaver, 232, 380
 - DREN (Defense Research and Engineering Network), 368
 - DRM (Digital Rights Management)
 - converting to MP3 format, 110
 - MP4 files encrypted for, 122
 - overview of, 336
 - drop caps, 27, 311
 - drop shadows, 28, 311
 - Drupal, 381
 - DSP (digital signal processing), digital audio, 111
 - DTV (Digital Television), 169
 - dubbing, 168
 - DVD-Audio formats, 113
 - DVD Forum, 436
 - DVD-R/DVD-RW, 436
 - DVD-RAM, 436
 - DVD-ROM disks, 208, 321
 - DVD-RW (read and write) disks, 208
 - DVD-Video disks, 208
 - DVD+R/DVD+RW, 436
 - DVD+R/+RW recorders, 435
 - DVD+RW, 435
 - DVD+RW Alliance, 436
 - DVDs (Digital Versatile Discs)
 - Blu-ray vs., 208
 - delivering on, 10, 434–436
 - designing project for, 165
 - using anamorphic widescreen, 182
 - using MPEG-2 compression, 178
 - in workspace, 207–208
 - DVI (Digital Video Interface), analog video, 167
 - DXF file format, 97
 - Dynamic HTML, using CSS, 62
 - Dynamic Hypertext Markup Language. See DHTML (Dynamic Hypertext Markup Language)
 - dynamic web pages
 - building, 378
 - and XML, 372–373
- ## E
-
- e-Ink electronic display, 38
 - easing, with animation software tools, 153
 - Easy Morph, 147
 - eBooks, 37
 - ECMAScript standard, ActionScript, 230
 - editing
 - choosing authoring tool for, 231
 - digital audio, 108–111, 135
 - digital video, 184–188
 - fonts, 50–53
 - images, 77, 403
 - MIDI audio, 116
 - MIDI audio vs. digital audio files, 119
 - postproduction cost of, 276
 - role of multimedia video specialist, 249
 - sound, 125
 - text, 214–215
 - editors, HTML, 377–378
 - EDLs (edit decision lists), NLE software, 190
 - Edwards, Kevin (web site producer), 253–254
 - Eldred v. Ashcroft, 334
 - electronic image stabilization, for handheld cameras, 181
 - electronic rights, 332
 - <EMBED> tag, HTML, 384–385, 395, 413
 - employees
 - cost to employer, 277–278
 - independent contractors vs., 279
 - ownership of works and, 343–347
 - rate billed to customer, 277–278
 - English
 - alphabet, 46
 - power and irregularity of, 21–22
 - ENIAC computer, 206
 - envelope of sound, MIDI files, 118
 - environment, multimedia, 2
 - EPROMs (programmable ROMs), 206
 - equalization, of digital audio recordings, 110
 - eRate, 4
 - eReaders, 37
 - error correction, on CDs, 432
 - escape sequence, HTML, 401
 - estimating costs, 274–277
 - Ethernet, LANs using, 202
 - event-driven authoring tools, 229
 - .exe extension, Windows, 428
 - executive summary, in bid proposal, 286
 - expanded characters, 23
 - experiential learning, with multimedia, 4
 - extended character sets, 43, 48
 - eXtensible Markup Language (XML)
 - building dynamic web pages, 372–373, 378
 - creating multimedia web projects, 1
 - extrusion, modeling 3-D objects, 85
 - eyes
 - movement reduced when reading on computer, 36
 - perception of color by, 90
- ## F
-
- fade-ins, digital audio recordings, 110
 - fade-outs, digital audio recordings, 110
 - fair use law
 - copyrighted material and, 335–336
 - derivative works and, 340
 - FairPlay, 336
 - family process, making CDs, 430
 - FAQs (frequently asked questions)
 - for new software and features, 212
 - preparing for delivery, 426
 - search engines on Web, 358–359
 - fathers, making CDs, 430
 - favicon.ico file, 307
 - feasibility study, 269
 - Feedback Alligators, 275
 - feedback, beta test, 424
 - fiber-optic lines, delivering through leased, 11
 - fields for reading, 36–38
 - file archives, delivery stage, 427–429
 - file formats
 - animation, 149–150
 - audio, converting, 110
 - audio, determining when adding to project, 124
 - audio, types of, 121–123, 135
 - compact disc, 434
 - for compressed file archives, 427–428
 - converting, 200
 - digital video containers, 173–174
 - image, 71, 97, 401
 - video converters, 178
 - file-naming conventions, 321
 - file size
 - MIDI advantages over digital audio files, 114, 118–119
 - preparing animation files for Web, 149
 - quality of digital audio recordings and, 111–113
 - vector-drawn object vs. bitmaps, 81–82

File Transfer Protocol (FTP), and daemons, 368

FileMaker Pro database, 226

filters

- for bitmapped images, 79
- in image-editing applications, 221

FireWire

- in digital video, 169
- flash memory devices integrated with, 207
- overview of, 205

.fla format, animation, 149

flare, modeling 3-D scenes, 85

Flash

- animation formats (.fli and .flc), 149
- creating hot spots with, 304–306
- external libraries extending, 150
- as most widely used animation tool, 150–151
- overview of, 414
- replacing in mobile era, 373
- sound for Internet using, 130–131
- time-based authoring with, 230
- Trace Bitmap option, 82–83
- using SWF format, 123

Flash CS4, for 3-D, 384

flash memory devices, in workspace, 207

Flash Video (.flv files) format, 123, 173, 176

flat-screen displays, LCD or plasma, 171

.flc format, AnimatorPro, 149

.fli format, AnimatorPro, 149

Flick, on small devices, 396

flicker effect, preventing, 142, 171–172

flight simulators, using VR, 9

flowcharting, choosing authoring tool, 231–232

fluorescent tubes, for white light, 90

font foundries, 41

font mapping, 45

font substitution, 45

font wars, 40–42

Fontlab, Ltd., 51–52

Fontographer, 23, 51–52

fonts

- case sensitivity and, 24
- choosing, 27–31
- defined, 22
- designing buttons, 35–36, 303
- designing proposal cover and package, 286
- designing web text, 398
- for ease of reading, 36–37
- editing and design tools, 50–53
- and faces, 22–24
- how to use, 1
- installed, 29–31
- making text pretty, 52–53
- mapping text across platforms, 45–46
- PostScript, 41
- serif vs. sans serif, 24–25, 398

- sources of free, 31, 41–42
- wars are over, 40–42

footage, obtaining video, 179

form•Z tool, 3-D, 83

format converters, 222

formats. See file formats

foundry, font, 41

4:3 aspect ratio

- computer screen resolution, 172
- converting to 16:9 in video production, 181–182
- digital television resolution, 173
- HDTV vs. VGA, 170

“404-not found” error message, finding URLs after receiving, 212

frames, animation and digital video movies, 221

Freehand, autotracing feature, 82

frequency

- color and, 88
- determining perception of loudness, 105
- word search method in hypermedia systems, 58

frequently asked questions. See FAQs (frequently asked questions)

FTP (File Transfer Protocol), and daemons, 368

Fust, Johann, 19

G

Gantt charts, 265

GanttProject software, 263–264

Gates, Bill, 201

Gecko engine, 395

genealogy software, 5

General MIDI numbering system, 116–117, 119

General Public License (GNU GPL), 341–342

generation loss, NLE software, 190

Georgia font, for web pages, 31

Get Info panel, icons in Mac OS, 306

GIF Animator, ULead, 145, 155

GIF Construction Set Pro, 145

.gif format, 149

GIF (Graphic Interchange File) images

- browsers enabled for HTML5 reading/displaying, 382
- for button animation, 304
- for buttons on Web, 305
- color palettes for, 95
- image file format, 71
- interlaced, 407
- JPEGs vs., 404
- saving image for Web in Photoshop as, 406
- for Web, 402–403

GIF89a animation format

- creating bouncing ball animation, 152–155
- defined, 149, 152

- overview of, 413–414
- for transparency, 407–408

GIFfun, Stone Design, 155

gigabytes, DVDs, 436

Glik, Simon, 133

GLV (Grating-Light-Valve) technologies, 211

GNU GPL (General Public License), 341–342

gold, delivery stage, 271–272, 425

golden master, delivery stage, 425

Goldfarb, Charles, 373

Google Books, 333–335

Google’s SketchUp, 3-D, 83

gradients, user interface design, 311

grammar checker, for production, 223

Graphic Artists Guild, 277

graphical user interfaces (GUIs), 2, 309–310

graphics

- anti-aliasing, 53
- applications with clip art and useful, 74
- creating hot spots, 303–306
- improving retention rate with, 2
- for proposal cover and package, 286
- and user interface design, 310–311

graphics designers (artists), 255

Grating-Light-Valve (GLV) technologies, 211

Green Book standard, 431, 433–434

green screen, in digital video editing, 184

GreenSock’s TweenMax, 150

GSM (Global System for Mobile Communications) mobile phones, 3gp files, 123

GUIs (graphical user interfaces), 2, 309–310

Gutenberg, Johann Gensfleisch zum, 19

H

H.264 codec, 174, 176

Han characters, Unicode standard, 44

handwriting, OCR software recognizing, 210

hard disks, 206

hardware

- budgeting for test platforms, 422
- connections, 203–205
- input devices, 209–210
- managing beta test feedback, 424
- memory and storage devices, 205–208
- networking Windows and Macintosh computers, 202–203
- output devices, 210–212
- overview of, 200–201
- project manager understanding strengths/limitations of, 242
- web server configurations, 376
- Windows vs. Macintosh, 201–202

hardwiring links vs. hypertext systems, 57

Harris, Chip (multimedia audio specialist), 250–251

Harry Fox Agency, 132

hazards, production stage, 322–324

- HD (high-definition), shooting footage in, 182–183
- HDMI (High-Definition Multimedia Interface) connector, analog video, 167
- HDTV (High Definition Television), 169–170, 208
- <HEAD> element, HTML, 307–308
- headlines, 27
- Heckbert's median cut algorithm, 95
- helical scan recording, analog video, 166–167
- Help page, for delivery, 426
- helper applications, 381
- helpful accessories, software, 222
- hexadecimal numbers, RGB, 93
- HFS (Hierarchical File System), 432
- Hierarchical File System (HFS), 432
- hierarchical navigation, 296–297
- High-Definition (HD), shooting footage in, 182–183
- High-Definition Multimedia Interface (HDMI) connector, analog video, 167
- High Definition Television (HDTV), 169–170, 208
- highlighting buttons or objects, 304
- hints, Type 1 PostScript fonts, 41
- history, of Internet, 359–360
- home, multimedia at, 5–6
- Hoo Technologies, 122
- hot software products, 302
- hot spots
 - creating client-side image maps, 411–412
 - designing, 303–306
 - positioning in user interface, 297
- hot-swapping, 205
- HSB (hue, saturation, brightness) color model, 93
- HSL (hue, saturation, lightness) color model, 93
- HSPACE attribute, tag, 400–402
- HTML (Hypertext Markup Language)
 - beyond, 383–385
 - creating hot spots, 304–306
 - delivering multimedia on Web with, 372–373, 377–378, 395–396
 - extended de facto by commercial interests, 374–375
 - going beyond vanilla abilities of, 372–373
 - as markup language for Web, 393–396
 - as native language of Web, 19–20
 - SharePoint Designer supporting, 380
 - special characters, 48–49
 - as standard document format used for web pages, 39–40, 62
 - tools for validation of, 423
 - translators, 378–379
- HTML5
 - features of, 38
 - Flash in mobile era vs., 373
 - tags used in, 130, 176–177, 393–395
 - for web video, 414–415
- HTTP (Hypertext Transfer Protocol), 368, 372
- hue, saturation, brightness (HSB) color model, 93
- hue, saturation, lightness (HSL) color model, 93
- hues, human eye differentiating many, 90
- human hearing, 104–106
- human response to color, 90
- Human Software's Squizz (morphing tool), 147
- humor, in user interface design, 312
- hybrid format, Mac and PC files on same CD, 434
- hyperlinks
 - designing, 303–306
 - downloading/installing plug-ins using, 381
- hypermedia
 - defined, 1
 - and hypertext, 53–55
 - as powerful learning resource, 56
 - structures, 58–59
 - word search, 57–58
- hypertext
 - hardwiring links vs., 57
 - hypermedia structures, 58–60
 - links and nodes in, 58
 - overview of, 54–55
 - power of, 55–56
 - searching for words, 57–58
 - tools, 60
 - using, 56–57
- Hypertext Markup Language. See HTML (Hypertext Markup Language)
- Hypertext Transfer Protocol (HTTP), 368, 372
-
- ICANN (Internet Corporation for Assigned Names and Numbers), and DNS, 361
- .ico file, 307
- icons
 - authoring tools, 229
 - creating hot spots, 303–304
 - designing, 306–308
 - editors for, 307
 - in multimedia, 32–33
- IDE (Integrated Drive Electronics), 204
- idea analysis
 - with idea management software, 263–265
 - paper napkin example of, 265–266
 - process of making project, 262–263
- idea management software, 263–264
- IGS/IGES (Initial Graphics Exchange Standard) format, CAD drawings, 97
- i.Link, 169, 205
- Illustrator
 - AI file format, 97
 - autotracing, 82
 - saving vector graphics in SVG format, 80
 - vector-based drawing program, 76
- image capture software, 3
- image maps, client-side, 411–412
- images
 - altering and distorting text with, 28
 - coloring. See color
 - configuring computer workspace for, 69–70
 - creating hot spots with button, 303
 - editing tools, 220–221
 - multimedia file formats, 97
 - organizing tools for, 69
 - overview of, 68
 - planning, 69
 - reading and displaying with plug-ins, 382–383
 - review, 98–103
 - scanning, 78–79
 - Web design with. See World Wide Web design, images for
- images, still
 - 3-D drawing and rendering, 83–88
 - bitmaps. See bitmaps
 - overview of, 70–71
 - vector-drawn objects, 80–81
 - vector-drawn objects vs. bitmaps, 81–83
- tag, HTML, 395, 414
- iMovie for Macs, Apple, 188, 190
- independent contractors
 - billing rates and, 279
 - ownership of works and, 347
- InDesign, Adobe, 76, 380
- Indexed Color, 406
- indexes, hypertext, 57
- information, density of text for users seeking, 26
- information designers, 243–244
- infrared light, 88, 90
- initial caps, 27–28
- Initial Graphics Exchange Standard (IGS/IGES) format, CAD drawings, 97
- inks, computer animation, 146
- input devices, 209–210
- input events, on small devices, 396
- installed fonts, 29
- installers, preparing for delivery, 425
- instant messaging jargon words, 22
- instant multimedia, making, 224–227
- instructional designers, 243
- Integrated Drive Electronics (IDE), 204
- integrated multimedia, 2
- intellectual property law, 331
- intelligent tutors, 244
- interactive multimedia
 - becoming hypermedia, 53
 - choosing authoring tool, 233
 - defined, 1
 - evolution of, 11
 - multimedia designer creating, 244
- Interactive TV (ITV), in schools, 4–5
- intercaps, 24
- interface designers, 243, 245–246

- interlacing
 - GIFs on Web, 407
 - in HDTV standard, 170
 - preventing flicker on CRTs, 171–172
 - in video frames, 166
 - on Web, 172
 - intermediate words, search method in hypermedia systems, 58
 - International Organization for Standardization. See ISO (International Organization for Standardization)
 - Internet addresses
 - IP addresses and data packets, 364–365
 - overview of, 361
 - second-level domains, 362–363
 - top-level domains, 361–362
 - US domain and country codes, 363–364
 - Internet and multimedia
 - bandwidth bottleneck, 365–367
 - beyond HMTL, 383–385
 - choosing authoring tool for, 234
 - connections, 365
 - delivering multimedia to client, 321
 - history of, 359–360
 - Internetworking, 360–361
 - MIME-types, 369–371
 - overview of, 358–359
 - plug-ins and delivery vehicles, 381–383
 - review, 386–391
 - search engines, 377
 - services, 367–368
 - sound for, 129
 - tools for World Wide Web, 374–375
 - web browsers, 376
 - web page makers and site builders, 377–381
 - web servers, 375–376
 - World Wide Web and HTML, 372–373
 - Internet backbone site, ARL, 368
 - Internet Explorer browser, 376–377
 - Internet service providers. See ISPs (Internet service providers)
 - Internet Streaming Media Alliance (ISMA), 336
 - inverse kinematics, 147
 - IP addresses, 364–365
 - iPhone using M4r files, Apple, 122–123
 - iris setting, shooting video using, 186
 - ISMA (Internet Streaming Media Alliance), 336
 - ISO (International Organization for Standardization)
 - 10149, audio CDs, 128–129
 - 9660, for CD-ROMs, 433–434
 - defined, 175
 - ISO/IEC 10646, 43–44
 - ISPs (Internet service providers)
 - assigning IP address numbers, 364
 - connecting to backbone of Internet through, 365
 - offering plug-ins to web site visitors and, 382
 - serving experimental MIME-types for multimedia, 371
 - WAN connected to Internet by, 202–203
 - iTunes Store
 - Digital Rights Management and, 336
 - link to Compact Disc Database on, 129
 - using AAC format, 123
 - ITV (Interactive TV), in schools, 4–5
- J**
- jaggies, avoiding, 53
 - Japanese, kanji alphabet, 46, 48
 - Java, browser support for, 375
 - JavaScript
 - animation for Web and, 413
 - browser support for, 375
 - creating hot spots, 304–306
 - in HTML pages for special functions, 372
 - Joomla, as CMS, 381
 - JPEG (Joint Photographic Experts Group) images
 - browsers enabled for HTML5 reading/displaying, 382
 - creating web buttons with, 305
 - GIFs vs., 404
 - as image file format, 71
 - lossy compression used by, 403
 - progressive-scan, 407
 - saving image for Web in Photoshop as, 405–406
 - for Web, 403–404
- K**
- Karaoke CD (Video CD), 232
 - Kerning, 23, 27
 - keyboard shortcuts, 70
 - keyboard skills, word processors, 214
 - keyboards, MIDI, 114–116
 - keyframes, in cel animation, 144
 - keyframes, in computer-based animation, 145
 - kinematics, 146–147
 - kiosks, in public places, 7
- L**
- labels, 33
 - landscape vs. portrait orientation, for text, 37
 - language
 - importance of word choice, 20–21
 - multilanguage web pages, 49–50
 - the power and irregularity of English, 21–22
 - special characters in HTML, 48–49
 - in world of computers, 46–48
 - LANs (local area networks), internetworking with, 202, 360–361
 - lasso type tools, bitmap editors, 77
 - lathing, 3-D objects, 85
 - Law of Minimums
 - Liebig's, 123
 - Vaughan's. See Vaughan's Law of Multimedia Minimums
 - layers
 - in computer-based animation, 145
 - PSD files containing, 405
 - Lazzaro, Nicole, (multimedia interface designer), 245–246
 - LCD (liquid crystal display)
 - flat-screen displays, 171
 - panels for project, 211
 - using additive color method, 91
 - LCOS (liquid crystal on silicon) projectors, 211
 - leading
 - adjusting in most programs, 23
 - adjusting in text blocks, 27
 - computer fonts providing, 22
 - learning-curve costs, 276
 - legal issues. See content acquisition; copyright
 - Letterbox (hard matte) method, 182
 - licenses
 - clip art usage, 335
 - copyleft, 341–342
 - digitized clip sounds with unlimited-use, 132
 - music, 132
 - negotiating content rights, 337–338
 - obtaining video footage, 179
 - licensing agreements, 338
 - Liebig's Law of the Minimum, 123
 - light, common sources of, 90
 - lighting
 - avoiding excessive backlighting in video, 186
 - modeling 3-D scenes with, 85
 - for quality video results, 183–184
 - Lightwave, NewTek, 83
 - linear navigation, 296–297, 302–303
 - linear project, 2
 - Linear Pulse Code Modulation (LPCM), for music CDs, 121
 - Lingo, Director utilizing, 230
 - link anchor, 58
 - link end, 58
 - links
 - designing hyperlinks, 303–306
 - downloading/installing plug-ins using hyperlinks, 381
 - in hypertext systems, 58
 - liquid crystal display. See LCD (liquid crystal display)
 - liquid crystal on silicon (LCOS) projectors, 211
 - live Internet pay-for-play gaming, 6
 - LiveStage Pro, Totally Hip, 174
 - local area networks (LANs), internetworking with, 202, 360–361
 - localization, 48

logarithmic scales, 104–105
 “look and feel,” multimedia planning stage, 196
 lossless codecs, 123
 lossless compression, 403–404
 lossy codecs, 123
 lossy compression
 lossless compression vs., 403–404
 of MP3 format, 122
 Lotus SmartSuite Millennium, 266–267
 loudness, perception of, 105
 low entry barrier enterprise, making multimedia
 as, 278–279
 lowercase, 24
 LPCM (Linear Pulse Code Modulation), for
 music CDs, 121
 Lunch Box DV, 144

M

M4r files, 122
 Macintosh operating system (OS)
 GUI design, 309
 history of sound in, 124
 icon image files, 306–307
 iMovie for, 188–189
 for multimedia projects, 200–201
 networking, 202–203
 screen-grabbers and format
 converters, 222
 self-extracting archives in, 428
 Windows OS vs., 201–202
 Worldwide OS Market Share of, 201
 management
 budgeting for hidden costs of, 276
 project manager responsibility, 242
 <MAP> tag of tag, 411–412
 mapping text across platforms, 45–46
 maps, navigation, 35
 marking up HTML, 378
 .max format, animation, 149
 Maya, Autodesk, 83, 143, 218
 meaning, power of, 20–21
 measurement, of type, 22–23
 medicine, teaching through multimedia, 4
 memory
 considerations when adding sound,
 125–126
 multimedia projects and, 205–206
 vector-drawn objects vs. bitmaps and,
 81–82
 menus, navigation, 34–35
 messaging, 3
 metadata, in digital video containers, 173–174
 metaphors, GUI design using well-known,
 309–310
 Mickey Mouse
 Copyright Clause and, 334
 significance of white gloves, 144

microphones
 audio quality affected by, 210
 shooting video with external, 181
 Microsoft
 ASP, 378
 font wars, 41
 Internet Explorer browser, 376–377
 Internet Gaming Zone, 6–7
 PowerPoint, 226, 383
 SharePoint Designer, 380
 Windows Live Movie Maker, 188–189
 Windows Media Rights Manager, with
 DRM, 336
 Windows OS. See Windows operating
 system (OS)
 Word, 215
 Microsoft v. Vizcaino, 279
 MIDI keyboards, 114
 MIDI (Musical Instrument Digital Interface)
 audio
 adding sound, 124
 digital audio vs., 118–120
 managing over Web, 383
 overview of, 113–118
 playing from web page, 130
 review, 134–135
 sound-editing tools for, 221
 testing and evaluating, 131
 milestones
 multimedia projects and, 273
 reporting for prototypes, 269
 MILNET, 368
 MIME-types (Multipurpose Internet Mail
 Extensions)
 helper applications to view, 381
 offering plug-ins to web site visitors, 382
 overview of, 369–371
 mirroring, SCSI, 204
 mixed mode track layout, 432
 MMS (Multimedia Messaging Service), 3, 22
 mobile phones
 e-Ink not required to read, 38
 multimedia piped to, 7
 police fighting recordings on, 133
 sound for, 129
 Mobisodes, 349
 modal interfaces, 307
 modeling 3-D objects, 84–85
 modifiers, object-based authoring programs,
 230–231
 money, project estimates, 276–277
 monitors
 additive color used on, 91–92
 configuring computer workspace with
 multiple, 69–70
 designing multimedia project, 211
 mono vs. stereo recordings, 111
 morphing
 in computer-based animation, 147–149
 manipulating still images, 77–78

Most Unwanted songs, 127
 Most Wanted songs, 127
 mothers, making CDs, 430
 motion capture, cel animation, 144
 .mov files. See QuickTime (.mov) format
 Moving Picture Experts Group. See MPEG
 (Moving Picture Experts Group)
 Mozilla Firefox, 376
 MP3 files
 AIFF converter converting formats
 to, 122
 converting digital audio recordings
 to, 110
 development of, 122
 most mobile phones playing, 129
 overview of, 122
 sampled for quality of music, 126
 MPC (multimedia PC) specification, 202
 MPEG (Moving Picture Experts Group)
 defined, 175
 developing MP3 format, 122
 for digital video, 175
 MPEG-1, 175
 MPEG-2, defined, 175
 MPEG-2, DVD video using, 178, 435
 MPEG-2, DVDs storing full-motion
 video, 208
 MPEG-4, 175, 178
 preparing 3-D animation files for
 Web, 149
 multicasting sounds, Web, 383
 multiformat VCRs, 168
 multiframe images, GIF89a, 414
 multimedia
 in business, 2–3
 definitions, 1–2
 delivery methods, 9–12
 at home, 5–7
 overview of, 0–1
 in public places, 7–9
 review, 13–17
 in schools, 3–5
 virtual reality and, 9
 multimedia designers, 243–245
 multimedia developers, 1
 Multimedia Messaging Service (MMS), 3, 22
 Multimedia PC Marketing Council, 202
 multimedia PC (MPC) specification, 202
 multimedia programmers, 251–252
 multimedia projects
 authoring systems, 222–234
 defined, 1
 need for communication, 200
 need for creativity, 197–198
 need for organization, 198–199
 review, 235–239
 stages of, 196–197
 multimedia projects, hardware
 connections, 203–205
 input devices, 209–210

- memory and storage devices, 205–208
- networking Windows and Macintosh computers, 202–203
- output devices, 210–212
- overview of, 200–201
- Windows vs. Macintosh, 201–202
- multimedia projects, software
 - 3-D modeling and animation tools, 218–219
 - animation, video, and digital movie tools, 221–222
 - helpful accessories, 222
 - image-editing tools, 220–221
 - OCR software, 215–216
 - overview of, 212–214
 - painting and drawing tools, 216–217
 - sound-editing tools, 221
 - text editing and word processing tools, 214–215
- multimedia skill set, 240
- multimedia skills
 - overview of, 240–241
 - review, 256–259
 - team building, 254–255
- multimedia skills, of team members
 - audio specialist, 250–251
 - interface designer, 245–246
 - multimedia designer, 243–245
 - multimedia programmer, 251–252
 - overview of, 241
 - producer of multimedia for Web, 253–254
 - project manager, 241–243
 - video specialist, 248–249
 - writer, 246–248
- multimedia title, 1
- multiple tracks, digital audio recordings, 111
- Multipurpose Internet Mail Extensions. See MIME-types (Multipurpose Internet Mail Extensions)
- Musical Instrument Digital Interface. See MIDI (Musical Instrument Digital Interface) audio
- musical notation, MIDI vs. digital audio files, 119
- mySQL, CMSs built on PHP and, 381
- Mysterium, 8

N

- naming conventions, 321
- National Archives, Washington, D.C., 335
- National Grid for Learning (NGfL), 4
- National Television Standards Committee (NTSC), 167–168
- natural light, 88–90
- navigation
 - designing, 296–297
 - hypermedia structures, 58–60
 - menus, 34–35

- navigation (site) maps
 - as architectural drawings for project, 300–301
 - buttons that make sense, 304
 - designing, 296
 - as nonlinear, 298
 - sidebars for, 411
 - surface structure when designing, 298
 - Web background images, 409–410
- needs analysis, bid proposals, 286
- negation, word search method in hypermedia systems, 58
- negotiations, for content usage rights, 332
- NetLingo, 22
- Netscape, 376–377
- networking, 202–203, 360–361
- Neumann, John von, 206
- NGfL (National Grid for Learning), 4
- nibbling
 - at sound elements, 413
 - in Web design, 397–398
- NIPRNET (nec MILNET), 368
- NLE (nonlinear editing), digital video, 188–190
- nodes, in hypertext systems, 58
- nonlinear editing (NLE), digital video, 188–190
- nonlinear navigation
 - defined, 296–297
 - of navigation maps, 298, 300
- nonlinear projects, 2
- normalizing, digital audio sound level, 109–110
- notation software, for MIDI scores, 114–115
- Novice/Expert modes, user interface design, 308
- NSF (National Science Foundation), 359
- NTSC (National Television Standards Committee), 167–168

O

- Object/Embed method, HTML, 395
- <OBJECT> tag, HTML, 384–385, 395
- objects
 - 3-D scenes consisting of, 84
 - authoring programs based on, 230–231
 - icon-and object-based authoring tools, 229
- OCR (optical character recognition) software
 - in barcode readers, 210
 - for multimedia projects, 215–216
 - for scanners, 209
- office suite, 214
- Ogg (.ogg files) format, 173, 176
- “on the fly,” creating vector-drawn objects, 82
- online references
 - 3-D tools, 385
 - America Online font foundries, 41–42
 - animation overuse, 140
 - animation styles and tips, 414
 - Audacity sound digitization, 108
 - commonly installed fonts, 29
- copyright licenses, 342
- country codes, 364
- design, 313
- developing multimedia for Internet, 358
- Digital Rights Management, 336
- DVD standards, 436
- finding multimedia talent, 267–268
- Fontlab, Ltd., 51
- Fontographer, 23
- Google Books, 334
- hierarchical rules for addresses in US domain, 364
- Hoo Technologies, 122
- HTML and CSS, 38
- HTML character entity references, 49
- HTML tools, 378
- icon editors, 307
- instant messaging jargon words, 22
- kinematics, 147
- Lunch Box DV for frame editing and timing, 144
- MIME-types, 369
- morphing, 147
- Most Wanted and Most Unwanted songs, 127
- nonunion talent release forms, 352
- OpenOffice, 215
- page-based authoring tools, 228
- panoramas, 88
- police fight cellphone recording, 133
- SemanticWeb development, 372
- stock footage, 333
- Totally Hip’s LiveStage Pro, 174
- Vatican artwork collection, 331
- video titles created with templates, 187
- Washington On Line, 4–5
- web site promotion and search engine submission, 439
- XML, 373
- OpenOffice, 215
- OpenType, 41, 52–53
- operating systems, smartphone, 395
- optical character recognition. See OCR (optical character recognition) software
- Orange Book standard, 431–434
- organization
 - choosing authoring tool for, 231–232
 - in multimedia projects, 198–199
- outline font language, 40
- output devices, 210–212
- overscan, 170, 173
- ownership
 - of content created for project, 343–347
 - of someone else’s content, 332

P

- packages, for delivery, 436–438
- packages, proposal, 286
- page-based authoring tools, 228–229

- paint
 - in cel animation, 144
 - in computer-based animation, 146
- Painter, 76
- painting software, 216–217
- PAL (Phase Alternate Line) system, 167–168
- palettes
 - color, 94–96
 - creating images for Web in Photoshop, 406
- Pan and Scan method, 182
- Panorama Factory, 88
- panoramas
 - avoiding when shooting video, 185
 - working with, 88
- Papervision3D, 150, 384
- paragraphs, displaying whole, 36–37
- parent and child relationships, object-based
 - authoring programs, 230–231
- passwords, and case sensitivity, 24
- patents, typeface designs and, 50
- path animation, in 2-D space, 142
- payment schedule, for outside client, 277–280
- PCM (Pulse Code Modulation), music CDs, 121
- PCX file format, 97
- PDA's
 - e-Ink not required to read, 38
 - multimedia piped to, 7
- PDF's (Portable Document Files), 97, 380
- pels, 71
- pencil test, in cel animation, 144
- people, in project estimates, 276–277
- performance, authoring tools for tuning, 233
- permissions, negotiating content rights, 340–341
- persistence of vision, in animation, 141
- PERT (Program Evaluation Review Technique) charts, 264–265
- Phase Alternate Line (PAL) system, 168
- phi phenomenon, in animation, 141
- PhotoCD Orange Book layout, 432
- photography effects, for bitmaps, 79
- Photoshop
 - creating animated rolling ball, 151
 - creating images for Web, 405–408
 - as most widely used image-editing tool, 76
 - PSD file format, 97
- PHP, 372–373, 381
- PICT file format, 97
- Picture file, Mac, 77
- pillars, converting aspect ratios in video, 182
- Pinch Open/Pinch Closed, on small devices, 396
- Ping utility, discovering IP addresses, 365
- pixels
 - in bitmaps, 71
 - defined, 23
 - history of aspect ratios, 40
- pixilation, in bitmaps, 82
- Placeshifting, 349
- Planck, Max, 88
- planning and costing stage
 - alpha development, 271
 - beta development, 271
 - billing rates, 277–280
 - delivery, 271–272
 - estimating, 274–277
 - idea analysis, 262–266
 - overview of, 196–197
 - pretesting, 266
 - process of making multimedia, 260–262
 - prototype development, 268–271
 - review, 288–293
 - RFPs and bid proposals, 280–287
 - scheduling, 273–274
 - task planning, 266–268
- plasma displays
 - defined, 171
 - using additive color method, 91
- platform-independent delivery, failures, 200–201
- platforms, multimedia
 - defined, 2
 - mentioning in bid proposal, 287
 - visualizing flow of text on all, 28–29
- playback, authoring tool for, 233
- players
 - defined, 381
 - video for web page, 415–416
- plug-and-play devices, USB devices as, 205
- plug-ins
 - bitmap, 79
 - browser support for third-party, 375
 - image, 382
 - Internet, 381–383
 - sound, 124, 383
 - text and document, 382
 - Web video, 414–416
- PNG (Portable Network Graphics) images
 - browsers enabled for HTML5 reading/displaying of, 382
 - color palettes, 95
 - developed to replace GIF, 403
 - image file format, 71
 - using for transparency, 407–408
- points, type sizes in, 22
- police, fighting cellphone recordings, 133
- POP (Post Office Protocol), daemons
 - supporting, 368
- Portable Document Files (PDFs), 97, 380
- Portable Network Graphics. See PNG (Portable Network Graphics) images
- portrait vs. landscape orientation, for text, 37
- Poser, 3-D modeling program, 146–147
- Post Office Protocol (POP), daemons
 - supporting, 368
- post-production, incorporating sound in, 131
- post-session, incorporating sound in, 131
- PostScript, for pretty text, 52–53
- PowerPoint
 - managing presentations with, 383
 - multimedia linking and embedding features, 226
- preexisting content, locating, 333–335
- preload attribute of <AUDIO> tag, 413
- prerequisites, PERT charts showing, 265
- presentation slides, text, 26
- presentations, PowerPoint, 383
- pressed CD-Rs, 430
- Presto engine, 395
- pretesting project, 266
- Pricing & Ethical Guidelines (Graphic Artists Guild), 277
- primitives, importing shapes for 3-D objects
 - from, 85
- printing
 - CMYK used in, 91–92, 93
 - in multimedia development environment, 212
 - PNG images, 143
 - text documents, 26–27
 - use of ROM in, 206
 - vector-drawn objects used in, 80
 - WYSIWYG, 25
- printing press, invention of, 19
- privacy rights, 133
- production phase
 - copyrights, 321–322
 - costs, 280
 - hazards and annoyances, 322–324
 - of multimedia for Web, 253–254
 - overview of, 318–319
 - project manager responsibility in, 242
 - review, 325–329
 - starting up, 319
 - tracking, 321
 - working with clients, 320–321
- production value, of content, 330
- professionals. See talent
- profiling data, 298
- Program Evaluation Review Technique (PERT) charts, 264–265
- program manager role in team, 242–243
- programmable ROMs (EPROMs), 206
- programmer role, 251–252
- programming features, choosing authoring tool, 232–233
- progressive-scan system
 - HDTV for computers as, 170
 - for JPEGs on Web, 407
 - overview of, 171–172
- project development costs, 280
- project implementation, bid proposals, 287
- project managers, multimedia, 241–243, 264–265
- Prometheus (Fifth Symphony by Scriabin), 8
- proof-of-concept, 196–197, 269

properties
 of 3-D objects and elements, 84
 adjusting bitmap, 75
 in object-based authoring programs,
 230–231

prototype development
 alpha stage, 271
 beta stage, 271
 planning stage, 196
 pretesting phase, 266
 in process of making multimedia project,
 268–271

PSD file format, 97, 405

public domain material, 74, 333–335

public places, multimedia in, 7–8

Pulse Code Modulation (PCM), music CDs, 121

Q

quality
 and file size of digital audio recordings,
 111–113
 MIDI vs. digital audio files, 119
 reducing storage by sacrificing sound, 126

quantum theory, 88

QuickTime (.mov) format
 creating Virtual Reality files, 416
 digital video container, 173–174
 MP4 format based on, 122

R

RAID (Redundant Array of Independent Disks),
 for high-speed data transfer rates, 165

RAM (random access memory), 205–206

random access memory (RAM), 205–206

rasterizing, 23

rate cards, 338

read-only memory (ROM), 206

Read.Me file, project distribution disc, 426

README.TXT file, project distribution
 disc, 426

real estate, screen, 69

Real Media (.rm files) format, digital video, 173

real-time teleconferencing, 3

recording
 audio, 126–128
 digital audio, 108–111, 135
 police fighting cellphone, 133

Red Book audio standard
 for audio CDs, 129
 CD-R blanks holding 84 minutes of, 430
 defined, 431
 track layout, 432

red-green color blindness, 73

Redundant Array of Independent Disks
 (RAID), for high-speed data transfer
 rates, 165

release candidate, project delivery stage, 425

release forms, for nonunion talent, 351

rendering
 3-D animations, 146
 3-D images, 86–87

RenderZone Plus, form*Z, 83

resampling, digital audio recordings, 110

resolution
 HDTV high, 170
 sampling rates and, 111–113
 web images in Photoshop, 405
 web page design and, 395

Reunion genealogy software, 5

reversed graphics, user interface design, 311

reversing sound, digital audio recordings, 111

RFC 1480, 363–364

RFPs (Request for Proposals), 280–285

RGB (red, green, blue) color model
 in additive color method, 91
 for monitor color, 92
 overview of, 92–93
 PNG images only using, 143
 for web images in Photoshop, 405–406

rights
 to content created by others, 332
 copyright issues. See copyright
 Digital Rights Management, 336
 ownership of works, 343–347
 for preexisting content, 333–335

rights-managed images, 74

rights, negotiating content
 copyleft, 342–343
 derivative works, 339–340
 overview of, 336–337
 permissions, 340–341

ringtones, mobile phone, 129

.rm files (Real Media) format, digital video, 173

rolling ball animation, 151–152

rollovers, for clickable buttons, 36

ROM (read-only memory), 206

Roman numerals, 48

rotating, modeling 3-D objects by lathing, 85

rotational speed, of CDs, 433

ROY G. BIV, 88

royalties, clip art, 335

royalty-free images, 74–75

Runtime Revolution, page-based authoring
 system, 228–229

Russian alphabet, 46

+RW, and DVD formats, 435

S

S-Video (Separate Video), 166–167

SACD (Super Audio CD) formats, 113

safe title area, 170, 173

SAG (Screen Actors Guild)
 acquiring talent from, 348
 working with union contracts, 349–351

sampling
 digital audio recordings, 110
 file size vs. quality and, 111–113
 speech and music, 126

sans serif, vs. serif, 24–25, 398

saturation, of images across platforms, 78

scalability, of vector-drawn objects, 82

scanners
 image, 78–79
 OCR, 215–216

scenes
 creating 3-D, 84–86
 creating animated, 155–157

scheduling
 with idea management software, 264
 multimedia projects, 273–274

scope creep, 275

scope, determining project, 260

Score facility, Director, 230

Screen Actors Guild (SAG)
 acquiring talent from, 348
 working with union contracts, 349–351

screen-grabbers, 222

screen savers, and CRT screens, 171

Scriabin, 19th-century multimedia work of, 8

scripting
 adding sound with, 125
 choosing authoring tool for, 232
 determining navigation with, 2
 Unicode standard and, 44

scriptwriters, multimedia, 246–248

SCSI (Small Computer System Interface),
 204–205

.sea extension, Macintosh, 428

SeaMonkey browser, 378

search engines, 358–359, 377
 overview of, 377
 URLs for, 439

SECAM (Sequential Color and Memory),
 167–168

second-level domains, 362–363

Second Life, 3-D, 384

sectors, CD data storage, 432

self-extracting archives, 428

SemanticWeb, 372

Separate Video (S-Video), 166–167

sequencer software, for MIDI scores, 114–116

Sequential Color and Memory (SECAM),
 167–168

serif, vs. sans serif, 24–25, 398

servers, web, 360, 375–376

services, Internet, 367–368

shading
 applying to 3-D objects, 86
 rendering background and object into
 image with, 86–87
 in user interface design, 311

shapes, 3-D modeling with, 85

SharePoint Designer, 380

- Shockwave player
 - delivering 3-D, 384
 - video for web page, 415–416
- shooting video. *See* video, shooting and editing
- Short Message Service (SMS) text messages, 21–22
- shotgun microphones, shooting video, 181
- SHOUTING, online messaging, 24
- sidebars, web background, 411
- simple branching, for interactivity, 233
- 16:9 aspect ratio
 - computer monitor resolution, 172
 - converting to 4:3 in video production, 181–182
 - digital television resolution, 173
 - HDTV vs. VGA, 170
- sizing, vector-drawn object vs. bitmaps, 82
- SMALL CAPS, accenting words with, 27
- Small Computer System Interface (SCSI), 204–205
- small-device workspace, web design, 396–397
- smartphones, web page layout for, 395
- Smith Micro's Poser 3-D modeling program, 146–147
- SMS (Short Message Service) text messages, 21–22
- snack-size media, 349
- sodium vapor lamps, for street lighting, 90
- SoftImage 3-D modeling software, Avid, 218
- software
 - 3-D modeling and animation, 218–219
 - animation, video, and digital movie, 221–222
 - beta test feedback, 424
 - bitmap, 76–77
 - digital audio files vs. MIDI, 120
 - dithering, 96
 - helpful accessories, 222
 - hot, simple and deep, 302
 - idea management, 263–264
 - image-editing, 220–221
 - for MIDI scores, 114–116
 - networking computers with client/server, 202
 - OCR, 215–216
 - overview of, 212–214
 - painting and drawing, 216–217
 - project manager understanding, 242
 - sound-editing, 221
 - text editing and word processing, 214–215
 - web server configurations, 376
- software engineer, role in multimedia, 251
- software robots, 56
- Soldier, Dave, 127
- Sonny Bono Copyright Term Extension Act, 334
- sons (or stampers), for CDs, 430
- Sony's Station web site, 6–7
- sound
 - audio file formats, 121–123
 - audio interface design, 312–313
 - digital audio, 106–113
 - editing tools, 221
 - locating preexisting content from libraries of, 335
 - managing over Web, 383
 - MIDI audio, 113–118
 - MIDI audio vs. digital, 118–120
 - multimedia audio specialists role, 250–251
 - multimedia systems and, 120–121
 - police fight against cellphone recordings, 133
 - power of, 104–106
 - review, 134–138
 - Vaughan's Law of Multimedia Minimums and, 123–124
 - for Web, 413
- sound, adding to your multimedia project
 - audio CDs, 128–129
 - audio recording, 126–128
 - copyright issues, 131–132
 - for Internet, 130–131
 - keeping track of your sounds, 128
 - overview of, 124–125
 - space considerations, 125–126
 - testing and evaluation, 131
 - for your mobile, 129
- Sound Control Panel, 120–121
- sound synthesizer, 114–117
- sound waves, 104
- source material, adding sound to project, 124
- space, adding sound to project, 125–126
- speakers, designing multimedia project, 211
- special characters in HTML, 401
- speech files, Web, 383
- spell checker, 223
- spelling, irregularity of English, 21–22
- splicing and assembly, editing digital recordings, 109
- spreadsheets
 - enhancing content of, 224–225
 - scheduling multimedia projects, 273–274
- sprites, animation, 221
- SQL (Structured Query Language), 372–373
- Squizz (morphing tool), 147
- stage, Director authoring tool, 230
- stampers (or sons), for CDs, 430
- standalone project version, authoring tool for delivery of, 234
- Standard Television (STV), 169
- standards
 - analog broadcast video, 167–168
 - compact disc, 431–434
 - DVD, 436–438
- Stansberry, Domenic (multimedia scriptwriter), 247–248
- startup stage, production, 319
- Station web site, Sony, 6–7
- steady-cam balancing attachment, shooting platforms, 181
- stereo vs. mono recordings, 111
- still images
 - 3-D drawings and renderings for, 83–88
 - animated scenes with, 155–158
 - bitmaps for. *See* bitmaps
 - coloring. *See* color
 - computer animation from multiple, 150–155, 158–159
 - overview of, 70–71
 - vector-drawn objects for, 80–81
 - vector-drawn objects vs. bitmaps, 81–83
- still photo libraries, 335
- stock footage, 333, 335
- Stone Design's GIFfun, 155
- storage media, 320–321
- storage space
 - adding sound to project, 125–126
 - evaluating sound files in multimedia projects, 131
 - multimedia, 206–208
- storyboard
 - adding sound using, 124
 - as architectural drawing, 300–301
 - choosing authoring tool for, 231–232
 - costs of, 276
 - creating animated scene with, 155–157
 - designing projects with, 295, 314–315
 - determining navigation with, 2
 - preplanning video project with, 183
 - video titles, 186
- Strata 3D modeling software, 218
- streaming files, sound over Web, 130
- streaming latency, 130
- streaming playback, sound over Web, 383
- Streuli, Oliver (multimedia video specialist), 249
- structural depth design, 297–303
- structural design
 - hot spots, 303–306
 - hyperlinks, 303–306
 - icons, 306–308
 - navigation, 296–297
 - structural depth, 297–303
- structural design, buttons, 303–306
- Structured Query Language (SQL), 372–373
- STV (Standard Television), 169
- styles
 - font, 22
 - HTML document markup with tags, 38
 - production design, 223
 - text button design, 303
 - text design for Web, 398
 - using AJAX, 373
- subject matter expert, 242
- subtractive color method, 91–92

sunlight, white light from, 90
 Super Audio CD (SACD) formats, 113
 surface structures, 297–298
 Surmacz, Jon, 133
 sustain of sound, MIDI files, 118
 .svg file format. See SVG (Scalable Vector Graphics) files
 SVG (Scalable Vector Graphics) files
 for animation, 149–150
 browsers enabled for HTML5 reading/
 displaying, 382
 file size advantage of, 82
 overview of, 80
 SWF format (.swf)
 animation, 149
 defined, 123
 video for web page, 415–416
 Swish, animation software, 414
 symbols, 32–33
 system sounds, 120–121

T

table of contents
 bid proposals, 286
 for production work, 223
 <TABLE> tag, HTML, 398–399
 tables, for production work, 223
 tablet computers, 37
 Tagged Interchange File Format (TIFF), 97
 tags, HTML
 companies releasing not yet approved,
 374–375
 developing multimedia for Web, 378,
 393, 395–396
 in HTML5, 393–395
 marking up HTML documents, 38
 talent
 acquiring releases, 351–352
 agencies, 348
 locating professionals, 348–349
 overview of, 347–348
 review, 353–357
 working with union contracts, 349–351
 target audience, bid proposals, 287
 task planning
 process of making project, 266–268
 project estimates, 274–277
 scheduling project, 273–274
 TCP/IP (Transmission Control Protocol/
 Internet Protocol), 364
 TCP (Transmission Control Protocol), and IP
 addresses, 364
 team
 building, 254–255
 building matrix chart of required skills,
 267–268
 hazards and annoyances of working
 with, 323
 skills of. See multimedia skills, of team
 members
 web sites for finding talent, 267–268
 technical specifications, in bid proposals, 287
 templates
 creating video titles, 186–187
 for production work, 223
 terabytes, 206–207
 testing project
 alpha stage, 271
 beta stage, 271
 costs of, 280
 overview of, 197
 prototype, 269
 sound files, 125, 131
 by team members, 242
 before work is finalized and released,
 423–425
 text
 animating, 31–32
 anti-aliasing, 53
 authoring tools for, 232
 buttons, 35–36
 character sets and alphabets, 42–44
 designing with, 26–27
 editing tools for, 214–215
 embedding multimedia materials into
 documents, 224–225, 227
 fields for reading, 36–38
 font wars, 40–42
 fonts. See fonts
 hot spots, 303
 HTML documents and, 39–40
 hypertext, 53–60
 languages in world of computers, 46–50
 mapping text across platforms, 45–46
 navigation menus using, 34–35
 overview of, 18–20
 permission to use copyrighted, 340
 plug-ins for, 382
 power and irregularity of English, 21–22
 power of meaning, 20–21
 review, 61–67
 symbols and icons, 32–33
 user interface design using 2-D and
 3-D, 311
 video titles with, 186–188
 for Web, 398–402
 word processing tools, 214–215
 text anchors, 305
 textures, 3-D objects, 85
 Theora video codec, 173–174, 176
 thesaurus, importance of word choice, 21
 third-party players, and browser
 performance, 375
 3-D animation
 computer-based, 146
 kinematics in, 146–147
 overview of, 143
 preparing files for Web, 149
 realism of, 142
 of text in user interface design, 311
 3-D images
 creating panoramas, 88
 creating virtual reality with, 9
 drawing and rendering, 83–87
 vector-drawn objects, 80
 3-D modeling software, 218–219
 3-D technologies, on Web, 384–385
 3D Invigorator, 143
 3D Studio Max, 149
 3gp files, GSM mobile phones, 123
 thumb drives, 207
 TIFF (Tagged Interchange File Format), 97
 tilde (~), Spanish, localization and, 49
 time-based authoring tools, 229–230
 time-based structure, chronological navigation
 maps, 302–303
 time, estimating project, 276–277
 time-shifting, 349
 time stretching, digital audio recordings, 111
 Times Roman font, for web text, 398
 timing, in cel animation, 144
 titles
 choosing font, 27
 creating video, 186–188
 packaging project for delivery, 437
 TiVo technology, 5
 TLDs (top-level domains), 361–362
 token language, encoding speech files for Web
 into, 383
 ToolBook, page-based authoring system,
 228–229
 top-level domains (TLDs), 361–362
 Totally Hip's LiveStage Pro, 174
 Touch and Hold, on small devices, 396
 tracking
 adjusting analog video tape during
 playback, 166–167
 defined, 23
 receipt of materials for project, 321
 tracks, audio CD, 431–432
 training programs, using multimedia, 3
 transfer rates, for connections, 203
 translate, animation, 142
 Transmission Control Protocol/Internet
 Protocol (TCP/IP), 364
 Transmission Control Protocol (TCP), and IP
 addresses, 364
 transparency, creating web image, 407–408
 transportation, of project to remote clients, 321
 Trident engine, 395
 trimming, digital recordings, 109
 tripods, stable shooting platform, 181
 TrueType, 41, 52–53
 truncation, word search method in hypermedia
 systems, 58
 tungsten lamp filaments, 90

tweening
 in cel animation, 144
 in computer-based animation, 145

TweenMax, 150

24-bit color systems, 95

2 1/2-D animation, 142–143, 145

2-D animation
 cel-based, 145
 computer-based, 145–146
 defined, 142
 examples of, 142
 for text in user interface design, 311
 translating into 3-D, 218–219

Type 1 and 3 PostScript fonts, 41

typeface
 avoiding interlacing flicker on CRTs, 171–172
 choosing text fonts, 27
 defined, 22
 designs, 50–53
 serif vs. sans serif, 25

U

ULead COOL 360, 88

ULead's GIF Animator, 145, 155

Ultimatte, 184

ultraviolet light, damaging to humans, 90

umlaut (¨), German, 49–50

underscan, and computer monitor, 173

Unicode standard, 43–44

Uniform Resource Locator. See URL (Uniform Resource Locator) addresses

unions
 acquiring talent from, 348
 working with contracts, 349–351

Unisys, and GIF images, 402–403

Universal Product Code (UPC), barcode readers, 210

Universal Serial Bus (USB), 204–205, 207

unlimited use, of rights, 338

UPC (Universal Product Code), barcode readers, 210

uppercase, 24

URL (Uniform Resource Locator) addresses
 case sensitivity of, 24
 handling “404-not found” errors, 212
 notifying server as to which daemon to bring into play, 368

US domain, Internet addresses in, 363–364

USB (Universal Serial Bus), 204–205, 207

USEMAP attribute of tag, 411–412

user interface design
 defined, 308
 engineering details for, 297
 graphical approaches, 310–312
 GUIs, 309–310
 Novice/Expert modes, 308
 online references for, 313

V

validation, online tools for code, 423

Vatican artwork collection on Internet, 331

Vaughan, Victor C., 6

Vaughan's General Rule for Interface Design, 309

Vaughan's Law of Multimedia Minimums
 balancing production value of project, 330
 choosing authoring tool for editing, 231
 overview of, 123–124
 for video equipment and services, 180–181

Vaughan's Rule for Keeping Up, new software and features, 212

VCA connectors, for analog video display, 167

VCRs (video cassette recorders), 167–168

vector-based drawing program, 76

vector-drawn objects
 converting between bitmaps and, 82–83
 how it works, 80–81
 overview of, 70, 80
 vs. bitmaps, 81–83

vectors
 defined, 80
 plug-ins enabling viewing of, 382–383

VectorWorks 3-D modeling software, 218–219

Verdana font, designing text for Web, 31, 398

version control, for project files, 321

very high level language (VHLL), and authoring tools, 232

VGA video standard
 aspect ratio, 40
 comparing HDTV to, 170
 screen resolutions for computer monitors, 172

VHLL (very high level language), and authoring tools, 232

video
 analog, 166–168
 digital, 168–173
 digital video containers, 173–178
 how it works and is displayed, 165–166
 making movies from, 221–222
 multimedia in schools, 4
 obtaining clips, 179–180
 overview of, 164
 using, 164–165
 for Web, 414–416

video cassette recorders (VCRs), 167–168

Video CD (Karaoke CD), 431

video, shooting and editing
 chroma keys, 184–185
 composition, 185–186
 lighting, 183–184
 nonlinear editing, 188–190
 overview of, 180–181
 review, 190–195
 shooting platform, 181–183
 storyboarding, 183

titles and text, 186–188
 video specialist role in, 248–249

video specialists, 248–249

video streams, 383

<VIDEO>tag, HTML5, 395, 414–415

viewport, 395–396

visual programming, choosing authoring tool, 232

Vizcaino v. Microsoft, 279

voice recognition systems, 210

volume, adjusting in digital recordings, 109

Vorbis audio codec, 173, 176

VR (virtual reality) files, 9, 416

VRML (Virtual Reality Modeling Language), 9, 384

VSPACE attribute, tag, 400–402

W

W3C Semantic Web Activity, 372

Walt Disney Company, 334

WANs (wide area networks), 202–203, 360–361

Washington On Line, 4–5

WAV (wave format) files, 120–121

Web
 2.0 sites, 374
 importance of text on, 19–20
 standards for transmitting VR scenes, 9

web browsers. See browsers

web page makers, 377–381

web pages
 coding initial caps for, 28
 fonts for, 31
 hot spots in, 304–306
 MIDI vs. digital audio files, 119
 multilanguage, 49–50
 optimal length of, 26–27
 putting vital text elements and menus at top of, 28
 sound for, 130
 XML and dynamic, 372–373

Web-safe color palette, 94

web servers, 360, 375–376

web site
 builders, 377–381
 downloading image bitmap from, 74
 online tools for code validation, 423
 producers, 253–254
 skills needed, 1
 URLs for, 439

Websites, 349

WebKit engine, 395

white balance, shooting video using, 186

White Book standard, for Video CD (Karaoke CD), 431

white space, 28, 311

white, using, 90

wide area networks (WANs), 202–203, 360–361

- WiFi, LANs using, 202
 - Williams, Mark (multimedia program manager), 242–243
 - Winamp, AOL, 129
 - Windows Audio Video Interleaved (.avi) format, 3-D animation for Web, 149
 - Windows Live Movie Maker, 188–189
 - Windows Media Audio (WMA), 122
 - Windows Media Format (.wmv files), 173
 - Windows Media Player 12, incorporating DRM, 336
 - Windows Media Rights Manager, with DRM, 336
 - Windows operating system (OS)
 - GUI design, 309
 - icon image files, 306–307
 - Macintosh capable of running, 202
 - Macintosh vs., 201–202
 - for multimedia projects, 200–201
 - networking, 202–203
 - screen-grabbers and format converters, 222
 - self-extracting archives in, 428
 - Worldwide OS Market Share of, 201
 - Wine, Hal (multimedia programmer), 251–252
 - WinImages, 147
 - wizards, for production work, 223
 - WMA (Windows Media Audio), 122
 - WMV containers, codec wars, 176
 - .wmv files (Windows Media Format), 173
 - word choice
 - importance of meaning, 20–21
 - instant messaging jargon, 21–22
 - word processing programs
 - embedding multimedia materials into, 224–225, 227
 - overview of, 214–215
 - word processors, 214–215
 - word relationships, searching in hypermedia systems, 57
 - word searching, in hypermedia systems, 57–58
 - WordPerfect, word processor, 215
 - workgroups, communication among members of, 200
 - World Wide Web
 - delivering on, 438–440
 - HTML and, 372–373
 - hypertext and. See hypertext search engines on, 358–359
 - tools for, 374–375
 - World Wide Web design
 - animation for, 413–414
 - desktop workspace, 396
 - developing for, 392–393
 - HTML as markup language, 393–396
 - nibbling, 397–398
 - overview of, 392
 - review, 417–421
 - small-device workspace, 396–397
 - sound for, 413
 - text for, 398–402
 - video for, 414–416
 - World Wide Web design, images for
 - background, 409–410
 - backgrounds, 405–408
 - clickable buttons, 411
 - client-side image maps, 411–412
 - flowing text around, 400–402
 - GIF and PNG images, 402–403
 - JPEG images, 403–404
 - overview of, 402
 - separate Internet HTTP connection required for every, 396
 - using GIF vs. JPEG, 404
 - using Photoshop, 405–408
 - WORM (write-once, read only) CD-ROMs, 431, 433–434
 - worship, multimedia in places of, 8–9
 - writers, multimedia, 246–248
 - .wrl extension, VRML, 9
 - WYSIWYG (What You See Is What You Get) support
 - printouts from computer monitor, 25
 - of web page makers and site builders, 379–380
-
- ## X
-
- x-height, fonts, 22
 - XML (eXtensible Markup Language)
 - building dynamic web pages, 372–373, 378
 - creating multimedia projects on Web, 1
-
- ## Y
-
- YCC color model, 94
 - YELLING, in online messaging, 24
 - Yellow Book standard, 431, 433–434
 - YIQ color model, 94
 - YUV color model, 94
-
- ## Z
-
- z axis. See 3-D images
 - Zaxwerks, 143

LICENSE AGREEMENT

THIS PRODUCT (THE "PRODUCT") CONTAINS PROPRIETARY SOFTWARE, DATA AND INFORMATION (INCLUDING DOCUMENTATION) OWNED BY THE MCGRAW-HILL COMPANIES, INC. ("MCGRAW-HILL") AND ITS LICENSORS. YOUR RIGHT TO USE THE PRODUCT IS GOVERNED BY THE TERMS AND CONDITIONS OF THIS AGREEMENT.

LICENSE: Throughout this License Agreement, "you" shall mean either the individual or the entity whose agent opens this package. You are granted a non-exclusive and non-transferable license to use the Product subject to the following terms:

(i) If you have licensed a single user version of the Product, the Product may only be used on a single computer (i.e., a single CPU). If you licensed and paid the fee applicable to a local area network or wide area network version of the Product, you are subject to the terms of the following subparagraph (ii).

(ii) If you have licensed a local area network version, you may use the Product on unlimited workstations located in one single building selected by you that is served by such local area network. If you have licensed a wide area network version, you may use the Product on unlimited workstations located in multiple buildings on the same site selected by you that is served by such wide area network; provided, however, that any building will not be considered located in the same site if it is more than five (5) miles away from any building included in such site. In addition, you may only use a local area or wide area network version of the Product on one single server. If you wish to use the Product on more than one server, you must obtain written authorization from McGraw-Hill and pay additional fees.

(iii) You may make one copy of the Product for back-up purposes only and you must maintain an accurate record as to the location of the back-up at all times.

COPYRIGHT; RESTRICTIONS ON USE AND TRANSFER: All rights (including copyright) in and to the Product are owned by McGraw-Hill and its licensors. You are the owner of the enclosed disc on which the Product is recorded. You may not use, copy, decompile, disassemble, reverse engineer, modify, reproduce, create derivative works, transmit, distribute, sublicense, store in a database or retrieval system of any kind, rent or transfer the Product, or any portion thereof, in any form or by any means (including electronically or otherwise) except as expressly provided for in this License Agreement. You must reproduce the copyright notices, trademark notices, legends and logos of McGraw-Hill and its licensors that appear on the Product on the back-up copy of the Product which you are permitted to make hereunder. All rights in the Product not expressly granted herein are reserved by McGraw-Hill and its licensors.

TERM: This License Agreement is effective until terminated. It will terminate if you fail to comply with any term or condition of this License Agreement. Upon termination, you are obligated to return to McGraw-Hill the Product together with all copies thereof and to purge all copies of the Product included in any and all servers and computer facilities.

DISCLAIMER OF WARRANTY: THE PRODUCT AND THE BACK-UP COPY ARE LICENSED "AS IS." MCGRAW-HILL, ITS LICENSORS AND THE AUTHORS MAKE NO WARRANTIES, EXPRESS OR IMPLIED, AS TO THE RESULTS TO BE OBTAINED BY ANY PERSON OR ENTITY FROM USE OF THE PRODUCT, ANY INFORMATION OR DATA INCLUDED THEREIN AND/OR ANY TECHNICAL SUPPORT SERVICES PROVIDED HEREUNDER, IF ANY ("TECHNICAL SUPPORT SERVICES").

MCGRAW-HILL, ITS LICENSORS AND THE AUTHORS MAKE NO EXPRESS OR IMPLIED WARRANTIES OF MERCHANTABILITY OR FITNESS FOR A PARTICULAR PURPOSE OR USE WITH RESPECT TO THE PRODUCT.

MCGRAW-HILL, ITS LICENSORS, AND THE AUTHORS MAKE NO GUARANTEE THAT YOU WILL PASS ANY CERTIFICATION EXAM WHATSOEVER BY USING THIS PRODUCT. NEITHER MCGRAW-HILL, ANY OF ITS LICENSORS NOR THE AUTHORS WARRANT THAT THE FUNCTIONS CONTAINED IN THE PRODUCT WILL MEET YOUR REQUIREMENTS OR THAT THE OPERATION OF THE PRODUCT WILL BE UNINTERRUPTED OR ERROR FREE. YOU ASSUME THE ENTIRE RISK WITH RESPECT TO THE QUALITY AND PERFORMANCE OF THE PRODUCT.

LIMITED WARRANTY FOR DISC: To the original licensee only, McGraw-Hill warrants that the enclosed disc on which the Product is recorded is free from defects in materials and workmanship under normal use and service for a period of ninety (90) days from the date of purchase. In the event of a defect in the disc covered by the foregoing warranty, McGraw-Hill will replace the disc.

LIMITATION OF LIABILITY: NEITHER MCGRAW-HILL, ITS LICENSORS NOR THE AUTHORS SHALL BE LIABLE FOR ANY INDIRECT, SPECIAL OR CONSEQUENTIAL DAMAGES, SUCH AS BUT NOT LIMITED TO, LOSS OF ANTICIPATED PROFITS OR BENEFITS, RESULTING FROM THE USE OR INABILITY TO USE THE PRODUCT EVEN IF ANY OF THEM HAS BEEN ADVISED OF THE POSSIBILITY OF SUCH DAMAGES. THIS LIMITATION OF LIABILITY SHALL APPLY TO ANY CLAIM OR CAUSE WHATSOEVER WHETHER SUCH CLAIM OR CAUSE ARISES IN CONTRACT, TORT, OR OTHERWISE. Some states do not allow the exclusion or limitation of indirect, special or consequential damages, so the above limitation may not apply to you.

U.S. GOVERNMENT RESTRICTED RIGHTS: Any software included in the Product is provided with restricted rights subject to subparagraphs (c), (1) and (2) of the Commercial Computer Software-Restricted Rights clause at 48 C.F.R. 52.227-19. The terms of this Agreement applicable to the use of the data in the Product are those under which the data are generally made available to the general public by McGraw-Hill. Except as provided herein, no reproduction, use, or disclosure rights are granted with respect to the data included in the Product and no right to modify or create derivative works from any such data is hereby granted.

GENERAL: This License Agreement constitutes the entire agreement between the parties relating to the Product. The terms of any Purchase Order shall have no effect on the terms of this License Agreement. Failure of McGraw-Hill to insist at any time on strict compliance with this License Agreement shall not constitute a waiver of any rights under this License Agreement. This License Agreement shall be construed and governed in accordance with the laws of the State of New York. If any provision of this License Agreement is held to be contrary to law, that provision will be enforced to the maximum extent permissible and the remaining provisions will remain in full force and effect.