



TWISTED THROTTLE

Bolt-On Touring Accessories that fit YOUR motorcycle!



ERGONOMICS

- Windscreens
- Footpegs & Rearsets
- Shift Levers
- Brake & Clutch Levers
- Mirror Wideners
- Bar Risers & Barbacks
- Throttle Locks

LUGGAGE

- Topcases
- Sidecases
- Saddlebags
- Dry Bags
- Tankbags
- Rearbags

PROTECTION

- Crashbars
- Skid plates
- Frame Sliders
- Handguards
- Engine Case Covers
- Engine Case Sliders
- Radiator Guards
- Axle Sliders

RIDING GEAR

- Men's Jackets & Pants
- Women's Jackets & Pants
- Gloves
- Boots
- Helmets
- Base Layers
- Heated Gear
- Socks

ELECTRONICS

- Auxiliary Lighting
- Communicators
- Video Cameras
- GPS
- Radar Detectors
- Gadget Mounts & Cradles
- Air Horns

CAMPING

- Flashlights
- Tents
- Sleeping Bags
- Sleeping Pads

Visit us online to find more bike-specific products, photos, and reviews from other riders.

WWW.TWISTEDTHROTTLE.COM

TIRES & TOOLS

Twisted Throttle Factory Store and Showroom

Come visit our awesome World Headquarters, Factory Store and Showroom at 570 Nooseneck Hill Rd in Exeter, Rhode Island.

Our Factory Store includes a well-equipped 4,500 square foot showroom, an installation and service department, prototyping shop, video studio, a café with a presentation stage, 10' wide movie screen, and PS3 racing games! We even have free wifi for motorcycle travelers.

As if that's not enough, we've opened our on-site campground so long-distance motorcycle travelers can pitch a tent and stay overnight. We also host seminars, maintenance days, training events, moto movie nights, holiday parties and other epic happenings. Count on this being a future venue for rallies and other gatherings.

We're located near some of the best motorcycling roads and trails in Southern New England, making the Factory Store a great destination for shopping or hanging out with fellow riding fanatics.

We rent fully equipped "Twisted" motorcycles (pages 10-11) for those visiting from out of town that want to try our products or just discover the beauty of New England.

Twisted Throttle
Factory Store and Showroom
570 Nooseneck Hill Rd
Exeter, RI 02822
GPS: 41.564325,-71.659223



Come to our Open House Party on May 24, 2014!
Enjoy free food, giveaways, presentations, discounts and one heck of a good time.

Twisted Throttle Canada

Starting in 2014, Twisted Throttle is branching out to the Great White North with our Canadian distribution center in Ontario to better serve our loyal Canadian customers.

Twisted Throttle acquired "A Vicious Cycle", a Southern Ontario-based parts and accessories distributor and long-time Twisted Throttle dealer. This acquisition will enable Twisted Throttle to expand our reach into the Canadian market, allow access to additional distributed brands, and most importantly, provide better customer service to all our Canadian customers.

This transition will take place over the course of 2014, with no disruption to customers. Until operational processes are merged, there will be no change in Canadian order processing or fulfillment. Soon, we will begin to utilize A Vicious Cycle's Ontario warehouse to shorten delivery times to our Canadian customers and reduce any cross-border shipping inconveniences.



Who is Twisted Throttle? - Twisted Today - Our Brands - Factory Store - Service Department - Project Bikes - Rent a Twisted Bike - Adventures with Twisted Throttle - Community Sponsored Riders	THE TWISTED EXPERIENCE	2
Footpegs - Crossbars - Handlebar Risers & Mounts - Heated Grips - Mirrors - Mirror Wideners - Clutch/Brake Levers - Shift Levers - Rearsets - Throttle Locks - Windscreens and more	ERGONOMICS	16
Crashbars - Bar End Sliders - Engine Case Covers - Exhaust Protectors - Frame Sliders - Front Axle Sliders - Swingarm Sliders - Handguards - Headlight Guards - Radiator & Oil Cooler Guards - Skid Plates	PROTECTION	37
Heated Clothing - Riding Jackets - Riding Pants - Motorcycle Gloves - Helmets - Boots - Gear Accessories - Armor Upgrades - Socks - Base Layers - Rainsuits	RIDING GEAR	62
Bluetooth Intercoms - Video Cameras - GPS - Gadget Mounts - Device Cradles - Horns - Electrical Sockets - Tankbag electrification - Auxiliary Lighting & Mounts - Power Distribution - Heated Grips - LED Lighting	ELECTRONICS	92
Sidecases - Topcases - Soft Luggage - TraX Boxes - Luggage Racks - Luggage Accessories - Visibility Kits - RotoPax	LUGGAGE	122
Tents - Tarps - Sleeping Bags - Sleeping Pads - Camp Chairs - Flashlights - Wine Storage - Camping Accessories	CAMPING	177
Tires - Tire Tools - Tire Repair Kits - Oil Filters - Air Filters - Mini Air Compressors - Manuals - Inner Tubes - Oil - Chain Oilers - Steel Braided Brake Lines - Batteries - Battery Chargers - Gifts	TOOLS & CONSUMABLES	182
Find Accessories That Fit Your Bike	WHAT FITS MY BIKE?	192
Index - Event Calendar - How to Order	INDEX & ORDERING INFO	270

CATALOG

Visit [TwistedThrottle.com/freecatalog](https://www.twistedthrottle.com/freecatalog) to let us know if you would like to receive a catalog for yourself or a friend.

MAILING LIST

We do not share our mailing list with any outside organizations and will only send you the Twisted Throttle email newsletter upon your request.

[TwistedThrottle.com/newsletter](https://www.twistedthrottle.com/newsletter)

WHERE ARE ALL THE PRICES?

If we've missed the price of an item, please visit [TwistedThrottle.com](https://www.twistedthrottle.com), or call **+1 (855) 255-5550** for pricing. *Prices printed in this catalog are subject to change.*



Twisted History



The seeds of Twisted Throttle were sown in 2002 when Erik "Mr. Twisted" Stephens discovered that he couldn't find quality touring gear for his new Suzuki V-Strom. Erik tracked down a German manufacturer that produced the accessories he was pining for. The manufacturer told him that they would only consider shipping to the US if he ordered a dozen bikes worth of parts. This prompted Erik to organize a group buy for a handful of early Suzuki V-Strom fanatics. Recognizing the unmet need in North America for high quality adventure gear coupled with outstanding service, Erik set up shop. His garage became the center of operations and a name was chosen to give his new venture an identity: Twisted Throttle.



The original headquarters in 2004 with a whopping 200 square feet.



Erik working hard in 2006 to make Twisted what it is today.



By 2010, Twisted Throttle was well established in Peacedale, RI.

Today, Twisted Throttle is housed in a 27,000 square foot facility with warehouse and showroom in Exeter, RI.

Twisted Throttle Today



Today, there are over 30 Twisted employees working in a newly renovated, 27,000 square foot facility in Exeter, RI that includes a warehouse, installation bays, prototyping shop, café, photo studio, and a beautifully designed and well-equipped 4,500 square foot retail showroom.

Twisted Throttle specializes in expert product development and exceptional customer service. We serve as the North American distributor and marketing engine for most of the brands we carry, including SW-MOTECH/Bags Connection, R&G, Barkbusters, Denali, DrySpec, Macna, and others. We have an in-house marketing team for dealer support, branding, event marketing, web development, and video production. Our services also include custom fabrication, short run manufacturing, and accessory development for motorcycle manufacturers.

Also, because Twisted Throttle believes in education, we are now offering various training opportunities for street and off-road riders, including an adventure camp and track days, as well as skills seminars at our factory store.

For 2014 Twisted Throttle continues on our path toward providing the best customer service and support, designing and building the finest products, and, most of all, having a lot of fun doing it.

See the 2014 **EVENT CALENDAR** in the back of the catalog and go to our events page at: www.twistedthrottle.com/news-and-events



Our World Headquarters in Exeter, RI.



The Twisted crew now numbers over 30.



Our facility in Exeter, RI has 27,000 square feet of motorcycle gear.



Say hello at shows and rallies throughout the year.



Our headquarters is located near some of the best motorcycle roads in New England, drawing riders from the region to shop and visit.

We're a Bit Different



There are a lot of companies selling motorcycle accessories and riding gear, so what makes Twisted Throttle so great? One thing is that all our employees ride motorcycles, so they know their products; that can't be said for many companies selling motorcycle accessories.

We're passionate about providing you with an expert pit crew of riders, mechanics, and adventurers to give useful advice on gearing up for your next adventure. And that advice is always based on personally experiencing our products. Whether you're crossing town, the racetrack, or the Sahara, we'll help you focus on enjoying your ride.

Likewise, we stand behind the claims we make on our gear. Every item on our website has been tested by a member of the Twisted Crew, often for months or years of personal riding time. If we say it's waterproof, we know it because someone in our office probably rode 300 miles in a hurricane just to make sure. If we say it'll handle 30 amps of power, it's because one of our guys loaded it up with more and more widgets until he blew the fuse. If we say a crashbar will handle a crash, it's because we played crash test dummy.

If a product is in our catalog or on our website you can rest assured that it fits, it works and it does what we say it will. If you have any problems with an installation, call our gear experts and we will walk you through the process and share any tricks we've learned to make the process easier.

Items you buy from us might not be the cheapest on the planet, but the premium quality products you get from us will last for many years and miles. We use and abuse the products we sell to ensure they will last in the hands of the most demanding riders!

What you get when you shop with us:

- 2 year Twisted Throttle warranty on all products, regardless of whether the manufacturer warranty is shorter
- Lifetime tech support
- 5% cash back to use toward future orders
- Free shipping for all USA orders over \$199.99 (\$350.00 for Canada orders)
- Moneyback guarantee without restocking fee
- Pricematch guarantee
- Blindingly fast order processing

For more details, visit <http://www.TwistedThrottle.com/twisted-difference>

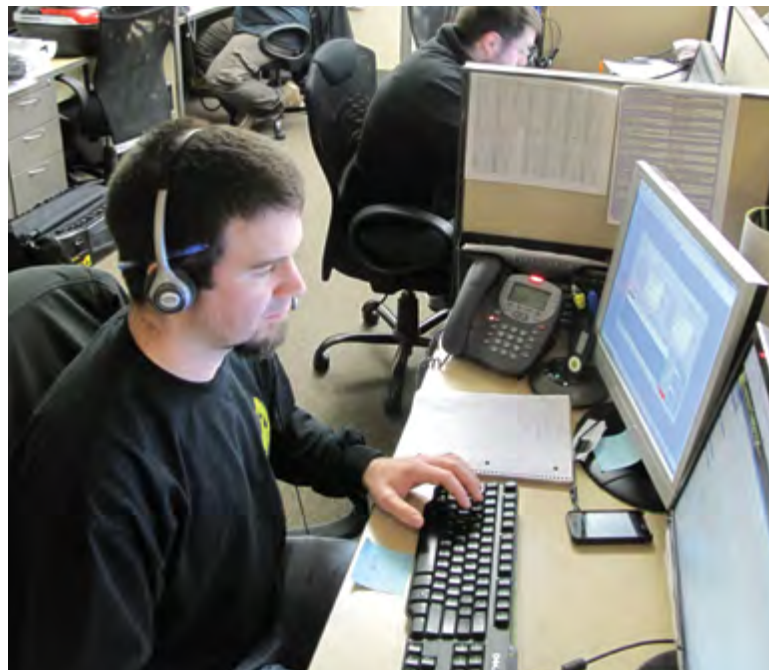

All our friendly customer service staff are Gear Experts that ride.



Testing underway with the Twisted R1200GS LC.



The Twisted Crew goes for a weekend dual-sport adventure in Vermont.



Adam douses Erik to prove the waterproof properties of his Macna jacket, gloves and pants.



Erik putting the company Triumph Street Triple through its paces.

The Twisted Brands



Twisted Throttle believes that quality reflects directly on our reputation for providing top-shelf products. That is why we are very particular about what brands we associate with and the products we choose to carry. You won't find lower quality accessories and riding gear that many other retailers choose to sell. We understand the importance of having products that withstand the rigors of a life on two wheels. Our product range is carefully curated to provide the easiest installation, best ease-of-use, and durability available.

You may not recognize many of the brands we carry. That's because we scour the world to bring unique, well made and innovative accessories as well as gear to our continent. This means a lot of travel to really cool places to test really cool products. It's the sacrifice we're willing to make to bring you the best.

Sometimes we find cool stuff, but it doesn't quite meet our standards. In this case, we coach our suppliers to add the features and durability we know our North American riders will demand.

Sometimes, there is no manufacturer making something we know our customers are asking for. This is when we prototype our own products. We design and manufacture many of these products right here in North America. Some of the brands we've developed include DrySpec, PowerHub, and Denali.

The quest for perfect products has led us to custom fabrication, short run manufacturing, and accessory development for motorcycle manufacturers.



Nate is our product development, prototyping and fabricating guru who has developed the Denali and DrySpec brands.



DENALI™



A design discussion at the SW-MOTECH/Bags-Connection factory in Rauschenberg, Germany.



interphone

The Twisted Factory Store



Riding gear, crash protection, electronics, lighting, and expert gear advice are just some of the things you will find in our 4,500 square foot showroom. Check out all the cool products for you and your motorcycle. Ask questions and ponder the possibilities. Once you have decided how to spoil yourself and your bike, you can either install your new goodies yourself, or sit back and let our in-house master mechanics do the work. The next time you're in the market for high quality sport touring, street, adventure, and dual-sport bike accessories, stop by the Twisted Throttle Factory Store.

Twisted Throttle's location is right in the heart of the finest motorcycling roads in Southern New England and close to the ocean destinations Rhode Island is known for. This makes Twisted Throttle an ideal destination for riders wanting to shop, hang out and watch videos on our BIG movie screen. Our on-site motorcycle-themed Twisted Cafe is waiting to accommodate hungry travelers.

See the 2014 EVENT CALENDAR in the inside back cover of the catalog or visit our "Events" page at TwistedThrottle.com



Come visit the Twisted Throttle Factory Store and Service Center!



Do not miss the annual Twisted Open House at our World Headquarters in May.



Check out our products in person and get expert advice.



Sign up for our mailing list to learn about various training opportunities.



The Twisted Cafe is ready to serve some hot coffee and entertainment.



Our on-site campground is now up and running for 2014!



Our expert advice makes everyone smile.

Twisted Service Center



Product Installations & Service Done Right!

You can expect expert knowledge and know-how when you trust Twisted's Service Department with your service needs. You can feel confident that your bike is in great hands and the work performed will be top-notch. Our techs welcome customers to observe and ask questions while we work. We don't just want to improve the bikes we're working on, we also want to educate riders along the way.

Available Services:

- Complex wiring and accessory installation
- Tire mounting and pressure monitor installation
- Chain and sprocket installation
- Oil, filter and other fluids
- Routine maintenance tasks
- Brake maintenance, coolant flushes
- Complete outfitting for touring
- Custom fabrication
- Race and track day prep



All maintenance services are available.



No job too big or too small.



Our tech staff is available for accessory installation, electrical installations, tire mounting service and custom fabrication.



Nate installs sidecarriers on a BMW.



We have the expertise to get any job done.



We'll give your bike the attention it needs to perform at its best during your next adventure.



Our well-equipped service department has all the tools necessary for the most complex projects.

Twisted Project Bikes



We prototype, test and IMPROVE our products!

Twisted Throttle is not like most other motorcycle product distributors. We IMPROVE our products based on testing and customer feedback. Most companies have no creative control over what they sell. We do!

Every year, we select a few special motorcycles to deck out with our products and put them to the test in real-world conditions so that we can improve what we sell. Take a look through the photo gallery of project bikes to get an idea of just how far we go to test our products: TwistedThrottle.com/project-bikes

To expand the scope of testing, we also partner with touring/rental companies like MotoQuest, GSM MotoRent and California Superbike School. These companies give us feedback about how our products hold up over the long-term on bikes that take tons of abuse.

This information helps us to improve existing products and develop new items that we feel confident will withstand the toughest riding conditions. We also work with OEM manufacturers to improve their products. Recently, we developed a Zero electric police bike prototype. Honda Canada has also commissioned us to develop parts for the Honda Varadero.

Things we do:

- Prototyping and custom fabrication
- Short run manufacturing of metal, textiles and electronics
- Co-branding of textile luggage and Macna riding gear available
- Brand development
- OEM product development and manufacturing

Check out the Twisted Project Bikes:

TwistedThrottle.com/project-bikes



2012 Suzuki DL650 V-Strom

A great bike deserves great add-ons and our V-Strom project bike received the full Twisted Treatment. Protection, comfort, and style.



2005 Suzuki DR-Z400SM

Our Suzuki DR-z400 SM is the workhorse of the Twisted stable. It serves as track bike, commuter and occasional trailbike. A Jack of all trades.



2013 Triumph Explorer 1200

The office favorite! The Twisted 1200 Explorer is a rock solid on-and-off-road machine that is equipped with tough parts and accessories from SW-MOTECH, R&G, Barkbusters, MRA and more.



2013 BMW R1200GS LC

We outfitted our R1200GS with storage and crash protection products from SW-MOTECH/Bags-Connection, as well as Barkbusters Handguards, a Kaoko throttle lock, R&G axle sliders, and Denali lighting to create a complete adventure-bike package. To see products available for your R1200GS turn to pages 204-208. [See the video of the mighty GS in action at our "Project Bike" page at www.TwistedThrottle.com.](#)



2010 BMW S1000RR

Our BMW S1000RR turns heads at the track and on the highway. Equipped with rock-solid crash protection products and style enhancements from R&G and SW-MOTECH, this is a Twisted favorite. See page 202 for S1000RR products.



2012 Triumph Street Triple R

Our Twisted Street Triple R is setup to handle commuting, back road blasting, long distance travel, and even a fun day at the track.



2013 Honda NC700X

Did someone say budget-friendly battle commuter? That is exactly what we set out to do with our Honda NC700X project bike. It has everything you need to commute to work and take weekend trips in comfort and style.



2010 KTM 690 SMC

The KTM SMC is Mr. Twisted's favorite scoot. With a powerful thumper motor in a lightweight, but razor-sharp frame, the KaTooM rails around racetracks and still can get the job done around town.



2011 Yamaha Super Tenere

The Yamaha Super Tenere handles the twisties and off-road routes with ease. Turn to page 269 for a list of products for the Super Tenere.



2012 ZERO Electric Police Bike

We teamed with Zero to create a police version of the Zero S. Our product designer, Nate, fabricated a custom top rack to carry a TraX topbox and installed a windshield and gadget mount. The result is a functional urban police cruiser that can quietly and effectively hunt down bad guys.

Check out all of the Twisted Project Bikes: TwistedThrottle.com/project-bikes

Twisted Bike Rentals: Explore the beautiful Northeast



Rent a Twisted project bike and tour New England

Motorcycle rentals are available at the Twisted Throttle World Headquarters in Exeter, Rhode Island. Our rental motorcycles include Honda, Kawasaki, BMW and Suzuki Twisted Project Bikes. These bikes are outfitted with premium luggage and accessories that are proven tough and reliable.

Rentals include:

- Tankbag
- Tailbag or saddlebags
- 12-volt power socket (form varies by bike, electrical adapters available for purchase)
- RAM accessory mounting ball (RAM device holders available for purchase)
- Heated handlebar grips (on bikes 650cc or greater)
- Free local maps with suggested dirt and scenic paved roads
- Free airport pickup and drop-off at Providence Airport (PVD)

Available Bikes:

- 2005 Suzuki DR-Z400SM
- 2008 Kawasaki KLR650E
- 2012 Suzuki DL650 V-Strom
- 2013 Honda NC700X
- 2013 BMW R1200GS LC
- More to come

Visit our www.twistedthrottle.com/factory-store/rentals



2013 Honda NC700X



2012 Suzuki DL650 V-Strom



2008 Kawasaki KLR650E



2013 BMW R1200GS LC



2005 Suzuki DR-Z400SM



Backwoods adventure is just minutes from Twisted Headquarters.



New England riding at its finest.

GSM MotoRent: Explore the Smoky Mountains

Twisted Throttle is the official outfitter for the GSM MotoRent rental fleet.

Experience a great motorcycle adventure while discovering just how wonderfully the products supplied by Twisted Throttle work.

Located in the heart of the Smoky Mountains outside of Knoxville, Tennessee, GSM MotoRent is your premiere motorcycle rental destination. GSM is located minutes from world class riding, including the famous Tail of the Dragon. GSM provides touring and dual-sport motorcycles and the surrounding area provides riding for every skill level. GSM is owned and operated by Debbie and Dan Dickie and their southern charm will win you over. To find out more visit gsmmotorent.com.

Available Bikes:

- Twisted Triumph Explorer 1200
- Suzuki DL1000 V-Strom (2014)
- BMW F700GS
- BMW R1200GS
- BMW R1200RT
- Kawasaki KLR650
- Suzuki DR200
- Suzuki DR650



Suzuki DL1000 V-Strom (NEW!)



Suzuki DR200



Kawasaki KLR650



Triumph Explorer 1200



BMW R1200GS

Twisted Triumph Explorer

Available for rent is a totally Twisted Explorer 1200. Well-equipped with TraX luggage, Bags-Connection tankbag, comfort and ergonomic add-ons, and a ton of crash protection. Explore the Smoky Mountains in style on one of the most capable adventure bikes out there!

MotoQuest Rentals and Tours: Explore Alaska and Beyond

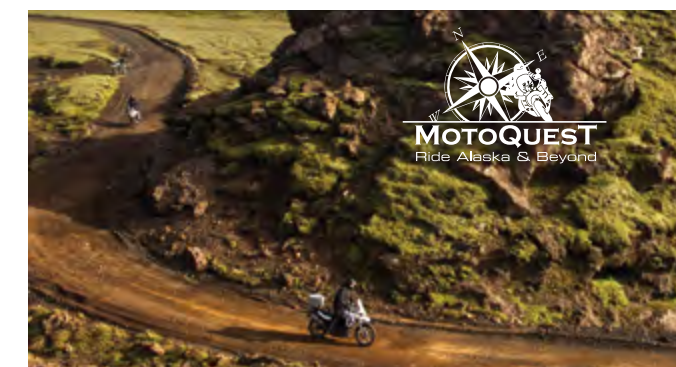

Twisted Throttle is proud to be the exclusive accessory sponsor for MotoQuest!

MotoQuest has been organizing adventure motorcycle tours, both guided and self-guided, since 1998. They go to the ends of the earth, offering experiences in exotic cultures and remote regions. Education and adventure are interwoven into every motorcycle tour.

MotoQuest is headquartered in Anchorage, AK and maintains a rental fleet of dual-sport bikes outfitted with Twisted Throttle gear. Each of MotoQuest's bikes sees over 20,000 miles of off-road terrain a year providing Twisted Throttle with feedback that helps us make a more durable product.

Alaska Motorcycle Rentals:

MotoQuest has been renting motorcycles in the Municipality of Anchorage, Alaska since 1998. Formally Alaska Rider Tours, MotoQuest rebranded in 2008 after expanding outside of Alaska. MotoQuest was founded and is still operated by a born and raised Alaskan, Phil Freeman. Phil's passion and experience in Alaska has throttled MotoQuest into position as one of the premier rental shops in Alaska.

West Coast Motorcycle Rentals:

Motorcycles are available for rent in Long Beach, CA, San Francisco, CA, Seattle, WA and Portland, OR!

For a complete list of Tours, visit MotoQuestTours.com

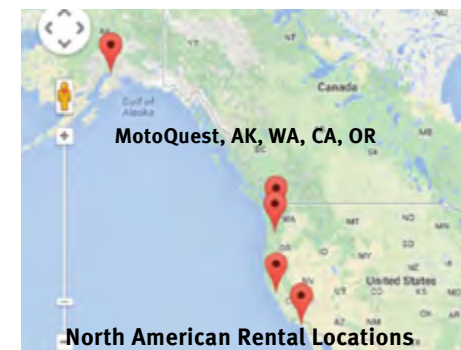



Twisted Off-Road Experts

We Know Dirt!

Twisted Throttle has been outfitting off-road bikes for as long as we've been in business. The adventure bike and dual-sport segments have grown like crazy in the last several years and we've been right there providing the rugged accessories and protection off-road riders demand.

Go to any dual sport or adventure bike event and you'll see our skid plates, crashbars, radiator guards, brake guards and off-road luggage being used by the most demanding riders.



Nate rides the Super Tenere in Tennessee.



Teach drifts the R1200GS during the filming of the Twisted GS video.



How many Twisted Throttle employees does it take to remove a KLR from Rhode Island mud?



A MotoQuest KLR ready for duty in Alaska Territory.



An imminent blasting-related road closure gave our crew 5 minutes to make a hasty roadside tire repair in the Andes Mountains of Chile.



A GS makes a big splash during the MarchMotoMadness trials competition in Tellico Plains, TN.



Erik's borrowed KLX poses in Big Bend National Park, TX.



Twisted Street Experts

We Know Street!

Twisted Throttle doesn't limit our attention to just dual-sport and adventure bikes. We also provide accessories for a wide range of street bikes, including touring, sport touring, sport and standard bike types. We partner with the California Superbike School and Tony's Track Days as suppliers of racetrack protection and performance products.



Jane borrows Erik's KTM 690 SMC for a few laps at New Hampshire Motor Speedway.



Erik at New Hampshire Motor Speedway.



Twisted's BMW sport tourer at the Americade touring rally.



Teach McNeil entertains the crowd on his BMW S1000RR.



Jeannine tours the Back of the Dragon in Western, VA on her ZX6R.



Ken carves a bit of the Blue Ridge Parkway in Virginia on his Triumph Sprint RS.



Willy unleashes the power of his Triumph Daytona at New Hampshire Motor Speedway.

Every year, Twisted Throttle picks a few adventure riders to work with, usually to help raise money for charities. We help outfit their bikes and prepare them for round-the-world adventures undertaken to raise money for a good cause. We also provide their trip with added media visibility. If you're interested in working with us on a charitable project, send your proposals to sponsorships@twistedthrottle.com.

Paul Pelland

My name is Paul Pelland and my life's road has been recalculated. I made a decision one day that changed every aspect of my life. I decided to share my life long passion of long distance motorcycle riding, and for the first time, openly discuss my dealings with the everyday challenges brought on by having the disabling diagnosis of Multiple Sclerosis.

I plan to share all of it, including my long distance rides, my record attempts, my triumphs and also my defeats. Everything from choosing and building the perfect machine, choosing, modifying, and mounting highly specialized equipment, to choosing and planning each and every trip, endurance event, or record setting attempt. I will share every ride, every road, every mile. Please join me, climb aboard my bike, travel with me, and support my long term mission of documenting one million miles for MS.



"I once was told a cure for MS was a million miles away, so I figured I would just go get it and bring it back."

Longhaulpaul 2012

photo credit: Tobie Stevens 2013



A man with Multiple Sclerosis... a motorcycle... and a million miles!

My mission is called the Endless Road Tour, an odyssey of motorcycle adventures including endurance rallies, extreme rides, and attempts at setting a few motorcycle endurance records. My goal is to raise awareness of MS, while reaching out to others along the way who also have been dealt tough challenges in life; helping them recalculate their life's road.

www.longhaulpaul.com

Chris "Teach" McNeil

Who is "Teach" McNeil? Teach is a school teacher known worldwide as one of the most skilled stunt riders on the planet. A two-time XDL East Coast Champion and 2008 Stuntwars World Champion, McNeil has put his ability to the test and WON! A lot!

We outfitted Teach's BMW F800GS and S1000RR so that he can do the brutal R&D that none of us are willing to do. Teach intentionally crashes his bikes during his stunt shows as a way to demonstrate just how durable our crash protection is!

Teach educates us about how well each piece of crash protection performs to see if improvements can be made. This type of R&D is infinitely valuable in helping us to offer the toughest luggage and strongest protection available to our customers. It's what we do.

See Teach perform at events around the country.

www.teachtrix.com



Teach demonstrates just how tough Barkusters handguards, TraX boxes, and SW-MOTECH crashbars really are.



Teach performed at the annual Twisted Open House, it was a performance that stole the show and had everybody wanting more.



Patrick Trahan

You may recall that Patrick suffered terrible injuries from a crash with a pick-up truck at 75 mph while riding his Honda XR650L. Twisted Throttle built and sponsored Patrick on his quest to raise money for **Children's Wish Foundation** by circumnavigating the African continent.

By 2012, Patrick had recovered enough to tour Morocco on a BMW equipped with Twisted Throttle luggage and other goodies. Later, he rode an electric bike in a rally in Morocco.

We are always interested in hearing about Patrick's adventures and learning about how our products perform. Patrick sure puts our luggage, crash protection and ergonomic products to the test. Keep up the good work, Patrick!

www.pat-trahan.com



www.mototeenworld.com

Stephanie Tarian

Stephanie Tarian is a young lady whose passion for motorcycling is shared with her father, Arthur. Stephanie rides to raise money for the **Make-A-Wish Foundation**.

We outfitted Stephanie's 2011 BMW G650GS with rugged SW-MOTECH crashbars and skid plate for crash protection, as well as sidecarriers with TraX ALU-Boxes. To help light her way, we also installed a set of Denali LED lights!

Stephanie says of her trip: "I would do it all over again because it was the best experience ever. Thanks to Twisted Throttle for all the accessories you supplied for me."

Ari Henning

Ari's name may be familiar to some of our Twisted customers. He is one of the road test editors for *Motorcyclist* magazine and motorcyclistonline.com. Why is he in our catalog as a sponsored rider? Because of his dedication to the spirit of competition.

Not only is Ari an expert moto-scribe, he is also competing on a Ninja 250 Superbike outfitted with R&G protection. Being a guy who likes to win means that sometimes crashes happen. Ari is a believer in the R&G product line and has proven its ruggedness. Hopefully his R&D testing is at an end and he can concentrate solely on winning. Good Luck, Ari!

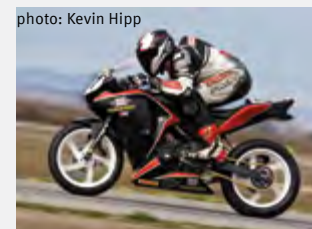

R&G frame and axle sliders allowed Ari to race later that day.

photo: Kevin Hipp



The **MRA X-creeen Add-on Spoiler** is an adjustable wind deflector that attaches directly to your bike's existing windshield. The X-creeen works with almost any motorcycle windshield, regardless of its curvature by clamping or screwing into place. X-creeen Add-on Spoilers come in two sizes: Sport and Tour. **Available in clear or smoke gray.**



MRA X-creeen Tour

MRA X-creeen Tour Add-on Spoilers are designed for large scooters and touring machines. The MRA X-creeen Tour spoiler attaches to your existing windshield and acts as an adjustable wind deflector that can be set to redirect the airflow and volume for optimal touring comfort.

The spoiler is about 14" wide and 6" tall (360 mm x 150 mm) and can be mounted with a simple joint (angle adjustable only) or a double joint (adjustable for angle and a height range of 4.3" or 110 mm).

The X-creeen Tour can be permanently attached using the included bolt-on surface mount, or temporarily clamps to your windshield using the optional clamp mount.

Available in clear or smoke gray.



Ducati Multistrada with X-creeen Spoiler bolted to an MRA screen

Bolt-on version: \$129.99
MRA.XCA.0 clear
MRA.XCA.1 smoke gray

Clamp-on version: \$157.98
MRA.XCC.0 clear
MRA.XCC.1 smoke gray



X-creeen Sport: \$114.99
MRA.XCA.S.0 clear
MRA.XCA.S.1 smoke

MRA X-creeen Sport

MRA X-creeen Sport Add-on Spoilers are the ideal size for smaller scooters and sport-bikes. The MRA X-creeen Sport spoiler attaches to your existing windshield and acts as an adjustable wind deflector that can be set to redirect the air flow just the way you want.

The spoiler is about 10" wide and 4" tall (260 mm x 100 mm) and is height and angle adjustable using double-jointed mounting arms. Using the included hardware, the X-creeen Sport can either be temporarily attached using a removable clamp or permanently bolted onto your windshield.

Available in clear or smoke gray.



Yamaha R6 with X-creeen Sport spoiler clamped to the original screen.

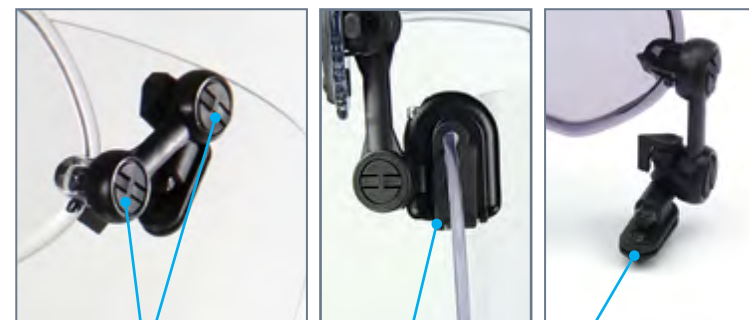

Dual pivots allow height and angle adjustments.

Clamp-on mount.

Bolt-on surface mount for permanent attachment.

Aprilia Caponord 1200 with X-creeen Sport spoiler bolted to the original screen.



Suzuki GSXR-600 with X-creeen Sport spoiler clamped to the original screen.



Turn upper levers to unlock and adjust top pivot angle.



The X-creeen Tour version comes with both a single joint for angle adjustments only and a double joint for both angle and height adjustments (double joint shown).



Levers unlock and adjust bottom pivot angle for height adjustment.



Hardware for clamping the X-creeen to your windshield. Soft foam pads protect the screen.



Bolt-on surface mounts are included.

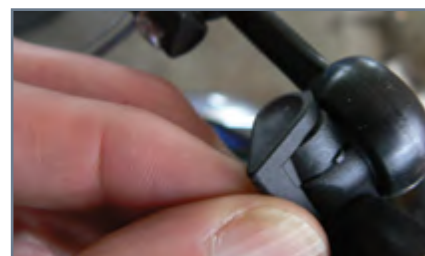

Levers unlock to adjust both upper and lower arm angles.



X-creeen Full Replacement Screens (bike-specific)

Starting At
\$212⁵⁰

The X-creeen spoiler is 14.1" wide x 5" tall and has 4.3 inches of vertical travel.



X-creeen Full Replacement Screens

The X-creeen is MRA's most versatile replacement screen offering superior adjustability and performance. Once installed, adjustment of the X-creeen blade requires no tools. Drop the X-creeen down for off-road, put it up for highway riding or adjust it to shoot air directly into your helmets vents. No replacement windshield offers more air flow adjustability. Available as full replacement screens with Tour-sized or Sport-Sized spoilers for most models. **Available in clear or smoke gray.**

The spoiler's angle and height can be adjusted independently.

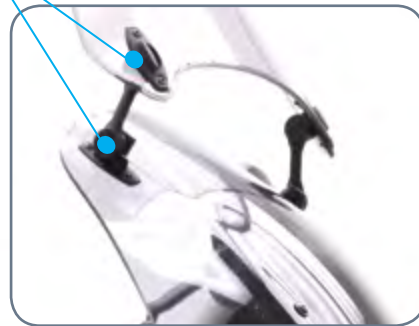

Visit TwistedThrottle.com for the latest X-creeen application list.



The Twisted Suzuki DL650 Project Bike

R - Double Bubble RacingScreen (bike-specific)

Starting At
\$107⁵⁰

Double Bubble RacingScreens

The RacingScreen's raised center bubble takes wind pressure off the helmet and provides exceptional stability at track speed in a full racer crouch. Air vents have been added at the front edge of the screen to reduce the vacuum underneath the bubble and reduce turbulent air flow.

Available in clear or smoke gray.



Designed to generate ride stability at speed. Double bubble windshields decrease lift, applying a downward force to the front end of the motorcycle while reducing helmet buffeting.

For a complete MRA application list, see page 22 or visit TwistedThrottle.com



The Twisted BMW S1000RR Project Bike

VT - VarioTouringScreen (bike-specific)

Starting At
\$159⁹⁹

The VarioTouringScreen is similar to the X-creeen, but has a slightly smaller factory-installed adjustable spoiler at the top of the windshield that allows you to manually adjust the angle and height of the spoiler to redirect airflow. Adjustable to seven different positions this compact and clean design, reduces wind turbulence and buffeting to increase rider stamina.

The VarioTouring spoiler is approximately 3.5" tall and has a smaller range of adjustability than the X-creeen with one angle per height adjustment. Unlike the X-creeen, the VarioTouringScreen has no adjustment levers and can be adjusted on the fly without leaving your seat.

Available in clear or smoke gray.

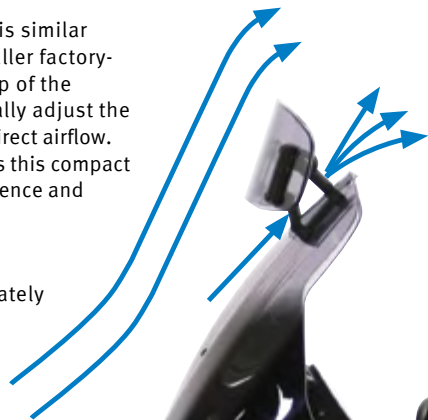

For a complete MRA application list, see page 22 or visit TwistedThrottle.com



BMW F800GS
MRA.07.017.VTM

T - TouringScreen (bike-specific)

Starting At
\$117⁵⁰

Best for upright highway touring

TouringScreens are similar in shape to your bike's original windshield, but elongated. Touring screens reflect the wind over the rider for a relaxed ride, particularly on longer trips.



Designed to enhance rideability. Think of the TouringScreen as an extension of your bike's original screen. MRA evaluates and designs its screens based on the unique ride characteristics, profile of the machine and its use.

Available in clear or smoke gray.



Yamaha Super Tenere

For an application list, see page 22 or visit TwistedThrottle.com

RNB - RacingScreen **Best Seller** **\$99⁹⁹**

The RacingScreen accentuates the visual appearance of your bike while offering excellent wind protection as you ride. This shield is available in black, clear and smoke gray.

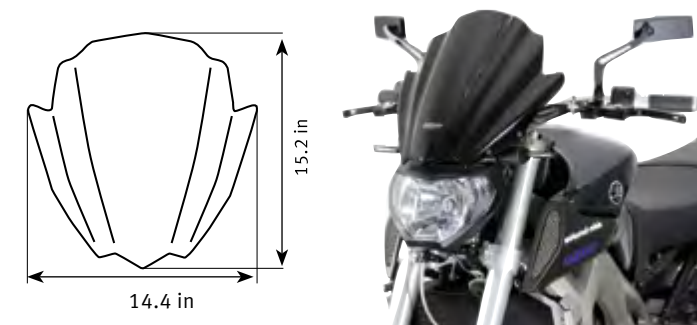

Diagram dimensions: 15.2 in height, 14.4 in width.

SPS - SpeedScreen **Best Seller** **\$99⁹⁹**

The SpeedScreen is a sporty screen with edgy styling. The SpeedScreen is suitable for riders looking for wind protection while retaining sporty good looks. Available in clear, black and smoke gray.

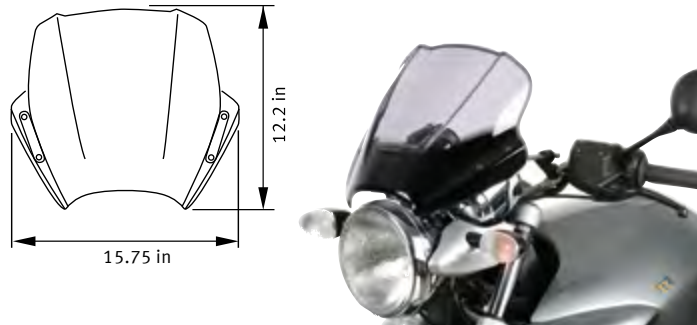

Diagram dimensions: 12.2 in height, 15.75 in width.

HI - HighwayShield **\$102⁵⁰**

The striking design of this shield fits sporty naked bikes and roadsters. The size of the shield protects the entire upper part of the body up to the helmet from wind and weather. This shield is available in clear and smoke gray.

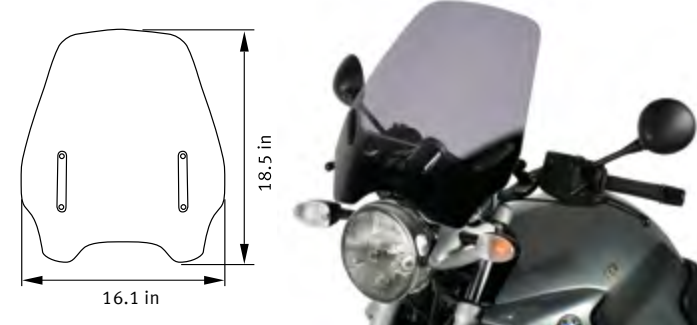

Diagram dimensions: 18.5 in height, 16.1 in width.

RO - RoadShield **Best Seller** **\$86⁹⁹**

The RoadShield is a small shield optimally suited for enduros and sporty naked bikes. The shield is deliberately made wide for its height to avoid side turbulence. Available in clear and smoke gray.

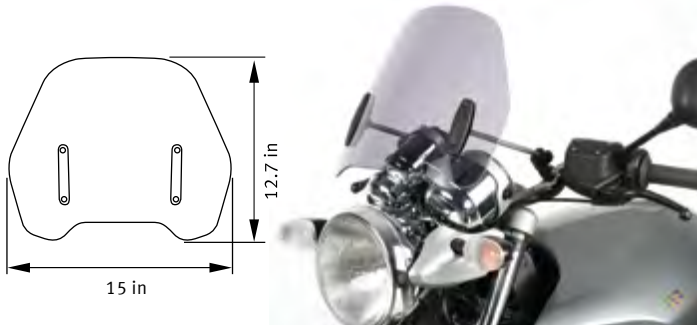

Diagram dimensions: 12.7 in height, 15 in width.

VTNB - VarioTouringScreen **\$169⁹⁹**

The VarioTouringScreen is a "small shield with a big effect". This compact shield's extra spoiler reduces airflow velocity approaching the helmet and upper body without generating turbulence. With 7 manually adjustable positions, it's easy to find an optimal position to suit your riding style. Available in clear and smoke gray.

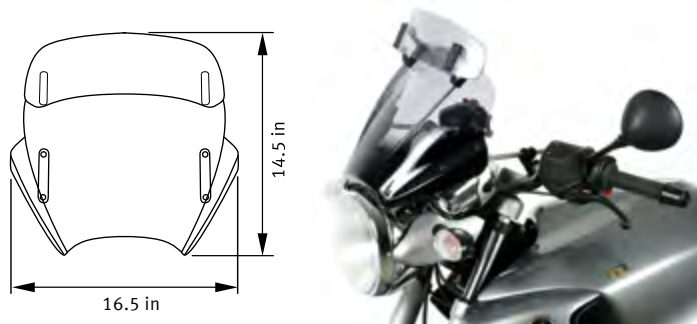

Diagram dimensions: 14.5 in height, 16.5 in width.

V-Flow Screen "C" & "Z" **NEW** **\$102⁵⁰**

The V-Flow is designed for naked sport bikes, cruisers, enduro and dual sport motorcycles that need more room for protruding instruments at its base. Select the curved "C" shape for round headlights or the angled "Z" shape for angular headlights.

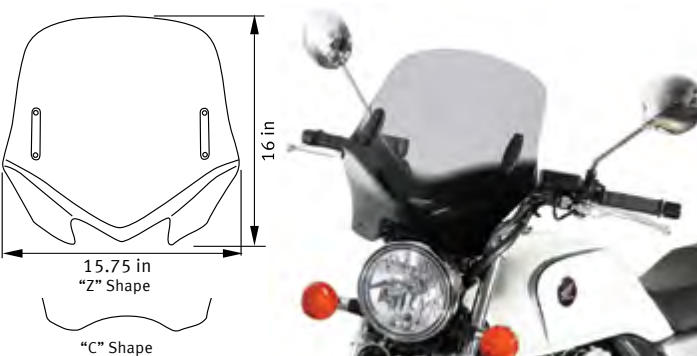

Diagram dimensions: 16 in height, 15.75 in "Z" Shape width.

CU - CustomShield **\$99⁹⁹**

Similar in shape to the HighwayShield, the CustomShield's contours are considerably rounder and more suited to the appearance of cruisers and choppers. Available in clear and smoke gray.

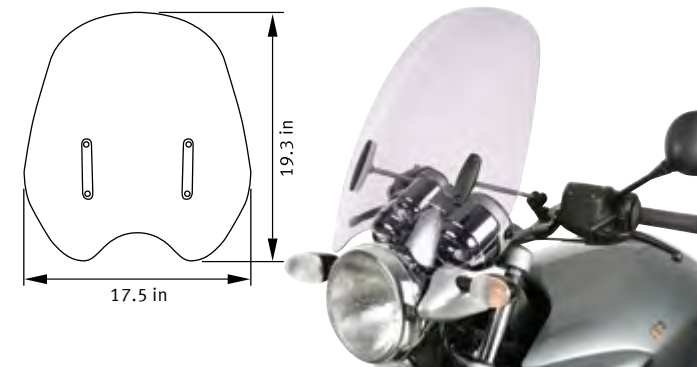

Diagram dimensions: 19.3 in height, 17.5 in width.

ROC - RoadShield Classic **\$86⁹⁹**

The RoadShield Classic is a small, unobtrusive fly-screen. The shield is made wide for its height to avoid side turbulence. Available in clear and smoke gray.

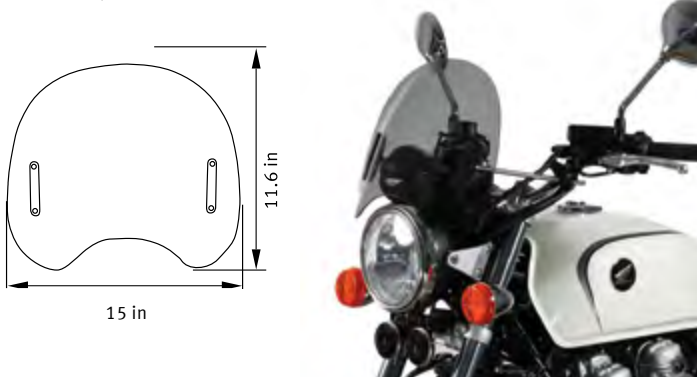

Diagram dimensions: 11.6 in height, 15 in width.

V-Flow X-creeen Sport "C" & "Z" **NEW** **\$189⁹⁹**

The V-Flow X-creeen Sport features a tool-less adjustable sport-sized blade. Select the curved "C" shape for round headlights or the angled "Z" shape for angular headlights.

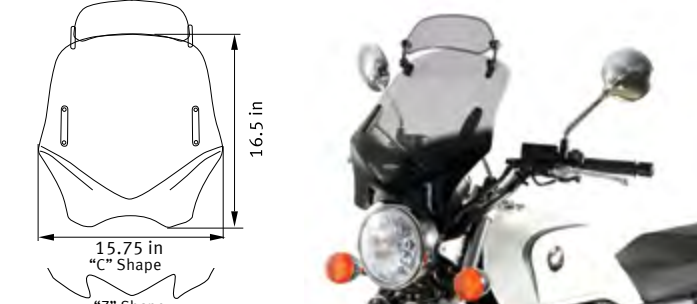

Diagram dimensions: 16.5 in height, 15.75 in "C" Shape width.

V-Flow VarioTouring Screen "C" & "Z" **NEW** **\$174⁹⁹**

The V-Flow VarioTouring features a larger tool-less adjustable touring blade. Select the curved "C" shape for round headlights or the angled "Z" shape for angular headlights.

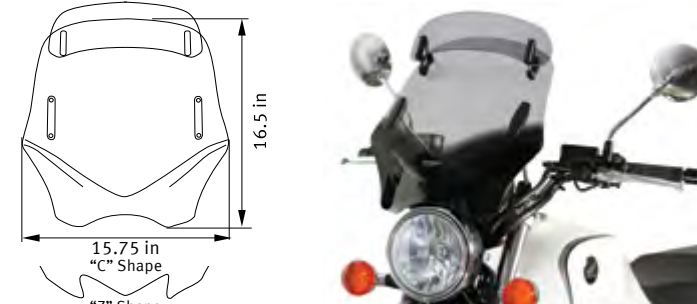

Diagram dimensions: 16.5 in height, 15.75 in "C" Shape width.

ST- StreetShield **\$86⁹⁹**

The StreetShield is MRA's smallest screen, specially designed to unobtrusively compliment the style of smaller on or off-road naked bikes. It offers good protection for the size.

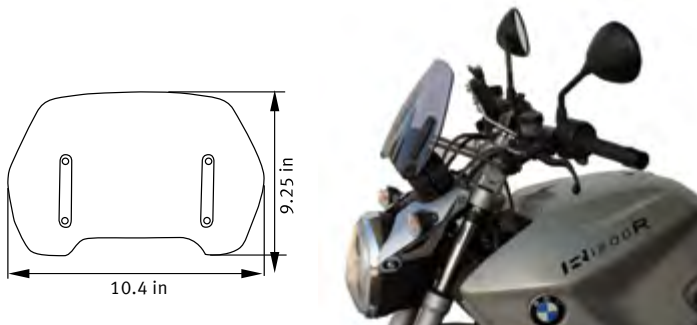

Diagram dimensions: 9.25 in height, 10.4 in width.

MRA Windshield Color Options for Faired and Naked Bikes



Gloss Black (opaque) Smoke Gray
Clear

VNB - VarioScreen **Best Seller** **\$189⁹⁹**

The VarioScreen is a two-part windshield. The upper shield is adjustable in height by 2" (5 cm). This shield offers the most adjustability and wind protection available in any MRA handlebar-mounted screen. An inlet at the lower end of the upper shield allows air to circulate and minimize turbulence. Select the rounded "VNB" shape or the angular "A" shape.

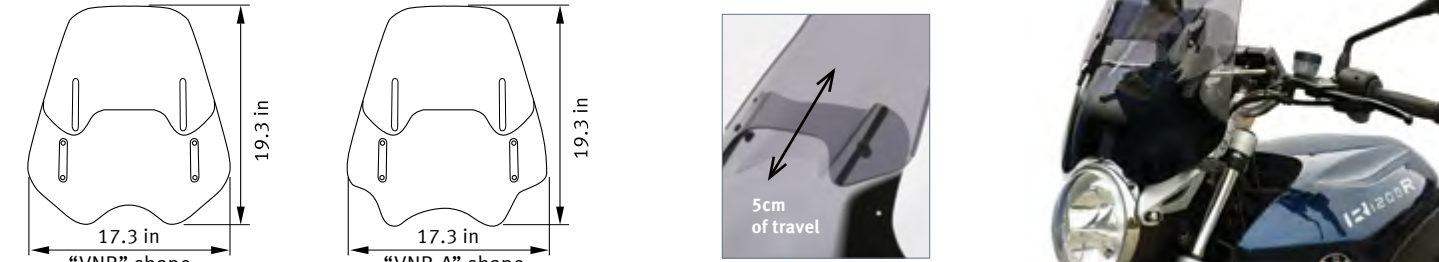

Diagram dimensions: 19.3 in height, 17.3 in width for both "VNB" and "VNB-A" shapes.

5cm of travel

Handlebar Mounting Kits **\$47⁹⁹**

Mounting Kits for MRA naked bike windscreens are sold separately from the windscreens.

Universal Mounting Kit for 22mm (7/8") and 25mm (1") diameter handlebars: *MRA.HK*

Long Mounting Kit, 260mm (10.24") for 22mm (7/8") and 25mm (1") diameter handlebars for Suzuki SV650 & others: *MRA.HK.L*

Mounting Kit for 28mm (1.1") & 32mm (1.26") diameter handlebars: *MRA.HKS28/32*

Offset Mounting Kit for BMW R850R, R1100R, Ducati Diavel & others: *MRA.HKSD*

Mounting Kit for Honda CB599 '11-'13, & Yamaha FZ8N: *MRA.HKSG*



MRA.HK Universal Mounting Kit

Visit TwistedThrottle.com to find fitments for your bike.



Here is a list of some popular MRA windscreens.
MRA windscreens are available for many more bike models.
Go to TwistedThrottle.com to find out if MRA makes a windscreen for your bike.

Styles:
R=Double-Bubble RacingScreen
T=TouringScreen*
V=VarioScreen*
VT=VarioTouringScreen*
XC = X-Creen
Colors: Clear, Smoke Gray, Gloss Black (opaque).
Not all colors are available for every bike.
* = available in Clear and Smoke Gray only

Aprilia	R	T	V	VT	XC
RSV1000R Mille '04-'09	X				
BMW	R	T	V	VT	XC
F650GS '08-'12 & F800GS '08-'14			X	X	
F800S & F800ST '06-'12		X	X	X	
G650GS '11-'14		X	X	X	
K1200R '06-'08		X	X	X	
K1300R '09-'14		X	X	X	
K1200S '06-'08	X	X	X	X	
K1300S '09-'12	X	X	X	X	
R1150GS & R1150GS Adv		X	X	X	
R1200GS & R1200GS Adv '04-'12		X	X	X	
R1200GS '13-'14		X	X	X	
R1200GS Adv '14 In Dev. Pls Call					
R1200RT					X
S1000RR '09-'12		X			
Can-Am	R	T	V	VT	XC
Spyder Roadster		X	X	X	
Ducati	R	T	V	VT	XC
748 (R) / 916 / 996 / 998	X	X			
749 / 999 '05 & Later	X				
SS1000DS '03 & Later	X	X			
Multistrada 1100, 1000 & 620					X
Multistrada 1200/S		X	X	X	
1098 & 1098S	X				
1198 & 1198S	X				
Panigale 899 '14 (In Dev. Pls Call)					
Panigale 1199	X				

For MRA Naked Bike Screen fitments please visit TwistedThrottle.com/Naked-Screens.



Ducati Multistrada with VarioTouringScreen



Triumph Explorer 1200 with TouringScreen



Starting At \$6999

SW-MOTECH Convertible Footpegs

provide an extra-wide platform for enhanced control, comfort, and grip on and off-road! A single bolt allows you to remove the rubber pad for off-road riding and reinstall it when you reach the asphalt again. A second bolt allows you to raise or lower the footpeg by 15mm for improved ergonomics.

- Attaches to the original footpeg mount.
- Footpeg mounting kit is CNC-milled from high strength aluminum alloy.
- Removable rubber pads reduce vibration for street riding.
- Toothed surface provides superior traction for off-road riding.
- 3.5" long x 2.25" wide, larger than most original footpegs for enhanced comfort and grip control.
- Footpegs are made from high-grade, corrosion-resistant stainless steel.

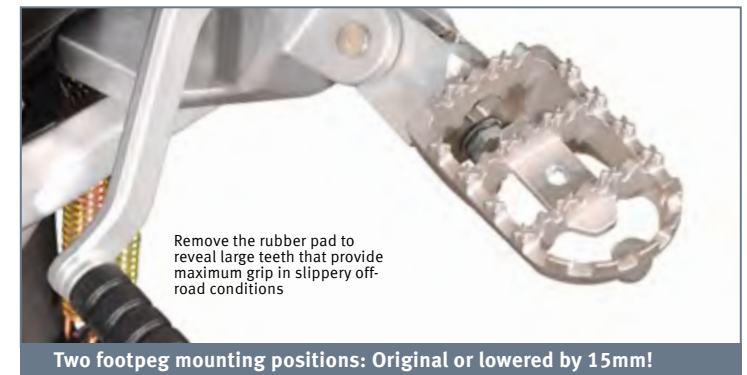
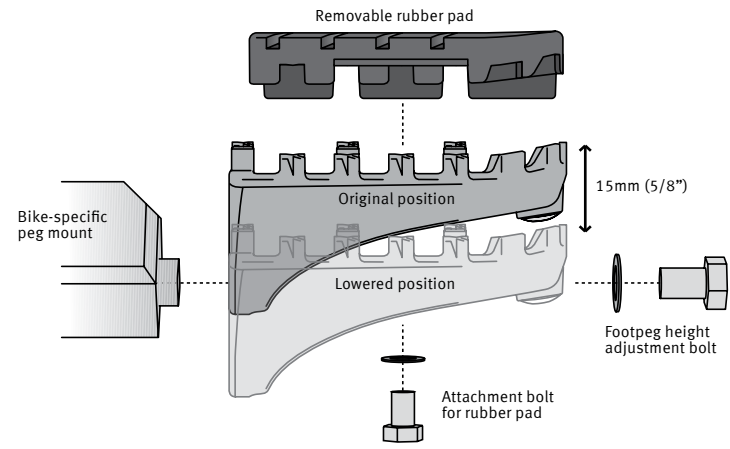

BMW	Part Number
F800R '08-'13	FRS.05.011.10001.S
G650GS '08-'10	FRS.07.011.10001.S
Scarver 650CS '02-'06	FRS.01.011.10400.S
G650GS Sertao	FRS.07.011.10001.S
F650GS single '00-'07	FRS.07.011.10001.S
F650GS twin '08-'10	FRS.07.011.10001.S
F700GS '13-'14	FRS.07.011.10100.S
F800GS '08-'14	FRS.07.011.10100.S
F800R	FRS.05.011.10000.S
R1200GS '04-'12	FRS.07.011.10500.S
R1200GS LC '13-'14	FRS.07.011.10300.S
R1200R '06-'13	FRS.11.011.10100.S
Ducati	Part Number
Multistrada 1200 '10-'14	FRS.22.011.10000.S
Hypermotard & Hyperstrada 820	FRS.22.011.10000.S
Honda	Part Number
CB500X/F '13-'14	FRS.01.011.10400.S

Honda (continued)	Part Number
NC700X/S '12-'14	FRS.01.011.10301.S
XL1000V Varadero '07-'13	FRS.01.011.10400.S
CB1300 / S '03-'10	FRS.01.011.10400.S
VFR1200	FRS.01.011.10300.S
Husqvarna	Part Number
TR650 Strada & Terra	FRS.03.011.10000.S
Kawasaki	Part Number
Versys 650 '07-'14	FRS.08.011.10000.S
Versys 1000 '12-'13	FRS.08.011.10100.S
Z1000 '07-'13	FRS.08.011.10000.S
ZRX1200R '01-'06	FRS.08.011.10000.S
KLR650E '08-'14	FRS.08.011.10200.S
KTM	Part Number
690 Duke '07-'12	FRS.04.011.10100.S
LC8 Adv 950, 990 '03-'13	FRS.04.011.10100.S
950 Supermoto '06-'08	FRS.04.011.10100.S
950 Supermoto R '07-'08	FRS.04.011.10100.S

KTM (continued)	Part Number
990 SM, SMR, & SMT '08-'14	FRS.04.011.10100.S
1190 Adventure/R	FRS.04.011.10100.S
Moto Guzzi	Part Number
Stelvio 1200 '08-'12	FRS.17.011.10000.S
Suzuki	Part Number
DL650 V-Strom '04-'14	FRS.05.011.10000.S
GSX650F '10-'14	FRS.05.011.10100.S
DL1000 V-Strom '02-'13	FRS.17.011.10000.S
GSF1250 Bandit S '07-'12	FRS.05.011.10100.S
GSX1250F ABS '09-'13	FRS.05.011.10100.S
Triumph	Part Number
Speed Triple 1050 '04-'08	FRS.01.011.10400.S
Tiger 800 & Tiger 800XC '11-'14	FRS.11.011.10100.S
Tiger 1050, '06-'11	FRS.11.011.10000.S
Explorer 1200 '12-'14	FRS.11.011.10100.S
Yamaha	Part Number
XT 1200 Z Super Tenere '11-'14	FRS.06.011.10000.S

Footpeg kits for more bikes are in development. Check out TwistedThrottle.com for the latest models!

Adjustable Shift Levers



SW-MOTECH Adjustable Shift Levers are CNC machined from high tensile strength aluminum and hard-coat anodized for extra durability. These levers provide style and a custom fit for enhanced comfort and control. The two-piece lever allows up to 3cm (1.18") of forward and rearward adjustment. The spring-loaded toe lever folds out of harm's way in a drop. An optional toe lever extension is also available.



Toe lever is approx. 2.25" (57mm) long without extension

15mm toe lever extension
FSC.00.127.10000.S



Suzuki V-Strom 650

The lever folds!



Kawasaki Versys 1000



Triumph Tiger 800

BMW	Years	Part Number
F650GS	'07-'11	FSC.07.127.10000.B
F700GS	'12-'14	FSC.07.127.10000.B
F800GS	'08-'14	FSC.07.127.10000.B
F800GS Adventure	'14	FSC.07.127.10000.B
R1200GS	'04-'12	FSC.07.127.10100.B
R1200GS Adventure	'04-'13	FSC.07.127.10100.B
F800GT	'12-'14	FSC.07.127.10200.B
F800R	'09-'14	FSC.07.127.10200.B
R1200GS LC	'13-'14	FSC.07.127.10300.B
Honda	Years	Part Number
CB1000R	'08-'14	FSC.01.127.10000.B
CBR600RR	'13-'14	FSC.01.127.10000.B
NC700S & NC700X	'11-'12	FSC.01.127.10100.B
Kawasaki	Years	Part Number
Versys 1000	'12-'14	FSC.08.127.10000.B
Suzuki	Years	Part Number
DL650 V-Strom	'12-'14	FSC.05.127.10000.B
Triumph	Years	Part Number
Tiger 800	'11-'14	FSC.11.127.10000.B
Tiger 800 XC	'11-'14	FSC.11.127.10000.B
Explorer	'12-'14	FSC.11.127.10100.B
Explorer XC	'12-'14	FSC.11.127.10100.B



BMW F800GS

Adjustable toe lever!



BMW R1200GS

Honda NC700X

Starting At
\$169⁹⁹

Adjustable Rearsets



R&G Adjustable Rearsets let you tune your motorcycle's ergonomics for maximum comfort and control. R&G Adjustable Rearsets offer an exceptionally wide range of adjustability with 11 mounting positions. Both shift and brake levers are height and angle adjustable, while the location of the toe contact pieces can be modified to suit every rider. Specially textured footrests ensure maximum grip in all conditions. R&G Adjustable Rearsets are handsomely crafted from black anodized billet aluminum for a strong yet lightweight rearset with an premium custom look. Some are available in both street shift (5 up, 1 down) and race shift (1 up, 5 down) patterns.

BMW S1000RR Adjustable Rearset, left side (street shift pattern)

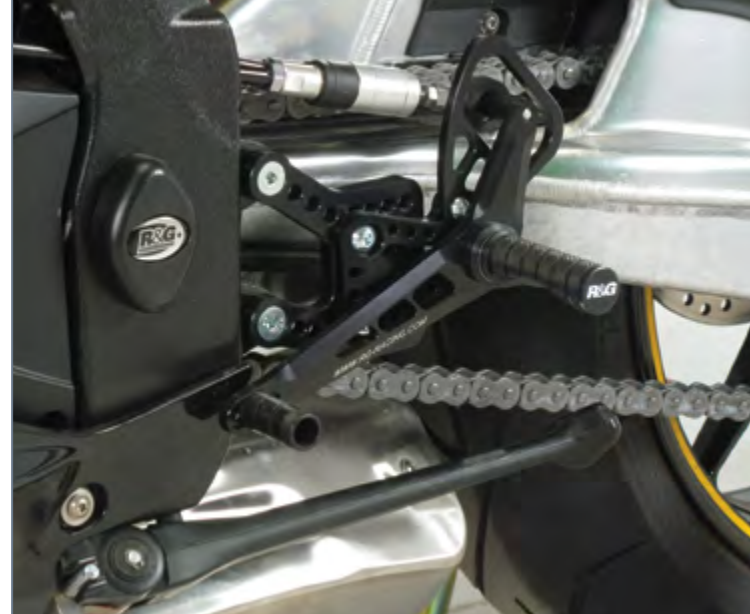

BMW S1000RR Adjustable Rearset, right side



Kawasaki ZX6R Adjustable Rearset, left side (Street shift pattern)



Replacement parts

- Replacement footpeg: *RG.PEG0001BK*: \$47.99
- Replacement pedal tip: *RG.PT0001BK*: \$7.25
- Replacement heel guards (Right): *RG.HP0004BK*: \$29.25
- Replacement heel guards (Left): *RG.HP0003BK*: \$29.25
- Replacement heel guards (S1000RR-Left): *RG.HP0001BK*: \$29.25
- Replacement heel guards (S1000RR-Right): *RG.HP0002BK*: \$29.25

\$524⁹⁹

per set

Aprilia	Part Number
RSV4 '09-'13 (Street or Race shift)	RG.RSET14BK
BMW	Part Number
S1000RR '10-'14	RG.RSET01.BK
S1000RR '10-'14 (Race shift)	RG.RSET04.BK
Ducati	Part Number
848, 1098 and 1198 (not '11 1198)	RG.RSET11BK
Honda	Part Number
CBR1000RR '08-'13	RG.RSET02.BK
CBR600RR '03-'14	RG.RSET22.BK
Kawasaki	Part Number
ZX6R '05-'13 (Street shift, non-ABS)	RG.RSET17.BK
ZX6R '05-'13 (Race shift, non-ABS)	RG.RSET18.BK
ZX10R '11-'14 (Street shift only)	RG.RSET07.BK
Suzuki	Part Number
GSXR600 & 750 '06-'10	RG.RSET05.BK
GSXR600 & 750 '11-'14	RG.RSET06.BK
GSXR1000 '09-'14	RG.RSET03.BK
Triumph	Part Number
675 Daytona '06-'12 (Street or Race shift)	RG.RSET12.BK
Yamaha	Part Number
R1 '07-'08	RG.RSET10.BK
R1 '09-'12	RG.RSET08.BK
R6 '06-'11	RG.RSET09.BK



Handlebar Risers

Handlebar risers change the position of the handlebar for greater comfort during long rides or improved standing ergonomics off-road. Our handlebar risers are CNC-milled from billet aluminum or die cast. All required mounting hardware is included.

Most models
\$60 to \$170

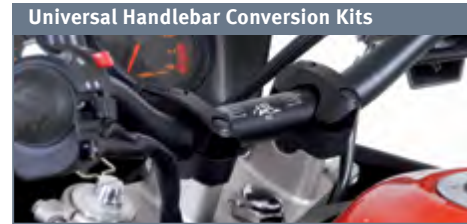

Traditional handlebar risers move the handlebar straight up from its original position and are available for more models in heights of 20mm (0.8"), 25mm (1"), 30mm (1.2") & 50mm (2"). Available for 22mm or 28mm diameter bars.

Handlebar conversion kits combine a 20mm riser with the ability to use a stronger 28mm diameter "fatbar" on a bike that originally used 22mm diameter handlebars.

Barback risers move the handlebar both upward and rearward towards the rider.

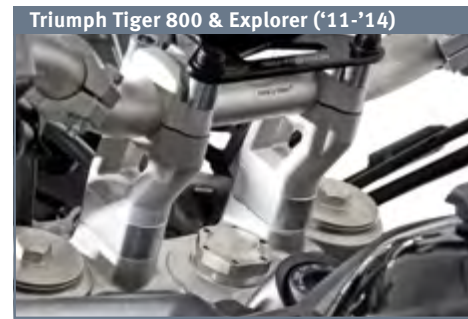
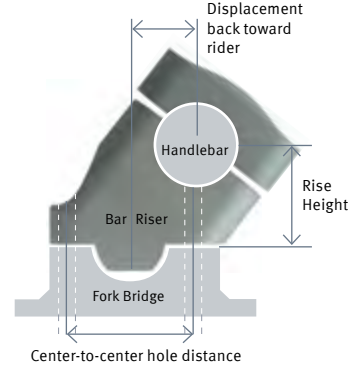
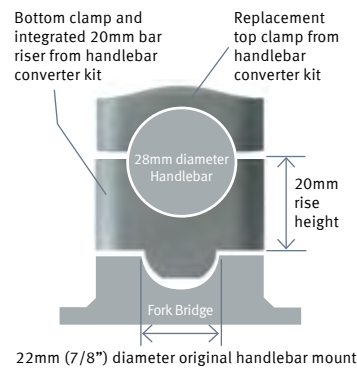
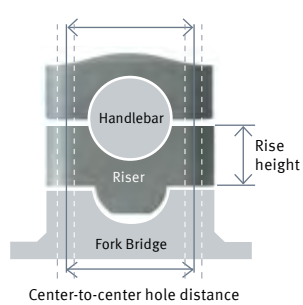

Universal handlebar risers		
For 7/8" (22mm) diameter bars	Notes	Part Number
20mm (0.8") rise	Fits hole distances 32-38mm w/ M8 bolts. Black or Silver	LEH.00.039150.20
25mm (1.0") rise	Fits hole distances 32-38mm w/ M8 bolts. Black or Silver	LEH.00.039150.25
30mm (1.2") rise	Fits hole distances 32-38mm w/ M8 bolts. Black or Silver	LEH.00.039150.30
50mm (2.0") rise	Fits hole distances 32-38mm w/ M8 bolts. Black or Silver	LEH.00.039150.50
31mm (1.25 ") up and 22mm (7/8") back	Fits hole distances 32-38mm w/ M8 bolts. Black or Silver	LEH.00.039.152
For 1.125" (28mm) diameter bar		
Notes	Part Number	
30mm (1.2") rise	Fits hole distances 37-46mm w/ M8 bolts. Black or Silver	LEH.00.039.20300
30mm (1.25 ") up and 22mm (7/8") back	Fits hole distances 37-46mm w/ M8 bolts. Black or Silver	LEH.00.039.20000
Bike-specific handlebar risers		
BMW	Notes	Part Number
F650GS & F650GS/Dakar ('00-'07) & G650GS ('09-'14)	20mm (0.8") rise. Silver.	BB.B55
F650GS, F700GS & F800GS ('08-'14)	20mm (0.8") rise. Silver.	LEH.07.039118.20.S
F700GS, F800GS ('08-'14) & F800GS Adventure '14	30mm (1.2") rise. Silver.	LEH.07.039118.30.S
R1200RT ('05-'13)	25mm (1") rise and angled toward rider. Silver.	LEH.07.039.12301.S
R1200GS & R1200GS Adventure ('04-'07)	30mm (1.2") rise. Black.	LEH.07.039.111.B
R1200GS & R1200GS Adventure ('08-'12)	30mm (1.2") rise. Silver. 22mm (0.9") rise, 30mm (1.2") back. Silver.	LEH.07.039.117.S LEH.07.039.12200.S
R1200GS LC ('13-'14)	40mm (1.6") rise. Silver or Black. Barback 32mm rise, 25mm back. Black	LEH.07.039.12401 LEH.07.039.12600
Buell	Notes	Part Number
XB12X Ulysses, Blast, XB9/XB12 Lightning	Moves bars 2" closer to rider	ROX.3R-P2SSM
Ducati	Notes	Part Number
Multistrada 1200 ('10-'14)	30mm (1.2") rise. Black.	LEH.22.039.10000.B
Honda	Notes	Part Number
CB1000R ('08-'10)	20mm (0.8") rise. Black or silver available.	LEH.00.039150.20
XL1000V Varadero ('98-'11)	20mm (0.8") or 25 mm (1") rise. Black or silver available.	LEH.00.039150
ST1300	Up 32mm (1.3") and back 25mm (1.0"). Silver.	GM.H101
Kawasaki	Notes	Part Number
Concours GTR1400 ('08-'14)	Up 38mm (1.5") and back 22mm (7/8"). Silver	GM.K405
Ninja 500R	38mm (1.5") rise. Black.	GM.K107
Ninja 650R / ER6-N	20mm (0.8") rise. Black.	LEH.08.039.120.B
KLR650E ('08-'14 including "New Edition")	20mm (0.8"), 25mm (1.0") or 30mm (1.2") rise.	LEH.00.039150
Versys 650	18mm (0.7") rise. Silver.	LEH.08.039.119.S
Versys 1000	20mm (0.8") rise. Black.	LEH.00.039150.20
Z750, Z750S, & Z1000 ('07-'09)	Up 38mm (1.5") and back 25mm (1.0"). Black.	LEH.08.039.12100.B
ZX-14 & ZZR1400	Up 25mm (1.0") and back 16mm. Black.	GM.K115
KTM	Notes	Part Number
KTM LC4 with 28mm dia. handlebar	For models with MAGURA or ProTaper handlebars. 30mm (1.2") rise. Silver.	LEH.00.039.101
KTM Supermoto & Super Enduro 950/990	30mm (1.2") rise. Silver.	LEH.00.039.106
KTM 990 Adventure ('06-'13)	30mm (1.2") rise. Black or Silver. 30mm (1.2") rise and 28mm (1.1") back. Black or Silver.	LEH.00.039.20300 LEH.00.039.20000
KTM 1190 Adventure / R ('13-'14)	30mm (1.2") rise. Black or Silver.	LEH.00.039.20300
Suzuki	Notes	Part Number
V-Strom 650 ('04-'14)	20mm (0.8") or 25 mm (1") rise. Black or silver available.	LEH.00.039.150
GSX1340R Hayabusa ('08-'14)	0.75" rise. Black. 1.25" rise. Black.	GM.S222 GM.S223
Triumph	Notes	Part Number
Bonneville	Up 1.25" and back 0.75". Silver.	GM.T114
Street Triple ('07-'10) & Speed Triple 1050 ('05-'07)	22mm (7/8") rise.	LEH.00.039150
Street Triple ('12-'14)	20mm (0.8") rise. Silver.	LEH.11.039.10201.S
Speed Triple 1050 / R ('10-'14)	28mm (1.1") rise. Black or silver.	LEH.00.039.20300
Tiger 800, 800XC & 1200 Explorer	20mm (0.8") rise. Silver.	LEH.11.039.10000.S
Tiger 1050 ('07-'10)	Replaces stock handlebar. 28mm taper handlebar with 45mm rise (from original position).	BB.VSB-BC
Yamaha	Notes	Part Number
FJR1300 ('06-'13)	25mm (1.0") rise & 13mm back. Silver.	GM.Y203
V-Max 1200 (2008 & Later)	25mm (1.0") rise & 32mm (1.25") back. Brushed aluminum or powdercoated black.	GM.Y124
XT1200Z Super Tenere	Up 25mm. Silver	LEH.06.039.10100.S

This page and the application chart is only a partial list of risers we carry. Visit TwistedThrottle.com to find fits for many more bikes.



MFW's Adjustable Vario Levers enhance the comfort, control and look of any motorcycle with 8 possible positions over a wide range. It only takes a few seconds to adjust.

MFW adjustable levers are CNC-machined from billet aluminum and fit a wide range of motorcycles. All levers are sold in pairs.

Starting At \$149.99 in pairs

Lever tip adjusts in 4 increments from standard length to "shorty."

Black lever with black trim shown

Adjustment knob and lever tip replacements are available in silver, red or blue anodized finishes.

Short fingers are no problem, these levers have 8 positions of span adjustment.



Table with columns: Brand, From, To, Brake, Clutch. Rows include Aprilia, BMW, and Ducati models.

Table with columns: Brand, From, To, Brake, Clutch. Rows include Ducati and Honda models.

Table with columns: Brand, From, To, Brake, Clutch. Rows include Honda, Kawasaki, KTM, Moto Guzzi, and Suzuki models.

Table with columns: Brand, From, To, Brake, Clutch. Rows include Suzuki, Triumph, and Yamaha models.

doubletake MIRROR

Doubletake Dual Sport Mirrors

The team at Twisted Throttle is proud to introduce the only mirror you will ever need! With outstanding visibility from the convex shaped mirror glass, a virtually indestructible body, and the convenience of a RAM ball at the end, the Doubletake Mirror is the perfect choice for replacing or adding mirrors to your bike.

Doubletake Mirrors won't move even at triple digit speeds thanks to tough RAM components. They also stay put when folded down for riding off-road!

Doubletake Mirror features:

- Virtually indestructible reinforced Zytel body
- SAE spec convex lens
- Easy to fold, remove or swap between bikes
- Guaranteed against breakage for the life of the product (excluding mirror glass)
- 4" diameter mirror
- 8.5" overall length



Fold them out of the way when your off-roading gets SERIOUS!

STEP 1 Buy Doubletake mirror

\$2375

DTM.00.M

STEP 3 Choose RAM base



Handlebar U-Bolt Mount
RAM-B-231ZU: \$13.37



Twist & Tilt Base - fits standard handlebar mirror mounts
RAM-B-360U: \$19.76



Base for unthreaded hole - fits most handlebar mirror mounts
RAM-B-252U: \$11.42



Handlebar Mirror Mount Clamp
DTM.SCA: \$5.00



M10 x 1.25 RAM ball
RAM-B-349U: \$8.16



Yamaha Reverse Thread Mirror Adapter
DTM.YA: \$5.00

STEP 2 Choose RAM arm



RAM-B-201U-A \$12.35 RAM-B-201U \$12.21 RAM-B-201U-C \$18.41

Bike	Base
BMW F650GS twin	BMW Stud Base - M10 x 1.5 (RAM-B-349-1U)
BMW F800GS twin	BMW Stud Base - M10 x 1.5 (RAM-B-349-1U)
BMW F-GS Singles	Varies: Ball Stud Base - M10 x 1.25 (RAM-B-349U) or Toughball M8 x 1.25 (RAP-B-379U-M81208)
BMW R1200GS	BMW Stud Base (RAM-B-349-1U)
BMW X Challenge / X Country	Ball Stud Base - M10 x 1.25 (RAM-B-349U)
Honda	Ball Stud Base - M10 x 1.25 (RAM-B-349U)
Husqvarna	Ball Stud Base - M10 x 1.25 (RAM-B-349U)
Kawasaki	Ball Stud Base - M10 x 1.25 (RAM-B-349U)
KTM	Ball Stud Base - M10 x 1.25 (RAM-B-349U)
Suzuki	Ball Stud Base - M10 x 1.25 (RAM-B-349U)
Triumph	Ball Stud Base - M10 x 1.25 (RAM-B-349U)
Yamaha	Ball Stud Base - M10 x 1.25 (RAM-B-349U) R/H Reverse Thread Yamaha Adapter (DTM.YA)

Note: These applications are just a few known fits.

For other mounting options see pages 101-103 or visit TwistedThrottle.com.

SW-MOTECH BAGS-CONNECTION

Starting At \$174.99

SW-MOTECH KOBRA Handguards

feature top quality and an edgy, modern style. These badarse plastics provide great protection and aggressive styling for you Dark Knights of Enduro.

Made from high-performance polypropylene with a powder coated black aluminum backbone, plastics come in menacing black only.

Features:

- polypropylene plastic
- full-wrap, aluminum frame
- 1-point mounting or mounted to the handlebar inside thread

Included:

- 2 KOBRA Handguards
- 2 solid aluminum frames
- mounting hardware
- mounting instructions



The optional integrated CE-approved LED turn signals are exceptionally bright for maximum conspicuity. The LED turn signal upgrade requires a resistor to prevent super-fast blinking. Two different resistors are available: one for bikes with 10 watt original indicators and another for bikes with 21 watt original indicators (See page 119).

Optional LED Turn Signal Upgrade Kit & Extension

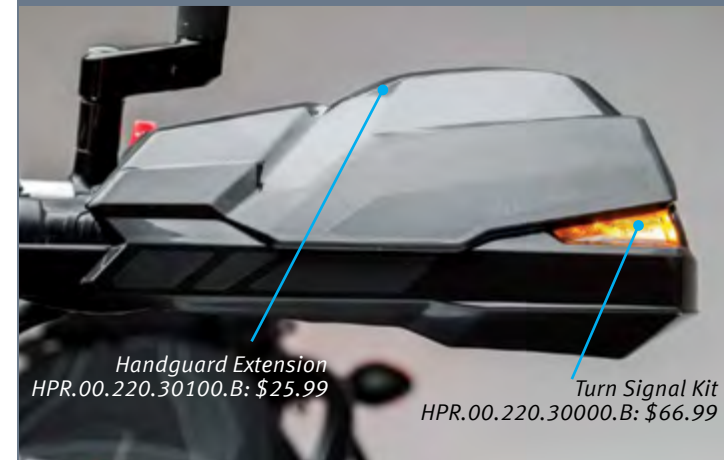

Handguard Extension
HPR.00.220.30100.B: \$25.99

Turn Signal Kit
HPR.00.220.30000.B: \$66.99

BMW	from	to	Part Number
F650GS	'08	'11	HPR.00.220.20100.B
F700GS, F800GS/ GSA	'13	'14	HPR.00.220.20800.B
F800GS	'08	'11	HPR.00.220.20100.B
R1100GS, R1150GS	'07	'04	HPR.00.220.20600.B
R1200GS & Adventure	'04	'12	HPR.00.220.20100.B
Ducati			
Multistrada 1200	'10	'13	HPR.00.220.21000.B
Honda			
Transalp XL 600, 650, 700 V	'89	'13	HPR.00.220.20600.B
NC700X & NC700S	'11	'13	HPR.00.220.20200.B
Kawasaki			
ER-6n	'12	'13	HPR.00.220.20900.B
Versys 650, '07-'08	'07	'14	HPR.00.220.20300.B
KTM			
690 Duke/Enduro/SM			HPR.00.220.20400.B
950&990 SM/ADV/SMR/SMT/Super Duke			HPR.00.220.20400.B
Triumph			
Tiger 800XC	'11	'13	HPR.00.220.20500.B
Explorer 1200	'12	'13	HPR.00.220.20500.B
Yamaha			
XT1200Z Super Tenere	'10	'13	HPR.00.220.20800.B
WR Models	'07		HPR.00.220.20400.B

ULTIMATE PROTECTION
Barkbusters
HANDGUARDS

The ORIGINAL Motorcycle Handguard!

These are the toughest handguards anywhere - they don't call 'em Barkbusters for nothing!

Barkbusters handguards were first manufactured in 1984 and now have over 28 years of motorcycle industry experience and riding enthusiasm. That history means Barkbuster has what it takes to produce the finest handguards available on the market today. Barkbusters integrates a hardened aluminum backbone with a stylish, replaceable plastic guard to create a truly functional handguard. No more busted levers or knuckles! In the unlikely event that you break a part of the handguard, every piece is replaceable.

Barkbusters handguards are designed to work with Kaoko throttle locks. (See page 32)



Handguards for Off-Road & Motocross Bikes

Barkbusters JET Full-Wrap Trail & Enduro Handguards

JET The new JET handguard is designed for Trail and Enduro riders.

- Strong aluminum backbones are heat treated for maximum strength
- Full-wrap backbones with two-point mounting
- Drop-down design of the backbone is ideal for bikes with long levers
- Includes impact-resistant plastic handguards
- Three axis mounting clamps for easy installation

22mm (7/8") Handlebars: BB.JET01 MSRP \$99.99
28mm (1 1/8") tapered Handlebars: BB.JET02 MSRP \$112.50



Available with black, blue, green, orange, red, white, or yellow plastics.

Barkbusters VPS-MX Single-Sided Motocross Handguards

VPS-MX Single-sided handguards for competition motocross use.

Barkbusters VPS-MX handguards use VPS plastics on a **single-sided mount**, providing a lightweight handguard that meets competition motocross regulations.

- Easy to install, clamp-on mounting kit that fits 7/8" diameter handlebars
- Plenty of clearance for bikes with longer levers
- Incorporates high impact nylon support brackets for plastic VPS guard
- Handguard position can easily be adjusted

Available in black, blue, green, red, yellow, silver, orange, white, or pink.

BB.BHG7: \$62.00



Barkbusters EGO Enduro and Trail Full-Wrap Handguards

EGO Ultra-compact full-wrap handguards ideal for tight off-road trail use.

The EGO is the toughest and most durable handguard on the market. EGO handguards are a compact full-wrap handguard to help you protect your knuckles & levers during intense trail riding.

- Specifically designed for enduro and MX bikes with short levers (See VPS for long lever applications)
- Strong aluminum backbones are heat treated for maximum strength
- Full-wrap backbones with two-point mounting

Available with black, blue, green, orange, red, white, or yellow plastics. See pages 40-41 for fitting information.

BB.E55.2: \$112.99



Handguards for Street, Trail & Adventure Bikes

Barkbusters Storm Handguards

Storm Maximum wind and rain protection for street and adventure-touring bikes!

Storm handguards have an aerodynamic design and a larger profile that wraps around to offer excellent wind and weather protection. The wide profile is great for street riding and open trails.

Available with black plastics.

Storm handguards are available in single-point and full-wrap mounting styles. See next page to find mounting hardware that fits your bike.



Storm Full-Wrap Backbone
With hardened aluminum and two mounting points, this is the strongest backbone available, and is recommended for dual-sport and adventure touring bikes.

Storm Open-ended Backbone
Designed specifically for street bikes and mounted to a single point on the handlebars.
BB.S1: Fits 7/8" diameter handlebars
BB.S2: Fits 1" diameter handlebars

Storm Bar End Mount Backbone
This hardened aluminum frame mounts to the end of the handlebar. Ideal for bikes with limited space on the handlebar.
BB.S5: Fits hollow 7/8" or 1" diameter handlebars
BB.S7: Fits bar ends with 6 or 8mm threaded holes

Barkbusters VPS Full-Wrap Supermoto, Trail & Adventure Bike Handguards

VPS Versatile full-wrap handguards that provide tough obstacle protection with moderate weather coverage.

- Specifically designed for **bikes with long brake and clutch levers**, including most street and adventure-touring bikes
- Hardened aluminum, full-wrap backbones with two-point mounting hardware
- Appropriate for both street, adventure and trail riding
- Choose from VPS or Storm plastics (sold separately)

Available with black, blue, green, red, yellow, silver, orange, white, or pink plastics. A **Variable Height Wind Deflector** is included to provide extra wind protection. See next page for fitting information.



Optional Accessories

VPS Variable Height Wind Deflector (included with Full-Wrap VPS handguards)

- Variable-height wind deflectors provide extra wind protection
- Available in black or white only
- For VPS & VPS-MX Handguards only

BB.BHG4: \$21.25

VPS skid plates

- Optional replaceable skid plates protect the outer end of the backbone
- Perfect for Supermoto bikes
- For VPS guards only

BB.BHG2: \$19.75

Barkbusters Bar End Weights

Add 180 grams of mass to each end of your handlebars to reduce vibration.

Compatible with full-wrap Storm and VPS Handguards.

BB.B66: \$49.99



Blizzard Universal Handguards

Extend your riding season with these semi-rigid handguards. Block wind, rain and snow to keep your hands warm and controls dry.

\$109.99

BB.BBZ-01

Designed for faired sportbikes, sport tourers and large touring motorcycles, the Blizzards are made from a semi rigid material and covered on the outside with tough Cordura. They're also suitable for most street, dual-purpose, adventure tourers, dirt bikes, ATVs and snowmobiles.

Blizzards have an internal aluminum stiffener so the handguards hold their shape and position on bikes that don't already have rigid handguards. Complete hardware mounting kit is included to fit every possible handlebar configuration.





R&G Products

R&G offers a wide range of products to fit most modern sportbikes, including frame sliders, front axle sliders, bar end sliders, exhaust and tank protectors, and aluminum radiator guards.

R&G sets the bar high when it comes to manufacturing innovative crash protection. Modern CNC machining, aircraft-grade metals and cooperative R&D testing with the California Superbike School and motorcycle insurance companies help R&G to produce the toughest, most functional sport bike protection on the planet.

R&G also offers 11-position adjustable rearsets, toe chain guards and rear fender eliminator kits for many sportbike models.

Public Relations Manager "Hollywood" Ken Condon



Frame Sliders

R&G frame sliders are made with heavy-duty machined steel and aluminum, low-friction HDPE (high-density polyethylene), and are a frame-mount design that provides for maximum support. R&G also uses special high-tensile steel mounting bolts that are de-embrittled withstand the force of a vast majority of crashes. In an extreme impact, these bolts are designed to bend and keep your bike protected, rather than snapping off. Even with bent bolts, the R&G frame sliders stay in place, and continue to protect your bike well after impact. You can inexpensively repair single-sided crash damage with the purchase of one-side "repair kits." R&G frame sliders come in two styles, "Classic" and "Aero."

Classic Style Frame Sliders

Starting At \$10250 per pair

Aero Style Frame Sliders

Starting At \$11999 per pair

Traditional cylindrical shape

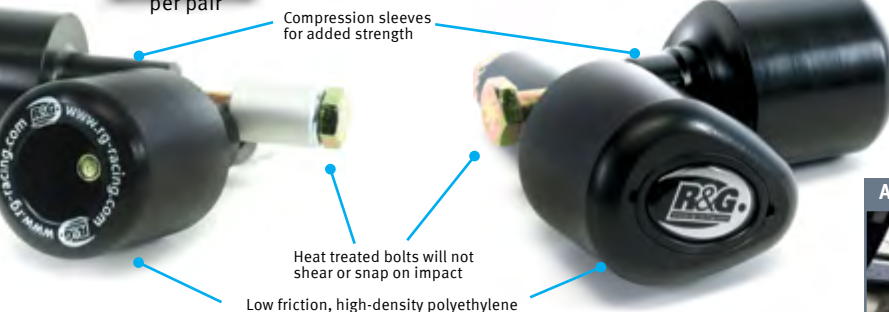

Cutting the fairing is required on some motorcycles. No-cut Frame Sliders are available for some of models. See pages 192-269 for bike-specific applications or visit TwistedThrottle.com.



Underbody Sliders

These sliders sit just behind the fairing panels for support in the event of a crash. The fairing may be sacrificed, but the underbody slider provides protection for the motorcycle frame and engine without the risk of the slider catching on the road and flipping the bike. This is a tried and true form of frame protection used in AMA, World Superbike, and MotoGP racing. Underbody Sliders are a viable no-cut alternative. Available for the Ducati 1098/1198/848, MV Agusta 312R/312RR, Kawasaki Ninja 650R, and many other models.

Underbody Slider for Kawasaki Ninja 650R

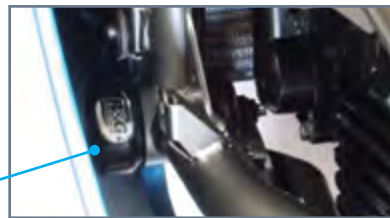

Frame Skidders combine excellent crash resistance with subtle styling compared to a traditional frame slider. You can inexpensively fix single-sided crash damage with the purchase of half kits. Available for Tuono, RSV4, Tiger 800, S1000RR, and more.

Made from high-density polyethylene



Starting At \$19499 per pair

2011 Aprilia Tuono



Axle & Swingarm Sliders



Front axle sliders, swingarm sliders, and spools protect your swingarm and axles from crash damage. Each slider is constructed of heavy-duty machined steel and aluminum with high-density nylon pucks for maximum protection. These sliders also give your bike a race look.

Front Axle Sliders

Starting At \$5999 per pair

Front axle sliders protect expensive axles, fork legs and calipers with a through-bolt design for secure and easy installation.



All necessary hardware included

Swingarm Sliders/Spools

Starting At \$6999 per pair

Swingarm spools protect the swingarm from damage and provide a secure support when lifting your bike using a race stand. Mounts to stock swingarm bosses.



Constructed from tough high-density polyethylene

Offset Swingarm Sliders/Spools

Starting At \$9099 per pair

Offset swingarm spools use M10 bolts and an aluminum block for the strongest possible slider. Ideal for swingarms without threaded bosses. Provides a secure lifting point.



Black anodized aluminum bracket (included)

Front Axle Slider - Triumph Sprint GT



Swingarm Spool - Tiger 800



Offset Swingarm Spool - BMW S1000RR



Swingarm Spool Applications

Universal	Notes	Part Number
M8	Black	RG.CR0001.BK
M6	Black	RG.CR0002.BK
M10	Black	RG.CR0003.BK
BMW	Notes	Part Number
S1000RR '10-'14	Black, offset.	RG.CR0033.BK
S1000RR '10-'14	Black.	RG.CR0032.BK
Honda	Notes	Part Number
CBR250R '11-'14	Black, offset.	RG.CR0039BK
CRF250L/M '13-'14	Black, offset.	RG.CR0046.BK
CBR500F, CB500F '13-'14 & CB500X	Black, offset.	RG.CR0045.BK
CBR600RR '07-'13	Black.	RG.CR0013.BK
CBR600RR '07-'13 & CBR1000RR '08-'12	Black, offset.	RG.CR0027.BK
NC700X/S	Black, offset.	RG.CR0041.BK
Kawasaki	Notes	Part Number
Ninja 300 & 250	Black.	RG.CR0020.BK
ZX6R '07-'13	Black, offset.	RG.CR0029.BK
ZX6R '07-'14	Black.	RG.CR0007.BK
ZX10R '04-'10	Black, offset.	RG.CR0016.BK
ZX10R '11-'14	Black, offset.	RG.CR0035.BK

Swingarm Spool Applications

KTM	Notes	Part Number
690 Duke '12 & 690 Duke R '13-'14	Black.	RG.CR0042.BK
990 SuperDuke & 1190 Adventure	Black.	RG.CR0009.BK
Suzuki	Notes	Part Number
GSX-R600/750 '11-'14	Black.	RG.CR0036.BK
GSX-R1000 '07-'14	Black.	RG.CR0028.BK
Triumph	Notes	Part Number
Street Triple '07-'14, Street Triple R '13-'14 & Daytona 675 '06-'14	Black, offset.	RG.CR0026.BK
Street Triple / R '13-'14	Black.	RG.CR0032.BK
Tiger 800	Black.	RG.CR0011.BK
Yamaha	Notes	Part Number
R6 '06-'14	Black, offset.	RG.CR0021.BK
FZ-09	Black, offset.	RG.CR0048.BK
R1 '07-'13	Black, offset.	RG.CR0022.BK

Don't see your bike or part listed? Visit TwistedThrottle.com for a complete listing of all the bikes that fit R&G products.

Check pages 192-269 to see which R&G products are available for your bike or visit TwistedThrottle.com.

Check pages 192-269 to see which R&G products are available for your bike.



Carbon Kevlar Tank & Tail Sliders

R&G Tank Sliders are made from Kevlar-reinforced carbon fiber, offering excellent crash protection and wear resistance. These sliders are specially molded to the areas of the fuel tank or tail section most likely to impact in a crash or drop. Save your tank and tail from expensive scratches, dents or even replacement. Installation is quick and easy with included self-adhesive panels.

Starting At
\$124⁹⁹



Yamaha R6 ('06 & later) Tank Sliders



Don't see your bike listed? Visit TwistedThrottle.com for a complete listing of all the bikes that fit R&G products.

BMW	Year	Tank Slider	Tail Slider
S1000RR	'12-'14		RG.TLS0009.C
Ducati	Year	Tank Slider	Tail Slider
848, 1098 & 1198	All	RG.TS0005.C	RG.TLS0005.C
Panigale 899 & 1199	All	RG.TS0009.C	RG.TLS0001.C
Honda	Year	Tank Slider	Tail Slider
CBR500R	'14	RG.TS0019.C	RG.TLS0014.C
CBR600RR	'13-'14	RG.TS0018.C	RG.TLS0013.C
CBR1000RR	'08-'11	RG.TS0015.C	RG.TLS0008.C
CBR1000RR	'12	RG.TS0010.C	RG.TLS0002.C
Kawasaki	Year	Tank Slider	Tail Slider
ZX6R	'09-'12	RG.TS0011.C	RG.TLS0003.C
ZX636	'13-'14	RG.TS0016.C	RG.TLS0011.C
ZX10R	'04-'07	RG.TS0013.C	
ZX10R	'08-'10	RG.TS0011.C	
ZX10R	'11-'14	RG.TS0004.C	RG.TLS0004.C
Suzuki	Year	Tank Slider	Tail Slider
GSXR1000	'09-'14	RG.TS0007.C	
Triumph	Year	Tank Slider	Tail Slider
Daytona 675	'13	RG.TS0002.C	RG.TLS0012.C
Street Triple / R	'13-'14	RG.TS0017.C	
Yamaha	Year	Tank Slider	Tail Slider
YZF R6	'08-'14	RG.TS0001.C	
YZF R1	'09-'14	RG.TS0006.C	

Bar End Sliders

R&G Bar End Sliders protect your bar ends, upper fairing, and windscreen. R&G bar end sliders are made from steel with high-density polyethylene and are designed not to snap off on impact. These sliders are a direct replacement for the original bar end weights on your bike. Will not fit with handguards.

Starting At
\$46⁹⁹
per pair



Constructed of tough steel and high-density polyethylene



BMW	Part Number
F650GS '08-'12 & F800GS '08-'14	RG.BE0047BK
F800R '09-'14	RG.BE0049BK
F800GT	RG.BE0073BK
R1200GS '13-'14	RG.BE0072BK
Ducati	Part Number
Hypermotard 820 / Hyperstrada 820	RG.BE0071BK
Diavel & Diavel Strada	RG.BE0074BK
Honda	Part Number
Grom	RG.BE0075BK
NC700X/S & NT700V Deauville '06-'10	RG.BE0058.BK
VFR1200 & CB1100 '13-'14	RG.BE0034BK

Kawasaki	Part Number
Kyle Racing Bars	RG.BE0001BK
ZX10R '06-'14	RG.BE0024BK
Z1000 '10-'14 & Versys 1000	RG.BE0032BK
KTM	Part Number
690SM, 990 Super Duke & 990R Super Duke	RG.BE0022BK
690 Duke '12, 690 Duke R & 990 SMR '08-'12 & 1290 Super Duke	RG.BE0060BK
RC8 '08-'14	RG.BE0040BK
1190 Adventure	RG.BE0070BK
Suzuki	Part Number
V-Strom DL650 & DL1000	RG.BE0017BK
SV650 & SV1000	RG.BE0012BK

Suzuki continued	Part Number
Hayabusa '08-'14	RG.BE0037BK
Triumph	Part Number
Street Triple '07-'12	RG.BE0009BK
Street Triple / R '13-'14	RG.BE0009BK
Daytona 675 '06-'14	RG.BE0026BK
Tiger 800 (not XC)	RG.BE0053BK
Yamaha	Part Number
FZ6 '04-'08	RG.BE0013BK
R1, FZ1, R6 '06-'11 & FJR1300	RG.BE0009BK
Super Tenere 1200 (with OEM Handguards)	RG.BE0052BK

Check pages 192-269 to see which R&G products are available for your bike or visit TwistedThrottle.com.

Shock Protectors

R&G Shocktubes prevent damage to your rear shock caused by road salt, water spray, stone chips, dust and dirt. The Shocktube is a high-impact, waterproof, vented Neoprene™ tube that is lined with stretch nylon on both sides.

Starting At
\$47⁹⁹

The Shocktube can be fitted to most motorcycles with either monoshock or twin shock rear suspension without removing the shock absorber!



Shocktubes are designed for specific shocks. Call 855-255-5550 or visit TwistedThrottle.com to make sure you get the Shocktube that fits YOUR bike.

Toe Chain Guards

Toe Chain Guards keep your feet or hands from being caught between the chain and rear sprocket in the event of a crash. R&G's toe guard has been developed with help from multi-time winner of the Isle of Mann TT, Ryan Farquhar. R&G toe chain guards are made from either ABS, aluminum or lightweight, high-density polyethylene, depending on the application.

Starting At
\$45⁹⁹



Some applications require drilling and tapping the underside of the swingarm (installation instructions included).

Toe Chain Guard for Suzuki GSX-R600 and GSX-R750



Check pages 192-269 to see which R&G products are available for your bike or visit TwistedThrottle.com.

Generic	Notes	Part Number
Shark's Fin Toe guard	Black	RG.TG0001.BK
Shark's Fin Toe guard	Silver	RG.TG0001.CL
Anodized generic toe guard	Silver	RG.TG0002.A2
Anodized generic toe guard	Black	RG.TG0002.B2
BMW	Notes	Part Number
F650GS '08-'12, F700GS '13-'14, F800GS '08-'14, F800R '09-'14		RG.TG0008.BK
S1000RR '10-'12	Black	RG.TG0006.BK
Husqvarna	Notes	Part Number
Nuda & TR650 Strada	Black	RG.TG0008.BK
Suzuki	Notes	Part Number
Suzuki GSX-R600 '11-'14	Black	RG.TG0007.BK
Triumph	Notes	Part Number
Street Triple '07-'12 & Daytona 675 '06-'12	Black	RG.TG0002.B1
Street Triple '07-'12 & Daytona 675 '06-'12	Silver	RG.TG0002.A1
Street Triple / R '13-'14 & Daytona 675 '13-'14	Black	RG.TG0009.BK
Street Triple / R '13-'14 & Daytona 675 '13-'14	Silver	RG.TG0009.SI
Yamaha	Notes	Part Number
R6 '03-'05	Black	RG.TG0002.B1
R6 '03-'05	Silver	RG.TG0002.A1

Depending on the application, not all Toe Chain Guards have the "shark fin" shape. The above chart is only a partial list of what we carry. Check TwistedThrottle.com for a complete list of bike fitments.



Exhaust Protectors

R&G Exhaust Protectors reduce the likelihood of scrapes to your bike's exhaust in a fall. Exhaust protectors feature shock absorbing, thermal silicone rubber underneath a protective slider. With a clamp incorporated into the design, installation is quick and easy. Guards available for oval, round, and many other common exhaust shapes.

Starting At
\$52⁹⁹



BMW S1000RR Akrapovic exhaust with Exhaust Protector



Fitment	Notes	Part number
Oval, LHS	Black.	RG.EP0004.BK1
Oval, RHS	Black.	RG.EP0004.BK2
Oval Supermoto Style	Black.	RG.EP0005.BK
Round Supermoto Style 4.5"-5.5"	Black.	RG.EP0006.BK
Tri Oval, LHS	Black.	RG.EP0007.BK1
Tri Oval, RHS	Black.	RG.EP0007.BK2
Akrapovic Hexagonal	Black.	RG.EP0008.BK
Round 5.5"-6.5" Tiger 800 & Bandit 1250	Black.	RG.EP0009.BK
Yoshi R-77	Black.	RG.EP0011.BK
Scorpion Serket	Black.	RG.EP0012.BK
125cc Exhausts (226mm circumference)	Suitable for Arrow / Scorpion RP-1 GP	RG.EP0013.BK
Aprilia Caponord 1200	Black.	RG.EP0016.BK
BMW C650GT	Exhaust Slider, Black.	RG.ES0005.BK
Kawasaki Z1000 '03-'06	Exhaust Slider, Black.	RG.ES0001.BK
Kawasaki Z1000 '07-'09	Exhaust Slider (pair), Black.	RG.ES0002.BK
Kawasaki Z750 '07-'09 & Z750R	Exhaust Slider, Black.	RG.ES0003.BK
Kawasaki Versys 1000, Kawasaki Ninja 300/250 '13-'14, KTM 1190 Adventure, Honda CBR125R/250R/1000RR '08-'14	Black.	RG.EP0014.BK
Suzuki GSX-R600 '11-'14, GSXR750 '11-'14, CBR250R '11-'14, CB600 '11-'14, CBR600F '11-'14, CBR1000RR '08-'14, Daytona 675 '13 with Arrow Exhaust	Black.	RG.EP0010.BK

Exhaust Hangers

R&G Exhaust Hangers provide a custom-look, lightweight alternative to your original exhaust hangers. Replaces the passenger peg mounts for solo sport-bike riders or track warriors. A passenger footrest blanking plate (sold separately) is available for the non-exhaust side for a clean look.

Starting At
\$80⁹⁹



Kawasaki	Notes	Part Number
Ninja 300	Black. Exhaust hanger only.	RG.EH0055.BK
ZX6RR/636 '03-'04	Silver. Exhaust hanger only.	RG.EH0013.SI
ZX6R '09-'14	Black. Exhaust hanger only.	RG.EH0043.BK
ZX6R '09-'14	Black. Exhaust hanger & Rear Footrest Blanking Plate.	RG.EH0043.BKA
ZX10R '04-'05	Black. Exhaust hanger only.	RG.EH0018.BK
ZX10R '08-'10	Black. Exhaust hanger only.	RG.EH0035.BK
ZX10R '11-'14	Black. Exhaust hanger only.	RG.EH0047.BK
ZX10R '11-'14	Black. Exhaust hanger & Rear Footrest Blanking Plate.	RG.EH0047.BKA
Z1000 '10-'14 & Ninja 1000 '10-'13	Black. Exhaust hanger only.	RG.EH0054.BK
Ninja 1000 '14 (Not touring version)	Black. Exhaust hanger only.	RG.EH0058.BK
KTM	Notes	Part Number
690 Duke '12-'13 & 690 Duke R '13	Silver. Exhaust hanger only.	RG.EH0052.SI
Super Duke 1290	Black. Exhaust hanger only.	RG.EH0059.BK
Suzuki	Notes	Part Number
SV650 '03-'12	Black or Silver. Exhaust hanger only.	RG.EH0026
GSX-R1000 '07-'08	Pair, Black or Silver. Exhaust hanger only.	RG.EH0039
GSX-R1000 '09-'11	Pair, Black. Exhaust hanger only.	RG.EH0042.BK
GSX-R600 & 750 '08-'10	Black. Exhaust hanger only.	RG.EH0046.BK
GSX-R600 & 750 '11-'14	Black. Exhaust hanger only.	RG.EH0048.BK
GSX-R1000 '12-'14	Black. Exhaust hanger only.	RG.EH0051.BK
Yamaha	Notes	Part Number
FZ8 '11-'13	Black. Exhaust hanger only.	RG.EH0044.BK
FZ1 S/N '06-'14	Black. Exhaust hanger only.	RG.EH0038

Footrest Blanking Plates tidy up the rear of your bike, for solo riders who remove the passenger footpeg brackets. Mounting hardware is included.

Sold as kit with Exhaust Hangers.
Starting at: \$127.50



Blanking Plate - BMW S1000RR



Passenger footpeg
bracket removed

Blanking plate installed



Frame Plugs & Mirror Block-off Plates

Frame Plugs fill frame voids to keep out dirt and to provide a clean, custom look. Mounting hardware is included.

Starting At
\$26⁷⁵



Frame plug installed

Frame Plug - BMW S1000RR



R&G Frame Inserts		
BMW	Notes	Part Number
F650GS '08-'12 & F700GS '13-'14	LHS or RHS	RG.FI0040.BK
S1000RR '10-'11	LHS	RG.FI0027.BK
S1000RR '10-'11	RHS	RG.FI0028.BK
S1000RR '12-'13	LHS	RG.FI0041.BK
S1000RR '12-'13	RHS	RG.FI0042.BK
R1200GS '05-'12	LHS or RHS	RG.FI0001.BK
R1200GS '13-'14	set of 7	RG.FI0069.BK
Honda	Notes	Part Number
CBR600RR '09-'13	LHS	RG.FI0024.BK
CBR600RR '09-'13	RHS	RG.FI0025.BK
CBR1000RR '08-'12	RHS	RG.FI0012.BK
CBR1000RR '08-'12	LHS	RG.FI0011.BK
VFR1200 '10-'11	LHS	RG.FI0029.BK
VFR1200 '10-'11	RHS	RG.FI0030.BK
Kawasaki	Notes	Part Number
ZX6 '07-'08 & FZ8 '10-'11	LHS	RG.FI0004.BK
ZX6R '07-'08	RHS	RG.FI0011.BK
ZX6 '09	LHS	RG.FI0011.BK
ZX6R '09-'12	RHS	RG.FI0023.BK
ZX6R '13-'14	LHS	RG.FI0023.BK

Mirror Block-off Plates

Removing your mirrors for safety on the track? Building a custom sport bike where stock mirrors are "optional"? These aluminum block-off plates cover exposed mounting brackets, and keep the fairings from flapping, after mirrors are removed.

Starting At
\$52⁹⁹



Mounting hardware is included.

Mirror Block Off Plate - BMW S1000RR

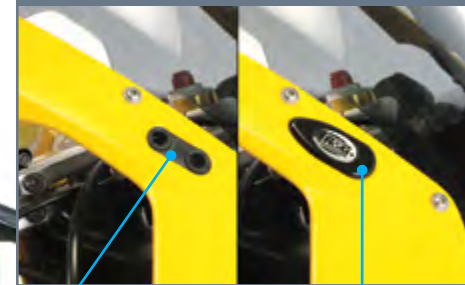

Mirror removed

Block-off plate installed

Kawasaki (continued)		
Kawasaki	Notes	Part Number
ZX6R '13-'14	RHS	RG.FI0058.BK
Ninja 1000 '10-'13	RHS	RG.FI0009.BK
Ninja 1000 '10-'13	LHS	RG.FI0010.BK
ZX10R '08-'11, Ninja 1000 '11-'14	RHS	RG.FI0010.BK
KTM	Notes	Part Number
1190 Adventure & 1290 Super Duke	pair	RG.FI0060.BK
Suzuki	Notes	Part Number
GSX-R600/750 '06-'11	LHS	RG.FI0007.BK
GSX-R600/750 '06-'11	RHS	RG.FI0008.BK
GSX-R1000 '07-'14	LHS, Lower	RG.FI0017.BK
GSX-R1000 '07-'14	RHS, Lower	RG.FI0018.BK
GSX-R1000 '07-'14	RHS or LHS, Upper	RG.FI0019.BK
Triumph	Notes	Part Number
Speed Triple '05-'10, Sprint ST '05-'10 & Sprint GT '10	LHS	RG.FI0003.BK
Speed Triple '05-'10, Sprint ST '05-'10 & Sprint GT '10	RHS	RG.FI0004.BK
Tiger 800 '11-'14	LHS or RHS	RG.FI0035.BK
Speed Triple '11-'14	LHS or RHS	RG.FI0034.BK
Yamaha	Notes	Part Number
R6 '06-'14	LHS, lower	RG.FI0013.BK
R6 '06-'14	RHS, lower	RG.FI0014.BK
R6 '06-'14	LHS or RHS, Upper	RG.FI0020.BK
R1 '07-'09	LHS or RHS, top	RG.FI0016.BK

R&G Mirror Block-off Plates

BMW	Part Number
S1000RR '10-'12	RG.MBP0002.BK
Ducati	Part Number
848 / 1098 / 1198	RG.MBP0009.BK
Panigale 899 & 1199	RG.MBP0010.BK
Honda	Part Number
CBR500R, CBR600RR '03-'08 & CBR1000RR '04-'07	RG.MBP0013.BK
CBR1000RR '08-'13	RG.MBP0007.BK
Kawasaki	Part Number
Ninja 300 & ZX6R '13-'14	RG.MBP0014.BK
ZX6R '09-'12	RG.MBP0003.BK
ZX10R '11-'14	RG.MBP0004.BK
Suzuki	Part Number
GSXR 600 & 750 '06-'10	RG.MBP0011.BK
GSXR 600 & 750 '11-'12	RG.MBP0012.BK
Triumph	Part Number
675 Daytona '06-'12	RG.MBP0008.BK
675 Daytona '13-'14	RG.MBP0015.BK

Check pages 192-269 to see which R&G products are available for your bike or visit TwistedThrottle.com.

Engine Case Covers

R&G Engine Case Covers

are an easy, inexpensive, and innovative way to protect vulnerable and expensive crankcases and water pump cases from crash damage. The R&G Engine Case Covers are vacuum-formed from durable 4mm polypropylene for great protection and good looks. These covers are motorcycle-specific and form-fit to simply bolt over the existing OEM covers.



Starting At
\$70⁹⁹

Includes all necessary mounting hardware. R&G Engine Case Covers are AMA approved.

BMW	RHS	LHS
F650GS '09-'12, F700GS, F800GS '08-'14, F800R	RG.ECC0149.BK	RG.ECC0148.BK
F800GT	RG.ECC0149.BK	RG.ECC0154.BK
S1000RR '10-'14	RG.ECC0044.BK (water pump) RG.ECC0045.RG (clutch)	RG.ECC0043.BK (generator)
Ducati	RHS	LHS
StreetFighter 848	RG.ECC0132.BK (clutch)	
Hypermotard 820 & Hyperstrada 820	RG.ECC0152.BK (clutch)	
Panigale 899/1199	RG.ECC0126.BK (clutch)	
Multistrada 1200	RG.ECC0082.BK	-
Diavel & Diavel Strada	RG.ECC0118.BK (clutch)	RG.ECC0117.BK (water pump)
Honda	RHS	LHS
CBR500R, CB500F '13 & CB500X	RG.ECC0151.BK	RG.ECC0150.BK
CBR600RR '07-'14	RG.ECC0022.BK	RG.ECC0021.BK
NC700X/S	RG.ECC0134.BK (manual only)	RG.ECC00133.BK
CBR1000RR '08-'13	RG.ECC0018.BK	RG.ECC0017.BK
CB1000R	RG.ECC0024.BK	RG.ECC0023.BK
VFR1200	RG.ECC0084.BK (Not DCT)	RG.ECC0083.BK
Kawasaki	RHS	LHS
Ninja 300	RG.ECC0139.BK	RG.ECC0140.BK
ER6 '09-'14 & Versys 650 '10-'14	RG.ECC0122.BK (clutch)	RG.ECC0212.BK (generator)
ZX6 '09-'13	RG.ECC0036.BK (clutch) RG.ECC0037.BG (small starter)	RG.ECC0035.BK (generator)
ZX10R '06-'07	RG.ECC0039.BK (clutch) RG.ECC0040.BK (idle gear)	RG.ECC0038.BK (generator)
ZX10R '08-'10	RG.ECC0041.BK (clutch) RG.ECC0042.BK (small starter)	RG.ECC0038.BK (generator)
ZX10R '11-'14	RG.ECC0095.BK (clutch) RG.ECC0096.BK (starter)	RG.ECC0094.BK (generator)

BMW S1000RR Engine Case Covers

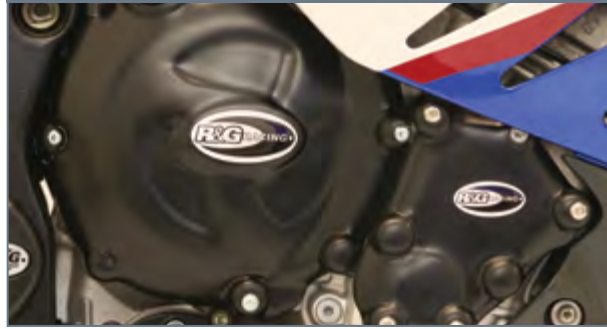

Kawasaki	RHS	LHS
Z1000 '10-'14, Ninja 1000 & Versys 1000	RG.ECC0077.BK (generator) RG.ECC0079.BK (clutch)	
KTM	RHS	LHS
Duke 690 '12, 690 Duke R '13-'14, 690SM, 690SMC, 690SMR & 690 Enduro R	RG.ECC0138.BK	RG.ECC0137.BK
1290 Super Duke & 1190 Adventure	RG.ECC0156.BK	RG.ECC0155.BK
Suzuki	RHS	LHS
GSX-R600 & 750 '08-'11	RG.ECC0003.BK	
SV650 '03-'12 & V-Strom 650 '04-'14	RG.ECC0071.BK (clutch)	RG.ECC0070.BK (generator)
GSX-R1000 '09-'14	RG.ECC0005.BK (clutch & idle gear)	RG.ECC0004.BK
Ducati	RHS	LHS
Daytona 675 & Street Triple '07-'11	RG.ECC0099.BK	RG.ECC0016.BK
Street Triple / R '12-'13 & 675 Daytona '12	RG.ECC0120.BK	RG.ECC0119.BK
675 Daytona '13-'14	RG.ECC0142.BK (starter)	RG.ECC0141.BK
Tiger 800	RG.ECC0107.BK (clutch)	RG.ECC0106.BK (generator)
Speed Triple '08-'13	RG.ECC0048.BK (clutch)	RG.ECC0047.BK (alternator)
Explorer 1200	RG.ECC0136.BK	RG.ECC0137.BK
Yamaha	RHS	LHS
R6 '06-'14	RG.ECC0033.BK ('08-'14 only) RG.ECC0034.BK (oil pump)	RG.ECC0032.BK
FZ-09	RG.ECC0162.BK (pulse) RG.ECC0163 (clutch)	RG.ECC0161.BK (water pump & generator)
FZ1	RG.ECC0028.BK (oil pump)	RG.ECC0054.BK (clutch)
R1 '09-'14	RG.ECC0030.BK RG.ECC0031.BK (oil pump)	RG.ECC0029.BK

Engine Case Sliders

R&G Engine Case Sliders

Crafted from High Density Polyethylene or Carbon Kevlar for strength, durability and good looks, the R&G Engine Case Sliders compliment the R&G crash protectors perfectly in keeping the delicate parts of your motorcycle off the tarmac. The covers simply bolt on over the original engine casing. Slimline for maximum ground clearance, ultra lightweight, matte finish and protecting one of the most vulnerable parts of the machine. These could save you hundreds of dollars in the event of an accident.



Ducati Panigale 899/1199
RG.ECS0068.C



Suzuki GSX-R600/750 '11-'14
RG.ECS0069.BK

Starting At
\$54⁹⁹

Includes mounting instructions and hardware.

Check pages 192-269 to see which R&G products are available for your bike.

SW-MOTECH Axle & Swingarm Sliders

SW-MOTECH Axle & Swingarm Sliders

feature excellent protection while providing a higher level of aesthetics than most sliders on the market. Made from tough, abrasion-proof synthetic material these sliders are durable and protective. Available for BMW, Kawasaki, KTM, Suzuki, and Triumph models.



Frame Sliders

SW-MOTECH Frame Sliders offer rugged protection and a sporty, integrated design and are constructed of a CNC-milled PA6 MO Polyamide and aluminum alloy for high strength. Slider pads are made from high-performance UV-resistant plastic that provide enhanced load bearing, excellent abrasion and wear resistance for maximum protection. Replacement slider pads are available.

For some bikes fairing cut-outs are required. Templates and center punches are included to make installation precise and easy.



Starting At
\$157⁵⁰

BMW S1000RR
STP.07.590.10600.B



Kawasaki 1000 Ninja '11-'14



Honda CB1000RR '08-'12

Starting At
\$85⁹⁹

SW-MOTECH
BAGS-CONNECTION

Axle and Swingarm Sliders	Front axle	Swingarm
BMW F800GS/ADV ('13-'14)	STP.07.176.10400.B	
BMW F800GS, F700GS		STP.07.176.10500.B
BMW R1200GS ('04-'12)	STP.07.176.10100.B	STP.07.176.10000.B
Kawasaki Versys ('10-'13)	STP.08.176.10100.B	STP.08.176.10000.B
Kawasaki Versys 1000 ('12-'13)	STP.08.176.10300.B	STP.08.176.10200.B
KTM 690 Duke 4	STP.04.176.10000.B	STP.04.176.10100.B
KTM 990 Adventure	STP.04.176.10400.B	STP.04.176.10300.B
KTM 990 SMR	STP.04.176.10500.B	STP.04.176.10200.B
Suzuki DL1000 ('01-07)	STP.05.176.10000.B	
Triumph Tiger 800, 800XC ('11-'13)	STP.11.176.10000.B	
Triumph Explorer 1200 ('12-'13)	STP.11.176.10000.B	
Triumph Tiger 1050 ('06-'12)	STP.11.176.10300.B	STP.11.176.10400.B

BMW	from	to	Part Number
F800R	'09	'13	STP.07.590.10500.B
F800ST	'07	'12	STP.07.590.10400.B
S1000RR	'10	'14	STP.07.590.10601.B
DUCATI	from	to	Part Number
848 Streetfighter	'11	'14	STP.22.590.10000.B
HONDA	from	to	Part Number
CBR600RR	'07	'14	STP.01.590.10500.B
CB1000R	'08	'14	STP.01.590.10000.B
CBF1000	'06	'09	STP.01.590.10101.B
CBF1000F	'10	'13	STP.01.590.10101.B
CBR1000RR	'08	'12	STP.01.590.10200.B
KAWASAKI	from	to	Part Number
Ninja 650R	'09	'14	STP.08.590.10100.B
ER-6N	'09	'14	STP.08.590.10200.B
Versys	'07	'09	STP.08.590.10000.B
Versys	'10	'14	STP.08.590.10600.B
Z1000	'10	'13	STP.08.590.10500.B
1000 Ninja	'11	'13	STP.08.590.10700.B
ZX10R	'08	'10	STP.08.590.10300.B
ZX10R	'11	'14	STP.08.590.10800.B
SUZUKI	from	to	Part Number
GSX-R600	'08	'10	STP.05.590.10500.B
GSX-R600 & GSX-R750	'11	'14	STP.05.590.10700.B
SPV650 Gladius	'09	'14	STP.05.590.10000.B
GSX-R1000	'09	'09	STP.05.590.10600.B
TRIUMPH	from	to	Part Number
Street Triple 675	'08	'12	STP.11.590.10100.B
Street Triple 675	'13	'14	STP.11.590.10400.B
Speed Triple 1050	'08	'10	STP.11.590.10000.B
Speed Triple 1050	'11	'14	STP.11.590.10300.B
Sprint GT	'10	'14	STP.11.590.10200.B
YAMAHA	from	to	Part Number
FZ6 & FZ1	'06	'14	STP.06.590.10000.B
FZ6R	'10	'14	STP.06.590.10800.B
YZF-R6	'08	'14	STP.06.590.10200.B
FZ8	'10	'13	STP.06.590.11000.B
FZ-09	'14	'14	STP.06.590.10900.B
YZF-R1	'09	'14	STP.06.590.10400.B
FJR1300	'08	'14	STP.06.590.10301.B
Replacement Slider Set	Replacement pads for SW-MOTECH Frame Slider Kits. In pairs.		STP.00.590.10000.B



Aluminum Radiator Guards

Your radiator is a vulnerable component that needs protection. The R&G Radiator Guard is made from pressed aluminum and features a neat, seamless frame. The attractive black finish looks terrific while helping to protect your expensive radiator from flying debris.



Starting At
\$99⁹⁹

Triumph Tiger 800 XC Aluminum Radiator Guard



Oil Cooler Guards

Wouldn't it stink to be miles from anywhere when you find that something punctured your oil cooler? Avoid that nightmare with an R&G Oil Cooler Guard. These black, pressed aluminum oil cooler guards are designed to prevent punctures caused by flying rocks, sticks and other objects. Easy to install and good looking protection.



Starting At
\$68⁹⁹

BMW R1200GS Oil Cooler Guard



Stainless Steel Radiator Guards

New for 2014. The R&G Stainless Steel Radiator Guard are a more rugged version of our existing aluminum offering designed particularly for adventure bikes.

Construction from 1mm stainless steel sheet allows the guard to be incredibly strong and impervious to rust – perfect for bikes and riders who may tackle demanding terrain and conditions. The laser-cut grills are designed for maximum airflow so that radiator cooling isn't compromised. The Radiator Guard is as good looking as it is purposeful.

No modifications need to be made to the bike for installation.



Starting At
\$132⁵⁰

Check pages 192-269 to see which R&G products are available for your bike or visit TwistedThrottle.com.

BMW R1200GS Stainless Steel Radiator Guard



Ducati Multistrada 1200 Stainless Steel Radiator Guard



Radiator and Oil Cooler Guards

Protect your radiator from rocks, bugs, and other UFOs. SW-MOTECH and R&G radiator guards and oil cooler guards improve the looks of your bike and help to protect your expensive and vulnerable radiator and oil cooler from flying debris. Instructions and all mounting hardware are included. No drilling, welding, zip ties or duct tape needed.

Kawasaki Versys 1000



Honda NC700X



Triumph Street Triple



Brand	from	to	Notes	Brand	Part Number
Aprilia					
Tuono	'11	'12	Radiator Guard	R&G	RG.RAD0109
RSV4	'08	'11	Radiator Guard	R&G	RG.RAD0076
Dorsoduro 1200	'11	'12	Radiator Guard	R&G	RG.RAD0107
BMW	from	to	Notes	Brand	Part Number
S1000RR	'09	'13	Radiator Guard	R&G	RG.RAD0087
S1000RR	'09	'13	Oil Cooler Guard	R&G	RG.OCG0005
R1200GS	'09	'12	Oil Cooler Guard	SW	KLS.07.719.10000.B
Ducati	from	to	Notes	Brand	Part Number
Multistrada 1200	'10	'13	Radiator Guard	R&G	RG.RAD0092
Streetfighter 1098	'09	'12	Radiator & Oil Cooler Guard	R&G	RG.RAD9016
Honda	from	to	Notes	Brand	Part Number
CBR1000RR	'08	'12	Radiator Guard	R&G	RG.RAD0065
CBR600RR	'07	'12	Radiator Guard	R&G	RG.RAD0077
NC700X	'12	'13	Radiator Guard	R&G	RG.RAD0115
VFR1200F	'10	'13	Radiator Guard (manual clutch)	R&G	RG.RAD0089
VFR1200F	'10	'13	Radiator Guard (auto clutch)	R&G	RG.RAD0097
Kawasaki	from	to	Notes	Brand	Part Number
Ninja 300	'13	'13	Radiator Guard	R&G	RG.RAD0139
GTR1400 Concours	'07	'13	Radiator Guard	R&G	RG.RAD0080
ZX-14	'06	'13	Radiator Guard	R&G	RG.RAD0080
Z1000	'10	'12	Radiator Guard	R&G	RG.RAD0090
Z750	'07	'12	Radiator Guard	R&G	RG.RAD0090
ER6, Versys 650	'10	'12	Radiator Guard	R&G	RG.RAD0091
Versys 1000	'12	'13	Radiator Guard	SW	KLS.08.204.10000.B
Versys 1000	'12	'13	Radiator Guard	R&G	RG.RAD0090
ZX6R	'07	'12	Radiator Guard	R&G	RG.RAD0078
ZX10R	'08	'13	Radiator Guard	R&G	RG.RAD0068
KLX250S / SF	'05	'12	Radiator Guard	SW	KLS.08.426.10000.S
KTM	from	to	Notes	Brand	Part Number
LC8 Adventure 990/1190	'06	'13	Radiator Guard	SW	KLS.04.389.100
LC8 Adventure 950	'03	'05	Radiator Guard	SW	KLS.04.389.100
Suzuki	from	to	Notes	Brand	Part Number
DL650 V-Strom	'04	'13	Radiator Guard	R&G	RG.RAD0112
Gladius	'09	'13	Radiator Guard	R&G	RG.RAD0074
GSX1250FA	'07	'12	Radiator Guard	R&G	RG.RAD0093
GSX-R 600	'06	'12	Radiator Guard	R&G	RG.RAD0066
GSX-R 750	'04	'12	Radiator Guard	R&G	RG.RAD0066
GSX-R 1000 K7-K8	'07	'09	Radiator Guard	R&G	RG.RAD0069
GSX-R1000	'09	'12	Radiator Guard	R&G	RG.RAD0084
Hayabusa & B-King	'08	'12	Radiator Guard	R&G	RG.RAD0086
Triumph	from	to	Notes	Brand	Part Number
Street Triple	'07	'12	Radiator Guard	R&G	RG.RAD0070
Speed Triple	'06	'09	Radiator & Oil Cooler Guard	R&G	RG.RAD0083
Speed Triple	'10	'10	Radiator & Oil Cooler Guard	R&G	RG.RAD0098
Speed Triple	'11	'13	Radiator Guard	R&G	RG.RAD0099
Tiger 800	'11	'13	Radiator & Oil Cooler Guard	R&G	RG.RAD0101
Tiger 1050	'07	'13	Radiator & Oil Cooler Guard	R&G	RG.RAD0073
Trophy	'13	'13	Radiator Guard	R&G	RG.RAD0134
Yamaha	from	to	Notes	Brand	Part Number
FZ-8, FZ-1	'10	'13	Radiator Guard	R&G	RG.RAD0094
YZF-R6	'06	'13	Radiator Guard	R&G	RG.RAD0067
YZF-R1	'04	'06	Radiator Guard	R&G	RG.RAD0072
YZF-R1	'07	'08	Radiator Guard	R&G	RG.RAD0067
YZF-R1	'09	'13	Radiator Guard	R&G	RG.RAD0071
XT1200Z Super Tenere	'11	'13	Downpipe Grill	R&G	RG.DG0001

Yamaha XT1200Z Super Tenere



SBL.06.162.1000.B

SW-MOTECH Crashbars offer vital protection for your motorcycle. Each crashbar is carefully designed for an integrated look, precision fit, and for heavy-duty performance.

During production, crashbars are sandblasted and powder coated to provide a corrosion-resistant finish.

Starting At
\$159⁹⁹

See the "What Fits My Bike?" section of the catalog (pages 192-269) for bike-specific crashbar information.

Triumph Explorer 1200



SBL.11.485.10000

KTM 1190 Adventure & Adventure R



SBL.04.338.10000.B

Honda NC700X & NC700S



SBL.01.132.10000

Suzuki DL650 V-Strom, '12-'14



SBL.05.757.10000

BMW F650GS Twin, F700GS & F800GS



SBL.07.556.100

Upper Tank Crashbars for BMW R1200GS LC, '13-'14



SBL.07.788.10000

Available for the **BMW R1200GS**, our beefy Upper Tank Crashbars protect your tanks and fairing during your off-road adventures. Upper Tank Crashbars require our Lower Crashbars (SBL.07.783.10000).

The Upper Tank Crashbars include integrated mounting points for auxiliary driving lights, like our Denali LED Light Kits - check them out on page 112.

See pages 204-208 for more BMW R1200GS accessories.

'04-'07 SBL.07.552.100: **\$244⁹⁹**

'08-'12 SBL.07.565.100: **\$244⁹⁹**

'13-'14 SBL.07.788.1000: **\$272⁵⁰**

Crashbar Accessories expand your bike's versatility and ergonomics. Quickly and easily mount auxiliary lighting, footpegs, and cameras onto standard size tubular handlebars and crashbars with these accessories.

Customer Favorite

\$34⁹⁹

Folding Footpeg Mounts for Crashbars

Increase long haul comfort, be it the Iron Butt Rally or a meandering vacation tour, by mounting fold away footpegs onto your crashbars. MFW's sweet bar-mounted footpeg system is easy to install and sharp looking. With Four footpeg styles to choose from (see below) you can choose the look and function that is right for you. Footpegs and folding mounts are sold separately.

The MFW system fits 0.85"-1.125" (21.3mm-28mm) diameter bars, including all SW-MOTECH and Givi crashbars.

Flat surface mounts are available for mounting MFW footpegs on any flat surface with a 10mm mounting hole or the built-in mounting hole found on some SW-MOTECH crashbars: MFW.050.00.10.M10 \$75.99 per pair

Footpegs for use with Crashbar Mounts

Four choices of MFW footpegs are available to complete your crashbar footpeg installation. Footpegs and folding mounts are sold separately.

MFW Stash Pegs

Need to store some emergency cash? Check out the MFW Stash Pegs on page 24.



NEW



Racing Pegs

MFW.050.00.01.00-1 Silver
MFW.050.00.01.00-8 Black
\$34.99 per pair

Super Grip Pegs

MFW.050.00.04.00-1 Silver
MFW.050.00.04.00-8 Black
\$59.99 per pair

Master Grip Pegs

MFW.050.00.03.00-1 Silver
MFW.050.00.03.00-8 Black
\$34.99 per pair

Craving more comfort? Check out MFW's adjustable footpegs on page 24-25.

IMPORTANT: MFW mounts and footpegs are sold separately.

Auxiliary Light Mount Clamps

These stylish clamps are machined from 6061-T6 Aluminum for strength and durability. The kit allows fitment of any Denali LED Lighting Kit (page 112-113) to any tubular bar ranging from 22mm to 28mm in diameter.

The bracket can be mounted in numerous positions allowing light pods to be placed for optimal beam projection, while keeping themselves protected.

For use on SW-MOTECH, Givi, Hepco-Becker and most original BMW crashbars.

Includes:

- 2 sets of black anodized aluminum machined clamps
- Mounting Hardware

\$62⁹⁹

LAH.00.10300



Suzuki DL650 V-Strom Crashbars with Denali LED Lights

Camera Mounts

More camera mount options on pages 102-105.



GoPro Mount Kit

Fits bars from 0.5" to 1.25" diameter. Consists of a zinc coated U-bolt base, 3" double socket arm and 1" diameter ball with custom GoPro® Hero adapter. Base includes black cover caps to tidy and protect the exposed ends of U-bolt.

\$45⁷⁶

RAM-B-149Z-GOP1

GoPro Cameras page 96.

Universal Camera Mount Kit

Includes bar mount, 3" extension arm and camera holder with a 1/4-20 threaded stud (standard video camera tripod mount).

\$30⁴⁰

RAM-B-149Z-C1U

Contour Mount Kit

Includes bar mount, 3" extension arm, and camera holder with 1/4-20 threaded stud. Ideal for Contour GPS and Contour HD cameras. Fits bars up to 1.25" diameter.

\$28⁸⁸

RAM-B-149Z-237U





Aluminum Skid Plates

Our skid plates are built tough from laser-cut, TIG-welded aluminum and provide heavy-duty protection from baby heads, log crossings, and other ride-ending calamities.

Skid plates feature:

- Oil drain plug access hole.
- Rubber mounting to isolate from engine underside and minimize noise & vibration.
- Recessed mounting bolts to prevent damage from rocks and stumps.
- Riveted or welded construction.
- On riveted skid plates the 4mm bottom plate with 3mm side plates overlap to create impact-resistant 7mm thick side rails.

See the "What Fits My Bike?" section of the catalog (pages 192-269) or visit TwistedThrottle.com for bike-specific skid plate information.

Suzuki DL650 V-Strom '12-'14
MSS.05.759.10000.B

Starting At
\$129⁹⁹

Also available:
Suzuki DL650 V-Strom '04-'11
MSS.05.296.10001.B

Yamaha XT1200Z Super Tenere, '10-'14



MSS.06.150.10000.S

Kawasaki Versys 650, '07-'14



MSS.08.712.10000.B

Ducati Multistrada 1200, '10-'14



MSS.22.143.10000.S

BMW R1200GS, '04-'12 & R1200GS Adventure, '08-'13



Available in natural aluminum or black.

MSS.07.781.10000

Triumph Tiger 800 & 800XC, '11-'14



MSS.11.752.10000.B

Kawasaki KLR650E, '08-'14



MSS.08.469.10000



Rear Brake Master Cylinder Guards

SW-MOTECH Rear Brake Master Cylinder Guards protect your master cylinder from flying rocks or damage from your massive boot heel.

Most models
\$32⁹⁹

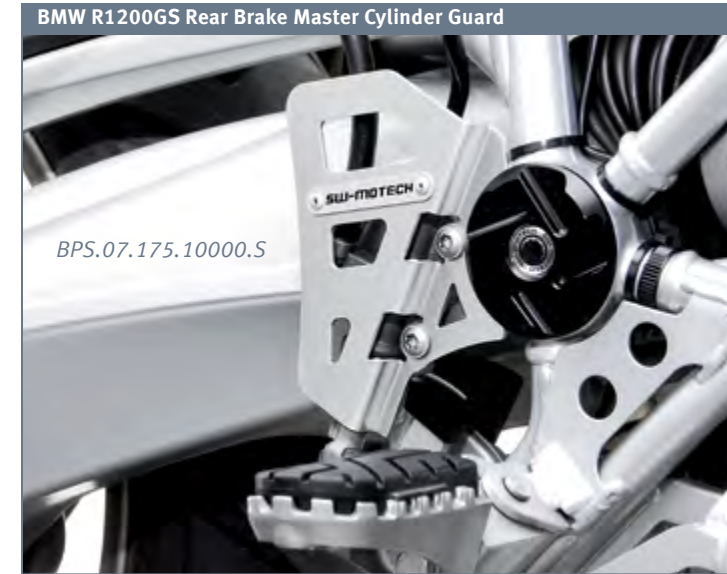

BMW R1200GS Rear Brake Master Cylinder Guard

BPS.07.175.10000.S

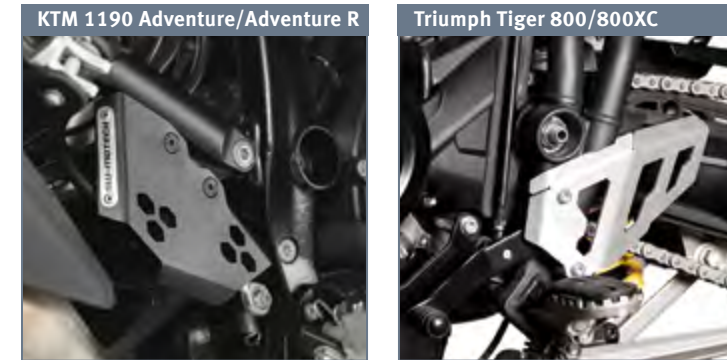

KTM 1190 Adventure/Adventure R

Triumph Tiger 800/800XC

BMW	Notes	Part Number
F650GS twin, '08-'12	Silver.	BPS.07.175.10101.S
F650GS single, '00-'07	Silver.	BPS.07.175.10101.S
G650GS, '09-'14	Silver.	BPS.07.175.10101.S
F700GS & F800GS, '08-'14	Silver.	BPS.07.175.10101.S
R1200GS, '08-'12	Silver.	BPS.07.175.10001.S
R1200GS Adv, '10-'13	Silver.	BPS.07.175.10000.S
Husqvarna	Notes	Part Number
TR650 Strada & Terra	Silver.	BPS.07.175.10101.S
Kawasaki	Notes	Part Number
KLR650, '87-'14	Black or silver.	GRD.00.804.10001
KTM	Notes	Part Number
990 Adventure/Adventure R	Black.	BPS.04.175.10000.B
990 SMR, '07-'14	Black.	BPS.04.175.10000.B
1190 Adventure/Adventure R	Black.	BPS.04.175.10100.B
Suzuki	Notes	Part Number
DL650 V-Strom, '04-'14	Silver.	BPS.05.175.10000.S
Triumph	Notes	Part Number
Tiger 800 & 800XC, '10-'14	Silver.	SCT.11.174.10100

For additional fittings see the "What Fits My Bike?" section of the catalog (pages 192-269) or visit TwistedThrottle.com.

Most models
\$35⁹⁹

Rear Brake Reservoir Guards

SW-MOTECH Rear Brake Reservoir Guards protect this vital container while adding rugged style to your ride.



Triumph Tiger 800 & Tiger 800XC

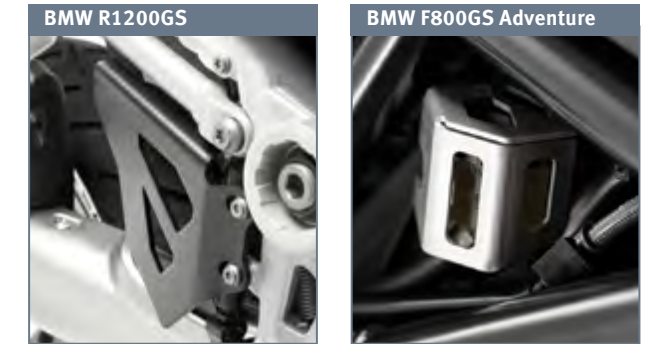

BMW R1200GS

BMW F800GS Adventure

BMW	Part Number
F650GS twin, '08-'12	SCT.07.174.10100.S
F800GS, '08-'12	SCT.07.174.10100.S
F800GS Adventure, '14	SCT.07.174.10600.S
R1200GS, '08-'12	SCT.07.174.10300.S
R1200GS LC, '13-'14	SCT.07.174.10500.B
Triumph	Part Number
Tiger 800 & 800XC, '10-'13	SCT.11.174.10000.S

Regulator and Potentiometer Guards



BMW F800GS Regulator Guard

BMW R1200GS Potentiometer Guard

Mounts on the right side of the '08-'12 F800GS.

Mounts behind the left side cylinder to protect the potentiometer of the '08-'12 BMW R1200GS.

BMW	Notes	Part Number
F800GS, '08-'12	Regulator Guard	SCT.07.174.10000.S
R1200GS, '08-'12	Potentiometer Guard	SCT.07.174.10200.S



Centerstands make chain maintenance, oil changes, and roadside tire repair much easier. It's also much more convenient packing and unpacking your luggage when your bike is level. To keep your sporting edge, our centerstands are tested to make sure they do not limit the bike's maximum lean angle or ground clearance.

Centerstands are constructed using mild steel tubing, which absorb the impact of a fall by bending before your bike's frame has to. Prior to powder coating, all centerstands are sandblasted and chemically treated to provide optimal protection against corrosion.

See the "What Fits My Bike?" section of the catalog (pages 192-269) for bike-specific centerstand fits.



Starting At
\$15750

Suzuki DL1000 V-Strom
HPS.05.159.100



Centerstands keep your bike level for easy packing and maintenance.



Does not limit maximum lean angle.



Foot levers provide excellent leverage, making it easy to centerstand your bike.



Optimal clearance for cornering and OEM fit.



Spring Puller Tool for easy installation.
WFF.00.138.100: \$35.99



Centerstand Skid Plate for BMW R1200GS LC ('13-'14)

MSS.07.781.10300.S



KLR650 lifting handle, '87-'13

HPS.08.364.LIFT

Sidestand Foot Enlargers

SW-MOTECH and R&G Sidestand Foot Enlargers mount to your original sidestand to provide a wider, more stable platform for your motorcycle. Unlike other brands with sharp, serrated sheet metal designs, our rounded, machined billet aluminum designs won't cut your riding pants or scrape up your boots. Black mount with silver foot.



Most models
\$4999



SW-MOTECH	
BMW	Part Number
G650GS single, '09-'13	STS.07.102.10200.S
F650GS single, '07 and earlier	STS.07.102.10200.S
F650GS twin, '08-'12	STS.07.102.10100.S
F800GS, '08-'14	STS.07.102.10100.S
F800GS Adventure, '14	STS.07.102.10100.S
R1200GS, '04-'12	STS.07.102.10000.S
R1200GS Adventure, '08-'13	STS.07.102.10000.S
Husqvarna	Part Number
TR650 Terra & Strada	STS.07.102.10100.S
Kawasaki	Part Number
Versys 1000, '12-'14	STS.08.102.10000.S
KTM	Part Number
990 Adventure, '06-'12	STS.04.102.10000.S
1190 Adventure, '13-'14	STS.04.102.10000.S
Suzuki	Part Number
DL650 V-Strom, '04-'14	STS.05.102.10001.S
Triumph	Part Number
Tiger 800 & XC, '11-'14	STS.11.102.10000.S
Tiger Explorer, '12-'14	STS.11.102.10100.S



R&G	
BMW	Part Number
F700GS	RG.PKS0004.SI
F800GT	RG.PKS0021.SI
R1200GS, '13-'14	RG.PKS0020.SI
Ducati	Part Number
Hypermotard / Hyperstrada 820	RG.PKS0018.SI
Multistrada 1200, '10-'14	RG.PKS0018.SI
Honda	Part Number
CBR500R, F & X, '13-'14	RG.PKS0016.SI
CBR600RR, '13-'14	RG.PKS0017.SI
NT700V Deauville, '98-'10	RG.PKS0031.SI
XL700V Transalp, '08-'13	RG.PKS0040.SI
CBF1000, '06-'10	RG.PKS0030.SI
CB1000R, '08-'14	RG.PKS0038.SI
CBR1100XX Blackbird, '96-'08	RG.PKS0029.SI
Kawasaki	Part Number
Ninja 300, '13-'14	RG.PKS0002.SI
ZX6R, '03-'04	RG.PKS0006.SI
ZX6R, '07-'08	RG.PKS0006.SI
ZX6R, '12	RG.PKS0006.SI
ZX636, '13-'14	RG.PKS0012.SI
Versys 650, '11	RG.PKS0024.SI
ZX10R, '11-'14	RG.PKS0006.SI
Ninja 1000, '12	RG.PKS0012.SI
Z1000, '14	RG.PKS0041.SI
Concourse 1400, '13-'14	RG.PKS0033.SI
KTM	Part Number
690 Duke, '12	RG.PKS0008.SI
690 Duke R, '13-'14	RG.PKS0011.SI
990 Super Duke, '05-'13	RG.PKS0034.SI
990 SMT	RG.PKS0008.SI
1290 Super Duke	RG.PKS0034.SI
Suzuki	Part Number
SV650, '03-'12	RG.PKS0028.SI
GSX1250, '07-'13	RG.PKS0014.SI
Hayabusa, '08-'14	RG.PKS0035.SI
Triumph	Part Number
Daytona 675, '13-'14	RG.PKS0001.SI
Tiger 1050, '07-'09	RG.PKS0005.SI
Tiger 1050, '10-'12	RG.PKS0003.SI
Yamaha	Part Number
FZ-09, '14	RG.PKS0037.SI
FZ6N & FZ6, '09-'14	RG.PKS0037.SI
FJR1300, '06-'14	RG.PKS0023.SI



Pyramid Plastics Fenda Extenda Fender Extensions

protect the front of your engine, radiator and frame from road grime and gravel kicked up by the front tire, while adding a custom look.

Fenda Extendas attach to your bike's original fender with adhesive strips, four provided screws or push rivets. Installation requires that you drill four holes in the extender and original fender. Adhering the Fenda Extenda to the original fender without the screws or rivets is not recommended.



Aprilia	from	to	Part Number
ETV1000 Caponord	'01	'07	PP.057130
BMW	from	to	Part Number
F650GS	'02	'07	PP.054215
F650GS	'09	'12	PP.054201
G650GS	'09	'14	PP.054215
F800GS	'08	'11	PP.054201
F800S, F800ST	'06	'12	PP.054200
K1200S	'05	'08	PP.054011
R1200RT	'05	'12	PP.054051
R1200GS / GSA	'04	'12	PP.054160
R1200GS LC	'13	'14	PP.054235
K1200GT	'06	'08	PP.054230
K1300GT	'09	'13	PP.054230
K1600GT / GTL	'11	'13	PP.054230
R-Bikes	'70	'84	PP.05420
Ducati	from	to	Part Number
Hyermotard 796, 1100	'08	'12	PP.055140
Multistrada 1000DS	'05	'06	PP.05510
Multistrada 1100	'07	'09	PP.05510
Multistrada 1200	'10	'13	PP.055110
Honda	from	to	Part Number
Grom	'13	'14	PP.051811
CBR250	'11	'13	PP.051025
CB500X, CB500F, CBR500RR	'13	'14	PP.051809

Honda (continued)	from	to	Part Number
NC700X / S	'12	'14	PP.051801
Varadero XL1000V	'08	'09	PP.05123
VFR1200F	'10	'13	PP.051350
ST1300 Pan European	'02	'13	PP.05126
Kawasaki	from	to	Part Number
Versys 650	'07	'09	PP.053420
Versys 650	'10	'14	PP.053421
Ninja 650R, ER6f, ER6n	'09	'11	PP.05330
Ninja 650R	'12	'13	PP.053441
Ninja ER6f	'12	'13	PP.053441
Ninja ER6n	'12	'13	PP.053441
Z750R	'11	'12	PP.053443
Versys 1000	'12	'13	PP.053442
Ninja 1000	'10	'14	PP.053304
Z1000	'10	'13	PP.053303
ZRX1200	'01	'05	PP.05325
Concours GTR1400	'08	'13	PP.053400
ZX14R	'06	'13	PP.053400
ZZR1400	'06	'13	PP.053400
KTM	from	to	Part Number
Duke 690	'08	'11	PP.059310
990 Adventure	'06	'08	PP.059350
Super Duke 990	'07	'12	PP.059300
1190 Adventure	'13	'14	PP.0593521

Moto Guzzi	from	to	Part Number
Stelvio	'08	'12	PP.058730
Suzuki	from	to	Part Number
SV650	'99	'02	PP.05010
SV650	'03	'09	PP.05020
Gladius	'09	'13	PP.050410
DL650 V-Strom	'02	'11	PP.05025
DL650 V-Strom	'12	'14	PP.050300
GSF650 Bandit	'05	'08	PP.050001
DL1000 V-Strom	'02	'11	PP.05025
SV1000	'03	'09	PP.05020
GSF1200 Bandit	'00	'06	PP.050001
GSF1250 Bandit	'07	'10	PP.050001
Triumph	from	to	Part Number
Daytona 675 Triple	'06	'11	PP.056120
Street Triple 675	'08	'12	PP.056120
Tiger 800XC	'11	'14	PP.056110
Tiger 1050	'07	'13	PP.056100
Speed Triple	'07	'13	PP.056100
Explorer 1200	'12	'14	PP.056522
Yamaha	from	to	Part Number
FZ8	'11	'13	PP.05230
FZ-09	'13	'14	PP.052311
XT1200Z Super Tenere	'11	'13	PP.052100
FJR1300	'06	'13	PP.052200

Fender Eliminators

Rear Fender Eliminators clean up the visual clutter of the typical stock rear fender and give your motorcycle that "racebike" look. The kit includes an integrated license plate holder, installation instructions and an LED license plate illumination light.

Pair an R&G fender eliminator with R&G Micro Turn Signals or R&G LED Micro Turn Signals (page 119) for an even cleaner look.

Starting At \$82.99



Suzuki GSXR600/750 '11-'14
RG.LP0102.BK



Kawasaki Versys 1000
RG.LP0117.BK

BMW	Part Number
S1000RR '10-'14	RG.LP0092.BK
Ducati	Part Number
Monster 696, 796, 1100	RG.LP0097BK
Hypermotard 820	RG.LP0142.BK
Hyperstrada 820	RG.LP0145.BK
848 Streetfighter	RG.LP0116.BK
848 ('08-'10) 1198 (all years)	RG.LP0041BK
Panigale 899 & 1199	RG.LP0115.BK
Multistrada 1200 (w/o sidecases)	RG.LP0096.BK
Honda	Part Number
Grom (w/ original indicators)	RG.LP0146.BK
CRF250L & CRF250M '13-'14	RG.LP0150.BK
CBR250R '11-'14	RG.LP0104.BK
CBR500R, CB500F '13 & CB500X '13-'14	RG.LP0141.BK
CBR600RR '13-'14	RG.LP0139.BK
CBR600RR '03-'06 & CBR1000RR '04-'07	RG.LP0008.BK
CBR600RR '07-'12	RG.LP0042.BK
NC700X & NC700S	RG.LP0114.BK
CBR1000RR '08-'11	RG.LP0063.BK
CB1000R '08-'14	RG.LP0074.BK
CBR1000RR '10-'11	RG.LP0093.BK
CBR1000RR '12-'14	RG.LP0113.BK

Kawasaki	Part Number
Ninja 250R '08-'12	RG.LP0071.BK
Ninja 300 & 250	RG.LP0130.BK
Versys 650 '06-'09	RG.LP0039.BK
ER6 '12-'14	RG.LP0119.BK
ZX6R '07-'08	RG.LP0047.BK
ZX6R '09-'14 & ZX10 '08-'14	RG.LP0064.BK
Ninja 650 '09-'11	RG.LP0080.BK
Versys 650 '10-'14	RG.LP0110.BK
ZX10R '11-'14	RG.LP0101.BK
Versys 1000	RG.LP0117.BK
Z1000 '10 & Ninja 1000 (w/o Kawasaki sidecases)	RG.LP0095.BK
Z1000 '07-'09	RG.LP0048.BK
Z1000 '14	RG.LP0156.BK
ZX-14 '06-'12	RG.LP0037.BK
KTM	Part Number
690 SM & 690 Duke III '08-'14	RG.LP0052.BK
690 Enduro '08-, 690 SMC '08-'11 & 690 SMCR '12	RG.LP0073.BK
690 Duke '12 & 690 Duke R '13-'14	RG.LP0122.BK
Superduke 990 & Superduke R '12-'14	RG.LP0043.BK
990SM '08-'14, 990 SMR '08-'14, 990 SMT & 950 SM/SMR '05-	RG.LP0124.BK
1290 Super Duke	RG.LP0158.BK

Suzuki	Part Number
DRZ400 & DRZ400SM	RG.LP0018.BK
GSX-R600 & GSX-R750 '08-'10	RG.LP0065.BK
Gladius '09-'13	RG.LP0083.BK
SV650 '08-'12	RG.LP0062.BK
GSX-R1000 '07-'08	RG.LP0045.BK
GSX-R1000 '09-'11	RG.LP0077.BK
GSX-R600 & GSX-R750 '11-'14	RG.LP0102.BK
Hayabusa GSX1300R '08-'14	RG.LP0059.BK
Triumph	Part Number
675 Daytona '06-'12 (Arrow Round Ti Exhaust)	RG.LP0025.BK
Street Triple '07-'12	RG.LP0056.BK
Street Triple / R '13-'14 & 675 Daytona '13-'14	RG.LP0133.BK
Bonnie ('06-'14) Thruxton ('08-'14)	RG.LP0123BK
Speed Triple '08-'10	RG.LP0066.BK
Speed Triple '11-'14	RG.LP0099.BK
Yamaha	Part Number
R6 '06-'14	RG.LP0020.BK
FZ6 '04-'14	RG.LP0038.BK
FZ8	RG.LP0024.BK
FZ-09 '13-'14	RG.LP0153BK
FZ1	RG.LP0024.BK
R1 '07-'14	RG.LP0040.BK

Bike Covers

R&G Motorcycle Covers protect your bike from both the elements and prying eyes. R&G bike covers are waterproof, breathable and feature a soft top inner liner to protect your bike's paint.

An elasticized bottom offers a snug fit, while loopholes at both ends accept a lock and chain for security and tie downs for high winds. Three sizes to choose from.

Superbike/Naked Size RG.BC0001.BK: \$79.99
Adventure Bike Size RG.BC0003.BK: \$92.99
Touring Bike/Cruiser Size RG.BC0004.BK: \$112.50



If your bike is fortunate enough to live indoors but still gets dust, dirt and cat prints on it, protect it with the R&G dust cover for naked and sportbikes. Not waterproof.

Dust Cover for Sport & Naked Bikes RG.DC00.BKSI: \$56.99

Rear Huggers

Rear Huggers enhance the look of your bike and protect the shock and sub-frame under-tray from dirt and debris kicked up by your rear tire.

Starting At \$142.50

Fitment	Part Number
Honda NC700X & NC700S '13-'14	RG.RGH0007.BK
Honda CBR1000RR '08-'12	RG.RGH0006.BK
Honda VFR1200 '10-'14	RG.RGH0001.BK
Kawasaki Z750R '11-'12	RG.RGH0004.BK
Triumph Tiger 800 & 800XC '11-'14	RG.RGH0003.BK
Yamaha FZ8 '11-'14 & FZ1 '06-'14	RG.RGH0002.BK



Check page 192-269 to see which R&G products are available for your bike.



Body and weight control are essential techniques with not only aggressive & performance riding, but also with sport & casual touring. By gripping the tank with your legs, you can improve overall control of your body motion, weight position and posture. TechSpec's theory for achieving a solid grip is based on material properties and surface area contact.

Snake Skin Tank Grip Pads

Benefits:

- Increase control
- Eliminate sliding
- Improve body position
- Decrease body fatigue
- Improve weight adjustment
- Protect tank from abuse
- Improve re-sale value
- Remove and re-use
- Improve style
- Provide grip material damaging leathers
- Developed in the U.S.A.

Starting at
\$19.95



Suzuki GSX-R600 & GSX-R750, '11-'14

Snake Skin

The Snake Skin design is a thin (1/8") tank grip with a low profile diamond pattern.

The Snake Skin rubber padding properties provide a positive grip onto your tank and less pressure on your wrists, elbows and shoulders. An excellent product for all riders.

The Snake Skin uses a "Releasable Adhesive," so you can reposition the tank grip if necessary.

Beveled edges minimize any snagging.

Easy installation.



Triumph Street Triple, '13-'14

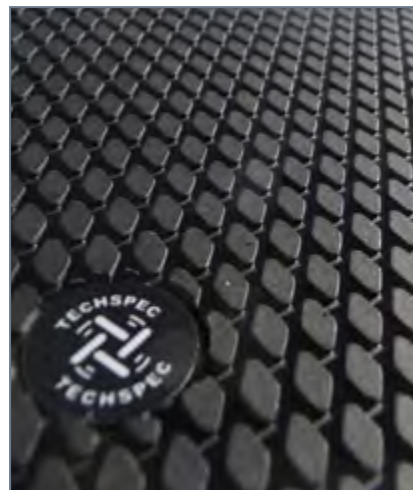

Yamaha Super Tenere, '10-'14



Universal	Notes	Part Number
Universal 7.5" x 13" sheets	Snake Skin	62-0002-SS
Center Tank Protector 7.75" x 5.75"	Snake Skin	62-0073-SS
BMW	Notes	Part Number
F800GS '13-'14	Snake Skin	62-1005-SS
K1200 & K1300 GT '06-'12	Snake Skin	62-0059-SS
K1200 & K1300S '04-'12	Snake Skin	62-0058-SS
K1200R & K1300RR '05-'13	Snake Skin	62-0060-SS
R1200GS '04-'07 & GS Adv '04-'13	Snake Skin	62-0056-SS
R1200GS '08-'12	Snake Skin	62-0062-SS
R1200GS LC '13-'14	Snake Skin	62-1010-SS
S1000RR '08-'14	Snake Skin	62-1000-SS
Ducati	Notes	Part Number
696, 796, 1100 Monster '09-'14	Snake Skin	62-1500-SS
1198 /1098 / 848 '07-'13	Snake Skin	62-0035-SS
Hypermotard '07-'12	Snake Skin	62-0092-SS
Multistrada '02-'09	Snake Skin	62-0033-SS
Multistrada '10-'14	Snake Skin	62-1502-SS
Street Fighter '08-'14	Snake Skin	62-1501-SS
Panigale 1199 '12-'14 & 899 '14	Snake Skin	62-1506-SS
Honda	Notes	Part Number
CBR500R & CB500F '13-'14	Snake Skin	62-2011-SS
CBR600RR '07-'12	Snake Skin	62-0074-SS
CBR600RR '13-'14	Snake Skin	62-2010-SS
Goldwing '11-'14	Snake Skin	62-2006-SS
VFR1200 '10-'14	Snake Skin	62-2000-SS
CBR1000 '12-'14	Snake Skin	62-2005-SS
CBR600RR '07-'12	Snake Skin	62-0074-SS
Kawasaki	Notes	Part Number
Concourse 14 '10-'14	Snake Skin	62-2500-SS
KLR650 '98-'14	Snake Skin	62-2501-SS
Ninja 1000 '13-'14 & Z1000 '13-'14	Snake Skin	62-2504-SS
Versys 650 '08-'14	Snake Skin	62-2512-SS
ZX-6R 636, '13-'14	Snake Skin	62-2509-SS
ZX10 '11-'14	Snake Skin	62-2502-SS
KTM	Notes	Part Number
950 Adventure & 990 Adventure	Snake Skin	62-0019-SS
Suzuki	Notes	Part Number
GSX-R1000 '09-'14	Snake Skin	62-0094-SS
GSX-R600 & GSX-R750 '11-'14	Snake Skin	62-3001-SS
SV650 & SV1000 '03-'13	Snake Skin	62-0064-SS
V-Strom DL650 '00-'11 & DL1000 '00-'12	Snake Skin	62-3003-SS
V-Strom DL650 '12-'14	Snake Skin	62-2003-SS
Hayabusa '97-'14	Snake Skin	62-0069-SS
Triumph	Notes	Part Number
Daytona 675 '13-'14 & Street Triple '13-'14	Snake Skin	62-3502-SS
Daytona 675 '06-'12 & Street Triple '09-'12	Snake Skin	62-0071-SS
Explorer '12-'14	Snake Skin	62-3504-SS
Tiger 800 & 800XC '11-'14	Snake Skin	62-3505-SS

Yamaha	Notes	Part Number
FJR1300 '06-'14	Snake Skin	62-0066-SS
FZ-09 '14	Snake Skin	62-4008-SS
FZ1 '06-'14	Snake Skin	62-0097-SS
R1 '09-'14	Snake Skin	62-0095-SS
R6 '08-'14	Snake Skin	62-0075-SS
Super Tenere '10-'14	Snake Skin	62-4004-SS



Kawasaki Versys, '08-'14

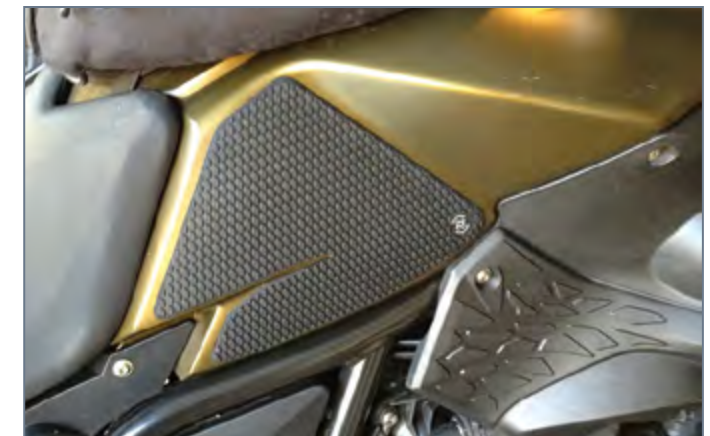

BMW F800GS, '13-'14



Ducati Panigale 1199 & 899, '11-'14



Chili Night Eye Jacket

Serious gear for serious riders.

Textile Materials: What Does Macna Use?

- **C-Touch** is a Polyamide 500d that has a medium abrasion resistance with the look and feel of cotton.
- **R-Tech** is a Polyamide 600d with medium-high abrasion resistance.
- **Durylon** is a Polyamide/Polyester with high abrasion resistance.
- **Dynex** is a Polyamide 420d with high abrasion resistance.
- **SuperFabric** is a rugged texturized material that provides the highest abrasion resistance and a high-tech look.

Sizing Charts

Macna apparel is Euro sized, so please use the chart below to determine proper sizing. Call or email our gear experts if you have questions.

MACNA							MACNA						
Men's JACKET							Women's JACKET						
	S/48	M/50	L/52	XL/54	XXL/56	XXXL/58		XS	S/36	M/38	L/40	XL/42	XXL/44
Chest width	37-38.25	38.5-39.75	40-41.5	41.75-43	43.25-44.5	44.75-46	Chest width	33.75-35	35.5-36.5	37-38.25	38.5-39.75	40-41.5	42.5-44.125
Waist width	31.75-33.5	33.75-35	35.5-37.5	37.75-39.25	39.75-41.75	42.125-44	Waist width	28-29.125	29.5-30.75	30.75-32	32.5-34	34.25-35.5	35.75-37
Men's PANTS							Women's PANTS						
	S/48	M/50	L/52	XL/54	XXL/56	XXXL/58		XS	S/36	M/38	L/40	XL/42	XXL/44
Hip width	37.5-38.5	39-39.5	39.75-40.25	40.5-41.75	42.125-43.25	43.5-44.5	Hip width	37-38.25	38.5-39.75	40-41.5	41.75-42.5	43-44	44.5-45.75
Inseam length	31	31.5	31.75	32.25	32.5	33	Inseam length	28.75	29.375	29.5	30	30.5	30.75

all measurements are in inches

Long and Short length versions are available for select Macna pants. Add or subtract 3.5" to or from inseam measurements.

Quality and Innovation: Features of Macna Jackets & Pants



The Summer Comfort System quickly transforms the men's Geo 2 and women's Lunar jacket into a warm-weather garment. Remove the liners and simply unzip the collar panel to reveal the huge panel of high-tech **3D mesh** designed to maximize airflow over your body and keep you cool.

This unique system ensures that you're ready for anything Mother Nature throws at you!

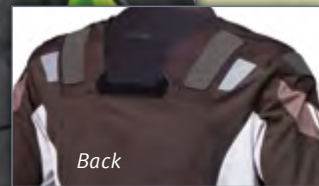

Back



Vision Vest



LED Light



Visibility is integral to our safety as motorcyclists. To that end, Macna has developed several features that will enhance your visibility to other motorists, including the **LED-Ready** system and the unique high viz **Vision Vest** system.

The LED Light (page 77) attaches to LED-Ready Macna jackets via an integrated Velcro patch, while the Vision Vest (page 77) zips onto most Macna jackets and does not interfere with access to pockets or zippers.

Quality and Innovation: Features found in Macna Jackets & Pants



Protection: where we never cut corners. You'll find quality **SAS-Tec** or **Knox** CE-approved shoulder, elbow, and knee protection in all Macna jackets and pants. Armor upgrades are available for most models to replace the standard back and hip foam protectors with CE Level 2 armor (see page 77).



Truly waterproof to keep you dry. A **Raintex waterproof and breathable membrane** keeps you 100% dry. Combined with the **thermal liner** and outer shell, you've got a highly protective garment that will keep the elements out and you comfortable. Found in waterproof jackets and pants only.



Convenience. You'll love the convenient features found on Macna jackets, including a heavy duty hanger loop, **Grip Strips** at the edge of pocket flaps to allow easy access even when wearing gloves, adjustable arm straps, easy-to-use zipper tabs, and zippered pants connections.



Innovative **ComFix** collar design makes it easy to fasten and adjust your collar with one hand. Found on select jackets.



Side Eye reflective graphics provide extra conspicuity from the sides, designed to be visible when in the riding position.



The **Easy Cuff system** uses a unique zipper system to fasten the liners to the outer shell of most jackets, making for a smooth cuff.



night eye

The next step
in visibility at night.

Microscopic glass beads on the Night Eye fabric work like tiny satellite dishes, reflecting light directly back to the source. A simple and stylish gray by day, Night Eye illuminates like a beacon in the night when targeted by an oncoming car's headlights. Even small amounts of light produce bright results!



Geo 2 Jacket
Night Eye

Bedoine Pant
Night Eye



Night Eye
(Daytime)

Concrete Jacket
shown



Night Eye
(Nighttime)

See page 70 for details.

night eye



Geo 2 Night Eye Jacket

\$569⁹⁹

MN.3225.810

The Geo 2 Jacket and Bedoine
Pants are perfect mates.

See page 66 for details.



Bedoine Night Eye Pant

\$449⁹⁹

MN.2032.811

See page 66 for details.



Chili Mesh Night Eye Jacket

\$299⁹⁹

MN.3503.810

See page 69 for details.



Concrete Night Eye Jacket

\$399⁹⁹

MN.3302.808

See page 70 for details.



Jura Night Eye Jacket

\$449⁹⁹

MN.3226.881

See page 67 for details.



Nova Women's Night Eye Jacket

\$419⁹⁹

MN.3245.810

See page 74 for details.

Staff Favorite



Geo 2 Jacket

The Geo 2 is a top-of-the line jacket with a very stylish look and top-notch function. We can attest to just how great this jacket is... you'll find several Twisted staffers wearing them. Enjoy excellent cold weather waterproof protection while the Summer Comfort System transforms the Geo 2 into a summer jacket by simply removing the liners and collar panel to reveal a 3D mesh panel underneath. You'll remain comfortable in all weather wearing this crafty transformer.

Men's Geo 2 Jacket Features

- R-tech, C-touch, and Dynax materials
- 3-layer liner system with independently detachable membrane and thermal liner
- Side Eye visibility system
- Vision Vest ready (see page 77)
- LED Light ready (see page 77)
- Air Vents in arms, Summer Comfort System.
- SAS-Tec© "Powertector" CE-armor protection at shoulder and elbow
- CE back protector ready (see page 77)
- Superfabric
- Coat hanger, arm adjustment straps, click puller, Grip strips, SP Cuff, Easy Cuff, and 3D mesh
- Full-circumference pant connection zipper
- Available in S-6XL

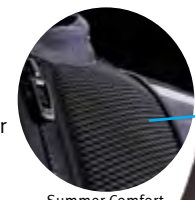

Mates with Bedoine Pants

Non-Night Eye \$469⁹⁹
Night Eye \$569⁹⁹
 MN.3225

Macna apparel is Euro sized. Please refer to sizing chart on page 63 for fitment.

Bedoine Pant

The Bedoine motorcycle pants feature detachable waterproof and thermal layers to keep you warm and dry, with plenty of air vents and 3D mesh for those hot, dry days!

Men's Bedoine Pant Features

- R-tech, Durylon, and Dynamic materials
- 3-layer liner system with detachable Raintex membrane and thermal liner
- Side Eye visibility system
- Air Vents in a thighs
- SAS-Tec© "Powertector" CE-armor knee protection
- Quick Pocket externally adjustable knee armor
- CE Hip protector ready (see page 77)
- Waist-lock Flexbelt, Grip strips, long pant connection zipper, Easy Cuff, and 3D mesh
- Suspender ready
- Available in S-3XL
- Short lengths available in L-3XL
- Long lengths available in M-3XL

Mates with Geo 2 Jacket



Black \$349⁹⁹
Night Eye \$449⁹⁹
 MN.2032

Macna apparel is Euro sized. Please refer to sizing chart on page 63 for fitment.

Jura Jacket

The Macna Jura Jacket is a waterproof all-season jacket with a combination of abrasion-resistant nylon in the impact zones and 3-D mesh panels for maximum airflow. Adjustable waist and arm straps ensure a custom fit. Great for touring or enduro riding.

Men's Jura Jacket Features

- R-tech, Poly 500, and Durylon materials
- 3-layer liner system with independently detachable membrane and thermal liner
- 3D mesh air panels in chest, air inlets in arms
- Side Eye visibility system
- Vision Vest ready (see page 77)
- LED Light ready (see page 77)
- Knox CE-armor protection at shoulder and elbow
- CE back protector available (See page 77)
- Short pant connection zipper
- Easy Cuff system
- Coat hanger loop
- Arm adjustment straps
- Back pocket "Game Pouch"
- Grip Strips
- Cordstopper
- Available in S-4XL

Non-Night Eye \$349⁹⁹
Night Eye \$449⁹⁹
 MN.3226

Macna apparel is Euro sized. Please refer to sizing chart on page 63 for fitment.



New for 2014



Mates with Jumper or Bedoine Pants

Jumper Overpant

Jumper waterproof motorcycle overpants are designed to be worn over jeans or other pants. The Jumper motorcycle pants feature a mesh comfort liner, rugged nylon shell, and an integrated waterproof Raintex membrane for 100% waterproof protection. Knee to ankle zippers make it easy to take the Jumper on and off.

Jumper Overpant Features

- All season use
- Kodra, R-tech materials
- Raintex membrane
- Side Eye reflective material
- 2 Hip pockets, one waist pocket
- Adjustable CE knee protection
- Hip pads
- Short connection zippers
- Anti-slip strips
- Zipper strips made from suede-like material edging the pockets
- Zipper grip strips made from rubber at the cuff zippers
- Heat shield fabric
- Moisture drain at cuffs
- Knee-to Ankle zippers for easy entry and exit
- Available in S-3XL
- Short lengths available in L-3XL
- Black

\$169⁹⁹
 MN.2060

Mates with Jura Jacket

Macna apparel is Euro sized. Please refer to sizing chart on page 63 for fitment.





Impact Jacket

New for 2014

The Macna Impact jacket is a waterproof all-season jacket featuring a Direct Laminate waterproof outer shell and removable thermal liner. Adjustable waist and arm straps ensure a custom fit. Great for touring. **A perfect match to the Men's Logic Pant (see below).**

Men's Impact Jacket Features

- Soft-flex Direct Laminate, and Durylon materials
- Detachable membrane and thermal liner
- Air inlets in arms
- Side Eye visibility system
- Vision Vest ready (see page 77)
- LED Light ready (see page 77)
- Knox CE-armor protection at shoulder and elbow
- CE back protector available (see page 77)
- Pant connection zippers (short and long)
- Easy Cuff system
- Coat hanger loop
- Arm adjustment straps
- Back pocket
- Cordstopper waist pulls
- Available in S-4XL

\$449⁹⁹

MN.3015

Mates with Logic Pants

Macna apparel is Euro sized. Please refer to sizing chart on page 63 for fitment.



Logic Pant

The Logic pants feature a Direct Laminate waterproof outer shell and a removable thermal liner. A non-bulky riding pant providing protection from the elements, as well as style and comfort.

Logic Overpant Features

- All season use
- Durylon materials
- Raintex DL membrane
- Removable thermal liner
- Side Eye reflective material
- Upper leg pockets
- Adjustable Knox CE knee protection
- CE hip pad ready (see page 77)
- Jacket connection zippers (short and full-circumference)
- Anti-slip strips
- Heat shield fabric
- Waist-lock
- Flexbelt 2.0 double layer waist adjustment system
- Available in S-4XL
- Black

\$325⁰⁰

MN.2402

Mates with Impact Jacket

Macna apparel is Euro sized. Please refer to sizing chart on page 63 for fitment.



Chili Mesh Jacket

The Macna Chili jacket is a warm weather/summer riding jacket that still offers all the protection you expect, including 3D mesh and CE armor in the elbows and shoulders. Adjustable waist and arm straps ensure a custom fit. **A perfect match to the Men's Silicum pant (see below), Alert Rain jacket (see page 71) and Flight Rain jacket (see page 71).**

Men's Chili Jacket Features

- Accepts the optional Alert Waterproof Jacket (page 71)
- Abrasion-resistant Nylon in the impact zones
- R-tech, 3-D mesh panels
- Comfort lined collar
- CE-armor protection at shoulder and elbow
- Foam back protector included, CE back protector available (See page 77)
- Short pant connection zipper
- Side Eye visibility system
- Vision Vest ready (See page 77)
- Coat hanger loop
- Arm adjustment straps
- Available in S-3XL

Black or gray \$199⁹⁹

Night Eye \$299⁹⁹

MN.3503

Macna apparel is Euro sized. Please refer to sizing chart on page 63 for fitment.



Mates with Silicum Pants

Silicum Mesh Pant

Silicum motorcycle mesh pants provide warm weather comfort and protection. Silicum pants are made from a combination of abrasion-resistant nylon in the impact zones with a 3-D mesh to increase the flow of air through the pants. **The styling and color of the Silicum pants match the Chili jacket for a sharp looking, well vented suit.**

Silicum Pant Features

- Warm weather use
- R-tech, 3-D mesh materials
- Side Eye reflective material
- 2 Hip pockets, one waist pocket
- Adjustable CE knee protection
- Hip pads
- Short connection zippers
- Anti-slip strips
- Heat shield at bottom of leg
- Long leg zippers for easy entry & exit
- Available in S-3XL
- Gray or Black

\$179⁹⁹

MN.2050

Macna apparel is Euro sized. Please refer to sizing chart on page 63 for fitment.

Mates with Chili Jacket





Concrete Jacket

Macna's Concrete jacket will protect you from the elements in all seasons and keep you looking good in the process. Designed with a stylish cut and a ton of comfort and safety features, the Concrete jacket is a rugged and attractive jacket, both on and off the bike. Choose from Black or the *Night Eye* if you really want to shine at night!

Concrete Jacket Features

- Heavy Duty C-touch material
- 2-layer system with detachable thermal liner
- Adjustable collar
- Side Eye visibility system
- Vision Vest ready (see page 77)
- Air Vents in Chest
- CE-armor protection at shoulder and elbow
- CE back protector ready (see page 77)
- Grip strips
- Short pant connection zipper
- Single pull cuff
- Available in Black or Night Eye
- Available in S-3XL



Macna apparel is Euro sized. Please refer to sizing chart on page 63 for fitment.

Black
\$299⁹⁹

Night Eye
\$399⁹⁹

MN.3302



Alert Rain Jacket

The Macna Alert motorcycle rain jacket is a heavy duty, all day waterproof and windproof jacket that was designed to be worn over the Macna Chili motorcycle jacket (see page 69), but can be worn as a stand-alone rain jacket as well. The Alert jacket is constructed of a waterproof 2100 denier Polyester for complete protection from the elements.

Alert Rain Jacket Features

- Designed for use with Macna Chili motorcycle jacket
- 2100 Polyester construction
- Direct Laminate Raintex waterproof membrane
- Side Eye visibility system
- Waterproof chest pocket
- Arm adjustment straps
- Waist adjustment straps
- Hook and loop over-sized wind flap
- Bungee lock waist
- Jacket-to-shell cuff adjustment system
- Jacket-to-shell 3/4 sleeve and collar attachment zippers
- Can be worn as a standalone waterproof jacket
- Sized to fit over a jacket
- Available in S-3XL



Mates with Chili Jacket

\$179⁹⁹

MN.1352

Rush Mesh and Command Jackets

If you are looking for a jacket that's simple, functional, and stylish, look no further than the Rush Mesh or Command Jackets. The Command features an integrated Raintex waterproof membrane and Removable thermal liner for those chilly evenings. The Rush, with huge mesh panels, is your best bet for those hot city commutes.

Command Jacket Features

- Poly material
- Raintex waterproof liner
- Side Eye visibility system
- Chest pockets
- CE-armor protection at shoulder and elbow
- CE back protector ready (see page 77)
- Loop for connecting jacket to jeans
- Available in S-4XL

Rush Mesh Jacket Features

- Poly Twill and Mesh material
- Side Eye visibility system
- Mesh panels in chest and arms
- CE-armor protection at shoulder and elbow
- CE back protector ready (see page 77)
- Integrated hanger loop
- Loop for connecting jacket to jeans
- Available in S-4XL



\$229⁹⁹

MN.3601

\$189⁹⁹

MN.3506

Flight Softshell/Rain Jacket

This lightweight and compact waterproof softshell is destined to become a staff favorite! Wear the Flight under a mesh jacket for those damp, chilly mornings or mountaintop rainstorms. When you stop for the evening it's a perfect camp jacket. With its Side Eye reflective graphics or in the High-Viz color it would also be a great softshell for bicycling...or riding around town...well, you can see why we like it so much!

Flight Softshell Jacket Features

- Soft touch fabric
- Raintex Direct Laminate waterproofing
- Side Eye visibility system
- Available in S-4XL



\$69⁹⁹

MN.1354



Macna Gloves

are some of the most **comfortable** gloves we've ever tried. The **thoughtful** design touches, **safety** and comfort, and **total waterproof** features have made these gloves several staffers' **go-to choice**.

Twisted Tested. Twisted Approved.

What We Love About Macna Gloves



The revolution in performance and comfort for waterproof, breathable gloves available in select Macna Gloves
OutDry technology does not use the standard seam-sealed waterproof manufacturing techniques. Instead, Macna has developed a patented lamination process where the waterproof/breathable membrane is directly bonded to the external layer of the glove, perfectly sealing any possible water entry point. Say goodbye to waterlogged gloves!



RainTex is used in most Macna gloves, offering a breathable 100% waterproof fit. Integrated water vents allow excess moisture to escape to avoid waterlogging.

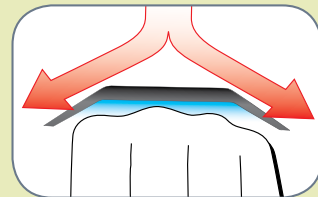

RISC protectors are used on knuckles and palms. These are designed to absorb and spread impact, and slide smoothly along the pavement in a fall.



We love our gadgets. So we love Macna's **Touch Tip** feature (available on some gloves), that lets us use our touchscreen devices without removing our gloves.



Comfort and convenience. All Macna gloves feature a **30 Degree Buckle** that places the wrist strap at an angle for increased comfort when you're holding the bars, as well as precurved **Ergo Thumbs**. Some gloves also feature an integrated rubber **Screen Cleaner**.



MEN'S GLOVES	
Hand width	S M L XL XXL XXXL XXXXL
	17-19 20-21 22-23 24-25 26-27 28 29
LADIES GLOVES	
Hand width	XS S M L XL XXL
	15 17 18 19 20 21

measurements are in centimeters

Men's Vented Summer

Scalpel

A sport glove to keep you looking and feeling cool.

- Soft goat leather
- Nylon liner
- Perforated leather venting
- Molded knuckle protection
- Roller buckle
- S-XXXL



\$89⁹⁹ MN.6174.101

Catch

A motocross-inspired glove with protection for the street.

- Soft goat leather
- Heavy Mesh
- Bemberg liner
- TPU knuckle protection
- S-XXXL



\$69⁹⁹ MN.6175.101

Equator

A mesh gauntlet glove that's breezy and protective.

- Soft goat leather
- Mesh panels
- Nubuck leather
- Nylon liner
- EVA knuckle protection
- S-XXXL



\$96⁰⁰ MN.6162.101

Men's Leather/Sport

Street R

A track-ready glove with Kevlar reinforced leather.

- Kevlar-lined goat & cow leather
- Bemberg liner
- RISC knuckle and palm protection
- Also available in Black
- S-4XL



\$149⁹⁹ MN.6206.101

Vortex

A sporty, full-featured glove with hard knuckle armor.

- Soft goat & cow leather
- Bemberg liner
- RISC knuckle and palm protection
- Also available in Black
- S-4XL



\$119⁹⁹ MN.6201.101

Borasco

Ready for a ride around town or a sprint up the canyon.

- Soft goat leather
- Bemberg liner
- Molded hidden knuckle armor
- S-XXXL



\$115⁰⁰ MN.6167.101

Men's Waterproof 3-Season

Revenge

Premium OUTDRY waterproof weather protection.

- Soft goat leather
- Nubuck
- Textile
- OUTDRY membrane
- Bemberg liner
- RISC palm protection
- TPU knuckle protection
- ScreenCleaner
- M-XXXL



\$159⁹⁹ MN.6178.101

Talon

A foul-weather companion.

- Soft goat leather
- Spandex
- Raintex membrane
- Sensigrip
- Bemberg lining
- TPU knuckle protection
- ScreenCleaner
- TouchTip
- S-4XL



\$99⁹⁹ MN.6207.101

Men's Waterproof Heated

Proton

An electrically heated glove for maximum warmth.

- 5 temp settings
- Goat leather, Durylon
- Raintex membrane
- TouchTip smartphone compatible
- TPU knuckle protectors
- ScreenCleaner
- Includes controller, wiring
- Compatible with other heated gear brands
- S-4XL



\$249⁹⁹ MN.6600.101

Men's Waterproof Cold Weather

Polarctic

Premium OUTDRY waterproof protection as well as warmth.

- Goat leather, Nubuck, textile
- OUTDRY membrane
- Thermolite insulation
- Bemberg liner
- RISC knuckle and palm armor
- ScreenCleaner
- S-XXXL



\$249⁹⁹ MN.6127.101

Borax

Combat the chill.

- Soft goat leather
- R-tech
- Raintex membrane
- Thermolite insulation, Isofur liner
- Semi-hard TPU knuckle protectors
- ScreenCleaner
- S-XXXL



\$124⁹⁹ MN.6119.101



Women's Nova Jacket

Who says ladies' gear needs to skimp on features or protection?

Macna womens' riding jackets offer the same comfort and protection features found in their men's jackets, including detachable waterproof and thermal liners, venting, and impact protection. Add the form-fitting cut and adjustable waist for a custom fit and you've got a quality jacket for the true female rider.

Nova Jacket

The Nova is a waterproof all-season touring jacket best suited for moderate to colder climates. Detachable waterproof and thermal liners make the Nova warm and comfortable, and arm vents offer cooling on warm days. A back protector and SAS-Tec CE armor in the shoulders and elbows round out this versatile jacket.

Rush Mesh Jacket

Ride even the hottest days in comfort and style with the Rush mesh jacket. Simple styling looks good no matter what you ride. Includes a back protector and CE armor in the elbows and shoulders for crash protection, while retroreflective graphics look great and increase conspicuity.



Nova Jacket Features

- Poly 500, R-tech fabric
- Removable Raintex waterproof membrane and thermal liner
- Arm Vents
- CE-armor in shoulders and elbows
- CE back protector available

- Arm adjustment straps
- Easycuff
- Precurved collar with ComFix system
- Available in Black, Yellow/Black, Gray/White, or Night Eye
- Available in XS-XXL

Night Eye
\$419.99
MN.3245.810



Rush Jacket Features

- Large mesh panels
- Poly Twill shoulders and upper arms
- Side Eye visibility graphics
- CE-armor in shoulders and elbows
- CE back protector available

- Coat hanger
- Jeans loop
- Black
- Available in XS-XXL

Lunar Jacket

The Lunar is Macna's top-of-the-line women's all-season jacket, matching the men's Geo 2 feature-for-feature. Detachable Raintex waterproof and thermal liners, the proprietary Summer Comfort System with 3D mesh, and forearm vents make the Lunar the kind of jacket that will become your go-to choice ride after ride. You'll be riding with the best in crash protection, with SuperFabric panels, SAS-Tec CE armor in the shoulders and elbows, and a pocket for a CE back protector.



Lunar Jacket Features

- Durylon, R-tech, C-touch, SuperFabric & Dynax
- 3-layer liner system with detachable Raintex waterproof membrane and thermal liner
- Arm Vents
- Summer Comfort System
- SAS-Tec Powerector CE armor in shoulders and elbows

- CE back protector ready
- Coat hanger, arm adjustment straps, Easy Cuff, Grip strips, back pocket, short pant-connection zipper, and locking zipper.
- Black
- Available in XS-XXL

Onyx 2 Pant

A perfect match for the Lunar or Nova jackets, the Onyx 2 Women's riding pants provide all-season comfort, Raintex waterproofing, and exceptional protection. Superfabric panels and CE knee armor keep you safe, while the ladies' specific cut keeps you comfortable.



Women's Onyx 2 Pant Features

- C-touch, R-Tech, & SuperFabric
- Detachable Raintex membrane
- Detachable thermal liner
- Side Eye reflective material
- Air vents in thighs
- Adjustable CE-approved knee armor

- CE hip armor ready
- Easy Cuff
- Short connection zipper
- Heat shield at bottom of leg
- Waist lock
- Available in XS-XXL
- Black

Women's Gloves

<p>Jewel Summer Glove</p> <ul style="list-style-type: none"> • Soft goat leather • Bemberg Lining • Soft hidden knuckle protection • ErgoThumb • XS-XXL <p>\$69.99 MN.6204</p>	<p>Lane Summer Glove</p> <ul style="list-style-type: none"> • Soft goat leather • Temper foam knuckle protection • ErgoThumb • XS-XXL <p>\$89.99 MN.6161.101</p>	<p>Candy Waterproof 3-Season Glove</p> <ul style="list-style-type: none"> • Soft goat leather, textile • Raintex Membrane • Soft hidden knuckle protection • Screen Cleaner • Touchscreen ready • ErgoThumb • XS-XXL <p>\$99.99 MN.6206</p>	<p>Ruby Waterproof Cold Weather Glove</p> <ul style="list-style-type: none"> • Soft goat leather, Poly 500, R-tech • Raintex membrane • Thermolite lining • EVA knuckle protection • ScreenCleaner • ErgoThumb • XS-XXL <p>\$114.90 MN.6122.101</p>
---	--	--	--

Macna apparel is Euro sized. Please refer to size chart on page 63 for sizing.



Shelter Rain Jacket

Macna Shelter rain jackets are good looking, but more importantly, they will keep you dry even in all-day torrential rain. The Shelter features wrist, waist and arm straps for a snug, flap-free fit, and retroreflective "Side Eye" graphics for extra visibility.

Shelter Rain Jacket Features

- 100% waterproof Polyamide shell
- Polyester Lining
- Arm straps to adjust fit
- Waist adjustment belts
- Side Eye visibility system
- Black or High-Viz
- Includes stuff sack
- Unisex S-3XL

Packed Size: 11.4" x 4.3" x 4.3"
Total Weight: approximately 1 pound



\$94⁹⁹

MN.1353

Shelter Rain Pant

The Macna Shelter rain pants pair well with the Shelter jacket to keep you 100% protected from wet weather. Shelter pants feature elastic panels at the waist, reinforced crotch, heat shield protection from hot exhaust pipes, and retroreflective "Side Eye" graphics to help drivers to see you better on dark wet days.

Shelter Rain Pant Features

- 100% waterproof Polyamide shell
- Polyester lining
- Side Eye visibility system
- Heat shield lower leg protection
- Anti-slip strips on seat
- Black
- Includes stuff sack
- Unisex S-3XL

Packed Size: 11.4" x 4.3" x 4.3"
Total Weight: approximately 1 pound



\$69⁹⁹

MN.2108



Armor Upgrades

Upgrade standard hip and back protection with SAS-Tec CE Level 2 approved armor.

- Visco-elastic foam with outstanding shock absorption values.
- Protectors are not destroyed by an impact and can be reused
- Meets stringent European Standard EN 1621-2, Level 2
- Anatomically shaped for maximum comfort
- Washable



See website for fitment details

\$39⁹⁹

SAS-Tec Back Protector:

Small: 40x28cm
Large: 49x33cm
MN.9013 MN.9012

SAS-Tec Hip Protector:

MN.9014

\$79⁹⁹
pair



Visibility

Vision Vests fully integrate with most Macna jackets for a touch of high-viz...but only when YOU want it! The bright neon yellow color and large reflective graphics will boost your visibility day and night. The vest attaches in seconds using two integrated buckles in front and a built-in zipper in back.

- Attaches to the outside of Macna jackets
- Side Eye reflective material
- High-viz poly 600D
- Sizes to fit all jacket sizes

\$45⁰⁰

MN.8003



Vision LED Light

Be seen with this rechargeable LED light that attaches to the upper back of your Macna jacket. Using hook and loop fasteners located beneath the collar, the high position maximizes its visibility to other drivers. With 5 powerful LEDs it can be used for up to 3 hours continuous or 6 hours in strobe mode. Charging is simply done by connecting the USB cable to the included wall charger or even your computer.

For use with the following jackets:

- Geo 2
- Jura
- Chili
- Impact

\$35⁹⁹

MN.8100



Vision 4 All Mesh Vests

are designed to be worn over any jacket. 3D stretch mesh for Summer comfort and a flap-free ride. Uses Side-Eye retro-reflective graphics and high-viz yellow for maximum conspicuity.

- Side Eye reflective material
- 3-D Stretch Mesh Panels
- XS-XXXL

\$69⁹⁹

MN.8004



Vision 4 All Night Eye Vests take a standard high-viz vest and add Macna's amazing Night Eye technology for maximum visibility at night!

- Poly 600D
- Mesh lining
- Waterproof Chest Pocket
- Night Eye Technology
- Side Eye reflective material
- 3-D Stretch Mesh Panels
- XS-XXXL

\$99⁹⁹

MN.8017



Night Eye stands out at night



Macna Dry Cooling Vest



Evaporative Dry Cooling Vest



Got heat?

Stay cool with the revolutionary Dry Cooling Vest from Macna.

The summer heat is no match for you with Macna's Dry Cooling Vest! This vest will keep you cool AND dry during hot weather.

The process is simple - pop open the filler cap on the chest and fill with 500 ml of tap water (about the same as a standard 16oz bottle of water).

The water soaks into the patented fabric inside the vest, and using the principles of evaporative cooling the vest draws your body heat away, while keeping you dry and cool as a cucumber! Holes in the vest help accelerate the cooling effect as you ride, much like cranking up the AC in your car.

Depending on the conditions, the Dry Cooling Vest typically provides effective cooling for 1 - 3 days thanks to its ultra-efficient design.

Wear this vest under your riding jacket and over a base layer (see page 82 for TWISTEDCORE base layers) and stay not only cool, but completely dry, inside and out. Conventional water-cooled vests will get you wet. Not so with the Macna dry vest.

Overfilling the vest diminishes its ability to evaporate properly and renders the vest less effective. Stick to the instructions!

- Anti Microbial
- Machine Washable
- Available in XS-M, L-XL, 2XL-3XL, 4-5XL, and 6-7XL sizes

Sizing:

As a rule, order your normal T-shirt size.

The vest should be worn snug, but not tight. A bit of an air cushion between the body and the vest allows wind to pass through and aids in the evaporative cooling effect.



\$169⁹⁹
MN.8050

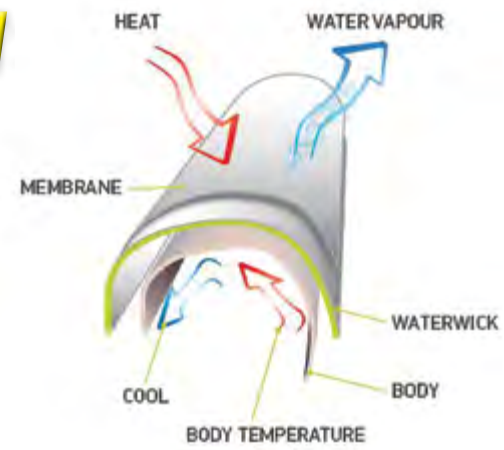

Does it work in humidity?

We've tested it and the answer is YES. However, at 80% humidity or higher the cooling effect starts to diminish. This is most apparent when you are standing still. As long as you and your bike are moving, air is pushed through the cooling vest to enhance evaporation, which offsets diminished performance caused when humidity levels are high.



The most advanced hearing protection for motorcyclists

Wind noise while riding regularly exceeds the levels at which hearing damage will occur. Protect your hearing without blocking the sounds you want to hear with the NoNoise Motorsport filtering earplugs.

NoNoise earplugs were originally developed for the Dutch Military & Mounted Police to protect them from the harmful sounds of gunfire and engines yet still allow them to hear their surroundings. NoNoise ceramic filtration technology will help protect your hearing from harmful noise levels while allowing lower level noises such as in-helmet speakers, approaching cars, sirens, and horns to be heard. Reduces wind and road noise

- Allows communication and intercom use
- Preserves situational awareness
- Comfortable, washable and re-usable
- No muffling or blocked ear feeling
- Hollow filter allows pressure equalization with altitude change

Over 20 years experience in industry and military hearing protection.

Specific NoNoise Earplugs are also available for:

- Shooting NN.3PROM0163
- Music NN.3PROM0159
- Water Sports NN.3PROM0162
- Travel NN.3PROM0161
- DIY and Garden NN.3PROM0164
- Work NN.3PROM0158
- Sleep NN.3PROM0157



\$29⁹⁵
pair



Includes aluminum carry case

\$29⁹⁵
pair

Motorsport:
NN.3PROM0160

Venturi shaped sound channel

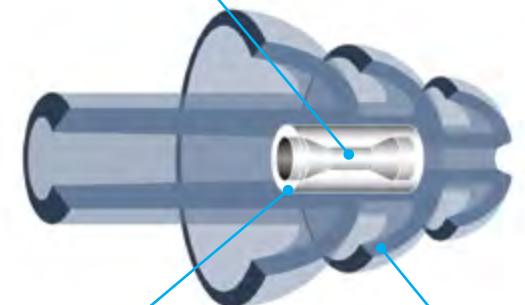

Zirconium oxide ceramic filter

Silicone-free Thermoplastic outer construction is hypoallergenic (unlike typical silicone earplugs)

How does NoNoise work?

The patented ceramic filter inside each NoNoise earplug is specifically tuned to filter out certain damaging frequencies and reduce, or attenuate, the sound level. Below is an example graph for the Motorsports hearing protectors: you can see that the greatest attenuation, or noise reduction, occurs in the 2000-8000Hz range, which is where most wind and engine noise occurs. The graph below shows the overall attenuation at High, Medium, and Low frequencies, and the overall noise reduction rating (21dB). Call our gear experts at 855-255-5550 or chat live at twistedthrottle.com to get more information about how NoNoise can benefit you.

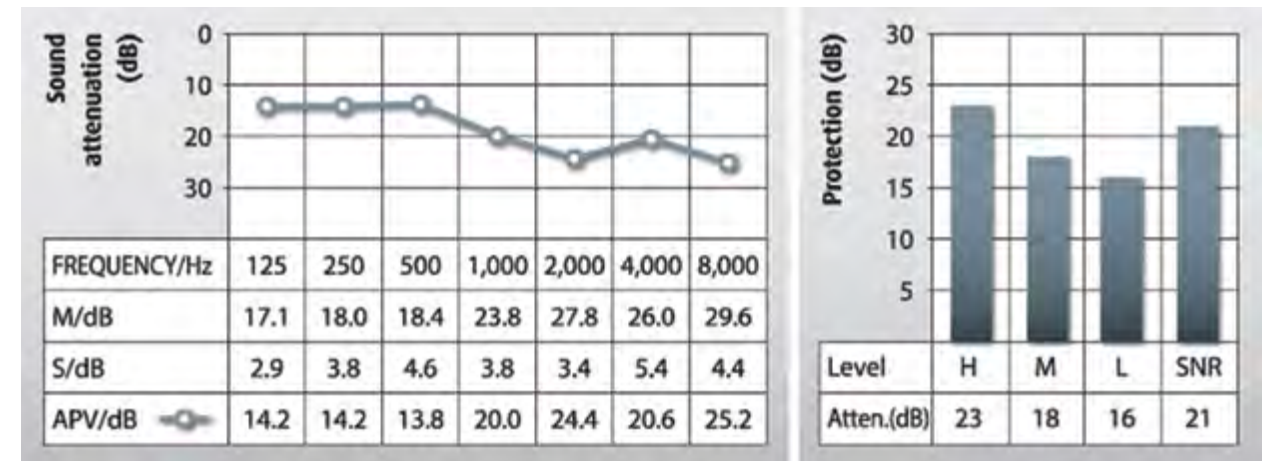

Exceeds strict European EN352-2 guidelines and certified to ISO9001:2008



In a world of distracted drivers, sharp edges, and the unknown lurking around any corner, why compromise on the things that protect you from danger? That's why we sell Arai helmets, and why so many of us wear one.



\$609⁹⁵

ARAI.CTZ.SOL

CT-Z Open Face Solid

Perfect for touring or passengers.

- Extended lower jaw protection
- Removable/adjustable peak
- Dual Pivot full face shield
- Tons of ventilation
- Intermediate Oval head shape
- Black or White
- XS-3XL



\$599⁹⁵

ARAI.RXQ.SOL

RX-Q Solid

The ultimate street-sport helmet.

- Wide peripheral vision
- Improved aerodynamics for a lighter feel
- Removable neckroll and emergency cheekpad removal
- Intermediate Oval head shape
- Gloss Black, Aluminum Silver, or Black Frost
- XS-3XL



\$619⁹⁵

ARAI.SIGQ.SOL

Signet-Q Solid

An RX-Q for the rest of us!

- An elongated version of the RX-Q
- Wide peripheral vision
- Improved aerodynamics for a lighter feel
- Removable neckroll and emergency cheekpad removal
- Long Oval head shape
- White or Black
- XS-3XL

Arai XD4

There's a reason this is one of the most popular dual-sport/adventure helmets on the market: it is, quite simply, the best.

- Removable visor can be used with or without goggles
- Truly functional adjustable, Removable peak
- New, more aerodynamic shell shape
- Vents, vents, and more vents
- Microfit system for a custom fit
- Intermediate Oval head shape
- Black, White, Silver Aluminum, or Black Frost
- XS-3XL



\$609⁹⁵

ARAI.XD4.SOL

XD4 Adventure Solid



\$619⁹⁵

ARAI.XD4.HIVIS
XD4 Adventure High-Viz



\$719⁹⁵

ARAI.XD4.GRPH
XD4 Adventure Graphic

HJC RPHA Helmets

HJC has been making motorcycle helmets since 1971, and the RPHA series represents their top-of-the-line offerings. All RPHA helmets are Snell certified for great protection at a great price.



\$314⁹⁹

1562

HJC RPHA X Motorcross

- Carbon fiber/Aramid/Fiberglass shell
- "ACS" Advanced Channel Ventilation
- Large eye port for superior goggle fit
- White, Gloss Black, or Matte Black
- Graphics finishes available
- XS-2XL



Graphics \$359⁹⁹

1569



\$449⁹⁹

1592

HJC RPHA Max Align Modular

- Carbon fiber/Aramid/Fiberglass shell
- Lightweight (approx 3.5lbs)
- One-handed chin bar release
- Integrated internal sun shield
- Black & white graphic
- XS-2XL



\$323⁹⁹

1570

HJC RPHA 10 Anthrocite

- Carbon fiber/Aramid/Fiberglass shell
- Lightweight (approx 3.3lbs)
- Worn by MotoGP racers
- Adjustable air vents
- Black
- Graphic finishes available
- XS-2XL



Graphics \$359⁹⁹

1574

1580

Helmet Accessories

Sunblocker

The helmet sunblocker is a plasticized, polymer film which installs on the inside of your visor above your line of sight. This transparent polymer lets in light, but not the glare. Available for universal or Arai fitment.



\$15⁹⁵

HHC.HSB

Visor Transporter

It's important to be able to see clearly for safety. For riders who use dark shields, this means carrying a clear visor for cloudy days, inclement weather, or nighttime riding. The Stowaway Visor Transporter saves your spare helmet visor from scratches and other damage.

\$30⁰⁰

OXF.OF588



Clear Shot Lens Cleaning Kit

Clear Shot is an all-in-one, compact anti-fogging/lens cleaning kit perfect for safely cleaning all types of lenses, including goggles and helmet visors. Designed for easy use without removing your gloves. Includes 1oz spray bottle that will last a few weeks of dirty, all-day riding or 3 to 6 months of commuting. 8oz refill bottle available. Cases are available in Cobalt Blue, Racing Red, Safety Orange, and Matte Silver.

How to use:

- Open the caps and remove the spray
- Pick a cloth
- Spray and wipe clean
- Put fluid and cloths away and stow case

Includes:

- Rugged ABS case (choice of four colors)
- 1oz anti-fog cleaning spray
- Blue micro-fiber cloth for removing grime
- White micro-fiber polishing cloth



8oz refill bottle: CLR.1131: \$16.95

\$19⁹⁵

CLR.100



Jane
Twisted Throttle Controller

The first step towards a more comfortable ride...

Whether it's a track day, a ride with your friends to that awesome burger joint you've just heard about, or a weeklong adventure into the backcountry, choosing the right base layer is key.

TWISTEDCORE was designed by a track day organizer specifically to address the needs of motorcyclists. Unlike your typical off-the-rack sporting goods store base layer, TWISTEDCORE features:



Gradient Compression

Have you ever noticed how football players wear tight compression garments under their uniforms? That's not just to look cool - the proper use of compression **increases bloodflow** and **reduces muscle fatigue**. TWISTEDCORE takes that a step further with Gradient Compression in the forearms and lower legs of their base layers, the two places a motorcyclist needs it the most. After a day at the track or standing on the pegs off-road, you'll be less tired and more comfortable.

Comfortable fit

TWISTEDCORE garments are designed with special **Flatlock seams** that won't chafe or irritate your skin even when worn under armor or a leather suit. The shoulders are cut wide to allow free movement on the bike, and the use of **technical mesh** on the shirt back, the insides of the legs, and the backs of the knees let your skin stay cool and comfortable all day. Longer hem lengths provide full coverage in any riding position to eliminate exposure and ensure that everyone enjoys your ride.

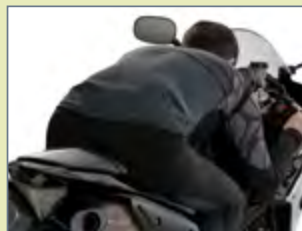
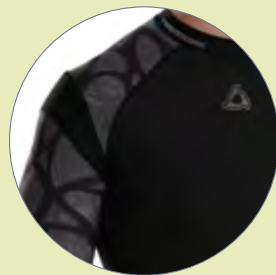

Melt-Resistant Fabric

Unlike other base layers, TWISTEDCORE uses a special melt-resistant fabric at the hips and rear of their pants and shorts. Sliding along pavement at speed generates a tremendous amount of heat, and if your base layer uses traditional polyester it can actually melt onto your skin, even if your leathers don't burn through! Ouch!

Manufactured in the USA • Anti-Microbial Fabrics • Moisture Wicking

TWISTEDCORE Base Layers



(back)
Summer Shirt
\$59⁹⁹
TCSB103

- TWISTEDCORE Base Layer Shirt**
- Wider shoulders and upper back
 - Targeted gradient compression in forearms
 - Elongated tail
 - Available in Summer (technical mesh back) or Winter (thicker, warmer fabric)
 - Unisex sizes XS-2XL



(back)
Summer Pants
\$49⁹⁹
TCSB104

- TWISTEDCORE Base Layer Pants**
- No-melt fabric at hips
 - Technical Mesh behind knees
 - Targeted gradient compression
 - Available in Summer (technical mesh) or Winter (thicker, warmer fabric)
 - Unisex sizes S-2XL



(back)
Winter Shirt
\$59⁹⁹
TCSB101



(back)
Winter Pants
\$49⁹⁹
TCSB102

All Season Shorts
\$39⁹⁹
TCSB105



- TWISTEDCORE Base Layer Shorts**
- Targeted gradient compression
 - Technical Mesh inside legs
 - Unisex sizes S-2XL

Touring/Sport Touring Boots

\$149⁹⁵**Alpinestars Ridge Waterproof Boot**

Looking for a comfortable everyday riding boot? The Alpinestars Ridge has what you need: Waterproof full grain leather, a midsole made for walking as well as riding, and a secure over-the-ankle fit.

Men's US Sizes 6 - 13

\$230⁰⁰**Sidi Tour Rain Waterproof Boot**

Quick rain showers and long miles are no match for the Sidi Tour Rain. Sidi boots feature a midsole that resists side compression for added safety. Sidi Tour is also available in breathable Gore-Tex.

Men's Euro Sizes 41 - 48

\$269⁹⁵**Alpinestars SMX-5-Waterproof Boot**

If your sport touring has an emphasis on "sport"...yet you don't pull under the nearest overpass at the first sight of rain, this is your boot! Also available in vented non-waterproof for you desert dwellers.

Men's Euro Sizes 36 - 50

\$220⁰⁰**Sidi Men's Fusion Air Boot**

Ride the warmest days in comfort with this fully vented sport boot. Replaceable toe sliders, heel cups and a stiff sole that can withstand heavy peg pressure make the Fusion Air a versatile boot.

Men's Euro Sizes 37 - 50

\$220⁰⁰**Sidi Men's Fusion Boot**

The non-vented version of the Fusion is a mainstay 3-season, non-waterproof street sport boot. Sidi's legendary quality and a great price make this a best seller.

Men's Euro Sizes 37 - 50

\$175⁰⁰**Sidi Men's Doha Boot**

It's a shoe! It's a boot! It's...both! Perfect for trips around town or for walking the paddock at the races.

Men's Euro Sizes 36 - 48

Ladies' Touring/Sport Touring Boots

\$220⁰⁰**Sidi Women's Fusion Lei Boot**

The ladies' version of the popular Fusion boasts all the features of the men's version, plus a female-specific last and shorter height to better fit ladies' legs.

Women's Euro Sizes 37 - 43

\$230⁰⁰**Sidi Women's Livia Waterproof Boot**

Just like the men's Sidi Tour, the Livia is a great go-to choice for the casual tourer. Rear reflective details and a compression resistant sole give you some added peace of mind.

Women's Euro Sizes 37 - 43

Don't see the boot you want here?

We've got lots more boots on our website, along with real-time stock status. You can also see sizing charts and more product details.

Plus you can always read other Twisted users' reviews and ratings to see how these boots stack up.

Visit www.twistedthrottle.com for more information!

Adventure Boots

\$249⁹⁵**Alpinestars Waterproof Scout Boot**

The Scout is consistently rated one of the best values in ADV boots out there. We've put it through its paces in Alaska and have to agree: it's pretty awesome. Totally waterproof full leather construction, all day comfortable fit, low profile toe for excellent lever feel, and a lugged outsole for tenacious grip are our favorite features.

Men's US Sizes 8 - 13

\$395⁹⁵**Gaerne Waterproof Balance Oiled Boot**

We have to say, this has got to be one of the best-looking boots out there. The oiled brown leather upper and gum rubber soles not only look great but are superbly functional too!

Men's US Sizes 8 - 13

\$360⁰⁰**Sidi Canyon Gore-Tex Waterproof Boot**

If you're in the market for a light adventure or touring boot, the Sidi Canyon is worth a look. Our own Kevin owns a pair and loves the combination of comfort and protection these boots offer. With leather uppers and Gore-Tex lining we think you will agree. The sole is also replaceable so when you wear them out because you love these boots so much, you can simply have them resoled.

Men's US Sizes 7.5 - 13

\$279⁹⁵**Gaerne Waterproof G-Adventure Boot**

These Italian made boots appeal to ATV, dual sport, and ADV riders with their deeply lugged soles, stiff protective upper, and full height waterproof gaitors. Not a particularly tactile boot, so if you're a dirt rider you'll likely be comfortable in these; riders new to dirt boots may find them a bit stiff.

Men's US Sizes 8 - 12

\$400⁰⁰**Sidi Adventure Rain Waterproof Boot**

The Adventure Rain is a simpler, water resistant version of the top-of-the-line Adventure Gore boot. It boasts all the features and protection of its more expensive sibling but less breathable.

Men's US Sizes 8 - 13

\$550⁰⁰**Sidi Adventure Gore-Tex Waterproof Boot**

This is it: The best of the best in ADV boots. Full Gore-Tex waterproofing, fully replaceable sole and other components, a superb fit, and the hallmark quality of Sidi.

Men's US Sizes 8 - 13



Why wool?

Natural wool is comfortable, wicks moisture, is superior at regulating body temperature, and maintains its insulating properties even when wet. Plus, it doesn't stink!

Over the Calf Socks

Ideal for ADV, dirt, or track boots. Choose Ski socks if you prefer a thicker cushion on your shin (great for stiff dirt boots), or the Mountaineering socks if you don't want the added bulk in the shin. All Smartwool socks feature their unique 4 Degree Elite™ fit system and ReliaWool™ technology.

 <p>\$23⁹⁵ SW005</p>	 <p>\$23⁹⁵ SW008</p>	 <p>\$25⁹⁵ SW006</p>	 <p>\$25⁹⁵ SW009</p>	 <p>\$25⁹⁵ SW048</p>
<p>Men's PHD® Ski Light Socks</p> <p>Knit in USA:</p> <ul style="list-style-type: none"> • 64% Merino Wool • 34% Nylon • 2% Elastane • Light cushioning • Black 	<p>Women's PHD® Ski Light Socks</p> <p>Knit in USA:</p> <ul style="list-style-type: none"> • 65% Merino Wool • 33% Nylon • 2% Elastane • Light cushioning • Black 	<p>Men's PHD® Ski Medium Socks</p> <p>Knit in USA:</p> <ul style="list-style-type: none"> • 70% Merino Wool • 28% Nylon • 2% Elastane • Medium cushioning • Black 	<p>Women's PHD® Ski Medium Socks</p> <p>Knit in USA:</p> <ul style="list-style-type: none"> • 70% Merino Wool • 28% Nylon • 2% Elastane • Medium cushioning • Black 	<p>PHD® Mountaineering Socks</p> <p>Knit in USA:</p> <ul style="list-style-type: none"> • 76% Merino Wool • 22% Nylon, 2% Elastane. • 14" overall height • Unisex • Thick cushioning • Black/Red

Crew Socks

The lower height of the Crew socks is perfect for more casual riding boots. Pack them with you on trips to wear around the campsite, or carry a pair as a spare. Their smaller size means they'll pack down smaller than the Ski socks.

 <p>\$20⁹⁵ SW044</p>	 <p>\$20⁹⁵ SW054</p>	 <p>\$23⁹⁵ SW045</p>	 <p>\$24⁹⁵ SW046</p>	 <p>\$20⁹⁵ SW725-100</p>
<p>Men's PHD® Outdoor Light Crew</p> <p>Knit in USA:</p> <ul style="list-style-type: none"> • 68% Merino Wool • 29% Nylon • 3% Elastane • Black 	<p>Women's PHD® Outdoor Light Crew</p> <p>Knit in USA:</p> <ul style="list-style-type: none"> • 69% Merino Wool • 29% Nylon • 2% Elastane • Deep Sea Blue 	<p>Men's PHD® Outdoor Medium Crew</p> <p>Knit in USA:</p> <ul style="list-style-type: none"> • 72% Merino Wool • 26% Nylon • 2% Elastane • Charcoal 	<p>PHD® Outdoor Heavy Crew</p> <p>Knit in USA:</p> <ul style="list-style-type: none"> • 78% Merino Wool • 20% Nylon • 2% Elastane • Unisex • Black 	<p>Women's Saturnsphere Medium Crew</p> <p>Knit in USA:</p> <ul style="list-style-type: none"> • 67% Merino Wool • 31% Nylon • 2% Elastane • Black/Multi-color • Sometimes you just want a cute sock

Scarves and Balaclavas



\$37⁹⁹
MN.7002.180

Macna's Balaclava is made from microfleece and Spandex and provides a comfortable base beneath your helmet, helping to regulate your body temperature. Holes over the mouth area keep your breathing easy. We have definitely *not* ever worn these around the office pretending we were ninjas. We promise.





\$12²⁵
BKL.00.010.005



SW-MOTECH Bags-Connection Biker Scarf is not just any old neck scarf, this microfiber tube doubles as a doo rag or a really really tight tube top. Helps keep wasps off your neck, wets down for evaporative cooling in the summer, and keeps the wind out in the winter. Don't leave home without it!

Hats and Glove Liners

 <p>\$25⁰⁰ SW950.001</p> <p>Smartwool NTS Mid 250 Headliner</p> <p>Featuring a contoured three-panel design with flatlock stitching, this headliner fits perfectly under most helmets. The thin, single layer of fabric will wick moisture off your head while insulating you on cooler days.</p> <p>Knit in Vietnam of 100% Merino Wool</p> <ul style="list-style-type: none"> • Single layer Interlock knit construction • Contoured 3 panel design with clean finish flatlock seams • Black 	 <p>\$28⁰⁰ SC968.008</p> <p>Smartwool NTS Light 195 Reversible Training Beanie</p> <p>Reversible Training Beanie features a double layer design with clean finish seams for a bulk-free fit. Made from 100% Merino wool, this beanie shows off a contrast color interior.</p> <p>Knit in Vietnam of 100% Merino Wool</p> <ul style="list-style-type: none"> • Reversible Jersey knit construction with contrast color interior • Double layer design with clean finish seams for a bulk free fit • Black 	 <p>\$24⁰⁰ SC558.001</p> <p>Smartwool Liner Glove</p> <p>A favorite liner glove with a modern twist suitable for touchscreen technology.</p> <p>Knit in Taiwan:</p> <ul style="list-style-type: none"> • Body - 95% Merino Wool, 5% Elastane; Index Finger and Thumb Tips - 90% Polyester, 10% Carbon Fiber • Versatile lightweight knit for ease of movement • Rib knit cuff finishing for a bulk free fit • Knit in touch screen capability on thumb and index finger
---	---	---

T-shirts & SWAG



IRON PIG

“Eisenschwein”, as our beloved BMWs are known in their home-land. Wear it with pride!

S, M, L, XL, XXL, & XXXL
Color: White
TT.TS.8: **\$15.00**



KLR ARMY

You know who you are!

S, M, L, XL, XXL, & XXXL
Color: Olive Drab
TT.TS.10: **\$15.00**



Twisted Throttle Women's Fitted

S, M, L, XL, XXL, & XXXL
Color: Black
TT.TS.3: **\$10.00**



Twisted Throttle Men's Classic

S, M, L, XL, XXL, & XXXL
Color: Black
TT.TS.1: **\$10.00**

Motorist Eye Exam

Back text: “Stop get off the phone put down the burger stop creeping Facebook nobody cares you are a hazard to everyone including yourself”. ‘Nuff said.

S, M, L, XL, XXL, & XXXL
Color: High Viz Yellow
TT.TS.9: **\$15.00**



Back

Ready for Adventure

Packing the essentials. Are YOU ready for adventure?

S, M, L, XL, XXL, & XXXL
Color: Orange
TT.TS.6: **\$15.00**



Front Detail



Twisted Throttle Pit Shirt

You've seen us wearing these at events and rallies worldwide... now you can join our pit crew! The Twisted Pit Shirt features the logos of our major brands on the sleeves. 100% Polyester. Full dye-sublimation printing!
XS, S, M, L, XL, XXL, XXXL
TT.PIT.1: **\$99.99**



Twisted Throttle Baby Onesie

6M, 12M, 18M, & 24M
Adult sizes in development
Color: Black
TT.CREEPER: **\$14.99**



Motorcycle vs Prius!

Admit it, you laughed.

S, M, L, XL, XXL, & XXXL
Color: Navy
TT.TS.7: **\$15.00**



My Dirtbike Has Slicks

Last chance for this one! Limited sizes available while they last.

XL, XXL, & XXXL
Color: Black
TT.TS.11: **\$15.00**



Twisted Throttle Kick Pad

Tired of using a crushed soda can under your sidestand foot? How about using one of our Twisted Throttle sidestand pucks?
Black or yellow.
TT.SSP.101: **\$3.99**



Twisted Throttle Low-Profile Baseball Cap

TT.HAT.2: **\$12.50**



Twisted Throttle Patch
Sew it on your favorite denim jacket!
TT.PATCH: **\$1.99**

Reflective Sticker
Slap it on your bike and improve night-time visibility the Twisted way!
TT.stk.01: **\$1.00**



Twisted Throttle Gift Cards
Can't decide what to get that special motorcyclist in your life? Trying to figure out the perfect gift for your buddy's birthday? We've got you covered. Available in any amount over \$15.
TT.GC

Extend your riding season!

VentureHeat's PowerSports gear features the latest in innovation and heating technology, enabling you to create your own personal micro-climate. Designed to be powered by your vehicle's battery, you can connect your heated gear to a motorcycle, snowmobile, ATV or scooter for endless heated comfort.



Xtreme Comfort Technology eliminates bulky insulation and coils which impede mobility, and is replaced with hair-thin, micro fibers allowing for a more flexible range of motion without heavy layers.



Heated Jacket Liner With Wireless Remote

Heated Vest

VentureHeat's 12V Heated Jacket Liner is a dream come true for any motorcycle rider taking on the elements. This lightweight jacket is windproof and waterblocking to help protect you from the cold weather. Its slim design and form-fitting construction allow you to wear it comfortably underneath your regular riding jacket.

VentureHeat's 12V Heated Grand Touring Motorcycle Vest is one of the most versatile vests on the market. This heated vest features 4 heating panels to keep your entire core warm. A built-in temperature controller allows you to adjust the heat settings on the go.

With a **built-in temperature controller**, you can adjust the heat to 3 different settings with just the touch of a button. This heated jacket also features a **wireless remote** which can be attached to your handlebars so that you can stay comfortable without ever having to take your eyes off the road.

The vest is constructed with a windproof, stretchable soft shell material to keep you protected from the elements. **Pre-wired glove connectors** also give you the option to plug-in a set of VentureHeat heated motorcycle gloves to help minimize the amount of cable and maximize your comfort while out riding.



\$199⁰⁰

VH.MC38

Sizes
XS-3XL



\$180⁰⁰

VH.GT28

Sizes
XS-3XL

Heated Pant Liner

Heated Touring Gloves by Macna

VentureHeat's 12V Heated Motorcycle Pant Liners are perfect for taking on the elements and riding in comfort. These heated pant liners are constructed with a windblocking soft shell on the front, and a stretchable back to help fit comfortably underneath your regular riding pants.



The Proton Heated Glove from Macna is the most comfortable heated glove we've ever used. It features a smart temperature controller that maintains the temperature setting exactly as you choose - no more constant fiddling with a controller trying to keep the temperature stable! Simply set it to your desired setting and, just like the furnace in your house, it automatically regulates itself to maintain that temperature.

The Proton is 100% waterproof, touchscreen friendly, and comes with everything you need to hook up to your bike or to other heated gear!



- 5 temp settings
- Goat leather, Durylon
- Raintex membrane
- TouchTip
- TPU knuckle protectors
- ScreenCleaner
- Includes controller and wiring
- Compatible with other heated gear brands
- S-4XL

\$249⁹⁹
pair

MN.6600.101



\$170⁰⁰

VH.GT30

Sizes
XS-XXL

Oxford Heated Grips & Muffs



Sport & Touring Grips

Designed for 7/8" diameter handlebars. 7/8" grips have an open-ended design that replace grips that are between 4.75" to 4.9".

"Sport", "Adventure" and "Touring" controller features:

- Waterproof
- Maximum temperature of 122° F (50° C)
- 5 power settings (100%, 75%, 40%, 30%, off)
- Draws under 4 AMPS
- LED indicates current power setting
- Auto-off when bike is turned off to prevent accidental battery drainage
- Includes bracket for mounting controller on left-side handlebar (pre-drilled for two 6mm mounting screws spaced 31mm-35mm apart on center)
- Controller size: 56mm (2.2") wide x 54mm (2.1") tall x 20mm (0.8") thick



\$89⁹⁹

OXF.OF692Z

7/8" Sport Style



\$89⁹⁹

OXF.OF691Z

7/8" Touring Style



\$89⁹⁹

OXF.OF690Z

7/8" Adventure Style

Cruiser Grips

Designed for 1" diameter handlebars. Comes with a chrome end cap. These soft rubber comfort grips are 5 1/4" long.

"Cruiser" 1" controller features:

- Maximum temperature of 122° F (50° C)
- Waterproof
- 5 temperature settings
- Draws under 4 AMPS
- Chrome rotating control knob with mounting bracket



\$79⁹⁵

OXF.OF697

1" Cruiser Style

1" Cruiser Grip Controller

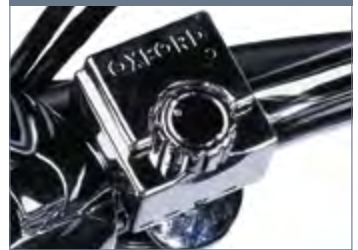

All controllers include high temperature epoxy and a fused, pre-terminated wiring harness with two 1.4" (6mm) ring terminals for connecting to a 12-volt battery.

Oxford HotHands Heated Overgrips

Wrap these heated grips over your existing grips when the weather gets chilly.

- Easy to attach in winter and easy to remove when the weather warms up
- Attach with Hook & Loop fasteners
- Connects directly to battery
- Switch with LED warning light included
- Very low battery drain
- 2 year warranty

\$69⁹⁵
pair

OXF.OF694



Oxford Handlebar Muffs

- These hand covers mount to your handlebars to keep your hands warm and dry even in the coldest riding weather
- Pre-formed opening for ease of access to controls
- Total weather protection: waterproof heavy duty 1500 denier polyester outer shell with Thermoacel insulation
- Highly reflective 3M piping for increased visibility and safety
- Includes a pocket for Oxford HotHands or disposable hand warmers (sold separately) for the ultimate heated muff
- Not for use with handguards



\$49⁹⁵

OXF.OF82

R&G Heated Grips

R&G Heated Grips provide warmth and comfort on those cold riding days. We really like the included digital controller and compact wiring harness. Awarded RiDE magazine's Best Buy award, these grips provide great quality at a great price.

\$59⁹⁹

RG.HG000122C

Fits 7/8 "diameter handlebars. Included control unit is fully waterproof and has 5 adjustable heat settings. In only 2 minutes your grips can heat up to 95°F (35°C) and on those really cold days, increase the heat setting to get warmth up to a toasty 140°F (60°C).

Included in Kit:

- 2 Heated Grips
- Adjustable Control
- Unit Power Cables



Hand, Body & Toe Warmers

Disposable hand warmers are an easy and inexpensive way to keep your hands warm. These air-activated warmers work for over 7 hours. Just place the packet inside your glove and feel the warmth. Body and toe warmers are also available.

- Duration: 7+ hours
- Avg Temp: 135F (57C)
- Max Temp: 156F (69C)

Hand warmers
2" x 3.5"
HWES \$1.29 per pair

Hand/Toe warmers
3" x 4"
HTES1 \$2.49 per pair

Body warmer
4" x 5"
MWES \$1.29 each



interphone

BLUETOOTH RIDER COMMUNICATION

Interphone's rider communication systems range from kits for bike-to-bike communication to solo units for listening to music or Bluetooth devices. Exceptional audio clarity and a wide volume range allow easy communication at speeds up to 110 mph. Interphone's long-lasting battery life won't leave you in silent isolation on all-day rides.



F5 with modular/open face microphone installed.

NEW FEATURES
for 2014

Interphone F5MC Communication for up to six riders!

The F5 Conference offers full-duplex communication system for groups of up to 6 riders. Effective maximum range starts at 0.8 miles between a pair of riders and increases to 1.5 miles across a group of 6 riders. Full-duplex communication allows all six people to talk at once.

Features:

- Bluetooth 3.0: longer range, better connection
- A2DP stereo Bluetooth for HD audio
- 11-hour talk time per charge
- 5 independent buttons: volume up, volume down, next track/station, last track/station, and function
- Head unit responds to voice commands
- Text-to-speech capability lets you **listen to text messages**
- Automatic volume control
- Noise suppression microphone
- FM radio (8 station memory and station scan function)
- 3.5mm stereo music input jack
- Backwards-compatible with F4 head units

Each headset kit includes:

- INTERPHONEF5S
- STEREO Hi-Fi slim speakers
- Universal boom microphone
- Full-Face comfort microphone
- Includes one USB charger/sync cable
- Wall charger (3 hour recharge time)
- Lithium battery
- 1 3M adhesive slide mount
- 1 sliding mount clip

interphone F5MC



5 pointed easy-to-feel buttons provide maximum ease-of-use, even with thick gloves.

Additional microphone and (slim-line) headset kit allows the use of communicator on an additional helmet
Full face helmet - ULTRASLIMF5FFKIT: \$34.99
Open face helmet - MICINTERPHOF5UNI: \$34.99
Additional USB adapter cable: CUSBINTERPHONEF5: \$12.99

Twin Kit
MSRP
\$449⁹⁹
INTERPHONEF5MCTP
Single Kit
MSRP
\$249⁹⁹
INTERPHONEF5MC

Interphone Accessories

Interphone's Splitter plugs into the headphone jack as a way to take a wired 3.5mm audio source and transmit to one or two Bluetooth headsets of any brand.



MSRP ~~\$69⁹⁹~~ **Our Price \$28³⁶**
BTSPLITTER35
*While supplies last.

Effective range: 32.8 feet
Dimensions: 1.25 x 1.75 x .25"
3.5mm jack cable length: 3.125"

The battery:

- Long-life lithium ion battery
- Carries up to a 10 hour charge
- Recharges in 2 1/2 hours via the supplied USB cable

Universal Adapter For Honda & Harley-Davidson Factory Audio Systems

Allows you to plug in a standard mini headphone or headset for audio listening via the Interphone Splitter. Works on both Honda and Harley-Davidson factory audio systems. For listening only; does not make use of headset's microphone.



\$24⁹⁵
EC.03300

Interphone 3.5mm Connector Cable has a 3.5 mm audio input jack which allows you to use ear buds with (or without) a microphone. Designed for use of the Interphone F5, F5S, F5XT, F5MC, F4MC & F3MC without a helmet or in place of the Interphone speakers and microphone.



\$34⁹⁹
CONAU35F5

Interphone Bluetooth Remote Control

- Controls all INTERPHONE F5 functions
- Movement sensor turns unit on & off
- Replaceable long-life lithium battery
- Waterproof (IP 67)
- Soft-touch covering
- For 20 to 32 mm handlebars
- Includes mounting kit



\$129⁹⁹
REMOTECONTROLF

Powerbank 5200mAh Allows you to recharge your USB compatible devices many times without access to an outlet or computer. Turn the Powerbank 5200 into a flashlight with the Interphone USB light.

- Dimensions: 154mm x 23.2mm
- Lithium polymer battery
- 5200 mAh capacity
- Weight: 147 g



\$79⁹⁹
POWERBANK5200



USB Light
\$14⁹⁹
POWERUSBBANK

interphone

BLUETOOTH RIDER COMMUNICATION

Interphone F4MC - Communication for a pair of riders on separate bikes

The F4MC offers reliable, crystal-clear communication for a pair of riders.

Features:

- Bluetooth technology
- A2DP stereo Bluetooth for HD audio
- Range of 0.3 miles
- 10-hour talk time per charge
- 3 independent buttons
- Can be paired to a single F4 or F5 head unit
- Music from any A2DP source (Bluetooth player or smartphone)
- Automatic volume adjustment
- Fully waterproof (IP67)

Each headset kit includes:

- INTERPHONEF4MC
- 1 3M adhesive slide mount
- 1 sliding mount clip
- STEREO Hi-Fi slim speakers
- Universal boom microphone
- Full-Face comfort microphone
- Wall charger (3 hour recharge time)
- Lithium battery
- Fastening kit
- User manual

interphone F4MC



3 easy-to-operate buttons

Twin Kit
MSRP
\$369⁹⁹
INTERPHONEF4MCTP
Single Kit
MSRP
\$209⁹⁹
INTERPHONEF4MC

Additional microphone and (slim-line) headset kit allows the use of communicator on an additional helmet
Full face helmet - ULTRASLIMF5FFKIT: \$34.99
Open face helmet - MICINTERPHOF5UNI: \$34.99
Additional USB adapter cable: CUSBINTERPHONEF5: \$12.99

Port for Headset & USB charging cable

Interphone F3MC for rider and passenger on the same bike

F3MC is designed for rider-to-passenger intercom capabilities in addition to Bluetooth stereo music, GPS, and cell phone.

Features:

- Bluetooth® technology
- A2DP stereo Bluetooth for HD audio
- 8-hour talk time per charge
- 3 independent buttons
- Music listening from any A2DP source (Bluetooth® player or smartphone)
- Automatic volume adjustment
- Fully waterproof (IP67)

Each headset kit includes:

- INTERPHONE F3MC
- 1 3M adhesive slide support
- 1 sliding clamp clip
- STEREO Hi-Fi slim speakers
- Universal boom microphone
- Full-Face comfort microphone (NEW!)
- Wall charger (3 hour recharge time)
- Lithium battery

interphone F3MC



Twin Kit
MSRP
\$269⁹⁹
INTERPHONEF3MCTP
Single Kit
MSRP
\$149⁹⁹
INTERPHONEF3MC

Additional microphone and (slim-line) headset kit allows the use of communicator on an additional helmet
Full face helmet - ULTRASLIMF5FFKIT: \$34.99
Open face helmet - MICINTERPHOF5UNI: \$34.99
Additional USB adapter cable: CUSBINTERPHONEF5: \$12.99

Last Year's models - Get them at an awesome price while they last!

F2S F2S is a solo Bluetooth headset designed for riders who do not need intercom capabilities and are looking for the ability to listen to Bluetooth stereo music, GPS, and cell phone.



Single Kit
MSRP ~~\$129⁹⁹~~ **Our Price \$72³⁰**
INTERPHONEF2SJP

F3S The F3S kit includes two Bluetooth headsets that will allow for wireless intercom between rider and passenger, in addition to GPS, music and cell phone use.



Twin Kit
MSRP ~~\$229⁹⁹~~ **Our Price \$124⁶⁶**
INTERPHONEF3SJP

F4 The F4 kit is a single Bluetooth headset that will allow for GPS, music and cell phone use. Purchase a second kit to use intercom between two riders.



Single Kit
MSRP ~~\$179⁹⁹~~ **Our Price \$99⁷³**
INTERPHONEF4PLJP

F3XT The F3XT kit is a Bluetooth headset that will allow for GPS, music and cell phone use. Purchase a twin kit or two single kits to use intercom between rider and passenger.



Twin Kit
MSRP ~~\$249⁹⁹~~ **Our Price \$147⁹⁹**
INTERPHONEF3XTTP
Single Kit
MSRP ~~\$130⁹⁹~~ **Our Price \$81⁹⁹**
INTERPHONEF3XT

F4XT The F4XT kit is a Bluetooth headset that will allow for GPS, music and cell phone use. Purchase a twin kit or two single kits to use intercom between two riders.



Twin Kit
MSRP ~~\$349⁹⁹~~ **Our Price \$217⁹⁹**
INTERPHONEF4XTTP
Single Kit
MSRP ~~\$199⁹⁹~~ **Our Price \$120⁹⁴**
INTERPHONEF4XT

F5XT The F5XT kit is a Bluetooth headset that will allow for GPS, music and cell phone use. Purchase a twin kit or single kits to use intercom between up to 6 riders.



Single Kit
MSRP ~~\$249⁹⁹~~ **Our Price \$147⁹⁹**
INTERPHONEF5XT

Sena Bluetooth Intercoms

Sena Bluetooth Intercoms use advanced Bluetooth 3.0 & 4.0 technology, which allows superior clarity over real-world useable distances. Sena intercoms also allow music streaming, multi-phone pairing, and many other features. See each unit's feature list for details.



Sena 20S Bluetooth Communication System

The unit provides a sleek and aerodynamic design that offers a versatile jog dial that maximizes the ease of use for riders. With the 20S, you can call handsfree on your Bluetooth mobile phone, listen to stereo music or voice instructions of GPS navigations by wireless Bluetooth, and have intercom conversations in full duplex with a passenger or other motorcycle riders.

- Bluetooth 4.0
- Industry first dual Bluetooth module communication system
- Audio Multitasking™: advanced audio management of intercom, phone, music and FM radio (patent pending)
- Advanced Noise Control™
- Versatile bike-to-bike conference intercom
- Intercom working distance up to 2.4km (1.5 miles)
- Multipoint Bluetooth for dual mobile phone
- HD Quality crystal clear sound
- Intuitive voice prompts and commands
- Up to 13 hours talk time, 10 days stand-by time
- Built-in FM radio tuner with a station scan and save function
- All-in-one helmet clamp kit
- Quick Bluetooth pairing
- Universal Intercom™: intercom with other brand communication systems
- Water resistant for use in inclement weather
- Firmware upgradeable
- Two-year warranty



Twin Kit
Our Price
\$TBD

SENA.20S-01D

Single Kit
Our Price
\$TBD

SENA.20S-01

Sena SMH10 Bluetooth Intercom

The SMH10 is a Bluetooth 3.0 stereo headset with long-range Bluetooth intercom designed specifically for motorcycles. With the SMH10, you can call handsfree on your Bluetooth mobile phone, listen to stereo music or voice instructions of GPS navigations by Bluetooth wirelessly, and have intercom conversations in full duplex with a passenger or other motorcycle riders.

- Bluetooth 3.0 intercom up to 900 meters (980 yards)
- Four-way conference intercom
- Conference phone call with intercom participant
- Multipoint Bluetooth for dual mobile phone
- Voice prompts
- Bluetooth stereo headset for Bluetooth audio devices such as MP3 players
- Bluetooth music playback control
- Easy operation by versatile Jog Dial
- Integrated audio booster
- Bluetooth headset or stereo headset for Bluetooth GPS
- Speed dialing
- Stereo music by 3.5mm audio cable
- Water resistant for use in inclement weather
- Crystal clear and natural sound
- Advanced Noise Control™
- Up to 12 hours talk time, 10 days stand-by time
- Can be used while charging
- Individual volume control for each audio source
- Firmware upgradeable
- Two-year warranty



Twin Kit
Our Price
\$281²⁵

SENA.SMH10D-10

Single Kit
Our Price
\$156⁷⁵

SENA.SMH10-10

Sena SPH10H Bluetooth Intercom for Half Helmets

The SPH10H is a Bluetooth Headset & Intercom designed for Half Helmets. By simply attaching the SPH10H to your half helmet, you can call handsfree on your Bluetooth mobile phone and listen to stereo music by wireless Bluetooth, and have intercom conversations in full duplex with other users.

- Bluetooth Specification 3.0
- Bluetooth intercom up to 500 meters (540 yards)
- Four-way Conference Intercom
- Multipoint Bluetooth for dual mobile phone
- Voice Prompts
- Bluetooth stereo headset for Bluetooth audio devices such as MP3 players
- Bluetooth music playback control by AVRCP: play, pause, track forward and track back
- Advanced Noise Control™
- Crystal clear sound quality
- Simple ear pad design for quick installation to half helmets
- Compatible with shorty helmets
- Easy Headset Controls by versatile Jog Dial (Patent pending)
- Bluetooth handsfree for Bluetooth mobile phones
- Water resistant for use in inclement weather
- 10 hours talk time, 7 days stand-by time
- Firmware upgradeable
- Two-year warranty



Single Kit
Our Price
\$197¹⁰

SENA.SPH10H-01

Sena SM10 Dual Stream Stereo Transmitter

The SM10 is a Bluetooth stereo audio adapter based on Bluetooth 2.1+EDR technology. You can connect various audio devices such as a mobile phone or MP3 player by using the SM10. It also supports onboard audio systems of specific brands by using optional audio cables. Along with the dual streaming feature, both you and your passenger can listen to the same music or radio at the same time by using aftermarket Bluetooth headsets. The SM10 has AUX audio input that enables you to connect additional non-Bluetooth audio devices such as radar/laser detectors or GPS navigation.

- Bluetooth 2.1+EDR
- Advanced Audio Distribution Profile (A2DP), Audio Video Remote Control Profile (AVRCP)
- Dual audio streaming for two Bluetooth headsets
- Motorcycle handlebar mount
- Auxiliary stereo input for GPS or radar/laser detector
- Water resistant for use in inclement weather
- Optional interface cable for onboard motorcycle audio systems
- Firmware upgradeable
- Two-year warranty
- Works with all brands of Bluetooth headsets



\$134¹⁰

SENA.SM10-01

Sena SR10 Bluetooth Two-way Radio Adapter

The SR10 is a Bluetooth Two-way Radio Adapter based on Bluetooth 2.1+EDR technology. You can connect various two-way radio devices by using SR10 and may talk wirelessly using Bluetooth headsets. SR10 has two auxiliary ports that enable you to connect non-Bluetooth devices such as a radar detector or GPS navigation. Talk by phone or by two-way radios at the same time, listen to alarm signal from a radar detector and listen to the guides from GPS Navigation.

- Bluetooth handsfree adapter for two-way radios
- Bluetooth handsfree gateway for mobile phones
- Connect 1 two-way radio and 1 mobile phone simultaneously
- Compatible with standard stereo or mono Bluetooth headsets
- Auxiliary input for GPS or radar/laser detector
- Handlebar mounting & belt clamping
- Wired PTT button extension for handlebar grip mounting
- Optional 12V bike-powered kit with on/off control by ignition switch
- Firmware upgradeable
- Two-year warranty
- Works with all brands of Bluetooth headsets
- Visit TwistedThrottle.com for adapter plugs for specific 2-way radios



\$179¹⁰

SENA.SR10-10

Sena Prism Bluetooth Camera

The Sena Bluetooth Prism Camera is the first camera on the market that provides authentic Bluetooth technology. The Sena Prism is an ideal solution for the users who want to record their adventures while capturing their video and voice on-the-fly. The all new Prism is Bluetooth 4.0 capable with 1080 FHD video recording featuring Bluetooth-based remote control and voice prompt. Sena provides a unique quick-release motorcycle mounting system which enables quick and creative camera mounting.

Compatibility:

- 20S - Fully function remote control with voice and music overlay.
- SMH10 - Fully functional remote control with voice overlay.
- Full functional remote control with other Bluetooth Headsets.

\$TBD

SENA.SCA-M01



\$99⁰⁰

SENA.GP10-01

Sena Bluetooth Pack for GoPro

The Sena Bluetooth Pack for GoPro® is a specially designed adapter for the GoPro® HERO3 & HERO3+ (see page 96) allowing for Bluetooth capabilities. With the use of Bluetooth headsets, the Sena Bluetooth Pack for GoPro® allows users to add their voice to the video on-the-fly using the Bluetooth Audio Recording™ feature. With Bluetooth products, users may add not only their own voice but also audio from their companions through the use of the intercom to create a mixed audio experience.





GoPro HERO3

NEW! Smaller, Lighter and More Powerful!
 30% smaller, 25% lighter and 2 times more powerful than previous models.

HERO3+ Black Edition

The Hero3+ Black Edition offers professional picture quality, slow motion and time-lapse clips.

Features:

- High-res video modes: 1440p48, 1080p60, 960p100 & 720p120
- Auto Low Light mode
- Rechargeable Lithium-ion Battery
- 12MP photo capture with 30 fps burst
- Wi-Fi Built-In
- Wi-Fi Remote (included)
- GoPro App Compatible (FREE)
- Waterproof Housing (included)
- 3-Way Pivot
- Remote Charging Cable
- USB Charging Cable
- Assorted mounts and hardware included

\$399⁹⁵

CHDMX-302



WiFi Remote (Included with Black Edition)

HERO3: Silver Edition

The Hero3 Silver Edition offers great picture quality for a great price.

Features:

- Professional 1080p60, 960p100 & 720p120
- 10MP photo capture with fps burst
- Wi-Fi Built-In
- Wi-Fi Remote Compatibility (sold separately)
- GoPro App Compatible (FREE)
- Waterproof Housing (included)
- 3-Way Pivot
- USB Charging Cable
- Assorted mounts and hardware included

\$299⁹⁹

CHDHN-302



ADAPTIV TECHNOLOGIES



TPX Radar & Laser Detector TPX.A-01-01

\$299⁰⁰

TPX Visual Alert TPX.A-02-02

\$45⁰⁰

TPX Radar & Laser Detector System 2.0 features a water, shock, and vibration resistant housing, and includes a fused 12-volt harness for direct hookup to your battery. TPX detectors have big buttons that are easy to use while wearing bulky motorcycle gloves, a backlit LCD screen that's readable while riding, as well as an LED visual alert so you don't have to take your eyes off the road. The TPX includes a 3.5mm auxiliary audio jack for integration with other audio or communication systems.

- Exceptional radar and laser detection
- Water resistant construction
- Shock and vibration resistant design
- Oversize, backlit control buttons
- Angled, backlit, daylight visible LCD
- LED visual alert included
- Compatible with other communication or audio systems
- Simple installation

The included quick-release adapter plate is compatible with most RAM, Techmount, and SW-MOTECH motorcycle device mounts.

TPX Systems have been performance certified by *Speed Measurement Laboratories, Inc.*, an independent laboratory that specializes in testing radar and laser detectors.

Optional Accessories	Part Number
Wireless Headset	TPX.A-02-01
Automotive mount with 12-volt power cord	TPX.A-05-03

Battery BacPac™

The Battery BacPac attaches to your GoPro camera to extend battery life. Works with HERO3+, HERO3 & HD HERO2.



ABPAK-302
\$49.99

Rechargeable Li-ion Battery

Use this 1080 mAh lithium-ion rechargeable battery as a spare or replacement for your HERO3+ or HERO3 camera.



AHDBT-301
\$19.99

Wall Charger

Charge up to two GoPro cameras quickly, in US, UK, EU & AU wall sockets. For use with all cameras.



AWALC-001
\$39.99

Wi-Fi Remote

Full remote control of up to 50 GoPro cameras at once.



ARMTE-001
\$79.99

Hero Camera Tethers

Use these camera tethers and adhesive anchors to further secure your GoPro camera in extreme conditions.



ATBKT-005
\$19.99

Hero Suction Cup Mount

Use the suction cup to attach your camera to any flat, or mostly flat, surface. Proven to hold at speeds over 150mph.



AUCMT-302
\$39.99

Side Mount Hardware

Attach your GoPro camera to the side of helmets, vehicles, gear and more. 3-way pivot adjustability.



AHEDM-001
\$12.99

Hero Chest Harness

Attach your GoPro to your chest to get a different, awesome angle.



GCHM30-001
\$39.99

LCD Touch BacPac™

The LCD Touch BacPac is a removable LCD touch screen for HERO3+ & HERO3 GoPro cameras. Makes aiming easy.



ALCDB-303
\$79.99

Handlebar/Crashbar Mount Kit

Fits bars from 5.0" to 1.25" diameter. Consists of a zinc coated u-bolt base, 3" double socket arm and 1" diameter ball with custom GoPro® Hero adapter. Base includes black cover caps to be placed over the exposed ends of the u-bolt.



RAM-B-149Z-GOP1
\$31.69

RAM Ball GoPro Adapter

This 1" ball adapter attaches directly to the under-side of the camera, replacing the factory mounting bracket.



RAP-B-202U-GOP1
\$6.20

Hero Tripod Mount

Connects a GoPro camera to a standard tripod.



ABQRT-001
\$9.99

Grab Bag of Mounts

The Grab Bag consists of add-on parts for GoPro quick-release camera owners wanting more mounts.



AGBAG-001
\$19.95

GPS Units

See GPS holders on pages 100-105

► **Garmin's zumo 390LM Motorcycle GPS** features the new Curvy Roads routing which navigates to the twistiest roads in the area! Zumo is fuel-resistant, waterproof (IPX7), offers free lifetime maps, and has a display that is both sunlight-readable and glove-friendly. The zumo 390LM allows hands-free phone control and lets you hear spoken directions via your Bluetooth-enabled helmet or headset. A Service History Log records bike maintenance and there's even an automotive mount for car navigation – if you must. Zumo 390LM is also compatible with our Tire Pressure Monitor System (additional purchase required for each wheel; metal valve stems only. Not intended for automotive use).

Features:

- Curvy road routing to guide via windy roads
- Exit services display
- Service History Log to track maintenance
- Tire pressure monitor system with individual sensors (sold separately)
- Includes motorcycle and car mounting power cable and hardware
- Preloaded with City Navigator NT North America street maps
- Lifetime Map Updates
- Glove friendly display
- Rechargeable lithium-ion battery with up to 7 hours of operational time
- Waterproof to 1m for 30min (IPX7 rating)
- Up to 1000 waypoints/favorites/locations
- Up to 100 routes
- Measures: 5.12" x 3.7" x 1.18" (130mm x 94mm x 30mm)
- Display size: 3.7" x 2.2" (94mm x 56mm)
- 4.3" (109mm) diagonal
- Weighs 9.5oz. (270g)
- Fuel and UV resistant
- Accepts microSD data cards
- Internal speaker for voice direction prompts
- Calculates routes based on traffic flow
- Lane assist advises proper lane
- Multiple destination routing
- Bluetooth enabled
- Speed limit display
- Locate closest services from any location
- Trip log
- Compass display
- Trip planning software included



Garmin zumo 390LM 010-01186-00 **\$699⁹⁹**



zumo 390LM tire pressure monitoring screen

► **Garmin zumo 660 & 665 Motorcycle GPS Units** have many of the same features as the 350LM, including a wide 4.3" touchscreen and lifetime maps.

The **zumo 660** adds the ability to simultaneously connect to both a Bluetooth™ headset and a phone or MP3 music player. The **zumo 665** offers the same features as the Zumo 660, but includes the GXMT™ 40 XM antenna. Simply add an XM subscription (not included) to receive real-time XM Radio®.



Garmin zumo 665LM

\$649⁹⁹

Garmin zumo 660LM
5.3"W x 3.3"H
010-00727-04

Garmin zumo 665LM
5.3"W x 3.3"H
010-00727-08

\$799⁹⁹

► **Garmin Tire Pressure Monitor Sensor**

Garmin's Tire Pressure Monitor Sensor (TPMS) enables you to monitor your motorcycle's tire pressure easily and conveniently, as you ride. Fasten 1 TPMS sensor to each metal tire valve stem, then pair TPMS with your zumo 390LM. View the real-time data right on your zumo display.

TPMS lets you set custom pressure thresholds. If tire pressure changes, TPMS issues an alert. TPMS is the smallest motorcycle tire pressure sensor on the market. Each TPMS sensor is powered by a single, replaceable battery that may last up to 18 months, depending on individual use. To preserve battery life, TPMS rests in low-power mode, then "wakes up" when movement is detected.



\$69⁹⁹
Each

010-11997-00

GPS Units

See GPS holders on pages 100-105

Garmin Montana 650t

A big, tough GPS with preloaded topographic maps. Take it hiking, take it hunting or take it on the water. Montana 650t features a bold 4" color touchscreen dual-orientation display and TOPO U.S. 100K maps, supports multiple mapping options such as BirdsEye Satellite Imagery, and it has a 5 megapixel camera to boot.

The Montana has a 3-axis tilt-compensated compass and barometric altimeter. Pair it with an auto mount and City Navigator NT® maps to get spoken turn-by-turn driving directions.

Features:

- Dimensions: WxHxD 2.9" x 5.7" x 1.4"
- Display size: WxH 2" x 3.5"; 4" diag
- Display resolution: 272 x 480 pixels
- Bright, transreflective 65k color TFT, dual-orientation touchscreen; sunlight readable display
- Included rechargeable lithium-ion battery (16 hours life)
- Will also take 3 AA batteries (22 hours life)
- Waterproof to IPX7
- High-speed USB and NMEA 0183 compatible
- Preloaded basemap
- Preloaded with TOPO U.S. 100K maps
- Ability to add additional maps
- Built-in memory: 3.5 GB
- Accepts microSD™ data cards (not included)
- Waypoints/favorites/locations: 4000
- Routes: 200
- Track log: 10,000 points, 200 saved tracks



Garmin Montana 650t
010-00924-02

\$599⁹⁹

What's in the box:

- Montana 650t
- Lithium-ion battery pack
- USB cable
- AC charger
- Quickstart Guide



Top Back

Trail Tech Voyager GPS

Designed specifically to meet the needs of off-road riders, the Voyager GPS allows you to create, log and ride trails, and when you are finished, share them with friends. You can also monitor the engine temperature, ambient temperature, distance, voltage, compass, elevation, and engine RPM. The 2.7" screen uses the most up-to-date technology for amazing viewing, even in direct sunlight.

Need to edit saved trails? Voyager comes with free complimentary software, RideLeader, to help you create, edit and save epic rides.

Trail Tech Voyager GPS

\$289⁹⁵

- GPS speed, distance, compass, altitude, temperature, maps
- View, organize, edit and share entire trail systems in 3D
- 240x400 WQVGA LCD - readable in intense sunlight
- Engine performance linked to GPS data
- Crash resistant, off-road design
- Upload routes from any GPS
- Customizable user screens
- Model-specific kits for most trail, off-road and dualsport bikes
- Accurate tracks, even in the toughest terrain
- Runs on vehicle power or internal rechargeable Lithium Ion battery(11 hour typical life)
- Back-lit for operation in the dark



Temperature sensor



Wheel speed sensor

What's in the box:

- Voyager GPS
- Water temp. sensor
- Magnet sensor
- Wheel sensor
- Universal mounting kit
- Wiring harness
- Ignition sensor
- Micro SD card reader
- 1GB Micro SD card

Bike Specific Voyager GPS Kits	Part Number
KTM SX/SX-F/MXC/EXC/XC/XC-F/XC-W/XCF-W/EXC-R 125-530 ('00-13)	912-102
Husaberg FE/TE 250-570 ('09-'13)	912-102
Husqvarna TE/TX	912-102
Suzuki RMZ 250/450 ('08-'13)	912-301
Suzuki DRZ 400 ('00-'13)	912-301
Kawasaki KLX 400 ('00-'13) Radiator Screw Sensor	912-301
Suzuki DR 650 All Years	912-302
Honda CRF 250X/450X ('04-'13)	912-401
Honda XR 250R/400R/600R/650L All Years	912-402
CanAm Renegade 500/800/1000 R/X/XC ('09-'13)	912-503
Kawasaki KLR 650 ('08-'14)	912-503

SPOT Satellite Units

SPOT Satellite Connect

What to do when your adventure-takes you out of cell reception? The SPOT Satellite Connect can turn your smartphone into a one-way satellite communicator that lets you send messages and GPS coordinates from virtually anywhere on the planet. Simply pair your smartphone to the Satellite Connect to send email, Facebook posts and custom text messages, as well as SOS messages requesting emergency assistance.

Features:

- Send messages from anywhere via satellite
- Compact size: 3" x 2.6" x 1.2", weighs 4.9oz
- 2 AA Energizer Ultimate Lithium batteries only
- Waterproof up to a depth of 1 meter for up to 30 minutes (IPX7)
- On device SOS button for stand alone emergency operation
- Compatible with iPod touch (2nd 3rd & 4th gen), iPhone 5, iPhone 5S, iPhone 4S, iPhone3GS, iPhone3G, and Android 2.0 & later



\$149⁹⁵

SPT.COM.SPH.01



iPhone interface



RAM Cradle for SPOT Connect
RAM-HOL-SPO3U

\$16⁰⁸

SPOT Trace

The SPOT Trace offers advanced theft-alert tracking for anything. Instantly receive a text or email when your most valuable assets move, or follow them on Google Maps anytime on your phone or computer. Custom tracking options allow you to select the rate at which updates are sent – every 2½, 5, 10, 30 or 60 minutes.

Features:

- Track anything: Cars, motorcycles, pets, even luggage
- Receive text/email messages when movement is detected
- Satellite technology tracks beyond the reach of traditional cell coverage
- Compact size: 2.02" x 2.69" x 1", weighs 3.1oz. including battery
- Waterproof up to a depth of 1 meter for up to 30 minutes (IPX7)
- 3 power options: USB 5v hard wire, 4 AAA Lithium batteries or 4 AAA LiMH rechargeable batteries
- Mounting accessories included



\$99⁹⁵

SPT.TRACE.01

SPOT Gen3 Satellite GPS Messenger

provides a vital line of communication with friends and family when you want it, and emergency assistance when you need it. Using satellite technology, SPOT works virtually anywhere in the world, even where cell phones don't - all with the push of a button.

SPOT Gen3's customized tracking take your SPOT experience to the next level. Only with SPOT Gen3, is tracking motion-activated with Unlimited or Extreme tracking upgrades. A vibration sensor tells your SPOT to send track updates when you are moving and to stop when you do. (This is a great new battery-saving feature! And, you don't have to remember to re-set your tracking after 24 hours.)

Features:

- Send S.O.S. with one button push
- Compact size: 3.43" x 2.56" x 1", weighs 4.0oz including battery
- Unlimited tracking
- Check In: Let friends & family know you're ok when out of cell coverage area
- Others can watch your adventure in near real-time and know exactly where in the world you are
- 3 power options: USB 5v hard wire, 4 AAA Lithium batteries or 4 AAA LiMH rechargeable batteries



\$149⁹⁵

SPT.SPOT.30



RAM Cradle for SPOT Connect
RAM-HOL-SPO4U

\$15⁸⁰

The SPOT Global Phone

allows you to communicate with family, friends, work and emergency services from virtually anywhere in the world. SPOT Global Phone is the ultimate easy to use, lightweight handheld satellite phone, boasting superior voice quality and the fastest data speeds in mobile satellite industry today.

Features:

- 24/7/365 9-1-1 Emergency response
- Size: 5.3" x 2.2" x 1.5", weighs 7.1oz including battery
- Airtime plans as low as 25¢ a minute
- 10-digit local phone number
- Free long distance to U.S. and Canada
- Connect phone to computer when you're off the grid
- Battery: Lithium-ion 3.7V, up to 36 hours of stand-by time, 4 hours of talk time
- Lighted keypad
- Rechargeable Lithium-ion battery with up to 36 hours standby time and 4 hours talk time



\$499⁰⁰

SPT.PHONE.B.254

Gadget Mounts allow you to attach your cell phone, iPod, XM Radio, or radar detector to your motorcycle. Choose from SW-MOTECH, Techmount and RAM mounts. Each offers a different way to mount your gadgets.

Bike-specific QUICK-LOCK Vibration-damped GPS Mounts

SW-MOTECH Gadget Mounts

Best for adventure touring and off-road applications by using fewer moving parts to make it uber rugged. SW-MOTECH mounts are designed for specific motorcycles and position the device near the center of the handlebar, without obscuring the speedometer or other important instruments.

- Rubber dampers reduce vibration to the GPS.
- Pivots for optimal viewing angles.
- Quick-release from bike.
- Strongest gadget mount available for off-road use.

For use with all Bags-Connection device pockets (see page 104), all RAM, Garmin Zumo, and TomTom Rider device cradles (see page 103), and all other device cradles with an AMPS hole pattern.

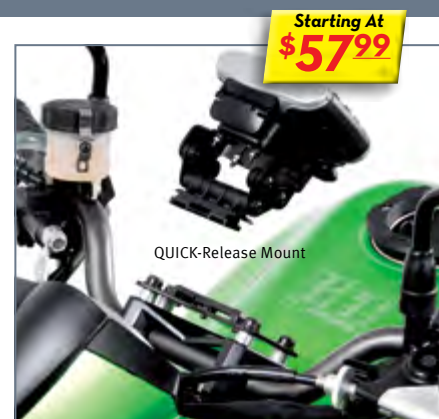

Vibration-damped GPS Mounts	Part Number
BMW F800GS, F800GS Adv, F650GS twin '08-'12 & F700GS '13-'14	GPS.07.646.10300.B
BMW F800R & F800GT '12-'14	GPS.07.646.10101.B
BMW R1200GS '04-'07	GPS.00.646.10500.B
BMW R1200GS '08-'12 (attach to windshield mounting bar)*	GPS.07.447.10100.S
BMW R1200GS '08-'09 & R1200GS Adventure '08-'13	GPS.07.646.10700.B
BMW R1200GS LC '13-'14	GPS.07.646.11000.B
BMW R1200R '11-'14	GPS.07.646.10800.B
BMW K1200GT & K1300GT	GPS.07.646.10200.B
Ducati 848 Streetfighter '12-'14	GPS.22.646.10100.B
Ducati Multistrada 1200 '10-'14	GPS.22.646.10000.B
Honda NC700X & NC700S '12-'14	GPS.00.646.10200.B
Honda CB500F & CB500F '13-'14	GPS.01.646.10301.B
Kawasaki KLR650 '87-'14	GPS.00.646.10500.B
Kawasaki Ninja 1000 '11-'13	GPS.08.646.10300.B
Kawasaki Versys 1000	GPS.08.646.10500.B
Kawasaki Z1000 '07-'09, Z750 '07-'12 & Z750S '11-'12	GPS.08.646.10100.B
Kawasaki Concours GTR1400 '08 and later *	GPS.08.085.100_TWT

* Not vibration-damped

Vibration-damped GPS Mounts	Part Number
KTM LC4 Adventure, 620 Enduro	GPS.00.646.10400.B
KTM 990 Adventure, SM, SMR, SMT, Duke 4 & Duke 4 R	GPS.00.646.10400.B
KTM 1190 Adventure & 1190 Adventure R '13-'14	GPS.04.646.10000.B
Moto Guzzi Stelvio (not quick release)	GPS.17.666.10000.B
Suzuki SFV 650 Gladius '09-'14	GPS.01.646.10301.B
Suzuki GSF650 Bandit, GSF650 Bandit S, GSR600, GSX650F	GPS.00.646.10200.B
Suzuki DL650 V-Strom '12-'14*	GPS.05.646.10200.B
Suzuki DL1000 '04-'13 and DL650 V-Strom '04-'11*	GPS.05.013.10000.B
Suzuki GSX1300R Hayabusa (all), '99-'12	GPS.05.646.10100.B
Yamaha FZ8 '10-'13	GPS.00.646.10000.B
Triumph Tiger 800, 800XC '11-'14 & Tiger 1050 SE '11-'13	GPS.11.646.10201.B
Triumph Speed Triple 1050 '04-'07 & Tiger 1050 '05-'11	GPS.00.646.10000.B
Triumph Speed Triple & Speed Triple R, '08-'10	GPS.11.646.10000.B
Triumph Speed Triple & Speed Triple R, '11-'14	GPS.11.646.10301.B
Triumph Explorer 1200 & Explorer 1200 XC '12-'14	GPS.11.646.10201.B
Yamaha Super Tenere '10-'14	GPS.06.646.10100.B
Yamaha FJR1300, '04-'14	GPS.06.646.10200.B

QUICK-LOCK Vibration-damped GPS Mounts for Handlebar Crossbars

GPS.00.646.10500.B Compatible with most handlebar crossbars, including the SW-MOTECH universal handlebar crossbar (see below) or any other 10mm - 12.5mm diameter crossbar. This includes the original handlebar crossbar on the BMW F650GS and G650GS, as well as the Kawasaki KLR650E (2008 - 2014).

\$77.99

GPS.07.637.10000.B Fits any 16mm - 16.5mm diameter crossbar, including the BMW R1200GS Adventure's original windscreen support bar.

\$57.99



No handlebar crossbar? You can add one!

- 1/2" (12.4mm) diameter x 10-3/4" (273mm) long
- Fits most 7/8" (22mm) & 1-1/8" (28mm) diameter handlebars using the included clamps
- Verified fit on Suzuki DL1000 and DL650 V-Strom, Triumph Tiger 1050, and many other adventure-touring bikes



Suzuki DL650 (Wee-Strom) with Crossbar installed



Black: LST.00.244.100.B

Silver: LST.00.244.100.S



RAM Mounts offer the widest range of affordable and versatile device mounting options for GPS, video cameras, smartphones and MP3 players. Choose from several available bases, four arm lengths, and the cradle that matches your device. No matter what your accessory, there is a RAM Mount solution available! For use with all Bags-Connection device pockets (see page 104) and many types of GPS device cradles (see pages 103-104). You can also mount iPods, toll passes, and other devices using any cradle with a standard AMPS 4-hole pattern.

GPS mounted on RAM Mounting System with Bags-Connection Device Pocket (see page 104).



Record video of your rides safely and securely.



There are three basic components in the RAM Mounting System: Bases, Arms, and Cradles.



What to Order:

STEP 1 Choose Your Base

RAM Mount Bases come in a wide variety of applications, so you will have no problem customizing how you want to display your devices. See next page for more information on RAM Bases.

STEP 2 Choose Your Arm

RAM Mount Arms come in four different lengths: 2", 3", 4.13", and 5.25". See page 103 for information on arms.

STEP 3 Choose Your Cradle

RAM Mount Cradles are available for a wide variety of devices. See pages 103-104 for information on device cradles and pockets.

STEP 1 Choose Your Base

RAM bases connect directly to your handlebars, mirror mounts, fork stem, or other parts of your bike. They provide the “base” for your RAM mounting system.

Choose one of the bases below to start your RAM Mounting System.

Round flat base plate - 2.5" diameter base



RAM-B-202U \$6.48

Handlebar base with U-bolt for 0.5" - 1.25" bar



RAM-B-231ZU \$13.37

Base for 1/4-20 threaded hole



RAM-B-237U \$7.32

Base with 10mm unthreaded hole (fits most handlebar mirror mounts)



RAM-B-252U \$11.42

Base with 8mm unthreaded hole



RAM-B-272U \$11.93

Base for 6mm unthreaded hole



RAM-B-309-3U \$10.86

Clutch/brake control mount with U-bolt for 1-1/8", 1", 7/8", 3/4" and 1/2" bars



RAM-B-309-7U \$15.19

Offset ball on brake/clutch reservoir cover
Fits many BMW, Honda, Kawasaki, Suzuki, & Yamaha models.



RAM-B-346U \$21.16

Centered ball on brake/clutch reservoir cover
Fits K1200GT, K1200LT, K1200RS, R1150GS, & many other BMWs.



RAM-B-345U \$21.20

Fork stem nut base
RAM-B-342U \$14.73
Fits hollow steering stem nuts with 12, 14, 16, 18, 20 or 28mm inside diameter.



Base for 10mm x 1.25 pitch threaded hole
Thread boss fits many handlebar mirror mounts.



RAM-B-349U \$8.16

Twist & Tilt base for 8mm or 10mm threaded hole
Fits standard handlebar mirror mounts.
Pivots & turns in many directions!

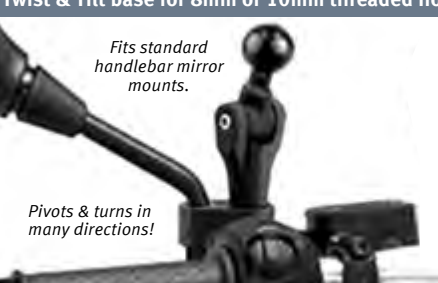

RAM-B-360U \$19.76

Bike specific kit for Can-Am Spyder Roadster



RAM.30.807.10000 \$14.99

Base for 8mm threaded hole



RAM-B-367U \$10.48

Base for 6mm threaded hole



CPA.00.424.112 \$26.00

STEP 2 Choose Your Arm

Now that you have chosen the best base for your bike, it is time to choose which length of arm to use. RAM arms connect the base to the device holder and can be pivoted in many directions.

Optional RAM Products

1" double ball arm connector
RAM-B-230U \$14.49



This optional double 1" rubber ball adapter allows you to attach two RAM extension arms together. The double ball connector is 1.75" when measured from ball center to ball center.



2"
RAM-B-201U-A \$12.35

3"
RAM-B-201U \$12.21

5.25"
RAM-B-201U-C \$18.41

4.13"
The RAM Variable Swivel Arm is used when the arm needs to be positioned at a right-angle to your device.
RAM-B-200-12U \$15.89

Arm tightener with keyed lock
RAM-KNOB3LU \$20.60



This optional locking knob replaces the original thumb screw in RAM extension arms. In the locked position, turning the knob will only tighten the extension arm screw. Provides extra security when leaving electronic devices on your bike!

STEP 3 Choose Your Device Cradle

What do you plan on attaching to your bike? A GPS? Smartphone? Toll pass? Camera? Radar detector? High-output blue spectrum cutting laser? To complete your RAM Mounting System, purchase the cradle adapter below and the appropriate cradle or pocket from page 104.

Step 3a: Buy a cradle adapter OR a camera mount adapter

A RAM Cradle Adapter is required and will attach to all cradles or pouches that use the industry standard AMPS hole pattern. If you want to mount a camera that uses the standard 1/4"-20 camera thread, choose the Camera Mount Adapter instead of the Cradle Adapter.

Cradle Adapter
Required with all RAM device cradles. 2.25"x 1.25" diamond base.
RAM-B-238U: \$6.52



Camera Mount Adapter
Required for holding a camera. 2.5" diameter plate with 1/4"-20 threaded stud.
RAM-B-202AU: \$9.41



GoPro Hero Base
The adapter replaces the factory mounting bracket. 1" diameter ball.
RAP-B-202U-GOP1: \$6.20



Step 3b: Choose a Device Cradle

Choose a GPS cradle from the list below:

Choose a cradle for your device	Part No:
Garmin Astro 220, GPS 60, GPSMAP 60, 60C, 60CSx and 60Cx	RAM-HOL-GA12U
Garmin BMW Navigator II/III, StreetPilot 2610, 2620, 2650, 2660, 2720, 2730 & 2820	RAM-HOL-GA9U
Garmin GPSMAP 176, 176C, 196, 276C, 296, 376C, 378, 396, 478 & 496	RAM-HOL-GA7U
Garmin Montana 600, 650 & 650t	RAM-HOL-GA46U
Garmin nuvi 50 & 50LM	RAM-HOL-GA50U
Garmin nuvi 200, 205, 250, 255, 260, 265T & 270	RAM-HOL-GA24U
Garmin nuvi 200W, nuvi 250W & nuvi 260W	RAM-HOL-GA25U
Garmin nuvi 220, 500, 510, 550 & zumo 220	RAM-HOL-GA32U
Garmin nuvi 300, 310, 350, 360 & 370	RAM-HOL-GA21U
Garmin nuvi 600, 610, 650, 660, 670 & 680	RAM-HOL-GA23U
Garmin nuvi 710, 750, 755T, 760, 765T, 770, 775T, 780 & 785T	RAM-HOL-GA26U
Garmin nuvi 800, 850, 855, 860, 880 & 885T	RAM-HOL-GA30U
Garmin nuvi 1440, 1450 & 1490T	RAM-HOL-GA35U
Garmin nuvi 2450, 2450LM, 2460LT, 2460LMT, 2555LT & 2555LMT	RAM-HOL-GA52U
Garmin Quest & Quest 2	RAM-HOL-GA15U
Garmin StreetPilot i-Series and G Ball	RAM-HOL-GA22U

Starting at: **\$8.34**

Continue to the next page for more cradle options. →



STEP 3 Choose Your Device Cradle (continued)

RAM Spring-loaded Device Cradle

This adjustable/universal cradle is for mounting smartphones. The top clamp is spring-loaded and is expandable to hold larger/taller phones. The side holders are manually adjusted.



Holds devices 4.75" - 6.25" tall x 2.25" - 3.25" wide phone.

- Fits:**
- Apple iPhone 5, 4s, 4, 3Gs, & 3G
 - Blackberry Bold & Storm 2
 - HTC Droid Incredible, Evo 4G & G2
 - Motorola Droid Pro, Droid 2 & Droid X
 - Nokia N8, N900 & X6
 - Samsung Galaxy S & Wave
 - Windows Phone 7
 - Phones with skins, sleeves, bumpers and cases
- Mounts directly to any RAM-B-238 base, or to any Techmount or SW-MOTECH GPS mount.

RAM-HOL-PD3U: \$15.36

RAM Spring-loaded X-Grip™

The spring-loaded RAM X-Grip™ has a clean and clever four leg design that expands and contracts to fit your device. Rubber coated tips hold device firmly. The X-Grip™ attaches to RAM ball mounts and allows for multiple adjustment angles.



The X-Grip™ holder is available in 2 sizes which mounts directly to any RAM-B-238 base, any Techmount or any SW-MOTECH GPS mount.

Phone Holder
 RAM-HOL-UN7BU: \$21.44
 Min. Width = 0.875"
 Max. Width = 3.25"
 (0.875" devices must be a minimum of 4" in height)

Large Phone / Phablet Holder
 RAM-HOL-UN10BU: \$22.93
 Min. Width = 1.75"
 Max. Width = 4.5"

HR Gripper Universal Device Holder

Friction-fit cradle for mounting devices with shapes that won't fit standard RAM Device Cradles. Mounts directly to any RAM-B-238 base, Techmount or SW-MOTECH GPS mount.



Large - Holds devices 2.4" to 3.6" wide and up to 4.1" tall.

TM.ARO40: \$34.95

Small - Holds devices 1.5" to 2.8" wide.

TM.ARO15: \$34.95

Bags-Connection GPS Pockets and Dry Bags

GPS/PDA Pockets are perfect holders and protection for navigation devices and smartphones. Bags feature a sturdy base for secure mounting and eyelets to pass-through electrical or audio cables. These pockets mount directly to a RAM-B-238 base, Techmount or SW-MOTECH GPS mount. iPhone and Android touchscreens can be used through the clear window. While the pouch is water-resistant, if you need a 100% weatherproof solution and don't mind slower entry, use the roll-top GPS Dry Bag.

Small Pocket

Fits Apple iPhones, Samsung Nexus, Motorola Atrix, HTC EVO 4G and similar. Dimensions: 5.3" x 3.5" x 1" deep



BC.GPS.00.004.1000: \$29.99

Large Pocket

The large bag provides extra depth for thicker PDAs. Dimensions: 5.7" x 3.9" x 1.8" deep



BC.GPS.00.002.1000: \$30.00

Medium Pocket

Fits Garmin Nuvi 30, 40, 1350, 3750, 2300LM, Tom Tom XXL 540TM, Go2435, Magellen 1424, and similar. Dimensions: 5.7" x 3.7" x 1.4" deep



BC.GPS.00.003.1000: \$33.00

XL Pocket

The extra-large bag provides even more depth compared to the large bag. Fits some XM radios and GPS units. Dimensions: 5.7" x 3.9" x 3.0" deep



BC.GPS.00.001.1000: \$25.00

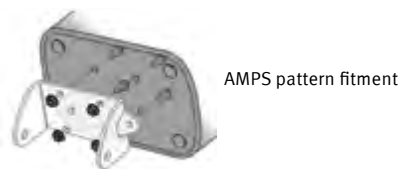

AMPS pattern fitment

GPS Dry Bag

100% weatherproof (not submersible) Dimensions: 5.3" x 3.5" x 1.2" deep

BC.GPS.00.005.1000: \$25.00



GPS Dry Bag mounted on GPS mount (GPS mount sold separately).

EZ-Pass/Toll Pass Holder

Riding "toll pass only" lanes? You will need our specifically designed toll pass holder. Made from lightweight and durable ABS resin, the toll pass holder mounts directly to tubular handlebars ranging from 1" to 1.5" diameter. Fits EZ Pass™, M-Tag™, IPASS™, Smart-Tag™, I-Zoom™ and FastLane™. The holder does not work with the FastTrak in CA or the SunPass in FL.



JSN-011: \$19.99



EZ Pass Holder Adapter for 0.5" or smaller bars. JSN-1/2: \$3.00



Techmount Gadget Mounts

Our cleanest looking gadget mounting solution. Techmount products are made from beautifully CNC-machined aluminum. Available for center, left, or right mounting positions, the new Gen 4 Techmounts feature a 17mm ball allowing unlimited positioning of your gadgets.

Cradles and pouches attach by either directly bolting, adding a quick-release adapter, or using a 4-hole AMPS pattern-compatible mount.

- For use with:**
- All Bags-Connection device pockets (page 104)
 - All RAM, Garmin zumo, and TomTom Rider device cradles (page 103)
 - All other device cradles with an AMPS hole pattern

Universal Stem Mount

Kit includes six O-ring posts: 13mm, 16mm, 17mm, 18mm, 19mm, 24mm



TM.4-10105.B: \$29.95

Fits a wide range of Honda, Kawasaki, Suzuki and Yamaha bikes with hollow steering stem nuts.

Universal Handlebar Mount

Fits 7/8" (22mm) to 1 1/4" (32mm) handlebars



TM.4-30912: \$29.95

The Universal Handlebar Mount includes hardware that fits all standard handlebar diameters, including 7/8", 1", 1-1/8", and 1-1/4".

Control Mount for BMWs



TM.4-21007: \$44.95

Mounts on handlebar control pinch bolts (clutch or brake side).

Control Mount

Replaces hand control pinch bolts.



TM.4-31001: \$39.95

The Control Mount fits a wide range of Harley-Davidson and metric bikes (clutch or brake side). Replaces the two factory pinch bolts with new stainless bolts and spacers on the handlebar controls.

10mm Mirror Mount

Threads into any 10mm x 1.25 standard or reverse threaded mirror hole.



TM.4-31000: \$39.95

10mm Mirror Mounts are designed to thread into the unused mirror mounting holes found on many metric motorcycles. Threads into a 10mm x 1.25 standard (brake side) or reverse (clutch side) mirror holes.

BMW Mirror Mount

Fits into unused mirror holes, left or right side.



TM.4-21004: \$39.95

The BMW mirror mount takes advantage of the unused BMW handlebar mirror mount holes. This item can be used on both left and right hand sides.

Gadget Mounting Plate



AMPS Mounting Plate for Techmount Gen 4 ball mounts Mount any device that uses a 4-hole AMPS pattern to this plate or drill your own holes. Plate measures 2.25" x 1.875".

TM.4-AMPS: \$4.95

Techmount Quick-Change Adapter

The Techmount Quick-Change Adapter allows you to quickly swap the accessory cradle or pouch attached to your Techmount. It slides easily onto the Techmount top plate and locks into place with a spring-loaded locating pin. Accommodates any cradle or pouch with a 4-hole AMPS pattern (see page 104).

TM.60003: \$19.95 (for Gen-3 & Gen-4 round top plates)

Visit TwistedThrottle.com for more mounting options from Techmount!



Spring-loaded pin

Spring-loaded pin slips into hole

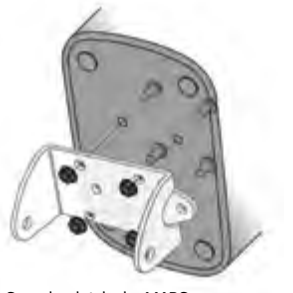

Standard 4-hole AMPS pattern

Weatherproof AMPS-compatible phone cases

\$67⁹⁹

Keep your iPhone or Galaxy 2 protected, dry, and charged.

This waterproof case protects your iPhone from the elements, while maintaining touchscreen usability through the clear touch-sensitive screen membrane. "Wake/sleep" and "home" buttons can be used with the phone inside the case. Membrane-protected openings for the rear and front camera lenses let you take video or pictures while you ride. Weather-protected stereo jack and dock connector let you listen on the go and in the wet. The rotating base allows you to pivot the case 360°. The quick-release adapter has an AMPS hole pattern for easy attachment to all RAM, SW-MOTECH, or Techmount gadget mounts.



iPhone 3G, 3Gs, 4, & 4s:
GPS.00.646.20000.B

iPhone 5 & 5s:
GPS.00.646.20200.B



Samsung Galaxy S2:
GPS.00.646.20100.B

All-in-one waterproof phone and GPS cases & tubular handlebar mount kits

interphone

Waterproof iPhone 5/5S and iPhone 4/4S case

- Case quickly releases from included mounting bracket
- Adjustable 360° viewing angle
- Quick-engage safety lock
- Anti-shock lining
- Removable internal silicone adapter
- Water resistant
- Full access to all phone buttons
- Phone can be recharged while in use
- For handlebars with diameter of 12 to 30mm



SMIPHONE5 \$69.99
SMIPHONE4: \$59.99

interphone

Waterproof Samsung Galaxy S III Case

- Case quickly releases from included mounting bracket
- Adjustable 360° viewing angle
- Quick-engage safety lock
- Anti-shock lining
- Removable internal silicone adapter
- Water resistant
- Full access to all phone buttons
- Phone can be recharged while in use
- For handlebars with diameter of 12 to 30mm



SMGALAXYS3: \$69.99

interphone

Waterproof Samsung Galaxy S4 Case

- Case quickly releases from included mounting bracket
- Adjustable 360° viewing angle
- Quick-engage safety lock
- Anti-shock lining
- Removable internal silicone adapter
- Water resistant
- Full access to all phone buttons
- Phone can be recharged while in use
- For handlebars with diameter of 12 to 30mm



SMGGALAXYS4R: \$59.99

interphone

Universal Smartphone Holder

- Handlebar mounting bracket with adjustable viewing angle
- Compatible with all touch screens
- Internal dimensions can be adjusted with the 3 shims included in the package
- Safety band
- Waterproof zippers
- Allows cable access
- For handlebars with diameter of 13 to 30mm
- Fits iPhone 3G, 3Gs, 4 & 5 and other devices



Internal dimensions:
135mm x 60mm x 27mm

SMSMARTPHONE: \$49.99

All-in-one water resistant GPS Holders

interphone

Universal GPS Holders

- Universal holder with quick-release system
- Adjustable 360° viewing angle
- Quick-engage safety lock
- Anti-shock lining
- Water resistant
- Full access to navigation functions
- Battery charger cable slot
- Available for tubular or non-tubular handlebars



Interphone device mounts and pouches are all-inclusive. Everything you need is in the box.

For tubular handlebars (from 12 to 30 mm diameter):
SMGPS35: \$59.99
SMGPS43: \$59.99
SMGPS54: \$59.99

Also available cases for iPad and iPad Mini
SMIPADMINI: \$77.99
SMIPAD: \$84.99

Starting At
\$59⁹⁹

LifeProof products are sleek, elegant and beautiful. By delivering capabilities and freedom you never thought possible, we take the worry out of living your lifestyle. We promise premium performance, superior quality, exceptional value and excellence in every dimension of your LifeProof experience.



iPhone Cases

The LifeProof Case for iPhone defends your device against water, dirt, snow and shock—and delivers so much more. The thinnest, lightest, all-protective case ever built contains LifeProof's Sound Enhancement System, CrystalClear optics and the optimal use of every iPhone feature. Plus, the sleek style showcases Apple's breathtaking design.

- CrystalClear AR-coated optical-glass lens
- Nonstick cover never collects dirt or lint
- Waterproof seals on all ports and openings
- Polycarbonate frame absorbs impacts
- Waterproof ports on all microphones and speakers
- Scratch-resistant and waterproof screen protector
- Shock-absorbing elastomeric inner-layer
- Works great with the RAM X-Grip



Apple iPhone 5 (Front, back and side view)



Apple iPhone 4/4s:
TM.LP4CASE

Apple iPhone 5:
TM.LP5CASE

Apple iPhone 5s:
TM.LP.5S

Apple iPhone 5c:
TM.LP.5C

iPad Mini Case

LifeProof Case for iPad Mini

LifeProof defends your mini from dunks, drops and day-to-day dangers in a case that's barely there. In fact, LifeProof for iPad mini is so slim and sleek, you won't even notice it's there — until you're glad it is!



Works great with the RAM X-grip!
RAM-B-149Z-UN8

\$99⁹⁹

Apple iPad Mini:
TM.LP.IPDM.F.BB

Techmount iPhone Mounts

Handlebar mount for LifeProof iPhone 4/4s & 5

Allows iPhone4/4s and iPhone 5 LifeProof case to be mounted onto any GEN 4 TechMount system (see page 105). LifeProof case sold separately.



\$24⁹⁵

For iPhone 4/4s:
TM.4-MOTO4
For iPhone 5/5s:
TM.4-MOTO5

Galaxy Smartphone Cases

LifeProof Waterproof Samsung Galaxy S3 Case

Equipped with LifeProof's proven technology, our Samsung Galaxy S3 case features a built-in touchscreen scratch protector and our legendary protection—freeing you to take your Galaxy S3 anywhere and everywhere without worry.



\$79⁹⁵

Samsung Galaxy 3:
TM.LP.GS3.F.B

LifeProof Waterproof Samsung Galaxy S4 Case

Designed for maximum protection and ultimate functionality, the Samsung Galaxy S4 case is the best of both galaxies. It's fortified with LifeProof's proven and off-copied touchscreen scratch protector, and gives complete access to Galaxy's every feature and function.



\$79⁹⁵

Samsung Galaxy 4:
TM.LP.GS4.F.B

Both work great with the RAM X-grip!
RAM-HOL-UN7BU

Our weatherproof auxiliary power sockets come with a fused battery hookup harness. Sockets can either be flush-mounted or handlebar-mounted using the brackets shown below.

12-Volt Mini-Euro Socket (matches the size of BMW and Triumph 12-Volt power ports)



EMA.00.107.10100: \$34.99



Handlebar mounted 12-Volt Mini-Euro Socket.

Handlebar Mount for Mini 12-Volt Socket



For 22mm (7/8") handlebar clamps only
CPA.00.006.150: \$20.25

12-Volt Cigarette Socket



EMA.00.107.10200 \$34.99



Handlebar mounted 12-Volt cigarette socket.

Handlebar Mount for 12-Volt Cigarette Socket



22mm (7/8") diameter handlebar clamps CPA.00.006.160 \$20.25
28mm (1 1/8") diameter handlebar clamps CPA.07.006.18000.B \$21.00

Additional 12-Volt Socket Accessories

Convertible Mini-Euro/Cigarette Replacement Plug



Fits into Mini-Euro Sockets and Cigarette Sockets.
EMA.00.107.11800: \$11.50

Mini-Euro-to-Cigarette Socket Converter



Cigarette Socket
Mini-Euro Plug
Cable length 8" EMA.00.107.11600: \$24.25
Cable length 40" EMA.00.107.11700: \$28.50

USB Charger for Cigarette Socket

This adapter fits inside a cigarette lighter socket and will accommodate a USB charging cable.

Single USB 1 amp :
EMA.00.107.11200: \$14.99

Single USB 2.1 amp :
POW.AAC-006: \$19.95
Dual USB 1 amp :
MICROCBRUSBUDUAL: \$19.99



Charge Your Electronics In Your Tankbag

Pass power into tankbag from handlebar socket using wall pass-through



Choose adapters appropriate for the electronics inside your tankbag



STEP 1 Pass power from handlebar socket to the tankbag

From Cigarette Lighter Socket to SAE Connector



12 V. 55 cm cable (21.7")
EMA.00.107.10500: \$14.99

From Mini-Euro Socket to SAE Connector



12 V. 100 cm cable (39.4")
EMA.00.107.10400: \$14.99

Direct Battery to SAE Connector



24" cable
POW.PKT.001.24: \$16.95
48" cable
POW.PKT.001.48: \$19.95

STEP 2 Pass power through the tankbag wall

SAE Tankbag Wall Pass-through Kit



The Wall Pass-through Kit provides a cap and is water-resistant. Provides SAE to SAE 12-volt wires for your Bags-Connection tankbag system.

EMA.00.107.10600: \$29.99

Power terminates inside tankbag as SAE connector



SAE connector on the exterior has a weatherproof cap



STEP 3 Distribute power inside the tankbag

Connect SAE adapter to 12-Volt sockets



SAE to Single Cigarette Socket



12 V. 20cm cable (7.8")
EMA.00.107.10800: \$14.99

SAE to Dual Cigarette Socket



12V. 25cm cable (9.8")
EMA.00.107.11000: \$29.99

SAE to Cigarette & Mini-Euro Sockets



12 V. 55cm cable (21.7")
EMA.00.107.10900: \$29.99

USB Charger for 12-volt Cigarette Socket

This adapter fits inside a Cigarette Socket and will accommodate a USB charging cable.



Single USB 1 amp :
EMA.00.107.11200: \$14.99

Single USB 2.1 amp :
POW.AAC-006: \$19.95

Dual USB 1 amp :
MICROCBRUSBUDUAL: \$19.99

Convert cigarette socket into a USB charger



Tapp™ Direct to Battery USB Chargers

These compact USB Chargers are the weatherproof answer to powering Apple iPads, iPhones, most cell phones, GPS units or MP3 players. They mount easily to your handlebars or to any flat or curved surface, using the included self-adhesive mount. A tethered sealing cap protects the charger from dust and water. The included fused battery hookup harness is diode protected against reverse polarity. Just hook the Tapp directly to your battery or the Denali PowerHub2 (see page 118), secure the USB connector to an appropriate surface, plug in your device and go!



1 amp output:
3BR.150.0034.02: \$29.66

2.1 amp iPad ready:
3BR.150.0056.01: \$40.46



Tapp™ USB Chargers with Mini-Euro Plug

This USB Charger is used on BMWs with a Mini-Euro Socket. This unit charges USB accessories: including cell phones, most GPS units, MP3 players, and some digital cameras. A tethered seal cap protects the charger from dust and water. The Mini-Euro plug makes installation simple. Just attach the Tapp using the Universal Mounting Bracket and plug the Mini-Euro Plug into your bike's power socket.

- DIN 4165 Mini-Euro plug
- Cable length: 6 inches
- Removable seal cap
- Protection Rating: IP64 waterproof when capped
- Available output of 2.1 amp (suitable for iPads)



3BR.150.0058.06: \$46.76

Garmin Mini-USB Charging Cables

This cable allows you to charge your Garmin GPS unit through its mini USB port without forcing the device into the unusable "computer data sync" mode. Right angle adapter is 5" long; 3' coil cable can expand to 6' and ends in a convertible Mini-Euro/Cigarette Socket plug.



BC.POW.00.003.100: \$43.00

Micro-USB Charging Cable

For charging the most popular navigation systems, PDA's, digital cameras and other electronic devices. With a highly effective flyback converter and an integrated protection against short-circuit, polarity reversal and overload. Ends in a convertible Mini-Euro/Cigarette Socket plug.



EMA.00.107.11400: \$43.00

Tankbag Wall Pass-through kit



The water-resistant pass-through kit enables you to run audio cables or a hydration system through your tankbag wall.

EMA.00.107.10700: \$14.99

Hydration tube pass-through



Audio cable pass-through

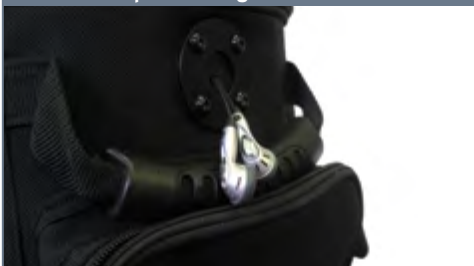

SoundBomb Compact Dual-Tone Air Horn by Denali

DENALI



LOUD! Stylish! Rugged!

Starting At
\$44.99

TT-SB.10000.B

Producing an earsplitting 120 decibels of sound, the SoundBomb is eight times louder than a standard motorcycle horn!

The Denali SoundBomb was designed for those who want to be heard, but still want to maintain a stylish look. Thanks to its compact design and blacked-out housing, the SoundBomb will practically disappear once installed.

The unique design of our compact horn features a rugged molded clamp that mechanically mates the compressor to the acoustic unit. This makes the SoundBomb virtually indestructible even in high vibration applications.

Specifications:

- Sound Output: 120 dB at 3 feet
- Current Draw: 20 Amp
- Dimensions: 5.4" (137mm) wide x 4.5" (116mm) high x 3.6" (86 mm) deep
- Stylish All Black Design

Included:

- Single Piece Electro-pneumatic Horn
- 12 volt, 30 amp relay

Mounting bracket and wiring harness sold separately, see below.

Plug-N-Play Wiring Harness for SoundBomb Air Horn

Our pre-assembled wiring harness makes horn installation fast and easy! No stripping, splicing, cutting, crimping, or trips to the hardware store required! Just clip one lead to your original horn trigger wire, one lead to battery ground, one fused lead to battery positive, one high current lead to the horn, and plug the harness into the SoundBomb's included relay. Also works on Stebel horns. Includes one 30-amp ATC fuse and assembly instructions. Made in U.S.A.



TT-00002.10000: \$34.99

Also available is a similar plug-n-play wiring harness that is *not* made in U.S.A. TT-00012.10000: \$24.99

Do-It-Yourself Wiring Kit for SoundBomb Air Horn

The DIY kit gives you all the supplies and parts you need if you want to spend a significant part of your day wiring your horn yourself. If you want to take the easy way out, buy the plug-n-play kit to the left.

Uses a 40 amp ATC in-line fuse. Designed for use with SoundBomb horns, but can also be used with other replacement horns requiring a dedicated relay.



TT-00013.10000: \$12.50

Universal Horn Mounting Brackets

Our heavy duty accessory mounts come in many shapes and sizes! These mounting brackets can also be used to mount other small items (such as auxiliary headlights) on your bike. All mounts have a 3/8" (10mm) diameter mounting holes.



\$9.50

- L-bracket 0.6" x 2.55" center-to-bend: TWT-00-013-001
- Straight 3" (2" center-to-center): TWT-00-013-003
- Straight 4" (3" center-to-center): TWT-00-013-004
- Straight 6" (5" center-to-center): TWT-00-013-006



\$54.95

Tubular Mount 0.85", 7/8", 1", 1.07", 1-1/8" & 1.25" diameter bars: TM.51125

Bike-specific Horn Mounting Brackets

Bike	Part Number	Shape/Size	Price
Kawasaki KLR650E, '08-'14	TWT.HMT.08.004.100	L-bracket	\$12.50
Suzuki V-Strom DL650, '04-'13	HMT.05.10100	17m - 19m	\$12.99
Triumph Explorer 1200, '12-'14	HMT.11.10200	Bolt & spacer	\$5.00

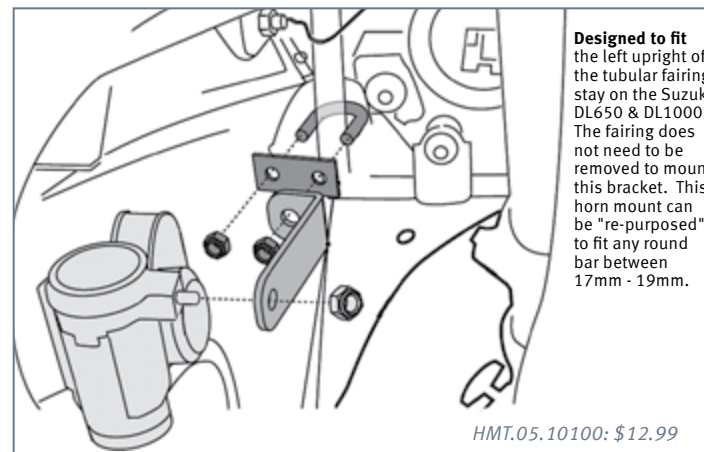

Designed to fit the left upright of the tubular fairing stay on the Suzuki DL650 & DL1000. The fairing does not need to be removed to mount this bracket. This horn mount can be "re-purposed" to fit any round bar between 17mm - 19mm.

HMT.05.10100: \$12.99

DENALI

LED Light Kits

All Denali LED lights are housed in a rugged waterproof aluminum housing (submersible up to 3 meters under-water). Our LED's boast an average life span of 50,000 hours; that's 6 years without ever being shut off. Yes, we went overboard. It's what we do.

Making our light kits easy to mount and install to your motorcycle is a top priority for us. Every light kit includes a universal M8 mounting bracket and detailed wiring diagrams that are simple and easy to understand. Bike specific light mounts are also available for many popular bike models at TwistedThrottle.com.



Daytime Visibility Specialist

DM Denali DM Mini LED Light Kit

The ultra compact size of the DM light is ideal for street bikes where you want to maintain a clean inconspicuous look without sacrificing brightness. The DM is also ideal for daytime visibility as the smaller optic intensifies the brightness of the light when looking at the light from the front. Consuming only 5 watts of power per lamp, the Denali DM lights throw a blazing beam of light 240 feet down the road in front of you. That's 85 feet further than your typical motorcycle high beam.

Denali DM Features:

- Pod Size: 1.7" round x 2.4" long
- Beam Distance: 240'
- Power Draw: 5 watts per lamp
- Intensity: Single
- Beam Angle: 10° or 40° lenses
- Waterproof: IP-68
- Mount: Universal M8
- Includes 2 LED pods, fused harness, and switch

Complete Kits From **\$229⁹⁹**

TT-DM per pair

.75

AMP
POWER DRAW

240

FEET
BEAM DISTANCE

DAY TIME VISIBILITY

SINGLE INTENSITY

DENALI DM BEAM DISTANCE COMPARISON

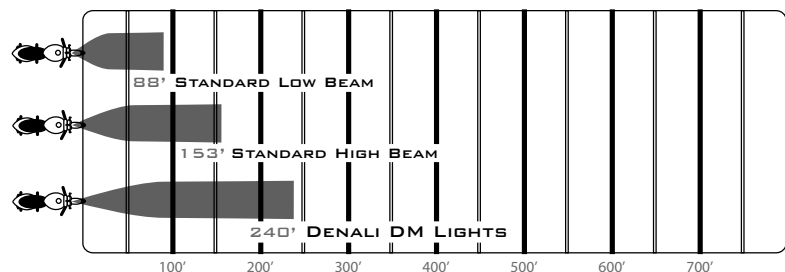

*Chart indicates Beam Distance only. Does not illustrate Beam Angle.

DENALI

Dual Intensity Technology

Our Denali lights are so bright, we developed a dual intensity LED harness to create the ideal lighting solution for on and off road riders who want an uncompromised beam of light illuminating the road in front of them. The dual intensity technology allows you to switch the brightness to half intensity when passing oncoming traffic with your bikes existing high/low beam switch. The lights can also be wired to run at full intensity all the time independent of your high/low beam switch.



Best Seller



Best All Around Light

D2 Denali D2 Dual Intensity LED Light Kit

The unique optic in the D2 light was designed to create a massive beam of light that is the perfect balance between distance and width. You won't believe how much light is thrown out in front of you, and off to the sides. Consuming only 10 watts of power per lamp, the Denali D2 lights throw a blazing beam of light 423 feet down the road in front of you. That's 3 times further than your typical motorcycle high beam.

Denali D2 Features:

- Pod Size: 2" round x 2.4" long
- Beam Distance: 423'
- Power Draw: 10 watts per lamp
- Intensity: Dual
- Beam Angle: 10° or 40° lenses
- Waterproof: IP-68
- Mount: Universal M8
- Includes 2 LED pods, fused harness, and switch

Complete Kits From **\$359⁹⁹**

TT-D2 per pair

1.5

AMP
POWER DRAW

423

FEET
BEAM DISTANCE

DAY TIME VISIBILITY

DUAL INTENSITY

DENALI D2 BEAM DISTANCE COMPARISON

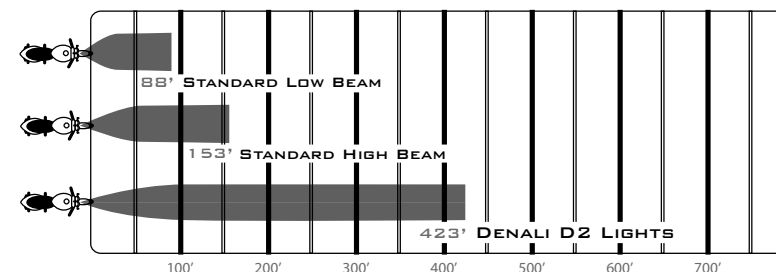

*Chart indicates Beam Distance only. Does not illustrate Beam Angle.

NEW



Distance Specialist

DR1 Denali DR1 Single Intensity LED Light Kit

The large 10° optic in the DR1 maximizes the distance you can see down the road by concentrating a spot beam pattern at the center of the road. The DR1 is ideal for night riding in on/off road conditions where maximum beam distance is desired. Consuming only 10 watts of power per lamp, the Denali DR1 lights throw a blazing beam of light 695 feet down the road. That's over 4 times further than your typical motorcycle high beam.

Denali DR1 Features:

- Pod Size: 3" round x 3.75" long
- Beam Distance: 695'
- Power Draw: 10 watts per lamp
- Intensity: Single
- Beam Angle: 10° lenses
- Waterproof: IP-68
- Mount: Universal M8
- Includes 2 LED pods, fused harness, and switch

Complete Kits From **\$339⁹⁹**

TT-DR1 per pair

1.5

AMP
POWER DRAW

695

FEET
BEAM DISTANCE

DAY TIME VISIBILITY

SINGLE INTENSITY

DENALI DR1 BEAM DISTANCE COMPARISON

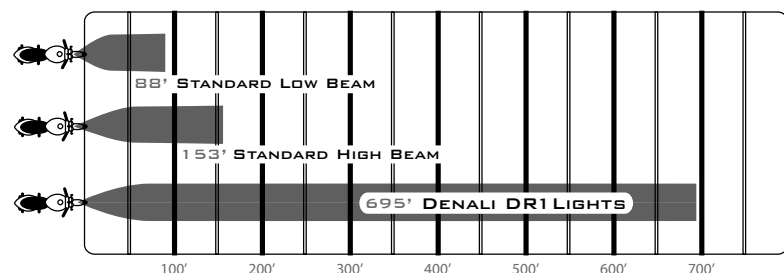

*Chart indicates Beam Distance only. Does not illustrate Beam Angle.

NEW



Flood & Spot Hybrid

D4 Denali D4 Hybrid LED Light Kit

Simply put; the D4 is a beast. It is our most powerful and most versatile light packing the punch of four DM lights in one rugged housing. The four LED pod is equipped with two 40° elliptical flood lenses and two 10° spot beam lenses to create the ultimate hybrid beam pattern; a super wide close-range flood and a piercing spot beam in one rugged housing. Consuming 20 watts of power per lamp, the Denali D4 lights throw a blazing beam of light 550 feet down the road in front of you. That's over 3 times further (and way wider) than your typical motorcycle high beam.

Denali D4 Features:

- Pod Size: 3.9" square x 2.5" long
- Beam Distance: 550'
- Power Draw: 20 watts per lamp
- Intensity: Single
- Beam Angle: 10° and 40° lenses
- Waterproof: IP-68
- Mount: Universal M8
- Includes 2 LED pods, fused harness, and switch

Complete Kits From **\$309⁹⁹**

TT-D4 per pair

3

AMP
POWER DRAW

550

FEET
BEAM DISTANCE

DAY TIME VISIBILITY

SINGLE INTENSITY

DENALI D4 BEAM DISTANCE COMPARISON

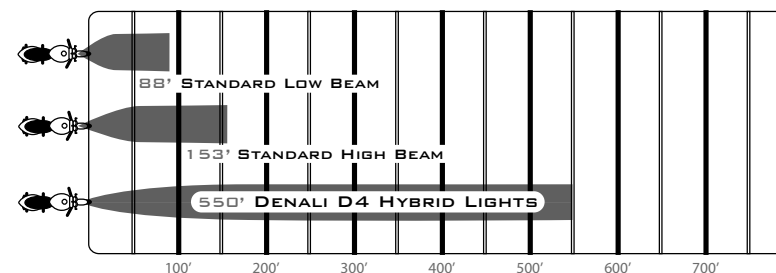

*Chart indicates Beam Distance only. Does not illustrate Beam Angle.

DENALI

Auxiliary Light Mounts and Accessories



Universal Articulating Mounts

Our most versatile mounting solution, this kit includes a clever combination of steel bushings, heavy duty steel brackets, spacers and hardware to allow you to affix any Denali lights to any convenient M5, M6, or M8 bolt point on your motorcycle with full 3-axis adjustability.



LAH.00.10000 \$49.99/pair



Handlebar & Crashbar Mounts

These stylish clamps are machined from 6061-T6 Aluminum for strength and durability. The kit allows fitment of any Denali LED Lighting Kit to any tubular bar ranging from 22mm to 28mm in diameter. The bracket can be mounted in numerous positions allowing the light pods to be placed for optimal beam projection, while keeping the pods themselves protected.



LAH.00.10300 \$62.99/pair



Starting At \$399 each

Hinge Mounts

Use one of these M6, M8, or M10 2-axis hinge mounts for Denali D1 and Denali D2 lights so they can be easily mounted directly to an M6, M8, or M10 mounting hole. The M8 hinge mount is included with the Denali D1 and D2 LED light kit.



6mm bolt: TT-D1.P-SHM6
8mm bolt: TT-D1.P-SHM8
10mm bolt: TT-D1.P-SHM10

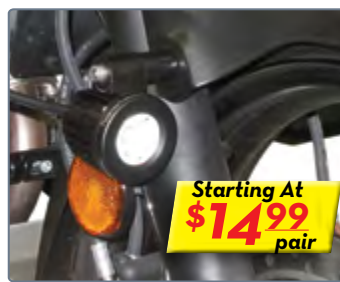

Starting At \$1499 pair

Fender Mounts

Compatible with Denali DM, D1, and D2 lights. Single axis adjustment. Mounts to any threaded M5 or M6. Includes spacers to accommodate tight spaces.

M5 & M6 fender bolts for DM: LAH.00.10100
M5 & M6 fender bolts for D2: LAH.00.10200



Made in USA

Single/Double Switch Mounts

The perfect solution for quick on/off switch access. Available in single & double platforms with vertical or horizontal screw mounting.

Single Horizontal: MBK.00.10100 \$9.99
Single Vertical: MBK.00.10300 \$10.99
Double Horizontal: MBK.00.10200 \$9.99
Double Vertical: MBK.00.10400 \$10.99

Replacement Bulb	Wattage	Part No.
1100X lamp, single	55w	70215
1156, pair	27w	72620
1157, pair	27w / 8w	72720
9005 (HB3), single	60w	71556
9006 (HB4), single	51w	19016
9007 (HB5), single	65w / 55w	19017
H1, single	55w	70165
H11, single	55w	70555

Replacement Bulb	Wattage	Part No.
H3, single	85w	70368
H3, single	35w	70323
H3, single	55w	70325
H4, single	60w / 55w	70456
H6M, single	35w / 35w	70023
H7, single	55w	70755
H9, single	65w	70955

PIAA
High-Performance Replacement Bulbs

Looking for higher performance out of your head-lights, but not ready to go for an auxiliary light kit? Try these PIAA Xtreme replacement bulbs, which offer a whiter beam and higher light output than your original headlight bulbs without drawing more power.

Starting At \$1850

Call or visit TwistedThrottle.com for bike-specific bulb fit information!



Hawk LED & Halogen Auxiliary Lights

LED lights provide more safety on the road by offering daytime visibility to help other drivers see you and for you to see better at night.



Hawk LED 4" Fog Lights

New for 2014 are the larger Hawk LED fog lights. The Hawk LED Fog Lights are the new generation of LED lighting from SW-MOTECH. Housed in a watertight aluminum housing, these lights run off standard 12 volts and only draw 10 watts each. Kit includes 2 lights, Waterproof switch and wiring harness with fuse.

NEW

Hawk Fog Light Features:

- LED version: voltage 12V, 10W
- ECE test mark
- Solid aluminum housing
- Included: 2 HAWK LED Fog Lights, 1 water-resistant cockpit switch, cable harness with fuse

\$399⁹⁹
NSW.00.004.10500.B



Hawk Halogen Lights



Hawk LED Lights

Choose from Halogen spot or LED spot or Halogen fog

Hawk 2" Off-Road Lights

Available in LED Spot, 55W Halogen Spot, or 55W Halogen Fog.

Hawk LED spot lights, available in a black or silver aluminum housing, throw a 12 degree spot beam using 10-watt LED, 550 lumen lamp. The Hawk 55W halogen spot lights throw a similar beam pattern but use H3 55-watt, 500 lumen lamp. The Hawk 55W fog lights also use H3 55-watt lamp but throw a wide beam pattern with broad dispersion. All lights share the same aluminum waterproof housing and come in pairs with a wiring harness and waterproof switch.

See page 116-117 for mounts (sold separately).



Hawk Light Guard, black or silver
NSW.00.004.10300: \$49.99

Hawk LED Spot Light

Best for long distance illumination with low power draw.

- LED light with white lamp (12V / 10W)
- Silver or black powder coated aluminum body

Includes:

- 2 spot lights
- Harness with fuse
- Waterproof toggle switch
- Mounting instructions

\$399⁹⁹

NSW.00.004.10400

Hawk Halogen Spot Light

Great for for long distance illumination.

- Ellipsoid light with H3, 55W lamp
- Silver or black powder coated aluminum body

Includes:

- 2 spot lights
- Harness with fuse
- Waterproof toggle switch
- Mounting instructions

\$229⁹⁹

NSW.00.004.10200

Hawk Halogen Fog Light

Broad light dispersion for fog.

- Ellipsoid light with H3, 55W lamp
- Silver or black powder coated aluminum body

Includes:

- 2 fog lights
- Harness with fuse
- Waterproof toggle switch
- Mounting instructions

\$229⁹⁹

NSW.00.004.10100

DENALI POWERHUB2

POWER DISTRIBUTION MODULE



\$11999

ELC.00.30000

The PowerHub2 Power Distribution Module allows you to safely connect up to 6 electronic devices to your motorcycle in a clean, workmanlike manner. It is CANbus compatible and includes six 15-amp rated fused outputs, six ground posts, and a plug-and-play wiring harness for direct battery hookup. Each of the six outputs can be individually set as "always on" or "switched" on/off with the ignition of the motorcycle. Instead of attaching multiple ring terminals to your battery, use a PowerHub2!

Features:

- Dimensions: L 3" x W 4" x H 1"
- 6 circuits can handle up to 15amps (180W) each
- CANbus-compatible
- 60" long, 10 gauge wiring harness with Posi-lock connectors
- Uses Mini ATM fuses (sold separately)
- Replaceable 30 amp micro relay
- Made in U.S.A.

Mini ATC fuse kit (sold separately)

Package contains:

- four 2amp fuses
- four 3amp fuses
- two 5amp fuses
- two 7.5amp fuses
- two 10amp fuses
- one 15 amp fuse

TT-00015: \$7.95



The entire unit is rated for 30 Amps (360 watts). Each of the six circuits can handle up to 15A (180W) each - without exceeding a total sum of 30 Amps simultaneously.

PDM60 Power Distribution Module

The PDM60 Power Distribution Module has 6 power circuits, making it easy to handle all your electronic accessories. The bright LED indicators keep you informed of the status of each circuit. Built with components selected for superior power management capability, and extended service life, it's designed with one goal in mind: to provide years and years of superior, hassle free performance. The PDM60 unit is fully encapsulated to protect against rain, dust, humidity, etc. Whether it's off-road, or cross-country via interstate, these units are built to last under the harshest of conditions.

\$19999

PDM60

- 6 individually programmable circuits
- CANbus compatible
- Eliminates fuses and relays when adding electronic accessories
- Dimensions: 2" x 3" x 0.9" (51mm x 76mm x 24mm)
- Each circuit is fully programmable for 8 modes
- LED display indicates circuit status (green is good, yellow is unused, red is faulted)
- Free PC programming software download



LED Battery Voltage Monitor

The smallest and simplest monitoring device available! This flush mount kit includes a 1/4" diameter LED that displays voltage levels using colors in a stoplight-style arrangement:

- RED** - Danger, Will Robinson! Less than 11.5 volts
- AMBER** - 11.9 to 11.5 volts
- GREEN** - 12 volts and up

Fuse protection, wiring, connector assortment and complete instructions are included. Simple 2 wire installation. Drilling a single 1/4" diameter hole to accommodate the LED is required to install on any flat surface near your instrument panel.

\$2995

EC.04101



194 Marker Bulb CANbus Adapter for some BMW, Ducati & Triumph motorcycles

Many late model European motorcycles use "CANbus" electrical systems that can malfunction if add-on electrical accessories are spliced directly into the wiring harness. Our CANbus adapter provides a "hot" trigger wire that activates a relay to safely power electrical accessories (driving lights, accessory fuse blocks, GPS, heated grips, etc.) when such motorcycles are turned on. The adapter simply plugs into the bike's existing "City Light" 194 headlight marker bulb socket.

\$1995

EC.02350



AdMore LED light bars get attention!

Running light, modulated brake light, and turn signals all in one compact unit. When you brake, a built-in modulator causes the light bar to flash 3 times before turning solid at 100% intensity, helping to alert drivers behind that you are slowing down or stopping. When a turn signal is on, 1/3 of the light bar flashes amber sequentially in the direction of the turn while the remainder of the light bar stays red. Both light bars mount easily using the included hardware to any flat surface, license plate bracket, or the underside of most rear luggage racks, with or without a topcase mounted.

Housed in a black polycarbonate case with clear or smoke lens.

AdMore Large LED Light Bar

This large 10.75" light bar enhances visibility and safety! Fits well on large touring motorcycles as well as 4-wheeled vehicles. When a turn signal is on, two of the four clusters will flash amber.

Constructed of 72 high-intensity **bi-color LEDs**. Approximately 10.75" across, 1.625" tall, and 1" thick.

Clear lens
AML.LED7226.SMT.TS

\$13900

Smoke lens
AML.LED7226.SMT.TS.SMK

\$14400



AdMore simplifies installation by providing Posi-Tap™ electrical connectors, which allows you to wire the light bar to your original wiring harness without tools; no stripping, crimping, or soldering required!

AdMore light bars are CANbus compatible.

AdMore Mini LED Light Bar

The Mini 8" light bar gets attention! Similar to the large light bar, but 8-inches wide. Fits well on the license plate brackets of most bikes.

Constructed of 78 high-intensity **bi-color LEDs**. Approximately 8" across, 1.25" tall, and 1" thick.

Clear lens AML.LED5420SMT.TS

\$12900

Smoke lens AML.LED5420SMT.TS.1

\$13400



Replacement Turn Signals

R&G Micro Turn Signals are designed to fit R&G Fender Eliminators or replace the OEM turn signals and include both clear and amber lenses: available in either 10-watt incandescent or LED versions. Resistors may be necessary for proper flash speed when using the LED version.

10-watt Micro Turn Signals
RG.RG370: \$48.99

LED Micro Turn Signals
RG.RG371: \$48.99



R&G Plug 'n Play Resistors for LED turn signals

After replacing your bike's original incandescent turn signals you may find that the signals flash too fast or too slow. Adding a resistor resolves this issue. No cutting, crimping or soldering required.

Original Turn Signal	Resistor	Part No.
LED	----	----
10 watt incandescent	21.5 ohm	RG.RGR0002
21 watt incandescent	9.8 ohm	RG.RGR0001

21.5 ohm resistors
RGR0002: \$6.00 /pair

9.8 ohm resistors
RGR0001: \$6.00 /pair





While Coocase and Givi offer basic add-on brake lights for a few topcase models, AdMore Lighting's LED conversion kits kick it up a notch. AdMore Lighting provides super-bright brake lights, running lights, and turn signals for many popular models of Givi and other hard-shelled cases.

Why use one of AdMore Lighting's LED kits? Simply put, they're brighter, consume less power, and are more durable and longer lasting than incandescent bulbs.

Each easy-to-install LED light kit includes LED light strips, wiring connectors, mini controller, and easy-to-follow instructions.



Running Light, Brake Light, and Turn Signal Kits

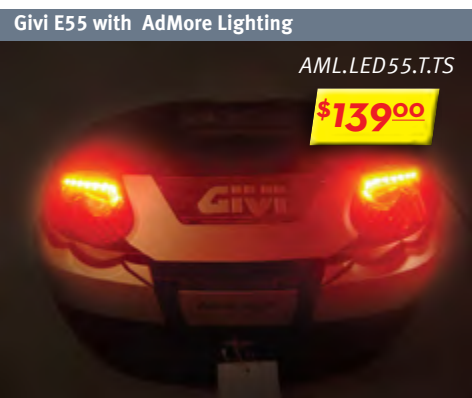

Installation of brake, running, and turn signal kits requires drilling a hole in your Givi case to accommodate AdMore Lighting's proprietary wiring connector (drill bit included).

Mini Kits with running and brake lights only

Do you already have an original Coocase or Givi brake light kit and want to upgrade to a brighter LED brake light/running light? AdMore Lighting Mini Kits retain your case's quick-release hands-free connector and install without drilling any holes in your case! Mini Kits require an existing Coocase or Givi brake light and do not provide turn signal functionality.

Case	Orientation	Function	Part Number	Price
Coocase S48 & S50*	Topcase	running/brake only	AML.LED48.CC.TM	\$69.00
Givi E450	Topcase	running/brake only	AML.LED450.TM	\$69.00
Givi E460	Topcase	running/brake only	AML.LED460.TM	\$79.00
Givi E470	Topcase	running/brake only	AML.LED470.TM	\$69.99
Givi V46	Topcase	running/brake only	AML.LEDV46.TM	\$69.00
Givi E52	Topcase	running/brake only	AML.LED52.TM	\$79.00

*Compatible with S48 and S50 Volt cases only



Self Adhesive Flush-Mount LED Running, Brake, and Turn Signal Kits

Our flush-mount LED kits transform your two-wheeled stealth fighter into a blazing ball of light that no mortal eyes can miss. While designed primarily for installation on the flat rear surfaces of aluminum sidecases or topcases, these LEDs can be installed on any flat surface. The kit's dual-intensity (high and low) LED strips are clear when turned off, but bright red when energized.

The kit is easy to install. Each kit contains two self-adhesive high-intensity weatherproof LED strips and a mini-controller harness for splicing into your running, turn signal, and brake light wires. The mini controller fits neatly under your seat or behind the taillight assembly. The kit includes a quick-release mechanism so the wiring won't interfere with the removal of your cases. The LEDs glow at low intensity when riding, brighten when you apply your brakes, and flash at high intensity with your turn signal lights.

Bicolor (amber turn signals)
Sidecase set: AML.LED1614.S.TS \$159.00
Topcase set: AML.LED1614.T.TS \$149.00

Single color (bright red turn signals)
Sidecase set: AML.LED.4014.S.TS \$129.99
Topcase set: AML.LED.4014.T.TS \$119.99



What's in the box? Yeah. This is in the box.

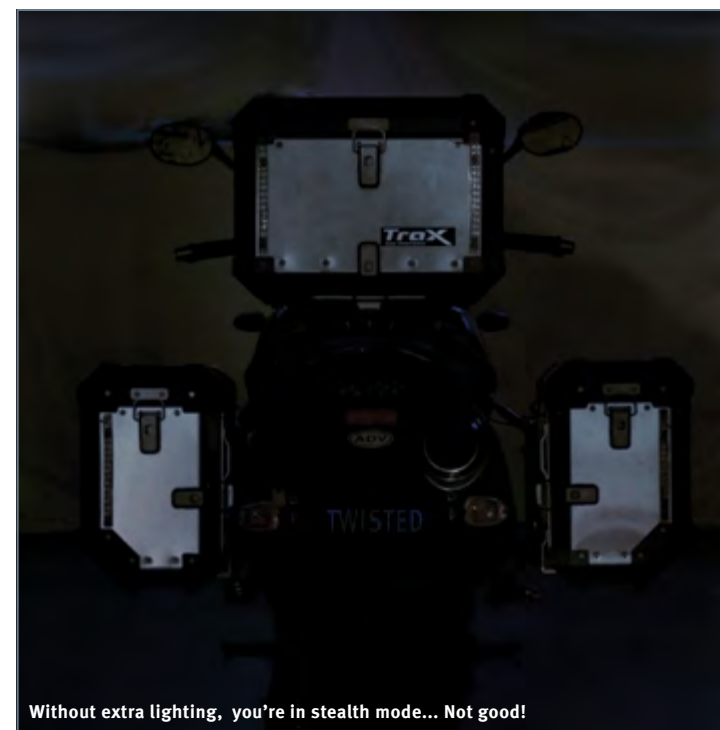

AdMore LED Flush-Mount Turn Signals maximize your visibility to approaching vehicles by adding these high powered amber LED light strips to your bike's luggage, mirrors, handguards or any other flat surface.

Great for any front or side facing application (amber is not legal in most states as a rear running light). Micro-controllers are included to provide integrated running and turn signal functionality. Fully weatherproof and only 3/8" wide.

4.5" long- AML.LED.2711.Y: \$79.00





Steel Topracks are a rugged, inexpensive way to mount your hard or soft luggage, or even a RotopaX fuel tank. Steel Topracks are bike-specific and are shaped to follow the lines of your bike.

Steel Topracks are a permanently-mounted flat luggage rack with pre-drilled holes for mounting a variety of hard luggage cases. There are also plenty of tie-down slots for strapping soft luggage to your bike. A Steel Expansion Rack is available that creates a large, sturdy surface for larger luggage items.

One of the great things about the Steel Rack is its versatility. Steel Racks accept TraX, Pelican, DrySpec, or Givi topcases, as well as RotopaX auxiliary fuel tanks with additional adapter hardware. You can even mount certain tankbags that have the QUICK-LOCK tanking system. Adapter hardware is sold separately.

Steel Topracks are bike-specific. See pages 192-269 to find a Steel Toprack that fits your motorcycle.

Starting At
\$66⁹⁹

Topcase adapter sold separately

GPT.11.747.20001.B
Triumph Tiger 800XC



Yamaha XT1200Z Super Tenere
GPT.06.148.20001.B



Kawasaki KLR650E
GPT.08.365.20001.B



Ducati Multistrada 1200
GPT.22.139.20001.B

Seat Rack

New for 2014 from SW-MOTECH is the Seat Rack. Made of 4mm aluminum and powder coated black, the Seat Rack replaces the passenger seat and uses the same locking mechanism. Installation is as easy as removing the passenger seat and clicking the seat rack in. That's it!

The seat rack features strap holes for securing rear bags, dry bags or whatever you might carry. It's also pre-drilled for an SW-MOTECH Bags Connection QUICK-LOCK tanking allowing you to use any flat-bottomed Bags-Connection QUICK-LOCK Tankbag as rear luggage (holes are sealed with rubber plugs). The underside of the seat rack has a foam rubber seal to keep dirt and water out.

No modification to the bike is necessary.

Starting At
\$189⁹⁹

Seat Racks are bike-specific. See pages 192-269 to see if one is available for your motorcycle or visit TwistedThrottle.com.

Soft foam rubber seals out dirt and water



Seat Rack on BMW R1200GS



Seat Rack on KTM 1190



Pre-drilled for QUICK-LOCK tankings. See page 145.



Additional adapter hardware allows you to mount your TraX, Pelican, DrySpec, or Givi topcases, as well as RotopaX auxiliary fuel tanks to a Steel Toprack.

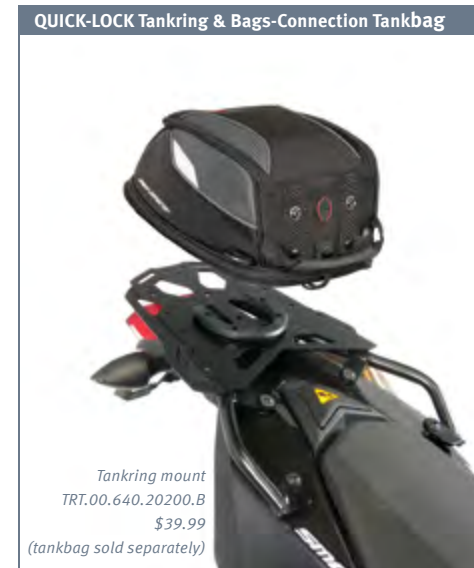

QUICK-LOCK Tanking & Bags-Connection Tankbag

Tanking mount
TRT.00.640.20200.B
\$39.99
(tankbag sold separately)



RotopaX Fuel Tank

RotopaX mount: RX.PM \$29.95
Locking mount: RX.LOX.PM \$44.95
Extension for a second RotopaX: RX.EXT \$23.95 (See page 175)



Coocase Topcase with Adapter Plate

Adapter Plate included with all Coocase topcases.



DrySpec H36 Topcase with Mil-Spec Adapter Kit

GPA.00.800.50500.B
\$29.75



TraX Topcase with TraX Adapter Kit

GPT.00.152.20100.B
\$20.25

Additional adapter hardware allows you to mount your Givi/Kappa or Shad topcases to a Steel Toprack.

Topcase Adapters	Notes	Item Number	Price
Givi/Kappa Monokey Topcase Adapter		Givi E251	\$74.00
Givi/Kappa Monolock Topcase Adapter	This adapter is included with purchase of all Givi Monolock topcases		
Shad Topcase Adapter	For small-sized SH40 & SH45 Shad topcases	GPT.00.152.48000	\$38.00
Shad Topcase Adapter	For large-sized SH48, SH49 & SH50 Shad topcases	GPT.00.152.49000	\$55.99

Steel Expansion Rack

Increase the size of your Steel Toprack. Want to carry a large duffel or dry bag? No problem, just loosen the four securing bolts and slide the wings outward. Tighten the bolts and you've got a wide and sturdy surface for the most challenging cargo.

- Can be adjusted and locked to create any width between 12" and 16.5" wide
- Use it to attach soft luggage to a SW-MOTECH Steel Toprack
- Expand for a high-capacity Steel Toprack platform
- Retract for a clean look
- Secure 4 bolt installation

Starting At
\$49⁹⁹

GPA.00.804.10000.B





ALU-RACK Topracks are a sturdy and elegant solution to mounting your topcase. ALU-RACKS are made from high-strength, lightweight aluminum for durability. ALU-RACKS are bike-specific and are shaped to follow the lines of your motorcycle.

ALU-RACKS accept TraX, Pelican, DrySpec, or Givi topcases using additional adapter plate. Topcase adapter plates are sold separately.

Starting At \$104⁹⁹

Topcase adapter sold separately

ALU-RACK Topracks are bike-specific. See pages 192-269 to find an ALU-RACK Toprack that fits your motorcycle.



Kawasaki ZX14R
GPT.08.161.15000.B



Triumph Speed Triple 1050

GPT.11.502.100.B



Kawasaki Ninja 1000 '11-'14

GPT.08.185.10000.B



Kawasaki Versys '10-'14

GPT.08.714.15000.B

ALU-RACK QUICK-LOCK Adapter Plates

ALU-RACK QUICK-LOCK Adapter Plates are used to mount TraX, Pelican, DrySpec, or Givi topcases. When not using your topcase, the adapter plate can be removed in seconds for a clean, minimalist look.

- Quarter-turn fasteners allow the adapter plate to be connected to or removed from the ALU-RACK in seconds.
- Three point mounting system keeps the plate stable and secure.
- Topcase adapter plates are specific to the brand of topcase you're attaching to the ALU-RACK.
- Soft Luggage Carrier Adapter available (see next page and 168).



Kawasaki Ninja 250R

How to attach an adapter plate to an ALU-RACK



Place the adapter plate onto the ALU-RACK. Using a flathead screwdriver, turn the three QUICK-LOCK fasteners 90°. Voila! The adapter plate is attached to the bike and ready to carry a topcase!



Additional adapter hardware allows you to mount your TraX, Pelican, DrySpec or Givi topcases, a QUICK-LOCK tankbag, or most soft luggage to an ALU-RACK.

Soft Luggage Adapter on ALU-RACK



GPT.00.152.430
\$ 66.99

DrySpec H36 Topcase on ALU-RACK



GPA.00.800.50200.B
\$64.00

ALU-RACK with QUICK-LOCK TraX ALU-BOX Adapter Plate



GPT.00.152.400
\$40.00

QUICK-LOCK Tankring & Bags-Connection Tankbag



TRT.00.640.20400.B
\$66.99

Coccase Topcase on ALU-RACK



Electric and non-electric Coccase adapter plates available (see below).

Additional adapter hardware allows you to mount your Coccase, Givi/Kappa or Shad topcases to an ALU-RACK Toprack.

QUICK-LOCK Topcase Adapters for ALU-RACKS	Notes	Part Number	Price	
Coccase Topcase Adapter Plates	Required to mount Coccases onto ALU-RACKS.	S28 or V37 non-electric case	GPT.00.152.46000.B	\$39.99
		S50 non-electric case	GPT.00.152.46100.B	\$44.99
		S28 or V37 electric case	GPT.00.152.46200.B	\$44.99
		S50 electric case	GPT.00.152.46300.B	\$46.99
Givi / Kappa Monokey Topcase Adapter Plate		GPT.00.152.405	\$40.00	
Givi / Kappa Monolock Topcase Adapter Plate		GPT.00.152.406	\$40.00	
Shad Topcase Adapter Plate	Fits SH40, SH45, SH48, SH49 & SH50 Shad topcases.	GPT.00.152.10000	\$52.00	
Adapter Plate Accessories	Notes	Part Number	Price	
Replacement QUICK-LOCK Fastener	Includes QUICK-LOCK and retention washer.	CAM.00.GPT	\$8.25	
Quick-Disconnect Wiring Kit	For use with GPT.00.152.405 & GPT.00.152.406 adapter plates and Givi luggage with integrated brake lights.	TT-00001.10000	\$28.99	
Rackpack	Soft luggage bag specifically for use with Soft Luggage Carrier.	BC.HTA.00.305.1000	\$209.99	

SW-MOTECH
BAGS-CONNECTION

QUICK-LOCK: the fastest way to remove luggage racks from your bike.

Use a coin to turn a standard QUICK-LOCK fastener



Standard QUICK-LOCKS

- Attach and detach an QUICK-LOCK Sidecarrier from your bike in seconds with a 1/4 turn of each fastener.
- QUICK-LOCK fasteners can be turned using a coin (as shown in the photo to the left) or a flathead screwdriver.
- Standard QUICK-LOCKS are included with purchase of all EVO Sidecarriers.



SW-MOTECH is the originator of the QUICK-LOCK system

Keyed lockable QUICK-LOCKS add security without sacrificing convenience

EVO Sidecarrier with Keyed Locking QUICK-LOCK



- Replacing one standard QUICK-LOCK in each EVO Sidecarrier with a keyed locking QUICK-LOCK prevents unwanted removal of your sidecarriers.

QLS.00.046.10100.B: \$53.99/pair

Lock your EVO Sidecarrier to the motorcycle



Bottle Mount & Fuel Bottle



Add a Bottle Mount to the interior of your EVO Sidecarrier using our Sidecarrier Accessory Mounting Kit .

Basic Bottle Mount

This bottle mount bolts permanently to the outside of any flat-sided surface, including sidecases, and can be used to carry our MSR 30oz. Fuel Bottle and Twisted Throttle 30oz. Water Bottle. It can hold any bottle with a height of 8" to 12" and a diameter of 2.5" to 4". Velcro straps and a top-end bungee cord are provided for added security.

Bottle mount includes hardware for attachment to a flat sidecase. Installation on an EVO Sidecarrier requires the Sidecarrier Accessory Mounting Kit (sold separately).

BMT.00.805.10000.B: \$19.99
See page 176 for fuel and water bottles.



Storage Tube with Flush Mount Kit

This storage tube attaches directly to the outside of any flat-sided sidecase and can be used to carry our MSR 30oz Fuel Bottle, Twisted Throttle Water Bottle, or any other gear that can fit inside of it. Internal dimensions are 3.25" diameter and 11.5" tall.

DJA.67670.100: \$15.99



Sidecarrier Accessory Mounting Kit

This kit allows you to add our Basic Bottle Mount or Storage Tube to the inner side of your EVO Sidecarrier. Basic Bottle Mount and Storage Tube are sold separately.

MBK.00.806.10000.B: \$24.99

SW-MOTECH
BAGS-CONNECTION

QUICK-LOCK Contour Carrier

- For use *only* with Givi V35 PLX or Kappa K33N K-ROAD sidecases.
- Contoured shape to fit the profile of your motorcycle for increased volume in a streamlined profile.
- Attaches and detaches from the bike in seconds.
- Provides the narrowest aftermarket hard luggage solution available.
- Constructed of tubular steel.
- No sidecase adapter necessary.
- Optional keyed lockable QUICK-LOCK fasteners prevent unauthorized removal of Contour Carriers. QLS.00.046.10100.B
- Optional hard-bolt kit increases security and durability on rougher road surfaces. KFA.00.840.10000.S: \$49.99

Starting At
\$299.99
per pair



Suzuki GSF1250 Bandit

See page 137 for information on Givi V35 cases.

Contour Carriers are bike-specific - see pages 192-269 to find a Contour Carrier that fits your motorcycle.

QUICK-LOCK Contour Carrier



Shown with Givi V35 Sidecase Attached



Mounting Points for QUICK-LOCK Sidecarriers



Narrow Bike Profile

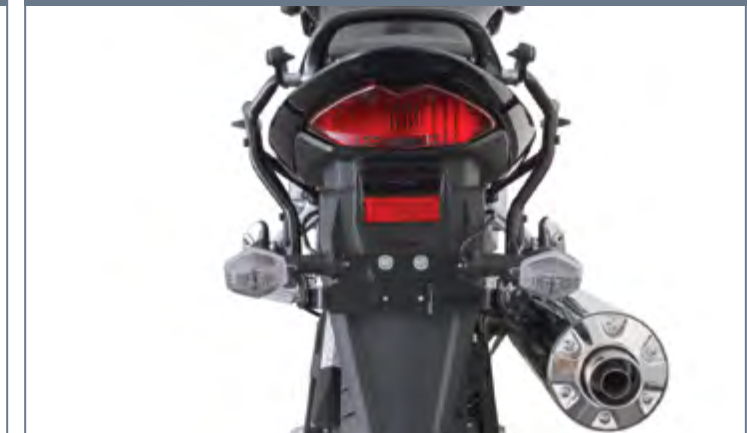



QUICK-LOCK EVO Sidecarriers are used to attach Aero, TraX, Pelican, Hepco & Becker, Shad, Krauser, DrySpec or Givi sidecases to your motorcycle. When not using your sidecases, the sidecarriers can be removed in seconds to retain the bike's original appearance.

Features:

- Removable, narrow luggage carrier for many types of side luggage.
- Sidecarrier attaches and detaches from the bike in seconds.
- Robust, tubular mild steel construction.
- Sidecarriers can be used to prevent soft saddlebags from getting burned on your exhaust or caught on your rear wheel.
- Optional keyed locking QUICK-LOCK fasteners are available to prevent removal of sidecarriers.
- Hard-bolt kits available for permanent, rigid and strong mounting to withstand rough off-road riding.

Simply put, SW-MOTECH Sidecarriers provide the best warranty, heaviest duty construction, and most precise fit you can buy. While other racks are great for light street use, SW-MOTECH provides the best rack for years of on and off-road abuse.

EVO Sidecarriers are bike-specific.
See pages 192-269 to find a sidecarrier that fits your motorcycle.



Adapters Starting At \$25.99



Sidecase Adapter Kits are necessary for attaching your luggage to the QUICK-LOCK Sidecarriers. Each adapter is specific to the brand of luggage you're attaching to your EVO Sidecarriers. Adapter kits are available for TraX, Aero, Pelican, Givi, Kappa, Hepco & Becker, Krauser, DrySpec and Shad sidecases. Adapters are sold separately from sidecarriers and sidecases. **Note:** There are different adapters for the older "Original" style carriers and the newer "EVO" style carriers.

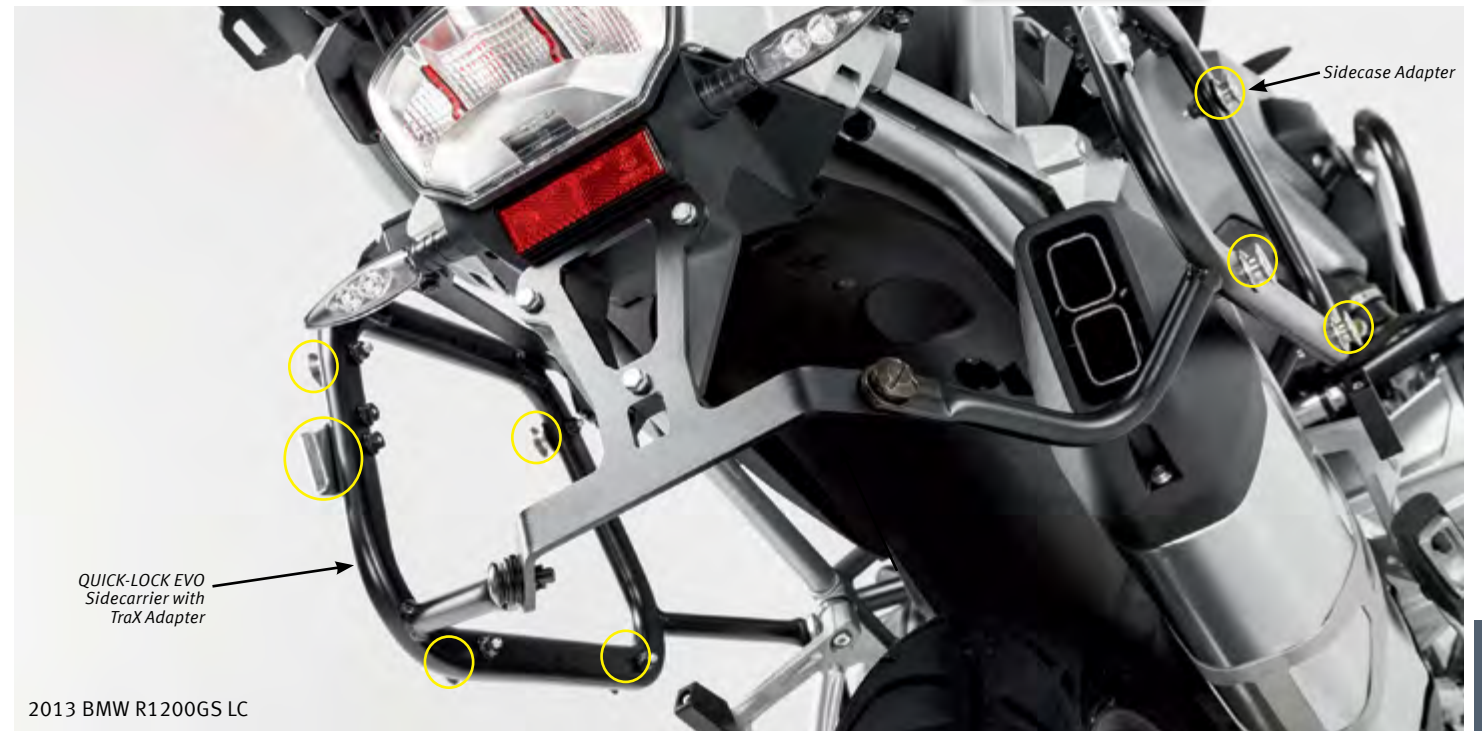

Thumb-sized mounting points remain on the bike when carrier is removed



EVO Sidecarriers are narrower than most other brands of sidecarriers

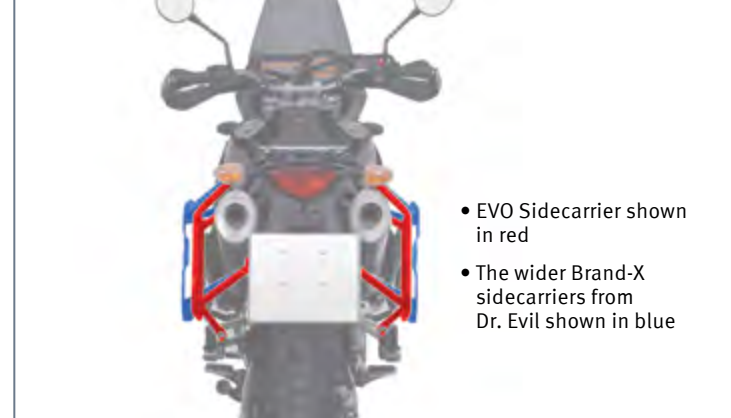

- EVO Sidecarrier shown in red
- The wider Brand-X sidecarriers from Dr. Evil shown in blue

Givi / Kappa Sidecase Adapter	TraX ALU-BOX Sidecase Adapter	DrySpec H36 & Other Mil-Spec Sidecase Adapter
 KFT.00.152.205 \$ 26.00	 KFT.00.152.200: \$26.00	 KFA.00.800.50100.B: \$ 41.99

EVO Sidecarriers are bike specific - see pages 192-269 to find a Sidecarrier that fits your motorcycle. Sidecase Adapter is sold separately from EVO Sidecarrier.

Sidecase Adapters for Sidecarriers	Notes	Adapter for "Original" style sidecarriers	Price	Adapter for "EVO" style sidecarriers	Price
TraX ALU-BOX Adapter	Sold in pairs	KFT.00.152.100	\$25.99	KFT.00.152.200	\$26.00
DrySpec H36 and other Mil-Spec Adapter	Sold in pairs. For use with DrySpec H36 cases. Also fits other flat-backed Mil-Spec cases. (see page 161)	KFA.00.800.50100.B	\$41.99	KFA.00.800.50100.B	\$41.99
Givi / Kappa Monokey Adapter	Pairs. Older cases may additionally require KFT.00.152.150	KFT.00.152.105	\$20.25	KFT.00.152.205	\$26.00
Hepco & Becker Plastic Case Adapter	Sold in pairs. For Journey, Junior, and Gobi cases	KFT.00.152.110	\$26.00	KFT.00.152.210	\$53.99
Hepco & Becker Alu Case Adapter	Sold in pairs. For Alu-Standard and Alu-Exclusive cases	KFT.00.152.111	\$60.99	N/A	
Shad Adapter	Sold in pairs	KFT.00.152.115	\$53.99	KFT.00.152.215	\$53.99
Krauser Adapter	Sold in pairs. For K3, K4, K5, Alu, and Bison cases	KFT.00.152.120	\$53.99	KFT.00.152.220	\$53.99
Aero Sidecase Adapter	Sold in pairs	N/A		KFT.00.152.22500.B	\$26.75
Accessories for Adapter Plates	Notes	Part No.		Part No.	
Replacement QUICK-LOCK Fastener	Includes QUICK-LOCK and retention washer	CAM.00.KFT	\$8.25	CAM.00.KFT	\$8.25
Keyed QUICK-LOCK Locking Fastener	Sold in pairs	QLS.00.046.10100.B	\$53.99	QLS.00.046.10100.B	\$53.99
Hard-bolt Adapter Kit	Increased security and added durability in harder terrain	KFA.00.840.10000	\$49.99	KFA.00.840.10000	\$49.99
Cam Lock Protective Caps	Cover your Cam Locks when the sidecarriers are taken off	KFT.00.152.30000.B	\$16.50	KFT.00.152.30000.B	\$16.50



Starting At
\$349⁹⁹
Each

Carriers and adapters sold separately



TraX EVO ALU-BOX: the ultimate in durable, dependable luggage.

- Compatible with QUICK-LOCK EVO Sidecarrier, QUICK-LOCK Sidecarrier, ALU-RACK, Steel Toprack, and most tubular topracks.
- Secure, stable construction.
- 1.5mm thick aluminum plate.
- Durable stainless steel mounting hardware.
- Sidecases include 4 tie-down points.
- Black cases have a powdercoated interior to protect your belongings from getting smudged with aluminum oxide.
- Sheet metal construction with no-pierce, super-strong, rivet technology (the same technology that holds Audi TT frames together) for superior strength and water resistance.
- Hinges function as lid-stays.
- Strong polyamide composite corners.
- Includes dry bag liner bags.

Cable lid stays also available. Each set includes 2 lid stays suitable for one TraX case ALK.00.165.30300.B: \$32.99



Sidecases

45-Liter Sidecases

Black powder coat or silver aluminum
Dimensions: 19.3" x 11" x 14.6"
Weight: 10.3 lbs.

Left: ALK.EVO.45LD
Right: ALK.EVO.45RD



\$396.98 each



\$421.98 each

37-Liter Sidecases

Black powder coat or silver aluminum
Dimensions: 19.3" x 9.1" x 14.6"
Weight: 9.5 lbs.

Left: ALK.EVO.37LD
Right: ALK.EVO.37RD



\$381.98 each



\$409.49 each

Topcases

38-Liter Topcases

Black powder coat or silver aluminum
Dimensions: 16.1" x 13.4" x 13"
Weight: 11.2 lbs.

ALK.EVO.38TD



\$396.98



\$421.98

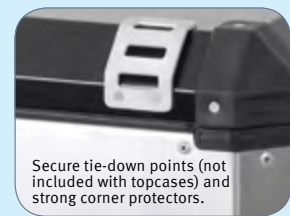

Secure tie-down points (not included with topcases) and strong corner protectors.



Durable hinges



Sturdy Mounting plate



Dry bag liner bag included with purchase of each TraX case. Made from welded PVC with an integrated carry handle.

Extra Bags: \$31.99

Drybag Liner for Sidecases: BCK.ALK.00.165.10000.B
38-Liter Drybag Liner for Topcases: BCK.ALK.00.165.15000.B

TraX Locksets

TraX boxes do not come with lock cylinders. Instead, matched lock cylinder and key sets are sold separately for 1 topcase, 2 sidecases or 3 cases (1 topcase and 2 sidecases).

1 case set: ALK.00.165.16502 \$10.75
2 case sets: ALK.00.165.16402 \$20.25
3 case sets: ALK.00.165.16302 \$25.99



Sidecase Carrying Handles

Attach to lid tie-down points and are available for all TraX cases.

BCK.ALK.00.165.116: \$28.79 (each)



TraX Backrest

Keep your rider partner comfortable with the TraX passenger backrest. Made of EPS foam, this backrest attaches to the 38L TraX ALU-BOX.

All mounting hardware and a fitting template is included to mount the backrest to TraX topcases.

ALK.00.165.30000.B: \$59.99



TraX Strap-on Expansion Bag

Expands from 8 to 14 liters and attaches to the lid of 37-liter & 45-liter TraX sidecases, as well as BMW OEM sidecases. Includes waterproof interior liner bag.

17" long x 8.5" wide x 5"-7" tall
BCK.ALK.00.165.117: \$93.99 (each)



Compressed to 8 liters.



Expanded to 14 liters.

Topcase Tie-down Points

Make your TraX topcase more versatile with these 4 tie-down points. Drilling holes in your TraX topcase is required to install these tie-down points. Includes mounting hardware.

Note: These are for topcases. 4 tie-down points are included pre-installed in each TraX sidecase and do not need to be purchased separately.

ALK.00.165.105-4: \$32.00 Set of 4



TraX Stowable Camp Table & Legs

Our aluminum camp table stows easily inside your TraX sidecases and provides a stable 16.5" x 27" platform when used with 2 TraX boxes. Folds in half to fit easily inside the lid of a TraX EVO sidecase using the included stow bar.

ALK.00.165.30500: \$99.99

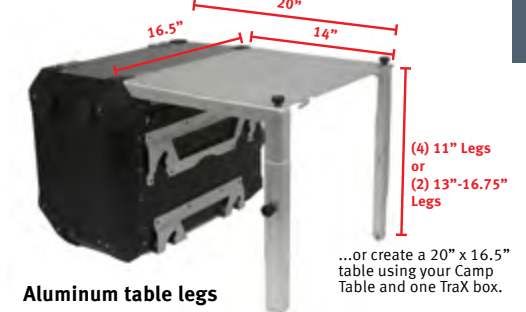

Aluminum table legs attach to the camp table with included thumbscrews. Use the four fixed-length legs to create a stand-alone table or convert the four fixed-length legs into two adjustable-length legs when used with a single TraX box. 13" long x 1.5" wide x 1.5" deep.

ALK.00.165.30600: \$69.99

Retroreflective Kit for TraX Cases

ReflectGard reflective kits add a custom-cut piece of automotive-grade 3M Scotchlite™ reflective sheeting to your TraX ALU-BOX luggage, making you more visible when targeted by another vehicle's headlights!

For Sidecases: JMH.RG-TRXSC-01

For Topcases: JMH.RG-TRXTC-02



Starting At \$29⁹⁹

AdMore LED Kit for TraX Cases

Our flush-mount LED kits mount on aluminum sidecases or topcases. The kit's dual-intensity LED strips are clear when turned off, glow at low intensity when riding, brighten when you apply your brakes, and flash at high intensity with your turn signal lights. See page 121.

For Sidecases: AML.LED.4014.S.TS

For Topcases: AML.LED.4014.T.TS



Starting At \$119⁰⁰



Fit TraX to any brand of sidecarrier.

You can attach TraX 37-liter and TraX 45-liter ALU-BOX sidecases to almost any sidecarrier system with the appropriate adapter kit, including sidecarriers from:

- SW-MOTECH
- Givi
- Hepco-Becker
- BMW "Adventure" case racks
- Custom fabricated sidecarriers

Sidecarriers sold separately. See pages 192-269 for sidecarriers that fit your bike.

One-time installation of the adapter kit allows fast, lockable attachment of TraX sidecases as often as you like.

TraX adapter for SW-MOTECH EVO sidecarriers



TraX adapter hardware for EVO Sidecarriers.
KFT.00.152.200

\$26⁰⁰
per pair

See page 192-269 for sidecarriers that fit your bike.

TraX adapter for original SW-MOTECH sidecarriers



TraX adapter hardware for Original QUICK-LOCK Sidecarriers.

KFT.00.152.100

\$25⁹⁹
per pair

TraX adapter for Givi sidecarriers



KFT.00.152.10700.B: \$93.99 /pair
Powder coated black

TraX adapter for BMW R1200GS Adventure ('06-'13)



Sheet metal loop included.

KFT.00.152.10800.S: \$130.00 /pair
Powder coated silver

TraX adapter for Hepco-Becker sidecarriers



KFT.00.152.10600.B: \$93.99/pair

For "DIY" projects: SW-MOTECH Sidecarrier EVO Loop

This mild steel EVO side carrier loop does not have pre-welded arms for attachment to a motorcycle. Grab a MIG welder and go make your own attachment points!

The EVO loop is intended for custom fabrication projects and cannot be returned once modified.

TraX adapter for SW-MOTECH EVO sidecarriers sold separately.



PR.KFT.00.152.020.L - left side
PR.KFT.00.152.020.R - right side
\$86.99/each



Fit a TraX Topcase to any brand of topcarrier.

TraX adapter for Givi Topracks

You can mount a TraX topcase on most Givi SR-series top racks and all FZ-series Monoracks. Givi top racks sold separately.

\$84⁹⁹

GPT.00.152.159



TraX adapter for SW-MOTECH Steel Racks

Attach a TraX ALU-BOX Topcase to an SW-MOTECH Steel Toprack using a TraX adapter kit.



Adapter kit for Steel Topracks

GPT.00.152.20100.B

\$20²⁵

Steel Topracks (pages 122-123)

TraX adapter for SW-MOTECH ALU-RACKS

Attach a ALU-BOX Topcase to an SW-MOTECH ALU-RACK Toprack using a removable TraX adapter plate for a sleeker look.



Adapter plate for ALU-RACKS

GPT.00.152.400

\$40⁰⁰



ALU-RACKS (pages 124-125)

Steel Topracks and ALU-RACKS are bike-specific. See pages 192-269 to find a Toprack that fits your motorcycle.

Universal Adapter Plate for mounting TraX Topcases

\$99⁹⁹

The TraX Universal adapter plate is used for mounting a TraX Topcase directly to flat original and aftermarket rear luggage racks. GPB.00.152.165

- Easy attachment and detachment of the TraX Topcase.
- The plate provides a flat, stable surface that can be used as a solid top rack when the topcase is not needed.
- Constructed of steel, powder coated black.
- Includes mounting hardware and instructions for attaching to generic tubular-steel flat rear luggage racks.

NOTE: This plate cannot be used if your bike does not already have an existing tubular-steel flat rear luggage rack.

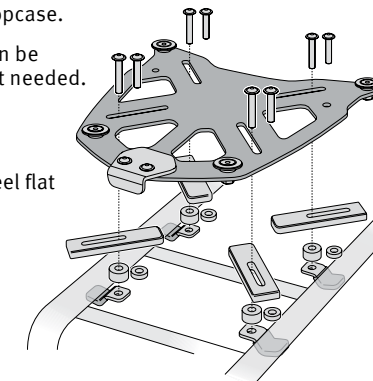

Shown on BMW R1200GS Adventure '06-'13



DrySpec H36 Sidecases

Protect your gear from water, dust and impact with the DrySpec H36 sidecases.

Designed for extreme survivability, the DrySpec H36 waterproof 36 liter motorcycle case is military approved and rugged enough to take whatever abuse your adventures will dish out. Molded from lightweight impact-resistant polypropylene resin with rounded corners and thick wall construction to absorb impact, the high performance gasket, stainless steel hardware, and lever latching system keep water and dust out of your gear. This is DrySpec. This is what we do.

- 36 liter capacity to keep your adventure well stocked
- Waterproof rated for submersion at 3 feet for 30 minutes
- Impact resistant construction is designed to take abuse and protect your gear
- Lockable with 2 padlockable hasps molded directly into the case
- High performance gasket for years of dry and dust free contents
- Automatic pressure release allows opening of case in changing atmospheric conditions and altitudes
- Soft grip foldable carry handle makes moving your gear to and from your bike comfortable
- Lever latching system provides powerful & secure closures
- Lightweight, impact resistant polypropylene resin construction will never corrode

Specifications:

- Exterior: 21.7" x 16.9" x 8.5" (55.7cm x 42.9cm x 21.6cm)
- Interior: 20" x 14" x 8" (50.8cm x 35.6cm x 20.3cm)
- Weight: 8.4 lbs. (3.8kg)
- Lid depth: 2.1" (5.3cm)
- Base depth: 5.9" (15cm)
- Max buoyancy: 80 lbs. (36.3kg)

Certifications:

- ATA 300: Impact test
- ASTM D4169: Falling rain - Vibration - Drop tests
- MIL-STD-810F: Immersion test
- IP 67: Ingress protection tests (dust & immersion)



Padlock hasp

Pressure release valve

Soft grip handle



Bolt-on Kit:
PEL.00.10000 \$19.99

Bolts the cases to SW-MOTECH sidecarriers making them non-removable.



DrySpec H36 Sidecases shown on the Twisted DL650 V-Strom with a DrySpec B65 dry bag.

\$120⁶⁷

DrySpec H36 Standard Case (single case only): DSL.H36.10000



Lots of room for all your travel and rally stickers!

20" (50.8 cm)

14" (35.6 cm)

8" (20.3 cm) deep

DrySpec H36 Topcase Package

Topcase Kits transform a single H36 case into a quick release motorcycle topcase. The quick release case adapters feature integrated, keyed snap locks which attach and lock your cases to your motorcycle in one simple motion. The quick release case adapter is designed to mount to SW-MOTECH ALU-RACK and Steel Topracks.

The topcase kit includes:

- (1) DrySpec H36 case
- (1) Quick-release case adapter
- (1) Keyed-alike rack lock (locks the case to your top rack)

Starting at \$219⁹⁹

Topcase Kit:
Alu-rack: DSL.H36.100.A
Steel Toprack: DSL.H36.100.S

SW-MOTECH ALU-RACK and Steel Topracks are sold separately. See pages 122-124.



DrySpec H36 Sidecase Package



Quick Release Mounting Kit for 2 sidecases

Transforms two DrySpec H36 cases into quick release motorcycle side luggage. The quick release case adapters feature an integrated keyed snap lock which attaches and locks your cases to your motorcycle in one simple motion. The quick release case adapter is designed to mount to SW-MOTECH or Givi sidecarriers.

This sidecase kit includes:

- (2) DrySpec H36 cases
- (2) Quick-release case adapters
- (2) Keyed-alike rack locks (locks the cases to your sidecarriers)
- (1) Sidecarriers mounting hardware kit (for 2 cases)

\$420⁹⁹

Sidecase Kit: DSL.H36.200

Sidecarriers sold separately. See pages 128-129.

DrySpec H36 3 Case Package

Quick Release Mounting Kit for 3 cases

Includes three DrySpec H36 cases to create a complete luggage system with one topcase and two sidecases. The quick release case adapter is designed to mount to SW-MOTECH or Givi sidecarriers and SW-MOTECH ALU-RACK or Steel Topracks (sold separately).

The 3-Case kit includes:

- (3) DrySpec H36 cases
- (3) Quick-release case adapters
- (3) Keyed-alike rack locks (locks cases to your racks)
- (1) Sidecarriers mounting hardware (for 2 cases)
- (1) Toprack mounting hardware

Starting at \$640⁹⁹

3-case Kit:
Alu-rack: DSL.H36.100.A
Steel Toprack: DSL.H36.100.S



Universal Quick Release Case Adapter

Universal Quick Release Case Adapters

Turn your favorite Mil-spec cases, including those by DrySpec, Pelican, SKB, and Seahorse, into quick release motorcycle luggage. Simply mount the U-shaped quick release adapter to your case and mount the rack adapter hardware to your top rack or side rack. The integrated snap lock enables effortless one-handed attachment and removal of the cases.

To attach the case, just line up the bottom feet with the guides on the rack and snap the case into the lock catch. You will hear a snap as the case engages and locks to the rack. To remove the case, just turn the key and lift up.

The Quick-Release Case Adapters work on SW-MOTECH top racks and sidecarriers and Givi sidecarriers (sold separately).



Adapter dimensions: 10.5" wide by 12" tall.

Adapter only (each). Cases, top rack and sidecarriers sold separately.

- 1 Case Kit: PEL.105 \$96.35
- 2 Case Kit: PEL.205 \$176.13
- 3 Case Kit: PEL.305 \$272.48

Spacer kit for Suzuki DL650 ('04-'11) & Tiger 1050: KFA.05.00 \$9.99



Givi Monokey sidecases are waterproof, lockable, heavy-duty cases designed for use with motorcycles and large scooters. Accessories available for Givi Monokey topcases include inner nylon liner bags, brake lights, backrests, and top luggage racks that can be used to attach large bulky items (e.g., a tent or sleeping bag) to the lid of your topcase. All Givi cases can be locked, unlocked, and removed from the bike with just one key. Givi Monokey cases cannot be attached to Givi Monolock luggage carriers but are compatible with bike specific topcases and sidecarriers manufactured by Givi and SW-MOTECH (sold separately). We carry all luggage racks from these manufacturers. Visit www.TwistedThrottle.com for bike-specific fitting information!



E22 (Pair) - Sidecases (22L)

Starting At
\$249⁰⁰
per pair



Givi E22.N
Matte Black
22 Liter
7.5" D x 13.5" H x 16.5" L
Cannot fit a helmet

E41 (Pair) - Sidecases (41L)

Starting At
\$569⁰⁰
per pair



Givi E41
Matte Black
Gloss Silver
Satin Silver
41 Liter
11" D x 17" H x 22" L
Fits 1 helmet

V47N- Topcase (47L)

Starting At
\$349⁰⁰



Givi V47N
Matte Black
47 Liter
17.7" D x 12.6" H x 23.2" L
Fits 2 helmets

Givi V35 PLX Sidecases (35L)

This sidecase system hugs the tail section of your bike, providing a sleek, integrated look to your luggage. For use only with Givi PLX sidecarriers and SW-MOTECH Contour Carriers (see page 127). V35 sidecases hold some full-face helmets. Sold in pairs.

Satin Silver (A900)



\$625⁰⁰
per pair
GIVI V35

Gloss Silver (G730)



\$649⁰⁰
per pair
GIVI V35

Matte Black (N)



\$579⁰⁰
per pair
GIVI V35



Dimensions: 20.7"W x 12.4"D x 15.5"H
Weight capacity: 22 lbs per sidecase
Volume: 35 liters/case

E460 - Topcase / Sidecase (46L)

\$273⁶⁰
each



Givi E460
Matte Black
46 Liter
17" D x 12" H x 22" W
Fits 2 small helmets

E52 - Topcase (52L)

Starting At
\$329⁰⁰



Givi E52
Gloss Black
Gloss Silver
Matte Black
Matte Black with
Brake Light
52 Liter
16.8" D x 11.5" H x 23" W
Fits 2 large helmets

E360 - Topcase / Sidecase (40L)

\$230⁰⁰
each



Givi E360
Matte Black
40 Liter
11" D x 17" H x 22" L
Fits 1 helmet

B33 - Topcase (33L)

\$169⁰⁰
Monolock

\$199⁰⁰
Monokey



Givi B33
Matte Black
with Silver
33 Liter
17.7" L x 16.5" W x 12.2" D
Fits 1 helmet

E55 - Topcase (55L)

Starting At
\$365⁰⁰
each



Givi E55
Gloss Black
Gloss Silver
Satin Silver
Matte Black
Burgman Blue
Candy Apple Red

**E55NT
(Clear Lens)**



55 Liter
18.9" D x 12.6" H x 23.2" L
Fits 2 large helmets

V46 - Topcase (46L)

Starting At
\$299⁹⁹
each



Givi V46
Gloss Black
Gloss Silver
Satin Silver
Matte Black
Matte Black with Brake Light
Additional C46 bike-specific color plates available.

**V46NT
(Clear Lens)**



46 Liter
17" D x 13" H x 22" W
Fits 2 small helmets

Givi TREKKER Luggage

Available in 33, 46 and 52 liter sizes, TREKKER cases can be used as sidecases or topcases. TREKKER cases are constructed of rugged, durable plastic with a metallic finish.

Their unique design allows you the option to open either the entire lid or just the smaller upper opening. This allows easy access to gear when using the cases as sidecases WITHOUT accidentally emptying your belongings onto the pavement.

Sold individually and in pairs.

Givi TREKKER cases can be attached to your bike using topcase and sideracks by Givi or SW-MOTECH.

33L (20" x 16.2" x 9.1")
GIVI TRK33N: \$339.00 each

46L (20" x 16.2" x 12.2")
GIVI TRK46N: \$355.00 each

52L (20" x 16.2" x 12.2")
GIVI TRK52N: \$409.00 each

TREKKER as topcase



TREKKER as sidecase



Givi TREKKER Outback Aluminum Sidecases

Designed with an emphasis on security, comfort and strength, the Givi Trekker Outback Aluminum Sidecases are available in 37 liter and 48 liter sizes with black or aluminum finish. They are ideal for the adventure motorcyclist who is looking for a rugged and great looking, long-distance enduro touring pannier.

- Aluminum construction.
- Top loading design.
- Off-road shock and stress resistant.
- Reinforced techno-polymer protection on corners.
- Thin alloy reinforcement for likely impact zones.
- Aluminum locking mechanisms
- Squared design for maximum loading capacity.
- Lockable, detachable lid.
- Same key for lid and mount release.
- Requires new CAM-Side, 4 point sidecarrier (not compatible with conventional Monokey sidecarriers).
- Available in Silver or Black finish.

37L (19.5" x 15.3" x 9.7")
GIVI OBK37: \$460.00 each

48L (19.5" x 15.3" x 12")
GIVI OBK48: \$475.00 each



Want your Givi luggage to stand out at night? See page 120-121 for Admore LED lighting kits!



NEW

DAKAR Waterproof Soft Saddlebags

Regardless of how long you ride or how hard you ride, DAKAR panniers are built to survive in the roughest conditions. The 2-layer system of the bag combines a tough exterior outer layer with a waterproof inner layer to create a super-durable drybag.

Features: waterproof velcro roll closure, preformed ABS honeycomb panel on interior for a rigid form on the side close to the bike and a lightweight bike-specific sidecarrier system.

Each kit includes:

- 2 DAKAR bags
- 2 waterproof inner bags
- 2 bike-specific sidecarriers

Volume: 32 liters per bag (64 liters total)
 Size: 13.7" x 17.7" x 9.8" (h x w x d) per bag
 Weight: 3.5 lbs. per bag
 Material: 1680 D Ballistic Nylon
 Color: Grey / Black

Starting At
\$539⁹⁹



2014 KTM 1190 Adventure



Daisy chain on outer edges of bags is perfect for securing an additional bag or holding zombie-killing shot gun shells.

2013 BMW R1200GS LC

BMW	Year	Part Number
R1200GS LC	'13-'14	BC.HTA.07.741.10000.B
Ducati	Year	Part Number
Multistrada	'10-'14	BC.HTA.22.741.10000.B
Kawasaki	Year	Part Number
KLR650	'08-'14	BC.HTA.08.741.10100.B
Versys 1000	'12-'14	BC.HTA.08.741.10000.B
KTM	Year	Part Number
950 Adventure	'03-'06	BC.HTA.04.741.10100.B
990 Adventure	'06-'13	BC.HTA.04.741.10100.B
1190 Adventure	'13-'14	BC.HTA.04.741.10000.B
Suzuki	Year	Part Number
DL650 V-Strom	'11-'14	BC.HTA.05.741.10000.B
Triumph	Year	Part Number
Explorer 1200	'11-'14	BC.HTA.11.741.10100.B
Tiger 800 & Tiger 800 XC	'10-'14	BC.HTA.11.741.10200.B
Yamaha	Year	Part Number
Super Tenere XT1200Z	'10-'14	BC.HTA.06.741.10000.B



2013 Kawasaki KLR650

Bike specific sidecarriers (R1200GS LC shown)



Secure saddlebags to passenger seat with Velcro flap



Slide saddlebags on from bottom



STEP 1

Saddlebags snap onto sidecarriers



Six large D-rings on the outer corners of each bag for additional tie down options.





NEW

AERO ABS Sidecase Set

The convenience and security of hard luggage in a lightweight molded textile design.

\$439⁹⁹
per pair

BC.HTA.00.675.1100



Sidecarrier and adapter sold separately

AERO Sidecases are innovative, rigid saddlebags with the look of soft saddlebags, but with the benefits of hard sidecases. The 25-liter AERO bags are constructed with a rigid 2.5 mm thick ABS plastic shell that is covered by a Nylon laminate. The surface looks like Ballistic Nylon soft luggage, but the case has the strength and rigidity of hard luggage while remaining lightweight (less than 13 pounds per pair, not including sidecarrier). AERO bags are mounted using the SW-MOTECH EVO, Givi, or Hepco-Becker sidecarriers with AERO sidecase adapters. Integrated locks prevent the theft of the bags.

Includes:

- Sidecases (pair)
- Waterproof inner liner dry bags (pair)
- Locking sidecarrier adapters and keys (2)
- Zipper locks (2)

Specs:

- ABS / 600 Nylon
- 25 liter capacity each (50 Liters total)
- Dimensions: 21" W x 15" T x 9.4" D (at the widest point)



The included waterproof welded tarpaulin liner bags fit perfectly into AERO sidecases to keep your stuff nice and dry. Simply wrap and connect buckles to close.

Each AERO Sidecase comes with its own Bags-Connection inner liner dry bags!

How to attach AERO Sidecases to your bike:

AERO Sidecases attach to your bike using the AERO adapter for the EVO Sidecarrier.

STEP 1



Install an SW-MOTECH EVO, Givi, or Hepco-Becker sidecarrier with Aero adapters on your bike

STEP 2



Slide the AERO sidecase onto the mounting points on the sidecarrier, clicking it into place.

STEP 3



GO RIDE!



Aero adapter for Givi sidecarriers
KFT.00.152.22700.B
sale price \$92.99

Aero Adapter	Part Number	MSRP
Aero adapter for SW-MOTECH EVO sidecarriers	KFT.00.152.22500.B	\$26.75
Aero adapter for Givi sidecarriers	KFT.00.152.22700.B	\$92.99
Aero adapter for Hepco-Becker sidecarriers	KFT.00.152.22600.B	\$92.99

Optional AERO Laptop Bag

The AERO laptop carrying bag accommodates wide-screen laptops with up to 17" diagonal screens. Maximum laptop dimensions: 15.5" x 11.5" x 1.75"



BC.HTA.00.675.1010 \$23.75



Integrated elastic straps hold your laptop bag securely in place, while the included rain liner protects the laptop from the elements.

Sidecarriers (sold separately) are bike-specific - see pages 192-269 to find a sidecarrier that fits your bike.



The best quick-release sportbike saddlebag system!

Starting at
\$249⁹⁹
 per pair
 Mounting hardware included



Support arm holders bolt to passenger footpeg mounts



Support arms snap into holders in seconds



Support arms prevent movement of saddlebags



Tired of burnt straps, tire friction holes and cooked saddlebags? Bags-Connection Blaze Sport Saddlebags are the solution!

The Blaze Sport Saddlebag System features an aerodynamically-shaped saddlebag that fits many modern sport bikes. Blaze Sport Saddlebags are constructed of 1680 Ballistic Nylon. Each has a volume of 14 liters (21 liters when expanded).

What's really unique about the Blaze Sport Saddlebag system is the support arms. These quick-release arms support the saddlebags so they don't move. No more worrying about whether your sagging saddlebags are touching your hot exhaust or are about to get caught in your wheels.

When you're done riding for the day, the saddlebags and support arms can be removed in less than a minute, returning your sportbike to its original look. No funky-looking luggage carriers!

Each kit includes:

- Saddlebags (pair)
- Waterproof liner bags (pair)
- Bike-specific support arm mounts (pair)
- Bike-specific support arms (pair)

Bike-specific saddlebag kits are listed on the next page.



Each sport saddlebag expands by 70mm, providing a volume of 14 to 21 liters per bag

Not large enough to fit a full face helmet.

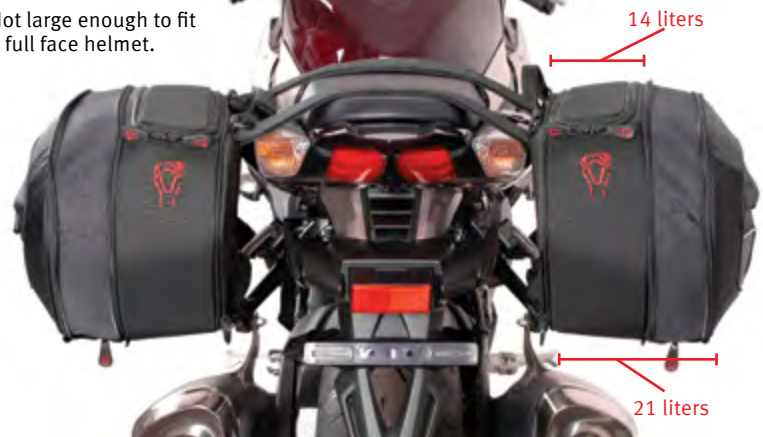

Turn your sportbike into a touring bike in seconds!

STEP 1



Insert the support arms into the preinstalled bracket. CLICK.

STEP 2



Slide the receiving sleeve of the saddlebag onto the support arm.

STEP 3



Secure the Velcro flaps over the passenger seat.

STEP 4



Connect the safety clip at the front end of each bag to the passenger footpeg mount. Now, you're ready to ride!

Mounting hardware is designed to provide a safe position for the Blaze Sport Saddlebags on bikes with the original factory exhaust.

Visit TwistedThrottle.com for the Blaze Sport Saddlebag System that fits your bike!

BMW	Year	Part Number
F800R	'09 - '13	HTA.07.740.10200
S1000RR	'10 - '11	HTA.07.740.10000
S1000RR	'12 - '14	HTA.07.740.10300
R1200R	'11 - '13	HTA.07.740.10100
Ducati	Year	Part Number
848 Evo	'09 - '13	HTA.22.740.10000
848 Streetfighter	'11 - '13	HTA.22.740.10100
1098	'07 - '09	HTA.22.740.10000
1198	'09 - '13	HTA.22.740.10000
1199 Panigale / S	'12 - '14	HTA.22.740.10200
Honda	Year	Part Number
599, CBR600F	'07 - '13	HTA.01.740.10300
CBF600S	'08 - '11	HTA.01.740.10200
CBR600RR	'07 - '14	HTA.01.740.10000
NC700X & NC700S	'12 - '14	HTA.01.740.10700
CB1000R	'08 - '12	HTA.01.740.10100
CBF1000 & CBF1000F	'06 - '13	HTA.01.740.10200
CBR1000RR	'04 - '07	HTA.01.740.10600
CBR1000RR	'08 - '14	HTA.01.740.10400
Kawasaki	Year	Part Number
Ninja 250R	'08 - '12	HTA.08.740.10600
ZX6R Ninja	'09 - '12	HTA.08.740.10100
ER6N & Ninja 650R	'09 - '11	HTA.08.740.10400
ER6N & Ninja 650R	'12 - '14	HTA.08.740.11000
Z1000	'07 - '09	HTA.08.740.10700
Z1000	'10 - '13	HTA.08.740.10200
Ninja 1000 & Z1000SX	'11 - '13	HTA.08.740.10500
ZX10R Ninja	'08 - '10	HTA.08.740.10000
ZX10R Ninja	'11 - '14	HTA.08.740.10800
ZX-14R	'11 - '14	HTA.08.740.10900
KTM	Year	Part Number
690 Duke 4	'11 - '13	HTA.04.740.10000
Suzuki	Year	Part Number
GSX-R600 & GSX-R750	'05 - '10	HTA.05.740.10200
GSX-R600 & GSX-R750	'11 - '14	HTA.05.740.10000
GSF650 Bandit S	'09 - '13	HTA.05.740.10300
GSX650F	'07 - '13	HTA.05.740.10100
SVF650 Gladius	'09 - '14	HTA.05.740.10400
GSX-R1000	'09 - '14	HTA.05.740.10000
GSX1250F & GSF1250 Bandit S	'07 - '13, '09-'13	HTA.05.740.10100
GSX-1300R Hayabusa	'08 - '13	HTA.05.740.10500
Triumph	Year	Part Number
Daytona 675	'06 - '11	HTA.11.740.10400
Street Triple 675	'08 - '12	HTA.11.740.10200
Bonneville, T100 & SE, Thruxton 900	'04 - '14	HTA.11.740.10500
Speed Triple 1050	'08 - '10	HTA.11.740.10300
Speed Triple 1050	'11 - '14	HTA.11.740.10100
Sprint GT 1050	'10 - '13	HTA.11.740.10000
Yamaha	Year	Part Number
YZF-R6	'08 - '14	HTA.06.740.10400
FZ6 S2	'07 - '11	HTA.06.740.10200
FZ6R & XJ6	'08 - '14	HTA.06.740.10500
FZ8	'10 - '13	HTA.06.740.10300
FZ1	'06 - '14	HTA.06.740.10300
YZF-R1	'09 - '14	HTA.06.740.10000



The Fastest, Cleanest Way to Mount a Tankbag

QUICK-LOCK EVO tankrings are an innovative way to mount Bags-Connection QUICK-LOCK tankbags.

Topping attaches to tankbag using through-bolts.

Tanking bolts to gas cap ring using existing threaded holes.

Features:

- Allows tankbags to be securely attached and detached in seconds.
- No magnets: works with plastic and aluminum tanks.
- No straps: won't scratch the paint on your tank.
- Tankring bolts to gas cap using included screws: no drilling or tank modification required.
- Tankring does not interfere with gas cap use.
- Location of tankbag is customizable by mounting the topping further forward or back on the bottom of the tankbag.

Topping installed on tankbag.

Once you've installed the tankring, attaching your tankbag is easy!

STEP 1 Position tankbag directly over tankring.

STEP 2 Press down on tankbag, locking it into position.

Detach the tankbag with one hand and lift it off in one second!

STEP 1 Pull cord to release locking mechanism.

STEP 2 Lift bag up.

Bags-Connection EVO Locking Kit.

Lock the bag to the bike with this zipper lock & lock pin. TRT.00.640.20000.B: \$20.25



QUICK-LOCK tankring adapter kits for fuel tanks without traditional gas cap rings

Starting At \$49⁹⁹

Does your bike lack a gas cap ring?

There are some bikes that make it difficult to mount a QUICK-LOCK tankring and tankbag. But rest assured, SW-MOTECH has the solution. With the QUICK-LOCK tankring adapter kit, you can mount SW-MOTECH Bags-Connection tankbags directly to your bike. The charts below are only a partial list of bikes that we have tankring adapter kits for. If you don't see your bike listed, please visit TwistedThrottle.com. Tankring adapter kits are available to fit both the original QUICK-LOCK topplings (see website) and the newer EVO style topplings.



Adapter for bikes with a screwless gas cap			
Aprilia	from	to	Ring Type
Tuono VR2	'12	'13	Type 300 EVO
BMW	from	to	Ring Type
R1200GS, R1200GS Adv. & HP2 Sport	'08	'08	Type 123 EVO
R1200GS, R1200GS Adv. & HP2 Sport	'09	'12	Type 127 EVO
R1200R	'07	'08	Type 124 EVO
R1200R	'09	'10	Type 128 EVO
R1200R	'11	'13	Type 128 EVO
R1200S	'06	'08	Type 124 EVO
S1000RR	'09	'13	Type 127 EVO
Ducati	from	to	Ring Type
696 Monster	'09	'12	Type 300 EVO
848 Street-fighter	'11	'13	Type 300 EVO
1100 Monster	'09	'12	Type 203 EVO
1199 Panigale/S	'12	'13	Type 300 EVO
Moto Guzzi	from	to	Ring Type
Stelvio 1200	'08	'13	Type 300 EVO
MotoMorini	from	to	Ring Type
Granpasso 1200	'08	'13	Type 300 EVO
Suzuki	from	to	Ring Type
B-King	'07	'13	Type 131 EVO

Adapter for bikes without a gas cap

BMW	from	to	Ring Type
G650GS	'11	'13	Type 205 EVO
G650GS Sertao	'11	'13	Type 205 EVO
F650GS twin	'08	'13	Type 201 EVO
F700GS	'12	'13	Type 201 EVO
F800GS	'08	'13	Type 201 EVO
F800R	'09	'13	Type 206 EVO
F800ST	'06	'13	Type 206 EVO



Tankring Adapter Kits for Rear Luggage Racks

Want to mount a tankring to your tail section? It's easy with this rear luggage rack adapter.

ALU-RACK adapter for QUICK-LOCK EVO tankbags

Attach and detach the tankring adapter to your ALU-RACK toprack in seconds.

\$66⁹⁹

Simply fit the adapter into the rack cutout and then turn the fastener to secure the adapter to the rack. Attach your tankbag and go!

What's in the kit:

- QUICK-LOCK EVO tankring adapter
- QUICK-LOCK EVO tankring
- Mounting hardware & Instructions

See pages 124-125 for more information on ALU-RACKs (ALU-RACK sold separately).

Steel Toprack adapter for QUICK-LOCK EVO tankbags

Permanently installs a tankring onto your Steel Toprack using through bolts.

\$39⁹⁹

What's in the kit:

- QUICK-LOCK EVO tankring
- Mounting hardware & Instructions

See pages 122-123 for more information on Steel Topracks (Steel Topracks sold separately).



Compatible tankbags: Sport, Micro, and Daypack (see pages 149-150)



Add electrical power to your QUICK-LOCK EVO Tankbag!

You will need to buy a QUICK-LOCK Tankbag and an electric tankbag mounting kit for your bike. Here's how to install it:

STEP 1 Install an Electric QUICK-LOCK Tankring on your tank's gas cap.

Bolt the tankring onto your gas cap, then run the power cable under the front of the tank.



Connect the tankring's power cable to the motorcycle's battery.



STEP 2 Install QUICK-LOCK electric toping onto the bottom of a QUICK-LOCK Tankbag.



The Electric Tankring wires run up through a hole in the bottom of the tankbag and terminate in an SAE connector that allows you to charge cell phones, cameras, iPods and other gadgets through the tankbag.

The electric tankring attaches to the bottom of a QUICK-LOCK tankbag with 4 bolts. Drill a fifth hole in the bottom of the bag and pass the SAE cable through.

STEP 3 Distribute electrical power within the tankbag.

Connect an electrical socket of your choice to the SAE connector.

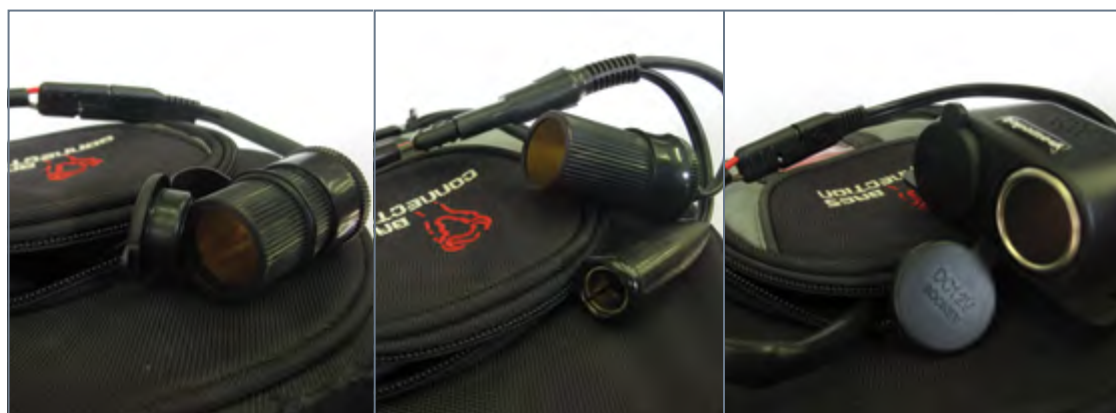

Single cigarette socket *EMA.00.107.10800 \$14.99* Cigarette socket & mini-Euro socket *EMA.00.107.10900 \$29.99* Dual cigarette socket *EMA.00.107.11000 \$29.99*

USB Charging Adapter

Converts a 12-Volt cigarette socket into a USB socket, allowing you to charge any device that you normally charge via a computer's USB port.



Single USB 1 amp: *EMA.00.107.11200: \$14.99*

Single USB 2.1 amp: *POW.AAC-006: \$19.95*

Dual USB 1 amp: *MICROCBRUSBUDUAL: \$19.99*

Mounting Options for QUICK-LOCK Tankbags:

	Non-Electric EVO Tankring Buy this if you want to attach a non-electric QUICK-LOCK EVO tankbag to your motorcycle. (Tankbags sold separately).	Electric EVO Tankring Buy this if you want to have the ability to charge and run electronic devices in your QUICK-LOCK EVO tankbag.	Non-Electric ION Electric Tankring Buy this tankring if you are buying or already have a Bags-Connection ION tankbag. (The ION tankrings cannot be electrified).
Motorcycle Manufacturer*	Non-Electric EVO Tankring	Electric EVO Tankring	Non-electric ION Tankring
Aprilia	Type 175 EVO	Type 175 Electric	Type 175 ION
Benelli	Type 190 EVO	Type 190 Electric	Type 190 ION
BMW	Type 120 EVO	Type 120 Electric	Type 120 ION
BMW F650 ST & F650 Funduro ('93-'96)	Type 118 EVO	Type 118 Electric	Type 118 ION
BMW F650 ST & F650 Funduro ('97-'00)	Type 116 EVO	Type 116 Electric	Type 116 ION
BMW R1200S ('06-'08) R1200GS, R1200GS Adventure & HP2 Sport ('08)	Type 124 EVO	Type 124 Electric	Type 124 ION
BMW R1200S, R1200GS, R1200GS Adventure, & HP2 Sport, S1000RR ('09 & Later)	Type 127 EVO	Type 127 Electric	Type 127 ION
BMW R1200ST & R1200RT ('05 & later)	Type 129 EVO	Type 129 Electric	Type 129 ION
BMW K1300GT, K1300R, & K1300S	Type 126 EVO	Type 126 Electric	Type 126 ION
Cagiva	Type 190 EVO	Type 190 Electric	Type 190 ION
Ducati	Type 110 EVO	Type 110 Electric	Type 110 ION
Ducati Multistrada 1200 ('10-'13)	Type 126 EVO	Type 126 Electric	Type 126 ION
Fischer	Type 115 EVO	Type 115 Electric	Type 115 ION
Honda	Type 106 EVO	Type 106 Electric	Type 106 ION
Hyosung	Type 115 EVO	Type 115 Electric	Type 115 ION
Kawasaki	Type 140 EVO	Type 140 Electric	Type 140 ION
Kawasaki	Type 135 EVO	Type 135 Electric	Type 135 ION
KTM	Type 170 EVO	Type 170 Electric	Type 170 ION
Moto Guzzi	Type 180 EVO	Type 180 Electric	Type 180 ION
MV Agusta	Type 195 EVO	Type 195 Electric	Type 195 ION
MZ	Type 165 EVO	Type 165 Electric	Type 165 ION
Triumph	Type 160 EVO	Type 160 Electric	Type 160 ION
Suzuki	Type 125 EVO	Type 125 Electric	Type 125 ION
Suzuki	Type 115 EVO	Type 115 Electric	Type 115 ION
Victory ('05 & Later)	Type 110 EVO	Type 110 Electric	Type 110 ION
Yamaha	Type 110 EVO	Type 110 Electric	Type 110 ION
Yamaha	Type 115 EVO	Type 115 Electric	Type 115 ION

* For gas tanks without traditional gas caps see page 145.

Fit kits for other tanks	Notes	Part No.
Adjustment kit for curved tanks	Allows easier attachment/detachment to steeply sloped tanks by lowering the rear slots in the tankbag. Useful for installation on ST1300, Tiger 1050, most BMW K-bikes, and many others. Necessary for ION tankbags only.	TWT.TRT.00.005.100
Drill-on electrical bottom tankring kit	For BMW F650GS & F650GS/Dakar, '07, F800S, F800ST, & Buell Ulysses.	Type 100 EVO
Electrical Tankbag Accessories	Notes	Part No.
QUICK-LOCK Electrical Topring	For use with corresponding old style (gray color) electrical bottom tankring.	TRE.00.475.102
Splitter (bullet connector style)	Allows connection of an additional socket inside tankbag (sold separately).	TT-00005
SAE Adapter	For use with splitter (sold separately). Converts original bullet connectors within an electric tankbag into an SAE connector.	TT-00004

Electric Tankbag Upgrade Kits

Upgrade from a non-electric tankring with this kit (call to order).

Kit Includes:

Electric Topring

This electric topiring replaces the non-electric tankring included when you purchase a Bags-Connection QUICK-LOCK EVO tankbag so that it can be used with an electrified tankring.

SAE adapter

Converts the bullet connectors on the QUICK-LOCK EVO Electric Tankring into an SAE connector.

QUICK-LOCK EVO Electric Bottom Ring Adapter

Replaces an insert in your existing EVO tankring and connects to your bike's electrical system. Compatible with all QUICK-LOCK EVO tankrings.

(QUICK-LOCK tankbag and electrical sockets sold separately).

TRE.00.640.10200.B: \$149.99





The BAGS-CONNECTION product line of tankbags sets a new standard for quality and refinement in motorcycle touring luggage. Using durable materials with smart features, these premium-quality bags fit perfectly on a wide variety of motorcycles.

Bags-Connection bags will provide years of service and just may be the last motorcycle luggage you ever buy.



Tankbag Features



All tankbags include a weather-proof interior liner or a rain cover with a clear map window.



GPS mount sleeves provide a secure and quick way to add a GPS mount to your tankbag. Included on all tankbags except the Micro. GPS mounts sold separately (see page 156).



All bags have cable pass-throughs. The forward cable pass-through can be used to run GPS/gadget wires, and the rear pass-through can be used for headphone cables or a hydration tube.



Interior lid organizer; configuration varies among bags.



Need more space? Unzip the expansion zipper and increase the volume of your bag!

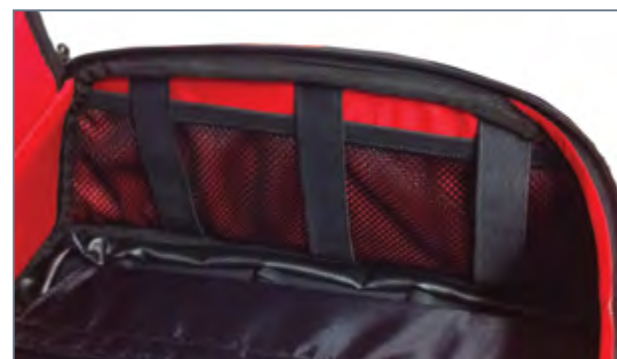

Keep the interior tidy with sidewall pockets (both sides of the bag) and elastic cable organizer straps (right side).



Lock the bag to the bike with the available lock pin and zipper lock (see page 169).



Super durable 1680 Ballistic nylon has higher abrasion and tear resistance than most materials found in armored riding jackets.



Zipper keepers prevent zipper pulls from flapping around. Say that 5 times fast!



Sport QUICK-LOCK Tankbag

This large tankbag fits wide flat tanks found on modern sportbikes, including most Honda CBR, Kawasaki Ninja, Suzuki GSX-R, and Ducati supersport models.

- Volume 14-21 liters
- 15.75" long x 13.4" wide x 6.7" tall
- Includes rain cover, QUICK-LOCK topring, and shoulder strap
- Carry handle on front of bag

*Note: This bag will also work as a tailbag (see page 145).

Non-Electric: BC.TRS.00.101.2000
Electrified: BC.TRE.00.101.2000

Starting At \$254⁹⁹



Integrated GPS Mount Sleeves (bracket sold separately).



Expands to 21 liters

Interior lid and wall organizer pockets





Micro QUICK-LOCK Tankbag

This **extra-small** tankbag fits all tanks and provides just enough storage for your wallet, sunglasses, and a few other small items.

- Volume 2.5-5 liters
- 10.6" long x 8.3" wide x 4.3" tall
- Includes rain cover and QUICK-LOCK topring

*Note: This bag will also work as a tailbag (see page 145).



Non-Electric: BC.TRS.00.110.2000
Electrified: BC.TRE.00.110.2000

Starting At \$99⁹⁹



Expands to 5 liters



*Note: The Micro is the only EVO tankbag that does not have the integrated GPS mount sleeves at the front of the bag.



Engage QUICK-LOCK Tankbag

This **medium-sized** tankbag looks great on slightly sloped tanks found on many naked sportbikes, including Ducati Monster, Kawasaki ER-6n, and Triumph Street Triple.

- Volume 7 liters
- 14.2" long x 10.6" wide x 5.1" tall
- Includes rain cover, QUICK-LOCK topring, and shoulder strap



Non-Electric: BC.TRS.00.107.2000
Electrified: BC.TRE.00.107.2000

Starting At \$189⁹⁹



Integrated GPS mount sleeves bracket sold separately (See page 156).



Optional map holder



Included rain cover



Daypack QUICK-LOCK Tankbag

This **small** tankbag fits all tanks and provides ample room for a wallet, sunglasses, and other basics for a commuting or short day trips.

- Volume 5-9 liters
- 11.8" long x 8.3" wide x 5.9" tall
- Includes rain cover and QUICK-LOCK topring

*Note: This bag will also work as a tailbag (see page 145).



Non-Electric: BC.TRS.00.108.2000
Electrified: BC.TRE.00.108.2000

Starting At \$129⁹⁹



Integrated GPS mount sleeves (bracket sold separately).



Expands to 9 liters



Trial QUICK-LOCK Tankbag

This **large** tankbag fits the same bikes as the Engage, and is also popular on the Suzuki V-Strom and other dual-sport bikes with slightly sloped tanks.

- Volume 15-22 liters
- 15" long x 13" wide x 7.5" tall
- Includes rain cover, QUICK-LOCK topring, and shoulder strap



Non-Electric: BC.TRS.00.102.2000
Electrified: BC.TRE.00.102.2000

Starting At \$229⁹⁹



Integrated GPS mount sleeves bracket sold separately (See page 156).



Expands to 22 liters





City QUICK-LOCK Tankbag

This best selling **medium-sized** tankbag fits well on the steeply sloped tanks found on many dual-sport bikes, including the BMW R1200GS and Triumph Tiger 1050.

- Volume 11-15 liters
- 14.1" long x 11" wide x 7.9" tall
- Includes rain cover, QUICK-LOCK topring, and shoulder strap



Non-Electric: BC.TRS.00.104.2000
Electrified: BC.TRE.00.104.2000

Starting At **\$219⁹⁹**



Integrated GPS mount sleeves bracket sold separately (See page 156).



Enduro Strap-mount Tankbag

This **medium-sized** tankbag fits well on the steeply sloped tanks found on many dual-sport bikes, including the BMW R1200GS and Triumph Tiger 1050.

- Volume 13-22 liters
- 14.2" long x 13" wide x 9" tall
- Includes weatherproof inner bag (instead of rain cover), fitting straps with retention loop, and tank-protection film
- Can be used as a backpack



BC.TRS.00.130.1000

\$199⁹⁹

Interior lid and sidewall organizer pockets



Enduro LT Strap-mount Tankbag

This **small** tankbag stays out of your way when standing on the footpegs during dirt riding. Perfect for smaller dual sport bikes like the Suzuki DR-Z400 or KTM 690 Enduro R. Also good for larger bikes like the BMW F800GS if you're the kind of guy that uses an adventure bike for motocross riding.

- Volume 5-7.5 liters
- 8.3" long x 8.3" wide x 6.7" tall
- Includes weatherproof inner bag (instead of rain cover), QUICK-LOCK topring, and shoulder strap
- Can be used as a backpack



BC.TRS.00.131.1000

\$124⁹⁹

Interior lid and sidewall organizer pockets



GS QUICK-LOCK Tankbag

This **large** tankbag suits riders that want to carry EVERYTHING on their tank. Originally designed for the R1200GS, this tankbag fits many large adventure bikes.

- Volume 16 - 22 liters
- 16.1" long x 12.2" wide x 9.8" tall
- Includes rain cover, QUICK-LOCK topring, and shoulder strap



Non-Electric: BC.TRS.00.103.2000
Electrified: BC.TRE.00.103.2000

Starting At **\$259⁹⁹**



Interior lid and sidewall organizer pockets





The new ION series from Bags-Connection are budget minded tankbags that are not built on a budget. Simplicity saves you money, but doesn't lessen durability!

ION 1 QUICK-LOCK Tankbag

The ION 1 is a **small, expandable tankbag** that is loaded with many of the same features as the higher priced EVO bags with 600D polyester material, expansion zippers and interior pockets. The ION 1 fits most tank shapes and is perfect for quick trips where you don't need a lot of storage space.

- Volume 5-9 liters
- 11.8" long x 8.26" wide x 5.9" tall
- Includes rain cover and ION QUICK-LOCK topring (bike specific tankring sold separately)



Interior lid and sidewall organizer pockets

Cable pass-through on front of tankbag

*Note: ION tankbags cannot use electric tankrings and lack the integrated GPS mount sleeves of the other Bags-Connection tankbags.



BC.TRS.00.201.10000

\$109⁹⁹



Bottom zipper expands volume from 5 liters to 9 liters



ION 2 QUICK-LOCK Tankbag

The new ION 2 is a **medium-sized, expandable tankbag** that is perfect for long tours with a max capacity of 20 liters. The ION 2 fits perfectly on most tanks and includes features such as tough 600D polyester construction, reflective piping carry handle and map window.

- Volume 13-20 liters
- 15" long x 10.2" wide x 6.7" tall
- Includes rain cover, ION QUICK-LOCK topring, and shoulder strap (bike specific tankring sold separately)



BC.TRS.00.202.10000

\$154⁹⁹



Expands to 20 liters

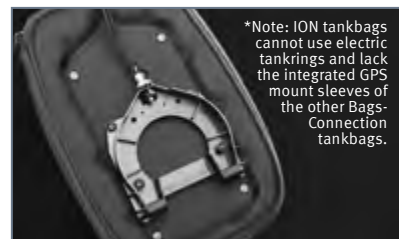

*Note: ION tankbags cannot use electric tankrings and lack the integrated GPS mount sleeves of the other Bags-Connection tankbags.



ION 3 QUICK-LOCK Tankbag

The new ION 3 is a **large bag** that fits perfectly on tanks that are slightly curved and is perfect for longer trips where you need more storage space than the ION 1 or ION 2. The ION 3 is constructed from 600D polyester and features interior compartments, large map window, dual external side pockets and reflective piping.

- Volume 15-22 liters
- 15" long x 13" wide x 7.5" tall
- Includes rain cover, ION QUICK-LOCK topring, and shoulder strap (bike specific tankring sold separately)



BC.TRS.00.203.10000

\$164⁹⁹

*Note: ION tankbags cannot use electric tankrings and lack the integrated GPS mount sleeves of the other Bags-Connection tankbags.



Front cable pass-through

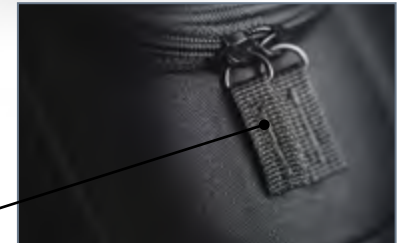

Large zipper pulls for gloved hands



ION 4 Strap-mount Tankbag

The new ION 4 is a **medium-sized bag** that fits perfectly on most enduro & dual sport tanks and is perfect for longer trips where you need a little extra storage space. Circular zipper connects base panel to tankbag, simply unzip for removal and easy refueling.

- Volume 13 - 22 liters
- 14.2" long x 13" wide x 9" tall
- Includes weatherproof inner bag instead of rain cover



BC.TRS.00.204.10000

\$139⁹⁹

*Note: ION tankbags lack the integrated GPS mount sleeves of the other Bags-Connection tankbags.





GPS/Phone/Radar Bracket

Features:

- The GPS/PDA bracket slides into two sleeves at the front of the tankbag.
- For use with:
 - all Bags-Connection device pockets (below),
 - all RAM, Garmin Zumo, and TomTom Rider device cradles (see pages 100-103)
 - all other device cradles with an AMPS hole pattern (see page 105).



Dimensions: 6.25"L x 4.5"W x 1.5" deep
BCK.GPS.00.010.100: \$39.99



Simply slide the bracket into the sleeves on the bag and snap.

Fits the following SW-MOTECH/Bags-Connection tankbags:

- Daypack
- Engage
- Trial
- Sport
- City
- GS
- Enduro
- Enduro LT

See pages 148-152 for QUICK-LOCK Tankbags.
NOTE: Does not fit ION tankbags.

Gadget Pouches and Dry Bags

GPS/PDA Pockets with Sun Visor

Weather-resistant, splash-proof GPS/PDA bags are perfect for navigation devices and smartphones. Bags feature a sturdy base for secure mounting and eyelets to pass-through electrical or audio cables. Mounts directly to a RAM-B-238 base, any Techmount, or any SW-MOTECH GPS holder. iPhone and Android touchscreens can be used through the clear window. The pocket's perimeter zipper makes accessing your device extremely fast, but also makes the pocket somewhat permeable to heavy downpours. If you need a 100% weatherproof solution and don't mind slower entry, use the roll-top GPS Dry Bag.



Medium Pocket fits Garmin Nuvi 30, 40, 1350, 3750, 2300LM, Tom Tom XXL 540TM, Go2435, Magellen 1424, and similar.
Dimensions: 5.7" x 3.7" x 1.4" deep

BC.GPS.00.003.1000: \$33.00



XL Pocket
The extra-large bag provides even more depth compared to the large bag. Fits some XM radios and GPS units.
Dimensions: 5.7" x 3.9" x 3.0" deep

BC.GPS.00.001.1000: \$25.00



Small Pocket
Fits Apple iPhones, Samsung Nexus, Motorola Atrix, HTC EVO 4G and similar.
Dimensions: 5.3" x 3.5" x 1" deep

BC.GPS.00.004.1000: \$29.99



Large Pocket
The large bag provides extra depth for thicker PDAs.
Dimensions: 5.7" x 3.9" x 1.8" deep

BC.GPS.00.002.1000: \$30.00



GPS Dry Bag
100% weatherproof (not submersible)
Fits Apple iPhones, Samsung Nexus, Motorola Atrix, HTC EVO 4G and similar.
Dimensions: 5.3" x 3.5" x 1.2" deep

BC.GPS.00.005.1000: \$25.00

Dry Bag Device Holders for Bags-Connection Tankbags

These roll-top welded dry bags are sized to hold your smartphone or tablet and are 100% weatherproof (not submersible). The dry bags can be securely connected to all Bags-Connection tankbags except the Micro, ION 1 and ION 2. iPhone and Android touchscreens can be used through the clear window!

Tablet Dry Bag

Holds an Apple iPad!
BC.TRS.00.151.1000: \$44.99



iPad 2 inside Tablet Dry Bag. Shown mounted on the BC Sport EVO Tankbag.

Smartphone Dry Bag

Holds all Apple iPhones and most Android smartphones.
BC.TRS.00.152.1000: \$31.00



Smartphone Dry Bag shown mounted on an BC Engage EVO Tankbag with iPhone 4s inside.

Map Pouch for Bags-Connection Tankbags

Map Holder for QUICK-LOCK Tankbags

Fits the following tankbags: Daypack, Engage, Sport, Trial, Enduro, Enduro LT, City, GS, ION 3 and ION 4.



Dimensions:
Exterior - 10"W x 10.5"L
Interior - 9.5"W x 10"L

BC.TRS.00.150.1000: \$34.99



*Note: Map Holder is equipped with a touch sensitive membrane that allows gadgets like iPhones and Android smartphones to be operated when in map pouch.

Waterproof Dry Bag Liners for Bags-Connection Tankbags

While all SW-MOTECH Bags-Connection tankbags feature either a weatherproof, seam-sealed rain cover or inner liner, water can be a diabolical thing. It always seems to find a way to get in. For riders who travel in extremely wet conditions, these tankbag liners offer 100% waterproof security for your electronics and other items. Dry bags feature roll top closure, waterproof tarpaulin PVC material and custom fit for specific tankbags.



Inner dry bag for Engage
BCK.WDI.00.031.100
\$19.99



Inner dry bag for City
BCK.WDI.00.041.100
\$19.99



Inner dry bag for Enduro
BCK.WDI.00.054.100
\$19.99



Inner dry bag for Trial
BCK.WDI.00.033.100
\$19.99



Inner dry bag for GS
BCK.WDI.00.038.100
\$19.99

"Highbeam" Mini Flashlight

This compact, rechargeable 35 lumen LED flashlight NEVER needs batteries. The Highbeam charges in any 12-volt power socket (cigarette lighter) and glows red when charging. Just turn the bezel clockwise to activate the LED, and turn the bezel counter-clockwise to turn off. The Highbeam is constructed with anodized aircraft grade aluminum and is weather-resistant.

Flashlight requires full sized cigarette socket.



It's only 2 inches long! Recharges in your tankbag's cigarette socket.
NEB.HB: \$9.99



A perfect tankbag lighting solution!



Slipstream

- Volume: 13 liters
- Dimensions: 14" long x 13" wide x 8.5" tall
- Includes waterproof inner bag, 4 elastic bungee cords, 2 backpack straps, and tank-protection film

Fits on:
 - Most rear seats
 - Larger rear luggage racks

Not recommended for use with sissy bar racks. This bag cannot accommodate a helmet.

BC.HTA.00.307.1000

\$155⁹⁹



Outer compartments and bungee tie-downs



Can be used as a backpack



Jetpack

- Volume: 20-33 liters
- Dimensions: 19" long x 13" wide x 7" tall
- Includes rain cover, tank-protection film, and 2 adjustable fitting straps

Fits on:
 - Most rear seat of bikes without a backrest or topcase.
 - Larger rear luggage racks.

This bag cannot be used on bikes with a backrest or topcase, as it overhangs past the rear of most passenger seats.

BC.HTA.00.303.1000

\$256⁰⁰



Expands to 33 liters



Expansion zipper



Can be used as a backpack.



Rearbag

- Volume: 24-36 liters
- Dimensions: 17.5" long x 13.5" wide x 10" tall
- Includes waterproof inner bag, 4 mounting straps, 2 backpack straps, and 2 license plate fittings
- Can be used as a backpack

BC.HTA.00.304.1000

\$239⁹⁹

Fits on:
 - Most rear seats

Not recommended for use with rear luggage racks or sissy bar racks. This bag can accommodate a full face helmet plus other gear when bag is expanded.

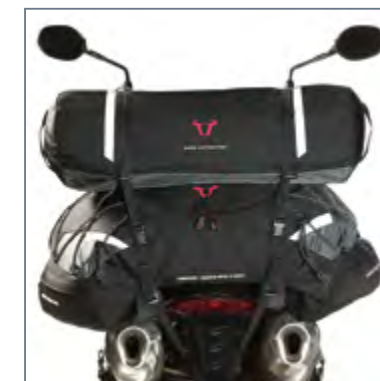

Tentbag secured to Cargobag (Tentbag sold separately, see page 161).



Interior lid organizer



Carry handle

Cargobag

- Volume: 50 liters
- Dimensions: 27.5" long x 17.5" wide x 15.5" tall
- Includes waterproof inner bag, 4 mounting straps, 2 compression straps, 2 license plate strap mounts, and tank-protection film

Fits on:
 - Most rear seats

Not recommended for use with rear luggage racks or sissy bar racks. This bag can accommodate a full-face helmet plus other gear.

BC.HTA.00.306.1000

\$229⁹⁹



Forward carry handle



Durable metal buckles



Racepack

- Volume: 50-65 liters
- Dimensions: 27.5" long x 12" wide x 12" tall
- Includes instructions, waterproof inner bag, 4 mounting straps, 2 license plate fittings, shoulder strap, and tank-protection film

Fits on:
- All rear seats

Not recommended for use with rear luggage racks or sissy bar racks. This bag can accommodate a helmet plus other gear.

BC.HTA.00.302.1000

\$324⁹⁹



Inner removable dry bag liner.



Tentbag

- Volume: 22 liters
- Dimensions: 22" long x 8" Diameter
- Zipper opening located on the underside of bag
- Can be attached to any non Bags-Connection luggage by using DrySpec or ROK Straps

BC.HTA.00.350.1000

\$54⁹⁹

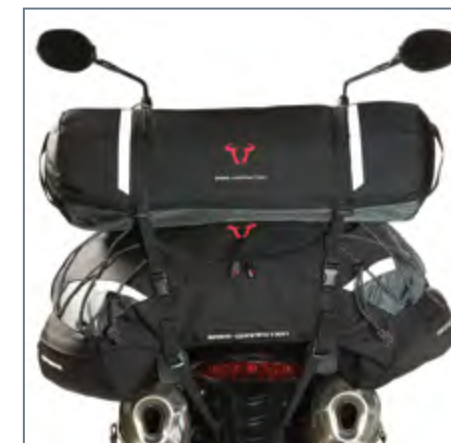

Tentbag secured to the Cargobag



Tentbag secured to the Speedpack



Tentbag secured to the Racepack

Speedpack

- Volume: 75-90 liters
- Dimensions: 29.5" long x 12.5" wide x 24" tall
- Includes 3-part luggage system with inner bags, 4 mounting straps, 2 compression straps, 2 support straps for license plate installation, scratch resistant adhesive film, and shoulder carry strap
- Fits bikes with a tail-section width of up to approximately 8.3"

Fits on:
- Most rear seats

Not recommended for use with rear luggage racks or sissy bar racks. This bag can accommodate a full-face helmet plus other gear.

BC.HTA.00.301.1000

\$435⁰⁰



Inner removable dry bag liner.

Rackpack

- Large enough for one full face helmet and a change of clothes
- Volume: 36-45 liters
- Fits a full-faced helmet
- Dimensions: 16.5" long x 11.8" wide x 11.8" tall
- 2 outer compartments and 1 main compartment
- Waterproof inner bag
- Includes shoulder carry strap
- Reflective piping for night time visibility
- Ways to attach it to your bike:
 1. Four tie-down straps for your rear luggage rack or passenger seat
 2. Sissybar strap for cruisers
 3. Underseat strap for sport bikes
 4. Soft Luggage Carriers GPT.00.152.430 for ALU-RACKS, R1200GS Soft Luggage Carrier (GPB.07.710.10000.S) (See page 168)

BC.HTA.00.305.1000

\$209⁹⁹



Not recommended for use with a sissy bar where a rear rack is not present.



Metal buckles with strap keepers



Multiple ways to keep your items secure: (For zipper lock, see page 169).



Bags-Connection roll-top dry bags are made from waterproof welded tarpaulin PVC. Even when sitting in a puddle, your stuff stays dry! The 35-liter size works well as a stand-alone rear bag. The larger 60-liter size works well placed across the rear seat and panniers or lengthwise covering the rear seat and luggage rack.

Dry Bag Features:

- Stable 4-point tie-down system.
- Available in two sizes: 60 and 35 liters.
- Includes 4 mounting straps and a shoulder strap.
- Fits nearly all sport, sport-touring, enduro, or cruiser motorcycles and scooters.



60-liter Drybag 600
27.5" long x 12" diameter
BC.WPB.002.10001 **\$109⁹⁹**

35-liter Drybag 350
22.8" long x 9.8" diameter
BC.WPB.001.10001 **\$90⁰⁰**

Bags-Connection End-Roll Dry Bags

End-Roll Dry Bags from Bags-Connection are made from the same tough, waterproof welded tarpaulin PVC as their roll-top dry bags. Both bags feature 4-point attachment straps, carry handle, retroreflective details and are completely waterproof.

45-liter Drybag 450
24.4" long x 10.2" diameter
BC.WBP.009.10000

\$79⁹⁹

25-liter Drybag 250
19.7" long x 8.7" diameter
BC.WBP.008.10000

\$65⁰⁰



Bags-Connection Drybag 80 Tank/Tailbag

NEW

The brand new Drybag 80 from Bags-Connection was designed to be used as a tankbag, tailbag or wherever else you might need small waterproof storage. Easily remove it from the bike and sling it over your shoulder and take it with you.

Drybag 80
13.8" L x 7.5" W x 3.5" H
BC.WBP.010.10000

\$95⁰⁰

Features:

- 3-point tie-down system
- 8 liter capacity
- Made of waterproof welded tarpaulin PVC
- Fits nearly all motorcycles but ideal for small dualsports and dirt bikes



Drybag 80 as a tailbag



Drybag 80 as a small tankbag



Baracuda 30L Waterproof Backpack

Roll-top, dry bag backpack

Versatile backpacks for work, play and everyday use with smart features tailored for motorcyclists. Bags-Connection backpacks are designed to hold everything you need without weighing you down.

- Made from welded waterproof PVC
- 30-liter volume
- Size: 28.75" H x 15" W x 8.25" D
- Weight: 3.5 pounds
- Retroreflective trim
- Interior pockets for organization
- Easy-lock shoulder strap detaches on right side using a Fastex connector, making it easy to put on the backpack when wearing a stiff, armored motorcycle jacket
- Molded back cushions provide comfort as well as air channels to keep your back cool in the summer
- Chest and waist straps connect the shoulder straps to help carry the load, keeping you comfortable
- Padded interior sleeve fits up to a 17" laptop computer

Top waterproof seal rolls closed

\$199⁹⁹

BC.WPB.00.003.10000



Triton 20L Waterproof Backpack

Roll-top, dry bag backpack

The Triton shares all the same features as the Baracuda but in a smaller 20 liter size.

- 20-liter volume
- Size: 26" H x 13.75" W x 5.5" D
- Weight: 2.6 pounds

\$149⁹⁹

BC.WPB.00.004.10000



DrySpec D20 Saddle Bag Set



NEW



The D20 saddlebag set is constructed of RF welded 22oz. vinyl that guarantees 100% waterproof performance even when submerged. Unlike all other saddlebags, the D20's interchangeable center strap is the core innovation that allows the bags to be so versatile. The bags mount directly to a bike with or without sideracks and can attach directly to other D-Series dry bags. Use the Velcro center strap for convenience, the solid nylon strap for extremely muddy conditions, or remove the center strap all together to mount the bags directly to a D28 or D38 dry bag. Mounting the D20 saddlebags to the D28 or D38 dry bag is the ideal solution for riders who want the extra storage but can't mount traditional saddlebags due to high exhausts.

Features:

- Modular packing (mates with D28 and D38)
- Universal slip-lock mounting straps (included)
- Interchangeable center straps (Velcro or solid nylon)
- Mounts with or without sideracks
- Retroreflective logo
- Available in black, orange, or gray

Specs:

- 40 liters (20 liters each side)
- 100% waterproof (Radio Frequency Welded Seams)
- 17" long x 6" wide x 12" tall
- 22oz Vinyl & coated Cordura



\$149⁹⁹

DSL.D20.10000



DrySpec D28 Dual-End Dry Bag

NEW UPDATED



Gray

The D28 is constructed of RF welded 22oz. vinyl that guarantees 100% waterproof performance even when submerged. Unlike other dry bags, the D28 features a dual-end roll design that allows access to belongings from either end of the bag without having to disconnect the mounting straps. The D28 is perfect by itself for short trips, but is the ideal add on bag for a D38 or your existing sidecases.

Features:

- Dual-ended opening
- Modular packing (mates with D20 and D38)
- Universal quick release mounting straps (included)
- Mounts with or without toprack
- Infinitely useful daisy chain mounting strip
- Retroreflective logo
- Strap keepers to secure excess webbing
- Available in black, orange, or gray

Specs:

- 28 Liters
- 100% waterproof (RF Welded Seams)
- 22" long x 9" wide x 9" tall
- Welded carry handle
- 22oz Vinyl & coated Cordura



Black



Get creative! Use the D28 as an expansion bag for your sidecases.

\$74⁹⁹

DSL.D28.10001

DrySpec D38 Rigid Dry Bag

NEW UPDATED



Gray

The D38 is constructed of RF welded 22oz. vinyl that guarantees 100% waterproof performance even when submerged. The D38 features a rigid core that enables the bag to be mounted to any bike, with or without a top rack, even when the bag is completely empty. Try that with a traditional dry bag! The rigid construction and unique 4-point strap mounting system work together enabling easy access to contents without loosening straps or removing the bag from the bike.

Features:

- Rigid Core Construction
- Modular packing (mates with D20 and D28)
- Universal slip-lock mounting straps (included)
- Mounts with or without toprack
- Infinitely useful daisy chain mounting strip
- Retroreflective logo
- Adjustable & detachable carry handle
- Strap keepers to secure excess webbing
- Available in black, orange, or gray

Specs:

- 38 Liters
- 100% waterproof (RF Welded Seams)
- 22" long x 12" wide x 9" tall
- 22oz Vinyl & coated Cordura



Black

Orange



No rack needed!

\$139⁹⁹

DSL.D38.10001

Modular packing has significant advantages over a single bag of the same volume. The Denali Modular system makes packing and organizing your gear easier, allows for quicker access to your gear, and enables strategic separation of your gear. Keep your clean clothes separate from your wet tent. Each D-Series bag is also designed to mount directly to your bike. It's like getting three different bags in one.

DrySpec D66 Modular Packing System



Gray

The D66 includes one D28 and one D38 dry bag to create 66 liters of 100% waterproof storage.

Use the D28 on local trails, strap on the D38 for around town, or connect the D66 for longer adventures.

MSRP: \$214.98

Special Price!
\$192⁹⁹

DSL.D66.10001



Orange



Black

Features:

- Includes a complete D28 & D38 dry bag
- Modular packing (also mates with D20 saddlebags)
- Universal slip-lock mounting straps (included)
- Universal quick release mounting straps (included)
- Mounts with or without toprack
- Infinitely useful daisy chain mounting strip
- Retroreflective logo
- Strap keepers to secure excess webbing
- Available in black, orange, or gray

Specs:

- 66 Liters
- 100% waterproof (RF Welded Seams)
- 22" long x 12" wide x 18" tall
- 22oz Vinyl & coated Cordura

The Mighty D106!

Special Price!
\$329⁹⁹

Combine the D66 Modular Packing System with the D20 Saddlebags for the most storage possible from the DrySpec line, 106 liters, and save 10%!

DSL.D106.10000: MSRP \$364.99

DrySpec D68 Modular Packing System



The D68 includes one D20 saddlebag set and one D28 dry bag to create 68 liters of 100% waterproof storage.

The D68 is ideally suited for riders on smaller enduro bikes who need big storage capacity but don't want to be weighed down with bulky sideracks just to keep the bags off your exhaust.

MSRP: \$224.99

Special Price!
\$204⁹⁹

DSL.D68.10000



Features:

- Includes a complete D20 saddlebag set & D28 dry bag
- Modular packing (also mates with D38 dry bag)
- Universal slip-lock mounting straps (included)
- Universal quick release mounting straps (included)
- Mounts with or without toprack
- Infinitely useful daisy chain mounting strip
- Retroreflective logo
- Strap keepers to secure excess webbing
- Available in black, orange, or gray

Specs:

- 68 Liters
- 100% waterproof (RF Welded Seams)
- 22" long x 21" wide x 12" tall
- 22oz Vinyl & coated Cordura

DrySpec D78 Modular Packing System



The D78 includes one D20 saddlebag set and one D38 dry bag to create 78 liters of 100% waterproof storage.

The D78 is ideally suited for riders on mid-size to large bikes who want massive storage capacity but don't want to be weighed down with bulky sideracks just to keep the bags off your exhaust.

MSRP: \$289.99

Special Price!
\$259⁹⁹

DSL.D78.10000



Features:

- Includes a complete D20 saddlebag set & D38 dry bag
- Modular packing (also mates with D28 dry bag)
- Universal slip-lock mounting straps for D20 (included)
- Universal slip-lock mounting straps for D38 (included)
- Mounts with or without toprack
- Infinitely useful daisy chain mounting strip
- Retroreflective logo
- Strap keepers to secure excess webbing
- Available in black, orange, or gray

Specs:

- 78 Liters
- 100% waterproof (RF Welded Seams)
- 22" long x 24" wide x 14" tall
- 22oz Vinyl & coated Cordura

DrySpec B50 Wide Mouth Dry Bag



The B50 is constructed of RF welded 22oz. vinyl that guarantees 100% waterproof performance even when submersed. The B50 features a wide opening and an adjustable/removable handle attached to D-rings. These D-rings serve double duty, acting as the attachment points to secure a wide variety of strap styles up and over the bag. The B50 is the ideal bag for riders who want high capacity luggage at the best price point.

Features:

- Wide mouth opening
- Mounts with or without top rack
- 4 oversized D-Ring accept wide variety of mounting strap styles
- Compatible with DrySpec Cam Strap Set (See page 167)
- Adjustable & detachable carry handle
- Retroreflective logo
- Available in black

Specs:

- 50 Liters
- 100% waterproof (RF Welded Seams)
- 22" long x 12" wide x 12" tall
- 22oz Vinyl & coated Cordura

Mounting straps sold separately.



Wide opening makes it easy to pack and find your stuff

Removable carry handle

Coated Cordura

DrySpec Cam Straps (sold separately)



\$95⁰⁰

DSL.B50.10000



DrySpec B65 Wide Mouth Dry Bag

The B65 is constructed of RF welded 22oz. vinyl that guarantees 100% waterproof performance even when submersed. The B65 features a wide opening and an adjustable/removable handle attached to D-rings. These D-rings serve double duty, acting as the attachment points to secure a wide variety of strap styles up and over the bag. The B65 is the ideal bag for riders who want high capacity luggage at the best price point.

Features:

- Wide mouth opening
- Mounts with or without top rack
- 4 oversized D-Rings accept a wide variety of mounting strap styles
- Compatible with DrySpec Cam Strap Set (See page 167)
- Adjustable & detachable carry handle
- Retroreflective logo
- Available in black

Specs:

- 65 Liters
- 100% waterproof (RF Welded Seams)
- 28" long x 12" wide x 12" tall
- 22oz Vinyl & coated Cordura

Mounting straps sold separately.



Wide opening makes it easy to pack and find your stuff

Coated Cordura

Removable carry handle



\$105⁰⁰

DSL.B65.10000

DrySpec Cam Straps

The cam strap set includes two complete cam straps that feature a low profile black anodized cam buckle. Each strap has an open loop on each end ensuring that they can be attached anywhere on your bike. The cam strap set is ideal for mounting medium to large loads like the DrySpec B50 and B65 dry bags.



DSL.STP.10000:
\$16.99/pair



DrySpec Quick Release Straps

The quick-release strap set is included with the D28 because it is the ideal strap system for attaching luggage on top of other luggage or directly to a rack. Each quick-release strap features a side release buckle in the center and two tension locks on either side to secure your load. Includes two complete straps.



DSL.STP.10100:
\$16.99/pair



DrySpec Slip-Lock Straps

The slip-lock straps were developed by DrySpec to create the strongest, lowest profile mounting solution. The tri-glides on the ends of each strap are designed to slip through and lock into the one inch hardware loop on the bag. This strap set is included with the DrySpec D38 and D20. Includes three slip-lock straps.

DSL.STP.10200:
\$14.99/set of three



DrySpec Fender Hooks

Coated in vinyl rubber to prevent scratching, the fender hooks are designed to grab the edge of fenders, body panels, and tanks when there is no frame for the loop straps to loop around. No need to buy all new straps, the fender hooks loop into place on your existing straps. Compatible with all DrySpec straps sets.



DSL.STP.10300:
\$9.99/set of four



Fold loop flat and push through slot in hook.



Pull tag end of strap through loop and pull tight forming a girth hitch.

Stash Box lockable license plate storage box

The Stash Box is a weather-resistant storage box that mounts between the motorcycle's fender and the license plate. It is ideal for storing your registration, wallet, and other small objects. The Stash Box is unobtrusive, inexpensive, and secure!

- Sized to work with all standard US & Canadian license plates
- External Dimensions: 7" x 4" x 1" (plus 1" lock assembly)
- Internal Dimensions: 6.3" x 2.2" x 0.8"
- Includes lock and two keys.
- Made from molded polypropylene
- Includes all mounting hardware, retention pouch for paper documents, and foam insert

\$19⁹⁹

TT.SBX.10000



QUICK-LOCK Soft Luggage Carrier for SW-MOTECH ALU-RACKS

Removable quick-release adapter plate for mounting soft luggage or enlarging the surface area of the SW-MOTECH ALU-RACK. This adapter plate provides lots of possibilities for attaching tie-down straps to different points on the rack. Attaches/detaches in seconds using three quarter-turn fasteners.

Dimensions:
 - Depth: 10"
 - Front width: 15.5"
 - Rear width: 13"



GPT.00.152.430 (for ALU-RACKS) \$66.99

GPB.07.710.10000.S (permanent mount version for BMW R1200GS, '04-'12) \$93.99



ALU-RACK required (See pages 124-125).



Mount soft luggage carrier to ALU-RACK.



Rackpack II attached to Soft Luggage Carrier (see page 161).

Expansion Rack for SW-MOTECH Steel Topracks

Sliding expansion plate for mounting soft luggage or enlarging the surface area of a SW-MOTECH Steel Toprack. Create a large surface for luggage or retract for a clean look.

Expands your Steel Toprack by up to 4.5" giving you a range of 12"-16.5" of total platform space.

- Secure 4 bolt installation.
- Loosen 4 attachment bolts to slide the wings inward or outward as needed for your luggage.
- Use it to attach soft luggage to an SW-MOTECH Steel Toprack.



GPA.00.804.10000.B \$49.99



Steel Toprack required (see page 122-123).



Retracted Mounted Expansion Rack.



Tent strapped to the Expansion Rack.



Bags-Connection Zipper Lock

- The Bags-Connection Zipper Lock is ideal for securing the contents of any rear bag or AERO sidecase. Not for use with Bags-Connection tankbags.
- Ultra-compact design makes these locks easy to carry.
- Simply pull through any compatible zipper pulls and engage the lock.
- Programmable combination.

BCK.LOC.00.001.001: \$8.25

Cable lock securing Rackpack



Cable lock securing Tankbag

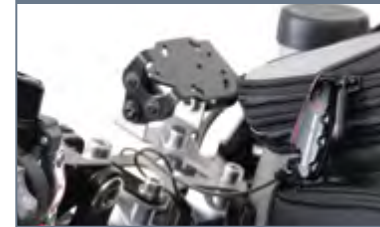

50cm (19.7") long: \$19.99

100cm (39.4") long: \$24.99

BC.LOC.00

Bags-Connection Cable Lock

- Ideal for securing tankbags and rear bags to the bike.
- Simply loop the combination end around the frame of the bike and through the loop on the other end of the cable and attach it to the bag's zipper pull and/or D-rings.
- Programmable combination lock.



Helmet Guardian locking 2 helmets



Helmet Guardian

- Easy to install on either the upper or lower license plate bolts.
- Consists of two high quality, spring-loaded helmet locks attached to a steel plate that is pre-drilled for attachment to most US and Canadian license plates.
- Powder coated black
- 11" W x 2.5" L

STA.HG.B: \$51.95



Bungee Net

Easy to use, strong elastic bungee net.

- 6 nylon-coated steel hooks
- 17" x 17"
- Great for transporting bulky, lightweight items that don't easily fit inside your luggage

OXF.OF1.77: \$9.95

Bungie Buddies

Easy to install, strong tie-down anchors that you can add almost anywhere you want.

- Strong, secure tie down
- Stainless steel with a nylon lock nut and plastic loop
- Seals tightly, no leaks



Pack of 4 - HYP.WBB4: \$9.95

ROK Straps

These flat stretch straps have a soft-loop design that allow you to secure the straps without scratching your motorcycle. Loops on both ends can be secured to just about anything, while the mid-strap buckle allows you to tighten the strap to your needs. Sold in pairs and available in multiple styles, sizes and colors.



Adjustable Moto Strap shown

ROK Straps	Notes	Price	Part Number
12" Non-adjustable Moto Straps	Sold in pairs. 3/4" wide. Color: Moto Plaid.	\$15.00	ROK.04.10002
18" Non-adjustable Moto Straps	Sold in pairs. 3/4" wide. Color: Moto Plaid.	\$16.50	ROK.04.10003
24" Non-adjustable Moto Straps	Sold in pairs. 3/4" wide. Color: Moto Plaid.	\$18.00	ROK.04.10004
30" Non-adjustable Moto Straps	Sold in pairs. 3/4" wide. Color: Moto Plaid.	\$19.50	ROK.04.10005
Adjustable Moto Straps 18" - 60"	18" to 60" long, 1" wide. Colors: Moto Plaid, Pink/Black, Hi-Viz/Black, Black/Orange, Black, Camo or Reflective Black. Sold in pairs.	\$24.00	ROK.01
Adjustable Moto Straps 12" - 42"	12" to 42" long, 5/8" wide. Colors: Moto Plaid, Pink, Hi-Viz/Black, Black/Orange, Black, Camo or Reflective Black. Sold in pairs.	\$13.95	ROK.02
Adjustable Commuter Straps	Up to 28" long, 3/8" wide. Colors: Reflective Orange or Reflective Green. Sold in pairs.	\$12.95	ROK.03

HelmetLok is a rubber coated carabiner with a 4-digit combination lock. Use it to secure your helmet to the bike's frame or handlebars with the Helmet's D-ring. Add a cable to the HelmetLok run through your jacket's sleeve to secure your jacket too.



9338328000220
\$29.95

adventurePOCKETS

Handy storage for essential items

MotoPOCKET Topcase Lid Organizer Bag

Designed for mounting on the inside of your motorcycle's topcase or other hard luggage. The motoPOCKET topcase organizer bag is a convenient and removable storage solution for items that need to remain organized. Available with solid nylon or net pocket.

- Glove-friendly zipper pull.
- Dimensions: 11.5"W x 9"T x 1.5"D.
- 600 Denier polyester PVC-backed material.
- Loop carry handle.
- Mounts to the inside of topcase or other hard luggage.
- Velcro mount for convenient removal.
- Includes self adhesive hook & loop pad, and application tool.

Solid version: APK.10002 \$42.95
Net version: APK.10003 \$45.95



MotoPOCKET Sidecase Lid Organizer Bag

Designed for mounting on the inside of your motorcycle's sidecase or other hard luggage, the motoPOCKET sidecase organizer bag is a convenient and removable storage solution for items that need to remain organized. Available with solid nylon or net pocket.

- Glove-friendly zipper pull.
- Dimensions 14" wide by 6" tall by 2" deep.
- 600 Denier polyester PVC-backed material.
- Loop carry handle.
- Mounts to the inside of sidecase or other hard luggage.
- Velcro mount for convenient removal.
- Includes self adhesive hook & loop pad and application tool.

Solid version: APK.10005 \$35.95
Net version: APK.10006 \$39.95



MotoPOCKET Glove Box Organizer Bag

Designed for mounting on the underside of your motorcycle's windscreen, the motoPOCKET Glove Box is a convenient and removable storage solution for items that need to be kept at arms length

- Glove friendly zipper pull.
- Dimensions: 11" wide, 7" tall, 1.75" deep.
- 600 Denier polyester PVC backed material.
- Mounts to underside of windshield.
- Velcro mount for convenient removal.
- Includes self adhesive hook & loop pad, and application tool.

APK.10001 \$39.95



MotoPOCKET Handlebar Bag

Designed for mounting on your motorcycle's handlebars, the Adventure POCKETS, motoPOCKET Handlebar Bag is a convenient and removable storage solution for items that need to be kept at arms length.

- Glove friendly zipper pull.
- Dimensions 11" wide, 7" tall, 1.75" deep.
- 600 Denier polyester PVC backed material.
- Velcro straps for convenient removal.

APK.10004 \$35.95

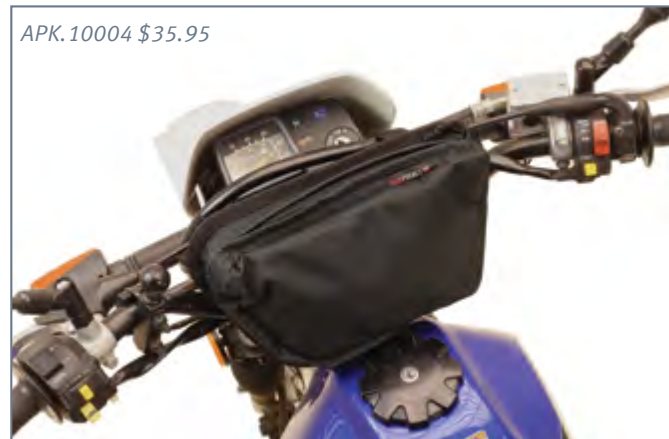

ROTO PAX™

RotopaX Fuel and Water Cells

Leak-proof RotopaX 1-gallon fuel and water packs allow you to ride longer with extended fuel capacity! Designed as a modular system to stack and lock to optional pack mounts (see below).



Fuel Cell

- 1-gallon fuel capacity
- 9.5" x 13.25" x 3"
- New and improved spout!
- Spouts turn around and store inside of the fuel packs
- Pack mounts sold separately

\$54⁹⁵

RX.1G



Water Cell

- 1-gallon water capacity
- 9.5" x 13.25" x 3"
- Pack mounts sold separately

\$39⁹⁵

RX.1W

Twist & Lock Mounting Hardware

Pack Mount

The quickest, strongest way to mount your RotopaX.

- Anodized aluminum
- Bolt the pack mount directly to a solid surface with two bolts for a clean look, or use the included base plate to distribute the load to 4 mounting points
- Base plate included
- Mounting hardware included
- Bolts directly to SW-MOTECH Steel Topracks

RX.PM: \$29.95



Pack Mount Extension

Enables two RotopaX to be mounted on top of each other.

Use in conjunction with pack mounts. (RX-PM, RX-LOX-PM)

RX.EXT: \$23.95



Pack Mount with Pack Mount Extension.



SW-MOTECH Steel Topracks have pre-drilled holes that accept RotopaX Pack Mounts. See page 192-269 for more information on Steel Topracks.

LOX Pack Mount

Includes a locking mechanism in the handle, preventing theft of your RotopaX.

- Anodized aluminum
- Locks fuel cells or storage packs
- Mounting hardware included
- Base plate included
- Bolts directly to SW-MOTECH Steel Topracks

RX.LOX.PM: \$44.95



Backing Plate

The optional backing plate can be used in conjunction with the included base plate to provide additional support to the backside of the mounting surface.

- Powder coated steel
- 5.5" round, 16 gauge (.063")
- Pre-drilled holes for 8mm bolts

RX.BP: \$5.50



RotopaX Fuel Cell mounted to 38-liter TraX ALU-BOX.

Looking for extra storage?

Basic Bottle Mount

This bottle mount bolts permanently to the outside of any flat-sided surface, including sidecases, and can be used to carry our MSR 30oz Fuel Bottle and Twisted Throttle 30 oz Water Bottle. It can hold any bottle with a height of 8" to 12" and a diameter of 2.5" to 4". Velcro straps and a top-end bungee cord are provided for added security. Mounting hardware included.

Bottle mount includes hardware for attachment to flat surfaces, including sidecases. Installation onto an QUICK-LOCK EVO Sidecarrier requires the Sidecarrier Accessory Mounting Kit (sold separately, see below).

BMT.00.805.10000.B: \$35.00

MSR 30oz (887ml) Fuel Bottle

Air-tight seal allows fuel to be stored longer by preventing air from entering and degrading fuel. Made from a single-piece of impact-extruded aluminum to prevent leaks and cracks. Bolstered shoulder and base to resist bulging when pressurized. Diameter 3.15"

CCD.11832: \$19.95

Storage Tube with Flush Mount Kit

This storage tube attaches directly to the outside of most flat-sided sidecase and can be used to carry our MSR 30oz. Fuel Bottle and Twisted Throttle Water Bottle, as well as any other gear that can fit inside of it. It has an internal diameter of 3.25" and an internal height of 11.5". The storage tube mounting kit includes the proper size drill bit, hex head screws, sealing washers, and large exterior washers.



Storage Tube with MSR 30oz. Fuel Bottle

DJA.67670.100: \$14.99



Twisted Throttle 32oz (946ml) Water Bottle

Take us with you on the go with this swanky Twisted Throttle branded water bottle. Measuring 10.6" tall with a diameter of 3.15", this aluminum water bottle holds 32oz. and is completely BPA free. Fits inside tool tube and comes with clip-on non-weight bearing carabiner.

GWB-39376: \$9.95



Sidecarrier Accessory Mounting Kit

If you would like a more discreet way of mounting extra storage, you can attach the Basic Bottle Mount or Storage Tube to an SW-MOTECH EVO Sidecarrier with this mounting kit.

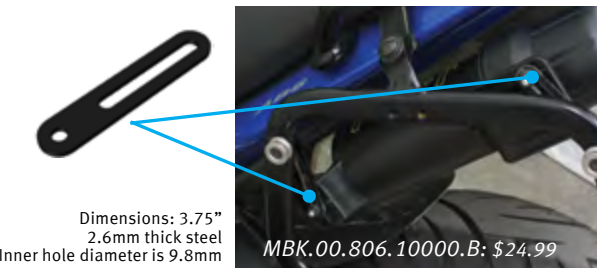

Dimensions: 3.75" x 2.6mm thick steel
Inner hole diameter is 9.8mm

MBK.00.806.10000.B: \$24.99

QUICK-LOCK Bottle Mounts

QUICK-LOCK Baseplate:

This baseplate bolts permanently to the outside of most flat-sided surfaces, including TraX and Pelican sidecases. The QUICK-LOCK fuel canister holder (see right) will slide into the base plate and lock in place. To release the holder from the base plate, just press the release switch. Base plate kit includes drill bit, bolts, nuts, and washers for easy installation.

ALK.TT.00: \$49.99

QUICK-LOCK Baseplate on TraX sidecase

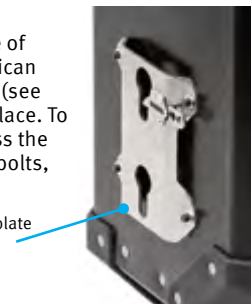

Bottle Mount - Single

Secure this bottle mount to the Quick-Lock Baseplate. Bottle Mount comes with 2 straps to secure bottle. Suitable for most fuel or water bottle. Quick-Lock Baseplate sold separately.

ALK.00.165.30700.S: \$52.99



Bottle Mount - Double (Not shown)

Also available is a wider bottle mount that is used for mounting two bottles. Attaches to Quick-Lock Baseplate (sold separately).

ALK.00.165.30800.S: \$86.99

QUICK-LOCK Fuel Canister with Holder:

Kit includes one 2-liter black plastic fuel canister and holder with straps. This unit requires the ALK.TT.00 QUICK-LOCK baseplate (see left). Approximate bottle dimensions: 8.25"H x 5.5" W x 3.3" D.

ALK.00.165.31100.B: \$74.99



QUICK-LOCK fuel bottle holder 2 liter fuel bottle



SW-MOTECH 20oz (600ml) Water Bottle
Silver aluminum water bottle holds 20oz. and is completely BPA free.

ALK.00.165.31000.S: \$25.25

NEBO Highbeam™ Rechargeable Flashlight

No Batteries!

The Highbeam is a compact, rechargeable 35 lumen LED flashlight that NEVER needs batteries. Casting a soft light for short-distance campsite illumination or nighttime reading, the Highbeam charges in any 12-volt power socket (cigarette lighter) and glows red when charging.

Features

- High-power LED outputs 35 lumens of light (rated for 110,000+ hours of life)
- Anodized aircraft grade aluminum
- Waterproof
- Available in blue, gray, pink, brown, green and black
- Compact (measures 2.5" long x 0.75" diameter)

\$999

NEB.HB



actual size

LED glows red when charging

NEBO REDLINE® Tactical LED Flashlight

High-end technology in a compact, extremely powerful light!

The REDLINE® is exceptionally bright with 220 lumens of pure white light! To put the power of this flashlight in perspective, anything above 50 lumens within a 10 yard distance may cause temporary blindness. 3 AAA batteries are included, eye patches are not. The REDLINE®'s adjustable wide angle lens adjusts from a floodlight that illuminates everything within 20 yards, to a spotlight with a 150 yard range.

Features

- Output of 220 lumens of light
- 0.428 lbs.
- 4 hours at 100% illumination
- 8 hours at 50% illumination
- Aircraft grade aluminum
- 4.5" long x 1.25 diameter
- Water-resistant

\$3499

NEB.5610

\$3999

NEB.5624



Quick-release mount attaches to .87" to 1.25" diameter handlebars.

REDLINE® (NEB.5610) has 5 modes:

- 100% - 220 lumens
- 50% - 110 lumens
- 10% - 22 lumens
- S.O.S. mode - 220 lumens
- Defensive strobe mode - 220 lumens

REDLINE® Bike Light (NEB.5624) has 3 modes:

- 100% - 220 lumens
- 50% - 110 lumens
- Defensive strobe mode - 220 lumens

NEBO REDLINE RC300 Rechargeable LED Flashlight

Big power and no batteries!

What could be better than a 300 lumen REDLINE flashlight? The answer is a 300 lumen flashlight that you don't have to put batteries in...EVER! The REDLINE RC300 is NEBO's first fully rechargeable flashlight.

Integrated with a heat-sink design, anodized aluminum body and aggressive face, the RC has everything that you'd expect a REDLINE to have. The RC comes with 2 adapters (AC & DC) to charge the light anytime, anywhere. Not only is the RC300 bright but it also has an adjustable light output. Just press the button to turn the light on and hold down the button to dim the light from 100% to 10% brightness.

Features

- High power 300 lumen LED. (Bulb rated for 110,000+ hours of life)
- Heat-sink bezel design
- Dimmable beam from 100% to 10%
- Anodized aircraft-grade aluminum water-resistant body
- Charging port
- AC wall plug charger and DC cigarette lighter charger included
- Powered by one 2000mAh rechargeable lithium ion rechargeable battery (included)
- Size - 7.4" x 1" Weight - .2 lbs.
- Run time - 2.5 hours @ 100%, 36 hours at 10% brightness
- Viewing distance - 650 feet @ 100%, 82 feet @ 10%

\$5999

NEB.6007



NEBO Bat Light

Na na, na na, na na, na na, Bat Light!

Ok, it's not for signaling the Caped Crusader. It's an LED flashlight that's shaped like a small baseball bat. We hope you'll never have to use this 16.25 inch long, aircraft-grade aluminum Bat Light for self-defense, just like we hope you'll never have to use its 200 lumen LED light to fix your bike on a cold, rainy night. There's a lot of fun things the Bat Light can do, like pound in tent stakes, tenderize a steak, knock mud chunks off your bike or play an impromptu game of Wiffle Ball.

Features

- High power 200 lumen LED
- 3 power modes, 100%, 50% and strobe
- Runs on 4 AA batteries (included)
- Anodized aircraft-grade aluminum water-resistant body
- 8 hours of light at 100%
- Viewing distance - 300 feet @ 100%
- Lanyard included
- Size - 16.25" long x 1.5" diameter
- Weight - .45lbs.
- Ergonomic textured handle

\$3999

NEB.5904



NEW

Redverz Series II Expedition Tent



Base Camp Big Daddy

The Redverz Series II Expedition tent not only shelters riders, but also a motorcycle and gear out of the elements and under one roof. This is the tent you need to establish a base camp. It packs 1.9 times larger than the MSR Hubba Hubba, but its convenience is well worth it once your home base is set up- especially on wet rainy trips!

The Redverz features expedition-grade ripstop nylon floors that offer superior protection, while the double wall design of the sleeping bay helps eliminate condensation.

The spacious garage bay shelters your motorcycle and can be used as a workshop, dressing room, cooking area (no open fire, please) and sitting area.

Specs:

- 13.5 lbs.
- 30 sq. ft. (sleeping area sleeps 3)
- 61 sq. ft. (motorcycle bay)
- Peak height: 77"
- Packed size: 21" long x 10" dia.
- Non-free standing design (requires stakes)

Available accessories:

Awning kit RDV.NET.AWNING: \$59.00

Ground cloth RDV.NET02.BN : \$35.00



BMW R1200GS ADV fits in easily

Enough space for a party of 10 to cook out.

\$449⁰⁰

Green: RDV.NET01.GN
Yellow: RDV.NET01.YW

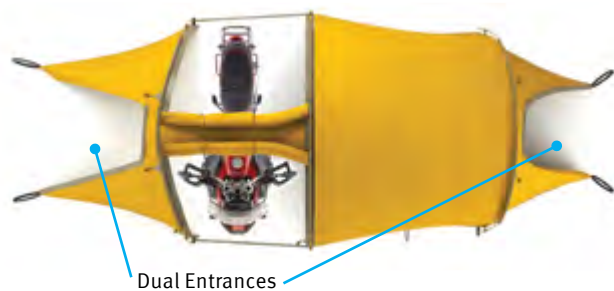
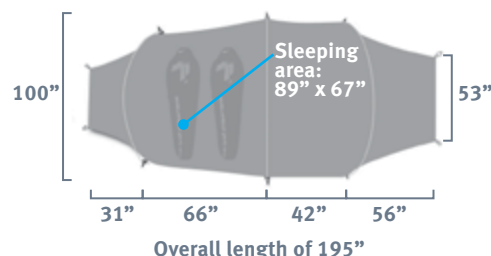

Dual Entrances
Available in Green or Yellow

MSR Fast Stash Tent

When talk turns to the most versatile ultralight shelters made, the Fast Stash is sure to be at the top of the list. With more than ample room for two plus gear, a full-protection, single-wall body with DuraShield™ coating pitches quickly with the included poles. Ideal for a range of conditions, the side wings can be pulled in for maximum protection, pulled out for increased air circulation and covered exterior storage, or pulled back completely exposing broad side vents for maximum, flow-through ventilation. A covered entry allows the broad front door to easily be enjoyed by two, even in the rain. Includes 2 poles.

Specs:

- 4 lbs.
- 36.5 sq. ft. (sleeps 2)
- 48" peak height
- Packed size: 20" long x 6" dia.
- Includes 2 poles
- Rainfly fabric: 30D ripstop nylon 1500mm Durashield polyurethane & silicone
- Floor fabric: 40D 30D ripstop nylon 3000mm Durashield polyurethane & DWR
- Single entrance, (2) internal storage pockets, reinforced guy points, and factory seam taped DuraShield-coated fabrics
- Non-free standing (requires stakes)

Available accessories:

Footprint CCD.05169: \$39.95

\$199⁹⁵

CCD.05153

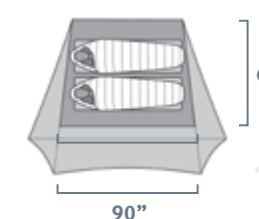

Side wings pulled in.

MSR Hubba Hubba NX Tent

The MSR Hubba Hubba 2-person tent is an ideal choice for the solo motorcyclist, with its spacious main area and dual vestibules, there is plenty of space for you and your gear to spread out and stay out of the elements. Ultra-compact and precision-engineered, the tent feels as light and efficient to use as it does to carry. From its optimized, symmetrical geometry and non-tapered floor that maximize space, down to its integrated, adjustable stake-out loops that speed setup, this tent redefines livability. Whether you're setting out to Ushuaia or Prudhoe Bay, the freestanding, 3-season Hubba Hubba tent lets you enjoy the full backcountry experience — including time spent in the tent.

Specs:

- 3 lbs. 7 oz.
- 29 sq. ft. floor area (sleeps 2)
- 17.5 sq. ft. vestibule area
- 39" peak height
- Packed size: 18" long x 6" dia.
- Rainfly fabric: 20D ripstop nylon 1200mm Durashield polyurethane & silicone
- Floor fabric: 40D 30D ripstop nylon 3000mm Durashield polyurethane & DWR
- Includes selective guy lines, poles and compression stuff sack
- Free standing

Available accessories:

Footprint CCD.05164: \$39.95

\$389⁹⁵

CCD.02750



2 Entrances
2 Vestibules

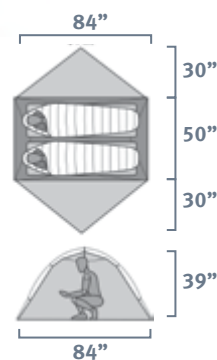

Rain fly shut.

MSR E-Wing Tarp

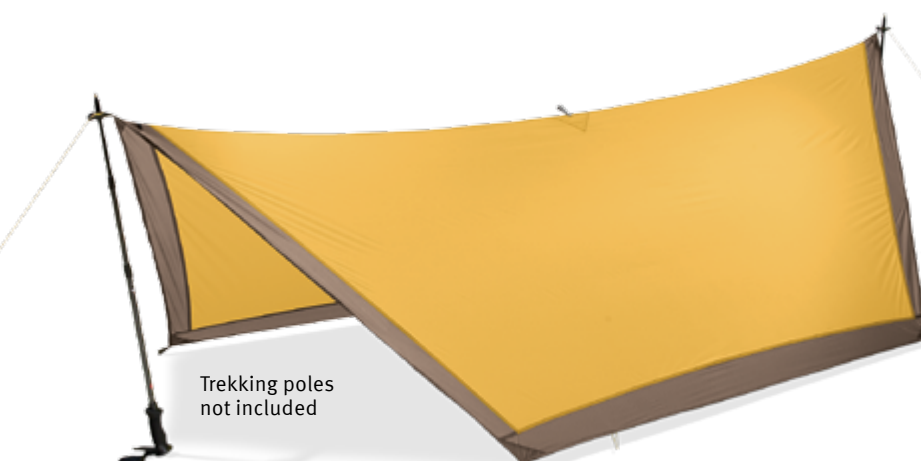

Trekking poles not included

Traveling light? The E-Wing ultralight tent now offers ample coverage and protection for ounce-counting minimalists. A straightforward Silnylon canopy with burly DuraShield waterproof coating pitches with poles (not included), trees, your bike or overhead objects to deliver on-the-spot shelter. This ultralight tarp-tent can also be tossed into a tankbag on any trip for use as a lightweight emergency shelter for two.

Specs:

- 1 lbs. 3oz.
- 65 sq. ft. (sleeps 2)
- Adjustable peak height
- Packed size: 9" long x 4.5" dia.
- Fabric: 30D ripstop nylon 1500mm Durashield polyurethane & silicone
- Multiple pitch options
- Non-free standing (requires poles & stakes)

\$174⁹⁵

CCD.05149

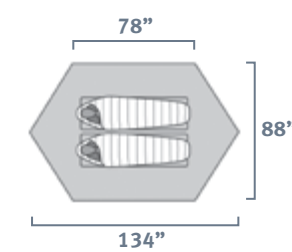

Mini Groundhog 6" Tent Stakes

The proven Y-beam design of the Mini Groundhog Tent Stakes penetrates and holds in medium to firm soil, while the 7000-series aluminum provides years of strength and durability. They don't break. We tried with the Bat Light, they wouldn't give in.

A pull loop allows for easy removal. Comes in a pack of 6 stakes.

.35 oz each (10g)

6" long (15cm)

CCD.06893: \$17.95



Sexy Hotness 20° Synthetic Sleeping Bag by Alite

The Sexy Hotness sleeping bag was designed to keep you warm in the Spring, Summer, and early Fall months. Well...actually...it was designed for you to have sex in while camping in the woods. (There, we said it.) Zip two or more Sexy Hotness sleeping bags together to make double or triple room. The body of the sleeping bag is wide and roomy so no claustrophobia when you zip up. Unzip the handy middle zipper to create "legs" for walking or get some air into those nether regions. Interior fleece slippers and padded bottoms make walking a reality. Perfect for when nature calls, and you don't feel like leaving the comforts of your bed. Large size weighs 3.9 lbs. Packed size is 10.5" long x 15" dia.

Features: drawstring hood, arm holes, storage & stuff sack

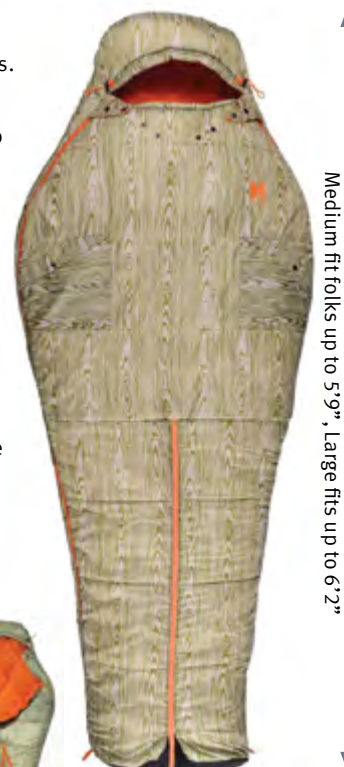

Medium fit folks up to 5'9", Large fits up to 6'2"

\$179⁰⁰

Large
ADI.02-01A-WDG6



Snuggle up to your honey when you zip 2 Sexy Hotness bags together!

Antares 15° Down Sleeping Bag by MSR

The three-season Antares sleeping bag should handle it all – from late-season snowstorms to early frosts. The award-winning, Antares™ down sleeping bag delivers that performance in an ultralight package without sacrificing the warmth and comfort you need for a great night's rest. Additional box-baffling holds more loft and eliminates drafts, resulting in a temperature rating of 15F (-9C). The performance didn't add any weight though, keeping the Antares a lightweight sleeping bag that can go the distance on the trail. Weighs 2.2 lbs. Regular version fits people up to 6 foot tall, long version fits 6'6." Packed size is 7" dia. x 12" long.

Features: draft tubes & collar, snag free zipper, stash pocket, sculptured hood, trapezoidal footbox, storage & stuff sack



Regular 78" (198 cm), Long 80" (203 cm)

Starting At
\$379⁹⁵

Regular
CCD.0698.4
Long
CCD.0698.5



SynergyLink Connectors securing the Saros to a NeoAir XLite pad.

Regular 62" (158 cm)
Long 64" (163 cm)

NeoAir XLite Sleeping Pad by Therm-a-rest

The NeoAir XLite mattress delivers more warmth and comfort per ounce than any other three-season air mattress available. Patent-pending technologies deliver that performance with minimal weight and less bulk than a one-liter water bottle. The made-in-USA XLite is 2.5" thick and has a baffled internal structure that provides unrivaled stability and support. Inflated, it measures 77" long and 25" wide at its widest part. Packed size is 11" long x 4.5" dia.

Included: stuff sack.

\$159⁹⁵

CCD.0664



Packs as small as a water bottle



LuxuryLite UltraLite Cot by Therm-a-rest

Get your self off the ground and get a good night's sleep! Weighing just 2 pounds (.9 kg), the award-winning UltraLite Cot is lighter and packs smaller than any cot on the market. The patented BowFrame™ cot design creates a stretch-free fabric bed that offers superior, off-the-ground sleeping comfort. The cot is made from ultralight ripstop nylon with aluminum poles, nylon feet and comes with a stuff sack for easy packing. Made in the USA. Measures 77" x 26" and weighs 3.5 pounds.

Included: stuff sack.

\$239⁹⁵

CCD.0639.6



Packed size: 17" x 5" dia.



Saros 20° Synthetic Sleeping Bag by MSR

The Saros sleeping bag is the perfect choice for trips that start with a shaky forecast. EraLoft™ synthetic insulation offers warmth and weather resistance that's ideal in wet weather and temperatures down to 20F (-7C). SynergyLink Connectors create a direct connection to your mattress, preventing it from slipping out and ensuring you stay warm and comfortable all night long. Weighs 3.1 lbs. Regular version fits people up to 6 foot tall, long version fits 6'6." Packed size is 8" dia. x 18" long.

Features: draft tubes & collar, snag free zipper, stash pocket, sculptured hood, trapezoidal footbox, storage & stuff sack



Regular 76" (193 cm), Long 82" (208 cm)

Starting At
\$189⁹⁵

Regular
CCD.069.88
Long
CCD.069.89



Regular 62" (158 cm)
Long 64" (163 cm)

SynergyLink Connectors securing the Saros to a NeoAir XLite pad.

Cosmo Air Sleeping Pad by Nemo

Cosmo Air™ is a lightweight sleeping pad with a built-in pump and integrated valve. This pad has a generous 3" thickness but weighs only about 2 lbs, making it ideal for backpacking, motorcycling, or other ultralight travel. Packs down smaller than typical self-inflating mattresses that are only 1/2" thick! The Cosmo™ takes only 1.5 minutes to inflate!

Included: Stuff sack, compression strap, and repair patches.

\$149⁹⁵*

NEMO.814041010276
*See website for current price.

Packed size:
9" long x 4.5" diameter
1 lb. 13 oz.



Inflates quickly using the integrated foot pump. A mouth valve is included for manual inflation.



76" (193 cm)

25" (64 cm)

Mayfly Camp Chair by Alite

When you sit down in the Mayfly Chair, the first thing you notice is how comfortable it is! Its removable front foot can be used to give the chair stability, or remove it to pop campfire wheelies while you enjoy your beer. When you are ready to go, the Mayfly collapses down into a much smaller package than standard outdoor chairs, that can easily fit into your panniers. It only weighs 1.4 lbs, so it's extremely easy to carry around but it can hold up to 250 pounds. It's also color coded for easy assembly.

Included: Stuff sack.

Black - ADI.01-04A-BLK5: \$100.00

Jupiter Orange - ADI.01-04A-JOR5: \$100.00



Packed size:
11.5" x 4.3" dia.
Weighs 1.4 lbs.



PlatyPreserve Canteen

The PlatyPreserve is designed for the wine connoisseur but it works great for any spirit or beverage. Oxygen can hurt the taste of wine so the PlatyPreserve makes it easy to squeeze the extra air out, which also saves space. Transporting cans or glass bottles is a recipe for disaster in your bike's luggage. Careful packing and the PlatyPreserve's thick Nylon/PE bladder greatly reduces the chance of all your belongings smelling like a bar.

- 6.3" W x 10.25" H
- .8 liters/27 fluid ounces
- Made in USA
- Food-grade lining is 100% taste free



Single PlatyPreserve CCD.0707.1: \$9.95
4-pack PlatyPreserve CCD.0707.2: \$29.95



Fillo Travel Pillow

Fillo™ is our favorite travel pillow. The Fillo™ features 3" thick inflatable cells, 1" of memory foam, and a microfiber top. The Fillo™ cover is made of a velvety-soft machine-washable microfiber fabric.

NEMO.814041011426: \$44.95



The Fillo™ packs to 6" x 4" and weighs only 0.3 lbs.

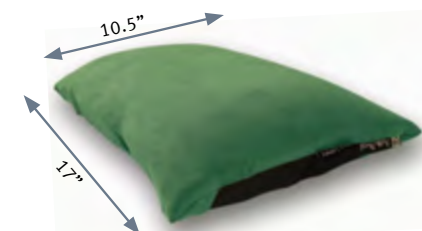

An integrated shock cord allows you to add clothing to increase the height of Fillo™ for optimal neck support.



Stop & Go is the originator of the first complete roadside motorcycle tire repair kit and the brand most asked for by name - and with good reason. Pocket Tire Plugging Kits offer a lightweight, compact solution for roadside tire repairs. With innovative tire repair options for both tubed and tubeless tires, Stop & Go will get you on the road again in no time!



Pocket Tire Plugging Kit for Tubeless Tires

The revolutionary Pocket Plugging device allows you to easily install a professional style mushroom-shaped rubber plug into any tubeless tire without removing the tire from the wheel. With a turn of the included hex wrench, the Pocket Plugging device drives the plug into the offending hole. Once the plug is inserted, inflate the tire, and the plug expands under pressure to fill the punctured area. A firm pull on the plug stem with your pliers seats the mushroom head on the inner wall, allowing no air to escape. This technology insures maximum reliability while reducing your downtime in any situation, all without the use of messy liquid glues!

Includes:

- Nozzle
- Tire Plugging Device
- Probe Tool
- Reamer/Rasp Tool
- Laminated Instructions
- (15) Mushroom Plugs (5/16" diameter shaft x 3/4" length stem)
- Vinyl Zippered Pouch (7.5" x 3.5" x 1") is smaller than a 4 oz. bag of tasty beef jerky and fits under most motorcycle seats
- Hex Wrench
- Retractable Razor Knife
- Extra Zip Lock Bag
- Weighs only 12 oz!

SNG.1000: \$34.95

Automatic Tire Inflation Kit

Each of these four threaded steel canisters contains 16 grams of 100% pure, high velocity CO₂ gas. In seconds, 8-9 lbs. of inflation is discharged into your tire by each canister. The re-usable loss-less valve adapter is solid brass and allows no leakage. A full-size sport or adventure-touring motorcycle tire, generally requires all four canisters to reach 24-32 lbs. This kit is suitable for motorcycles, scooters, ATVs, golf carts, lawn mowers, and small utility tires.

Includes:

- (4) Steel Canisters containing 16 grams each of 100% pure high-velocity CO₂ gas
- Tire Valve Adapter with brass fittings
- Compact Pouch (5" x 3.5" x 1") is about the size of a wallet
- Full Instructions
- Weighs only 10 oz!

SNG.1090: \$23.95



Dynaplug Tubeless Tire Repair Kit

For the ultimate in light weight and compact size, the Dynaplug is a new take on traditional sticky worm tire patches. Engineered for repairing punctures in tubeless tires for cars, trucks, motorcycles, scooters, and more with a maximum tire thickness of 1-1/8" and a minimum thickness of 3/16" at the point of the puncture. Easy-to-use, neat and clean. No need for "reamers," messy glues or solvents. All Dynaplug products are designed to repair a punctured tire in less than a minute without taking the tire off the wheel. This plug can permanently seal the puncture hole from the inside out without compromising the tire balance.

Features:

- Plugs, insertion tip and cleaner store inside handle
- Made in U.S.A.
- Weighs only 3 oz!
- 5.4" long x 0.9" diameter



Ultralite: DPU-1229 \$29.99
 Pro-Stainless: DPP-SS-1236 \$69.99
 Pro-Aluminum: DPP-AL-1243 \$59.99
 To learn more about what's included in each kit, visit TwistedThrottle.com.



Tire Lever Set (Pair)

These heavy duty tire irons are ideal for emergency tire repair, but are also quite useful for fighting zombies. (If fighting vampires or werewolves, please call to inquire about our garlic-scented silver-plated tire levers.)

- Specially designed tip for easy tire removal
- 8" (20cm) long
- 2 levers per package
- Made of forged steel

PT.TL.5C: \$23.95



Tubed Tire Patch Kit

If you have tubed tires, don't worry - Twisted Throttle hasn't forgotten you. The Tubed Tire Patch Kit includes six patches in three different sizes, rubber cement, and an abrasive pad in a zip-lock bag.

SNG.3003: \$5.75

Stop & Go Portable Mini-Air Compressor

The Stop & Go Portable Mini-Air Compressor is a truly compact motorcycle pump at a great price. The built-in gauge allows you to monitor pressures up to 120 psi. It also comes with a built-in LED light letting you know that it is receiving power and helps you connect to the tire valve after dark. Your motorcycle tire will be fully inflated in less than 10 minutes and you'll also have the ability to fill inflatable balls & camping equipment.

Product Contents:

- Compressor unit 12V
- Built-in LED light
- Built-in gauge 0-120 psi.
- 4 inch tire valve hose
- 66 inch power cord
- 12 inch extension alligator clips
- 36 inch extension lighter adapter
- Sports needle adapter
- Inflatable adapter
- Complete instructions
- Rugged zippered carry case
- Measures 4" x 2" x 6"
- Weight: 14 oz.

SNG.RCP: \$36.95



BestRest TireIron BeadBrakR Motorcycle Tire Removal Kit

Breaking the bead, or starting the separation of the tire from the rim of modern motorcycle tires, can be a cumbersome task, especially on the trail or miles from a service provider. The TireIron BeadBrakR will provide the mechanical advantage you need to effect repair and get you rolling again on your adventure.

Features:

- Made in the U.S.A.
- Suitable for tubed and tubeless tires
- Field tested and proven on large touring motorcycles
- Take down design for compact storage
- Kit measures 2" x 5.5" x 12"
- Weighs 3.1 lbs.
- Works as sidewall lever for accessing tubes or valve stems

Includes:

- Cordura storage pouch
- 3 gold zinc plated steel 8.5" tire irons
- Corner, Plunger, Lever, and Lockbar stainless steel components for BeadBrakR
- Quick lock pins with plastic lanyard
- Sand foot for soft surface use
- Valve stem multitool for valve core removal and valve stem setting
- Rim protectors
- Tire mounting lubricant
- Instructions

BRP.TIBB.SI.Tubed: \$195.00



Oxford DigiGauge

If Spock carried an air pressure gauge, this would be it. A backlit digital display makes it the top choice for Vulcans in need of nighttime pressure readings on alien highways.

- Measures 0 to 199 PSI in 0.1 psi increments
- Displays in your choice of PSI/BAR/kPa/KG-CM²
- Rotating dual valve system: Schrader and Presta
- Bleeder valve button for pressure adjustment
- Displays the last tire pressure reading collected

OXF.OF294: \$29.95



Twisted Throttle Tire Gauge

Fancy electronic gauges are all well and good, but nothing beats the nostalgia and battery-free confidence inspired by a traditional pencil-type tire gauge. Measures pressures 0 to 50 psi. 5.75" long. Includes a fancy clip so you can attach it to your pocket protector. Don't leave home without it.

TT.AG: \$3.99



BestRest CyclePump Tire Inflator

When you need the ultimate high quality, compact motorcycle air compressor built to last (not built to a price-point) there is only one: the expedition-ready BestRest CyclePump 12v Adventure Motorcycle Air Compressor Tire Inflator.

Designed specifically for the harsh conditions and demands of adventure motorcycles, the CyclePump 12 volt motorcycle air compressor tire inflator will help to refill your tires from that unplanned flat or needed air-down to keep your trip rolling.

Features:

- 5 year manufacturers warranty
- Powerful 12 volt 10 amp electric motor
- High quality metal compressor
- Includes 12v cigarette style plug, SAE plug, terminal clips, inflation hose, and storage pouch
- Made in the U.S.A.
- Aircraft grade aluminum alloy construction
- Average fill rates of 2-3 minutes for most front tires, 3-5 minutes for most rear tires
- Suitable for tube or tubeless tires
- Rated to above 100psi
- Compressor measures 2" x 4" x 6"

BRP.CPA: \$100.00



Oxford Tool Kit

The Oxford tool kit has a useful selection of small basic tools and fits easily under most motorcycle seats.

- Carry case designed to fit under most rear seats (4" x 7" 1.25")
- Made from high quality carbon steel
- 28 piece set

Components

- Needlenose pliers
- Wire snips
- Driver with philips (#1, #2 #3), flathead (3, 4 & 5mm), Pozidriv (#1, #2 & #3) and metric socket bits (5, 6, 7, 8, 9, 10, & 11 mm)
- Allen wrenches (2, 3, 4, 5, & 6 mm)
- Mini screwdrivers (philips #0 & flathead 3mm)
- 3" long 1/4" drive extension

OXF.OF291: \$18.95



Dual-Sport Tires

Street Tires



TWISTED THROTTLE SERVICE CENTER

Tire changing and balancing is available at our retail store in Exeter, RI. Stop by on your way to Maine, Nova Scotia, and beyond! Visit www.twistedthrottle.com/factory-store/hours-directions for hours & directions.



Continental TKC80

Tried and True 80/20 dual-sport tire for bigger dual-sport bikes



Designed for large dual-sport and adventure bikes this DOT approved multi-use tire performs well both on and off-road. The TKC80 offers good road handling and mileage for long trips, while off-road, it's an able performer, with a self-cleaning tread pattern and high level side stability on soft surfaces. The TKC80 is original equipment on the BMW R1200GS Adventure and the KTM 690 Enduro R.

The **ONLY 17" FRONT knobby** on the market. Great for Supermotos, NC700X, Versys and other crossover bikes that are ridden in the dirt.

Rated from 99mph (159 kmh) to 118mph (190 kmh) depending on tire.

Starting At **\$147⁹⁵**

TKC80 - Sizes		
Front	Rear	
120/70-17	120/90-17	4.00-18
100/90-19	130/80-17	4.10-18
110/80-19	5.10-17	110/80-18
2.50-21	140/80-17	120/90-18
2.75-21	150/70-17	140/80-18
80/90-21	3.25-18	150/70-18
90/90-21	3.50-18	180/55-17
3.00-21		

Heidenau K60 Scout

A true 50/50 dual-sport tire for big bikes



Heidenau's K60 Scout Dual Sport Motorcycle Tire offers great street riding performance while still providing good off-road grip and excellent wear.

Now, with an improved tread and compound, the Scout delivers better cornering stability and wet weather grip on the pavement, while delivering surprising off-road performance.

Rated to 118mph (190 kmh)

Starting At **\$119⁰⁰**

Heidenau K60 - Sizes		
Front	Rear	
120/70-17	120/90-17	110/80-18
100/90-19	130/80-17	120/90-18
110/80-19	140/80-17	140/80-18
90/90-21	150/70-17	150/70-18
	4.10-18	

MEFO Explorer and Heidenau K60 pair well together in front/rear combinations.

Mefo Explorer

The long distance dual-sport tire



MEFO's long-distance dual-sport tires are world renown for an impressive combination of off-road grip, on-road cornering, wet weather traction and durability outlasting typical dual sport tires by thousands of miles. Recommended for 50% street and 50% dirt riding. A great tire that will go anywhere, then take you home!

Rated to 118mph (190 kmh)

DOT-approved.

Starting At **\$132⁵⁰**

Explorer - Sizes		
Front	Rear	
100/90-19	120/90-17	120/90-18
2.75-21	4.50/4.60-17	4.00-18
90/90-21	130/80-17	130/80-18
3.00-21	5.10-17	4.60/5.10-18
80/100-21	4.10-18	140/80-18
	110/80-18	150/70-18
	120/80-18	

Avon Distanzia

The all-rounder for adventure and dual-sport bikes



- Specially designed for on-pavement use.
- Capable on well packed dirt roads.
- Engineered to cope with the loads of a sport-touring motorcycle.
- Superb all-weather grip.
- Gives excellent mileage.

Starting At **\$88⁴⁵**

Distanzia - Sizes	
Front	Rear
80/90-21 48S	110/80-18 58S
90/90-21 54T	120/90-17 64S
90/90-21 54H	120/80-18 62S
100/90-19 57H	130/80-17 65T
110/80-19 H	130/80R17 65H
120/70R17 58H*	150/60R17 66H*
	160/60R17 69H*
	4.00-18 64S
	4.10-18 60S
	4.60-18 63S

*= race compound supermoto tire

Pilot Road 3

Dual compound, high-mileage sport-touring radial tire



- Unbeatable tread life thanks to Michelin's latest-generation 2CT dual-compound technology.
- Features a soft rubber compound on the tread shoulders and a wear-resistant compound down the middle.
- Unrivalled grip in the wet, thanks to revolutionary new Michelin X-Sipe Technology.
- Even wear and life-long performance thanks to full-depth XST sipes.

Starting At **\$212⁹⁵**

Pilot Road 3 - Sizes	
Front	Rear
110/70ZR17 54W	150/70ZR17 69V
120/60ZR17 55W	150/70ZR17 69W
120/70ZR17 58W	160/60ZR17 69W
110/80ZR18 58W	170/60ZR17 72W
120/70ZR18 59W	180/55ZR17 73W
110/80R19 59V	180/55ZR17B* 73W
	190/50ZR17 73W
	190/55ZR17 75W
	160/60ZR18 70W

*= B version designed for loaded touring or frequent riding with a passenger

Pilot Power 3

Dual-compound, high performance sport tire



- Hard compound in the center helps resist wear from braking, while the softer compound in the shoulders provides more grip from cornering.
- 2CT technology enhances tread rigidity and cornering stability.
- Casing profile optimized for excellent feedback and handling.
- All new compound for exceptional wet grip.
- Tread pattern designed to inhibit irregular wear.

Starting At **\$184⁹⁵**

Pilot Power 3 - Sizes	
Front	Rear
120/60ZR17 55W	160/60ZR17 69W
120/70ZR17 58W	180/55ZR17 73W
	190/50ZR17 73W
	190/55ZR17 75W





Scottoil has been making automatic motorcycle chain oilers for over 25 years. Their experience combined with the quality of the product and the exceptional service they offer have made Scottoil the global market leaders in this field. Scottoilers have increased the chain life for over 320,000 motorcycles worldwide while saving riders time, money and hassle.



SKU	Make	Product
SCT.SA-0004US	Any	High Temperature Red Scottoil 500ml Chain Lubricant
SCT.SA-0005US	Any	Standard Blue Scottoil 250ml Chain Lubricant
SCT.SA-0007US	Any	High Temperature Red Scottoil 250ml Chain Lubricant
SCT.SA-0008US	Any	Standard Blue Scottoil 250ml Chain Lubricant
SCT.SO-0035US	Any	Dual Injector Chain Lubricant Dispenser Accessory
SCT.SO-0040US	Any	FS365 Corrosion Inhibitor 1L Spray
SCT.SO-0045US	Any	FS365 Corrosion Inhibitor 5L Refill
SCT.SO-0050US	Any	Lube Tube Chain Lubricant Reservoir Accessory
SCT.SO-0051US	Any	High Temperature Lube Tube Chain Lubricant Reservoir Accessory
SCT.SO-1007US	Motorcycles with EVAP Systems	vSystem Vacuum Operated Chain Oiler
SCT.SO-1020US	Motorcycles with EVAP Systems	High Temperature vSystem Vacuum Operated Chain Oiler
SCT.SO-3005US	KTM LC8, RC8, 690, 640, 625 Adventure, Duke, Supermoto, Supercomp	Vacuum Operated Chain Oiler
SCT.SO-3020US	KTM LC8, RC8, 690, 640, 625 Adventure, Duke, Supermoto, Supercomp	High Temperature Vacuum Operated KTM Chain Oiler
SCT.SO-4015US	Ducati Monster '09-'13 & All Ducati Models '09	Vacuum Operated Chain Oiler
SCT.SO-4020US	Ducati Monster '09-'13 & All Ducati Models '09	vSystem Vacuum Operated Chain Oiler
SCT.SO-9005US	Any	eSystem Electronic Chain Oiler
SCT.SO-9020US	Any	High Temperature eSystem Electronic Chain Oiler

RUNNING HOT OR COLD?
All Scottoilers are designed to use two different formulations of chain oil based on the temperature range you will be riding in. It is important to use the correct oil to get the correct flow rate. The standard oil (blue label) is formulated for 32°F to 86°F. The high temp oil (red label) is made for 68°F to 104°F. If you need a different temperature oil or refills, visit www.twistedthrottle.com or call us at 855-255-5550.



Scottoil eSystem Electronic Chain Oiler

Keep the drive chain and sprockets on your motorcycle properly lubricated while you ride with the Scottoil eSystem Electronic Chain Oiler. Designed for motorcycles with 12-volt electrical systems, the Scottoil eSystem Electronic Chain Oiler will automatically lubricate and increase the life of your motorcycle's chain and sprocket.

\$279⁹⁵

Standard Temp. eSystem 32°F-86°F
SCT.SO-9005US
High Temp. eSystem 68°F-104°F
SCT.SO-9020US

- Increase chain and sprocket life up to 7 times
- Reduces chain maintenance
- Motion Sensitive
- Graphic Display
- Lubricant oil level gauge
- Adjustable flow rate
- Lubricates while you ride
- Includes 250ml bottle of chain lubricant
- Up to 1800 miles between refills
- Compatible with Traditional Blue Scottoil or High Temperature Red Scottoil
- Bike Specific Installation Guides

Scottoil vSystem Vacuum Operated Chain Oiler

Designed specifically for motorcycles with an evaporative emissions (EVAP) system, the Scottoil vSystem Vacuum Operated Chain Oiler will automatically lubricate and increase the life of your motorcycle's chain and sprocket.

- Vacuum operated
- Lubricates while you ride
- Adjustable flow rate
- 500-1000 miles between refills
- Compatible with Traditional Blue Scottoil or High Temperature Red Scottoil
- Bike Specific Installation Guides
- CARB EO certified



\$129⁹⁵

Standard Temp. vSystem 32°F-86°F
SCT.SO-1007US
High Temp. vSystem 68°F-104°F
SCT.SO-1020US

Dual Injector Chain Lubricant Dispenser

Improve the efficiency of your Scottoil Chain Oiler by flowing oil to both sides of the rear sprocket and chain of your motorcycle with the Scottoil Dual Injector Chain Lubricant Dispenser Accessory. Works with all Scottoilers.

SCT.SO-0035US: \$34.95

Scottoil Lube Tube Lubricant Reservoir

Designed specifically for all Scottoil Chain Oilers, the Lube Tube Chain Lubricant Reservoir Accessory increases the refill range of your Scottoil Chain Oiler by three times with a flexible silicone reservoir.

SCT.SO-0050US: \$34.95

OXFORD MAXIMISER 360T



Oxford's smart charger has multiple charging rates that analyze battery condition, check polarity, charge, "float charge", and maintain a charge for battery longevity. Suitable for all 12-volt motorcycle, car, and truck batteries.

Intelligent 12-volt battery charger won't leave you with a dead battery come spring!

7 stage charging:

1. Tests battery connection polarity.
2. Analyzes your battery and diagnoses condition.
3. Gently recovers even heavily discharged batteries.
4. Quickly charges low batteries.
5. Checks voltage retention.
6. Monitors battery condition.
7. Maintains battery with a low current if the voltage drops below a set limit.

Features:

- Choose from 3 charge rates: MOTORCYCLE (600mA), CAR/TRUCK (3600mA) or BOOST (for AGM batteries and cold weather charging).
- Backlit LCD Display shows real-time charging of both battery charge voltage and amperage.
- Battery Condition Adviser shows if the battery is able to hold charge or is in need of replacement.
- Includes alligator clips and a quick-release permanent battery hookup.
- Included wall bracket and extra long cables make for ease-of-use in your garage.

Suggested Retail
~~\$149⁹⁵~~

Call for Price!
OXF.OF701US

Battery Condition Indicator



Alligator clips and battery hookup included



Battery Tender Junior High Efficiency

The Battery Tender Junior High Efficiency is much more than a trickle charger. It has a brain. It's lightweight, compact, and fully automatic; very easy to use, especially in small spaces. It will keep your battery fully charged so that it is ready to go when you are!

021-0123: \$39.95

Features:

- Complete 4-step charging program (Initialization, Bulk Charge, Absorption Mode, Float Mode)
- Automatically switches to float/maintenance voltage after fully charging the battery
- Solid state two color LED indicates stage of charger
- Spark proof
- Reverse polarity protected
- 12' output cord
- Safety timer: 80 hours
- 5 year warranty

Specs:

- Input: 120VAC, 60Hz
- Output: 12 Volts DC @ 750mA
- Perfect for all lead-acid, flooded or sealed maintenance free batteries (AGM and gel cell)



SAE Battery Tender Voltage Indicator

Easier than untangling your multimeter's test leads and hunting for your bike's battery under the seat, but way smarter than just guessing what the battery's charge state is. Plugs into a standard SAE Battery Tender connector and monitors voltage on an LCD screen. Three colored LEDs indicate general charge state at a quick glance. Designed for use on all 12-volt batteries. Display voltage range is 3 to 16 volts.

021-0128: \$69.95



Battery Tender Ring Terminals-to-SAE harness

Attach rings directly to battery terminals. Length is 18" and includes fuse holder with 3 amp fuse with weatherproof cap. SAE connector plugs into Battery Tender charger, other chargers, heated gear and many electrical accessories.

212123-SINGLE: \$6.95





CLYMER®

Whether it's routine maintenance, such as tune-ups and brake service, or more extensive repairs involving engine disassembly, Clymer and Haynes manuals provide the information required to do the job. Accurate, clear and concise text, combined with detailed illustrations, exploded parts views and photography, make it possible for even the novice to service, troubleshoot and repair their motorcycle. At the same time, the in-depth coverage provides technical information for those tackling more complicated jobs.

Aprilia	Years	SKU
RSV1000	'98-'03	RTFM.4255
BMW	Years	SKU
F650 Singles	'94-'07	RTFM.4761
F800/F650 Twins	'06-'10	RTFM.4872
R1200 dohc Twins	'10-'12	RTFM.4925
R1200 Twins	'04-'09	RTFM.4598
R850, R1100 & R1150 Twins	'93-'06	RTFM.3466
Honda	Years	SKU
CB600F Hornet	'98-'06	RTFM.3915
CBR1000RR Fireblade	'04-'07	RTFM.4604
CBR1100XX Super Blackbird	'97-'07	RTFM.3901
CBR125R	'04-'07	RTFM.4620
CBR600F4	'99-'06	RTFM.3911
CBR600RR	'03-'09	RTFM.4590
CBR600RR	'07-'12	RTFM.4795
CRF230	all	RTFM.M223
CRF250 & CRF450	'04-'06	RTFM.2630
Rebel & Nighthawk Twins	'85-'09	RTFM.2756
ST1300/ST1300A	'02-'11	RTFM.4908
VFR800 V-Fours	'97-'01	RTFM.3703
VFR800 VTECH	'02-'09	RTFM.4196
VTR1000F Super Hawk	'97-'08	RTFM.3744
XL600V/650V Transalp, XRV750 Africa Twin	'87-'07	RTFM.3919
XR650R	00-'07	RTFM.M225
Kawasaki	Years	SKU
Concours	'86-'06	RTFM.M409-2
EX650 & ER650	'06-'10	RTFM.4874
KLR650	'87-'07	RTFM.M474-3
KLR650	08-'12	RTFM.M240-2
Ninja 250R	'88-'11	RTFM.M241
ZX-6	'90-'04	RTFM.M468-2
Z750 & Z1000	'03-'08	RTFM.4762
ZX-6R & ZX-6RR	'03-'06	RTFM.4742
ZX6 D & E	'90-'04	RTFM.2146

* For a complete list of available manuals visit TwistedThrottle.com.



Haynes manuals have a 4 digit code, Clymer manuals have an M before a 3 digit code.

KTM	Years	SKU
EXC Enduro & SX Motocross	'00-'07	RTFM.4642
Suzuki	Years	SKU
DR650SE	'96-'13	RTFM.M272
DRZ400	'00-'12	RTFM.M477-4
DRZ400, DRZ400E, DRZ400S & DRZ400SM	'00-'10	RTFM.2933
GSF1200 Bandit	'96-'03	RTFM.M353
GSF600, 650 & 1200 Bandit Fours	'95-'06	RTFM.3367
GSF650/1250 Bandit & GSX650F	'07-'09	RTFM.4798
GSX-R1000	'01-'04	RTFM.M377
GSX-R600	'97-'00	RTFM.3553
GSX-R600, 750 & 1000	'00-'03	RTFM.3986
GSX-R600, 750 & 1000	'03-'06	RTFM.4382
GSX-R600/750	'06-'09	RTFM.4790
GSX-R750	'96-'99	RTFM.3553
GSX1400	'02-'07	RTFM.4758
GSX1300R Hayabusa	'99-'07	RTFM.M265
SV650 & SV650S	'99-'08	RTFM.3912
TL1000S, TL1000R & DL1000 V-Strom	'97-'04	RTFM.4083
Triumph	Years	SKU
1050 Sprint ST, Speed Triple, Tiger	'05-'09	RTFM.4796
Bonneville, T100, Speedmaster, American & Thruxton	'01-'12	RTFM.4364
Daytona & Speed Triple	'06-'10	RTFM.4876
Daytona, Speed Triple, Sprint & Tiger	'97-'05	RTFM.3755
Yamaha	Years	SKU
FZ-1	'01-'05	RTFM.M399
FZ6 Fazer	'04-'08	RTFM.4751
FZS1000 Fazer	'01-'05	RTFM.4287
VMX12000 V-Max	'85-'03	RTFM.4072
YZ/WR 4-stroke Motocross/Off-road	'98-'08	RTFM.2689
YZF-R1	'04-'06	RTFM.4605
YZF-R1	'98-'03	RTFM.3754
YZF-R6	'03-'05	RTFM.4601
YZF-R6	'99-'02	RTFM.3900
YZF600R	'96-'03	RTFM.3702
YZF750R, YZF750SP & YZF1000R	'93-'00	RTFM.3720

GALFER

Steel Braided Brake Lines from Galfer

If there is one item you can get that will make an instant, noticeable improvement to your brake feel and performance, a stainless steel braided line is it! When you squeeze your brake lever and force fluid through the hydraulic line to the caliper, rubber lines expand under pressure. This means that a good portion of the effort you put forth from your hand DOESN'T get to the caliper! By switching to a stainless steel braided brake line, you reduce the line expansion. This means that your hand pressure goes directly to the caliper!

Starting At \$55.00



Galfer Kawasaki KLR650 Oversize Front Brake Kit

\$289.00

'87 - '07 KLR650 GAL.KITOS50

'08 - '13 KLR650 GAL.KITOS51



As we know, the KLR is an outstanding all-around bike. It can do pretty much anything...except stop.

The Galfer KLR Oversize Rotor Kit includes a 320mm rotor, a relocation bracket, Galfer green pads, and a steel-braided brake line. Experience a huge difference in braking power and gain new confidence in your KLR. This upgrade kit will allow you to load up your bike and use it as an adventure tourer.



Galfer KLR650 Oversize Front Brake Kit on the 2008 Twisted Throttle KLR650 Project Bike.

BMW	Year	Line	Part Number
F650GS Non-ABS	'01-'07	Rear	GAL.FK003D284R
F650GS Non-ABS	'01-'07	Front	GAL.FK003D284.1
F650GS/Dakar Non-ABS	'01-'04	Rear	GAL.FK003D279R
F650GS/Dakar Non-ABS	'01-'04	Front	GAL.FK003D279.1
Kawasaki	Year	Line	Part Number
KLR650A	'86-'07	Rear	GAL.FK003D102R
KLR650A	'86-'07	Front	GAL.FK003D102
KLR650E	'08-'12	Rear	GAL.FK003D597R
KLR650E	'08-'12	Front	GAL.FK003D597
Versys 650	'07-'09	Rear	GAL.FK003D680R
Versys 650	'07-'09	Front	GAL.FK003D680.2
Versys 650	'10-	Rear	GAL.FK003D647R
Versys 650	'10-	Front	GAL.FK003D647.2
Suzuki	Year	Line	Part Number
DL1000 V-Strom	'02-'09 & '12	Clutch	GAL.FK003D327CL
DL1000 V-Strom	'02-'09 & '12	Rear	GAL.FK003D327R
DL1000 V-Strom	'02-'09 & '12	Front	GAL.FK003D327.2
DL650 V-Strom	'08-'11	Complete ABS kit	GAL.FK003D733.9
DL650 V-Strom	'04-'08	Rear	GAL.FK003D327R
DR650SE	'96-'12	Rear	GAL.FK003D217R
DR650SE	'96-'12	Front	GAL.FK003D217
DRZ400E	'00-'07	Rear	GAL.FK003D264R
DRZ400E	'00-'07	Front	GAL.FK003D264
DRZ400S	'00-	Front	GAL.FK003D291
DRZ400S	'00-	Rear	GAL.FK003D264R
DRZ400SM	'05-	Rear	GAL.FK003D539R
DRZ400SM	'05-	Front	GAL.FK003D539
Triumph	Year	Line	Part Number
Tiger 955i	'02-	Rear	GAL.FK003D350R
Tiger 955i	'02-	Front	GAL.FK003D350.2
Yamaha	Year	Line	Part Number
Super Tenere	'11-'12	Front and Rear	GAL.FK003D771.9

K&N Premium Canister & Cartridge Oil Filters

K&N's premium line of motorcycle and ATV wrench-off canister oil filters were designed to meet the high performance needs of racers. These canister style premium oil filters are designed to handle high oil pressures and can be used with the latest synthetic or semi-synthetic motor oils. K&N canister oil filters come with a 17mm nut welded to the top that makes removal easy.

- High flow rates & great filtration
- 17mm exposed nut for easy removal
- Heavy duty canister construction
- Traps 99% of harmful contaminants
- Can be used with the latest synthetic motor oils
- Drilled hole in nut for safety wire attachment



Starting At \$6.95

Visit TwistedThrottle.com for K&N oil filters that fit your bike.



K&N Replacement Air Filters

K&N air filters are designed to achieve high, virtually unrestricted air flow while maintaining filtration levels critical to ensure long engine life. K&N air filters will NOT void motorcycle warranties and are environmentally friendly by reducing the volume of disposable air filters that end up in landfills.

- Designed to provide increased horsepower and acceleration
- Pleated cotton media provides a large filtration area offering low restriction and long service intervals
- Washable & reusable, most are pre-oiled and ready to ride!
- Available for ALL motorcycles and ATVs



Starting At \$43.95

Visit TwistedThrottle.com for K&N replacement air filters that fit your bike.

K&N Recharger Kit

A six-step maintenance system designed to clean any K&N Filtercharger Air Filter. Restores air flow efficiency so your Filtercharger performs like new!

K&N's Recharger Filter Care Service Kit includes 8 oz. K&N Spray Oil and 12 oz. K&N Power Kleen Air Filter Cleaner.

99-5050: \$14.95



MOTOREX Lubricants



In business for over 90 years, MOTOREX is used by top factory race teams worldwide, by independent pros and top amateurs who demand the best performance from their machines. The complete MOTOREX line includes a broad range of synthetic engine oils, lubricants, aerosol sprays, cleaners and care products for motorcycles and ATVs. Twisted Throttle carries the complete line of MOTOREX lubricants, more than we are able to list in this catalog. Call or visit www.twistedthrottle.com for all MOTOREX products.

PowerSynt 4T	Formula 4T	Boxer 4T	Pro 4T
5W/40	10W/40	15W/50	0W/40
10W/50	15W/50		5W/30
10W/60			15W/50



Chain Lube

White chain lubricant, especially formulated for road-going motorcycles. Tested for O-rings, X-rings and Z-rings. Extremely good adhesion, resistant to water. Extends the working life of the chain and sprockets. 500ml (16.9 fl. oz.).



Racing - 621-051: \$17.79
Road - 623-051: \$13.19
Off Road - 622-050: \$13.19

Yuasa Batteries



Yuasa Battery Inc. is the number one powersports battery provider, supplying more OEM's than all other competitors combined. Yuasa has been manufacturing motorcycle batteries in the U.S.A. since 1979. Most of the large capacity Powersports batteries are manufactured in Laureldale, PA.



Starting At \$61.95

IRC Inner Tubes

IRC inner tubes are made from a blend of natural and butyl rubber for maximum performance and reliability.



Size	SKU	Price
3.25/3.50/4.10-17	T20051	\$11.95
4.25/4.50/5.10-18	T20064	\$13.95
2.75/3.25/3.60-21	T20078	\$12.95
110/100-18 Heavy Duty	T20057	\$19.95
80/100-21 Heavy Duty	T20076	\$18.95

Motorcycle Bookends

Lazer cut steel motorcycle bookends. 14.2" tall.

Sportbike - 183.1270.808: \$34.99
Cruiser - 183.1272.808: \$34.99
Dirt bike - 183.1271.808: \$34.99



Motorcycle Coathangers

Lazer cut steel motorcycle coathangers with 4 hooks. 21.25" wide. Mounting hardware not included.

Sportbike - 183.1278.808: \$34.99
Cruiser - 183.1276.808: \$34.99
Dirt bike - 183.1277.808: \$34.99



Motorcycle Key Hangers

Lazer cut steel motorcycle key hangers with 3 hooks. 13.8" wide. Mounting hardware not included.

Sportbike - 183.1274.808: \$22.99
Cruiser - 183.1273.808: \$22.99
Dirt bike - 183.1275.808: \$22.99



Wooden Motorcycle Puzzles

These 3 hand made motorcycle puzzles are fun to solve and look great as home or office decoration. 7.9" wide.

Dirt bike - 183.1253.707: \$29.99
Touring bike - 183.1251.707: \$29.99
Cruiser - 183.1252.707: \$29.99



Sportbike Piggy Bank

Save up for your next bike with this road racing motorcycle figurine. 7.8" long.

183.1173.251: \$14.99



Scooter Piggy Bank

Scooter figurine that you can save all your spare change in. 5.7" long.

Red - 183.1085.303: \$19.99
Blue - 183.1085.505: \$19.99



Wedding Motorbike

Groom with bride passenger motorcycle figurine. 6.7" long.

183.1029.210: \$28.50



Wedding Motorbike

Bride with groom passenger motorcycle figurine. 6.7" long.

183.1030.210: \$28.50



Wedding Motorbike

Groom with bride passenger motorcycle figurine. 6.7" long.

183.1031.321: \$28.50



Wedding Scooter

Groom with bride passenger scooter figurine. 6.0" long.

183.1032.250: \$28.50



Aprilia RSV4 & Caponord 1200

[See more at TwistedThrottle.com/MyBike](http://www.twistedthrottle.com/MyBike)



Caponord 1200



RSV4

R&G Rear Fender Eliminator, Tail Tidy



R&G Adjustable Rearsets



RSV4	from	to	Notes	Part Number
QUICK-LOCK Tankring	'13	'14	For QUICK-LOCK Tankbags. See page 144.	Type 300
R&G Frame Sliders	'09	'14	Aero-style. See page 42.	RG.CP0257BL
R&G Engine Case Cover Kit	'09	'14	Left & right covers. See page 48.	RG.KEC0031.BK
R&G Oil Cooler Guard	'09	'14	Aluminum. Black. See page 50.	RG.OCG0012BK
R&G Rear Fender Eliminator	'09	'14	Tail Tidy. See page 59.	RG.LP0084BK
R&G Adjustable Rearsets	'09	'14	Road configurable. See page 27.	RG.RSET14BK
MRA Windshields	'09	'14	Various shapes. See page 16	MRA.21.017
Caponord 1200	from	to	Notes	Part Number
QUICK-LOCK Tankring	'14	'14	For QUICK-LOCK Tankbags. See page 144.	In Development
R&G Crashbars	'14	'14	See page 52.	RG.AB0013.BK
R&G Engine Case Cover Kit	'14	'14	Left, Right & Waterpump covers. Page 48.	RG.KEC0058.BK
R&G Frame Sliders	'14	'14	Aero-style. See page 42.	RG.CP0221BL
R&G Rear Fender Eliminator	'14	'14	Tail Tidy. See page 59.	RG.LP0147BK
R&G Radiator Guard	'14	'14	Aluminum. Black. See page 50.	RG.RAD0153.BK
R&G Bar End Sliders	'14	'14	See page 44.	RG.BE0045BK
R&G Front Axle Sliders	'14	'14	See page 43.	RG.FP0020BK
R&G Swingarm Spools	'14	'14	See page 43.	RG.SP0052.BK
MRA Windshields	'14	'14	Various shapes. See page 16.	MRA.21.019

BMW C600 Sport ('12-'14) & C650GT ('12-'14)

[See more at TwistedThrottle.com/MyBike](http://www.twistedthrottle.com/MyBike)



C600 Sport



C650 GT

C600 Sport & C650GT	from	to	Notes	Part Number
Aluminum Toprack	'12	'14	C650 GT only. For Givi Monokey Topcase.	GIVI SRA5106
Aluminum Toprack	'12	'14	C600 only. For Givi Monokey Topcase.	GIVI SRA5105
Easylock Saddlebag Supports	'12	'14	C600 only. For Givi TPH10 Easylock Saddlebags.	GIVI TE5105
R&G Front Axle Slider	'12	'14	See page 43.	RG.FP0117BK
R&G Bar End Slider	'12	'14	See page 43.	RG.BE0063.BK
R&G Exhaust Slider	'12	'14	C650 GT only.	RG.ES0005.BK
R&G Footboard Slider	'12	'14	C600 only.	RG.TP0005BK
R&G Footboard Slider	'12	'14	C650 GT only.	RG.TP0006BK
Kaoko Throttle Lock	'12	'14	See page 32.	KAO. CCF915

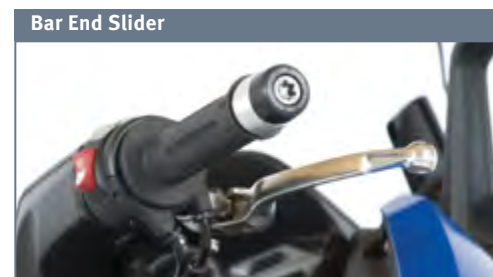

BMW F650GS, F650GS Dakar ('00-'07) & G650GS ('09-'10)



BMW G650GS ('11-'14)



F650GS Single

For F650GS Twin ('08-'12)
See page 195.

[See more at TwistedThrottle.com/MyBike](http://www.twistedthrottle.com/MyBike)

F650GS/ F650GS Dakar ('00-'07) & G650 ('09-'10)	from	to	Notes	Part Number
ALU-RACK Toprack, Silver	'04	'07	For TraX, Givi & other topcases. See page 134.	GPT.07.353.100.S
ALU-RACK Toprack, Black	'09	'10	For TraX, Givi & other topcases. See page 134.	GPT.07.613.100.B
Steel Toprack, Black	'04	'07	Provides easy access to rear storage compartment. For TraX, Givi & other topcases. See page 122.	GPT.07.353.20001.B
QUICK-LOCK EVO Sidecarrier	'00	'07	For TraX, Givi & other sidecases. See page 128.	KFT.07.094.20000
QUICK-LOCK Tankring	'00	'10	For QUICK-LOCK Tankbags. See page 144.	Type 100
Skid Plate	'03	'06	F650GS only. Aluminum. See page 54.	MSS.07.777.10000.B
Crashbars	'00	'07	Black. See page 52.	SBL.07.101.100
Crashbars	'09	'10	Black. See page 52.	SBL.07.629.100
Centerstand	'00	'10	See page 56.	Various
Brake Master Cylinder Guard	'03	'07	Rear. See page 55.	BPS.07.175.10100.S
Mirror Wideners	'00	'07	See page 34.	SVL.00.505.101
Mirror Wideners	'09	'10	See page 34.	SVL.00.505.102
Barkbusters Handguards	'00	'10	Various shapes & colors. See page 38.	BB.BHG10



2011 G650GS

G650GS	from	to	Notes	Part Number
ALU-RACK Toprack, Silver	'11	'14	For TraX, Givi & other Topcases. See page 134.	GPT.07.353.100.S
Steel Toprack, Black	'11	'14	Provides easy access to rear storage compartment For TraX, Givi & other Topcases. See page 122.	GPT.07.353.20001.B
QUICK-LOCK EVO Sidecarrier	'11	'14	For TraX, Givi & other Sidecases. See page 128.	KFT.07.094.20000
QUICK-LOCK Tankring	'11	'14	For QUICK-LOCK Tankbags. See page 144.	Type 205
QUICK-LOCK GPS Mount	'11	'14	Vibration-damped. Black. See page 100.	GPS.07.646.10000.B
Skid Plate	'09	'14	See page 54.	MSS.07.777.10000.B
Crashbars, black	'11	'14	Mild steel. See page 52.	SBL.07.775.10000.B
Mirror Wideners	'11	'14	Universal mirror widener. See page 34.	SVL.00.505.101
Barkbusters Handguards	'11	'14	See page 38.	BB.BHG45
MRA Windscreens	'11	'14	Various shapes available: See page 16.	MRA.07.020

BMW G650GS Sertao ('12-'14)



2012 G650GS Sertao

[See more at TwistedThrottle.com/MyBike](http://www.twistedthrottle.com/MyBike)

G650GS Sertao	from	to	Notes	Part Number
ALU-RACK Toprack	'12	'14	Silver. For TraX, Givi & other topcases. See page 134.	GPT.07.353.100.S
Steel Toprack	'12	'14	Black. Provides easy access to rear storage compartment. For TraX, Givi & other topcases. See page 122.	GPT.07.353.20001.B
QUICK-LOCK EVO Sidecarrier	'12	'14	For TraX, Givi & other sidecases. See page 128.	KFT.07.094.20000
QUICK-LOCK Tankring	'12	'14	For QUICK-LOCK Tankbags. See page 144.	Type 205
QUICK-LOCK GPS Mount	'12	'14	Vibration-damped. Black. See page 100.	GPS.07.646.10000.B
Crashbars	'12	'14	Black. See page 52.	SBL.07.775.10000.B
Holy Hand Grenade Pouch	'12	'14	To hold 5, no wait, 3 Holy Hand Grenades	In Development
Centerstand	'12	'14	See page 56.	HPS.07.280.100
Skid Plate	'12	'14	See page 54.	MSS.07.777.10000.B
On/Off-Road Footpegs	'12	'14	Convertible Footpegs. See page 23.	FRS.07.011.10001.S
Mirror Wideners	'12	'14	See page 34.	SVL.00.505.101
Barkbusters Handguards	'12	'14	Various shapes & colors. See page 38.	BB.BHG45
MRA Windscreens	'12	'14	Various shapes. See page 16.	MRA.07.020
Kaoko Throttle Lock	'12	'14	Throttle lock cruise control. See page 32.	KAO.CCF120
Kaoko Throttle Lock	'12	'14	With Barkbusters handguards only. See page 32.	KAO.KBB600
Scottolier Chain Oiler	'12	'14	Vacuum-operated oiler. See page 186.	SCT.SO-1007US
Doubletake Adventure Mirror	'12	'14	DTM.SCA mount required. See page 36.	DTM.00.M

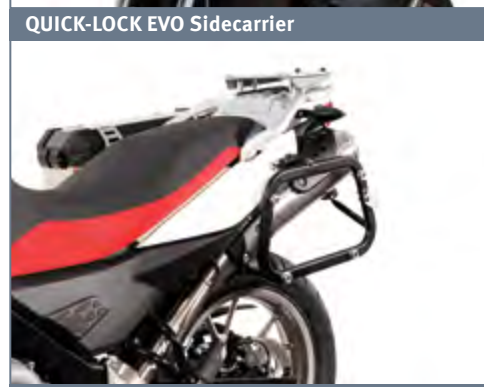
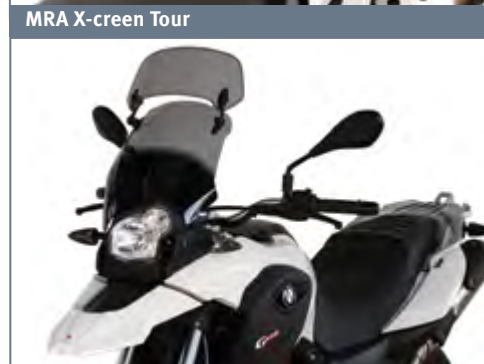

BMW F650GS Twin ('08-'12)



[See more at TwistedThrottle.com/MyBike](http://www.twistedthrottle.com/MyBike)

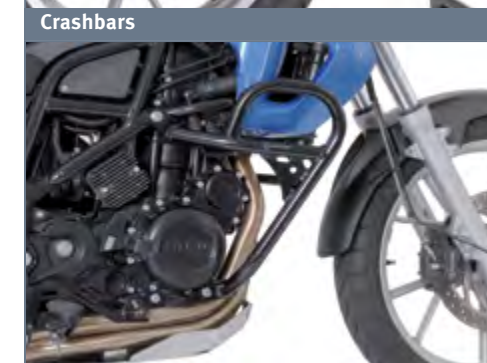
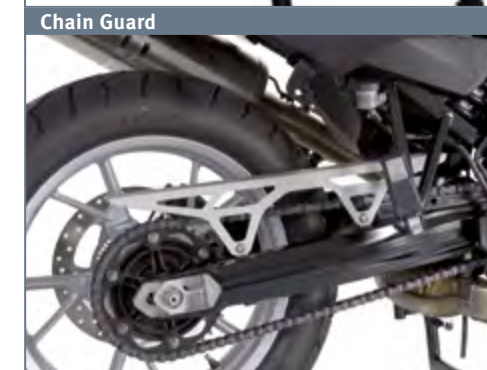
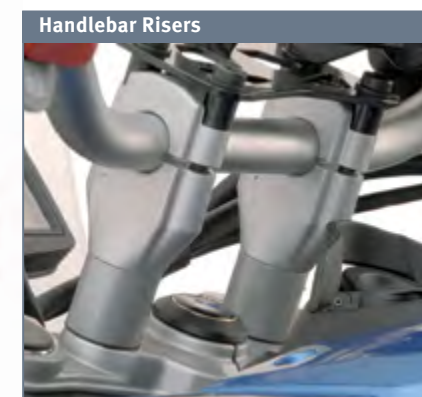

F650GS ('08-'12)	from	to	Notes	Part Number
Steel Toprack	'08	'12	For TraX, Givi & other topcases. See page 122.	GPT.07.558.20002.B
QUICK-LOCK EVO Sidecarrier	'08	'12	For TraX, Givi & other sidecases. See page 128.	KFT.07.559.20002.B
QUICK-LOCK Tankring	'08	'12	For QUICK-LOCK Tankbags. See page 144.	Type 201
QUICK-LOCK GPS Mount	'08	'12	Vibration-damped. Black. See page 100.	GPS.07.646.10300.B
Skid Plate	'08	'12	Aluminum. See page 54.	MSS.07.560.10001.S
Crashbars	'08	'12	Black. See page 52.	SBL.07.556.10000.B
Chain Guard	'08	'12	Aluminum. Silver. See page 45.	KTS.07.125.100
Brake Master Cylinder Guard	'08	'12	Rear. Aluminum. Silver. See page 55.	BPS.07.175.10101.S
Headlight Guard	'08	'12		LPS.07.387.100
Mirror Wideners	'08	'12	Universal mirror extension. See page 34.	SVL.00.505.102
Handlebar Risers	'08	'12	See page 28: 20mm (0.8") rise	LEH.07.039118.20.S
Auxiliary Light Mount	'08	'12	For Denali, Hawk & other lighting. See page 112.	TM.51005
On/Off-road Footpegs	'08	'12	Convertible Footpegs. See page 23.	FRS.07.011.10000.S
Centerstand	'08	'12	See page 56.	HPS.07.470.10000.B
Sidestand Foot Enlarger	'08	'12	Silver foot, black mount. See page 57.	STS.07.102.10100.S
R&G Bar End Sliders	'08	'12	See page 44.	RG.BE0047BK
Barkbusters Handguards	'08	'12	See page 38.	BB.BHG32
MRA windscreen	'08	'12	Various shapes: See page 16.	MRA.07.017

BMW F700GS ('13-'14)



See more at TwistedThrottle.com/MyBike

Adjustable Shift Lever



GPS Mount

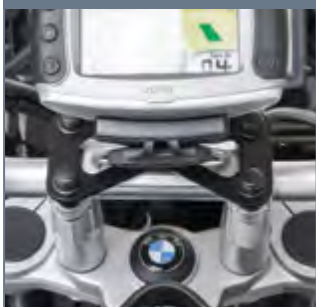

SW-MOTECH Axle Slider



F700GS ('13-'14)	from	to	Notes	Part Number
Steel Toprack	'13	'14	For TraX, Givi & other topcases. See page 122.	GPT.07.558.20002.B
QUICK-LOCK EVO Sidecarrier	'13	'14	For TraX, Givi & other sidecases. See page 128.	KFT.07.559.20002.B
QUICK-LOCK Tankring	'13	'14	For QUICK-LOCK Tankbags. See page 144.	Type 201
QUICK-LOCK GPS Mount	'13	'14	Vibration-damped. Black. See page 100.	GPS.07.646.10300.B
Skid Plate	'13	'14	Aluminum. See page 54.	MSS.07.560.10001.S
Toolbox for Skid Plate	'13	'14	Aluminum. Lockable.	WZX.00.014.10000.S
Crashbars	'13	'14	Black. See page 52.	SBL.07.556.10000.B
Chain Guard	'13	'14	Aluminum. Silver. See page 45.	KTS.07.125.100
Brake Master Cylinder Guard	'13	'14	Rear. Aluminum. Silver. See page 55.	BPS.07.175.10101.S
SW-MOTECH Axle Slider	'13	'14	See page 43.	STP.07.176.10500.B
Mirror Wideners	'13	'14	See page 34.	SVL.00.505.102
Handlebar Risers	'13	'14	Various heights. See page 28.	LEH.07.039.118
28mm Handlebar Converter	'13	'14	Handlebar not included	LEH.00.039.16200
Auxiliary Light Mount	'13	'14	For Denali, Hawk & other lighting. Page 112.	TM.51005
On/Off-road Footpegs	'13	'14	Convertible. Stainless steel. Silver. Page 23.	FRS.07.011.10100.S
Centerstand	'13	'14	See page 56.	HPS.07.470.10000.B
R&G Bar End Sliders	'13	'14	See page 44.	RG.BE0025BK
Barkbusters Handguards	'13	'14	See page 38.	BB.BHG40.2
Koako Throttle Lock	'13	'14	Throttle lock cruise control. See page 32.	KAO.CCF500
MRA Windshields	'13	'14	Various shapes. See page 16.	MRA.07.023

Brake Master Cylinder Guard



Steel Toprack



QUICK-LOCK Tankring



QUICK-LOCK EVO Sidecarrier

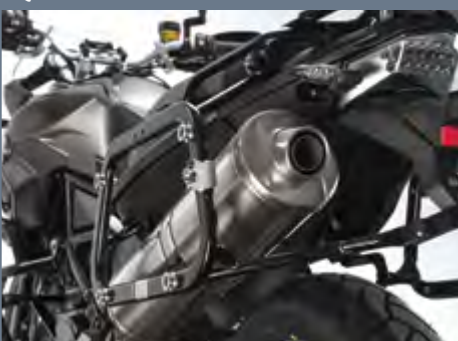

Skid Plate



BMW F800GS ('08-'12)



TWISTED BMW F800GS

This GS lives up to its rugged family history, but we knew we could make it better with durable SW-MOTECH crash protection, comfortable ergonomic upgrades, and much more. Our F800GS was the grand prize for the GS Challenge held at the 2011 BMW MOA Rally in Bloomsburg, PA. Congratulations Josh!



GS Giant winner and proud new owner of the Twisted F800GS - Josh F.

F800GS ('08-'12)	from	to	Notes	Part Number
Steel Toprack	'08	'12	For TraX, Givi & other topcases. See page 122.	GPT.07.558.20002.B
QUICK-LOCK Tankring	'08	'12	For QUICK-LOCK Tankbags. See page 144.	Type 201
QUICK-LOCK EVO Sidecarrier	'08	'12	For TraX, Givi & other sidecases. See page 128.	KFT.07.559.20002.B
QUICK-LOCK GPS Mount	'08	'12	Detachable, Vibration-damped. See page 100.	GPS.07.646.10300.B
Skid Plate	'08	'12	Aluminum. See page 54.	MSS.07.560.10002.S
Brake Master Cylinder Guard	'08	'12	Rear. Aluminum. Silver. See page 55.	BPS.07.175.10100.S
Regulator Guard	'08	'12	Aluminum. Silver. See page 186.	SCT.07.174.10100.S
Crashbars	'08	'12	Black. See page 52.	SBL.07.556.10000.B
Chain Guard	'08	'12	Aluminum. Silver. See page 45.	KTS.07.125.100
Headlight Guard	'08	'12		LPS.07.387.100
Mirror Wideners	'08	'12	See page 34.	SVL.00.505.102
Handlebar Risers	'08	'12	30mm height. See page 28.	LEH.07.039118.30.S
Centerstand	'08	'12	See page 56.	HPS.07.557.10000.B
Sidestand Foot Enlarger	'08	'12	See page 57.	STS.07.102.10100.S
On/Off-Road Footpegs	'08	'12	Convertible. Stainless steel. Silver. See page 23.	FRS.07.011.10100.S
R&G Front Axle Sliders	'08	'12	See page 43.	RG.FP0089BK
Fenda Extenda	'08	'12	Front fender extension. See page 58.	PP.054201
MRA Windscreen	'08	'12	Various shapes. See page 16.	MRA.07.017
Barkbusters Handguards	'08	'12	Various shapes & colors. See page 38.	BB.BHG32
Kaoko Throttle Lock	'08	'12	With Barkusters handguards only. See page 32.	KAO.KBB700-S
Kaoko Throttle Lock	'08	'12	With original handguards only. See page 32.	KAO.CCF900

Handguard & Throttle Lock



QUICK-LOCK EVO Sidecarrier



Crashbars

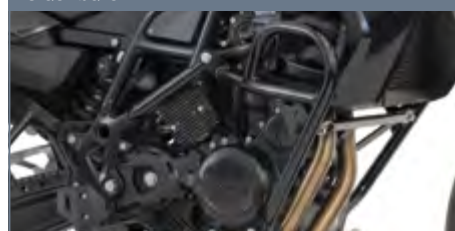

Skid Plate



Centerstand



Steel Toprack



On/Off-Road Footpegs



Rear Master Cylinder Guard



Regulator Guard



BMW F800GS ('13-'14)



[See more at TwistedThrottle.com/MyBike](http://www.twistedthrottle.com/MyBike)

F800GS ('13-'14)	from	to	Notes	Part Number
Steel Toprack	'13	'14	For TraX, Givi & other topcases. See page 122.	GPT.07.558.20002.B
ALU-RACK Toprack	'13	'14	For TraX, Givi & other topcases. See page 134.	GPT.07.558.15000.B
QUICK-LOCK EVO Sidecarrier	'13	'14	For TraX, Givi & other sidecases. See page 128.	KFT.07.559.20002.B
QUICK-LOCK Tankring	'13	'14	For QUICK-LOCK Tankbags. See page 144.	Type 201
QUICK-LOCK GPS Mount	'13	'14	Vibration-damped. Black. See page 100.	GPS.07.646.10300.B
Skid Plate	'13	'14	Aluminum. See page 54.	MSS.07.560.10001.S
Toolbox for Skid Plate	'13	'14	Skid Plate required. Aluminum. Lockable.	WZX.00.014.10000.S
Crashbars	'13	'14	Black. See page 52.	SBL.07.556.10000.B
Chain Guard	'13	'14	Aluminum. Silver.	KTS.07.125.100
Headlight Guard	'13	'14		LPS.07.307.10000.B
Brake Master Cylinder Guard	'13	'14	Rear. Aluminum. Silver. See page 55.	BPS.07.175.10101.S
SW-MOTECH Swingarm Slider	'13	'14	See page 43.	STP.07.176.10500.B
SW-MOTECH Front Axle Slider	'13	'14	See page 43.	STP.07.176.10400.B
Mirror Wideners	'13	'14	See page 34.	SVL.00.505.102
Handlebar Risers	'13	'14	Various heights. See page 28.	LEH.07.039.118
Auxiliary Light Mounts	'13	'14	For Denali, Hawk & other lighting. Page 112.	NSW.07.004.10300.B
On/Off-Road Footpegs	'13	'14	Convertible. Stainless steel. Silver. See page 23.	FRS.07.011.10100.S
Adjustable Gear Shift Lever	'13	'14	See page 26.	FSC.07.127.10000.B
Centerstand	'13	'14	See page 56.	HPS.07.557.10000.B
Sidestand Foot Enlarger	'13	'14	See page 57.	STS.07.102.10100.S
R&G Engine Case Cover	'13	'14	Left side cover. See page 48.	RG.ECC0148BK
R&G Engine Case Cover	'13	'14	Right side cover. See page 48.	RG.ECC0149BK
R&G Engine Case Cover Kit	'13	'14	Left & right covers. See page 48.	RG.KEC0055.BK
R&G Sidestand Foot Enlarger	'13	'14	See page 57.	RG.PKS0007.SI
Kaoko Throttle Lock	'13	'14	With original handguards only. See page 32.	KAO.CCF910
Kaoko Throttle Lock	'13	'14	With Barkbusters handguards only. See page 32.	KAO.CCF500
Barkbusters Handguards	'13	'14	Various shapes & colors. See page 38.	BB.BHG40.2
SW-MOTECH KOBRA Handguards	'13	'14	Integrated LED compatible. See page 37.	HPR.00.220.20800.B
KOBRA LED Indicators	'13	'14	For KOBRA handguards only. See page 37.	HPR.00.220.30000.B

Brake Master Cylinder Guard



Steel Toprack



Centerstand

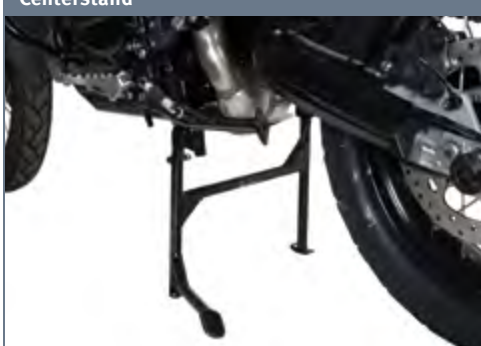

Skid Plate Toolbox



QUICK-LOCK EVO Sidecarrier



BMW F800GS Adventure ('14)

QUICK-LOCK GPS Mount Crossbar

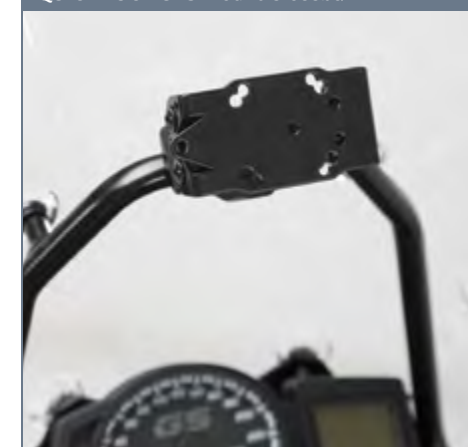

Skid Plate



Upper Crashbars



Brake Reservoir Guard



[See more at TwistedThrottle.com/MyBike](http://www.twistedthrottle.com/MyBike)

F800GS Adventure	from	to	Notes	Part Number
Steel Toprack	'14	'14	For TraX, Givi & other topcases. See page 122.	GPT.07.558.20002.B
ALU-RACK Toprack	'14	'14	For TraX, Givi & other topcases. See page 134.	GPT.07.558.15000.B
QUICK-LOCK Tankring	'14	'14	For QUICK-LOCK Tankbags. See page 144.	Type 201
QUICK-LOCK GPS Mount Crossbar	'14	'14	See page 100.	GPS.00.646.10600.B
Skid Plate	'14	'14	Aluminum. Silver. See page 54.	MSS.07.560.10002.S
Toolbox for Skid Plate	'14	'14	Skid Plate required. Aluminum. Lockable.	WZX.00.014.10000.S
Upper Crashbars	'14	'14	Fits with original crashbars. Black. See page 52.	SBL.07.427.10000.B
Headlight Guard	'14	'14		LPS.07.307.10000.B
Centerstand	'14	'14	See page 56.	HPS.07.557.10000.B
Chain Guard	'14	'14	Aluminum. See page 45.	KTS.07.125.100
Brake Master Cylinder Guard	'14	'14	Rear. Silver. See page 55.	BPS.07.175.10101.S
Brake Reservoir Guard	'14	'14	Aluminum. Silver. See page 186.	SCT.07.174.10600.S
Mirror Wideners	'14	'14	See page 34.	SVL.00.505.102
Handlebar Risers	'14	'14	Black. 30mm height. See page 28.	LEH.07.039.111.B
Sidestand Foot Enlarger	'14	'14	See page 57.	STS.07.102.10100.S
Adjustable Gear Shift Lever	'14	'14	See page 26.	FSC.07.127.10000.B
R&G Engine Case Cover	'14	'14	Left side cover. See page 48.	RG.ECC0148BK
R&G Engine Case Cover	'14	'14	Right side cover. See page 48.	RG.ECC0149BK
R&G Engine Case Cover Kit	'14	'14	Left & right covers. See page 48.	RG.KEC0055.BK
R&G Sidestand Foot Enlarger	'14	'14	See page 57.	RG.PKS0007.SI
MRA Windscreen	'14	'14	Various shapes. See page 16.	MRA.07.017
Kaoko Throttle Lock	'14	'14	With original handguards only. See page 32.	KAO.CCF910
Kaoko Throttle Lock	'14	'14	With Barkbusters handguards only. See page 32.	KAO.CCF500
Barkbusters Handguards	'14	'14	Various shapes & colors. See page 38.	BB.BHG40.2
SW-MOTECH KOBRA Handguards	'14	'14	Integrated LED compatible. See page 37.	HPR.00.220.20800.B
KOBRA Handguard LED Indicators	'14	'14	For KOBRA handguards only. See page 37.	HPR.00.220.30000.B

BMW F800GT ('13-'14)



F800GT	from	to	Notes	Part Number
ALU-RACK Toprack, Black	'13	'14	For TraX, Givi & other topcases. See page 134.	GPT.07.306.15000.B
QUICK-LOCK EVO Sidecarrier	'13	'14	For TraX, Givi & other sidecases. See page 128.	KFT.07.665.20000.B
Blaze Sport Saddlebags	'13	'14	Removable soft luggage. See page 142.	HTA.07.740.10200
QUICK-LOCK Tankring	'13	'14	For QUICK-LOCK Tankbags. See page 144.	Type 206
QUICK-LOCK GPS Mount	'13	'14	Vibration-damped. Black. See page 100.	GPS.07.646.10101.B
Mirror Wideners	'13	'14	See page 34.	SVL.07.501.11000.B
On/Off-Road Footpegs	'13	'14	Convertible. Stainless steel. Silver. See page 23.	FRS.05.011.10000.S
Adjustable Gear Shift Lever	'13	'14	See page 26.	FSC.07.127.10200.B
R&G Frame Sliders	'13	'14	Aero-style. See page 42.	RG.CP0345.BL
R&G Front Axle Sliders	'13	'14	See page 43.	RG.FP0141.BK
R&G Engine Case Cover Kit	'13	'14	Left & right covers. See page 48.	RG.KEC0056.BK
R&G Radiator Guards	'13	'14	Aluminum. Black. See page 50.	RG.RAD0082BK
R&G Rear Fender Eliminator	'13	'14	Without original sideracks. Tail Tidy. See page 59.	RG.LP0144BK
R&G Rear Fender Eliminator	'13	'14	With original sideracks only. Tail Tidy. Page 59.	RG.LP0143BK
R&G Sidestand Foot Enlarger	'13	'14	See page 57.	RG.PKS0021.SI

See more at TwistedThrottle.com/MyBike



BMW F800S & F800ST ('06-'12)



F800S & F800ST	from	to	Notes	Part Number
ALU-RACK Toprack	'06	'12	Black. For TraX, Givi & other Topcases. See page 134.	GPT.07.306.15000.B
Centerstand	'06	'12	See page 56.	HPS.07.303.100
Crashbars	'06	'10	Black. F800S only See page 52.	SBL.07.304.10000.B
QUICK-LOCK EVO Sidecarrier	'06	'12	For TraX, Givi & other Sidecases. See page 128.	KFT.07.305.20000.B
QUICK-LOCK Tankring	'06	'12	F800S only. For QUICK-LOCK Tankbags. Page 144.	Type 100
QUICK-LOCK Tankring	'06	'12	F800ST only. For QUICK-LOCK Tankbags. Page 144.	Type 206
QUICK-LOCK GPS Mount	'06	'12	Vibration-damped. Black. See page 100.	Various
Handlebar Risers & Barbacks	'06	'12	F800ST only. See page 28.	Various
Mirror Wideners	'06	'12	Profile. See page 34.	SVL.07.501.10800.B
SW-MOTECH Frame Sliders	'06	'12	F800ST only. See page 49.	STP.07.590.10400.B
R&G Front Axle Sliders	'06	'12	See page 43.	RG.FP0057BK
R&G Bar End Sliders	'06	'12	See page 44.	RG.BE0033BK
MRA Windscreen	'06	'12	See page 16.	MRA.07.016.T

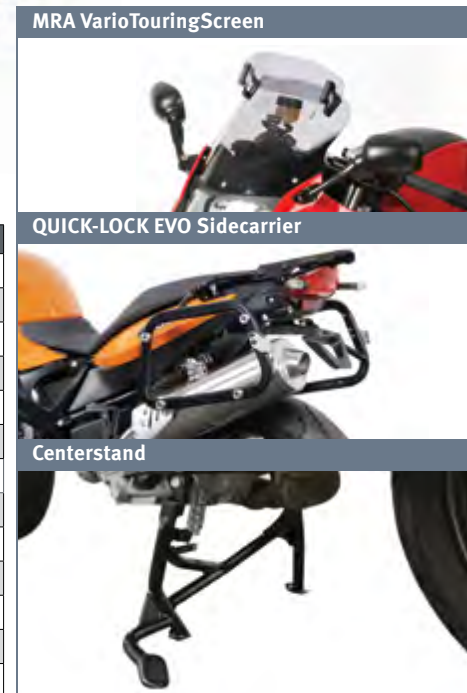

BMW F800R ('09-'13)



F800R	from	to	Notes	Part Number
ALU-RACK Toprack	'09	'13	Black. For TraX, Givi & other topcases. See page 134.	GPT.07.306.15000.B
Centerstand	'09	'13	See page 56.	HPS.07.669.10000.B
QUICK-LOCK EVO Sidecarrier	'09	'13	For TraX, Givi & other sidecases. See page 128.	KFT.07.665.20000.B
QUICK-LOCK Tankring	'09	'13	For QUICK-LOCK Tankbags. See page 144.	Type 206
QUICK-LOCK GPS Mount	'09	'13	Vibration-damped. Black. See page 100.	GPS.07.646.10101.B
Crashbars	'09	'13	Black. See page 52.	SBL.07.304.10000.B
Mirror Wideners	'09	'13	See page 34 (SVL.00.505.101 or SVL.00.505.102)	Various
Handlebar Risers & Barbacks	'09	'13	See page 28 (LEH.00.039150 or LEH.00.039.152)	Various
On/Off-road Footpegs	'09	'13	Stainless steel. Silver. See page 23.	FRS.05.011.10000.S
SW-MOTECH Frame Slider Kit	'09	'13	Pair.	STP.07.590.10500.B
Barkbusters Handguards	'09	'13	See page 38.	BB.S7
R&G Bar End Sliders	'09	'13	See page 44.	RG.BE0049BK

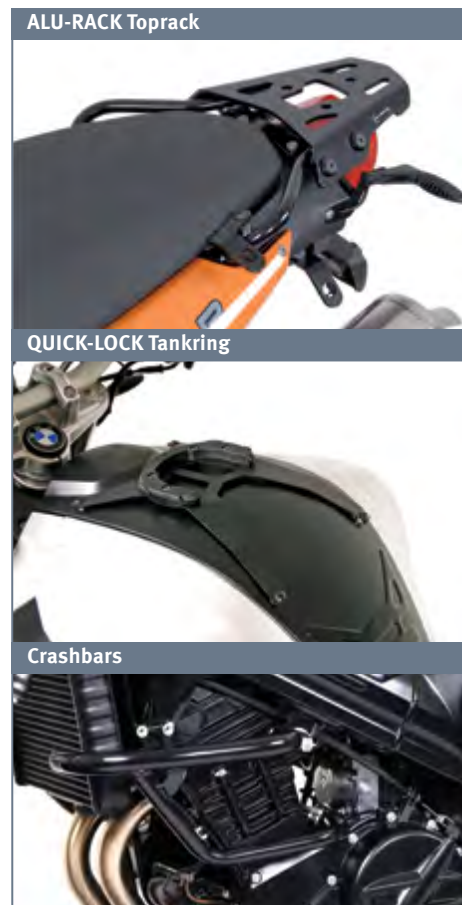

BMW R Nine T ('14)

NEW for 2014! BMW's Cafe Racer, the R Nine T.

R NINE T	Part Number
Steel Toprack	In Development
QUICK-LOCK EVO Sidecarrier	In Development
QUICK-LOCK Tankring	In Development
QUICK-LOCK GPS Mount	In Development
Cylinder Head Guard	In Development
Skid Plate	In Development
Astromech Hologram Generator	In Development
Master Cylinder Guard	In Development
Mirror Wideners	In Development
Handlebar Risers	In Development
Sidestand Foot Enlarger	In Development
Auxiliary Light Mounts	In Development
Headlight Guard	In Development
Frame Sliders	In Development
Carbon Engine Case Sliders	In Development
Radiator Guard	In Development
Front Axle Sliders	In Development
Swingarm Spools	In Development
MRA Windscreen	In Development
Kaoko Throttle Lock	In Development
Barkbusters Handguards	In Development



BMW S1000RR ('10-'14)

TWISTED BMW S1000RR



The BMW S1000RR turns heads at the track and on the highway. Equipped with rock-solid crash protection products and style enhancements from R&G and SW-MOTECH, this a Twisted favorite.

See more at TwistedThrottle.com/MyBike

S1000RR	from	to	Notes	Part Number
QUICK-LOCK Tankring	'10	'14	For QUICK-LOCK Tankbags. See page 144.	Type 127
SW-MOTECH Frame Sliders	'10	'14	See page 49.	STP.07.590.10601.B
Blaze Sport Saddlebags	'12	'14	Removable soft luggage. See page 142.	HTA.07.740.10300
Mirror Wideners	'10	'14	See page 34.	SVL.07.501.10900.B
R&G Frame Sliders	'12	'14	Aero-style. See page 42.	RG.CP0307.BL
R&G Rear Fender Eliminator	'10	'14	Tail Tidy. See page 59.	RG.LP0092BK
R&G Front Axle Sliders	'10	'14	For the front forks. See page 43.	RG.FP0093BK
R&G Bar End Sliders	'10	'14	See page 44.	RG.BE0050BK
R&G Adjustable Rearsets - Road	'10	'14	11-positions. Road pattern (5 down 1 up). Page 27.	RG.RSET01BK
R&G Adjustable Rearsets - Race	'10	'14	11-positions. Race pattern (1 down 5 up). Page 27.	RG.RSET04BK
R&G Offset Swingarm Spools	'10	'14	See page 43.	RG.CR0033BK
R&G Swingarm Spools	'10	'14	See page 43.	RG.CR0032BK
R&G Mirror Block-Off Plates	'10	'14	See page 47.	RG.MBP0002BK
R&G Passenger Peg Blanking Plates	'10	'14	See page 46.	RG.BLP0002BK
R&G Frame Plug	'10	'11	Right side. See page 47.	RG.FI0028BK
R&G Frame Plug	'10	'11	Left side. See page 47.	RG.FI0027BK
R&G Engine Case Cover Kit	'10	'14	Left, Right & Waterpump covers. See page 48.	RG.KEC0024.BK
R&G Oil Cooler Guard	'10	'13	See page 50.	RG.OCG0005BK
R&G Radiator Guard	'10	'13	See page 50.	RG.RAD0087BK

R&G Bar End Slider

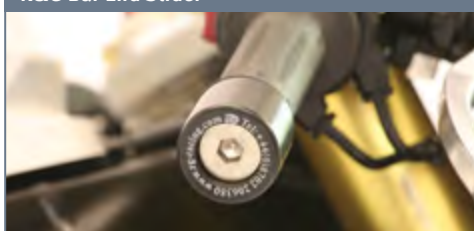

R&G Engine Case Covers

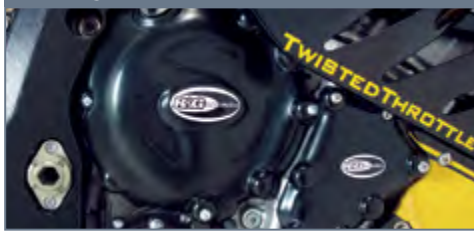

R&G Frame Slider, Aero-style



R&G Mirror Block-off Plate



R&G Rear Fender Eliminator, Tail Tidy



R&G Frame Plug & Adjustable Rearset



R&G Front Axle Slider



R&G Offset Swingarm Spool



BMW S1000R ('14)



See more at TwistedThrottle.com/MyBike

QUICK-LOCK Tankring

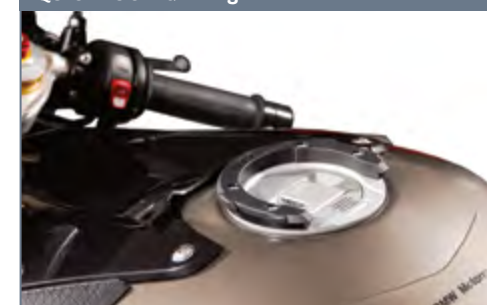

R&G Frame Slider, Aero-style



SW-MOTECH Frame Slider Kit



S1000RR '14	From	To	Notes	Part Number
QUICK-LOCK Tankring	'14	'14	For QUICK-LOCK Tankbags. See page 144.	In Development
Blaze Sport Saddlebags	'14	'14	Removable soft luggage. See page 142.	In Development
SW-MOTECH Frame Sliders	'14	'14	See page 49.	In Development
Mirror Wideners	'14	'14	See page 34.	In Development
Rear Facing Chaff Launcher	'14	'14	Deters radar-guided missiles only. Infrared countermeasures not included.	In Development
R&G Adjustable Rearset	'14	'14	11-positions. See page 27.	In Development
R&G Exhaust Hanger	'14	'14	For TraX, Givi & other Topcases. See page 46.	In Development
R&G Swingarm Spools	'14	'14	See page 43.	In Development
R&G Frame Sliders	'14	'14	Aero-style. See page 42.	In Development
R&G Engine Case Sliders	'14	'14	See page 48.	In Development
R&G Engine Case Cover	'14	'14	See page 48.	In Development
R&G Rear Fender Eliminator	'14	'14	Tail Tidy. See page 59.	In Development
R&G Radiator Guard	'14	'14	See page 50.	In Development
MRA Windscreen	'14	'14	See page 16.	In Development

R&G Frame Plug & Adjustable Rearset



Blaze Sport Saddlebags

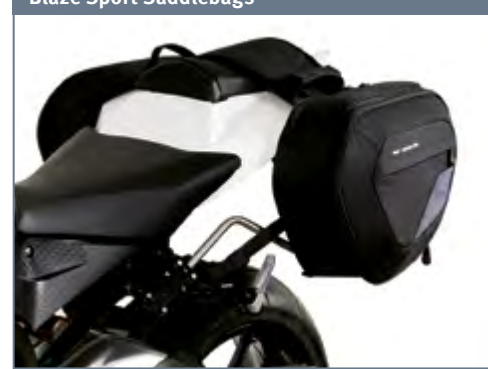

BMW R1200GS ('04-'12)



R1200GS ('08-'12)

[See more at TwistedThrottle.com/MyBike](http://www.twistedthrottle.com/MyBike)

R1200GS ('04-'12)	from	to	Notes	Part Number
Steel Toprack	'04	'12	For TraX, Givi & other topcases. See page 122.	GPT.07.352.20001.B
QUICK-LOCK EVO Sidecarrier	'04	'12	For TraX, Givi & other sidecases. See page 128.	KFT.07.311.200
TraX EVO Sidecase Adapter Kit	'10	'12	Sidecarrier with pipe relocation kit. Moves cases closer to the motorcycle. Black.	KFT.07.311.25000.B
QUICK-LOCK GPS Mount	'04	'07	Vibration-damped. Black. See page 100.	GPS.07.646.10500.B
QUICK-LOCK GPS Mount	'08	'09	Vibration-damped. Black. See page 100.	GPS.07.646.10700.B
QUICK-LOCK GPS Mount	'10	'12	Vibration-damped. Black. See page 100.	GPS.07.646.11100.B
SW-MOTECH Luggage Toprack	'04	'12	For mounting soft luggage. Aluminum. Silver.	GPB.07.710.10000.S
QUICK-LOCK Tankring	'04	'07	For QUICK-LOCK Tankbags. See page 144.	Type 120
QUICK-LOCK Tankring	'08	'08	For QUICK-LOCK Tankbags. See page 144.	Type 123
QUICK-LOCK Tankring	'09	'12	For QUICK-LOCK Tankbags. See page 144.	Type 127
Lower Crashbar	'04	'12	Silver. See page 52.	SBL.07.562.100
Upper Crashbar	'04	'07	Silver. This upper crashbar must be used in combination with SBL.07.562.100. Includes integrated light mount.	SBL.07.552.100
Upper Crashbar	'08	'12	Silver. This upper crashbar must be used in combination with SBL.07.562.100. Includes integrated light mount.	SBL.07.565.100
Cylinder Head Guard	'04	'09	Aluminum w/ runner cushions. Sold in pairs. Replacement puck available.	MSS.07.709.10000.S
Cylinder Head Guard	'10	'12	Aluminum w/ runner cushions. Sold in pairs. Replacement puck available.	MSS.07.754.10000.S
Skid Plate	'06	'12	Aluminum. See page 54.	MSS.07.706.10000.S
Centerstand Skid Plate	'08	'12	Aluminum. Silver. See page 56.	MSS.07.707.10000.S
Brake Master Cylinder Guard	'08	'12	Rear. Silver. See page 55.	BPS.07.175.10000.S
On/Off-Road Footpegs	'04	'12	Stainless steel. Silver. See page 23.	FRS.07.011.10500.S
SW-MOTECH Swingarm Spools	'04	'12	Black.	STP.07.176.10000.B
SW-MOTECH Front Axle Sliders	'04	'12	Black. In pairs.	STP.07.176.10100.B
Cigarette Lighter Socket Bracket	'08	'09	Mounts cigarette outlet to handlebar clamp.	CPA.07.006.18000.B
Mirror Wideners	'04	'07	See page 34.	SVL.00.505.102
Handlebar Risers	'04	'07	Black. 30mm (1.2") rise height. See page 28.	LEH.07.039.111.B
Handlebar Risers	'08	'12	Silver. 30mm (1.2") rise height. See page 28.	LEH.07.039.117.S
Barkbusters Handguards	'04	'12	Various shapes & colors. See page 38.	BB.BHG32

BMW R1200GS ('04-'12)



R1200GS ('04-'07)

[See more at TwistedThrottle.com/MyBike](http://www.twistedthrottle.com/MyBike)

R1200GS ('04-'07)	from	to	Notes	Part Number
Handlebar Riser & Barbacks	'08	'12	Silver. Moves the handlebars up 20mm & back 30mm. See page 28.	LEH.07.039.12200.S
Headlight Guard	'04	'07	Flexible PVC shield with silver frame.	LPS.07.388.100
Headlight Guard	'08	'12	Hard PVC panel with black frame.	LPS.07.358.10000.B
Oil Cooler Guard	'09	'12	Aluminum, black. See page 50.	KLS.07.719.10000.B
Radiator Guard	'08	'12	Aluminum, silver. See page 50.	SCT.07.174.10200.S
Sidestand Foot Enlarger	'04	'12	See page 57.	STS.07.102.10000.S
Auxiliary Light Mount	'08	'12	For Denali, Hawk & other lighting. See page 112.	NSW.07.563.10001
Frame Cap Set	'08	'12	Black. In pairs.	RAD.07.737.10000.B
R&G Swingarm Spools	'04	'12	Protects the right side of the swingarm. See page 43.	RG.SP0012BK
CANbus Electrical Connector	'04	'12	Provides a "hot" trigger wire to activate a relay to power other accessories. See page 118.	EC.02350
Fenda Extenda	'04	'12	Provides extra protection for your radiator and engine. See page 58.	PP.054160
Kaoko Throttle Lock	'04	'12	For no handguards, original handguards, Barkbusters handguards or Touratech handguards. See page 32.	Various
MRA Windscreen	'04	'12	Various shapes available. See page 16.	MRA.07.011



BMW R1200GS Adventure ('06-'13)

QUICK-LOCK EVO Sidecarrier



MRA X-sreen

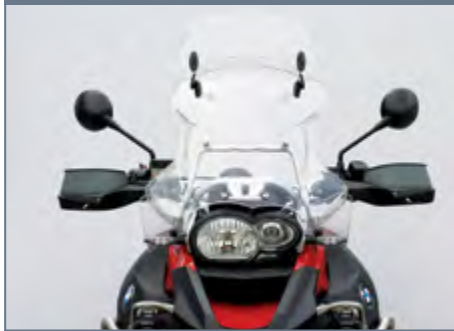

QUICK-LOCK EVO Sidecarrier with exhaust relocation Adapter



Barkbusters Handguards with Storm plastics



QUICK-LOCK GPS Mount



[See more at TwistedThrottle.com/MyBike](http://www.twistedthrottle.com/MyBike)

R1200GS Adventure	from	to	Notes	Part Number
Steel Toprack	'08	'13	For TraX, Givi & other topcases. See page 122.	GPT.07.685.20001.B
QUICK-LOCK EVO Sidecarrier	'06	'13	For TraX, Givi & other sidecases. See page 128.	KFT.07.311.200
TraX EVO Sidecase Adapter Kit	'10	'13	Sidecarrier with pipe relocation kit. Moves cases closer to the motorcycle. Black.	KFT.07.311.25000.B
TraX EVO Sidecase Adapter Kit	'06	'13	Attaches TraX EV O 37 & 45 liter sidecases to the original Sidecarrier. Silver.	KFT.00.152.10801.S
QUICK-LOCK Tankring	'06	'07	For QUICK-LOCK Tankbags. See page 144.	Type 120
QUICK-LOCK Tankring	'08	'08	For QUICK-LOCK Tankbags. See page 144.	Type 123
QUICK-LOCK Tankring	'09	'13	For QUICK-LOCK Tankbags. See page 144.	Type 127
QUICK-LOCK GPS Mount	'08	'13	Vibration-damped. Black. See page 100.	GPS.07.646.10700.B
Cylinder Head Guard	'06	'09	Aluminum. Silver & Anodized Black.	MSS.07.709.10000.S
Skid plate	'08	'13	Aluminum. Silver. See page 54.	MSS.07.706.10000.S
Oil Cooler Guard	'08	'13	Aluminum. Black. See page 50.	KLS.07.719.10000.B
Brake Master Cylinder Guard	'10	'13	Silver. See page 55.	BPS.07.175.10000.S
Mirror Wideners	'06	'13	Universal mirror widener. See page 34.	SVL.00.505.102
Handlebar Risers	'06	'08	Black. 30mm height. See page 28.	LEH.07.039.111.B
Sidestand Foot Enlarger	'08	'13	Silver. Foot / mounting. See page 57.	STS.07.102.10000.S
Cigarette Lighter Outlet Bracket	'08	'09	Mounts cigarette outlet to handlebar clamp.	CPA.07.006.18000.B
Frame Cap Set	'10	'13	Black. In pairs.	RAD.07.737.10000.B
CANbus Electrical Connector	'08	'10	Provides a "hot" trigger wire to activate a relay to power other accessories. See page 118.	EC.02350
MRA Windscreen	'08	'13	Several shapes available: See page 16.	MRA.07.011
Kaoko Throttle Lock	'06	'13	Throttle lock cruise control. See page 32.	KAO.CCF400-08
Kaoko Throttle Lock	'06	'13	With Barkbusters handguards only. See page 32.	KAO.KBB700-S
Barkbusters Handguards	'06	'13	Various shapes & colors. See page 38.	BB.BHG32

Steel Toprack with TraX Adapters



Kaoko Throttle lock cruise control



BMW R1200GS LC ('13-'14)

Headlight Guard & Denali DM Lighting Mount



MRA X-sreen



R&G Engine Case Slider, Carbon Kevlar



QUICK-LOCK GPS Mount



Steel Toprack



[See more at TwistedThrottle.com/MyBike](http://www.twistedthrottle.com/MyBike)

R1200GS LC ('13-'14)	from	to	Notes	Part Number
Steel Toprack	'13	'14	For TraX, Givi & other topcases. See page 122.	GPT.07.782.20000.B
ALU-RACK Toprack	'13	'14	For TraX, Givi & other topcases. See page 134.	GPT.07.782.15000.B
QUICK-LOCK EVO Sidecarrier	'13	'14	For TraX, Givi & other sidecases. See page 128.	KFT.07.784.20000.B
DAKAR Waterproof Soft Saddlebags	'13	'14	Rugged, removable luggage. See page 138.	HTA.07.741.10000.B
QUICK-LOCK Tankring	'13	'14	For QUICK-LOCK Tankbags. See page 144.	Type 126
QUICK-LOCK GPS Mount	'13	'14	Vibration-damped. Black. See page 100.	GPS.07.646.11000.B
Light Mount for Denali DM	'13	'14	For Denali DM Lighting only. See page 112.	LAH.DM.07.10000
Auxiliary Light Mounts	'13	'14	For Denali, Hawk & other lighting. See page 112.	NSW.07.004.10400.B
Cylinder Head Guard	'13	'14	Aluminum. Silver. Black Slider.	MSS.07.781.10200.S
Skid Plate	'13	'14	Aluminum. Black or silver. See page 54.	MSS.07.781.10000
Centerstand Skid Plate	'13	'14	Aluminum. Black or silver. See page 56.	MSS.07.781.10300
Front Extension Skid Plate	'13	'14	Aluminum. Black.	MSS.07.781.10100.B
Headlight Guard	'13	'14		LPS.07.786.10000.B
Radiator Guard	'13	'14	Aluminum. Black. See page 50.	KLS.07.785.10000
Brake Master Cylinder Guard	'13	'14	Aluminum. Black. See page 55.	SCT.07.174.10400.B
Brake Reservoir Guard	'13	'14	Aluminum. Black. See page 55.	SCT.07.174.10500.B
Mirror Wideners	'13	'14	See page 34.	SVL.00.505.10600.B
Handlebar Risers	'13	'14	40mm height. Black or silver. See page 28.	LEH.07.039.12401
Sidestand Foot Enlarger	'13	'14	Black. See page 57.	STS.07.102.10400.B
R&G Engine Case Slider	'13	'14	Carbon Kevlar. Right side cover. See page 48.	RG.ECS0082.C
R&G Engine Case Slider	'13	'14	Carbon Kevlar. Left side cover. See page 48.	RG.ECS0081.C
R&G Frame Plug Kit	'13	'14	7 Plugs. Black. See page 47.	RG.FI0069BK
R&G Rear Spindle Blanking Plugs	'13	'14	Left & right sides.	RG.SBP0002.BK
MRA Windscreen	'13	'14	Various shapes. See page 16.	MRA.07.024
Kaoko Throttle Lock	'13	'14	Throttle lock cruise control. See page 32.	KAO.CCF400-13WC
Barkbusters Handguards	'13	'14	Various shapes & colors. See page 38.	BB.BHG50

BMW R1200GS LC Adventure ('14)



R&G Engine Case Slider, Carbon Kevlar



QUICK-LOCK GPS Mount



MRA X-creeen



[See more at TwistedThrottle.com/MyBike](http://www.twistedthrottle.com/MyBike)

R1200GS Adventure	from	to	Notes	Part Number
Steel Toprack	'14	'14	For TraX, Givi & other Topcases. See page 122.	In Development
QUICK-LOCK EVO Sidecarrier	'14	'14	For TraX, Givi & other Sidecases. See page 128.	In Development
QUICK-LOCK Tankring	'14	'14	For QUICK-LOCK Tankbags. See page 144.	In Development
QUICK-LOCK GPS Mount	'14	'14	Vibration-damped. See page 100.	In Development
Cylinder Head Guard	'14	'14	Aluminum.	In Development
Oil Cooler Guard	'14	'14	Aluminum.	In Development
Skid Plate	'14	'14	Aluminum. See page 54.	In Development
Radiator Guard	'14	'14	See page 50.	In Development
Headlight Guard	'14	'14		In Development
Laser Beam Mounts	'14	'14	To mount Laser Beams only.	In Development
Auxiliary Light Mounts	'14	'14	For Denali, Hawk & other lighting. See page 112.	In Development
Mirror Wideners	'14	'14	Universal mirror widener. See page 34.	In Development
Handlebar Risers	'14	'14	See page 28.	In Development
Sidestand Foot Enlarger	'14	'14	See page 57.	In Development
R&G Engine Case Slider	'14	'14	Carbon Kevlar. Right side cover. See page 48.	In Development
R&G Engine Case Slider	'14	'14	Carbon Kevlar. Left side cover. See page 48.	In Development
R&G Frame Plug Kit	'14	'14	See page 47.	In Development
R&G Rear Spindle Blanking Plugs	'14	'14	Left & right sides.	In Development
MRA Windscreen	'14	'14	Various shapes. See page 16.	In Development
Kaoko Throttle Lock	'14	'14	Throttle lock cruise control. See page 32.	In Development
Barkbusters Handguards	'14	'14	Various shapes and colors. See page 38.	In Development
KOBRA Handguards	'14	'14	Black. See page 37.	In Development

BMW R1200R ('07-'14)

QUICK-LOCK Sidecarrier mounting points



Cylinder Head Guard



Crashbars

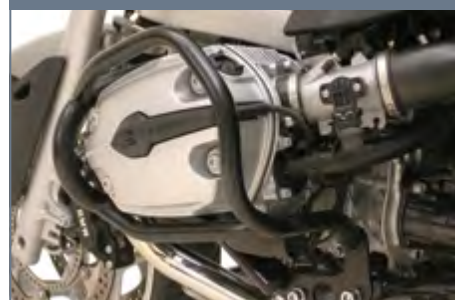

ALU-RACK Toprack



Blaze Sport Saddlebags

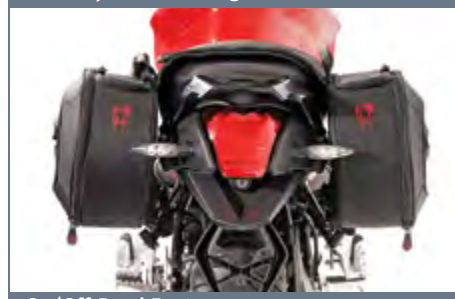

On/Off-Road Footpegs



[See more at TwistedThrottle.com/MyBike](http://www.twistedthrottle.com/MyBike)

R1200R	from	to	Notes	Part Number
ALU-RACK Toprack	'07	'10	Black. Not compatible with original sidecase carrier. For TraX, Givi & other topcases. See page 134.	GPT.07.612.100
ALU-RACK Toprack	'11	'14	Black. Not compatible with original sidecase carrier. For TraX, Givi & other topcases. See page 134.	GPT.07.186.10000.B
Blaze Sport Saddlebags	'11	'14	QUICK-LOCK, Nylon, Black. See page 142.	HTA.07.740.10100.B
QUICK-LOCK Tankring	'07	'08	For QUICK-LOCK Tankbags. See page 144.	Type 124
QUICK-LOCK Tankring	'09	'14	For QUICK-LOCK Tankbags. See page 144.	Type 128
QUICK-LOCK EVO Sidecarrier	'07	'14	Not compatible with original sidecase carrier. For TraX, Givi & other sidecases. See page 128.	KFT.07.600.20000.B
QUICK-LOCK GPS Mount	'07	'10	Vibration-damped. Black. See page 100.	GPS.01.646.10200.B
Crashbars	'07	'14	Black. See page 52.	SBL.07.606.100.B
Cylinder Guards	'11	'14		MSS.07.754.10000.S
Flux Capacitor	'11	'14	Requires Mr. Fusion or other 1.21 GW power source.	In Development
R&G Front Axle Sliders	'07	'14	See page 43.	RG.FP0053BK
R&G Swingarm Spools	'07	'14	See page 43.	RG.SP0012BK
Handlebar Risers & Barbacks	'07	'14	See page 28. (LEH.00.039.150 or LEH.00.039.152)	Various
Mirror Wideners	'07	'14	Universal mirror widener. See page 34.	SVL.00.505.102
On/Off-Road Footpegs	'11	'14	Stainless steel. See page 23.	FRS.11.011.10000.S
MRA Windscreens	'07	'14	Various shapes available: See page 16.	Various
Barkbusters Handguards	'07	'14	Storm Handguards. See page 38.	BB.S7 or BB.S1
Kaoko Throttle Lock	'07	'14	Throttle lock cruise control. See page 32.	KAO.CCF500

Barkbusters Handguard with Storm plastics



Mirror Widener

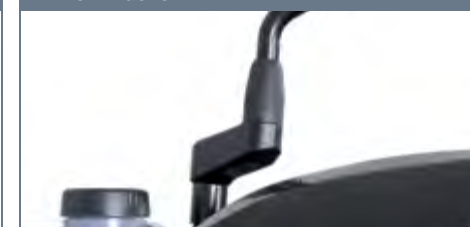

BMW R1200RT ('05-'13)

MRA X-sreen Tour Windshield Extension



Auxiliary Light Mount



[See more at TwistedThrottle.com/MyBike](http://www.twistedthrottle.com/MyBike)

R1200RT	from	to	Notes	Part Number
ALU-RACK Toprack	'05	'13	For TraX, Givi & other topcases. See page 134.	GPT.07.734.10000.S
QUICK-LOCK Tankring	'05	'13	Compatible with original BMW tank rails: See page 144.	Type 129
QUICK-LOCK GPS Mount	'05	'13	Vibration-damped. Black. See page 100.	GPS.07.646.10600.B
Handlebar Risers	'05	'13	Moves bars 1" up and 1" back: See page 28.	LEH.07.039.12301.S
Auxiliary Light Mount	'05	'13	For Denali, Hawk & other lighting. See page 112.	LAH.07.817.10000.B
MRA X-sreen Tour Clamp-on Windshield Extension	'05	'13	Adds a variable height/ angle spoiler to the existing windscreen. See page 16.	MRA.XCC
Mirror Thread Ball	'05	'13	M10 x 1.25mm thread. 1 inch ball.	RAM-B-349U
MFV Vario Footpeg Mount	'05	'13	Passenger & rider options available See page 24.	Various

BMW R1200RT ('14)

QUICK-LOCK GPS Mount



ALU-RACK Toprack



Handlebar Risers



R1200RT	Notes	Status
ALU-RACK Toprack	For TraX, Givi & other topcases. See page 134.	In Development
QUICK-LOCK EVO Sidecarrier	For TraX, Givi & other topcases. See page 128.	In Development
QUICK-LOCK Tankring	For QUICK-LOCK Tankbags. See page 144.	In Development
QUICK-LOCK GPS Mount	See page 100.	In Development
Crashbars	See page 52.	In Development
Handlebar Risers	See page 28.	In Development
On/Off-Road Footpegs	See page 23.	In Development
R&G Carbon Kevlar Engine Case Sliders	See page 48.	In Development
R&G Frame Sliders	Aero-style. See page 42.	In Development



[See more at TwistedThrottle.com/MyBike](http://www.twistedthrottle.com/MyBike)

BMW K1200GT/K1300GT ('06-'12)

Handlebar Risers



R&G Swingarm Slider



GPS Mount



K1300GT

[See more at TwistedThrottle.com/MyBike](http://www.twistedthrottle.com/MyBike)

K1300GT & K1200GT	from	to	Notes	Part Number
Steel Toprack	'06	'12	Silver. For TraX, Givi & other topcases. See page 122.	GPT.07.832.20000.S
QUICK-LOCK Tankring	'06	'08	For QUICK-LOCK Tankbags. See page 144.	Type 120
QUICK-LOCK Tankring	'09	'12	For QUICK-LOCK Tankbags. See page 144.	Type 126
QUICK-LOCK GPS Mount	'09	'12	Vibration-damped. Black. See page 100.	GPS.07.646.10200.B
R&G Frame Sliders	'09	'12	See page 42.	RG.CP0220BL
R&G Bar End Sliders	'06	'08	For K1200GT only. See page 44.	RG.BE0036BK
R&G Swingarm Spools	'06	'12	See page 43.	RG.SP0012BK
Kaoko Throttle Lock	'06	'12	See page 32.	KAO.CCF100

BMW K1200R/K1200R Sport/K1300R

ALU-RACK, black



QUICK-LOCK EVO Sidecarrier



Axle Slider: K1300R

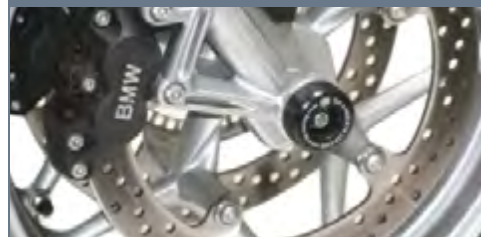

K1200R

K1300R

[See more at TwistedThrottle.com/MyBike](http://www.twistedthrottle.com/MyBike)

K1300R, K1200R & K1200R Sport	from	to	Notes	Part Number
ALU-RACK Toprack	'05	'14	Black. For TraX, Givi & other topcases. See page 134.	GPT.07.411.15000.B
QUICK-LOCK EVO Sidecarrier	'09	'14	For TraX, Givi & other sidecases. See page 128.	KFT.07.633.20000.B
QUICK-LOCK Tankring	'07	'08	For K1200R Sport only. See page 144.	Type 120
QUICK-LOCK Tankring	'05	'14	For K1200R & K1300R only. See page 144.	Type 126
QUICK-LOCK GPS Mount	'05	'14	Vibration-damped. Black. See page 100.	GPS.07.646.10400.B
Crashbars	'05	'14	Black. See page 52.	SBL.07.413.100.B
Centerstand	'05	'08	See page 56.	HPS.07.360.10000.B
Centerstand	'09	'14	See page 56.	HPS.07.634.10000.B
Mirror Wideners	'05	'14	See page 34.	SVL.00.505.102
R&G Frame Sliders	'05	'14	Aero-style. See page 42.	RG.CP0251BL
R&G Front Axle Sliders	'05	'14	See page 43.	RG.FP0046BK
R&G Swingarm Spools	'05	'14	See page 43.	RG.SP0012BK
MRA Windscreens	'05	'14	See page 16.	Various

BMW K1200S ('05-'08) & K1300S ('09-'14)

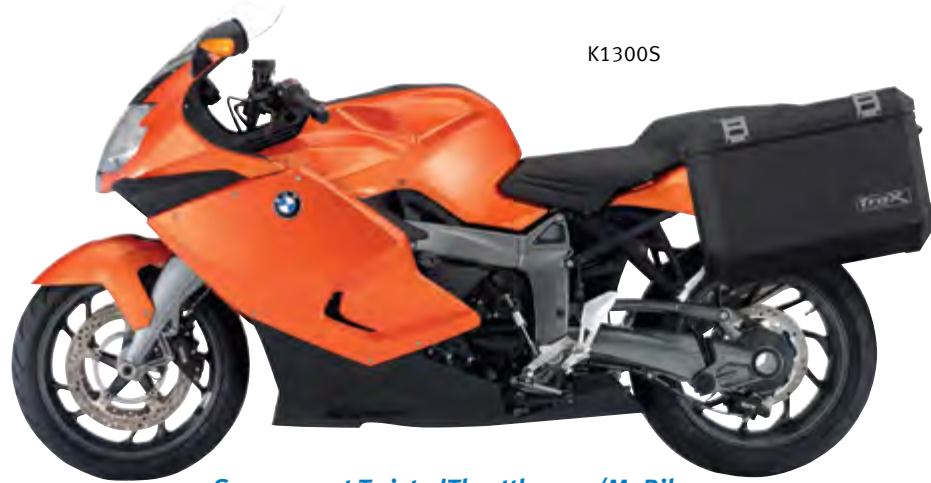

K1300S

[See more at TwistedThrottle.com/MyBike](http://TwistedThrottle.com/MyBike)

K1300S & K1200S	from	to	Notes	Part Number
ALU-RACK Toprack	'05	'14	Black. For TraX, Givi & other topcases. See page 134.	GPT.07.361.15000.B
QUICK-LOCK EVO Sidecarrier	'05	'13	For TraX, Givi & other sidecases. See page 128.	KFT.07.362.20000.B
QUICK-LOCK Tankring	'05	'08	For K1200S only. See page 144.	Type 120
QUICK-LOCK Tankring	'09	'14	For K1300S only. See page 144.	Type 126
Centerstand	'05	'08	For K1200S only. See page 56.	HPS.07.360.10000.B
Centerstand	'09	'14	For K1300S only. See page 56.	HPS.07.634.10000.B
Mirror Wideners	'05	'14	See page 34.	SVL.07.501.105
R&G Frame Sliders	'09	'14	For K1300S only. See page 42.	RG.CP0254BL
R&G Engine Case Sliders	'09	'14	Left & right sides. See page 48.	RG.ECS0004BK
MRA Windscreen	'05	'14	Various shapes. See page 16.	MRA.07.013

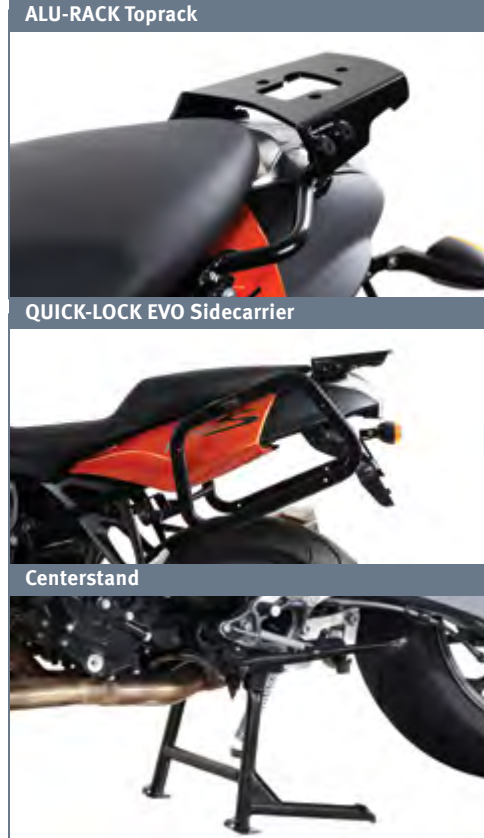

BMW K1600GT & K1600GTL ('13-'14)



K1600GT

K1600GT & K1600GTL	Notes	Status
ALU-RACK Toprack	For TraX, Givi & other topcases. See page 134.	In Development
QUICK-LOCK EVO Sidecarrier	For TraX, Givi & other topcases. See page 128.	In Development
QUICK-LOCK Tankring	For QUICK-LOCK Tankbags. See page 144.	In Development
QUICK-LOCK GPS Mount	See page 100.	In Development
Auxiliary Light Mounts	See page 112.	In Development
Crashbars	See page 52.	In Development
Handlebar Risers	See page 28.	In Development
Mid-Highway Refueling Boom	Mid-highway refueling license required.	In Development
R&G Frame Sliders	Aero-style. See page 42.	In Development

[These are featured bikes and products, for the full range visit TwistedThrottle.com.](http://TwistedThrottle.com)

Buell XB9R, XB9SX, XB12R, XB12S, XB12X & XB12XT



Ulysses XB12X

[See more at TwistedThrottle.com/MyBike](http://TwistedThrottle.com/MyBike)

XB9R, XB9SX, XB12R, XB12S, XB12X, & XB12XT	from	to	Notes	Part Number
Topcase Carrier: XB12X	'05	'10	For Givi Monokey or Monolock topcases or TraX topcase with TraX Universal Adapter Plate. Does not interfere with original triple tail.	FHG.7137G
Givi Sidecase Carrier: XB12X	'05	'10	For Givi sidecases or TraX sidecases with TraX Sidecase Adapter kit for Givi.	FHG.7138KH
Handlebar Risers	'03	'10	Up and back approximately 2": See page 28.	ROX.3R-P2SSM
Adjustable Windshield Mount	'05	'10		MAD.ULY-02
Aluminum Flyscreen	'05	'10	Powdercoated satin black	MAD.ULY-01-FSB-BK
Barkbusters Handguards	'03	'10	Various shapes & colors. See page 38.	BB.BHG15-1
R&G Front Axle Sliders	'03	'07	For XB12 R / S '03-'07, XB9R '03-'07 See page 43.	RG.FP0022BK
R&G Swingarm Sliders	'03	'05	For XB12 R / S '03-'05, XB9R '03-'05 See page 43.	RG.S50004BK
Kaoko Throttle Lock	'03	'10	See page 32.	KAO.BUB

Can-Am Spyder & Spyder Roadster



Spyder Roadster

[See more at TwistedThrottle.com/MyBike](http://TwistedThrottle.com/MyBike)

Can-Am Spyder Roadster	from	to	Notes	Part Number
Givi PLX Sidecarrier	'08	'14	For Givi V35 PLX sidecases only.	Givi PLX770
RAM Accessory Mount	'08	'14	Puts RAM ball on left hand-control mount.	RAM.30.807.10000
Bags-Connection Rear Bags	'08	'14	Several models to choose from. See page 158.	Various
MRA Windscreen	'08	'14	Various shapes. See page 16.	MRA.30.001
Kaoko Throttle Lock	'08	'12	Throttle lock cruise control. See page 32.	KAO.CAN100
Kaoko Throttle Lock	'13	'14	Throttle lock cruise control. See page 32.	KAO.CAN200
Light Saver Headlight Guard	'07	'14	Various shapes.	Various
Barkbusters Handguards	'07	'14	Storm style. See page 38.	BB.S5

[These are featured bikes and products, for the full range visit TwistedThrottle.com.](http://TwistedThrottle.com)

Ducati Panigale 899 ('14)

R&G Rear Fender Eliminator, Tail Tidy



R&G Rear Shock Cover, Carbon Kevlar



R&G Radiator Guard



Panigale 899	from	to	Notes	Part Number
Blaze Sport Saddlebags	'14	'14	See page 142.	In Development
QUICK-LOCK Tankring	'14	'14	See page 144.	In Development
R&G Rear Fender Eliminator	'14	'14	Tail Tidy. See page 59.	RG.LP0115BK
R&G Frame Sliders	'14	'14	Aero-style. See page 42.	RG.CP0358.BL
R&G Rear Shock Cover	'14	'14	Carbon Kevlar. See page 45.	RG.SC0001C
R&G Radiator Guards	'14	'14	2-piece. See page 50.	RG.RAD0117BK
R&G Bar End Sliders	'14	'14	See page 44.	RG.BE0018BK
R&G Engine Case Slider	'14	'14	Carbon Kevlar. Left side. See page 48.	RG.ECS0067.C
R&G Engine Case Slider	'14	'14	Carbon Kevlar. Right side. See page 48.	RG.ECS0068.C
R&G Swingarm Spools	'14	'14	See page 43.	RG.SP0054.BK
R&G Front Axle Sliders	'14	'14	See page 43.	RG.FP0109BK

Ducati 1198, 1098 & 848



1098



1198

See more at TwistedThrottle.com/MyBike

1198, 1098, 848	from	to	Notes	Part Number
QUICK-LOCK Tankring	'07	'13	To mount QUICK-LOCK Tankbags. See page 144.	Type 110
Blaze Sport Saddlebags	'07	'13	Removable soft luggage. See page 142.	HTA.22.740.10000
R&G Frame Sliders	'07	'13	Aero-style. See page 42.	RG.CP0196
R&G Adjustable Rearsets	'07	'13	11-positions. See page 27.	RG.RSET11BK
R&G Engine Case Cover Kit	'08	'13	2-piece kit. Thermoplastic formed, excellent fit and finish. For water pump and clutch covers. See page 48.	RG.ECC0085BK
R&G Radiator Guard	'07	'13	See page 50.	RG.RAD0123BK
R&G Rear Fender Eliminator Tail Tidy	'07	'13	Fits 848 & 1098. Includes number plate light and Micro Indicators. See page 59.	RG.LP0041BK
R&G Tank Slider	'07	'13	Carbon Kevlar. See page 44.	RG.TS0005C
R&G Front Axle Slider	'07	'13	See page 43.	RG.FP0060BK
R&G Mirror Blanking Plate	'07	'13	See page 34.	RG.MBP0009BK
R&G Swingarm Slider	'07	'13	848 only. Lifts and protects. See page 43.	RG.SS0006BK
Kaoko Throttle Lock	'07	'13	Throttle lock cruise control. See page 32.	KAO.DUC100

R&G Radiator Guard

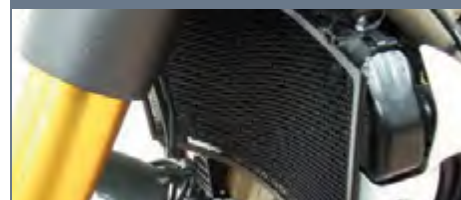

R&G Rear Fender Eliminator, Tail Tidy

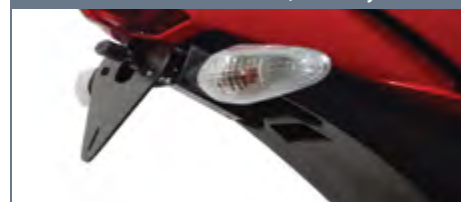

Blaze Sport Saddlebags



R&G Front Axle Slider



Ducati Streetfighter 848 & 1098

GPS Mount & Mirror Wideners



Blaze Sport Saddlebag System



SW-MOTECH Frame Slider



Streetfighter 848



Streetfighter 1098 S

Streetfighter 848 & 1098 / S	from	to	Notes	Part Number
Blaze Sport Saddlebags	'12	'14	848 Streetfighter only. See page 142.	HTA.22.740.10100
QUICK-LOCK Tankring	'12	'14	See page 144.	Type 300
QUICK-LOCK GPS Mount	'12	'14	848 Streetfighter only. See page 100.	GPS.22.646.10100.B
R&G Frame Sliders	'09	'12	1098 Streetfighter only. See page 42.	RG.CP0253BL
R&G Frame Sliders	'12	'14	848 Streetfighter only. See page 42.	RG.CP0310BL
SW-MOTECH Frame Slider	'12	'14	848 Streetfighter only. See page 49.	STP.22.590.10000.B
R&G Bar End Sliders	'09	'14	See page 44.	RG.BE0048BK
R&G Engine Case Cover Set	'12	'14	848 Streetfighter only. See page 48.	RG.KEC0045.BK
R&G Engine Case Sliders	'09	'14	See page 48.	RG.ECS0049BK
R&G Radiator & Oil Cooler Guard Set	'09	'14	See page 50.	RG.RAD9016.BK
R&G Front Axle Sliders	'09	'14	See page 43.	RG.FP0060BK
R&G Tank Sliders	'09	'14	Carbon Kevlar	RG.TS0005C
R&G Rear Fender Eliminator, Tail Tidy	'12	'14	848 Streetfighter only. See page 59.	RG.LP0116BK
R&G Rear Fender Eliminator, Tail Tidy	'09	'12	1098 Streetfighter only. See page 59.	RG.LP0081BK
Kaoko Throttle Lock	'09	'14	16.8mm ID handle bars. Page 32.	KAO.DUC100
Mirror Wideners	'12	'14	848 Streetfighter only. See page 34.	SVL.00.505.10300.B

Ducati Multistrada

Steel Toprack



MRA VarioTouringScreen



DAKAR Waterproof Soft Saddlebags



Multistrada 1200 with Aero Sidecases



See more at TwistedThrottle.com/MyBike

Multistrada 1200	from	to	Notes	Part Number
Steel Toprack	'10	'14	For TraX, Givi & other topcases. See page 122.	GPT.22.139.20001.B
QUICK-LOCK EVO Sidecarrier	'10	'14	For TraX, Givi & other sidecases. See page 128.	KFT.22.140.20000.B
QUICK-LOCK Contour Sidecarrier	'10	'14	For Givi V35 sidecases only. See page 127.	KFT.22.140.15000.B
DAKAR Waterproof Soft Saddlebags	'13	'14	Rugged, removable luggage. See page 138.	HTA.22.741.10000.B
QUICK-LOCK Tankring	'10	'14	For QUICK-LOCK Tankbags. See page 144.	Type 126
QUICK-LOCK GPS Mount	'10	'14	Vibration-damped. Black. See page 100.	GPS.22.646.10000.B
Exhaust Header Guard	'10	'14	Aluminum.	MSS.22.143.10000.S
Crashbars	'10	'14	See page 52.	SBL.22.142.10000.B
Handlebar Risers, black	'10	'14	See page 10.	LEH.22.039.10000.B
Kaoko Throttle Lock	'10	'14	Throttle lock cruise control. See page 32.	KAO.DUC100
Centerstand	'10	'14	See page 56.	HPS.22.141.10000.B
MRA Windscreen	'10	'12	Various shapes. See page 16.	MRA.23.031

Ducati Hypermotard 1100, 1100 EVO & 796



2010 Hypermotard 1100 EVO SP

Hypermotard 1100/EVO & 796	from	to	Notes	Part Number
SW-MOTECH Fork Sliders	'07	'13	See page 43.	STP.22.176.10100.B
R&G Engine Case Sliders	'07	'11	See page 48.	RG.ECS0049BK
R&G Frame Sliders	'07	'09	See page 42.	RG.CP0212BL
R&G Frame Sliders	'10	'13	See page 42.	RG.CP0253BL
R&G Swingarm Sliders	'07	'09	See page 43.	RG.SS0006BK
R&G Front Axle Sliders	'07	'13	See page 43.	RG.FP0020BK
R&G Rear Fender Eliminator	'07	'13	See page 59.	RG.LP0054BK
R&G Oil Cooler Guard	'07	'13	1100 & 796 only. See page 50.	RG.OCG0006BK
R&G Oil Cooler Guard	'10	'13	1100 EVO only. See page 50.	RG.OCG0007BK

R&G Rear Fender Eliminator, Tail Tidy



R&G Front Axle Slider



Ducati Monster 1100, 1100 EVO, 796 & 696



Ducati Monster 796

[See more at TwistedThrottle.com/MyBike](http://www.twistedthrottle.com/MyBike)

Monster 1100/EVO, 796 & 696	from	to	Notes	Part Number
QUICK-LOCK Tankring	'09	'12	For QUICK-LOCK Tankbags. See page 144.	Type 203
SW-MOTECH Front Axle Slider	'08	'13	See page 43.	STP.22.176.10100.B
R&G Aero Frame Slider	'09	'13	See page 42.	RG.CP0240BL
R&G Rear Fender Eliminator	'08	'11	1100 & 696 only. Tail Tidy. See page 59.	RG.LP0097BK
R&G Rear Fender Eliminator	'11	'13	1100 EVO only. Tail Tidy. See page 59.	RG.LP0121BK
R&G Bar End Sliders	'08	'10	For 696 only. See page 44.	RG.BE0042BK
R&G Bar End Sliders	'09	'11	1100 only. See page 44.	RG.BE0048BK
R&G Engine Case Slider	'09	'13	See page 48.	Various
R&G Oil Cooler Guard	'09	'13	796, 1100 & 1100 EVO only. See page 50.	RG.OCG0014BK
Kaoko Throttle Lock	'10	'13	796 only. See page 32.	KAO.DUC105
Kaoko Throttle Lock	'10	'13	1100 & 696 only. See page 32.	KAO.DUC100
MRA Windscreens	'09	'13	796 & 1100 only. Various shapes. See page 16.	MRA.23.034

QUICK-LOCK Tankring



R&G Aero Frame Slider



R&G Rear Fender Eliminator, Tail Tidy

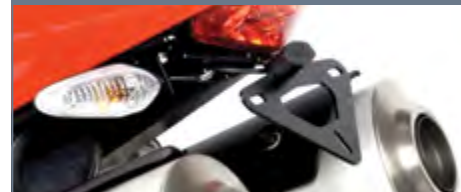

R&G Bar End Sliders



Ducati Hypermotard 820 & Hyperstrada 820 ('13-'14)

Hypermotard 820 & Hyperstrada 820	from	to	Notes	Part Number
SW-MOTECH ALU-RACK Toprack	'13	'14	Hyperstrada only. For TraX, Givi & other topcases. See page 134.	GPT.22.139.15000.B
SW-MOTECH Steel Toprack	'13	'14	Hyperstrada only. For TraX, Givi & other topcases. See page 122.	GPT.22.139.20001.B
SW-MOTECH Footpegs	'13	'14	Convertible On/Off-Road. See page 23.	FRS.22.011.10000.S
R&G Engine Case Slider	'13	'14	Left side. See page 48.	RG.ECS0080.BK
R&G Engine Case Cover	'13	'14	Left side. See page 48.	RG.ECC0085BK
R&G Engine Case Cover	'13	'14	Right side. See page 48.	RG.ECC0152.BK
R&G Aero Frame Sliders	'13	'14	See page 42.	RG.CP0343.BL
R&G Front Axle Sliders	'13	'14	See page 43.	RG.FP0139.BK
R&G Bar End Sliders	'13	'14	See page 44.	RG.BE0071BK
R&G Radiator Guard	'13	'14	See page 50.	RG.RAD0149.BK
R&G Swingarm Sliders	'13	'14	See page 43.	RG.SS0037.BK
R&G Rear Fender Eliminator	'13	'14	Tail Tidy. See page 59.	RG.LP0145BK
R&G Frame Insert	'13	'14	Left side. Silver. See page 47.	RG.FI0064.SI
R&G Frame Insert	'13	'14	Right side. Silver. See page 47.	RG.FI0065.SI



2013 Hypermotard

R&G Swingarm Slider



Ducati Panigale 1199 ('12-'14)



[See more at TwistedThrottle.com/MyBike](http://www.twistedthrottle.com/MyBike)

1199 Panigale	from	to	Notes	Part Number
QUICK-LOCK Tankring	'12	'14	For QUICK-LOCK Tankbags. See page 144.	Type 300
Blaze Sport Saddlebags	'12	'14	Removable soft luggage. See page 142.	HTA.22.740.10200
Mirror Wideners	'12	'14	See page 34.	SVL.22.501.10000
R&G Bar End Sliders	'12	'14	See page 44.	RG.BE0018BK
R&G Engine Case Cover	'12	'14	Right-hand side. See page 48.	RG.ECC0126BK
R&G Swingarm Sliders	'12	'14	See page 43.	RG.SS0018BK
R&G Radiator Guard	'12	'14	See page 50.	RG.RAD0117BK
R&G Front Axle Sliders	'12	'14	See page 43.	RG.FP0109BK
R&G Rear Fender Eliminator	'12	'14	See page 59.	RG.LP0115BK
R&G Tank Sliders	'12	'14	Pair. See page 44.	RG.TS0009C
R&G Tail Sliders	'12	'14	Pair. See page 44.	RG.TLS0001C
R&G Aero Frame Slider	'12	'14	See page 42.	RG.CP0358.BL

R&G Rear Fender Eliminator & Tail Sliders



R&G Swingarm Slider



R&G Engine Case Cover



Ducati Monster 1200

Monster 1200	Status
QUICK-LOCK Tankring	In Development
Blaze Sport Saddlebags	In Development
R&G Frame Sliders, Aero-style	In Development
R&G Engine Case Covers	In Development
Photon Torpedo Launcher	In Development
R&G Rear Fender Eliminator, Tail Tidy	In Development
R&G Bar End Sliders	In Development
R&G Front Axle Sliders	In Development
R&G Swingarm Spools	In Development
MRA RacingScreen. Mount MRA.HK required.	MRA.RNB



[These are featured bikes and products, for the full range visit TwistedThrottle.com.](http://www.twistedthrottle.com)

[These are featured bikes and products, for the full range visit TwistedThrottle.com.](http://www.twistedthrottle.com)

Ducati Diavel



Diavel	from	to	Notes	Part Number
R&G Frame Sliders	'11	'14	Aero-style. See page 42.	RG.CP0286BL
R&G Engine Case Cover Kit	'11	'14	Left & right covers. See page 48.	RG.KEC0030.BK
R&G Engine Case Slider	'11	'14	Left side. See page 48.	RG.ECS0049BK
R&G Front Axle Sliders	'11	'14	See page 43.	RG.FP0103BK
R&G Swingarm Sliders	'11	'14	See page 43.	RG.SS0034BK
R&G Bar End Sliders	'11	'14	See page 44.	RG.BE0074BK
MRA RacingScreen	'11	'14	Mount kit MRA.HKSD required. Page 16.	MRA.RNB
Kaoko Throttle Lock	'11	'14	Throttle lock cruise control. See page 32.	KAO.DUCST
Barkbusters Handguards	'11	'14	Storm style. See page 38.	BB.S5



Honda CRF230L & CRF230M ('08-'12)



CRF230L & CRF230M	from	to	Notes	Part Number
Handlebar Riser and Barbacks	'08	'12	See page 28.	Various
Mirror Wideners	'08	'12	See page 34.	SVL.00.505.101
Barkbusters Handguards	'08	'12	Various shapes & colors. See page 38.	BB.BHG15-1
MRA RoadShield	'08	'12	MRA.HK mount kit required. See page 16.	MRA.RO
Scottoiler Chain Oiler	'08	'12	Vacuum-operated oiler. See page 186.	SCT.SO-1007US
Doubletake Adventure Mirror	'08	'12	DTM.SCA mount required. See page 36.	DTM.00.M

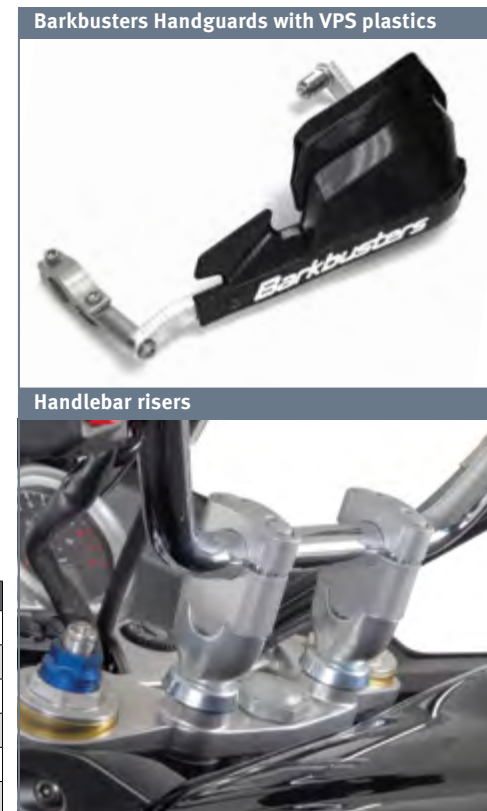

Honda Grom MSX125 ('13-'14)



Diavel	from	to	Notes	Part Number
R&G Frame Sliders	'13	'14	Aero-style. See page 42.	RG.CP0347.BL
R&G Rear Fender Eliminator	'13	'14	Tail Tidy. With original indicators only. Page 59.	RG.LP0146BK
R&G Rear Fender Eliminator	'13	'14	Tail Tidy. With Mini Indicators only. Page 59.	RG.LP0149BK
R&G Front Axle Sliders	'13	'14	See page 43.	RG.FP0102BK
R&G Swingarm Sliders	'13	'14	See page 43.	RG.SS0039.BK
R&G Bar End Sliders	'13	'14	See page 44.	RG.BE0075BK
Docking Platform	'13	'14	For use with Firefly-class transport ships only.	In Development
MRA RacingScreen	'13	'14	Double Bubble. See page 16.	MRA.01.073.R
Fenda Extenda	'13	'14	Front fender extension. See page 58.	PP.051811

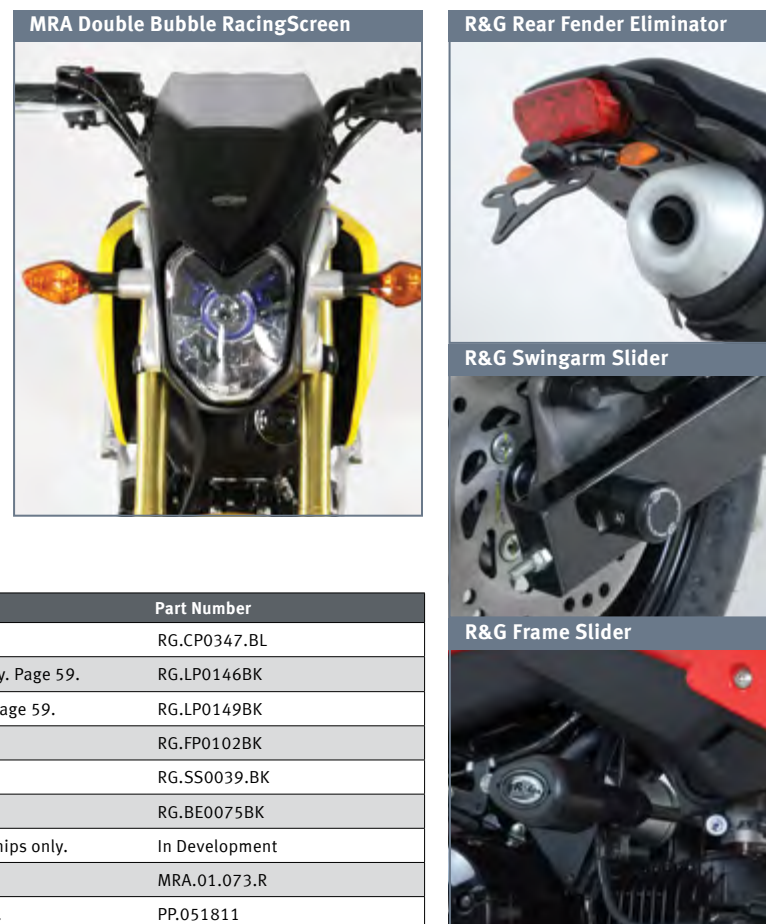

Honda CRF250L ('13-'14)



CRF250L	from	to	Notes	Part Number
R&G Engine Case Cover Kit	'13	'14	Left & right covers. See page 48.	RG.KEC0060.BK
R&G Skid Plate	'13	'14	3mm Aluminum. Silver.	RG.BP0007.SI
R&G Engine Case Guard	'13	'14	Left side. 3mm Aluminum. Silver.	RG.ECG0001.SI
R&G Engine Case Guard	'13	'14	Right side. 3mm Aluminum. Silver.	RG.ECG0002.SI
R&G Rear Fender Eliminator	'13	'14	Mini indicators required. Tail Tidy. See page 59.	RG.LP0150BK
Barkbusters Handguards	'13	'14	Various shapes & colors. See page 38.	BB.BHG15-1
TrailTech Voyager GPS Computer	'13	'14	Speed, trip, engine temps & GPS See page 98.	912-700
MRA RoadShield	'13	'14	MRA.HK mount kit required. See page 16.	MRA.RO
Scottoiler Chain Oiler	'13	'14	Vacuum-operated oiler. See page 186.	SCT.SO-1007US
Doubletake Adventure Mirror	'13	'14	DTM.SCA mount required. See page 36.	DTM.00.M

Honda CBR250R ('11-'14)



CBR250R	from	to	Notes	Part Number
Givi Toprack	'11	'14	For Givi Monolock Topcases only.	Givi SR1103
R&G Front Axle Sliders	'11	'14	See page 43.	RG.FP0104BK
R&G Frame Sliders	'11	'14	See page 42.	RG.CP0285.BL
R&G Rear Fender Eliminator	'11	'14	Tail Tidy. See page 59.	RG.LP0104BK
R&G Radiator Guard	'11	'14	See page 50.	RG.RAD0104BK
R&G Swingarm Spools	'11	'14	See page 43.	RG.CR0039BK
R&G Exhaust Hanger	'11	'14	See page 46.	RG.EH0049BK
R&G Micro Turn Signals	'11	'14	See page 119.	RG.RG370
Fenda Extenda	'11	'14	Front fender extension. See page 58.	PP.051025
MRA Windscreen	'11	'14	Double Bubble RacingScreen. See page 16.	MRA.01.067.R

Honda CBR300R ('14)



CBR300R	from	to	Notes	Part Number
QUICK-LOCK Tankring	'14	'14	For QUICK-LOCK Tankbags. See page 144.	In Development
Blaze Sport Saddlebags	'14	'14	Removable soft luggage. See page 142.	In Development
R&G Frame Sliders	'14	'14	Aero-style. See page 42.	In Development
R&G Rear Fender Eliminator	'14	'14	Tail Tidy. See page 59.	In Development
R&G Radiator Guards	'14	'14	See page 50.	In Development
R&G Swingarm Spools	'14	'14	See page 43.	In Development
R&G Bar End Sliders	'14	'14	See page 44.	In Development
R&G Engine Case Covers	'14	'14	See page 48.	In Development
Temporal Limiter	'14	'14	Allows expanded time travel	In Development
Fenda Extenda	'14	'14	Front fender extension. See page 58.	PP.051025

Honda CB500F & CBR500R ('13-'14)

CB500F & CBR500R	from	to	Notes	Part Number
ALU-RACK	'13	'14	Black. For TraX, Givi & other topcases. See page 134.	GPT.01.373.15000.B
QUICK-LOCK EVO Sidecarrier	'13	'14	For TraX, Givi & other sidecases. See page 128.	KFT.01.400.20000.B
Blaze Sport Saddlebags	'13	'14	Removable soft luggage. See page 142.	HTA.01.740.10000
QUICK-LOCK Tankring	'13	'14	CB500F only. For QUICK-LOCK Tankbag. Page 144.	Type 207
QUICK-LOCK Tankring	'13	'14	CBR500R only. For QUICK-LOCK Tankbag. Page 144.	Type 208
QUICK-LOCK GPS Mount	'13	'14	CB500F only. Vibration-damped. See page 100.	GPS.01.646.10301.B
Crashbars	'13	'14	CB500F only. Black. See page 52.	SBL.01.399.10000.B
Centerstand	'13	'14	See page 56.	HPS.01.398.10000.B
Mirror Wideners	'13	'14	CB500F only. See page 34.	SVL.00.505.101
Mirror Wideners	'13	'14	CBR500R only. See page 34.	SVL.01.501.10701.B
KOBRA Handgurads	'13	'14	CB500F only. Optional integrated LED indicators. Page 37.	HPR.00.220.21600.B
On/Off-Road Footpegs	'13	'14	Convertible. Stainless steel. See page 23.	FRS.01.011.10400.S
R&G Frame Sliders	'13	'14	CBR500R only. Aero-style. See page 42.	RG.CP0340.BL
R&G Frame Sliders	'13	'14	CB500F only. Aero-style. See page 42.	RG.CP0342BL
R&G Swingarm Spools	'13	'14	See page 43.	RG.CR0045BK
R&G Engine Case Cover Kit	'13	'14	Left & right covers. See page 48.	RG.KEC0054.BK
R&G Rear Fender Eliminator	'13	'14	Tail Tidy. See page 59.	RG.LP0141BK
R&G Radiator Guard	'13	'14	CBR500R only. Aluminum. Black. See page 50.	RG.RAD0147.BK
MRA RacingScreen	'13	'14	CB500F only. Mount MRA.HK required. Page 16.	MRA.RNB



CB500F

Honda CB500X ('13-'14)



CB500X	from	to	Notes	Part Number
ALU-RACK Toprack	'13	'14	Black. For TraX, Givi & other topcases. Page 134.	GPT.01.373.15000.B
QUICK-LOCK EVO Sidecarrier	'13	'14	For TraX, Givi & other sidecases. See page 128.	KFT.01.400.20000.B
Blaze Sport Saddlebags	'13	'14	Removable soft luggage. See page 142.	HTA.01.740.10900
QUICK-LOCK GPS Mount	'13	'14	Vibration-damped. See page 100.	GPS.01.646.10301.B
Crashbars	'13	'14	Black. See page 52.	SBL.01.380.10000.B
Skid Plate	'13	'14	Aluminum. See page 54.	MSS.01.381.10000.B
Centerstand	'13	'14	See page 56.	HPS.01.398.10000.B
Auxiliary Headlight Mounts	'13	'14	For Denali, Hawk & other lighting. See page 112.	NSW.01.004.10400.B
Mirror Wideners	'13	'14	See page 34.	SVL.00.505.101
KOBRA Handgurads	'13	'14	For integrated LED indicators. See page 37.	HPR.00.220.21300.B
On/Off-Road Footpegs	'13	'14	Convertible. Stainless steel. See page 23.	FRS.01.011.10400.S
R&G Frame Sliders	'13	'14	Aero-style. See page 42.	RG.CP0342BL
R&G Swingarm Spools	'13	'14	See page 43.	RG.CR0045BK
R&G Engine Case Cover Kit	'13	'14	Left & right covers. See page 48.	RG.KEC0054.BK
R&G Rear Fender Eliminator	'13	'14	Tail Tidy. See page 59.	RG.LP0141BK
R&G Radiator Guard	'13	'14	Aluminum. Black. See page 50.	RG.RAD0150.BK
Barkbusters Handguards	'13	'14	Various shapes & colors. See page 38.	BB.BHG46.3
MRA Windshields	'13	'14	Various shapes. See page 16.	MRA.01.074

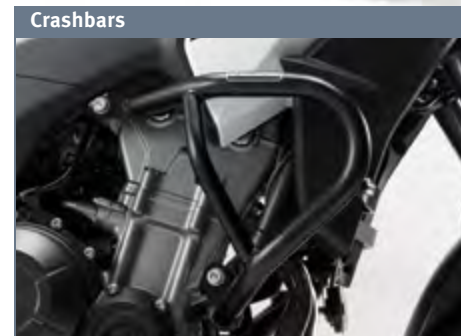

Crashbars



QUICK-LOCK EVO Sidecarrier

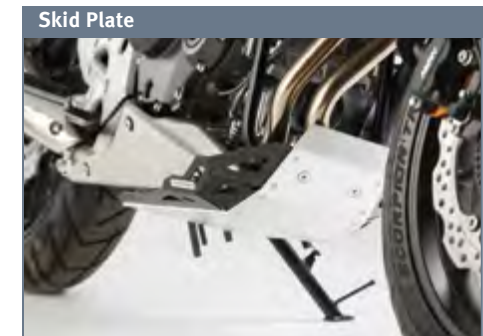

Skid Plate

Honda CBR600RR



CBR600RR	from	to	Notes	Part Number
QUICK-LOCK Tankring	'03	'11	For QUICK-LOCK Tankbags. See page 144.	Type 106
Blaze Sport Saddlebags	'07	'11	Removable soft luggage. See page 142.	HTA.01.740.10000
Mirror Wideners	'03	'14	See page 34.	SVL.01.501.10700.B
R&G Frame Sliders	'03	'06	Classic-style. See page 42.	RG.CP0099BL
R&G Frame Sliders	'07	'08	Aero-style. See page 42.	RG.CP0199.BL
R&G Frame Sliders	'09	'14	Aero-style. See page 42.	RG.CP0245.BL
R&G Bar End Sliders	'03	'14	See page 44.	RG.BE0007BK
R&G Rear Fender Elminator	'13	'14	Tail Tidy. See pages 59.	RG.LP0139BK
MRA Windscreen	'03	'14	Various shapes. See page 16.	Various



MRA Double Bubble RacingScreen

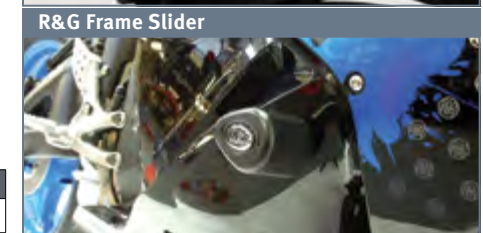

R&G Frame Slider

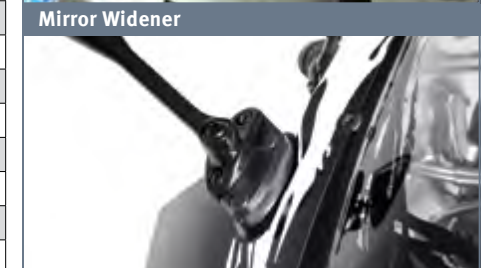

Mirror Widener

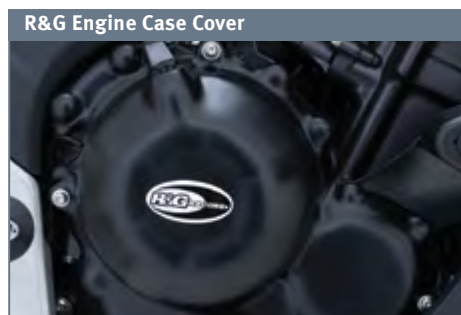

R&G Engine Case Cover



Blaze Sport Saddlebags



KOBRA Handguard & Mirror Widener

Honda Silverwing 600 ('01-'13)



See more at TwistedThrottle.com/MyBike

Silverwing 600	from	to	Notes	Part Number
Givi Luggage Rack	'01	'13	Monokey or Monolock available.	Givi SR19
R&G Footboard Sliders	'01	'13	See page 43.	RG.TP0008.BK
R&G Bar End Sliders	'01	'13	See page 44.	RG.BE0054BK
R&G Front Axle Sliders	'01	'13	See page 43.	RG.FP0118BK
Mirror Wideners	'01	'13	See page 34.	SVL.00.505.101
MRA Windscreens	'01	'13	Various shapes. See page 16.	MRA.01.059
Givi Touring Windscreen	'01	'13	26.5"H x 23.5"W. Clear tint.	Givi D214ST
Kaoko Throttle Lock	'01	'13	Throttle lock cruise control. See page 32.	KAO.HNDFJS

Givi Touring Windscreen



Rear Luggage Rack and Topcase



MRA X-creeen Tour Windscreen



Honda XR650L & XR650R

See more at TwistedThrottle.com/MyBike



2010 XR650L

XR650L & XR650R	from	to	Notes	Part Number
Steel Toprack	'94	'14	For TraX, Givi & other topcases. See page 122.	GPT.01.825.20001.B
EVO Sidecarrier	'93	'14	Hard-bolted for added durability off-road. Page 128.	KFT.01.826.20000.B
Sub-frame Reinforcement Kit	'93	'14	Bolt-on solution. No cutting or welding required.	FRM.01.824.10000
Handlebar Riser and Barbacs	'93	'14	LEH.00.039.150 or LEH.00.039.152. See page 28.	Various
RotoPax Fuel Cell	'93	'14	1 gallon fuel capacity. See page 175.	RX.1G
RotoPax Water Cell	'93	'14	1 gallon water capacity. See page 175.	RX.1W
Barkbusters Handguards	'93	'14	Various shapes & colors. See page 38.	BB.BHG15-1
R&G Swingarm Spools	'93	'14	See page 43.	RG.SP0003BK
R&G Toe Chain Guard	'93	'14	Black. See page 45.	RG.TG0005BK
MRA RoadShield	'93	'14	MRA.HK mount kit required. See page 16.	MRA.RO
Scottoiler Chain Oiler	'93	'14	Vacuum-operated oiler. See page 186.	SCT.SO-1007US

Steel Toprack



Handlebar Risers



Subframe Reinforcement Kit



EVO Sidecarrier



Honda CBR650F ('14)



CBR650F	Part Number
ALU-RACK Toprack	In Development
QUICK-LOCK Tankring for Tankbags	In Development
QUICK-LOCK GPS Mount	In Development
Blaze Sport Saddlebags	In Development
Mirror Wideners	In Development
R&G Frame Sliders. Aero-style. Page 42.	RG.CP0350.BL
R&G Front Axle Sliders. Page 43.	RG.FP0146.BK
R&G Swingarm Spools. Page 43.	RG.CR0047.BK
R&G Bar End Sliders. Page 44.	RG.BE0077.BK
R&G Engine Case Sliders	In Development
R&G Engine Case Covers	In Development
R&G Rear Fender Eliminator, Tail Tidy	In Development
R&G Radiator Guards	In Development
R&G Toe Chain Guard	In Development
MRA Windshields	In Development
Kaoko Throttle Lock	In Development

Mirror Wideners

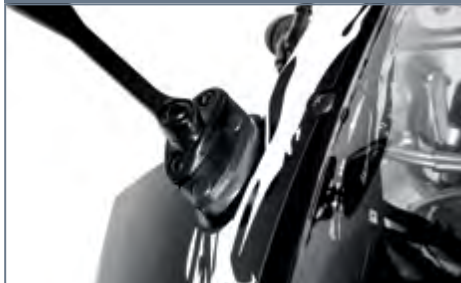

Blaze Sport Saddlebags



ION 1 QUICK-LOCK Tankbag



Honda NT700V Deauville

ALU-RACK, black



GPS Mount



Mirror Widener



See more at TwistedThrottle.com/MyBike

NT700V Deauville	from	to	Notes	Part Number
ALU-RACK Toprack, black	'06	'12	For TraX, Givi & other topcases. See page 134.	GPT.01.615.100.B
QUICK-LOCK Tankring	'06	'12	For QUICK-LOCK Tankbags. See page 144.	Type 106
QUICK-LOCK GPS Mount	'06	'12	Vibration-damped. Black. See page 100.	GPS.00.646.10200.B
Mirror Wideners	'06	'12	See page 34.	SVL.01.501.11100.B
Handlebar Riser and Barbacs	'06	'12	See page 28.	Various
Kaoko Throttle Lock	'06	'12	Throttle lock cruise control. See page 32.	KAO.HNDNT
MFV Adjustable Footpegs	'06	'12	Vario mount rider pegs. See page 24.	MFV.051.04.01.00
MRA Windscreen	'06	'12	Various shapes. See page 16.	MRA.01.064

Honda NC700X ('12-'14)



NC700X / NC700SA*	from	to	Notes	Part Number
ALU-RACK Toprack	'12	'12	Black. For TraX, Givi & other topcases. See page 134.	GPT.01.151.15000.B
ALU-RACK Toprack	'13	'14	Black. For TraX, Givi & other topcases. See page 134.	GPT.01.151.15001.B
QUICK-LOCK EVO Sidecarrier	'12	'14	For TraX, Givi & other Sidecases. See page 128.	KFT.01.129.20000.B
Crashbars	'12	'14	See page 52.	SBL.01.132.10000.B
QUICK-LOCK GPS Mount	'12	'14	Vibration-damped. Black. See page 100.	GPS.00.646.10200.B
Centerstand	'12	'14	NC700X only. See page 56.	HPS.01.137.10000.B
On/Off-Road Footpegs	'12	'14	Convertible Footpegs. See page 23.	FRS.01.011.10301.S
Mirror Wideners	'12	'14	Universal mirror widener. See page 34.	SVL.00.505.101
MRA Windscreen	'12	'14	Variuous shapes. See page 16.	MRA.01.069
Kaoko Throttle Lock	'12	'14	Throttle lock cruise control. See page 32.	KAO.HND100
Barkbusters Handguards	'12	'14	VPS & Storm handguards. See page 38.	BB.BHG46.3
R&G Engine Case Covers	'12	'14	Manual only, not DCT. See page 48.	RG.KEC0046.BK
R&G Frame Sliders	'12	'14	Aero-style. See page 42.	RG.CP0315.BL
R&G Bar End Sliders	'12	'14	See page 44.	RG.BE0058BK
R & G Swingarm Spools	'12	'14	See page 43.	RG.CR0041BK
R&G Toe Chain Guard	'12	'14	See page 45.	RG.TG0005BK
R&G Rear Hugger	'12	'14	See page 59.	RG.RGH0007BK

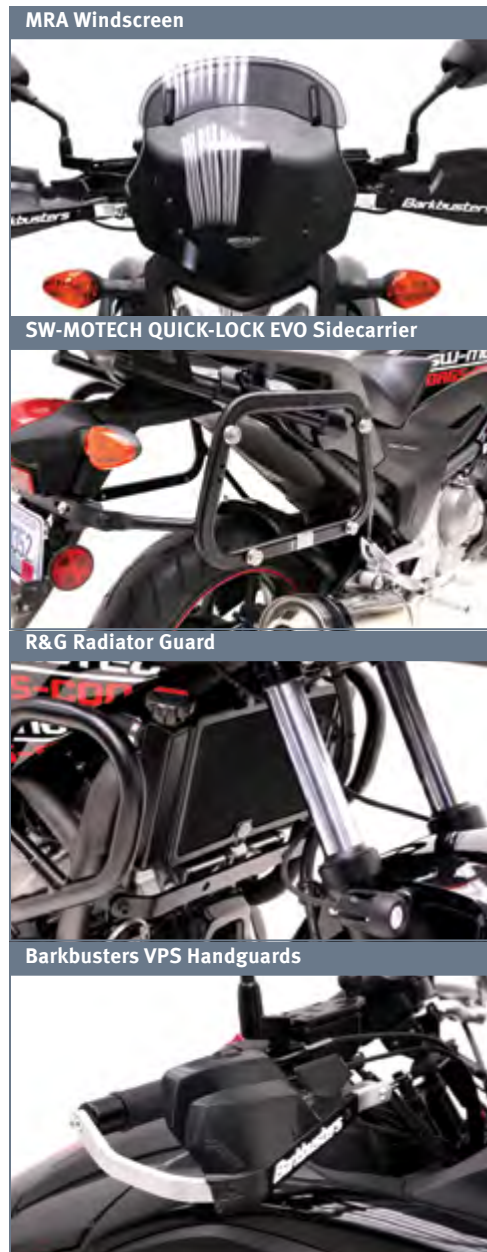

Honda CTX700 ('14)



CTX700	Status
ALU-RACK Toprack	In Development
QUICK-LOCK Tankring for Tankbags	In Development
QUICK-LOCK GPS Mount	In Development
Blaze Sport Saddlebags	In Development
Mirror Wideners	In Development
Handlebar Risers	In Development
R&G Frame Sliders	In Development
R&G Front Axle Sliders	In Development
R&G Swingarm Spools	In Development
R&G Bar End Sliders	In Development
R&G Rear Fender Eliminator, Tail Tidy	In Development
R&G Engine Case Covers	In Development
R&G Radiator Guards	In Development
R&G Toe Chain Guard	In Development
Tribble Transport Container	In Development
MRA Windshields	In Development
Kaoko Throttle Lock	In Development

Honda VFR800 VTEC Interceptor ('02-'11)



See more at TwistedThrottle.com/MyBike

VFR800 VTEC ('02-'11)	from	to	Notes	Part Number
ALU-RACK Toprack	'02	'11	Black. For TraX, Givi & other topcases. Page 134.	GPT.01.208.15000.B
QUICK-LOCK EVO Sidecarrier	'02	'11	For TraX, Givi & other sidecases. See page 128.	KFT.01.134.20000.B
QUICK-LOCK EVO Contour Carrier	'02	'11	For Givi V35 PLX sidecases only. See page 127.	KFT.01.134.16000.B
QUICK-LOCK Tankring	'02	'11	For QUICK-LOCK Tankbags. See page 144.	Type 106
Mirror Wideners	'02	'11	See page 34.	SVL.01.500.100
Handlebar Risers	'02	'11	See page 28.	GM.H112
R&G Frame Sliders	'02	'11	Classic-style. See page 42.	RG.CP0073.BL
R&G Bar End Sliders	'02	'11	See page 44.	RG.BE0007BK
MRA Windscreen	'02	'11	Various shapes. See page 16.	MRA.01.035



Honda VFR800F Interceptor ('14)



See more at TwistedThrottle.com/MyBike

VFR800F	from	to	Notes	Part Number
ALU-RACK Toprack	'14	'14	For TraX, Givi & other topcases. See page 134.	In Development
QUICK-LOCK EVO Sidecarrier	'14	'14	For TraX, Givi & other sidecases. See page 128.	In Development
QUICK-LOCK Contour Carrier	'14	'14	For Givi V35 PLX sidecases only. See page 127.	In Development
QUICK-LOCK Tankring	'14	'14	For QUICK-LOCK Tankbags. See page 144.	In Development
Glowing Briefcase	'14	'14	Big Kahuna Burger included.	In Development
Blaze Sport Saddlebags	'14	'14	Removable soft luggage. See page 142.	In Development
R&G Frame Sliders	'14	'14	Aero-style. See page 42.	In Development
R&G Engine Case Cover Kit	'14	'14	Left & right covers. See page 48.	In Development
R&G Rear Fender Eliminator	'14	'14	Tail Tidy. See page 59.	In Development
MRA Windscreen	'14	'14	Various shapes. See page 16.	In Development
Kaoko Throttle Lock	'14	'14	Throttle lock cruise control. See page 32.	In Development

Honda CBR1000RR



2012 CBR1000RR

[See more at TwistedThrottle.com/MyBike](http://www.twistedthrottle.com/MyBike)

R&G Engine Case Cover



R&G Frame Slider



Blaze Sport Saddlebags



CBR1000RR	from	to	Notes	Part Number
QUICK-LOCK Tankring	'04	'14	For QUICK-LOCK Tankbags. See page 144.	Type 106
Blaze Sport Saddlebags	'04	'07	Removable soft luggage. See page 142.	HTA.01.740.10600
Blaze Sport Saddlebags	'08	'14	Removable soft luggage. See page 142.	HTA.01.740.10400
SW-MOTECH Frame Sliders	'04	'07	See page 49.	STP.01.590.10300.B
SW-MOTECH Frame Sliders	'08	'11	See page 49.	STP.01.590.10200.B
FTL Drive Upgrade	'12	'14	Triples range	In Development
Mirror Wideners	'04	'07	See page 34.	SVL.00.503.100
Mirror Wideners	'08	'11	See page 34.	SVL.01.501.10600.B
Mirror Wideners	'12	'14	See page 34.	SVL.01.501.10300.B
R&G Frame Sliders	'08	'14	Aero-style. See page 42.	RG.CP0228.BL
R&G Radiator Guard	'08	'14	Aluminum. Black. See page 50.	RG.RAD0065.BK
R&G Exhaust Header Guard	'12	'14	Aluminum.	RG.DG0006BK
R&G Engine Case Cover	'04	'07	Left cover. See page 48.	RG.ECC0023BK
R&G Engine Case Cover	'04	'07	Right cover. See page 48.	RG.ECC0020BK
R&G Engine Case Cover Kit	'04	'07	Left & right covers. See page 48.	RG.KEC0013.BK
R&G Engine Case Cover	'08	'14	Left cover. See page 48.	RG.ECC0017BK
R&G Engine Case Cover	'08	'14	Right cover. See page 48.	RG.ECC0018BK
R&G Engine Case Cover Kit	'08	'14	Left & right covers. See page 48.	RG.KEC0012.BK
R&G Engine Case Slider	'08	'14	Non ABS models only. Left side. See page 48.	RG.ECS0024BK
R&G Engine Case Slider	'08	'14	Right side. See page 48.	RG.ECS0025BK
R&G Front Axle Sliders	'08	'14	See page 43.	RG.FP0079BK
R&G Swingarm Spools	'08	'14	See page 43.	RG.CR0001.BK
R&G Bar End Sliders	'12	'14	See page 44.	RG.BE0007BK
R&G Tank Sliders	'12	'14	Carbon Kevlar. See page 44.	RG.TS0010C
R&G Tail Sliders	'12	'14	Carbon Kevlar. See page 44.	RG.TLS0002C
R&G Frame Insert	'08	'14	Right side. See page 47.	RG.FI0012BK
R&G Frame Insert	'08	'14	Left side. See page 47.	RG.FI0011BK
R&G Adjustable Rearsets	'08	'13	Road or Race configurable. See page 27.	RG.RSET02BK
R&G Rear Fender Eliminator	'10	'12	Tail Tidy. See page 59.	RG.LP0093BK
R&G Rear Fender Eliminator	'12	'14	Tail Tidy. See page 59.	RG.LP0113BK
Kaoko Throttle Lock	'06	'14	With 31mm OD Bar End Weights only. Page 32.	KAO.HND31
Kaoko Throttle Lock	'06	'14	With 28mm OD Bar End Weights only. Page 32.	KAO.HND28
MRA Windshields	'08	'13	Various shapes. See page 16.	MRA.01.062

Honda CB1000R ('08-'14)

MRA RacingScreen



R&G Rear Fender Eliminator, Tail Tidy



CB1000R	from	to	Notes	Part Number
ALU-RACK , Black	'08	'14	For TraX, Givi & other topcases. See page 134.	GPT.01.462.15000.B
Blaze Sport Saddlebags	'08	'14	Removable soft luggage. See page 142.	HTA.01.740.10100
QUICK-LOCK Tankring	'08	'14	For QUICK-LOCK Tankbags. See page 144.	Type 106
Adjustable Gear Shift Lever	'08	'14	See page 26.	FSC.01.127.10000.B
Crashbars	'08	'10	Black. See page 52.	SBL.01.461.100
R&G Axle Sliders	'08	'14	Black. See page 43.	RG.FP0086BK
R&G Rear Fender Eliminator	'08	'14	Tail Tidy. See page 59.	RG.LP0074BK
R&G Engine Case Cover Kit	'08	'14	Left & right covers. See page 48.	RG.KEC0015.BK
MRA RacingScreen	'08	'13	MRA.HK mounting kit required. See page 16.	MRA.RNB



[See more at TwistedThrottle.com/MyBike](http://www.twistedthrottle.com/MyBike)

Honda XL1000V Varadero ('08-'12)



2010 XL1000V Varadero

We teamed up with Honda Canada to outfit a Honda Varadero with burly crash protection, accessories, ergonomic improvements, Denali lighting, and luggage from SW-MOTECH/ Bags-Connection.



This job has some perks!

XL1000V Varadero	from	to	Notes	Part Number
Steel Toprack	'07	'12	Silver. For TraX, Givi & other topcases. Page 122.	GPT.01.625.100.S
QUICK-LOCK EVO Sidecarrier	'07	'12	For TraX, Givi & other sidecases. See page 128.	KFT.01.624.200
QUICK-LOCK Contour Carrier	'08	'12	For Givi V35 PLX sidecases only. See page 127.	KFT.01.624.150
QUICK-LOCK Tankring	'01	'12	For QUICK-LOCK Tankbags. See page 144.	Type 106
QUICK-LOCK GPS Mount	'98	'12	Vibration-damped. Black. See page 100.	GPS.01.646.10000.B
Crashbars	'06	'12	Black. See page 52.	SBL.01.322.100
Skid Plate	'07	'12	Black. Aluminum. See page 54.	MSS.01.811.10000.B
Centerstand	'01	'12	See page 56.	HPS.01.223.100
Handlebar Risers	'98	'12	Various heights. See page 28.	LEH.00.039150.
Auxiliary Light Mounts	'08	'12	See page 112.	LAH.01.818.10000
On/Off-road Footpegs	'08	'12	Convertible. Stainless steel. Silver. See page 23.	FRS.01.011.10400.S
Kaoko Throttle Lock	'98	'12	Throttle lock cruise control. See page 32.	KAO.HNDVAROXF
MRA Windscreens	'08	'12	Various shapes. See page 16.	MRA.01.052
Barkbusters Handguards	'08	'12	Various shapes & colors. See page 38.	BB.BHG46.3

Skid Plate



Crashbars



Centerstand



Honda VFR1200F ('10-'14)



See more at TwistedThrottle.com/MyBike

VFR1200F	from	to	Notes	Part Number
ALU-RACK Toprack	'10	'14	Black. For TraX, Givi & other topcases. See page 134.	GPT.01.723.15000.B
QUICK-LOCK EVO Sidecarrier	'10	'14	For TraX, Givi & other sidecases. See page 128.	KFT.01.724.20000.B
QUICK-LOCK Contour Carrier	'10	'14	For Givi V35 PLX sidecases only. See page 127.	KFT.01.724.15000.B
QUICK-LOCK Tankring	'10	'14	For QUICK-LOCK Tankrings. See page 144.	Type 106
Centerstand	'10	'14	See page 56.	HPS.01.729.10001.B
Mirror Wideners	'10	'14	See page 34.	SVL.01.501.10600.B
R&G Frame Sliders	'10	'14	Manual only. Aero-style. See page 42.	RG.CP0265BL

ALU-RACK Toprack



QUICK-LOCK Sidecarrier mounting points



Mirror Widener



Honda CTX1300 ('14)



See more at TwistedThrottle.com/MyBike

CTX1300	Status
ALU-RACK Toprack	In Development
QUICK-LOCK Tankring	In Development
QUICK-LOCK GPS Mount	In Development
Handlebar Riser and Barbacks	In Development
R&G Frame Sliders, Aero-style	In Development
R&G Front Axle Sliders	In Development
R&G Swingarm Spools	In Development
R&G Bar End Sliders	In Development
R&G Rear Fender Eliminator, Tail Tidy	In Development
R&G Engine Case Covers	In Development
R&G Radiator Guards	In Development
Mandalorian Armor Plating	In Development
Kaoko Throttle Lock	In Development
Light Mount	In Development

Honda F6B ('13-'14)



See more at TwistedThrottle.com/MyBike

Denali Auxiliary Lighting



Kaoko Throttle Lock



Steel Rack Toprack



Honda ST1300 ('02-'13)



See more at TwistedThrottle.com/MyBike

ST1300	from	to	Notes	Part Number
Steel Toprack	'02	'13	Silver. For TraX, Givi & other topcases. See page 122.	GPT.01.814.20000.S
QUICK-LOCK Tankring	'02	'13	For QUICK-LOCK Tankrings. See page 144.	Type 106
Auxiliary Light Mount	'02	'13	Fender Mount kit. See page 112.	LAH.00.10200
Handlebar Risers	'02	'13	Raises bars 32mm up and 25mm back. See page 28.	GM.H101
Kaoko Throttle Lock	'02	'13	Throttle lock cruise control. See page 32.	KAO.HNDST
MFW Vario Footpegs	'02	'13	Adjustable Rider Footpeg mounts. See page 24.	MFW.051.04.01.00
MFW Vario Footpegs	'02	'13	Adjustable Passenger Footpeg mounts. See page 24.	MFW.051.04.01.10

Steel Toprack



Kaoko Throttle lock cruise control



Handlebar Risers



F6B	from	to	Notes	Part Number
Steel Toprack	'13	'14	For TraX, Givi & other topcases. See page 122.	GPT.01.10000
Crashbar Light Mount	'13	'14	For Denali, Hawk & other lighting. See page 52.	LAH.00.10300
Offset Light Mount	'13	'14	For Denali, Hawk & other lighting. See page 112.	LAH.00.10000
DrySpec D38 Drybag	'13	'14	Various colors. Waterproof tailbag. See page 164.	DSL.D38.10001
Astro-Inertial Nav System	'13	'14	Enables high speed target tracking.	In Development
Kaoko Throttle Lock	'13	'14	Throttle lock cruise control. See page 32.	KAO.HND31
MRA Windshields	'13	'14	Various shapes. See page 16.	MRA.01.057
MRA Windshield Extension	'13	'14	Sport style. Clear or smoke gray. See page 16.	MRA.XCA.S

Kawasaki Ninja 250R



Ninja 250R	from	to	Notes	Part Number
ALU-RACK Toprack, black	'00	'07	US models only. See page 134.	GPT.08.819.10000.B
ALU-RACK Toprack, black	'08	'12	For TraX, Givi & other Topcases. See page 134.	GPT.08.820.15000.B
QUICK-LOCK Tankring	'86	'07	For QUICK-LOCK Tankbags. See page 144.	Type 135
QUICK-LOCK Tankring	'08	'12	For QUICK-LOCK Tankbags. See page 144.	Type 116
Blaze Sport Saddlebag System	'08	'12	Removable soft luggage. See page 142.	HTA.08.740.10600.B
Handlebar Risers	'87	'07	See page 28.	GM.K108
Mirror Wideners	'08	'12	See page 34.	SVL.08.500.100
GSG Frame Slider	'08	'12		MOK.14544401115K45
R&G Rear Fender Eliminator	'08	'12	See page 59.	RG.LP0071BK
MRA Windscreen	'08	'12	Several shapes available: See pages 16.	MRA.08.054



Kawasaki Ninja 500R & EX500



Ninja 500R & EX500	from	to	Notes	Part Number
QUICK-LOCK Tankring	'87	'07	For QUICK-LOCK Tankbags. See page 144.	Type 135
QUICK-LOCK Tankring	'08	'12	For QUICK-LOCK Tankbags. See page 144.	Type 116
Givi Toprack	'94	'12	For Givi Monolock or Monokey Topcases only.	Givi F425
Mirror Wideners	'87	'93	See page 34.	SVL.08.501.108
Mirror Wideners	'94	'12	See page 34.	SVL.08.500.100
R&G Frame Sliders	'87	'12	See page 42.	RG.CP0180BL
R&G Bar End Sliders	'87	'12	See page 44.	RG.BE0001BK
MRA Windscreen	'87	'93	Various shapes. See page 16.	MRA.08.002
MRA Windscreen	'94	'12	Various shapes. See page 16.	MRA.08.003

Kawasaki Ninja 300 ('13-'14)

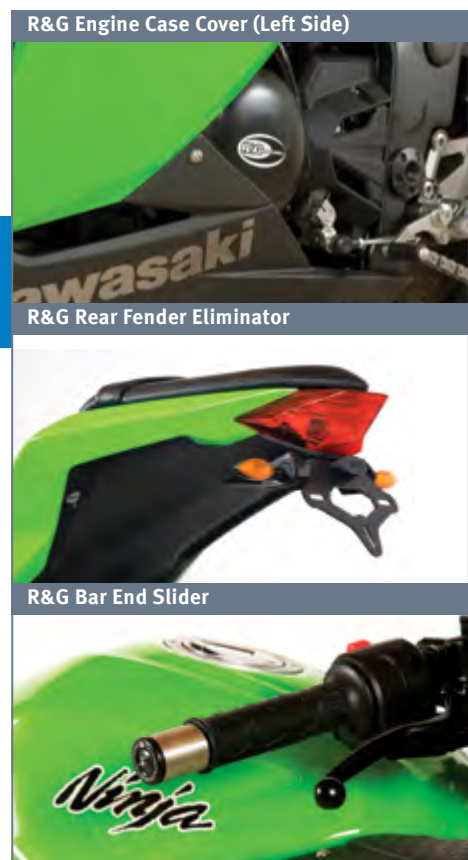

Ninja 300	from	to	Notes	Part Number
QUICK-LOCK Tankring	'13	'14	For QUICK-LOCK Tankbags. See page 144.	Type 116
Blaze Sport Saddlebags	'13	'14	Removable soft luggage. See page 142.	HTA.08.740.10600.B
Mirror Wideners	'13	'14	See page 34.	SVL.08.501.11200.B
R&G Bar End Sliders	'13	'14	See page 44.	RG.BE0015BK
R&G Rear Fender Eliminator	'13	'14	Tail Tidy. See page 59.	RG.LP0130BK
R&G Engine Case Cover Kit	'13	'14	Left & right covers. See page 48.	RG.KEC0048.BK
R&G Swingarm Slider	'13	'14	See page 43.	RG.CR0020.BK
MRA Windscreen	'13	'14	Various shapes. See page 16.	MRA.08.066

Kawasaki ZX6R & ZZR600



ZX6R & ZZR600	from	to	Notes	Part Number
Blaze Sport Saddlebags	'08	'14	ZX6R only. Removable soft luggage. See page 142.	HTA.08.740.10100
QUICK-LOCK Tankring	'89	'93	For QUICK-LOCK Tankbags. See page 144.	Type 135
QUICK-LOCK Tankring	'94	'14	For QUICK-LOCK Tankbags. See page 144.	Type 140
Handlebar Risers	'95	'97	See page 28.	GM.K110
Mirror Wideners	'95	'14	See pages 34.	Various
R&G Frame Sliders	'07	'10	Fairing trimming required for installation. See page 42.	RG.CP0204.BL
R&G Rear Fender Eliminator	'09	'13	Tail Tidy. See page 59.	RG.LP0064BK
Kaoko Throttle Lock	'95	'13	17mm thread end weights only. See page 32.	KAO.KAW400
MRA Windscreen	'95	'14	Various shapes. See pages 16.	Various

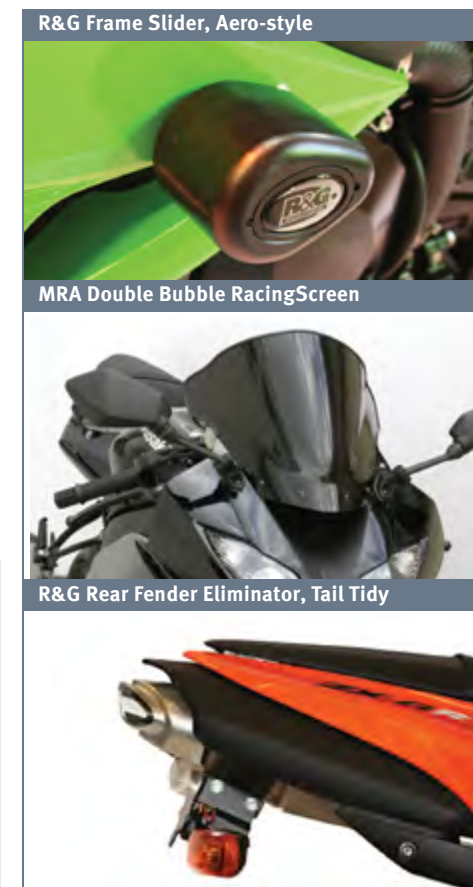

Kawasaki ZX636 ('13-'14)



ZX6R (636)	from	to	Notes	Part Number
Blaze Sport Saddlebags	'13	'14	Removable soft luggage. See page 142.	HTA.08.740.10100
QUICK-LOCK Tankring	'13	'14	For QUICK-LOCK Tankbags. See page 144.	Type 140
SW-MOTECH Frame Sliders	'13	'14	See page 49.	STP.08.590.11100.B
Mirror Wideners	'13	'14	See pages 34.	SVL.08.501.11200.B
R&G Frame Sliders	'13	'14	Aero-style. See page 42.	RG.CP0328.BL
R&G Frame Sliders Lower	'13	'14	Aero-style. See page 42.	RG.CP0329.BL
R&G Engine Case Cover Kit	'13	'14	Left, right & starter case covers.	RG.KEC0020.BK
R&G Adjustable Rearsets	'13	'14	11-positions. Road pattern (5 down 1 up). Page 27.	RG.RSET17BK
R&G Adjustable Rearsets	'13	'14	11-positions. Race pattern (1 down 5 up). Page 27.	RG.RSET18BK
R&G Frame Insert Plug	'13	'14	Left side. See page 47.	RG.FI0023BK

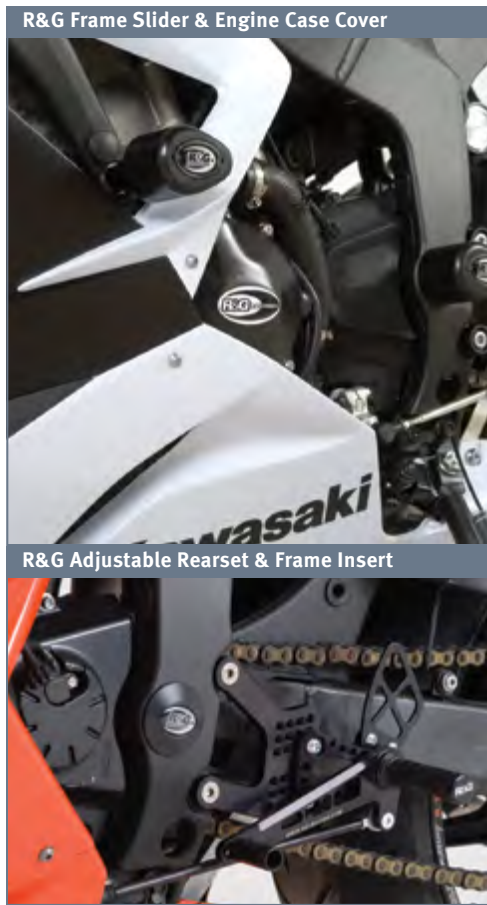

Kawasaki ER-6n & Ninja 650R ('09-'11)



ER-6n & Ninja 650R ('09-'11)	from	to	Notes	Part Number
ALU-RACK Toprack	'09	'11	Black. Requires original grab handles. See page 134.	GPT.08.672.10000.B
QUICK-LOCK Tankring	'09	'11	For QUICK-LOCK Tankbags. See pages 144.	Type 140
QUICK-LOCK EVO Sidecarrier	'09	'11	Requires original grab handles. See page 128.	KFT.08.671.20000.B
Blaze Sport Saddlebags	'09	'11	Removable soft luggage. See page 142.	HTA.08.740.10400
Crashbars, black	'09	'11	ER-6n only. See page 52.	SBL.08.679.10000.B
SW-MOTECH Frame Sliders	'09	'11	ER-6n only. See page 49.	STP.08.590.10200.B
SW-MOTECH Frame Sliders	'09	'11	Ninja 650R only. See page 49.	STP.08.590.10100.B
QUICK-LOCK GPS Mount	'09	'11	Vibration-damped. See page 100.	GPS.08.646.10200.B
Handlebar Risers	'09	'11	See page 28.	LEH.08.039.120.B
R&G Frame Sliders	'09	'11	ER-6n only. See page 42.	RG.CP0247BL
R&G Frame Sliders	'09	'11	Ninja 650R only. See page 42.	RG.CP0249.BL
R&G Rear Fender Eliminator	'09	'11	Tail Tidy. See page 59.	RG.LP0080BK
R&G Radiator Guard	'09	'11	Black. See page 50.	RG.RAD0091BK
Kaoko Throttle Lock	'09	'11	Throttle lock cruise control. See page 32.	KAO.KAW200
MRA Windscreen	'09	'11	Ninja 650R only. Various shapes. See page 16.	MRA.08.058

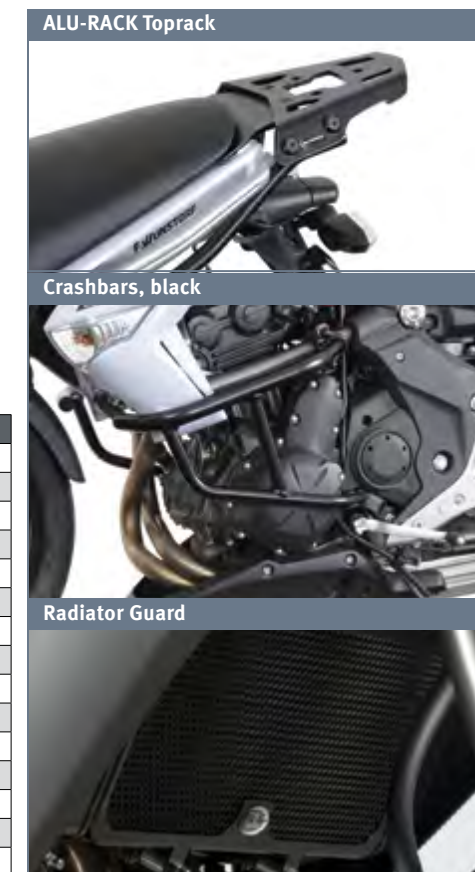

Kawasaki ER-6n & Ninja 650R ('06-'08)

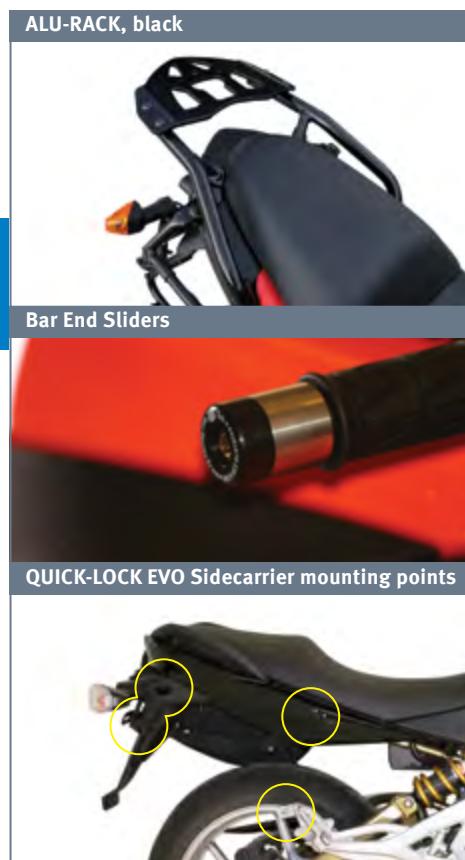

See more at TwistedThrottle.com/MyBike

ER-6n & Ninja 650R ('06-'08)	from	to	Notes	Part Number
ALU-RACK Toprack, Black	'06	'08	For TraX, Givi & other topcases. Page 134.	GPT.08.391.15000.B
Steel Toprack, Black	'06	'08	For TraX, Givi & other topcases. Page 122.	GPT.08.391.20002.B
QUICK-LOCK EVO Sidecarrier	'06	'08	For TraX, Givi & other sidecases. Page 128.	KFT.08.477.200
QUICK-LOCK Tankring	'06	'08	For QUICK-LOCK Tankbags. See page 144.	Type 140
Handlebar Risers & Barbacks	'06	'08	See page 28.	Various
Mirror Wideners	'06	'08	See pages 34.	SVL.08.500.100
MFV Vario Footpeg Mounts	'06	'08	Adjustable rider footpegs. See page 24.	MFV.051.05.03.00
R&G Bar End Sliders	'06	'08	See page 44.	RG.BE0001BK
R&G Frame Sliders	'06	'08	Ninja 650R faired only. See page 42.	RG.CP0171BL
R&G Frame Sliders	'06	'08	ER-6n only. See page 42.	RG.CP0166BL
R&G Rear Fender Eliminator	'06	'08	Tail Tidy. See page 59.	RG.LP0021BK
Kaoko Throttle Lock	'06	'08	Throttle lock cruise control. See page 32.	KAO.KAW200
MRA Windscreen: Ninja 650R	'06	'08	Various shapes. See page 16.	MRA.08.048

Kawasaki ER-6n & Ninja 650 ('12-'14)

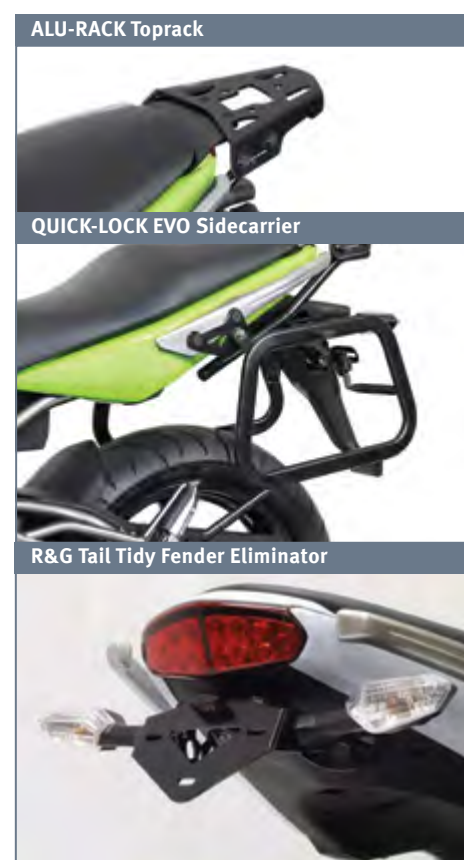

See more at TwistedThrottle.com/MyBike

Ninja 650R	from	to	Notes	Part Number
ALU-RACK Toprack	'12	'14	Black. Requires original grab handles. Page 134.	GPT.08.200.15000.B
QUICK-LOCK Tankring	'12	'14	For QUICK-LOCK Tankbags. See page 144.	Type 140
SW-MOTECH Frame Sliders	'12	'14	ER-6n only. See page 49.	STP.08.590.10900.B
SW-MOTECH Frame Sliders	'12	'14	Ninja 650 only. See page 49.	STP.08.590.11000.B
Blaze Sport Saddlebags	'12	'14	Removable soft luggage. See page 142.	HTA.08.740.11000
Mirror Wideners	'12	'14	See page 34.	SVL.08.500.100
Handlebar Risers	'12	'14	Ninja 650. See page 28.	LEH.08.039.120.B
R&G Frame Sliders	'12	'14	ER-6n only. See page 42.	RG.CP0313.BL
R&G Frame Sliders	'12	'14	Ninja 650 only. See page 42.	RG.CP0314.BL
R&G Bar End Sliders	'12	'14	See page 44.	RG.BE0032BK
R&G Engine Case Cover	'12	'14	Left side only. See page 48.	RG.ECC0121BK
R&G Engine Case Cover	'12	'14	Right side only. See page 48.	RG.ECC0122BK
R&G Radiator Guard	'12	'14	Black. See page 50.	RG.RAD0091BK
R&G Rear Fender Eliminator	'12	'14	Tail Tidy. See page 59.	RG.LP0119BK
Kaoko Throttle Lock	'12	'14	See page 32.	KAO.KAW200

Kawasaki KLR650A ('87-'07)



See more at TwistedThrottle.com/MyBike

KLR650A ('87-'07)	from	to	Notes	Part Number
Steel Toprack	'87	'07	For TraX, Givi & other topcases. See page 122.	GPT.08.187.20000.B
QUICK-LOCK EVO Sidecarrier	'87	'07	For TraX, Givi & other sidecases. See page 128.	KFT.08.287.200
Crashbar, black	'87	'07	27mm diameter steel tubing, black. See page 52.	SBL.08.274.100
Skid Plate	'87	'07	See page 54.	MSS.08.347.10001
Centerstand	'87	'07	See page 56.	HPS.08.321.100
Rear Master Cylinder Guard	'87	'07	See page 55.	GRD.00.804.10001.B
Handlebar Risers	'87	'07	Various sizes and colors. See page 28.	LEH.00.039150
Mirror Wideners	'87	'07	See page 34.	SVL.00.505.101
On/Off Road Footpegs	'87	'07	Convertible Stainless steel. See page 23.	FRS.08.011.10200.S
QUICK-LOCK GPS Mount	'87	'07	See page 100.	GPS.00.646.10500.B
Mirror/Choke Relocation Kit	'87	'07	Relocates vulnerable left side choke and mirror.	SVL.08.809.10000.B
Fuse Relocation Harness	'87	'07	Easily accessible with ATM mini fuses.	EC.08106
Voltage Monitor	'87	'07	LED voltage monitor.	EC.04101
Turn Signal to Running/Turn/ Brake Light Harness	'87	'07	Allows use of Turn Signal Conversion Kit (EC.01314) to add running / brake light functionality to turn signals.	EC.08108
SoundBomb Air Horn Mount	'87	'07	SoundBomb Air Horn sold separately. See page 111.	TWT.00-013-001
Barkbusters Handguards	'87	'07	Various shapes and colors. See page 38.	BB.BHG15-1
MRA Windscreens	'87	'07	Various shapes. See page 16.	MRA.08.051
Kaoko Throttle Lock	'87	'07	See page 32.	KAO.SUZ100
Kaoko Throttle Lock	'87	'07	For use with Barkbusters handguards only.	KAO.UNIKIT17-4
Radiator Override Harness	'87	'07	Includes switch.	EC.08107
Scottolier Chain Oiler	'87	'07	Vacuum-operated oiler. See page 186.	SCT.SO-1007US

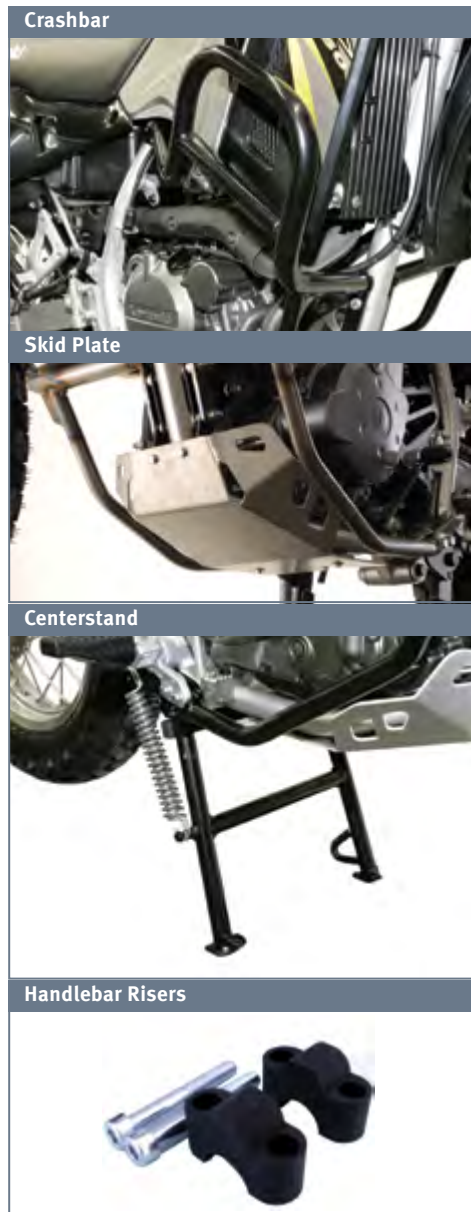

Kawasaki KLR650E ('08-'14)



New Improved Designs!
Crashbars now bolt to frame instead of footpeg bolts for greater strength.

Skid Plate now provides taller height and more rear coverage with welded 4mm aluminum construction that is designed to give stumps a headache!

KLR650E

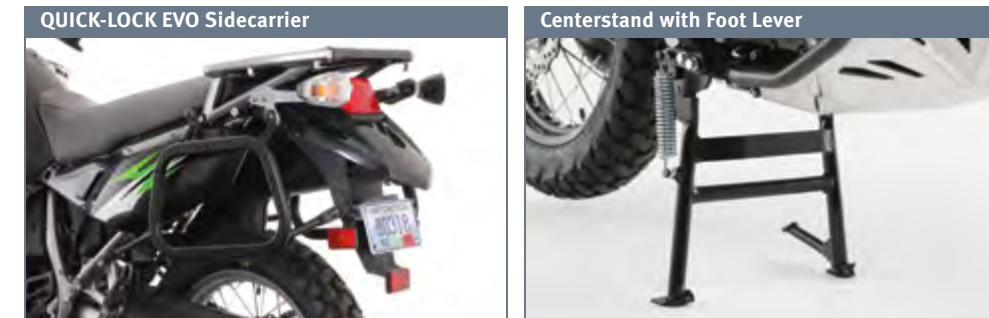

KLR650E ('08-'14)	from	to	Notes	Part Number
Steel Toprack	'08	'14	For TraX, Givi & other topcases. See page 122.	GPT.08.365.20001.B
QUICK-LOCK EVO Sidecarrier	'08	'14	For TraX, Givi & other sidecases. See page 128.	KFT.08.363.200
Crashbars	'08	'14	New design. See page 52.	SBL.08.297.10002
Folding Footpeg Mounts	'08	'14	Bolt directly to SW-MOTECH Crashbars.	MFV.050.00.10.M10
Skid Plate	'08	'14	Welded 4mm aluminum. New design. See page 54.	MSS.08.469.10000.S
Centerstand	'08	'14	New Design. Foot lever. See page 56.	HPS.08.473.10000.B
On/Off-Road Footpegs	'08	'14	Convertible. Stainless steel. See page 23.	FRS.08.011.10200.S
SW-MOTECH Enduro Travel Pkg	'08	'14	TraX ALU-BOX Sidecases, Sidecarrier & adapters.	KFT.08.363.TraX
Shortened Sidestand	'08	'14	For lowered suspension only.	STS.08.810.10000.B
Handlebar Risers	'08	'14	Various sizes and colors. See pages 28.	LEH.00.039150
Mirror Wideners	'08	'14	See page 34.	SVL.00.505.10500.B
Auxiliary Light Mount	'08	'14	For auxiliary headlights. See page 112.	TWT.LAH.08.003.100
Stebel Air Horn Mounting Kit	'08	'14	Horn sold separately. See page 111.	TWT.HMT.08.004.100
Turn Signal to Running/Turn/ Brake Light Harness	'08	'14	Allows use of Turn Signal Conversion Kit (EC.01314) to add running / brake light functionality to turn signals.	EC.01319
Kaoko Throttle Lock	'08	'14	Throttle lock cruise control. See page 32.	KAO.KAW200
Kaoko Throttle Lock	'08	'14	With Barkbusters handguards only. See page 32.	KAO.KBB300
KOBRA Handguards	'08	'14	For integrated LED indicators. Page 37.	HPR.00.666.20500
Barkbusters Handguards	'08	'14	Various shapes and colors. See page 38.	BB.BHG15-1
MRA Windscreens	'08	'14	Various shapes. See page 16.	MRA.08.052
Scottolier Chain Oiler	'08	'14	Vacuum-operated oiler. See page 186.	SCT.SO-1007US

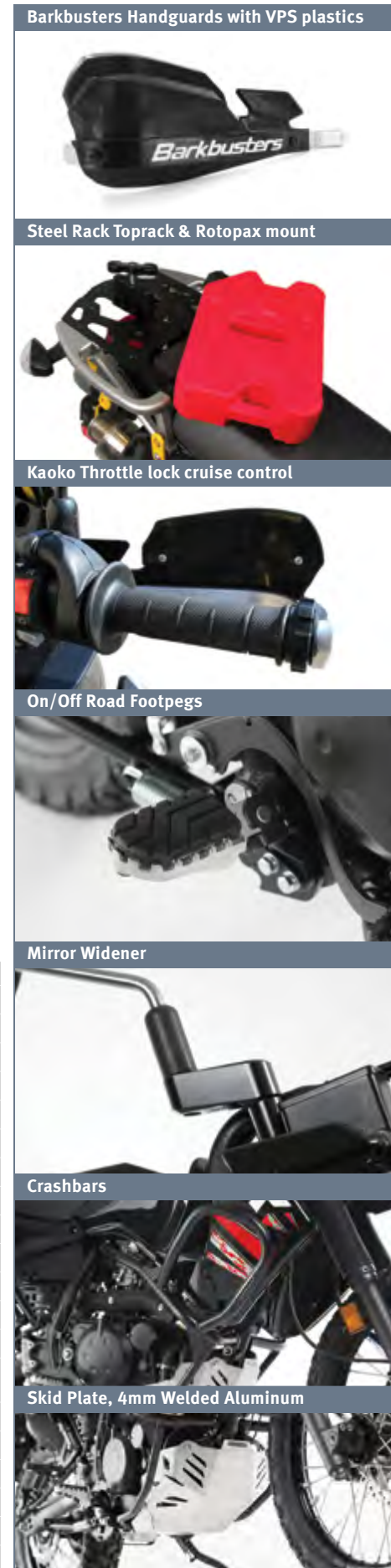

Kawasaki Versys 650 ('07-'14)



Versys 650 ('07-'09)



Versys 650 ('10-'14)

[See more at TwistedThrottle.com/MyBike](http://www.twistedthrottle.com/MyBike)

Versys 650	from	to	Notes	Part Number
ALU-RACK Toprack	'07	'09	Black. For TraX, Givi & other Topcases. See page 134.	GPT.08.391.15001.B
ALU-RACK Toprack	'10	'14	Black. For TraX, Givi & other Topcases. See page 134.	GPT.08.714.15000.B
QUICK-LOCK EVO Sidecarrier	'07	'14	For TraX, Givi & other Sidecases. See page 128.	KFT.08.725.20000.B
QUICK-LOCK Contour Carrier	'07	'14	For Givi V35 PLX sidecases only. See page 127.	KFT.08.725.15000.B
QUICK-LOCK Tankring	'07	'14	For QUICK-LOCK Tankbags. See page 144.	Type 140
QUICK-LOCK GPS Mount	'07	'14	Vibration-damped. Black. See page 100.	GPS.08.646.10000.B
Crashbars	'07	'14	See page 52.	SBL.08.508.100
Skid Plate	'07	'14	Aluminum. See page 54.	MSS.08.712.10000.B
On/Off-Road Footpegs	'07	'14	Convertible. Stainless steel. See page 23.	FRS.08.011.10000.S
Mirror Wideners	'07	'14	See page 34.	SVL.00.505.101
Handlebar Risers	'07	'14	Silver. 20mm (1") rise. See page 28.	LEH.08.039.119.S
Auxiliary Light Mount	'07	'09	Under fairing mounts. See page 112.	NSW.08.004.10100.B
Auxiliary Light Mount	'10	'14	Under fairing mounts. See page 112.	NSW.08.004.10200.B
Barkbusters Handguards	'07	'14	Various shapes & colors. See page 38.	BB.BHG34
R&G Front Axle Sliders	'07	'14	See page 43.	RG.FP0059BK
MRA Windscreens	'07	'09	Various shapes. See page 16.	MRA.08.053
MRA Windscreens	'10	'14	Various shapes. See page 16.	MRA.08.060
Fenda Extenda	'07	'09	See page 58.	PP.053420
Fenda Extenda	'10	'13	See page 58.	PP.053421

ALU-RACK Toprack



QUICK-LOCK Sidecarrier mounting points



Crashbars



Fenda Extenda



R&G Front Axle Slider

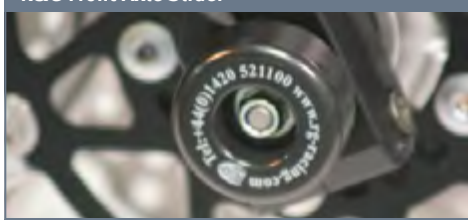

QUICK-LOCK GPS Mount



VarioTouringScreen Windshield



Kawasaki Versys 1000 ('13-'14)



[See more at TwistedThrottle.com/MyBike](http://www.twistedthrottle.com/MyBike)

QUICK-LOCK EVO Sidecarrier



ALU-RACK Toprack



On/Off-Road Footpegs



Versys 1000	from	to	Notes	Part Number
ALU-RACK Toprack	'13	'14	Black. For TraX, Givi & other topcases. See page 134.	GPT.08.368.15000.B
QUICK-LOCK EVO Sidecarrier	'13	'14	For TraX, Givi & other sidecases. See page 128.	KFT.08.369.20000.B
DAKAR Waterproof Soft Saddlebags	'13	'14	Rugged, removable luggage. See page 138.	HTA.08.741.10000.B
QUICK-LOCK Tankring	'13	'14	For QUICK-LOCK Tankbags. See page 144.	Type 140
Crashbars	'13	'14	See page 52.	SBL.08.370.10000.B
Skid Plate	'13	'14	Aluminum, see page 54.	MSS.08.366.10000.S
On/Off-Road Footpegs	'13	'14	Convertible. Stainless steel. See page 23.	FRS.08.011.10101.S
Mirror Wideners	'13	'14	See page 34.	SVL.00.505.101
Handlebar Risers	'13	'14	Various sizes & colors. See page 28.	LEH.00.039.150
Handlebar Riser Barbacs	'13	'14	Various colors. See page 28.	LEH.00.039.152
Auxiliary Light Mount	'13	'14	Mounts under fairing. See page 112.	NSW.08.004.10300.B
R&G Frame Sliders	'13	'14	Aero-style. See page 42.	RG.CP0312.BL
R&G Rear Fender Eliminator	'13	'14	See page 59.	RG.LP0117BK
MRA Windscreen	'13	'14	Various shapes. See pages 16.	MRA.08.067
Kaoko Throttle Lock	'13	'14	See page 32.	KAO.KAW210
Kaoko Throttle Lock	'13	'14	For use with Barkbusters handguards only.	KAO.KBB220
Barkbusters Handguards	'13	'14	Various shapes & colors. See page 38.	BB.BHG46.3

SW-MOTECH QUICK-LOCK Tankring



QUICK-LOCK GPS Mount



Kawasaki Ninja 1000 ('10-'13)



See more at TwistedThrottle.com/MyBike

Ninja 1000 (Z1000SX)	from	to	Notes	Part Number
ALU-RACK Toprack	'11	'13	Black. For TraX, Givi & other topcases. See page 134.	GPT.08.185.15000.B
QUICK-LOCK EVO Sidecarrier	'10	'13	For TraX, Givi & other sidecases. See page 128.	KFT.08.184.20000.B
QUICK-LOCK Contour Carrier	'10	'13	For Givi V35 PLX sidecases only. See page 127.	KFT.08.184.15000.B
Blaze Sport Saddlebags	'11	'13	Removable soft luggage. See page 142.	HTA.08.740.10500
QUICK-LOCK Tankring	'11	'13	For QUICK-LOCK Tankbags. See page 144.	Type 140
QUICK-LOCK GPS Mount	'11	'13	Vibration-damped. Black. See page 100.	GPS.08.646.10300.B
SW-MOTECH Frame Sliders	'11	'13	See page 49.	STP.08.590.10700.B
R&G Frame Sliders	'11	'13	Aero-style. See page 42.	RG.CP0278BL
R&G Rear Fender Eliminator	'11	'13	Tail Tidy. See page 59.	RG.LP0095BK
R&G Swingarm Sliders	'11	'13	See page 43.	RG.SS0030BK
MRA Windscreen	'11	'13	Various shapes. See page 16.	MRA.08.061



Kawasaki Z1000 ('14)



Z1000 ('14)	Status
ALU-RACK Toprack	In Development
QUICK-LOCK Tankring	In Development
QUICK-LOCK GPS Mount	In Development
Blaze Sport Saddlebags	In Development
Mirror Wideners	In Development
R&G Frame Sliders, Aero-style, page 42	RG.CP0264.BL
R&G Front Axle Sliders, page 43	RG.FP0151.BK
R&G Swingarm Sliders, page 43	RG.SS0030BK
R&G Bar End Sliders, page 44	RG.BE0032BK
R&G Rear Fender Eliminator, Tail Tidy	RG.LP0156.BK
R&G Engine Case Cover Kit, page 48	RG.KEC0028.BK
R&G Radiator Guards, aluminum, page 50	RG.RAD0090BK
R&G Exhaust Hanger	RG.EH0054.BK
MRA Windshields	In Development
Kaoko Throttle Lock	In Development

Kawasaki Z1000 ('04-'13)

Z1000 ('04-'13)	from	to	Notes	Part Number
ALU-RACK Toprack	'10	'13	Black. For TraX, Givi & other topcases. See page 134.	GPT.08.648.10000.B
QUICK-LOCK Tankring	'04	'13	For QUICK-LOCK Tankbags. See page 144.	Type 140
Blaze Sport Saddlebags	'10	'13	Removable soft luggage. See page 142.	HTA.08.740.10200
Crashbars	'10	'13	See page 52.	SBL.08.647.10000.B
Mirror Wideners	'04	'09	See page 34.	SVL.00.505.101
SW-MOTECH Frame Sliders	'10	'13	See page 49.	STP.08.590.10500.B
Centerstand	'03	'06	See page 56.	HPS.08.217.100
R&G Frame Sliders	'10	'13	Aero-style. See page 42.	RG.CP0264.BL
R&G Engine Case Cover	'10	'13	Left side only. See page 48.	RG.ECC0077BK
R&G Engine Case Cover	'10	'13	Right side only. See page 48.	RG.ECC0079BK
Kaoko Throttle Lock	'10	'13	For 30mm OD bar weights only. See page 32.	KAO.KAW150
Kaoko Throttle Lock	'11	'13	For 37.8mm OD bar weights only. See page 32.	KAO.KAW160
MRA Windscreen	'04	'13	Various shapes. See page 16.	Various

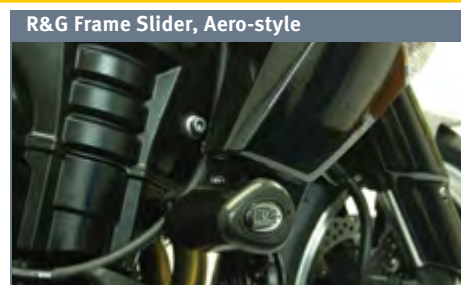

Kawasaki ZX10R



See more at TwistedThrottle.com/MyBike

ZX10R	from	to	Notes	Part Number
QUICK-LOCK Tankring	'04	'14	For QUICK-LOCK Tankbags. See page 144.	Type 140
Blaze Sport Saddlebags	'11	'14	Removable soft luggage. See page 142.	HTA.08.740.10800
R&G Frame Sliders	'11	'14	Aero-style. See page 42.	RG.CP0335.BL
R&G Rear Fender Eliminator	'11	'14	Tail Tidy. See page 59.	RG.LP0101BK
R&G Bar End Sliders	'06	'14	See page 44.	RG.BE0024BK
MRA Windshields	'11	'14	Various shapes. See page 16.	MRA.08.062

Kawasaki Ninja 1000 ('14)



Ninja 1000 (Z1000SX)	Status
ALU-RACK Toprack	In Development
QUICK-LOCK Tankring	In Development
QUICK-LOCK GPS Mount	In Development
Blaze Sport Saddlebags	In Development
Mirror Wideners	In Development
Handlebar Risers	In Development
R&G Frame Sliders, Aero-style, page 42	RG.CP0278BL
R&G Front Axle Sliders, page 43	RG.FP0095BK
R&G Swingarm Sliders	RG.SS0030BK
R&G Bar End Sliders	RG.BE0032BK
R&G Rear Fender Eliminator, Tail Tidy	RG.LP0095BK
R&G Engine Case Cover Kit, page 48	RG.KEC0028.BK
R&G Radiator Guards	RG.RAD0090BK
R&G Exhaust Hanger, page 46	RG.EH0058.BK
Articulating Pizza Thrower	In Development
MRA Windshields	In Development
Kaoko Throttle Lock	In Development

Kawasaki Concours 1400



[See more at TwistedThrottle.com/MyBike](http://www.twistedthrottle.com/MyBike)

GTR1400 Concours	from	to	Notes	Part Number
Steel Toprack	'08	'14	For TraX, Givi & other topcases. See page 122.	GPT.08.406.20001.B
QUICK-LOCK Tankring	'10	'14	For QUICK-LOCK Tankbags. See page 144.	Type 140
GPS Mount	'08	'14	See page 100.	GPS.08.085.100
Handlebar Riser	'08	'14	See page 32.	GM.K405
R&G Crashbars	'10	'14	No cutting required. See page 52.	RG.AB0002BK
R&G Front Axle Sliders	'08	'14	See page 43.	RG.FP0007BK
R&G Bar End Sliders	'08	'14	See page 44.	RG.BE0032BK
R&G Frame Sliders	'08	'14	Aero-style. See page 42.	RG.CP0213BL
R&G Frame Insert	'10	'14	See page 47.	RG.FI0030BK
MFW Vario Footpeg Mount	'08	'14	Adjustable rider or passenger mounts. See page 24.	MFW.051.05.03
Kaoko Throttle Lock	'08	'14	Throttle lock cruise control. See page 32.	KAO.KAW200
MRA Windscreens	'08	'14	Various shapes. See pages 16.	MRA.08.056

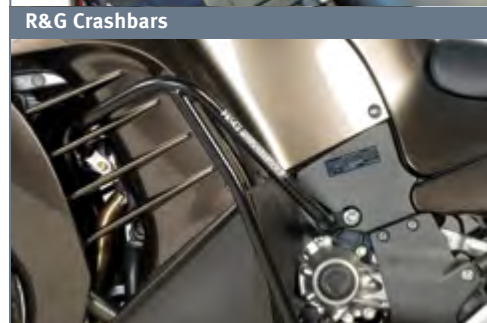

Kawasaki zZR1400 / ZX14 Ninja



ZX14

[See more at TwistedThrottle.com/MyBike](http://www.twistedthrottle.com/MyBike)

ZZR 1400 / ZX14 Ninja	from	to	Notes	Part Number
ALU-RACK Toprack	'06	'14	Black. For TraX, Givi & other topcases. Euro tail cover or some modifications required. Page 134.	GPT.08.161.15000.B
QUICK-LOCK Sidecarrier	'06	'11	For TraX, Givi & other sidecases.	KFT.08.514.20000.B
QUICK-LOCK Contour Carrier	'06	'11	For Givi V35 PLX sidecases only. See page 127.	KFT.08.514.150
Blaze Sport Saddlebags	'11	'14	Removable soft luggage. See page 142.	BC.HTA.08.740.10900.B
QUICK-LOCK Tankring	'06	'14	For QUICK-LOCK Tankbags. See page 144.	Type 140
Mirror Wideners	'06	'14	Hinge Mirror Wideners. See page 34.	SVL.08.500.100
Centerstand	'06	'14	See page 56.	HPS.08.516.100
R&G Rear Fender Eliminator	'06	'14	Tail Tidy. See page 59.	RG.LP0037
R&G Frame Sliders	'12	'14	Aero-style. See page 42.	RG.CP0311BL
R&G Bar End Sliders	'06	'12	See page 44.	RG.BE0032BK
MRA Windscreen	'06	'14	Various shapes. See page 16.	MRA.08.047



KTM EXC



520 EXC

EXC	from	to	Notes	Part Number
Barkbusters Handguards	'00	'14	Various colors. Tapered bars only. See page 38.	BB.BHG15-2
Skid Plate with Side Protection	'00	'07	3mm-thick aluminum. See page 54.	MSS.04.025.100
Handlebar Risers	'00	'14	Various heights. See page 28.	LEH.00.039.150
R&G Swingarm Spools	'08	'14	See page 43.	RG.SP0002BK
TrailTech Voyager GPS Computer	'00	'14	Speed, trip, engine temps & GPS See page 98.	912-102
MRA RoadShield	'00	'14	MRA.HK mount kit required. See page 21.	MRA.RO
Scottoiler Chain Oiler	'00	'14	Vacuum-operated oiler. See page 186.	SCT.SO-1007US
MEFO Explorer Rear Tire	'00	'14	DOT dual-sport. 120/90-18. See page 184.	MEFO.MED19
MEFO Explorer Front Tire	'00	'14	DOT dual-sport. 90/90-21. See page 184.	MEFO.MED25
MEFO Stone Master Rear Tire	'00	'14	DOT knobby 120/90-18.	MEFO.MCE06
MEFO Stone Master Front Tire	'00	'14	DOT knobby 90/90-21.	MEFO.MCE21

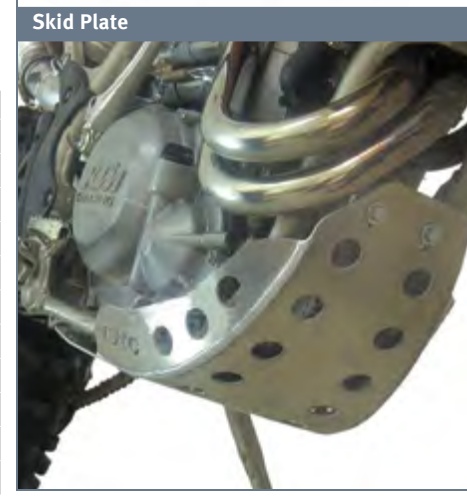
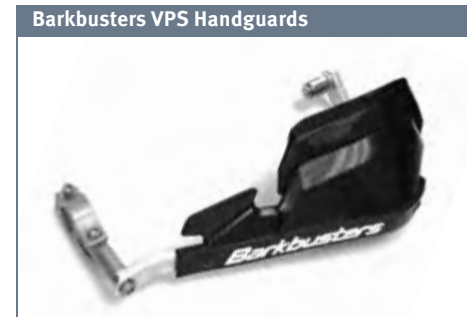

KTM 690 Enduro & 690 SMC



The Twisted 690 SMC

[See more at TwistedThrottle.com/MyBike](http://www.twistedthrottle.com/MyBike)

690 Enduro & 690 SMC	from	to	Notes	Part Number
Steel Toprack	'08	'14	For TraX, Givi & other topcases. See page 122.	GPT.04.439.20001.B
ALU-RACK Toprack	'08	'14	Black. For TraX, Givi & other topcases. See page 134.	GPT.04.439.100.B
QUICK-LOCK GPS Mount	'08	'14	Vibration-damped. Black. See page 100.	GPS.00.646.10400.B
Barkbusters Handguards	'08	'14	Various shapes & colors. See page 38.	BB.BHG15-2
Kaoko Throttle Lock	'08	'14	With original handguards only. See page 32.	KAO.KTMAD
Kaoko Throttle Lock	'08	'14	With Barkbusters handguards only.	KAO.KBBAD
Kaoko Throttle Lock	'08	'14	With no handguards (SMC) only.	KAO.KTM100
R&G Engine Case Cover Kit	'08	'14	Left & right side covers. See page 48.	RG.KEC0049.BK
R&G Rear Fender Eliminator	'08	'14	Tail Tidy. See page 59.	RG.LP0073BK
R&G Bar End Sliders	'08	'14	With no handguards. See page 44.	RG.BE0044BK
R&G Front Axle Sliders	'08	'14	See page 43.	RG.FP0148.BK
R&G Swingarm Spools	'08	'14	See page 43.	RG.SP0002BK
R&G Spool Slider	'08	'12	See page 43.	RG.CR0009BK



KTM 690 Duke ('08-'14)

[See more at TwistedThrottle.com/MyBike](http://www.twistedthrottle.com/MyBike)

SEAT-RACK Luggage Rack



Blaze Sport Saddlebags



KOBRA Handguards & Mirror Wideners



690 Duke	from	to	Notes	Part Number
ALU-RACK Toprack	'11	'14	Black. For TraX, Givi & other Topcases. See page 134.	GPT.04.181.15001.B
SEAT-RACK Luggage Rack	'11	'14	For soft luggage. Replaces passenger seat.	GPT.04.181.40000/B
Blaze Sport Saddlebags	'11	'14	Removable soft luggage. See page 142.	HTA.04.740.10000
KOBRA Handguards	'11	'14	Integrated LED indicators available. Page 37.	HPR.00.220.20400.B
Mirror Wideners	'08	'14	See page 34.	SVL.00.505.101
On/Off-road Footpegs	'11	'14	Convertible. Stainless steel. See page 23.	FRS.17.011.10000.S
QUICK-LOCK GPS Mount	'11	'14	See page 100.	GPS.00.646.10400.B
R&G Rear Fender Eliminator	'12	'14	Tail Tidy. See page 59.	RG.LP0122BK
R&G Sidestand Enlarger	'12	'14	See page 57.	RG.PKS0008.SI
R&G Engine Case Cover Kit	'12	'14	Left & right side covers. See page 48.	RG.KEC0049.BK
Barkbusters Handguards	'02	'14	Various shapes & colors. See page 38.	BB.BHG15-2

KTM 950 SM, 990 SM & 990 SMR



990 SM

On/Off-Road Footpegs



QUICK-LOCK EVO Sidecarrier mounting points



950SM, 990SM & 990SMR	from	to	Notes	Part Number
Steel Toprack	'05	'08	Black. 950SM only. For TraX & Givi. See page 122.	GPT.04.526.20001.B
Steel Toprack	'07	'13	Black. 990SM/R only. For TraX & Givi. See page 122.	GPT.04.526.20001.B
QUICK-LOCK EVO Sidecarrier	'05	'13	For TraX, Givi & other sidecases. See page 128.	KFT.04.621.20001.B
Crashbars	'07	'13	See page 52.	SBL.04.650.10000.B
Centerstand	'05	'13	See page 56.	HPS.04.684.10000.B
Skid Plate	'07	'13	990SMR only. See page 54.	MSS.04.651.10000.B
Handlebar Risers	'05	'13	Black or silver. 30mm height. See page 28.	LEH.00.039.20300
Mirror Wideners	'05	'13	Black. See page 34.	SVL.00.505.101
QUICK-LOCK GPS Mount	'05	'13	See page 100.	GPS.00.646.10400.B
On/Off-Road Footpegs	'05	'13	Convertible. Stainless steel. See page 23.	FRS.04.011.10100.S
R&G Frame Sliders	'05	'13	Classic-style. Lower. See page 42.	RG.CP0154BL
R&G Frame Sliders	'08	'13	990SM only. Classic-style. Upper. See page 42.	RG.CP0153BL
R&G Radiator Guard	'08	'13	Black. 990SM/R only.	RG.RAD0128BK
R&G Rear Fender Eliminator	'05	'13	Tail Tidy. See page 59.	RG.LP0124BK
R&G Engine Case Cover Kit	'05	'13	Left & right side covers. See page 48.	RG.KEC0010.BK
R&G Engine Case Slider	'05	'13	Right side cover. Carbon Kevlar. See page 48.	RG.ECS0010C
R&G Engine Case Slider	'05	'13	Left side cover. Carbon Kevlar. See page 48.	RG.ECS0011C
Kaoko Throttle Lock	'05	'13	See page 32.	KAO.KTM100

QUICK-LOCK GPS Mount



Mirror Wideners



KTM 950 Adventure / 990 Adventure



990 Adventure

Auxiliary Light Mount



Crashbars



Radiator Guard



LC8 Adventure 950 & 990	from	to	Notes	Part Number
Steel Toprack	'03	'13	For TraX, Givi & other topcases. See page 122.	GPT.04.256.20001.B
ALU-RACK Toprack	'03	'13	Black. For TraX, Givi & other topcases. See page 134.	GPT.04.256.100.B
QUICK-LOCK EVO Sidecarrier	'03	'13	For TraX, Givi & other sidecases. See page 128.	KFT.04.262.20002.B
DAKAR Waterproof Soft Saddlebags	'03	'13	Rugged, removable luggage. See page 138.	HTA.04.741.10100.B
Skid Plate	'03	'13	Black or Silver aluminum. See page 54.	MSS.04.250.100
Crashbars	'03	'13	Black. See page 52.	SBL.04.488.100
SW-MOTECH Radiator Guard	'03	'13	Silver. See page 50.	KLS.04.389.100
Brake Pedal Extension	'06	'13		SCT.04.174.10000.S
Auxiliary Light Mounts	'03	'13	Under-cowling mounts. See page 112.	NSW.04.004.10000.B
Handlebar Risers	'03	'13	Silver. 30mm height. See page 28.	LEH.00.039.20300.S
R&G Engine Case Cover Kit	'03	'13	Left & right covers. See page 48.	RG.KEC0010.BK
Barkbusters Handguards	'03	'13	Various shapes & colors. See page 38.	BB.BHG15-2

KTM 990 SMT



990 SMT

990 SMT	from	to	Notes	Part Number
Steel Toprack	'10	'13	For TraX, Givi & other topcases. See page 122.	GPT.04.616.20001.B
QUICK-LOCK EVO Sidecarrier	'10	'13	For TraX, Givi & other sidecases. See page 128.	KFT.04.621.20001.B
Skid Plate	'10	'13	Powder coated black. See page 54.	MSS.04.651.10000.B
Crashbar	'10	'13	See page 52.	SBL.04.650.10000.B
Chain Guard	'10	'13	Aluminum. See page 45.	KTS.04.652.10000.B
Centerstand	'10	'13	See page 56.	HPS.04.696.10000.B
Handlebar Risers	'10	'13	See page 28.	LEH.00.039.106
Mirror Wideners	'10	'13	Universal Mirror Extensions: See page 34.	SVL.00.505.101
Auxiliary Headlight Mount	'10	'13	For Denali, Hawk & other lighting. See page 112.	NSW.04.004.10100
On/Off-road Footpegs	'10	'13	Stainless steel. Silver. See page 23.	FRS.04.011.10100.S
Auxiliary Light Mount	'10	'13	All mounting hardware & instructions included.	NSW.04.004.10000.B
Kaoko Throttle Lock	'10	'13	See page 32.	KAO.KTM100

[See more at TwistedThrottle.com/MyBike](http://www.twistedthrottle.com/MyBike)

Crashbars



Skid Plate & Centerstand



Steel Toprack with TraX Adapters



KTM 1190 Adventure & Adventure R



1190 Adventure R



1190 Adventure

[See more at TwistedThrottle.com/MyBike](http://www.twistedthrottle.com/MyBike)

R&G Engine Case Cover



Dakar Soft Saddlebags



Crashbars



1190 Adventure	from	to	Notes	Part Number
ALU-RACK Toprack	'14	'14	Black. For TraX, Givi & other topcases. See page 134.	GPT.04.790.15000.B
Steel Toprack	'14	'14	Black. For TraX, Givi & other topcases. See page 122.	GPT.04.790.20000.B
SEAT-RACK Luggage Rack	'14	'14	For soft luggage. Replaces passenger seat.	GPT.04.790.40000/B
DAKAR Waterproof Soft Saddlebags	'14	'14	Rugged, removable luggage. See page 138.	HTA.04.741.10000.B
QUICK-LOCK EVO Sidecarrier	'14	'14	For TraX, Givi & other sidecases. See page 128.	KFT.04.333.20001.B
QUICK-LOCK Tankring	'14	'14	For QUICK-LOCK Tankbags. See page 144.	Type 126
QUICK-LOCK GPS Mount	'14	'14	Vibration-damped. See page 100.	GPS.04.646.10000.B
Crashbars	'14	'14	Black. See page 52.	SBL.04.338.10000.B
Skid Plate	'14	'14	Aluminum. Black. See page 54.	MSS.04.657.10000.B
Brake Pedal Extension	'14	'14		SCT.04.174.10000.S
Mirror Wideners	'14	'14	See page 34.	SVL.00.505.10500.B
Handlebar Risers	'14	'14	Silver or black. 30mm height. See page 28.	LEH.00.039.20300
Auxiliary Light Mounts	'14	'14	For Denali, Hawk & other lighting. See page 112.	NSW.04.004.10200.B
R&G Engine Case Cover Kit	'14	'14	Left & right covers. See page 48.	RG.KEC0057.BK
R&G Engine Case Slider	'14	'14	Ride side. See page 48.	RG.ECS0085.BK
R&G Engine Case Slider	'14	'14	Left side. See page 48.	RG.ECS0033BK
R&G Swingarm Spools	'14	'14	See page 43.	RG.CR0009BK
R&G Radiator Guards	'14	'14	Black aluminum. See page 50.	RG.RAD0148.BK
Barkbusters Handguards	'14	'14	Various shapes & colors. See page 38.	BB.BHG15-02

Skid Plate



Steel Toprack with TraX Adapters



KTM 1290 Super Duke R

1290 Super Duke R	Status
QUICK-LOCK Tankring, page 144	In Development
Blaze Sport Saddlebags, page 142	In Development
QUICK-LOCK GPS Mount	In Development
SW-MOTECH Frame Sliders	In Development
Automatic wheelie counter	In Development
R&G Frame Sliders, Aero, page 42	RG.CP0361.BL
R&G Engine Case Cover Kit, page 48	RG.KEC0057.BK
R&G Engine Case Slider, Right, page 48	RG.ECS0034BK
R&G Engine Case Slider, Left, page 48	RG.ECS0033BK
R&G Swingarm Sliders, page 43	RG.SS0041.BK
R&G Front Axle Sliders, page 43	RG.FP0138.BK
R&G Rear Fender Eliminator, Tail Tidy	RG.LP0158.BK
R&G Sidestand Foot Enlarger, page 57	RG.PKS0034.SI
R&G Radiator Guard, Black	RG.RAD0168.BK
MRA Windscreens, page 16	In Development
Barkbusters Handguards, page 38	In Development



[See more at TwistedThrottle.com/MyBike](http://www.twistedthrottle.com/MyBike)

KTM 1190 RC8 & 1190 RC8 R



RC8

[See more at TwistedThrottle.com/MyBike](http://www.twistedthrottle.com/MyBike)

1190 RC8 & 1190 RC8 R	from	to	Notes	Part Number
QUICK-LOCK Tankring	'11	'14	For QUICK-LOCK Tankbags. See page 144.	Type 301
R&G Frame Slider	'08	'14	RC8 only. Aero-style. See page 42.	RG.CP0234
R&G Frame Slider	'09	'14	RC8 R only. Aero-style. See page 42.	RG.CP0256
R&G Radiator Guard	'08	'14	Black. See page 50.	RG.RAD0133BK
R&G Rear Fender Eliminator	'08	'14	Tail Tidy. See page 59.	RG.LP0070BK
R&G Bar End Slider	'08	'14	See page 44.	RG.BE0040BK
R&G Engine Case Slider	'08	'14	Left side. See page 48.	RG.ECS0033BK
R&G Engine Case Slider	'08	'14	Right side. See page 48.	RG.ECS0034BK
R&G Front Axle Sliders	'08	'14	See page 43.	RG.FP0083BK
R&G Swingarm Spools	'08	'14	See page 43.	RG.SP0026BK
R&G Chain Toe Guard	'08	'14	See page 45.	RG.TG0005BK
Kaoko Throttle Lock	'08	'13	See page 32.	KAO.KTMRC

R&G Frame Slider



R&G Radiator Guard



R&G Engine Case Slider



Suzuki DR-Z400S & DR-Z400SM



DRZ400SM

[See more at TwistedThrottle.com/MyBike](http://www.twistedthrottle.com/MyBike)

DRZ400S & DRZ400SM	from	to	Notes	Part Number
Steel Toprack	'02	'14	For TraX, Givi & other topcases. See page 122.	GPT.05.827.20001.B
QUICK-LOCK EVO Sidecarrier	'02	'13	For TraX, Givi & other sidecases. See page 128.	KFT.05.801.20000.B
Doubletake Mirror	'02	'14	DTM.SCA mount required. See page 36.	DTM.00.M
Scottoiler Chain Oiler	'02	'14	Vacuum-operated oiler. See page 186.	SCT.SO-1007US
R&G Front Axle Sliders	'02	'14	DRZ400S only. See page 43.	RG.FP0028BK
R&G Front Axle Sliders	'02	'14	DRZ400SM only. See page 43.	RG.FP0127.BK
Barkbusters Handguards	'02	'14	Various shapes & colors. See page 38.	BB.BHG15-1
MRA RoadShield	'02	'14	MRA.HK mount kit required. See page 21.	MRA.RO

Doubletake Mirrors

Barkbusters Handguard with VPS plastics

Steel Toprack

QUICK-LOCK EVO Sidecarrier with TraX luggage

Suzuki GSX-R600 & GSX-R750

R&G Adjustable Rearset

MRA Double Bubble RacingScreen

Exhaust Protector & Exhaust Hanger



GSX-R600

[See more at TwistedThrottle.com/MyBike](http://www.twistedthrottle.com/MyBike)

GSX-R600 & GSX-R750	from	to	Notes	Part Number
Blaze Sport Saddlebags	'05	'10	Removable soft luggage. See page 142.	HTA.05.740.10200
Blaze Sport Saddlebags	'11	'14	Removable soft luggage. See page 142.	HTA.05.740.10000
QUICK-LOCK Tankring	'03	'14	For QUICK-LOCK Tankbags. See page 144.	Type 125
SW-MOTECH Frame Slider	'11	'14	See page 49.	STP.05.590.10700.B
R&G Engine Case Cover Kit	'08	'14	Left & right side covers. See page 48.	RG.KEC0002.BK
R&G Adjustable Rearsets	'11	'14	11-positions. See page 27.	RG.RSET06BK
R&G Frame Sliders	'11	'14	Aero-style. See page 42.	RG.CP0280BL
R&G Rear Fender Eliminator	'11	'14	Tail Tidy. See page 59.	RG.LP0102BK
R&G Exhaust Hanger	'11	'14	See page 46.	RG.EH0048BK
MRA Windscreen	'00	'14	Various shapes. See page 16.	Various

Suzuki GS500E & GS500F

R&G Bar End Sliders

ALU-RACK Toprack, black

Crashbars (GS500/E only)



GS500F

[See more at TwistedThrottle.com/MyBike](http://www.twistedthrottle.com/MyBike)

GS500E & GS500F	from	to	Notes	Part Number
ALU-RACK Toprack	'01	'06	Black. For TraX, Givi & other topcases. See page 134.	GPT.05.285.100.B
QUICK-LOCK Tankring	'89	'06	For QUICK-LOCK Tankbag. See page 144.	Type 115
Crashbars, Black	'89	'06	GS500E only. See page 52.	SBL.05.339.100
Handlebar Risers	'89	'06	Various heights & colors. See page 28.	LEH.00.039150
R&G Bar End Sliders	'89	'06	See page 44.	RG.BE0017BK
R&G Frame Sliders	'89	'06	For GS500/E only: See page 42.	RG.CP0157BL
R&G Frame Sliders	'04	'06	For GS500F only: See page 42.	RG.CP0158BL
MRA Windscreen	'89	'06	For GS500F only. Various colors. See page 16.	MRA.05.005

Suzuki DR650SE

Barkbusters Handguards with VPS plastics

ALU-RACK Toprack

Skid Plate, silver



[See more at TwistedThrottle.com/MyBike](http://www.twistedthrottle.com/MyBike)

DR650SE	from	to	Notes	Part Number
ALU-RACK Toprack	'96	'14	Black. For TraX, Givi & other topcases. See page 134.	GPT.05.153.100.B
QUICK-LOCK Sidecarrier	'96	'14	For TraX, Givi & other sidecases.	KFT.05.149.100
Skid Plate	'96	'14	Silver, aluminum. See page 54.	MSS.05.123.100
Centerstand	'96	'14	See page 56.	HPS.05.167.100
Barkbusters Handguards	'96	'14	Various shapes & colors. See page 38.	BB.BHG15-1
Mirror Wideners	'96	'14	See page 34.	SVL.00.505.101
Kaoko Throttle Lock	'96	'14	Throttle lock cruise control. See page 32.	KAO.DR650SE
Handlebar Risers	'96	'14	Various heights & colors. See page 28.	LEH.00.039150
MRA RoadShield	'96	'14	MRA.HK mount kit required. See page 21.	MRA.RO
Scottoiler Chain Oiler	'96	'14	Vacuum-operated oiler. See page 186.	SCT.SO-1007US
Trailtech Voyager GPS Computer	'96	'14	Speed, trip, engine temps & GPS. See page 98.	912-302

Suzuki AN650 Burgman & Executive

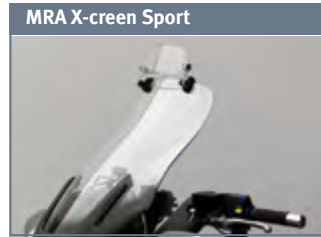

AN650 Burgman Executive*

AN650/AN650 Executive Burgman	from	to	Notes	Part Number
MRA X-creen Sport	'02	'14	Clear or smoke gray. See page 16.	MRA.XCA.S
Sidecase Carrier	'02	'12	Fit kit FHG.7828ZHV or Fehling crashbars required.	FHG.7847KH
Toprack	'02	'12	For Givi Monolock or Monokey Topcases.	GIVI E529
Toprack	'13	'14	For Givi Monokey Topcases only.	GIVI SR3104.M5
GPS Mount	'02	'12	For all Garmin Zumo or TomTom Rider GPS.	GPS.05.090.100
Handlebar Risers	'02	'14	Up 1" & back 1". See page 28.	LEH.00.039.152
Touring Windscreen	'02	'12	Standard model only. Clear tint.	GIVI D257ST
Touring Windscreen	'02	'12	Executive model only. Clear tint.	GIVI D263ST
Kaoko Throttle Lock	'02	'14	Throttle lock cruise control. See page 32.	KAO.SUZ400.Q

*Items also available for the AN400 Burgman as well. Visit TwistedThrottle.com for more information.

[See more at TwistedThrottle.com/MyBike](http://TwistedThrottle.com/MyBike)

Suzuki GSF650 & GSF650S Bandit



GSF650 Bandit

GSF650 & GSF650S Bandit	from	to	Notes	Part Number
ALU-RACK Toprack	'05	'13	Black. GSF650 only. For topcases. See page 134.	GPT.05.299.100
ALU-RACK Toprack	'05	'13	Black. GSF650S only. For topcases. See page 134.	GPT.05.299.15000.B
QUICK-LOCK EVO Sidecarrier	'09	'13	For TraX, Givi & other sidecases. See page 128.	KFT.05.597.20000.B
QUICK-LOCK Contour Sidecarrier	'09	'13	EVO style. For Givi V35 sidecases. See page 127.	KFT.05.597.15000.B
QUICK-LOCK Tankring	'05	'13	For QUICK-LOCK Tankbags. See page 144.	Type 125
Blaze Sport Saddlebags	'09	'13	Removable soft luggage. See page 142.	HTA.05.740.10300
Crashbars	'07	'13	Black. GSF650 only. See page 52.	SBL.05.384.100
R&G Frame Sliders	'07	'13	Classic-style. See page 42.	RG.CP0206BL
R&G Engine Case Cover Kit	'07	'13	Left & right side covers. See page 48.	RG.KEC0006.BK
MRA Windscreen	'05	'13	Various shapes. See page 16.	Various

[See more at TwistedThrottle.com/MyBike](http://TwistedThrottle.com/MyBike)

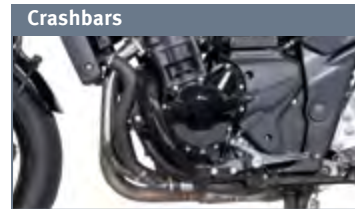

Suzuki GSX650F



GSX650F

GSX650F	from	to	Part Number
ALU-RACK	'08	'13	Black. For TraX, Givi & other topcases. See page 134.
QUICK-LOCK EVO Sidecarrier	'08	'13	For TraX, Givi & other sidecases. See page 128.
QUICK-LOCK Contour Carrier	'08	'13	For Givi V35 PLX sidecases only. See page 127.
QUICK-LOCK Tankring	'08	'13	See page 144.
Blaze Sport Saddlebags	'08	'13	Removable soft luggage. See page 142.
R&G Frame Sliders	'10	'13	Aero-style. See page 42.
R&G Rear Fender Eliminator	'08	'13	Tail Tidy. See page 59.
Kaoko Throttle Lock	'08	'13	Throttle lock cruise control. See page 32.
MRA Windscreen	'08	'13	Various shapes. See page 16.

[See more at TwistedThrottle.com/MyBike](http://TwistedThrottle.com/MyBike)

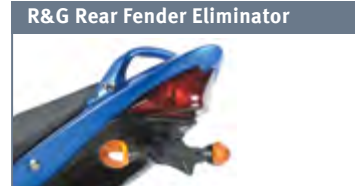

Suzuki SV650N, SV650S & SV650SF



SV650S

[See more at TwistedThrottle.com/MyBike](http://TwistedThrottle.com/MyBike)

SV650N, SV650S, & SV650F	from	to	Notes	Part Number
ALU-RACK Toprack	'03	'12	Black. For TraX, Givi & other topcases. See page 124.	GPT.05.232.100.B
QUICK-LOCK Sidecarrier	'03	'03	For TraX, Givi & other topcases.	KFT.05.227.100
QUICK-LOCK Sidecarrier	'04	'12	For TraX, Givi & other topcases.	KFT.05.226.100
QUICK-LOCK Tankring	'03	'12	For QUICK-LOCK Tankbags. See page 144.	Type 125
Mirror Wideners	'98	'12	SV650N only. See page 34.	SVL.00.505.101
Mirror Wideners	'03	'12	SV650S & SV650SF only. See page 34.	SVL.05.500.100
Centerstand	'03	'12	See page 56.	HPS.05.219.100
Handlebar Risers	'98	'12	SV650N only. See page 28.	LEH.00.039150
R&G Radiator Guard	'05	'12	Black. See page 50.	RG.RAD0136.BK
R&G Frame Sliders	'03	'12	SV650SF only. Classic-style. See page 42.	RG.CP0124BL
R&G Frame Sliders	'03	'12	SV650S & SV650N only. Classic-style. See page 42.	RG.CP0138BL
R&G Rear Fender Eliminator	'03	'12	Tail Tidy. See page 59.	RG.LP0010BK
MRA Windscreen	'03	'07	Several shapes available: See page 16.	Various

Suzuki SFV650

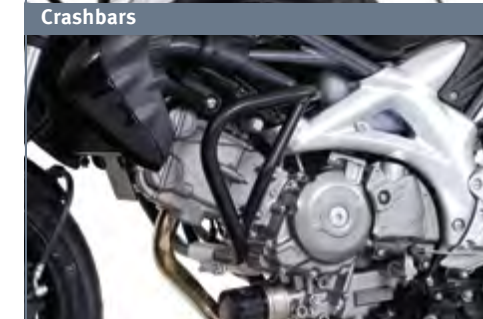

[See more at TwistedThrottle.com/MyBike](http://TwistedThrottle.com/MyBike)

Gladius SFV650	from	to	Notes	Part Number
ALU-RACK Toprack	'09	'14	Black. For TraX, Givi & other topcases. See page 134.	GPT.05.631.15000.B
QUICK-LOCK EVO Sidecarrier	'09	'14	For TraX, Givi & other sidecases. See page 128.	KFT.05.630.20000.B
QUICK-LOCK Tankring	'09	'14	For QUICK-LOCK Tankbags. See page 144.	Type 125
Blaze Sport Saddlebags	'09	'14	Removable soft luggage. See page 142.	HTA.05.740.10400
Crashbars	'09	'10	Black. See page 52.	SBL.05.632.10000.B
Crashbars	'11	'14	Black. See page 52.	SBL.05.192.10000.B
SW-MOTECH Frame Sliders	'09	'14	See page 49.	STP.05.590.10000.B
R&G Radiator Guard	'09	'14	Black. See page 50.	RG.RAD0074.BK
R&G Frame Sliders	'09	'14	Aero-style. See page 42.	RG.CP0255BL
R&G Rear Fender Eliminator	'09	'14	Tail Tidy. See page 59.	RG.LP0083BK
R&G Bar End Sliders	'09	'14	See page 44.	RG.BE0002BK
MRA RacingScreen	'09	'14	Mount kit MRA.HK.L required. See page 19.	MRA.RNB

Suzuki DL650 V-Strom ('04-'11)



See more at TwistedThrottle.com/MyBike

DL650 V-Strom	from	to	Notes	Part Number
Steel Toprack	'04	'11	For TraX, Givi & other topcases. See page 122.	GPT.05.293.20001.B
ALU-RACK Toprack	'04	'11	For TraX, Givi & other topcases. See page 134.	GPT.05.293.15000.B
QUICK-LOCK EVO Sidecarrier	'04	'11	For TraX, Givi & other sidecases. See page 128.	KFT.05.294.200
QUICK-LOCK Tankring	'04	'11	For QUICK-LOCK Tankbags. See page 144.	Type 115
QUICK-LOCK GPS Mount	'04	'11	Vibration-damped. Black. See page 100.	GPS.00.646.10100.B
Givi Contour PLX Sidecarrier	'04	'11	For Givi V35 PLX sidecases only.	Givi PLX532
QUICK-LOCK GPS Mount	'04	'11	See page 100.	GPS.00.646.10100.B
Crashbars	'04	'11	Black. See page 52.	SBL.05.674.10000.B
Radiator Guard	'04	'11	Aluminum. Black or silver. See page 50.	KLS.05.401.100
Chain Guard	'04	'11	Aluminum. See page 45.	KTS.05.164.100
Skid Plate	'04	'11	SW-MOTECH or original crashbars required. Pg 54.	MSS.05.296.10001.B
Brake Master Cylinder Guard	'04	'11	Rear. See page 55.	BPS.05.175.10000.S
Handlebar Risers	'04	'11	Various heights & colors. See page 28.	LEH.00.039150
Mirror Wideners	'04	'11	See page 34.	SVL.00.505.101
Centerstand	'04	'11	See page 56.	HPS.05.257.100
Auxiliary Headlight Mount	'04	'11	For Denali, Hawk & other lighting. See page 112.	LAH.05.456.100
On/Off-Road Footpegs	'04	'11	Convertible. Stainless steel. See page 23.	FRS.05.011.10000.S
R&G Front Axle Sliders	'04	'11	See page 43.	RG.FP0023BK
R&G Frame Sliders	'06	'11	No cutting required: See page 42.	RG.CP0144.BL
Barkbusters Handguards	'04	'11	Various shapes & colors. See page 38.	BB.BHG46.3
MRA Windscreens	'04	'11	Various shapes. See page 16.	MRA.05.037
Adjustable Windshield Bracket	'04	'11	MadStad. For MRA, Givi & original windscreens.	MAD.AWM-05
Kaoko Throttle Lock	'04	'11	Throttle lock cruise control. See page 32.	KAO.VS1000UW

Steel Toprack



QUICK-LOCK EVO Sidecarrier mounting points



Auxiliary Headlight Mount



Crashbars



Centerstand



Skid Plate



Radiator Guard, silver



Suzuki DL650 V-Strom ('12-'14)

When the DL650, known by many as the "Wee" Strom, was updated in 2012, Twisted Throttle couldn't resist. We broke out the Farkle Cannon and blasted this bike with just about everything in our arsenal.



TWISTED "WEE"-STROM



Shawn, one of our Tech Reps, unloading the "patient" before her facelift.

See more at TwistedThrottle.com/2012VStrom



QUICK-LOCK EVO Sidecarrier



Steel Toprack with TraX Adapters



Auxiliary Light Mount (light not included)

DL650 V-Strom	from	to	Notes	Part Number
Steel Toprack	'12	'14	For TraX, Givi & other topcases. See page 122.	GPT.05.758.20001.B
ALU-RACK Toprack	'12	'14	For TraX, Givi & other topcases. See page 134.	GPT.05.758.15000.B
QUICK-LOCK EVO Sidecarrier	'12	'14	For TraX, Givi & other sidecases. See page 128.	KFT.05.765.20000.B
DAKAR Waterproof Soft Saddlebags	'12	'14	Rugged, removable luggage. See page 138.	HTA.05.741.10000.B
QUICK-LOCK Tankring	'12	'14	For QUICK-LOCK Tankbags. See page 144.	Type 125
QUICK-LOCK GPS Mount	'12	'14	Vibration-damped. See page 100.	GPS.05.646.10200.B
Crashbars	'12	'14	Black. See page 52.	SBL.05.757.10000.B
Skid Plate	'12	'14	Aluminum. Black & silver. See page 54.	MSS.05.759.10001.B
Mirror Wideners	'12	'14	See page 34.	SVL.00.505.10500.B
Handlebar Risers	'12	'14	Various heights & colors. See page 28.	LEH.00.039150
Auxiliary Light Mounts	'12	'14	For Denali, Hawk & other lighting. See page 112.	NSW.05.004.10100.B
Centerstand	'12	'14	See page 56.	HPS.05.764.10000.B
On/Off-Road Footpegs	'12	'14	Convertible. Stainless steel. See page 23.	FRS.05.011.10000.S
Givi Contour PLX Sidecarrier	'12	'14	For Givi V35 PLX sidecases only.	Givi PLX3101
R&G Frame Sliders	'12	'14	Aero-style. See page 42.	RG.CP0297BL
R&G Radiator Guard	'12	'14	See page 50.	RG.RAD0112BK
MRA Windscreens	'12	'14	Various shapes. See page 16.	MRA.05.059
Barkbusters Handguards	'12	'14	See page 38.	BB.BHG46.3
Kaoko Throttle Lock	'12	'14	Throttle lock cruise control. See page 32.	KAO.VS1000UW-S

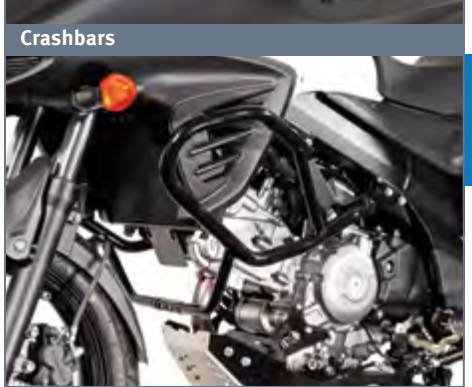

Crashbars



Barkbusters Handguard & Admore Turn Signals

Suzuki DL1000 V-Strom ('02-'13)



See more at TwistedThrottle.com/MyBike

DL1000 V-Strom	from	to	Notes	Part Number
Steel Toprack	'02	'13	For TraX, Givi & other topcases. See page 122.	GPT.05.293.20001.B
ALU-RACK Toprack	'02	'13	For TraX, Givi & other topcases. See page 134.	GPT.05.293.15000.B
QUICK-LOCK Tankring	'02	'13	For QUICK-LOCK Tankbags. See page 144.	Type 115
QUICK-LOCK EVO Sidecarrier	'02	'12	For TraX, Givi & other sidecases. See page 128.	KFT.05.158.200
Givi PLX Contour Sidecarrier	'02	'13	For Givi V35 PLX sidecases only.	Givi PLX528
Crashbars	'02	'13	Black. See page 52.	SBL.05.170.100
Chain Guard	'02	'13	Aluminum. See page 45.	KTS.05.264.100
Skid Plate	'02	'13	SW-MOTECH or original crashbars required. Black or Silver aluminum. Page 54.	MSS.05.265.100
On/Off-Road Footpegs	'02	'13	Convertible. Stainless steel. See page 23.	FRS.17.011.10000.S
Mirror Wideners	'04	'13	See page 34.	SVL.00.505.101
Handlebar Risers	'02	'13	Various heights & colors. See page 28.	LEH.00.039150
QUICK-LOCK GPS Mount	'04	'13	Vibration-damped. Black. See page 100.	GPS.00.646.10100.B
Centerstand	'02	'13	See page 56.	HPS.05.159.100
Auxiliary Headlight Mount	'02	'13	For Denali, Hawk & other lighting. See page 112.	LAH.05.456.100
Adjustable Windshield Bracket	'04	'13	MadStad. For MRA, Givi & original windscreens.	MAD.AWM-05
R&G Frame Sliders	'06	'13	Classic-style. See page 42.	RG.CP0187.BL
R&G Front Axle Sliders	'02	'13	See page 43.	RG.FP0023BK
R&G Radiator Guard	'02	'13	Black. See page 50.	RG.RAD0156.BK
Barkbusters Handguards	'02	'13	Various shapes & colors. See page 38.	BB.BHG46.3
Fenda Extenda	'04	'13	See page 58.	PP.05025
Kaoko Throttle Lock	'02	'13	Throttle lock cruise control. See page 32.	KAO.VS1000UW-S
MRA Windscreens	'04	'13	Various shapes. See page 16.	MRA.05.037

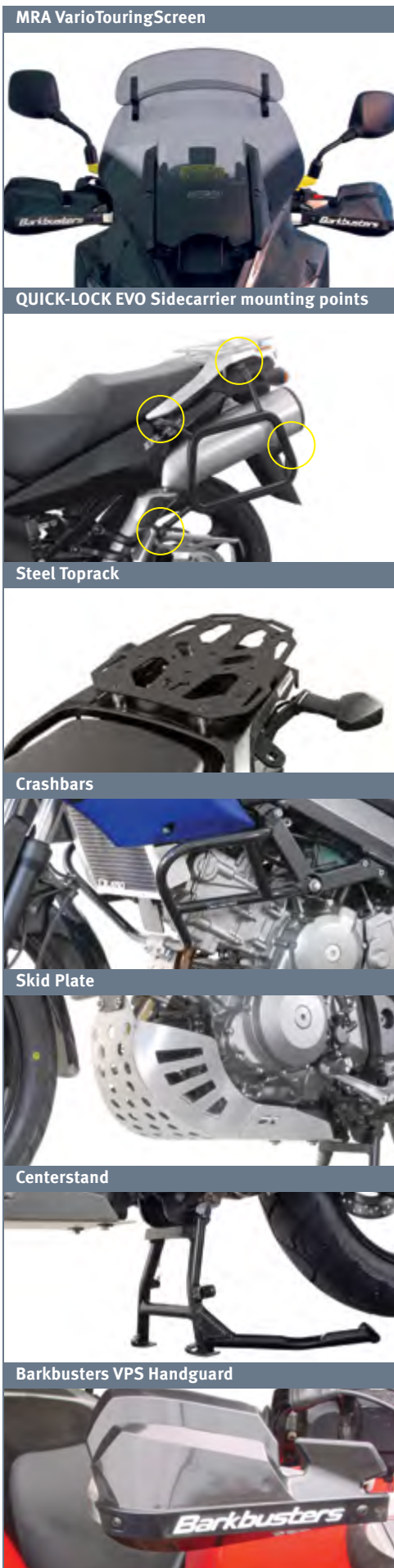

Suzuki DL1000 V-Strom ('14)



DL1000 V-Strom ('14)	Status
Steel Toprack	In Development
ALU-RACK Toprack	In Development
QUICK-LOCK EVO Sidecarrier	In Development
QUICK-LOCK Tankring	In Development
QUICK-LOCK GPS Mount	In Development
Skid Plate	In Development
Crashbars	In Development
Auxiliary Light Mounts	In Development
Handlebar Risers	In Development
Mirror Wideners	In Development
On/Off-Road Footpegs	In Development
Adjustable Tricorder Mount	In Development
R&G Engine Case Covers	In Development
R&G Engine Case Sliders	In Development
R&G Frame Sliders, Classic, page 42	RG.CP0187.BL
R&G Swingarm Spools	RG.CR0001.BK
R&G Front Axle Sliders	In Development
R&G Bar End Sliders	RG.BE0017BK
R&G Radiator Guard	RG.RAD0156.BK
R&G Toe Chain Guard	In Development
MRA Windshields	In Development
Kaoko Throttle lock cruise control	In Development
Barkbusters Handguards	In Development

Suzuki GSX-R1000



See more at TwistedThrottle.com/MyBike

GSX-R1000	from	to	Notes	Part Number
QUICK-LOCK Tankring	'01	'14	For QUICK-LOCK Tankbags. See page 144.	Type 125
Blaze Sport Saddlebags	'09	'14	Removable soft luggage. See page 142.	HTA.05.740.10000
Mirror Wideners	'09	'14	See page 34.	SVL.05.501.10800.B
R&G Adjustable Rearsets	'09	'14	11-positions. See page 27.	RG.RSET03BK
R&G Front Axle Sliders	'12	'14	See page 43.	RG.FP0112BK
R&G Bar End Sliders	'01	'14	See page 44.	RG.BE0002BK
R&G Rear Fender Eliminator	'09	'14	Tail Tidy. See page 59.	RG.LP0077BK
R&G Engine Case Cover Kit	'09	'14	Left & right covers. See page 48.	RG.KEC0003.BK
Kaoko Throttle Lock	'01	'14	Throttle lock cruise control. See page 32.	KAO.SU2100
MRA Windscreen	'09	'14	Various shapes & tints. See page 16.	MRA.05.058



Suzuki sv1000 & SV1000S



SV1000S

[See more at TwistedThrottle.com/MyBike](http://www.twistedthrottle.com/MyBike)

SV1000 & SV1000S	from	to	Notes	Part Number
ALU-RACK Topcase	'03	'09	Black. For TraX, Givi & other topcases. See page 134.	GPT.05.232.100.B
QUICK-LOCK Sidecarrier	'04	'09	For TraX, Givi & other sidecases.	KFT.05.226.100
QUICK-LOCK Tankring	'03	'09	See page 144.	Type 125
Mirror Wideners	'03	'09	SV1000S only. See page 34.	SVL.05.500.100
Mirror Wideners	'03	'09	SV1000 only. See page 34.	SVL.00.505.101
Handlebar Risers	'03	'09	SV1000 only. See page 28.	LEH.00.039150
R&G Frame Sliders	'06	'09	Classic-style. See page 42.	RG.CP0123BL
R&G Bar End Sliders	'03	'09	See page 44.	RG.BE0012BK
R&G Rear Fender Eliminator	'03	'09	Tail Tidy. See page 59.	RG.LP0010BK
Kaoko Throttle Lock	'03	'09	Throttle lock cruise control. See page 32.	KAO.SUZ300
MRA Windscreen	'03	'09	SV1000S only. Various shapes. See page 16.	MRA.05.017
MRA SpeedScreen	'03	'09	SV1000 only. MRA.HK mount kit required. Page 20.	MRA.SPS

ALU-RACK Toprack



QUICK-LOCK Sidecarrier



R&G Frame Slider, Classic-style



Suzuki GSX1250FA

ALU-RACK Toprack



QUICK-LOCK EVO Sidecarrier



R&G Front Axle Slider



[See more at TwistedThrottle.com/MyBike](http://www.twistedthrottle.com/MyBike)

GSX1250FA	from	to	Notes	Part Number
ALU-RACK Toprack	'10	'14	Black. For TraX, Givi & other topcases. See page 134.	GPT.05.299.15000.B
QUICK-LOCK EVO Sidecarrier	'10	'14	For TraX, Givi & other sidecases. See page 128.	KFT.05.403.200
QUICK-LOCK Contour Carrier	'10	'14	For Givi V35 Sidecases only. See page 127.	KFT.05.403.150
Blaze Sport Saddlebags	'10	'14	Removable soft luggage. See page 142.	HTA.05.740.10100
QUICK-LOCK Tankring	'10	'14	For QUICK-LOCK Tankbags. See page 144.	Type 125
R&G Front Axle Sliders	'10	'14	See page 43.	RG.FP0065BK
R&G Frame Sliders	'10	'14	Aero-style. See page 42.	RG.CP0267BL
R&G Engine Case Cover Kit	'10	'14	Left, right & idle gear covers. See page 48.	RG.KEC0006.BK
MRA Windscreen	'10	'14	Various shapes. See page 16.	MRA.05.056

Suzuki GSF1250N & GSF1250S Bandit



GSF1250S Bandit

[See more at TwistedThrottle.com/MyBike](http://www.twistedthrottle.com/MyBike)

GSF1250N & GSF1250S Bandit	from	to	Notes	Part Number
ALU-RACK Toprack	'07	'13	Black. For TraX, Givi & other topcases. See page 134.	GPT.05.299.15000.B
QUICK-LOCK EVO Sidecarrier	'10	'13	GSF1250N only. For TraX, Givi & other sidecases.	KFT.05.597.20000.B
QUICK-LOCK Contour Carrier	'10	'13	GSF1250N only. For Givi V35 Sidecases only.	KFT.05.597.15000.B
QUICK-LOCK Tankring	'07	'13	See page 144.	Type 125
Blaze Sport Saddlebags	'07	'09	Removable soft luggage. See page 142.	HTA.05.740.10100
Blaze Sport Saddlebags	'10	'13	GSF1250N only. Removable soft luggage. Pg 142.	HTA.05.740.10300
Crashbars	'07	'13	GSF1250N only. Black. See page 52.	SBL.05.383.100
Mirror Wideners	'07	'13	GSF1250S only. See page 34.	SVL.05.501.10900.B
Mirror Wideners	'07	'13	GSF1250N only. See page 34.	SVL.00.505.101
Handlebar Risers	'07	'13	Various heights & colors. See page 28.	LEH.00.039150
R&G Bar End Sliders	'07	'13	See page 44.	RG.BE0017BK
Kaoko Throttle Lock	'07	'13	Throttle lock cruise control. See page 32.	KAO.SUZ100
MRA Windscreens	'07	'13	GSF1250S only. Various shapes. See page 16.	MRA.05.052
MRA SpeedScreen	'07	'13	GSF1250N only. Mount MRA.HK required. Page 20.	MRA.SPS

ALU-RACK Toprack



QUICK-LOCK EVO Sidecarrier



Crashbars



Chain Guard



Suzuki Hayabusa GSX1300R



Hayabusa GSX1300R

[See more at TwistedThrottle.com/MyBike](http://www.twistedthrottle.com/MyBike)

GSX1300R Hayabusa	from	to	Notes	Part Number
ALU-RACK Toprack	'08	'14	Black. For TraX, Givi & other topcases. See page 134.	GPT.05.576.15000.B
QUICK-LOCK EVO Sidecarrier	'08	'14	For TraX, Givi & other sidecases. See page 128.	KFT.05.575.200
QUICK-LOCK Contour Carrier	'08	'14	For Givi V35 PLX sidecases only. See page 127.	KFT.05.575.150
QUICK-LOCK Tankring	'08	'14	For QUICK-LOCK Tankbags. See page 144.	Type 125
Blaze Sport Saddlebags	'08	'14	Removable soft luggage. See page 142.	HTA.05.740.10500
Handlebar Risers	'08	'14	Various heights. See page 28.	GM.S22
Mirror Wideners	'00	'14	See page 34.	SVL.05.501.101
R&G Rear Fender Eliminator	'08	'14	Tail Tidy. See page 59.	RG.LP0059BK
R&G Engine Case Slider	'08	'14	Left side. See page 48.	RG.ECS0008BK
R&G Frame Sliders	'08	'14	Aero-style. See page 42.	RG.CP0222.BL
Kaoko Throttle Lock	'08	'14	Throttle lock cruise control. See page 32.	KAO.SUZ200-08
MRA Windscreen	'08	'14	Various shapes. See page 16.	MRA.05.055

ALU-RACK Toprack



QUICK-LOCK EVO Sidecarrier mounting points



R&G Frame Slider, Aero-style



Triumph Daytona 675 Triple ('06-'12)



Daytona 675 Triple	from	to	Notes	Part Number
Blaze Sport Saddlebags	'06	'12	Removable soft luggage. See page 142.	HTA.11.740.10400
QUICK-LOCK Tankring	'06	'12	For QUICK-LOCK Tankbags. See page 144.	Type 160
Mirror Wideners	'06	'11	See page 34.	SVL.11.501.10000.B
R&G Adjustable Rearsets	'06	'12	Road or Race configurable. See page 27.	RG.RSET12BK
R&G Frame Sliders	'06	'12	Aero-style. See page 42.	RG.CP0309BL
R&G Front Axle Sliders	'06	'12	See page 43.	RG.FP0047BK
R&G Swingarm Sliders	'06	'12	See page 43.	RG.SS0013BK
R&G Engine Case Cover Kit	'12	'12	Left & right covers. See page 48.	RG.KEC0009.BK
R&G Engine Case Cover Kit	'06	'11	Left & right covers. See page 48.	RG.KEC0011.BK
R&G Rear Fender Eliminator	'06	'12	OEM exhaust only. Tail Tidy. See page 59.	RG.LP0023
R&G Bar End Sliders	'06	'12	See page 44.	RG.BE0026BK
R&G Tank Sliders	'06	'12	Carbon Kevlar. See page 44.	RG.TS0002C
R&G Radiator Guard	'06	'12	Black. See page 50.	RG.RAD0119BK



Triumph Daytona 675 ('13-'14)



See more at TwistedThrottle.com/MyBike

Daytona 675	from	to	Notes	Part Number
QUICK-LOCK Tankring	'13	'14	For QUICK-LOCK Tankbags. See page 144.	Type 160
Blaze Sport Saddlebags	'13	'14	Removable soft luggage. See page 142.	In Development
SW-MOTECH Frame Sliders	'13	'14	See page 49.	In Development
Main Force Patrol Badge	'13	'14	Bronze.	In Development
R&G Frame Sliders	'13	'14	Aero-style. See page 42.	In Development
R&G Radiator Guard	'13	'14	See page 50.	In Development
R&G Engine Case Sliders	'13	'14	Carbon Kevlar. See page 48.	In Development
R&G Front Axle Sliders	'13	'14	See page 43.	In Development
R&G Swingarm Spools	'13	'14	See page 43.	In Development
R&G Rear Fender Eliminator	'13	'14	See page 59.	In Development
R&G Bar End Sliders	'13	'14	See page 44.	In Development

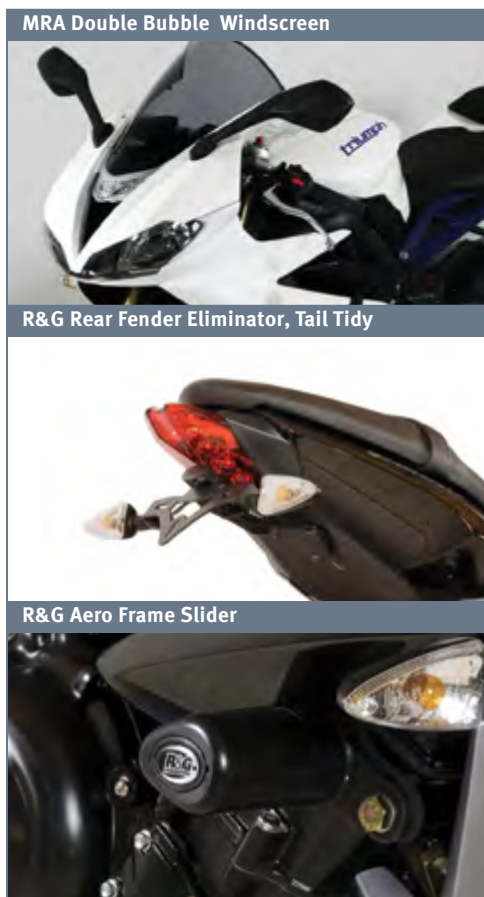

Triumph Street Triple & Street Triple R ('06-'12)

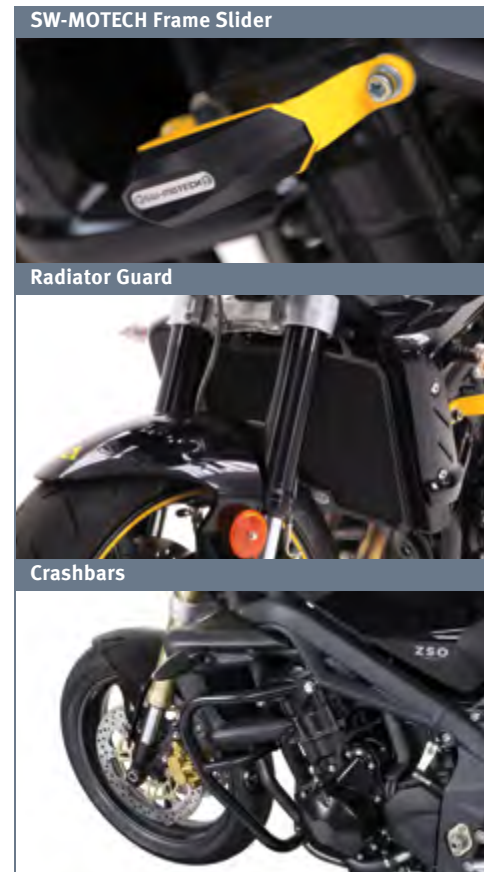

Street Triple/Street Triple R	from	to	Notes	Part Number
ALU-RACK Toprack	'13	'14	Black. For TraX, Givi & other topcases. See page 134.	GPT.11.283.15000.B
QUICK-LOCK Tankring	'13	'14	For QUICK-LOCK Tankbags. See page 144.	Type 160
Blaze Sport Saddlebags	'13	'14	Removable soft luggage. See page 142.	HTA.11.740.10600
SW-MOTECH Frame Sliders	'13	'14	See page 49.	STP.11.590.10400.B
R&G Frame Sliders	'13	'14	Aero-style. See page 42.	RG.CP0330.BL
R&G Front Axle Sliders	'13	'14	See page 43.	RG.FP0132.BK
R&G Swingarm Spools	'13	'14	See page 43.	RG.CR0032BK
R&G Engine Case Slider	'13	'14	Right side. See page 48.	RG.ECS0064BK
R&G Engine Case Slider	'13	'14	Left side. Carbon Kevlar. See page 48.	RG.ECS0063C
R&G Engine Case Cover Kit	'13	'14	Left & right covers. See page 48.	RG.KEC0009.BK
R&G Rear Fender Eliminator	'13	'14	Tail Tidy. See page 59.	RG.LP0133.BK

See more at TwistedThrottle.com/MyBike

TWISTED STREET TRIPLE



The Twisted Throttle 2012 Triumph Street Triple R is one of the most fun machines we have in our stable, feeling right at home on the street or racetrack.



Mr. Twisted rides the Triple at a track day.

Street Triple/Street Triple R	from	to	Notes	Part Number
ALU-RACK Toprack	'07	'12	Black. For TraX, Givi & other topcases. See page 134.	GPT.11.574.15000.B
QUICK-LOCK Tankring	'07	'12	For QUICK-LOCK Tankbags. See page 144.	Type 160
Blaze Sport Saddlebags	'07	'12	Removable soft luggage. See page 142.	HTA.11.740.10200
Crashbars	'07	'12	Black. See page 52.	SBL.11.431.10000.B
SW-MOTECH Frame Sliders	'07	'12	See page 49.	STP.11.590.10100.B
R&G Frame Sliders	'07	'12	Aero-style. See page 42.	RG.CP0217.BL
R&G Radiator Guard	'07	'12	Various colors. See page 50.	RG.RAD0070
R&G Front Axle Sliders	'07	'12	See page 43.	RG.FP0047BK
R&G Swingarm Spools	'06	'12	See page 43.	RG.CR0001BK
R&G Rear Fender Eliminator	'07	'12	Tail Tidy. See page 59.	RG.LP0056BK
R&G Bar End Sliders	'07	'12	See page 44.	RG.BE0010BK
R&G Engine Case Cover Kit	'07	'11	Left & right covers. See page 48.	RG.KEC0011.BK

Triumph Street Triple & Street Triple R ('13-'14)



See more at TwistedThrottle.com/MyBike



Street Triple/Street Triple R	from	to	Notes	Part Number
ALU-RACK Toprack	'13	'14	Black. For TraX, Givi & other topcases. See page 134.	GPT.11.283.15000.B
QUICK-LOCK Tankring	'13	'14	For QUICK-LOCK Tankbags. See page 144.	Type 160
Blaze Sport Saddlebags	'13	'14	Removable soft luggage. See page 142.	HTA.11.740.10600
SW-MOTECH Frame Sliders	'13	'14	See page 49.	STP.11.590.10400.B
R&G Frame Sliders	'13	'14	Aero-style. See page 42.	RG.CP0330.BL
R&G Front Axle Sliders	'13	'14	See page 43.	RG.FP0132.BK
R&G Swingarm Spools	'13	'14	See page 43.	RG.CR0032BK
R&G Engine Case Slider	'13	'14	Right side. See page 48.	RG.ECS0064BK
R&G Engine Case Slider	'13	'14	Left side. Carbon Kevlar. See page 48.	RG.ECS0063C
R&G Engine Case Cover Kit	'13	'14	Left & right covers. See page 48.	RG.KEC0009.BK
R&G Rear Fender Eliminator	'13	'14	Tail Tidy. See page 59.	RG.LP0133.BK

Triumph America, Bonneville, Thruxton & Scrambler



Bonneville T100

Bonneville America

Thruxton 900

Scrambler

See more at TwistedThrottle.com/MyBike

Bonneville & Bonneville T100	from	to	Notes	Part Number
Blaze Sport Saddlebags	'04	'14	Removable soft luggage. See page 142.	HTA.11.740.10500
Crashbars	'04	'14	Black. See page 52.	SBL.11.249.10000.B
Mirror Wideners	'04	'14	See page 34.	SVL.00.505.101
Handlebar Risers	'01	'14	Raises up 1-1/4" (32mm) and back 3/4" (19mm).	GM.T114
R&G Frame Sliders	'08	'14	Classic-style. See page 42.	RG.CP0259BL
R&G Front Axle Sliders	'04	'14	See page 43.	RG.FP0091BK
R&G Bash Plate	'06	'14	3mm aluminum. Black.	RG.BP0001.BK
R&G Rear Fender Eliminator	'06	'14	Mini indicators required. Tail Tidy. Page 59.	RG.LP0123BK
Kaoko Throttle Lock	'01	'14	Except SE (mag wheels). Cruise Control. Page 32.	KAO.BONI
Kaoko Throttle Lock	'10	'14	SE only (mag wheels). Cruise Control. Page 32.	KAO.SCRAM
MRA Roadshield	'01	'14	MRA.HK mount kit required. See page 21.	MRA.RO
Bonneville America	from	to	Notes	Part Number
Kaoko Throttle Lock	'02	'14	Throttle lock cruise control. See page 32.	KAO.BONI
MRA RoadShield	'02	'14	MRA.HK mount kit required. See page 21.	MRA.RO
MRA HighwayShield	'02	'14	MRA.HK mount kit required. See page 21.	MRA.HI
Thruxton 900	from	to	Notes	Part Number
Blaze Sport Saddlebags	'04	'14	Removable soft luggage. See page 142.	HTA.11.740.10500
Crashbars	'04	'14	Black. See page 52.	SBL.11.249.10000.B
Mirror Wideners	'04	'07	See page 34.	SVL.00.505.101
R&G Frame Sliders	'04	'14	Classic-style. See page 42.	RG.CP0259BL
R&G Bash Plate	'08	'14	3mm aluminum. Black.	RG.BP0001.BK
R&G Rear Fender Eliminator	'06	'14	Micro indicators required (page 119). Tail Tidy. Pg 59.	RG.LP0123BK
Kaoko Throttle Lock	'04	'14	Throttle lock cruise control. See page 32.	KAO.THRUX
Scrambler	from	to	Notes	Part Number
Handlebar Risers	'06	'11	Raise height by 20mm, 25mm, 30mm or 50mm.	LEH.00.039150
R&G Frame Sliders	'06	'14	Classic-style. See page 42.	RG.CP0259BL
R&G Front Axle Sliders	'06	'14	See page 43.	RG.FP0091BK
R&G Bash Plate	'06	'14	3mm aluminum. Black.	RG.BP0001.BK
R&G Rear Fender Eliminator	'08	'14	Mini indicators required (page 119). Tail Tidy. Pg 59.	RG.LP0123BK
Kaoko Throttle Lock	'06	'14	Throttle lock cruise control. See page 32.	KAO.SCRAM
MRA RoadShield	'06	'14	MRA.HK mount kit required. See page 21.	MRA.RO



Triumph Tiger 800 & 800XC

TWISTED TIGER 800 XC

We outfitted this Tiger 800XC with R&G and SW-MOTECH crash protection, comfort upgrades, and luggage. This bike is ready for any road or trail.



See more at TwistedThrottle.com/MyBike



Tiger 800 and 800XC,	from	to	Notes	Part Number
Steel Toprack	'11	'14	Black. For TraX, Givi & other topcases. See page 122.	GPT.11.747.20001.B
QUICK-LOCK EVO Sidecarrier	'11	'14	For TraX, Givi & other sidecases. See page 128.	KFT.11.748.20000.B
DAKAR Waterproof Soft Saddlebags	'11	'14	Rugged, removable luggage. See page 138.	HTA.08.741.10000.B
QUICK-LOCK Tankring	'11	'14	For QUICK-LOCK Tankbags. See page 144.	Type 160
Crashbars	'11	'14	See page 52.	SBL.11.749.10000.B
Skid Plate	'11	'14	See page 54.	MSS.11.752.10000.B
Headlight Guard	'11	'14	Black.	LPS.11.124.10000.B
Brake Reservoir Guard	'11	'14	4mm aluminum. Silver. See page 55.	SCT.11.174.10000.S
Heel Guard Right Side	'11	'14	4mm aluminum. Silver. Right side.	SCT.11.174.10100
Heel Guard Left Side	'11	'14	4mm aluminum. Silver. Left-side.	SCT.11.174.10200
Auxiliary Light Mount	'11	'14	For Denali, Hawk & other lighting. See page 112.	NSW.11.004.10100.B
On/Off-Road Footpegs	'11	'14	Convertible. Stainless steel. Silver. See page 23.	FRS.11.011.10100.S
Centerstand	'11	'14	Canadian & Euro 800XC only. See page 56.	HPS.11.751.10000.B
Centerstand	'11	'14	Canadian & Euro 800 only. See page 56.	HPS.11.753.10000.B
Handlebar Risers	'11	'14	20mm height. See page 28.	LEH.11.039.10000.S
Adjustable Gear Shift Lever	'11	'14	See page 23.	FSC.11.127.10000.B
Barkbusters Handguards	'11	'14	Various shapes & colors. See page 38.	BB.BHG47
Kaoko Throttle Lock	'11	'14	Throttle lock cruise control. See page 32.	KAO.TIGXC
MRA Windscreen	'11	'14	Various shapes. See page 16.	MRA.11.017

Triumph Speed Triple 955 & 1050

Speed Triple 1050



[See more at TwistedThrottle.com/MyBike](http://www.twistedthrottle.com/MyBike)

Speed Triple 955 & 1050	from	to	Notes	Part Number
ALU-RACK Toprack	'11	'14	Black. For TraX, Givi & other topcases. See page 134.	GPT.11.183.15000.B
QUICK-LOCK Tankring	'01	'14	See page 144.	Type 160
Blaze Sport Saddlebags	'11	'14	For QUICK-LOCK Tankbags. See page 142.	HTA.11.740.10100
QUICK-LOCK GPS Mount	'11	'14	Vibration-damped. Black. See page 100.	GPS.11.646.10301.B
SW-MOTECH Frame Slider	'11	'14	See page 49.	STP.11.590.10300.B
Handlebar Risers	'11	'14	30mm height. Silver or black. See page 28.	LEH.00.039.20300
Mirror Wideners	'11	'14	See page 34.	SVL.00.505.101
Centerstand	'01	'14	See page 56.	HPS.11.292.10000.B
R&G Frame Sliders	'11	'14	Aero-style. See page 42.	RG.CP0273BL
Engine Case Cover Kit	'08	'14	Left & right covers. See page 48.	RG.KEC0025.BK
R&G Bar End Sliders	'11	'14	See page 44.	RG.BE0031BK
R&G Rear Fender Eliminator	'11	'14	Tail Tidy. See page 59.	RG.LP0099BK
R&G Front Axle Sliders	'11	'14	See page 43.	RG.FP0098BK



Triumph Tiger 1050 ('07-'11)



Tiger 1050	from	to	Notes	Part Number
ALU-RACK Toprack	'07	'11	Without original sideracks only. For TraX, Givi & other.	GPT.11.619.15000.B
ALU-RACK Toprack	'07	'11	With original sideracks only. For TraX, Givi & other.	GPT.11.527.15000.B
QUICK-LOCK EVO Sidecarrier	'07	'11	For TraX, Givi & other Sidecases. See page 128.	KFT.11.605.200
QUICK-LOCK Tankring	'07	'11	For QUICK-LOCK Tankbags. See page 144.	Type 160
Crashbars	'07	'11	Black. See page 52.	SBL.11.610.100
Skid Plate	'07	'11	Aluminum. Silver or black. See page 54.	MSS.11.520.100
Centerstand	'07	'11	See page 56.	HPS.11.611.100
QUICK-LOCK GPS Mount	'07	'11	Vibration-damped. See page 100.	GPS.00.646.10500.B
R&G Frame Sliders	'07	'11	Aero-style. See page 42.	RG.CP0248BL
MRA Windscreen	'07	'11	Various shapes. See page 16.	MRA.11.016
Kaoko Throttle Lock	'07	'11	Throttle lock cruise control. See page 32.	KAO.TIG1050
Barkbusters Handguards	'07	'11	Various shapes & colors. See page 38.	BB.S1 or BB.S7



Triumph Sprint ST 1050 & Sprint GT 1050

Sprint ST 1050



[See more at TwistedThrottle.com/MyBike](http://www.twistedthrottle.com/MyBike)

Sprint ST & Sprint GT 1050	from	to	Notes	Part Number
ALU-RACK Toprack	'10	'13	Black. GT only. For Givi & other topcases. See page 134.	GPT.11.744.10000.B
ALU-RACK Toprack	'05	'11	Black. ST only. For Givi & other topcases. See page 134.	GPT.11.527.15000.B
QUICK-LOCK Sidecarrier	'05	'11	ST only. For Givi & other Sidecases.	KFT.11.528.100
QUICK-LOCK Tankring	'05	'13	For QUICK-LOCK Tankbags. See page 144.	Type 160
SW-MOTECH Frame Sliders	'10	'13	GT only. See page 49.	STP.11.590.10200.B
Mirror Wideners	'10	'13	GT only. See page 34.	SVL.11.501.10100.B
Handlebar Risers	'05	'13	See page 28.	GM.T118
R&G Frame Sliders	'05	'13	Aero-style. See page 42.	RG.CP0269BL
R&G Front Axle Sliders	'05	'13	See page 43.	RG.FP0026BK
R&G Rear Fender Eliminator	'05	'11	ST only. Tail Tidy. See page 59.	RG.LP0013BK
R&G Radiator Guard	'05	'13	See page 50.	RG.RAD0095BK
MRA Windscreen	'05	'11	ST only. Various shapes. See page 16.	MRA.11.015

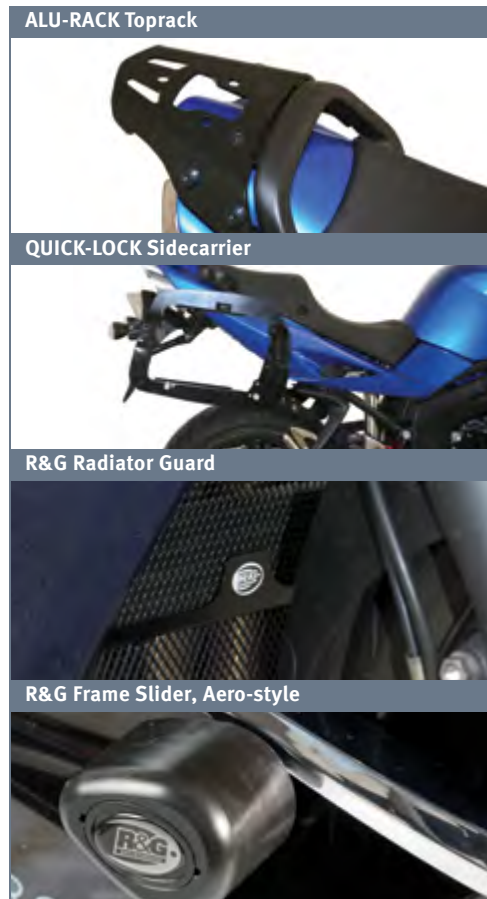

Triumph Trophy 1200 SE ('13-'14)



[See more at TwistedThrottle.com/MyBike](http://www.twistedthrottle.com/MyBike)

Trophy 1200 SE	from	to	Notes	Part Number
Steel Toprack	'13	'14	For TraX, Givi & other topcases. See page 122.	In Development
R&G Crashbars	'13	'14	Black.	RG.AB0009BK
R&G Radiator Guard	'13	'14	Aluminum. Black. See page 50.	RG.RAD0134BK
R&G Swingarm Spools	'13	'14	See page 43.	RG.SP0033BK
R&G Front Axle Sliders	'13	'14	See page 43.	RG.FP0120BK
R&G Bar End Sliders	'13	'14	See page 44.	RG.BE0065BK

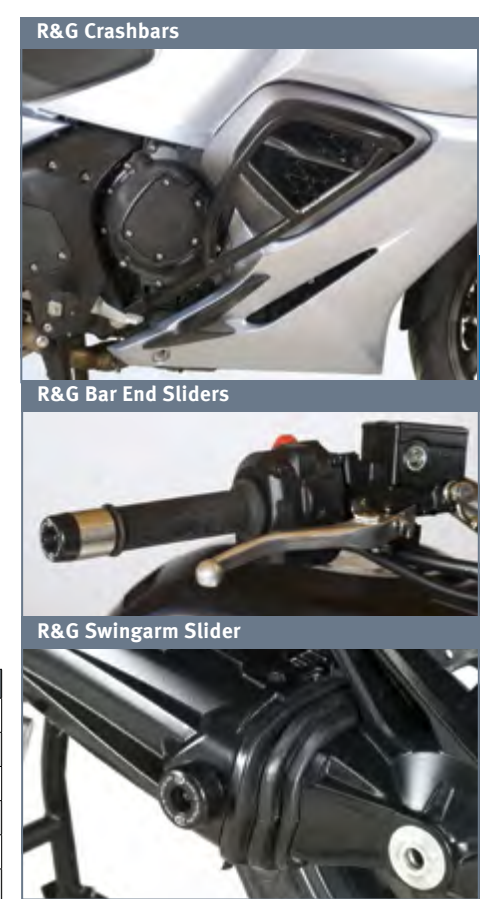

Triumph Tiger Explorer 1200 & 1200 XC

TWISTED EXPLORER 1200



The 2013 Triumph Explorer is a bike that grabs attention with its intimidating stance and aggressive styling. We made it even more capable of handling the roughest terrain by outfitting it with products that provide greater protection, as well as goodies that increase comfort and expand its carrying capacity. This Explorer can now live up to its name with confidence.

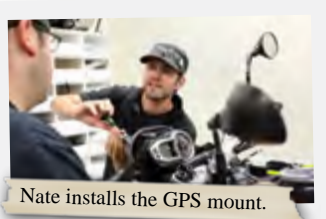

Nate installs the GPS mount.



Shawn wiring the Denali DX LED Lights

See more at TwistedThrottle.com/MyBike

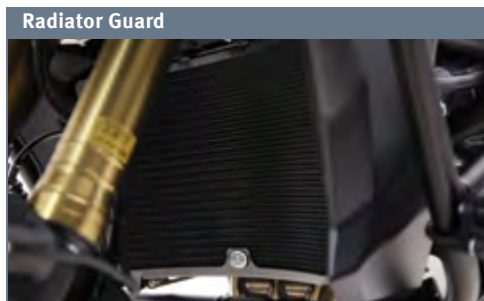
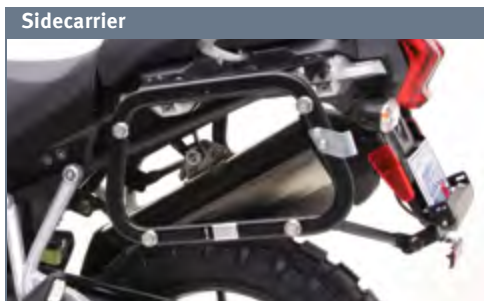
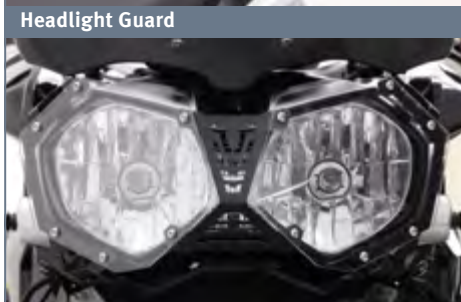

Tiger Explorer 1200	from	to	Notes	Part Number
Steel Toprack	'12	'14	For TraX, Givi & other topcases. See page 122.	GPT.11.482.20001.B
QUICK-LOCK EVO Sidecarrier	'12	'14	For TraX, Givi & other sidecases. See page 128.	KFT.11.483.20000.B
DAKAR Waterproof Soft Saddlebags	'12	'14	Rugged, removable luggage. See page 138.	HTA.11.741.10100.B
QUICK-LOCK Tankring	'12	'14	For QUICK-LOCK Tankbags. See page 144.	Type 160
Crashbars	'12	'14	Black. See page 52.	SBL.11.485.10000.B
Headlight Guard	'12	'14		LPS.11.124.10000.B
Skid Plate	'12	'14	Silver. See page 54.	MSS.11.484.10000.S
Mirror Wideners	'12	'14	See page 34.	SVL.00.505.10500.B
Handlebar Risers	'12	'14	20mm height. Silver. See page 28.	LEH.11.039.10000.S
On/Off-road Footpegs	'12	'14	Convertible. Stainless steel. Silver. See page 23.	FRS.11.011.10100.S
QUICK-LOCK GPS Mount	'12	'14	Vibration-damped. See page 100.	GPS.11.646.10200.B
Auxiliary Headlight Mount	'12	'14	For Denali, Hawk & other lighting. See page 112.	NSW.11.004.10200.B
R&G Front Axle Sliders	'12	'14	See page 43.	RG.FP0110BK
R&G Radiator Guard	'12	'14	See page 50.	RG.RAD0118BK
MRA Windshield	'12	'14	Various shapes. See page 16.	MRA.11.019
Kaoko Throttle Lock	'12	'14	Throttle lock cruise control. See page 32.	KAO.TIG100

Yamaha WR250R & WR250X



WR250X & WR250R	from	to	Notes	Part Number
Handlebar Risers	'08	'14	31mm Height. Silver or black. See page 28.	LEH.00.039.152
R&G Rear Fender Eliminator	'08	'14	WR250X only. Tail Tidy. See page 59.	RG.LP0082BK
R&G Swingarm Spools	'09	'14	WR250X only. See page 43.	RG.SP0027BK
R&G Front Axle Sliders	'09	'14	WR250X only. See page 43.	RG.FP0090BK
MRA RoadScreen	'08	'14	Mount kit MRA.HK.L required. See page 21.	MRA.RO
Barkbusters Handguards	'08	'14	Various colors. See page 38.	BB.BHG15-1
Barkbusters EGO Handguards	'08	'14	Various colors. See page 38.	BB.ES1



Yamaha Majesty 400



Majesty 400	from	to	Notes	Part Number
Toprack	'04	'14	For Givi Monokey or Monolock topcase only.	GIVI E331
Mirror Wideners	'04	'14	Universal mirror widener. See page 34.	SVL.00.504.101
Givi Backrest	'04	'14	With Givi topcase only. Passenger backrest.	GIVI TB47
Givi Backrest	'04	'14	Passenger backrest.	GIVI TB48
Givi Windscreen	'04	'14		GIVI D137ST
MRA VarioTouringScreen	'04	'14	See page 18.	MRA.06.054.VT.1



Yamaha T-Max 500



T-Max 500	from	to	Notes	Part Number
Givi Toprack	'08	'11	For Givi Monokey or Monolock Topcase	Givi SR364
Givi Backrest	'08	'11	Passenger Backrest.	GIVI TB2013
Givi Windscreen	'08	'11	Various shapes.	Givi D442
R&G Rear Fender Eliminator	'12	'14	Tail Tidy. See page 59.	RG.LP0127.BK
R&G Footboard Sliders	'12	'14	See page 43.	RG.TP0012.BK
Kaoko Throttle Lock	'08	'14	Throttle lock cruise control. See page 32.	KAO.YAMTMAX
MRA Windscreen	'08	'11	Various shapes. See page 16.	MRA.06.063



Yamaha FZ6 Fazer & FZ6 Fazer S2



FZ6 S2



[See more at TwistedThrottle.com/MyBike](http://www.twistedthrottle.com/MyBike)

FZ6	from	to	Notes	Part Number
ALU-RACK Toprack	'07	'10	Black. For TraX, Givi & other topcases. See page 134.	GPT.06.313.100.B
QUICK-LOCK EVO Sidecarrier	'04	'06	For TraX, Givi & other sidecases. See page 128.	KFT.06.314.20000.B
QUICK-LOCK EVO Sidecarrier	'07	'10	FZ6 only. For TraX, Givi & other sidecases. Page 128.	KFT.06.348.20000.B
QUICK-LOCK Contour Carrier	'07	'10	For Givi V35 PLX sidecases only. See page 127.	KFT.06.348.150
QUICK-LOCK Tankring	'04	'10	For QUICK-LOCK Tankbags. See page 144.	Type 110
Crashbars	'04	'10	Black. See page 52.	SBL.06.316.100.B
SW-MOTECH Frame Sliders	'04	'10	See page 49.	STP.06.590.10000.B
Centerstand	'04	'10	See page 56.	HPS.06.315.100
Handlebar Risers	'04	'10	Various heights & colors.	LEH.00.039150
Mirror Wideners	'04	'10	See page 34.	SVL.00.504.101
R&G Frame Sliders	'04	'10	Classic-style. See page 42.	RG.CP0110BL
R&G Frame Sliders	'04	'10	No lower fairing only. Aero-style. See page 42.	RG.CP0288.BL
R&G Front Axle Sliders	'04	'10	See page 43.	RG.FP0054BK
R&G Rear Fender Eliminator	'04	'10	Tail Tidy. See page 59.	RG.LP0038BK
R&G Bar End Sliders	'04	'10	See page 44.	RG.BE0013BK

Yamaha YZF-R6 & R6S



YZF-R6



[See more at TwistedThrottle.com/MyBike](http://www.twistedthrottle.com/MyBike)

R6 & R6S	from	to	Notes	Part Number
QUICK-LOCK Tankring	'03	'14	For QUICK-LOCK Tankbags. See page 144.	Type 110
SW-MOTECH Frame Sliders	'08	'14	See page 49.	STP.06.590.10200.B
Blaze Sport Saddlebags	'08	'14	Removable soft luggage. See page 142.	HTA.06.740.10400
Mirror Wideners	'08	'14	See page 34.	SVL.06.501.10600.B
R&G Frame Sliders	'06	'14	Lower. Aero-style. See page 42.	RG.CP0202.BL
R&G Engine Case Cover Kit	'08	'14	Left, right & oil pump covers. See page 48.	RG.KEC0019.BK
R&G Engine Case Slider	'06	'14	Left side. See page 48.	RG.ECS0001BK
R&G Engine Case Slider	'08	'14	Right side. See page 48.	RG.ECS0028BK
R&G Bar End Sliders	'06	'14	See page 44.	RG.BE0009BK
R&G Swingarm Spools	'00	'14	See page 43.	RG.CR0002.BK
R&G Front Axle Slider	'05	'14	See page 43.	RG.FP0030BK
MRA Windscreen	'08	'14	Various shapes. See page 16.	MRA.06.057

Yamaha FZ6R



[See more at TwistedThrottle.com/MyBike](http://www.twistedthrottle.com/MyBike)

FZ6R	from	to	Notes	Part Number
ALU-RACK Toprack	'10	'14	Black. For TraX, Givi & other topcases. See page 134.	GPT.06.479.15000.B
QUICK-LOCK EVO Sidecarrier	'10	'12	For TraX, Givi & other sidecases. See page 128.	KFT.06.478.20000.B
QUICK-LOCK Tankring	'10	'14	For QUICK-LOCK Tankbags. See page 144.	Type 110
Centerstand	'10	'14	See page 56.	HPS.06.656.10000.B
SW-MOTECH Frame Sliders	'12	'14	See page 49.	STP.06.590.10100.B
R&G Rear Fender Eliminator	'10	'14	Tail Tidy. See page 59.	RG.LP0079BK
R&G Frame Sliders	'10	'14	Aero-style. See page 42.	RG.CP0271BL
R&G Radiator Guard	'10	'13	See Page 50.	RG.RAD0096BK
R&G Sidestand Foot Enlarger	'10	'14	See page 57.	RG.PKS0037.SI
MRA Windscreen	'10	'14	Various shapes. See page 16.	MRA.06.064

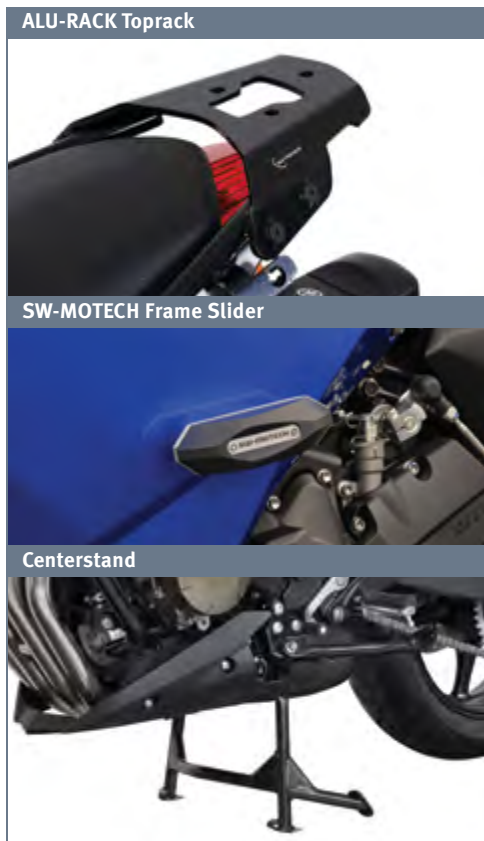

Yamaha FZ8



[See more at TwistedThrottle.com/MyBike](http://www.twistedthrottle.com/MyBike)

FZ8	from	to	Notes	Part Number
ALU-RACK Toprack	'10	'14	Black. For TraX, Givi & other topcases. See page 134.	GPT.06.171.15000.B
QUICK-LOCK Evo Sidecarrier	'10	'14	For TraX, Givi & other sidecases. See page 128.	KFT.06.727.20000.B
QUICK-LOCK Contour Carrier	'10	'14	For Givi V35 PLX sidecases only. See page 127.	KFT.06.727.15000.B
QUICK-LOCK Tankring	'10	'14	For QUICK-LOCK Tankbags. See page 144.	Type 110
QUICK-LOCK GPS Mount	'10	'14	Vibration-damped. Black. See page 100.	GPS.00.646.10000.B
Blaze Sport Saddlebags	'10	'14	Removable soft luggage. See page 142.	HTA.06.740.10300
Centerstand	'10	'14	Black. See page 56.	HPS.06.173.10000.B
Handlebar Risers	'10	'14	Various heights & colors. See page 28.	LEH.00.039150
Mirror Wideners	'10	'14	See page 34.	SVL.00.504.101
SW-MOTECH Frame Sliders	'10	'14	See page 49.	STP.06.590.11000.B
R&G Rear Fender Eliminator	'10	'14	Tail Tidy. See page 59.	RG.LP0024BK
MRA Windscreen	'10	'14	Various shapes. See page 16.	MRA.06.062

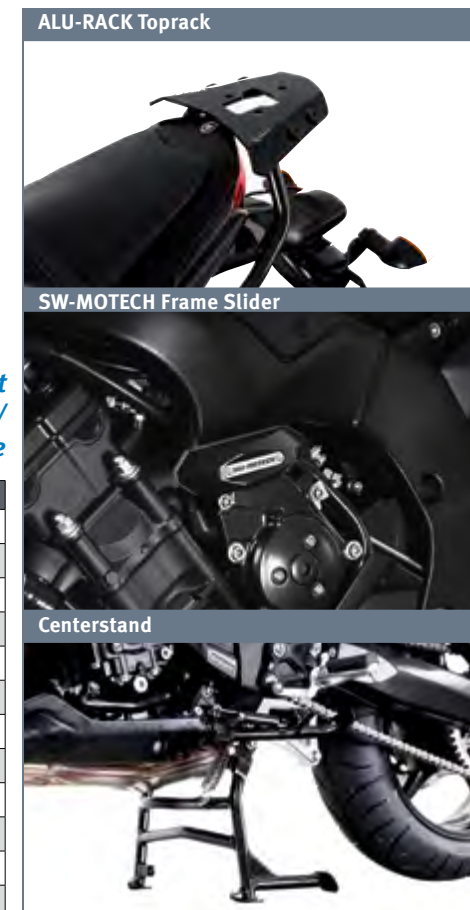

Yamaha FZ-09



[See more at TwistedThrottle.com/MyBike](http://www.twistedthrottle.com/MyBike)

FZ-09	from	to	Notes	Part Number
ALU-RACK Toprack	'13	'14	Black. For TraX, Givi & other topcases. See page 134.	GPT.06.453.15000.B
QUICK-LOCK EVO Sidecarrier	'13	'14	For TraX, Givi & other sidecases. See page 128.	In Development
Blaze Sport Saddlebags	'13	'14	Removable soft luggage. See page 142.	In Development
SW-MOTECH Frame Sliders	'13	'14	See page 49.	STP.06.590.10900.B
SW-MOTECH Front Axle Sliders	'13	'14	See page 43.	STP.08.176.10400.B
SW-MOTECH Swingarm Spools	'13	'14	See page 43.	STP.06.176.10200.B
Mirror Wideners	'13	'14	See page 34.	SVL.00.504.101
R&G Frame Sliders	'13	'14	Aero-style. Middle to front bridge. See page 42.	RG.CP0357.BL
R&G Frame Sliders	'13	'14	Aero-style. Front. See page 42.	RG.CP0354.BL
R&G Frame Sliders	'13	'14	Aero-style. Middle. See page 42.	RG.CP0355.BL
R&G Swingarm Spools	'13	'14	See page 43.	RG.CR0002.BK
R&G Rear Axle Block Sliders	'13	'14	Includes chain adjuster blocks. See page 43.	RG.CR0048.BK
R&G Front Axle Sliders	'13	'14	See page 43.	RG.FP0149.BK
R&G Bar End Sliders	'13	'14	See page 44.	RG.BE0013BK
R&G Radiator Guard	'13	'14	See page 50.	RG.RAD0159.BK
R&G Chain Guard	'13	'14	Stainless steel. Silver. See page 45.	RG.CG0004SI
R&G Engine Case Cover Kit	'13	'14	Left, right & starter covers. See page 48.	RG.KEC0059.BK
R&G Rear Fender Eliminator	'13	'14	Tail Tidy. See page 59.	RG.LP0153BK
R&G Passenger Peg Plate Kit	'13	'14	Blanking plates to remove passenger pegs.	RG.BLP0031.BK
R&G Sidestand Foot Enlarger	'13	'14	See page 57.	RG.PKS0037.SI
Fenda Extenda	'13	'14	Front fender extension. See page 58.	PP.052311
MRA Windshields	'13	'14	Various shapes. See page 16.	MRA.06.065

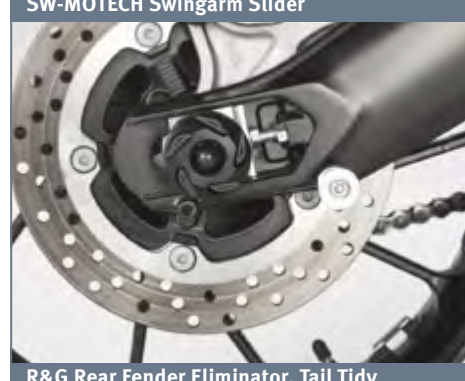
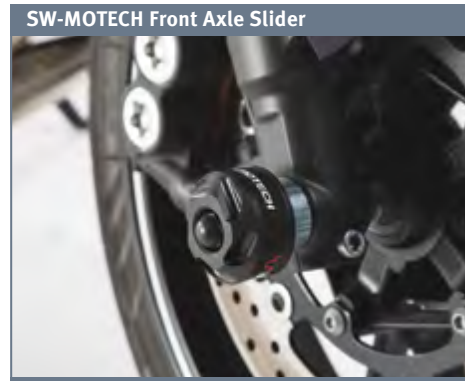

Yamaha FZ1 ('06-'14)



[See more at TwistedThrottle.com/MyBike](http://www.twistedthrottle.com/MyBike)

FZ1 & FZ1 Fazer	from	to	Notes	Part Number
ALU-RACK Toprack	'06	'14	Black. For TraX, Givi & other topcases. See page 134.	GPT.06.541.15000.B
QUICK-LOCK EVO Sidecarrier	'06	'14	For TraX, Givi & other sidecases. See page 128.	KFT.06.533.20000.B
QUICK-LOCK Contour Carriers	'06	'14	For Givi V35 PLX sidecases only. See page 127.	KFT.06.533.150
QUICK-LOCK Tankring	'06	'14	For QUICK-LOCK Tankbags. See page 144.	Type 110
Blaze Sport Saddlebags	'06	'14	Removable soft luggage. See page 142.	HTA.06.740.10300
Crashbars	'06	'14	Black. See page 52.	SBL.06.542.100
SW-MOTECH Frame Sliders	'06	'14	See page 49.	STP.06.590.10000.B
Centerstand	'06	'14	See page 56.	HPS.06.499.100
Handlebar Risers	'06	'09	Various heights. Silver or black. See page 28.	LEH.00.039150
Mirror Wideners	'06	'14	See page 34.	SVL.00.504.101
KOBRA Handguards	'06	'14	For integrated LED indicators. Page 37.	HPR.00.220.25100/B
R&G Frame Sliders	'06	'14	Aero-style. See page 42.	RG.CP0268BL
R&G Front Axle Sliders	'06	'14	See page 43.	RG.FP0054BK
R&G Swingarm Spools	'06	'14	See page 43.	RG.CR0002.BK
R&G Radiator Guard	'06	'14	Aluminum. Black. See page 50.	RG.RAD0094BK
R&G Engine Case Cover Kit	'06	'14	Left, right & oil pump covers. See page 48.	RG.KEC0064.BK
R&G Engine Case Slider	'06	'14	Right side. See page 48.	RG.ECS0038BK
R&G Engine Case Slider	'06	'14	Left side. See page 48.	RG.ECS0037BK
R&G Exhaust Hanger	'06	'14	See page 46.	RG.EH0038BK
Kaoko Throttle Lock	'06	'14	See page 32.	KAO.YAM300
MRA Windscreens	'06	'14	FZ1 Fazer only. Various shapes. See page 16.	MRA.06.051

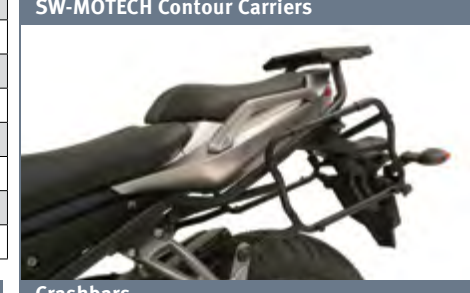
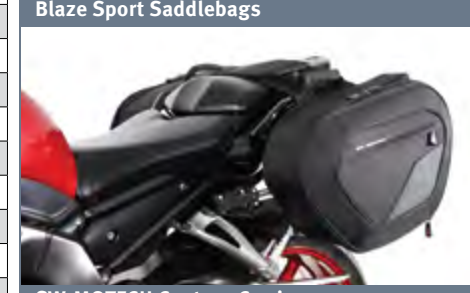
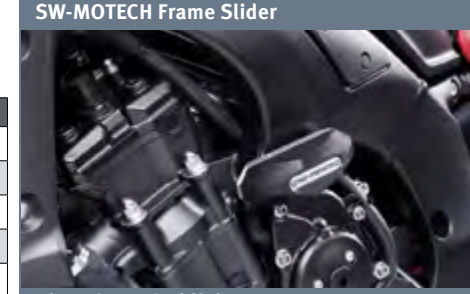

Yamaha YZF-R1

R&G Bar End Slider



R&G Frame Slider, Aero-style



MRA Double Bubble RacingScreen



See more at TwistedThrottle.com/MyBike

YZF-R1	from	to	Notes	Part Number
QUICK-LOCK Tanking	'97	'14	For QUICK-LOCK Tankbags. See page 144.	Type 110
Blaze Sport Saddlebags	'09	'14	Removable soft luggage. See page 142.	HTA.06.740.10000
SW-MOTECH Frame Sliders	'09	'14	See page 49.	STP.06.590.10400.B
Mirror Wideners	'09	'14	See page 34.	SVL.06.501.10500
R&G Frame Sliders	'07	'14	Aero-style. See page 42.	RG.CP0195.BL
R&G Engine Case Cover Kit	'09	'14	Left, right & ignition pickup covers. See page 48.	RG.KEC0018.BK
R&G Bar End Sliders	'99	'14	See page 44.	RG.BE0009BK
R&G Swingarm Spools	'07	'14	See page 43.	RG.CR0002.BK
R&G Rear Fender Eliminator	'07	'14	Tail Tidy. See page 59.	RG.LP0040BK
R&G Adjustable Rearsets	'09	'11	Road or Race configurable. See page 27.	RG.RSET08BK
Kaoko Throttle Lock	'04	'14	Throttle lock cruise control. See page 32.	KAO.YAM500
MRA Windscreen	'09	'14	Various shapes. See page 16.	MRA.06.058

Yamaha FJR1300



See more at TwistedThrottle.com/MyBike

FJR1300	from	to	Notes	Part Number
Steel Toprack	'06	'14	Silver. For TraX, Givi & other topcases. See page 122.	GPT.06.498.20001.B
QUICK-LOCK Tanking	'00	'14	For QUICK-LOCK Tankbags. See page 144.	Type 110
QUICK-LOCK GPS Mount	'04	'14	Vibration-damped. Black. See page 100.	GPS.06.646.10200.B
Mirror Wideners	'06	'14	See page 34.	SVL.06.501.11000.B
Handlebar Risers	'06	'14	See page 28.	GM.Y203
Auxiliary Light Mount	'06	'14	For Denali, Hawk & other lighting. See page 112.	LAH.06.816.10001
SW-MOTECH Frame Sliders	'06	'14	See page 49.	STP.06.590.10301.B
R&G Frame Sliders	'13	'14	Aero-style. See page 42.	RG.CP0346BL
R&G Bar End Sliders	'06	'14	See page 44.	RG.BE0009BK
Kaoko Throttle Lock	'06	'14	Throttle lock cruise control. See page 32.	KAO.YAM500
MRA Windscreen	'06	'12	Various shapes. See page 16.	MRA.06.060

Steel Toprack



Auxiliary Light Mount



MRA Windscreen

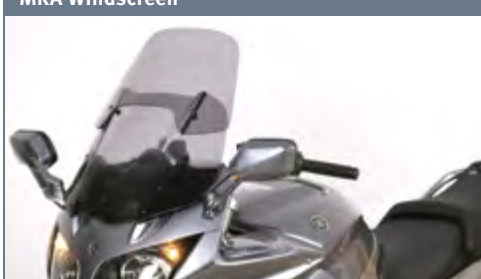

Yamaha XT1200Z Super Tenere

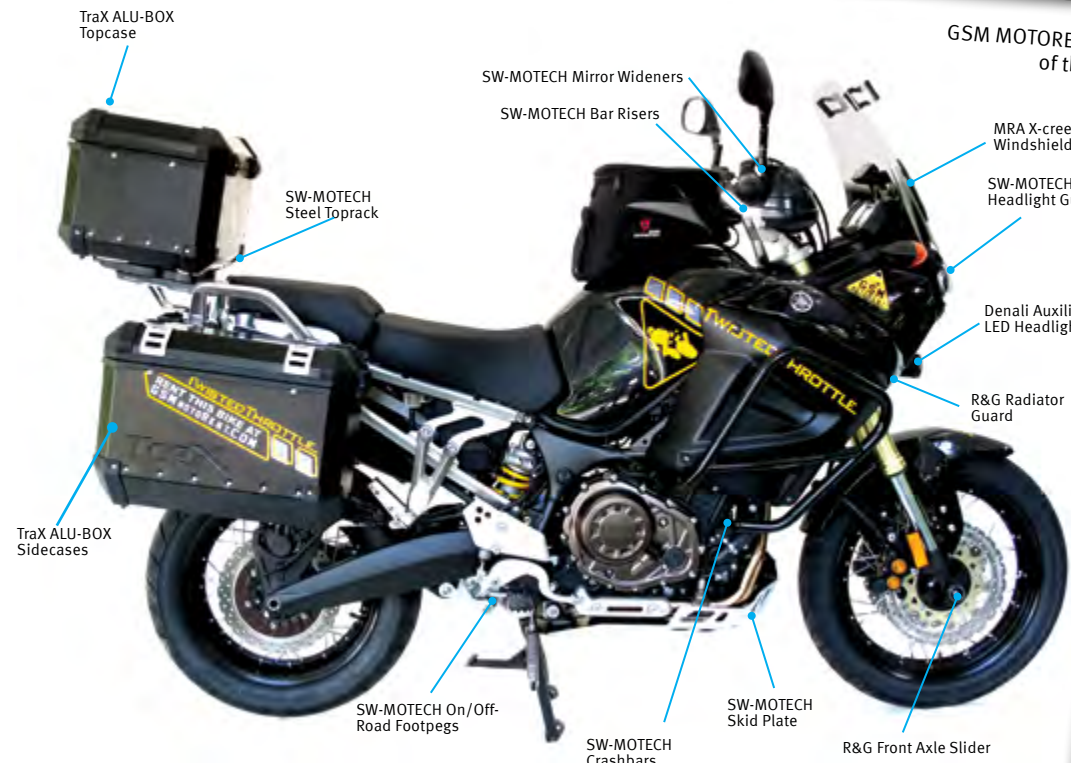

- TraX ALU-BOX Topcase
- SW-MOTECH Mirror Wideners
- SW-MOTECH Bar Risers
- MRA X-creeen Windshield
- SW-MOTECH Steel Toprack
- SW-MOTECH Headlight Guard
- Denali Auxiliary LED Headlights
- R&G Radiator Guard
- TraX ALU-BOX Sidecases
- SW-MOTECH On/Off-Road Footpegs
- SW-MOTECH Skid Plate
- R&G Front Axle Slider
- SW-MOTECH Crashbars

See more at TwistedThrottle.com/MyBike

TWISTED TENERE XT1200Z

GSM MOTORENT asked us to outfit the newest member of their rental fleet...a Yamaha Super Tenere!

You can tour the Great Smoky Mountains and ride the Twisted Tenere! Go to GSMmotorent.com for details on rental and lodging.



Dan of GSM poses with Matt B. and Nate B. at Deals Gap.



Dan from GSM MotoRent enjoying the Tenere.

QUICK-LOCK EVO Sidecarrier



Handlebar Risers

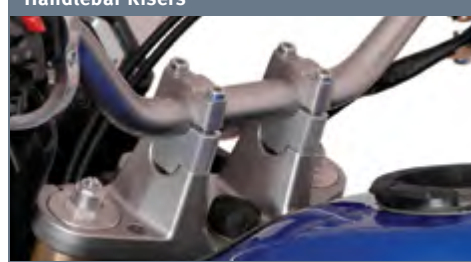

Skid Plate



Steel Toprack



Crashbars



XT1200Z Super Tenere 1200	from	to	Notes	Part Number
Steel Toprack	'12	'14	For TraX, Givi & other topcases. See page 122.	GPT.06.148.20002.B
ALU-RACK Toprack	'12	'14	Black. For TraX, Givi & other topcases. See page 134.	GPT.06.148.15000.B
QUICK-LOCK EVO Sidecarrier	'12	'14	For TraX, Givi & other sidecases. See page 128.	KFT.06.145.20000.B
QUICK-LOCK Tanking	'12	'14	For QUICK-LOCK Tankbags. See page 144.	Type 110
Handlebar Risers	'12	'14	25mm height. See page 28.	LEH.06.039.10100.S
QUICK-LOCK GPS Mount	'12	'14	Detachable. Vibration-damped. See page 100.	GPS.06.646.10100.B
On/Off-Road Footpegs	'12	'14	Convertible. Stainless steel. See page 23.	FRS.06.011.10000.S
Crashbars	'12	'14	Black. See page 52.	SBL.06.162.10000.B
Skid Plate	'12	'14	Aluminum. Silver. See page 54.	MSS.06.150.10000.S
Mirror Wideners	'12	'14	See page 34.	SVL.00.504.101
Auxiliary Light Mount	'12	'14	For Denali, Hawk & other lighting. See page 112.	NSW.06.004.10100.B
Adjustable Windshield Bracket	'12	'14	MadStad. Includes crossbar. See page 16.	MAD.S10CR
R&G Front Axle Sliders	'12	'14	See page 43.	RG.FP0054BK
Kaoko Throttle Lock	'12	'14	With original or Barkbusters handguards. Pg 32.	KAO.YAM630
Barkbusters Handguards	'12	'14	Various shapes & colors. See page 38.	BB.BHG40.2
MRA Windscreens	'12	'14	Various shapes. See page 16.	MRA.06.061
Fenda Extenda	'12	'14	See page 58.	PP.052100

These are featured bikes and products, for the full range visit TwistedThrottle.com.

Symbols

12-volt electrical accessories 108, 110, 118, 146-147, 187
 12-volt electrical connectors 109
 12-volt electrical sockets 108-110, 146
 12-volt socket mounts 108

A

Adaptive Technologies 97
 Adventure Pockets 174
 AdMore Lighting 119-121
 Air filters 190
 Air compressors 183
 Alpinestars 85
 ALU-RACKS 124
 Aprilia 192
 Arai 80
 Armor 77
 Auxiliary fuel storage 175-176
 Auxiliary lighting 112-117
 Axle sliders 43

B

Backpacks 163
 Bar end sliders 44
 Barkbusters 32, 38-41
 Base layers 82-83, 86-87
 Bat light 177
 Batteries 190
 Battery chargers 187
 BestRest 183
 Bluetooth 92-96
 BMW 192-213
 Boots 84-85
 Bottle mounts 126, 176
 Brake levers, adjustable 30-31
 Brake lights 119
 Buell 213

C

Camera 95-96
 Camera mounts 53, 96, 101-103, 105
 Camping gear 178-181
 Can-Am 213
 CANbus 118
 Centerstands 56
 Centerstand skid plate 56
 Chain lube 190
 Chain oilers 186
 Clutch levers, adjustable 30-31
 Communication 92-95
 Cooling vest 78

Crashbar footpegs 53
 Crashbars 52
 Crossbar 100
 Cruise control 32-33

D

Denali 53, 111-114, 116-118
 Doubletake Mirrors 36
 Dry bags 157, 162-166
 DrySpec 134-135, 164-167
 Ducati 214-218

E

Ear plugs 79
 Engine case covers & sliders 48
 Event calendar 272
 Exhaust hangers 46
 Exhaust protectors 46

F

Factory Store 6
 Fender eliminators 59
 Fender extenders 58
 Flashlights 92, 157, 177
 Footpegs 23-25, 53
 Footrest blanking plates 46
 Frame plugs 47
 Frame skidders 42
 Frame sliders 42, 49
 Fuel bottles 176
 Fuses 118

G

Gadget mounts 100-107, 156
 Gaerne 85
 Garmin 97-98
 Gifts 191
 Gift cards 89
 Givi 136-137
 Gloves 73, 75, 90
 GoPro 53, 95-96
 GPS cases 106
 GPS mounts 100-105, 156
 GPS receivers 97-98
 GSM MotoRent 11

H

Hand warmers 91
 Handguards 37-41
 Handlebar risers 28-29
 Hard luggage 130-131, 134-137, 140-141
 Headlight bulbs 114

Headsets 92-95
 Heated clothing 90
 Heated gloves 73, 90
 Heated grips 91
 Helmet accessories 81
 Helmets 80-81
 Highway pegs 53
 HJC 81
 Honda 218-229
 Horn mounts 111
 Horns 111

I

Inner tubes 190
 Interphone 92-93, 106

J

Jackets 65-71, 74-75

K

Kaoko 32-33
 Kawasaki 230-240
 KTM 241-245

L

LED brake lights 120-121, 131
 LED lights 112-113, 115
 LED tail lights 119
 LED top box lights 120
 LED turn signals 37, 119, 121
 Lifeproof 107
 Lifting handle 56
 Light mounts 53, 114, 116-117
 Locks 126, 131, 169

M

Macna 62-78, 87
 Macna Gloves 73, 75, 90
 Manuals 188
 Map holders 157
 Men's gloves 72-73, 90
 Men's jackets 65-71
 Men's pants 65-69
 MFW 24-25, 30-31, 53
 Mini air compressors 183
 Mirrors 36
 Mirror block-off plates 47
 Mirror wideners 34-35
 MotoQuest Tours 11
 Motorcycle covers 58
 MRA 16-22
 MSR 176-178, 180

N

NEBO 177
 Night Eye 64-67, 69-70, 74, 77
 Noise filters 79
 NoNoise 79

O

Oil 190
 Oil cooler guards 50-51
 Oil filters 190
 Organizer bag 174
 Oxford 91

P

Pants 65-69, 75
 Phone cases 104, 106-107, 156
 PIAA 114
 Potentiometer guards 55
 Power distribution blocks 118
 Project bikes 8-9
 Pyramid Plastics 58

R

Radar detectors 97
 Radiator guards 50-51
 Rain jackets 71, 76
 Rain pants 76
 RAM mounts 36, 53, 101-104
 Rear bags 158-161
 Rear brake master cylinder guards 55
 Rear brake reservoir guards 55
 Rear huggers 59
 Rearsets, adjustable 27
 Redverz 178
 Regulator guards 55
 Rental bikes 10-11
 Resistors 119
 Rider visibility 77
 Riding gear 62-78, 80-90
 ROK Straps 169
 RotopaX 175
 R&G 27, 42-48, 50-51, 57-59, 119

S

Saddlebags 138-139, 142-143, 164-165
 Satellite phone 99
 Satellite tracker 99
 Scottoiler 186
 Seat racks 122
 SENA 94, 95
 Service Center 7

Shift levers, adjustable 26
 Shock protectors 45
 Sidecarrier accessories 126
 Sidecarrier 127-129, 132, 138-139
 Sidecase accessories 131
 Sidecase adapters 129, 132, 135, 141
 Sidecase liners 130
 Sidecases 130, 134-137, 140-141
 Sidestand feet 57
 Sidestand pads 89
 Sidi 84, 85
 Sizing chart 72
 Sizing charts 63
 Skid plates 54
 Sleeping bags 180
 Sleeping pads 180-181
 Small item storage 167, 174
 Smartwool 86-87
 Soft luggage 138-139, 142-167, 170-174
 Socks 86
 Sponsored riders 14-15
 SPOT 99
 Steel braided brake lines 189
 Steel top racks 122
 Stickers 89, 131
 Straps 167, 169
 Suzuki 246-255
 Swingarm sliders 43
 Swingarm spools 43
 Switch mounts 114
 SW-MOTECH 23, 26, 28-29, 34-35, 37, 49-50, 52, 54-57, 100, 104, 106, 108, 115-117, 122-133, 138-163, 168, 176

T

Table of contents 1
 Tablet cases 107, 157
 Tail Tidy 59
 Tank grips 60-61
 Tank sliders 44
 Tankbag liners 157
 Tankbags 109-110, 144-157, 163
 Tankrings 144-147
 Tarps 179
 Techmount 105
 TechSpec 60-61
 Tents 178-179
 Throttle locks 32-33
 Tire gauges 183
 Tire repair kits 182
 Tires 184, 185

Tire pressure monitor 97
 Toe chain guards 45
 Toll pass holder 104
 Tools 182-183, 187
 Tool tube 126, 176
 Topcase adapters 123-125, 133, 135
 Topcases 134-137
 Toprack accessories 123, 125, 168, 175
 Topracks 122-125, 168
 Trail Tech 98
 TraX 130-133
 Triumph 256-262
 T-shirts 88-89
 TWISTEDCORE 82-83
 Twisted gear 89

U

Underbody sliders 42
 Upper crashbars 52

V

VentureHeat 90
 Video 95-96
 Voltage monitor 118

W

Water bottles 176, 181
 Windscreens 16-22
 Women's boots 84
 Women's gloves 72, 75
 Women's jackets 65, 74-75
 Women's pants 75

X

X-creeen 16-18, 22

Y

Yamaha 263-269

Visit Twisted Throttle at these rallies around the country!

Events subject to change without notice.

Visit www.TwistedThrottle.com/calendar for the latest schedule!

 = **Attended event.** Twisted Throttle will be in attendance so stop by and see us!

 = **Sponsored event.** Twisted Throttle may not attend but will offer prizes and event support.



Twisted Throttle Garage Sale
Twisted Throttle Headquarters
Exeter, RI

March 1, 2014



Daytona Bike Week
Daytona International Speedway
1801 W. International Speedway Blvd
Daytona, FL

March 7-15, 2014

www.officialbikeweek.com



March Moto Madness
Adventure Rally 2013
Tellico Plains, TN

March 28-30, 2014

www.marchmotomadness.com



Georgia Mountain Rally
Georgia Mountain Fairgrounds
Lake Chatuge, GA

May 2-4, 2014

<http://www.bmwmcoga.org/>



13th Annual Rick's Rendezvous
(Formally ADV Rider Eastern Rendezvous)
Black Bear Resort, Hampton, TN

May 15-18, 2014

www.advrider.com



12th Annual V-Strom Gathering
Iron Horse Motorcycle Lodge & Resort
1755 Lower Stecoah Road
Stecoah, NC

May 15-18, 2014

<http://vsari.com/>



Overland Expo
Mormon Lake Lodge
Flagstaff, AZ

May 16 - 18, 2014

www.overlandexpo.com



Twisted Throttle 12th Annual Open House & discounts on great stuff!
570 Nooseneck Hill Rd
Exeter, RI 02822

Saturday, May 24, 2014

www.twistedthrottle.com



BMW RA Rally
Barber Motorsports Museum
Birmingham, AL

May 29 - 31, 2014

www.bmwra.org



Americade Tour Expo
2200 State Route 9
Lake George, NY

June 2-7, 2014

www.tourexpo.com



MSTA Rally
Rapid City, South Dakota

June 8-11, 2014

www.ridemsta.com



COG "Silverdammit" National Rally
Johnson City, TN

June 16-20, 2014

www.concours.org



Horizons Unlimited Campfire & Ride
Grant, CO

July 11-13, 2014

www.horizonsunlimited.com/



Road Runner Touring Weekend
Snowshoe, WV

July 17-20, 2014

www.roadrunner.travel



4th Annual Flying Monkey Adventure Rally
Zion Ponderosa Ranch Resort
East Zion, UT

July 19-22, 2014

www.advrider.com



BMW MOA 42st National Rally
Rollin' By The River 2014
St. Paul, MN

July 24-27

www.bmwmoa.org



North East V-Strom Adventure
Historic Valley Campground
200 Windsor Lake Road
North Adams, MA 01247

Aug 1-3

<http://vsari.com/>



KTM National Rally
TBA

September, 2014



Ocean State BMW Rally
Gathering of the Clams
Wakefield, RI

Sept 12-14, 2014

www.bmwmoa.org



Barber Vintage Festival
Barber Motorsports Park
Birmingham, AL

October 10-12

www.barbervintagefestival.org



American International Motorcycle Expo
Orlando, FL

October 15-19

www.aimexpousa.com



Progressive Insurance International Motorcycle Shows (2014 dates TBA)
San Mateo, CA
Dallas, TX
Atlanta, GA
Long Beach, CA
NYC, NY
Novi, MI
Washington, DC
Minneapolis, MN
Phoenix, AZ
Cleveland, OH
Chicago, IL
Seattle, WA

www.motorcycleshows.com



MMIC and COHV Canadian Motorcycle Shows (2014 dates TBA)
Calgary
Toronto
Edmonton
Vancouver
Montreal
Ottawa

www.mmic.ca/



North American International Motorcycle Supershow
International Centre, Toronto, ON

Jan 2015

www.motorcyclesupershow.ca



North American International Motorcycle Supershow
International Centre, Toronto, ON

Jan 2015

www.motorcyclesupershow.ca



AIME Expo 2013



Twisted Throttle
Open House 2013



Overland Expo 2013

How to Order



We're just a call or a click away!

Order 2 ways:

1. Order online 24/7 at TwistedThrottle.com

2. Call Us

+1 (855) 255-5550 toll free in North America

+1 (401) 284 4200 International

Monday - Friday 9:00am - 7:30pm Eastern Time (GMT-5)

Saturday 10:00am - 6:00pm Eastern Time (GMT-5)

Sunday 9:30am - 3:00pm Eastern Time (GMT-5) (April 1 to August 30)

COME VISIT!

If you are traveling through New England, come visit our factory store and showroom near the nearby Southern Rhode Island coastline! Give us a call and we'll help you with hotels, campgrounds, directions, etc. You can download maps and directions at TwistedThrottle.com/retail-store.

GPS: +41.56484, -71.65942

PAYMENT METHODS



We accept Visa, MasterCard, Discover, and American Express for online, phone, and fax orders. Checks, money orders, and wire transfers are acceptable for mail orders. We also accept PayPal.

GIFT CARDS

Need to find a gift for your favorite motorcyclist, but not sure what they need for their next big trip?

Purchase a gift card online at TwistedThrottle.com/gift-cards and we'll send you, or the recipient, a Gift Card for the requested amount along with a copy of our catalog!



DISCOUNTS

We offer a 10% discount to active MSF Instructors, media test riders and writers for print magazines. We hope that this will encourage introduction of our products to potential customers through rider-to-rider endorsements. Give us a call or send us an email to get set up with the discount. We also offer a 10% military discount with an active and valid ID.

OUTLET STORE (Scratch and Dent)

We offer discounts on returned, scratched, dented, overstocked, and discontinued closeout items through our outlet store at TwistedThrottle.com/outletstore. Also save big by visiting our factory store during one of our Garage Sale Events!

Upcoming garage sale event dates:

September 20, 2014 & March 21, 2015.

SHIPPING POLICY

We ship Monday through Friday. Orders for in-stock items will leave the warehouse on the same shipping day for:

- FedEx and USPS orders placed by 3PM ET,
- LTL freight orders placed by 9AM ET.

Transit times will be noted at checkout. USPS Priority Mail provides 2-3 days in transit in the USA and 6-10 day days in transit to Canada. If you choose FedEx Home Delivery, estimated shipping times vary from between 1 day to over 7 days depending on your location. International orders may be delayed by customs.

We ship worldwide, including APO/FPO addresses. We recommend using USPS Express Mail or Priority Mail for international shipments to avoid the high brokerage fees charged by FedEx for international shipping.



New England location: Exeter, RI USA



Canadian location: New Dundee, Ontario, Canada

For domestic orders, we ship in-stock items immediately and ship other items as they become available. There is no additional charge for us to ship those items separately. International orders with out-of-stock items will be shipped complete once all backordered items have arrived.

RETURN POLICY

If you are unsatisfied with your purchase, you may return new, unused items for a full refund within 60 days. Refunds will be issued to the same form of payment used in the original transaction.

Windscreens must be returned in unopened original packaging.

To arrange a return, call (855) 255-5550 for a return authorization number (RA#). Instructions will be included to help complete your return.

Once return items have been received at our facility we will process and initiate your refund within 5 business days.

DEALERS – WE WANT YOU!

If your company is interested in selling products distributed by Twisted Throttle, please visit TwistedThrottle.com/becomeadealer.



Did we goof up?

Is something confuzzled? Help us make our catalog better! If you're the first person to point out a particular error in our catalog, we'll send you a free Twisted Throttle T-shirt. Woohoo!



TWISTED THROTTLE

SW-MOTECH
BAGS-CONNECTION



WATER PROOF **DRYSPEC**

DENALI

ULTIMATE PROTECTION
Barkbusters
HANDGUARDS

MAGNA



KAOKO
Cruise Controls



interphone

MF GERMANY
MOTORCYCLE PRODUCTS

nonoise

TWISTEDCORE

AdMore
LIGHTING INC.
Innovative LED Lighting Solutions

ROK
straps

MEFO
sport
Motorcycle Tires

PYRAMID

RAM
MOUNTS

TECHMOUNT
Accessory Mounting Systems

Twisted Throttle LLC
570 Nooseneck Hill Rd
Exeter, RI 02822 USA 41.56484 N, 71.65942 W

+1(855) 255-5550 toll free within North America
+1(401) 284-4200 phone
+1(401) 223-6954 fax
info@twistedthrottle.com - www.twistedthrottle.com

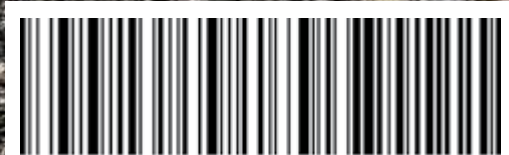

tt.catalog2014

Cover Photo: ©Jim Kohl Photography
JimKohl.com

