

A new technological innovation, HP BladeSystem c-class

Mike Montez
Blade Business Development
Industry Standard Server Group



Why HP BladeSystem?



HP sets the new blade agenda

Adaptive Infrastructure in a 17 inch box

- **Adaptive Infrastructure**
 - Automated, 24 x 7 lights-out computing
 - Low cost pooled IT assets
- **HP Blade strategy**
 - Blade everything desktop to datacenter
 - Leverage innovations across HP
- **New HP BladeSystem: Innovations leapfrog competition**
 - Management – **Insight Control**
 - Power and cooling – **Thermal Logic**
 - Virtualization – **Virtual Connect**
- **Managing customers' Blade transitions**
 - Investment protection and comprehensive HP and Partner solutions portfolio



Notable Media and Analyst Headlines



- *"HP's competitors should look at the c-Class and be concerned."*



- *"The c-Class might be the original product that shows HP unlocking some of the value of the highly criticized merger with Compaq. Innovations from NonStop servers to printer-like system management panels."*



- HP Ups the Server Market Ante With New BladeSystem



- HP to "blade everything" - including IBM. IBM users get incentives to switch blades



- Cooling Computers with Tiny Jet Engines



- HP aims to stick IBM with new blades



- HP Adds Cutting-Edge Features To New Blade Server Line



- HP's Blades Power Play



- Breakthrough HP Blade Design can Save Customers Millions



- HP debuts 'data center in a box'



It's a racked, stacked and wired world

The root cause of datacenter pain

The functionality of today's datacenter is constrained by the form of their building blocks and the processes required to manage them

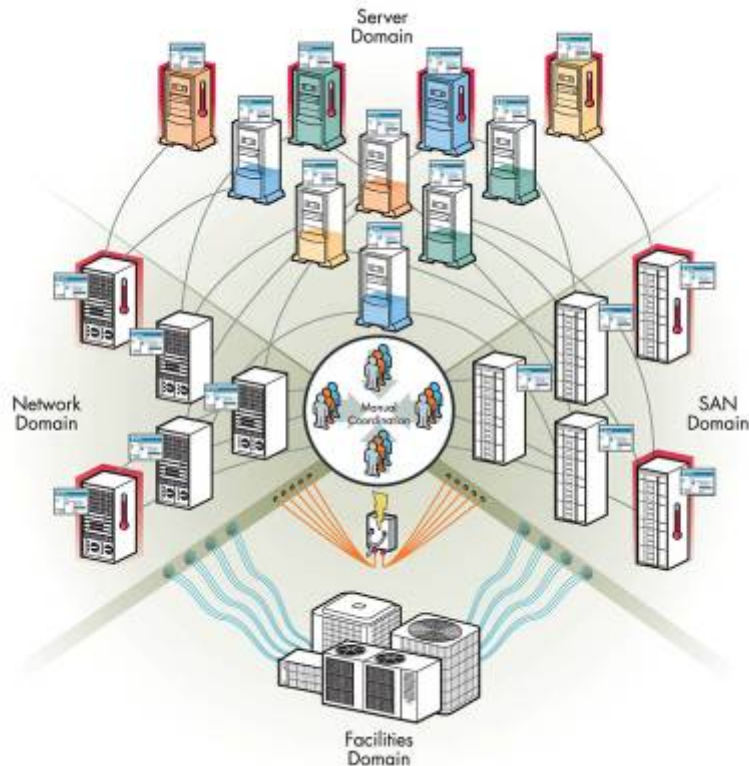

Inflexible: Static and hardwired

Manually coordinated: Change requires too many people and steps

Over-provisioned: Wasting power, cooling, space, people and money

Managed 1 by 1: Processes are unique, with unique tools and inconsistency

Expensive: More expensive to own than to build

Because of conventional IT's limited form and processes, the potential to improve the operational efficiency, cost and flexibility are limited

The HP BladeSystem approach to simplify infrastructure

Consolidate

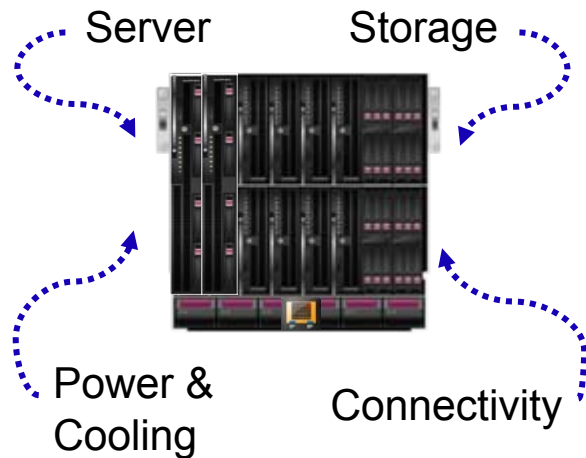

- Modularize and integrate components
- Surround with intelligence
- Manage as one

Virtualize



- Create logical, abstracted connection to LAN/SAN
- Pool and share server, storage, network, and power

Automate



- Simplify routine tasks and processes to save time
- Keep control

Reduce time and cost to buy, build and maintain

Greater resource efficiency and flexibility

Free IT resources for revenue bearing projects

HP focused on bigger, faster growing costs

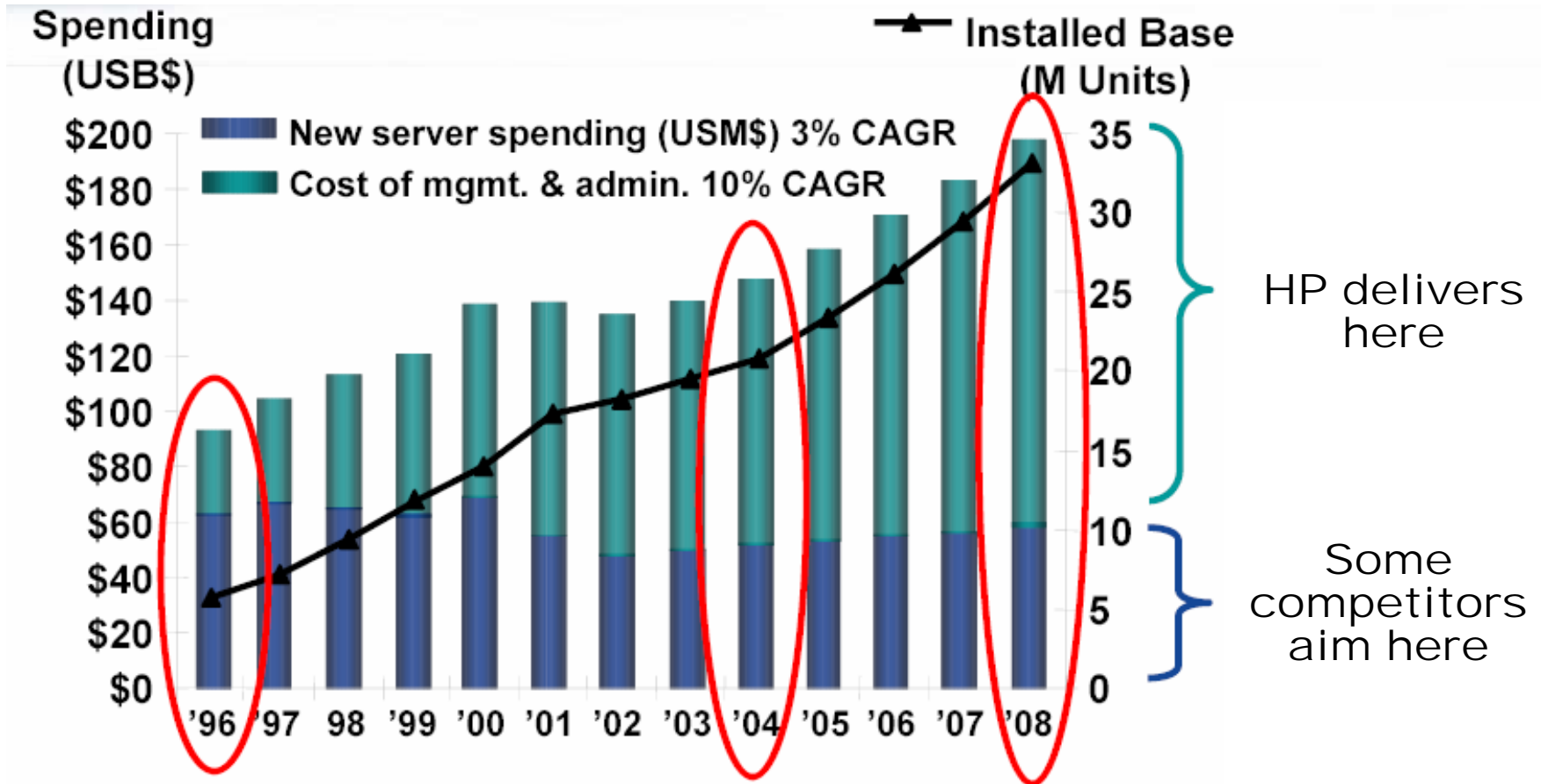

Source: IDC, July 2004

Delivering Tangible Savings for Business

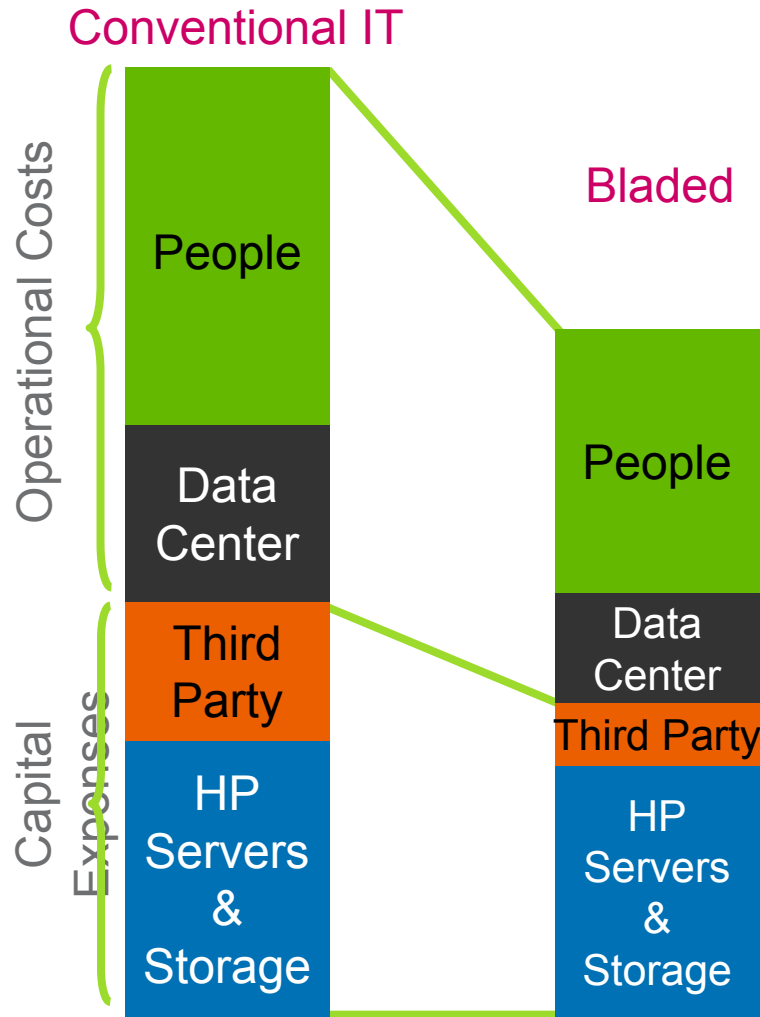

Lower costs, greater agility

- Reduce or eliminate lengthy processes
- Simplify procedures
- Reduce complexity
- Lower power, fewer cables
- Less space

- Reduced Ethernet/FC costs
- Lower cost HP management tools

- Integration of components
- Sharing of resources
- Infrastructure control software

Blade Market Overview

Blades are the fastest growing market

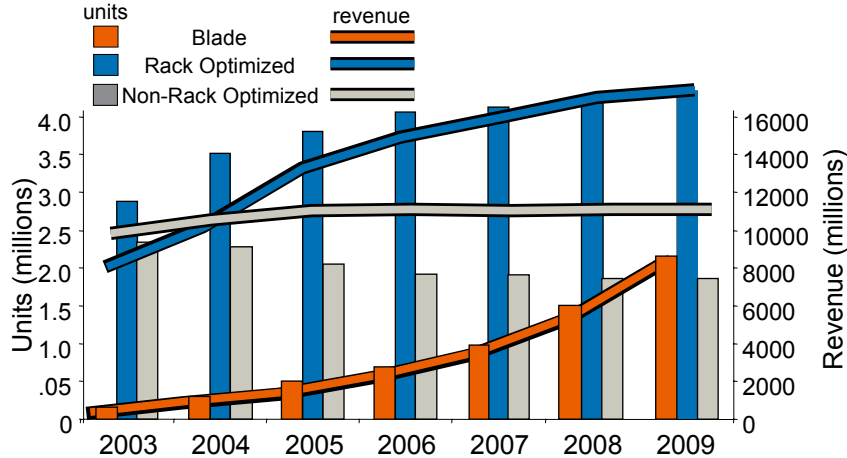

Two Horse Race Today

Future Industry Target

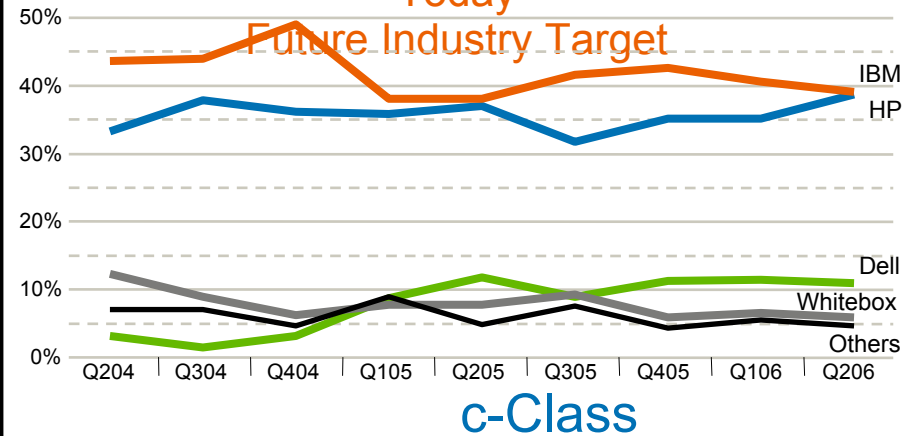

c-Class

Blades Driving Server Growth & Richness

Server Category*	CAGR% '06-'09
Blade Servers	40.3%
x86 Servers (non blades)	1.4%
All Servers (non-blades)	0%
Server Category*	AUP
HP Blade Servers + Options	\$6,354
HP Blade Server + Options + Storage + Services + Software	\$7,956
HP x86Rack Servers + Options	\$4,237

SMB to Client to Data Center

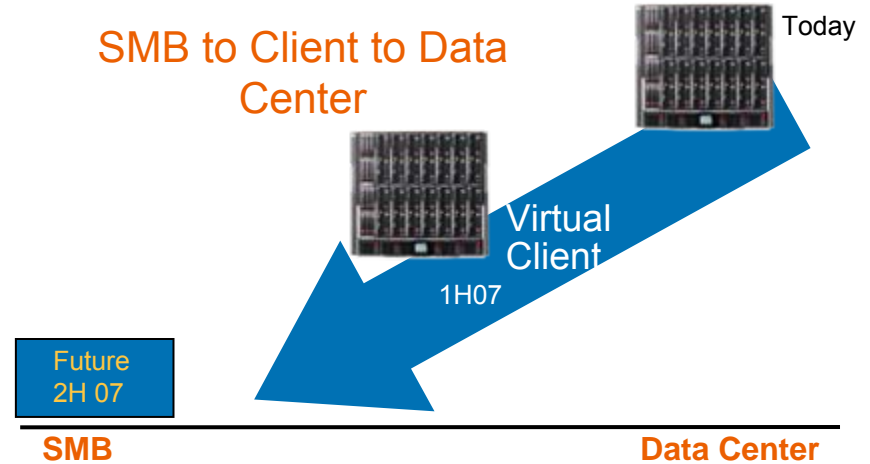

** IDC Server Forecast 9.7.06

*HP Sales data



BladeSystem c-Class Portfolio



New Blades for today's p-Class



HP ProLiant BL20p
HP ProLiant BL25p
HP Integrity BL60p

Full-Height 2P Server Blade

- Intel Xeon, AMD Opteron, or Intel Itanium processors
- Occupies a full slot
- 8 servers in a 6U enclosure



HP ProLiant BL35p

Half-Height 2P Server Blade

- AMD Opteron processors
- Occupies a half slot
- 16 servers in a 6U enclosure



HP ProLiant BL45p

Full-Height 4P Server Blade

- AMD Opteron processors
- Occupies two slots
- 4 servers in a 6U enclosure

Complete freedom to mix ProLiant and Integrity blades

Transition at own pace with coexistence

2002

2003

2004

2005

2006

2007

2008

2009

2012+

BladeSystem p-Class

- 5+ years of technology support
- New blades
 - BL60p IPF blade server (HP-UX)
 - Latest Intel Xeon: BL20p G4
 - AMD Opteron Rev F: BL25p G2, BL45p G2



Support 5 yrs

- Same unified infrastructure management
- Same connection to the datacenter
 - Power
 - Network/SAN
 - Rack
- Same standard ProLiant technologies
- Support for 5-7 years of technologies
- Next generations of virtualization
- Storage blades & new fabrics

Transition period



BladeSystem c-Class

Taking server blades to the next level

C-class	More memory capacity compared to today's Intel blades!
	More I/O expansion compared to today's blades!
	Support for the future technologies: >4Gb FC, 10GbE, 20 Gb/s Infiniband!
	Hot-plug SAS hard drive support on every blade!
P-class	Only 2 interconnect bays (max 2 ethernet sw and 2 FC sw) Support only 1 GbE, and 2 Gb FC No Half Height server with RAID and FC support



HP BladeSystem infrastructure portfolio

- Common unified management
- Consistent industry standards
- Choice for any environment

c-Class

Automated and virtualized infrastructure

c7000



Datacenter optimized

New 2006

p-Class

Optimized to simplify scale-out servers



New Nov 1st!

Integrity BL60p

New 2006

BL20p G4

BL25p G2 & BL45p G2

PC Blade solutions

Optimized for density



New Nov 7th!

AMD Athlon PC blade

HP and HP Channel Partner Viewable

c7000 Enclosure

Front View

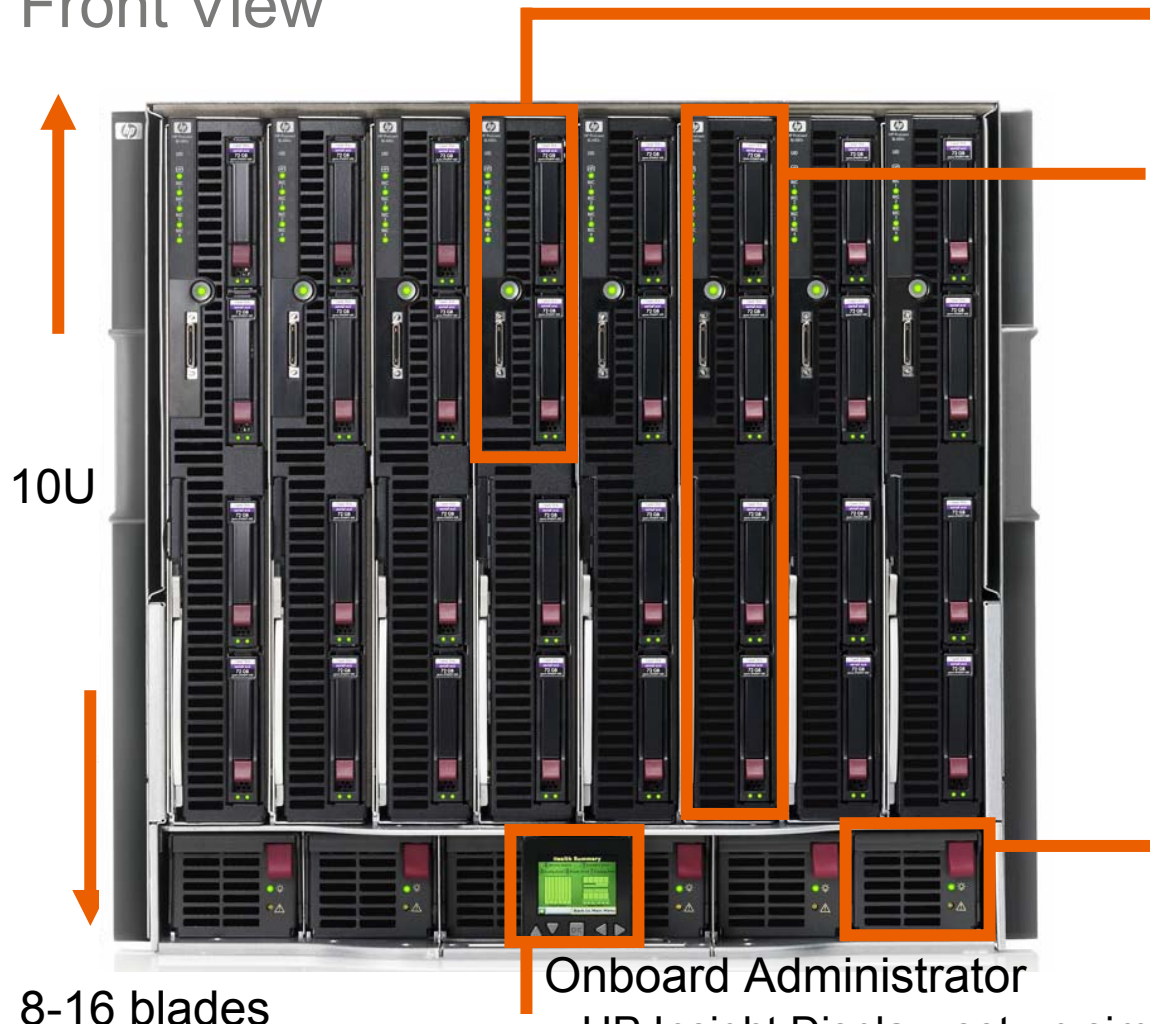

Half-Height Blade Server

- Up to 16 per enclosure

Full-Height Blade Server

- Up to 8 per enclosure

Integrated power

- Simplified configuration and greater efficiency
- Same flexibility, capacity and redundancy

Onboard Administrator

- HP Insight Display, set-up simplification

8-16 blades

HP and HP Channel Partner Viewable

c7000 Enclosure – fully redundant

Rear View

Active Cool fans

Adaptive flow for maximum power efficiency, air movement & acoustics

- 8 bays; up to 4 redundant I/O fabrics
- Redundant fan design
- Up to 94% reduction in cables

Ethernet, Fibre Channel, iSCSI, SAS,

On-board Administrator

- Enclosure Mid-plane aggregate
- Remote administration view
- Power with capacity of 5Tbs
- Robust, multi-enclosure control
- Redundant connections to each server
- Single or single phase or three-phase enclosures
- Redundant Active/Passive design
- Mid-plane is fully redundant (no active components)
- AC redundant mode or power supply redundant mode
- Both OA's can fail, and the enclosure will still run!
- Best performance per watt
- Only 3 PS needed for a full enclosure



HP c-Class BladeSystem Server Positioning

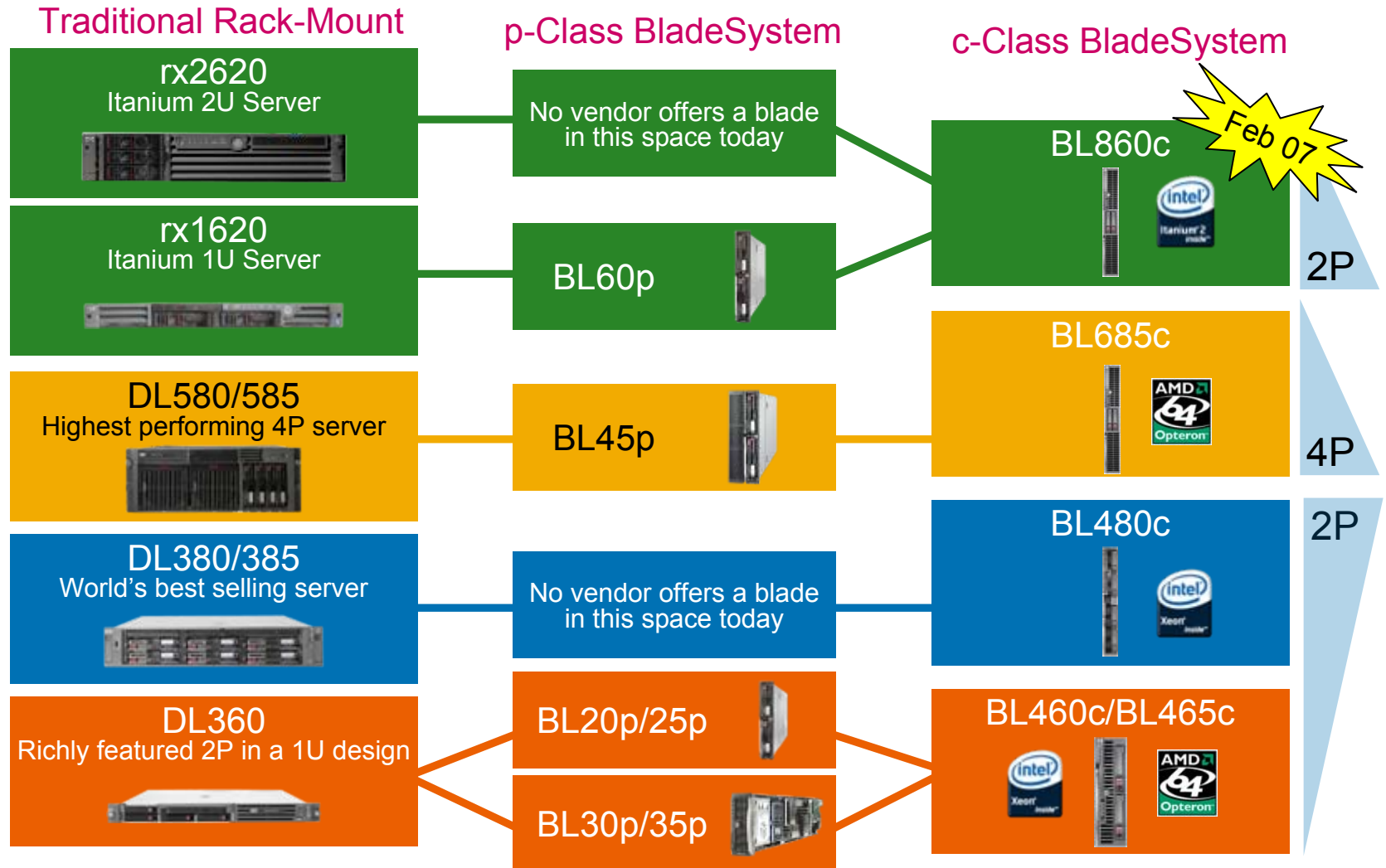

HP ProLiant BL460c



BL460c

Processor

Up to two Quad-Core Intel Xeon processors
Up to two Dual-Core Intel Xeon processors

Memory

- FBDIMM 667MHz
- 8 DIMM Slots
- 32GB max

Internal Storage

- 2 Hot-Plug SFF SAS/SATA HDDs
- Standard RAID 0/1 controller with optional BBWC

Networking

2 integrated Multifunction Gigabit NICs

Mezzanine Slots

2 mezzanine expansion slots

Management

Integrated Lights Out 2
Standard Blade Edition



HP ProLiant BL460c

Internal View



Embedded Smart Array E200i

Controller integrated on drive backplane

Two Mezzanine Slots:

- One x4
- One x8

Two hot-plug
SAS/SATA
drive bays



8 DIMM Slots

Fully-Buffered DIMMs
DDR2 667MHz

HP ProLiant BL480c



BL480c



Processor

Up to two Quad-Core Intel Xeon processors
Up to two Dual-Core Intel Xeon processors

Memory

- FBDIMM 667MHz
- 12 DIMM Slots
- 48GB max

Internal Storage

- 4 Hot-Plug SFF SAS/SATA HDDs
- Standard RAID 0/1/5 controller with optional BBWC

Networking

- 2 integrated Multifunction Gigabit NICs
- 2 integrated Gigabit NICs

Mezzanine Slots

3 mezzanine expansion slots

Management

Integrated Lights Out 2
Standard Blade Edition

HP ProLiant BL480c

Internal View

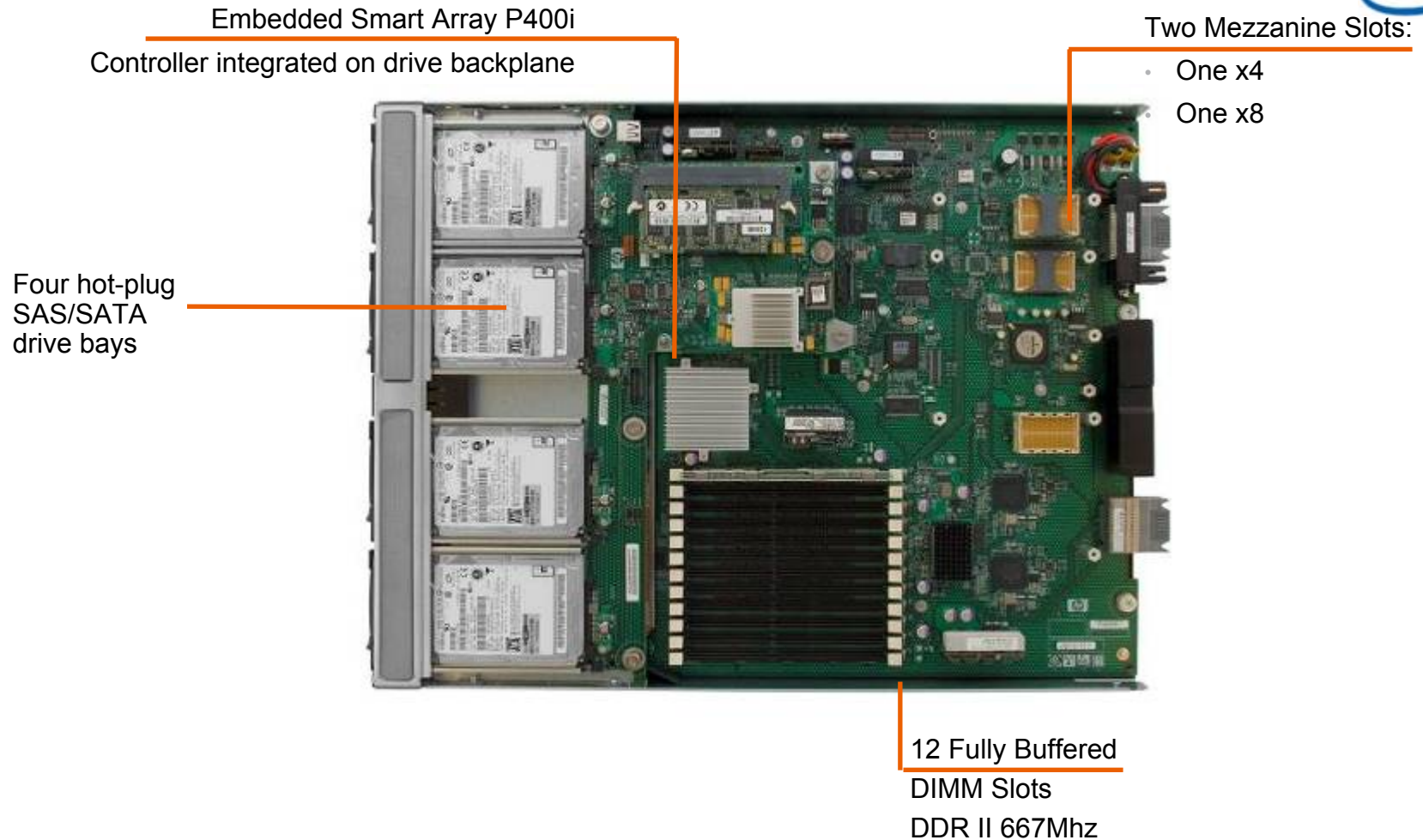

HP ProLiant BL465c



BL465c



Processor

Up to two AMD Opteron™ 2000 Series processors

Memory

- PC2-5300 Registered DDR2 (667 MHz)
- 8 DIMM Sockets
- 32GB max (with 4GB DIMMs)

Internal Storage

- 2 Hot-Plug SFF SAS HDDs
- SmartArray E200i controller (64MB cache) with optional BBWC
- RAID 0/1 support

Networking

2 integrated Multifunction Gigabit NICs
Additional NICs via mezzanine card

Mezzanine Slots

2 PCIe mezzanine expansion slots

Management

Integrated Lights Out 2
Standard Blade Edition

Density

16 server blades in 10U enclosure

HP ProLiant BL465c

Internal View

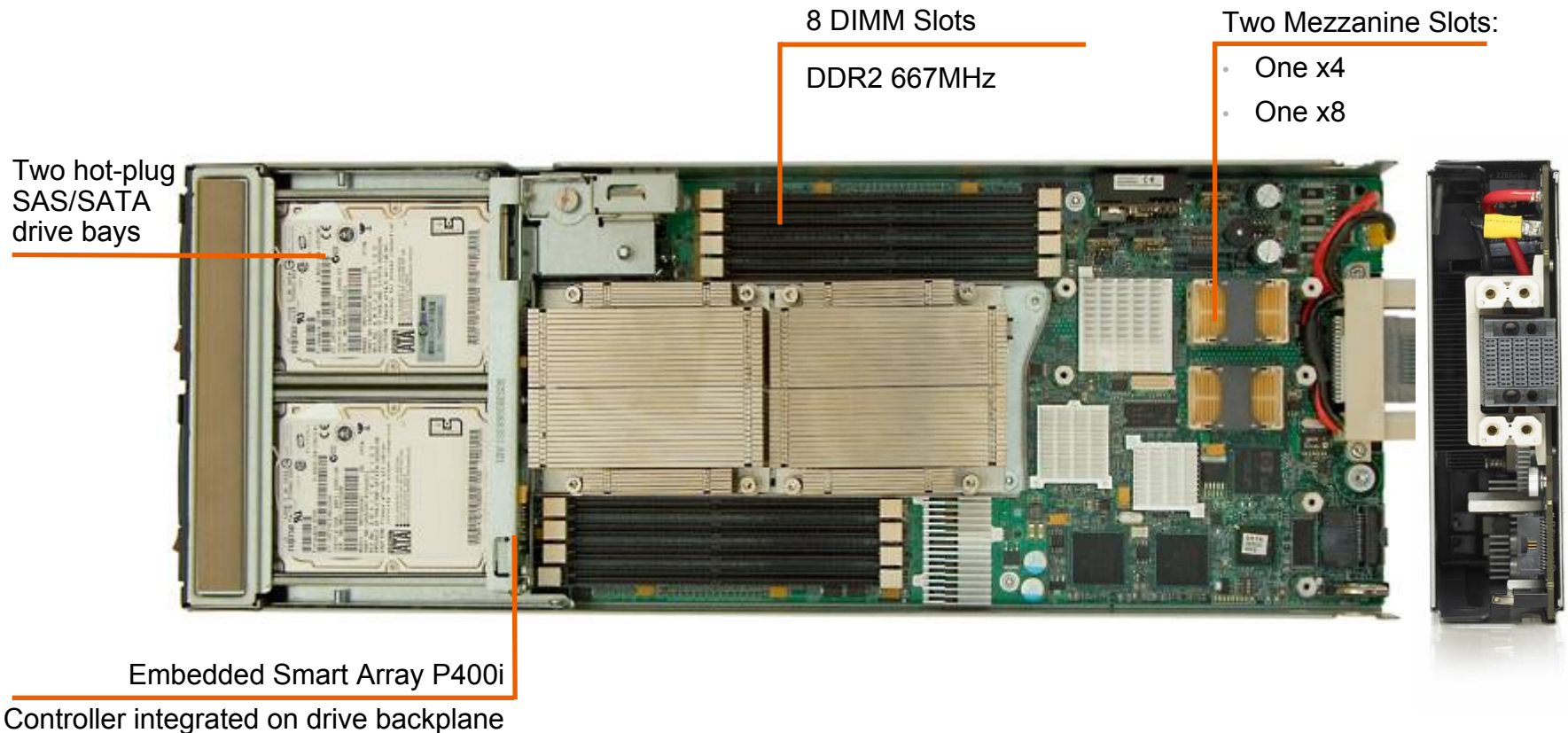

HP ProLiant BL685c



BL685c



Processor

Up to four AMD Opteron™ 8000 Series processors

Memory

- PC2-5300 Registered DDR2 (667 MHz)
- 16 DIMM Sockets
- 64GB max (with 4GB DIMMs)

Internal Storage

- 2 Hot-Plug SFF SAS HDDs
- SmartArray E200i controller (64MB cache) with optional BBWC
- RAID 0/1 support

Networking

- 2 integrated Multifunction Gigabit NICs
- 2 integrated Gigabit NICs

Mezzanine Slots

3 PCIe mezzanine expansion slots

Management

Integrated Lights Out 2
Standard Blade Edition

Density

8 server blades in 10U enclosure

HP ProLiant BL685c

Internal View



Embedded Smart Array P400i
Controller integrated on drive backplane

Two hot-plug
SAS/SATA
drive bays

Three Mezzanine Slots:

- One x4
- One x8

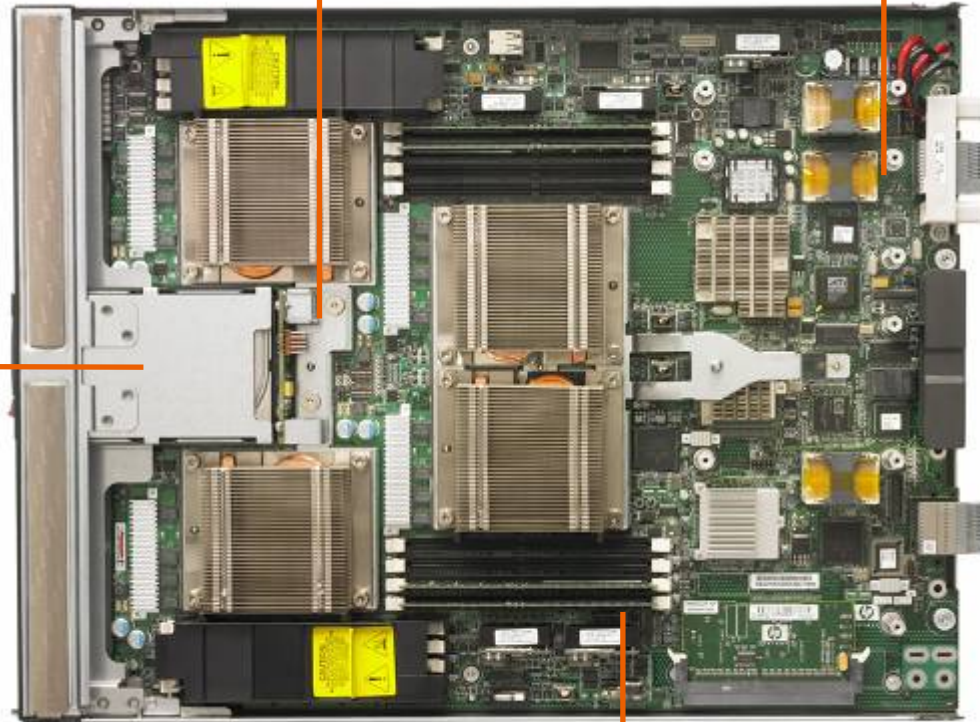

8 DIMM Slots
DDR2 667MHz



HP c-Class BladeSystem Storage Blade

HP StorageWorks SB40c storage blade

Key new features

- Support for up to six hot-pluggable SFF SAS or SATA HDDs
 - The SB40c storage blade allows for the mix of SAS and SATA drives in the same enclosure at the same time and is tailored to the needs of HP blade server customers who require optimized direct attach storage
- Includes an onboard SA-P400 controller
 - Smart Array P400 RAID controller with 256MB cache, supports RAID 0, 1, 1+0, 5, and 6 (ADG)

Available



<http://h18004.www1.hp.com/products/blades/components/c-class-storage.htm>

HP and HP Channel Partner Viewable

HP c-Class BladeSystem Storage Blade with HH Blades



HP StorageWorks
SB40c storage blade

A new paradigm for
“bladed” storage solutions

Direct Attach Storage Blade
Dedicated 6-drive JBOD blade

Connected via the
backplane
Must be placed in an adjacent
bay, either left or right, in the
same partition



Up to 8 storage blades

HP and HP Channel Partner Viewable

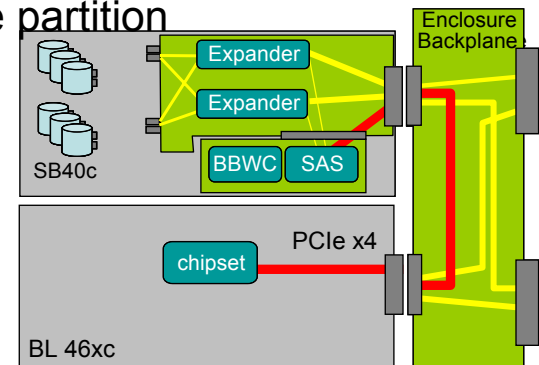

HP c-Class BladeSystem Storage Blade with FH Blades

Feb 07

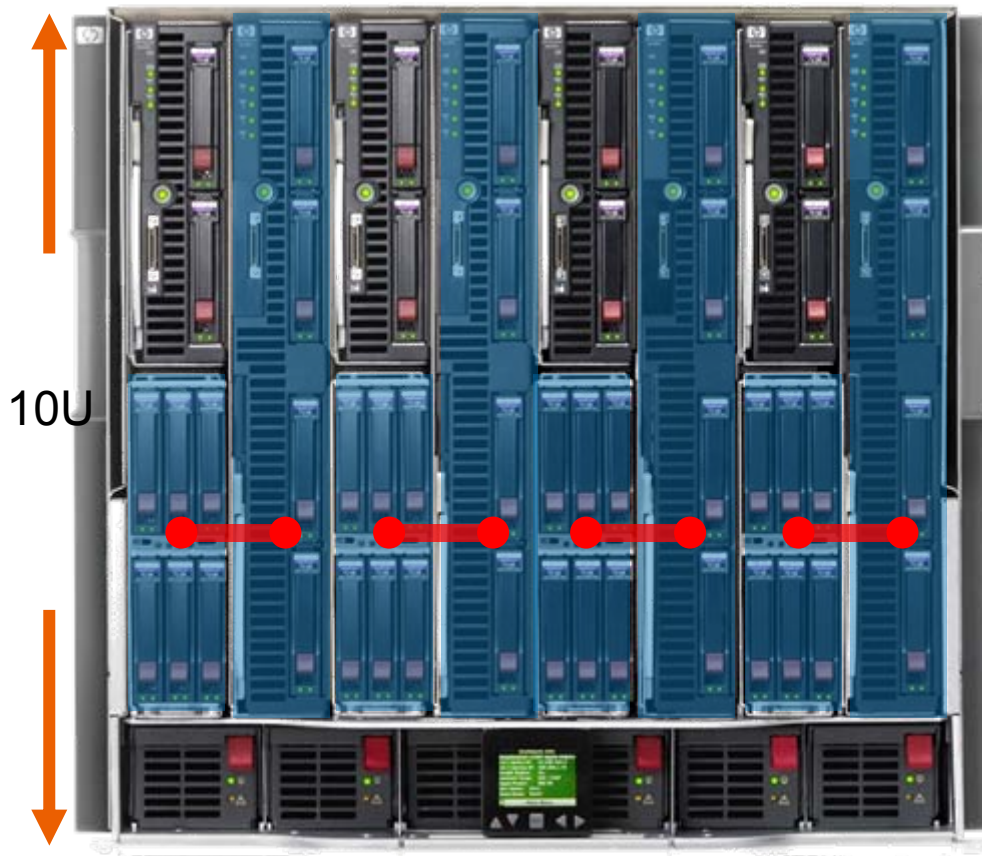

With a FH Blade, the SB40c must be placed

- in an adjacent lower bay
- either left or right, in the same partition

Requires an HP PCIe Mezz Pass-Thru card in mezz-3

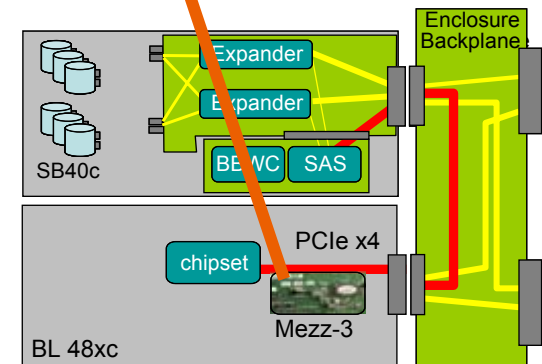

Up to 4 storage blades

HP and HP Channel Partner Viewable

HP c-Class BladeSystem Storage Blade

Direct-Attach Storage Blade
SB40c Storage Blade

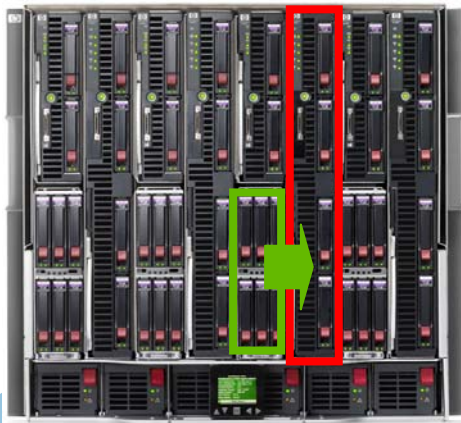

Up to 6 hot-plug SAS or SATA drives for adjacent blade

- Simple way to add additional drive capacity – add up to 6 hot-plug SAS or SATA drives
- Delivers high performance – better performance than internal drives
- HW based RAID 0,1 and 5
- Connected via the backplane to an adjacent server blade

HP and HP Channel Partner Viewable

Shared Storage Blade



Up to 15 storage blades for the entire enclosure to share

- Optimized for boot, swap, and non-mission-critical data
- Stateless blades – get drives out of the server without giving up local storage
- Single GUI for storage mgmt and provisioning – easy set-up for server admin
- HW based RAID 0,1 and 5

HP BladeSystem c-Class key technologies

Build IT Change-Ready

New! HP Virtual Connect architecture

Eliminating manual coordination across domains.

Build IT Energy-Thrifty

New! HP Thermal Logic technology

Most energy efficiency at a rack, row and datacenter level.

Build IT Time-Smart

New! HP Insight Control management

Best savings, greatest control and most flexibility

across your infrastructure.

HP BladeSystem c-Class

The best-run IT infrastructure out of the box

HP innovations that solve the biggest cost drivers and change barriers of today's datacenters.

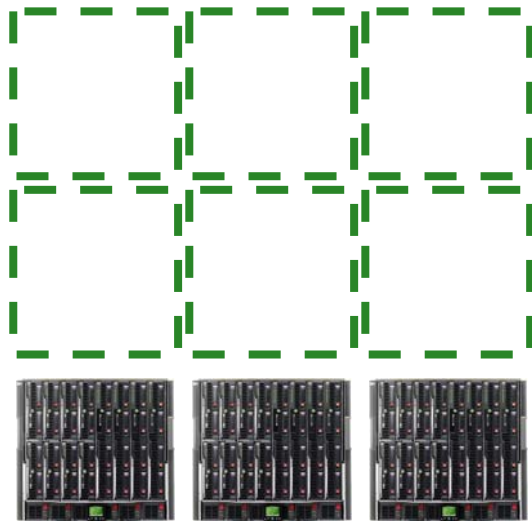

The new, modular building block of next-generation datacenters.

HP and HP Channel Partner Viewable

Build IT Change-Ready

New! HP Virtual Connect architecture

Eliminating manual coordination across domains.

Build IT Energy-Thrifty

New! HP Thermal Logic technology

Most energy efficiency at a rack, row and datacenter level.

Build IT Time-Smart

New! HP Insight Control management

Best savings, greatest control and most flexibility

across your infrastructure.

Too many cables or too many switches and everyone gets in the act...

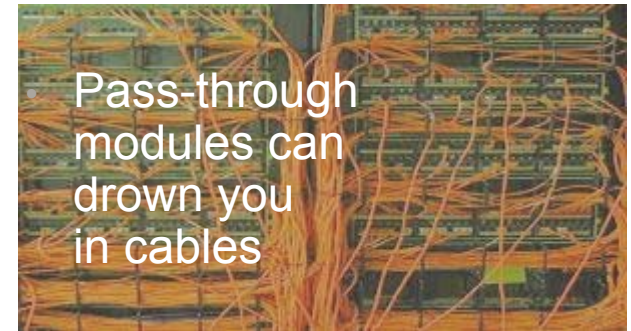
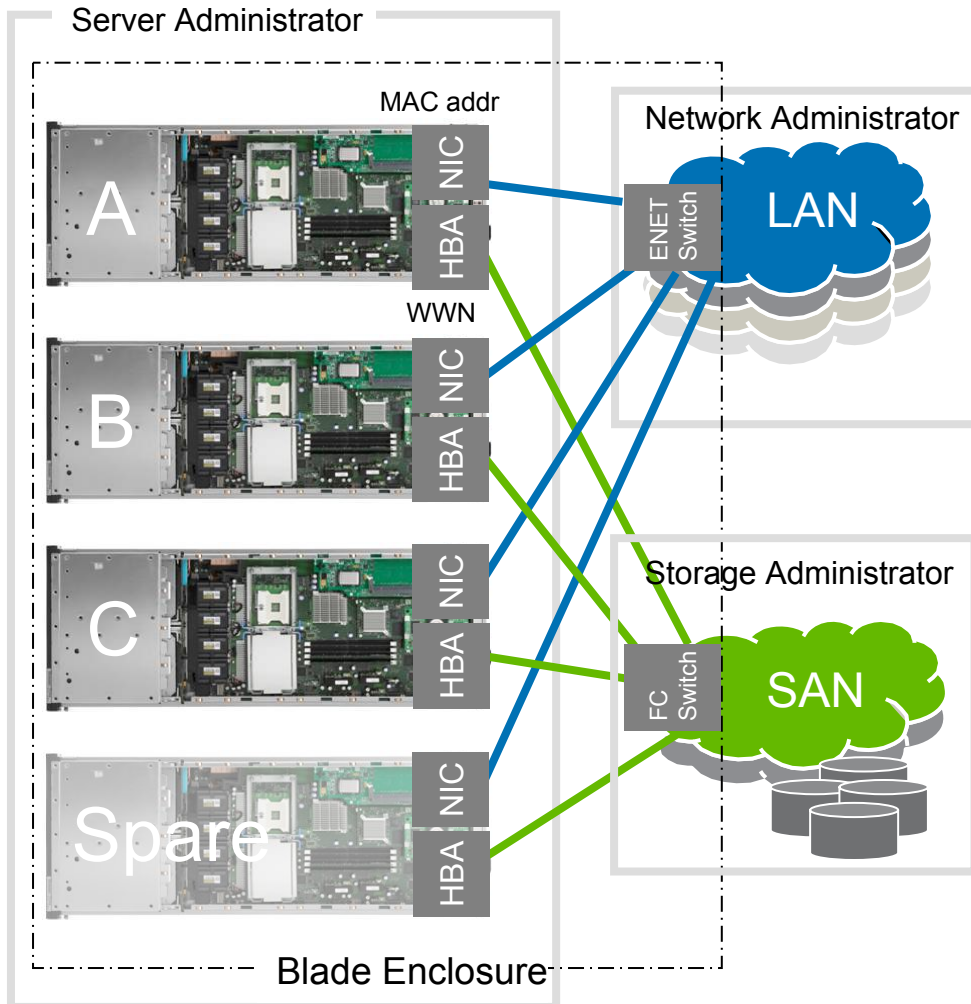

- Switches work great but can overwhelm in numbers 
- LANs & SANs must follow the moving server, requiring effort from everyone and delaying resolution

Virtual Connect solves these & makes IT change-ready

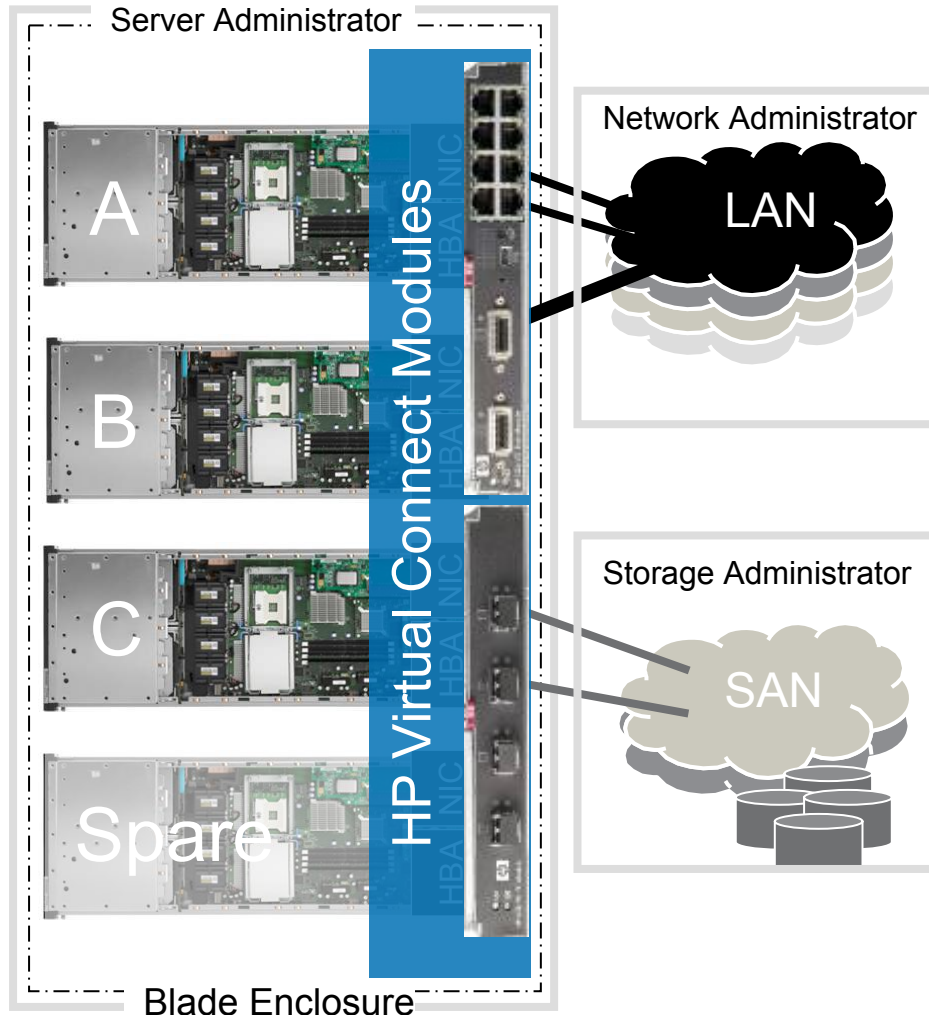

- Reduces cables w/o adding switches to manage
- No new FC domains
- Maintains end-to-end connections of your favorite brands (Cisco, Nortel, Brocade, McData, etc.)
- Cleanly separates Server from LAN & SAN
- Relieves LAN & SAN admins from server maintenance
- Servers are Change-Ready - add, move, replace, upgrade w/o affecting LAN or SAN
 - MAC & WWN are locally administered so LAN & SAN connections stay constant
- Change servers when your business needs it, not when you can fit it into everyone's calendar

Simplify and make your datacenter change-ready with Virtual Connect



Pass-Thru Modules bring too many cables and most expensive connections

Cisco/BNT/Brocade Switches require management effort like large standalone switches

HP and HP Channel Partner Viewable

- **Simplify networks**
 - Reduce cables without adding switches to manage
- **Simplify server connections**
 - Cleanly separate server enclosure from LAN and SAN
- **Change servers in minutes, not days**
 - Add, move, and replace servers fast without affecting your LANs or SANs

change-ready is about how often + how fast

how often is server change? might be more than you realize
& now easier, so you don't need to avoid it...

deployment

addition

development to test

failure

upgrade

test to production

replacement

removal

production to development

how fast is server change? might be slower than you realize

recognize & troubleshoot failure

remove server

replace server

inform & schedule LAN admin

adjust LAN

inform & schedule SAN admin

adjust SAN

test server

Why tie up 3 people when 1 can do the
job?

*if LAN & SAN admins don't need to help,
resolution is faster & they can devote their time to
building & maintaining LANs & SANs*

Example

Wire-Once and LAN & SAN are done!

Traditional Switch/Pass-through Environment

- install rack & enclosure
- cable blade switches/pass-thrus to LAN & SAN switches
- assign LANs & SANs to installed servers

later, when needed



- add new server
 - install server
 - get LAN connection
 - get SAN connection
- add new server
 - install server
 - get LAN connection
 - get SAN connection
- add new server
 - install server
 - get LAN connection
 - get SAN connection



Virtual Connect Environment

- install rack & enclosure
- cable switches/pass-thrus to LAN & SAN switches
- assign all LANs & SANs to pool of 1 to 4 enclosures (1-64 servers)





later, when needed

- install new server & connect 
- install new server & connect 
- install new server & connect 

Example

Virtual Connect Server Sparing: fast + affordable

Traditional Switch/Pass-through Environment

- Either fast or affordable
- Fast N+N:
\$\$buy 2 for every
1 you need
 - assign same LANs & SANs to both
 - on failure use hot standby 
- Affordable N+1:
1 spare for N servers
 - replace failed server with spare
 - update LANs 
 - update SANs 

Virtual Connect Environment

- Fast + Affordable
- N+1:
1 spare for all your c-Class servers
 - assign all LANs & SANs to Virtual Connect pool of servers 
 - replace failed server w/spare

HP BladeSystem c-Class

The best-run IT infrastructure out of the box

HP innovations that solve the biggest cost drivers and change barriers of today's datacenters.



The new, modular building block of next-generation datacenters.

HP and HP Channel Partner Viewable

Build IT Change-Ready

New! HP Virtual Connect architecture

Eliminating manual coordination across domains.

Build IT Energy-Thrifty

New! HP Thermal Logic technology

Most energy efficiency at a rack, row and datacenter level.

Build IT Time-Smart

New! HP Insight Control management

Best savings, greatest control and most flexibility

across your infrastructure.

What's using the power?

- The processor power growth is the largest single contributor but there are many other areas- the more you pack into a server the more power it needs!

BladeSystem helps
in this area

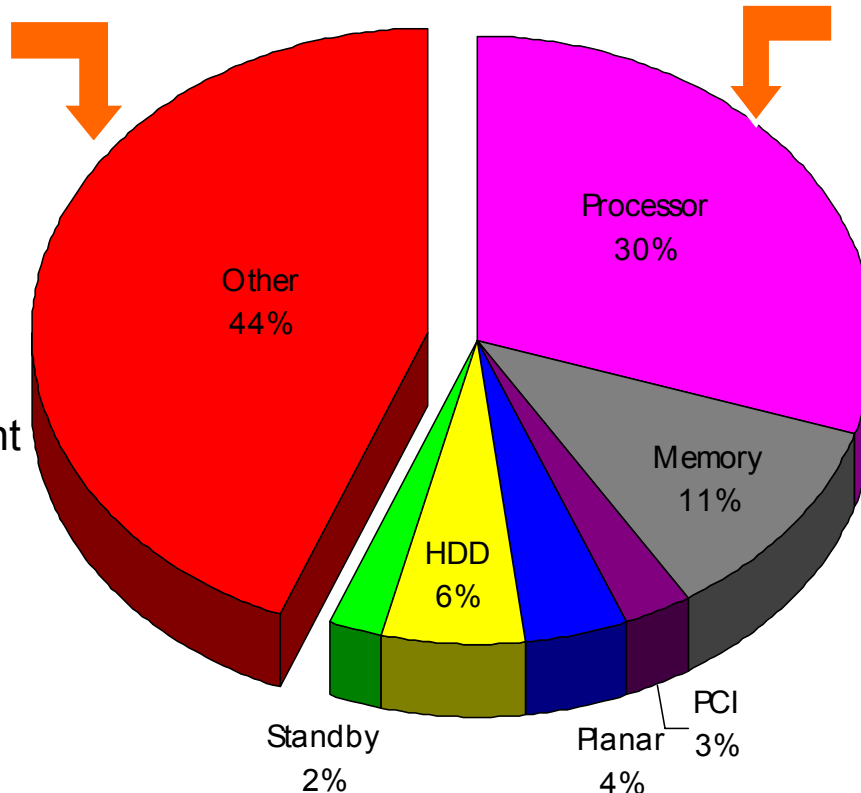

Power Regulator
for ProLiant and
Low Voltage
processors help in
this area

OTHER?

- AC to DC Transitions
- DC to DC Deliveries
- Fans and air movement

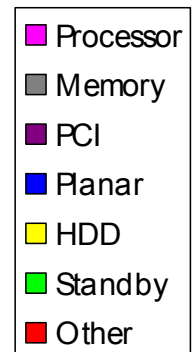

Thermal Logic technology with c-class

- HP Dynamic Power Saver
 - Enables the enclosure to operate at optimum efficiency. Real time monitoring to achieve the best efficiency
- HP Thermal Logic technology
 - Dynamically adapt thermal controls to optimize performance, power, and cooling capacity to maximize power budget and ensure availability.
- Active Cool fans
 - Control algorithm to optimize Airflow, Acoustics, Power, and Performance

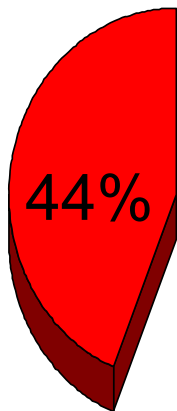

Onboard Administrator

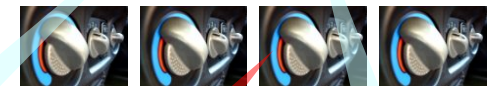

Instant thermal monitoring Real-time heat, power and cooling data

Control algorithm to optimize Airflow, Acoustics, Power, and Performance

Why it matters

- Understand your actual power consumption (greater insight)
- Maximize the performance for given power and cooling envelope/footprint
- Reduces cost to power and plan for availability; for the same number of blades vs. rack mount
- Simplifies up front planning
- Lives with your datacenter's existing power budget

Thermal Logic Management

(Monitoring actual power and cooling in datacenter)



HP Active Cool Fan

- Custom fan design delivering better than industry performance
- High air flow
- High pressure
- Best in class reliability
- Superior acoustics across entire operating range
- Cool Facts
 - 4 Active Cool fans could cool an IBM BladeCenter with N+1 redundancy
 - 1 Active Cool fan could cool 5 DL360G4

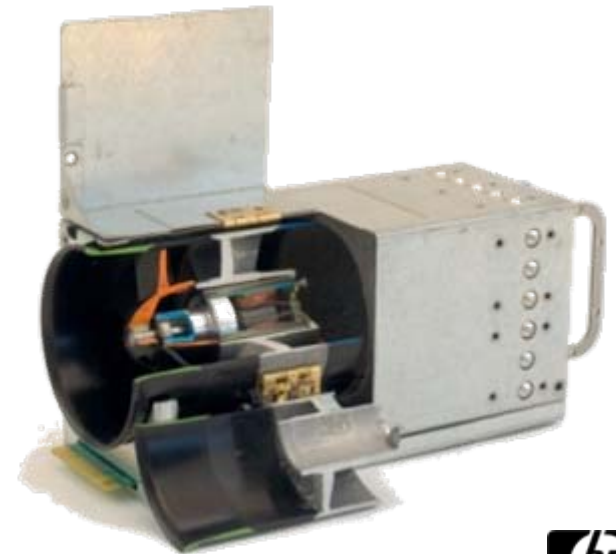

HP BladeSystem c-Class

The best-run IT infrastructure out of the box

HP innovations that solve the biggest cost drivers and change barriers of today's datacenters.



The new, modular building block of next-generation datacenters.

HP and HP Channel Partner Viewable

Build IT Change-Ready

New! HP Virtual Connect architecture

Eliminating manual coordination across domains.

Build IT Energy-Thrifty

New! HP Thermal Logic technology

Most energy efficiency at a rack, row and datacenter level.

Build IT Time-Smart

New! HP Insight Control management

Best savings, greatest control and most flexibility

across your infrastructure.

Introducing Insight Control Management

Powerful combination of new HP BladeSystem intelligent infrastructure and HP management software

HP Systems Insight Manager and Essentials Software



+

Intelligent Infrastructure



Integrated Lights-Out (iLO 2)



Insight Display

Onboard Administrator

=

Total Control

- Take complete control of your blade infrastructure
- Stable and predictable environment

Most Flexibility

- Point and click provisioning and deployment
- Optimize resource allocation to respond quickly to business needs

Tangible Time and Cost Saving

- Maximize admin-to-server efficiencies
- Minimize manual and reactive tasks

HP Onboard Administrator

Simplified enclosure management out-of-the-box

- Simple setup and configuration typical: less than 5 minutes
- Diagnostics for rapid troubleshooting
- Automated power and cooling management
- Integrated local and remote management
- Role based security for servers, network, and storage administrators
- Integrates with Insight Control management software

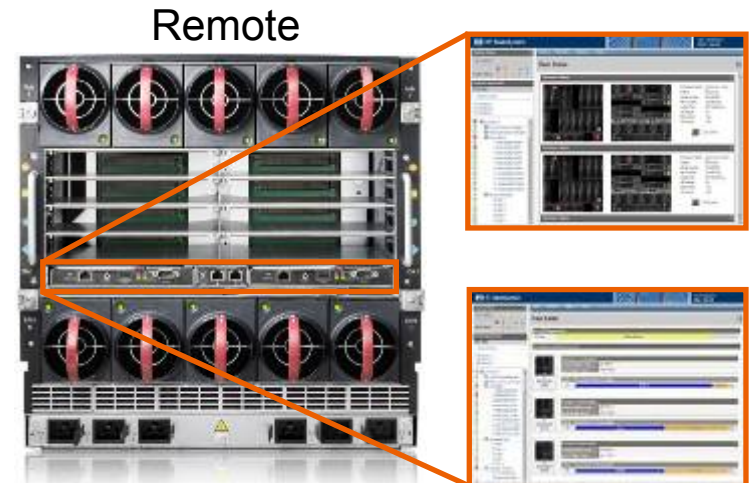

HP Insight Display

Local BladeSystem Management

Simple and easy to learn!

- Simplifies installation and setup
- Visual indicators of faults
- Visual info on ambient inflow temperatures
- Monitors device status
- Graphical instructions on fixing configuration issues
- Secure local management



HP Onboard Administrator

Remote BladeSystem Management



The intelligence of the c7000 BladeSystem!

- Real-time power and cooling control
- Device health and configuration (enclosure, blade, switch)
- Integrated iLO 2 with each server blade providing single sign-on for easy access

HP and HP Channel Partner Viewable

c-Class rack status

HP Onboard Administrator

System Status: 0 0 0 0 1

Wizards Options Help

Rack Overview - HPdevlab02

Rack Topology Rack Power and Thermal

Enclosure 1

Front View Rear View

Enclosure Name: NormBrit01
Serial Number: USE62317RY
Part Number: 412152-B21
Asset Tag: OA-0000Max
UID State: Off

Insight Display
Primary Connection

Enclosure 2

Front View Rear View

Enclosure Name: Snorfmann
Serial Number: 1Z34AB7890
Part Number: 412152-B21
Asset Tag: OA-0000Snorf
UID State: Off

Insight Display
Linked - Logged In

Enclosure 3

Linked - Not Logged In

User Name:

Systems and Devices

Rack Overview

- NormBrit01
- Snorfmann

Enclosure 1

- NormBrit01
 - Enclosure Settings
 - Active Onboard Administrator
 - Server Bays
 - Interconnect Bays
 - Power and Thermal
 - Users/Authentication
 - Insight Display

Enclosure 2

- Snorfmann

Enclosure 3

- Linked - Not Logged In

Status of multiple enclosures

Easy configuration of multiple enclosures, iLOs, and Interconnect consoles

Insight Control Data Center Edition

Next Generation Management for HP BladeSystem



- Integrated software suite simplifies HP BladeSystem provisioning and management
- Single DVD media
- Integrated wizard-driven installer
 - Rapidly install and configure HP SIM and ProLiant Essentials software
- Streamlined licensing model
 - Consolidated key for core ProLiant Essentials management software
 - Simplified license application
- Delivered with HP c-Class Enclosures
 - Software option for p-Class

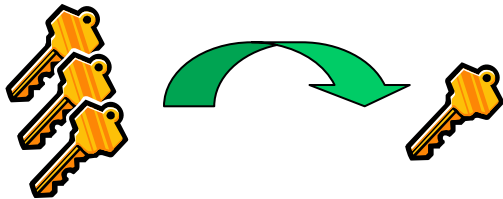

Insight Control Data Center Edition v1.0

Integrated Tools for Time-Smart Management

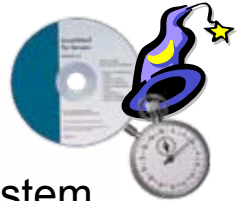

HP Systems Insight Manager

- Central management services
- Unified server and storage mgmt



Graphical BladeSystem
Discovery, Monitoring,
and Administration



Rapid Server and
OS Deployment

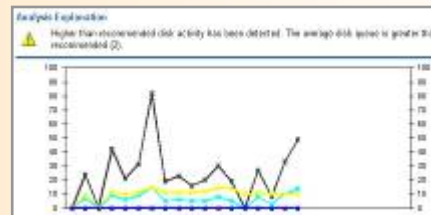

Performance
Management and
Bottleneck Analysis

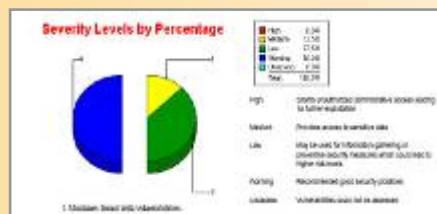

Consolidated Vulnerability
and Patch Management

HP BladeSystem c-Class interconnects options



HP BladeSystem c-Class connect any way you want

Bays for 8 Single-Wide or
4 Double-Wide Interconnect Modules



- Choose the Ethernet, FC, & IB modules you need & plug them in
- Two of same module side-by-side provides redundancy

Interconnect Module Classes

- Virtual Connect
 - Reduce cables without adding switches to manage
 - Cleanly separate Server enclosure from LAN & SAN
- Managed Ethernet and FC Switches
 - Reduce cables with your favorite switch brands
- Pass-Through Modules
 - When you must have a 1:1 server/network connection
 - Ethernet and FC

HP Blade Mezzanines

- Type I Mezz Card
 - Universal Mezz Card
 - 3.97"(100.84)x4.46"(113.28)
 - Max power 15W
 - PCI-Express x4 or x8 interface
- Type II Mezz Card
 - 5.32"(135.13)x4.46"(113.28)
 - Max power 25W
 - PCI-Express x8 interface
- Type I Server Slot
 - Accepts only Type I Mezz cards
 - PCI-Express x4 or x8
- Type II Server Slot
 - Accepts Type I or Type II Mezz cards
 - PCI-Express x8



	Type I x4 Slot	Type I x8 Slot	Type II x8 Slot
Type I x4 Mezz	Yes	Yes	Yes
Type I x8 Mezz	Yes x4 Speed	Yes	Yes
Type II x8 Mezz	No	No	Yes

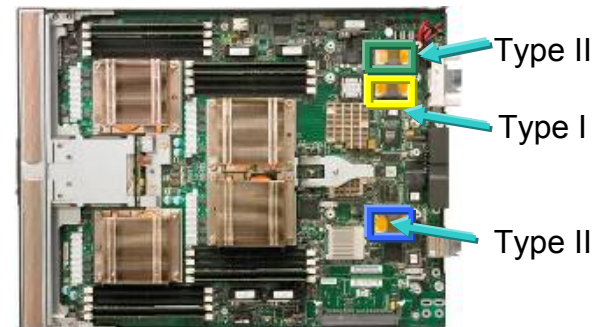

Intel Half-Height Server Blade



Mezz Slot 2

- Type II
- PCI Express x8
- Interconnect Bay 5-6

Mezz Slot 1

- Type I
- PCI Express x4
- Interconnect Bay 3-4

Intel Full-Height Server Blade



Mezz Slot 2

- Type II
- PCI Express x8
- Interconnect Bay 5-6

Mezz Slot 1

- Type I
- PCI Express x4
- Interconnect Bay 3-4

Mezz Slot 3

- Type II
- PCI Express x8
- Interconnect Bay 7-8

Interconnect Mapping with c-class

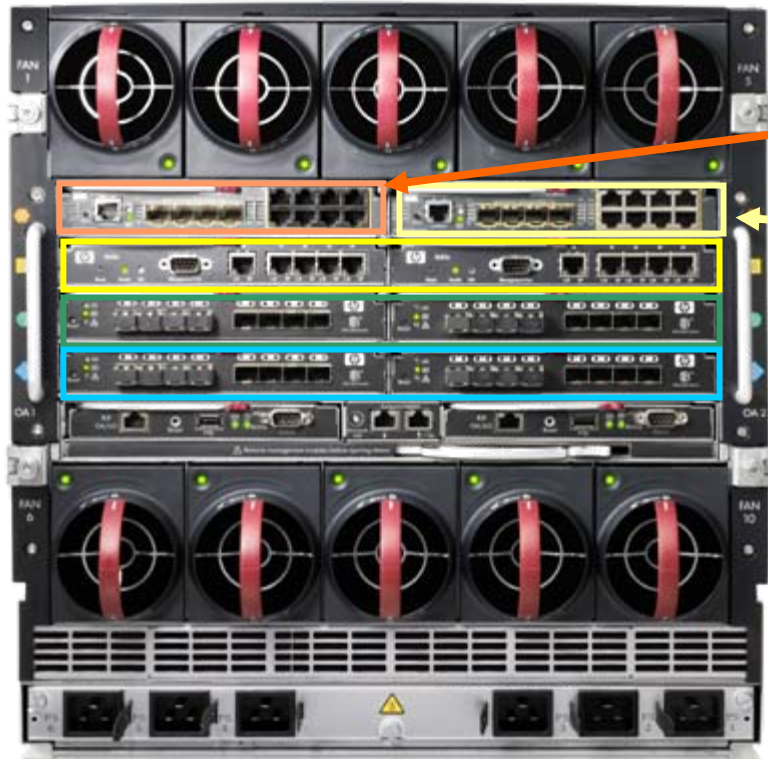

Interconnect bay	Server blade signal
1	NIC 1 and NIC 3 (embedded)
2	NIC 2 and NIC 4 (embedded)
3 and 4	Mezzanine 1
5 and 6	Mezzanine 2
7 and 8	Mezzanine 3 (full-height server blade only)

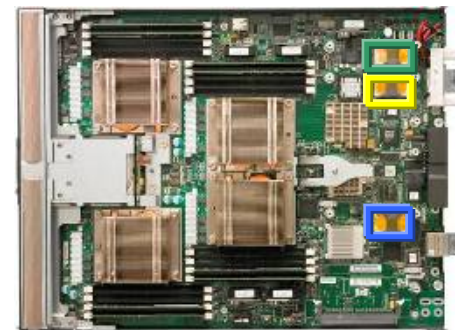
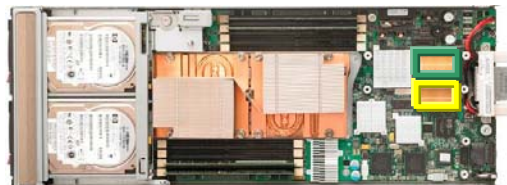

c7000 Interconnect Model (Half-Height Server Blade)

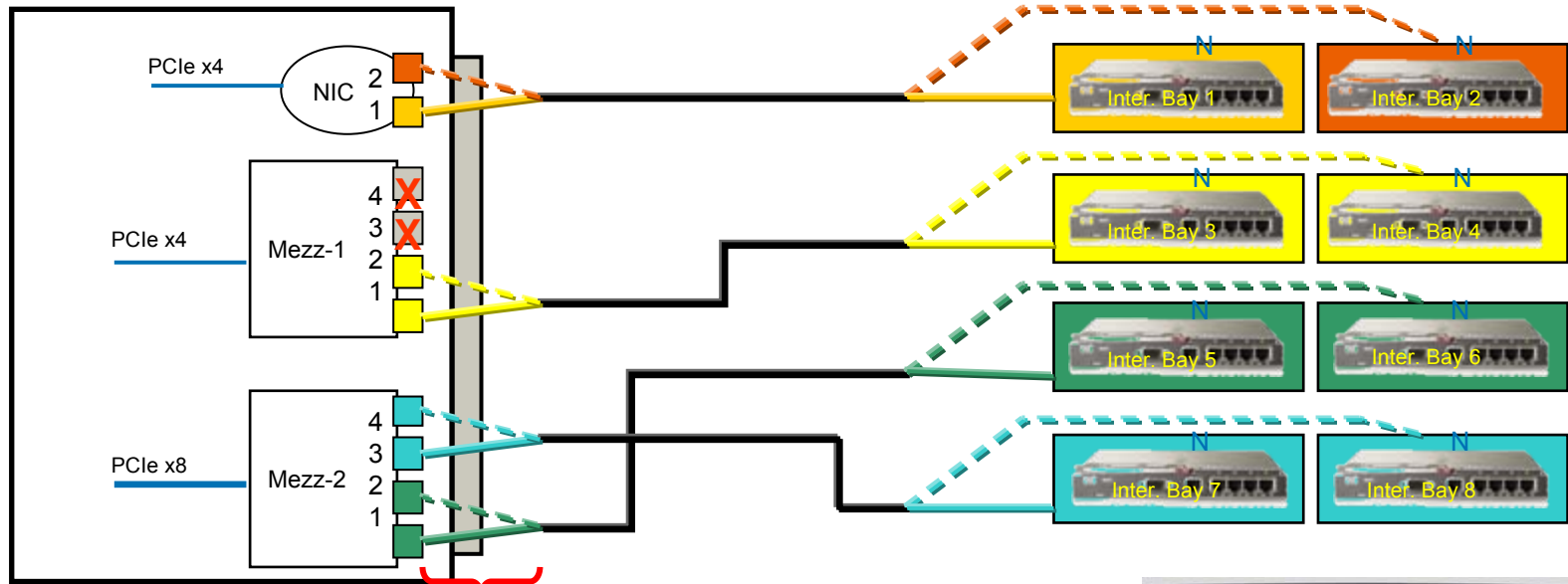

Half-Height Server Blade N
(N= 1 16)

16 Lanes per connector = up to 80 Gb/s

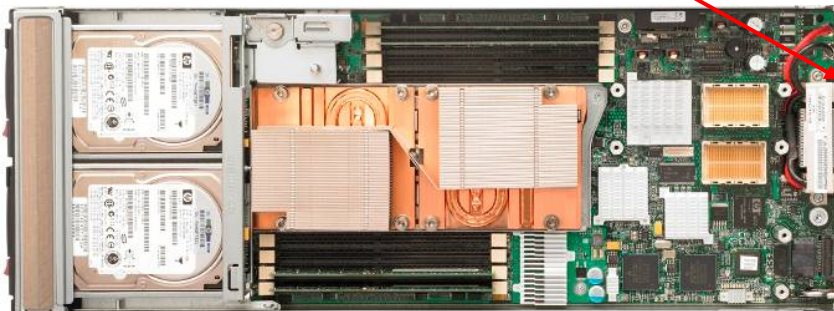

- x1 = 1 lane = 5 Gb/s FD
Can run 2 1Gb NIC
- x4 = 4 lanes = 20 Gb/s FD
Can run 10 1Gb NIC
1 10Gb NIC
- x8 = 8 lanes = 40 Gb/s FD
Can run 20 1Gb NIC
2 10Gb NIC



c7000 Interconnect Model (Full-Height Server Blade)

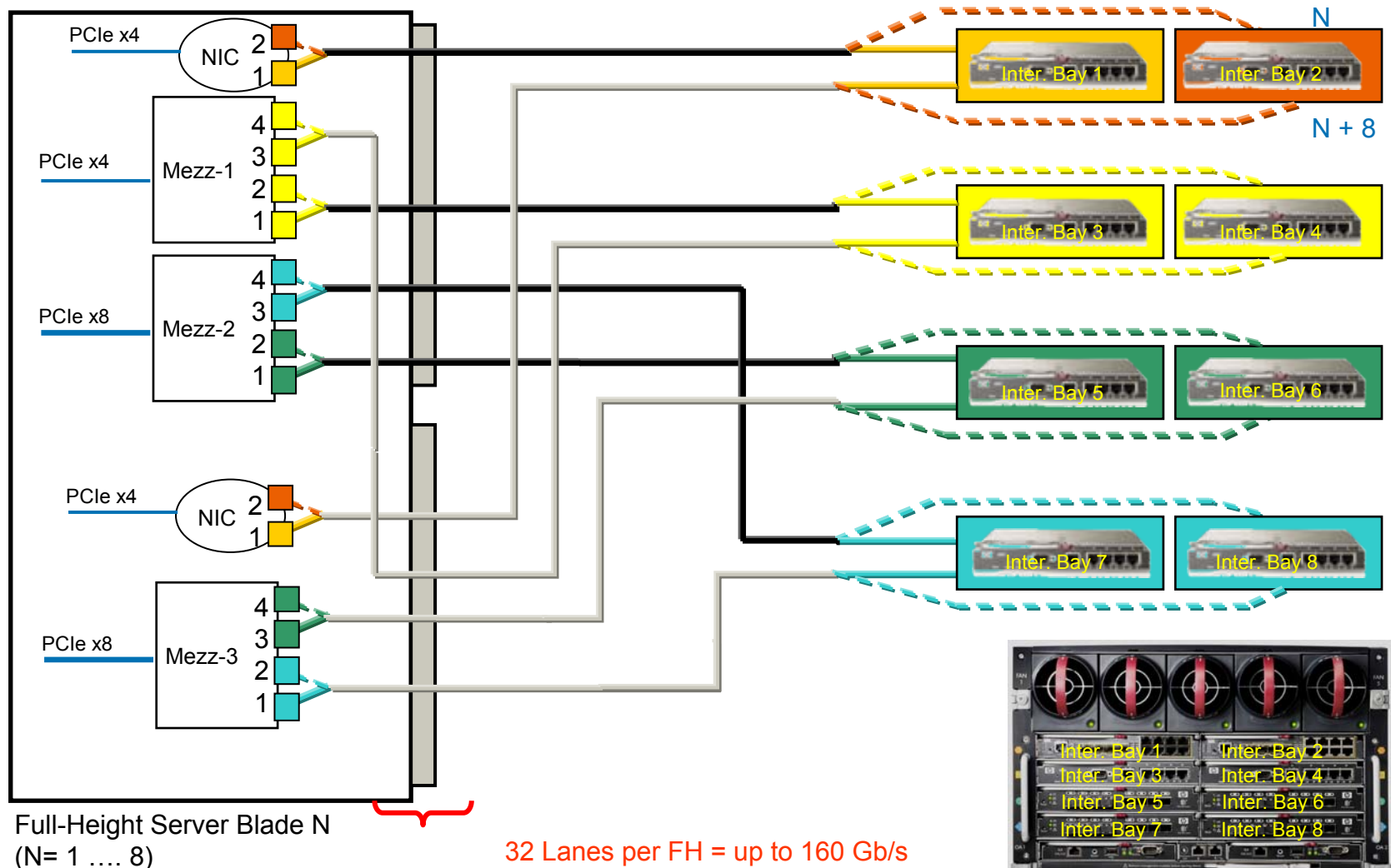

Full-Height Server Blade N
(N= 1 8)

32 Lanes per FH = up to 160 Gb/s

HP and HP Channel Partner Viewable



HP NC326m PCI-Express **Dual-Port** Gigabit Server Adapter for ...HP c-Class BladeSystem

Key new features

- The NC326m is a dual port Gigabit server adapter for c-Class BladeSystems
- Integrated on the BL480c server blade
- Supports the following IEEE standards 802.3, 802.3ab, 802.3ad, 802.3x, 802.3p, 802.1Q
- Each port appears as a four lane (x4) PCI-Express interface for the available mezzanine slots on the blade server
- Comes with a total of 156KB onboard memory

BCM5715S ASIC

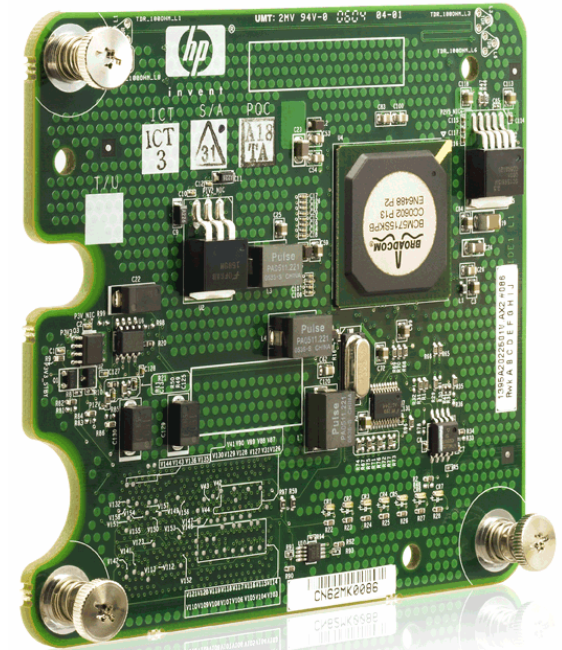

HP NC325m PCI-Express **Quad-Port** Gigabit Server Adapter for HP c-Class BladeSystem

Targeted to customers who need very high port density!

Key new features

Quad-port, PCI-Express copper Gigabit, Type 1 Mezzanine card for c-Class BladeSystem servers
Uses NCDE 8.40 (BCM57xx, TG3 Linux, & NetWare software driver support).

BCM5715S ASIC (x2) w/ bridge ASIC



Port density examples

- BL460c

Embedded NIC ports

2

Mezz ports

2 ports from Mezz 1
4 ports from Mezz 2
Up to 8 ports total

Limitation: The NC325m will function in 2-port BladeSystem mezzanine slots but will only provide connectivity on 2 of its 4 ports.

- Both BL480c & BL685c

4

4 ports on Mezz 1,2, & 3
Up to 16 ports total

HP Multifunction NC373m PCI-Express Dual-Port Gigabit Server Adapter for HP c-Class BladeSystem

HP NC373m PCI Express Dual Port Multifunction Gigabit Server Adapter for HP BladeSystem

Key new features

- First PCI Express dual port multifunction network adapter for HP c-Class BladeSystems
- It supports TOE, iSCSI, RDMA

BCM5708S ASIC

Networking Benchmarks	BW Mbps	CPU Util %	Perf. Index
1Gb/ s Enet	1000	60%	17
TOE	1000	40%	25
1Gb/ s RDMA	1250	15%	74
10Gb/ s RDMA	8500	15%	567

Note: Based on internal HP projections

4X
30X

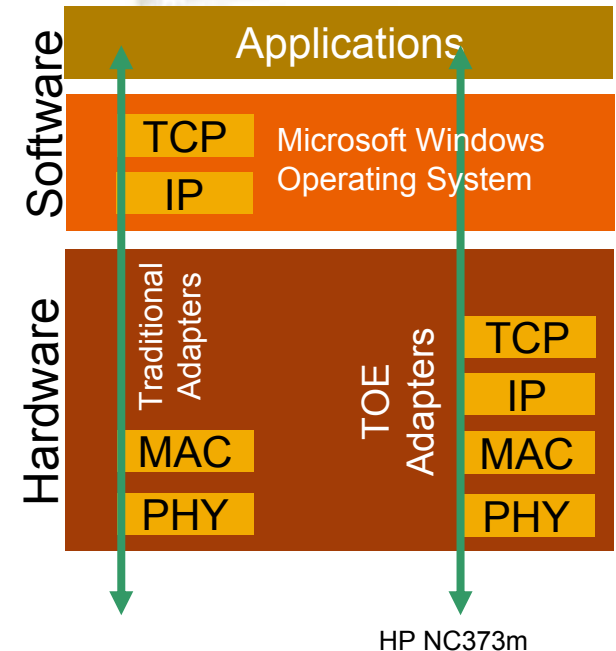

HP 4X DDR IB Mezz HCA

Key new features

4X DDR (double data rate)

20Gb/s each direction

PCI-Express interface

Support multiple mezz HCAs per blade

x8 mezzanine slot for full bandwidth

x4 mezzanine slot at reduced bandwidth

Memory free - Low cost - Low power

Support Voltaire IB driver and host software stack

Same driver and host software stack used in HP's Unified Cluster Portfolio with ProLiant servers

Plan to support Cisco IB stack

Plan to support OpenFabrics stack

Mellanox ASIC

20 Gb/s

World First 20Gbps,
3μsec Latency Capable
Network interface for Blades



Interconnect Modules

Single Wide FC Interconnects



IB Double Wide Interconnect



- **Single-Wide**
 - 16 1x/2x downlinks to server bays
 - Brocade SAN Switch
 - Cisco/BNT LAN Switch
 - FC & LAN Pass Through
- **Double-Wide**
 - IB Quad-DDR
 - Two backplane connectors
 - 16 4X downlink to server bays

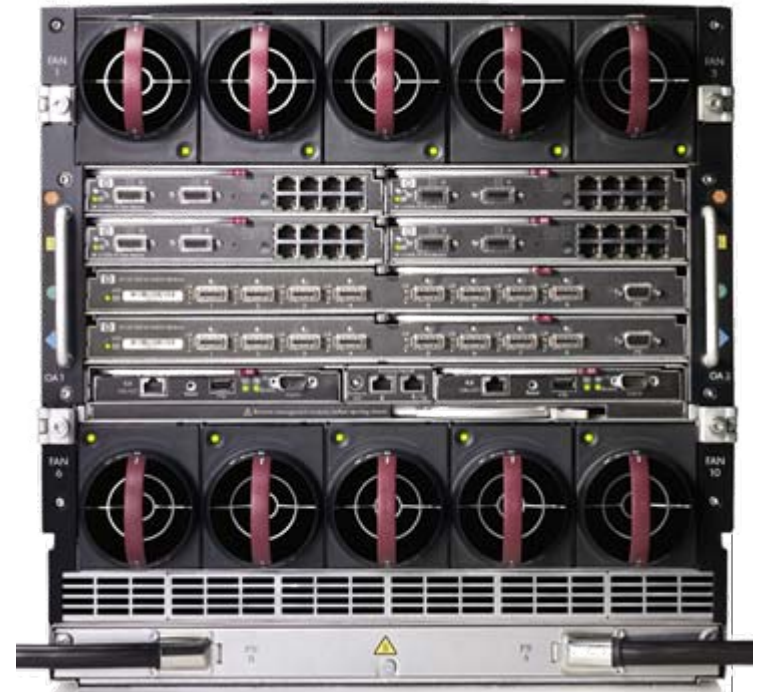

Integrated Gigabit Switches Advantages



- Pass-Through Modules
 - When you must have a 1:1 server/network connection

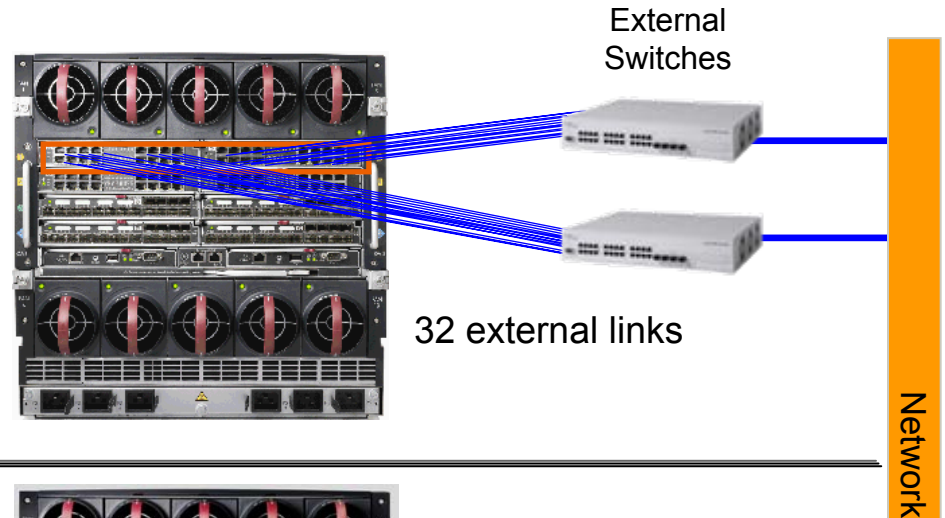

- Ethernet and FC Managed
 - Reduce cables with your favorite switch brands

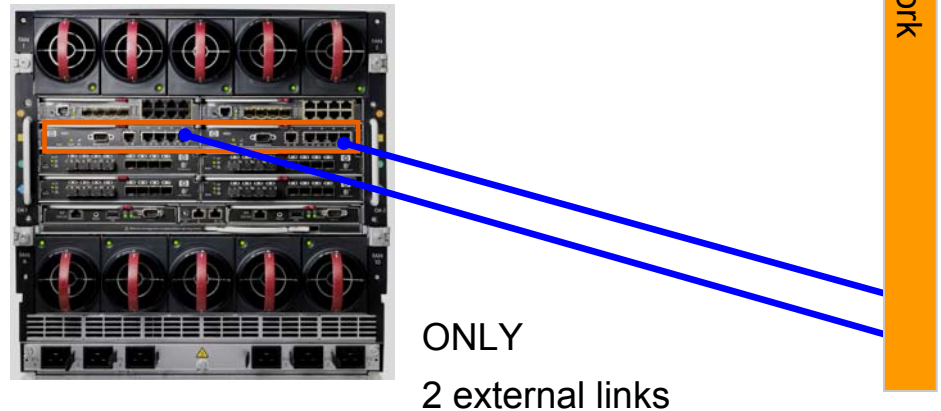

HP BladeSystem c-Class Ethernet Interconnect Portfolio

HP c-Class Ethernet Pass- Through



- Supplier: HP
- BLADE Designed
- Straight-through LAN connectivity
- 1:1 NIC to patch panel connection
- Non-Blocking
- No need for LAN management inside the enclosure
- Full Duplex 1G Ethernet only
- No Autonegotiation
- Redundant connections from servers to external switches with a pair of pass through modules
- Avail: NOW
- **RoHS Compliant**

\$999.00 US

HP c-Class C-GbE2c interconnect kit



- Supplier: HP
- BLADE Designed
- Layer 2 Switching (next version Layer 3)
- 256 VLANs
- 16 STG's
- 5x10/100/1000Base-T (uplinks)
- Avail: NOW
- **RoHS Compliant**

\$1,499.00 US

HP c-Class CGESM interconnect kit



- Supplier: HP/Cisco
- Cisco Designed
- Layer 2+ (QoS)
- 1005 VLANs
- 128 STG's
- 8x10/100/1000Base-T (uplinks and cross connect)
- 4x1000 Fiber SX SFP
- (can be used in lieu of top 4x10/100/1000)

\$4,799.00 US

HP 4X DDR IB Switch Module



- 960Gb/sec total switching bandwidth
- Fully non-blocking Switch
 - 16 4X DDR down links connecting blade servers
 - 8 External 4X DDR ports for scale out
- Multiple switches supported in a c7000 enclosure
 - Redundancy and Aggregate bandwidth

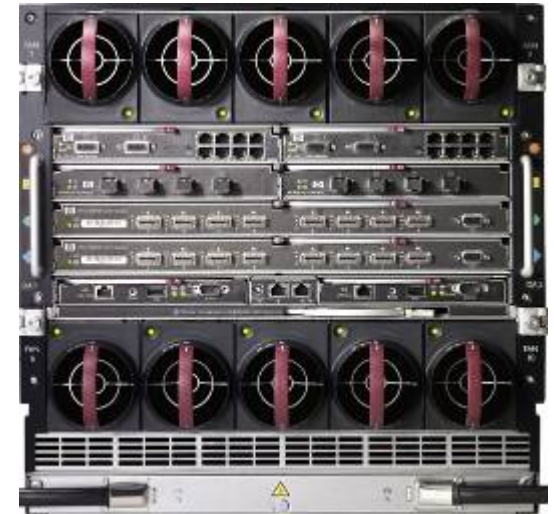

HP BladeSystem c-Class Fibre Channel interconnects



HP BladeSystem c-Class Fiber Channel Interconnect Portfolio

HP c-class Fiber channel Mezzanines



Emulex
LPe1105 FC



QLogic
QMH2462 FC

- Supplier: HP
- BLADE Mezzanine Designed
- Dual port 4Gb Fibre Channel to PCI Express Mezzanine HBA
- PCI Express x 4 bus speeds
- Emulex/Qlogic design and manufacturing
- Simplified SAN Management
- Comprehensive O/S support
- Full fabric support with automatic topology and speed adaptation
- Guaranteed interoperability
- Support for HP StorageWorks and third party storage targets

\$749.00 US

HP c-class Fibre Channel Pass-Through Module



- Supplier: HP
- BLADE Designed
- 16 port FC pass-through
- Fully independent FC ports
- 1 pass-through module per kit
- Order 2 kits for redundant fabric connections
- SFPs included in kit
- Support auto-negotiate feature with independent fabric speed for each port
- 1, 2, & 4Gb connections
- iLO Link for Management

\$4,499.00 US

HP c-Class Brocade 4Gb SAN Switch



- Supplier: HP/Brocade
- Brocade Designed
- Latest generation Goldeneye ASIC
- Designed to interoperate with all industry leading SAN environments (HP, EMC, IBM, and HDS)
- Greatly simplifies packaging and reduces set up times
- “Zero footprint” SAN connectivity
- Eliminates need for host to switch SFPs and cables
- Reduced cost and complexity
- Lower list price than stand alone switches
- Compatibility with all Brocade switches

\$9,500.00 US

HP BladeSystem c-Class

The best-run IT infrastructure out of the box

HP innovations that solve the biggest cost drivers and change barriers of today's datacenters.

Build IT Change-Ready

New! HP Virtual Connect architecture

Eliminating manual coordination across domain

Build IT Energy-Thrifty

New! HP Thermal Logic technology

Most energy efficiency at a rack, row and datacenter level.

Build IT Time-Smart

New! HP Insight Control management

Best savings, greatest control and most flexibility

across your infrastructure



The new, modular building block of next-generation datacenters.

Looking forward

The industry's most comprehensive blade portfolio

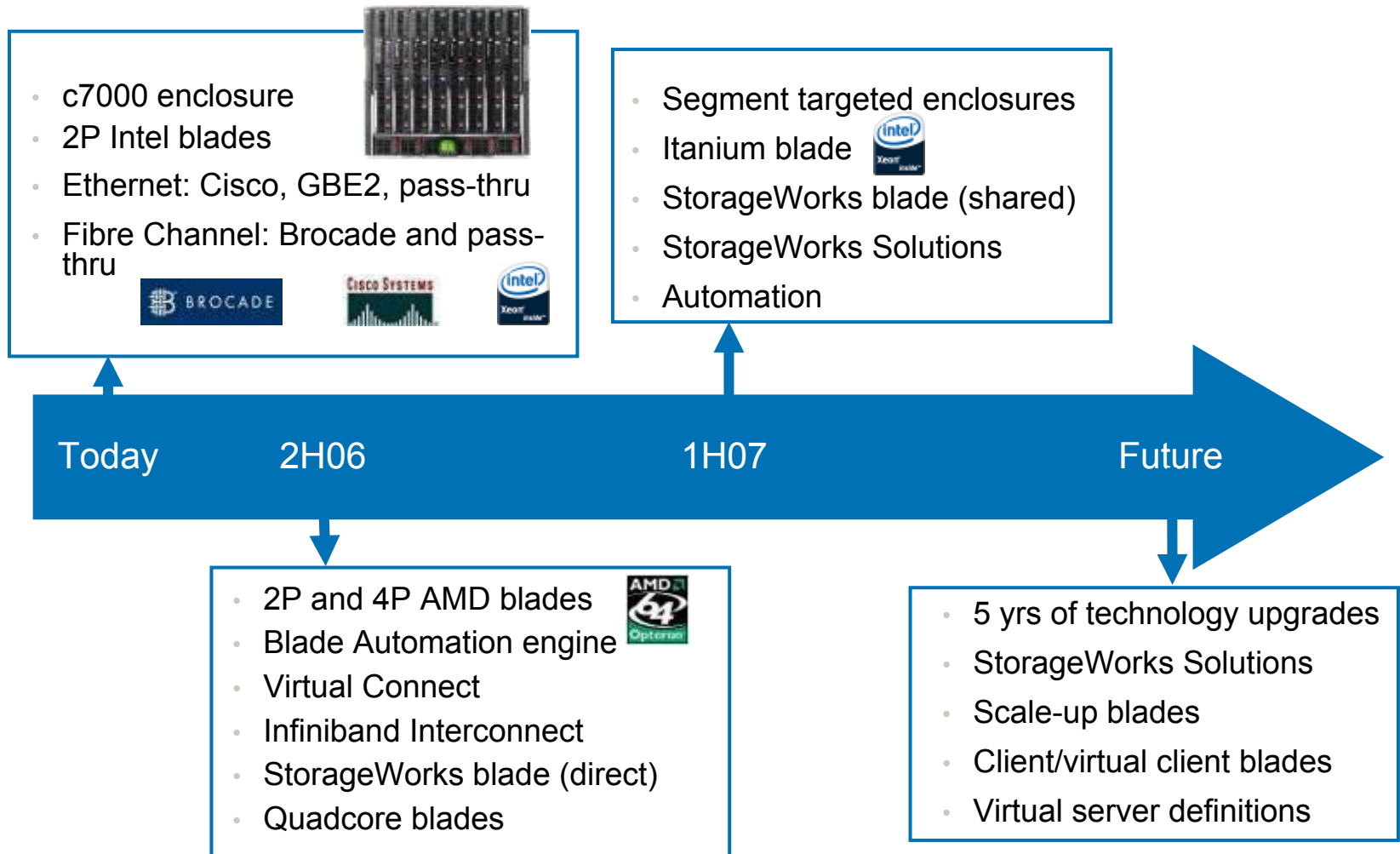

Questions

