

Contents



If you're in a hurry, click on a heading to fast-forward to the information you need ►►

- 1 Thank you**
 - 2 Receiving and unpacking**
 - 3 Handling**
 - 4 Introduction**
 1. Features
 2. Specifications and dimensional drawings
 - 5 Safety first**
 1. Mechanical safety
 2. Electrical and fire safety
 3. Hearing safety
 - 6 Coverage**
 1. Vertical and horizontal responses
 2. Placement
 3. Wall mounting and yoke accessories
 - 7 Connectors and pin-outs**
 1. Phoenix connector
 2. Speakon connector
 3. Loudspeaker polarity
 - 8 Loudspeaker cables**
 1. Recommended cable types and lengths
 2. F101 impedance
 - 9 Amplifier considerations**
 1. Recommended Funktion One power amplifiers
 2. Suitable power ranges
 3. Simple system patches with external control
 4. System patches with Funktion One XO series loudspeaker management
 - 10 Combining with bass systems**
 1. Bass to mid-high alignment
 - 11 Limiters**
 1. XO series limiters with 32dB amplifiers
 2. Limiter settings vs amplifier gain
 3. Limiter settings vs amplifier sensitivity
- Appendix**
- A. Clipping
 - B. Gain structure

1 Thank you

Thank you for purchasing a Funktion One F101 system.

All Funktion One loudspeaker systems are designed and built in England. Our design philosophy is to achieve outstanding sonic accuracy and efficiency through innovative acoustical design rather than relying on headroom-robbing equalisation. This approach provides an audible sense of immediacy and involvement reminiscent of the finest musical instruments.

We know that you'll be eager to install your F101 system and get it up and running immediately, but reading this user guide will help you to achieve the best performance - just as Funktion One intended.

2 Receiving and unpacking

Please check that your shipment is complete and in good condition before signing for the delivery.

- Palletised and wrapped/strapped multiple cartons should only be moved using a fork-lift truck driven by a qualified forklift driver
- Single cartons should be manually handled one at a time

All Funktion One products are tested and inspected thoroughly before being despatched.

Contents

Each F101 carton should contain:

- 1 x F101 complete with:
 - 2 x M8 blanking screws fitted to the side yoke bushes
 - 4 x M8 blanking screws fitted to the rear mounting bushes
 - If Phoenix option has been specified - 1 x 2-pin Phoenix plug (usually fitted plugged onto rear connector)
- 1 x printed Quick Start guide

Unpacking and inspecting

Inspect your shipment packaging and its contents for any signs of abuse or transit damage as soon as you receive it.



Caution

Although F101 systems are not particularly heavy, please be aware that the combination of smooth enclosure finishes and concentrated driver masses can make even small loudspeakers surprisingly easy to drop. Always unpack your systems on a softly covered work-top or on a carpeted floor to avoid accidental damage.

Inform your dealer immediately if your shipment is incomplete or any of its contents are found to be damaged or missing.

We suggest that you keep some of the original F101 cartons in case you have to return a unit for repair or replacement. Funktion One Research Limited and its distributors cannot be held liable for product damaged through the use of non-approved packaging, shipping or handling methods.

3 Handling

- If your F101 systems are destined for an installation, ensure that they remain protected by their packaging until the installation site is clean, secure and ready to accept them
- Try to avoid placing F101 systems face-down. Although fitted with tough, powder-coated steel grilles, these grilles are optimised for unimpeded sound transmission and may suffer dents and scratches from heavy handling

4 Introduction

The F101 loudspeaker brings Funktion One's unique sound quality and purity of design to a wider audience than ever before, offering a fresh choice to those searching for sonic involvement from a small source.

The F101 delivers excellent bass definition and vocal intelligibility, attributes not usually present in compact loudspeakers. In common with our larger scale systems, this loudspeaker also provides high imaging detail and clarity. Furthermore, with Funktion One's exceptional enclosure tuning and driver optimisation, no processor or system equalisation is required, maximising the fidelity, performance, natural simplicity and cost effectiveness of this product. Its sensitivity of 101dB for 1 Watt at 1 Metre is unprecedented for this class of loudspeaker. Out of operating band low frequency protection is incorporated.

The F101 neatly fills a niche between the F81 and the Resolution 1 being ideal for many applications including studio reference monitoring, AV presentations and theatre use. In 2010, the F101 was awarded the DJ Magazine Tech Award for Studio Monitor of the Year.

The F101 forms a potent system when complemented with Funktion One bass enclosures including the MB210LP, MB212, F118 and F215

4.1 Features

- Compact enclosure with high output
- Wide dispersion
- 10" and 1" drivers optimised to Funktion One specification.
- Excellent Sensitivity
- High passive crossover point to HF driver for low distortion
- Choice of Speakon or Installation connectors
- M8 mounting and attachment points
- Curved powder-coated mild steel grill
- Integral pole mount

4.2 Specifications

Driver complement:	10" cone driver 1" compression driver
Frequency response:	85Hz – 19kHz
Dispersion:	90° horizontal x 70° vertical
Sensitivity:	101dB spl for 1W at 1m
AES power:	150W
Max long-term rms voltage:	34.6vrms
Max peak voltage:	69.2vpk
Recommended amp power:	300-600W into 8ohms/600-1200W into 4ohm with suitable limiters
Nominal impedance:	8 ohms
Connectors:	2 x NL4 Speakon or Phoenix installation connector
Fittings:	Integral "top-hat" pole mount 2 x M8 yoke mounting bushes (one per side) 4 x M8 wall bracket bushes on rear
Weight:	10.1kg (22.2lb)

Dimensions

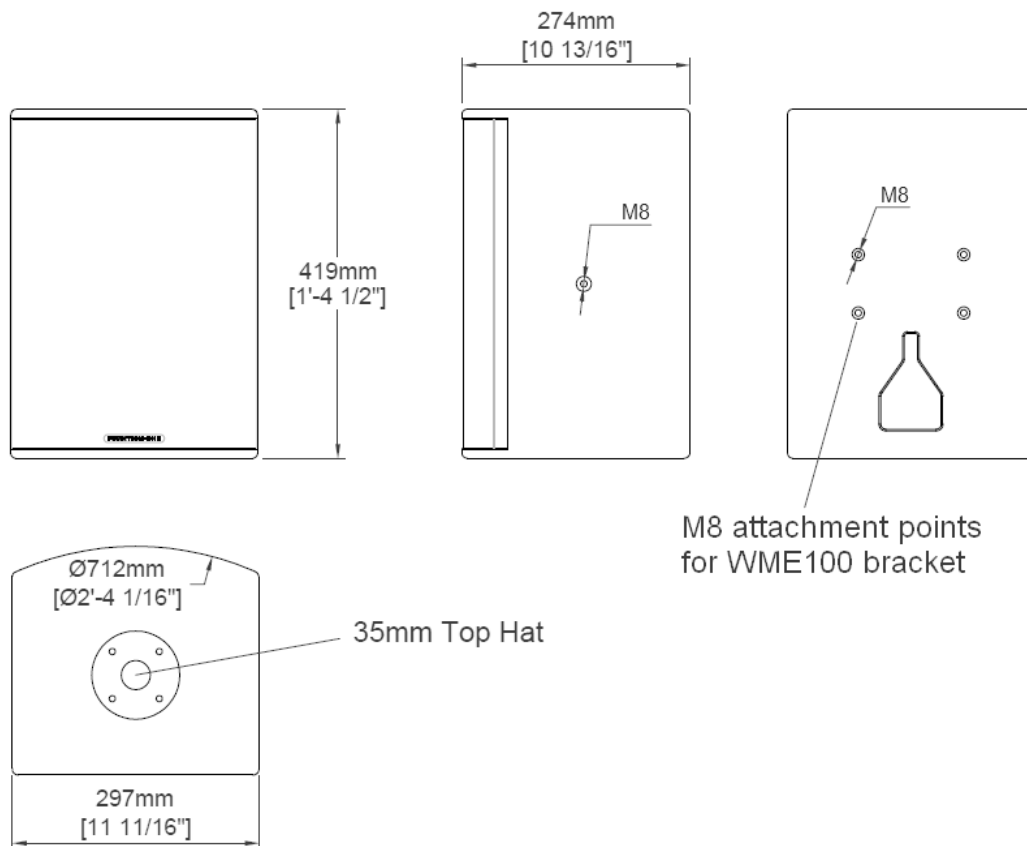

Fig 4.2-1 (all dimensions in millimetres and feet & inches)

5 Safety first

Funktion One wants you to continue to enjoy the world of music. Please take time to review the following safety advice for your own wellbeing and for the wellbeing of those around you.

5.1 Mechanical safety



Qualified and experienced installers

Ensure that rigging and installation work is completed by fully qualified and experienced installation personnel

Your F101 loudspeaker system comes complete with an M8 bush on each side for yoke mounting, four M8 bushes on the rear of the enclosure for bracket mounting and a “top hat” socket on the bottom for pole mounting.

For safety, and ease of installation:

Free standing loudspeakers

- Free-standing loudspeakers can vibrate and move when driven hard. Always secure loudspeakers so that they cannot fall and cause injury

Brackets and yokes

- Use only Funktion One-recommended brackets and yokes with your F101. [See section 6.3](#)
- Do not mount more than one F101 from a single yoke or bracket
- Always attach a separate safety wire rope to each yoke’s safety point
- Follow the mounting advice. [See section 6.3](#)

Pole mounting

- Make sure your pole mount is compatible with the F101’s 35mm pole socket and is a snug fit. Always check the stand manufacturer’s specifications
- Make sure that the pole mount stand will support the weight of the loudspeaker. Again, check the stand manufacturer’s specifications
- If using more than one F101 on the same stand, check that the stand is designed for multiple loudspeakers
- Always place your stand on a level surface and check that its legs are fully extended and locked
- Make sure that stands do not present a trip hazard
- Use a load spreader under each stand foot if the ground is soft or water-logged
- Fully secure outdoor stands so that they cannot fall over in high winds
- Make sure that cables do not present a trip hazard which could cause injury or pull the speaker over

Observe similar precautions when combining full-range loudspeakers with subwoofers.

5.2 Electrical and fire safety



Qualified and experienced technicians

Funktion One F101 loudspeakers are very efficient and require relatively low voltage levels. However, in line with any other electrically powered device, a few precautions are worth noting. If in doubt, seek help from a professional system technician.

Cabling

- Use only Funktion One recommended loudspeaker connectors wired so that the cable conductors are fully shrouded
- Use the appropriate cable conductor gauge. [See section 8.](#)
- Ensure that your cables are in good condition and free from damage
- Ensure that there are no loose conductor strands to short out and create a fire hazard
- If you re-use older cables, strip them back a little, wherever possible, to expose clean conductor ends that are free from corrosion
- Use fire retardant or low emission cables where these have been specified by the contract or by local safety regulations

Amplification

- We suggest electronically limiting maximum amplifier power of 150W average/ 600W peak
- Remember that heavily clipped signals can double a power amplifier's output. [See appendix A.](#) If heavily clipped signals are expected due to equipment with inadequate headroom in the signal path, inexperienced operators etc., set rms and peak output limiter thresholds 3dB below the loudspeaker's AES ratings. [See section 11.](#)

General

- There are no user-serviceable parts inside your F101 system. Do not dismantle the unit
- F101's are not designed for use in damp conditions and should not be exposed to water

5.3 Hearing safety



Enjoy your system responsibly

Funktion One loudspeaker systems are designed to provide extensive audience coverage at low distortion and are capable of producing very high near-field sound pressure levels.

The richness and impact of a powerful sound system can be great fun and very exhilarating; but please enjoy your Funktion One system responsibly by following the advice below...

- Don't place your ears too close to high power loudspeaker systems. Erroneous patching or unmuting could generate unexpected and damaging sound pressure levels during set-up.
- Don't place high power loudspeakers too close to audience members. Individual audience members should not be exposed to levels significantly greater than the sound operating area
- Wearing ear plugs may be a sensible precaution during system set-ups but remember that you have a duty of care towards the venue staff and the audience. Mix engineers, DJs, subcontractors and venue management should avoid making not make system level and equalisation decisions whilst wearing ear plugs as this could overexpose venue staff or the public in the vicinity
- Hearing loss is cumulative and can result from long-term exposure to sound pressure levels as low as 85dBA. Installers should consider long-term staff exposure when making high power loudspeaker placement and aiming decisions. Check the relevant noise exposure/noise at work regulations and comply with them. If in doubt, seek expert advice.

6 Coverage

Your F101 loudspeaker system has been designed to provide excellent performance without resorting to complex positional or spacing requirements, but it's worth spending a couple of minutes reading through the following sections on horizontal and vertical coverage, placement and mounting accessories to ensure you get the best performance possible at all times.

6.1 Vertical and horizontal responses

The horizontal and vertical response plots show the on-axis (upper trace) and off-axis (lower trace) responses.

The F101 has been designed to work well as a stand-alone system without off-axis room colouration.

Its high frequency response maintains a useful off-axis spectral balance.

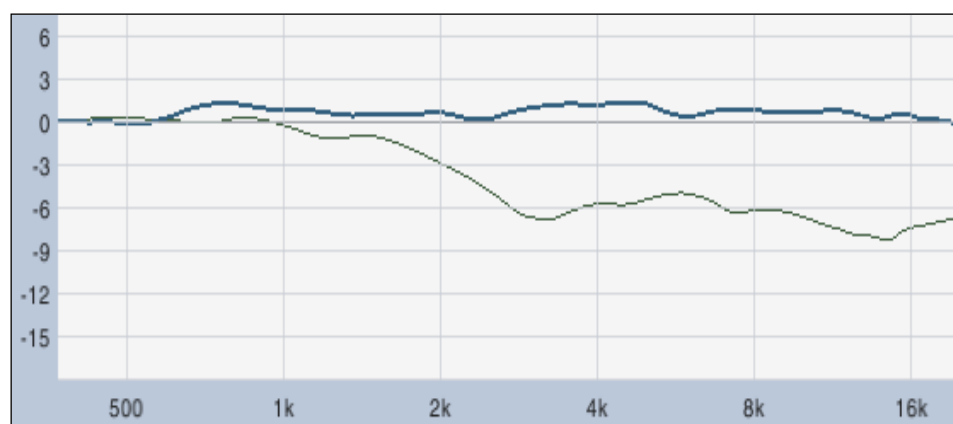

Fig 6.1-1

On-axis vs horizontal 45° off-axis response

This has several advantages:

- The system sounds good over a wide listening area
- Off-axis spill is lobe-free - minimising room colouration



Fig 6.1-2 On-axis vs vertical 35° off-axis response

6.2 Placement

Vertical aiming



Fig 6.2-1 Poor vertical aiming

Avoid aiming your F101 straight over the audience's heads as this will increase room effects causing poor impact and intelligibility.

Even if the room has good acoustical properties, your audience will enjoy far better sound quality if the system is aiming towards them.

Mounting your F101 systems 2.8 – 3.3m above the floor and aiming them towards head height about 2/3rds across the audience will provide smooth coverage without over-exciting the room.

See next page...

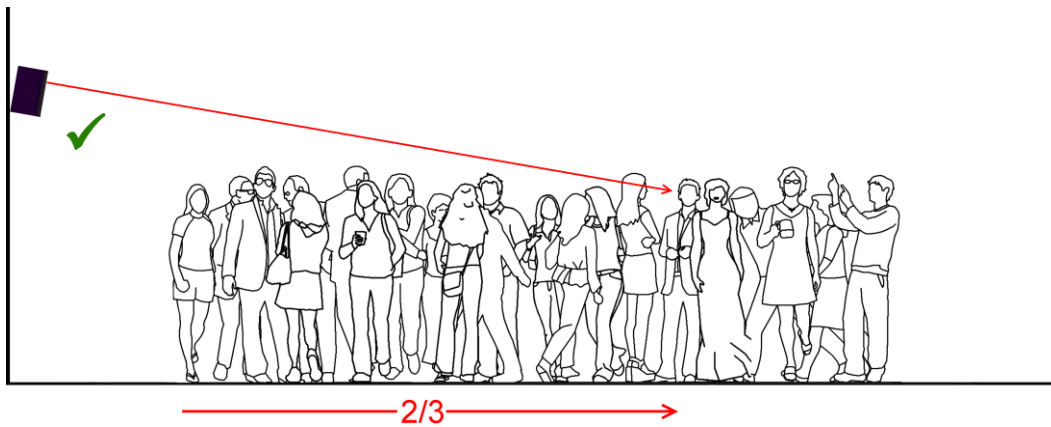

Fig 6.2-2 Improved vertical aiming

Audience members near the F101s will benefit from their smooth vertical mid-high characteristics. These listeners will still enjoy the F101s' rich, broadband sound, but the subtle off-axis roll-off will compensate for proximity.

Multiple loudspeaker systems

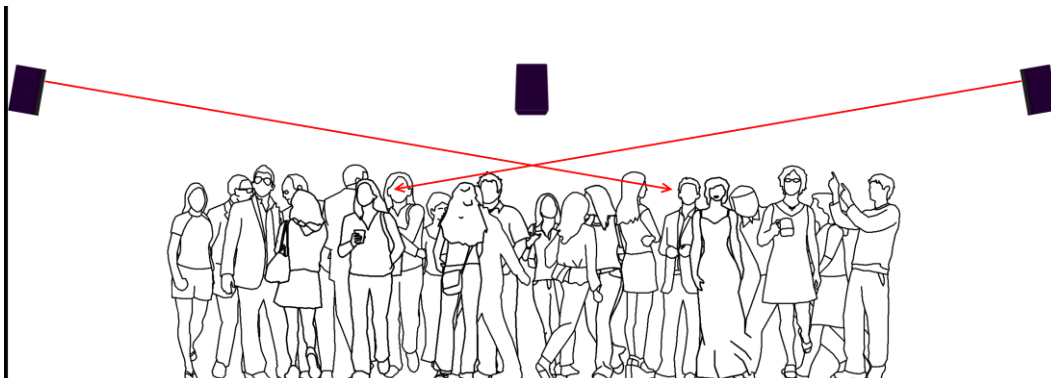

Fig 6.2-3 Aiming multiple F101s for concentrated coverage

Multiple F101s may be used to concentrate coverage into a specific area. This will provide audience members with a pleasant, enveloping experience.

Minimising difficult room effects

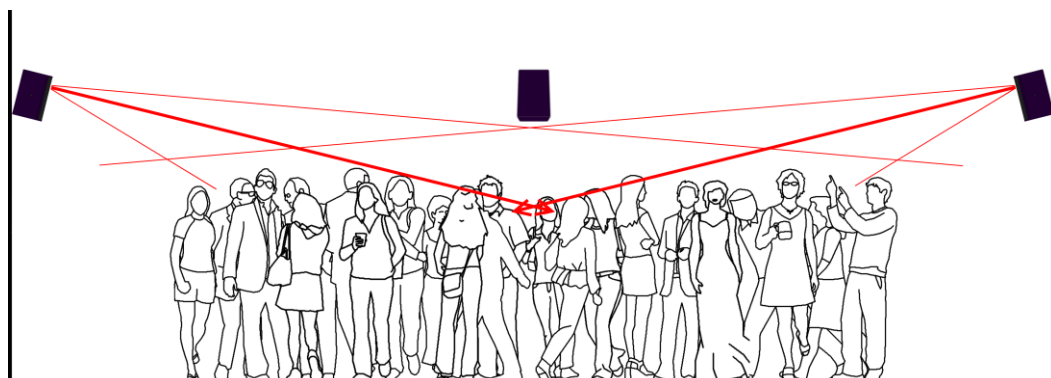

Fig 6.2-4 Raising and tilting F101s for more concentrated central coverage in difficult acoustics

Difficult room effects can be minimised by aiming your F101s towards head height at the centre of the audience area. This ensures that coverage is concentrated onto the main audience area and away from the walls.

The strong central summation combined with the smooth off-axis performance around the edges will provide even coverage with minimal overspill.

Horizontal aiming

Stereo set-ups



Fig 6.2-5

Poor horizontal aiming

Avoid aiming your F101 straight out as this can increase side wall effects and will cause coverage gaps in between the loudspeakers.

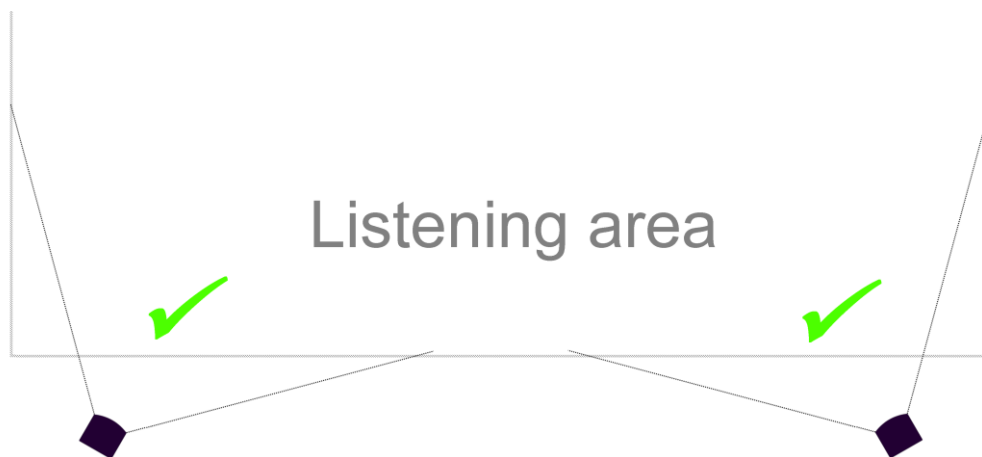

Fig 6.2-6

Improved horizontal aiming

Even if the room has good acoustical properties, your audience will enjoy far better sound quality if the system is toed in towards them rather than reflecting off the side walls.

The classic 60° stereo set-up (see next page) was devised for personal monitoring or home listening over a relatively small listening area. Achieving good stereo imaging for larger spaces can be a challenge due to the much larger left-right propagation times involved.

The 60° angle is not critical. The appropriate set-up for your particular application will be an intelligent compromise between stereo imaging and coverage without too much spill onto side walls.

The best way to ensure the widest possible stereo listening area is to aim your left and right F101 systems, both horizontally and vertically, so that their on-axis lines cross over at ear height at approximately 2/3 the distance to the rear of the audience.

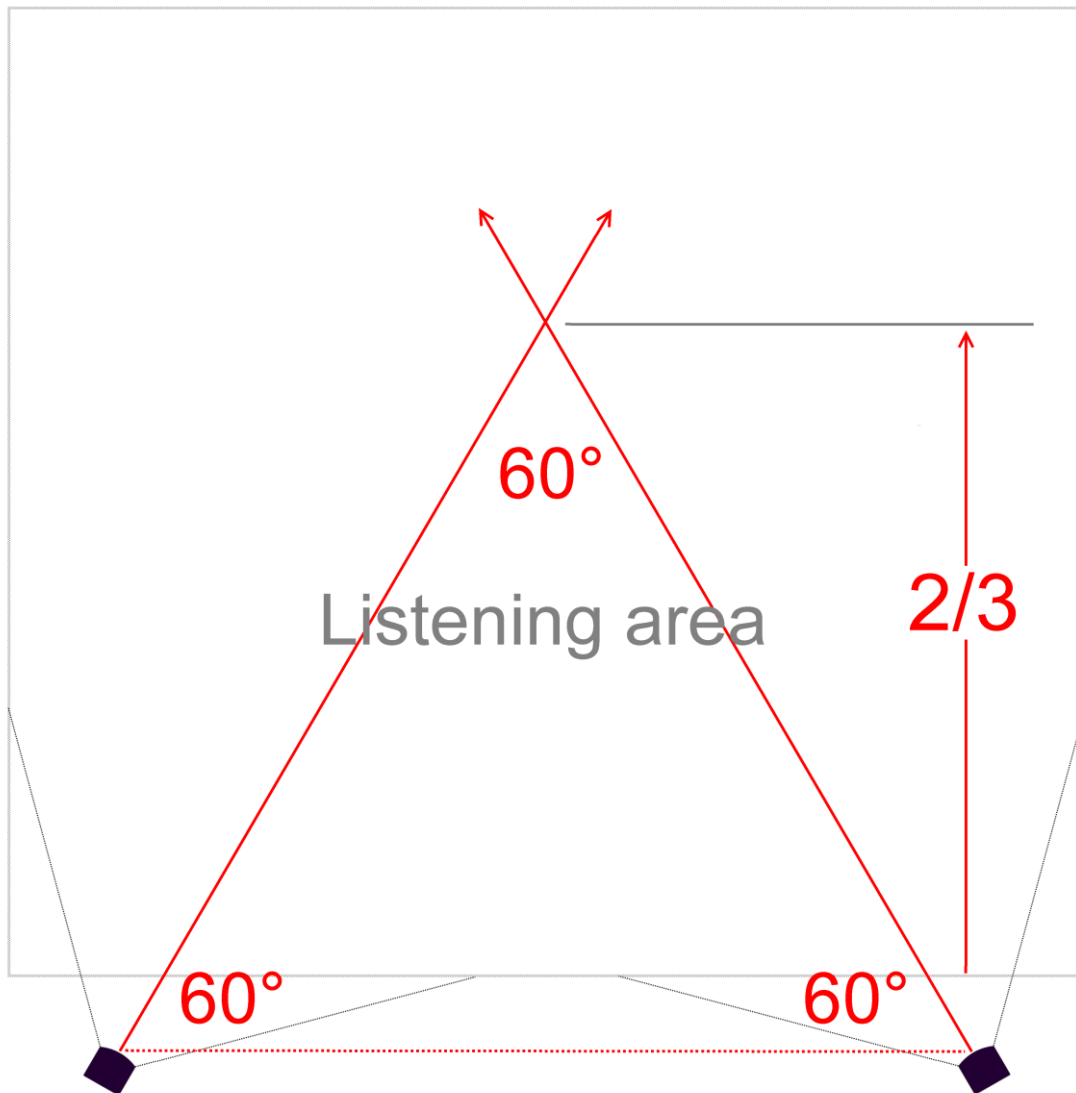

Fig 6.2-7

Classic stereo set-up



2/3rds rule for audio-visual applications

If your loudspeaker system is providing front left and right sound for a specific video screen, place your loudspeakers so that their high frequency units are approximately 2/3rds up the screen and then tilt them so that they aim approximately 2/3rds across the audience area.

The above aiming rules still apply, of course.

Multiple loudspeaker systems

Where multiple loudspeakers are to be used to concentrate coverage into a specific area, your F101's 90° horizontal coverage allows simple four-corner set-ups for foreground music coverage.



Generally speaking, every time you double the number of loudspeakers at equal distances from you, you'll increase sound pressure level by between 3 and 6dB. The exact figure will depend on the programme material.

If you're at the central "sweet spot" of a stereo loudspeaker system, centrally-panned signals – e.g. vocals or bass – will sum up to 6dB, whereas stereo signals will sum up to 3dB.

In the 4-speaker example, this summation effect will be doubled and concentrated towards the centre of the audience area. As audience members move towards the centre – away from the loudspeakers - this 4-speaker summation will partially compensate for distance. This leads to very smooth level coverage.

If the architecture allows, always try to keep your loudspeaker positions symmetrical in the room.

Large-scale distributed loudspeaker systems

If wide coverage is more important than stereo or multi-channel operation (e.g. for a conference venue or large lecture theatre), a mono, distributed system may be a better option.

The example (overleaf) uses 12 F101s to cover a 40m wide, 180°, fan-shaped audience.

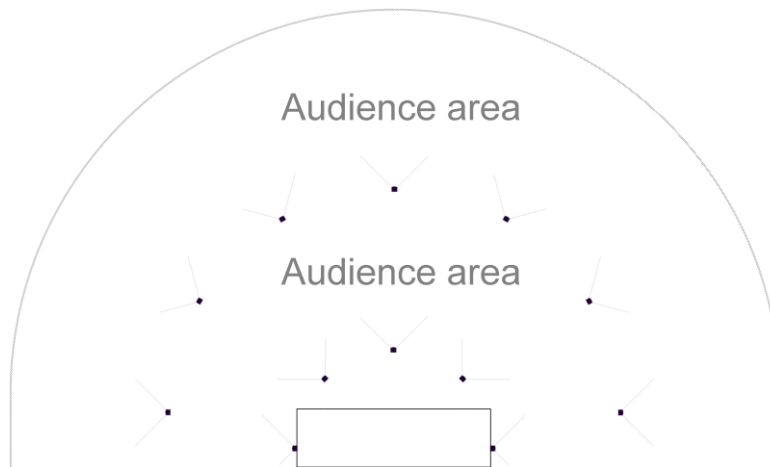

Fig 6.2-9 Large-scale distributed system - horizontal

Remember that, in circular or fan-shaped rooms, the second (delay) ring covers a radially expanding audience area so more loudspeakers are required to maintain smooth coverage.

In this example the platform F101s are placed every 45° and the second ring F101s are placed every 30°.

Vertical aiming and time alignment

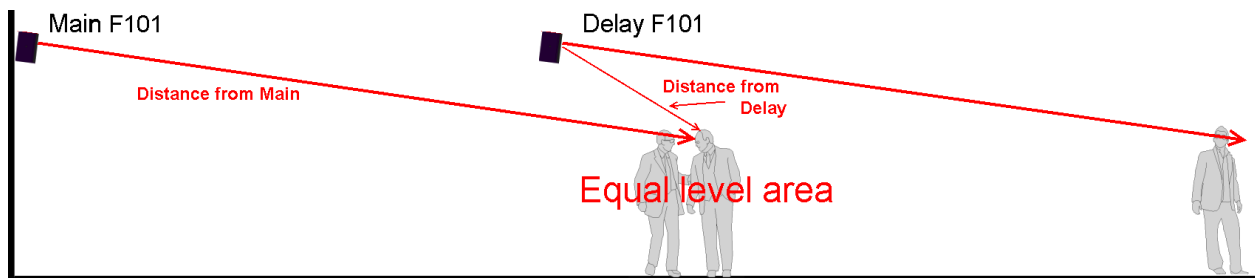

Fig 6.2-4 Distributed system – vertical

Aiming

Design the system for a smooth coverage “crossover”, at ear level, between main and delay areas. But avoid excessive overlap as this will cause multiple arrivals and could reduce intelligibility.

Alignment procedure

- Adjust the Delay F101 spl level for a smooth, equal level overlap area
- Add the appropriate electronic delay* to the Delay F101 signal
 - * This additional delay can be calculated if you know the relevant distances.
 - The required delay, in milliseconds, will be:

Metric: $(\text{Distance in metres from Main F101} - \text{Distance in metres from Delay F101}) \times 2.91 \text{ milliseconds}$

Imperial: $(\text{Distance in feet from Main F101} - \text{Distance in feet from Delay F101}) \times 0.887 \text{ milliseconds}$

(Hint: If you don't have a calculator, the multipliers may be rounded to 3.0 for metric and 0.9 for imperial)



Real-world testing

Make final level adjustments in a real-world situation - with lots of audience absorption, background noise and chatter. This will highlight any coverage or intelligibility weak spots that may need correcting.

6.3 Wall mounting and yoke accessories

Wall bracket

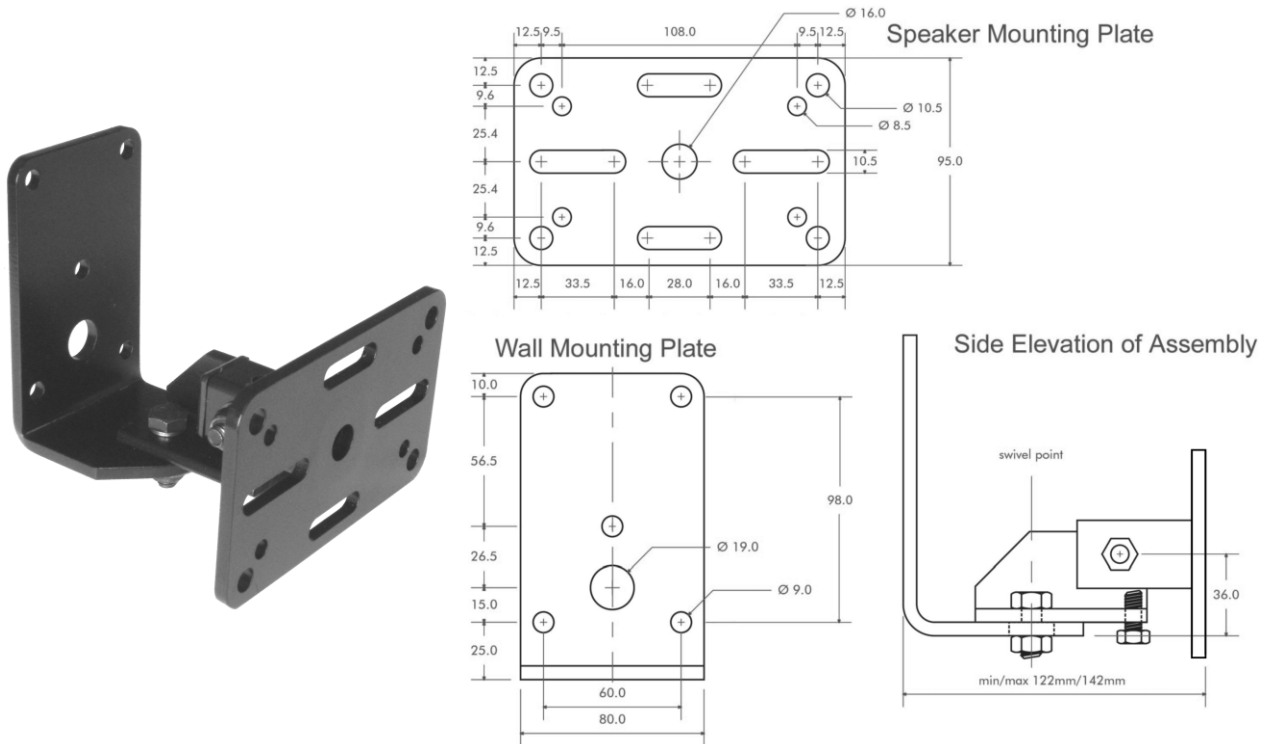

Fig 6.3-1 WME-100 wall mounting bracket (all dimensions in mm)

The optional WME-100 wall mounting bracket allows your F101 to be mounted on a wall and aimed accurately.

1st and 2nd fit

The wall mounting plate may be removed and sent to site for pre-installation if required.

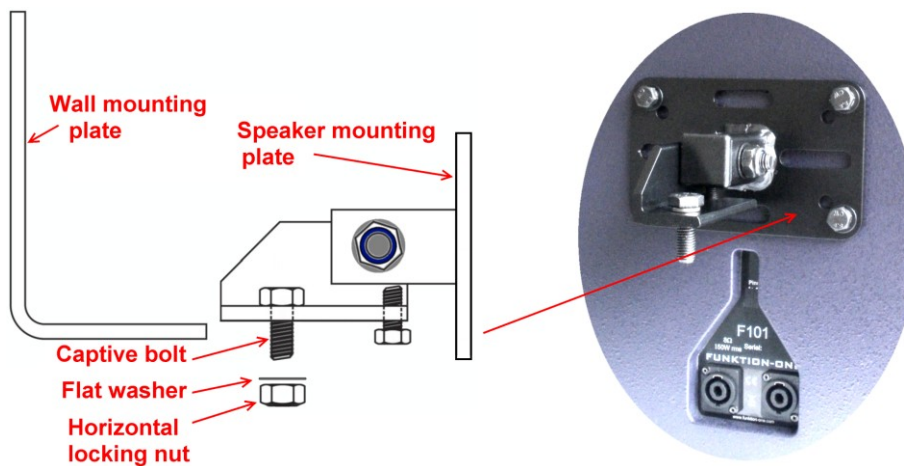

Fig 6.3-2 Wall mounting plate removed for fitting on site Speaker mounting plate fitted to F101



Always discuss your required wall mounting plate positions, the weight of your loudspeaker and wall anchorage methods with an expert builder or the architect to make sure you comply with the relevant building and safety regulations

The speaker mounting plate is attached to your F101 with the M8 hex-head bolts, flat washers and spring washers provided.

The hex-head bolts, flat washers and spring washers replace the countersunk blanking bolts at the rear of your F101. The countersunk bolts should be retained for future use.

Tighten the hex-head bolts so that the spring-washers are fully compressed – (example on right).

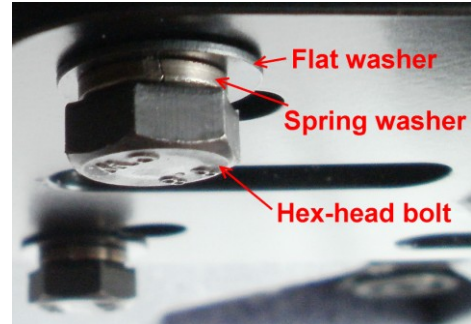

Fig 6.3-3



Remember to replace the rear bolts

Do not run the system with its rear bolts missing as this will detune the cabinet and cause air-flow noise. If you remove the wall bracket, always refit the original countersunk blanking bolts.

Reassemble the wall bracket system on site using the flat washer and the horizontal locking nut supplied before make final swivel and tilt adjustments.

Swivel & tilt

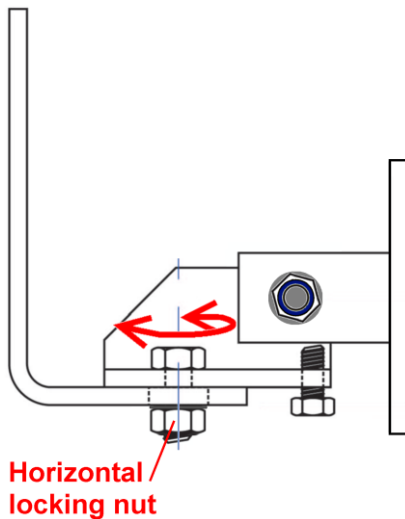

Fig 6.3-4 Horizontal swivel

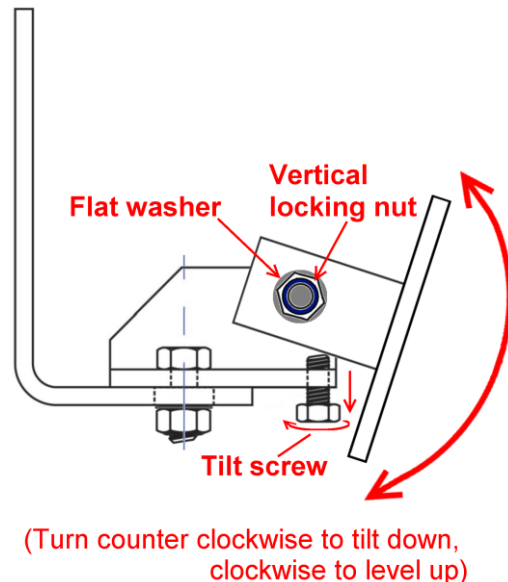

Fig 6.3-5 Vertical tilt

Horizontal swivel

Loosen the horizontal locking nut (**Fig 6.3-4**) to swivel the main assembly to the required position. Retighten the horizontal locking nut once you're happy with the position.

Vertical tilt

Loosen the vertical locking nut to allow the loudspeaker plate to be tilted to the required position using the tilt screw (see Fig 6.3-5 on previous page).

If the loudspeaker is already attached to the speaker mounting plate, this is much easier to do if you get a helper to lift the loudspeaker gently whilst you make the adjustment.

Retighten the vertical locking nut once you are happy with the vertical positioning. Then give the tilt screw a final tweak just to make sure it's still tight.

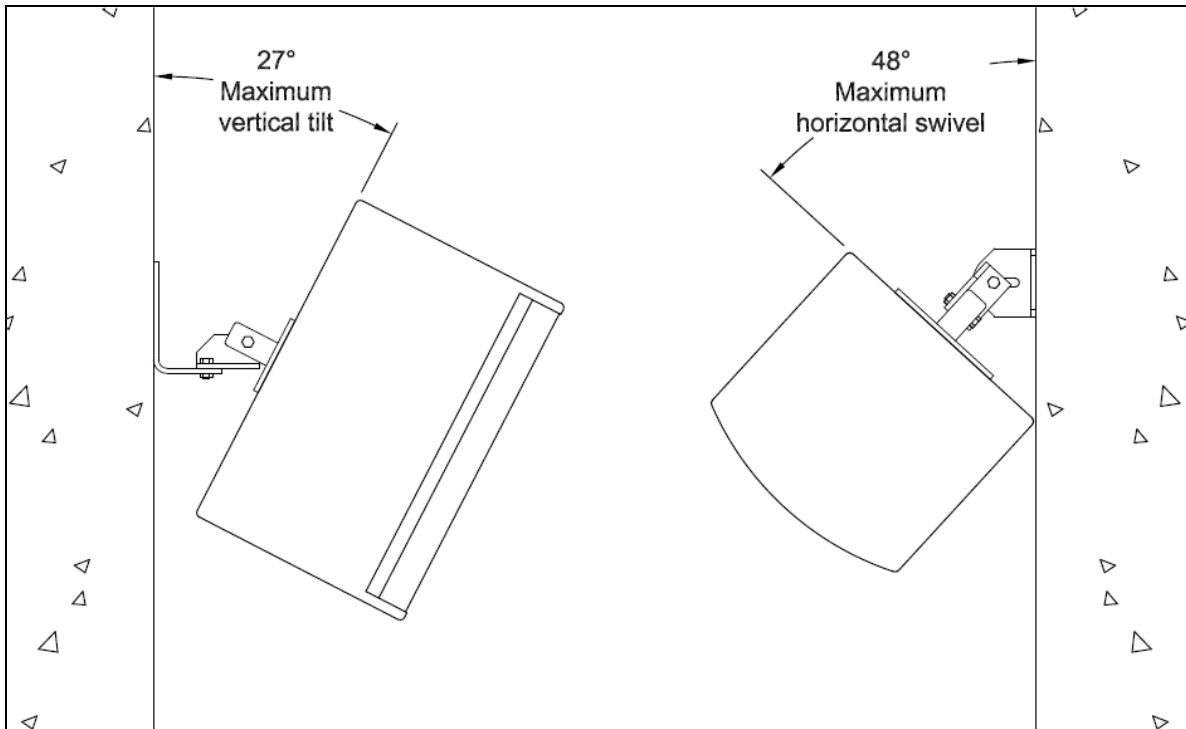

Fig 6.3-6

Maximum tilt and swivel angles

Yoke kit

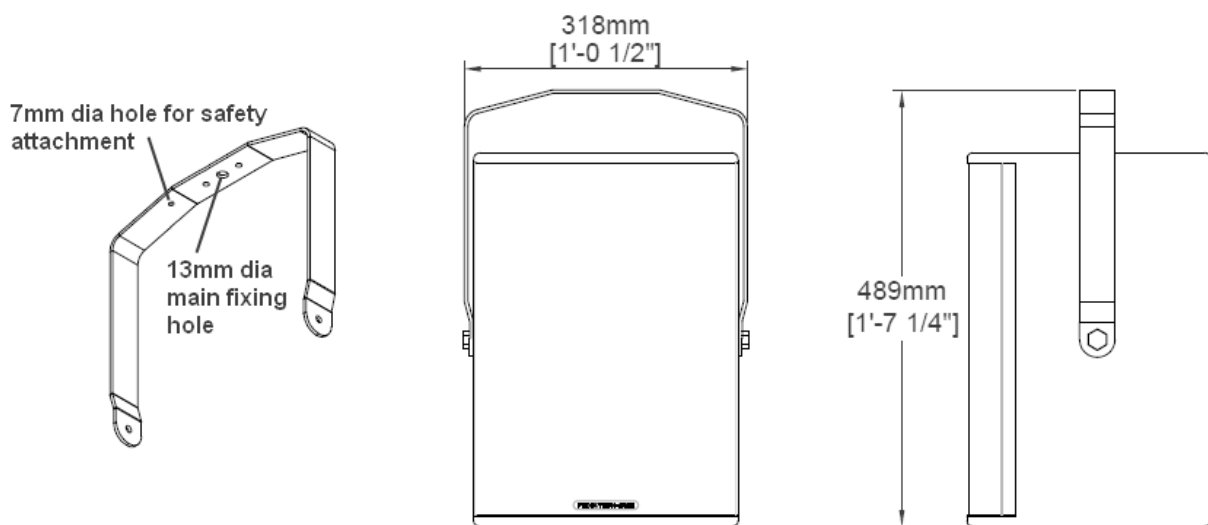

Fig 6.3-7

YF101-K1 yoke kit (all dimensions in millimetres and feet & inches)



F101 with yoke
(M8 bolt fixing shown)

The optional YF101-K1 yoke kit allows you to fly your F101 from a truss or 51mm barrel via a standard half-coupler using the 13mm main fixing hole.

The yoke also has a 7mm safety wire attachment hole.

The F101 has integral M8 side bushes so that the yoke may be fitted using M8 hex-head bolts and flat washers for fixed installations.

M8 hand-wheels are available for easy tilt adjustment during temporary set-ups.



Remember to replace the side bolts

Do not run the system with its side bolts missing as this will detune the cabinet and cause air-flow noise. If you remove the yoke, always refit the original countersunk blanking bolts.

Stand-top adaptor

Your F101 comes complete with a fixed 35mm “top hat” pole socket for vertical mounting.

Where a tilt is required, the YF101-K1 yoke kit can be fitted with an optional stand-top adaptor.

Both 32mm and 35mm stand-top adaptor are available. These bolt through the yoke’s main fixing hole with an M12 bolt and is clamped to the stand pole using a wing-bolt.



M12 stand-top adaptor



Fitted to YF101-K1 yoke
(F101 viewed from underneath)

7 Connectors and pin-outs

Rear connector options

F101s are supplied to order with either...

- One 2-pin Phoenix PC4 connector for fixed installations

Or

- Two parallel Speakon NL4 connectors for portable PA use

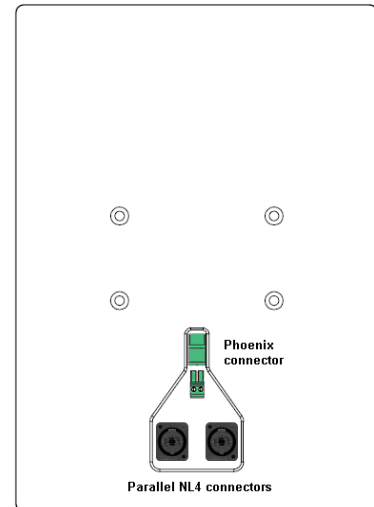

Fig 7-1 F101 rear view

7.1 Phoenix connector option

The Phoenix connector option is intended for fixed installations. A cable plug is supplied – attached to the F101's rear chassis socket.

PC4/2-ST-7.62 connectors are an industry standard. Additional connectors are available through a variety of distributors worldwide.

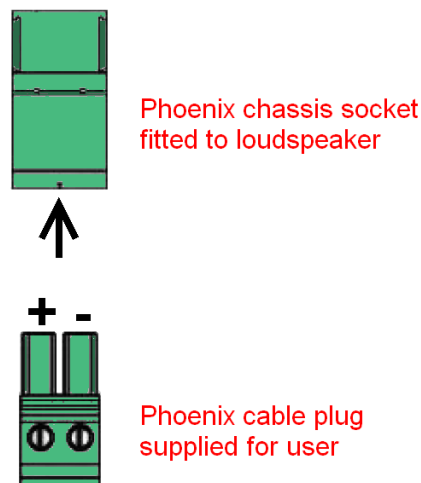
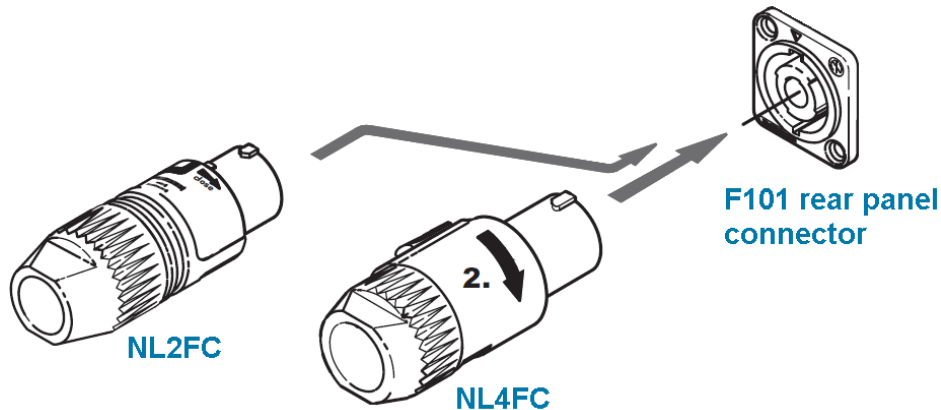

Fig 7.1-1 Phoenix PC4 pin-out
(Looking towards rear of loudspeaker)

7.2 Speakon connector option

The Speakon NL4 option is intended for quick deployment applications. The two NL4s are internally connected. One is used for the input. The other is used as an output for additional (parallel-connected) F101s.

Note that the F101 uses only two of the four available NL4 pins. Suitable cable connectors include the industry standard Speakon NL4FC and the Speakon NL2FC (compatible with NL4 chassis connectors for 2-pin use).



(Original image courtesy Neutrik)

Fig 7.2-1 Your F101's rear NL4 connectors will accept either NL2 or NL4 connector types

The following illustrations show the cable connector pin views looking towards the rear of the loudspeaker - as they would be seen if the cable plugs were plugged into the F101 with their covers removed.

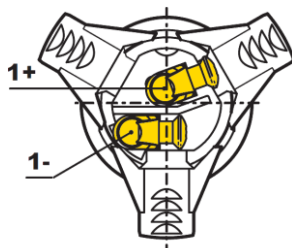

Fig 7.2-2 NL2FC (cable grab open)

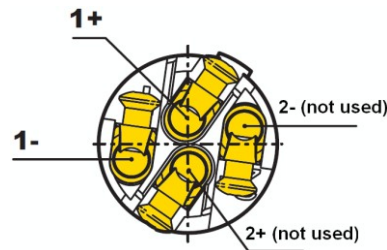

Fig 7.2-3 NL4FC pin-out

(Original image courtesy Neutrik)

Use **1+** for F101 **+ve**, **1-** for F101 **-ve**.

For further information on the Speakon connector series, see the **Speakon System** assembly instruction pdf available from www.neutrik.com.

7.3 Loudspeaker polarity

Loudspeaker cones and diaphragms create sound by moving in and out to modulate air pressure. It is important that all loudspeakers in a sound system move in the same direction when driven in unison. In other words, they should all have the same polarity.

Same polarity (“in phase”)

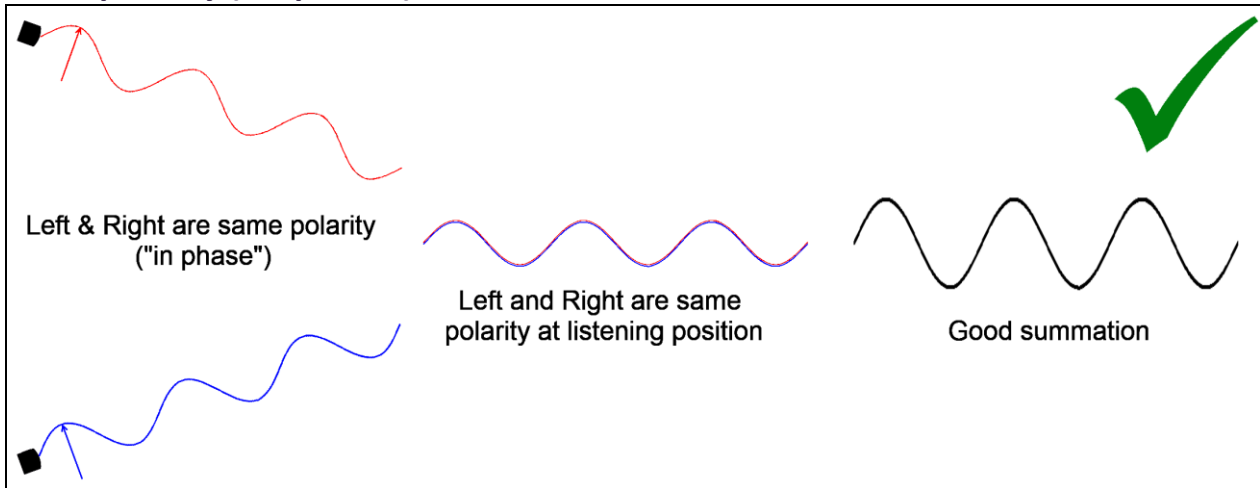

Fig 7.3-1

Loudspeakers with the same polarity, will give:

- Good bass extension
- Good bass impact
- Good “between the speakers” stereo imaging with a smooth central transition
- Solid centre-panned vocal imaging

Opposite polarity (“out of phase”)

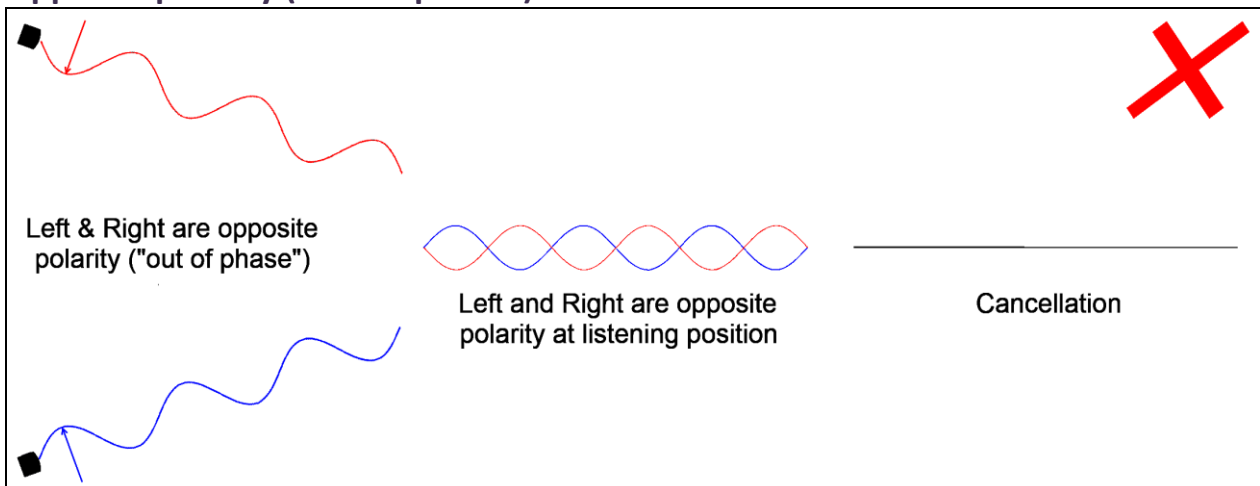

Fig 7.3-2

Loudspeakers with opposing polarities, will give:

- Poor bass extension
- No bass impact
- Poor “between the speakers” imaging. Just hard left or hard right “distant” effects
- No solid central vocal image. Centre-panned vocals will sound indistinct or thin and, again, the “distant” effect will be evident.

It is usually fairly easy to ensure that your loudspeakers are wired to the same polarity if all your loudspeakers are being driven via identical signal paths and equipment. Simply check that the same loudspeaker cable core colours are wired to the same + or – pins at the amplifier end and at the loudspeaker connector end.

If you cannot be certain that your signal paths are identical – you may be using a mix of old and new equipment or equipment from different manufacturers, for instance – it makes sense to check out the system using a polarity checker.

A good polarity checker, such as the Funktion One ASPC1, will allow you to check not only your amplifier-loudspeaker combinations but, and this is important, the entire signal path including mixers and crossover connections.

Introducing the Funktion One Audio Systems Polarity Checker (ASPC1)

Pulse generator

- XLR pulse generator output
- LED pulse indicator

Detector

- Built in microphone
- LED polarity indicators

General

- Belt pouch included
- Batteries included
- User Instruction Card



The ASPC1 is a two-part system comprising a pulse generator and a detector. The pulse generator allows you to inject a special test signal anywhere in the signal path whilst the detector microphone lets you check the resulting loudspeaker polarity acoustically. See the ASPC1 user guide for more information.



Absolute polarity and live sound

Maintaining absolute polarity through a sound system not only means making sure all your loudspeakers are “in phase” but also ensuring that your microphones give a positive-going output voltage for a positive-going pressure, that there are no polarity reversals anywhere in the signal path and that your loudspeaker systems provide a positive pressure in response to that positive-going signal.

Professional sound engineers, who are used to working with wide-bandwidth, phase coherent systems with real bodily impact, should recognise the importance of maintaining absolute polarity from stage microphones to PA - and, of course, to stage monitors where a close-coupled polarity reversal could make things sound thin, coloured and lifeless.

Many natural sound sources, especially percussion and vocals, produce asymmetrical waveforms. It makes sense to ensure that a positive-going percussive impact creates a positive-going pressure for the audience to maintain that all-important bodily impact. Some recording engineers are also adamant that vocals overlay the band more clearly if absolute polarity is maintained.

Common sense, then, suggests that, as long as we’re using polarity-matched microphones and well-documented signal paths, why not maintain absolute polarity – if only for consistency?

8 Loudspeaker cables

8.1 Recommended cable types and lengths

F101 loudspeaker systems do not require particularly exotic cables. Standard pro-audio copper core loudspeaker cables are usually oxygen-free and perfectly suitable for this application.

Good examples are:

- Van Damme Black Series Tour Grade twin-axial (For general portable PA use)
- Van Damme Ecoflex Install Grade Speaker Cable LSZH (For installations in public buildings, clubs and cruise ships where Low Smoke Zero Halogen cables are specified. These cables are compliant with IEC60092, IEC60332.1, IEC60332.3C, IEC60754.1, IEC60754.2 and IEC60134.2)

The following table gives the maximum cable lengths allowable to keep level losses below 0.6dB.

Copper core cross sectional area mm ²	Nearest suitable AWG size	Maximum cable length for a single F101 metres (ft)	Maximum cable length for 2 x F101 in parallel metres (ft)
1.50 mm ²	15awg	22m (72ft)	11m (36ft)
2.50 mm ²	13awg	36m (118ft)	18m (59ft)
4.00 mm ²	11awg	58m (190ft)	29m (95ft)

8.2 F101 impedance

Loudspeakers are conventionally specified as having a nominal impedance of 4, 8 or 16 ohms. In practice, of course, loudspeakers are electro-mechanical devices that interact with local acoustical conditions. They also have internal electrical networks. All these factors result in loudspeakers having quite complex impedance characteristics that vary with frequency.



Fig 8.2-1 F101 half-space, 1/12th octave impedance (ohms) vs frequency (Hz)

The F101 impedance curve is very well behaved and presents an easy load for power amplifiers – even where pairs of F101s are connected in parallel.

Notes

- Low frequency impedance characteristics may vary slightly with local boundary conditions
- F101 internal networks include a protective DC blocking capacitor. This will cause your F101 to look open circuit when measured with a regular dc resistance meter.

9 Amplifier considerations

Unless otherwise stated, power ratings in this section are average power (rms voltage x rms current – sometimes called rms power). Your F101 has an AES 8 ohm power rating of 150W.

9.1 Recommended Funktion One power amplifiers

Funktion One E15 2-channel power amplifier (with PRC set to 0dB)

425W per channel into 8 ohms, 750W per channel into 4 ohms, 1400W per channel into 2 ohms

Funktion One F40Q 4-channel power amplifier

600W per channel into 8 ohms, 1000W per channel into 4 ohms

9.2 Suitable power ranges

Choosing an amplifier at the high end of the following ranges will avoid peak clipping. See [appendix A](#) and the note below.

Recommended range = 150W - 600W into 8Ω, 300W – 1200W into 4Ω or 600W – 2400W into 2Ω

- Most amplifiers are rated into 8 ohms (1 x F101) and 4 ohms (2 x F101s in parallel)
- Amplifiers with a genuine 2 ohm specification can power up to 4 x F101s in parallel – but remember to use thicker cable when connecting multiple loudspeakers in parallel.



Loudspeaker power ratings and recommended amplifier power

A loudspeaker's AES (Audio Engineering Society) power rating is the maximum power it can withstand for prolonged periods of time. This is usually governed by the system's ability to dissipate heat without damage.

Many transients, however, don't last long enough to allow significant heat build-up so most loudspeaker systems can handle short-term peaks up to 6dB higher than their AES power rating without damage.

You can get the best of both worlds by choosing an amplifier powerful enough to reproduce the short-term transients and using a Funktion One XO series loudspeaker management system to provide long-term limiting.

For further information on Funktion One XO series loudspeaker management systems go to www.funktion-one.com and click through > **Products** > **Electronic Products**, then...

> **XO2 Audio Management System** for a 2 in/ 6 out loudspeaker management system or...

> **XO4 Audio Management System** for a 4 in/ 8 out loudspeaker management system

Then click through **Downloads** > **Other** and download **4 series manual.pdf**.

For limiter recommendations, see [section 11](#).

Using a bigger amplifier to provide full peak power, whilst restricting long-term power with limiters, also avoids long-term clipping.



Caution

Heavily clipped signals can subject your loudspeakers and cables to double their rated amplifier power. In extreme cases this could pose a fire hazard.

For more information about clipping, see [appendix A](#).

9.3 Simple system patches with external control

F101s may be used without loudspeaker management systems in set-ups where signal levels are carefully controlled – e.g. in installations where limiters are built into the zone controllers.

2-channel patches with external control

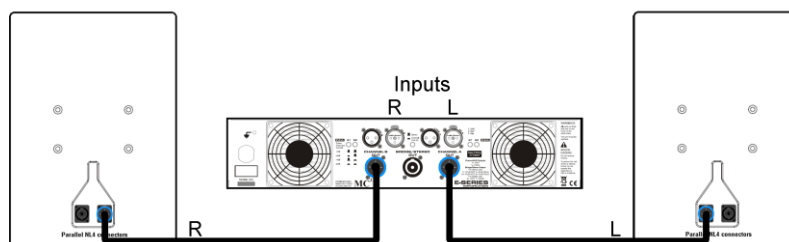

Fig 9.3-1 2-channel 8 ohm patch using Funktion One E15 power amplifier (F101s with Speakon connectors)

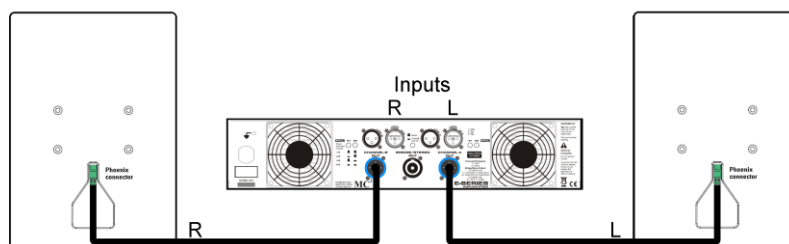

Fig 9.3-2 2-channel 8 ohm patch using Funktion One E15 power amplifier (F101s with Phoenix connectors)

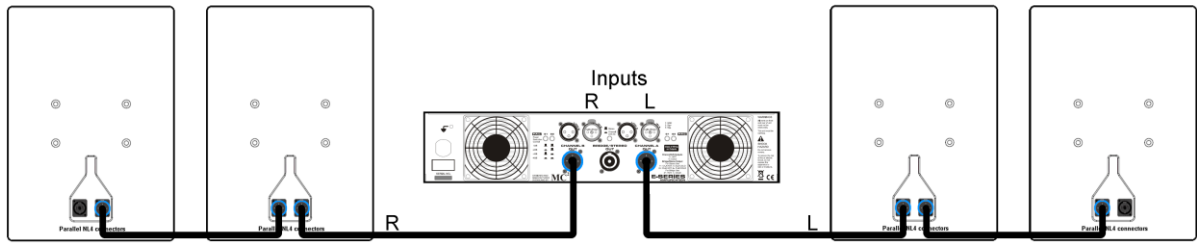

Fig 9.3-3 2-channel 4 ohm patch using Funktion One E15 power amplifier (F101s with Speakon connectors)

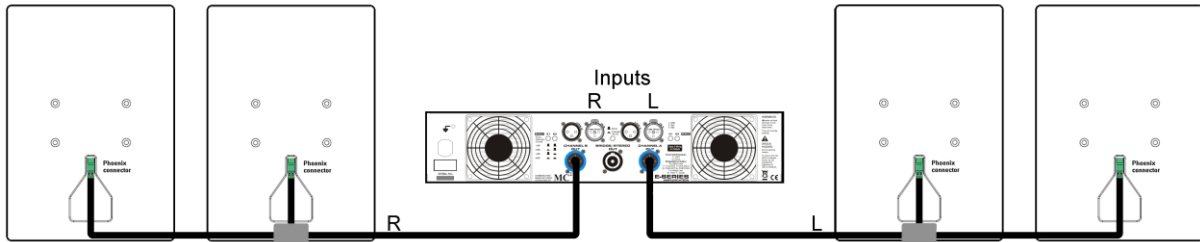

Fig 9.3-4 2-channel 4 ohm patch using Funktion One E15 power amplifier (F101s with Phoenix connectors)

Note the connector blocks in lower illustration. Avoid cramming two cables into one Phoenix connector.

4-channel 8 ohm patches with external control

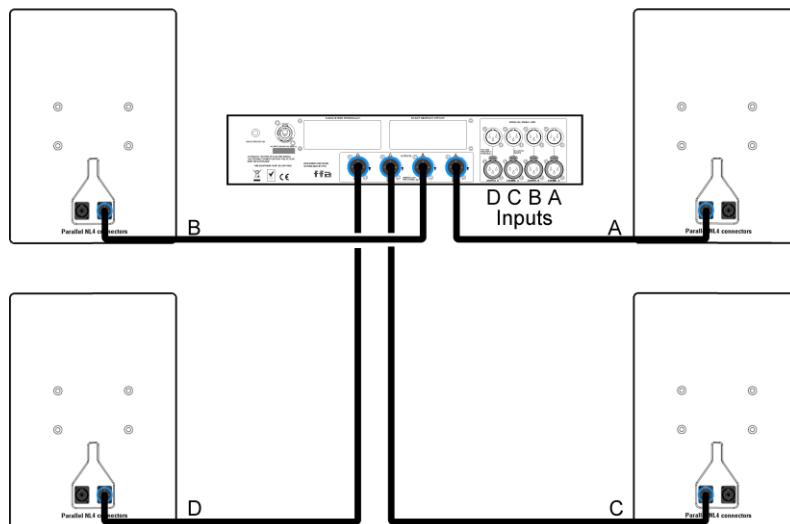

Fig 9.3-5 4-channel 8 ohm patch using Funktion One F40Q power amplifier (F101s with Speakon connectors)

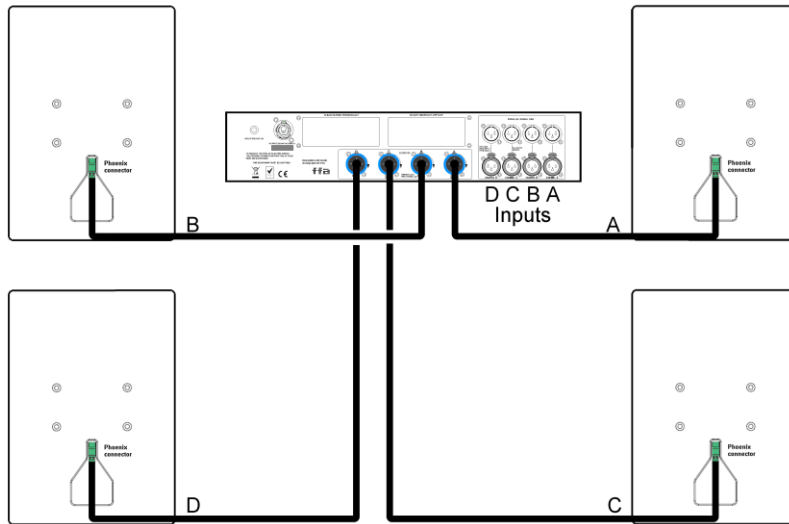

Fig 9.3-6 4-channel 8 ohm patch using Funktion One F40Q power amplifier (F101s with Phoenix connectors)

4-channel 4 ohm patches with external control

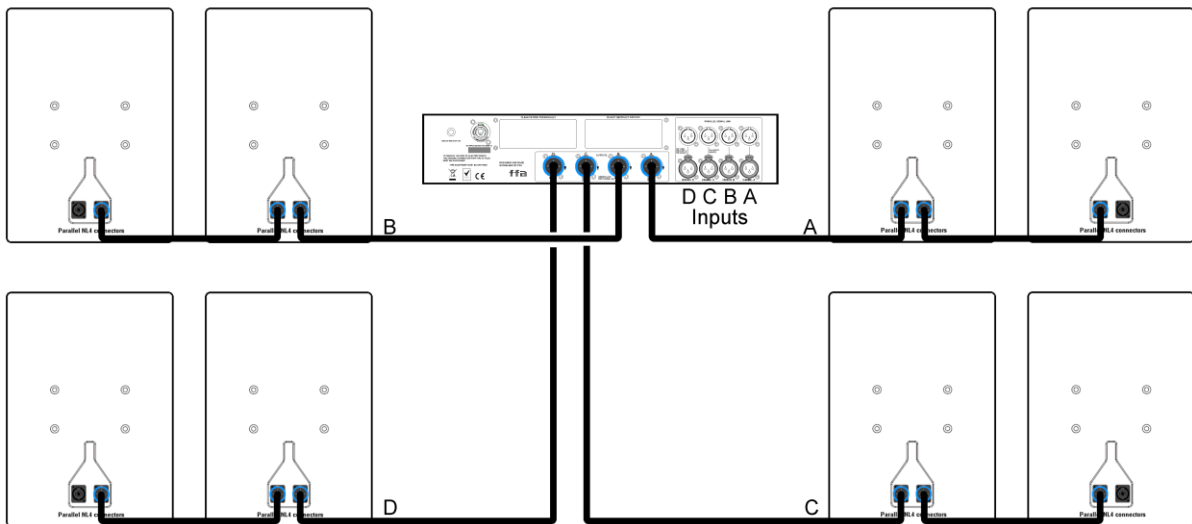

Fig 9.3-7 4-channel 4 ohm patch using Funktion One F40Q power amplifier (F101s with Speakon connectors)

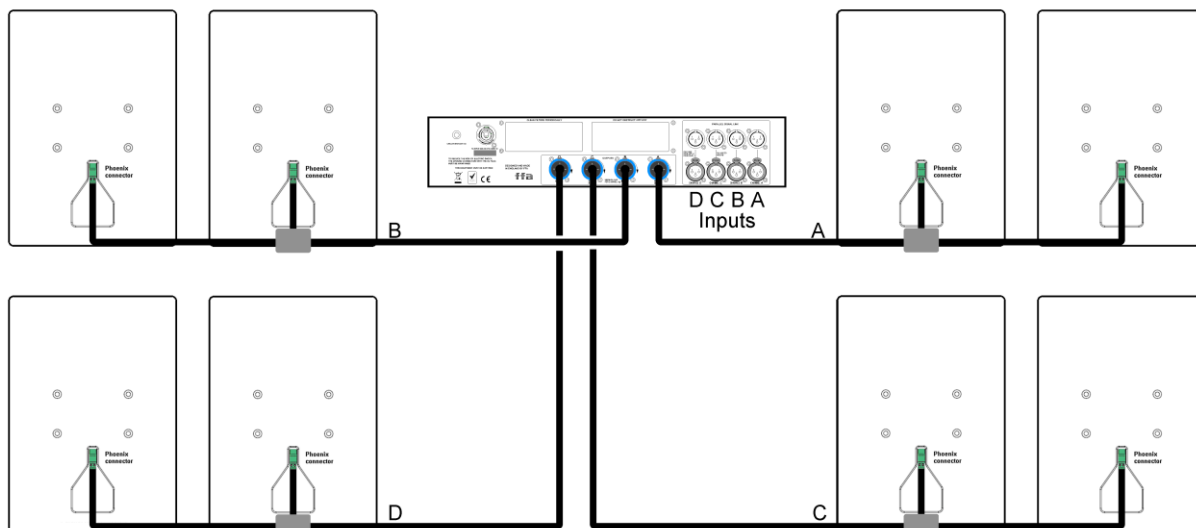

Fig 9.3-8 4-channel 4 ohm patch using Funktion One F40Q power amplifier (F101s with Phoenix connectors)

Again, note the connector blocks in lower illustration. Avoid cramming two cables into one Phoenix connector.

9.4 System patches with loudspeaker management

Where F101s are likely to be used with a wide variety of source material, including live performances and DJs, a high quality system controller is recommended. Funktion One XO2, XO4 or XO4A loudspeaker management systems provide all the necessary cross-over functions plus, of course, protective limiting.

2-channel patches with XO2 loudspeaker management system

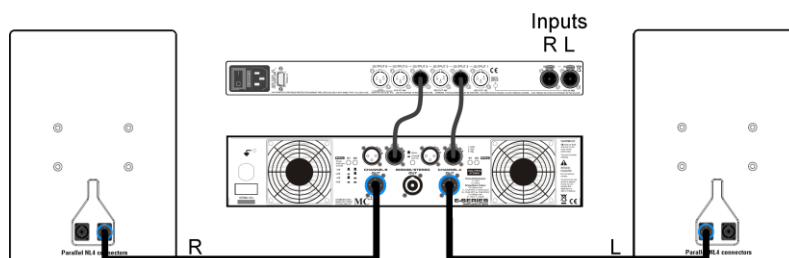

Fig 9.4-1 2-channel 8 ohm patch using Funktion One XO2 controller and E15 amp (2 x 2-way + 2 x mono configuration shown, F101s with Speakon connectors)

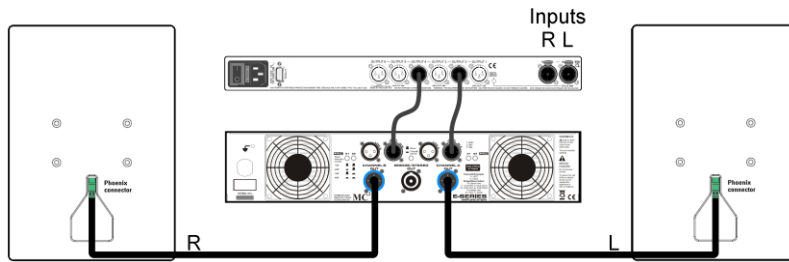

Fig 9.4-2 2-channel 8 ohm patch using Funktion One XO2 controller and E15 amp (2 x 2-way + 2 x mono configuration shown, F101s with Phoenix connectors)

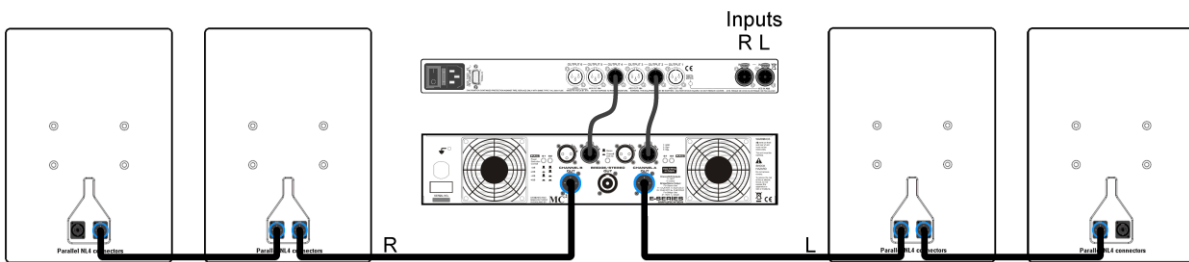

Fig 9.4-3 2-channel 4 ohm patch using Funktion One XO2 controller and E15 amp (2 x 2-way + 2 x mono configuration shown, F101s with Speakon connectors)

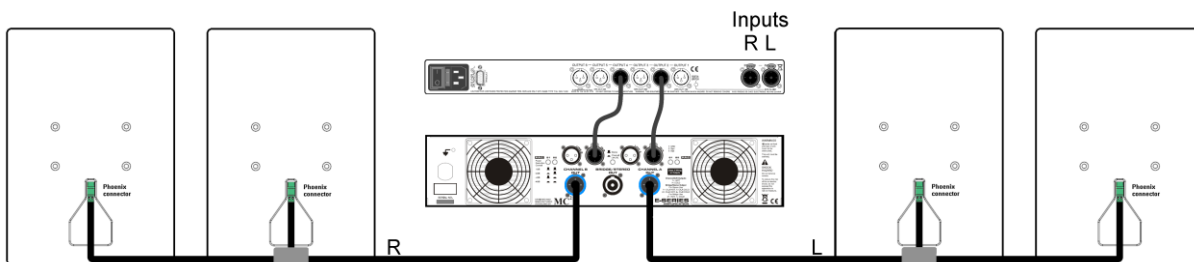

Fig 9.4-4 2-channel 4 ohm patch using Funktion One XO2 controller and E15 amp (2 x 2-way + 2 x mono configuration shown, F101s with Phoenix connectors)

Note the connector blocks in lower illustration. Avoid cramming two cables into one Phoenix connector.



Notes

XO series outputs channel allocations will vary depending on loudspeaker/bass system combinations – see XO series user manuals for typical configurations.

See Section 11 of this User Guide for advice on XO series limiter settings vs amplifier gain etc.

See Appendix A at the end of this User Guide for a discussion about clipping.

See Appendix B at the end of this User Guide for a discussion about system gain structure.

4-channel 8 ohm patches with XO4/4A loudspeaker management system

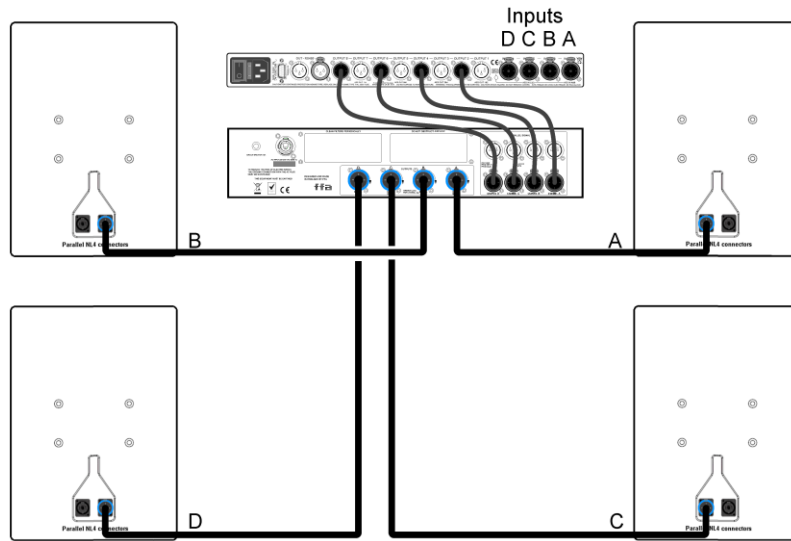

Fig 9.4-5 4-channel 8 ohm patch using Funktion One XO4A controller and F40Q amp (4 x 2-way configuration shown, F101s with Speakon connectors)

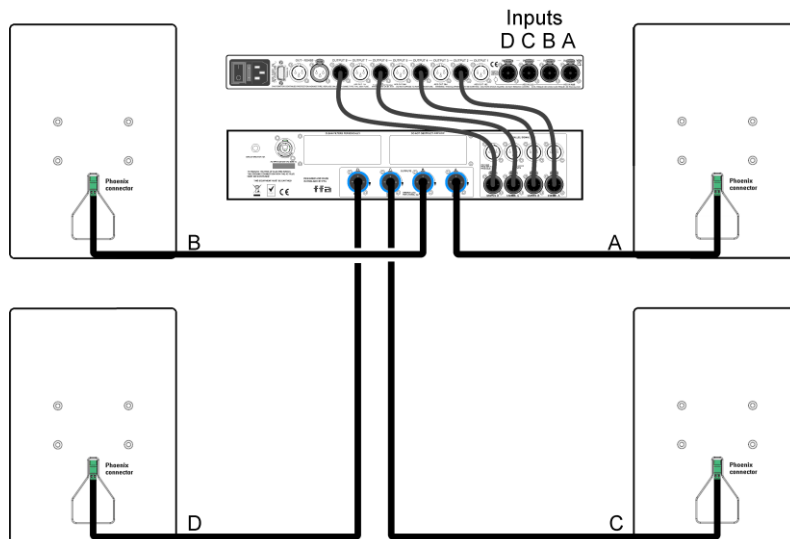

Fig 9.4-6 4-channel 8 ohm patch using Funktion One XO4A controller and F40Q amp (4 x 2-way configuration shown, F101s with Phoenix connectors)

4-channel 4 ohm patches with XO4/4A loudspeaker management system

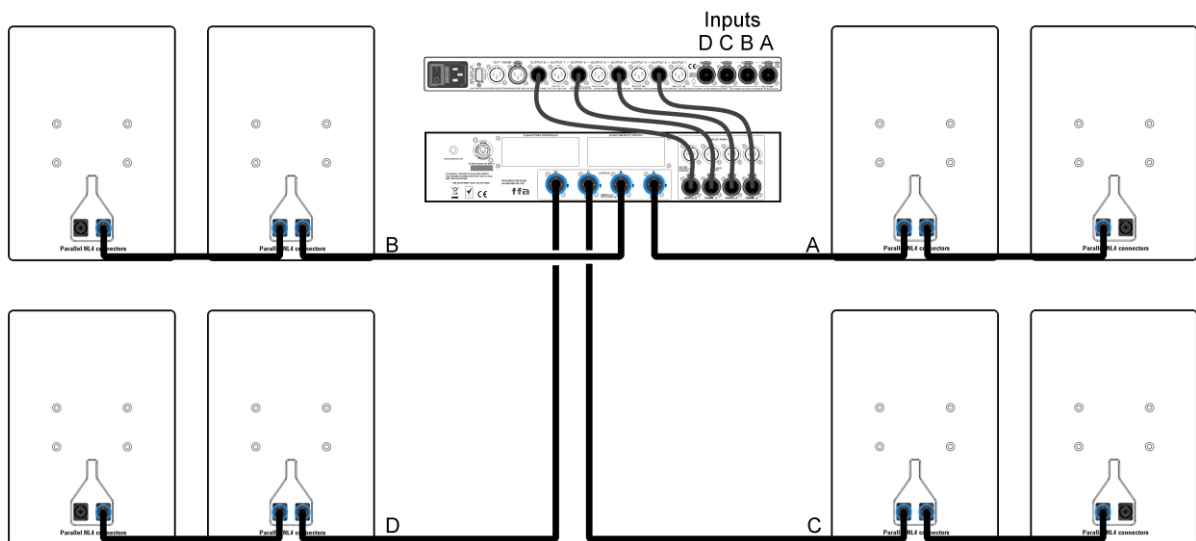

Fig 9.4-7 4-channel 4 ohm patch using Funktion One XO4A controller and F40Q amp (4 x 2-way configuration shown, F101s with Speakon connectors)

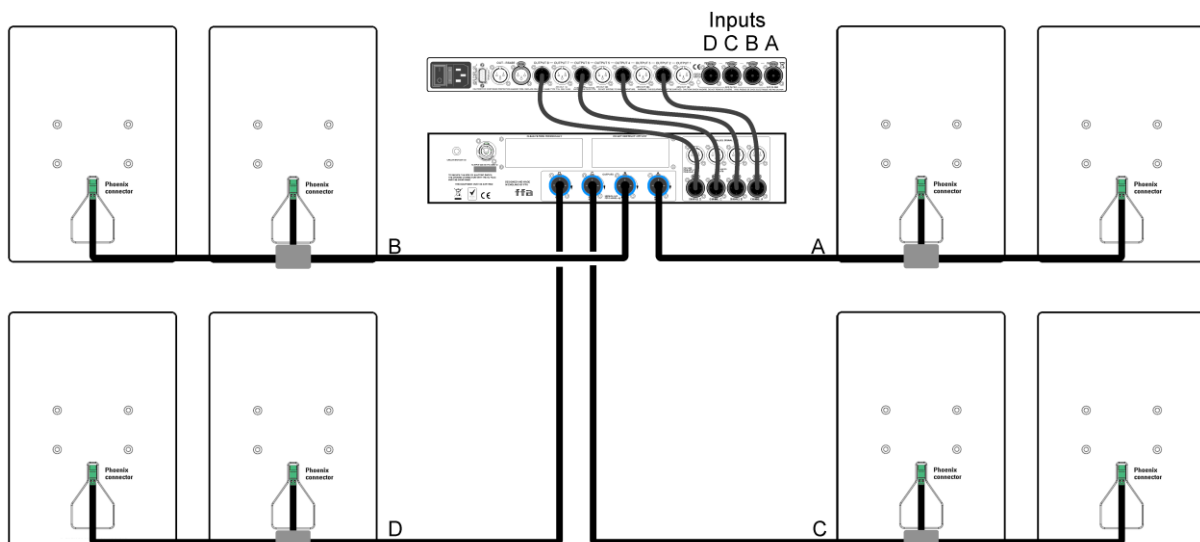

Fig 9.4-8 4-channel 4 ohm patch using Funktion One XO4A controller and F40Q amp (4 x 2-way configuration shown, F101s with Phoenix connectors)

Again, note the connector blocks.



Limiters settings for 4 ohm operation

XO series limiters control the maximum **voltage** applied across the loudspeaker terminals by limiting the signal voltage delivered to the power amplifier. This means that, as long as you have a good, stiff mains supply, you can use the same limiter voltage thresholds irrespective of 8 ohm or 4 ohm operation.

However, if your mains supply voltage drops by more than 2% or 3% on load, you may need to reduce the recommended long-term limiter threshold levels by a dB or so to prevent the power amplifier from prematurely clipping. See [section 11](#) for further information on limiters settings.

10 Combining with bass systems

Your F101 system may be combined with a variety of Funktion One bass systems for extra low frequency extension and headroom. Suitable systems include – but are certainly not restricted to – the following:

Funktion One MB210 LP

The MB210 LP (Low Profile) is one of Funktion One's most compact and low profile bass enclosures and ideal for restricted architectural spaces.

MB210 LP bass systems can be installed under banquettes in bars and clubs, for instance.

The MB210 LP consists of two 10" Neodymium loudspeakers driving a ported resonant chamber enclosure handling 600 Watts.



The MB210LP's 4 ohm impedance yields an average sensitivity of 103dBspl (1W/1m) between 60Hz and 160Hz.

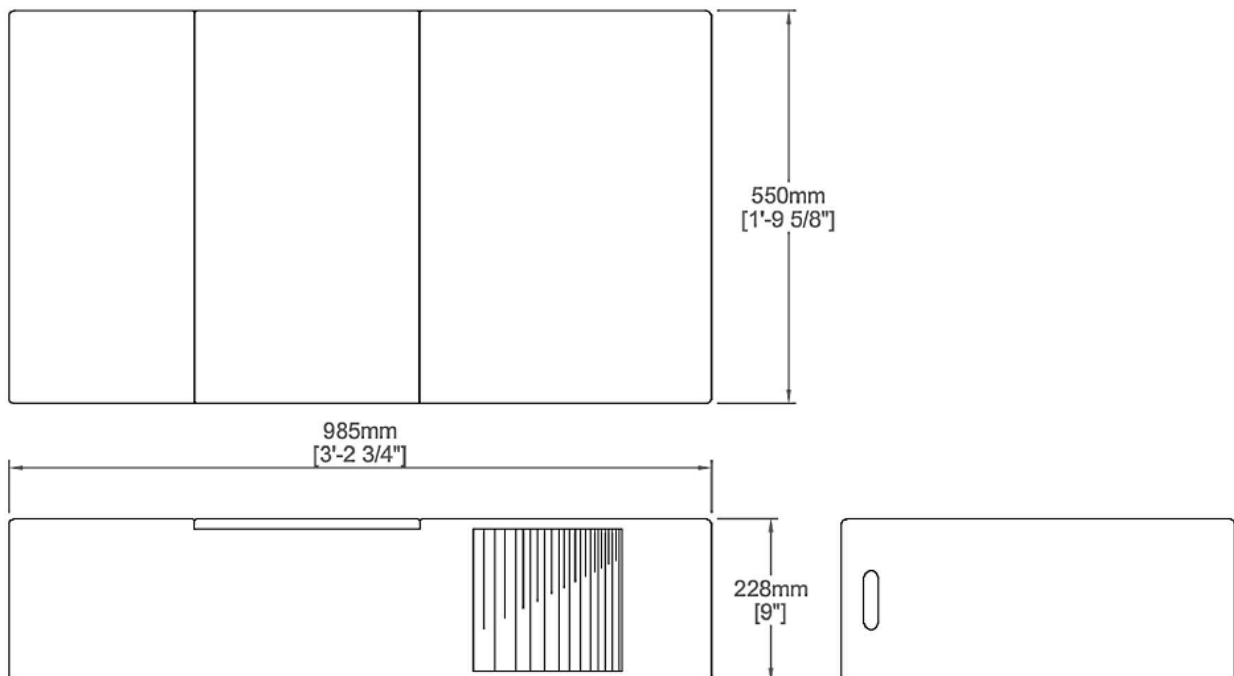

Fig 10-1 (all dimensions in millimetres and feet & inches)

Funktion One Minibass 212

The Minibass 212 is a smaller iteration of Funktion One's patented Infrabass technology and is the perfect complement to the F101 where a more powerful bass extension is required.

The Minibass incorporates 2 x Funktion One 16 Ohm 12" loudspeakers which drive a ported resonant chamber enclosure.

It handles 600 Watts with an average sensitivity of 104dBspl (1W/1m) between 40Hz and 125Hz.



Again, the efficient 8ohm enclosure allows multiple units to be driven by one amplifier.

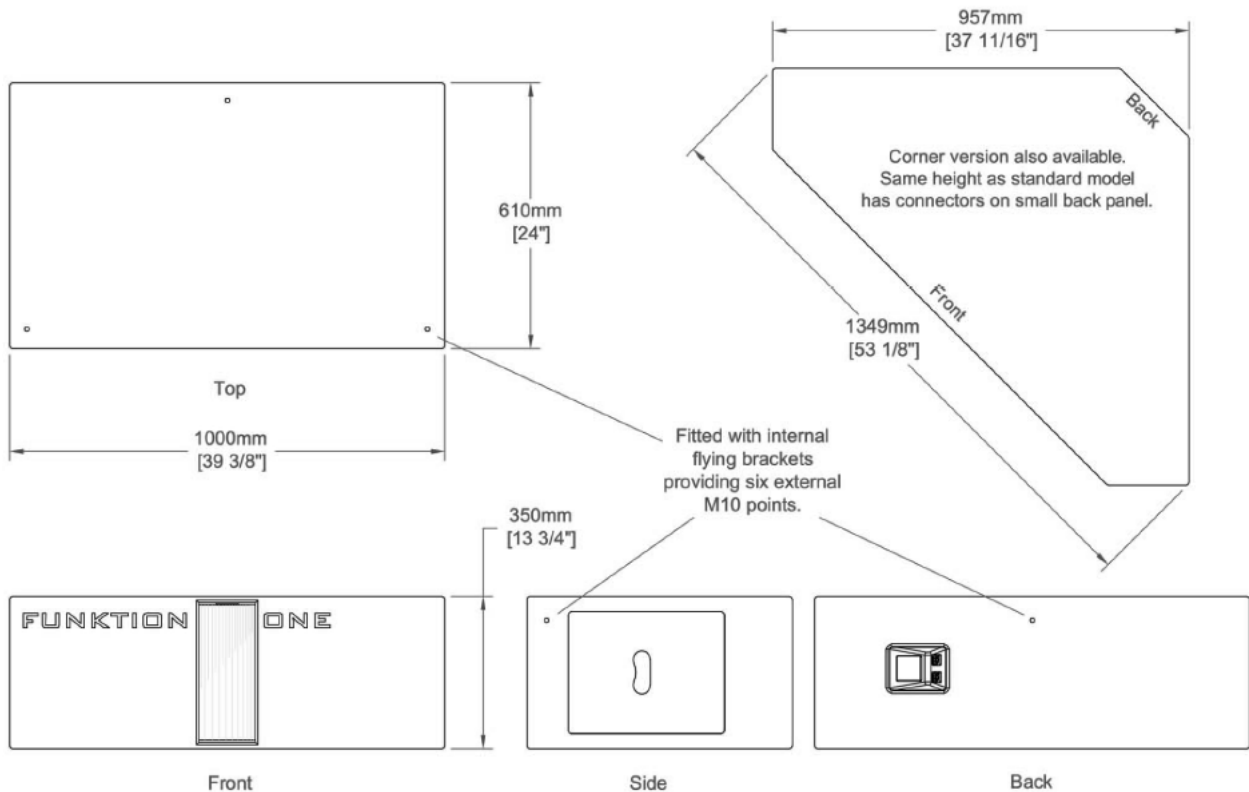

Fig 10-2 (all dimensions in millimetres and feet & inches)

A corner version is also available - see above. This is the same height as the standard Minibass = 350mm.

Funktion One F215

The F215 is a double 15" bass enclosure which utilises the same horn loading technology as Funktion One's highly regarded F218.

This product has similar performance characteristics to the F218.

It is pitched higher (50Hz – 250Hz) giving slightly less low end extension but even tighter and punchier upper bass.

It uses the same Funktion One designed 15" loudspeaker driver that is used in the Resolution 2 enclosure.

The F215 has a sensitivity figure of 105dBspl (1W/1m).

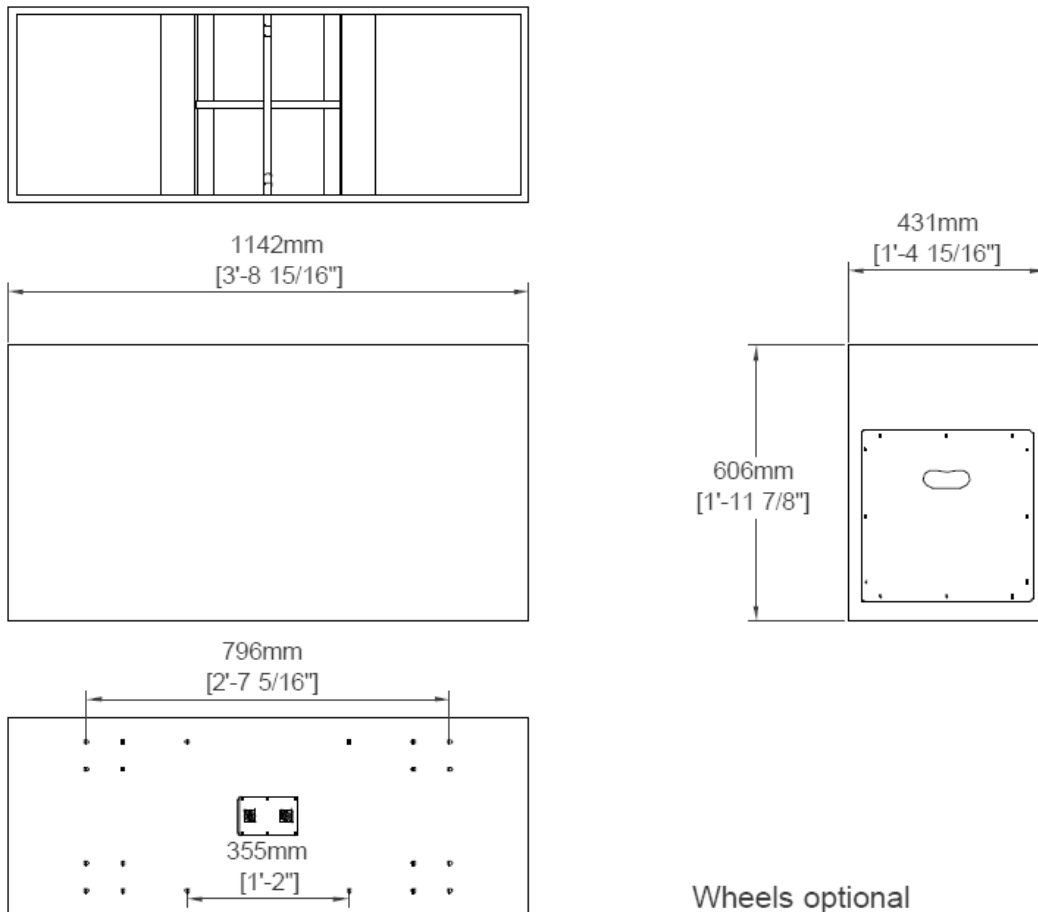

Wheels optional

Fig 10-3 (all dimensions in millimetres and feet & inches)

Please see www.funktion-one.com for further information and user guidance for the complete range of Funktion One bass systems.

Funktion One F118

The F118 is for those who require a smaller enclosure. In common with the F218, the Mark 2 release brings refined loading, improved heat dissipation and an updated driver specification.

Outdoor installation version available with appropriate suspension hardware,

It provides large quantities of tight, punchy, well-defined, clean bass from a small and manageable package.

The F118 has a sensitivity figure of 103dBspl (1W/1m).

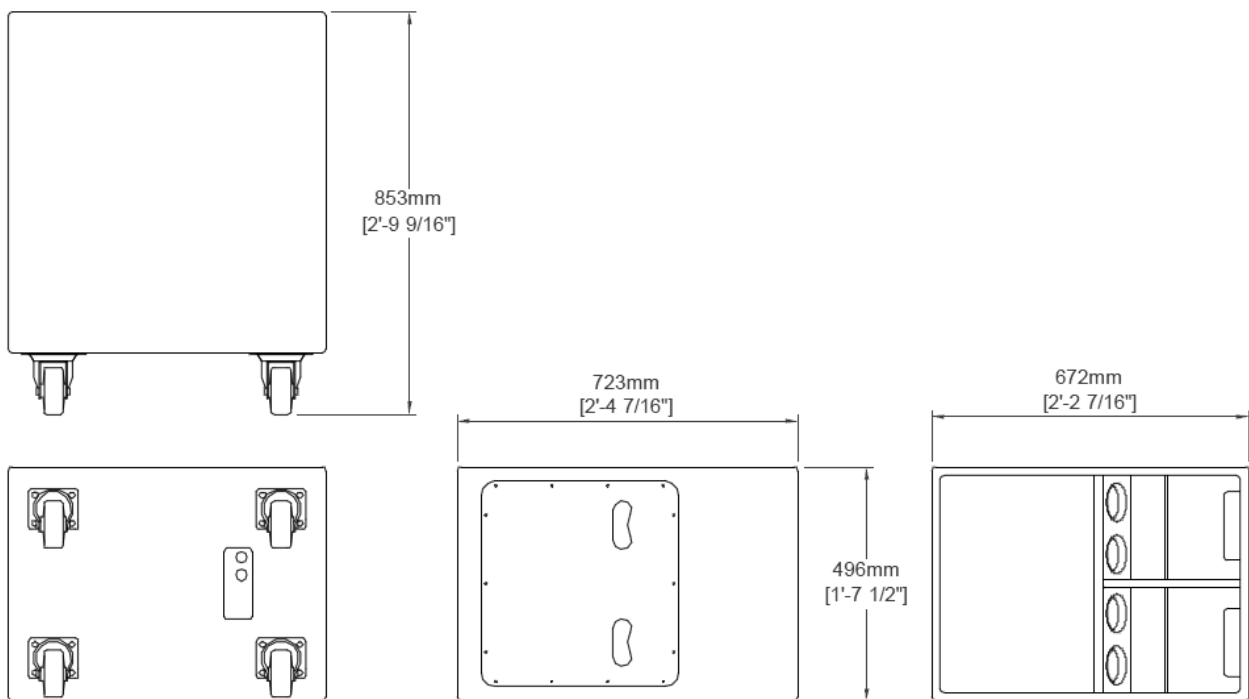

Fig 10-4 (all dimensions in millimetres and feet & inches)

Please see www.funktion-one.com for further information and user guidance for the complete range of Funktion One bass systems.

10.1 Bass to mid-high alignment

For maximum impact and headroom it is important to accurately set the cross over point and time alignment when using F101s with your chosen bass system.

Crossover frequency examples

Application	Bass system and crossover*	F101 crossover*
Normal use	MB210 or MB212 – Low pass filter 85-100Hz 24dB/octave Linkwitz-Riley	High pass filter 85-100Hz 24dB/octave Linkwitz-Riley
High power use.	F215 or F118 – Low pass filter up to 200Hz 24dB/octave Linkwitz-Riley	High pass filter up to 200Hz 24dB/octave Linkwitz-Riley

*The final crossover frequency setting will depend on boundary condition and headroom requirements.

Note that the higher the crossover frequency the harder the bass and the less stressed the F101.

For suggested limiter settings see **Section 11**.

For further crossover advice, go to www.funktion-one.com and click on **Settings**.

Ensuring good mid-bass impact through crossover

If you want good mid-bass impact from your system, start with Funktion One's recommended loudspeaker management bass-to-top system settings. This will ensure that internal driver offsets are already allowed for.

- 1) Physically align the relevant F101 and bass systems so that they are as close together as is practical for good coverage and ensure that they are aimed in the same direction – see below
- 2) Time align the systems where required using electronic delay to compensate for any physical offset *with respect to the audience chest height* – see below

Physical alignment

Typical architectural layouts require the bass enclosures to be on the floor or under seating and call for the mid-high enclosures to be flown just above head height.

If you're catering for a flat-floor audience, ideally mount your F101s so that the front of the enclosure is directly above the front of the bass enclosure at a height of 2.8m – 3.3m.

Aim the F101s towards ear height about 2/3 of the distance down the audience area.

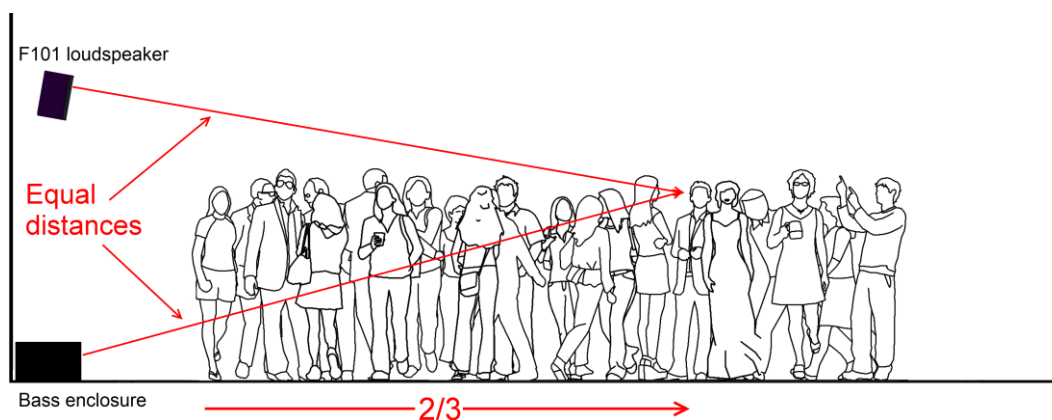

Fig 10.1-1 If possible, mount your main F101 loudspeakers so that the front of the enclosure is directly above the front of the bass enclosure

Time alignment

Where exact physical alignment isn't possible it is best to employ the electronic delay facility built into a good electronic crossover system. A Funktion One XO series loudspeaker management system may be used to delay the nearest element back to the furthest.

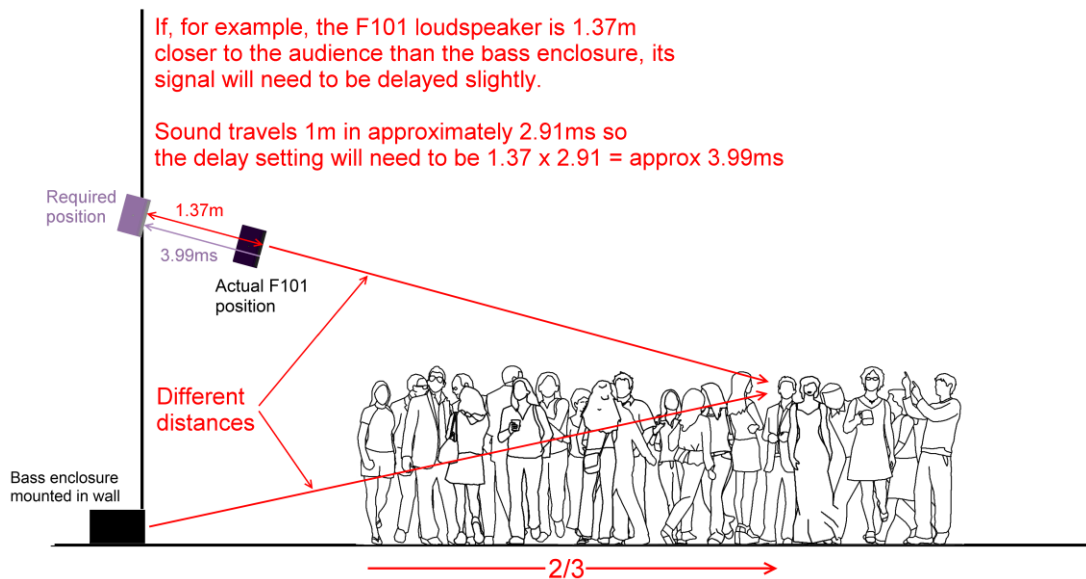

Fig 10.1-2 Time aligning the F101 with the bass enclosure for a 2/3 audience reference position

Time alignment procedure

Start with Funktion One's recommended loudspeaker management bass-to-mid-high alignment settings. This will ensure that internal driver offsets are already allowed for. See www.funktion-one.com or the appropriate bass enclosure user guide for details.

- 1) Accurately measure the distance to the front of the mid-high enclosure and the front of the bass enclosure from your preferred reference/mix/dance position.
- 2) Sound travels 1 metre in approximately 2.91ms (2.91 milliseconds)
 - a) If the bass system is closer than the F101 system, increase the bass output channel delay by 2.91ms for every metre of misalignment.
 - b) If the F101 system is closer than the bass system, increase the F101 output channel delay by 2.91ms for every metre of misalignment.



Imperial measurements

If you're working with imperial measurements, the physical offset in feet should be multiplied by 0.887 to get the required delay in milliseconds.

In the above example, the F101 enclosure is 4ft 6" closer to the audience. Sound travels 1ft in approximately 0.887 milliseconds so the required delay is $4.5 \times 0.887 = 3.99\text{ms}$.

(Hint: If you don't have a calculator, the multipliers may be rounded to 3.0 for metric and 0.9 for imperial)

Note that horn loaded and bandpass bass enclosures exhibit their own fixed acoustical delay due to internal path lengths. Your mid-high delay may need to be slightly longer to allow for this.

Fine tuning and phase alignment

The null method

Local walls and floors (known as boundaries) will tend to reflect sound and cause phase shifts at low frequencies where systems tend to be less directional. Multiple boundary effects can make mid-high-to-bass enclosure alignment quite complex but there is a simple phase alignment procedure that requires very little test equipment apart from a graphic equaliser and some kind of pink noise or bass-rich music source. This “null method” makes use of the fact that two signals with opposite polarities create a very audible dip in output when perfectly aligned.

You’ll need to set up a narrow band signal at the crossover frequency to make this alignment method easier. Music or noise via a 1/3rd octave Graphic EQ is great for this, with all faders pulled down except for one at the required frequency. If a graphic equaliser is not available use a boosted, narrow band PEQ in the input stage of the Loudspeaker Management System. Don’t use a sine wave tone in case you’re in a room null.

- 1) To avoid aligning a whole cycle out, make sure you follow the physical or time alignment procedures first using the appropriate Funktion One settings as the starting point. See earlier
- 2) Listen to the bass enclosure and the mid-high enclosure ***one at a time*** at your chosen reference position and adjust each one by ear to give the same approximate level with the narrow-band signal
- 3) Once level balanced, switch the bass system ***temporarily*** to reverse polarity
- 4) Now ***run both sections together*** and fine trim the mid-high enclosure delay for a dip in level at the reference position.

Note: If the mid-high enclosure is near a large local boundary (a ceiling or wall, for example) it may be necessary to put the mid-high delay setting back where it was and fine adjust the bass enclosure delay instead. A little experimentation may be required

- 5) ***Now switch the bass system back to the correct polarity*** – this should give you maximum alignment and impact through crossover

If no obvious dip is heard – even with delay adjustments of several milliseconds – the room characteristics may be too complex and confusing to deal with easily. If this is the case, it’s probably best to reinstate the standard recommended delay settings and fine tune by ear.

- Experience teaches us that the “ideal” setting is not always as predicted because the real-world acoustical environment is so complex. Calculations, if not absolutely correct, are usually pretty close though,
- To confirm that the above adjustments have been effective, the system can be rechecked using a variety of known, well recorded tracks from different genres. If necessary, try varying the timing slightly until the most satisfying result are heard and felt. This method can also help to affirm that the above methods have been applied correctly.

Important note on bass enclosure placement

Most bass enclosures are fairly omnidirectional because of their small size relative to bass wavelengths. They therefore tend to be affected by a nearby wall and care has to be taken to ensure that direct and reflected bass do not destructively interfere with each other.

Wherever possible, position bass enclosures hard against a wall; so that the time difference between direct and reflected sound is minimised. The further the bass enclosure is placed from the wall, the more the reflected sound will be out of time with the direct sound. This can cause cancellation (reduction in level) due to the phase difference.

However, if the bass enclosure is positioned at an increment of half a wavelength from the wall the reflected and direct sound can combine once again maximising the energy despite the phase lag.

The most dangerous position for destructive interference is close to but not against a wall or boundary. Reinforcement and cancellation are dependent on the specific frequency and dimensions.

Frequency	Wavelength	½ wavelength
40Hz	8.60m	4.30m
80Hz	4.30m	2.15m
160Hz	2.15m	1.075m

For instance, an enclosure 1m from a wall will have an extra distance of 1m there and 1m back. 86Hz has a wavelength of 4m so the 2m round trip will cause a ½ wavelength delay. ½ wavelength delay will cause the reflected wave at 86Hz to have a 180° phase lag.

This will cause maximum cancellation when it combines with direct wave at the front of the enclosure.

For a more in depth understanding of this, please see the *Funktion One handbook*.

Boundary effects (and how they cause low frequency phase shifts)

Smaller loudspeaker systems are less directional than larger ones at low frequencies and are, therefore, more affected by a nearby floor, wall or ceiling. These local boundaries can affect the low frequency phase response of F101 and bass systems differently leading to phase misalignment through the F101-to-bass crossover region. The effect can be compensated for using a Funktion One XO series loudspeaker management system.

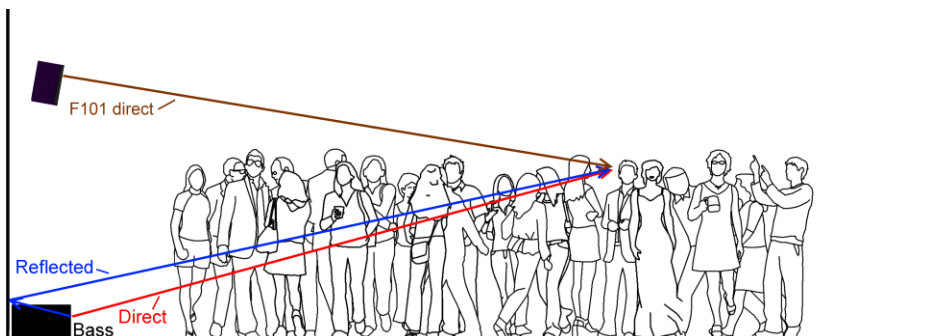

Fig 10.1-3 Direct bass (red) plus a close rear wall reflection (blue)
 (In reality, of course, multiple boundary effects will occur for both F101 and bass enclosures)

In the example shown on the previous page, the direct sound from the bass system (red) is closely followed, a few milliseconds later, by bass sound reflected from the rear boundary (blue).

If the reflected bass arrives within ¼ of a wavelength for frequencies up to the bass-F101 crossover frequency, then the direct and reflected levels will add – albeit with an overall phase lag.

The addition varies from almost +6dB for very small phase lags to 0dB (unity gain) for 120° phase lag.

Note that subtraction will start to occur for phase differences beyond 120° with complete cancellation occurring at 180°.

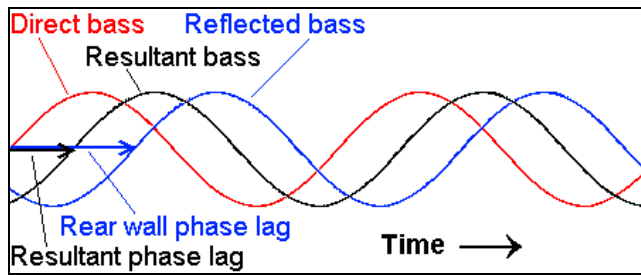

Direct and reflected components with resultant bass wave
Fig 10.1-4

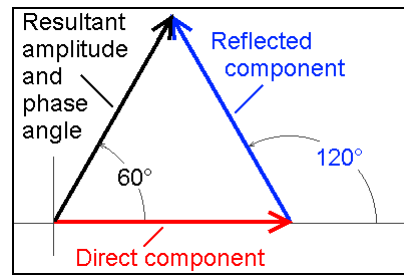

Vector representation
Fig 10.1-5

The simplified example (Fig 10.1-4) shows the reflected bass (blue) arriving $\frac{1}{2}$ wavelength (120°) later than the direct bass (red) at the crossover frequency resulting in an overall 60° phase lag (black). The F101 system would need to be realigned with the bass system by applying a small extra delay to create a matching phase lag through the crossover region.

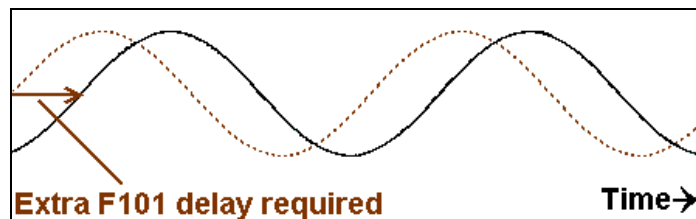

F101-to-resultant bass alignment for the simplified example
Fig 10.1-6

11 Limiters

For suggested crossover settings see [Section 10.1](#).

For further crossover advice, go to www.funktion-one.com and click on **Settings**.

Limiters are usually built into loudspeaker management systems - like the Funktion One XO2, XO4 or XO4A, for example.

Installation and touring companies prefer to use separate loudspeaker management systems driving a variety of power amplifiers set to a standard voltage gain. The advantage of this set-up is that the power amplifiers stay simple and can be swapped or re-patched without reprogramming. Funktion One loudspeaker management systems also have much higher quality limiters than most power amplifiers.

Funktion One power amplifiers all have clearly defined voltage gains and support the industry standard 32dB gain.



Multiple limiters

Avoid using multiple limiters in the signal path as they will make your system sound confused and powerless as the various attack, decay and latency times trip over each other.

Use loudspeaker management system limiters in preference to integral power amplifier limiters as a lot of them can compromise audio quality. However, where a dedicated loudspeaker management system is unavailable the E Series Amplifier Power Reduction Controls or the F Series optional XO40Q/XO60Q crossover cards with built-in limiters can be used to provide a degree of safety.

Some power amplifiers are equipped with "clip limiters" that can be too crude and sap power. These old-style clip limiters are best left switched out unless you are using a significantly over-powered amplifier.

Remember that we are trying to provide two types of voltage limiting:

- **Long-term rms limiters** – to protect against over-powering drivers (And, for advanced users, to maintain musical balance)
- **Clip limiters** – to prevent power amplifier clipping

Long-term limiters can usually be identified by user-adjustable features like threshold voltage and attack/decay times. These limiters are strongly recommended for all but the cosiest of domestic set-ups.

Recommended long-term limiter threshold voltages usually limit the loudspeaker drive voltage to 1dB or more below that required to reach a loudspeaker's maximum power rating. Threshold voltage recommendations will depend on your power amplifier's voltage gain or sensitivity – see the following tables.

These recommended long-term limiter thresholds must never be exceeded. They may, however, be reduced to maintain spectral balance (i.e. the appropriate musical level vs frequency) when the system is being driven on the limit. This is because different loudspeaker sections in a system have different sensitivities. A mid frequency horn, for instance, may be more efficient (i.e. produce greater spl at its power limit) than, say, an accompanying bass enclosure. In this example, both sections would be set to the recommended long-term limiter thresholds initially, and then the mid frequency horn threshold reduced to maintain musical balance on a listening test with high quality tracks of the appropriate genre.

Clip limiters, such as those provided by the Funktion One XO4 or XO4A, provide additional protection from short-term peaks and prevent amplifier clipping. Clip limiter threshold voltages are usually set a few dB above the relevant long-term limiter threshold and help maintain audio quality at high drive level.



Limiter settings for different system impedances

As mentioned in the [Section 9.4](#), XO series limiters control the maximum **voltage** applied, via the power amplifier, across the loudspeaker terminals. This means that, as long as you have a good, stiff mains supply, you can use the same limiter voltage thresholds irrespective of 8, 4 or 2 ohm operation.

However, if your mains supply voltage drops by more than 2 or 3% on load, you may need to reduce the recommended long-term limiter threshold levels by a dB or so to prevent the power amplifier from prematurely clipping with the increased mains current demand when driving a 4 or 2 ohm load.

11.1 XO series limiters with 32dB amplifiers

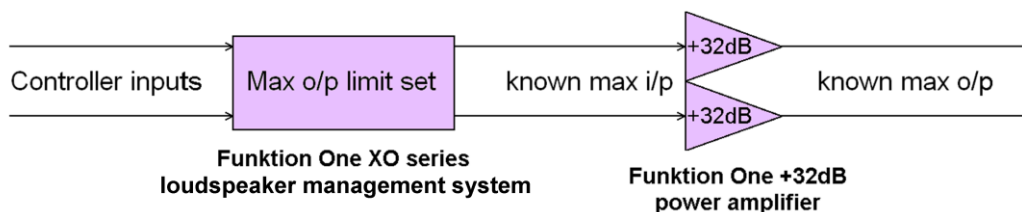

Fig 11.1-1

If you're using power amplifiers such as the Funktion One E15 (PRC set to 0dB, gain set to 32dB) or the Funktion One F40Q (pre-set to 32dB), set your loudspeaker management system output limiters as shown on the next page.

Loudspeaker	XO series main o/p limiter threshold level	XO series main o/p limiter attack time	XO series main o/p limiter decay multiplier	Clip limiter "over" level (where fitted)	Clip limiter speed (where fitted)
F101	0dBu	Automatic (16ms)	Automatic (x16)	+5dB (E15) +6dB (F40Q)	medium

Note that the **main** limiter settings are essential. Setting Clip limiter "over" levels alone is not enough.

XO series limiter settings for F101 systems with standard 32dB amplifiers

Notes

- These settings will limit the amplifier's long-term output to 1dB below your F101's AES power rating
- The Clip limiter will prevent hard peak clipping - although you may see the occasional momentary clip indication
- Check that the above limiter settings are preventing hard clipping by testing the controller/amplifier combination at high signal levels off-load (i.e. with the loudspeaker unplugged)
- If necessary, reduce the output limiter threshold level to reduce or eliminate the hard clipping. Adjustments of more than 1 or 2dB may indicate a problem with the mains voltage or the amplifier gain settings
- These figures will also work for most professional standard 32dB amplifier/controller combinations

11.2 Limiter settings vs amplifier gain

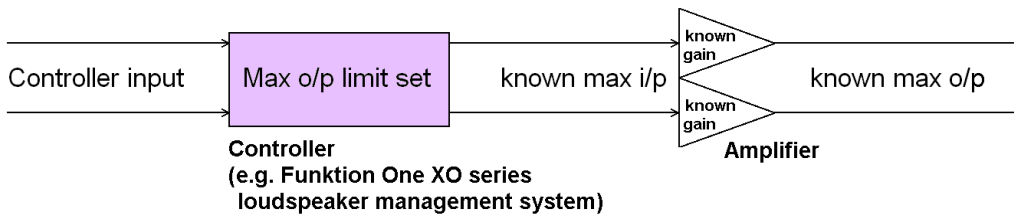

Fig 11.2-1

Voltage gain of Power amplifier driving F101s	Controller long-term/main o/p limiter threshold level	Controller long-term/main o/p limiter attack time	Controller long-term/main o/p limiter decay multiplier
26dB (x 20.0)	+6dBu	Automatic (16ms)	Automatic (x 16)
27dB (x 22.4)	+5dBu		
28dB (x 25.1)	+4dBu		
29dB (x 28.2)	+3dBu		
30dB (x 31.6)	+2dBu		
31dB (x 35.5)	+1dBu		
32dB (x 39.8)	0dBu		
33dB (x 44.7)	-1dBu		
34dB (x 50.1)	-2dBu		
35dB (x 56.2)	-3dBu		
36dB (x 63.1)	-4dBu		
37dB (x 70.8)	-5dBu		
38dB (x 79.4)	-6dBu		
39dB (x 89.1)	-7dBu		
40dB (x 100)	-8dBu		

Amplifier limiter settings for F101 systems

Max amp output	150W/8Ω	200W/8Ω	250W/8Ω	300W/8Ω	375W/8Ω	500W/8Ω	600W/8Ω
	300W/4Ω	400W/4Ω	500W/4Ω	600W/4Ω	750W/4Ω	1000W/4Ω	1200W/4Ω
Clip limiters (dB above long-term)	Not applicable	+1dB	+2dB	+3dB	+4dB	+5dB	+6dB

Controller Clip limiter settings (if fitted)

Notes

- These settings will limit the amplifier’s long-term output to 1dB below your F101’s power rating
- Check that the main output limiter settings are preventing continuous clipping by testing the controller/amplifier combination at high signal levels off-load (i.e. with the loudspeaker unplugged)
- If necessary, reduce the output limiter threshold level to eliminate any continuous clipping
- Assuming that the amplifier has adequate continuous power, adjustments of more than 1 or 2dB may indicate a problem with the mains voltage or the amplifier gain settings

11.3 Limiter settings vs amplifier sensitivity

If gain figures are not available, the table below will allow you to estimate long term controller limiters for your F101s from your amplifier’s output and sensitivity figures.

Max amplifier output →				150W/ 8ohm	200W/ 8ohm	250W/ 8ohm	300W/ 8ohm	375W/ 8ohm	500W/ 8ohm	600W/ 8ohm	
				300W/ 4ohm	400W/ 4ohm	500W/ 4ohm	600W/ 4ohm	750W/ 4ohm)	1000W/ 4ohm	1200W/ 4ohm	
Sensitivity ↓		Voltage Gain ↓	Long-term limiter threshold for 1dB margin ↘								
dBV	vrms			dBu							
-10dBV	0.316v	-7.8dBu	41dB	-9dBu	-10dBu	-11dBu	-12dBu	-13dBu	-14dBu	-15dBu	
-9.2dBV	0.35v	-7dBu	40dB	-8dBu	-9dBu	-10dBu	-11dBu	-12dBu	-13dBu	-14dBu	
-8.2dBV	0.39v	-6dBu	39dB	-7dBu	-8dBu	-9dBu	-10dBu	-11dBu	-12dBu	-13dBu	
-7.2dBV	0.44v	-5dBu	38dB	-6dBu	-7dBu	-8dBu	-9dBu	-10dBu	-11dBu	-12dBu	
-6.2dBV	0.49v	-4dBu	37dB	-5dBu	-6dBu	-7dBu	-8dBu	-9dBu	-10dBu	-11dBu	
-5.2dBV	0.55v	-3dBu	36dB	-4dBu	-5dBu	-6dBu	-7dBu	-8dBu	-9dBu	-10dBu	
-4.2dBV	0.62v	-2dBu	35dB	-3dBu	-4dBu	-5dBu	-6dBu	-7dBu	-8dBu	-9dBu	
-3.2dBV	0.69v	-1dBu	34dB	-2dBu	-3dBu	-4dBu	-5dBu	-6dBu	-7dBu	-8dBu	
-2.2dBV	0.775v	0dBu	33dB	-1dBu	-2dBu	-3dBu	-4dBu	-5dBu	-6dBu	-7dBu	
-1.2dBV	0.87v	1dBu	32dB	0dBu	-1dBu	-2dBu	-3dBu	-4dBu	-5dBu	-6dBu	
0dBV	1v	2.2dBu	31dB	1dBu	0dBu	-1dBu	-2dBu	-3dBu	-4dBu	-5dBu	
0.8dBV	1.09v	3dBu	30dB	2dBu	1dBu	0dBu	-1dBu	-2dBu	-3dBu	-4dBu	
1.8dBV	1.23v	4dBu	29dB	3dBu	2dBu	1dBu	0dBu	-1dBu	-2dBu	-3dBu	
3dBV	1.41v	5.2dBu	28dB	4dBu	3dBu	2dBu	1dBu	0dBu	-1dBu	-2dBu	
3.8dBV	1.55v	6dBu	27dB	5dBu	4dBu	3dBu	2dBu	1dBu	0dBu	-1dBu	
4.8dBV	1.74v	7dBu	26dB	6dBu	5dBu	4dBu	3dBu	2dBu	1dBu	0dBu	
5.8dBV	1.95v	8dBu	25dB	7dBu	6dBu	5dBu	4dBu	3dBu	2dBu	1dBu	
6.8dBV	2.18v	9dBu	24dB	8dBu	7dBu	6dBu	5dBu	4dBu	3dBu	2dBu	

Initial controller limiter settings vs amplifier output and sensitivity for F101 systems

Timing and clip limiter settings on next page...

Max amp output	150W/8Ω	200W/8Ω	250W/8Ω	300W/8Ω	375W/8Ω	500W/8Ω	600W/8Ω
	300W/4Ω	400W/4Ω	500W/4Ω	600W/4Ω	750W/4Ω	1000W/4Ω	1200W/4Ω
Clip limiters (dB above long-term)	Not applicable	+1dB	+2dB	+3dB	+4dB	+5dB	+6dB

Controller Clip limiter settings (if fitted)

XO series main o/p limiter attack time	XO series main o/p limiter decay multiplier
Automatic (16ms)	Automatic (x16)

Limiter attack and decay settings

Notes

- Always use the maximum output power figure given for the **highest** impedance (usually 8 ohms) as this gives the best indication of your amplifier's maximum output swing and the most accurate indication of voltage gain. Lower impedance continuous power figures often underestimate an amplifier's dynamic performance due to loading effects
- Always check limiter threshold operation with the power amplifier off-load. See previous page.



Appendix A - Clipping



Caution

Prolonged heavy clipping can subject loudspeaker voice coils and passive crossover components to double their rated power dissipation leading to overheating, premature ageing or early failure. The high frequency components are particularly vulnerable in systems with passive crossovers.

In extreme cases this could pose a fire hazard.

What is clipping and why is it a problem?

When an audio signal is amplified beyond the voltage or maximum digit capabilities of the equipment in use, the peaks of the waveform can get flattened. This is referred to as clipping and is heard as distortion.

Here's a normal signal at maximum level – just below clipping and still within the available “headroom”... (The clip level sets the maximum available headroom)

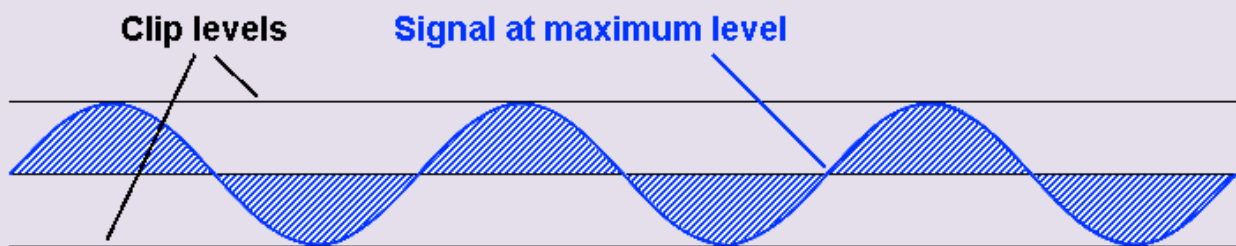

Pure tone (single frequency) signal just below clip level
(Vertical = voltage, horizontal = time)

The blue positive and negative shaded areas represent the power the signal would cause to be dissipated in a load – usually a loudspeaker voice coil.

Here's the same signal amplified beyond the available “headroom” – i.e. beyond the clip level...

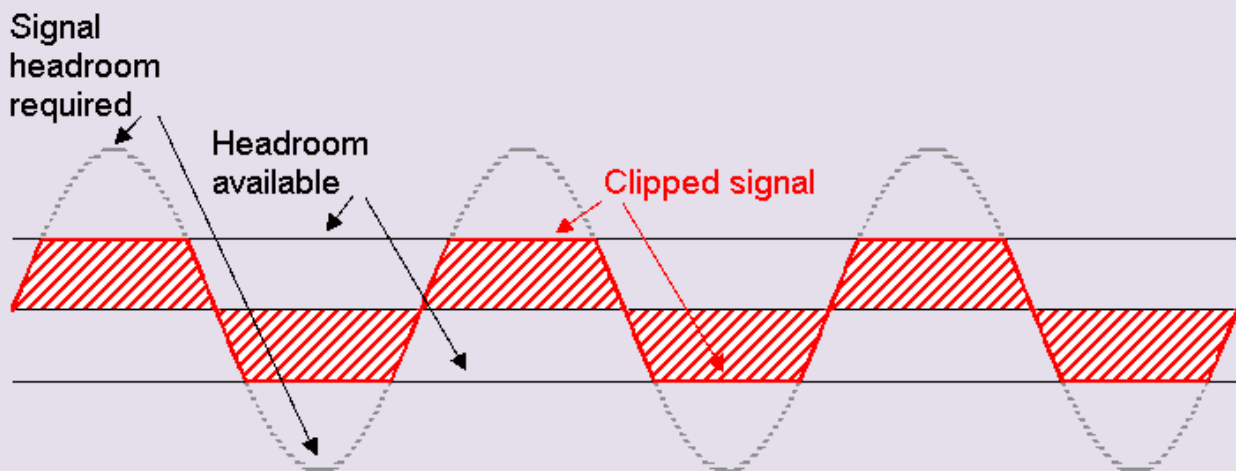

Signal amplified beyond clip level

When a signal is clipped, its waveform squares off.

The cross-hatched areas cover a significantly larger area because the signal stays at the maximum positive and negative values for more each cycle. This is easier to see if we overlay the normal and clipped waveform illustrations. The clipped signal's extra content can be seen as the extra red shaded areas.

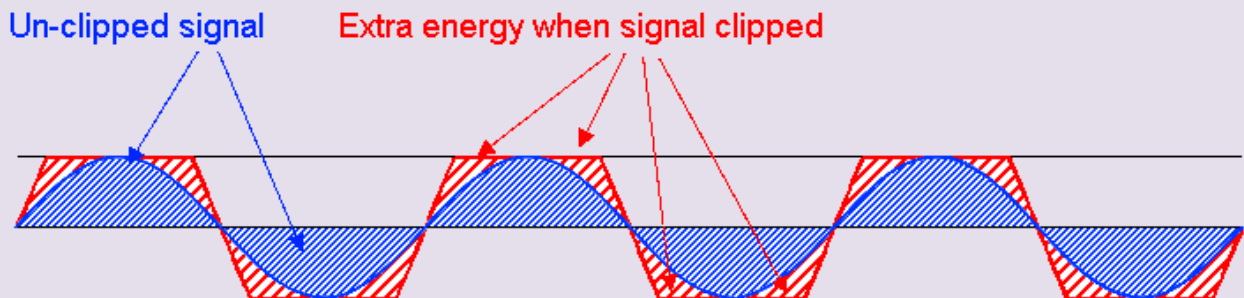

Extra energy of a clipped signal

In extreme cases, the waveform is so heavily clipped that it can resemble a square wave. This increases the rms voltage delivered to the loudspeaker to $\sqrt{2}$ (approx 1.4142) times what would be expected.

The power delivered to the loudspeaker is dependent on the rms voltage².

$\sqrt{2} \times \sqrt{2} = 2$ so the power delivered to your loudspeakers is doubled!

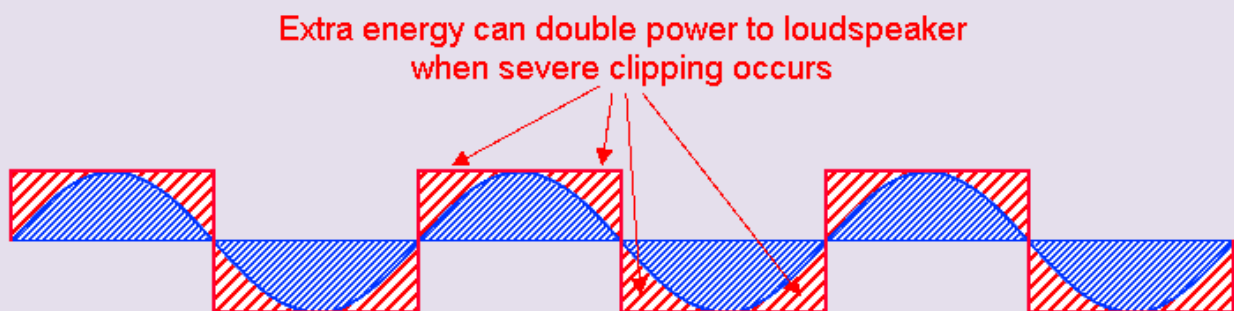

Note that, in all cases, the two waveforms have similar peak voltage levels so this extra energy doesn't always show up on digital audio systems where meters are usually calibrated with respect to maximum digital level (full scale). This is usually written as dBFS.

Digital level meters don't usually take the shape of the waveform (and its potential voice coil heating effect!) into account - hence the warning at the beginning of this Appendix.

To avoid overheating loudspeaker voice coils – particularly HF voice coils in passive loudspeaker systems – try not to clip signals repeatedly or for long periods.

Clipping and its effect on frequency content

All waveforms are made up of combinations of fundamental frequencies (main tones) and harmonics (multiples of the fundamental frequencies, also known as overtones) in a variety of amplitude and phase relationships.

Spectrum analysers can be used to show this. In the screen shot below, an unclipped pure tone (approximately 1kHz) can be seen as a single frequency line.

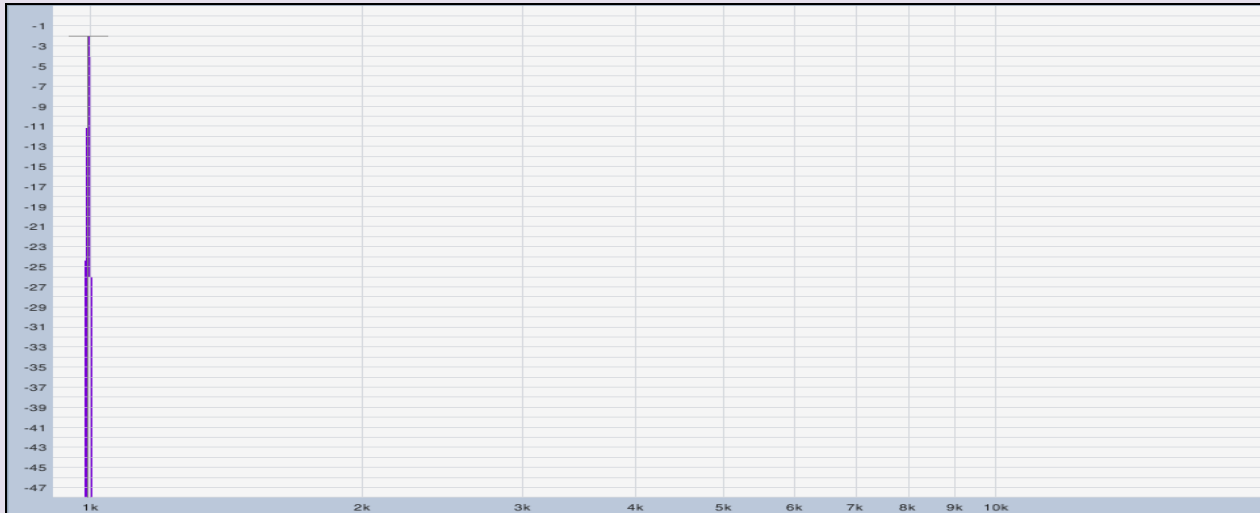

1kHz pure tone just below clip level
 (Vertical = level in decibels, horizontal = frequency)

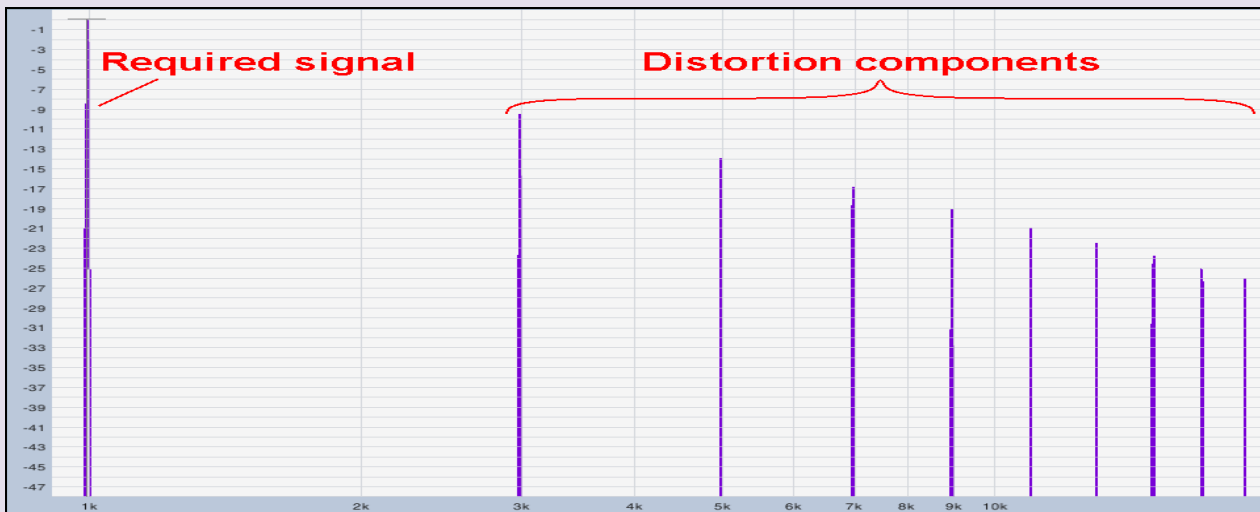

1kHz heavily clipped signal

The heavily clipped signal (see previous illustration) shows clipping distortion as a series of odd harmonics at 3kHz, 5kHz, 7kHz etc., whose levels decrease with frequency at approximately 6dB per octave. Where clipping occurs before the system crossover, clipping harmonics can crossover into the HF driver and the HF driver can be called upon to dissipate far more power than normal.

Note that the example shows a single frequency fundamental. Musical signals will be a lot more complex and the distortion content will be denser. Asymmetrical clipping (from studio or backline valve amplifiers, for instance) would also include even harmonics.

As mentioned earlier, long-term clipping can be avoided – and performance improved - if you choose mixers, effects units, controllers and amplifiers with adequate headroom and set your limiter thresholds to below clipping levels. You can also avoid clipping your signals at source by setting your console and effects system “gain structure” carefully. See [appendix B...](#)



Appendix B – Gain structure

What is gain structure all about and why is it important?

When an audio signal passes through an analogue or digital audio system, it is important to maintain the optimum signal operating level through the various sections of the signal path. Microphone levels must be boosted to make them compatible with line level and analogue-to-digital converter stages and mix stages must allow enough headroom for multi-channel summation.

The various gain settings throughout a piece of audio equipment are collectively known the system's gain structure.

Signal level too low

If the signal level is too low it will be wallowing around in the analogue noise floor losing resolution and becoming fuzzy, distorted and noisy in the digital domain.

Avoiding digital garbage

If you have to go digital for your multi-channel live sound operations, use 24-bit systems - if they are available - so that you can maintain enough headroom to mix without sinking into the digital mush. And, of course, if you like to use lots of effects, try to use one, comprehensive, studio-quality effects system that runs its internal processing at 32-bit floating point. This reduces the build-up of mush you get every time your signal goes through a different processor.

Signal level too high

If your operating levels are too high, there won't be enough headroom to allow for performance peaks and multi-channel mixing. You may end up with distortion caused by peak clipping - or even long-term clipping.

If you're using all-analogue equipment, the odd peak clip may go unnoticed as long as it's not sustained enough to damage your HF drivers. This is because analogue clipping components are harmonically related to the original signal.

Avoiding digital mush

Unfortunately, digital overload isn't as simple. You get clipping when the digital stage runs out of digits – usually referred to as 0dBFS – and the higher order harmonics generated can then alias with clock frequencies creating all sorts of strange sum and difference frequencies. These aliasing products can be interesting if you're a robot but are generally heard by humanoids as nasty and unmusical. They can also turn cymbal "tings" into "shhhhs" and make vocals excessively sibilant.

To make matters worse, any over-sampling or delay-based processes built into effects units, can stretch these nasty artefacts in the time domain and make them far more audible than their relatively low levels would suggest. Also remember that aliasing will be compounded as the overloaded signal passes through successive processes.

Signal level just right

If your operating signal levels are just right, you won't run out of headroom, clip or run out of digits – even on musical peaks. And you'll still run well above the analogue noise floor and stay clear of the digital mush.

So what is “just right”?

It all depends on the type of audio material and your application.

Live sound mixing

If you're going to be mixing audio from a variety of live musical instruments or you're going to be creating some broadband effects over a wide dynamic range, you'll need to allow plenty of operating headroom to avoid analogue clipping or, worse still, running out of digits.

DJ mixing with pre-recorded material

If you were only ever going to work with pre-recorded, auto-levelled material, you'll probably get away with just enough headroom to mix tracks and add the odd effect – but read the whole section anyway, you may find it instructive.

Live sound operating levels

It is important to retain enough headroom to maintain good transient response, details and impact for live sound mixing – not only to allow for backline systems being turned up to “11” mid-set and for high peak-to-rms percussion transients, but also to allow for the natural signal level build-up through the console, once you start tweaking eqs, adding effects and sub-grouping multiple channels.

Assuming a professional quality analogue or 24-bit digital console, run each channel's pre-fader or level and each group's mix level at around **0dBu/+4dBu (analogue)** or **-18dBFS (digital)** if at all possible.

Modern 24-bit systems with good studio quality converters usually work well at -18dBFS but some MI products may use lower grade converters which will need to be run at higher operating levels to avoid sounding mushy. If you suspect this is the case with your system, you'll need to run the PFL or group levels around the -12 to -9dBFS level and keep an eagle-eye open for signal clipping during the live performance.

Understanding level meters

This section spends a lot of time discussing meters because, without an understanding of their typical calibration levels, it's difficult to get your gain structure and operating levels properly optimised.

Professional live sound meters calibrated with respect to “Full Scale” (dBFS)

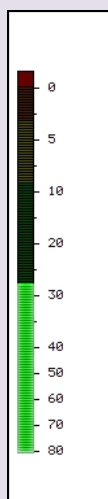

Too low (-28dBFS)
Wasting dynamic range

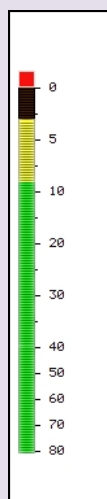

Too high (-3dBFS)
Peaks could be clipped

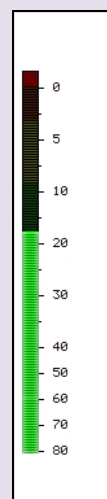

Just right (-18dBFS)
Noise-free without clipping

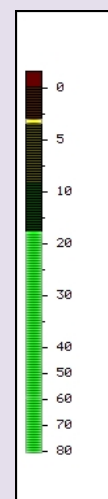

Peak-hold option
May not be true peak

The illustrations above show levels on a typical bar meter with a dedicated peak LED at the top. Some analogue peak LEDs don't respond to very fast transients and some digital ones don't respond until the processor has seen several maximum bits in a row. Peak-hold indicators often hold maximum rms – not true waveform peaks – so they are not always a good indicator of potential clipping.

If, for live sound, your bar meter is way above the -18dB mark, you're probably clipping peaks and transients irrespective of what the peak LED or peak-hold indicator is telling you.

Q & A

Q) Surely 18dB below clipping (-18dBFS) won't drive my loudspeaker system hard enough?

A) Remember that 18dB below clipping represents about +4dBu/0VU output level on most pro-audio consoles. Effects, eq., mixing and natural performance dynamics will require the 18dB of headroom through your channel, effects and subgroup sections.

Lower-cost digital console calibration and limited converter quality may push you towards an operating level only 12 to 9dB (-12 to -9dBFS) below clipping as mentioned earlier. -9dBFS is an old DIN standard but it's the exception rather than the rule – particularly with modern 24-bit systems.

Once you've done all this without crashing the mix, you can then use the **master faders** to push the required level to your main system amplifier racks where your controller limiters will take care of the odd rogue peak.

Standard EBU alignment level for digital audio is also 18dB below full scale (maximum digital level) – usually written as -18dBFS – so sticking to the 18dB rule will also make you compatible with broadcasters when working at festivals and VIP DJ events.

Professional live sound analogue meters calibrated with respect to +4dBu

Most pro-audio analogue equipment can handle internal and output signal levels of approximately 10vrms before clipping. 10vrms is approximately +22dBu so 18dB below that clip levels is approximately +4dBu.

Traditionally, most pro-audio VU-meters (and VU-scaled bar meters) were calibrated so that 0VU corresponded to the industry standard +4dBu to give you 18dB of headroom.

More Qs & As

Q) What's a dBu?

A) dBu (sometimes written as dBv) refers to so many dB with respect to approximately 0.775vrms. You've probably seen the 0.775vrms standard used for power amplifier sensitivity.

Q) Why the strange voltage reference?

A) The original standard was devised for telephone circuitry and early audio. It was originally called dBm and was defined as 1mW into 600 ohms. Work out $0.775^2/600$ and you'll get a milliwatt.



Too low (-10VU = 28dB below clip)
Wasting dynamic range

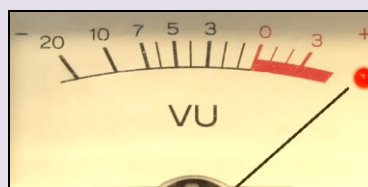

Too high
Peaks could be heavily clipped



Just right (0VU = 18dB below clip)
Noise-free without clipping

Professional analogue and digital peak programme meters (PPMs)

Peak programme meters don't actually measure short signal bursts or transients. They are designed for estimating programme levels.

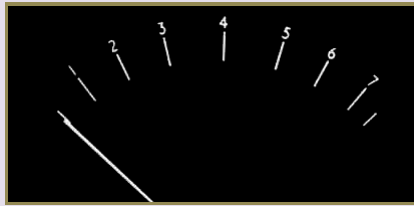

UK "BBC" PPM scale – in 4dB steps
"4" is usually set for -18dBFS

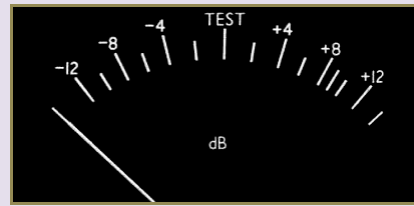

EBU PPM scale – also in 4dB steps
"Test" is usually set for -18dBFS

There are almost as many PPM scales as there are broadcasting authorities – including a "DIN" standard - where "0" is only -9dBFS!

PPMs move faster than most rms meters in response to tone-bursts and fall back more slowly – making them easier to read. But they still underestimate very short bursts and often ignore transients altogether so the 18dB below clip rule must still apply.

K-meters

K-meters – named after Bob Katz, the well-known mastering engineer – usually measure rms levels with a fixed 600ms integration and fall-back time over a very wide levels range.

Some versions include peak facilities. K-meters usually have switchable scaling: K-20 indicates 0dB at -20dBFS, K-14 has 0dB at -14dBFS and K-12 has 0dB at -12dBFS.

As most K-meters are software-based, it is possible to select K-20, K-14 etc as required. Live sound users should use the K-20 standard wherever possible.

K-meters were designed for recording applications – and as an attempt to get some consistency in control room monitoring levels. For recording purposes, 0dB is set for 83dBspl but this isn't relevant for live sound use.

A K-meter's main advantage in live sound applications is its accurate indication of levels with reference to full scale.



Sondris Meter
(Set to K-20)

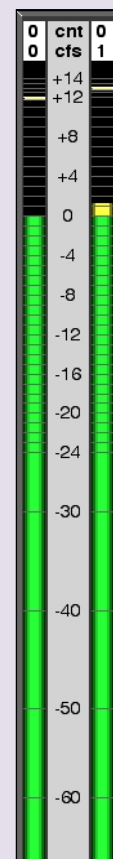

Spectrafoo meter
(Set to K-14)

Gain structure basics for live sound console users

- 1: Ensure that all inserts, gates, compressors or plug-ins are bypassed before initially setting your gain structure! See **Outboards effects set-up** later...
- 2: Adjust your input channel mic/line gains for PFL (pre-fade listen) levels around +4dBu/OVU (analogue), -18dBFS (digital) or the top green indicator (DJ)

You may need to trim input gains if the input levels change dramatically during the set. Remember that musicians tend to play louder with an excitable audience in place so allow at least 6dB of spare gain control

If your signals are too hot, even with the gain control below the 9 o'clock position, use a less sensitive input, perhaps line instead of mic, or the console pad switch

If your mic signals are too weak, even with the gain control above the 3 o'clock position, recheck your patch and make sure any input pad or insert points are switched out. It's also worth checking your mic specifications –in case the mic needs phantom power

- 3: Once you have a healthy PFL level, adjust the relevant subgroup or fader for AFL (after-fade listen) levels around +4dBu/OVU (analogue), or -18dBFS (digital) with the channel routed and faded up to the nominal 0dB fader mark

Note that, for professional analogue consoles, this assumes that the nominal 0dB fader mark is 10dB below full fader level and that there is gain make-up between the sub-group fader output and the AFL point. Non-professional consoles may not have this gain make-up so you may need to run at lower AFL levels (around -6dBu) to maintain pre- subgroup fader headroom

- 4: Channel faders will eventually be set to the levels required for artistic balance. Large numbers of channels routed to the same subgroup or output will raise overall mix bus levels and you may have to drop channel fader levels by 2-3dB every time you double the number of channels routed to the same mix bus to maintain headroom
- 5: Adjust your master/output faders for the required sound level
- 6: Readjust channel gain controls for suitable pfl levels if specific input levels change, or after tweaking any channel strip effects or eqs

Note that short-term transients and peaks in live music - plus mix summing - can easily use up your headroom. Don't be tempted to drive channel rms levels much beyond +4dBu/OVU/-18dBFS if you want to minimise peak clipping and signal degradation further down the signal path.

Again, remember that you can always push the system harder using the master fader, once you've developed a clean mix.

Outboard effects set-up

Assuming you have set the relevant console channel with everything bypassed as above, switch in your inserts. **If the outboard gear isn't too noisy or mushy, use the 18dB-below-clip rule.**

Outboard gain structure

- 1: With your outboard equipment's input gain set to a nominal level (about 10 o'clock if it's an analogue knob), set the relevant insert send control on your console so that your outboard gear's general level is indicating around 18dB below its own maximum (usually -18dBFS on digital gear).

- 2: *With your outboard equipment's output control set to nominal, set the relevant insert return control on your console for PFLs around +4dBu/0VU (analogue) or -18dBFS (digital).*
- 3: *Listen to the required effect – on headphones first and then on the PA.*

If the outboard gear is too noisy or has poor quality converters, you may have to compromise on headroom by increasing the insert send level by a few dB and decreasing the insert return level by the same amount.

If the outboard gear is starting to sound distorted at your likely maximum effect, you may need to bring its internal signal level down by reducing your console insert send level and increasing the insert return sensitivity by the same amount.

DJ equipment standards

Funktion One FF-4000 and FF-6000 Dual Format DJ Mixer levels

Funktion One FF-4000 and FF-6000 Dual Format DJ Mixers have full a pro-audio output capability of up to +22dBu. This gives maximum headroom and dynamic range.

Due to the more compressed nature of most DJ tracks, and the pro-audio headroom of Funktion One DJ mixers, pre-fade/cue signal levels may be kept quite high as long as they stay within the green section of the Cue meter most of the time.

The excellent output capabilities of the FF-4000 and FF-6000 mixers allows them to be used with a very wide range of controller/ amplifier combinations

-10dBV/2.0V DJ and MI (music industry) equipment levels

A lot of DJ and music-industry products run at a nominal operating level of -10dBV.

dBV (note the upper-case V) refers to so many dB with respect to 1vrms.

-10dBV is approximately 0.316vrms. The maximum analogue output (for a maximum digital level of 0dBFS) is usually around +6dBV (2.0Vrms) so nominal operating levels are, in theory, -16dB with respect to maximum output.

In practise, however, many DJs run considerably hotter than this; partly to “drive through” the dubious digital audio converter quality of some systems that sound distinctly lacking at low levels, and partly because they don't need the kind of headroom required for live sound as they know their favourite tracks very well and they are in a more controlled environment.

Note that loudspeaker amplifier systems must have sensitivity figures below 2.0Vrms to prevent DJs and MI operators from pushing their DJ consoles into clip before reaching maximum dance floor levels.

Level setting for DJ mixer users

(Normally known as Gain Structure)

The Funktion One/ Formula Sound FF-4000 is used in this example although the principles of keeping the signal clean apply to any mixer. The suggestions assume the user or installer is familiar with the basic mixer functions

Initial input-output calibration

- 1: *Ensure that all inserts or effect loops are switched out (bypassed) before initially setting your gain structure! See **Outboards effects set-up** later...*

- 2: Set all your front panel input **GAIN** and **EQ** (HF, MID and BASS) controls, initially, to the 12 o'clock position.
- 3: With typical input signal levels – and the appropriate input source selected for each channel strip, of course - adjust the rear panel input channel gain trims so that the 5-segment input meters are towards the top of the green section with only the occasional very brief excursions into the amber.

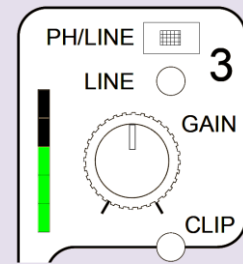

Important note!

Never run your input levels into the red as this would indicate input clipping.

Broadband input clipping will sound very unpleasant in the main listening area. And you certainly won't be able to "fix it in the mix" with further EQ or, even worse, compression. Further processing will simply make matters worse.

Once calibrated, you can then use the **GAIN** and **EQ** controls to adjust for different programme material. But always use EQ sensitively. Excessive EQ may sound impressive, initially, but will quickly cause listener fatigue and irritate your audience.

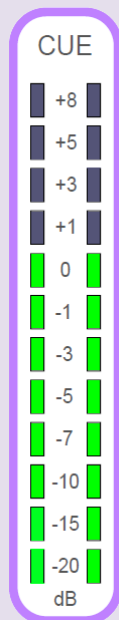

If you wish, you can also finely adjust your input levels using the **Cue** meter via the channel strip **CUE** buttons. Make sure the **CUE BAL** control is set fully counter clockwise to **CUE**. Once you've initially set the healthy input levels above, finely adjust for Cue meter levels between -3dB and 0dB with one channel Cued or between 0dB and +3dB with two channels Cued.

Notes

If you run out of gain adjustment or run into constant distortion, your input may be plugged into an inappropriate input socket, you may have the wrong input selected or your rear panel phono/line selectors may be wrongly set. Re-patch or reset as necessary.

If your mic signals are too weak, even with the gain control above the 3 o'clock position, it's worth checking your mic specifications in case the mic needs phantom power.

If your input signal levels are too high and input media player operations sometimes create a loud bang, check that your external source isn't inadvertently patched to a phantom-powered mic socket!

- 4: With a healthy signal level on one input, make sure neither A nor B X-Fade buttons are pressed (very important) and set the input fader to approximately 80% - two lines down from maximum.
- 5: **With your system controllers or power amplifiers muted, initially**, adjust your **MASTER LEVEL** so that your master output meter indicates a level appropriate for your amplifier/ loudspeaker sensitivity. The output meter is calibrated in dBu where 0dB = 0dBu (0.775vrms). See sections 9 and 11 for further information on system patching, limiter settings, amplifier gains etc.

Keep this configuration – with your system controllers or power amplifiers still muted – and use it to set up your inserts and loops for outboard effects

Master Insert and FX loop set-ups using outboard gear

Assuming you start with the relevant input channel gains, channel faders and master control settings (and your power amplifiers muted) as in 1 to 5 above...

MASTER INSERT gain structure

- a: Patch your effects unit into the FF-4000's rear panel **MAIN INSERT** left and right jack sockets (tip = send, ring = return) and switch it in circuit using the **MASTER INSERT IN/ OUT** button.
- b: Set your outboard equipment's input gain control so that its input signal indicators read approximately -12dB below clip.
- If your outboard gear only has signal present and clip input level indicators, adjust its input gain control until the clip indicator just flashes and then back off the control by about 90° if analogue – or by about 30% if digital.
- c: If your outboard gear has separate output controls, set these for an output indication of approximately -12dB below clip.
- Again, if your outboard gear only has signal present and clip output level indicators, adjust its output gain control until the clip indicator just flashes and then back off the control by about 90° if analogue – or by about 30% if digital.
- d: Now turn the FF-4000's **MASTER LEVEL** control all the way down (fully counter clockwise) and unmute your power amplifiers.
- e: Slowly increase the **MASTER LEVEL** and listen to the inserted effect.
- If the outboard gear is too noisy or has poor quality converters, you may have to compromise on headroom by increasing the outboard equipment's input gain by a few dB and decreasing its output gain by the same amount. A little experimentation may be required.
- If the outboard gear is starting to sound distorted at your likely maximum effect, you may need to reduce its input and/or output gain slightly. Again, a little experimentation may be required.

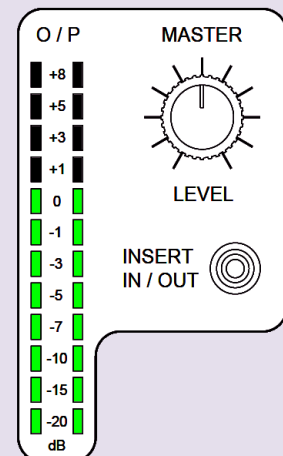

A and B FX LOOP gain structure

X-Fade A/ FX Loop 1 is used as the example. The procedure for the X-Fade B/ FX Loop 2 is the same - with the appropriate routing and selection changes, of course.

Again, assuming you start with the same input level signal - plus the relevant input channel gains, channel faders and master control settings - and your power amplifiers muted, as in 1 to 5 above...

- a: Patch your effects unit into the FF-4000's rear panel **FX LOOP 1** left and right jack sockets (tip = send, ring = return) and switch it in circuit using the X-Fade A **Latch ON** button
- (Make sure the **LOOP SWAP** button is not pressed – FX Loop 1 should follow A – and make sure the X-Fade control has not been switched off)
- b: Press the input channel strip **X-FADE A** and set the **A-B** cross-fader to **A**

c: Set your outboard equipment's input gain control to a nominal position (1 o'clock if analogue, about 70% full if digital) and fine adjust the FF-4000's rear panel **SEND TRIM FX LOOP 1** control so that the outboard effect unit input signal indicators read approximately -12dB below clip.

If your outboard gear only has signal present and clip input level indicators, adjust the FF-4000's rear panel **SEND TRIM FX LOOP 1** control until the effect unit clip indicator just flashes and then back off the send trim control by about 90° if analogue – or by about 30% if digital.

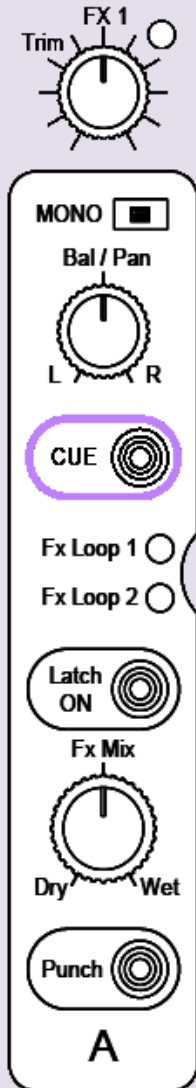

d: If your outboard gear has separate output controls, set these for an indication of approximately -12dB below clip.

Again, if your outboard gear only has signal present and clip output level indicators, adjust its output gain until the clip indicator just flashes and then back off the control by about 90° if analogue – or by about 30% if digital.

e: Set the FF-4000's X-Fade A **Bal/Pan** control to **L**.

f: Adjust your front panel **FX1 Trim** (effects return level) control using the Cue meter via the X-Fade A **CUE** button. Make sure the **CUE BAL** control is set fully counter clockwise to **CUE**. Finely adjust for Cue meter levels around 0 or +1dB

g: Set the X-Fade A **Fx Mix** control to **Wet**.

h: Now turn the **MASTER LEVEL** control all the way down (fully counter clockwise) and unmute your power amplifiers.

i: Slowly increase the **MASTER LEVEL** and listen to the inserted effect.

If the outboard gear is too noisy or has poor quality converters, you may have to compromise on headroom by increasing the outboard equipment's input gain by a few dB and decreasing its output gain by the same amount. A little experimentation may be required.

If the outboard gear is starting to sound distorted at your likely maximum effect you may need to reduce its input and/or output gain slightly. Again, a little experimentation may be required.

j: If necessary, finely adjust the FF-4000's **FX1 Trim** (effects return level) to balance the Fx Mix Direct vs Wet levels whilst swapping the **FX Mix** control between **Dry** and **Wet**.