

HP DeskJet 930C Series Printer User's Guide for Macintosh

English



Expanding Possibilities



HP Customer Care

Thank you for buying an HP DeskJet printer. Because HP wants owning your printer to be a trouble-free experience, we back your purchase with **HP Customer Care**—award-winning service and support that includes:



HP Customer Care Online

Click your way to a quick solution! **HP Customer Care Online** is a great place to start for answers to questions about your HP DeskJet printer—24 hours a day, seven days a week.

If you have a modem connected to your computer and subscribe to an online service, or have direct access to the Internet, you can obtain a wide variety of information about your printer at the following web sites:

English:	http://www.hp.com/support/home_products
French:	http://www.hp.com/cposupport/fr/
German:	http://www.hp.com/cposupport/de/
Japanese:	http://www.jpn.hp.com/CPO_TC/eschome.htm
Portuguese:	http://www.hp.com/cposupport/pt/
Spanish:	http://www.hp.com/cposupport/es/

From **HP Customer Care Online** you can link to **HP Customer Care User Forums** and **HP Customer Care Email**.



HP Customer Care by Phone

Call us direct and connect with a service technician who specializes in your product and who can typically answer your questions in one phone call. (See page 47 in this User's Guide for phone numbers.)

Acknowledgments

Apple, the Apple logo, AppleTalk, ColorSync, the ColorSync logo, Mac, Macintosh, MacOS, PowerBook, Power Macintosh, and QuickDraw are trademarks of Apple Computer, Inc., registered in the U.S. and other countries.

Notice

The information contained in this document is subject to change without notice.

Hewlett-Packard Company makes no warranty of any kind with regard to this material, including, but not limited to, the implied warranties of merchantability and fitness for a particular purpose.

Hewlett-Packard shall not be liable for any errors or for incidental or consequential damages in connection with the furnishing, performance, or use of this material.

All rights reserved. Reproduction, adaptation, or translation of this manual is prohibited without prior written permission of Hewlett-Packard Company, except as allowed under the copyright laws.

No part of this document may be photocopied, reproduced, or translated to another language without the prior written consent of Hewlett-Packard Company.

Edition 1, December 1999

© Copyright Hewlett-Packard Company and Apple Computer, Inc. 1999

Portions © Copyright 1989-1999 Palomar Software, Inc. HP DeskJet 930C Series printers include printer driver technology licensed from Palomar Software, Inc., www.palomar.com.

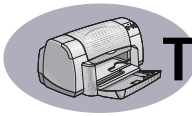
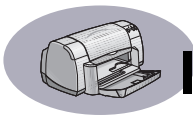

Table of Contents

Introduction	iii
Chapter 1 Printing Basics	
Buttons and Lights	1
Paper Trays.....	2
Printer Maintenance Tips	3
Chapter 2 Using Your Printer Software	
Choosing Your Printer.....	4
Other Ways to Select a Default Printer	4
Desktop Printing.....	5
Checking Printer Status	5
Page Setup - Controlling Page Layout	6
Print Dialog Box	7
Printing on Different Types of Paper and Media	13
HP DeskJet Utility Window	25
Chapter 3 Using and Caring for Your Print Cartridges	
Print Cartridge Status	27
Replacing Print Cartridges.....	29
Storing Print Cartridges	31
Cleaning Print Cartridges.....	32
Damage Resulting from Refilling the Print Cartridges.....	35
Chapter 4 Getting Help When Things Go Wrong	
Troubleshooting Tips	36
HP Customer Care	46
Chapter 5 Supplies and Accessories	
Printer Supplies.....	50
Printer Quick Start Posters and User's Guide for Macintosh	50
Paper and Other Media.....	51
Ordering Information	52



Appendix A	Setup Instructions	
	Using a USB Connection	54
Appendix B	Specifications	57
Appendix C	Legal Information	
	Regulatory Notices	60
	Limited Warranty Statement	61
	HP Year 2000 Warranty	61
Index	62



Introduction

Thank You For Buying an HP DeskJet Printer!

Here's what comes in the box. If something is missing, talk to your HP dealer or call HP Customer Care. (See page 47 for phone numbers.)

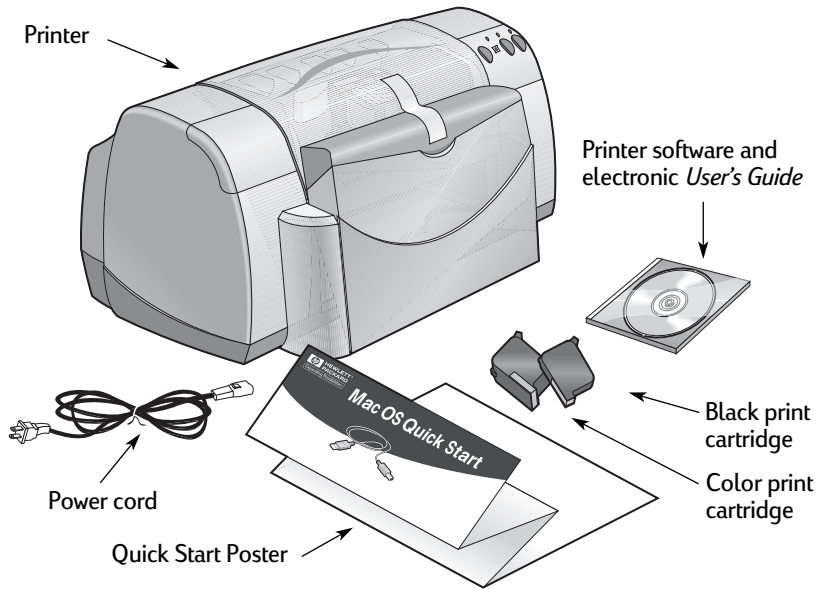



Special Features of Your HP DeskJet Printer

Your new HP DeskJet printer is equipped with these special features:

- Stunning photo quality through HP's Color Layering Technology
- Laser-quality black text
- Excellent print quality on plain paper
- Uncompromising performance with print speeds of up to 9 pages per minute for black text and 7.5 pages per minute for text with color graphics
- Sleek design with space-saving Fold-Up paper tray

Finding More Information

This *User's Guide* shows you how to operate your printer. For more information:

- Use the *Quick Start Poster* for installation.
- Turn on balloon help in the **Help** menu. Move your cursor over any print setting to view an explanation.
- Visit the HP web site at http://www.hp.com/support/home_products for the latest product information, troubleshooting, and printer software updates.

1 Printing Basics

Buttons and Lights

The HP DeskJet printer buttons (shown below) let you turn the printer on and off, cancel a print job, or resume printing. The lights give you visual cues about the state of your printer. The buttons and lights from left to right are:



Cancel Button – Press this button to cancel the current print job.



Print Cartridge Status Light – When lit, the light above this symbol indicates that you need to check the status of your print cartridges. See “Print Cartridge Status” on page 27 for more information.



Resume Button and Light – When this light flashes an action is needed such as load paper or clear a paper jam. To continue printing, press the Resume Button . See “What do the flashing lights mean?” on page 41.



Power Button and Light – Use the Power Button to turn the printer on and off. When the green light above the Power Button flashes, printing is in progress.

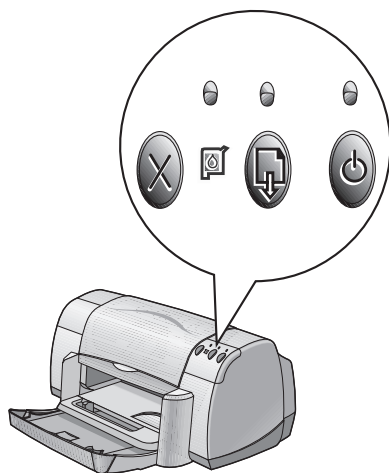

Warning

Always use the Power Button on the front of the printer to turn the printer on and off. Using a power strip, surge protector, or a wall-mounted switch to turn the printer on and off may cause premature printer failure.

Paper Trays

Fold-Up Tray

The Fold-Up tray, at the front of the printer, contains the IN and OUT trays. The Fold-Up tray must always be lowered to print or to access the ink cartridges.

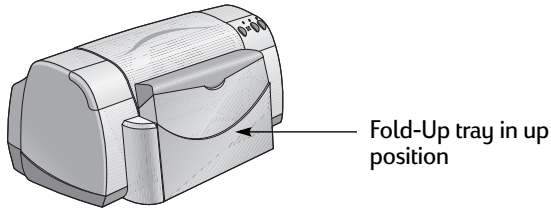

IN Tray

To print, place paper or other media types in the IN tray. Lower the Fold-Up tray and pull out the IN tray. Be sure to slide the paper guides out of the way before loading the media print side down. Slide all media as far as it will go into the IN tray. Once you insert the media you want to use, slide the paper guides so they rest snugly against the media. When printing on small media, make sure the IN tray is pushed back in.

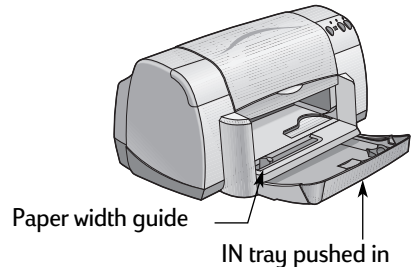
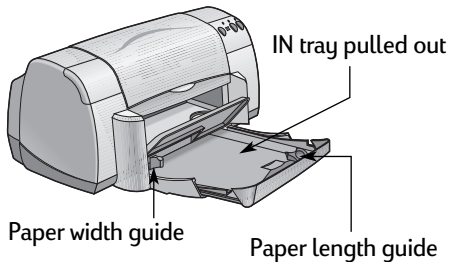

When printing on legal-sized paper, leave the IN tray pulled out.

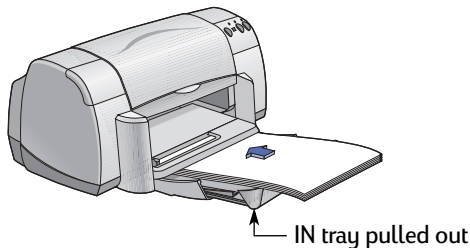

OUT Tray

The printer sends finished pages to the OUT tray.

OUT Tray Flap Down – This is the typical position for most types of printing. The down position also allows single envelope printing and printing on media smaller than 100 x 148 mm or 4 x 5 5/8 inches. For information about printing on other media, see Chapter 2.

Out Tray Flap Up – The OUT Tray Flap must be in the up position to properly load banner paper. The OUT Tray Flap must remain in the up position to print banners,.

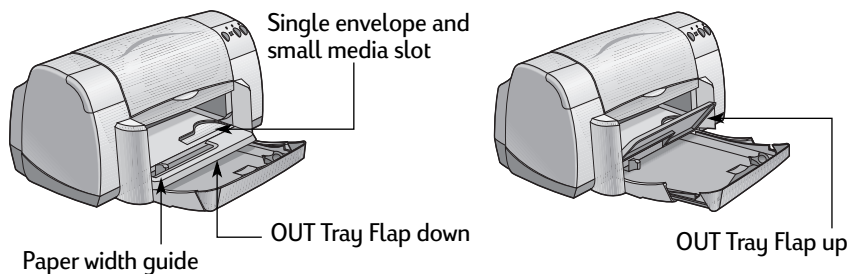

Printer Maintenance Tips

Because the printer ejects ink onto the paper in a fine mist, ink smudges will eventually appear on the printer case. To remove smudges, stains, and/or dried ink from the exterior of the printer, use a soft cloth moistened with water.

When cleaning your printer, keep these tips in mind:

- **Do not** clean the interior of the printer. Keep all fluids away from the interior.
- **Do not** use household cleaners or detergent. In the event that a household cleaner or detergent is used on the printer, wipe the printer's exterior surfaces with a soft cloth moistened with water.
- **Do not** lubricate the print cartridge support rod. Noise is normal when the print cartridge cradles slide back and forth.

For information on cleaning print cartridges and the print cartridge cradle, see page 32.

2 Using Your Printer Software

Choosing Your Printer

Note: You should have already installed your printer software. If not, please see the *Quick Start Poster* or the HP Printer Software CD that came with your printer.

If you haven't already selected your HP DeskJet printer as the default printer in the **Chooser**, follow the directions below to do so now.

- 1 Make sure the computer and printer are turned on, and your printer is connected to your computer with a USB cable.
- 2 From the **Apple** menu, select **Chooser**.
- 3 In the left side of the Chooser window, click the **DeskJet 900 Series** icon.
- 4 In the right side of the Chooser window, click **DeskJet 930C**.
- 5 Close the **Chooser**.

Other Ways to Select a Default Printer

Besides using the Chooser, you can also select a default printer in the following ways:

- Select the desired printer by clicking on the menu bar **printer icon** at the top of the screen, and choosing the **DeskJet 930C**.
- If your control strip is on, then select the desired printer by clicking the **printer icon** in the control strip, and choosing the **DeskJet 930C**.
- Drag the document you want to print to the desktop icon of the printer you want to use.
- Click the HP DeskJet printer icon you want to use, and choose **Set Default Printer** from the **Printing** menu.

The Print command will send your documents to this printer until you select a new default printer. If you switch printers, check your document before you print it to see whether the formatting or pagination changed.

Desktop Printing

Desktop printing is useful when you have a number of documents to print at once, or when you have a document that is already formatted for printing on a particular printer. There are two methods to print documents from the desktop. To perform desktop printing, either:







- Drag the icons of the documents you want to print to the desktop icon of the printer you want to use.

OR

- Select the icons of the documents you want to print, then choose **Print** from the **File** menu. When the **Print** dialog box appears, select your print options, then click the **Print** button.

Checking Printer Status

You can tell the status of a printer by looking at its desktop icon:

Icon	Description	Icon	Description
 DESKJET 930C	Idle printer (default)	 DESKJET 930C	Printing stopped on default printer
 DESKJET 930C	Idle printer (not default)	 DESKJET 930C	Error on default printer
 DESKJET 930C	Printing on default printer	 DESKJET 930C	Printer not available or connected

Page Setup - Controlling Page Layout

You control settings such as paper size, scaling, and page orientation from the **HP DeskJet 900 Series Page Setup** dialog box. To get to this dialog box:

- 1 Open the software program used to create your document.
- 2 From the **File** menu, select **Page Setup**.

Paper Size, Scaling, and Page Orientation

Make sure you correctly choose the size of paper, envelopes, or other media you have in the IN tray.

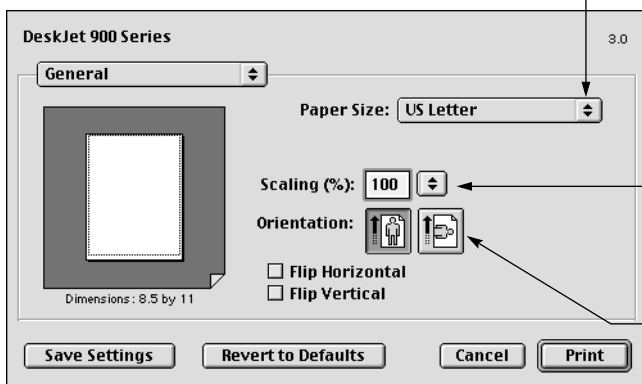

Enter a number from 20 to 400. Numbers smaller than 100 reduce the image size, and numbers greater than 100 enlarge it. Changing size may change pagination.

Click the appropriate icon to choose page orientation.

Print Dialog Box

You control settings such as number of copies, all or specific pages to print, paper type, print quality, page layout, color, and background printing from the HP DeskJet 900 Series Print dialog box. To get to this dialog box, select **Print** from your software program's **File** menu.

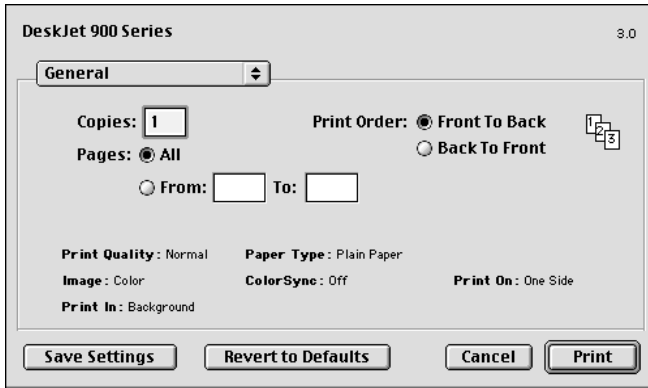

Buttons

There are four buttons at the bottom of every Print dialog box:

- **Save Settings** saves any print settings you select for this and future documents
- **Revert to Defaults** returns your print settings to the original HP-defined settings
- **Cancel** cancels settings you have entered and closes the Print dialog box
- **Print** starts printing

General

General is the default panel selected in the Print dialog box. This panel lets you select the number of copies you want to print, whether you want to print the entire document or select pages, and whether you want to print from the front of your document or begin printing from the end forward.

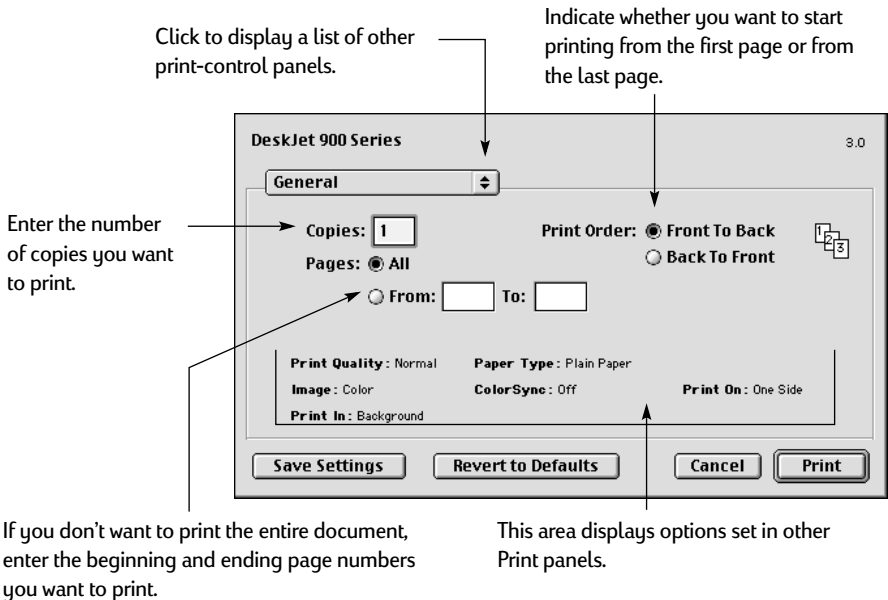

You may also access the following print-control panels from the **General** menu:

- **Paper Type/Quality** (see “Paper Type/Quality” on page 9)
- **Layout** (see “Layout” on page 9)
- **Color** (see “Color” on page 10)
- **Background Printing** (see “Background Printing” on page 11)
- **Ink Controls** allows you to adjust the ink volume and dry time

Paper Type/Quality

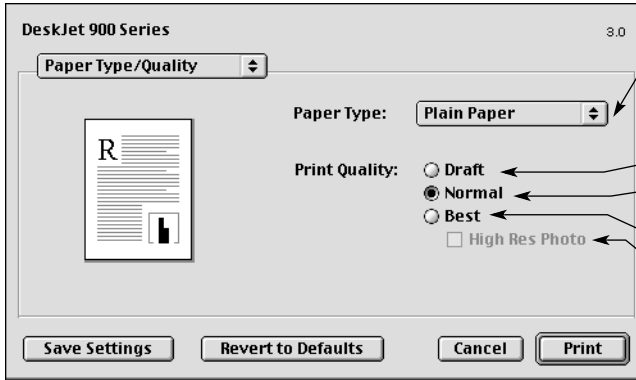

Choose from a wide range of paper types.

Print Quality

Draft: Quick printing

Normal: Everyday printing

Best: Highest quality

High Res Photo: Photo quality when photo media and Best are selected.

Layout

This dialog box allows you to specify the number of pages printed on each sheet of paper, or to print a poster by specifying the number of pages printed across and down.

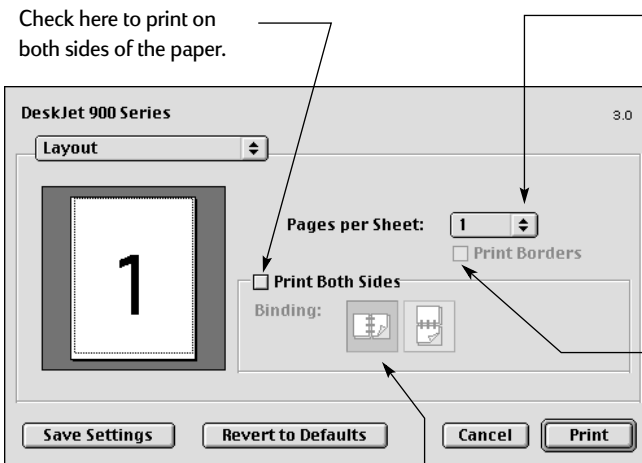

Check here to print on both sides of the paper.

Choose the number of pages (1, 2, or 4) to print on each sheet. *OR*

Print a poster:

Choose the size of your poster by choosing the number of pages across and down (2x2, 3x3, or 4x4).

Check to print a border around each page.

If you check **Print Both Sides**, choose appropriate **Binding** (side or top).

Color

Your HP DeskJet 900 Series printer uses HP's Color Matching technology to intelligently analyze each element on a page—text, graphics, and photographs—and provide the best color output.

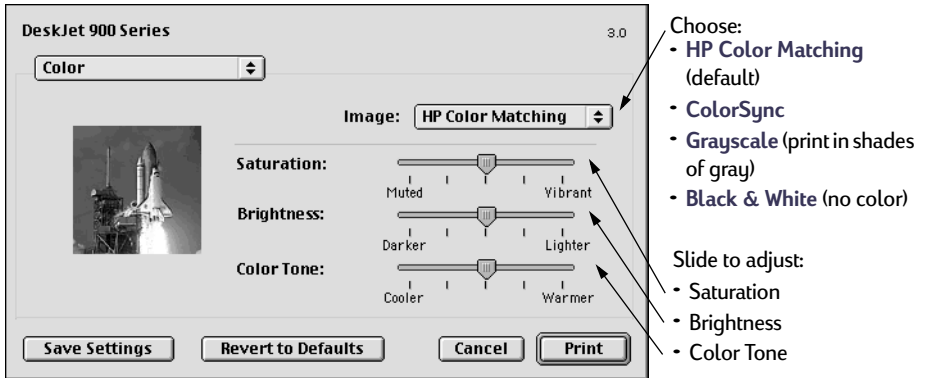

HP Color Matching is the default **Image** setting on the Color panel. While you can adjust saturation, brightness, and color tone with the sliders that appear when you choose this option, the center position of the sliders is optimized for most printing uses and types of media.

The **ColorSync** setting can be used for color matching with other components using the ColorSync matching system.

Grayscale prints in shades of gray. With this setting, you also have the option to optimize printing for fax and photocopy.

Black & White prints only in black and white (no color, no gray).

Background Printing

Choose **Background** if you want to continue working while printing takes place. If you choose **Foreground** printing, printing will be faster, but you won't be able to work on other tasks until the printing is complete.

Choose:

- **Background** to continue working while printing
- **Foreground** for faster printing

Click the button that matches the desired timing for your print job

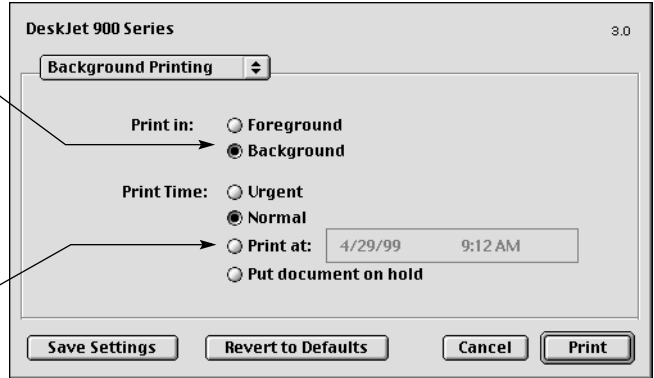

The following table describes additional features available when using background printing. To access these features from the desktop, double-click the DeskJet 930C printer icon.

Background Printing Options	Instructions
Delete a print job	<ul style="list-style-type: none"> • Select the job title or icon, then click the Trash icon. or • Drag the document's icon to the Trash on your desktop. <p>These methods delete only the print job, not the document itself.</p>
Hold/pause a print job	<ul style="list-style-type: none"> • Select the job title or icon, then click the Pause button. <p>The print request will pause until you select its title again and click the Resume button.</p> <p>or</p> <ul style="list-style-type: none"> • Drag the document icon to the Waiting to Print list of documents.
Mark a print request "Urgent"	<ul style="list-style-type: none"> • Select the job title or icon, then click the small clock. • In the dialog box that appears, click Urgent. This moves the print request to the top of your print list.
Print at a specific time	<ul style="list-style-type: none"> • Select the job title or icon, then click the small clock. • In the dialog box that appears, click At Time, then set the time and date to print.
Sort/change the order of print jobs	<ul style="list-style-type: none"> • From the View menu, choose the title of the column by which you want to sort or choose. • To see and change the print order, sort by Print Time. • Drag and drop the print job title to the desired place in the list.
Stop and restart printing	<ul style="list-style-type: none"> • Choose Stop Print Queue from the Printing menu. • To resume printing, choose Start Print Queue. <p>This is a good way to save print requests when using a portable computer while away from your printer.</p>
Change printers	<p>To move a print job from one printer to another printer of the same type:</p> <ul style="list-style-type: none"> • Drag the icon for the print request to the icon of the desired printer. <p>If you're not sure whether the two printers are of the same type, try moving the print request anyway; the printer software won't let you move a print request to an incompatible printer.</p>

Printing on Different Types of Paper and Media

The HP DeskJet 930C Series printer is designed to encompass so many different types of print media that you're practically set up as a small print shop. This chapter explains how to use the different printing materials.

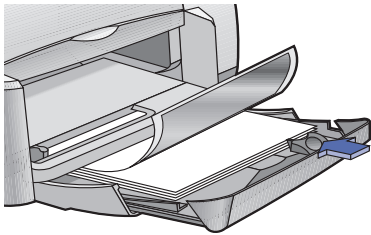

Printing Photographs

I want to print...	I should...
<p>8.5 x 11 in. or A4 Photo Paper</p> 	<ol style="list-style-type: none"> 1 Remove all paper from the IN tray. 2 Insert up to 30 sheets of the photo paper (printable side down) into the IN tray. 3 Slide the paper guides snugly against the edges of the paper. Make sure the IN tray is pushed in. 4 Choose the print settings that match the type and size of the photo paper. 5 Print the photos.
HP print settings to choose	Guidelines to remember
<p>Page Setup</p> <ul style="list-style-type: none"> - <i>Paper Size</i>: Choose appropriate paper size - <i>Orientation</i>: Choose appropriate orientation <p>Paper Type/Quality</p> <ul style="list-style-type: none"> - <i>Paper Type</i>: Choose appropriate photo paper type - <i>Print Quality</i>: Choose Best <p>Layout</p> <ul style="list-style-type: none"> - <i>Pages per Sheet</i>: 1 - <i>Print Both Sides</i>: Unchecked 	<ul style="list-style-type: none"> • For best results use HP Photo Paper. • The photo needs to be in electronic (digital) form, before you can print it. Take a digital picture, scan a photo, or have your local camera shop provide an electronic file of your photo.

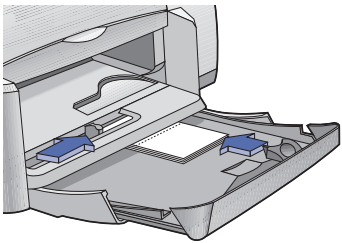

Printing Greeting Cards and Hagaki

I want to print...	I should...
	<ol style="list-style-type: none"> 1 Slide out both of the paper guides, and remove all paper from the IN tray. 2 Insert up to 5 cards into the IN tray as far as they will go. 3 Slide the paper guides snugly against the edges of the cards. 4 Choose the print settings that match the type and size of the cards. 5 Print the cards.
HP print settings to choose	Guidelines to remember
<p>Page Setup</p> <ul style="list-style-type: none"> - <i>Paper Size</i>: Choose appropriate card size - <i>Orientation</i>: Choose Portrait icon <p>Paper Type/Quality</p> <ul style="list-style-type: none"> - <i>Paper Type</i>: Choose greeting card type or Plain Paper or Inkjet Paper for Hagaki - <i>Print Quality</i>: Choose Normal <p>Layout</p> <ul style="list-style-type: none"> - <i>Pages per Sheet</i>: 1 - <i>Print Both Sides</i>: Unchecked 	<ul style="list-style-type: none"> • For best results use HP Greeting Card Paper. • For Hagaki, use Plain Paper or Inkjet Paper. • Use Plain Paper setting to print Hagaki's address side. • If you have pre-folded greeting cards, unfold the cards, then load the cards into the IN tray. • Align the card edges before inserting the cards. • For ease of loading small cards, pull out the IN tray and raise the OUT Tray Flap. After you have inserted the cards, push the IN tray in and lower the OUT Tray Flap.

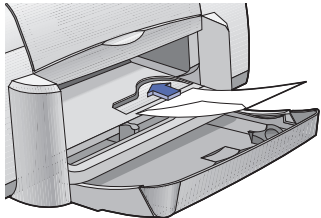

Printing Envelopes and Other Small Media

I want to print...	I should...
<p>Single envelope and small media [sized between 77 x 127 mm (3 x 5 in.) and 100 x 148 mm (4 x 5 5/8 in.)]</p> 	<ol style="list-style-type: none"> 1 Slide the envelope, with its flap side on the left and flap facing up, or other small media into the single envelope slot. Push the envelope in until it stops. 2 Choose the print settings that match the type and size of the envelope. 3 Print the media.
HP print settings to choose	Guidelines to remember
<p>Page Setup</p> <ul style="list-style-type: none"> - <i>Paper Size:</i> Choose appropriate envelope size - <i>Orientation:</i> Choose Portrait icon <p>Paper Type/Quality</p> <ul style="list-style-type: none"> - <i>Paper Type:</i> Choose Plain Paper - <i>Print Quality:</i> Choose Normal <p>Layout</p> <ul style="list-style-type: none"> - <i>Pages per Sheet:</i> 1 - <i>Print Both Sides:</i> Unchecked 	<ul style="list-style-type: none"> • Make sure the OUT Tray Flap is in the down position. • Avoid envelopes that have clasps or windows. • Avoid envelopes that are shiny or embossed, envelopes with thick, irregular, or curled edges, or envelopes that are wrinkled, torn, or otherwise damaged. • If your software program includes an envelope-printing feature, follow those instructions instead of the procedure here.

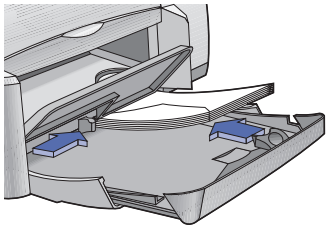
I want to print...	I should...
<p>Stack envelopes</p> 	<ol style="list-style-type: none"> 1 Slide out both of the paper guides, and remove all paper from the IN tray. 2 Slide up to 15 envelopes, with their flap side on the left and flap facing up, into the IN tray as far as they will go. 3 Slide the paper guides snugly against the edges of the envelopes. 4 Choose the print settings that match the type and size of the envelopes. 5 Print the envelopes.
HP print settings to choose	Guidelines to remember
<p>Page Setup</p> <ul style="list-style-type: none"> - <i>Paper Size</i>: Choose appropriate envelope size - <i>Orientation</i>: Choose Portrait icon <p>Paper Type/Quality</p> <ul style="list-style-type: none"> - <i>Paper Type</i>: Choose Plain Paper - <i>Print Quality</i>: Choose Normal <p>Layout</p> <ul style="list-style-type: none"> - <i>Pages per Sheet</i>: 1 - <i>Print Both Sides</i>: Unchecked 	<ul style="list-style-type: none"> • Never load more than 15 envelopes at one time. • Align the envelope edges before inserting them. • Avoid envelopes that have clasps or windows. • Avoid envelopes that are shiny or embossed, envelopes with thick, irregular, or curled edges, or envelopes that are wrinkled, torn, or otherwise damaged. • If your software program includes an envelope-printing feature, follow those instructions instead of the procedure here.

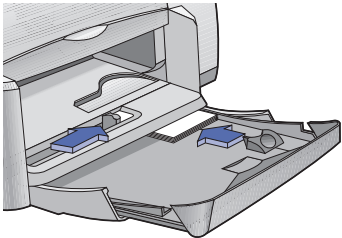

Printing Small Media

I want to print...	I should...
<p>Small Media (larger than 100 x 148 mm) (4 x 5 5/8 in.)</p> 	<ol style="list-style-type: none"> 1 Make sure the IN tray is pushed in. 2 Raise the OUT Tray Flap to the up position. 3 Insert small media into the IN tray as far as they will go. 4 Slide the paper guides snugly against the edges of the media. 5 Lower the OUT Tray Flap. 6 Choose the print settings that match the type and size of the cards. 7 Print.
HP print settings to choose	Guidelines to remember
<p>Page Setup</p> <ul style="list-style-type: none"> - <i>Paper Size</i>: Choose appropriate card size - <i>Orientation</i>: Choose Portrait icon <p>Paper Type/Quality</p> <ul style="list-style-type: none"> - <i>Paper Type</i>: Choose Plain Paper - <i>Print Quality</i>: Choose Normal <p>Layout</p> <ul style="list-style-type: none"> - <i>Pages per Sheet</i>: 1 - <i>Print Both Sides</i>: Unchecked 	<ul style="list-style-type: none"> • Align the card edges before inserting the cards. • If you get an “out of paper” message, make sure that the photo paper or other small media is positioned properly in the IN tray. Place the media on the right side and towards the printer. The IN tray should be pushed in so that the paper length guide can hold the media in place. • If your media is smaller than 100 x 148 mm (4 x 5 5/8 inches), use the single envelope slot to load your media one sheet at a time.



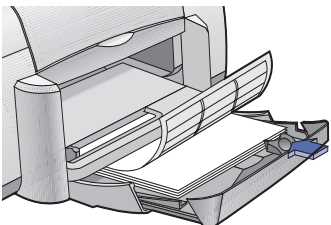

Printing Labels

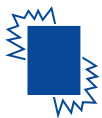
I want to print...	I should...
	<ol style="list-style-type: none"> 1 Slide out both of the paper guides, and remove all paper from the IN tray. 2 Fan the edges of the label sheets to separate them, then align the label edges. Insert up to 20 label sheets (label side down). 3 Slide the paper guides snugly against the sheets. 4 Choose the print settings that match the type and size of labels. 5 Print the labels.
HP print settings to choose	Guidelines to remember
<p>Page Setup</p> <ul style="list-style-type: none"> - <i>Paper Size:</i> Choose A4 or Letter (8.5x11 in.) - <i>Orientation:</i> Choose appropriate orientation <p>Paper Type/Quality</p> <ul style="list-style-type: none"> - <i>Paper Type:</i> Choose Plain Paper - <i>Print Quality:</i> Choose Normal <p>Layout</p> <ul style="list-style-type: none"> - <i>Pages per Sheet:</i> 1 - <i>Print Both Sides:</i> Unchecked 	<ul style="list-style-type: none"> • Use only paper labels that are designed specifically for use with inkjet printers. • Never load more than 20 sheets at one time. • Use only full sheets of labels. • Make sure the sheets are not sticky, wrinkled, or pulling away from their protective backing. • Do not use plastic or clear labels. The ink will not dry when used with plastic or clear labels.

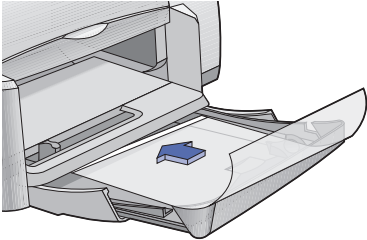

Printing Transparencies

I want to print...	I should...
	<ol style="list-style-type: none"> 1 Slide out both of the paper guides, and remove all paper from the IN tray. 2 Fan the edges of the transparency sheets to separate them, then align the edges. 3 Insert a stack of up to 25 transparency sheets, rough side down and the adhesive strip towards the printer. 4 Slide the paper guides snugly against the transparencies. 5 Choose the print settings that match the type and size of the transparencies. 6 Print the transparencies. 7 The printer waits for transparencies to dry before releasing them automatically. Press the Resume Button  to continue printing.
HP print settings to choose	Guidelines to remember
<p>Page Setup</p> <ul style="list-style-type: none"> - <i>Paper Size</i>: Choose appropriate size - <i>Orientation</i>: Choose appropriate orientation <p>Paper Type/Quality</p> <ul style="list-style-type: none"> - <i>Paper Type</i>: Choose transparency type - <i>Print Quality</i>: Choose Normal or Best <p>Layout</p> <ul style="list-style-type: none"> - <i>Pages per Sheet</i>: 1 - <i>Print Both Sides</i>: Unchecked 	<ul style="list-style-type: none"> • For best results, use HP Premium Inkjet Transparency Film or HP Premium Inkjet Rapid-dry Transparencies. The film coating on HP Premium Inkjet Rapid-Dry Transparencies is especially developed to work with HP inks, giving you crisp images and text and the fastest drying times. In addition, they won't jam your printer.

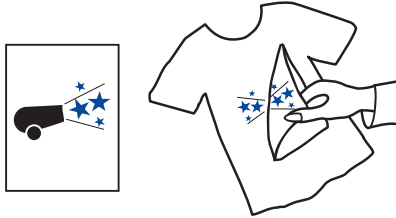

Printing Iron-on Transfers

I want to print...	I should...
	<ol style="list-style-type: none"> 1 Slide out both of the paper guides, and remove all paper from the IN tray. 2 Load the transfer paper transparent (or glossy) side down. 3 Slide the paper guides snugly against the sheets. 4 Choose the print settings that match the type and size of your iron-on transfers. 5 Print your transfer.
HP print settings to choose	Guidelines to remember
<p>Page Setup</p> <ul style="list-style-type: none"> - <i>Paper Size</i>: Choose appropriate size - <i>Orientation</i>: Choose appropriate orientation - <i>Flip Horizontal</i>: Check <p>Paper Type/Quality</p> <ul style="list-style-type: none"> - <i>Paper Type</i>: Choose HP Premium Inkjet Paper - <i>Print Quality</i>: Choose Best <p>Layout</p> <ul style="list-style-type: none"> - <i>Pages per Sheet</i>: 1 - <i>Print Both Sides</i>: Unchecked 	<ul style="list-style-type: none"> • If you want the text or picture on your t-shirt as you see it on the screen, flip the document by clicking Flip Horizontal. • For best results, use HP Iron-On T-Shirt Transfers.

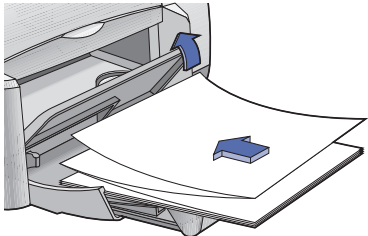

Printing Banners

I want to print...	I should...
	<ol style="list-style-type: none"> 1 Tear off the number of sheets (up to 20) you need. 2 Tear off and discard the perforated strips, if any. 3 Slide out the paper guides, and remove all paper from the IN tray. 4 Raise the OUT Tray Flap and leave it in the up position to print your banners. 5 Put the banner paper in the IN tray so that the unattached edge of the banner paper stack is toward the printer. 6 Slide the paper guides snugly against the sheets. 7 Choose the print settings that match the type, size, and orientation of the banner. 8 Print the banner.
HP print settings to choose	Guidelines to remember
<p>Page Setup</p> <ul style="list-style-type: none"> - <i>Paper Size:</i> Choose U.S. Letter Banner or A4 Banner - <i>Orientation:</i> Choose appropriate orientation <p>Paper Type/Quality</p> <ul style="list-style-type: none"> - <i>Paper Type:</i> Choose Plain Paper or HP Banner Paper - <i>Print Quality:</i> Choose Normal <p>Layout</p> <ul style="list-style-type: none"> - <i>Pages per Sheet:</i> 1 - <i>Print Both Sides:</i> Unchecked 	<ul style="list-style-type: none"> • When printing banners, be sure that the OUT Tray Flap is placed in the up position. • For best results, use HP Banner Paper. • If you are having problems printing a banner, see “Banners aren’t printing correctly.” on page 44.

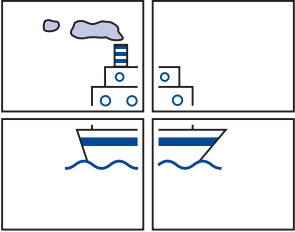

Printing Posters

I want to print...	I should...
	<ol style="list-style-type: none"> 1 Load paper in the IN tray. 2 Slide the paper guides snugly against the sheets. 3 Choose the print settings that match the type and size of your poster. 4 Print your poster.
HP print settings to choose	Guidelines to remember
<p>Page Setup</p> <ul style="list-style-type: none"> - <i>Paper Size</i>: Choose appropriate size - <i>Orientation</i>: Choose appropriate orientation <p>Paper Type/Quality</p> <ul style="list-style-type: none"> - <i>Paper Type</i>: Choose Plain Paper - <i>Print Quality</i>: Choose Normal <p>Layout</p> <ul style="list-style-type: none"> - <i>Pages per Sheet</i>: 2x2 Poster, 3x3 Poster, or 4x4 Poster - <i>Print Both Sides</i>: Unchecked 	<ul style="list-style-type: none"> - After printing, trim the edges on each sheet and tape the sheets together.

Two-Sided Printing

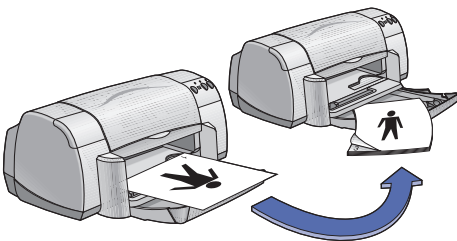
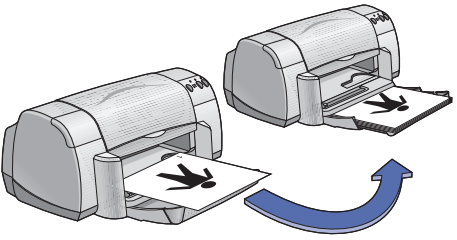
I want to print...	I should...
<p>Manual Two-Sided Printing Book Binding</p>  <p>Tablet Binding</p> 	<ol style="list-style-type: none"> 1 Remove all paper from the OUT tray. 2 Load paper into the IN tray. 3 Slide the paper guides snugly against the sheets. 4 In the Layout dialog box, click Print Both Sides, then select either the Book or Tablet icon, and uncheck Automatic. 5 Choose the print settings that match the type and size of your paper. 6 Begin printing. 7 Carefully follow the reloading instructions displayed on your computer screen. 8 When the paper is properly reloaded, click Continue in the message box on your computer screen.
HP print settings to choose	Guidelines to remember
<p>Page Setup</p> <ul style="list-style-type: none"> - <i>Paper Size</i>: Choose appropriate size - <i>Orientation</i>: Choose appropriate orientation <p>Paper Type/Quality</p> <ul style="list-style-type: none"> - <i>Paper Type</i>: Choose appropriate type - <i>Print Quality</i>: Choose Normal <p>Layout</p> <ul style="list-style-type: none"> - <i>Pages per Sheet</i>: 1 - <i>Print Both Sides</i>: Check this box, then choose the Book icon (for binding on the side) or Tablet icon (for binding at the top). Uncheck Automatic. 	<ul style="list-style-type: none"> • The printer prints one side of the paper first. Then, a message on your computer screen tells you how to reload the paper and resume printing. The reverse side of the paper is then printed. • If you want to do two-sided printing automatically, you can purchase a Two-Sided Printing Module. This accessory may not be available in all countries (see “Supplies and Accessories” on page 50 for ordering information).

Printing on Legal (8.5 x 14 in.) Paper

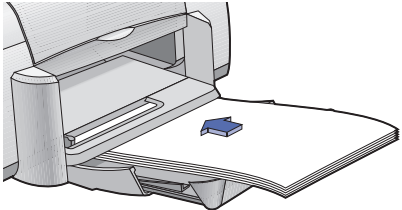
I want to print...	I should...
	<ol style="list-style-type: none"> 1 Raise the OUT Tray Flap and pull out the IN tray. 2 Slide out both of the paper guides. 3 Insert a stack of legal-sized paper into the IN tray, printable side down. Make sure you slide the paper as far as it will go into the IN tray, leaving the remainder of the paper resting over the edge of the IN tray. 4 Slide the paper width guide snugly against the stack. 5 Lower the OUT Tray Flap. 6 Choose the appropriate print settings. 7 Print your document.
HP print settings to choose	Guidelines to remember
<p>Page Setup</p> <ul style="list-style-type: none"> - <i>Paper Size:</i> Choose Legal (8.5 x 14 in.) - <i>Orientation:</i> Choose appropriate orientation <p>Paper Type/Quality</p> <ul style="list-style-type: none"> - <i>Paper Type:</i> Choose appropriate type - <i>Print Quality:</i> Choose Normal <p>Layout</p> <ul style="list-style-type: none"> - <i>Pages per Sheet:</i> 1 - <i>Print Both Sides:</i> Unchecked 	<ul style="list-style-type: none"> • Leave IN tray out when printing on Legal (8.5 x 14 in.) paper. • Legal paper will extend over edge of IN tray.

HP DeskJet Utility Window

The HP DeskJet Utility is located in the Utilities folder on your hard drive's main directory. The HP DeskJet Utility window has seven panels, as shown below:



- **Select** allows you to select the **DeskJet 930C** from the list of printers connected to your computer (see “Select Panel” on page 26)
- **WOW!** demonstrates the HP DeskJet 930C’s photo print quality
- **Ink Level** displays the approximate amount of ink remaining in each print cartridge
- **Test** allows you to print a test document
- **Clean** allows you to automatically clean your print cartridges
- **Calibrate** allows you to automatically align the Color and Black print cartridges, and allows you to calibrate the Photo Tray
- **Support** provides links to HP’s Customer Care web site and printer software updates

Simply click a panel, then choose your option(s).

Select Panel

Use this panel when any of the functions on the Utility window prompt you to select a printer. For example, if you want to calibrate your printer by choosing the **Calibrate** panel, you will be prompted to first select your printer if it is not already selected.

To select your printer from the **HP DeskJet Utility** window:

- 1 Click the **Select** panel on the **Utility** window.
- 2 Select **USB**.
- 3 In the **Connect To:** list, choose the appropriate HP DeskJet printer.

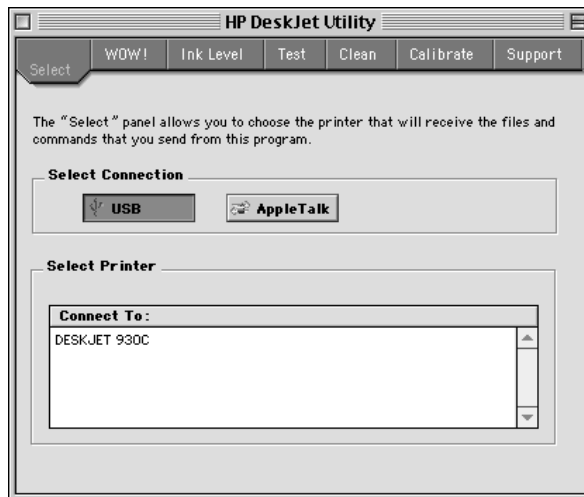

3 Using and Caring for Your Print Cartridges

Print Cartridge Status



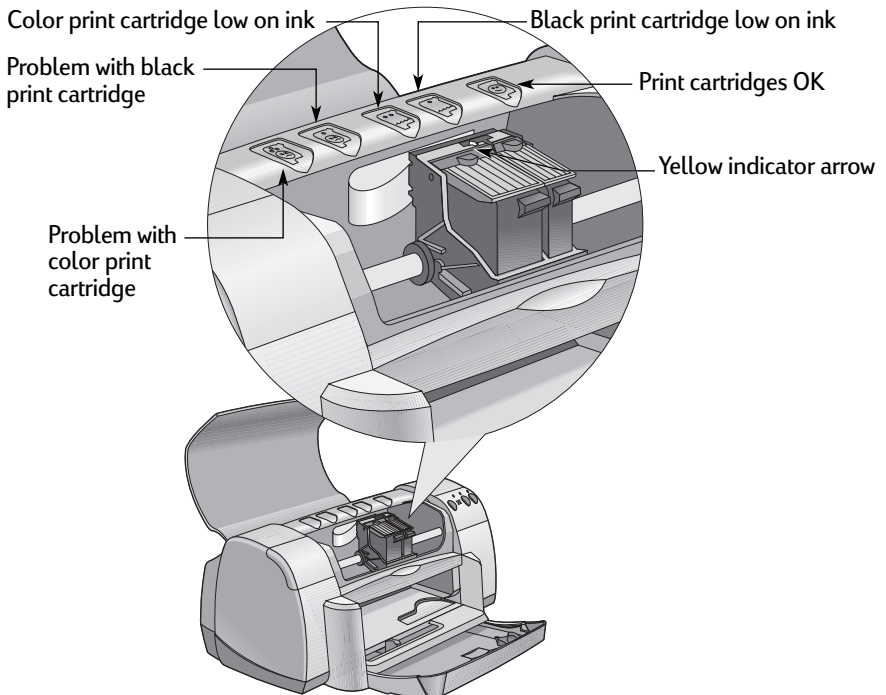
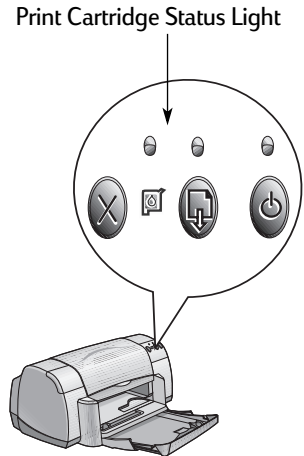

The Print Cartridge Status Light flashes when one or both of your print cartridges are low on ink, improperly installed, or malfunctioning. It will also flash if you are trying to use the wrong print cartridge type. If the problem is low ink, the light will stop flashing when you open the top cover. For any other print cartridge-related problem, the Print Cartridge Status Light will continue to flash.

To check the status of your print cartridges, open the printer's top cover. The yellow arrow on the print cartridge cradle aligns with one of five Print Cartridge Status icons.



Using and Caring for Your Print Cartridges

When the Print Cartridge Status Light flashes, open the printer's top cover and follow the instructions below. For more information on replacing print cartridges see page 29.

If the arrow points to...	It means...	To solve the problem...
Problem with color print cartridge 	The print cartridge is either: <ul style="list-style-type: none"> • missing • improperly installed • the wrong print cartridge for the printer • defective 	<ol style="list-style-type: none"> 1 Insert a print cartridge if it is missing. 2 Remove and reinsert the existing print cartridge. 3 If there is still a problem, verify that the cartridge is an HP C6578 Series, easy reference number 78, cartridge. 4 If the problem persists, replace the cartridge.
Problem with black print cartridge 	The print cartridge is either: <ul style="list-style-type: none"> • missing • improperly installed • the wrong print cartridge for the printer • defective 	<ol style="list-style-type: none"> 1 Insert a print cartridge if it is missing. 2 Remove and reinsert the existing print cartridge. 3 If there is still a problem, verify that the cartridge is an HP 51645 Series, easy reference number 45, cartridge. 4 If the problem persists, replace the cartridge.
Color print cartridge low on ink 	Color print cartridge is running low on ink.	Consider replacing the color cartridge with an HP C6578 Series, easy reference number 78 , cartridge.
Black print cartridge low on ink 	Black print cartridge is running low on ink.	Consider replacing the black cartridge with an HP 51645 Series, easy reference number 45 , cartridge.
Print cartridges OK 	Print cartridges are operational.	No problems.

Replacing Print Cartridges

Note: When buying replacement print cartridges, check the part numbers carefully. The print cartridge numbers for your printer are:

- Black HP 516**45** Series, easy reference number **45**.
- Tri-Color HP C65**78** Series, easy reference number **78**.

Note: When a print cartridge runs out of ink, leave the empty cartridge in the cradle until you can replace it. The printer does not print with only one print cartridge in the cradle.

To replace a print cartridge:

- 1 To access the print cartridge cradle, press the Power Button  to turn on the printer.
- 2 Open the top cover. The cradle moves to an accessible position.
- 3 Raise the cradle latch.
- 4 Lift the print cartridge out and discard it.

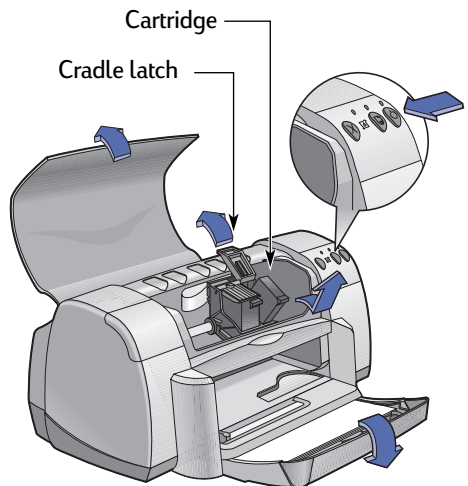

Warning

Keep print cartridges out of the reach of children.

Using and Caring for Your Print Cartridges

- Remove the replacement print cartridge from its packaging and carefully remove the protective vinyl tape.

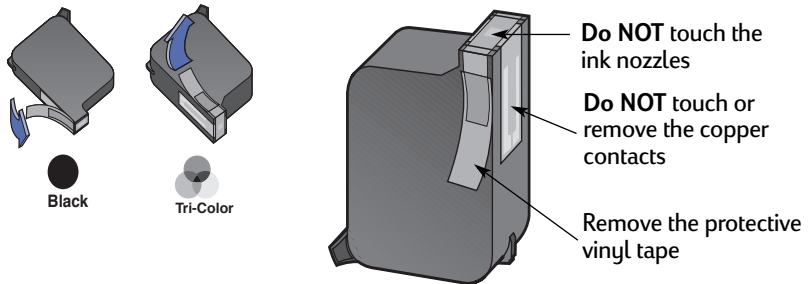

Warning

Do NOT touch the print cartridge ink nozzles or copper contacts. Touching these parts will result in clogs, ink failure, and bad electrical connections. Also, **do NOT** remove the copper strips; these are required electrical contacts.

- Push the print cartridge firmly, straight down into the print cartridge cradle.
- Close the cradle latch. When the latch is fully closed, you will hear a click.
- Load plain white paper in the IN tray.
- Close the top cover, then a calibration page will print.

Note: Any time you install a new print cartridge, the printer software prints a calibration page to ensure your print quality. If you are in the middle of printing and stop to change a print cartridge, the software will wait until your printing has completed before it executes the calibration test.

- If the Print Cartridge Status  Light continues to blink after you install the new print cartridge, check the part number on the print cartridge to ensure you installed the correct one.

Storing Print Cartridges

To maintain excellent print quality from your print cartridges:

- Keep all print cartridges in their sealed packages, at room temperature (60-78° F or 15.6-26.6° C), until you are ready to use them.
- Once installed, leave the print cartridges in their cradle at all times to keep them from drying out or becoming clogged.
- Store unsealed print cartridges in an airtight plastic container.
- **Do NOT** unplug the printer until printing is complete and the print cartridge cradles have returned to their home position on the right side of the printer. The print cartridges will dry out if not stored in their home position.

Warning

Only use the Power Button  on the front of the printer to turn the printer on and off. Using a power strip, surge protector, or a wall-mounted outlet switch to turn the printer on and off may cause premature failure.

Cleaning Print Cartridges

When Do You Need to Clean?

Clean the print cartridges if your printed page is missing lines or dots, or if it contains ink streaks.



If You See Missing Lines or Dots...

Clean the print cartridges from the **HP DeskJet Utility** window by doing the following:

- 1 Double-click the **HP DeskJet Utility** icon in the Utilities folder on your hard drive's main directory.
- 2 Click the **Clean** panel, then click the **Clean** button. Follow the on-screen directions.

Note: Unnecessary cleaning wastes ink and shortens the life of the print cartridge.

If You See Ink Streaks...

Clean the print cartridges and the print cartridge cradle by following the instructions below.

- 1 Double-click the **HP DeskJet Utility** icon in the Utilities folder on your hard drive's main directory.
- 2 Click the **Clean** panel, then click the **Clean** button. Follow the on-screen directions. If this does not prevent streaks, follow the instructions for "Manually Cleaning the Print Cartridges" on the next page.

=sn-ame-justja-
 ßiam-noft-juestl
 † labore-quisft v
 :d*kitft ghoçknc

Caution

Be careful not to get ink on your hands or clothing.

Manually Cleaning the Print Cartridges and Print Cartridge Cradle

In order to properly clean the print cartridges and cradle, you will need distilled or bottled water and cotton swabs or a similar lint-free absorbent material that will not stick to the cartridges.

Manually Cleaning the Print Cartridges

- 1 Press the Power Button  to turn the printer on, then lift the top cover.
- 2 After the print cartridges move into an accessible position, unplug the power cord from the back of the printer.

Warning

Keep new and used print cartridges out of the reach of children.

- 3 Remove the print cartridges and set them on a piece of paper with the ink nozzle plate facing up.

Caution

Do NOT touch the print cartridge ink nozzles or copper contacts. Touching these parts will result in clogs, ink failure, and bad electrical connection. Also, **do NOT** remove the copper strips; these are required electrical contacts.

- 4 Dip a clean cotton swab into distilled water and squeeze any excess water from the swab.
- 5 Clean the **face and edges** of the print cartridge as shown. **Do NOT** wipe the nozzle plate.
- 6 Inspect the cartridge for fibers on the face and edges. If fibers are still present, repeat the cleaning process.

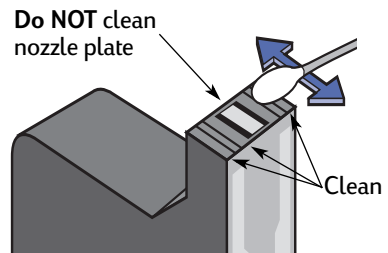

- 7 Repeat the cleaning process for the other print cartridge.

Caution

Once you've removed the print cartridges, make sure that they are not outside of the print cartridge cradle longer than 30 minutes.

Manually Cleaning the Print Cartridge Cradle

- 1 Using clean, moistened swabs, wipe the underside of each wall of the cradle.
- 2 Repeat until no ink residue is seen on a clean swab.
- 3 Reinsert the print cartridges, then close the printer's top cover.
- 4 Load paper into the IN tray.
- 5 Reinsert the electrical power cord into the back of the printer.
- 6 Print a test page. Double-click the **HP DeskJet Utility**, icon in the Utilities folder on your hard drive's main directory. Click the **Test** panel, then click the **Test** button.

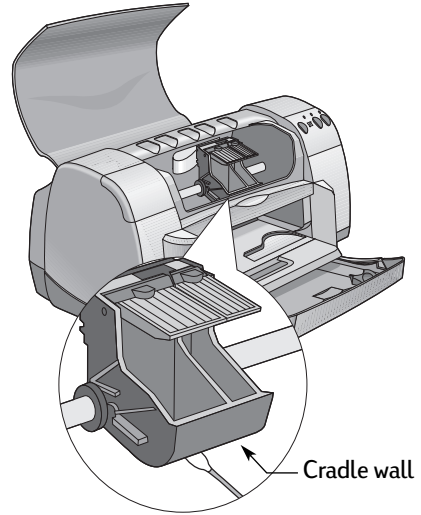

Note: If streaking still appears, repeat the procedure until the test printout is clean. You will find additional maintenance tips at: http://www.hp.com/support/home_products

Damage Resulting from Refilling the Print Cartridges

To get the best performance from your printer, Hewlett-Packard recommends using only genuine HP supplies for HP DeskJet printers, including genuine factory-filled HP print cartridges.

Damage resulting from the modification or refilling of HP print cartridges is specifically excluded from the coverage of HP printer warranties.

Note: When buying replacement print cartridges, check the part numbers carefully. The print cartridge numbers for your printer are:

- Black HP 516**45** Series, easy reference number **45**.
- Tri-Color HP C65**78** Series, easy reference number **78**.

4 Getting Help When Things Go Wrong

Troubleshooting Tips

It's frustrating when things go wrong, but the following pages contain tips that can help you determine what the problem is and how to fix it.

Be sure cable connections are secure. Make sure that you are using the right cable for your operating system. Check if your question is similar to those listed below and then follow the instructions found in that section:



The printer software won't install, what's wrong? See pages 36–37.



Why won't it print? See pages 38–40.



What do the flashing lights mean? See page 41.



Is there a problem with your printout? See pages 42–45.



The printer software won't install, what's wrong?

What is the problem?	Possible cause	To solve the problem...
I inserted a CD, but the computer couldn't read it.	<ul style="list-style-type: none"> • The CD wasn't properly inserted. <i>OR</i> • The CD player may be damaged. <i>OR</i> • The CD may be damaged. <i>OR</i> • The CD-ROM extensions may be turned off. 	<ol style="list-style-type: none"> 1 Reinsert the CD and try again. If this doesn't solve your problem... 2 Try inserting a CD that you know works. If that CD doesn't work, you may need to replace your CD player. 3 If other CD's work but the printer software CD doesn't, you may have a damaged CD. You can download the printer software from the HP Customer Care web site: www.hp.com/support/home_products 4 If you don't have Web access, contact HP Customer Care. See page 47, to locate the phone number nearest you. 5 Go to your Extensions Manager to ensure the Apple CD extension is turned on.











The printer software won't install, what's wrong? *continued*

What is the problem?	Possible cause	To solve the problem...
<p>The software did not install correctly.</p>	<ul style="list-style-type: none"> • There may be a conflict with your virus protection program. <i>OR</i> • There may be a conflict with another software program. <i>OR</i> • Your printer software didn't install properly. 	<ol style="list-style-type: none"> 1 Uninstall your printer software. Insert the printer software CD into your computer, select Uninstall from the Installer, then repeat the installation procedure. 2 Close any virus protection programs that are active. 3 If you have been using Apple's QuickDraw GX software, turn it off. Your HP DeskJet printer is not compatible with QuickDraw GX. 4 Exit all of your software programs. 5 Reinstall the printer software. See the "Install Printer Software" step on the <i>Quick Start Poster</i> or see page 56 in this <i>User's Guide</i>. <p>If you are still having problems with the software installation, call an HP authorized dealer or HP Customer Care. For the phone number of the HP Customer Care Center nearest you, see page 47.</p>

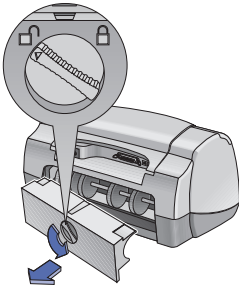

Why won't it print?

What is the problem?	Possible cause	To solve the problem...
 <p>No page came out of the printer.</p>	<p>Power may be off or there may be a loose connection.</p>	<ol style="list-style-type: none"> 1 Make sure the power is on. 2 Make sure that all cable connections are secure.
	<p>You may not have any paper in the IN tray.</p>	<p>Double-check that the media is placed in the IN tray correctly.</p>
	<p>The printer's top cover may be open.</p>	<p>Close the printer's top cover.</p>
	<p>A problem may exist with one of the print cartridges.</p>	<p>If the Print Cartridge Status Light  is blinking, lift the printer's cover, check the Print Cartridge Status. Verify that the print cartridges are installed properly. See page 29.</p>
	<p>The printer may be slow.</p>	<p>If the Power Light  is blinking, the printer is in the process of printing. Be patient.</p>
	<p>The printer is waiting for you to press the Resume Button .</p>	<p>If the Resume Light is flashing, press the Resume Button .</p>
	<p>There may be a paper jam.</p> 	<ol style="list-style-type: none"> 1 Pull the paper out of either the IN tray or the OUT tray. 2 Press the Resume Button  on the front of the printer. 3 If you were printing labels, make sure a label did not become unglued from the label sheet while going through the printer. 4 If the paper jam has cleared, print your document again. 5 If the paper jam hasn't cleared, open the Rear Access Door by turning the knob (counter-clockwise) and removing the door. 6 Pull the jammed paper out of the printer, then replace the Rear Access Door.
	<p>The Fold-Up tray may not be down.</p>	<ol style="list-style-type: none"> 1 Lower the Fold-Up tray, and pull out the IN tray. 2 Slide out both of the paper guides. 3 Load paper and print your document.
<p>The Rear Access Door may be disengaged.</p>	<ol style="list-style-type: none"> 1 Insert the Rear Access Door and engage lock. 2 Print your document again. 	





Why won't it print? *continued*

What is the problem?	Possible cause	To solve the problem...
 A blank page came out of the printer.	You may be out of ink.	<ol style="list-style-type: none"> 1 Lift the printer cover and check the Print Cartridge status icons to make sure you are not out of ink. See "Print Cartridge Status" on page 27. 2 If you are out of ink, replace the print cartridge. See "Replacing Print Cartridges" on page 29. 3 Print your document again.
	You may have forgotten to remove the vinyl tape from the print cartridge.	Make sure you have removed the protective piece of vinyl tape on each of the print cartridges. See "Replacing Print Cartridges" on page 29.
	You may be trying to print a fax.	<ol style="list-style-type: none"> 1 Save the fax in a graphic format, such as TIFF. 2 Place it in a word processing document and print it from there.













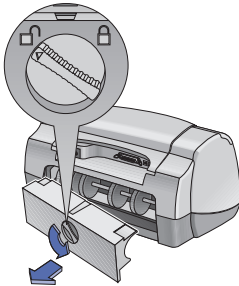

Why won't it print? *continued*

What is the problem?	Possible cause	To solve the problem...
The printer is really slow.	Your computer may have less than the minimum system requirements.	<ol style="list-style-type: none"> 1 Check the amount of RAM and processor speed in your computer. See “System Requirements” on page 57. 2 Free up some space on your hard drive. Having less than 100MB of free space on your computer’s hard drive can mean longer processing times.
	Too many software programs may be running at the same time.	Close all unnecessary software programs.
	You may be using outdated printer software.	Check the printer driver you are using. Be sure to check the HP web site at http://www.hp.com/support/home_products for the most recent software updates.
	You may be printing a complex document containing graphics or photographs.	Be patient. Large, complex documents containing graphics or photographs print slower than text-only documents.



What do the flashing lights mean?

What is the problem?	Possible cause	To solve the problem...
The Power Light  is flashing.	Your printer may be receiving data.	Be patient.
The Resume Light  is flashing.	You may be out of paper.	<ol style="list-style-type: none"> 1 Insert paper. 2 Press the Resume Button .
	You may have a paper jam. 	<ol style="list-style-type: none"> 1 Pull the paper out of either the IN tray or the OUT tray. 2 Press the Resume Button  on the front of the printer. 3 If you were printing labels, make sure a label did not become unglued from the label sheet while going through the printer. 4 If the paper jam has cleared, print your document again. 5 If the paper jam hasn't cleared, open the Rear Access Door by turning the knob (counter clockwise) and removing the door. 6 Pull the jammed paper out of the printer, then replace the Rear Access Door.
	You may be printing a two-sided document by hand and the first side has finished printing.	<ol style="list-style-type: none"> 1 Follow the on-screen directions for how to insert the paper. 2 Press the Resume Button .
The Print Cartridge Status Light  is flashing.	The top cover may be open.	Close the top cover.
	There may be a problem with one of the print cartridges.	See "Print Cartridge Status" on page 27.
All of the lights are flashing.	The printer may need to be reset.	<ol style="list-style-type: none"> 1 Press the Power Button  to turn the printer off. Then press the Power Button  again to turn the printer back on. 2 If that doesn't solve the problem, press the Power Button  to turn the printer off. 3 Unplug the printer. 4 Plug the printer back in. 5 Press the Power Button  to turn the printer on.



Is there a problem with your printout?

What is the problem?	Possible cause	To solve the problem...
 Parts of the document are missing or are in the wrong place.	Paper may not be loaded correctly.	<ol style="list-style-type: none"> 1 Make sure the media is correctly oriented in the IN tray. 2 Make sure the paper guides fit snugly against the media.
	You may have selected the wrong paper orientation.	Make sure you have selected the correct orientation (portrait or landscape) on the Page Setup dialog box. See “Page Setup - Controlling Page Layout” on page 6.
	You may have selected the wrong paper size.	Make sure you have selected the correct paper size in the Page Setup dialog box. See “Page Setup - Controlling Page Layout” on page 6.
	You may be trying to print text or graphics that are larger than your paper size.	Make sure text and graphics are scaled correctly in your document. See “Paper Size, Scaling, and Page Orientation” on page 6.
	You may have selected the wrong margins.	Make sure the margins are within the printable area. See “Minimum Printing Margins” on page 59.
	You may have accidentally left Poster Printing selected.	Uncheck Poster Printing in the Layout panel. See “Layout” on page 9.







Is there a problem with your printout? *continued*

What is the problem?	Possible cause	To solve the problem...
 Print quality is poor.	You may not be using the most appropriate media for the desired output.	<ul style="list-style-type: none"> • Make sure that you are using media intended for HP DeskJet printers. • Print quality is dramatically improved if you print on paper specifically designed for a certain output (photographs, for example), rather than using plain paper.
	You may be printing on the wrong side of the media.	Make sure that the media is loaded print side down.
	You may not have selected the correct paper type in the printer software.	Make sure that you have selected the correct paper type on the Paper Type/Quality dialog box. See “Paper Type/Quality” on page 9.
	You may be printing in Draft mode.	If printing appears faded or dull, click Normal or Best instead of Draft on the Paper Type/Quality dialog box. See “Paper Type/Quality” on page 9.
	If you have smearing, you may be using too much ink.	<ol style="list-style-type: none"> 1 Click Normal or Draft instead of Best on the Paper Type/Quality dialog box. See “Paper Type/Quality” on page 9. 2 Reduce the amount of ink. From the HP DeskJet 900 Series Print dialog box, select the Ink Controls panel. Use the sliders to adjust ink volume. 3 Increase the dry time. From the HP DeskJet 900 Series Print dialog box, select the Ink Controls panel. Use the sliders to adjust dry time.
	You may be running out of ink.	<ol style="list-style-type: none"> 1 Check the print cartridges status. See “Print Cartridge Status” on page 27. 2 If you are running out of ink, replace the print cartridge. See “Replacing Print Cartridges” on page 29.
	You may need to clean the print cartridges.	See “Cleaning Print Cartridges” on page 32.





Is there a problem with your printout? *continued*

What is the problem?	Possible cause	To solve the problem...
 Print quality is poor. (continued)	You may have forgotten to remove the vinyl tape from the print cartridge.	Make sure that you have removed the protective piece of vinyl tape on each of the print cartridges. See “Replacing Print Cartridges” on page 29.
	You may have the incorrect “Image” setting in the Color panel of the Print dialog box.	Click the Revert to Defaults button in the Color panel of the Print dialog box. See “Color” on page 10.
	Your print cartridges may be out of alignment.	If the color and black ink aren’t lining up on the printed page, go to the HP DeskJet Utility located in the Utilities folder in your hard drive’s main directory. Click the Calibrate tab, then click the Align button. See “HP DeskJet Utility Window” on page 25.
 Banners aren’t printing correctly.	You may have forgotten to raise the OUT Tray Flap.	Make sure that the OUT Tray Flap is up.
	You may have problems with the paper.	<ul style="list-style-type: none"> • If several sheets feed into the printer together, unfold and refold the paper. • If paper doesn’t feed into the printer correctly, be sure that the unattached edge of the banner paper stack is toward the printer (see page 21). • If the paper creases going through the printer, the paper might be unsuitable for banner printing.
	You may have problems with your banner software.	Make sure you selected the paper size U.S. Letter Banner or A4 Banner on the Page Setup dialog box. See “Page Setup - Controlling Page Layout” on page 6.



Is there a problem with your printout? *continued*

What is the problem?	Possible cause	To solve the problem...
 Photos aren't printing correctly.	You may not have inserted the photo media correctly.	Insert the photo media <i>glossy side down</i> .
	The photo paper may not be fully engaged.	<ol style="list-style-type: none"> 1 Review the printing instructions on page 13. 2 Make sure that the paper length guides are snug up against the photo paper.
	You may not have selected the appropriate Paper Type or Paper Size .	<ol style="list-style-type: none"> 1 From the Page Setup dialog box, select Photo 4 x 6 in., 102 x 152 mm (with tear-off tab) as the Paper Size. See "Page Setup - Controlling Page Layout" on page 6. 2 In your software program, choose Print from the File menu. On the Paper Type/Quality panel of the Print dialog box, select HP Premium Plus Photo Paper, Glossy as the Paper Type. See "Print Dialog Box" on page 7. 3 Click Save Settings. 4 Print your document.
	You may not have selected Best print quality.	<ol style="list-style-type: none"> 1 Go to the Paper Type/Quality dialog box. See "Paper Type/Quality" on page 9. 2 Select Best print quality.
Binding margin appears in the wrong place when trying to do Two-Sided Printing.	You may have selected the wrong paper orientation.	<ul style="list-style-type: none"> - Make sure you have selected the correct Binding option in the Layout panel of the Print dialog box. See "Layout" on page 9.



HP Customer Care

HP DeskJet printers set the standard for quality and reliability, so you have made an excellent choice. Should you need help, however, HP Customer Care's award-winning service and support is nearby to provide expert advice on using your HP printer or to answer specific questions about a problem you are having. Whether online or by phone, you'll find the support you need—and you'll find it fast.



HP Customer Care Online

Click your way to a quick solution! **HP Customer Care Online** is a great place to go for answers to questions about your HP products. You'll get instant access to everything from helpful printing tips to the latest product and software updates—24 hours a day, seven days a week, all at no charge to you.

If you have a modem connected to your computer and subscribe to an online service or have direct access to the Internet, you can obtain a wide variety of information about your printer at the following web sites:

English:

http://www.hp.com/support/home_products

French:

<http://www.hp.com/cposupport/fr/>

German:

<http://www.hp.com/cposupport/de/>

Japanese:

http://www.jpn.hp.com/CPO_TC/eschome.htm

Portuguese:

<http://www.hp.com/cposupport/pt/>

Spanish:

<http://www.hp.com/cposupport/es/>

From HP Customer Care Online you can link to **HP Customer Care User Forums** and **HP Customer Care Email**.

HP Customer Care User Forums

They're friendly. They're informative. Check out our online user forums. Simply review existing messages left by other HP users to find the answers you're looking for. You can also post your questions, then check back later for ideas and suggestions from knowledgeable users and system operators.

HP Customer Care by Email

Connect with HP via email and receive a personal reply from an HP Customer Care service technician. Responses are normally provided within 24 hours of receipt (excluding holidays). A great option for those non-urgent questions.

Printer Software

Printer software (also referred to as a printer driver) allows your printer to talk with your computer. HP provides several options for getting printer software and software updates:

- Download the printer software by accessing the **HP Customer Care Online** web site. See “HP Customer Care Online” on page 46 for the addresses of the HP web sites.
- If you are in the U. S. and need a software update, you can download the printer software from:
http://www.hp.com/support/home_products. If you do not have access to the web site, call (661) 257-5565. Software updates are available for the cost of the CDs plus shipping.
- If you are outside the U.S. and cannot download the driver from **HP Customer Care Online** (see page 46), call the **HP Customer Care Center** (see page 47) nearest you.



HP Customer Care Repair

If your HP printer is ever in need of repair, simply call the **HP Customer Care Center**. A trained service technician will diagnose the problem and coordinate the repair process for you. This service is free during your printer’s standard warranty. Beyond the warranty period, repairs are charged on a time and materials basis.



HP Customer Care by Phone

Within 90 days from the time of your purchase, phone support is provided to you free of charge. However, if you are calling long distance, long-distance charges may apply. Before placing a call for help, please make sure that:

- 1 You have checked your *Quick Start Poster* and this *User’s Guide* for installation and troubleshooting tips.
- 2 You have checked **HP Customer Care Online** (see page 46) for product help.
- 3 If you cannot solve your problem using the above, then call an HP service technician while you’re in front of your computer and printer. Before you call, be sure you have the following information:
 - Your printer’s serial number (the label is on the printer’s bottom).

 - Your printer’s model number (the label is on the front of the printer).

 - The model of the computer.

 - The version of the printer and software program (if applicable).

Then we can help you with your questions immediately!

See the list below for your country's **HP Customer Care Center** phone number:

Africa/Middle East	41 22/780 41 11	Portugal	351 (0) 1 318 00 65
Argentina	(541) 778-8380	Russia	7095 923 50 01
Australia	+61 3 8877 8000	Singapore	65 272 5300
Austria	43 (0) 660 6386	Spain	34 (9) 02321 123
Belgium (Dutch)	32 (0)2 62688 06	Sweden	46 (0) 8 6192170
Belgium (French)	32 (0)2 62688 07	Switzerland	41 (0) 84 8801111
Brazil	011 829-6612	Taiwan	886 2-2717-0055
Canada	(905) 206-4663	Thailand	(66-2) 661 4011
Chile	800 36 0999	Turkey	90 1 224 59 25
China	8610-65645959	United Kingdom	44 (0) 171 512 5202
Czech Republic	42 (2) 471 7321	U.S.	(208) 344-4131
Denmark	45 (0) 39 294099	Venezuela	800 47 888
Finland	358 (9) 2034 7288	Venezuela, Caracas	207 8488
France	33 (0) 143623434		
Germany	49 (0) 180 532 6222		
Greece	30 1 689 64 11		
Hong Kong	(800) 96 7729		
Hungary	36 (1) 252 4505		
India	91 11 682 60 35		
Indonesia	6221 350 3408		
Ireland	353 (0) 1662 5525		
Israel	972-9-9524848		
Italy	39 (0) 2 264 10350		
Japan, Tokyo	81 3 3335-8333		
Japan, Osaka	81 6 6838 1155		
Korea	02 3270 0700		
Malaysia	03 2952566		
Mexico D.F.	258 9922		
Mexico, Guadalajara	01 800 472 6684		
Middle East/Africa	41 22/780 41 11		
Netherlands	31 (0) 20 606 8751		
New Zealand	(09) 356-6640		
Norway	47 (0) 22 116299		
Philippines	65 272 5300		
Poland	(+48) 22 519 06 00		

After the Free Phone Support Period

You can still get help from HP for a fee. Prices are subject to change without notice. **HP Customer Care Online** help (see page 46) on the internet is still available for free!

- For quick questions in the United States only, call (900) 555-1500. The charges are \$2.50 per minute and begin when you connect with a service technician.
- For calls from Canada, or for calls in the U.S. that you anticipate might be longer than ten minutes in length, call (800) 999-1148. The fee is US \$25 per call, charged to your Visa or MasterCard.
- If, during your phone call, it is determined that your printer requires repair and you are within your printer's Limited Warranty period (see page 61, Printer), you will not be charged for the phone support service. However, for countries where the above toll-free phone numbers are not available, the regular long-distance charges may apply.

Extended Warranty Options

If you would like to extend your printer coverage beyond the one year factory warranty, you have the following options:

- Consult your reseller to get extended coverage.
- If your reseller does not offer service contracts, please call HP directly and ask about our HP Service Agreements. In the U.S., call (800) 446-0522; in Canada, call (800) 268-1221. For HP Service Agreements outside the U.S. and Canada, contact your local HP Sales Office.

5

Supplies and Accessories

Printer Supplies

For ordering information see page 52.

Part Name	Part Number
Interface Cables	
HP USB-Compliant Interface Cable	C6518A
Print Cartridges	
● Black	HP 51645 Series
● Tri-color	HP 6578 Series
Power Cords	
U.S., Canada, Brazil, Latin America, Saudi Arabia	8120-8900
Japan	8121-0021
Singapore, Malaysia, Hong Kong	8121-0026
South Africa	8121-0020
India	8121-0025
Argentina	8121-0019
Australia	8121-0018
China, Taiwan, Philippines	8121-0024
Korea	8121-0017
Europe, Jordan, Lebanon, North Africa, Israel, Russia, Baltic countries, Thailand, Indonesia, Caribbean, Latin America	8121-0023
U.K., Middle East	8121-0022
Other Replaceable Parts	
DJ930C Series Printer Cleanout Access Door Assembly	C6426-60038
Accessories	
Two-Sided Printing Module (not available in all countries)	C6463A

Printer Quick Start Posters and User's Guide for Macintosh

Most HP printer documentation is available for viewing and printing at http://www.hp.com/support/home_products.

Language	Part Number	
	Quick Start Poster	User's Guide
Dutch	C6427-90061	C6427-90072
English	C6427-90062	C6427-90071
French	C6427-90063	C6427-90073
German	C6427-90064	C6427-90074
Greek	C6427-90065	
Italian	C6427-90066	C6427-90075
Japanese	C6427-90067	
Portuguese	C6427-90085	C6427-90105
Spanish	C6427-90068	C6427-90077
Swedish	C6427-90069	C6427-90078
Turkish	C6427-90070	

Paper and Other Media

Availability of special media varies by country.

Paper Type/Description	Part Number	Paper Type/Description	Part Number
HP Bright White Inkjet Paper		HP Premium Inkjet Transparency Film	
A4 (210 x 297 mm), 200 sheets	C5977A	A4 (210 x 297 mm), 20 sheets	C3832A
A4 (210 x 297 mm), 500 sheets	C1825A	A4 (210 x 297 mm), 50 sheets	C3835A
U.S. letter, 200 sheets	C5976A	U.S. letter, 20 sheets	C3828A
U.S. letter, 500 sheets	C1824A	U.S. letter, 50 sheets	C3834A
HP Premium Inkjet Paper		HP Premium Inkjet Rapid-dry Transparencies	
A4 (210 x 297 mm), 200 sheets	C51634Z	A4 (210 x 297 mm), 50 sheets	C6053A
U.S. letter, 200 sheets	C51634Y	U.S. letter, 50 sheets	C6051A
HP Premium Inkjet Heavyweight Paper		HP Banner Paper	
A4 (210 x 297 mm), 100 sheets	C1853A	A4 (210 x 297 mm), 100 sheets	C1821A
U.S. letter, 200 sheets	C1852A	U.S. letter, 100 sheets	C1820A
HP Professional Brochure & Flyer Paper, Matte		HP Matte Greeting Cards, White/Quarter-fold	
U.S. letter, 50 sheets	C6955A	A4 (210 x 297 mm), 20 sheets, 20 envelopes	C6042A
HP Professional Brochure & Flyer Paper, Glossy		U.S. letter, 20 sheets, 20 envelopes	C1812A
Asian A4 (210 x 297 mm), 50 sheets	C6819A	HP Felt-textured Greeting Cards, Ivory/Half-fold	
European A4 (210 x 297 mm), 50 sheets	C6818A	U.S. letter, 20 sheets, 20 envelopes	C6828A
U.S. letter, 50 sheets	C6817A	HP Glossy Greeting Cards, White/Half-fold	
HP Photo Paper, Two-Sided, Satin/Glossy		A4 (210 x 297 mm) 10 sheets, 10 envelopes	C6045A
Asian A4 (210 x 297 mm), 20 sheets	C6765A	U.S. letter, 20 sheets, 20 envelopes	C6044A
European A4 (210 x 297 mm), 20 sheets	C1847A	HP Iron-on T-Shirt Transfers	
U.S. letter, 20 sheets	C1846A	Asian A4, (210 x 297 mm), 10 sheets	C6065A
HP Premium Photo Paper, Glossy		European A4 (210 x 297 mm), 10 sheets	C6050A
Asian A4 (210 x 297 mm), 15 sheets	C6043A	U.S. letter, 10 sheets	C6049A
European A4 (210 x 297 mm), 15 sheets	C6040A	HP Restickables, Large Round Inkjet Stickers	
U.S. letter, 15 sheets	C6039A	U.S. letter, 10 sheets (90 stickers)	C6822A
HP Premium Plus Photo Paper, Glossy		HP Restickables, Large Square Inkjet Stickers	
European A4 (210 x 297 mm), 20 sheets	C6832A	U.S. letter, 10 sheets (90 stickers)	C6823A
U.S. letter, 20 sheets	C6831A		
HP Premium Plus Photo Paper, Matte			
European A4 (210 x 297 mm), 20 sheets	C6951A		
U.S. letter, 20 sheets	C6950A		
HP Premium Plus Photo Paper, Glossy Snapshot			
European A4 (102 x 152 mm finished size), 20 sheets	C6945A		
U.S. (4 x 6 in. finished size), 20 sheets	C6944A		

Note: To find out which recycled papers are recommended for your printer, contact your local HP Sales Office and ask for the HP Inkjet Printer Family Paper Specifications Guide, HP part number 5961-0920.

Ordering Information

To order printer supplies or accessories, call your nearest HP dealer or call HP DIRECT at the following numbers for fast shipping service.

In the U.S., you can buy supplies and accessories directly from HP at www.hpshopping.com, or call the HP Shopping Village at 1-888-999-4747.

- **Argentina:** (54 1) 787-7100
Fax: (54 1) 787-7213
Hewlett-Packard Argentina,
Montañeses 2150 1428
Buenos Aires, Argentina
- **Australia/New Zealand:** (03) 895-2895
China Resources Bldg.
26 Harbour Road
Wanchai, Hong Kong
- **Austria-South-East Area:** (43-0222) 25 000, ext. 755
Fax: (43-0222) 25 000, ext. 610
Hewlett-Packard Ges.m.b.H.
Ersatzteilverkauf Liebg. 1
A-1222 Wien
- **Belgium:** 02/778 3092 (or 3090, 3091)
Fax: 02/778 3076
Hewlett-Packard Belgium SA/NV
100 bd. de la Woluwe/Woluwedal
1200 BRUXELLES
- **Brazil:** Centro de Informacoes HP
Grande São Paulo: 822-5565
Demais Localidades: 0800-157751
Fax: (011) 829-7116
Centro de Informacoes HP
Hewlett Packard Brasil S.A.
Caixa Postal 134, Rua Clodomiro Amazonas, 258
CEP 04534-011, São Paulo - SP
- **Canada:** (800) 387-3154, (905) 206-4725
Fax: (905) 206-3485/-3739
Hewlett-Packard (Canada) Ltd.
5150 Spectrum Way
Mississauga, Ontario L4W 5G1
Toronto: (416) 671-8383
- **Chile:** (56 2) 203-3233
Fax: (56 2) 203-3234
Hewlett-Packard de Chile SA
Av. Andres Bello 2777, Oficina 1302
Los Condes, Santiago, Chile
- **Denmark:** 45 99 14 29
Fax: 42 81 58 10
Hewlett-Packard A/S
Kongevejen 25, 3460 BIRKEROD
- **Finland:** (90) 8872 2397
Fax: (90) 8872 2620
Hewlett-Packard Oy
Varaosamynti, Piispankalliontie 17
02200 ESPOO
- **France:** (1) 40 85 71 12
Fax: (1) 47 98 26 08
EuroParts
77 101 avenue du Vieux Chemin de Saint-Denis
92625 GENNEVILLIERS
- **Germany:** 07031-145444
Fax: 07031-141395
Hewlett-Packard GmbH, HP Express Support
Ersatzteil-Verkauf, Herrenberger Str. 130
71034 BÖBLINGEN
- **International Sales Branch:** (41) 22 780 4111
Fax: (41) 22 780-4770
Hewlett-Packard S. A., ISB
39, rue de Veyrot 1217 MEYRIN 1
GENEVE - SUISSE
- **Italy:** 02/9212.2336/2475
Fax: 02/92101757
Hewlett-Packard Italiana S. P. A.
Ufficio Parti di ricambio
Via G. Di Vittorio, 9
20063 Cernusco s/N (MI)
- **Japan:** (03) 3335-8333
Hewlett-Packard Japan Ltd.
29-21 Takaido-Higashi 3-chone, sugninami-ku
Tokyo 168-8585
- **Latin America Headquarters:** (305) 267-4220
Fax: (305) 267-4247
5200 Blue Lagoon Drive, Suite 950
Miami, FL 33126
- **Mexico:** (52 5) 258-4600
Fax: (54 1) 258-4362
Hewlett-Packard de México, S.A. de C.V.
Prolongación Reforma #470
Colonia Lomas de Santa Fe, C.P. 01210 México, D.F.

- **Netherlands:** 0 33 450 1808
Fax: 0 33 456 0891
Hewlett-Packard Nederland B. V.
Parts Direct Service
Basicweg 10
3821 BR AMERSFOORT
- **Norway:** 22735926
Fax: 22735611
Hewlett-Packard Norge A/S, Express Support
Drammensveien 169-171
0212 Oslo
- **Spain:** 1 6 31 14 81
Fax: 1 6 31 12 74
Hewlett-Packard Española S.A.
Departamento de Venta de Piezas
Ctra N-VI, Km. 16,500
28230 LAS ROZAS, Madrid
- **Sweden:** 8-4442239
Fax: 8-4442116
Hewlett-Packard Sverige AB
Skalholtsgatan 9, Box 19
164 93 KISTA
- **Switzerland:** 056/279 286
Fax: 056/279 280
Elbatex Datentechnik AG
Schwimmbadstrasse 45, 5430 WETTINGEN
- **United Kingdom:**
+44 1765 690061
Fax: +44 1765 690731
Express Terminals, 47 Allhallowgate
Ripon, North Yorkshire
- +44 181 568 7100
Fax: +44 181 568 7044
Parts First, Riverside Works
Isleworth, Middlesex, TW7 7BY
- +44 1734 521587
Fax: +44 1734 521712
Westcoast, 28-30 Richfield Avenue
Reading, Berkshire, RG1 8BJ
- **United States:** (800) 227-8164
- **Venezuela:** (58 2) 239-4244/4133
Fax: (58 2) 207-8014
Hewlett-Packard de Venezuela C.A.
Tercera Transversal de Los Ruices Norte
Edificio Segre, Caracas 1071, Venezuela
Apartado Postal 50933, Caracas 1050

Elsewhere in the world

- **Hewlett-Packard Company**
Intercontinental Headquarters,
3495 Deer Creek Road,
Palo Alto, CA 94304, U.S.A.

A Setup Instructions

Using a USB Connection

You can connect your HP DeskJet 900 Series directly to your computer using a USB cable if your computer supports USB (Universal Serial Bus). Before you connect your printer to your computer, make sure your configuration meets these requirements:

- Your computer must support USB
- You will need a USB-compliant interface cable, such as HP Part Number C6518A
- Your computer must be turned on and running MacOS 8.1 or higher

1 Plug in the electrical power cord

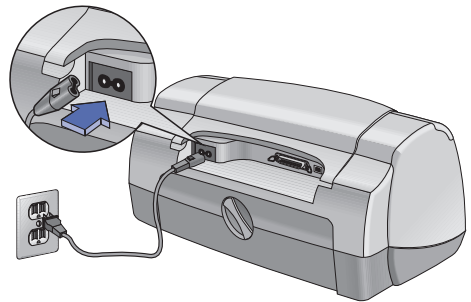

2 Load white paper

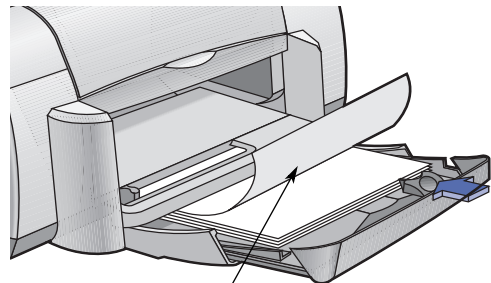

Printable side
down

3 Insert the print cartridges

- a Press Power Button  to turn on printer.
- b Remove vinyl tape from print cartridges.
Do NOT touch or remove copper strip on print cartridges.
- c Open top cover, then insert print cartridges.
- d Close top cover.
Printer will print a calibration page.

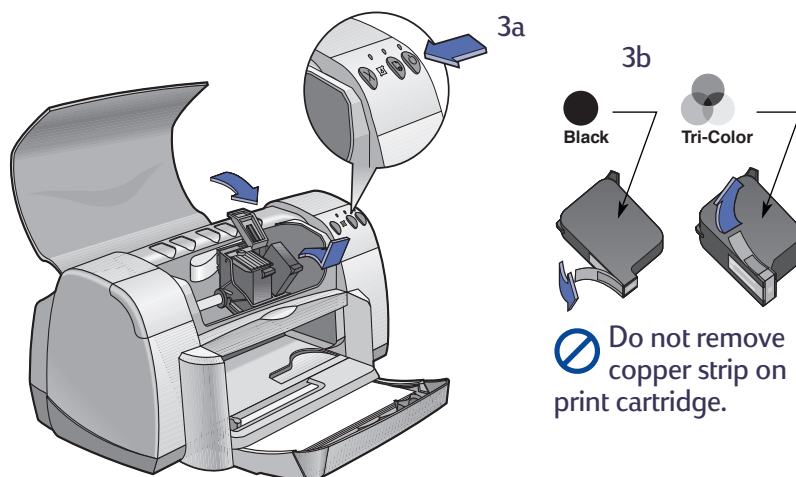

4 Connect the USB cable

- You can connect to any USB port.
- A USB cable, such as an HP USB-Compliant Interface Cable (part number C6518A), should be purchased separately.

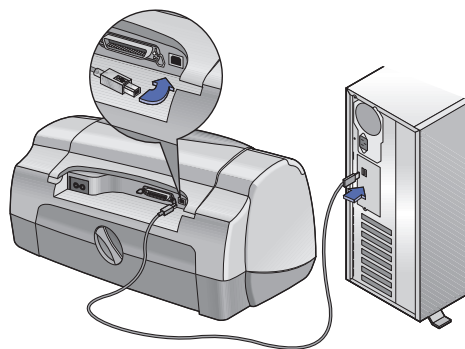

5 Install the printer software

- a** Insert the HP Printer Software CD into your CD-ROM drive.
- b** Double-click the **HP DeskJet 900 Series Installer** icon.



HP DeskJet 900 Series Installer

- c** Follow the on-screen instructions to complete the installation. Your computer will restart when the installation is complete.
- d** After your computer restarts, the **HP DeskJet Utility (Select Printer)** dialog box opens.
Follow the instructions in this dialog box to select the **DeskJet 900 Series** printer.

B Specifications

DeskJet 930C model no. C6427A

DeskJet 932C model no. C6427B

DeskJet 935C model no. C6427C

Print Technology

Drop-on-demand thermal inkjet printing

Black Text Print Speed *

Draft: 9 pages per min.

Mixed Text with Color Graphics Print Speed *

Draft: 7.5 pages per min.

Black TrueType™ Text Resolution (depends on paper type)

Draft: 300 x 600 dpi

Normal: 600 x 600 dpi

Best: 600 x 600 dpi

Color Resolution (depends on paper type)

Draft: 300 x 600 dpi

Normal: Color Layering

Best: Color Layering **

Software Compatibility

USB Connection: MacOS version 8.1 or later

System Requirements

USB Connection:

PowerPC MacOS computer with a USB port

MacOS version 8.1 or later

32 MB RAM

8 MB (minimum) available hard-disk space

Duty Cycle

2,000 pages per month

Memory

4 MB built-in RAM

Buttons/Lights

Cancel Button

Print Cartridge Status Light

Resume Button and Light

Power Button and Light

I/O Interface

Centronics Parallel, IEEE 1284-Compliant with 1284-B receptacle

Universal Serial Bus

Dimensions

440 mm wide x 196 mm high x 400 mm deep (tray down with paper) or 250 mm deep (tray up)

17.34 in wide x 7.72 in high x 15.76 in deep (tray down with paper) or 9.85 in deep (tray up)

Weight

5.72 kg (12.61 lb) without print cartridges

Operating Environment

Maximum operating temperature: 41 to 104°F, 5 to 40°C

Humidity: 5 to 80% RH noncondensing

Recommended operating conditions for best print quality:

59 to 95°F or 15 to 35°C

20 to 80% RH noncondensing

Storage temperature: -40 to 140°F, -40 to 60°C

Power Consumption

2 watts maximum when off

4 watts average non-printing

25 watts average when printing

Power Requirements

Input Voltage: 100 to 240 VAC (±10%)

Input Frequency: 50/60 Hz (+3 Hz)

Automatically accommodates the world-wide range of AC line voltages and frequencies.

Declared noise emissions in accordance with ISO 9296

Sound power level, LWAd (1B=10dB): 5.9 B in normal mode.

Sound pressure level, LpAm (bystander positions):

46 dB in normal mode.

* Approximate figures. Exact speed will vary depending on the system configuration, software program, and document complexity.

** A High Resolution Mode of 2400 x 1200 dpi is also available.

Media Weight

Paper:	
U.S. Letter	60 to 90 g/sm ² (16 to 24 lb)
Legal	75 to 90 g/sm ² (20 to 24 lb)
Envelopes:	75 to 90 g/sm ² (20 to 24 lb)
Cards:	110 to 200 g/sm ² (110 lb index max.)
Banner Paper:	60 to 90 g/sm ² (16 to 24 lb)

Media Handling

Sheets:	up to 100
Banners:	up to 20 sheets
Envelopes:	up to 15
Cards:	up to 30 cards
Greeting cards:	up to 5 cards
Transparencies:	up to 25
Labels:	up to 20 sheets of labels (use only U.S. letter- or A4-sized sheets)
OUT tray capacity:	up to 50 sheets

Alignment

Vertical:	+/- .058 mm (.002 in.) in normal mode
Skew:	+/- .152 mm (.006 in.) on plain paper +/- .254 mm (.010 in.) on HP transparency films

Media Size

Paper:	
U.S. Letter	216 x 279 mm (8.5 x 11 in.)
Legal	216 x 356 mm (8.5 x 14 in.)
Executive	184 x 279 mm (7.25 x 10.5 in.)
A4	210 x 297 mm
A5	148 x 210 mm
B5-JIS	182 x 257 mm
User Defined:	
Width	77 to 216 mm (3.0 to 8.5 in.)
Length	127 to 356 mm (5.0 to 14 in.)
Banner:	
U.S. Letter	216 x 279 mm (8.5 x 11 in.)
A4	210 x 297 mm
Envelopes:	
U.S. No. 10	105 x 241 mm (4.3 x 9.5 in.)
Invitation A2	111 x 146 mm (4.37 x 5.75 in.)
DL	220x110 mm
C6	114x162 mm
Index/Greeting Cards:	
	76 x 127 mm (3 x 5 in.)
	102 x 152 mm (4 x 6 in.)
	127 x 203 mm (5 x 8 in.)
A6:	105 x 148.5 mm
Hagaki:	100 x 148 mm
Labels:	
U.S. Letter	216 x 279 mm (8.5 x 11 in.)
A4	210 x 297 mm
Transparencies:	
U.S. Letter	216 x 279 mm (8.5 x 11 in.)
A4	210 x 297 mm
Photo (with tear-off tab):	102 x 152 mm (4 x 6 in.)

Minimum Printing Margins

The printer cannot print outside a certain area of the page, so you must make sure the contents of your document fall within the printable area.

When you use nonstandard paper sizes and select the **Custom Paper Size** setting from the **Page Setup** dialog box, the paper width must be between 77 and 215 mm (3 and 8.5 inches) and the paper length must be between 127 and 356 mm (5 and 14 inches).

Letter, Legal, and Executive Paper

Left:	6.4 mm (0.25 in.)
Right:	6.4 mm (0.25 in.)
Top:	1.8 mm (0.07 in.)
Bottom:	11.7 mm (0.46 in.)

A4 Paper

Left:	3.4 mm (0.134 in.)
Right:	3.4 mm (0.134 in.)
Top:	1.8 mm (0.07 in.)
Bottom:	11.7 mm (0.46 in.)

A5, B5, and Custom Paper Size

Left:	3.2 mm (0.125 in.)
Right:	3.2 mm (0.125 in.)
Top:	1.8 mm (0.07 in.)
Bottom:	11.7 mm (0.46 in.)

Cards (3 x 5, 4 x 6, 5 x 8, and A6)

Left:	3.2 mm (0.125 in.)
Right:	3.2 mm (0.125 in.)
Top:	1.8 mm (0.07 in.)
Bottom:	11.7 mm (0.46 in.)

Hagaki Postcards

Left:	3.2 mm (0.125 in.)
Right:	3.2 mm (0.125 in.)
Top:	1.8 mm (0.07 in.)
Bottom:	11.7 mm (0.46 in.)

Envelopes

Left:	3.2 mm (0.125 in.)
Right:	3.2 mm (0.125 in.)
Top:	1.8 mm (0.07 in.)
Bottom:	11.7 mm (0.46 in.)

Banners, A4 (210 x 297 mm, 8.27 x 11.7 in)

Left:	3.4 mm (0.134 in.)
Right:	3.4 mm (0.134 in.)
Top:	0.0 mm (0.00 in.)
Bottom:	0.0 mm (0.00 in.)

Banners, Letter (8.5 x 11 in.)

Left:	6.4 mm (0.25 in.)
Right:	6.4 mm (0.25 in.)
Top:	0.0 mm (0.00 in.)
Bottom:	0.0 mm (0.00 in.)

Photo with tear-off tab 112 x 152 mm (4 x 6.5 in.)

Left:	3.2 mm (0.125 in.)
Right:	3.2 mm (0.125 in.)
Top:	3.2 mm (0.125 in.)
Bottom:	3.2 mm (0.125 in.)

C Legal Information

Regulatory Notices

Hewlett-Packard Company

This device complies with part 15 of the FCC Rules.

Operation is subject to the following two conditions:

- (1) This device may not cause harmful interference, and
- (2) this device must accept any interference received, including interference that may cause undesired operation.

Pursuant to Part 15.21 of the FCC Rules, any changes or modifications to this equipment not expressly approved by Hewlett-Packard Company may cause harmful interference, and void your authority to operate this equipment. Use of a shielded data cable is required to comply with the Class B limits of Part 15 of the FCC Rules.

For further information, contact:

Hewlett-Packard Company
Manager of Corporate Product Regulations
3000 Hanover Street
Palo Alto, Ca 94304
(415) 857-1501

NOTE: This equipment has been tested and found to comply with the limits for a Class B digital device, pursuant to part 15 of the FCC rules. These limits are designed to provide reasonable protection against harmful interference in a residential installation. This equipment generates, uses, and can radiate radio frequency energy and, if not installed and used in accordance with the instructions, can cause harmful interference to radio communications. However, there is no guarantee that interference will not occur in a particular installation. If this equipment does cause harmful interference to radio or television reception, which can be determined by turning the equipment off and on, the user is encouraged to try to correct the interference by one or more of the following measures:

- Reorient or relocate the receiving antenna.
- Increase the separation between the equipment and the receiver.
- Connect the equipment into an outlet on a circuit different from that to which the receiver is connected.
- Consult the dealer or an experienced radio/TV technician for help.

LED Indicator Statement

The display LEDs meet the requirements of EN 60825-1.

この装置は、情報処理装置等電波障害自主規制協議会（VCCI）の基準に基づくクラスB情報技術装置です。この装置は、家庭環境で使用することを目的としていますが、この装置がラジオやテレビジョン受信機に近接して使用されると受信障害を引き起こすことがあります。
取り扱い説明書に従って正しい取り扱いをして下さい。

사용자 안내문 (A급 기기)

이 기기는 업무용으로 전자파장애감정을 받은 기기이오니, 만약 잘못 구입하셨을 때에는 구입한 곳에서 비업무용으로 교환하시기 바랍니다.

사용자 안내문 (B급 기기)

이 기기는 비업무용으로 전자파장애감정을 받은 기기로서, 주거지역에서는 물론 모든 지역에서 사용할 수 있습니다.

Limited Warranty Statement

HP Product	Duration of Limited Warranty
Software	90 Days
Ink cartridges	90 Days
Printer	1 Year

A. Extent of Limited Warranty

- Hewlett-Packard (HP) warrants to the end-user customer that the HP products specified above will be free from defects in materials and workmanship for the duration specified above, which duration begins on the date of purchase by the customer. Customer is responsible for maintaining proof of date of purchase.
- For software products, HP's limited warranty applies only to a failure to execute programming instructions. HP does not warrant that the operation of any product will be uninterrupted or error free.
- HP's limited warranty covers only those defects which arise as a result of normal use of the product, and do not apply to any:
 - Improper or inadequate maintenance or modification;
 - Software, interfacing, media, parts, or supplies not provided or supported by HP; or
 - Operation outside the product's specifications.
- For HP printer products, the use of a non-HP ink cartridge or a refilled ink cartridge does not affect either the warranty to the customer or any HP support contract with the customer. However, if printer failure or damage is attributable to the use of a non-HP or refilled ink cartridge, HP will charge its standard time and materials charges to service the printer for the particular failure or damage.
- If HP receives, during the applicable warranty period, notice of a defect in any software, media, or ink cartridge product which is covered by HP's warranty, HP shall replace the defective product. If HP receives, during the applicable warranty period, notice of a defect in any hardware product which is covered by HP's warranty, HP shall either repair or replace the defective product, at HP's option.
- If HP is unable to repair or replace, as applicable, a defective product which is covered by HP's warranty, HP shall, within a reasonable time after being notified of the defect, refund the purchase price for the product.
- HP shall have no obligation to repair, replace, or refund until the customer returns the defective product to HP.
- Any replacement product may be either new or like-new, provided that it has functionality at least equal to that of the product being replaced.
- HP's limited warranty is valid in any country where the covered HP product is distributed by HP except for the Middle-East, Africa, Argentina, Brazil, Mexico, Venezuela, and France's "Departements D'Outre-Mer"; for those excepted areas, the warranty is valid only in the country of purchase. Contracts for additional warranty services, such as on-site service, may be available from any authorized HP service facility where the product is distributed by HP or by an authorized importer.

B. Limitations of Warranty

- TO THE EXTENT ALLOWED BY LOCAL LAW, NEITHER HP NOR ITS THIRD PARTY SUPPLIERS MAKE ANY OTHER WARRANTY OR CONDITION OF ANY KIND, WHETHER EXPRESS OR IMPLIED, WITH RESPECT TO THE HP

PRODUCTS, AND SPECIFICALLY DISCLAIM THE IMPLIED WARRANTIES OR CONDITIONS OF MERCHANTABILITY, SATISFACTORY QUALITY, AND FITNESS FOR A PARTICULAR PURPOSE.

C. Limitations of Liability

- To the extent allowed by local law, the remedies provided in this Warranty Statement are the customer's sole and exclusive remedies.
- TO THE EXTENT ALLOWED BY LOCAL LAW, EXCEPT FOR THE OBLIGATIONS SPECIFICALLY SET FORTH IN THIS WARRANTY STATEMENT, IN NO EVENT SHALL HP OR ITS THIRD PARTY SUPPLIERS BE LIABLE FOR DIRECT, INDIRECT, SPECIAL, INCIDENTAL, OR CONSEQUENTIAL DAMAGES, WHETHER BASED ON CONTRACT, TORT, OR ANY OTHER LEGAL THEORY AND WHETHER ADVISED OF THE POSSIBILITY OF SUCH DAMAGES.

D. Local Law

- This Warranty Statement gives the customer specific legal rights. The customer may also have other rights which vary from state to state in the United States, from province to province in Canada, and from country to country elsewhere in the world.
- To the extent that this Warranty Statement is inconsistent with local law, this Warranty Statement shall be deemed modified to be consistent with such local law. Under such local law, certain disclaimers and limitations of this Warranty Statement may not apply to the customer. For example, some states in the United States, as well as some governments outside the United States (including provinces in Canada), may:
 - Preclude the disclaimers and limitations in this Warranty Statement from limiting the statutory rights of a consumer (e.g., the United Kingdom);
 - Otherwise restrict the ability of a manufacturer to enforce such disclaimers or limitations; or
 - Grant the customer additional warranty rights, specify the duration of implied warranties which the manufacturer cannot disclaim, or not allow limitations on the duration of implied warranties.
- FOR CONSUMER TRANSACTIONS IN AUSTRALIA AND NEW ZEALAND, THE TERMS IN THIS WARRANTY STATEMENT, EXCEPT TO THE EXTENT LAWFULLY PERMITTED, DO NOT EXCLUDE, RESTRICT, OR MODIFY, AND ARE IN ADDITION TO, THE MANDATORY STATUTORY RIGHTS APPLICABLE TO THE SALE OF HP PRODUCTS TO SUCH CUSTOMERS.

HP Year 2000 Warranty

Subject to all of the terms and limitations of the HP Limited Warranty Statement stated above, HP warrants that this HP Product will be able to accurately process date data (including, but not limited to, calculating, comparing, and sequencing) from, into, and between the twentieth and twenty-first centuries, and the years 1999 and 2000, including leap year calculations, when used in accordance with the Product documentation provided by HP (including any instructions for installing patches or upgrades), provided that all other products (e.g. hardware, software, firmware) used in combination with such HP Product(s) properly exchange date data with it. The duration of the Year 2000 warranty extends through January 31, 2001.

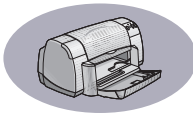

Index

- A**
 - accessories **iii**, **50**
- B**
 - background printing **11**, **12**
 - banners
 - choosing paper for **21**
 - ordering **51**
 - printing **3**, **21**
 - problems **44**
 - specifications **58**
 - Best mode **57**
 - black and white printing **10**
 - book binding **23**
 - brightness **10**
 - buttons
 - Cancel **1**, **7**, **57**
 - Power **1**, **29**, **31**, **33**, **41**, **57**
 - Print **7**
 - Resume **1**, **19**, **38**, **41**, **57**
 - Revert to Default **7**
 - Save Settings **7**
- C**
 - cables
 - ordering **50**
 - recommended **iii**
 - USB **iii**
 - Cancel button **1**, **7**, **57**
 - capacity, paper tray **iv**
 - cards
 - printing **14–17**
 - specifications **51**, **58**, **59**
 - change printers **12**
 - change the order of print jobs **12**
 - cleaning
 - print cartridge cradle **34**
 - print cartridges **33**
 - printer **3**
 - Color panel **10**
 - color resolution **57**
 - color tone **10**
 - ColorSync **10**
 - computer, controlling from **4**
 - connections
 - USB **4**
 - Customer Care **46**
 - customer support **46**
- D**
 - default printer **4**
 - delete a print job **12**
 - desktop printing **5**
 - door, rear access **38**, **41**
 - dpi, 2400 printing
 - Color Layering **57**
 - Draft mode **57**
 - drivers, *see printer software*
 - duty cycle **57**
- E**
 - energy usage **57**
 - envelope slot **3**
 - envelopes
 - printing single **15**
 - printing stack **16**
 - specifications **58**, **59**
 - environment, operating **57**
- F**
 - fax printing, problems **39**
 - FCC statement **60**
 - features **iv**
 - foreground printing **11**
- G**
 - General panel **8**
 - getting help, *see help*
 - grayscale **10**
 - greeting cards
 - printing **14–17**
 - specifications **58**, **59**
- H**
 - help
 - customer **46**
 - electronic **iv**
 - HP Customer Care **46–49**
 - information sources **iv**
 - technical support **46**
 - user forums **iv**
 - web sites **iv**
 - High Res Photo mode **9**
 - HP Color Matching **10**
 - HP Customer Care **46–49**
- I**
 - I/O interface **57**
 - icons
 - print cartridge status **28**
 - printer status **5**
 - IN tray
 - capacity of **58**
 - use **2**
 - index cards
 - printing **17**
 - specifications **58**, **59**
 - tray capacity **58**
 - ink
 - density **43**
 - ordering **50**
 - replacing **29**
 - streaking **32**
 - ink cartridges
 - cleaning **32–33**
 - damage from refilling **35**
 - Light **30**
 - ordering **50**
 - part numbers **29**, **35**
 - problems **31**, **32**
 - replacment **29**
 - status **27**
 - storing **31**
 - using **31**



- installing
 - printer software **36, 37**
 - problems **36, 37**
 - software **36**
- iron-on transfers
 - ordering **51**
 - printing **20**

- J**
- jams, *see paper jams*

- L**
- labels
 - paper jams with **38**
 - printing **18**
 - specifications **58**
 - tray capacity **58**

- Layout panel **9**
- lights
 - Online **1**
 - Power **1, 57**
 - Print Cartridge Status **1, 27, 30**
 - Resume **1, 57**

- Low on Ink
 - checking ink level **27**
 - print cartridge status light **27, 28**

- M**
- maintenance
 - print cartridges **27**
 - printer **3**
- manual two-sided printing **23**
- margins, minimum printing **59**
- media, *see paper*
- metric paper sizes **58**
- modes
 - Best **57**
 - Draft **57**
 - High Res Photo **9, 57**
 - Normal **57**
 - printing speeds **57**

- N**
- noise, emissions **57**
- Normal mode **57**

- O**
- online support, web site **iv**
- operating environment **57**
- ordering
 - parts and accessories **52**
 - supplies **50**
- OUT tray
 - capacity **58**
- OUT tray flap **3**

- P**
- page orientation **6**
- Page Setup dialog box **6**
- paper
 - adjusting paper guides **2**
 - printing on different types **13**
 - specifications **58, 59**
 - supplies **51**
 - User Defined Size **58**
 - weight, recommended **58**
- paper guides **2**
- paper jams, clearing **38, 41**
- paper size **6**
 - specifications **58, 59**
- paper sizes
 - User Defined **58**
- paper trays
 - adjusting paper guides **2**
 - capacity **iv, 58**
 - envelope slot **3**
 - IN tray **2**
 - OUT tray **3**
 - positions **2**
- Paper Type/Quality panel **9**
- parts
 - numbers **50**
 - ordering **50**
 - supplies **50**
- pausing/holding a print job **12**
- posters, printing **9, 22**
- Power
 - button **57**
 - consumption **57**
 - cord **iii**
 - cord, ordering **50**
 - light **57**

- print
 - at a specific time **12**
- Print button **7**
- print cartridge status **27**
 - icons **28**
- Print Cartridge Status light **57**
- print cartridges
 - cleaning **32–33**
 - damage from refilling **35**
 - light **30**
 - low on ink **28**
 - ordering **50**
 - part numbers **29, 35, 50**
 - problems **30, 31**
 - recommended temperatures **31**
 - replacement **29**
 - status **27**
 - status icons **28**
 - status light **1**
 - storing **31**
 - using **31**
- Print dialog box **7**
- print margins, specifications **59**
- print problems, *see problems*
- print quality **iv**
 - 2400 dpi **57**
- cleaning print cartridges **32**
 - improving **43**
 - problems **43, 45**
 - using refilled print cartridges **35**
- print technology **57**
- printer
 - accessories **iii, 50**
 - buttons **1**
 - cable
 - parallel **50**
 - USB **50**
 - cleaning **3**
 - components **iii**
 - connections **38**
 - controlling **4**
 - driver updates, *see software updates*



- drivers, *see printer software*
- Lights 1
- maintenance 3
- noise 57
- package contents iii
- paper trays 58
- parts 50
- recommended cables iii
- selecting default 4
- setting up iii
- smudges on 3
- software 47
- software updates 47
- specifications 57
- status 5
- trays 2
- printer software
 - downloading 47
 - problems installing 36
 - updates iv
- printing
 - 2400 dpi 57
 - banners 21
 - book 23
 - business cards 17
 - cards 14–17
 - envelopes, single 15
 - envelopes, stack 16
 - faxes 39
 - from the desktop 5
 - greeting cards 14–17
 - index cards 17
 - iron-on transfers 20
 - labels 18
 - posters 9, 22
 - quality 30, 43
 - stop/restart 12
 - tablet 23
 - transparencies 19
 - two-sided, book 23
 - two-sided, tablet 23
- printing problems, *see problems*
- problems
 - banner printing 44
 - blank page came out of printer 39
 - CD, not reading 36
 - fax 39
 - flashing lights 41
 - help 36
 - ink streaks 32
 - installing printer software 37
 - jam 38
 - lights flashing 41
 - missing lines or dots 32
 - no page not came out 38
 - output 42, 43
 - page did not print 38
 - paper jam 38
 - parts of output in wrong place 42
 - parts of output missing 32, 42
 - photos 45
 - power light flashing 41
 - print cartridge status light flashing 41
 - print cartridges 31
 - print quality 43, 45
 - printing 38–40
 - resume light flashing 41
 - slow printer 40
 - software installation 37
 - software, not reading 36
 - too much ink 43
- Q**
 - quality iv
 - See print quality*
 - Quick Start Poster
 - ordering 50
- R**
 - rear access door
 - removing 38, 41
 - replacement parts 50
 - recycle 66
 - regulatory notices 60
- resolution
 - 2400 dpi 57
 - best 57
 - color 57
 - draft 57
 - normal 57
 - specifications 57
 - TrueType Text 57
- restart printing 12
- Resume button 57
- Resume light 57
- Revert to Default button 7
- S**
 - saturation 10
 - Save Settings button 7
 - scaling 6
 - Select panel 26
 - selecting a default printer 4
 - setting up printer iii
 - setup
 - problems 36–37
 - single envelope slot 3
 - size
 - media 58
 - User Defined Paper Size 58
 - software compatibility 57
 - software, *see printer software*
 - sort the order of print jobs 12
 - specifications 58
 - speed, printing 57
 - status, Print Cartridge Status light 1
 - stop printing 12
 - streaking ink 32
 - stuck paper, *see paper jams*
 - supplies 50
 - ordering 50
 - paper and other media 51
 - part names and numbers 50
- T**
 - tablet binding 23
 - technical support 46
 - transfers, printing 20
 - transparencies
 - ordering 51
 - printing 19
 - specifications 58



trays

- capacity **58**
- envelope slot **3, 15**
- IN tray **2, 58**
- OUT tray **58**
- OUT tray flap **3**
- photo **2**
- positions **2**
- use **2**

troubleshooting, *see problems*

TrueType Text resolution **57**

two-sided printing **23**

U

updates for software **47**

urgent print requests **12**

USB connection **4**

User's Guide, ordering **50**

Utility window **25, 26**

W

warranty

- extensions **49**

- statement **61**

web sites **iv, 34, 36, 40, 50, 52**

weight

- paper **58**

- printer **57**

- recommended media **58**

Environmental Statement

Hewlett-Packard continuously improves the design processes of HP DeskJet printers to minimize the negative impact on the office environment and on the communities where printers are manufactured, shipped, and used. Hewlett-Packard has also developed processes to minimize the negative impact of the disposal of the printer at the end of printing life.

Reduction and Elimination

Paper Use: The printer's automatic/manual two-sided printing capability reduces paper usage and the resulting demands on natural resources. This printer is suited for the use of recycled papers according to DIN 19 309.

Ozone: Ozone-depleting chemicals such as CFCs have been eliminated from Hewlett-Packard manufacturing processes.

Recycling

Design for recycling has been incorporated into this printer. The number of materials has been kept to a minimum while ensuring proper functionality and reliability. Dissimilar materials have been designed to separate easily. Fasteners and other connections are easy to locate, access, and remove using common tools. High priority parts have been designed to access quickly for efficient disassembly and repair. Plastic parts have been primarily designed in no more than two colors to enhance recycling options. A few small parts are colored specifically to highlight customer access points.

Printer Packaging: The packaging materials for this printer have been selected to provide maximum protection for the least cost possible, while attempting to minimize environmental impact and facilitate recycling. The rugged design of the HP DeskJet printer assists in minimizing both packaging materials and damage rates.

Plastic parts: All major plastics and plastic parts are marked according to international standards. All plastic parts used in the printer housing and chassis are technically recyclable and all use a single polymer.

Product Longevity: To ensure the longevity of your DeskJet Printer, HP provides the following:

- Extended Warranty - HP SupportPack provides coverage for the HP hardware and product and all HP supplied internal components. HP SupportPack must be purchased by the customer within 30 days of purchase. Contact the nearest HP dealer about this service.
- Spare Parts and Consumables are available for five years after production has stopped.
- Product Take-back - To return this product and ink cartridges to HP at the end of its useful life, call your local HP Sales or Service Office for instructions.

Energy Consumption

This printer was designed with energy conservation in mind. This printer averages 4 watts in stand-by mode. Not only does this save natural resources, but it also saves money without affecting the high performance of this printer. This product qualifies for the ENERGY STAR Program (U.S. and Japan). ENERGY STAR is a voluntary program established to encourage the development of energy-efficient office products. ENERGY STAR is a US registered service mark of the US EPA. As an ENERGY STAR partner, Hewlett-Packard Company has determined that this product meets ENERGY STAR Guidelines for energy efficiency.



Energy consumption in off-mode: When the printer is off, a minimal amount of energy is still being consumed. Energy consumption can be prevented by turning the printer power off, then disconnecting the end of the printer power cord from the electrical source.