

HP Photosmart M417/M517 Digital Camera with HP Instant Share



User's Manual

Legal and notice information

© Copyright 2005 Hewlett-Packard Development Company, L.P.

The information contained herein is subject to change without notice. The only warranties for HP products and services are set forth in the express warranty statements accompanying such products and services. Nothing herein should be construed as constituting an additional warranty. HP shall not be liable for technical or editorial errors or omissions contained herein.

Windows® is a U.S. registered trademark of Microsoft Corporation.



SD Logo is a trademark of its proprietor.

Important recycling information for our customers in the European Union: To preserve the environment, this product must be recycled after its useful life as required by law. The symbol below indicates that this product may not be disposed in the general trash. Please return the product for proper recovery/disposal to the authorized collection location nearest to you. For more information regarding return and recycling of HP products generally, please visit:

www.hp.com/hpinfo/globalcitizenship/environment/recycle/index.html



For future reference, please enter the following information:

Model Number (on the front of the camera) _____

Serial Number (10-digit number on the bottom of the camera) _____

Date the camera was purchased _____

Printed in China

Contents

1	Getting Started	9
	Setup	10
	1 Attach the Wrist Strap	10
	2 Install the Batteries	11
	3 Turn on the Camera	12
	4 Choose the Language.	12
	5 Set the Region	13
	6 Set the Date and Time	13
	7 Install and Format a Memory Card (Optional).	15
	8 Install the Software.	17
	Windows®	17
	Macintosh.	18
	User's Manual on the CD	18
	Camera Parts	19
	Top of the Camera	19
	Back and Right Side of the Camera	20
	Front, Left Side, and Bottom of the Camera.	24
	Camera States	25
	Camera Menus	26
	Camera Status Screen	28
	Restoring Previous Settings.	29
	Viewing the On-Camera Demo	29
2	Taking Pictures and Recording Video Clips.	31
	Taking Still Pictures	31
	Recording Audio with Still Pictures.	32
	Recording Video Clips.	33
	Using Live View	34

Focusing the Camera	35
Obtaining Optimum Focus	35
Using Focus Lock	37
Using Zoom	38
Using Optical Zoom.	38
Using Digital Zoom	38
Setting the Flash	40
Using the Shooting Modes	42
Using the Self-Timer Settings	44
Using the Burst Setting	46
Using the Capture Menu	47
Help for the Menu Options	48
Image Quality	48
Adaptive Lighting.	51
Color	53
Date & Time Imprint	53
EV Compensation	55
White Balance	56
ISO Speed	57
3 Reviewing Images and Video Clips	59
Using Playback.	59
Total Images Summary Screen.	62
Viewing Thumbnails.	63
Magnifying Images	64
Using the Playback Menu.	65
Delete	67
Remove Red Eyes.	68
Rotate	69
Record Audio	69
4 Using HP Instant Share.	71
Using the HP Instant Share Menu	72
Setting Up Online Destinations in the Camera	74
Sending Images to Destinations.	76

5	Transferring and Printing Images	79
	Transferring Images to a Computer	79
	Printing Images Directly from the Camera	81
6	Using the Setup Menu	85
	Display Brightness	86
	Camera Sounds	87
	Live View at Power On	88
	Date & Time	89
	USB Configuration	90
	TV Configuration	91
	Language	92
	Move Images to Card	93
7	Troubleshooting and Support	95
	Resetting the Camera	96
	HP Image Zone Software	96
	System Requirements (Windows Only)	97
	HP Image Zone Express (Windows Only)	98
	Using Your Camera without Installing the HP Image Zone Software	99
	Transferring Images to a Computer without HP Image Zone Software	100
	Using a Memory Card Reader	100
	Configuring the Camera as a Disk Drive	103
	Problems and Solutions	105
	Error Messages on the Camera	120
	Error Messages on the Computer	134
	Getting Assistance	136
	HP Accessibility Website	136
	HP Photosmart Website	136
	Support Process	137

Phone Support in the United States and Canada	139
Phone Support in Europe, the Middle East, and Africa	139
Other Phone Support Worldwide.	142
A Managing Batteries	145
Top Points About Batteries	145
Extending Battery Life.	146
Safety Precautions for Using Batteries.	147
Performance per Battery Type.	148
Number of Shots per Battery Type.	149
Power Indicators	150
Recharging NiMH Batteries	151
Safety Precautions for Recharging NiMH Batteries	153
Sleep Time-out for Power Conservation	154
B Purchasing Camera Accessories	155
C Caring for Your Camera	159
Basic Camera Care.	159
Cleaning the Camera	160
Cleaning the Camera Lens	161
Cleaning the Camera Body and Image Display.	161
D Specifications	163
Memory Capacity	169
M417 Memory Capacity	169
M517 Memory Capacity	170

1 Getting Started

Congratulations on your purchase of the HP Photosmart M417/M517 digital camera, and welcome to the world of digital photography!

This manual explains camera features you can use to ensure great results while enjoying the photographic experience. Some of these features are:

- **HP adaptive lighting technology**—Automatically bring out details lost in shadows. See page 51.
- **In-camera red-eye removal**—Identify and remove red eyes from the subjects in still images that were taken with a flash. See page 68.
- **7 shooting modes**—Choose a preset shooting mode for best exposure for common picture scenes. See page 42.
- **HP Instant Share**—Easily select still images in your camera to be automatically sent to a variety of destinations such as e-mail addresses, web pages, or a printer the next time your camera is connected to a computer. Your recipients can then view your images without the burden of large file attachments. See page 71.
- **Direct print**—Print directly from your camera to any PictBridge-certified printer without having to connect to your computer. See page 81.
- **On-camera Help**—Use on-screen instructions for help on using camera features when you don't have the manual with you.

To further enhance your experience, you can purchase an HP Photosmart M-series dock. The camera dock allows you to easily transfer images to a computer, send images to a printer, view images on a television, and recharge batteries in your camera. The dock also provides a convenient home for your camera.



Setup

To locate a part on your camera (such as a button or a light) while following the instructions in this section, see **Camera Parts** on page 19.

1. Attach the Wrist Strap

Attach the wrist strap to the wrist strap mount on the side of the camera as shown.

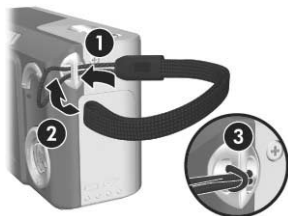

2. Install the Batteries

1. Open the Battery/Memory card door on the side of the camera by sliding the door toward the bottom of the camera.
2. Insert the batteries as indicated inside the door.
3. Close the Battery/Memory card door by pushing the door down and sliding the door toward the top of the camera until the door latches.



For the performance of Alkaline, Lithium, and NiMH batteries when used with this camera, see **Performance per Battery Type** on page 148. For hints on optimizing battery performance, see **Appendix A, Managing Batteries**, starting on page 145.

TIP: You can also use an optional HP AC power adapter to power the camera. If you use rechargeable NiMH batteries, you can recharge the batteries in the camera using the optional HP AC power adapter or the optional HP Photosmart M-series dock, or recharge the batteries separately in the optional HP Photosmart Quick Recharger. For more information, see **Appendix B, Purchasing Camera Accessories**, starting on page 155.



3. Turn on the Camera

Turn the camera on by sliding the ► ON/OFF switch to the right and then releasing it.

The lens extends and the Power light to the left of the ► ON/OFF switch turns on solid green. The HP logo also displays on the Image Display as the camera powers up.

4. Choose the Language

The first time you turn the camera on, you are prompted to choose a language.

1. Scroll to the language that you want by using the ▲▼ ◀▶ buttons on the **Controller** .
2. Press the  button to select the highlighted language.



TIP: If you need to change the language later, you can do this with the **Language** setting in the **Setup** menu. See **Language** on page 92.

5. Set the Region

After choosing a language, you are prompted to choose the continent where you live. The **Language** and **Region** settings determine the defaults for the date format and the format of the video signal for displaying camera images on a television (see **TV Configuration** on page 91).

1. Scroll to the region that you want by using the ▲▼ buttons on the **Controller** .
2. Press the  button to select the highlighted region.



6. Set the Date and Time

The camera has a clock that records the date and time at which you take each picture. This information is recorded in the image properties, which you can see when viewing the image on your computer. You can also choose to have the date and time imprinted on the image (see **Date & Time Imprint** on page 53).

1. The first item highlighted is the date and time format. If you want to change the format, use the ▲▼ buttons. If the date and time format is correct, press the ► button to move to the Date.
2. Adjust the highlighted selection using the ▲▼ buttons.
3. Press the ◀▶ buttons to move to the other selections.
4. Repeat steps 2 and 3 until the date and time are set correctly.



5. Press the $\frac{\text{Menu}}{\text{OK}}$ button when you have entered the proper values for the date and time. A confirmation screen appears, asking if the correct date and time have been set. If the date and time are correct, press the $\frac{\text{Menu}}{\text{OK}}$ button to select **Yes**.

If the date and time are incorrect, press the ▼ button to highlight **No**, and then press the $\frac{\text{Menu}}{\text{OK}}$ button. The **Date & Time** screen appears again. Repeat steps 1 through 6 to set the correct date and time.

TIP: If you need to change the date and time settings later, you can do this with the **Date & Time** setting in the **Setup Menu**. See **Date & Time** on page 89.

7. Install and Format a Memory Card (Optional)

Your camera contains internal memory that allows you to store images and video clips. However, you can use a memory card (purchased separately) instead to store images and video clips. For more information about supported memory cards, see **Storage** on page 166.

1. Turn off the camera and open the Battery/Memory card door on the side of the camera.
2. Insert the memory card in the small slot above the batteries, with the notched side of the card going in first, as shown. Make sure the memory card snaps into place.
3. Close the Battery/Memory card door and turn on the camera.



To help prevent corrupted cards and images, you should format memory cards before you use them for the first time, as follows:

1. Press the $\frac{\text{Menu}}{\text{OK}}$ button, then use the \blacktriangleright button to move to the **Playback Menu** \blacktriangleright .
2. Press the \blacktriangledown button to highlight **Delete**, and then press the $\frac{\text{Menu}}{\text{OK}}$ button to display the **Delete** sub-menu.
3. Use the \blacktriangledown button to highlight **Format Card**, and then press the $\frac{\text{Menu}}{\text{OK}}$ button to display the **Format Card** confirmation screen.

4. Press the ▼ button to highlight **Yes**, and then press the  button to format the card.

Formatting Card... appears in the Image Display while the camera is formatting the memory card. When the camera has completed the formatting, the Total Images Summary screen is displayed (see **Total Images Summary Screen** on page 62).

To remove the memory card from the camera, first turn the camera off. Then open the Battery/Memory card door, press down on the top edge of the memory card, and it will spring outward from the slot.

NOTE: When you install a memory card in the camera, all new images and video clips will be stored on the card. To use internal memory and view images stored there, remove the memory card. You can also transfer images from the internal memory to the memory card (see **Move Images to Card** on page 93).

8. Install the Software

The HP Image Zone software allows you to transfer images from the camera, and then view, edit, print, or e-mail them. It also allows you to configure the **HP Instant Share Menu** on the camera.

NOTE: If you do not install the HP Image Zone software, you can still use the camera, but certain features will be affected. For details, see **Using Your Camera without Installing the HP Image Zone Software** on page 99.

NOTE: If you have trouble installing or using the HP Image Zone software, see the HP Customer Support website: www.hp.com/support for more information.

Windows®

To install the HP Image Zone software successfully, your computer must have a minimum of 64MB of RAM, Windows 2000, XP, 98, 98 SE, or Me, and Internet Explorer 5.5 Service Pack 2 or higher. Internet Explorer 6 is recommended. If your computer meets these requirements, the installation process automatically installs either the full version of the HP Image Zone Software, or the HP Image Zone Express version. HP Image Zone Express lacks some features contained in the full version. For details, see **HP Image Zone Software** on page 96.

1. Close all programs and temporarily disable any virus protection software running on your computer.
2. Insert the HP Image Zone software CD into the CD drive of your computer and follow the on-screen instructions. If the installation screen does not appear, click **Start**, click **Run**, type **D:\Setup.exe**, where **D** is the letter of your CD drive, then click **OK**.

3. When the HP Image Zone software has finished installing, re-enable the virus protection software you disabled in step 1.

Macintosh

The full version of the HP Image Zone software is always installed on Macintosh computers.

1. Close all programs and temporarily disable any virus protection software running on your computer.
2. Insert the HP Image Zone software CD into the CD drive of your computer.
3. Double-click the CD icon on the computer desktop.
4. Double-click the installer icon, and then follow the on-screen instructions to install the software.
5. When the HP Image Zone software has finished installing, re-enable the virus protection software you disabled in step 1.

User's Manual on the CD

Copies of this User's Manual in different languages are located on the HP Image Zone software CD. To view the User's Manual:

1. Insert the HP Image Zone software CD into the CD drive of your computer.
2. **On Windows:** Click **View User's Manual** on the Main page of the CD installation screen.

On Macintosh: Look in the **readme** file in the **docs** folder of the HP Image Zone software CD to locate the User's Manual in your language.

Camera Parts

Refer to the pages in parentheses after the part names in the following tables for more information about those parts.

Top of the Camera







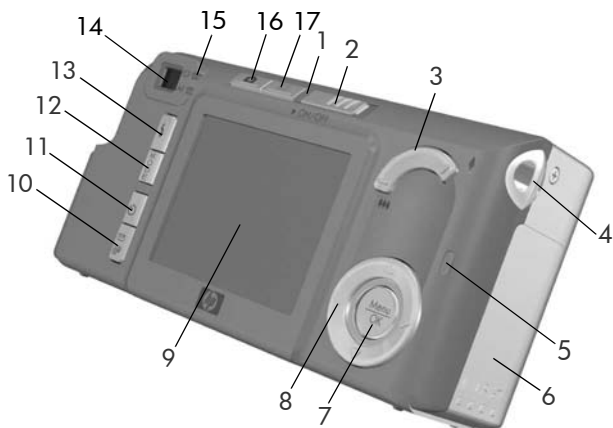









#	Name	Description
1	Shutter button (pages 31, 33)	<ul style="list-style-type: none">• Focuses and takes a picture.• Records audio clips.
2	 Video button (page 33)	Starts and stops recording a video clip.





Back and Right Side of the Camera



#	Name	Description
1	Power light	<ul style="list-style-type: none">• Solid—Camera is on.• Blinking rapidly—Camera is shutting down due to lack of battery power.• Blinking slowly—Camera is charging the batteries using the optional HP AC power adapter.• Off—Camera is off.
2	▶ ON/OFF switch (page 12)	Turns the camera power on and off.

#	Name	Description
3	Zoom lever (page 38)	<ul style="list-style-type: none"> •  Zoom Out—While taking still pictures, zooms out the lens to the wide angle position. •  Thumbnails—While in Playback, allows you to view still images and the first frames of video clips arranged in a matrix of nine thumbnail images per screen. •  Zoom In—While taking still pictures, zooms in the lens to the telephoto position. •  Magnify—While in Playback, allows you to magnify a still image.
4	Wrist strap mount (page 10)	Allows you to attach a wrist strap to the camera.
5	Memory light	<ul style="list-style-type: none"> • Blinking rapidly—Camera is writing to either the internal memory or an optional memory card that is installed. • Off—Camera is not writing to memory.
6	Battery/Memory card door (page 11)	Allows access to insert and remove the batteries and an optional memory card.
7	 button (pages 47, 65)	Allows you to display the Capture and Playback menus, select menu options, and confirm certain actions on the Image Display.
8	 Controller with   and   buttons	Allows you to scroll through menus and images on the Image Display.



#	Name	Description
9	Image Display (page 34)	Allows you to frame pictures and video clips using Live View and review them afterward in Playback , and to view all the menus.
10	 /  HP Instant Share/ Print button (page 71)	Turns the HP Instant Share Menu on and off on the Image Display.
11	 Timer/Burst button (pages 44, 46)	Allows you to select between the Normal , Self-Timer , Self-Timer - 2 Shots , and Burst settings.
12	MODE button (page 42)	Allows you to select between different shooting modes for taking still pictures.
13	 Flash button (page 40)	Allows you to select between the different flash settings.
14	Viewfinder (page 31)	Allows you to frame the subject of your pictures or video clips.

#	Name	Description
15	Viewfinder lights	<ul style="list-style-type: none"> •  Solid red—Video is recording. • AF solid green—When you press the Shutter button halfway down, this light turns on solid when the camera is ready to take a picture (auto exposure and auto focus are locked, and the flash is ready). Or, when you press the Shutter button all the way down to take a picture, this light turns on solid to indicate that auto exposure and auto focus were successful. • AF blinking green—When you press the Shutter button halfway down or all the way down, either a focus warning occurred, the flash is still charging, or the camera is still processing a picture. • Both  and AF blinking—An error has occurred that prevents the camera from taking the picture.
16	 Live View button (page 34)	<ul style="list-style-type: none"> • Turns Live View on and off on the Image Display. • If the Image Display is off but the camera is on, allows you to turn the Image Display on. • If a menu is open in the Image Display, allows you to close the menu.
17	 Playback button (page 59)	<ul style="list-style-type: none"> • Turns Playback on and off on the Image Display. • Allows you to access the on-camera demo (see page 29).

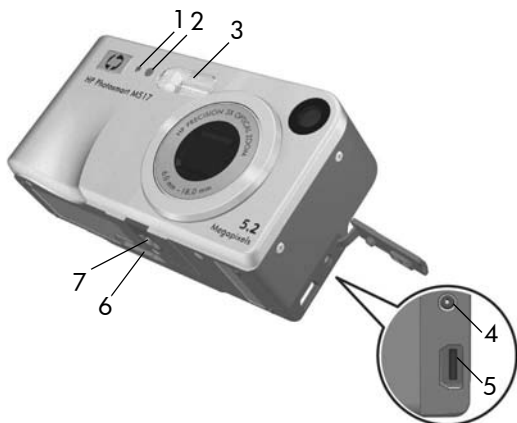
Front, Left Side, and Bottom of the Camera



#	Name	Description
1	Microphone (page 32)	Records audio clips that are attached to still images and the audio portion of video clips.
2	Self-Timer/Video light (page 44)	Blinks during the countdown before taking a picture or recording video when the camera is set to Self-Timer or Self-Timer - 2 shots . Also turns on solid when recording video.
3	Flash (page 40)	Provides additional light to improve picture-taking.

#	Name	Description
4	 Power adapter connector	Allows you to connect an optional HP AC power adapter to the camera to either operate the camera without batteries, or recharge NiMH rechargeable batteries in the camera.
5	 USB connector (pages 79, 81)	Allows you to connect a USB cable from the camera to a USB-enabled computer or any PictBridge-certified printer.
6	Camera dock connector (page 155)	Allows you to connect the camera to the optional Photosmart M-series dock.
7	Tripod mount	Allows you to mount the camera on a tripod.

Camera States

Your camera has two main states that allow you to complete certain tasks. Each of these states has an associated menu that you can use to adjust camera settings or perform tasks in that state. See the following section, **Camera Menus**.

- **Capture**—Allows you to take still pictures and record video clips. For information about using **Capture**, see **Chapter 2, Taking Pictures and Recording Video Clips**, starting on page 31.
- **Playback**—Allows you to review the still images and video clips that you capture. For information about using **Playback**, see **Chapter 3, Reviewing Images and Video Clips**, starting on page 59.



Camera Menus

Your camera has five menus that, when accessed, appear in the Image Display on the back of the camera.

To access the menus, press the $\frac{\text{Menu}}{\text{OK}}$ button, then use the $\blacktriangleleft\blacktriangleright$ buttons to move to the menu you want. To select a menu option, use the $\blacktriangle\blacktriangledown$ buttons to highlight it, then press the $\frac{\text{Menu}}{\text{OK}}$ button to display the menu option's sub-menu and modify the settings.

TIP: In the **Capture** and **Setup Menus**, you can modify settings by highlighting the menu option and using the $\blacktriangleleft\blacktriangleright$ buttons to change the setting.

To exit a menu, you can do one of the following:

- Press the **Live View**  or **Playback**  button.
- Use the $\blacktriangle\blacktriangledown$ buttons to scroll to the menu tabs at the top of the screen. You can then select another menu by using the $\blacktriangleleft\blacktriangleright$ buttons, or you can press the $\frac{\text{Menu}}{\text{OK}}$ button to exit the menus and return to **Live View** or **Playback**.
- Use the $\blacktriangle\blacktriangledown$ buttons to scroll to the \leftarrow **EXIT** menu option and press the $\frac{\text{Menu}}{\text{OK}}$ button.

The **Capture Menu**  lets you specify settings for taking a picture such as image quality, special lighting and exposure, ISO speed, color settings, and imprinting the date and time on the images. For information about using this menu, see **Using the Capture Menu** on page 47.





The **Playback Menu**  lets you remove red eye from images taken with a flash, rotate images, add audio, and delete images from the internal memory or optional memory card. For information about using this menu, see **Using the Playback Menu** on page 65.



The **HP Instant Share Menu**  lets you select images to be sent to printers, e-mail addresses, and other online services. For information about using this menu, see **Using the HP Instant Share Menu** on page 72.



NOTE: To use the **HP Instant Share Menu**  to send images to destinations other than printers (such as e-mail addresses or online services), you must first set up the menu. See **Setting Up Online Destinations in the Camera** on page 74.



The **Setup Menu**  lets you modify configuration settings such as display brightness, date and time, language, and TV configuration, among others. It also allows you to move images from the internal memory to an optional memory card. For information about using this menu, see **Chapter 6, Using the Setup Menu**, starting on page 85.

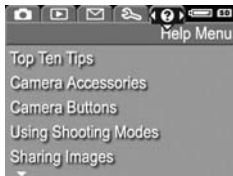

The **Help Menu**  provides helpful information and tips on topics such as battery life, camera buttons, recording audio, reviewing images you have taken, and other useful topics. Use this menu when you do not have your User's Manual with you.



Camera Status Screen

A status screen appears for a few seconds in the Image Display any time you press the **Flash** , **MODE**, or **Timer/Burst**  buttons either when you are in **Playback**  or when a menu is displayed.





The top of the screen shows the name of the current setting selected. Beneath that, icons for the current flash, shooting mode, and timer/burst settings are shown, with the icon for the button that was just pressed highlighted. The bottom of the screen shows whether a memory card is installed (indicated by the  icon), low battery indicator (see **Power Indicators** on page 150), the number of pictures remaining, and the **Image Quality** setting (indicated in the example by the **5MP**).

NOTE: The status screen does not display any time **Live View** is on, except when the **Capture Menu** is also displayed. Instead, the icon for the new flash, shooting mode, or timer/burst setting displays in the **Live View** screen.

Restoring Previous Settings

The flash, shooting mode, and timer/burst settings, as well as some of the **Capture Menu** settings that you set, reset to their default values after you turn the camera off. However, you can restore your settings from the last time the camera was on by holding down the  button while turning the camera on. The icons for the restored settings are then displayed in the **Live View** screen.

Viewing the On-Camera Demo

This camera has a slideshow of its major features. You can display the slideshow at any time by holding down the **Playback**  button for approximately three seconds. The Image Display will go black for a moment before the slideshow starts. To exit the slideshow at any time, press the  button.

2 Taking Pictures and Recording Video Clips

Taking Still Pictures

You can take a picture almost any time the camera is on, regardless of what is being shown on the Image Display. For example, if a menu is currently displayed when you press the **Shutter** button, the menu will be canceled, and the camera will take a picture. To take a still picture:

1. Frame the subject for your picture in the viewfinder.
2. Hold the camera steady and press the **Shutter** button on the top of the camera halfway down. The camera measures and locks the focus and exposure. The focus brackets in the Image Display turn solid green when focus is locked (see **Obtaining Optimum Focus** on page 35 for details).
3. Press the **Shutter** button all the way down to take the picture. The camera beeps after taking the picture.



TIP: Hold the camera with both hands to reduce camera shake when pressing the **Shutter** button.

After a picture is taken, the image appears for several seconds on the Image Display. This is called **Instant Review**. You can delete the image during **Instant Review** by pressing the ◀ button, then selecting **This Image** in the **Delete** sub-menu.

You can also use **Playback** to review the pictures you have taken. See **Using Playback** on page 59.

Recording Audio with Still Pictures

There are two ways to attach an audio clip to a still picture:

- Record the audio while you are taking the picture, as explained in this section. You will not be able to use this method when using the **Self-Timer** or **Burst** settings.
- Add an audio clip to the picture later, or replace the audio clip that was captured when the picture was taken. For details on how to do this, see **Record Audio** on page 69.

To record audio while taking a picture:





1. After you have pressed the **Shutter** button to take a picture, continue holding it down to record the audio clip. A microphone icon  and audio counter appear on the Image Display during recording.
2. To stop recording audio, release the **Shutter** button; otherwise, the audio will continue recording until the camera runs out of memory. The camera will discard any audio clip that is less than 2 seconds long.

To delete or record a new audio clip, use the **Record Audio** option in the **Playback** menu. See **Record Audio** on page 69.

To hear audio clips that have been attached to your still images, transfer them to your computer and use the HP Image Zone software. If you have an optional HP Photosmart M-series dock, you can also review the audio clips by connecting the camera to a TV via the camera dock. To do this, see the dock User's Manual for instructions.

Recording Video Clips

NOTE: Zoom is not available while recording video clips.



1. Frame the subject for your video in the viewfinder.
2. To start recording video, press and release the **Video**  button on the top of the camera. If **Live View** is on, a video , **REC**, a video counter, and a message instructing how to end the video appear on the Image Display. The  viewfinder light on the back of the camera and the Self-Timer/Video light on the front of the camera turn on solid red.
3. To stop recording video, press and release the **Video**  button again; otherwise, the video will continue recording until the camera runs out of memory.



After recording has stopped, the last frame of the video clip appears for several seconds on the Image Display. This is called **Instant Review**. You can delete the video clip during **Instant Review** by pressing the  button, then selecting **This Image** in the **Delete** sub-menu.

TIP: A video clip includes audio. To hear the audio portion of your video clips, transfer them to your computer and use the HP Image Zone software. If you have an optional HP Photosmart M-series dock, you can also review the audio portion of your video clips by connecting the camera to a TV via the camera dock. To do this, see the dock User's Manual for instructions.



Using Live View

The Image Display allows you to frame pictures and video clips using **Live View**. To activate **Live View** from the menus or when the Image Display is off, press the **Live View**  button. To turn off **Live View**, press the **Live View**  button again.

TIP: Using **Live View** increases the rate of battery drain. To conserve battery power, use the viewfinder instead.

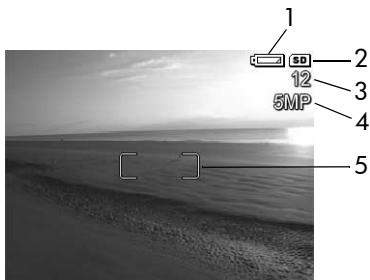
The following table describes the information that is displayed in the **Live View** screen of the Image Display when the camera settings are at their default values and an optional memory card is installed in the camera. If you change other camera settings, icons for those settings will also be displayed in the **Live View** screen.



#	Icon	Description
1		Power indicator, such as this low battery level indicator (see Power Indicators on page 150)
2		Indicates that a memory card is installed in the camera

#	Icon	Description
3	12	Remaining pictures count (actual number depends on the current Image Quality setting and how much space remains in memory)
4	5MP	Image Quality setting (default is 5MP)
5		Focus brackets (see the next section, Focusing the Camera)

Focusing the Camera

The focus brackets in the **Live View** screen show the focus region for the still picture you are taking or the video clip you are recording. When you press the **Shutter** button halfway down to take a still picture, the camera automatically measures and locks the focus and exposure in the focus region. The focus brackets in the **Live View** screen turn green when the camera has found and locked the focus and exposure. This is called auto focus.

Obtaining Optimum Focus



When you have set the camera to any of the shooting modes other than **Macro**  (see **Using the Shooting Modes** on page 42), the camera will attempt to auto focus using the normal focus range of 50 cm (20 in) to infinity. However, when the camera cannot focus in these shooting modes, one of the following occurs:

- The **AF** viewfinder light will blink green and the focus brackets in **Live View** will turn red. If you press the **Shutter** button all the way down, the camera will still take the picture, but the picture may be out of focus.

To focus the picture, release the **Shutter** button, re-frame the subject for your picture, and then press the **Shutter** button halfway down again.

If the **AF** viewfinder light continues to blink green and the focus brackets continue to turn red after several tries, there may not be enough contrast or light in the focus region. Try using a technique called **Focus Lock** to focus on a higher-contrast or brighter object about the same distance away, and then, without releasing the **Shutter** button, point the camera at the subject you were originally trying to photograph (see **Using Focus Lock** on page 37). You can also simply turn on more light, if that is possible.

- The **AF** viewfinder light will blink green, the focus brackets will turn red, and the **Macro**  icon will blink in the **Live View** screen. In this case, the camera detects that the focus is closer than the normal range. The camera will still take the picture, but the picture may be out of focus. To focus the picture, either move farther away from the subject you are trying to photograph, or set the camera to the **Macro** shooting mode (see **Using the Shooting Modes** on page 42).

If the camera is set to the **Macro**  shooting mode and the camera cannot focus, the **Live View** screen displays a blinking **Macro**  icon, an error message, and the focus brackets turn red. Both viewfinder lights will also blink. In these cases, the camera will not take the picture.

If the subject for the picture is not within the **Macro** range (10 to 80 cm or 4 to 32 in), either move farther away from or closer to the subject, or set the camera to a shooting mode other than **Macro**  (see **Using the Shooting Modes** on page 42).

If there is not enough contrast or light in the focus region, try using a technique called **Focus Lock** to focus on a higher-contrast or brighter object about the same distance away, and then, without releasing the **Shutter** button, point the camera at the subject you were originally trying to photograph (see the next section, **Using Focus Lock**). You can also simply turn on more light, if that is possible.

Using Focus Lock

Focus Lock allows you to focus on a subject that is not in the center of the picture, or to capture action shots more quickly by pre-focusing in the area where the action will occur. You can also use **Focus Lock** to help achieve focus in low light or low contrast situations.

1. Frame the subject for your picture within the focus brackets.
2. Press the **Shutter** button halfway down to lock the focus and exposure.
3. Continue to hold the **Shutter** button halfway down while you re-frame or adjust your subject for proper positioning.
4. Press the **Shutter** button all the way down to take the picture.





Using Zoom

The more you zoom in on the subject of your picture, the more small movements of the camera are magnified. This is called camera shake. So, especially at full telephoto zoom (3x), you must hold the camera steady in order to take a picture that is not blurry. If an icon of a shaking hand  appears in the **Live View** screen, you should hold the camera steadier, such as closer to your body or against a steady object, or set the camera on a tripod or stable surface; otherwise, the picture will likely be blurry.

Using Optical Zoom

Optical zoom works like the zoom on a traditional film camera, where physical lens elements move inside the camera to make the subject of your picture appear closer.

Press **Zoom Out**  and **Zoom In**  on the **Zoom lever** to move the lens between wide angle (1x) and telephoto (3x) positions.

NOTE: Optical zoom is not available while recording video clips.



Using Digital Zoom

Unlike optical zoom, digital zoom uses no moving lens parts. The camera essentially crops the image to give an appearance of the subject of the picture being an additional 1.05x to 7x larger on the HP Photosmart M417, and 1.05x to 8x larger on the HP Photosmart M517.



1. Press **Zoom In**  on the **Zoom lever** to optically zoom in to the maximum level, then release the button.

2. Press **Zoom In**  again and continue to press it until you reach the desired size in the Image Display. A yellow frame surrounds the area of the image that will be captured, and the image enlarges in the yellow frame.



The resolution number on the right side of the screen also becomes smaller as you digitally zoom. For example, **4.3MP** appears in place of **5MP**, indicating that the image is being reduced to a size of 4.3 Megapixels.



3. When the image is at the desired size, press the **Shutter** button halfway down to lock focus and exposure, and then press it all the way down to take the picture.





To turn digital zoom off and return to optical zoom, press **Zoom Out**  on the **Zoom lever** until digital zooming stops. Release **Zoom Out** , and then press it again.

NOTE: Digital zoom is not available while recording video clips.

NOTE: Digital zoom reduces the resolution of an image, so your picture will tend to be more grainy than the same image taken with optical zoom. If you intend to e-mail an image or post it to a website, this loss of resolution will probably not be noticeable; but in situations where you need higher quality (such as for printing), limit the use of digital zoom. It is also recommended that you use a tripod to hold the camera steady when using digital zoom.

Setting the Flash

The **Flash**  button allows you to cycle through the flash settings on the camera. To change the flash setting, press the **Flash**  button until the desired setting appears on the Image Display. The following table describes each of the flash settings on the camera.

Setting	Description
Auto Flash 	The camera measures the light level and uses the flash if necessary.
Red-Eye 	The camera measures the light level and uses the flash with red-eye reduction if necessary (see Red Eye on page 41 for a description of red-eye reduction).
Flash On 	The camera always uses flash. If the light is behind your subject, you can use this setting to increase the light on the front of your subject. This is called fill-flash.
Flash Off 	The camera will not use flash, no matter the lighting conditions. Use this setting to capture poorly lit subjects that are beyond the flash range. Exposure times may be increased when using this setting, so you should use a tripod to avoid blurry pictures from camera shake.
Night 	The camera uses the flash with red-eye reduction if necessary to illuminate objects in the foreground (see Red Eye on page 41 for a description of red-eye reduction). The camera then continues to expose as if the flash had not been used, to gather the light in the background. Exposure time may be increased when using this setting; therefore, you should use a tripod or set the camera on a stable surface to avoid camera shake.

If the flash setting is anything other than the default **Auto Flash** setting, the icon for the setting (in the previous table) will appear in the **Live View** screen. The new setting remains in effect until it is changed again or until the camera is turned off. The flash setting resets to the default **Auto Flash** setting when you turn the camera off.

NOTE: The flash is not available with the **Burst** setting, **Fast Shot** shooting mode, nor while recording video clips.

TIP: To restore the flash setting to what it was when you last turned the camera off, hold down the $\frac{\text{Menu}}{\text{OK}}$ button as you turn the camera back on.

Red Eye



The red-eye phenomenon is caused by light from the flash reflecting off the subjects' eyes, which sometimes makes a human's eyes appear red or an animal's eyes appear green or white in the captured image. When you use a flash setting with red-eye reduction, the camera flashes quickly multiple times to minimize the subject's pupils, thus reducing the effect of the red-eye phenomenon, before the camera uses the main flash. It will take longer to take a picture using red-eye reduction, because the shutter is delayed for the additional flashes. Therefore, make sure your subjects wait for the additional flashes.





TIP: You can also remove red eyes in pictures you have already taken. See **Remove Red Eyes** on page 68.

Using the Shooting Modes

Shooting modes are pre-defined camera settings that are optimized for taking still pictures of certain scene types to give you better results. In each shooting mode, the camera selects the best settings, such as the ISO speed, F-number (aperture), and shutter speed, optimizing them for the particular scene or situation.

To change the shooting mode, press the **MODE** button on the back of the camera until the desired shooting mode appears on the Image Display. The following table describes each of the shooting mode settings on the camera.

Setting	Description
Auto Mode	Use Auto Mode when you need to take a good shot quickly, and do not have time to select a special shooting mode on the camera. Auto Mode works well for most shots in normal situations. The camera automatically selects the best F-number (aperture) and shutter speed for the scene.
Macro 	Use Macro mode to take close-up pictures of subjects less than 80 cm (32 in) away. In this mode, auto focus has a distance range of 10 to 80 cm (4 to 32 in), and the camera will not take a picture if it cannot find focus (see Focusing the Camera on page 35). It is recommended that you not use zoom while in the Macro  shooting mode.
Fast Shot 	Use Fast Shot mode in bright light conditions when the subject is moderate to long distances away. The camera uses a fixed focus instead of auto focus, allowing you to take pictures very quickly.



Setting	Description
Action 	Use Action mode to capture sporting events, moving cars, or any scene where you want to stop the action. The camera uses fast shutter speeds and higher ISO speeds to stop motion.
Portrait 	Use Portrait mode for pictures that have one or more people as their primary subject. The camera combines a smaller F-number to blur the background, with lower sharpness for a more natural effect.
Landscape 	Use Landscape mode to capture scenes with deep perspective, such as mountains or city skylines, when you want the foreground and the background to be in focus. The camera combines a higher F-number for better depth of field with higher sharpness for a more vivid effect.
Beach & Snow 	Use Beach & Snow mode to capture bright outdoor scenes and balance out harsh lighting.

If the shooting mode setting is anything other than the default **Auto Mode** setting, the icon for the setting will appear in the **Live View** screen. The new setting remains in effect until it is changed again or until the camera is turned off. The shooting mode setting resets to the default **Auto Mode** setting when you turn the camera off.

NOTE: The shooting mode does not apply when you are recording video clips.

TIP: To restore the shooting mode setting to what it was when you last turned the camera off, hold down the Menu button as you turn the camera back on. OK

Using the Self-Timer Settings

1. Secure the camera to a tripod or set it on a stable surface.
2. Press the **Timer/Burst**  button until **Self-Timer**  or **Self-Timer - 2 Shots**  appears in the Image Display. The icon for the self-timer setting will appear in the **Live View** screen.
3. Frame the subject in either the viewfinder or in **Live View**. (See **Using Live View** on page 34.)
4. The next steps depend on whether you are capturing stills or video clips.

For Still Pictures:

- a. Press the **Shutter** button halfway down. The camera measures and then locks the focus and exposure. The camera will hold these settings until it takes the picture.
- b. Press the **Shutter** button all the way down. If **Live View** is on, a 10-second countdown appears on the Image Display. The Self-Timer/Video light on the front of the camera then blinks for 10 seconds before the camera takes the picture. If you set the camera to **Self-Timer - 2 Shots**, after the first picture is taken, the Self-Timer/Video light blinks for a few more seconds until the second picture is taken.

TIP: If you immediately press the **Shutter** button all the way down, the camera will lock the focus and exposure just before the end of the 10-second countdown. This is useful when one or more subjects will be entering the picture during the 10-second countdown period.

TIP: You cannot record audio with a still picture when using the self-timer settings, but you can add an audio clip later (see **Record Audio** on page 69).

For Video Clips:

To start recording video, press the **Video**  button and then release it. If **Live View** is on, a 10-second countdown appears on the Image Display. The Self-Timer/Video light on the front of the camera then blinks for 10 seconds before the camera starts recording the video.

To stop recording the video clip, press the **Video**  button again; otherwise, the video will continue recording until the camera runs out of memory.

NOTE: With either the **Self-Timer** or the **Self-Timer - 2 Shots** setting, only one video clip is recorded after the 10-second countdown.



The self-timer setting resets to the default **Normal** setting after the picture is taken or the video clip is recorded.

TIP: If you are taking pictures in low light, you can use the self-timer setting to help you take good pictures. Set the camera on something sturdy, such as a tripod, and frame your picture. Then, carefully press the **Shutter** button all the way down and remove your hand from the camera. The camera will take the picture 10 seconds later rather than when you press the shutter button. This will eliminate any possibility of you shaking the camera when the picture is taken.

TIP: To restore the self-timer setting to what it was when you last turned the camera off, hold down the  button as you turn the camera back on.

Using the Burst Setting

Burst allows you to take up to 4 still pictures as quickly as possible. The camera then continues taking burst pictures at a slower rate until you release the **Shutter** button or the camera runs out of memory.

1. Press the **Timer/Burst**  button until **Burst**  appears in the Image Display.
2. Frame the subject in either the viewfinder or in **Live View**. (See **Using Live View** on page 34.)
3. Press the **Shutter** button all the way down and hold it. The camera takes 4 pictures as quickly as possible and continues taking burst pictures until you release the **Shutter** button or the camera runs out of memory.

The Image Display remains off during the burst capture. After the burst pictures have been taken, each image appears one at a time on the Image Display.

When **Burst** is selected, the **Burst**  icon will appear in the **Live View** screen. The burst setting remains in effect until it is changed again or until the camera is turned off. The camera resets to the default **Normal** burst setting when you turn the camera off.

NOTE: The burst setting is not available while recording video clips. You also cannot record audio when using the burst setting, but you can add an audio clip later (see **Record Audio** on page 69). Also, the flash is not available while using the burst setting.

TIP: To restore the timer/burst setting to what it was when you last turned the camera off, hold down the  button as you turn the camera back on.

Using the Capture Menu

The **Capture Menu** allows you to adjust various camera settings that affect the characteristics of the images and video clips you capture with your camera.

1. To display the **Capture Menu**, press the **Live View**  button, and then press the $\frac{\text{Menu}}{\text{OK}}$ button. If **Live View** is already on, simply press the $\frac{\text{Menu}}{\text{OK}}$ button.



2. Use the \blacktriangle \blacktriangledown buttons to scroll through the **Capture Menu** options.
3. Either press the $\frac{\text{Menu}}{\text{OK}}$ button to select a highlighted option and display its sub-menu, or use the \blacktriangleleft \blacktriangleright buttons to change the setting for the highlighted option without going to its sub-menu.
4. Within a sub-menu, use the \blacktriangle \blacktriangledown buttons and then the $\frac{\text{Menu}}{\text{OK}}$ button to change the setting for the **Capture Menu** option.
5. To exit the **Capture Menu**, press the **Live View**  button. For other ways to exit a menu, see **Camera Menus** on page 26.

TIP: Some **Capture Menu** settings that you change from their default values reset to their default settings when you turn the camera off. To restore **Capture Menu** settings to what they were when you last turned the camera off, hold down the $\frac{\text{Menu}}{\text{OK}}$ button as you turn the camera back on.

Help for the Menu Options

Help... is the last option in each of the sub-menus within the **Capture Menu**. The **Help...** option provides information about that **Capture Menu** option and its settings. For example, if you press the $\frac{\text{Menu}}{\text{OK}}$ button when **Help...** is highlighted in the **White Balance** sub-menu, the **White Balance Help** screen is displayed, as shown.

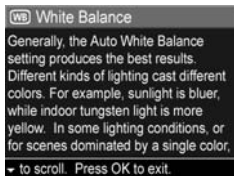

Use the \blacktriangle \blacktriangledown buttons to scroll through the Help screens. To exit the Help and return to the particular sub-menu within the **Capture Menu**, press the $\frac{\text{Menu}}{\text{OK}}$ button.

Image Quality

This setting allows you to set the resolution and JPEG compression of the still images you capture with your camera. The **Image Quality** sub-menu has five settings.

1. In the **Capture Menu** (page 47), select **Image Quality**.
2. In the **Image Quality** sub-menu, use the \blacktriangle \blacktriangledown buttons to highlight a setting.
3. Press the $\frac{\text{Menu}}{\text{OK}}$ button to save the setting and return to the **Capture Menu**.



The following table explains the **Image Quality** settings in more detail:

Setting	Description
5MP Best	Images will be full resolution and have the lowest compression. This setting produces very high quality images, with greater color accuracy, but uses the most memory. This setting is recommended if you plan to print images to a size larger than 297 by 420 mm (11 by 17 in).
5MP	Images will be full resolution and have medium compression. This setting produces high quality images, but uses less memory than the 5MP Best setting above. This is the default setting and is recommended if you plan to print images up to a size of 297 by 420 mm (11 by 17 in).
3MP	Images will be approximately 3MP resolution and have medium compression. This is a memory-efficient setting, recommended if you plan to print images up to a size of 210 by 297 mm (8.5 by 11 in).
1MP	Images will be approximately 1MP resolution and have medium compression. This is a memory-efficient setting that produces lower-quality images. This setting is good for images that you want to send via e-mail or post to the Internet.
VGA	Images will be 640 by 480 (lowest) resolution and have medium compression. This is the most memory-efficient setting, but produces lower-quality images. This setting is good for images that you want to send via e-mail or post to the Internet.

The **Image Quality** setting not only affects the quality of the images but, as a result, also the number of images that can be stored either in the internal memory in the camera or on an optional memory card. For example, the **5MP Best** setting results in the highest quality images, but consumes more storage space in memory than the next lower setting, **5MP**. Likewise, many more still images can be stored in memory at the **1MP** or **VGA** settings than at **5MP**; however, these settings will result in lower-quality images.

The **Pictures remaining** count at the bottom of the **Image Quality** sub-menu screen updates when you highlight each setting. See **Memory Capacity** on page 169 for more information about how the **Image Quality** setting affects the number of images that can be saved in the internal memory in the camera.

The **Image Quality** setting (in the previous table) will appear in the **Live View** screen. The new setting remains in effect until it is changed again, even when you turn the camera off.

NOTE: This setting does not apply when recording video clips.

NOTE: When you use digital zoom, the resolution reduces as you zoom in. See **Using Digital Zoom** on page 38.

Adaptive Lighting

This setting balances the relationship between bright and dark areas in a picture, preserving gentle contrasts but reducing harsh contrasts. Dark areas in the picture are lightened, while brighter areas are left alone. Here is an example of how **Adaptive Lighting** can enhance an image:

Without **Adaptive Lighting**:



With **Adaptive Lighting**:



Adaptive Lighting is useful in situations like these:

- Outdoor scenes with a mixture of sun and shade
- Cloudy days when there is a lot of glare from the sky
- Indoor scenes that use flash photography (to soften or even out the effect of the flash)
- Backlit scenes where the subject is too far away for the regular flash to reach

You can use **Adaptive Lighting** with or without the flash, but it is not recommended as a replacement for the flash. Unlike the flash, **Adaptive Lighting** does not affect exposure settings, so brightened areas may appear noisy or grainy, and indoor or night images may be blurry if taken without a flash or a tripod.

1. In the **Capture Menu** (page 47), select **Adaptive Lighting**.
2. In the **Adaptive Lighting** sub-menu, use the ▲▼ buttons to highlight a setting.
3. Press the $\frac{\text{Menu}}{\text{OK}}$ button to save the setting and return to the **Capture Menu**.



The following table explains the settings in more detail:

Setting	Description
Off	The camera will process the image as normal. This is the default setting.
On 	The camera will gently brighten the dark regions of the image without changing brightly lit areas.

If the new setting is **On**, the corresponding icon will appear in the **Live View** screen.

The new setting remains in effect until it is changed again, even when you turn the camera off.

NOTE: This setting does not apply when recording video clips.

NOTE: When **Adaptive Lighting** is turned on, the camera will take longer to store an image in memory, since the image requires extra processing before storing it.

Color

This setting allows you to control the color in which your images will be captured. For example, when you set **Color** to **Sepia**, your images will be captured in brown colors to make them look aged or old-fashioned.

NOTE: After you have taken a picture using either the **Black & White** or **Sepia** setting, the image cannot be adjusted back to **Full Color** later.

1. In the **Capture Menu** (page 47), select **Color**.

2. In the **Color** sub-menu, use the ▲▼ buttons to highlight a setting. The new setting is applied to the **Live View** screen behind the menu, so you can see the effect each setting will have on the picture.



3. Press the $\frac{\text{Menu}}{\text{OK}}$ button to save the setting and return to the **Capture Menu**.

The new setting remains in effect until it is changed again or until the camera is turned off. The **Color** setting resets to the default **Full Color** setting when you turn the camera off.

Date & Time Imprint

This setting imprints either the date or the date and time of when the image was captured in the lower left-hand corner of the image. After you select either of the **Date & Time Imprint** settings, the date or date and time will be imprinted on all subsequent still images that are captured, not to previously captured images.



After you have taken a picture using either the **Date Only** or **Date & Time** setting, the date or date and time that is imprinted on the image cannot be removed later.

TIP: Verify that the date and time setting is correct before using this feature (see **Date & Time** on page 89).

1. In the **Capture Menu** (page 47), select **Date & Time Imprint**.
2. In the **Date & Time Imprint** sub-menu, use the ▲▼ buttons to highlight a setting.
3. Press the $\frac{\text{Menu}}{\text{OK}}$ button to save the setting and return to the **Capture Menu**.



The following table explains the settings in more detail:

Setting	Description
Off	The camera will not imprint a date or date and time on the image.
 Date Only	The camera will permanently imprint the date in the lower left-hand corner of the image.
 Date & Time	The camera will permanently imprint the date and time in the lower left-hand corner of the image.

If the new setting is anything other than the default **Off** setting, the icon for the setting (in the previous table) will appear in the **Live View** screen. The new setting remains in effect until it is changed again, even when you turn the camera off.

NOTE: This setting does not apply when recording video clips.

EV Compensation

In difficult lighting conditions, you can use **EV** (Exposure Value) **Compensation** to override the automatic exposure setting that the camera makes.

EV Compensation is useful in scenes that contain many light objects (like a white object against a light background) or many dark objects (like a black object against a dark background). Scenes containing many light objects or many dark objects could turn out gray without the use of **EV Compensation**. For a scene with many light objects, increase the EV Compensation to a positive number to produce a brighter result. For a scene with many dark objects, decrease the EV Compensation to darken the scene to be closer to black.

1. In the **Capture Menu** (page 47), select **EV Compensation**.
2. In the **EV Compensation** sub-menu, use the ◀▶ buttons to change the EV setting in 0.5 steps from -2.0 to +2.0. The new setting is applied to the **Live View** screen behind the menu, so you can see the effect each setting will have on the picture.
3. Press the $\frac{\text{Menu}}{\text{OK}}$ button to save the setting and return to the **Capture Menu**.



If the setting is anything other than the default setting of **0.0**, the number value will appear in the **Live View** screen next to the  icon. The new setting remains in effect until it is changed again or until the camera is turned off. The **EV Compensation** setting resets to the default **0.0** setting when you turn the camera off.

White Balance

Different kinds of lighting conditions cast different colors. For example, sunlight is more blue, while indoor tungsten light is more yellow. Scenes dominated by a single color may require an adjustment of the white balance setting to help the camera reproduce colors more accurately and ensure that whites appear white in the final image. You can also adjust the white balance to produce creative effects. For example, using the **Sun** setting can produce a warmer look to the image.



1. In the **Capture Menu** (page 47), select **White Balance**.



2. In the **White Balance** sub-menu, use the ▲▼ buttons to highlight a setting. The new setting is applied to the **Live View** screen behind the menu, so you can see the effect each setting will have on the picture.



3. Press the $\frac{\text{Menu}}{\text{OK}}$ button to save the setting and return to the **Capture Menu**.

The following table explains the settings in more detail:

Setting	Description
Auto	The camera automatically identifies and corrects for scene illuminance. This is the default setting.
Sun 	The camera balances color assuming the subject is outdoors under sunny or bright cloudy conditions.
Shade 	The camera balances color assuming the subject is outdoors in shade, in dark cloudy conditions, or at dusk.

Setting	Description
Tungsten 	The camera balances color based on incandescent or halogen lighting (typically found in homes).
Fluorescent 	The camera balances color based on fluorescent lighting.

If the setting is anything other than the default **Auto** setting, the icon for the setting (in the previous table) will appear in the **Live View** screen. The new setting remains in effect until it is changed again or until the camera is turned off. The **White Balance** setting resets to the default **Auto** setting when you turn the camera off.

ISO Speed

This setting adjusts the sensitivity of the camera to light. When **ISO Speed** is set to the default **Auto** setting, the camera selects the best ISO speed for the scene.

Lower ISO speeds will capture the best quality images with the least amount of grain (or noise), but result in slower shutter speeds. If taking a picture in low light conditions without a flash at **ISO 100**, you may want to use a tripod. In contrast, higher ISO numbers allow faster shutter speeds, and can be used when taking pictures in dark areas without a flash, or when taking pictures of fast moving objects. Higher ISO speeds produce pictures with more grain (or noise).

1. In the **Capture Menu** (page 47), select **ISO Speed**.
2. In the **ISO Speed** sub-menu, use the ▲▼ buttons to highlight a setting.
3. Press the $\frac{\text{Menu}}{\text{OK}}$ button to save the setting and return to the **Capture Menu**.





If the setting is anything other than the default **Auto** setting, the icon for the setting (as shown in the **ISO Speed** sub-menu) will appear in the **Live View** screen. The new setting remains in effect until it is changed again or until the camera is turned off. The **ISO Speed** setting resets to the default **Auto** setting when you turn the camera off.

NOTE: This setting does not apply when recording video clips, or when the shooting mode is set to **Action**, **Portrait**, **Landscape**, or **Fast Shot**.

3 Reviewing Images and Video Clips

You can use **Playback** to review the images and video clips stored in your camera. When reviewing images in **Playback**, you can use the **Zoom lever** to view thumbnails of images, or to magnify images so you can take a closer look at them on the camera. See **Viewing Thumbnails** on page 63 and **Magnifying Images** on page 64. In addition, the **Playback Menu** allows you to delete images or video clips, record audio to attach to still images, remove red eyes, and rotate images. See **Using the Playback Menu** on page 65.

Using Playback

1. There are two ways to activate **Playback**.
 - With the camera turned on, press the **Playback**  button.
 - With the camera turned off, hold down the **Playback**  button while also sliding the **▶ ON/OFF** switch to turn the camera on. This allows you to activate **Playback** without the camera lens extending.

The most recently taken or reviewed image or video clip appears on the Image Display.

2. Use the **◀▶** buttons to scroll through your images and video clips. Press and hold either of the **◀▶** buttons to scroll faster.







You only see the first frame of each video clip, which is indicated by the video  icon. Video clips play automatically after the first frame of the video clip has displayed for 2 seconds.

3. To turn off the Image Display after reviewing your images and video clips, press the **Playback**  button again.

NOTE: To hear audio clips that have been attached to your still images, transfer them to your computer and use the HP Image Zone software. If you have an optional HP Photosmart M-series dock, you can review the audio by connecting the camera to a TV via the camera dock. To do this, see the dock User's Manual for instructions.



During **Playback**, the Image Display indicates information about each image or video clip. The following table describes this information.



#	Icon	Description
1		Displays when battery reaches low power state (see Power Indicators on page 150).
2		Displays only when an optional memory card is installed in the camera.
3		Displays for the first few seconds when you enter Playback to indicate that you can scroll through the images or video clips using the ◀▶ buttons.
4	 3	Indicates this image has been selected to be sent to 3 destinations using HP Instant Share (see Using HP Instant Share on page 71).
5	 2	Indicates this image has been selected for printing 2 copies using HP Instant Share (see Using HP Instant Share on page 71).
6	18 of 43	Shows the number of this image or video clip out of the total number of images and video clips that are stored in memory.
7	0:29  or 	<ul style="list-style-type: none"> Shows the recorded length of this audio or video clip. Indicates this image has an audio clip attached. Indicates this is a video clip.

Total Images Summary Screen



When you press the ► button while viewing the last image, the Total Images Summary screen appears showing the number of pictures taken, and the number of pictures remaining. Counters indicating the total number of images selected for

HP Instant Share  and for printing  are shown in the upper left-hand corner of the screen. In addition, icons are shown in the upper right-hand corner of the screen for an optional memory card if installed (indicated by the ) and the power indicator (such as the low battery level indicator; see **Power Indicators** on page 150).











Viewing Thumbnails

Thumbnail view allows you to view the still images you have taken and the first frames of the video clips you have recorded, arranged in a matrix of nine thumbnail images and video clip frames per screen.

1. While in **Playback** (page 59), press **Thumbnails**  (same as **Zoom Out** ) on the **Zoom lever**. A **Thumbnail** view of up to nine images and video clip frames appears on the Image Display. A yellow border surrounds the current image or video clip frame.









2. Use the   buttons to scroll horizontally to the previous or next thumbnail.
3. Press the   buttons to scroll vertically to the thumbnail directly above or below the current thumbnail.
4. Press the  button to exit **Thumbnail** view and return to **Playback**. The current image or video clip (that was in the yellow border in **Thumbnail** view) is displayed in full view on the Image Display again.

At the bottom of each thumbnail, an **HP Instant Share**  icon signifies that the still image is selected for one or more **HP Instant Share** destinations, a printer  icon signifies that it is selected for printing, a video  icon signifies that this is a video clip, and an audio  icon signifies that an audio clip is attached to this still image.

Magnifying Images

This feature is for viewing purposes only; it does not permanently alter the image.



1. While in **Playback** (page 59), press **Magnify**  (same as **Zoom In**  on the **Zoom lever**). The currently displayed image is automatically magnified 2x. The center portion of the magnified image is displayed along with four arrows, which indicate that you can pan around the magnified image.
2. Use the  and  buttons to pan around the magnified image.
3. Use **Zoom In**  and **Zoom Out**  to increase or decrease the magnification.
4. Press the  button to exit **Magnify** view and return to **Playback**. The current image is displayed in full view on the Image Display again.



NOTE: This feature is only available for still images; video clips cannot be magnified.





Using the Playback Menu

The **Playback Menu** allows you to view and delete still images or video clips, undelete images, and format the camera's internal memory or optional memory card. Additionally, you can remove red eyes from the subjects in still images taken with a flash, manipulate still images by rotating them, and attach audio clips to still images.

1. To display the **Playback Menu**, press the $\frac{\text{Menu}}{\text{OK}}$ button while you are in **Playback**. If you are not currently in **Playback**, press the **Playback**  button first, then press the $\frac{\text{Menu}}{\text{OK}}$ button.
2. Use the \blacktriangle \blacktriangledown buttons to highlight the **Playback Menu** option that you want to use on the left side of the Image Display. The **Playback Menu** options are explained later in this section.
3. Move to the image or video clip you want to use by pressing the \blacktriangleleft \blacktriangleright buttons.
4. Select the highlighted **Playback Menu** option by pressing the $\frac{\text{Menu}}{\text{OK}}$ button. Follow the instructions on the screen to complete the selected task.
5. To exit the **Playback Menu** and return to **Playback**, press the **Live View**  button. For other ways to exit a menu, see **Camera Menus** on page 26.

The following table summarizes the **Playback Menu** options.



#	Icon	Description
1		Delete —Presents a sub-menu where you can delete the current image or video clip, delete all images and video clips, format the internal memory or an optional memory card, and undelete the last deleted image. (See Delete on page 67.)
2		Remove Red Eyes —Corrects the red effect which appears in the eyes of human subjects in still images taken with a flash. (See Remove Red Eyes on page 68.)
3		Rotate —Rotates the currently displayed still image 90 degrees in the selected direction. (See Rotate on page 69.)
4		Record Audio —Records an audio clip to attach to this still image. (See Record Audio on page 69.)
5		EXIT —Exits the Playback Menu .

Delete

In the **Playback Menu** (page 65), when you select **Delete**, the **Delete** sub-menu displays. Use the ▲▼ buttons to highlight an option, then press the $\frac{\text{Menu}}{\text{OK}}$ button to select it.

The **Delete** sub-menu provides the following options:



- **Cancel**—Returns you to the **Playback Menu** without deleting the currently displayed image or video clip.
- **This Image**—Deletes the currently displayed image or video clip.
- **All Images (in Memory/on Card)**—Deletes all of the images and video clips either in internal memory, or on an optional memory card that is installed in the camera.
- **Format (Memory/Card)**—Deletes all of the images, video clips, and files in internal memory or on an optional memory card, and then formats the internal memory or memory card.

To help prevent corrupted cards and images, use **Format Card** to format optional memory cards before you use them for the first time. Also use **Format Card** when you want to delete all of the images and video clips stored on a card.

- **Undelete Last**—Recovers the most recently deleted image or images, depending on whether **This Image** or **All Images (in Memory/on Card)** was selected from the **Delete** sub-menu. (This option is only displayed after a **Delete** operation has been performed.)

NOTE: With the **Undelete Last** option, you can recover only the most recent delete operation. When you proceed to another operation, for example, powering off the camera or taking another picture, the last delete operation you performed becomes permanent, and the camera can no longer recover the image or images you last deleted.

Remove Red Eyes

In the **Playback Menu** (page 65), when you select **Remove Red Eyes**, the camera immediately begins processing the current still image to remove red eyes from the subjects in the image. The red-eye removal process takes a few seconds. After processing is complete, the corrected image displays with green boxes around corrected areas, along with the **Remove Red Eyes** sub-menu, which lists three options:

- **Save Changes**—Saves the red eye changes (overwriting the original image) and returns to the **Playback Menu**.
- **View Changes**—Displays a magnified view of the image which has green boxes around the portions that were corrected for red eyes. You can zoom in and pan around the image in this view. To return to the **Remove Red Eyes** sub-menu, press the Menu
OK button.
- **Cancel**—Returns to the **Playback Menu** without saving the red eye changes.

NOTE: This menu option is only available for still images that were taken with a flash. **Remove Red Eyes** is not available for video clips.

Rotate

In the **Playback Menu** (page 65), when you select **Rotate**, the camera displays a sub-menu that allows you to rotate the image in 90-degree increments.

1. In the **Playback Menu**, select **Rotate**.
2. Use the ◀▶ buttons to rotate the image clockwise or counter-clockwise. The image rotates in the Image Display.
3. After you have rotated the image to the desired orientation, press the $\frac{\text{Menu}}{\text{OK}}$ button to exit the **Rotate** sub-menu and save the new image.

NOTE: This menu option is not available for video clips.

Record Audio

To record an audio clip for a still image that does not already have an audio clip attached to it:

1. In the **Playback Menu** (page 65), select **Record Audio**. Audio recording starts immediately after you select this menu option. A microphone  icon and an elapsed time counter are displayed during recording.
2. To stop recording, press the $\frac{\text{Menu}}{\text{OK}}$ button; otherwise the audio continues to record until the camera runs out of memory. When recording stops, the display returns to the **Playback Menu**.

If the currently displayed image already has an audio clip attached to it, the **Record Audio** sub-menu is displayed when you select **Record Audio**. This sub-menu lists several options:

- **Keep Current Clip**—Retains the current audio clip and returns to the **Playback Menu**.

- **Record New Clip**—Begins to record audio, replacing the previous audio clip.
- **Delete Clip**—Deletes the current audio clip and returns to the **Playback Menu**.

TIP: To hear audio clips that have been attached to your still images, transfer them to your computer and use the HP Image Zone software. If you have an optional HP Photosmart M-series dock, you can review the audio clips by connecting the camera to a TV via the camera dock. To do this, see the dock User's Manual for instructions.

NOTE: This menu option is not available for video clips.

4 Using HP Instant Share

This camera has an exciting feature called **HP Instant Share**. With it, you can easily select still images in your camera to be automatically sent to a variety of destinations or to a printer the next time you connect the camera to your computer or printer. You can also customize the **HP Instant Share Menu** to include e-mail addresses (including group distribution lists), online albums, or other online services that you specify. Once you have taken pictures with your camera, using **HP Instant Share** is simple:







1. Set up destinations on your camera (see page 74).
2. Select images in your camera to send to online destinations (see page 76).

NOTE: You must have the full version of the HP Image Zone software on your computer to use **HP Instant Share** features. If your computer uses the Windows operating system, see **System Requirements (Windows Only)** on page 97 to determine if the full version was installed. The full version of the HP Image Zone software is always installed on Macintosh computers.

NOTE: Available online services vary by region. Visit www.hp.com/go/instantshare to see **HP Instant Share** in action.





Using the HP Instant Share Menu

The default **HP Instant Share Menu** lets you select images for printing automatically the next time you connect your camera to your computer or printer. You can add destinations such as e-mail addresses (including group distribution lists), online albums, or other online services to the **HP Instant Share Menu** through the **HP Instant Share Setup...**  menu option (see **Setting Up Online Destinations in the Camera** on page 74).

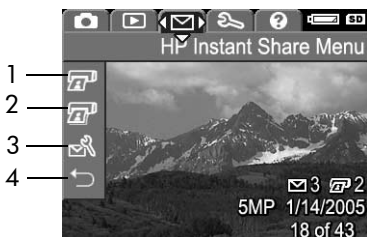
1. To display the **HP Instant Share Menu**, press the **HP Instant Share/Print**  /  button on the back of the camera. The most recently taken or viewed image appears on the Image Display, with the **HP Instant Share Menu** overlaid on top.
2. Use the   buttons to scroll through the **HP Instant Share Menu**  options.
3. Press the  button to select a highlighted option.
4. To exit the **HP Instant Share Menu**, press the **Live View**  button. For other ways to exit a menu, see **Camera Menus** on page 26.

The following table describes each of the default **HP Instant Share Menu** options.



#	Icon	Description
1		Print 1 copy of the currently displayed image when connected to a computer or printer. (See Sending Images to Destinations on page 76).
2		Print 2 copies of the currently displayed image.
3		HP Instant Share Setup... allows you to add e-mail and other HP Instant Share destinations to the HP Instant Share Menu . See Setting Up Online Destinations in the Camera on page 74.
4		EXIT allows you to exit the HP Instant Share Menu .





TIP: If you select images to print using **HP Instant Share** and then take them to a photo printing service for printing, let the printing service know that there is a standard DPOF file that specifies which, and how many, images you want printed.

Setting Up Online Destinations in the Camera

You can set up a maximum of 32 **HP Instant Share** destinations (such as individual e-mail addresses or group distribution lists) in the **HP Instant Share Menu**.

NOTE: You will need an Internet connection to complete this procedure.

NOTE: If you have a memory card in the camera, make sure the memory card is not locked and has some free space on it.

1. Make sure that the full version of the HP Image Zone software is installed on your computer (see pages 17 and 96).
2. Turn on the camera and press the **HP Instant Share/Print**  button.
3. Use the  button to highlight **HP Instant Share Setup...** , and press the  button. A message will appear in the Image Display asking you to connect the camera to your computer.
4. Without turning off the camera, connect it to your computer using the USB cable that came with your camera. Connect the larger end of the cable to your computer, and the smaller end to the USB connector on the side of the camera.



















Another way to connect the camera to the computer is with the optional HP Photosmart M-series dock—simply put the camera in the dock and press the **Save/Print**  button on the dock.

5. The next step is slightly different on a Windows and Macintosh computer:
 - **Windows:** Connecting the camera to the computer activates the **HP Instant Share Setup** program. If some other dialog box appears in addition, close that dialog box by clicking **Cancel**. In the **HP Instant Share Setup** program, click **Start**, then simply follow the directions on the screen to set up destinations on the computer and save them to your camera.
 - **Macintosh:** Connecting the camera to the computer activates the **HP Instant Share Setup Assistant**. Click **Continue**, then simply follow the directions on the screen to set up destinations on the computer and save them to your camera.

Sending Images to Destinations

You can send one or more still images to any number of **HP Instant Share** destinations. You cannot send video clips.

1. Turn on the camera, and then press the **HP Instant Share/Print**  /  button to display the **HP Instant Share Menu** .
2. Use the   buttons to highlight the first destination to which you want to send one or more images.
3. Use the   buttons to scroll to a still image that you want to send to the selected destination.
4. Press the  button and a  appears over that destination in the **HP Instant Share Menu**. To deselect the destination, press the  button again.
5. Select any other destinations for the current image by using the   buttons to highlight a destination and then press the  button to select it.
6. Scroll to other images by using the   buttons, and select destinations for those images in the same manner.
7. When you are finished selecting destinations, exit the **HP Instant Share Menu** by pressing the **Live View**  button. For other ways to exit a menu, see **Camera Menus** on page 26.

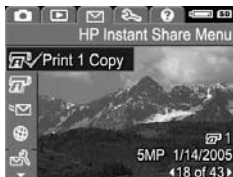

8. Connect the camera to your computer as explained in **Transferring Images to a Computer** on page 79. The images will be sent automatically to their respective **HP Instant Share** destinations.
- Images that were selected to be sent to e-mail destinations are not e-mailed as attachments. Rather, the images are uploaded to a secure HP website, and a message is sent to each e-mail address. The message contains thumbnail images, as well as a link to the web page where the recipient can do things like reply to you, print the images, save images to their computer, forward images, and more. This makes it easy for people who use different e-mail programs to be able to see your images without the difficulty of dealing with e-mail attachments.
 - Images that were selected to be sent to **Print** destinations will be printed automatically from the computer.

NOTE: If you connect the camera directly to a printer, as explained in **Printing Images Directly from the Camera** on page 81, any images that were selected for printing will print automatically.

5 Transferring and Printing Images

Transferring Images to a Computer

TIP: You can also perform this task using either a memory card reader (see **Using a Memory Card Reader** on page 100) or the optional HP Photosmart M-series dock (see the dock User's Manual).

1. Confirm the following:
 - Either the HP Image Zone software or HP Image Zone Express is installed on your computer (see **Install the Software** on page 17). To transfer images to a computer that does not have the HP Image Zone software installed on it, see **Using Your Camera without Installing the HP Image Zone Software** on page 99.
 - If images on the camera are selected for printing or selected for **HP Instant Share** destinations, make sure the computer is connected to a printer and/or the Internet.

2. Your camera came with a special USB cable for connecting the camera to a computer. Connect the larger end of that USB cable to the computer.
3. Open the door on the side of the camera and connect the smaller end of the USB cable to the USB connector on the camera.
4. Turn on the camera.



- **On Windows:** The HP Image Transfer software provides the download functionality. In the **Transfer Images from Camera/Card** screen, click **Start Transfer**. The images are transferred to the computer, and then, if there are any still images that were previously selected for HP Instant Share destinations (page 76), those actions are started. When the **Image Action Summary** screen appears on the computer, you can disconnect the camera from the computer.
- **On Macintosh:** Image Capture or iPhoto provides the download functionality. The **Actions are ready to process** screen appears, allowing you to transfer images to the computer. When the download is complete, you can disconnect the camera from the computer.

Printing Images Directly from the Camera

You can connect the camera directly to any PictBridge-certified printer to print images. To determine if your printer is PictBridge-certified, look for the PictBridge logo on your printer.



1. Check that the printer is turned on. There should be no blinking lights on the printer or error messages displayed about the printer. Load paper into the printer, if needed.
2. Connect your camera to the printer.

- a. Make sure the camera's **USB Configuration** setting is set to **Digital Camera** (see **USB Configuration** on page 90).

- b. Using the USB cable that came with your camera, connect the larger, flat end of the USB cable to the corresponding connector on the PictBridge-certified printer.



TIP: The PictBridge connector is usually located on the front of the printer.

3. Open the rubber door on the side of the camera and connect the small end of the USB cable to the USB connector on the camera.

4. When the camera is connected to the printer, a **Print Setup** menu displays on the camera. If you already selected images to print using the camera **HP Instant Share Menu**, the number of images selected is shown.



Otherwise, **Images: ALL** is displayed.

There is a print preview in the lower right-hand corner of the **Print Setup** screen showing the page layout that will be used for printing images. This print preview updates as you change the settings for the **Print Size** and **Paper Size**.

If **default** is displayed for the **Print Size** or **Paper Size**, then no print preview is shown. The printer will automatically determine the page layout that will be used for printing images.

5. To change the settings in the **Print Setup** menu, use the ▲▼ buttons on the camera to select a menu option, then use the ◀▶ buttons on the camera to change the setting.
6. When the settings are correct, press the $\frac{\text{Menu}}{\text{OK}}$ button on the camera to begin printing.

After connecting the camera to the printer, you can print selected images (see page 76).

NOTE: Video clips cannot be printed directly from the camera. If your printer has a memory card slot and can print video clips, you can insert the memory card directly in the printer's memory card slot and print the video clip. See your printer's manual for more information.

NOTE: If you connect the camera to a non-HP printer and encounter problems with printing, contact your printer manufacturer. HP does not provide customer support for non-HP printers.

TIP: In addition to the method described in this section, you can print images directly from the camera using one of the following methods:

- If you have an optional memory card that has images stored on it that you want to print, and your printer has a memory card slot, remove the optional memory card from the camera and insert it into the printer's memory card slot. See your printer's manual for specific instructions.
- If you have an optional HP Photosmart M-series dock, you can connect the camera to the printer using the dock. See the dock User's Manual for instructions.

6 Using the Setup Menu

The **Setup Menu** allows you to adjust a number of camera settings, such as the camera sounds, date and time, and the configuration of the USB or TV connection.

1. To display the **Setup Menu**, first display any other menu (see **Camera Menus** on page 26) and then use the ◀▶ buttons to move to the menu tab for the **Setup Menu** 🔑.



2. Use the ▲▼ buttons to scroll through the **Setup Menu** options.
3. Either press the $\frac{\text{Menu}}{\text{OK}}$ button to select a highlighted option and display its sub-menu, or use the ◀▶ buttons to change the setting for the highlighted option without going to its sub-menu.
4. Within a sub-menu, use the ▲▼ buttons and then the $\frac{\text{Menu}}{\text{OK}}$ button to change the setting for the **Setup Menu** option.
5. To exit the **Setup Menu**, press the **Live View** 📷 button. For other ways to exit a menu, see **Camera Menus** on page 26.

Display Brightness

This setting allows you to adjust the brightness of the Image Display for the viewing conditions. You can use this setting to increase the brightness for harsh lighting environments, or reduce the brightness to extend battery life.

The default **Display Brightness** setting is **Medium**.

1. In the **Setup Menu** (page 85), select **Display Brightness**.

2. In the **Display Brightness** sub-menu, highlight the brightness level you prefer for the Image Display. The new setting is applied to the **Live View** screen behind the menu so you can see the effect the setting will have on the display brightness.



3. Press the $\frac{\text{Menu}}{\text{OK}}$ button to save the setting and return to the **Setup Menu**.

The new setting remains in effect until it is changed again, even when you turn the camera off.

Camera Sounds

Camera sounds are the sounds that the camera makes when you turn it on, press a button, or take a picture. Camera sounds are not the audio sounds recorded with images or video clips.

The default **Camera Sounds** setting is **On**.

1. In the **Setup Menu** (page 85), select **Camera Sounds**.
2. In the **Camera Sounds** sub-menu, highlight **Off** or **On**.
3. Press the $\frac{\text{Menu}}{\text{OK}}$ button to save the setting and return to the **Setup Menu**.

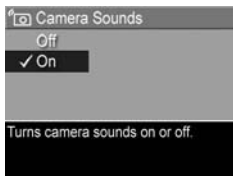

The new setting remains in effect until it is changed again, even when you turn the camera off.

Live View at Power On

This setting allows you to have the camera automatically display **Live View** every time you turn the camera on, or to have the Image Display turned off every time you turn the camera on.

The default **Live View at Power On** setting is **Live View On**.

TIP: Setting **Live View at Power On** to **Live View Off** can save battery power.

1. In the **Setup Menu** (page 85), select **Live View Setup**.
2. In the **Live View at Power On** sub-menu, highlight **Live View On** or **Live View Off**.
3. Press the $\frac{\text{Menu}}{\text{OK}}$ button to save the setting and return to the **Setup Menu**.

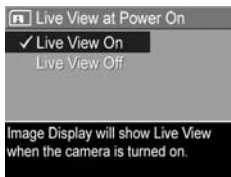

The new setting remains in effect until it is changed again, even when you turn the camera off.

Date & Time

This setting allows you to set the date/time format, as well as the current date and time for the camera. This is usually done when you first set up the camera; however, you may need to reset the date and time when you are traveling to different time zones, after the camera has been without power for an extended time, or if the date or time is incorrect.

The date/time format chosen will be used to display the date information in **Playback**. Also, the format chosen in this setting is what is used in the **Date & Time Imprint** feature (see **Date & Time Imprint** on page 53).

1. In the **Setup Menu** (page 85), select **Date & Time**.
2. In the **Date & Time** sub-menu, adjust the value of the highlighted selection by using the ▲▼ buttons.
3. Press the ◀▶ buttons to move to the other selections.
4. Repeat steps 2 and 3 until the correct date/time format, date, and time are set.
5. Press the $\frac{\text{Menu}}{\text{OK}}$ button to save the setting and return to the **Setup Menu**.



The date/time format setting remains in effect until it is changed again, even when you turn the camera off. The date and time settings also remain current as long as the camera batteries that are installed have a charge, or batteries are removed for less than 10 minutes, or the camera is connected to an optional HP AC power adapter.

USB Configuration

This setting determines how the camera is recognized when connected to a computer.

1. In the **Setup Menu** (page 85), select **USB**.
2. In the **USB Configuration** sub-menu, highlight one of these two choices:



- **Digital Camera**—Causes the computer to recognize the camera as a digital camera using the Picture Transfer Protocol (PTP) standard. This is the default setting on the camera.
 - **Disk Drive**—Causes the computer to recognize the camera as a disk drive using the Mass Storage Device Class (MSDC) standard. Use this setting to transfer images to a computer that does not have the HP Image Zone software installed on it (see **Transferring Images to a Computer without HP Image Zone Software** on page 100). You may be unable to use this setting with a Windows 98 computer that does not have the HP Image Zone software installed on it.
3. Press the $\frac{\text{Menu}}{\text{OK}}$ button to save the setting and return to the **Setup Menu**.

The new setting remains in effect until it is changed again, even when you turn the camera off.

TV Configuration

This setting allows you to set the format of the video signal for displaying camera images on a television (TV) that is connected to the camera with an optional HP Photosmart M-series camera dock.

The default **TV Configuration** setting depends on the language and region that you selected when you turned on the camera for the first time.

1. In the **Setup Menu** (page 85), select **TV Configuration**.
2. In the **TV Configuration** sub-menu, highlight one of these two choices:

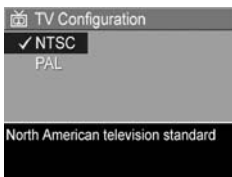

- **NTSC**—This format is used primarily in North America, parts of South America, Japan, Korea, and Taiwan.
- **PAL**—This format is used primarily in Europe, Uruguay, Paraguay, Argentina, and parts of Asia.

TIP: If the current setting does not work where you live, try the other setting.









3. Press the $\frac{\text{Menu}}{\text{OK}}$ button to save the setting and return to the **Setup Menu**.

The new setting remains in effect until it is changed again, even when you turn the camera off.

For more information on connecting the camera to a TV, see the dock User's Manual.

Language

This setting allows you to set the language used in the camera interface, such as the text in menus.

1. In the **Setup Menu** (page 85), select     .
2. In the **Language** sub-menu, use the   and   buttons to highlight the language you want to use.
3. Press the  button to save the setting and return to the **Setup Menu**.



The new setting remains in effect until it is changed again, even when you turn the camera off.

Move Images to Card

This option allows you to move images from the internal memory to an optional memory card that you have installed (see **Install and Format a Memory Card (Optional)** on page 15). This option is available in the **Setup Menu** if an optional memory card is installed in the camera and the internal memory contains at least one image.

1. In the **Setup Menu** (page 85), highlight **Move Images to Card...** and press the $\frac{\text{Menu}}{\text{OK}}$ button.
2. A confirmation screen appears in the Image Display.
 - If there is room on the memory card for all the images in internal memory, the confirmation screen asks if you want to move all the images.
 - If only some of the images will fit, the confirmation screen tells you how many images it can move and asks if you want to move them.
 - If no images can be moved to the memory card, the confirmation screen displays **CARD FULL**.

During the move, a progress bar is shown. All of the images that are successfully moved to the memory card are then deleted from the camera's internal memory. When the move is complete, you return to the **Setup Menu**.

7 Troubleshooting and Support

This chapter contains information on the following topics:

- Resetting the camera (page 96)
- HP Image Zone software, including system requirements and HP Image Zone Express (page 96)
- Using the camera without installing the HP Image Zone software (page 99)
- Possible problems, causes, and solutions (page 105)
- Error messages on the camera (page 120)
- Error messages on the computer (page 134)
- Getting assistance from HP, including web and phone support (page 136)

NOTE: For more information about solutions to problems mentioned here, as well as any other issues you might have with your camera or the HP Image Zone software, see the HP Customer Support website:

www.hp.com/support

Resetting the Camera

If your camera does not respond when you press any buttons, try resetting the camera as follows:

1. Turn off the camera.
2. If you have an optional memory card installed, remove it. (Although removing an optional memory card is not necessary for performing the reset, it eliminates the memory card as a possible cause of the problem.)
3. Remove all power (batteries and AC power) from the camera for at least 5 seconds.
4. Reinsert the batteries and close the Battery/Memory card door, and/or reconnect the HP AC power adapter to the camera.
5. After verifying that the camera works without an optional memory card, reinsert the card, if you have one.

When you reset the camera, the camera settings will return to the factory defaults. Any images stored in memory will be retained.

HP Image Zone Software

The HP Image Zone software provides several features that enhance your camera's capabilities. With the full version of the HP Image Zone software, you can use **HP Instant Share** to e-mail images to addresses you specify (including distribution lists), create online albums, or print images automatically when you connect your camera to your computer (see **Transferring Images to a Computer** on page 79).

If your computer uses the Windows operating system, the HP Image Zone software installation process (see **Install the Software** on page 17) automatically installs either the full version of the HP Image Zone software, the HP Image Zone Express version, or no HP Image Zone software. This depends on your computer's system configuration, as explained in the next section. HP Image Zone Express lacks some features contained in the full version of HP Image Zone. See **HP Image Zone Express (Windows Only)** on page 98.

System Requirements (Windows Only)

NOTE: The system requirements in this section apply only to computers using the Windows operating system.

Depending on your computer's system configuration, the installation process automatically installs either the full version of the HP Image Zone software, the HP Image Zone Express version, or no HP Image Zone software.

- If your computer has Windows 2000 or XP and 128MB of RAM or more, the installation process installs the full version of the HP Image Zone software.
- If your computer has Windows 2000 or XP and between 64MB and 128MB of RAM, the installation process installs the HP Image Zone Express software. See **HP Image Zone Express (Windows Only)** on page 98.
- If your computer has Windows 98, 98 SE, or ME and at least 64MB of RAM, the installation process installs the HP Image Zone Express software.

- If your computer has less than 64MB of RAM, you cannot install the HP Image Zone software. You can still use your camera, but you will not be able to use the **HP Instant Share** feature on the camera. See **Using Your Camera without Installing the HP Image Zone Software** on page 99.

HP Image Zone Express (Windows Only)

HP Image Zone Express allows you to transfer images from your camera to your computer. However, it lacks several features contained in the full version:

- You cannot use the HP Image Zone Express software with any of the **HP Instant Share** features on your camera. You cannot, for example, select images to print and then use the HP Image Zone Express software to print those images automatically. You can, however, select images to print in the **HP Instant Share Menu** on the camera and then print them directly to a printer (see **Printing Images Directly from the Camera** on page 81). You can also use **HP Instant Share** features available in the HP Image Zone Express software itself.
- You can transfer video clips to your computer using HP Image Zone Express. However, you must view them using another viewer software package.

Using Your Camera without Installing the HP Image Zone Software

If you do not, or cannot, install the HP Image Zone software (neither the full version nor HP Image Zone Express), you can still use your camera to take pictures and video clips.

However, some of the things you can do with the camera will be affected:

- The **HP Instant Share** feature depends on the HP Image Zone software. So, if the software is not installed on your computer, you will not be able to use the **HP Instant Share** feature on the camera.
- Images you have marked for printing using the **HP Instant Share Menu** on the camera will not print out automatically when the camera is connected to the computer. However, this feature will still work in the following scenarios:
 - When you connect the camera directly to a printer.
 - If your printer has a memory card slot in it, and if you are using a memory card in your camera, you can simply remove the memory card from the camera and insert it into the memory card slot in the printer.
- The process for transferring images and video clips from the camera to your computer will be different, since, normally, the HP Image Zone software handles this task. See the following section for details.

Transferring Images to a Computer without HP Image Zone Software

NOTE: If you have a Windows Me, 2000, or XP system, or a Mac OS X system, you do not need to read this section. Simply connect the camera to your computer with the USB cable, and the operating system will launch a program to help you transfer images.

If you do not, or cannot, install HP Image Zone on your computer, there are two ways to transfer images from your camera to the computer: using a memory card reader, or configuring the camera as a disk drive.

Using a Memory Card Reader

If you are using a memory card in your camera, you can simply remove it from the camera and put it into a memory card reader (purchased separately). The memory card reader acts just like a floppy disk drive or CD-ROM drive. In addition, some computers and HP Photosmart printers have memory card slots built into them, and you can use these memory card slots as you would use a regular memory card reader to save images to the computer.

Transferring Images to a Windows Computer Using a Memory Card Reader

1. Remove the memory card from your camera and insert it into the memory card reader (or the memory card slot in your computer or printer).
2. Right-click on the **My Computer** icon on your desktop, then select **Explore** from the menu.

3. A screen appears that shows a list of disk drives under **My Computer**. The memory card shows up as a removable disk drive. Click on the + sign just to the left of the removable disk.
4. Two directories (folders) appear under the removable disk. Click on the + sign next to the folder called **DCIM**, and a subdirectory should appear. When you click on the subdirectory under **DCIM**, the list of your images should appear on the right side of the Explorer screen.
5. Select all the images (in the **Edit** pull-down menu, click on **Select All**), then copy them (in the **Edit** menu, click on **Copy**).
6. Click on the **Local Disk** under **My Computer**. You are now working in your computer's hard disk drive.
7. Create a new folder under **Local Disk** (go to the **File** pull-down menu and click on **New**, then click on **Folder**. A folder called **New Folder** appears in the right side of the Explorer screen). While the text of this new folder is highlighted, you can type in a new name (for example, **Pictures**). To change the name of the folder later, you can simply right-click on the folder name, choose **Rename** from the menu that appears, then type in the new name.
8. Click on the new folder you just created, then go to the **Edit** pull-down menu and click on **Paste**.
9. The images you copied in step 5 are pasted into this new folder on your computer's hard drive. To verify that the images were successfully transferred from the memory card, click on the new folder. You should see the same list of files in that folder that you saw when you looked at them on the memory card (step 4).

10. When you have verified that the images were successfully transferred from the memory card to your computer, put the card back into your camera. To free up space on the card, you can either delete the images or format the card (under the **Delete** option in the **Playback Menu** in the camera).

NOTE: It is recommended that you format the card rather than delete the images, because it will help prevent corrupted images or cards.

Transferring Images to a Macintosh Computer Using a Memory Card Reader

1. Remove the memory card from your camera and insert it into the memory card reader (or the memory card slot in your computer or printer).
2. Depending on the configuration and/or version of the Mac operating system you are running, either an application called Image Capture or one called iPhoto will launch automatically and guide you through the process of transferring images from your camera to your computer.
 - If the Image Capture application is launched, click on either the **Download Some** or **Download All** button to transfer the images to your computer. By default, the images will be put in the **Pictures** or **Movies** folder (depending on which kind of file they are).
 - If the iPhoto application is launched, click on the **Import** button to transfer the images to your computer. The images will be stored in the iPhoto application. So, to access the images later, simply run iPhoto.

- If no application launches automatically, or if you want to copy the images manually, look on the desktop for a disk drive icon which represents the memory card, then copy the images from there to your local hard drive. For more information about how to copy files, visit Mac help, the help system included with your computer.

Configuring the Camera as a Disk Drive

This method sets up your camera to function as a disk drive when it is connected to your computer, so you can transfer images without using the HP Image Zone software.

NOTE: You may be unable to use this method with Windows 98 computers.

1. Set your camera to act as a **Disk Drive** (you only need to do this step once):
 - a. Turn on the camera, then press the $\frac{\text{Menu}}{\text{OK}}$ button to display the **Capture Menu**.
 - b. Use the \blacktriangleright button to navigate to the **Setup Menu** .
 - c. Use the \blacktriangledown button to highlight the **USB** menu option, and then press the $\frac{\text{Menu}}{\text{OK}}$ button.
 - d. Use the \blacktriangledown button to select **Disk Drive**, and then press the $\frac{\text{Menu}}{\text{OK}}$ button.
 - e. Use the \blacktriangledown button to highlight \leftarrow **EXIT**, and then press the $\frac{\text{Menu}}{\text{OK}}$ button.
2. When you have set your camera to **Disk Drive**, connect the camera to your computer using the USB cable.

3. At this point, the process for transferring images is the same as described in the section **Using a Memory Card Reader** on page 100. On Windows computers, the camera will appear as a removable disk in the Windows Explorer screen. On Macintosh computers, either the Image Capture or iPhoto application will launch automatically.
4. When you have finished transferring images from the camera to the computer, simply disconnect the camera from the computer. If your computer is running Windows 2000 or XP, you may get an "Unsafe Removal" warning upon disconnecting the camera. You can disregard this warning.

NOTE: On Macintosh computers, if either Image Capture or iPhoto does not launch automatically, look on the desktop for a disk drive icon with the label **HP_M417** or **HP_M517**. For more information about how to copy files, visit Mac help, the help system included with your computer.

Problems and Solutions

Problem	Possible Cause	Solution
The camera does not turn on.	The batteries either are functioning incorrectly, are over-discharged, are installed incorrectly, are missing, or are the wrong type.	<ul style="list-style-type: none">• The charge in the batteries could be low or completely drained. Try installing new or recharged batteries.• Ensure that the batteries are installed correctly (see page 11).• Do not use ordinary Alkaline batteries. For best results, use Energizer Lithium AA or rechargeable NiMH AA batteries.
	If you are using an optional HP AC power adapter, it is not connected to the camera, or is not plugged into a power outlet.	Ensure that the HP AC power adapter is connected to the camera and is plugged into a working electrical outlet.
	The optional HP AC power adapter is not functioning correctly.	Ensure that the HP AC power adapter is not damaged and is plugged into a working electrical outlet.
	The camera has stopped operating.	Reset the camera (see page 96).



Problem	Possible Cause	Solution
<p>The camera does not turn on (continued).</p>	<p>The optional memory card is not a supported card or is corrupted.</p>	<p>Ensure that the memory card is the proper type for your camera (see page 166). If the card is the proper type, remove the memory card and see if you can turn on the camera. If you can turn on the camera with the memory card removed, then the card is probably corrupted. Replace the memory card.</p>
<p>The Power light is on but my camera seems stuck and won't operate properly.</p>	<p>The camera may have experienced a transient problem.</p>	<p>Reset the camera (see page 96).</p>
<p>I have to replace or recharge the batteries frequently.</p>	<p>Extended Image Display use for Live View or video recording, excessive flash use, and excessive zooming increase the rate of battery drain.</p>	<p>See Extending Battery Life on page 146.</p>



Problem	Possible Cause	Solution
I have to replace or recharge the batteries frequently (continued).	The NiMH batteries you are using were recharged incorrectly, or have drained on their own because they have not been used lately.	NiMH batteries are not fully charged when new, and they discharge over time whether or not they are installed in a camera. Batteries that are new or have not been charged recently must be recharged to reach full capacity (see page 151).
	Battery chemistry type is inappropriate for the way the camera is being used.	See Performance per Battery Type on page 148.
The camera batteries will not charge.	Rechargeable batteries are not inserted.	Install NiMH batteries. Lithium and Alkaline batteries cannot be recharged.
	Batteries are already charged.	Battery charging will not start if the NiMH batteries were recently charged. Try charging them again after they have drained awhile.
	The wrong AC power adapter is being used.	Use only the HP AC power adapter approved for use with this camera (see page 155).

Problem	Possible Cause	Solution
The camera batteries will not charge (continued).	Battery voltage is too low for charging to start.	The camera will not attempt to charge NiMH batteries that may be damaged or over-discharged. Remove the batteries from the camera and charge them in the optional HP Photosmart Quick Recharger for M-series cameras (purchased separately), then try them in the camera again. If this does not work, it is likely that one or both of the batteries are defective. Purchase new NiMH batteries and try again.
	The batteries are damaged or defective.	NiMH batteries degrade over time and can fail. If the camera detects a problem with the batteries, it will not start charging or will stop charging prematurely. Purchase new batteries.
	Batteries are not inserted correctly.	Ensure that the batteries are inserted correctly (see page 11).



Problem	Possible Cause	Solution
The camera does not respond when I press a button.	The camera is turned off or has shut down.	Turn on the camera, or turn it off and then on again.
	The camera is connected to a computer.	Most of the camera buttons do not respond when the camera is connected to a computer. If they respond, it is only to turn on the Image Display if it is off, or, in some cases, turn off the Image Display if it is on.
	The camera is processing an image.	Wait until the Memory light turns off, indicating the camera has completed processing the previously-taken image.
	The batteries are drained.	Replace or recharge the batteries.
	The optional memory card is not a supported card or is corrupted.	Ensure that the memory card is the proper type for your camera (see page 166). If the card is the proper type, turn off the camera, remove the memory card, turn on the camera, and see if the camera responds when you press a button. If so, then the card is probably corrupted. Replace the memory card.
	The camera has stopped operating.	Reset the camera (see page 96).

Problem	Possible Cause	Solution
A long delay occurs between pressing the Shutter button and the camera taking a picture.	The camera needs time to lock focus and exposure.	Use Focus Lock (see page 37).
	The scene is dark and the camera is taking a long exposure.	<ul style="list-style-type: none"> • Use the flash. • If using flash is not possible, then use a tripod to keep the camera steady during the long exposure time.
	The camera is using a flash setting with red-eye reduction.	It will take longer to take a picture with red-eye reduction. The shutter is delayed because of the additional flashes. In turn, make sure your subjects wait for the additional flashes.
The camera does not take a picture when I press the Shutter button.	You did not press the Shutter button hard enough.	Press the Shutter button all the way down.
	The internal memory or the optional memory card that is installed is full.	Transfer images from the camera to your computer, then format the internal memory or the memory card (see pages 15 and 67). Or replace the card with a new one.
	The optional memory card that is installed is locked.	With the camera turned off, remove the memory card and switch the locking tab on the card to the unlocked position.

Problem	Possible Cause	Solution
The camera does not take a picture when I press the Shutter button (continued).	The flash is recharging.	Wait until the flash has recharged before taking another picture.
	The camera is set to the Macro  shooting mode and cannot take a picture until it finds focus.	<ul style="list-style-type: none"> • Re-focus the camera (try using Focus Lock; see page 37). • Make sure the subject of the picture is within the Macro (close-up) range (see page 42).
	The camera is still saving the last picture you took.	Wait a few seconds for the camera to finish processing the last image before taking another picture.
The Image Display is not working.	The charge in the batteries is too low, the batteries are completely drained, or the camera has stopped working.	<ul style="list-style-type: none"> • Replace or recharge the batteries. If the Image Display does not turn on, remove the batteries and connect to the HP AC power adapter to see if the Image Display turns on. • If the Image Display does not turn on, reset the camera (see page 96).
My image is blurry.	The light is low and the flash is set to Flash Off 	In dim light, the camera requires a longer exposure. Use a tripod to hold the camera steady, improve lighting conditions, or set the flash to Flash On  see page 40).

Problem	Possible Cause	Solution
My image is blurry (continued).	The subject was close-up and the camera should have been set to the Macro  shooting mode.	Set the camera to the Macro  shooting mode and try taking the picture again (see page 42).
	You moved the camera while you took the picture.	Hold the camera steady as you press the Shutter button, or use a tripod. Watch for the  icon in the Image Display (this means that it is almost impossible to hold the camera steady, and you should use a tripod).
	The camera focused on the wrong thing, or was unable to focus.	<ul style="list-style-type: none"> • Make sure the focus brackets turn green before taking the picture (see page 35). • Use Focus Lock (see page 37).
My image is too bright.	The flash provided too much light.	<ul style="list-style-type: none"> • Turn the flash off (see page 40). • Move back from the subject and use the zoom to get the same framing.

Problem	Possible Cause	Solution
<p>My image is too bright (continued).</p>	<p>A natural or artificial source other than the flash provided too much light.</p>	<ul style="list-style-type: none"> • Try taking the picture from a different angle. • Avoid pointing the camera directly toward a bright light or reflective surface on a sunny day. • Decrease the EV Compensation (see page 55).
	<p>The scene had many dark-colored objects, such as a black object against a dark background.</p>	<p>Decrease the EV Compensation (see page 55).</p>
	<p>The Display Brightness is set to High for outdoor display, making images appear too bright on the Image Display.</p>	<p>Change the Display Brightness in the Setup Menu for more accurate brightness on the Image Display (see page 86).</p>
	<p>You used EV Compensation when you should not have.</p>	<p>Set EV Compensation to 0.0 (see page 55).</p>

Problem	Possible Cause	Solution
My image is too dark.	There was not enough light.	<ul style="list-style-type: none"> • Wait for natural lighting conditions to improve. • Add indirect lighting. • Use the flash (see page 40). • Increase the EV Compensation (see page 55). • Use Adaptive Lighting (see page 51).
	The flash was on, but the subject was too far away.	Make sure your subject is within the flash working range (see page 164). If not, try using the Flash Off  setting (see page 40), which will require a longer exposure (use a tripod).
	A light is behind the subject.	<ul style="list-style-type: none"> • Use the Flash On  setting (see page 40) to brighten the subject. This is called fill-flash. • Increase the EV Compensation (see page 55). • Use Adaptive Lighting (see page 51).
	Your finger blocked the flash.	Be sure to move your fingers away from the flash when you take a picture.

Problem	Possible Cause	Solution
My image is too dark (continued).	The scene had many light-colored objects, such as a white object against a light background.	Increase the EV Compensation (see page 55).
My image is grainy.	The camera was too warm when the picture was taken. The camera may have been on for a long time or had been stored in a hot location.	This effect, which can happen on all digital cameras, is probably not noticeable in most images. The effect will diminish as the camera cools. For best image quality, avoid storing the camera in very hot locations. If the camera is warm after using it for a long time, consider turning off the Image Display to minimize heating. As with all electronic devices, avoid leaving the camera in very hot locations, such as the dashboard of a car in the sun.
	The ISO Speed setting was too high.	Use a lower ISO Speed setting (see page 57).
	The Image Quality setting was too low.	Use the highest image quality setting (5MP Best), which has the lowest image compression (see page 56).

Problem	Possible Cause	Solution
My image is grainy (continued).	There was not enough light.	<ul style="list-style-type: none"> • Wait for natural lighting conditions to improve. • Add indirect lighting. • Use the flash (see page 40).
Some menu options are grayed out in the Playback Menu.	The menu option is not available for the image.	This is normal behavior. For example, if a video clip is selected, you cannot rotate it. Or, if a still image taken without a flash is selected, you cannot remove red eye.
	The image was taken with another camera and cannot be edited on this camera.	Transfer the images from the camera to your computer (see page 79), then view or modify them using the HP Image Zone software.
Images are missing on my camera.	You installed a memory card after taking one or more images.	Move the images from the internal memory to the memory card (see page 93).
The wrong date and/or time is shown.	The date and/or time was set incorrectly or the time zone has changed.	Reset the date and time by using the Date & Time option in the Setup Menu (see page 89).
	The batteries were drained or were removed from the camera for too long.	Reset the date and time by using the Date & Time option in the Setup Menu (see page 89).

Problem	Possible Cause	Solution
The camera responds very sluggishly when trying to review images.	A slow optional memory card that is installed or too many images on the card can affect actions like scrolling through images, magnifying, deleting, etc.	See pages 166 and 169 for tips about memory cards.
	The camera may be processing an image.	Wait until the Memory light turns off, indicating that the camera has finished processing.
The camera gets warm (or even hot) to the touch.	You are using the optional HP AC power adapter to power the camera or to charge the batteries in the camera, or you have been using the camera for a prolonged period of time (15 minutes or longer).	This is normal. However, if anything seems out of the ordinary, turn off the camera, unplug the camera from the HP AC power adapter, and allow the camera to cool. Then examine the camera and the batteries for signs of possible damage.

Problem	Possible Cause	Solution
My camera stalls when establishing a connection to the computer.	The USB cable is not inserted far enough into the camera or computer.	Ensure that the USB cable is properly connected to the camera and computer. If that does not fix the problem, try connecting the USB cable to another USB port on the computer.
	The camera may have experienced a transient problem.	<ul style="list-style-type: none"> • Turn the camera off, then on again. If that does not fix the problem, reset the camera (see page 96). • If the problem persists, contact HP Support (see page 136).
I cannot transfer images from the camera to my computer.	The HP Image Zone software is not installed on the computer.	Either install the HP Image Zone software (see page 17), or see page 99.
	The computer is unable to understand the Picture Transfer Protocol (PTP) standard.	Set your camera to act as a Disk Drive (see page 103).

Problem	Possible Cause	Solution
I receive an error message when transferring images to my computer.	A power surge or electrostatic discharge may have interrupted the transfer.	Close the HP Image Zone Transfer software, disconnect the camera from the computer (or remove it from the camera dock), and reset the camera (see page 96). Then, restart the image transfer process (see page 79).
I am having a problem installing or using the HP Image Zone software.		Refer to the HP Customer Support website: www.hp.com/support

Error Messages on the Camera

Message	Possible Cause	Solution
BATTERIES DEPLETED.	Battery power is too low to continue operation.	Replace or recharge the batteries, or use an optional HP AC power adapter.
Batteries are non-rechargeable.	The batteries are not rechargeable.	Verify that there are rechargeable batteries in the camera, then retry charging the batteries a couple of times. If that fails, purchase new batteries and try again.
Batteries cannot be charged.	Either an error occurred during charging, an AC power disruption occurred during charging, the wrong AC power adapter is being used, batteries are over-discharged, batteries are defective, or no batteries are installed in the camera.	Retry charging the batteries a couple of times. If that fails, try charging the batteries in an external charger. If the batteries still will not charge, purchase new batteries and try again.









Message	Possible Cause	Solution
BATTERIES LOW.	Alkaline or Lithium batteries are installed, and they are now low.	Purchase new batteries and try again. For best battery life, use Lithium or rechargeable NiMH batteries.
UNSUPPORTED CARD	The optional memory card that is installed in the memory slot is not a supported memory card.	Ensure that the memory card is the proper type for your camera (see page 166).
CARD IS UNFORMATTED Press OK to format card	The optional memory card that is installed needs to be formatted.	Format the memory card by following the instructions on the Image Display (or remove the card from the camera if you do not want it to be formatted). Formatting the memory card will delete all files on the card.
CARD HAS WRONG FORMAT Press OK to format card	The optional memory card that is installed is formatted for a different device, such as an MP3 player.	Reformat the memory card by following the instructions on the Image Display (or remove the card from the camera if you do not want it to be reformatted). Formatting the memory card will delete all files on the card.

Message	Possible Cause	Solution
Unable to Format Try Again	The optional memory card that is installed is corrupted.	Replace the memory card, or if you have a memory card reader, try formatting the card on your computer. See your card reader documentation for instructions.
The card is locked. Please remove the card from your camera.	When trying to configure your HP Instant Share Menu , the optional memory card that is installed is locked.	With the camera turned off, switch the locking tab on the card to the unlocked position or simply remove the memory card from the camera and continue the HP Instant Share task.
CARD LOCKED	The optional memory card that is installed is locked.	With the camera turned off, remove the memory card from the camera and switch the locking tab on the card to the unlocked position.
MEMORY FULL or CARD FULL	There is insufficient room to save more images in internal memory or on the optional memory card that is installed.	Transfer images from the camera to your computer (see page 79), then delete all images in internal memory or on the memory card (see page 67). Or replace the card with a new one.

Message	Possible Cause	Solution
<p>Memory too full to record audio. or Card too full to record audio.</p>	<p>There is insufficient room to record more than 3 seconds of audio.</p>	<p>Transfer images, video clips, and/or audio files from the camera to your computer (see page 79), then delete all files in internal memory or on the memory card (see page 67). Or replace the card with a new one.</p>
<p>Memory full. Camera cannot save Share selections. or Card full. Camera cannot save Share selections.</p>	<p>Internal memory or the optional memory card is full, preventing HP Instant Share destinations from being saved to the camera, or preventing images from being marked for HP Instant Share.</p>	<p>Transfer images from the camera to your computer (see page 79), then delete all images in internal memory or on the memory card (see page 67). Then set up the HP Instant Share destinations again (see page 74).</p>
<p>Insufficient space on card to rotate image. or Insufficient space in memory to rotate image.</p>	<p>There is insufficient room in internal memory or on the optional memory card to save a rotated image.</p>	<ul style="list-style-type: none"> • Delete an image to free up memory space, then try rotating the image again. • Transfer images from the camera to your computer (see page 79), then rotate the image using the HP Image Zone software or another image editing package.

Message	Possible Cause	Solution
<p>Insufficient space on card to save updated image. or Insufficient space in memory to save updated image.</p>	<p>There is insufficient room in internal memory or on the optional memory card to save the image after red-eye removal.</p>	<p>Transfer images from the camera to your computer (see page 79), then delete all images in internal memory or on the memory card (see page 67). Then remove red eyes from the image using the HP Image Zone software.</p>
<p>The image is too large to magnify.</p>	<p>The image was taken with another camera.</p>	<p>Transfer the image to your computer (see page 79) and magnify it using the HP Image Zone software.</p>
<p>The image is too large to rotate.</p>	<p>The image was taken with another camera.</p>	<p>Transfer the image to your computer (see page 79) and rotate it using the HP Image Zone software.</p>
<p>Unknown image error. Unable to complete request.</p>	<p>The camera could not complete the image modification you requested.</p>	<ul style="list-style-type: none"> • Try modifying the image again. • If the same message displays, transfer the image to your computer (see page 79) and modify it using the HP Image Zone software.

Message	Possible Cause	Solution
CARD IS UNREADABLE	The camera is having trouble reading the optional memory card that is installed. The card may be corrupted or an unsupported type.	<ul style="list-style-type: none"> • Try turning the camera off and then back on. • Ensure that the memory card is the proper type for your camera (see page 166). If the memory card is the proper type, try reformatting the card using the Format option in the Delete sub-menu of the Playback Menu (see page 67). If it will not format, it is probably corrupted. Replace the memory card.
PROCESSING...	The camera is processing data, such as saving the last picture you took.	Wait a few seconds for the camera to finish processing before taking another picture or pressing another button.
CHARGING FLASH...	The camera is recharging the flash.	It takes longer to charge the flash when the battery is low. If you see this message a lot, you may need to replace or recharge the battery.

Message	Possible Cause	Solution
FOCUS TOO FAR	The focus distance is beyond where the camera can focus in the Macro  shooting mode.	<ul style="list-style-type: none"> • Select a shooting mode other than Macro  (see page 42). • Move closer to the subject, within the range of the Macro  shooting mode (see page 42).
FOCUS TOO CLOSE	The focus distance is closer than the camera can focus in the Macro  shooting mode.	Move farther away from the subject, within Macro range (see page 42).
Blinking 	The focus distance is closer than the camera can focus without being in the Macro  shooting mode.	Set the camera to Macro  shooting mode or move farther away.
UNABLE TO FOCUS and blinking 	The camera cannot find focus in the Macro  shooting mode, possibly due to low contrast.	<ul style="list-style-type: none"> • Use Focus Lock (see page 37). Point at a part of the scene that is brighter or has a high-contrast edge. • Make sure the subject is within Macro range (see page 42).

Message	Possible Cause	Solution
NOT ENOUGH LIGHT FOR FAST SHOT	The light is low and the image is likely to be noisy due to the small aperture setting used in Fast Shot mode.	Add light to the scene. (Flash is set to Flash Off in Fast Shot mode.)
 (camera shake warning)	The light is low and the image is likely to be blurry due to the long exposure required.	Use the flash (see page 40), set the camera on a stable surface, or use a tripod.
ERROR SAVING IMAGE or ERROR SAVING VIDEO	The optional memory card that is installed was half-locked or was removed before the camera finished writing to the card.	<ul style="list-style-type: none"> • Always wait until the Memory light stops blinking before removing the memory card from the camera. • With the camera turned off, remove the memory card and check to see if the locking tab on the edge of the card is fully in the unlocked position.

Message	Possible Cause	Solution
<p>Cannot display image. <filename></p>	<p>The image was taken with another camera, or the image file was corrupted when the camera was shut down improperly.</p>	<ul style="list-style-type: none"> • The image may still be okay. Transfer the image to your computer (see page 79) and try opening it with the HP Image Zone software. • Do not remove the memory card when the camera is turned on.
<p>No devices are connected to camera dock.</p>	<p>The camera may not be properly seated in the dock, or the cables may not be firmly connected.</p>	<p>Make sure the camera is properly inserted into dock and check the USB cable connectors at both the dock and printer, computer, or television.</p>
<p>No printable images in memory. or No printable images on card.</p>	<p>The camera you connected to the printer has no still images. Video clips cannot be printed directly from the camera.</p>	<p>Disconnect the camera from the printer, then take still images before reconnecting the camera to the printer.</p>

Message	Possible Cause	Solution
Cannot print video clips.	You have selected Print 1 copy or Print 2 copies in the HP Instant Share Menu and have scrolled to a video clip. Video clips cannot be printed from the camera.	If your printer supports printing video clips, transfer the video clip to your computer (see page 79) and print the clip from your computer.
Camera has experienced an error	The camera may have experienced a transient problem.	Turn the camera off and then on again. If that does not fix the problem, try resetting the camera (see page 96). If the problem persists, note the error code and then call HP Support (see page 136).

Message	Possible Cause	Solution
Unable to communicate with printer	There is no connection between the camera and printer.	<ul style="list-style-type: none"> • Check that the printer is turned on and has no errors. • Make sure the cable is connected between the printer and the camera or the optional HP Photosmart M-series dock. If that does not work, turn off the camera and disconnect it from the USB cable. Turn the printer off and then on again. Re-connect the camera and turn it on.
Printer top cover is open	The printer is open.	Close the top cover of the printer.
Printer ink cover is open.	The door to the ink cartridge is open.	Close the door to the ink cartridge.
Incorrect or missing print cartridge.	The printer cartridge is the incorrect model or is missing.	Install a new printer cartridge, turn the printer off, then turn it back on.
Incorrect or missing print head.	The print head is the incorrect model or is missing.	Install a new print head, turn the printer off, then turn it back on.



Message	Possible Cause	Solution
Unable to print. Error reading image file.	The printer is unable to read the file that was trying to print. The file may be corrupted.	Try printing again. If that does not work, try printing from the computer.
Printer has a paper jam or The print carriage has stalled	Paper has jammed in the printer or the printer carriage has stalled.	Turn off the printer. Completely clear the paper jam, then turn the printer back on.
Printer is out of paper	The printer is out of paper.	Load paper into the printer, and then press the OK or Continue button on the printer.
Unsupported USB cable	Your camera dock is connected to a printer using the wrong type of cable, or the printer is not a PictBridge-certified printer.	Use the USB cable that came with your camera. The larger, flat end connector on the cable (see page 81) should connect to the printer, usually on the front of the printer. If your printer does not have a connector for this type of USB cable connection, then it is not a PictBridge-certified printer, and it is not a supported printer with your camera. The printer must have the official PictBridge logo.

Message	Possible Cause	Solution
Selected print size is larger than selected paper size.	Print size is too large for the paper size.	Press the $\frac{\text{Menu}}{\text{OK}}$ button on the camera to return to the Print Setup screen and select a print size that matches the paper size. Or, select a larger paper size and load larger paper into the printer.
Paper is not loaded correctly in the printer.	Paper is not aligned correctly in the paper tray.	Realign paper and try printing again.
The selected combination of paper type and paper size is not supported.	The paper type and size in the printer is not supported.	Load the printer with paper of the type and size that is supported.
There is a problem with the printer's ink.	The ink cartridge may be low, or the ink cartridge type may not be supported for the printer.	Replace the ink cartridge with a supported cartridge type, turn the printer off, then turn it back on.
Low ink.	The printer cartridge is running low on ink.	Replace the ink cartridge. You may be able to print some images using the current cartridge, but their color and quality may not be of high quality.

Message	Possible Cause	Solution
Printer is out of ink.	The printer has run out of ink.	Replace the ink cartridge.
Printing canceled	The print job has been canceled.	Press the $\frac{\text{Menu}}{\text{OK}}$ button on the camera to return to the Print Setup screen. Complete the print request again.

Error Messages on the Computer

Message	Possible Cause	Solution
Cannot Connect To Product	The computer needs to access files in memory during HP Instant Share setup. But either the internal memory is full, or if an optional memory card is installed, the card is full.	If internal memory or the optional memory card is full, transfer the images to a computer (see page 79) and then delete the images from the camera to free-up space (see page 67).
	The camera is turned off.	Turn on the camera.
	The camera is not working correctly.	Try connecting the camera directly to a PictBridge-certified printer, and print an image. This will verify that the optional memory card, USB connection, and the USB cable are functioning correctly.
	The cable is not connected correctly.	Make sure that the cable is firmly connected to the computer and camera.

Message	Possible Cause	Solution
Cannot Connect To Product (continued)	The camera is set to the Digital Camera setting in the USB Configuration sub-menu of the Setup Menu , but the computer cannot recognize the camera as a digital camera.	Change the USB Configuration setting to Disk Drive in the Setup Menu (see page 90.) This allows the camera to appear as another disk drive on the computer so that you can easily copy the image files from the camera to the computer hard drive.
	The camera is connected to the computer through a USB hub, and your USB hub is not compatible with the camera.	Connect the camera directly to a USB port on the computer.
	You are using the optional HP Photosmart M-series dock and forgot to press the Save/Print  button.	Press the Save/Print  button on the dock.
	The optional memory card that is installed is locked.	With the camera turned off, remove the memory card and switch the locking tab on the card to the unlocked position.
	The USB connection failed.	Reboot the computer.

Message	Possible Cause	Solution
Could Not Send To Service	The computer is not connected to the Internet.	Make sure your computer is online.
Communication Problem	Other HP Instant Share software is running with exclusive access to your camera.	Close the other HP Instant Share program.

Getting Assistance

This section contains support information for your digital camera, including support website information, an explanation of the support process, and support phone numbers.

HP Accessibility Website

Customers with disabilities can get help by visiting www.hp.com/hpinfo/community/accessibility/prodserv

HP Photosmart Website

Visit www.photosmart.hp.com or www.hp.com/photosmart for the following information:

- Tips on using your camera more effectively and creatively
- HP digital camera driver updates and software
- Register your product
- Subscribe to newsletters, driver and software updates, and support alerts

Support Process

The HP support process works most effectively if you perform the following steps in the order specified:

1. Review the troubleshooting section of this User's Manual (see **Problems and Solutions** on page 105).
2. Access the HP Customer Care website for support. If you have access to the Internet, you can obtain a wide range of information about your digital camera. Visit the HP website for product help, drivers, and software updates at **www.hp.com/support**

Customer Support is available in the following languages: Dutch, English, French, German, Italian, Portuguese, Spanish, Swedish, Traditional Chinese, Simplified Chinese, Japanese, Korean. (Danish, Finnish, and Norwegian support information is available in English only.)

3. Access HP e-support. If you have access to the Internet, connect with HP via e-mail by going to: **www.hp.com/support**. You will receive a personal reply from an HP Customer Support technician. E-mail support is available in the languages listed at that website.
4. (US and Canadian customers, skip this step and go on to Step 5.) Contact your local HP dealer. If your digital camera has a hardware failure, take it to your local HP dealer for a solution. Service is free during your digital camera's limited warranty period.

5. Contact HP Customer Care for support by phone. Please consult the following website to check the details and conditions of phone support in your country/region: **www.hp.com/support**. As a part of HP's continuing efforts to improve phone support information services, we advise you to check the HP website on a regular basis for new information regarding service features and delivery. If you cannot solve the problem using the above options, call HP while you are in front of your computer and digital camera. For faster service, please be prepared to provide the following information:
- The digital camera's model number (on the front of the camera)
 - The digital camera's serial number (on the bottom of the camera)
 - The computer's operating system and available RAM
 - The version of the HP software (on the CD label)
 - Messages displayed at the time the situation occurred

The applicable conditions for HP phone support are subject to change without notice. Telephone support is free for:

- One year from the date of purchase for the following regions: Africa, Asia Pacific, Canada, Latin America, Middle East, and United States.
- One year from the date of purchase throughout most of Europe.
- Two years from the date of purchase for the following countries in Europe: Czech Republic, Slovakia, Turkey, and Portugal.

Phone Support in the United States and Canada

Support is available both during and after the warranty period.

Within the period of your warranty, telephone support is provided free of charge. Call **1-(800)-474-6836 (1-800-HP invent)**.

HP Total Care phone support is available 24x7 in English (US and Canada), Spanish (US only), and French (Canada only). (Days and hours of support may change without notice.)

After the warranty period, call **1-(800)-474-6836 (1-800-HP invent)**. A service charge will be required, which will be charged to your credit card. If you think your HP product needs service, please call HP Total Care and a Total Care Representative will help you determine your service options.

Phone Support in Europe, the Middle East, and Africa

HP Customer Support phone numbers and policies may change. Visit the following website to check the details and conditions of phone support in your country/region:

www.hp.com/support

Algeria	+213 61 56 45 43
Austria	+43 1 86332 1000 0810-001000 (in-country)
Bahrain	800 171 (in-country toll-free)

Belgium	070 300 005 (Dutch) 070 300 004 (French)
Czech Republic	+420 261307310
Denmark	+45 70 202 845
Egypt	+20 2 532 5222
Finland	+358 (0)203 66 767
France	+33 (0)892 69 60 22 (Euro 0.34/minute)
Germany	+49 (0)180 5652 180 (Euro 0.12/minute)
Greece	+30 210 6073603 (international number) 801 11 22 55 47 (in-country) 800 9 2649 (toll-free from Cyprus to Athens)
Hungary	+36 1 382 1111
Ireland	1890 923 902
Israel	+972 (0) 9 830 4848
Italy	848 800 871
Luxembourg	900 40 006 (French) 900 40 007 (German)
Middle East	+971 4 366 2020 (international number)
Morocco	+212 22 404747
Netherlands	0900 2020 165 (Euro 0.10/minute)
Nigeria	+234 1 3204 999
Norway	+47 815 62 070
Poland	+48 22 5666 000
Portugal	808 201 492
Romania	+40 (21) 315 4442

Russian Federation	+7 095 7973520 (Moscow) +7 812 3467997 (St. Petersburg)
Saudi Arabia	800 897 1444 (in-country toll-free)
Slovakia	+421 2 50222444
South Africa	086 0001030 (Republic of South Africa) +27 11 2589301 (international number)
Spain	902 010 059
Sweden	+46 (0)77 120 4765
Switzerland	0848 672 672 (German, French, Italian— Peak time 0.08 CHF/Outside peak 0.04 CHF)
Tunisia	+216 71 89 12 22
Turkey	+90 216 579 71 71
Ukraine	+7 (380 44) 4903520 (Kiev)
United Arab Emirates	800 4520 (in-country toll-free)
United Kingdom	+44 (0)870 010 4320
West Africa	+351 213 17 63 80 (French-speaking countries only)

Other Phone Support Worldwide

HP Customer Care phone numbers and policies may change. Visit the following website to check the details and conditions of phone support in your country/region:

www.hp.com/support.

Argentina	(54)11-4778-8380 or 0-810-555-5520
Australia	1 300 721 147 (during warranty period) 1 902 910 910 (after the warranty period)
Brazil	0800-15-7751 or 11-3747-7799
Canada	1-800-474-6836 (905-206-4663 from within local Mississauga calling area)
Chile	800-360-999
China	+86 (21) 3881 4518
Colombia	01-800-51-HP-INVENT
Costa Rica	0-800-011-4114 or 1-800-711-2884
Ecuador	999-119 (Andinatel) +1-800-711-2884 (Andinatel) 1-800-225-528 (Pacifitel) +1-800-711-2884 (Pacifitel)
Guatemala	1-800-999-5105
Hong Kong SAR	+852 2802 4098
India	1 600 447737
Indonesia	+62 (21) 350 3408
Jamaica	1-800-711-2884

Japan	0570 000 511 (inside Japan) +81 3 3335 9800 (outside Japan)
Korea, Republic of	+82 1588-3003
Malaysia	1 800 805 405
Mexico	01-800-472-6684 or (55)5258-9922
New Zealand	+64 (9) 356 6640
Panama	001-800-711-2884
Peru	0-800-10111
Philippines	+63 (2) 867 3551
Republica Dominicana	1-800-711-2884
Singapore	+65 6272 5300
Taiwan	+886 0 800 010055
Thailand	+66 (0)2 353 9000
Trinidad & Tobago	1-800-711-2884
United States	+1 (800) 474-6836
Venezuela	0-800-4746-8368
Vietnam	+84 88234530

A Managing Batteries

Your camera uses two AA batteries. For best results, use Energizer Lithium AA or rechargeable Nickel Metal Hydride (NiMH) AA batteries.

Alkaline batteries provide far less battery life than Lithium or NiMH batteries. If you must use Alkaline batteries, use high-grade “ultra” or “premium” varieties instead of ordinary Alkaline batteries. Depending on your camera usage, Lithium batteries will provide approximately 4-8 times more battery life than Alkaline batteries. If you prefer rechargeable batteries, NiMH will provide approximately 2-5 times more battery life than Alkaline.

Top Points About Batteries

- The first time that you use a set of NiMH batteries, be sure that you fully charge them before using them in the camera.
- If you do not intend to use your camera for an extended period of time (more than two months), HP recommends that you remove the batteries unless you are using rechargeable batteries and are leaving the camera docked or connected to an optional HP AC power adapter.
- When inserting the batteries in the camera, always be sure to orient the batteries as directed by the markings in the battery compartment. If the batteries are inserted improperly, the compartment door may close but the camera will not operate.

- Never use batteries of different chemistries (for example, a Lithium and NiMH battery), brands, or ages. This can cause erratic camera behavior, as well as battery leakage. Always use two identical batteries of the same chemistry, brand, and age.
- The performance of all batteries will decrease as the temperature drops. For best performance in cold environments, use Energizer Lithium AA batteries. NiMH batteries may also provide acceptable low-temperature performance. To improve the performance of all battery types, keep the camera and/or batteries stored in a warm inside pocket when in a cold environment.

Extending Battery Life

Here are some tips for extending battery life:

- Turn off the Image Display and use the viewfinder instead when framing pictures and video. Leave the Image Display off whenever possible.
- Change the **Live View at Power On** setting in the **Setup Menu** to **Live View Off**, so that your camera does not power on in **Live View** (see **Live View at Power On** on page 88).
- Change the **Display Brightness** setting in the **Setup Menu** to **Low**, so that the Image Display consumes less power when in **Live View** (see **Display Brightness** on page 86).
- Minimize the use of flash by setting your camera to **Auto Flash**, instead of **Flash On** (see **Setting the Flash** on page 40).
- Use zoom only when necessary to minimize moving the lens (see **Using Zoom** on page 38).

- Minimize unnecessary power cycling. If you expect to average more than two pictures every five minutes, leave the camera on with the Image Display off, rather than turning off the camera after each shot. This minimizes the number of times the lens must extend and retract.
- Use the optional HP AC power adapter or HP Photosmart M-series dock when the camera will be on for extended periods of time, such as when you transfer images to your computer or when printing.

Safety Precautions for Using Batteries

- Do not charge any batteries other than NiMH batteries in the camera, the optional HP Photosmart M-series dock, or the optional HP Photosmart Quick Recharger.
- Do not place a battery in fire or heat the battery.
- Do not connect the positive terminal and the negative terminal of a battery to each other with any metal object (such as wire).
- Do not carry or store a battery together with coins, necklaces, hairpins, or other metal objects. Placing a battery in contact with coins is especially dangerous to you! To avoid injury, do not drop a battery into a change-filled pocket.
- Do not pierce a battery with nails, strike a battery with a hammer, step on a battery, or otherwise subject it to strong impacts or shocks.
- Do not solder directly onto a battery.
- Do not expose a battery to water or salt water, or allow a battery to get wet.
- Do not disassemble or modify a battery. A battery contains safety and protection devices, which, if damaged, may cause the battery to generate heat, explode, or ignite.

- Immediately discontinue use of a battery if, while using, charging, or storing the battery, the battery emits an unusual smell, feels excessively hot (note that it is normal for a battery to feel warm), changes color or shape, or appears abnormal in any other way.
- In the event a battery leaks and the fluid gets into your eye, do not rub the eye. Rinse well with water and immediately seek medical care. If left untreated, the battery fluid could cause damage to the eye.

Performance per Battery Type

The following table shows how Alkaline, Lithium, and rechargeable NiMH batteries perform in different types of use scenarios.

Type of use	Alkaline	Lithium	NiMH
Most economical if you take more than 30 pictures per month	Poor	Fair	Good
Most economical if you take less than 30 pictures per month	Fair	Good	Fair
Heavy use of flash, frequent pictures	Poor	Good	Good
Heavy use of video	Poor	Good	Good
Heavy use of Live View	Poor	Good	Good
Overall battery life	Poor	Good	Fair
Low temperature/winter use	Poor	Good	Fair
Infrequent use (without dock)	Fair	Good	Fair
Infrequent use (with dock)	Fair	Good	Good
Want to recharge batteries	No	No	Yes

Number of Shots per Battery Type

The following table shows the approximate number of shots under heavy, light, and average use conditions for Alkaline, Lithium, and rechargeable NiMH batteries.





Battery type	Approximate number of shots under heavy use	Approximate number of shots under light use	Approximate number of shots under average use
Alkaline	50	150	100
Lithium	300	700	500
NiMH	150	300	225

In the table above, please note that, in all cases, four pictures are taken per session with at least a 5 minute break between sessions. In addition:

- The heavy use number of shots is obtained with extensive use of **Live View** (30 seconds per picture) and **Playback** (15 seconds per picture), and **Flash On**.
- The light use number of shots is obtained with minimal use of **Live View** (10 seconds per picture) and **Playback** (4 seconds per picture). Flash is used on 25% of shots.
- The average use number of shots is obtained with **Live View** used at 15 seconds per picture and **Playback** used for 8 seconds per picture. Flash is used on 50% of shots.

Power Indicators

The following icons may be displayed on the status screen, in **Live View**, in **Playback**, and when the camera is connected to a computer or printer. If no icon is displayed, this means that the camera has sufficient battery power to function normally.

Icon	Description
	Batteries are running low. Camera will power down soon.
 Blinking	Battery is depleted. Camera will proceed to power down.
	Camera is operating on AC power (with non-rechargeable batteries or no batteries installed).
Animated battery filling up	Camera is operating on AC power and is charging the batteries.
	Camera has successfully completed battery charging and is operating on AC power.

NOTE: When you remove the batteries from the camera, the date and time settings are preserved for approximately 10 minutes. If the camera is without batteries for longer than 10 minutes, the clock is set to the last date and time at which the camera was turned off. You may be prompted to update the date and time the next time you power on the camera.

Recharging NiMH Batteries

NiMH batteries can be recharged in the camera when the camera is connected to an optional HP AC power adapter or HP Photosmart M-series dock. NiMH batteries can also be recharged with the optional HP Photosmart Quick Recharger. For information about these optional accessories, see **Appendix B, Purchasing Camera Accessories**, starting on page 155.

When the HP AC power adapter is used to charge the batteries and the camera is off, the Power light on the back of the camera will blink during charging. When the dock is used, the dock light will blink. When the quick recharger is used, the light on the quick recharger will be red to indicate charging.

The following table shows the average time it takes to recharge NiMH batteries that have been fully discharged, depending on where the batteries are being charged. The table also notes the signal you will see when the batteries have been recharged.

Where batteries are charged	Average charge time	Signal when charging has completed
In camera with HP AC power adapter connected	12 to 15 hours	If the camera is off, the power light on the camera stops blinking and turns off. If the camera is on with the Image Display on, the  icon appears.

Where batteries are charged	Average charge time	Signal when charging has completed
In camera while camera is in the dock	12 to 15 hours	Power light on the dock stops blinking and turns on solid.
In HP quick recharger	1 hour for 2 batteries About 2 hours for 4 batteries	Light on quick recharger turns on solid green.

If you will not be using your camera immediately after charging the batteries, we recommend that you leave the camera in the dock or plugged in to the HP AC power adapter. The camera will top off the batteries periodically to ensure that the camera is always ready for use.

Some things to keep in mind when using NiMH batteries are as follows:

- The first time that you use a set of NiMH batteries, be sure that you fully charge them before using them in the camera.
- You may notice that the first several times you use NiMH batteries, the battery life seems shorter than what you expect. Performance will improve and become optimal after the batteries have been charged and then discharged (used) completely four or five times. You can use the camera normally to discharge the batteries during this conditioning period.
- Always recharge both NiMH batteries at the same time. One low-charged battery will reduce the battery life for the other battery in the camera.

- NiMH batteries discharge when not in use, whether they are installed in a camera or not. If they have not been used for more than two weeks, recharge them before using them again. Even if you are not using your batteries, it is a good idea to charge them every six months to a year to prolong their useful life.
- The performance of all rechargeable batteries, including NiMH, will degrade over time, especially if they are stored and used at high temperatures. If battery life has become unacceptably reduced over time, replace the batteries.
- The camera, the dock, or the quick recharger may be warm while operating and charging NiMH batteries. This is normal.
- NiMH batteries can be left in the camera, the dock, or the quick recharger for any period of time without harm to the batteries or the camera, the dock, or the quick recharger. Always store charged batteries in a cool location.

Safety Precautions for Recharging NiMH Batteries

- Do not charge any batteries other than NiMH batteries in the camera, the dock, or the quick recharger.
- Insert the NiMH batteries in the correct orientation in the camera, the dock, or the quick recharger.
- Use the camera, the dock, or the quick recharger in a dry location only.
- Do not charge NiMH batteries in a hot location, such as in direct sunlight or near a fire.
- When recharging NiMH batteries, do not cover the camera, the dock, or the quick recharger in any way.

- Do not operate the camera, the dock, or the quick recharger if the NiMH batteries appear damaged in any way.
- Do not disassemble the camera, the dock, or the quick recharger.
- Unplug the HP AC power adapter or the quick recharger from the electrical outlet before cleaning the power adapter or quick recharger.

Sleep Time-out for Power Conservation

To conserve battery power, the Image Display turns off automatically if there is no button activity for 20 seconds when in **Live View**, or for 30 seconds when in any other mode. When the camera is connected to a computer, the Image Display turns off automatically 10 seconds after the connection is made. When the camera is in this “sleep” state, pressing any button will wake up the camera again. If no buttons are pressed during the sleep state, the camera will turn off after an additional 5 minutes.

B Purchasing Camera Accessories

You can purchase additional accessories for your camera.

For information on your HP M417 or HP M517 camera and compatible accessories, go to:

- www.hp.com/photosmart (US)
- www.hp.ca/photosmart (Canada)
- www.hp.com (all other countries)

To purchase accessories, visit your local retailer or order online at:

- www.hpshopping.com (US)
- www.hpshopping.ca (Canada)
- www.hp.com/eur/hpoptions (Europe)
- www.hp.com/apac/homeandoffice (Asia Pacific)

Below are some accessories for this digital camera. These camera accessories may not be available in all regions.

- **HP Photosmart M-series dock—**
C8907A/C8907B

Recharge the AA NiMH batteries in your camera so your camera is always ready to go. Transfer photos easily to your computer, send photo e-mails via **HP Instant Share**, or print photos at the touch of a button. Connect to your TV and view photo slideshows.



Includes a dock with two rechargeable AA NiMH batteries, an audio/video cable, a USB cable, and an HP AC power adapter.

- **HP Photosmart M-series quick recharge kit**—L1815A/L1815B

One-hour recharging of AA NiMH batteries, plus stylish protection for your HP Photosmart M-series camera.

Includes all you need to provide a home away from home for your camera: an ultra-lightweight portable recharger, a camera case, and four high-capacity rechargeable AA NiMH batteries.

- **HP Photosmart 3.3V AC power adapter for HP Photosmart M-series cameras**—C8912B/C8912C

This is the only power adapter supported for use with M-series cameras.

- **HP Photosmart SD memory cards**

(For important information about supported types of memory cards, see **Storage** on page 166.)

- HP Photosmart 64MB SD memory card—L1872A/L1872B
- HP Photosmart 128MB SD memory card—L1873A/L1873B
- HP Photosmart 256MB SD memory card—L1874A/L1874B
- HP Photosmart 512MB SD memory card—L1875A/L1875B
- HP Photosmart 1GB SD memory card—L1876A/L1876B

- **HP Photosmart M-series camera case—Q6214A**
Stylish, tailored-to-fit protection for your HP Photosmart M-series camera. Made of durable, thin, leather-like black material that protects without adding bulk. Includes a handy pocket for storing an extra memory card.
- **HP Photosmart camera black sport case—Q6216A**
Lightweight, durable, and sporty protection for your HP Photosmart M-series camera. You can easily fasten your camera to clothing or luggage using the included neck strap, belt loop, and integrated clip. Also includes two pockets for storing extra batteries and memory cards.
- **HP Photosmart camera silver sport case—Q6217A**
Attractive and lightweight, this sporty case protects your HP Photosmart M-series camera from scratches, bumps, and light weather while providing style and durability. Includes convenient pockets for storing extra batteries and memory cards. Also includes a neck strap and belt loop for hands-free carrying.
- **www.casesonline.com**—Go to **www.casesonline.com** to design your own custom case to fit your HP Photosmart M-series camera. Choose the style, material, and color for your camera case.

C Caring for Your Camera

Taking some basic precautions when using your camera will enhance your digital camera experience.

Basic Camera Care

You should take some basic precautions to ensure that your camera continues to perform optimally.

- Store your digital camera in a cool, dry place away from windows, furnaces, and damp basements.
- Always turn the camera off when you are not using it, to protect the lens. When the camera is off, the camera lens retracts and the lens wink mechanism closes over the lens to protect it.
- Clean your camera body, Image Display, and lens regularly with cleaning supplies designed specifically for cameras. See **Cleaning the Camera** on page 160.
- Keep your camera and accessories in a padded case with a good strap for easy transport. Most HP digital camera cases have built-in pockets for batteries and memory cards. See **Purchasing Camera Accessories** on page 155.
- Always keep your camera equipment with you as carry-on when you travel. Never check it with the suitcases, since rough handling and extreme weather can damage it.

- Never open your camera's casing or attempt to repair the camera yourself. Touching the inside of a digital camera can result in electrical shock. Contact an authorized HP Service Center for repairs.

NOTE: For information about handling batteries safely, see **Appendix A, Managing Batteries**, starting on page 145.

Cleaning the Camera

TIP: If your camera needs cleaning beyond what is described in this section, take the camera to a camera store that specializes in cleaning digital cameras.

Cleaning your camera not only keeps it looking its best, it also improves the quality of your photos. It is especially important to clean the lens regularly because dust particles and fingerprints can mar the quality of photos you take.

To clean your camera, you will need lens-cleaning tissue and a soft, dry, lint-free cloth commonly available at photo-specialty stores. You can also purchase these items in a camera cleaning kit.

NOTE: You should purchase lens-cleaning tissue that has not been chemically treated. Some chemically treated lens tissue can cause scratching of the lens and Image Display.

Cleaning the Camera Lens

Do the following to remove any lubricant that has seeped from the lens wink mechanism onto the camera lens, as well as fingerprints, dust, and so forth that have accumulated on the lens.

1. Turn the camera on to open the lens wink mechanism and to extend the lens.
2. Wrap the lens cleaning paper around the end of the cotton swab.
3. Using the cotton swab with the lens paper, wipe the lens clean using a circular motion.

When handling the camera after cleaning the lens, use care not to press on the wink mechanism cover when the lens is in the retracted position because this may cause lubricant to seep from the wink mechanism onto the lens.

Cleaning the Camera Body and Image Display

Do the following to remove any fingerprints, dust, moisture, and so forth that have accumulated on the camera body and Image Display.

1. Blow gently on the Image Display to eliminate dust.
2. Wipe the entire surface of the camera and the Image Display using a clean, dry, soft cloth.

NOTE: You can also wipe the Image Display with lens-cleaning tissue.

D Specifications

Feature	Description
Resolution	Still pictures: <ul style="list-style-type: none">• 5.36 MP (2690 by 1994) total pixel count• 5.19 MP (2620 by 1984) effective pixel count Video clips: <ul style="list-style-type: none">• 320 by 240 total pixel count
Sensor	Diagonal 7.194 mm (1/2.5-inch, 4:3 format) CCD
Color depth	36 bit (12 bits by 3 colors)
Lens	Focal length: <ul style="list-style-type: none">• Wide—6.0 mm• Telephoto—18.0 mm• 35 mm equivalent, approximately 36 mm to 108 mm F-Number: <ul style="list-style-type: none">• Wide—f/2.91 to f/4.86• Telephoto—f/4.86 to f/8.0
Lens threads	None
Viewfinder	Optical real image zoom type viewfinder, 3x magnification, without diopter adjust
Zoom	<ul style="list-style-type: none">• Optical Zoom—3x• Digital Zoom:<ul style="list-style-type: none">• M417—7x• M517—8x

Feature	Description
Focus	TTL auto focus. Focus ranges: <ul style="list-style-type: none"> • Normal (default)—500 mm (20 in) to infinity • Macro—100 mm to 800 mm (4 in to 32 in)
Shutter speed	1/2000 to 2 seconds
Tripod mount	Yes
Built-in flash	Yes, 8-second typical recharge time
Flash working range	Zoom Position: Wide Maximum (Auto ISO): 3.8 meters (12.5 feet) Zoom Position: Telephoto Maximum (Auto ISO): 2.2 meters (7.2 feet)
External flash	No
Flash settings	Auto, Auto with Red-Eye, Flash Off, Flash On, Night
Image Display	<ul style="list-style-type: none"> • M417—1.8-inch color active matrix TFT LTPS with backlight, 130,338 pixels (557 by 234) • M517—2-inch color active matrix TFT LTPS with backlight, 130,572 pixels (558 by 234)

Feature	Description
Image capture options	<ul style="list-style-type: none"> • Still (default) • Self-Timer—still picture or video clip taken after 10-second delay • Self-Timer - 2 shots—still picture taken after 10-second delay, then a second picture taken about 3 seconds later. Single video taken after 10-second delay. • Burst—camera takes 4 shots in a row as quickly as it possibly can, and then continues taking pictures until the camera runs out of memory • Video—30 frames per second (includes audio), until the camera runs out of memory
Audio capture	<ul style="list-style-type: none"> • Still pictures—max audio clip length is until the camera runs out of memory • Burst—audio capture not available • Video clips—audio is recorded automatically
Shooting modes	Auto (default), Macro , Fast Shot , Action , Portrait , Landscape , Beach & Snow
Image Quality settings	<ul style="list-style-type: none"> • 5MP Best • 5MP (default) • 3MP • 1MP • VGA
Adaptive lighting	Yes, using HP adaptive lighting technology
Color settings	Full Color (default), Black & White , Sepia
Date & Time Imprint settings	Off (default), Date Only , Date & Time

Feature	Description
EV Compensation settings	Can be set manually from -2.0 to +2.0 EV (Exposure Value) in 0.5 EV increments.
White Balance settings	Auto (default), Sun, Shade, Tungsten, Fluorescent
ISO Speed settings	Auto (default), 100, 200, 400
Storage	<ul style="list-style-type: none"> • M417: 16MB internal NAND flash memory • M517: 32MB internal NAND flash memory • 64MB SDRAM • Slot for memory card • This camera supports both standard and high-speed Secure Digital (SD) and MultiMediaCard (MMC) memory cards from 16MB up to 1GB. Only MMC cards that have been verified compliant to the MultiMediaCard specification are supported. Compliant MMC memory cards have the  MultiMediaCard logo on the card or package. SD cards are recommended, as they are faster than MMC cards at reading and writing data. • This camera supports memory cards up to 1GB. A high-capacity card itself does not affect camera performance, but a large number of files (over 300) does affect the time it takes for the camera to turn on. • The number of images that can be saved in memory depends on the Image Quality settings (see Memory Capacity on page 169).

Feature	Description
Compression format	<ul style="list-style-type: none"> • JPEG (EXIF) for still images • EXIF2.2 for still images with embedded audio • MPEG1 for video clips
Interfaces	<ul style="list-style-type: none"> • USB mini B connector to a computer or PictBridge-certified printer • DPS (Direct Printing Standard) • DC input 3.3 Vdc @ 2500 mA • Audio/video out to TV via M-series dock • HP Photosmart M-series dock
Orientation Sensor	No
Standards	<ul style="list-style-type: none"> • PTP transfer (15740) • MSDC transfer • NTSC/PAL • JPEG • MPEG1 level 1 • DPOF 1.1 • EXIF 2.2 • DCF 1.0 • DPS

Feature	Description
Power	<p>Typical power usage: 2.1 Watts with Image Display on. 4.5 Watts maximum power usage. Power sources include:</p> <ul style="list-style-type: none"> • Either two non-rechargeable AA Alkaline or Lithium batteries, or two rechargeable AA NiMH batteries. Rechargeable batteries can be recharged either in the camera using the optional HP AC power adapter or optional HP Photosmart M-series dock, or separately in the optional HP Photosmart Quick Recharger. Average recharging times of NiMH batteries via each of these methods are provided in the section Recharging NiMH Batteries on page 151. • Optional HP AC power adapter (3.3 Vdc, 2500 mA, 8.25 W) • Optional HP Photosmart M-series dock <p>Recharging in camera with the optional HP AC power adapter or optional HP Photosmart M-series dock: 100% in 15 hours.</p>
External body dimensions	<p>Measurements with camera off and lens retracted, not including wrist strap holder: 107 mm (L) by 36 mm (W) by 53 mm (H) 4.28 in (L) by 1.44 in (W) by 2.12 in (H)</p>
Weight	<p>149 grams (.33 pound) without battery</p>
Temperature range	<p>Operational: 0 to 50° C (32 to 122° F) at 15 to 85% relative humidity</p> <p>Storage: -30 to 65° C (-22 to 149° F) at 15 to 90% relative humidity</p>

Memory Capacity

The following tables list the approximate number and average size of still images that can be stored in the 16MB of internal memory in the HP Photosmart M417 and in the 32MB of internal memory in the HP Photosmart M517 when the camera is set to different **Image Quality** settings available in the **Capture Menu**.

NOTE: Not all 16MB of internal memory in the M417 or 32MB of internal memory in the M517 is available for storing images, because some memory is used for internal camera operations. Also, the actual file sizes and number of still images that can be stored in the internal memory in the camera or on an optional memory card will vary, depending on the content of each still image and the length of audio that has been recorded.

M417 Memory Capacity

5MP Best	5 images (2.5MB each)
5MP (default)	8 images (1.6MB each)
3MP	11 images (1.1MB each)
1MP	22 images (550KB each)
VGA	92 images (140KB each)

M517 Memory Capacity

5MP Best	11 images (2.5MB each)
5MP (default)	18 images (1.6MB each)
3MP	26 images (1.1MB each)
1MP	52 images (550KB each)
VGA	207 images (140KB each)

Index

A

- AC power adapter
 - connector on camera 25
 - purchasing 156
- accessories for camera 155
- Action mode, setting 43
- Adaptive Lighting, setting 51
- AF viewfinder light 23
- arrow buttons on Controller 21
- audio clips, record 32, 69
- automatic exposure, override 42

B

- batteries
 - door on camera 21
 - extend life of 146
 - indicators 150
 - install 11
 - performance 148
 - quick recharge kit 156
 - recharging NiMH 151
 - shots per type 149
 - top points about use 145
- Beach & Snow mode, setting 43

- blinking lights on camera 20, 21, 23, 24
- brackets in Live View screen 35
- brightening an image 55
- Burst
 - restore setting 45, 46
 - setting 46
 - Timer/Burst button 22
- buttons on camera 19
- buying camera
 - accessories 155

C

- camera
 - accessories 155
 - caring for 159
 - menus 26
 - reset 96
 - specifications 163
 - states 25
- camera dock
 - connector on camera 25
 - description 10
 - purchasing 155
- camera parts
 - back and right side of camera 20

- front, left side, and bottom of camera 24
- top of camera 19
- Camera Sounds, setting 87
- capacity of internal memory 169
- Capture Menu
 - Help for menu options 48
 - restore settings 47
 - using 47
- caring for your camera 159
- Color of images, setting 53
- compression format 167
- computer, connect
 - camera to 79
- connections
 - as a Picture Transfer Protocol (PTP) device 90
 - as a USB Mass Storage Device Class (MSDC) 90
 - to computer 79
 - to printer 81
- connectors
 - AC power adapter 25
 - camera dock 25
 - USB 25
- conserving battery life 146
- Controller with arrow buttons, description 21
- customer support 137

D

- darkening an image 55
- Date & Time Imprint, setting 53
- Date & Time, setting 13, 89
- delete during Instant Review 31, 33
- Delete, using 67
- digital zoom 38
- direct print
 - HP Instant Share/Print button 22
 - printing images from camera to printer 81
- disk drive, camera as 90
- Display Brightness, setting 86

E

- error messages
 - on camera 120
 - on computer 134
- EV Compensation, setting 55
- extending battery life 146

F

- Fast Shot mode, setting 42
- flash
 - description 24
 - restore setting 41
 - settings 40
 - using 40

- Flash button, description 22
- focus
 - brackets, using 35
 - camera shake 38
 - lock 37
 - range 164
- format
 - internal memory 67
 - memory card 15, 67
- H**
- help from customer support 137
- Help, on-camera
 - for Capture Menu options 48
 - Help Menu 28
- HP AC power adapter
 - connector on camera 25
 - purchasing 156
- HP Image Zone Express software 98
- HP Image Zone software
 - description 96
 - installing 17
 - not using 99
 - Windows requirements 97
- HP Instant Share
 - description 71
 - HP Instant Share/Print button 22
 - sending images 76
 - using the HP Instant Share Menu 72
- HP Instant Share Menu
 - description 73
 - sending images 76
 - setting up destinations 74
 - using 72
- HP web sites 136
- I**
- Image Display
 - description 22
 - Live View at Power On setting 88
 - Live View button 23
 - status screen 28
 - using 34
- Image Quality, setting 48
- images
 - Adaptive Lighting 51
 - brightening 55
 - Color setting 53
 - darkening 55
 - Date & Time Imprint 53
 - Image Quality setting 48
 - ISO Speed setting 57
 - magnifying 64
 - number remaining 28, 35, 62
 - number saved in internal memory 169
 - record audio clips 32
 - Rotate 69

- shooting modes 42
- thumbnails view 63
- too dark/light 55
- transferring from camera
 - to computer 79
- White Balance setting 56

- images per battery
 - type 149
- indicators, power 150

install

- batteries 11
- memory card 15
- software 17, 18
- wrist strap 10

internal memory

- format 67
- image capacity of 169
- pictures remaining 28,
35, 62

ISO Speed, setting 57

L

Landscape mode, setting 43

Language

- change setting 92
- choose at first startup 12

LEDs (lights) on camera

- AF viewfinder light 23
- Memory light 21
- Power light 20
- Self-Timer/Video light 24
- Video viewfinder light 23

life of battery,
conserving 146

Live View

- button 23
- using 34

Live View at Power On,
setting 88

low battery indicator 150

M

Macintosh computer, install
software 18

Macro mode, setting 42

Magnify

- control on Zoom lever 21
- using 64

magnifying images 64

memory card

- door on camera 21
- format 15, 67
- install 15
- pictures remaining 28,
35, 62
- supported types and
sizes 166

Memory light,
description 21

memory, internal

- format 67
- image capacity 169
- pictures remaining 28,
35, 62

- Menu/OK button, description 21
- menus
 - Capture 47
 - HP Instant Share 72
 - overview 26
 - Playback 65
 - Setup 85
- messages
 - on camera 120
 - on computer 134
- microphone, description 24
- MODE button 22
- Move Images to Card 93

N

- NiMH batteries
 - recharging 151
 - safety precautions 147
- number of
 - images stored in internal memory 169
 - pictures remaining 28, 35, 62

O

- ON/OFF switch, description 20
- on-camera demo, viewing 29

- on-camera Help
 - for Capture Menu options 48
 - Help Menu 28
- online destinations, setting 74
- optical zoom 38
- over-exposing an image 55
- override automatic exposure 42

P

- parts of camera
 - back and right side of camera 20
 - front, left side, and bottom of camera 24
 - top of camera 19
- Playback 59
 - button, description 23
- Playback Menu 65
- Portrait mode, setting 43
- power
 - indicators 150
 - light 20
 - specifications 168
- power adapter, HP AC 25
 - connector on camera 25
 - purchasing 156
- Power light, description 20
- Power ON/OFF switch, description 20

- print images
 - directly to printer 81
 - HP Instant Share/Print button 22
 - using HP Instant Share 71
- problems,
 - troubleshooting 95
- product support 137
- purchasing camera accessories 155

R

- range
 - Exposure Compensation 166
 - F-number 163
 - focus 164
- recharging NiMH batteries 151
- record
 - audio clips 32, 69
 - video clips 33
- red-eye reduction
 - description 41
 - Remove Red Eyes 68
- Region, setting 13
- remaining pictures count 28, 35, 62
- reset camera 96
- restore settings 29, 41, 43, 45, 46, 47
- reviewing images 59
- rotate images 69

S

- safety precautions for NiMH batteries 147
- selecting images for HP Instant Share destinations 76
- Self-Timer
 - light 24
 - settings 44
 - Timer/Burst button 22
- settings, restore 29, 41, 43, 45, 46, 47
- Setup Menu, using 85
- share pictures 71
- shooting mode
 - button 22
 - restore setting 43
 - settings 42
- shots per battery type 149
- Shutter button
 - description 19
 - lock exposure and focus 35
- shutter speed range 164
- software
 - installing 17, 18
 - using camera without 99
- sounds of camera 87
- space remaining in memory 28, 35, 62
- specifications 163
- states, camera 25

status screen 28
still pictures, take 31
support for users 137

T

technical support 137
Thumbnails
 control on Zoom lever 21
 using 63
Time & Date Imprint,
 setting 53
Time & Date, setting 13, 89
Timer/Burst button 22
total images summary
 screen 62
transfer images to
 computer 79
tripod mount,
 description 25
troubleshoot problems 95
TV (television) Configuration
 setting 91

U

under-exposing an
 image 55
USB
 configuration setting 90
 connector on camera 25

V

Video button,
 description 19
video clips, recording 33
Video viewfinder light 23
viewfinder
 description 22
 lights 23
 using 35

W

web sites for HP 136
White Balance, setting 56
Windows computer
 install software 17
 system requirements for
 software 97
wrist strap, attaching to
 camera 10

Z

zoom
 digital 38
 optical 38
 specifications 163
Zoom lever, description 21
Zoom Out and Zoom In
 controls 21