

HP StorageWorks

6000 Virtual Library System user guide



Part number: 394591-001
First edition: May 2005



Legal and notice information

Copyright © 2005 Hewlett-Packard Development Company, L.P.

Hewlett-Packard Company makes no warranty of any kind with regard to this material, including, but not limited to, the implied warranties of merchantability and fitness for a particular purpose. Hewlett-Packard shall not be liable for errors contained herein or for incidental or consequential damages in connection with the furnishing, performance, or use of this material.

This document contains proprietary information, which is protected by copyright. No part of this document may be photocopied, reproduced, or translated into another language without the prior written consent of Hewlett-Packard. The information contained in this document is subject to change without notice.

Hewlett-Packard Company shall not be liable for technical or editorial errors or omissions contained herein. The information is provided "as is" without warranty of any kind and is subject to change without notice. The warranties for Hewlett-Packard Company products are set forth in the express limited warranty statements for such products. Nothing herein should be construed as constituting an additional warranty.

Printed in the U.S.A.

6000 Virtual Library System user guide

Contents

About this Guide	13
Overview	14
Intended audience	14
Prerequisites	14
Related documentation	14
Conventions	15
Document conventions	15
Text symbols	16
Equipment symbols	17
Rack stability	18
Getting help	19
HP technical support	19
HP storage web site	19
HP authorized reseller	19
1 Introduction	21
Features	21
Benefits	22
Self-managing RAID configurations	23
Disk array hard drives	23
Node hard drives	24
System status monitoring	24
Redundancy	25
Models	26
VLS6105	26
VLS6510	28
2 Installation	31
Preparing for the installation	32
Tools for installation	32
Taking ESD precautions	32
Grounding methods to prevent electrostatic discharge	33
Unpacking	34
Removing the VLS from the shipping carton	34
Removing the packing materials	34
Rack planning resources	35
Rack requirements	35

Rack warnings	36
Optimum environment	37
Space and airflow requirements	37
Temperature requirements	38
Power requirements	38
Electrical grounding requirements	39
Identifying the shipping carton contents	40
Node shipping carton	40
Disk array shipping carton	41
Installing the node into a rack	42
Installing the disk array(s) into a rack	43
Rack mounting requirements	44
Mounting into a rack	45
Installing cables	50
3 Operation	55
Powering up the disk array(s)	55
Powering up the node	56
Rebooting the node	57
Powering down the node	58
Powering down the disk array(s)	59
4 User interfaces	61
User interface requirements	62
Command View VLS	63
Window regions	64
Opening a Command View VLS session from a web browser	65
Opening a Command View VLS session from Command View TL	67
Installing the SSL certificate into your web browser	68
Restarting Command View VLS	71
Closing a Command View VLS session	71
Secure shell and serial user interfaces	72
Opening a secure shell session	73
Closing a secure shell session	73
Opening a serial session	74
Closing a serial session	74
5 Configuration	75
Setting the network settings	76
Setting the network settings using the VLS discovery utility	76
Setting the network settings using the CLI command set	79
Setting the user preferences	81
Editing the default Fibre Channel host port settings	83
Enabling and disabling oversubscription	85
LUN management	87

Default LUN numbering	87
Operating system LUN requirements and restrictions	88
LUN masking	89
LUN mapping	91
Creating a virtual library	93
Creating tape drives	98
Creating cartridges	102
Destroying a virtual library	106
Destroying a tape drive	108
Destroying cartridges	110
Adding and removing barcode templates	112
6 Management	115
Changing the account passwords	116
Managing cartridges	117
Freeing up storage space	120
Adding capacity	121
Installing capacity licenses	122
Restarting the VLS device emulations	124
Updating the software	126
Saving configuration settings	128
7 Monitoring	131
Status information in the Status pane	132
Status icons	133
Device status icon	133
Navigation tree icon	134
Notification alerts	135
Command View VLS	136
Email notification	138
Editing the mail server settings	138
Edit the email settings	139
SNMP notification	142
Editing the SNMP settings	142
Trace log files	144
Viewing trace log files	144
Saving a trace log file	145
Creating a support ticket	146
8 CLI command set	147
Commands	147
Conventions	147
CLI-only commands	148
Connection commands	148
Output commands	148

VLS commands	149
Network settings configuration commands	149
Configuration commands	152
Management commands	160
Monitoring commands	163
9 Component identification	169
Node components, LEDs, and buttons	169
Node front panel components	169
Node front panel LEDs and buttons	170
Node rear panel components	173
Node rear panel LEDs and buttons	174
System board components	176
System board LEDs	177
Node LEDs and internal health LED combinations	179
Node fan module locations	181
Node processor zone fan module LED	181
Disk array components, LEDs, and buttons	182
Disk array front panel components	182
Disk array front panel LEDs	183
Disk array rear panel components	185
Disk array rear panel LEDs and buttons	186
10 Component replacement	187
Safety considerations	187
Preventing electrostatic discharge	187
Grounding methods to prevent electrostatic damage	188
Warnings and cautions	188
Preparation procedures	189
Extending the node from the rack	190
Removing the node access panel	191
Installing the node access panel	191
Node hard drive	192
DVD/CDRW drive	193
Node power supply	194
Node power supply zone fan module	196
Node processor zone fan module	197
Node DIMM	198
Node processor	199
Disk array hard drive	203
Disk array fan module	205
Disk array power supply	206
Disk array controller module	207
11 Disaster recovery	209

Recovering from a disk array RAID volume failure	210
Recovering from a node RAID volume failure	211
Restoring the configuration settings	212
Restoring the virtual library configuration from a configuration file	212
Rebuilding the virtual library configuration	214
Re-installing the VLS capacity licenses	215
Recovering from operating system failure	216

A Troubleshooting	217
Common issues	218

B Regulatory compliance notices	221
Regulatory compliance identification numbers	221
Battery statement	222
Federal Communications Commission notice	223
FCC rating label	223
Class A equipment	223
Class B equipment	224
Declaration of Conformity for products marked with the FCC logo, United States only	224
Modification	225
Cables	225
Canadian notice (Avis Canadien)	226
Class A equipment	226
Class B equipment	226
European Union notice	226
Japanese notices	227
Korean notices	228
Class A equipment	228
Class B equipment	228
Taiwanese notices	229
BSMI Class A notice	229
Taiwan battery recycle statement	229
Laser compliance	230
Dutch laser notice	231
French laser notice	231
German laser notice	232
Italian laser notice	232
Japanese laser notice	233
Spanish laser notice	233
Recycling notices	234
Disposal of waste equipment by users in private household in the European Union	234
Dutch notice	234
Czechoslovakian notice	235

Estonian notice	235
Finnish notice	236
French notice	236
German notice	236
Greek notice	237
Hungarian notice	237
Italian notice	238
Latvian notice	238
Lithuanian notice	239
Polish notice	239
Portuguese notice	240
Slovakian notice	240
Slovenian notice	241
Spanish notice	241
Swedish notice	242
Battery replacement notices	243
Dutch battery notice	243
French battery notice	244
German battery notice	245
Italian battery notice	246
Japanese battery notice	247
Spanish battery notice	248
C Specifications	249
Node specifications	249
Node serial ATA hard drive specifications	250
DVD/CDRW drive specifications	251
MSA20 disk array specifications	253
Environmental specifications	254
Glossary	255
Index	261

Figures

1 Disk array RAID volume configuration	23
2 Disk array rack mounting order	44
3 Position the rack mounting template	45
4 Engage the rack rail with the marked hole in the front of the rack	46
5 Engage the rack rail with the marked hole in the rear of the rack	47
6 Loosen the locknut on the shipping bracket	47
7 Align the disk array with the rails	48
8 Remove the mounting bracket covers	48
9 Slide the bracket forward to engage with the disk array	49
10 Connect SAN and LAN cabling to the node	50
11 Connect the VHDCI connector on each disk array to the appropriate VHDCI connector on the node	51
12 Connect the node power supply(s) to an AC power source	52
13 Secure the power cord with the strain relief clip	53
14 Connect the disk array power supplies to an AC power source	53
15 Node LED status during normal operation	56
16 Command View VLS login window	66
17 Security Alert window	68
18 Certificate window	69
19 Certificate Import Wizard window	70
20 Restart Command View VLS window	71
21 VLS discovery utility – main window	77
22 VLS discovery utility – Device Configuration window	78
23 User Preferences window	81
24 Fibre Channel Host Ports window	84
25 Chassis details window	85
26 Host LUN Mapping Mode window	90
27 Library Parameters – Map LUNs window	92
28 Create Virtual Library Wizard window (1 of 12)	94
29 Create Virtual Library Wizard window (2 of 12)	95
30 Create Virtual Library Wizard window (3 of 12)	96
31 Create Virtual Library Wizard window (4 of 12)	97
32 Create Virtual Library Wizard window (5 of 12)	99
33 Create Virtual Library Wizard window (6 of 12)	100
34 Create Virtual Library Wizard window (7 of 12)	101
35 Create Virtual Library Wizard window (8 of 12)	102
36 Create Virtual Library Wizard window (9 of 12)	103
37 Create Virtual Library Wizard window (10 of 12)	104
38 Create Virtual Library Wizard window (11 of 12)	105
39 Create Virtual Library Wizard window (12 of 12)	105
40 Virtual library details window	107

41 Tape drive details window	109
42 Cartridges details window	110
43 Cartridges parameters window	111
44 Add/Remove Barcode Templates window	112
45 Edit Accounts window	116
46 Cartridge details window	117
47 Cartridges parameters window	118
48 Identity tab window	123
49 Restart Emulations window	125
50 Software Update window	126
51 Save Configuration window	129
52 Device status icon in the Status banner	133
53 Navigation tree icon	134
54 Notification alert examples	135
55 Notifications Tab window	136
56 Edit Mail Server Settings window	138
57 Edit Email Settings window	140
58 Edit SNMP Settings window	143
59 Log Viewer window	144
60 Support Ticket window	146
61 Slide the node out of the rack	190
62 Remove the node hard drive	192
63 Eject the DVD/CDRW drive	193
64 Remove the node power supply	194
65 Install the AC power supply	195
66 Place the power cord in the strain relief clip	195
67 Remove the node power supply zone fan module	196
68 Remove the processor zone fan module	197
69 Remove the node DIMM	198
70 Lift the processor retaining card	200
71 Release the processor retaining clips and lift locking lever	200
72 Remove the protective cover from the processor	201
73 Align the processor pins with the socket holes	201
74 Close the processor locking lever and retaining clips	202
75 Remove the disk array hard drive	203
76 Remove the disk array fan module	205
77 Remove the disk array power supply	206
78 Remove the disk array controller module	207
79 Restore Config window	213

Tables

1 Document Conventions	15
2 VLS6105 capacity	27
3 VLS6510 capacity	29
4 VLS user interfaces	62
5 CLI connection commands	148
6 CLI output commands	148
7 CLI network settings configuration commands	150
8 CLI configuration commands	152
9 CLI management commands	160
10 CLI monitoring commands	163
11 Interpreting the disk array hard drive status LEDs	183

About this Guide

This user guide provides information to help you:

- Become familiar with HP StorageWorks 6000 Virtual Library System (VLS) features, models, and components
- Install and operate your VLS
- Configure your VLS to meet the data backup needs of your environment
- Manage your VLS so that it continues to meet the data backup needs of your environment
- Monitor your VLS's hardware status
- Replace failed customer-replaceable components
- Perform disaster recovery
- Troubleshoot configuration problems

"About this Guide" topics include:

- [Overview](#)
- [Conventions](#)
- [Rack stability](#)
- [Getting Help](#)

Overview

This section covers the following topics:

- [Intended audience](#)
- [Prerequisites](#)
- [Related documentaton](#)

Intended audience

This book is intended for use by system administrators who are experienced with setting up and managing system backups over a Storage Area Network (SAN).

Prerequisites

Before beginning, make sure you are familiar with the items below.

- Tape backup technologies, tape libraries, and backup software
- SAN environments
- Fibre Channel

Before installing the appliance, make sure you have:

- A Phillips screwdriver.
- An HP System E rack or HP 10000 Series rack with enough unused space to mount a VLS. Other racks might also be suitable, but have not been tested with the VLS.
- Two persons to perform the installation.

Related documentation

In addition to this guide, HP provides related information:

- *HP StorageWorks 6000 Virtual Library System Release Notes*
- *HP StorageWorks 6000 Virtual Library System Solutions Guide*

See the Documentation CD provided with the VLS and our web site (<http://www.hp.com>) for related documentation.

Conventions

Conventions consist of the following:

- Document conventions
- Text symbols
- Equipment symbols

Document conventions

This document follows the conventions in [Table 1](#).

Table 1 Document Conventions

Convention	Element
Blue text: Figure 1	Cross-reference links
Bold	Menu items, buttons, and key, tab, and box names
Italics	Text emphasis and document titles in body text
Monospace font	User input, commands, code, file and directory names, and system responses (output and messages)
Monospace, italic font	Command-line and code variables
Blue underlined sans serif font text	Web site address

Text symbols

The following symbols may be found in the text of this guide. They have the following meanings:



WARNING!

Text set off in this manner indicates that failure to follow directions in the warning could result in bodily harm or death.



CAUTION:

Text set off in this manner indicates that failure to follow directions could result in damage to equipment or data.



NOTE:

Text set off in this manner presents commentary, sidelights, or interesting points of information.



IMPORTANT:

Text set off in this manner presents highlighted or emphasized points of information.

Equipment symbols

The following equipment symbols may be found on hardware to which this guide pertains. They have the following meanings:



WARNING!



These symbols, which mark an enclosed surface or area of the equipment, indicate the presence of electrical shock hazards. The enclosed area contains no operator serviceable parts.

WARNING: To reduce the risk of injury from electrical shock hazards, do not open this enclosure.



WARNING!

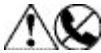

These symbols, which mark an RJ-45 receptacle, indicate a network interface connection.

WARNING: To reduce the risk of electrical shock, fire, or damage to the equipment, do not plug telephone or telecommunications connectors into this receptacle.



WARNING!



These symbols, which mark a surface or area of the equipment, indicate the presence of a hot surface or hot component. Contact with this surface could result in injury.

WARNING: To reduce the risk of injury from a hot component, allow the surface to cool before touching.



WARNING!



Power supplies or systems marked with these symbols indicate the presence of multiple sources of power.

WARNING: To reduce the risk of personal injury from electrical shock, remove all power cords to completely disconnect power from the power supplies and systems.



WARNING!



Any product or assembly marked with these symbols indicates that the component exceeds the recommended weight for one individual to handle safely.

WARNING: To reduce the risk of personal injury or damage to the equipment, observe local occupational health and safety requirements and guidelines for manually handling material.

Rack stability

Rack stability protects personnel and equipment.



WARNING!

To reduce the risk of personal injury or damage to the equipment, be sure that:

- The leveling jacks are extended to the floor.
 - The full weight of the rack rests on the leveling jacks.
 - In single rack installations, the stabilizing feet are attached to the rack.
 - In multiple rack installations, the racks are coupled.
 - Only one rack component is extended at any time. A rack may become unstable if more than one rack component is extended for any reason.
-

Getting help

If you still have a question after reading this guide, contact an HP authorized service provider or access our web site: <http://www.hp.com>.

HP technical support

Telephone numbers for worldwide technical support are listed on the following HP web site: <http://www.hp.com/support/>. From this web site, select the country of origin.



NOTE:

For continuous quality improvement, calls may be recorded or monitored.

Be sure to have the following information available before calling:

- Technical support registration number (if applicable)
- Product serial numbers
- Product model names and numbers
- Applicable error messages
- Operating system type and revision level
- Detailed, specific questions

HP storage web site

The HP web site has the latest information on this product, as well as the latest drivers. Access storage at: <http://www.hp.com/country/us/eng/prodserv/storage.html>. From this web site, select the appropriate product or solution.

HP authorized reseller

For the name of your nearest HP authorized reseller:

- In the United States, call 1-800-345-1518
- In Canada, call 1-800-263-5868
- Elsewhere, see the HP web site for locations and telephone numbers: <http://www.hp.com>.

1 Introduction

This section describes the HP StorageWorks 6000 Virtual Library System features and models.

Features

The HP StorageWorks 6000 Virtual Library System (VLS) is a RAID 5, serial ATA disk-based SAN backup device that emulates physical tape libraries, allowing you to perform disk-to-virtual tape (disk-to-disk) backups using your existing backup application(s). The many benefits of performing data backups to a VLS instead of physical tape are described in [Benefits](#).

The VLS emulates a variety of physical tape libraries, including the tape drives and cartridges inside the libraries. You determine the number and types of tape libraries a VLS emulates, and the number and type of tape drives and cartridges included in each tape library to meet the needs of your environment. You configure the size of the virtual cartridges in your VLS, which provides even more flexibility. The VLS emulates up to 16 tape libraries, 64 tape drives, and 1024 cartridges.

The VLS accommodates mixed IT platform and backup application environments, allowing all your servers and backup applications to access the virtual media simultaneously. You can specify which servers are allowed to access each virtual library and tape drive you configure. You can change the default LUNs assigned to the virtual library and tape drives for each host as needed to accommodate different operating system requirements and restrictions.

Data stored on a VLS is easily cloned to physical tape for offsite disaster protection or long-term archival using a backup application.

Benefits

Integrating a VLS into your existing storage and backup infrastructure delivers the following benefits:

- **Faster backups**

Backup speeds are limited by the number of tape drives available to the SAN hosts. The VLS emulates many more tape drives than are available in physical tape libraries, allowing more hosts to run backups concurrently.

The VLS is optimized for backups and delivers faster performance than a simple disk-to-disk solution.

- **Faster single file restores**

A single file can be restored much faster from disk than tape.

- **Lower operating costs**

Fewer physical tape drives and cartridges are required as full backups to tape are eliminated. Also, fewer cartridges are required as small backups stored on multiple virtual cartridges can be copied to one physical cartridge.

- **More efficient use of storage space**

Physical tape libraries cannot share storage space with other physical tape libraries, and physical cartridges cannot share storage space with other physical cartridges. This unused storage space is wasted.

Storage space is not wasted in a VLS, because VLS storage space is dynamically assigned as it is used. Storage space is shared by all the libraries and cartridges configured on a VLS.

- **Reduced risk of data loss and aborted backups**

RAID 5-based storage is more reliable than tape storage.

Aborted backups caused by tape drive mechanical failures are eliminated.

Self-managing RAID configurations

Configuration of the VLS disk array and node hard drives is fully automated and self-managed by the VLS - no administrator action is required. The VLS software automatically builds the disk array and node hard drive RAID volumes and repairs any RAID volume failures when failed disks are replaced.



CAUTION:

Do not alter the disk array or node hard drive configurations in any way. System failure will result.

Disk array hard drives

VLS disk storage consists of one to four MSA20 disk arrays each configured into two 5+1 (5 data disks, 1 parity disk) RAID 5 volumes presented as two LUNs (one LUN per RAID volume) (Figure 1). All the disk arrays are logically grouped together to form one storage pool.

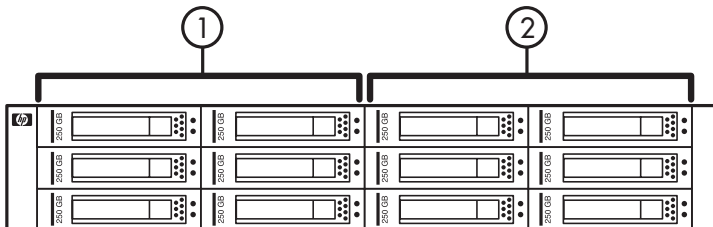

Figure 1 Disk array RAID volume configuration

Item	Description
1	RAID volume 1
2	RAID volume 2

This RAID configuration prevents data loss if one hard drive fails in any of the RAID volumes. It also prevents a single hard drive failure in any of the RAID volumes from causing a backup window to be missed.



CAUTION:

Replace a failed disk array hard drive as soon as possible. If a second disk in a RAID volume fails before the first failed disk is replaced, the entire RAID volume will fail and the data on that RAID volume will be destroyed.

Since, virtual media data is evenly striped across all the RAID volumes for high performance, it is very likely that a single RAID volume failure will affect every piece of virtual media, making all the data stored on the disk arrays unrecoverable.

Node hard drives

The VLS node (head unit) contains two system hard drives configured into a RAID 1 (mirrored) volume. This provides dual boot capability if one of the system hard drives fail.

System status monitoring

VLS hardware, environmental, and virtual device (library, tape drive, cartridge) status is constantly monitored by the VLS software and displayed on the VLS web user interface, Command View VLS.

A notification alert is generated by the VLS software when a hardware or environmental failure is detected or predicted. VLS notification alerts are displayed on Command View VLS, and can also be sent as email to the email addresses you specify and/or SNMP traps to the management consoles you specify.

For more information about viewing VLS hardware status, and/or receiving VLS notification alerts by email or as SNMP traps, see [Monitoring](#).

Redundancy

The VLS includes some important redundancy features:

- **Redundant fans**

Both the disk array and node include redundant fans. If a fan module fails in a disk array, the remaining fan module runs at a faster speed, temporarily providing enough cooling. If a fan fails in the node (head unit), the remaining fans in the fan module run at a faster speed, temporarily providing enough cooling.

- **Redundant power supply**

The disk array includes a redundant power supply, and a redundant power supply can be added to the node as an option. With redundant power supplies, if one power supply fails in a disk array or node, the remaining functional power supply provides enough power for the disk array or node to function. HP recommends that each power supply source be connected to a separate power circuit at the site.



CAUTION:

Replace a failed fan or power supply as soon as possible to maximize the life expectancy of the remaining fan(s) or power supply and to maintain redundancy.

For more information about VLS features, visit the HP web site: <http://www.hp.com>

Models

The VLS family includes two models that vary in storage capacity and performance:

- 2.5 TB base capacity model: VLS6105
- 5 TB base capacity model: VLS6510

VLS6105

A VLS6105 consists of a node (head unit) and one Modular Smart Array 20 (MSA20) disk array. The node includes a single processor, two 2 GB Fibre Channel host ports, and two VHDCI connectors. The disk array contains twelve 250 GB serial ATA disks.

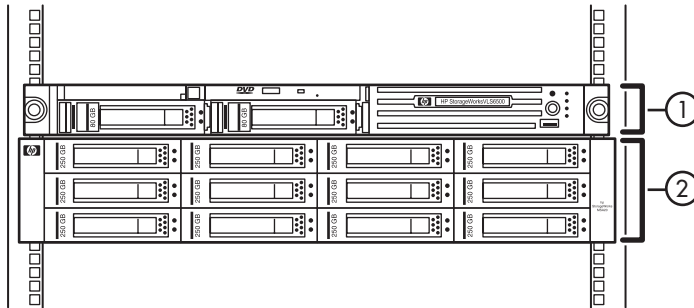

Item	Description
1	Node
2	Disk array

An optional second MSA20 disk array can be added to a VLS6105 by purchasing a VLS 2.5TB capacity bundle. A VLS 2.5TB capacity bundle includes a disk array with twelve 250 GB serial ATA disks and a capacity license for the additional disk array. Adding a second disk array doubles the VLS6105 storage capacity as shown in [Table 2](#). It also increases the performance.



NOTE:

You can also re-use an existing MSA20 disk array with twelve blank 250 GB serial ATA disks and the latest MSA20 firmware, and purchase a capacity license for the additional disk array separately.

Table 2 VLS6105 capacity

Description	Base model	Base model + capacity bundle
No data compression (1:1)	2.5 TB	5 TB
Data compression enabled (2:1)	5 TB	10 TB

VLS6510

A VLS6510 consists of a node (head unit) and two MSA20 disk arrays. The node contains dual processors, four 2 GB Fibre Channel host ports, and four VHDCI connectors. Each disk array contains twelve 250 GB serial ATA disks.

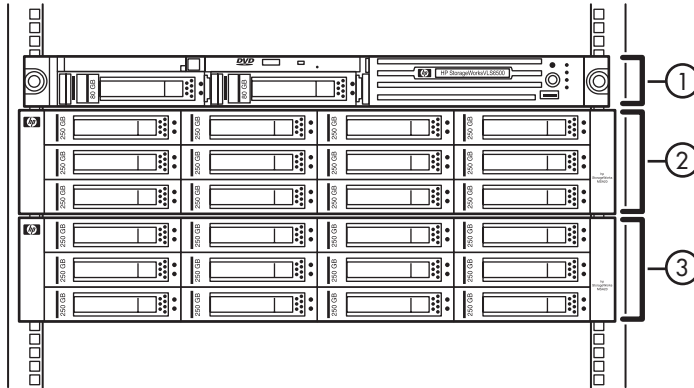

Item	Description
1	Node
2	Disk array 1
3	Disk array 2

An optional third and fourth disk array can be added to a VLS6510 by purchasing one or two VLS 2.5TB capacity bundles. A VLS 2.5TB capacity bundle includes a disk array with twelve 250 GB serial ATA disks and a capacity license for the additional disk array.

Adding a third and fourth disk array doubles the VLS6510 storage capacity as shown in [Table 3](#). It also increases the performance.



NOTE:

You can also re-use an existing MSA20 disk array with twelve blank 250 GB serial ATA disks and the latest MSA20 firmware, and purchase a capacity license for the additional disk array separately.

Table 3 VLS6510 capacity

Description	Base model	Base model + 1 capacity bundle	Base model + 2 capacity bundle
No data compression (1:1)	5 TB	7.5 TB	10 TB
Data compression enabled (2:1)	10 TB	15 TB	20 TB

2 Installation

This section details the steps to install the VLS hardware. Installation consists of six steps:

- Preparing for the installation
- Unpacking
- Identifying the VLS shipping carton contents
- Installing the node into a rack
- Installing the disk array(s) into a rack
- Installing cables

Preparing for the installation

Tools for installation

- Two people
- Phillips screwdriver
- Box cutting knife

Taking ESD precautions

To prevent damaging the system, be aware of the precautions you need to follow when setting up the system or handling parts. A discharge of static electricity from a finger or other conductor may damage system boards or other static-sensitive devices. This type of damage may reduce the life expectancy of the device.

To prevent electrostatic damage:

- Avoid hand contact by transporting and storing products in static-safe containers.
- Keep electrostatic-sensitive parts in their containers until they arrive at static-free workstations.
- Place parts on a grounded surface before removing them from their containers.
- Avoid touching pins, leads, or circuitry.
- Always be properly grounded when touching a static-sensitive component or assembly.

Grounding methods to prevent electrostatic discharge

Several methods are used for grounding. Use one or more of the following methods when handling or installing electrostatic-sensitive parts:

- Use a wrist strap connected by a ground cord to a grounded workstation or computer chassis. Wrist straps are flexible straps with a minimum of 1 megaohm ± 10 percent resistance in the ground cords. To provide proper ground, wear the strap snug against the skin.
- Use heel straps, toe straps, or boot straps at standing workstations. Wear the straps on both feet when standing on conductive floors or dissipating floor mats.
- Use conductive field service tools.
- Use a portable field service kit with a folding static-dissipating work mat.

If you do not have any of the suggested equipment for proper grounding, have an authorized reseller install the part.

For more information on static electricity or assistance with product installation, contact your authorized reseller.

Unpacking

Place the shipping carton as close to the installation site as possible. Before unpacking the VLS, inspect the shipping carton for damage that may have occurred during shipment. If you detect any damage, notify the carrier and HP before unpacking the unit.

Removing the VLS from the shipping carton



WARNING!



The MSA20 disk array weighs 24.6 kg (54.3 lb) full. At least two people are required to lift and move the disk array.

The node weighs 16.78 kg (37 lb) full. At least two people are required to lift and move the node.

Removing the packing materials

To unpack the VLS:

1. Open the top of the shipping cartons.
2. Carefully lift the units out of the boxes and remove the packing materials.
3. Place the units on a stable work surface.



NOTE:

Inspect the units for any damage that may have occurred during shipment. If damage is detected, contact your authorized service representative.

4. Remove the accessory kits and documentation from the shipping cartons. Set them aside for later use.
5. Place shipping materials back into the shipping cartons.
6. Set the shipping cartons aside for future use.

Rack planning resources

The rack resource kit ships with all HP or Compaq branded 9000, 10000, and H9 series racks. A summary of the content of each resource follows:

- Custom Builder is a web-based service for configuring one or many racks. Rack configurations can be created using:
 - A simple, guided interface
 - Build-it-yourself model
- The Installing Rack Products video provides a visual overview of operations required for configuring a rack with rack-mountable components. It also provides the following important configuration steps:
 - Planning the site
 - Installing rack servers and rack options
 - Cabling servers in a rack
 - Coupling multiple racks
- The Rack Products Documentation CD enables you to view, search, and print documentation for HP and Compaq branded racks and rack options. It also helps you set up and optimize a rack in a manner that best fits your environment.

Rack requirements

HP supports the HP System E racks and the HP 10000 Series racks for use with the VLS. Other racks might also be suitable, but have not been tested with the VLS.

Rack warnings



WARNING!

To reduce the risk of personal injury or damage to the equipment, be sure that:

- The leveling jacks are extended to the floor.
 - The full weight of the rack rests on the leveling jacks.
 - The stabilizing feet are attached to the rack if it is a single-rack installation.
 - The racks are coupled together in multiple-rack installations.
 - Only one component is extended at a time. A rack may become unstable if more than one component is extended for any reason.
-



WARNING!



To reduce the risk of personal injury or equipment damage when unloading a rack:

- At least two people are needed to safely unload a rack from a pallet. An empty 42U rack can weigh as much as 115 kg (253 lb), can stand more than 2.1 m (7 ft) tall, and may become unstable when being moved on its casters.
 - Never stand in front of a rack when it is rolling down the ramp from the pallet. Always handle a rack from both sides.
-

Optimum environment

When installing a VLS in a rack, select a location that meets the environmental standards described in this section and [Environmental specifications](#).

Space and airflow requirements

To allow for servicing and adequate airflow, observe the following space and airflow requirements when deciding where to install a rack:

- Leave a minimum clearance of 122 cm (48 in) in front of the rack.
- Leave a minimum clearance of 76.2 cm (30 in) behind the rack.
- Leave a minimum clearance of 122 cm (48 in) from the back of the rack to the back of another rack when racks are back-to-back.

The VLS draws in cool air through the front door and expels warm air through the rear door. Therefore, the front and rear rack doors must be adequately ventilated to allow ambient room air to enter the cabinet, and the rear door must be adequately ventilated to allow the warm air to escape from the cabinet.



CAUTION:

To prevent improper cooling and damage to the equipment, do not block the ventilation openings.

When vertical space in the rack is not filled by a VLS or rack component, the gaps between the components cause changes in airflow through the rack and across the servers. Cover all gaps with blanking panels to maintain proper airflow.



CAUTION:

Always use blanking panels to fill empty vertical spaces in the rack. This arrangement ensures proper airflow. Using a rack without blanking panels results in improper cooling that can lead to thermal damage.

The Compaq 10000 Series racks provide proper VLS cooling from flow-through perforations in the front and rear doors that provide 64 percent open area for ventilation.



CAUTION:

If a third-party rack is used, observe the following additional requirements to ensure adequate airflow and to prevent damage to the equipment:

- Front and rear doors—If the 42U rack includes closing front and rear doors, you must allow 5,350 sq cm (830 sq in) of holes evenly distributed from top to bottom to permit adequate airflow (equivalent to the required 64 percent open area for ventilation).
- Side—The clearance between the installed rack component and the side panels of the rack must be a minimum of 7 cm (2.75 in).

Temperature requirements

To ensure continued safe and reliable equipment operation, install or position the system in a well-ventilated, climate-controlled environment.

The maximum recommended ambient operating temperature (TMRA) for the VLS is 35°C (95°F). The temperature in the room where the rack is located must not exceed 35°C (95°F).



CAUTION:

To reduce the risk of damage to the equipment when installing third-party options:

- Do not permit optional equipment to impede airflow around the VLS or to increase the internal rack temperature beyond the maximum allowable limits.
 - Do not exceed the TMRA.
-

Power requirements

Installation of a VLS must comply with local and regional electrical regulations governing the installation of information technology equipment by licensed electricians. This equipment is designed to operate in installations covered by NFPA 70, 1999 Edition (National Electric Code) and NFPA-75, 1992 (code for Protection of Electronic Computer/Data Processing Equipment). For electrical power ratings on options, see the product rating label or the user documentation supplied with that option.



WARNING!

To reduce the risk of personal injury, fire, or damage to the equipment, do not overload the AC supply branch circuit that provides power to the rack. Consult the electrical authority having jurisdiction over wiring and installation requirements of your facility.



CAUTION:

Protect the VLS from power fluctuations and temporary interruptions with a regulating uninterruptible power supply (UPS). This device protects the hardware from damage caused by power surges and voltage spikes and keeps the system in operation during a power failure.

When installing a VLS with more than one disk array, you may need to use additional power distribution devices to safely provide power to all devices. Observe the following guidelines:

- Power up one MSA20 disk array at a time.
- Balance the device power load between available AC supply branch circuits.
- Do not allow the overall system AC current load to exceed 80 percent of the branch circuit AC current rating.
- Do not use common power outlet strips for this equipment.
- Provide a separate electrical circuit for each device.

Electrical grounding requirements

The VLS must be grounded properly for proper operation and safety. In the United States, you must install the equipment in accordance with NFPA 70, 1999 Edition (National Electric Code), Article 250, as well as any local and regional building codes. In Canada, you must install the equipment in accordance with Canadian Standards Association, CSA C22.1, Canadian Electrical Code. In all other countries, you must install the equipment in accordance with any regional or national electrical wiring codes, such as the International Electrotechnical Commission (IEC) Code 364, parts 1 through 7. Furthermore, you must be sure that all power distribution devices used in the installation, such as branch wiring and receptacles, are listed or certified grounding-type devices.

Because of the high ground-leakage currents associated with multiple VLS and servers connected to the same power source, HP recommends the use of a power distribution unit (PDU) that is either permanently wired to the building's branch circuit or includes a nondetachable cord that is wired to an industrial-style plug. NEMA locking-style plugs or those complying with IEC 60309 are considered suitable for this purpose. Using common power outlet strips for a VLS is not recommended.

Identifying the shipping carton contents

Unpack the VLS shipping cartons and locate the materials and documentation necessary for installing the VLS. All the rack mounting hardware and documentation necessary for installing the VLS node into a rack is included in the node shipping carton. All the rack mounting hardware and documentation necessary for installing the VLS disk array into a rack is included in the disk array shipping carton.

Node shipping carton

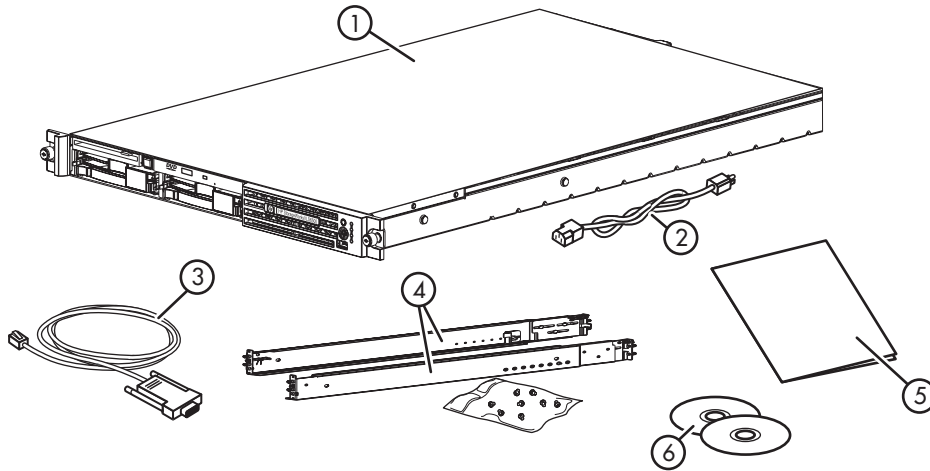

Item	Description	Item	Description
1	Node	4	1U rack mounting hardware kit and documentation
2	Node power cord	5	Printed VLS node installation poster
3	Serial cable	6	Documentation CD and VLS Quick Restore CD

Disk array shipping carton

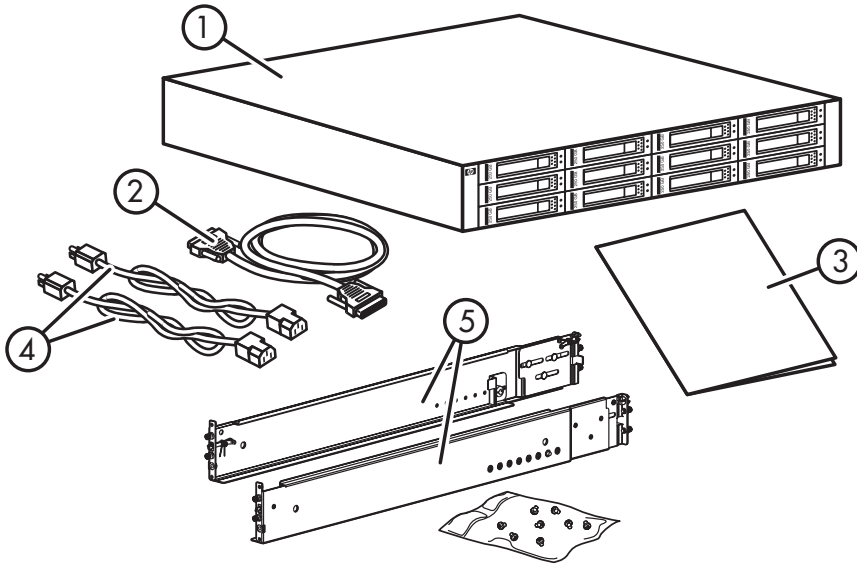

Item	Description	Item	Description
1	MSA20 disk array	4	Disk array power cords (2)
2	SCSI cable	5	2U rack mounting hardware kit and documentation
3	Printed VLS disk array installation poster		

Installing the node into a rack

To install the node into a rack with square, round, or threaded holes, see the instructions that ship with the 1U rack hardware kit.



NOTE:

Allow enough rack space above and/or below the node to mount the disk array(s). A disk array requires a vertical rack space of 2U (equivalent to 89 mm, or 3.5 inches).

Do not plan to mount more than two disk arrays above or below the node, as doing so will prevent you from extending the node from the rack due to length of the SCSI cable(s) that attaches the disk array(s) to the node. Longer SCSI cables may be substituted.

If you are installing the node into a telco rack, order the appropriate option kit at the RackSolutions.com web site: <http://www.racksolutions.com/hp>. Follow the instructions on the web site to install the rack brackets.

Installing the disk array(s) into a rack

This section describes how to install the MSA20 disk array.



WARNING!

Do not use the handles on the disk array power supply units to lift or hold the disk array. These handles are designed only for holding the power supply units or removing them from the disk array, not for supporting the weight of the disk array.



CAUTION:

Before installing a VLS 2.5TB capacity bundle, install the capacity license shipped with the capacity bundle on the VLS as described in [Installing capacity licenses](#). If a capacity bundle is installed before its capacity license is installed, a license violation will occur when the VLS node is powered up. This will disable all the VLS storage capacity until the capacity license is installed and the VLS is rebooted.



NOTE:

Once a disk array is added to the VLS, the only way it can be removed from the VLS configuration (storage pool) is by re-installing the VLS operating system and then rebuilding the virtual library configuration.

Rack mounting requirements

Each disk array requires a vertical rack space of 2U (equivalent to 89 mm, or 3.5 inches).



NOTE:

No more than two disk arrays should be mounted above or below the node, as doing so will prevent you from extending the node from the rack due to length of the SCSI cable(s) that attaches the disk array(s) to the node. Longer SCSI cables may be substituted.

HP recommends that you mount the disk arrays in the order shown in [Figure 2](#).

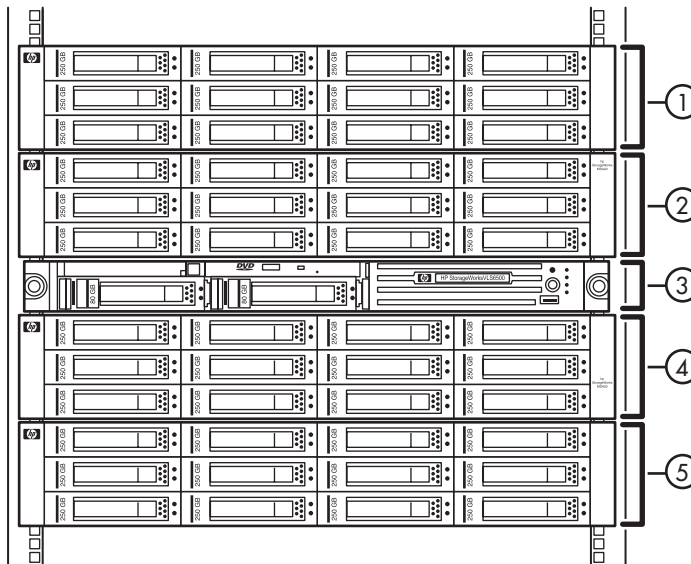

Figure 2 Disk array rack mounting order

Item	Description
1	Disk array 4
2	Disk array 3
3	Node
4	Disk array 1
5	Disk array 2

Mounting into a rack



WARNING!



The disk array weighs 24.6 kg (54.3 lb) full. At least two people are required to lift, move, and install the disk array.

1. Use the 2U rack mounting template as a guide to indicate where on the rack the rails for the disk array are to be mounted.
 - a. At the front of the rack, with the front of the template facing you, align the lower edge of the template with the bottom of the rack (or the top of the previous rack component). Be sure that the lower edge of the template is level.
 - b. Push the template tabs into the holes in the rack uprights to hold the template in place.

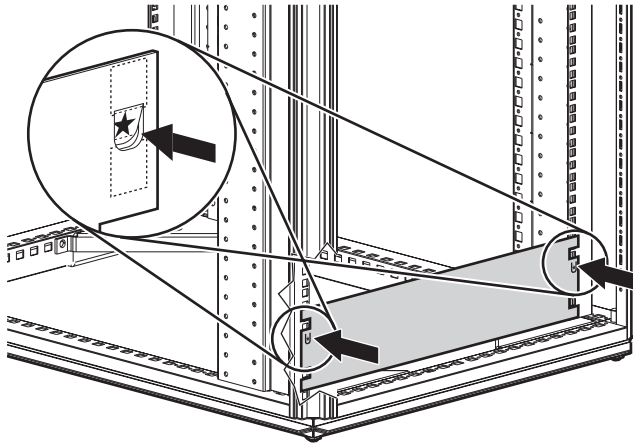

Figure 3 Position the rack mounting template

- c. Use a permanent marker pen to indicate the holes in the rack uprights into which the scissor-like locking latches are to be inserted, as specified by the template.
 - d. Repeat these steps to mark the back of the rack, using the information on the back of the template as a guide to the required location of the locking latches in this case.



WARNING!

The pins in the rails are load-bearing. Do not remove the pins except to replace them with the pins for round-hole racks.

2. If the holes in the rack uprights are round instead of square, remove the standard pins from the rails and replace them with the round-hole pins provided in the rack mounting hardware kit.
3. Identify the left (L) and right (R) rack rails by markings stamped into the rails.
4. Slide the front end of the right rack rail toward the inside front of the rack until the locking latch engages with the marked hole in the front rack upright.

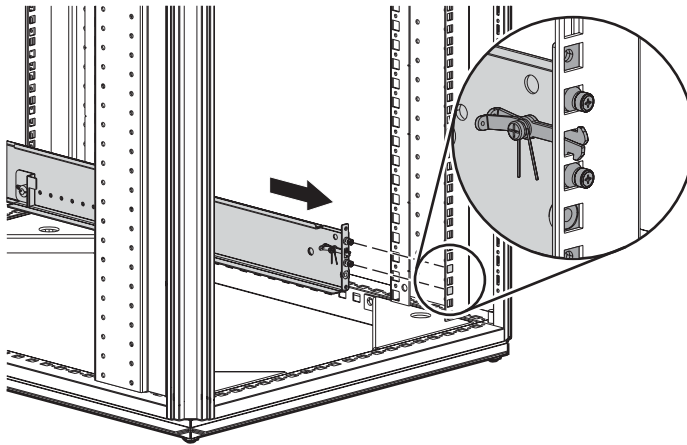

Figure 4 Engage the rack rail with the marked hole in the front of the rack

5. Extend the back end of the rail toward the inside rear of the rack until the locking latch engages with the marked hole in the rear rack upright.

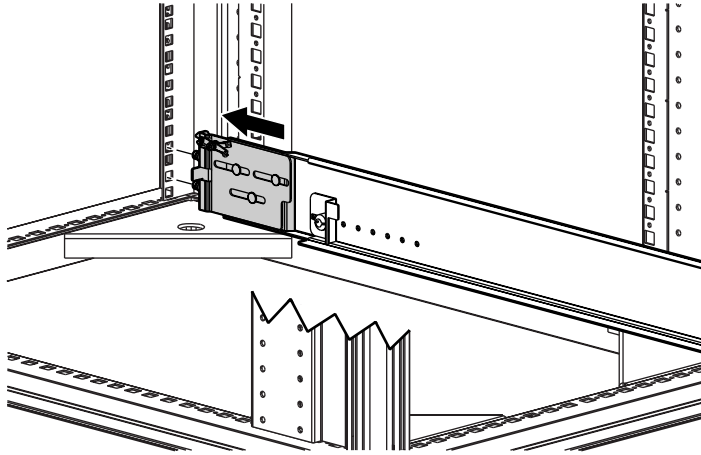

Figure 5 Engage the rack rail with the marked hole in the rear of the rack

6. Loosen the locknut on the shipping bracket, and move the bracket to the rearmost position on the rail.

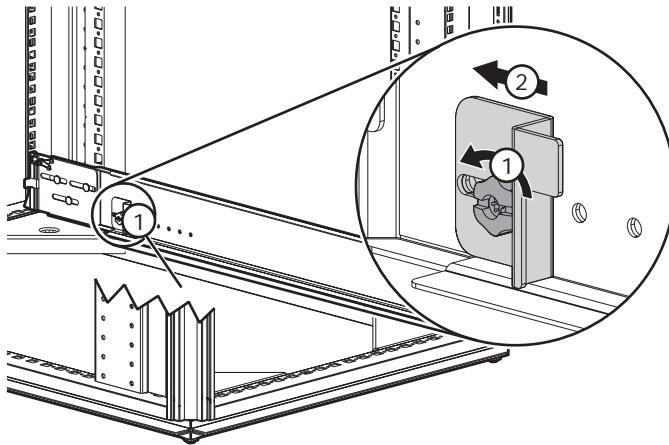

Figure 6 Loosen the locknut on the shipping bracket

7. Repeat steps 4 through 6 for the left rack rail.
8. Align the disk array with the rails, and slide it into the rack.

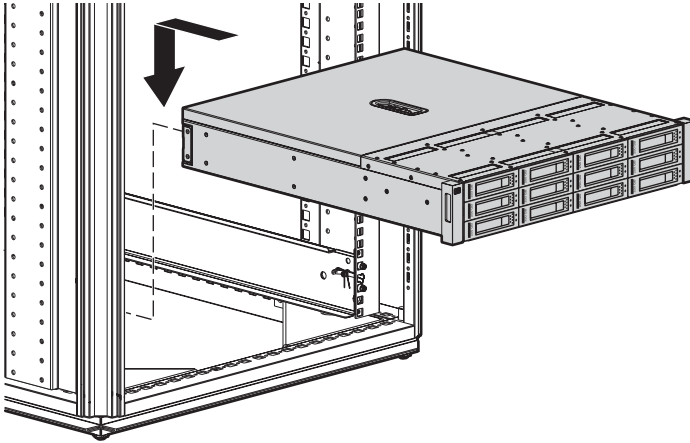

Figure 7 Align the disk array with the rails

9. Remove the mounting bracket covers, and tighten the thumbscrews to secure the disk array to the rack.

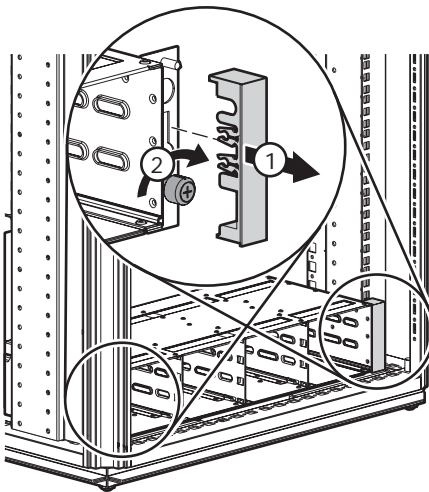

Figure 8 Remove the mounting bracket covers

10. Replace the mounting bracket covers.
11. If you intend to move the rack while the disk array is installed, adjust the shipping brackets on each rail to secure the disk array to the rack.
 - a. Loosen the shipping bracket locknut.
 - b. Slide the bracket forward until it engages with the disk array chassis.

- c. Tighten the locknut.
- d. Repeat this procedure for the other rail.

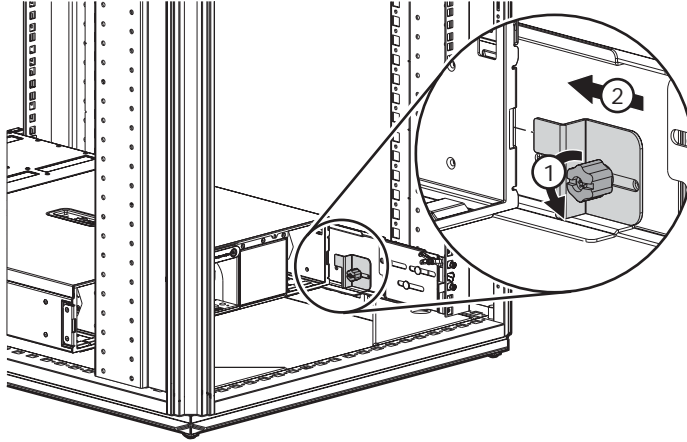

Figure 9 Slide the bracket forward to engage with the disk array

Installing cables

1. Connect Fibre Channel cables from your SAN media server to the node Fibre Channel host ports, starting with Fibre Channel host port 0 and working towards Fibre Channel host port 3 (Figure 10).

Leave the Fibre Channel loopback plug in any unused Fibre Channel host port(s). This will prevent you from receiving Fibre Channel notification alerts, which are generated by the VLS when no signal is detected at a Fibre Channel host port.

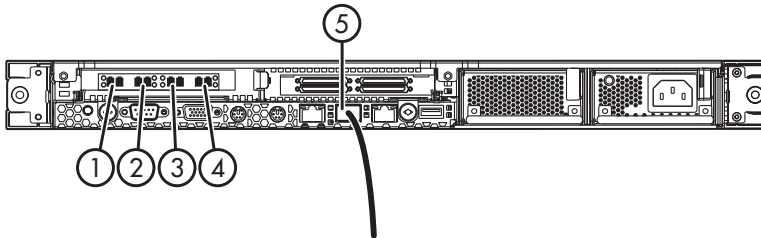

Figure 10 Connect SAN and LAN cabling to the node

Item	Description
1	Fibre Channel host port 0
2	Fibre Channel host port 1
3	Fibre Channel host port 2
4	Fibre Channel host port 3
5	10/100/1000 NIC 1 connector

2. Connect a standard Ethernet (CAT-5) cable from your local IP network (LAN) to the 10/100/1000 NIC 1 (RJ-45) connector (Figure 10).



WARNING!

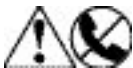

To reduce the risk of electric shock, fire, or damage to the equipment, do not plug telephone or telecommunications connectors into RJ-45 (NIC) connectors.

3. Connect the VHDCI connector on each disk array to the appropriate VHDCI connector on the node (Figure 11).

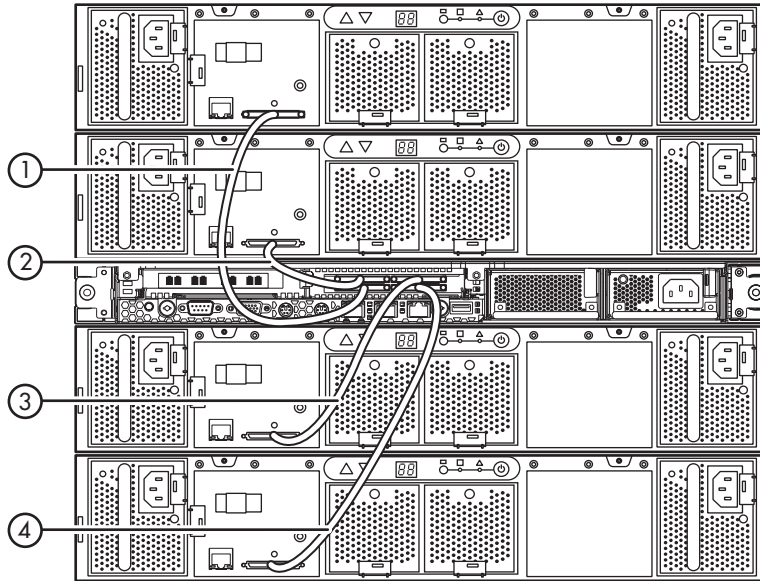

Figure 11 Connect the VHDCI connector on each disk array to the appropriate VHDCI connector on the node

Item	Description
1	VHDCI connector B2, connect to disk array 4
2	VHDCI connector B1, connect to disk array 3
3	VHDCI connector A1, connect to disk array 1
4	VHDCI connector A2, connect to disk array 2



WARNING!



To reduce the risk of electric shock or damage to the equipment:

- Do not disable the power cord grounding plug. The grounding plug is an important safety feature.
- Plug the power cord into a grounded (earthed) electrical outlet that is easily accessible at all times.
- Unplug the power cord from the power supply to disconnect power to the equipment.
- Do not route the power cord where it can be walked on or pinched by items placed against it. Pay particular attention to the plug, electrical outlet, and the point where the cord extends from the node.

4. Connect the AC input socket of the node power supply(s) to an AC power source using the power cable(s) provided (Figure 12).

The VLS base configuration includes only one power supply. An optional second, redundant power supply (shown) may be purchased.

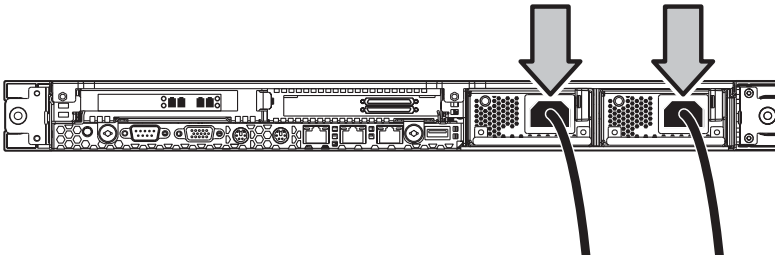

Figure 12 Connect the node power supply(s) to an AC power source

5. Use the strain relief clip from the node hardware kit to secure the power cord (Figure 13).

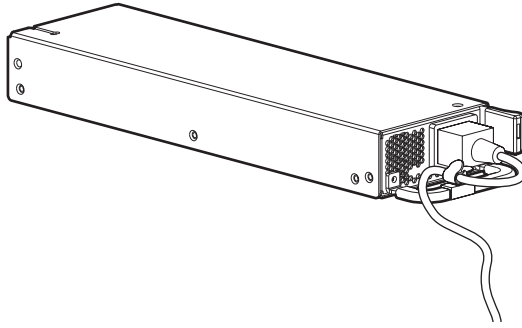

Figure 13 Secure the power cord with the strain relief clip

6. Connect the AC input socket of each disk array power supply to an AC power source using the power cables provided (Figure 14).

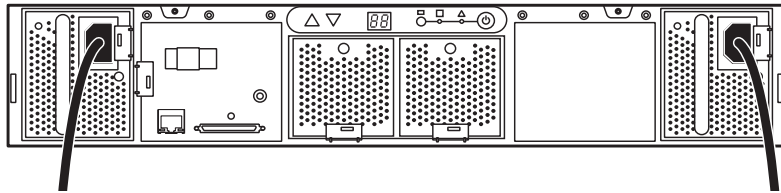

Figure 14 Connect the disk array power supplies to an AC power source

Installation is complete. You may now power up the disk array(s) and then the node as described in [Operation](#).

3 Operation

This section describes how to power up and power down the VLS node and disk arrays. It is comprised of the following topics:

- Powering up the disk arrays
- Powering up the node
- Rebooting the node
- Powering down the node
- Powering down the disk arrays

Powering up the disk array(s)



CAUTION:

Only power up one disk array at a time to avoid overloading the AC power source.

To power up a disk array:

1. Press the power button on the rear of the disk array.
2. Confirm that the disk array components are all functioning normally by observing the condition of their status LEDs, which should all be green. If the amber LED on any component is illuminated, the component needs attention for one of these reasons:
 - It has suffered a critical fault.
 - It is not seated properly in the disk array.
 - In the case of a hard drive, it is predicted to fail in the near future (assuming that it is seated properly in the disk array).
 - In the case of a power supply, it is not plugged in.



NOTE:

The hard drive LEDs may not immediately illuminate when the disk array is powered on. The LEDs illuminate after the hard drives are configured by the VLS software.

Powering up the node

To power up the node:

1. Plug the node AC power cord(s) into a power source if not already connected.
2. Press the Power On/Standby button. See [Node front panel LEDs and buttons](#).
3. Confirm that the VLS components are all functioning normally and the VLS is cabled correctly by observing the condition of their status LEDs. The LED statuses should match those shown in the following table.

If an LED status does not match the status shown in the following table, a component needs attention.

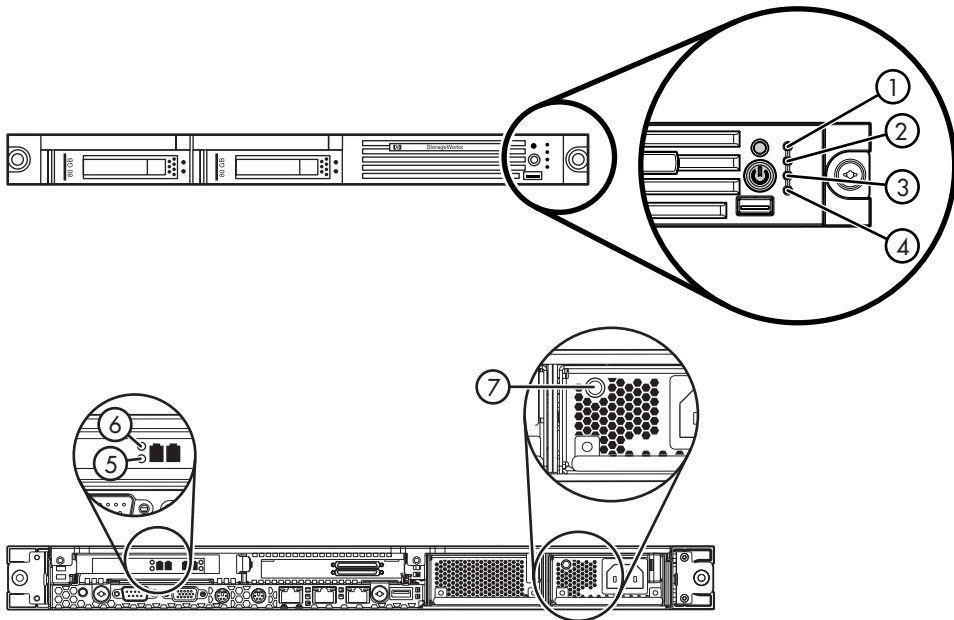

Figure 15 Node LED status during normal operation

Item	Description	Status
1	Internal health LED	LED is green.
2	External health LED (power supply)	LED is green if there are two power supplies. LED is amber if there is one power supply.

Item	Description	Status
3	NIC 1 link LED	LED is green.
4	NIC 2 link LED	LED is off.
5, 6	Fibre Channel port LEDs	Green LED is illuminated. Amber LED is not illuminated.
7	Power supply LED	LED is green.

Rebooting the node

To reboot the node:

1. Verify that any backup or restore operation has completed and that the VLS is idle.
2. Open a secure shell session and log in as the administrator. See [Opening a secure shell session](#).
3. Initiate a reboot of the VLS by entering:

```
restartSystem
```

Powering down the node



WARNING!



To reduce the risk of personal injury, electric shock, or damage to the equipment, remove the power cord to remove power from the node before removing the access panel. The front panel Power On/Standby button does not completely shut off system power. Portions of the power supply and some internal circuitry remain active until AC power is removed.

To power down the node:

1. Verify that any backup or restore operation has completed and that the VLS is idle.
2. Open a serial session and log in as the administrator. See [Opening a serial session](#).
3. Initiate a shutdown of the VLS by entering:

```
shutdownSystem
```

4. When the VLS has completed its shutdown operation, press the UID LED button. See [Node front panel LEDs and buttons](#).

Blue LEDs illuminate on the front and rear panels of the node.

5. Press the **Power On/Standby** button to place the node in standby mode.

When the node activates standby power mode, the system power LED changes to amber.

6. Go to the back of the rack and locate the node by identifying the illuminated rear UID LED button.
7. Unplug the node AC power cord(s) from the power source if you will be removing the access panel.

The node is now without power.

Powering down the disk array(s)



CAUTION:

Always power down the node before disconnecting a VHDCI cable or powering down a disk array to prevent the appliance from erroneously detecting a disk array RAID volume failure.



NOTE:

It is not necessary to power down a disk array when replacing a disk array fan module, power supply, or hard drive.

To power down a disk array:

1. Power down the node. See [Powering down the node](#).
2. Press the power button on the rear of the disk array.

4 User interfaces

This section describes the three user interfaces (UIs) that can be used to configure, manage, and monitor the VLS over the web, remotely over the LAN, or through a serial connection. It also provides instructions on how to open and close a connection to the VLS for each type of user interface. It is comprised of the following topics:

- [User interface requirements](#)
- [Command View VLS](#)
- [Secure shell and serial user interfaces](#)

User interface requirements

Table 4 lists the VLS user interfaces and their requirements. Of the three user interfaces, Command View VLS should be used in most circumstances. It is the most intuitive and easiest to learn and use.

Multiple user interface sessions may be open at once.

Table 4 VLS user interfaces

User interface	Requirements	Configuration	For more information
Command View VLS	PC or workstation networked attached to the VLS running Microsoft Internet Explorer 6.0 or higher, or Netscape Navigator 4.7 or higher	10/100/1000 BaseT Ethernet port configured with an appropriate IP address, host name, domain name, subnet mask, and gateway <ul style="list-style-type: none">• Can login as Administrator or User.	See Command View VLS .
Secure shell (ssh)	Secure shell client (such as PuTTY)	10/100/1000 BaseT Ethernet port configured with an appropriate IP address, subnet mask, and gateway <ul style="list-style-type: none">• Can login as Administrator only.	See Secure shell and serial user interfaces .
Serial	Null-modem cable and terminal emulation program (such as Windows Hyperterminal) configured to 115200 baud	Only one serial connection at a time is permissible. <ul style="list-style-type: none">• Can login as Administrator or Emergency user.	See Secure shell and serial user interfaces .

Command View VLS

Command View VLS is a web browser-based GUI that you can use to configure, manage, and monitor your VLS through a LAN. Command View VLS provides the following:

- Configuration and management of VLS virtual devices (libraries and tape drives) and cartridges, including LUN masking and LUN mapping
- Changing of the default Fibre Channel host port settings
- Viewing and deletion of VLS notification alerts
- Configuration of VLS email and SNMP notification alert settings
- Editing of VLS account passwords
- Enabling and disabling of storage capacity oversubscription
- Viewing VLS hardware and virtual device status
- Installation of VLS software updates
- Saving and restoring VLS network settings and virtual library configurations
- Restarting the VLS device emulations and Command View VLS
- Viewing and saving VLS trace log files

Command View VLS is installed on the VLS and communicates through the LAN. Users can open a Command View VLS session from a web browser on the LAN, HP StorageWorks CommandView TL, or HP Systems Insight Manager.

Window regions

Command View VLS windows consist of five regions. Not all regions are displayed on all windows.

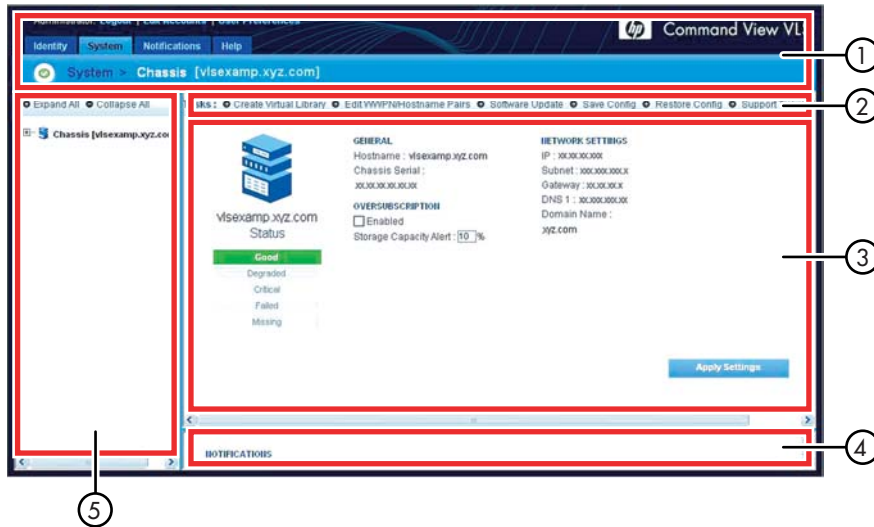

Item	Description
1	Status banner
2	Task bar
3	Status pane
4	Notifications pane
5	Navigation tree



NOTE:

You can enlarge or reduce any region on the window. To change the size of a region, position your cursor on the border of a pane, and press the left mouse button while simultaneously dragging the border.

Opening a Command View VLS session from a web browser



NOTE:

Before you can open a Command View VLS session, you must set the VLS network settings. See [Setting the network settings](#).

To open a Command View VLS session from a web browser:

1. Launch a web browser.
2. In the web browser URL box, enter:

```
https://<fully qualified name of the VLS>
```



NOTE:

Entering "[http://<fully qualified name>](#)" instead of the above URL automatically redirects you to the secure "[https://<fully qualified name>](#)" connection. All communications are over a secure connection.

3. If a Security Alert window opens and prompts you to accept the Secure Sockets Layer (SSL) certificate, install the SSL certificate as described in [Installing the SSL certificate into your web browser](#).

The first time you open a Command View VLS session (and the first time you open a Command View VLS session after changing the fully qualified name of the VLS), a Security Alert window opens and prompts you to accept the Secure Sockets Layer (SSL) certificate.



Figure 16 Command View VLS login window

4. Enter administrator or user in the **Username** box (Figure 16). The username is case sensitive.



NOTE:

Logging in as administrator gives you full privileges to all VLS functions available through Command View VLS. Logging in as a user gives you only viewing and cartridge management privileges.

5. Enter the appropriate password in the **Password** box for the username entered (Figure 16).

The default administrator password is `admin`. The default user password is `guest`. The password is case sensitive.

6. Click **Login**.

Opening a Command View VLS session from Command View TL



NOTE:

Before you can open a Command View VLS session from Command View TL, you must first install Command View TL on a PC or workstation and then add the VLS to Command View TL. See the *HP OpenView Command View for TL User Guide* for instructions.

Command View TL gives you the ability to manage and license multiple virtual and physical tape libraries from a single management application.

To open a Command View VLS session from Command View TL:

1. Start Command View TL.
2. From the **Library Selection** tab of the **Launcher** window, double-click the VLS from the list of libraries.
3. If a Security Alert window opens and prompts you to accept the Secure Sockets Layer (SSL) certificate, install the SSL certificate as described in [Installing the SSL certificate into your web browser](#).

The first time you open a Command View VLS session (and the first time you open a Command View VLS session after changing the fully qualified name of the VLS), a Security Alert window opens and prompts you to accept the Secure Sockets Layer (SSL) certificate.

4. Enter administrator or user in the **Username** box ([Figure 16](#)). The username is case sensitive.



NOTE:

Logging in as administrator gives you full privileges to all VLS functions available through Command View VLS. Logging in as a user gives you only viewing and cartridge management privileges.

5. Enter the appropriate password in the **Password** box for the username entered ([Figure 16](#)).

The default administrator password is `admin`. The default user password is `guest`. The password is case sensitive.

6. Click **Login**.

Installing the SSL certificate into your web browser

The first time you open a Command View VLS session (and the first time you open a Command View VLS session after changing the fully qualified name of the VLS), a Security Alert window opens and prompts you to accept the Secure Sockets Layer (SSL) certificate.

Install the SSL certificate into your web browser:

1. Click **Yes**.



Figure 17 Security Alert window

2. Click **Install Certificate**, and then click **OK**.

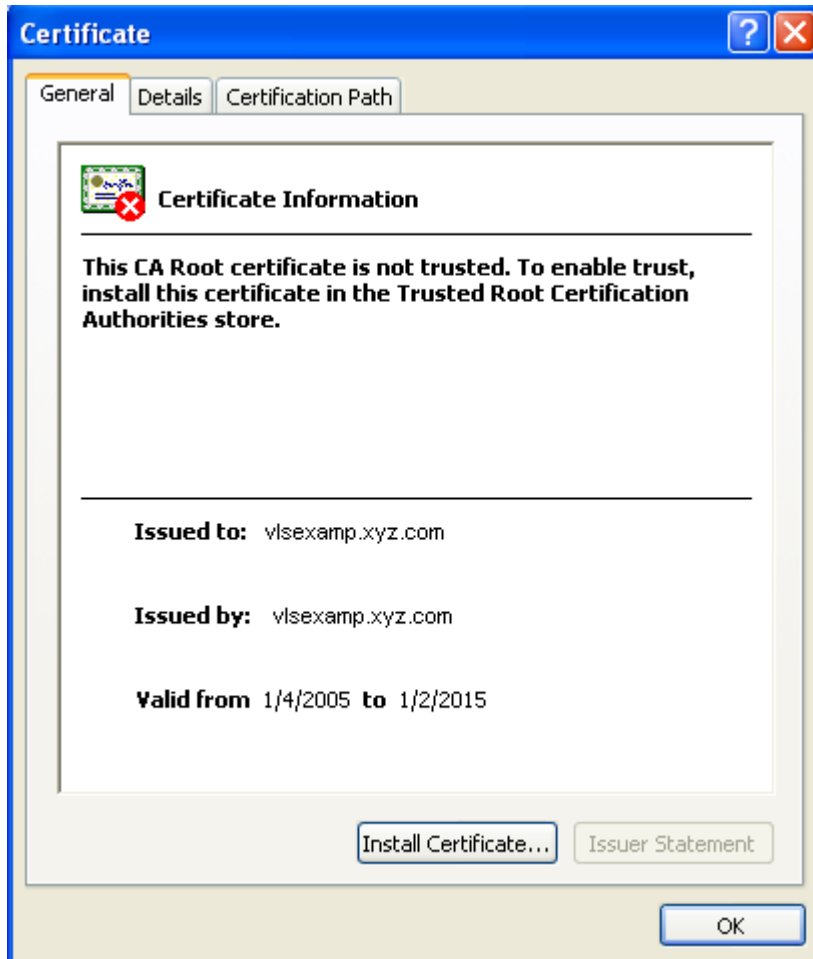

Figure 18 Certificate window

3. Select **Automatically** select the certificate store based on the type of certificate, and then click **Next**.

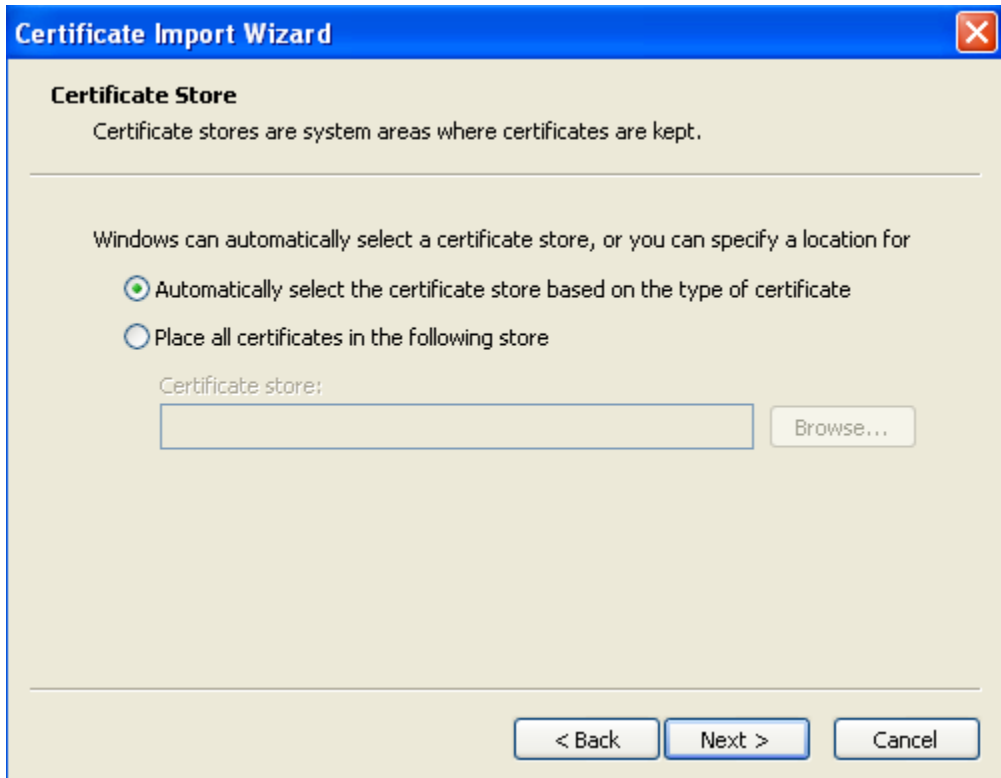

Figure 19 Certificate Import Wizard window

4. On the Certificate Store window, click **Yes** to add the certificate.
5. Continue to click **OK** or **Finish** on each window that displays until the Command View VLS login window displays.

Restarting Command View VLS

To restart Command View VLS:

1. Click **User Preferences** in the Status banner.

The User Preferences window opens (Figure 23).

2. Click **Restart Command View VLS** in the Task bar.

The Restart Command View VLS window opens (Figure 20).

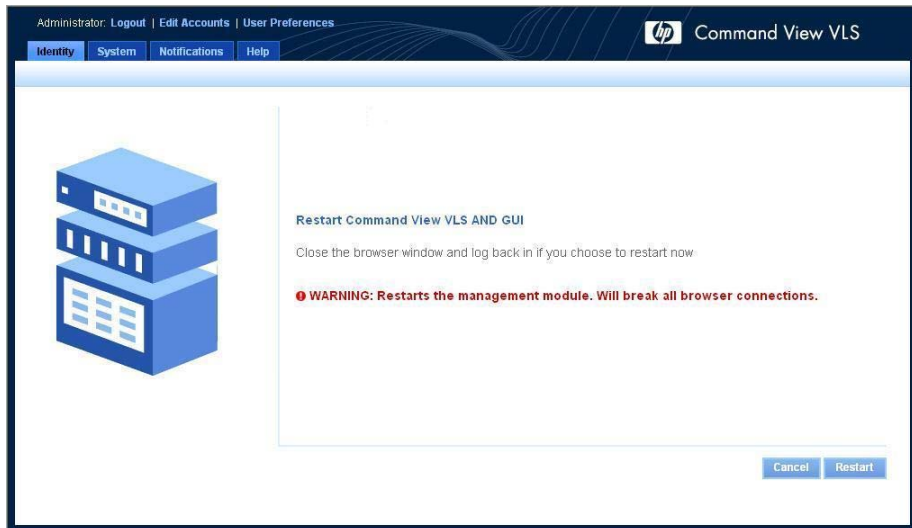

Figure 20 Restart Command View VLS window

3. Click **Restart** to confirm.

Closing a Command View VLS session

To close a Command View VLS session, click **Logout** in the Status banner or simply close the web browser.

Secure shell and serial user interfaces

The secure shell user interface provides remote configuration and management of your VLS over a LAN using the VLS command-line interface (CLI) command set. The serial user interface provides local configuration and management of your VLS through the serial connector on the rear of the VLS node using the same VLS CLI command set.

A secure shell or serial session provides the following:

- Setting the VLS network settings
- Configuration and management of VLS virtual devices (libraries and tape drives) and cartridges
- Changing of the default Fibre Channel host port settings
- Viewing and deletion of VLS notification alerts
- Configuration of VLS email and SNMP notification alert settings
- Editing of VLS account passwords
- Enabling and disabling of storage capacity oversubscription
- Viewing VLS hardware status
- Saving and restoring VLS network settings and virtual library configurations
- Restarting the VLS device emulations and Command View VLS
- Rebooting and powering down the VLS

The serial user interface also provides:

- Emergency login access that allows you to change the administrator password if it is forgotten.

Opening a secure shell session



NOTE:

Before you can open a secure shell session, you must set the VLS network settings. See [Setting the network settings](#).

To open a secure shell session:

1. Open a secure shell session to the VLS using a secure shell program (such as PuTTY) or by entering:

`ssh <fully qualified name of the VLS>` and then press **Enter**.
2. At the `login as:` prompt, enter `administrator` and then press **Enter**.
3. At the `password:` prompt, enter the administrator password and then press **Enter**.

The default administrator password is `admin`.

Closing a secure shell session

To close a secure shell session:

Enter `logout`, `done`, `quit`, `bye`, or `exit` and then press **Enter**.

Opening a serial session

To open a serial session:

1. Connect a PC or workstation to the serial connector on the rear of the VLS using the null-modem (serial) cable provided. See [Node rear panel components](#).
2. Establish a CLI session using a terminal emulation program, such as Windows Hyperterminal.
3. Enter `administrator` or `emergency` for username.
4. Enter the password for the username entered.

The default administrator password is `admin`. The emergency login password is `repair`.



NOTE:

Logging in as administrator or using the emergency login gives you full privileges to all VLS functions available through the CLI command set.

Closing a serial session

To close a serial session, click **Logout** at the top of the Console Manager window. This logs you out of the Console Manager and displays the Logon window.

5 Configuration

This section describes how to configure the VLS network settings, user preferences, Fibre Channel host ports (optional), virtual libraries, tape drives, and cartridges. It is comprised of the following topics:

- [Setting the network settings](#)
- [Setting the user preferences](#)
- [Editing the default Fibre Channel host port settings](#)
- [Enabling and disabling oversubscription](#)
- [LUN management](#)
- [Creating a virtual library](#)
- [Creating tape drives](#)
- [Creating cartridges](#)
- [Destroying a virtual library](#)
- [Destroying a tape drive](#)
- [Destroying cartridges](#)
- [Adding and removing barcode templates](#)

Setting the network settings

Before you can open a Command View VLS or secure shell session, you set the network settings. The network settings can be set using either the VLS discovery utility or the CLI command set using the serial user interface.

Setting the network settings using the VLS discovery utility

The VLS discovery utility looks for all the devices on the same subnet as the Windows computer on which it is running. It then lists the devices and indicates whether they are configured (have an IP address) or are unconfigured.

You can use the VLS discovery utility to set the network settings on an unconfigured VLS, and to view the network settings of configured devices.



NOTE:

The VLS discovery utility can only be used to change the network settings on a VLS with no IP address. Once a VLS has an IP address, either through the DHCP or the VLS discovery utility, its network settings cannot be changed using the VLS discovery utility. Use the CLI command set to change the network settings on a VLS that has an IP address. See [Setting the network settings using the CLI command set](#).

To set the network settings using the VLS discovery utility:

1. Insert the VLS Documentation CD into the CD drive on a Windows system that is on the same subnet as the VLS.

The CD auto-launches.

2. Click **VLS discovery utility**.

The VLS discovery utility opens and lists all the devices it sees on the subnet ([Figure 21](#)).

The **Configured** box for a device is checked if the device has an IP address.

The device type, host name, IP address (if available), and serial number are displayed for each device listed.

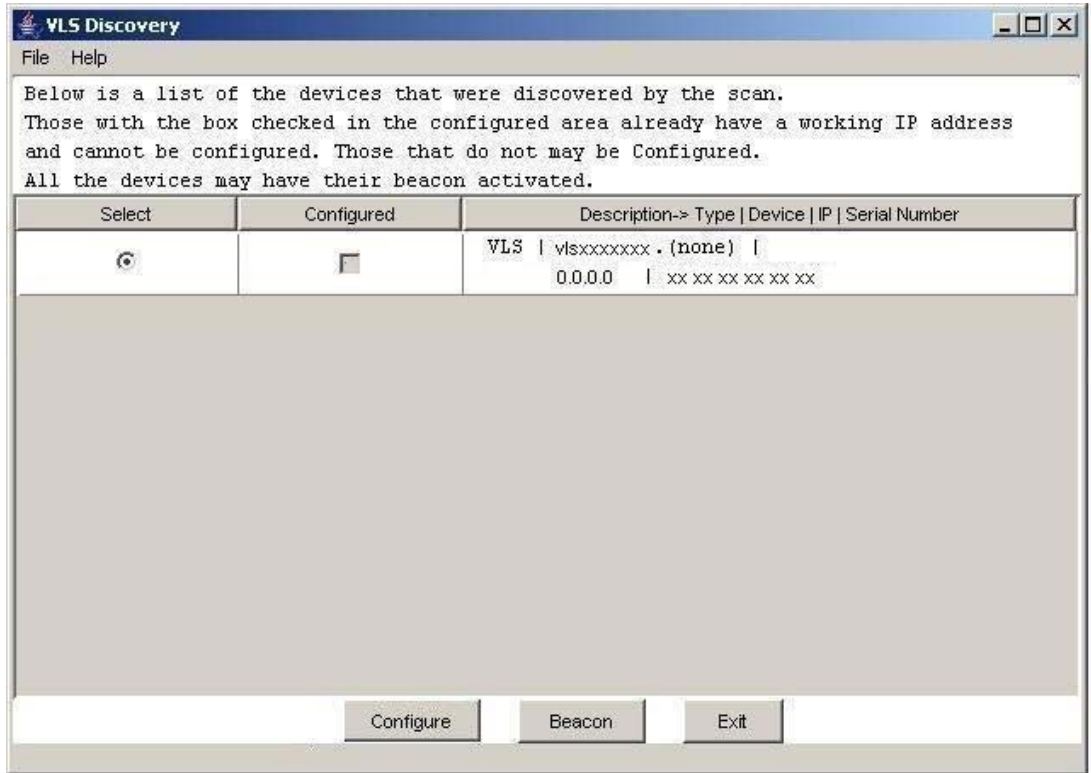

Figure 21 VLS discovery utility – main window

3. (Optional) To visually identify a device listed, select the device from the list and click **Beacon**. This will illuminate and LED on the device for the specified length of time.

In the case of the VLS, the UID LED button on the VLS node illuminates. See [Node front panel LEDs and buttons](#).

4. Select the VLS from the list of devices and click **Configure**.

The Device Configuration window opens ([Figure 22](#)).

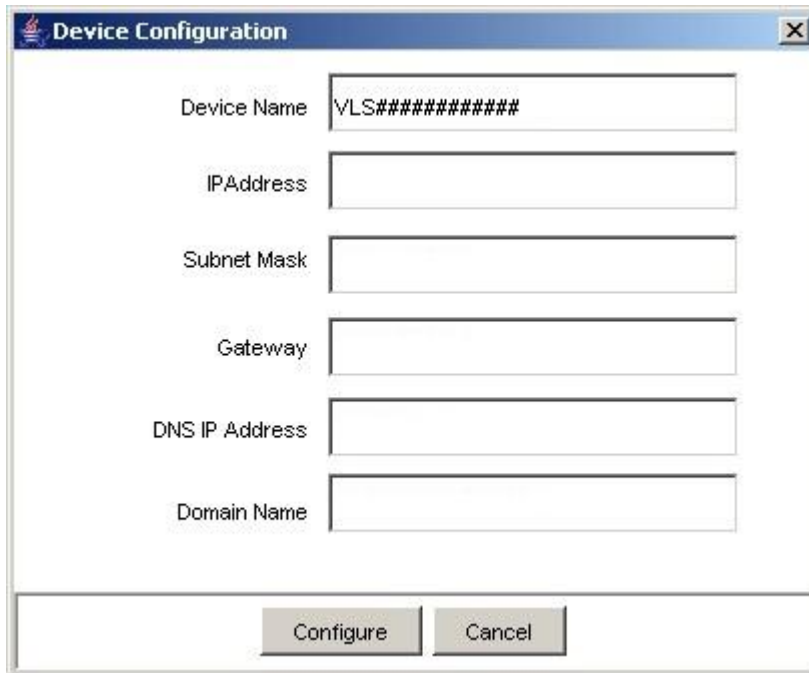

Figure 22 VLS discovery utility – Device Configuration window

5. Leave the default host name or enter a new host name in the **Host Name** box.
The default VLS host name is `VLS<VLS serial number>`.
The host name cannot contain spaces.
6. Enter an IP address in the **IP Address** box.
7. Enter the subnet mask in the **Subnet Mask** box.



NOTE:

To display the correct subnet mask, gateway, DNS server, and domain name settings for the VLS, open a DOS window on the computer running the VLS discovery utility and type `ipconfig /all`

8. Enter the gateway in the **Gateway** box.
9. Enter the DNS server IP address in the **DNS IP Address** box.
10. Enter the domain name in the **Domain Name** box.

11. Click **Configure** to save the network settings to the VLS.

12. Click **Exit** to close the VLS discovery utility.

Setting the network settings using the CLI command set

To set the network settings using the CLI command set, set either the:

- DHCP usage and host name, or
- Fully qualified host name (or host name and DNS domain name separately), DNS server address, IP address, gateway, and netmask

To set the network settings using the CLI command set:

1. Open a serial session and log in to the administrator account. See [Opening a serial session](#).
2. To see the current configuration settings, at the prompt enter:

```
showConfig
```

3. Set each desired configuration value by entering:

```
setConfigValue <-tag> [value]
```

where <-tag> can be any of the following:

Tag	Description
-host	Host name (such as vlsexamp) (unqualified)
-do-main	DNS domain name (such as xyz.com)
-full-host	Fully qualified name (such as vlsexamp.xyz.com)
-dnsaddr	DNS server address (replaces all addresses with one line)
-dnsaddr1	First DNS server address (cannot use with dnsaddr)
-dnsaddr2	Second DNS server address (cannot use with dnsaddr)
-dhcp	Has no value, indicates you want to configure the public Ethernet connection using DHCP (reset is -dhcp=false)
-ipaddr	IP address of public Ethernet connection

Tag	Description
-gate	Gateway to network (xx.xx.xx.x)
-mask	Netmask. Default is 255.255.255.0



NOTE:

More than one network value can be set at a time or you can set them individually. To reset a value, enter " " (quoted space) as the value.

4. Verify the network setting(s) has been changed by entering:

```
showConfig
```

5. When all the network parameters are set to your desired values, save the settings by entering:

```
commitConfig
```

Setting the user preferences

Setting the user preferences allows you to:

- Set the frequency at which the system state is checked and the browser is refreshed
- Add the VLS administrator's name, email, and phone number, and the VLS location to the Identity tab window

To set the user preferences:

1. Open a Command View VLS session and log in as the administrator. See [Opening a Command View VLS session from Command View TL](#).
2. Click **User Preferences** in the Status banner.

The User Preferences window opens ([Figure 23](#)).

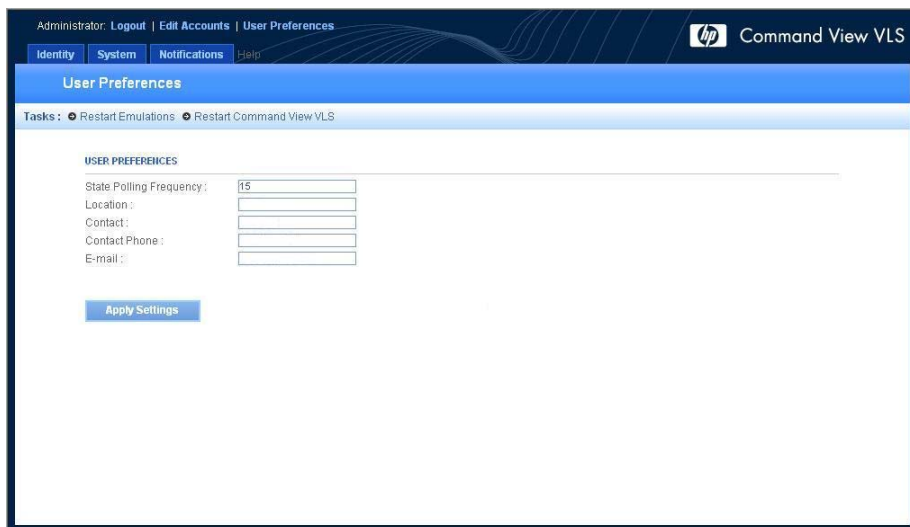

The screenshot shows the 'User Preferences' window in the Command View VLS interface. The window has a blue header with the title 'User Preferences' and a sub-header 'Tasks: Restart Emulations, Restart Command View VLS'. Below the header, there are several input fields for user preferences: 'State Polling Frequency' (with the value '15'), 'Location', 'Contact', 'Contact Phone', and 'E-mail'. An 'Apply Settings' button is located at the bottom of the form area. The top of the window shows navigation tabs for 'Identity', 'System', 'Notifications', and 'Help', along with the HP logo and 'Command View VLS' text.

Figure 23 User Preferences window

3. Enter a value (in seconds) in the **State Polling Frequency** box.
The default state polling frequency is 15 seconds.
4. Enter the city and state where the VLS is located in the **Location** box.
5. Enter the VLS administrator's name in the **Contact** box.

6. Enter the VLS administrator's phone number, including area code, in the **Contact Phone** box.
7. Enter the VLS administrator's email address in the **Email** box.

The email address entered is assigned to the **Email Administrator** link on the Login window. Users can click this link to send an email to the administrator when they need help or are unable to log in to Command View VLS.

8. Click **Apply Settings**.

Editing the default Fibre Channel host port settings

Only edit the Fibre Channel host port settings if you do not want to use the default settings, if some system problem is occurring, or if the "AUTO" setting is not working properly.



NOTE:

The Actual values displayed are the actual values found by the VLS for the Fibre Channel host port.



NOTE:

If you enter a value that is not supported by the Fibre Channel port (for example, you enter Fabric in the Topology column but the port uses the Loop topology), your entry remains in the Preferred box, but the Actual column will display the correct value when Command View VLS performs its occasional status checks.

To change the default Fibre Channel host port settings:

1. Open a Command View VLS session and log in as the administrator. See [Opening a Command View VLS session from Command View TL](#).
2. Click the **System** tab.
3. Expand **Chassis** in the Navigation tree.
4. Expand **Node** in the Navigation tree.
5. Select **Fibre Channel** in the Navigation tree.

The Fibre Channel Host Ports window opens ([Figure 24](#)).

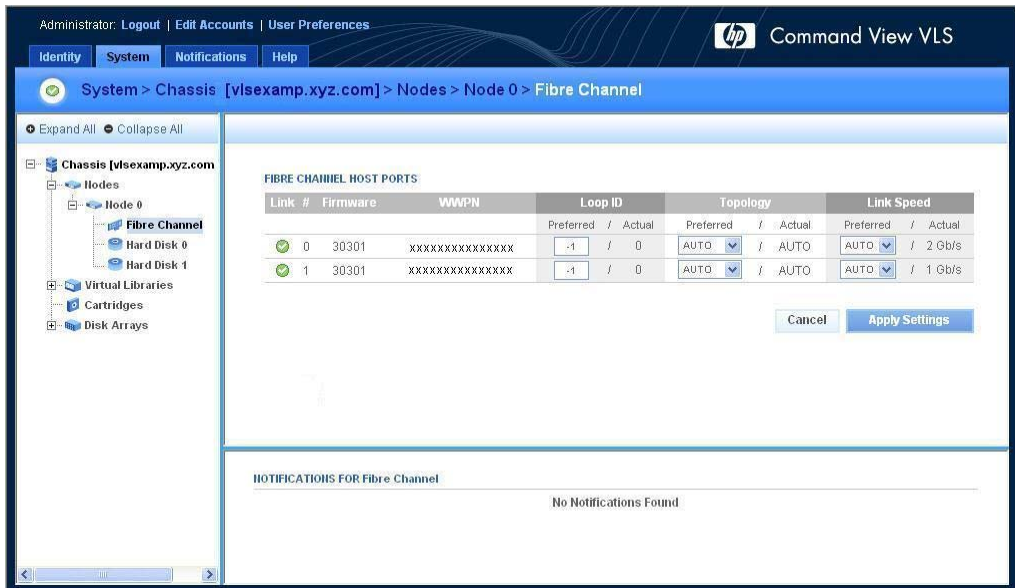

Figure 24 Fibre Channel Host Ports window

6. (Optional) Enter a value for the Loop ID in the **Loop ID Preferred** box for each Fibre Channel host port to use for prioritizing communication requests with the VLS.
If the Fibre Channel host port's topology is Fabric, the Loop ID value is ignored.
7. (Optional) Select the Fibre Channel host port's topology in the **Topology Preferred** box for each Fibre Channel host port.
Auto—Allows the VLS to determine the Fibre Channel port's topology
Loop—Sets the topology type to an arbitrated loop
Fabric—Sets the topology type to fabric
8. (Optional) Select a link speed in the **Link Speed Preferred** box for each Fibre Channel host port.
Auto—Allows the VLS to determine the Fibre Channel port's link speed
1—1 GB per second
2—2 GB per second
9. When you are finished configuring the Fibre Channel ports, click **Apply Settings**.
10. Restart the VLS device emulations to make the changes take effect. See [Restarting the VLS device emulations](#).

Enabling and disabling oversubscription

Because the VLS dynamically allocates storage space as data is written to virtual media, the VLS allows you to allocate more cartridge capacity than is physically installed. This oversubscription feature permits configuring your system for anticipated storage growth.

By default, oversubscription is disabled.

To enable oversubscription:

1. Open a Command View VLS session and log in as the administrator. See [Opening a Command View VLS session from Command View TL](#).
2. Click the **System** tab.
3. Select **Chassis** in the Navigation tree.

The chassis details window opens ([Figure 25](#)).

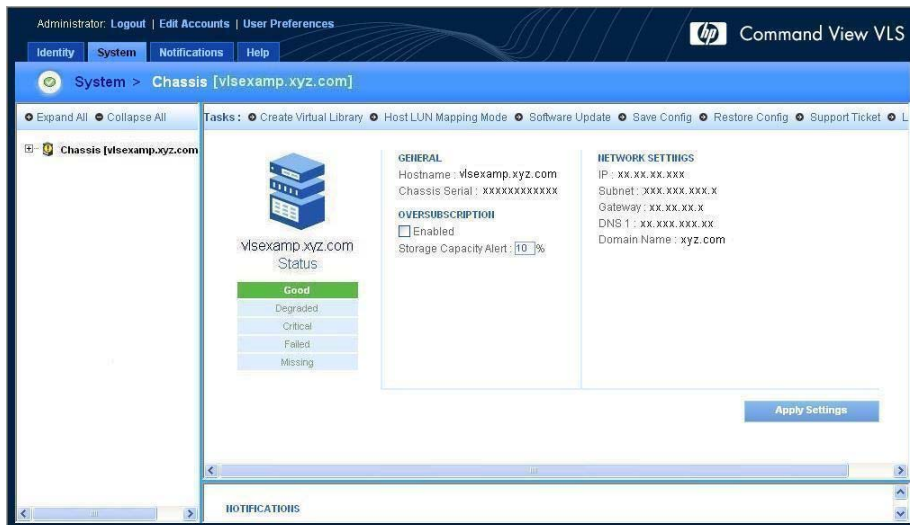

Figure 25 Chassis details window

4. Click the **Enabled** box to select it.
5. Enter a percentage value in the **Storage Capacity Alert** box.

This percentage value is the threshold of available storage space remaining that when reached will trigger a storage capacity notification alert.

6. Click **Apply Settings**.

To disable oversubscription, click the **Enabled** box to unselect it.



NOTE:

Oversubscription cannot be disabled while cartridge capacity is oversubscribed.

LUN management

The VLS has a LUN masking, a LUN mapping, and a port mapping feature that allows you to restrict host access to the LUNs (virtual libraries and tape drives) configured on the VLS as needed, manually assign LUN numbers to the virtual devices by host as needed, and assign each virtual device to a specific Fibre Channel host port. These features allow you to allocate the virtual devices to individual hosts as needed and distribute the virtual tape drives across the Fibre Channel host ports to achieve maximum bandwidth.

By default, the VLS allows all hosts connected to the VLS through the SAN to access to all virtual devices configured on the VLS, and the VLS software manages the LUN mapping so that the virtual device LUN assignments always meet operating system requirements and restrictions. See [Default LUN numbering](#) and [Operating system LUN requirements and restrictions](#). Optionally, you can restrict host access to individual virtual devices using the LUN masking feature, and then, for each LUN masked host, manually assign LUN numbers to any virtual devices you want the host to be able to access using the LUN mapping feature. See [LUN masking](#) and [LUN mapping](#) for reasons you may want to use the LUN masking and mapping features.

Port mapping is required and allow you to assign each virtual device to one of the Fibre Channel host ports.

Default LUN numbering

The VLS automatically assigns a logical unit number (LUN) to each virtual library and tape drive created on the VLS in the order in which they are created by you, starting with LUN0 and incrementing by one as each new virtual library or tape drive is created on a Fibre Channel host port (LUN1, LUN2 and so on). The first virtual device port mapped to anyone of the Fibre Channel host ports is assigned the LUN number LUN0. The second virtual device port mapped to a Fibre Channel host port is assigned the LUN number LUN1, and so on.

The default LUN numbers are changed by the VLS software when the VLS device emulations are restarted if:

- A virtual device has been deleted since the last restart, creating a gap in the LUN numbering, or
- A virtual tape drive has been added to a library since the last restart and the default LUN number it was assigned is not consecutive with the other virtual tape drives in the same library.

Restarting the VLS device emulations changes the default LUN numbers as necessary to remove the gap or to make the virtual tape drive LUN numbers consecutive in each library. This is done so that the virtual device LUN numbering meets the operating system LUN requirements.

Operating system LUN requirements and restrictions

Most operating systems require that each VLS Fibre Channel host port connected to the SAN has a virtual device with the LUN number LUN0 and no gaps in the LUN numbering (LUN0, LUN1, LUN2, and so on). If the operating system does not see a LUN0 on a VLS Fibre Channel host port when it is scanning for new hardware on the SAN, it will stop looking for LUNs on that port and erroneously reports that there are no LUNs (virtual devices) on that port. If the operating system sees a LUN0, LUN1, and LUN2 but not a LUN3 on the port, it will stop looking for LUNs on that port when the gap in the LUN numbering is encountered. Even though there may be more LUNs (such as LUN4), the operating system will erroneously report that there are only three LUNs on the port.

In addition, operating systems are configured to only look for a maximum number of LUNs per device and no more. Once the maximum number of LUNs is detected, the operating system stops looking. In the case of the VLS, the operating system considers each Fibre Channel host port to be one device with its own set of LUNs. So, if the maximum number of LUNs an operating system is configured to see is eight, the operating system will only see LUN0, LUN1, ..., LUN7 and will not see LUN8, LUN9, ..., and up on each Fibre Channel host port.

To get around the maximum LUNs per device restriction, you can either:

- Increase the maximum LUNs per device setting for the operating system. See [Troubleshooting](#) for more information.
- Use the VLS's LUN masking feature to restrict the number of virtual devices the host's operating system sees on the VLS Fibre Channel host port(s). Then, use the VLS's LUN mapping feature to assign LUNs to the virtual devices the host can see, such that the LUN numbers on each Fibre Channel host port include a LUN0 and no gaps in the LUN numbering. See [LUN masking](#) and [LUN mapping](#) for instructions.

LUN masking

By default all hosts on the SAN can access all the virtual libraries on the VLS. You can restrict a host's access to the virtual libraries and/or tape drives (virtual devices) on the VLS by performing LUN masking.

LUN masking should also be used when there are more virtual devices (LUNs) port mapped to a Fibre Channel host port than the operating system LUN restrictions support, and this prevents the host's operating system from seeing the virtual devices it needs to see on the port. For example, if a host's operating system is configured to only see up to eight LUNs per Fibre Channel host port, the host will not be able to see the virtual devices numbered LUN8, LUN9, ..., and up. LUN masking limits the virtual devices (LUNs) the host's operating system can see on the port, so that only the virtual devices the host needs to see are visible.

To perform LUN masking:

1. Open a Command View VLS session and log in as the administrator. See [Opening a Command View VLS session from Command View TL](#).
2. Click the **System** tab.
3. Select **Chassis** in the Navigation tree.
4. Click **Host LUN Mapping Mode** in the Task bar.

The Host LUN Mapping Mode window opens and displays a list of the host world wide port numbers (WWPNs) seen by the VLS Fibre Channel host ports on the SAN ([Figure 26](#)).

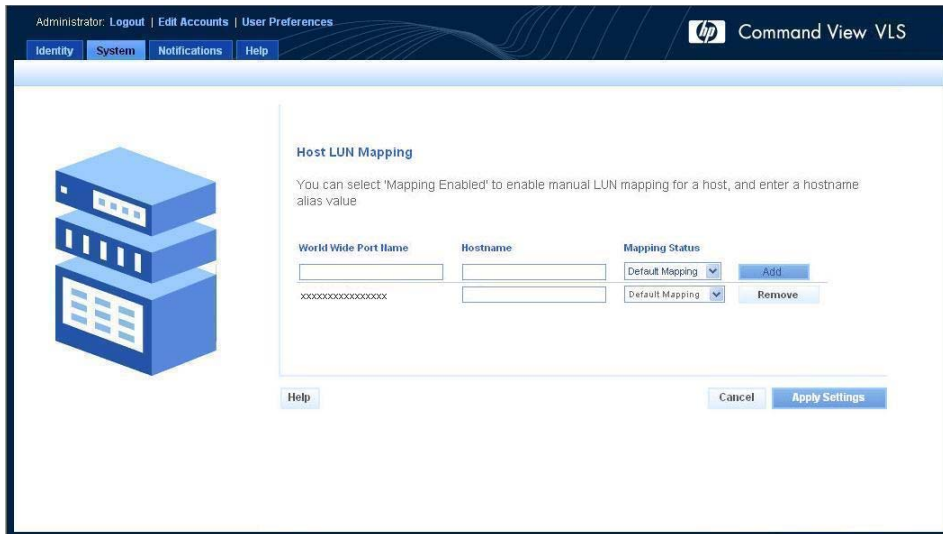

Figure 26 Host LUN Mapping Mode window

5. Select **Mapping Enabled** in the **Mapping Status** box for each host for which you want to perform LUN masking.

The hosts with mapping enabled selected are not able to access any of the virtual devices on the VLS until you give them access by performing [LUN mapping](#).

6. To assign a host name alias to a host WWPN listed, enter the host name in the **Hostname** box.
7. To add a host WWPN to the list that is not plugged into the SAN yet, enter the host WWPN number and then click **Add**.
8. When you are finished making changes, click **Apply Settings**.

LUN mapping

By default all hosts on the SAN see the LUN numbers that have been assigned to the virtual devices by the VLS software. You have the option of assigning a different LUN number to a virtual device by host using the LUN mapping feature. For example, you can assign Library 2 the LUN number LUN0 for host1, and the other hosts will still see Library 2 as the LUN number assigned by the VLS software.

LUN mapping is by host and is used to allow host access to hosts that are LUN masked, and to present only a subset of the VLS virtual devices to a host.

LUN mapping should only be used if the host requires LUN masking. For example, if host1 is LUN masked so it cannot see all the virtual libraries and/or virtual tape drive on a Fibre Channel host port, the LUN numbers it can see may not include LUN0 and have no gaps in the LUN numbering as required by the operating system. See [Operating system LUN requirements and restrictions](#).

To perform LUN mapping:

1. Perform [LUN masking](#) and select **Mapping Enabled** for the hosts for which you want to perform LUN mapping.
2. Click the **System** tab.
3. Select a virtual library or tape drive in the Navigation tree that you want to make visible (accessible) to the host.
4. Click **Map LUNs** in the Task bar.

The Map LUNs window opens and displays the hosts with mapping enabled selected on the Host LUN Mapping Mode window ([Figure 27](#)).

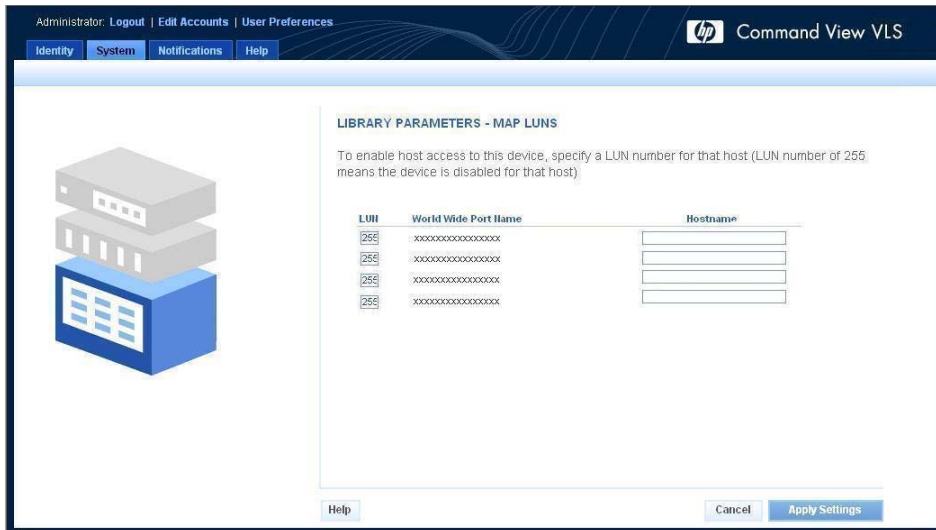

Figure 27 Library Parameters – Map LUNs window

5. To allow a listed host to access the virtual library, enter a LUN value in the **LUN** box (such as 0, 1, 2, and so on).

The LUN value entered is assigned to the virtual library for that specific host. The default value 255 means the host does not have access.

6. When you are finished making changes, click **Apply Settings**.
7. Repeat steps 3 through 6 for the rest of the virtual libraries and tape drives configured on the VLS that you want to make visible to the host.



CAUTION:

Each virtual device must be assigned a unique LUN number on the Fibre Channel host port to which it is mapped. If two virtual devices have the same LUN number on the same Fibre Channel host port, the virtual device with the lowest virtual device ID number assigned by the VLS is recognized as that LUN number by the host's operating system. The other virtual device is ignored by the operating system.

Creating a virtual library

Before creating a virtual library, you must first:

- Determine the best way to manage VLS virtual library and tape drive LUNs for your environment (see [LUN management](#))
- Determine the best way to configure virtual libraries and tape drives on your VLS for your environment. See the *HP StorageWorks 6000 Virtual Library System Solutions Guide*.

You can configure any combination of virtual tape libraries and virtual tape drives up to the maximum number supported on the VLS. You can configure one library with up to 64 tape drives, or up to 16 libraries with a total of up to 64 tape drives.

To create a new virtual library:

1. Open a Command View VLS session and log in as the administrator. See [Opening a Command View VLS session from Command View TL](#).
2. Click the **System** tab.
3. Select **Chassis** in the Navigation tree.
4. Click **Create Virtual Library** in the Task bar.

The Create Virtual Library Wizard opens ([Figure 28](#)).

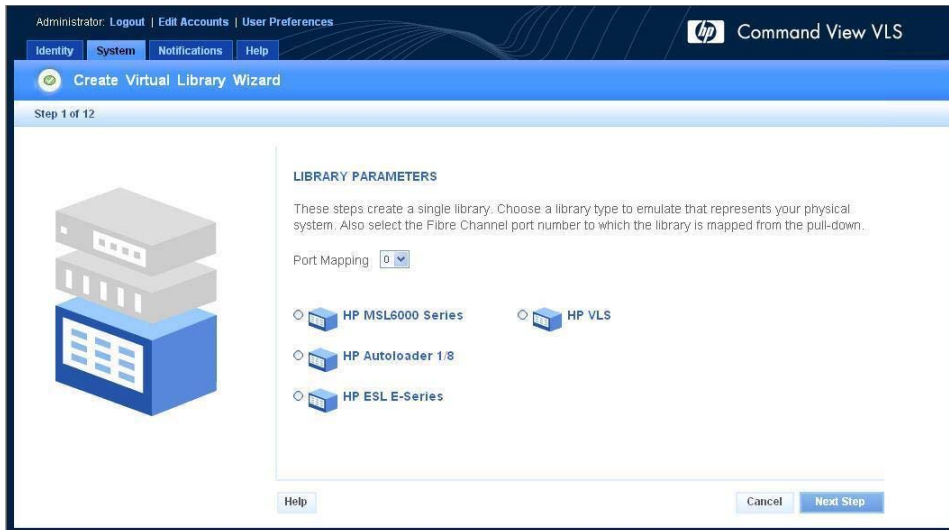

Figure 28 Create Virtual Library Wizard window (1 of 12)

5. Select the Fibre Channel host port on which to present the virtual library.
Only one port may be selected.
6. Select the type of tape library to emulate.



NOTE:

The only library emulation Veritas supports for use with Netbackup is the HP VLS emulation. The HP VLS emulation was created specifically for use with Netbackup. It is not intended for use with other backup applications.

7. Click **Next Step**.

The next wizard window opens and displays the default values in the Maximum Slots, Maximum Ports, and Maximum Drives boxes based on the physical tape library emulation selected (Figure 29).

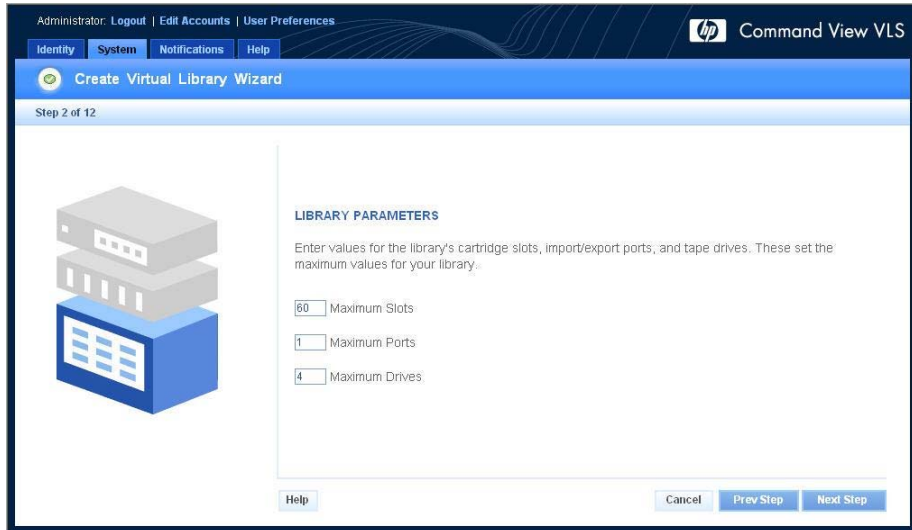

Figure 29 Create Virtual Library Wizard window (2 of 12)

8. Enter the maximum number of cartridge slots that may be added to the library in the **Maximum Slots** box.

The default values in **Maximum Slots** box is based on the physical tape library you selected.



CAUTION:

Changing the defaults can have unpredictable results if your backup application expects a certain number of slots in a specific library type.

9. Enter the maximum number of input/export ports on which the library may be configured to be visible in the **Maximum Ports** box.
10. Enter the maximum number of tape drives the library may contain **Maximum Drives** box.



NOTE:

The maximum values entered cannot be changed later. So, consider your potential future environmental requirements when entering values.

Not all the tape drives and cartridges must be created at this time. You may add tape drives later.

11. Click **Next Step**.

A window opens indicating that, by default, all libraries connected to the VLS have access to all hosts (Figure 30).

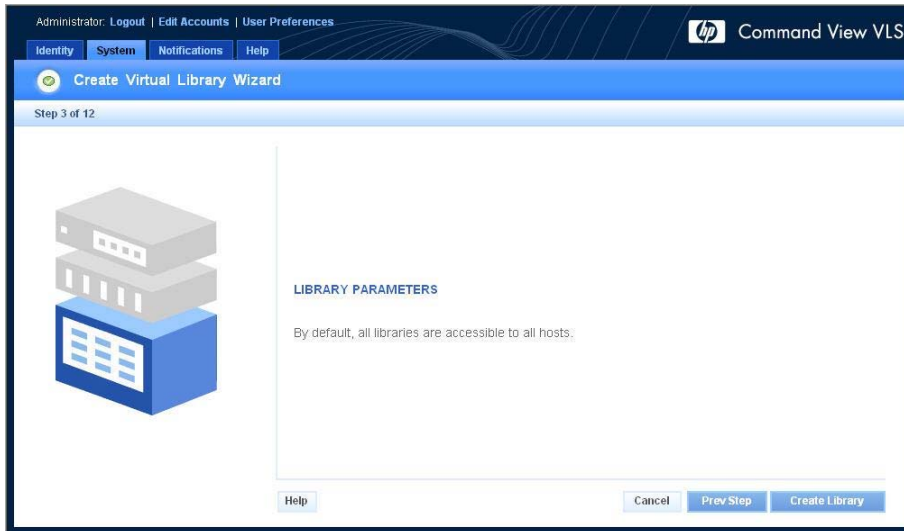

Figure 30 Create Virtual Library Wizard window (3 of 12)

12. Click **Create Library.**

A summary window opens and displays details about the library emulation created (Figure 31).



Figure 31 Create Virtual Library Wizard window (4 of 12)

13. Choose one of the following options:

- To perform LUN mapping for the virtual library, click **Map LUNs** and proceed to [LUN mapping](#) for further instructions.
- To continue creating the virtual library, click **Create Tape Drive(s)** and proceed to [Creating tape drives](#).
- To exit the wizard, click **Cancel**.
The library is created but does not contain any tape drives or cartridges. You can add tape drives and cartridges later.

Creating tape drives



NOTE:

If you add a virtual tape drive to a library after another library has been created, the default LUN number assigned to the tape drive will not be consecutive with the other virtual tape drives in the same library. To correct this, restart the VLS device emulations. See [Restarting the VLS device emulations](#). The VLS software will change the virtual device LUN numbers on the VLS, so that all the default tape drive LUN in a library are consecutive.



NOTE:

A virtual library may only contain one type of tape drive.

To add a tape drive(s) to a virtual library:

1. If you are already in the Create Library Wizard window ([Figure 31](#)), click **Create Tape Drive(s)**.

The Tape Drive Parameters window opens ([Figure 32](#)).

2. If not:
 - a. Click the **System** tab.
 - b. Select the library in the Navigation tree to which you want to add tape drives.
 - c. Click **Create Tape Drive** in the Task bar.

The Tape Drive Parameters window opens ([Figure 32](#)).

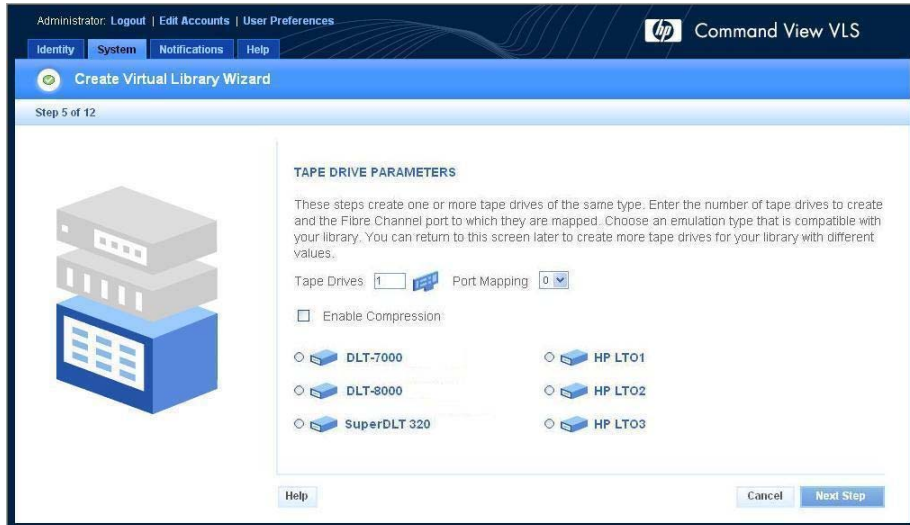

Figure 32 Create Virtual Library Wizard window (5 of 12)

3. Enter the number of tape drives you want to create in the library at this time in the **Tape Drives** box, if different from the default value.

You can add more tape drives to the library later. The Tape Drives box defaults to the standard number of drives for the library type.



NOTE:

All the tape drives created at one time are mapped to the same Fibre Channel host port. Make sure to load-balance the tape drives across the Fibre Channel host ports to obtain maximum performance. Tape drives in a library do not have to be mapped to the same port as the library.

4. Enter the Fibre Channel host port on which to present the tape drive(s) in the **Port Mapping** box.
5. To enable data compression for the tape drive(s), select the **Enable Compression**.

Data compression (2:1) is performed only on data handled by tape drives with data compression enabled. Data compression allows the VLS to store more data.



NOTE:

A tape drive created with data compression enabled cannot be changed later so that data compression is disabled.

6. Select the type of physical tape drive to emulate.

7. Click **Next Step**.

A window opens indicating that, by default, all hosts connected to the VLS have access to all the tape drives (Figure 33).

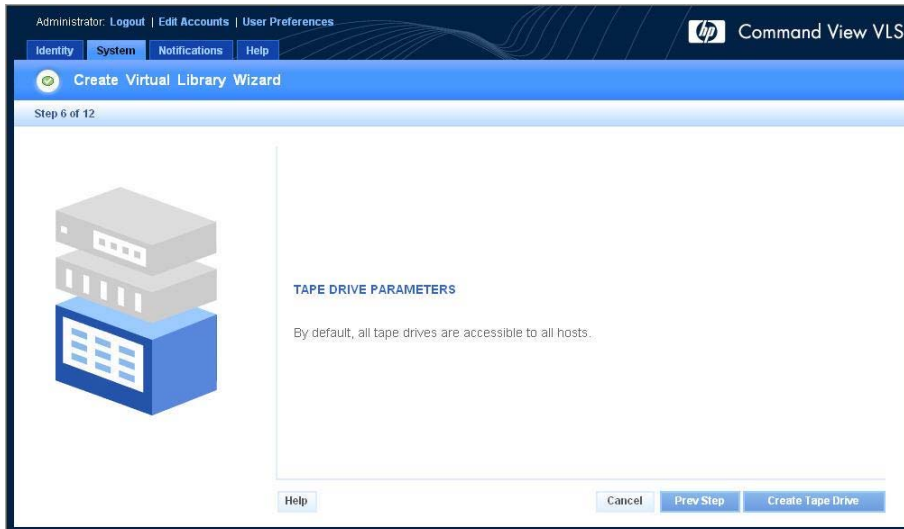

Figure 33 Create Virtual Library Wizard window (6 of 12)

8. Click **Create Tape Drive**.

A summary window opens and displays details about the tape drive(s) created (Figure 34).



Figure 34 Create Virtual Library Wizard window (7 of 12)

9. Choose one of the following options:

- To perform LUN mapping for the virtual tape drive, click **Map LUNs** and proceed to [LUN mapping](#) for further instructions.
- To create more tape drives, click **Create More Tape Drives**.
- To add cartridges to the virtual library, click **Create Cartridges** and proceed to [Creating cartridges](#).
- To exit the wizard, click **Cancel**.

At this point the library and tape drives have been created, but the library does not contain any cartridges. You can add cartridges later.

Creating cartridges

To add cartridges to a virtual library:

1. If you are already in the Create Library Wizard window (Figure 34), click **Create Cartridges**.

The Cartridge Parameters window opens (Figure 35).

2. If not:
 - a. Click the **System** tab.
 - b. Select the virtual library in the Navigation tree to which you want to add cartridges.
 - c. Click **Create Cartridge** in the Task bar.

The Cartridge Parameters window opens (Figure 35).

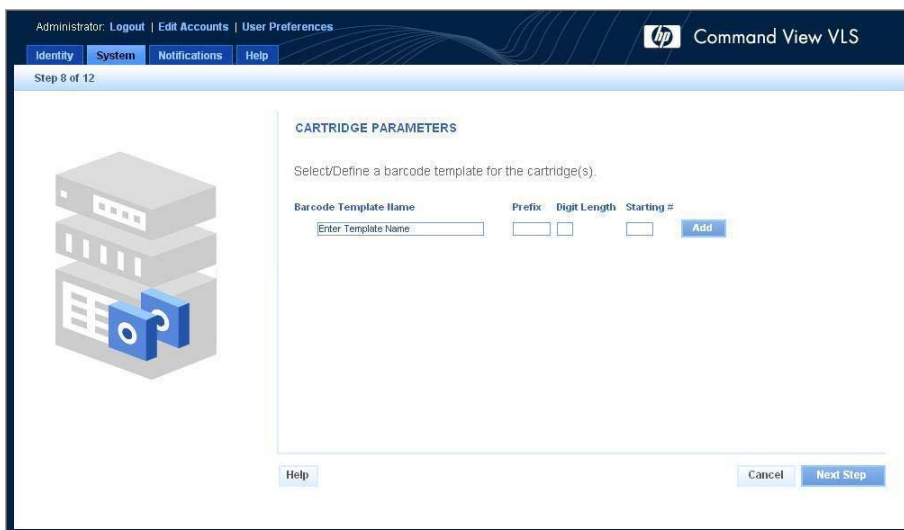

Figure 35 Create Virtual Library Wizard window (8 of 12)

3. To add a barcode template:
 - a. Enter a descriptive name for the barcode template in the **Barcode Template Name** box.

You may want to use the same names as in your physical library, as it provides a one-to-one match when you back up the virtual media to physical tape.

- b. Enter the barcode prefix (one to five alpha characters) in the **Prefix** box.
 - c. Enter the number of digits for the barcode number in the **Digit Length** box.
 - d. Enter the starting barcode number in the **Starting #** box.
 - e. Click **Add** to add the new barcode template.
 - f. To add another barcode template, repeat steps a through e.
4. Click the radio button next to the barcode template you want to use to create the cartridges.



NOTE:

Select a six character (or less) barcode number if your backup application is Veritas Netbackup. Veritas Netbackup has a six character barcode number limit.

5. Click **Next Step**.
6. Select the type of physical cartridge to emulate ([Figure 36](#)).
7. Click **Next Step**.

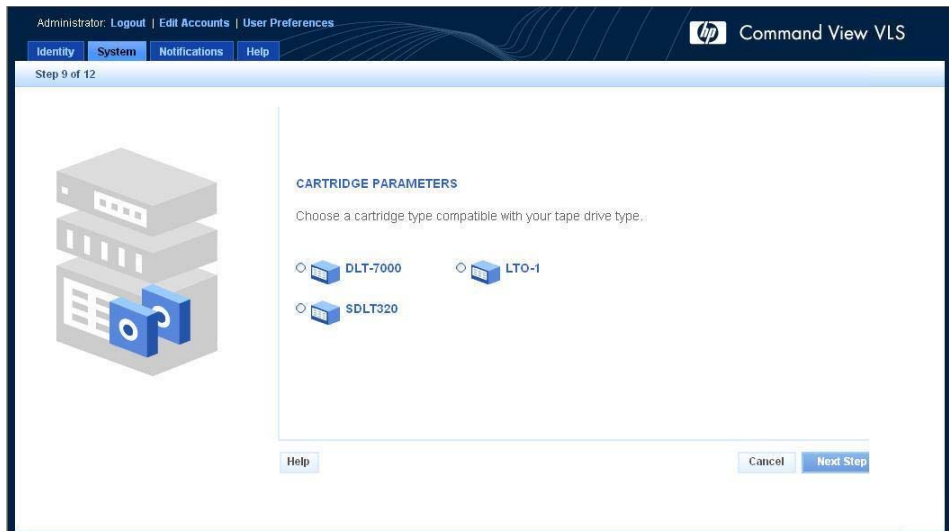

Figure 36 Create Virtual Library Wizard window (9 of 12)

8. Enter the number of cartridges and the cartridge size in the appropriate boxes ([Figure 37](#)).

The default number of cartridges is based on the maximum number of slots configured for the virtual library. The default cartridge size is based on the actual size of the type of cartridge emulated.

The system calculates and displays the amount of required storage. If the required storage exceeds what is available, the overage appears in red. You can allow the oversubscription of storage capacity (see [Enabling and disabling oversubscription](#)), or you can change either the number of cartridges or the cartridge size (or both) to correct the overage condition.

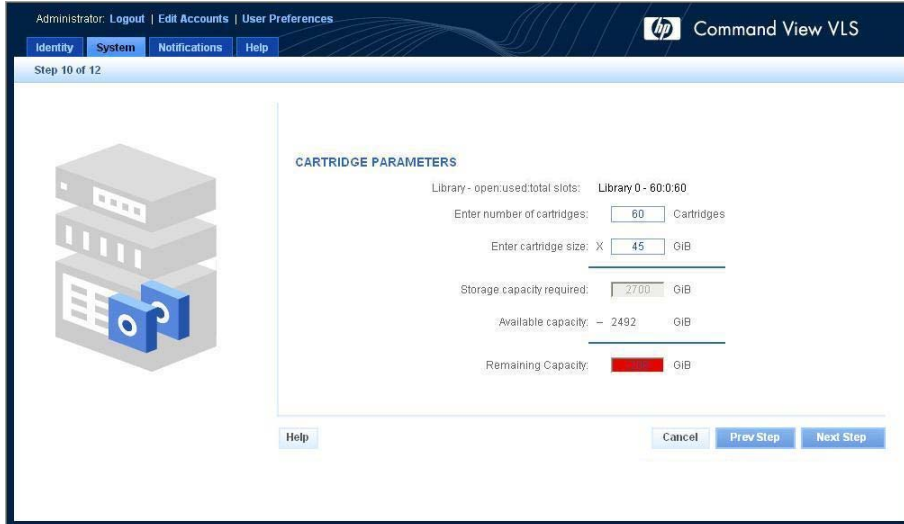

Figure 37 Create Virtual Library Wizard window (10 of 12)

9. Click **Next Step.**

A summary window opens and displays details about the cartridges you created ([Figure 38](#)).



Figure 38 Create Virtual Library Wizard window (11 of 12)

10. Click **Next**.

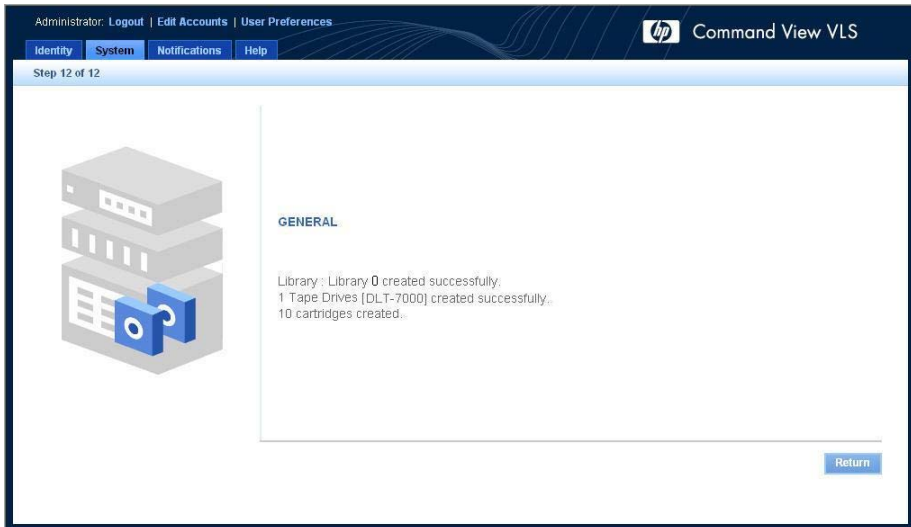

Figure 39 Create Virtual Library Wizard window (12 of 12)

11. Click **Return**.

The System tab window opens. You can now select the new library, tape drive(s), and cartridges in the Navigation tree to view their configuration information, such as their serial numbers and default LUN numbers.

Destroying a virtual library



NOTE:

Destroying a virtual library may create a gap in the default LUN numbering on the Fibre Channel host port to which it was mapped. If a gap is created, restart the VLS device emulations to remove the gap. See [Restarting the VLS device emulations](#).

Most operating systems will ignore (cannot access) any virtual devices with LUN numbers that follow a gap in the LUN numbering on a Fibre Channel host port.



NOTE:

You cannot destroy a library that is currently being accessed by a backup application.

When a virtual library is destroyed, all the tape drives associated with the library are also destroyed. The cartridges in the virtual library, however, are not destroyed. They are moved to the Firesafe where they are stored until you either destroy them or associate them with a virtual library. See [Managing cartridges](#).

To destroy (delete) a virtual library:

1. Open a Command View VLS session and log in as the administrator. See [Opening a Command View VLS session from Command View TL](#).
2. Click the **System** tab.
3. Select the virtual library in the Navigation tree.

The virtual library details window opens ([Figure 40](#)).

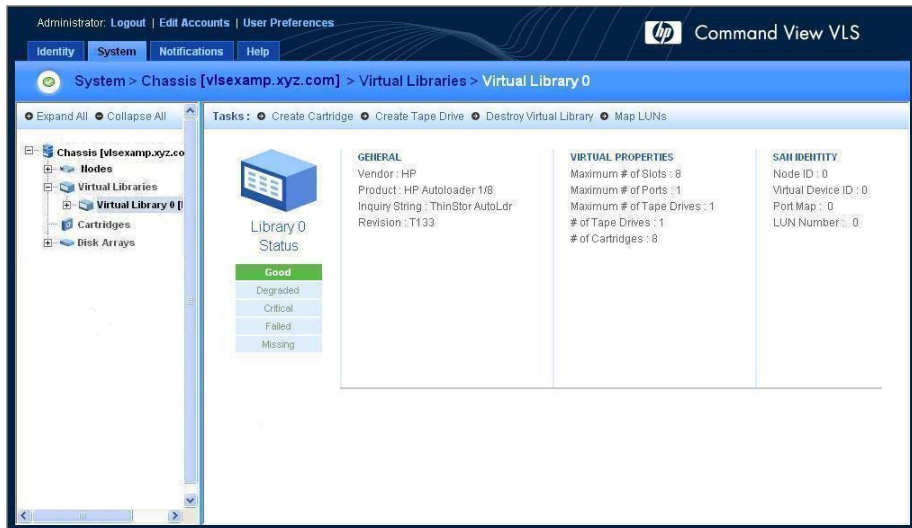

Figure 40 Virtual library details window

4. Click **Destroy Virtual Library** in the Task bar.
5. Click **Yes** to confirm.
6. Click **Finish**.

Destroying a tape drive



NOTE:

Destroying a tape drive may create a gap in the default LUN numbering on the Fibre Channel host port to which it was mapped. If a gap is created, restart the VLS device emulations to remove the gap. See [Restarting the VLS device emulations](#).

Most operating systems will ignore (cannot access) any virtual devices with LUN numbers that follow a gap in the LUN numbering on a Fibre Channel host port.



NOTE:

You cannot destroy a tape drive that is currently being used by a backup application.

To destroy a tape drive:

1. Open a Command View VLS session and log in as the administrator. See [Opening a Command View VLS session from Command View TL](#).
2. Click the **System** tab.
3. Select the tape drive in the Navigation tree.

The tape drive details window opens ([Figure 4-1](#)).

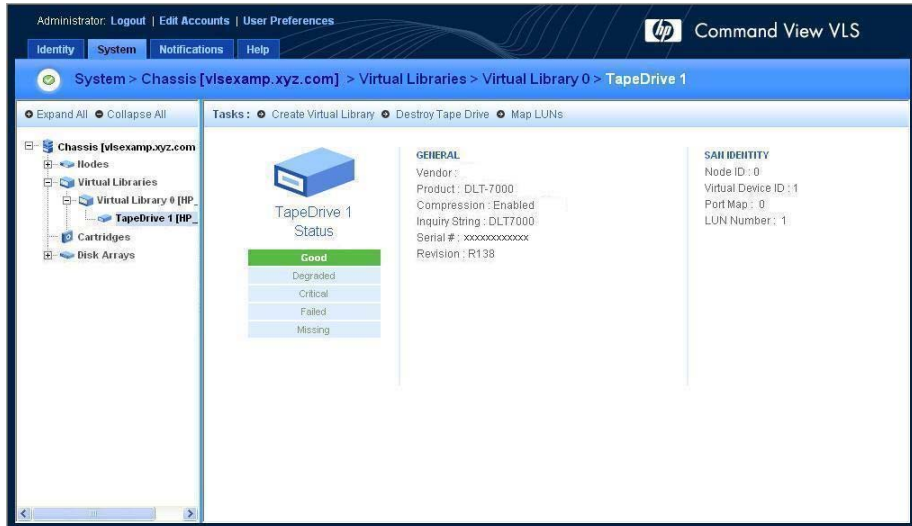

Figure 41 Tape drive details window

4. Click **Destroy Tape Drive** in the Task bar.
5. Click **Yes** to confirm.
6. Click **Finish**.

Destroying cartridges



CAUTION:

If you want to keep data that is currently on a cartridge that you are going to delete, copy the data to another cartridge using a backup application before performing this task.



NOTE:

You cannot destroy a cartridge that is currently being accessed by a backup application.

To destroy cartridges:

1. Open a Command View VLS session and log in as the administrator. See [Opening a Command View VLS session from Command View TL](#).
2. Click the **System** tab.
3. Select **Cartridges** in the Navigation tree.

The cartridges details window opens (Figure 42).

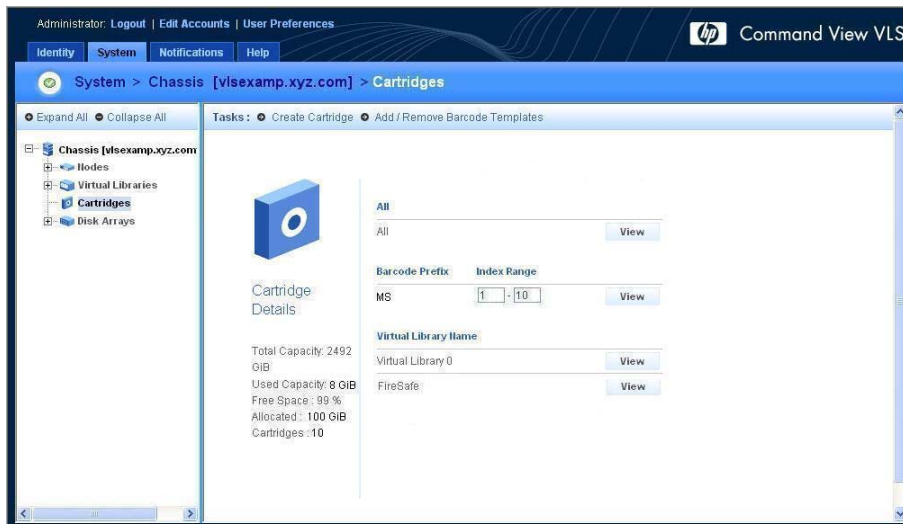

Figure 42 Cartridges details window

4. Click the **View** button beside the category that contains the cartridge(s) you want to delete.

The cartridges parameters window opens (Figure 43).

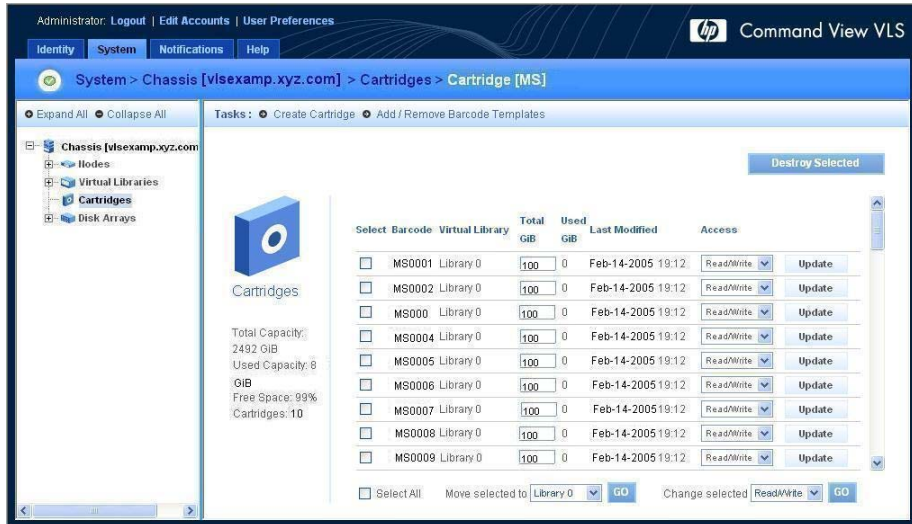

Figure 43 Cartridges parameters window

5. Select the **Select** box next to each cartridge that you want to delete. Select **Select All** if you want to destroy all the cartridges listed.
6. Click **Destroy Selected**.
7. Click **Yes** to confirm.
8. Click **Finish**.



NOTE:

Barcode number that were assigned to cartridges that have been destroyed can be reused. To reuse a barcode number, either:

- Create a new barcode template with the appropriate values to use the barcode number(s)
- Delete the barcode template used to create the original cartridge(s), and then recreate the barcode template with the appropriate values to use the barcode number(s)

Adding and removing barcode templates

You can add and remove (delete), but not edit, cartridge barcode templates at any time.



NOTE:

Deleting a barcode template does not affect the cartridges that were created using it.

To add or delete a barcode template:

1. Open a Command View VLS session and log in as the administrator. See [Opening a Command View VLS session from Command View TL](#).
2. Click the **System** tab.
3. Select **Cartridges** in the Navigation tree.
4. Click **Add/Remove Barcode Templates** in the Task bar.

The Add/Remove Barcode Templates window opens ([Figure 44](#)).

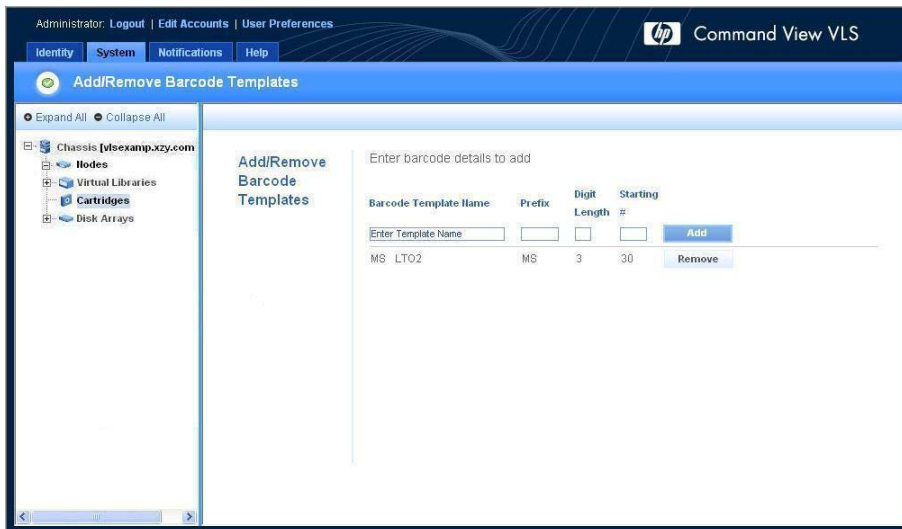

Figure 44 Add/Remove Barcode Templates window

5. To delete a barcode template, click the **Remove** button for the barcode template. The window refreshes when the deletion operation is finished.
6. To add a barcode template:

- a. Enter a descriptive name for the barcode template in the **Barcode Template Name** box.

You may want to use the same names as in your physical library, as it provides a one-to-one match when you back up the virtual media to physical tape.

- b. Enter the barcode prefix (one to five alpha characters) in the **Prefix** box.
- c. Enter the number of digits for the barcode number in the **Digit Length** box.
- d. Enter the starting barcode number in the **Starting #** box.
- e. Click **Add** to add the new barcode template.
- f. To add another barcode template, repeat steps a through e.

6 Management

This section details the VLS management procedures. It is comprised of the following topics:

- [Changing the account passwords](#)
- [Managing cartridges](#)
- [Freeing up storage space](#)
- [Adding capacity](#)
- [Installing capacity licenses](#)
- [Restarting the VLS device emulations](#)
- [Updating the software](#)
- [Saving configuration settings](#)

Changing the account passwords

To change the administrator and/or user account password:

1. Open a Command View VLS session and log in as the administrator. See [Opening a Command View VLS session from Command View TL](#).
2. Click **Edit Accounts** in the Status banner.

The Edit Accounts window opens ([Figure 45](#)).

Account	Old Password	New Password	Retype New Password
Administrator	<input type="text"/>	<input type="text"/>	<input type="text"/>
User	<input type="text"/>	<input type="text"/>	<input type="text"/>

[Apply Settings](#)

Figure 45 Edit Accounts window

3. Enter the current password in the **Old Password** box. The password is case sensitive.
4. Enter a new password in the **New Password** box.
5. Enter the new password again in the **Retype New Password** box.
6. Click **Apply Settings**.



NOTE:

You can change the user or administrator account password separately, or change both at the same time.

7. Restart Command View VLS. See [Restarting Command View VLS](#).

Managing cartridges

You can change the following parameters for existing cartridges:

- Library with which they are associated
- Capacity
- Write access

To view and/or modify cartridges settings:

1. Open a Command View VLS session and log in as the administrator. See [Opening a Command View VLS session from Command View TL](#).
2. Click the **System** tab.
3. Select **Cartridges** in the Navigation tree.

The cartridge details window opens ([Figure 46](#)).

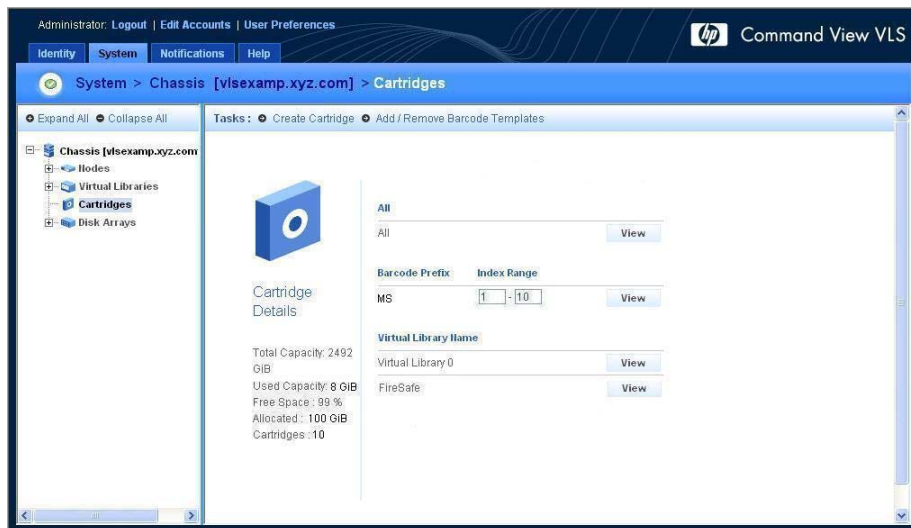

Figure 46 Cartridge details window

4. Click the **View** button beside the group of cartridges you want to edit.

If viewing by barcode, enter a cartridge range to view a specific cartridge(s) or leave the default values to view all the cartridges with the barcode.

The cartridges parameters window opens ([Figure 47](#)).

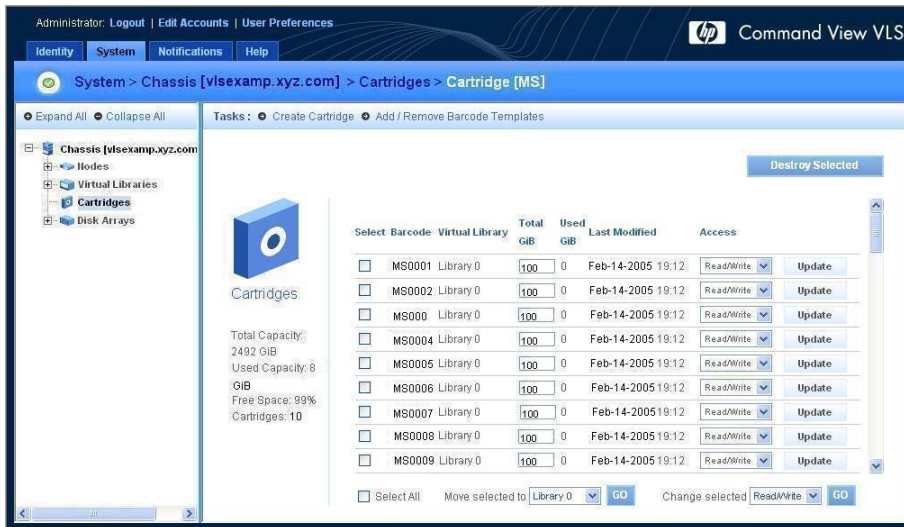

Figure 47 Cartridges parameters window



CAUTION:

Be careful when moving cartridges to a library other than the Firesafe. If the total number of cartridges for a library exceeds the number of slots available for that library, the backup application cannot access the additional cartridges.

5. To change the library association for one or more cartridges:
 - a. Select the **Select** box next to each cartridge that you want to edit.
 - b. Set the desired library in the **Move selected to** box.
 - c. Click the **Go** button next to the **Move selected to** box.
6. To change a cartridge's total capacity:
 - a. Select the **Select** box next to each cartridge that you want to edit.
 - b. Enter a new value, in GiB, in the **Total** box.
 - c. Click **Update**.
7. To change a cartridges' read and write access:
 - a. Select the **Select** box next to each cartridge that you want to edit.
 - b. Select the desired access from the **Access** box.

Freeing up storage space

Storage space can be freed up by erasing the data on or destroying virtual media that is no longer used, such as:

- Cartridges that are no longer used by a backup application
- Cartridges that have been moved to the Firesafe that are no longer needed

Use the backup application to erase data on virtual media that is no longer used.

Destroy virtual media that is no longer needed using Command View VLS. See [Destroying cartridges](#).



NOTE:

Reducing the size of the cartridges in a virtual library will not free up disk space. Storage space is dynamically assigned by the VLS as it is used. It is not reserved.

Adding capacity

You can increase the capacity of a VLS by enabling device-side data compression when creating a new tape drive(s).

You can also add capacity by adding a VLS 2.5TB capacity bundle to the VLS, or by adding an existing MSA20 disk array with twelve blank 250 GB hard drives and the latest MSA20 firmware, and a capacity license to the VLS.



NOTE:

Once a disk array is added to the VLS, the only way it can be removed from the VLS storage pool is by re-installing the VLS operating system and then rebuilding the virtual library configuration.

To add a disk array:

1. Install the capacity license shipped with the VLS capacity bundle. See [Installing capacity licenses](#).

If you added an existing MSA20 disk array, purchase a VLS capacity license for the disk array and install it.



CAUTION:

If a capacity bundle or existing disk array is added to the VLS before the capacity license is installed for the disk array, a capacity license violation will occur. This will disabled the VLS storage capacity, so that the VLS is unable to perform for read/write operations. VLS storage capacity is re-enabled once the capacity license is installed on the VLS and the VLS is rebooted.

2. Power down the node. See [Powering down the node](#).
3. Install the MSA20 disk array into the rack. See [Installing the disk array\(s\) into a rack](#).
4. Connect the VHDCI connector on the disk array to a VHDCI connector on the node. See [Installing cables](#).
5. Connect the AC input socket of each disk array power supply to an AC power source.
6. Power up the disk array. See [Powering up the disk arrays](#).
7. Power up the node. See [Powering up the node](#).

Installing capacity licenses

A VLS capacity license must be installed on the VLS for each VLS capacity bundle or existing MSA20 disk array added to the VLS base configuration.



NOTE:

See the *HP OpenView Command View for TL User Guide* for instructions on performing the following steps.

The VLS network settings must be set before a capacity license can be installed. See [Setting the network settings](#).

To install a capacity license on the VLS:

1. Install Command View TL.
2. Start Command View TL.
3. Complete the Command View TL initial configuration steps.
4. Add the VLS to Command View TL.
5. Open a Command View VLS session from Command View TL for the VLS. See [Opening a Command View VLS session from Command View TL](#).
6. Click the **Identity** tab.

The Identity tab window opens ([Figure 48](#)).



Figure 48 Identity tab window

7. Record the VLS serial number listed on the Identity tab window.
8. Obtain a license key from the HP web site (<http://www.webware.hp.com>) using the VLS serial number and license registration number.



NOTE:

Make sure to enter the VLS serial number correctly when obtaining the license key. If it is entered incorrectly, the license key generated will not work and the license registration number will become locked to the wrong serial number. If this occurs, contact HP Support to obtain a new license registration number.

9. Add the license key to Command View TL.

Command View TL installs the license key on the VLS.

Restarting the VLS device emulations

Restart the VLS device emulations:

- If the VLS locks up
- After destroy a virtual device (library or tape drive) on the VLS and doing so leaves a gap in the virtual device LUN numbering on a Fibre Channel host port
- After adding a virtual tape drive and the default LUN number assigned to it is not consecutive with the other virtual tape drives in the same library



CAUTION:

Restarting the VLS device emulations changes the default virtual device LUN numbers if there is a gap in the LUN numbering, or if there is a tape drive whose LUN number is not consecutive with the other tape drives in the same library. The software changes the LUN numbers as necessary to remove the gap or to make the virtual tape drive LUN numbers consecutive in each library, so that the virtual device LUN numbering meets the operating system LUN requirements. When this occurs, on each host:

- Rescan the SAN with the operating system for hardware changes.
 - Rescan for new devices with the backup application and update the backup application device files.
-



CAUTION:

Restarting the VLS device emulations places the VLS cartridges back into the library slots in alphanumeric order. This can confuse the backup application, which will look for the cartridges in the slots they were placed in after they were last used. If this occurs, change the cartridge slot positions on the backup application so they match the new cartridge slot positions on the VLS.

To restart the VLS device emulations:

1. Open a Command View VLS session and log in as the administrator. See [Opening a Command View VLS session from Command View TL](#).
2. Click **User Preferences** in the Status banner.
3. Click **Restart Emulations** in the Task bar.

The Restart Emulations window opens ([Figure 49](#)).

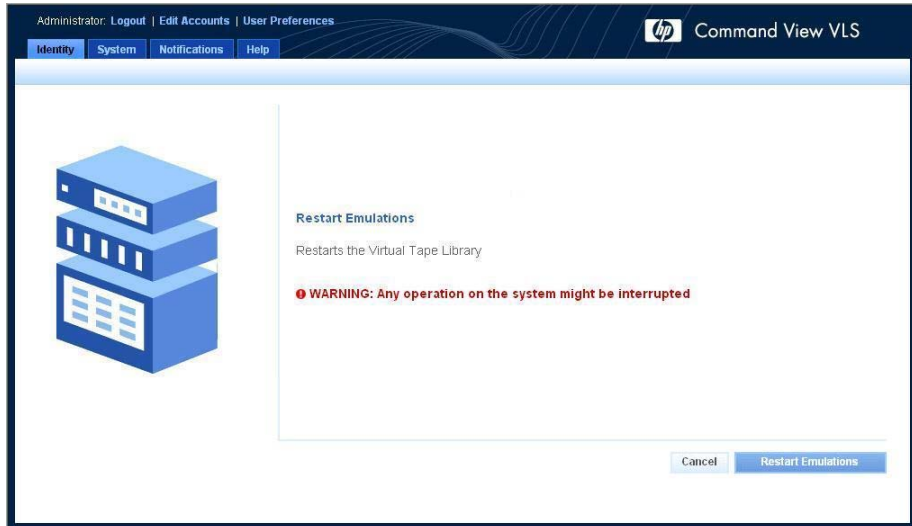

Figure 49 Restart Emulations window

4. Click **Restart Emulations** to confirm.

When the restart is finished, a window appears stating the restart was successful.

Updating the software



CAUTION:

The VLS restarts automatically when a software update is installed.

To update the VLS software:

1. Obtain the VLS software update zip file from HP.
2. Open a Command View VLS session and log in as the administrator. See [Opening a Command View VLS session from Command View TL](#).
3. Select **Chassis** in the Navigation tree.
4. Click **Software Update** in the Task bar.

The Software Update window opens ([Figure 50](#)).

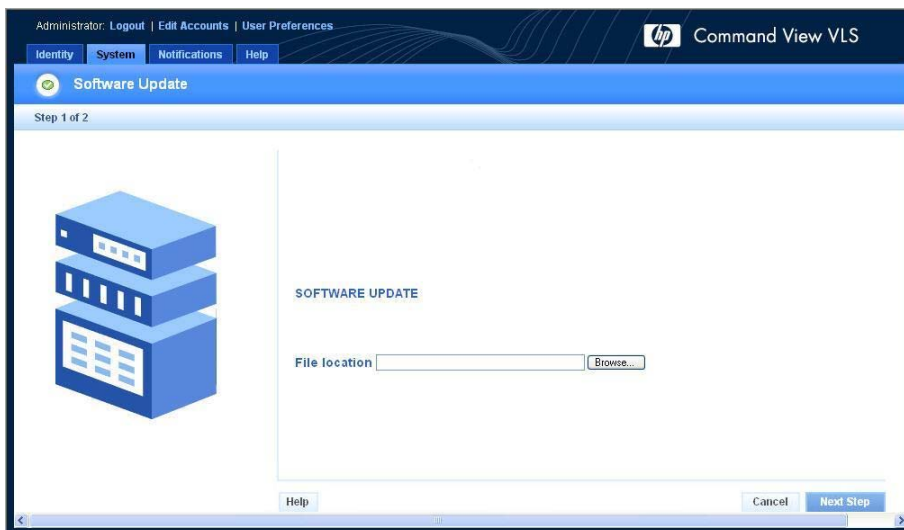

Figure 50 Software Update window

5. Click **Browse**.
6. Select the `firmware.zip` file.
7. Click **Next Step**.

The window displays:

Uploading the file

8. Click **Next Step** to confirm that you want to load the new software.

The Software Update Finished window opens and displays a message indicating that the upgrade was successful.

9. Click **Finish** to return to the System tab window.

Saving configuration settings



NOTE:

The VLS software ensures a persistent VLS serial number and Fibre Channel port WWPNs, so that in the event of any hardware failure and replacement (such as the system board or Fibre Channel host bus adapter card), the VLS still appears exactly the same to the external SAN. It does this by generating a VLS serial number and Fibre Channel port WWPNs at first boot, which are based on the system board's MAC address. The VLS serial number and Fibre Channel port WWPNs are saved on the VLS hard drives and with the virtual library configuration settings in the configuration file.

HP highly recommends that you save your virtual library configuration and the VLS network settings to an external configuration file, so they can be restored in the event of a disaster.

To save your virtual library configuration and the VLS network settings to an external configuration file:

1. Open a Command View VLS session and log in as the administrator. See [Opening a Command View VLS session from Command View TL](#).
2. Select **Chassis** in the Navigation tree.
3. Click **Save Config** in the Task bar.

The Save Configuration window opens ([Figure 51](#)).



Figure 51 Save Configuration window

- 4.** Right-click **Download Configuration Files**.
- 5.** Select **Save Target As**.
A zip file is displayed in the File name box.
- 6.** Click **Save**, wait for the file to finish downloading, and then click **Close**.
The Save Configuration window re-opens.
- 7.** Click **Finish**.

7 Monitoring

This section describes the various tools you can use to monitor the status of the VLS hardware and virtual devices (libraries and tape drives), and how to use them. These monitoring tools include:

- [Status information in the Status pane](#)
- [Status icons](#)
- [Notification alerts](#)
- [Trace log files](#)

Status information in the Status pane

Status information for the VLS hardware components and virtual devices is displayed on Command View VLS in the Status pane when an individual hardware component or virtual device is selected in the Navigation tree.



The five device statuses are as follows:

- **Good**— The component, part of a component, or virtual device is operating normally.
- **Degraded**—The component, or one or more parts of the component, has failed or is operating outside of its normal range, but is still operational.
- **Critical** —The component, or one or more parts of the component, has failed or exceeded its limits. Although it is still operational, VLS failure is imminent.
- **Failed**—The component, or one or more parts of the component, has failed and the VLS is inoperable. Immediate service is needed.
- **Missing** —The VLS cannot detect the component or a part of the component.

In addition to the five device statuses, a red or yellow alert bar will highlight specific parts of a component when that particular element within the component has failed (red) or is operating outside its normal range (yellow).

To view the status information for a VLS hardware component or virtual device:

1. Open a Command View VLS session. See [Opening a Command View VLS session from Command View TL](#).
2. Click the **System** tab.
3. Click the object in the Navigation tree that represents the hardware component or virtual device that you want to view.

The status information for the object selected, and its subobjects in the Navigation tree, is displayed in the Status pane.

Status icons

The current overall status of the VLS is displayed on Command View VLS as an icon in the Status banner. In addition, components or parts of a component whose condition is not “good” are marked with an icon in the Navigation tree.

Device status icon





The device status icon in the Command View VLS Status banner indicates the overall VLS device health. The device status icon is displayed in the Status banner regardless of the tab selected.

If multiple system health conditions exist simultaneously (for example, two components are experiencing problems and have a status of warning and error, respectively), the icon representing the most serious status is displayed in the Status banner.



Figure 52 Device status icon in the Status banner

A device status icon can be one of four states:

-  **Unknown**—A component’s operating condition is unknown. Contact HP Technical Support.
-  **Normal**—All components within the VLS are operating normally.
-  **Warning**—A component’s operating condition has degraded.
-  **Error**—A component has failed.

Navigation tree icon

An  icon appears just to the left of objects in the Navigation tree when an unknown, warning, or error condition is present with a component. It also appears just to the left of the parent objects of that component. For example, if the icon is displayed by Fibre Channel in the Navigation tree, it will also be displayed by its parent objects (Node 0, Nodes, and Chassis).

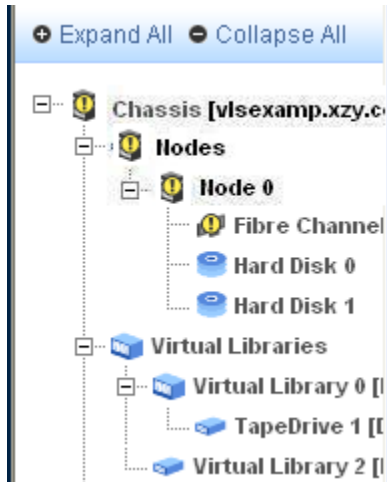

Figure 53 Navigation tree icon

Notification alerts

If a VLS hardware component or an environmental condition degrades or fails, the VLS generates a notification alert. Notification alerts are displayed on Command View VLS in the Notification pane and on the Notification tab window. Click the **View Details** link to view the details of a notification alert.

Notification alerts are also emailed to the addresses you specify and sent as SNMP traps to the management consoles you specify.





NOTIFICATIONS	
<input type="checkbox"/>	02/16/05 18:19:09  FibreChannel_1 (vlsexamp.xyz.com > Head 0 > FibreChannel 1) View Details
<input type="checkbox"/>	02/16/05 18:19:09  FibreChannel_0 (vlsexamp.xyz.com > Head 0 > FibreChannel 0) View Details
<input type="checkbox"/>	02/14/05 18:34:11  FibreChannel_0 (vlsexamp.xyz.com > Head 0 > FibreChannel 0) View Details
<input type="checkbox"/>	02/14/05 18:34:11  PowerSupply_0 (vlsexamp.xyz.com > DiskArray 127.0.0.1 > Enclosure 0 > PowerSupply 0) View Details
<input type="checkbox"/>	02/14/05 17:08:46  INFO (vlsexamp.xyz.com > DiskArray 127.0.0.1 > HardDisk 7) View Details
<input type="checkbox"/>	02/14/05 17:08:46  INFO (vlsexamp.xyz.com > DiskArray 127.0.0.1 > Enclosure 0 > PowerSupply 0) View Details

Figure 54 Notification alert examples

A notification alert can be one of four states:

 **Unknown**—The operating condition of the component or component part is unknown. Contact HP Technical Support.

 **Info**—The component or component part’s operating condition has improved to good (OK).

 **Warning**—The component or component part’s operating condition has degraded.

 **Error**—The component or component part has failed.

Command View VLS

To view the current and historical notification alerts for all the VLS hardware components:

1. Open a Command View VLS session. See [Opening a Command View VLS session from Command View TL](#).
2. Click the **Notifications** tab.

The Notifications Tab window opens ([Figure 55](#)).

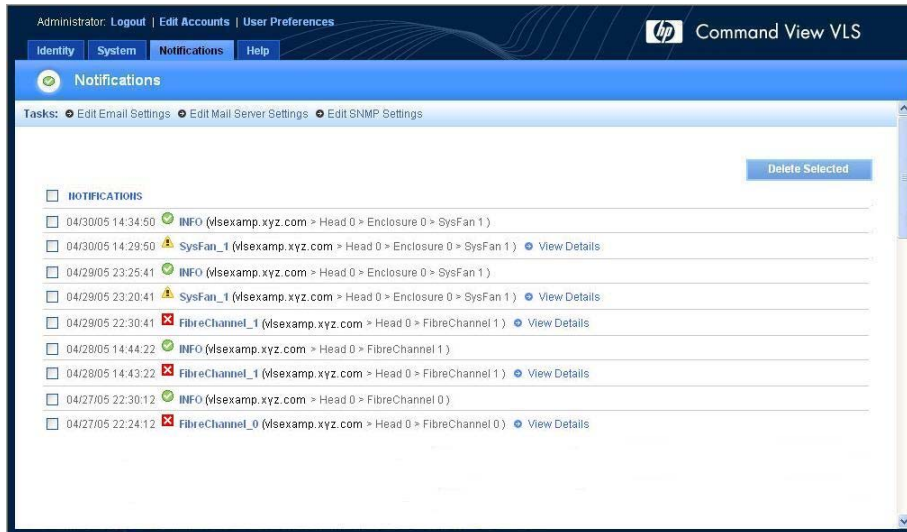

Figure 55 Notifications Tab window

3. Click the **View Details** link for a notification alert to view more information about the notification alert.

To view the notification alerts for a specific VLS hardware component:

1. Open a Command View VLS session. See [Opening a Command View VLS session from Command View TL](#).
2. Click the **System** tab.
3. Select the object in the Navigation tree that represents the hardware component that you want to view.

The notification alerts relevant to the object selected and its subobjects in the Navigation tree are listed in the Notifications pane.

4. Click the **View Details** link for a notification alert to view more information about that notification alert.

To delete notification alerts from Command View VLS:

1. Open a Command View VLS session. See [Opening a Command View VLS session from Command View TL](#).

2. Click the **Notifications** tab.

The Notifications Tab window opens ([Figure 55](#)).

3. Select the boxes next to the notification alerts that you want to delete.

4. Click **Delete Selected**.

The notification alerts are deleted from the Notification tab window and can no longer be viewed.

Email notification

To receive VLS notification alerts by email, you must edit the mail server settings and then edit the email settings.

Editing the mail server settings



NOTE:

You must enter the mail server settings before editing the email settings.

To edit the mail server settings:

1. Open a Command View VLS session and log in as the administrator. See [Opening a Command View VLS session from Command View TL](#).

2. Click the **Notifications** tab.

The Notifications Tab window opens ([Figure 55](#)).

3. Click **Edit Mail Server Settings** in the Task bar.

The Edit Mail Server Settings window opens ([Figure 56](#)).

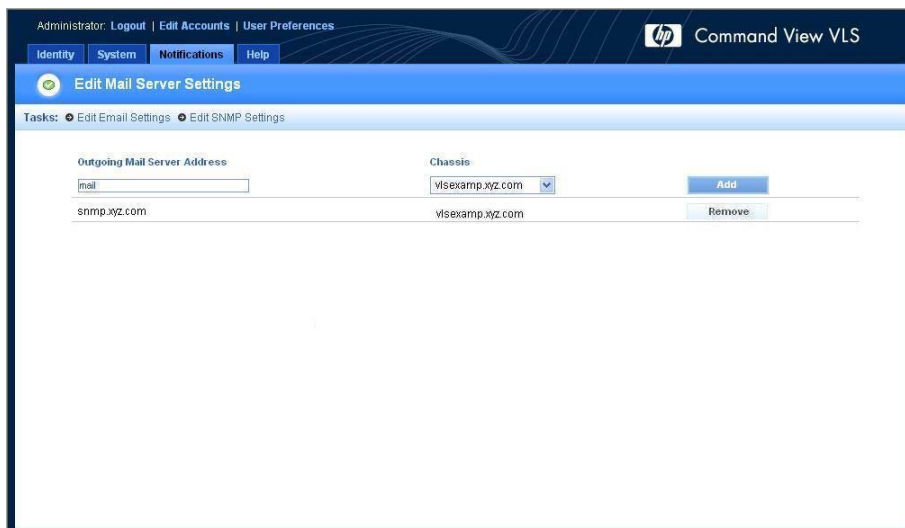

Figure 56 Edit Mail Server Settings window

4. To add a mail server:

- a. Enter the domain name for a mail server with an SMTP gateway that will process mail from the VLS in the **Outgoing Mail Server** box.
 - b. Click **Add**.
 - c. To add another mail server, repeat steps a through b.
5. To delete a mail server from the list, click the **Remove** button for the mail server.

Edit the email settings

Email notification is sent to the persons you include on the email distribution list in the email settings. You specify the email notification alert severity and format settings for each person on the distribution list.

To create an email distribution list for notification alerts, add an email address to the list, or remove an email address from the list:

1. Log in to Command View VLS as the administrator. See [Opening a Command View VLS session from Command View TL](#).
2. Click the **Notifications** tab.
The Notifications Tab window opens ([Figure 55](#)).
3. Click **Edit Email Settings** in the Task bar.
The Edit Email Settings window opens ([Figure 57](#)).

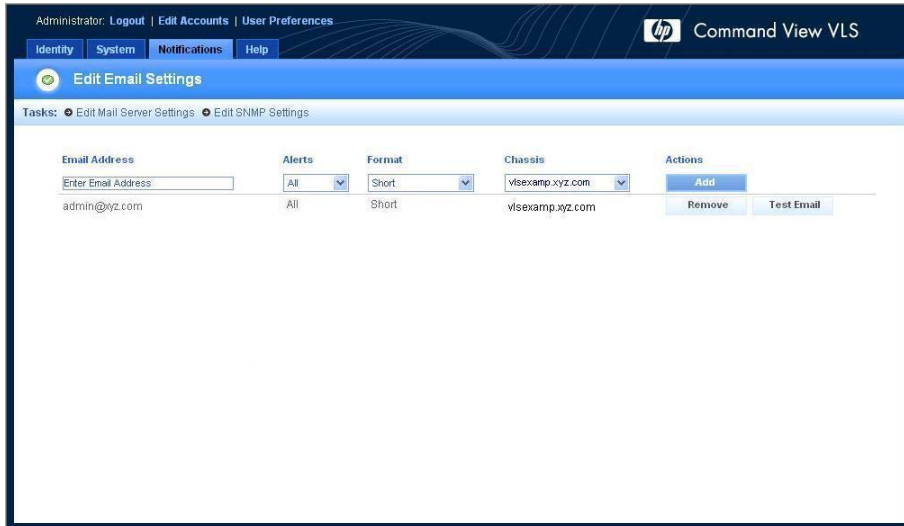

Figure 57 Edit Email Settings window

4. To add an email address:
 - a. Enter an email address in the **Email Address** box.
 - b. Select the type of notification alerts to send in the **Alerts** box.
 - **All**—Sends all notifications
 - **Errors**—Sends only errors
 - **Warnings**—Sends only warnings
 - **None**—Sends no notifications
 - c. Select a notification alert format in the **Format** box.
 - **Short**—Sends short email messages
 - **Long**—Sends detailed email messages
 - **Long + Attachment**—Sends detailed email messages and relevant log files
 - d. Click **Add**.
 - e. To add another email address, repeat steps a through d.
5. To delete an email address, click the **Remove** button for the email address.
6. To test an email address entry, click **Test Email**.

If the email is not received at the email address, check the mail server settings.

SNMP notification

To receive VLS notification alerts on a management console(s), you must edit the SNMP settings to specify the management console(s) you want to receive VLS SNMP traps.

Editing the SNMP settings



NOTE:

To display VLS notification alerts on a management console, the management console must be running HP Systems Insight Manager, and be configured to receive SNMP traps from the VLS.

To add a management console(s) to the SNMP alert distribution list:

1. Log in to Command View VLS as the administrator. See [Opening a Command View VLS session from Command View TL](#).
2. Click the **Notifications** tab.
The Notifications Tab window opens ([Figure 55](#)).
3. Click **Edit SNMP Setting** in the Task bar.
The Edit SNMP Settings window opens ([Figure 58](#)).

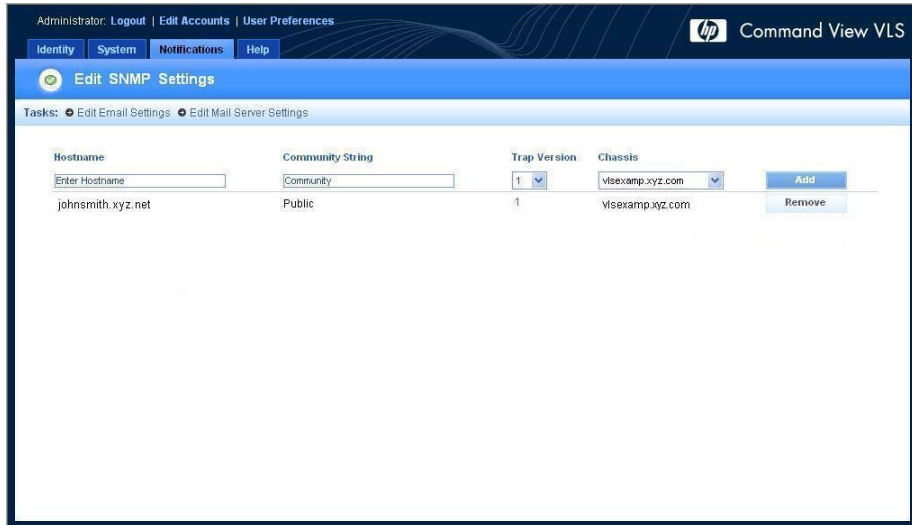

Figure 58 Edit SNMP Settings window

4. To add management consoles:
 - a. Enter the host name of a management console that you want to receive VLS SNMP traps in the **Hostname** box.
 - b. Enter the string name that is passed with the set to get commands from the management console in the **Community String** box.
This value is typically set to Public.
 - c. Select the appropriate trap version for the management application that will receive the SNMP traps in the **Trap Version** box.
Select **1** for the trap version if your management application is HP Systems Insight Manager.
 - d. Click **Add**.
 - e. To add another management console, repeat steps a through d.
You can up to 10 management consoles.
5. To delete a management console from the list, click the **Remove** button for the management console.

Trace log files

You can view the current diagnostic VLS trace log files for troubleshooting purposes. You can also save one or more of the trace log files to external text files, or to a single zip file to create a support ticket.

Viewing trace log files

To view the current diagnostic VLS trace log files:

1. Log in to Command View VLS as the administrator. See [Opening a Command View VLS session from Command View TL](#).
2. Click the **System** tab.
3. Select **Chassis** in the Navigation tree.
4. Click **Log Viewer** in the Task bar.

The Log Viewer window opens ([Figure 59](#)).

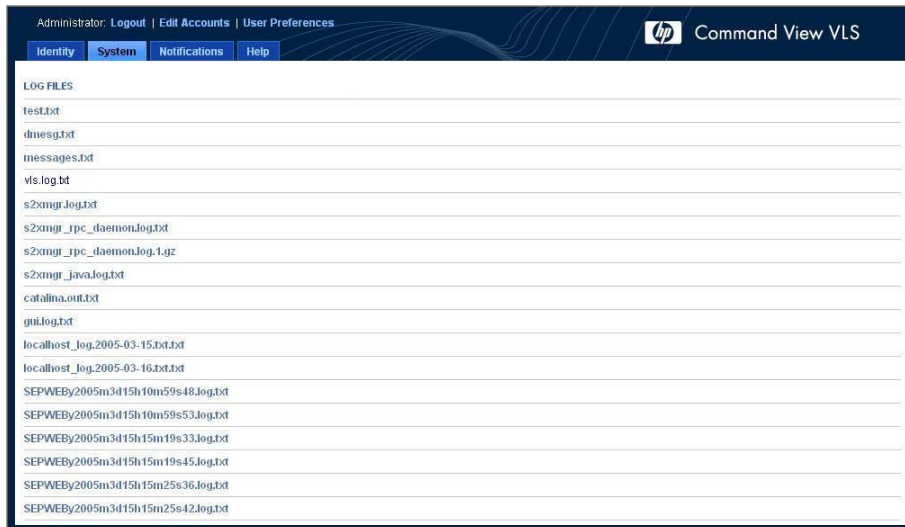

Figure 59 Log Viewer window

5. Double-click the trace log file that you want to view.

The contents of the trace log file opens.

Saving a trace log file

To save a trace log file to an external file:

1. Log in to Command View VLS as the administrator. See [Opening a Command View VLS session from Command View TL](#).
2. Click the **System** tab.
3. Select **Chassis** in the Navigation tree.
4. Click **Log Viewer** in the Task bar.

The Log Viewer window opens ([Figure 59](#)).

5. Right-click the trace log file from the list and select **Save Target As**.
6. Enter a name for the file and click **Save**.

Creating a support ticket

To save all the current diagnostic VLS trace log files to a single zipped file to create a support ticket:

1. Log in to Command View VLS as the administrator or user.
2. Click the **System** tab.
3. Select **Chassis** in the Navigation tree.
4. Click **Support Ticket** in the Task bar.

The Support Ticket window opens (Figure 60).

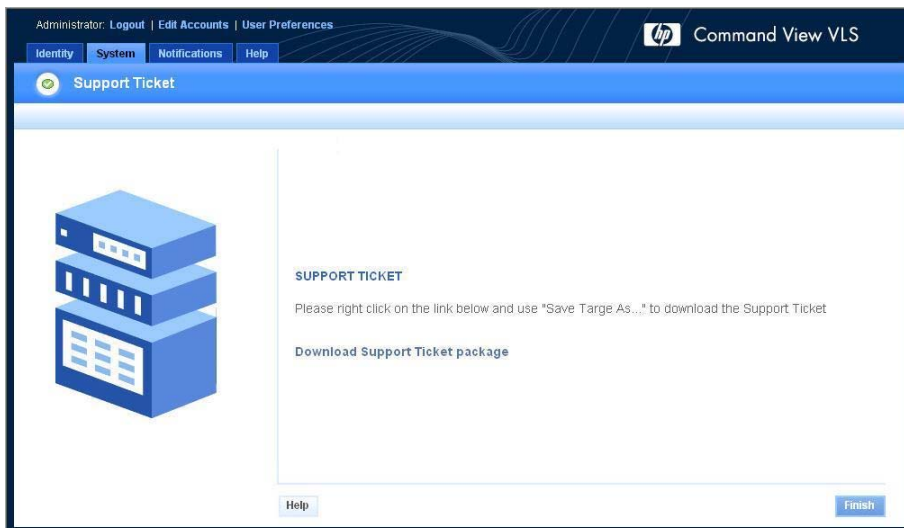

Figure 60 Support Ticket window

5. Right-click **Download Support Ticket package**.
6. Select **Save Target As**.

The name of a zip file is displayed in the File name box.

7. Click **Save**.
8. Click **Close**.
9. Click **Finish**.

8 CLI command set

This section describes the VLS command-line interface (CLI) command set. The CLI command allows you to remotely configure, manage, and monitor the VLS over the LAN using a secure shell session. It also allows you to locally configure, manage, and monitor the VLS through the serial connection.

Commands

There are two types of CLI commands:

- **CLI-only commands**
Commands that are processed by the CLI and affect only the CLI.
- **VLS commands**
Commands that are passed to the VLS to configure, manage, and monitor the VLS.

Conventions

All command arguments are case-sensitive and optional. They can be specified in any order. There are several option tags associated with a command. The following conventions are used in this section to identify option tags and arguments:

- An option tag is preceded by either - or /.
- The argument is separated from the option tag by a space.
- If an argument contains a space, it must be enclosed by either two single quotes or two double quotes.
- If there is no argument after an option tag, the option is a switch.
- An * after an argument means the argument (including its option tag) can be repeated.
- A | between a compound argument means one or the other argument.

CLI-only commands

This section describes the CLI-only commands in the VLS CLI command set.

Connection commands

Use the CLI commands in [Table 5](#) to establish or close a VLS secure shell or serial user interface session.

Table 5 CLI connection commands

Command	Description
bye done exit logout quit	Terminates the CLI session.
close	Close the connection to the VLS.
getHost	Displays the fully qualified name of the VLS and its IP address.

Output commands

Use the CLI commands in [Table 6](#) to control the output and display help information for the CLI commands.

Table 6 CLI output commands

Command	Description
trace	Displays the stack trace after an exception has occurred.
verbose	Toggles verbose output on and off. When on, all messages are output to the screen.
version	Indicates current CLI version. If verbose is on, the module revisions display also.
help	Displays CLI command usage information. <ul style="list-style-type: none">• where <i><-tag></i> can be:<ul style="list-style-type: none">-<i>c<command></i> - Provides help information for the specified CLI command-all - Lists all CLI commands and their help information

VLS commands

This section describes the VLS commands in the VLS CLI command set.

Network settings configuration commands

Use the CLI commands in [Table 7](#) to configure the VLS network settings via a serial session. See [Opening a serial session](#).

Changing the network configuration parameters modifies four system files:

```
/etc/hosts
```

```
/etc/sysconfig/network
```

```
/etc/resolv.conf
```

```
/etc/sysconfig/network-scripts/ifcfg-eth1
```

Table 7 CLI network settings configuration commands

Command	Description
<code>showConfig</code>	Lists host name, DNS domain name, DNS address, and various other addresses. This command shows both the current internal values, as well as the original values. It also lists the current and new content of all files affected by the changes.
<code>setConfigValue</code> <code><-tag> [value]</code>	<p>Sets the value of the corresponding configuration parameter. To reset a value, enter " " (quoted space) as the value. More than one tag and value can be set at a time.</p> <ul style="list-style-type: none">• where <code><-tag></code> can be:<ul style="list-style-type: none">-<code>host</code> - Host name (such as vlsexamp) (unqualified)-<code>domain</code> - DNS domain name (such as xyz.com)-<code>fullhost</code> - Fully qualified name (such as vlsexamp.xyz.com)-<code>dnsaddr</code> - DNS server address (replaces all addresses with one line)-<code>dnsaddr1</code> - First DNS server address (cannot use with <code>dnsaddr</code>)-<code>dnsaddr2</code> - Second DNS server address (cannot use with <code>dnsaddr</code>)-<code>dhcp</code> - Has no value, indicates you want to configure the public Ethernet connection using DHCP (reset is <code>-dhcp=false</code>)-<code>ipaddr</code> - IP address of public Ethernet connection-<code>gate</code> - Gateway to network (xx.xx.xx.x)-<code>mask</code> - Netmask. Defaults to 255.255.255.0
<code>getDateTIme</code>	Displays the day, date, time, timezone, and year (such as Mon March 14 11:30:46 EST 2005)
<code>setDateTIme</code>	<code>-d<s></code> - Sets the date and time. Enter date and time in yyyy-mm-dd hh:mm format (hh is 24 hour from 0).
<code>commitConfig</code>	Saves the system values changed using <code>setConfigValue</code> .



NOTE:

To reset a value to its default setting, set the option tag to " " (quoted space). For example:

```
fullhost=" "
```

The exception to this is the dhcp tag. DHCP is disabled by entering:

```
-dhcp=false
```

Any network configuration changes made using `setConfigValue` do not take effect until "committed", using the `commitConfig` command.

Configuration commands

Use the CLI commands in [Table 8](#) to:

- Edit the Fibre Channel host port settings
- Enable oversubscription and view oversubscription settings
- View LUN mapping
- Create, view, and destroy virtual libraries, tape drives, or cartridges
- Add, view, or remove barcode templates

Table 8 CLI configuration commands

Command	Usage ^a
updateFC	<p>Changes the default Fibre Channel host port connection settings.</p> <ul style="list-style-type: none">• where the options are:<ul style="list-style-type: none">-a <n> - ID number of node to modify (0, ...) (optional)-i <n> - Fibre Channel index (0, 1, ...) (required)-l <n> - If attached in arbitrated loop mode, specifies a hard ALPA value between 0 and 125. A value of -1 specifies a dynamically assigned ALPA. If not attached to an arbitrated loop, this parameter is ignored (required)-r <n> - Port number of the Fibre Channel port to modify (required)-s <n> - Preferred speed(s) (0-Auto, 1-One GB, 2-Two GB, 4-Four GB, or 10-Ten GB) (required)-t <n> - Preferred topology(s) (0-Auto, 1-Point to Point, 2-Loop, 3-Fabric, or 4-Public Loop) (required)-h - Displays command usage information (optional)

Command	Usage ^a
setOverSubscription	<p>Enables or disables oversubscription and specifies the percent storage remaining for notification.</p> <ul style="list-style-type: none"> • where the options are: <ul style="list-style-type: none"> -e <n> - Enable/disable oversubscription (0-Disabled or 1-Enabled) (required) -p <n> - Percentage of capacity remaining for alert notification (required) -h - Displays command usage information (optional)
getOverSubscription	<p>Returns whether the oversubscription feature is enabled or disabled and the capacity remaining percentage for notification alert. Oversubscription is enabled when "enabled = 0". Oversubscription is disabled when "enabled = 1".</p>
getLunMap	<p>Returns existing LUN mapping configured on the VLS for the LUN specified.</p> <ul style="list-style-type: none"> • where the options are: <ul style="list-style-type: none"> -a <n> - Number of the node (0, ...) (required) -l <n> - LUN number of device whose LUN map you wish to view (required) -h - Displays command usage information (optional)
getLibTypes	<p>Returns a list of available library emulation types. Displays each library emulation's name, type, product, revision, and vendor information.</p>

Command	Usage ^a
createLibrary	<p>Creates a new library with the specified maximum number of cartridge slots, input/export ports, and tape drives.</p> <ul style="list-style-type: none"> • where the options are: <ul style="list-style-type: none"> -a <n> - Node ID of the node on which the library emulation will reside (0, ...) (required) -l <n> - LUN number to assign to library (-1 to 128) (optional) -n <n> - Maximum number of tape drives (required) -p <s> - Product (spaces allowed) (MSL6000, ...) (required) -pm <n> - Fibre Channel port to which this library is mapped (0, 1, ...) (required) -pt <n> - Maximum number of input/export ports (required) -r <s> - Revision (0430, ...) (required) -sl <n> - Maximum number of cartridge slots (required) -t <s> - Library type name (required) -v <s> - Vendor (HP, ...) (required) -y <n> - Library type to emulate (2051, ...) (required) -h - Displays command usage information (optional)
getLibs	Returns a list of the libraries defined on the VLS.
getLib	<p>Returns a summary of the specified library.</p> <ul style="list-style-type: none"> • where the options are: <ul style="list-style-type: none"> -a <s> - Name of library (Library_0, ...) (required) -h - Displays command usage information (optional)
getLibOpenSlots	Returns a summary of the slot status for each defined library (open:used:total).

Command	Usage ^a
destroyLib	<p>Deletes the specified library from the VLS. This operation takes several minutes to perform.</p> <ul style="list-style-type: none"> • where the options are: <ul style="list-style-type: none"> -a <n> - Node number on which the library emulation resides (0, ...) (optional) -f - Force. Do the destroy without a prompt (optional) -l <n> - LUN number of the library to delete (required) -h - Displays command usage information (optional)
getTapeTypes	<p>Returns a list of all tape drive emulation types available. Displays each tape drive emulation's name, type, product, revision, and vendor information.</p>
createTapeDrive	<p>Creates the specified number of tape drives of a particular type and associates them with the specified library.</p> <ul style="list-style-type: none"> • where the options are: <ul style="list-style-type: none"> -a <n> - Node ID of node on which the tape drive emulation will reside (0, ...) (required) -c <n> - Data compression (0=Disabled, 1=Enabled) (required) -l <n> - LUN number to assign to tape drive (-1 to 128) (optional) -la <n> - Node number on which the library emulation of the library to associate with the tape drive(s) resides (0 to 3) (required) -ll <n> - LUN number of library with which to associate tape drive (0, 1, ...) (required) -n <n> - Number of tape drives (required) -p <s> - Product (DLT7000, SDLT320, ...) (required) -pm <n> - Fibre Channel port to which this tape drive is mapped. (required) -r <s> - Revision (R138, ...) (required) -t <s> - Tape drive type name (required) -v <s> - Vendor (Quantum, HP, ...) (required) -y <n> - Tape drive type (3, 4, ...) (required) -h - Displays command usage information (optional)

Command	Usage ^a
getTapeDrives	<p>Returns a list of all tape drives defined in the VLS.</p> <ul style="list-style-type: none"> • where the options are: <ul style="list-style-type: none"> -a <<i>s</i>> - Library name (Library_0, ...) (required) -h - Displays command usage information (optional)
getTapeDrive	<p>Returns the configuration information for the specified tape drive.</p> <ul style="list-style-type: none"> • where the options are: <ul style="list-style-type: none"> -a <<i>s</i>> - Name of desired tape drive (TapeDrive_1, ...) (required) -l <<i>s</i>> - Name of library with which tape drive is associated (Library_0, ...) (required) -h - Displays command usage information (optional)
destroyTapeDrive	<p>Deletes the specified tape drive from the VLS.</p> <ul style="list-style-type: none"> • where the options are: <ul style="list-style-type: none"> -a <<i>n</i>> - Node number on which the tape drive resides (0 to 3) (optional) -f - Force. Do the destroy without a prompt (optional) -l <<i>n</i>> - LUN number of the tape drive to delete (1, 2, ...) (required) -la <<i>n</i>> - Number of the node on which the library emulation to which the tape drive is associated resides (required) -ll <<i>n</i>> - LUN number of the library associated with the tape drive to delete (required) -h - Displays command usage information (optional)

Command	Usage ^a
addBarCodes	<p>Creates a new barcode template.</p> <ul style="list-style-type: none"> • where the options are: <ul style="list-style-type: none"> -a <<i>s</i>> - Barcode template name (up to 20 alphanumeric characters, spaces allowed) (required) -b <<i>s</i>> - Barcode prefix to use for the barcode (up to 5 alpha characters) (required) -i <<i>n</i>> - Starting numeric value for the cartridges created with this template (1 to 1024) (required) -u <<i>n</i>> - Barcode suffix length. Number of digits for cartridge sequencing (1 to 16) (required) -h - Displays command usage information (optional)
getBarCodes	<p>Returns a list of all the barcode templates (and their settings) that have been defined. Displays each barcode template's name, prefix, start index, and suffix length.</p>
deleteBarCode	<p>Deletes the specified barcode template.</p> <ul style="list-style-type: none"> • where the options are: <ul style="list-style-type: none"> -a <<i>s</i>> - Barcode prefix (required) -f - Force. Do the delete without a prompt (optional) -h - Displays command usage information (optional)
getCartTypes	<p>Returns a list of available cartridge emulation types. Displays each cartridge emulation's name, type, and capacity information.</p>
getCartTypesByTape	<p>Returns a list of available cartridge emulation types for the tape drive specified. Displays each cartridge emulation's name, type, and capacity information.</p> <ul style="list-style-type: none"> • where the options are: <ul style="list-style-type: none"> -a <<i>s</i>> - Name of tape drive type (required) -h - Displays command usage information (optional)

Command	Usage ^a
createCartridge	<p>Creates the specified number of cartridges with the specified barcode and associated with the specified library.</p> <p>Note: If you specify more cartridges than slots defined for the library, this command only creates enough cartridges for the slots available. That is, if your library has 100 slots and you specify 125 total cartridges, this command creates 100 cartridges. Likewise, if 50 cartridges were already created for this library, this command would create only 50 more cartridges, even though 125 are specified by the command.</p> <ul style="list-style-type: none"> • where the options are: <ul style="list-style-type: none"> -a <s> - Cartridge name (DLT, ...) (required) -b <s> - Barcode prefix (required) -c <n> - Capacity in gigabytes (required) -i <n> - Barcode start index (required) -l <s> - Library name (Library_0, ...) (required) -n <n> - Number of cartridges (required) -ov <n> - Oversubscribe (0 or 1) (required) -u <n> - Barcode suffix length (required) -y <n> - Cartridge type (2, ...) (required) -h - Displays command usage information (optional)
getCartridges	<p>Returns a list of the cartridges that have been created. All cartridges have both a VLS filename (cartridge name) and a barcode label. This command returns the following cartridge metadata:</p> <ul style="list-style-type: none"> • Storage pool the cartridge resides (SD_1_0) • Cartridge VLS filename • Cartridge capacity (in GB) • Consumed capacity (in GB) • Cartridge type • Timestamp value for when it was last loaded • Whether or not it is write-enabled (0) or write-protected (1) • Library to which it belongs • Barcode label

Command	Usage ^a
getCartsByLib	<p>Returns a list of the cartridges associated with the specified library.</p> <ul style="list-style-type: none"> where the options are: <ul style="list-style-type: none"> -a <s> - Name of library (Library_0, ...) (required) -h - Displays command usage information (optional)
getCartsByBarcode	<p>This command returns the cartridge metadata for the number of cartridges indicated having the specified barcode.</p> <ul style="list-style-type: none"> where options are: <ul style="list-style-type: none"> -b<s> - Barcode prefix (required) -i<n> - Starting numeric value for the cartridges created with this template (required) -n <n> - Ending numeric value for the cartridges to retrieve (required) -u <n> - Number of digits for cartridge sequencing (required) -h - Displays command usage information (optional)
removeCartridge	<p>Deletes the specified cartridge and its user data from the VLS.</p> <ul style="list-style-type: none"> where the options are: <ul style="list-style-type: none"> -a <s> - VLS filename of cartridge to delete (required) -b <s> - Barcode value of cartridge to delete (required) -c <n> - Capacity of cartridge to delete in gigabytes (required) -f - Force. Do the remove without a prompt (optional) -l <s> - Name of library with which cartridge is associated (Library_0, ...) (required) -h - Displays command usage information (optional)
getStorageCapacity	<p>Returns the total usable storage capacity of the VLS.</p>

^a <s> = string; <n> = number; <f> = filename

Management commands

Use the CLI commands in [Table 9](#) to:

- Change the account passwords
- Manage cartridges
- Restart the VLS device emulations
- Save configuration settings
- Restore configuration settings

Table 9 CLI management commands

Command	Usage ^a
changePassword	<p>Reset the administrative password, or change the administrative or user password. Restart Command View VLS (<code>restartWebServer</code>) after changing the password(s) to make the changes take effect.</p> <ul style="list-style-type: none">• where the options are:<ul style="list-style-type: none">-admin - Reset the administrator password (-u and -p are ignored) (optional)-p - Password (no spaces) (optional)-u - Username (administrator or user). Default is current user. (optional)-h - Displays command usage information (optional)

Command	Usage ^a
editCartridge	<p>Change an existing cartridge parameters.</p> <ul style="list-style-type: none"> • where the options are: <ul style="list-style-type: none"> -a <<i>s</i>> - VLS filename of the cartridge (required) -b <<i>s</i>> - Barcode label of the cartridge (required) -c <<i>n</i>> - Current capacity of the cartridge in gigabytes (optional). Only required if changing the cartridge capacity. -l <<i>s</i>> - Name of library in which the cartridge resides (Library_0, ...) (required) -nc <<i>n</i>> - Desired new capacity of the cartridge in gigabytes (optional) -nl <<i>s</i>> - Name of the new library if moving cartridge (Library_1, ..) (optional) -w - Write protect? (0-read/write or 1-read only) (optional) -y <<i>n</i>> - Cartridge emulation type (2, 3, ...) (required) -h - Displays command usage information (optional)
restartEmulations	Restarts the VLS device emulations.
restartCommandViewVLS	Restarts Command View VLS.
restartSystem	Shuts down and restarts the VLS node.
shutdownSystem	Shuts down the VLS node so it can be powered off.

Command	Usage ^a
saveAllConfig	<ul style="list-style-type: none"> • where the options are: <ul style="list-style-type: none"> -o <S> - Saves the VLS virtual library configuration and network settings to the specified external configuration file. -h - Displays command usage information (optional)
restoreAllConfig	<ul style="list-style-type: none"> • where the options are: <ul style="list-style-type: none"> -in <S> - Restores the VLS virtual library configuration and network settings from the specified external configuration file. -h - Displays command usage information (optional)

^a <s> = string; <n> = number; <f> = filename

Monitoring commands

Use the CLI commands in [Table 10](#) to:

- View the VLS health status
- View or delete notification alerts
- Add, view, or delete mail servers to route notification alerts
- Add, view, or delete email addresses for notification alerts
- Add, view, or delete SNMP management consoles to receive notification alerts

Table 10 CLI monitoring commands

Command	Usage ^a
<code>getHealth</code>	Returns the VLS health status as a number (0-good, 1-degraded, 2-critical, 3-failed, 4-missing).
<code>getNavTree</code>	Returns the VLS navigation tree in XML format.
<code>getVTLTree</code>	Returns the VLS navigation tree in XML format.
<code>getChassis</code>	Returns information about the VLS displayed on the Identity Tab window.
<code>getNode</code>	Returns information about the specified node. <ul style="list-style-type: none">• where the options are:<ul style="list-style-type: none">-a <S> - Node name (Head_0, ...) (required)-h - Displays command usage information (optional)
<code>getNodeNames</code>	Returns the list of nodes in the VLS.
<code>getNodeFault</code>	Returns fault information for the specified node. <ul style="list-style-type: none">• where the options are:<ul style="list-style-type: none">-a <S> - Node name (Head_0, ...) (required)-h - Displays command usage information (optional)

Command	Usage ^a
getArray	<p>Returns the current configuration of the specified array.</p> <p>Note: This command returns the disk array name (disk array IP address), its health state, and a listing of its major components. With the verbose option turned on, a much more comprehensive report is produced.</p> <p>A "rack" value of 0 indicates that the disk array is located in the primary or only rack associated with the system.</p> <ul style="list-style-type: none"> • where the options are: <ul style="list-style-type: none"> -a <s> - IP address (required) -h - Displays command usage information (optional)
getArrayNames	Returns the IP address of the disk arrays.
getArrayFault	<p>Returns the current health status for the specified array (0 = healthy 1 = degraded 2 = critical 3 = failed 4 = missing).</p> <ul style="list-style-type: none"> • where the options are: <ul style="list-style-type: none"> -a <s> - IP address of the desired array (required) -h - Displays command usage information (optional)
getFreeArrayList	Returns a list of arrays not yet configured into a storage pool. This command reports "No disk arrays found" if all arrays have been added to a storage pool.
getNotificationsCount	<p>Returns the number of notification messages specified counting back from the most recent.</p> <ul style="list-style-type: none"> • where the options are: <ul style="list-style-type: none"> -n <n> - Maximum number of notifications to return (required) -h - Displays command usage information (optional)

Command	Usage ^a
getNotificationsDate	<p>Returns all the notification alert messages that occurred starting with the specified date.</p> <ul style="list-style-type: none"> where the options are: <ul style="list-style-type: none"> -d - mm/dd/yy on or after this date (required) -h - Displays command usage information (optional)
deleteNotifications	<p>Deletes the specified notification alerts from the VLS.</p> <ul style="list-style-type: none"> where the options are: <ul style="list-style-type: none"> -id <s> - ID number of notification to delete (required) -h - Displays command usage information (optional)
addEmailServer	<p>Specifies an email server with an SMTP gateway to route notification alerts from the VLS.</p> <ul style="list-style-type: none"> where the options are: <ul style="list-style-type: none"> -a <s> - Email server address (required) -c <s> - node IP address (required) -h - Displays command usage information (optional)
getLuns	<p>Return the list of LUNs configured on all the VLS disk arrays and their configuration status.</p>
getLunsbyArray	<p>Return the list of LUNs configured on the specified disk array and its configuration status.</p> <ul style="list-style-type: none"> where the options are: <ul style="list-style-type: none"> -a <s> - IP address (required) -h - Displays command usage information (optional)
getEmailServer	<p>Returns the email server configuration settings for notification alerts.</p>

Command	Usage ^a
deleteEmailServer	<p>Deletes the specified email server from the email notification alerts settings.</p> <ul style="list-style-type: none"> • where the options are: <ul style="list-style-type: none"> -a <s> - Email server address (required) -c <s> - VLS node IP address (required) -f - Force - Do the delete without a prompt (optional) -h - Displays command usage information (optional)
addEmail	<p>Adds an email address and desired report formatting to the email notification alert settings.</p> <ul style="list-style-type: none"> • where the options are: <ul style="list-style-type: none"> -a <s> - Email address (required) -c <s> - VLS IP address (required) -f <n> - Frequency (0-Never, 1-Daily, 2-Weekly, or 4-Monthly) (optional) -s <n> - Severity (1-Error, 2-Warning, 4-Info, or 8-Unknown) (optional) -y <n> - Email type (1-Long with attachment, 2-Long, 4-Short, or 8-Reports) (optional) -h - Displays command usage information (optional)
getEmail	<p>Returns the report settings for each email address configured for notification alerts.</p>

Command	Usage ^a
deleteEmail	<p>Deletes the specified email address from the email notification alert settings.</p> <ul style="list-style-type: none"> • where the options are: <ul style="list-style-type: none"> -a <S> - Email address (required) -c <S> - VLS node IP address (required) -f - Force. Do the delete without a prompt (optional) -h - Displays command usage information (optional)
addSnmpServer	<p>Specifies an SNMP management console to receive SNMP traps from the VLS.</p> <ul style="list-style-type: none"> • where the options are: <ul style="list-style-type: none"> -a <S> - SNMP server IP address (required) -c <S> - VLS node IP address (required) -m <S> - Community (Public, ...) (required) -v <S> - Trap version (required) -h - Displays command usage information (optional)
getSnmp	<p>Returns the SNMP management console configuration settings for notification alerts.</p>
deleteSnmpServer	<p>Deletes the specified SNMP management console from the SNMP notification alert settings.</p> <ul style="list-style-type: none"> • where the options are: <ul style="list-style-type: none"> -a <S> - SNMP server IP address (required) -c <S> - VLS node IP address (required) -f - Force. Do the delete without a prompt (optional) -h - Displays command usage information (optional)

^a <s> = string; <n> = number; <f> = filename

9 Component identification

This section provides illustrations and descriptions of the VLS node and disk array components, LEDs, and buttons.

Node components, LEDs, and buttons

Node front panel components

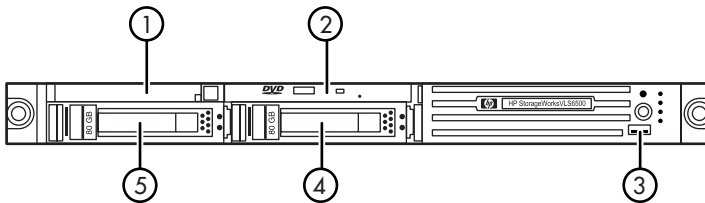

Item	Description
1	Diskette drive blank
2	DVD/CDRW drive
3	Front USB port
4	Hard drive 0
5	Hard drive 1

Node front panel LEDs and buttons

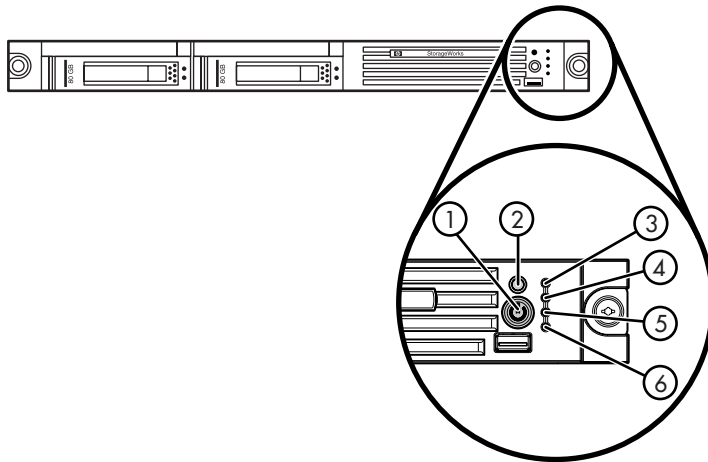

Item	Description	Status
1	Power On/Standby button and system power LED	<ul style="list-style-type: none"> • Green = System is on. • Amber = System is shut down, but power is still applied. • Off = Power cord is not attached, power supply failure has occurred, no power supplies are installed, facility power is not available, or the DC-to-DC converter is not installed.
2	UID button/LED	<ul style="list-style-type: none"> • Blue = Identification is activated. • Flashing blue = System is being remotely managed. • Off = Identification is deactivated.

Item	Description	Status
3	Internal health LED	<ul style="list-style-type: none"> • Green = System health is normal. • Amber = System is degraded. To identify the component in a degraded state, refer to system board LEDs. • Red = System critical. To identify the component in a critical state, refer to system board LEDs. • Off = System health is normal (when in standby mode).
4	External health LED (power supply)	<ul style="list-style-type: none"> • Green = Power supply health is normal when there are two power supplies. • Amber = Power redundancy failure occurred when there are two power supplies. Power supply health is normal when there is only one power supply. • Off = Power redundancy failure has occurred when there are two power supplies. When the node is in standby mode, power supply health is normal.
5	NIC 1 link/activity LED	<ul style="list-style-type: none"> • Green = Network link exists. • Flashing green = Network link and activity exist. • Off = No link to network exists. <p>If power is off, view the LEDs on the RJ-45 connector for status by referring to the rear panel LEDs. See Node rear panel LEDs and buttons.</p>
6	NIC 2 link/activity LED	<ul style="list-style-type: none"> • Green = Network link exists. • Flashing green = Network link and activity exist. • Off = No link to network exists. <p>If power is off, the front panel LED is not active. View the LEDs on the RJ-45 connector for status by referring to the rear panel LEDs. See Node rear panel LEDs and buttons.</p>



NOTE:

SATA hard drive LED functionality is not currently supported.

Node rear panel components

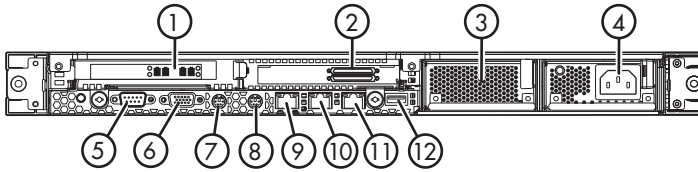

Item	Description
1	Fibre Channel host ports ^a
2	VHDCI connectors ^a
3	Power supply bay 2
4	Power supply bay 1 (populated)
5	Serial connector
6	Video connector
7	Keyboard connector
8	Mouse connector (not used)
9	iLO management LAN port (service port)
10	10/100/1000 NIC 1 (user network)
11	10/100/1000 NIC 2 (service port)
12	Rear USB connector

^a VLS6105 shown

Node rear panel LEDs and buttons

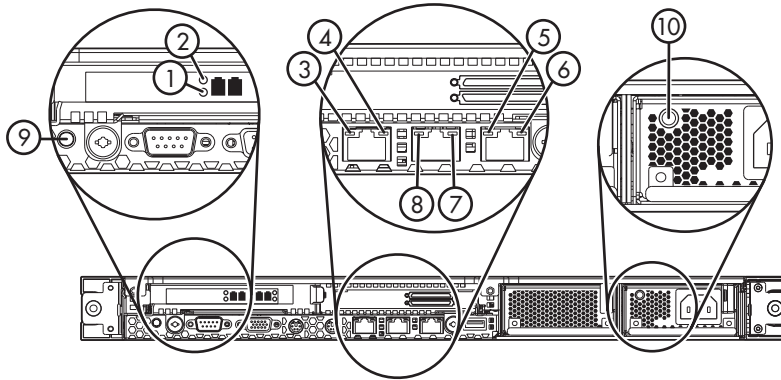

Item	Description	Status
1, 2	Fibre Channel host port LEDs ^a	<ul style="list-style-type: none"> Green and Amber = Power on. Green = Online. Amber = Signal acquired. Amber flashing = Loss of synchronization. Green and Amber flashing = Firmware error.
3	iLO activity LED	<ul style="list-style-type: none"> Green = Activity exists. Flashing green = Activity exists. Off = No activity exists.
4	iLO link LED	<ul style="list-style-type: none"> Green = Link exists. Off = No link exists.
5	10/100/1000 NIC 2 activity LED	<ul style="list-style-type: none"> Green = Activity exists. Flashing green = Activity exists. Off = No activity exists.
6	10/100/1000 NIC 2 link LED	<ul style="list-style-type: none"> Green = Link exists. Off = No link exists.

Item	Description	Status
7	10/100/1000 NIC 1 link LED	<ul style="list-style-type: none"> • Green = Link exists. • Off = No link exists.
8	10/100/1000 NIC 1 activity LED	<ul style="list-style-type: none"> • Green = Activity exists. • Flashing green = Activity exists. • Off = No activity exists.
9	UID button/LED	<ul style="list-style-type: none"> • Blue = Identification is activated. • Flashing blue = System is being managed remotely. • Off = Identification is deactivated.
10	Power supply LED	<ul style="list-style-type: none"> • Green = Powered on • Amber = Power supply failure has occurred or the power supply is not seated properly, not plugged in to a power source, or not receiving power from the power source.

ª VLS6105 shown. The VLS6510 does not have Fibre Channel host port LEDs.

System board components

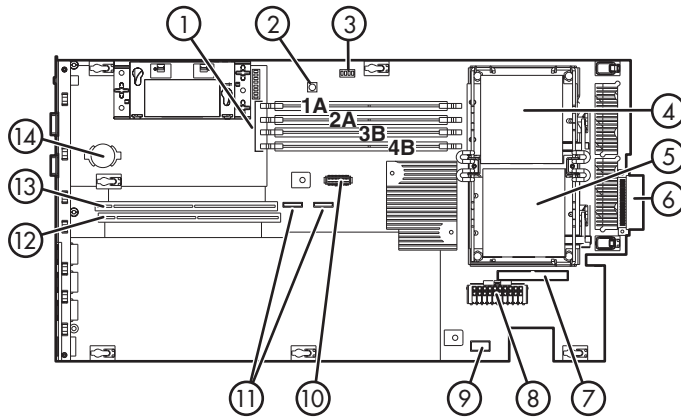

Item	Description	Item	Description
1	DIMM slots (1-4)	8	Power supply connector
2	NMI switch	9	Power supply signal connector
3	System maintenance switch (SW2)	10	Remote management connector
4	Processor 1 socket	11	SATA connectors
5	Processor 2 socket	12	PCI riser board assembly connector (for slot 2 riser board)
6	Processor zone fan module connector	13	PCI riser board assembly connector (for slot 1 riser board)
7	DVD/CDRW drive connector	14	System board battery connector

System board LEDs

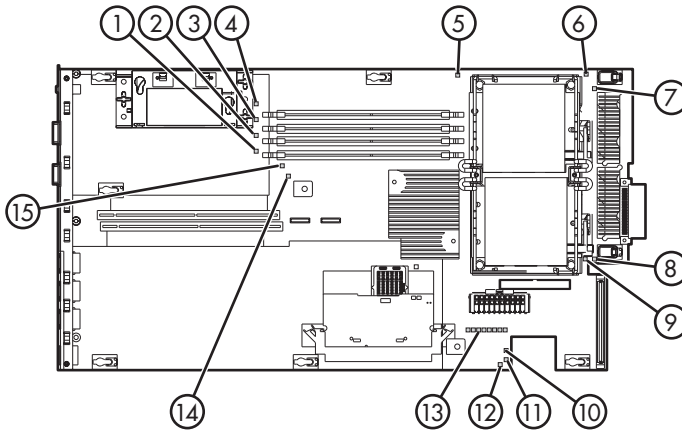

Item	Description	Status
1	DIMM 4B failure	<ul style="list-style-type: none"> • Amber = DIMM has failed. • Off = DIMM is operating normally.
2	DIMM 3B failure	<ul style="list-style-type: none"> • Amber = DIMM has failed. • Off = DIMM is operating normally.
3	DIMM 2A failure	<ul style="list-style-type: none"> • Amber = DIMM has failed. • Off = DIMM is operating normally.
4	DIMM 1A failure	<ul style="list-style-type: none"> • Amber = DIMM has failed. • Off = DIMM is operating normally.
5	Overtemperature	<ul style="list-style-type: none"> • Amber = System has reached cautionary or critical temperature level. • Off = Temperature is OK.
6	Processor 1 failure	<ul style="list-style-type: none"> • Amber = Processor has failed. • Off = Processor is operating normally.
7	PPM 1 failure	<ul style="list-style-type: none"> • Amber = PPM has failed. • Off = PPM is operating normally.

Item	Description	Status
8	PPM 2 failure	<ul style="list-style-type: none"> • Amber = PPM has failed. • Off = PPM is operating normally.
9	Processor 2 failure	<ul style="list-style-type: none"> • Amber = Processor has failed. • Off = Processor is operating normally.
10	Power supply signal connector interlock failure	<ul style="list-style-type: none"> • Amber = Power supply signal cable is not connected. • Off = Power supply signal cable is connected.
11	Standby power good	<ul style="list-style-type: none"> • Green = Auxiliary power is applied. • Off = Auxiliary power is not applied.
12	Power supply fan module failure	<ul style="list-style-type: none"> • Amber = One fan in this module has failed. • Red = Multiple fans in this module have failed. • Off = All fans in this module are operating normally.
13	System diagnostic	Refer to the <i>HP Remote Lights-Out Edition II User Guide</i> .
14	Online spare memory	<ul style="list-style-type: none"> • Amber = Failover has occurred. Online spare memory is in use. • Green = Online spare memory is enabled, but not in use. • Off = Online spare memory is disabled.
15	Riser interlock	<ul style="list-style-type: none"> • Amber = PCI riser assembly is not seated. • Off = PCI riser assembly is seated.

Node LEDs and internal health LED combinations

When the internal health LED on the front panel of the node illuminates either amber or red, the server is experiencing a health event. Combinations of illuminated system board LEDs and the internal health LED indicate node status.

System board LED and color	Internal Health LED Color	Status
Processor failure, socket X (Amber)	Red	One or more of the following conditions may exist: <ul style="list-style-type: none"> • Processor in socket X has failed. • Processor in socket X failed over to the offline spare. • Processor X is not installed in the socket. • Processor X is unsupported. • ROM detects a failed processor during POST.
	Amber	Processor in socket X is in a pre-failure condition.
Processor failure, both sockets (Amber)	Red	Processor types are mismatched.
PPM failure (Amber)	Red	PPM has failed.
DIMM failure, slot X (Amber)	Red	<ul style="list-style-type: none"> • DIMM in slot X has failed. • DIMM in slot X is an unsupported type, and no valid memory exists in another bank.
	Amber	<ul style="list-style-type: none"> • DIMM in slot X has reached single-bit correctable error threshold. • DIMM in slot X is in a pre-failure condition. • DIMM in slot X is an unsupported type, but valid memory exists in another bank.

System board LED and color	Internal Health LED Color	Status
DIMM failure, all slots in one bank (Amber)	Red	No valid or usable memory is installed in the system.
Overtemperature (Amber)	Amber	The Health Driver has detected a cautionary temperature level.
	Red	The server has detected a hardware critical temperature level.
Riser interlock (Amber)	Red	The PCI riser board assembly is not seated.
Online spare memory (Amber)	Amber	Bank X failed over to the online spare memory bank.
Power converter module interlock (Amber)	Red	The power converter module is not seated.
Fan module (Amber)	Amber	A redundant fan has failed.
Fan module (Red)	Red	The minimum fan requirements are not being met in one or more of the fan modules. One or more fans have failed or are missing.
Power supply signal interlock (Amber)	Red	The power supply signal cable is not connected to the system board.

Node fan module locations

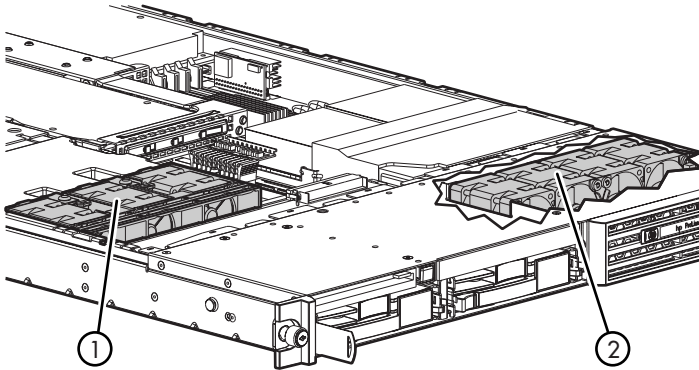

Item	Description
1	Power supply zone fan module (fan 1)
2	Processor zone fan module (fan 2)

Node processor zone fan module LED

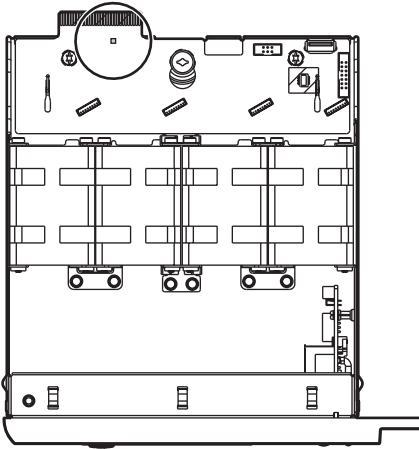

Description
Amber = One fan in this module has failed.
Red = Multiple fans in this module have failed.
Off = All fans in this module are operating normally.

Disk array components, LEDs, and buttons

Disk array front panel components

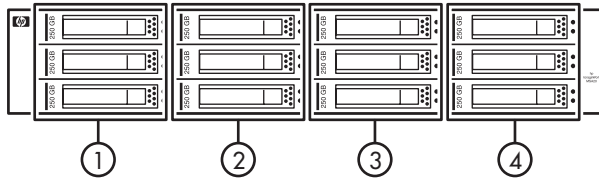

Item	Description
1	Drives 0, 1, and 2 (from top to bottom)
2	Drives 3, 4, and 5
3	Drives 6, 7, and 8
4	Drives 9, 10, and 11

Disk array front panel LEDs

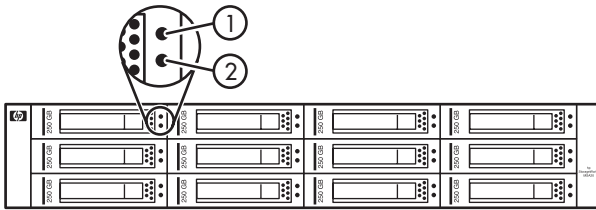

Item	Description	Status
1	Fault/ID bicolor LED	<ul style="list-style-type: none"> Blue = The unit identification button on the rear of the disk array has been pressed. Amber = The drive has failed or is predicted to fail in the near future.
2	Online LED	<ul style="list-style-type: none"> Green = The drive is online. Off = The drive is offline or the disk array is powered down.

For more information about the meaning of the various drive LED illumination patterns, see [Table 11](#).

Table 11 Interpreting the disk array hard drive status LEDs

Online LED (green)	Fault/ID LED (amber/blue)	Status
On, off, or flashing	Alternating between amber and blue	The drive has failed, or a predictive failure alert has been received for this drive. It has also been selected by the VLS management application.
On, off, or flashing	Steadily blue	The drive is operating normally, and it has been selected by the VLS management application.
On	Amber, flashing regularly (1 Hz)	A predictive failure alert has been received for this drive. Replace the drive as soon as possible.
On	Off	The drive is online, but it is not currently active.

Online LED (green)	Fault/ID LED (amber/blue)	Status
Flashing regularly (1 Hz)	Amber, flashing regularly (1 Hz)	A predictive failure alert has been received for this drive. To minimize the risk of data loss, replace the drive.
Flashing regularly (1 Hz)	Off	The drive is rebuilding.
Flashing irregularly	Amber, flashing regularly (1 Hz)	The drive is active, but a predictive failure alert has been received for this drive. Replace the drive as soon as possible.
Flashing irregularly	Off	The drive is active, and it is operating normally.
Off	Steadily amber	A critical fault condition has been identified for this drive, and the controller has placed it offline. Replace the drive as soon as possible.
Off	Amber, flashing regularly (1 Hz)	A predictive failure alert has been received for this drive. Replace the drive as soon as possible.
Off	Off	The drive is offline or the disk array is powered down.

Disk array rear panel components

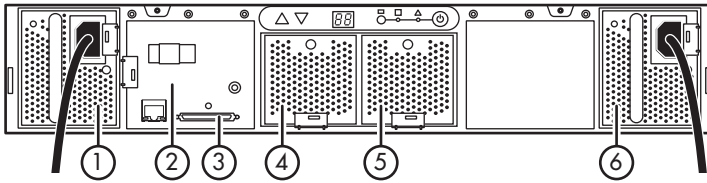

Item	Description
1	Power supply bay 0 (populated)
2	Controller module
3	VHDCI connector
4	Fan module 0
5	Fan module 1
6	Power supply bay 1 (populated)



WARNING!

Do not use the handles on the power supply units to lift or hold the disk array. These handles are designed only for holding the power supply units or removing them from the disk array, not for supporting the weight of the disk array.

Disk array rear panel LEDs and buttons

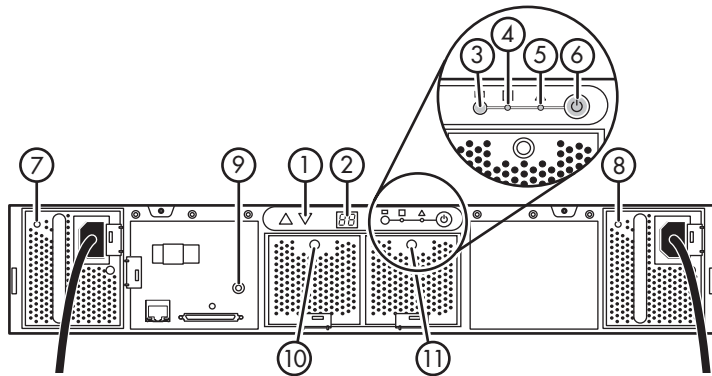

Item	Description
1	Arrow buttons (not used)
2	Disk array ID display (not used)
3	Unit identification button. Temporarily illuminates the blue LED on all the drives in the disk array.
4	Disk array monitor status LED (not used)
5	Disk array fault LED (not used)
6	Disk array power button
7	Power supply 0 LED
8	Power supply 1 LED
9	Controller module LED
10	Fan module 0 LED
11	Fan module 1 LED

10 Component replacement

This section provides detailed instructions for replacing customer-replaceable VLS components. If you need to replace a VLS component not listed in this section, contact an authorized reseller to install the part.



CAUTION:

Always replace components with the same make, size, and type of component. Changing the hardware configuration voids the warranty.

Safety considerations

Before performing component replacement procedures, review all the safety information in this guide.

Preventing electrostatic discharge

To prevent damaging the system, be aware of the precautions you need to follow when setting up the system or handling parts. A discharge of static electricity from a finger or other conductor may damage system boards or other static-sensitive devices. This type of damage may reduce the life expectancy of the device.

To prevent electrostatic damage:

- Avoid hand contact by transporting and storing products in static-safe containers.
- Keep electrostatic-sensitive parts in their containers until they arrive at static-free workstations.
- Place parts on a grounded surface before removing them from their containers.
- Avoid touching pins, leads, or circuitry.
- Always be properly grounded when touching a static-sensitive component or assembly.

Grounding methods to prevent electrostatic damage

There are several methods for grounding. Use one or more of the following methods when handling or installing electrostatic-sensitive parts:

- Use a wrist strap connected by a ground cord to a grounded workstation or computer chassis. Wrist straps are flexible straps with a minimum of 1 megaohm \pm 10 percent resistance in the ground cords. To provide proper ground, wear the strap snug against the skin.
- Use heel straps, toe straps, or boot straps at standing workstations. Wear the straps on both feet when standing on conductive floors or dissipating floor mats.
- Use conductive field service tools.
- Use a portable field service kit with a folding static-dissipating work mat.

If you do not have any of the suggested equipment for proper grounding, have an authorized reseller install the part. For more information on static electricity, or assistance with product installation, contact your authorized reseller.

Warnings and cautions

Before removing the node access panel, be sure that you understand the following warnings and cautions.



WARNING!

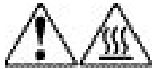

To reduce the risk of personal injury from hot surfaces, allow the internal system components to cool before touching them.



CAUTION:

Do not operate the node for long periods without the access panel. Operating the node without the access panel results in improper airflow and improper cooling that can lead to thermal damage.

Preparation procedures

To access some components and perform certain replacement procedures, you must perform one or more of the following procedures:

- Extend the node from the rack. See [Extending the node from the rack](#).
If you are performing service procedures in an HP, Compaq branded, telco, or third-party rack cabinet, you can use the locking feature of the rack rails to support the node and gain access to internal components.

For more information about telco rack solutions, see the RackSolutions.com web site (<http://www.racksolutions.com/hp>).

- Power down the node. See [Powering down the node](#).
If you must remove a non-hot-plug component from the node, power down the node.
- Remove the node access panel. See [Removing the node access panel](#).
If you must remove a component located inside the node, remove the access panel.

Extending the node from the rack



WARNING!

To reduce the risk of personal injury or equipment damage, be sure that the rack is adequately stabilized before extending the node from the rack.



WARNING!

To reduce the risk of personal injury, be careful when pressing the node rail-release latches and sliding the node into the rack. The sliding rails could pinch your fingers.

1. Loosen the thumbscrews that secure the node faceplate to the front of the rack.
2. Extend the node on the rack rails until the node rail-release latches engage.

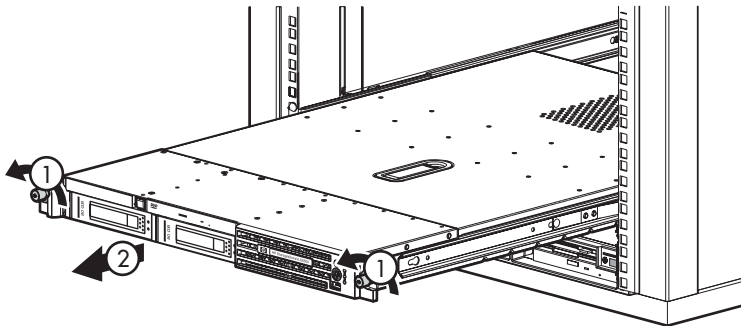

Figure 61 Slide the node out of the rack

3. After performing the replacement procedure, slide the node back into the rack:
 - a. Press the node rail-release latches and slide the node fully into the rack.
 - b. Secure the node by tightening the thumbscrews.

Removing the node access panel



WARNING!



To reduce the risk of personal injury from hot surfaces, allow the internal system components to cool before touching them.



CAUTION:

Do not operate the node for long periods without the access panel. Operating the node without the access panel results in improper airflow and improper cooling that can lead to thermal damage.

1. Power down the node. See [Powering down the node](#).
2. Extend the node from the rack. See [Extending the node from the rack](#).
3. Lift up on the hood latch handle which slides the panel toward the rear of the unit. Lift up to remove the panel.

Installing the node access panel

1. Set the access panel on top of the node about a $\frac{3}{4}$ inch from the opening with the hood latch open.
2. Engage the anchoring pin with the corresponding hole in the latch.
3. Push down on the hood latch.

The access panel slides to a closed position.

Node hard drive



CAUTION:

To prevent improper cooling and thermal damage, do not operate the node unless all bays are populated with either a component or a blank.



NOTE:

SATA hard drive LED functionality and hot-plug capability are not currently supported.

1. Power down the node. See [Powering down the node](#).
2. Press the drive latch release button (1).
3. Pull the hard drive out of the node by the latch handle (2).

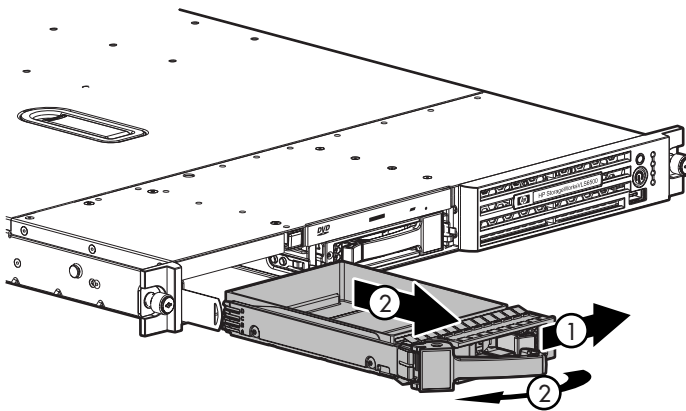

Figure 62 Remove the node hard drive

4. To replace the drive, pull out the latch handle out as far as it can go and slide the drive into the bay until the latch mechanism engages the chassis. Then, firmly push in the latch handle to lock the drive in the drive bay.
5. Power up the node. See [Powering up the node](#).

On reboot, the replacement drive is automatically configured to RAID 1 — no administrator action is required.

DVD/CDRW drive

1. Power down the node. See [Powering down the node](#).



NOTE:

The DVD/CDRW ejector button is recessed to prevent accidental ejection; it may be helpful to use a small, blunt object, such as a pen, to push the ejector button.

2. Press the ejector button in firmly until the DVD/CDRW drive ejects (1).
3. Pull the DVD/CDRW out of the node.

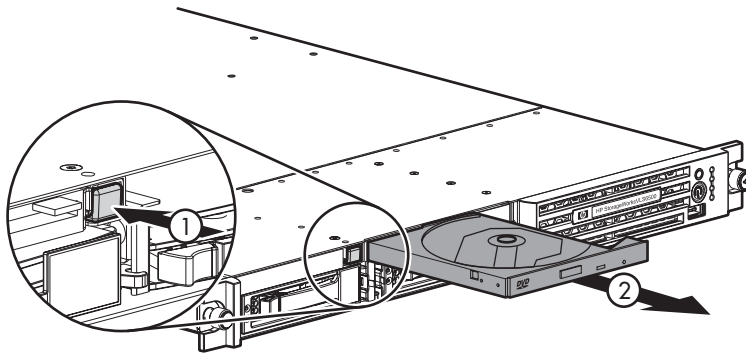

Figure 63 Eject the DVD/CDRW drive

To replace the component:

1. Carefully align the connector on the rear of the drive with the connector on the DVD/diskette drive interface board.
2. Slide the drive into the bay until it clicks.

Node power supply



CAUTION:

To prevent improper cooling and thermal damage, do not operate the node unless all bays are populated with either a component or a blank.

1. If the node is configured with only one power supply, power down the node. See [Powering down the node](#). Otherwise, skip to step 2.
2. Disconnect the power cord from the power supply.
3. Press the power supply release lever (1), and then pull the power supply from the node.

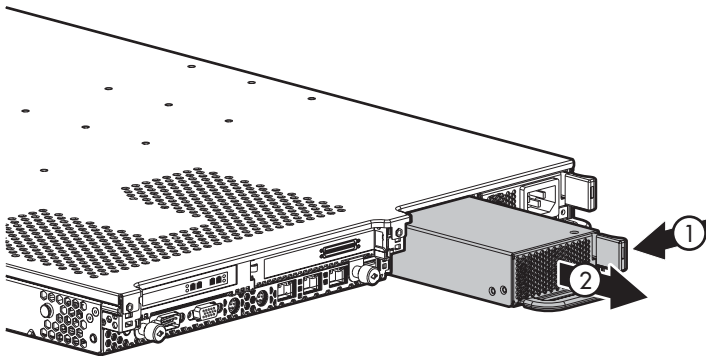

Figure 64 Remove the node power supply

To replace the component:



WARNING!



To reduce the risk of electric shock or damage to the equipment, do not connect the power cord to the power supply until the power supply is installed.

1. Remove the protective cover from the connector pins on the power supply.
2. Slide the power supply into the bay until it clicks.

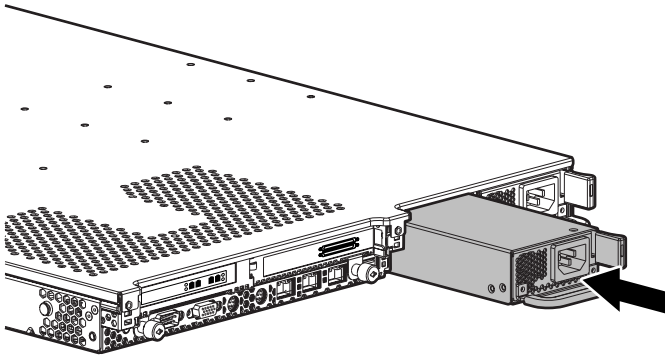

Figure 65 Install the AC power supply

3. Use the strain relief clip to secure the power cord (Figure 66).

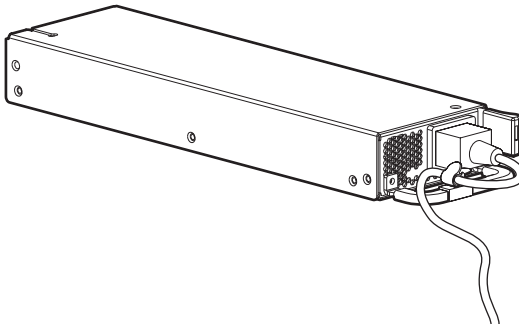

Figure 66 Place the power cord in the strain relief clip

4. Connect the power cord to the power supply.
5. If the node was powered down, power up the node. See [Powering up the node](#).
6. Be sure that the power supply LED is green. See [Node rear panel LEDs and buttons](#).

Node power supply zone fan module



CAUTION:

Do not operate the node for long periods without the access panel. Operating the node without the access panel results in improper airflow and improper cooling that can lead to thermal damage.

1. Power down the node. See [Powering down the node](#).
2. Extend or remove the node from the rack. See [Extending the node from the rack](#).
3. Remove the access panel. See [Removing the node access panel](#).
4. Remove the SATA cable from the cable clip to avoid damaging the cable.
5. Push levers on either side of the middle fan toward the front of the chassis (1). Rock the fan module slightly and pull up and out of the node.

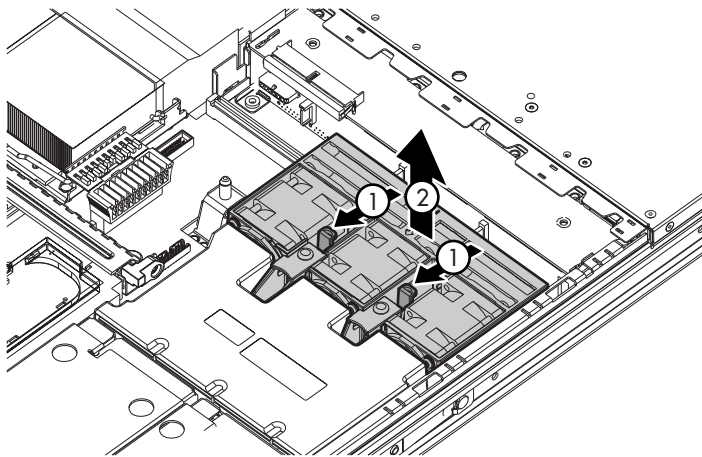

Figure 67 Remove the node power supply zone fan module



CAUTION:

When replacing the component, be sure the power converter module, which is located just in front of the fan module, is properly seated in the node chassis.

To replace the component, reverse the removal procedure.

Node processor zone fan module



CAUTION:

Do not operate the node for long periods without the access panel. Operating the node without the access panel results in improper airflow and improper cooling that can lead to thermal damage.

1. Extend or remove the node from the rack. See [Extending the node from the rack](#).
2. Remove the access panel. See [Removing the node access panel](#).
3. Loosen the single thumbscrew that secures the processor fan module to the node (1).
4. Push on the sheet metal tab near the thumbscrew to separate the fan tray connector from the system board connector (2).
5. Slide the component out the front of the node.

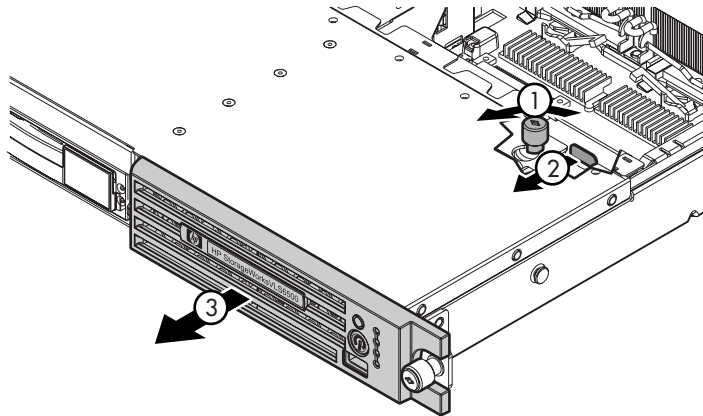

Figure 68 Remove the processor zone fan module

To replace the component, reverse the removal procedure.

Node DIMM

1. Power down the node. See [Powering down the node](#).
2. Extend or remove the node from the rack. See [Extending the node from the rack](#).
3. Remove the access panel. See [Removing the node access panel](#).
4. Open the DIMM slot latches (1).
5. Remove the DIMM.

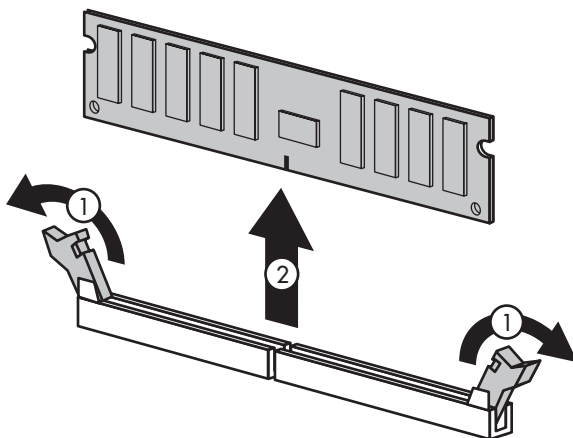

Figure 69 Remove the node DIMM



CAUTION:

Use only Compaq branded or HP DIMMs. DIMMs from other sources may adversely affect data integrity.

To replace the component, reverse the removal procedure.



NOTE:

DIMMs do not seat fully if turned the wrong way.

When replacing a DIMM, align the DIMM with the slot and insert the DIMM firmly, pressing down until the DIMM snaps into place. When fully seated, the DIMM slot latches lock into place.

Node processor

The VLS6105 includes one processor. The VLS6510 includes two processors. With two processors installed, the node supports boot functions through the processor installed in processor socket 1. However, if processor 1 fails, the system automatically boots from processor 2 and provides a processor failure message.

The server uses embedded PPMs as DC-to-DC converters to provide the proper power to each processor.



CAUTION:

To prevent thermal instability and damage to the node, do not separate the processor from the heatsink. The processor, heatsink, and retaining clip make up a single assembly.



CAUTION:

To prevent possible node malfunction and damage to the equipment, replace the processors with the same make and type of processor.

To remove a processor:

1. Power down the node. See [Powering down the node](#).
2. Extend the node from the rack. See [Extending the node from the rack](#).
3. Remove the access panel. See [Removing the node access panel](#).
4. Rotate the processor retaining card upward ([Figure 70](#)).

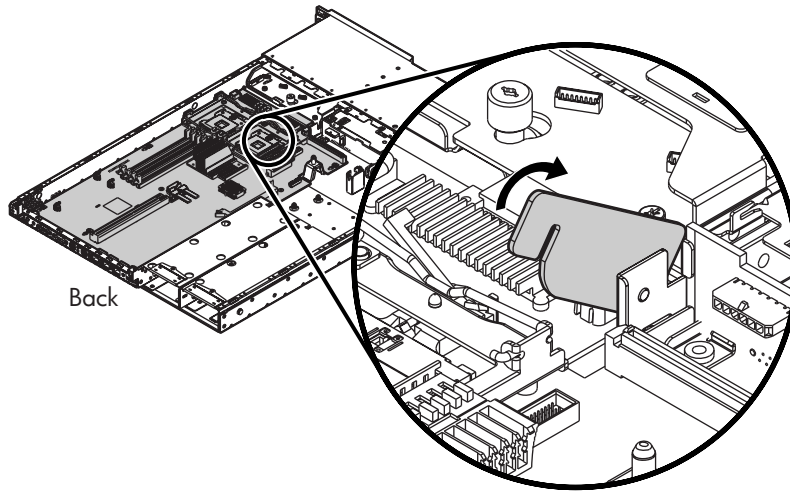

Back

Figure 70 Lift the processor retaining card

5. Release the processor retaining clips on either side of the processor assembly (1) (Figure 71).
6. Unlock the processor from the connector by lifting and swinging the locking lever over about 180 degrees (2).

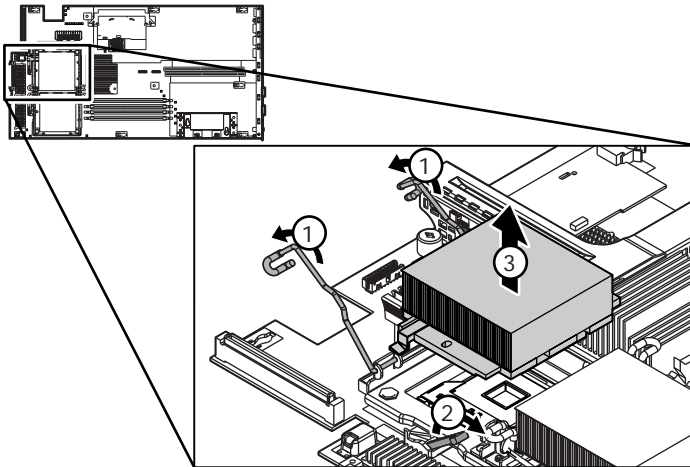

Figure 71 Release the processor retaining clips and lift locking lever

7. Lift the heatsink and processor from the node.

To install a processor:

1. Remove the protective cover from the processor (Figure 72).

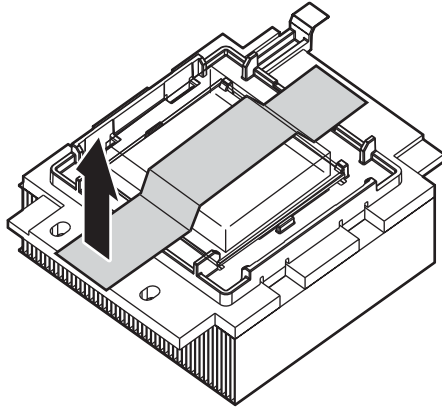

Figure 72 Remove the protective cover from the processor

2. Align the holes in the heatsink with the guiding pegs on the processor cage (Figure 73).



CAUTION:

To prevent possible node malfunction or damage to the equipment, be sure to align the processor pins with the corresponding holes in the socket.

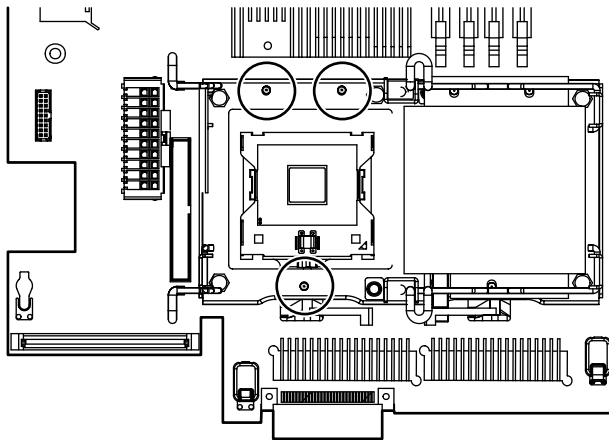

Figure 73 Align the processor pins with the socket holes

3. Install the processor and close the processor locking lever (2) and processor retaining clips (1).

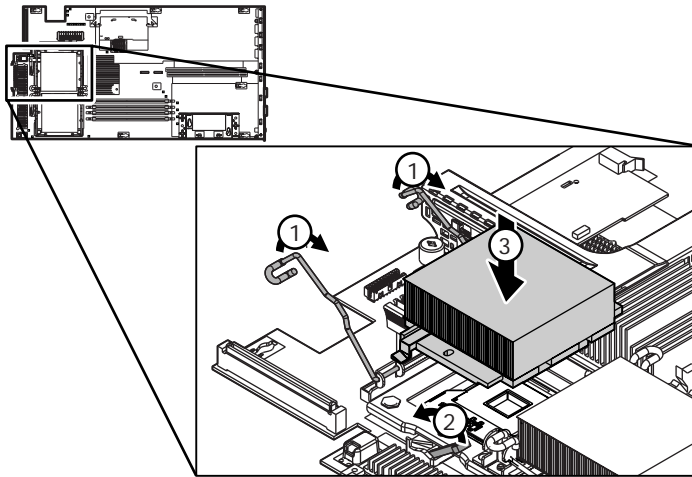

Figure 74 Close the processor locking lever and retaining clips

4. Install the access panel. See [Installing the node access panel](#).
5. Slide the node into the rack.
6. Power up the node. See [Powering up the node](#).

Disk array hard drive



CAUTION:

Before removing a hard drive from the disk array, be sure that a replacement hard drive is immediately available. Removing a hard drive causes a significant change in the airflow within the disk array, and the disk array could overheat if a replacement hard drive is not installed within a relatively short time.

Be careful when replacing a drive. The drives in the disk array are fragile.

1. Press the drive latch release button.
2. Pull the drive out of the disk array by its latch handle about 3 cm (1 inch) so that it is disconnected from the backplane connector.



CAUTION:

A drive with a rapidly spinning disk can be difficult to hold securely. To decrease the chance of dropping the drive, do not remove it completely from the disk array until the disk has stopped rotating. This usually takes a few seconds.

3. When the disk is no longer spinning, remove the drive from the disk array.

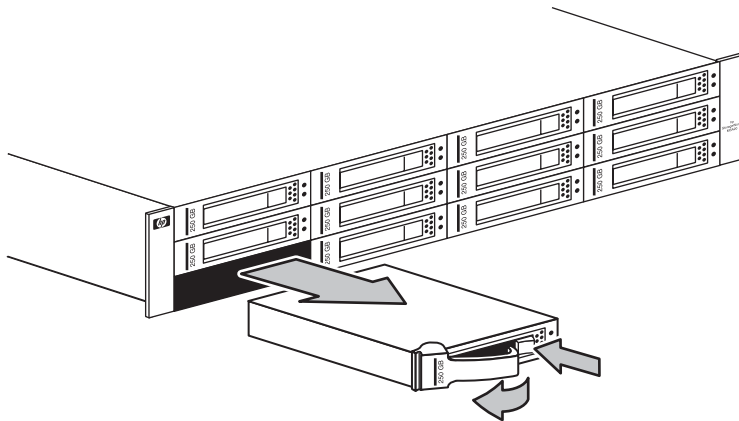

Figure 75 Remove the disk array hard drive

To replace the component:

1. Pull out the latch handle on the drive out as far as it can go.
2. Slide the replacement drive into the bay until it can go no further. About 1 cm (0.5 inch) of the drive protrudes from the bay.
3. Push the release lever all the way in. This action installs the drive completely in the bay and seats it firmly against the connector in the disk array.
4. Firmly close the latch handle to lock the drive in the drive bay.
5. Observe the drive status LEDs to confirm that the replacement drive is functioning correctly. See [Disk array front panel LEDs](#).

Disk array fan module



CAUTION:

Before removing a fan module from the disk array, be sure that a replacement fan module is immediately available. Removing a fan module causes a significant change in the airflow within the disk array, and the disk array could overheat if a replacement fan module is not installed within a relatively short time.

1. Lift the release lever and pull the fan module out of the enclosure.

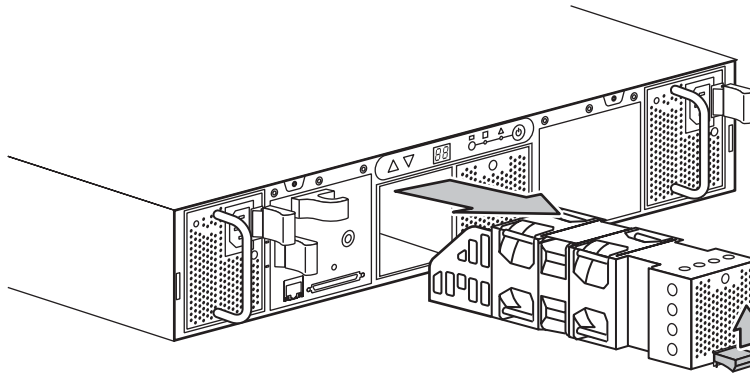

Figure 76 Remove the disk array fan module

2. Slide the replacement fan module into the disk array until it is firmly seated in the disk array.
3. Confirm that the fan module starts operating immediately and that the status LED is illuminated green.

Disk array power supply



CAUTION:

Before removing a power supply from the disk array, be sure that a replacement power supply is immediately available. Removing a power supply causes a significant change in the airflow within the disk array, and the disk array could overheat if a replacement power supply is not installed within a relatively short time.

1. Disconnect the AC power cord from the defective power supply unit.
2. Squeeze the handle and the release lever together and pull the defective power supply unit out of the disk array by the handle.

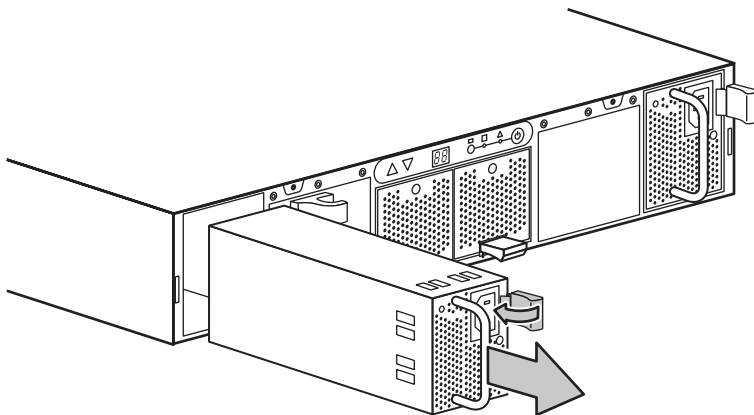

Figure 77 Remove the disk array power supply

3. Insert the replacement power supply unit into the empty bay until it is firmly seated in the disk array.
4. Connect the AC power cord.
5. Confirm that the status LED on the replacement power supply is illuminated green.

Disk array controller module

1. Stop backup application data transfers.
2. Power down the disk array. See [Powering down the disk arrays](#).
3. Disconnect the SCSI cable from the VHDCI connector on the controller module.
4. Squeeze the release lever and the finger hook together while pulling the controller module out of the disk array.

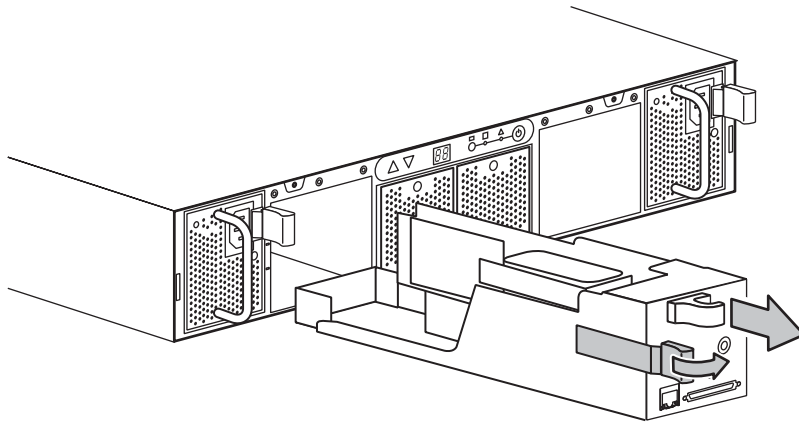

Figure 78 Remove the disk array controller module

5. Insert the replacement controller module into the disk array until it is firmly seated in the disk array.
6. Connect the SCSI cable to the VHDCI connector on the controller module.



CAUTION:

To prevent damage to the VHDCI connector, do not use excessive force when tightening the thumbscrews on the connector.

7. Confirm that the status LED on the replacement module is illuminated green.
8. Power up the disk array. See [Powering up the disk arrays](#).
9. Power up the node. See [Powering up the node](#).

11 Disaster recovery

This section detailed the VLS disaster recovery procedures. It is comprised of the following topics:

- [Recovering from a disk array RAID volume failure](#)
- [Recovering from a node RAID volume failure](#)
- [Recovering from operating system failure](#)

Recovering from a disk array RAID volume failure

If two or more hard drives have failed in a single disk array RAID volume, a disk array RAID volume failure has occurred. Since all the disk arrays in a VLS are configured into one storage pool, a disk array RAID volume failure will corrupt all the data stored on the VLS disk arrays, making it unrecoverable.



NOTE:

Only perform this procedure if a RAID volume failure has actually occurred. Other factors can result in a false RAID volume failure being reported, such as a disk array being powered down or the SCSI cabling to a disk array being disconnected at either end.

To recover from a disk array RAID volume failure:

1. Replace the failed hard drives in the RAID volume. See [Disk array hard drive](#).
2. Erase all the virtual media from the disk arrays and rebuild all the RAID volumes:
 - a. Select **Cartridges** in the Navigation tree.
 - b. Click the **Rebuild Storage Pool** in the Task bar.
 - c. Click **Rebuild**.
 - d. Click **Yes** to confirm.
3. Recreate the cartridges that existed on the VLS.

VLS cartridge configuration information is stored on the disk array(s) and has been erased.

Recovering from a node RAID volume failure

To recover from a node RAID volume failure, which occurs when both node hard drives fail:

- 1.** Replace the failed node hard drives. See [Node hard drive](#).
- 2.** After the VLS finishes rebuilding the RAID volume, install the operating system on the new hard drives.
 - a.** Connect a keyboard to the keyboard connector. See [Node rear panel components](#).
 - b.** Connect a monitor to the video connector. See [Node rear panel components](#).
 - c.** Insert the VLS Quick Restore CD into the DVD/CDRW drive.

The VLS Quick Restore CD auto starts.
 - d.** Press **R** on the keyboard to start the re-installation of the operating system.

The installation takes 30 minutes or less to complete. The screen may freeze for the last 10 minutes of the installation. This is normal.

The VLS Quick Restore CD is ejected and the system reboots when the installation is complete.
- 3.** Restore the configuration settings. See [Restoring the configuration settings](#).
- 4.** If one or more capacity bundles (or existing disk arrays) have been added to the VLS, re-install the VLS capacity license(s). See [Re-installing the VLS capacity licenses](#).

Restoring the configuration settings

The VLS virtual library configuration and network settings can be quickly restored from the configuration file created when performing [Saving configuration settings](#). See [Restoring the virtual library configuration from a configuration file](#).

If a configuration file was not created, you must reconfigure the network settings, rebuild the virtual library configuration, and move the virtual media from the Firesafe back into the appropriate virtual libraries. See [Rebuilding the virtual library configuration](#) and then [Managing cartridges](#).

Restoring the virtual library configuration from a configuration file

Restoring the virtual library configuration from the configuration file restores the virtual library configuration, and administrative and network settings (including the VLS serial number and persistent Fibre Channel port WWPNs), and then moves the virtual media back into the appropriate virtual libraries.

To restore the virtual library and network settings from the configuration file:

1. Set the network settings so you can open a Command View VLS session. See [Setting the network settings](#).
2. Open a Command View VLS session and log in as the administrator. See [Opening a Command View VLS session from Command View TL](#).
3. Select **Chassis** in the Navigation tree.
4. Click **Restore Config** in the Task bar.

The Restore Config window opens ([Figure 79](#)).

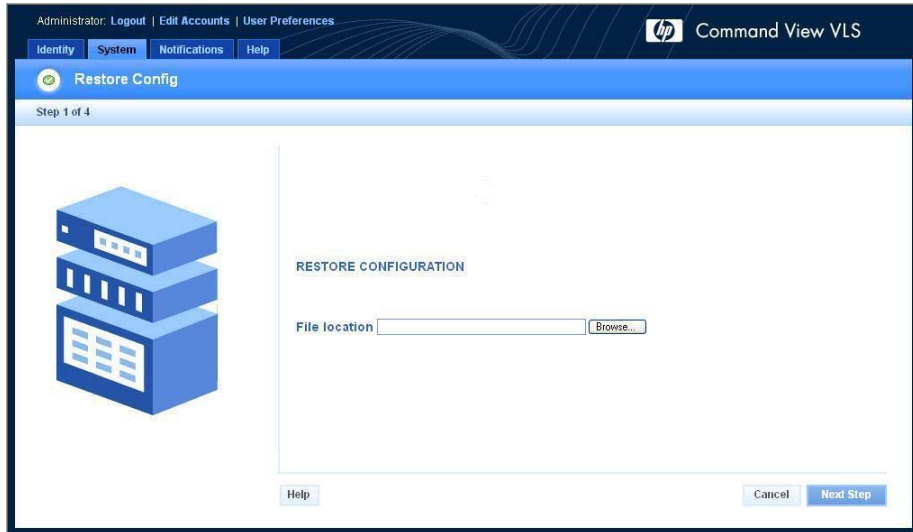

Figure 79 Restore Config window

5. Click **Browse**.
6. Locate and select the desired configuration file.
7. Click **Open**.
8. Click **Next Step**.

A message is displayed indicating that the file was uploaded successfully.

9. Click **Next** to start loading the configuration file.

Rebuilding the virtual library configuration

To reconfigure the network settings and rebuild the virtual library configuration:

1. Set the network settings so you can open a Command View VLS session. See [Setting the network settings](#).
2. Rebuild the virtual library configuration (except for the cartridges, whose configuration is saved on the disk arrays) and re-enter your other configuration settings, such as the notification alert settings. See [Configuration](#), [Management](#), and [Monitoring](#).
3. Associate the cartridges with the correct virtual libraries. See [Managing cartridges](#).



NOTE:

If the node system board was ever changed and the virtual library configuration and network settings were not saved to a configuration file, the persistent VLS serial number and Fibre Channel port WWPNs are lost and cannot be recovered. The VLS software will automatically generate a new VLS serial number and new Fibre Channel port WWPNs based on the node system board's MAC address. If this occurs, you must reconfigure your SAN to reflect the new Fibre Channel port WWPNs, and obtain and install capacity license keys from HP technical support for any installed capacity bundle disk arrays using the new VLS serial number.

Re-installing the VLS capacity licenses

If one or more capacity bundles (or existing disk arrays) were added to the VLS, re-install the VLS capacity license(s) using Command View TL.



NOTE:

See the *HP OpenView Command View for TL User Guide* for instructions on performing the following steps.

To re-install the capacity license(s):

1. Start Command View TL.
2. Delete the VLS capacity licenses in Command View TL.
3. Ignore the message saying to reboot the device.
4. Re-install the VLS license key(s) using Command View TL.

Your VLS license key(s) was emailed to you when you requested it. If you no longer have this email, contact HP technical support to obtain a new license key(s).

Recovering from operating system failure

Re-install the operating system if it becomes corrupted or is lost as a result of node RAID volume failure.



CAUTION:

Only install the VLS operating system on the node hard drives. Installing any other operating system on the node hard drives voids the warranty.



NOTE:

The VLS operating system contains all the hardware device drivers, firmware, and utilities required to operate the VLS.

To re-install the operating system:

1. Connect a keyboard to the keyboard connector. See [Node rear panel components](#).
2. Connect a monitor to the video connector. See [Node rear panel components](#).
3. Insert the VLS Quick Restore CD into the DVD/CDRW drive.

The VLS Quick Restore CD auto starts.

4. Press **R** on the keyboard to start the re-installation.

The re-installation takes 30 minutes or less to complete. The screen may freeze during the last 10 minutes of the re-installation. This is normal.

The VLS Quick Restore CD is ejected and the system reboots when the re-installation is complete..

5. Restore the configuration settings. See [Restoring the configuration settings](#).
6. If one or more capacity bundles (or existing disk arrays) have been added to the VLS, re-install the VLS capacity license(s). See [Re-installing the VLS capacity licenses](#).

A Troubleshooting

This appendix describes some common issues you may encounter while configuring the VLS.

Common issues

Symptom	Possible causes	Solution
Some of the virtual devices are not detected by the operating system when it scans the SAN for new hardware.	There are more LUNs on the Fibre Channel host ports than the operating system is configured to see. Once the maximum number of LUNs on a device is detected, the operating system stops looking for more LUNs. In the case of the VLS, the operating system considers each Fibre Channel host port to be one device. So, if the maximum number of LUNs an operating system is configured to see is eight, the operating system will only see LUN0, LUN1, ..., LUN7 and will not see LUN8, LUN9, ..., and up on each Fibre Channel host port. By default Windows and HP-UX hosts can see a maximum of 8 LUNs per Fibre Channel host port.	<p>Increase the maximum number of LUNs per device the operating system is configured to see. To change the maximum LUN per device setting:</p> <ul style="list-style-type: none"> • Microsoft Windows—See http://support.microsoft.com/default.aspx?scid=kb%3ben-us%3b310072. • HP-UX—The value cannot be changed. • Other operating systems—See the operating system web site.
	There is a gap in the LUN numbering on the Fibre Channel host port. Most operating systems will stop looking for virtual devices on a Fibre Channel host port once a gap in the LUN numbering is detected. For example, say LUN0, LUN1, and LUN3 are mapped to a Fibre Channel host port. The operating system will see LUN0 and LUN1, but when it does not find a LUN2, it will assume there are no more LUNs on the port and stop looking.	Remove the gap in the LUN numbering by editing the host's LUN mapping (see LUN mapping), or if a virtual device(s) has been destroyed on the VLS, creating a gap in the LUN numbering, restart the VLS device emulations. The VLS software will reassign LUNs to the virtual devices as necessary to remove any gaps in the LUN numbering. See Restarting the VLS device emulations .

Symptom	Possible causes	Solution
The VLS cartridge barcode numbers displayed on Veritas Netbackup do not match the actual VLS cartridge barcode numbers.	Netbackup has a 6 character barcode limit. Only 6 characters of the actual VLS cartridge barcode numbers will be displayed.	See the Netbackup web site to determine if the six character limit can be changed. If the shortening of the cartridge barcode numbers removes characters from the barcode numbers, making them no longer unique, the barcode numbers cannot be used with Netbackup. You must create new cartridges with no more than six character barcode numbers.
Netbackup on HP-UX cannot build a device file for a VLS library(s).	Netbackup on HP-UX cannot see virtual devices on a VLS.	Manually create the device file for the virtual library(s). See the Veritas Netbackup manual.
Netbackup does not display the cartridge barcodes for Autoloader library emulations on the VLS.	Real autoloader libraries do not support barcodes.	This is normal and will not cause problems.
HP StorageWorks Data Protector 5.1 does not display the VLS cartridge barcodes.	By default, the barcode reader support is turned off in Data Protector 5.1.	To turn on barcode reader support in Data Protector: <ol style="list-style-type: none"> 1. Click Device & Media. 2. Right-click the VLS library name and select Properties. 3. Click the Control tab. 4. Click the Barcode reader support box to select it.
VLS performance is being reduced by test unit readys (TURs) from a Windows host(s) with access to the VLS	The Removable Storage Manager or Removable Storage program on a Windows host is submitting TURs to the VLS	Stop the Removable Storage Manager or Removable Storage program, and set the startup type to Disabled on the Windows host using the Services utility located under Control Panel > Administrative Tools.
At reboot, there are spurious critical Fibre Channel port failures reported as notification alerts, normally on every port. Then, a little while later, Info notification alerts for each Fibre Channel host port are generated, indicating	This is expected behavior and does not indicate a problem.	None

Symptom	Possible causes	Solution
the Fibre Channel ports are operating normally		

B Regulatory compliance notices

This section contains regulatory notices for the HP StorageWorks 6000 Virtual Library System.

Regulatory compliance identification numbers

For the purpose of regulatory compliance certifications and identification, this product has been assigned a unique regulatory model number. The regulatory model number can be found on the product nameplate label, along with all required approval markings and information. When requesting compliance information for this product, always refer to this regulatory model number. The regulatory model number is not the marketing name or model number of the product.

Product specific information:

HP StorageWorks 6000 Virtual Library System disk array

Regulatory model number : HSTNM-S001

FCC and CISPR classification: Class A

HP StorageWorks 6000 Virtual Library System node (head unit)

Regulatory model number: HSTNS-2105

FCC and CISPR classification: Class B

These products contain laser components. See Class 1 laser statement in [Laser compliance](#).

Battery statement



WARNING!

This product contains one lithium manganese dioxide, a vanadium pentoxide, or an alkaline battery, and four nickel metal hydride (NiMH) battery packs:

- The system processor board contains one CR2450N lithium manganese dioxide, a vanadium pentoxide, or an alkaline button cell battery, HP P/N 179322-001.
- The Smart Array 6400 Series Controller board contains two nickel metal hydride (NiMH) battery packs, HP P/N 307132-001.
- The disk array controller module contains two nickel metal hydride (NiMH) battery packs, HP P/N 307132-001.

Lithium may be considered a hazardous material. Dispose of these batteries in accordance with local, state, and federal laws. In addition:

- Do not attempt to recharge the battery if removed from the system processor board, Smart Array Controller, or disk array controller module.
- Do not expose the batteries to water or to temperatures higher than 60°C (140°F).
- Do not disassemble, crush, puncture, short external contacts, or dispose of in fire or water.
- Do not short external contacts or dispose of in fire or water.
- Replace batteries only with the designated HP spares.

Batteries, battery packs, and accumulators should not be disposed of together with general household waste. To forward them to recycling or proper disposal, please use the public collection system or return them to HP, an authorized HP Partner, or their agents.

For more information about battery replacement or proper disposal, contact an authorized reseller or an authorized service provider.

Federal Communications Commission notice

Part 15 of the Federal Communications Commission (FCC) Rules and Regulations has established Radio Frequency (RF) emission limits to provide an interference-free radio frequency spectrum. Many electronic devices, including computers, generate RF energy incidental to their intended function and are, therefore, covered by these rules. These rules place computers and related peripheral devices into two classes, A and B, depending upon their intended installation. Class A devices are those that may reasonably be expected to be installed in a business or commercial environment. Class B devices are those that may reasonably be expected to be installed in a residential environment (for example, personal computers). The FCC requires devices in both classes to bear a label indicating the interference potential of the device as well as additional operating instructions for the user.

FCC rating label

The FCC rating label on the device shows the classification (A or B) of the equipment. Class B devices have an FCC logo or ID on the label. Class A devices do not have an FCC logo or ID on the label. After you determine the class of the device, refer to the corresponding statement.

Class A equipment

This equipment has been tested and found to comply with the limits for a Class A digital device, pursuant to Part 15 of the FCC rules. These limits are designed to provide reasonable protection against harmful interference when the equipment is operated in a commercial environment. This equipment generates, uses, and can radiate radio frequency energy and, if not installed and used in accordance with the instructions, may cause harmful interference to radio communications. Operation of this equipment in a residential area is likely to cause harmful interference, in which case the user will be required to correct the interference at personal expense.

Class B equipment

This equipment has been tested and found to comply with the limits for a Class B digital device, pursuant to Part 15 of the FCC Rules. These limits are designed to provide reasonable protection against harmful interference in a residential installation. This equipment generates, uses, and can radiate radio frequency energy and, if not installed and used in accordance with the instructions, may cause harmful interference to radio communications. However, there is no guarantee that interference will not occur in a particular installation. If this equipment does cause harmful interference to radio or television reception, which can be determined by turning the equipment off and on, the user is encouraged to try to correct the interference by one or more of the following measures:

- Reorient or relocate the receiving antenna.
- Increase the separation between the equipment and receiver.
- Connect the equipment into an outlet on a circuit that is different from that to which the receiver is connected.
- Consult the dealer or an experienced radio or television technician for help.

Declaration of Conformity for products marked with the FCC logo, United States only

This device complies with Part 15 of the FCC Rules. Operation is subject to the following two conditions: (1) this device may not cause harmful interference, and (2) this device must accept any interference received, including interference that may cause undesired operation.

For questions regarding this FCC declaration, contact us by mail or telephone:

- Hewlett-Packard Company P.O. Box 692000, Mail Stop 510101 Houston, Texas 77269-2000
- Or call 1-281-514-3333

Modification

The FCC requires the user to be notified that any changes or modifications made to this device that are not expressly approved by Hewlett-Packard Company may void the user's authority to operate the equipment.

Cables

When provided, connections to this device must be made with shielded cables with metallic RFI/EMI connector hoods in order to maintain compliance with FCC Rules and Regulations.

Canadian notice (Avis Canadien)

Class A equipment

This Class A digital apparatus meets all requirements of the Canadian Interference-Causing Equipment Regulations.

Cet appareil numérique de la class A respecte toutes les exigences du Règlement sur le matériel brouilleur du Canada.

Class B equipment

This Class B digital apparatus meets all requirements of the Canadian Interference-Causing Equipment Regulations.

Cet appareil numérique de la class B respecte toutes les exigences du Règlement sur le matériel brouilleur du Canada.

European Union notice

Products bearing the CE marking comply with the EMC Directive (89/336/EEC) and the Low Voltage Directive (73/23/EEC) issued by the Commission of the European Community.

Compliance with these directives implies conformity to the following European Norms (in parentheses are the equivalent international standards and regulations):

- EN 55022 (CISPR 22)—Electromagnetic Interference
- EN55024 (IEC61000-4-2, 3, 4, 5, 6, 8, 11)—Electromagnetic Immunity
- EN61000-3-2 (IEC61000-3-2)—Power Line Harmonics
- EN61000-3-3 (IEC61000-3-3)—Power Line Flicker
- EN 60950 (IEC60950)—Product Safety

Japanese notices

ご使用になっている装置にVCCIマークが付いていましたら、次の説明文をお読み下さい。

この装置は、情報処理装置等電波障害自主規制協議会（VCCI）の基準に基づくクラスB情報技術装置です。この装置は、家庭環境で使用することを目的としていますが、この装置がラジオやテレビジョン受信機に近接して使用されると、受信障害を引き起こすことがあります。

取扱説明書に従って正しい取り扱いをして下さい。

VCCIマークが付いていない場合には、次の点にご注意下さい。

この装置は、情報処理装置等電波障害自主規制協議会（VCCI）の基準に基づくクラスA情報技術装置です。この装置を家庭環境で使用すると電波妨害を引き起こすことがあります。この場合には使用者が適切な対策を講ずるよう要求されることがあります。

Japanese power cord statement

製品には、同梱された電源コードをお使い下さい。
同梱された電源コードは、他の製品では使用出来ません。

Please use the attached power cord.
The attached power cord is not allowed to use with other product.

Korean notices

Class A equipment

A급 기기 (업무용 정보통신기기)

이 기기는 업무용으로 전자파적합등록을 한 기기이오니 판매자 또는 사용자는 이 점을 주의하시기 바라며, 만약 잘못판매 또는 구입하였을 때에는 가정용으로 교환하시기 바랍니다.

Class B equipment

B급 기기 (가정용 정보통신기기)

이 기기는 가정용으로 전자파적합등록을 한 기기로서 주거지역에서는 물론 모든지역에서 사용할 수 있습니다.

Taiwanese notices

BSMI Class A notice

警告使用者:

這是甲類的資訊產品，在居住的環境中使用時，可能會造成射頻干擾，在這種情況下，使用者會被要求採取某些適當的對策。

Taiwan battery recycle statement

Recovery mark: <ul style="list-style-type: none">• Four-in-one recycling symbol	Recovery text: <ul style="list-style-type: none">• "Please recycle waste batteries"
	廢電池請回收

Laser compliance

This device may contain a laser that is classified as a Class 1 Laser Product in accordance with U.S. FDA regulations and the IEC 60825-1. The product does not emit hazardous laser radiation.



WARNING!

Use of controls or adjustments or performance of procedures other than those specified herein or in the laser product's installation guide may result in hazardous radiation exposure. To reduce the risk of exposure to hazardous radiation:

- Do not try to open the module enclosure. There are no user-serviceable components inside.
- Do not operate controls, make adjustments, or perform procedures to the laser device other than those specified herein.
- Allow only HP Authorized Service technicians to repair the unit.

The Center for Devices and Radiological Health (CDRH) of the U.S. Food and Drug Administration implemented regulations for laser products on August 2, 1976. These regulations apply to laser products manufactured from August 1, 1976. Compliance is mandatory for products marketed in the United States.

Dutch laser notice



WAARSCHUWING: dit apparaat bevat mogelijk een laser die is geclassificeerd als een laserproduct van Klasse 1 overeenkomstig de bepalingen van de Amerikaanse FDA en de richtlijn IEC 60825-1. Dit product geeft geen gevaarlijke laserstraling af.

Als u bedieningselementen gebruikt, instellingen aanpast of procedures uitvoert op een andere manier dan in deze publicatie of in de installatiehandleiding van het laserproduct wordt aangegeven, loopt u het risico te worden blootgesteld aan gevaarlijke straling. Het risico van blootstelling aan gevaarlijke straling beperkt u als volgt:

- Probeer de behuizing van de module niet te openen. U mag zelf geen onderdelen repareren.
 - Gebruik voor de laserapparatuur geen andere knoppen of instellingen en voer geen andere aanpassingen of procedures uit dan die in deze handleiding worden beschreven.
 - Alleen door HP geautoriseerde technici mogen het apparaat repareren.
-

French laser notice



AVERTISSEMENT : cet appareil peut être équipé d'un laser classé en tant que Produit laser de classe 1 et conforme à la réglementation de la FDA américaine et à la norme 60825-1 de l'IEC. Ce produit n'émet pas de rayonnement dangereux.

L'utilisation de commandes, de réglages ou de procédures autres que ceux qui sont indiqués ici ou dans le manuel d'installation du produit laser peut exposer l'utilisateur à des rayonnements dangereux. Pour réduire le risque d'exposition à des rayonnements dangereux :

- Ne tentez pas d'ouvrir le boîtier renfermant l'appareil laser. Il ne contient aucune pièce dont la maintenance puisse être effectuée par l'utilisateur.
 - Tout contrôle, réglage ou procédure autre que ceux décrits dans ce chapitre ne doivent pas être effectués par l'utilisateur.
 - Seuls les Mainteneurs Agréés HP sont habilités à réparer l'appareil laser.
-

German laser notice



VORSICHT: Dieses Gerät enthält möglicherweise einen Laser, der nach den US-amerikanischen FDA-Bestimmungen und nach IEC 60825-1 als Laserprodukt der Klasse 1 zertifiziert ist. Gesundheitsschädliche Laserstrahlen werden nicht emittiert.

Die Anleitungen in diesem Dokument müssen befolgt werden. Bei Einstellungen oder Durchführung sonstiger Verfahren, die über die Anleitungen in diesem Dokument bzw. im Installationshandbuch des Lasergeräts hinausgehen, kann es zum Austritt gefährlicher Strahlung kommen. Zur Vermeidung der Freisetzung gefährlicher Strahlungen sind die folgenden Punkte zu beachten:

- Versuchen Sie nicht, die Abdeckung des Lasermoduls zu öffnen. Im Inneren befinden sich keine Komponenten, die vom Benutzer gewartet werden können.
 - Benutzen Sie das Lasergerät ausschließlich gemäß den Anleitungen und Hinweisen in diesem Dokument.
 - Lassen Sie das Gerät nur von einem HP Servicepartner reparieren.
-

Italian laser notice



AVVERTENZA: AVVERTENZA Questo dispositivo può contenere un laser classificato come prodotto laser di Classe 1 in conformità alle normative US FDA e IEC 60825-1. Questo prodotto non emette radiazioni laser pericolose.

L'eventuale esecuzione di comandi, regolazioni o procedure difformi a quanto specificato nella presente documentazione o nella guida di installazione del prodotto può causare l'esposizione a radiazioni nocive. Per ridurre i rischi di esposizione a radiazioni pericolose, attenersi alle seguenti precauzioni:

- Non cercare di aprire il contenitore del modulo. All'interno non vi sono componenti soggetti a manutenzione da parte dell'utente.
 - Non eseguire operazioni di controllo, regolazione o di altro genere su un dispositivo laser ad eccezione di quelle specificate da queste istruzioni.
 - Affidare gli interventi di riparazione dell'unità esclusivamente ai tecnici dell'Assistenza autorizzata HP.
-

Japanese laser notice



警告: 本製品には、US FDA規則およびIEC 60825-1に基づくClass 1レーザー製品が含まれている場合があります。本製品は人体に危険なレーザー光は発しません。

本書およびレーザー製品のインストールガイドに示されている以外の方法で制御、調整、使用した場合、人体に危険な光線にさらされる場合があります。人体に危険な光線にさらされないため、以下の項目を守ってください。

- モジュール エンクロージャを開けないでください。ユーザーが取り扱えるコンポーネントは含まれていません。
- 本書に示されている以外の方法で、レーザー デバイスを制御、調整、使用しないでください。
- HPの正規サービス技術者のみが本ユニットの修理を許可されています。

Spanish laser notice



ADVERTENCIA: Este dispositivo podría contener un láser clasificado como producto de láser de Clase 1 de acuerdo con la normativa de la FDA de EE.UU. e IEC 60825-1. El producto no emite radiaciones láser peligrosas.

El uso de controles, ajustes o manipulaciones distintos de los especificados aquí o en la guía de instalación del producto de láser puede producir una exposición peligrosa a las radiaciones. Para evitar el riesgo de exposición a radiaciones peligrosas:

- No intente abrir la cubierta del módulo. Dentro no hay componentes que el usuario pueda reparar.
 - No realice más operaciones de control, ajustes o manipulaciones en el dispositivo láser que los aquí especificados.
 - Sólo permita reparar la unidad a los agentes del servicio técnico autorizado HP.
-

Recycling notices

Disposal of waste equipment by users in private household in the European Union



■ This symbol on the product or on its packaging indicates that this product must not be disposed of with your other household waste. Instead, it is your responsibility to dispose of your waste equipment by handing it over to a designated collection point for recycling of waste electrical and electronic equipment. The separate collection and recycling of your waste equipment at the time of disposal will help to conserve natural resources and ensure that it is recycled in a manner that protects human health and the environment. For more information about where you can drop off your waste equipment for recycling, please contact your local city office, your household waste disposal service, or the shop where you purchase the product.

Dutch notice

Verwijdering van afgedankte apparatuur door privé-gebruikers in de Europese Unie



Dit symbool op het product of de verpakking geeft aan dat dit product niet mag worden gedeponerd bij het normale huishoudelijke afval. U bent zelf verantwoordelijk voor het inleveren van uw afgedankte apparatuur bij een inzamelingspunt voor het recyclen van oude elektrische en elektronische apparatuur. Door uw oude apparatuur apart aan te bieden en te recyclen, kunnen natuurlijke bronnen worden behouden en kan het materiaal worden hergebruikt op een manier waarmee de volksgezondheid en het milieu worden beschermd. Neem contact op met uw gemeente, het afvalinzamelingsbedrijf of de winkel waar u het product hebt gekocht voor meer informatie over inzamelingspunten waar u oude apparatuur kunt aanbieden voor recycling.

Czechoslovakian notice

Likvidace zařízení soukromými domácími uživateli v Evropské unii



Tento symbol na produktu nebo balení označuje výrobek, který nesmí být vyhozen spolu s ostatním domácím odpadem. Povinností uživatele je předat takto označený odpad na předem určené sběrné místo pro recyklaci elektrických a elektronických zařízení. Okamžité třídění a recyklace odpadu pomůže uchovat přírodní prostředí a zajistí takový způsob recyklace, který ochrání zdraví a životní prostředí člověka.

Další informace o možnostech odevzdání odpadu k recyklaci získáte na příslušném obecním nebo městském úřadě, od firmy zabývající se sběrem a svozem odpadu nebo v obchodě, kde jste produkt zakoupili.

Estonian notice

Seadmete jäätmete kõrvaldamine eramajapidamistes Euroopa Liidus



See tootel või selle pakendil olev sümbol näitab, et kõnealust toodet ei tohi koos teiste majapidamisjäätmetega kõrvaldada. Teie kohus on oma seadmete jäätmed kõrvaldada, viies need elektri- ja elektroonikaseadmete jäätmete ringlussevõtmiseks selleks ettenähtud kogumispunkti. Seadmete

jäätmete eraldi kogumine ja ringlussevõtmine kõrvaldamise ajal aitab kaitsta loodusvarasid ning tagada, et ringlussevõtmine toimub viisil, mis kaitseb inimeste tervist ning keskkonda. Lisateabe saamiseks selle kohta, kuhu oma seadmete jäätmed ringlussevõtmiseks viia, võtke palun ühendust oma kohaliku linnakantselei, majapidamisjäätmete kõrvaldamise teenistuse või kauplusega, kust Te toote ostsite.

Finnish notice

Laitteiden hävittäminen kotitalouksissa Euroopan unionin alueella



Jos tuotteessa tai sen pakkauksessa on tämä merkki, tuotetta ei saa hävittää kotitalousjätteiden mukana. Tällöin hävitettävä laite on toimitettava sähkölaitteiden ja elektronisten laitteiden kierrätyspisteeseen. Hävitettävien laitteiden erillinen käsittely ja kierrätys auttavat säästämään luonnonvaroja ja varmistamaan, että laite kierrätetään tavalla, joka estää terveyshaitat ja suojelee luontoa. Lisätietoja [REDACTED] paikoista, joihin hävitettävät laitteet voi toimittaa kierrätettäväksi, saa ottamalla yhteyttä jätehuoltoon tai liikkeeseen, josta tuote on ostettu.

French notice

Élimination des appareils mis au rebut par les ménages dans l'Union européenne



Le symbole apposé sur ce produit ou sur son emballage indique que ce produit ne doit pas être jeté avec les déchets ménagers ordinaires. Il est de votre responsabilité de mettre au rebut vos appareils en les déposant dans les centres de collecte publique désignés pour le recyclage des équipements électriques et électroniques. La collecte et le recyclage de vos appareils mis au rebut [REDACTED] indépendamment du reste des déchets contribue à la préservation des ressources naturelles et garantit que ces appareils seront recyclés dans le respect de la santé humaine et de l'environnement. Pour obtenir plus d'informations sur les centres de collecte et de recyclage des appareils mis au rebut, veuillez contacter les autorités locales de votre région, les services de collecte des ordures ménagères ou le magasin dans lequel vous avez acheté ce produit.

German notice

Entsorgung von Altgeräten aus privaten Haushalten in der EU



Das Symbol auf dem Produkt oder seiner Verpackung weist darauf hin, dass das Produkt nicht über den normalen Hausmüll entsorgt werden darf. Benutzer sind verpflichtet, die Altgeräte an einer Rücknahmestelle für Elektro- und Elektronik-Altgeräte abzugeben. Die getrennte Sammlung und ordnungsgemäße Entsorgung Ihrer Altgeräte trägt zur Erhaltung der natürlichen Ressourcen bei und garantiert eine Wiederverwertung, die die Gesundheit des Menschen und die Umwelt schützt. Informationen dazu, wo Sie Rücknahmestellen für Ihre Altgeräte finden, erhalten Sie bei Ihrer Stadtverwaltung, den örtlichen Müllentsorgungsbetrieben oder im Geschäft, in dem Sie das Gerät erworben haben.

Greek notice

Απόρριψη άχρηστου εξοπλισμού από χρήστες σε ιδιωτικά νοικοκυριά στην Ευρωπαϊκή Ένωση



Το σύμβολο αυτό στο προϊόν ή τη συσκευασία του υποδεικνύει ότι το συγκεκριμένο προϊόν δεν πρέπει να διατίθεται μαζί με τα άλλα οικιακά σας απορρίμματα. Αντίθετα, είναι δική σας ευθύνη να απορρίψετε τον άχρηστο εξοπλισμό σας παραδίδοντάς τον σε καθορισμένο σημείο συλλογής για την ανακύκλωση άχρηστου ηλεκτρικού και ηλεκτρονικού εξοπλισμού.

Η ξεχωριστή συλλογή και ανακύκλωση του άχρηστου εξοπλισμού σας κατά την απόρριψη θα συμβάλει στη διατήρηση των φυσικών πόρων και θα διασφαλίσει ότι η ανακύκλωση γίνεται με τρόπο που προστατεύει την ανθρώπινη υγεία και το περιβάλλον. Για περισσότερες πληροφορίες σχετικά με το πού μπορείτε να παραδώσετε τον άχρηστο εξοπλισμό σας για ανακύκλωση, επικοινωνήστε με το αρμόδιο τοπικό γραφείο, την τοπική υπηρεσία διάθεσης οικιακών απορριμμάτων ή το κατάστημα όπου αγοράσατε το προϊόν.

Hungarian notice

Készülékek magánháztartásban történő selejtezése az Európai Unió területén



A készüléken, illetve a készülék csomagolásán látható azonos szimbólum annak jelzésére szolgál, hogy a készülék a selejtezés során az egyéb háztartási hulladéktól eltérő módon kezelendő. A vásárló a hulladékká vált készüléket köteles a kijelölt gyűjtőhelyre szállítani az elektromos és elektronikai készülékek újrahasznosítása céljából. A hulladékká vált készülékek selejtezési begyűjtése és újrahasznosítása hozzájárul a természeti erőforrások megőrzéséhez, valamint biztosítja a selejtezett termékek környezetre és emberi egészségre nézve biztonságos feldolgozását. A begyűjtés pontos helyéről bővebb tájékoztatást a lakhelye szerint illetékes önkormányzattól, az illetékes személtakarító vállalatától, illetve a terméket elárúsító helyen kaphat.

Italian notice

Smaltimento delle apparecchiature da parte di privati nel territorio dell'Unione Europea



Questo simbolo presente sul prodotto o sulla sua confezione indica che il prodotto non può essere smaltito insieme ai rifiuti domestici. È responsabilità dell'utente smaltire le apparecchiature consegnandole presso un punto di raccolta designato al riciclo e allo smaltimento di apparecchiature elettriche ed elettroniche. La raccolta differenziata e il corretto riciclo delle apparecchiature da smaltire permette di proteggere la salute degli individui e l'ecosistema. Per ulteriori informazioni relative ai punti di raccolta delle apparecchiature, contattare l'ente locale per lo smaltimento dei rifiuti, oppure il negozio presso il quale è stato acquistato il prodotto.

Latvian notice

Nolietotu iekārtu iznīcināšanas noteikumi lietotājiem Eiropas Savienības privātajās mājāsaimniecībās



Šāds simbols uz izstrādājuma vai uz tā iesaiņojuma norāda, ka šo izstrādājumu nedrīkst izmest kopā ar citiem sadzīves atkritumiem. Jūs atbildat par to, lai nolietotās iekārtas tiktu nodotas speciāli iekārtotos punktos, kas paredzēti izmantoto elektrisko un elektronisko iekārtu savākšanai otrreizējai pārstrādei. Atsevišķa nolietoto iekārtu savākšana un otrreizējā pārstrāde palīdzēs saglabāt dabas resursus un garantēs, ka šīs iekārtas tiks otrreizēji pārstrādātas tādā veidā, lai pasargātu vidi un cilvēku veselību. Lai uzzinātu, kur nolietotās iekārtas var izmest otrreizējai pārstrādei, jāvēršas savas dzīves vietas pašvaldībā, sadzīves atkritumu savākšanas dienestā vai veikalā, kurā izstrādājums tika nopirkts.

Lithuanian notice

Vartotojų iš privačių namų ūkių įrangos atliekų šalinimas Europos Sąjungoje



Šis simbolis ant gaminio arba jo pakuotės rodo, kad šio gaminio šalinti kartu su kitomis namų ūkio atliekomis negalima. Šalintinas įrangos atliekas privalote pristatyti į specialią surinkimo vietą elektros ir elektroninės įrangos atliekoms perdirbti. Atskirai surenkamos ir perdirbamos šalintinos įrangos atliekos padės saugoti gamtinius išteklius ir užtikrinti, kad jos bus perdirbtos tokiu būdu, kuris nekenkia žmonių sveikatai ir aplinkai. Jeigu norite sužinoti daugiau apie tai, kur galima pristatyti perdirbtinas įrangos atliekas, kreipkitės į savo seniūniją, namų ūkio atliekų šalinimo tarnybą arba parduotuvę, kurioje įsigijote gaminį.

Polish notice

Pozbywanie się zużytego sprzętu przez użytkowników w prywatnych gospodarstwach domowych w Unii Europejskiej



Ten symbol na produkcie lub jego opakowaniu oznacza, że produktu nie wolno wyrzucać do zwykłych pojemników na śmieci. Obowiązkiem użytkownika jest przekazanie zużytego sprzętu do wyznaczonego punktu zbiórki w celu recyklingu odpadów powstałych ze sprzętu elektrycznego i elektronicznego. Osobna zbiórka oraz recykling zużytego sprzętu pomogą w ochronie zasobów naturalnych i zapewnią ponowne wprowadzenie go do obiegu w sposób chroniący zdrowie człowieka i środowisko. Aby uzyskać więcej informacji o tym, gdzie można przekazać zużyty sprzęt do recyklingu, należy się skontaktować z urzędem miasta, zakładem gospodarki odpadami lub sklepem, w którym zakupiono produkt.

Portuguese notice

Descarte de Lixo Elétrico na Comunidade Européia



Este símbolo encontrado no produto ou na embalagem indica que o produto não deve ser descartado no lixo doméstico comum. É responsabilidade do cliente descartar o material usado (lixo elétrico), encaminhando-o para um ponto de coleta para reciclagem. A coleta e a reciclagem seletivas desse tipo de lixo ajudarão a conservar as reservas naturais; sendo assim, a reciclagem será feita de uma forma segura, protegendo o ambiente e a saúde das pessoas. Para obter mais informações sobre locais que reciclam esse tipo de material, entre em contato com o escritório da HP em sua cidade, com o serviço de coleta de lixo ou com a loja em que o produto foi adquirido.

Slovakian notice

Likvidácia vyradených zariadení v domácnostiach v Európskej únii



Symbol na výrobku alebo jeho balení označuje, že daný výrobok sa nesmie likvidovať s domovým odpadom. Povinnosťou spotrebiteľa je odovzdať vyradené zariadenie v zbernom mieste, ktoré je určené na recykláciu vyradených elektrických a elektronických zariadení. Separovaný zber a recyklácia vyradených zariadení prispieva k ochrane prírodných zdrojov a zabezpečuje, že recyklácia sa vykonáva spôsobom chrániacim ľudské zdravie a životné prostredie. Informácie o zberných miestach na recykláciu vyradených zariadení vám poskytnie miestne zastupiteľstvo, spoločnosť zabezpečujúca odvoz domového odpadu alebo obchod, v ktorom ste si výrobok zakúpili.

Slovenian notice

Odstranjevanje odslužene opreme uporabnikov v zasebnih gospodinjstvih v Evropski uniji



Ta znak na izdelku ali njegovi embalaži pomeni, da izdelka ne smete odvreči med gospodinjske odpadke. Nasprotno, odsluženo opremo morate predati na zbirališče, pooblaščen za recikliranje odslužene električne in elektronske opreme. Ločeno zbiranje in recikliranje odslužene opreme prispeva k ohranjanju naravnih virov in zagotavlja recikliranje te opreme na zdravju in okolju neškodljiv način. Za podrobnejše informacije o tem, kam lahko odpeljete odsluženo opremo na recikliranje, se obrnite na pristojni organ, komunalno službo ali trgovino, kjer ste izdelek kupili.

Spanish notice

Eliminación de residuos de equipos eléctricos y electrónicos por parte de usuarios particulares en la Unión Europea



Este símbolo en el producto o en su envase indica que no debe eliminarse junto con los desperdicios generales de la casa. Es responsabilidad del usuario eliminar los residuos de este tipo depositándolos en un "punto limpio" para el reciclado de residuos eléctricos y electrónicos. La recogida y el reciclado selectivos de los residuos de aparatos eléctricos en el momento de su eliminación contribuirá a conservar los recursos naturales y a garantizar el reciclado de estos residuos de forma que se proteja el medio ambiente y la salud. Para obtener más información sobre los puntos de recogida de residuos eléctricos y electrónicos para reciclado, póngase en contacto con su ayuntamiento, con el servicio de eliminación de residuos domésticos o con el establecimiento en el que adquirió el producto.

Swedish notice

Bortskaffande av avfallsprodukter från användare i privathushåll inom Europeiska Unionen



Om den här symbolen visas på produkten eller förpackningen betyder det att produkten inte får slängas på samma ställe som hushållssopor. I stället är det ditt ansvar att bortskaffa avfallet genom att överlämna det till ett uppsamlingsställe avsett för återvinning av avfall från elektriska och elektroniska produkter. Separat insamling och återvinning av avfallet hjälper till att spara på våra naturresurser och gör att avfallet återvinns på ett sätt som skyddar människors hälsa och miljön. Kontakta ditt lokala kommunkontor, din närmsta återvinningsstation för hushållsavfall eller affären där du köpte produkten för att få mer information om var du kan lämna ditt avfall för återvinning.

Battery replacement notices

Dutch battery notice

Verklaring betreffende de batterij



WAARSCHUWING: dit apparaat bevat mogelijk een batterij.

- Probeer de batterijen na het verwijderen niet op te laden.
 - Stel de batterijen niet bloot aan water of temperaturen boven 60° C.
 - De batterijen mogen niet worden beschadigd, gedemonteerd, geplet of doorboord.
 - Zorg dat u geen kortsluiting veroorzaakt tussen de externe contactpunten en laat de batterijen niet in aanraking komen met water of vuur.
 - Gebruik ter vervanging alleen door HP goedgekeurde batterijen.
-

Batterijen, accu's en accumulators mogen niet worden gedeponerd bij het normale huishoudelijke afval. Als u de batterijen/accu's wilt inleveren voor hergebruik of op de juiste manier wilt vernietigen, kunt u gebruik maken van het openbare inzamelingsstelsel voor klein chemisch afval of ze terugsturen naar HP of een geautoriseerde HP Business of Service Partner.

Neem contact op met een geautoriseerde leverancier of een Business of Service Partner voor meer informatie over het vervangen of op de juiste manier vernietigen van accu's.

Avis relatif aux piles



AVERTISSEMENT : cet appareil peut contenir des piles.

- N'essayez pas de recharger les piles après les avoir retirées.
 - Évitez de les mettre en contact avec de l'eau ou de les soumettre à des températures supérieures à 60°C.
 - N'essayez pas de démonter, d'écraser ou de percer les piles.
 - N'essayez pas de court-circuiter les bornes de la pile ou de jeter cette dernière dans le feu ou l'eau.
 - Remplacez les piles exclusivement par des pièces de rechange HP prévues pour ce produit.
-

Les piles, modules de batteries et accumulateurs ne doivent pas être jetés avec les déchets ménagers. Pour permettre leur recyclage ou leur élimination, veuillez utiliser les systèmes de collecte publique ou renvoyez-les à HP, à votre Partenaire Agréé HP ou aux agents agréés.

Contactez un Revendeur Agréé ou Mainteneur Agréé pour savoir comment remplacer et jeter vos piles.

Hinweise zu Batterien und Akkus



VORSICHT: Dieses Produkt enthält unter Umständen eine Batterie oder einen Akku.

- Versuchen Sie nicht, Batterien und Akkus außerhalb des Gerätes wieder aufzuladen.
 - Schützen Sie Batterien und Akkus vor Feuchtigkeit und Temperaturen über 60°.
 - Verwenden Sie Batterien und Akkus nicht missbräuchlich, nehmen Sie sie nicht auseinander und vermeiden Sie mechanische Beschädigungen jeglicher Art.
 - Vermeiden Sie Kurzschlüsse, und setzen Sie Batterien und Akkus weder Wasser noch Feuer aus.
 - Ersetzen Sie Batterien und Akkus nur durch die von HP vorgesehenen Ersatzteile.
-

Batterien und Akkus dürfen nicht über den normalen Hausmüll entsorgt werden. Um sie der Wiederverwertung oder dem Sondermüll zuzuführen, nutzen Sie die öffentlichen Sammelstellen, oder setzen Sie sich bezüglich der Entsorgung mit einem HP Partner in Verbindung.

Weitere Informationen zum Austausch von Batterien und Akkus oder zur sachgemäßen Entsorgung erhalten Sie bei Ihrem HP Partner oder Servicepartner.

Istruzioni per la batteria



AVVERTENZA: Questo dispositivo può contenere una batteria.

- Non tentare di ricaricare le batterie se rimosse.
 - Evitare che le batterie entrino in contatto con l'acqua o siano esposte a temperature superiori a 60° C.
 - Non smontare, schiacciare, forare o utilizzare in modo improprio la batteria.
 - Non accorciare i contatti esterni o gettare in acqua o sul fuoco la batteria.
 - Sostituire la batteria solo con i ricambi HP previsti a questo scopo.
-

Le batterie e gli accumulatori non devono essere smaltiti insieme ai rifiuti domestici. Per procedere al riciclaggio o al corretto smaltimento, utilizzare il sistema di raccolta pubblico dei rifiuti o restituirli a HP, ai Partner Ufficiali HP o ai relativi rappresentanti.

Per ulteriori informazioni sulla sostituzione e sullo smaltimento delle batterie, contattare un Partner Ufficiale o un Centro di assistenza autorizzato.

Japanese battery notice

バッテリーに関する注意



警告: 本製品はバッテリーを内蔵している場合があります。

- バッテリーを取り外している場合は、充電しないでください。
- バッテリーを水にさらしたり、60°C (140°F) 以上の温度にさらさないでください。
- バッテリーを誤用、分解、破壊したり、穴をあけたりしないでください。
- 外部極を短絡させたり、火や水に投棄しないでください。
- バッテリーを交換する際は、HP指定の製品と交換してください。

バッテリー、バッテリーパック、蓄電池は一般の家庭廃棄物と一緒に廃棄しないでください。リサイクルまたは適切に廃棄するため、公共の収集システム、HP、HPパートナー、またはHPパートナーの代理店にお送りください。

バッテリー交換および適切な廃棄方法についての情報は、HPのサポート窓口にお問い合わせください。

Declaración sobre las baterías



ADVERTENCIA: Este dispositivo podría contener una batería.

- No intente recargar las baterías si las extrae.
 - Evite el contacto de las baterías con agua y no las exponga a temperaturas superiores a los 60 °C (140 °F).
 - No utilice incorrectamente, ni desmonte, aplaste o pinche las baterías.
 - No cortocircuite los contactos externos ni la arroje al fuego o al agua.
 - Sustituya las baterías sólo por el repuesto designado por HP.
-

Las baterías, los paquetes de baterías y los acumuladores no se deben eliminar junto con los desperdicios generales de la casa. Con el fin de tirarlos al contenedor de reciclaje adecuado, utilice los sistemas públicos de recogida o devuélvalas a HP, un distribuidor autorizado de HP o sus agentes.

Para obtener más información sobre la sustitución de la batería o su eliminación correcta, consulte con su distribuidor o servicio técnico autorizado.

C Specifications

This section provides the VLS node and disk array specifications.

Node specifications

Item	Specification
Height	4.32 cm (1.70 in)
Depth	69.22 cm (27.25 in)
Width	42.62 cm (16.78 in)
Weight (fully loaded)	16.78 kg (37 lb)
Weight (no drives installed)	12.47 kg (27.5 lb)
Rated input voltage	100 VAC to 240 VAC
Rated input frequency	50 Hz to 60 Hz
Rated input current	6.0 A (110 V) to 3.0 A (220 V)
Rated input power	580 W
BTUs per hour	1990
Rated steady-state power	460 W

Node serial ATA hard drive specifications

Item	Specification
Capacity	80 GB
Height	1.028 in
Width	4.0 in
Interface	Serial ATA
Transfer rate	1.5 GB/s
Rotational speed	7,200 rpm
Bytes per sector	512
Logical blocks	156,301,488

DVD/CDRW drive specifications

Item	Specification
Height	12.7 mm (0.50 in)
Depth	129.4 mm (5.1 in)
Width	128 mm (5.04 in)
Weight	0.34 kg (0.75 lb)
Applicable disk	DVD-ROM, DVD-R (Read Only), 2.6 GB/side DVD-RAM (Read Only), 5.2 GB/side DVD-RAM (Read Only), CD-ROM Mode-1 data disc, CD-ROM Mode-2 data disc, CD Audio disc, CD-Extra, CD-RW, CD-R, CD Text, PhotoCD, CD-I (mode 2), CD-I Ready, and CD-Bridge
Loading mechanism	Tray type
Speed	8X with DVD and 24X Max. when used with CD-ROM/Rs
Interface	EIDE (ATAPI)
Data transfer rate (sustained)	DVD-ROM Single Layer: 10.8 MB/sec. max., DVD-RAM: 2.77 MB/sec. max., CD-ROM: 7.2 MB/sec. max.
Access times (typical)	Random: DVD-ROM < 120 ms, CD-ROM < 110 ms, Full-Stroke: DVD-ROM < 240 ms, CD-ROM < 160 ms
Audio output level (typical)	Line-out: CD 0.7 Vrms at 47 Kohms load
Cache buffer	2 MB
Startup time	< 10 s
MTBF	120,000 Power On Hours (POH)
Media capacity	
DVD-ROM	DVD-SL: 4.7 GB/side, DVD-DL: 8.5 GB/side, Double Sided: 9.40 GB/side
DVD-R	3.95 GB/side

Item	Specification
DVD-RAM	2.6 GB/side and 5.2 GB/side
CD-ROM	Mode-1: 650 MB (550 MB), Mode-2: 742 MB (640 MB)
Media block size	
DVD	2,048 bytes
CD	2,352 (Mode-0); 2352, 2340, 2336, 2048 bytes (Mode-1); 2352, 2340, 2336, 2048 bytes (Mode-2)
Media diameter	120 mm, 80 mm (with adapter at vertical mounting mode)

MSA20 disk array specifications

Item	Specification
Dimensions	59.7 cm x 48.8 cm x 8.8 cm (23.5 in x 19.2 in x 3.5 in)
Weight	<ul style="list-style-type: none">• Empty: 14 kg (32 lb)• Fully loaded: 24.6 kg (54.3 lb)
Input frequency ($\pm 5\%$)	<ul style="list-style-type: none">• 50 or 60 Hz (nominal)• 47 to 63 Hz (range)
Input voltage	<ul style="list-style-type: none">• 110 or 240 V (nominal)• 90 to 254 V RMS (autoranging)
Steady-state maximum current	<ul style="list-style-type: none">• At 240 V = 1.8 A (one power supply) or 1.9 A (two power supplies)• At 120 V = 3.7 A (one power supply) or 3.9 A (two power supplies)
Standby current	<ul style="list-style-type: none">• 0.21 A at 240 V, 60 Hz• 0.15 A at 120 V, 60 Hz

Environmental specifications

	Operating	Non-operating	Shipping
Temperature ^a	10°C to 35°C (50°F to 95°F)	-40°C to 66°C (-40°F to 150°F)	-40°C to 66°C (-40°F to 150°F)
Relative humidity (noncondensing) ^b	40% to 60%	10% to 95%	5% to 95%
Altitude	-1000 ft to 10,000 ft	-1000 ft to 10,000 ft	-1000 ft to 40,000 ft
Vibration	5-1000-5 Hz, 0.25 g, sinusoidal, 1 Octave/min., 3-axis	5-1000-5 Hz, 1.0 g, sinusoidal, 1 Octave/min., 3-axis	5-1000-5 Hz, 2.0 g, sinusoidal, 1 Octave/min., 3-axis
Shock	5 g, every 11ms, 1/2 sine pulse, 3 axis	25 g, every 11ms, 1/2 sine pulse, 3 axis	30 g, every 11ms, 1/2 sine pulse, 3 axis

^aAll temperature ratings shown are for sea level. An altitude derating of 1°C per 300 m (1.8°F per 1,000 ft) to 3048 m (10,000 ft) is applicable. No direct sunlight allowed.

^bStorage maximum humidity of 95% is based on a maximum temperature of 45°C (113°F). Altitude maximum for storage corresponds to a pressure minimum of 70 KPa.

Glossary

This glossary defines terms used in this guide or related to this product and is not a comprehensive glossary of computer terms.

appliance	An intelligent device programmed to perform a single well-defined function. Appliances differ from general-purpose computers in that their software is normally customized for the function they perform, pre-loaded by a vendor, and not alterable by the user.
automigration	Data intended for tape storage is written to virtual tape and after the backups are complete written to physical tape in the background. One virtual tape emulates one physical tape to the host system. Data is held on the virtual tape, which greatly improves restore times over the slow loading process of a robotic library. The VLS will be able to perform automigration in the future.
bandwidth	Also known as data transfer rate. The amount of data that can be carried from one point to another in a given time period. A real communications path usually consists of a succession of links, each with its own bandwidth. If one of these is much slower than the rest, it is said to be a bandwidth bottleneck.
cartridge	1) A removable storage module that contains magnetic or optical disks, magnetic tape or memory chips. (2) Software emulation of the behavior and contents of a physical tape cartridge on alternate media, such as disk, is called a virtual tape or virtual media. See <i>also</i> virtual tape.
chassis	A metal box that houses computer hardware.
command line interface (CLI)	A user interface to an application that accepts typed-in commands one line at a time typically through a console screen.
data backup	The activity of copying files or databases so that they will be preserved in case of equipment failure or other catastrophe. The retrieval of files you backed up is called restoring files. See <i>also</i> data restore.

data compression	A software or hardware process that shrinks data files so that they occupy less storage space, and can be transmitted faster and easier. Data is encoded so it takes up less storage space and less bandwidth for transmission. <i>See also</i> bandwidth.
data migration	The process of moving data from one storage device to another, such as migrating data from virtual media to physical media.
data restore	To recover data files stored on virtual or physical media.
data retention period	The length of time data is retained (stored) on virtual or physical media.
disk array	Two or more hard drives combined as a single logical unit for increased capacity, speed, and/or fault-tolerant operation. Disk arrays are logically grouped into a storage pool. <i>See also</i> storage pool.
disk mirroring	A technique in which data is written to two duplicate disks simultaneously. Mirroring provides data protection in the case of disk failure, because data is constantly updated to both disks. This way if one of the hard drives fails, the system can instantly switch to the other disk without any loss of data or service. <i>See also</i> RAID 1-level data storage and failover protection.
disk striping	The process of dividing a body of data into blocks and spreading the data blocks across several partitions on several disks. <i>See also</i> RAID.
disk-to-disk backup	Typically refers to backing up data on disks rather than on tape. Disk-to-disk backup systems provide a very fast single file restore capability compared with disk-to-tape backup. <i>See also</i> data restore and virtual tape.
disk-to-disk-to-tape backup	Archiving in which data is initially copied to backup storage on a disk-based storage system, such as a VLS, and then periodically copied again to a tape storage system. <i>See also</i> data migration.
dynamic disk filesystem	A finely-tuned filesystem developed to handle large block I/O typical of a streaming backup/restore environment. This filesystem is optimized for sequential access and very large file sizes.
extent	The minimum amount of disk space allocated for writing by the VLS dynamic disk filesystem. A smaller extent reduces wasted

disk space, but decreases restore performance. The VLS extent size is 32MB.

See *also* data restore.

failover protection	A backup operational mode in which the functions of a system component (such as a hard drive or power supply) are assumed by secondary system components when the primary component becomes unavailable through either failure or scheduled down time.
Fibre Channel	A technology for transmitting data between computer devices at data rates of up to 1 or 2 Gbps. Fibre Channel is especially suited for connecting computer servers to shared storage devices.
file	A VLS file is a virtual cartridge.
Firesafe	The holding area for virtual media that is not assigned to a virtual library. Data cannot be restored from virtual media located in the Firesafe until the media is moved into a library.
hot plug	The ability to add and remove devices to an appliance while the appliance is running and have the operating system automatically recognize the change.
infrastructure	The physical hardware used to interconnect computers. Infrastructure also includes the software used to send, receive, and manage the signals that are transmitted.
initiator	Media (host) server that runs the backup/restore application that passes commands and data between the network and the VLS.
inputs/outputs per second	A measure of performance for a host-attached storage device or RAID controller.
library	A storage device that handles multiple units of media and provides one or more drives for reading and writing them, such as a physical tape library and virtual tape library. Software emulation of a physical tape library is called a virtual tape library. See <i>also</i> virtual tape library.
logical unit number (LUN)	An address used in the SCSI protocol to access a device within a target. In the case of the VLS, a LUN is assigned to each virtual library and tape drive.
LUN mapping	A mechanism of changing the LUN assignments for a specific host.

LUN masking	An authorization process that makes a LUN available to some hosts and unavailable to other hosts.
master server	A computer that provides administration and control for backup and restore operations for all clients and servers in a master and media server cluster.
mean time until data loss (MTDL)	The average time until a component failure can be expected to cause data loss. This includes the consideration that RAID redundancy can protect against data loss from the failure of a single component.
media access control (MAC) address	A low-level unique hardware identifier for every Ethernet port in the world that is physically stored inside a network card or similar network interface. MAC addresses are assigned by the IEEE.
media server	A computer whose purpose is to move or copy data from one location to another, such as from network clients to tape cartridges in a library.
node	A server that contains the hardware and software required to run a virtual library system. This refers to a hardware assembly containing a power supply, cooling fans, motherboard, expansion boards, and internal hard drives to support the VLS system.
oversubscription	A condition that exists when more virtual media storage is configured on a VLS than there is physical storage available. Because the VLS dynamically allocates storage space as user data is written, the VLS allows you to allocate more storage for virtual media than is physically available.
port mapping	A mechanism of assigning a LUN (virtual device), such as a virtual library or tape drive, to a specific Fibre Channel host port. Port mapping allows you to load-balance the LUNs among the Fibre Channel host ports to maximize bandwidth. At this time, you must manually load-balance the virtual tape drives in a VLS.
RAID	A RAID volume appears to the operating system to be a single logical disk. RAID improves performance by disk striping, which involves partitioning each drive's storage space into units. By placing data on multiple disks, I/O operations can overlap in a balanced way, improving performance.
RAID 1-level data storage	Consists of at least two drives that uses mirroring (100% duplication of the storage of data). There is no striping. Read performance is improved since either disk can be read at the

same time. Write performance is the same as for single disk storage.

RAID 5-level data storage	Provides data striping at the byte level and also stripe error correction information. RAID 5 configurations can tolerate one drive failure. Even with a failed drive, the data in a RAID 5 volume can still be accessed normally.
redundancy	In a redundant system, if you lose part of the system, it can continue to operate. For example, if you have two power supplies with one that takes over if the other one dies, that's redundancy.
secure sockets layer (SSL) certificate	<p>A protocol designed to enable applications to transmit information back and forth securely. Applications that use this protocol inherently know how to give and receive encryption keys with other applications, as well as how to encrypt and decrypt data sent between the two.</p> <p>Some applications that are configured to run SSL include web browsers like Internet Explorer and Netscape, email programs like GroupWise, Outlook, and Outlook Express, FTP (file transfer protocol) programs, etc. These programs are automatically able to receive SSL connections.</p> <p>To send an SSL connection, however, or to open a secure connection, your application must first have an encryption key assigned to it by a Certification Authority. Once it has a unique key of its own, you can establish a secure connection with every other application that can "speak" the SSL protocol.</p>
serial ATA disk	The evolution of the ATA (IDE) interface that changes the physical architecture from parallel to serial and from master-slave to point-to-point. Unlike parallel ATA interfaces that connect two drives; one configured as master, the other as slave, each serial ATA drive is connected to its own interface.
simple network management protocol (SNMP)	A widely used network monitoring and control protocol. Data is passed from SNMP agents, which are hardware and/or software processes reporting activity in each network device (hub, router, bridge, etc.) to the workstation console used to oversee the network. The agents return information contained in a MIB (Management Information Base), which is a data structure that defines what is obtainable from the device and what can be controlled (turned off, on, etc.).
small computer systems interface (SCSI)	A standard, intelligent parallel interface for attaching peripheral devices to computers, based on a device independent protocol.

storage area network (SAN)	A centrally managed network that allows any-to-any interconnection of servers and storage systems.
storage pool	Multiple disk arrays logically grouped together from which the dynamic disk filesystem allocates storage. The disk arrays in a VLS are automatically configured into one storage array.
tape drive	(1) A device that reads data from and writes data onto tape. (2) A software emulation of a tape drive is called a virtual tape drive.
virtual tape	Also known as a piece of virtual media or a VLS cartridge. A disk drive buffer that emulates one physical tape to the host system and appears to the host backup application as a physical tape. The same application used to back up to tape is used, but the data is stored on disk. Data can be written to and read from the virtual tape, and the virtual tape can be migrated to physical tape.
virtual tape drive	An emulation of a physical transport in a virtual tape library that looks like a physical tape transport to the host backup application. The data written to the virtual tape drive is really being written to disk. <i>See also</i> virtual tape library.
virtual tape library	A disk drive buffer containing virtual tape and virtual tape drives. <i>See also</i> virtual tape drive.
world wide port name (WWPN)	A unique 64-bit address used in a Fibre Channel storage network to identify each device in a Fibre Channel network.

Index

A

additional information, 14
audience, 14
authorized reseller, 19

B

barcode templates
 adding, 112, 157
 removing, 112, 157
 assigning, 103
battery replacement notices, 243
benefits, 22

C

cabling, 50
Canadian notice, 226
capacity
 adding, 121
 VLS6105, 27
 VLS6510, 29
capacity bundle
 adding, 121
 rack mounting, 43
capacity license
 installing, 122
 re-installing, 215
 requirements, 122
cartridges
 changing capacity, 117, 161
 changing library association, 117, 161
 changing write access, 117, 161
 creating, 102, 158
 destroying, 110, 159
 reusing barcode numbers, 111
 viewing details, 117, 158
CLI command set, 147
 help, 148

 network settings configuration commands, 149

 output commands, 148
 configuration commands, 152
 connection commands, 148
 conventions, 147
 management commands, 160
 monitoring commands, 163

Command View VLS

 closing a session, 71
 description, 63
 Login window, Email Administrator link, 82
 opening a session from a web browser, 65
 opening a session from Command View TL, 67

 restarting, 71, 161
 window regions, 64

 component identification, 169

 component replacement, 187

 configuration, 75, 152
 restoring settings, 162, 212
 saving settings, 128, 162

 copying data to physical tape, 21

D

 data compression, 99, 121

 date and time setting

 setting, 150
 viewing, 150

 Declaration of Conformity, 224

 DHCP

 deselecting, 151
 selecting, 79, 150

 disaster recovery

 disk array RAID volume failure, 210
 node RAID volume failure, 211
 operating system failure, 216

 disk array

 powering down, 59

- powering up, 55
- cabling, 50
- front panel components, 182
- front panel LEDs, 183
- rack mounting, 43
- RAID volume failure recovery, 210
- rear panel components, 185
- rear panel LEDs and buttons, 186
- specifications, 253
- disk array controller module
 - LED, 186
 - location, 185
 - replacing, 207
 - VHDCI connector, 185
- disk array fan module
 - LED, 186
 - locations, 185
 - redundancy, 25
 - replacing, 205
- disk array hard drive
 - capacity, 26
 - LED combinations, 183
 - LEDs, 183
 - locations, 182
 - RAID configuration, 23
 - replacing, 203
- disk array power supply
 - LED, 186
 - locations, 185
 - redundancy, 25
 - replacing, 206
- Disposal of waste equipment, European Union, 234
- DNS server address, setting, 79, 150
- document conventions, 15
- document scope, 13
- domain name, setting, 79, 150

E

- electrical damage, reducing risk, 52
- electrical shock, reducing risk, 52
- electrostatic discharge
 - grounding methods, 33
 - preventing, 32, 187
- emergency login, 72
- environmental requirements

- electrical grounding, 39
- power, 38
- space and airflow, 37
- temperature, 38
- environmental specifications, 254
- European Union notice, 226

F

- features, 21
- Federal Communications Commission notice, 223
- Fibre Channel host port
 - changing settings, 152
 - changing the default settings, 83
 - LUN management, 87
 - LEDs, 174
 - locations, 173
- Firesafe, 106
- fully qualified name, setting, 79, 150

G

- gateway to network, setting, 80, 150
- glossary, 255
- grounding methods, 188

H

- help, obtaining, 19
- host name, setting, 79, 150
- host WWPN alias, creating , 90

I

- icon
 - Navigation tree, 134
 - Notification alert, 135
 - Status banner, 133
- Identity tab
 - Contact, 81
 - Contact Phone, 82
 - E-mail, 82
 - IP address, 76
 - Location, 81
 - VLS serial number, 128
 - VLS IP address, 150

installation, 31
IP address, setting, 79, 150

J

Japanese notices, 227

K

Korean notices, 228

L

laser compliance notices, 230

library

- creating, 154
- destroying, 155
- Netbackup requirement, 94
- creating, 93
- destroying, 106

LUN management, 87

- default LUN numbering, 87
- LUN mapping, 91
- LUN masking, 89
- operating system LUN requirements and restrictions, 88

M

management, 115, 160

models, 26

monitoring system status, 131, 163

N

Netbackup, library requirement, 94

netmask, setting, 80, 150

network settings

- setting, 76, 150
- viewing, 76, 150

node

- powering down, 58
- powering up, 56
- rebooting, 57
- access panel, installing, 191
- access panel, removing, 191
- cabling, 50

- extending from the rack, 190
- front panel components, 169
- front panel LEDs and buttons, 170
- internal health LED combinations, 179
- processor zone fan module LED, 181
- rack mounting, 42
- RAID volume failure recovery, 211
- rear panel components, 173
- rear panel LEDs, 174
- rebooting, 161
- specifications, 249
- system board components, 176
- system board LEDs, 177

node DIMM

- LED combinations, 179
- LEDs, 177
- replacing, 198

node DVD/CDRW drive

- location, 169
- replacing, 193
- specifications, 251

node fan module

- LED combinations, 180
- locations, 181
- power supply zone fan module LED, 178
- processor zone fan module LED, 181
- redundancy, 25
- replacing the power supply zone fan module, 196
- replacing the processor zone fan module, 197

node hard drive

- LEDs, 172
- locations, 169
- RAID configuration, 24
- replacing, 192
- specifications, 250

node power supply

- front panel LED, 171
- LED combinations, 180
- locations, 173
- rear panel LED, 175
- redundancy option, 25
- replacing, 194

node processor

- LED combinations, 179
- LEDs, 177

- replacing, 199
- notification alerts, 24, 135
 - deleting, 137, 165
 - receiving as SNMP traps, 142, 167
 - receiving by email, 138, 165
 - testing the email notification settings, 141
 - viewing on Command View VLS, 136
 - viewing using CLI, 165

O

- operating system
 - failure recovery, 216
 - re-installing, 216
- operation, 55
- oversubscription, 104
 - enabling and disabling, 85, 153

P

- passwords
 - emergency, 74
 - changing, 116, 160
 - default, 66
 - forgot administrator password, 72

R

- rack
 - disk array mounting, 43
 - disk array space required, 44
 - moving with VLS disk array installed, 48
 - planning resources, 35
 - requirements, 35, 42
 - safety considerations, 18
 - node mounting, 42
 - warnings, 36
- RAID configurations
 - disk array hard drives, 23
 - node hard drives, 24
- recycling notices, 234
- redundancy
 - fan module, 25
 - power supply, 25
- regulatory compliance
 - battery statement, 222
 - Canadian notice, 226

- European Union notice, 226
- identification numbers, 221
- Japanese notices, 227
- Korean notices, 228
- recycling notices, 234
- Taiwanese notices, 229

S

- secure shell user interface, 72
 - closing a session, 73
 - opening a session, 73
- serial number, VLS, 128
- serial user interface, 72
 - closing a session, 74
 - emergency login, 72
 - opening a session, 74
- shipping carton contents
 - disk array, 41
 - node, 40
- software, updating, 126
- specifications, 249
- state polling frequency, setting, 81
- storage space, freeing up, 120
- storage, dynamically assigned, 22, 85, 120
- support ticket, creating, 146
- symbols in text, 16
- symbols on equipment, 17
- system status monitoring, 24
 - individual hardware and virtual device status, 132, 163
 - overall device status, 133, 163

T

- Taiwanese notices, 229
- tape drive
 - creating, 98, 155
 - data compression, 99
 - destroying, 108
- technical support, 19
- telco racks, 189
- tools, installation, 32
- trace log files
 - creating a support ticket, 146
 - saving to individual files, 145
 - viewing, 144

troubleshooting, 218

U

unpacking, 34

user interfaces, 62

 Command View VLS, 63

 serial connection, 72

 secure shell connection, 72

user preferences, setting, 81

V

VLS device emulations, restarting, 124, 161

VLS6105, 26

VLS6510, 28

W

world wide port numbers (WWPNs), VLS, 128