

hp StorageWorks
Ultrium tape drive

getting started guide

removable model

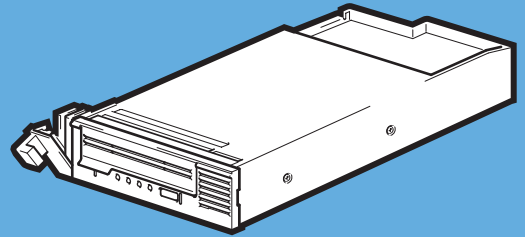

ULTRIUM
LTO

Ultrium 448m



i n v e n t

1

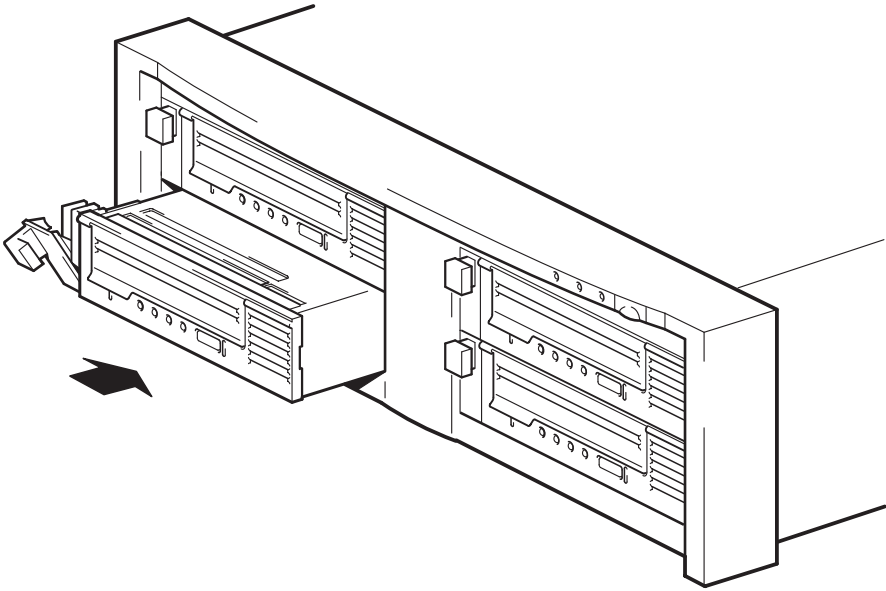

hp tape array 5300

2

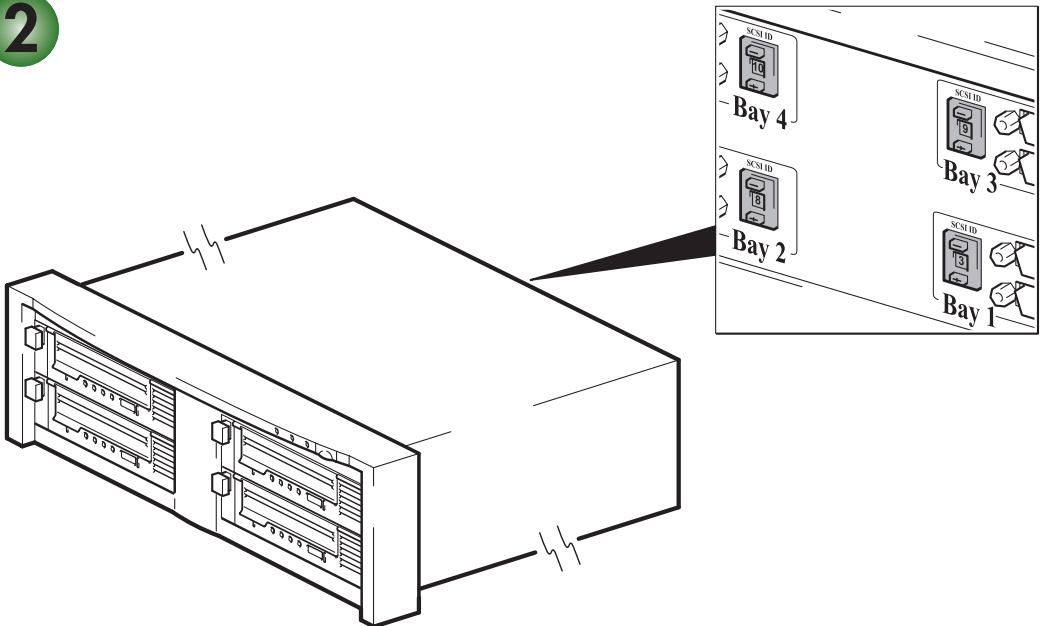

hp tape array 5300

Removable drives - contents

Pre-Installation

Before you start	page 3
Backup software and drivers	page 5
Usage models	page 7
Using the CD-ROM	page 9

Installing the tape drive

Step 1: Check the SCSI connection	page 11
Step 2: Install the drive	page 13
Step 3: Set the drive's SCSI ID	page 15
Step 4: Verify installation	page 17

Using the tape drive

Your HP StorageWorks Ultrium tape drive	page 19
Use the correct media	page 21
Register your tape drive	page 23
Replacing the drive	page 25
Using HP OBDR	page 27
Diagnostic tools	page 30
Optimizing performance	page 32
Troubleshooting	page 34
Understanding the LEDs	page 40
Problems with cartridges	page 40
Other sources of information	page 45

Copyright © 2005 by Hewlett-Packard Limited.

February 2005

Part Number: DW019-90902

Hewlett-Packard Company makes no warranty of any kind with regard to this material, including, but not limited to, the implied warranties of merchantability and fitness for a particular purpose. Hewlett-Packard shall not be liable for errors contained herein or for incidental or consequential damages in connection with the furnishing, performance, or use of this material.

This document contains proprietary information, which is protected by copyright. No part of this document may be photocopied, reproduced, or translated to another language without the prior written consent of Hewlett-Packard. The information contained in this document is subject to change without notice.

Linear Tape-Open, LTO, LTO Logo, Ultrium and Ultrium Logo are trademarks of Certance, HP and IBM in the US, other countries or both.

Patented under one or more of U.S. Patents Nos. 5,003,307; 5,016,009; 5,463,390; 5,506,580; held by Hi/fn, Inc.

Microsoft®, MS-DOS®, MS Windows®, Windows® and Windows NT® are U.S. registered trademarks of Microsoft Corporation.

UNIX® is a registered trademark of The Open Group.

Hewlett-Packard Company shall not be liable for technical or editorial errors or omissions contained herein. The information is provided "as is" without warranty of any kind and is subject to change without notice. The warranties for Hewlett-Packard Company products are set forth in the express limited warranty statements for such products. Nothing herein should be construed as constituting an additional warranty.

Printed in the U.K.

Product Details

Write your tape drive details here so you can find them easily if you need them. The model name is on the front of the drive and the product and serial numbers are on a label on the bottom of the drive.

Model (type of drive):	
Model (number):	
Serial (number):	
Date purchased/installed:	
SCSI ID:	

Before you start

HP StorageWorks Ultrium tape drives are high-performance Ultra 160 SCSI half-height devices with a maximum burst transfer speed of 160 MB/second. They are designed to operate on a low voltage differential SCSI bus (LVDS). For a detailed product specification, please refer to our World Wide Web site (www.hp.com).

Before starting to install your tape drive, you should consider the following:

Which operating systems are supported?

HP StorageWorks Ultrium drives can be connected to servers running under Windows®, NetWare, HP-UX, Tru64, Linux and several other industry-standard operating systems. Refer to the “HP StorageWorks Tape Software Compatibility” topic on our World Wide Web site (www.hp.com/go/connect) for more information about the operating systems and versions that are supported.

Which rackmount systems can I use?

HP StorageWorks removable tape drives are used in conjunction with the HP StorageWorks Tape Array 5300 system, which can be used with both full-height and half-height tape drives. It will hold up to four HP StorageWorks Ultrium 448 (or up to two HP StorageWorks Ultrium 230, 460 or 960 tape drives). The tape array is designed to be installed into HP, IBM and other compatible 19” rackmount systems. It must be properly installed and configured. Refer to your tape array documentation for further details.

Airflow requirements

As long as the tape array is fully populated, it will provide adequate airflow for your HP StorageWorks Ultrium tape drives. You should ensure that ventilation is adequate at the front and rear of the tape array.

If you have unused bays in the tape array, you must install the blanking plates provided with the tape array. This ensures that there is adequate airflow to the drives. See the documentation with the tape array for details on installing blanking plates.

How do I connect the drive to my server?

Check the usage models on page 7. This shows how the HP StorageWorks Ultrium tape drive can be used in different system architectures.

The individual tape drives are connected to their host server via the high-density LVD/SE SCSI connectors on the back of the tape array. They do not require any SCSI cables to plug into the tape array. However, cabling and terminators are required to connect the tape array with the SCSI host. See also “Do I need additional items for installation?” on page 4.

You will need a properly installed and configured SCSI host bus adapter (HBA) or a built-in SCSI controller on your server.

For optimum performance your tape drive should only be connected to a SCSI bus that can transfer data at a rate that supports the tape drive’s maximum burst transfer speed, see Table 2, “supported SCSI bus types,” on page 11, and it should be the only device on the SCSI bus. Do **not** attach the drive to the same SCSI bus as your disk drive or RAID controller (unless you are connecting to a ProLiant server with a Smart Array 6i RAID controller).

The server should be connected via a 68-pin, wide, LVDS-rated cable to the tape array. The standard, recommended configuration is a direct, one-to-one SCSI connection between the tape drive and the host server, so that the drive is the only device on the SCSI bus. It is possible to daisy-chain two tape drives together within the tape array, see Table 2, “supported SCSI bus types,” on page 11. Do **not** daisy-chain more than two drives together, as this will degrade their individual performance with respect to transfer rate.

How can I check the SCSI bus?

We strongly recommend that you use HP Library & Tape Tools to check your server’s current SCSI configuration (see “Step 3: Set the drive’s SCSI ID” on page 15). This will provide information about the SCSI bus and the SCSI IDs in use.

HP Library & Tape Tools is the recommended diagnostic and support tool for your HP tape storage product. It is available on the CD shipped with your product or as a free download from the HP web site and is supported on nearly all major operating systems.

See www.hp.com/support/tapetools for compatibility information, updates and the latest version of the tool.

Do I need additional items for installation?

- You will need to order the correct size SCSI cables and terminators to suit the particular configuration of your tape array. Cable and terminator options are listed at the HP tape array support web site: www.hp.com/support/tapearray, and can be ordered from your local HP sales office. Refer to your tape array’s Getting Started Guide for details of how to install SCSI cables and terminators on the rear panel of the tape array. The latest version of this document can also be downloaded from www.hp.com/support/tapearray.
- If you do not have a spare, suitably rated SCSI connector on your server, you must install a new HBA (also known as a SCSI card). The SCSI bus rating should match or be higher than the SCSI rating of your tape drive. See Table 2, “supported SCSI bus types,” on page 11 for recommended HBAs. For specific details relevant to your server model please refer to www.hp.com/go/connect. You will need to purchase and install the new HBA into an unused, 64-bit PCI expansion slot within your server before installing your tape drive. (The kit can also be installed in a 32-bit PCI expansion slot, but this may limit performance.)

Refer to our World Wide Web site for recommended products, configurations and ordering information: www.hp.com/go/connect or www.hp.com/support/ultrium.

Backup software and drivers

Backup software

For optimum performance it is important to use a backup application that is appropriate for your system's configuration. In a direct attach configuration, where the tape drive is attached to a standalone server, you can use backup software that is designed for a single-server environment. In network configurations you will need backup software that supports enterprise environments. HP, Veritas, Yosemite, Legato and Computer Associates all provide suitable products. Further details about these and other products that may be appropriate can be found on our connectivity web site.

- 1 Go to our connectivity web site: www.hp.com/go/connect.
- 2 Select software compatibility.
- 3 Select your combination of operating system and tape drive model in the table. A list of supported backup applications is displayed. This will also tell you whether your configuration is compatible with HP One-Button Disaster Recovery, HP OBDR. (All HP StorageWorks Ultrium tape drives support HP OBDR. However, you can only use this feature, if your system configuration and backup application also support it. See "Using HP OBDR" on page 27.)
- 4 Make sure you have a backup application that supports your HP StorageWorks Ultrium tape drive and download any upgrades or patches, if required.

Drivers

Windows users

The driver available from Microsoft update is acceptable, but the HP driver (available on the CD-ROM or the web) provides better support for all the features of your new tape drive.

After you connect the tape drive, insert the *HP StorageWorks Tape* CD-ROM and follow the link to download the HP driver from our web site: www.hp.com/support, see "Step 4: Verify installation" on page 17. Refer to the accompanying README file for specific installation instructions for Windows 2000, Windows XP and Windows Server 2003 drivers.

Note: We recommend that you install drivers from the web link on the CD-ROM rather than the Windows Hardware Installation Wizard, because you can also use HP Library & Tape Tools software on the CD-ROM to verify that your installation is correct (see "Step 4: Verify installation" on page 17). If you do not have internet access, you can also install drivers directly from the *HP StorageWorks Tape* CD-ROM, but these may not be the latest versions available.

UNIX users

The recommended backup applications use the operating system's standard, built-in device drivers. To upgrade drivers we recommend that you patch to the latest version of the operating system, following the instructions in the patch documentation. You will also find information about configuring device files in the *UNIX Configuration Guides* on the CD-ROM.



Direct attach - SCSI

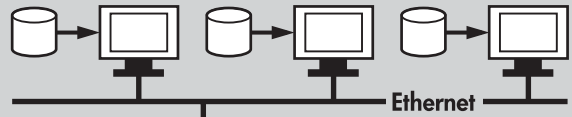

Network attach - SCSI

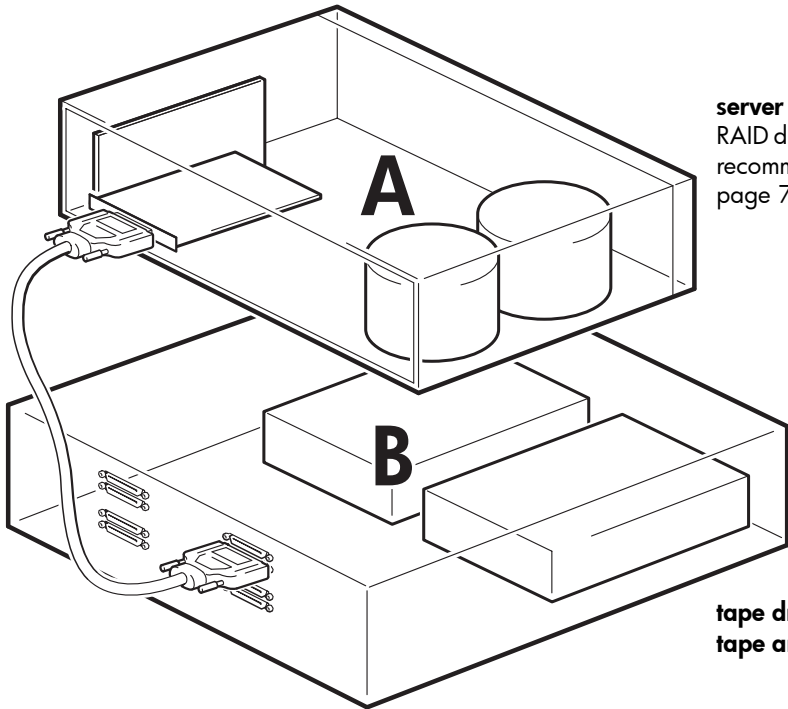

server (A)
RAID disk subsystem
recommended, see
page 7

**tape drives in
tape array (B)**

Figure 1: usage models

Usage models

The tape drive is installed in a tape array(B), which can be used in a standalone or network environment. The tape array should always be directly attached to a VHD SCSI connector on the storage server (A), as shown in Figure 1.

Recommended models

The following table shows the recommended usage models and “Optimizing performance” on page 32 provides further information about factors that can affect performance.

	Direct Attach, single storage server	Across the Network, single storage server, multiple clients
Ultrium 448	Recommended	Recommended anything less than Gigabit Ethernet may limit performance

table 1: recommended usage models

A RAID disk subsystem is recommended, especially for Ultrium 448 drives. A single disk, particularly a fast disk such as a 15K RPM drive, will also be sufficient, but be aware of other factors that can affect performance—such as, compressibility of data, disk fragmentation and the number of files. You can use our free performance assessment tools, which are available standalone or integrated into HP Library & Tape Tools, to check tape performance and test whether your disk subsystem can supply data at the optimum transfer rate. You can also use these tools to calibrate your restore performance and maximal tape performance with more compressible data.

Other models

The tape drive may work with other usage models, such as network attach storage (NAS) and storage area networks (SAN), but HP does not currently provide technical support for installing and using standalone Ultrium tape drives with these architectures. Similarly, connection to fibre channel may be possible, if you purchase and install a fibre channel/SCSI bridge, but it is not currently a supported option.

Please check www.hp.com/go/connect for the latest supported configurations.

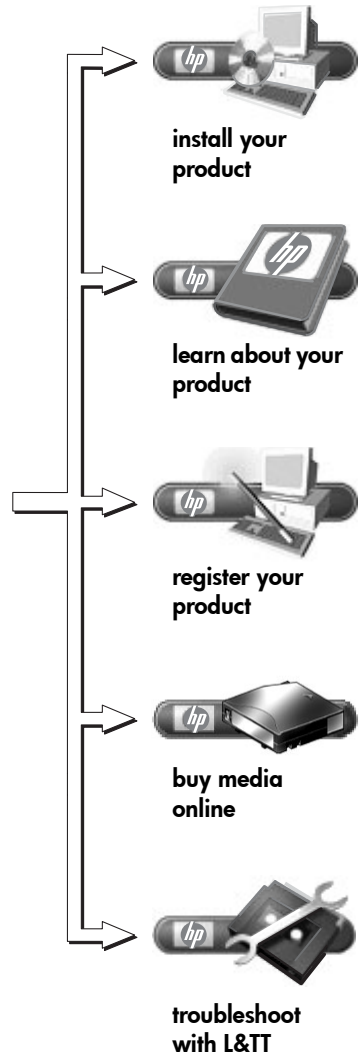

Figure 2: the HP StorageWorks Tape CD-ROM

Using the CD-ROM

The *HP StorageWorks Tape* CD-ROM is a central source of information about your tape drive with utilities for getting the best performance from your tape drive.

Use the *HP StorageWorks Tape* CD-ROM to check installation, as described in this guide, and to verify and troubleshoot performance after installation. It helps you to:

- Install your product, which includes access to drivers, an installation check, and performance information and tools
- Learn about your product, which includes a *UNIX Configuration Guide*.
- Register you product
- Buy media online
- Troubleshoot with HP Library & Tape Tools.

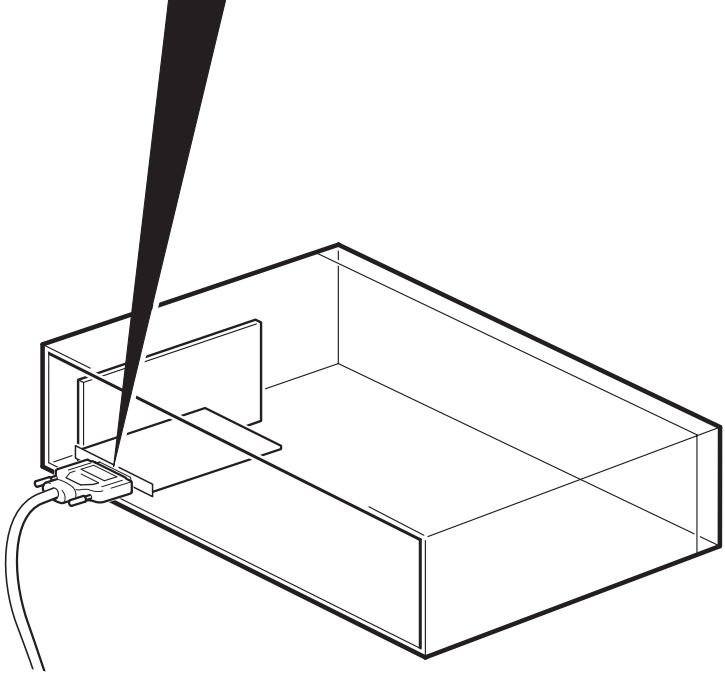
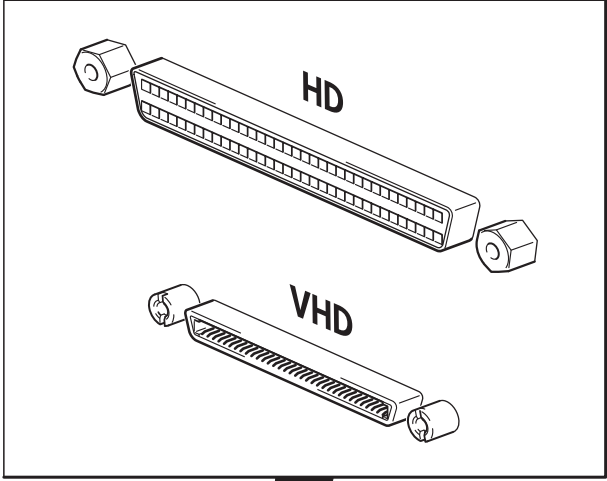

connecting to an HBA card in the server

Figure 3: checking the SCSI connection

Step 1: Check the SCSI connection

Use the following questions to help you check your SCSI connection. Most users can use HP Library & Tape Tools to check the SCSI bus, see page 30. If you answer 'Yes' to all these questions, you are ready to install your tape drive. If you answer 'No', you will probably need to purchase and install additional items.

For product details, go to www.hp.com/go/connect

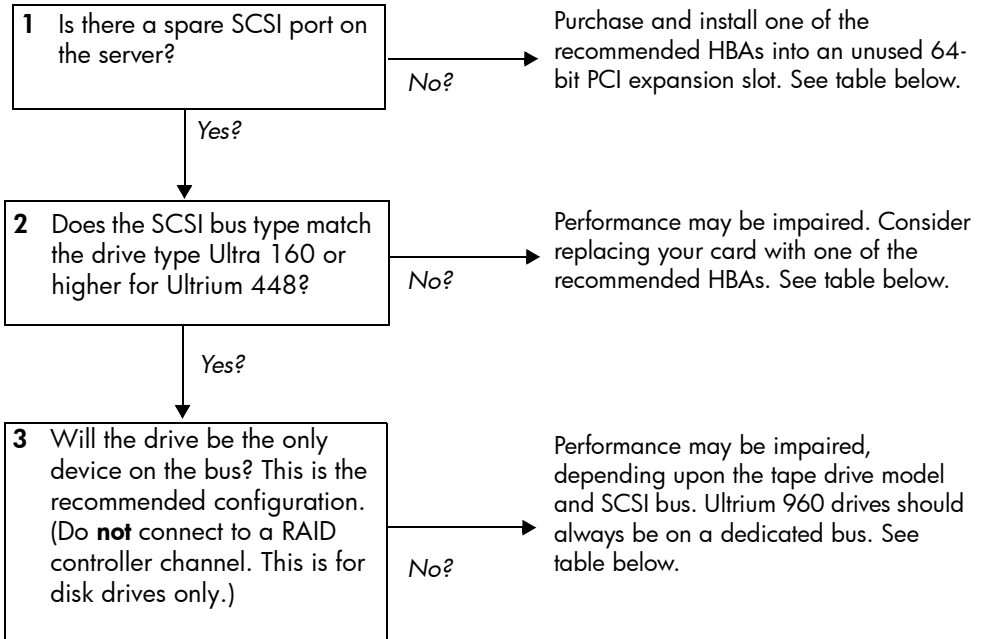

SCSI Bus Type	Bus Transfer Speed	Supported	
Ultra 160 LVD	Up to 160 MB/s	Yes, for up to two drives per bus, recommended	
Ultra 2 LVD	Up to 80 MB/s	Yes, one drive only per bus	Yes, up to two drives per bus
Ultra 320 LVD	Up to 320 MB/s	Yes, recommended, but do not daisy-chain with Ultra 320 devices.	
SE Wide	Up to 40 MB/s	Not recommended	
SE Narrow	Up to 20 MB/s	No, this will severely restrict performance.	
High Voltage Differential	Up to 40 MB/s	No. The drive will not work and you may damage the drive or controller.	

table 2: supported SCSI bus types

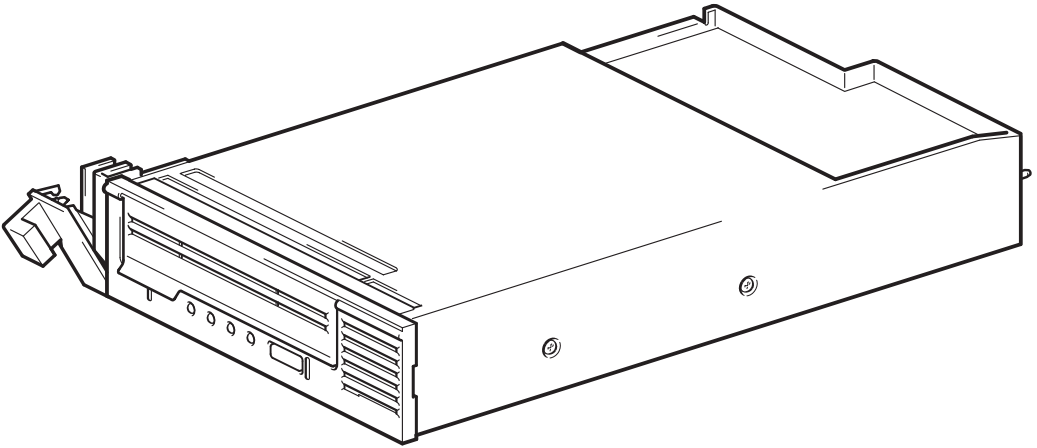

Figure 4a: extractor lever in the out position

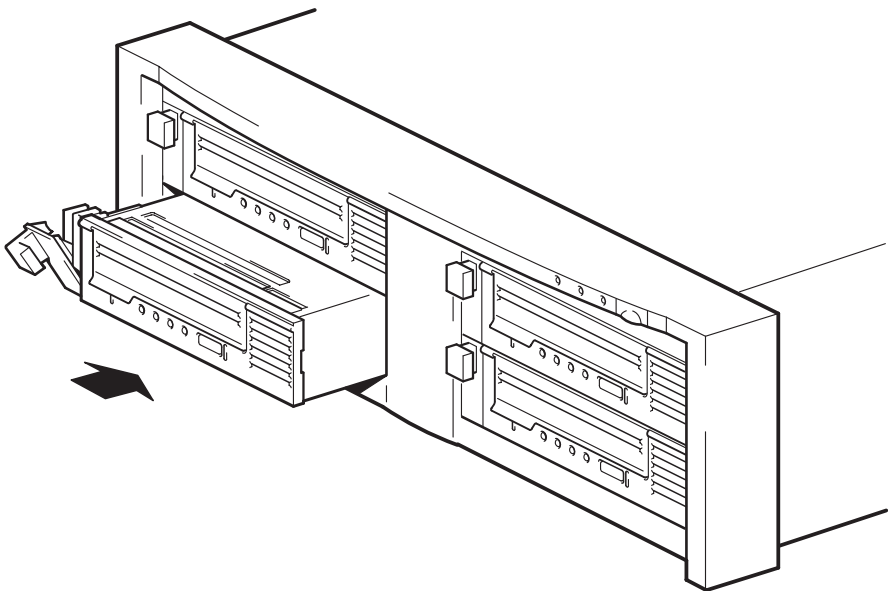

Figure 4b: installing the drive

Step 2: Install the drive

Airflow requirements for the Ultrium 448 tape drive are 6 cfm (0.17m³/minute or 10.08m³/hour) at 40° C ambient operation. This reduces to 4 cfm at 35° C ambient operation. Ventilation must be adequate at the front and rear of the Tape Array unit to ensure that airflow is maintained.

- 1 Ensure that the extractor lever on the drive is in the *out* position, as shown in Figure 4.
- 2 Lift the drive carefully.
- 3 Align the rear of the drive with the guides on the side of the tape array.
- 4 Slide the drive along the guides, until the connectors on the back mate with the connectors at the back of the enclosure.
- 5 Push the extractor lever in until it locks the drive in position.

The HP StorageWorks Tape Array 5300 is designed to provide adequate airflow for up to two full-height tape drives (like the HP StorageWorks Ultrium 230, 460 or 960 drives) or up to four half-height drives (like the HP StorageWorks Ultrium 448 drives). If you are installing only one half-height drive in the tape array, you must use blanking plates in the unused bays. See the documentation with the tape array for details on installing blanking plates.

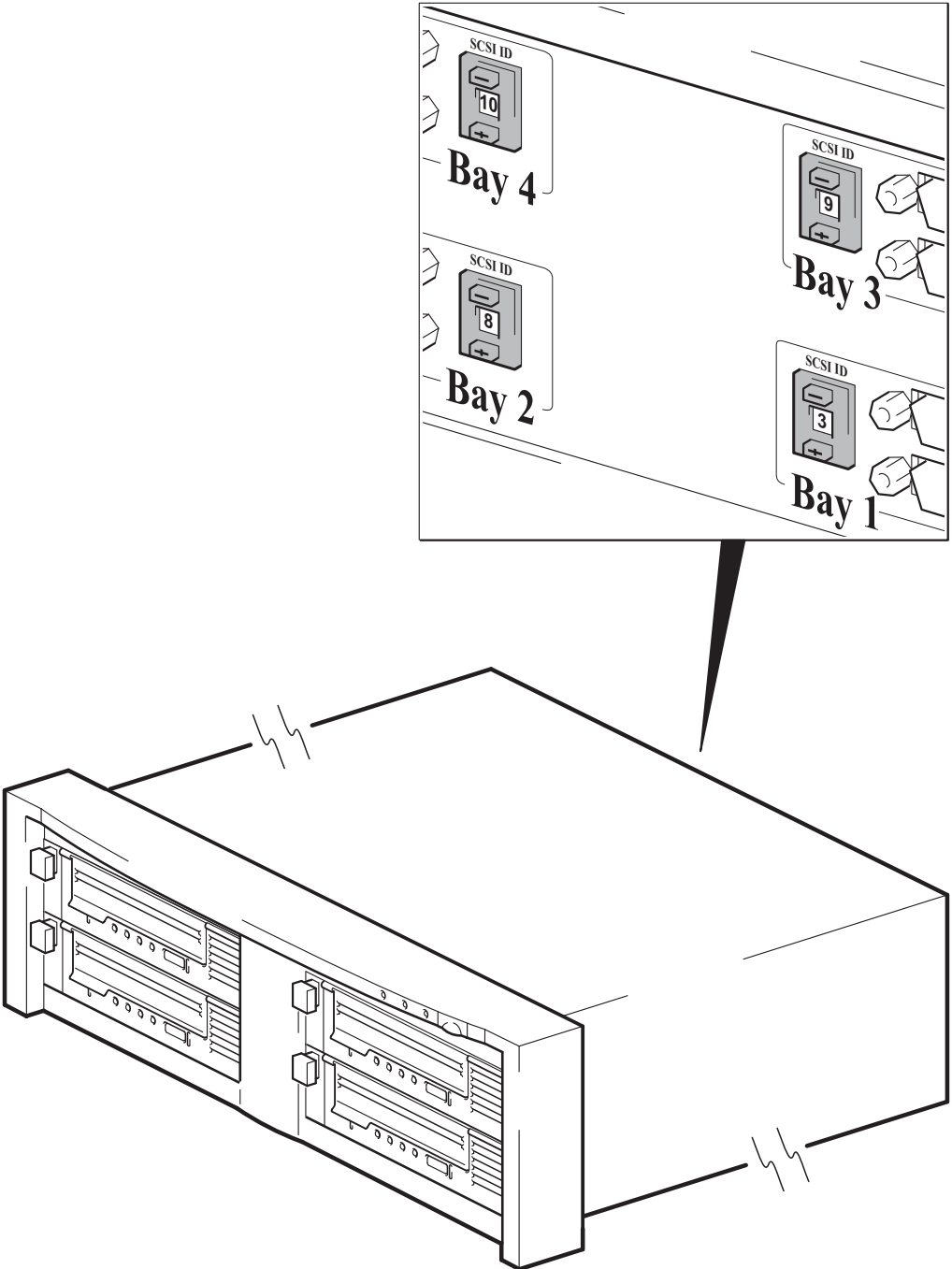

Figure 5: setting the SCSI ID

Step 3: Set the drive's SCSI ID

To set the tape drive's SCSI ID you need to set the appropriate switch on the rear of the tape array. The number of address switches corresponds to the number of tape drives that can be inserted into the tape array. Each drive can be assigned any unused ID between 0 and 15. Do not use SCSI ID 7, which is reserved for the SCSI controller, or SCSI ID 0, which is typically assigned to the boot disk.

- 1 Decide which SCSI ID to use.

For most operating systems you can run HP Library & Tape Tools from the *HP StorageWorks Tape CD-ROM* to check your computer's SCSI configuration. This will provide information about the SCSI bus and the SCSI IDs currently in use. To do this, select the 'troubleshoot with L&TT' option from the CD-ROM menu. (See also page 30.)

- 2 Set the appropriate switch. Figure 5 shows the address switch on the back panel of the HP StorageWorks Tape Array 5300.

The HP StorageWorks Tape Array 5300 has four SCSI ID switches to enable the installation of up to four half-height drives. When installing two HP StorageWorks Ultrium full-height tape drives, use SCSI ID switches 1 and 2 only.

- 3 Make sure that a SCSI terminator is attached to the appropriate SCSI-OUT connector on the back of the tape array.

If you daisy-chain devices, make sure that each device on the same SCSI bus has a unique SCSI ID. Do not daisy-chain more than two devices on the same SCSI bus and make sure that the end device is terminated. Do not mix drive families (only daisy-chain with other Ultrium tape drives) and do not put drives on the same bus as any Ultra 320 device, such as the Ultrium 960 tape drive.

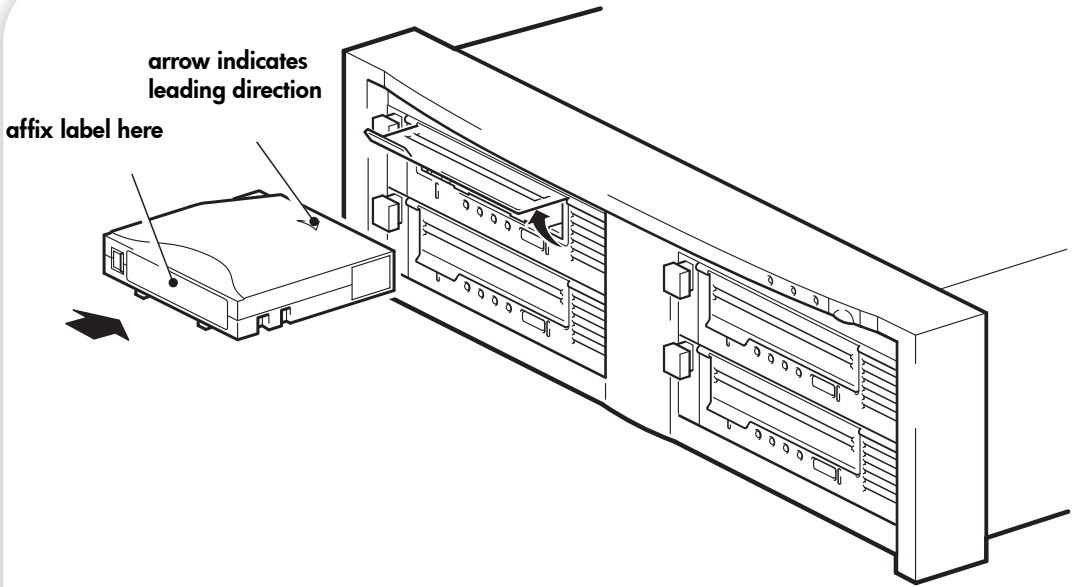

Figure 6a: loading a cartridge

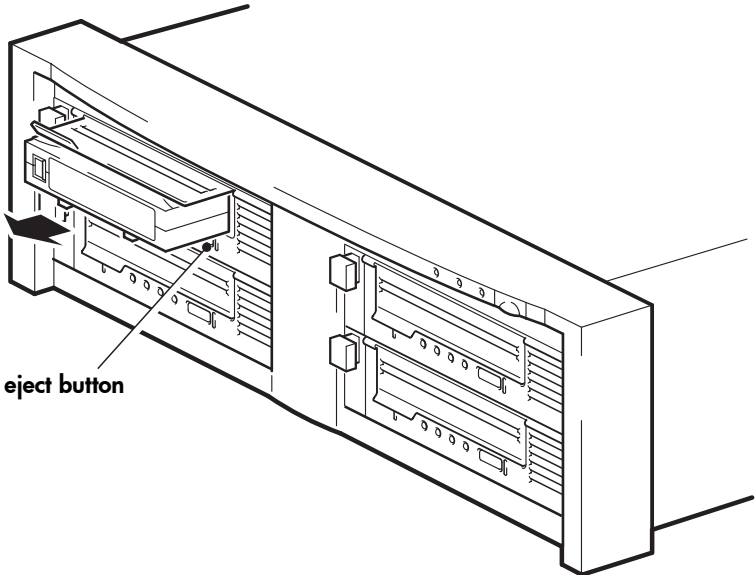

Figure 6b: unloading a cartridge

Step 4: Verify installation

Check operation

1 Switch on the tape array and the server. The tape drive will run its hardware self-test, which takes about 5 seconds. If self-test passes, the green Ready LED flashes and then shows steady green. If the test fails, the Drive Error and Tape Error LEDs flash, while the Ready and Clean LEDs are off. This continues until the drive is reset. See “LEDs during self-test” on page 40 for more information about the LEDs.

2 Install drivers and backup software.

On Windows systems, the Windows Hardware Installation wizard is displayed automatically. We recommend that you close the wizard and install the drivers from the link on the *HP StorageWorks Tape* CD-ROM. Insert the CD-ROM, select “install your product” and then select “get drivers”. For all operating systems ensure that you have downloaded any upgrades necessary for your backup application (see page 5).

3 Verify that the tape drive installation was successful.

Select “install your product” from the link on the *HP StorageWorks Tape* CD-ROM and then select “install check”. See page 30 for more information.

The *UNIX Configuration Guide* on the *HP StorageWorks Tape* CD-ROM also includes a verification procedure.

Note If you encounter a problem during this verification procedure, turn to “Troubleshooting” on page 34 for help in diagnosing and fixing the problem.

4 Carry out a backup and restore test to check that the drive can write data to tape. Refer to your backup application documentation for specific instructions. Use the blank cartridge supplied with the tape drive. See “Use the correct media” on page 21 for more information about recommended cartridges.

To load a cartridge

1 Lift the cartridge door and insert the cartridge into the slot in the front of the drive with the white arrow uppermost and facing the drive door. Apply gentle pressure until the drive takes the cartridge and loads it. (See Figure 6a.)

2 The Ready light flashes green while the drive performs its load sequence. When the cartridge is loaded, the Ready light shows steady green.

To unload a cartridge

Caution Never try to remove a cartridge before it is fully ejected and avoid powering off the tape drive while a cartridge is still loaded (because the tape loses tension in the power-off state).

1 Press the Eject button on the front panel. (See Figure 6b.)

2 The drive will complete its current task, rewind the tape to the beginning, and eject the cartridge. The rewind process may take up to 10 minutes. The Ready light will flash to indicate that the unload is still in progress.

Ultrium 448

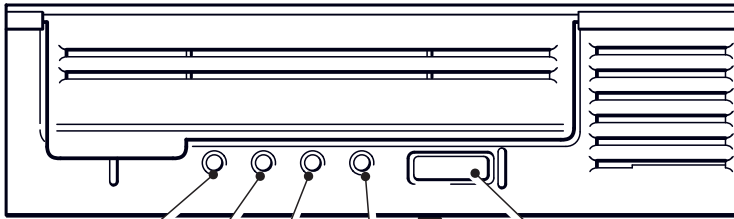

Clean

Tape

Drive

Ready

Eject button

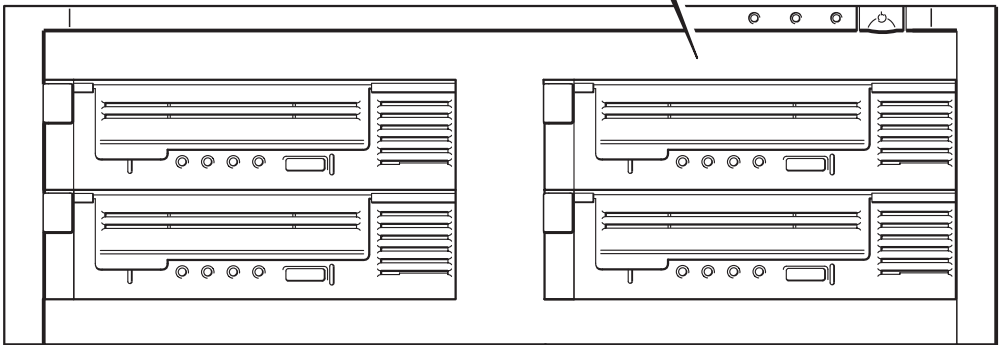

Figure 7: tape drive controls and indicators

Your HP StorageWorks Ultrium tape drive

Your Ultrium tape drive has four LEDs (light emitting diodes) on the front panel, which indicate drive status. These LEDs provide useful troubleshooting information, see also “Understanding the LEDs” on page 40. See page 17 for more information about using the eject button in normal operation and page 43 for details about force eject.

Front panel LEDs

There are four LEDs as illustrated in the diagram. (See Figure 7.)

Ready (green)

- On: the drive is ready for use
- Off: the drive power is off or there was a failure during self-test
- Flashing: the drive is busy
- Flashing repeated pattern: the drive is in OBDR mode

Drive (amber)

- Off: no fault has been detected
- Flashing: the drive mechanism has detected a hardware error.

Tape (amber)

- Off: no fault has been detected
- Flashing: the tape currently in the drive is faulty. This LED could come on for a number of reasons, but they all relate to the tape being in error in some way, such as damaged media or unsupported tape. Do not use the cartridge; replace it. The LED will go out when another tape is inserted.

Clean - (amber)

- On: cleaning cartridge in use
- Off: the drive does not require cleaning
- Flashing: the drive needs cleaning

Accessibility features

The front panel of the HP StorageWorks Ultrium tape drive has been designed for increased accessibility for persons with disabilities. This includes large font labeling of the Status LEDs and an Eject button that has been designed for ease of use.

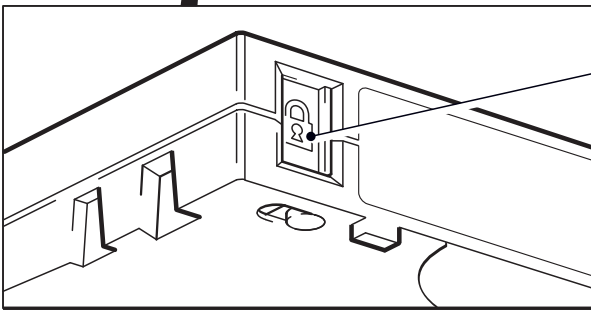
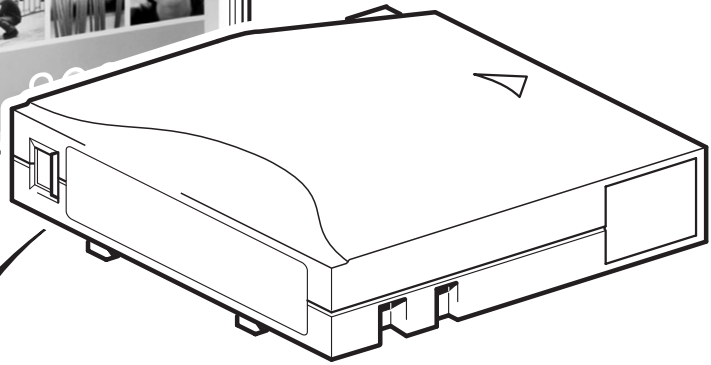
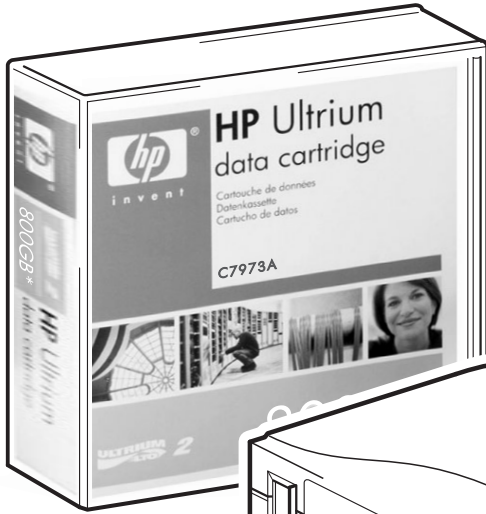

padlock indicates
cartridge is protected

Figure 8: write-protecting cartridges

Use the correct media

For best performance we recommend HP branded media. Order online at: www.hp.com/go/storagemedia/ultrium.

Data cartridges

HP StorageWorks Ultrium tape drives use Ultrium tape cartridges. These are single-reel cartridges that match your drive's format and are optimized for high capacity, throughput and reliability. Compatible media can be recognized by the Ultrium logo, which is the same as the logo on the front of your drive. Do not use other format cartridges in your tape drive and do not use Ultrium cartridges in other format tape drives.

For optimum performance always use a data cartridge that matches the specification of your tape drive, (see Table 3). A lower specification will have a lower transfer speed and may not support write activities; a higher specification will not support read or write. We recommend:

- Ultrium 400 GB* tape cartridges (C7972A) for use with Ultrium 448 tape drives.

* All values assume 2:1 compression.

	Ultrium 200 GB*	Ultrium 400 GB*	Ultrium 800 GB*
Type of Drive			
Ultrium 448 drives	Write and Read	Write and Read	No

table 3: Ultrium data cartridge and HP StorageWorks Ultrium tape drive compatibility

Write-protecting cartridges

If you want to protect the data on a cartridge from being altered or overwritten, you can write-protect the cartridge.

Always remove the cartridge from the tape drive before you change the write protection.

- To write-protect a cartridge, push the switch to the right to prevent any data recording on the cartridge. Note the padlock on the tab that indicates that the cartridge is protected.
- To write-enable a cartridge, push the switch to the left to allow data recording on the cartridge. Figure 8 illustrates the location of the write-protect tab.

Write-protection will not prevent a cartridge being erased by bulk-erasure or degaussing. **Do not bulk erase Ultrium format cartridges.** This will destroy pre-recorded servo information and make the cartridge unusable.

Cleaning cartridges

You must use Ultrium cleaning cartridges with HP StorageWorks Ultrium tape drives, as other cleaning cartridges will not load and run. We recommend the HP Ultrium universal cleaning cartridge (see table 3). Unlike some earlier Ultrium cleaning cartridges, the orange-colored HP Ultrium universal cleaning cartridge is designed to work with any Ultrium drive.

Type of cartridge	Recommended cartridge	Other options
Cleaning	HP Ultrium universal cleaning cartridge C7978A (Orange)	HP Ultrium cleaning cartridge C7979A (Blue). Do not use Ultrium 1 cartridges from other manufacturers.

table 4: cleaning cartridge compatibility

To clean the tape drive

HP StorageWorks Ultrium tape drives do not require regular cleaning. An Ultrium universal cleaning cartridge should only be used when the orange Clean LED is flashing.

- 1** Insert the Ultrium universal cleaning cartridge.
- 2** The drive will carry out its cleaning cycle and eject the cartridge on completion (which can take up to 5 minutes). During the cleaning cycle the orange Clean LED will be on solidly and the green Ready LED will flash.

Each HP Ultrium universal cleaning cartridge (C7978A) can be used up to 50 times with Ultrium tape drives. (The blue HP Ultrium cleaning cartridges, C7979A, can only be used up to 15 times with any tape drive.) If the cleaning cartridge is ejected immediately with the Tape LED on, it has expired.

Caring for cartridges

It is important that you look after your HP media and adhere to the recommended guidelines. See "Looking after cartridges" on page 43.

Register your tape drive

Once you have installed and tested your HP StorageWorks Ultrium tape drive, please take a few minutes to register your product. You can register via the web at www.register.hp.com.

To ensure your registration is complete, there are a number of questions on the electronic form that are mandatory. Other questions are optional. However, the more you feel able to complete, the better we can meet your needs.

Note HP and its subsidiaries are committed to respecting and protecting your privacy. For further information, please visit our World Wide Web site (www.hp.com) and click on Privacy Statement.

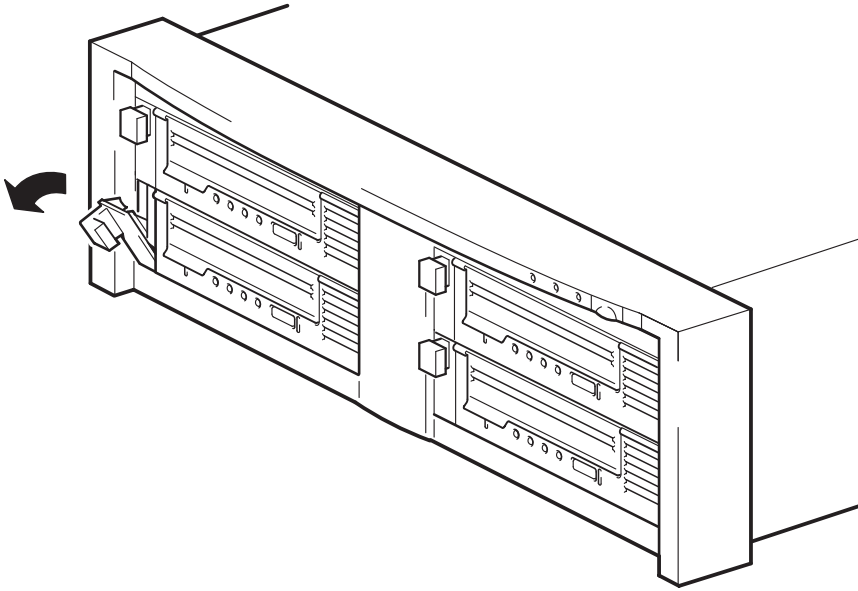

Figure 9a: pulling out the extraction lever

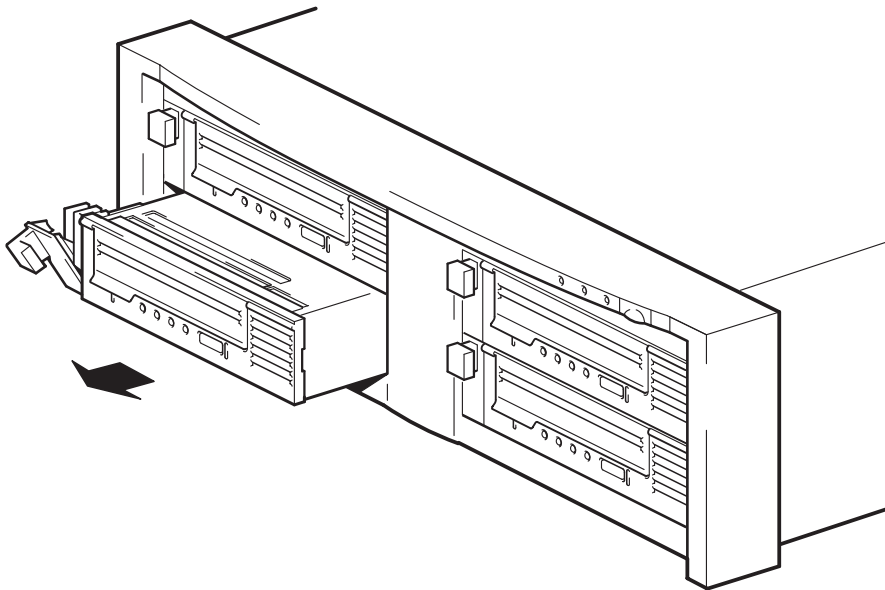

Figure 9b: removing the drive

Replacing the drive

HP StorageWorks Ultrium removable drives can be removed and replaced without powering down the tape array. However you should be aware of the following:

- If all drives in the tape array are powered up when the system is turned on, the host will be aware of those drives. You can remove any of those drives and replace it with another drive as long as there is no activity on the bus.
- Do not remove or add drives to a bus that already has drives connected and running, for example backing up or restoring data. Wait until there is no activity on the bus before removing or adding drives.
- If a drive is not powered up or you place a drive in an empty slot *after* the system has been powered up, the system will have to be reset before the host will recognize the drive.
- The SCSI IDs are controlled by the tape array, not by the drives themselves, so if you remove a drive and replace it with another the ID will not change.

- 1 Pull the extraction lever of the drive that you want to replace so that it is in the out position. (See Figure 9a.)
- 2 Using the extraction lever, pull the drive gently and firmly out of the tape array. (See Figure 9b.)
- 3 To insert another drive, follow the instructions in “Step 2: Install the drive” on page 13.

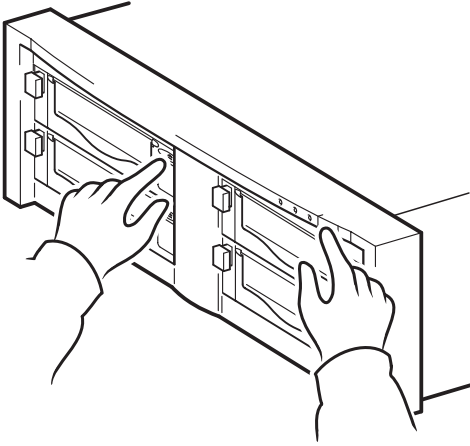

Figure 10a: using HP OBDR, step 1

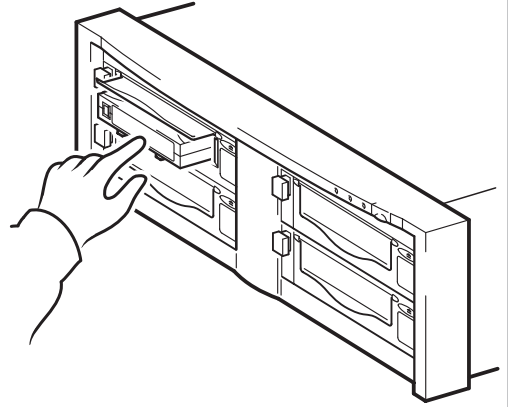

Figure 10b: using HP OBDR, step 2

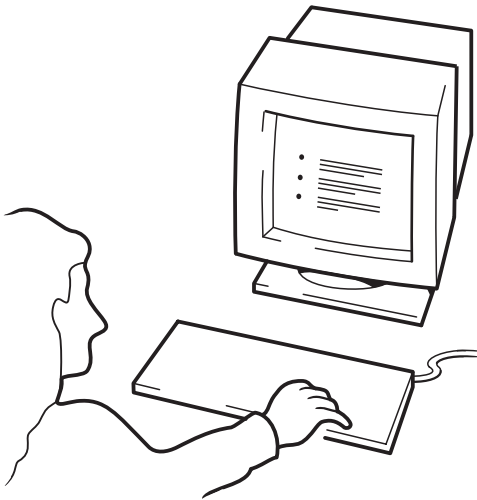

Figure 10c: using HP OBDR, step 3

Using HP OBDR

Compatibility

HP One-Button Disaster Recovery is a standard feature on all HP StorageWorks Ultrium tape drives. However, it can only be used with specific configurations and, although it can be used in a network environment, will only recover the server to which the tape drive is directly connected.

To check whether your system (hardware, operating system and backup software) is OBDR-compatible, please refer to our World Wide Web site www.hp.com/go/connect.

For more specific information concerning the benefits of OBDR and the latest new features please refer to our World Wide Web site www.hp.com/go/obdr.

Note HP OBDR is not applicable to HP-UX and other non-Intel UNIX operating systems, and it is not compatible with Intel-based Solaris systems. HP OBDR is supported on a server with a RAID controller, if the tape drive is connected directly to a host bus adapter (HBA). On a ProLiant server, if the controller is a Smart Array 6i, the tape drive may be connected directly to a SCSI port on the controller.

If your system does not support HP One-Button Disaster Recovery, you can still use your tape drive normally to back up and restore data. However, you must remember to create a separate set of emergency recovery disks for your operating system whenever you change your system configuration.

What does HP OBDR do?

Using just the tape drive and the most recent backup cartridge HP OBDR allows you to recover from the following types of system disaster:

- Hard disk failures, as long as the replacement hard disk is the same size or larger than the original and uses the same interface (for example, replace a SCSI hard disk with another SCSI disk)
- Hardware failures where the server is replaced by an **identical** component
- File corruption because of an operating system error
- File corruption because of an application software error
- Viruses that prevent you from booting your system correctly
- User errors that stop you from booting your system correctly

When you run HP One-Button Disaster Recovery, your tape drive goes through the following sequence:

- 1 It goes into a special disaster recovery mode that enables it to restore your operating system and reboot. It acts like a bootable CD-ROM. (Your system's ability to boot from CD-ROM is normally enabled by default. If you have changed this setting, you will need to enable it again. Refer to your system BIOS manual for further details.)
- 2 It returns to normal tape drive mode and restores the data.

Remote disaster recovery (ProLiant servers only)

The HP Remote Insight Lights-Out Edition (RILOE) on ProLiant servers gives the IT Administrator the ability to completely recover a failed server at a remote location without physically traveling to where the server resides. The on-site, non-technical person need only insert the bootable cartridge into the tape drive, when asked to do so by the administrator.

Refer to the HP OBDR web site at www.hp.com/go/obdr for more information about using this feature and compatibility.

Testing for compatibility

We recommend that you perform a full disaster recovery immediately after installation—if possible, onto a blank hard disk. If you do not have a blank hard disk and do not want to overwrite your system, you can safely cancel the disaster recovery process at step 3 in the following procedure.

Refer to our connectivity web site (www.hp.com/go/connect) for more information about suitable backup applications.

Running HP OBDR

HP OBDR can only be used with backup applications that support one-button disaster recovery and methods of operating OBDR will vary between different software companies.

Check our World Wide Web site (www.hp.com/go/obdr) for the latest information about firmware upgrades and troubleshooting before you use HP OBDR.

- 1 Lift the cartridge door and insert the latest bootable cartridge that you have assigned to HP OBDR in the tape drive (see Figure 10a). The cartridge must be written by a backup application that writes data to tape in CD-ROM format.
- 2 Hold down the eject button of the tape drive. Keeping the eject button pressed down, power on your tape array and server (see Figure 10b). This activates the HP One-Button Disaster Recovery process. Release the button as soon as the Ready LED on the front panel flashes in the OBDR sequence. This is a repeated pattern of: flashing-steady on-flashing.

Keyboard shortcut for HP ProLiant servers

There is no need to press the Eject button. Just power on your server and press the [F8] Function key during the Power On Self Test (POST). This invokes OBDR to restore your system. For more information and specific instructions please refer to our World Wide Web site at www.hp.com/go/obdr.

- 3 Follow the on-screen instructions to set up the operating system (see Figure 10c). These will vary depending upon the backup software. Normally, you can accept the default response to all the prompts, for example, just press <Enter>.
- 4 The LEDs will flash in OBDR mode (as described in step 2) while the tape drive restores your operating system to a state, where it can run a normal data restore.

- 5 Once the operating system has been set up and rebooted, the Ready LED display on the tape drive changes to constant green and you can remove the backup cartridge, if you wish. You are now ready to run a normal data restore. Follow the normal process for your restore application.

If restore fails

If the restore fails for any reason, refer to our World Wide Web site (www.hp.com/go/obdr) for detailed troubleshooting information.

Diagnostic tools

HP Library & Tape Tools

HP StorageWorks Library & Tape Tools is the recommended diagnostic and support tool for your HP tape storage product. It is available on the CD shipped with your product or as a free download from the HP web site. It is supported on nearly all major operating systems.

See www.hp.com/support/tapetools for compatibility information, updates and the latest version of the tool.

Checking drive installation with Library & Tape Tools

The tape drivers must already be installed to run this check. You will also need to provide a tape cartridge that can be written to during the test.

- 1 From the HP StorageWorks CD, select "install your product" and then "install check". This will run Library & Tape Tools directly from the CD (no installation on the server) in a special mode for installation checking.
- 2 Select the appropriate tests to verify the installation of your drive.
 - Verify device connectivity
 - Verify configuration (bus and driver configuration)
 - Verify drive health (writing and reading to a test cartridge)
 - Verify drive performance (data rates to the drive)
 - Verify system performance (data rates from the disk subsystem)
 - Verify drive cooling
- 3 At the end of the test you will be given a summary of the test results and recommendations to resolve any issues found.

Troubleshooting with Library & Tape Tools

- 1 From the HP StorageWorks CD, select "troubleshoot".

This will allow you to run Library & Tape Tools in standard mode, either directly from the CD (no installation on the server) or as an installation on your server. HP recommends installation of Library & Tape Tools, so that it can be quickly accessed at any time. HP Support will also request that you use Library & Tape Tools should you need to contact them in the future, so it is a good idea to have it installed.
- 2 When Library & Tape Tools is first run, it will scan for HP tape drives and libraries on your system and ask you to select the one to work with. At this time you can see the HBA configuration of your server, how your devices are connected and the SCSI IDs of those devices.
- 3 Once you have selected your device you have a number of choices for troubleshooting.
 - Device identification: shows part number, serial number and information about any cartridge loaded
 - Firmware upgrade: allows you to locate and upgrade to the latest firmware. You will need

to be connected to the internet for this.

- **Run tests:** allows you to run proactive tests on your drive, such as the drive assessment test, which will verify the functionality of your drive in around 20 minutes. HP recommends running this test before calling HP Support. You will need to provide a 'trusted' cartridge that can be written to during this test.
- **Generate a support ticket:** this is a full dump of the drive logs along with interpretation and is used by HP Support to learn about the condition of your drive. Most useful is the device analysis section which is the output from approximately 20 rules forming a comprehensive analysis of the health of your drive. These rules may give advice such as cleaning the head or trying a different tape if issues are found. The support ticket can be sent to HP Support for further analysis.
- **Run the performance tests:** the tests to measure the write/read performance of your tape drive and the data generation rates of your disk subsystem are also integrated into Library & Tape Tools. Use these tests to find the performance bottleneck in your system.

Performance Assessment Tools

For maximum performance your disk sub-system needs to be able to supply data at 24 MB/second (uncompressed) for Ultrium 448 drives.

You can use our free, standalone performance assessment tools to check tape performance and test whether your disk subsystem can supply data at the maximum transfer rate.

The tools are located online at www.hp.com/support/pat along with a complete guide to understanding the performance needs of your backup system and recommendations on finding and fixing performance issues. In nearly all cases when performance is not as expected, it is the data rates of the disk subsystem that cause the bottleneck. Please follow the guide and try the tools before calling HP Support.

Note that the performance tools are also integrated into HP Library & Tape Tools, which is available both online (www.hp.com/support/tapetools) and on the CD-ROM supplied with your tape drive.

Optimizing performance

We strongly recommend that you check the information on our web site at www.hp.com/support/pat. This contains detailed support information that will enable you to identify bottlenecks and take full advantage of the performance capabilities of the Ultrium family of tape drives.

Various factors can affect data throughput, particularly in a network environment or if the drive is not on a dedicated SCSI bus. If your tape drive is not performing as well as expected—for example, if backup windows are longer than expected—consider the points in this section before contacting HP Support at www.hp.com/support.

Is the tape drive on a dedicated SCSI bus?

We recommend that the tape drive is the only device on the SCSI bus. If it is not, ensure other devices are LVD-compliant. If they are single-ended, the bus will switch to single-ended mode with a lower transfer speed. There will also be restrictions on cable length.

Can your system deliver the required performance?

- The Ultrium 448 tape drive can write uncompressed data at up to 24 MB/s (86 GB/hour) or compressed data at up to 48 MB/s (172 GB/hour), assuming 2:1 compression.

To get this performance it is essential that your whole system can deliver this performance. In most cases, the backup application will provide details of the average time taken at the end of the backup.

Typical areas where bottlenecks can occur are:

- **Disk subsystem**
A single spindle disk may not be able to deliver good data throughput at poor compression ratios. Best practice to ensure good throughput is to utilize multiple disk spindles or data sources.
- **System architecture**
Be aware of the architecture of your data protection environment; the aggregation of multiple client sources over a network provides a good way of delivering good performance, but anything less than Gigabit Ethernet may limit performance for Ultrium 448 tape drives. Some enterprise class backup applications can be made to interleave data from multiple sources, such as clients or disks, to keep the tape drive working at optimum performance.
- **Tape media type**
The data cartridge should match the specification of the tape drive. A lower specification will have a lower transfer speed (see “Data cartridges” on page 21). Use Ultrium 400 GB cartridges with Ultrium 448 tape drives.

- **Data and file types**

The type of data being backed up or restored can affect performance. Typically, small files incur greater overhead in processing and access than large files. Equally, data that is not compressible will always limit the speed at which the drive can write/read data. You will achieve no more than native rates with uncompressible data.

Examples of files that compress well are plain text files, spreadsheets; those that compress poorly are those that are either compressed as part of their format (such as, JPEG photographic files) or stored as compressed (such as, .ZIP files or .gz/.Z files on Unix platforms).

Troubleshooting

The first step in problem-solving is establishing whether the problem lies with the cartridge, the drive, the host server and its connections, or with the way the system is being operated.

Most modern SCSI host bus adapters locate and display attached devices when the system is booting up. On Windows systems, if you swap or connect a product when your system is running, you will need to reboot the system. IA32 systems also usually need to be rebooted. UNIX systems may have pluggable drivers, which allow drives to be attached to a running system and detected without rebooting.

If the device is not detected on boot up, there is probably a problem with the physical hardware: cables, termination, connections, power or the host bus adapter itself. If the device is displayed during boot up but cannot be found in the operating system, this is more likely to be a software problem.

- If you encounter a problem during installation and need further clarification, refer to the “Problems encountered during installation” section on page 35.
- If a problem arises during testing after you have installed the drive, refer to the symptom-based section “Testing after installation” on page 37.
- For more information about LED sequences, refer to “Understanding the LEDs” on page 40.
- For information about cartridges, refer to “Problems with cartridges” on page 43.

Most users can use HP Library & Tape Tools to help them diagnose problems, see page 30.

Web troubleshooting guide

Please refer also to the detailed troubleshooting guide on the web at www.hp.com/go/support. This contains the most comprehensive and up-to-date troubleshooting information.

Problems encountered during installation

Unpacking

Description	Further information
Some parts appear to be missing or damaged.	Contact your vendor if any parts need replacing. Note that SCSI cables and terminators are not shipped with your tape drive, or with the tape array. You need to order the correct size cables and terminators to suit your particular configuration. Cable and terminator options are listed at the HP tape array support web site: //www.hp.com/support/tapearray .

It is unclear which SCSI ID to use

Description	Further information
It is uncertain which ID numbers are available.	Use HP Library & Tape Tools (see page 30) to provide information on your current SCSI settings. The HP StorageWorks Ultrium drive has its SCSI ID set to 3 by default. This should be left unchanged unless this number is already in use. Full instructions on how to change the SCSI ID are given on page 15.

How should the SCSI bus be configured?

Description	Further information
Correct configuration of the SCSI bus with multiple drives can be a complex area and more help may be required. Daisy chaining devices is not generally recommended.	Refer to the instructions in this guide or your supplier for further details.

How should the SCSI bus be terminated?

Description	Further information
It is unclear if the bus is already terminated or where an additional terminator should be placed.	Both ends of a SCSI bus must be terminated. Assuming that the host bus adapter is already correctly terminated, there are typically two possibilities: <ul style="list-style-type: none">• The tape drive is being connected in a direct one-to-one configuration to the host server - termination must be used.• The tape drive is being daisy-chained with other tape devices onto the host server - only the last device must be terminated. The terminator plugs directly onto either SCSI connection on the rear of the tape array. Terminators must be ordered separately.

Is the correct SCSI host bus adapter installed?

Description	Further information
The server already has a SCSI host bus adapter but it is difficult to determine what type it is.	If your server is in its original configuration (no SCSI adapters have been added or removed) then use www.hp.com/go/connect to check the compatibility of your system. You can also check the SCSI configuration from the boot-up screen or from the Windows Control Panel, or by using HP Library & Tape Tools (see page 30).
The server may not have a SCSI host bus adapter installed.	Use HP Library & Tape Tools (see page 30) to check whether you have a SCSI host adapter on your system. If not, you will need to purchase one.

Do drivers need to be installed and, if so, which ones

Description	Further information
It is unclear whether there is a need to install drivers onto the system and more help is required.	Detailed information specific to your system can be found on the www.hp.com/go/connect web site. For support on Windows operating systems, drivers can be obtained from the <i>HP StorageWorks Tape</i> CD-ROM or from www.hp.com/support/ultrium . For support on UNIX systems, see the UNIX Configuration Guide on the <i>HP StorageWorks Tape</i> CD-ROM. (Backup software that states support for HP StorageWorks Ultrium tape drives also provides the required drivers.)
The required drivers do not appear to be available.	Future drivers will be provided via the support web site when they become available.

Testing after installation

Remember that the system recognizes devices during boot-up. If you swap or connect a product when your system is running, you will need to reboot the system. Rebooting the system will reset devices and will often resolve problems. It is good practice to reboot every time you add a driver or install firmware.

Caution Never power off the drive while a cartridge is still loaded or during a firmware upgrade.

The server does not reboot after installation

Possible reason	Recommended action
You have connected the tape drive to an existing SCSI bus that has other devices connected to it and the SCSI address of your HP StorageWorks Ultrium drive is identical to the address used by another device.	Make sure that each device on the SCSI bus has a unique ID. We recommend that the HP StorageWorks Ultrium tape drive is connected to a dedicated host bus adapter. Do not connect the drive to a disk RAID controller as this is not supported, unless it is a ProLiant server with a Smart Array 6i RAID controller.
You have installed an additional SCSI host bus adapter and its resources are clashing with an existing adapter.	Remove the new host bus adapter and check the server documentation.
You have disconnected the power or SCSI cable from the server's boot disk during the drive installation process.	Check that the cables to all devices are firmly connected.

The server boots but does not recognize the tape drive

Possible reason	Recommended action
The power or SCSI cable is not connected properly.	Check that the cables to the tape drive are firmly connected. Ensure that the SCSI cable is LVDS-compliant and does not have any bent pins. Replace, if necessary.
The SCSI bus is not terminated correctly.	Check that the SCSI bus is actively terminated. (Refer also to the documentation for your SCSI controller and any other SCSI devices you may have.)
The tape drive's SCSI ID address is not unique.	Make sure that each device connected to the SCSI controller has a unique SCSI ID. Remember that 7 is normally reserved for the host bus adapter. (You can run HP Library & Tape Tools to check the SCSI IDs of each device attached to the SCSI bus, see page 30.)

The computer no longer recognizes the tape drive

Possible reason	Recommended action
You powered up the drive or added it to the tape array after the host system was turned on.	The host computer system only identifies which IDs are present on SCSI buses after power-on or a reset. To make the host look for devices on the bus, you need to reset the host. You should be able to do this using the SCSI management software on your computer. As a last resort, you could turn the host system off and on again
You changed the drive's SCSI ID after the host system was turned on.	<ul style="list-style-type: none"> • If you have replaced a drive that was recognized by the host, the host should recognize the new drive at the same SCSI ID as its predecessor. • If you make any changes to SCSI IDs (on the back on the tape array), you need to reset the bus for the host to recognize the changes.
The drive is not inserted correctly.	Check that the drive is properly inserted into the tape array so that it mates with the connections at the rear of the enclosure. The extraction lever should be pushed in, locking the drive in position.
The SCSI bus is not terminated correctly.	<ul style="list-style-type: none"> • Check that the SCSI cable from the tape array is firmly connected to the SCSI connector in the computer. • If there are other devices in the SCSI bus, make sure that each device has a unique ID. Use HP Library & Tape Tools to find details of the devices on the bus. • If there is more than one SCSI bus attached to your system, check that the system is looking for the drive on the correct SCSI bus. • Make sure that the bus is terminated correctly. If the array is the only device or the last device on the bus, it must have a terminator fitted. If some other device is last on the bus, it should have a terminator fitted and the tape array should not.
There is a fault with the host system.	<ul style="list-style-type: none"> • Make sure that the system is configured to recognize the correct device at each SCSI ID. • Ensure that the correct driver for the tape drive is installed. Look at the SCSI host adapter documentation and backup software documentation for further advice.

The application does not recognize the tape drive

Possible reason	Recommended action
The application does not support the tape drive.	Use HP Library & Tape Tools to check that the drive is installed properly. Refer to our World Wide Web site (www.hp.com/go/connect) for details of software applications that support the HP StorageWorks Ultrium tape drive. Load any service packs as necessary.
Some applications require drivers to be loaded.	Check that the correct SCSI and tape drive drivers are installed. Consult the software application's installation notes for details.

The drive does not work

Possible reason	Recommended action
If the drive does not power up (all LEDs are off), the power cable may not be connected to the drive properly.	Check the power cable connection and replace the cable if necessary. If the power supply is present and all LEDs remain off, call for assistance.
If the self-test fails (see "LEDs during self-test" on page 40), there may be a hardware or firmware failure.	If there is a cartridge in the drive, remove it. Reset or power down the drive and power it up again. If the self-test still fails, call for assistance.

Cartridge-related problems

Please see "Problems with cartridges" on page 43.

Emergency reset

As a last resort, if the drive has disappeared off the SCSI bus and appears to have failed, it can be reset by holding the eject button down for 20 seconds. This will allow the drive to reset its internal hardware, including the SCSI port, and potentially make it visible to a host again. The reset process may take up to 10 minutes (the maximum rewind time) to complete.

Note This form of reset will clear the internal buffers and, therefore, lose any data in them. If the drive was writing at the time, data may be lost and the cartridge will not have an EOD, which means that subsequent restores are likely to fail. Discard the cartridge.

Understanding the LEDs

LEDs during self-test

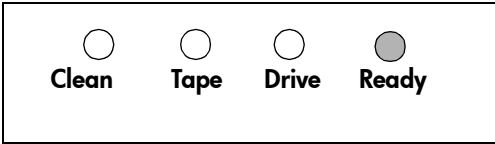

Your Ultrium tape drive has four LEDs (light emitting diodes) on the front panel, which indicate drive status. These LEDs provide useful troubleshooting information.



The tape drive performs a power on self-test whenever power is applied or the drive is reset. The test takes about 5 seconds.







- 1 The green Ready light flashes several times and then remains on if self-test passes. All other LEDs remain off.
- 2 If the self-test fails, the Drive and Tape LEDs flash, while the Ready and Clean LEDs are off. This continues until the drive is reset.

Using the LEDs for troubleshooting

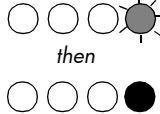
If you cannot resolve a problem, contact customer service at www.hp.com/support.

Use the following table to interpret the front panel LED sequences and the appropriate action to take, if any.

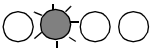
LED Sequence and Cause	Action required
 <p><i>All LEDs OFF.</i></p> <p>Drive may not have power, may be faulty or may have been power cycled or reset during a firmware upgrade.</p>	<p>Make sure the drive is switched on.</p> <p>If this is not on, check the power cable connection and replace the cable if necessary.</p> <p>If the power supply is present and all LEDs remain off, power cycle or reset the drive (see page 43). If it still fails, call for service.</p>
 <p><i>Ready and Clean OFF. Drive and Tape FLASHING.</i></p> <p>The drive has failed to execute power-on self test (POST).</p>	<p>Power cycle or reset the drive (see page 43).</p> <p>If the error condition reappears, call for service.</p>
 <p><i>Ready is ON.</i></p> <p>The drive is ready for operation.</p>	<p>None. This is normal.</p>

LED Sequence and Cause	Action required
 <p><i>Ready is FLASHING.</i></p> <p>The drive is carrying out a normal activity (read, write).</p>	<p>None.</p> <p>If the drive is upgrading firmware, do not reset or power cycle it.</p>
 <p><i>Ready is FLASHING-steady ON-FLASHING</i></p>	<p>The drive is in OBDR mode.</p> <p>See "Running HP OBDR" on page 28 for further details.</p>
 <p><i>Ready is FLASHING fast.</i></p> <p>The drive is downloading firmware.</p>	<p>None.</p> <p>Do not reset or power cycle the drive.</p>
 <p><i>Ready is OFF, others are ON.</i></p> <p>Firmware is being reprogrammed.</p>	<p>None.</p> <p>Do not reset or power cycle the drive.</p>
 <p><i>Clean is FLASHING.</i></p> <p>The drive requires cleaning.</p>	<p>Load the Ultrium cleaning cartridge. See page 21 for supported cartridges and instructions.</p> <p>If the Clean LED is still flashing when you load a new or known data cartridge after cleaning, call for service.</p>
 <p><i>Ready is FLASHING and Clean is ON.</i></p> <p>Cleaning is in progress.</p>	<p>None. The cleaning cartridge will eject on completion.</p> <p>The cleaning cycle can take up to 5 minutes to complete.</p>
 <p><i>Tape is FLASHING.</i></p> <p>The drive believes the current tape or the tape just ejected is faulty.</p>	<p>Unload the tape cartridge. Make sure that you are using the correct format cartridge; an Ultrium data cartridge or Ultrium universal cleaning cartridge. (See page 21.)</p> <p>Reload the cartridge. If the Tape LED still flashes or starts flashing during the next backup, load a new or known, good cartridge.</p> <p>If the Tape LED is now off, discard the 'suspect' tape cartridge. If it is still on, call for service.</p>
 <p><i>The tape is ejected immediately and Tape is FLASHING, or Drive FLASHES on unloading tape.</i></p> <p>The tape cartridge memory (CM) may be faulty</p>	<p>Write-protect the cartridge by sliding the switch on the tape cartridge, see page 21. The tape can be loaded and the data read. Once the data is recovered, the cartridge must be discarded.</p>

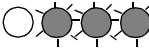
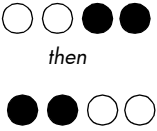
LED Sequence and Cause	Action required
 <p><i>Drive FLASHING.</i></p> <p>The drive mechanism has detected an error.</p>	<p>Load a new cartridge. If the error persists, power cycle or reset the drive.</p> <p>If the Drive LED remains on, call for service.</p>
 <p><i>Drive, Tape and Ready FLASHING.</i></p> <p>There is a firmware download problem.</p>	<p>Insert a cartridge to clear the LED sequence. If the condition persists, call for service.</p>
 <p><i>Drive and Ready ON with Tape and Clean OFF.</i> <i>Sequence alternates repeatedly.</i></p> <p>The drive has a firmware error.</p>	<p>Power cycle or reset the drive.</p> <p>Upgrade the firmware. If the condition persists, call for service.</p>

Problems with cartridges

If you experience any problems using HP branded cartridges, check:

- You are using the correct cartridge for your tape drive, see “Use the correct media” on page 21.
- The cartridge case is intact and that it contains no splits, cracks or damage.
- The cartridge has been stored at the correct temperature and humidity.
- The write-protect switch is fully operational. It should move from side to side with a positive click.
- The World Wide Web site for more detailed troubleshooting information: www.hp.com/support/ultrium.

Looking after cartridges

- Do not touch the tape media.
- Do not attempt to clean the tape path or tape guides inside the cartridge.
- Do not leave cartridges in the drive. The tape loses tension in the power-off state, which can lead to problems, particularly if the drive has been moved.
- Do not leave cartridges in excessively dry or humid conditions.
- Do not leave cartridges in direct sunlight or in places where magnetic fields are present (for example, under telephones, next to monitors or near transformers).
- Do not drop cartridges or handle them roughly.
- Stick labels onto the label area only.
- Do not bulk erase Ultrium format cartridges.

Operating and storage environment

To prevent condensation and for long life, the cartridge should only be operated or stored as follows:

- Day-to-day storage (in plastic container): 16° C to 32° C (60° F to 90° F)
- Operation: 10° C to 45° C (50° F to 113° F)
- Humidity: 20% to 80% Relative Humidity

Tapes intended for archiving data should be stored in the plastic containers, at temperatures between 5°C and 23°C (41°F and 73°F) and 10% to 50% relative humidity. Wet bulb temperature should not exceed 26°C (78°F).

We also recommend storing cartridges on their side.

Cartridge is jammed

If the cartridge is jammed or the backup application is unable to eject it, you can force eject the cartridge. It is good practice to run Library & Tape Tools to diagnose the problem. If the failure occurs regularly, contact customer service at www.hp.com/support.

- 1 Press and hold the Eject button on the front of the tape drive for 10 seconds.
- 2 Wait for the cartridge to be ejected. This process may take up to 10 minutes (the maximum

rewind time). It is important that you allow sufficient time for the drive to complete this process. If you interrupt it, you may damage the media or the tape drive.

- 3 If the cartridge is still jammed, contact customer service at www.hp.com/support.

The drive will not accept cartridge (or ejects it immediately)

The cartridge is probably incompatible, check Table 3, "Ultrium data cartridge and HP StorageWorks Ultrium tape drive compatibility," on page 21 and Table 4, "cleaning cartridge compatibility," on page 22. If the cartridge is compatible, it may have been damaged, for example it may have been dropped, the cartridge memory may be corrupted or the drive may have a fault.

Caution Never force the cartridge into the drive.

- 1 Check that the drive has power (the power cable is properly connected and the ready LED is on).
- 2 Check that you are using the correct media. Only use Ultrium media, we recommend the HP Ultrium 400 GB cartridge for Ultrium 448 drives (see page 21).
- 3 Make sure that you have loaded the cartridge with the correct orientation (see "To load a cartridge" on page 17).
- 4 Check for damage to your media (to the cartridge case, leader pin or cartridge teeth) and discard it if it is damaged. See the troubleshooting section of the User's Guide on the *HP StorageWorks Tape* CD-ROM for more information about checking the leader pin and cartridge teeth.
- 5 Use a new or known, good piece of media and see if it loads. If it does, the original cartridge is faulty and should be discarded.
- 6 Check if another Ultrium drive will accept the cartridge. If it does, the original drive may be faulty. Before calling customer service, please check that the tape drive is responding and that it can be seen on the SCSI bus. Most users can use HP Library & Tape Tools, see page 30.

Other sources of information

You will also find troubleshooting information and contact details on the HP web site. In particular:

- The HP support web site contains a link to www.hp.com/support/ultrium that takes you to HP's Customer Care web site for a wide range of up-to-date information about your product.
- The HP web site at www.hp.com/go/connect provides details of recommended products and configurations.
- The HP web site at www.hp.com/support/tapetools provides compatibility information about HP Library & Tapetools, updates and the latest version of the tool.
- The HP web site at www.hp.com/support/pat provides access to our free, standalone, performance assessment tools to check tape performance and test whether your disk sub-system can supply data at the optimum transfer rate.
- The HP web site at www.hp.com/go/obdr provides detailed information about HP One-Button Disaster Recovery.

How to contact HP

You can also use the HP Customer Call Centers for specialist technical help. Contact details can be found at www.hp.com. Click on the link to "contact HP".

To make the best use of this service, we ask that you work with our Support Specialists to resolve any issues with your drive. This may include downloading diagnostic software, that will assist in the rapid resolution of your problems.



<http://www.hp.com/go/storagemedia>

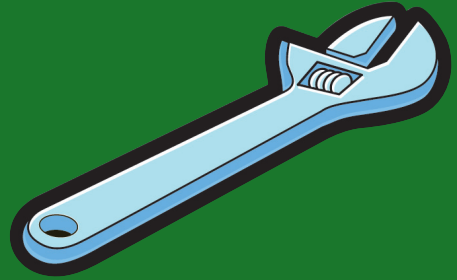

<http://www.hp.com/support/ultrium>