





# HP Designjet Z6100 Printer series

---

Quick reference guide



## **Legal notices**

The information contained in this document is subject to change without notice.

The only warranties for HP products and services are set forth in the express warranty statements accompanying such products and services. Nothing herein should be construed as constituting an additional warranty. HP shall not be liable for technical and editorial errors or omissions contained herein.

Adobe®, Photoshop®, and PostScript® are trademarks of Adobe Systems Incorporated.

Microsoft® and Windows® are U.S. registered trademarks of Microsoft Corporation.

PANTONE®\* is \*Pantone, Inc.'s check-standard trademark for color.

---

# Table of contents

## 1 Introduction

Using this guide .....	1
Introduction .....	1
Warnings and Cautions .....	1
The printer's main components .....	1
Front view 42-in printer .....	1
Front view 60-in printer .....	2
Rear view 42-in and 60-in printers .....	3
Take-up reel motor .....	3
The front panel .....	4
Turn the printer on and off .....	6
Access the Embedded Web Server .....	7
Printing paper info .....	7

## 2 Handle the paper

Load a roll onto the spindle .....	9
Load a roll into the printer .....	11
Unload a roll from the printer .....	15
The normal procedure (roll attached to spindle) .....	15
Roll is detached from spindle .....	16
No paper visible .....	16
Use the take-up reel .....	16
Attach a roll to the take-up reel .....	17
Unload a roll from the take-up reel .....	22
View information about the paper .....	23
Perform paper advance calibration .....	24
Overview of the paper advance procedure .....	25
Return to default calibration .....	25
Download paper profiles .....	25

## 3 Handle the ink system

Remove an ink cartridge .....	27
Insert an ink cartridge .....	29
Remove a printhead .....	29
Insert a printhead .....	32
Align the printheads .....	34
Use the Printhead status plot .....	35
Print the Printhead status plot .....	35
Interpret the Printhead status plot .....	36
Corrective action .....	37
What to do if problems persist .....	37
Remove the maintenance cartridge .....	38
Insert the maintenance cartridge .....	39
Check the status of the ink system .....	40

## 4 Manage print options

Select print quality .....	41
Use the Embedded Web Server .....	41
Use a driver .....	41
Use the front panel .....	42
Select page size .....	42
Custom page sizes .....	42
Use the Embedded Web Server .....	42
Use a driver .....	43
Use the front panel .....	43
Adjust margins and layout options .....	43
Use the Embedded Web Server .....	44
Use a driver .....	44
Use the front panel .....	45
Print crop lines .....	45
Use the Embedded Web Server .....	45
Use a driver .....	45
Use the front panel .....	46
Nest jobs to save paper .....	46
Configure the nesting option .....	46
How job compatibility is defined .....	47
Nest with crop lines .....	48

## 5 Manage calibration

Color calibration .....	49
Color profiling .....	50
Create your own profile .....	51
Use a third-party profile .....	52
Color adjustment options .....	52
Color emulation modes .....	53
CMYK color emulation .....	54
RGB color emulation .....	56

## 6 Troubleshoot print-quality issues

General advice .....	57
The Embedded Web Server Print Quality Troubleshooting wizard .....	57
Lines are too thick, too thin, or missing .....	58
Lines appear stepped or jagged .....	59
Parts of lines or text are missing .....	59
Lines are printed double or in wrong colors .....	60
Lines are blurred (ink bleeds from lines) .....	60
Dark or light horizontal lines across the image (banding) .....	61
The image is grainy .....	62
The image has a metallic hue (bronzing) .....	63
The printed output is not flat .....	63
The print smudges when touched .....	63
Ink marks appear on the paper .....	64
Smears on the front of coated paper .....	64
Smears or scratches on the front of glossy paper .....	64

Defects near the top of a print .....	64
Colors are inaccurate .....	65
The output is completely blank .....	66
The output contains only a partial print .....	66
The image is clipped .....	66
One image overlays another on the same print .....	67
The image has a wood-grain appearance (aeroworms) .....	68

## 7 Troubleshoot paper issues

The paper cannot be loaded successfully .....	69
The paper has jammed .....	69
Check the printhead path .....	69
Check the paper path .....	70
Automatic paper-cutter does not function .....	71
Take-up reel paper jammed .....	71
Take-up reel does not wind .....	71

## 8 Troubleshoot ink system issues

Clean the printheads .....	74
Align the printheads .....	74
Reinsert printheads procedure .....	75
Image Quality Maintenance menu procedure .....	76
Scan errors during alignment .....	77

## 9 Front-panel error messages

### 10 Get help

Introduction .....	82
HP Instant Support .....	82
HP Proactive Support .....	82
HP Customer Care .....	82
Telephone numbers .....	84
HP Designjet Online .....	86
Other sources of information .....	86

### 11 Legal information

Hewlett-Packard Limited Warranty—HP (HP Designjet Z6100 Printer series) .....	87
A. Extent of HP Limited Warranty .....	87
B. Limitation of warranty .....	89
C. Limitations of liability .....	89
D. Local law .....	89
Hewlett-Packard Software License Agreement .....	89
HP SOFTWARE LICENSE TERMS .....	90
Open source software .....	91
Open source acknowledgments .....	91
Open source written offer .....	91
Regulatory notices .....	91

Material Safety Data Sheet .....	91
Regulatory Model Number .....	92
Regulatory Statements .....	92
DECLARATION OF CONFORMITY .....	96

<b>Index .....</b>	<b>98</b>
--------------------	-----------



# 1 Introduction

## Using this guide

The *Hp Start-up Kit* CD/DVD is the most complete source of information about this product and is organized into the following chapters.

## Introduction

This chapter provides a brief introduction to the printer and its documentation. The remaining chapters offer information about how to use and maintain the printer, and how to troubleshoot issues.

## Warnings and Cautions

Symbols are used in this manual to ensure the proper use of the printer and to prevent printer damage. Follow the instructions that are marked with these symbols.



**WARNING!** Failure to follow the guidelines that are marked with this symbol could result in serious personal injury or death.



**CAUTION:** Failure to follow the guidelines that are marked with this symbol could result in minor personal injury or damage to the product.

## The printer's main components

The following views illustrate the main components of the HP Designjet Z6100 42-in and 60-in Printers.

### Front view 42-in printer

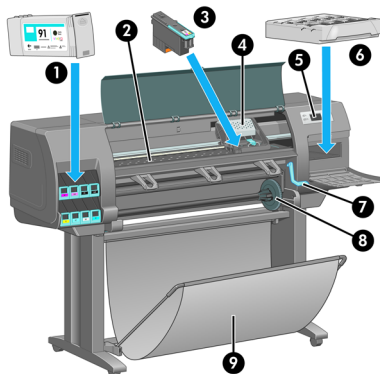

1. Ink cartridge
2. Platen

3. Printhead
4. Printhead carriage
5. Front panel
6. Maintenance cartridge
7. Paper-load lever
8. Spindle
9. Bin

### Front view 60-in printer

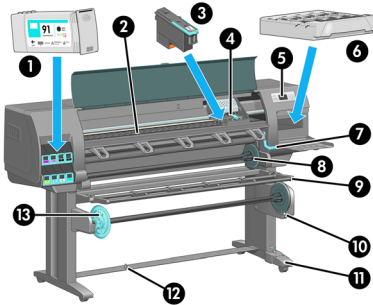

1. Ink cartridge
2. Platen
3. Printhead
4. Printhead carriage
5. Front panel
6. Maintenance cartridge
7. Paper-load lever
8. Spindle
9. Take-up reel deflector
10. Take-up reel motor
11. Take-up reel cable and sensor housing unit
12. Stand
13. Front panel

12. Take-up reel sensor
13. Take-up reel spindle hub

## Rear view 42-in and 60-in printers

HP Designjet Z6100 42-in Printer

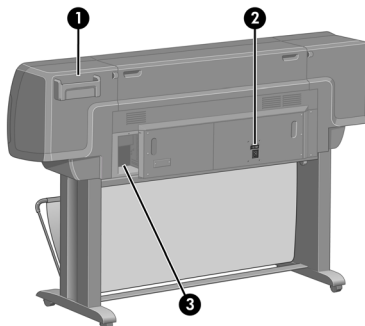

HP Designjet Z6100 60-in Printer

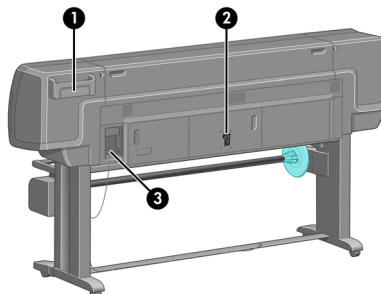

1. Quick Reference Guide holder
2. Hard power switch and power-cord plug in
3. Sockets for communication cables and optional accessories

## Take-up reel motor



**NOTE:** The take-up reel is a standard feature on the HP Designjet Z6100 60-in Printer. It is an optional accessory on the HP Designjet Z6100 42-in Printer.

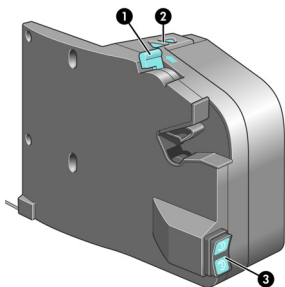

1. Take-up reel spindle lever
2. Manual winding buttons
3. Wind-direction switch

## The front panel

Your printer's front panel is located on the front of the printer, on the right-hand side. Use it for the following functions:

- Use it to perform certain operations, such as loading and unloading paper.
- View up-to-date information about the status of the printer, the ink cartridges, the printheads, the maintenance cartridge, the paper, the print jobs, and other parts and processes.
- Get guidance in using the printer.
- See warning and error messages, when appropriate.
- Use it to change the values of printer settings and the operation of the printer. However, settings in the Embedded Web Server or in the driver override changes made on the front panel.

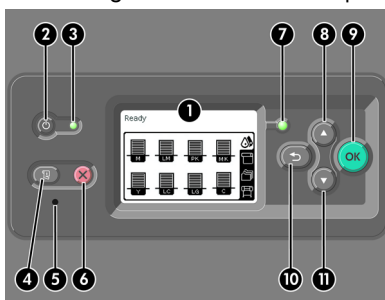

The front panel has the following components:

1. The display area, shows information, icons, and menus.
2. The **Power** button turns the printer on and off. If the printer is in sleep mode, this button will wake it up. (This is different from the hard power switch on the back of the printer. See [Turn the printer on and off on page 6.](#))
3. The Power light is off when the printer is off. This light is amber when the printer is in sleep mode, green when the printer is on, green and flashing when the printer is in transition between off and on.
4. The **Form Feed and Cut** button normally advances and cuts the roll. Here is a list of its other functions:
  - If the printer is waiting for more pages to be nested, this button cancels the waiting time and prints the available pages immediately.
  - If the printer is drying the ink after printing, this button cancels the waiting time and releases the page immediately.
  - If the take-up reel is enabled, this button advances the paper 10 cm (3.9 inches), but does not cut the paper.
5. The **Reset** button restarts the printer (as if it were turned off and turned on again). You will need a non-conductive implement with a narrow tip to operate the **Reset** button.
6. The **Cancel** button cancels the current operation. It is often used to stop the current print job.
7. The Status light is off when the printer is not ready to print: the printer is either off, or in sleep mode. The Status light is green when the printer is ready and idle, green and flashing when the printer is busy, amber when a serious internal error has occurred, and amber and flashing when the printer is awaiting human attention.
8. The **Up** button moves to the previous item in a list, or increases a numerical value.
9. The **OK** button is used to select the item that is currently highlighted.
10. The **Back** button is used to return to the previous menu. If you press it repeatedly, or hold it down, you return to the main menu.
11. The **Down** button moves to the next item in a list, or decreases a numerical value.

To *highlight* an item on the front panel, press the **Up** or **Down** button until the item is highlighted.

To *select* an item on the front panel, first highlight it and then press the **OK** button.

The four front-panel icons are all found on the main menu. If you need to select or highlight an icon, and you do not see the icons in the front panel, press the **Back** button until you can see them.

Sometimes this guide shows a series of front panel items like this: **Item1 > Item2 > Item3**. A construction like this indicates that you should select **Item1**, select **Item2**, and then select **Item3**.

You will find information about specific uses of the front panel throughout this guide.

## Turn the printer on and off



**TIP:** Turn the printer on with the hard power switch on the back of the printer or by pressing the Power button on the front panel. You can leave the printer on without wasting energy. Leaving it on improves response time and overall system reliability. When the printer has not been used for a certain period of time, it saves power by going into sleep mode. Any interaction with the printer returns it to active mode, and it can resume printing immediately.

If you want to turn the printer on or off, the normal and recommended method is to use the **Power** button on the front panel. When you turn off the printer this way, the printheads are automatically stored with the maintenance cartridge, which prevents them from drying out.

However, if you plan to leave the printer turned off for a long period of time, you are recommended to turn it off using the **Power** button, and then also switch off the power switch at the rear.



**NOTE:** In sleep mode, the printer wakes up from time to time to do maintenance service to the printheads. This avoids the need of doing long preparation after long idle periods.

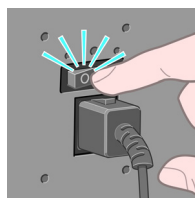
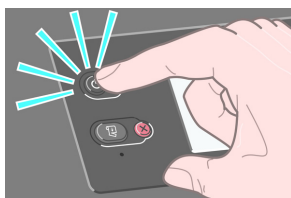

To turn it back on later, use the power switch at the rear, and then press the **Power** button.

When the printer is turned on, it will take some time to initialize itself. This time is about 10 minutes for the HP Designjet Z6100 Printer series.

## Access the Embedded Web Server

Use the Embedded Web Server to manage your printer remotely through an ordinary Web browser running on any computer.



**NOTE:** To use the Embedded Web Server, you must have a TCP/IP connection to your printer.

The following browsers are known to be compatible with the Embedded Web Server:

- Internet Explorer 5.5 or later for Windows
- Safari 1, 2, 3 or later for Mac OS X
- Netscape Navigator 6.01 or later
- Mozilla 1.5 or later
- Mozilla Firefox 1.0 or later

To use the Embedded Web Server on any computer, open your Web browser and type the printer address. The printer address appears on the status screen on the printer's front panel (192.168.1.1 in this example):

Ready

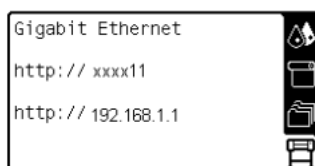

If you follow these instructions but fail to open the Embedded Web Server, see *Cannot access the embedded web server* in *Using your printer*.

## Printing paper info

Enable the **Printing paper info** option to see the printer's estimation of the remaining roll length. The information is a combination of barcode and text that is printed on the leading edge of the roll when the paper is unloaded from the printer.



**NOTE:** The paper-length estimation is only available if the printer registered the amount of paper that was on the roll when you loaded it. To provide this information to the printer, specify the roll length on the front panel when loading the paper, or load a roll that has the paper-data barcode printed on it.

To enable the Printing paper info option, select the  icon in the printer's front panel, and then select **Paper handling options** > **Enable Printing paper info**.



## 2 Handle the paper

### Load a roll onto the spindle

1. Make sure that the printer wheels are locked (the brake lever is pressed down) to prevent the printer from moving.
2. Remove the first end of the spindle from the right side of the printer, and then move the spindle to the right in order to extract the other end. Do not insert your fingers into the spindle supports during the removal process.

The spindle has a hub at each end to keep the roll in position. Remove the blue hub at the left end to mount a new roll. The hub slides along the spindle to hold rolls of different widths.

Slide the lever-lock on the blue spindle hub to the unlocked position and remove the hub (1) from the left end of the spindle.

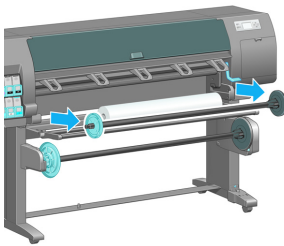

3. Rest the roll of paper that you want to load on the take-up reel deflector. The roll might be long and heavy, and you might need two people to handle it.

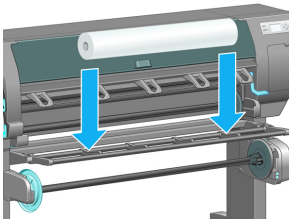

4. Slide the spindle into the roll. Make sure that no space exists between the roll and the fixed hub at the right end of the spindle.

Make sure that the paper will wind off the roll in the correct direction. If it does not, remove the spindle from the roll, turn the roll 180° and rest it on the deflector. Then slide the spindle into the roll.



**NOTE:** A label on the spindle also shows the correct winding direction.

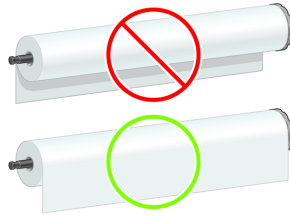
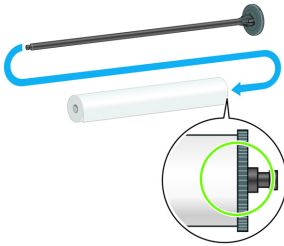

5. Put the blue hub on to the upper end of the spindle, and push it towards the end of the roll as shown in step 1 in the following image. Then slide the lever-lock to the locked position as shown in step 2.

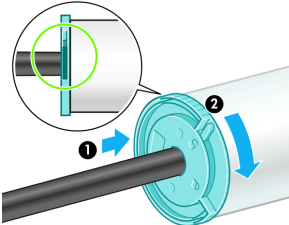

6. With the blue hub on the left, insert the spindle into the left side of the printer (1), and then into the right side of the printer (2).

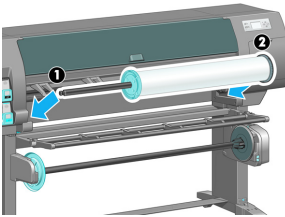

If you regularly use different paper types, you can change rolls more quickly if you pre-load rolls of different paper types on different spindles. Extra spindles are available for purchase.

# Load a roll into the printer



**NOTE:** To start this procedure, you need to have a roll loaded on the spindle. See [Load a roll onto the spindle on page 9](#).

1.

At the printer's front panel, select the  icon, and then select **Paper load > Load roll**.

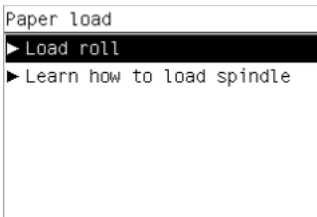

2.

Wait until the front panel prompts you to open the printer window. After you have opened the printer window, lift the paper-load lever.

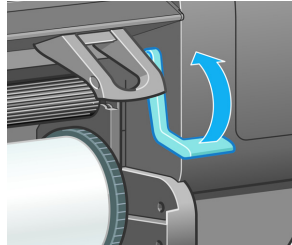
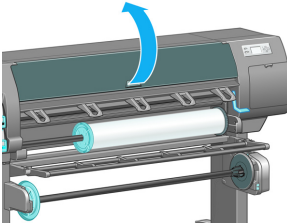

3.

Pull out approximately 1 m (3 feet) of paper.

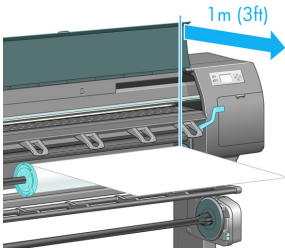

4.

Carefully insert the leading edge of the roll above the black-ribbed roller. Wait until the paper emerges from the printer.

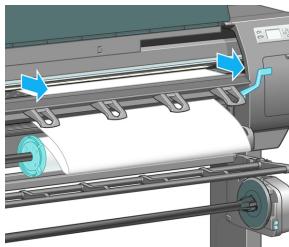
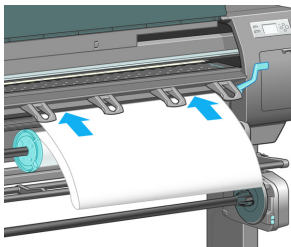

**WARNING!** Take care not to touch the rubber wheels on the platen while loading paper. These wheels can rotate and trap skin, hair, or clothing. Take care not to push your fingers inside the printer's paper path.



**NOTE:** If you have an unexpected problem at any stage of the paper loading process, see [The paper cannot be loaded successfully on page 69](#).

- Align the edge of the paper with the blue line and the left edge of the semi-circle to the right of the platen.



**TIP:** It may be helpful to also align the lead edge of the paper with the front edge of the platen. You can use a blade or scissors to improve the lead edge of the paper if it is not straight or is not cut well.

When the paper is correctly aligned with the blue line and half-circle, lower the paper-load lever.

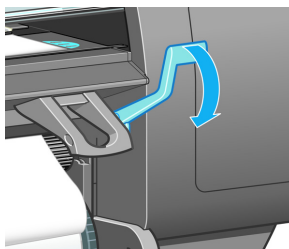
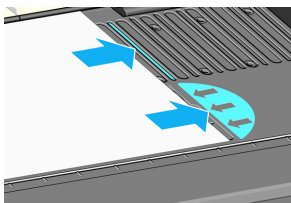

- Wait for the front-panel message that prompts you to wind excess paper onto the roll.  
Wind the excess paper onto the roll. Use the hub to turn the roll in the direction shown.

Wind excess paper onto roll.  
Close window to continue

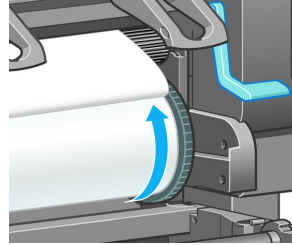

7. Lower the printer window.
8. Wait for the front panel to again prompt you to wind excess paper onto the roll.

Loading roll

Wind any excess paper onto roll to ensure image quality when printing.

Press **OK** to continue

9. The printer will perform a color calibration if it has not already calibrated the paper type you are using, and if color calibration is turned on. See [Color calibration on page 49](#).
10. Select the paper category and paper type of the roll you are loading. Then select the length of the roll you are loading.



**NOTE:** If it is not clear which paper category or paper type to select, see the Supported paper types section in the *HP Start-up Kit CD/DVD*.

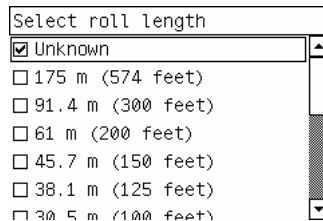
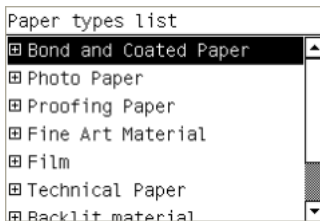



**NOTE:** If the paper that you are using has a paper-data barcode printed on the leading edge of the roll, the paper information is automatically loaded into the printer.



11. If you have a take-up reel (a standard feature on the 60-in printer and an optional accessory on the 42-in printer) and it is enabled, you will see the “Take-up reel enabled” message on the front-panel **Paper** tab. In this case, a message will appear on the front panel asking if you want to load paper into the reel. If you select **No** (or if you do not have a take-up reel) the front panel displays the **Ready** message and the printer is ready to print. If you select **Yes**, a message will appear on the front panel asking if you want to load the take-up reel now or during printing.

Would you like to load paper onto take-up reel now or save paper and load it later during printing?

Load take-up reel now

Load it during printing

- If you want to load the take-up reel now, select **Load take-up reel now**, read through the introductory text in the section [Use the take-up reel on page 16](#), and then continue to step 3 of the procedure.
- If you want to load the take-up reel during printing, select **Load it during printing**, read through the introductory text in the section [Use the take-up reel on page 16](#), and then continue to step 3 of the procedure.



**NOTE:** Familiarize yourself with the procedural steps, because loading the take-up reel while printing requires you to complete the procedure while the printer is feeding and printing paper. Loading the take-up reel during printing saves approximately 1 m (3 feet) of paper.

If the take-up reel is not enabled and you would like to enable it, select the



icon, and then select **Take up reel > Enable**.



**NOTE:** During the initial printer set up, printhead alignment and color calibration is performed automatically after the roll is loaded into the printer.

## Unload a roll from the printer



**NOTE:** If you used the take-up reel (a standard feature on the 60-in printer and an optional accessory on the 42-in printer) during printing, unload the printed roll from the take-up reel before attempting to remove the roll from the printer. See [Unload a roll from the take-up reel on page 22](#).

Initiate the procedure for unloading a roll from the printer the front panel or by lifting the paper-load lever. In either case, a front-panel animation guides you through the remainder of the procedure.

Before unloading a roll, check whether the end of the roll is still attached to the spindle, and follow the appropriate procedure as described in the following sections.

### The normal procedure (roll attached to spindle)

If the end of the roll is still attached to the spindle, use the following procedure.

1. At the printer's front panel, select the  icon, and then select **Unload paper**.
2. The paper is ejected from the printer.  
If for some reason the paper is not automatically ejected from the printer, the front-panel display prompts you to lift the paper-load lever and wind the roll by hand until the paper leaves the printer. When you have finished, lower the paper-load lever.
3. Turn the hub by hand, until the paper is fully wound onto the roll.
4. Press the **OK** button.
5. Remove the roll from the printer, pulling out the right end on the right side of the printer first. Do not insert your fingers into the spindle supports during the removal process.

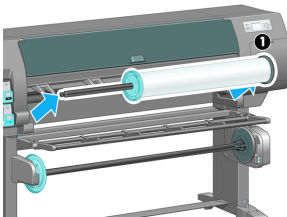

## Roll is detached from spindle

Use the following procedure if the end of the roll is visible but no longer attached to the spindle:

1. If you have already selected **Paper unload** at the front panel, press the **Cancel** button to cancel that procedure.
2. Lift the paper-load lever. If the front panel shows a warning about the lever, ignore it.
3. Pull out the paper from the front of the printer.
4. Remove the empty spindle from the printer, pulling out the end on the right side of the printer first. Do not insert your fingers into the spindle supports during the removal process.
5. Lower the paper-load lever.
6. If the front panel shows a warning message, press the **OK** button to clear it.

## No paper visible

Use this procedure if the end of the roll has entirely disappeared into the printer:

1. Press the **Form Feed and Cut** button on the front panel to eject the remaining paper.
2. Remove the empty spindle from the printer, pulling out the end on the right side of the printer first. Do not insert your fingers into the spindle supports during the removal process.

## Use the take-up reel



**CAUTION:** Make sure the printer is turned off when installing the take-up reel motor on the printer.

The take-up reel must be enabled and operated from the front panel. When the take-up reel is enabled, the "Take-up reel enabled" message appears on the **Paper** tab on the front panel. If the take-up reel is not enabled and you would like to enable it,



select the  icon and then select **Take up reel > Enable**.

Follow these guidelines when taping rolls to the take-up reel spindle core:

- Make sure that the paper is straight when it is attached to the spindle core. Otherwise it skews as it winds onto the core.
- The spindle core on the take-up reel must be the same width as the paper that you are using.



- Check that neither side of the spindle core has end caps, and make sure the spindle core is pushed firmly into both spindle guides.
- If you are using a HP Designjet Z6100 42-in Printer, make sure that the bin loop is placed behind the foot brace so that it does not block the take-up reel sensors.



**NOTE:** If you want to load the take-up reel during printing, familiarize yourself with the procedural steps. Loading the take-up reel during printing requires you to complete the procedure while the printer is feeding and printing paper. Loading the take-up reel during printing saves approximately 1 m (3 feet) of paper.

## Attach a roll to the take-up reel

1. On the printer's front panel, select the  icon, and then select **Take-up reel > Load take-up reel**.
2. If you want to load the take-up reel now, select **Load take-up reel now** on the front panel. If you want to load the take-up reel during printing, select **Load it during printing** on the front panel.

Would you like to load paper onto take-up reel now or save paper and load it later during printing?

Load take-up reel now

Load it during printing

3. Make sure that the take-up reel deflector is in its upright position. Unlock the take-up reel spindle by pushing the spindle lever to its uppermost position.

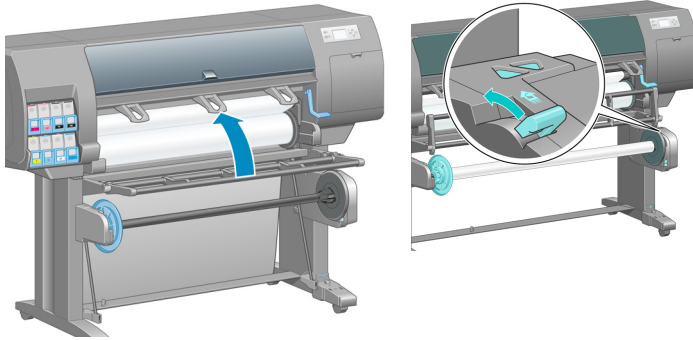

**4.** Remove the take-up reel spindle.

The front-panel display guides you through the process of loading the take-up reel spindle core onto the take-up reel spindle. When that task is complete, load the take-up reel spindle into the printer by pushing firmly on both ends of the spindle.

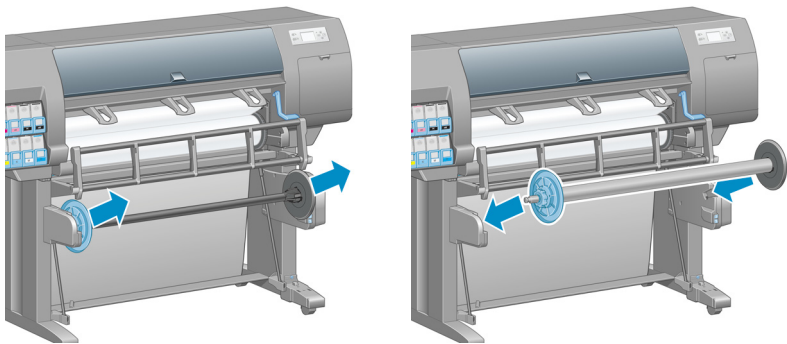

**5.** Press the OK button on the front panel.

The printer advances the paper. Make sure that the paper passes in front of the take-up reel deflector.

On the front panel, select a winding direction.

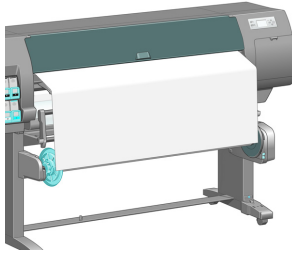

Select the printed roll winding direction
<input type="checkbox"/> Printed face outwards
<input type="checkbox"/> Printed face inwards

6. Pull the paper taut to the take-up reel spindle core. Do *not* attempt to pull more paper out of the printer. Use tape to secure the paper to the spindle core. You might need to use more tape than is shown in the following image. The paper should be secure enough to support the weight of the loop-shaping core, which you insert in step 10.



**NOTE:** If you are loading the take-up reel *during* printing you do not need to pull the paper taut. Tape the paper to the spindle core when an adequate length of paper has fed from the printer after printing begins.

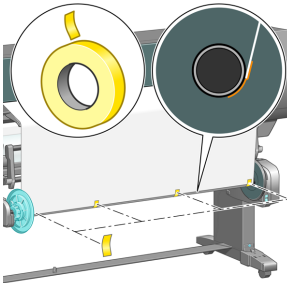

**NOTE:** To avoid having the paper skew as it winds onto the spindle core, make sure the paper is straight when you attach it. It is sometimes useful to use the core grooves to align the paper.

7. Use the wind-direction switch on the take-up reel motor to select the winding direction. Setting **1** winds the paper so that the printed image faces in. Setting **2** winds the paper so that the printed image faces out. The front panel shows you to the correct setting based on the winding-direction decision you made in step 5.

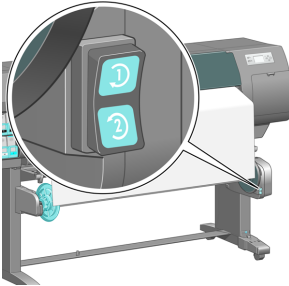

8. Gently lower the take-up reel deflector, and then press the OK button on the front panel. The printer advances the paper. Assemble a loop-shaping core by matching the shape-coded and color-coded lengths of plastic tubing. The loop-shaping core must be the same width as the paper that you are using. Make sure that both end caps are firmly fitted on the ends of the loop-shaping core.



**NOTE:** The front-panel display shows the required length of the loop-shaping core based on the width of the roll that you have loaded into the printer.

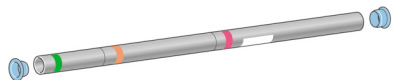
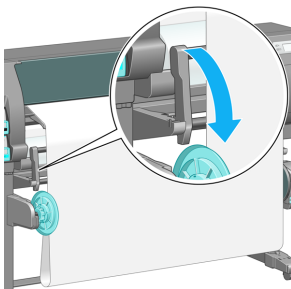

9. Press the OK button on the front panel. The printer advances the paper.

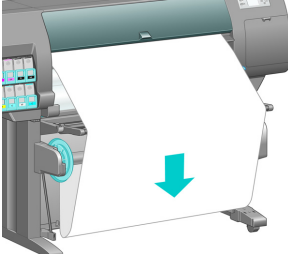

**NOTE:** Make sure that you insert the loop-shaping core. The take-up reel will not function correctly without it. The loop-shaping core must have end caps. Make sure that the end caps extend over the edges of the paper.

10. Carefully insert the loop-shaping core, and then press the OK button on the front panel. The **Ready** message appears.



**NOTE:** You are *not* required to press the OK button if you are loading the take-up reel *during* printing.

**NOTE:** Make sure the loop-shaping core is inserted. The take-up reel will not function correctly without it. The loop-shaping core must have end caps. Make sure that the end caps extend over the edges of the paper.

When the printer is printing and the take-up reel is operating, the paper is fed from the printer, drops down in a loop, and then up into the take-up reel spindle.

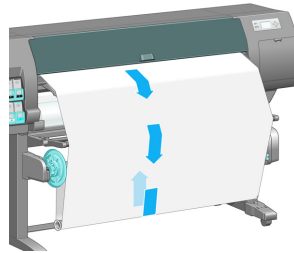
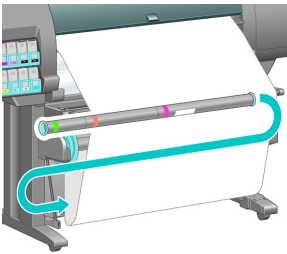

**NOTE:** While the take-up reel is operating, make sure that the take-up reel sensors are not blocked.

**NOTE:** The automatic paper-cutter is disabled when the take-up reel is in use.

## Unload a roll from the take-up reel

1.

At the printer's front panel, select the  icon, then **Paper unload > Unload roll**.

The printer advances the paper to allow for cutting.

2.

Lift the take-up reel deflector to its upright position.

Switch the wind-direction switch to the Off position. The switch is in the off position when it is centered (in other words, when the switch is neither in position 1 nor position 2).

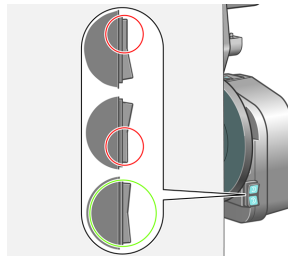
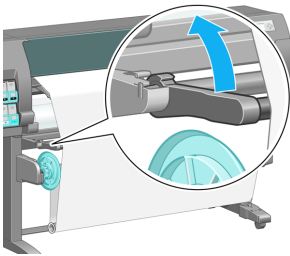

3. Remove the loop-shaping core.

Use the winding button on the take-up reel motor to wind the excess paper around the take-up reel spindle.

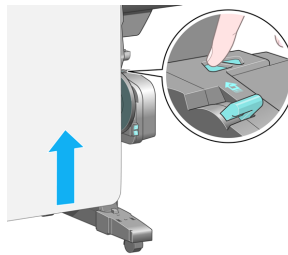
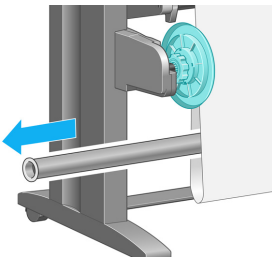

4. Press the OK button on the front panel.

5. The printer knows if the type of paper that is loaded is suitable for the automatic paper-cutter. The paper is cut if it is suitable. If the paper is not suitable, cut the paper manually.



**NOTE:** The automatic paper-cutter feature is disabled for some of the heaviest media types, because they can damage the cutter.

Use the winding button on the take-up reel motor to wind the remainder of the paper around the take-up reel spindle.

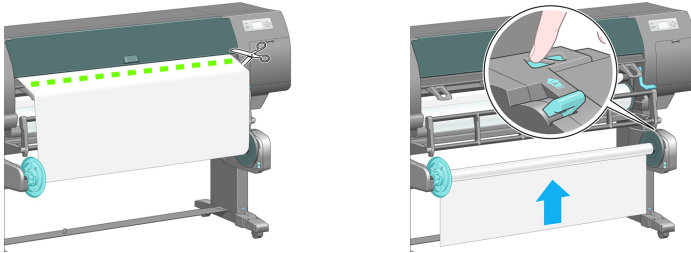

6. Press the OK button on the front panel.  
The amount of printed paper that is on the take-up reel spindle appears on the front panel.
7. Unlock the take-up reel spindle by pushing the spindle lever to its uppermost position.  
Remove the roll from the printer, pulling out the end on the right side of the printer first. Do not insert your fingers into the spindle supports during the removal process.

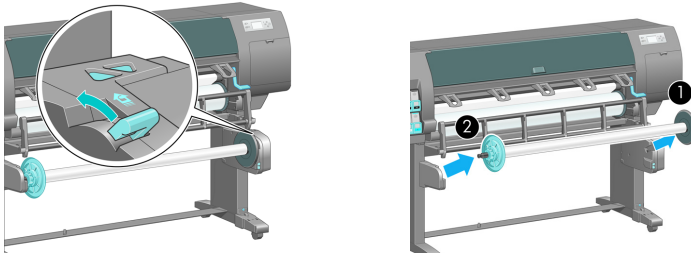

8. To remove the roll from the printer after you have unloaded the take-up reel, see [Unload a roll from the printer on page 15](#).

## View information about the paper

On the printer's front panel, select the  icon, and then select **View loaded paper** > **View paper details**.

The following information appears on the front panel:

- The roll status
- The paper type you have selected
- The width of the paper in millimeters (estimated by the printer)
- The length of the paper in millimeters (estimated by the printer)

If no paper is loaded, the message **Out of paper** appears.

The same information appears on the Embedded Web Server's Supplies page.

## Perform paper advance calibration

The printer is calibrated to advance correctly when printing all the papers that appear on the front panel. When you select the type of loaded paper, the printer adjusts the rate at which it advances the paper while printing. However, to fine-tune the image quality of your print, you might need to calibrate the rate at which the paper advances. See [Troubleshoot print-quality issues on page 57](#) to determine whether paper-advance calibration is the solution for your issue.

Accurate paper advance controls proper placement of dots on the paper. If the paper is not advanced correctly, light or dark bands appear in the printed image and the grain in the image might increase.

To check the paper advance calibration status of the paper, select the  icon, and then select **View loaded paper** > **View paper details**. The status appears:

- **DEFAULT:** this status appears when an HP paper is loaded. Unless you experience image-quality problems in your printed image, such as banding or graininess, HP recommends that you do not calibrate the paper advance.
- **RECOMMENDED:** this status appears when you create a new paper. The paper advance values for this paper are inherited from the family type. HP recommends that you perform a paper advance calibration to optimize the values.
- **OK:** this status indicates that the loaded paper has been calibrated previously. However, you might need to repeat the calibration if you experience image-quality problems, such as banding or graininess in your printed image.



**NOTE:** Whenever you update the printer firmware, the paper-advance calibration values are reset to the factory default.

**NOTE:** Colored papers, glossy canvas, and transparent materials such as translucent bond, clear film, natural tracing paper, and vellum are not suitable for paper-advance calibration.



## Overview of the paper advance procedure

1. On the front panel, select the  icon, and then select **Image quality maintenance > Paper advance calibration > Calibrate paper advance**. The printer automatically calibrates the paper-advance and prints a paper advance calibration image.
2. Wait until the front panel shows the status screen, and then reprint your image.



**NOTE:** The calibration procedure takes approximately six minutes. The front-panel display shows any errors in the process.

If you are satisfied with your image, continue using this calibration for your paper type. If you see improvement in your image, continue with step 3. If you are dissatisfied with the calibration, return to the default calibration. See [Return to default calibration on page 25](#).

3. To fine-tune the calibration, select the  icon, and then select **Image quality maintenance > Paper advance calibration > Adjust paper advance**.
4. Select the percentage of change from -100% to 100%. To correct light banding, decrease the percentage. To correct dark banding, increase the percentage.
5. Press the **OK** button on the front panel to save the value.
6. Wait until the front panel shows the status screen, and then reprint your image.

## Return to default calibration

Returning to the default calibration sets all the paper-advance calibration to zero. To return to the default paper advance-calibration value, you must reset the calibration.

1. On the front panel, select the  icon, and then select **Image quality maintenance > Paper advance calibration > Reset paper advance**.
2. Wait until the front panel shows that the operation has been successfully completed before you press the **Back** button to return to the **Ready** screen.

## Download paper profiles

Each supported paper type has its own characteristics. The printer changes the way it prints on each different paper type. For example, some might need more ink and some might require a longer drying time. The printer requires a description of the requirements of each paper type. This description is called the “paper profile”.

The paper profile contains the ICC profile, which describes the color characteristics of the paper. It also contains information about other characteristics and requirements of the paper that are not directly related to color. Existing paper profiles for your printer are installed in the printer's software.

Your printer contains paper profiles for only the most commonly used paper types. If you buy a paper type for which your printer has no profile, you cannot select that paper type in the front panel.

You can assign a profile for a new paper type in three ways:

- Use a HP factory paper profile by selecting the closest category and type on the front panel, in HP Easy Printer Care (Windows), or in HP Printer Utility (Mac OS)



---

**NOTE:** Because colors might not be accurate, this method is not recommended for high-quality prints.

---

- Go to <http://www.hp.com/go/designjet/downloads> and click the **HP Designjet ICC/Media profiles and PANTONE tables** link. Select from the **HP Designjet media profiles** drop-down menu.



---

**NOTE:** HP only provides profiles for HP paper types. If you do not find the paper profile that you want on the Web, it might have been added to the latest firmware for your printer. Check the firmware release notes for information.

---

- Add a custom paper type and create an ICC profile for either HP or non-HP papers.

# 3 Handle the ink system

## Remove an ink cartridge



**CAUTION:** The procedure to remove an ink cartridge must be initiated from the front panel. Do not remove an ink cartridge until the front panel prompts you.

Ink cartridges should be removed for the following two reasons:

- The ink cartridge is very low and you want to replace it with a full cartridge for unattended printing. You can use the remaining ink in the first cartridge at a more convenient time.
- The ink cartridge is empty or faulty, and you must replace it to continue printing.

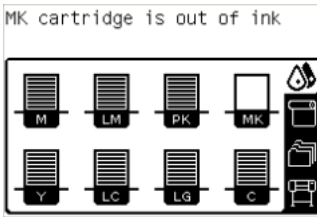

**CAUTION:** Do not try to remove an ink cartridge while printing.

**CAUTION:** Remove an ink cartridge only if you are ready to insert another one.



**WARNING!** Make sure that the printer wheels are locked (the brake lever is pressed down) to prevent the printer from moving.

1.

At the printer's front panel, select the  icon, and then select **Replace ink cartridges**.

Grip the blue tab in front of the cartridge that you want to remove.

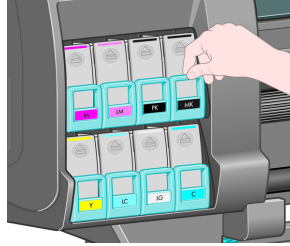

2. Pull the blue tab down and then pull it outwards, towards you. The cartridge comes out, in its drawer.

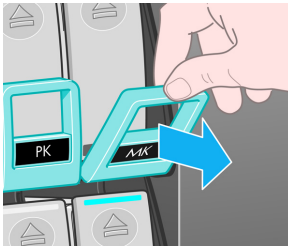

3. Lift the cartridge out of its drawer. The front-panel display identifies the missing ink cartridge.



**NOTE:** Avoid touching the end of the cartridge that is inserted into the printer, because the connection might be coated with ink.

**NOTE:** If necessary, store a partially-used ink cartridge in the same position as if it were inserted in the printer. Avoid using a partially-used cartridge that has been stored on its end.

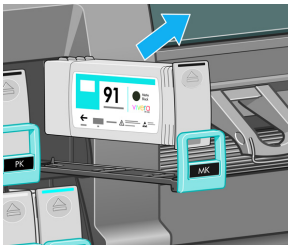

Ink cartridge missing.  
Install ink cartridge

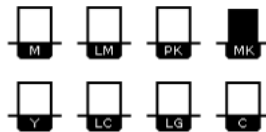

## Insert an ink cartridge

1. Pick up the new ink cartridge and find the label that identifies the ink color. Hold the ink cartridge so that you can see the label at the top of the side that is facing you.
2. Check that the colored label above the empty slot in the printer matches the color of the label on the cartridge.
3. Shake the cartridge vigorously for about 15 seconds.
4. Insert the ink cartridge into the cartridge drawer.  
Slide the drawer and cartridge into the slot until they lock into position. If you have difficulty, see Cannot insert an ink cartridge in *Using your printer*.

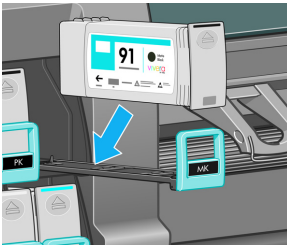

5. The front-panel display confirms that all cartridges have been correctly inserted.

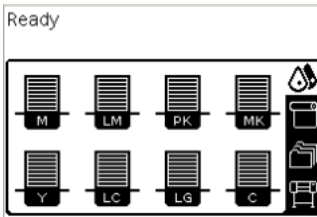

## Remove a printhead



**WARNING!** Make sure that the printer wheels are locked (the brake lever is pressed down) to prevent the printer from moving.

Printhead replacement must be performed after the printer has been turned on at the hard power switch.

1.

At the printer's front panel, select the  icon, and then select **Replace printheads**.

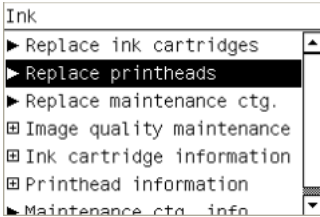

2. The printer moves the carriage into the correct position.



**CAUTION:** If the carriage remains in the removal position for more than 3 minutes without inserting or removing any printheads, it will attempt to return back to its home position to the right.

3. When the carriage has stopped moving, the front panel prompts you to open the printer window.

4. Locate the carriage on the right side of the printer. Pull up and release the latch on top of the carriage.

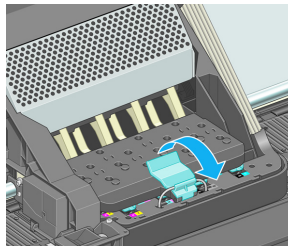
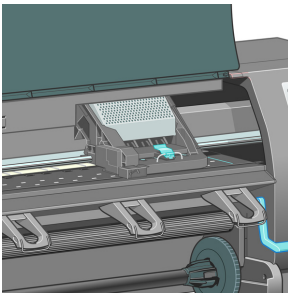

5. Lift up the cover. This provides access to the printheads.

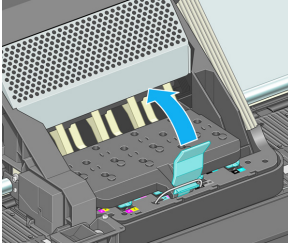

6. To remove a printhead, lift up the blue handle. Using the blue handle, gently disengage the printhead.

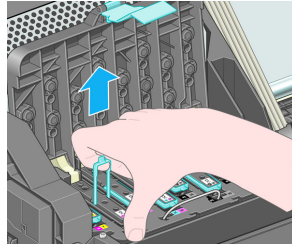
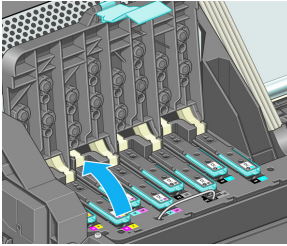

7. Gently pull the blue handle upward until the printhead is released from the carriage.



**CAUTION:** Do not pull abruptly. That action can damage the printhead.

The front-panel display identifies the missing printhead.

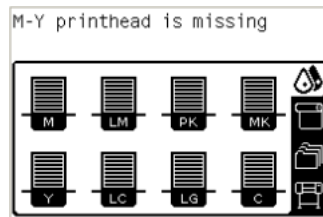
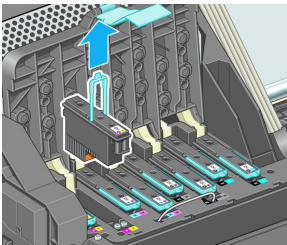

## Insert a printhead

1. If the printhead is new, shake it vigorously before removing the protective caps. Hold the printhead upright (with the protective caps facing down) and shake the printhead vigorously in a smooth up and down motion for about 15 seconds.



**NOTE:** Be careful not to strike the printhead against anything while shaking it, because this could cause damage.

Remove the orange protective caps by pulling them down.

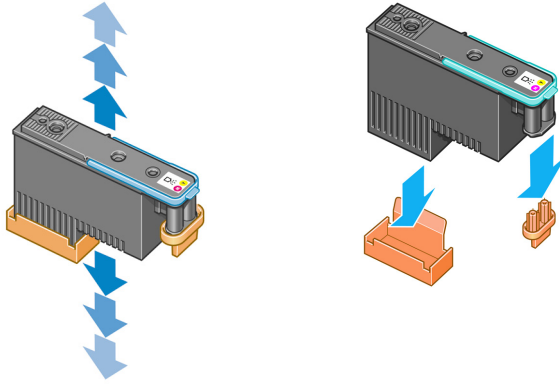

2. The printhead is designed to prevent you from accidentally inserting it into the wrong slot. Check that the colored label on the printhead matches the colored label of the carriage slot into which the printhead is to be inserted.
3. Insert the new printhead into its correct slot in the carriage.



**CAUTION:** Insert the printhead slowly and vertically, straight down. It can be damaged if you insert it too quickly, or at an angle, or if you rotate it as you insert it.

Push down as indicated by the arrow.



**CAUTION:** You might feel some resistance when installing the new printhead, so you need to press it down firmly but smoothly. You should hear a beep and see confirmation on the front-panel display that the printhead has been inserted. If you have difficulty, see *Cannot insert a printhead in Using your printer*.



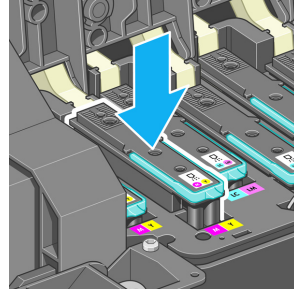
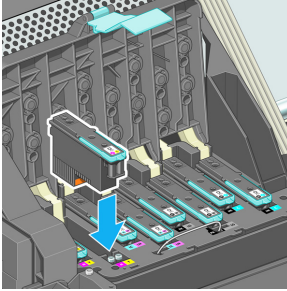

4. Insert all of the other printheads that need to be installed, and close the carriage cover.

Make sure that the end of the blue handle catches the wire loop on the near side of the carriage.

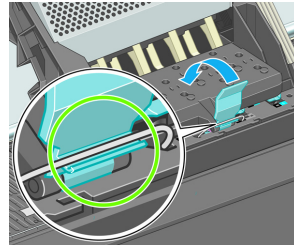
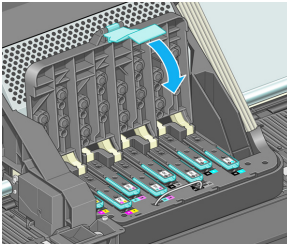

5. Lower the handle to rest on the carriage cover.

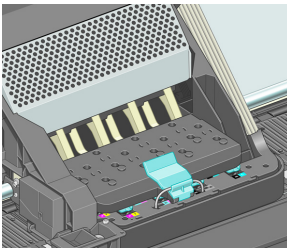

When all of the printheads have been inserted correctly and the printer has accepted them, the printer beeps.



**NOTE:** If the printer does not beep when you insert the printhead and the **Replace** message appears on the front-panel display, you might need to reinsert the printhead.

6. Close the printer window.
7. The front-panel display confirms that all of the printheads are correctly inserted. The printer starts checking and preparing the printheads. The default routine process, when all printheads are changed, takes about 18 minutes. If the printer identifies a problem when preparing the printheads, the process takes longer, up to 30 minutes. For a single printhead insertion, the time varies between 10 and 20 minutes. After all printheads are checked and prepared, the printhead realignment procedure runs automatically if paper is loaded. See [Align the printheads on page 34](#).

## Align the printheads

The printer performs printhead alignment whenever printheads are replaced. If no paper is loaded when a printhead is replaced, the printer will perform the alignment the next time you load paper.

Also align the printheads if the Printhead status plot indicates an alignment error. See [Use the Printhead status plot on page 35](#).

1. Make sure that you have a roll of opaque, white paper loaded in the printer. Colored papers, glossy canvas, and transparent materials such as translucent bond, clear film, tracing paper, and vellum are not suitable for printhead alignment.

2. To request printhead alignment (if the alignment is not being performed

automatically), go to the front panel, select the  icon, and then select **Image quality maintenance > Align printheads**.

The process takes about 10 minutes and starts immediately, unless an image is currently being printed. If a print job is in process, the alignment will be done as soon as the current print job is finished.



**NOTE:** Occasionally, if the paper in the printer is very close to the beginning of a roll, the front panel might report that the printer needs to feed up to 3 m ( $\approx$  10 ft) of paper before starting the printhead alignment. This is necessary to ensure a successful alignment. You can continue with the printhead alignment and allow the printer to feed as much paper as necessary, delay the alignment until later, or cancel the alignment.

## Use the Printhead status plot

The Printhead status plot consists of patterns that are designed to highlight printhead-reliability problems. It helps you to check the performance of the printheads that are currently installed in your printer, and to determine whether any printhead is experiencing clogging or other problems.

### Print the Printhead status plot

To print the Printhead status plot:

1. Use the same paper type that you were using when you detected a problem.
2. Verify that the selected paper type is the same as the paper type that is loaded into the printer.
- 3.

On the printer's front panel, select the  icon, and then select **Image quality maintenance > Printhead diagnostics image**.

It takes about 2 minutes to print the Printhead status plot.

## Interpret the Printhead status plot

The print is divided into two parts, both of which test printhead performance.

- Part 1 (top) consists of rectangles of pure colors, one for each printhead. This part represents the print quality that you will get from each color.
- Part 2 (bottom) consists of small dashes, one for each nozzle on each printhead. This part complements the first, and detects how many faulty nozzles are on each printhead.

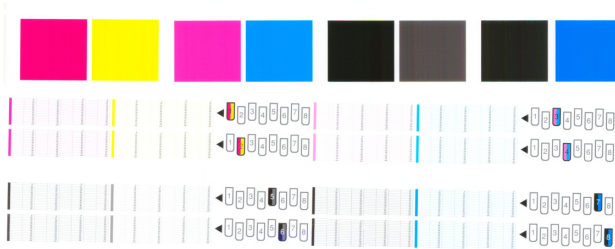

First look at the top part of the print. Each colored rectangle should be a uniform color without any horizontal lines across it.

Then look at the bottom part of the print. For each individual colored pattern, make sure that most of the dashes are present.

If you see horizontal lines in the top part and also see missing dashes in the bottom part for the same color, the printhead for that color needs to be cleaned. However, if the rectangles look solid, do not worry about a few missing dashes in the bottom part, because the printer can compensate for a few clogged nozzles.

The graphic shown illustrates printhead 2 in a bad state:

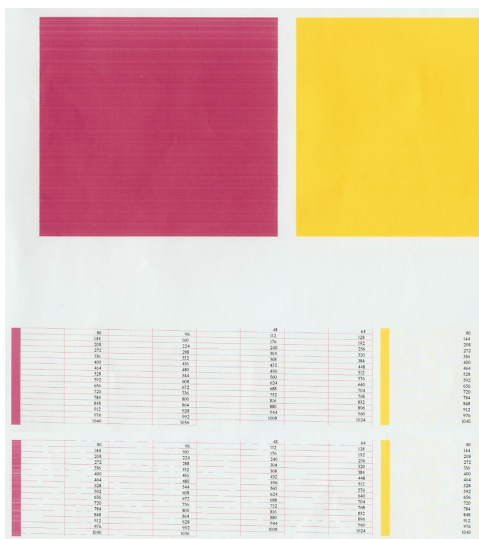

## Corrective action

1. Clean any faulty printheads. See [Clean the printheads on page 74](#). Then reprint the Printhead status plot to see whether the problem has been solved.
2. If the problem persists, clean the printheads again, and reprint the Printhead status plot to see whether the problem has been solved.
3. If the problem persists, consider cleaning your printheads manually. See [Clean the printheads on page 74](#). Also try reprinting your current print job, in case it now prints satisfactorily.
4. If the problem continues to persist, replace any persistently faulty printheads.

## What to do if problems persist

If you still experience print-quality problems after applying the advice in this chapter, here are some additional tips to consider:

- Try using a higher print-quality option. See [Select print quality on page 41](#).
- Check the driver you are using to print with. If it is a non-HP driver, consult the driver vendor about the problem. You could also try using the correct HP driver, if that workaround is acceptable to you. Download the latest HP drivers from <http://www.hp.com/go/designjet/>.
- If you are using a non-HP raster image processing (RIP), its settings might be incorrect. See the documentation that came with the RIP.
- Verify that your printer firmware is up to date.

- Verify that you have the correct settings in your software program.
- Contact HP Support.

## Remove the maintenance cartridge

A message appears on the front panel when you must change the maintenance cartridge. Follow these precautions when removing a maintenance cartridge:

- Be careful not to get ink on your hands. Ink might be on, around, and inside the replaced maintenance cartridge.
- Always handle and store the replaced maintenance cartridge upright to avoid spilling any ink.



**CAUTION:** A message appears on the front panel when the maintenance cartridge is almost full and again when it is completely full and must be changed. You can ignore the alert and continue printing by pressing the OK button on the front panel. However, HP strongly recommends that you change the maintenance cartridge when prompted. Ignoring the alert can result in serious damage to the printer.



**WARNING!** Make sure that the printer wheels are locked (the brake lever is pressed down) to prevent the printer from moving.

1.

On the printer's front panel, select the  icon, and then select **Replace maintenance ctg.**

The maintenance cartridge is located in a slot underneath the front panel, at the front of the printer. Open the door.

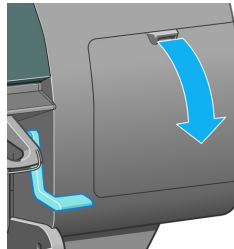
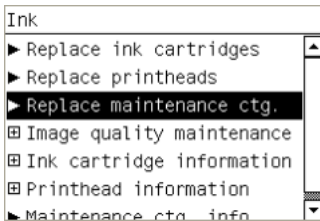

2. The maintenance cartridge has a handle on the front. To remove the cartridge, press inward and upward as indicated by the arrow, until the cartridge is released.

Lift up the maintenance cartridge to remove it from the slot, and slide it out.

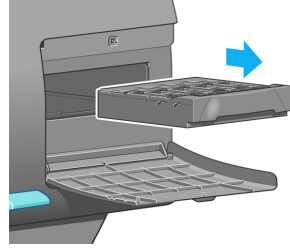
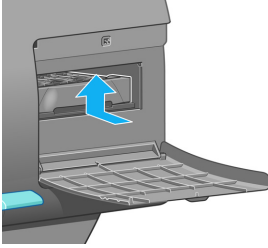

## Insert the maintenance cartridge

The plastic bag in which the new maintenance cartridge comes can be used to dispose of the old maintenance cartridge.

1. Insert the maintenance cartridge into the slot, in the direction indicated by the arrow.

When the maintenance cartridge has been pushed all the way in, press inwards and downwards as indicated, until it clicks into place.

If you have difficulty, see *Cannot insert the maintenance cartridge in Using your printer.*



**NOTE:** The front panel will not show the new maintenance cartridge until the door is closed.

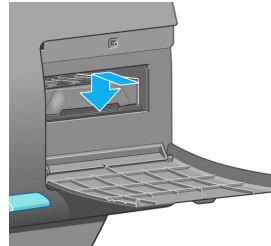
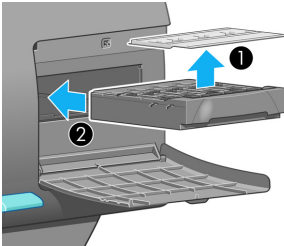

- When you have inserted the maintenance cartridge into the printer, close the door.

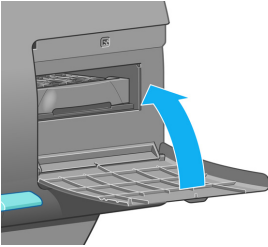

**NOTE:** The printer needs all the ink cartridges, printheads and maintenance cartridge to be installed before it can continue.

- If no paper is loaded, the front panel will instruct you to load some.



**NOTE:** Make sure that the printer window and the door to the right are closed after you replace the supplies. The printer will not print while these are open.

## Check the status of the ink system

- Access the Embedded Web Server.
- Go to the Supplies page on the **Main** tab.

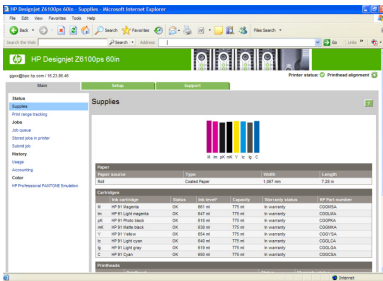

The Supplies page shows you the status of the ink cartridges (including the ink levels), the printheads, the maintenance cartridge, and the loaded paper.



---

## 4 Manage print options

### Select print quality

The printer has various print-quality options. The best quality printing requires some loss of speed, while maximum-speed printing can cause some reduction in print quality. The printer has four different print-quality options.



**NOTE:** If you have set the print quality in the printer driver or through the Embedded Web Server, that setting overrides a print-quality setting established on the front panel.

**NOTE:** You cannot change the print quality of pages that the printer is already receiving or has already received (even if they have not started to print yet).

---

### Use the Embedded Web Server

To specify the print quality through the Embedded Web Server, go to the **Submit Job** page on the **Main** tab. In the **Job Settings** tree, select **Basic settings** and then select one of the settings from the **Print quality** drop-down menu: **Fast**, **Normal-Fast**, **Normal**, or **Best**.



**NOTE:** Be aware that when you submit more than one job at a time by clicking the **Add files** button in the Embedded Web Server, all of the jobs that you submit will adopt the settings of the final job that you submit. However, none of the jobs in the print queue are affected.

---

### Use a driver

You can specify the print quality in the following ways:

- In the Windows HP-GL/2 or Postscript driver, go to the **Paper/Quality** tab and look at the Print Quality section. If you select **Standard Options**, you can use the slider to select some compromise between speed and quality. If you select **Custom Options**, you can choose **Fast**, **Normal-Fast**, **Normal** or **Best**.
- In the Mac OS **Print** dialog box, go to the **Image Quality** panel. If you select **Standard** quality options, you can use the slider to select some compromise between speed and quality. If you select **Custom** quality options, you will see the specific print-quality options.



**NOTE:** In the Windows driver dialog box, the rendering resolution for your job appears in the **Custom Print Quality Options** dialog box. In the Mac OS **Print** dialog box, it appears in the **Summary** panel.

---

## Use the front panel

On the front panel, select the  icon, and then select **Printing preferences** > **Select quality level**.

## Select page size

Select the page size through the Embedded Web Server, in a driver, or on the front panel. The size that you select should be the page size in which the document was created. You can resize the document for printing. See *Resize a print* in *Using your printer*.



**NOTE:** If you set the page size from your computer, that setting overrides the page size setting on the front panel.

## Custom page sizes

Custom page sizes can be defined in a driver or through the Embedded Web Server. The two types of custom page sizes are differentiated by how they were created, and therefore, which users have accessibility to them.

- Custom papers: custom papers are custom page sizes that have been defined in a driver and that reside on the user's hard drive. Therefore, custom papers are not available to other users in the network.
- Printer forms: printer forms are custom page sizes that have been defined through the Embedded Web Server and are visible to all network users who share that print queue. Users require at least Print operator network permissions to create printer forms.

## Use the Embedded Web Server

To select the page size through the Embedded Web Server, go to the **Submit Job** page on the **Main** tab. In the **Job Settings** tree, select **Advanced settings** > **Paper** > **Page size** and then select **Standard** or **Custom** page size.

- Standard: use the drop-down menus to set the **Size** and **Orientation**.
- Custom: use the free-text fields to specify a **Width** and **Length**, and use the **Page size** drop-down menu to define the units of measurement.



**NOTE:** Be aware that when you submit more than one job at a time by clicking the **Add files** button in the Embedded Web Server, all of the jobs that you submit will adopt the settings of the final job that you submit. However, none of the jobs in the print queue are affected.

## Use a driver

Select the page size in the following ways:

- In the Windows HP-GL/2 or PostScript driver, click the **Paper/Quality** tab, and then select **Document Size**.
- In the Mac OS **Print** driver dialog, select **Page Setup** from the **File** menu, select your printer in the **Format for** popup menu, and then select **Paper size**.

To define a custom paper size that does not appear in the list of paper sizes:

- In the Windows and PostScript drivers, use one of two different methods:
  - In the driver dialog, select **Custom** from the **Document size** drop-down menu on the **Paper/Quality** tab. Type a name for the custom size and click **Save**. Then specify the paper dimensions and click **OK** to save your custom paper size.



**NOTE:** The custom paper size you define is not available for selection in the list of custom sizes until you have exited and opened the Printing Preferences/Properties again. Then, you can select **More** from the **Document size** drop-down menu and find the custom paper size in the list.

- On the **Start** menu, select **Printers and Faxes**, and then from the **File** menu select **Server Properties**. On the **Forms** tab, click the **Create a new form** check box, specify the name and dimensions of the new form, and then click **Save Form**.
- In Mac OS X V10.4, select **Paper Size > Manage Custom Sizes** in the **Page Setup** dialog box.
- In Mac OS X V10.2 or V10.3, select **Settings > Custom Paper Size** in the **Page Setup** dialog box.

## Use the front panel



On the front panel, select the  icon, and then select **Printing preferences > Paper options > Select paper size**.

## Adjust margins and layout options

The printer margins determine the area between the edges of your image and the edges of the paper. For information about the exact sizes (in millimeters) of the available margin settings, see Margins in *Using your printer*.

Depending on the method that you use to adjust the margins, at least some of the following layout options are available.

- **Standard.** Your image is printed on a page of the size that you have selected, with a narrow margin between the edges of the image and the edges of the paper. The image should be small enough to fit between the margins.
- **Oversize.** Your image is printed on a page slightly larger than the size that you have selected. If you cut off the margins, the remaining page is the size you selected, with no margins between your image and the edges of the paper.
- **Clip Contents By Margins.** Use this setting when the contents have white borders and a size equal to that of the paper that you have selected in the driver. The printer uses the white border for its margins and you get a page size that is equal to what was selected in the driver.

See the Usage and Preview sections of the **Paper/Quality** tab for tips about deciding which margins and layout option best suit your needs.



**NOTE:** If margins are set in the printer driver or through the Embedded Web Server, they override the margins that are set on the front panel.

## Use the Embedded Web Server

To set the margins through the Embedded Web Server, go to the **Submit Job** page on the **Main** tab. In the **Job Settings** tree, select **Advanced settings > Paper > Layout/Margins**. Then use the **Select margins** drop-down menu to set the margins. Select from: **Default, Small, Normal** and **Extended**.



**NOTE:** Be aware that when you submit more than one job at a time by clicking the **Add files** button in the Embedded Web Server, all of the jobs that you submit will adopt the settings of the final job that you submit. However, none of the jobs in the print queue are affected.

## Use a driver

Specify the margins in the following ways:

- In the Windows HP-GL/2 **Normal** margins and **Standard** layout are selected by default. To change the margins and layout options, click the **Paper/Quality** tab and click the **Layout** button.
- In the Windows PostScript driver, **Normal** margins and **Standard** layout are selected by default. To change the margins, click the **Paper/Quality** tab, select **More** from the **Document size** drop-down menu, and then select the desired page size and the margins at the same time. Click the **Layout** button to change the layout options.
- In the Mac OS driver, select **Page Setup** from the **File** menu, select your printer in the in the **Format for** popup menu, and then select **Paper size**. You select the page size and the margins at the same time.



**NOTE:** In the Windows PostScript driver, you have the option of selecting a paper size with no margins. The **No margins** option should only be selected in conjunction with the **Oversized** and **Clip contents by margins** layout settings.

**NOTE:** In Mac OS driver, the available margins options depend on the paper size that you selected in the **Page Setup** dialog box.

You have the option of selecting a paper size with no margins. To select the **No margins** option, click the **Printing** dialog, select the **Finishing** panel, and then click the **Layout** tab. The **No margins** option should only be selected in conjunction with the **Oversized** and **Clip contents by margins** layout settings.

## Use the front panel



On the front panel, select the  icon, and then select **Printing preferences** > **Margins** > **Select margins**.

## Print crop lines

Crop lines are lines that are printed onto the paper during a print job to indicate where the paper should be cut to achieve a specific paper size. Crop lines can be printed for individual jobs or for multiple jobs that are printed with the nesting feature.

For information about how to print crop lines for multiple jobs that are printed with the nesting feature, see [Nest with crop lines on page 48](#).

## Use the Embedded Web Server

To enable crop lines through the Embedded Web Server, go to the **Submit Job** page on the **Main** tab. In the **Job Settings** tree, select **Advanced settings** > **Roll options** and then select a setting from the **Enable crop lines** drop-down menu.



**NOTE:** Be aware that when you submit more than one job at a time by clicking the **Add files** button in the Embedded Web Server, all of the jobs that you submit will adopt the settings of the final job that you submit. However, none of the jobs in the print queue are affected.

## Use a driver

- In the Windows driver, go to the **Features** tab and in the **Roll Options** section, select the **Enable Crop lines** checkbox
- In the Mac OS **Print** dialog box, go to the **Finishing** panel and select the **Crop lines** check box.

## Use the front panel

On the front panel, select the  icon, and then select **Printing preferences** > **Paper options** > **Enable crop lines**.

## Nest jobs to save paper

Nesting means placing pages side-by-side on the paper, rather than one after the other. Do this to avoid wasting paper. The graphic below to the left illustrates the general concept of nested print jobs. The graphic below to the right illustrates three that have been print jobs printed with the nesting feature disabled.

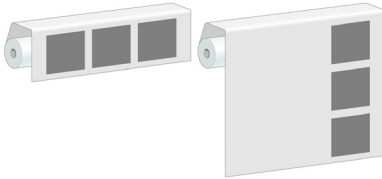

## Configure the nesting option

On the printer's front panel: select the  icon, and then select **Job management options** > **Nest options** > **Enable nesting** and select **Off, In order**, or **Optimized order**.

The following are three nesting options:

- **Off**  
Select the **Off** setting to disable the nesting feature.
- **In order**  
Pages are nested on the roll in the same order in which they are submitted to the printer. The nest is broken and printed as soon as one of three conditions is met:
  - The nest is full, meaning that the remaining paper on the roll is insufficient to accommodate the next page that is submitted.
  - The nesting timeout elapses.
  - The next page to arrive is incompatible with the pages that are already nested.

For more information about the compatibility of a page, see [How job compatibility is defined on page 47](#).

The advantage of In-order nesting is that the wait time for pages to nest – and therefore the total printing time – is typically reduced because more conditions exist to break the nest. The disadvantage is that the nest is broken by the first incompatible page submitted, even if a sufficient length of paper and additional

compatible pages are in the queue. This means that a higher probability exists that the paper will not be used efficiently.

- **Optimized order**

Pages are nested on the roll independent of when they are submitted to the printer. An incompatible page does not break a nest. Instead, the printer waits for more compatible pages and queues the incompatible pages until one of three conditions is met:

- The nest is full, meaning that the remaining length of paper on the roll is too small to accommodate the next page submitted
- The nesting timeout elapses
- The incompatible-page queue is full. The printer queues up to six incompatible pages while it nests compatible pages. Upon receiving the seventh incompatible page, the nest is broken and printed. Then the pages in the incompatible-page queue print.

For more information about the compatibility of a job, see [How job compatibility is defined on page 47](#).

The advantage of Optimized order nesting is that it typically wastes less paper because the nest is not broken when an incompatible page is submitted. The disadvantage is the overall printing time is typically longer because the printer waits for compatible pages.



**NOTE:** Pages might not be printed in the order that they were submitted to the printer when the Optimized order option is selected.

## How job compatibility is defined

In order to be in the same nest, the individual pages must be compatible in all of the following ways:

- All pages must have the same print-quality setting.
- The **Maximum Detail** setting must be the same on all pages.
- The **Mirror** setting must be the same for all pages.
- The **Rendering Intent** must be the same for all pages.
- The **Cutter** setting must be the same for all pages.
- The color adjustment settings must be the same for all pages. These are known as **Advanced Color Settings** in the Windows driver, and **CMYK Settings** in the Mac OS driver.
- Pages must be all color or all grayscale. The pages cannot be a mix of color and grayscale.

- All pages must be in one of the following two groups; the two groups cannot be mixed in the same nest:
  - HP-GL/2, RTL, and CALS G4
  - PostScript, PDF, TIFF, and JPEG
- JPEG, TIFF, and CALS G4 pages that have a resolution greater than 300 dpi might not nest with other pages.

## Nest with crop lines

Crop lines are lines that are printed onto the paper during a print job to indicate where the paper should be cut to create a specific paper size. Crop lines can be printed for individual jobs or for multiple jobs printed with the nesting feature.



**NOTE:** Selecting the crop lines option in the **Nest options** menu overrides the setting in the **Printing options** menu for an individual job.

To print crop lines for multiple jobs printed with the nesting feature through the Embedded Web Server:

1. Go to the **Printer Settings** page on the **Setup** tab.
2. Select **Printer settings** > **Job management** and then select Yes from the **Nest** drop-down menu.
3. Go to the **Submit Job** page on the **Main** tab.
4. In the **Job Settings** tree, select **Advanced settings** > **Roll options**, and then select **Yes** from the **Enable crop lines** drop-down menu.

For information about how to print crop lines for individual jobs, see [Print crop lines on page 45](#).



## 5 Manage calibration

### Color calibration

Your printer uses color calibration to produce consistent colors with the specific printheads, inks, and paper type that you are using, and in your particular environmental conditions. After color calibration, you can expect to get identical prints from any two different printers that are situated in different geographical locations.

Calibration should be done in any of the following circumstances:

- Whenever a printhead is replaced
- Whenever a new paper type is introduced that has not yet been calibrated with the current set of printheads
- Whenever a certain amount of printing has been done since the last calibration
- Whenever the printer has been turned off for a long period of time
- Whenever the environmental conditions (temperature and humidity) change significantly

The printer usually reminds you with an alert whenever you need to perform color calibration, unless you have disabled the alerts. However, if the environmental conditions change, the printer will not be aware of it.

You can check the color calibration status of the currently loaded paper at any time

by selecting the  icon, and then selecting **View loaded paper > View paper details**. The status can be one of the following conditions:

- Pending: the paper has not been calibrated



**NOTE:** Whenever you update the printer's firmware, the color calibration status of all papers is reset to PENDING.

- Recommend: the printer software recommends that you calibrate the printer because it has recognized a condition that might require calibration
- Obsolete: the paper has been calibrated, but the calibration is now out of date and should be repeated
- OK: the paper has been calibrated, and the calibration is up to date
- Disabled: this paper cannot be calibrated



**NOTE:** Colored papers; glossy canvas; and transparent materials such as translucent bond, clear film, tracing paper; and vellum are not suitable for color calibration.

You can also check the color calibration status by using HP Easy Printer Care (Windows) or HP Printer Utility (Mac OS).

Calibrate a paper type before creating its color profile. Later recalibration does not require a new color profile.

You can start color calibration in the following ways:

- From the printer alert that recommends calibration
- From the HP Color Center: select **Calibrate Your Printer**
- From the front panel: select the  icon, and then select **Image quality maintenance > Calibrate color**

After launching calibration, the process is fully automatic and can be performed unattended after you have loaded appropriate paper. The paper must be at least 24 inches wide.

The process takes about 8 minutes and consists of the following steps.

1. A calibration test chart is printed, which contains patches of each ink that your printer uses.



2. To stabilize the colors, the test chart dries for a period of time that depends on the paper type.
3. The HP Embedded Spectrophotometer scans and measures the test chart.
4. The printer uses the measurements to calculate the necessary correction factors for consistent color printing on that paper type. It also calculates the maximum amount of each ink that can be applied to the paper.

## Color profiling



**NOTE:** Color profiling information applies only to PostScript printers.

Color calibration provides consistent colors, but consistent colors are not necessarily accurate colors.

In order to print accurate colors, convert the color values in your files to the color values that will produce the correct colors when using your printer, your inks, and your paper. An ICC color profile is a description of a printer, ink, and paper combination that contains all the information for these color conversions.

When you have defined and calibrated a new paper type, the printer is ready to create a ICC profile for use with your paper, which allows you to print on it with the best possible color accuracy. Alternatively, if your paper type is already known to the printer, you already have its appropriate ICC profile.

## Create your own profile

Create a color profile easily by using the HP Color Center to select **Create and Install ICC Profile**. The printer prompts for information about the paper, and then creates and installs the new profile automatically.

The process takes about 15 to 20 minutes and consists of the following steps.

1. A profiling test chart is printed, which contains patches of each ink used in your printer. Unlike a calibration test chart, most of the patches contain combinations of ink.

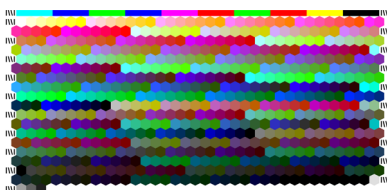

**NOTE:** To use a longer drying time, instruct the HP Color Center to create the test chart without creating a profile (Windows: select **Print target only**; Mac OS: select **Print ICC profiling chart**). Later, when the chart is completely dry, restart the HP Color Center and request a profile that uses the test chart that you have already created (Windows: select **Create ICC profile from a target that has already been printed**; Mac OS: select **Scan ICC profiling chart and create ICC profile**). The scan will begin after the spectrophotometer warms up.

2. The HP Embedded Spectrophotometer scans and measures the test chart.
3. The printer uses the measurements to calculate the necessary correction factors for consistent color printing on that paper type. It also calculates the maximum amount of each ink that can be applied to the paper.
4. The new ICC profile is stored in the correct system folder on your computer, where your software programs can find it.

The profile is also stored in the printer so other computers that are connected to the same printer can copy it. A profile can be accessed and used as soon as a job is submitted from the Embedded Web Server. HP Easy Printer Care (Windows) or HP Printer Utility (Mac OS) will notify you if your printer has profiles that are not yet stored on your computer.



**NOTE:** You might need to quit and restart some programs in order to use a profile that has just been created.

## Use a third-party profile

If you have obtained an ICC profile through means other than using the printer's built-in profiling software (for instance from an Internet download or a third-party profiling software package), you can install it for use with your printer and paper.



**NOTE:** You can only import and export CMYK profiles.

The printer needs to know which paper type the profile corresponds to. First select a paper type from the list of papers that the printer recognizes. When selecting a paper type, try to pick one that resembles your actual paper type as closely as possible.

The paper type determines the amount of ink that is used and other basic printing parameters, so making a good choice here is fundamental to achieving good results later on. If you find that you cannot obtain satisfactory results with the profile and paper type that you picked, try selecting different types, and use the one that works best.

If the paper that you are using is not listed, or if you cannot find a paper type that resembles yours closely enough, you can define a new type. The printer then calibrates itself for use with that paper, after which you can return to installing the ICC profile.

After you have selected the paper type, browse to the file that contains the ICC profile to use with your printer and paper. Normally, ICC profile file names end in the extension ".icc" (for International Color Consortium) or ".icm" (for Image Color Matching). The profile is stored in the correct system folder on your computer, and in the printer.

## Color adjustment options

The objective of color management is to print accurate colors. Perform color management correctly to print accurate colors without manual color adjustments. However, manual adjustments might be useful in the following situations:

- Your color management is not providing accurate colors
- You want colors that are subjectively pleasing rather than accurate

You can adjust the colors of your print in similar ways in Windows and Mac OS:

- **In the Windows driver:** click the **Color** tab, and then select **Print in color**. Make sure that the **Advanced Color Adjustments** check box is selected, and then click the **Settings** button.
- **In the Mac OS Print dialog box:** select the **Color options** panel, and then select **CMYK Settings**.

In either operating system, you can make adjustments by using the black slider and the three color sliders.

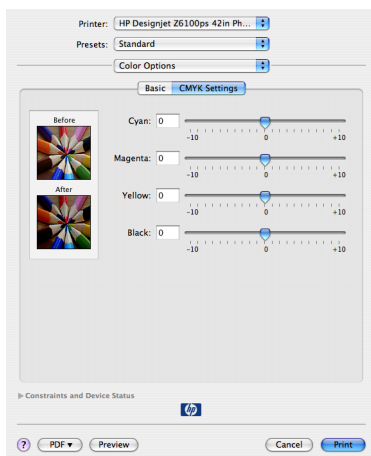

- Use the black slider to make the entire print lighter or darker.
- Use the color sliders to fade or emphasize each of the primary colors in the print. The primary colors are red, green, and blue or cyan, magenta, and yellow, depending on the color model that is used in the image.

## Color emulation modes

If you want to print a particular print job and to see approximately the same colors that you would get from printing the same job on a different HP Designjet series printer, use the printer's emulation mode.



**NOTE:** Color emulations do *not* apply to TIFF and JPEG jobs.

- In the Windows driver: click the **Color** tab, select **Printer Managed Colors**, and then select **Printer Emulation** from the **Source profile** drop-down menu. Then select from the **Emulated printer** drop-down menu.
- In the Mac OS **Print** dialog box: select the **Color Options** panel, and then select **Printer Emulation**. Then select from the **Emulated printer** drop-down menu.
- On the front panel: select the  icon, and then select **Printing preferences > Color options > Emulate Printer**.
- Through the Embedded Web Server: select the **Submit Job** page, and then **Job settings > Advanced settings > Color > Color management** and the desired emulation mode.

You can emulate the following printers:

- HP Designjet 1050c Plus
- HP Designjet 1055cm Plus
- HP Designjet 5500 UV series
- HP Designjet 5500 Dye series

The following table shows approved combinations of print-quality settings and papers for the best printer-emulation results.

	Best	Normal	Normal-Fast	Fast
<b>HP Premium Instant-Dry Gloss Photo Paper</b>	Yes	Yes	No	No
<b>HP Universal Instant-Dry Photo Gloss</b>	Yes	Yes	No	No
<b>HP Heavyweight Coated Paper</b>	Yes	Yes	No	Yes
<b>HP Coated Paper</b>	Yes	Yes	Yes	Yes
<b>HP Bright White Inkjet Bond Paper</b>	Yes	Yes	Yes	Yes



**NOTE:** The HP Designjet 5500 UV printer series does *not* support HP Bright White Inkjet Bond Paper.

The HP Designjet 1050c Plus and HP Designjet 1055cm Plus printer series do *not* support HP Premium Instant-Dry Gloss Photo Paper or HP Universal Instant-Dry Photo Gloss Paper.

## CMYK color emulation

All CMYK emulation options apply to PDF, PostScript, TIFF, and JPEG files only.

A traditional workflow defines color in the CMYK space. For best results, the colors must be adjusted to the printer, because different printers will produce different colors from the same CMYK data. If the image file that you are printing was not created

specifically for your HP Designjet Z6100 printer, it will require some readjustment, which can be done using one of the following options provided with your printer:

- **U.S. Web Coated (SWOP) 2** uses specifications that are designed to produce quality separations that use U.S. inks under the following printing conditions: 300% total area of ink coverage, negative plate, coated publication-grade stock.
- **U.S. Web Uncoated 2** uses specifications that are designed to produce quality separations that use U.S. inks under the following printing conditions: 260% total area of ink coverage, negative plate, uncoated white offset stock.
- **U.S. Sheetfed Coated 2** uses specifications that are designed to produce quality separations that use U.S. inks under the following printing conditions: 350% total area of ink coverage, negative plate, bright white offset stock.
- **U.S. Sheetfed Uncoated 2** uses specifications that are designed to produce quality separations that use U.S. inks under the following printing conditions: 260% total area of ink coverage, negative plate, uncoated white offset stock.
- **Euroscale Coated 2** uses specifications that are designed to produce quality separations that use Euroscale inks under the following printing conditions: 350% total area of ink coverage, positive plate, bright white coated stock
- **Euroscale Uncoated 2** uses specifications that are designed to produce quality separations that use Euroscale inks under the following printing conditions: 260% total area of ink coverage, positive plate, uncoated white offset stock.
- **Europe ISO Coated FOGRA27** uses the FOGRA27 press characterization. It is designed to produce quality separations for standard ISO printing using: 350% total ink coverage, positive film and coated paper"
- **HP CMYK Plus:** a set of HP proprietary re-rendering rules that produce a good result for most digital commercial printing jobs by expanding the reduced gamut of your press into the wider gamut of your printer.
- **JMPA:** Japanese standard for offset press
- **Photoshop 4 Default CMYK**
- **Photoshop 5 Default CMYK**
- **Japan Color 2001 Coated** uses the Japan Color 2001 specification for type 3 (coated) paper. It is designed to produce quality separations by using 350% total ink coverage, positive film, and coated paper.
- **Japan Color 2001 Uncoated** uses the Japan Color 2001 specification for type 4 (uncoated) paper. It is designed to produce quality separations by using 310% total ink coverage, positive film, and uncoated paper.
- **Japan Web Coated (Ad)** uses specifications that are developed by the Japan Magazine Publisher Association for digital proofing of images in the Japanese magazine and advertising market.

- **Japan Color 2002 Newspaper** uses the Japan Color 2002 for Newspapers specification. It is designed to produce quality separations using: 240% total ink coverage, positive film and standard newsprint paper"
- **Toyo** is designed to produce quality separations for Toyo printing presses.
- **DIC** is designed to produce quality separations for Dainippon Ink Company printing presses.
- Other **HP Designjet** printers can be emulated.
- **None (Native)**: no emulation, for use when the when the software or operating system complete the color conversion. Therefore, the data arrives at the printer already color-managed



---

**NOTE:** These options have no effect if the software defines its own CMYK space, known as calibrated CMYK or CIEBasedDEFG in PostScript terminology.

---

## RGB color emulation

These options apply to PDF, PostScript, TIFF, and JPEG files. For HP-GL/2 and RTL files, only sRGB and AdobeRGB are supported.

If you want to print an RGB image, it must be converted to CMYK data. You might be able to do the conversion in the software or operating system. To perform this conversion on the printer, use the following color profiles:

- **None (Native)**: no emulation. The printer uses its default internal conversion from RGB to CMYK, without following any color standard. This does not imply that results will be bad.
- **sRGB IEC61966-2.1** emulates the characteristics of the average PC monitor. This standard space is endorsed by many hardware and software manufacturers, and is becoming the default color space for many scanners, printers, and software programs.
- **ColorMatch RGB** emulates the native color space of Radius Pressview monitors. This space provides a smaller gamut alternative to Adobe RGB (1998) for print-production work.
- **Apple RGB** emulates the characteristics of the average Apple monitor, and is used by a variety of desktop publishing applications. Use this space for files that you plan to display on Apple monitors, or for working with old desktop publishing files.
- **Adobe RGB (1998)** provides a fairly large gamut of RGB colors. Use this space if you need to do print-production work that includes a broad range of colors.



# 6 Troubleshoot print-quality issues

## General advice

Use the following approach when you have any print-quality problem:

- To achieve the best performance from your printer, use only genuine HP supplies and accessories, whose reliability and performance have been thoroughly tested to give trouble-free performance and best-quality prints.
- Make sure that the paper type that you select on the front panel is the same as the paper type that is loaded in the printer. Make sure that the paper type has been calibrated. Also make sure that the paper type that you select in your software is the same as the paper type that you loaded in the printer.



**CAUTION:** If you have the wrong paper type selected, you might experience poor print quality and incorrect colors, and damage to the printheads might occur.

- Make sure that you are using the most appropriate print-quality settings for your purposes. See [Select print quality on page 41](#). You are likely to see lower print quality if you have moved the print-quality slider to the **Fast** end of the scale, or set the custom quality level to **Fast**.
- Make sure that your environmental conditions (temperature, humidity) are in the recommended range.
- Make sure that your ink cartridges and printheads have not passed their expiration dates.
- Avoid touching the paper while printing is in progress.

## The Embedded Web Server Print Quality Troubleshooting wizard

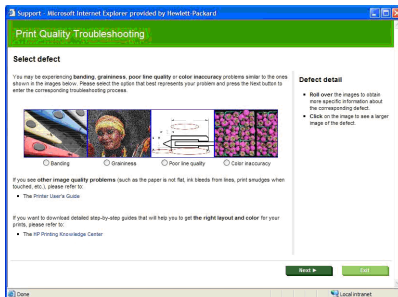

The Embedded Web Server Print Quality Troubleshooting wizard is designed to help you resolve some of the most common print-quality issues that users encounter in large-

format printing. The wizard guides you through the resolution of the following print-quality issues:



- Dark or light horizontal lines across the image (banding)
- Graininess
- Poor line quality
- Inaccurate color

To access the Embedded Web Server Print Quality Troubleshooting wizard, click the **Print Quality Troubleshooting** link on the **Support** tab. Select the print-quality issue that you are experiencing and click the **Next** button.

A list of suggestions for corrective action appears along with help to guide you through the corrective action.

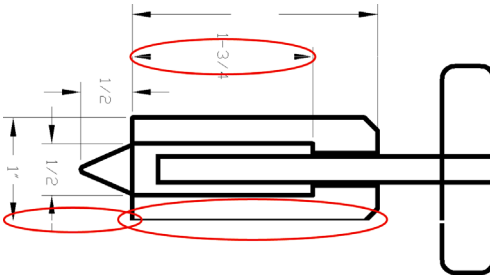
## Lines are too thick, too thin, or missing



1. Verify that the paper type that you have loaded corresponds to the paper type that you selected on the front panel and in your software.
2. Make sure that you are using the appropriate print-quality settings for your purposes. See [Select print quality on page 41](#).
3. If you are using a HP-GL/2 driver and the resolution of your image is greater than the printing resolution, you might notice a loss of line quality. You can find the **Max. Application Resolution** option on the Windows driver **Advanced** tab, under **Document Options > Printer Features**. If you change this option, reprint your job if the problem has been solved.
4. If lines are too thin or missing, print the Printhead status plot. See [Use the Printhead status plot on page 35](#).
5. Try aligning the printheads. See [Align the printheads on page 34](#). After alignment, reprint your job if the problem has been solved.
6.  Select the  icon on the printer's front panel, and then **View loaded paper** to see the paper-advance calibration status. If the status is PENDING,

perform a paper-advance calibration. See [Perform paper advance calibration on page 24](#).

If the problem persists after you complete these actions, contact your customer service representative for further support.

## Lines appear stepped or jagged

Use the following procedure if lines in your image appear stepped or jagged when printed:



1. The problem might be inherent in the image. Try to improve the image within the software program that you are using to edit it.
2. Make sure that you are using appropriate print-quality settings. See [Select print quality on page 41](#).
3. If you are using an HP-GL/2 driver, change your image-rendering resolution to 300 dpi or 600 dpi, depending on your printing need. The **Max. Application Resolution** option in the Windows driver dialog's **Advanced** tab, under **Document Options > Printer Features**.

## Parts of lines or text are missing

A high-quality large-format print job often requires a large amount of data, and in some specific workflows, the output might not look like you expected. Here are some suggestions to help you to avoid this problem:

- Select a smaller page size and scale to the final page size in the driver or on the front panel.
- Save the file in another format, such as TIFF or EPS, and open it in another program.
- Use a RIP to print the file.
- Reduce the resolution of the bitmap images in your software.
- Select a lower print quality in order to reduce the resolution of the printed image.
- On the **Advanced** tab of the Windows driver dialog, select **Document options, Printer features**, and then establish the following settings:
  - Set **Send job as bitmap** to **Enabled** (HP-GL/2 driver only).
  - Set **16-bit App. Compatibility** to **Enabled**.
  - Set **Max. Application resolution** to 300.



**NOTE:** These settings are described for troubleshooting purposes only and might adversely affect the final output quality or the time necessary to generate the print job. Therefore, restore these settings to their default values if they do not help to solve the problem.

## Lines are printed double or in wrong colors

This problem can have various visible symptoms:

Colored lines are printed double, in different colors, or the borders of colored blocks are wrongly colored.

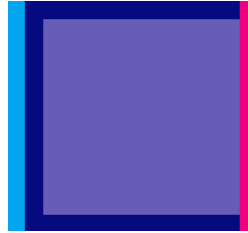
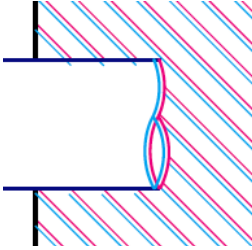

Use these steps to correct this kind of problem:

1. Align the printheads. See [Align the printheads on page 34](#).
2. Make sure that you are using appropriate print-quality settings. See [Select print quality on page 41](#).

## Lines are blurred (ink bleeds from lines)



Humidity can cause ink to soak into the paper, making the lines look blurred and fuzzy. Try the following remedies:

1. Make sure that your environmental conditions (temperature, humidity) are suitable for high-quality printing.
2. Verify that the paper type that you select on the front panel is the same as the paper type that you are using. To check, select the  icon from the printer's front panel, and then select **View loaded paper**.
3. Try changing to a heavier paper type, such as HP Heavyweight Coated Paper, HP Super Heavyweight Coated Paper, or Digital Fine Art paper.
4. If you are using glossy paper, try changing to a different type of glossy paper.
5. Align the printheads. See [Align the printheads on page 34](#).

## Dark or light horizontal lines across the image (banding)

Try the following remedies if your printed image suffers from added horizontal lines as shown (the color may vary):



1. Make sure that the paper type you have loaded corresponds to the paper type that you select on the front panel and in your software.
2. Make sure that you are using appropriate print-quality settings for your purposes. See [Select print quality on page 41](#). In some cases, you can overcome a print-quality problem merely by selecting a higher print-quality level. For instance, if you have set the print-quality slider to **Fast**, try setting it to **Best**. If you change the print-quality settings, reprint your job if the problem has been solved.
3. Print the Printhead status plot. See [Use the Printhead status plot on page 35](#).

4. Check the paper-advance calibration status on the front panel. If the status is PENDING, you should perform paper-advance calibration. See [Perform paper advance calibration on page 24](#).
5. Try aligning the printheads. See [Align the printheads on page 34](#). After alignment, reprint your job if the problem has been solved.

If the problem persists, contact your customer service representative for further support.

## The image is grainy



1. Verify that the paper type you have loaded corresponds to the paper type that you select on the front panel and in your software.
2. Verify that you are printing on the correct side of the paper.
3. Make sure that you are using appropriate print-quality settings. See [Select print quality on page 41](#). In some cases, you can overcome a print-quality problem merely by selecting a higher print-quality level. For instance, if you have set the print-quality slider to **Fast**, try setting it to **Best**. If you change the print-quality settings, reprint your job if the problem has been solved.
4. Try aligning the printheads. See [Align the printheads on page 34](#). After alignment, reprint your job if the problem has been solved.
5. Check the paper-advance calibration status on the front panel. If the status is PENDING, you should perform paper-advance calibration. See [Perform paper advance calibration on page 24](#).

If the problem persists, contact your customer service representative for further support.

## The image has a metallic hue (bronzing)

Bronzing describes an image that has a metallic hue when it is viewed from specific angles. Bronzing occurs most commonly when you print pigmented inks on non-matte paper, such as photo paper. If you are using standard print-quality options and the image contains the bronzing effect, move the slider to **Quality**. See [Select print quality on page 41](#).

If you are experiencing bronzing when printing grayscale images on glossy paper, try using the **Full Set of Inks** printing option. To do so from the Windows driver, click the **Color** tab and select **Print In Grayscale**, and then select the **Full Set of Inks** option from the drop-down menu.

## The printed output is not flat

If the paper does not lie flat when it comes out of the printer, but instead contains shallow waves, you are likely to see defects in the printed image, such as vertical stripes. This can happen when you use thin paper that becomes saturated with ink.



1. Make sure that the paper type you have loaded corresponds to the paper type that you select on the front panel and in your software.
2. Try changing to a thicker paper type, such as HP Heavyweight Coated Paper, HP Super Heavyweight Coated Paper, or thicker Digital Fine Art papers.

## The print smudges when touched

The black ink pigment can smudge when a finger or pen touches it. This is particularly noticeable on: vellum, translucent bond, films, productivity photo paper, and natural tracing paper.

Try these remedies to reduce the smudging:

- Try to print in an environment that is not too humid for the printer.
- Change pure black objects in your image to a dark color, such as dark brown, so that they are printed with colored inks instead of black ink.
- Use HP Heavyweight Coated Paper.
- Increase the drying time.

## Ink marks appear on the paper

This problem can occur for several different reasons.

### Smears on the front of coated paper

If a lot of ink is used on coated paper, the paper absorbs the ink quickly and expands. As the printheads move over the paper, the printheads come into contact with the paper and smear the printed image.

Whenever you notice this problem, cancel the printing job immediately. Press the **Cancel** button on the front panel and also cancel the job from your computer software. Otherwise the soaked paper might damage the printheads.

Try the following suggestions to avoid this problem:

- Use a recommended paper type.
- If the image you are printing contains intense color, try using HP Heavyweight Coated Paper.
- Use extended margins (see [Adjust margins and layout options on page 43](#)), or try to increase the margins by relocating the image within the page by using your software program.
- If necessary, try changing to a non-paper-based material such as transparent film.

### Smears or scratches on the front of glossy paper

Glossy paper can be extremely sensitive to the bin or to anything else that it contacts soon after printing. This depends on the amount of ink that has been deposited on the paper and the environmental conditions at the time of printing. Avoid any contact with the paper surface and handle the print with care.

### Defects near the top of a print

In a defect that affects only the start of a print, within 5.5 cm of the leading edge of the paper, a band of inconsistent color appears:



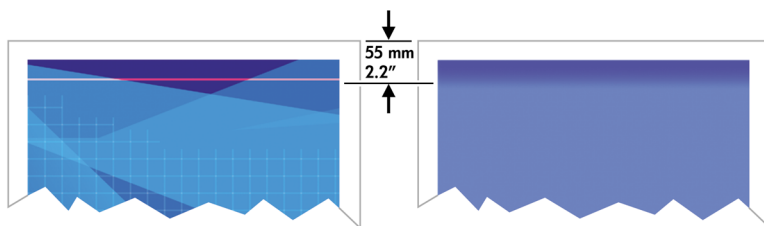

Use these steps to avoid this problem:

1. The easiest solution might be to select the **Extended Margins** option in the driver, through the Embedded Web Server, or on the front panel. Using this remedy means that the area of the paper affected by the problem (at the start of the page) might not be printed on. See [Adjust margins and layout options on page 43](#).
2. Align the printheads. See [Align the printheads on page 34](#).
3. Make sure that you are using appropriate print-quality settings. See [Select print quality on page 41](#).

## Colors are inaccurate

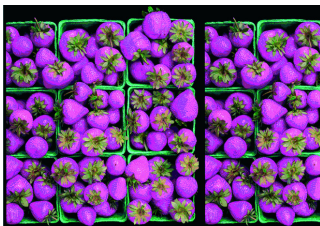

If the colors of your print do not match your expectations, try the following remedies:

1. Verify that the paper type you have loaded corresponds to the paper type that you selected on the front panel and in your software. At the same time, check the color-calibration status. If the status is RECOMMENDED or OBSOLETE, you should perform color calibration. See [Color calibration on page 49](#). If you have made any changes, reprint your job if the problem has been solved.
2. Verify that you are printing on the correct side of the paper.
3. Make sure that you are using the appropriate print-quality settings. See [Select print quality on page 41](#). If you have selected the **Fast** options, you might not get accurate colors. If you change the print-quality settings, reprint your job if the problem has been solved.

4. If you are using Application Color Management, make sure that the color profile that you are using corresponds to the selected paper type and print-quality settings. If you have doubts about which color settings to use, see [Manage calibration on page 49](#). If you need to create a color profile, see [Color profiling on page 50](#).
5. If the problem consists of color differences between your print and your monitor, follow the instructions in the “How to calibrate your monitor” section of the HP Color Center. Reprint your job if the problem has been solved.
6. Print the Printhead status plot. See [Use the Printhead status plot on page 35](#).
7. Consult the HP Knowledge Center at <http://www.hp.com/go/knowledge-center/djz6100/> for step-by-step color assistance with different software programs (English language content only).

If the problem persists, contact your customer service representative for further support.

## The output is completely blank

If the front-panel graphic language setting is **Automatic** (the default), try the other settings: **PostScript** for a PostScript file, **HP-GL/2** for an HP-GL/2 file, and so on. Then send the file again.

When you have finished this particular print, remember to reset the graphic language to **Automatic**.

## The output contains only a partial print

- If you pressed **Cancel** before the printer received all the data, you ended the data transmission and will have to print the page again.
- The **I/O timeout** setting might be too short. This setting determines how long the printer waits for the computer to send more data, before deciding that the job is finished. On the front panel, increase the **I/O timeout** setting to a longer

period and then send the print again by selecting the  icon, and then selecting **Connectivity > Advanced > Select I/O timeout**.

- A communications problem between your computer and the printer might exist. Check your USB or network cable.
- Verify that your software settings are correct for your current page size (for example, long-axis prints).
- If you are using network software, make sure that it has not timed out.

## The image is clipped

Clipping normally indicates a discrepancy between the actual printable area on the loaded paper and the printable area as described by your software. You can often

identify this kind of problem before printing by previewing your print. See Hold for preview in *Using your printer*.

- Check the actual printable area for the paper size that you have loaded.  
printable area = paper size – margins
- Check what your software understands to be the printable area (which it might cite as "printing area" or "imageable area"). For example, some software programs assume standard printable areas that are larger than those used in this printer.
- If you have defined a custom page size that has very narrow margins, the printer might impose its own minimal margins and clip your image slightly. You might want to use a larger paper size. See [Adjust margins and layout options on page 43](#).
- If your image contains its own margins, you might be able to print it successfully by using the **Clip Contents by margins** option. See [Adjust margins and layout options on page 43](#).
- If you are trying to print a very long image on a roll, make sure that your software can print an image of that size.
- You might have asked to rotate the page to landscape orientation on a paper size that is not sufficiently wide.
- If necessary, reduce the size of the image or document in your software, so that it fits between the margins

Other explanations exist for a clipped images. Some programs, such as Adobe Photoshop, Adobe Illustrator, and CorelDRAW, use an internal 16-bit coordinate system which means that they cannot handle an image of more than 32,768 pixels. If you try to print a larger image, the bottom of the image will be clipped. To print the entire image, try these suggestions:

- If you are using an HP-GL/2 driver, you can reduce the resolution so that the whole image requires fewer than 32,768 pixels. The Windows driver includes an option called **16-bit App. Compatibility**, which reduces the resolution automatically. The option is on the **Advanced** tab, under **Document Options > Printer Features**.
- Save the file in another format, such as TIFF or EPS, and open it in another program.
- Use a RIP to print the file.

## One image overlays another on the same print

The **I/O timeout** setting might be too long. On the front panel, decrease the setting

and print again. Select the  icon, and then select **Connectivity > Advanced > Select I/O timeout**.

## The image has a wood-grain appearance (aeroworms)



Aeroworms are wavy, horizontal bands produced by air-induced dot placement error (DPE). In extreme cases, aeroworms give the image a wood-grain appearance. The problem occurs most commonly on print jobs that are set for low-quality and high-speed. It does not occur when the custom print-quality setting is set to “best.”

To eliminate aeroworms, select a higher IQ print setting. See [Select print quality on page 41](#).

## 7 Troubleshoot paper issues

### The paper cannot be loaded successfully

Here are a few things to check if you cannot successfully load the paper.

- The paper might be loaded at an angle (skewed or mislocated). Make sure that the right edge of the paper is aligned with the half-circle on the right-hand side of the platen, and that the leading edge of the paper is aligned with the metal bar in the platen.
- The paper might be crumpled or warped, or have irregular edges.
- If the paper jams in the paper path to the platen, the leading edge of the paper might not be straight or clean. Remove the initial 2 cm (1 in) of paper from the roll and try again. This might be necessary even with a new roll of paper.
- Make sure that the spindle is correctly inserted.
- Make sure that the paper is correctly loaded on the spindle, and that it loads over the roll towards you.
- Verify that the paper is wound tightly on the roll.

### The paper has jammed

When a jam occurs, the **Possible paper jam** message usually appears in the front panel, with one of two error codes:

- 81:01 indicates that paper cannot advance into the printer.
- 86:01 indicates that the printhead carriage cannot move from side to side.

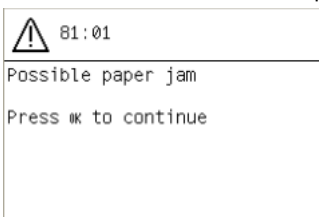

### Check the printhead path

1. Turn off the printer at the front panel, then also switch off the power switch at the rear.
2. Open the printer window.
3. Try to move the printhead carriage out of the way. Lift the paper-load lever as far up as it will go.

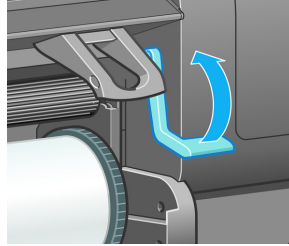
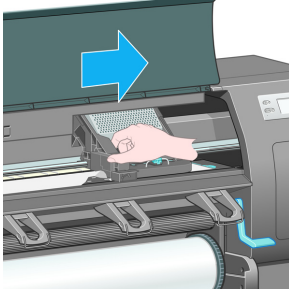

4. Carefully remove any of the jammed paper that you can lift up and out from the top of the printer.

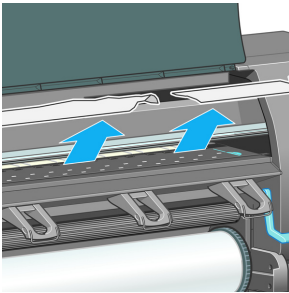

5. Carefully pull the rest of the roll down and out of the printer.
6. Turn on the printer.
7. Reload the roll. See [Load a roll into the printer on page 11](#).
8. If some paper continues to cause an obstruction within the printer, it can often be cleared by loading a rigid paper type into the printer.
9. If you find that you have print-quality problems after a jam, try realigning the printheads. See [Align the printheads on page 34](#).

## Check the paper path

- This problem can occur when a roll has finished and the end of the roll is stuck to the cardboard core. If this has happened, cut the end of the roll away from the core. Then feed the paper through the printer, and load a new roll.
- Otherwise, follow the procedure described above, under [Check the printhead path on page 69](#)

## Automatic paper-cutter does not function

The automatic paper-cutter is disabled when the take-up reel is in use. To use the cutter on the paper, uninstall (disable) the take-up reel on the front panel by selecting



the icon, and then selecting **Take-up reel > Disable take-up reel**.



**NOTE:** The automatic paper-cutter feature is disabled for some of the heaviest media types, because they might damage the cutter.

## Take-up reel paper jammed

If the paper is severely damaged on the take-up reel spindle core, do not use the printer's cutter to cut and remove the paper. Instead, cut the paper manually as close as possible to the printer window, and then remove the roll. See [Unload a roll from the printer on page 15](#).

## Take-up reel does not wind

Predictably, if the take-up reel is not winding as anticipated, the printed output is likely to end up on the floor. If the printer recognizes a problem with the take-up reel, it will interrupt the print job until the issue is corrected. If the printer does not recognize a problem, the job will continue to print. The following table highlights possible issues and solutions.

Take-up reel LED status	Issue	Print job interrupted?	Possible cause	Possible solution
Blinking quickly	Take-up reel is not winding	Yes	The sensor beam was blocked for more than 3 seconds.	Make sure that the take-up reel sensors are not blocked by a strip of paper, the collection bin if you are using the HP Designjet Z6100 42-in Printer, or any objects. See the following graphic. Make sure that the collection bin is placed behind the foot brace.  Also ensure that the take-up reel power switch is in the On position.
Blinking slowly	Take-up reel is not winding	No	The sensor cables are loose or unplugged.	Ensure that the sensor cables are correctly secured.

Take-up reel LED status	Issue	Print job interrupted?	Possible cause	Possible solution
Solid red	Take-up reel is not winding	No	There is too much resistance on the take-up reel motor.	Ensure that the paper is not winding too tightly. A loop-shaping core should be inserted and hanging as shown in step 10 of <a href="#">Use the take-up reel on page 16</a> .
Solid green	Take-up reel is not winding	No	The take-up reel power switch is in the Off position	Ensure that the take-up reel power switch is in the On position.
Solid green	Take-up reel is winding in the wrong direction	No	The take-up reel wind-direction switch is in the wrong winding position.  After 3 seconds, the printer recognizes the problem and interrupts the print job. See the first error listed in this table.	Flip the take-up reel wind-direction switch to the correct position.

The following graphic shows the take-up reel sensors and cable.



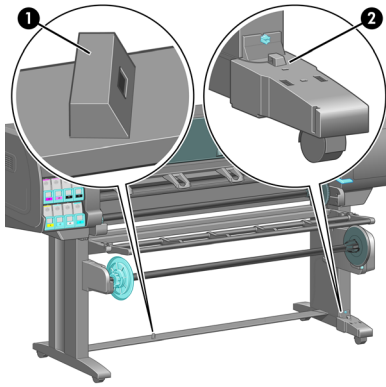

1. Take-up reel sensor
2. Take-up reel sensor and cable housing unit

## 8 Troubleshoot ink system issues

### Clean the printheads

Periodic printhead cleaning is performed automatically, as long as the printer is kept turned on. However, you should clean the printheads if you are experiencing poor image quality and cannot resolve the issues by other methods. This ensures that there is fresh ink in the nozzles and helps to prevent nozzle clogs.

If you have printed the Printhead status plot, you know which colors are failing. Clean the pair of printheads that are not performing adequately. If you are not sure which printheads to clean, clean all of the printheads.

To clean the printheads, go to the printer's front panel and select the  icon, select **Image quality maintenance > Clean printheads**, and then select which printheads you want to clean. You can clean all of the printheads or only some of them. Your choices are:

- Clean all
- Clean M-Y
- Clean LM-LC
- Clean PK-LG
- Clean MK-C
- Purge ink

Cleaning all of the printheads takes about 5 minutes. Cleaning any two printheads takes about 3 minutes. Purging the ink takes about 6 minutes.



**NOTE:** Cleaning all printheads uses more ink than cleaning a single pair.

**NOTE:** HP recommends that you purge the ink from the printheads before printing a job if the printer has been turned off for more than six weeks or if you are experiencing inconsistent colors from print to print after long storage periods. Purging the ink from the printheads helps to ensure maximum color consistency; it is *not* a remedy for poor printhead health.

### Align the printheads

Precise alignment between printheads is essential for color accuracy, smooth color transitions, and sharp edges in graphical elements. Your printer has an automatic printhead alignment process which runs whenever a printhead has been accessed or replaced.

In the case of a paper jam, if you have used a custom paper, or if you are experiencing problems with color accuracy; you might need to align the printheads. See [Align the printheads on page 34](#).



---

**NOTE:** If you experience a paper jam, HP recommends that you reinsert the printheads and align the printheads.

---



**TIP:** Use the same paper you intend to print on to align the printheads. Photo paper is recommended for the best results. Plain; bond; and thin, coated papers are acceptable, but provide marginal results.

---



**WARNING!** Colored papers, glossy canvas, and transparent materials such as translucent bond, clear film, tracing paper, and vellum are not suitable for aligning the printheads. However, if you must perform printhead alignment with a material that is not supported, make sure you use a material with the same thickness as the material you are going to use for printing.

---

## Reinsert printheads procedure

1. If the printhead alignment process is running and the wrong paper is loaded, press the **Cancel** button on the front panel.



**CAUTION:** Do not print if the printhead alignment process has been canceled.

---

2. Load the paper you want to use. Photo paper is recommended for the best results.



**WARNING!** Colored papers, glossy canvas, and transparent materials such as translucent bond, clear film, tracing paper, and vellum are not suitable for aligning the printheads. However, if you must perform printhead alignment with a material that is not supported, make sure you use a material with the same thickness as the material you are going to use for printing.

---

3. Remove and reinsert all of the printheads. See [Remove a printhead on page 29](#) and [Insert a printhead on page 32](#). This starts the printhead alignment process.



**NOTE:** Make sure the printer window is closed during printhead alignment.

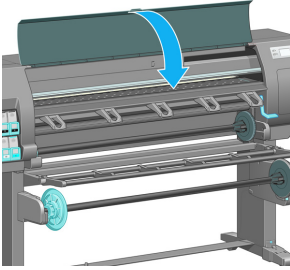

4. The process takes about 6 minutes. Wait until the front panel shows that the process is complete before using the printer.



**NOTE:** A calibration image is printed during the printhead alignment process. The front panel shows if there were any errors in the process.

## Image Quality Maintenance menu procedure

1. Load the paper you want to use. Photo paper is recommended for the best results. Plain; bond; and thin, coated papers are acceptable, but provide marginal results.



**WARNING!** Colored papers, glossy canvas, and transparent materials such as translucent bond, clear film, tracing paper, and vellum are not suitable for aligning the printheads. However, if you must perform printhead alignment with a material that is not supported, make sure you use a material with the same thickness as the material you are going to use for printing.

- 2.



Go to the front panel and select the  icon, and then select **Image quality maintenance > Align printheads**. The printer verifies that a sufficient amount of paper exists to perform printhead alignment.

3. If the paper type that is loaded is acceptable for printhead alignment, the printer performs the alignment and prints an alignment pattern.



**NOTE:** Make sure the printer window is closed during printhead alignment.

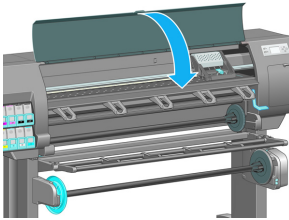

4. The process takes about 5 minutes. Wait until the front panel shows that the process is complete before using the printer.

## Scan errors during alignment

If the alignment process fails, a **Scanning problems** message appears on the front panel. This indicates that the alignment was not completed successfully. Therefore, the printheads are not aligned and the alignment should be repeated before printing. The problem might be because of one of the following scenarios:

- The type of paper used in the printhead alignment process was not acceptable. Repeat the alignment process using one of the recommended paper types.
- The printheads are not clean. Clean the printheads. See [Clean the printheads on page 74](#).
- The printer window was open during the printhead alignment process. Repeat the alignment process with the printer window closed.

If the problem persists after following the recommended remedies, try replacing all of the printheads. If the problem persists after replacing the printheads, a failure in the scanning system may exist.

## 9 Front-panel error messages

Under certain circumstances, a front-panel error message appears. Follow the advice in the Recommendation column to resolve the error.

If an error message appears on the front panel that is *not* included in this list, and you are in doubt over the correct response, contact HP Support. See [HP Customer Care on page 82](#).

**Table 9-1 Text messages**

Message	Recommendation
[Color] cartridge has expired	Replace the cartridge. See <a href="#">Remove an ink cartridge on page 27</a> and <a href="#">Insert an ink cartridge on page 29</a> .
[Color] cartridge is missing	Insert a cartridge of the correct color. See <a href="#">Insert an ink cartridge on page 29</a> .
[Color] cartridge is out of ink	Replace the cartridge. See <a href="#">Remove an ink cartridge on page 27</a> and <a href="#">Insert an ink cartridge on page 29</a> .
[Color] printhead #[n] error: not present	Insert the correct printhead. See <a href="#">Insert a printhead on page 32</a> .
[Color] printhead #[n] error: please remove	Remove the incorrect printhead and insert a new printhead of the correct type (color and number). See <a href="#">Remove a printhead on page 29</a> and <a href="#">Insert a printhead on page 32</a> .
[Color] printhead #[n] error: replace	Remove the non-functional printhead and insert a new printhead. See <a href="#">Remove a printhead on page 29</a> and <a href="#">Insert a printhead on page 32</a> .
[Color] printhead #[n] error: reset	Remove and reinsert the same printhead, or try cleaning the electrical connections. If necessary, insert a new printhead.
[Color] printhead #[n] out of warranty	The printhead's warranty has ended, because of the length of time it has been in operation or because of the volume of ink used. See <a href="#">Legal information on page 87</a> .
[Color] printhead #[n] warranty warning	The printhead's warranty may be invalidated by the use of the wrong kind of ink. See <a href="#">Legal information on page 87</a> .
[Warning] internal failure: Unable to create print	The internal print files are not available in the printer. Load the internal print files through the Embedded Web Server.

**Table 9-1 Text messages (continued)**

Message	Recommendation
IO error	Restart the printer. If the problem persists, contact HP Support. See <a href="#">HP Customer Care on page 82</a> .
IO warning	Try again; if the problem persists, contact HP Support. See <a href="#">HP Customer Care on page 82</a> .
PDL Error: Ink system not ready	Clean the printheads. See <a href="#">Clean the printheads on page 74</a> .
PDL Error: Job clipped	The image is too large for the paper or for the printer. Load larger paper if possible, or reduce the image size.
PDL Error: memory full	Restart the printer and try resending the job; if necessary, reduce the complexity of the job.
PDL Error: out of paper	Load more paper.
PDL Error: parsing error	The print job is unintelligible to the printer. Try to recreate and resend it. Check your cable connections.
PDL Error: print mode error	The paper type or print quality specified for the job are incorrect. Change the loaded paper type or the print settings.
PDL Error: printing error	Try sending the job again.
PDL Error: virtual memory full	Restart the printer and try resending the job; if necessary, reduce the complexity of the job.
Replace [color] cartridge	Replace the cartridge. See <a href="#">Remove an ink cartridge on page 27</a> and <a href="#">Insert an ink cartridge on page 29</a> .
Reseat [color] cartridge	Remove and reinsert the same cartridge. See <a href="#">Remove an ink cartridge on page 27</a> and <a href="#">Insert an ink cartridge on page 29</a> .
Update: failed. Invalid file	Make sure that you have selected the correct firmware update file. Then try again to perform the update.

Under certain circumstances, a front-panel numeric error message appears. Follow the advice in the Recommendation column to resolve the error.

If an error message appears on the front panel that is *not* included in this list, turn off the printer and then turn it back on. If the problem persists, contact HP Support. See [HP Customer Care on page 82](#).

**Table 9-2 Numeric error messages**

Error code	Recommendation
26.n.01 (where n = the subject ink cartridge number)	Remove the subject ink cartridge and reinstall it in the printer. If the error persists, replace the subject ink cartridge. If the problem persists, contact HP Support. See <a href="#">HP Customer Care on page 82</a> .
29.01	The maintenance cartridge is not inserted correctly. Open the maintenance cartridge door on the right side of the printer, make sure that the maintenance cartridge is correctly seated, and then close the door. If the problem persists, replace the maintenance cartridge. If the problem persists, contact HP Support. See <a href="#">HP Customer Care on page 82</a> .
32.1.01	A take-up reel error has occurred. Make sure that the paper is adequately taped to the take-up reel spindle core, and then make sure that the winding direction is correctly set.
32.2.01	The take-up reel can not be detected. Make sure that the take-up reel sensor cable is correctly connected.
61.01	<p>The file format is incorrect and the printer cannot process the job. Try the following remedies:</p> <ul style="list-style-type: none"> <li>• Turn off the printer by using the Power button on the front panel and the power switch at the back of the printer, and then disconnect the power cord—then reconnect the power cord and turn on the printer.</li> <li>• Make sure that the graphic language setting is correct.</li> <li>• Resubmit the file to the printer.</li> <li>• Verify that your printer firmware is up to date.</li> </ul> <p>If the problem persists, contact HP Support. See <a href="#">HP Customer Care on page 82</a>.</p>
63.04	<p>An input/output problem has occurred with the network card. Try the following remedies:</p> <ul style="list-style-type: none"> <li>• Make sure that the network cable is correctly connected to the network card.</li> <li>• Verify that your printer firmware is up to date.</li> </ul> <p>If the problem persists, contact HP Support. See <a href="#">HP Customer Care on page 82</a>.</p>
71.03	An “out of memory” failure has occurred. HP recommends that you remove any unnecessary files from the printer’s hard disk through the Embedded Web Server.



**Table 9-2 Numeric error messages (continued)**

Error code	Recommendation
74.01	<p>An error occurred when uploading the firmware update file. Try the following remedies:</p> <ul style="list-style-type: none"> <li>• Turn off the printer by using the Power button on the front panel and the power switch at the back of the printer, and then disconnect the power cord—then reconnect the power cord and turn on the printer.</li> <li>• Try again to upload the firmware update file to the printer.</li> </ul> <p>If the problem persists, contact HP Support. See <a href="#">HP Customer Care on page 82</a>.</p>
76.03	<p>A “disk out of space” has occurred. Try the following remedies:</p> <ul style="list-style-type: none"> <li>• Turn off the printer by using the Power button on the front panel and the power switch at the back of the printer, and then disconnect the power cord—then reconnect the power cord and turn on the printer.</li> <li>• Resubmit the file to the printer.</li> <li>• HP recommends that you remove any unnecessary files from the printer's hard disk through the Embedded Web Server.</li> <li>• Perform an Electrically Erasable Read-Only Memory (EEROM) reset and then resubmit the file to the printer.</li> </ul> <p>If the problem persists, contact HP Support. See <a href="#">HP Customer Care on page 82</a>.</p>
77.04	<p>An Embedded Web Server internal software error has occurred. Try the following remedies:</p> <ul style="list-style-type: none"> <li>• Turn off the printer by using the Power button on the front panel and the power switch at the back of the printer, and then disconnect the power cord—then reconnect the power cord and turn on the printer.</li> <li>• Verify that your printer firmware is up to date.</li> </ul> <p>If the problem persists, contact HP Support. See <a href="#">HP Customer Care on page 82</a>.</p>
81.01, 81.03, 86.01	<p>Open the printer window and make sure that there are no obstacles restricting the movement of the drive roller. If the paper has jammed and is restricting the movement of the drive roller, lift the paper load lever and clear the obstruction. If the problem persists, contact HP Support. See <a href="#">HP Customer Care on page 82</a>.</p>

# 10 Get help

## Introduction

HP Customer Care offers award-winning support to ensure that you get the most from your HP Designjet. HP Customer Care provides comprehensive, proven support expertise and new technologies to give you unique end-to-end support. Services include setup and installation, troubleshooting tools, warranty upgrades, repair and exchange services, phone and Web support, software updates, and self-maintenance services. For more information about HP Customer Care, go to: <http://www.hp.com/go/designjet/>.

## HP Instant Support

HP Instant Support Professional Edition is HP's suite of troubleshooting tools that collect diagnostic information from your printer and match it with intelligent solutions from HP's knowledge bases, allowing you to resolve problems as quickly as possible. To start an HP Instant Support session, click on the link in the **Support** tab of your printer's Embedded Web Server. See [Access the Embedded Web Server on page 7](#).

To use HP Instant Support, the following conditions must be met:

- Because HP Instant Support is accessible only through the Embedded Web Server, you must have a TCP/IP connection to your printer.
- Because HP Instant Support is a Web-based service, you must have access to the World Wide Web,

HP Instant Support is currently available in English, Korean, Simplified Chinese, and Traditional Chinese.

For more information about HP Instant Support, go to: <http://www.hp.com/go/ispe/>.

## HP Proactive Support

HP Proactive Support is a troubleshooting support tool that identifies, diagnoses, and resolves issues you might encounter when using your commercial imaging and printing products. HP Proactive Support is embedded into multiple HP software programs including the HP Easy Printer Care (Windows) and HP Printer Utility (Mac OS), allowing you to easily and conveniently monitor, update and maintain all of your HP printers.

For more information about HP Proactive Support, go to: <http://www.hp.com/go/proactivesupport>.

## HP Customer Care

As your strategic support partner, we make it our business to help keep your business running smoothly. HP Customer Care offers award-winning support to ensure that you get the most from your HP Designjet.

HP Customer Care provides comprehensive, proven support expertise and leverages new technologies to give customers unique end-to-end support. Services include setup and installation, troubleshooting tools, warranty upgrades, repair and exchange services, phone and Web support, software updates, and self-maintenance services. To find out more about HP Customer Care, go to <http://www.hp.com/go/designjet/>. For the most current contact information, click on the **Contact HP** link or call the appropriate telephone numbers.

What to do before you call:

- Review the troubleshooting suggestions in this guide.
- Review the relevant driver documentation supplied with this printer (for users sending PostScript files or those using Microsoft Windows).
- If you have installed third-party software drivers and RIPs, refer to their documentation.
- If the problem appears to be related to your software program, first contact your software vendor.
- If you call one of the Hewlett-Packard offices, have the following information available to help us answer your questions more quickly:
  - The printer you are using (the product number and the serial number, found on the label at the back of the printer)
  - The printer's Service ID: select the  icon, and then **View printer information**
  - If there is an error code on the front panel, make note of it.
  - The brand name and model number of the computer you are using
  - Any special equipment or software you are using (for example, spoolers, networks, switch-boxes, modems, or special software drivers)
  - The part number of the network cable you are using and the name of the store though which it was purchased
  - The type of interface used on your printer (USB or network)
  - The software name and version you are using
  - Print out the service information prints. You may be asked to fax them to the support center helping you.

On the front panel: select the  icon, and then select **Internal prints > Service information prints > Print all pages**.

Through the Embedded Web Server: go to the **Service support** page in the **Support** tab, and then select **Printer information > All pages**.

## Telephone numbers

For an up-to-date list of HP Support telephone numbers, go to [http://welcome.hp.com/country/us/en/wwcontact\\_us.html](http://welcome.hp.com/country/us/en/wwcontact_us.html). If you do not have access to the Web, try one of the numbers below.

- Algeria: 213 17 63 80
- Argentina: 0 800 777 HP INVENT, local 5411 4778 8380
- Australia: 13 10 47
- Austria: 0810 00 10 00
- Bahrain: 800 171
- Belgium: (0) 78 600 600
- Bolivia: 0 800 1110, local 54 11 4708 1600
- Brazil: 0800 157 751, local 55 11 3747 7799
- Canada: 1 800 HP INVENT
- Caribbean: 1 800 711 2884
- Central America: 1 800 711 2884
- Chile: 800 HP INVENT, 123 800 360 999
- China: 800 810 59 59, 10 6564 59 59
- Colombia: 01 8000 51 HP INVENT, local 571 606 9191
- Czech Republic: 420 261 307 310
- Denmark: 70 11 77 00
- Ecuador: 999 119, 1 800 225 528
- Egypt: 202 532 5222
- Finland: 0203 53232
- France: 08 26 10 49 49
- Germany: 0180 52 58 143
- Greece: 210 6073603, 801 11 22 55 47
- Guadeloupe: 0800 99 00 11, 877 219 8791
- Guatemala: 1 800 999 5105, 1 800 711 2884
- Hong Kong: 852 3002 8555
- Hungary: 06 1 382 1111
- India: 1 600 112 267
- Indonesia: 350 3408
- Ireland: 1 890 946500
- Israel: 09 830 4848
- Italy: 02 3859 1212
- Jamaica: 0 800 711 2884

- Japan: software 0120 014121, hardware 0120 742594
- Korea: 82 1588 3003
- Luxembourg: 27 303 303
- Malaysia: 1 800 80 5405
- Martinique: 0 800 99 00, 877 219 8671
- Mexico: 01 800 472 6684, local 5258 9922
- Middle East: 4 366 2020
- Morocco: 2240 4747
- Netherlands: 0900 1170 000
- New Zealand: 09 365 9805
- Norway: 800 62 800
- Paraguay: 00 811 800, 800 711 2884
- Panama: 001 800 711 2884
- Peru: 0 800 10111
- Philippines: 632 888 6100
- Poland: 22 566 6000
- Portugal: 213 164 164
- Puerto Rico: 1 800 652 6672
- RSA: 27 11 258 9301, local 086 000 1030
- Romania: 40 21 315 4442
- Russia: 095 797 3520, 812 3467 997
- Saudi Arabia: 6272 5300
- Slovakia: 2 50222444
- South Africa: 0800 001 030
- Spain: 902 010 333
- Sweden: 077 130 30 00
- Switzerland: 0848 80 20 20
- Taiwan: 886 2 872 28000
- Thailand: 0 2353 9000
- Tunisia: 71 89 12 22
- Turkey: 216 444 71 71
- UAE: 800 4520, 04 366 2020
- Ukraine: 44 4903520
- United Kingdom: 0870 842 2339
- United States: 1 800 HP INVENT

- Uruguay: 54 11 4708 1600
- Venezuela: 0 800 HP INVENT, local 58 212 278 8000
- Vietnam: 84 8 823 45 30
- West Africa (French): 351 213 17 63 80

## HP Designjet Online

HP offers dedicated services and resources to ensure you always get the best performance from your HP Designjet products and solutions.

Register at HP Designjet Online, your large-format printing community at <http://www.hp.com/go/designjet/> for unrestricted access to:

- Downloads of the latest printer firmware, drivers, software, paper profiles, and so on
- Technical support, including online troubleshooting, customer care contacts, and more
- Forums for direct contact with the experts, both HP and your colleagues
- Warranty tracking online, for your peace of mind
- Technical documentation and training videos
- Latest product information about printers, supplies, accessories, software, and so on
- Supplies Center for all you need to know about ink and paper

You decide the information you need by customizing your registration for the products you have purchased and your type of business, and by setting your communication preferences.

Register at HP Designjet Online for the best performance.

HP Designjet Online is available in English, German, French, Italian, Spanish, Portuguese, Japanese, Korean, Simplified Chinese, and Traditional Chinese.

## Other sources of information

More information is available from the following sources:

- The Embedded Web Server provides information about your printer status, technical support, online documentation, and so on. See Printer software in *Using your printer*.
- The Printer assembly document that came with your printer

# 11 Legal information

## Hewlett-Packard Limited Warranty—HP (HP Designjet Z6100 Printer series)

HP product	Limited Warranty Period
Printer	1 year (from the date of purchase by the customer)
Software	90 days (from the date of purchase by the customer)
Printhead	Until the “end of warranty” date printed on the product is reached, or 1200 ml of HP ink have been cycled through the printhead, whichever occurs first
Ink cartridge	Until the genuine HP ink is depleted as indicated by the printer, or the “end of warranty” date printed on the product is reached, whichever occurs first

### A. Extent of HP Limited Warranty

1. HP warrants to you, end-user customer, that the HP hardware products specified above will be free from defects in materials and workmanship during the Limited Warranty Period specified above. The Limited Warranty Period starts on the date of purchase. Your dated sales or delivery receipt, showing the date of purchase of the product, is your proof of purchase date. You may be required to provide proof of purchase as a condition of receiving warranty service.
2. For software products, HP’s Limited Warranty applies only to a failure to execute programming instructions during the Limited Warranty Period specified above.
3. HP does not warrant that the operation of any product will be uninterrupted or error free.
4. HP’s Limited Warranty covers only those defects that arise as a result of normal use of the HP products, and does not cover any other problems, including those that arise as result of:
  - a. Improper or inadequate maintenance or modification;
  - b. Software, interfacing, paper, parts, or supplies not provided or supported by HP;
  - c. Operation outside the product’s specifications; or
  - d. Unauthorized modification or misuse.

Routine printer maintenance operations in the HP Designjet Z6100 Printer series, such as cleaning and preventive maintenance services (including parts

contained in any preventive maintenance kit and HP service engineer visits), are not covered by HP's Limited Warranty.

5. YOU SHOULD MAKE PERIODIC BACKUP COPIES OF THE DATA STORED ON THE PRINTER'S HARD DISK OR OTHER STORAGE DEVICES AS A PRECAUTION AGAINST POSSIBLE FAILURES, ALTERATION, OR LOSS OF THE DATA. BEFORE RETURNING ANY UNIT FOR SERVICE, BE SURE TO BACK UP DATA AND REMOVE ANY CONFIDENTIAL, PROPRIETARY, OR PERSONAL INFORMATION. HP IS NOT RESPONSIBLE FOR DAMAGE TO OR LOSS OF ANY FILES, STORED BY YOU ON THE PRINTER'S HARD DISK OR OTHER STORAGE DEVICES. HP IS NOT RESPONSIBLE FOR THE RECOVERY OF LOST FILES OR DATA.
6. For HP printer products, the use of a refilled or non-original HP consumable product (ink, printhead or ink cartridge) does not affect either HP's Limited Warranty to you or any HP support contract with you. However, if printer failure or damage is attributable to the use of a non-HP or refilled ink cartridge, HP will charge its standard time and materials charges to service the printer for the particular failure or damage.
7. If HP receives, during the applicable warranty period, notice of a defect in any product which is covered by this Limited Warranty:
  - a. HP shall replace any defective HP software, media, or consumable product which is covered by this Limited Warranty, and deliver another product to you to replace the defective one.
  - b. HP, at its sole discretion, shall either repair on site or replace any defective hardware product or component part. If HP elects to replace any component part, HP will provide to you (i) a replacement part, in return of the defective one, and (ii) remote part installation assistance, if needed.
8. If HP is unable to repair or replace, as applicable, a defective product which is covered by this Limited Warranty, HP shall, within a reasonable time after being notified of the defect, refund the purchase price for the product.
9. HP shall have no obligation to replace or refund until you return the defective components, parts, consumables, media, or hardware product to HP. All components, parts, consumables, media or hardware products, removed under this Limited Warranty become the property of HP. Notwithstanding the above mentioned, HP may waive the requirement for you to return the defective part.
10. Unless otherwise stated, and to the extent permitted by local law, HP products may be manufactured using new materials or new and used materials equivalent to new in performance and reliability. HP may repair or replace products (i) with equivalent products to the products being repaired or replaced but which may have been subject to prior use; or (ii) with an equivalent product to an original product that has been discontinued.



11. This Limited Warranty is valid in any country/region where HP or its authorized providers offer warranty services and HP has marketed the HP product covered by this Limited Warranty. However, warranty service availability and response time may vary from country/region to country/region. HP will not alter form, fit, or function of the product to make it operate in a country for which it was never intended to function for legal or regulatory reasons.
12. Contracts for additional services may be available for any authorized HP service facility where the listed HP product is distributed by HP or an authorized importer.

## **B. Limitation of warranty**

TO THE EXTENT ALLOWED BY LOCAL LAW, NEITHER HP NOR ITS THIRD PARTY SUPPLIERS MAKE ANY OTHER WARRANTY OR CONDITION OF ANY KIND, WHETHER EXPRESS OR IMPLIED, WITH RESPECT TO THE HP PRODUCTS, AND SPECIFICALLY DISCLAIM THE IMPLIED WARRANTIES OR CONDITIONS OF MERCHANTABILITY, SATISFACTORY QUALITY, AND FITNESS FOR A PARTICULAR PURPOSE.

## **C. Limitations of liability**

TO THE EXTENT ALLOWED BY LOCAL LAW, EXCEPT FOR THE OBLIGATIONS SPECIFICALLY SET FORTH IN THIS LIMITED WARRANTY, IN NO EVENT SHALL HP OR ITS THIRD PARTY SUPPLIERS BE LIABLE FOR DIRECT, INDIRECT, SPECIAL, INCIDENTAL, OR CONSEQUENTIAL DAMAGES (INCLUDING ANY LOSS OF PROFITS OR SAVINGS), WHETHER BASED ON CONTRACT, TORT, OR ANY OTHER LEGAL THEORY AND WHETHER ADVISED OF THE POSSIBILITY OF SUCH DAMAGES.

## **D. Local law**

1. This Limited Warranty gives you specific legal rights. You may also have other rights which vary from state to state in the United States, from province to province in Canada, and from country to country elsewhere in the world. You are advised to consult applicable state, province, or national laws for full determination of your rights.
2. To the extent that this Warranty Statement is inconsistent with local law, this Warranty Statement shall be deemed modified to be consistent with such local law. THE WARRANTY TERMS CONTAINED IN THIS LIMITED WARRANTY, EXCEPT TO THE EXTENT LAWFULLY PERMITTED, DO NOT EXCLUDE, RESTRICT, OR MODIFY AND ARE IN ADDITION TO THE MANDATORY STATUTORY RIGHTS APPLICABLE TO THE SALE OF THIS PRODUCT TO YOU.

Revision: December 10th, 2006

## **Hewlett-Packard Software License Agreement**

ATTENTION: USE OF THE SOFTWARE IS SUBJECT TO THE HP SOFTWARE LICENSE TERMS SET FORTH BELOW. USING THE SOFTWARE INDICATES YOUR

ACCEPTANCE OF THESE LICENSE TERMS. IF YOU DO NOT ACCEPT THESE LICENSE TERMS, YOU MAY RETURN THE SOFTWARE FOR A FULL REFUND. IF THE SOFTWARE IS SUPPLIED WITH ANOTHER PRODUCT, YOU MAY RETURN THE ENTIRE UNUSED PRODUCT FOR A FULL REFUND.

## HP SOFTWARE LICENSE TERMS

The following terms govern your use of the software integrated into your HP Designjet Z6100 Printer series, unless you have a separate agreement with HP.

**Definitions.** HP Designjet Z6100 Printer series software includes HP software product ("the Software") and Open Source Software components.

"Open Source Software" means various open source software components including, but not limited to, Apache, Tomcat, MySQL, and omniORB, licensed under terms of applicable open source license agreements included in the materials relating to such software (please see "Open Source Software" section below).

**License Grant.** HP grants you a license to use one copy of the Software pre-installed in the HP Designjet Z6100 Printer series. "Use" means storing, loading, executing or displaying the Software. You may not modify the Software or disable any licensing or control features of the Software.

**Ownership.** The Software is owned and copyrighted by HP or its third party suppliers. Your license confers no title to, or ownership in, the Software and is not a sale of any rights in the Software. HP's third party suppliers may protect their rights in the event of any violation of these License Terms.

**Copies and Adaptations.** You may only make copies or adaptations of the Software for archival purposes or when copying or adaptation is an essential step in the authorized Use of the Software. You must reproduce all copyright notices in the original Software on all copies or adaptations. You may not copy the Software onto any public network.

**No Disassembly or Decryption.** You may not disassemble or decompile the Software unless HP's prior written consent is obtained. In some jurisdictions, HP's consent may not be required for limited disassembly or decompilation. Upon request, you will provide HP with reasonably detailed information regarding any disassembly or decompilation. You may not decrypt the Software unless decryption is a necessary part of the operation of the Software.

**Transfer.** Your license will automatically terminate upon any transfer of the Software. Upon transfer, you must deliver the Software, including any copies and related documentation, to the transferee. The transferee must accept these License Terms as a condition to the transfer.

**Termination.** HP may terminate your license upon notice for failure to comply with any of these License Terms. Upon termination, you must immediately destroy the Software, together with all copies, adaptations and merged portions in any form or, if the Software is supplied integrated into the HP Designjet Z6100 Printer series, stop using the HP Designjet Z6100 Printer series.

**Export Requirements.** You may not export or re-export the Software or any copy or adaptation in violation of any applicable laws or regulations.

**U.S. Government Restricted Rights.** The Software and accompanying documentation have been developed entirely at private expense. They are delivered and licensed, as defined in any applicable DFARS, FARS, or other equivalent federal agency regulation or contract clause, as either "commercial computer software" or "restricted computer software", whichever is applicable. You have only those rights provided for such Software and Documentation by the applicable clause or regulation or by the HP standard software agreement for the product involved.

**Open Source Software.** The Open Source Software is composed of individual software components, each of which has its own copyright and its own applicable license conditions. You must review the licenses within the individual packages to understand your rights under them. The licenses can be found in the folder called **licenses** on the *Drivers and Documentation* CD that came with your printer. Copyrights to the Open Source Software are held by the copyright holders.

## Open source software

### Open source acknowledgments

- This product includes software developed by the Apache Software Foundation (<http://www.apache.org/>)
- The source code, object code, and documentation in the com.oreilly.servlet package is licensed by Hunter Digital Ventures, LLC

### Open source written offer

In accordance with the GNU General Public license, the SMAIL Public License, and the Sleepy Cat software license, HP is providing you with this written offer to receive on a CD-R, at the cost of \$30, a complete machine-readable copy of the source code corresponding to all the code distributed to you under a GNU General Public License, SMAIL Public License, and/or Sleepy Cat software licenses. You can request this CD-R from your local HP support representative; telephone numbers and e-mail addresses can be found at: <http://www.hp.com/go/designjet/support/>.

## Regulatory notices

This HP product contains a lithium battery located on an internal motherboard that may require special handling at end-of-life.

## Material Safety Data Sheet

You can obtain current Material Safety Data Sheets for the ink systems used in the printer by mailing a request to this address: Hewlett-Packard Customer Information Center, 19310 Pruneridge Avenue, Dept. MSDS, Cupertino, CA 95014, U.S.A.

There is also a Web page: [http://www.hp.com/hpinfo/community/environment/productinfo/psis\\_inkjet.htm](http://www.hp.com/hpinfo/community/environment/productinfo/psis_inkjet.htm)

## Regulatory Model Number

For regulatory identification purposes, your product is assigned a Regulatory Model Number. The Regulatory Model Number for your Printer is **BCLAA-0701** and the Take-Up Reel is **BCLAA-0702**. This regulatory number should not be confused with the marketing names (HP Designjet printer series or HP Take-Up Reel for Designjet printer series) or product numbers (Q####X – where X is any single letter and # is any number).

## Regulatory Statements

- **USA**

- **Electro-Magnetic Compatibility (EMC)**
- **FCC statements (USA)**

The U.S. Federal Communications Commission (in 47 cfr15.105) has specified that the following notices be brought to the attention of users of this product.

This device complies with part 15 of the FCC Rules. Operation is subject to the following two conditions: (1) This device may not cause harmful interference, and (2) this device must accept any interference received, including interference that may cause undesired operation.

- **Shielded cables**

Use of shielded data cables is required to comply with the Class A limits of Part 15 of the FCC Rules.



**CAUTION:** Pursuant to Part 15.21 of the FCC Rules, any changes or modifications to this equipment not expressly approved by the Hewlett-Packard Company may cause harmful interference and void the FCC authorization to operate this equipment.

This equipment has been tested and found to comply with the limits for a Class A digital device, pursuant to part 15 of the FCC Rules. These limits are designed to provide reasonable protection against harmful interference in a commercial environment. This equipment generates, uses, and can radiate radio frequency energy and, if not installed and used in accordance with the instructions, may cause harmful interference to radio communications. Operation of this equipment in a residential area is likely to cause harmful interference, in which case the user will be required to correct the interference at their own expense.

- **California**

Attention California users:

The battery supplied with this product may contain perchlorate material. Special handling may apply. See [www.dtsc.ca.gov/hazardouswaste/perchlorate](http://www.dtsc.ca.gov/hazardouswaste/perchlorate) for information.

Atención a los usuarios de California:

La pila proporcionada con este producto puede contener perclorato. Podría requerir manipulación especial. Consulte [www.dtsc.ca.gov/hazardouswaste/perchlorate](http://www.dtsc.ca.gov/hazardouswaste/perchlorate) para obtener más información.

- **Canada**

- **Electro-Magnetic Compatibility (EMC)**

- **Normes de sécurité (Canada)**

Le présent appareil numérique n'émet pas de bruits radioélectriques dépassant les limites applicables aux appareils numériques de Classe A prescrites dans le règlement sur le brouillage radioélectrique édicté par le Ministère des Communications du Canada.

- **DOC statement (Canada)**

This digital apparatus does not exceed the Class A limits for radio noise emissions from digital apparatus set out in the Radio Interference Regulations of the Canadian Department of Communications.

- **Korean EMI statement**

사용자 안내문 : A 급 기기

이 기기는 업무용으로 전자파적합등록을 받은 기기이오니, 판매자 또는 사용자는 이 점을 주의 하시기 바라며, 만약 잘못 구입 하셨을 때에는 구입한 곳에서 비업무용으로 교환 하시기 바랍니다.

- **Taiwanese EMI statement**

警告使用者：

這是甲類的資訊產品，在居住的環境中使用時，可能會造成射頻干擾，在這種情況下，使用者會被要求採取某些適當的對策。

- **VCCI Class A (Japan)**

この装置は、情報処理装置等電波障害自主規制協議会（VCCI）の基準に基づくクラスA情報技術装置です。この装置を家庭環境で使用すると電波妨害を引き起こすことがあります。この場合には使用者が適切な対策を講ずるよう要求されることがあります。

- **Safety power cord warning**

製品には、同梱された電源コードをお使い下さい。  
同梱された電源コードは、他の製品では使用出来ません。

translation  
Please use the attached power cord.  
The attached power cord is not allowed to use with other product.

- **Chinese EMI statement**

此为A级产品，在生活环境种，该产品可能会造成无线电干扰。在这种情况下，可能需要用户对其干扰采取切实可行的措施。

- **Germany**

**Sound:** Geräuschemission (Germany)  $LpA < 70$  dB, am Arbeitsplatz, im Normalbetrieb, nach DIN45635 T. 19.

- **Europe**



**WARNING!** This is a class A product. In a domestic environment this product may cause radio interference in which case the user may be required to take adequate measures.

- **Disposal of waste equipment by users in private households in the European Union**

This symbol on the product or on its packaging indicates that this product must not be disposed of with your other household waste. Instead, it is your responsibility to dispose of your waste equipment by handing it over to a designated collection point for the recycling of waste electrical and electronic equipment. The separate collection and recycling of your waste equipment at the time of disposal will help to conserve natural resources and ensure that it is recycled in a manner that protects human health and the environment. For more information about where you can drop off your waste equipment for recycling, please contact your local city office, your household waste disposal service or the shop where you purchased the product.

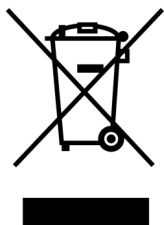

# DECLARATION OF CONFORMITY

according to ISO/IEC 17050-1 and EN 17050-1

Supplier's name:	Hewlett-Packard Company
Supplier's address:	Avenida Graells, 501 08174 Sant Cugat del Vallès Barcelona, Spain

## declares that the product

Regulatory Model Numbers <sup>(1)</sup> :	BCLAA-0701, BCLAA-0702
Product names and models:	HP Designjet Z6100 Printer series, HP Take-Up Reel for Designjet Z6100 Printer series
Product options:	All

## conforms to the following product specifications

Safety:	IEC 60950-1:2001 / EN 60950-1:2001
EMC:	EN 55022:1998 +A1:00 +A2:03/ CISPR 22:1997+A1:00 +A2:02 Class A EN 55024:1998 +A1:2001 +A2:2003 EN 61000-3-2:2000 +A2:2005/ IEC 61000-3-2:2000 +A1:2001 +A2:2004 EN 61000-3-3:1995+A1:2001/ IEC 61000-3-3:1994 +A1:2001

## Additional information

The product herewith complies with the requirements of the Low Voltage Directive 73/23/EEC and the EMC Directive 89/336/EEC and carries the CE-marking accordingly.

- This product is assigned a Regulatory Model Number which stays with the regulatory aspects of the design. The Regulatory Model Number is the main product identifier in the regulatory documentation and test reports, this number should not be confused with the marketing name or the product numbers.





Josep Maria Pujol  
Hardware Quality Manager  
Sant Cugat del Vallès (Barcelona)  
December 5th, 2006

---

# Index

## A

automatic paper-cutter doesn't work 71

## B

banding problems 24  
blank page 66  
blurred lines 60

## C

calibration  
    color 49  
cannot load paper 69  
clipped at bottom 66  
clipped image 66  
color calibration 49  
color profiling 50  
components of printer 1  
crop lines  
    nesting 48  
    printing 45  
Customer Care 82

## D

DECLARATION OF CONFORMITY 96  
Designjet Online 82, 86  
downloading media profiles 25

## E

Embedded Web Server  
    access 7  
    ink system status 40  
    troubleshooting wizard 57

## F

front panel 4  
front panel error messages  
    all 78  
front panel option  
    align printheads 76  
    calibrate color 50  
    print crop lines 46  
    select I/O timeout 66, 67  
front view 42-in printer 1  
front view 60-in printer 2

## G

graininess 62

## H

Hewlett-Packard Limited Warranty—HP Designjet Z6100  
    Printer series 87  
Hewlett-Packard Software License Agreement 89  
HP Customer Care 82  
HP Designjet Online 82, 86  
HP Instant Support 82

## I

image problems  
    blank page 66  
    clipped at bottom 66  
    clipped image 66  
    missing objects 59  
    overlapping images 67  
ink cartridge  
    inserting 29  
    removing 27  
ink system status 40  
Instant Support 82

## L

line thickness 58  
loading paper problems 69  
loading roll into printer 11  
loading roll onto spindle 9

## M

maintenance cartridge  
    inserting 39  
    removing 38  
margins  
    changing 43  
media profiles  
    downloading 25  
misaligned colors 60

## N

nesting 46

## O

open source software 91

overlapping images 67

## P

page size 42

paper

advance 24

cannot load 69

displaying information 7, 23

paper advance calibration 24

paper jam

take-up reel 71

paper not flat 63

print job

nesting 46

print quality

changing 41

print-quality problems

banding 61

blurred lines 60

bronzing 63

colors inaccurate 65

general 57

graininess 62

horizontal lines 61

ink marks 64

line thickness 58

misaligned colors 60

paper not flat 63

smudging 63

stepped lines 59

top of print 64

wood-grain appearance 68

printer's main components 1

printhead

align 74

aligning 34

clean; purge 74

inserting 32

removing 29

Printhead status plot 35

## R

rear view 42-in printer 3

rear view 60-in printer 3

regulatory notices 91

roll paper

loading into the printer 11

loading onto the spindle 9

unloading 15

## S

smudging 63

stepped lines 59

support services

HP Customer Care 82

HP Designjet Online 82, 86

HP Instant Support 82

## T

take-up reel

doesn't rewind 71

motor 3

telephone numbers 84

turn the printer on/off 6

## U

unloading roll from printer 15

using this guide 1