

**COMPAQ**

Compaq Presario A900 Notebook PC  
Maintenance and Service Guide

© Copyright 2007 Hewlett-Packard  
Development Company, L.P.

Intel, Celeron, and Core are trademarks or registered trademarks of Intel Corporation or its subsidiaries in the United States and other countries. Microsoft, Windows, and Windows Vista are either trademarks or registered trademarks of Microsoft Corporation in the United States and/or other countries. SD Logo is a trademark of its proprietor.

The information contained herein is subject to change without notice. The only warranties for HP products and services are set forth in the express warranty statements accompanying such products and services. Nothing herein should be construed as constituting an additional warranty. HP shall not be liable for technical or editorial errors or omissions contained herein.

First Edition: December 2007

Document Part Number: 460150-001

## Safety warning notice

---

- ⚠ **WARNING!** To reduce the possibility of heat-related injuries or of overheating the computer, do not place the computer directly on your lap or obstruct the computer air vents. Use the computer only on a hard, flat surface. Do not allow another hard surface, such as an adjoining optional printer, or a soft surface, such as pillows or rugs or clothing, to block airflow. Also, do not allow the AC adapter to contact the skin or a soft surface, such as pillows or rugs or clothing, during operation. The computer and the AC adapter comply with the user-accessible surface temperature limits defined by the International Standard for Safety of Information Technology Equipment (IEC 60950).
-



---

# Table of contents

## 1 Product description

## 2 External component identification

Display components .....	5
Top components .....	6
Buttons, lights, and speakers .....	6
Keys .....	8
Pointing devices .....	9
Front components .....	10
Right-side components .....	10
Left-side components .....	11
Bottom components .....	12

## 3 Illustrated parts catalog

Serial number location .....	13
Computer major components .....	14
Display assembly components .....	19
Plastics Kit .....	20
Mass storage devices .....	21
Miscellaneous parts .....	22
Sequential part number listing .....	23

## 4 Removal and replacement procedures

Preliminary replacement requirements .....	27
Tools required .....	27
Service considerations .....	27
Plastic parts .....	27
Cables and connectors .....	28
Drive handling .....	28
Grounding guidelines .....	29
Electrostatic discharge damage .....	29
Packaging and transporting guidelines .....	30
Workstation guidelines .....	30

Equipment guidelines .....	31
Unknown user password .....	32
Component replacement procedures .....	33
Serial number .....	33
Computer feet .....	33
Battery .....	34
Camera module .....	35
Hard drive .....	37
Memory module .....	39
WLAN module .....	41
Optical drive .....	44
Switch cover and keyboard .....	46
Display assembly .....	50
Top cover .....	55
USB board .....	57
Fan .....	58
Speaker assembly .....	59
System board .....	60
Power connector cable .....	63
RTC battery .....	65
Digital media board .....	67
Heat sink .....	69
Processor .....	71

## 5 Setup Utility

Starting the Setup Utility .....	73
Changing the language of the Setup Utility .....	73
Navigating and selecting in the Setup Utility .....	74
Displaying system information .....	74
Restoring default settings in the Setup Utility .....	74
Using advanced Setup Utility features .....	75
Closing the Setup Utility .....	75
Setup Utility menus .....	75

## 6 Specifications

Computer specifications .....	77
17.0-inch, WXGA display specifications .....	78
Hard drive specifications .....	79
DVD±RW and CD-RW SuperMulti Double-Layer Combo Drive specifications .....	80
DVD±RW and CD-RW Combo Drive specifications .....	81
System DMA specifications .....	82
System interrupt specifications .....	83
System I/O address specifications .....	84

System memory map specifications .....	86
<b>7 Screw listing</b>	
Phillips PM2.5×6.0 captive screw .....	88
Phillips PM3.0×4.0 screw .....	89
Phillips PM2.0×4.0 screw .....	90
Phillips PM2.5×9.0 screw .....	93
Phillips PM2.5×5.0 screw .....	96
Phillips PM2.5×7.0 screw .....	98
<b>8 Backup and recovery</b>	
Recovering system information .....	99
Creating recovery discs .....	99
Backing up your information .....	100
When to back up .....	100
Backup suggestions .....	100
Using system restore points .....	101
When to create restore points .....	101
Create a system restore point .....	101
Restore to a previous date and time .....	101
Performing a recovery .....	102
Recovering from the recovery discs .....	102
Recovering from the partition on the hard drive .....	102
<b>9 Connector pin assignments</b>	
Audio-out (headphone) .....	103
Audio-in (microphone) .....	103
External monitor .....	104
RJ-11 (modem) .....	105
RJ-45 (network) .....	106
S-Video-out .....	107
Universal Serial Bus .....	108
<b>10 Power cord set requirements</b>	
Requirements for all countries and regions .....	109
Requirements for specific countries and regions .....	110
<b>11 Recycling</b>	
Battery .....	111
Display .....	111
<b>Index .....</b>	<b>117</b>





# 1 Product description

Category	Description	Computers equipped with 965GM system board	Computers equipped with 960GL system board
<b>Product Name</b>	<b>Compaq Presario A900 Notebook PC</b>	√	√
<b>Processors</b>	<b>Intel® Core™ 2 Duo processors:</b>		
	T7250 2.00-GHz processor, 800-MHz FSB, 2-MB L2 cache	√	
	T5550 1.80-GHz processor, 667-MHz FSB, 2-MB L2 cache	√	
	T5450 1.67-GHz processor, 667-MHz FSB, 2-MB L2 cache	√	
	T5250 1.50-GHz processor, 667-MHz FSB, 2-MB L2 cache	√	
	<b>Intel Core Duo processors:</b>		
	T2330 1.60-GHz processor, 533-MHz FSB, 1-MB L2 cache		√
	T2310 1.46-GHz processor, 533-MHz FSB, 1-MB L2 cache		√
	<b>Intel Celeron® M processors:</b>		
	Celeron 550 2.00-GHz processor, 533-MHz FSB, 1-MB L2 cache		√
	Celeron 540 1.86-GHz processor, 533-MHz FSB, 1-MB L2 cache		√
	Celeron 530 1.73-GHz processor, 533-MHz FSB, 1-MB L2 cache		√
<b>Chipset</b>	Northbridge and Southbridge: Intel GM965	√	
	Northbridge and Southbridge: Intel GL960		√

Category	Description	Computers equipped with 965GM system board	Computers equipped with 960GL system board
<b>Graphics</b>	Unified Memory Architecture (UMA) graphics subsystem integrated with shared system memory (dynamically allocated)	√	√
	<ul style="list-style-type: none"> <li>up to 256-MB of total available graphics subsystem memory when computer system memory equals or is greater than 2048 MB</li> </ul>		
	<ul style="list-style-type: none"> <li>up to 128-MB of total available graphics subsystem memory when computer system memory equals or is greater than 1024 MB</li> </ul>		
	<ul style="list-style-type: none"> <li>up to 64-MB of total available graphics subsystem memory when computer system memory equals 512 MB</li> </ul>		
<b>Panel</b>	17.0-inch WXGA+BrightView display panel (1440 × 900)	√	√
	All display assemblies include 3 wireless local area network (WLAN) antennae	√	√
<b>Memory</b>	2 customer-accessible/upgradable memory module slots	√	√
	Supports dual-channel memory	√	√
	Supports up to 2 GB of system RAM	√	√
	PC2-5300, 667-MHz, DDR2	√	√
	Supports the following configurations: <ul style="list-style-type: none"> <li>2048-MB total system memory (1024 × 2, dual-channel)</li> <li>1024-MB total system memory (1024 × 1, only on computer models equipped with Windows Vista™ Basic)</li> <li>1024-MB total system memory (512 × 2, dual-channel)</li> <li>512-MB total system memory (512 × 1, only on computer models equipped with Windows Vista Basic)</li> </ul>	√	√
<b>Hard drives</b>	Supports 9.5-mm, 2.5-inch hard drives	√	√
	Customer-accessible	√	√
	Serial ATA (SATA)	√	√
	Supports the following drives: <ul style="list-style-type: none"> <li>160-GB, 5400-rpm</li> <li>120-GB, 5400-rpm</li> </ul>	√	√
<b>Optical drives</b>	Fixed (removal of 1 screw required)	√	√
	Customer-accessible	√	√
	Parallel ATA	√	√

Category	Description	Computers equipped with 965GM system board	Computers equipped with 960GL system board
	12.7-mm tray load	√	√
	Supports the following drives: <ul style="list-style-type: none"> <li>DVD±RW and CD-RW Super Multi Double-Layer Combo Drive with LightScribe</li> <li>DVD±RW and CD-RW Super Multi Double-Layer Combo Drive</li> </ul>	√	√
<b>Diskette drive</b>	Supports external USB diskette drive only	√	√
<b>Web camera</b>	VGA camera, 30 frames per second	√	√
<b>Microphone</b>	Integrated omnidirectional mono microphone	√	√
<b>Audio</b>	High-definition, Azalia technology audio	√	√
	2 Presario-branded Altec/Lansing speakers	√	√
<b>Modem</b>	56K V.92 38.1-mm (1.5-inch) data/fax modem	√	√
	Supports all world-wide certification requirements	√	√
<b>Ethernet</b>	10/100 network interface card (NIC)	√	√
<b>Wireless</b>	<b>Integrated WLAN options by way of wireless module:</b>		
	3 wireless antennae built into display assembly	√	√
	Support for the following WLAN formats: <ul style="list-style-type: none"> <li>Intel Pro 3945a/b/g</li> <li>Intel Pro 4965a/b/g/n</li> </ul>	√	
	Support for the following WLAN formats: <ul style="list-style-type: none"> <li>Atheros AR2425 802.11b/g</li> <li>Broadcom 802.11a/b/g</li> </ul>		√
<b>External media card</b>	Digital Media Slot supporting SD, MMC, MS, MSPro, xD. With adapter (not included), supports mini versions of SD, MMC, MS Duo.	√	√
<b>Ports</b>	Audio-in (mono microphone)	√	√
	Audio-out (stereo headphone)	√	√
	S-Video-out	√	√
	RJ-11 (modem)	√	√
	RJ-45 (Ethernet, includes link and activity lights)	√	√
	USB (3)	√	√
	VGA (Dsub 15-pin) supporting 1600 × 1200 external resolution at 75 Hz (hot plug/unplug with auto-detect)	√	√
	Multi-pin AC power	√	√
<b>Docking</b>	None	√	√

Category	Description	Computers equipped with 965GM system board	Computers equipped with 960GL system board
<b>Keyboard/ pointing devices</b>	Spill-resistant 36.6-cm (14.4-inch) keyboard	√	√
	TouchPad with 2 TouchPad buttons	√	√
	Supports 2-way scroll	√	√
	Taps enabled as default	√	√
<b>Power requirements</b>	65-W AC adapter with localized cable plug support	√	√
	6-cell, 2.20-Ah (47-Wh) Li-ion battery	√	√
<b>Security</b>	Security cable slot	√	√
<b>Operating system</b>	<b>Preinstalled:</b>		
	Windows Vista Premium 32	√	√
	Windows Vista Home Basic 32	√	√
<b>Serviceability</b>	<b>End-user replaceable parts:</b>		
	AC adapter	√	√
	Battery (system)	√	√
	Hard drive	√	√
	Memory module	√	√
	Optical drive	√	√
	WLAN module	√	√

## 2 External component identification

### Display components



Item	Component	Description
(1)	Internal display switch	Turns off the display if the display is closed while the computer is turned on.
(2)	Wireless antennae (3)*	Send and receive signals from one or more wireless devices. <b>NOTE:</b> The antennae are not visible from the outside of the computer. For optimal transmission, keep the areas immediately around the antennae free from obstructions.
(3)	Webcam light	On: The integrated camera is in use.
(4)	Webcam	Records video and captures still photographs.
(5)	Internal microphone	Records sound.

\*To see wireless regulatory notices, refer to the section of the *Regulatory, Safety and Environmental Notices* that applies to your country or region. These notices are located in Help and Support.

# Top components

## Buttons, lights, and speakers



Item	Component	Description
(1)	Speakers (2)	Produce sound.
(2)	Wireless button	Turns the wireless feature on or off, but does not establish a wireless connection.  <b>NOTE:</b> To establish a wireless connection, a wireless network must already be set up.
(3)	Caps lock light	On: Caps lock is on.
(4)	Wireless light	<ul style="list-style-type: none"><li>Blue: An integrated wireless device, such as a WLAN device, is turned on.</li><li>Amber: An integrated wireless device is turned off.</li></ul>
(5)	Drive light	Blinking: The hard drive or optical drive is being accessed.
(6)	Battery light	<ul style="list-style-type: none"><li>On: A battery is charging.</li><li>Blinking: A battery that is the only available power source has reached a low battery level or a critical battery level.</li><li>Off: If the computer is plugged into an external power source, the light is turned off when all batteries in the computer are fully charged. If the computer is not plugged into an external power source, the light stays off until the battery reaches a low battery level.</li></ul>
(7)	Power light	<ul style="list-style-type: none"><li>On: The computer is on.</li><li>Blinking: The computer is in the Sleep state.</li><li>Off: The computer is off or in Hibernation.</li></ul>

Item	Component	Description
(8)	Power button	<ul style="list-style-type: none"> <li>• When the computer is off, press the button to turn on the computer.</li> <li>• When the computer is on, press the button to initiate Sleep.</li> <li>• When the computer is in the Sleep state, press the button briefly to exit Sleep.</li> <li>• When the computer is in Hibernation, press the button briefly to exit Hibernation.</li> </ul> <p>If the computer has stopped responding and Windows® shutdown procedures are ineffective, press and hold the power button for at least 5 seconds to turn off the computer.</p> <p>To learn more about power settings, select <b>Start &gt; Control Panel &gt; System and Maintenance &gt; Power Options</b>.</p>
(9)	Num lock light	<p>On: Num lock is on or the embedded numeric keypad is enabled.</p>

## Keys

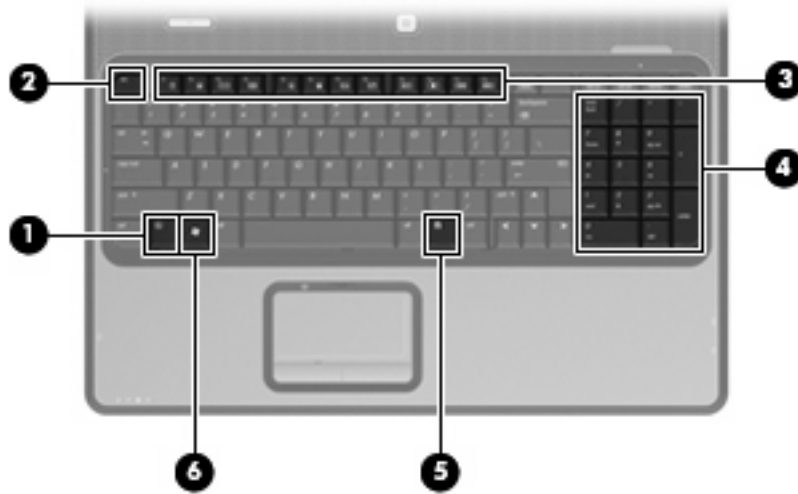

Item	Component	Function
(1)	fn key	Executes frequently used system functions when pressed in combination with a function key or the <code>esc</code> key.
(2)	esc key	Displays system information when pressed in combination with the <code>fn</code> key.
(3)	Function keys	Execute frequently used system functions when pressed in combination with the <code>fn</code> key.
(4)	Integrated numeric keypad keys	Can be used like the keys on an external numeric keypad.
(5)	Windows applications key	Displays a shortcut menu for items beneath the pointer.
(6)	Windows logo key	Displays the Windows Start menu.



## Pointing devices

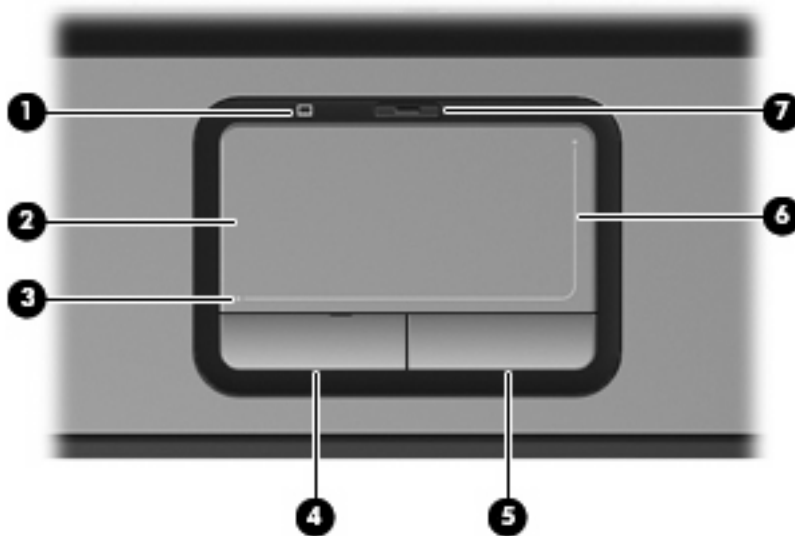

Item	Component	Function
(1)	TouchPad light	<ul style="list-style-type: none"> <li>• Blue: TouchPad is enabled.</li> <li>• Amber: TouchPad is disabled.</li> </ul>
(2)	TouchPad*	Moves the pointer and selects or activates items on the screen.
(3)	TouchPad horizontal scroll zone	Scrolls left or right.
(4)	Left TouchPad button*	Functions like the left button on an external mouse.
(5)	Right TouchPad button*	Functions like the right button on an external mouse.
(6)	TouchPad vertical scroll zone	Scrolls up or down.
(7)	TouchPad on/off button	Enables/disables the TouchPad.

\*This table describes factory settings. To view and change pointing device preferences, select **Start > Control Panel > Hardware and Sound > Mouse**.

## Front components



Item	Component	Function
(1)	Audio-out (headphone) jack	Produces sound when connected to optional powered stereo speakers, headphones, ear buds, a headset, or television audio.
(2)	Audio-in (microphone) jack	Connects an optional computer headset microphone, stereo array microphone, or monaural microphone.

## Right-side components

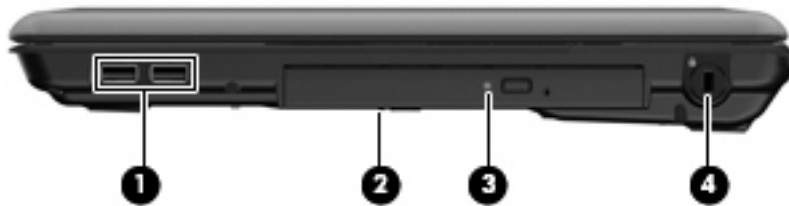

Item	Component	Function
(1)	USB ports (2)	Connect optional USB devices.
(2)	Optical drive	Reads optical discs and on select models also writes to optical discs.
(3)	Optical drive light	Blinking: The optical drive is being accessed.
(4)	Security cable slot	Attaches an optional security cable to the computer. <b>NOTE:</b> The security cable is designed to act as a deterrent, but it may not prevent the computer from being mishandled or stolen.

## Left-side components

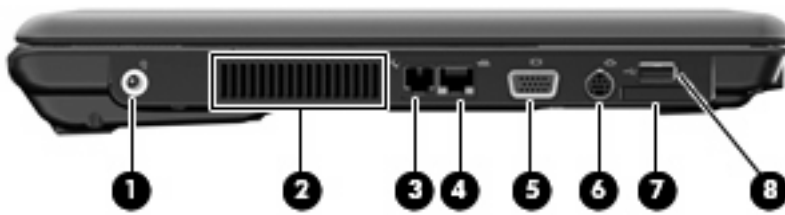

Item	Component	Function
(1)	Power connector	Connects an AC adapter.
(2)	Vent	Enables airflow to cool internal components.  <b>NOTE:</b> The computer fan starts up automatically to cool internal components and prevent overheating. It is normal for the internal fan to cycle on and off during routine operation.
(3)	RJ-11 (modem) jack	Connects a modem cable.
(4)	RJ-45 (network) jack	Connects a network cable.
(5)	External monitor port	Connects an external VGA monitor or projector.
(6)	S-Video-out jack	Connects an optional S-Video device such as a television, VCR, camcorder, overhead projector, or video capture card.
(7)	Digital Media Slot	Supports the following optional digital card formats: Secure Digital (SD) Memory Card, MultiMediaCard (MMC), Memory Stick (MS), Memory Stick Pro (MSP), xD-Picture Card (XD).
(8)	USB port	Connects an optional USB device.

## Bottom components

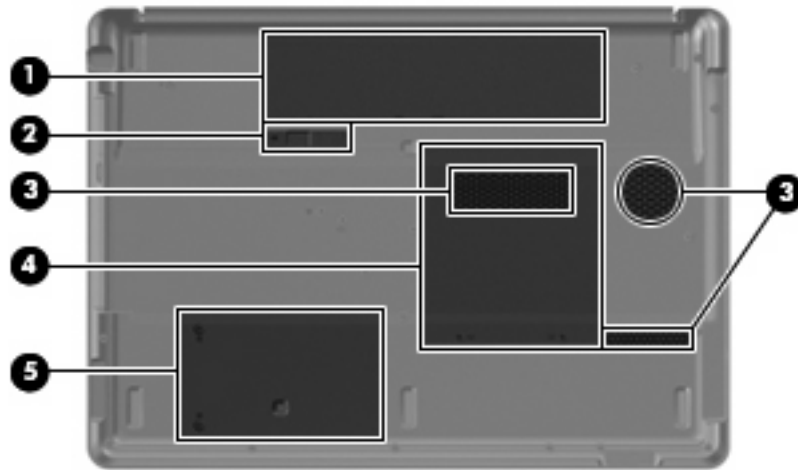

Item	Component	Function
(1)	Battery bay	Holds the battery.
(2)	Battery release latch	Releases the battery from the battery bay.
(3)	Vents (3)	Enable airflow to cool internal components. <b>NOTE:</b> The computer fan starts up automatically to cool internal components and prevent overheating. It is normal for the internal fan to cycle on and off during routine operation.
(4)	Memory/WLAN module compartment	Contains the memory module slots and the WLAN module slot.
(5)	Hard drive bay	Holds the hard drive.

---

## 3 Illustrated parts catalog

### Serial number location

When ordering parts or requesting information, provide the computer serial number and model number located on the bottom of the computer.

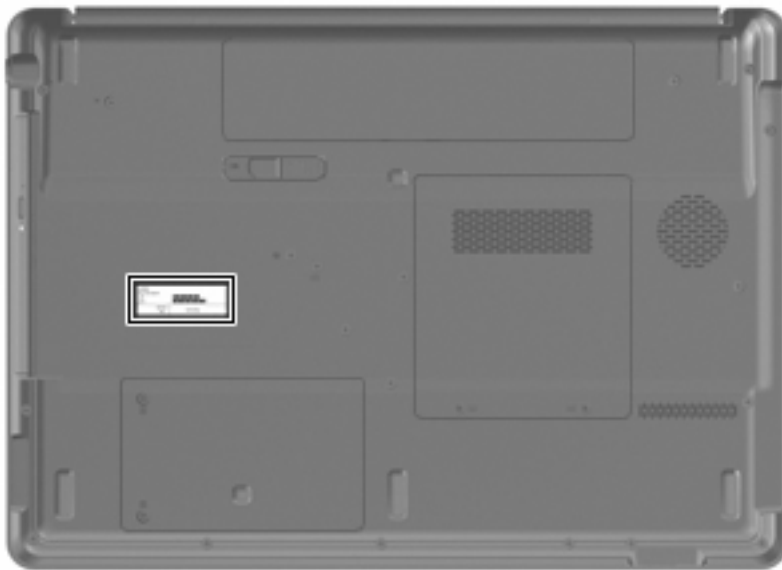

# Computer major components

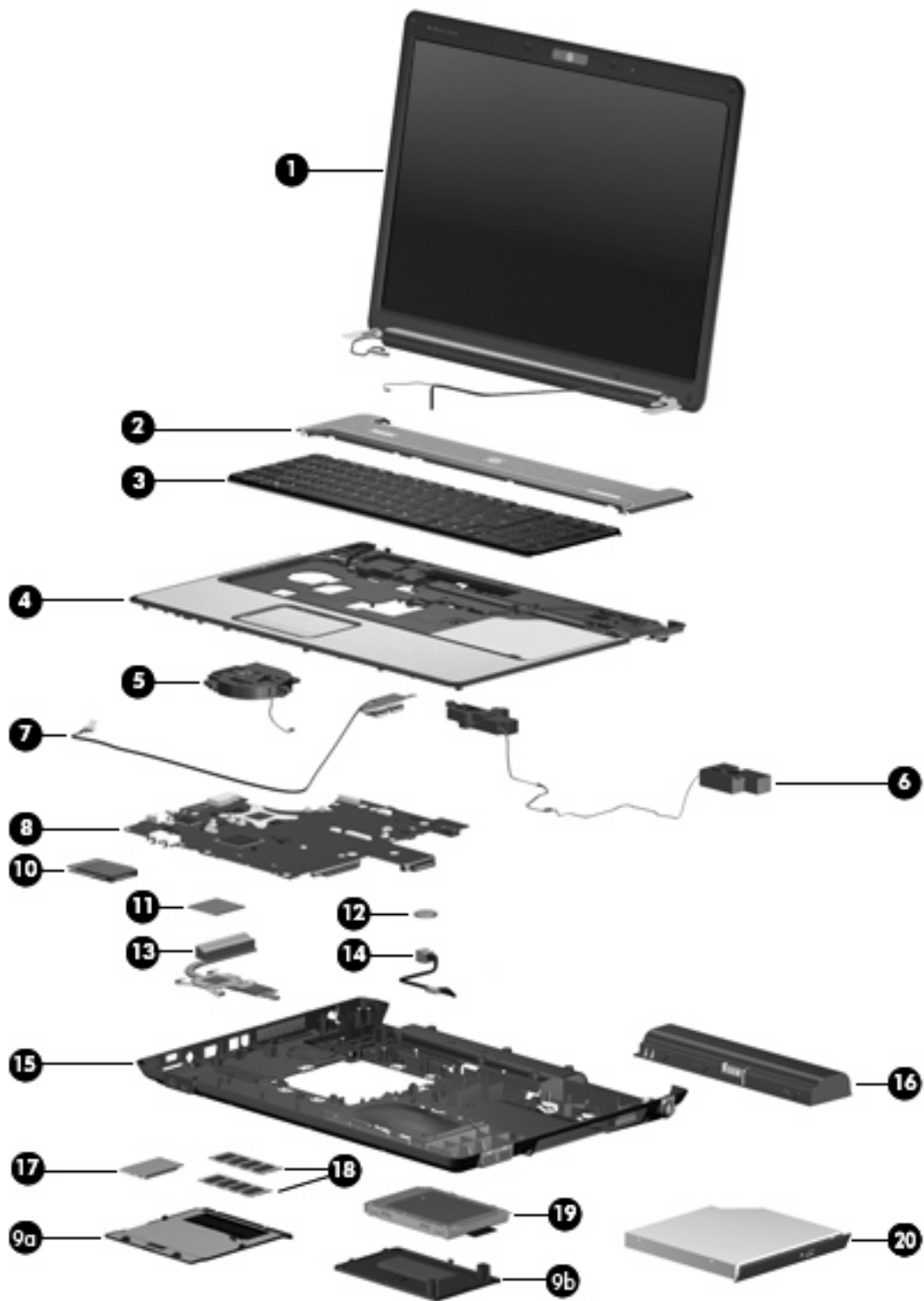

Item	Description	Spare part number
(1)	<b>17.0-inch, WXGA+BrightView display assembly</b> (includes 3 WLAN antenna transceivers and cables, camera module and cable, microphones and cables, and logo)	462319-001
	Refer to <a href="#">Display assembly components on page 19</a> , for more display assembly component spare part information.	
(2)	<b>Switch cover</b> (includes wireless button board and cable, power button board and cable, and num lock LED board and cable)	462399-001
(3)	<b>Keyboards</b> (include keyboard cable)	
	For use in Denmark, Finland, and Norway	462383-DH1
	For use in France	462383-051
	For use in French Canada	462383-121
	For use in Germany	462383-041
	For use in Italy	462383-061
	For use in the Netherlands	462383-B31
	For use in Saudi Arabia	462383-171
	For use in Spain	462383-071
	For use in Turkey	462383-141
	For use in the United Kingdom	462383-031
	For use in the United States	462383-001
(4)	<b>Top cover</b> (includes TouchPad and TouchPad cable and caps lock LED board and cable)	462401-001
(5)	<b>Fan</b>	462404-001
(6)	<b>Speaker assembly</b> (includes cables)	462581-001
(7)	<b>USB board</b> (includes USB board cable)	462406-001
(8)	<b>System boards</b> (include digital media card board and replacement thermal material)	
	GM965 system board, for use only with computer models equipped with Intel Core 2 Duo processors	462316-001
	GL960 system board, for use only with computer models equipped with Intel Core Duo and Intel Celeron M processors	462317-001
	<b>Plastics Kit</b> (see <a href="#">Plastics Kit on page 20</a> for more Plastics Kit spare part information)	462409-001
(9a)	Memory/WLAN module compartment cover	
(9b)	Hard drive cover	
(10)	<b>Digital media board</b>	462402-001
(11)	<b>Processors</b> (include replacement thermal material)	
	• Intel Core 2 Duo T7250 2.00-GHz processor (800-MHz FSB, 2-MB L2 cache)	456965-001
	• Intel Core 2 Duo T7100 1.80-GHz processor (800-MHz FSB, 2-MB L2 cache)	450586-001
	• Intel Core Duo T5550 1.83-GHz processor (533-MHz FSB, 2-MB L2 cache)	458247-001
	• Intel Core Duo T5550 1.67-GHz processor (533-MHz FSB, 2-MB L2 cache)	453195-001
	• Intel Core Duo T2330 1.60-GHz processor (533-MHz FSB, 1-MB L2 cache)	457314-001

Item	Description	Spare part number
	<ul style="list-style-type: none"> <li>Intel Core Duo T2310 1.46-GHz processor (533-MHz FSB, 1-MB L2 cache)</li> </ul>	457313-001
	<ul style="list-style-type: none"> <li>Intel Celeron M 550 2.00-GHz processor (533-MHz FSB, 1-MB L2 cache)</li> </ul>	454322-001
	<ul style="list-style-type: none"> <li>Intel Celeron M 540 1.86-GHz processor (533-MHz FSB, 1-MB L2 cache)</li> </ul>	454321-001
	<ul style="list-style-type: none"> <li>Intel Celeron M 530 1.73-GHz processor (533-MHz FSB, 1-MB L2 cache)</li> </ul>	457315-001
<b>(12)</b>	<b>RTC battery</b>	449137-001
<b>(13)</b>	<b>Heat sink</b> (includes replacement thermal material)	462405-001
<b>(14)</b>	<b>Power connector cable</b>	462403-001
<b>(15)</b>	<b>Base enclosure</b> (includes rubber feet)	462400-001
	<b>Rubber Foot Kit</b> (not illustrated, includes 7 computer feet)	462410-001
<b>(16)</b>	<b>6-cell, 47-Wh, 2.2-Ah battery</b>	462337-001
<b>(17)</b>	<b>WLAN modules</b>	
	<b>Intel 802.11 a/b/g/n WLAN modules:</b>	
	<ul style="list-style-type: none"> <li>For use in Antigua and Barbuda, Argentina, Aruba, the Bahamas, Barbados, Bermuda, Brunei, Canada, the Cayman Islands, Chile, Colombia, Costa Rica, the Dominican Republic, Ecuador, El Salvador, Guam, Guatemala, Haiti, Honduras, Hong Kong, India, Indonesia, Malaysia, Mexico, Panama, Paraguay, Peru, Saudi Arabia, Taiwan, Uruguay, the United States, Venezuela, and Vietnam</li> </ul>	441086-001
	<ul style="list-style-type: none"> <li>For use in Austria, Azerbaijan, Bahrain, Belgium, Brazil, Bulgaria, Croatia, Cyprus, the Czech Republic, Denmark, Egypt, Estonia, Finland, France, Georgia, Germany, Greece, Hungary, Iceland, Ireland, Israel, Italy, Latvia, Lebanon, Liechtenstein, Lithuania, Luxembourg, Malta, Monaco, the Netherlands, Norway, Oman, the Philippines, Poland, Portugal, Qatar, Romania, Russia, Serbia and Montenegro, Singapore, Slovakia, Slovenia, South Africa, Spain, Sri Lanka, Sweden, Switzerland, Turkey, Ukraine, the United Kingdom, and Uzbekistan</li> </ul>	441086-002
	<ul style="list-style-type: none"> <li>For use in Australia, New Zealand, Pakistan, the People's Republic of China, and South Korea</li> </ul>	441086-003
	<b>Broadcom 802.11 a/b/g WLAN modules:</b>	
	<ul style="list-style-type: none"> <li>For use in Canada, the Cayman Islands, Guam, Puerto Rico, the U.S. Virgin Islands, and the United States</li> </ul>	441075-001
	<ul style="list-style-type: none"> <li>For use in Afghanistan, Albania, Algeria, Andorra, Angola, Antigua and Barbuda, Argentina, Armenia, Aruba, Australia, Austria, Azerbaijan, the Bahamas, Bahrain, Bangladesh, Barbados, Belarus, Belgium, Belize, Benin, Bermuda, Bhutan, Bolivia, Bosnia and Herzegovina, Botswana, Brazil, the British Virgin Islands, Brunei, Bulgaria, Burkina Faso, Burundi, Cameroon, Cape Verde, the Central African Republic, Chad, Chile, Colombia, Comoros, the Congo, Costa Rica, Croatia, Cyprus, the Czech Republic, Denmark, Djibouti, Dominica, the Dominican Republic, East Timor, Ecuador, Egypt, El Salvador, Equatorial Guinea, Eritrea, Estonia, Ethiopia, Fiji, Finland, France, French Guiana, Gabon, Gambia, Georgia, Germany, Ghana, Gibraltar, Greece, the Grenadines, Guadeloupe, Guatemala, Guinea, Guinea-Bissau, Guyana, Haiti, Honduras, Hong Kong, Hungary, Iceland, India, Ireland, Israel, Italy, the Ivory Coast, Jamaica, Jordan, Kazakhstan, Kenya, Kiribati, Kyrgyzstan, Laos, Latvia, Lebanon, Lesotho, Liberia, Liechtenstein, Lithuania, Luxembourg, Macedonia, Madagascar, Malawi, Malaysia, the Maldives, Mali, Malta, the Marshall Islands, Martinique, Mauritania, Mauritius, Mexico, Micronesia, Monaco, Mongolia, Montenegro, Morocco, Mozambique, Namibia, Nauru, Nepal, the Nether Antilles, the Netherlands, New Zealand, Nicaragua, Niger, Nigeria, Norway, Oman, Pakistan, Palau, Panama, Papua New Guinea, Paraguay, the People's Republic of China, Peru, the Philippines, Poland, Portugal, the Republic of Moldova, Romania, Russia, Rwanda, Samoa,</li> </ul>	441075-002



Item	Description	Spare part number
	San Marino, Sao Tome and Principe, Saudi Arabia, Senegal, Serbia and Montenegro, the Seychelles, Sierra Leone, Singapore, Slovakia, Slovenia, the Solomon Islands, Somalia, South Africa, South Korea, Spain, Sri Lanka, St. Kitts and Nevis, St. Lucia, St. Vincent and the Grenadines, Suriname, Swaziland, Sweden, Switzerland, Taiwan, Tajikistan, Tanzania, Togo, Tonga, Trinidad and Tobago, Tunisia, Turkey, Turkmenistan, Tuvalu, Uganda, Ukraine, the United Arab Emirates, the United Kingdom, Uruguay, Uzbekistan, Vanuatu, Venezuela, Vietnam, Yemen, Zaire, Zambia, and Zimbabwe	
<b>Intel 802.11 a/b/g WLAN modules:</b>		
	<ul style="list-style-type: none"> <li>For use in Antigua and Barbuda, Argentina, Australia, the Bahamas, Barbados, Brunei, Canada, Chile, the Dominican Republic, Guam, Guatemala, Hong Kong, India, Indonesia, Malaysia, Mexico, New Zealand, Panama, Paraguay, Saudi Arabia, Taiwan, the United States, and Vietnam</li> </ul>	451861-001
	<ul style="list-style-type: none"> <li>For use in Aruba, Austria, Azerbaijan, Bahrain, Belgium, Bermuda, Brazil, Bulgaria, the Cayman Islands, Colombia, Croatia, Cyprus, the Czech Republic, Denmark, Egypt, El Salvador, Estonia, Finland, France, Georgia, Germany, Greece, Hungary, Iceland, Ireland, Italy, Jordan, Latvia, Lebanon, Liechtenstein, Lithuania, Luxembourg, Malta, Monaco, the Netherlands, Norway, Oman, the Philippines, Poland, Portugal, Romania, Russia, Serbia and Montenegro, Singapore, Slovakia, Slovenia, South Africa, Spain, Sri Lanka, Sweden, Switzerland, Turkey, the United Kingdom, and Uzbekistan</li> </ul>	451861-002
<b>Atheros AR2425 802.11b/g WLAN modules:</b>		
	<ul style="list-style-type: none"> <li>For use in Canada, the Cayman Islands, Guam, Puerto Rico, the U.S. Virgin Islands, and the United States</li> </ul>	459339-001
	<ul style="list-style-type: none"> <li>For use in Afghanistan, Albania, Algeria, Andorra, Angola, Antigua and Barbuda, Argentina, Armenia, Aruba, Australia, Austria, Azerbaijan, the Bahamas, Bahrain, Bangladesh, Barbados, Belarus, Belgium, Belize, Benin, Bermuda, Bhutan, Bolivia, Bosnia and Herzegovina, Botswana, Brazil, the British Virgin Islands, Brunei, Bulgaria, Burkina Faso, Burundi, Cambodia, Cameroon, Cape Verde, the Central African Republic, Chad, Chile, Colombia, Comoros, Congo, Costa Rica, Croatia, Cyprus, the Czech Republic, Denmark, Djibouti, Dominica, the Dominican Republic, East Timor, Ecuador, Egypt, El Salvador, Equatorial Guinea, Eritrea, Estonia, Ethiopia, Fiji, Finland, France, French Guiana, Gabon, Gambia, Georgia, Germany, Ghana, Gibraltar, Greece, the Grenadines, Guadeloupe, Guatemala, Guinea, Guinea-Bissau, Guyana, Haiti, Honduras, Hong Kong, Hungary, Iceland, India, Indonesia, Ireland, Israel, Italy, the Ivory Coast, Jamaica, Japan, Jordan, Kazakhstan, Kenya, Kiribati, Kuwait, Kyrgyzstan, Laos, Latvia, Lebanon, Lesotho, Liberia, Liechtenstein, Lithuania, Luxembourg, Macedonia, Madagascar, Malawi, Malaysia, the Maldives, Mali, Malta, the Marshall Islands, Martinique, Mauritania, Mauritius, Mexico, Micronesia, Monaco, Mongolia, Montenegro, Morocco, Mozambique, Namibia, Nauru, Nepal, the Nether Antilles, the Netherlands, New Zealand, Nicaragua, Niger, Nigeria, Norway, Oman, Pakistan, Palau, Panama, Papua New Guinea, Paraguay, the People's Republic of China, Peru, the Philippines, Poland, Portugal, Qatar, the Republic of Moldova, Romania, Russia, Rwanda, Samoa, Sao Tome and Principe, Saudi Arabia, Senegal, Serbia and Montenegro, Seychelles, Sierra Leone, Singapore, Slovakia, Slovenia, the Solomon Islands, Somalia, South Africa, South Korea, Spain, Sri Lanka, St. Kitts and Nevis, St. Lucia, St. Vincent and the Grenadines, Suriname, Swaziland, Sweden, Switzerland, Syria, Taiwan, Tajikistan, Tanzania, Thailand, Togo, Tonga, Trinidad and Tobago, Tunisia, Turkey, Turkmenistan, Tuvalu, Uganda, Ukraine, the United Arab Emirates, the United Kingdom, Uruguay, Uzbekistan, Vanuatu, Venezuela, Vietnam, Yemen, Zaire, Zambia, and Zimbabwe</li> </ul>	459339-002
<b>Broadcom 802.11b/g WLAN modules:</b>		
	<ul style="list-style-type: none"> <li>For use in Canada, the Cayman Islands, Guam, Puerto Rico, the U.S. Virgin Islands, and the United States</li> </ul>	441090-001
	<ul style="list-style-type: none"> <li>For use in Afghanistan, Albania, Algeria, Andorra, Angola, Antigua and Barbuda, Argentina, Armenia, Aruba, Australia, Austria, Azerbaijan, the Bahamas, Bahrain, Bangladesh, Barbados, Belarus, Belgium, Belize, Benin, Bermuda, Bhutan, Bolivia,</li> </ul>	441090-002

Item	Description	Spare part number
	Bosnia and Herzegovina, Botswana, Brazil, the British Virgin Islands, Brunei, Bulgaria, Burkina Faso, Burundi, Cameroon, Cape Verde, the Central African Republic, Chad, Chile, Colombia, Comoros, the Congo, Costa Rica, Croatia, Cyprus, the Czech Republic, Denmark, Djibouti, Dominica, the Dominican Republic, East Timor, Ecuador, Egypt, El Salvador, Equatorial Guinea, Eritrea, Estonia, Ethiopia, Fiji, Finland, France, French Guiana, Gabon, Gambia, Georgia, Germany, Ghana, Gibraltar, Greece, the Grenadines, Guadeloupe, Guatemala, Guinea, Guinea-Bissau, Guyana, Haiti, Honduras, Hong Kong, Hungary, Iceland, India, Ireland, Israel, Italy, the Ivory Coast, Jamaica, Jordan, Kazakhstan, Kenya, Kiribati, Kyrgyzstan, Laos, Latvia, Lebanon, Lesotho, Liberia, Liechtenstein, Lithuania, Luxembourg, Macedonia, Madagascar, Malawi, Malaysia, the Maldives, Mali, Malta, the Marshall Islands, Martinique, Mauritania, Mauritius, Mexico, Micronesia, Monaco, Mongolia, Montenegro, Morocco, Mozambique, Namibia, Nauru, Nepal, the Nether Antilles, the Netherlands, New Zealand, Nicaragua, Niger, Nigeria, Norway, Oman, Pakistan, Palau, Panama, Papua New Guinea, Paraguay, the People's Republic of China, Peru, the Philippines, Poland, Portugal, the Republic of Moldova, Romania, Russia, Rwanda, Samoa, San Marino, Sao Tome and Principe, Saudi Arabia, Senegal, Serbia and Montenegro, the Seychelles, Sierra Leone, Singapore, Slovakia, Slovenia, the Solomon Islands, Somalia, South Africa, South Korea, Spain, Sri Lanka, St. Kitts and Nevis, St. Lucia, St. Vincent and the Grenadines, Suriname, Swaziland, Sweden, Switzerland, Taiwan, Tajikistan, Tanzania, Togo, Tonga, Trinidad and Tobago, Tunisia, Turkey, Turkmenistan, Tuvalu, Uganda, Ukraine, the United Arab Emirates, the United Kingdom, Uruguay, Uzbekistan, Vanuatu, Venezuela, Vietnam, Yemen, Zaire, Zambia, and Zimbabwe	
	<b>Intel 802.11b/g WLAN module for use in Thailand</b>	451861-004
<b>(18)</b>	<b>Memory modules</b> (PC2-5300, 667-MHz, DDR2)	
	1024-MB	462330-001
	512-MB	462329-001
<b>(19)</b>	<b>Hard drives</b> (include hard drive bracket and SATA connector)	
	160-GB, 5400-rpm	462333-001
	120-GB, 5400-rpm	462332-001
	<b>Hard Drive Hardware Kit</b> (not illustrated, includes hard drive bracket and screws and hard drive SATA connector)	462331-001
<b>(20)</b>	<b>Optical drives</b> (include optical drive bezel and bracket)	
	DVD±RW and CD-RW Super Multi Double-Layer Combo Drive with LightScribe	462336-001
	DVD±RW and CD-RW Super Multi Double-Layer Combo Drive	462335-001
	<b>Optical Drive Bezel/Bracket Kit</b> (not illustrated, includes optical drive bezel and optical drive bracket and screws)	462334-001

# Display assembly components

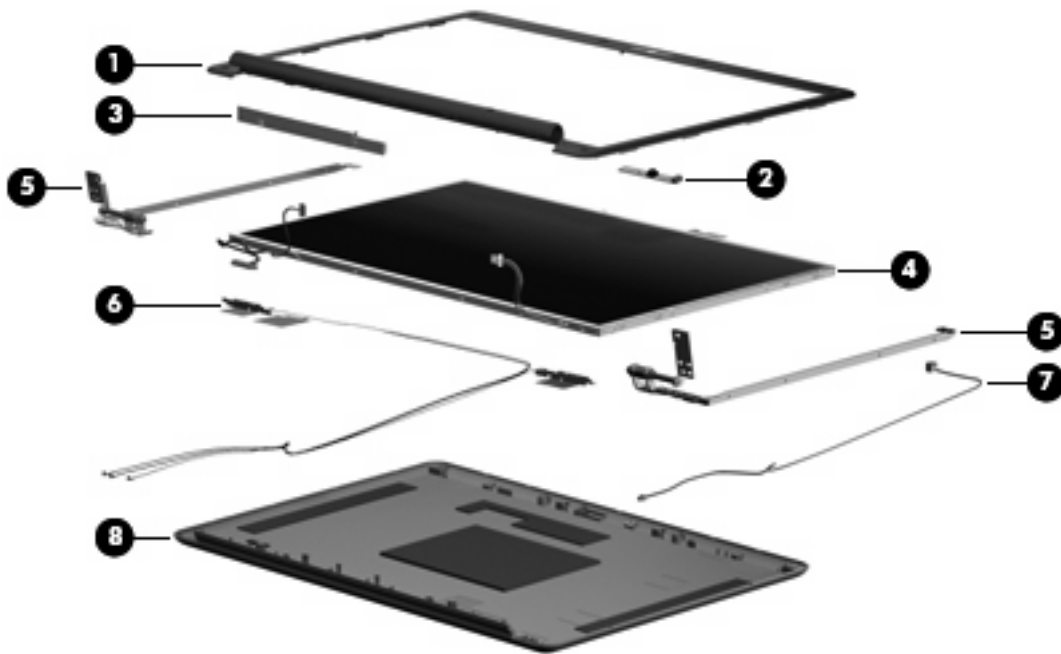

Item	Description	Spare part number
(1)	<b>Display bezel</b> (includes Compaq logo, and camera lens)	462391-001
(2)	<b>Camera module</b>	462580-001
(3)	<b>Display inverter</b>	462579-001
(4)	<b>17.0-inch, WXGA+BrightView display panel</b> (includes display panel cable and backlight cable)	462318-001
(5)	<b>Display Hinge Kit</b> (includes left and right display hinges)	462392-001
(6)	<b>Wireless Antenna Kit</b>	462394-001
(7)	<b>Microphone</b> (includes microphone receiver and cable)	462395-001
(8)	<b>Display enclosure</b> (includes wireless antenna transceivers and cables, microphone receiver and cable, and Compaq logo)	462389-001
	<b>Display Cable Kit</b> (not illustrated, includes display panel cable and camera module cable)	462393-001
	<b>Display Bracket Kit</b> (not illustrated, includes display panel top and bottom support brackets)	462396-001
	<b>Display Rubber Kit</b> (not illustrated, includes display bezel rubber screw covers)	462397-001
	<b>Display Screw Kit</b> (not illustrated)	462398-001

# Plastics Kit



Item	Description	Spare part number
	<b>Plastics Kit:</b>	462409-001
(1)	Memory/WLAN module compartment cover (includes one captive screw, secured by a C-clip)	
(2)	Hard drive cover (includes 2 captive screws, secured by C-clips)	

## Mass storage devices



Item	Description	Spare part number
<b>(1)</b>	<b>Optical drives</b> (include bezel and bracket)	
	DVD±RW and CD-RW Super Multi Double-Layer Combo Drive with LightScribe	462336-001
	DVD±RW and CD-RW Super Multi Double-Layer Combo Drive	462335-001
<b>(2)</b>	<b>Hard drives</b> (include hard drive bracket and screws and SATA connector)	
	160-GB, 5400-rpm	462333-001
	120-GB, 5400-rpm	462332-001

# Miscellaneous parts

Description	Spare part number
<b>65-W AC adapter</b>	417220-001
<b>Power cords:</b>	
For use in Australia	383496-011
For use in Europe	383496-021
For use in India	383496-D61
For use in Italy	383496-061
For use in the United Kingdom	383496-031
For use the United States	383496-001
<b>Screw Kit</b>	462408-001
<ul style="list-style-type: none"><li>• Phillips PM3.0×4.0 screw</li><li>• Phillips PM2.5×9.0 screw</li><li>• Phillips PM2.5×7.0 screw</li><li>• Phillips PM2.5×6.0 captive screw</li><li>• Phillips PM2.5×5.0 screw</li><li>• Phillips PM2.0×4.0 screw</li></ul>	

# Sequential part number listing

Spare part number	Description
383496-001	Power cord for use in the United States
383496-011	Power cord for use in Australia
383496-021	Power cord for use in Europe
383496-031	Power cord for use in the United Kingdom
383496-061	Power cord for use in Italy
383496-D61	Power cord for use in India
417220-001	65-W AC adapter
441075-001	Broadcom 802.11a/b/g WLAN module for use in Canada, the Cayman Islands, Guam, Puerto Rico, the U.S. Virgin Islands, and the United States
441075-002	Broadcom 802.11a/b/g WLAN module for use in Afghanistan, Albania, Algeria, Andorra, Angola, Antigua and Barbuda, Argentina, Armenia, Aruba, Australia, Austria, Azerbaijan, the Bahamas, Bahrain, Bangladesh, Barbados, Belarus, Belgium, Belize, Benin, Bermuda, Bhutan, Bolivia, Bosnia and Herzegovina, Botswana, Brazil, the British Virgin Islands, Brunei, Bulgaria, Burkina Faso, Burundi, Cameroon, Cape Verde, the Central African Republic, Chad, Chile, Colombia, Comoros, the Congo, Costa Rica, Croatia, Cyprus, the Czech Republic, Denmark, Djibouti, Dominica, the Dominican Republic, East Timor, Ecuador, Egypt, El Salvador, Equatorial Guinea, Eritrea, Estonia, Ethiopia, Fiji, Finland, France, French Guiana, Gabon, Gambia, Georgia, Germany, Ghana, Gibraltar, Greece, the Grenadines, Guadeloupe, Guatemala, Guinea, Guinea-Bissau, Guyana, Haiti, Honduras, Hong Kong, Hungary, Iceland, India, Ireland, Israel, Italy, the Ivory Coast, Jamaica, Jordan, Kazakhstan, Kenya, Kiribati, Kyrgyzstan, Laos, Latvia, Lebanon, Lesotho, Liberia, Liechtenstein, Lithuania, Luxembourg, Macedonia, Madagascar, Malawi, Malaysia, the Maldives, Mali, Malta, the Marshall Islands, Martinique, Mauritania, Mauritius, Mexico, Micronesia, Monaco, Mongolia, Montenegro, Morocco, Mozambique, Namibia, Nauru, Nepal, the Nether Antilles, the Netherlands, New Zealand, Nicaragua, Niger, Nigeria, Norway, Oman, Pakistan, Palau, Panama, Papua New Guinea, Paraguay, the People's Republic of China, Peru, the Philippines, Poland, Portugal, the Republic of Moldova, Romania, Russia, Rwanda, Samoa, San Marino, Sao Tome and Principe, Saudi Arabia, Senegal, Serbia and Montenegro, the Seychelles, Sierra Leone, Singapore, Slovakia, Slovenia, the Solomon Islands, Somalia, South Africa, South Korea, Spain, Sri Lanka, St. Kitts and Nevis, St. Lucia, St. Vincent and the Grenadines, Suriname, Swaziland, Sweden, Switzerland, Taiwan, Tajikistan, Tanzania, Togo, Tonga, Trinidad and Tobago, Tunisia, Turkey, Turkmenistan, Tuvalu, Uganda, Ukraine, the United Arab Emirates, the United Kingdom, Uruguay, Uzbekistan, Vanuatu, Venezuela, Vietnam, Yemen, Zaire, Zambia, and Zimbabwe
441086-001	Intel 802.11a/b/g/n WLAN module for use in Antigua and Barbuda, Argentina, Aruba, the Bahamas, Barbados, Bermuda, Brunei, Canada, the Cayman Islands, Chile, Colombia, Costa Rica, the Dominican Republic, Ecuador, El Salvador, Guam, Guatemala, Haiti, Honduras, Hong Kong, India, Indonesia, Malaysia, Mexico, Panama, Paraguay, Peru, Saudi Arabia, Taiwan, Uruguay, the United States, Venezuela, and Vietnam
441086-002	Intel 802.11a/b/g/n WLAN module for use in Austria, Azerbaijan, Bahrain, Belgium, Brazil, Bulgaria, Croatia, Cyprus, the Czech Republic, Denmark, Egypt, Estonia, Finland, France, Georgia, Germany, Greece, Hungary, Iceland, Ireland, Israel, Italy, Latvia, Lebanon, Liechtenstein, Lithuania, Luxembourg, Malta, Monaco, the Netherlands, Norway, Oman, the Philippines, Poland, Portugal, Qatar, Romania, Russia, Serbia and Montenegro, Singapore, Slovakia, Slovenia, South Africa, Spain, Sri Lanka, Sweden, Switzerland, Turkey, Ukraine, the United Kingdom, and Uzbekistan
441086-003	Intel 802.11a/b/g/n WLAN module for use in Australia, New Zealand, Pakistan, the People's Republic of China, and South Korea
441090-001	Broadcom 802.11b/g WLAN module for use in Canada, the Cayman Islands, Guam, Puerto Rico, the U.S. Virgin Islands, and the United States
441090-002	Broadcom 802.11b/g WLAN module for use in Afghanistan, Albania, Algeria, Andorra, Angola, Antigua and Barbuda, Argentina, Armenia, Aruba, Australia, Austria, Azerbaijan, the Bahamas, Bahrain, Bangladesh, Barbados, Belarus, Belgium, Belize, Benin, Bermuda, Bhutan, Bolivia, Bosnia and Herzegovina,

Spare part number	Description
	Botswana, Brazil, the British Virgin Islands, Brunei, Bulgaria, Burkina Faso, Burundi, Cameroon, Cape Verde, the Central African Republic, Chad, Chile, Colombia, Comoros, the Congo, Costa Rica, Croatia, Cyprus, the Czech Republic, Denmark, Djibouti, Dominica, the Dominican Republic, East Timor, Ecuador, Egypt, El Salvador, Equatorial Guinea, Eritrea, Estonia, Ethiopia, Fiji, Finland, France, French Guiana, Gabon, Gambia, Georgia, Germany, Ghana, Gibraltar, Greece, the Grenadines, Guadeloupe, Guatemala, Guinea, Guinea-Bissau, Guyana, Haiti, Honduras, Hong Kong, Hungary, Iceland, India, Ireland, Israel, Italy, the Ivory Coast, Jamaica, Jordan, Kazakhstan, Kenya, Kiribati, Kyrgyzstan, Laos, Latvia, Lebanon, Lesotho, Liberia, Liechtenstein, Lithuania, Luxembourg, Macedonia, Madagascar, Malawi, Malaysia, the Maldives, Mali, Malta, the Marshall Islands, Martinique, Mauritania, Mauritius, Mexico, Micronesia, Monaco, Mongolia, Montenegro, Morocco, Mozambique, Namibia, Nauru, Nepal, the Nether Antilles, the Netherlands, New Zealand, Nicaragua, Niger, Nigeria, Norway, Oman, Pakistan, Palau, Panama, Papua New Guinea, Paraguay, the People's Republic of China, Peru, the Philippines, Poland, Portugal, the Republic of Moldova, Romania, Russia, Rwanda, Samoa, San Marino, Sao Tome and Principe, Saudi Arabia, Senegal, Serbia and Montenegro, the Seychelles, Sierra Leone, Singapore, Slovakia, Slovenia, the Solomon Islands, Somalia, South Africa, South Korea, Spain, Sri Lanka, St. Kitts and Nevis, St. Lucia, St. Vincent and the Grenadines, Suriname, Swaziland, Sweden, Switzerland, Taiwan, Tajikistan, Tanzania, Togo, Tonga, Trinidad and Tobago, Tunisia, Turkey, Turkmenistan, Tuvalu, Uganda, Ukraine, the United Arab Emirates, the United Kingdom, Uruguay, Uzbekistan, Vanuatu, Venezuela, Vietnam, Yemen, Zaire, Zambia, and Zimbabwe
449137-001	RTC battery
450586-001	Intel Core 2 Duo T7100 1.80-GHz processor (800-MHz FSB, 2-MB L2 cache, includes replacement thermal material)
451861-001	Intel 802.11a/b/g WLAN module for use in Antigua and Barbuda, Argentina, Australia, the Bahamas, Barbados, Brunei, Canada, Chile, the Dominican Republic, Guam, Guatemala, Hong Kong, India, Indonesia, Malaysia, Mexico, New Zealand, Panama, Paraguay, Saudi Arabia, Taiwan, the United States, and Vietnam
451861-002	Intel 802.11a/b/g WLAN module for use in Aruba, Austria, Azerbaijan, Bahrain, Belgium, Bermuda, Brazil, Bulgaria, the Cayman Islands, Colombia, Croatia, Cyprus, the Czech Republic, Denmark, Egypt, El Salvador, Estonia, Finland, France, Georgia, Germany, Greece, Hungary, Iceland, Ireland, Italy, Jordan, Latvia, Lebanon, Liechtenstein, Lithuania, Luxembourg, Malta, Monaco, the Netherlands, Norway, Oman, the Philippines, Poland, Portugal, Romania, Russia, Serbia and Montenegro, Singapore, Slovakia, Slovenia, South Africa, Spain, Sri Lanka, Sweden, Switzerland, Turkey, the United Kingdom, and Uzbekistan
451861-004	Intel 802.11b/g WLAN module for use in Thailand
453195-001	Intel Core Duo T5550 1.67-GHz processor (533-MHz FSB, 2-MB L2 cache, includes replacement thermal material)
454321-001	Intel Celeron M 540 1.86-GHz processor (533-MHz FSB, 1-MB L2 cache, includes replacement thermal material)
454322-001	Intel Celeron M 550 2.00-GHz processor (533-MHz FSB, 1-MB L2 cache, includes replacement thermal material)
456965-001	Intel Core 2 Duo T7250 2.00-GHz processor (800-MHz FSB, 2-MB L2 cache, includes replacement thermal material)
457313-001	Intel Core Duo T2310 1.46-GHz processor (533-MHz FSB, 1-MB L2 cache, includes replacement thermal material)
457314-001	Intel Core Duo T2330 1.60-GHz processor (533-MHz FSB, 1-MB L2 cache, includes replacement thermal material)
457315-001	Intel Celeron M 530 1.73-GHz processor (533-MHz FSB, 1-MB L2 cache, includes replacement thermal material)
458247-001	Intel Core Duo T5550 1.83-GHz processor (533-MHz FSB, 2-MB L2 cache, includes replacement thermal material)
459339-001	Atheros AR2425 802.11b/g WLAN module for use in Canada, the Cayman Islands, Guam, Puerto Rico, the U.S. Virgin Islands, and the United States
459339-002	Atheros AR2425 802.11b/g WLAN module for use in Afghanistan, Albania, Algeria, Andorra, Angola, Antigua and Barbuda, Argentina, Armenia, Aruba, Australia, Austria, Azerbaijan, the Bahamas, Bahrain, Bangladesh, Barbados, Belarus, Belgium, Belize, Benin, Bermuda, Bhutan, Bolivia, Bosnia and Herzegovina,



Spare part number	Description
	Botswana, Brazil, the British Virgin Islands, Brunei, Bulgaria, Burkina Faso, Burundi, Cambodia, Cameroon, Cape Verde, the Central African Republic, Chad, Chile, Colombia, Comoros, Congo, Costa Rica, Croatia, Cyprus, the Czech Republic, Denmark, Djibouti, Dominica, the Dominican Republic, East Timor, Ecuador, Egypt, El Salvador, Equatorial Guinea, Eritrea, Estonia, Ethiopia, Fiji, Finland, France, French Guiana, Gabon, Gambia, Georgia, Germany, Ghana, Gibraltar, Greece, the Grenadines, Guadeloupe, Guatemala, Guinea, Guinea-Bissau, Guyana, Haiti, Honduras, Hong Kong, Hungary, Iceland, India, Indonesia, Ireland, Israel, Italy, the Ivory Coast, Jamaica, Japan, Jordan, Kazakhstan, Kenya, Kiribati, Kuwait, Kyrgyzstan, Laos, Latvia, Lebanon, Lesotho, Liberia, Liechtenstein, Lithuania, Luxembourg, Macedonia, Madagascar, Malawi, Malaysia, the Maldives, Mali, Malta, the Marshall Islands, Martinique, Mauritania, Mauritius, Mexico, Micronesia, Monaco, Mongolia, Montenegro, Morocco, Mozambique, Namibia, Nauru, Nepal, the Nether Antilles, the Netherlands, New Zealand, Nicaragua, Niger, Nigeria, Norway, Oman, Pakistan, Palau, Panama, Papua New Guinea, Paraguay, the People's Republic of China, Peru, the Philippines, Poland, Portugal, Qatar, the Republic of Moldova, Romania, Russia, Rwanda, Samoa, San Marino, Sao Tome and Principe, Saudi Arabia, Senegal, Serbia and Montenegro, Seychelles, Sierra Leone, Singapore, Slovakia, Slovenia, the Solomon Islands, Somalia, South Africa, South Korea, Spain, Sri Lanka, St. Kitts and Nevis, St. Lucia, St. Vincent and the Grenadines, Suriname, Swaziland, Sweden, Switzerland, Syria, Taiwan, Tajikistan, Tanzania, Thailand, Togo, Tonga, Trinidad and Tobago, Tunisia, Turkey, Turkmenistan, Tuvalu, Uganda, Ukraine, the United Arab Emirates, the United Kingdom, Uruguay, Uzbekistan, Vanuatu, Venezuela, Vietnam, Yemen, Zaire, Zambia, and Zimbabwe
462316-001	GM965 system board, for use only with computer models equipped with Intel Core 2 Duo processors (includes digital media card board and replacement thermal material)
462317-001	GL960 system board, for use only with computer models equipped with Intel Core Duo and Intel Celeron M processors (includes digital media card board and replacement thermal material)
462318-001	17.0-inch, WXGA+BrightView display panel (includes display panel cable and backlight cable)
462319-001	17.0-inch, WXGA+BrightView display assembly (includes 3 WLAN antenna transceivers and cables, camera module and cable, microphones and cables, and logo)
462329-001	512-MB memory module (PC2-5300, 667-MHz, DDR2)
462330-001	1024-MB memory module (PC2-5300, 667-MHz, DDR2)
462331-001	Hard Drive Hardware Kit (includes hard drive bracket and screws and hard drive SATA connector)
462332-001	120-GB, 5400-rpm hard drive (includes hard drive bracket and SATA connector)
462333-001	160-GB, 5400-rpm hard drive (includes hard drive bracket and SATA connector)
462334-001	Optical Drive Bezel/Bracket Kit (includes optical drive bezel and optical drive bracket and screws)
462335-001	DVD±RW and CD-RW Super Multi Double-Layer Combo Drive
462336-001	DVD±RW and CD-RW Super Multi Double-Layer Combo Drive with LightScribe
462337-001	6-cell, 47-Wh, 2.2-Ah battery
462383-001	Keyboard for use in the United States (includes keyboard cable)
462383-031	Keyboard for use in the United Kingdom (includes keyboard cable)
462383-041	Keyboard for use in Germany (includes keyboard cable)
462383-051	Keyboard for use in France (includes keyboard cable)
462383-061	Keyboard for use in Italy (includes keyboard cable)
462383-071	Keyboard for use in Spain (includes keyboard cable)
462383-121	Keyboard for use in French Canada (includes keyboard cable)
462383-141	Keyboard for use in Turkey (includes keyboard cable)
462383-171	Keyboard for use in Saudi Arabia (includes keyboard cable)

<b>Spare part number</b>	<b>Description</b>
462383-B31	Keyboard for use in the Netherlands (includes keyboard cable)
462383-DH1	Keyboard for use in Denmark, Finland, and Norway (includes keyboard cable)
462389-001	Display enclosure (includes wireless antenna transceivers and cables, microphone receiver and cable, and Compaq logo)
462391-001	Display bezel (includes Compaq logo, and camera lens)
462392-001	Display Hinge Kit (includes left and right display hinges)
462393-001	Display Cable Kit (includes display panel cable and camera module cable)
462394-001	Wireless Antenna Kit
462395-001	Microphone (includes microphone receiver and cable)
462396-001	Display Bracket Kit (includes display panel top and bottom support brackets)
462397-001	Display Rubber Kit (includes display bezel rubber screw covers)
462398-001	Display Screw Kit
462399-001	Switch cover (includes wireless button board and cable, power button board and cable, and num lock LED board and cable)
462400-001	Base enclosure (includes rubber feet)
462401-001	Top cover (includes TouchPad and TouchPad cable and caps lock LED board and cable)
462402-001	Digital media board
462403-001	Power connector cable
462404-001	Fan
462405-001	Heat sink (includes replacement thermal material)
462406-001	USB board (includes USB board cable)
462408-001	Screw Kit
462409-001	Plastics Kit (see <a href="#">Plastics Kit on page 20</a> for more Plastics Kit spare part information)
462410-001	Rubber Foot Kit (includes 7 computer feet)
462579-001	Display inverter
462580-001	Camera module
462581-001	Speaker assembly (include cables)

---

# 4 Removal and replacement procedures

## Preliminary replacement requirements

### Tools required

You will need the following tools to complete the removal and replacement procedures:

- Flat-bladed screwdriver
- Magnetic screwdriver
- Phillips P0 and P1 screwdrivers

### Service considerations

The following sections include some of the considerations that you must keep in mind during disassembly and assembly procedures.

---

 **NOTE:** As you remove each subassembly from the computer, place the subassembly (and all accompanying screws) away from the work area to prevent damage.

---

### Plastic parts

Using excessive force during disassembly and reassembly can damage plastic parts. Use care when handling the plastic parts. Apply pressure only at the points designated in the maintenance instructions.

## Cables and connectors

- 
- △ **CAUTION:** When servicing the computer, be sure that cables are placed in their proper locations during the reassembly process. Improper cable placement can damage the computer.
- 

Cables must be handled with extreme care to avoid damage. Apply only the tension required to unseat or seat the cables during removal and insertion. Handle cables by the connector whenever possible. In all cases, avoid bending, twisting, or tearing cables. Be sure that cables are routed in such a way that they cannot be caught or snagged by parts being removed or replaced. Handle flex cables with extreme care; these cables tear easily.

## Drive handling

- 
- △ **CAUTION:** Drives are fragile components that must be handled with care. To prevent damage to the computer, damage to a drive, or loss of information, observe these precautions:
- 

Before removing or inserting a hard drive, shut down the computer. If you are unsure whether the computer is off or in Hibernation, turn the computer on, and then shut it down through the operating system.

Before handling a drive, be sure that you are discharged of static electricity. While handling a drive, avoid touching the connector.

Before removing a diskette drive or optical drive, be sure that a diskette or disc is not in the drive and be sure that the optical drive tray is closed.

Handle drives on surfaces covered with at least one inch of shock-proof foam.

Avoid dropping drives from any height onto any surface.

After removing a hard drive, an optical drive, or a diskette drive, place it in a static-proof bag.

Avoid exposing a hard drive to products that have magnetic fields, such as monitors or speakers.

Avoid exposing a drive to temperature extremes or liquids.

If a drive must be mailed, place the drive in a bubble pack mailer or other suitable form of protective packaging and label the package "FRAGILE."

---

# Grounding guidelines

## Electrostatic discharge damage

Electronic components are sensitive to electrostatic discharge (ESD). Circuitry design and structure determine the degree of sensitivity. Networks built into many integrated circuits provide some protection, but in many cases, ESD contains enough power to alter device parameters or melt silicon junctions.

A discharge of static electricity from a finger or other conductor can destroy static-sensitive devices or microcircuitry. Even if the spark is neither felt nor heard, damage may have occurred.

An electronic device exposed to ESD may not be affected at all and can work perfectly throughout a normal cycle. Or the device may function normally for a while, then degrade in the internal layers, reducing its life expectancy.

△ **CAUTION:** To prevent damage to the computer when you are removing or installing internal components, observe these precautions:

Keep components in their electrostatic-safe containers until you are ready to install them.

Use nonmagnetic tools.

Before touching an electronic component, discharge static electricity by using the guidelines described in this section.

Avoid touching pins, leads, and circuitry. Handle electronic components as little as possible.

If you remove a component, place it in an electrostatic-safe container.

The following table shows how humidity affects the electrostatic voltage levels generated by different activities.

△ **CAUTION:** A product can be degraded by as little as 700 V.

Typical electrostatic voltage levels			
Event	Relative humidity		
	10%	40%	55%
Walking across carpet	35,000 V	15,000 V	7,500 V
Walking across vinyl floor	12,000 V	5,000 V	3,000 V
Motions of bench worker	6,000 V	800 V	400 V
Removing DIPS from plastic tube	2,000 V	700 V	400 V
Removing DIPS from vinyl tray	11,500 V	4,000 V	2,000 V
Removing DIPS from Styrofoam	14,500 V	5,000 V	3,500 V
Removing bubble pack from PCB	26,500 V	20,000 V	7,000 V
Packing PCBs in foam-lined box	21,000 V	11,000 V	5,000 V

## Packaging and transporting guidelines

Follow these grounding guidelines when packaging and transporting equipment:

- To avoid hand contact, transport products in static-safe tubes, bags, or boxes.
- Protect ESD-sensitive parts and assemblies with conductive or approved containers or packaging.
- Keep ESD-sensitive parts in their containers until the parts arrive at static-free workstations.
- Place items on a grounded surface before removing items from their containers.
- Always be properly grounded when touching a component or assembly.
- Store reusable ESD-sensitive parts from assemblies in protective packaging or nonconductive foam.
- Use transporters and conveyors made of antistatic belts and roller bushings. Be sure that mechanized equipment used for moving materials is wired to ground and that proper materials are selected to avoid static charging. When grounding is not possible, use an ionizer to dissipate electric charges.

## Workstation guidelines

Follow these grounding workstation guidelines:

- Cover the workstation with approved static-shielding material.
- Use a wrist strap connected to a properly grounded work surface and use properly grounded tools and equipment.
- Use conductive field service tools, such as cutters, screwdrivers, and vacuums.
- When fixtures must directly contact dissipative surfaces, use fixtures made only of static-safe materials.
- Keep the work area free of nonconductive materials, such as ordinary plastic assembly aids and Styrofoam.
- Handle ESD-sensitive components, parts, and assemblies by the case or PCM laminate. Handle these items only at static-free workstations.
- Avoid contact with pins, leads, or circuitry.
- Turn off power and input signals before inserting or removing connectors or test equipment.

## Equipment guidelines

Grounding equipment must include either a wrist strap or a foot strap at a grounded workstation.

- When seated, wear a wrist strap connected to a grounded system. Wrist straps are flexible straps with a minimum of one megohm  $\pm 10\%$  resistance in the ground cords. To provide proper ground, wear a strap snugly against the skin at all times. On grounded mats with banana-plug connectors, use alligator clips to connect a wrist strap.
- When standing, use foot straps and a grounded floor mat. Foot straps (heel, toe, or boot straps) can be used at standing workstations and are compatible with most types of shoes or boots. On conductive floors or dissipative floor mats, use foot straps on both feet with a minimum of one megohm resistance between the operator and ground. To be effective, the conductive strips must be worn in contact with the skin.

The following grounding equipment is recommended to prevent electrostatic damage:

- Antistatic tape
- Antistatic smocks, aprons, and sleeve protectors
- Conductive bins and other assembly or soldering aids
- Nonconductive foam
- Conductive tabletop workstations with ground cords of one megohm resistance
- Static-dissipative tables or floor mats with hard ties to the ground
- Field service kits
- Static awareness labels
- Material-handling packages
- Nonconductive plastic bags, tubes, or boxes
- Metal tote boxes
- Electrostatic voltage levels and protective materials

The following table lists the shielding protection provided by antistatic bags and floor mats.

Material	Use	Voltage protection level
Antistatic plastic	Bags	1,500 V
Carbon-loaded plastic	Floor mats	7,500 V
Metallized laminate	Floor mats	5,000 V

## Unknown user password

If the computer you are servicing has an unknown user password, follow these steps to clear the password:

---

 **NOTE:** These steps also clear CMOS.

---

1. Shut down the computer. If you are unsure whether the computer is off or in Hibernation, turn the computer on, and then shut it down through the operating system.
2. Disconnect all external devices connected to the computer.
3. Disconnect the power from the computer by first unplugging the power cord from the AC outlet and then unplugging the AC adapter from the computer.
4. Remove the battery (see [Battery on page 34](#)).
5. Remove the real-time clock (RTC) battery (see [RTC battery on page 65](#)).
6. Wait approximately 5 minutes.
7. Replace the RTC battery and reassemble the computer.
8. Connect AC power to the computer. Do not reinsert any batteries at this time.
9. Turn on the computer.

All passwords and all CMOS settings have been cleared.



## Component replacement procedures

This chapter provides removal and replacement procedures.

There are as many as 87 screws, in 7 different sizes, that must be removed, replaced, or loosened when servicing the computer. Make special note of each screw size and location during removal and replacement.

### Serial number

Report the computer serial number to HP when requesting information or ordering spare parts. The serial number is located on the bottom of the computer.

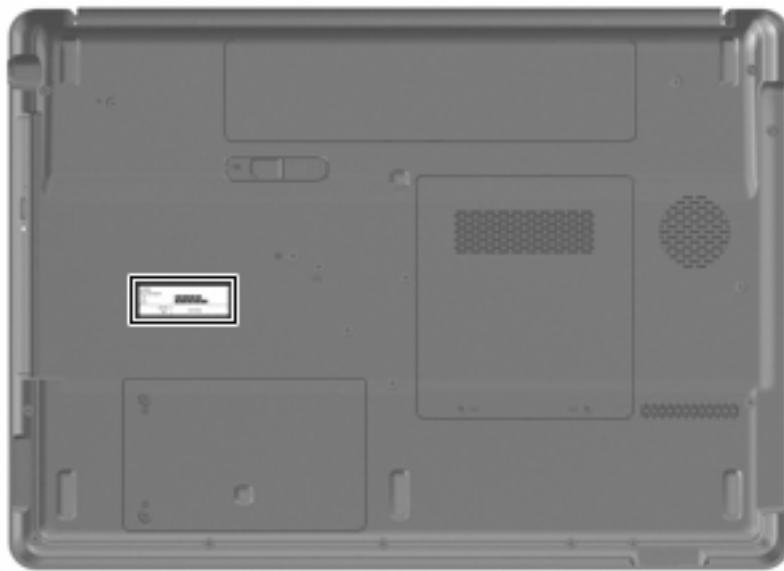

### Computer feet

The computer feet are adhesive-backed rubber pads. The feet are included with the base enclosure and are also available in the Rubber Foot Kit, spare part number 462410-001. There are 7 rubber feet that attach to the base enclosure in the locations illustrated below.

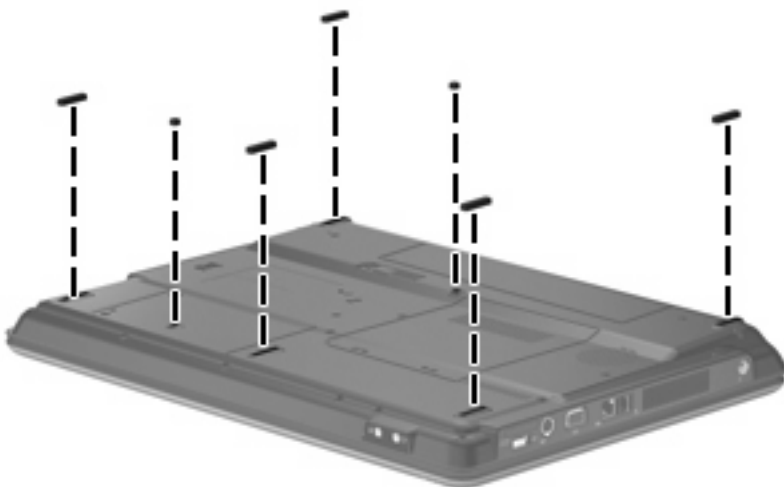

## Battery

Description	Spare part number
6-cell, 2.20-Ah (47-Wh) Li-ion battery	462337-001

Before disassembling the computer, follow these steps:

1. Shut down the computer. If you are unsure whether the computer is off or in Hibernation, turn the computer on, and then shut it down through the operating system.
2. Disconnect all external devices connected to the computer.
3. Disconnect the power from the computer by first unplugging the power cord from the AC outlet and then unplugging the AC adapter from the computer.

Remove the battery:

1. Turn the computer upside down on a flat surface, with the battery bay toward you.
2. Slide the battery release latch **(1)** to release the battery.
3. Pivot the battery **(2)** away from the computer and remove it from the computer **(3)**.

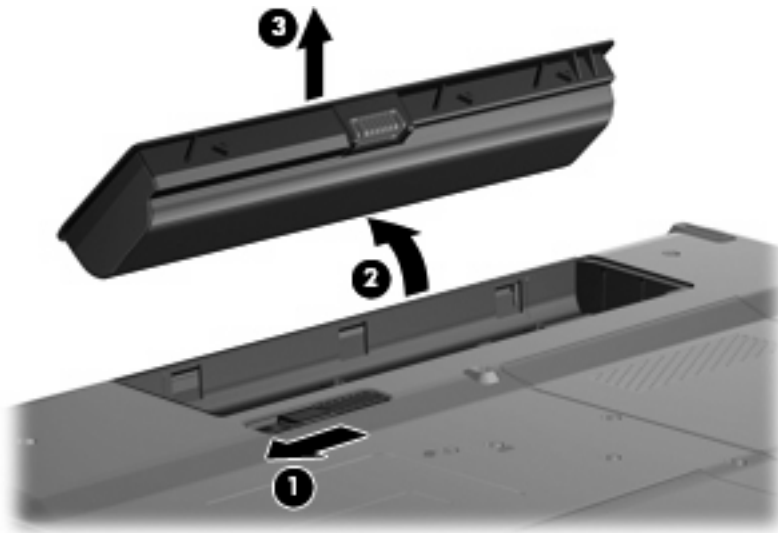

To insert the battery, insert the rear edge of the battery into the battery bay and rotate the battery downward until it is seated. The battery release latch automatically locks the battery into place.

## Camera module

Description	Spare part number
Camera module	462580-001

Before removing the camera module, follow these steps:

1. Shut down the computer. If you are unsure whether the computer is off or in Hibernation, turn the computer on, and then shut it down through the operating system.
2. Disconnect all external devices connected to the computer.
3. Disconnect the power from the computer by first unplugging the power cord from the AC outlet and then unplugging the AC adapter from the computer.
4. Remove the battery (see [Battery on page 34](#)).

Remove the camera module:

1. Turn the computer right-side up, with the front toward you.
2. Open the computer as far as possible.
3. Remove the four rubber screw covers **(1)** and the four Phillips PM2.5×7.0 screws **(2)** that secure the display bezel to the display assembly. The rubber screw covers are available in the Display Rubber Kit, spare part number 462397-001.

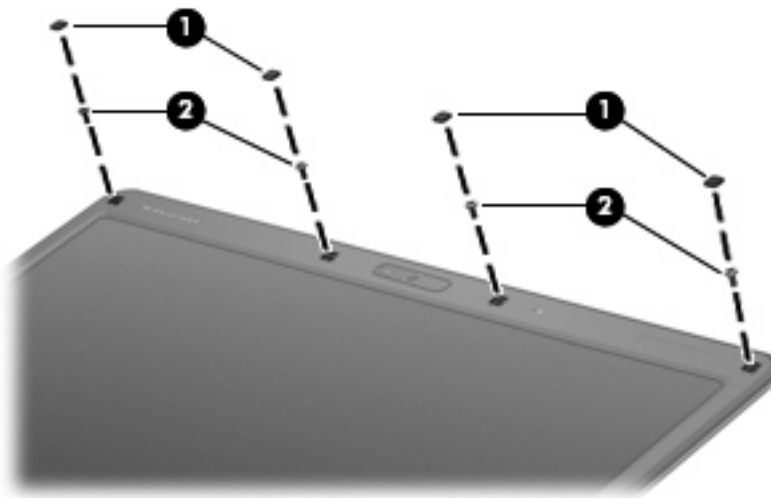

4. Flex the inside edge of the top edge **(1)** of the display bezel until the bezel disengages from the display enclosure.
5. Flex the inside edges of the left and right upper corners **(2)** of the display bezel until the bezel disengages from the display enclosure.

6. Separate the display bezel top edge **(3)** from the display assembly to access the camera module.

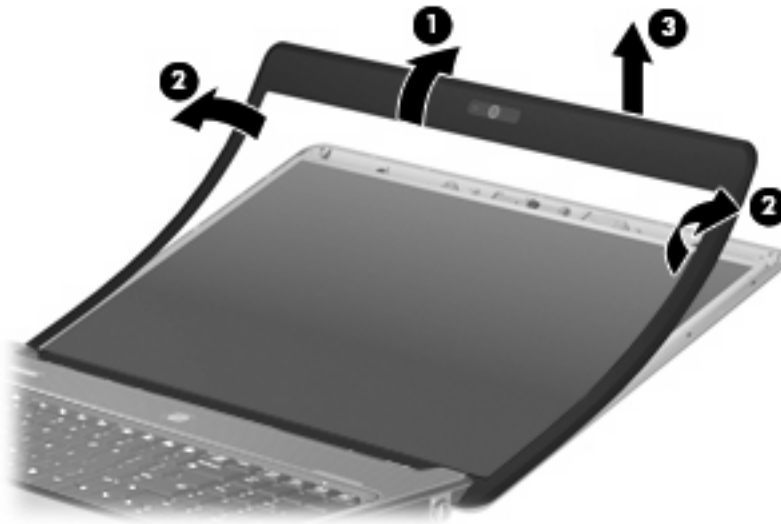

7. Remove the two Phillips PM2.0×3.0 screws **(1)** that secure the camera module to the display enclosure.
8. Release the camera module **(2)** as far from the display enclosure as the camera module cable allows.
9. Disconnect the camera module cable **(3)** from the camera module.

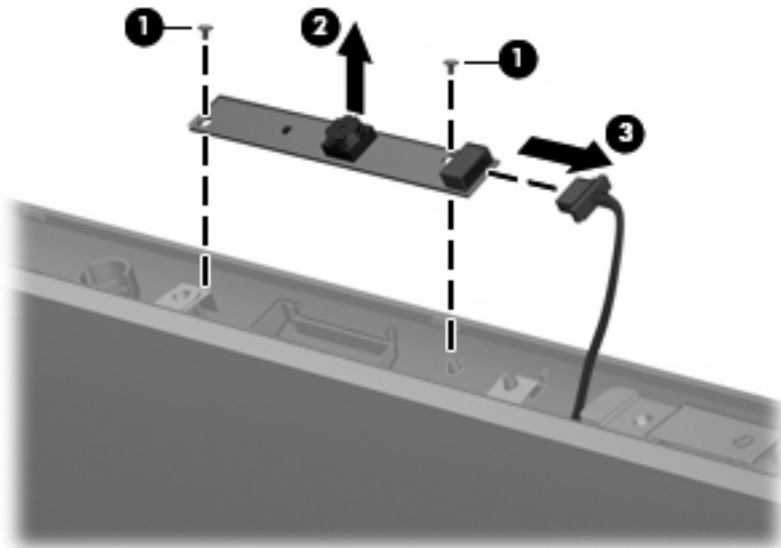

10. Remove the camera module and bracket.

Reverse this procedure to install the camera module.

## Hard drive

 **NOTE:** All hard drive spare part kits include a hard drive bracket.

Description	Spare part number
160-GB, 5400-rpm hard drive	462333-001
120-GB, 5400-rpm hard drive	462332-001
Hard Drive Hardware Kit (includes hard drive bracket, hard drive bracket screws, and hard drive connector)	462331-001

Before removing the hard drive, follow these steps:

1. Shut down the computer. If you are unsure whether the computer is off or in Hibernation, turn the computer on, and then shut it down through the operating system.
2. Disconnect all external devices connected to the computer.
3. Disconnect the power from the computer by first unplugging the power cord from the AC outlet and then unplugging the AC adapter from the computer.
4. Remove the battery (see [Battery on page 34](#)).

Remove the hard drive:

1. Position the computer with the front toward you.
2. Loosen the two Phillips PM2.5×6.0 captive screws **(1)** that secure the hard drive cover to the computer.
3. Lift the left side of the hard drive cover **(2)**, swing it up and to the right, and remove the cover. The hard drive cover is included in the Plastics Kit, spare part number 462409-001.



4. Grasp the Mylar tab **(1)** on the hard drive and slide the hard drive **(2)** to the left to disconnect it from the system board.

5. Remove the hard drive **(3)** from the hard drive bay.

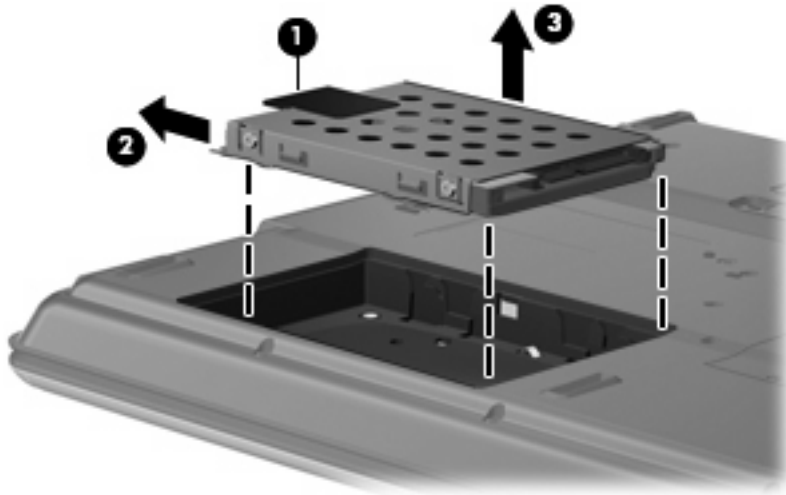

6. If it is necessary to replace the hard drive bracket, remove the two Phillips PM3.0x4.0 hard drive bracket screws **(1)** from each side of the hard drive.
7. Lift the bracket **(2)** straight up to remove it from the hard drive.

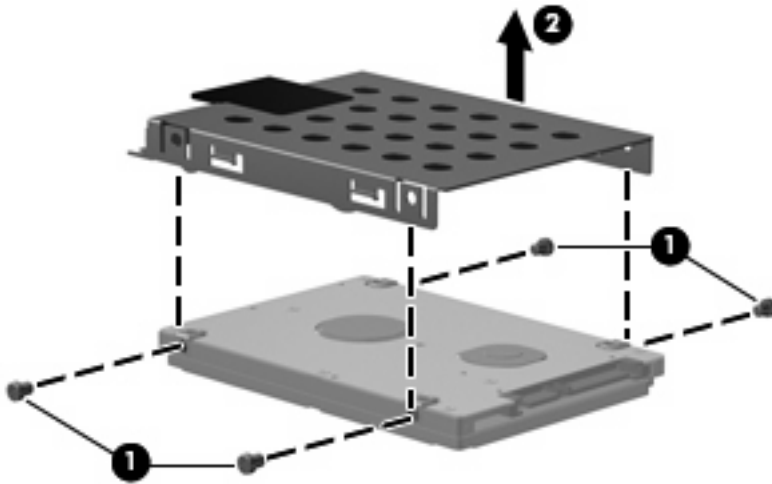

Reverse this procedure to reassemble and install the hard drive.

## Memory module

Description	Spare part number
1024-MB (PC2-5300, 667-MHz, DDR2)	462330-001
512-MB (PC2-5300, 667-MHz, DDR2)	462329-001

Before removing the memory module, follow these steps:

1. Shut down the computer. If you are unsure whether the computer is off or in Hibernation, turn the computer on, and then shut it down through the operating system.
2. Disconnect all external devices connected to the computer.
3. Disconnect the power from the computer by first unplugging the power cord from the AC outlet and then unplugging the AC adapter from the computer.
4. Remove the battery (see [Battery on page 34](#)).

Remove the memory module:

1. Loosen the two Phillips PM2.5×6.0 captive screws **(1)** that secure the memory/WLAN module compartment cover to the computer.
2. Lift the front edge of the cover **(2)**, swing it up and back, and remove the cover. The memory/WLAN module compartment cover is included in the Plastics Kit, spare part number 462409-001.

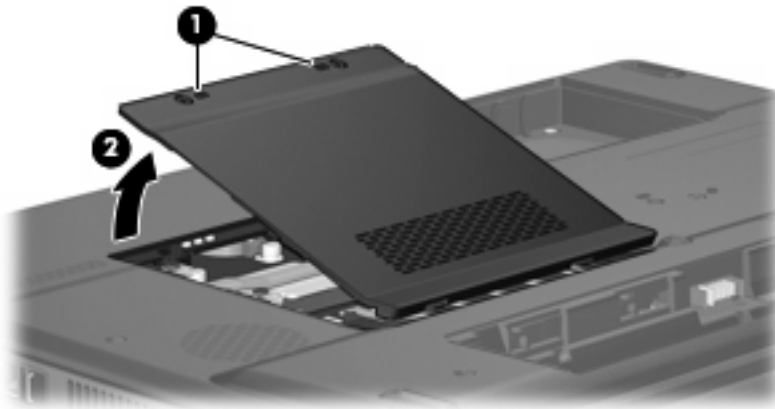

3. Spread the retaining tabs **(1)** on each side of the memory module slot to release the memory module. (The edge of the module opposite the slot rises away from the computer.)

4. Remove the memory module **(2)** by pulling the module away from the slot at an angle.

 **NOTE:** Memory modules are designed with a notch **(3)** to prevent incorrect installation into the memory module slot.

---

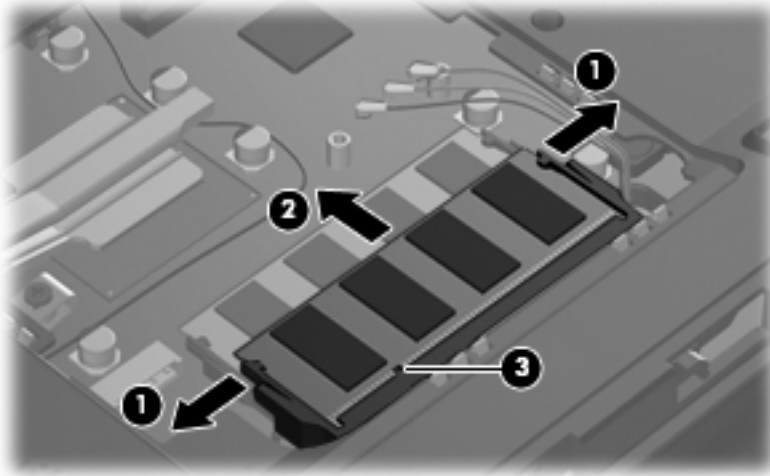

Reverse this procedure to install a memory module.



## WLAN module

Description	Spare part number
<b>Intel 802.11a/b/g/n WLAN modules:</b>	
<ul style="list-style-type: none"> <li>For use in use in Antigua and Barbuda, Argentina, Aruba, the Bahamas, Barbados, Bermuda, Brunei, Canada, the Cayman Islands, Chile, Colombia, Costa Rica, the Dominican Republic, Ecuador, El Salvador, Guam, Guatemala, Haiti, Honduras, Hong Kong, India, Indonesia, Malaysia, Mexico, Panama, Paraguay, Peru, Saudi Arabia, Taiwan, Uruguay, the United States, Venezuela, and Vietnam</li> </ul>	441086-001
<ul style="list-style-type: none"> <li>For use in Austria, Azerbaijan, Bahrain, Belgium, Brazil, Bulgaria, Croatia, Cyprus, the Czech Republic, Denmark, Egypt, Estonia, Finland, France, Georgia, Germany, Greece, Hungary, Iceland, Ireland, Israel, Italy, Latvia, Lebanon, Liechtenstein, Lithuania, Luxembourg, Malta, Monaco, the Netherlands, Norway, Oman, the Philippines, Poland, Portugal, Qatar, Romania, Russia, Serbia and Montenegro, Singapore, Slovakia, Slovenia, South Africa, Spain, Sri Lanka, Sweden, Switzerland, Turkey, Ukraine, the United Kingdom, and Uzbekistan</li> </ul>	441086-002
<ul style="list-style-type: none"> <li>For use in Australia, New Zealand, Pakistan, the People's Republic of China, and South Korea</li> </ul>	441086-003
<b>Broadcom 802.11a/b/g WLAN modules:</b>	
<ul style="list-style-type: none"> <li>For use in Canada, the Cayman Islands, Guam, Puerto Rico, the U.S. Virgin Islands, and the United States</li> </ul>	441075-001
<ul style="list-style-type: none"> <li>For use in Afghanistan, Albania, Algeria, Andorra, Angola, Antigua and Barbuda, Argentina, Armenia, Aruba, Australia, Austria, Azerbaijan, the Bahamas, Bahrain, Bangladesh, Barbados, Belarus, Belgium, Belize, Benin, Bermuda, Bhutan, Bolivia, Bosnia and Herzegovina, Botswana, Brazil, the British Virgin Islands, Brunei, Bulgaria, Burkina Faso, Burundi, Cameroon, Cape Verde, the Central African Republic, Chad, Chile, Colombia, Comoros, the Congo, Costa Rica, Croatia, Cyprus, the Czech Republic, Denmark, Djibouti, Dominica, the Dominican Republic, East Timor, Ecuador, Egypt, El Salvador, Equatorial Guinea, Eritrea, Estonia, Ethiopia, Fiji, Finland, France, French Guiana, Gabon, Gambia, Georgia, Germany, Ghana, Gibraltar, Greece, the Grenadines, Guadeloupe, Guatemala, Guinea, Guinea-Bissau, Guyana, Haiti, Honduras, Hong Kong, Hungary, Iceland, India, Ireland, Israel, Italy, the Ivory Coast, Jamaica, Jordan, Kazakhstan, Kenya, Kiribati, Kyrgyzstan, Laos, Latvia, Lebanon, Lesotho, Liberia, Liechtenstein, Lithuania, Luxembourg, Macedonia, Madagascar, Malawi, Malaysia, the Maldives, Mali, Malta, the Marshall Islands, Martinique, Mauritania, Mauritius, Mexico, Micronesia, Monaco, Mongolia, Montenegro, Morocco, Mozambique, Namibia, Nauru, Nepal, the Nether Antilles, the Netherlands, New Zealand, Nicaragua, Niger, Nigeria, Norway, Oman, Pakistan, Palau, Panama, Papua New Guinea, Paraguay, the People's Republic of China, Peru, the Philippines, Poland, Portugal, the Republic of Moldova, Romania, Russia, Rwanda, Samoa, San Marino, Sao Tome and Principe, Saudi Arabia, Senegal, Serbia and Montenegro, the Seychelles, Sierra Leone, Singapore, Slovakia, Slovenia, the Solomon Islands, Somalia, South Africa, South Korea, Spain, Sri Lanka, St. Kitts and Nevis, St. Lucia, St. Vincent and the Grenadines, Suriname, Swaziland, Sweden, Switzerland, Taiwan, Tajikistan, Tanzania, Togo, Tonga, Trinidad and Tobago, Tunisia, Turkey, Turkmenistan, Tuvalu, Uganda, Ukraine, the United Arab Emirates, the United Kingdom, Uruguay, Uzbekistan, Vanuatu, Venezuela, Vietnam, Yemen, Zaire, Zambia, and Zimbabwe</li> </ul>	441075-002
<b>Intel 802.11a/b/g WLAN modules:</b>	
<ul style="list-style-type: none"> <li>For use in Antigua and Barbuda, Argentina, Australia, the Bahamas, Barbados, Brunei, Canada, Chile, the Dominican Republic, Guam, Guatemala, Hong Kong, India, Indonesia, Malaysia, Mexico, New Zealand, Panama, Paraguay, Saudi Arabia, Taiwan, the United States, and Vietnam</li> </ul>	451861-001
<ul style="list-style-type: none"> <li>For use in Aruba, Austria, Azerbaijan, Bahrain, Belgium, Bermuda, Brazil, Bulgaria, the Cayman Islands, Colombia, Croatia, Cyprus, the Czech Republic, Denmark, Egypt, El Salvador, Estonia, Finland, France, Georgia, Germany, Greece, Hungary, Iceland, Ireland, Italy, Jordan, Latvia, Lebanon, Liechtenstein, Lithuania, Luxembourg, Malta, Monaco, the Netherlands, Norway, Oman, the Philippines, Poland, Portugal, Romania, Russia, Serbia and Montenegro, Singapore, Slovakia, Slovenia, South Africa, Spain, Sri Lanka, Sweden, Switzerland, Turkey, the United Kingdom, and Uzbekistan</li> </ul>	451861-002

Description	Spare part number
<b>Atheros AR2425 802.11b/g WLAN modules:</b>	
<ul style="list-style-type: none"> <li>For use in Canada, the Cayman Islands, Guam Puerto Rico the U.S. Virgin Islands, and the United States</li> </ul>	459339-001
<ul style="list-style-type: none"> <li>For use in Afghanistan, Albania, Algeria, Andorra, Angola, Antigua and Barbuda, Argentina, Armenia, Aruba, Australia, Austria, Azerbaijan, the Bahamas, Bahrain, Bangladesh, Barbados, Belarus, Belgium, Belize, Benin, Bermuda, Bhutan, Bolivia, Bosnia and Herzegovina, Botswana, Brazil, the British Virgin Islands, Brunei, Bulgaria, Burkina Faso, Burundi, Cambodia, Cameroon, Cape Verde, the Central African Republic, Chad, Chile, Colombia, Comoros, Congo, Costa Rica, Croatia, Cyprus, the Czech Republic, Denmark, Djibouti, Dominica, the Dominican Republic, East Timor, Ecuador, Egypt, El Salvador, Equatorial Guinea, Eritrea, Estonia, Ethiopia, Fiji, Finland, France, French Guiana, Gabon, Gambia, Georgia, Germany, Ghana, Gibraltar, Greece, the Grenadines, Guadeloupe, Guatemala, Guinea, Guinea-Bissau, Guyana, Haiti, Honduras, Hong Kong, Hungary, Iceland, India, Indonesia, Ireland, Israel, Italy, the Ivory Coast, Jamaica, Japan, Jordan, Kazakhstan, Kenya, Kiribati, Kuwait, Kyrgyzstan, Laos, Latvia, Lebanon, Lesotho, Liberia, Liechtenstein, Lithuania, Luxembourg, Macedonia, Madagascar, Malawi, Malaysia, the Maldives, Mali, Malta, the Marshall Islands, Martinique, Mauritania, Mauritius, Mexico, Micronesia, Monaco, Mongolia, Montenegro, Morocco, Mozambique, Namibia, Nauru, Nepal, the Nether Antilles, the Netherlands, New Zealand, Nicaragua, Niger, Nigeria, Norway, Oman, Pakistan, Palau, Panama, Papua New Guinea, Paraguay, the People's Republic of China, Peru, the Philippines, Poland, Portugal, Qatar, the Republic of Moldova, Romania, Russia, Rwanda, Samoa, San Marino, Sao Tome and Principe, Saudi Arabia, Senegal, Serbia and Montenegro, Seychelles, Sierra Leone, Singapore, Slovakia, Slovenia, the Solomon Islands, Somalia, South Africa, South Korea, Spain, Sri Lanka, St. Kitts and Nevis, St. Lucia, St. Vincent and the Grenadines, Suriname, Swaziland, Sweden, Switzerland, Syria, Taiwan, Tajikistan, Tanzania, Thailand, Togo, Tonga, Trinidad and Tobago, Tunisia, Turkey, Turkmenistan, Tuvalu, Uganda, Ukraine, the United Arab Emirates, the United Kingdom, Uruguay, Uzbekistan, Vanuatu, Venezuela, Vietnam, Yemen, Zaire, Zambia, and Zimbabwe</li> </ul>	45939-002
<b>Broadcom 802.11b/g WLAN modules:</b>	
<ul style="list-style-type: none"> <li>For use in Canada, the Cayman Islands, Guam, Puerto Rico, the U.S. Virgin Islands, and the United States</li> </ul>	441090-001
<ul style="list-style-type: none"> <li>For use in Afghanistan, Albania, Algeria, Andorra, Angola, Antigua and Barbuda, Argentina, Armenia, Aruba, Australia, Austria, Azerbaijan, the Bahamas, Bahrain, Bangladesh, Barbados, Belarus, Belgium, Belize, Benin, Bermuda, Bhutan, Bolivia, Bosnia and Herzegovina, Botswana, Brazil, the British Virgin Islands, Brunei, Bulgaria, Burkina Faso, Burundi, Cameroon, Cape Verde, the Central African Republic, Chad, Chile, Colombia, Comoros, the Congo, Costa Rica, Croatia, Cyprus, the Czech Republic, Denmark, Djibouti, Dominica, the Dominican Republic, East Timor, Ecuador, Egypt, El Salvador, Equatorial Guinea, Eritrea, Estonia, Ethiopia, Fiji, Finland, France, French Guiana, Gabon, Gambia, Georgia, Germany, Ghana, Gibraltar, Greece, the Grenadines, Guadeloupe, Guatemala, Guinea, Guinea-Bissau, Guyana, Haiti, Honduras, Hong Kong, Hungary, Iceland, India, Ireland, Israel, Italy, the Ivory Coast, Jamaica, Jordan, Kazakhstan, Kenya, Kiribati, Kyrgyzstan, Laos, Latvia, Lebanon, Lesotho, Liberia, Liechtenstein, Lithuania, Luxembourg, Macedonia, Madagascar, Malawi, Malaysia, the Maldives, Mali, Malta, the Marshall Islands, Martinique, Mauritania, Mauritius, Mexico, Micronesia, Monaco, Mongolia, Montenegro, Morocco, Mozambique, Namibia, Nauru, Nepal, the Nether Antilles, the Netherlands, New Zealand, Nicaragua, Niger, Nigeria, Norway, Oman, Pakistan, Palau, Panama, Papua New Guinea, Paraguay, the People's Republic of China, Peru, the Philippines, Poland, Portugal, the Republic of Moldova, Romania, Russia, Rwanda, Samoa, San Marino, Sao Tome and Principe, Saudi Arabia, Senegal, Serbia and Montenegro, the Seychelles, Sierra Leone, Singapore, Slovakia, Slovenia, the Solomon Islands, Somalia, South Africa, South Korea, Spain, Sri Lanka, St. Kitts and Nevis, St. Lucia, St. Vincent and the Grenadines, Suriname, Swaziland, Sweden, Switzerland, Taiwan, Tajikistan, Tanzania, Togo, Tonga, Trinidad and Tobago, Tunisia, Turkey, Turkmenistan, Tuvalu, Uganda, Ukraine, the United Arab Emirates, the United Kingdom, Uruguay, Uzbekistan, Vanuatu, Venezuela, Vietnam, Yemen, Zaire, Zambia, and Zimbabwe</li> </ul>	441090-002
<b>Intel 802.11b/g WLAN module for use in Thailand</b>	451861-004

Before removing the WLAN module, follow these steps:

1. Shut down the computer. If you are unsure whether the computer is off or in Hibernation, turn the computer on, and then shut it down through the operating system.
2. Disconnect all external devices connected to the computer.
3. Disconnect the power from the computer by first unplugging the power cord from the AC outlet and then unplugging the AC adapter from the computer.
4. Remove the battery (see [Battery on page 34](#)).

Remove the WLAN module:

1. Loosen the two Phillips PM2.5×6.0 captive screws **(1)** that secure the memory/WLAN module compartment cover to the computer.
2. Lift the front edge of the cover **(2)**, swing it up and back, and remove the cover. The memory/WLAN module compartment cover is included in the Plastics Kit, spare part number 462409-001.

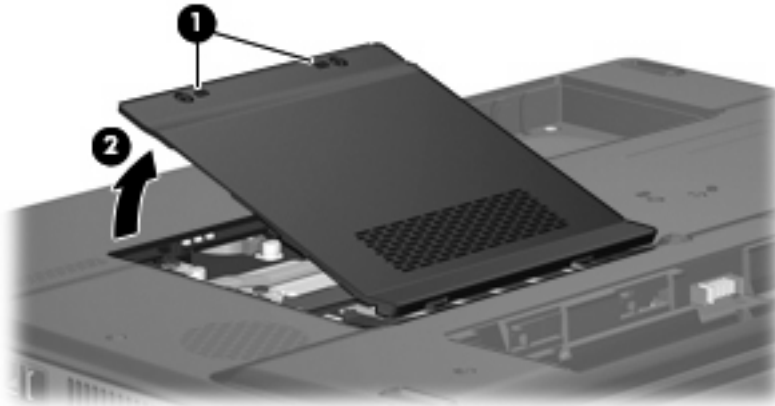

3. Disconnect the WLAN antenna cables **(1)** from the terminals on the WLAN module.

 **NOTE:** The black WLAN antenna cable is connected to the WLAN module “Main” terminal. The white WLAN antenna cable is connected to the WLAN module “Aux” terminal. If the computer is equipped with an 802.11a/b/g/n WLAN module, the yellow WLAN antenna cable **(2)** is connected to the middle terminal on the WLAN module.

4. Remove the two Phillips PM2.0×4.0 screws **(3)** that secure the WLAN module to the computer. (The edge of the module opposite the slot rises away from the computer.)

5. Remove the WLAN module **(4)** by pulling the module away from the slot at an angle.

 **NOTE:** WLAN modules are designed with a notch **(5)** to prevent incorrect installation.

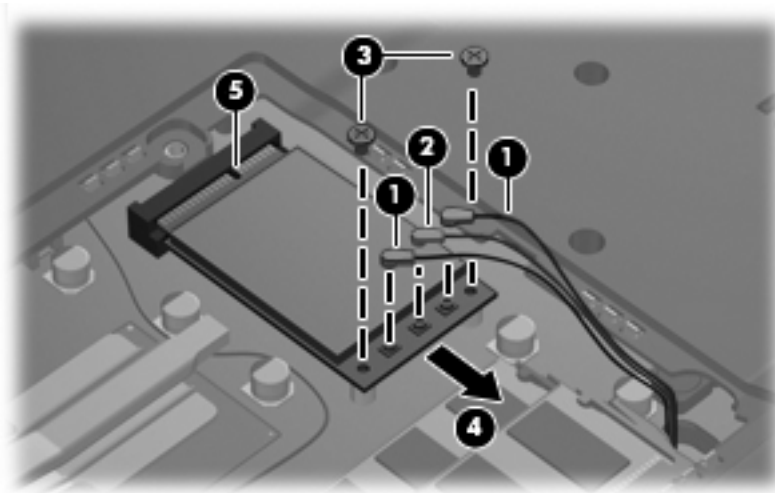

Reverse this procedure to install the WLAN module.

## Optical drive

 **NOTE:** All optical drive spare part kits include an optical drive bezel and optical drive bracket.

Description	Spare part number
DVD±RW and CD-RW Super Multi Double-Layer Combo Drive with LightScribe	462336-001
DVD±RW and CD-RW Super Multi Double-Layer Combo Drive	462335-001
Optical Drive Bezel/Bracket Kit (includes optical drive bezel and optical drive bracket and screws)	462334-001

Before removing the optical drive, follow these steps:

1. Shut down the computer. If you are unsure whether the computer is off or in Hibernation, turn the computer on, and then shut it down through the operating system.
2. Disconnect all external devices connected to the computer.
3. Disconnect the power from the computer by first unplugging the power cord from the AC outlet and then unplugging the AC adapter from the computer.
4. Remove the battery (see [Battery on page 34](#)).

Remove the optical drive:

1. Position the computer with the left side toward you.
2. Remove the Phillips PM2.5×9.0 screw **(1)** that secures the optical drive to the computer.
3. Insert a thin tool, such as a paper clip **(2)**, into the release access. (The optical drive disc tray is partially ejected from the optical drive.)

4. Use the disc tray frame to slide the optical drive **(3)** out of the computer.

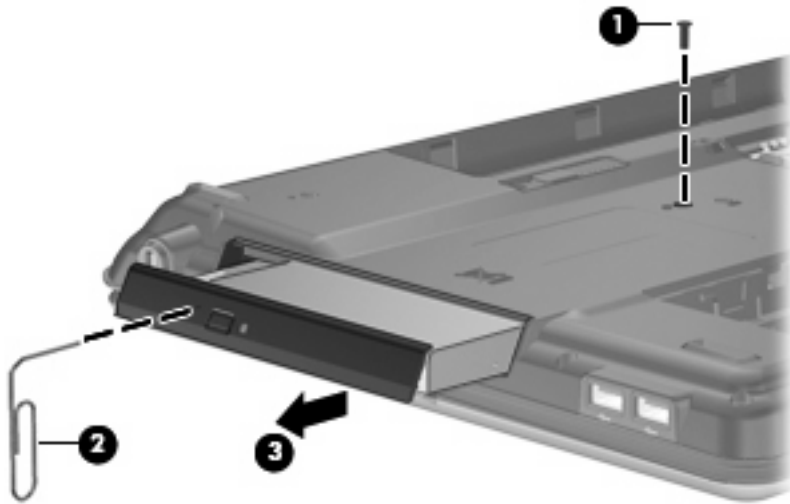

5. If it is necessary to replace the optical drive bracket, position the optical drive with the rear toward you.
6. Remove the two Phillips PM2.0x4.0 screws **(1)** that secure the optical drive bracket to the optical drive.
7. Remove the optical drive bracket **(2)**.

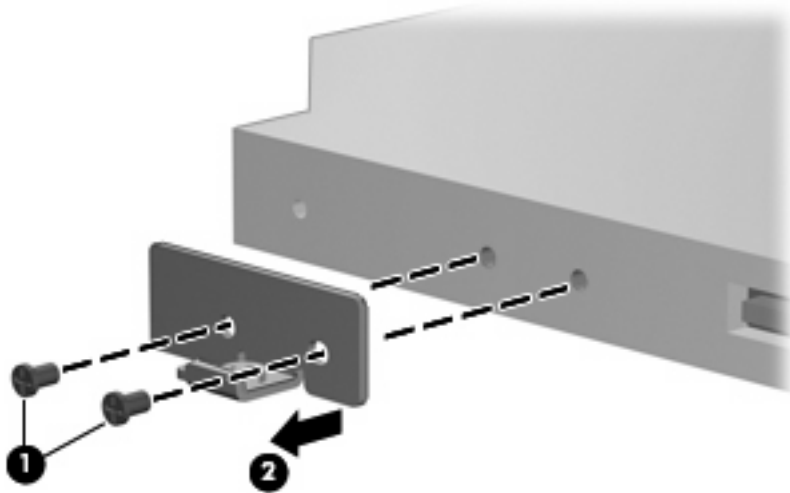

Reverse this procedure to reassemble and install an optical drive.

## Switch cover and keyboard

Description	Spare part number
Switch cover (includes wireless button board and cable, power button board and cable, and num lock LED board and cable)	462399-001

For use in:	Spare part number	For use in:	Spare part number
Denmark, Finland, and Norway	462383-DH1	Saudi Arabia	462383-171
France	462383-051	Spain	462383-071
French Canada	462383-121	Turkey	462383-141
Germany	462383-041	The United Kingdom	462383-031
Italy	462383-061	The United States	462383-001
The Netherlands	462383-B31		

Before removing the switch cover and keyboard, follow these steps:

1. Shut down the computer. If you are unsure whether the computer is off or in Hibernation, turn the computer on, and then shut it down through the operating system.
2. Disconnect all external devices connected to the computer.
3. Disconnect the power from the computer by first unplugging the power cord from the AC outlet and then unplugging the AC adapter from the computer.
4. Remove the battery (see [Battery on page 34](#)).

Remove the switch cover and keyboard:

1. Remove the following:

**(1)** Four Phillips PM2.5×9.0 screws that secure the switch cover to the computer

**(2)** One Phillips PM2.5×9.0 screw that secures the keyboard to the computer

**(3)** Six Phillips PM2.5×5.0 screws that secure the switch cover to the computer

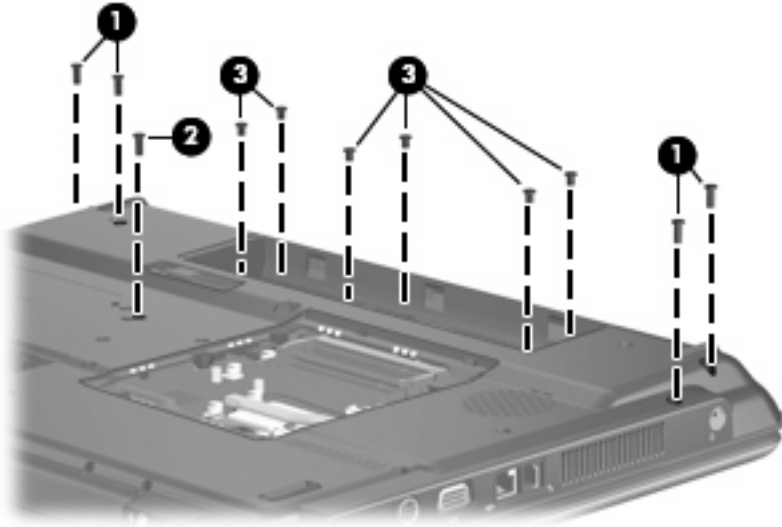

2. Turn the computer right-side up, with the front toward you.

3. Open the computer as far as possible.

4. Lift the left and right sides **(1)** of the switch cover until it disengages from the computer.

5. Release the switch cover **(2)** by sliding it back until it rests on the display bezel.



6. Remove the three Phillips PM2.0×4.0 screws that secure the keyboard to the computer.

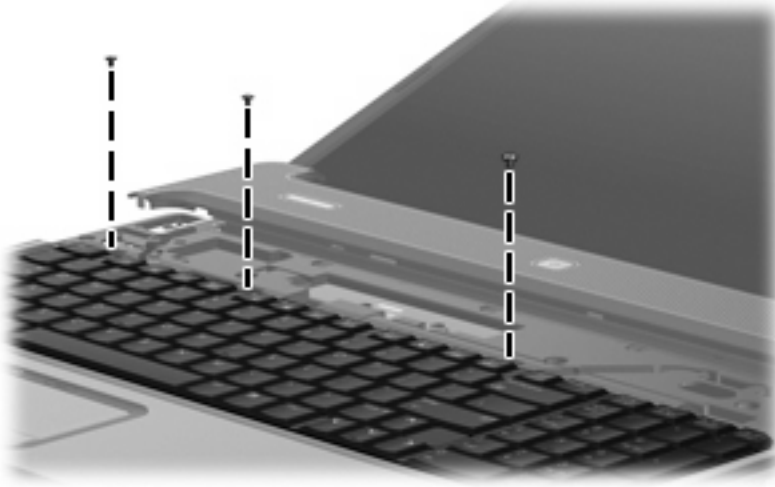

7. Lift the rear edge of the keyboard **(1)** until it rests at angle.
8. Release the keyboard **(2)** by sliding it back until it rests on the switch cover and display bezel.



9. Release the zero insertion force (ZIF) connector **(1)** to which the keyboard cable is attached, and then disconnect the keyboard cable **(2)**.

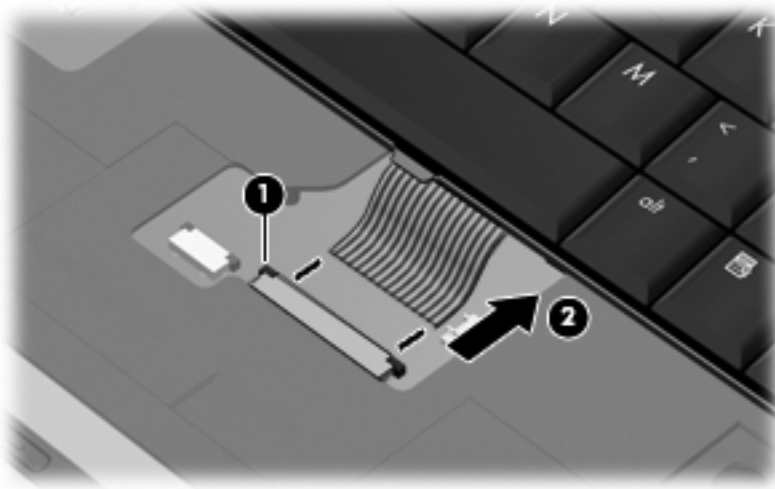



10. Remove the keyboard.
11. Release the ZIF connector **(1)** to which the LED board cable is attached, and then disconnect the LED board cable **(2)**.

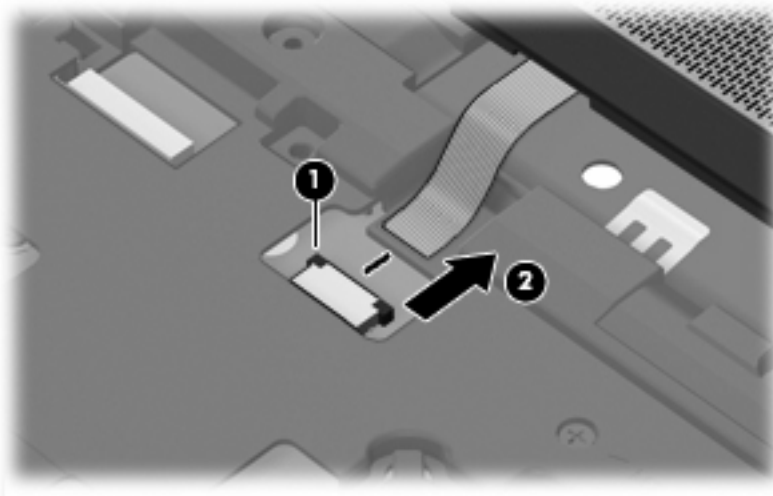

12. Remove the switch cover.

Reverse this procedure to install the switch cover and keyboard.

## Display assembly

Description	Spare part number
17.0-inch, WXGA+BrightView display assembly (includes 3 WLAN antenna transceivers and cables, camera module and cable, microphones and cables, and logo)	462319-001

Before removing the display assembly, follow these steps:

1. Shut down the computer. If you are unsure whether the computer is off or in Hibernation, turn the computer on, and then shut it down through the operating system.
2. Disconnect all external devices connected to the computer.
3. Disconnect the power from the computer by first unplugging the power cord from the AC outlet and then unplugging the AC adapter from the computer.
4. Remove the battery (see [Battery on page 34](#)).
5. Disconnect the wireless antenna cables from the WLAN module (see [WLAN module on page 41](#)).
6. Remove the switch cover and keyboard (see [Switch cover and keyboard on page 46](#)).

Remove the display assembly:

1. Disconnect the display panel cable **(1)** and the microphone cable **(2)** from the system board.
2. Remove the wireless antenna cables and the microphone cable from the clips **(3)** and routing channel.

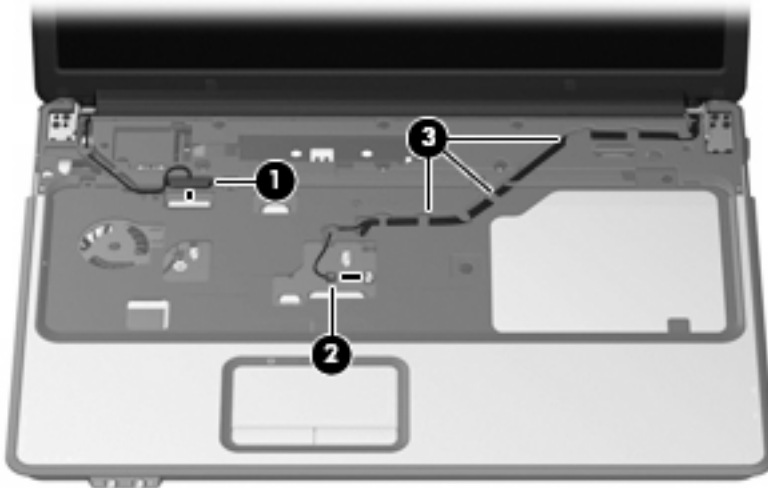

3. Remove the four Phillips PM2.5×9.0 screws **(1)** that secure the display assembly to the computer.

4. Lift the display assembly **(2)** straight up and remove it.

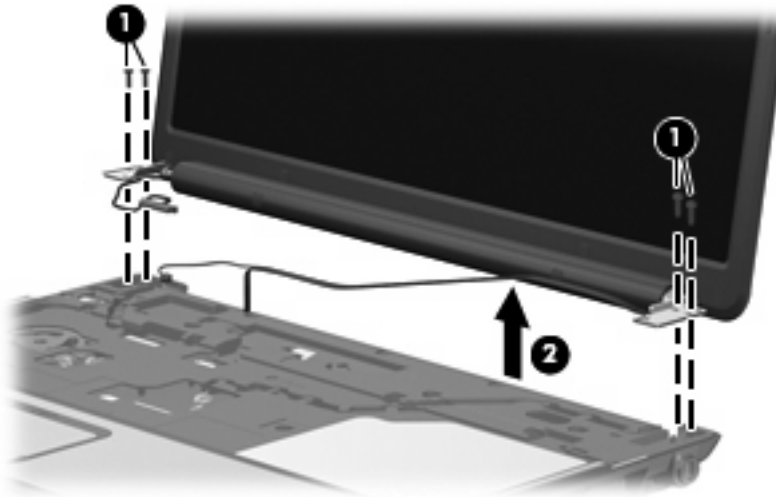

5. If it is necessary to replace the display bezel or the display assembly internal components, remove the following:

- (1)** Four rubber screw covers on the display bezel top edge. The rubber screw covers are included in the Rubber Kit, spare part number 462397-001.
- (2)** Two rubber screw covers on the display bezel bottom corners.
- (3)** Two rubber screw covers on the display bezel bottom edge.
- (4)** Eight Phillips PM2.5×7.0 screws that secure the display bezel to the display assembly.

 **NOTE:** See [Camera module on page 35](#) for camera module removal information.

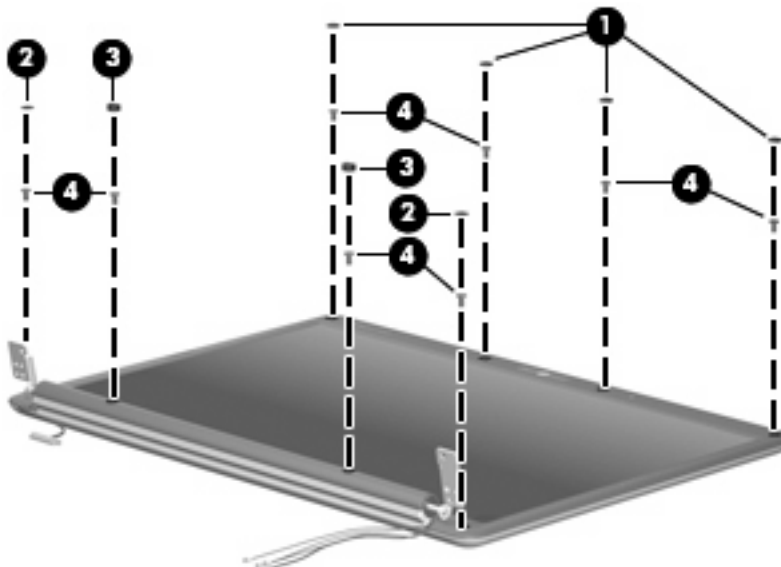

6. Flex the inside edges of the left and right sides **(1)** and the top and bottom sides **(2)** of the display bezel until the bezel disengages from the display enclosure.

7. Remove the display bezel **(3)**. The display bezel is available using spare part number 462391-001.

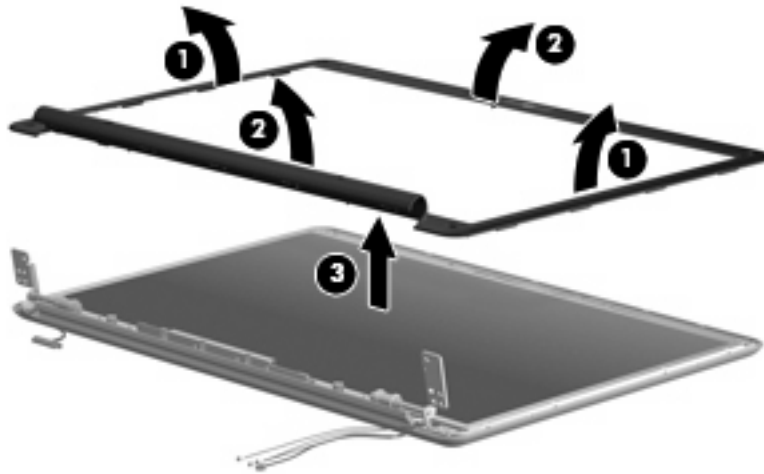

8. If it is necessary to replace the display inverter, release the inverter **(1)** as far as the display panel cable and backlight cable allow.
9. Disconnect the display panel cable **(2)** and the backlight cable **(3)** from the display inverter.

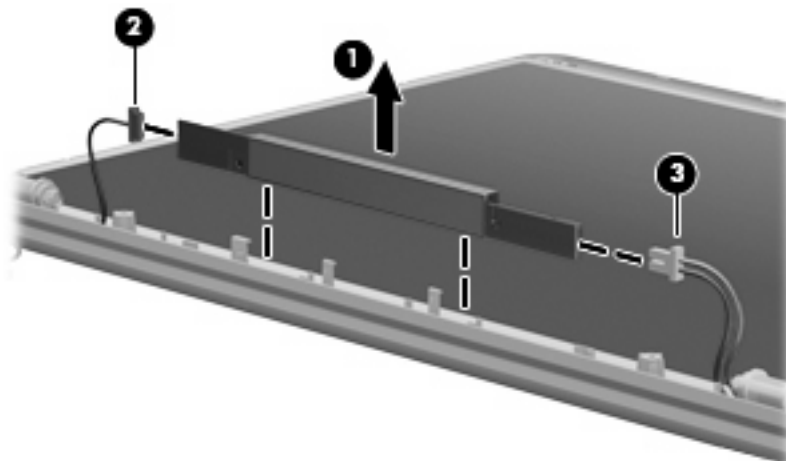

10. Remove the display inverter from the display enclosure. The display inverter is available using spare part number 462579-001.
11. If it is necessary to replace the display panel or hinges, remove the eight Phillips PM2.5×5.0 screws **(1)** that secure the display panel to the display enclosure.

12. Remove the display panel **(2)** from the display enclosure. The display panel is available using spare part number 462318-001.

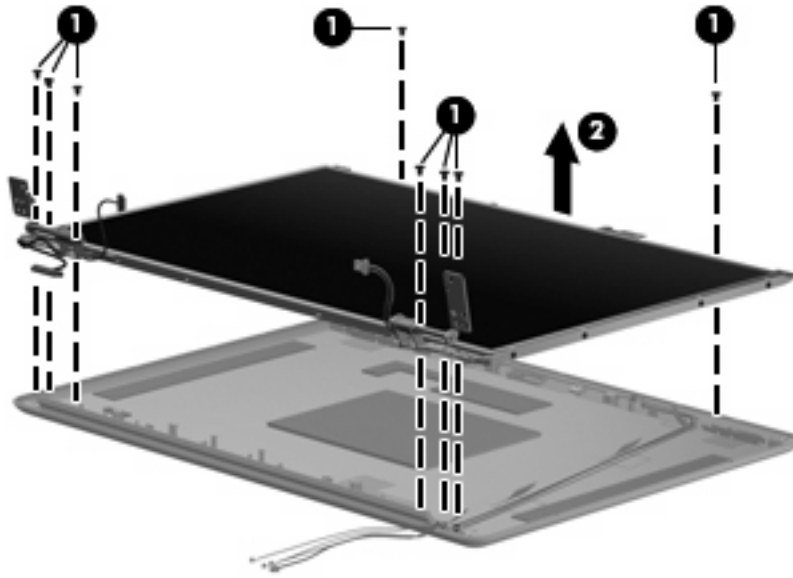

13. Remove the eight Phillips PM2.0x4.0 screws **(1)** that secure the hinges to the display panel.
14. Remove the display hinges **(2)** from the display panel. The display hinges are available using spare part number 462392-001.

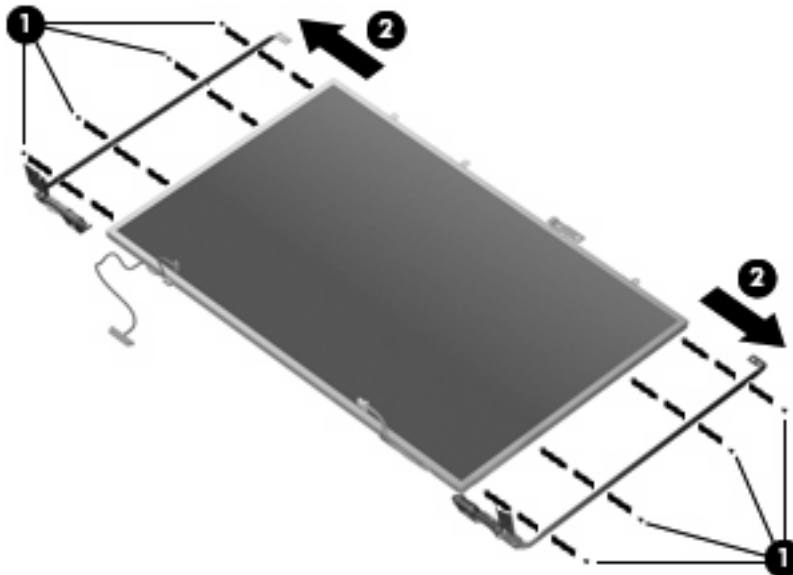

15. If it is necessary to replace the wireless antenna transceivers and cables, release the tabs **(1)** built into the display enclosure that secure the wireless antenna cables.

16. Remove the wireless antenna transceivers **(2)** and cables **(3)** from the display enclosure. The wireless antennae are available using spare part number 462394-001.

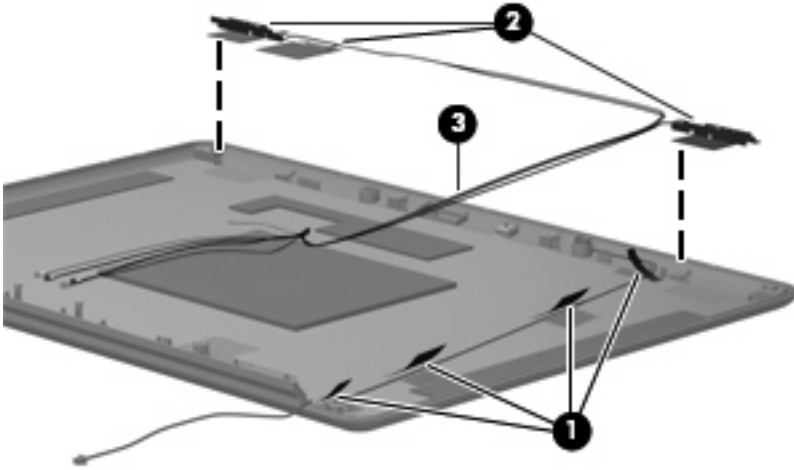

17. If it is necessary to replace the microphone receiver and cable, release the tabs **(1)** built into the display enclosure that secure the microphone cables.
18. Remove the microphone receiver **(2)** and cable **(3)** from the display enclosure. The microphone is available using spare part number 462395-001.

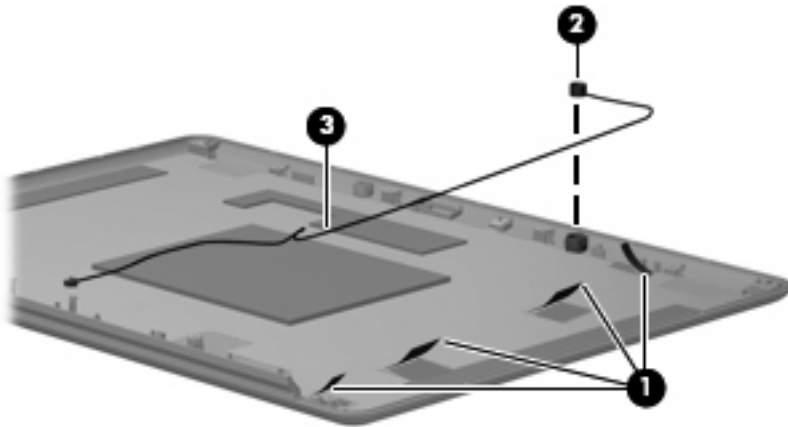

Reverse this procedure to reassemble and install the display assembly.

## Top cover

Description	Spare part number
Top cover (includes TouchPad and TouchPad cable and caps lock LED board and cable)	462401-001

Before removing the top cover, follow these steps:

1. Shut down the computer. If you are unsure whether the computer is off or in Hibernation, turn the computer on, and then shut it down through the operating system.
2. Disconnect all external devices connected to the computer.
3. Disconnect the power from the computer by first unplugging the power cord from the AC outlet and then unplugging the AC adapter from the computer.
4. Remove the battery (see [Battery on page 34](#)).
5. Remove the following components:
  - a. Hard drive (see [Hard drive on page 37](#))
  - b. Optical drive (see [Optical drive on page 44](#))
  - c. Switch cover and keyboard (see [Switch cover and keyboard on page 46](#))
  - d. Display assembly (see [Display assembly on page 50](#))

Remove the top cover:

1. Turn the computer upside down, with the front toward you.
2. Remove the fourteen Phillips PM2.5×9.0 screws that secure the top cover to the base enclosure.

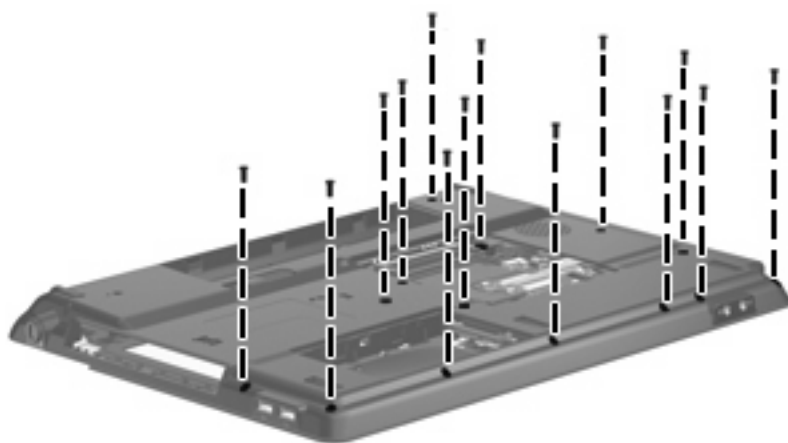

3. Remove the two Phillips PM2.5×5.0 screws that secure the top cover to the computer.

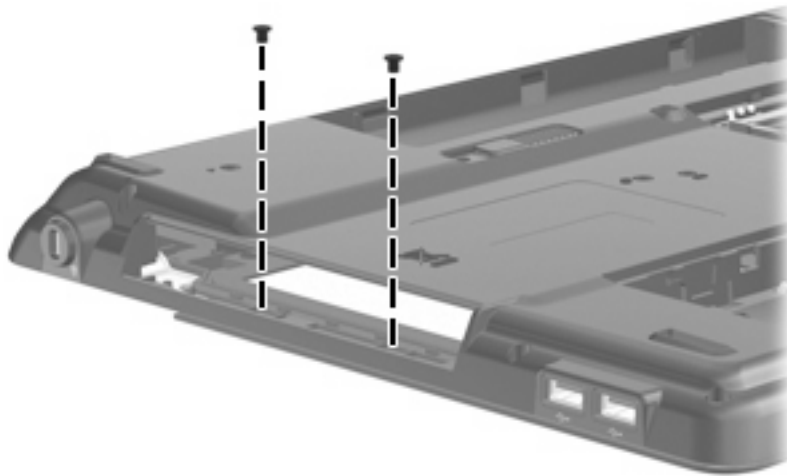

4. Disconnect the caps lock LED board cable **(1)** from the system board.
5. Release the ZIF connector to which the TouchPad cable **(2)** is connected, and then disconnect the TouchPad cable from the system board.
6. Remove the Phillips PM2.5×9.0 screw **(3)** that secures the top cover to the base enclosure.

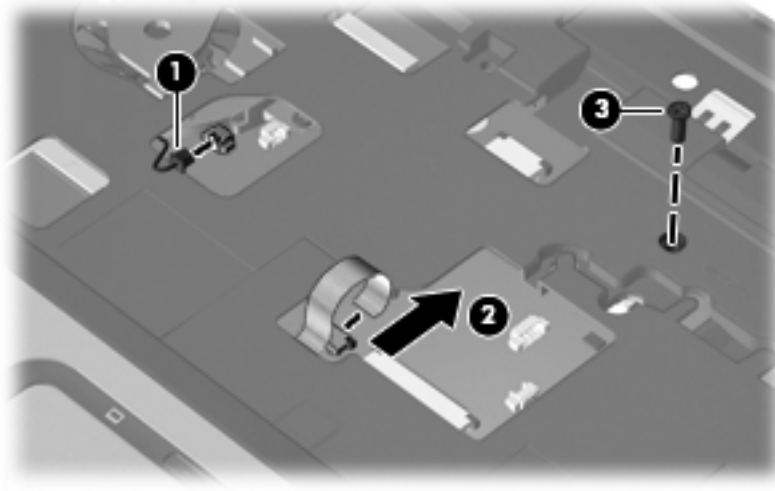

7. Lift the rear edge of the top cover **(1)**, and then swing it up and forward until it rests at an angle.



- Lift the top cover **(2)** straight up and remove it.



Reverse this procedure to install the top cover.

## USB board

Description	Spare part number
USB board (includes USB board cable)	462406-001

Before removing the USB board, follow these steps:

- Shut down the computer. If you are unsure whether the computer is off or in Hibernation, turn the computer on, and then shut it down through the operating system.
- Disconnect all external devices connected to the computer.
- Disconnect the power from the computer by first unplugging the power cord from the AC outlet and then unplugging the AC adapter from the computer.
- Remove the battery (see [Battery on page 34](#)).
- Remove the following components:
  - Hard drive (see [Hard drive on page 37](#))
  - Optical drive (see [Optical drive on page 44](#))
  - Switch cover and keyboard (see [Switch cover and keyboard on page 46](#))
  - Display assembly (see [Display assembly on page 50](#))
  - Top cover (see [Top cover on page 55](#))

Remove the USB board:

- Disconnect the USB board cable **(1)** from the system board.
- Remove the USB board cable from the clips **(2)** built into the base enclosure.
- Remove the Phillips PM2.5×5.0 screw **(3)** that secures the USB board to the base enclosure.

4. Remove the USB board **(4)**.

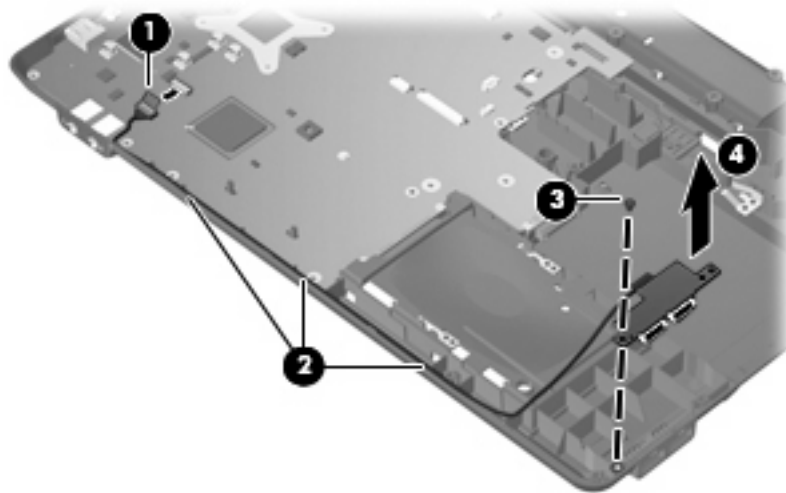

Reverse this procedure to reassemble and install the USB board.

## Fan

Description	Spare part number
Fan	462404-001

Before removing the fan, follow these steps:

1. Shut down the computer. If you are unsure whether the computer is off or in Hibernation, turn the computer on, and then shut it down through the operating system.
2. Disconnect all external devices connected to the computer.
3. Disconnect the power from the computer by first unplugging the power cord from the AC outlet and then unplugging the AC adapter from the computer.
4. Remove the battery (see [Battery on page 34](#)).
5. Remove the following components:
  - a. Hard drive (see [Hard drive on page 37](#))
  - b. Optical drive (see [Optical drive on page 44](#))
  - c. Switch cover and keyboard (see [Switch cover and keyboard on page 46](#))
  - d. Display assembly (see [Display assembly on page 50](#))
  - e. Top cover (see [Top cover on page 55](#))

Remove the fan:

1. Disconnect the fan cable **(1)** from the system board.
2. Remove the Phillips PM2.5×9.0 screw **(2)** that secures the fan to the base enclosure.

3. Remove the fan **(3)**.

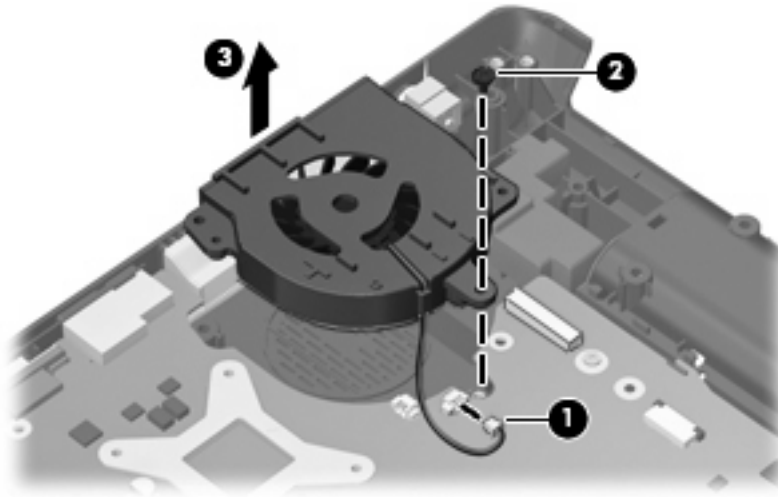

Reverse this procedure to install the fan.

 **NOTE:** To properly ventilate the computer, allow at least a 7.6-cm (3-inch) clearance on the left side of the computer.

The computer uses an electric fan for ventilation. The fan is controlled by a temperature sensor and is designed to turn on automatically when high temperature conditions exist. These conditions are affected by high external temperatures, system power consumption, power management/battery conservation configurations, battery fast charging, and software requirements. Exhaust air is displaced through the ventilation grill located on the left side of the computer.

## Speaker assembly

Description	Spare part number
Speaker assembly (include cables)	462581-001

Before removing the speaker assembly, follow these steps:

1. Shut down the computer. If you are unsure whether the computer is off or in Hibernation, turn the computer on, and then shut it down through the operating system.
2. Disconnect all external devices connected to the computer.
3. Disconnect the power from the computer by first unplugging the power cord from the AC outlet and then unplugging the AC adapter from the computer.
4. Remove the battery (see [Battery on page 34](#)).
5. Remove the following components:
  - a. Hard drive (see [Hard drive on page 37](#))
  - b. Optical drive (see [Optical drive on page 44](#))
  - c. Switch cover and keyboard (see [Switch cover and keyboard on page 46](#))

- d. Display assembly (see [Display assembly on page 50](#))
- e. Top cover (see [Top cover on page 55](#))

Remove the speaker assembly:

1. Remove the two Phillips PM2.5x5.0 screws **(1)** that secure the speaker assembly to the base enclosure.
2. Disconnect the speaker cable **(2)** from the system board.
3. Remove the speaker cables from the clips **(3)** built into the system board.
4. Remove the speaker assembly **(4)** from the base enclosure.

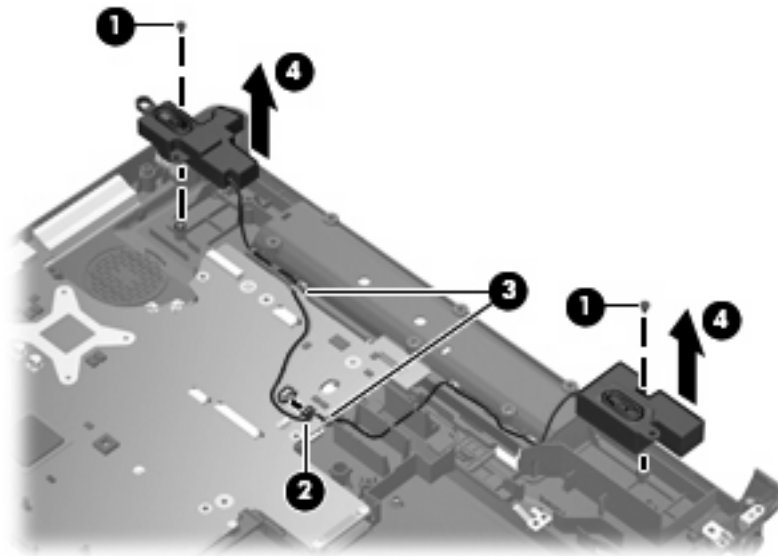

Reverse this procedure to install the speaker assembly.

## System board

 **NOTE:** All system board spare part kits include replacement thermal material.

Description	Spare part number
GM965 system board, for use only with computer models equipped with Intel Core 2 Duo processors (includes digital media card board)	462316-001
GL960 system board, for use only with computer models equipped with Intel Core Duo and Intel Celeron M processors (includes digital media card board)	462317-001

Before removing the system board, follow these steps:

1. Shut down the computer. If you are unsure whether the computer is off or in Hibernation, turn the computer on, and then shut it down through the operating system.
2. Disconnect all external devices connected to the computer.
3. Disconnect the power from the computer by first unplugging the power cord from the AC outlet and then unplugging the AC adapter from the computer.

4. Remove the battery (see [Battery on page 34](#)).
5. Remove the following components:
  - a. Hard drive (see [Hard drive on page 37](#))
  - b. Optical drive (see [Optical drive on page 44](#))
  - c. Switch cover and keyboard (see [Switch cover and keyboard on page 46](#))
  - d. Display assembly (see [Display assembly on page 50](#))
  - e. Top cover (see [Top cover on page 55](#))
  - f. Fan (see [Fan on page 58](#))

When replacing the system board, be sure that the following components are removed from the defective system board and installed on the replacement system board:

- Memory modules (see [Memory module on page 39](#))
- WLAN module (see [WLAN module on page 41](#))
- Heat sink (see [Heat sink on page 69](#))
- Processor (see [Processor on page 71](#))

Remove the system board:

1. Turn the computer upside down, with the front toward you
2. Disconnect the power connector cable from the system board.

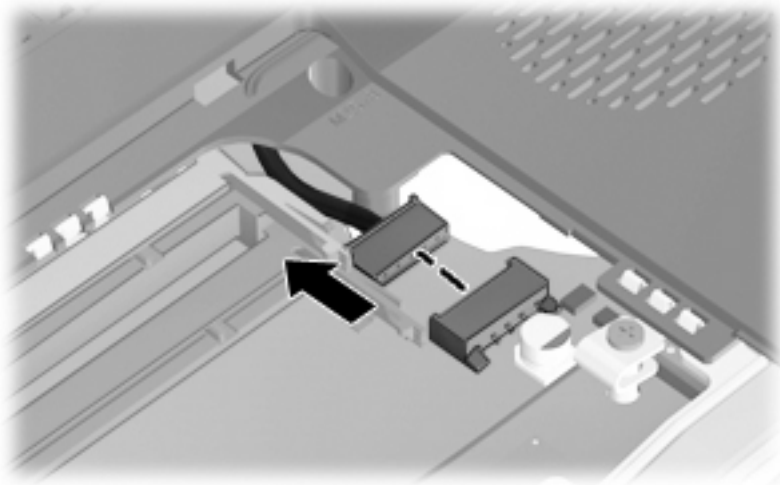

3. Turn the computer right-side up, with the front toward you.

4. Disconnect the USB board cable **(1)** and the speaker cable **(2)** from the system board.

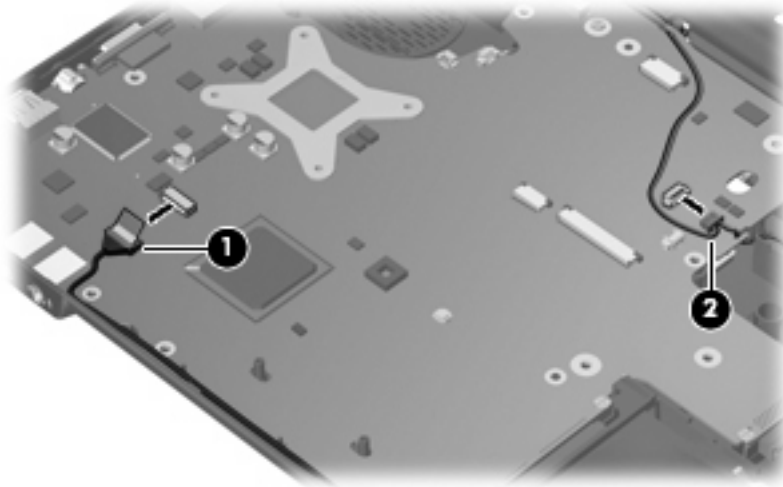

5. Remove the Phillips PM2.5x9.0 screw **(1)** that secures the system board to the base enclosure.
6. Flex the front edge **(2)** of the base enclosure outward until the audio connectors clear the openings in the base enclosure.
7. Use the optical drive connector **(3)** to lift the right side of the system board **(4)** until it rests at an angle.
8. Remove the system board **(5)** by sliding it up and to the right until it is clear of the base enclosure.

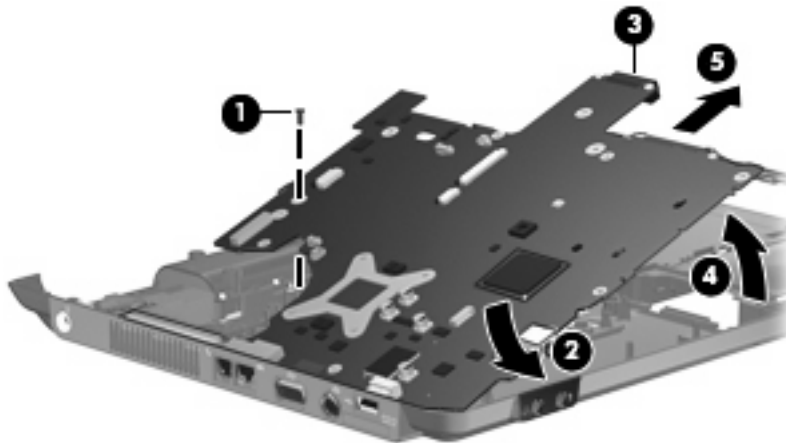

Reverse this procedure to install the system board.

## Power connector cable

Description	Spare part number
Power connector cable	462403-001

Before removing the power connector cable, follow these steps:

1. Shut down the computer. If you are unsure whether the computer is off or in Hibernation, turn the computer on, and then shut it down through the operating system.
2. Disconnect all external devices connected to the computer.
3. Disconnect the power from the computer by first unplugging the power cord from the AC outlet and then unplugging the AC adapter from the computer.
4. Remove the battery (see [Battery on page 34](#)).
5. Remove the following components:
  - a. Hard drive (see [Hard drive on page 37](#))
  - b. Optical drive (see [Optical drive on page 44](#))
  - c. Switch cover and keyboard (see [Switch cover and keyboard on page 46](#))
  - d. Display assembly (see [Display assembly on page 50](#))
  - e. Top cover (see [Top cover on page 55](#))
  - f. Fan (see [Fan on page 58](#))
  - g. System board (see [System board on page 60](#))

Remove the power connector cable:

1. Remove the power connector **(1)** from the clip built into the base enclosure.
2. Remove the power connector cable **(2)** from the clips and routing channel built into the base enclosure.

3. Remove the power connector cable **(3)**.

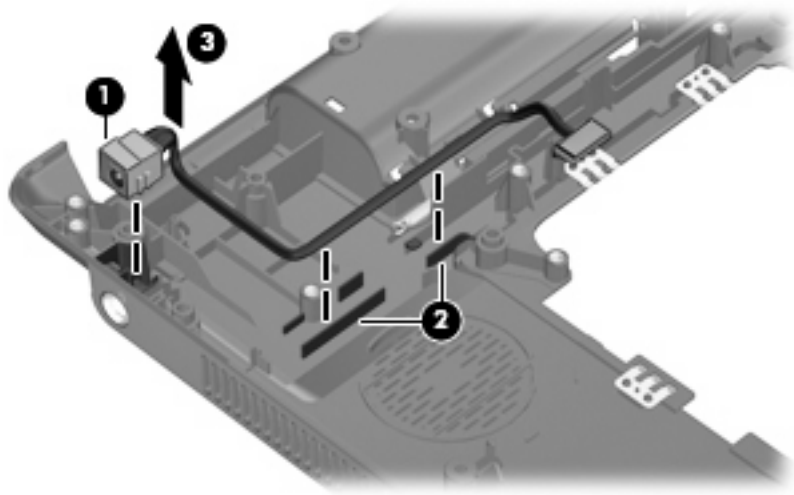

Reverse this procedure to install the power connector cable.



## RTC battery

 **NOTE:** Removing the RTC battery and leaving it uninstalled for 5 or more minutes causes all passwords and CMOS settings to be cleared.

Description	Spare part number
RTC battery	449137-001

Before removing the RTC battery, follow these steps:

1. Shut down the computer. If you are unsure whether the computer is off or in Hibernation, turn the computer on, and then shut it down through the operating system.
2. Disconnect all external devices connected to the computer.
3. Disconnect the power from the computer by first unplugging the power cord from the AC outlet and then unplugging the AC adapter from the computer.
4. Remove the battery (see [Battery on page 34](#)).
5. Remove the following components:
  - a. Hard drive (see [Hard drive on page 37](#))
  - b. Optical drive (see [Optical drive on page 44](#))
  - c. Switch cover and keyboard (see [Switch cover and keyboard on page 46](#))
  - d. Display assembly (see [Display assembly on page 50](#))
  - e. Top cover (see [Top cover on page 55](#))
  - f. Fan (see [Fan on page 58](#))
  - g. System board (see [System board on page 60](#))

Remove the RTC battery:

1. Turn the system board upside down, with the audio connectors toward you.

2. Remove the RTC battery.

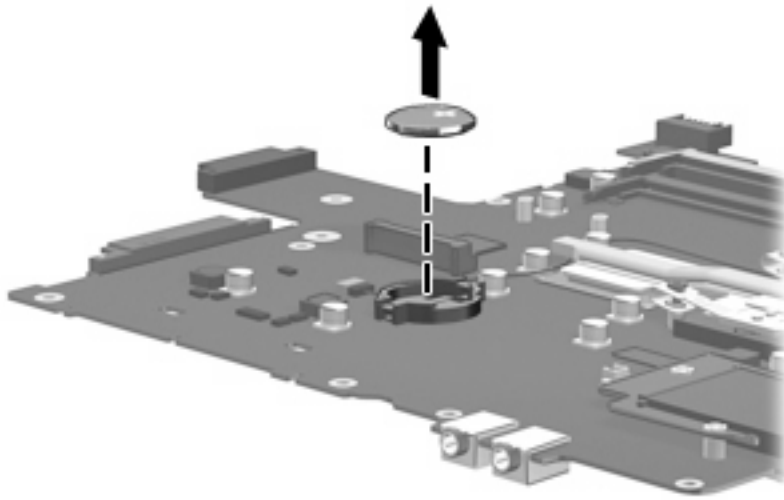

Reverse this procedure to install the RTC battery.

## Digital media board

Description	Spare part number
Digital media board	462402-001

Before removing the digital media board, follow these steps:

1. Shut down the computer. If you are unsure whether the computer is off or in Hibernation, turn the computer on, and then shut it down through the operating system.
2. Disconnect all external devices connected to the computer.
3. Disconnect the power from the computer by first unplugging the power cord from the AC outlet and then unplugging the AC adapter from the computer.
4. Remove the battery (see [Battery on page 34](#)).
5. Remove the following components:
  - a. Hard drive (see [Hard drive on page 37](#))
  - b. Optical drive (see [Optical drive on page 44](#))
  - c. Switch cover and keyboard (see [Switch cover and keyboard on page 46](#))
  - d. Display assembly (see [Display assembly on page 50](#))
  - e. Top cover (see [Top cover on page 55](#))
  - f. Fan (see [Fan on page 58](#))
  - g. System board (see [System board on page 60](#))

Remove the microphone:

1. Turn the system board upside down, with the audio connectors toward you.
2. Remove the three Phillips PM2.0×4.0 screws **(1)** that secure the digital media board to the system board.

3. Remove the digital media board **(2)** from the system board.

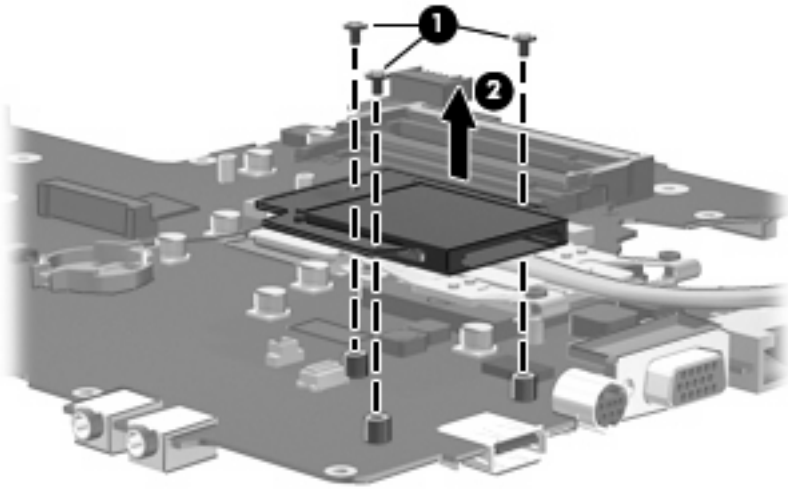

Reverse this procedure to install the digital media board.

## Heat sink

Description	Spare part number
Heat sink (includes replacement thermal material)	462405-001

Before removing the heat sink, follow these steps:

1. Shut down the computer. If you are unsure whether the computer is off or in Hibernation, turn the computer on, and then shut it down through the operating system.
2. Disconnect all external devices connected to the computer.
3. Disconnect the power from the computer by first unplugging the power cord from the AC outlet and then unplugging the AC adapter from the computer.
4. Remove the battery (see [Battery on page 34](#)).
5. Remove the following components:
  - a. Hard drive (see [Hard drive on page 37](#))
  - b. Optical drive (see [Optical drive on page 44](#))
  - c. Switch cover and keyboard (see [Switch cover and keyboard on page 46](#))
  - d. Display assembly (see [Display assembly on page 50](#))
  - e. Top cover (see [Top cover on page 55](#))
  - f. Fan (see [Fan on page 58](#))
  - g. System board (see [System board on page 60](#))

Remove the heat sink:

1. Turn the system board upside down, with the audio connectors toward you.
2. Loosen the four Phillips PM2.5×6.0 captive screws **(1)** that secure the heat sink to the system board.

3. Remove the heat sink **(2)** by lifting it straight up.

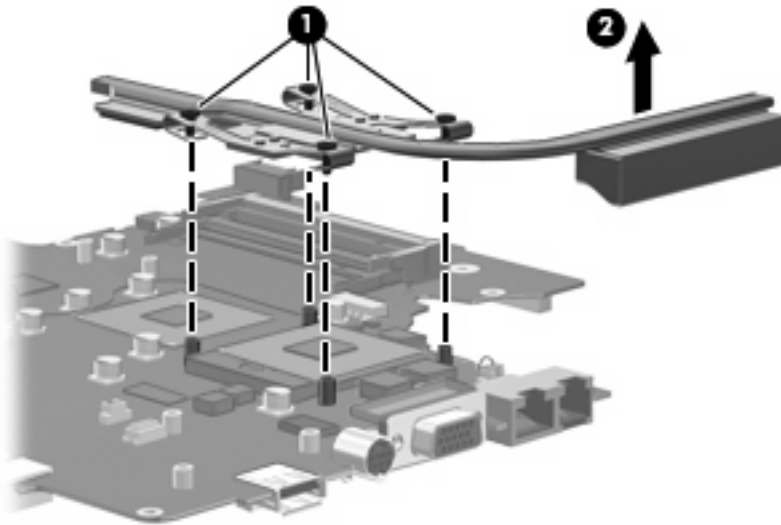

**NOTE:** The thermal material must be thoroughly cleaned from the surfaces of the heat sink **(1)** and **(2)**, the processor **(3)**, and graphics subsystem component **(4)** on the system board each time the heat sink is removed. Thermal material is included with all system board, heat sink, and processor spare part kits.

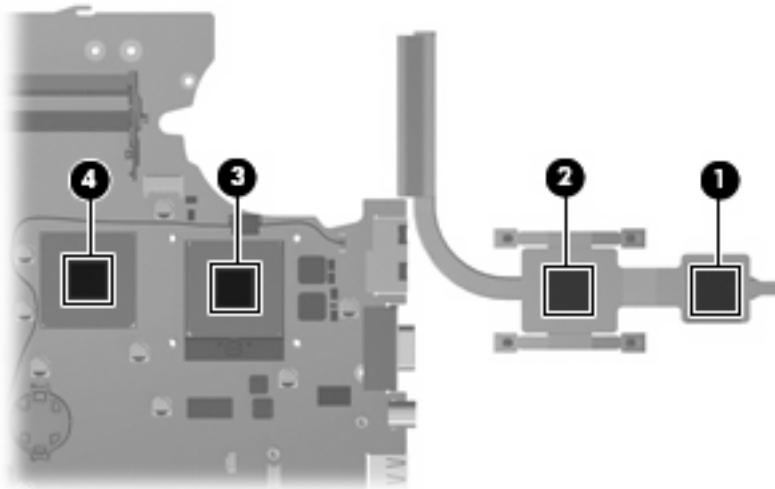

Reverse this procedure to install the heat sink.

## Processor

 **NOTE:** All processor spare part kits include replacement thermal material.

Description	Spare part number
<b>Intel Core 2 Duo processors (800-MHz FSB, 2-MB L2 cache)</b>	
T7250 2.00-GHz processor	456965-001
T7100 1.8-GHz processor	450586-001
<b>Intel Core Duo processors (667-MHz FSB, 2-MB L2 cache)</b>	
T5550 1.80-GHz processor	458247-001
T5450 1.67-GHz processor	453195-001
<b>Intel Core Duo processors (533-MHz FSB, 1-MB L2 cache)</b>	
T2330 1.66-GHz processor	457314-001
T2310 1.46-GHz processor	457313-001
<b>Intel Celeron-M processors (533-MHz FSB, 1-MB L2 cache)</b>	
550 2.00-GHz processor	454322-001
540 1.86-GHz processor	454321-001
530 1.73-GHz processor	457315-001

Before removing the processor, follow these steps:

1. Shut down the computer. If you are unsure whether the computer is off or in Hibernation, turn the computer on, and then shut it down through the operating system.
2. Disconnect all external devices connected to the computer.
3. Disconnect the power from the computer by first unplugging the power cord from the AC outlet and then unplugging the AC adapter from the computer.
4. Remove the battery (see [Battery on page 34](#)).
5. Remove the following components:
  - a. Hard drive (see [Hard drive on page 37](#))
  - b. Optical drive (see [Optical drive on page 44](#))
  - c. Switch cover and keyboard (see [Switch cover and keyboard on page 46](#))
  - d. Display assembly (see [Display assembly on page 50](#))
  - e. Top cover (see [Top cover on page 55](#))
  - f. Fan (see [Fan on page 58](#))
  - g. Heat sink (see [Heat sink on page 69](#))
  - h. System board (see [System board on page 60](#))

Remove the processor:

1. Turn the system board upside down, with the audio connectors toward you.
2. Use a flat-bladed screwdriver to turn the processor locking screw **(1)** one-half turn counterclockwise until you hear a click.
3. Lift the processor **(2)** straight up and remove it.

---

 **NOTE:** When you install the processor, the gold triangle **(3)** on the processor must be aligned with the triangle **(4)** embossed on the processor slot.

---

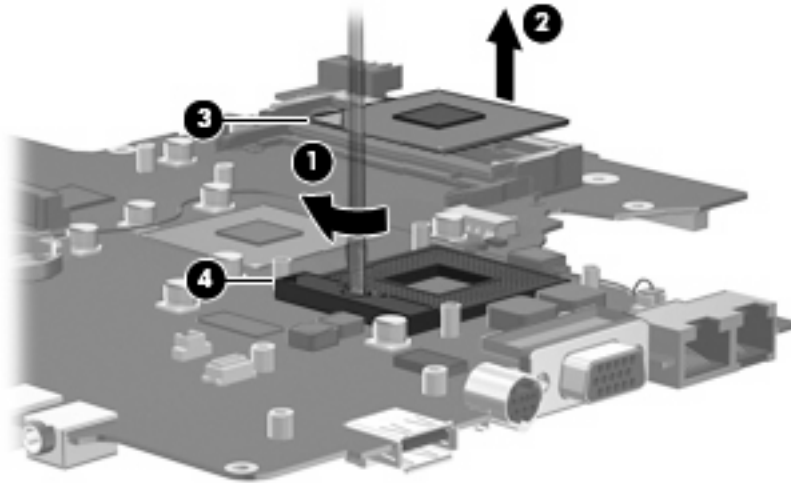

Reverse this procedure to install the processor.



---

# 5 Setup Utility

⚠ **WARNING!** Only authorized technicians trained by HP must repair this equipment. All troubleshooting and repair procedures are detailed to allow repair at only the subassembly or module level. Because of the complexity of the individual boards and subassemblies, do not attempt to make repairs at the component level or modify any printed wiring board. Improper repairs can create a safety hazard. Any indication of component replacement or printed wiring board modification may void any warranty or exchange allowances.

## Starting the Setup Utility

The Setup Utility is a ROM-based information and customization utility that can be used even when your Windows operating system is not working or will not load.

📝 **NOTE:** The fingerprint reader (select models only) does not work when accessing the Setup Utility.

The utility reports information about the computer and provides settings for startup, security, and other preferences.

To start the Setup Utility:

1. Turn on or restart the computer.
2. Before Windows opens and while “Press <F10> to enter setup” is displayed in the lower-left corner of the screen, press **f10**.

## Changing the language of the Setup Utility

The following procedure explains how to change the language of the Setup Utility. If the Setup Utility is not already running, begin at step 1. If the Setup Utility is already running, begin at step 2.

1. To start the Setup Utility, turn on or restart the computer, and then press **f10** while “Press <F10> to enter setup” is displayed in the lower-left corner of the screen.
2. Use the arrow keys to select **System Configuration > Language**, and then press **enter**.
3. Press **f5** or **f6** (or use the arrow keys) to select a language, and then press **enter** to select a language.
4. When a confirmation prompt with your preference selected is displayed, press **enter** to save your preference.
5. To set your preferences and exit the Setup Utility, press **f10** and then follow the instructions on the screen.

Your preferences go into effect when the computer restarts in Windows.

## Navigating and selecting in the Setup Utility

Because the Setup Utility is not Windows-based, it does not support the TouchPad. Navigation and selection are by keystroke.

- To choose a menu or a menu item, use the arrow keys.
- To choose an item in a drop-down list or to toggle a field, for example an Enable/Disable field, use either the arrow keys or **f5** or **f6**.
- To select an item, press **enter**.
- To close a text box or return to the menu display, press **esc**.
- To display additional navigation and selection information while the Setup Utility is open, press **f1**.

## Displaying system information

The following procedure explains how to display system information in the Setup Utility. If the Setup Utility is not open, begin at step 1. If the Setup Utility is open, begin at step 2.

1. To start the Setup Utility, turn on or restart the computer, and then press **f10** while “Press <F10> to enter setup” is displayed in the lower-left corner of the screen.
2. Access the system information by using the **Main** menu.
3. To exit the Setup Utility without changing any settings, use the arrow keys to select **Exit > Exit Discarding Changes**, and then press **enter**. (The computer restarts in Windows.)

## Restoring default settings in the Setup Utility

The following procedure explains how to restore the Setup Utility default settings. If the Setup Utility is not already running, begin at step 1. If the Setup Utility is already running, begin at step 2.

1. To start the Setup Utility, turn on or restart the computer, and then press **f10** while “Press <F10> to enter setup” is displayed in the lower-left corner of the screen.
2. Select **Exit > Load Setup Defaults**, and then press **enter**.
3. When the Setup Confirmation is displayed, press **enter** to save your preferences.
4. To set your preferences and exit the Setup Utility, press **f10**, and then follow the instructions on the screen.

The Setup Utility default settings are set when you exit the Setup Utility and go into effect when the computer restarts.

---

 **NOTE:** Your password, security, and language settings are not changed when you restore the factory default settings.

---

# Using advanced Setup Utility features

This section describes the Setup Utility features recommended for all users. For more information about the Setup Utility features recommended for advanced users only, refer to Help and Support, which is accessible only when the computer is in Windows.

The Setup Utility features available for advanced users include a hard drive self-test, a Network Service Boot, and settings for boot order preferences.

The “<F12> to boot from LAN” message that is displayed in the lower-left corner of the screen each time the computer is started or restarted in Windows is the prompt for a Network Service Boot.

The “Press <F9> to change boot order” message that is displayed in the lower-left corner of the screen each time the computer is started or restarted in Windows is the prompt to change the boot order.

## Closing the Setup Utility

You can close the Setup Utility with or without saving changes.

- To close the Setup Utility and save your changes from the current session, use either of the following procedures:
  - Press **f10**, and then follow the instructions on the screen.
  - or –
  - If the Setup Utility menus are not visible, press **esc** to return to the menu display. Then use the arrow keys to select **Exit > Exit Saving Changes**, and then press **enter**.

When you use the **f10** procedure, you are offered an option to return to the Setup Utility. When you use the Exit Saving Changes procedure, the Setup Utility closes when you press **enter**.

- To close the Setup Utility without saving your changes from the current session:

If the Setup Utility menus are not visible, press **esc** to return to the menu display. Then use the arrow keys to select **Exit > Exit Discarding Changes**, and then press **enter**.

After the Setup Utility closes, the computer restarts in Windows.

## Setup Utility menus

The menu tables in this section provide an overview of Setup Utility options.

 **NOTE:** Some of the Setup Utility menu items listed in this section may not be supported by your computer.

### Diagnostics menu

Select	To do this
Hard Disk Self Test	Run a comprehensive self-test on the hard drive. <b>NOTE:</b> On models with two hard drives, this menu option is called the <b>Primary Hard Disk Self Test</b> .
Memory Test (select models only)	Run a diagnostic test on the system memory.
Secondary Hard Disk Self Test (select models only)	Run a comprehensive self-test on a secondary hard drive.

## Main menu

Select	To do this
System information	<ul style="list-style-type: none"><li>• View and change the system time and date.</li><li>• View identification information about the computer.</li><li>• View specification information about the processor, memory size, system BIOS, and keyboard controller version (select models only).</li></ul>

## Security menu

Select	To do this
Administrator password	Enter, change, or delete an administrator password.
Power-On Password	Enter, change, or delete a power-on password.

## System Configuration menu

Select	To do this
Language Support	Change the Setup Utility language.
Boot Options	Set the following boot options: <ul style="list-style-type: none"><li>• <b>f10</b> and <b>f12</b> Delay (sec.)—Set the delay for the <b>f10</b> and <b>f12</b> functions of the Setup Utility in intervals of 5 seconds each (0, 5, 10, 15, 20).</li><li>• CD-ROM boot—Enable/disable boot from CD-ROM.</li><li>• Floppy boot—Enable/disable boot from Floppy.</li><li>• Internal Network Adapter boot—Enable/disable boot from Internal Network Adapter.</li><li>• Boot Order—Set the boot order for:<ul style="list-style-type: none"><li>◦ USB Floppy</li><li>◦ ATAPI CD/DVD-ROM Drive</li><li>◦ Hard drive</li><li>◦ USB Diskette on Key</li><li>◦ USB Hard drive</li><li>◦ Network adapter</li></ul></li></ul>
Button Sound (select models only)	Enable/disable the Quick Launch Button tapping sound.
Virtualization Technology	Enable/disable the processor Virtualization Technology.
Processor C4 State	Enable/disable the processor C4 sleep state.

# 6 Specifications

## Computer specifications

	Metric	U.S.
<b>Dimensions</b>		
Length	28.5 cm	11.22 in
Width	39.7 cm	15.63 in
Height (front to rear)	3.43 to 4.18 cm	1.35 to 1.65 in
<b>Weight</b>		
Equipped with battery and optical drive	3.12 kg	6.88 lbs
<b>Input power</b>		
Operating voltage	19.0 V dc @ 4.74 A – 65 W	
Operating current	4.74 A	
<b>Temperature</b>		
Operating (not writing to optical disc)	0°C to 35°C	32°F to 95°F
Operating (writing to optical disc)	5°C to 35°C	41°F to 95°F
Nonoperating	-20°C to 60°C	-4°F to 140°F
<b>Relative humidity</b>		
Operating	10% to 90%	
Nonoperating	5% to 95%	
<b>Maximum altitude</b> (unpressurized)		
Operating (14.7 to 10.1 psia)	-15 m to 3,048 m	-50 ft to 10,000 ft
Nonoperating (14.7 to 4.4 psia)	-15 m to 12,192 m	-50 ft to 40,000 ft
<b>Shock</b>		
Operating	125 g, 2 ms, half-sine	
Nonoperating	200 g, 2 ms, half-sine	
<b>Random vibration</b>		
Operating	0.75 g zero-to-peak, 10 Hz to 500 Hz, 0.25 oct/min sweep rate	

	Metric	U.S.
Nonoperating	1.50 g zero-to-peak, 10 Hz to 500 Hz, 0.5 oct/min sweep rate	

**NOTE:** Applicable product safety standards specify thermal limits for plastic surfaces. The computer operates well within this range of temperatures.

## 17.0-inch, WXGA display specifications

	Metric	U.S.
<b>Dimensions</b>		
Height	24.4 cm	9.6 in
Width	38.1 cm	15.0 in
Diagonal	43.2 cm	17.0 in
<b>Number of colors</b>	Up to 16.8 million	
<b>Contrast ratio</b>	200:1 (typical)	
<b>Brightness</b>	180 nits (typical)	
<b>Pixel resolution</b>		
Pitch	0.259 × 0.259 mm	
Format	1440 × 900	
Configuration	RGB vertical stripe	
<b>Backlight</b>	CCFT	
<b>Character display</b>	80 × 25	
<b>Total power consumption</b>	6.5 W	
<b>Viewing angle</b>	+/-45° horizontal, +15°/-35° vertical (typical)	

# Hard drive specifications

	160-GB*	120-GB*
<b>Dimensions</b>		
Height	9.5 mm	9.5 mm
Width	70 mm	70 mm
Weight	101 g	101 g
<b>Interface type</b>		
	SATA	SATA
<b>Transfer rate</b>		
	100 MB/sec	100 MB/sec
<b>Security</b>		
	ATA security	ATA security
<b>Seek times</b> (typical read, including setting)		
Single track	3 ms	3 ms
Average	13 ms	13 ms
Maximum	24 ms	24 ms
<b>Logical blocks</b>		
	312,560,640	234,420,480
<b>Disc rotational speed</b>		
	5400 rpm	5400 rpm
<b>Operating temperature</b>		
	5°C to 55°C (41°F to 131°F)	
* 1 GB = 1 billion bytes when referring to hard drive storage capacity. Actual accessible capacity is less. Actual drive specifications may differ slightly.		
<b>NOTE:</b> Certain restrictions and exclusions apply. Contact technical support for details.		

# DVD±RW and CD-RW SuperMulti Double-Layer Combo Drive specifications

<b>Applicable disc</b>	<b>Read:</b>	<b>Write:</b>
	CD-DA, CD+(E)G, CD-MIDI, CD-TEXT, CD-ROM, CD-ROM XA, MIXED MODE CD, CD-I, CD-I Bridge (Photo-CD, Video CD), Multisession CD (Photo-CD, CD-EXTRA, Portfolio, CD-R, CD-RW), CD-R, CD-RW, DVD-ROM (DVD-5, DVD-9, DVD-10, DVD-18), DVD-R, DVD-RW, DVD+R, DVD+RW, DVD-RAM	CD-R and CD-RW DVD+R, DVD+RW, DVD-R, DVD-RW, DVD-RAM
<b>Access time</b>	<b>CD</b>	<b>DVD</b>
Random	< 175 ms	< 230 ms
<b>Cache buffer</b>	2 MB	
<b>Data transfer rate</b>		
24X CD-ROM	3,600 KB/sec	
8X DVD	10,800 KB/sec	
24X CD-R	3,600 KB/sec	
16X CD-RW	2,400 KB/sec	
8X DVD+R	10,800 KB/sec	
4X DVD+RW	5,400 KB/sec	
8X DVD-R	10,800 KB/sec	
4X DVD-RW	5,400 KB/sec	
2.4X DVD+R(9)	2,700 KB/sec	
5X DVD-RAM	6,750 KB/sec	
<b>Transfer mode</b>	Multiword DMA Mode	



# DVD±RW and CD-RW Combo Drive specifications

<b>Applicable disc</b>	<b>Read:</b>	<b>Write:</b>
	CD-DA, CD+(E)G, CD-MIDI, CD-TEXT, CD-ROM, CD-ROM XA, MIXED MODE CD, CD-I, CD-I Bridge (Photo-CD, Video CD), Multisession CD (Photo-CD, CD-EXTRA, Portfolio, CD-R, CD-RW), CD-R, CD-RW, DVD-ROM (DVD-5, DVD-9, DVD-10, DVD-18), DVD-R, DVD-RW, DVD+R, DVD+RW, DVD-RAM	CD-R and CD-RW
<b>Access time</b>	<b>CD</b>	<b>DVD</b>
Random	< 110 ms	< 130 ms
<b>Cache buffer</b>	2 MB	
<b>Data transfer rate</b>		
24X CD-ROM	3,600 KB/sec	
8X DVD	3,600 KB/sec	
24X CD-R	3,600 KB/sec	
24X CD-RW	3,600 KB/sec	
<b>Transfer mode</b>	Multiword DMA mode 2	

## System DMA specifications

Hardware DMA	System function
DMA0	Not applicable
DMA1*	Not applicable
DMA2*	Not applicable
DMA3	Not applicable
DMA4	Direct memory access controller
DMA5*	Available for PC Card
DMA6	Not assigned
DMA7	Not assigned

\*PC Card controller can use DMA 1, 2, or 5.

# System interrupt specifications

Hardware IRQ	System function
IRQ0	System timer
IRQ1	Standard 101-/102-Key or Microsoft® Natural Keyboard
IRQ2	Cascaded
IRQ3	Intel 82801DB/DBM USB2 Enhanced Host Controller—24CD
IRQ4	COM1
IRQ5*	Conexant AC—Link Audio Intel 82801DB/DBM SMBus Controller—24C3 Data Fax Modem with SmartCP
IRQ6	Diskette drive
IRQ7*	Parallel port
IRQ8	System CMOS/real-time clock
IRQ9*	Microsoft ACPI-compliant system
IRQ10*	Intel USB UHCI controller—24C2 Intel 82852/82855 GM/GME Graphic Controller Realtek RTL8139 Family PCI Fast Ethernet Controller
IRQ11	Intel USB EHCI controller—24CD Intel USB UHCI controller—24C4 Intel USB UHCI controller—24C7 Intel Pro/Wireless 2200BG TI OHCI 1394 host controller TI PCI1410 CardBus controller
IRQ12	Synaptics PS/2 TouchPad
IRQ13	Numeric data processor
IRQ14	Primary IDE channel
IRQ15	Secondary IDE channel

\*Default configuration; audio possible configurations are IRQ5, IRQ7, IRQ9, IRQ10, or none.

**NOTE:** PC Cards may assert IRQ3, IRQ4, IRQ5, IRQ7, IRQ9, IRQ10, IRQ11, or IRQ15. Either the infrared or the serial port may assert IRQ3 or IRQ4.

# System I/O address specifications

I/O address (hex)	System function (shipping configuration)
000 - 00F	DMA controller no. 1
010 - 01F	Unused
020 - 021	Interrupt controller no. 1
022 - 024	Opti chipset configuration registers
025 - 03F	Unused
02E - 02F	87334 "Super I/O" configuration for CPU
040 - 05F	Counter/timer registers
044 - 05F	Unused
060	Keyboard controller
061	Port B
062 - 063	Unused
064	Keyboard controller
065 - 06F	Unused
070 - 071	NMI enable/RTC
072 - 07F	Unused
080 - 08F	DMA page registers
090 - 091	Unused
092	Port A
093 - 09F	Unused
0A0 - 0A1	Interrupt controller no. 2
I/O Address (hex)	System Function (shipping configuration)
0A2 - 0BF	Unused
0C0 - 0DF	DMA controller no. 2
0E0 - 0EF	Unused
0F0 - 0F1	Coprocessor busy clear/reset
0F2 - 0FF	Unused
100 - 16F	Unused
170 - 177	Secondary fixed disk controller
178 - 1EF	Unused
1F0 - 1F7	Primary fixed disk controller
1F8 - 200	Unused
201	JoyStick (decoded in ESS1688)
202 - 21F	Unused

<b>I/O address (hex)</b>	<b>System function (shipping configuration)</b>
220 - 22F	Entertainment audio
230 - 26D	Unused
26E - 26	Unused
278 - 27F	Unused
280 - 2AB	Unused
2A0 - 2A7	Unused
2A8 - 2E7	Unused
2E8 - 2EF	Reserved serial port
2F0 - 2F7	Unused
2F8 - 2FF	Infrared port
300 - 31F	Unused
320 - 36F	Unused
370 - 377	Secondary diskette drive controller
378 - 37F	Parallel port (LPT1/default)
380 - 387	Unused
388 - 38B	FM synthesizer—OPL3
38C - 3AF	Unused
3B0 - 3BB	VGA
3BC - 3BF	Reserved (parallel port/no EPP support)
3C0 - 3DF	VGA
3E0 - 3E1	PC Card controller in CPU
3E2 - 3E3	Unused
3E8 - 3EF	Internal modem
3F0 - 3F7	"A" diskette controller
3F8 - 3FF	Serial port (COM1/default)
CF8 - CFB	PCI configuration index register (PCIDIVO-1)
CFC - CFF	PCI configuration data register (PCIDIVO-1)

## System memory map specifications

Size	Memory address	System function
640 KB	00000000-0009FFFF	Base memory
128 KB	000A0000-000BFFFF	Video memory
48 KB	000C0000-000CBFFF	Video BIOS
160 KB	000C8000-000E7FFF	Unused
64 KB	000E8000-000FFFFF	System BIOS
15 MB	00100000-00FFFFFF	Extended memory
58 MB	04800000-07FFFFFF	Super extended memory
58 MB	04800000-07FFFFFF	Unused
2 MB	08000000-080FFFFF	Video memory (direct access)
4 GB	08200000-FFFFFFFF	Unused
64 KB	FFFF0000-FFFFFFFF	System BIOS

---

## 7 Screw listing

This section provides specification and reference information for the screws used in the computer. All screws listed in this section are available in the Screw Kit, spare part number 462408-001, and the Display Screw Kit, spare part number 462398-001.

## Phillips PM2.5×6.0 captive screw

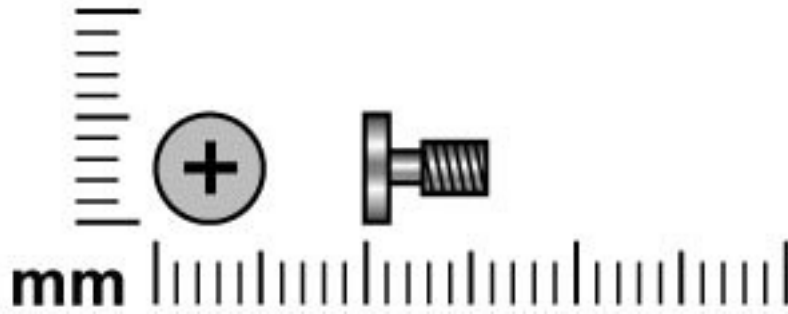

Color	Quantity	Length	Thread	Head diameter
Black	8	6.0 mm	2.5 mm	5.0 mm

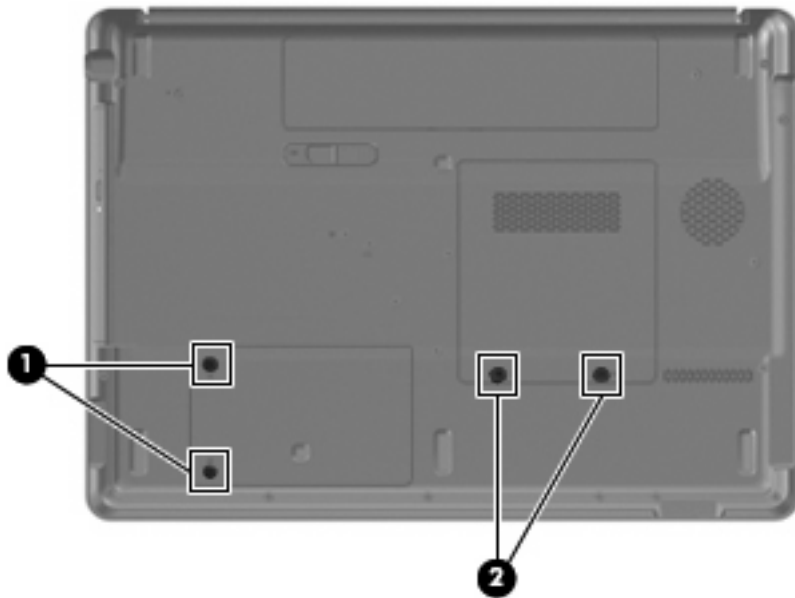

### Where used:

- (1) Two captive screws that secure the hard drive cover to the computer
- (2) Two captive screws that secure the memory/WLAN module drive cover to the computer



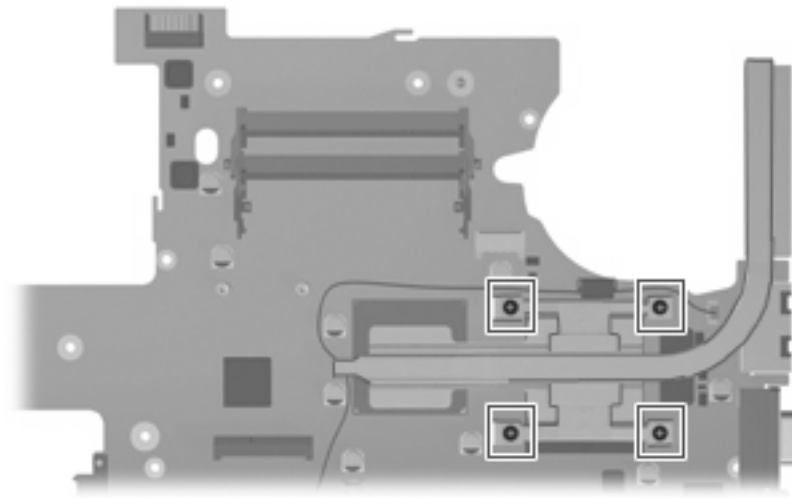

**Where used:** Four captive screws that secure the heat sink to the system board

## Phillips PM3.0×4.0 screw

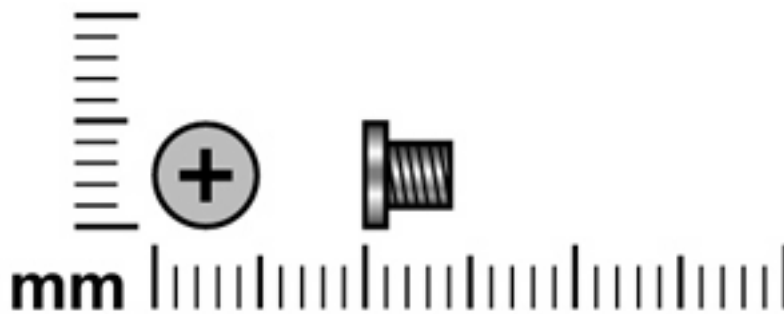

Color	Quantity	Length	Thread	Head diameter
Silver	4	4.0 mm	3.0 mm	5.0 mm

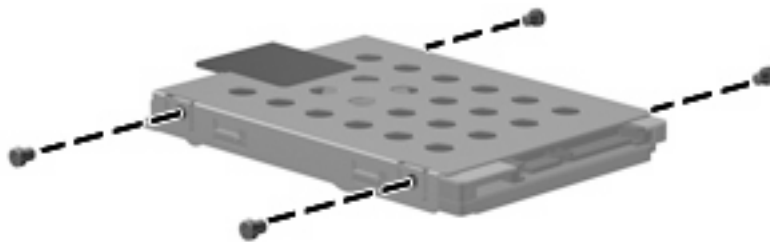

**Where used:** 4 screws that secure the hard drive bracket to the hard drive

## Phillips PM2.0×4.0 screw

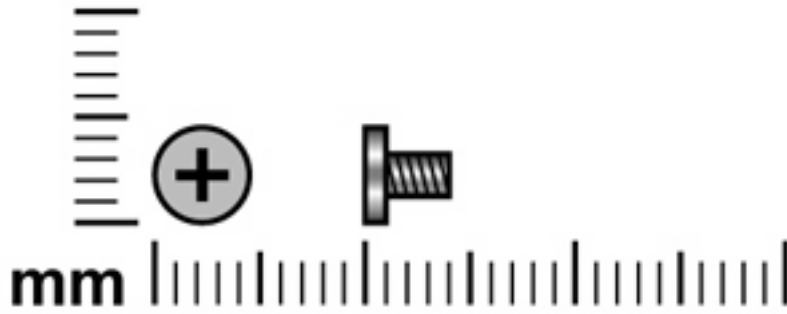

Color	Quantity	Length	Thread	Head diameter
Black	20	4.0 mm	2.0 mm	4.5 mm

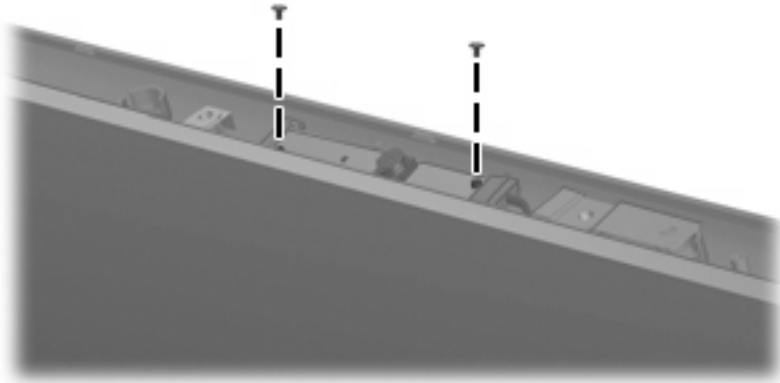

**Where used:** 2 screws that secure the camera module to the display enclosure

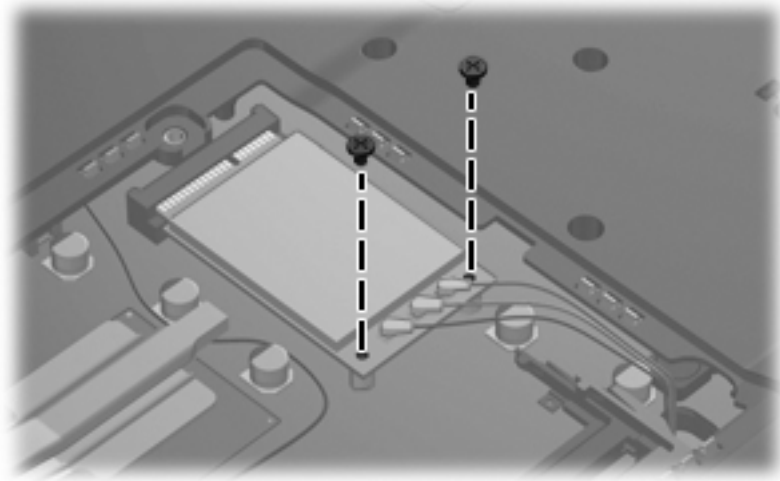

**Where used:** 2 screws that secure the WLAN module to the computer

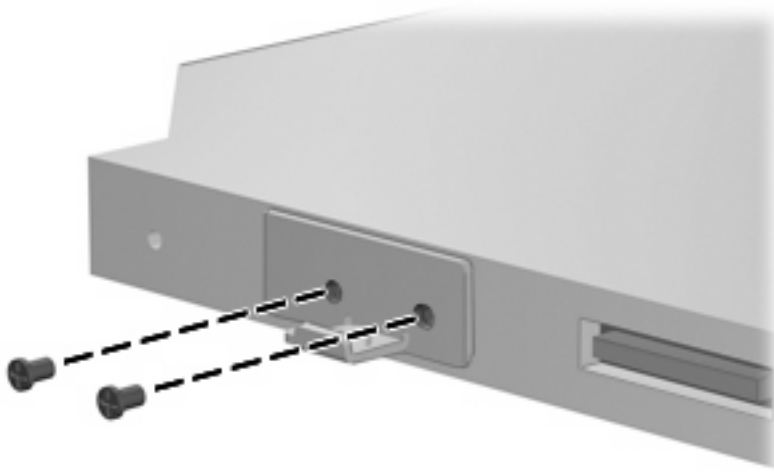

**Where used:** 2 screws that secure the optical drive bracket to the optical drive

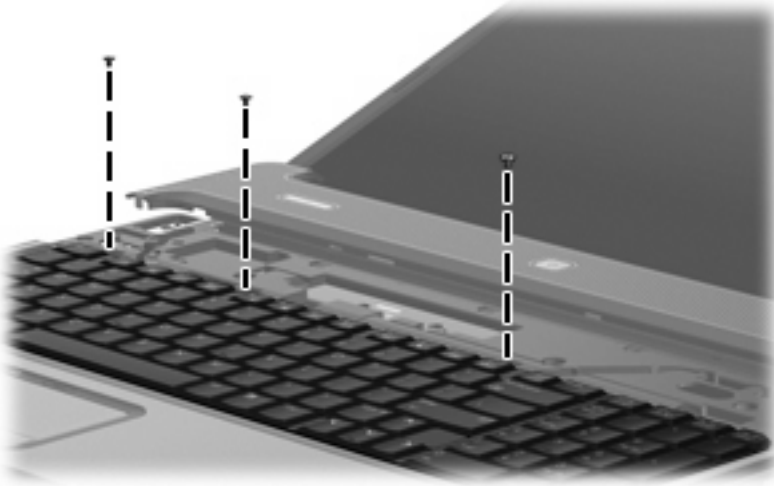

**Where used:** 3 screws that secure the keyboard to the computer

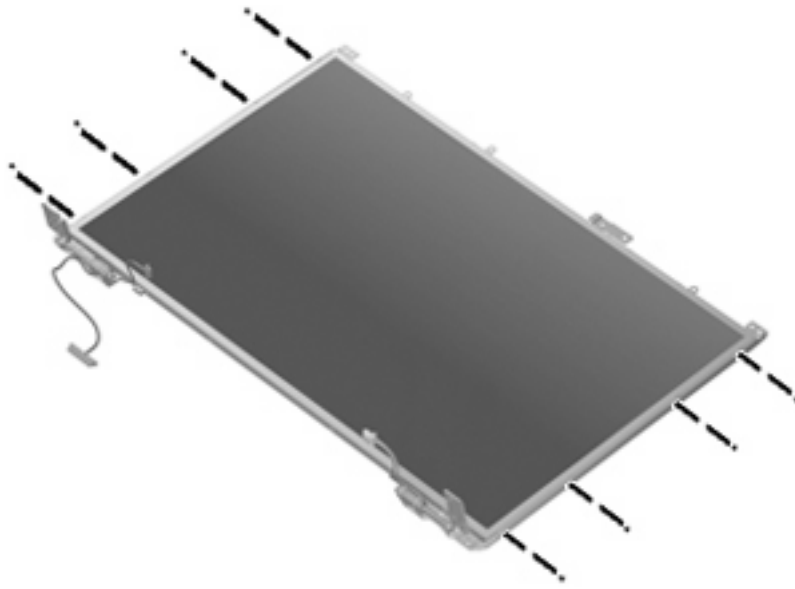

**Where used:** 8 screws that secure the display hinges to the display panel

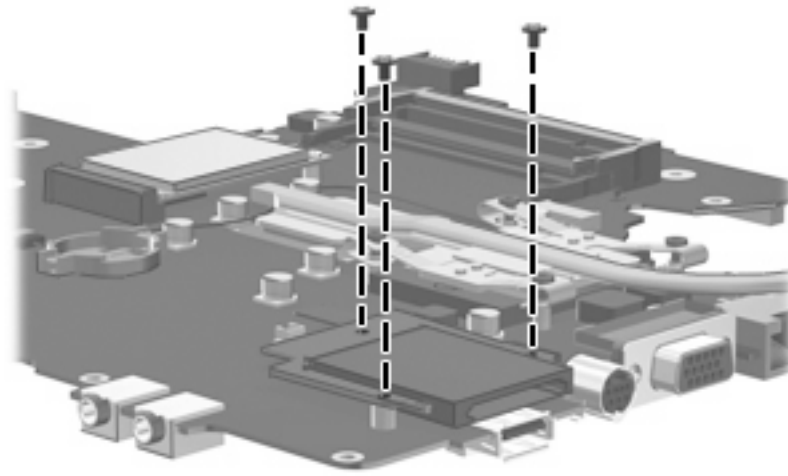

**Where used:** 3 screws that secure the digital media board to the system board

# Phillips PM2.5×9.0 screw

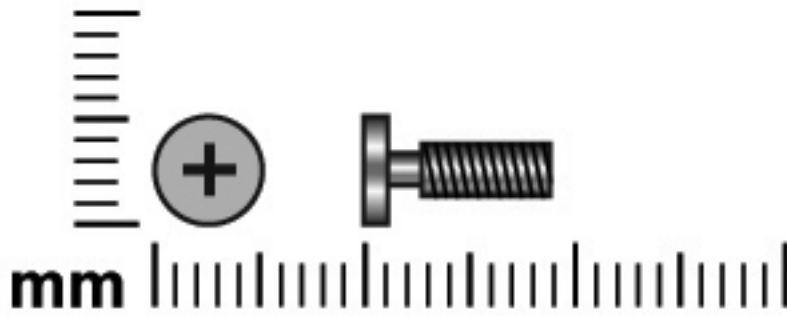

Color	Quantity	Length	Thread	Head diameter
Black	27	9.0 mm	2.5 mm	5.0 mm

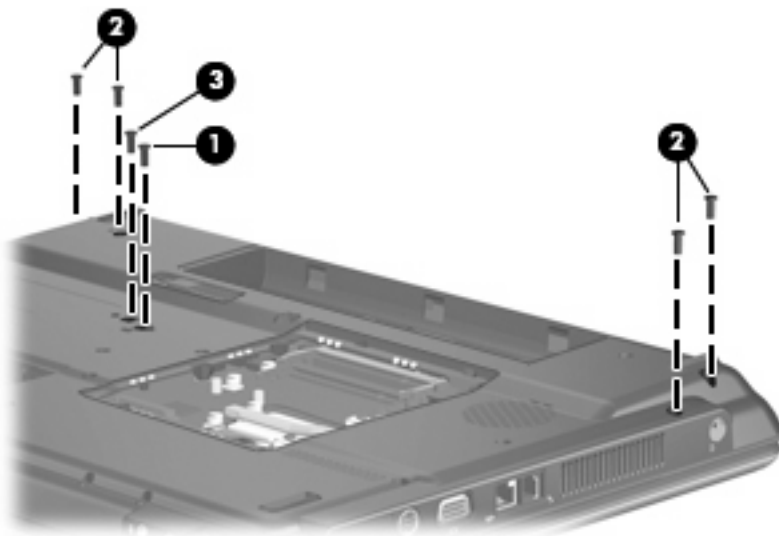

## Where used:

- (1) One screw that secures the optical drive to the computer
- (2) Four screws that secure the switch cover to the computer
- (3) One screw that secures the keyboard to the computer



**Where used:** 4 screws that secure the display assembly to the computer

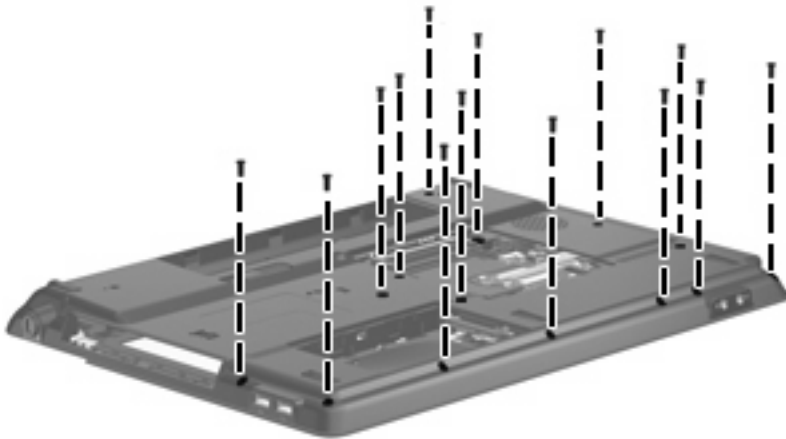

**Where used:** 14 screws that secure the top cover to the base enclosure

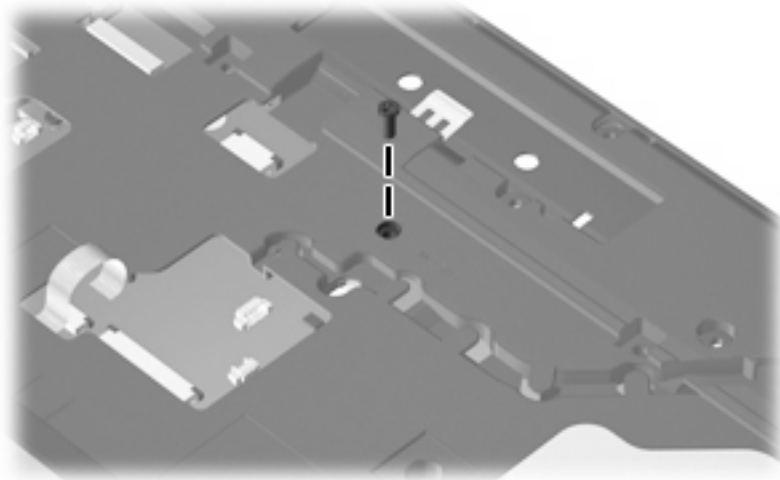

**Where used:** One screw that secures the top cover to the base enclosure

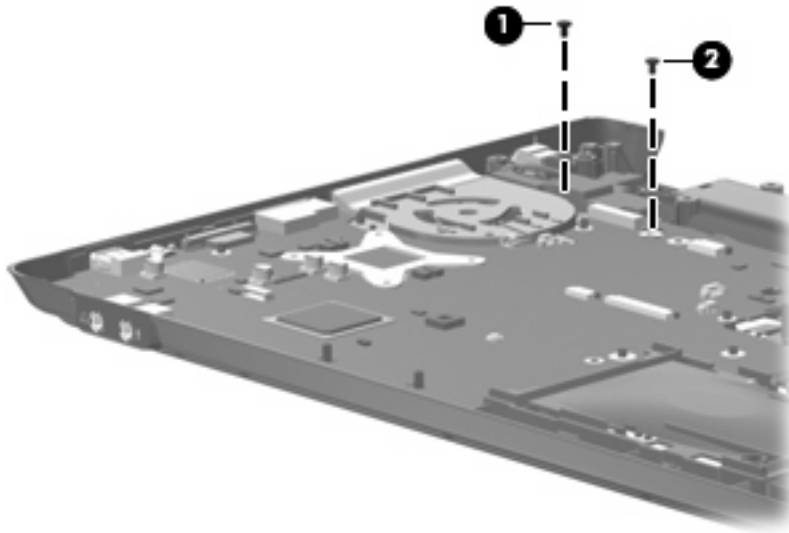

**Where used:**

- (1) One screw that secures the fan to the base enclosure
- (2) One screw that secures the system board to the base enclosure

## Phillips PM2.5×5.0 screw

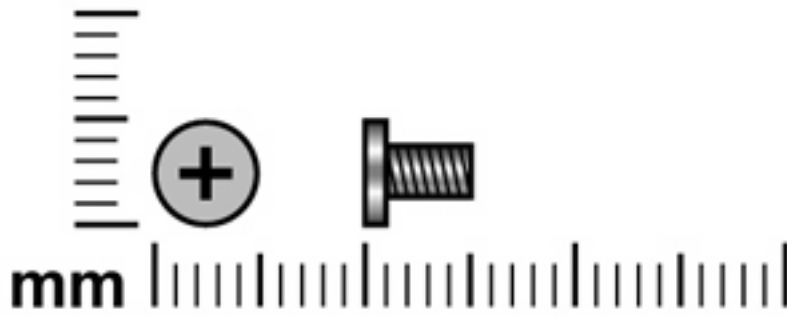

Color	Quantity	Length	Thread	Head diameter
Black	19	5.0 mm	2.5 mm	5.0 mm

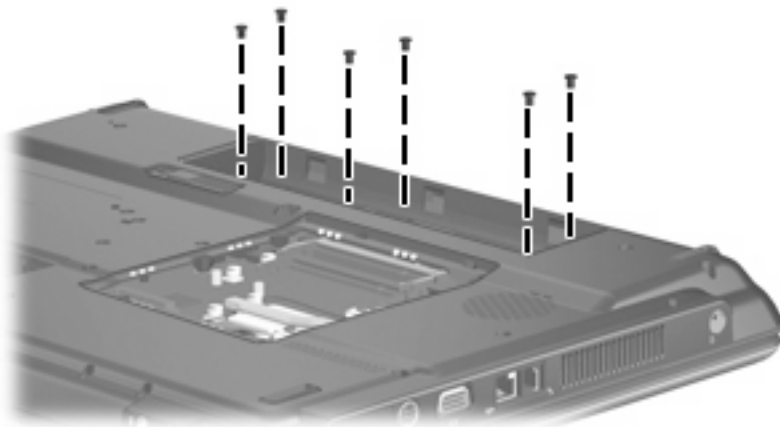

**Where used:** 6 screws that secure the switch cover to the computer

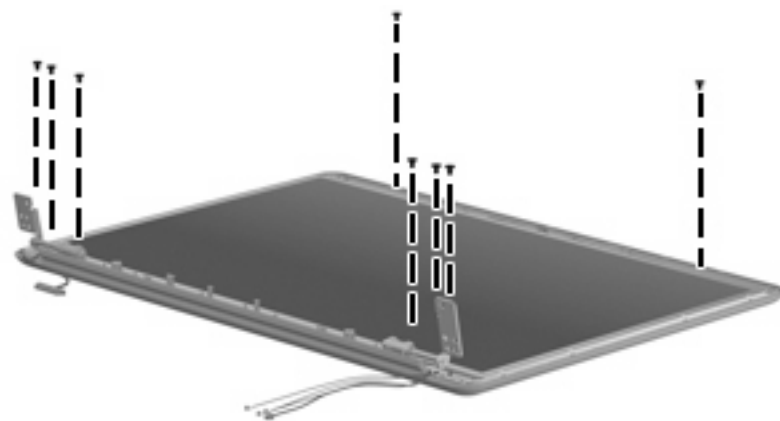

**Where used:** 8 screws that secure the display panel to the display enclosure



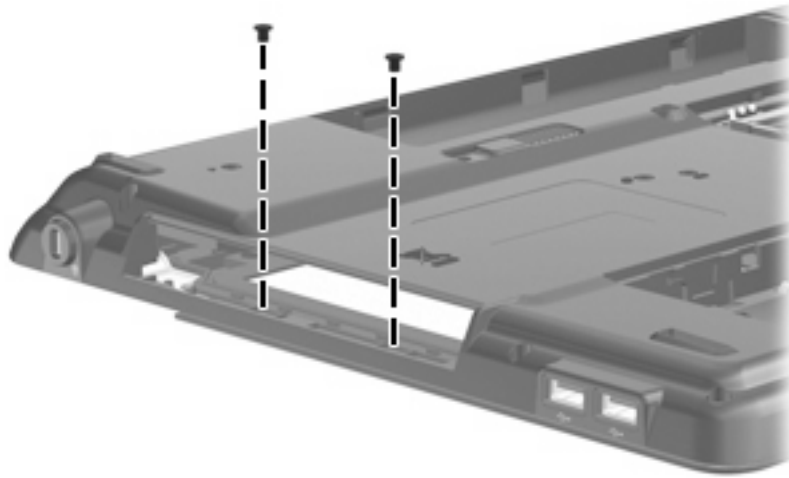

**Where used:** 2 screws that secure the top cover to the base enclosure

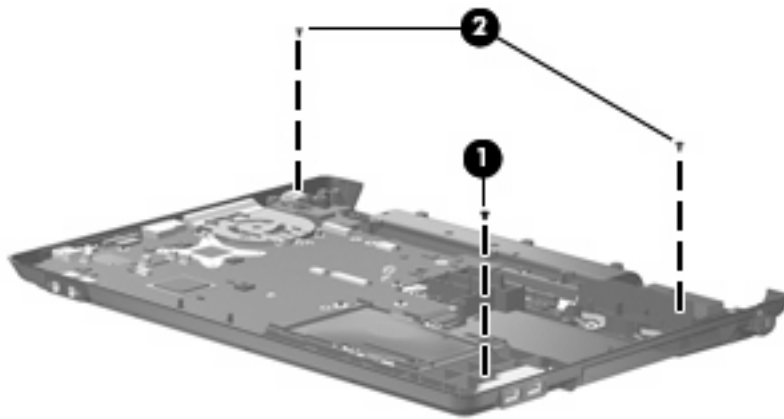

**Where used:**

**(1)** One screw that secures the USB board to the base enclosure

**(2)** Two screws that secure the speaker assembly to the base enclosure

## Phillips PM2.5×7.0 screw

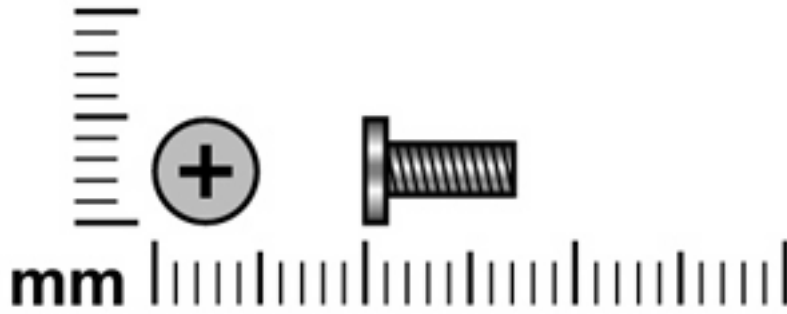

Color	Quantity	Length	Thread	Head diameter
Silver	8	7.0 mm	2.5 mm	5.0 mm

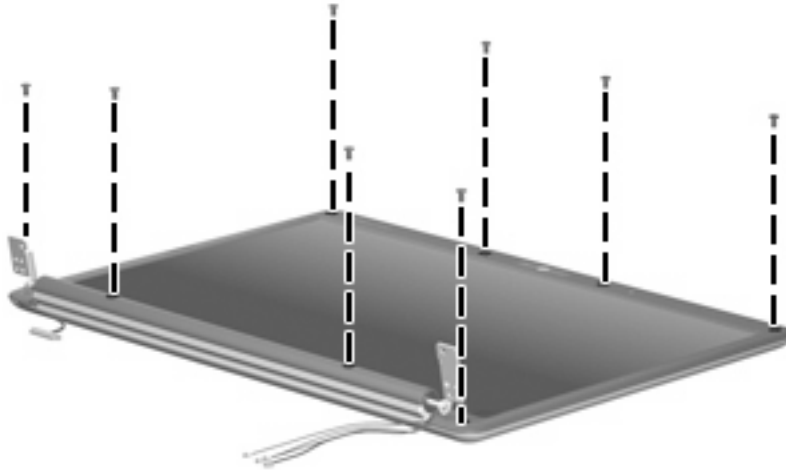

**Where used:** 8 screws that secure the display bezel to the display enclosure

---

# 8 Backup and recovery

## Recovering system information

Tools provided by the operating system and Recovery Manager software are designed to help you with the following tasks for safeguarding your information and restoring it in case of a system failure:

- Backing up your information regularly to protect your important system files.
- Making a set of recovery discs (Recovery Manager software feature). Recovery discs are used to start up (boot) your computer and restore the operating system and software programs to factory settings in case of system failure or instability.
- Creating system restore points (operating system feature). System restore points allow you to reverse undesirable changes to your computer by restoring the computer to an earlier state.
- Recovering a program or driver (Recovery Manager software feature). This feature helps you reinstall a program or driver without performing a full system recovery.
- Performing a full system recovery (Recovery Manager software feature). With Recovery Manager, you can recover your full factory image if you experience system failure or instability. Recovery Manager works from a dedicated recovery partition on the hard drive or from recovery discs you create.

## Creating recovery discs

After setting up the computer for the first time, be sure to create a set of recovery discs of the full factory image. The recovery discs are used to start up (boot) the computer and recover the operating system and software to factory settings in case of system instability or failure.

---

 **NOTE:** Handle these discs carefully and keep them in a safe place. The software allows the creation of only one set of recovery discs.

---

Note the following guidelines before creating recovery discs:

- Use any of the following types of discs: CD-R, DVD+R, DVD+R DL, DVD-R, or DVD-R DL (purchased separately). The discs you use will depend on the type of optical drive installed in your computer. Because DVDs store more information than CDs, DVDs and DVDs with double-layer (DL) support reduce the number of discs required.

---

 **NOTE:** Read-write discs, such as CD-RW, DVD+RW, and DVD-RW, are not compatible with the Recovery Manager software.

---

- The computer must be connected to AC power during this process.
- Only one set of recovery discs can be created per computer.

- Number each disc before inserting it into the computer optical drive.
- If necessary, you can exit the program before you have finished creating the recovery discs. The next time you open Recovery Manager, you will be prompted to continue the disc creation process.

To create a set of recovery discs:

1. Select **Start > All Programs > Recovery Manager > Recovery Manager**.

Recovery Manager opens.

2. Click **Advanced Options**.

---

 **NOTE:** If you are operating the computer on battery power, you will be prompted to connect to AC power before you can go to the next step.

---

3. Click **Recovery disc creation**, and then click **Next**.
4. Follow the on-screen instructions.

## Backing up your information

### When to back up

- On a regularly scheduled basis

---

 **NOTE:** Set reminders to back up your information periodically.

---

- Before the computer is repaired or restored
- Before you add or modify hardware or software

### Backup suggestions

- Create a set of recovery discs using Recovery Manager.
- Create system restore points using the Windows® System Restore feature, and periodically copy them to disc.
- Store personal files in the Documents folder and back up these folders periodically.
- Back up templates stored in their associated programs.
- Save customized settings in a window, toolbar, or menu bar by taking a screen shot of your settings. The screen shot can be a time saver if you have to reset your preferences.

To copy the screen and paste it into a word-processing document, follow these steps:

- a. Display the screen.
- b. Copy the screen:
  - To copy only the active window, press **alt+fn+prt sc**.
  - To copy the entire screen, press **fn+prt sc**.
- c. Open a word-processing document, and then select **Edit > Paste**.

## Using system restore points

When you back up your system, you are creating a system restore point. A system restore point allows you to save and name a snapshot of your hard drive at a specific point in time. You can then recover back to that point if you want to reverse subsequent changes made to your system.

 **NOTE:** Recovering to an earlier restore point does not affect data files saved or e-mails created since the last restore point.

You also can create additional restore points to provide increased protection for your system files and settings.

## When to create restore points

- Before you add or extensively modify software or hardware
- Periodically, whenever the system is performing optimally

 **NOTE:** If you revert to a restore point and then change your mind, you can reverse the restoration.

## Create a system restore point

1. Select **Start > Control Panel > System and Maintenance > System**.
2. In the left pane, click **System protection**.
3. Click the **System Protection** tab.
4. Under **Automatic restore points**, select the disk for which you want to create a restore point.
5. Click **Create**.  
The System Protection window opens.
6. Follow the on-screen instructions.

## Restore to a previous date and time

To revert to a restore point (created at a previous date and time), when the computer was functioning optimally, follow these steps:

1. Select **Start > Control Panel > System and Maintenance > System**.
2. In the left pane, click **System protection**.
3. Click the **System Protection** tab.
4. Click the **System Restore** button, and then click **Next**.  
The System Restore window opens.
5. Follow the on-screen instructions.

## Performing a recovery

 **NOTE:** You can only recover files that you have previously backed up. HP recommends that you use Recovery Manager to create an entire drive backup as soon as you set up your computer.

Recovery Manager software allows you to repair or restore the system if you experience system failure or instability. Recovery Manager works from recovery discs that you create or from a dedicated recovery partition on the hard drive.

 **NOTE:** Windows has its own built-in repair features, such as System Restore and driver rollback capabilities. If you have not already tried these features, try them before using Recovery Manager.

**NOTE:** Recovery Manager recovers only software that was preinstalled at the factory. Software not provided with this computer must be downloaded from the manufacturer's Web site or reinstalled from the disc provided by the manufacturer.

### Recovering from the recovery discs

To restore the system from the recovery discs:

1. Back up all personal files.
2. Insert the first recovery disc into the optical drive and restart the computer.
3. Follow the on-screen instructions.

### Recovering from the partition on the hard drive

You can perform a recovery from the partition on the hard drive from either the Start button or [f11](#).

To restore the system from the partition, follow these steps:

1. Access Recovery Manager in either of the following ways:
  - Select **Start > All Programs > Recovery Manager > Recovery Manager**.
  - or –
  - Restart the computer and press [f11](#) while the “Press <F11> for recovery” message is displayed on the screen. Then select **Recovery Manager**.

Recovery Manager opens.

2. Click **Advanced Options**.
3. Click **System recovery**, and then click **Next**.
4. Follow the on-screen instructions.

## 9 Connector pin assignments

### Audio-out (headphone)

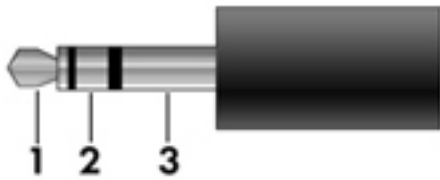

Pin	Signal
1	Audio out, left channel
2	Audio out, right channel
3	Ground

### Audio-in (microphone)

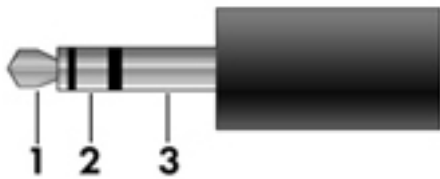

Pin	Signal
1	Audio signal in
2	Audio signal in
3	Ground

## External monitor

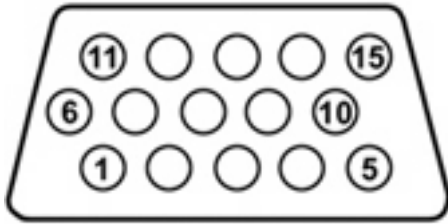

Pin	Signal
1	Red analog
2	Green analog
3	Blue analog
4	Not connected
5	Ground
6	Ground analog
7	Ground analog
8	Ground analog
9	+5 VDC
10	Ground
11	Monitor detect
12	DDC 2B data
13	Horizontal sync
14	Vertical sync
15	DDC 2B clock



## RJ-11 (modem)

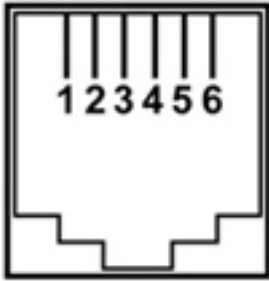

Pin	Signal
1	Unused
2	Tip
3	Ring
4	Unused
5	Unused
6	Unused

## RJ-45 (network)

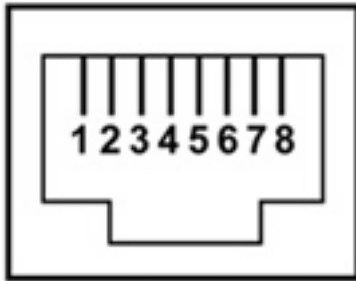

Pin	Signal
1	Transmit +
2	Transmit -
3	Receive +
4	Unused
5	Unused
6	Receive -
7	Unused
8	Unused

## S-Video-out



Pin	Signal
1	S-VHS color (C) signal
2	Composite video signal
3	S-VHS intensity (Y) signal
4	S-VHS color ground
5	TV-CD
6	S-VHS intensity ground
7	Composite video ground

## Universal Serial Bus

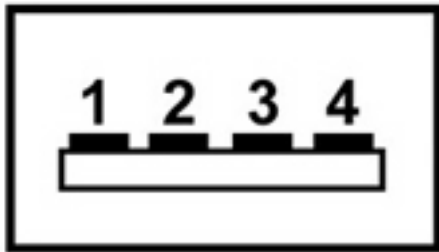

Pin	Signal
1	+5 VDC
2	Data -
3	Data +
4	Ground

---

# 10 Power cord set requirements

The wide range input feature of the computer permits it to operate from any line voltage from 100 to 120 volts AC or from 220 to 240 volts AC.

The 3-conductor power cord set included with the computer meets the requirements for use in the country or region where the equipment is purchased.

Power cord sets for use in other countries and regions must meet the requirements of the country or region where the computer is used.

## Requirements for all countries and regions

The requirements listed below are applicable to all countries and regions:

- The length of the power cord set must be at least 1.5 m (5.0 ft) and no more than 2.0 m (6.5 ft).
- All power cord sets must be approved by an acceptable accredited agency responsible for evaluation in the country or region where the power cord set will be used.
- The power cord sets must have a minimum current capacity of 10 amps and a nominal voltage rating of 125 or 250 V AC, as required by the power system of each country or region.
- The appliance coupler must meet the mechanical configuration of an EN 60 320/IEC 320 Standard Sheet C13 connector for mating with the appliance inlet on the back of the computer.

## Requirements for specific countries and regions

Country/region	Accredited agency	Applicable note number
Australia	EANSW	1
Austria	OVE	1
Belgium	CEBC	1
Canada	CSA	2
Denmark	DEMKO	1
Finland	FIMKO	1
France	UTE	1
Germany	VDE	1
Italy	IMQ	1
Japan	METI	3
The Netherlands	KEMA	1
Norway	NEMKO	1
The People's Republic of China	CCC	5
South Korea	EK	4
Sweden	SEMKO	1
Switzerland	SEV	1
Taiwan	BSMI	4
The United Kingdom	BSI	1
The United States	UL	2

1. The flexible cord must be Type HO5VV-F, 3-conductor, 1.0-mm<sup>2</sup> conductor size. Power cord set fittings (appliance coupler and wall plug) must bear the certification mark of the agency responsible for evaluation in the country or region where it will be used.
2. The flexible cord must be Type SPT-3 or equivalent, No. 18 AWG, 3-conductor. The wall plug must be a two-pole grounding type with a NEMA 5-15P (15 A, 125 V) or NEMA 6-15P (15 A, 250 V) configuration.
3. The appliance coupler, flexible cord, and wall plug must bear a "T" mark and registration number in accordance with the Japanese Dentori Law. The flexible cord must be Type VCT or VCTF, 3-conductor, 1.00-mm<sup>2</sup> conductor size. The wall plug must be a two-pole grounding type with a Japanese Industrial Standard C8303 (7 A, 125 V) configuration.
4. The flexible cord must be Type RVV, 3-conductor, 0.75-mm<sup>2</sup> conductor size. Power cord set fittings (appliance coupler and wall plug) must bear the certification mark of the agency responsible for evaluation in the country or region where it will be used.
5. The flexible cord must be Type VCTF, 3-conductor, 0.75-mm<sup>2</sup> conductor size. Power cord set fittings (appliance coupler and wall plug) must bear the certification mark of the agency responsible for evaluation in the country or region where it will be used.

---

# 11 Recycling

## Battery

When a battery has reached the end of its useful life, do not dispose of the battery in general household waste. Follow the local laws and regulations in your area for computer battery disposal.

## Display

- ⚠ **WARNING!** The backlight contains mercury. Caution must be exercised when removing and handling the backlight to avoid damaging this component and causing exposure to the mercury.
- ⚠ **CAUTION:** The procedures in this appendix can result in damage to display components. The only components intended for recycling purposes are the liquid crystal display (LCD) panel and the backlight. Careful handling must be exercised when removing these components.
- 📄 **NOTE: Materials Disposal.** This HP product contains mercury in the backlight in the display assembly that might require special handling at end-of-life. Disposal of mercury may be regulated because of environmental considerations. For disposal or recycling information, contact your local authorities, or see the Electronic Industries Alliance (EIA) Web site at <http://www.eiae.org>.

This section provides disassembly instructions for the display assembly. The display assembly must be disassembled to gain access to the backlight **(1)** and the liquid crystal display (LCD) panel **(2)**.



- 📄 **NOTE:** The procedures provided in this appendix are general disassembly instructions. Specific details, such as screw sizes, quantities, and locations, and component shapes and sizes, can vary from one computer model to another.

Perform the following steps to disassemble the display assembly:

1. Remove all screw covers **(1)** and screws **(2)** that secure the display bezel to the display assembly.

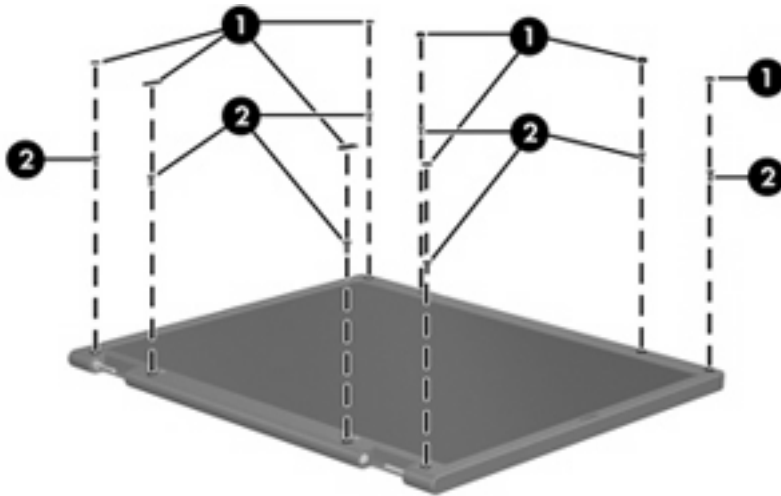

2. Lift up and out on the left and right inside edges **(1)** and the top and bottom inside edges **(2)** of the display bezel until the bezel disengages from the display assembly.
3. Remove the display bezel **(3)**.

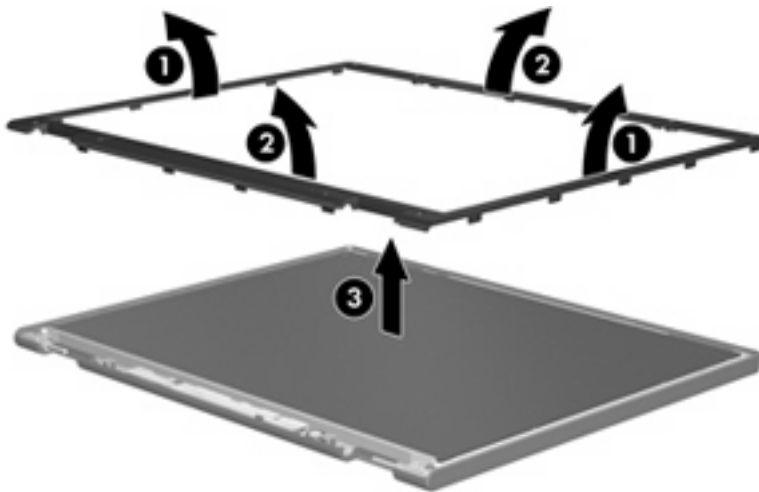



4. Disconnect all display panel cables **(1)** from the display inverter and remove the inverter **(2)**.

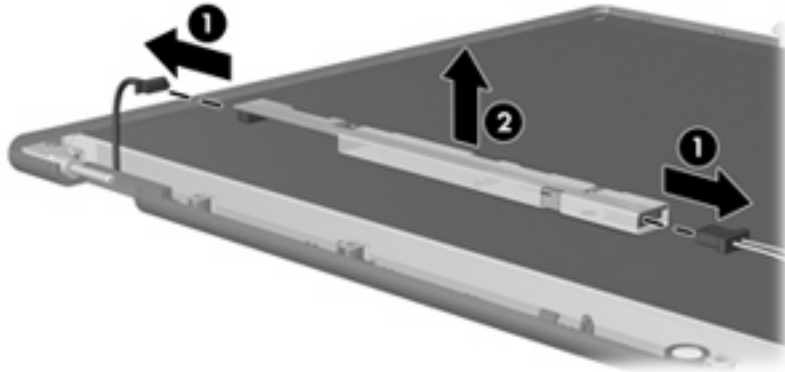

5. Remove all screws **(1)** that secure the display panel assembly to the display enclosure.
6. Remove the display panel assembly **(2)** from the display enclosure.

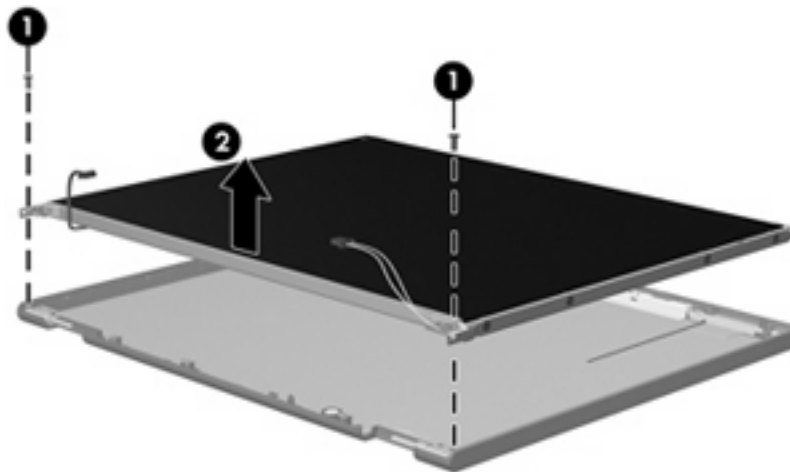

7. Turn the display panel assembly upside down.
8. Remove all screws that secure the display panel frame to the display panel.

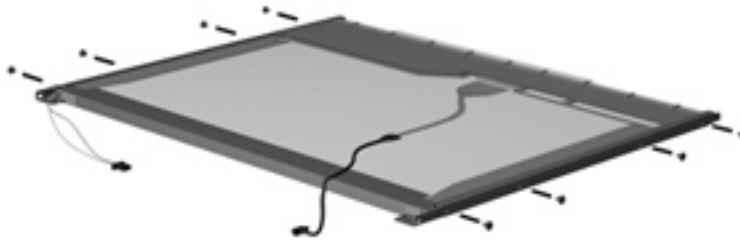

9. Use a sharp-edged tool to cut the tape **(1)** that secures the sides of the display panel to the display panel frame.

10. Remove the display panel frame **(2)** from the display panel.

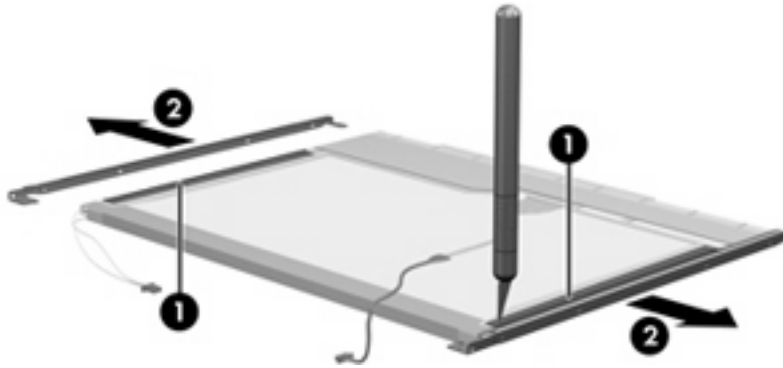

11. Remove the screws **(1)** that secure the backlight cover to the display panel.
12. Lift the top edge of the backlight cover **(2)** and swing it outward.

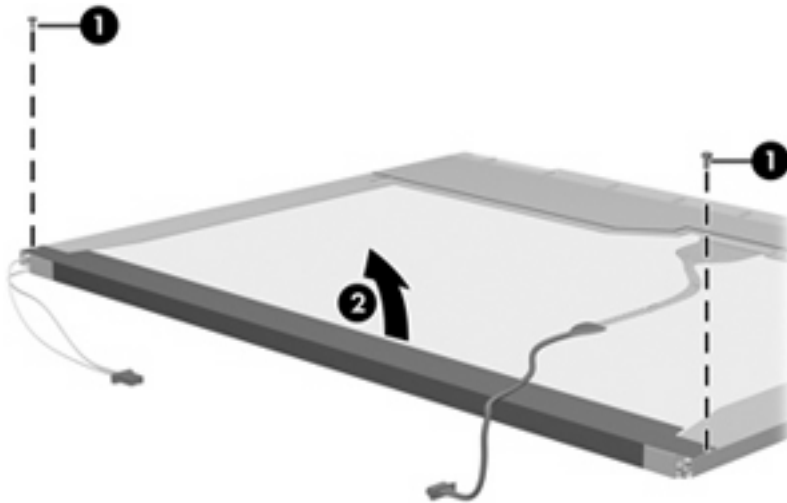

13. Remove the backlight cover.
14. Turn the display panel right-side up.

15. Remove the backlight cables (1) from the clip (2) in the display panel.

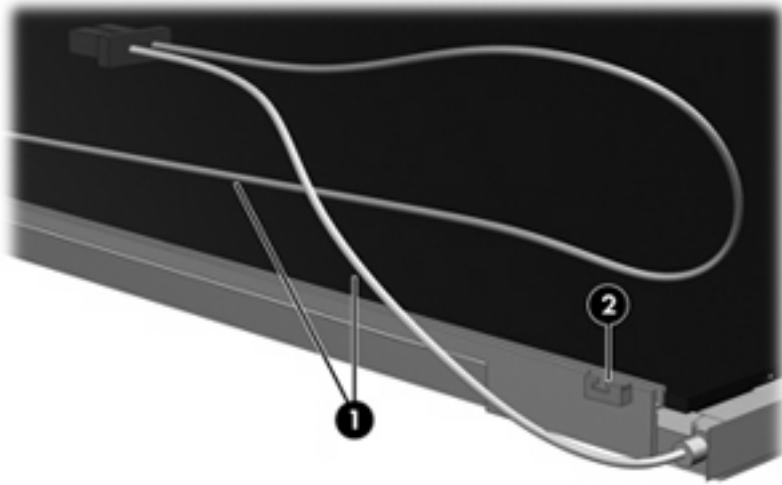

16. Turn the display panel upside down.
17. Remove the backlight frame from the display panel.

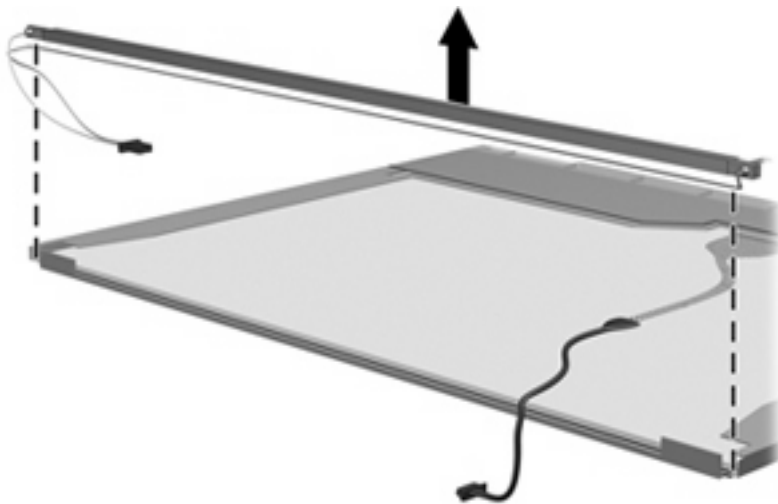

**⚠ WARNING!** The backlight contains mercury. Exercise caution when removing and handling the backlight to avoid damaging this component and causing exposure to the mercury.

18. Remove the backlight from the backlight frame.

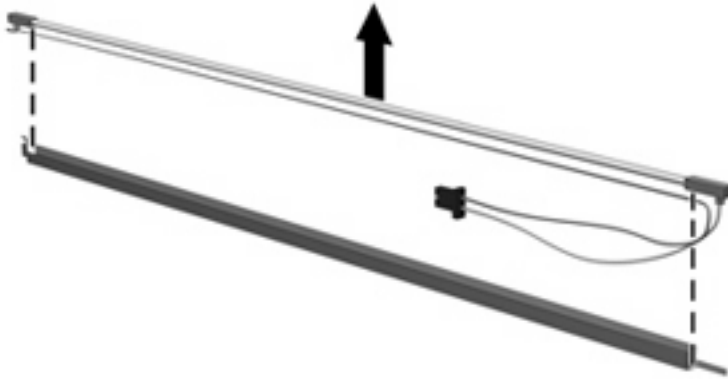

19. Disconnect the display cable (1) from the LCD panel.
20. Remove the screws (2) that secure the LCD panel to the display rear panel.
21. Release the LCD panel (3) from the display rear panel.
22. Release the tape (4) that secures the LCD panel to the display rear panel.

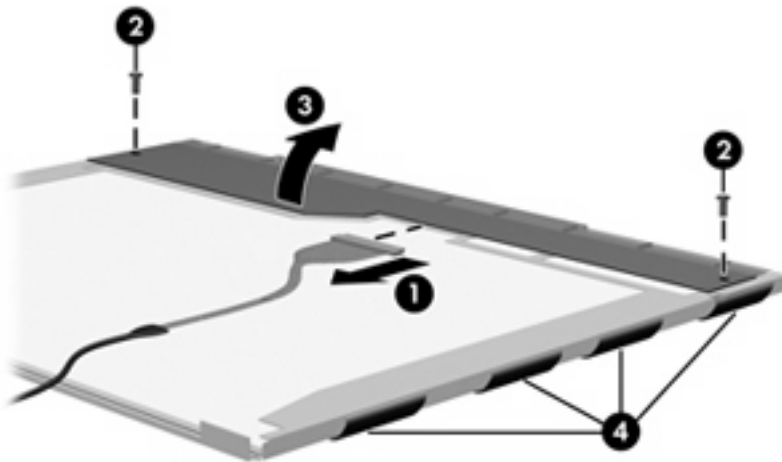

23. Remove the LCD panel.

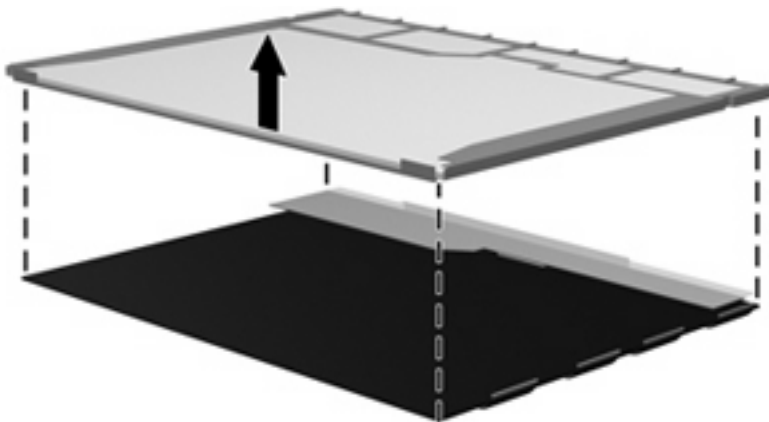

24. Recycle the LCD panel and backlight.

# Index

## A

- AC adapter, spare part number 22, 23
- administrator password 76
- advanced Setup Utility features 75
- antenna
  - disconnecting 43
  - locations 5
  - removal 53
  - spare part number 19, 26, 53
- audio, product description 3
- audio-in jack
  - location 10
  - pin assignments 103
- audio-out jack
  - location 10
  - pin assignments 103

## B

- backup 100
- base enclosure, spare part number 16, 26
- battery
  - location 12
  - removal 34
  - spare part number 16, 25, 34
- battery bay 12
- battery latch 12
- battery light 6
- boot options 76
- boot order 76
- bottom components 12
- button components 6
- button sound 76
- buttons
  - power 7

- TouchPad 9
- wireless 6

## C

- cables, service considerations 28
- camera 5
- camera light 5
- camera module
  - removal 35
  - spare part number 19, 26, 35
- caps lock light 6
- changing the Setup Utility language 73
- chipset, product description 1
- closing the Setup Utility 75
- CMOS clearing 32
- components
  - bottom 12
  - buttons 6
  - display 5
  - front 10
  - keys 8
  - left-side 11
  - lights 6
  - pointing devices 9
  - right-side 10
  - top 6
- computer feet
  - locations 33
  - spare part number 33
- computer specifications 77
- connectors
  - power 11
  - service considerations 28

## D

- Diagnostics menu 75

- digital media board
  - removal 67
  - spare part number 15, 26, 67
- Digital Media Slot 11
- diskette drive
  - precautions 28
  - product description 3
- display assembly
  - removal 50
  - spare part number 15, 25, 50
- display bezel
  - removal 51
  - spare part number 19, 26, 52
- Display Bracket Kit, spare part number 19, 26
- Display Cable Kit, spare part number 19, 26
- display components
  - recycling 111
- display enclosure, spare part number 19, 26
- display hinge
  - removal 53
  - spare part number 26, 53
- Display Hinge Kit, spare part number 19, 26
- display inverter
  - removal 52
  - spare part number 19, 26, 52
- display panel
  - product description 2
  - removal 52
  - spare part number 19, 25
- Display Rubber Kit, spare part number 19, 26

- Display Screw Kit, spare part number 19, 26
- display specifications 78
- display switch 5
- docking support, product description 3
- drive light 6
- drives
  - boot order 76
  - preventing damage 28
- DVD±RW and CD-RW Combo Drive
  - precautions 28
  - removal 44
  - spare part numbers 18, 21, 25, 44
  - specifications 80, 81
- E**
  - electrostatic discharge 29
  - esc key 8
  - Ethernet, product description 3
  - external media cards, product description 3
  - external monitor port
    - location 11
    - pin assignments 104
- F**
  - fan
    - removal 58
    - spare part number 15, 26, 58
  - feet
    - locations 33
    - spare part number 33
  - fingerprint reader 73
  - fn key 8
  - front components 10
  - function keys 8
- G**
  - graphics, product description 2
  - grounding equipment and methods 31
- H**
  - hard drive
    - location 12
    - precautions 28
    - product description 2
    - removal 37
  - spare part numbers 18, 21, 25, 37
  - specifications 79
  - hard drive bay 12
  - hard drive bracket, removal 38
  - hard drive cover
    - illustrated 20
    - removal 37
  - Hard Drive Hardware Kit, spare part number 18, 25, 37
  - hard drive self test 75
  - headphone jack
    - location 10
    - pin assignments 103
  - heat sink
    - removal 69
    - spare part number 16, 26, 69
  - hinge
    - removal 53
    - spare part number 19, 53
  - horizontal scroll zone 9
- I**
  - I/O address specifications 84
  - interrupt specifications 83
- J**
  - jacks
    - audio-in 10
    - audio-out 10
    - headphone 10
    - microphone 10
    - modem 11
    - network 11
    - RJ-11 11
    - RJ-45 11
    - S-Video-out jack 11
- K**
  - keyboard
    - product description 4
    - removal 46
    - spare part numbers 15, 25, 46
  - keypad keys 8
  - keys
    - esc 8
    - fn 8
    - function 8
    - keypad 8
- Windows applications 8
- Windows logo 8
- L**
  - language support 73, 76
  - left-side components 11
  - light components 6
  - lights
    - battery 6
    - caps lock 6
    - drive 6
    - num lock 7
    - power 6
    - wireless 6
- M**
  - main menu 76
  - mass storage devices, spare part numbers 21
  - memory map specifications 86
  - memory module
    - product description 2
    - removal 39
    - spare part numbers 18, 25, 39
  - memory test 75
  - memory/WLAN module
    - compartment 12
  - memory/WLAN module
    - compartment cover
      - illustrated 20
      - removal 39, 43
  - microphone
    - locations 5
    - product description 3
    - removal 54
    - spare part number 19, 26, 54
  - microphone jack
    - location 10
    - pin assignments 103
  - model name 1
  - modem jack
    - location 11
    - pin assignments 105
  - modem module, product description 3
  - monitor port
    - location 11
    - pin assignments 104

## N

navigating in the Setup Utility 74  
network jack  
    location 11  
    pin assignments 106  
num lock light 7

## O

operating system, product  
    description 4  
optical drive  
    location 10  
    precautions 28  
    product description 2  
    removal 44  
    spare part numbers 18, 21,  
        44  
    specifications 80, 81  
Optical Drive Bezel/Bracket Kit,  
    spare part number 18, 25, 44  
optical drive light 10

## P

packing guidelines 30  
password clearing 32  
passwords 76  
pin assignments  
    audio-in jack 103  
    audio-out jack 103  
    external monitor port 104  
    headphone jack 103  
    microphone jack 103  
    modem jack 105  
    monitor port 104  
    network jack 106  
    RJ-11 105  
    RJ-45 jack 106  
    S-Video-out 107  
    Universal Serial Bus (USB)  
        port 108  
plastic parts 27  
Plastics Kit  
    contents 20  
    spare part number 15, 20,  
        26  
pointing device components  
    horizontal scroll zone 9  
    illustrated 9  
    product description 4  
    TouchPad 9

TouchPad buttons 9  
TouchPad light 9  
TouchPad on/off button 9  
vertical scroll zone 9

## ports

external monitor 11  
monitor 11  
product description 3  
Universal Serial Bus (USB) 10,  
    11  
power button 7  
power connector 11  
power connector cable  
    removal 63  
    spare part number 16, 26,  
        63  
power cord  
    set requirements 109  
    spare part numbers 22, 23  
power light 6  
power requirements, product  
    description 4  
power-on password 76  
processor  
    product description 1  
    removal 71  
    spare part numbers 15, 24,  
        71  
processor C4 state 76  
product description  
    audio 3  
    chipset 1  
    diskette drive 3  
    display panel 2  
    docking support 3  
    Ethernet 3  
    external media cards 3  
    graphics 2  
    hard drives 2  
    keyboard 4  
    memory module 2  
    microphone 3  
    modem module 3  
    operating system 4  
    optical drives 2  
    pointing devices 4  
    ports 3  
    power requirements 4  
    processors 1  
    product name 1

security 4  
serviceability 4  
web camera 3  
wireless 3  
product name 1

## R

recovery discs 99  
recovery, system 102  
removal/replacement  
    preliminaries 27  
    procedures 33  
restore points 101  
right-side components 10  
RJ-11 jack  
    location 11  
    pin assignments 105  
RJ-45 jack  
    location 11  
    pin assignments 106  
RTC battery  
    removal 65  
    spare part number 16, 24,  
        65  
Rubber Foot Kit, spare part  
    number 16, 26

## S

S-Video-out jack  
    location 11  
    pin assignments 107  
Screw Kit  
    contents 87  
    spare part number 22, 26  
screw listing 87  
secondary hard drive self test 75  
security cable slot 10  
Security menu 76  
security, product description 4  
selecting in the Setup Utility 74  
serial number 13, 33  
service considerations 27  
serviceability, product  
    description 4  
Setup Utility  
    changing the language 73  
    Diagnostics menu 75  
    displaying system  
        information 74  
    Main menu 76

- navigating 74
- overview 73
- Security menu 76
- selecting 74
- starting 73
- System Configuration menu 76
- using advanced features 75
- speaker assembly
  - removal 59
  - spare part number 15, 26, 59
- speakers 6
- specifications
  - computer 77
  - display 78
  - DVD±RW and CD-RW Combo Drive 80, 81
  - hard drive 79
  - I/O addresses 84
  - interrupts 83
  - memory map 86
  - optical drive 80, 81
  - system DMA 82
- static-shielding materials 31
- switch cover
  - removal 46
  - spare part number 15, 26, 46
- system board
  - removal 60
  - spare part numbers 15, 25, 60
- System Configuration menu 76
- system DMA 82
- system information 74, 76
- system memory map 86

## T

- thermal material, replacement 70
- tools required 27
- top components 6
- top cover
  - removal 55
  - spare part number 15, 26, 55
- TouchPad 9
- TouchPad buttons 9
- TouchPad light 9
- TouchPad on/off button 9
- transporting guidelines 30

## U

- Universal Serial Bus (USB) port
  - location 10, 11
  - pin assignments 108
  - unknown password 32
- USB board
  - removal 57
  - spare part number 15, 26, 57

## V

- vents 11, 12
- vertical scroll zone 9
- virtualization technology 76

## W

- web camera
  - product description 3
- Windows applications key 8
- Windows logo key 8
- wireless antenna
  - disconnecting 43
  - locations 5
- Wireless Antenna Kit, spare part number 19, 26
- wireless button 6
- wireless light 6
- wireless, product description 3
- WLAN module
  - removal 41
  - spare part numbers 16, 23, 24, 41
- workstation guidelines 30



