



# HP Latex 3000 – Tips and Tricks

---

## Getting the best results with PVC banners on the HP Latex 3000

---

PVC banners are one of the most common substrates used in wide format printing. Economical and durable, they are widely used in outdoor advertising to promote products, events and exhibitions.

This document provides tips and tricks for getting the best results from the HP Latex 3000 Printer when printing on PVC-based flexible banner substrates.



Some of the common types of PVC banner are:

- **PVC frontlit banner** – also called PVC Flex banner, PVC Scrim Banner, or PVC Banner.
- **PVC backlit banner** – translucent versions, intended for retro-illumination.
- **PVC mesh banner** – small holes in the banner allow air to blow through, preventing the banner from pulling down scaffolding or fencing in high winds. See notes on Mesh Banner later in this document.
- **PVC blackout banner** – heavyweight versions, with a thick central layer that prevents the image on one side being seen from the other side. Often used for double sided printing.
- **PVC truck curtain tarpaulin** – the heaviest type of banner material, intended for heavy use and long term applications, such as truck side curtains in some countries.

Also covered in this document:

- **PVC wall coverings** – some heavy-duty wall covering materials have a top coating of PVC. This group is also covered in this document, as these substrates have similar printing requirements to the PVC Banner.

## NOT covered in this document

Although many people associate 'banners' uniquely with PVC, there are an increasing number of banner substrates made from other base materials, such as Polypropylene (PP), Polyethylene (PE), High Density Polyethylene (HDPE), Low Density Polyethylene (LDPE), Polyester (PET), Tyvek, and Textiles.

## HP Media Solutions Locator

Visit the HP Media Solutions Locator ([www.hp.com/go/mediasolutionslocator](http://www.hp.com/go/mediasolutionslocator)) to access a database of media presets and ICC profiles available for the HP Latex 3000. Use the HP database to check for media resources before printing on a new substrate, or to discover new media possibilities for the HP Latex 3000. The HP Media Solutions Locator is continuously updated with new entries, so be sure to check it regularly.

Information about type, grade and regional availability is provided for each media reference. In addition, note the *classification* level:

- **HP** – Original HP media have been designed as an integrated system with Original HP inks and HP printers for optimized performance.
- **ColorPro** – these media have been engineered with ColorPRO Technology to deliver color excellence in digital printing. For more information, refer to [www.hp.com/united-states/consumer/colorpro/learn/large-format](http://www.hp.com/united-states/consumer/colorpro/learn/large-format)
- **Certified** – certified compatibility with specified HP Latex printers and inks. Certified media testing is based on key areas such as print quality, printer-media interaction, and image processing and handling.
- Many other profiles are available in the Media Locator. Those media without a specific classification level have passed basic tests on printer compatibility and print quality but are not certified by HP.

**Note:** When using media presets and/or ICC profiles from the HP Media Solutions Locator, always check the quality and throughput they deliver before printing final jobs. You can then adjust to your specific requirements and preferences, if necessary.

## Roll weights supported

The maximum roll sizes and weights that can be loaded onto the HP Latex 3000 are:

- Maximum roll width: 3.2 m (126 in)
- Maximum roll weight: 160 kg (350 lbs)
- Maximum roll diameter: 30 cm (12 in)

Maximum roll lengths will depend on the width and grammage of the substrate. Some examples of rolls that can be supported are:

- a 150m x 3.2m roll of 340g (10 oz) Lightweight PVC Banner
- a 100m x 3.2m roll of 510g (15 oz) PVC Banner
- a 60m x 3.2m roll of 900g (26 oz) PVC Truck Curtain Tarpaulin

Always check the roll weight to ensure that the spindles and printer are not overloaded, as this can cause image quality defects and may damage the printer.

If required, dual rolls can also be used, up to a maximum roll weight of 2 x 70 kg (2 x 155 lbs) and maximum width of 2 x 1.6 m (2 x 63 in).

## Recommended solution space

When selecting a print mode to use, it is always recommended to start with one of the generic print modes offered by the printer. These generic modes have been tested on a range of media and provide an optimal balance between image quality and throughput. For reference, generic modes are shown in the table below (green boxes with white tick marks).

Although generic print modes are recommended, the printer has been designed to provide advanced operators with the flexibility to adjust and fine-tune settings, if necessary. In this case, use the preferred solution space shown below to select a working point from the range of throughput and ink density configurations. To move to a different position in the table, clone the generic PVC Banner preset or run the Add New Media Wizard (Media > Create). This will allow you to edit the newly created substrate.

PVC Banner		Ink density					
		70	80	90	100	110	120
Frontlit	2p	✓	✗	✗	✗	✗	✗
	3p	✓	✓	✓	✗	✗	✗
	4p	✓	✓	✓	✓	✓	✓
	6p	✓	✓	✓	✓	✓	✓
	8p	✓	✓	✓	✓	✓	✓

PVC Banner		Ink density					
		140	150	170	200	230	260
Backlit	10p	✓	✓	✓	✓	✓	✓
	14p	✓	✓	✓	✓	✓	✓
	18p	✓	✓	✓	✓	✓	✓

✓	available solution space substrate is compatible
✓	preferred solution space substrate is recommended
✓	generic default mode

## Recommended settings

For most conditions and materials, the following settings achieve a robust setup. These values are included in the generic print modes, and are provided here for your reference.

Media Input Tension	60 N/m
Media Output Tension	60 N/m
Vacuum	15 mmH <sub>2</sub> O
Optimizer	12%
Curing Temperature	80°C to 90°C depending on number of passes
Drying Power	50% to 75% depending on number of passes

## Media loading

It is important to load media straight and without skew – this will avoid wrinkles forming during printing, which may cause printhead smears and crashes. To load media straight, use the rules marked on the spindles to ensure that the roll is accurately centered and aligned on both the input spindle and the output spindle.

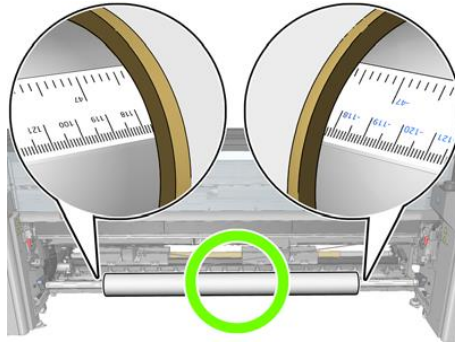

Some lower-quality rolls may be poorly wound onto the cores during manufacturing, resulting in skew and telescoping during printing. This may lead to smears and other image quality issues. The maximum tolerated skew or telescoping according to Latex 3000 printer specifications is 5mm (0.197 in).

Tips and tricks to manage such imperfections include:

- Trying to remove the telescoping by using a straight edge pushed up against the ends of the roll.
- Printing in roll-to-free fall or roll-to-collector configuration to reduce the risk of wrinkles forming during printing.
- Increasing tensions and vacuum following the table below until a suitable output is obtained. Beware that the risk of physical marks or IQ defects due to improper media advance increases when moving away from the recommended configuration.

	Vacuum	Input Tension	Output Tension
Recommended	15	60	60
Alternative i	15	60	65
Alternative ii	15	65	70
Alternative iii	25	70	75
Alternative iv	30	75	80
Alternative v	35	85	85

## Using edge holders

The substrate edge holders prevent substrate edges from lifting up and jamming while printing. There are also occasions when these are not required or not recommended.

- \* Install edge holder strips carefully and ensure that the cut-outs are aligned with the edge of the media (see diagram below). Incorrect placement may lead to wrinkles or smears, or even a carriage crash with the media edge holder.



- \* Make sure that input rolls have no skew or telescoping. Rolls with skew or telescoping can cause wrinkles or smears, as the media is likely to crash with the edge holder fixtures or leave the edge holder strip pressure zone.  
**Note:** When you use edge holders, your prints should have a minimum margin of 10 mm (0.39 in).
- \* When printing in dual roll configuration, make sure that the rolls are positioned with the correct spacing (43 mm / 1.7 in), so that a central edge holder can hold both rolls with the cut-outs correctly aligned.

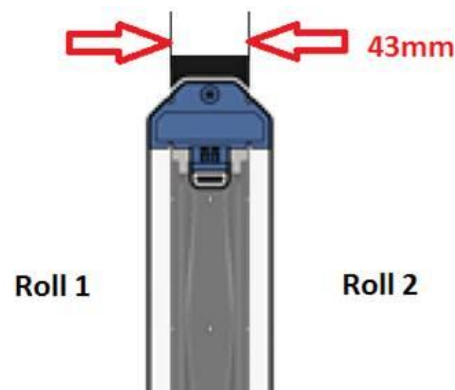

- \* Edge holders are not recommended when printing on substrates with thicknesses greater than 0.4 mm (15.7 mil) and cannot be used on substrates thicker than 0.7 mm (27.6 mil)
- \* As many PVC banners are thicker than 0.4 mm (15.7 mil), the edge holders are not required if there is no edge lifting. Substrates with widths less than 254 cm (100 in) can usually be printed without using edge holders. Otherwise, it is recommended to use them when printing on dual rolls, and when using a 320 cm (126 in) width roll in single configuration.

## Deformation of printed output

PVC Banners are a heat-sensitive substrate and tend to deform when heated. Although this is usually a temporary effect, in some materials this may lead to minor but permanent deformation, resulting in prints that do not lie completely flat.

To minimize this effect, it is recommended that the thermal energy applied during printing is reduced – this is not only relates to drying and curing temperatures, but also on the number of passes. A given temperature, a higher number of passes will expose the substrate to that temperature for a longer period (higher thermal energy is applied), consequently resulting in increased deformation.

**Note:** reducing loading tension may not reduce deformation, since it is caused by heat and not tension.

If deformation issues are observed, proceed in the following order (depending on the print mode the printer is fine-tuned for):

Throughput	Color saturation
<ol style="list-style-type: none"><li>1. Decrease curing temperature*</li><li>2. Decrease curing temperature* and ink amount</li><li>3. Decrease curing temperature* and increase number of passes</li><li>4. Decrease curing temperature* and ink amount, while increasing number of passes</li></ol>	<ol style="list-style-type: none"><li>1. Decrease curing temperature *</li><li>2. Decrease curing temperature* and increase number of passes</li></ol>

\* When decreasing temperature, always ensure that the ink is properly cured.

## Mesh banners

Printing unlined mesh banners requires an Ink Collector Kit, which will be available to purchase as an accessory from HP in 2014. Until this is available, only mesh banners with liners can be printed on the HP Latex 3000.

Printing unlined mesh banners without the Ink Collector installed will result in damage to the printer, due to ink deposits on the platen and also inside the printer.

**Note:** some mesh banners with non-woven liners can let some ink pass through. In this case, the use of an Ink Collector is also required. In order to determine if media is porous or not, refer to the procedure described in the Latex 3000 User Guide.

The perforated surface of a mesh banner usually results in the appearance of a lower color saturation than a non-perforated PVC banner printed with the same ink density. To compensate for this effect, a higher ink density may be required. In this case, the throughput should be adjusted following the recommendations in the section “Recommended Solution Space” of the User Guide.

## Poor image quality due to plasticizer migration

Some lower quality PVC banners contain high levels of plasticizer – these additives are used to increase the flexibility of the banner. Over time, the plasticizer will migrate to the surface of the banner and affect the wettability of the surface, resulting in poor print image quality – uneven distribution of the ink with severe pinholing and pronounced coalescence in homogeneous area fills.

**Note:** rolled media may also deteriorate over time, especially when exposed to high temperatures (for example during transportation and storage).

The severity of the image quality issues related to plasticizers can vary dramatically. In some cases it can be difficult to differentiate image quality issues caused by plasticizer migration from other root causes, such as poor printhead alignment or an ink level that is too high. One way to determine whether plasticizer migration is the cause of poor image quality is to clean a small portion of unprinted media with isopropyl alcohol (IPA), to remove any plasticizer, and then run a test print. If there is a significant difference in coalescence between cleaned and uncleaned areas, then the issue is very likely related to plasticizer migration.

### System parameters to minimize impact of plasticizer migration

There are three system parameters that can reduce image quality issues caused by plasticizer migration.

- |                             |    |   |
|-----------------------------|----|---|
| 1. Higher drying lamp power | -> | partially evaporates plasticizer before printing  |
| 2. Higher optimizer usage   | -> | better coalescence control                        |
| 3. Higher number of passes  | -> | multiplies the effect of the first two parameters |

All three parameters can be combined to reduce image quality issues, but in most cases they will not reach a level of 'defect free'. In cases with minor plasticizer migration, an overall image quality equivalent to an outdoor mode may be achieved adjusting only the first two parameters. In more severe cases, however, an additional reduction in throughput will be needed to achieve an image quality close to outdoor quality.

### General recommendation for substrates with confirmed image quality issues due to Plasticizer Migration:

**Minimum:**

Lamp power to 75% and Optimizer usage to 24%

**Additional:**

Number of passes +2 (4 pass to 6 pass to 8 pass)

## Display permanence

In testing performed by the HP Image Permanence Lab, outdoor prints achieved display permanence of up to three years when unlaminated, and up to five years when laminated.

Outdoor display permanence was tested according to SAE J2527, with HP Latex Inks on HP media; in a vertical display orientation in simulated nominal outdoor display conditions for selected high and low climates, including exposure to direct sunlight and water; performance may vary as environmental conditions change. Laminated display permanence was based on the use of HP Clear Gloss Cast Overlaminates. For more information, see [www.hp.com/go/supplies/printpermanence](http://www.hp.com/go/supplies/printpermanence).