



Maintenance and Service Guide

HP RP2 Retail System

© Copyright 2014, 2015 Hewlett-Packard Development Company, L.P. The information contained herein is subject to change without notice.

Microsoft and Windows are U.S. registered trademarks of the Microsoft group of companies.

The only warranties for HP products and services are set forth in the express warranty statements accompanying such products and services. Nothing herein should be construed as constituting an additional warranty. HP shall not be liable for technical or editorial errors or omissions contained herein.

This document contains proprietary information that is protected by copyright. No part of this document may be photocopied, reproduced, or translated to another language without the prior written consent of Hewlett-Packard Company.

Second Edition (March 2015)

First Edition (August 2014)

Document Part Number: 761489-002

Product notice

This guide describes features that are common to most models. Some features may not be available on your computer.

Not all features are available on all editions of Windows 8. This computer may require upgraded and/or separately purchased hardware, drivers, and/or software to take full advantage of Windows 8 functionality. See <http://www.microsoft.com> for details.

This computer may require upgraded and/or separately purchased hardware and/or a DVD drive to install the Windows 7 software and take full advantage of Windows 7 functionality. See <http://windows.microsoft.com/en-us/windows7/get-know-windows-7> for details.

Safety warning notice

⚠ WARNING! To reduce the possibility of heat-related injuries or of overheating the device, do not place the device directly on your lap or obstruct the device air vents. Use the device only on a hard, flat surface. Do not allow another hard surface, such as an adjoining optional printer, or a soft surface, such as pillows or rugs or clothing, to block airflow. Also, do not allow the AC adapter to contact the skin or a soft surface, such as pillows or rugs or clothing, during operation. The device and the AC adapter comply with the user-accessible surface temperature limits defined by the International Standard for Safety of Information Technology Equipment (IEC 60950).

Table of contents

1 Product overview	1
Product Models	1
Standard features	1
Rear components	3
Connecting a serial device	4
2 Installing and Customizing the Software	5
Installing the Windows Operating system	5
Installing or upgrading device drivers (Windows systems)	5
Customizing the monitor display (Windows systems)	5
Downloading Microsoft Windows updates	6
Accessing disk image (ISO) files	6
3 Illustrated parts catalog	7
Computer major components	7
Optional displays and USB devices	8
Cables	9
Misc parts	10
Plastic parts	11
4 Routine care, SATA drive guidelines, and disassembly preparation	12
Electrostatic discharge information	12
Generating static	12
Preventing electrostatic damage to equipment	13
Personal grounding methods and equipment	13
Grounding the work area	13
Recommended materials and equipment	14
Operating guidelines	14
Routine care	15
General cleaning safety precautions	15
Cleaning the Computer Case	15
Cleaning the monitor	15
Service considerations	15
Power supply fan	15
Tools and software Requirements	16
Screws	16

Cables and connectors	16
Hard Drives	16
Lithium coin cell battery	17
SATA hard drives	17
SATA hard drive cables	17
SATA data cable	17
SMART ATA drives	17
Cable management	18

5 Removal and replacement procedures 19

Preparation for disassembly	19
Mounting the RP2 to a wall, swing arm, or pole-mounted bracket	20
Routing cables to external devices	21
Stand feet	23
Power supply	24
Optional HP integrated USB peripheral modules	27
Front panel	31
Memory	34
DDR3-SDRAM SODIMM	34
Replacing the SODIMM	34
Hard drive	36
Battery	38
WLAN module	40
Drive connector and cables	42
Power button board	43
USB port assembly	44
Speakers	47
Touch board	49
Antennas and transceivers	50
System board	52
System board callouts	56
Display panel assembly	57

6 Configuring the software 58

Touch screen calibration	58
Calibration for Windows 7 Professional and Embedded POSReady 7	58
Calibration for Windows 8.1 Professional and Embedded 8.1 Industry Pro Retail	58
Configuring the MSR	58
Configuring powered serial ports	59

7 Computer Setup (F10) Utility	60
Computer Setup (F10) Utilities	60
Using Computer Setup (F10) Utilities	60
Computer Setup—File	62
Computer Setup—Storage	63
Computer Setup—Security	64
Computer Setup—Power	66
Computer Setup—Advanced	67
8 POST error messages	69
POST numeric codes and text messages	69
Interpreting POST diagnostic front panel LEDs and audible codes	73
9 Password security and resetting CMOS	76
Resetting the password jumper	76
Changing a Setup or Power-On password	77
Deleting a Setup or Power-On password	78
Clearing and resetting the CMOS	78
10 HP PC Hardware Diagnostics	80
Why run HP PC Hardware Diagnostics	80
How to access and run HP PC Hardware Diagnostics	80
Downloading HP PC Hardware Diagnostics (UEFI) to a USB device	80
11 System backup and recovery	82
Backing up, restoring, and recovering in Windows 8.1, Windows 8, or Industry 8.1	82
Creating recovery media and backups	82
Restoring and recovering using Windows tools	82
Using Reset when the system is not responding	83
Recovery using the Windows recovery USB flash drive	83
Recovery using Windows operating system media (purchased separately)	84
Backing up, restoring, and recovering in Windows 7 and POSReady 7	84
Creating recovery media	85
Creating recovery media using HP Recovery Manager (select models only)	85
Creating recovery discs with HP Recovery Disc Creator (select models only)	86
Creating recovery discs	86
Backing up your information	87
System Restore	87
System Recovery	88
System Recovery when Windows is responding	88

System Recovery when Windows is not responding	89
System Recovery using recovery media (select models only)	89
Using HP Recovery Disc operating system discs (select models only)	90
Appendix A Power cord set requirements	92
General requirements	92
Japanese power cord requirements	92
Country-specific requirements	93
Appendix B Specifications	94
Index	95

1 Product overview

Product Models

The HP RP2 Retail System offers 2 (two) base models which include different processors and touch technology, as identified below. For standard and optional features available on these two models, refer to [Standard features on page 1](#).

HP RP2 Retail System Models	Display	Touch Technology	Processor
Model 2000	14" Diagonal, Wide Aspect (16:9), LED-Backlit, Anti-Glare, (1366 x 768) With Bezel	5-Wire Resistive - Single Touch	Intel Quad Core J1900: Up to 2.41 GHz Max. Turbo Frequency (2.00 GHz base frequency)
Model 2020	14" Diagonal, Wide Aspect (16:9), LED-Backlit, Anti-Glare, (1366 x 768) Bezel Free	Projected Capacitive, 10 Multi-Touch	Intel Quad Core J1900: Up to 2.41 GHz Max. Turbo Frequency (2.00 GHz base frequency)
Model 2030	14" Diagonal, Wide Aspect (16:9), LED-Backlit, Anti-Glare, (1366 x 768) Bezel Free	Projected Capacitive, 10 Multi-Touch	Intel Quad Core J2900: Up to 2.66 GHz Max. Turbo Frequency (2.41 GHz base frequency)

Standard features



The HP RP2 Retail System includes the following features.

- Integrated All-in-One (AiO) form factor
- Designed for long-term deployment within general retail, hospitality, and other markets
- 14" diagonal, wide aspect (16:9) LCD Display (1366 x 768), LED-Backlit, Anti-Glare with choice of 2 (two) associate facing touch technologies:
 - 5-Wire Resistive, single-finger touch, with bezel, available with Model 2000 only
 - Projected Capacitive, 10-finger multi-touch, bezel free, available with Model 2020 and 2030 only

- Sealed and fanless unit
- Entire unit rated IP54, water and dust resistant
- VESA mounting holes (100 mm x 100 mm and 75 mm x 75 mm patterns)
- Flexible use with display tilt and height adjustments
- Optional HP peripherals:
 - MSR (single-head and dual-head models)
 - 2 x 20 LCD (complex and non-complex) customer facing display
 - 7" LCD customer facing display
 - 2D imager scanner
 - webcam
 - fingerprint reader
- Intel Quad Core processor choices
- DDR3 memory
- Operating system choices
- Integrated NIC and WiFi (some models)
- USB+PWR and cash drawer ports
- Hard drive and SSD choices
- Cable management features
- Energy Star 6 qualified, EU Compliant, RoHS2 Compliant
- 87% energy efficient internal power supply adapter
- HP Limited Warranty, 3/3/3 standard: 3 years parts, 3 years labor, and 3 years on-site services

Rear components

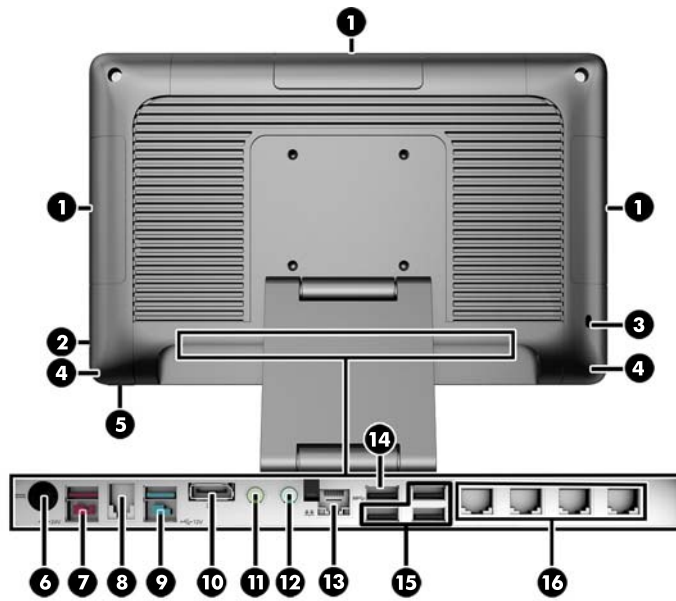

1	Optional HP Integrated USB Peripheral Modules	9	Powered USB 12V
2	Hard Drive Activity Light	10	DisplayPort (for a secondary display)
3	Security Lock Slot	11	Headset / Line-Out Connector for powered audio devices (green)
4	Integrated Speakers	12	Microphone / Line-in Audio Connector (blue)
5	Power Button	13	RJ-45 Network Connector
6	DC In Power Connector	14	USB 3.0 Port
7	Powered USB 24V	15	USB 2.0 Ports (3)
8	Cash Drawer Connector	16	RJ-50 Serial Ports (Power Configurable 5V/12V) (4)

NOTE: The 24-volt Powered USB connector and the 12-volt Powered USB connector are keyed differently as a precaution to prevent connection errors.

NOTE: The system ships with a set of plastic plugs that can be inserted into unused ports to help protect the system.

NOTE: The RP2 is shipped with the RJ-50 Serial Ports' power disabled. Enable power for each port within the HP BIOS. RJ-50 to DB9 cables are available from HP. Also refer to [Connecting a serial device on page 4](#).

NOTE: An optional DisplayPort to VGA adapter cable is available from HP.

CAUTION: The cash drawer connector is similar in size and shape to a modem jack. To avoid damage to the computer or external devices, DO NOT plug a network cable into the cash drawer connector or the RJ-50 serial port connectors.

Connecting a serial device

Some serial devices may require a DB9 connector. Available options from HP are RJ-50 to DB9 adapter cables (either 1 meter or 2 meters in length) as shown below.

 **NOTE:** The serial ports can be configured as 5V or 12V powered serial ports. Refer to [Configuring powered serial ports on page 59](#) for more information.



2 Installing and Customizing the Software

If your computer was not shipped with a Microsoft operating system, some portions of this documentation do not apply. Additional information is available in online help after you install the operating system.

 **CAUTION:** Do not add optional hardware or third-party devices to the computer until the operating system is successfully installed. Doing so may cause errors and prevent the operating system from installing properly.

Installing the Windows Operating system

The first time you turn on the computer, the operating system is installed automatically. This process takes about 5 to 10 minutes, depending on which operating system is being

 **CAUTION:** Once the automatic installation has begun, **DO NOT TURN OFF THE COMPUTER UNTIL THE PROCESS IS COMPLETE.** Turning off the computer during the installation process may damage the software that runs the computer or prevent its proper installation.

 **NOTE:** If the computer shipped with more than one operating system language on the hard drive, the installation process could take up to 60 minutes.

Installing or upgrading device drivers (Windows systems)

When installing optional hardware devices after the operating system installation is complete, you must also install the drivers for each of the devices.

If prompted for the i386 directory, replace the path specification with C:\i386, or use the Browse button in the dialog box to locate the i386 folder. This action points the operating system to the appropriate drivers.

Obtain the latest support software, including support software for the operating system, from <http://www.hp.com/support>. Select your country and language, select **Drivers & Downloads**, enter the model number of the computer, and click the Go button.

Customizing the monitor display (Windows systems)

If you wish, you can select or change the monitor model, refresh rates, screen resolution, color settings, font sizes, and power management settings.

To change display settings in Windows 7 and POSReady 7, right-click on the Windows Desktop and select Personalize.

In Windows 8.x and Industry 8.1, you can customize display settings for the Start screen and Desktop. To customize the Start screen, point to the upper-right or lower-right corner of the Start screen to display the charms. Select **Settings > Change PC Settings > Personalize** and change the display settings. To customize the Desktop, right-click on the Desktop, and then select Personalize to change the display settings.

For more information, refer to the online documentation provided with the graphics controller utility or the documentation that came with your monitor.

Downloading Microsoft Windows updates

Microsoft may release updates to the operating system. To help keep the computer running optimally, HP recommends checking for the latest updates during the initial installation and periodically throughout the life of the computer.

1. To set up your Internet connection, click **Start > Internet Explorer** and follow the instructions on the screen.
2. In Windows 7, POSReady 7, Windows XP, and POSReady 9, click **Start > All Programs > Windows Update**.

In Windows 7 and POSReady 7, the Windows Update screen appears. Click **view available updates** and make sure all critical updates are selected. Click the **Install** button and follow the instructions on the screen.

In Windows 8.x and Industry 8.1, point to the upper-right or lower-right corner of the Start screen to display the charms. Select **Settings > Change PC Settings > Windows Update** and follow the instructions on the screen.

It is recommended that you install all of the critical updates and service packs.

3. After the updates have been installed, Windows will prompt you to reboot the machine. Be sure to save any files or documents that you may have open before rebooting. Then select **Yes** to reboot the machine.
4. Run Windows Update monthly thereafter.

Accessing disk image (ISO) files

There may be disk image files (ISO files) included on your PC that contain the installation software for additional software. These CD image files are located in the folder C:\SWSetup\ISOs. Each .iso file can be burned to CD media to create an installation CD. It is recommended that these disks be created and the software installed in order to get the most from your PC.

3 Illustrated parts catalog

 **NOTE:** HP continually improves and changes product parts. For complete and current information on supported parts for your computer, go to <http://partsurfer.hp.com>, select your country or region, and then follow the on-screen instructions.

Computer major components

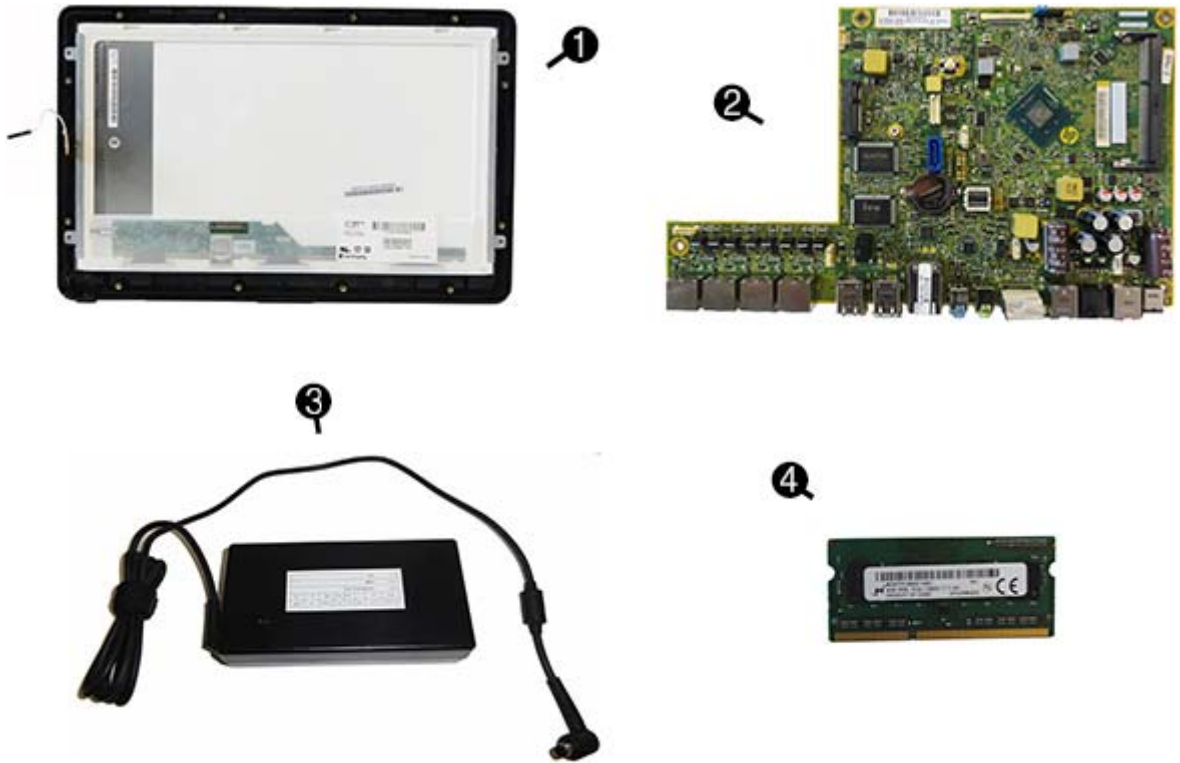

Item	Description
(1)	Display panel assembly (includes touch board that is pre-programmed to the touch glass) 5-Wire Resistive, single-finger touch panel, bezel, model 2000 only Projected Capacitive, 10-finger multi-touch, no bezel, model 2020 and 2030 only
(2)	System board (includes replacement thermal material) System board with Intel Pentium J2900 processor Windows 8.1 Windows Embedded 8.1 No Digital Product Key (DPK) System board with Intel Celeron J1900 processor

Item	Description
	Windows 8.1
	Windows Embedded 8.1
	No Digital Product Key (DPK)
(3)	Power supply , 180W; external
(4)	Memory modules (PC3,12800, CL11)
	8 GB
	4 GB

Optional displays and USB devices

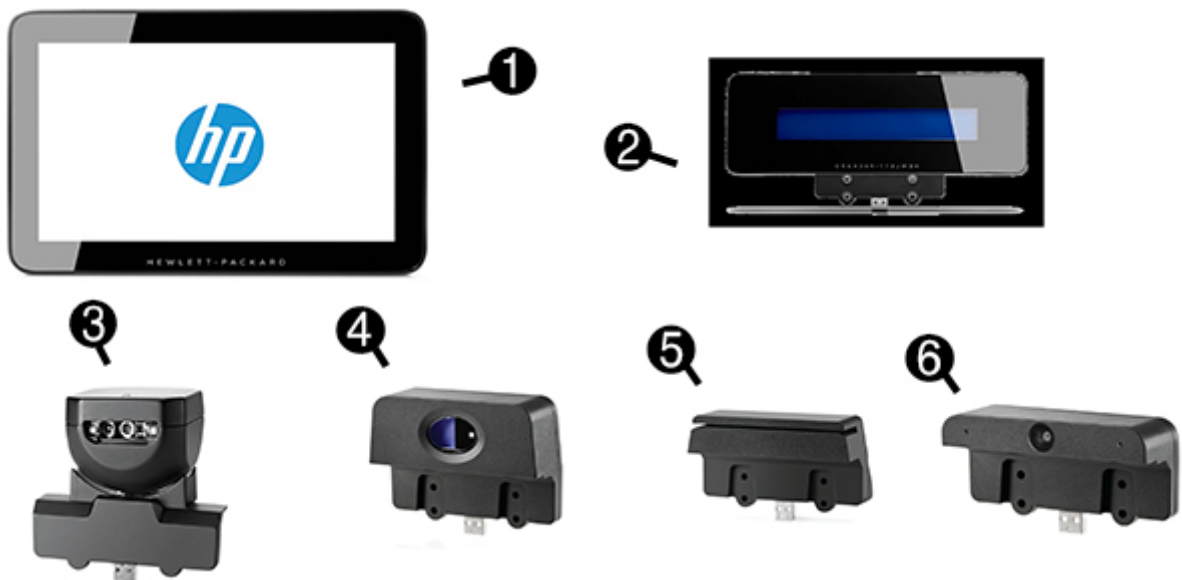

Item	Description
(1)	HP Retail Integrated 7-inch Customer Facing Display
(2)	HP Retail Integrated 2x20 Display
(3)	HP Retail Integrated Barcode Scanner
(4)	HP Retail Integrated Fingerprint Reader
(5)	HP Integrated Single-Head MSR
(6)	HP Retail Integrated Webcam

Cables

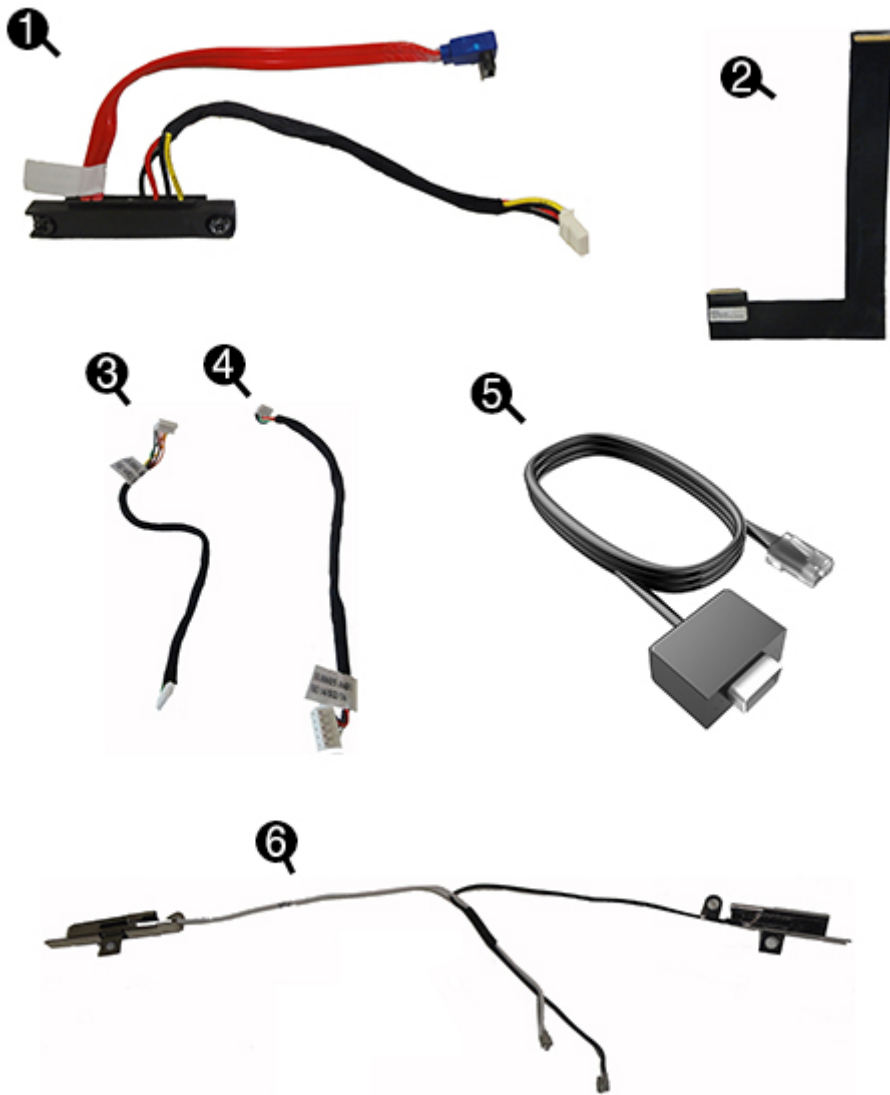

Item	Description
(1)	Hard drive connector and cable
(2)	Display (LVDS) cable
(3)	Power button board cable
(4)	Touch board cable
(5)	RJ50 to DB9 cable
	1 meter
	2 meter
(6)	Antennas and transceivers
	Adapter, DisplayPort to VGA (not illustrated)
	DisplayPort cable (not illustrated)

Misc parts

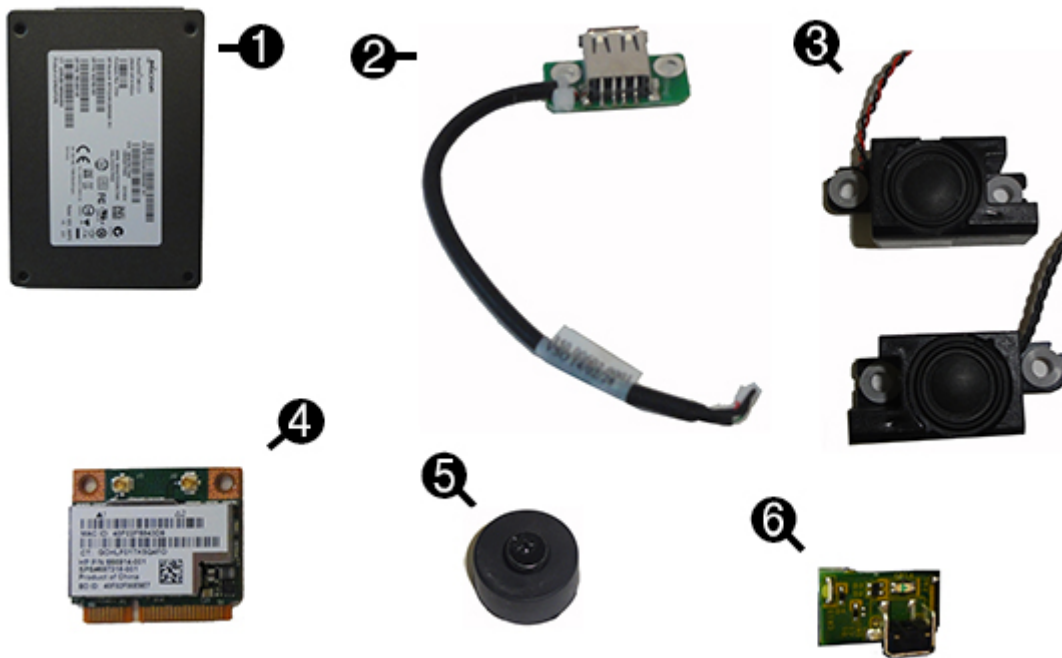

Item	Description
	Hard drives/Solid-state drives/Flash drives
	500 GB, 7200 rpm, 2.5 inch, self-encrypting (SED) (not illustrated)
	500 GB, 7200 rpm, 2.5 inch (not illustrated)
	320 GB, 7200 rpm, 2.5 inch (not illustrated)
(1)	256 GB Solid-state Drive (SSD), self-encrypting (SED)
	128 GB Solid-state Drive (SSD), self-encrypting (SED)
	64-GB, flash, MLC, 2.5-inch (not illustrated)
	32-GB, flash, MLC, 2.5-inch (not illustrated)
(2)	USB connector
(3)	Speakers
(4)	HP WLAN 802.11 a/b/g/n + Bluetooth 4.0 ()
(5)	Foot kit (includes rubber foot and screw)
(6)	Power button board
	Pad lock (not illustrated)
	Thermal pad kit (not illustrated)
	Grommet (hard drive screw, blue; not illustrated)

Plastic parts



Item	Description
(1)	Base side panel
(2)	USB assembly, plastic
(3)	Cable and I/O cover
(4)	USB cover plate
	I/O cover (not illustrated)
	Stand arm cable clip (not illustrated)

4 Routine care, SATA drive guidelines, and disassembly preparation

This chapter provides general service information for the computer. Adherence to the procedures and precautions described in this chapter is essential for proper service.

 **CAUTION:** When the computer is plugged into an AC power source, voltage is always applied to the system board. You must disconnect the power cord from the power source before opening the computer to prevent system board or component damage.

Electrostatic discharge information

A sudden discharge of static electricity from your finger or other conductor can destroy static-sensitive devices or microcircuitry. Often the spark is neither felt nor heard, but damage occurs. An electronic device exposed to electrostatic discharge (ESD) may not appear to be affected at all and can work perfectly throughout a normal cycle. The device may function normally for a while, but it has been degraded in the internal layers, reducing its life expectancy.

Networks built into many integrated circuits provide some protection, but in many cases, the discharge contains enough power to alter device parameters or melt silicon junctions.

Generating static

The following table shows that:

- Different activities generate different amounts of static electricity.
- Static electricity increases as humidity decreases.

Event	Relative Humidity		
	55%	40%	10%
Walking across carpet	7,500 V	15,000 V	35,000 V
Walking across vinyl floor	3,000 V	5,000 V	12,000 V
Motions of bench worker	400 V	800 V	6,000 V
Removing DIPs from plastic tube	400 V	700 V	2,000 V
Removing DIPs from vinyl tray	2,000 V	4,000 V	11,500 V
Removing DIPs from Styrofoam	3,500 V	5,000 V	14,500 V
Removing bubble pack from PCB	7,000 V	20,000 V	26,500 V
Packing PCBs in foam-lined box	5,000 V	11,000 V	21,000 V

These are then multi-packaged inside plastic tubes, trays, or Styrofoam.

 **NOTE:** 700 volts can degrade a product.

Preventing electrostatic damage to equipment

Many electronic components are sensitive to ESD. Circuitry design and structure determine the degree of sensitivity. The following packaging and grounding precautions are necessary to prevent damage to electric components and accessories.

- To avoid hand contact, transport products in static-safe containers such as tubes, bags, or boxes.
- Protect all electrostatic parts and assemblies with conductive or approved containers or packaging.
- Keep electrostatic sensitive parts in their containers until they arrive at static-free stations.
- Place items on a grounded surface before removing them from their container.
- Always be properly grounded when touching a sensitive component or assembly.
- Avoid contact with pins, leads, or circuitry.
- Place reusable electrostatic-sensitive parts from assemblies in protective packaging or conductive foam.

Personal grounding methods and equipment

Use the following equipment to prevent static electricity damage to equipment:

- **Wrist straps** are flexible straps with a maximum of one-megohm \pm 10% resistance in the ground cords. To provide proper ground, a strap must be worn snug against bare skin. The ground cord must be connected and fit snugly into the banana plug connector on the grounding mat or workstation.
- **Heel straps/Toe straps/Boot straps** can be used at standing workstations and are compatible with most types of shoes or boots. On conductive floors or dissipative floor mats, use them on both feet with a maximum of one-megohm \pm 10% resistance between the operator and ground.

Static Shielding Protection Levels

Method	Voltage
Antistatic plastic	1,500
Carbon-loaded plastic	7,500
Metallized laminate	15,000

Grounding the work area

To prevent static damage at the work area, use the following precautions:

- Cover the work surface with approved static-dissipative material. Provide a wrist strap connected to the work surface and properly grounded tools and equipment.
- Use static-dissipative mats, foot straps, or air ionizers to give added protection.
- Handle electrostatic sensitive components, parts, and assemblies by the case or PCB laminate. Handle them only at static-free work areas.
- Turn off power and input signals before inserting and removing connectors or test equipment.
- Use fixtures made of static-safe materials when fixtures must directly contact dissipative surfaces.
- Keep work area free of nonconductive materials such as ordinary plastic assembly aids and Styrofoam.
- Use field service tools, such as cutters, screwdrivers, and vacuums, that are conductive.

Recommended materials and equipment

Materials and equipment that are recommended for use in preventing static electricity include:

- Antistatic tape
- Antistatic smocks, aprons, or sleeve protectors
- Conductive bins and other assembly or soldering aids
- Conductive foam
- Conductive tabletop workstations with ground cord of one-megohm +/- 10% resistance
- Static-dissipative table or floor mats with hard tie to ground
- Field service kits
- Static awareness labels
- Wrist straps and footwear straps providing one-megohm +/- 10% resistance
- Material handling packages
- Conductive plastic bags
- Conductive plastic tubes
- Conductive tote boxes
- Opaque shielding bags
- Transparent metallized shielding bags
- Transparent shielding tubes

Operating guidelines

To prevent overheating and to help prolong the life of the computer:

- Keep the computer away from excessive moisture, direct sunlight, and extremes of heat and cold.
- Operate the computer on a sturdy, level surface. Leave a 10.2-cm (4-inch) clearance on all vented sides of the computer and above the monitor to permit the required airflow.
- Never restrict the airflow into the computer by blocking any vents or air intakes.
- Occasionally clean the air vents on all vented sides of the computer. Lint, dust, and other foreign matter can block the vents and limit the airflow. Be sure to unplug the computer before cleaning the air vents.
- Never operate the computer with the cover or side panel removed.
- Do not stack computers on top of each other or place computers so near each other that they are subject to each other's re-circulated or preheated air.
- If the computer is to be operated within a separate enclosure, intake and exhaust ventilation must be provided on the enclosure, and the same operating guidelines listed above will still apply.
- Keep liquids away from the computer.
- Never cover the ventilation slots on the monitor with any type of material.
- Install or enable power management functions of the operating system or other software, including sleep states.

Routine care

General cleaning safety precautions

1. Never use solvents or flammable solutions to clean the computer.
2. Never immerse any parts in water or cleaning solutions; apply any liquids to a clean cloth and then use the cloth on the component.
3. Always unplug the computer when cleaning with liquids or damp cloths.
4. Always unplug the computer before cleaning.

Cleaning the Computer Case

Follow all safety precautions in [General cleaning safety precautions on page 15](#) before cleaning the computer.

To clean the computer case, follow the procedures described below:

- To remove light stains or dirt, use plain water with a clean, lint-free cloth or swab.
- For stronger stains, use a mild dishwashing liquid diluted with water. Rinse well by wiping it with a cloth or swab dampened with clear water.
- For stubborn stains, use isopropyl (rubbing) alcohol. No rinsing is needed as the alcohol will evaporate quickly and not leave a residue.
- After cleaning, always wipe the unit with a clean, lint-free cloth.
- Occasionally clean the air vents on the computer. Lint and other foreign matter can block the vents and limit the airflow.

Cleaning the monitor

- Wipe the monitor screen with a clean cloth moistened with water or with a towelette designed for cleaning monitors. Do not use sprays or aerosols directly on the screen; the liquid may seep into the housing and damage a component. Never use solvents or flammable liquids on the monitor.
- To clean the monitor body follow the procedures in [Cleaning the Computer Case on page 15](#).

Service considerations

Listed below are some of the considerations that you should keep in mind during the disassembly and assembly of the computer.

Power supply fan

The power supply fan is a variable-speed fan based on the temperature in the power supply.

 **CAUTION:** The cooling fan is always on when the computer is in the “On” mode. The cooling fan is off when the computer is in “Standby,” “Suspend,” or “Off” modes.

You must disconnect the power cord from the power source before opening the computer to prevent system board or component damage.

Tools and software Requirements

To service the computer, you need the following:

- Torx T-15 screwdriver
- Flat-bladed screwdriver (may sometimes be used in place of the Torx screwdriver)
- Phillips #2 screwdriver
- Diagnostics software
- Tamper-resistant T-15 wrench

Screws

The screws used in the computer are not interchangeable. They may have standard or metric threads and may be of different lengths. If an incorrect screw is used during the reassembly process, it can damage the unit. HP strongly recommends that all screws removed during disassembly be kept with the part that was removed, then returned to their proper locations.

⚠ CAUTION: Metric screws have a black finish. U.S. screws have a silver finish and are used on hard drives only.

CAUTION: As each subassembly is removed from the computer, it should be placed away from the work area to prevent damage.

Cables and connectors

Most cables used throughout the unit are flat, flexible cables. These cables must be handled with care to avoid damage. Apply only the tension required to seat or unseat the cables during insertion or removal from the connector. Handle cables by the connector whenever possible. In all cases, avoid bending or twisting the cables, and ensure that the cables are routed in such a way that they cannot be caught or snagged by parts being removed or replaced.

⚠ CAUTION: When servicing this computer, ensure that cables are placed in their proper location during the reassembly process. Improper cable placement can damage the computer.

Hard Drives

Handle hard drives as delicate, precision components, avoiding all physical shock and vibration. This applies to failed drives as well as replacement spares.

- If a drive must be mailed, place the drive in a bubble-pack mailer or other suitable protective packaging and label the package “Fragile: Handle With Care.”
- Do not remove hard drives from the shipping package for storage. Keep hard drives in their protective packaging until they are actually mounted in the computer.
- Avoid dropping drives from any height onto any surface.
- If you are inserting or removing a hard drive, turn off the computer. Do not remove a hard drive while the computer is on or in standby mode.
- Before handling a drive, ensure that you are discharged of static electricity. While handling a drive, avoid touching the connector.

- Do not use excessive force when inserting a drive.
- Avoid exposing a hard drive to liquids, temperature extremes, or products that have magnetic fields such as monitors or speakers.

Lithium coin cell battery

The battery that comes with the computer provides power to the real-time clock and has a minimum lifetime of about three years.

See the appropriate removal and replacement chapter for the chassis you are working on in this guide for instructions on the replacement procedures.

⚠ WARNING! This computer contains a lithium battery. There is a risk of fire and chemical burn if the battery is handled improperly. Do not disassemble, crush, puncture, short external contacts, dispose in water or fire, or expose it to temperatures higher than 140°F (60°C). Do not attempt to recharge the battery.

📝 NOTE: Batteries, battery packs, and accumulators should not be disposed of together with the general household waste. In order to forward them to recycling or proper disposal, please use the public collection system or return them to HP, their authorized partners, or their agents.

SATA hard drives

Serial ATA Hard Drive Characteristics	
Number of pins/conductors in data cable	7/7
Number of pins in power cable	15
Maximum data cable length	39.37 in (100 cm)
Data interface voltage differential	400-700 mV
Drive voltages	3.3 V, 5 V, 12 V
Jumpers for configuring drive	N/A
Data transfer rate	6.0 Gb/s

SATA hard drive cables

SATA data cable

Always use an HP approved SATA 6.0 Gb/s cable as it is fully backwards compatible with the SATA 1.5 Gb/s drives.

Current HP desktop products ship with SATA 6.0 Gb/s hard drives.

SATA data cables are susceptible to damage if overflexed. Never crease a SATA data cable and never bend it tighter than a 30 mm (1.18 in) radius.

The SATA data cable is a thin, 7-pin cable designed to transmit data for only a single drive.

SMART ATA drives

The Self Monitoring Analysis and Recording Technology (SMART) ATA drives for the HP Personal Computers have built-in drive failure prediction that warns the user or network administrator of an impending failure or

crash of the hard drive. The SMART drive tracks fault prediction and failure indication parameters such as reallocated sector count, spin retry count, and calibration retry count. If the drive determines that a failure is imminent, it generates a fault alert.

Cable management

Always follow good cable management practices when working inside the computer.

- Keep cables away from major heat sources like the heat sink.
- Do not jam cables on top of expansion cards or memory modules. Printed circuit cards like these are not designed to take excessive pressure on them.
- Keep cables clear of sliding or moveable parts to prevent them from being cut or crimped when the parts are moved.
- When folding a flat ribbon cable, never fold to a sharp crease. Sharp creases may damage the wires.
- Some flat ribbon cables come prefolded. Never change the folds on these cables.
- Do not bend any cable sharply. A sharp bend can break the internal wires.
- Never bend a SATA data cable tighter than a 30 mm (1.18 in) radius.
- Never crease a SATA data cable.
- Do not rely on components like the drive cage, power supply, or computer cover to push cables down into the chassis. Always position the cables to lay properly by themselves.

5 Removal and replacement procedures

 **NOTE:** HP continually improves and changes product parts. For complete and current information on supported parts for your computer, go to <http://partsurfer.hp.com>, select your country or region, and then follow the on-screen instructions.

Adherence to the procedures and precautions described in this chapter is essential for proper service. After completing all necessary removal and replacement procedures, run the Diagnostics utility to verify that all components operate properly.

 **NOTE:** Not all features listed in this guide are available on all computers.

Preparation for disassembly

See [Routine care, SATA drive guidelines, and disassembly preparation on page 12](#) for initial safety procedures.

1. Remove/disengage any security devices that prohibit opening the computer.
2. Remove all removable media, such as compact discs or USB flash drives, from the computer.
3. Turn off the computer properly through the operating system, then turn off any external devices.
4. Disconnect the power cord from the power outlet and disconnect any external devices.

 **CAUTION:** Turn off the computer before disconnecting any cables.

Regardless of the power-on state, voltage is always present on the system board as long as the system is plugged into an active AC outlet. In some systems the cooling fan is on even when the computer is in the “Standby,” or “Suspend” modes. The power cord should always be disconnected before servicing a unit.

5. As applicable, lay the computer down on its side to achieve a safe working position.

 **NOTE:** During disassembly, label each cable as you remove it, noting its position and routing. Keep all screws with the units removed.

 **CAUTION:** The screws used in the computer are of different thread sizes and lengths; using the wrong screw in an application may damage the unit.

Mounting the RP2 to a wall, swing arm, or pole-mounted bracket

The RP2 can be attached to a wall, swing arm, pole-mounted bracket, or other mounting fixture. This RP2 supports the VESA industry standard 100 mm spacing between mounting holes.

 **NOTE:** There are two sets of VESA industry standard screw holes on the rear: a 75 mm x 75 mm pattern (1) and a 100 mm x 100 mm pattern (2). The stand attaches to the 75 mm x 75 mm pattern. The 100 mm x 100 mm pattern can be used to attach a mounting device, such as the HP Quick Release.

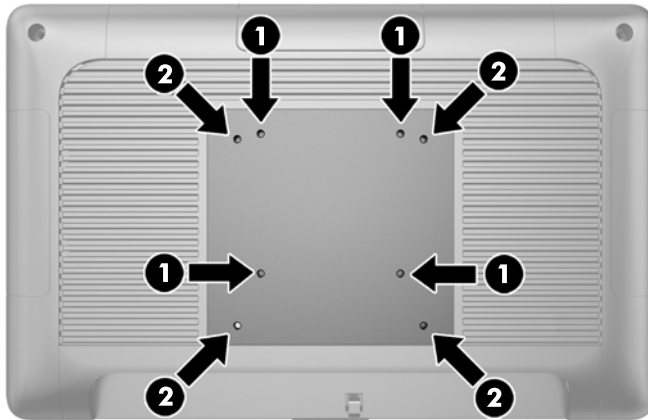

This apparatus is intended to be supported by UL or CSA Listed wall mount bracket. HP recommends that you use an HP Quick Release mounting bracket for wall mounting (part number EM870AA).

 **CAUTION:** To attach a third-party mounting solution to the RP2, four 4 mm, 0.7 pitch, and 10 mm long screws are required. Longer screws must not be used because they may damage the system. It is important to verify that the manufacturer's mounting solution is compliant with the VESA standard and is rated to support the weight of the system.

Routing cables to external devices

1. Turn off the computer properly through the operating system, then turn off any external devices.
2. Disconnect the power cord from the power outlet.

CAUTION: Regardless of the power-on state, voltage is always present on the system board as long as the system is plugged into an active AC outlet. You must disconnect the power cord to avoid damage to the internal components of the computer.

3. Push up on the bottom corners of the cable cover (1) and rotate the cover off the unit (2).

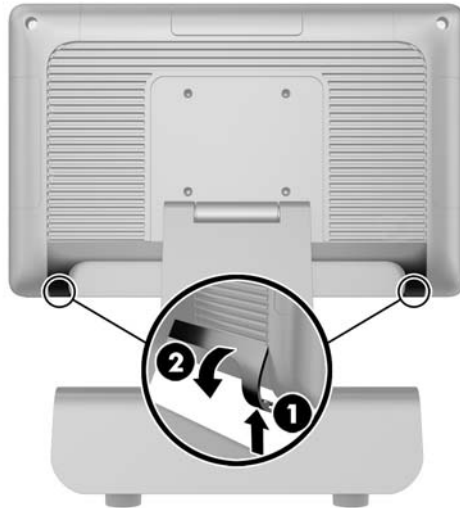

4. Connect the cables to the appropriate rear connectors.

NOTE: Tilt the display head back for easy access to the rear connectors.

5. Route the cables from the connectors on the rear panel through the hole in the center of the base (1), and then out the underside of the base (2). Secure the cables with the cable clip (3).

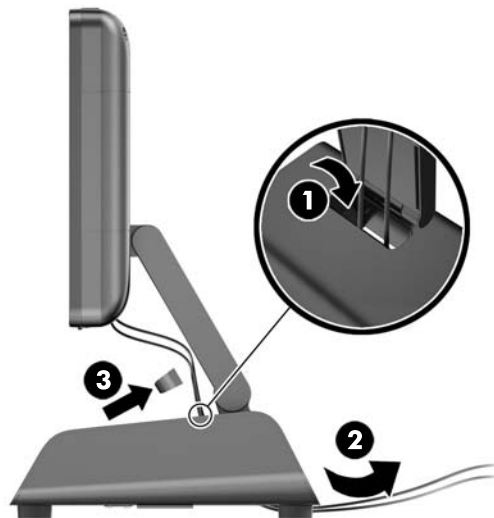

6. Insert the tabs on the top of the cable cover into the slots on the rear panel (1) and then rotate the bottom part of the cover on to secure it (2).

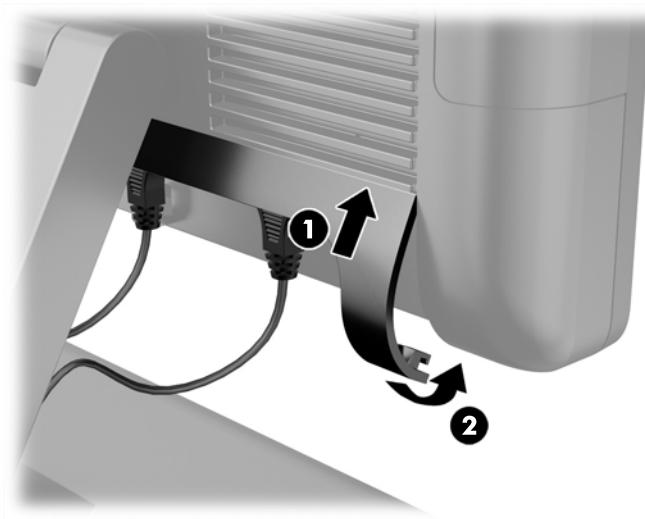

7. Reconnect the power cord and press the power button.

Stand feet

The bottom of the stand has four rubber feet. Each foot is secured to the stand with one Phillips screw.

To remove a foot from the bottom of the stand:

1. Prepare the computer for disassembly ([Preparation for disassembly on page 19](#))
2. Position the computer to allow access to the bottom of the stand.
3. Remove the Phillips screw that secures the foot to the bottom of the stand.
4. Remove the foot.



To install a foot, reverse the removal procedures.

Power supply

1. Turn off the computer properly through the operating system, then turn off any external devices.
2. Disconnect the power cord from the power outlet.

⚠ CAUTION: Regardless of the power-on state, voltage is always present on the system board as long as the system is plugged into an active AC outlet. You must disconnect the power cord to avoid damage to the internal components of the computer.

3. Unplug the DC power cable from the connector on the rear of the display head.
4. Remove the side panels from each side of the base. To do so, push up on each end of the bottom edge of the panel (1), and then pull the bottom edge of the panel off the base (2) followed by the top edge of the panel.

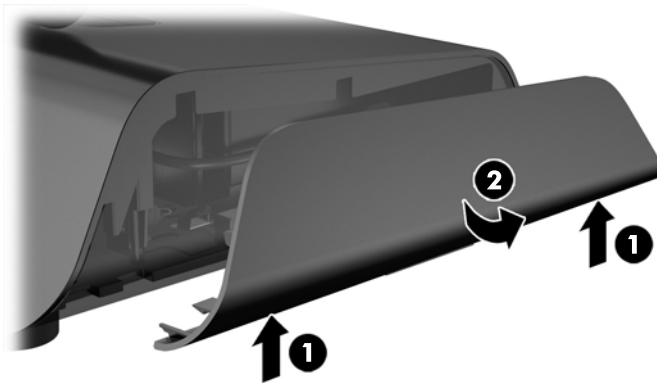

5. Unplug the AC power cord from the right side of the power supply.
6. Slide the lever on the left side of the power supply back (1) and pull the power supply out of the base (2).

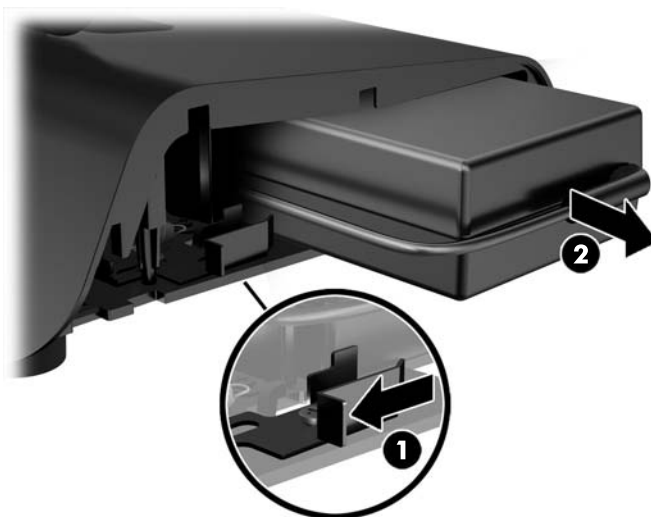

7. Slide the new power supply into the left side of the base.

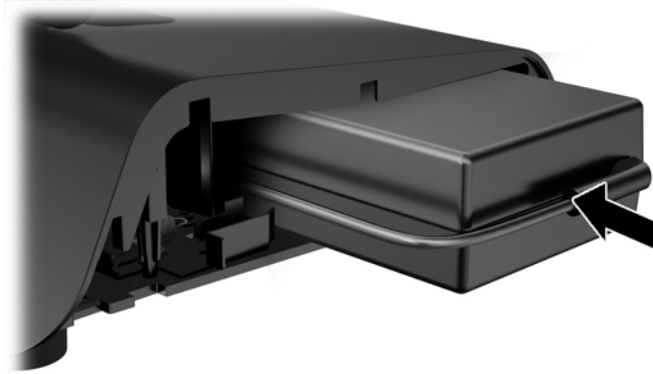

8. Connect the AC power cord to the right side of the power supply inside the base (1), insert the cord into the routing slot on the bottom edge of the base (2), and then route the cord under the base behind the foot (3) and out the rear of the base (4).

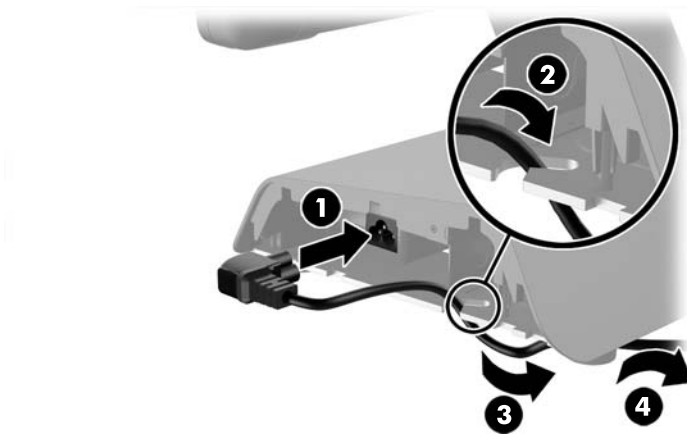

9. Route the DC cable on the left side of the base up through the hole in the center of the base and connect the cable to the DC power connector on the rear of the display head.

10. Replace the side panels on the base. To do so, insert the tabs at the bottom edge of the panel onto the base (1) then rotate the top edge of the panel onto the base (2) so that it snaps in place.

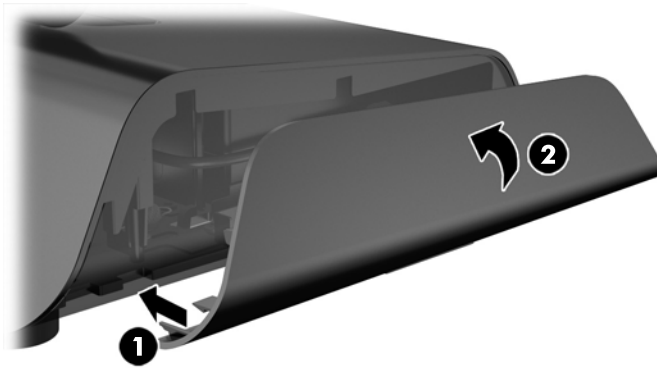



11. Connect the power cord to an electrical outlet.

Optional HP integrated USB peripheral modules

Description
HP Retail Integrated 7-inch Customer Facing Display
HP Retail Integrated 2x20 Display
HP Retail Integrated Barcode Scanner
HP Retail Integrated Fingerprint Reader
HP Integrated Single-Head MSR
HP Retail Integrated Webcam

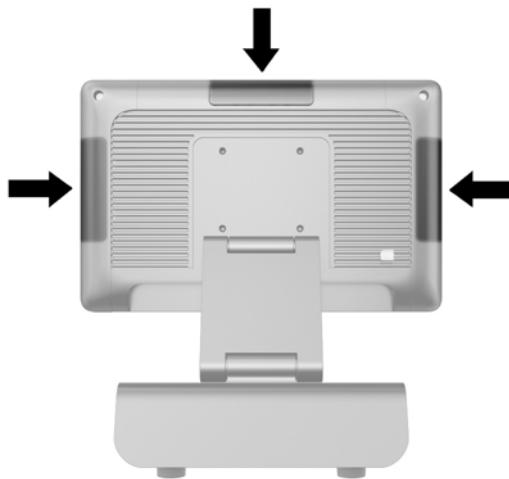
Only HP approved integrated USB peripheral modules will work with the RP2, such as the HP webcam, fingerprint reader, MSR (single-head and dual head), 2 x 20 LCD (complex and non-complex) customer facing display, 7" LCD customer facing display, and 2D imager scanner.



 **NOTE:** Do not install an HP webcam, 2 x 20 LCD (complex and non-complex) customer facing display, or a 7" LCD customer facing display on the sides of the display head. These three peripheral modules must be installed on top of the display head for proper video orientation.

 **NOTE:** Only install HP approved USB peripherals designed for these USB ports. The USB ports do not support optical drives or hard drives.

The procedure for installing an HP integrated USB peripheral module is the same for all modules. To install an HP USB peripheral module, follow the steps below.

1. Turn off the computer properly through the operating system, then turn off any external devices.
2. Disconnect the power cord from the power outlet.

 **CAUTION:** Regardless of the power-on state, voltage is always present on the system board as long as the system is plugged into an active AC outlet. You must disconnect the power cord to avoid damage to the internal components of the computer.

3. Pry off the bottom part of the USB cover plate (1) and then pull the cover plate off the unit (2).

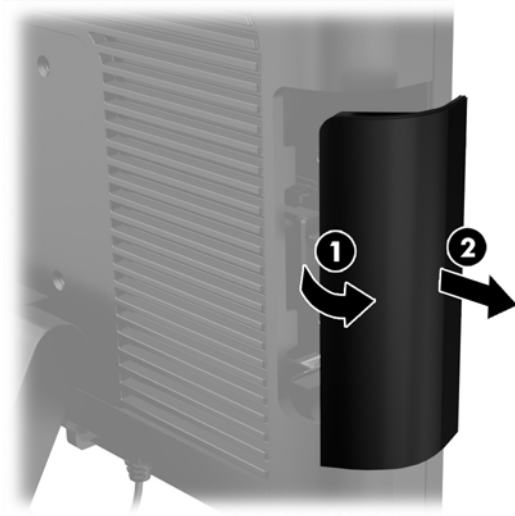

4. Pull the plug that is inserted in the USB port out of the port.

 **NOTE:** Some models do not have plugs in the USB ports.



5. Remove the two screws next to the USB port. The screws are needed to install the USB module.



6. Slide the screw hole cover plate on the module back (1) and insert the USB connector on the module into the USB port (2).



7. Install the two screws that were previously removed (1) and slide the cover plate on the module forward to cover the screws (2).

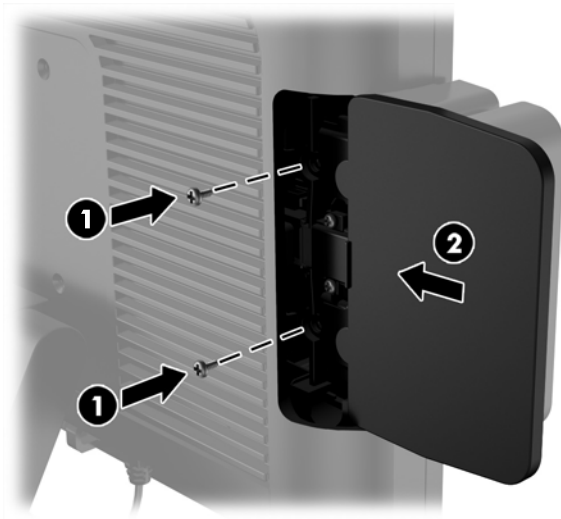

8. Reconnect the power cord and press the power button.

Front panel

To access the internal components of the computer, such as the hard drive and memory module, you must remove the front panel.

1. Push up on the bottom corners of the cable cover **(1)** and rotate the cover off the unit **(2)** to expose two of the screws that must be loosened to remove the front panel.



2. Disconnect all cables from the rear I/O connectors, including the power cord.
3. Loosen the two captive screws in the top corners of the panel and the two captive screws in the bottom corners of the panel.

 **NOTE:** The captive screws are not removable. They can only be loosened to the point that the panel is no longer secured by them.

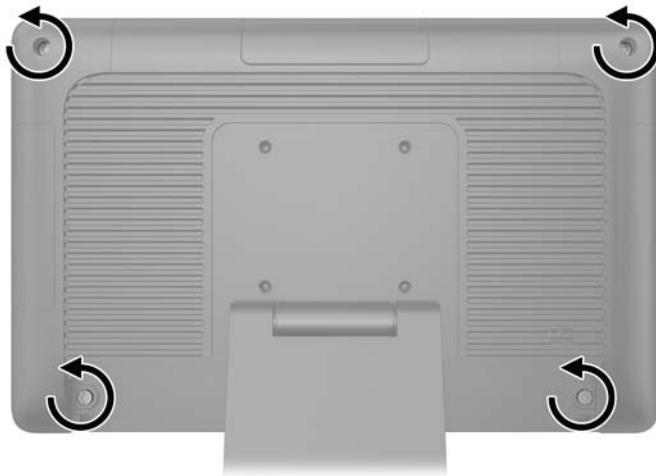

4. Rotate the display head back to the horizontal position.

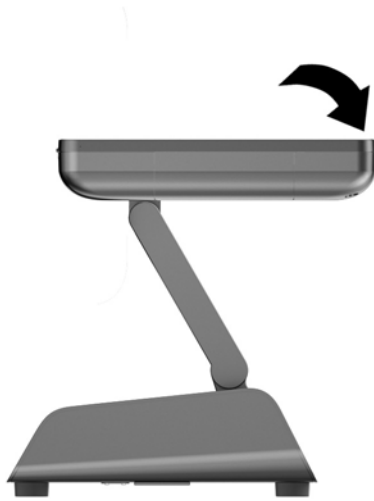

5. Lift the front panel straight up and off the rear casing.

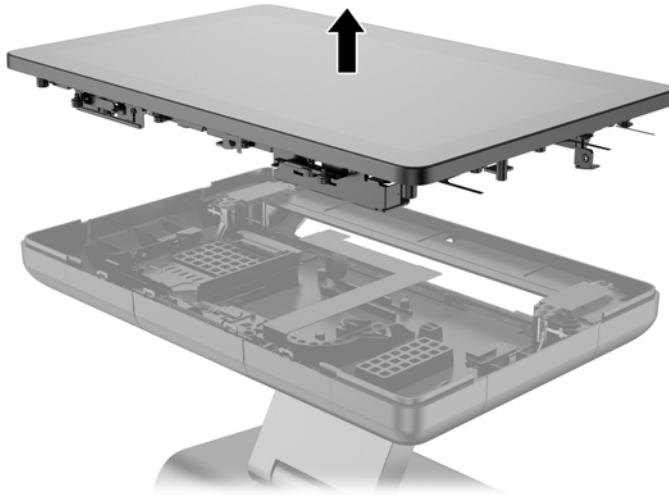

6. Use the following image to determine proper placement of thermal pads under the panel on the rear casing.

A thermal pad spare part kit is available.

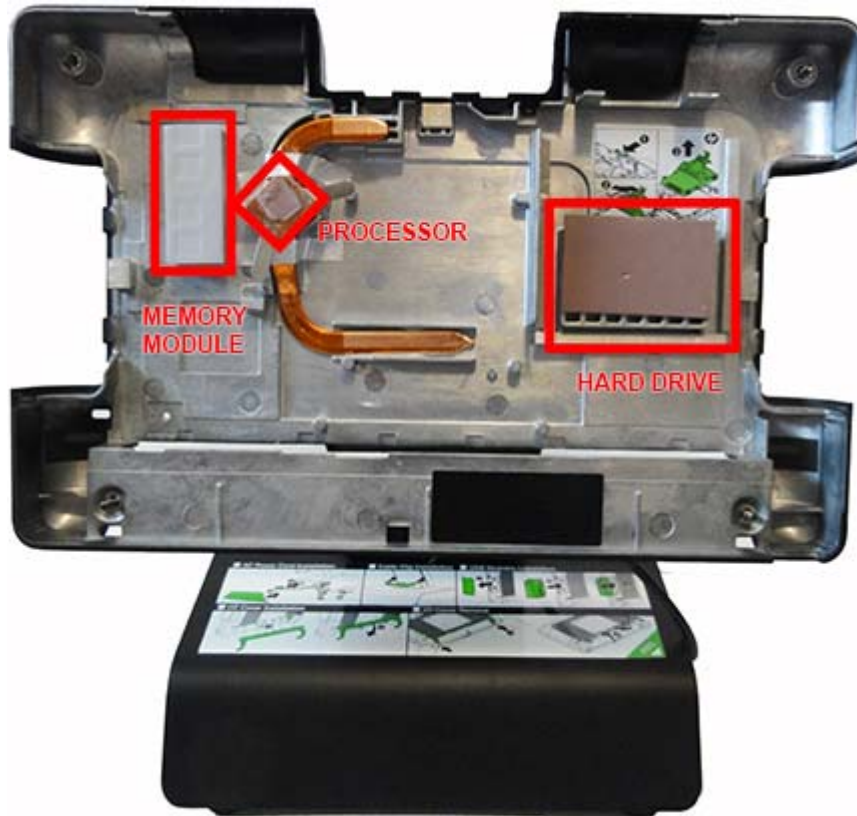

Memory

Description
8 GB (PC3,12800, CL11)
4 GB (PC3,12800, CL11)

The computer comes with one preinstalled double data rate 3 synchronous dynamic random access memory (DDR3-SDRAM) small outline dual inline memory module (SODIMM).

DDR3-SDRAM SODIMM

CAUTION: This product DOES NOT support DDR3 Ultra Low Voltage (DDR3U) memory. The processor is not compatible with DDR3U memory and if you plug DDR3U memory into the system board, it can cause the physical damage to the SODIMM or invoke system malfunction.

For proper system operation, the SODIMM must be:

- industry-standard 204-pin
- unbuffered non-ECC PC3-12800 DDR3-1600 MHz-compliant
- 1.5 volt DDR3-SDRAM SODIMM

The DDR3-SDRAM SODIMM must also:

- support CAS latency 11 DDR3 1600 MHz (11-11-11 timing)
- contain the mandatory Joint Electronic Device Engineering Council (JEDEC) specification

In addition, the computer supports:

- 512-Mbit, 1-Gbit, 2-Gbit, 4-Gbit, and 8-Gbit non-ECC memory technologies
- single-sided and double-sided SODIMMS
- SODIMMs constructed with x8 and x16 devices; SODIMMs constructed with x4 SDRAM are not supported

NOTE: The system will not operate properly if you install unsupported SODIMMs.

Replacing the SODIMM

CAUTION: You must disconnect the power cord and wait approximately 30 seconds for the power to drain before replacing the memory module. Regardless of the power-on state, voltage is always supplied to the memory module as long as the computer is plugged into an active AC outlet. Adding or removing the memory module while voltage is present may cause irreparable damage to the memory module or system board.

The memory module socket has gold-plated metal contacts. When upgrading the memory, it is important to use a memory module with gold-plated metal contacts to prevent corrosion and/or oxidation resulting from having incompatible metals in contact with each other.

Static electricity can damage the electronic components of the computer or optional cards. Before beginning these procedures, ensure that you are discharged of static electricity by briefly touching a grounded metal object.

When handling a memory module, be careful not to touch any of the contacts. Doing so may damage the module.

1. Turn off the computer properly through the operating system, then turn off any external devices.
2. Disconnect the power cord from the power outlet.

⚠ CAUTION: You must disconnect the power cord and wait approximately 30 seconds for the power to drain before replacing the memory module. Regardless of the power-on state, voltage is always supplied to the memory module as long as the computer is plugged into an active AC outlet. Adding or removing a memory module while voltage is present may cause irreparable damage to the memory module or system board.

3. Remove the front panel ([Front panel on page 31](#)).
4. To remove the SODIMM, press outward on the two latches on each side of the SODIMM **(1)** then pull the SODIMM out of the socket **(2)**.

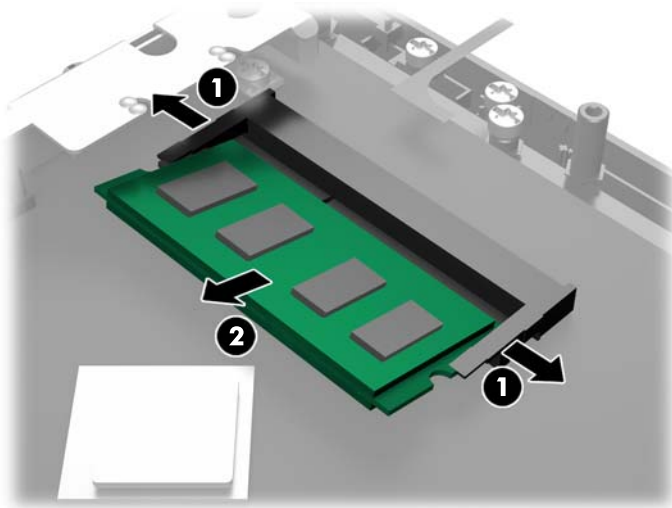

The computer automatically recognizes the additional memory when you turn on the computer.

To replace a memory module, reverse the removal procedures.

Hard drive

Description

500 GB, 7200 rpm, 2.5 inch, self-encrypting (SED)

500 GB, 7200 rpm, 2.5 inch

320 GB, 7200 rpm, 2.5 inch

256 GB Solid-state Drive (SSD), self-encrypting (SED)

128 GB Solid-state Drive (SSD), self-encrypting (SED)

64-GB, flash, MLC, 2.5-inch

32-GB, flash, MLC, 2.5-inch

⚠ CAUTION: If you are replacing a hard drive, be sure to back up the data from the old drive so that you can transfer the data to the new drive.

1. Turn off the computer properly through the operating system, then turn off any external devices.
 2. Disconnect the power cord from the power outlet.
-

⚠ CAUTION: Regardless of the power-on state, voltage is always present on the system board as long as the system is plugged into an active AC outlet. You must disconnect the power cord to avoid damage to the internal components of the computer.

3. Remove the front panel ([Front panel on page 31](#)).
 4. Press in the release latch on the left side of the hard drive carrier **(1)** and then rotate the carrier handle up **(2)**.
-

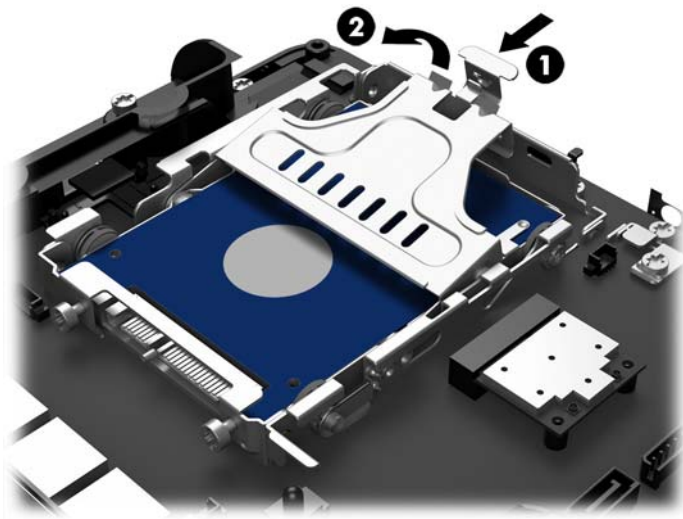

5. Lift the hard drive carrier straight up and out of the drive bay.

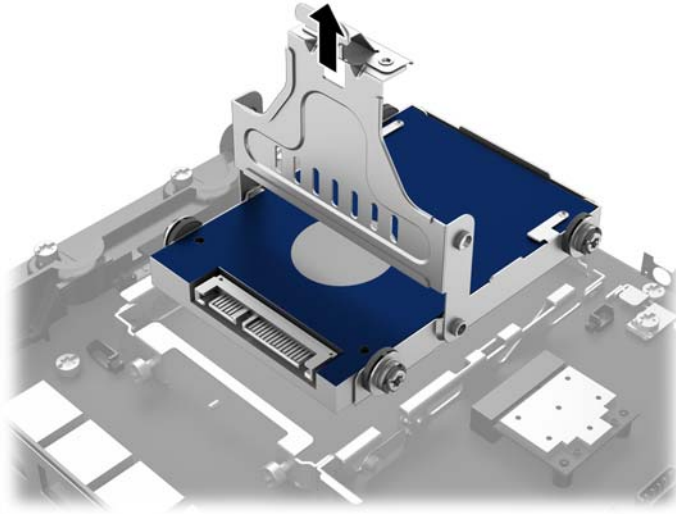

6. Remove the four grommet screws from the sides of the hard drive carrier.

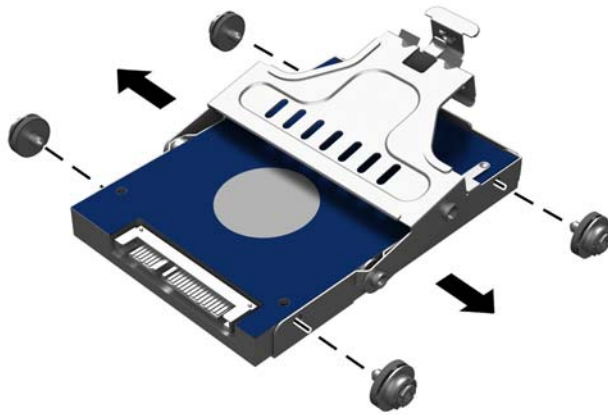

7. Slide the hard drive out of the carrier

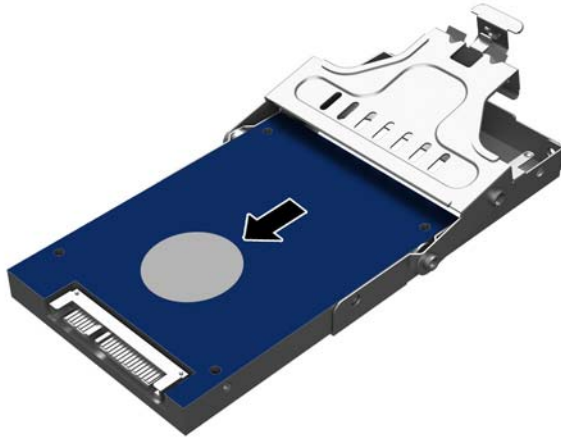

Reverse the removal procedures to install a hard drive.

When installing the hard drive assembly, make sure the thermal pad is installed on the hard drive.

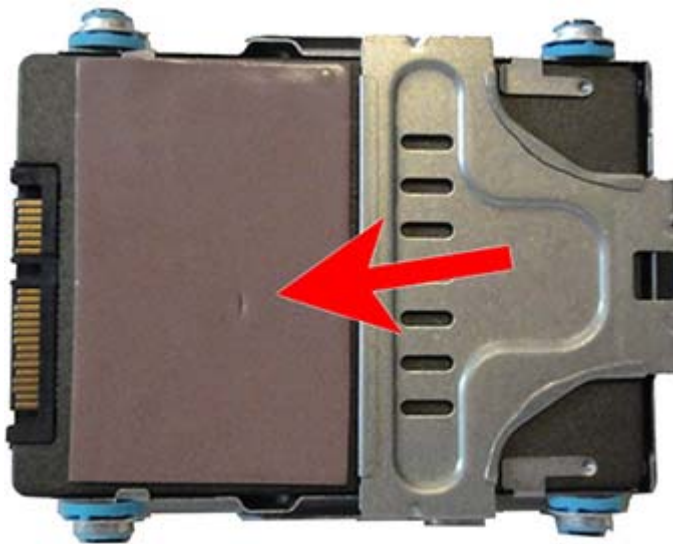

Battery

The battery that comes with the computer provides power to the real-time clock. When replacing the battery, use a battery equivalent to the battery originally installed in the computer. The computer comes with a 3-volt lithium coin cell battery.

⚠ WARNING! The computer contains an internal lithium manganese dioxide battery. There is a risk of fire and burns if the battery is not handled properly. To reduce the risk of personal injury:

Do not attempt to recharge the battery.

Do not expose to temperatures higher than 60°C (140°F).

Do not disassemble, crush, puncture, short external contacts, or dispose of in fire or water.

Replace the battery only with the HP spare designated for this product.

⚠ CAUTION: Before replacing the battery, it is important to back up the computer CMOS settings. When the battery is removed or replaced, the CMOS settings will be cleared.

Static electricity can damage the electronic components of the computer or optional equipment. Before beginning these procedures, ensure that you are discharged of static electricity by briefly touching a grounded metal object.

📝 NOTE: The lifetime of the lithium battery can be extended by plugging the computer into a live AC wall socket. The lithium battery is only used when the computer is NOT connected to AC power.

HP encourages customers to recycle used electronic hardware, HP original print cartridges, and rechargeable batteries. For more information about recycling programs, go to <http://www.hp.com/recycle>.

1. Turn off the computer properly through the operating system, then turn off any external devices.
2. Disconnect the power cord from the power outlet.

⚠ CAUTION: Regardless of the power-on state, voltage is always present on the system board as long as the system is plugged into an active AC outlet. You must disconnect the power cord to avoid damage to the internal components of the computer.

3. Remove the front panel ([Front panel on page 31](#)).
4. To release the battery from its holder, squeeze the metal clamp that extends above one edge of the battery. When the battery pops up, lift it out (1).
5. To insert the new battery, slide one edge of the replacement battery under the lip of the holder with the positive side up. Push the other edge down until the clamp snaps over the other edge of the battery (2).

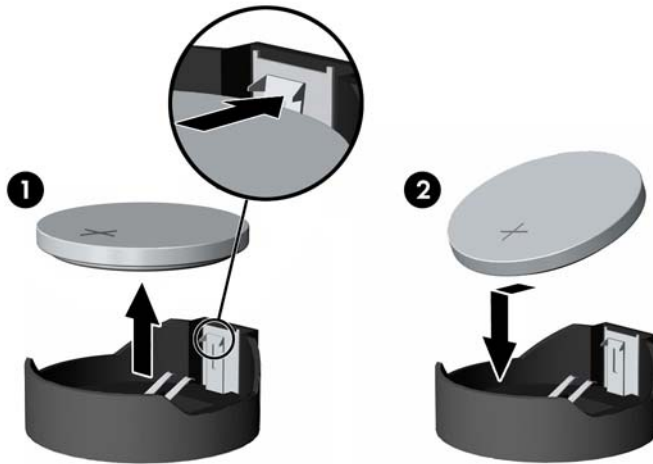

6. Replace the front panel.
7. Reconnect the power cord and press the power button.

WLAN module

The WLAN module is secured with one screw and has two connected antennas.

To remove the WLAN module:

1. Prepare the computer for disassembly ([Preparation for disassembly on page 19](#))
2. Remove the front panel ([Front panel on page 31](#)).
3. To remove a WLAN module, disconnect the antenna cables from the module **(1)**.
4. Remove the Phillips screw **(2)** that secures the module to the system board.



5. Lift the module to a 45-degree angle, and then pull it away to remove it from the socket.



To install a WLAN module, reverse the removal procedures.

Drive connector and cables

The drive connector and cables assembly is connected to the bottom of the drive cage.

1. Prepare the computer for disassembly ([Preparation for disassembly on page 19](#)).
2. Remove the front panel ([Front panel on page 31](#)).
3. Disconnect the drive data cable and drive power cable **(1)** from the system board.
4. Remove the two Torx screws that secure the connector to the drive cage **(2)**, and then remove the drive connector and cables from the computer **(3)**.

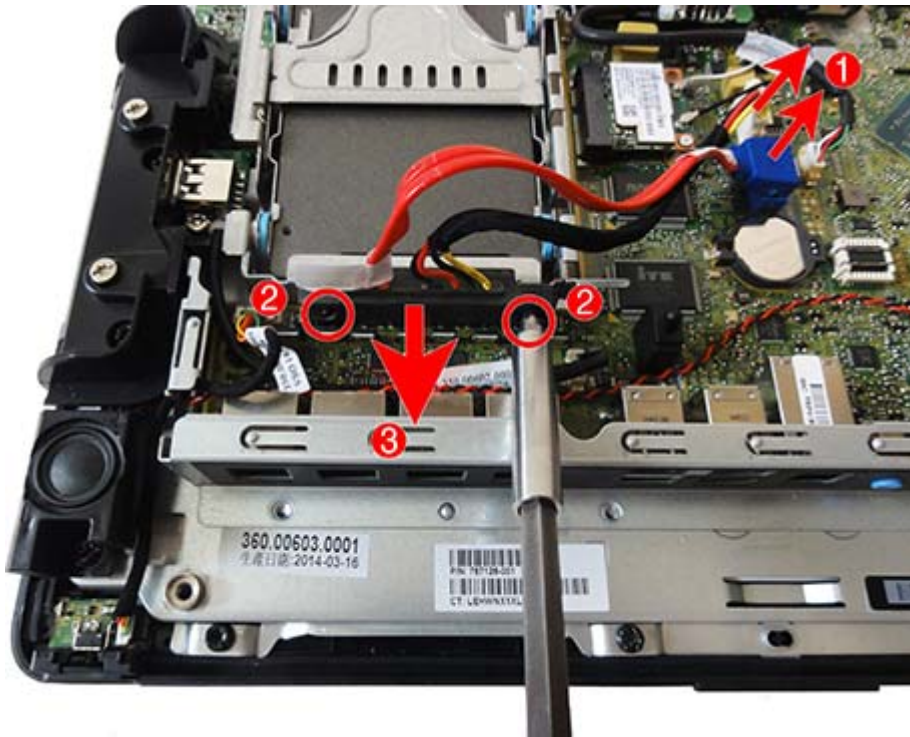

Power button board

The power button board is located at the bottom, left of the computer. A separate cable connects the power button board to the system board.

1. Prepare the computer for disassembly ([Preparation for disassembly on page 19](#)).
2. Remove the front panel ([Front panel on page 31](#)).
3. Disconnect the cable from the connector on the power button board.



4. Use a flat tool to carefully pry the board from its slot in the computer.

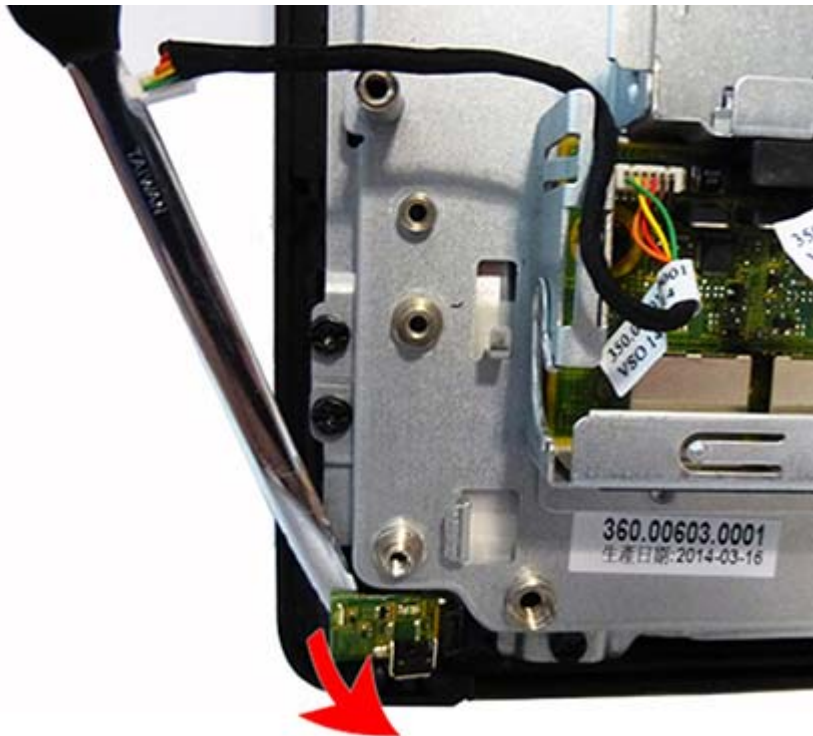

To reinstall the power button board, reverse the removal procedure.

USB port assembly

Description

USB port assembly (plastic body)

USB connector and cable

1. Prepare the computer for disassembly ([Preparation for disassembly on page 19](#)).
2. Remove the front panel ([Front panel on page 31](#)).
3. Remove the screw from the USB connector (**1**), disconnect the cable from the system board (**2**), and then remove the USB port and cable.



NOTE: Left USB connector shown. The procedure to remove the left and right USB connectors is similar.

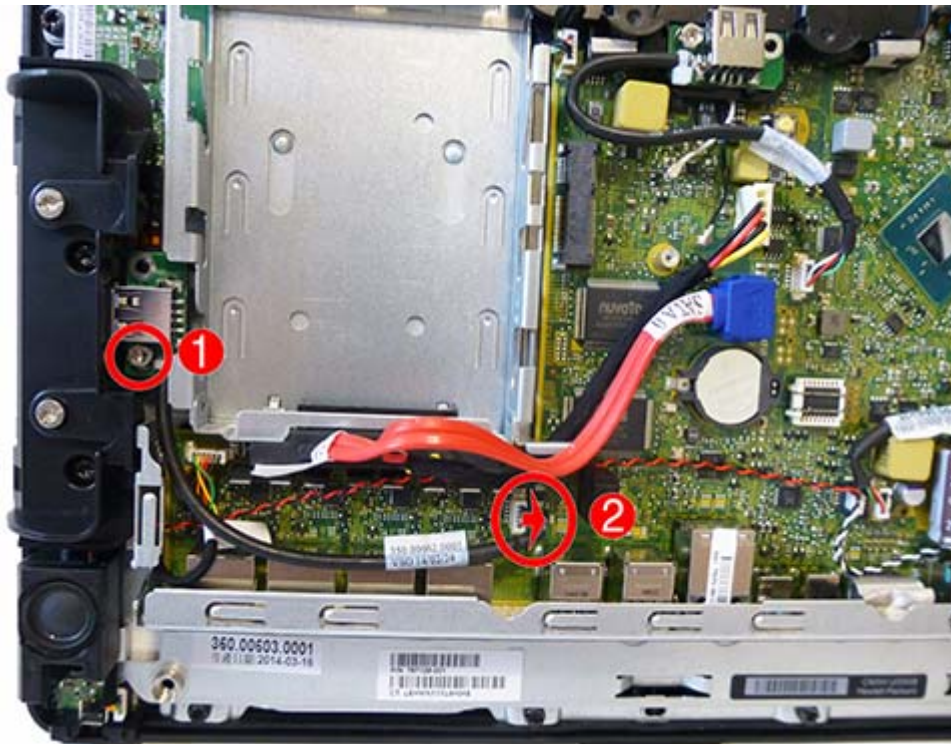

4. Remove the screws (1) from the USB assembly, and then rotate the assembly up and off the computer (2).

 **NOTE:** The screws you must remove differs depending on which USB assembly you are removing:

On the top USB assembly, you must remove only the two black screws.

On the left USB assembly, you must remove the two black screws and the bottom silver screw.

On the right USB assembly, you must remove the two black screws and the top silver screw.

If you need to remove the left top assembly:

Top USB assembly

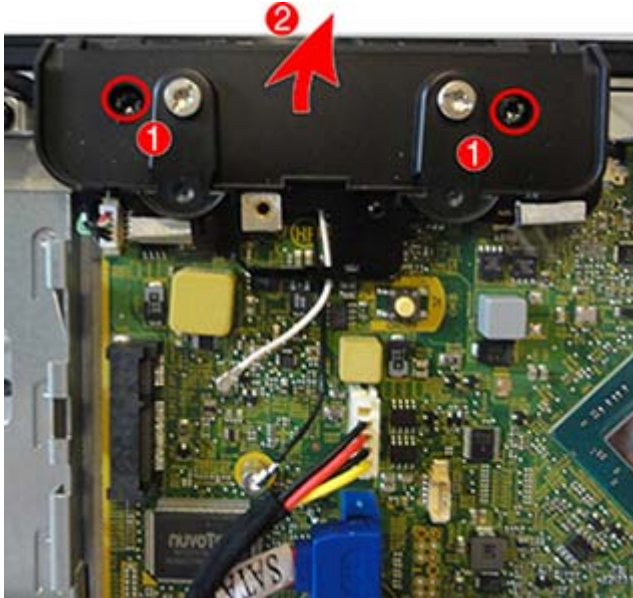

5. If you need to remove the left USB assembly:

Left USB assembly

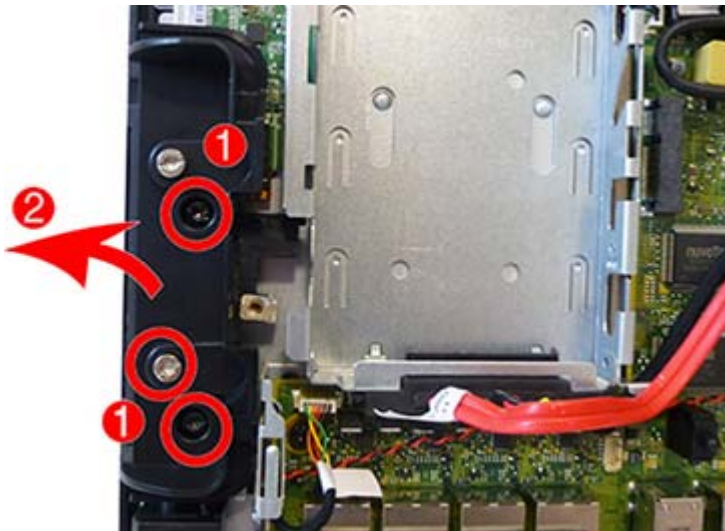

6. If you need to remove the right USB assembly:

Right USB assembly

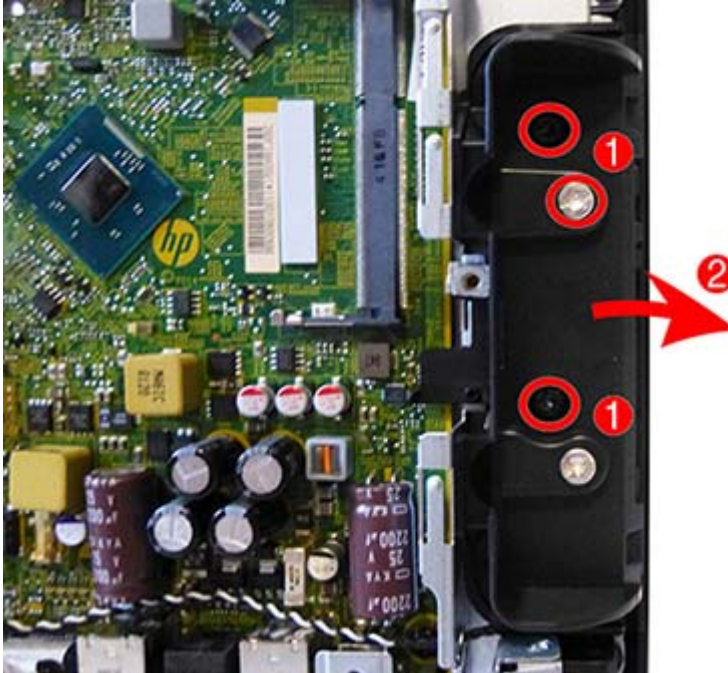

To install the USB assembly, reverse the removal procedures.

Speakers

The computer uses two speakers located on the bottom left and right sides. The speakers are wired together and plug into one connector.

1. Prepare the computer for disassembly ([Preparation for disassembly on page 19](#)).
2. Remove the front panel ([Front panel on page 31](#)).
3. Remove the left and right USB assemblies ([USB port assembly on page 44](#)).
4. Remove the two Torx screws **(1)** that secure the left speaker to the computer, and then lift the left speaker off the computer **(2)**.

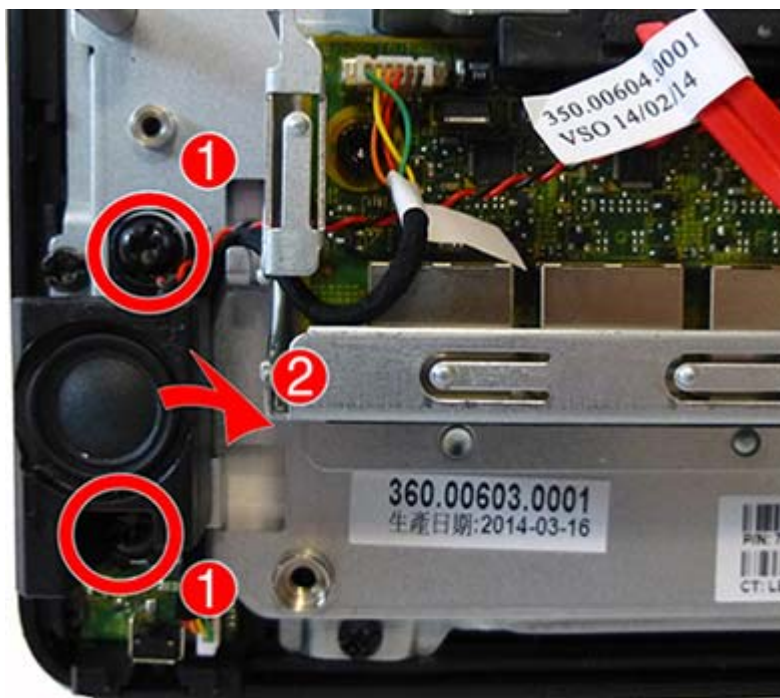

5. Remove the two Torx screws **(1)** that secure the right speaker to the computer, disconnect the speaker cable from the system board connector labeled SPKR **(2)**, and then lift the right speaker off the computer **(3)**.

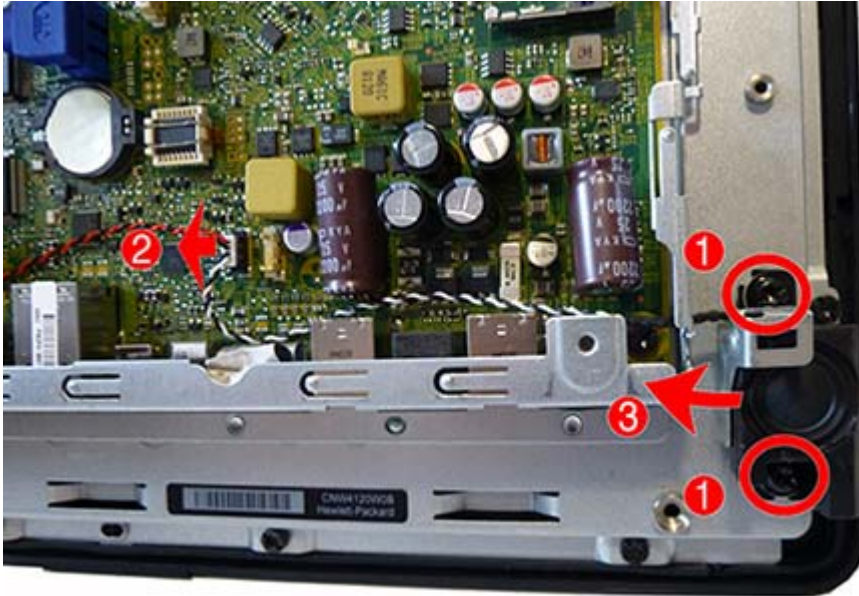

To replace the speakers, reverse the removal procedures.

Touch board

 **NOTE:** For R-touch models, the display panel assembly includes a resistive touch board that is pre-programmed to the touch glass and mounted separately to the chassis. Be sure to use the same board this is supplied with the replacement display. Do not mix and match panels and touch boards.

The touch board is not spared separately from the panel.

The touch board is located at the top, left of the computer. The touch pad connects to the system board using a separate cable.

To remove the touch board:

1. Remove the front panel ([Front panel on page 31](#)).
2. Remove the left USB assembly ([USB port assembly on page 44](#)).
3. Disconnect the cable from the top of the board (1).
4. Disconnect the cable from the bottom of the board (2).
5. Remove the two screws that secure the board to the computer (3).
6. Remove the board from the computer (4).

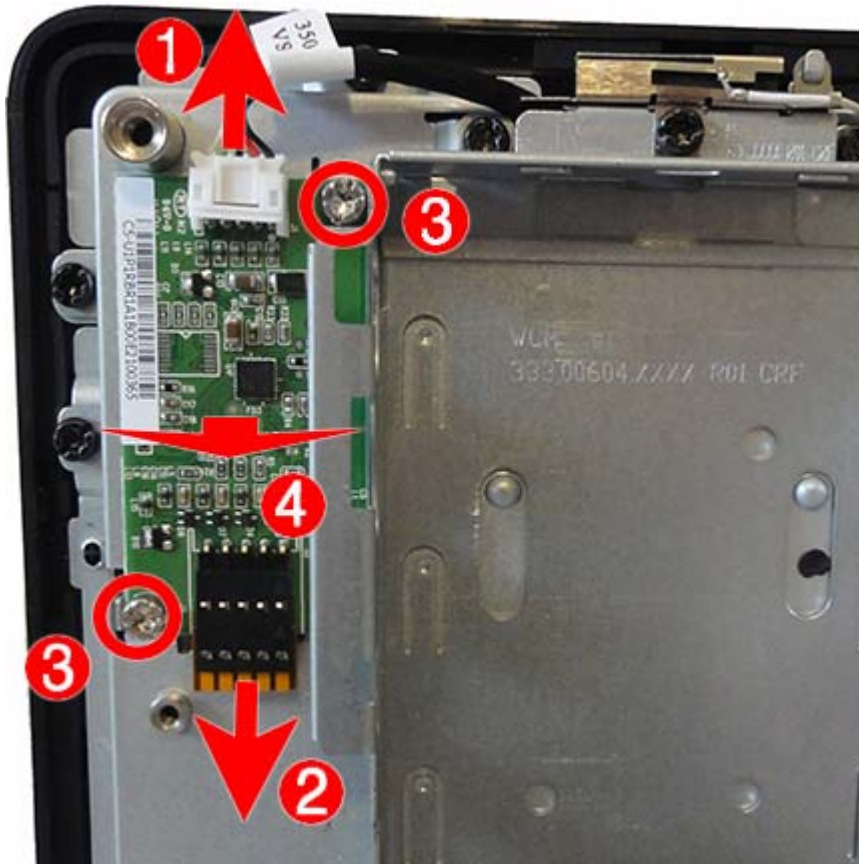

Antennas and transceivers

The wireless antennas connect from the WLAN module to transceivers at the top of the computer. Each transceiver is secured with one screw and sits atop a removable bracket.

1. Prepare the computer for disassembly ([Preparation for disassembly on page 19](#)).
2. Remove the front panel ([Front panel on page 31](#)).
3. Remove the top USB assembly ([USB port assembly on page 44](#)).
4. Remove the antenna cables from the clip near the top of the computer (**1**) that secures the assembly to the chassis.
5. Remove the two Torx screws that secure the antenna transceivers to the computer (**2**).
6. Rotate the transceivers upward (**3**) to remove them from the brackets underneath.



7. To remove the antenna brackets, rotate the top of the bracket downward, and then lift it up to remove it.



To reinstall the antennas, reverse the removal procedure.

When installing the antenna brackets, insert the tabs on the bottom of the brackets into the slots in the computer.



Be sure to install the eyelet on the transceiver onto the tab on the top of the antenna bracket.

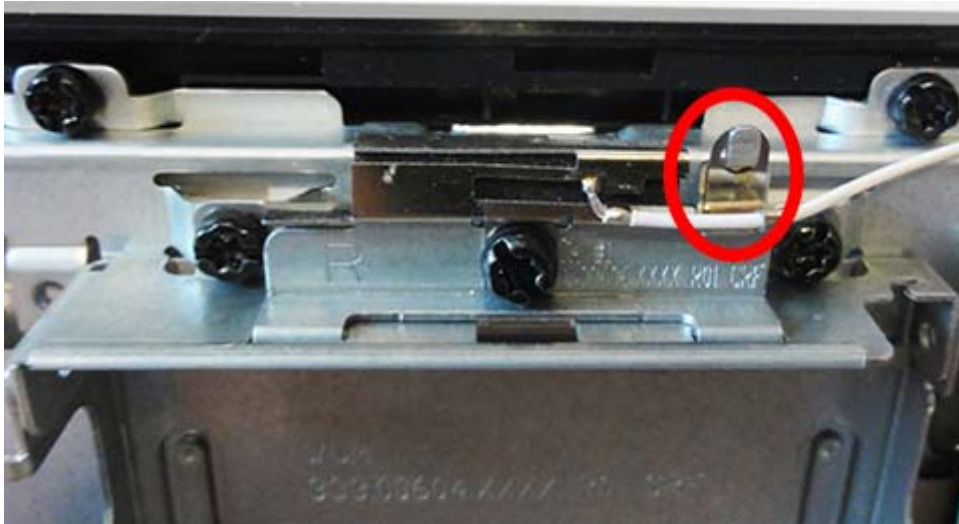

System board



NOTE: All system board spare part kits include replacement thermal material.

Description

System board with Intel Pentium J2900 processor

For use in models without Windows 8.1

For use in models with Windows 8.1 Standard

For use in models with Windows 8.1 Professional

System board with Intel Celeron J1900 processor

For use in models without Windows 8.1

For use in models with Windows 8.1 Standard

For use in models with Windows 8.1 Professional

Thermal pad kit

The system board is secured with four screws. You must remove the top USB assembly, drive cage, and the top bracket to remove the system board. Removal of the top bracket requires that you first remove the antenna transceivers.

1. Prepare the computer for disassembly ([Preparation for disassembly on page 19](#)).
2. Remove the front panel ([Front panel on page 31](#)).
3. Remove the top USB assembly ([USB port assembly on page 44](#)).
4. Remove the antennas and transceivers ([Antennas and transceivers on page 50](#)).
5. When replacing the system board, make sure the following components are removed from the defective system board and installed on the replacement system board:
 - Memory modules ([Memory on page 34](#))
 - WLAN module ([WLAN module on page 40](#))
6. Disconnect all cables connected to the system board, noting their location for reinstallation.
7. Remove the hard drive bracket:
 - a. Remove the two Torx screws **(1)** that secure the hard drive bracket to the chassis.

- b. Slide the bracket toward the top of the computer (2), and then lift it from the computer.

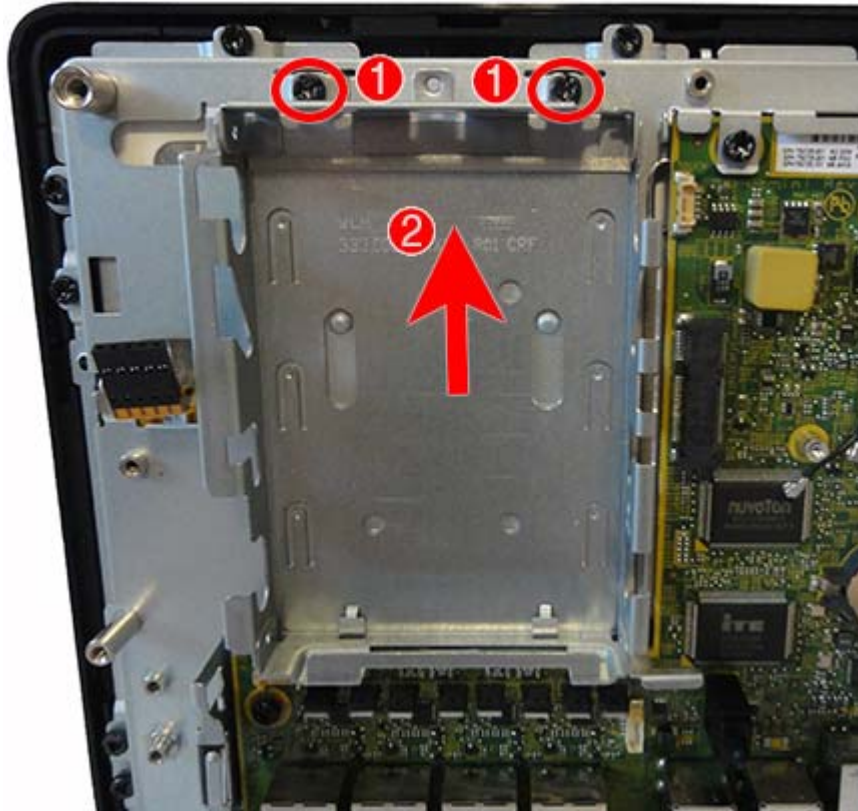

8. Remove the four Torx screws that secure the system board to the computer.

 **NOTE:** The two top system board screws also secure the top bracket.

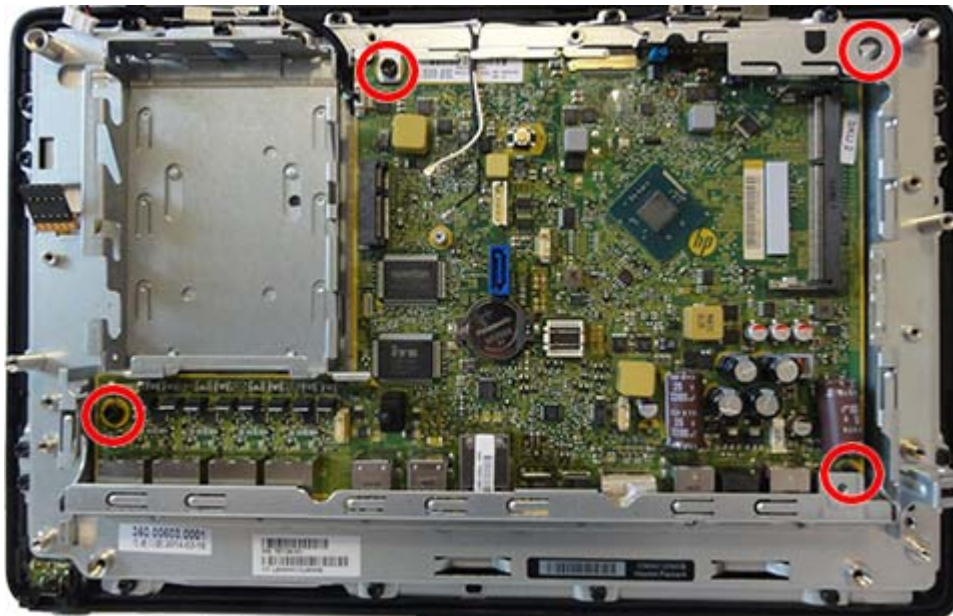

9. Rotate the top bracket up and remove it from the computer.

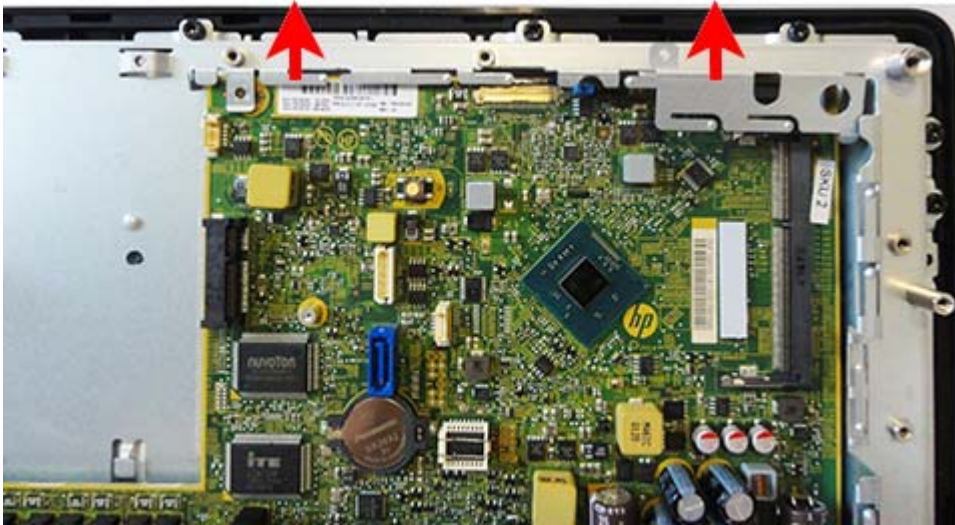

10. Lift the system board from the computer.

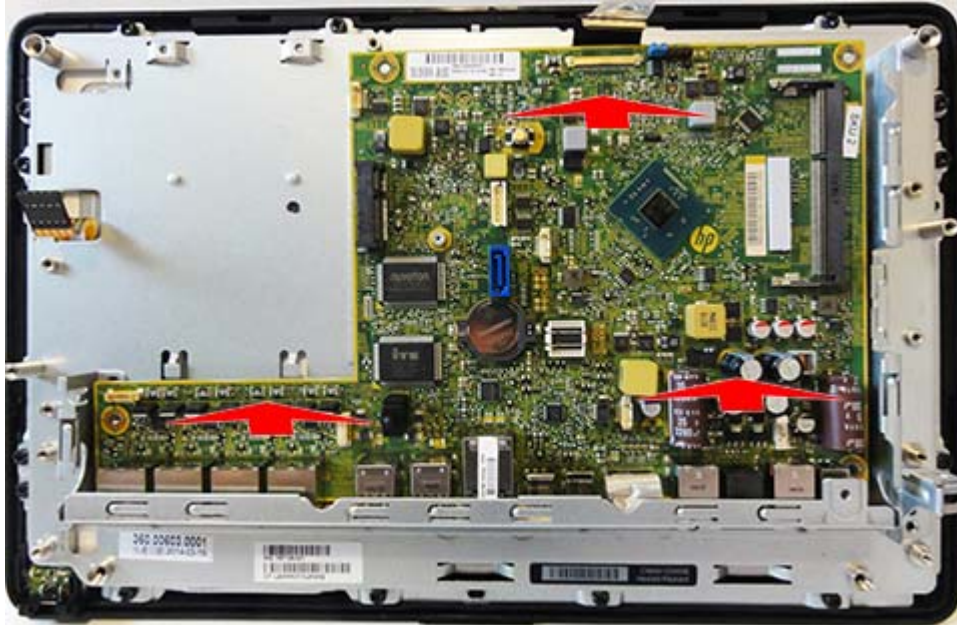

Use the following image to determine proper placement of thermal pads under the system board.

A thermal pad spare part kit is available.

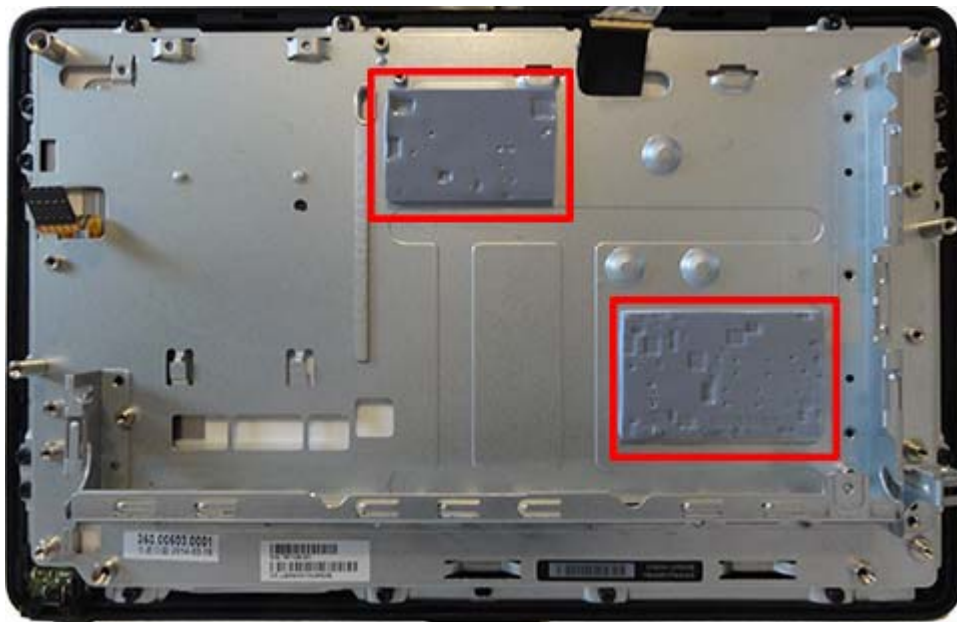

To install the system board, reverse the removal procedures.

 **NOTE:** When replacing the system board, you must change the chassis serial number in the BIOS.

System board callouts

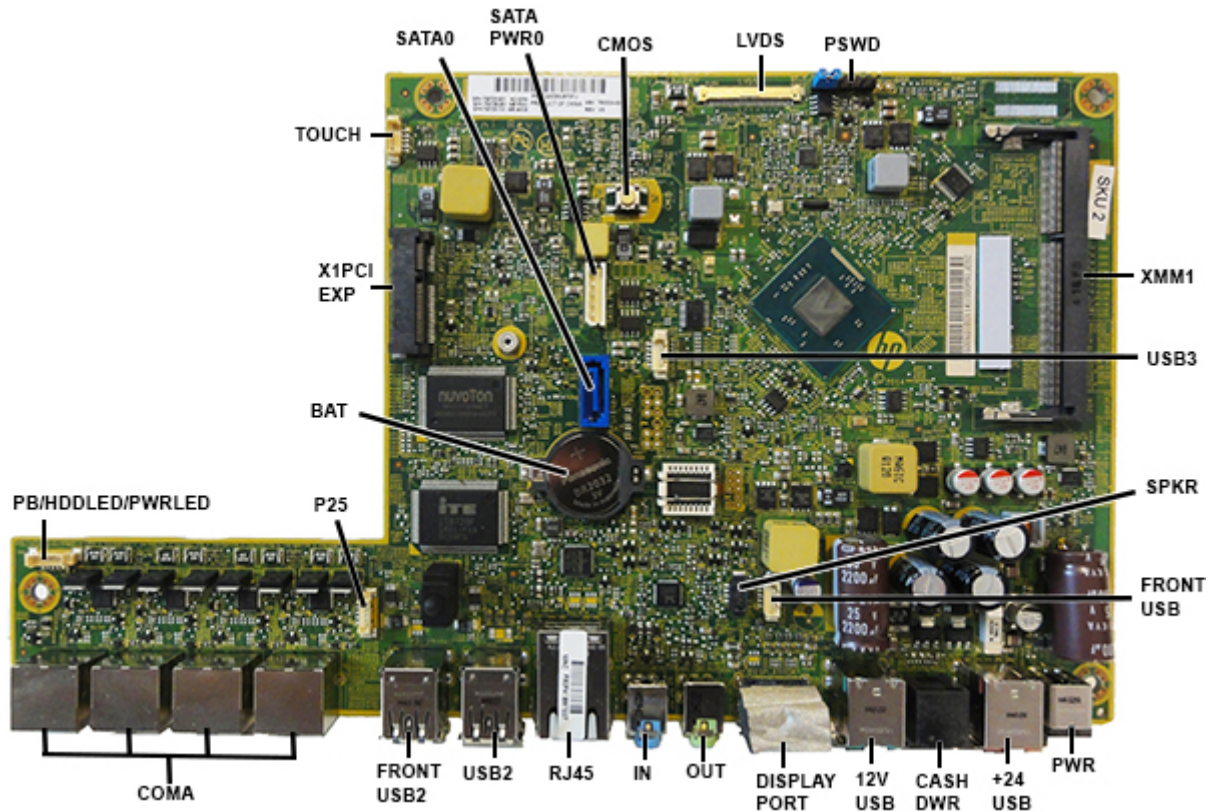

Sys Bd Label	Color	Component	Sys Bd Label	Color	Component
SATA0	Dark blue	Hard drive	12V USB	Silver	12V powered USB connector
SATAPWR0	White	Hard drive power connector	DISPLAYPORT	Silver	DisplayPort connector
CMOS	Yellow	Reset CMOS	OUT	Green	Headphone jack
LVDS	White	Display connector	IN	Blue	Microphone jack
PSWD	Blue	Clear system passwords	RJ45	Silver	Network connector
XMM1	Black	Memory module	USB2	Silver	Top: USB 3.0 connector Bottom: USB 2.0 connector
USB3	White	Top USB port	FRONT USB2	Silver	USB 2.0 connectors (2)
SPKR	White	Speaker	COMA	Black	RJ-50 serial ports
FRONT USB	White	Right USB port	PB/HDDLED/PWRLED	White	Power button board connector
PWR	Silver	External power connector	P25	White	Left USB port
+24 USB	Silver	24V powered USB connector	BAT	Black	RTC battery
CASHDWR	Black	Cash drawer connector	X1PCIEXP	Black	WLAN module

Display panel assembly

⚠ WARNING! To reduce risk of personal injury from hot surfaces, allow the internal system components to cool before touching.

1. Prepare the computer for disassembly ([Preparation for disassembly on page 19](#)).
2. Remove the front panel ([Front panel on page 31](#)).
3. Remove the USB assemblies ([USB port assembly on page 44](#)).
4. Remove the speakers ([Speakers on page 47](#)).
5. Remove the top system board bracket ([System board on page 52](#)).
6. Remove the antennas and transceivers ([Antennas and transceivers on page 50](#)).

📝 NOTE: You have to remove the antenna transceivers to move the top system board bracket. You need only to move the bracket aside when removing the display panel assembly.

7. Disconnect the cable from the touch board (1).
8. Disconnect the display cable from the system board (2).
9. Remove the 16 Torx screws (3) that secure the display panel assembly to the main computer bracket.

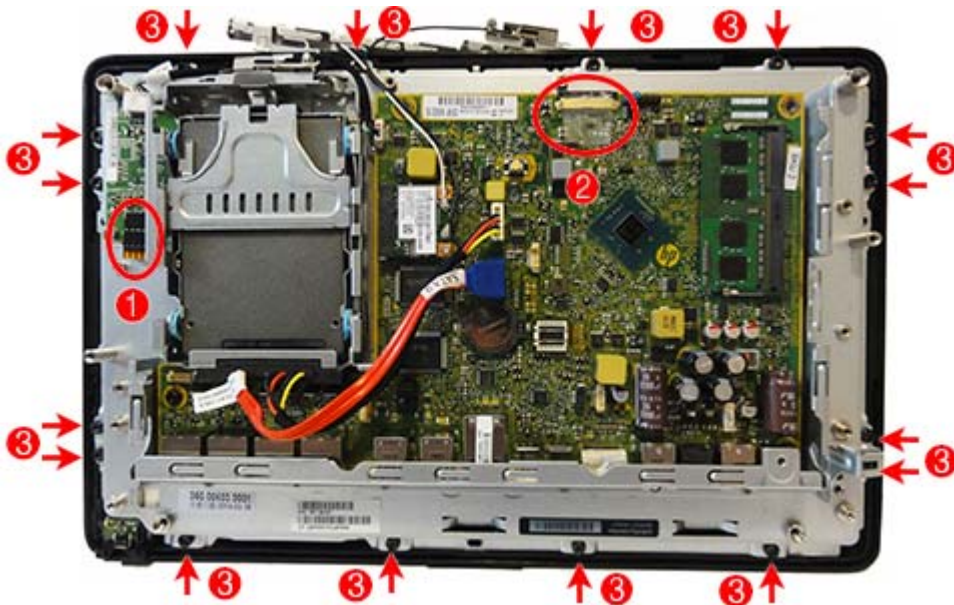

10. Lift the bracket off the display panel assembly.

📝 NOTE: For R-touch models, the display panel assembly includes a resistive touch board that is pre-programmed to the touch glass and mounted separately to the chassis. Be sure to use the same board this is supplied with the replacement display. Do not mix and match panels and touch boards.

The P-Cap board is mounted on the display panel rear side.

To replace the display panel assembly, reverse the removal procedures.

6 Configuring the software

Touch screen calibration

You do not need to install the touch driver software for Microsoft Windows 7 Professional or Embedded POSReady 7. Touch drivers are already included in those operating systems for this monitor.

HP recommends that you calibrate the touch screen before using the system to ensure that the touch point registers on the screen where the stylus or finger touches the screen. If at any time you find that the touch point is not registering properly, you may need to repeat the calibration process.

Calibration for Windows 7 Professional and Embedded POSReady 7

To calibrate the touch module in Windows 7 Professional and Embedded POSReady 7:

1. In the HP factory image, select **Start > All Programs > Load Windows Calibration Tool**, then proceed to step 2.

OR

Open the **Start** menu, tap the **Control Panel** link and type “calibrate” in the Search box. Under **Tablet PC Settings**, tap the **Calibrate the screen for pen or touch input** link. In the **Tablet PC Settings** dialog box, tap the **Calibrate** button, then proceed to step 2.

2. Follow the on-screen instructions to press the target marks on the touch screen. At the end of the calibration process, the touch module should be aligned with the video and the touch points will be accurate.

Calibration for Windows 8.1 Professional and Embedded 8.1 Industry Pro Retail

To calibrate the touch module in Windows 8.1 Professional and Embedded 8.1 Industry Pro Retail:

1. Launch the Control Panel. You can type “Control Panel” in the Search box to access it.
2. In the Control Panel type “calibrate” in the Search box. Under **Tablet PC Settings**, tap the **Calibrate the screen for pen or touch input** link. In the **Tablet PC Settings** dialog box, tap the **Calibrate** button, then proceed to step 3.
3. Follow the on-screen instructions to press the target marks on the touch screen. At the end of the calibration process, the touch module should be aligned with the video and the touch points will be accurate.

Configuring the MSR

To configure the MSR, refer to the *HP Point of Sale Configuration Guide* (available in English only). The guide is available on the system's hard drive. In Windows 7 Professional or Embedded POSReady 7, select **Start > HP Point of Sale Information** to access the guide.

Configuring powered serial ports

The serial ports can be configured as standard (non-powered) serial ports or powered serial ports. Some devices use a powered serial port. If the serial port is configured as a powered port, devices that support a powered serial interface do not require an external power source.

 **NOTE:** The computer ships with all serial ports configured in standard non-powered serial mode (0 Volts) by default.

The serial ports can be configured using the Computer F10 Setup utility. Under the **Onboard Devices** menu, you are given the option to select the following three settings for each individual serial port.

- 0 Volts
- 5 Volts
- 12 Volts

 **CAUTION:** Unplug all devices currently connected to the powered serial ports and reboot the computer before changing the serial port voltage settings in the Computer F10 Setup utility.

 **NOTE:** To access the Computer F10 Setup utility, restart the computer and press the **F10** key as soon as the HP logo screen is displayed (before the computer boots to the operating system).

7 Computer Setup (F10) Utility

Computer Setup (F10) Utilities

Use Computer Setup (F10) Utility to do the following:

- Change factory default settings.
- Set the system date and time.
- Set, view, change, or verify the system configuration, including settings for processor, graphics, memory, audio, storage, communications, and input devices.
- Modify the boot order of bootable devices such as hard drives, optical drives, or USB flash media devices.
- Establish an Ownership Tag, the text of which is displayed each time the system is turned on or restarted.
- Select Post Messages Enabled or Disabled to change the display status of Power-On Self-Test (POST) messages. Post Messages Disabled suppresses most POST messages, such as memory count, product name, and other non-error text messages. If a POST error occurs, the error is displayed regardless of the mode selected. To manually switch to Post Messages Enabled during POST, press any key (except **F1** through **F12**).
- Enter the Asset Tag or property identification number assigned by the company to this computer.
- Enable the power-on password prompt during system restarts (warm boots) as well as during power-on.
- Establish a setup password that controls access to the Computer Setup (F10) Utility and the settings described in this section.
- Secure integrated I/O functionality, including the serial, USB ports, audio, or embedded NIC, so that they cannot be used until they are unsecured.
- Enable or disable removable media boot ability.
- Solve system configuration errors detected but not automatically fixed during the Power-On Self-Test (POST).
- Replicate the system setup by saving system configuration information on a USB device and restoring it on one or more computers.
- Execute self-tests on a specified ATA hard drive (when supported by drive).

Using Computer Setup (F10) Utilities

Computer Setup can be accessed only by turning the computer on or restarting the system. To access the Computer Setup Utilities menu, complete the following steps:

1. Turn on or restart the computer.
2. Repeatedly press **F10** when the monitor light turns green to access the utility.

You can also press **Esc** to a menu that allows you to access different options available at startup, including the Computer Setup utility.

 **NOTE:** If you do not press **F10** at the appropriate time, you must restart the computer and again repeatedly press **F10** when the monitor light turns green to access the utility.

 **NOTE:** If the Computer Setup (F10) Utility is set to “fast boot”, use one of the following procedures to access Computer Setup:

- Before turning on the computer, press and hold **F10**. Turn on the computer and continue to hold **F10** until the Computer Setup (F10) Utility is displayed.
- or -
- Follow the Windows 8 instructions for rebooting the computer into the Computer Setup (F10) Utility.

-
3. A choice of five headings appears in the Computer Setup Utilities menu: File, Storage, Security, Power, and Advanced.
 4. Use the arrow (left and right) keys to select the appropriate heading. Use the arrow (up and down) keys to select the option you want, then press **Enter**. To return to the Computer Setup Utilities menu, press **Esc**.
 5. To apply and save changes, select **File > Save Changes and Exit**.
 - If you have made changes that you do not want applied, select **Ignore Changes and Exit**.
 - To reset to factory settings or previously saved default settings (some models), select **Apply Defaults and Exit**. This option will restore the original factory system defaults.

 **NOTE:** Not all settings shown in the following sections are available for all models

 **CAUTION:** Do NOT turn the computer power OFF while the BIOS is saving the Computer Setup (F10) changes because the CMOS could become corrupted. It is safe to turn off the computer only after exiting the F10 Setup screen.

Computer Setup—File



NOTE: Support for specific Computer Setup options may vary depending on the hardware configuration.

Table 7-1 Computer Setup—File

Option	Description
System Information	Lists: <ul style="list-style-type: none">• Manufacturer• Product name• SKU number• Serial number• Asset tag• Ownership tag• Born on date• System Board ID• BIOS Revision• BIOS Date• Processor type• Processor speed• Memory size• Integrated MAC
About	Displays copyright notice.
Set Time and Date	Allows you to set system time and date.
Default Setup	Save Current Settings as Default Saves the current system configuration settings as the default. Restore Factory Settings as Default Restores the factory system configuration settings as the default.
Apply Defaults and Exit	Applies the currently selected default settings and clears any established passwords.
Ignore Changes and Exit	Exits Computer Setup without applying or saving any changes.
Save Changes and Exit	Saves changes to system configuration or default settings and exits Computer Setup.

Computer Setup—Storage



NOTE: Support for specific Computer Setup options may vary depending on the hardware configuration.

Table 7-2 Computer Setup—Storage

Option	Description
Device Configuration	<p>Lists all installed BIOS-controlled storage devices.</p> <p>When a device is selected, detailed information and options are displayed. The following options may be presented:</p> <ul style="list-style-type: none"> • Hard Disk <ul style="list-style-type: none"> ◦ SATA0 - Size, model, firmware version, serial number, emulation type. ◦ USB – Size, model. • CD-ROM SATA 1: Model, firmware version, serial number. • Diskette USB: Model. <p>NOTE: Displays for USB diskette drives.</p>
Storage Options	<p>SATA Emulation</p> <p>Allows you to choose how the SATA controller and devices are accessed by the operating system. There are three supported options: IDE, RAID, and AHCI (default).</p> <p>CAUTION: SATA emulation changes may prevent access to existing hard drive data and degrade or corrupt established volumes.</p> <p>IDE - This is the most backwards-compatible setting of the options. Operating systems usually do not require additional driver support in IDE mode.</p> <p>RAID - Allows DOS and boot access to RAID volumes. Use this mode with the RAID device driver loaded in the operating system to take advantage of RAID features.</p> <p>AHCI (default option) - Allows operating systems with AHCI device drivers loaded to take advantage of more advanced features of the SATA controller.</p> <p>NOTE: The RAID/AHCI device driver must be installed prior to attempting to boot from a RAID/ AHCI volume. If you attempt to boot from a RAID/AHCI volume without the required device driver installed, the system will crash (blue screen). RAID volumes may become corrupted if they are booted to after disabling RAID.</p> <p>Removable Media Boot</p> <p>Enables/disables ability to boot the system from removable media. Default is enabled.</p>
DPS Self-Test	<p>Allows you to execute self-tests on ATA hard drives capable of performing the Drive Protection System (DPS) self-tests.</p> <p>NOTE: This selection will only appear when at least one drive capable of performing the DPS selftests is attached to the system.</p>
Boot Order (options vary based on operating system)	<p>Allows you to:</p> <ul style="list-style-type: none"> • UEFI Boot Sources: Specify the order in which EFI boot sources (such as a internal hard drive, USB hard drive, USB optical drive, or internal optical drive) are checked for a bootable operating system image. Each device on the list may be individually excluded from or included for consideration as a bootable operating system source. <p>EFI boot sources always have precedence over legacy boot sources.</p> <ul style="list-style-type: none"> • Legacy Boot Sources: Specify the order in which legacy boot sources (such as a network interface card, internal hard drive, USB optical drive, or internal optical drive) are checked for a bootable operating system image. Each device on the list may be individually excluded from or included for consideration as a bootable operating system source.

Table 7-2 Computer Setup—Storage (continued)

Specify the order of attached hard drives. The first hard drive in the order will have priority in the boot sequence and will be recognized as drive C (if any devices are attached).

NOTE: To drag a device to a preferred place, press **Enter**. To remove the device from consideration as a bootable device, press **F5**.

You can use **F5** to disable individual boot items, as well as disable EFI boot and/or legacy boot.

NOTE: MS-DOS drive lettering assignments may not apply after a non-MS-DOS operating system has started.

Shortcut to Temporarily Override Boot Order

To boot **one time** from a device other than the default device specified in Boot Order, restart the computer and press **Esc** (to access the boot menu) and then **F9** (Boot Order), or only **F9** (skipping the boot menu) when the monitor light turns green. After POST is completed, a list of bootable devices is displayed. Use the arrow keys to select the preferred bootable device and press **Enter**. The computer then boots from the selected non-default device for this one time.

Computer Setup—Security



NOTE: Support for specific Computer Setup options may vary depending on the hardware configuration.

Table 7-3 Computer Setup—Security

Option	Description
Setup Password	<p>Allows you to set and enable a setup (administrator) password.</p> <p>NOTE: If the setup password is set, it is required to change Computer Setup options, flash the ROM, and make changes to certain plug and play settings under Windows.</p> <p>NOTE: This selection will only appear when at least one drive that supports the DriveLock feature is attached to the system.</p>
Power-On Password	<p>Allows you to set and enable a power-on password. The power-on password prompt appears after a power cycle or reboot. If the user does not enter the correct power-on password, the unit will not boot.</p> <p>NOTE: This selection will only appear when at least one drive that supports the DriveLock feature is attached to the system.</p>
Password Options	<p>Allows you to enable/disable:</p> <ul style="list-style-type: none">• Lock Legacy Resources (determines whether or not Windows Device Manager is allowed to change resource settings for serial and parallel ports).• Setup Browse Mode (appears if a setup password is set) (allows viewing, but not changing, the F10 Setup Options without entering setup password). Default is enabled.• Password prompt on F9 & F12 (requires setup password to use these boot functions). Default is enabled.• Stringent security (enabling the stringent password disables the ability to reset the password by moving the jumper on the system board). Default is disabled. <p>CAUTION: If you enable the stringent security feature and you forget the setup password or the power-on password, the computer is inaccessible and can no longer be used.</p> <p>If you lose or forget the password, the system board must be replaced. This scenario is not covered under warranty.</p> <p>To prevent the computer from becoming permanently unusable, record your configured setup password or power-on password in a safe place away from your computer. Without these passwords, the computer cannot be unlocked.</p>

Table 7-3 Computer Setup—Security (continued)

Device Security (shows supported devices only)	Allows you to set Device Available/Device Hidden (default is 'Device Available') for: <ul style="list-style-type: none">• Serial Port A• Serial Port B• Serial Port C• Serial Port D• System Audio• Network Controller• SATA0
USB Security	Allows you to set Enabled/Disabled (default is Enabled) for: <ul style="list-style-type: none">• Front USB Ports• Rear USB Ports• Internal USB Ports
Slot Security	Allows you to disable the mini card slot. Default is enabled.
Network Boot	Enables/disables the computer's ability to boot from an operating system installed on a network server. (Feature available on NIC models only; the network controller must be either a PCI expansion card or embedded on the system board.) Default is enabled.
System IDs	Allows you to set: <ul style="list-style-type: none">• Product Name• Serial Number• Universal Unique Identifier (UUID) number. The UUID can only be updated if the current chassis serial number is invalid. (These ID numbers are normally set in the factory and are used to uniquely identify the system.)• SKU Number• Family Name• Asset tag (18-byte identifier), a property identification number assigned by the company to the computer.• Ownership tag (80-byte identifier) displayed during POST.• Feature Byte. The label includes spaces after every four characters. You can enter or ignore these spaces – their only purpose is to help with data entry. There is a character limitation of 40 bytes per line. When you reach this limit, go to the next line to continue data entry. BIOS ignores the spaces and lines.• Build ID• Keyboard locale setting
System Security (these options are hardware dependent)	Data Execution Prevention (enable/disable) - Helps prevent operating system security breaches. Default is enabled. Virtualization Technology (enable/disable) - Controls the virtualization features of the processor. Changing this setting requires turning the computer off and then back on. Default is disabled.
Secure Boot Configuration	<ul style="list-style-type: none">• Legacy Support—Enable/Disable. Allows you to turn off all legacy support on the computer, including booting to DOS, running legacy graphics cards, booting to legacy devices, and so on. If set to disable, legacy boot options in Storage > Boot Order are not displayed. Default is enabled.• Secure Boot—Enable/Disable. Allows you to make sure an operating system is legitimate before booting to it, making Windows resistant to malicious modification from preboot to full OS booting,

Table 7-3 Computer Setup—Security (continued)

	<p>preventing firmware attacks. UEFI and Windows Secure Boot only allow code signed by pre-approved digital certificates to run during the firmware and OS boot process. Default is disabled, except for Windows 8 systems which have this setting enabled. Secure Boot enabled also sets Legacy Support to disabled.</p> <ul style="list-style-type: none"> • Key Management—This option lets you manage the custom key settings. <ul style="list-style-type: none"> ◦ Clear Secure Boot Keys—Don't Clear/Clear. Allows you to delete any previously loaded custom boot keys. Default is Don't Clear. ◦ Key Ownership—HP Keys/Custom Keys. Selecting Custom Mode allows you to modify the contents of the secure boot signature databases and the platform key (PK) that verifies kernels during system start up, allowing you to use alternative operating systems. Selecting HP Keys causes the computer boot using the preloaded HP-specific boot keys. Default is HP Keys. • Fast Boot—Enable/Disable. Fast boot disables the ability to interrupt boot, such as pressing f keys to access items before the operating system loads. Default is enabled. <p>NOTE: If Windows 8 detects a serious error, it will interrupt the boot process automatically and display advanced boot options.</p> <p>From Windows 8, you can press Shift and select Restart to access the screen that lets you boot to a device or troubleshoot your computer.</p>
Smart Cover	<p>Allows you to:</p> <ul style="list-style-type: none"> • Set the Cover Removal Sensor to Disable/Notify User/Setup Password. <p>NOTE: <i>Notify User</i> alerts the user that the sensor has detected that the cover has been removed. <i>Setup Password</i> requires that the setup password be entered to boot the computer if the sensor detects that the cover has been removed.</p>

Computer Setup—Power



NOTE: Support for specific Computer Setup options may vary depending on the hardware configuration.

Table 7-4 Computer Setup—Power

Option	Description
OS Power Management	<ul style="list-style-type: none"> • Idle Power Savings—Extended/Normal. Allows certain operating systems to decrease the processors power consumption when the processor is idle. Default is extended. • Unique Sleep State Blink Rates—Enable/Disable. This feature is designed to provide a visual indication of what sleep state the system is in. Each sleep state has a unique blink pattern. Default is disabled. <ul style="list-style-type: none"> ◦ S0 (On) = Solid green LED. ◦ S3 (Stand By)= 3 blinks at 1Hz (50% duty cycle) followed by a pause of 2 seconds (green LED) — repeated cycles of 3 blinks and a pause. ◦ S4 (Hibernation)= 4 blinks at 1Hz (50% duty cycle) followed by a pause of 2 seconds (green LED) — repeated cycles of 4 blinks and a pause. ◦ S5 (Soft Off) = LED is off. <p>NOTE: If this feature is disabled, S4 and S5 both have the LED off. S1 (no longer supported) and S3 use 1 blink per second.</p>
Hardware Power Management	<p>PCI Express Power Management – Sets Active State Power Management (ASPM) of the bus. ASPM lets you set lower power modes that activate when the bus is not being used. Default is enabled.</p>

Table 7-4 Computer Setup—Power (continued)

S5 Maximum Power Savings – Turns off power to all nonessential hardware when system is off to meet EUP Lot 6 requirement of less than 0.5 Watt power usage. Default is disabled.

S5 Wake on LAN – Enables or disables remotely waking up the computer from S5 (power is off) power state. Default is disabled.

Computer Setup—Advanced



NOTE: Support for specific Computer Setup options may vary depending on the hardware configuration.

Table 7-5 Computer Setup—Advanced (for advanced users)

Option	Heading
Power-On Options	<p>Allows you to set:</p> <ul style="list-style-type: none">• POST messages (enable/disable). Enabling this feature will cause the system to display POST error messages, which are error messages displayed on the monitor during the Power On Self Test if the BIOS encounters some kind of problem while starting the PC. A POST error message will only display on screen if the computer is capable of booting this far. If the POST detects an error before this point, a beep code is generated instead. Default is disabled.• After Power Loss (off/on/previous state). Default is Power off. Setting this option to:<ul style="list-style-type: none">◦ Power off—causes the computer to remain powered off when power is restored.◦ Power on—causes the computer to power on automatically as soon as power is restored.◦ Previous state—causes the computer to power on automatically as soon as power is restored, if it was on when power was lost. <p>NOTE: If you turn off power to the computer using the switch on a power strip, you will not be able to use the suspend/sleep feature or the Remote Management features.</p> <ul style="list-style-type: none">• Remote Wakeup Boot Source (remote server/local hard drive). Default is Local hard drive.• Bypass F1 Prompt on Configuration Changes (Enable/Disable). Allows you to set the computer not to confirm when changes were made. Default is disabled.• POST Delay (in seconds). Enabling this feature will add a user-specified delay to the POST process. This delay is sometimes needed for hard disks on some PCI cards that spin up very slowly, so slowly that they are not ready to boot by the time POST is finished. The POST delay also gives you more time to select F10 to enter Computer (F10) Setup. Default is None.
BIOS Power-On	<p>Allows you to set the computer to turn on automatically at a time you specify.</p>
Onboard Devices	<ul style="list-style-type: none">• Allows you to set resources for or disable Legacy devices.• Allows to you change voltage settings for powered serial ports A - D. Available voltage settings are:<ul style="list-style-type: none">◦ 0v (default)◦ +5v◦ +12v
Bus Options	<p>Allows you to enable or disable:</p> <ul style="list-style-type: none">• PCI SERR# Generation. Default is enabled.
Device Options	<p>Allows you to set:</p> <ul style="list-style-type: none">• Num Lock State at Power-On (off/on). Default is 'on'.

Table 7-5 Computer Setup—Advanced (for advanced users) (continued)

	<ul style="list-style-type: none">• Turbo Mode (enable/disable). Allows you to enable and disable the Intel Turbo Mode feature, which allows one core of the system to run at a higher than standard frequency and power if other cores are idle. Default is enabled.• Cash Drawer Port (enable/disable). Default is 'Enable'.• USB EHCI Port Debug (enable/disable). Default is 'Disable'.• Internal Speaker (some models) (does not affect external speakers). Default is enabled.• NIC PXE Option ROM Download (enable/disable). Default is 'Enable'.
PCI Graphics Configuration	Lists all video devices installed in the system.

8 POST error messages

This appendix lists the error codes, error messages, and the various indicator light and audible sequences that you may encounter during Power-On Self-Test (POST) or computer restart, the probable source of the problem, and steps you can take to resolve the error condition.

POST Message Disabled suppresses most system messages during POST, such as memory count and non-error text messages. If a POST error occurs, the screen will display the error message. To manually switch to the POST Messages Enabled mode during POST, press any key (except **F10**, **F11**, or **F12**). The default mode is POST Message Disabled.

The speed at which the computer loads the operating system and the extent to which it is tested are determined by the POST mode selection.

 **NOTE:** For more information on Computer Setup, see [Computer Setup \(F10\) Utility on page 60](#).

POST numeric codes and text messages

This section covers those POST errors that have numeric codes associated with them. The section also includes some text messages that may be encountered during POST.

 **NOTE:** The computer will beep once after a POST text message is displayed on the screen.

Control panel message	Description	Recommended action
101-Option ROM Checksum Error	System ROM or expansion board option ROM checksum.	<ol style="list-style-type: none">1. Verify the correct ROM.2. Flash the ROM if needed.3. If an expansion board was recently added, remove it to see if the problem remains.4. Clear CMOS. (See Appendix B, Password security and resetting CMOS on page 76.)5. If the message disappears, there may be a problem with the expansion card.6. Replace the system board.
103-System Board Failure	DMA or timers.	<ol style="list-style-type: none">1. Clear CMOS. (See Appendix B, Password security and resetting CMOS on page 76.)2. Remove expansion boards.3. Replace the system board.
110-Out of Memory Space for Option ROMs	Recently added PCI expansion card contains an option ROM too large to download during POST.	<ol style="list-style-type: none">1. If a PCI expansion card was recently added, remove it to see if the problem remains.2. In Computer Setup, set Advanced > Device Options > NIC PXE Option ROM Download to DISABLE to prevent PXE option ROM for the internal NIC from being downloaded during POST to free more memory for an expansion card's

Control panel message	Description	Recommended action
		option ROM. Internal PXE option ROM is used for booting from the NIC to a PXE server.
162-System Options Not Set	Configuration incorrect. RTC (real-time clock) battery may need to be replaced.	Run Computer Setup and check the configuration in Advanced > Onboard Devices . Reset the date and time under Control Panel . If the problem persists, replace the RTC battery. See the Removal and Replacement section for instructions on installing a new battery, or contact an authorized dealer or reseller for RTC battery replacement.
163-Time & Date Not Set	Invalid time or date in configuration memory. RTC (real-time clock) battery may need to be replaced.	Reset the date and time under Control Panel (Computer Setup can also be used). If the problem persists, replace the RTC battery. See the Removal and Replacement section for instructions on installing a new battery, or contact an authorized dealer or reseller for RTC battery replacement.
163-Time & Date Not Set	CMOS jumper may not be properly installed.	Check for proper placement of the CMOS jumper if applicable.
164-MemorySize Error	Memory amount has changed since the last boot (memory added or removed).	Press the F1 key to save the memory changes.
164-MemorySize Error	Memory configuration incorrect.	<ol style="list-style-type: none"> 1. Run Computer Setup or Windows utilities. 2. Make sure the memory module(s) are installed properly. 3. If third-party memory has been added, test using HP-only memory. 4. Verify proper memory module type.
201-Memory Error	RAM failure.	<ol style="list-style-type: none"> 1. Ensure memory modules are correctly installed. 2. Verify proper memory module type. 3. Remove and replace the identified faulty memory module(s). 4. If the error persists after replacing memory modules, replace the system board.
213-Incompatible Memory Module in Memory Socket(s) X, X, ...	A memory module in memory socket identified in the error message is missing critical SPD information, or is incompatible with the chipset.	<ol style="list-style-type: none"> 1. Verify proper memory module type. 2. Try another memory socket. 3. Replace DIMM with a module conforming to the SPD standard.
214-DIMM Configuration Warning	Populated DIMM Configuration is not optimized.	Rearrange the DIMMs so that each channel has the same amount of memory.
219-ECC Memory Module Detected ECC Modules not supported on this Platform	Recently added memory module(s) support ECC memory error correction.	<ol style="list-style-type: none"> 1. If additional memory was recently added, remove it to see if the problem remains. 2. Check product documentation for memory support information.
501-Display Adapter Failure	Graphics display controller.	<ol style="list-style-type: none"> 1. Reseat the graphics card (if applicable).

Control panel message	Description	Recommended action
		<ol style="list-style-type: none"> 2. Clear CMOS. (See Appendix B, Password security and resetting CMOS on page 76.) 3. Verify monitor is attached and turned on. 4. Replace the graphics card (if possible).
510-Flash Screen Image Corrupted	Flash Screen image has errors.	Reflash the system ROM with the latest BIOS image.
511-CPU, CPUA, or CPUB Fan not Detected	CPU fan is not connected or may have malfunctioned.	<ol style="list-style-type: none"> 1. Reseat CPU fan. 2. Reseat fan cable. 3. Replace CPU fan.
512-Chassis, Rear Chassis, or Front Chassis Fan not Detected	Chassis, rear chassis, or front chassis fan is not connected or may have malfunctioned.	<ol style="list-style-type: none"> 1. Reseat chassis, rear chassis, or front chassis fan. 2. Reseat fan cable. 3. Replace chassis, rear chassis, or front chassis fan.
513-Front Chassis fan not detected	Front chassis fan is not connected or may have malfunctioned.	<ol style="list-style-type: none"> 1. Reseat front chassis fan. 2. Reseat fan cable. 3. Replace front chassis fan.
514-CPU or Chassis Fan not Detected	CPU or chassis fan is not connected or may have malfunctioned.	<ol style="list-style-type: none"> 1. Reseat CPU or chassis fan. 2. Reseat fan cable. 3. Replace CPU or chassis fan.
515-Power Supply fan not detected	Power supply fan is not connected or may have malfunctioned.	<ol style="list-style-type: none"> 1. Reseat power supply fan. 2. Reseat fan cable. 3. Replace power supply fan.
601-Diskette Controller Error	Diskette controller circuitry or floppy drive circuitry incorrect.	<ol style="list-style-type: none"> 1. Check and/or replace cables. 2. Clear CMOS. (See Appendix B, Password security and resetting CMOS on page 76.) 3. Replace diskette drive. 4. Replace the system board.
605-Diskette Drive Type Error	Mismatch in drive type.	<ol style="list-style-type: none"> 1. Disconnect any other diskette controller devices (tape drives). 2. Clear CMOS. (See Appendix B, Password security and resetting CMOS on page 76.)
660-Display cache is detected unreliable	Integrated graphics controller display cache is not working properly and will be disabled.	Replace system board if minimal graphics degrading is an issue.
912-Computer Cover Has Been Removed Since Last System Startup	Computer cover was removed since last system startup.	No action required.
917-Front Audio Not Connected	Front audio harness has been detached or unseated from motherboard.	Reconnect or replace front audio harness.

Control panel message	Description	Recommended action
918-Front USB Not Connected	Front USB harness has been detached or unseated from motherboard.	Reconnect or replace front USB harness.
921-Device in PCI Express slot failed to initialize	There is an incompatibility/problem with this device and the system or PCI Express Link could not be retrained to an x1.	Try rebooting the system. If the error reoccurs, the device may not work with this system
1151-Serial Port A Address Conflict Detected	Both external and internal serial ports are assigned to COM1.	<ol style="list-style-type: none"> 1. Remove any serial port expansion cards. 2. Clear CMOS. (See Appendix B, Password security and resetting CMOS on page 76.) 3. Reconfigure card resources and/or run Computer Setup or Windows utilities.
1152-Serial Port B Address Conflict Detected	Both external and internal serial ports are assigned to COM2.	<ol style="list-style-type: none"> 1. Remove any serial port expansion cards. 2. Clear CMOS. (See Appendix B, Password security and resetting CMOS on page 76.) 3. Reconfigure card resources and/or run Computer Setup or Windows utilities.
1155-Serial Port Address Conflict Detected	Both external and internal serial ports are assigned to same IRQ.	<ol style="list-style-type: none"> 1. Remove any serial port expansion cards. 2. Clear CMOS. (See Appendix B, Password security and resetting CMOS on page 76.) 3. Reconfigure card resources and/or run Computer Setup or Windows utilities.
1720-SMART Hard Drive Detects Imminent Failure	Hard drive is about to fail. (Some hard drives have a hard drive firmware patch that will fix an erroneous error message.)	<ol style="list-style-type: none"> 1. Determine if hard drive is giving correct error message. Run the Drive Protection System test under using F2 Diagnostics when booting the computer. 2. Apply hard drive firmware patch if applicable. (Available at http://www.hp.com/support.) 3. Back up contents and replace hard drive.
1796-SATA Cabling Error	One or more SATA devices are improperly attached. For optimal performance, the SATA 0 and SATA 1 connectors must be used before SATA 2 and SATA 3.	Ensure SATA connectors are used in ascending order. For one device, use SATA 0. For two devices, use SATA 0 and SATA 1. For three devices, use SATA 0, SATA 1, and SATA 2.
2212-USB Key Provisioning failure writing to device	USB device used for USB key provisioning will not allow BIOS to update provision file properly.	<ol style="list-style-type: none"> 1. Try a different USB key device for provisioning. 2. If the error persists, update to the latest BIOS version and ME firmware version. 3. If the error still persists, replace the system board.
2217-ME Firmware Version request failure	ME firmware is not properly responding to BIOS query for version information.	<ol style="list-style-type: none"> 1. Reboot the computer. 2. If the error persists, update to the latest BIOS version and ME firmware version. 3. If the error still persists, replace the system board.

Control panel message	Description	Recommended action
2218-ME Firmware Version should be updated	ME firmware must be updated to match current functionality contained in the system BIOS.	<ol style="list-style-type: none"> 1. Update to the latest ME firmware version. 2. If the error persists and system BIOS has been recently updated, restore previous system BIOS version. 3. If the error still persists, replace the system board.
2219-USB Key Provisioning file has invalid header identifier	Provisioning file contained on the USB key has been corrupted or is not a valid version for the current ME firmware.	<ol style="list-style-type: none"> 1. Recreate the provisioning file using third party management console software. 2. If the error persists and system BIOS has been recently updated, restore previous system BIOS version. Otherwise, update the ME firmware version. 3. If the error still persists, replace the system board.
2220-USB Key Provisioning file has mismatch version	Provisioning file contained on the USB key is not a valid version for the current ME firmware.	<ol style="list-style-type: none"> 1. Reboot the computer. 2. If the error persists and system BIOS has been recently updated, restore previous system BIOS version. Otherwise, update the ME firmware version. 3. If the error still persists, replace the system board.
Invalid Electronic Serial Number	Electronic serial number is missing.	Enter the correct serial number in Computer Setup.
Parity Check 2	Parity RAM failure.	Run Computer Setup and Diagnostic utilities.

Interpreting POST diagnostic front panel LEDs and audible codes

This section covers the front panel LED codes as well as the audible codes that may occur before or during POST that do not necessarily have an error code or text message associated with them.

 **WARNING!** When the computer is plugged into an AC power source, voltage is always applied to the system board. To reduce the risk of personal injury from electrical shock and/or hot surfaces, be sure to disconnect the power cord from the wall outlet and allow the internal system components to cool before touching.

 **NOTE:** Look for flashing LEDs on the front panel of the computer and refer to the following table to determine the front panel LED codes.

Recommended actions in the following table are listed in the order in which they should be performed.

Not all diagnostic lights and audible codes are available on all models.

Activity	Beeps	Possible cause	Recommended action
White Power LED On.	None	Computer on.	None
White Power LED flashes every two seconds.	None	Computer in Suspend to RAM mode (some models only) or normal Suspend mode.	None required. Press any key or move the mouse to wake the computer.

Activity	Beeps	Possible cause	Recommended action
Red Power LED flashes two times, once every second, followed by a two second pause. System beeps occur once, but LEDs continue until problem is solved. NOTE: Beeps do not continue after the first iteration for this error code.	2	Processor thermal protection activated: A fan may be blocked or not turning. OR The heat sink/fan assembly is not properly attached to the processor.	<ol style="list-style-type: none"> 1. Ensure that the computer air vents are not blocked and the processor cooling fan is running. 2. Open hood, press power button, and see if the processor fan spins. If the processor fan is not spinning, make sure the fan's cable is plugged onto the system board header. 3. If fan is plugged in, but is not spinning, then replace heat sink/fan assembly. 4. Contact an authorized reseller or service provider.
Red Power LED flashes four times, once every second, followed by a two second pause. Beeps stop after fifth iteration but LEDs continue until problem is solved.	4	Power failure (power supply is overloaded).	<ol style="list-style-type: none"> 1. Open the hood and ensure the 4 or 6-wire power supply cable is seated into the connector on the system board. 2. Check if a device is causing the problem by removing ALL attached devices (such as hard, diskette, or optical drives, and expansion cards). Power on the system. If the system enters the POST, then power off and replace one device at a time and repeat this procedure until failure occurs. Replace the device that is causing the failure. Continue adding devices one at a time to ensure all devices are functioning properly. 3. Replace the power supply. 4. Replace the system board.
Red Power LED flashes five times, once every second, followed by a two second pause. Beeps stop after fifth iteration but LEDs continue until problem is solved.	5	Pre-video memory error.	<p>CAUTION: To avoid damage to the DIMMs or the system board, you must unplug the computer power cord before attempting to reseat, install, or remove a DIMM module.</p> <ol style="list-style-type: none"> 1. Reseat DIMMs. 2. Replace DIMMs one at a time to isolate the faulty module. 3. Replace third-party memory with HP memory. 4. Replace the system board.
Red Power LED flashes six times, once every second, followed by a two second pause. Beeps stop after fifth iteration but LEDs continue until problem is solved.	6	Pre-video graphics error.	<p>For systems with a graphics card:</p> <ol style="list-style-type: none"> 1. Reseat the graphics card. 2. Replace the graphics card. 3. Replace the system board. <p>For systems with integrated graphics, replace the system board.</p>
Red Power LED flashes seven times, once every second, followed by a two second pause. Beeps stop after fifth iteration but LEDs continue until problem is solved.	7	System board failure (ROM detected failure prior to video).	Replace the system board.
Red Power LED flashes eight times, once every second,	8	Invalid ROM based on bad checksum.	<ol style="list-style-type: none"> 1. Reflash the system ROM with the latest BIOS image.

Activity	Beeps	Possible cause	Recommended action
followed by a two second pause. Beeps stop after fifth iteration but LEDs continue until problem is solved.			<ol style="list-style-type: none"> 2. Replace the system board.
Red Power LED flashes nine times, once every second, followed by a two second pause. Beeps stop after fifth iteration but LEDs continue until problem is solved.	9	System powers on but is unable to boot.	<ol style="list-style-type: none"> 1. Check that the voltage selector, located on the rear of the power supply (some models), is set to the appropriate voltage. Proper voltage setting depends on your region. 2. Unplug the AC power cord from the computer, wait 30 seconds, then plug the power cord back in to the computer. 3. Replace the system board.
Red Power LED flashes ten times, once every second, followed by a two second pause. Beeps stop after fifth iteration but LEDs continue until problem is solved.	10	Bad option card.	<ol style="list-style-type: none"> 1. Check each option card by removing the card (one at a time if multiple cards), then power on the system to see if fault goes away. 2. Once a bad card is identified, remove and replace the bad option card. 3. Replace the system board.
System does not power on and LEDs are not flashing.	None	System unable to power on.	<p>Press and hold the power button for less than 4 seconds. If the hard drive LED turns white, the power button is working correctly. Try the following:</p> <ol style="list-style-type: none"> 1. Check that the voltage selector (some models), located on the rear of the power supply, is set to the appropriate voltage. Proper voltage setting depends on your region. 2. Replace the system board. <p>OR</p> <p>Press and hold the power button for less than 4 seconds. If the hard drive LED does not turn on white then:</p> <ol style="list-style-type: none"> 1. Check that the unit is plugged into a working AC outlet. 2. Open hood and check that the power button harness is properly connected to the system board. 3. Check that both power supply cables are properly connected to the system board. 4. Check to see if the 5V_aux light on the system board is turned on. If it is turned on, then replace the power button harness. If the problem persists, replace the system board. 5. If the 5V_aux light on the system board is not turned on, remove the expansion cards one at a time until the 5V_aux light on the system board turns on. If the problem persists, replace the power supply.

9 Password security and resetting CMOS

This computer supports security password features, which can be established through the Computer Setup Utilities menu.

This computer supports two security password features that are established through the Computer Setup Utilities menu: setup password and power-on password. When you establish only a setup password, any user can access all the information on the computer except Computer Setup. When you establish only a power-on password, the power-on password is required to access Computer Setup and any other information on the computer. When you establish both passwords, only the setup password will give you access to Computer Setup.

When both passwords are set, the setup password can also be used in place of the power-on password as an override to log in to the computer. This is a useful feature for a network administrator.

If you forget the password for the computer, you can clear that password so you can gain access to the information on the computer by resetting the password jumper.

CAUTION: Pushing the CMOS button will reset CMOS values to factory defaults. It is important to back up the computer CMOS settings before resetting them in case they are needed later. Back up is easily done through Computer Setup. See [Computer Setup \(F10\) Utility on page 60](#) for information on backing up the CMOS settings.

Resetting the password jumper

CAUTION: If you enable the stringent security feature in Computer Setup and you forget the setup password or the power-on password, the computer is inaccessible and can no longer be used.

Enabling the stringent password disables the ability to reset the password by moving the jumper on the system board.

If you lose or forget the password, the system board must be replaced. This scenario is not covered under warranty.

To prevent the computer from becoming permanently unusable, record your configured setup password or power-on password in a safe place away from your computer. Without these passwords, the computer cannot be unlocked.

To disable the power-on or setup password features, or to clear the power-on or setup passwords, complete the following steps:

1. Shut down the operating system properly, then turn off the computer and any external devices, and disconnect the power cord from the power outlet.
2. With the power cord disconnected, press the power button again to drain the system of any residual power.

 **WARNING!** To reduce the risk of personal injury from electrical shock and/or hot surfaces, be sure to disconnect the power cord from the wall outlet, and allow the internal system components to cool before touching.

 **CAUTION:** When the computer is plugged in, the power supply always has voltage applied to the system board even when the unit is turned off. Failure to disconnect the power cord can result in damage to the system.

Static electricity can damage the electronic components of the computer or optional equipment. Before beginning these procedures, ensure that you are discharged of static electricity by briefly touching a grounded metal object. See the *Safety & Regulatory Information* guide for more information.

3. Remove the access panel.
4. Locate the header and jumper.

 **NOTE:** The password jumper is blue so that it can be easily identified. For assistance locating the password jumper and other system board components, see the system board components image at [System board on page 52](#).

5. Remove the jumper from pins 1 and 2.
6. Place the jumper on either pin 1 or 2, but not both, so that it does not get lost.
7. Replace the access panel and reconnect the external equipment.
8. Plug in the computer and turn on power. Allow the operating system to start. This clears the current passwords and disables the password features.
9. Shut down the computer, unplug the power, and disconnect the external equipment.
10. Remove the access panel.
11. Place the jumper on pins 1 and 2.
12. Replace the access panel.
13. Reconnect the external equipment and plug in the computer.

Changing a Setup or Power-On password

To change the power-on or setup password, complete the following steps:

1. Turn on or restart the computer.
 - To change the Setup password, go to step 2.
 - To change the Power-on password, go to step 3.
2. To change the Setup password, as soon as the computer turns on:
 - Press the Esc key while “Press the ESC key for Startup Menu” message is displayed.
 - Press the F10 key to enter Computer Setup.

3. When the key icon appears, type your current password, a slash (/) or alternate delimiter character, your new password, another slash (/) or alternate delimiter character, and your new password again as shown:

current password/new password/new password



NOTE: Type the new password carefully since the characters do not appear on the screen.

4. Press **Enter**.

The new password will take effect the next time the computer is restarted.

Deleting a Setup or Power-On password

To delete the power-on or setup password, complete the following steps:

1. Turn on or restart the computer.

To delete the Setup password, go to step 2.

To delete the Power-on password, go to step 3.

2. To delete the Setup password, as soon as the computer turns on:

- Press the Esc key while “Press the ESC key for Startup Menu” message is displayed.

- Press the F10 key to enter Computer Setup.

3. When the key icon appears, type your current password, a slash (/) or alternate delimiter character, your new password, another slash (/) or alternate delimiter character, and your new password again as shown:

current password/

4. Press **Enter**.

Clearing and resetting the CMOS

The computer’s configuration memory (CMOS) stores information about the computer’s configuration.

The CMOS button resets CMOS but does not clear the power-on and setup passwords.

1. Turn off the computer and any external devices, and disconnect the power cord from the power outlet.
2. Disconnect external equipment connected to the computer.



WARNING! To reduce the risk of personal injury from electrical shock and/or hot surfaces, be sure to disconnect the power cord from the wall outlet, and allow the internal system components to cool before touching.



CAUTION: When the computer is plugged in, the power supply always has voltage applied to the system board even when the unit is turned off. Failure to disconnect the power cord can result in damage to the system.

Static electricity can damage the electronic components of the computer or optional equipment. Before beginning these procedures, ensure that you are discharged of static electricity by briefly touching a grounded metal object. See the *Safety & Regulatory Information* guide for more information.

3. Remove the access panel.

CAUTION: Pushing the CMOS button will reset CMOS values to factory defaults. It is important to back up the computer CMOS settings before resetting them in case they are needed later. Back up is easily done through Computer Setup. See [Computer Setup \(F10\) Utility on page 60](#) for information on backing up the CMOS settings.

4. Locate, press, and hold the CMOS button in for five seconds.

NOTE: Make sure you have disconnected the AC power cord from the wall outlet. The CMOS button will not clear CMOS if the power cord is connected.



NOTE: For assistance locating the CMOS button and other system board components, see the system board components image at [System board on page 52](#).

5. Replace the access panel.
6. Reconnect the external devices.
7. Plug in the computer and turn on power.

NOTE: You will receive POST error messages after clearing CMOS and rebooting advising you that configuration changes have occurred. Use Computer Setup to reset any special system setups along with the date and time.

For instructions on Computer Setup, see [Computer Setup \(F10\) Utility on page 60](#).

10 HP PC Hardware Diagnostics

To help troubleshoot and diagnose failures, use the UEFI-based hardware diagnostic solution that HP includes on all products. This tool can even be used if the computer will not boot to the operating system.

Why run HP PC Hardware Diagnostics

The HP PC Hardware Diagnostic tools simplify the process of diagnosing hardware issues and expedite the support process when issues are found. The tools save time by pinpointing the component that needs to be replaced.

- **Isolate true hardware failures:** The diagnostics run outside of the operating system so they effectively isolate hardware failures from issues that may be caused by the operating system or other software components.
- **Failure ID:** When a failure is detected that requires hardware replacement, a 24-digit Failure ID is generated. This ID can then be provided to the call agent, who will either schedule support or provide replacement parts.

How to access and run HP PC Hardware Diagnostics

You can run the diagnostics from one of three places, depending on your preference and the health of the computer.

1. Turn on the computer and press **Esc** repeatedly until the BIOS Boot Menu appears.
2. Press **F2** or select **Diagnostics (F2)**.

Pressing **F2** signals the system to search for the diagnostics in the following locations:

- a. A connected USB drive (to download the diagnostics tools to a USB drive, see the instructions in [Downloading HP PC Hardware Diagnostics \(UEFI\) to a USB device on page 80](#))
- b. The hard disk drive
- c. A core set of diagnostics in the BIOS (for memory and hard disk drive) that are accessible only if the USB or hard disk drive versions are not detected

Downloading HP PC Hardware Diagnostics (UEFI) to a USB device

 **NOTE:** Instructions for downloading HP PC Hardware Diagnostics (UEFI) are provided in English only.

There are two options to download HP PC Hardware Diagnostics to USB device.

Option 1: HP PC Diagnostics homepage—Provides access to the latest UEFI version

1. Go to <http://www.hp.com/go/techcenter/pcdiags>.
2. Click the **UEFI Download** link, and then select **Run**.

Option 2: Support and Drivers pages—Provides downloads for a specific product for earlier and later versions.

1. Go to <http://www.hp.com>.
2. Point to Support, located at the top of the page, and then click **Download Drivers**.
3. In the text box, enter the product name, and then click **Go**.
– or –
Click **Find Now** to let HP automatically detect your product.
4. Select your computer model, and then select your operating system.
5. In the **Diagnostic** section, click **HP UEFI Support Environment**.
6. Click **Download**, and then select **Run**.

11 System backup and recovery

Backing up, restoring, and recovering in Windows 8.1, Windows 8, or Industry 8.1

Your computer includes tools provided by HP and Windows to help you safeguard your information and retrieve it if you ever need to. These tools will help you return your computer to a proper working state or even back to the original factory state, all with simple steps.

This section provides information about the following processes:

- Creating recovery media and backups
- Restoring and recovering your system

 **NOTE:** This section describes an overview of backing up, restoring, and recovering options. For more details about the tools provided, see Help and Support. From the Start screen, type `help`, and then select **Help and Support**.

Creating recovery media and backups

Recovery after a system failure is only as good as your most recent backup.

1. After you successfully set up the computer, create recovery media. This step creates a backup of the recovery partition on the computer. The backup can be used to reinstall the original operating system in cases where the hard drive is corrupted or has been replaced.

 **NOTE:** There is no recovery partition on systems with a 32GB SSD. For those systems, you must use the recovery media in the box or that can be obtained from HP Services.

You will use a USB flash drive to create a bootable recovery drive that can be used to troubleshoot a computer that is unable to start. The USB flash drive can be used to reinstall the original operating system and the programs that were installed at the factory.

 **NOTE:** Any information on the USB flash drive will be erased before the recovery media is created.

- To create the Windows 8.1 or Industry 8.1 recovery media, from the Start screen, type `recovery drive`, then click on **Create a recovery drive**. Follow the on-screen instructions to continue.
 - To create the Windows 8 recovery media, from the Start screen, type `recovery drive`, and then click on **Settings**, then click on **Create a recovery drive**. Follow the on-screen instructions to continue.
2. Use the Windows tools to create system restore points and create backups of personal information. For more information and steps, see Help and Support. From the Start screen, type `help`, and then select **Help and Support**.

Restoring and recovering using Windows tools

Windows offers several options for restoring from backup, refreshing the computer, and resetting the computer to its original state. For more information and steps, see Help and Support. From the Start screen, type `help`, and then select **Help and Support**.

Using Reset when the system is not responding

 **NOTE:** You may be prompted by User Account Control for your permission or password when you perform certain tasks. To continue a task, select the appropriate option. For information about User Account Control, see Help and Support. From the Start screen, type `help`, and then select **Help and Support**.

 **IMPORTANT:** Reset does not provide backups of your information. Before using Reset, back up any personal information you wish to retain.

If Windows recovery steps are not working and the system is not responding, use these steps to start Reset:

1. If possible, back up all personal files.
2. If possible, check for the presence of the HP Recovery partition:
 - For Windows 8.1 or Industry 8.1, from the Start screen, type `pc`, and then select **This PC**.
 - For Windows 8, from the Start screen, type `c`, and then select **Computer**.

 **NOTE:** If the HP Recovery partition is not listed, or you cannot check for its presence, you must recover using the recovery media you created; see [Recovery using the Windows recovery USB flash drive on page 83](#). Or you must use the Windows operating system media and the *Driver Recovery* media (purchased separately); see [Recovery using Windows operating system media \(purchased separately\) on page 84](#).

3. If the HP Recovery partition is listed, restart the computer, and then press `esc` while the HP logo is displayed. The computer Startup Menu displays.
4. Press `f11` to select the System Recovery option.
5. Choose your keyboard layout.
6. Select **Troubleshoot**.
7. Select **Reset**.
8. Follow the on-screen instructions to continue.

Recovery using the Windows recovery USB flash drive

To recover your system using the recovery USB flash drive you previously created:

 **NOTE:** If you did not create a recovery USB flash drive or the one you created does not work, see [Recovery using Windows operating system media \(purchased separately\) on page 84](#).

1. If possible, back up all personal files.
2. Insert the recovery USB flash drive you created into a USB port on your computer.
3. Restart the computer and as soon as you see the HP logo screen, press `f9` to display a list of boot devices. Use the arrow keys to select your USB flash drive from the UEFI Boot Sources list. Press `Enter` to boot from that device.
4. Choose your keyboard layout.
5. Select **Troubleshoot**.
6. Select **Refresh your PC**.
7. Follow the on-screen instructions.

Recovery using Windows operating system media (purchased separately)

To order a Windows operating system DVD, contact support. Go to <http://www.hp.com/support>, select your country or region, and follow the on-screen instructions.

 **CAUTION:** Using Windows operating system media completely erases the hard drive contents and reformats the hard drive. All files that you have created and any software that you have installed on the computer are permanently removed. When reformatting is complete, the recovery process helps you restore the operating system, as well as drivers, software, and utilities.

To initiate recovery using Windows operating system media:

 **NOTE:** This process takes several minutes.

1. If possible, back up all personal files.
2. Restart the computer, and then follow the instructions provided with the Windows operating system media to install the operating system.
3. When prompted, press any keyboard key.
4. Follow the on-screen instructions.

After the repair is completed and the Windows desktop appears:

1. Remove the Windows operating system media, and then insert the *Driver Recovery* media.
2. Install the Hardware Enabling Drivers first, and then install Recommended Applications.

Backing up, restoring, and recovering in Windows 7 and POSReady 7

Your computer includes tools provided by HP and Windows to help you safeguard your information and retrieve it if you ever need to. These tools will help you return your computer to a proper working state or even back to the original factory state, all with simple steps.

This section provides information about the following processes:

- Creating recovery media and backups
- Restoring and recovering your system

 **NOTE:** This section describes an overview of backing up, restoring, and recovering options. For more details about the Windows Backup and Restore tools provided, see Help and Support. To access Help and Support, select **Start > Help and Support**.

Recovery after a system failure is only as good as your most recent backup.

1. After you successfully set up the computer, create recovery media. This media can be used to reinstall the original operating system in cases where the hard drive is corrupted or has been replaced. See [Creating recovery media on page 85](#).
2. As you add hardware and software programs, create system restore points. A system restore point is a snapshot of certain hard drive contents saved by Windows System Restore at a specific time. A system restore point contains information that Windows uses, such as registry settings. Windows creates a system restore point for you automatically during a Windows update and during other system maintenance (such as a software update, security scanning, or system diagnostics). You can also manually create a system restore point at any time. For more information and steps for creating specific system restore points, see Help and Support. To access Help and Support, select **Start > Help and Support**.
3. As you add photos, video, music, and other personal files, create a backup of your personal information. If files are accidentally deleted from the hard drive and they can no longer be restored from the Recycle Bin, or if files become corrupted, you can restore the files that you backed up. In case of system failure, you can use the backup files to restore the contents of your computer. See [Backing up your information on page 87](#).



NOTE: HP recommends that you print the recovery procedures and save them for later use, in case of system instability.

Creating recovery media

After you successfully set up the computer, create recovery media. The media can be used to reinstall the original operating system in cases where the hard drive is corrupted or has been replaced.

There are two types of recovery media. To determine which steps to follow for your computer:

1. Click the **Start** button.
2. Click **All Programs**.
 - If **Security and Protection** is listed, continue with the steps in [Creating recovery media using HP Recovery Manager \(select models only\) on page 85](#).
 - If **Productivity and Tools** is listed, continue with the steps in [Creating recovery discs with HP Recovery Disc Creator \(select models only\) on page 86](#).

Creating recovery media using HP Recovery Manager (select models only)

- To create recovery discs, your computer must have a DVD writer. Use DVD+R or DVD-R discs (purchased separately). The discs you use will depend on the type of optical drive you are using.



NOTE: DVD+R DL, DVD-R DL, or DVD±RW disc are not supported.

- You have the option of creating a recovery USB flash drive instead, using a high-quality USB drive.
- If you are creating recovery discs, be sure to use high-quality discs. It is normal for the system to reject defective discs. You will be prompted to insert a new blank disc to try again.
- The number of discs in the recovery-disc set depends on your computer model (typically 3 to 6 DVDs). The Recovery Media Creation program tells you the specific number of blank discs needed to make the set. If you are using a USB flash drive, the program will tell you the size of the drive required to store all the data (minimum of 8 GB).



NOTE: The process of creating recovery media is lengthy. You can quit the process at any time. The next time you initiate the process, it resumes where it left off.

 **NOTE:** Do not use media cards for creating recovery media. The system may not be able to boot up from a media card and you may not be able to run system recovery.

To create recovery discs:

1. Close all open programs.
2. Click the **Start** button, click **All Programs**, click **Security and Protection**, click **Recovery Manager**, and then click **HP Recovery Media Creation**. If prompted, click **Yes** to allow the program to continue.
3. Click **Create recovery media using blank DVD(s)**, and then click **Next**.
4. Follow the on-screen instructions. Label each disc after you make it (for example, Recovery 1, Recovery 2), and then store the discs in a secure place.

To create a recovery USB flash drive:

 **NOTE:** You must use a USB flash drive with a capacity of at least 8 GB.

 **NOTE:** Recovery Media Creation formats the USB flash drive, deleting any files on it.

1. Close all open programs.
2. Insert the USB flash drive into a USB port on the computer.
3. Click the **Start** button, click **All Programs**, click **Security and Protection**, click **Recovery Manager**, and then click **Recovery Media Creation**.
4. Click **Create recovery media with a USB flash drive**, and then click **Next**.
5. Select the USB flash drive from the list of media. The program will let you know how much storage is required to create the recovery drive. If the USB flash drive does not have enough storage capacity, it will appear grayed out, and you must replace it with a larger USB flash drive. Click **Next**.
6. Follow the on-screen instructions. When the process is complete, label the USB flash drive and store it in a secure place.

Creating recovery discs with HP Recovery Disc Creator (select models only)

HP Recovery Disc Creator is a software program that offers an alternative way to create recovery discs on select models. After you successfully set up the computer, you can create recovery discs using HP Recovery Disc Creator. The recovery discs allow you to reinstall your original operating system as well as select drivers and applications if the hard drive becomes corrupted. HP Recovery Disc Creator creates two kinds of recovery discs:

- **Operating system DVD**—Installs the operating system without additional drivers or applications.
- **Driver Recovery DVD**—Installs specific drivers and applications only, in the same way that the HP Software Setup utility installs drivers and applications.

To create recovery discs, your computer must have a DVD writer. Use any of the following types of discs (purchased separately): DVD+R, DVD+R DL, DVD-R, DVD-R DL, or DVD±RW. The discs you use will depend on the type of optical drive you are using.

Creating recovery discs

 **NOTE:** The operating system DVD can be created only once. The option to create that media will not be available after you create a Windows DVD.

To create the Windows DVD:

1. Select **Start > All Programs > Productivity and Tools > HP Recovery Disc Creator**.
2. Select **Windows disk**.
3. From the drop-down menu, select the drive for burning the recovery media.
4. Click the **Create** button to start the burning process. Label the disc after you create it, and store it in a secure place.

After the Windows 7 operating system DVD has been created, create the *Driver Recovery* DVD:

1. Select **Start > All Programs > Productivity and Tools > HP Recovery Disc Creator**.
2. Select **Driver disk**.
3. From the drop-down menu, select the drive for burning the recovery media.
4. Click the **Create** button to start the burning process. Label the disc after you create it, and store it in a secure place.

Backing up your information

You should create your initial backup immediately after initial system setup. As you add new software and data files, you should continue to back up your system on a regular basis to maintain a reasonably current backup. Your initial and subsequent backups allow you to restore your data and settings if a failure occurs.

You can back up your information to an optional external hard drive, a network drive, or discs.

Note the following when backing up:

- Store personal files in the Documents library, and back it up regularly.
- Back up templates that are stored in their associated directories.
- Save customized settings that appear in a window, toolbar, or menu bar by taking a screen shot of your settings. The screen shot can be a time-saver if you have to reset your preferences.
- When backing up to discs, number each disc after removing it from the drive.

 **NOTE:** For detailed instructions on various backup and restore options, perform a search for these topics in Help and Support. To access Help and Support, select **Start > Help and Support**.

 **NOTE:** You may be prompted by User Account Control for your permission or password when you perform certain tasks. To continue a task, select the appropriate option. For information about User Account Control, see Help and Support: Select **Start > Help and Support**.

To create a backup using Windows Backup and Restore:

 **NOTE:** The backup process may take over an hour, depending on file size and the speed of the computer.

1. Select **Start > All Programs > Maintenance > Backup and Restore**.
2. Follow the on-screen instructions to set up your backup.

System Restore

If you have a problem that might be due to software that you installed on your computer, or if you want to restore the system to a previous state without losing any personal information, use System Restore to return the computer to a previous restore point.

 **NOTE:** Always use this System Restore procedure before you use the System Recovery feature.

To start System Restore:

1. Close all open programs.
2. Click the **Start** button, right-click **Computer**, and then click **Properties**.
3. Click **System protection**, **System Restore**, click **Next**, and then follow the on-screen instructions.

System Recovery

 **WARNING!** This procedure will delete all user information. To prevent loss of information, be sure to back up all user information so you can restore it after recovery.

System Recovery completely erases and reformats the hard disk drive, deleting all data files that you have created, and then reinstalls the operating system, programs, and drivers. However, you must reinstall any software that was not installed on the computer at the factory. This includes software that came on media included in the computer accessory box, and any software programs you installed after purchase. Any personal files must be restored from backups you made.

If you were not able to create system recovery DVDs or USB flash drive, you can order a recovery disc set from support. Go to <http://www.hp.com/support>, select your country or region, and follow the on-screen instructions.

 **NOTE:** Always use the System Restore procedure before you use the System Recovery program. See [System Restore on page 87](#).

You must choose one of the following methods to perform a System Recovery:

- Recovery image — Run System Recovery from a recovery image stored on your hard disk drive. The recovery image is a file that contains a copy of the original factory-shipped software. To perform a System Recovery from a recovery image, see [System Recovery when Windows is responding on page 88](#) or [System Recovery when Windows is not responding on page 89](#).
- Recovery media — Run System Recovery from recovery media that you have created from files stored on your hard disk drive or purchased separately. See [System Recovery using recovery media \(select models only\) on page 89](#).

System Recovery when Windows is responding

 **CAUTION:** System Recovery deletes all data and programs you created or installed. Before you begin, back up any important data to a CD or DVD or to a USB flash drive.

 **NOTE:** In some cases, you must use recovery media for this procedure. If you have not already created this media, follow the instructions in [Creating recovery media on page 85](#).

If the computer is working and Windows 7 is responding, use these steps to perform a System Recovery:

1. Turn off the computer.
2. Disconnect all peripheral devices from the computer except the monitor, keyboard, and mouse.
3. Turn on the computer.
4. When Windows has loaded, click the **Start** button, and then click **All Programs**.
 - If **Security and Protection** is listed, continue with step [5](#).
 - If **Productivity and Tools** is listed, follow the steps in [System Recovery when Windows is not responding on page 89](#).
5. Click **Security and Protection**, click **Recovery Manager**, and then click **Recovery Manager**. If prompted, click **Yes** to allow the program to continue.

6. Under **I need help immediately**, click **System Recovery**.
7. Select **Yes**, and then click **Next**. Your computer restarts.
8. When the computer restarts, you will see the Recovery Manager welcome screen again. Under **I need help immediately**, click **System Recovery**. If you are prompted to back up your files, and you have not done so, select **Back up your files first (recommended)**, and then click **Next**. Otherwise, select **Recover without backing up your files**, and then click **Next**.
9. System Recovery begins. After System Recovery is complete, click **Finish** to restart the computer.
10. When Windows has loaded, shut down the computer, reconnect all peripheral devices, and then turn the computer back on.

System Recovery when Windows is not responding

 **CAUTION:** System Recovery deletes all data and programs you created or installed.

If Windows is not responding, but the computer is working, follow these steps to perform a System Recovery.

1. Turn off the computer. If necessary, press and hold the power button until the computer turns off.
2. Disconnect all peripheral devices from the computer, except the monitor, keyboard, and mouse.
3. Press the power button to turn on the computer.
4. As soon as you see the HP logo screen, repeatedly press the **F11** key on your keyboard until the *Windows is Loading Files...* message appears on the screen.
5. At the HP Recovery Manager screen, follow the on-screen instructions to continue.
6. When Windows has loaded, shut down the computer, reconnect all peripheral devices, and then turn the computer back on.

System Recovery using recovery media (select models only)

Use the steps provided in this section if you created recovery media using [Creating recovery media using HP Recovery Manager \(select models only\) on page 85](#). If you used HP Recovery Disc Creator to create a Windows 7 operating system DVD and a *Driver Recovery* DVD, use the steps in [Using HP Recovery Disc operating system discs \(select models only\) on page 90](#).

 **CAUTION:** System Recovery deletes all data and programs you have created or installed. Back up any important data to a CD or DVD or to a USB flash drive.

To perform a System Recovery using recovery media:

1. If you are using a set of DVDs, insert the first recovery disc into the DVD drive tray, and close the tray. If you are using a recovery USB flash drive, insert it into a USB port.
2. Click the **Start** button, and then click **Shut Down**.

or

- If the computer is not responding, press and hold the power button for approximately 5 seconds or until the computer turns off.
3. Disconnect all peripheral devices from the computer except the monitor, keyboard, and mouse.
 4. Press the power button to turn on the computer, and press **Esc** as the computer is powering on to display the startup menu.
 5. Use the arrow keys to select the boot menu, and press **Enter**. Use the arrow keys to select the location where the recovery media is inserted (USB or DVD). Press **Enter** to boot from that device.

6. If Recovery Manager asks if you want to run System Recovery from Media or Hard Drive, select **Media**. On the Welcome screen, under **I need help immediately**, click **Factory Reset**.
7. If you are prompted to back up your files, and you have not done so, select **Back up your files first (recommended)**, and then click **Next**. Otherwise, select **Recover without backing up your files**, and then click **Next**.
8. If you are prompted to insert the next recovery disc, do so.
9. When Recovery Manager is finished, remove the recovery disc or the recovery USB flash drive from the system.
10. Click **Finish** to restart the computer.

Using HP Recovery Disc operating system discs (select models only)

Use the steps provided in this section if you used HP Recovery Disc Creator to create an operating system DVD and a *Driver Recovery* DVD. If you created recovery media using [Creating recovery media using HP Recovery Manager \(select models only\) on page 85](#), use the steps in [System Recovery using recovery media \(select models only\) on page 89](#).

If you cannot use the recovery discs you previously created using the HP Recovery Disc Creator (select models only), you must purchase an operating system DVD to reboot the computer and repair the operating system.

To order an operating system DVD, contact support. Go to <http://www.hp.com/support>, select your country or region, and follow the on-screen instructions.

 **CAUTION:** Using a Windows 7 or POSReady operating system DVD completely erases the hard drive contents and reformats the hard drive. All files that you have created and any software that you have installed on the computer are permanently removed. When reformatting is complete, the recovery process helps you restore the operating system, as well as drivers, software, and utilities.

To initiate recovery using a Windows 7 or POSReady operating system DVD:

 **NOTE:** This process takes several minutes.

1. If possible, back up all personal files.
2. Restart the computer, and then insert the operating system DVD into the optical drive before the Windows operating system loads.

 **NOTE:** If the computer does not boot to the DVD, restart the computer and press **Esc** as the computer is powering on to see the startup menu. Use the arrow keys to select the boot menu and press **Enter**. Use the arrow keys to select the location where the recovery DVD is inserted. Press **Enter** to boot from that device.

3. When prompted, press any keyboard key.
4. Follow the on-screen instructions.
5. Click **Next**.
6. Select **Install now**.
7. Follow the on-screen instructions.

After the repair is completed:

1. Eject the operating system DVD and then insert the *Driver Recovery* DVD.
2. Follow the on-screen instructions to install the Hardware Enabling Drivers first, and then install Recommended Applications.

A Power cord set requirements

The power supplies on some computers have external power switches. The voltage select switch feature on the computer permits it to operate from any line voltage between 100-120 or 220-240 volts AC. Power supplies on those computers that do not have external power switches are equipped with internal switches that sense the incoming voltage and automatically switch to the proper voltage.

The power cord set received with the computer meets the requirements for use in the country where you purchased the equipment.

Power cord sets for use in other countries must meet the requirements of the country where you use the computer.

General requirements

The requirements listed below are applicable to all countries:

1. The power cord must be approved by an acceptable accredited agency responsible for evaluation in the country where the power cord set will be installed.
2. The power cord set must have a minimum current capacity of 10A (7A Japan only) and a nominal voltage rating of 125 or 250 volts AC, as required by each country's power system.
3. The diameter of the wire must be a minimum of 0.75 mm² or 18AWG, and the length of the cord must be between 1.8 m (6 feet) and 3.6 m (12 feet).

The power cord should be routed so that it is not likely to be walked on or pinched by items placed upon it or against it. Particular attention should be paid to the plug, electrical outlet, and the point where the cord exits from the product.

 **WARNING!** Do not operate this product with a damaged power cord set. If the power cord set is damaged in any manner, replace it immediately.

Japanese power cord requirements

For use in Japan, use only the power cord received with this product.

 **CAUTION:** Do not use the power cord received with this product on any other products.

Country-specific requirements

Additional requirements specific to a country are shown in parentheses and explained below.

Country	Accrediting Agency	Country	Accrediting Agency
Australia (1)	EANSW	Italy (1)	IMQ
Austria (1)	OVE	Japan (3)	METI
Belgium (1)	CEBC	Norway (1)	NEMKO
Canada (2)	CSA	Sweden (1)	SEMKO
Denmark (1)	DEMKO	Switzerland (1)	SEV
Finland (1)	SETI	United Kingdom (1)	BSI
France (1)	UTE	United States (2)	UL
Germany (1)	VDE		

1. The flexible cord must be Type H05VV-F, 3-conductor, 0.75mm² conductor size. Power cord set fittings (appliance coupler and wall plug) must bear the certification mark of the agency responsible for evaluation in the country where it will be used.
2. The flexible cord must be Type SVT or equivalent, No. 18 AWG, 3-conductor. The wall plug must be a two-pole grounding type with a NEMA 5-15P (15A, 125V) or NEMA 6-15P (15A, 250V) configuration.
3. Appliance coupler, flexible cord, and wall plug must bear a “T” mark and registration number in accordance with the Japanese Dentori Law. Flexible cord must be Type VCT or VCTF, 3-conductor, 0.75 mm² conductor size. Wall plug must be a two-pole grounding type with a Japanese Industrial Standard C8303 (7A, 125V) configuration.

B Specifications

Temperature Range

Operating	50° to 95°F	10° to 35°C
Nonoperating	-22° to 140°F	-30° to 60°C

NOTE: Operating temperature is derated 1.0° C per 300 m (1000 ft) to 3000 m (10,000 ft) above sea level; no direct sustained sunlight. Maximum rate of change is 10° C/Hr. The upper limit may be limited by the type and number of options installed.

Relative Humidity (noncondensing)

Operating	10-90%	10-90%
Nonoperating (38.7°C max wet bulb)	5-95%	5-95%

Maximum Altitude (unpressurized)

Operating	10,000 ft	3048 m
Nonoperating	30,000 ft	9144 m

Power Supply

	180W
Rated Line Frequency	50-60 Hz
Operating Line Frequency	47-63 Hz

-
- ¹ This system utilizes an active power factor corrected power supply. This allows the system to pass the CE mark requirements for use in the countries of the European Union. The active power factor corrected power supply also has the added benefit of not requiring an input voltage range select switch.
 - ² High efficiency power supply is a requirement for ENERGY STAR® qualification in conjunction with a select range of processors and modules.

Index

A

antennas
 illustrated 9
 removal and replacement 50
audible codes 73

B

backup and recovery, Windows 7 84
Backup and Restore, Windows 7 87
backups
 creating Windows 7 85, 87
barcode scanner, illustrated 8
base side panel, illustrated 11
battery
 disposal 17
battery, replacing 38
beep codes 73

C

cable cover, illustrated 11
cable management 18
cable pinouts, SATA data 17
cable routing 21
cautions
 AC power 12
 cables 16
 cooling fan 15
 electrostatic discharge 12
CFD, illustrated 8
changing a Power-On password 77
changing a Setup password 77
cleaning
 computer 15
 safety precautions 15
CMOS
 backing up 76
 clearing and resetting 78
computer cleaning 15
country power cord set
 requirements 93

D

deleting a Power-On password 78
deleting a Setup password 78
disassembly preparation 19

display (2x20), illustrated 8
Display (LVDS) cable
 illustrated 9
display panel
 illustrated 7
display panel assembly
 removal and replacement 57
drive cable
 removal 42
drive connector
 removal 42
Driver Recovery DVD,
 creating 86
 using for restore 90
Driver Recovery media, Windows
 84
Driver Recovery media, Windows
 8.1 84

E

electrostatic discharge (ESD) 12
 preventing damage 13
error
 codes 69, 73
 messages 69

F

f11 recovery, Windows 8 82
f11 recovery, Windows 8.1 82
fan, power supply 15
features 1
feet
 removing 23
fingerprint reader, illustrated 8
flashing LEDs 73
front panel
 removal 31

G

grounding methods 13

H

hard drive
 illustrated 10
 installing 36

 proper handling 16
 removing 36
 SATA characteristics 17
hard drive connector and cable
 illustrated 9
hard drive recovery
 Windows 82
 Windows 7 88
 Windows 8.1 82
hard drives 8
Help and Support
 Windows 7 84
HP PC Hardware Diagnostics (UEFI)
 downloading 80
HP Recovery Disc Creator, using 86

L

LEDs 73

M

memory
 installing 34
 specifications 34
memory modules
 illustrated 8
models 1
MSR, configuring 58
MSR, illustrated 8

N

numeric error codes 69

O

operating guidelines 14
operating system media, Windows
 8 84
operating system media, Windows
 8.1 84
overheating, prevention 14

P

password
 clearing 76
 power-on 76
 setup 76

- passwords 77, 78
 - plastic parts 11
 - POST error messages 69
 - power button board
 - removal and replacement 43
 - power button board cable
 - illustrated 9
 - power cord set requirements
 - country specific 93
 - power supply
 - fan 15
 - illustrated 8
 - operating voltage range 94
 - power supply removal and replacement 24
 - Power-On password 77, 78
 - power-on password 76
- R**
- rear components 3
 - recovery discs, steps for creating
 - Windows 7 86
 - recovery discs, using for restore 90
 - recovery media, creating 86
 - recovery media, creating Windows 7 85
 - recovery partition, Windows 8 82
 - recovery partition, Windows 8.1 82
 - recovery USB flash drive, steps for creating Windows 7 86
 - recovery using Windows 8 operating system media 84
 - recovery using Windows 8.1 operating system media 84
 - removal and replacement
 - antennas 50
 - display panel assembly 57
 - power button board 43
 - speakers 47
 - system board 52
 - removal and replacement procedures
 - feet 23
 - WLAN module 40
 - removing
 - touch board 49
 - USB port assembly 44
 - resetting
 - CMOS 76
 - password jumper 76
 - restoring the hard drive, Windows 82
 - restoring the hard drive, Windows 8.1 82
 - RJ45 to DB9 cable
 - illustrated 9
- S**
- safety precautions
 - cleaning 15
 - SATA
 - connectors on system board 17
 - data cable pinouts 17
 - hard drive characteristics 17
 - screws, correct size 16
 - serial cable 4
 - serial ports, configuring for power 59
 - service considerations 15
 - Setup password 77, 78
 - setup password 76
 - side panel, illustrated 11
 - software
 - servicing computer 16
 - speakers
 - illustrated 10
 - removal and replacement 47
 - specifications
 - computer 94
 - static electricity 12
 - system board
 - illustrated 7
 - removal and replacement 52
 - SATA connectors 17
 - System Recovery using Windows 7 recovery media 89
 - System Recovery, Windows 7 88
 - system restore points, creating Windows 7 85
 - System Restore, Windows 7 87
- T**
- tamper-proof screws
 - tool 16
 - temperature control 14
 - tools, servicing 16
 - Torx T15 screwdriver 16
 - touch board
 - blank removal 49
 - touch board cable
 - illustrated 9
 - touch screen
 - calibration 58
 - transceivers
 - illustrated 9
- U**
- USB assembly plastic, illustrated 11
 - USB connector
 - illustrated 10
 - USB cover plate, illustrated 11
 - USB modules, installing 27
 - USB port assembly
 - removal 44
- V**
- ventilation, proper 14
- W**
- wall mount 20
 - webcam, illustrated 8
 - Windows 7
 - backing up information 87
 - backup and recovery 84
 - Backup and Restore 87
 - creating backups 85
 - creating recovery media 85
 - creating system restore points 85
 - hard drive recovery 88
 - Help and Support 84
 - steps for creating recovery discs 86
 - steps for creating recovery media 85
 - steps for creating recovery USB flash drive 86
 - System Recovery 88
 - System Recovery using recovery media 89
 - System Restore 87
 - Windows 7 operating system discs using for restore 90
 - Windows 7 operating system DVD
 - creating 86
 - using for restore 90
 - Windows 7 operating system media
 - creating 86
 - Windows 8
 - backup and restore 82

- Driver Recovery media 84
- f11 recovery 82
- hard drive recovery 82
- operating system DVD 84
- recovery partition 82
- restoring the hard drive 82
- Windows 8.1
 - backup and restore 82
 - Driver Recovery media 84
 - f11 recovery 82
 - hard drive recovery 82
 - operating system DVD 84
 - recovery partition 82
 - restoring the hard drive 82
- WLAN module
 - removing 40