



HP Point of Sale (POS) Peripherals Configuration Guide

Document Version 3.90
January 2018

© Copyright 2007-2017 HP Development Company, L.P. The information contained herein is subject to change without notice.

Microsoft, MS-DOS, Windows, WEPOS, POSReady and Windows NT are trademarks of Microsoft Corporation in the U.S. and other countries.

The only warranties for HP products and services are set forth in the express warranty statements accompanying such products and services. Nothing herein should be construed as constituting an additional warranty. HP shall not be liable for technical or editorial errors or omissions contained herein.

HP Point of Sale (POS) Peripherals Configuration Guide
Document Version 3.90.0001

January 2018

Contents

1	Introduction.....	10
2	General Information.....	10
2.1.1	Where to obtain the latest software for the HP POS Peripherals	10
2.1.2	OPOS and CCO Drivers/Application.....	10
3	Port Information.....	10
4	OPOS Name for HP Point of Sale Peripherals	11
5	OPOS Logical Device Name Utility	13
5.1	Main GUI.....	13
5.2	Obtain OPOS Logical Device Name(s).....	17
5.2.1	Overview Steps	17
5.2.2	Detailed Steps	17
5.3	Change OPOS Logical Device Name(s)	20
5.3.1	Overview Steps	20
5.3.2	Detailed Steps	20
5.4	Set HP branded device to factory default OPOS logical name.....	24
5.4.1	Overview Steps	24
5.4.2	Detailed Steps	24
5.4.3	Default INI File.....	31
5.4.4	Adding non-HP Peripherals to the default drop down	31
6	Peripherals Connection and Software Installation	34
6.1	HP Cash Drawer and Flip-Top Cash Drawer.....	34
6.1.1	Key lock position	35
6.1.2	Connection	36
6.1.3	Windows Drivers for the Cash Drawer Drivers.....	38
6.1.4	Cash Drawer Decimal Commands.....	38
6.1.5	Dual Cash Drawer Connection.....	39
6.1.5.1	Cash Drawer Cable Info	39
6.1.6	OPOS Drivers for the Cash Drawer	40
6.1.7	OPOS Test Applet for the Cash Drawer	40
6.1.7.1	Cash Drawer and Printer Utility	40
6.1.8	JPOS Drivers for the Cash Drawer	43
6.2	HP Integrated Cash Drawer Port.....	46
6.2.1	Connection	46
6.2.2	Integrated Cash Drawer Pinout (RJ12)	47
6.2.3	Dual Cash Drawer Connection.....	48
6.2.3.1	Cash Drawer Cable Info	48
6.2.4	Drivers and utilities for the Integrated Cash Drawer Port.....	49
6.2.5	OPOS Drivers for the Integrated Cash Drawer Port	49
6.2.5.1	HP Integrated OPOS Cash Drawer Utility	49
6.2.5.2	OPOS Cash Drawer and Printer Utility	52
6.2.6	JPOS Drivers for the Integrated Cash Drawer Port	56
6.2.6.1	JPOS Test Applet for the Integrated Cash Drawer Port.....	56
6.3	HP USB Cash Drawer.....	59
6.3.1	Connection	59
6.3.2	Drivers and utilities for the HP USB Cash Drawer	59
6.3.3	Windows Test Utility for USB Cash Drawer	59

6.3.4	OPOS Drivers for the HP USB Cash Drawer	62
6.3.4.1	OPOS Cash Drawer and Printer Utility	62
6.3.4.2	Dual Cash Drawer Connection	65
6.3.5	JPOS Drivers for the HP USB Cash Drawer	68
6.3.5.1	JPOS Test Applet for the USB Cash Drawer Port	68
6.4	HP Receipt Printer	74
6.4.1	Connection	74
6.4.2	Powered USB Cable	77
6.4.3	NATIVE mode	79
6.4.4	PRINTER CLASS Mode	81
6.4.5	COMM CLASS Mode	82
6.4.6	USB Mode Selector Utility	84
6.4.6.1	Set printer to NATIVE mode	85
6.4.6.2	Set printer to PRINTER CLASS mode (default)	86
6.4.6.3	Set printer to COMM CLASS mode (virtual serial port)	87
6.4.7	Serial Printer	88
6.4.8	Windows Drivers for the Receipt Printer Drivers	89
6.4.8.1	Windows Printer Driver (USB) for v1.0.5 for POSReady 2009	89
6.4.8.2	Windows Printer Driver (Serial) for v1.0.5 for POSReady 2009	93
6.4.8.3	Windows Printer Driver (Ethernet) for v1.0.5 for POSReady 2009	98
6.4.8.4	Windows Printer Driver (USB) for v1.0.0 – 1.0.3	109
6.4.8.5	Windows Printer Driver (Serial) for v1.0.0 – 1.0.3	114
6.4.8.6	Test Receipt Printer in Windows Environment (non-OPOS)	119
6.4.8.7	Windows Printer Driver (USB) for v1.0.3 and later for Windows 7 / 8.1 / 10	122
6.4.8.8	Windows Printer Driver (Serial) for v1.0.3 and later for Windows 7 / 8.1 / 10	127
6.4.8.9	Windows Printer Driver (Ethernet) for v1.0.3 & later for Windows 7 / 8.1 / 10	132
6.4.8.10	Windows Printer Driver Options for v1.0.3 and later for Windows 7 / 8.1 / 10	141
6.4.9	Knife Cut Commands	144
6.4.10	OPOS Drivers for the Receipt Printer	145
6.4.10.1	OPOS Installation - USB	145
6.4.10.2	OPOS Installation – Serial Port	149
6.4.10.3	OPOS Installation - Ethernet	154
6.4.10.4	OPOS – Ethernet IP Address (Registry)	157
6.4.10.5	OPOS – Ethernet IP Address (GUI)	160
6.4.10.6	OPOS Test Applet for the Receipt Printer - Receipt Printer and Cash Drawer Utility 163	
6.4.10.7	Rotate Left Testing	170
6.4.10.8	Bitmap / Barcode Testing	179
6.4.10.9	Receipt Printer and Cash Drawer Utility – Cash Drawer Testing	184
6.4.11	OPOS Test Applet for the MICR	188
6.4.12	OPOS Test Applet for the CheckScan	194
6.4.13	Receipt Printer Cash Drawer Signal	206
6.4.13.1	Cash Drawer Signal	206
6.4.13.2	Cash Drawer Signal Change	206
6.4.14	JPOS Drivers for the Receipt Printer Drivers – Serial Port Setting	207
6.4.15	JPOS Drivers for the Receipt Printer Drivers – Ethernet	209
6.4.16	JPOS Drivers for the Receipt Printer Drivers	212
6.4.17	JPOS Drivers for the Receipt Printer Drivers - CheckScanner	216
6.4.18	JPOS Drivers for the Receipt Printer Drivers - MICR	223
6.4.19	JPOS Drivers for the Receipt Printer Drivers – Slip Printing	229
6.4.20	JPOS Drivers for the Receipt Printer Drivers – Barcode Testing	236
6.4.21	JPOS Drivers for the Cash Drawer Drivers	251
6.4.22	HP Font Utility (ASIAN Font Download) – Single Station (A799 with 4MG) Printer	254
6.4.22.1	HP Font Utility (Asian Font Download Utility)	254
6.5	HP ap5000 MSR (Magnetic Stripe Reader)	259

6.5.1	Connection	259
6.5.2	Windows Drivers for the HP ap5000 MSR	259
6.5.3	OPOS Drivers for the HP ap5000 MSR	259
6.5.4	Testing HP ap5000 MSR.....	259
6.5.4.1	Testing HP ap5000 MSR in non-OPOS mode.....	259
6.5.4.2	Testing HP ap5000 MSR in OPOS mode.....	263
6.5.5	JPOS Drivers for the HP ap5000 MSR	266
6.6	HP Magnetic Stripe Readers (MSR).....	271
6.6.1	Connection	272
6.6.2	Interfaces.....	272
6.6.3	Configuration	272
6.6.4	Windows Drivers	275
6.6.5	OPOS Drivers for the MSR	276
6.6.6	Testing MSR.....	276
6.6.6.1	Testing MSR in USB HID Keyboard interface.....	276
6.6.6.2	Testing MSR in USB HID or USB HID Keyboard interface with OPOS	276
6.6.7	JPOS Drivers for the MSR	282
6.7	HP Barcode Scanner (Laser 1D)	288
6.7.1	Connection	288
6.7.2	Windows Drivers for the Barcode Scanner	288
6.7.3	OPOS Drivers for the Barcode Scanner	290
6.7.4	Testing the Barcode Scanner.....	290
6.7.4.1	Testing Barcode Scanner in non-OPOS.....	290
6.7.4.2	Testing the Barcode Scanner in OPOS	290
6.7.5	JPOS Drivers for the Barcode Scanner	292
6.8	HP Barcode Scanner H-Series	297
6.8.1	Connection	298
6.8.2	Interfaces.....	298
6.8.3	Configuration	298
6.8.4	Windows Drivers	300
6.8.5	OPOS Drivers.....	300
6.8.6	JPOS Drivers.....	300
6.8.7	Testing the Barcode Scanner.....	300
6.8.7.1	Testing in non-OPOS/JPOS	300
6.8.7.2	Testing in OPOS.....	300
6.8.7.3	Testing in JPOS.....	307
6.9	HP USB Barcode Scanners	313
6.9.1	Connection	314
6.9.2	Windows Drivers for Scanners.....	314
6.9.3	OPOS Drivers for the Scanners	322
6.9.4	Testing the Scanners	322
6.9.4.1	Testing scanners in non-OPOS.....	322
6.9.4.2	Testing the scanners in OPOS.....	322
6.9.5	JPOS Drivers for the Scanners	329
6.9.6	Imaging Testing.....	334
6.10	HP Retail Jacket for ElitePad Barcode Scanner	340
6.10.1	Connection	340
6.10.2	Operating Modes.....	340
6.10.3	Drivers	341
6.10.4	Testing the scanner.....	342
6.10.4.1	Testing the scanner in HID-POS mode.....	343
6.10.4.2	Testing the scanner in USB HID Keyboard mode	343
6.10.4.3	Testing the scanner in USB COM mode with OPOS	343

6.10.4.4	Testing the scanner in USB COM mode with JPOS	349
6.11	HP POS Keyboard	353
6.11.1	Connection	353
6.11.2	Windows Drivers for the HP POS Keyboard	353
6.11.3	OPOS Drivers for the HP POS Keyboard	356
6.11.4	Testing the HP POS Keyboard	356
6.11.5	JPOS Drivers for the HP POS Keyboard	356
6.12	HP USB POS Keyboard with Magnetic Stripe Reader	357
6.12.1	Connection	357
6.12.2	Windows Drivers for the HP USB POS Keyboard with Magnetic Stripe Reader	357
6.12.3	Enable OPOS/JPOS for the MSR	362
6.12.4	OPOS Drivers for the HP USB POS Keyboard with Magnetic Stripe Reader - Keyboard	367
6.12.5	OPOS Drivers for the HP USB POS Keyboard with Magnetic Stripe Reader - MSR	367
6.12.6	Testing the HP USB POS Keyboard with Magnetic Stripe Reader	367
6.12.6.1	Keyboard	367
6.12.6.2	MSR OPOS	367
6.12.7	JPOS Drivers for the HP USB POS Keyboard with Magnetic Stripe Reader	373
6.12.7.1	Keyboard	373
6.12.7.2	MSR JPOS	373
6.13	HP ap5000 VFD (Vacuum Fluorescent Display)	376
6.13.1	Connection	376
6.13.2	Windows Drivers for the HP ap5000 VFD	376
6.13.3	OPOS Drivers for the HP ap5000 VFD	376
6.13.4	Testing HP ap5000 VFD	376
6.13.4.1	Testing HP ap5000 VFD in non-OPOS mode	376
6.13.4.2	Testing HP ap5000 VFD in OPOS mode	379
6.13.5	JPOS Drivers for the HP ap5000 VFD	389
6.13.6	Utility to change power-on message	394
6.13.6.1	Utility to Change Default Power-On Message	394
6.13.6.2	Enable the VFD Default Power-On Message	396
6.13.7	HP ap5000 VFD BIOS Power Setting	398
6.13.7.1	F10 BIOS Method	398
6.13.7.2	Windows Graphical Method	398
6.14	HP Pole Display	401
6.14.1	Connection	401
6.14.2	Windows Drivers for the Pole Display	401
6.14.3	Utility to change power-on message	408
6.14.3.1	HP USB Pole Display	408
6.14.3.2	HP VFD Display	413
6.14.4	OPOS Drivers for the Pole Display	417
6.14.5	Testing Pole Display	417
6.14.5.1	Testing pole display in non-OPOS environment	417
6.14.5.1.1	HP USB Pole non-OPOS Test Utility	417
6.14.5.1.2	HP VFD Utility for HP USB Pole Display	419
6.14.5.1.3	HP VFD Utility for HP VFD Display	425
6.14.5.2	Testing pole display in OPOS environment – HP USB Pole Display	436
6.14.6	JPOS Drivers for the pole display	446
6.15	HP Biometric Fingerprint Readers	453
6.15.1	Connection	453
6.15.2	Windows Drivers for the HP Biometric Fingerprint Readers	453
6.15.3	OPOS Drivers / JPOS Drivers / SDK Kit	454
7	HP Touch Screen	455

7.1	HP L5006tm	455
7.1.1	Connection	455
7.1.2	Windows Drivers for the Touch Screen.....	455
7.1.3	Touch Screen Alignment	465
7.1.4	OPOS Drivers for the Touch Screen	468
7.1.5	Testing the Touch Screen	468
7.1.6	JPOS Drivers for the Touch Screen	468
7.2	HP L5009tm / HP L5015tm	469
7.2.1	Connection	469
7.2.2	Windows Drivers for the Touch Screen.....	469
7.2.3	Touch Screen Alignment	475
7.2.4	OPOS Drivers for the Touch Screen	478
7.2.5	Testing the Touch Screen	478
7.2.6	JPOS Drivers for the Touch Screen	478
7.3	HP ap5000 Touch Screen	479
7.3.1	Connection	479
7.3.2	Windows Drivers for the Touch Screen.....	479
7.3.3	OPOS Drivers for the ap5000 Touch Screen.....	485
7.3.4	Testing the Touch Screen	485
7.3.5	JPOS Drivers for the ap5000 Touch Screen.....	485
7.4	HP RP7 15inch Resistive (AFD)	486
7.4.1	Connection	486
7.4.2	Windows Drivers for the Touch Screen.....	486
7.4.3	Touch Screen calibration.....	489
7.4.4	OPOS Drivers for the Touch Screen	491
7.4.5	Testing the Touch Screen	491
7.4.6	JPOS Drivers for the Touch Screen.....	491
7.5	HP RP7 15 /17 inch Projective Capacitive AFD (Associate Facing Display)	492
7.5.1	Connection	492
7.5.2	Windows Drivers for the Touch Screen.....	492
7.5.3	Touch Screen calibration.....	495
7.5.4	Touch in Dual Monitor Configuration in POSReady 2009 or XP.....	495
7.5.5	Touch in Dual Monitor Setup in POSReady 7 or Windows 7	497
7.5.6	OPOS Drivers for the Touch Screen	498
7.5.7	Testing the Touch Screen	498
7.5.8	JPOS Drivers for the Touch Screen.....	498
7.5.9	Disable/Enable On-Screen Display (OSD).....	499
7.6	Touch Screen – HP L6015tm / L6017tm Projective Capacitive (PCap)	500
7.6.1	Connection	500
7.6.2	Windows Drivers for the Touch Screen.....	500
7.6.3	Touch Screen calibration.....	502
7.6.4	Touch in Dual Monitor Configuration in POSReady 2009 or XP.....	503
7.6.5	Touch in Dual Monitor Setup in POSReady 7 or Windows 7	505
7.6.6	OPOS Drivers for the Touch Screen	505
7.6.7	Testing the Touch Screen	505
7.6.8	JPOS Drivers for the Touch Screen	505
7.6.9	Disable/Enable On-Screen Display (OSD).....	506
7.6.10	Disable/Enable Power Button	506
8	HP ap5000 Point of Sale System	507
8.1	HP ap5000 10” Display	507
8.1.1	Connection	507
8.1.2	Windows Drivers for the HP ap5000 10” display.....	507

8.1.3	OPOS Drivers for the HP ap5000 10" Display	507
8.1.4	Testing the HP ap5000 10" Display	507
8.1.5	JPOS Drivers for the HP ap5000 10" Display	507
9	HP 7" CFD	508
9.1.1	Connection	508
9.1.2	Windows Drivers for the HP 7" CFD display	508
9.1.3	OPOS Drivers for the HP 7" CFD Display	511
9.1.4	JPOS Drivers for the HP 7" CFD Display	511
9.1.5	Testing the HP 7" CFD Display	511
9.1.6	HP 7 CFD Options	511
Q & A	512
9.2	General	512
9.3	HP Cash Drawer	513
9.4	HP USB Cash Drawer	513
9.5	HP Receipt Printer	514
9.6	HP USB Barcode Scanner	518
9.7	HP Touch Screen (HP L5006tm / HP L5009tm / HP L5015tm)	523
9.8	HP MSR.....	526
9.9	HP Font Loader	528
9.10	HP rp3000 Optical Door	530
9.11	HP Pole Display	531
9.12	HP OPOS Logical Device Name Utility	532
9.13	HP ap5000 VFD	533
9.14	HP ap5000 VFD (non-OPOS)	533
9.15	HP ap5000 VFD (JPOS)	534
9.16	HP ap5000 VFD (OPOS)	535
9.17	HP ap5000 MSR	536
9.18	HP ap5000 MSR (JPOS/OPOS).....	536
9.19	Imaging Scanner - JPOS.....	537
9.20	HP Imaging Barcode Scanner	539
9.21	Multiple HP Barcode Scanner	539
9.22	HP Biometric Fingerprint Reader	541
9.23	HP RP7 / RP3 Monitor	542
9.24	HP Retail Jacket for ElitePad Barcode Scanner	543
9.25	HP 7" CFD	545

Version Change History

Document Version	Description of Change(s)
3.90	<ul style="list-style-type: none"> • Removed USB OEM references for HP RP9 Integrated Bar Code Scanner. • Replaced Start Menu link references with default filesystem locations.
3.89	<ul style="list-style-type: none"> • Added HP Barcode Scanner H-Series section.
3.88	<ul style="list-style-type: none"> • Added HP ElitePOS G1 Retail System and peripherals.
3.87	<ul style="list-style-type: none"> • Updated HP 7" CFD section and Q & A HP 7" CFD section. • Added HP RP9 Integrated Dual-Head MSR.
3.86	<ul style="list-style-type: none"> • Updated Integrated Cash Drawer Port section.
3.85	<ul style="list-style-type: none"> • Updated HP Retail Jacket for ElitePad Barcode Scanner section.
3.84	<ul style="list-style-type: none"> • Added HP RP9 G1 Retail System reference to sections 7.2 and 7.4.
3.83	<ul style="list-style-type: none"> • Added HP RP9 G1 Retail System information and peripherals, including pictures. • Removed most references to HP Point of Sale System Software and Documentation CD since it is no longer being maintained. • Updated OPOS logical name table.
3.82	<ul style="list-style-type: none"> • Updated OPOS logical name table. • Added picture of the HP value wireless scanner. • Updated receipt printer section to include Ethernet info. • Added question of driver version in the printer Q&A section. • Added L5105tm info to the document in the L5009tm section. • Updated screen shots in L5006tm / L5009tm / L5015tm to reflect drivers version 5.6.0 • Removed the Hardware wizard section. • Added to the Q & A section a question in regards HP USB Cash Drawer.
3.81	<ul style="list-style-type: none"> • Updated MSR section to include single head MSR. • Updated OPOS logical name table. • Updated HP 7" CFD Q&A section. • Updated screen shoots in the receipt printer OPOS section.
3.80	<ul style="list-style-type: none"> • Added A798 Info. • Corrected numbering of the steps in section 7.4.20. • Added HP 7" CFD / DisplayLink section. • Updated several screen captures in the document. • Removed START MENU screen capture. • Added Receipt Printer Windows mini-driver v1.0.5 information. • Added info about HP LCM220 and LCM960 Display. • Added HP R2 Retail System Model 2000/2030 Info • Updated MSR JPOS screen captures.

1 Introduction

This document contains setup and quick testing information for HP Point of Sale (POS) peripherals and systems.

Note: All HP Point of Sale (POS) peripherals are not available worldwide; please check with the HP reseller in your area for the available HP peripherals.

2 General Information

2.1.1 Where to obtain the latest software for the HP POS Peripherals

The latest released versions of software for the HP peripherals are available on the HP.COM web site. Once you have navigated to your HP Point of Sale platform on the HP.COM web site and have selected the operating system you will see the “download by category” section (as shown below). Please go to the appropriate category to obtain the software package.

- Quick jump to downloads by category...
- » BIOS
 - » Diagnostic
 - » Driver - Audio
 - » Driver - Chipset
 - » Driver - Graphics
 - » Driver - Keyboard, Mouse and Input Devices
 - » Driver - Modem
 - » Driver - Network
 - » Driver - Storage
 - » Operating System - Enhancements and QFEs
 - » Software - Multimedia
 - » Software - PoS
 - » Software - PoS - Keyboard
 - » Software - PoS - MSR
 - » Software - PoS - Pole Line Display
 - » Software - PoS - Receipt Printer
 - » Software - PoS - Scanner
 - » Software - Solutions
 - » Software - System Management
 - » Utility - Tools

The “Software – POS” section is a generic section that is used for HP POS drivers that do not have their own category section on the web site. For example, the “OPOS Common Control Objects” Softpaq would be found there.

2.1.2 OPOS and CCO Drivers/Application

On the HP Point of Sale System that have HP’s Microsoft Windows operating image, the OPOS drivers for the HP branded peripherals have been installed in the image (thermal receipt printers / stand-alone MSR / hand scanner / POS keyboard with integrated MSR / pole display). The Common Control Object (CCO) version 1.9.000 (or later) have also been installed/registered in the HP Windows operating system image.

3 Port Information

To identify the type and number of ports available on the system, refer to the Hardware Reference Guide included in the HP factory image and available from the Product Information support section of HP.COM.

4 OPOS Name for HP Point of Sale Peripherals

The following are the Default OPOS logical names for the HP Point of Sale Peripherals:

Device	Default OPOS Logical Name
HP Barcode Scanners	
HP ElitePOS 2D Barcode Scanner	N3680-HP
HP Imaging Barcode Scanner	HPImagerScanner
HP Linear Barcode Scanner	HPLinearScanner
HP Linear Barcode Scanner II	HPLinearScanner
HP Presentation Barcode Scanner	HPPresentationScanner
HP Retail Integrated Barcode Scanner	HPIntegratedImagingBarcodeScanner
HP Retail Jacket for Elitepad Barcode Scanner	HPMobileScanner
HP RP9 Integrated Bar Code Scanner-Bottom	HPIntegratedSLImgScn
HP RP9 Integrated Bar Code Scanner-Side	HPIntegratedSLImgScn
HP Value 2D Wireless Scanner	HPQSWirelessScanner
HP Wireless Barcode Scanner	HPWirelessBTScanner
HP Cash Drawers	
HP Flip Top Cash Drawer	Connected to...
HP Heavy Duty Cash Drawer	Connected to...
HP Standard Duty Cash Drawer	Connected to...
Receipt Printer:	
HP Dual Serial USB Thermal Receipt Printer	A799-1 A799-2
HP ElitePOS Column Printer	CashDrawerH300C-1 CashDrawerH300C-2
HP ElitePOS Serial USB Thermal Printer	CashDrawerH300-1 CashDrawerH300-2
HP Hybrid POS Printer with MICR II	A776-1 A776-2
HP Hybrid Thermal Printer with MICR	A776-1 A776-2
HP LAN Thermal Receipt Printer	A799-1 A799-2
HP PUSB Thermal Receipt Printer	A799-1 A799-2
HP USB Receipt Printer	A794-1 A794-2
HP Value PUSB Receipt Printer	A798-1 A798-2
HP Value Serial USB Receipt Printer	A798-1 A798-2
HP Value Serial/USB Receipt Printer II	A798-1 A798-2
Retail Hub:	
Cash Drawer Port	HPCDPORT-1 HPCDPORT-2
Retail System:	
Cash Drawer Port	HP_CashDrawerPort-1 HP_CashDrawerPort-2
HP USB Cash Drawer	HPUSBCashDrawer-1 HPUSBCashDrawer-2

HP Line Displays	
HP ElitePOS Top Mount 2 x 20 CFD	HPTD620Display
HP Graphical POS Pole Display	HPPOSCCPoleDisplay
HP POS Pole Display	HP POS Pole Display
HP Retail Integrated 2x20 Complex	HPLCM960Display
HP Retail Integrated 2x20 Display	HPLCM220Display
HP Retail RP7 VFD Customer Display	HPPOSCCPoleDisplay
HP RP9 2x20 LCD Top Mount without Arm	HPLM940Display
HP RP9 Integrated 2x20 Display Btm w/Arm	HPLM940Display
HP RP9 Integrated 2x20 Display Top w/Arm	HPLM940Display
HP MSR's	
HP ap5000 Magnetic Stripe Reader	Hpap5000MSR
HP ElitePOS MSR	HPSinglenoSRDMSR
HP Retail Integrated Dual-Head Magnetic Stripe Reader	HPUSBDualMSR HPUSBDualEncryptMSR
HP Retail Jacket for Elitepad MSR	HPUSBShcMSR
HP RP2 Integrated Single Head MSR w/o SRED	HPSinglenoSRDMSR
HP RP7 Single Head Magnetic Stripe Reader w/o SRED	HPSinglenoSRDMSR
HP RP9 Integrated Dual-Head MSR	HPUSBDualMSR HPUSBDualEncryptMSR
HP RP9 Integrated Single-Head MSR	HPSinglenoSRDMSR
HP USB Mini Magnetic Stripe Reader with Brackets	HPUSBMiniMSR
HP POS Keyboards	
HP POS Keyboard	HPPOSKeyboard
HP USB POS Keyboard with Magnetic Stripe Reader	HPKBMSR
HP Receipt Printers	
HP Dual Serial USB Thermal Receipt Printer	A799
HP ElitePOS Column Printer	H300
HP ElitePOS Serial USB Thermal Printer	H300
HP Hybrid POS Printer with MICR II	A776
HP Hybrid Thermal Printer with MICR	A776
HP LAN Thermal Receipt Printer	A799
HP PUSB Thermal Receipt Printer	A799
HP USB Receipt Printer	A794
HP Value PUSB Receipt Printer	A798
HP Value Serial USB Receipt Printer	A798
HP Value Serial/USB Receipt Printer II	A798

5 OPOS Logical Device Name Utility

The “HP OPOS Logical Device Name Utility” can be used to obtain the logical name of the OPOS drivers that are installed on the unit. The utility also provides the ability to change the OPOS logical name of the device. For the HP Point of Sale (POS) peripherals the utility also provides the ability to set the HP POS peripherals back to the factory default logical name.

Note: In order to use this utility, the utility must be run from a location that has read/write access and one must have administrator privileges on the unit where the utility is being run on.

Please consult your point of sale application support center or your IT support department before making any changes to the OPOS device name.

5.1 Main GUI

The following is the GUI of the “HP OPOS Logical Device Name Utility” when the utility is opened:

Note: The screen captures are examples, what appears when the utility is run on the unit may differ than the screen capture in this section.

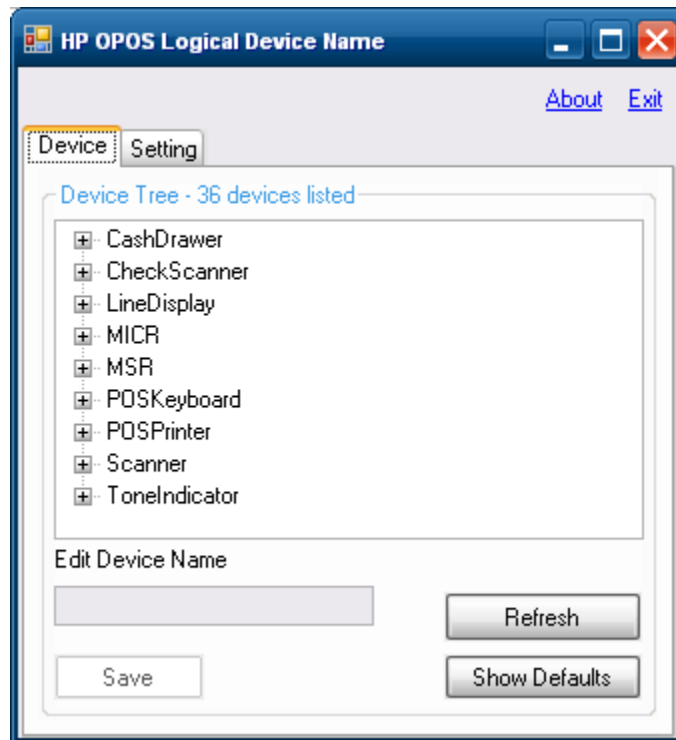

- The “Device” tab in the utility reflects the OPOS drivers that are installed on the unit:

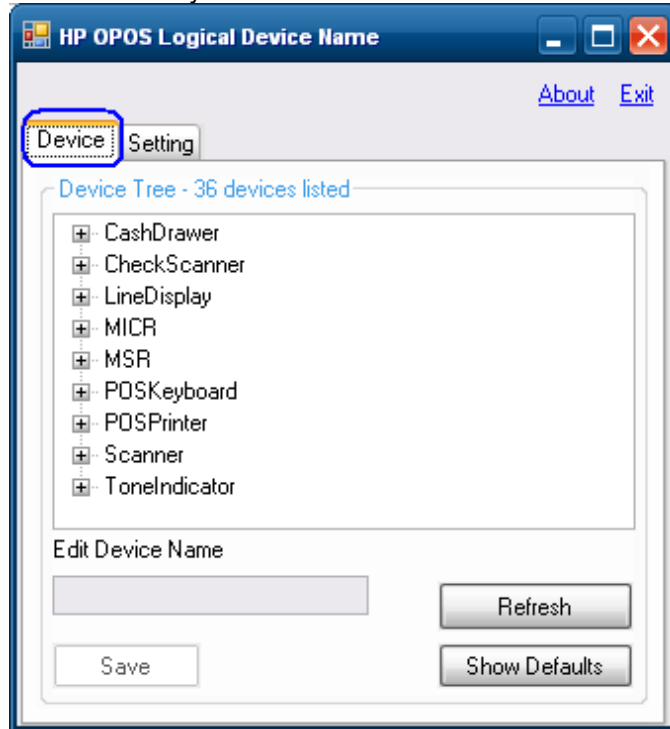

- The “Refresh” button will refresh the device tree information:

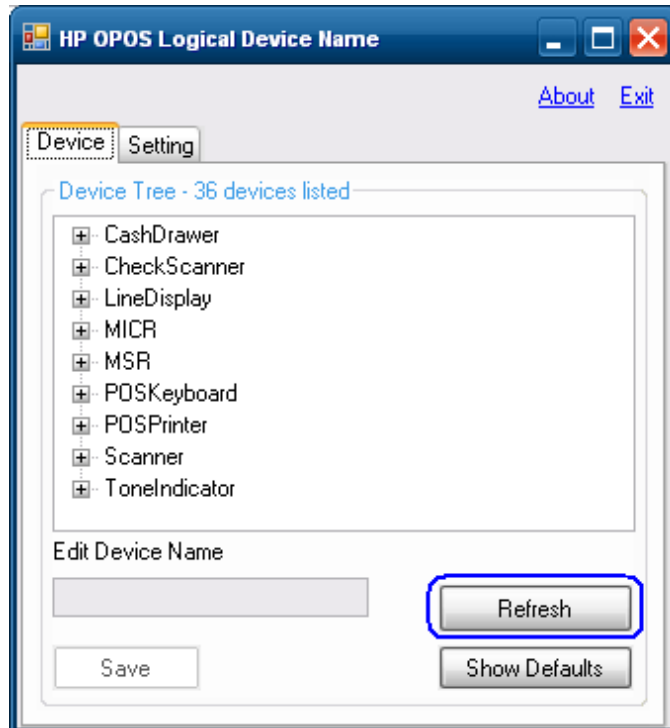

- The “Show Default” button will allow one to set the HP peripherals to default factory name (see section 5 for more details):

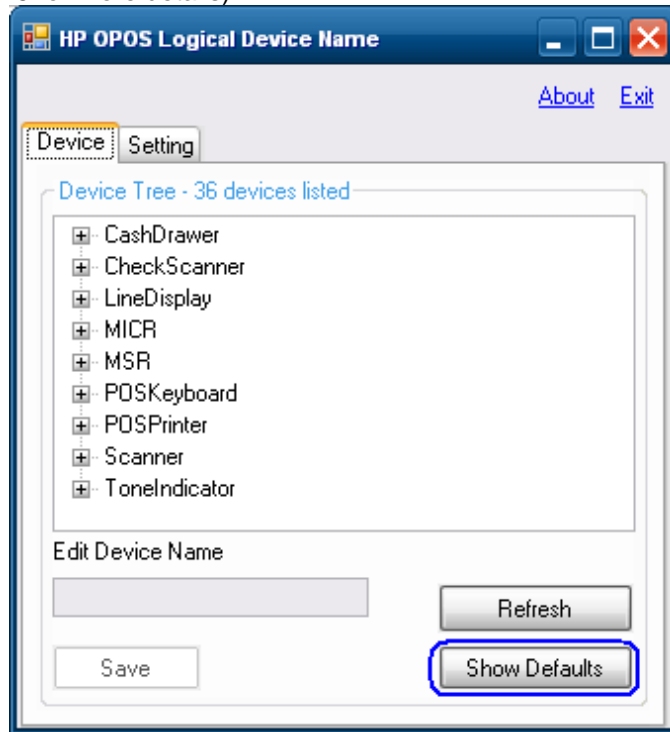

- The “Setting” tab in the utility reflects the registry location where the utility obtains the data that is displayed in the “device” tab:

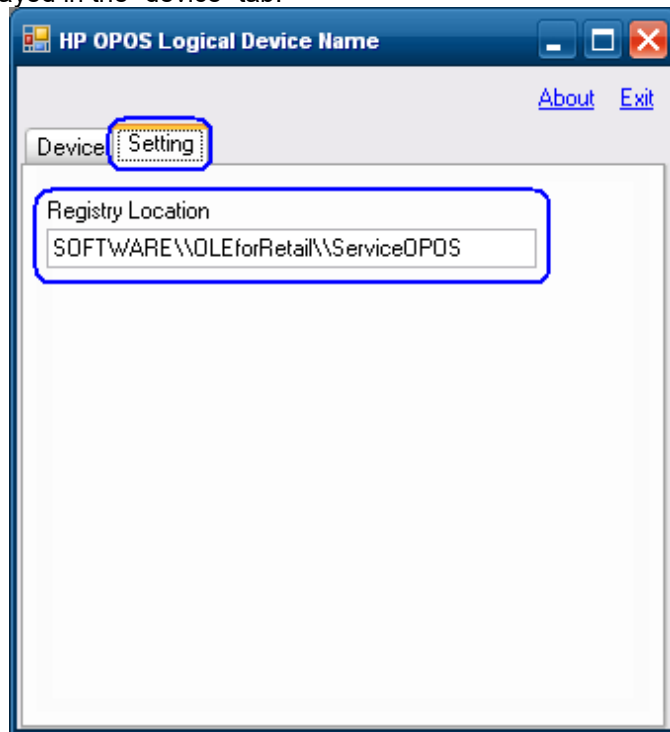

- The “About” tab provides version information on the utility:



- Either the “Exit” or “X” can be used to exit the application:

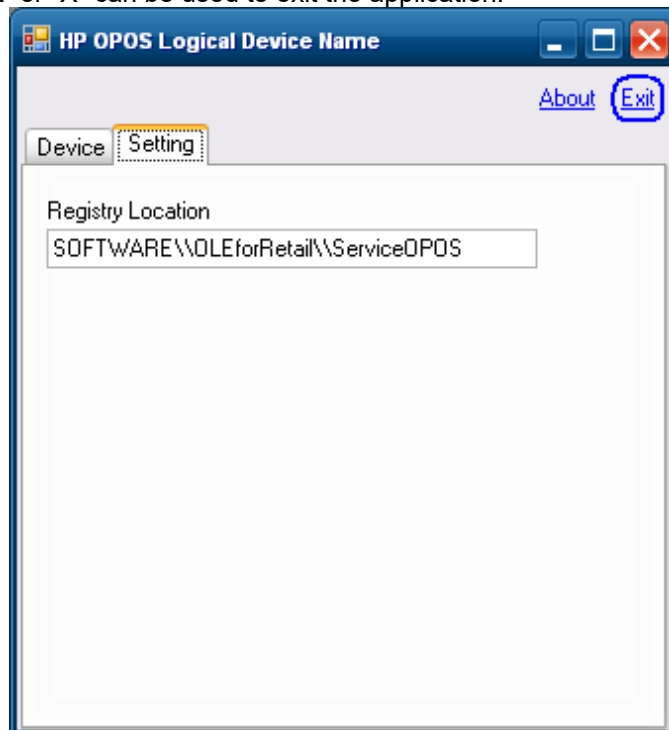

5.2 Obtain OPOS Logical Device Name(s)

The following section describes how to obtain the OPOS logical device names that are installed on the unit.

5.2.1 Overview Steps

The following is an overview of the steps to obtain the OPOS device name:

1. Open the utility.
2. Select the "Device" tab.
3. Expand the device tree for which you would like to obtain the OPOS device name.

5.2.2 Detailed Steps

The following are detailed steps to obtain the OPOS device name:

1. Open the utility.
2. Select the "Device" tab.



3. Expand the device tree for which you would like to obtain the OPOS device name.
 - o The following shows the “LineDisplay” tree expanded. The OPOS device name that is installed on the unit in this example is “HP POS Pole Display”

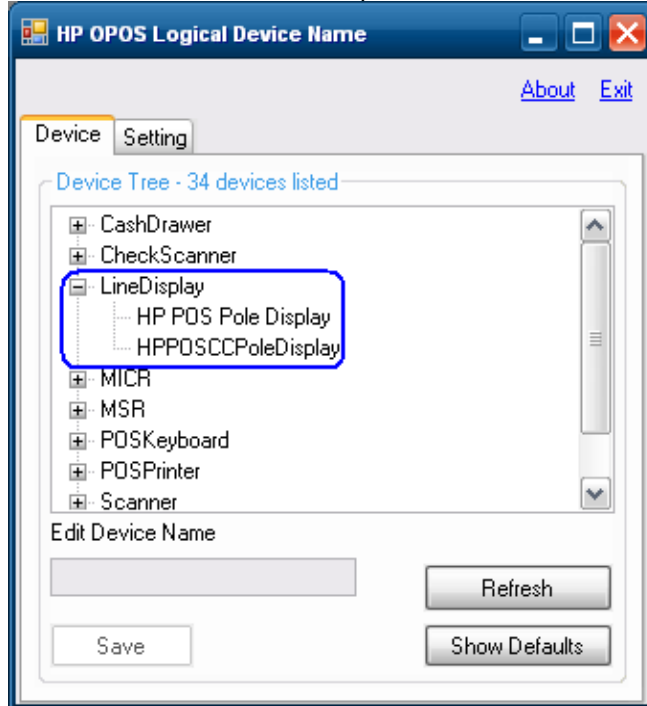

Note: This is an example and may not reflect what is installed on your system. Your system may have more or less items installed.

- o The following shows the “MSR” tree expanded. The OPOS device name that is installed on the unit in this example is “HPUSBMINIMSR”:

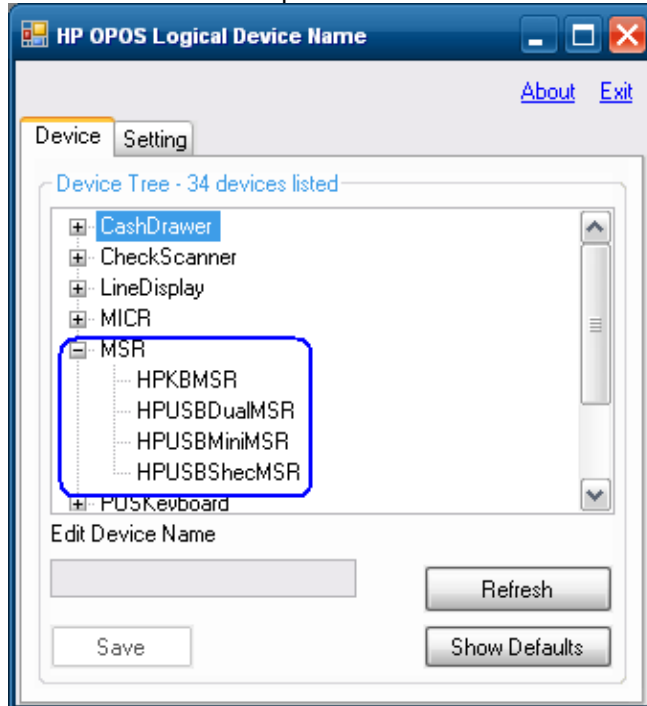

Note: This is an example and may not reflect what is installed on your system. Your system may have more or less items installed.

- The following shows the “POSPrinter” tree expanded. The OPOS device names that are installed on the unit in this example are “A776 / A794 / A798 / A799”:

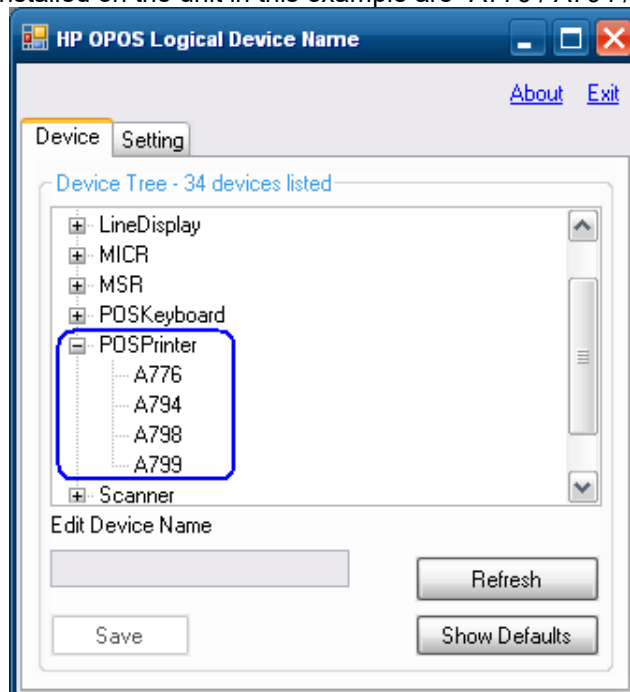

Note: This is an example and may not reflect what is installed on your system. Your system may have more or less items installed.

- The following shows the “Scale” tree expanded which is a non-HP branded device. The OPOS device name that is installed on the unit in this example is “Avery Scale”:

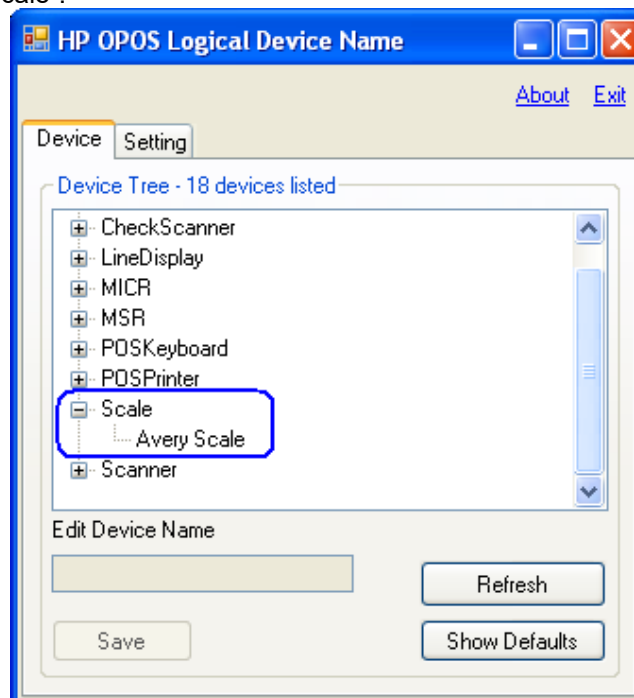

5.3 Change OPOS Logical Device Name(s)

The following section describes how to change the OPOS logical device names that are installed on the unit.

5.3.1 Overview Steps

The following is an overview of the steps to change the OPOS device name:

1. Once the utility is opened select the “Device” tab.
2. Expand the device tree for which you would like to change the OPOS device name.
3. Select the device name; it should also appear in the “Edit Device Name” box.
4. Enter the OPOS name that you wish the device to be.
5. Once the device name has been entered click on the “SAVE” button.
6. You will be asked to confirm that you want to make the change.

5.3.2 Detailed Steps

The following are detailed steps on how to change the OPOS device name:

1. Once the utility is opened select the “Device” tab.

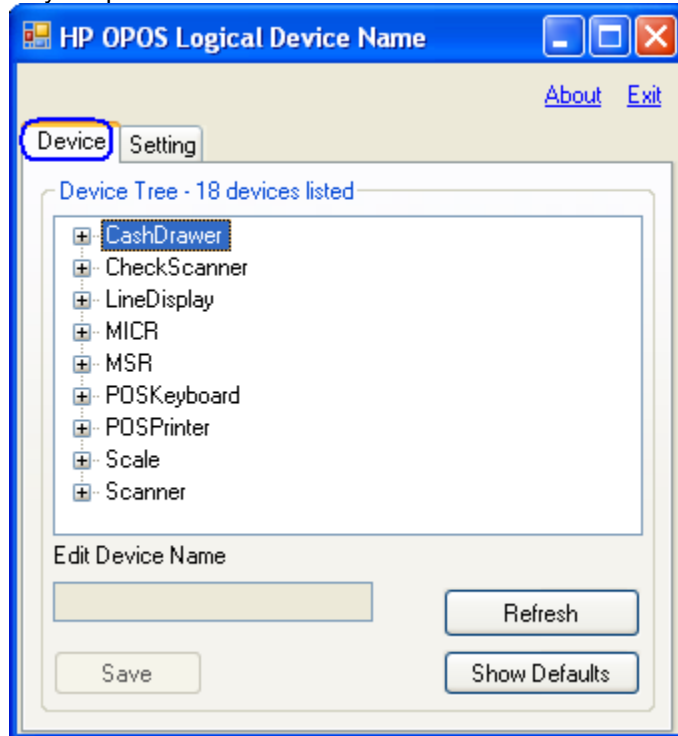

- Expand the device tree for which you would like to change the OPOS device name.

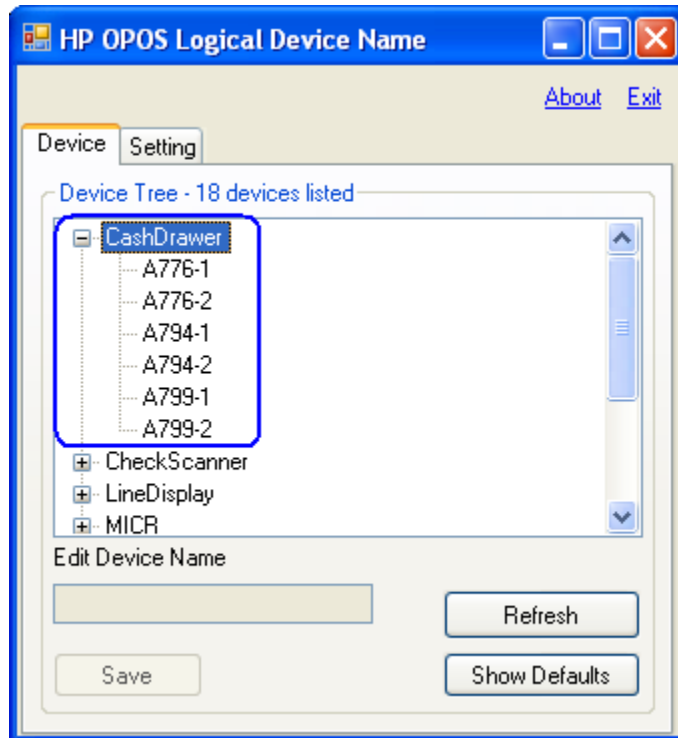

- Select the device name. The name should also appear in the "Edit Device Name" box once it is selected:

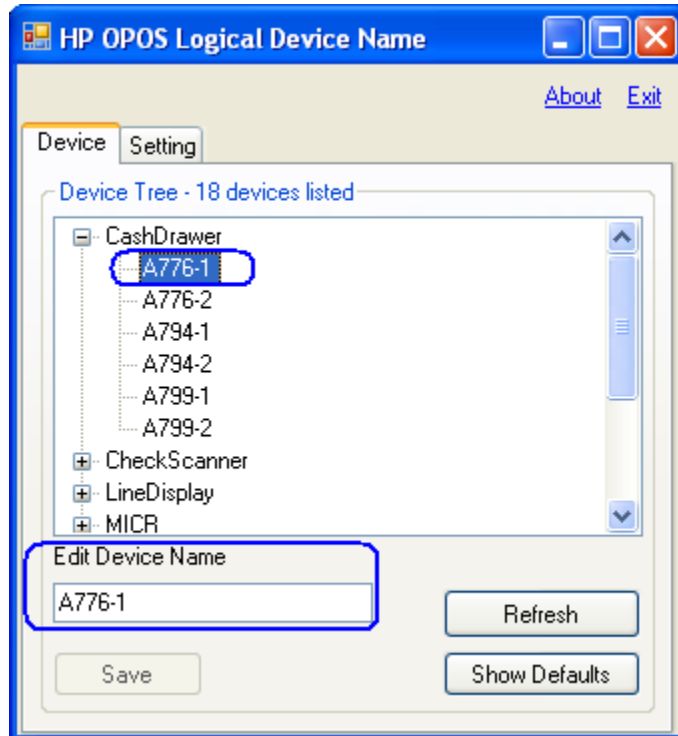

4. Enter/edit the OPOS name that you wish the selected device to be:

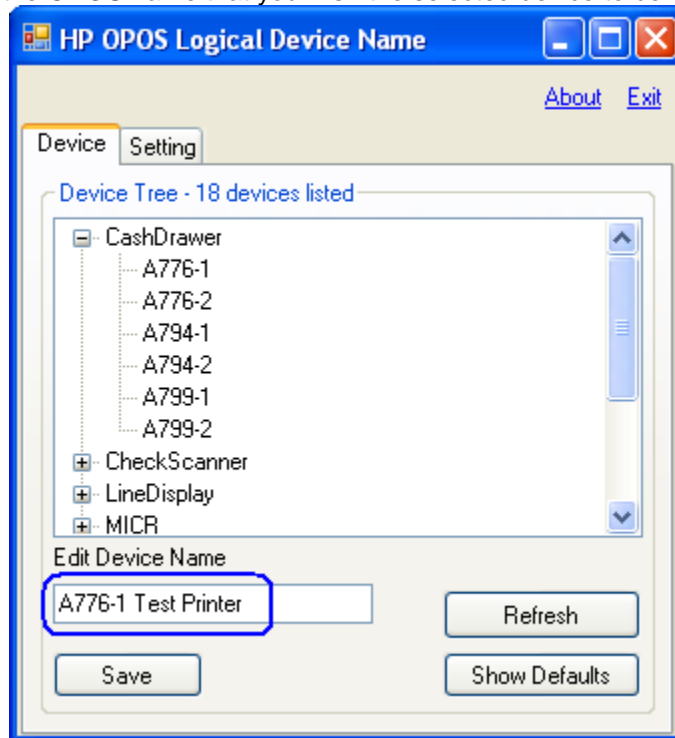

5. Once the device name has been entered in the edit box, click on the “SAVE” button:

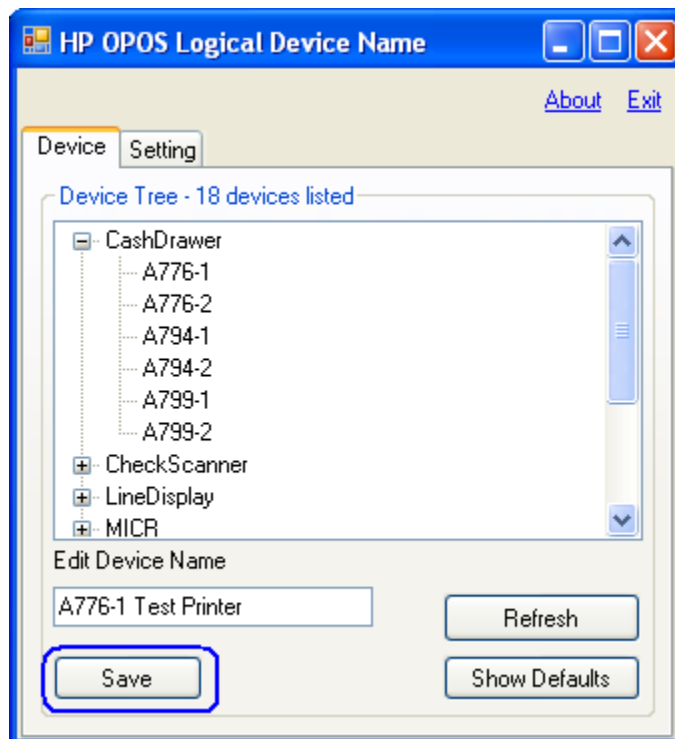

After clicking the "SAVE" button you will be prompted to confirm that you want to make the changes, click on "YES" to make the changes:

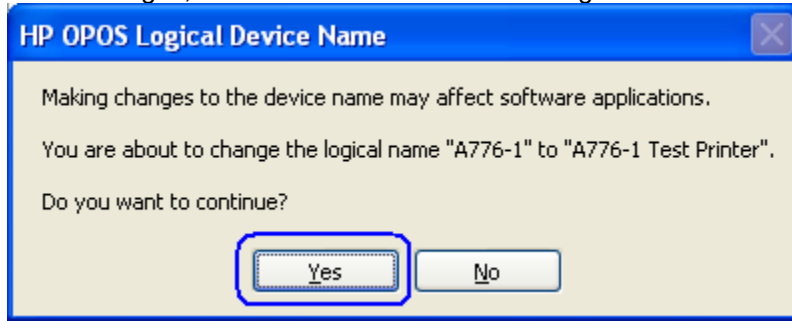

Once you have confirmed you want to make the changes the utility will refresh and close all the device trees. When one re-opens the particular tree that was changed, the device name that was changed is now highlighted (if you exit and re-open the application the device name will not be highlighted):

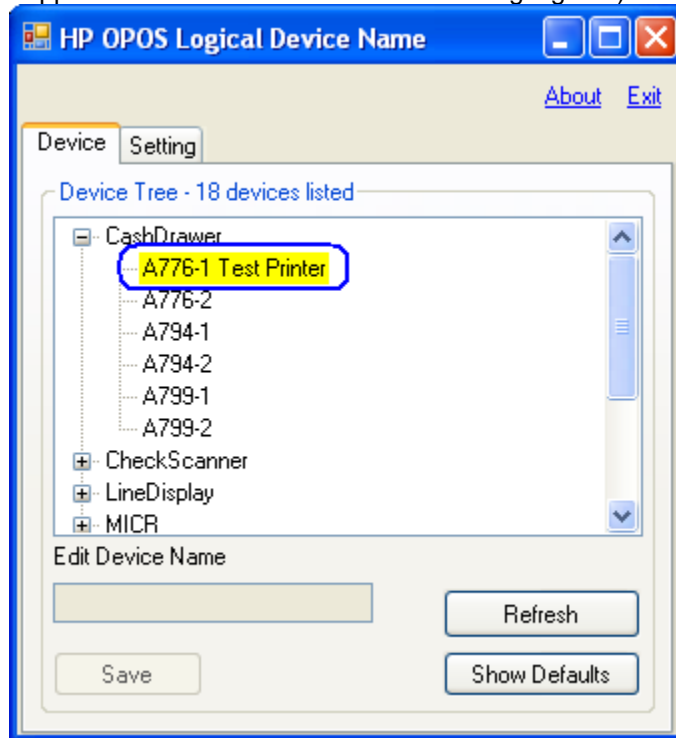

5.4 Set HP branded device to factory default OPOS logical name

The following section describes how to set the HP branded peripherals back to the factory default OPOS logical name.

Note: By default this utility will only set the HP branded peripherals to the factory default name if selected. Please refer to section 6 for non-HP branded peripherals being added to INI file.

5.4.1 Overview Steps

The following is an overview of the steps to change the OPOS device name:

1. Once the utility is opened select the “Device” tab.
2. Select the device you wish to change back to the factory default name.
3. Click on the “Show Default” button.
4. Select the category of the device that you would like to set back to the factory default OPOS name.
5. Select the device of the device that you would like to set back to the factory default OPOS name.
6. Click on “Set Default” button and you will be asked to confirm that you want to make the change.

5.4.2 Detailed Steps

The following are detailed steps to change the OPOS device name:

1. Once the utility is opened select the “Device” tab.

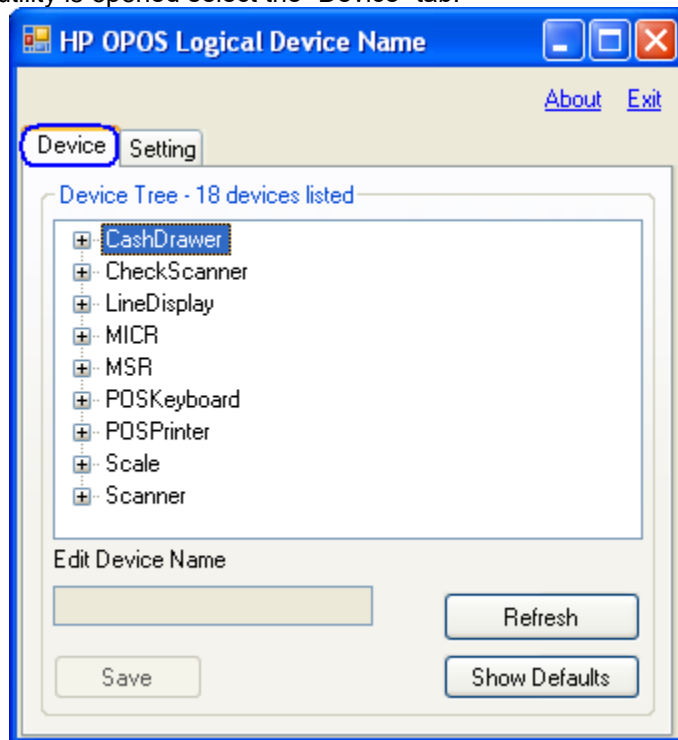

2. Select the device you wish to change back to the factory default name:

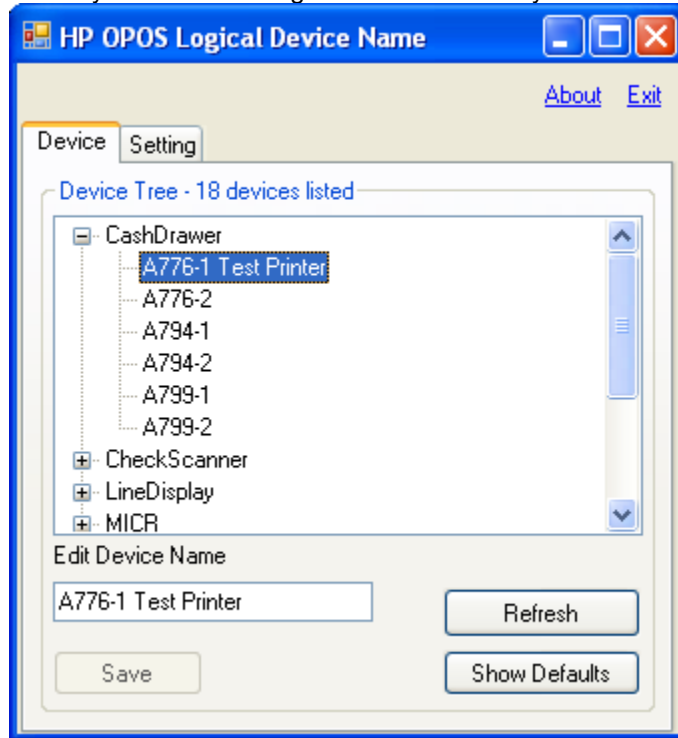

3. Click on the "Show Default" button:

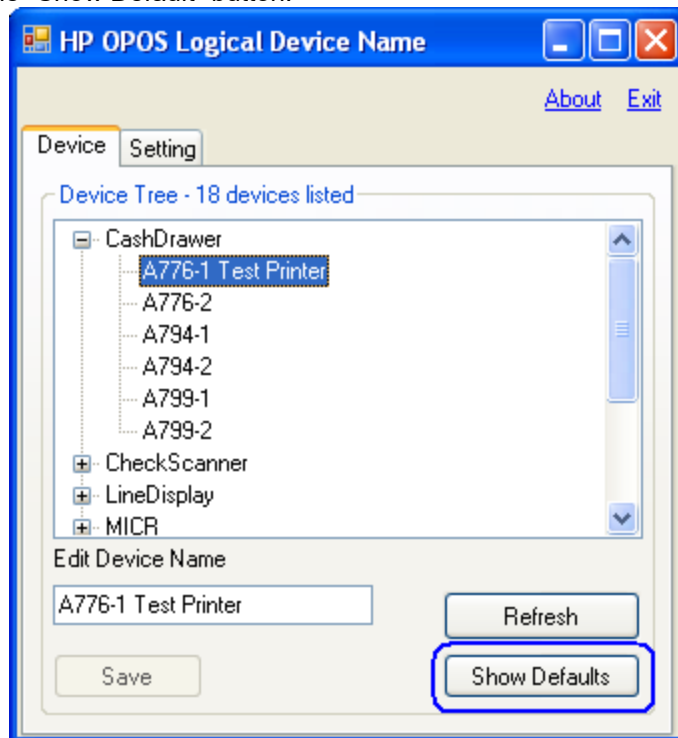

The following shows the utility GUI after the “Show Defaults” button has been clicked:

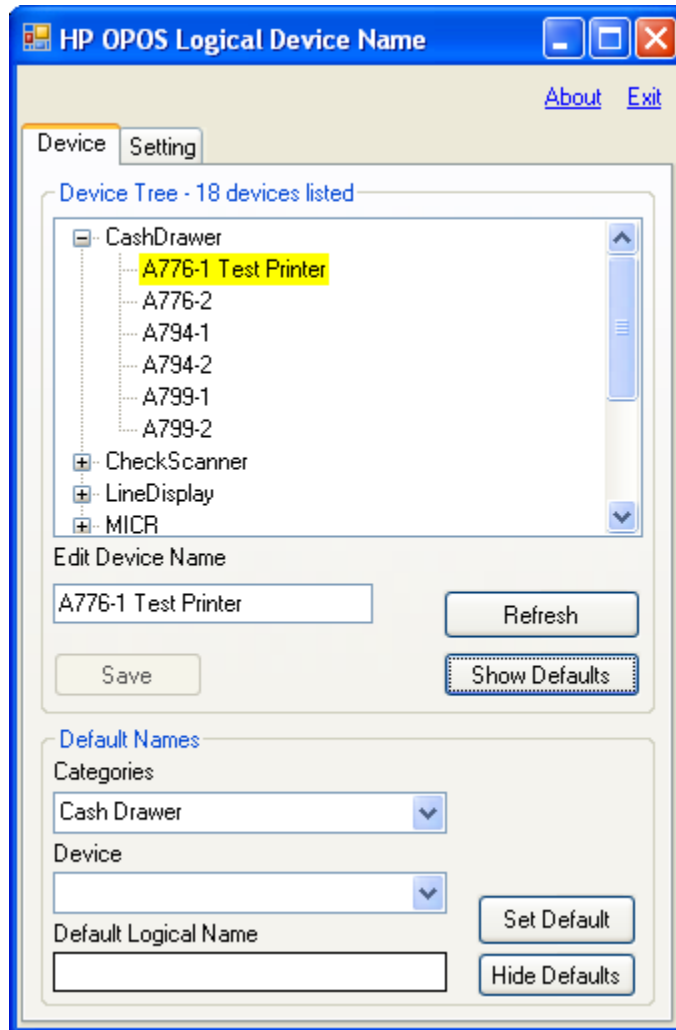

4. Select the category of the device that you would like to set back to the factory default OPOS name.

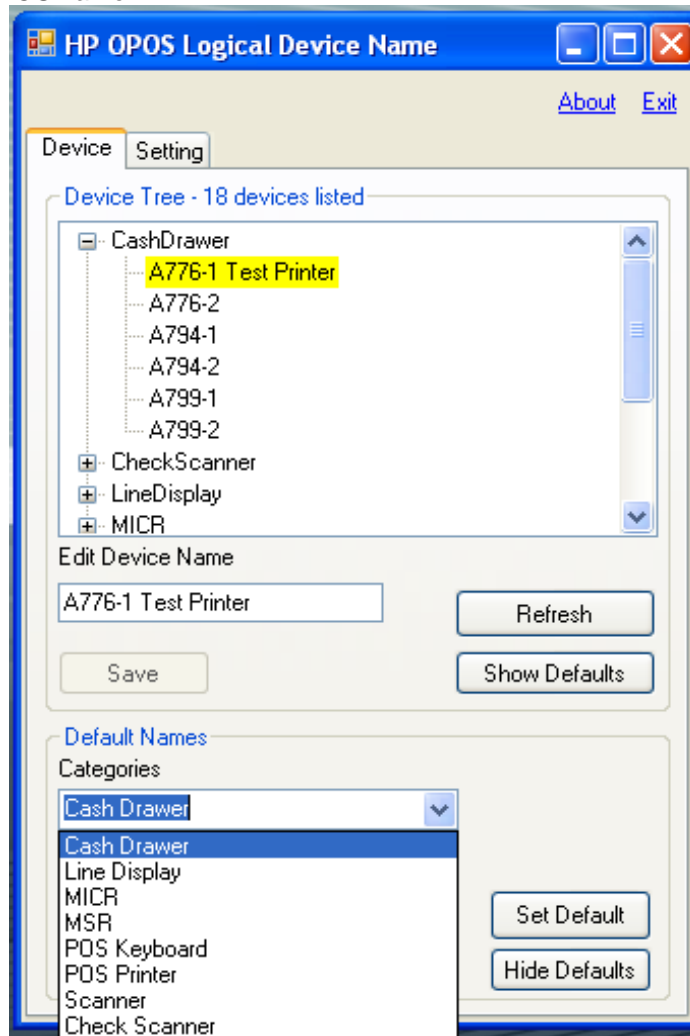

5. Select the device of the device that you would like to set back to the factory default OPOS name.

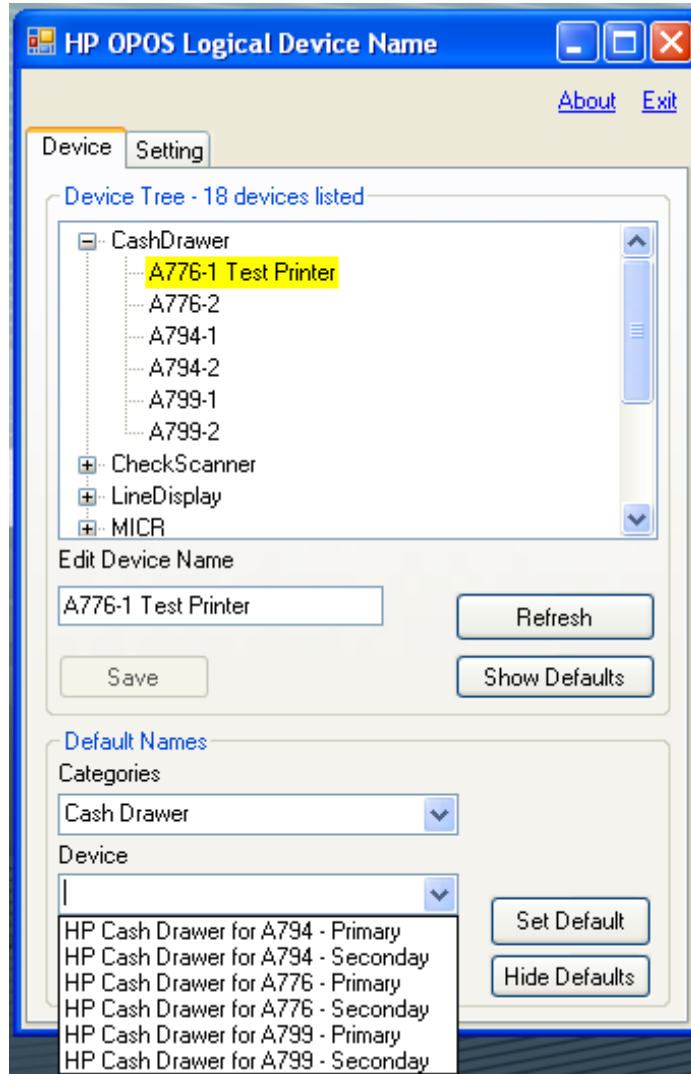

- Once you have selected the device the factory default name will be entered into the “Default Logical Name” box.

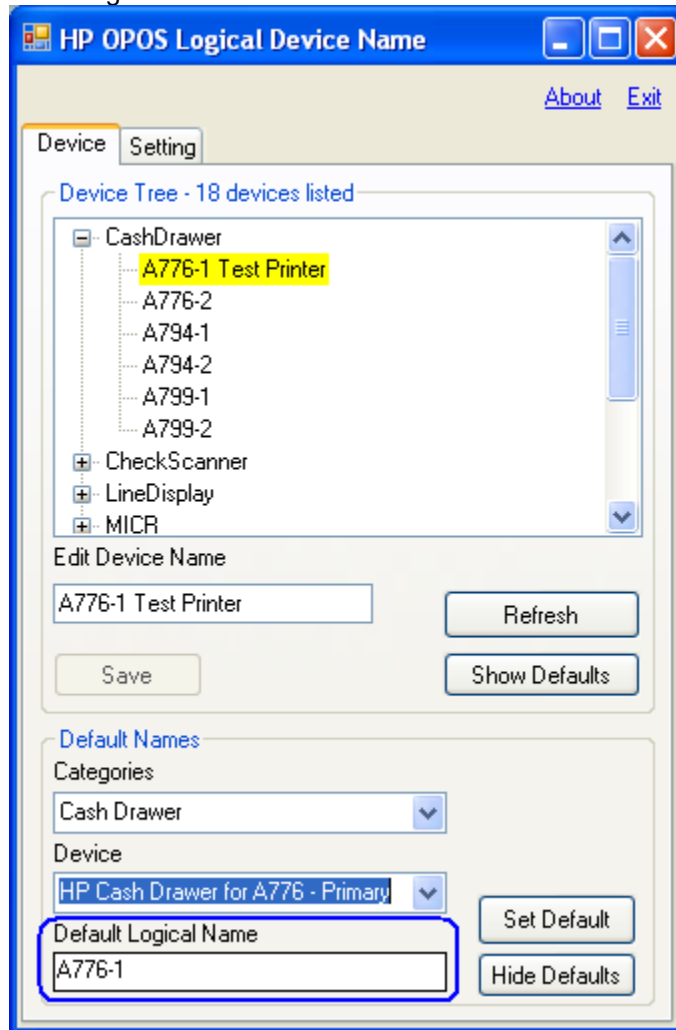

- To save the default name click on the “Set Default” button:

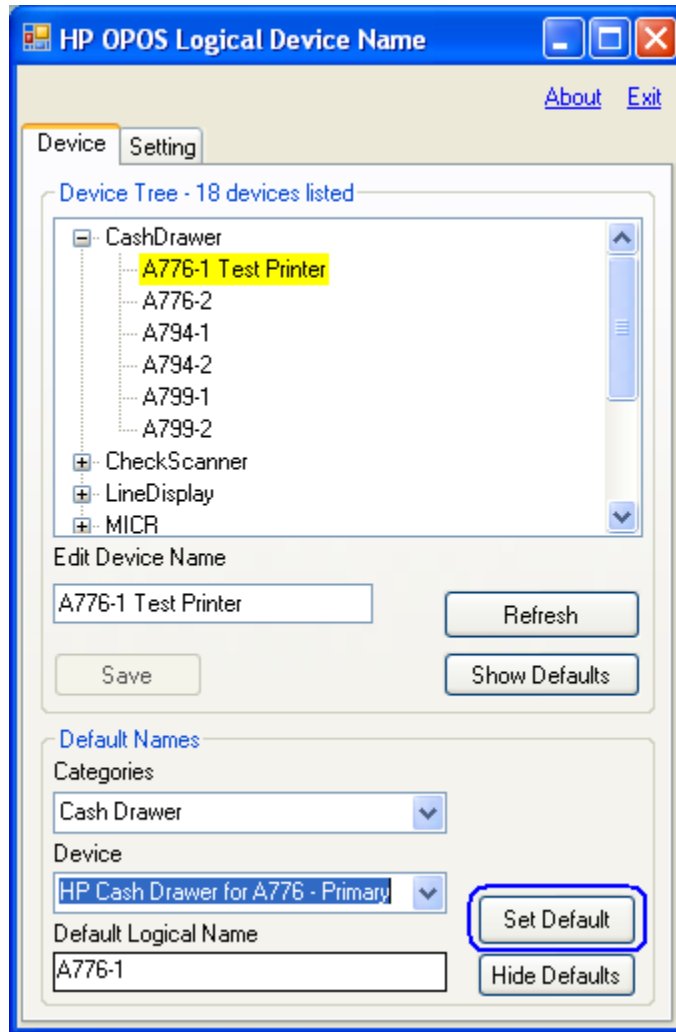

- 6. You will be asked to confirm that you want to make the change:

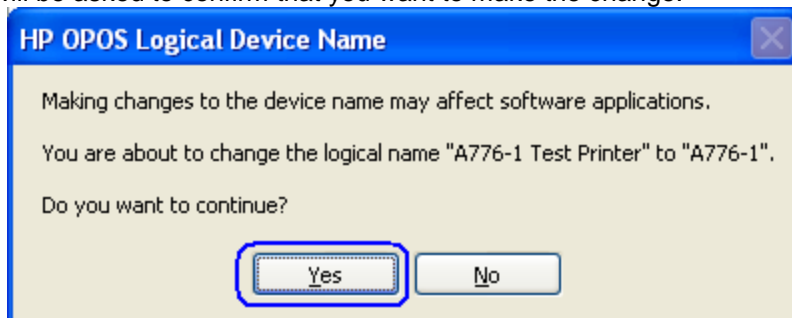

5.4.3 **Default INI File**

When the “HP OPOS Logical Device Name” utility is opened a default INI file is created if it does not already exist. The “default.ini” file is used by the utility for the default names of the HP peripherals in the default drop box section of the utility. If the “default.ini” is modified for non-HP peripherals those should appear in the default drop box section of the utility.

5.4.4 **Adding non-HP Peripherals to the default drop down**

One can add non-HP peripherals to the default INI file in order to have the device appear as a selectable device in the drop down menu in the default name section of the utility.

The following is example of adding a scale to the “default.ini” file so the name appears in the drop down menu.

The following is showing the drop down menu in the default state (no modification to the INI file):

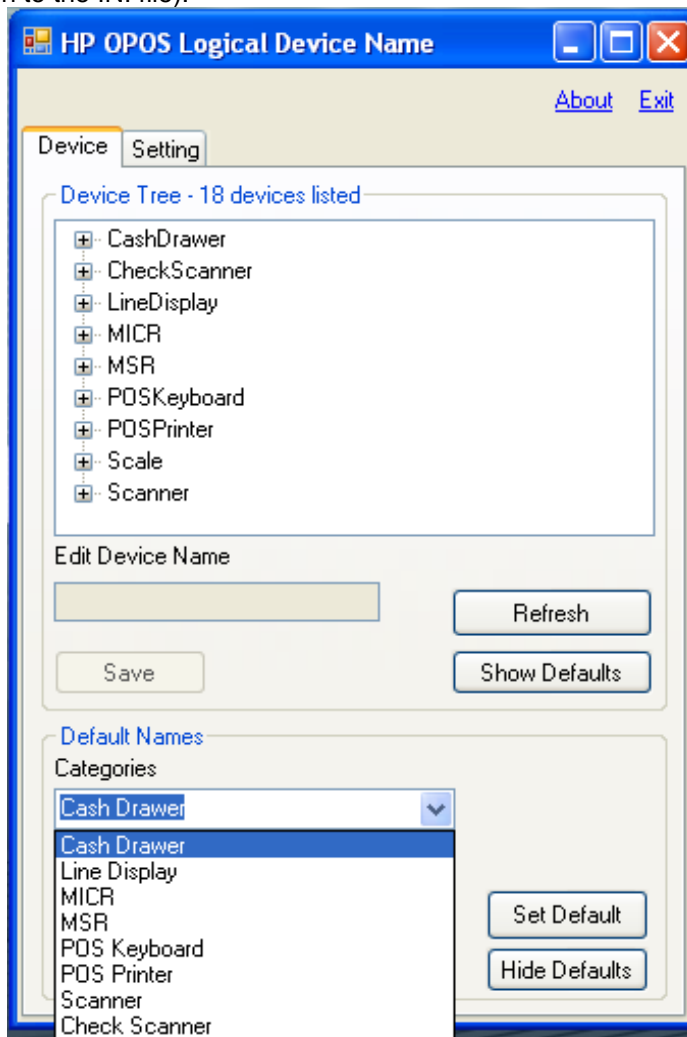

The following is showing the default INI file which reflects the above screen capture:

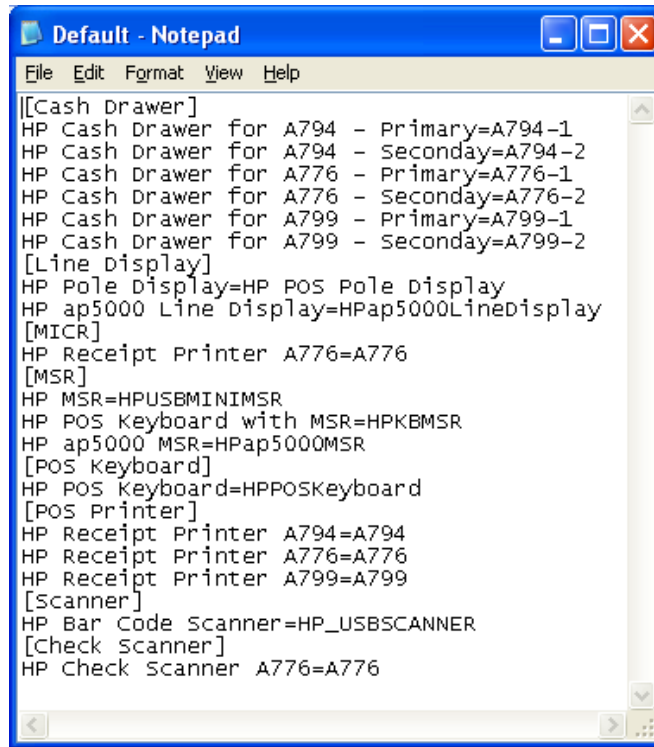

```
Default - Notepad
File Edit Format View Help
[[Cash Drawer]
HP Cash Drawer for A794 - Primary=A794-1
HP Cash Drawer for A794 - Seconday=A794-2
HP Cash Drawer for A776 - Primary=A776-1
HP Cash Drawer for A776 - Seconday=A776-2
HP Cash Drawer for A799 - Primary=A799-1
HP Cash Drawer for A799 - Seconday=A799-2
[Line Display]
HP Pole Display=HP POS Pole Display
HP ap5000 Line Display=HPap5000LineDisplay
[MICR]
HP Receipt Printer A776=A776
[MSR]
HP MSR=HPUSBMINIMSR
HP POS Keyboard with MSR=HPKBMSR
HP ap5000 MSR=HPap5000MSR
[POS Keyboard]
HP POS Keyboard=HPPOSKeyboard
[POS Printer]
HP Receipt Printer A794=A794
HP Receipt Printer A776=A776
HP Receipt Printer A799=A799
[Scanner]
HP Bar Code Scanner=HP_USBSCANNER
[Check Scanner]
HP Check Scanner A776=A776
```

If the “default.ini” file is modified to add a device (i.e. scale) the default INI file would look something like the following:

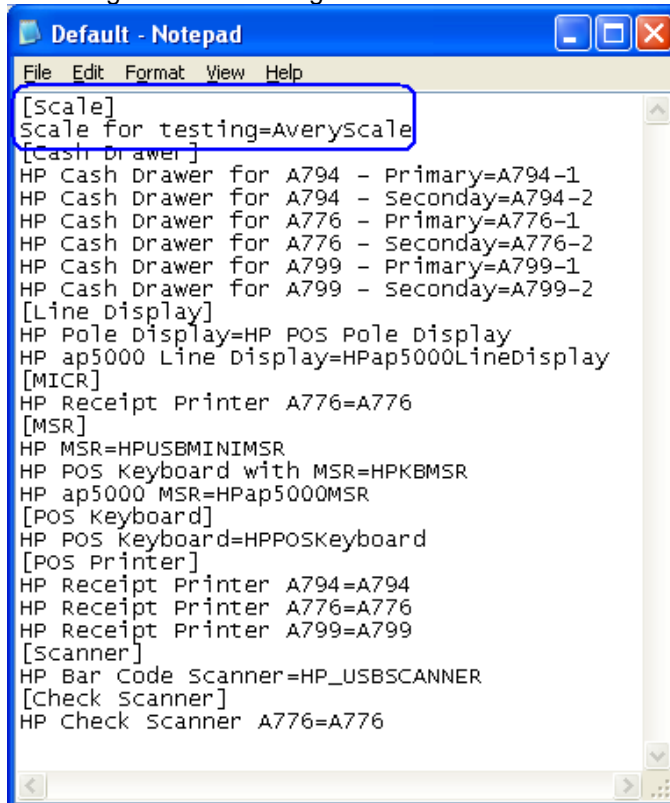

```
Default - Notepad
File Edit Format View Help
[Scale]
Scale for testing=Averyscale
[[Cash Drawer]
HP Cash Drawer for A794 - Primary=A794-1
HP Cash Drawer for A794 - Seconday=A794-2
HP Cash Drawer for A776 - Primary=A776-1
HP Cash Drawer for A776 - Seconday=A776-2
HP Cash Drawer for A799 - Primary=A799-1
HP Cash Drawer for A799 - Seconday=A799-2
[Line Display]
HP Pole Display=HP POS Pole Display
HP ap5000 Line Display=HPap5000LineDisplay
[MICR]
HP Receipt Printer A776=A776
[MSR]
HP MSR=HPUSBMINIMSR
HP POS Keyboard with MSR=HPKBMSR
HP ap5000 MSR=HPap5000MSR
[POS Keyboard]
HP POS Keyboard=HPPOSKeyboard
[POS Printer]
HP Receipt Printer A794=A794
HP Receipt Printer A776=A776
HP Receipt Printer A799=A799
[Scanner]
HP Bar Code Scanner=HP_USBSCANNER
[Check Scanner]
HP Check Scanner A776=A776
```

When the utility is opened with the updated default.INI file it will look like:

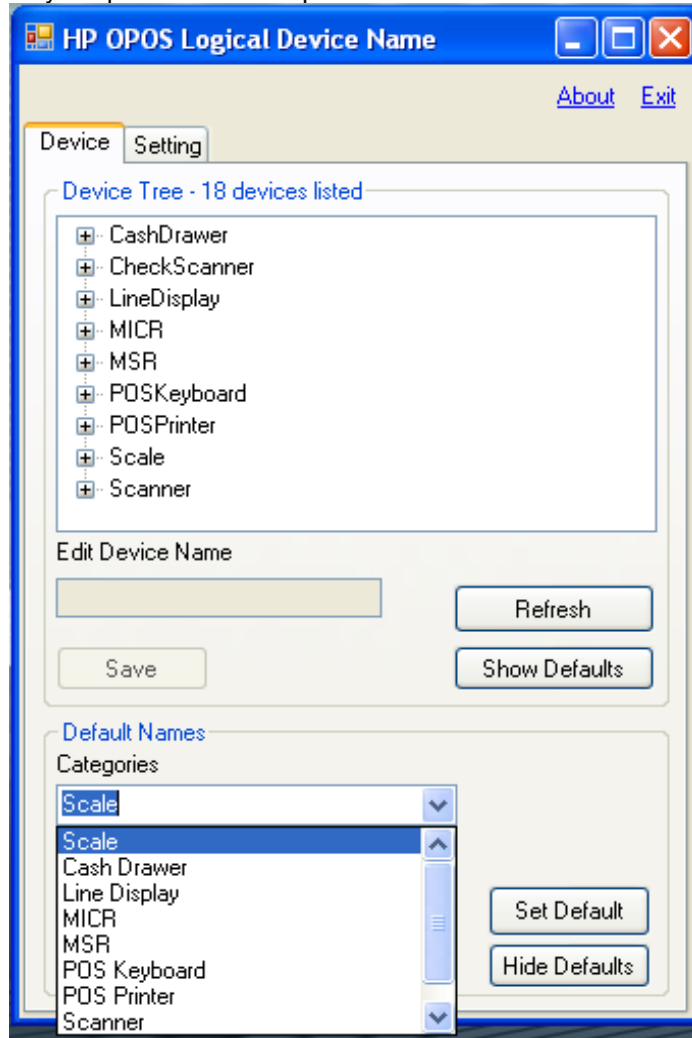

Note: If the OPOS drivers for the device are re-installed this may change the device name. The "HP OPOS Logical Device Name" utility does not install any OPOS drivers or any registry entries to the OPOS drivers.

6 Peripherals Connection and Software Installation

The USB peripherals should be installed after the Windows operating system has been unbundled. Installing one peripheral at a time will help determine which peripheral has an issue if a peripheral does not function. By installing one peripheral at a time, Windows may install the native drivers with very little user interaction needed during the native driver installation.

Please note that the drivers for the HP peripherals are included in the HP factory image and are also available from HP.COM.

In the following sections substitute “Compaq” or “SWSetup” for “xxxxx” when references are made to the HP factory image. For example when one sees “C:\xxxxx\Point of Sale\Receipt Printer\Cash Drawer” one would use “C:\Compaq\Point of Sale\Receipt Printer\Cash Drawer” for Windows XP Pro operating system and “C:\SWSetup\Point of Sale\Receipt Printer\Cash Drawer” for Vista / WEPOS / POSReady / Win7 / Win 8.1 / Win 10 operating system.

6.1 HP Cash Drawer and Flip-Top Cash Drawer



Heavy Duty Cash Drawer



Standard Duty Cash Drawer
and USB Cash Drawer



Flip-Top Cash Drawer

In the remainder of this document “cash drawer” will be used to refer to all cash drawers that are shown above.

6.1.1 Key lock position

The following shows the key lock position for the HP cash drawers:

Heavy Duty Cash Drawer

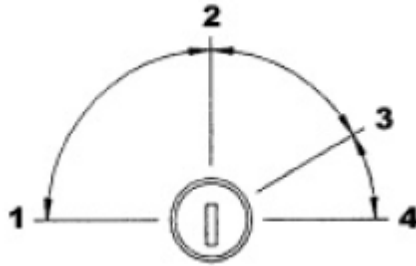

Lock Option	Description
1 (Locked Closed)	Prevents the cash drawer from being opened by electrical signal from the printer.
2 (Online)	Operation of the cash drawer is driven electronically by the printer.
3 (Manual Open)	Allow manual access to the contents of the cash drawer.
4 (Locked Open)	Prevents the cash drawer being latched closed.

Flip Top Cash Drawer / Standard Duty / USB Cash Drawer (below)

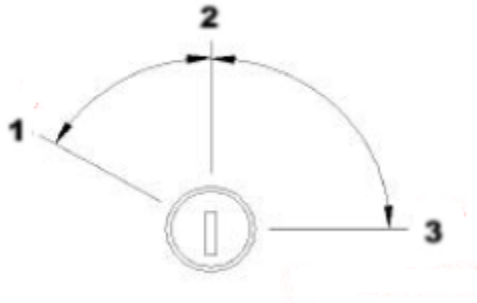

Lock Option	Description
1 (Manual Open)	Allow manual access to the contents of the cash drawer.
2 (Online)	Operation of the cash drawer is driven electronically by the printer.
3 (Locked)	Prevents the cash drawer being latched closed.

6.1.2 Connection

The cash drawer is attached to the back of the printer or integrated cash drawer port using a RJ12 type connector (the smaller connector).

The smaller connector connects to the back of the printer, the larger connector connects to the bottom of the cash drawer. The following are the cash drawer cable connectors:



The following is the bottom of the cash drawer where the bigger end of the cash drawer cable connects into:



The following is the back of the printer with the cover closed:



The following is the back of the printer with the cover open:



Close-up of cash drawer connector on the back of the printer:

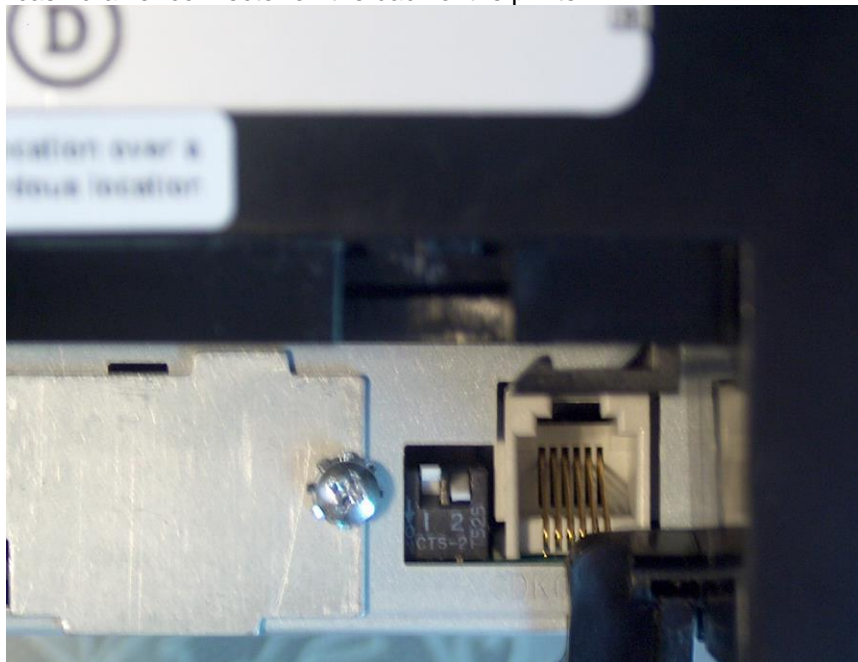

6.1.3 Windows Drivers for the Cash Drawer Drivers

There are no Windows drivers for the cash drawer. The cash drawer is controlled by the printer Windows mini-drivers thus the printer drivers need to be installed to electronically open the cash drawer.

Confirm that the cash drawer is connected to the back of the printer via the cash drawer cable.

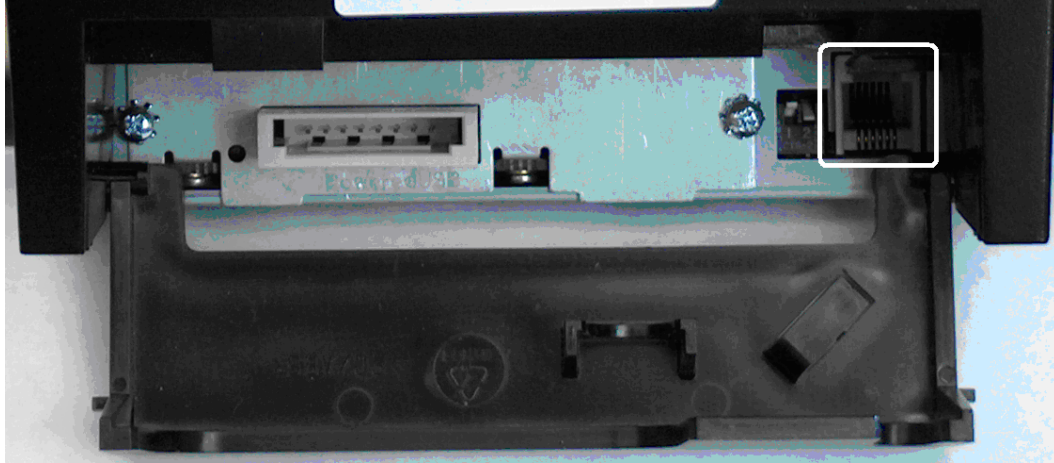

6.1.4 Cash Drawer Decimal Commands

Some POS application that use the Windows mini-drivers request the cash drawer open command so the application can open the cash drawer (i.e. No Sale). The following the decimal commands when attached to the HP receipt printer:

Cash drawer 1	Cash Drawer 2
27 112 0 8 8	27 112 1 8 8

Detailed explanation of the cash drawer command:

Generate pulse to open cash drawer

ASCII ESC p n p1 p2

Hexadecimal 1B 70 n p1 p2

Decimal 27 112 n p1 p2

Value of n: 00, 48 (Decimal) = Drawer 1;
01, 49 (Decimal) = Drawer 2

Value of p1: 0-255

Value of p2: 0-255

6.1.5 Dual Cash Drawer Connection

Dual cash drawer is possible with the HP Receipt printer or integrated cash drawer port. In order to have dual cash drawer configuration a Y-Cable is needed, and with this cable both the cash drawers are attached to the printer or integrated cash drawer port.

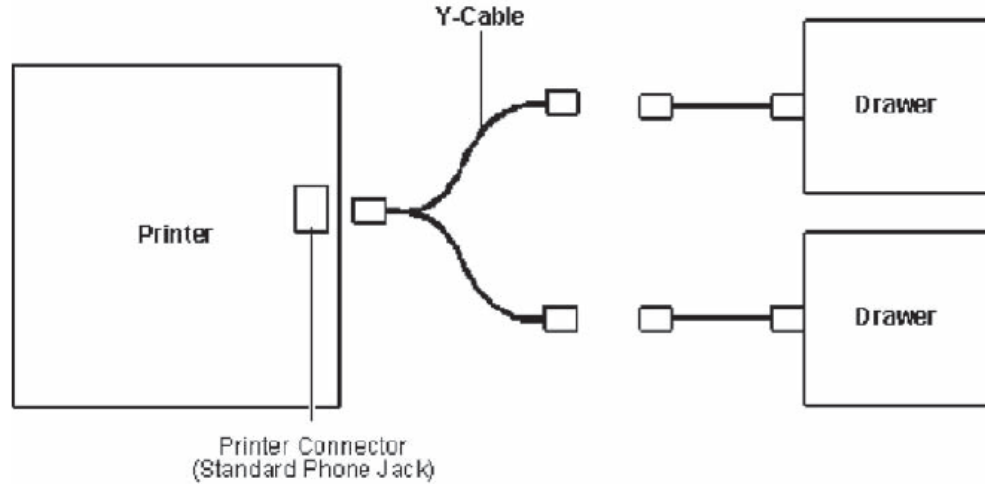

6.1.5.1 Cash Drawer Cable Info

In order to use dual cash drawer, one will need a Y-Adapter attached to the printer and will need to exchange one of the cash drawer cable with the 2nd cash drawer cable.

The following is the cash drawer cable part numbers for single cash drawer configuration:

1st Drawer**
CD-001A

The following are the cash drawer cable part numbers for a dual cash drawer configuration when the HP cash drawers are attached to HP receipt printer or directly to HP point of sale system that have integrated cash drawer port:

1st Drawer**	2nd Drawer	Y-Adapter
CD-001A	CD-001B	CD-D1D2

** This cable is shipped with the HP Cash drawer.

6.1.6 **OPOS Drivers for the Cash Drawer**

The OPOS drivers for the cash drawer are included in the printer OPOS driver installation. Confirm that the cash drawer is connected to the back of the printer via the cash drawer cable.

6.1.7 **OPOS Test Applet for the Cash Drawer**

The cash drawer may be tested with one of two utilities. The first utility will only test the cash drawer; the second utility will allow you to test both the cash drawer and the printer.

6.1.7.1 **Cash Drawer and Printer Utility**

The following is overview of the steps to test the cash drawer followed by detailed steps:

1. Open **OPOS Test Application**.
 - C:\xxxxx\Point of Sale\Receipt Printer\OPOS Test Utility\OPOS_Test_Application.exe.
2. Click the **CashDrawer** button.
3. Select correct device name for the cash drawer to be tested.
4. Click the **Open** button.
5. Click the **Enable** button.
6. Click **Open Drawer** button and the cash drawer should open. The GUI should also show status that the cash drawer is open.
7. Close the cash drawer and the GUI should give the status that the cash drawer is closed.
8. Exit the test utility.

Detailed Steps

1. Open **OPOS Test Application**.
 - C:\xxxxx\Point of Sale\Receipt Printer\OPOS Test Utility\OPOS_Test_Application.exe.
2. Click the **CashDrawer** button.

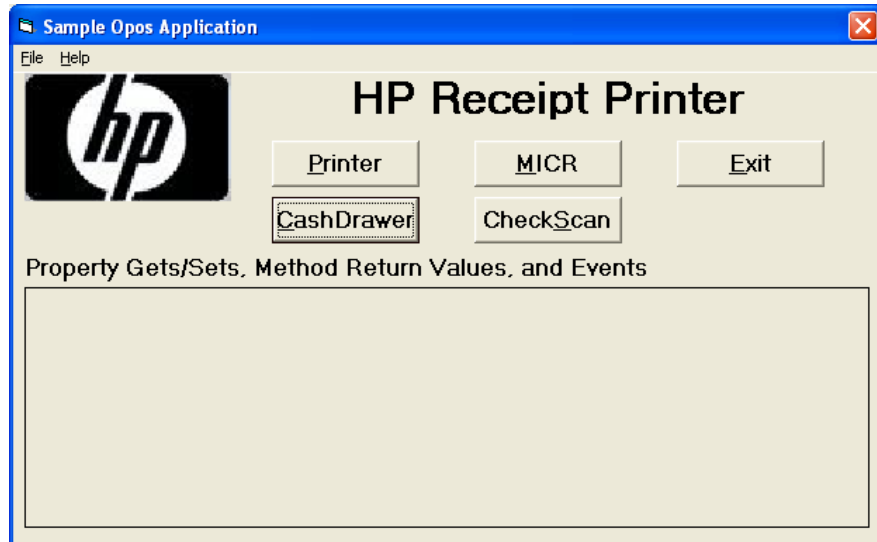

3. Select correct device name for the cash drawer to be tested.

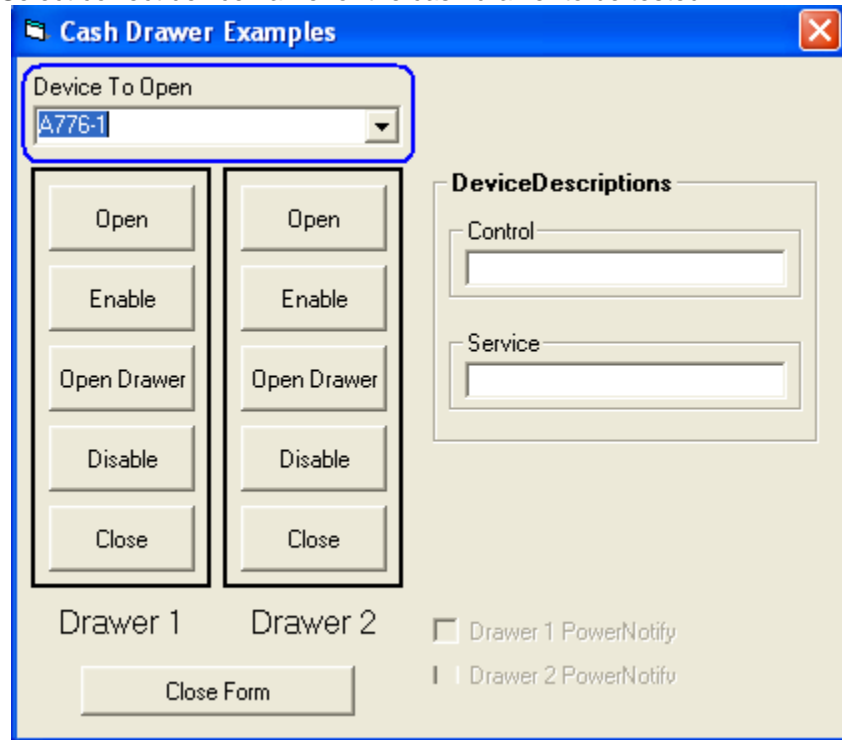

4. Click the **Open** button.
5. Click the **Enable** button.
6. Click the **Open Drawer** button and the cash drawer should open. The GUI should also show status that the cash drawer is open.

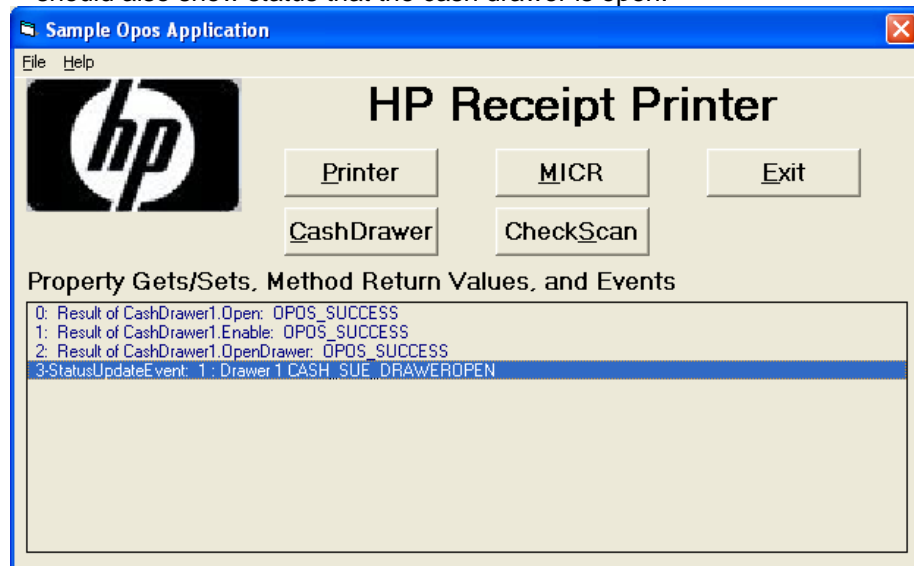

- Close the cash drawer and the GUI should give the status that the cash drawer is closed.

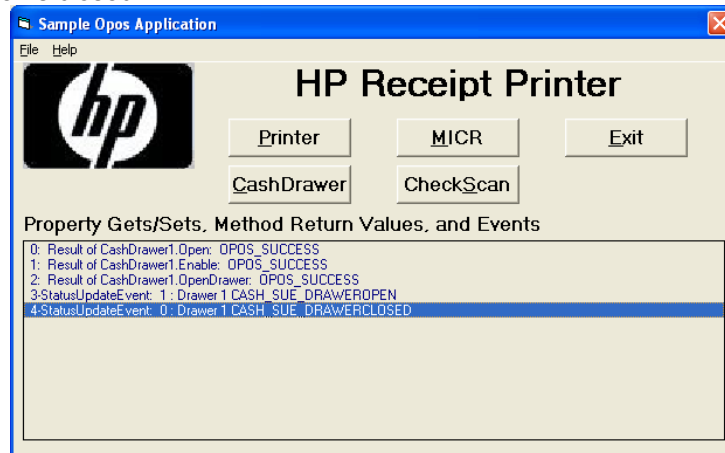

- Exit the test utility by clicking on DISABLE/CLOSE/CLOSE FORM and then click on EXIT.

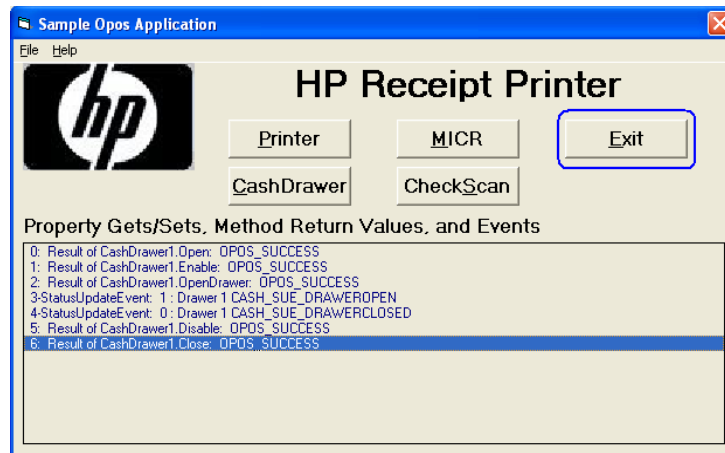
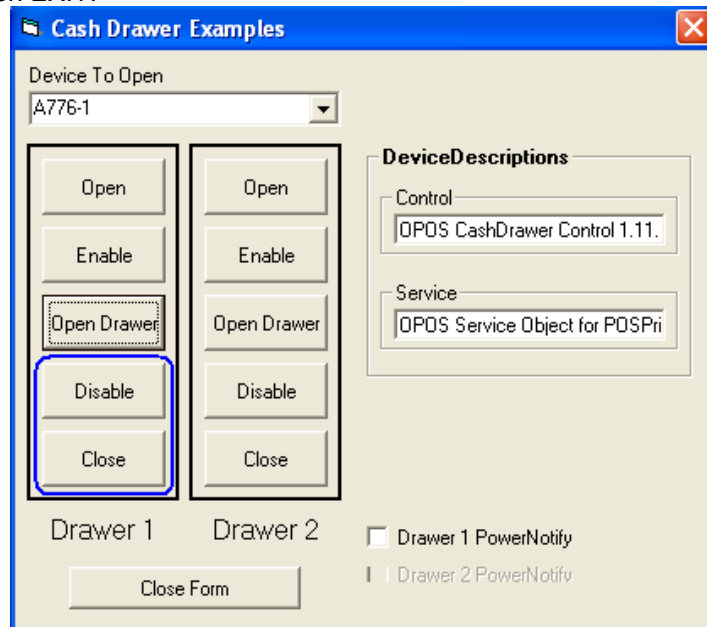

6.1.8 JPOS Drivers for the Cash Drawer

The JPOS drivers are included in the HP factory image and are also available from HP.COM.

The following is an overview of the steps to test the cash drawer followed by detailed steps:

1. Open **Printer/Cash Drawer/MICR Unit Test Application**.
 - C:\xxxx\Point of Sale\Receipt Printer\JPOS POS Printer\HPJPOSPrinter.bat.
2. Click on the CashDrawer tab.
3. Select the “CashDrawer” model in the Profile dropdown box:
4. Click the **Open** button.
5. Click the **Claim** button.
6. Click the **Enable** button.
7. To exit the application:
 - a. Click the **Disable** button.
 - b. Click the **Release** button.
 - c. Click the **Close** button.
 - d. Click the “X” in the upper righthand corner of the application.

Detailed Steps

1. Open **Printer/Cash Drawer/MICR Unit Test Application**.
 - C:\xxxx\Point of Sale\Receipt Printer\JPOS POS Printer\HPJPOSPrinter.bat.
2. After a few seconds the JPOS test utility GUI will appear as shown below; click on the CashDrawer tab.

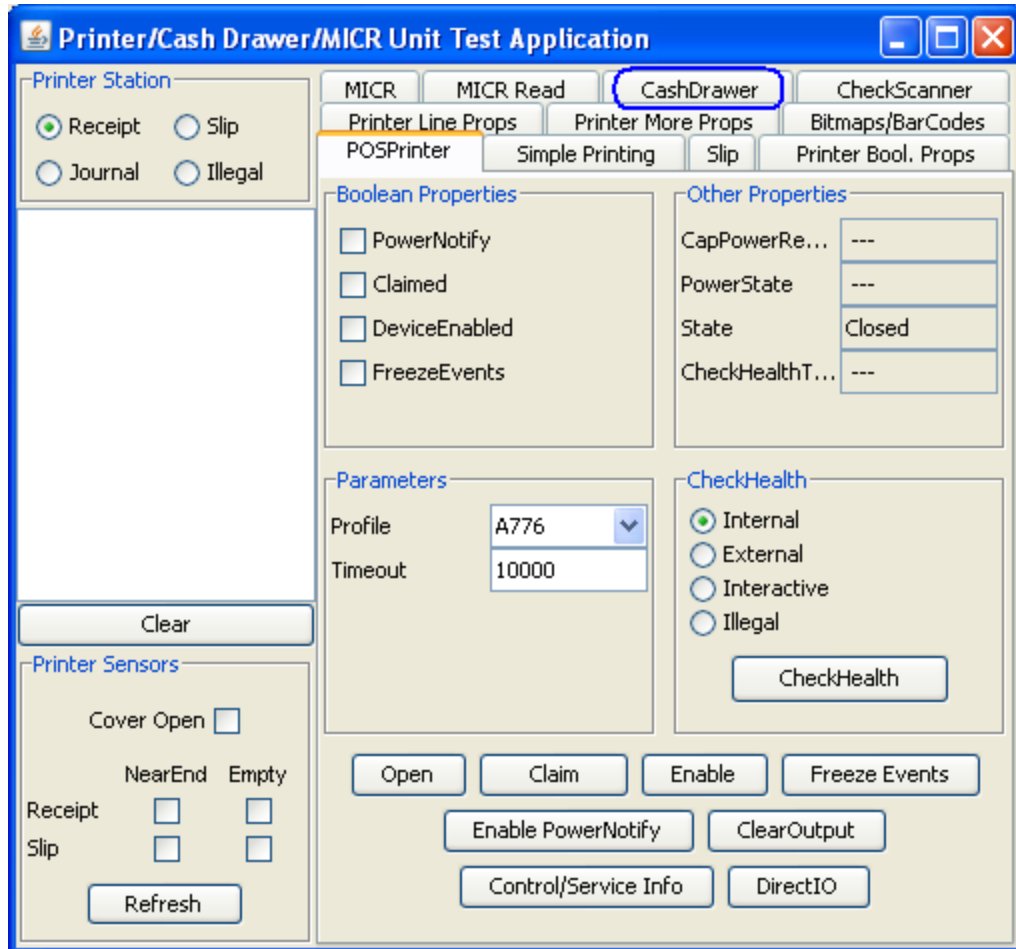

3. Select the "CashDrawer" model in the Profile dropdown box:

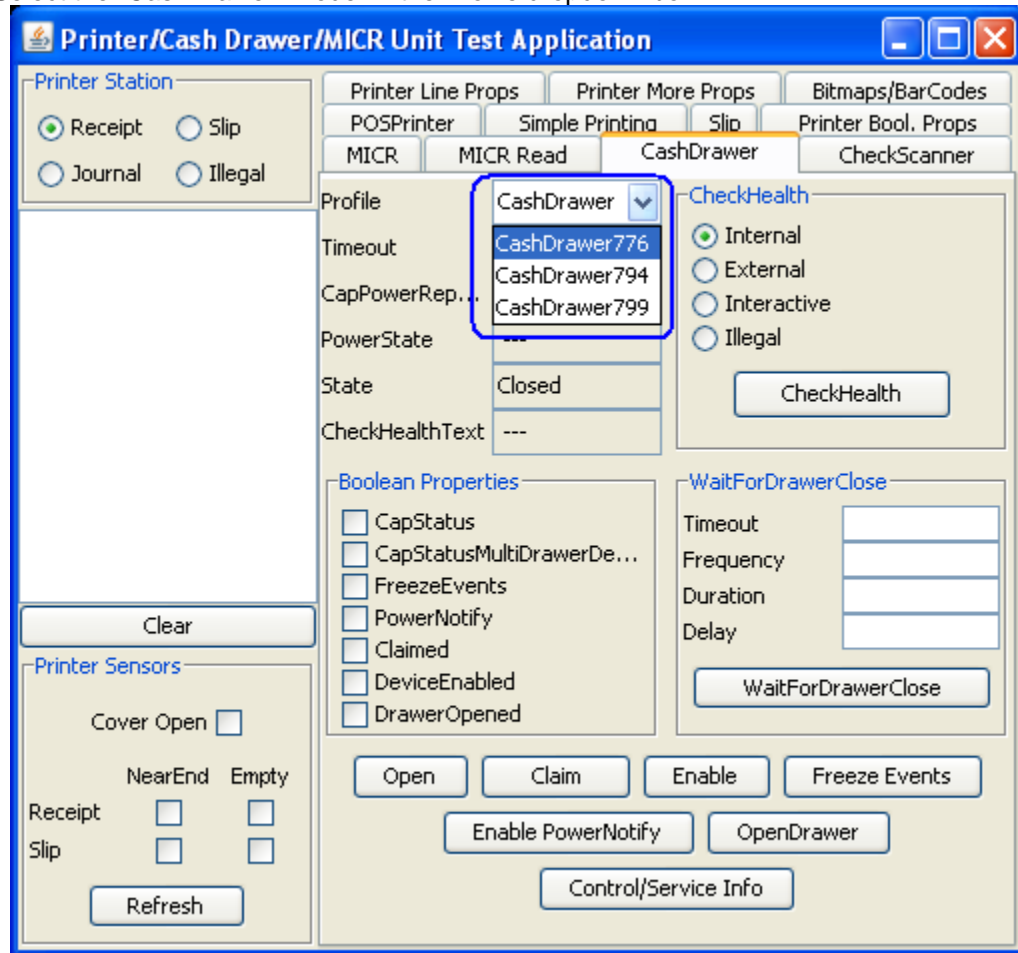

4. Click the **Open** button.
5. Click the **Claim** button.

- Click the **Enable** button.

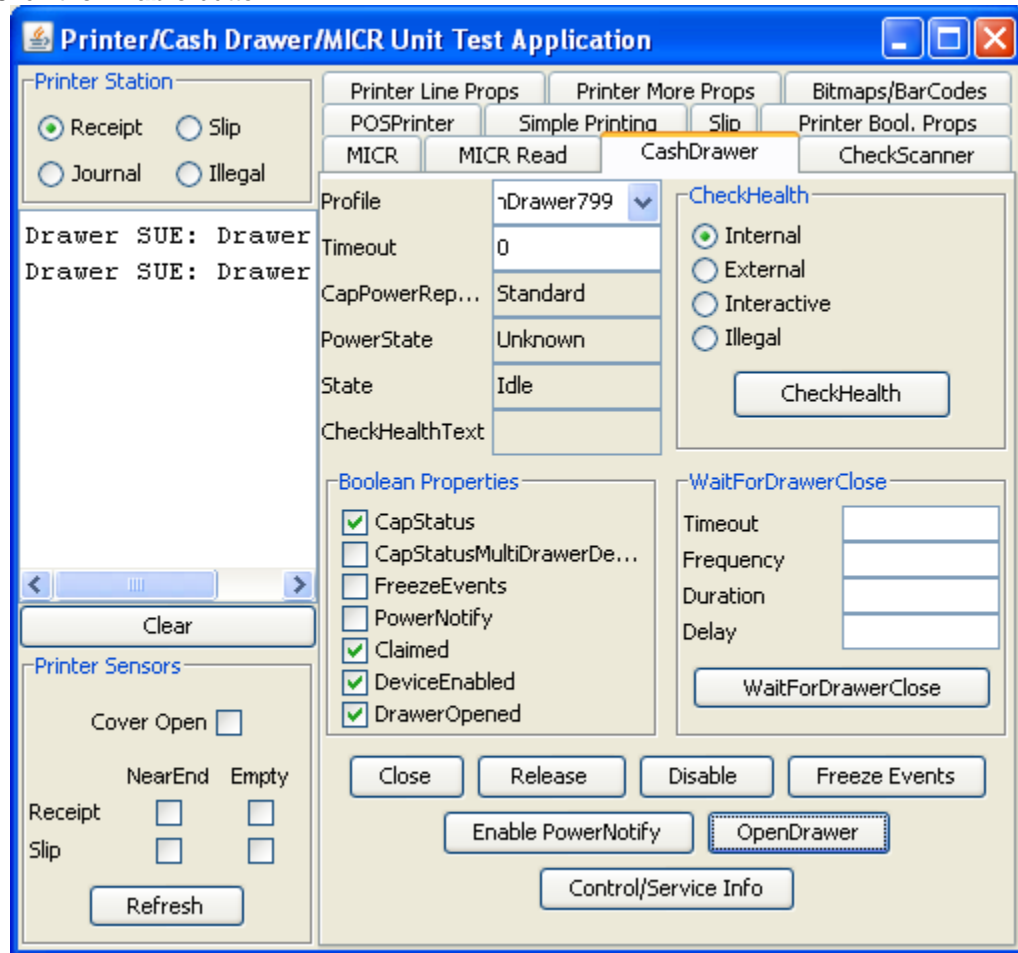

Note: Depending on the JPOS driver version (prior to March 2012 release) when you click on the "OpenDrawer" button the cash drawer should pop open. When the "Timeout" value set to "0", if the cash drawer is not closed within 10 seconds a "JPOSEXCEPTION CAUGHT" error message will appear, this is OK since the cash drawer is open.

- To exit the application:
 - Click the **Disable** button."
 - Click the **Release** button.
 - Click the **Close** button.
 - Click the "X" in the upper righthand corner of the application.

6.2 HP Integrated Cash Drawer Port

6.2.1 Connection

The HP Integrated Cash Drawer port is part of the system board, thus not removable (can be disabled). The cash drawer is attached to the integrated cash drawer port using a RJ12 type connector (the smaller connector).

Note: The integrated cash drawer port is to be used in conjunction with a cash drawer that has a 24VDC solenoid.

HP RP9 G1 Retail System:

Refer to the Hardware Reference Guide included in the HP factory image and available from HP.COM.

HP RP2 Model 2000/2030:



HP rp3100:



HP rp5800 and HP rp5810:

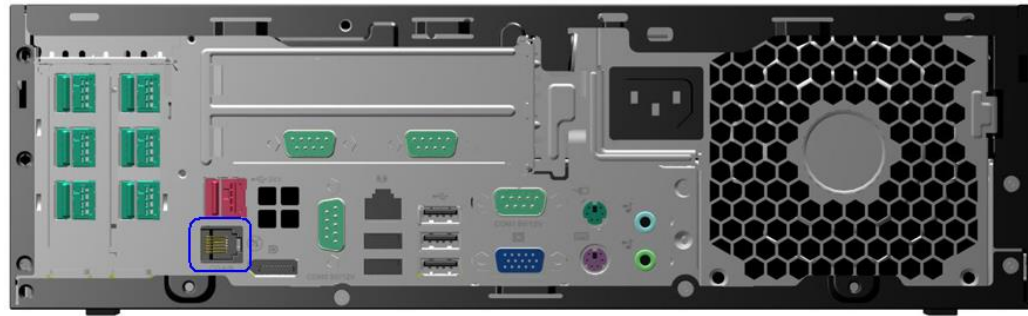

HP RP7 Model 7100/7800:



6.2.2 Integrated Cash Drawer Pinout (RJ12)

The integrated cash drawer port supports a 24VDC solenoid cash drawer (RJ12 connector). The following is the pin out for the integrated cash drawer port.

Pin #	Description
1	Chassis ground
2	Drawer 1 (24V)
3	Drawer status
4	24V
5	Drawer 2 (24V)
6	Ground

6.2.3 **Dual Cash Drawer Connection**

Dual cash drawers is possible with the integrated cash drawer port. In order to have a dual cash drawer configuration a Y-Cable is needed, and with this cable both the cash drawers are attached to the integrated cash drawer port.

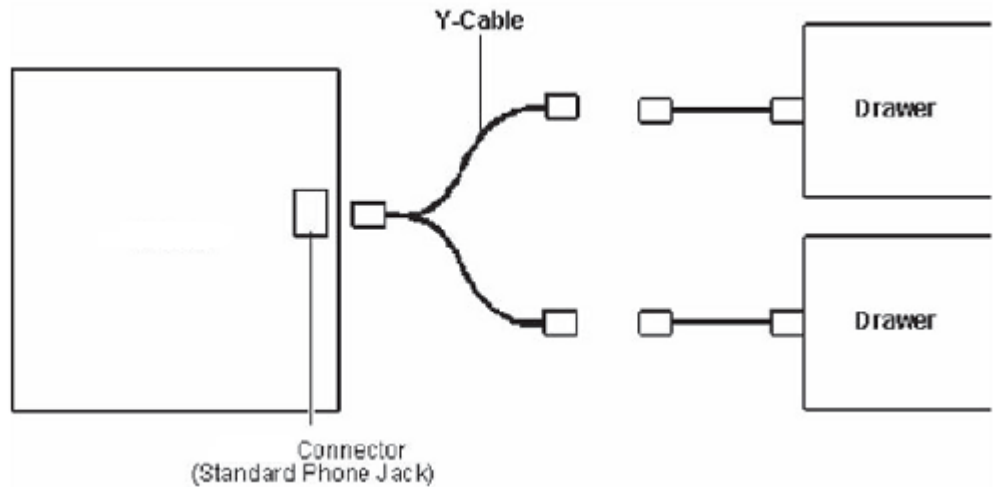

6.2.3.1 **Cash Drawer Cable Info**

In order to use dual cash drawers, one will need a Y-Adapter attached to the integrated cash drawer port and will need to exchange one of the cash drawer cable with the 2nd cash drawer cable.

The following is the cash drawer cable part number(s) for single cash drawer configuration:

1st Drawer**
CD-001A

The following are the cash drawer cable part numbers for a dual cash drawer configuration when the HP cash drawers are attached to integrated cash drawer port or directly to HP point of sale system that have integrated cash drawer port:

1st Drawer**	2nd Drawer	Y-Adapter
CD-001A	CD-001B	CD-D1D2

** This cable is shipped with the HP Cash Drawer.

6.2.4 **Drivers and utilities for the Integrated Cash Drawer Port**

The Integrated Cash Drawer may be tested with several utilities which are described in the following sections.

6.2.5 **OPOS Drivers for the Integrated Cash Drawer Port**

The Integrated Cash Drawer Port OPOS drivers are included in the HP factory image and are also available from HP.COM.

6.2.5.1 **HP Integrated OPOS Cash Drawer Utility**

The following is an overview of the steps to test the cash drawer followed by detailed steps:

1. Open the **HP Integrated OPOS Cash Drawer Utility**.
 - C:\<Program Files directory>\Hewlett-Packard\HP Integrated Cash Drawer\OPOS\HPOPOSCDUtility.exe.
2. Click the “Open” button.
3. Click the “Claim” button.
4. Click the “Enable” button. The “Drawer Status” will display a status event for the cash drawer current state.
5. Click the “Open Drawer” button to open the cash drawer. The “Drawer Status” should reflect the cash drawer open state.
6. Close the cash drawer. The “Drawer Status” should reflect the cash drawer closed state.
7. To exit the utility:
 - Click the “Disable” button.
 - Click the “Release” button.
 - Click the “Close” button.
 - Click the “X” in the upper right-hand corner of the utility window(s).

Detailed Steps

1. Open the **HP Integrated OPOS Cash Drawer Utility**.
 - C:\<Program Files directory>\Hewlett-Packard\HP Integrated Cash Drawer\OPOS\HPOPOSCDUtility.exe.

2. Click the “Open” button.
3. Click the “Claim” button.
4. Click the “Enable” button. The “Drawer Status” will display a status event for the cash drawer current state.

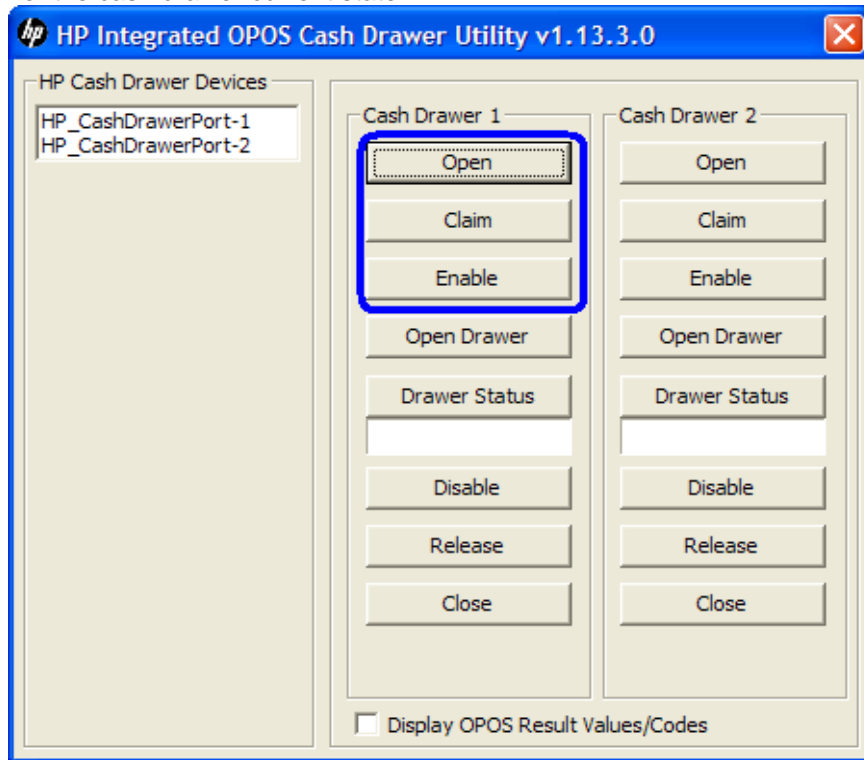

5. Click the “Open Drawer” button to open the cash drawer. The “Drawer Status” should reflect the cash drawer open state.

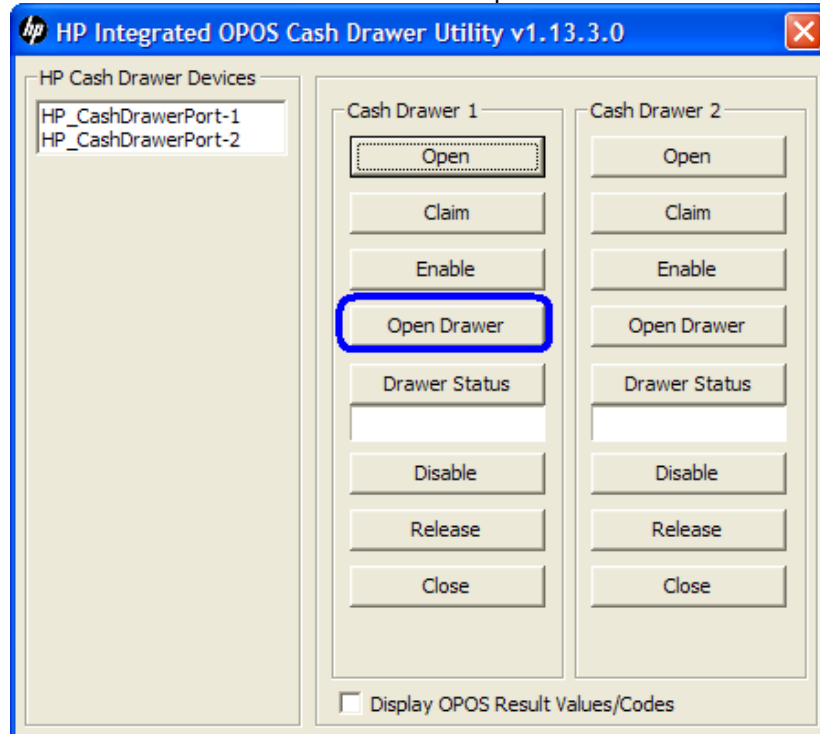

6. Close the cash drawer. The “Drawer Status” should reflect the cash drawer closed state.
7. To exit the utility:
 - Click the “Disable” button.
 - Click the “Release” button.
 - Click the “Close” button.
 - Click the “X” in the upper right-hand corner of the utility window(s).

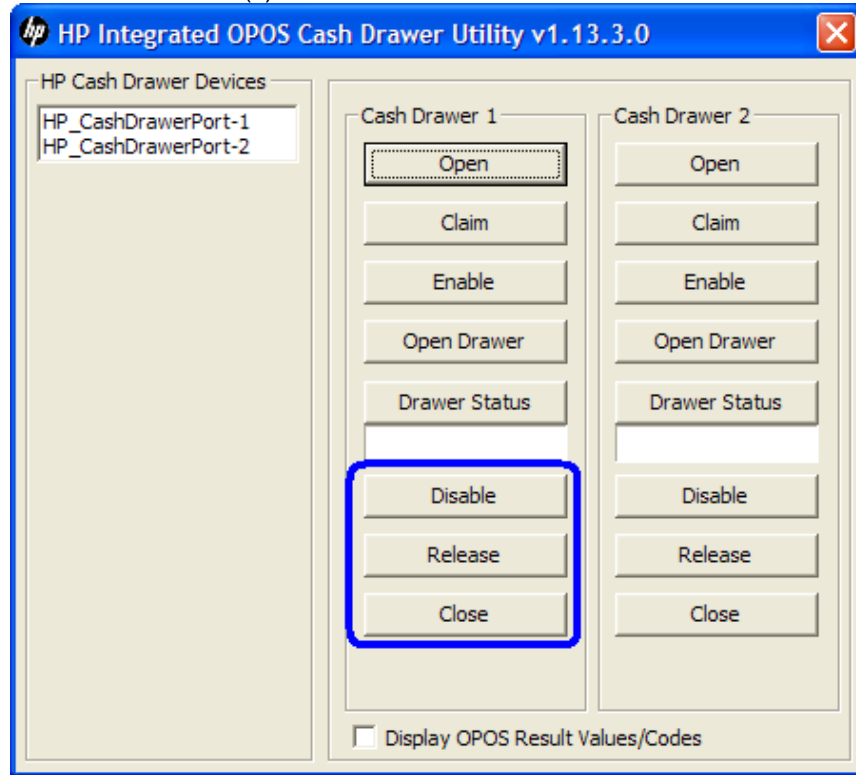

6.2.5.2 **OPOS Cash Drawer and Printer Utility**

This utility is included in the HP Factory image and can be obtained by downloading and installing the “HP USB Receipt Printer OPOS Test Application” Softpaq. The following is an overview of the steps to test the cash drawer followed by detailed steps:

1. Open **OPOS Test Application**.
 - C:\xxxxx\Point of Sale\Receipt Printer\OPOS Test Utility\OPOS_Test_Application.exe.
2. Click the **CashDrawer** button.
3. Under Device To Open, select the device name for the cash drawer to be tested.
4. Click the **Open** button.
5. Click the **Enable** button.
6. Click the **Open Drawer** button to open the cash drawer. A StatusUpdateEvent should be displayed reflecting the cash drawer open state.
7. Close the cash drawer. A StatusUpdateEvent should be displayed reflecting the cash drawer closed state.
8. To exit the utility:
 - Click the **Disable** button.
 - Click the **Close** button.
 - Click the “X” in the upper righthand corner of the utility window

Detailed Steps

1. Open **OPOS Test Application**.
 - C:\xxxxx\Point of Sale\Receipt Printer\OPOS Test Utility\OPOS_Test_Application.exe.
2. Click the **CashDrawer** button.

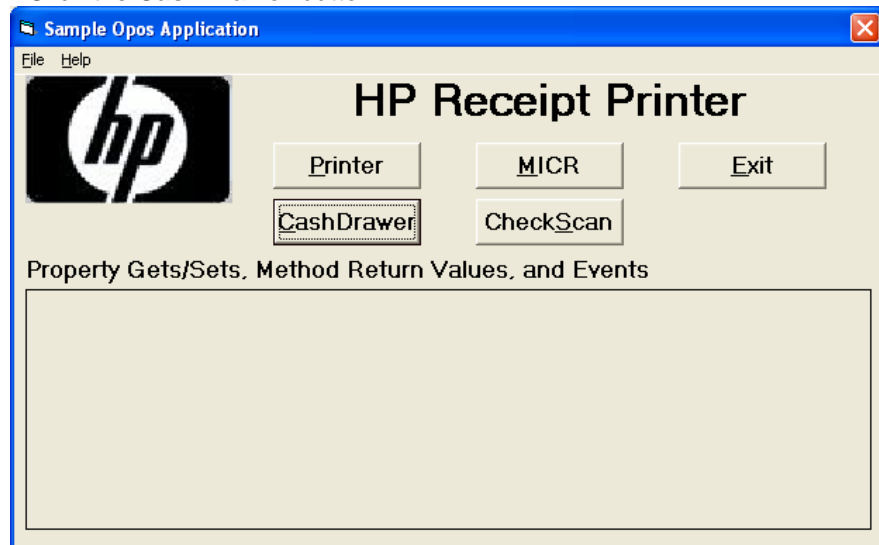

- Under Device To Open, select the device name for the cash drawer to be tested.

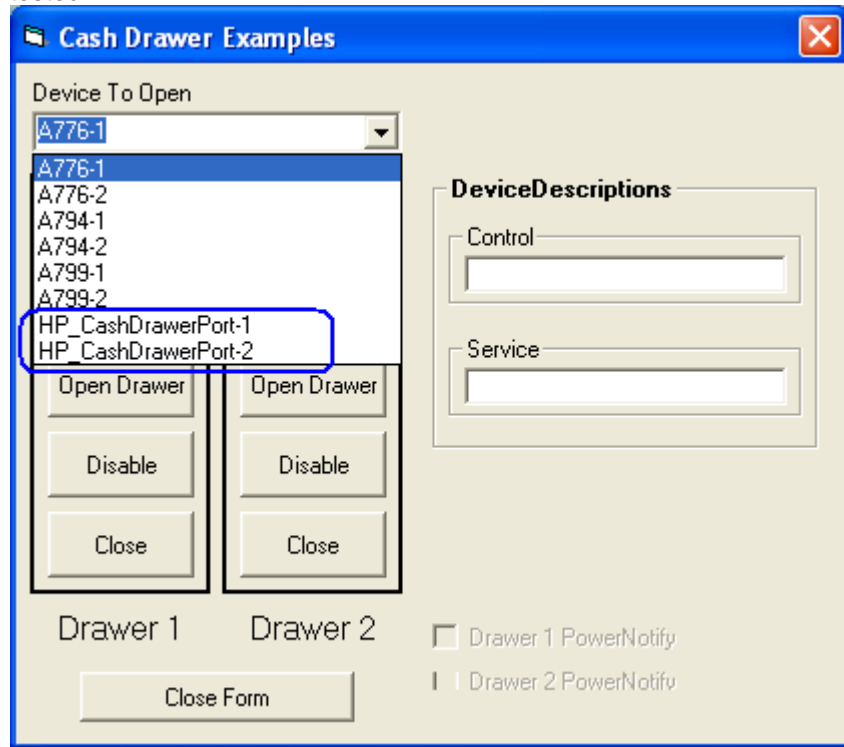

- Click the **Open** button.
- Click the **Enable** button.
- Click the **Open Drawer** button to open the cash drawer. A StatusUpdateEvent should be displayed reflecting the cash drawer open state.

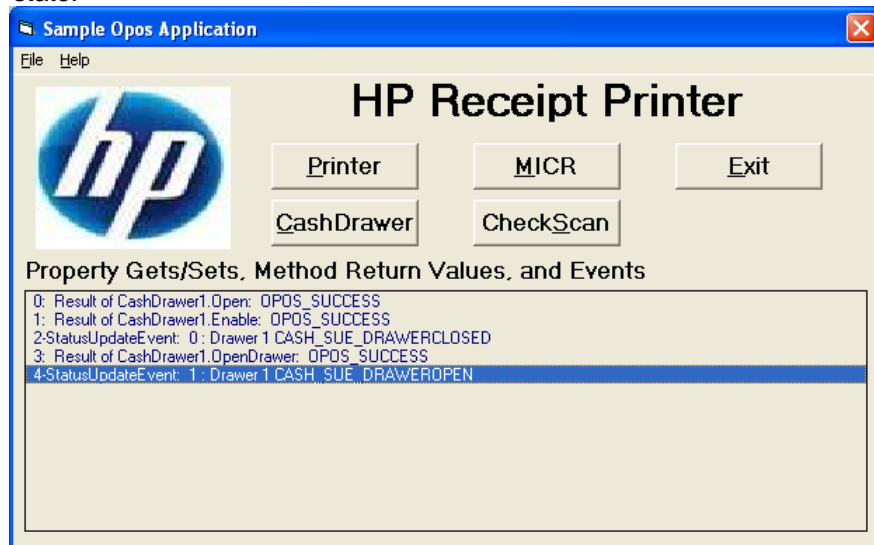

7. Close the cash drawer. A StatusUpdateEvent should be displayed reflecting the cash drawer closed state.

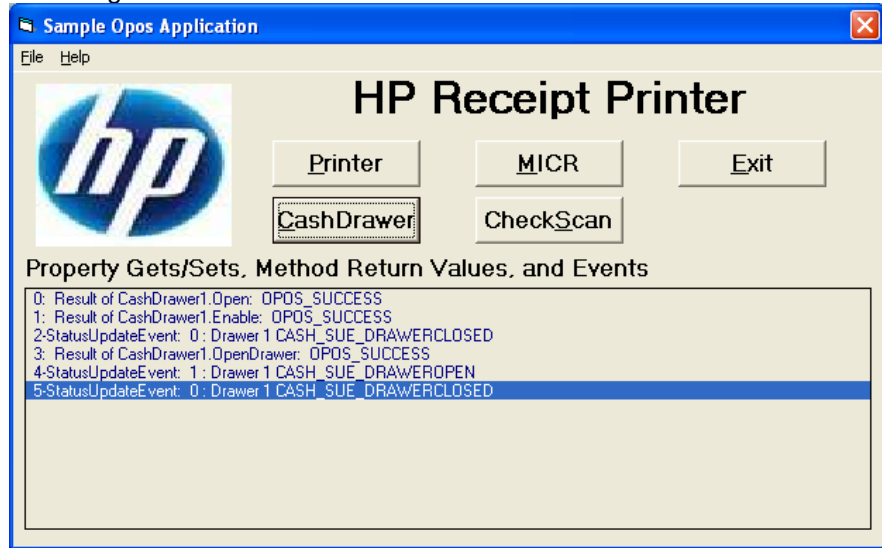

8. To exit the utility:
- Click the **Disable** button.
 - Click the **Close** button.
 - Click the "X" in the upper righthand corner of the utility window.

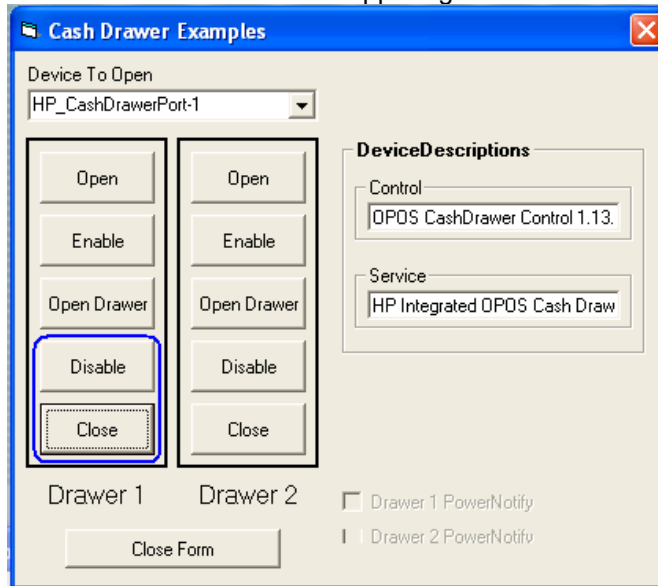

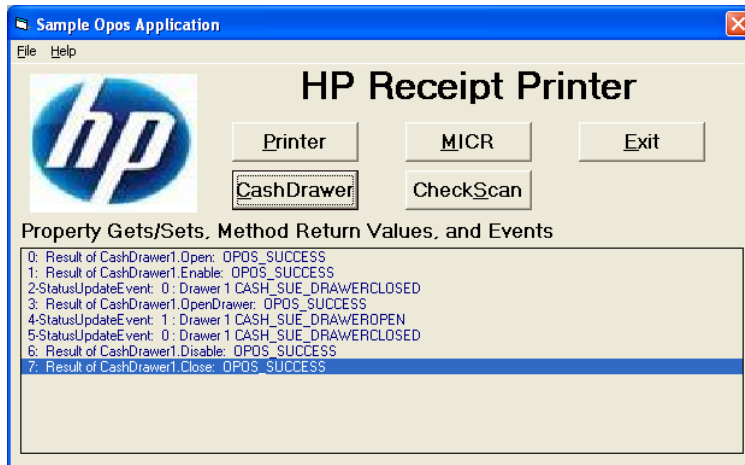

6.2.6 **JPOS Drivers for the Integrated Cash Drawer Port**

The Integrated Cash Drawer Port JPOS drivers are included in the HP factory image and are also available from HP.COM.

6.2.6.1 **JPOS Test Applet for the Integrated Cash Drawer Port**

The following is an overview of the steps to test the cash drawer followed by detailed steps:

1. Open **HP Integrated JavaPOS Cash Drawer Utility**.
 - C:\<Program Files directory>\Hewlett-Packard\HP Integrated Cash Drawer\JavaPOS\service\HPJPosCDUtility.exe.
2. Click the “Open” button.
3. Click the “Claim” button.
4. Click the “Enable” button. The “Drawer Status” will display a status event for the cash drawer current state.
5. Click the “Open Drawer” button to open the cash drawer. The “Drawer Status” should reflect the cash drawer open state.
6. Close the cash drawer. The “Drawer Status” should reflect the cash drawer closed state.
7. To exit the utility:
 - Click the “Disable” button.
 - Click the “Release” button.
 - Click the “Close” button.
 - Click the “X” in the upper right-hand corner of the utility window(s).

Detailed Steps

1. Open **HP Integrated JavaPOS Cash Drawer Utility**.
 - C:\<Program Files directory>\Hewlett-Packard\HP Integrated Cash Drawer\JavaPOS\service\HPJPosCDUtility.exe.
2. Click the “Open” button.
3. Click the “Claim” button.

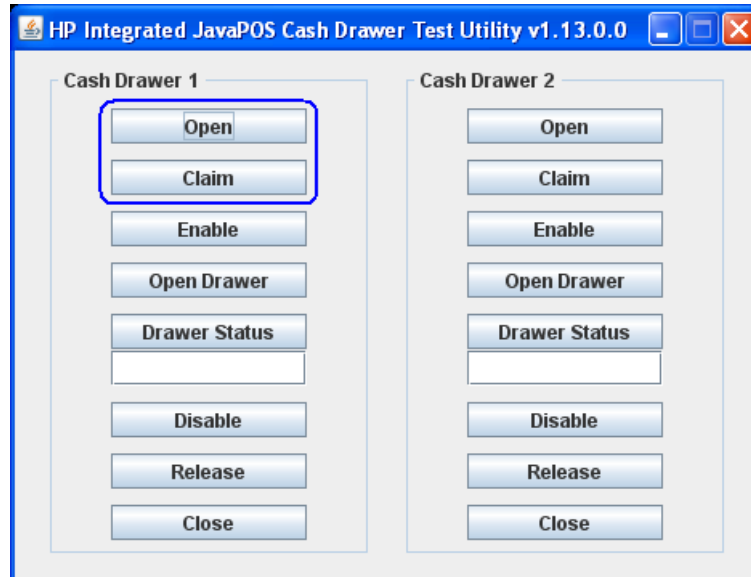

4. Click the “Enable” button. The “Drawer Status” will display a status event for the cash drawer current state.

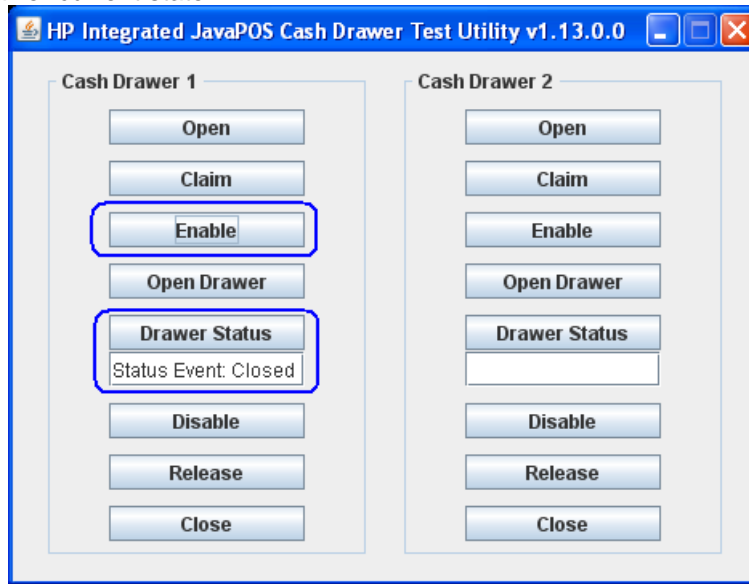

5. Click the “Open Drawer” button to open the cash drawer. The “Drawer Status” should reflect the cash drawer open state.

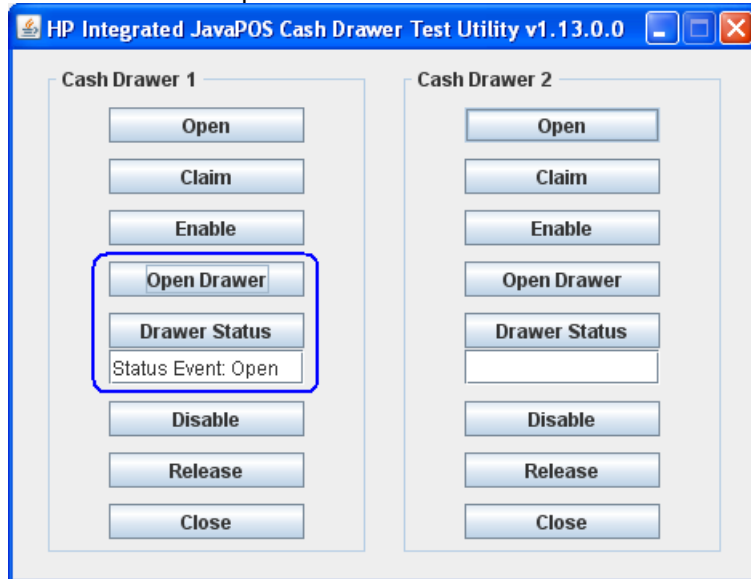

6. Close the cash drawer. The “Drawer Status” should reflect the cash drawer closed state.

7. To exit the utility:

- Click the “Disable” button.
- Click the “Release” button.
- Click the “Close” button.
- Click the “X” in the upper right-hand corner of the utility window(s).

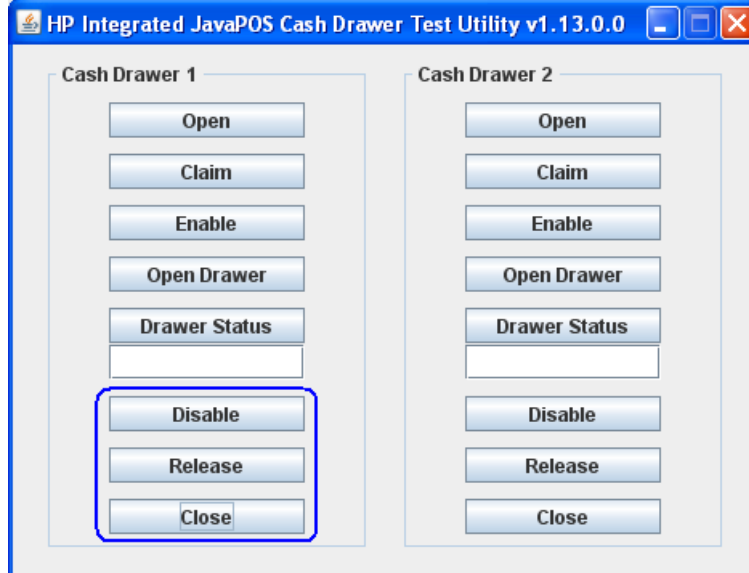

6.3 HP USB Cash Drawer



6.3.1 Connection

The HP USB Cash Drawer may be plugged into any free USB port. One may plug the USB cash drawer into the powered USB port in the 5v connection; when plugged into a powered USB port the power portion of USB port is not utilized.

6.3.2 Drivers and utilities for the HP USB Cash Drawer

The HP USB cash drawer may be tested with several utilities which are described in the following sections of the guide.

6.3.3 Windows Test Utility for USB Cash Drawer

The following is an overview of the steps to test the USB cash drawer in Windows environment which are followed by detailed steps:

1. Ensure the USB cash drawer is attached to the unit.
2. Open **HP USB Cash Drawer - Single Drawer**.
 - C:\xxxx\Point of Sale\Cash Drawer\USB Cash Drawer\USB Cash Drawer Windows\HP_USB_Cash_Drawer.exe.
3. Click the “Open Cash Drawer” button and the drawer should open and provide status.
4. Close the cash drawer.
5. Click the “X” button in the upper right corner to exit the utility.

Detailed Steps

1. Ensure the USB cash drawer is attached to the unit.
2. Open **HP USB Cash Drawer - Single Drawer**.
 - C:\xxxx\Point of Sale\Cash Drawer\USB Cash Drawer\USB Cash Drawer Windows\HP_USB_Cash_Drawer.exe.

3. Click on “Open Cash Drawer” button and the drawer should open and provide status.

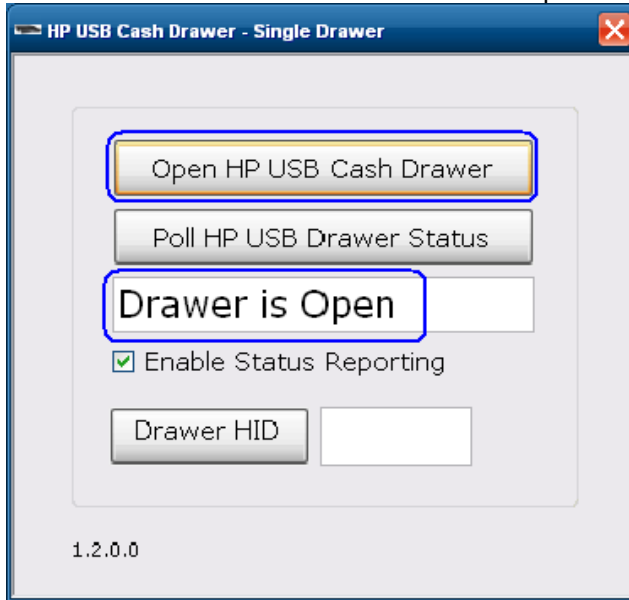

4. Close the cash drawer.

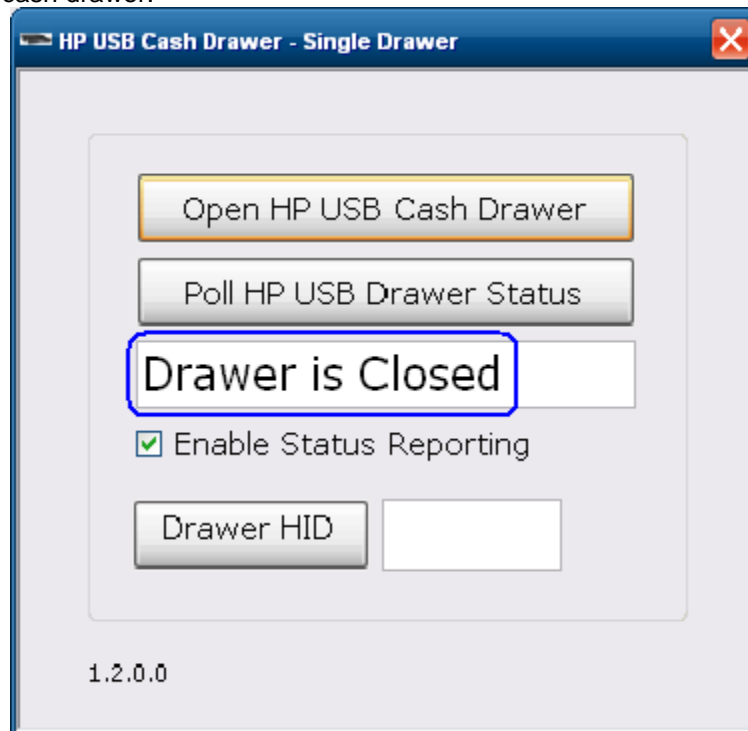

5. Click the "X" button in the upper right corner to exit the utility.

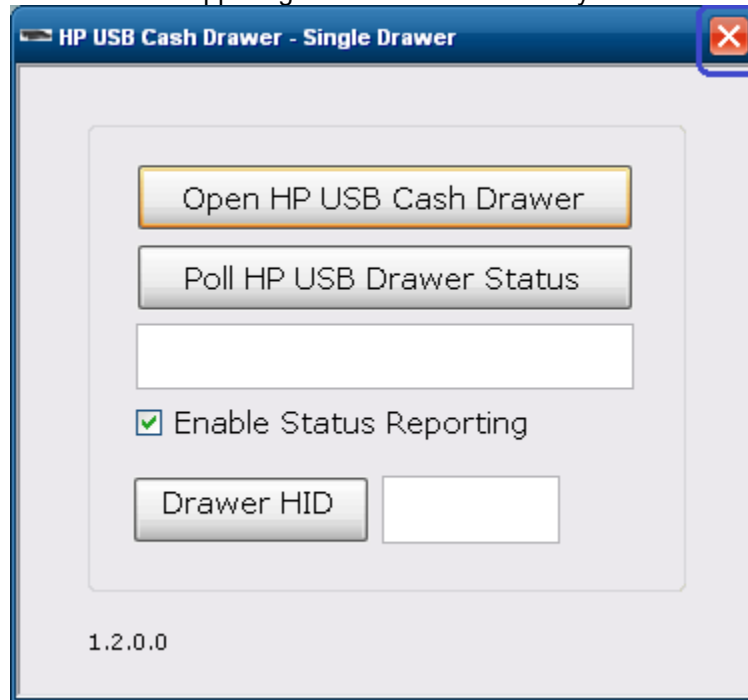

6.3.4 **OPOS Drivers for the HP USB Cash Drawer**

The HP USB Cash Drawer Port drivers are included in the HP factory image and are also available from HP.COM.

6.3.4.1 **OPOS Cash Drawer and Printer Utility**

The following is an overview of the steps to test the cash drawer followed by detailed steps:

1. Open **OPOS Test Application**.
 - C:\xxxxx\Point of Sale\Cash Drawer\USB Cash Drawer\Cash Drawer OPOS Test Utility\OPOS_Test_Application.exe.
2. Click the **CashDrawer** button.
3. Select the correct device name for the cash drawer to be tested. The OPOS name for the HP USB cash drawer is: **HPUSBCashDrawer-1**.
4. Click the **Open** button.
5. Click the **Enable** button.
6. Click the **Open Drawer** button and the cash drawer should open. The GUI should also show status that the cash drawer is open.
7. Close the cash drawer and the GUI should give the status that the cash drawer is closed.
8. Click the **Disable** button, then **Close** button, then **Close Form** button, and then the “X” button on the top right to exit.

Detailed Steps

1. Open **OPOS Test Application**.
 - C:\xxxxx\Point of Sale\Cash Drawer\USB Cash Drawer\Cash Drawer OPOS Test Utility\OPOS_Test_Application.exe.
2. Click the **CashDrawer** button.

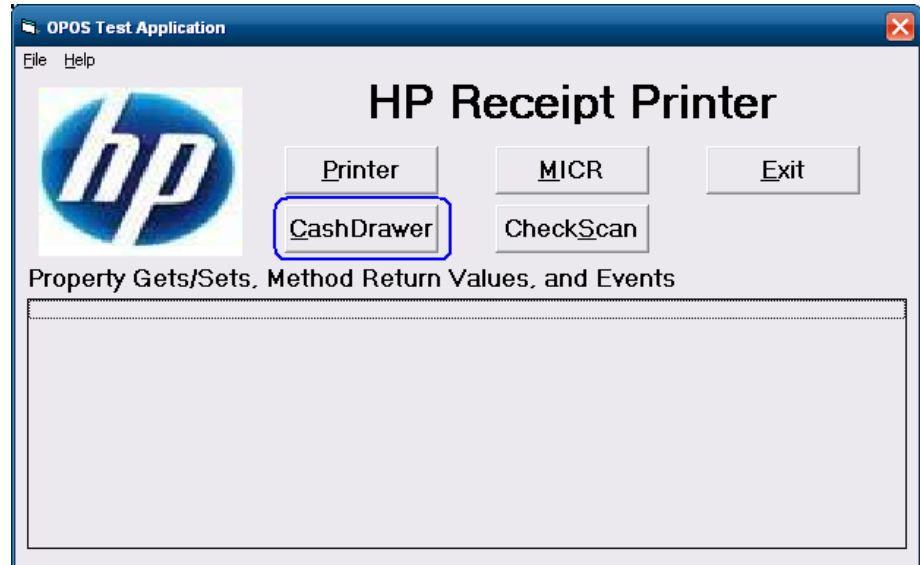

3. Select the correct device name for the cash drawer to be tested. The OPOS name for the HP USB cash drawer is: **HPUSBCashDrawer-1**.

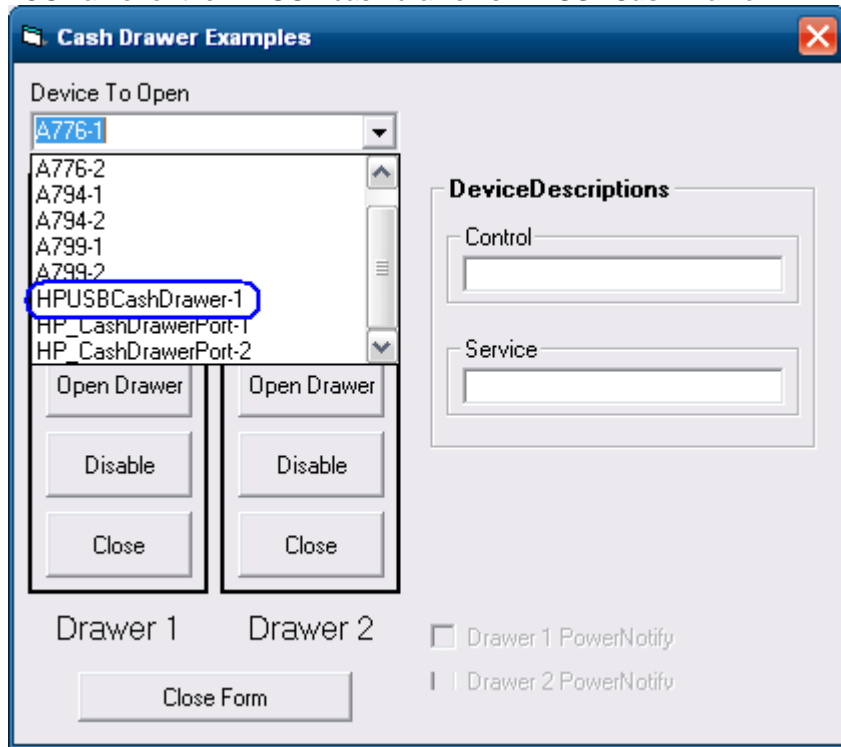

4. Click the **Open** button.
5. Click the **Enable** button.
6. Click the **Open Drawer** button and the cash drawer should open. The GUI should also show status that the cash drawer is open.

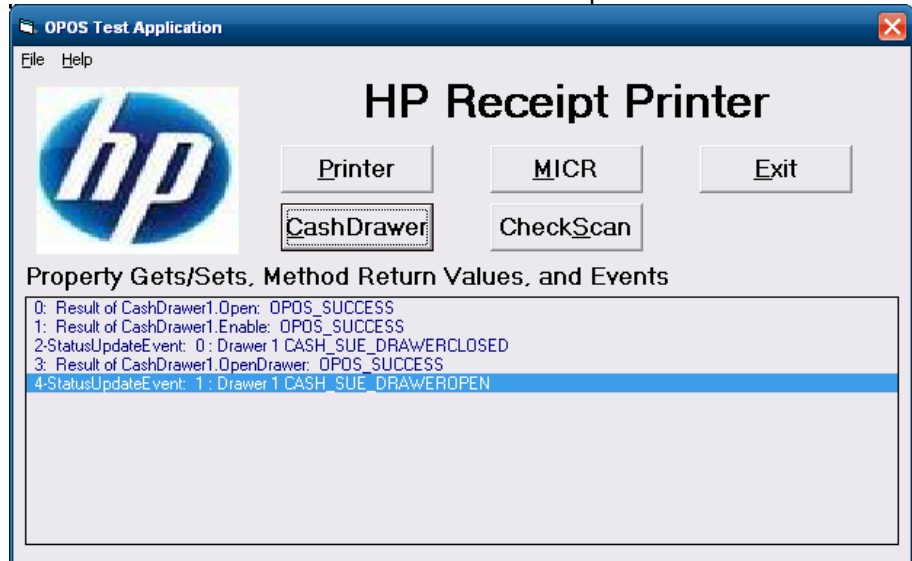

7. Close the cash drawer and the GUI should give the status that the cash drawer is closed.

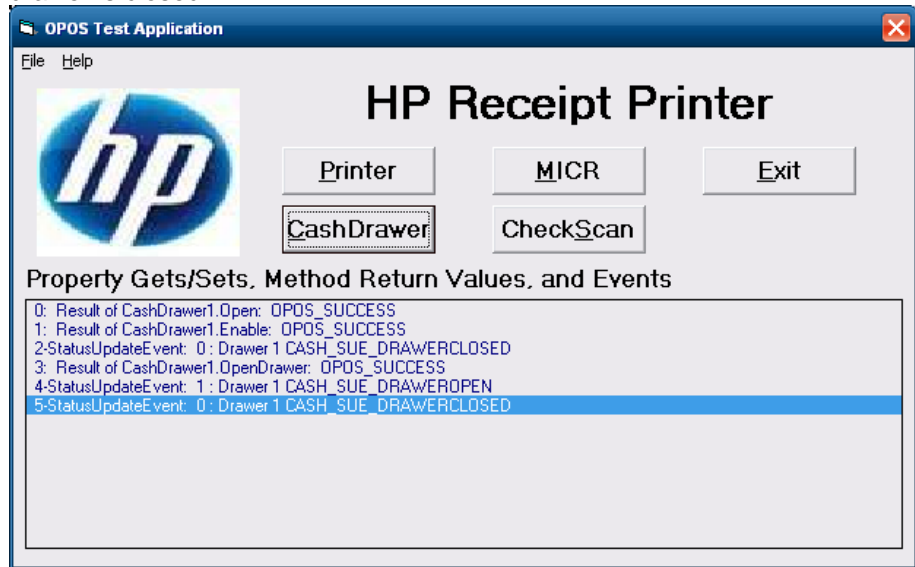

8. Click the **Disable** button, then **Close** button, then **Close Form** button, and then the "X" button on the top right to exit.

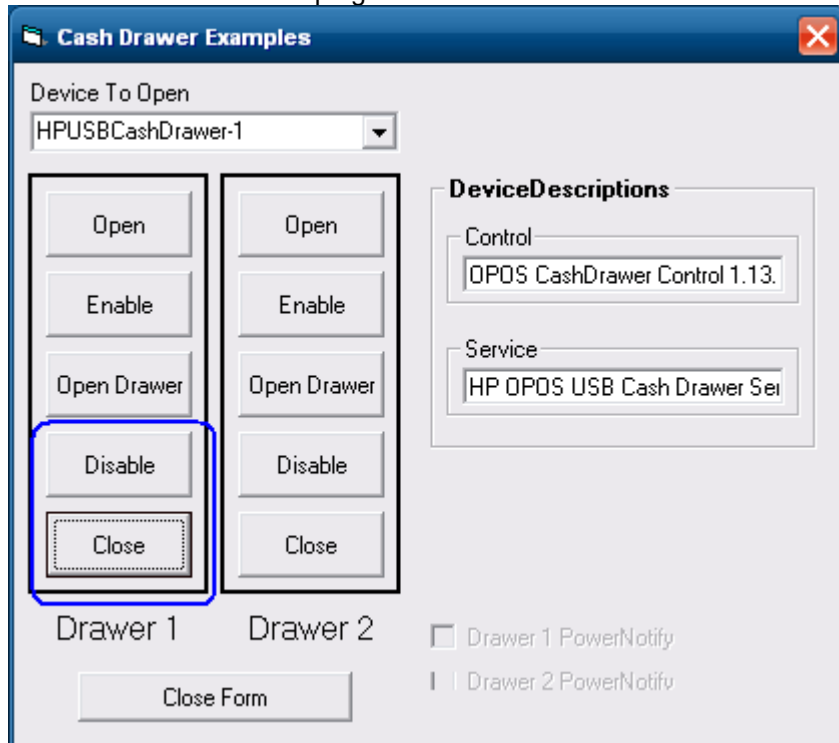

6.3.4.2 **Dual Cash Drawer Connection**

For dual USB cash drawer, attach a second HP USB cash drawer to USB connection.

The following is overview of the steps to add a second USB cash drawer followed by detailed steps in order for OPOS to recognize both cash drawers.

1. Open the "HPCDUtility" that is located in the "C:\Program Files\Hewlett-Packard\USB Cash Drawer".
2. Click on the icon that has a plus by the cash drawer or select "Add Device" in the "Edit" menu.
3. Click "Next" button.
4. Click on "Health Check (Interactive)" button.
5. Click on the "OK" button.
6. The cash drawer should be open with a GUI indicating the successful drawer.
7. Click on the "OK" button.
8. Click on the "Cancel" button to quit the health check.
9. Click on the "Finish" button.
10. Exit the test utility.

Detailed Steps

1. Open the "HPCDUtility" that is located in the "C:\Program Files\Hewlett-Packard\USB Cash Drawer".
2. Click on the icon that has a plus by the cash drawer or select "Add Device" in the "Edit" menu.

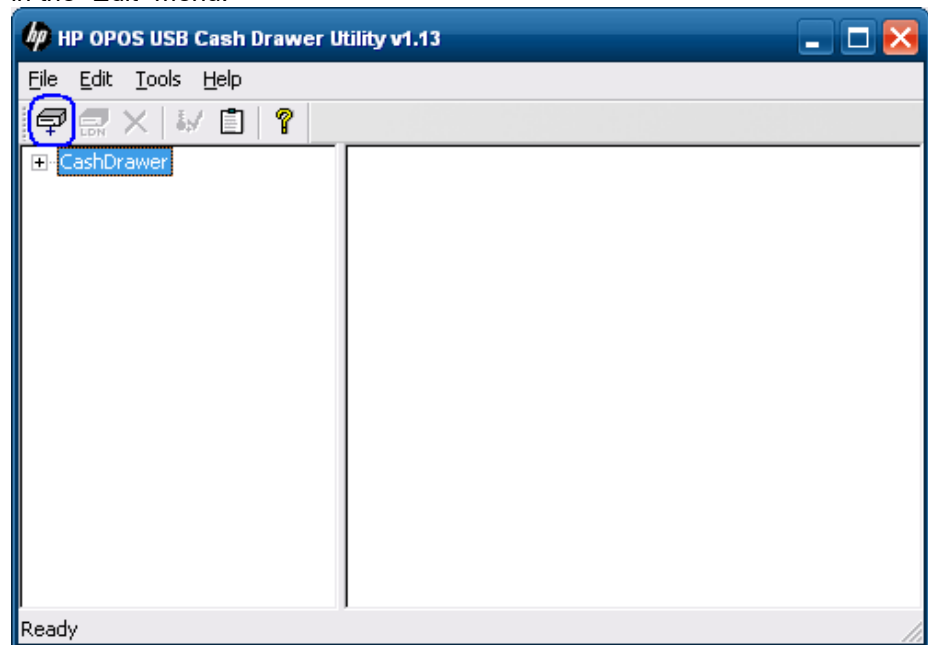

3. Click "Next" button.

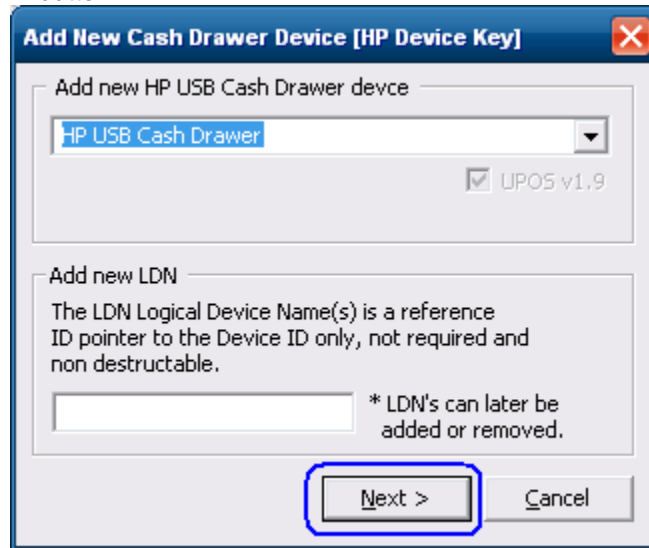

4. Click on "Health Check (Interactive)" button.

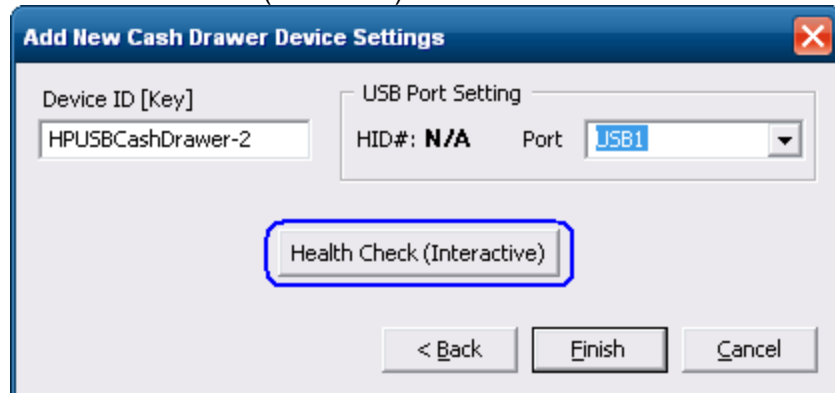

5. Click on the "OK" button.

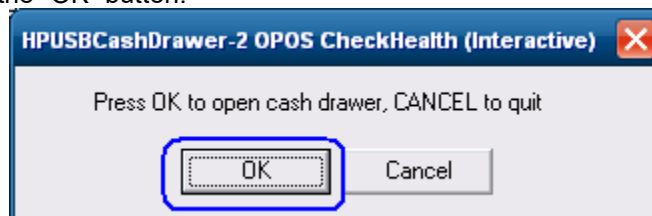

6. The cash drawer should be open with a GUI indicating the successful drawer.

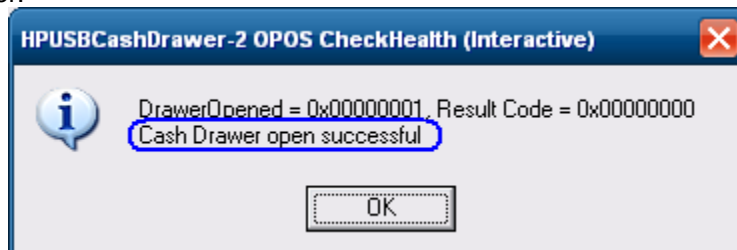

7. Click on the "OK" button.

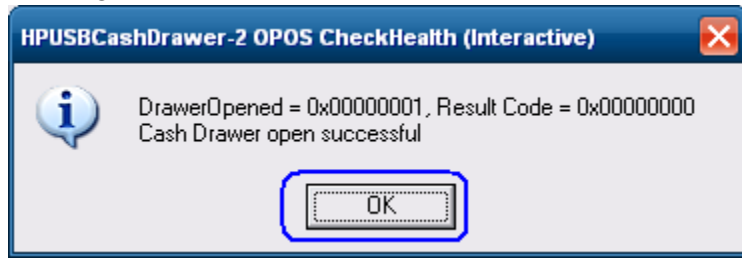

8. Click on the "Cancel" button to quit the health check.

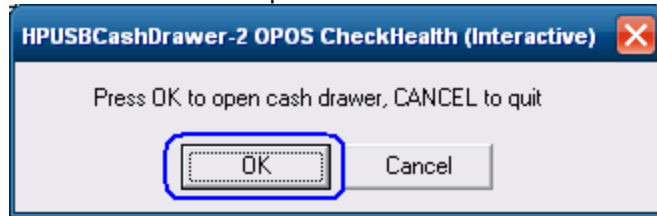

9. Click on the "Finish" button.

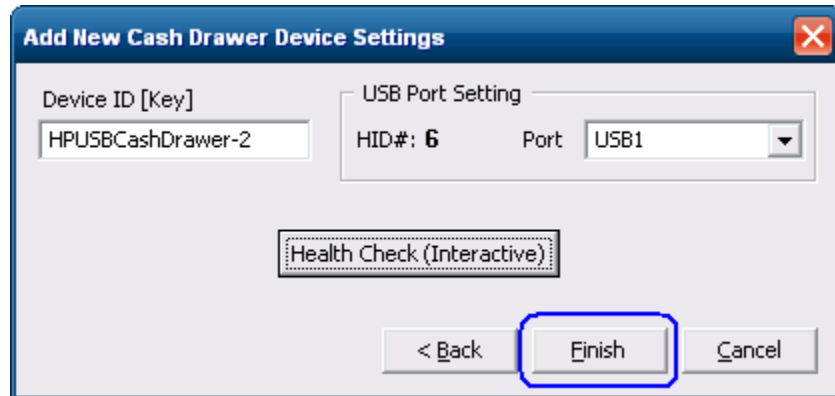

10. Exit the test utility.

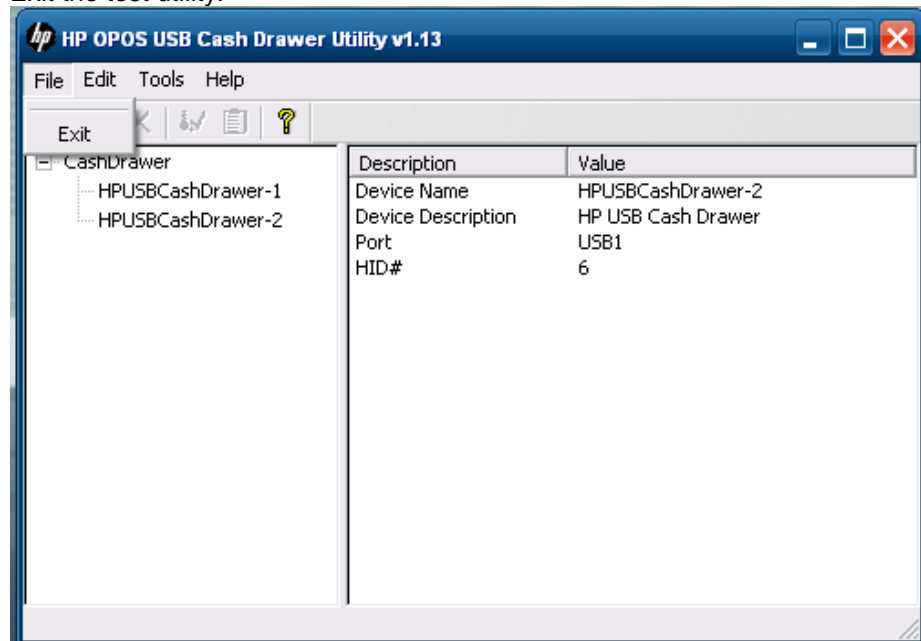

6.3.5 **JPOS Drivers for the HP USB Cash Drawer**

The HP USB Cash Drawer Port drivers are included in the HP factory image and are also available from HP.COM.

6.3.5.1 **JPOS Test Applet for the USB Cash Drawer Port**

1. Open **JavaPOSTester**.
 - C:\xxxxx\Point of Sale\Cash Drawer\USB Cash Drawer\USB Cash Drawer JPOS\HPJPOSUSBCashDrawer\POSTest.bat.
2. Click the **CashDrawer** tab.
3. Select the proper device from the dropdown menu.
4. Click the **Open** button.
5. Click the **Claim** button.
6. Check the **Device enabled** checkbox. The drawer status will appear in the GUI.
7. Click the **Open Cash Drawer** button to open the selected cash drawer.
8. After drawer has opened successfully, close the drawer and click the **Release** button.
9. Click the **Close** button.
10. Click the **Exit** button to close the test application.

Detailed Steps

1. Open JavaPOSTester.
 - C:\xxxxx\Point of Sale\Cash Drawer\USB Cash Drawer\USB Cash Drawer JPOS\HPJPOSUSBCashDrawer\POSTest.bat

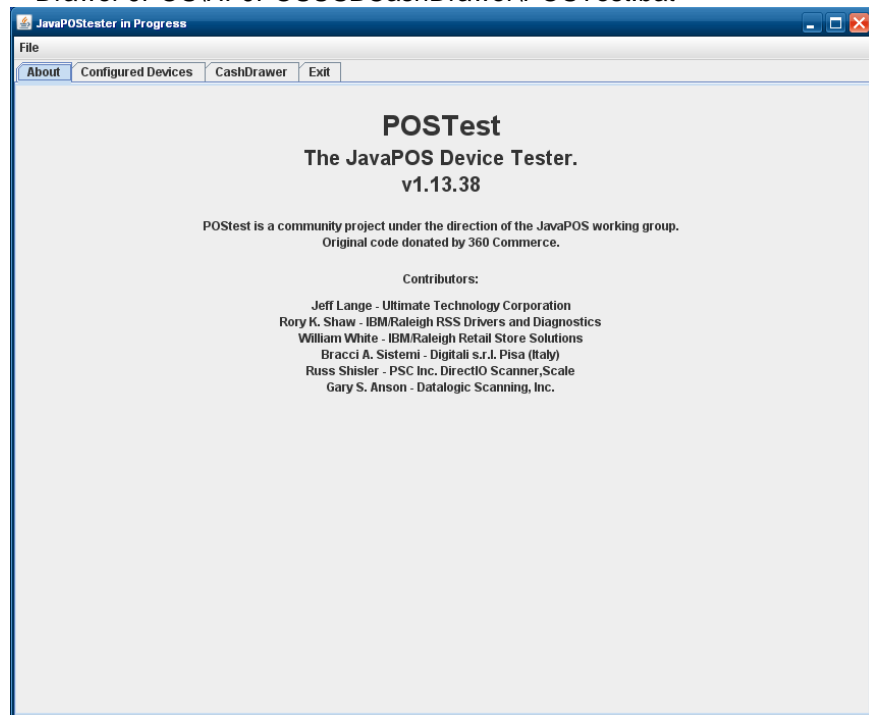

2. Click the **CashDrawer** tab.



3. Select the proper device from the dropdown menu.

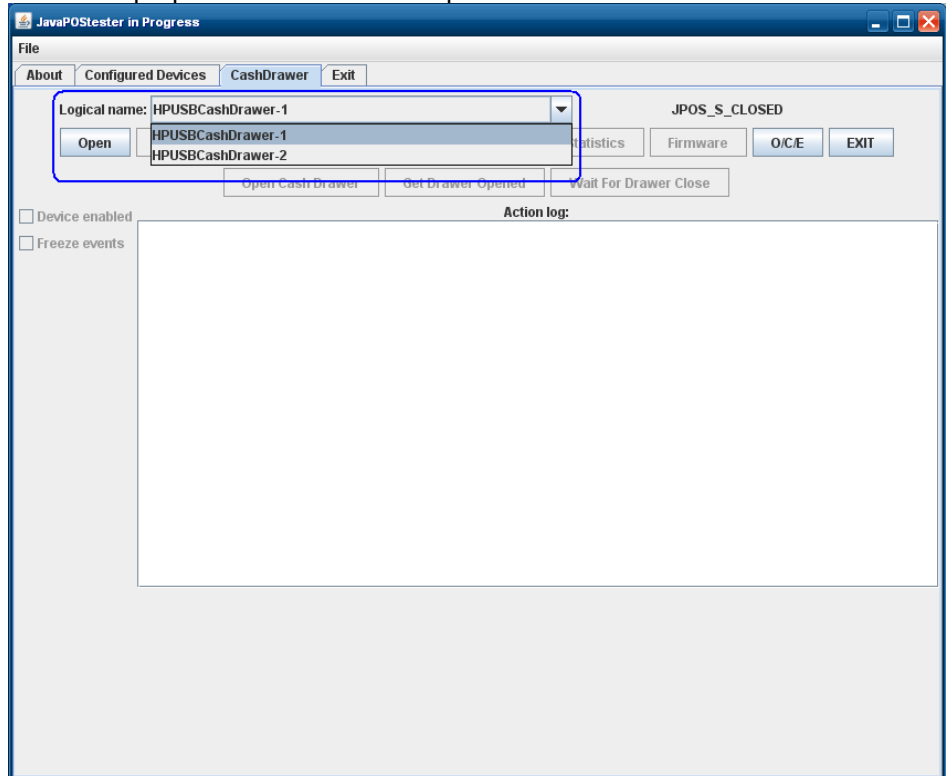

4. Click the **Open** button.

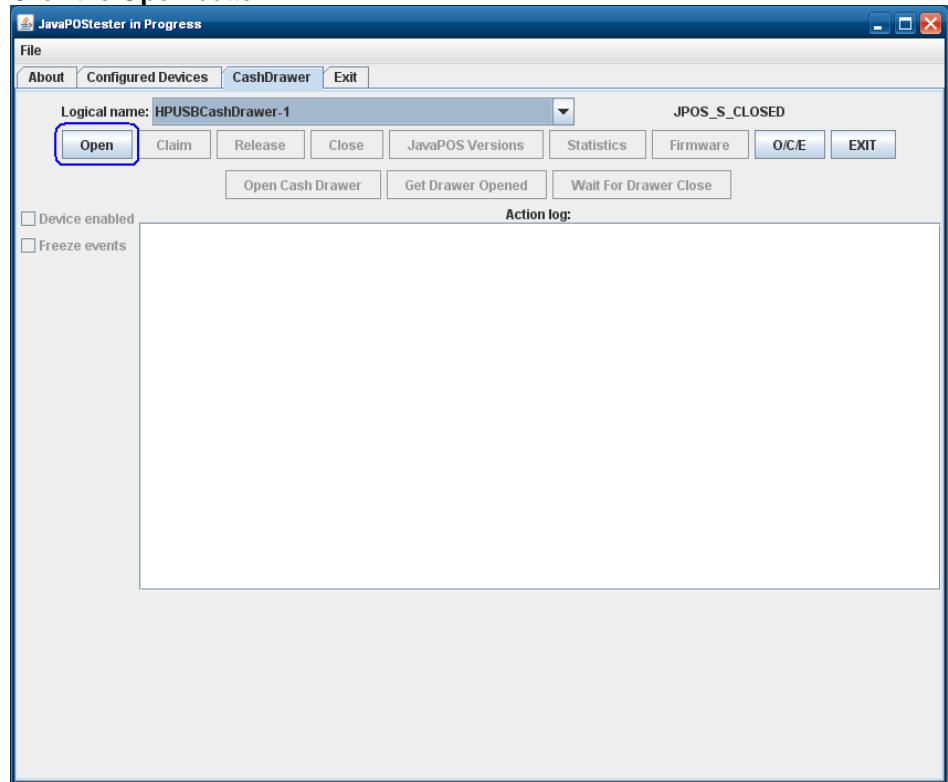

5. Click the **Claim** button.

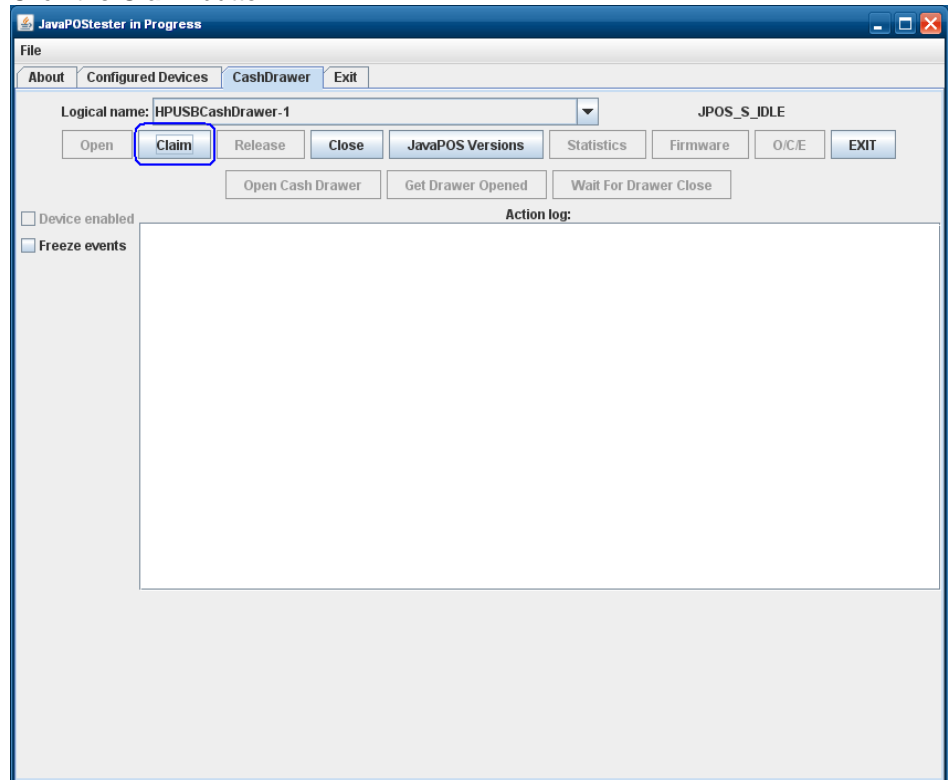

6. Check the **Device enabled** checkbox. The drawer status will appear in the GUI.

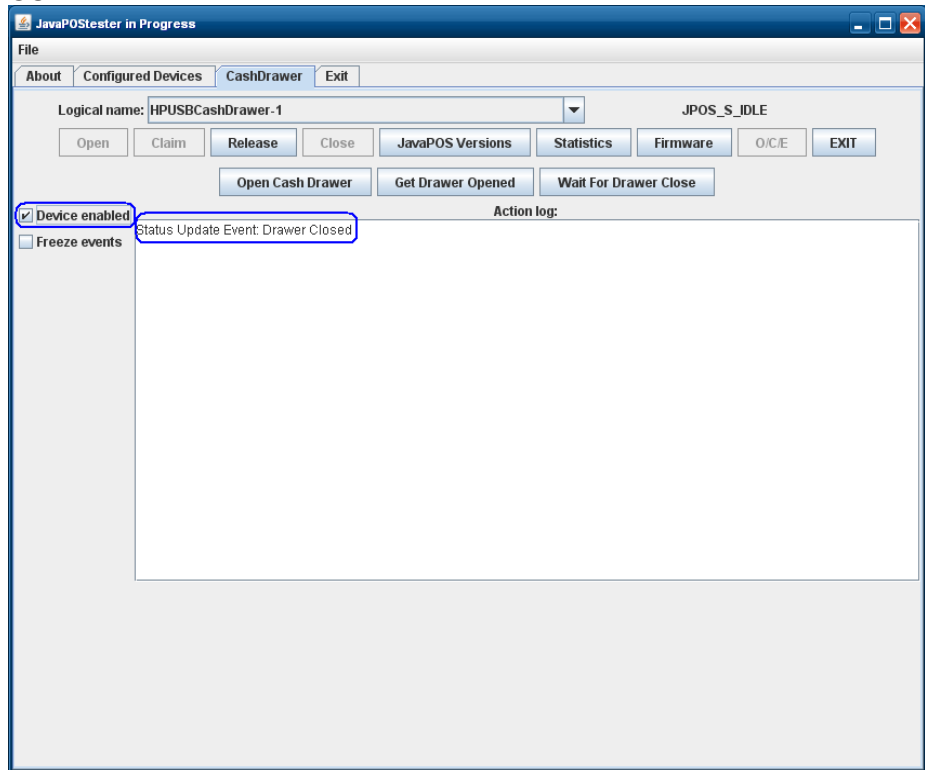

7. Click the **Open Cash Drawer** button to open the selected cash drawer.

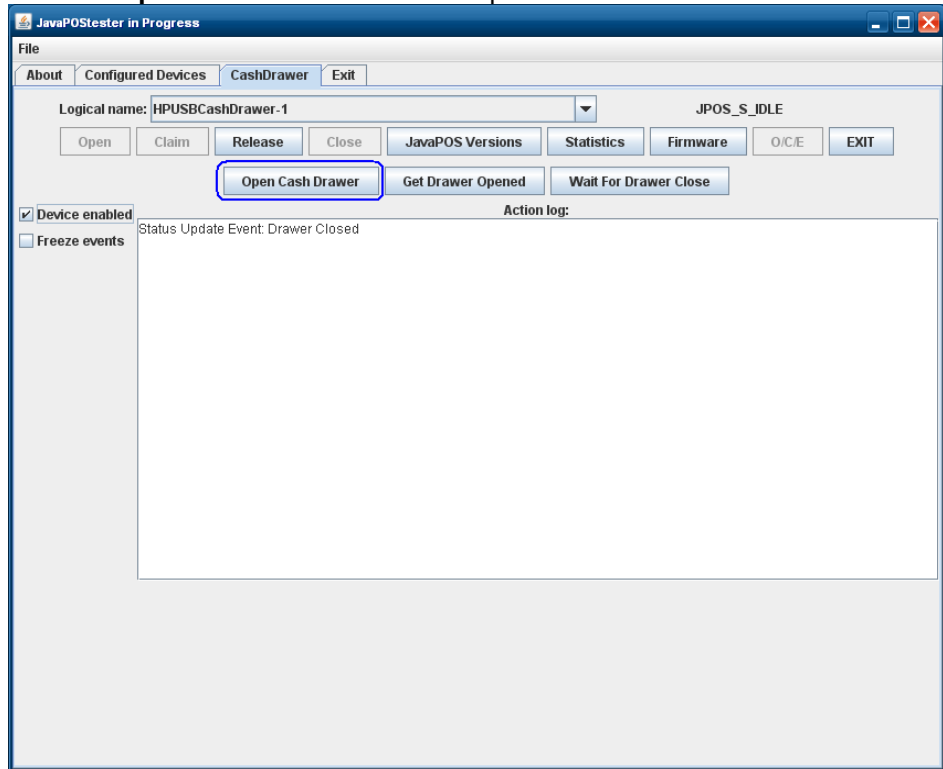

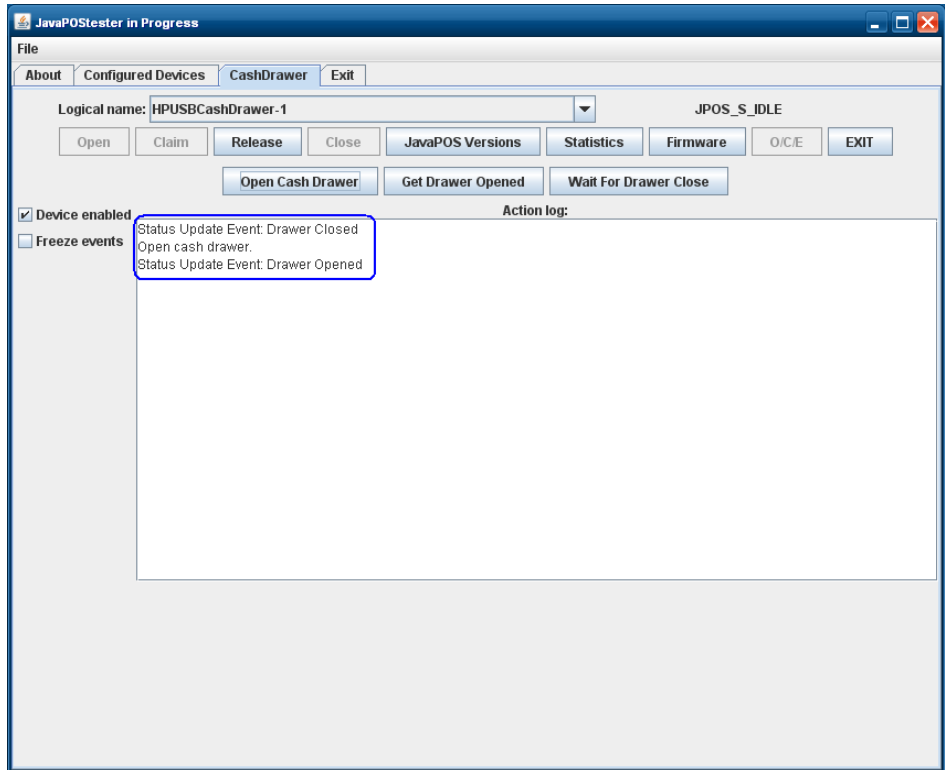

8. After drawer has opened successfully, close the drawer and click on the **Release** button.

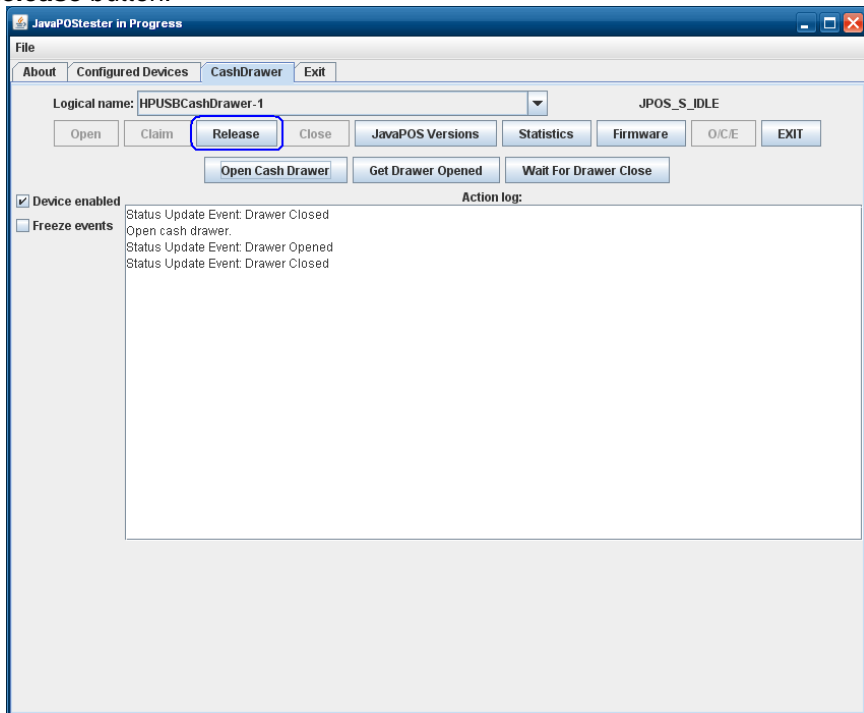

Note: Multiple STATUS UPDATE EVENTS with the same status may appear in the GUI.

9. Click the **Close** button.

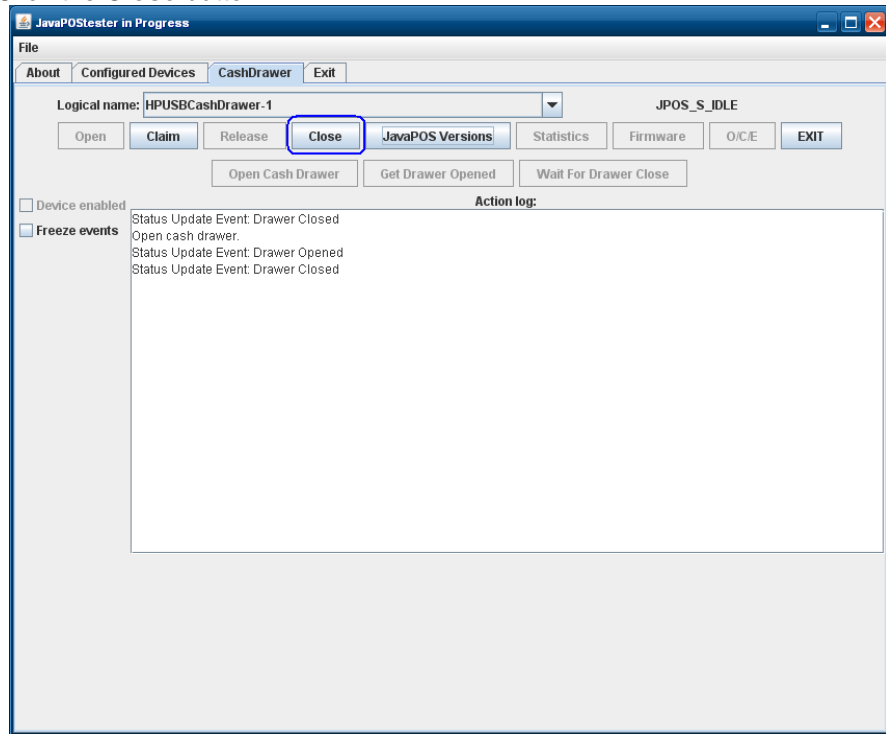

10. Click the **Exit** button to close the test application.

6.4 HP Receipt Printer



6.4.1 Connection

The HP receipt printer is installed in the 24V powered USB port on the HP POS system. The following show the back of the various HP POS units showing where the 24V power USB port is located.

HP ElitePOS G1 Retail System:

Refer to the Hardware Reference Guide included in the HP factory image and available from HP.COM.

HP RP9 G1 Retail System:

Refer to the Hardware Reference Guide included in the HP factory image and available from HP.COM.

HP RP2 Model 2000/2030:

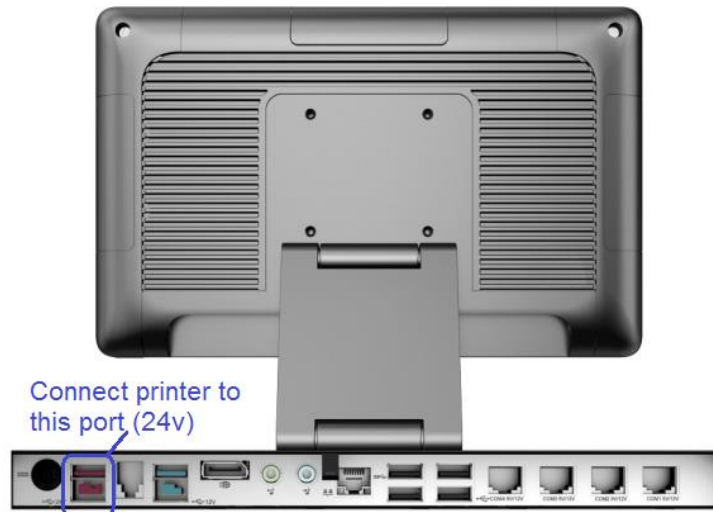

HP RP7 Model 7100 and HP RP7 Model 7800:

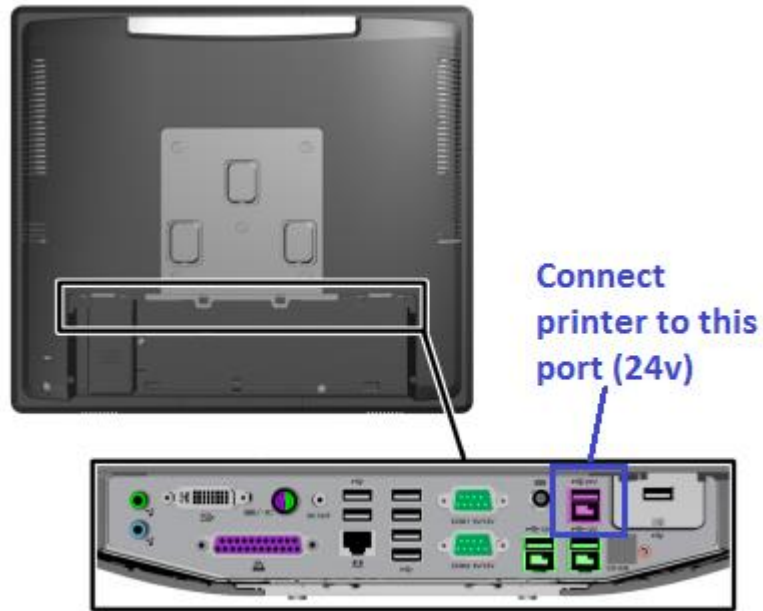

HP ap5000:

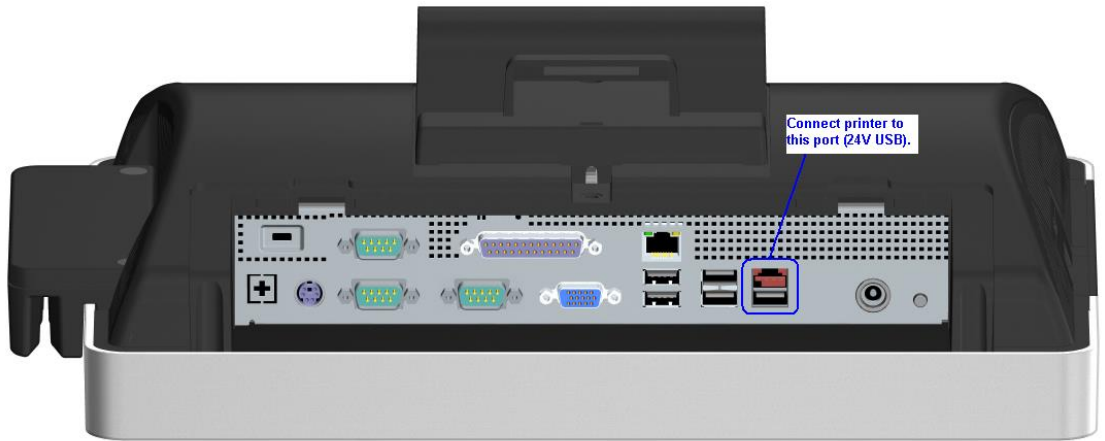

HP rp3000:



HP rp5700:

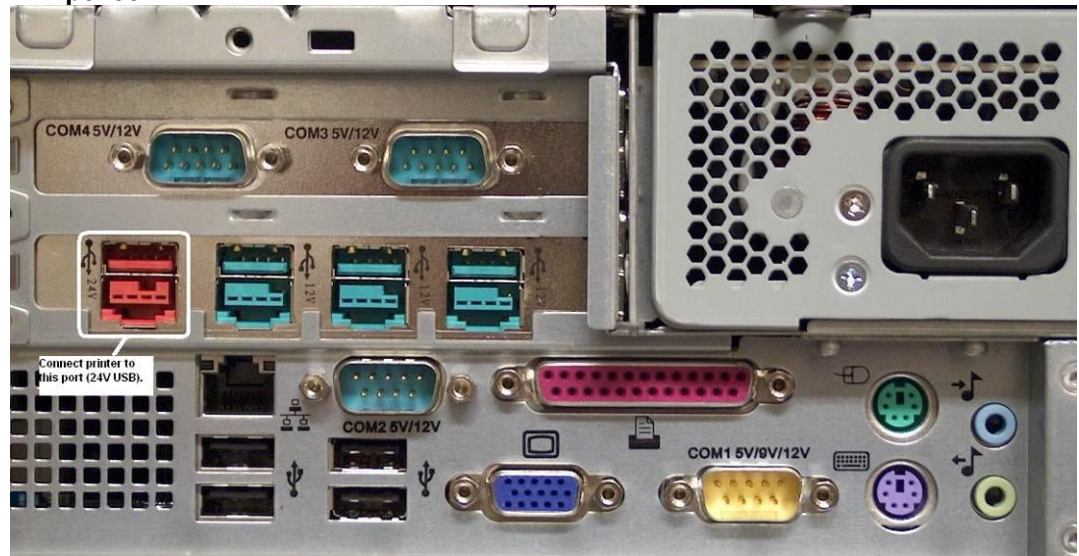

HP rp5800 and HP rp5810:



HP rp5000:

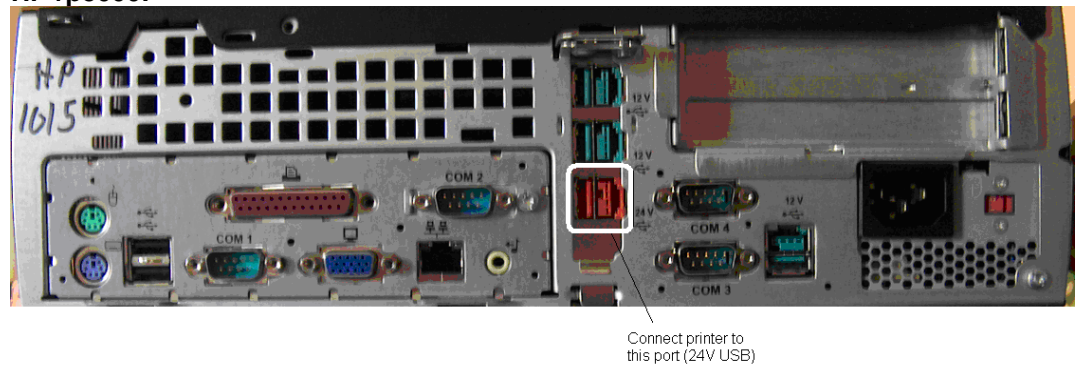

Note: The 24V powered USB port and cable are keyed differently than 12V powered USB connector, as well as the color.

6.4.2

Powered USB Cable

The following is the powered USB cable for single station printer and the hybrid printer (color of the cable maybe different than what is shown):

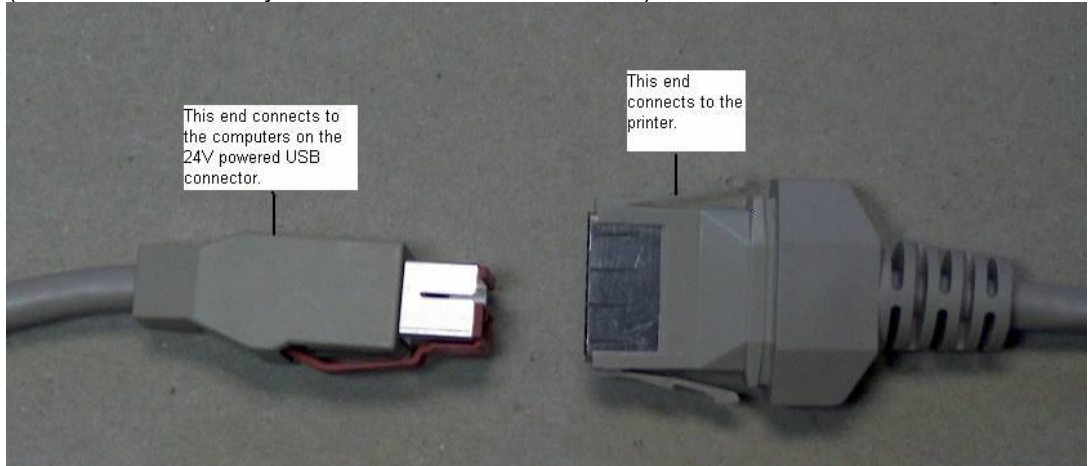

The following is the powered USB cable for the hybrid printer with imager:

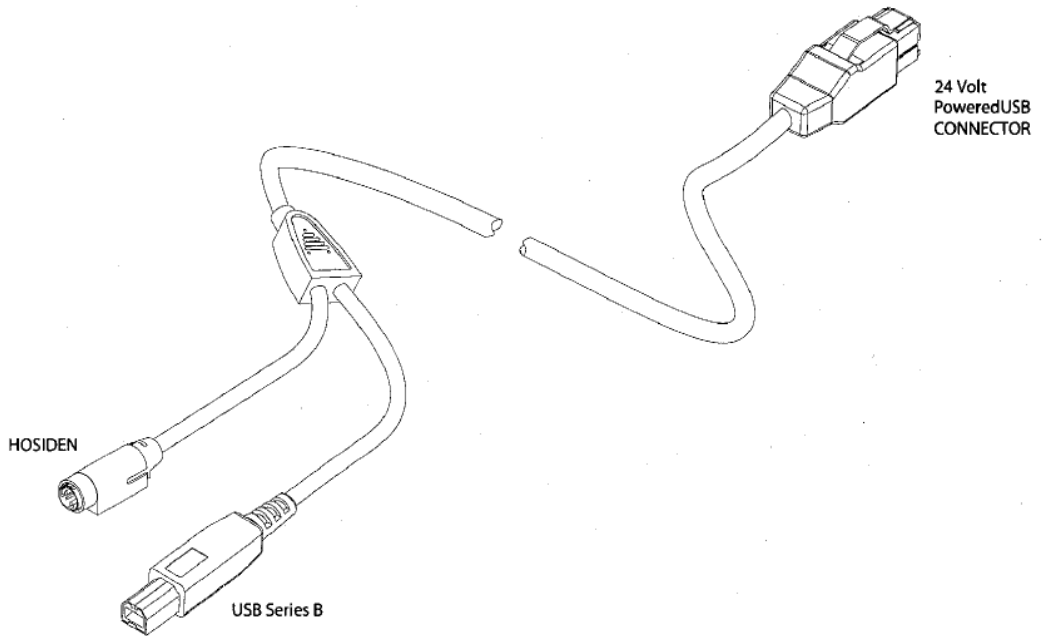

The single station printer with serial interface requires two cables: power (hosiden) and serial data cable.



The following is the powered (hosiden) cable for the single station printer with serial interface:

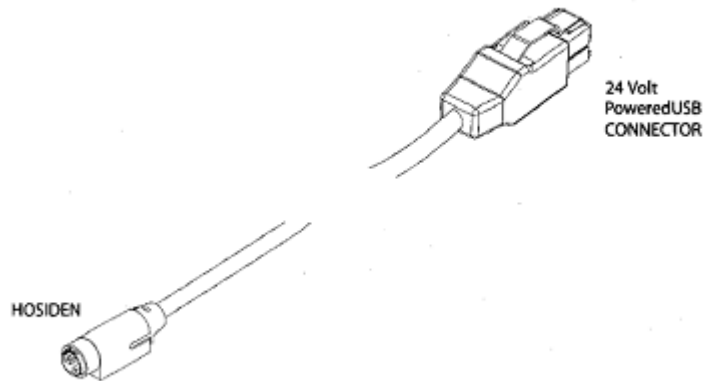

The serial data cable is standard null modem cable and the following is the pin out of the cable:

Pin #	Pin #
1	NC (no connect)
2	3
3	2
4	6
5	5
6	4
7	8
8	7
9	NC (no connect)
Shield	Frame Ground

6.4.3 **NATIVE mode**

Please note that PRINTER CLASS is the default mode of the printer; please see next section for more details on PRINTER CLASS.

On the HP Point of Sale units with Windows operating system, the drivers for Windows device manager are installed on the image from the HP factory. When the printer is attached to the unit via the powered USB connection, Windows will load the drivers for the HP POS printer.

If the Windows USB drivers are needed for Device Manager when the printer is in native mode, they can be found on HP.COM.

The following is showing what appears in Windows Device Manager after the driver has been loaded for the printer in NATIVE mode (native mode is only supported in XP based operating system – WePOS / POSReady 2009 / Windows XP Professional):

Single Station Printer in Native Mode

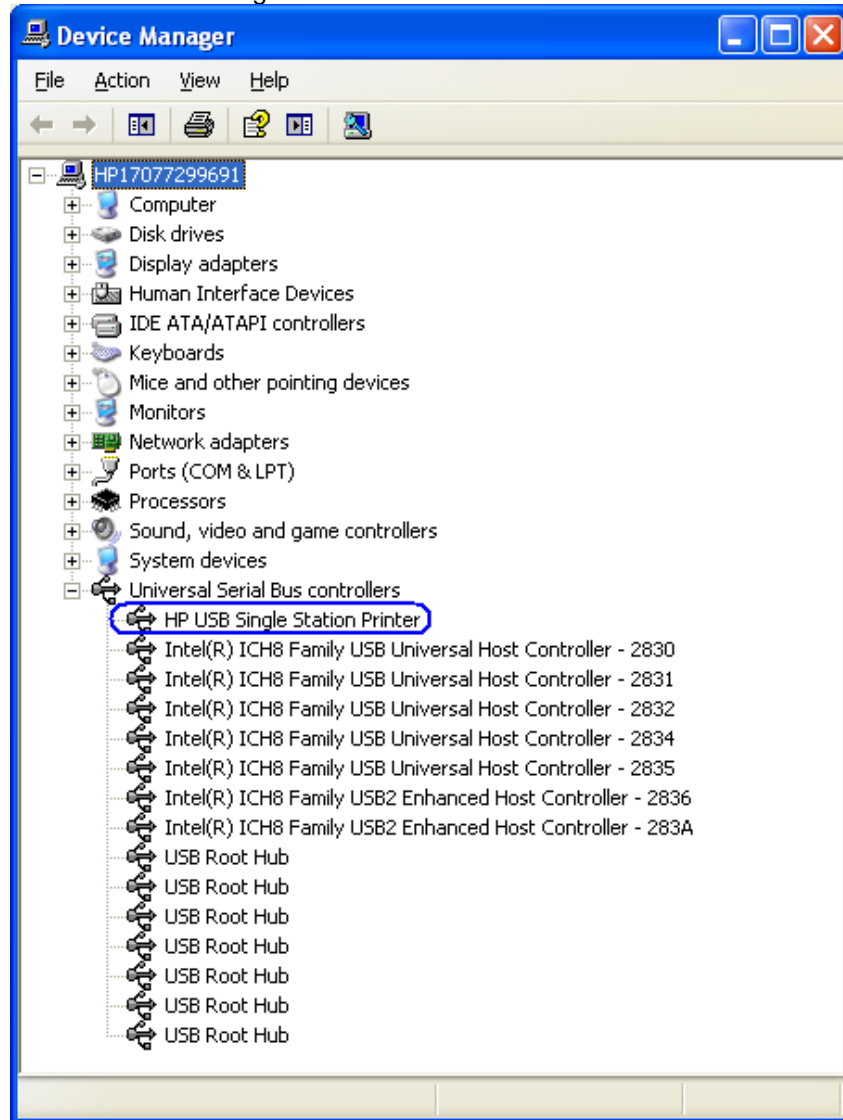

HP Hybrid Printer in Native mode

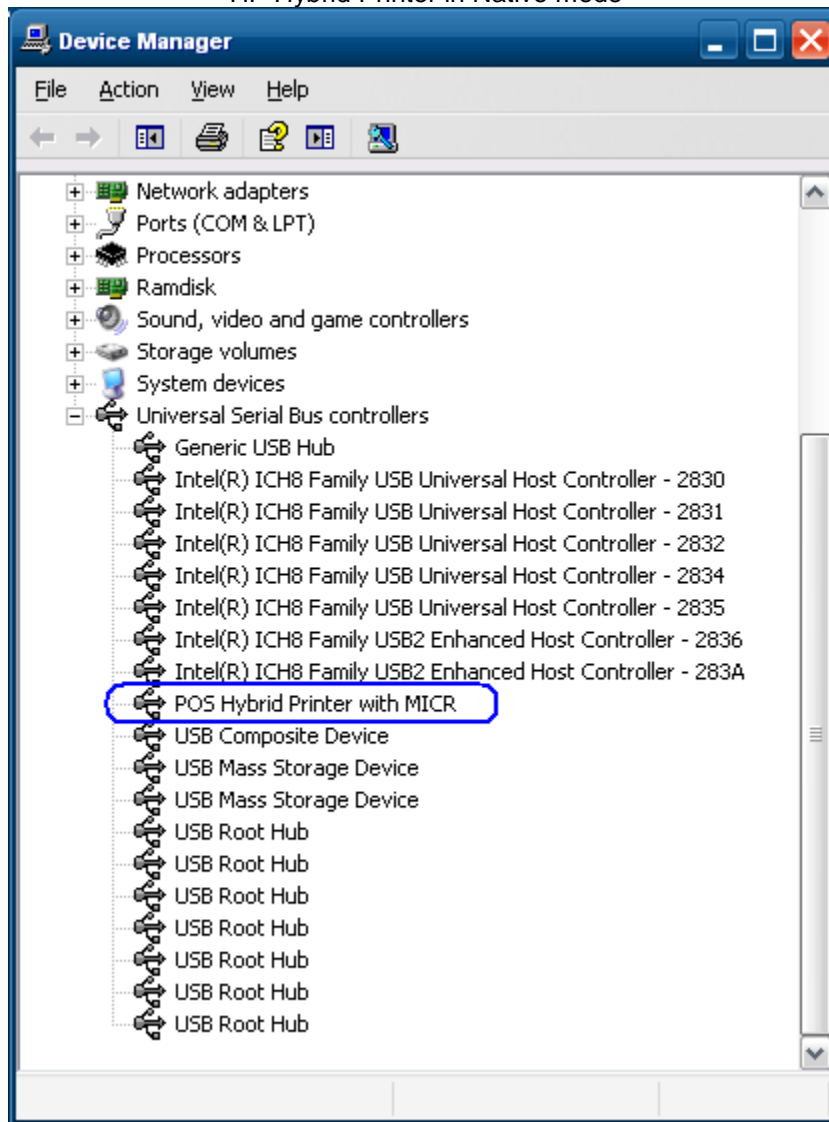

6.4.4 **PRINTER CLASS Mode**

When the printer is in PRINTER CLASS mode, the Microsoft Windows native drivers are loaded by operating system for device manager. PRINTER CLASS mode must be used when the POS application does not use OPOS driver to communicate the receipt printer.

The following is showing what appears in Windows Device Manager after the driver has been loaded for the printer in PRINTER CLASS mode:

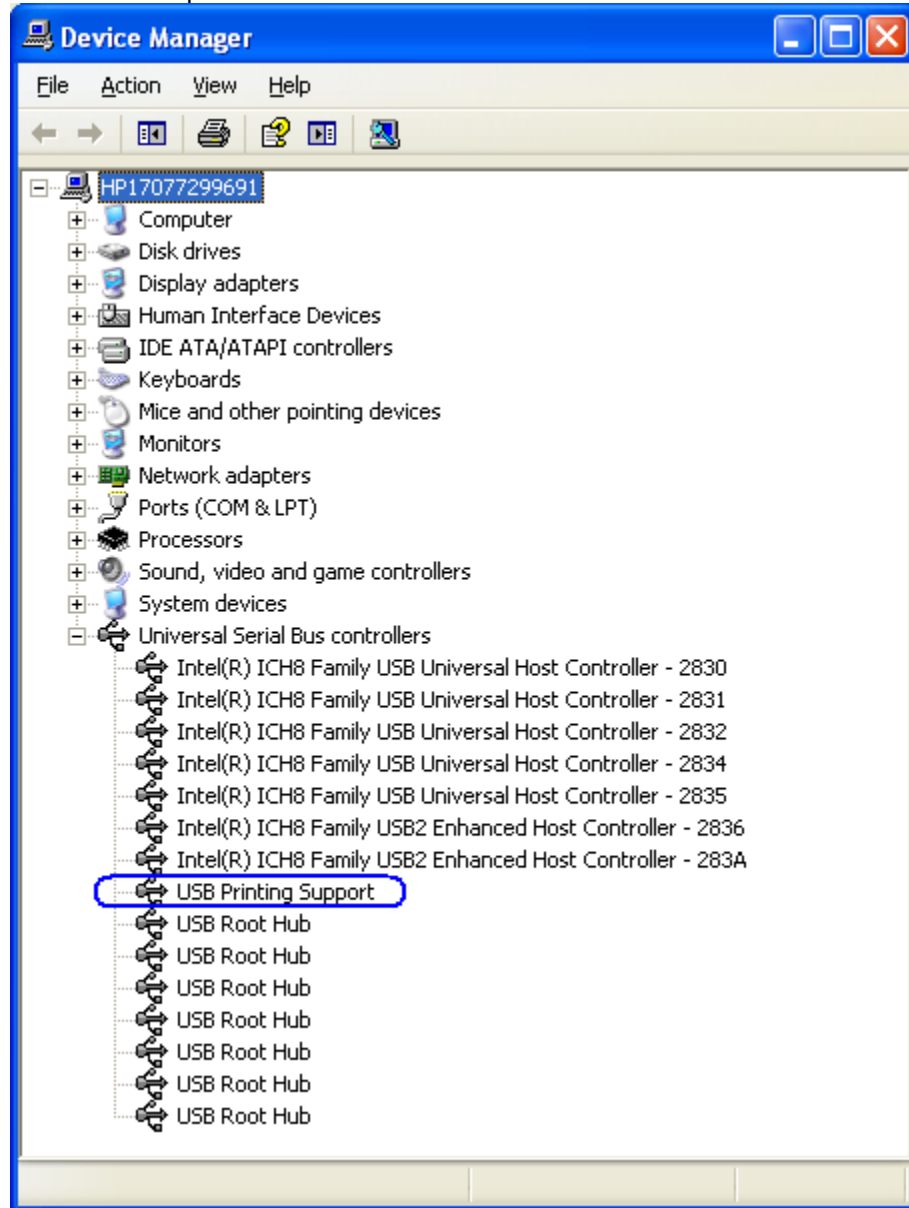

6.4.5 **COMM CLASS Mode**

If the correct boot and flash firmware level are present on the printer (see table below) the printer can be put into COMM CLASS. When the printer is in COMM CLASS mode a virtual COM port is assigned to the printer USB interface for application that only communicate to the printer via serial port. One can look in Windows Device Manager → PORTS to determine the virtual com port that Windows assigned to the virtual printer COM port. Steps to change COMM class are covered in [USB MODE SELECTOR](#) section of the document).

Note: The COMM CLASS option is available only on the A799 powered USB model and A776 printer. The following are minimum version of the firmware that supports the COMM CLASS option:

Firmware Version	A776	A799
Boot Firmware Version	1.25	1.06
Flash Firmware Version	2.00	1.08

Note: If the printer has later versions then what is listed in the above table, the printer firmware does not need to be downgraded to the version in the table.

In order to obtain the firmware that is installed on the printer, perform the following steps when you are in front of the printer:

1. Open the printer cover that holds the thermal receipt paper.
2. Hold down the printer form feed button and close the printer cover.
3. Release the form feed button on the printer and a diagnostics printout will be printed.

The following are examples of the diagnostics printout:

HP Single Station Printer (A799)

```

*** A799 - Diagnostics Form ***
ReceiptWare Enabled

Model number       : A799-C40D-HN00
Serial number      : K102100925

Boot Firmware
Revision           : V3.02
CRC                : 7E22
P/N               : 189-7940489B
Flash Firmware
Revision           : V3.01
CRC                : 4448
P/N               : 189-7940490A

H/W parameters
Flash Memory Size  : 8 Mbytes
Flash Logos/Fonts : 4800 kbytes
Flash User Storage : 64 kbytes
Flash Perm'nt Fonts: 2240 kbytes
Flash Journal Size : 64 kbytes
SDAM Size          : 512 kbytes
  
```

HP Hybrid Thermal Printer (A776)

```

*** A776 / B780 - Diagnostics Form ***
ReceiptWare Enabled

Model number       : A776-C21W-H000
Serial number      : K084905284

Boot Firmware
Revision           : V1.25
CRC                : FC97
P/N               : 189-7760899A
Flash Firmware
Revision           : V2.00
CRC                : B910
P/N               : 189-7760897A

H/W parameters
Flash Memory Size  : 2 Mbytes
Flash Logos/Fonts : 896 kbytes
Flash User Storage : 64 kbytes
  
```

The following is showing what appears in Windows Device Manager after the driver has been loaded for the printer in COMM CLASS mode:

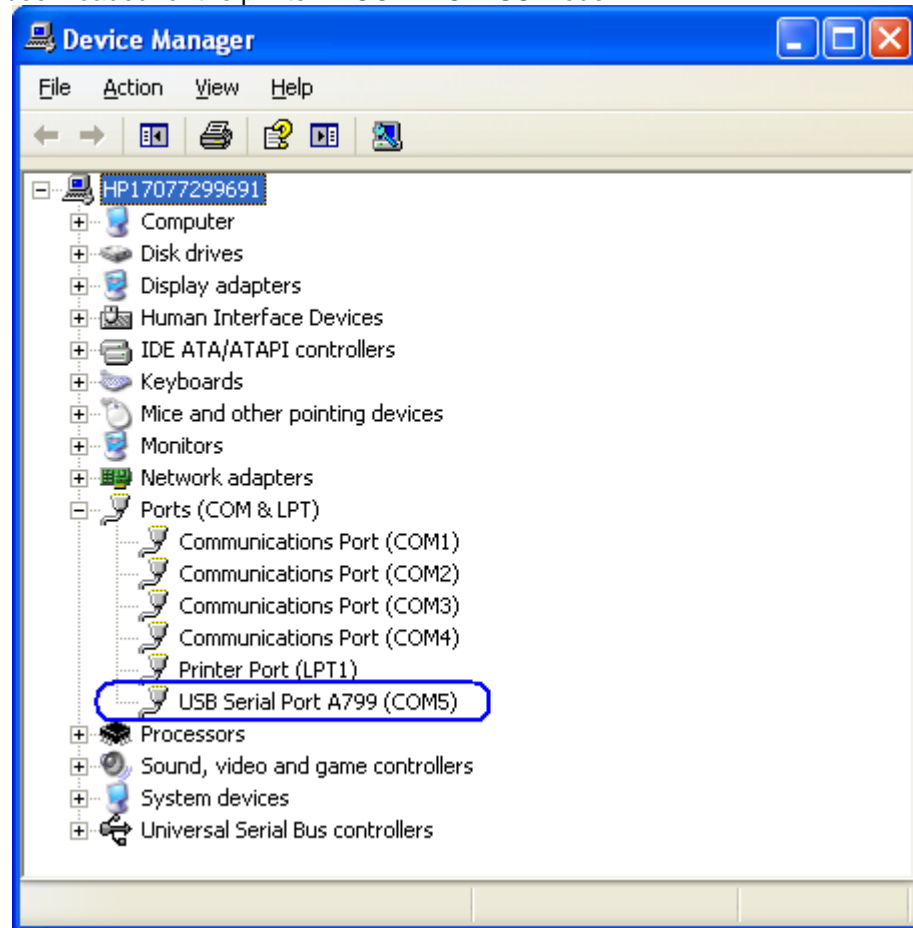

6.4.6 **USB Mode Selector Utility**

If the proper level of firmware is present on the receipt printer the USB MODE SELECTOR utility can be used to switch the printer between NATIVE / PRINTER / COMM Class mode. The HP USB receipt printer must be attached to the desktop computer and all Microsoft Windows device drivers must be loaded (no yellow exclamation marks in Device Manager) in order for the utility to work correctly.

The following is an overview of the steps to use the USB Mode Selector Utility:

1. Open **USB Mode Selector**.
 - C:\xxxxx\Point of Sale\Receipt Printer\HP Receipt USB Mode Selector Utility\UsbModeSelector.exe.
2. A dialog appears which reflects the mode the printer is currently set to.
 - a. Select the desired mode of the printer. If the printer is in COMM CLASS mode, the GUI will display the virtual com port that is assigned to the printer on the unit that utility is run on.
 - b. Click on the change button.
 - c. Exit the utility.

Note: The first time the printer is changed to a different mode, Windows may take a few minutes to completely load and enable the driver for the selected mode.

The following example shows the printer in PRINTER CLASS mode (item is circled in blue):

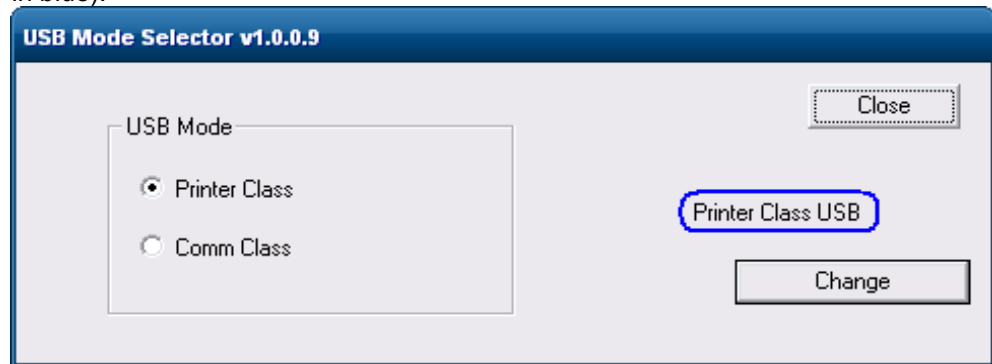

6.4.6.1 **Set printer to NATIVE mode**

The following are the steps to switch the printer to NATIVE MODE (native mode is only supported in XP based operating system – WePOS / POSReady 2009 / Windows XP Professional):

Note: Native Mode option is no longer available starting with version 1.0.0.9 of the utility.

1. Select NATIVE MODE in the GUI.

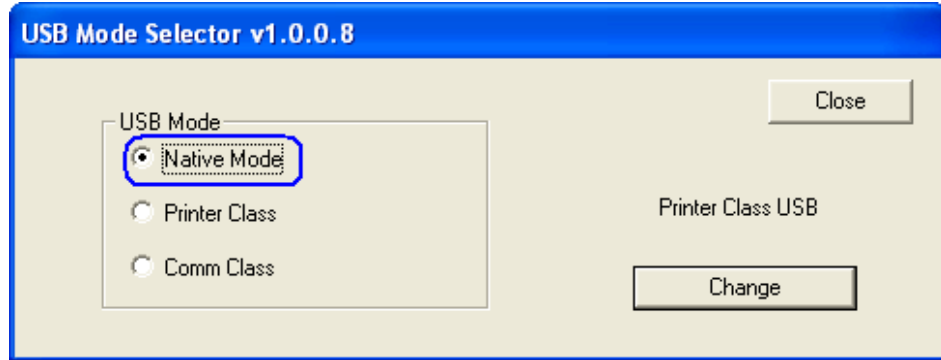

2. Click on the CHANGE button.

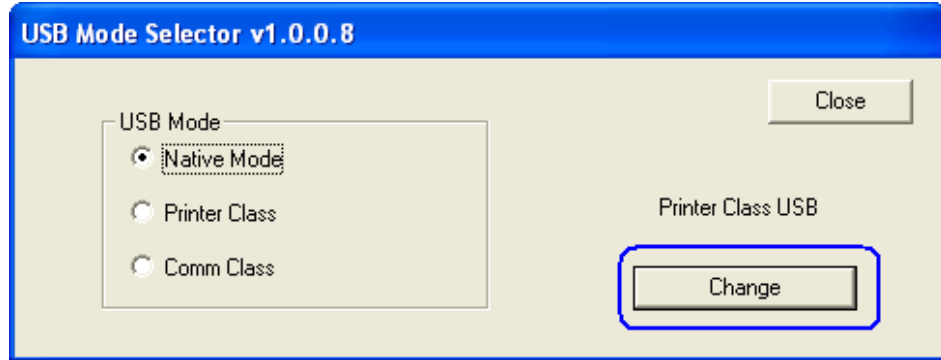

3. Once the printer has loaded the drivers and changed modes, the GUI will change the printer mode status to NATIVE USB.

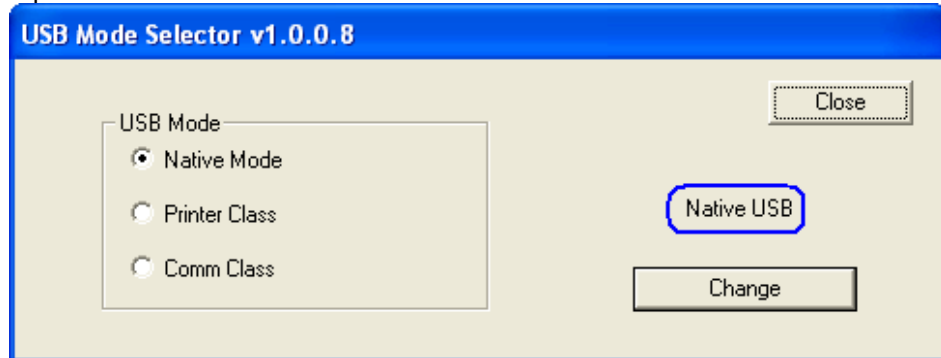

6.4.6.2 **Set printer to PRINTER CLASS mode (default)**

The following are the steps to switch the printer to PRINTER CLASS MODE (printer default):

1. Select PRINTER CLASS in the GUI.

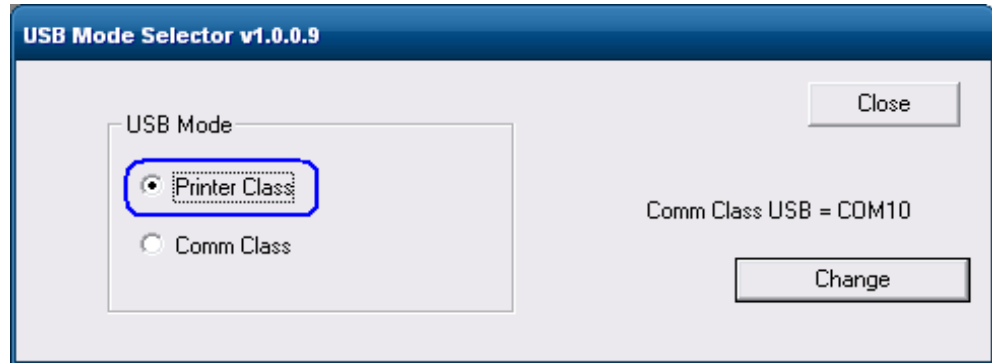

2. Click on the CHANGE button.

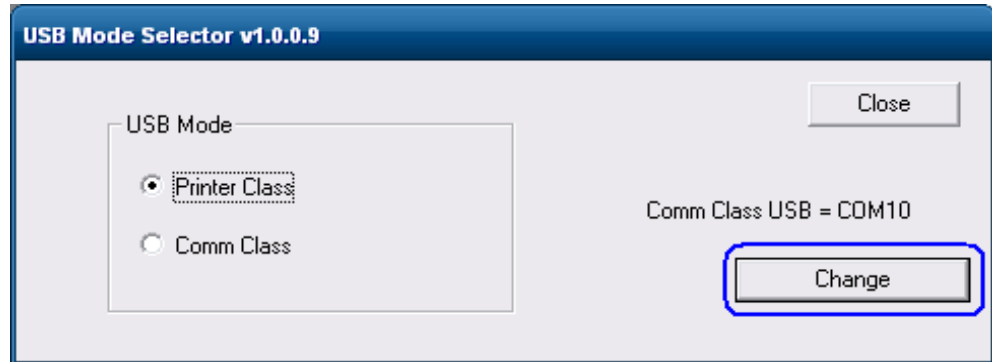

3. Once the printer has loaded the drivers and changed modes, the GUI will change the printer mode status to PRINTER CLASS USB.

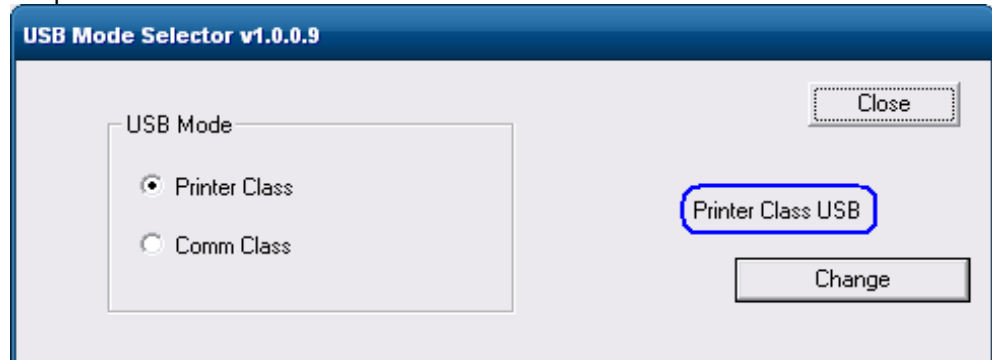

6.4.6.3 **Set printer to COMM CLASS mode (virtual serial port)**

The following are the steps to switch the printer to COMM CLASS MODE:

1. Select COMM CLASS in the GUI.

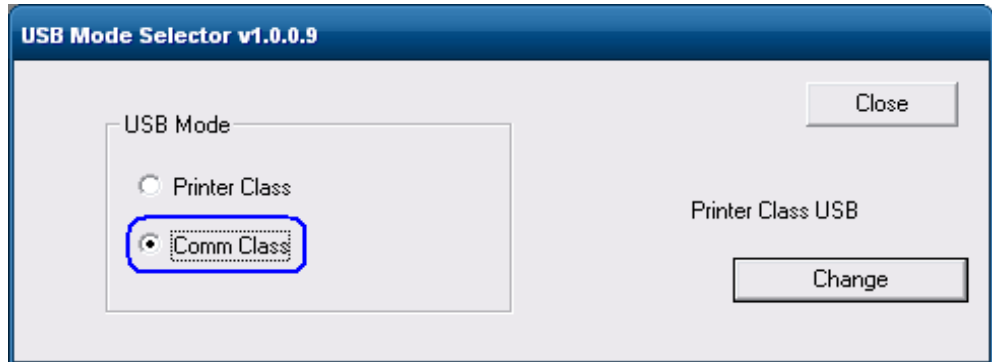

2. Click on the CHANGE button.

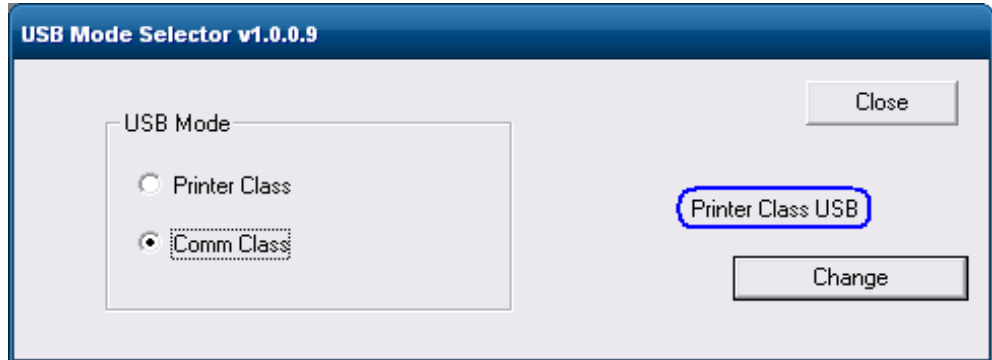

3. Once the printer has loaded the drivers, close and re-open the utility in order to have the utility display the virtual COMM PORT that was assigned by Windows.

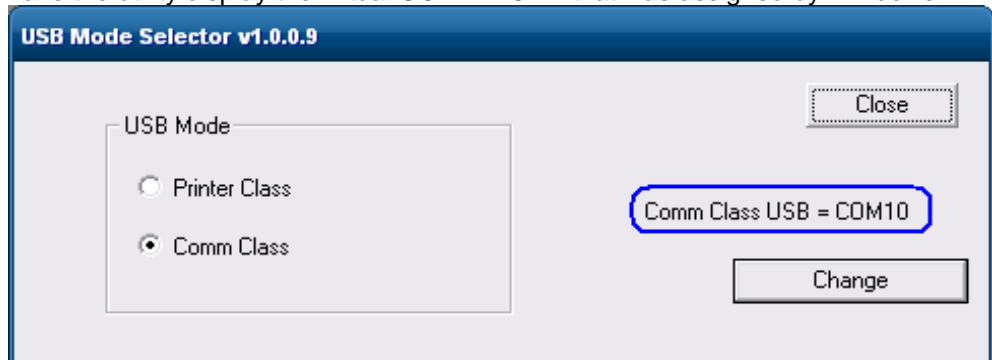

One may also look in Windows Device Manager → PORTS to see the virtual COMM PORT assignment.

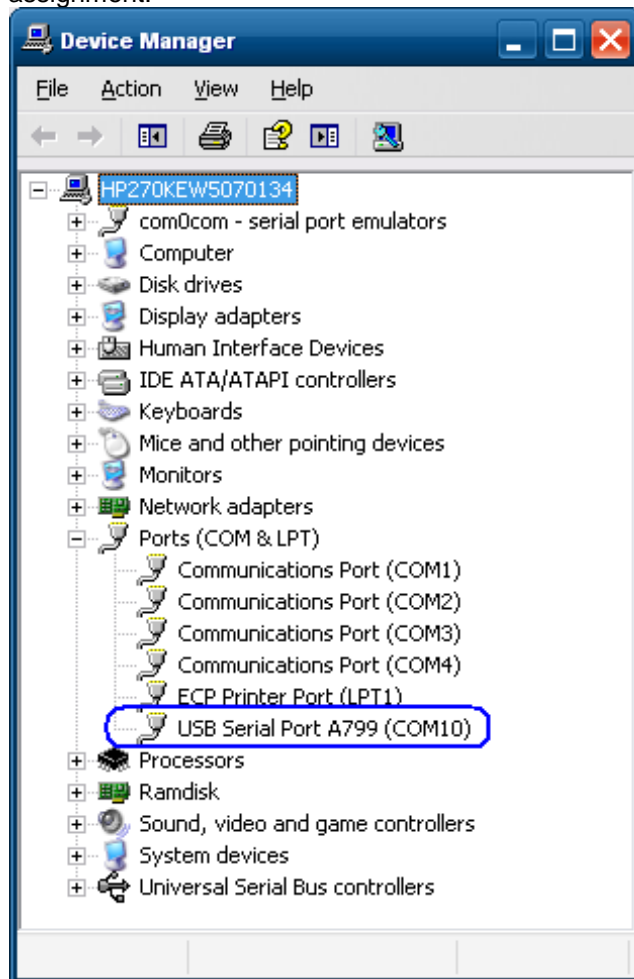

6.4.7 Serial Printer

The serial version of the printer will not show as a unique device in Windows device manager. Ensure that the serial port in device manager is present and does not have yellow bang.

6.4.8 Windows Drivers for the Receipt Printer Drivers

The printer has two modes: NATIVE and PRINTER CLASS. PRINTER CLASS is the default mode of the printer.

The PRINTER CLASS mode is used with POS application that use Windows printer driver to print, they do not use OPOS to communicate to the printer.

Note: The Windows mini-drivers and the OPOS drivers cannot be set to the same COM port.

6.4.8.1 Windows Printer Driver (USB) for v1.0.5 for POSReady 2009

The following is an overview of the steps to test the receipt printer followed by detailed steps:

1. Open **HPSetup**.
 - C:\xxxx\Point of Sale\Receipt Printer\Windows Receipt Printer Drivers\HP_Mini_Drivers.bat.
2. Select your printer model that appear on the screen.
3. Select the USBxxx (Virtual Printer Port of USB) printer port from the drop menu (towards the bottom of the drop down menu).
 - In order to make the printer the default printer select the option "Set as default printer".
 - If one wishes to print a test page, select the option "Print test page" in the GUI.
4. Click "OK" to install the printer driver and a test print out will occur if the option was selected.

Detailed Steps

1. Open **HPSetup**.
 - C:\xxxx\Point of Sale\Receipt Printer\Windows Receipt Printer Drivers\HP_Mini_Drivers.bat.

The following is the GUI that one will see when the "HPSETUP.EXE" is opened:



2. Select your printer model that appear on the screen.

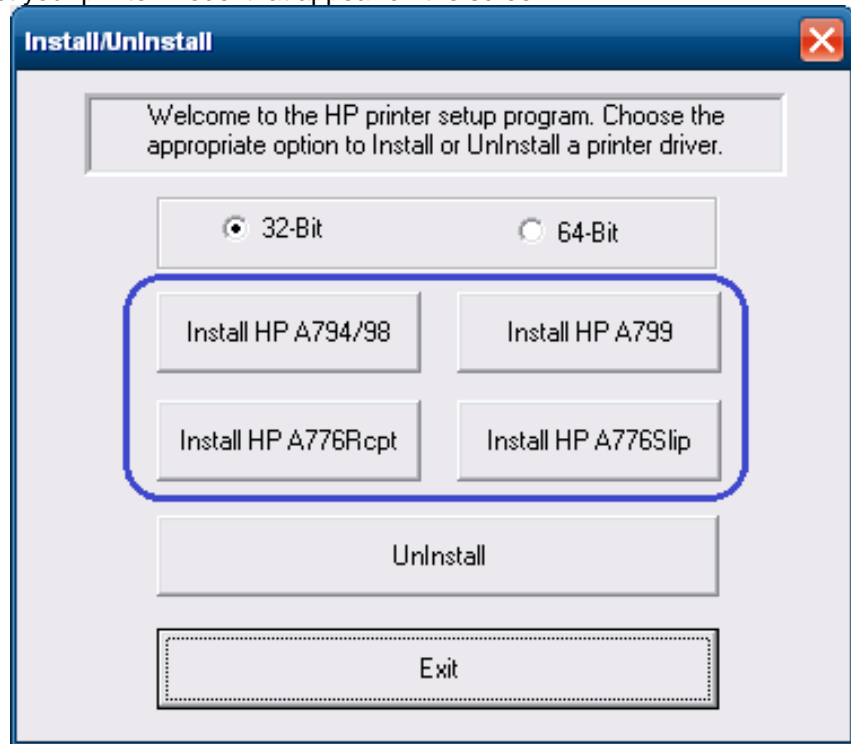

3. Select the USBxxx (Virtual Printer Port of USB) printer port from the drop menu (towards the bottom of the drop down menu).

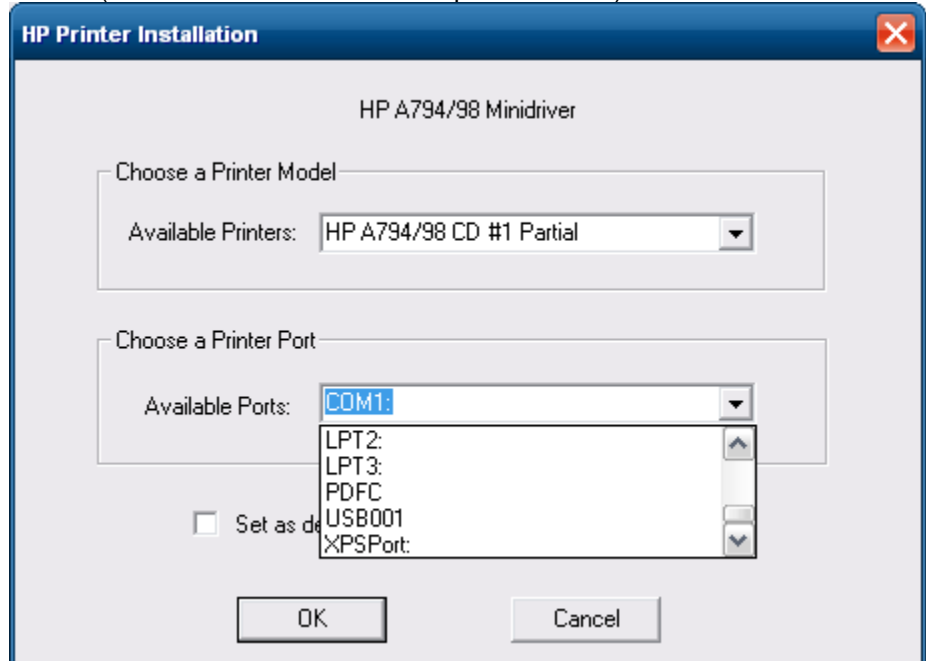

When the selections are made, the selection should be similar to the following screen:

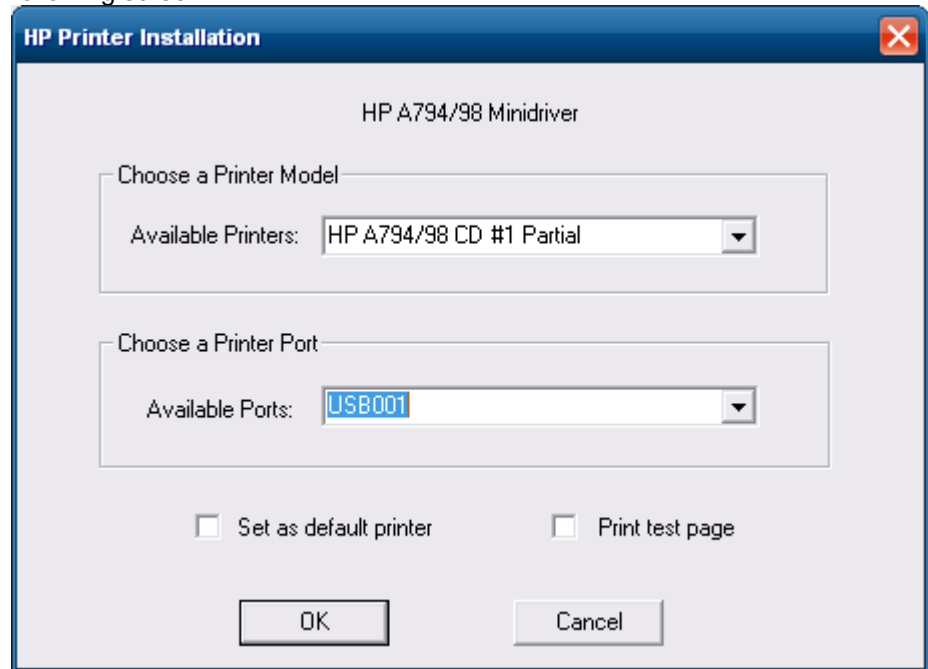

In order to make the printer the default printer select the option "Set as default printer".

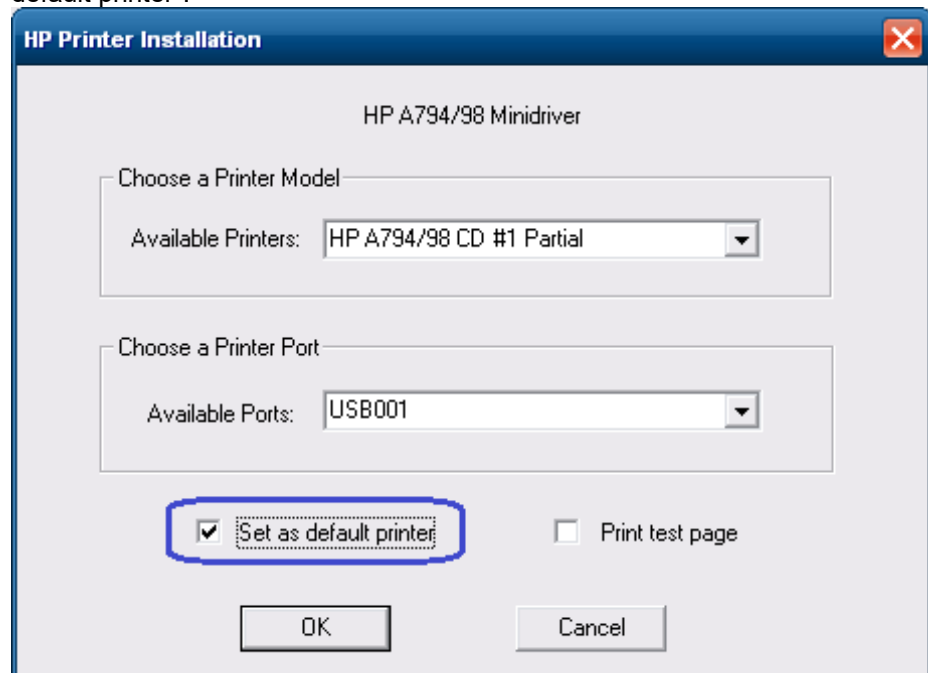

If one wishes to print a test page, select the option “Print test page” in the GUI.

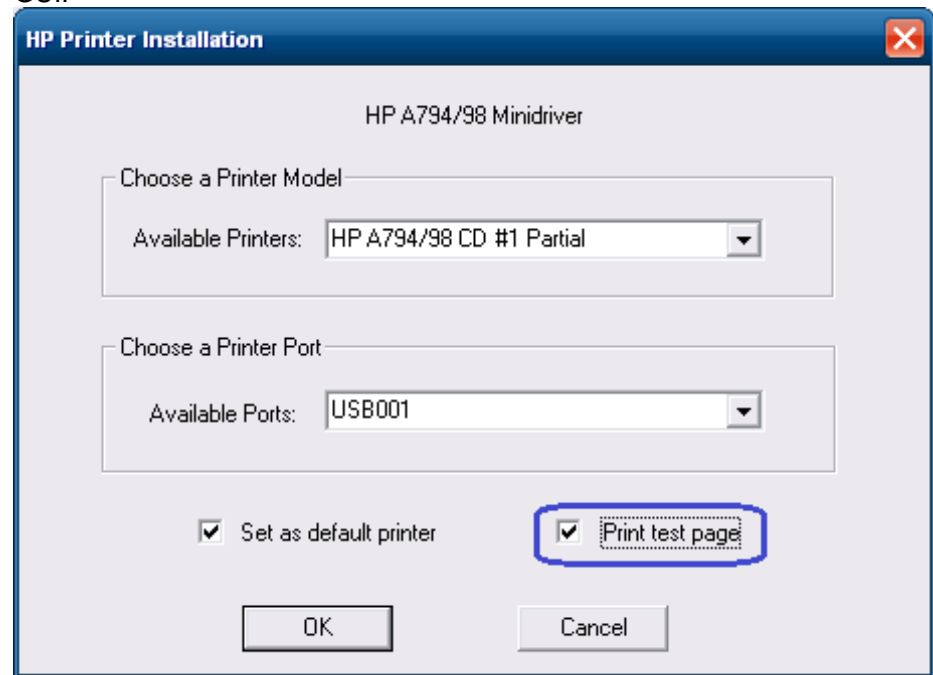

4. Click “OK” to install the printer driver and a test print out will occur if the option was selected.

6.4.8.2 **Windows Printer Driver (Serial) for v1.0.5 for POSReady 2009**

The following is an overview of the steps to test the receipt printer followed by detailed steps:

1. Print out the diagnostic form on the printer in order to obtain the baud rate the printer is set to.
2. Go into the communication port properties to change the Windows baud rate to the printer is set to on the diagnostics form (previous step) and flow control to "Hardware" for port that the printer is attached.
3. Start the setup program for the Windows mini-drivers by double clicking on "HP_Mini_Drivers.BAT" file and click "OK".
4. Select your printer model that appear on the screen.
5. Select the COM (serial) port the printer is attached to.
 - In order to make the printer the default printer select the option "Set as default printer".
 - If one wishes to print a very small test page, select the option "Print test page" in the GUI.
6. Click "OK" to install the printer driver and a test print out will occur if the option was selected.

Detailed Steps

1. Print out the diagnostic form on the printer in order to obtain the baud rate the printer is set to.
2. Go into the communication port properties to change the Windows baud rate to the printer is set to on the diagnostics form (previous step) and flow control to "Hardware" for port that the printer is attached.

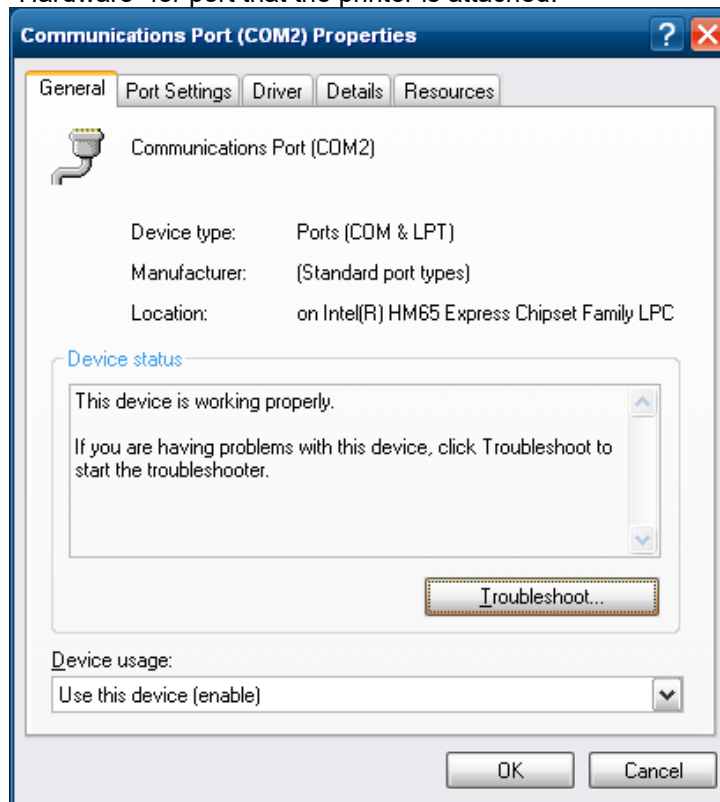

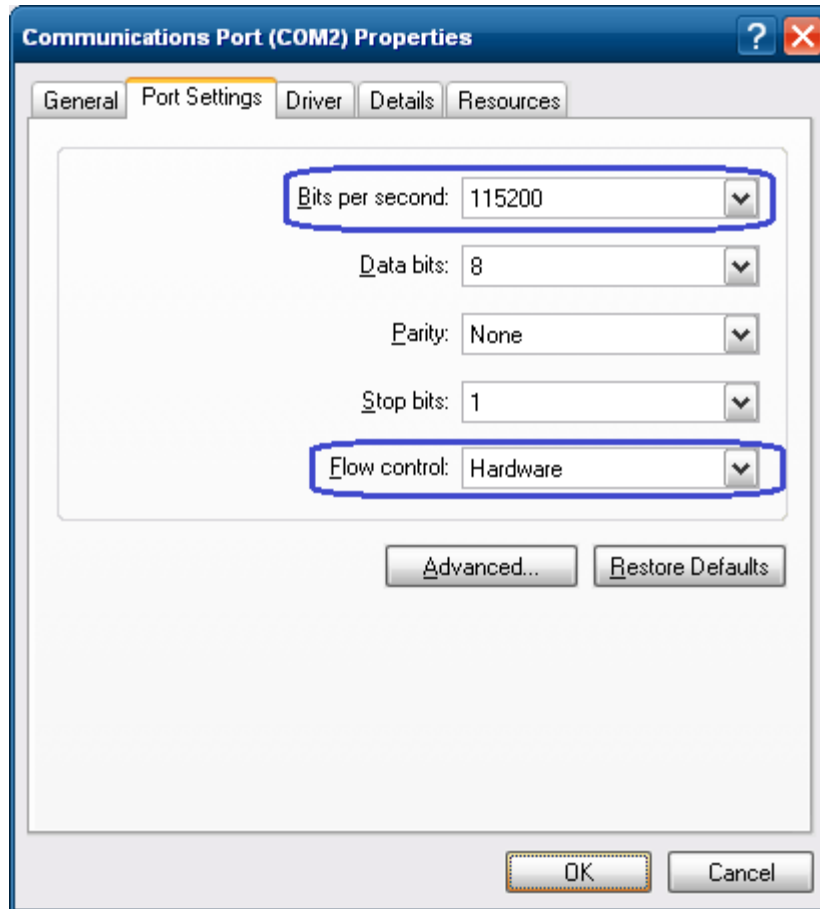

Note: The baud rate may be different than the screen shot shown above.

3. Start the setup program for the Windows mini-drivers by double clicking on "HP_Mini_Drivers.BAT" file and click "OK"

One can open the "HP_Mini_Drivers.BAT" file from the "C:\xxxx\Point of Sale\Receipt Printer\Windows Receipt Printer Drivers" folder and double click on the "HP_Mini_Drivers.BAT" file.

The following is the GUI that one will see when the "HPSETUP.EXE" is opened:

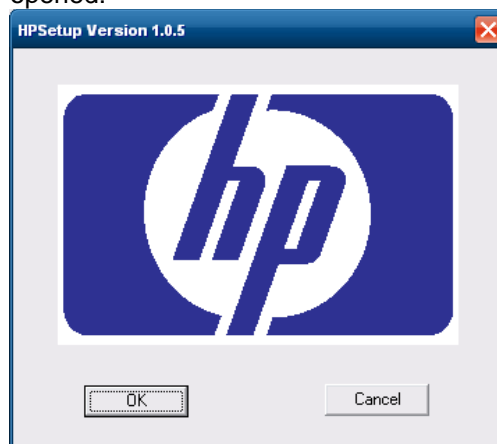

4. Select your printer model that appears on the screen.

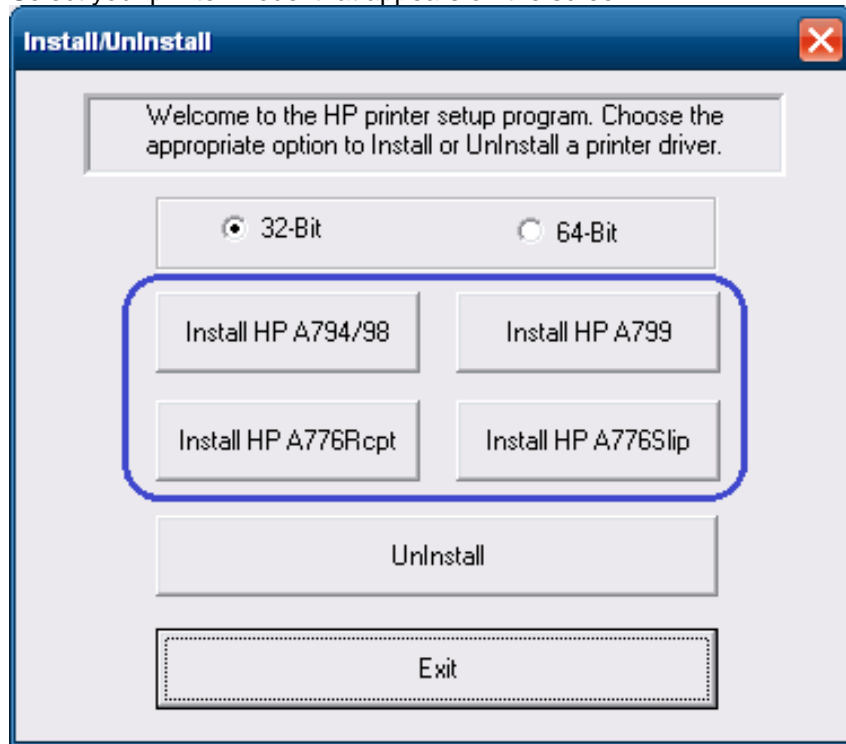

5. Select the COM (serial) port that the printer is attached to.

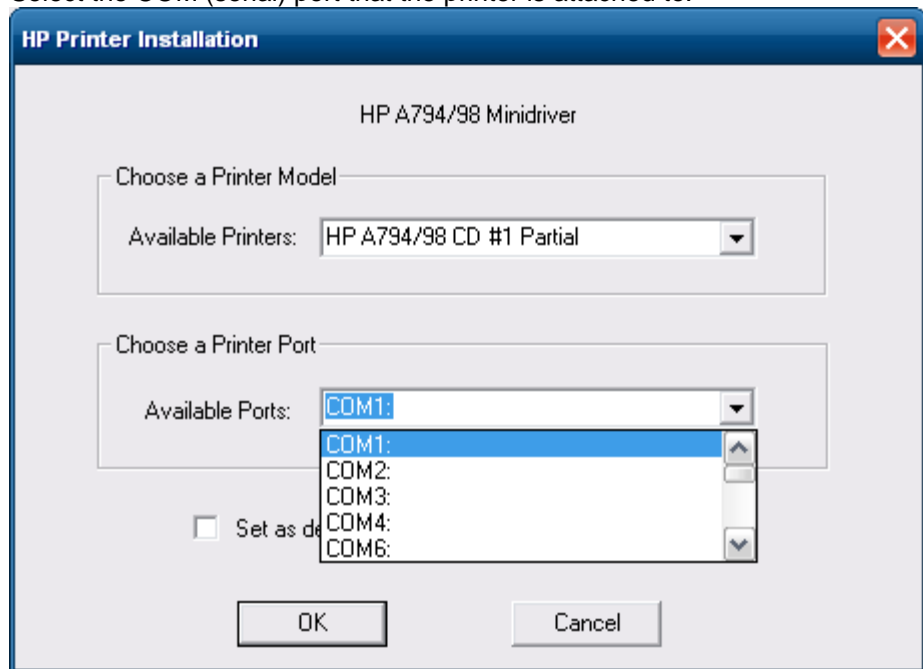

When the selections are made, the selection should be similar to the following screen:

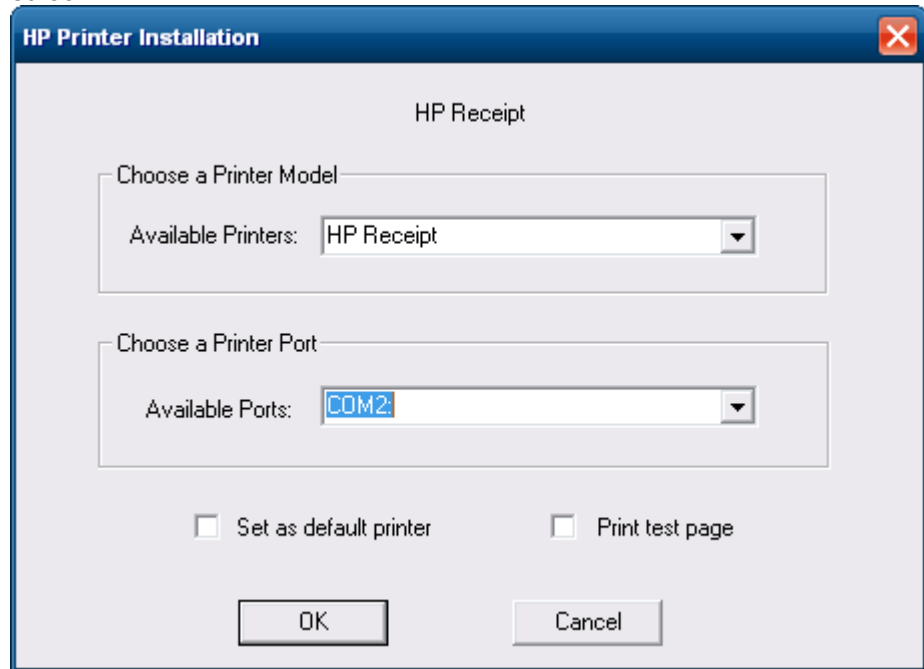

In order to make the printer the default printer, select the option "Set as default printer":

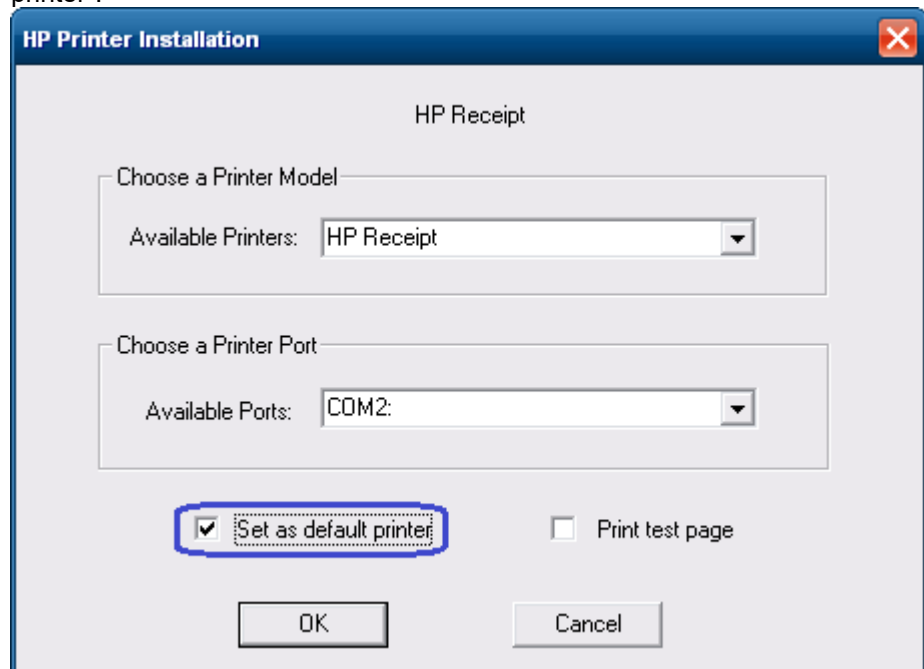

To print a small test page, select the option “Print test page”:

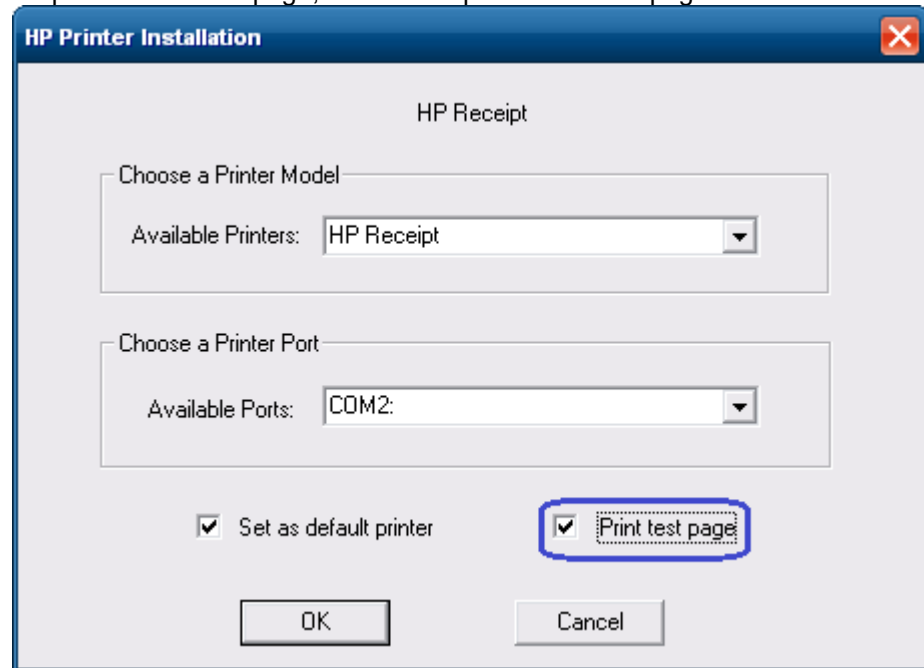

6. Click “OK” to install the printer driver and a test printout will occur if the option was selected.

6.4.8.3 **Windows Printer Driver (Ethernet) for v1.0.5 for POSReady 2009**

The following is an overview of the steps to test the receipt printer followed by detailed steps:

1. Print out the diagnostic form on the printer in order to obtain the IP Address and the RAW TCPIP Port information.
2. Go to Control Panel – Devices and Printers and select “Add a printer”.
3. Select “Add a local printer”. **Do not select the network option.**
4. Select “Create a new port” option.
5. Select “Standard TCP / IP Port” option and click on the next button.
6. Enter the IP Address that is printed on the diagnostics form and click on the “Next” button.
7. On the “Additional port information required” GUI select “Standard Generic Network Card” and click on “Next” and click the “Finish” button.
8. When the “Install the printer driver” GUI appears select “Have Disk” option.
9. When the “Install From Disk” option appears browse to the location where the drivers are located and select the “OEMPRINT.INF” file and click “Open”
10. When you are back to the “Install the printer Driver” GUI “HP Receipt” printer will appear, click on the “Next” button.
11. On the “Print Sharing” GUI select the option “Do not share this printer” and click on the “Next” button.
12. On the “Print Test Page” GUI select the “No” option and click on the “Next” button. The configuration is not complete is the reason for selecting no.
13. Click on the “Finish” button.
14. Go to the “Devices and Printers” and right click on the printer that was just installed and select “Properties”.
15. Select the “Ports” tab.
16. Highlight the port for the printer that was installed and select “Configure Port”.
17. Go to the “Raw Settings” section on the “Configure Standard TCP/IP Port monitor” GUI. In the “Port Number” section enter 9001 (double check the diagnostics form to confirm 9001 is on the “Raw TCPIP Port” and click OK.
18. Close the printer properties GUI screen.
19. Go to the “Devices and Printers” and right click on the printer that was just installed and select “Properties”.
20. Click on “Print Test Page” and printout should occur.

Detailed Steps

1. Print out the diagnostic form on the printer in order to obtain the IP Address and the RAW TCPIP Port information.

Steps to obtain a diagnostics printout

- A. Plug the printer into the network and have power to the printer.
- B. Run a diagnostic printout and obtain the printer IP address from the printout.
- C. Be sure paper is in the printer (1).
- D. Open the receipt cover (2).
- E. Press and hold the paper feed button (3).
- F. Close the receipt cover (2).

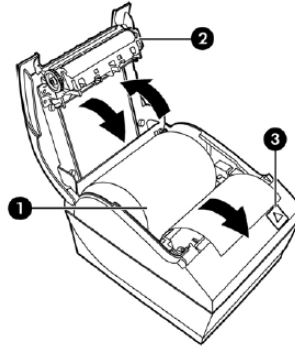

The following is partial A799II – Diagnostics Form printout showing the IP address and Port info:

```

Comm. Interfaces
Port Idle Timeout : disabled
Interface - USB
RX Buffer Size : 4096
USB Driver Type : Printer Class
USB Packet w/Error : Reject
Interface - RS232
RX Buffer Size : 4096
Parameters
Baud Rate : 115200
Data Bits : 8
Stop Bit : 1
Parity : NONE
Flow Control : DTR/DSR
Reception Errors : Ignore
Interface - Bluetooth
Status : not available
Interface - Ethernet
Ethernet Type : Wired
Parameters
MAC Address : 00:E0:70:F0:21:7C
IP Address : 10.1.3.18
Net Mask : 255.255.252.0
Gateway : 10.1.0.1
Raw TCPIP Port : 9001
Loop Back Port : Disabled
Http Server Port : 80
DHCP : Enabled
Client ID : 00E070F0217C
Idle Timeout : Disabled
Keep Alive Pings : Disabled

```

Note: The default IP address is 192.0.0.192. If this address appears on the printout, the printer has not obtained an IP address

2. Go to Control Panel – Devices and Printers and select “Add a printer”.

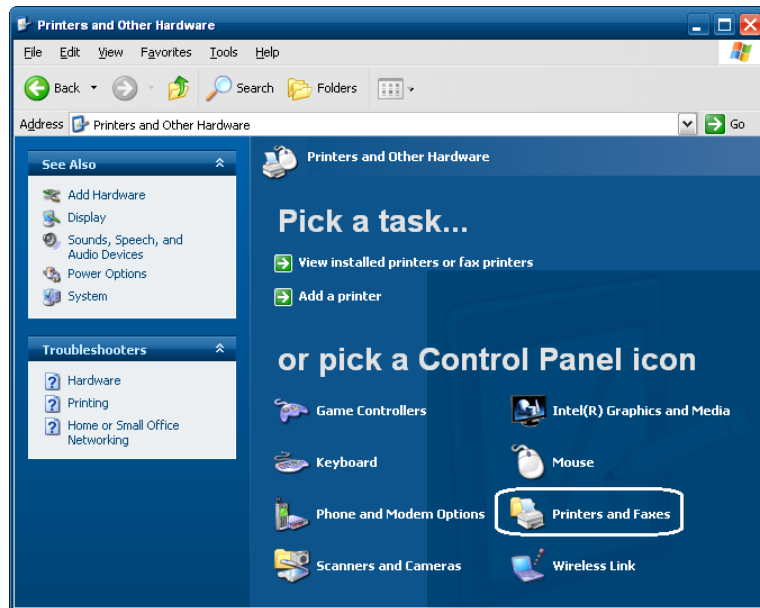
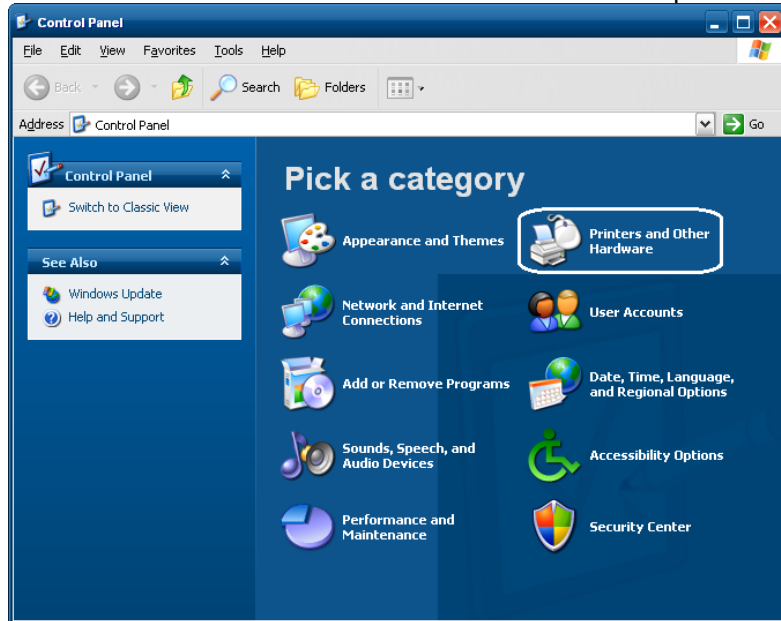

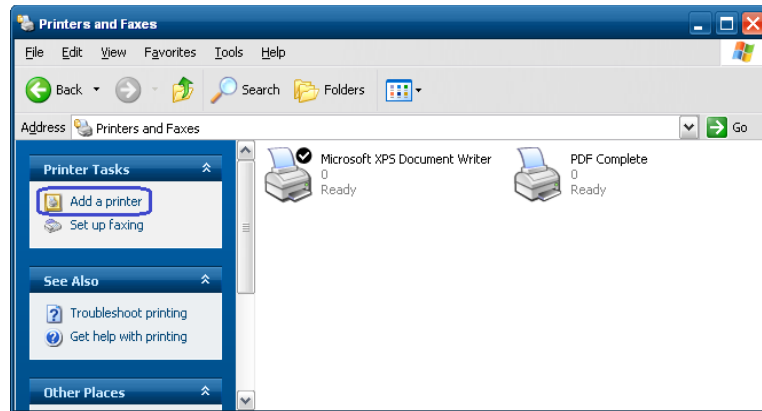

3. Select "Add a local printer". **Do not select the network option.**

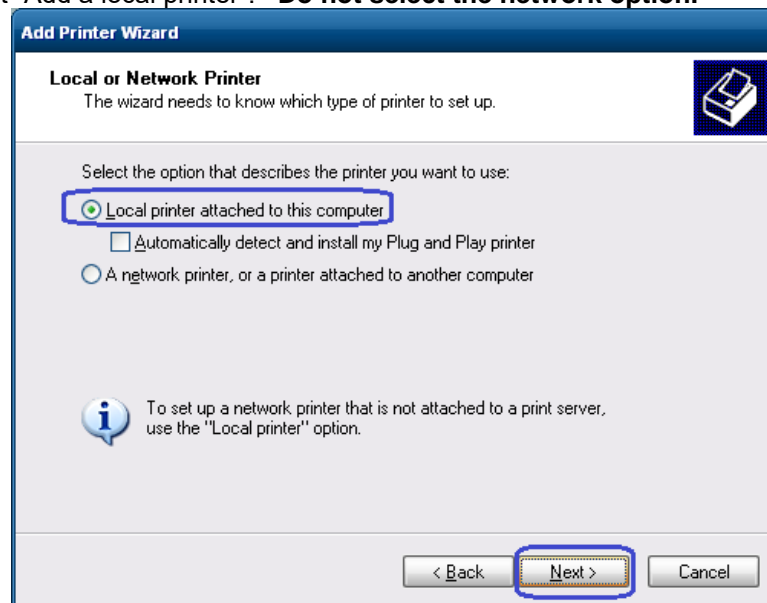

4. Select "Create a new port" option.

5. Select "Standard TCP / IP Port" option and click on the next button.

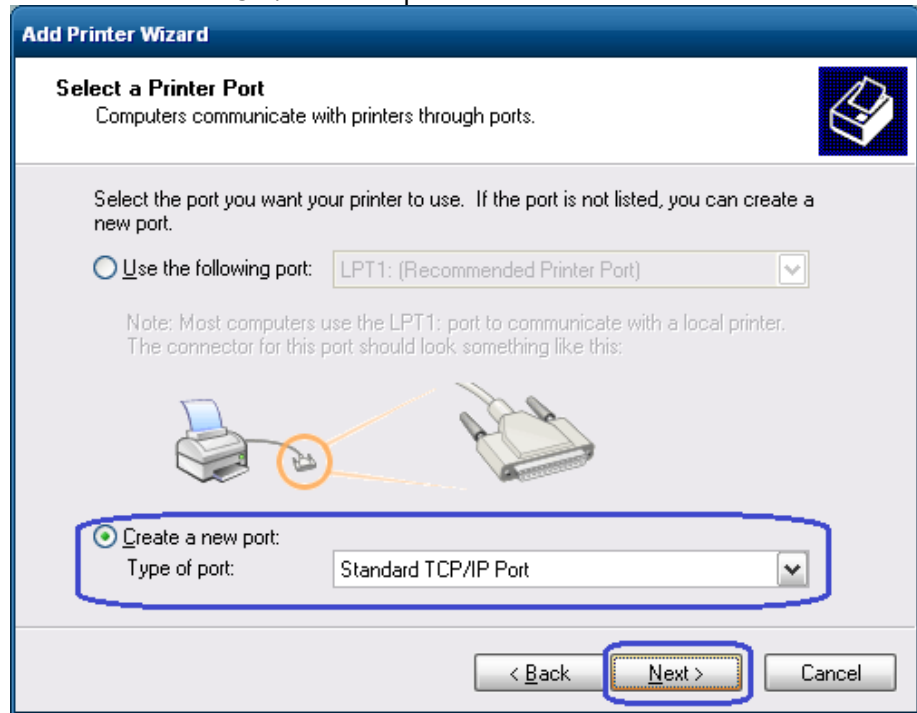

6. Enter the IP Address that is printed on the diagnostics form and click on the "Next" button.

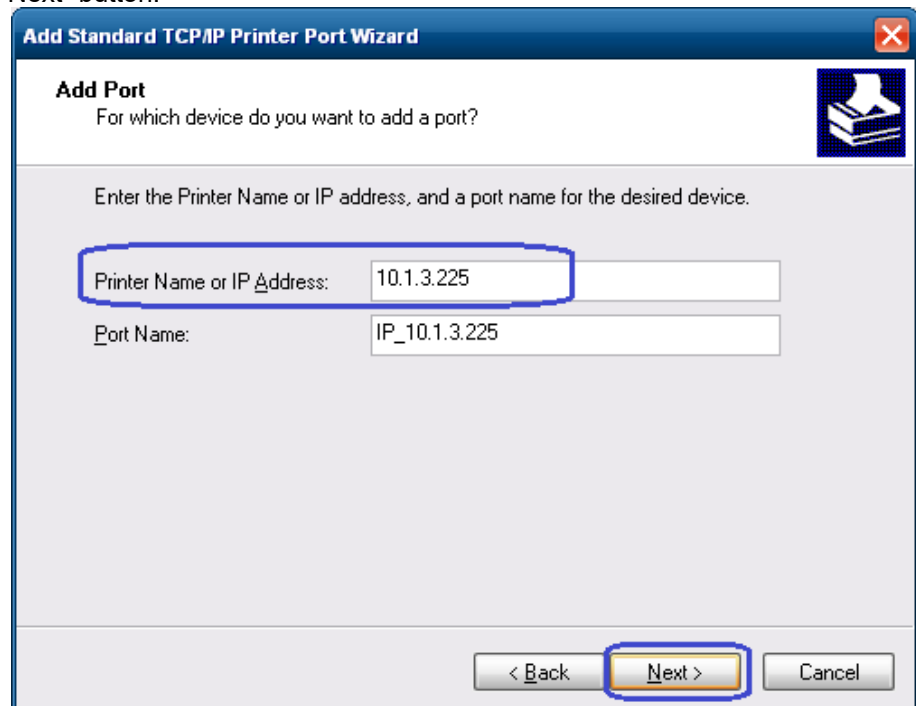

Note: The IP Address is an example, yours will differ.

7. On the “Additional port information required” GUI select “Standard Generic Network Card” and click on “Next” and click the “Finish” button.

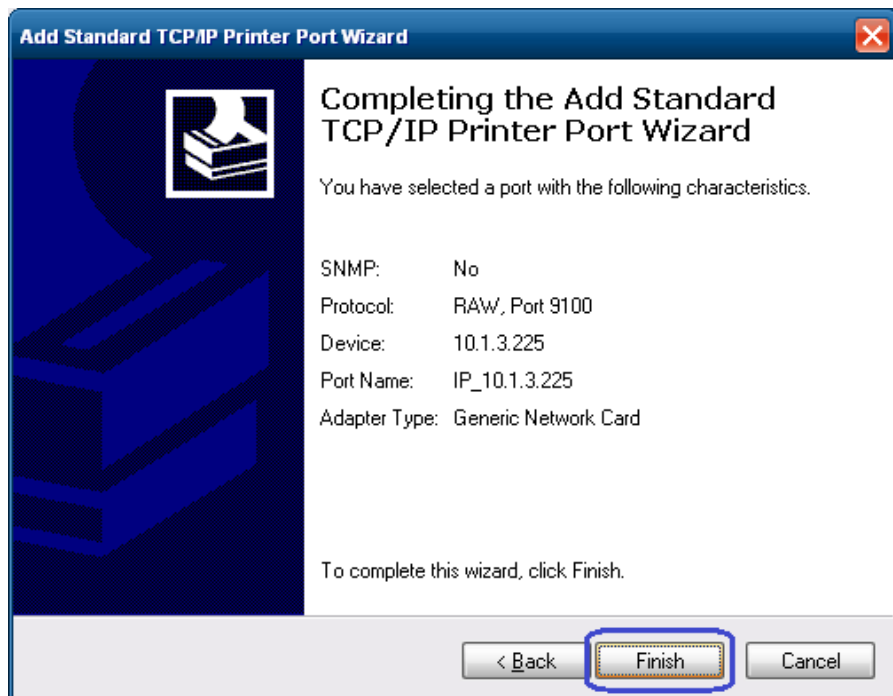
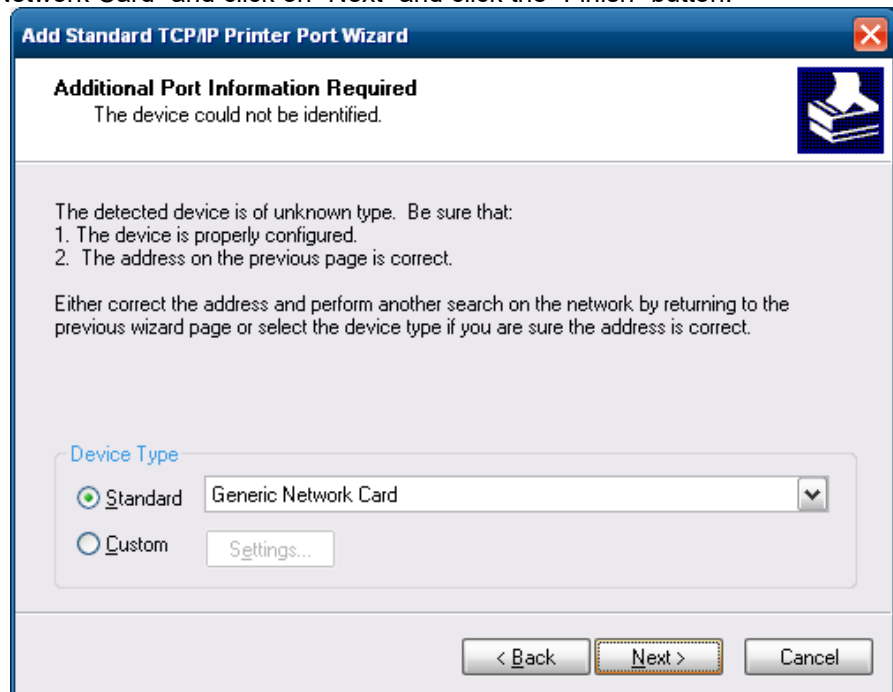

8. When the “Install the printer driver” GUI appears select “Have Disk” option.

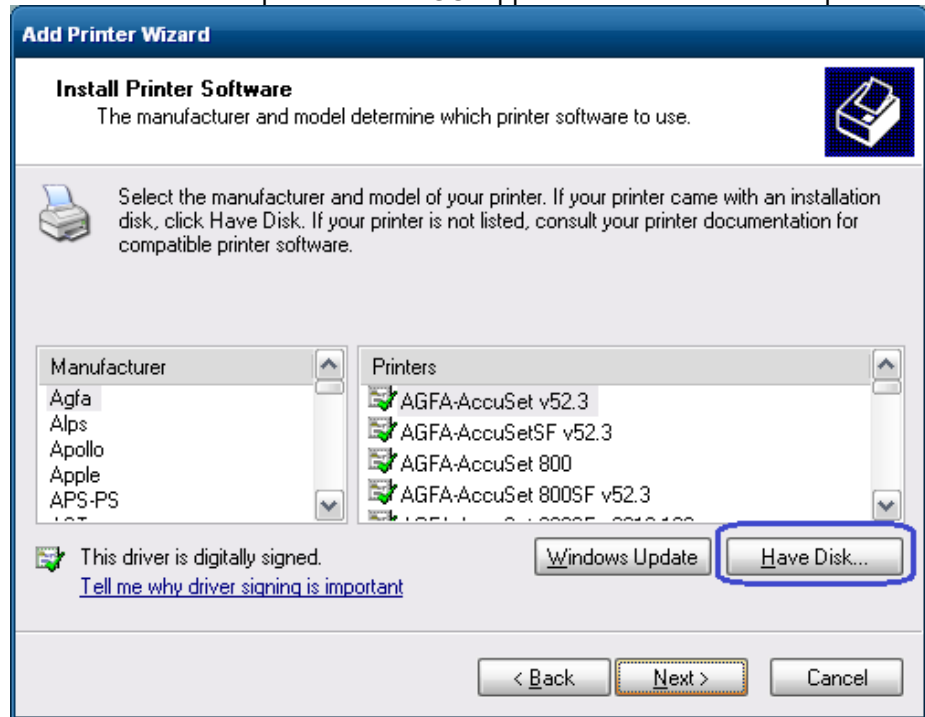

9. When the “Install From Disk” option appears browse to the location where the drivers are located and select the “OEMPRINT.INF” file and click “Open”

For the HP factory image the location are:

32Bit Image

C:\xxxxx\Point of Sale\Receipt Printer\Windows Receipt Printer Drivers\32Bit\ <go to the folder that matches your printer model>

For the A798 printer use the A794 folder.

10. When you are back to the “Install the printer Driver” GUI “HP Receipt” printer will appear, click on the “Next” button.

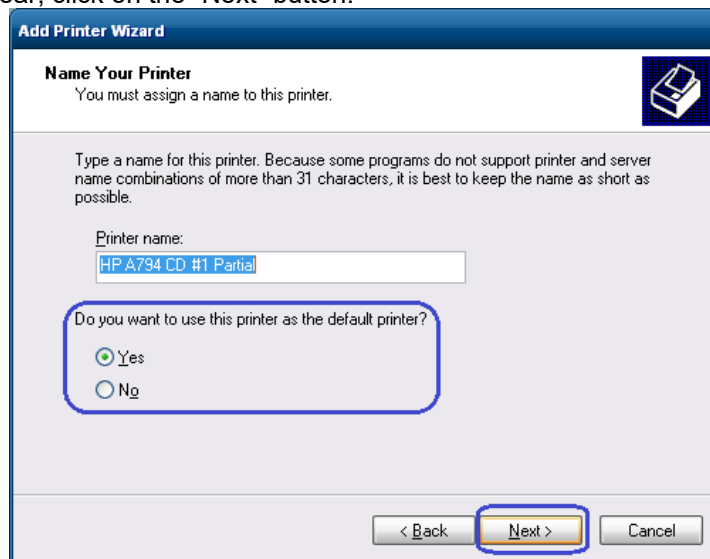

Note: Your model may differ than what is show in the above screen GUI.

11. On the “Print Sharing” GUI select the option “Do not share this printer” and click on the “Next” button.

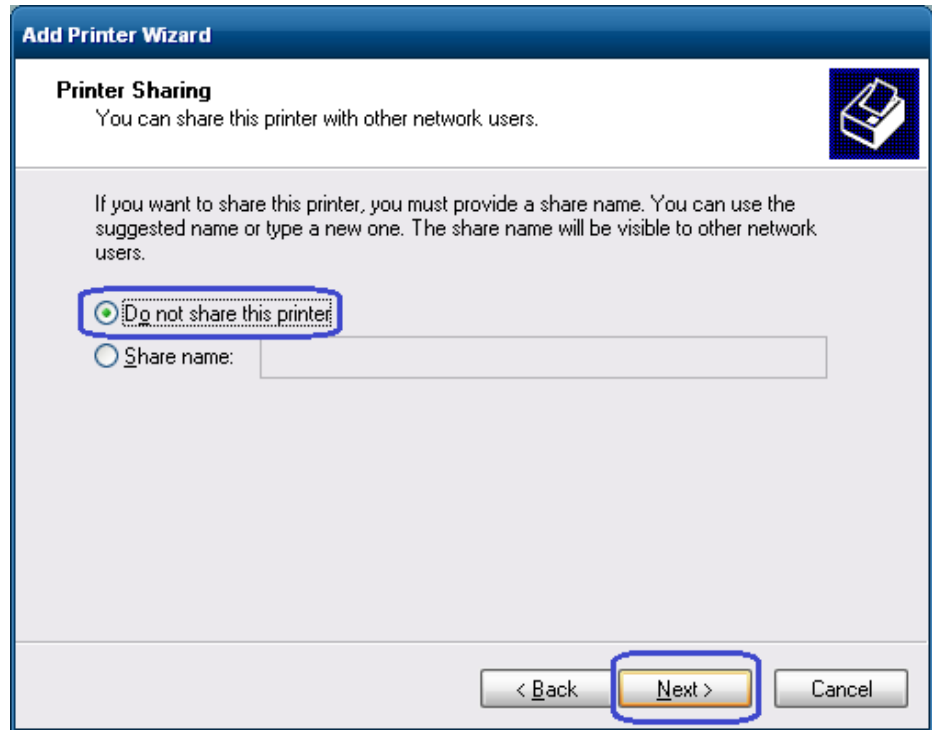

12. On the “Print Test Page” GUI select the “No” option and click on the “Next” button. The configuration is not complete is the reason for selecting no.

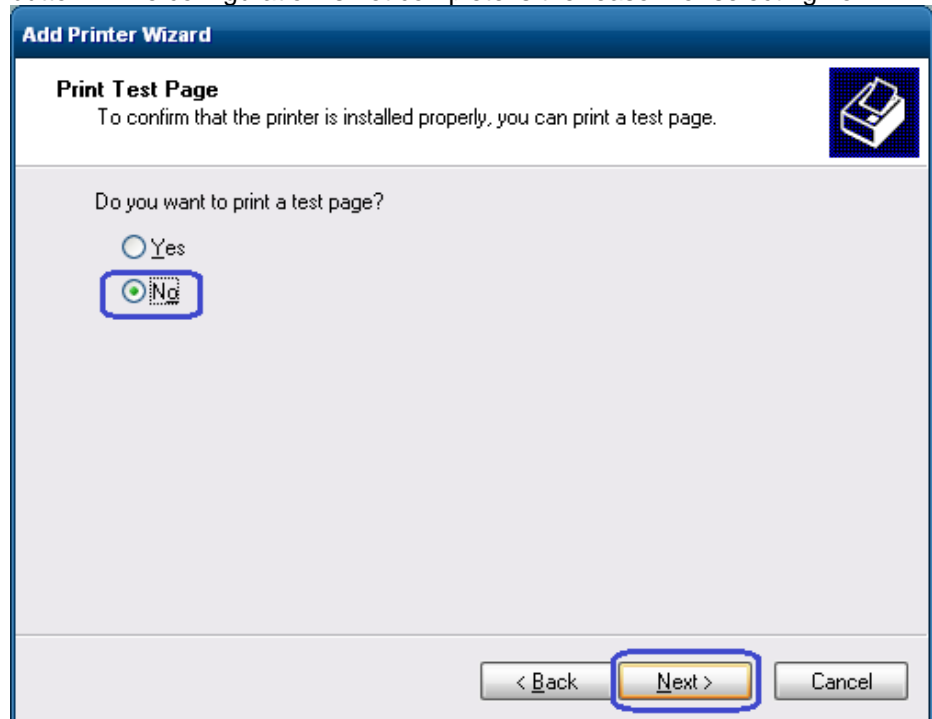

13. Click on the “Finish” button.

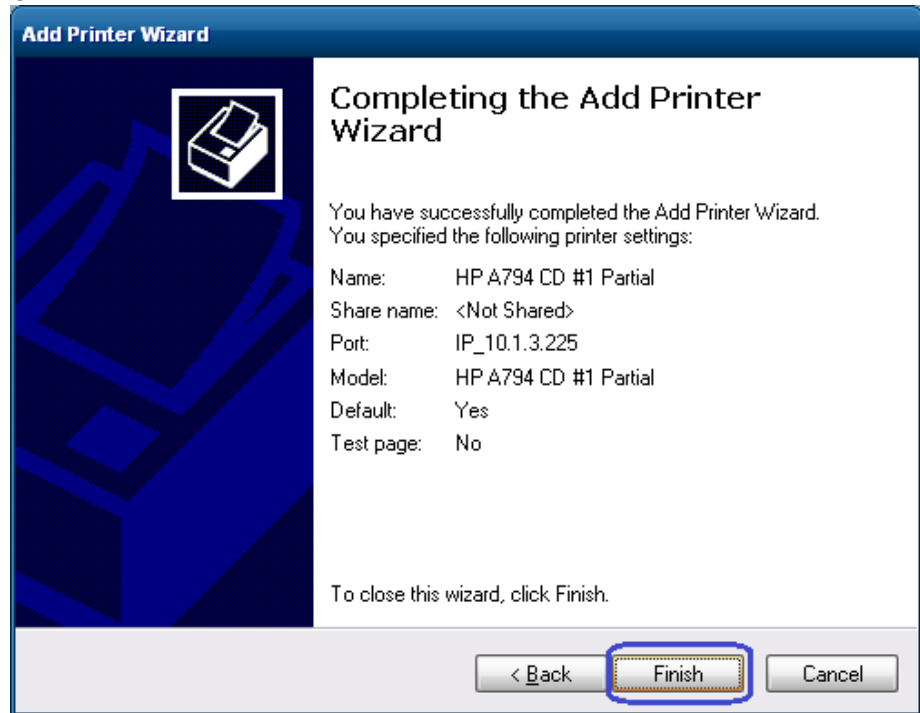

14. Go to the “Devices and Printers” and right click on the printer that was just installed and select “Properties”.

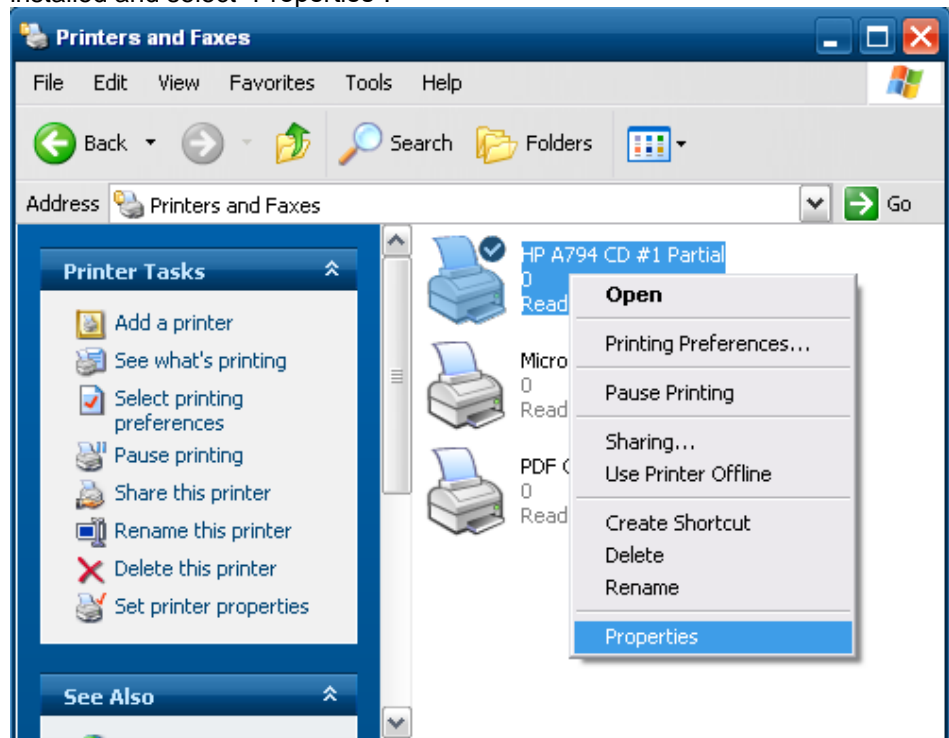

15. Select the "Ports" tab.
16. Highlight the port for the printer that was installed and select "Configure Port".

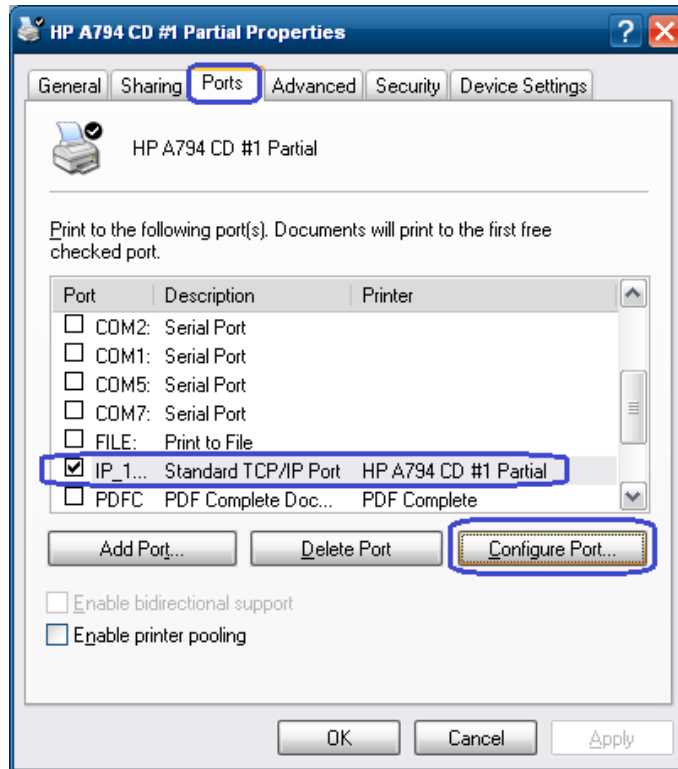

- Go to the “Raw Settings” section on the “Configure Standard TCP/IP Port monitor” GUI. In the “Port Number” section enter 9001 (double check the diagnostics form to confirm 9001 is on the “Raw TCPIP Port” and click OK.

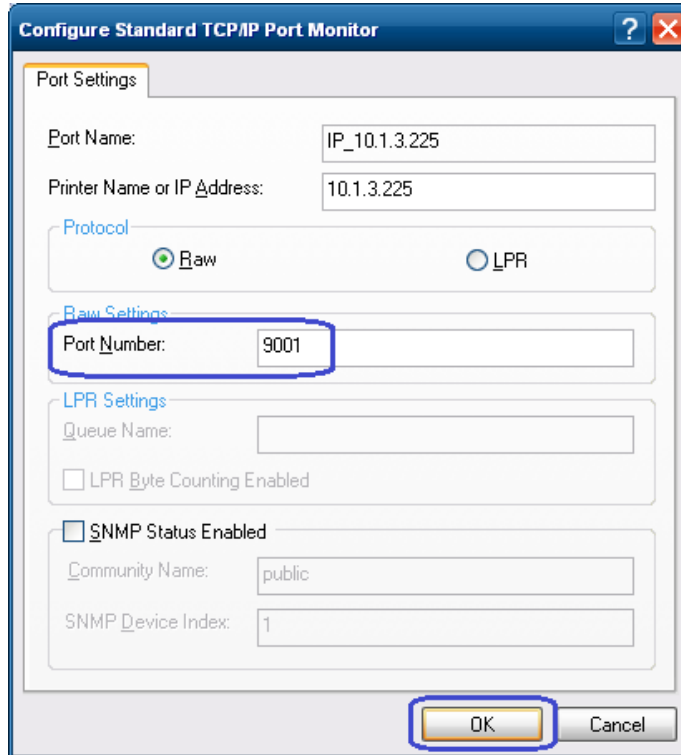

- Close the printer properties GUI screen.
- Go to the “Devices and Printers” and right click on the printer that was just installed and select “Properties”.
- Click on “Print Test Page” and printout should occur.

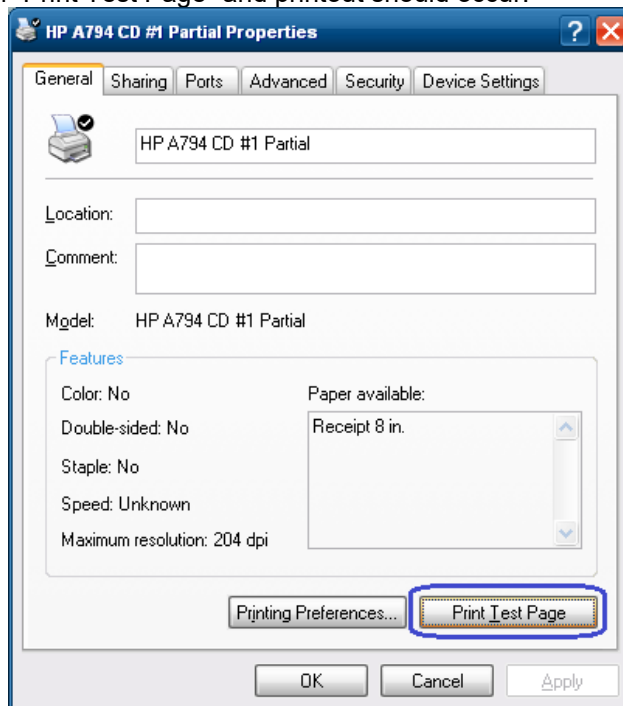

6.4.8.4 **Windows Printer Driver (USB) for v1.0.0 – 1.0.3**

The following is an overview of the steps to test the receipt printer followed by detailed steps:

1. Start the setup program for the Windows mini-drivers by opening the “HPSETUP.EXE” program and click “OK” on the main GUI (graphical user interface).
2. Select if running 32-Bit or 64-Bit operating system.
3. Select the printer model that you wish to install.
4. Select the printer driver option that you wish to install from the drop down menu.
5. Select the USBxxx (Virtual Printer Port of USB) printer port from the drop menu (towards the bottom of the menu).
6. Click “OK” to install the printer driver and a small test print out will occur if the option was selected.

Detailed Steps

1. Start the setup program for the Windows mini-drivers by double clicking on “HPSETUP.EXE” file and click “OK”.

One can open the “HPSETUP.EXE” file from the start menu or go to the “C:\xxxxx\Point of Sale\Receipt Printer\Windows Receipt Printer Drivers” folder and double click on the “HPSETUP.EXE” file.

The following is the GUI that one will see when the “HPSETUP.EXE” is opened:

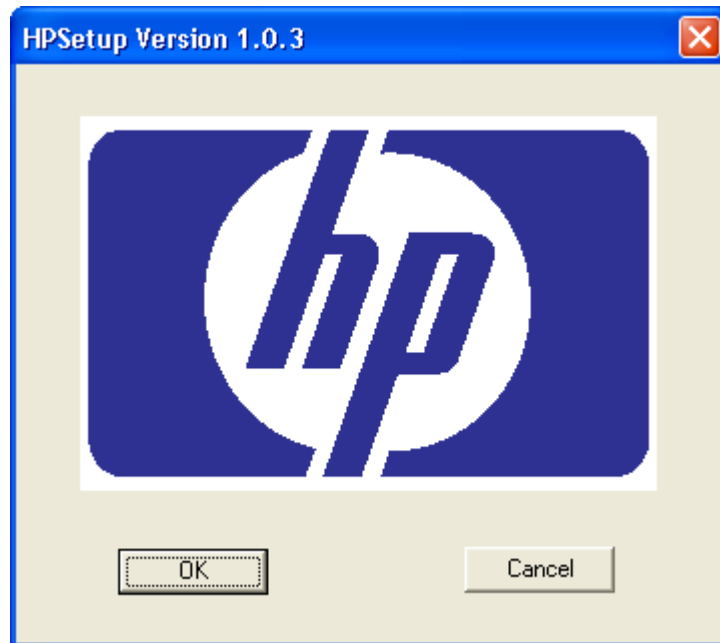

2. Select if running 32-Bit or 64-Bit operating system.

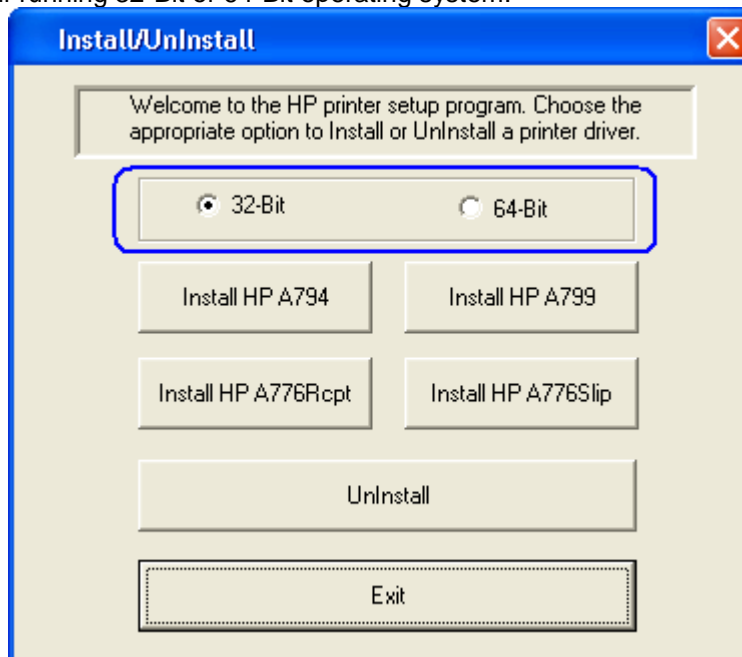

3. Select the printer model that you wish to install.

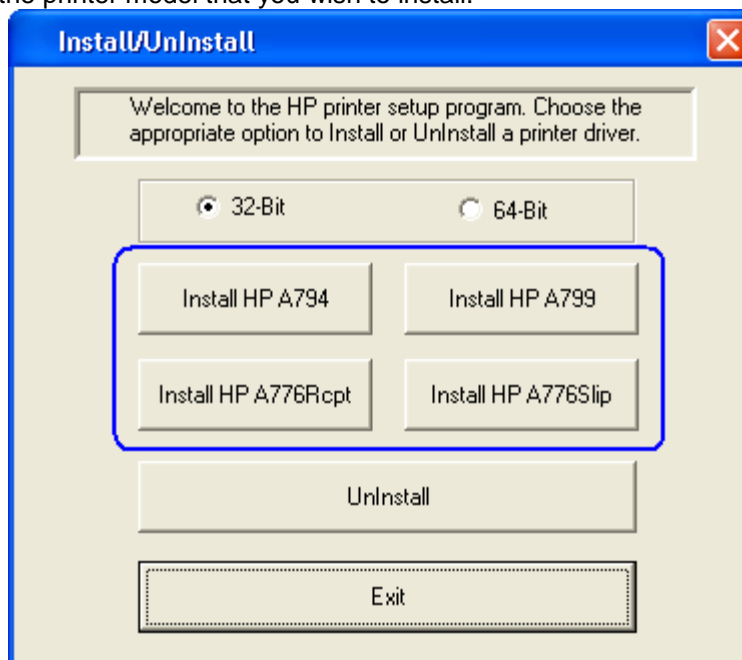

4. Select the printer driver option that you wish to install from the drop down menu.

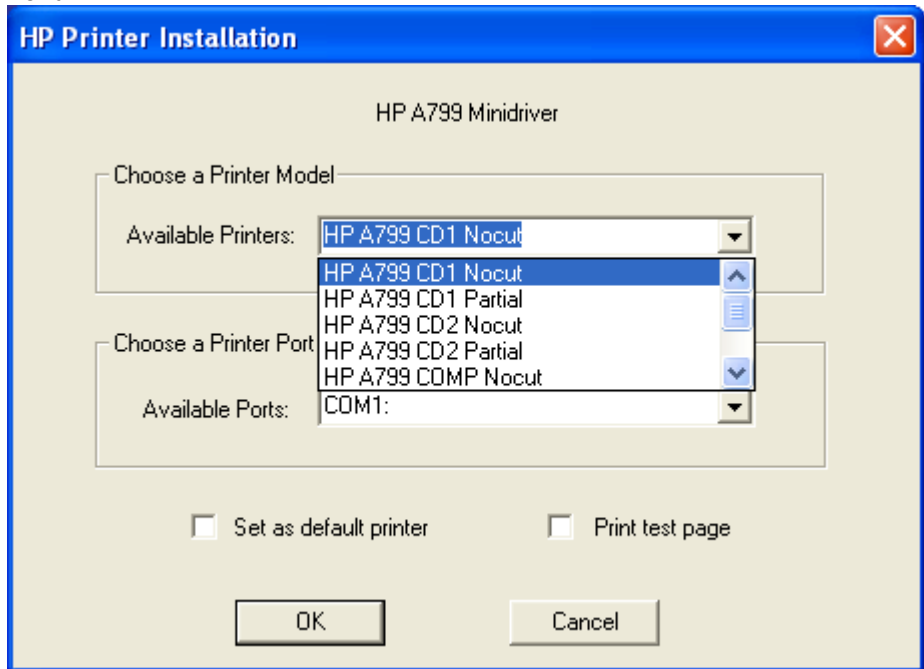

- The HP A7xx CD#1 and HP A7x CD#2 versions generate a pulse to open cash drawer 1 or 2, respectively after each document. The HP A7xx COMP version does not send the reset command at the start of every document.

Note: “xx” is the complete model number of the printer, (i.e. A794 / A799 / A776).

5. Select the USBxxx (Virtual Printer Port of USB) printer port from the drop menu (towards the bottom of the drop down menu).

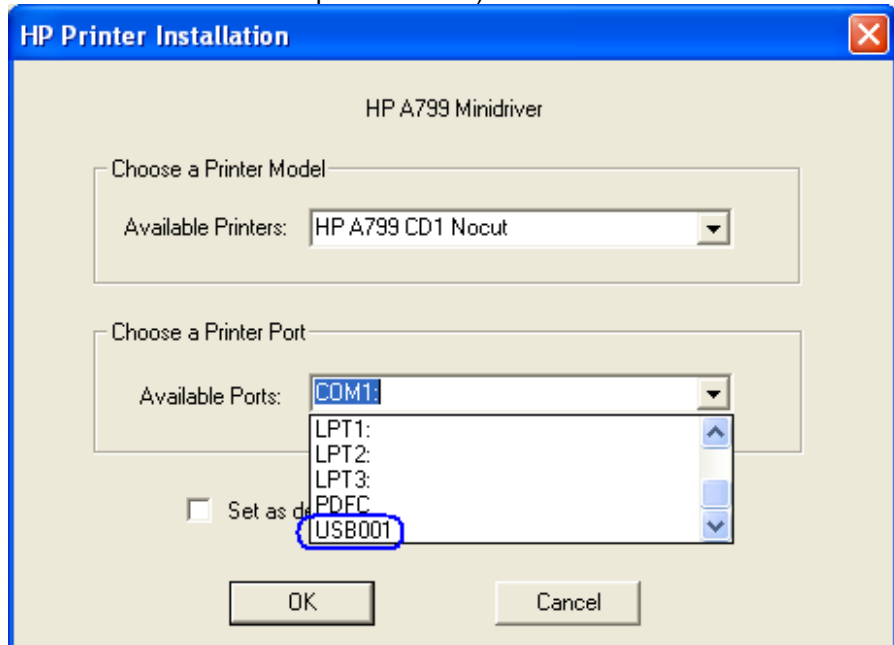

When the selections are made, the selection should be similar to the following screen:

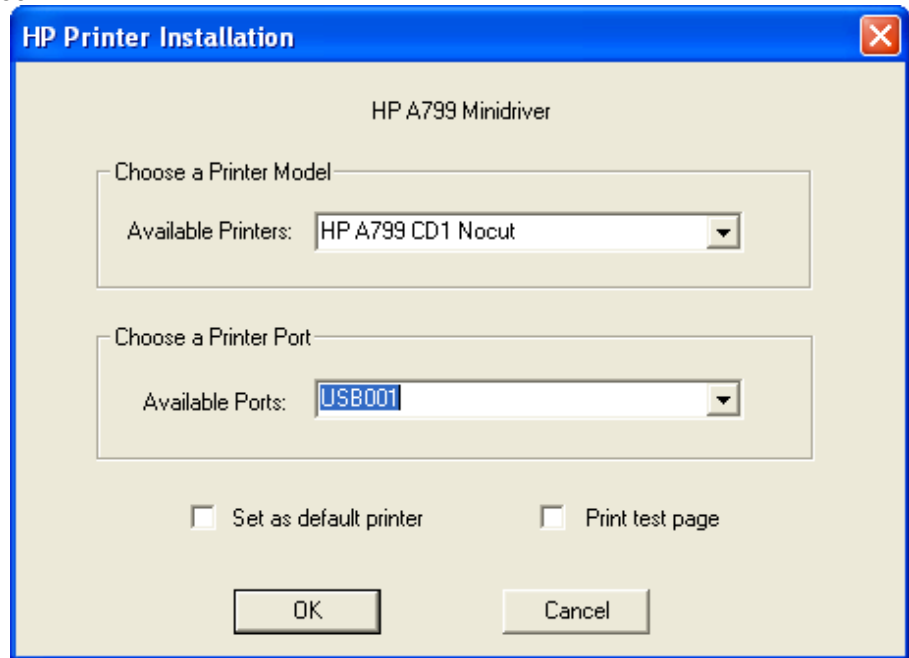

In order to make the printer the default printer select the option “Set as default printer”.

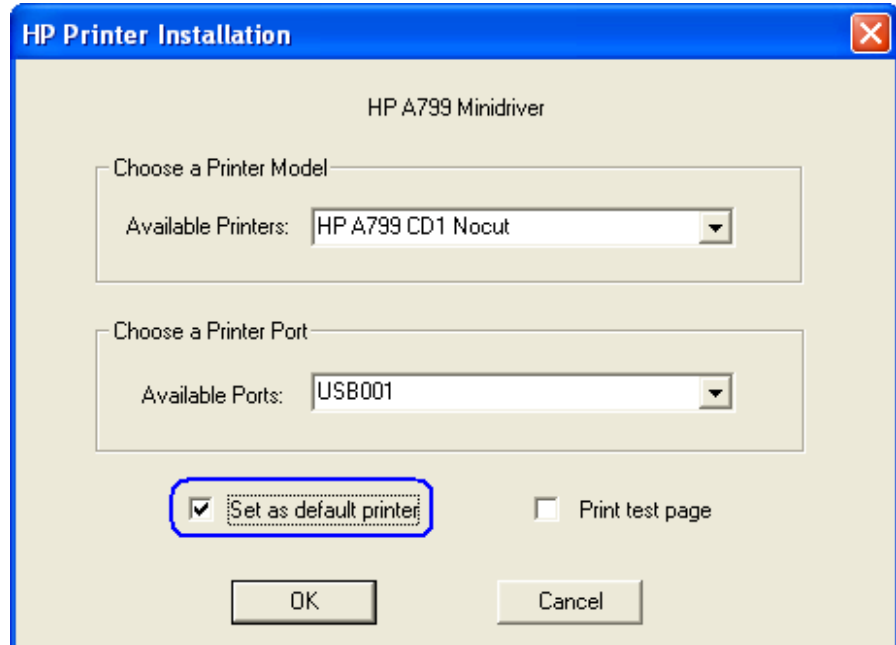

If one wishes to print a very small test page, select the option “Print test page” in the GUI.

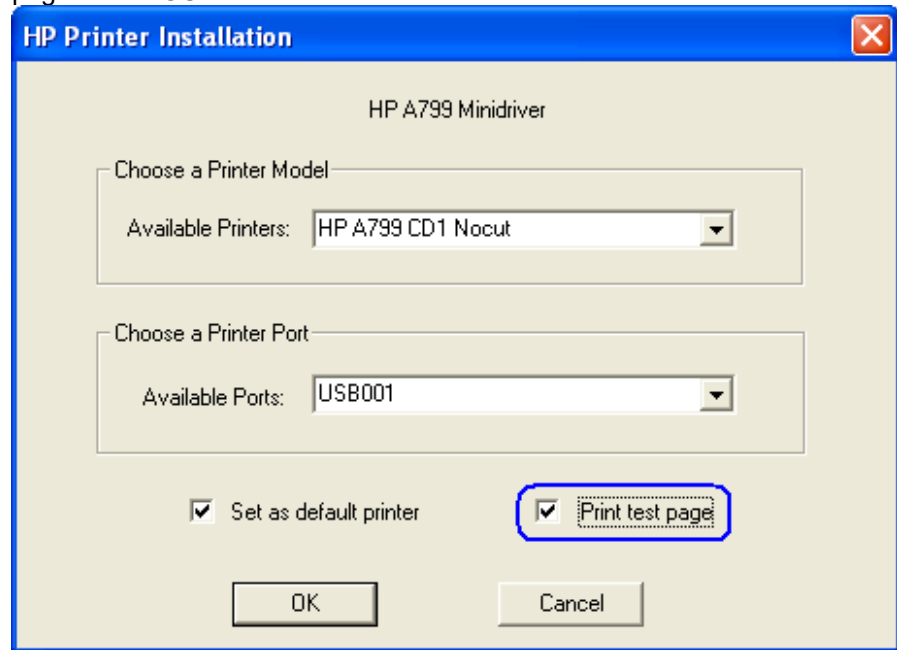

6. Click “OK” to install the printer driver and a small test print out will occur if the option was selected.

Note: If the option was selected to install the printer driver with “NoCut” when “Print Test Page” is selected during the driver install process, the test print out will print and it will cut the receipt paper.

6.4.8.5 **Windows Printer Driver (Serial) for v1.0.0 – 1.0.3**

The following is an overview of the steps to test the receipt printer followed by detailed steps:

1. Print out the diagnostic form on the printer in order to obtain the baud rate the printer is set to.
2. Go into the communication port properties to change the Windows baud rate to the printer is set to on the diagnostics form (previous step) and flow control to “Hardware” for port that the printer is attached.
3. Start the setup program for the Windows mini-drivers by opening the “HPSETUP.EXE” program and click “OK” on the main GUI (graphical user interface).
4. Select the printer model that you wish to install.
5. Select the printer driver option that you wish to install from the drop down menu.
6. Select the COM (serial) port the printer is attached to.
7. Click “OK” to install the printer driver and a small test print out will occur if the option was selected.

Detailed Steps

1. Print out the diagnostic form on the printer in order to obtain the baud rate the printer is set to.
2. Go into the communication port properties to change the Windows baud rate to the printer is set to on the diagnostics form (previous step) and flow control to “Hardware” for port that the printer is attached.

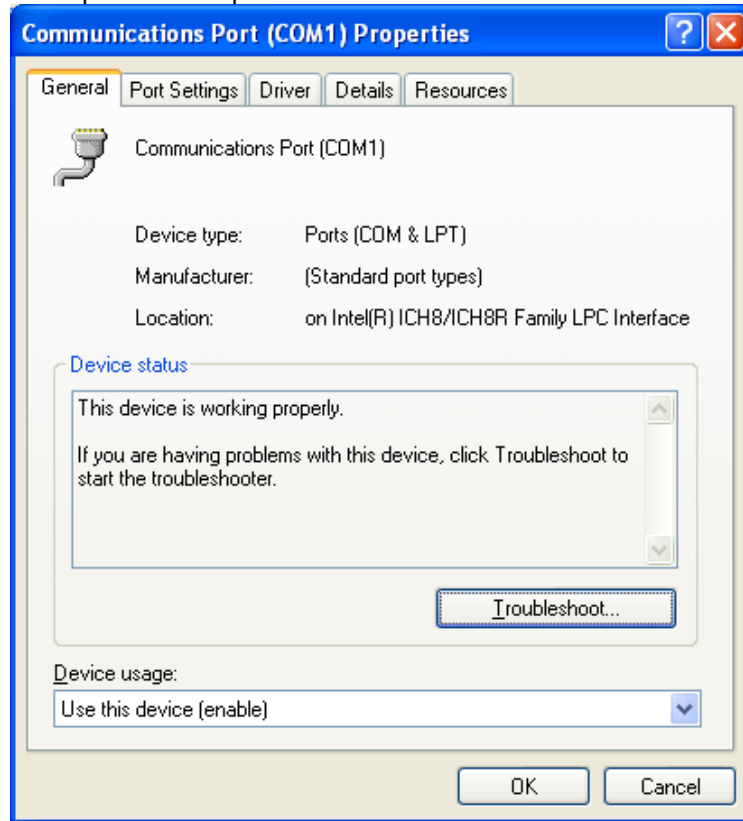

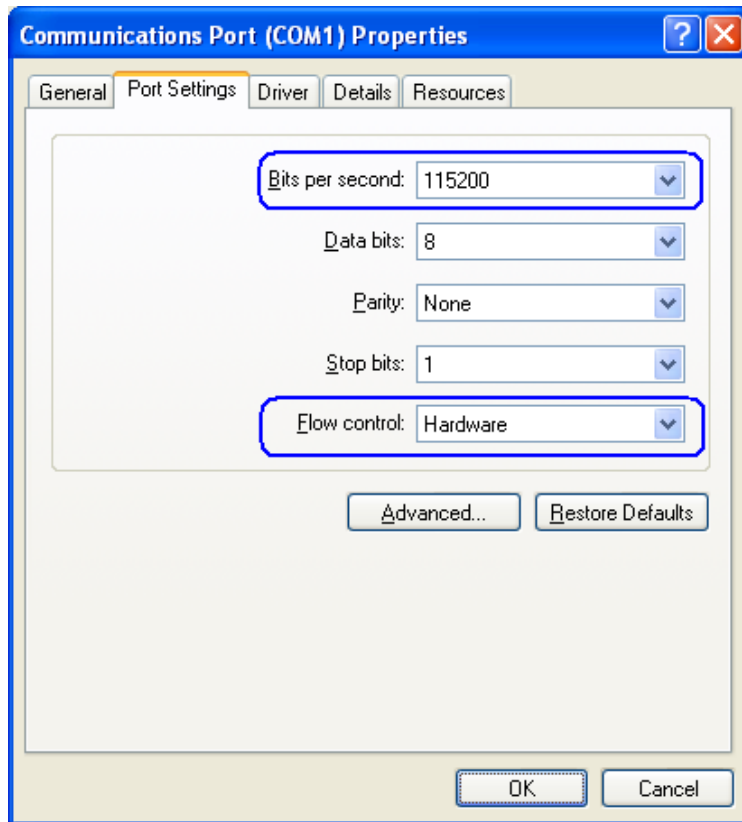

Note: The baud rate may be different than the screen shot shown above.

3. Start the setup program for the Windows mini-drivers by double clicking on "HPSETUP.EXE" file and click "OK".

One can open the "HPSETUP.EXE" file from the start menu or go to the "C:\xxxx\Point of Sale\Receipt Printer\Windows Receipt Printer Drivers" folder.

The following is the GUI that one will see when the "HPSETUP.EXE" is opened:

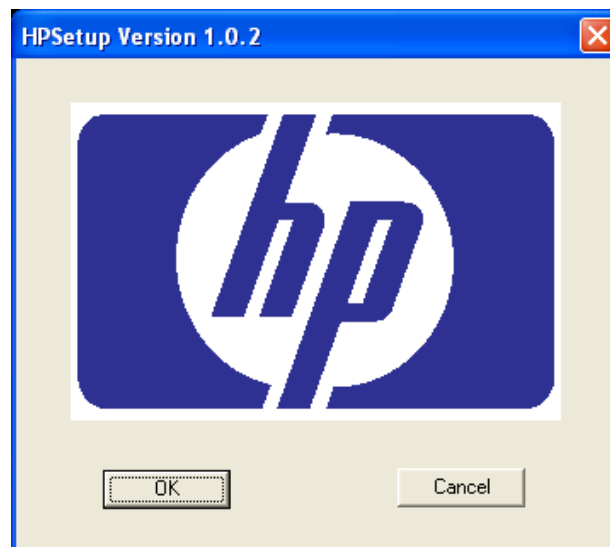

4. Select the printer model that you wish to install.

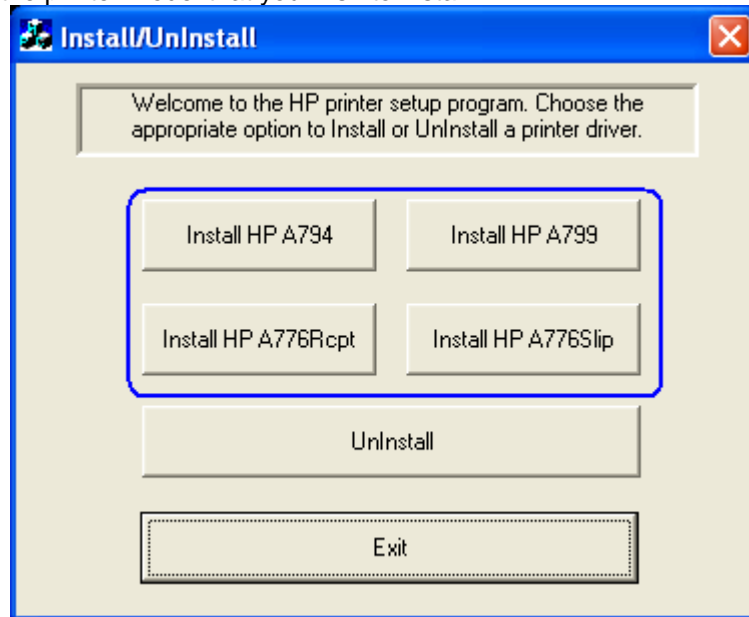

5. Select the printer driver option that you wish to install from the drop down menu.

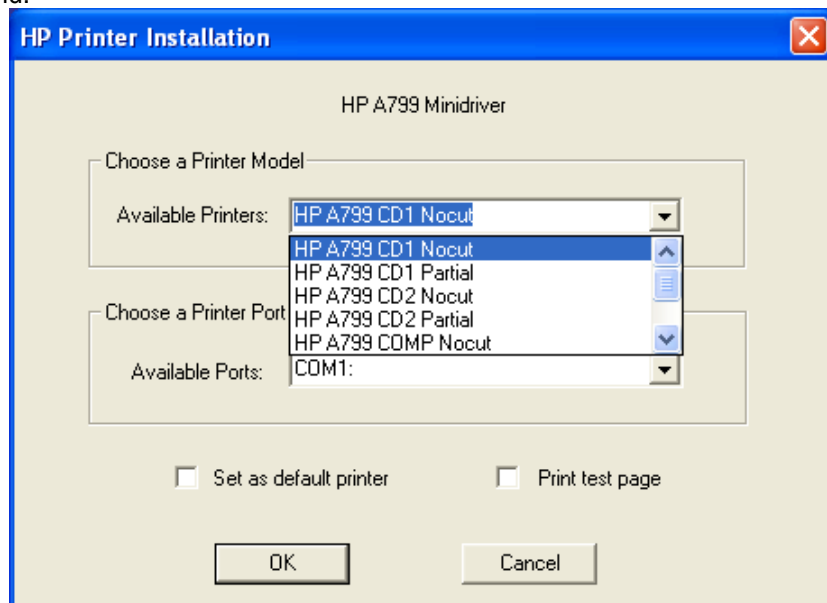

- The HP A7xx CD#1 and HP A7xx CD#2 versions generate a pulse to open cash drawer 1 or 2, respectively after each document. The HP A7xx COMP version does not send the reset command at the start of every document.

Note: “xx” is the complete model number of the printer, (i.e. A794 / A799 / A776).

6. Select the COM (serial) port the printer is attached to.

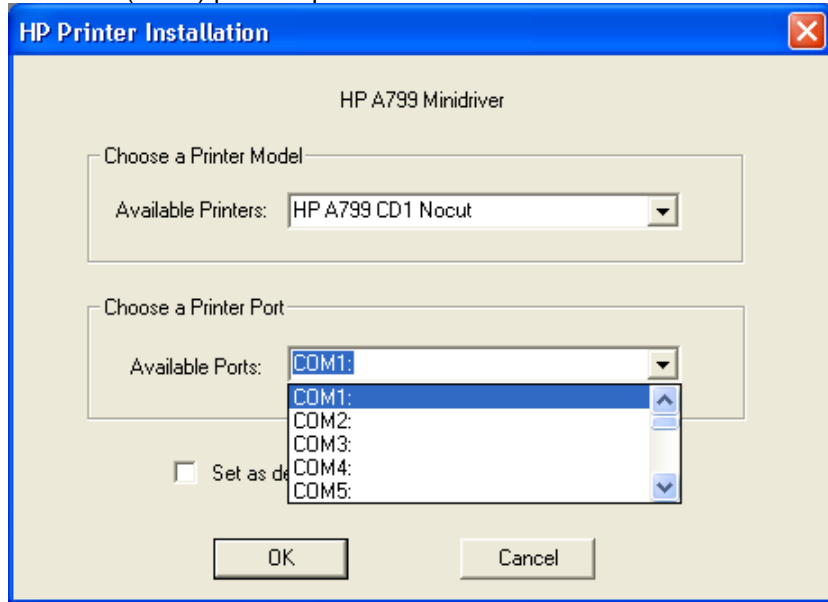

When the selections are made, the selection should be similar to the following screen:

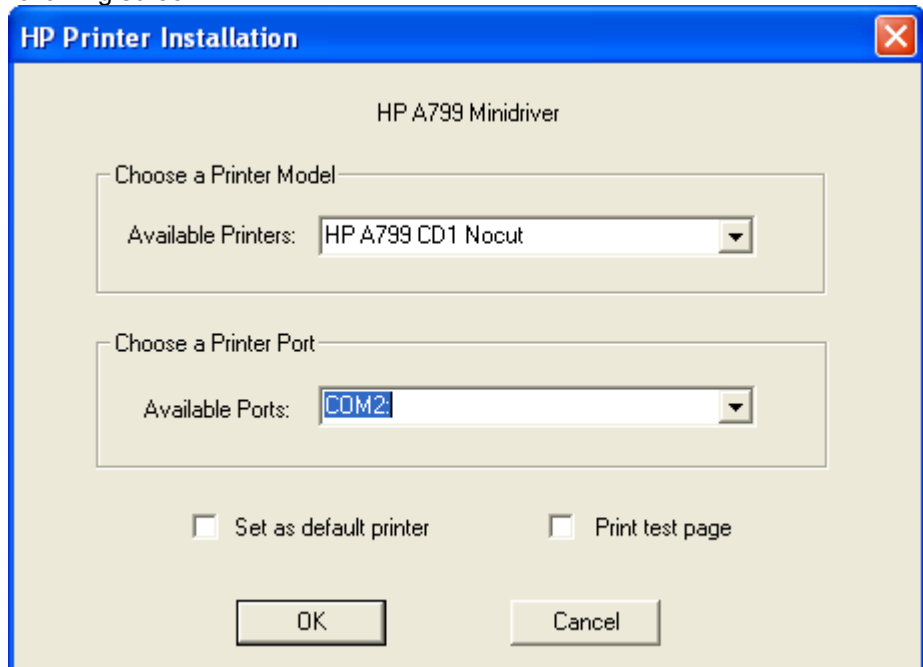

In order to make the printer the default printer select the option “Set as default printer”.

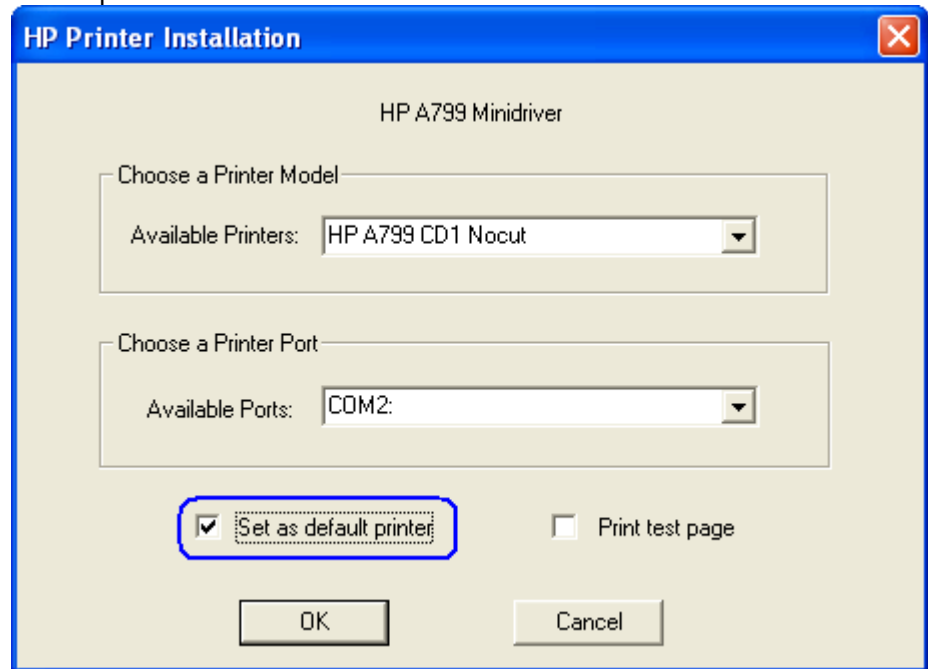

If one wishes to print a very small test page, select the option “Print test page” in the GUI.

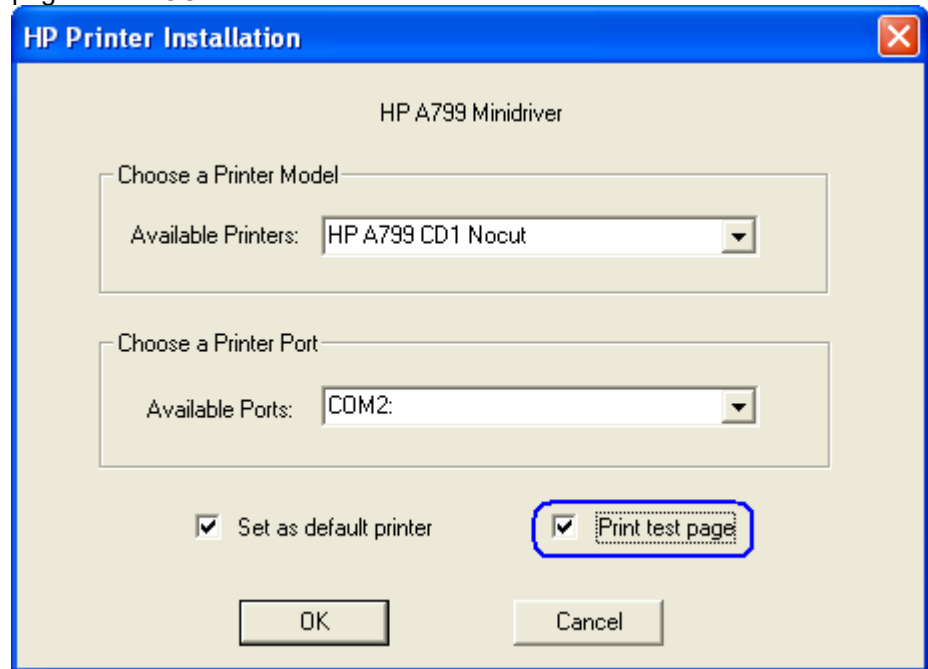

7. Click “OK” to install the printer driver and a small test print out will occur if the option was selected.

Note: If the option was selected to install the printer driver with “NoCut” when “Print Test Page” is selected during the driver install process, the test print out will print and it will cut the receipt paper.

6.4.8.6 **Test Receipt Printer in Windows Environment (non-OPOS)**

In addition to the test option during the Windows mini-drivers installation, once the printer driver is loaded one may use notepad (or WordPad) to confirm the drivers are loaded and communicating to the printer. Type in a sentence or two in Notepad/WordPad and select the option to print; what was type should appear on the print out. If the Windows mini-driver with "CD#1" was selected, the cash drawer should also open.

Included with the mini drivers is a file that can be used for testing using WordPad; this test file will have barcodes on the printout. The file can be found in the in the following location "C:\xxxx\Point of Sale\Receipt Printer\Windows Receipt Printer Driver". Ensure all the margins to the minimum setting in the page setup

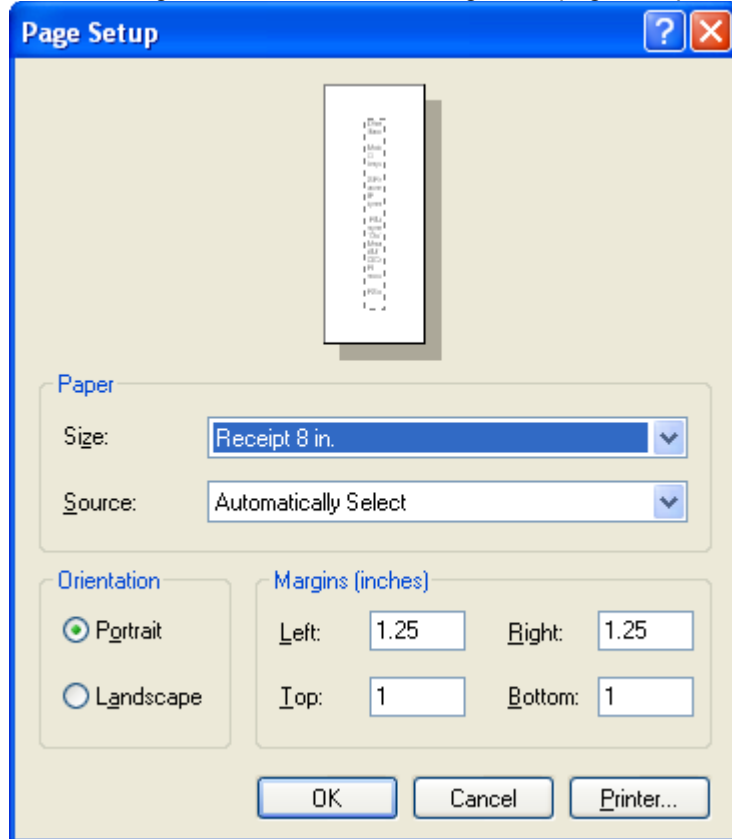

Or one can set all the margins to zero "0". By setting the margins to zero "0", WordPad to automatically sets the margins to the minimum setting.

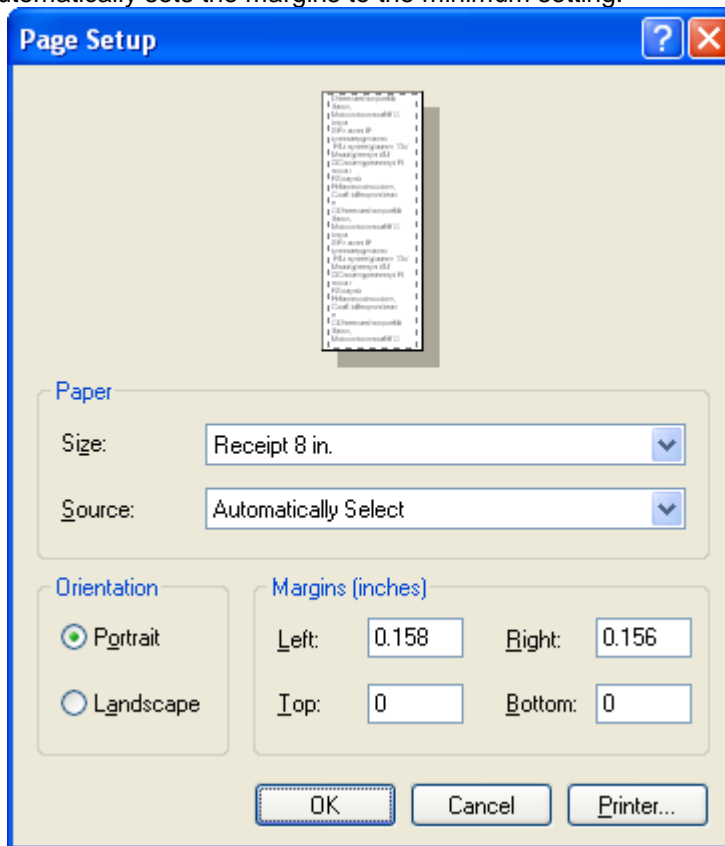

The following is a partial example of appears on the print out using the file that is included with mini-drivers:

HP A799 Minidriver
Fonts & Barcodes

123456789.....12345	tab	tab	
23456789	12345	tab	tab
3456789	12345	tab	tab
456789	12345	font change!	
56789	12345	height	
change			
6789	12345	width cig	
789	12345	pitch change	
89	12345		
9	12345		

Codabar Plain &
HRI:

E0D57+9\$32:A



D57+9\$32:A

Code 39 Plain &
HRI:



0123456789

ITF Plain & HRI:



54810548673912

Jan8 Plain & HRI:



12121212

Jan13 Plain & HRI:



6.4.8.7 **Windows Printer Driver (USB) for v1.0.3 and later for Windows 7 / 8.1 / 10**

The following is an overview of the steps to test the receipt printer followed by detailed steps:

1. Go to Control Panel – Devices and Printers and select “Add a printer”.
2. Select “Add a local printer”.
3. Select “Use an existing port” option and “USB00x (Virtual printer port for USB)”
4. When the “Install the printer driver” GUI appears select “Have Disk” option and click on “Next”.
5. When the “Install From Disk” option appears browse to the location where the drivers are located and select the “HP_Receipt_OEM” or “HP_Receipt_OEM64” file and click “Open”.
6. When you are back to the “Install the printer Driver” GUI “HP Receipt” printer will appear, click on the “Next” button.
7. Enter a printer name or use the default of “HP Receipt” and click on the “Next” button.
8. Once the printer drivers is installed click on the “Finish” button. Prior to clicking on the “Finish” button one can click “Print a test page”.

Detailed Steps

1. Go to Control Panel – Devices and Printers and select “Add a printer”.

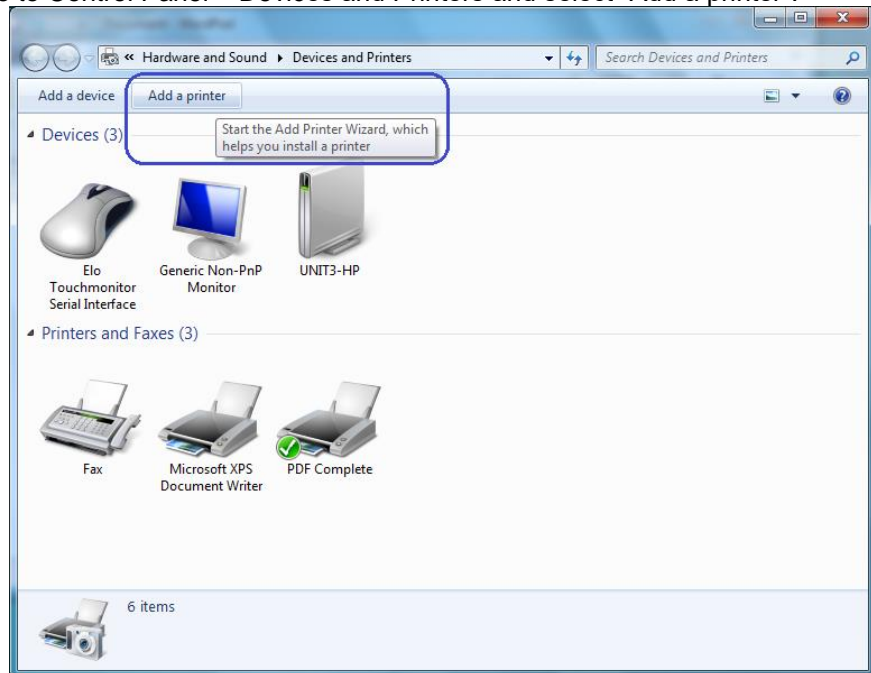

2. Select "Add a local printer".

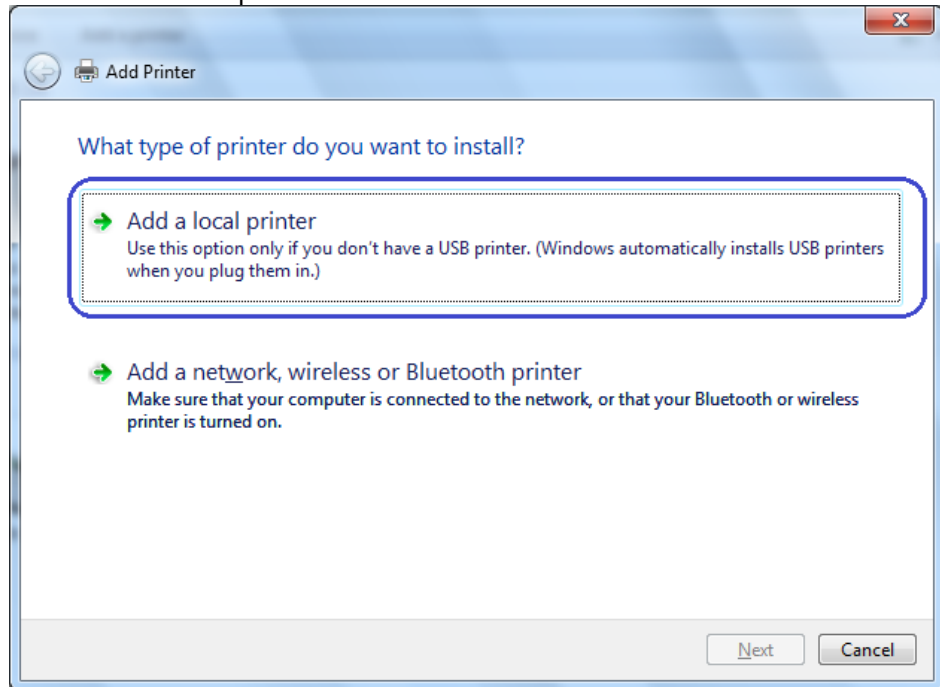

3. Select "Use an existing port" option and "USB00x (Virtual printer port for USB)"

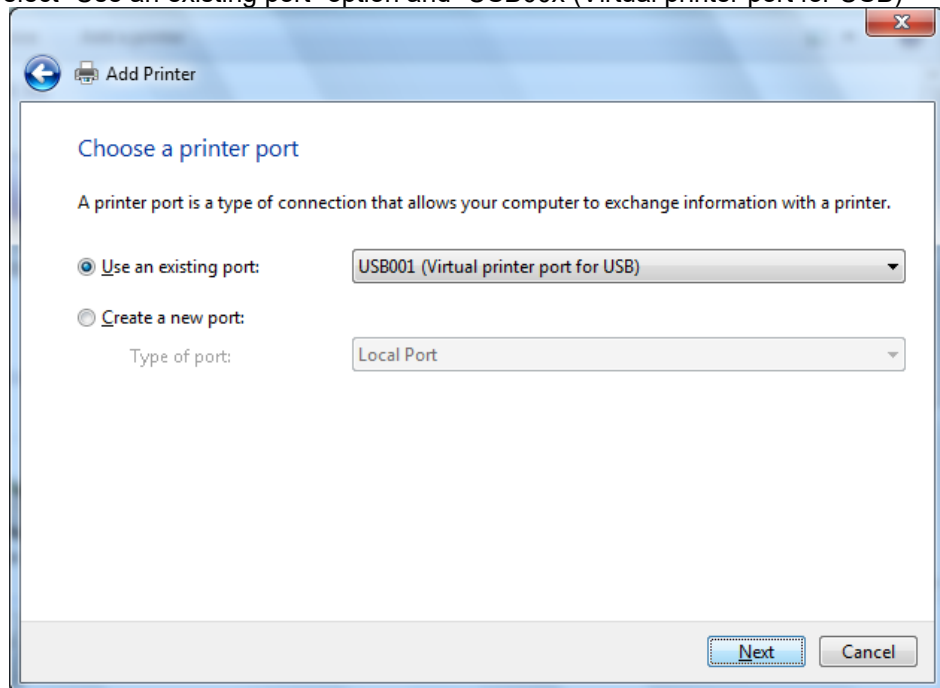

4. When the “Install the printer driver” GUI appears select “Have Disk” option and click on “Next”.

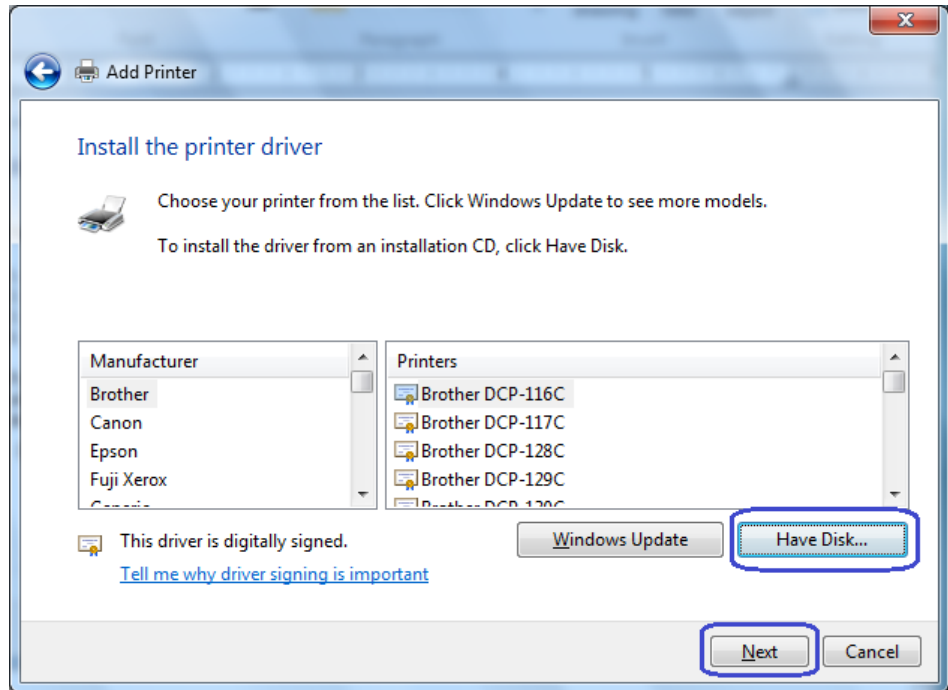

5. When the “Install From Disk” option appears browse to the location where the drivers are located and select the “HP_Receipt_OEM” or “HP_Receipt_OEM64” file and click “Open”

For the HP factory image the locations are:

32Bit Image

C:\xxxxx\Point of Sale\Receipt Printer\Windows Receipt Printer Drivers\32Bit_MiniDrivers\Receipt

64Bit Image

C:\xxxxx\Point of Sale\Receipt Printer\Windows Receipt Printer Drivers\64Bit_MiniDrivers\Receipt

6. When you are back to the “Install the printer Driver” GUI “HP Receipt” printer will appear, click on the “Next” button.

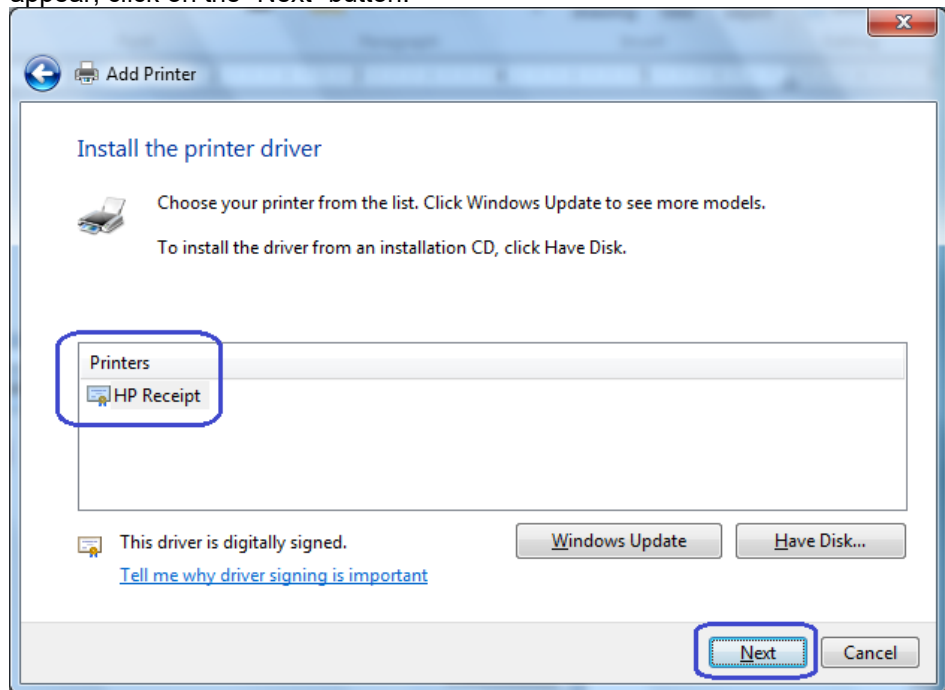

7. Enter a printer name or use the default of “HP Receipt” and click on the “Next” button.

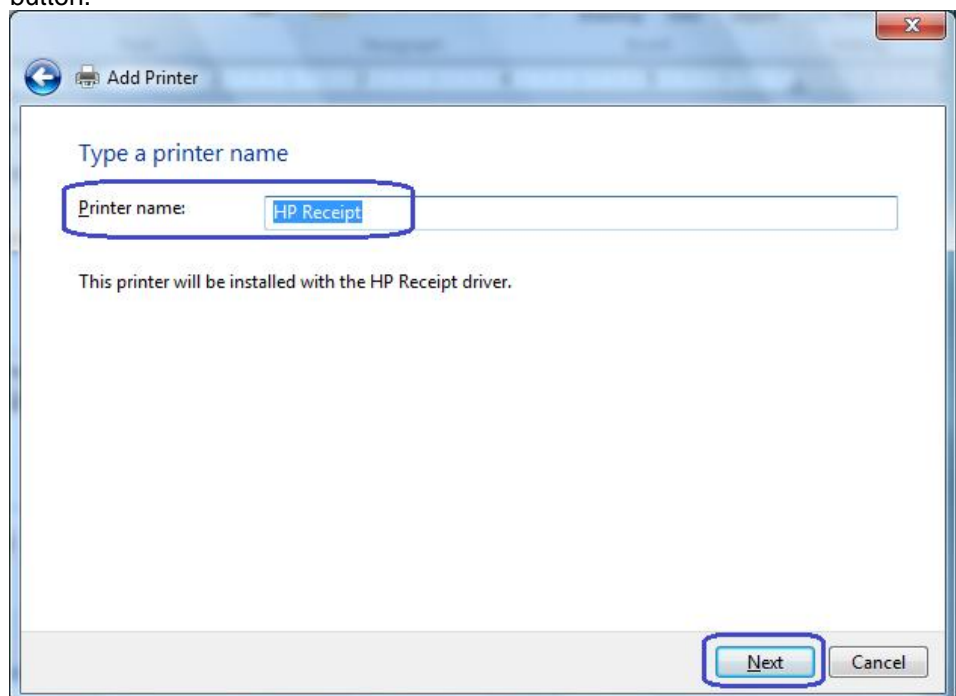

8. Once the printer drivers are installed, click on the "Finish" button. Prior to clicking on the "Finish" button, one can click "Print a test page".

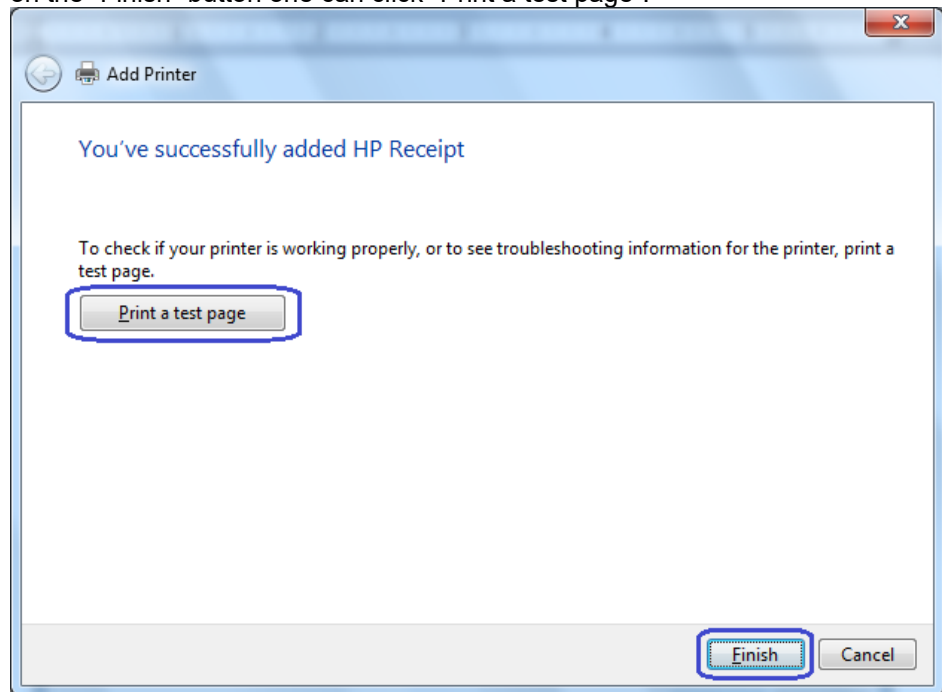

6.4.8.8 Windows Printer Driver (Serial) for v1.0.3 and later for Windows 7 / 8.1 / 10

The following is an overview of the steps to test the receipt printer followed by detailed steps:

1. Print out the diagnostic form on the printer in order to obtain the baud rate the printer is set to.
2. Go into the communication port properties to change the Windows baud rate to the printer is set to on the diagnostics form (previous step) and flow control to "Hardware" for port that the printer is attached.
3. Go to Control Panel – Devices and Printers and select "Add a printer".
4. Select "Add a local printer".
5. Select "Use an existing port" option and select the COM port the printer is attached to.
6. When the "Install the printer driver" GUI appears select "Have Disk" option and click on "Next".
7. When the "Install the printer driver" GUI appears select "Have Disk" option and click on "Next".
8. When the "Install From Disk" option appears browse to the location where the drivers are located and select the "HP_Receipt_OEM" or "HP_Receipt_OEM64" file and click "Open".
9. When you are back to the "Install the printer Driver" GUI "HP Receipt" printer will appear, click on the "Next" button.
10. Enter a printer name or use the default of "HP Receipt" and click on the "Next" button.
11. Once the printer drivers is installed click on the "Finish" button. Prior to clicking on the "Finish" button one can click "Print a test page".

Detailed Steps

1. Print out the diagnostic form on the printer in order to obtain the baud rate the printer is set to.
2. Go into the communication port properties to change the Windows baud rate to the printer is set to on the diagnostics form (previous step) and flow control to "Hardware" for port that the printer is attached.

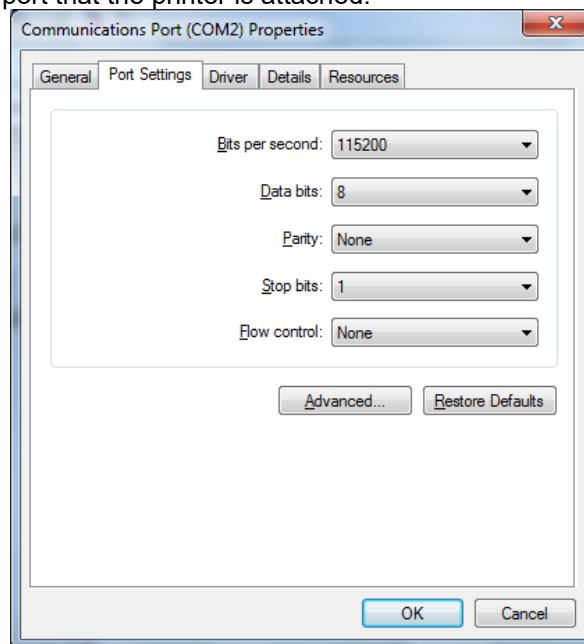

Note: The baud rate may be different than the screen shot shown above.

3. Go to Control Panel – Devices and Printers and select “Add a printer”.

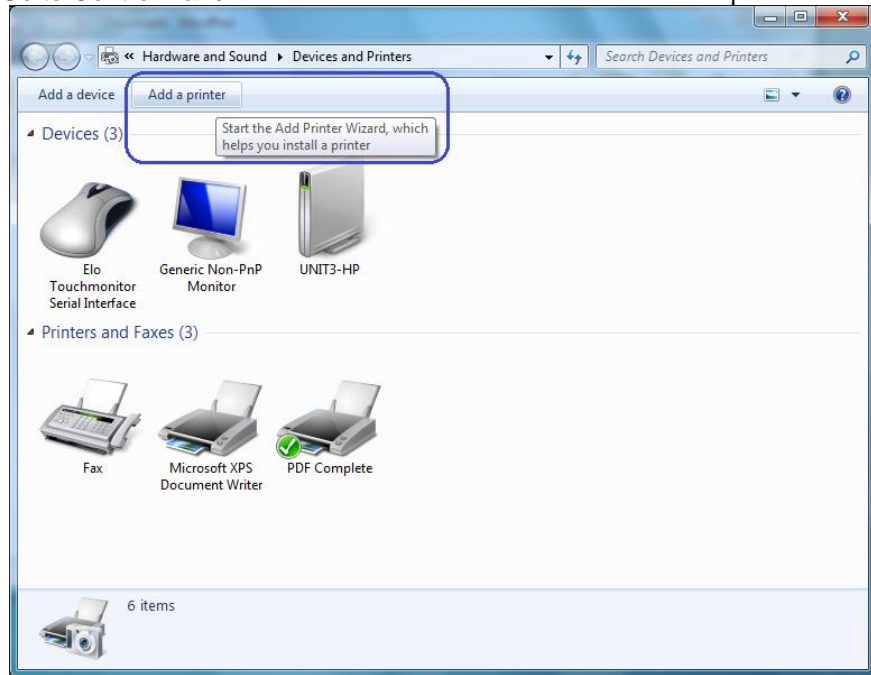

4. Select “Add a local printer”.

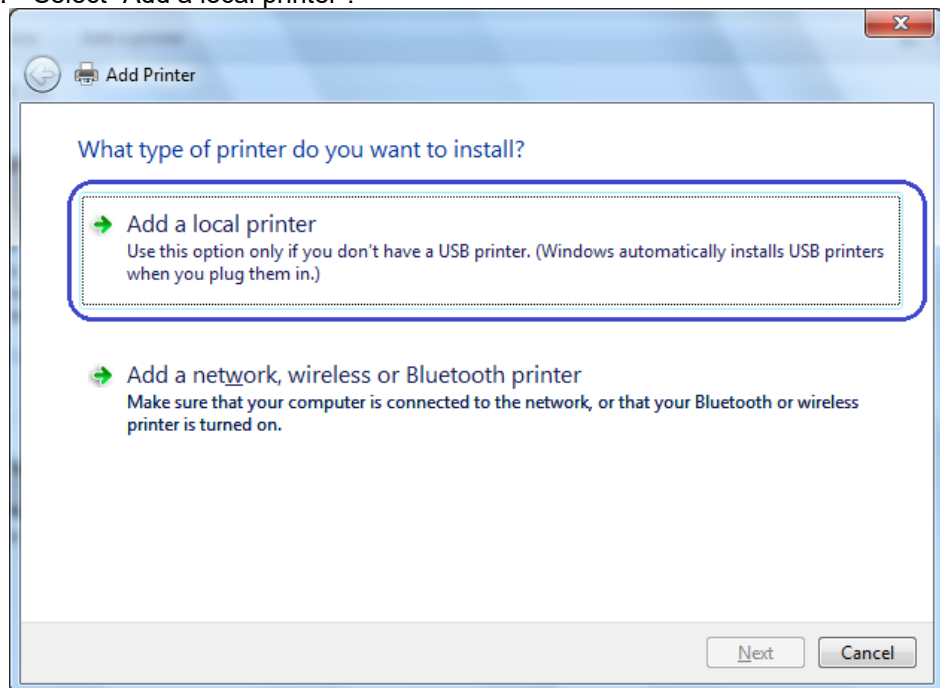

5. Select “Use an existing port” option and select the COM port the printer is attached to.

6. When the “Install the printer driver” GUI appears select “Have Disk” option and click on “Next”.

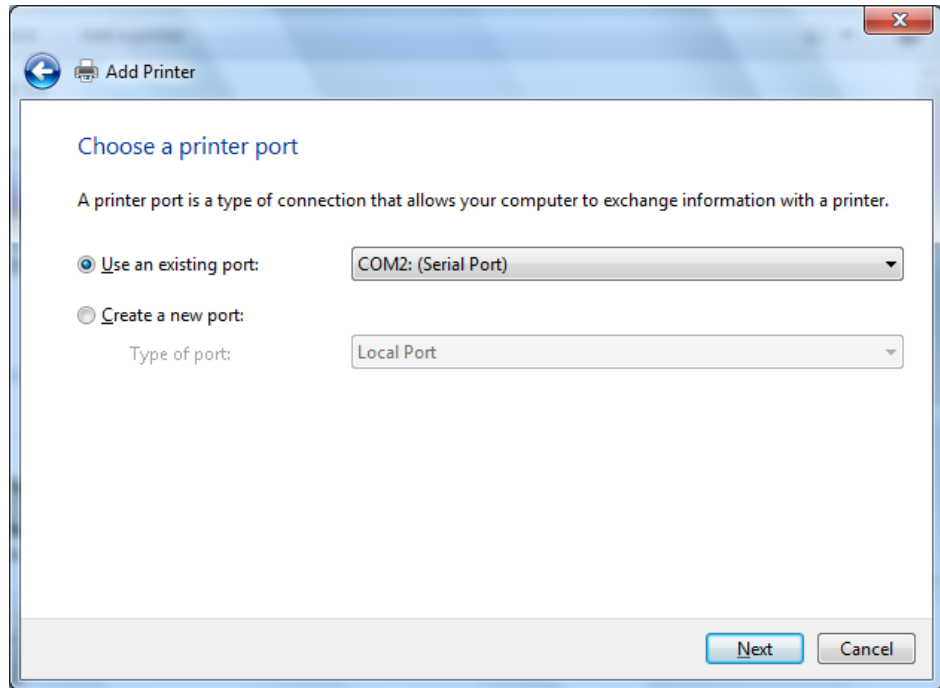

Note: The above COM port maybe differ than your setting.

7. When the “Install the printer driver” GUI appears select “Have Disk” option and click on “Next”.

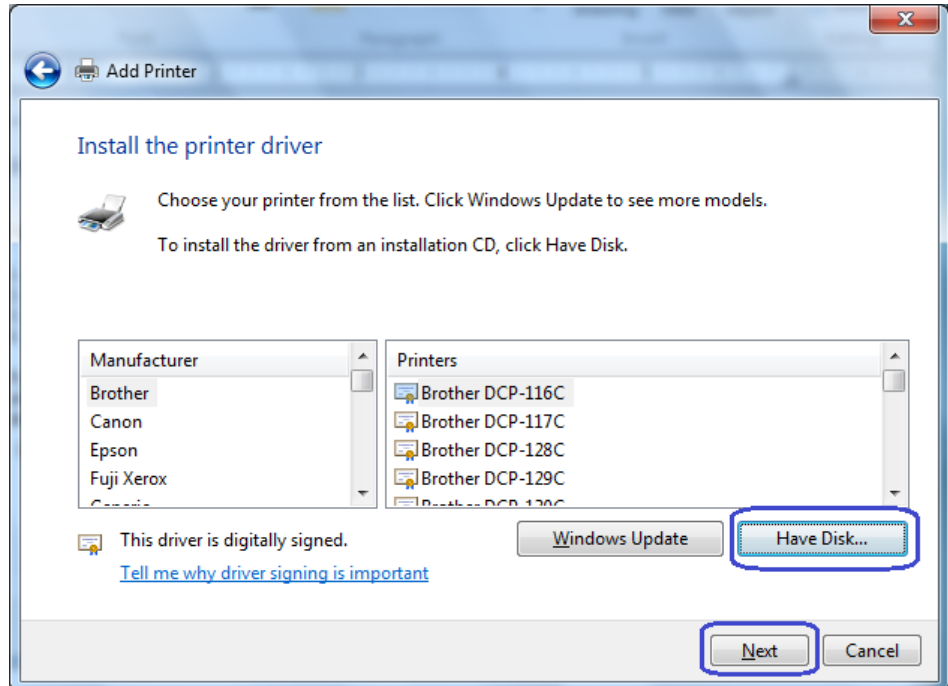

- When the “Install From Disk” option appears browse to the location where the drivers are located and select the “HP_Receipt_OEM” or “HP_Receipt_OEM64” file and click “Open”.

For the HP factory image the locations are:

32Bit Image

C:\xxxxx\Point of Sale\Receipt Printer\Windows Receipt Printer Drivers\32Bit_MiniDrivers\Receipt

64Bit Image

C:\xxxxx\Point of Sale\Receipt Printer\Windows Receipt Printer Drivers\64Bit_MiniDrivers\Receipt

- When you are back to the “Install the printer Driver” GUI “HP Receipt” printer will appear, click on the “Next” button.

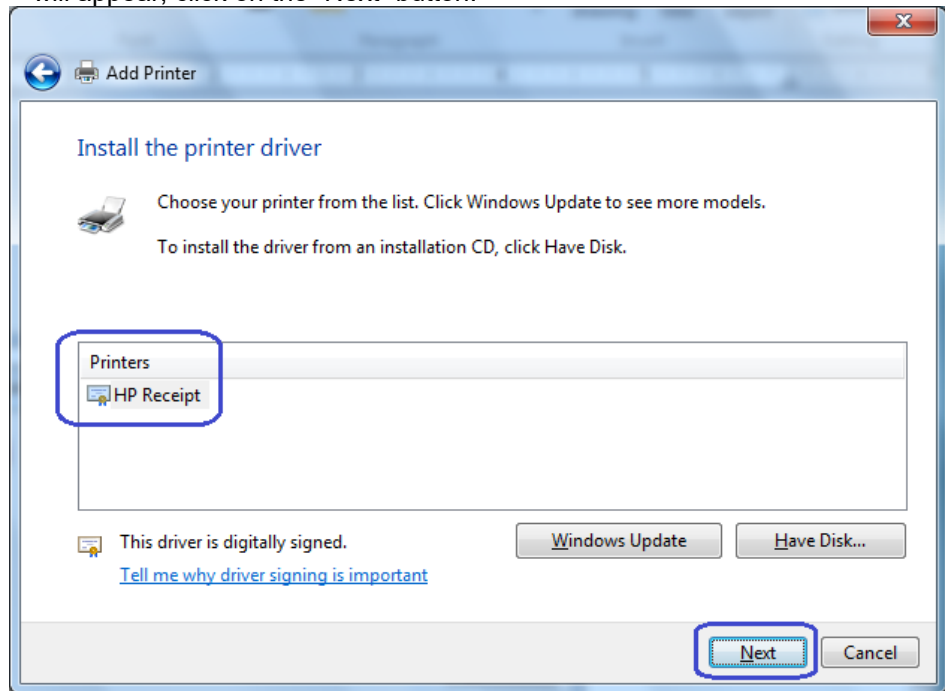

10. Enter a printer name or use the default of "HP Receipt" and click on the "Next" button.

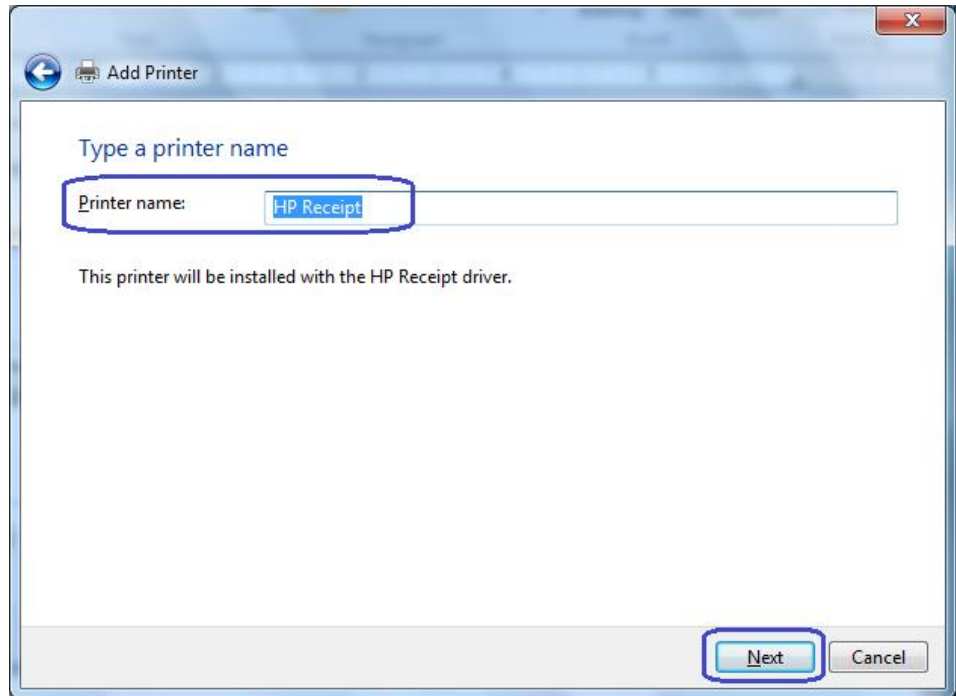

11. Once the printer drivers is installed click on the "Finish" button. Prior to clicking on the "Finish" button one can click "Print a test page".

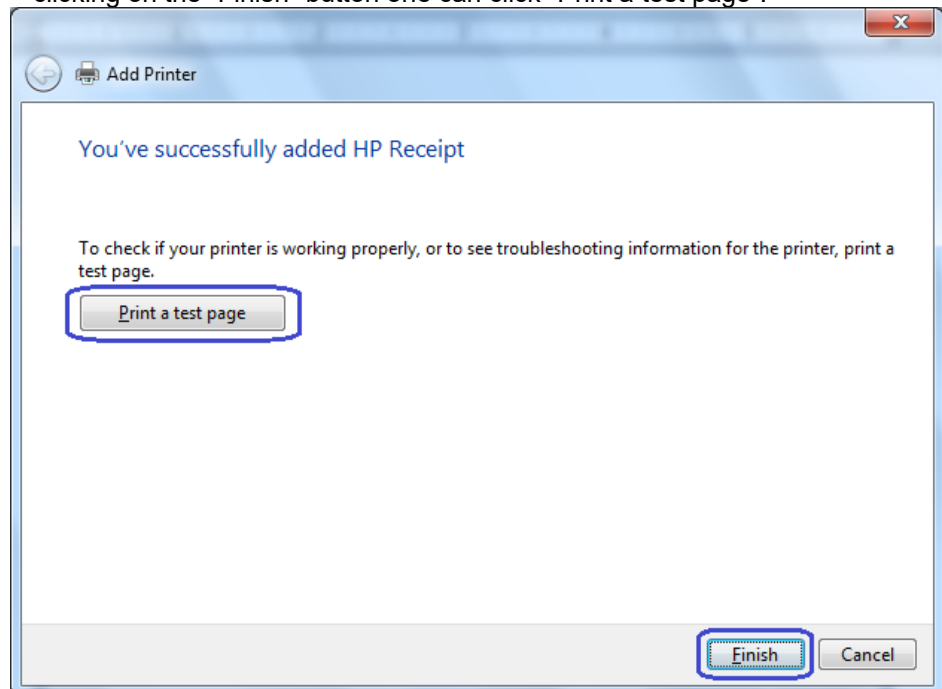

6.4.8.9 Windows Printer Driver (Ethernet) for v1.0.3 & later for Windows 7 / 8.1 / 10

The following is an overview of the steps to test the receipt printer followed by detailed steps:

1. Print out the diagnostic form on the printer in order to obtain the IP Address and the RAW TCPIP Port information.
2. Go to Control Panel – Devices and Printers and select “Add a printer”.
3. Select “Add a local printer”. **Do not select the network option.**
4. Select “Create a new port” option.
5. Select “Standard TCP / IP Port” option and click on the next button.
6. Uncheck “Query the printer and automatically select the driver to use.”
7. Enter the IP Address that is printed on the diagnostics form and click on “Next”.
8. On the “Additional port information required” GUI, select “Standard Generic Network Card” and click on “Next”.
9. When the “Install the printer driver” GUI appears select “Have Disk” option and click on “Next”.
10. When the “Install From Disk” option appears browse to the location where the drivers are located and select the “HP_Receipt_OEM” or “HP_Receipt_OEM64” file and click “Open”.
11. When you are back to the “Install the printer Driver” GUI “HP Receipt” printer will appear, click on the “Next” button.
12. Enter a printer name or use the default of “HP Receipt” and click on the “Next” button.
13. Once the printer drivers is installed click on the “Finish” button. **Do not** click on the “Print a test page” button since the configuration is not complete.
14. Go to the “Devices and Printers” and right click on the printer that was just installed and select “Printer Properties”.
15. Select the “Ports” tab.
16. Highlight the port for the printer that was installed and select “Configure Port”.
17. Go to the “Raw Settings” section on the “Configure Standard TCP/IP Port monitor” GUI. In the “Port Number” section enter 9001 (double check the diagnostics form to confirm 9001 is on the “Raw TCPIP Port” and click OK.
18. Close the printer properties GUI screen.
19. Go to the “Devices and Printers” and right click on the printer that was just installed and select “Printer Properties”.
20. Click on “Print Test Page” and printout should occur.

Detailed Steps

1. Print out the diagnostic form on the printer in order to obtain the IP Address and the RAW TCPIP Port information.

Steps to obtain a diagnostics printout

- A. Plug the printer into the network and have power to the printer.
- B. Run a diagnostic printout and obtain the printer IP address from the printout.
- C. Be sure paper is in the printer (1).
- D. Open the receipt cover (2).
- E. Press and hold the paper feed button (3).
- F. Close the receipt cover (2).

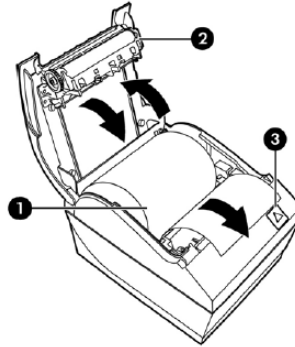

The following is partial A799II – Diagnostics Form printout showing the IP address and Port info:

```

Comm. Interfaces
Port Idle Timeout : disabled
Interface - USB
RX Buffer Size : 4096
USB Driver Type : Printer Class
USB Packet w/Error : Reject
Interface - RS232
RX Buffer Size : 4096
Parameters
Baud Rate : 115200
Data Bits : 8
Stop Bit : 1
Parity : NONE
Flow Control : DTR/DSR
Reception Errors : Ignore
Interface - Bluetooth
Status : not available
Interface - Ethernet
Ethernet Type : Wired
Parameters
MAC Address : 00:E0:70:F0:21:7C
IP Address : 10.1.3.18
Net Mask : 255.255.252.0
Gateway : 10.1.0.1
Raw TCPIP Port : 9001
Loop Back Port : Disabled
Http Server Port : 80
DHCP : Enabled
Client ID : 00E070F0217C
Idle Timeout : Disabled
Keep Alive Pings : Disabled
  
```

Note: The default IP address is 192.0.0.192. If this address appears on the printout, the printer has not obtained an IP address

2. Go to Control Panel – Devices and Printers and select “Add a printer”.

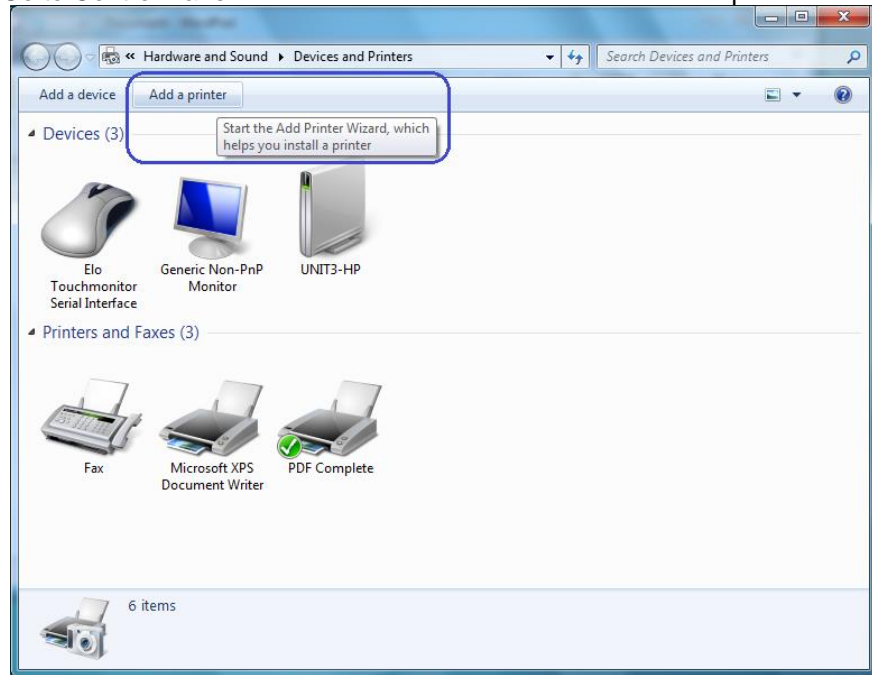

3. Select “Add a local printer”. **Do not select the network option.**

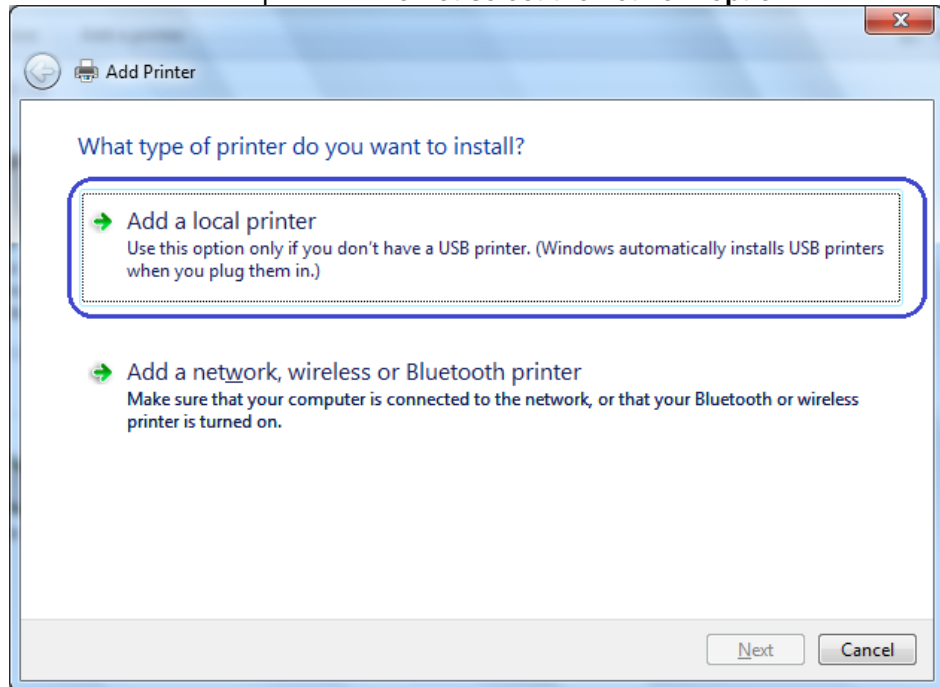

4. Select “Create a new port” option.

5. Select "Standard TCP / IP Port" option and click on the next button.

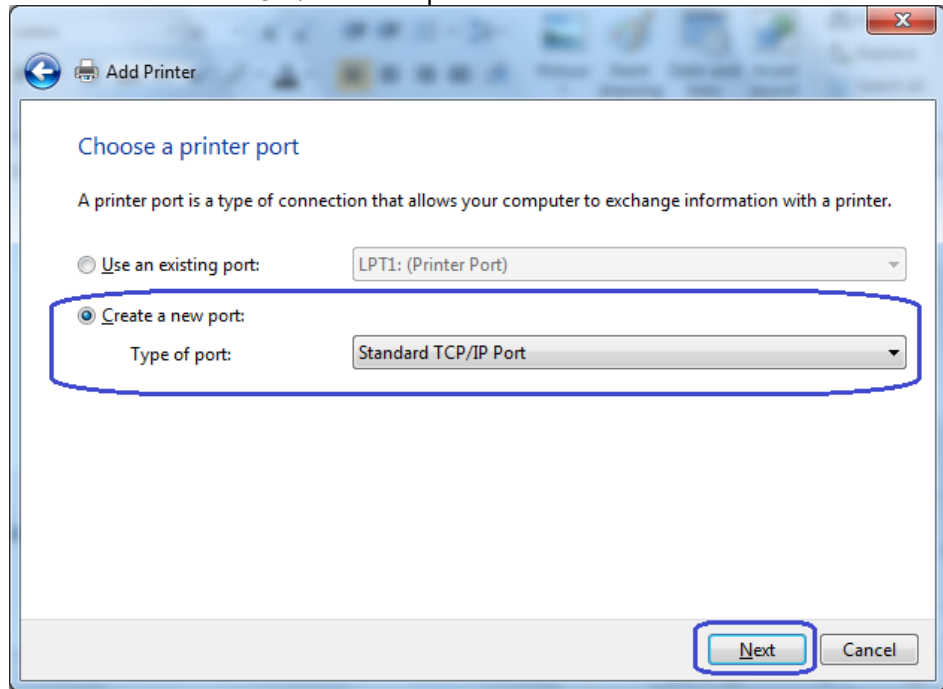

6. Uncheck "Query the printer and automatically select the driver to use"
7. Enter the IP Address that is printed on the diagnostics form and click on the "Next" button.

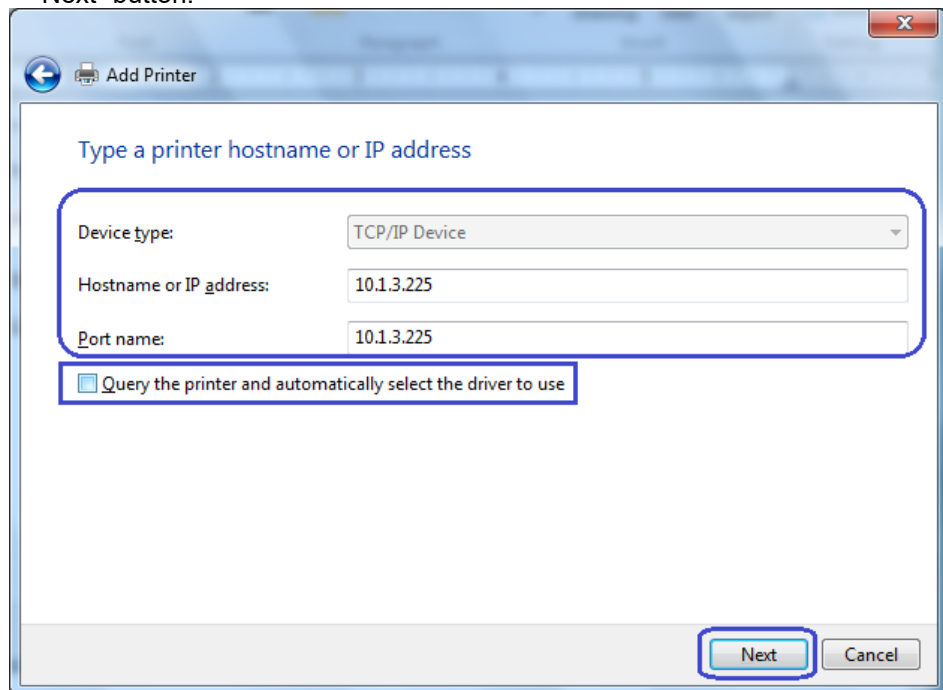

Note: The IP Address above is an example.

After click the “Next” button “Detecting TCP/IP Port” box will appear.

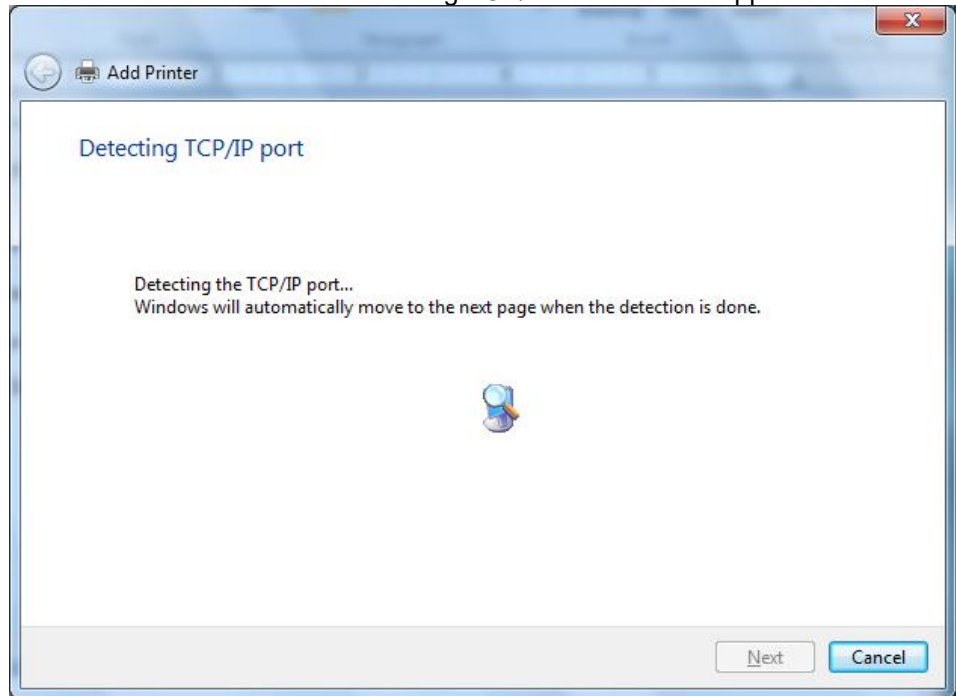

8. On the “Additional port information required” GUI select “Standard Generic Network Card” and click on “Next”.

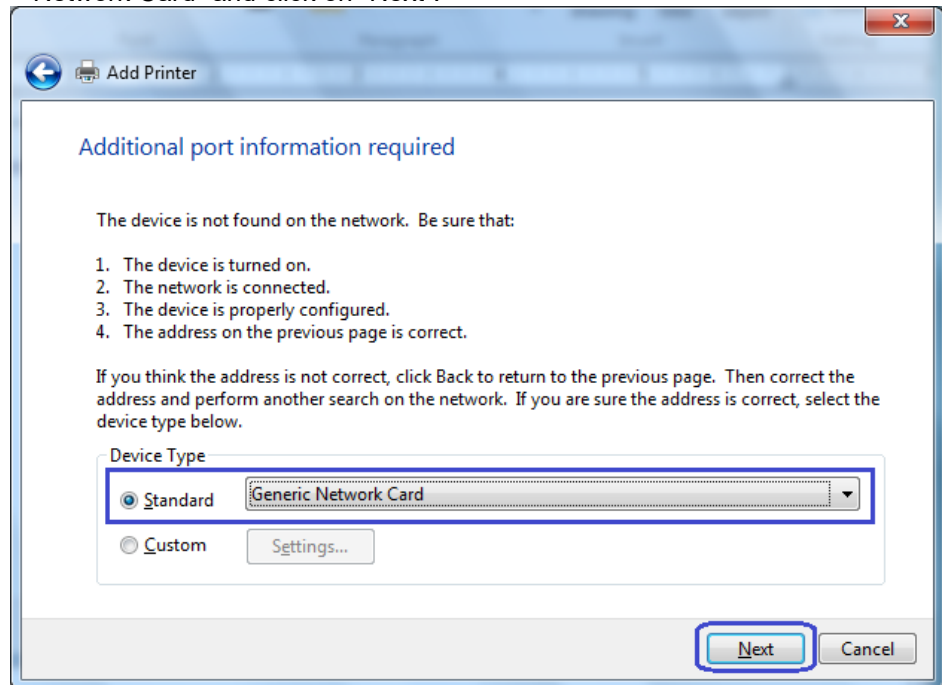

9. When the “Install the printer driver” GUI appears select “Have Disk” option and click on “Next”.

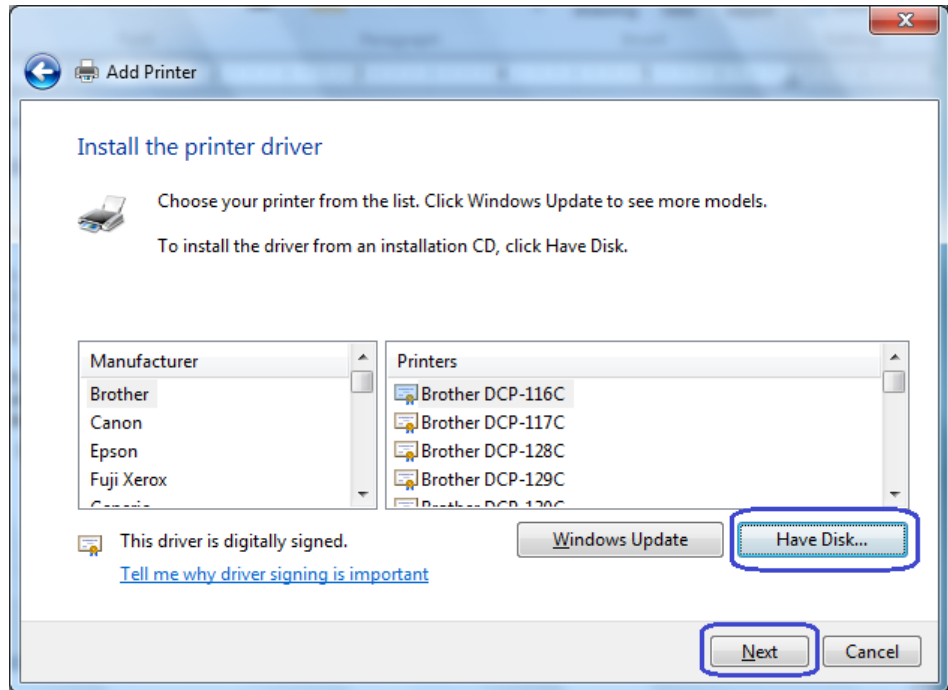

10. When the “Install From Disk” option appears browse to the location where the drivers are located and select the “HP_Receipt_OEM” or “HP_Receipt_OEM64” file and click “Open”

For the HP factory image the locations are:

32Bit Image

C:\xxxxx\Point of Sale\Receipt Printer\Windows Receipt Printer Drivers\32Bit_MiniDrivers\Receipt

64Bit Image

C:\xxxxx\Point of Sale\Receipt Printer\Windows Receipt Printer Drivers\64Bit_MiniDrivers\Receipt

11. When you are back to the “Install the printer Driver” GUI “HP Receipt” printer will appear, click on the “Next” button.

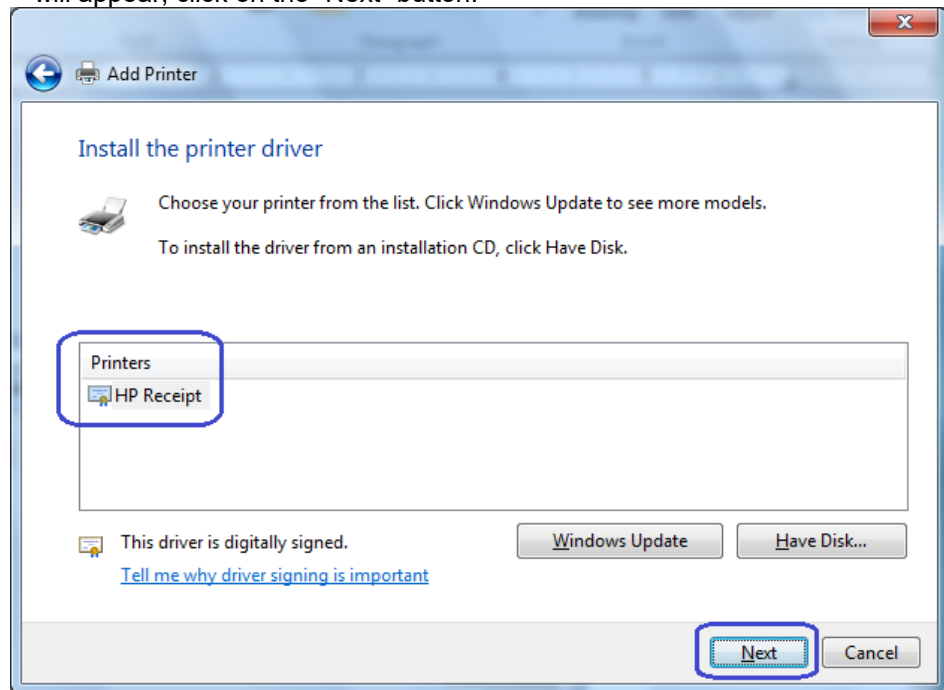

12. Enter a printer name or use the default of “HP Receipt” and click on the “Next” button.

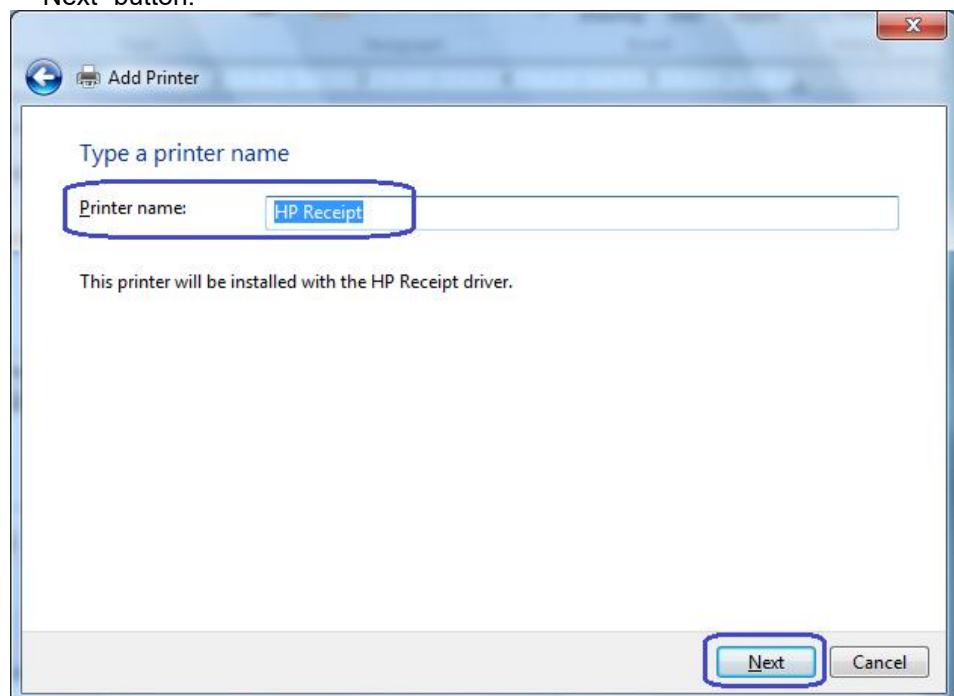

13. Once the printer drivers is installed click on the “Finish” button. **Do not** click on the “Print a test page” button since the configuration is not complete.

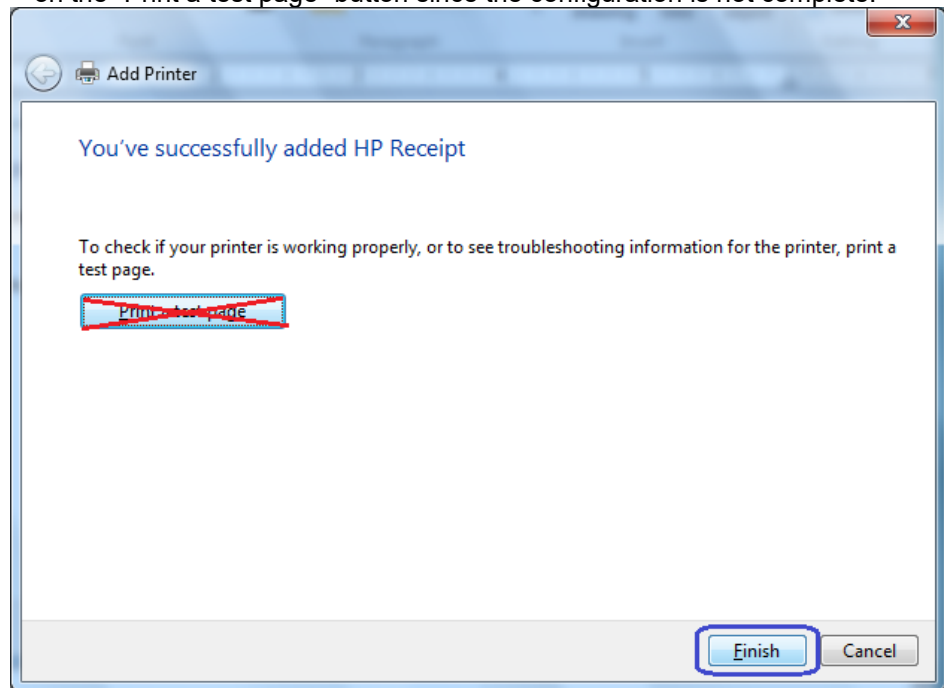

14. Go to the “Devices and Printers” and right click on the printer that was just installed and select “Printer Properties”.
15. Select the “Ports” tab.
16. Highlight the port for the printer that was installed and select “Configure Port”

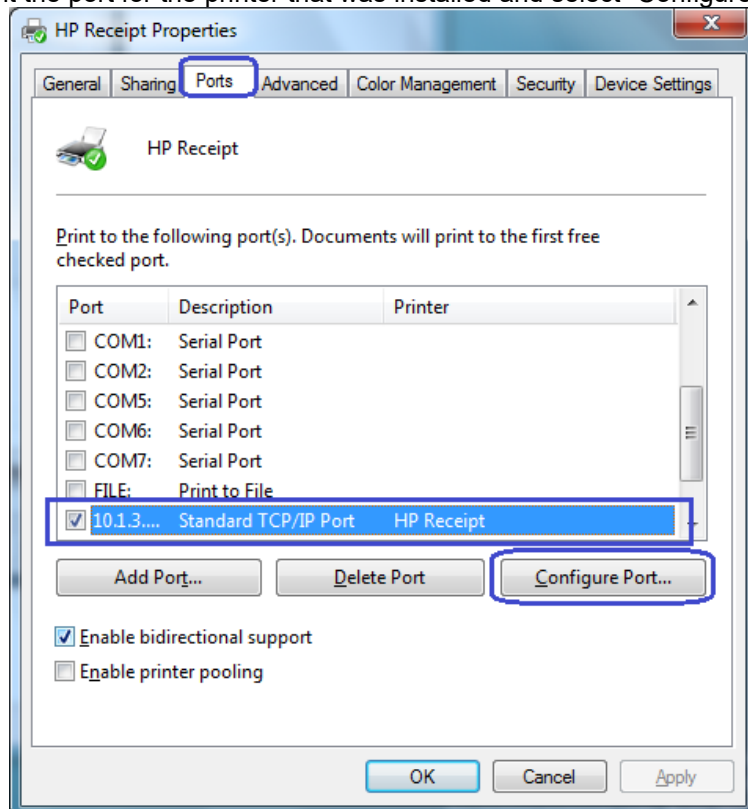

17. Go to the “Raw Settings” section on the “Configure Standard TCP/IP Port monitor” GUI. In the “Port Number” section enter 9001 (double check the diagnostics form to confirm 9001 is on the “Raw TCPIP Port” and click OK.

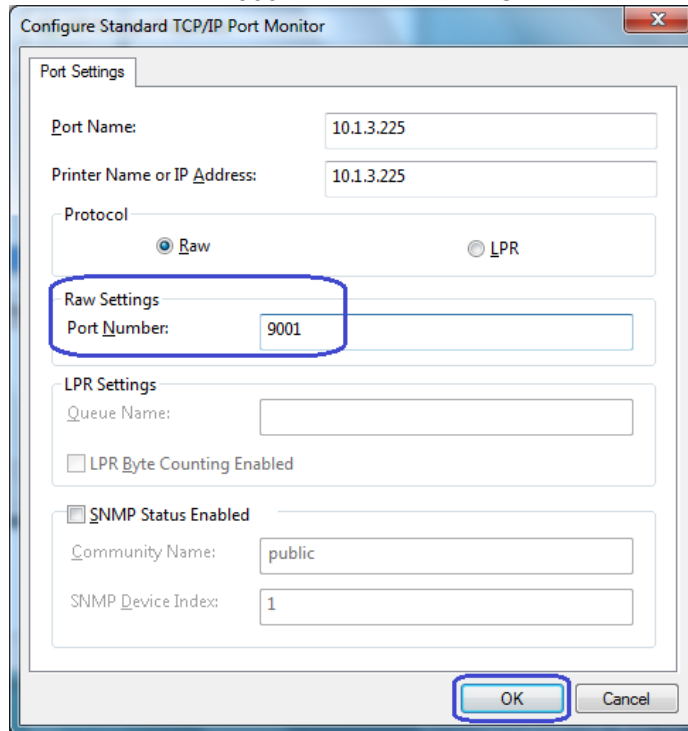

18. Close the printer properties GUI screen.
19. Go to the “Devices and Printers” and right click on the printer that was just installed and select “Printer Properties”.
20. Click on “Print Test Page” and printout should occur.

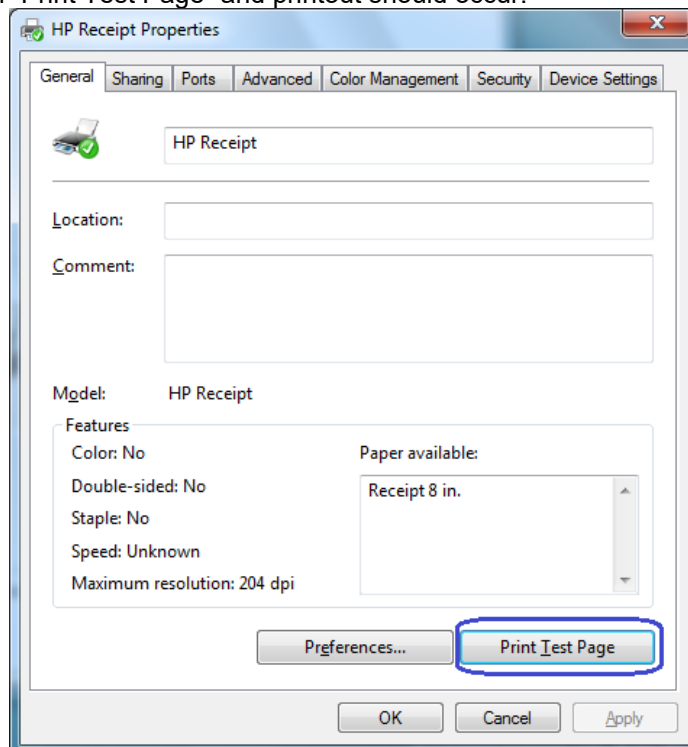

6.4.8.10 **Windows Printer Driver Options for v1.0.3 and later for Windows 7 / 8.1 / 10**

The options for full cut / partial cut / cash drawer / cash drawer selection are not located in the receipt printer advanced options.

1. Go the Printer and Faxes section in Windows.
2. Select the HP Receipt Printer and right click to go to the Printing Preferences.
3. Click on the Printing Preferences button.
4. Click on the Advance button.

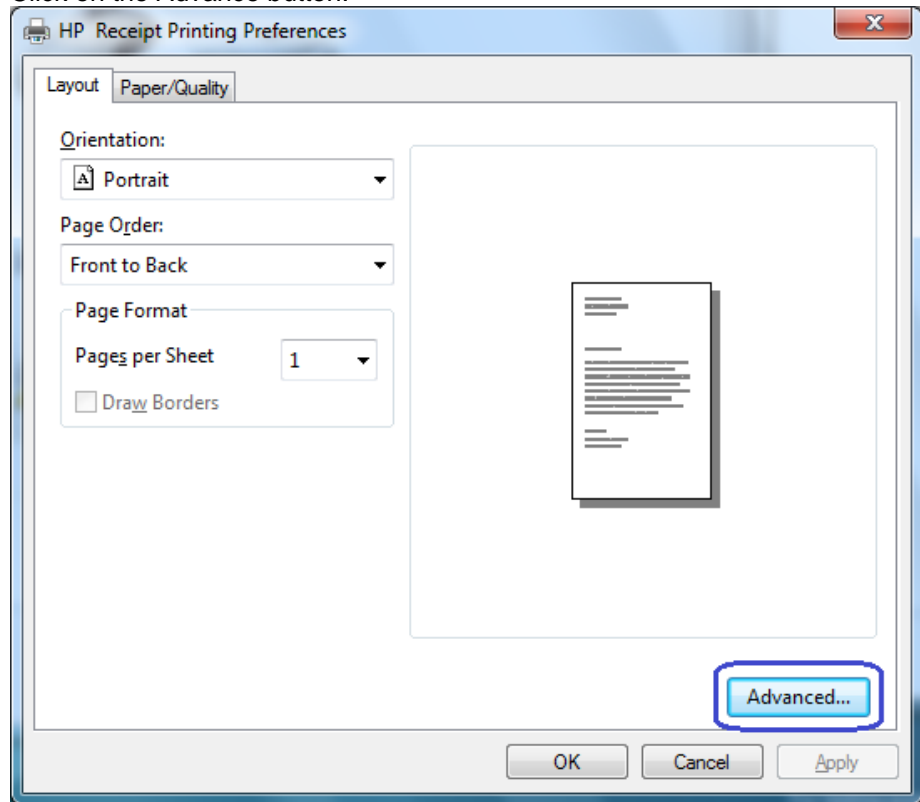

5. Selection the desired option in the Printer Features section.

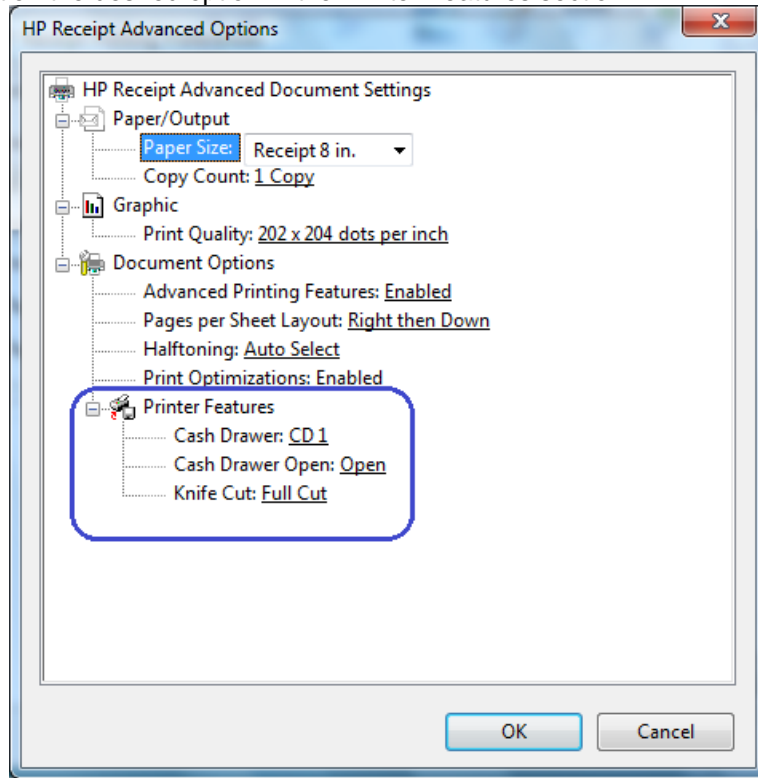

The following screens show the selections that are available in the each of the three areas:

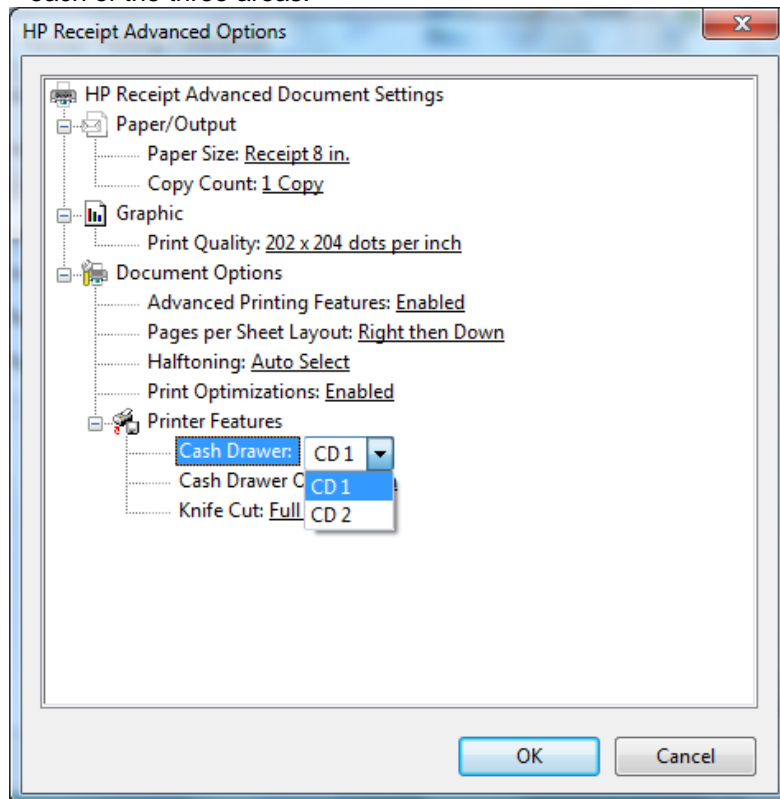

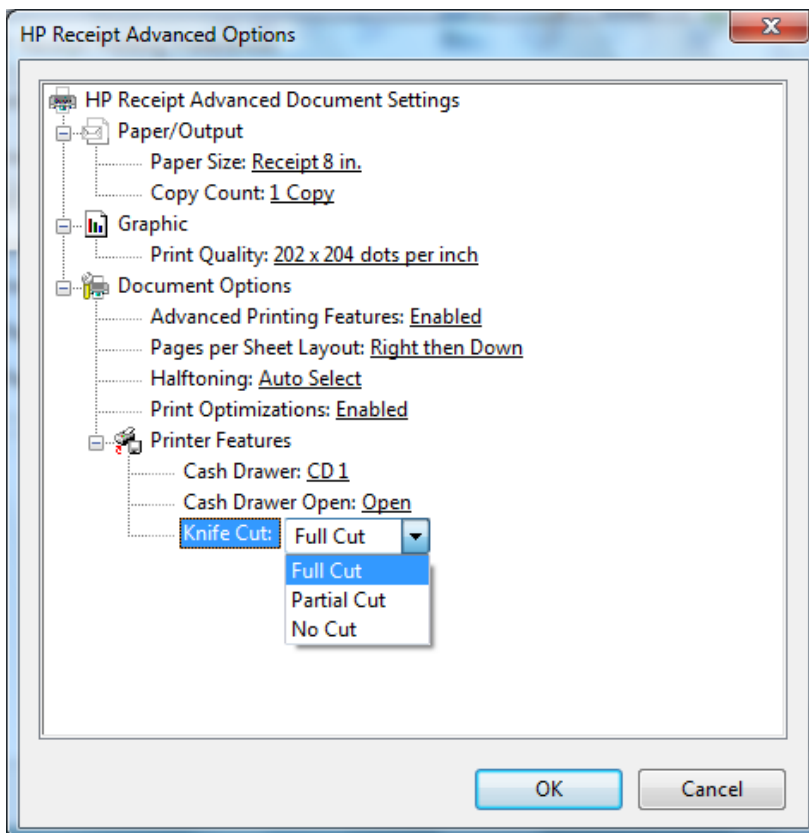
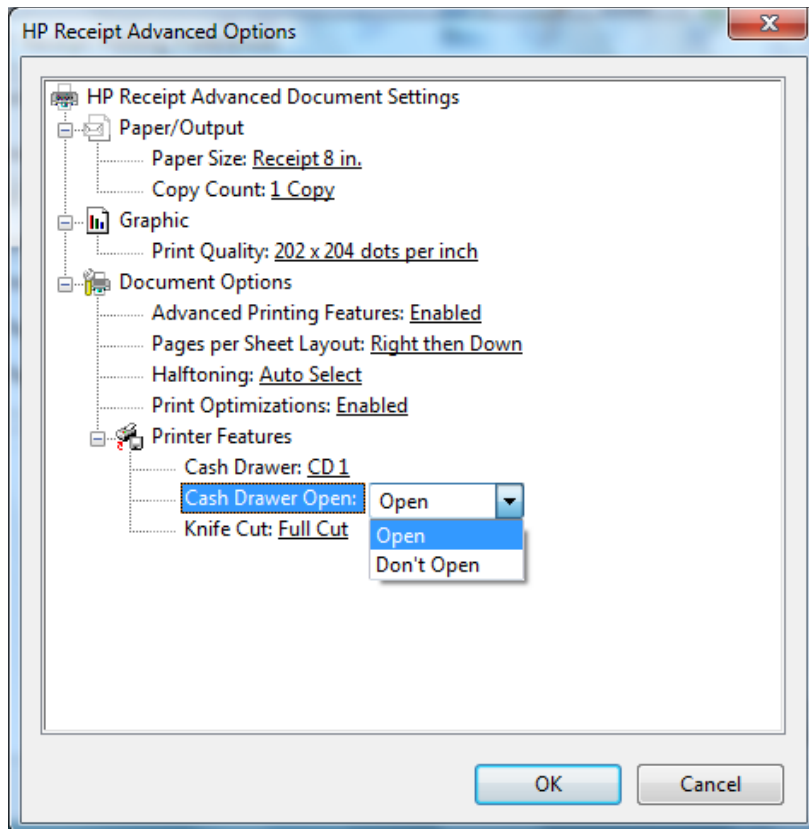

6.4.9 **Knife Cut Commands**

Some POS application that use the Windows mini-drivers request the knife cut command so the application can perform a cut after something is printed (i.e. No Sale). The following the decimal commands:

Perform full knife cut

ASCII	EM	ESC i
Hexadecimal	19	1B 69
Decimal	25	27 105

Perform partial knife cut

ASCII	SUB	ESC m
Hexadecimal	1A	1B 6D
Decimal	26	27 109

The partial knife cut leaves 5mm (0.20 inch) of paper on the left edge.

6.4.10 **OPOS Drivers for the Receipt Printer**

The receipt printer OPOS drivers are included in the HP factory image and are also available from HP.COM.

Note: If you are using the serial printer, one will need to uninstall the OPOS drivers and then re-install the OPOS driver (see details below of installation). HP OPOS driver version 1.0.1.34 (or later) supports the serial receipt printer.

OPOS driver 1.0.1.21 (or later) for the receipt printer will work with the printer in either NATIVE or PRINTER CLASS mode. During the installation process of the OPOS driver one will be prompted for which mode the printer is in (PRINTER CLASS is selected by default).

The Windows mini-drivers and the OPOS drivers cannot be set to the same COM port.

6.4.10.1 **OPOS Installation - USB**

The following is an overview of the steps to install the receipt printer followed by detailed steps:

1. Open **OPOS Support For HP Printers**.
 - C:\xxxxx\Point of Sale\Receipt Printer\POS Printer OPOS\setup.exe.
2. Select only the printer(s) that need to be installed.
3. Select the Emulation Mode of the printer being installed (HP H300 Printer is Generation II).
4. Select YES or NO to install OPOS Control Objects.
5. Select USB Communications as the Connection Method.
6. Select the USB connection method (printer class is the default).
7. For the remaining options, defaults can be selected until the installation is complete.

Detailed Steps

1. Open **OPOS Support For HP Printers**.
 - C:\xxxxx\Point of Sale\Receipt Printer\POS Printer OPOS\setup.exe.
2. Open the HP Receipt Printer OPOS executable.
3. Select only the printer(s) that need to be installed.

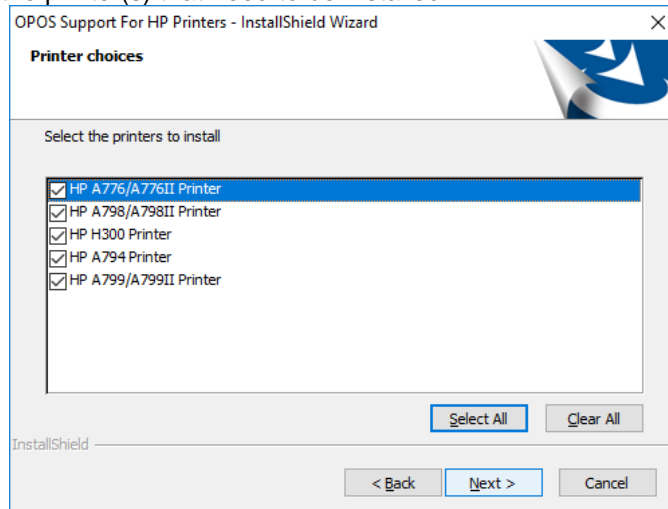

4. Select the Emulation Mode of the printer being installed (HP H300 Printer is Generation II).

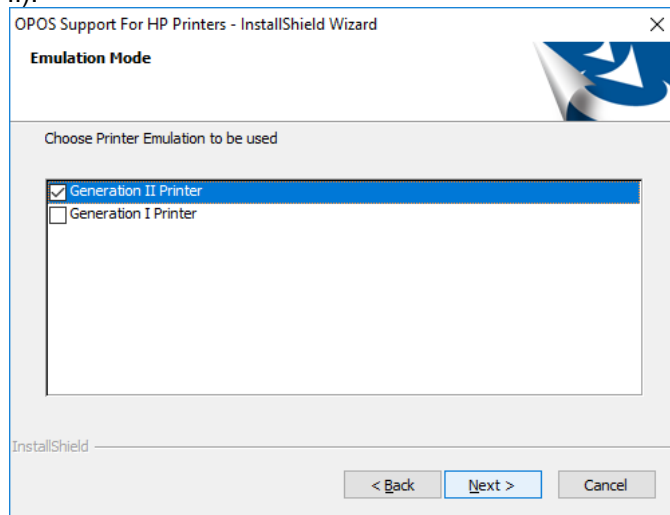

If HP A776/A776II Printer was selected, choose the appropriate Imager option.

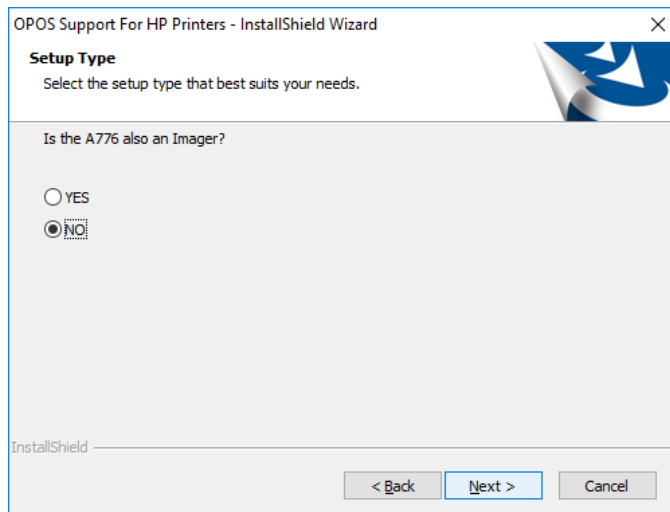

5. Select YES or NO to install OPOS Control Objects.

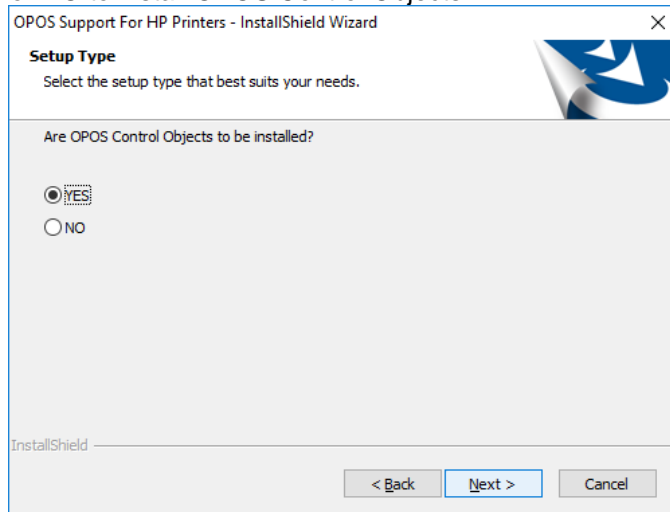

If "NO" is selected, ensure that the standalone CCO package is installed prior to using the OPOS test program or a Point Of Sale application. The CCO installation package can be found in the HP factory image or HP.COM.

6. Select USB Communications as the Connection Method.

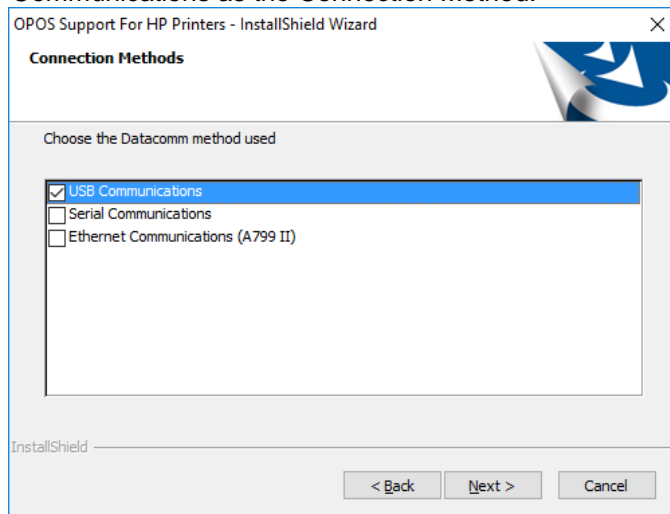

7. Select the USB connection method (printer class is the default).

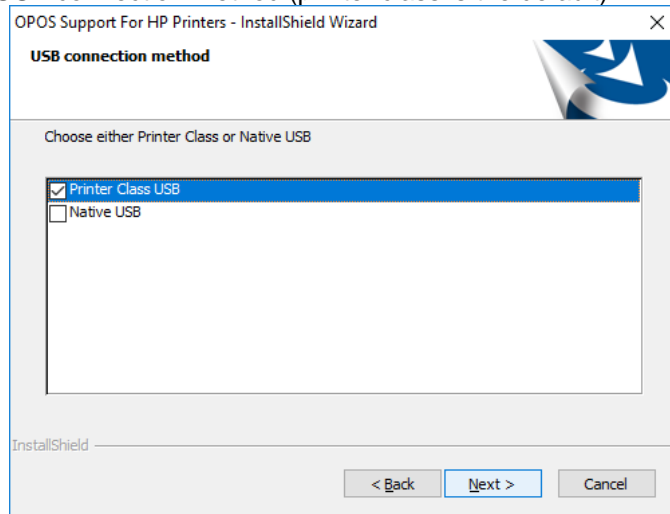

8. For the remaining options, defaults can be selected until the installation is complete.

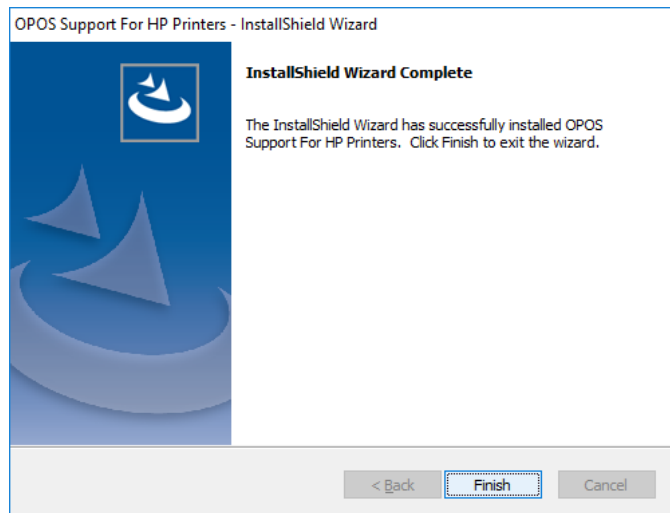

6.4.10.2 **OPOS Installation – Serial Port**

The following is an overview of the steps to install the receipt printer followed by detailed steps:

1. Print out the diagnostic form on the printer in order to obtain the baud rate the printer is set to.
2. Open **OPOS Support For HP Printers**.
 - C:\xxxx\Point of Sale\Receipt Printer\POS Printer OPOS\setup.exe.
3. Select only the printer(s) that need to be installed.
4. Select the Emulation Mode of the printer being installed (HP H300 Printer is Generation II).
5. Select YES or NO to install OPOS Control Objects.
6. Select Serial Communications as the Connection Method.
7. Select the COM (serial) port that the printer is attached.
8. Refer to the diagnostics form that was printed in step 1 for the baud rate of the printer and select the Baudrate for Serial Communications.
9. Select the Parity for Serial Communications.
10. Select the Flow Control for Serial Communications.
11. For the remaining options, defaults can be selected until the installation is complete.

Detailed Steps

1. Print out the diagnostic form on the printer in order to obtain the baud rate the printer is set to.
2. Open **OPOS Support For HP Printers**.
 - C:\xxxx\Point of Sale\Receipt Printer\POS Printer OPOS\setup.exe.
3. Select only the printer(s) that need to be installed.

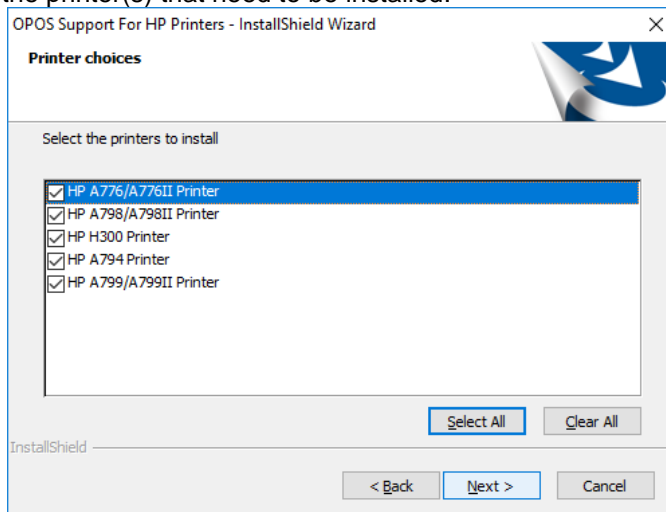

4. Select the Emulation Mode of the printer being installed (HP H300 Printer is Generation II).

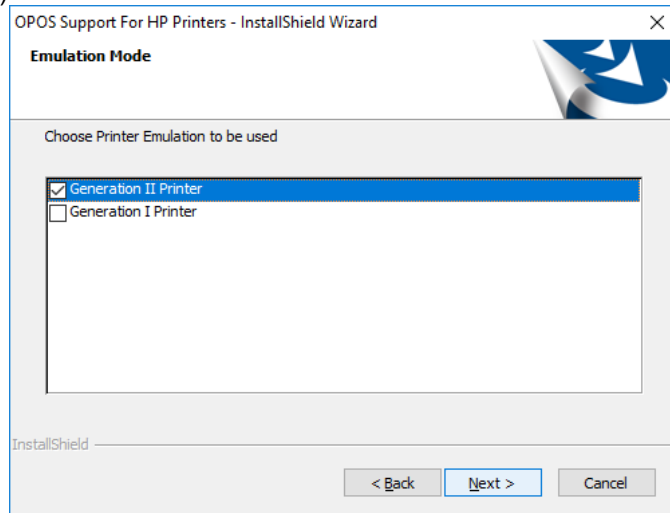

If HP A776/A776II Printer was selected, choose the appropriate Imager option.

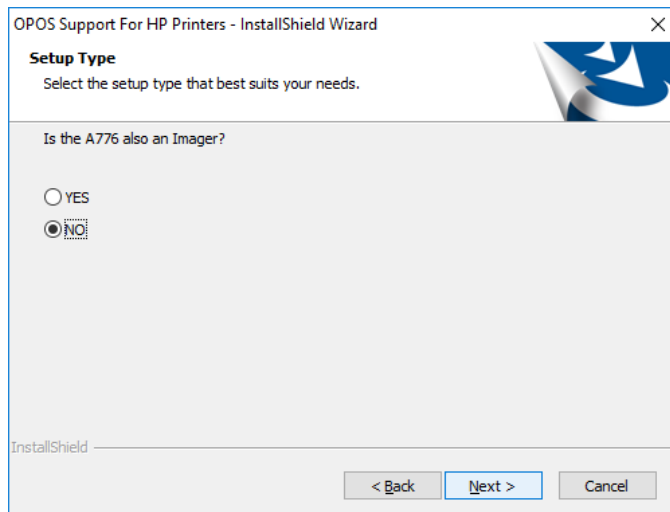

5. Select YES or NO to install OPOS Control Objects.

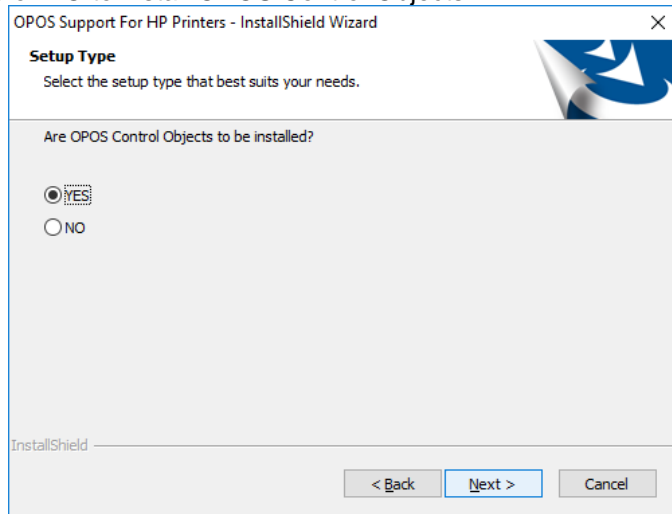

If "NO" is selected, ensure that the standalone CCO package is installed prior to using the OPOS test program or a Point Of Sale application. The CCO installation package can be found in the HP factory image or HP.COM.

6. Select Serial Communications as the Connection Method.

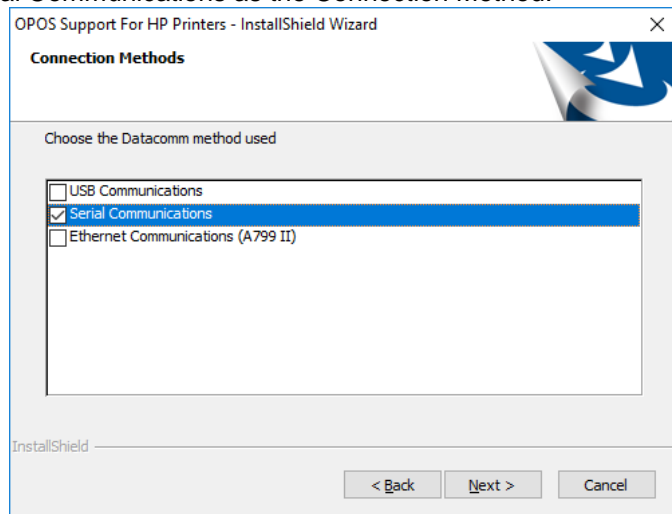

7. Select the COM (serial) port that the printer is attached.

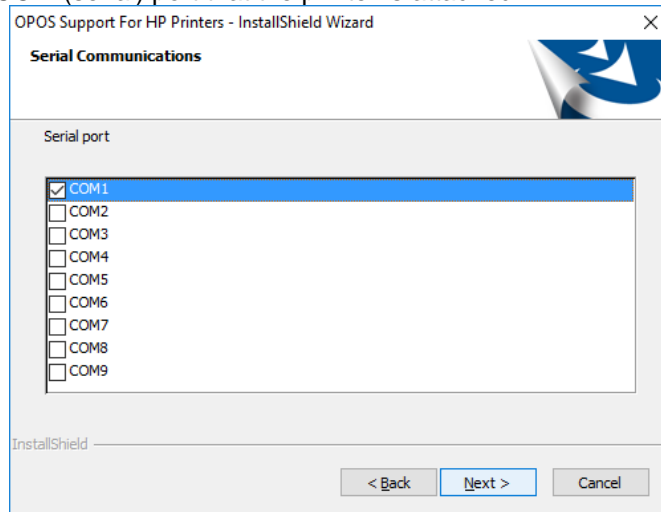

8. Refer to the diagnostics form that was printed in step 1 for the baud rate of the printer and select the Baudrate for Serial Communications.

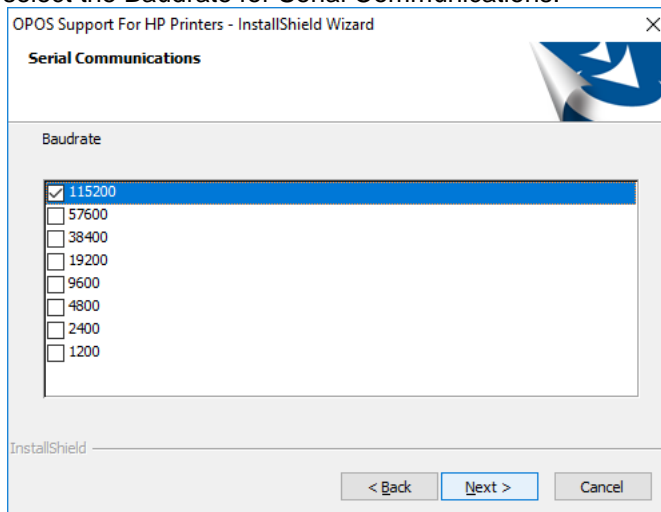

Note: The baud rate may be different than that shown above.

9. Select the Parity for Serial Communications.

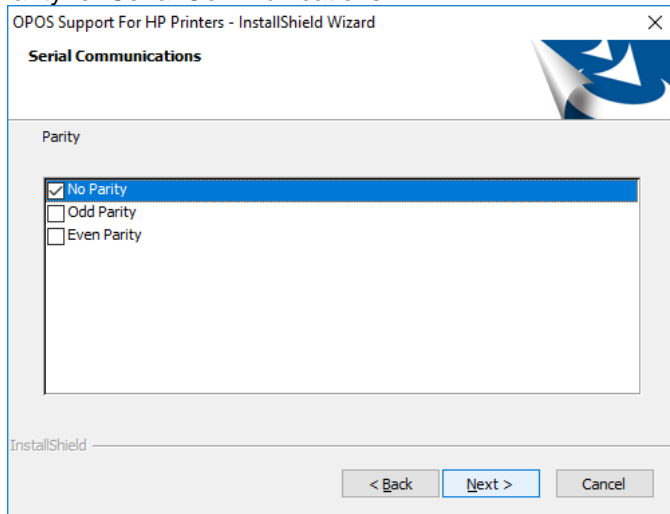

10. Select the Flow Control for Serial Communications.

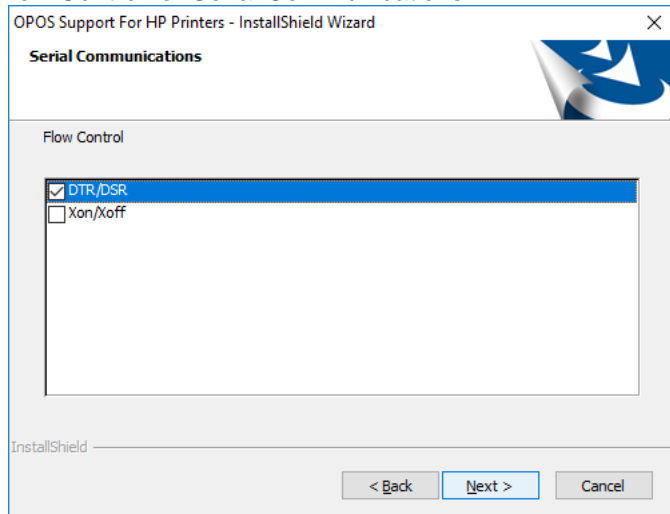

11. For the remaining options, defaults can be selected until the installation is complete.

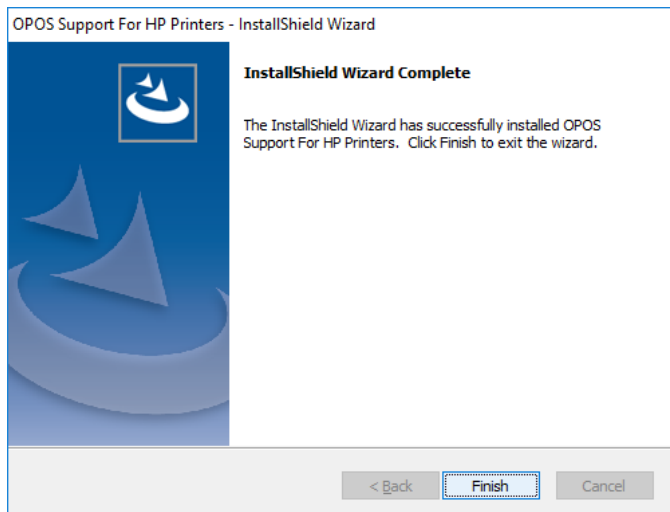

6.4.10.3 **OPOS Installation - Ethernet**

In the HP factory image the OPOS driver is installed in USB mode. Later in this section are the steps to change the OPOS driver from USB mode to Ethernet mode; see “OPOS – Ethernet IPS Address (Registry)” section. These steps will need to be used even if the printer driver Ethernet option is selected during installation in order to get the correct IP address into the registry.

The following is an overview of the steps to install the receipt printer followed by detailed steps:

1. Open **OPOS Support For HP Printers**.
 - C:\xxxxx\Point of Sale\Receipt Printer\POS Printer OPOS\setup.exe.
2. Select HP A799/A799II Printer for Printer choices. Currently this is the only model offered by HP that supports Ethernet.
3. Select Generation II Printer for Emulation Mode.
4. Select YES or NO to install OPOS Control Objects.
5. Select “Ethernet Communications (A799 II)” as the Connection Method.
6. For the remaining options, defaults can be selected until the installation is complete.

Detailed Steps

1. Open **OPOS Support For HP Printers**.
 - C:\xxxxx\Point of Sale\Receipt Printer\POS Printer OPOS\setup.exe.
2. Select HP A799/A799II Printer for Printer choices. Currently this is the only model offered by HP that supports Ethernet

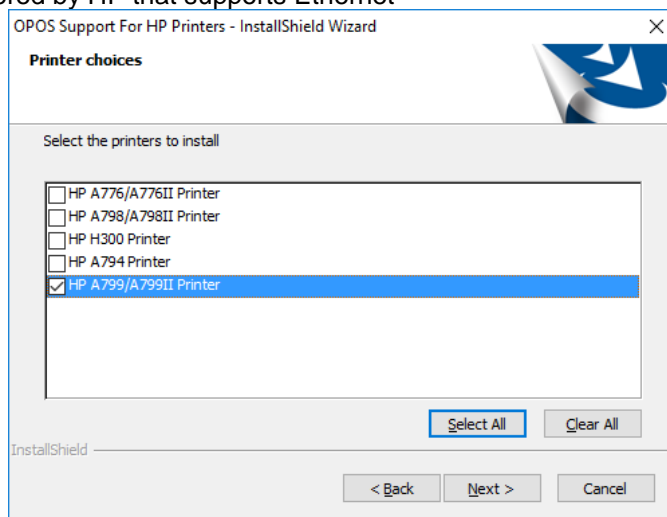

3. Select Generation II Printer for Emulation Mode.

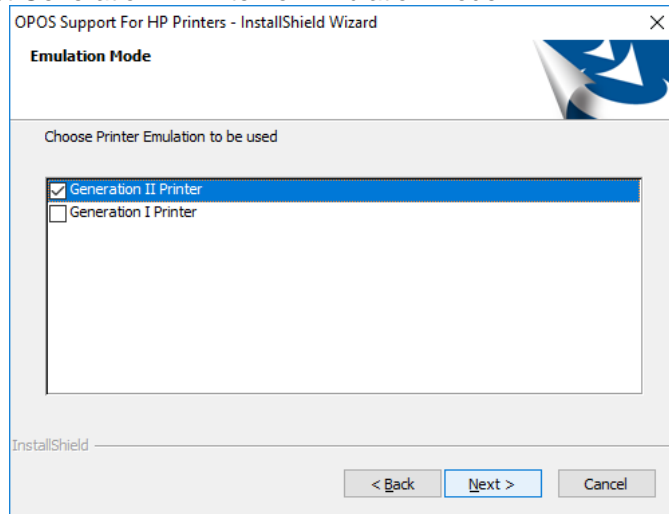

4. Select YES or NO to install OPOS Control Objects.

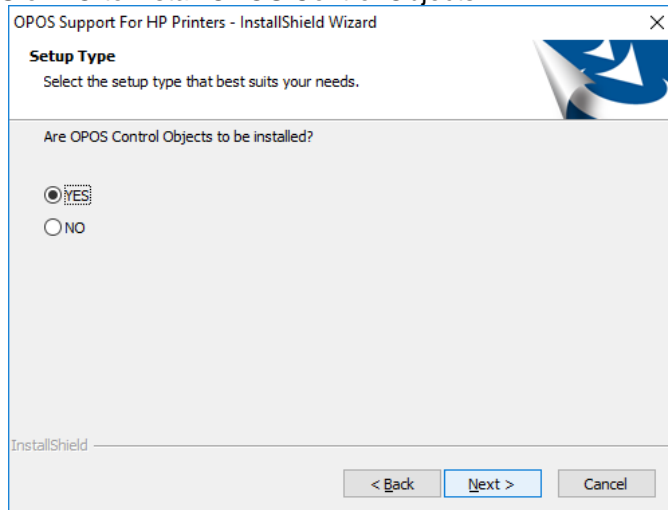

If "NO" is selected, ensure that the standalone CCO package is installed prior to using the OPOS test program or a Point Of Sale application. The CCO installation package can be found in the HP factory image or HP.COM.

5. Select Ethernet Communications (A799 II) as the Connection Method.

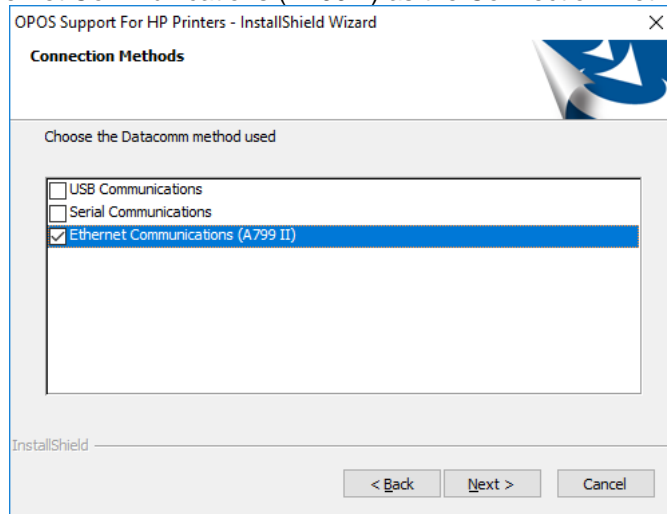

6. For the remaining options, defaults can be selected until the installation is complete.

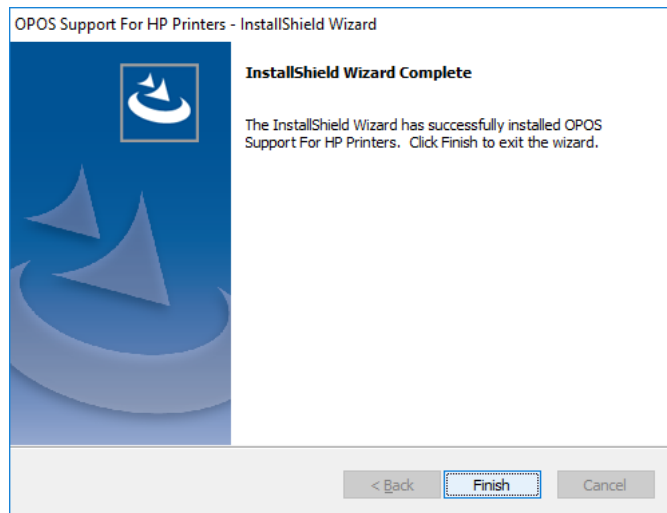

6.4.10.4 OPOS – Ethernet IP Address (Registry)

1. Plug the printer into the network and have power to the printer.
2. Run a diagnostic printout and obtain the printer IP address from the printout.

Steps to obtain a diagnostics printout.

- a) Be sure paper is in the printer (1).
- b) Open the receipt cover (2).
- c) Press and hold the paper feed button (3).
- d) Close the receipt cover (2).

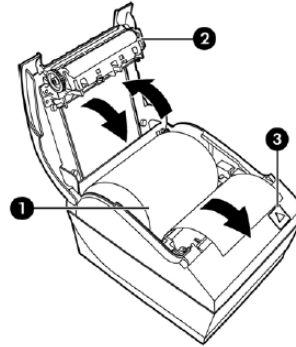

The following is partial A799II – Diagnostics Form printout showing the IP address and Port info:

```
Comm. Interfaces
Port Idle Timeout : disabled
Interface - USB
RX Buffer Size    : 4096
USB Driver Type  : Printer Class
USB Packet w/Error : Reject
Interface - RS232
RX Buffer Size    : 4096
Parameters
Baud Rate        : 115200
Data Bits        : 8
Stop Bit         : 1
Parity           : NONE
Flow Control     : DTR/DSR
Reception Errors : Ignore
Interface - Bluetooth
Status           : not available
Interface - Ethernet
Ethernet Type    : Wired
Parameters
MAC Address      : 00:E0:70:F0:21:7C
IP Address       : 10.1.3.18
Net Mask         : 255.255.252.0
Gateway          : 10.1.0.1
Raw TCPIP Port   : 9001
Loop Back Port   : Disabled
Http Server Port : 80
DHCP             : Enabled
Client ID       : 00E070F0217C
Idle Timeout     : Disabled
Keep Alive Pings : Disabled
```

Note: The default IP address is 192.0.0.192. If this address appears on the printout, the printer has not obtained an IP address.

3. Go to the "Ethernet" folder that is found in the OPOS package folder. Then go to the "Registry Files" folder within the package.

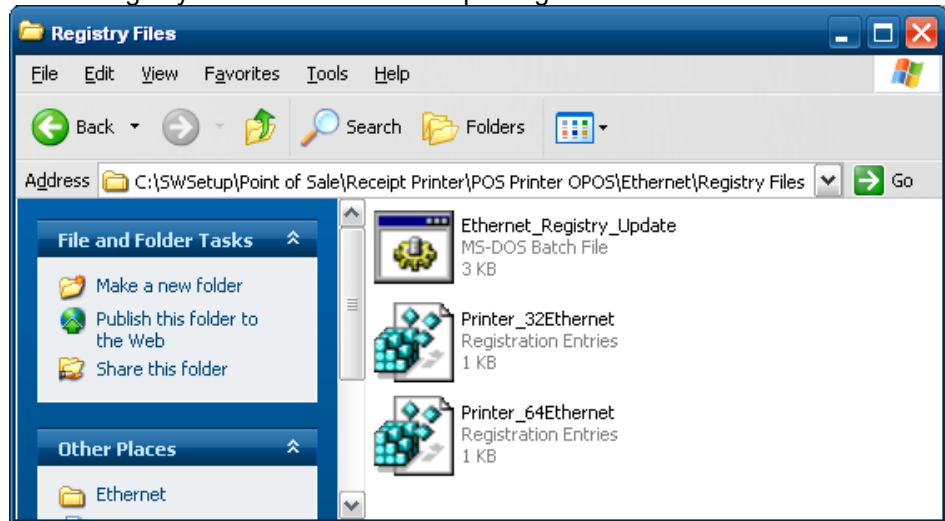

4. In 32Bit operating system using Notepad (or text editor) modify the "Printer_32Ethernet.REG" file with the Port / Address (IP Address) that is on the diagnostics printout that was obtained earlier.

In 64Bit operating system using Notepad (or text editor) modify the "Printer_64Ethernet.REG" file with the Port / Address (IP Address) that is on the diagnostics printout that was obtained earlier.

Below is modified 32Bit registry file:

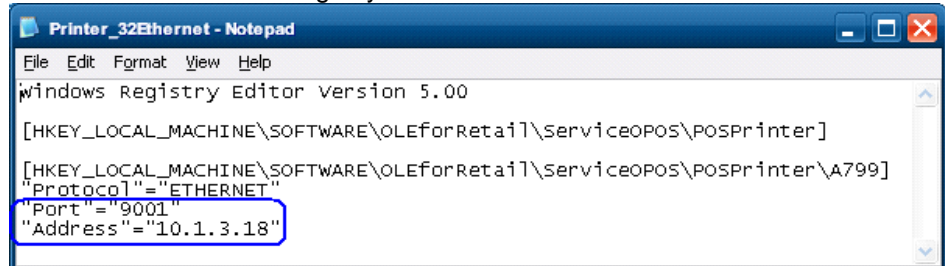

Below is modified 64Bit registry file:

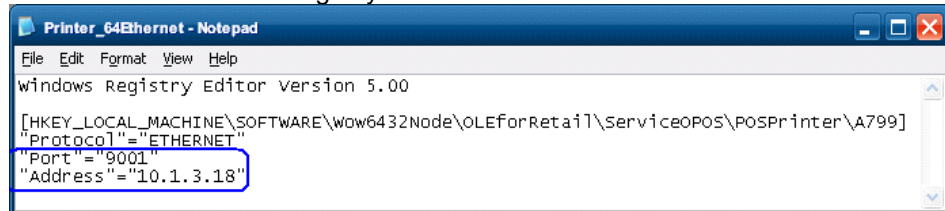

5. After the file has been changed and saved, close Notepad (or text editor).

6. Double click on the registry file to update the registry. One of the following messages will appear asking for confirmation. Click the YES button to allow the registry to be updated.

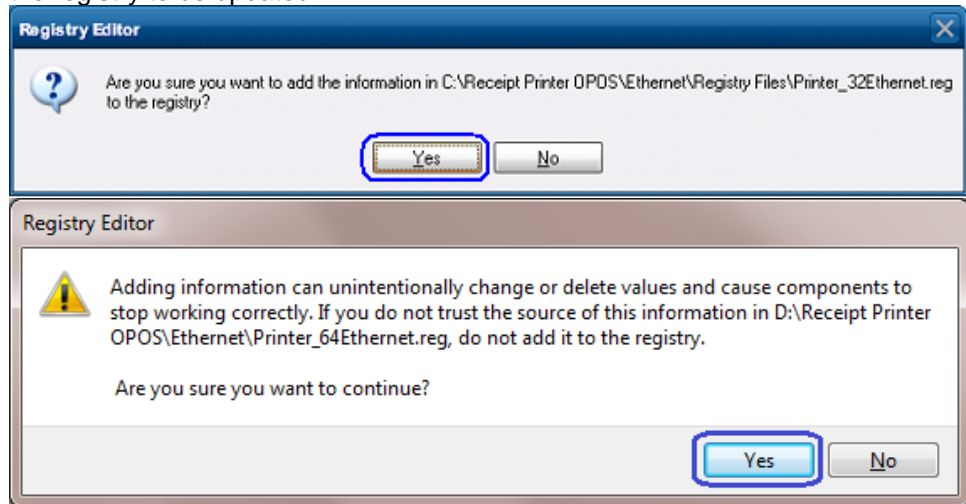

After clicking the YES button, one of the following confirmation screens will appear indicating that the update was successful. Click OK to complete the process.

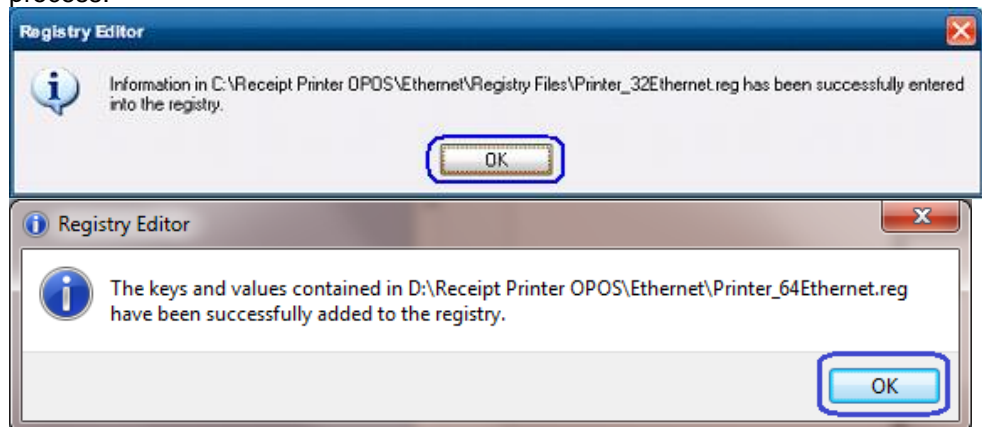

If you are not sure if you are on 32Bit or 64Bit operating system:

- Modify the "Printer_32Ethernet.REG" file with the Port / Address (IP Address) that is on the diagnostics printout that was obtained earlier.
- Modify the "Printer_64Ethernet.REG" file with the Port / Address (IP Address) that is on the diagnostics printout that was obtained earlier.
- Run the "Ethernet_Registry_Update.BAT" file with administrator rights.
- Confirm it is OK to update the registry by clicking on the YES button on the screen that ask for confirmation to update the registry.
- Click OK on the confirmation screen to complete the registry update process.

6.4.10.5 OPOS – Ethernet IP Address (GUI)

1. Plug the printer into the network and have power to the printer.
2. Run a diagnostic printout and obtain the printer IP address from the printout.

Steps to obtain a diagnostics printout.

- e) Be sure paper is in the printer (1).
- f) Open the receipt cover (2).
- g) Press and hold the paper feed button (3).
- h) Close the receipt cover (2).

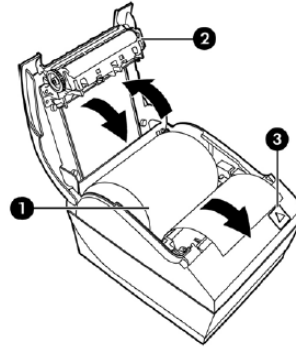

The following is partial A799II – Diagnostics Form printout showing the IP address and Port info:

```
Comm. Interfaces
Port Idle Timeout : disabled
Interface - USB
RX Buffer Size    : 4096
USB Driver Type  : Printer Class
USB Packet w/Error : Reject
Interface - RS232
RX Buffer Size    : 4096
Parameters
Baud Rate        : 115200
Data Bits        : 8
Stop Bit         : 1
Parity           : NONE
Flow Control     : DTR/DSR
Reception Errors : Ignore
Interface - Bluetooth
Status           : not available
Interface - Ethernet
Ethernet Type    : Wired
Parameters
MAC Address      : 00:E0:70:F0:21:7C
IP Address       : 10.1.3.18
Net Mask         : 255.255.252.0
Gateway          : 10.1.0.1
Raw TCPIP Port   : 9001
Loop Back Port   : Disabled
Http Server Port : 80
DHCP             : Enabled
Client ID        : 00E070F0217C
Idle Timeout     : Disabled
Keep Alive Pings : Disabled
```

Note: The default IP address is 192.0.0.192. If this address appears on the printout, the printer has not obtained an IP address.

3. Go to the "Ethernet" folder that is found in the OPOS package folder. Then go to the "GUI" folder within the package.

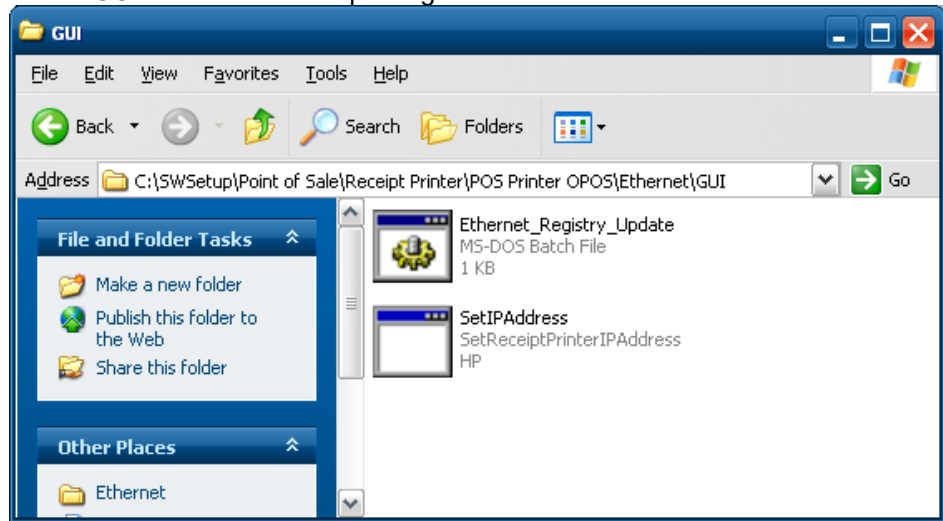

4. Open the Receipt Printer IP Address utility via the batch file (if one wants to open the GUI directly ensure it is done with administrative privileges). Enter the IP Address for the receipt printer in the GUI.

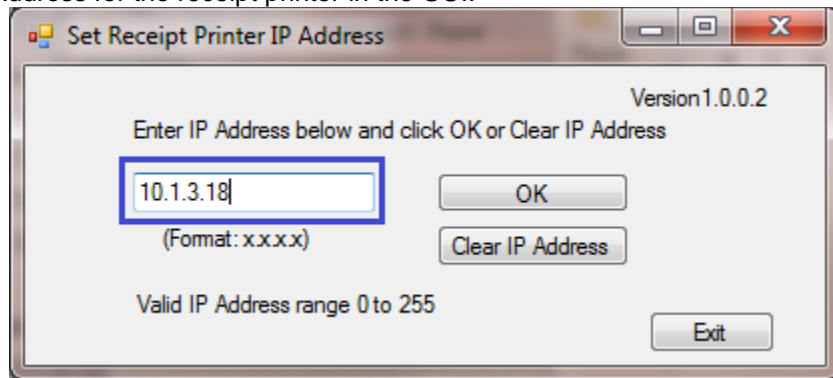

5. Press OK on the dialog box that appears that shows the IP address that was entered.

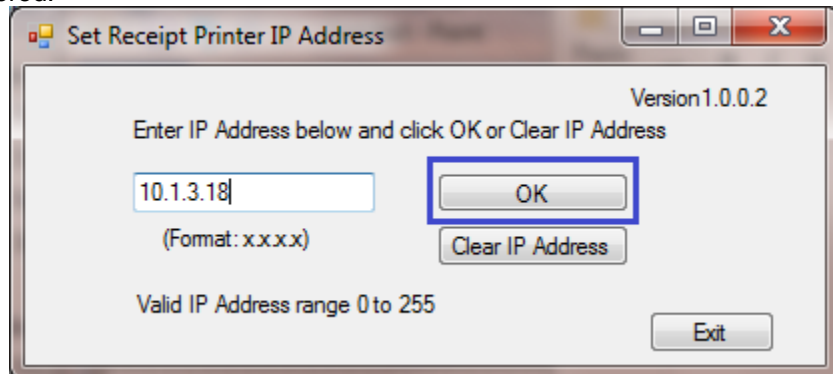

6. Close the Receipt Printer IP Address utility.

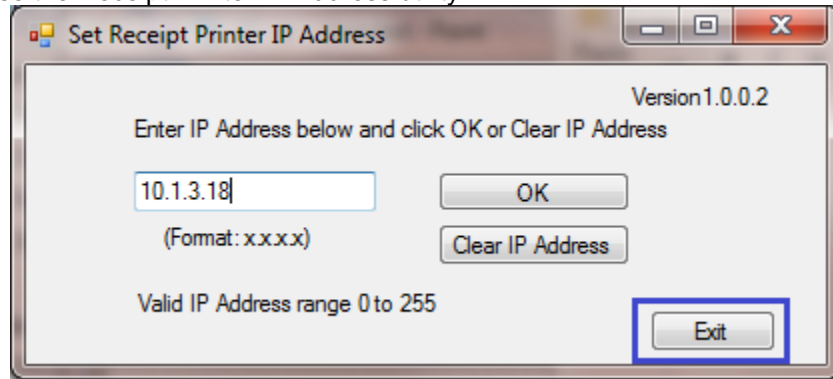

Button	Description
Blank Box	Where the IP Address for the receipt printer is entered.
OK	Will update the Windows registry with the information entered in the box.
	Note: If you are not sure of the address of the printer or what this is, contact your IT administrator.
Clear IP Address	Will clear the entry in the box.
Exit	Will close and exit the utility.

6.4.10.6 OPOS Test Applet for the Receipt Printer - Receipt Printer and Cash Drawer Utility

The following is overview of the steps to test the receipt printer followed by detailed steps:

1. Open **OPOS Test Application**.
 - C:\xxxxx\Point of Sale\Receipt Printer\OPOS Test Utility\OPOS_Test_Application.exe.
2. Click the **Printer** button
3. Select printer from the drop down menu.
4. Click "Open Printer"
5. Click "Claim Printer"
6. Click "Enable Printer"
7. What is type in the sample text to print box will be sent and printed on the receipt printer when one clicks "PRINT".
8. Click "Feed" to advance the paper in the receipt printer.
9. Click "Cut" to cut the receipt.
10. Exit the test application.

Detailed Steps

1. Open **OPOS Test Application**.
 - C:\xxxxx\Point of Sale\Receipt Printer\OPOS Test Utility\OPOS_Test_Application.exe.
2. Click the **Printer** button.

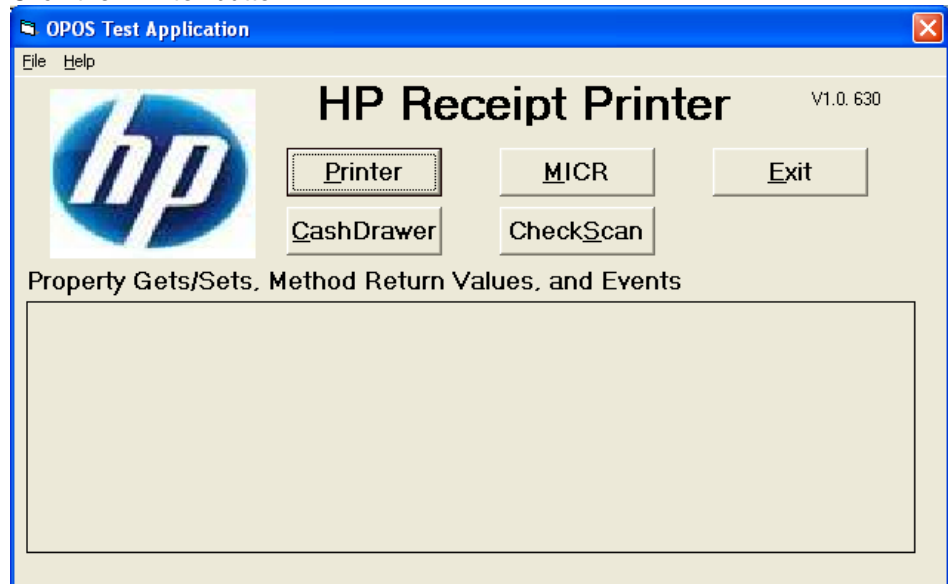

3. Select printer from the drop down menu.

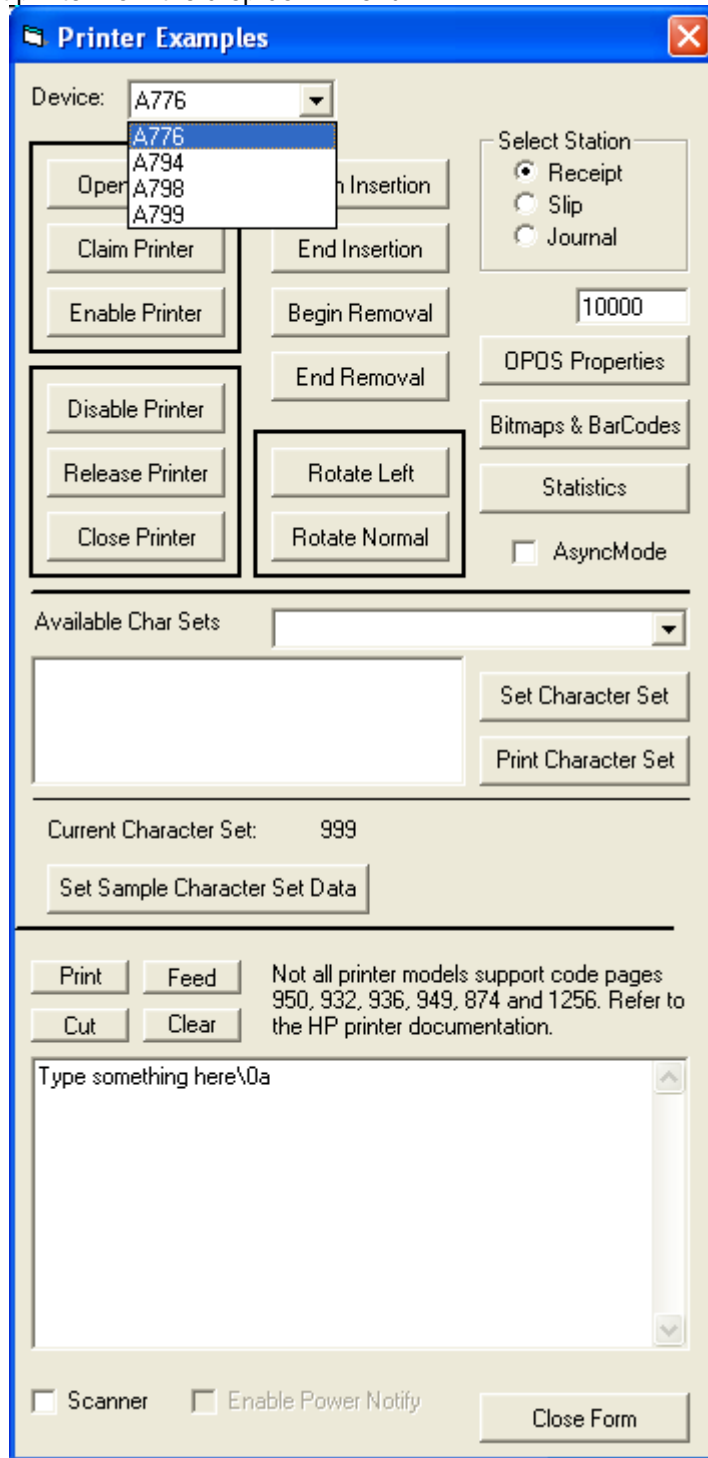

4. Click "Open Printer", in the main GUI one will receive status. If successful the status will say SUCCESS.

If failure occurs at this point make sure the printer is plugged in and the LED is on solid and the OPOS drivers are installed on the computer.

5. Click “Claim Printer”, in the main GUI one will receive status. If successful the status will say SUCCESS.

If failure occurs at this point confirm that the CCO 1.9 (or later) files are installed on this unit. If the CCO files need to be installed, they can be found in the HP factory image (C:\xxxx\Point of Sale\Common Control Object (CCO)) and are also available from HP.COM.

6. Click “Enable Printer”, in the main GUI one will receive status.

If successful the status will say SUCCESS as shown below for “Open Printer” / “Claim Printer” / Enable Printer”.

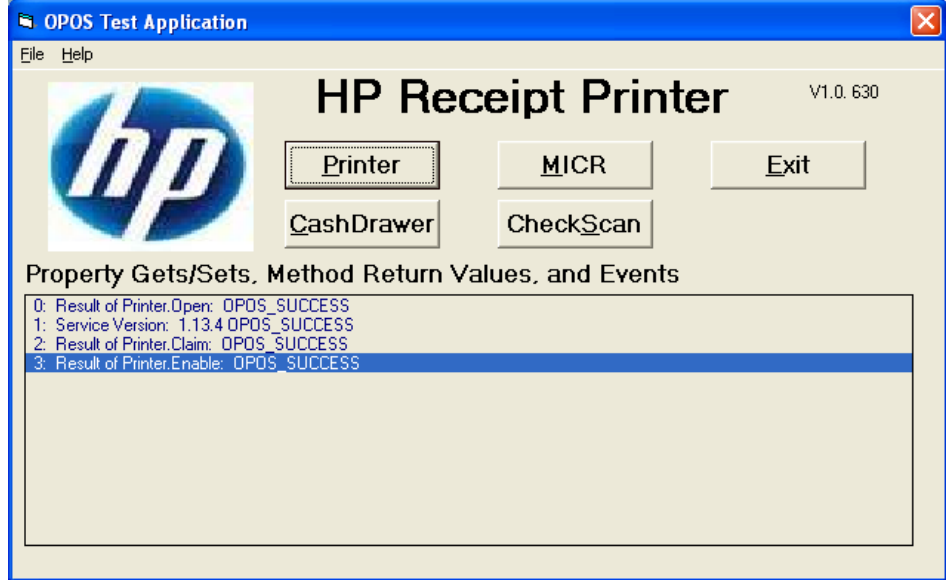

7. What is typed in the sample text to print box will be sent to the printer to be printed on the receipt printer when one clicks on "PRINT" button.

The image shows a software dialog box titled "Printer Examples". At the top, there is a "Device:" dropdown menu currently showing "A799". Below this, there are several groups of buttons: "Open Printer", "Claim Printer", "Enable Printer" (highlighted with a dashed border), "Disable Printer", "Release Printer", "Close Printer", "Begin Insertion", "End Insertion", "Begin Removal", "End Removal", "Rotate Left", and "Rotate Normal". To the right, there is a "Select Station" section with radio buttons for "Receipt" (selected), "Slip", and "Journal", and a numeric input field set to "10000". Below these are buttons for "OPOS Properties", "Bitmaps & BarCodes", "Statistics", and an "AsyncMode" checkbox. A section for "Available Char Sets" shows a dropdown set to "999-ANSI" and a list of character codes: "437, 850, 852, 857, 858, 860, 862, 863, 865, 866, 737, 1048, 1251, 1255, 998, 999, 101, 1252, 1256, 950, 936, 932, 949, 874". Buttons for "Set Character Set" and "Print Character Set" are next to the list. Below this, it shows "Current Character Set: 999-ANSI" and a "Set Sample Character Set Data" button. At the bottom, there are "Print", "Feed", "Cut", and "Clear" buttons. A note states: "Not all printer models support code pages 950, 932, 936, 949, 874 and 1256. Refer to the HP printer documentation." A text area with a blue border contains the text "Type something here\0a". At the very bottom, there are checkboxes for "Scanner" and "Enable Power Notify", and a "Close Form" button.

8. Click “Feed” to advance the paper 10 line feed that is in the receipt printer. In the GUI success status should appear after the “Feed” button is successful:

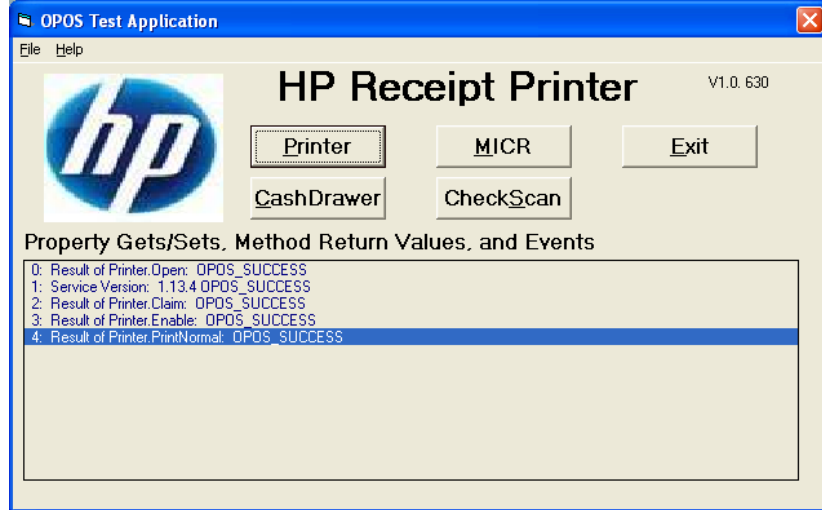

9. Click “Cut” to cut the receipt. In the GUI success status should appear after the “Cut” button is successful:

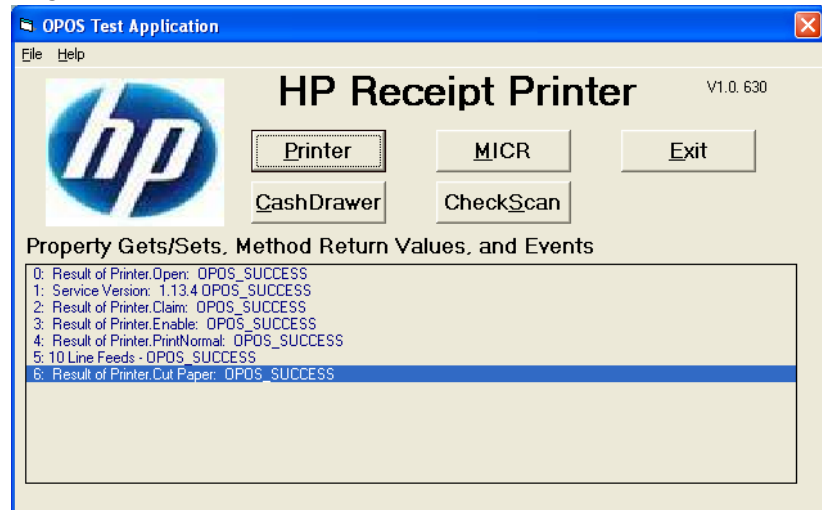

10. To exit the application clicking on “DISABLE PRINTER” / “Release Printer” / “Close Printer” and “Close Form”.

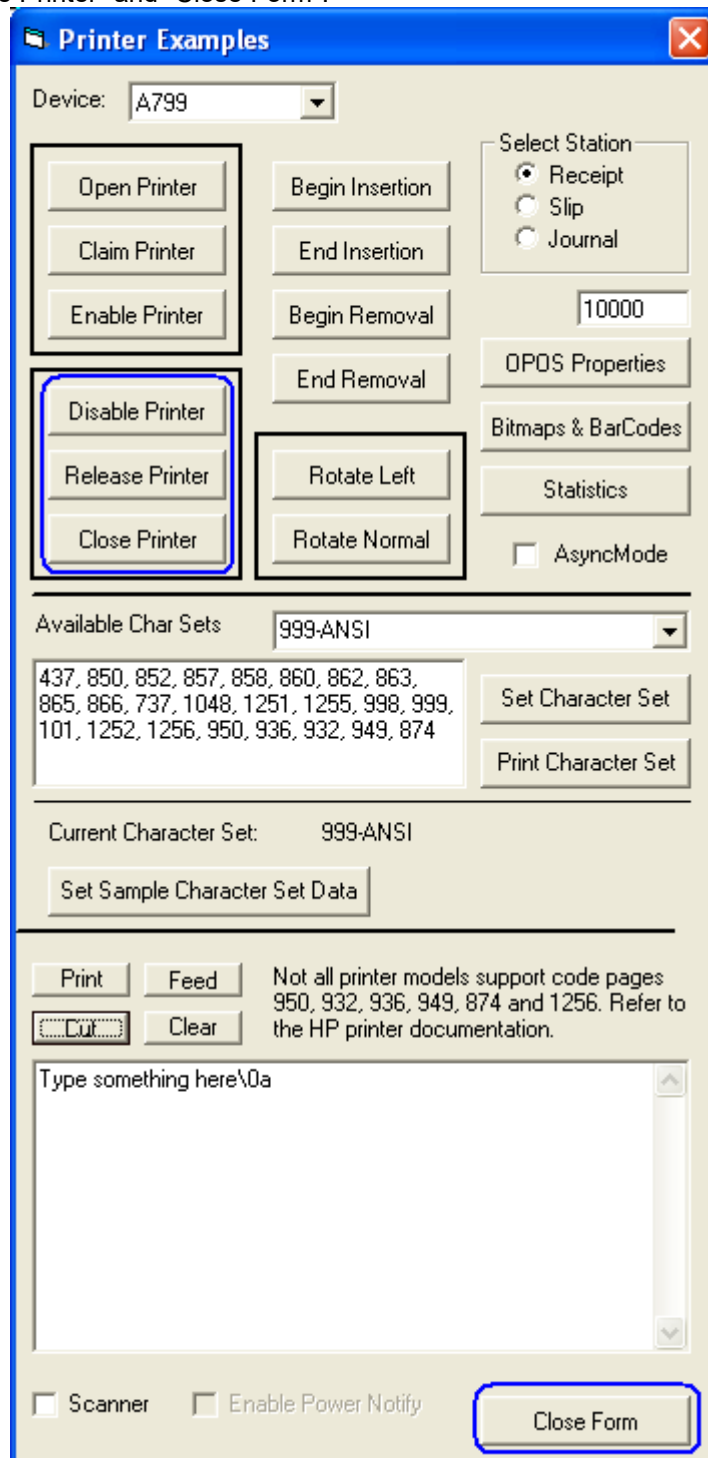

11. To close the main application GUI, click on EXIT.

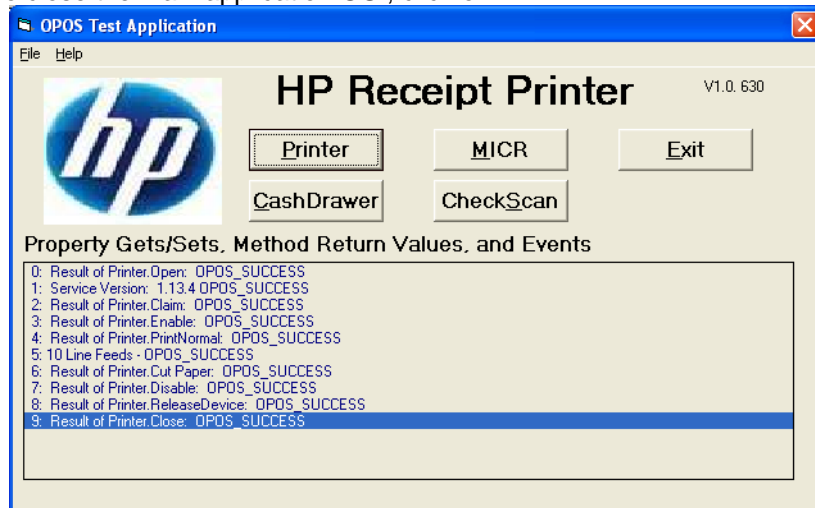

6.4.10.7 Rotate Left Testing

The following is overview of the steps to test the receipt printer followed by detailed steps:

1. Open **OPOS Test Application**.
 - C:\xxxxx\Point of Sale\Receipt Printer\OPOS Test Utility\OPOS_Test_Application.exe.
2. Click the **Printer** button.
3. Select your printer from the drop down menu.
4. Click “Open Printer”
5. Click “Claim Printer”
6. Click “Enable Printer”
7. Click on “Print” button to confirm that the printer is printing.
8. Click on “Rotate Left” button.
9. Click on “PRINT” button.
10. Click on “Rotate Normal” button.
11. Exit the test application.

Detailed Steps

1. Open **OPOS Test Application**.
 - C:\xxxxx\Point of Sale\Receipt Printer\OPOS Test Utility\OPOS_Test_Application.exe.
2. Click the **Printer** button.

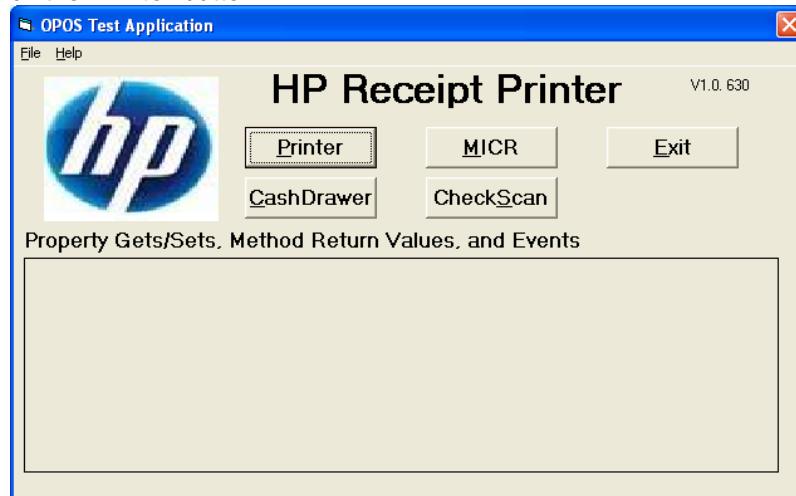

3. Select your printer from the drop down menu.

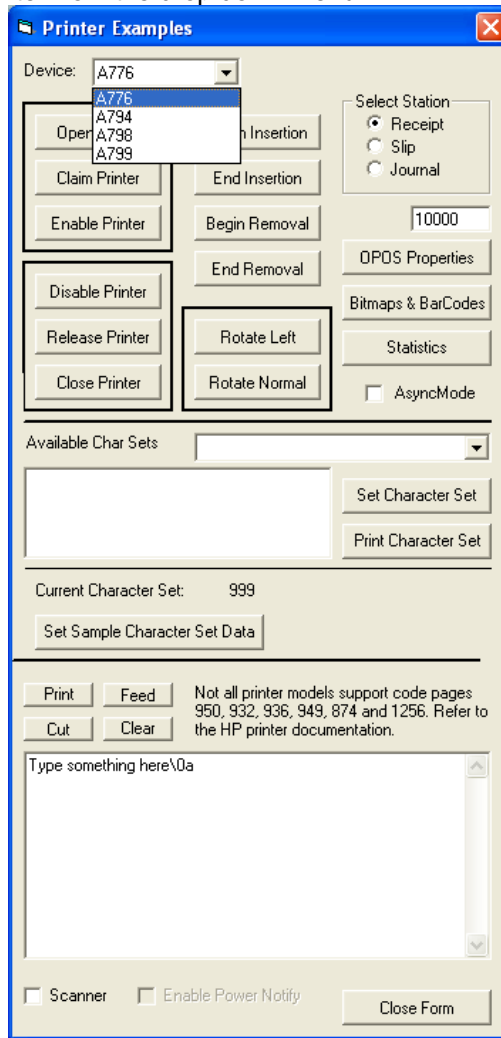

4. Click "Open Printer", in the main GUI one will receive status. If successful the status will say SUCCESS.

If failure occurs at this point make sure the printer is plugged in and the LED is on solid and the OPOS drivers are installed on the computer.

5. Click "Claim Printer", in the main GUI one will receive status. If successful the status will say SUCCESS.

If failure occurs at this point confirm that the CCO 1.9 (or later) files are installed.

6. Click "Enable Printer", in the main GUI one will receive status.

If successful, the status will say SUCCESS as shown below for "Open Printer" / "Claim Printer" / Enable Printer".

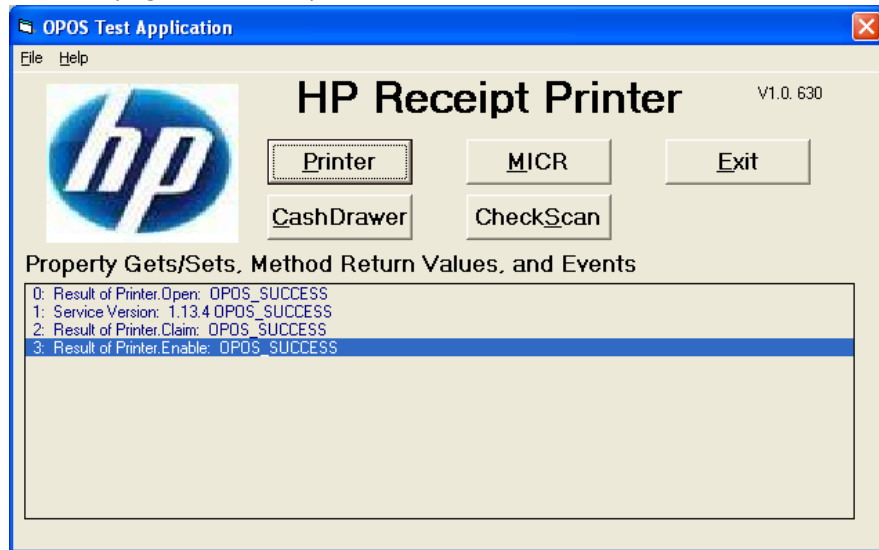

7. Click on "Print" button to confirm that the printer is printing.

Below is example of what is printed on the receipt:

Type something here

8. Click on "Rotate Left" button.

The image shows a software window titled "Printer Examples" with a blue title bar and a close button (X) in the top right corner. The window contains several sections of controls:

- Device:** A dropdown menu showing "A,799".
- Printer Control Buttons:** A group of buttons including "Open Printer", "Claim Printer", "Enable Printer", "Disable Printer", "Release Printer", and "Close Printer".
- Insertion/Removal Buttons:** "Begin Insertion", "End Insertion", "Begin Removal", and "End Removal".
- Rotation Buttons:** "Rotate Left" (highlighted with a blue dashed box) and "Rotate Normal".
- Select Station:** Radio buttons for "Receipt" (selected), "Slip", and "Journal".
- Count:** A text box containing "10000".
- Configuration Buttons:** "OPOS Properties", "Bitmaps & BarCodes", "Statistics", and "AsyncMode" (checkbox).
- Character Set Section:** "Available Char Sets" dropdown (999-ANSI), a list of character codes (437, 850, 852, 857, 858, 860, 862, 863, 865, 866, 737, 1048, 1251, 1255, 998, 999, 101, 1252, 1256, 950, 936, 932, 949, 874), "Set Character Set", and "Print Character Set" buttons.
- Current Character Set:** "Current Character Set: 999-ANSI" and "Set Sample Character Set Data" button.
- Printer Status/Action:** "Print", "Feed", "Cut", and "Clear" buttons. A note states: "Not all printer models support code pages 950, 932, 936, 949, 874 and 1256. Refer to the HP printer documentation."
- Text Area:** A text box containing "Type something here\0a".
- Bottom Section:** "Scanner" and "Enable Power Notify" checkboxes, and a "Close Form" button.

9. Click on "PRINT" button.

10. Click on "Rotate Normal" button.

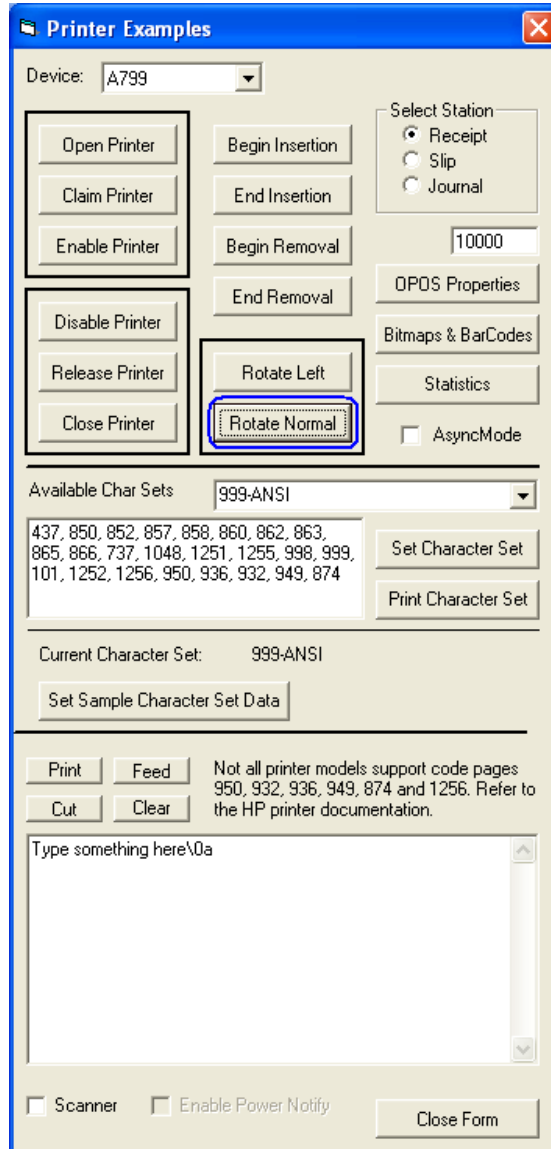

Below is example of what is printed on the receipt:

Type something here

Type something here

11. To exit the application clicking on “DISABLE PRINTER” / “Release Printer” / “Close Printer” and “Close Form”.

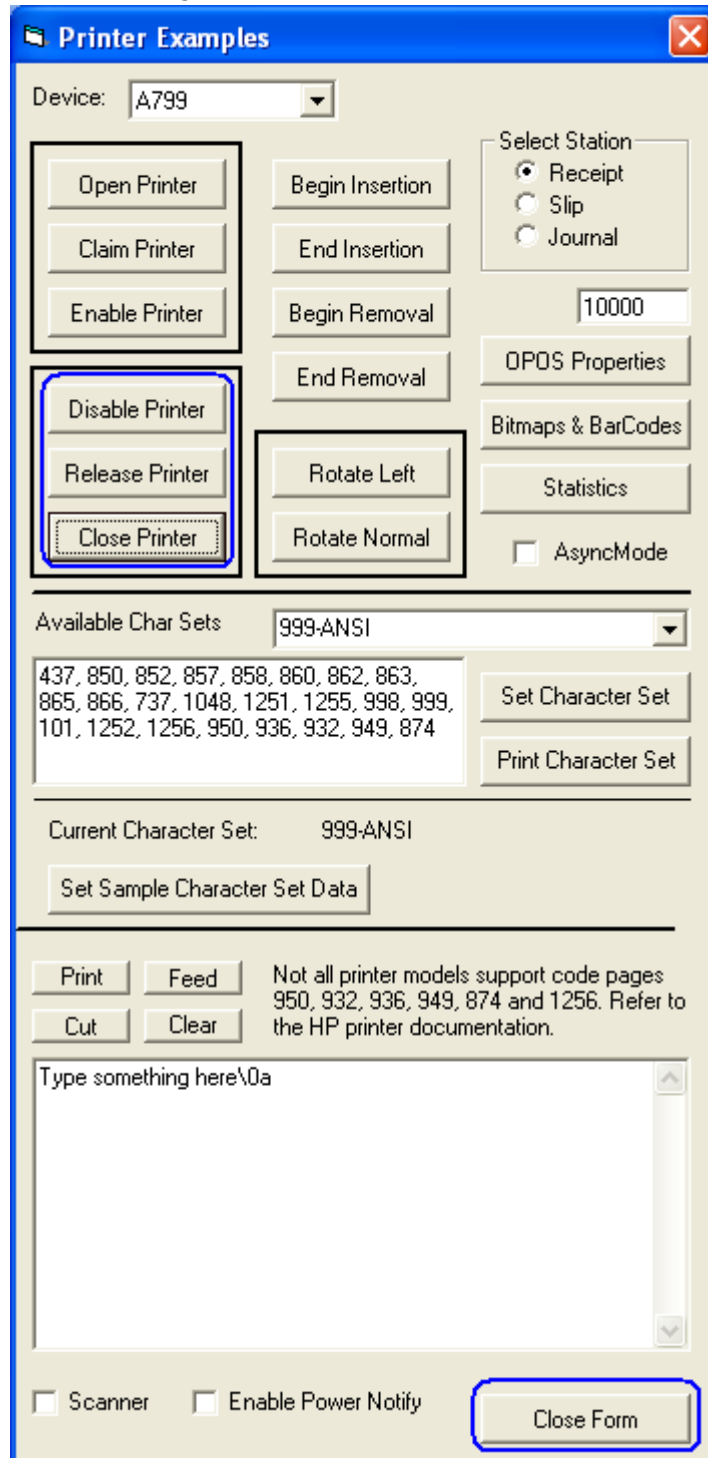

12. To close the main application GUI, click on EXIT.

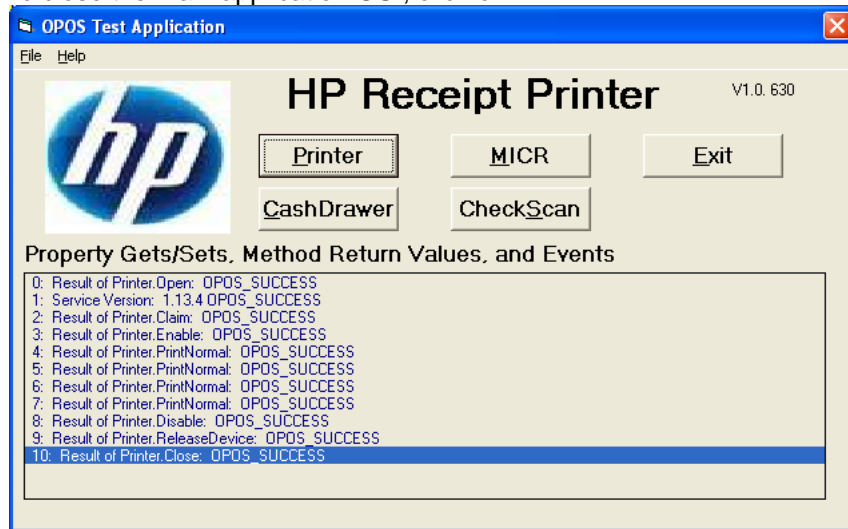

6.4.10.8 Bitmap / Barcode Testing

1. The following are the steps to test bitmap or barcode on the receipt printer:
 - a. If you have not enabled the printer, please complete steps in the previous section.
 - b. Click on "Bitmaps & Barcodes" button

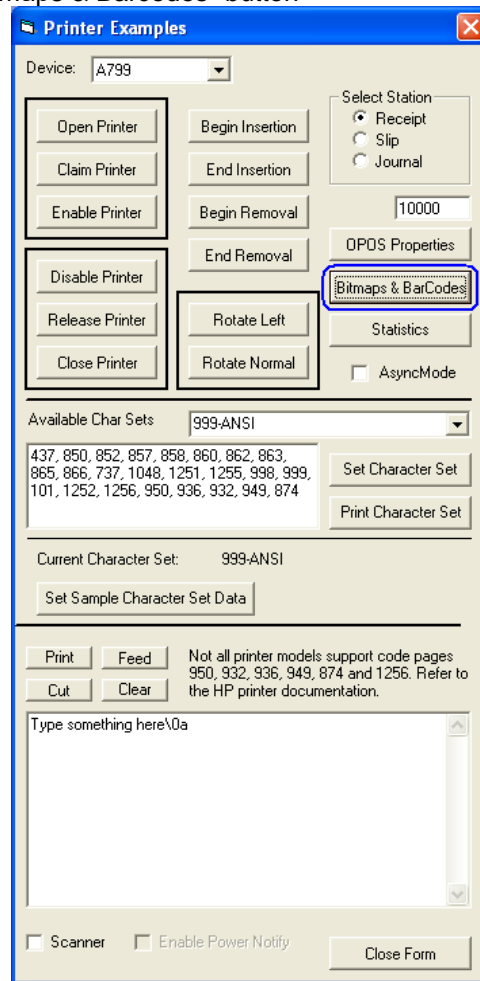

Bitmap

- i. There are three test bitmaps (GRID.BMP / HP.BMP / TEST.BMP) that can be used. These bitmaps are located in the “C:\xxxx\Point of Sale\Receipt Printer\OPOS Test Utility.
- ii. Select the bitmap alignment (left / center / right).
- iii. Select “I’ll set it” option. Set it to 500 in the Bitmap Width.

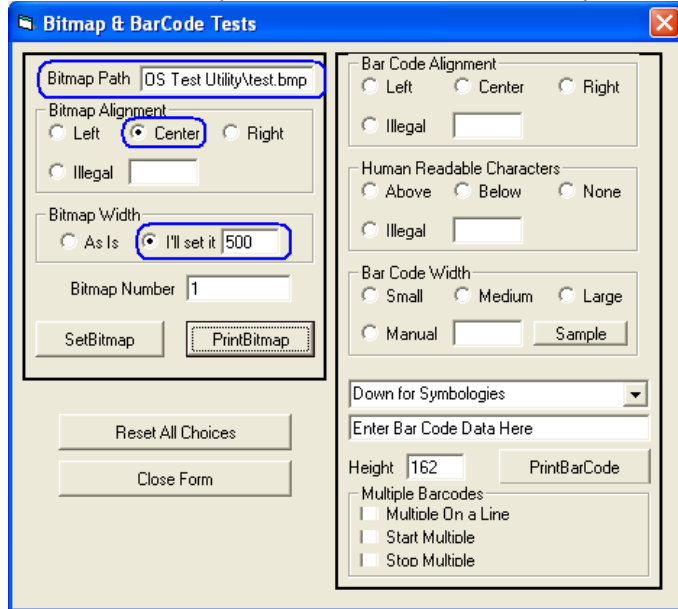

- iv. Click on “PrintBitmap” button. The printer should have printed the selected bitmap.

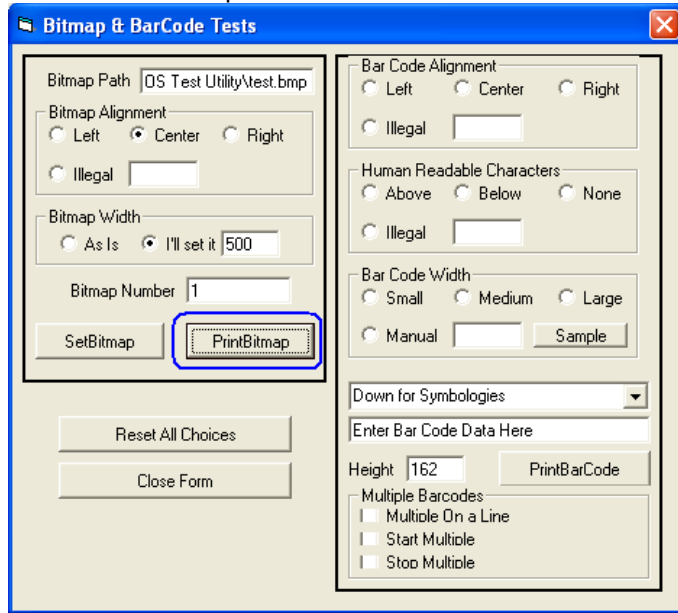

- v. Click on “CLOSE FORM” button.

- vi. Click on DISABLE PRINTER / RELEASE PRINTER / CLOSE PRINTER and CLOSE FORM button.

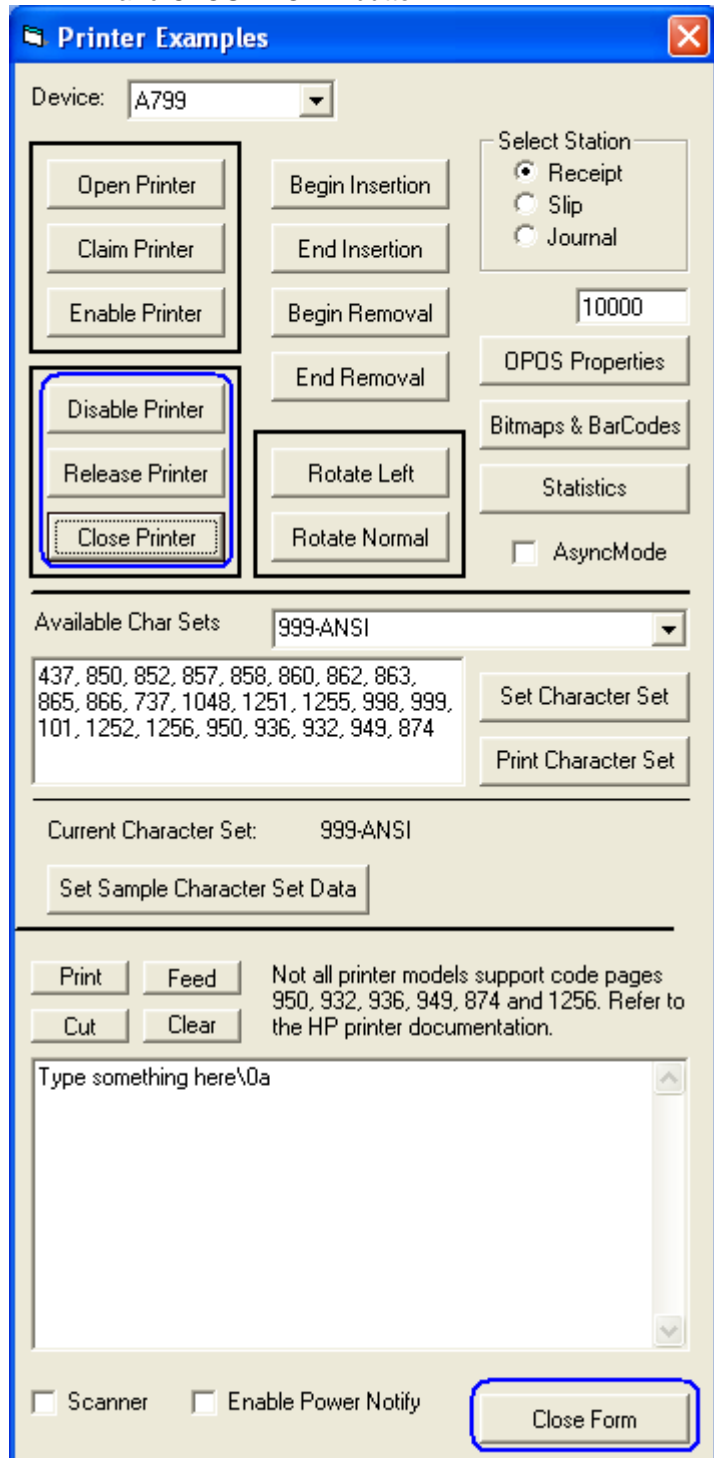

Barcode

- i. Select the bar code alignment (left / center / right).
- ii. Select "Human Readable Characters" (Above / Below / None).
- iii. Select Bar Code Width (Small / Medium / Large)
- iv. Select Interleaved 2 of 5 in the drop down box.
- v. Type in numerical value for the barcode.
- vi. Click on "PrintBarcode". The printer should have printed the barcode.

The screenshot shows the 'Bitmap & BarCode Tests' dialog box. The 'Bar Code Alignment' section has 'Center' selected. The 'Human Readable Characters' section has 'Below' selected. The 'Bar Code Width' section has 'Medium' selected. The 'Interleaved 2 of 5' dropdown is open, showing '1038316' entered in the text field below it. The 'PrintBarcode' button is visible.

- vii. Click on "Close Form" button.

The screenshot shows the 'Bitmap & BarCode Tests' dialog box. The 'Close Form' button is highlighted with a blue rectangle.

- viii. Click on "Disable Printer" button.
- ix. Click on "Release Printer" button.
- x. Click on "Close Printer" button.

- xi. Click on “Close Form” button.

6.4.10.9 Receipt Printer and Cash Drawer Utility – Cash Drawer Testing

The following is an overview of the steps to test the cash drawer followed by detailed steps:

1. Open **OPOS Test Application**.
 - C:\xxxxx\Point of Sale\Receipt Printer\OPOS Test Utility\OPOS_Test_Application.exe.
2. Click the **CashDrawer** button.
3. Select correct device name for the cash drawer to be tested.
4. Click the **Open** button.
5. Click the **Enable** button.
6. Click “OPEN Drawer” and the cash drawer should open. The GUI should also show status that the cash drawer is open.
7. Close the cash drawer and the GUI should give the status that the cash drawer is closed.
8. Exit the test application.

Detailed Steps

1. Open **OPOS Test Application**.
 - C:\xxxxx\Point of Sale\Receipt Printer\OPOS Test Utility\OPOS_Test_Application.exe.
2. Click the **CashDrawer** button.

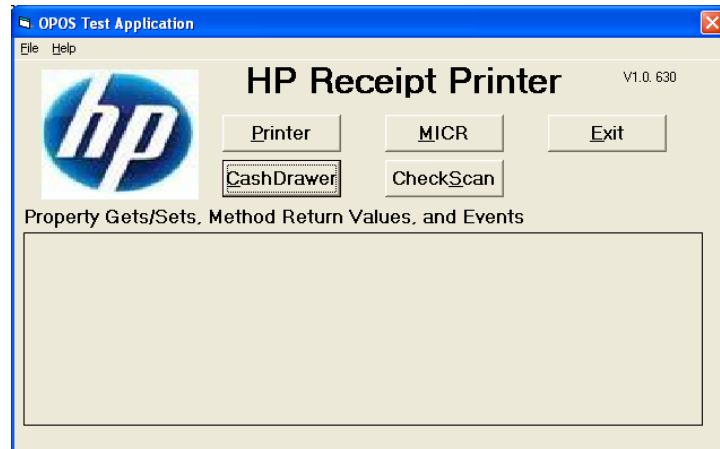

3. Select correct device name for the cash drawer to be tested.

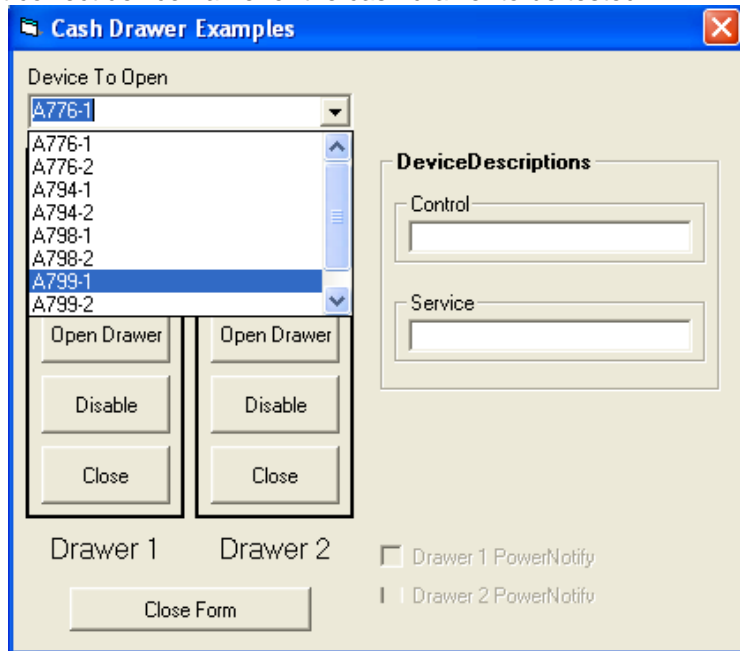

4. Click the **Open** button.
5. Click the **Enable** button.
6. Click "OPEN Drawer" and the cash drawer should open. The GUI should also show status that the cash drawer is open.

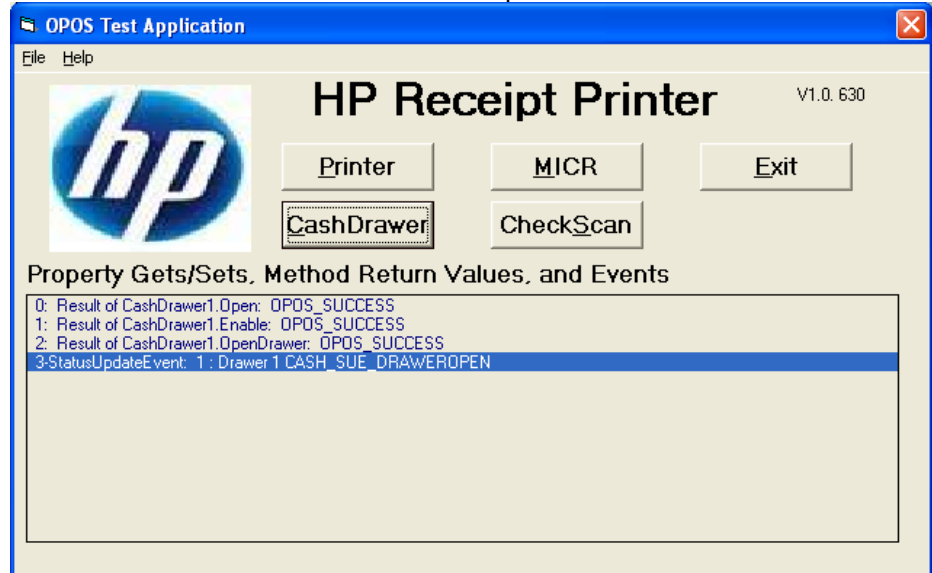

7. Close the cash drawer and the GUI should give the status that the cash drawer is closed.

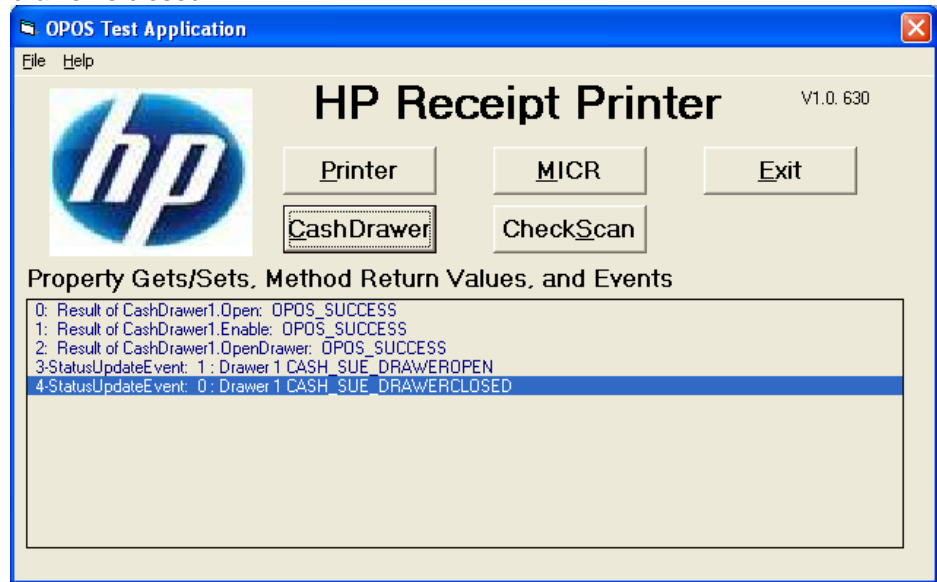

8. Exit the test utility the clicking on DISABLE/CLOSE/CLOSE FORM and then click on EXIT.

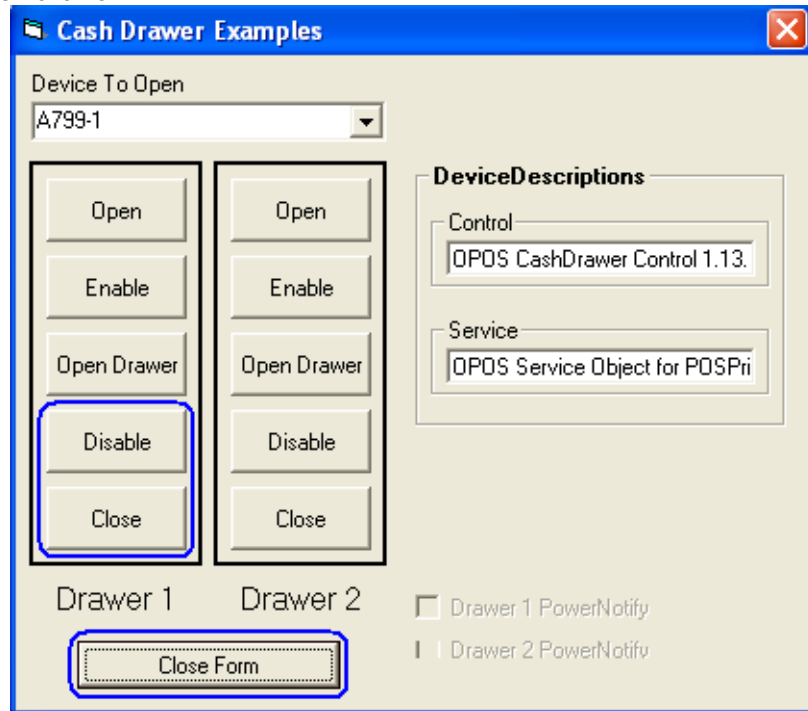

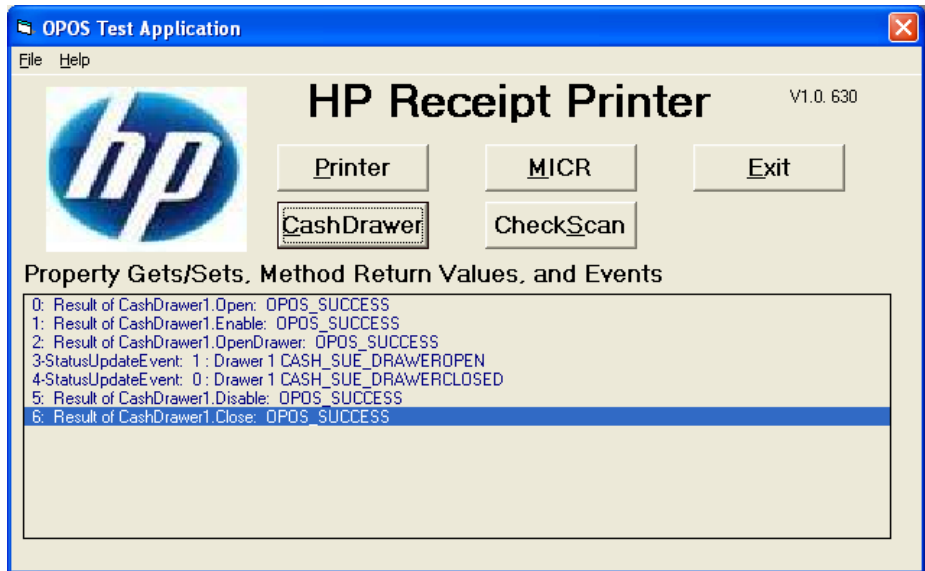

6.4.11 OPOS Test Applet for the MICR

The following is overview of the steps to test the receipt printer followed by detailed steps:

1. Open **OPOS Test Application**.
 - C:\xxxxx\Point of Sale\Receipt Printer\OPOS Test Utility\OPOS_Test_Application.exe.
2. Click the **MICR** button.
3. Click the **Open MICR** button.
4. Click the **Claim MICR** button.
5. Click the **Enable MICR** button.
6. Insert the check in the front of the printer until the front LED comes on.
7. Click the **Begin Insertion** button.
8. Click the **End Insertion** button. At this point the printer will perform the MICR operation; the document should come out the front and then will be returned back to the bottom portion of the printer.
9. Click the **Enable Data Event** button. The data from the check scan should appear in the bottom of the GUI.
10. Click the **Begin Removal** button and remove the check from the printer when it has been ejected.
11. Click the **End Removal** button.
12. Close the MICR.
13. Close the form.

Detailed Steps

1. Open **OPOS Test Application**.
 - C:\xxxxx\Point of Sale\Receipt Printer\OPOS Test Utility\OPOS_Test_Application.exe.
2. Click the **MICR** button. Another GUI will open as shown below:

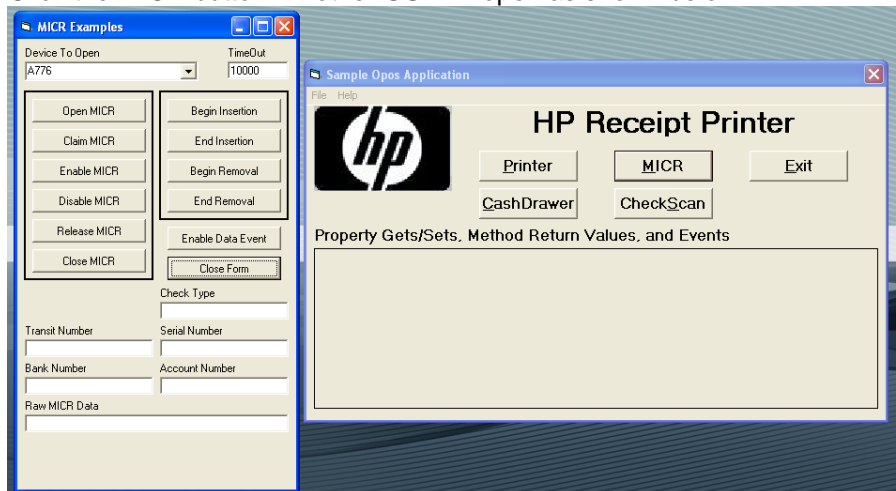

3. Click the **Open MICR** button. The main GUI should show SUCCESS.

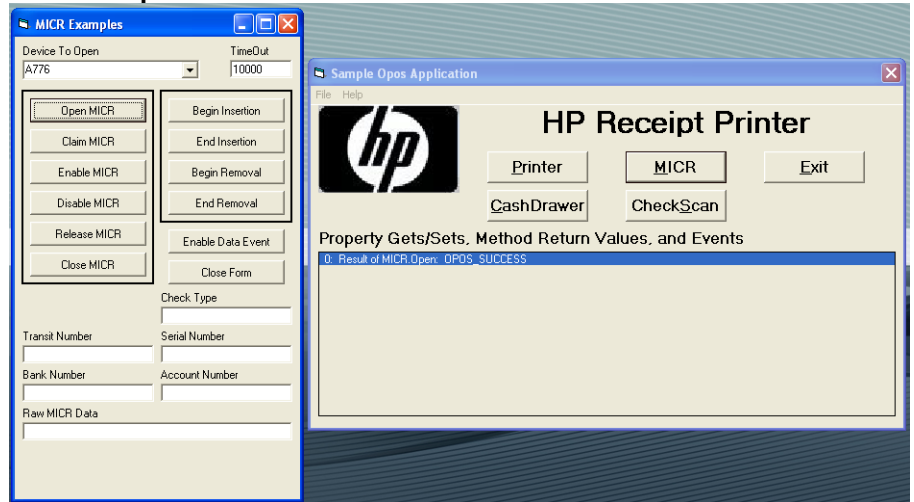

4. Click the **Claim MICR** button. The main GUI should show SUCCESS.

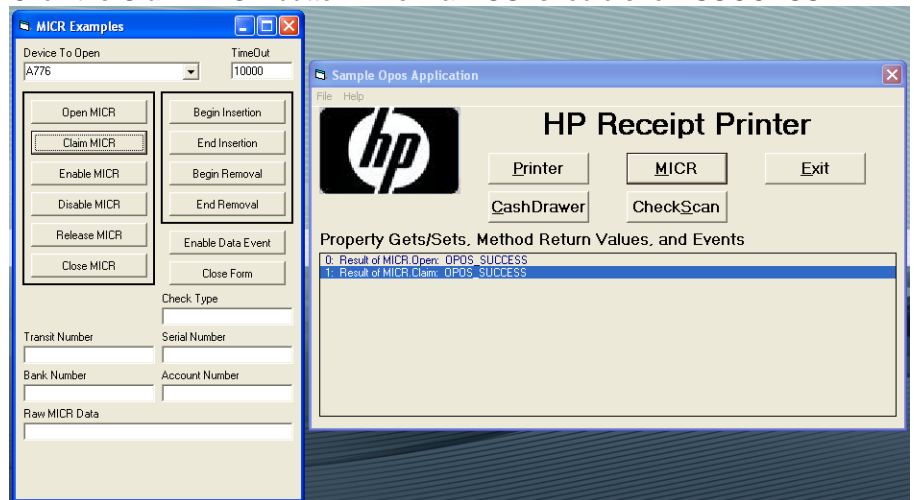

- Click the **Enable MICR** button. The main GUI should show SUCCESS.

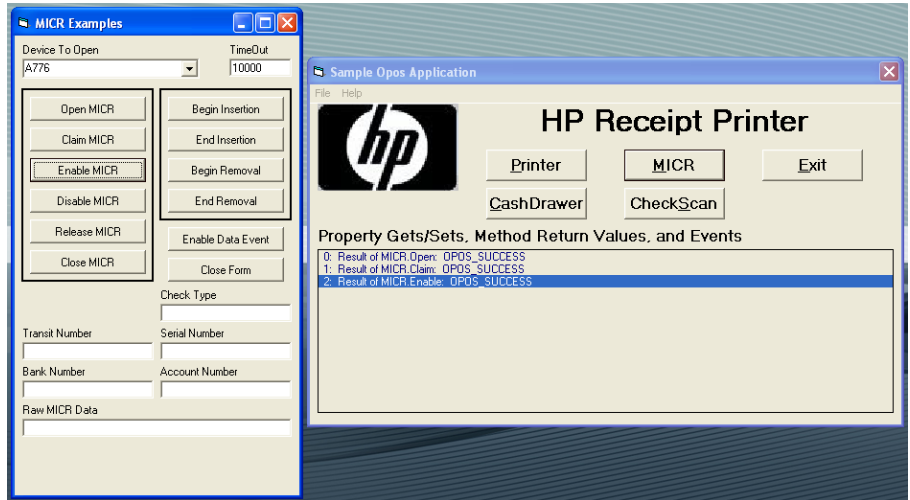

If one receives a message stating “NO Hardware” and the LED is blinking on the printer, please ensure that there is not a paper jam.

- Insert the check in the front of the printer until the front LED comes on.

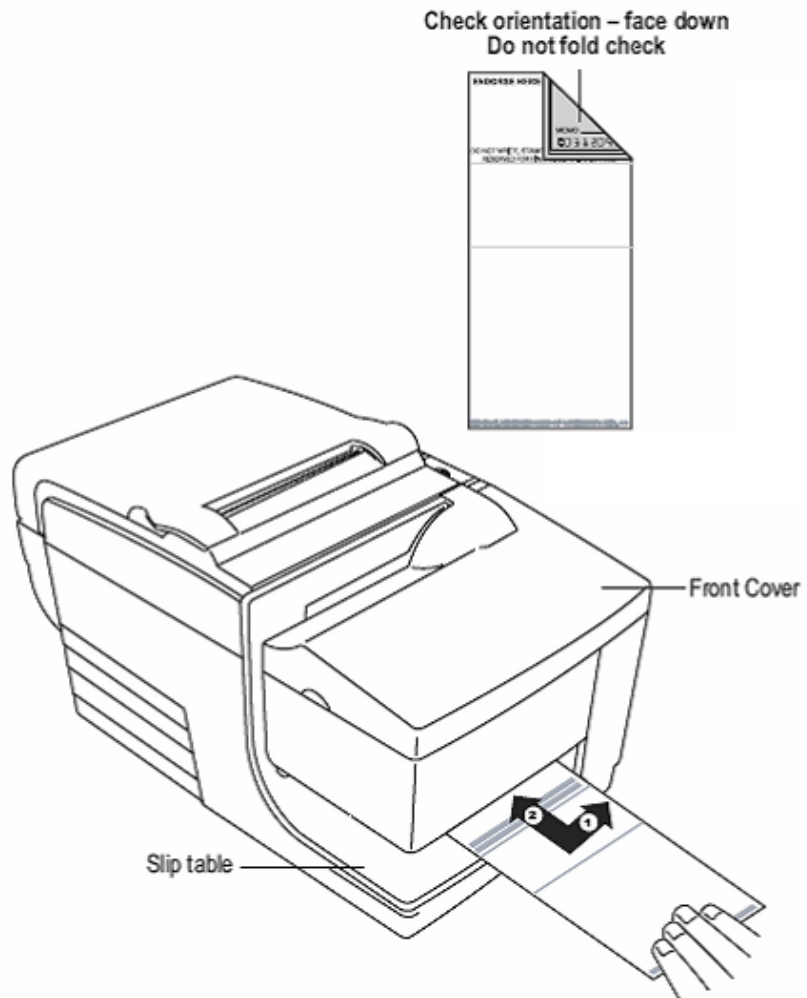

7. Click the **Begin Insertion** button.

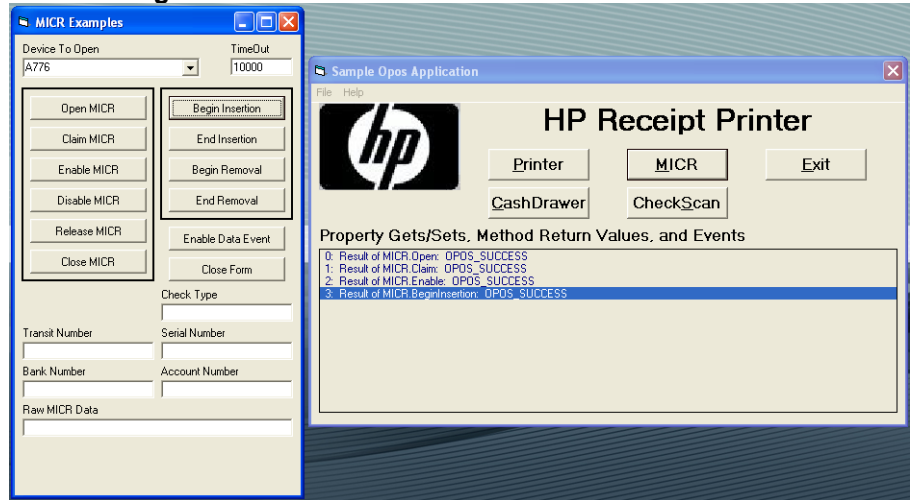

8. Click the **End Insertion** button. At this point the printer will perform the MICR operation; the document should come out the front and then will be returned back to the bottom portion of the printer.
9. Click the **Enable Data Event** button. The data from the MICR should appear in the bottom of the GUI.

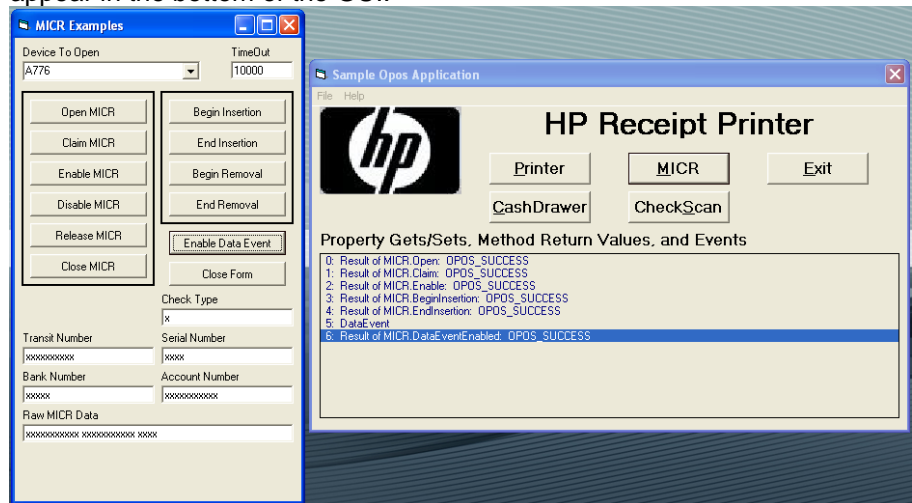

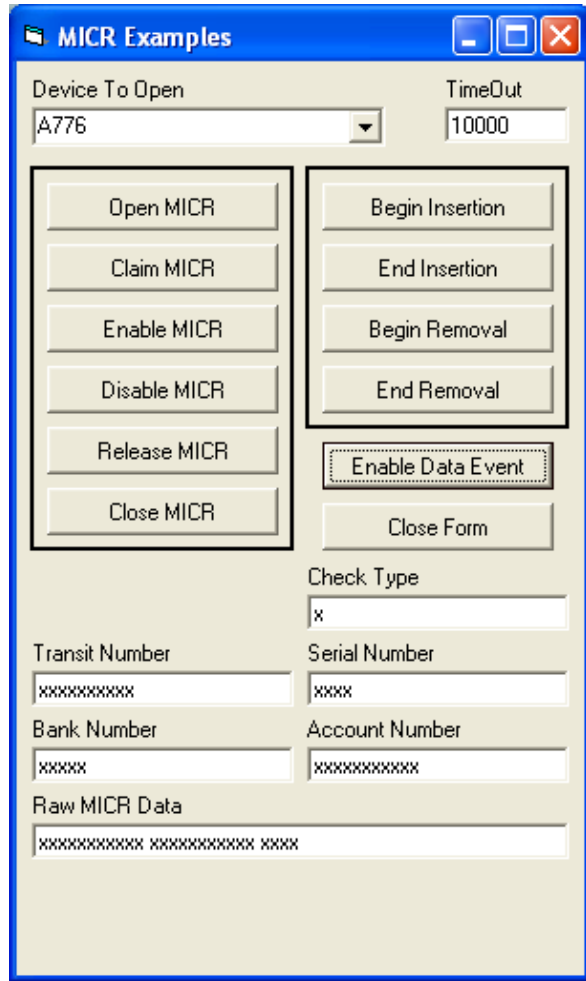

Note in the above example the actual number have been replaced the "x".

10. Click the **Begin Removal** button and remove the check from the printer when it has been ejected.
11. Click the **End Removal** button.

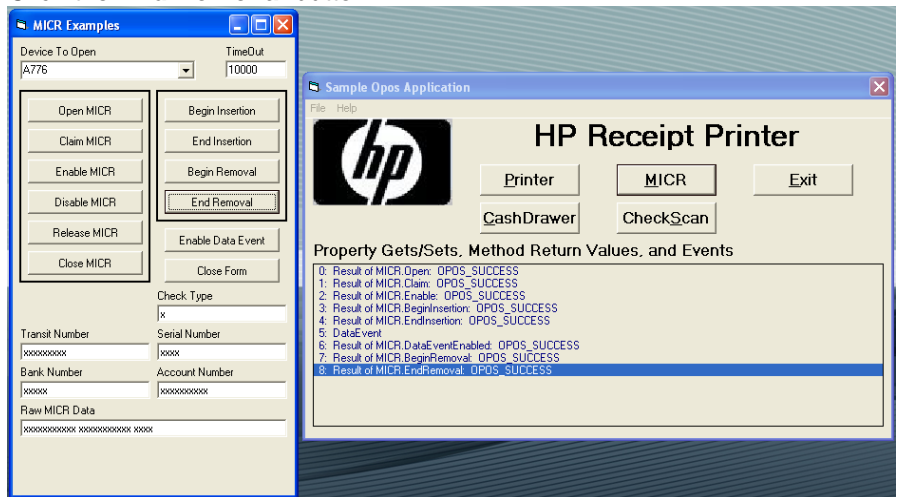

12. To exit the application, click the **Disable MICR** button, the **Release MICR** button, and the **Close MICR** button.

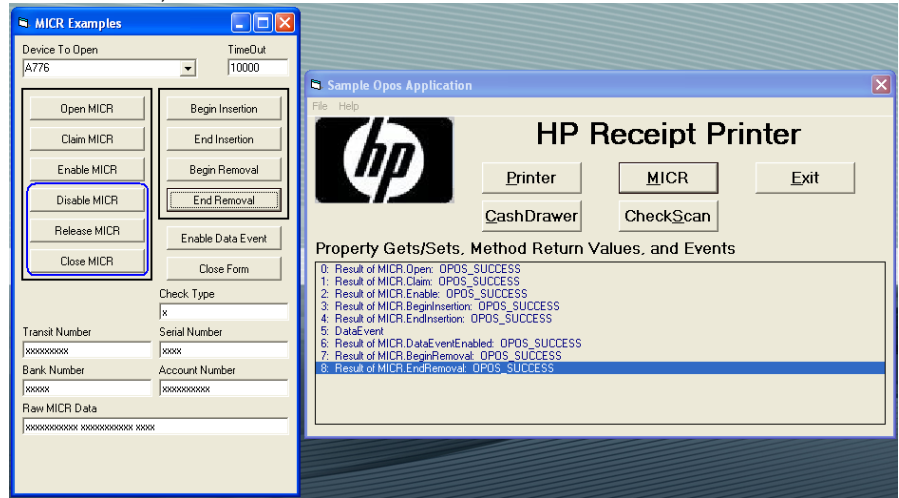

13. Click the **Close Form** button.

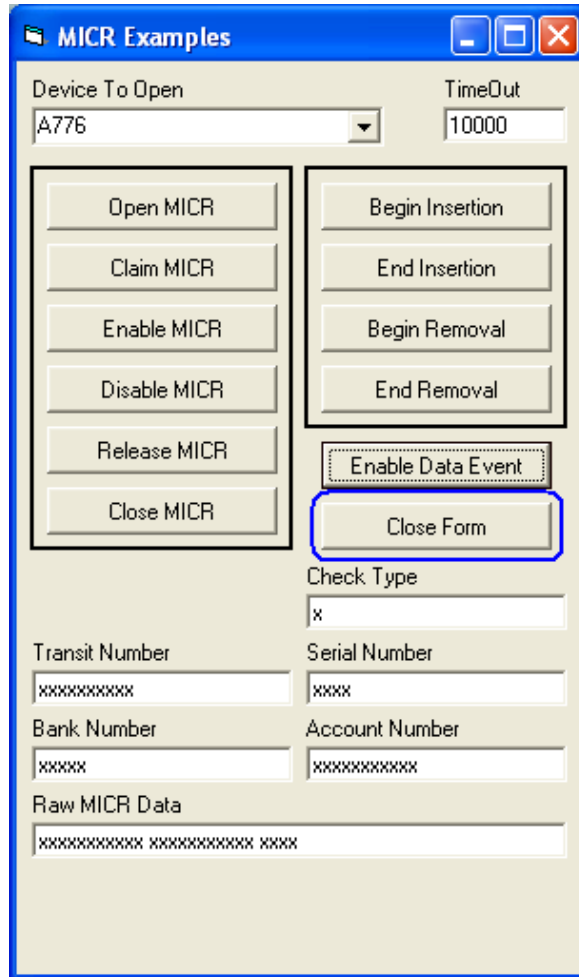

6.4.12 OPOS Test Applet for the CheckScan

Note: The check scanner feature is only available on the HP Hybrid printer that has imaging capabilities. The following is an image of the the HP Hybrid printer model with imaging capabilities:



The following is overview of the steps to test the receipt printer followed by detailed steps:

1. Open **OPOS Test Application**.
 - C:\xxxxx\Point of Sale\Receipt Printer\OPOS Test Utility\OPOS_Test_Application.exe.
2. Click the **CheckScan** button.
3. Click the **Open** button.
4. Click the **Claim** button.
5. Click the **Enable** button.
6. Click the **BeginInsertion** button. You should hear a click noise from the printer.
7. Insert the check face up in the front of the printer until the front LED comes on.
8. Click the **EndInsertion** button. The printer will perform the “CheckScan” operation; the document should come out the front and then will be returned back to the bottom portion of the printer.
9. Click the **Enable Data Event** button.
10. Click the **RetrievalImage** button.
11. Click on “SAVE AS” under “FILE” to save the image that was captured. Save the file with “TIF” extension.
12. Click the **BeginRemoval** button.
13. Click the **EndRemoval** button.
14. Close the “CheckScan”.
15. Close the form.

Detailed Steps

1. Open **OPOS Test Application**.
 - C:\xxxxx\Point of Sale\Receipt Printer\OPOS Test Utility\OPOS_Test_Application.exe.
2. Click the **CheckScan** button.

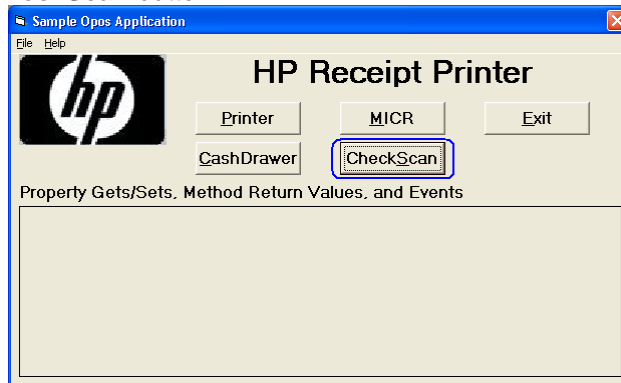

3. Click the **Open** button.

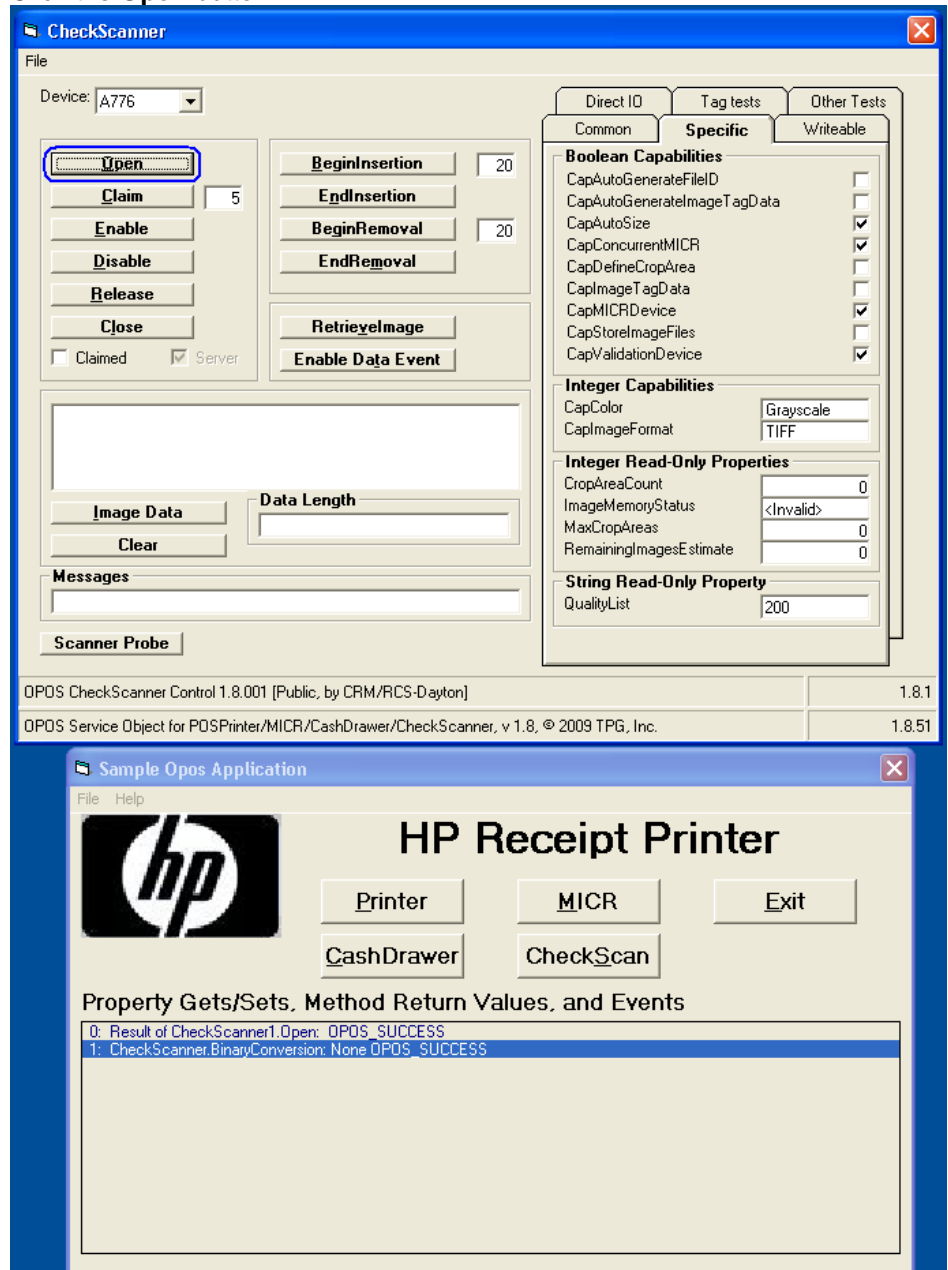

4. Click the **Claim** button.

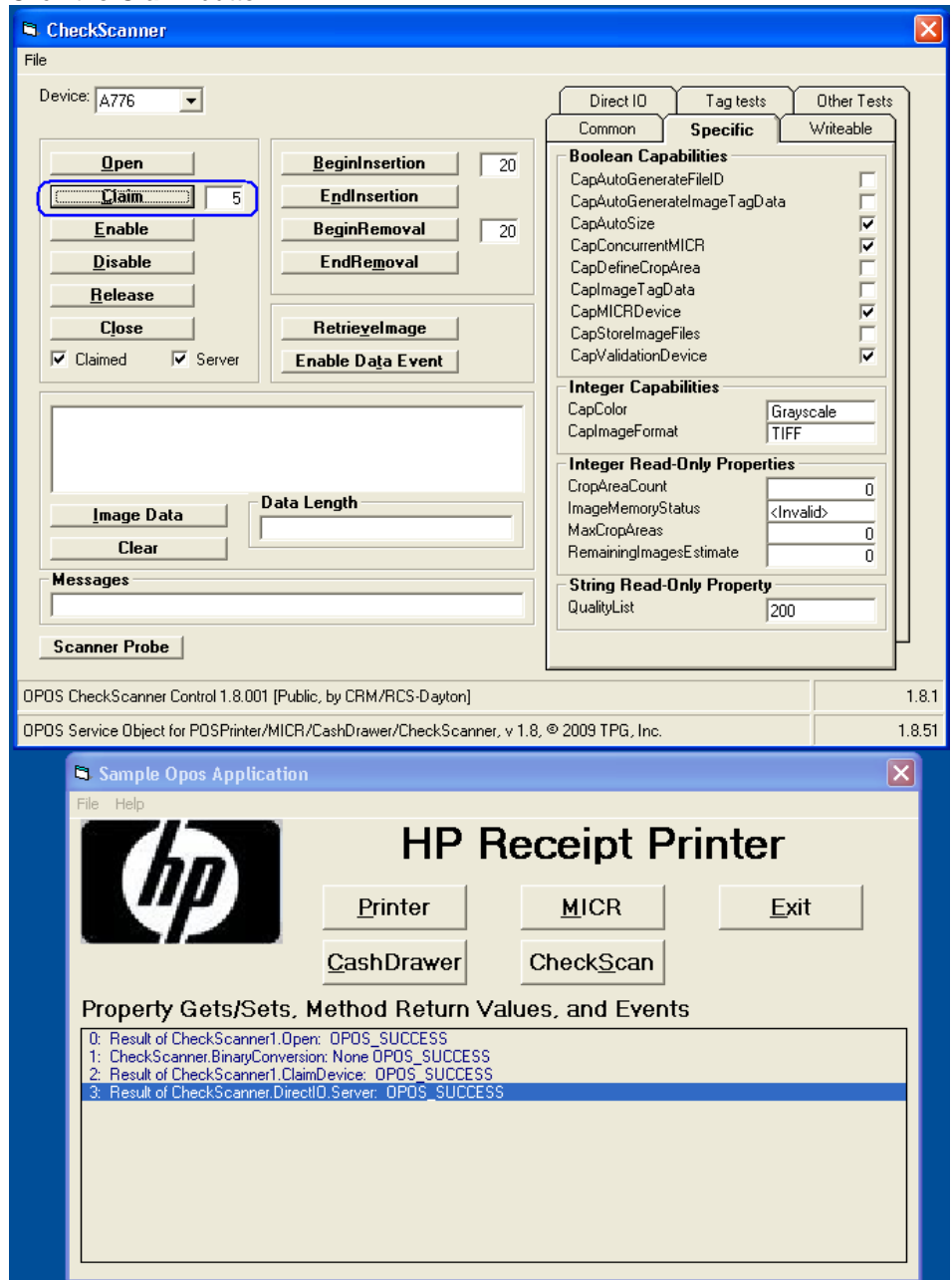

5. Click the **Enable** button.

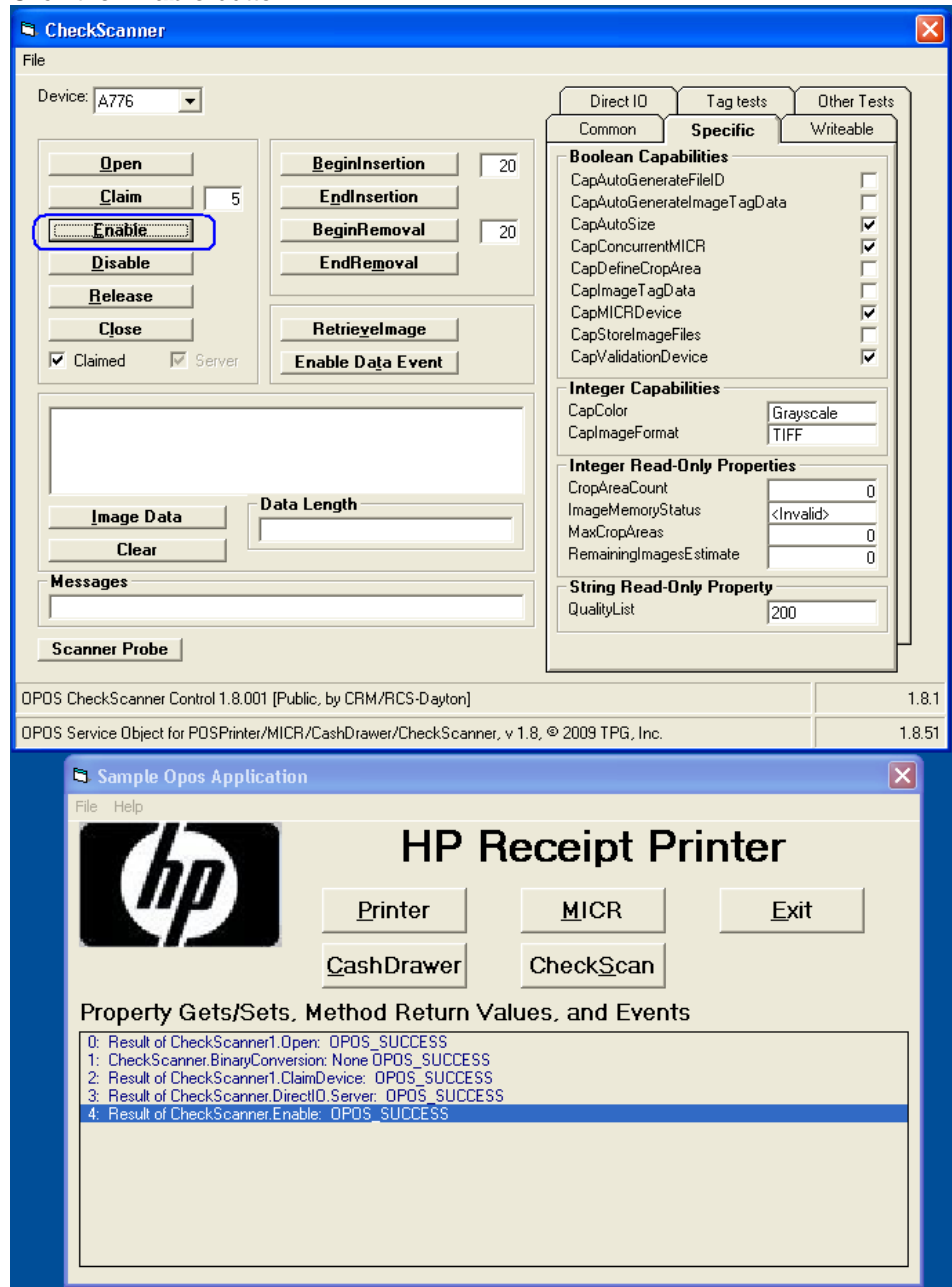

- Click the **BeginInsertion** button. You should hear a click noise from the printer.

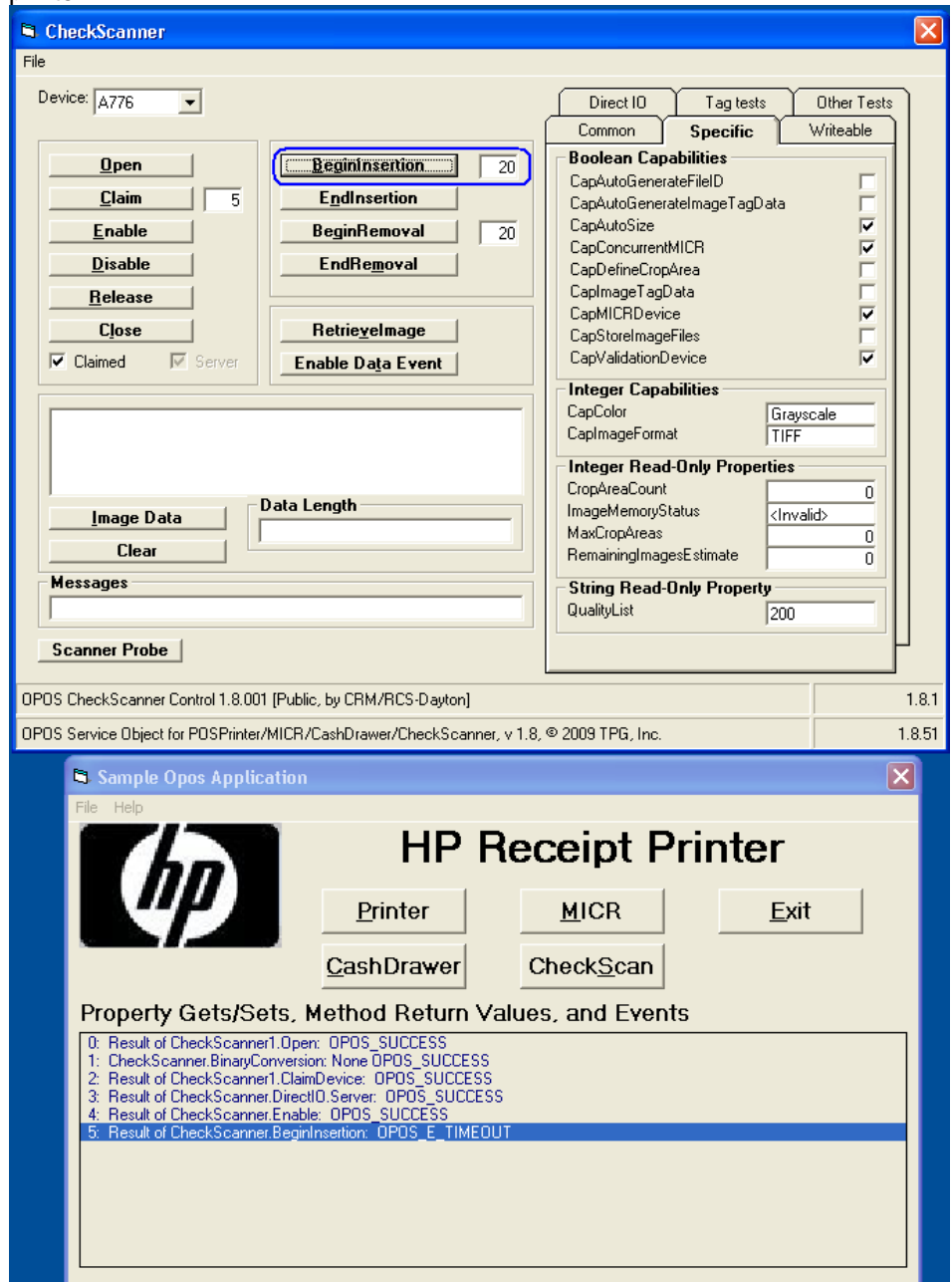

7. Insert the check face up in the front of the printer until the front LED comes on.
8. Click the **EndInsertion** button. At this point the printer will perform the "CheckScan" operation; the document should come out the front and then will be returned back to the bottom portion of the printer.

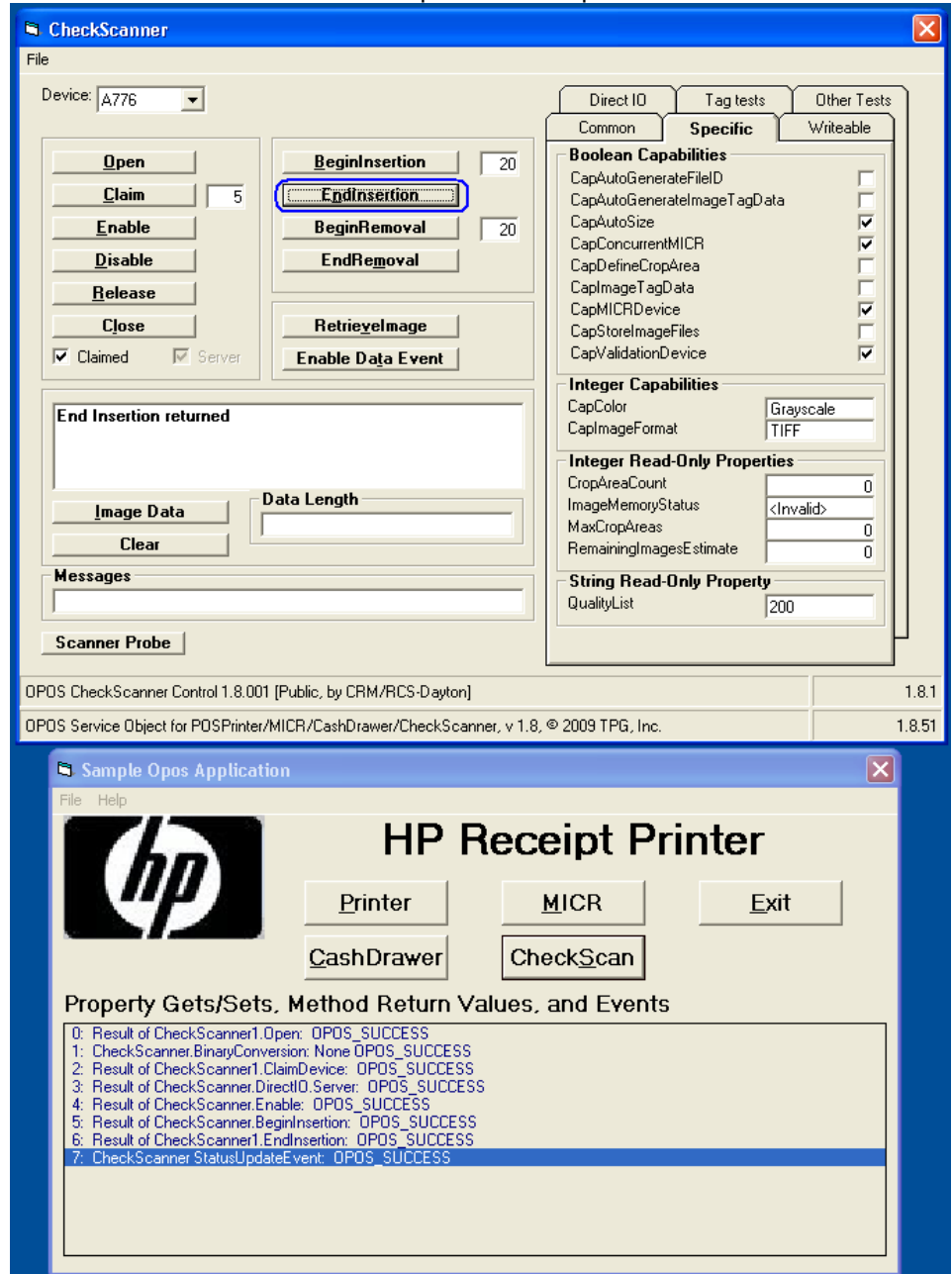

- Click the **Enable Data Event** button.

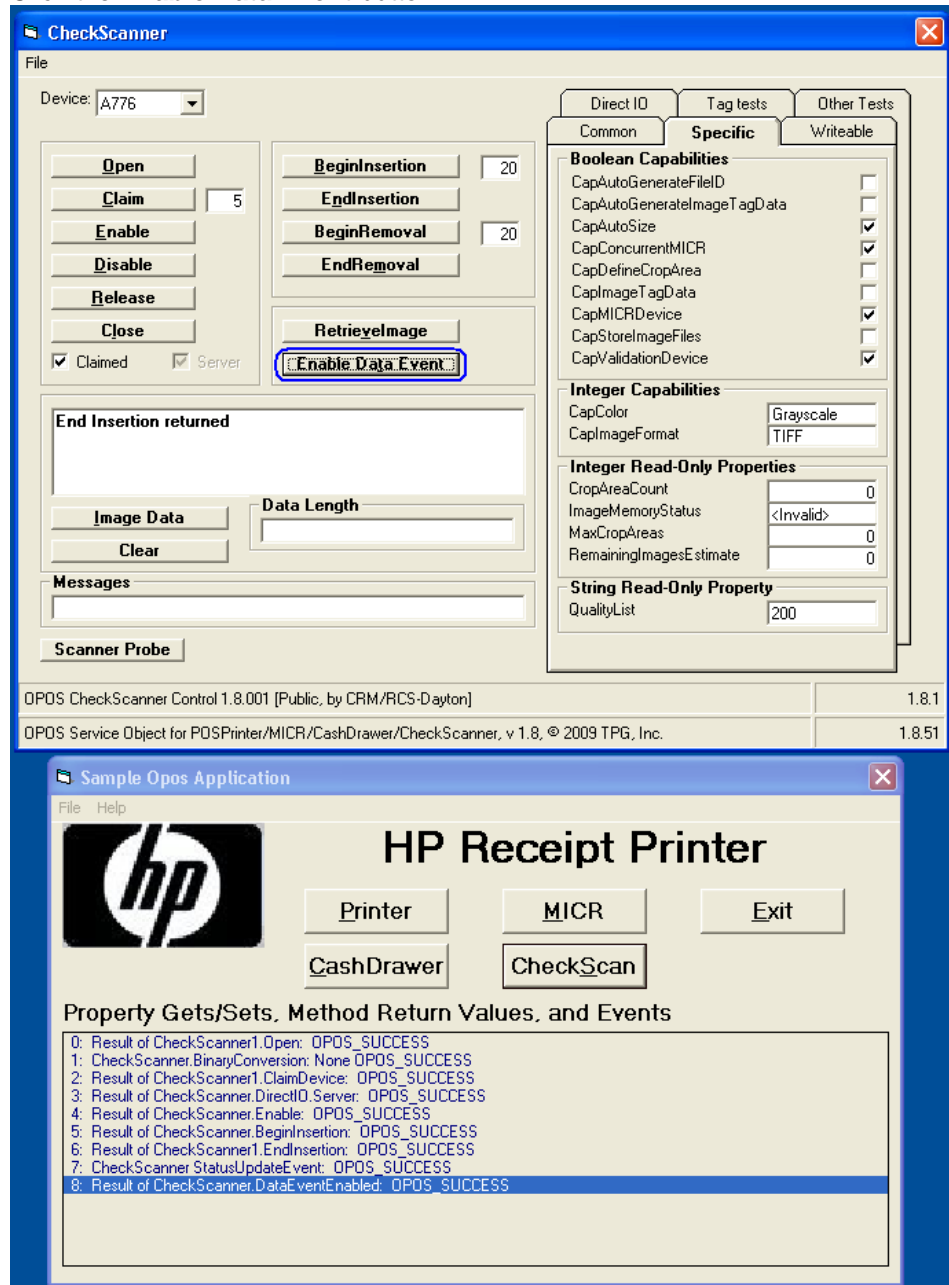

10. Click the **RetrievalImage** button.

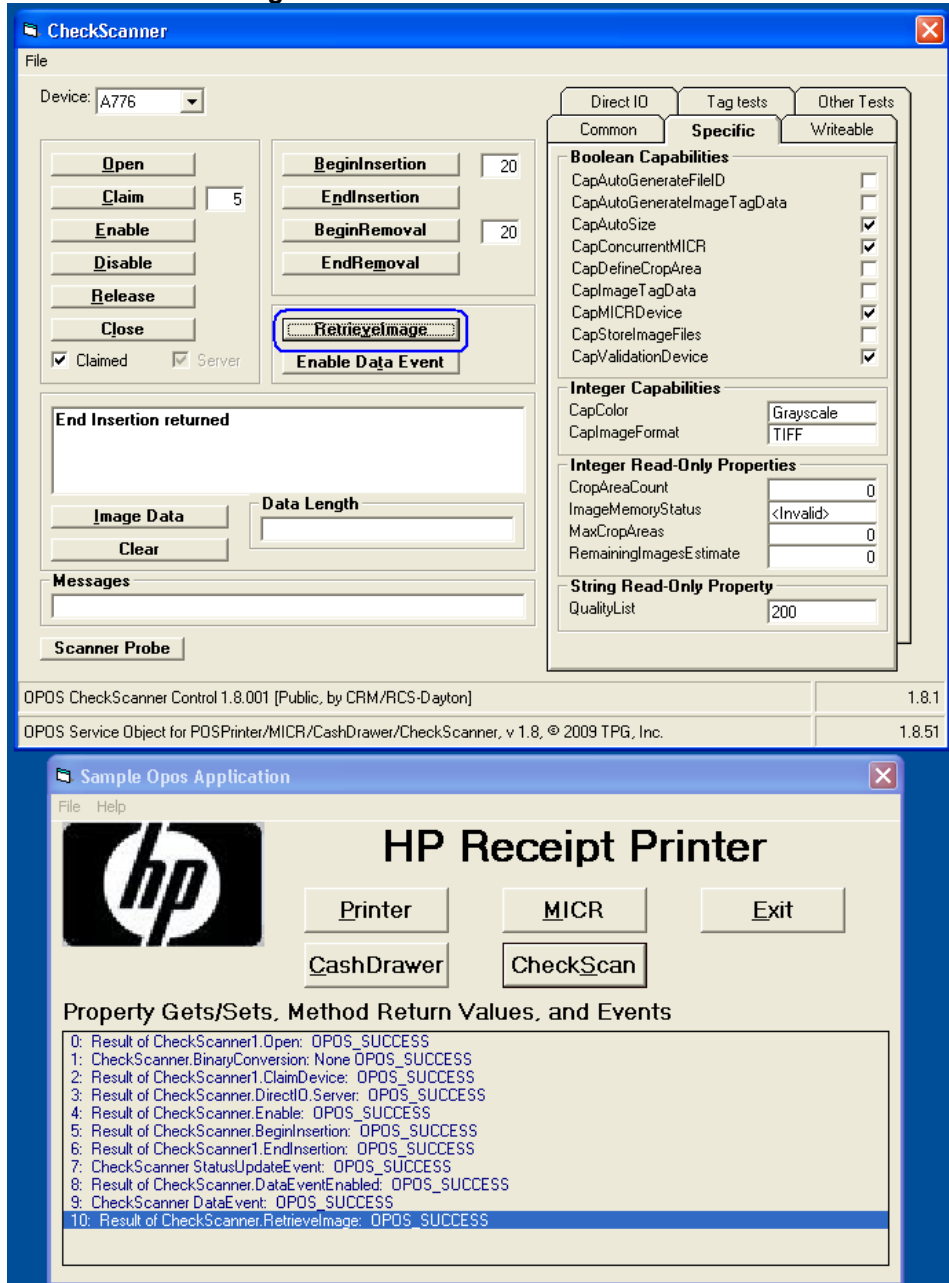

- Click on "SAVE AS" under "FILE" to save the image that was captured. Save the file with "TIF" extension. After the file is save in the message box will state "File Written".

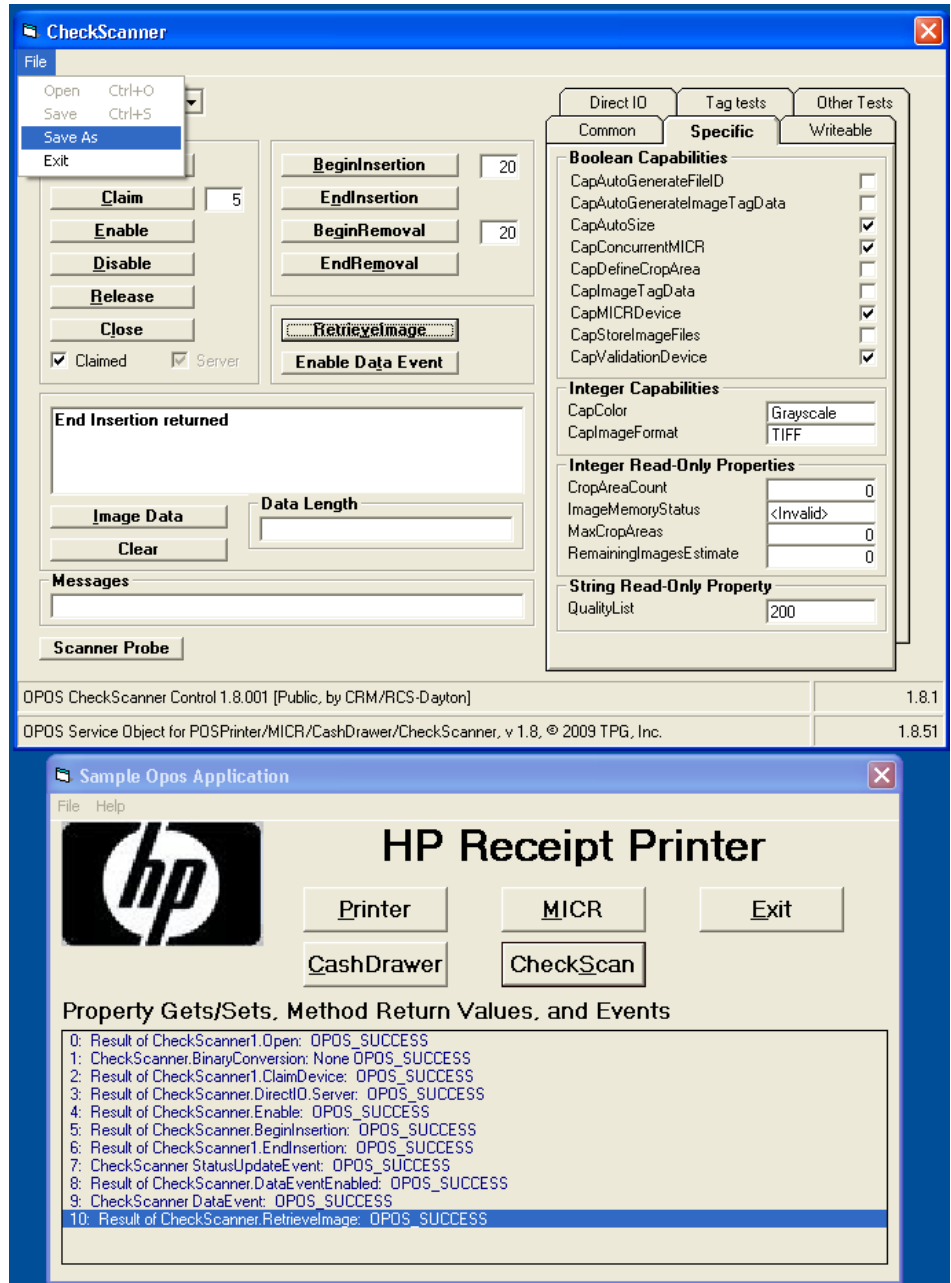

CheckScanner

File

Device: A776

20
 5

 20

Claimed
 Server

End Insertion returned

Direct IO	Tag tests	Other Tests
Common	Specific	Writeable
Boolean Capabilities		
CapAutoGenerateFileID		<input type="checkbox"/>
CapAutoGenerateImageTagData		<input type="checkbox"/>
CapAutoSize		<input checked="" type="checkbox"/>
CapConcurrentMICR		<input checked="" type="checkbox"/>
CapDefineCropArea		<input type="checkbox"/>
CapImageTagData		<input type="checkbox"/>
CapMICRDevice		<input checked="" type="checkbox"/>
CapStoreImageFiles		<input type="checkbox"/>
CapValidationDevice		<input checked="" type="checkbox"/>
Integer Capabilities		
CapColor	Grayscale	
CapImageFormat	TIFF	
Integer Read-Only Properties		
CropAreaCount	0	
ImageMemoryStatus	<Invalid>	
MaxCropAreas	0	
RemainingImagesEstimate	0	
String Read-Only Property		
QualityList	200	

OPOS CheckScanner Control 1.8.001 [Public, by CRM/RCS-Dayton] 1.8.1

OPOS Service Object for POSPrinter/MICR/CashDrawer/CheckScanner, v 1.8, © 2009 TPG, Inc. 1.8.51

Sample Opos Application

File Help



HP Receipt Printer

Property Gets/Sets, Method Return Values, and Events

```

0: Result of CheckScanner1.Open: OPOS_SUCCESS
1: CheckScanner.BinaryConversion: None OPOS_SUCCESS
2: Result of CheckScanner1.ClaimDevice: OPOS_SUCCESS
3: Result of CheckScanner.DirectIO.Server: OPOS_SUCCESS
4: Result of CheckScanner.Enable: OPOS_SUCCESS
5: Result of CheckScanner.BeginInsertion: OPOS_SUCCESS
6: Result of CheckScanner1.EndInsertion: OPOS_SUCCESS
7: CheckScanner.StatusUpdateEvent: OPOS_SUCCESS
8: Result of CheckScanner.DataEventEnabled: OPOS_SUCCESS
9: CheckScanner.DataEvent: OPOS_SUCCESS
10: Result of CheckScanner.RetrieveImage: OPOS_SUCCESS

```

12. Click the **BeginRemoval** button.

13. Click the **EndRemoval** button.

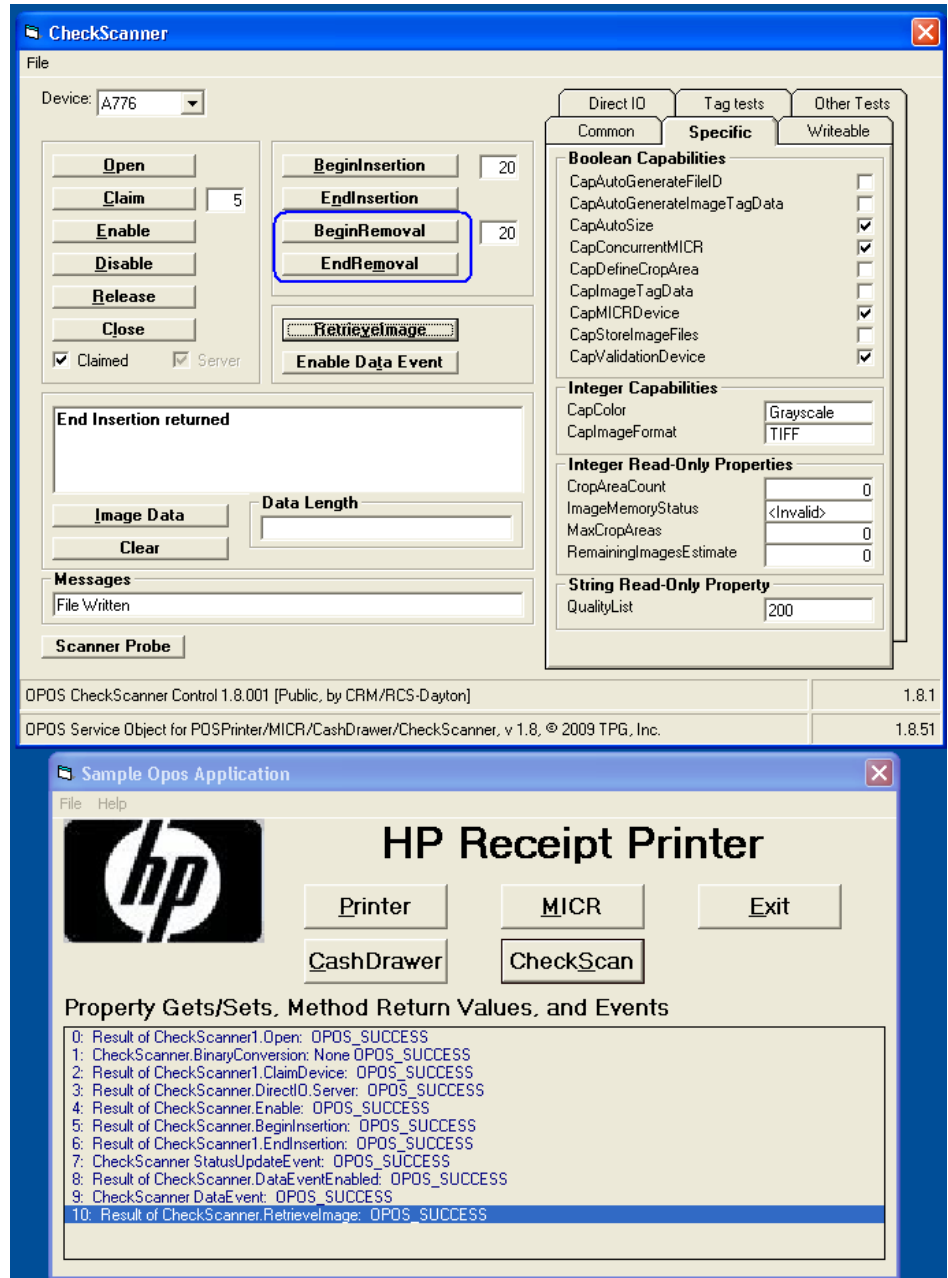

14. Close the "CheckScan" by clicking on DISABLE / RELEASE / CLOSE button in this order.

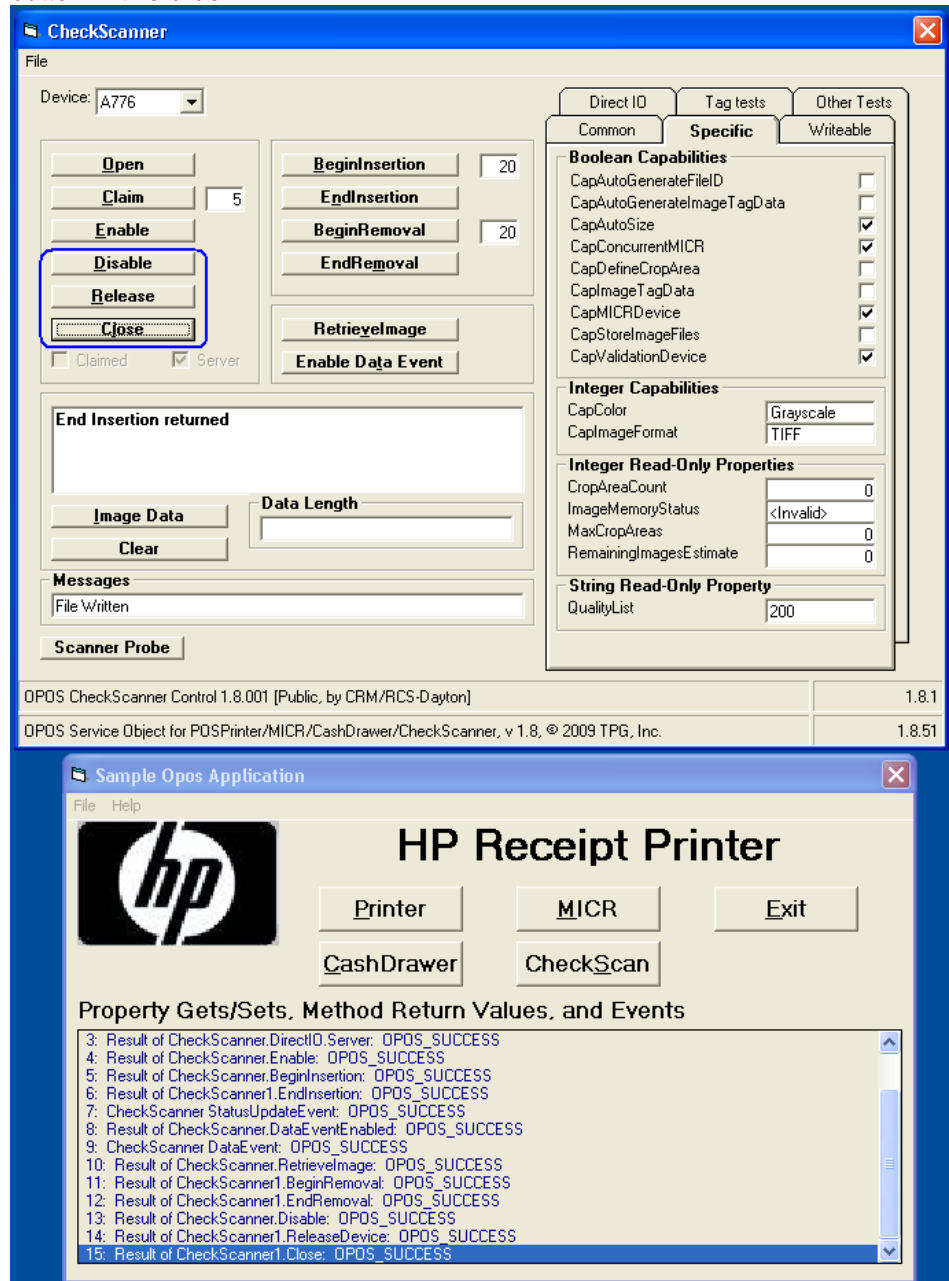

15. Close the form.

6.4.13 Receipt Printer Cash Drawer Signal

6.4.13.1 Cash Drawer Signal

The cash drawer is attached to the back of the printer using an RJ12 or similar connector (the smaller connector). On HP cash drawers, this connector sends a HIGH signal from the printer to open the cash drawer. The HIGH signal is the default setting for the HP OPOS receipt printer drivers installation.

However, there are other cash drawers that may be using an opposite LOW signal to open the cash drawer. In this case, a user may need to configure the driver to also send a low signal in order for the cash drawer to open correctly (steps provided later). If the user has tried both settings and the cash drawer is still not opening, a different cash drawer cable may be needed. Check with the cash drawer vendor or the cash drawer vendor's documentation in regards to the LOW and HIGH signal setting.

6.4.13.2 Cash Drawer Signal Change

The registry files needed to change the cash drawer signal option are included in the HP factory image in C:\xxxxx\Point of Sale\Receipt Printer\Cash Drawer Signal:

- **“HP Default Cash Drawer Signal.REG”**
Changes the cash drawer registry value to HIGH which is the default value when the OPOS drivers are installed and the value that is need when the HP cash drawer is attached to the HP Receipt printer.
- **“HP Non-Default Cash Drawer Signal.REG”**
Changes the cash drawer registry value to LOW which may be tried for a non-HP cash drawer if default HIGH option does not open the cash drawer.

You must have administrator right in order to make the change. When you double click on the file you will receive a prompt for confirmation that you want to make the changes.

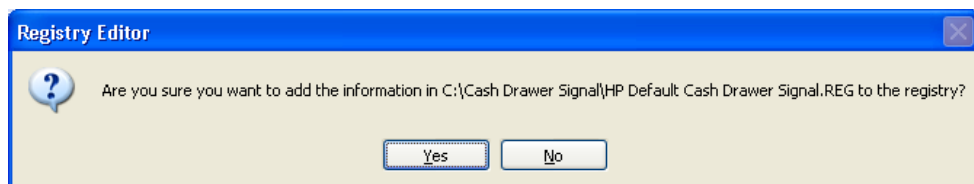

If you click YES then you will receive a confirmation that the change was made.



In order to test the signal cash, please refer to the cash drawer test section ([OPOS Test Applet for the Cash Drawer](#)) of this guide.

6.4.14 JPOS Drivers for the Receipt Printer Drivers – Serial Port Setting

If you are using the serial version of the receipt printer, the entry in the CONFIG.XML must be edited to reflect the COM (serial) port to which the printer is attached. The CONFIG.XML from HP is located in the “.\Receipt Printer JPOS\JPOS\jpos\res” folder, the location will most likely be in a different location for your point of sale application. Please contact your administrator or POS application provider to assist on making changes to the configuration setting.

The following is the default CONFIG.XML file that comes from HP:

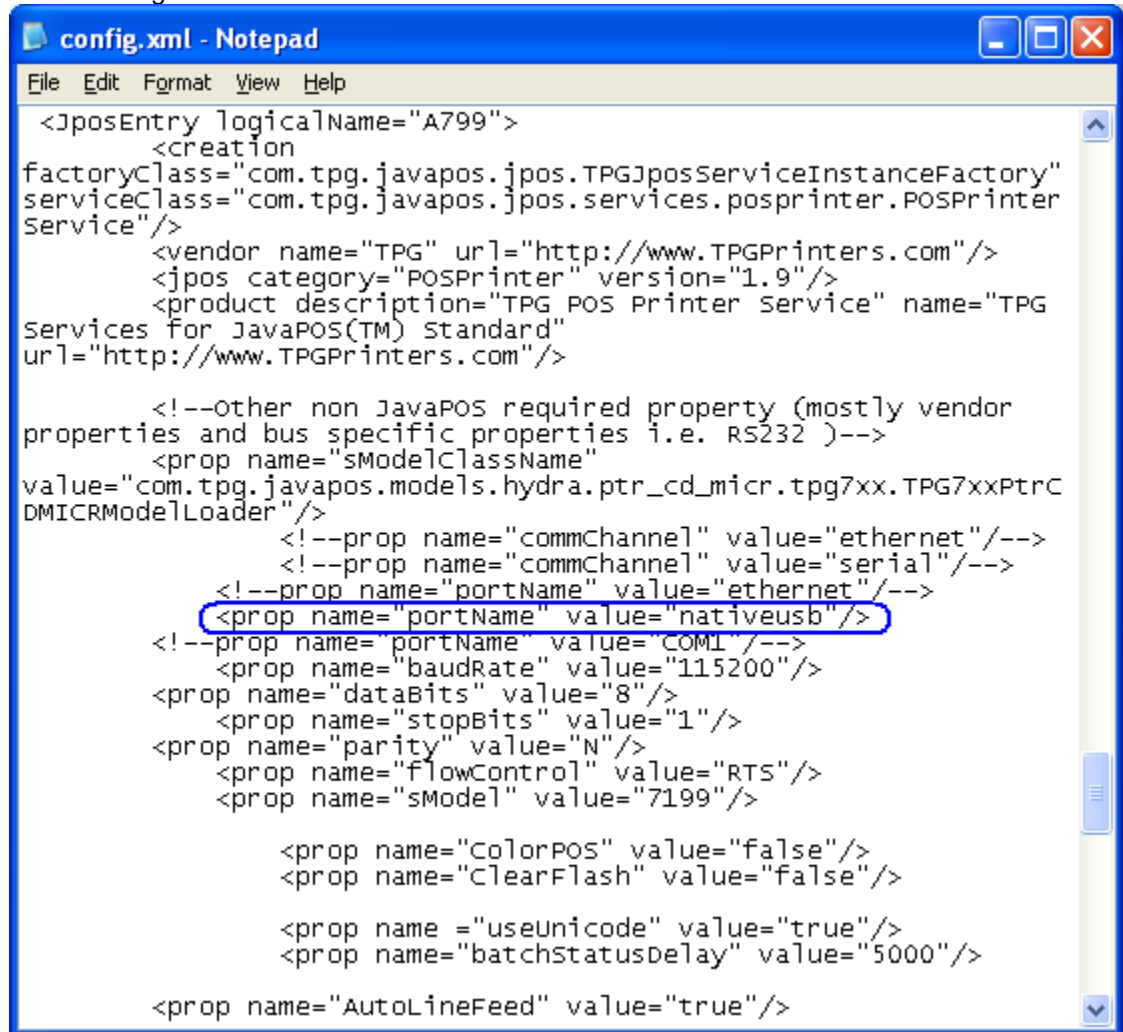

```
<jposEntry logicalName="A799">
  <creation
factoryClass="com.tpg.javapos.jpos.TPGJposServiceInstanceFactory"
serviceClass="com.tpg.javapos.jpos.services.posprinter.POSPrinter
Service"/>
  <vendor name="TPG" url="http://www.TPGPrinters.com"/>
  <jpos category="POSPrinter" version="1.9"/>
  <product description="TPG POS Printer Service" name="TPG
Services for JavaPOS(TM) Standard"
url="http://www.TPGPrinters.com"/>

  <!--Other non JavaPOS required property (mostly vendor
properties and bus specific properties i.e. RS232 )-->
  <prop name="sModelClassName"
value="com.tpg.javapos.models.hydra.ptr_cd_micr.tpg7xx.TPG7xxPtrc
DMICRModelLoader"/>
  <!--prop name="commChannel" value="ethernet"/-->
  <!--prop name="commChannel" value="serial"/-->
  <!--prop name="portName" value="ethernet"/-->
  <prop name="portName" value="nativeusb"/>
  <!--prop name="portName" value="COM1"/-->
  <prop name="baudRate" value="115200"/>
  <prop name="dataBits" value="8"/>
  <prop name="stopBits" value="1"/>
  <prop name="parity" value="N"/>
  <prop name="flowControl" value="RTS"/>
  <prop name="sModel" value="7199"/>

  <prop name="ColorPOS" value="false"/>
  <prop name="ClearFlash" value="false"/>

  <prop name="useUnicode" value="true"/>
  <prop name="batchStatusDelay" value="5000"/>

  <prop name="AutoLineFeed" value="true"/>
```

If the printer is attached to COM1, one needs to comment out the USB entry / enable the COM port entry and enter the correct COM port. The following is an example of what the changes would look like:

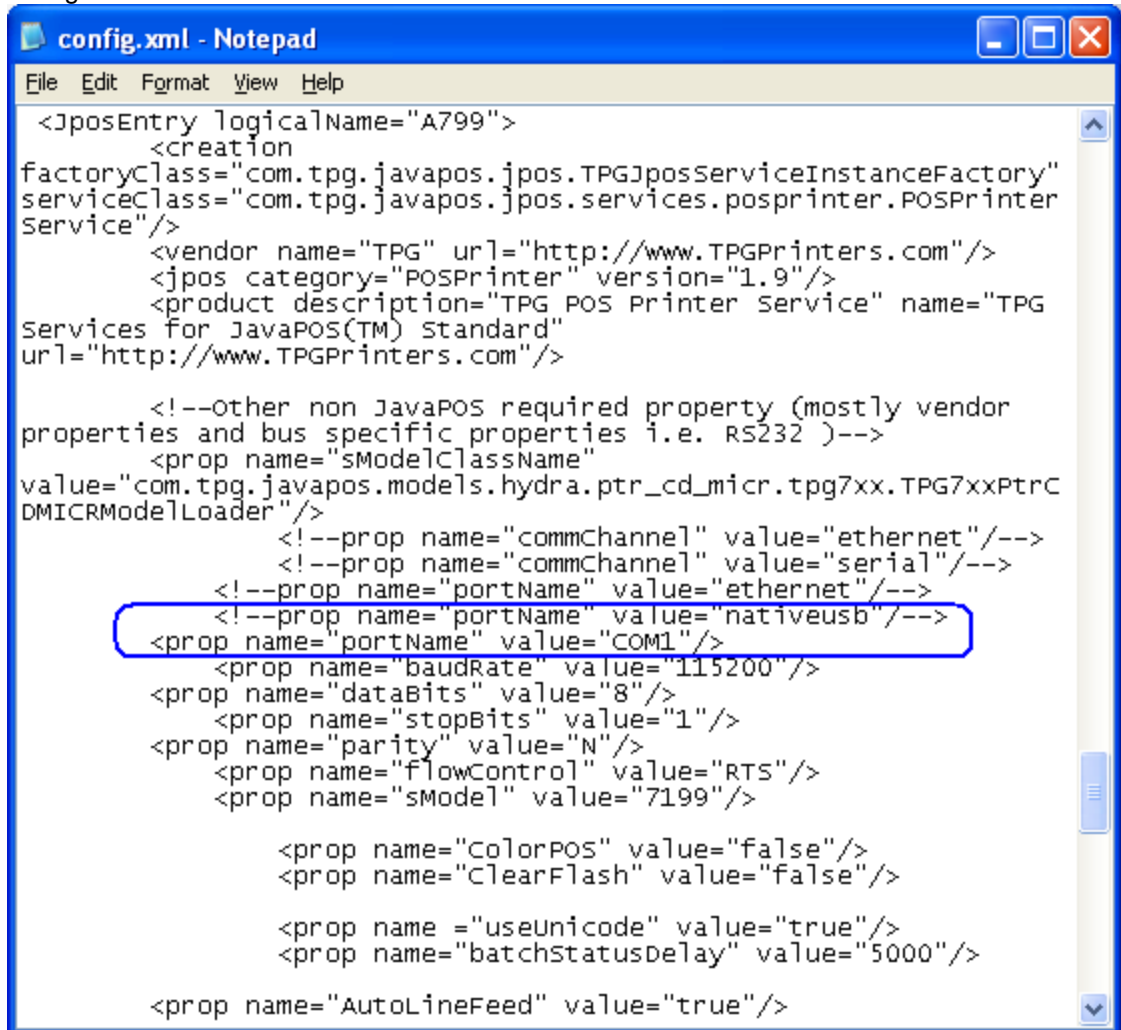

```
<JposEntry logicalName="A799">
  <creation
factoryClass="com.tpg.javapos.jpos.TPGJposServiceInstanceFactory"
serviceClass="com.tpg.javapos.jpos.services.posprinter.POSPrinter
Service"/>
  <vendor name="TPG" url="http://www.TPGPrinters.com"/>
  <jpos category="POSPrinter" version="1.9"/>
  <product description="TPG POS Printer Service" name="TPG
Services for JavaPOS(TM) Standard"
url="http://www.TPGPrinters.com"/>

  <!--Other non JavaPOS required property (mostly vendor
properties and bus specific properties i.e. RS232 )-->
  <prop name="sModelClassName"
value="com.tpg.javapos.models.hydra.ptr_cd_micr.tpg7xx.TPG7xxPtrc
DMICRModelLoader"/>
  <!--prop name="commChannel" value="ethernet"/-->
  <!--prop name="commChannel" value="serial"/-->
  <!--prop name="portName" value="ethernet"/-->
  <prop name="portName" value="COM1"/>
  <prop name="baudRate" value="115200"/>
  <prop name="dataBits" value="8"/>
  <prop name="stopBits" value="1"/>
  <prop name="parity" value="N"/>
  <prop name="flowControl" value="RTS"/>
  <prop name="sModel" value="7199"/>

  <prop name="ColorPOS" value="false"/>
  <prop name="ClearFlash" value="false"/>

  <prop name="useUnicode" value="true"/>
  <prop name="batchStatusDelay" value="5000"/>

  <prop name="AutoLineFeed" value="true"/>
```

Note: Make sure the other communication parameters (Baudrate / DataBits, etc) all match your Windows setting and printer.

6.4.15 JPOS Drivers for the Receipt Printer Drivers – Ethernet

If you are using the Ethernet version of the receipt printer, the entry in the CONFIG.XML must be edited to reflect the Ethernet port and IP Address to which the printer is attached. The CONFIG.XML from HP is located in the “..\Receipt Printer JPOS\JPOS\jpos\res” folder; the location will most likely be different location for you point of sale application. Please contact your administrator or POS application provider to assist on making changes to the configuration setting.

1. Plug the printer into the network and have power to the printer.
2. Run a diagnostic printout and obtain the printer IP address from the printout.

Steps to obtain a diagnostics printout.

- a) Be sure paper is in the printer (1).
- b) Open the receipt cover (2).
- c) Press and hold the paper feed button (3).
- d) Close the receipt cover (2).

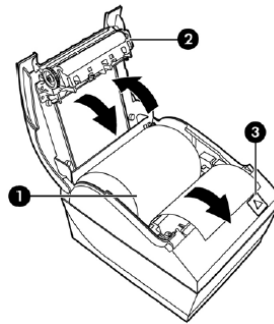

```
Comm. Interfaces
Port Idle Timeout : disabled
Interface - USB
RX Buffer Size : 4096
USB Driver Type : Printer Class
USB Packet w/Error : Reject
Interface - RS232
RX Buffer Size : 4096
Parameters
Baud Rate : 115200
Data Bits : 8
Stop Bit : 1
Parity : NONE
Flow Control : DTR/DSR
Reception Errors : Ignore
Interface - Bluetooth
Status : not available
Interface - Ethernet
Ethernet Type : Wired
Parameters
MAC Address : 00:E0:70:F0:21:7C
IP Address : 10.1.3.18
Net Mask : 255.255.252.0
Gateway : 10.1.0.1
Raw TCPIP Port : 9001
Loop Back Port : Disabled
Http Server Port : 80
DHCP : Enabled
Client ID : 00E070F0217C
Idle Timeout : Disabled
Keep Alive Pings : Disabled
```

Note: The default IP address is 192.0.0.192. If this address appears on the printout, the printer has not obtained an IP address.

3. Go the "Receipt Printer JPOS\JPOS\jpos\res" folder.
4. Using Notepad (or text editor) modify the A799 section in the "CONFIG.XML" file. The following items will need to be modified:
 - PortName for Ether will need to be uncommented out.
 - Remove"!--" (two dashes) from the beginning of the line and "--" (two dashes) towards the end of the line.
 - IPAddress that is on the diagnostics printout will need to be entered in the CONFIG.XML file.
 - Will also need to uncomment the line by removing"!--" (two dashes) from the beginning of the line and "--" (two dashes) towards the end of the line.
 - PortNumber that is on the diagnostics printout will need to be entered in the CONFIG.XML file.
 - Will also need to uncomment the line by removing"!--" (two dashes) from the beginning of the line and "--" (two dashes) towards the end of the line.
 - PortName for NativeUSB will need to be commented out.
 - Add"!--" (two dashes) towards the beginning of the line after the "<" and "--" (two dashes) to the end of the line before ">" to comment this line out in the CONFIG.XML file.

Below is modified CONFIG.XML file showing the Ethernet option enabled:

```

config.xml - Notepad
File Edit Format View Help
<prop name="cdPolarity" value="normal"/>
</jposEntry>
<jposEntry logicalName="A799">
  <creationFactoryClass="com.tpg.javapos.jpos.TPGjposServiceInstanceFactory"
  serviceClass="com.tpg.javapos.jpos.services.posprinter.POSPrinterService"/>
  <vendor name="TPG" url="http://www.TPGPrinters.com"/>
  <jpos category="POSPrinter" version="1.13"/>
  <product description="TPG POS Printer Service" name="TPG Services for JavaPOS(TM) Standard"
  url="http://www.TPGPrinters.com"/>
  <!--other non JavaPOS required property (mostly vendor properties and bus specific properties i.e. RS232 )-->
  <prop name="sModelClassName" value="com.tpg.javapos.models.hydra.ptr_cd_micr.tpg7xx.TPG7xxPTRCDMICRModelLoader"/>
  <!--prop name="commChannel" value="ethernet"!-->
  <!--prop name="commChannel" value="serial"!-->
  <prop name="portName" value="ethernet"/>
  <prop name="IPAddress" value="10.1.3.18"/>
  <prop name="portNumber" value="9001"/>
  <!--prop name="portName" value="nativeusb"!-->
  <!--prop name="portName" value="COM1"!-->
  <prop name="baudRate" value="115200"/>
  <prop name="dataBits" value="8"/>
  <prop name="stopBits" value="1"/>
  <prop name="parity" value="N"/>
  <prop name="FlowControl" value="RTS"/>
  <prop name="sModel" value="7199"/>
  <prop name="colorPOS" value="false"/>
  <prop name="clearFlash" value="false"/>
  <prop name="useUnicode" value="false"/>
  <prop name="batchStatusDelay" value="5000"/>
  <prop name="AutoLineFeed" value="true"/>
  <prop name="asciIBarCode" value="true"/>
  <!--prop name="LineFeedsB4cut" value="[int desired number of lines] If value = 0 then normal operation."!-->
  <prop name="LineFeedsB4cut" value="0"/>
  <prop name="IfAftercut" value="false"/>
  <!--prop name="Code93ssuppress" value=" If value = 0 [default value] will turn off this option."!-->
  <prop name="code93ssuppress" value="0"/>
  <prop name="USBPortID" value="HP USB Receipt printer"/>
  <prop name="vendorID" value="1497"/>
  <prop name="productID" value="42901"/>
  <!-- Following lists the 2-byte Asian characters resident in the printer-->
  <!--prop name="tbCodePages" value="950"/-->
  <!--prop name="tbCodePages" value="949, 950"/-->
  <!--prop name="tbCodePages" value="932, 949, 950"/-->
  <prop name="tbCodePages" value="874, 932, 936, 949, 950"/>
  <prop name="tblargeSize" value="true"/>
</jposEntry>
<jposEntry logicalName="CashDrawer 799-1">

```

```
config.xml - Notepad
File Edit Format View Help
<jposEntry logicalName="A799">
  <creationFactoryClass="com.tpg.javapos.jpos.TPGjposServiceInstanceFactory"
  serviceClass="com.tpg.javapos.jpos.services.posprinter.POSPrinterService"/>
  <vendor name="TPG" url="http://www.TPGPrinters.com"/>
  <jpos category="POSPrinter" version="1.13"/>
  <product description="TPG POS Printer Service" name="TPG Services for JavaPOS(TM) Standard"
  url="http://www.TPGPrinters.com"/>

  <!--other non JavaPOS required property (mostly vendor properties and bus specific properties i.e. RS232)-->
  <prop name="sModelClassName"
  value="com.tpg.javapos.models.hydra.ptr_cd_micr.tpg7xx.TPG7xxPtrCDMICRModelLoader"/>
  <!--prop name="commChannel" value="ethernet"/-->
  <!--prop name="commChannel" value="serial"/-->
  <prop name="portName" value="ethernet"/>
  <prop name="IPAddress" value="10.1.3.1"/>
  <prop name="portNumber" value="9001"/>
  <!--prop name="portName" value="nativeusb"/-->
  <!--prop name="portName" value="COM1"/-->
  <prop name="baudRate" value="115200"/>
  <prop name="dataBits" value="8"/>
  <prop name="stopBits" value="1"/>
  <prop name="parity" value="N"/>
  <prop name="flowControl" value="RTS"/>
  <prop name="sModel" value="7199"/>

  <prop name="colorPOS" value="false"/>
  <prop name="clearFlash" value="false"/>

  <prop name="useunicode" value="false"/>
  <prop name="batchStatusDelay" value="5000"/>

  <prop name="AutolineFeed" value="true"/>
  <prop name="asciiBarcode" value="true"/>

  <!--prop name="LineFeedsB4Cut" value="[int desired number of lines] If value = 0 then normal operation."/-->
  <prop name="LineFeedsB4Cut" value="0"/>
  <prop name="lfAftercut" value="false"/>

  <!--prop name="Code93Suppress" value=" If value = 0 [default value] will turn off this option."/-->
  <prop name="Code93sSuppress" value="0"/>

```

6.4.16 JPOS Drivers for the Receipt Printer Drivers

The JPOS drivers are included in the HP factory image (C:\xxxxx\Point of Sale\Receipt Printer\JPOS POS Printer) and are also available from HP.COM.

The following is an overview of the steps to test the receipt printer followed by detailed steps:

1. Open **Printer/Cash Drawer/MICR Unit Test Application**.
 - C:\xxxxx\Point of Sale\Receipt Printer\JPOS POS Printer\HPJPOSPrinter.bat.
2. Select the printer model in the profile drop down box.
3. Click the **Open** button.
4. Click the **Claim** button.
5. Click the **Enable** button.
6. Click on the **Simple Printing** tab.
7. Type the text you wish to print into the Print Data area.
8. Click the **PrintNormal** button. The receipt printer should print the text.

Note: In order to see the text you will need to press the line feed button on the printer unless you added several carriage returns to your text.

Detailed Steps

1. Open **Printer/Cash Drawer/MICR Unit Test Application**.
 - C:\xxxxx\Point of Sale\Receipt Printer\JPOS POS Printer\HPJPOSPrinter.bat.

After a few seconds the JPOS test utility GUI will appear as shown below:

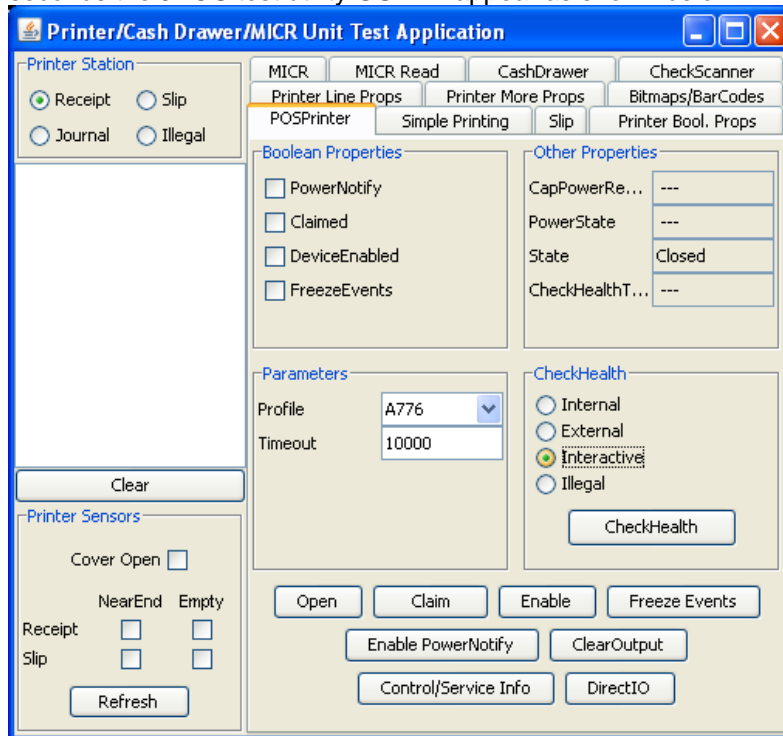

2. Select the printer model in the profile drop down box:

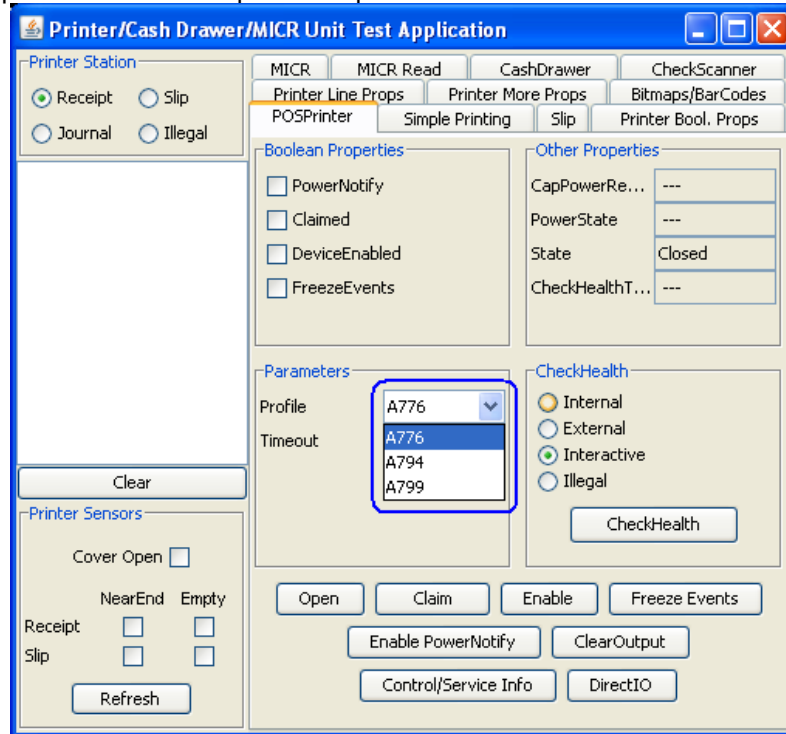

3. Click the **Open** button.
4. Click the **Claim** button.
5. Click the **Enable** button. After all three buttons are clicked the screen will look similar to the following screen capture:

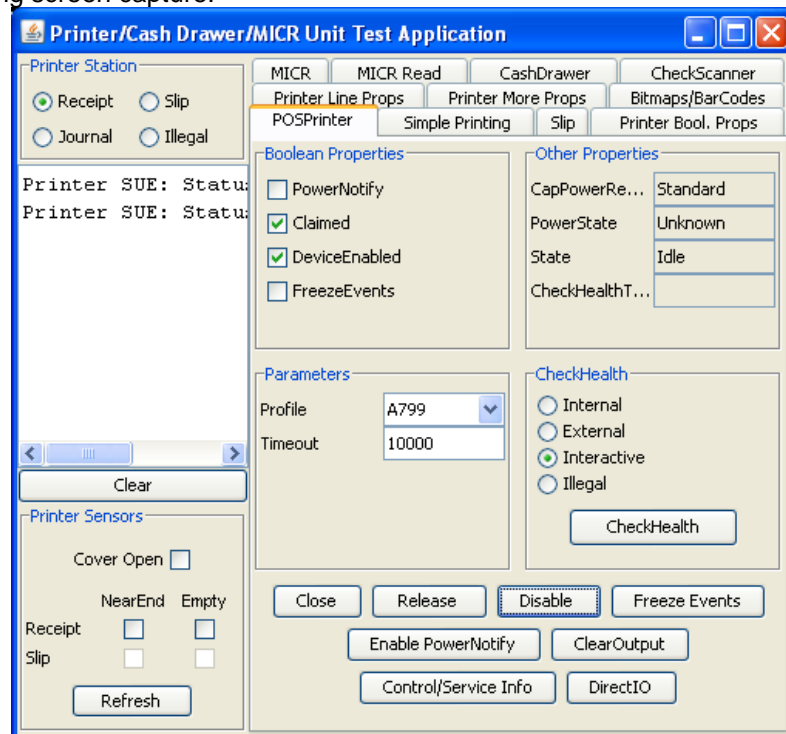

6. Click on the **Simple Printing** tab.

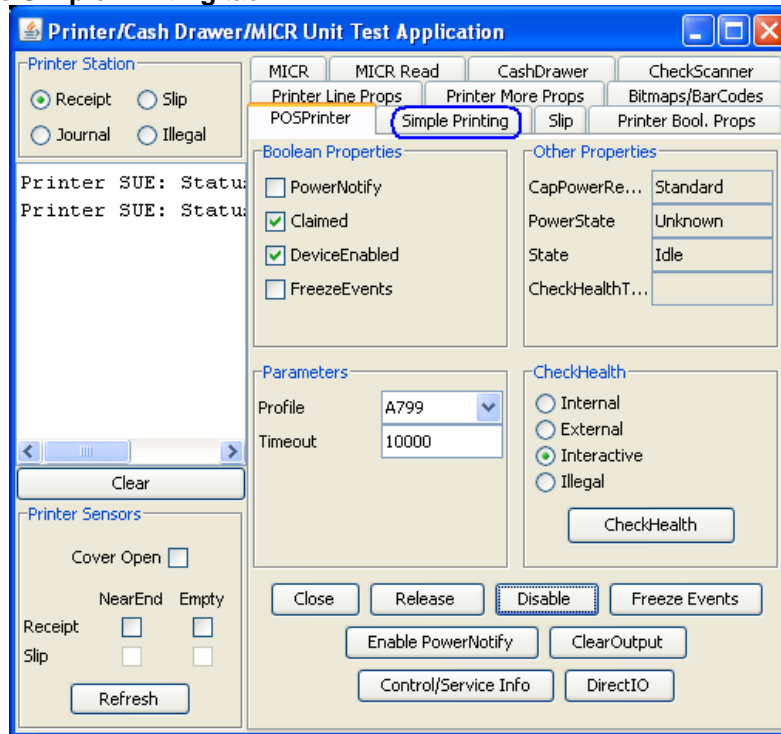

7. Type the text you wish to print into the Print Data area.

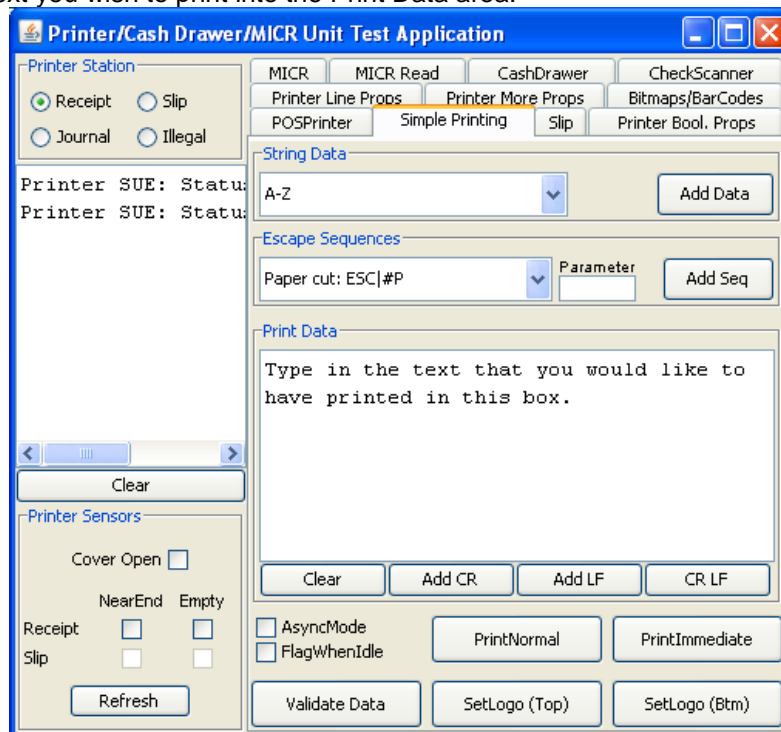

- Click the **PrintNormal** button. The receipt printer should print the text.

Note: In order to see the text you will need to press the line feed button on the printer unless you added several carriage returns to your text.

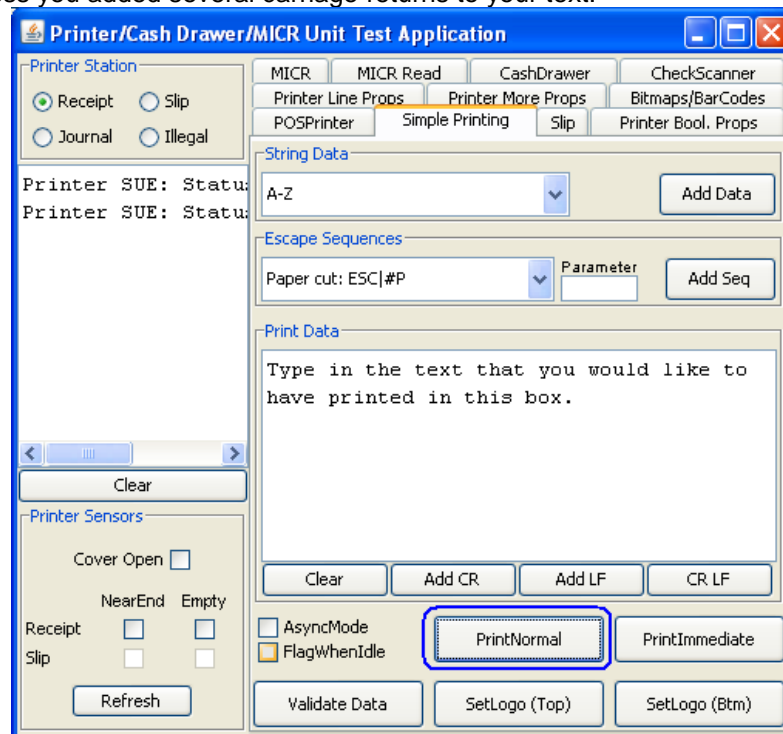

6.4.17 **JPOS Drivers for the Receipt Printer Drivers - CheckScanner**

Note: The check scanner feature is only available on the HP Hybrid printer that has imaging capabilities. The following is image of the model of the HP Hybrid printer with imaging capabilities:



The JPOS drivers are included in the HP factory image (C:\xxxxx\Point of Sale\Receipt Printer\JPOS POS Printer) and are also available from HP.COM.

The following is an overview of the steps to test the receipt printer followed by detailed steps:

1. Open **Printer/Cash Drawer/MICR Unit Test Application**.
 - C:\xxxxx\Point of Sale\Receipt Printer\JPOS POS Printer\HPJPOSPrinter.bat.
2. Click on the **CheckScanner** tab.
3. Click the **Open** button.
4. Click the **Claim** button.
5. Click the **Enable** button.
6. Insert a piece of paper face up that you wish to capture an image of during this test in the front of the printer until the LED comes on. The paper should be inserted face up in the slip portion of the printer.
7. Click the **Begin** button in the left TransactionPrint box.
8. Click the **End** button in the left TransactionPoint box. The printer will make some noise and move the paper through the imager.
9. Check the **Data Events Enabled** checkbox.
10. Click the **RetrieveImage** button. After the button is pressed the status will be updated and some information will be filled about the image.
11. Click the **DisplayImage** button to view the image that was scanned.
12. To Exit the application one needs to "Disable/Release/Close" the printer and then click on the "X" to close the application.
13. The piece of paper that was inserted in step 7 can be removed from the imager portion of the printer by pulling on the paper; there will be slight force needed when the paper is pulled.

Detailed Steps

1. Open **Printer/Cash Drawer/MICR Unit Test Application**.
 - C:\xxxxx\Point of Sale\Receipt Printer\JPOS POS Printer\HPJPOSPrinter.bat.
2. After a few seconds the JPOS test utility GUI will appear as shown below.

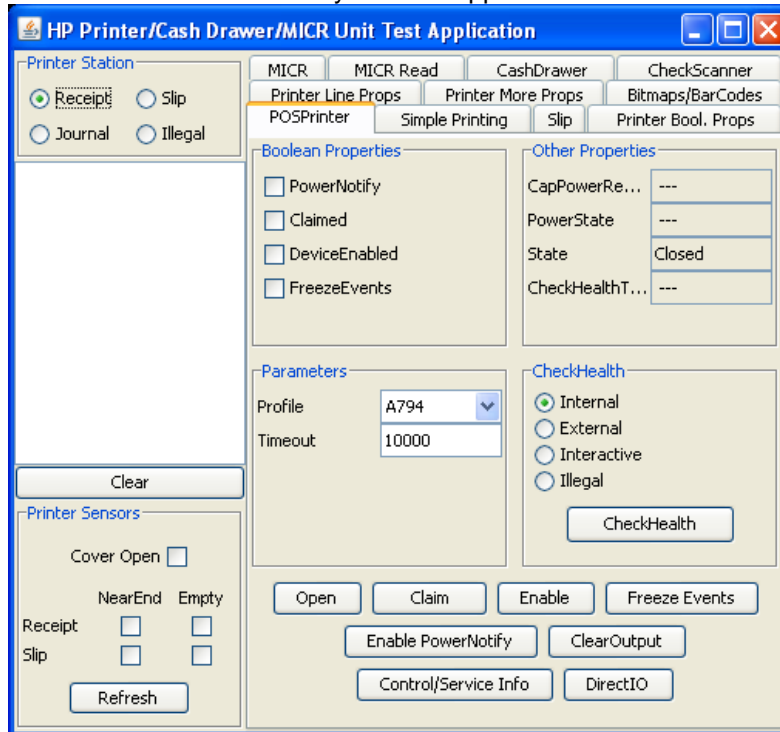

3. Click on the **CheckScanner** tab.

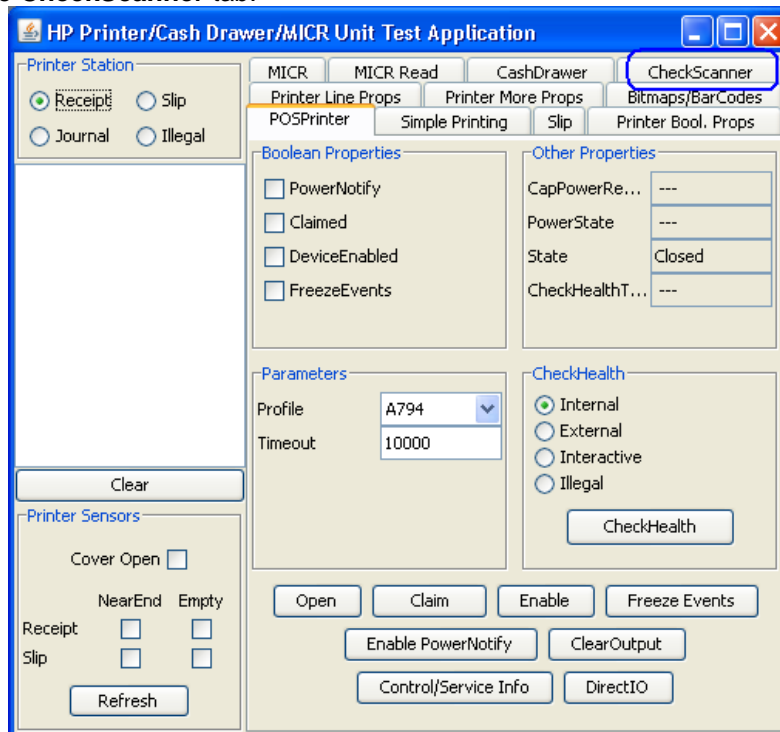

4. Click the **Open** button.
5. Click the **Claim** button.
6. Click the **Enable** button. After all three buttons on clicked the screen will look similar to the following screen capture:

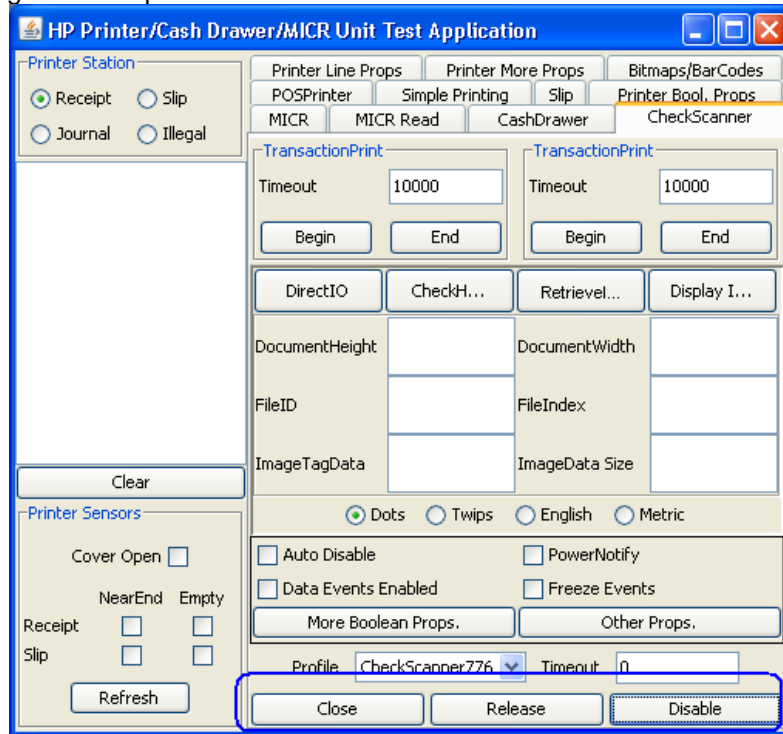

7. Insert a piece of paper face up that you wish to capture an image of during this test in the front of the printer until the LED comes on. The paper should be inserted face up in the slip portion of the printer. Click the **Begin** button in the left TransactionPrint box.

- Click the **End** button in the left TransactionPrint box. The printer will make some noise and move the paper through the imager. After a few seconds a status will appear in the status box.

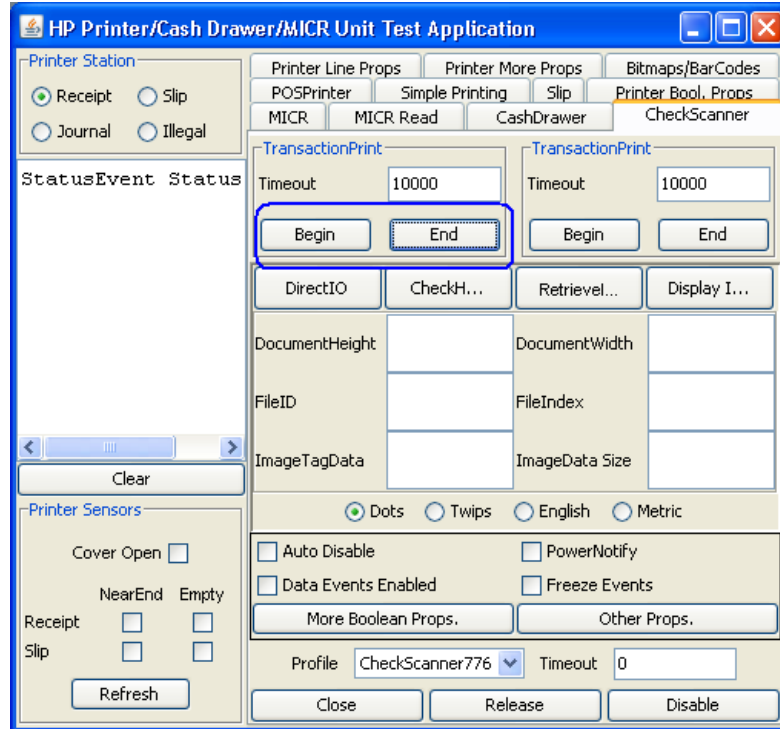

In the open CMD box, it will note the amount of time it took to for the image transfer. The following is an example of the box (the time will vary):

```

C:\WINDOWS\system32\cmd.exe

Usage :: PrinterTestApp <IdentifyPrinterTest <true/false>> <CommType (serial/ser
ialrxtx/usb/nativeusb)> <CommParameters>
-CommParameters :
  for usb <UsbDaemonRegistryPort<int> UsbDevicePort<int>>
  for serial/serialrxtx <COMPort<String> BaudRate<int> DataBits<int> StopB
its<int> Parity<int> FlowControl<int>>
Image Transmission <millisec> = 829
  
```

- Check the **Data Events Enabled** checkbox.

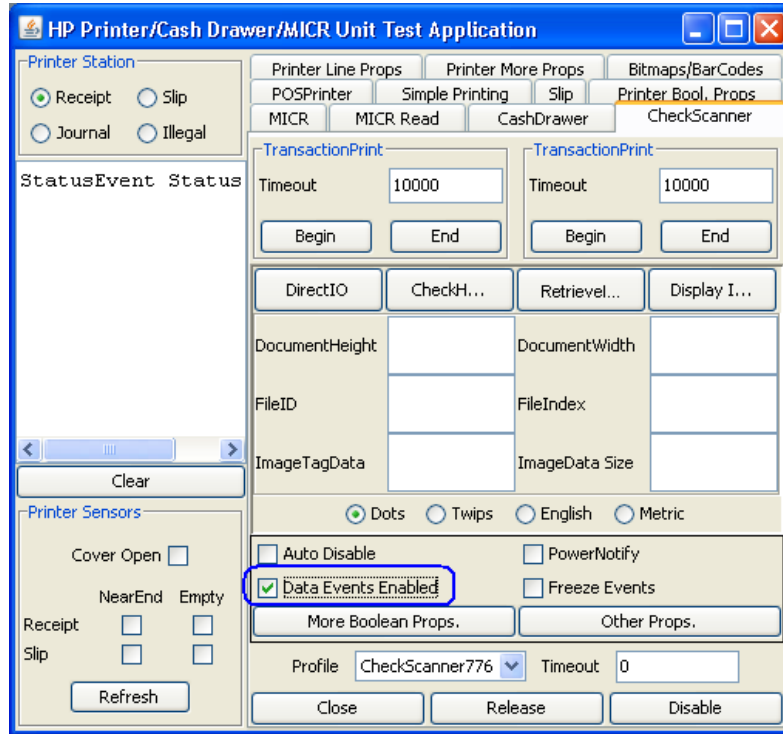

- Click the **RetrievalImage** button. After the button is pressed the status will be updated and some information will be filled about the image.

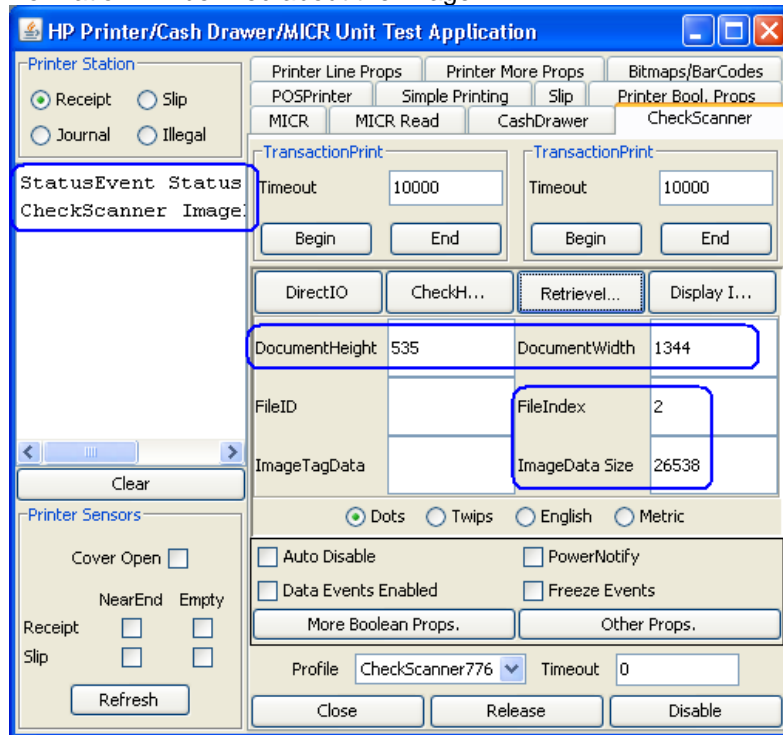

11. Click the **DisplayImage** button to view the image that was scanned.

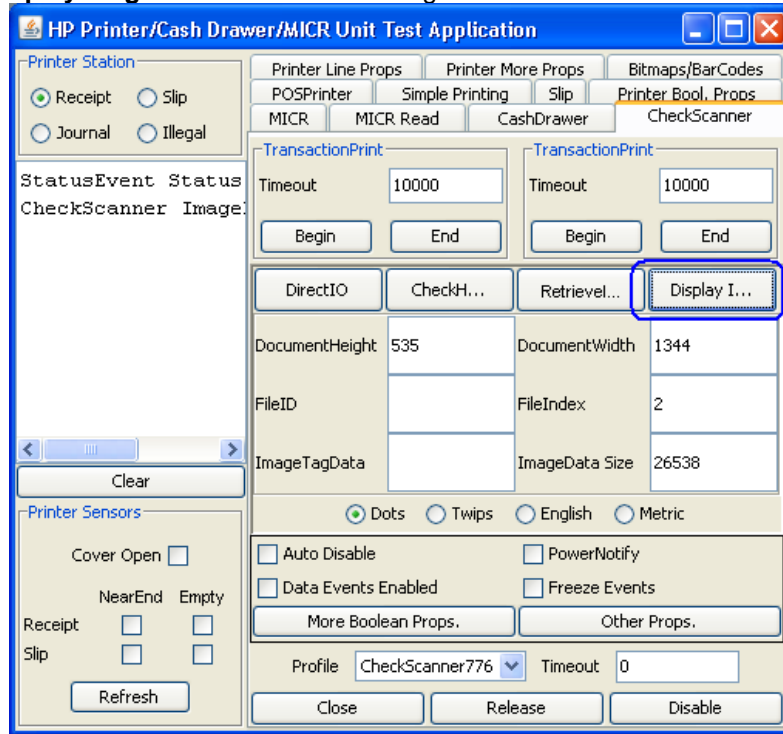

When the **DisplayImage** button is pressed another box will appear with the image, which will allow one to save the image if they wish.



12. To Exit the application one needs to “Disable/Release/Close” the printer and then click on the “X” to close the application.

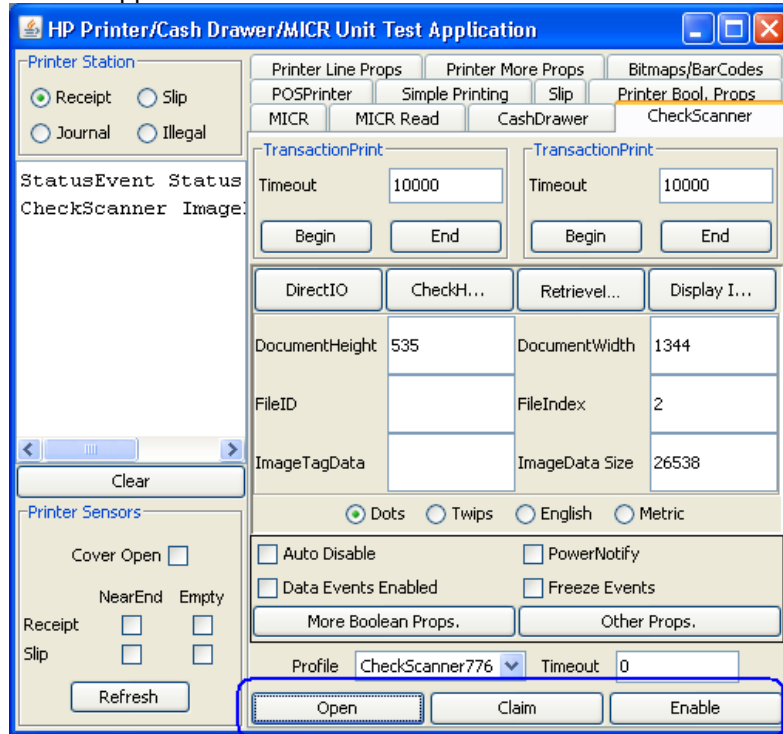

13. The piece of paper that was inserted in step 7 can be removed from the imager portion of the printer by pulling on the paper; there will be slight force needed when the paper is pulled.

6.4.18 JPOS Drivers for the Receipt Printer Drivers - MICR

The JPOS drivers are included in the HP factory image (C:\xxxxx\Point of Sale\Receipt Printer\JPOS POS Printer) and are also available from HP.COM.

The following is an overview of the steps to test the receipt printer followed by detailed steps:

1. Open **Printer/Cash Drawer/MICR Unit Test Application**.
 - C:\xxxxx\Point of Sale\Receipt Printer\JPOS POS Printer\HPJPOSPrinter.bat.
2. Click on the **MICR** tab.
3. Click the **Open** button.
4. Click the **Claim** button.
5. Click the **Enable** button.
6. Click on the **MICR Read** tab.
7. Slide the check facing down into the MICR until the LED comes on.
8. Click the **Enable Data Events** button.
9. Click the **Begin** button in the Insertion box.
10. Click the **End** button in the Insertion box.
11. Exit the application (ensure the device is closed and released).
12. The piece of paper that was inserted in step 7 can be removed from the imager portion of the printer by pulling on the paper; there will be slight force needed when the paper is pulled.

Detailed Steps

1. Open **Printer/Cash Drawer/MICR Unit Test Application**.
 - C:\xxxxx\Point of Sale\Receipt Printer\JPOS POS Printer\HPJPOSPrinter.bat.
2. After a few seconds the JPOS test utility GUI will appear as shown below.

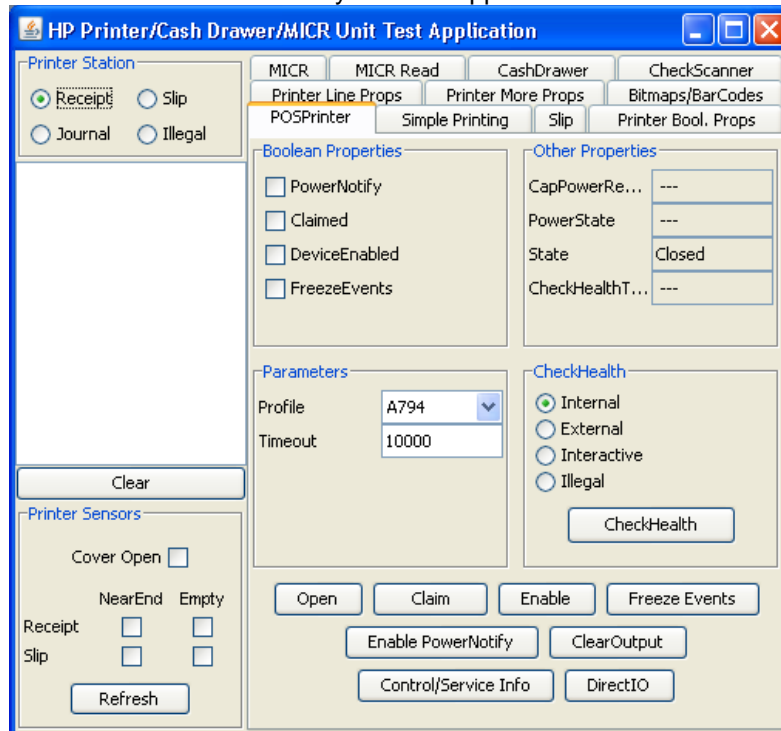

- Click on the **MICR** tab:

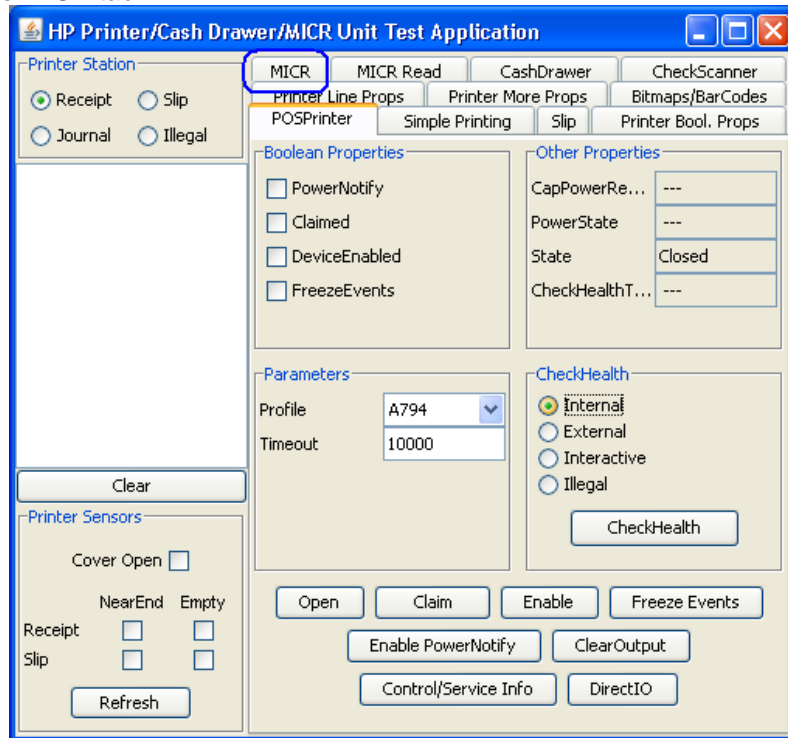

- Click the **Open** button.
- Click the **Claim** button.
- Click on the **Enable** button. After all three buttons are clicked the screen will look similar to the following screen capture:

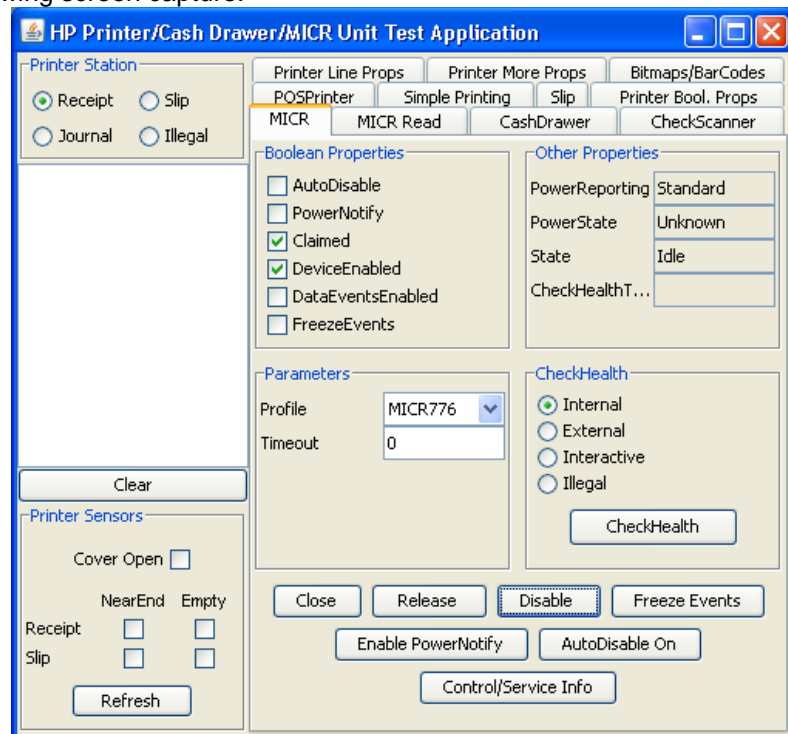

- Click on the **MICR Read** tab:

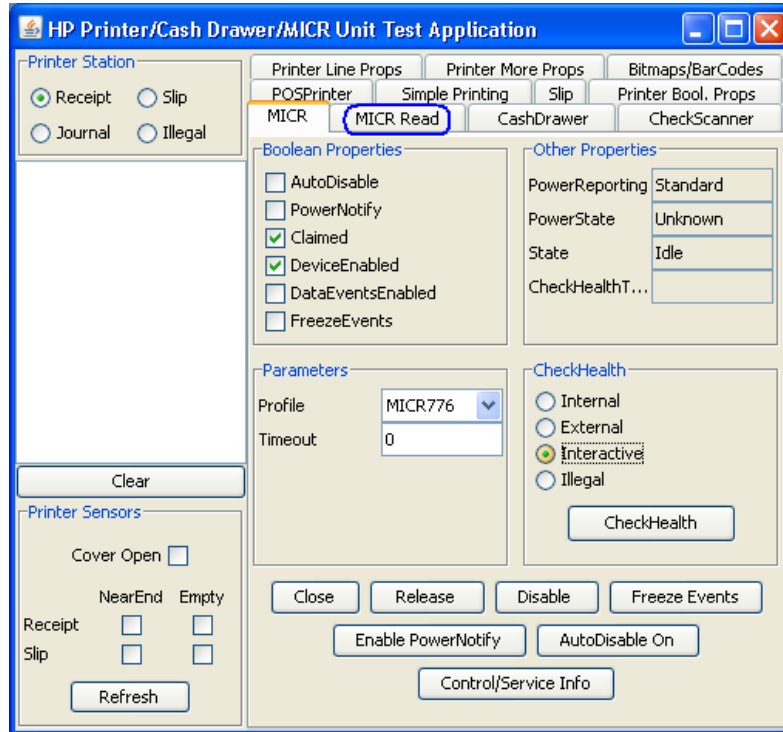

- Slide the check facing up into the MICR until the LED comes on.
- Click the **Enable Data Events** button.

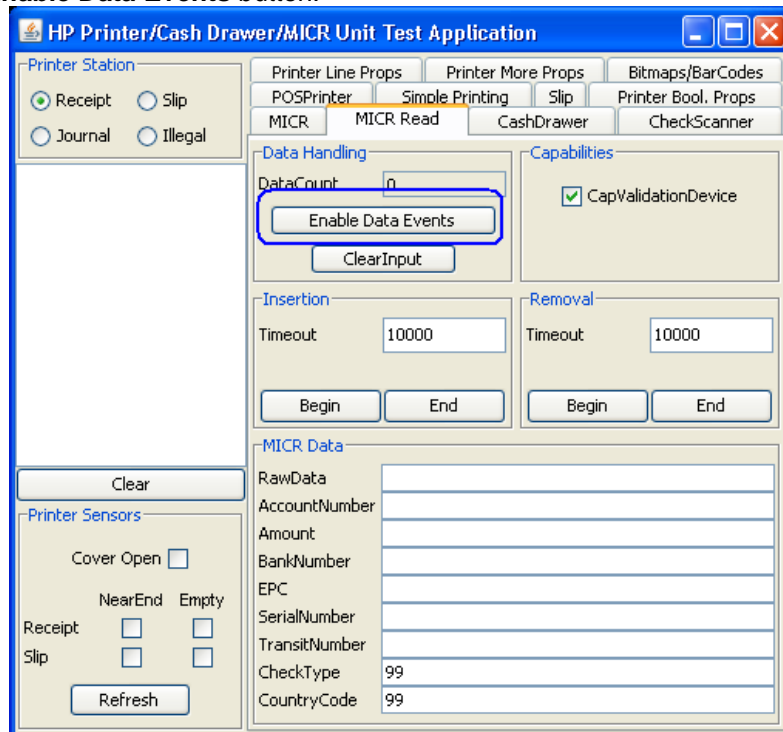

10. Click the **Begin** button in the Insertion box.

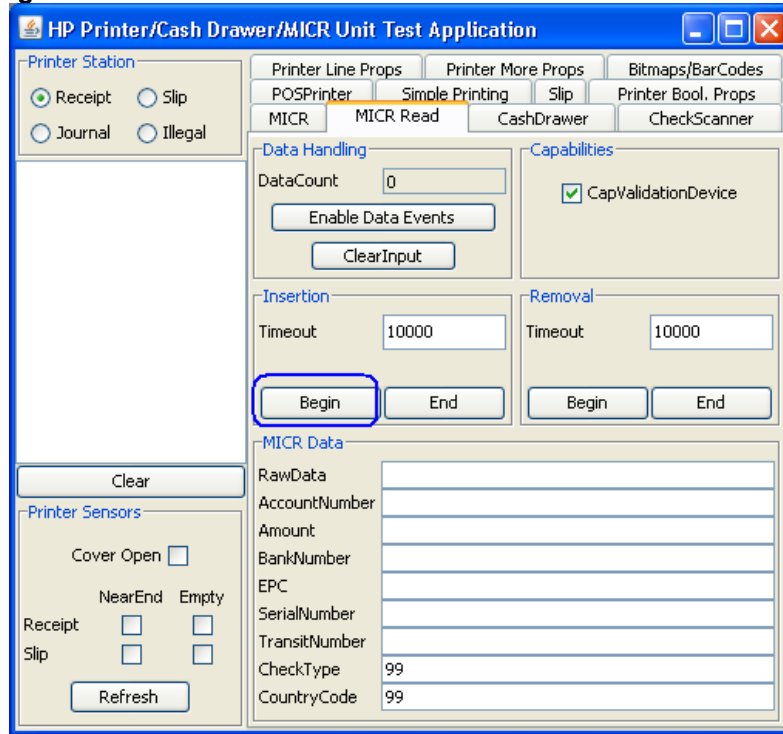

11. Click the **End** button in the Insertion box.

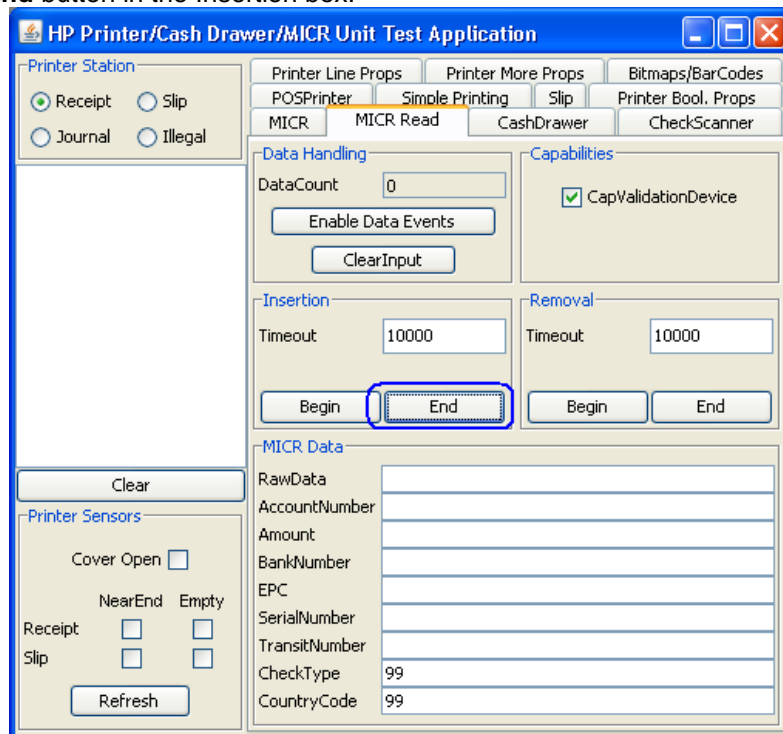

When End is clicked, the printer will engage and read the MICR information on the check.

The data that was read will appear in the **MICR Data** box (“x” represents where data that is read would appear).

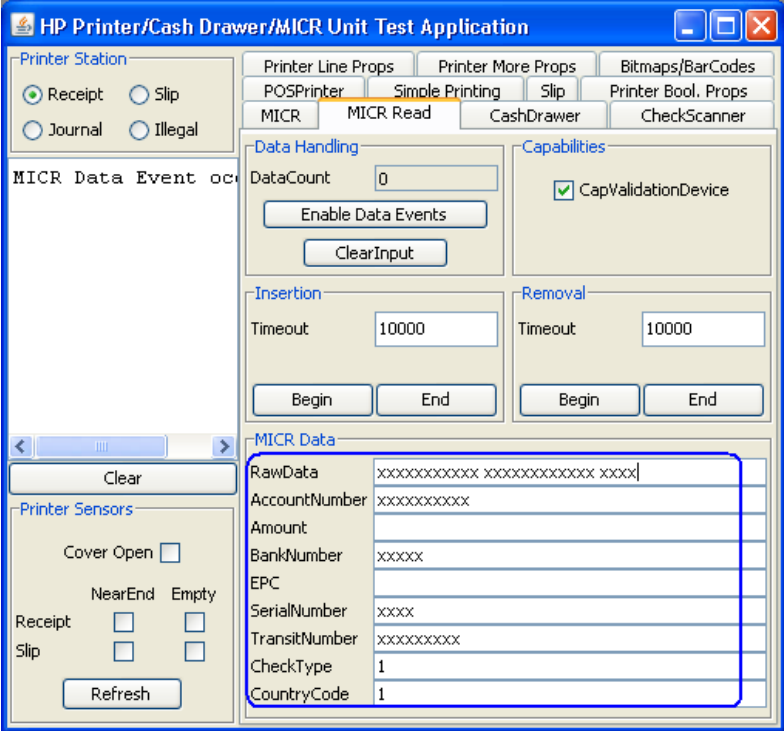

12. To exit the application, need to disable/release and close the MICR from the MICR tab. The following screen shows the MICR still being claimed by the test utility:

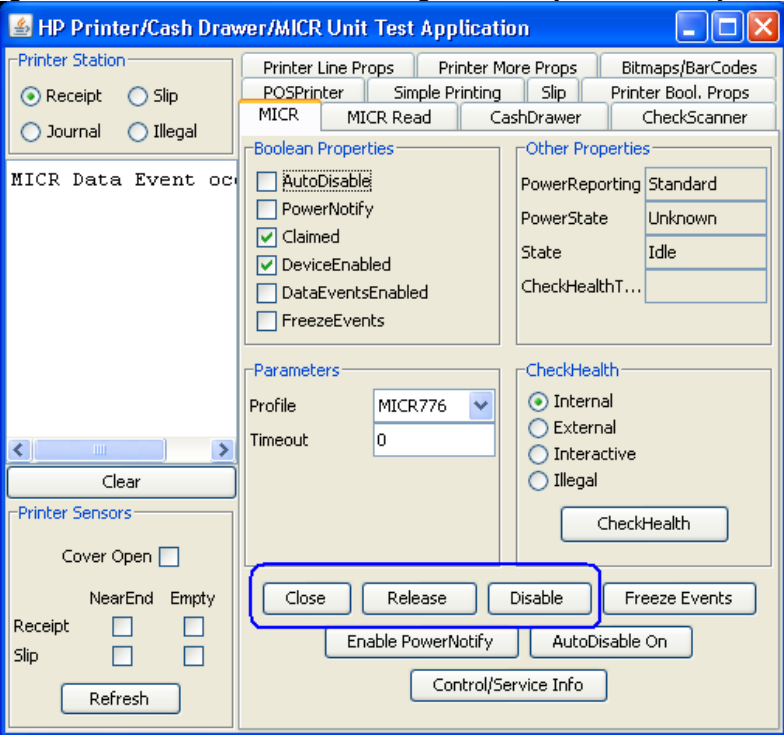

The following shows the device has been released and is available for other applications after the “Disable / Release / Close” buttons have been clicked:

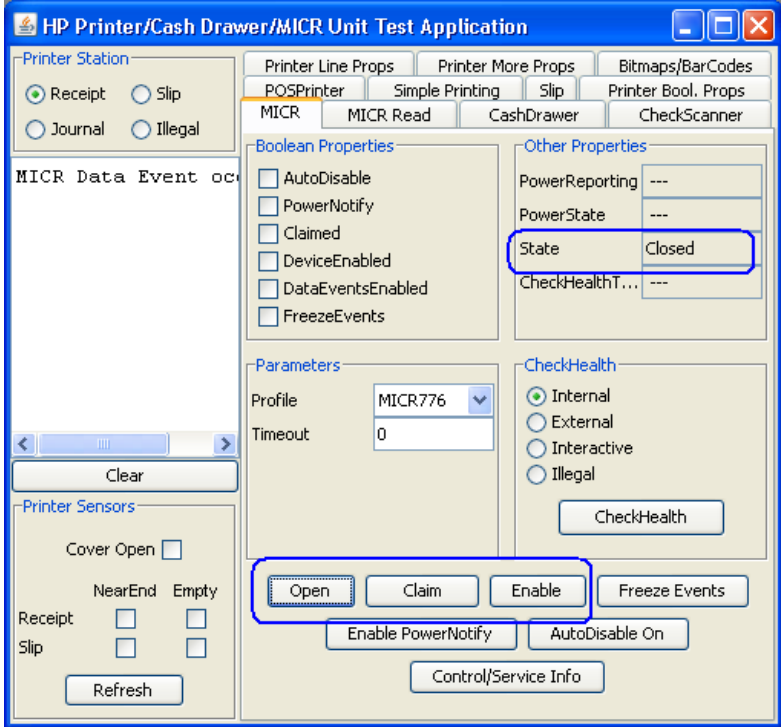

13. The piece of paper that was inserted in step 8 can be removed from the imager portion of the printer by pulling on the paper; there will be slight force needed when the paper is pulled.

6.4.19 JPOS Drivers for the Receipt Printer Drivers – Slip Printing

The JPOS drivers are included in the HP factory image (C:\xxxxx\Point of Sale\Receipt Printer\JPOS POS Printer) and are also available from HP.COM.

The following is an overview of the steps to test the receipt printer followed by detailed steps:

1. Open **Printer/Cash Drawer/MICR Unit Test Application**.
 - C:\xxxxx\Point of Sale\Receipt Printer\JPOS POS Printer\HPJPOSPrinter.bat.
2. Select the A776 printer from the dropdown menu on the POSPrinter tab.
3. Click the **Open** button.
4. Click the **Claim** button.
5. Click the **Enable** button.
6. Select the Slip option in the Printer Station box.
7. Click on the **Slip** tab:
8. Click the **Begin** button in the Insertion box.
9. Slide the paper in the front of the printer until it comes out from the top.
10. Click the **End** button in the Insertion box. The paper may move down and the LED light should stay on indicating paper is in the slip.
11. Click on the **Simple Printing** tab.
12. Type some text in the Print Data area; this is the text that should print on the receipt printer and click on the PrintNormal button.
13. Click on the **Slip** tab.
14. Click the **Begin** button in the Removal box. Once the paper comes out from the top remove the paper from the printer.
15. Click the **End** button in the Removal box.
16. To exit the application, disable/release and close the printer from the POSPrinter tab.

Detailed Steps

1. Open **Printer/Cash Drawer/MICR Unit Test Application**.
 - C:\xxxxx\Point of Sale\Receipt Printer\JPOS POS Printer\HPJPOSPrinter.bat.
2. Select the A776 printer from the drop down menu in “POSPrinter” tab.

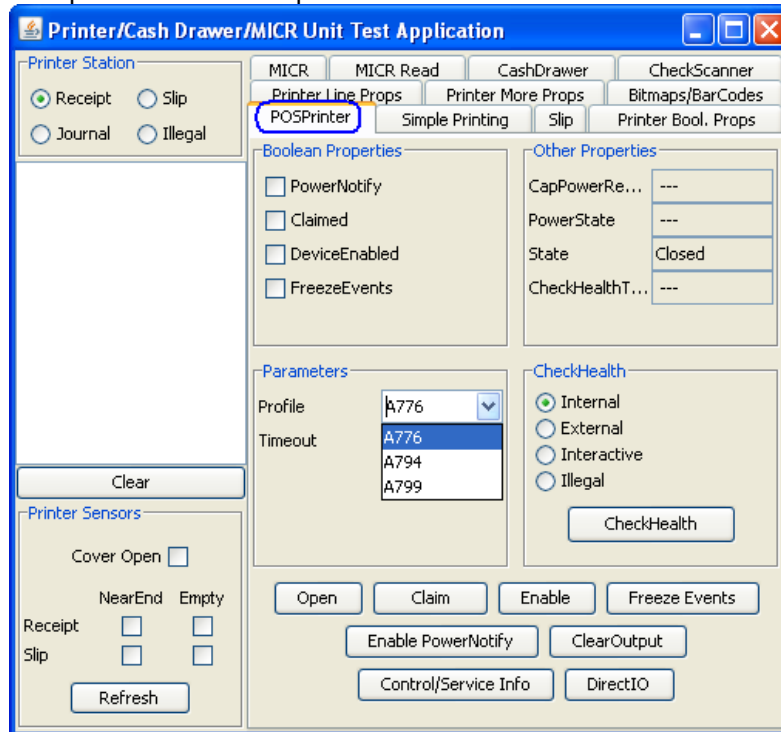

- Click the **Open** button.
- Click the **Claim** button.
- Click the **Enable** button. After all three buttons are clicked the screen will look similar to the following screen capture.

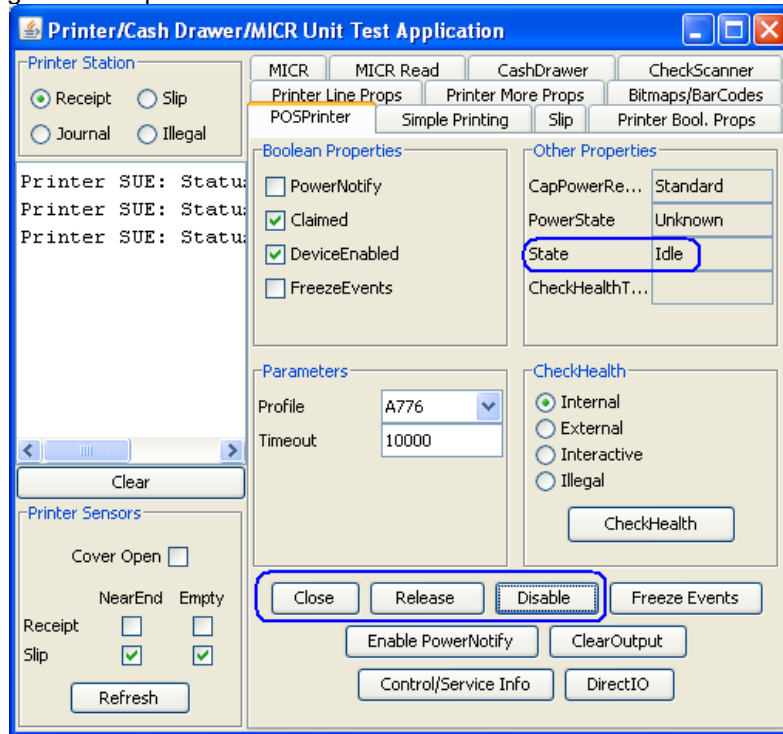

- Select the Slip option in the Printer Station box.

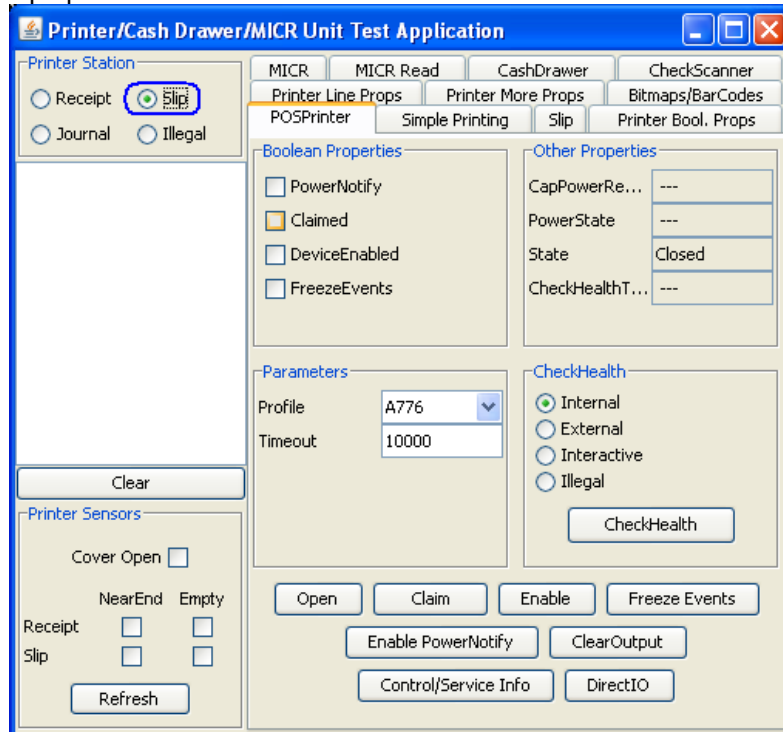

7. Click on the Slip tab.

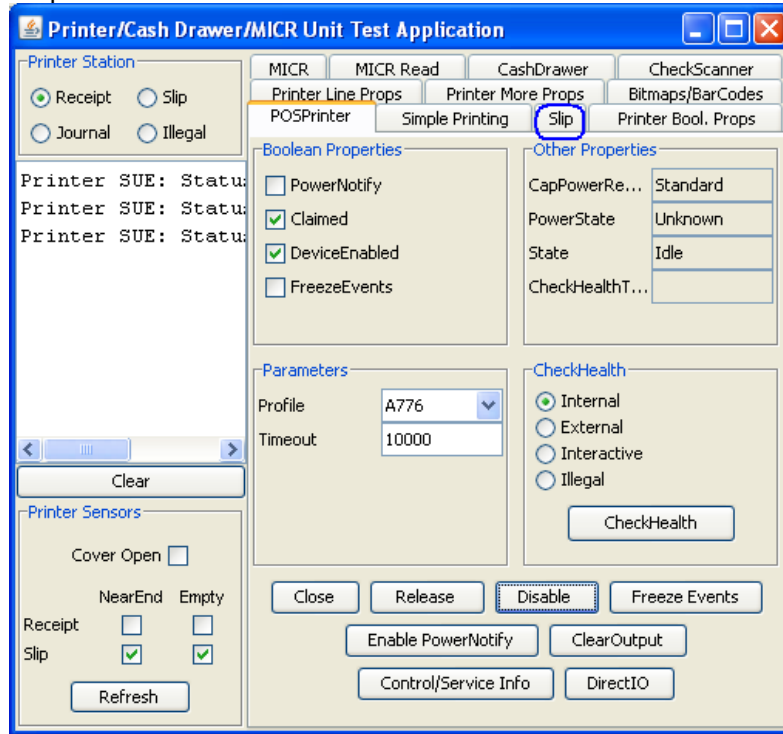

8. Click the Begin button in the Insertion box. Slide the paper in the front of the printer until it comes out from the top.

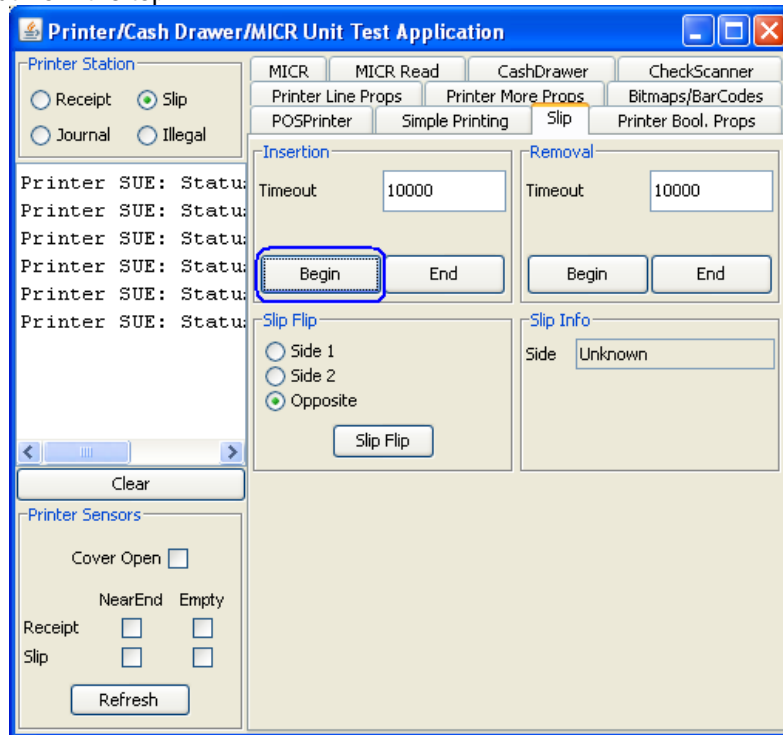

- Click the **End** button in the Insertion box. The paper may move down and the LED light should stay on indicating paper is in the slip.

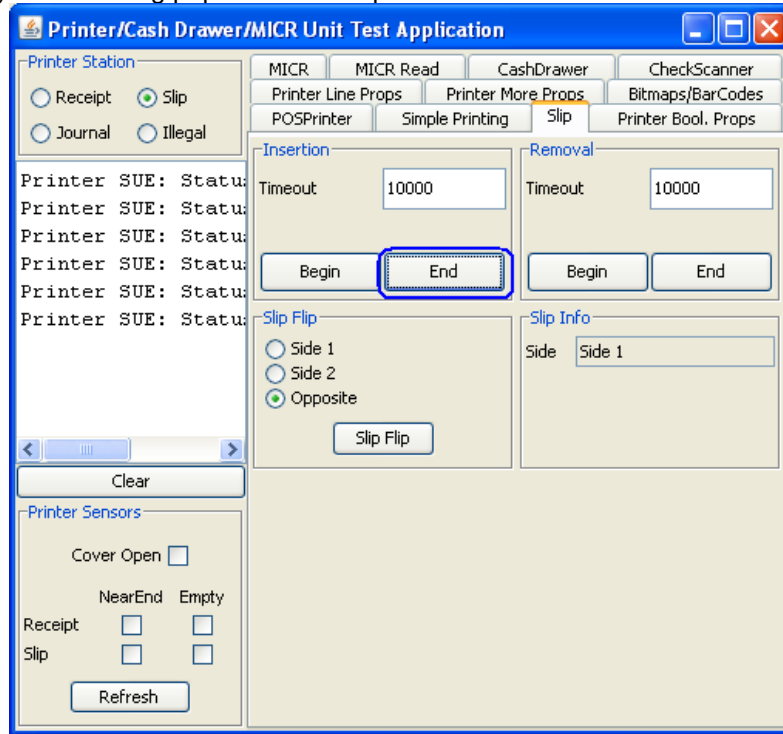

- Click on the Simple Printing tab.

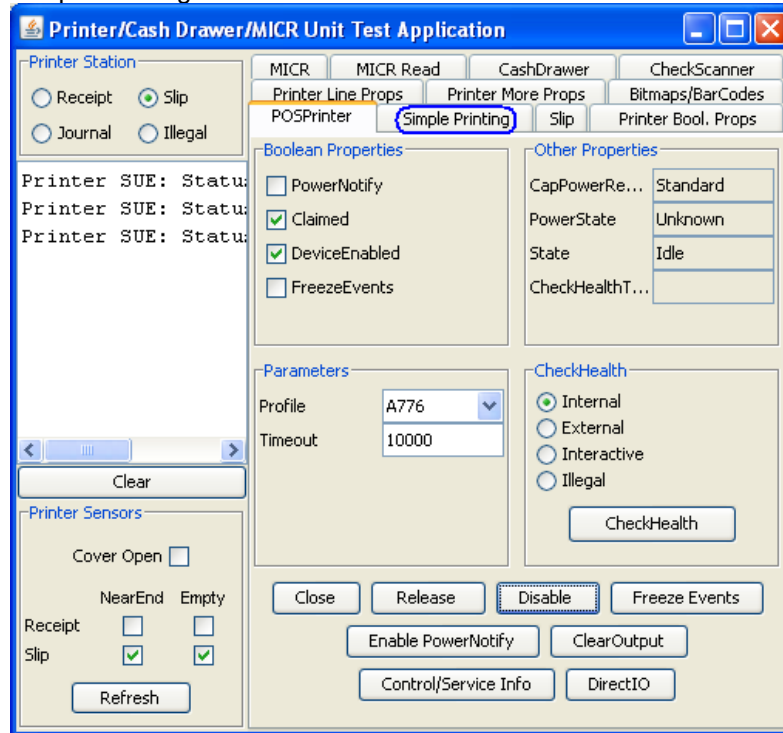

11. Type some text in the Print Data area; this is the text that should print on the receipt printer and click the PrintNormal button.

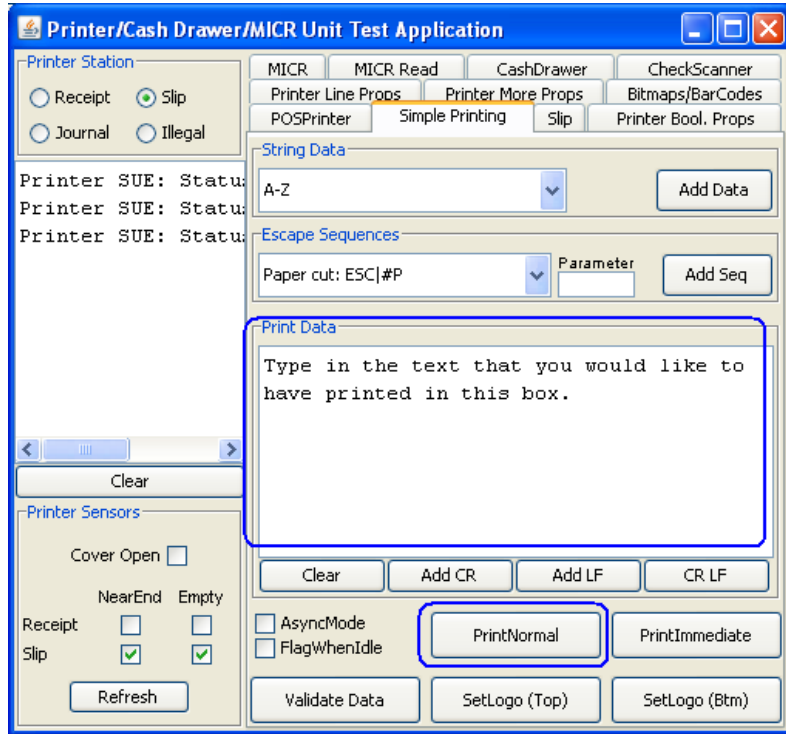

12. Click on the Slip tab.

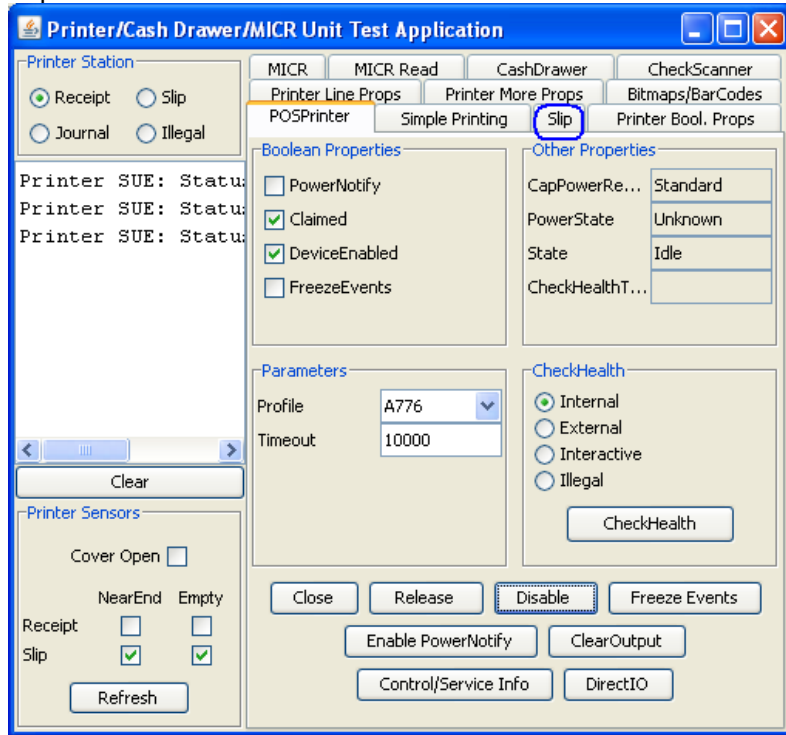

13. Click the Begin button in the Removal box. Once the paper comes out from the top remove the paper from the printer.
14. Click the End button in the Removal box.

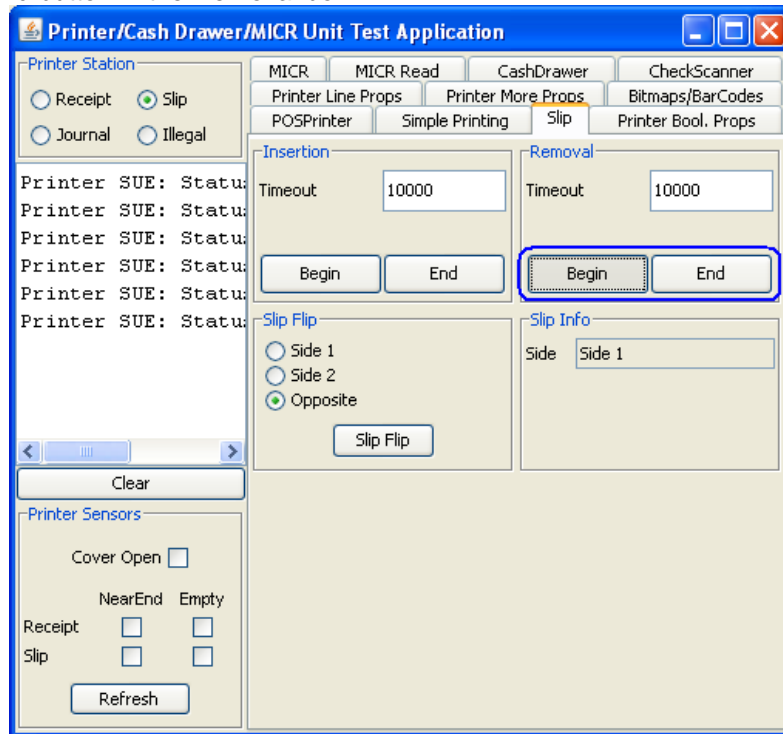

15. To exit the application, disable/release and close the printer from the "POSPrinter" tab. The following screen shows the printer still being claimed by the test utility:

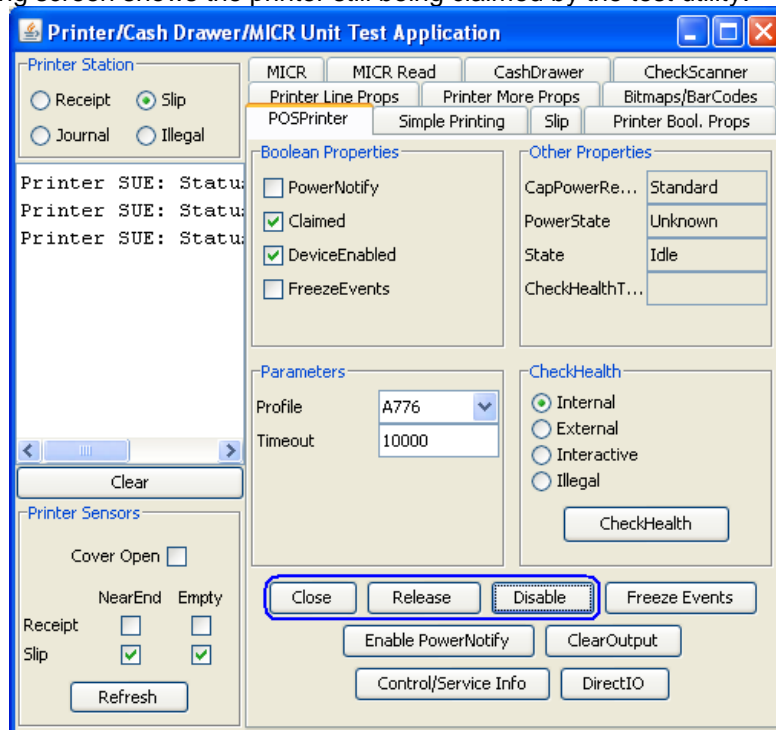

The following shows the printer has been released and is available for other applications after “Disable / Release / Close” button have been clicked:

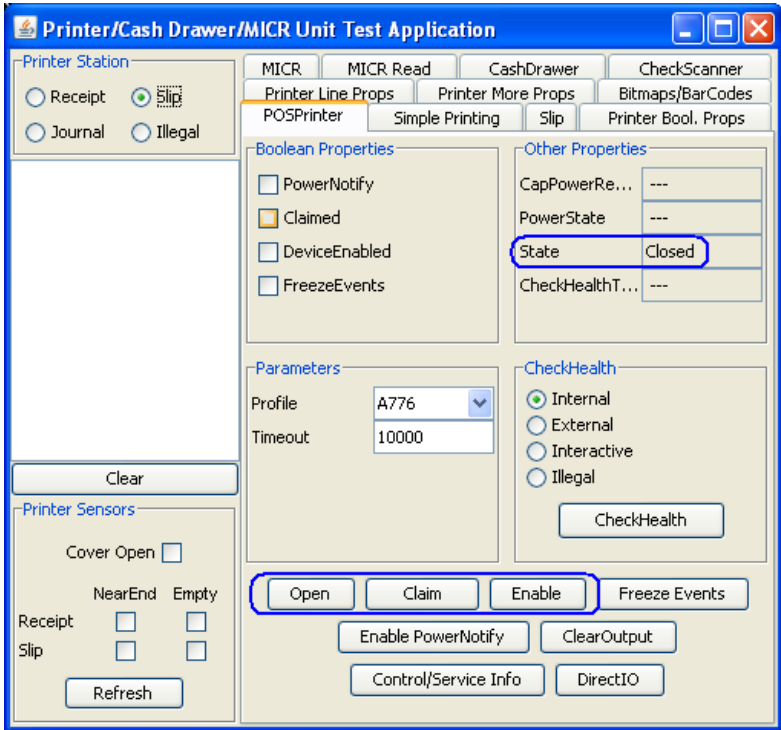

6.4.20 **JPOS Drivers for the Receipt Printer Drivers – Barcode Testing**
Detailed Steps

1. Open **Printer/Cash Drawer/MICR Unit Test Application**.
 - C:\xxxxx\Point of Sale\Receipt Printer\JPOS POS Printer\HPJPOSPrinter.bat.
2. Select the printer from the dropdown menu in the POSPrinter tab.

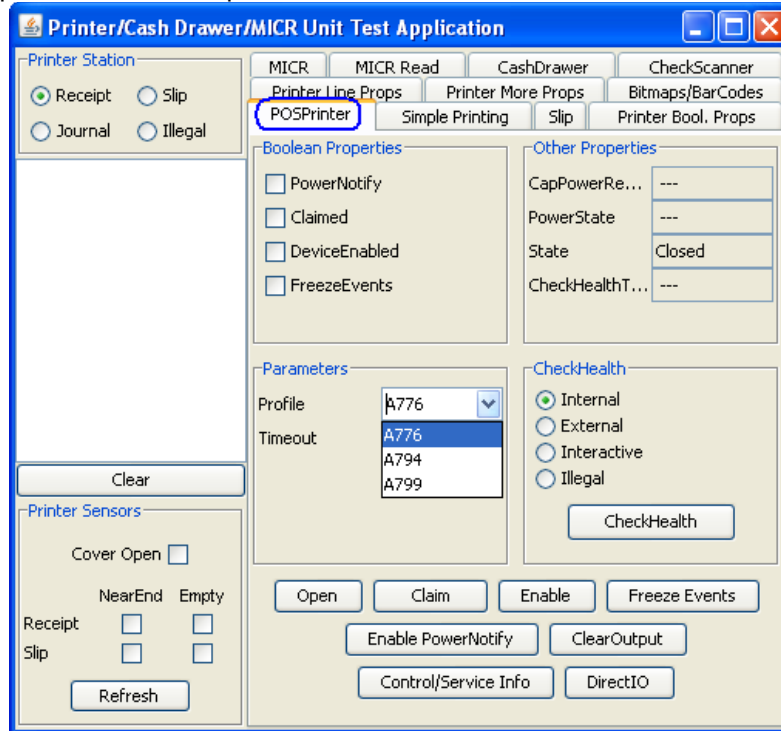

3. Click the **Open** button.
4. Click the **Claim** button.

5. Click the **Enable** button. After all three buttons are clicked the screen will look similar to the following screen capture:

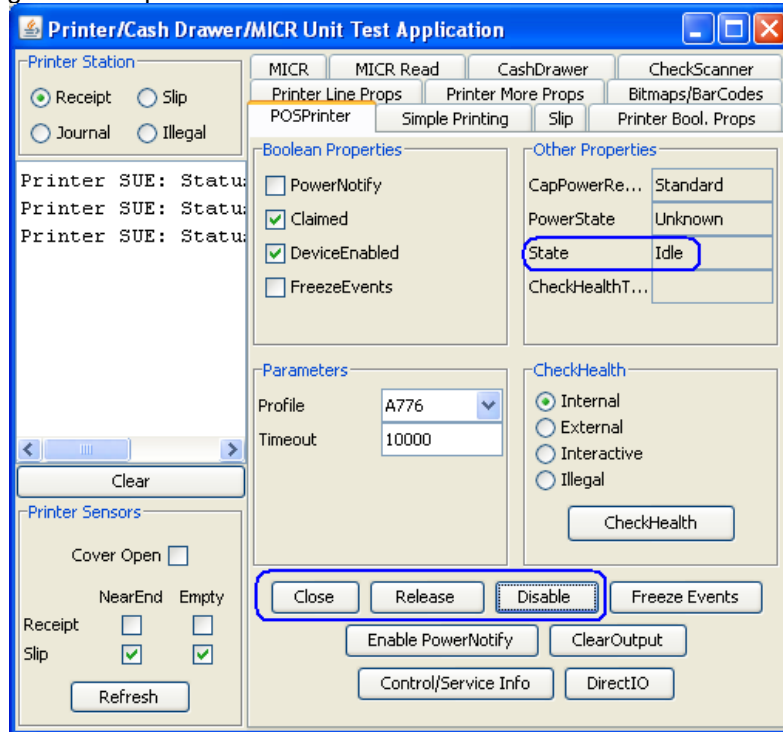

6. Click on the "Bitmaps/Barcode" tab. In the "Print BarCode" section, fill in the appropriate values for the barcode. Below are examples of the various barcode with the appropriate values for the various symbologies:

UPCA

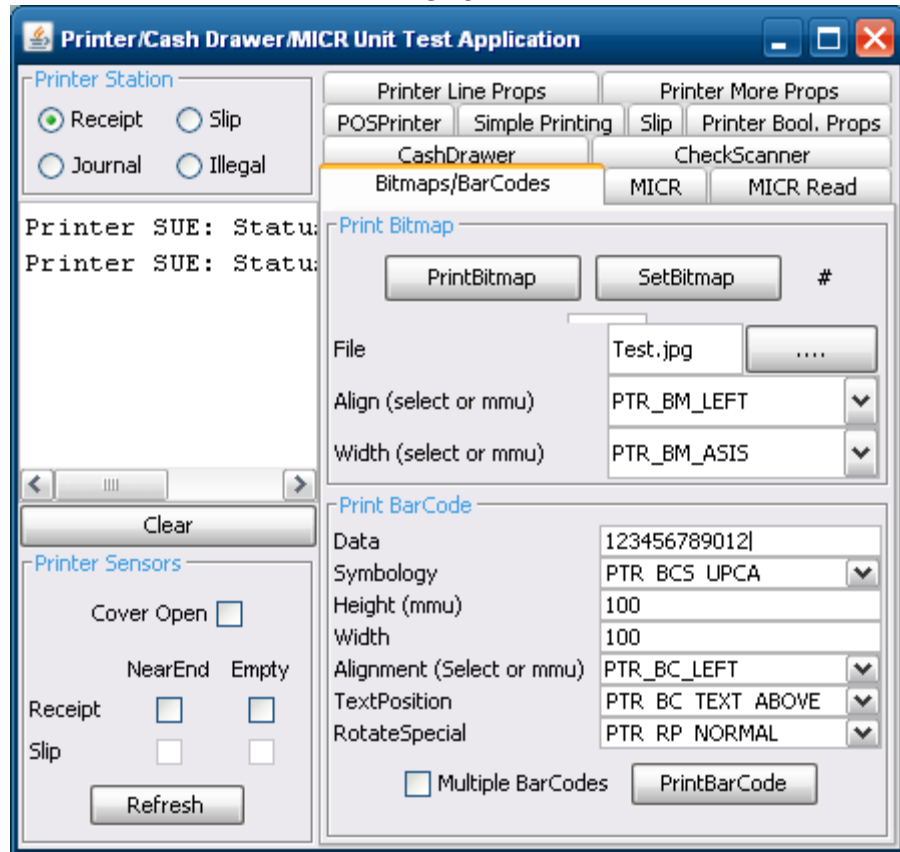

UPCE

Printer/Cash Drawer/MICR Unit Test Application

Printer Station

Receipt Slip
 Journal Illegal

Printer SUE: Statu:
Printer SUE: Statu:

Clear

Printer Sensors

Cover Open

NearEnd Empty
Receipt
Slip

Refresh

Printer Line Props **Printer More Props**

POSPrinter Simple Printing Slip Printer Bool. Props

CashDrawer **CheckScanner**

Bitmaps/BarCodes MICR MICR Read

Print Bitmap

PrintBitmap SetBitmap #

File Test.jpg

Align (select or mmu) PTR_BM_LEFT ▾

Width (select or mmu) PTR_BM_ASIS ▾

Print BarCode

Data 012200000345

Symbology PTR_BCS_UPCE ▾

Height (mmu) 100

Width 100

Alignment (Select or mmu) PTR_BC_LEFT ▾

TextPosition PTR_BC_TEXT_ABOVE ▾

RotateSpecial PTR_RP_NORMAL ▾

Multiple BarCodes **PrintBarCode**



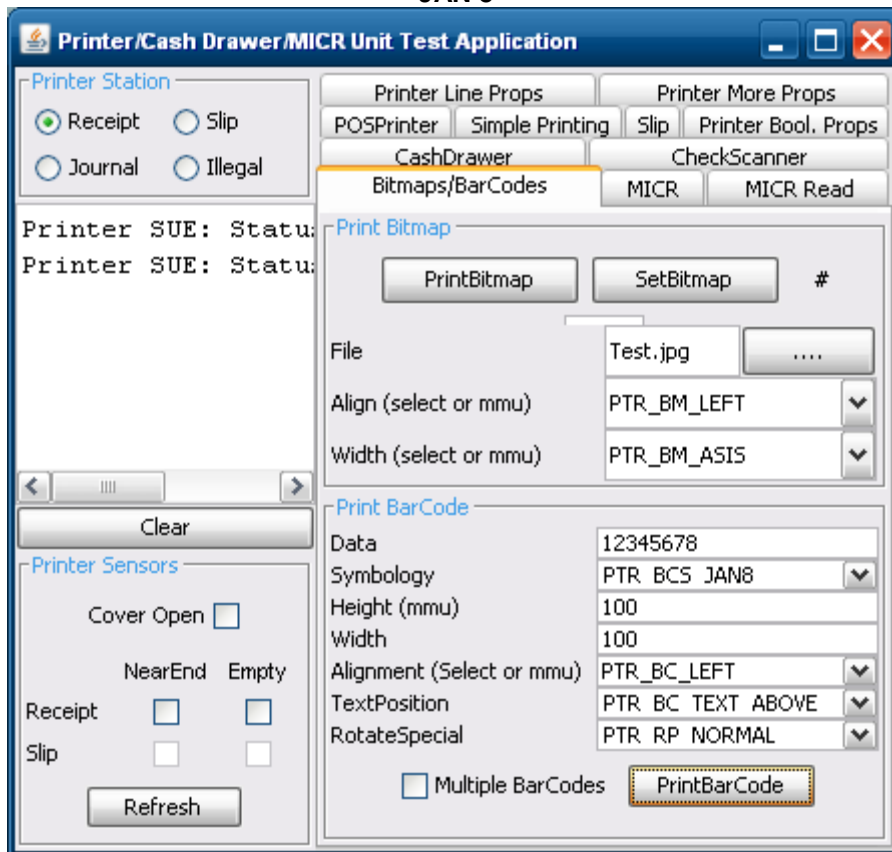

12345678



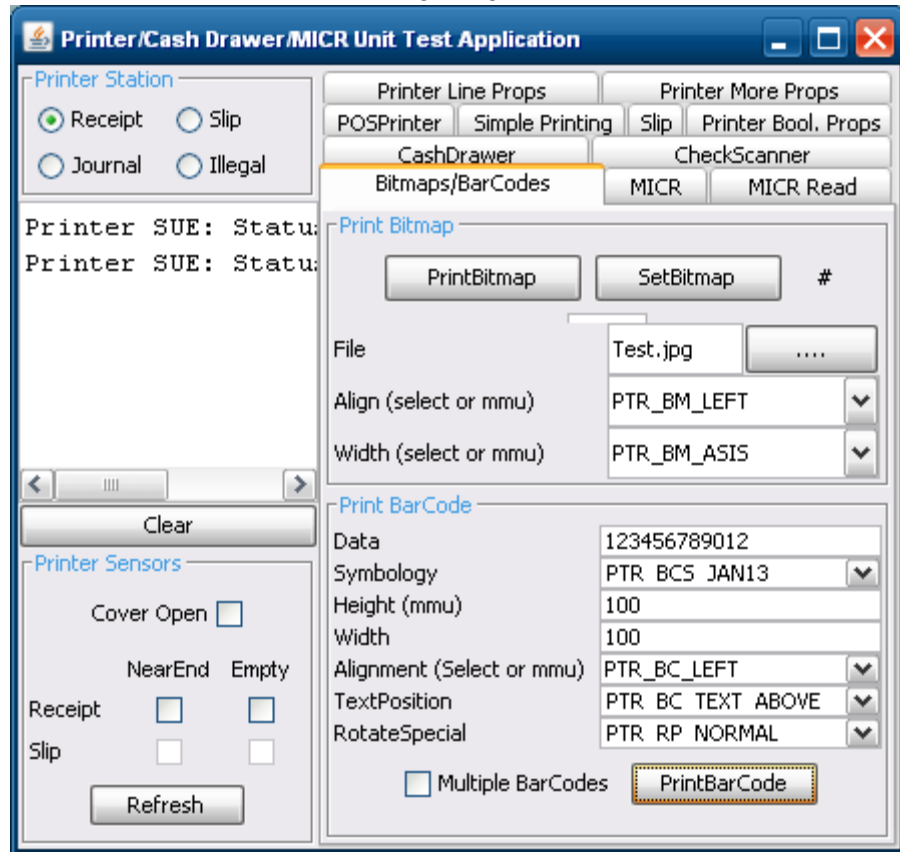

ITF

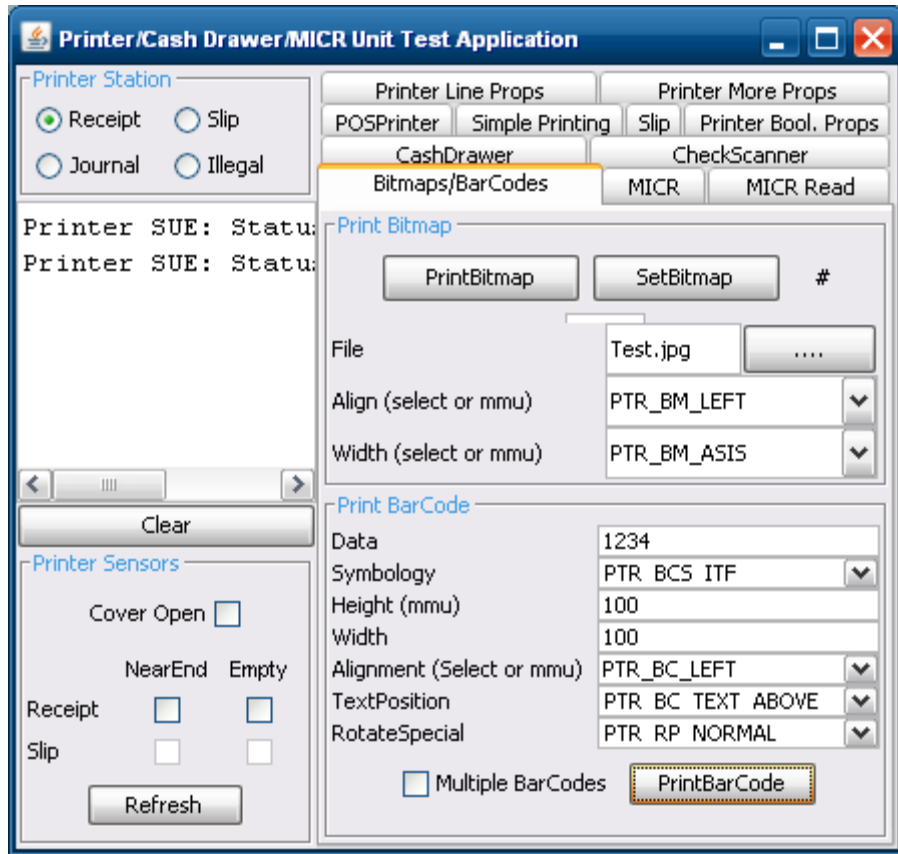

Codabar

Printer/Cash Drawer/MICR Unit Test Application

Printer Station

Receipt Slip
 Journal Illegal

Printer SUE: Statu:
Printer SUE: Statu:

Clear

Printer Sensors

Cover Open

NearEnd Empty
Receipt
Slip

Refresh

Printer Line Props **Printer More Props**

POSPrinter Simple Printing Slip Printer Bool. Props

CashDrawer **CheckScanner**

Bitmaps/BarCodes MICR MICR Read

Print Bitmap

PrintBitmap SetBitmap #

File Test.jpg

Align (select or mmu) PTR_BM_LEFT

Width (select or mmu) PTR_BM_ASIS

Print BarCode

Data A123456789B

Symbology PTR_BC5_Codabar

Height (mmu) 100

Width 100

Alignment (Select or mmu) PTR_BC_LEFT

TextPosition PTR_BC_TEXT_ABOVE

RotateSpecial PTR_RP_NORMAL

Multiple BarCodes **PrintBarCode**



Code 39

Printer/Cash Drawer/MICR Unit Test Application

Printer Station

Receipt Slip
 Journal Illegal

Printer SUE: Statu:
Printer SUE: Statu:

Clear

Printer Sensors

Cover Open

NearEnd Empty
Receipt
Slip

Refresh

Printer Line Props

POSPrinter Simple Printing

CashDrawer

Bitmaps/BarCodes

Printer More Props

Slip Printer Bool. Props

CheckScanner

MICR MICR Read

Print Bitmap

PrintBitmap SetBitmap #

File Test.jpg

Align (select or mmu) PTR_BM_LEFT

Width (select or mmu) PTR_BM_ASIS

Print BarCode

Data 1234567890

Symbology PTR_BCS_Code39

Height (mmu) 100

Width 100

Alignment (Select or mmu) PTR_BC_LEFT

TextPosition PTR_BC_TEXT_ABOVE

RotateSpecial PTR_RP_NORMAL

Multiple BarCodes **PrintBarCode**



Code 93

Printer/Cash Drawer/MICR Unit Test Application

Printer Station

Receipt Slip
 Journal Illegal

Printer SUE: Statu:
Printer SUE: Statu:

Clear

Printer Sensors

Cover Open

NearEnd Empty
Receipt
Slip

Refresh

Printer Line Props

POSPrinter Simple Printing

CashDrawer

Bitmaps/BarCodes

Printer More Props

Slip Printer Bool. Props

CheckScanner

MICR MICR Read

Print Bitmap

PrintBitmap SetBitmap #

File Test.jpg

Align (select or mmu) PTR_BM_LEFT

Width (select or mmu) PTR_BM_ASIS

Print BarCode

Data 1234567890

Symbology PTR_BC5_Code93

Height (mmu) 100

Width 100

Alignment (Select or mmu) PTR_BC_LEFT

TextPosition PTR_BC_TEXT_ABOVE

RotateSpecial PTR_RP_NORMAL

Multiple BarCodes **PrintBarCode**



Code 128

Printer/Cash Drawer/MICR Unit Test Application

Printer Station

Receipt Slip
 Journal Illegal

Printer SUE: Statu:
Printer SUE: Statu:

Printer Line Props **Printer More Props**
POSPrinter Simple Printing Slip Printer Bool. Props
CashDrawer **CheckScanner**
Bitmaps/BarCodes MICR MICR Read

Print Bitmap

PrintBitmap SetBitmap #

File: Test.jpg

Align (select or mmu): PTR_BM_LEFT

Width (select or mmu): PTR_BM_ASIS

Print BarCode

Data: i1234567890/01

Symbology: PTR_BC5 Code128

Height (mmu): 100

Width: 100

Alignment (Select or mmu): PTR_BC_LEFT

TextPosition: PTR_BC_TEXT_ABOVE

RotateSpecial: PTR_RP_NORMAL

Multiple BarCodes PrintBarCode

Printer Sensors

Cover Open

NearEnd Empty

Receipt

Slip

Refresh

Clear

4950515253545556574847484900



Code 128

Printer/Cash Drawer/MICR Unit Test Application

Printer Station

Receipt Slip
 Journal Illegal

Printer SUE: Statu:
Printer SUE: Statu:

Clear

Printer Sensors

Cover Open

NearEnd Empty
Receipt
Slip

Refresh

Printer Line Props **Printer More Props**

POSPrinter Simple Printing Slip Printer Bool. Props

CashDrawer **CheckScanner**

Bitmaps/BarCodes MICR MICR Read

Print Bitmap

PrintBitmap SetBitmap #

File Test.jpg

Align (select or mmu) PTR_BM_LEFT

Width (select or mmu) PTR_BM_ASIS

Print BarCode

Data i1234567890

Symbology PTR_BC5_Code128

Height (mmu) 100

Width 100

Alignment (Select or mmu) PTR_BC_LEFT

TextPosition PTR_BC_TEXT_ABOVE

RotateSpecial PTR_RP_NORMAL

Multiple BarCodes PrintBarCode

4950515253545556574800



Code 128 Parsed

Printer/Cash Drawer/MICR Unit Test Application

Printer Station
 Receipt Slip
 Journal Illegal

Printer SUE: Statu:
Printer SUE: Statu:

Clear

Printer Sensors
Cover Open
NearEnd Empty
Receipt
Slip
Refresh

POSPrinter Simple Printing Slip Printer Bool. Props
MICR MICR Read CashDrawer CheckScanner
Printer Line Props Printer More Props Bitmaps/BarCodes

Print Bitmap
PrintBitmap SetBitmap # 1

File Test.jpg
Align (select or mmu) PTR_BM_LEFT
Width (select or mmu) PTR_BM_ASIS

Print BarCode
Data {A123456789
Symbology PTR_BCS_Code128_Parsed
Height (mmu) 100
Width 100
Alignment (Select or mmu) PTR_BC_LEFT
TextPosition PTR_BC_TEXT_ABOVE
RotateSpecial PTR_RP_NORMAL
 Multiple BarCodes PrintBarCode



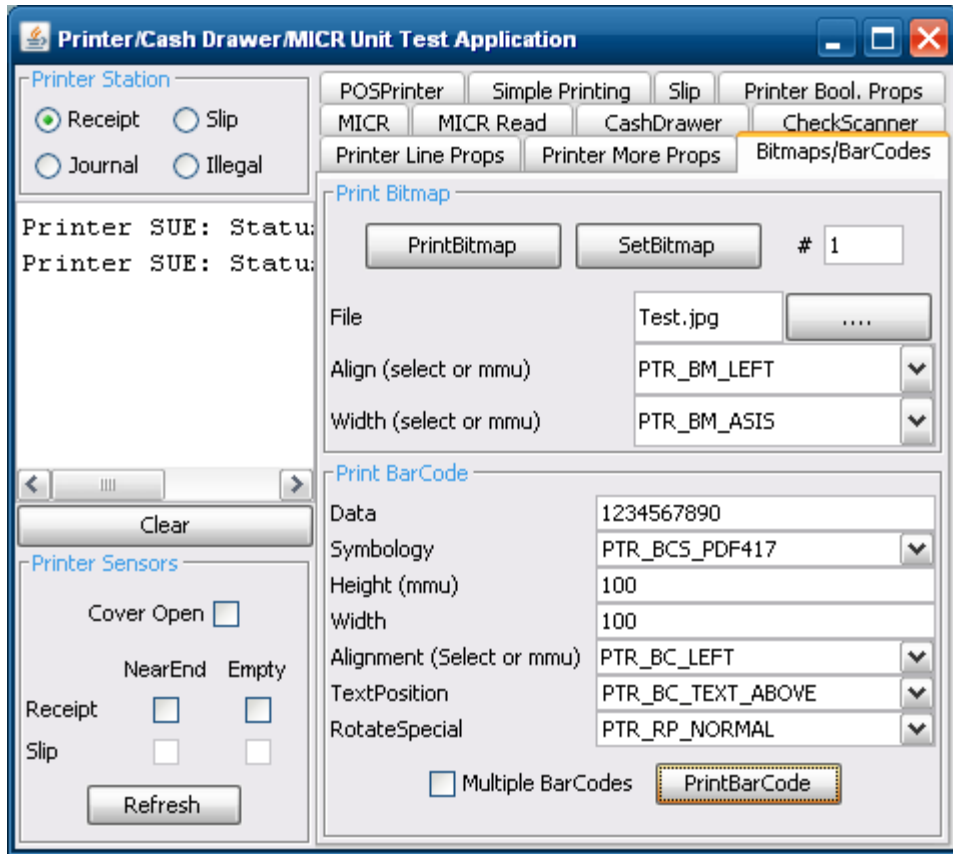

QR Code

Printer/Cash Drawer/MICR Unit Test Application

Printer Station

Receipt Slip
 Journal Illegal

Printer SUE: Statu:
Printer SUE: Statu:

POSPrinter Simple Printing Slip Printer Bool. Props
MICR MICR Read CashDrawer CheckScanner
Printer Line Props Printer More Props Bitmaps/BarCodes

Print Bitmap

PrintBitmap SetBitmap # 1

File Test.jpg
Align (select or mmu) PTR_BM_LEFT
Width (select or mmu) PTR_BM_ASIS

Print BarCode

Data ASDFGHJKL
Symbology PTR_BCS_QRCODE
Height (mmu) 200
Width 200
Alignment (Select or mmu) PTR_BC_LEFT
TextPosition PTR_BC_TEXT_NONE
RotateSpecial PTR_RP_NORMAL

Multiple BarCodes **PrintBarCode**

Printer Sensors

Cover Open
NearEnd Empty
Receipt
Slip
Refresh



6.4.21 JPOS Drivers for the Cash Drawer Drivers

The JPOS drivers are included in the HP factory image and are also available from HP.COM.

The following is an overview of the steps to test the receipt printer followed by detailed steps:

1. Open **Printer/Cash Drawer/MICR Unit Test Application**.
 - C:\xxxxx\Point of Sale\Receipt Printer\JPOS POS Printer\HPJPOSPrinter.bat.
2. Click on the CashDrawer tab.
3. Select the CashDrawer model in the Profile dropdown box:
4. Click the **Open** button.
5. Click the **Claim** button.
6. Click the **Enable** button.
7. To exit the application:
 - a. Click the **Disable** button.
 - b. Click the **Release** button.
 - c. Click the **Close** button.
 - d. Click the "X" in the upper righthand corner of the application.

Detailed Steps

1. Open **Printer/Cash Drawer/MICR Unit Test Application**.
 - C:\xxxxx\Point of Sale\Receipt Printer\JPOS POS Printer\HPJPOSPrinter.bat.
2. Click on the CashDrawer tab.

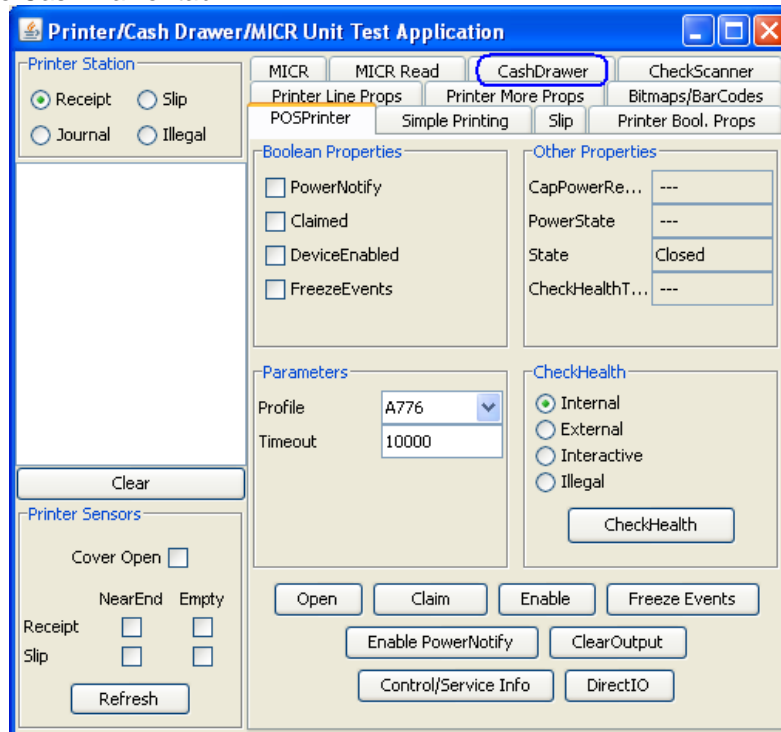

3. Select the CashDrawer model in the Profile dropdown box.

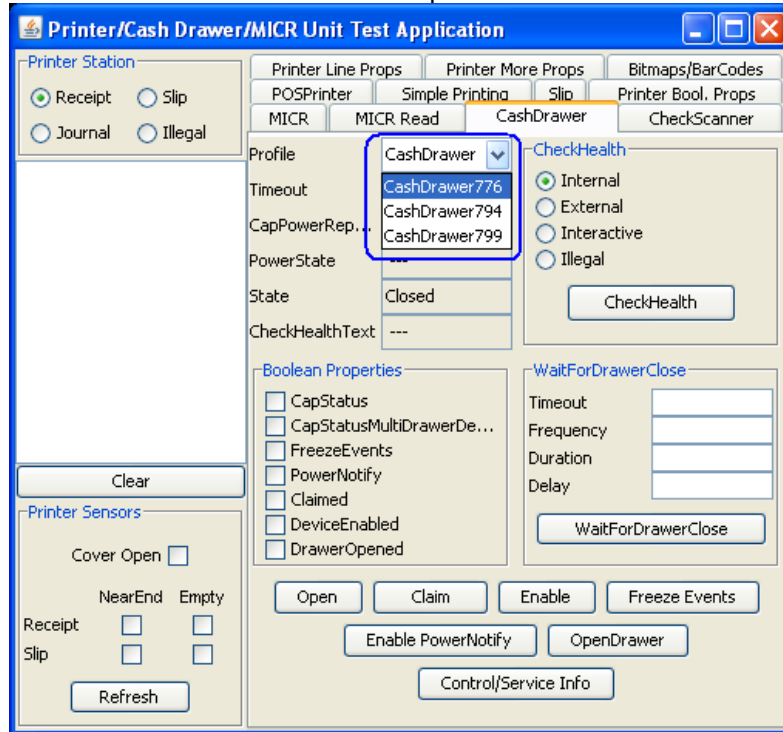

4. Click the **Open** button.
5. Click the **Claim** button.
6. Click the **Enable** button.

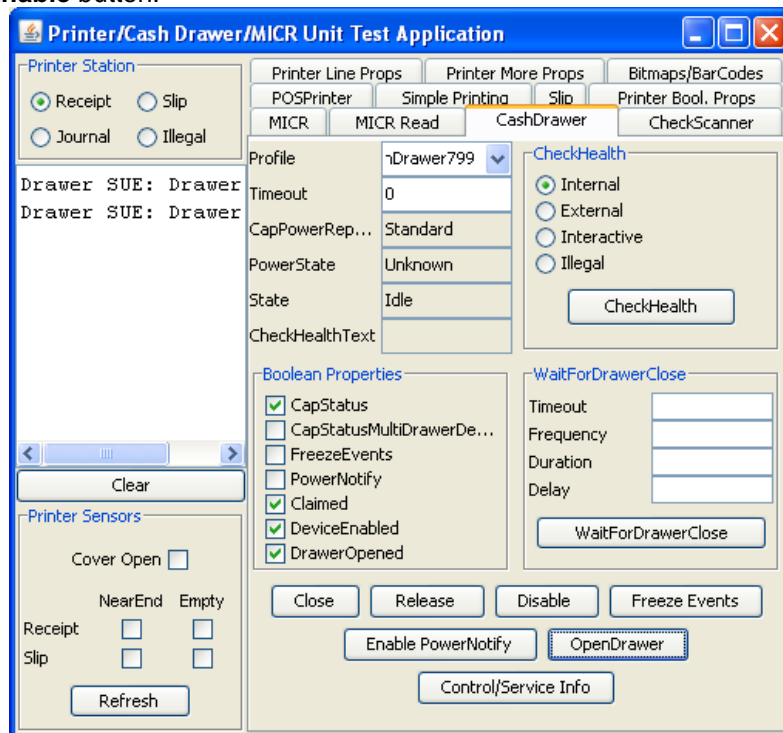

Note: Depending on the JPOS driver version (prior to March 2012 release) when you click on the "OpenDrawer" button the cash drawer should pop open. When the "Timeout" value set to "0", if the cash drawer is not closed within 10 seconds a "JPOSEXCEPTION CAUGHT" error message will appear, this is OK since the cash drawer is open.

7. To exit the application:
 - Click the **Disable** button.
 - Click the **Release** button.
 - Click the **Close** button.
 - Click the "X" in the upper righthand corner of the application.

6.4.22 **HP Font Utility (ASIAN Font Download) – Single Station (A799 with 4MG) Printer**

The single station printer can have an additional font downloaded to the printer via the HP Font Download utility. The English font will always be present in the printer even when an additional font is downloaded to the printer. The following fonts can be downloaded to the printer: Chinese / Kanji / Korean.

Note: This is only needs to be performed on the single station printer that has 4MB of memory. The printers that have 8MB of memory have the font already resident on the printer and do not need this utility.

6.4.22.1 **HP Font Utility (Asian Font Download Utility)**

The following is overview of the steps to test the receipt printer followed by detailed steps:

1. Install the HP Asian Font Downloader utility, the SETUP.EXE can be found on “HP POS Drivers and Documentation CD” or from the HP.COM web site. After the installation is complete, open the “HP FONT LOADER” from the Windows START menu.
2. Click on the “Allocate Memory for Fonts” button. The status box will indicate that the allocation process has been completed.
3. Click on the language that you would like to download to the printer. This process can take 10 minutes to complete; during the download process the LED on the printer will blink. When the process has completed downloading, the font the status box will indicate that is it complete.
4. Click on “Print Sample/Diagnostics” to confirm you are able to get a print out after the font download. Note the print out will be in English.
5. Click on “Exit” to leave and close the application.

Detailed Steps

1. Install the HP Asian Font Downloader utility, the SETUP.EXE can be found on “HP POS Drivers and Documentation CD” or from the HP.COM web site. After the installation is complete, open the “HP FONT LOADER” from the Windows START menu.

- Click on the “Allocate Memory for Fonts” button. The status box will indicate that the allocation process has been completed.

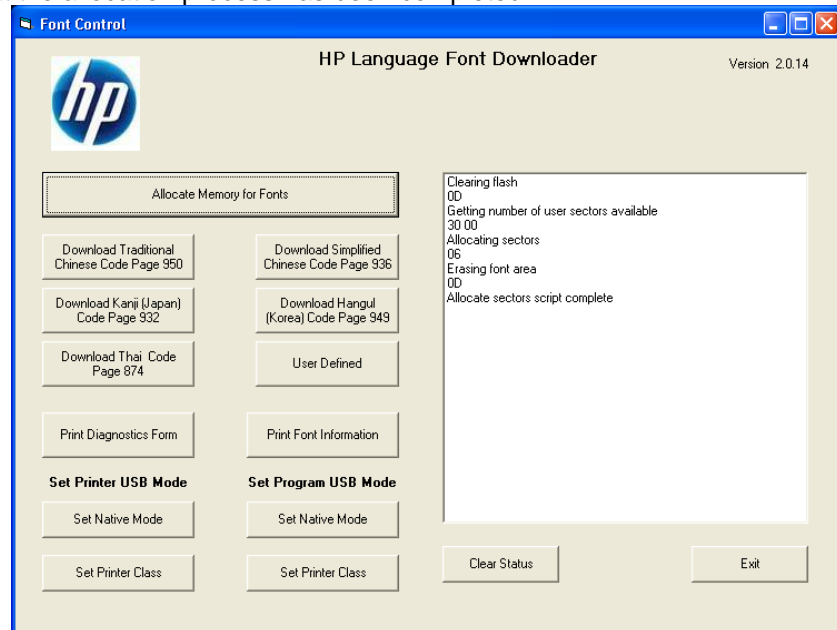

- Click on the language that you would like to download to the printer. This process can take up to 10 minutes to complete; during the download process the LED on the printer will blink. When the process has completed downloading, the font the status box will indicate that it is complete.

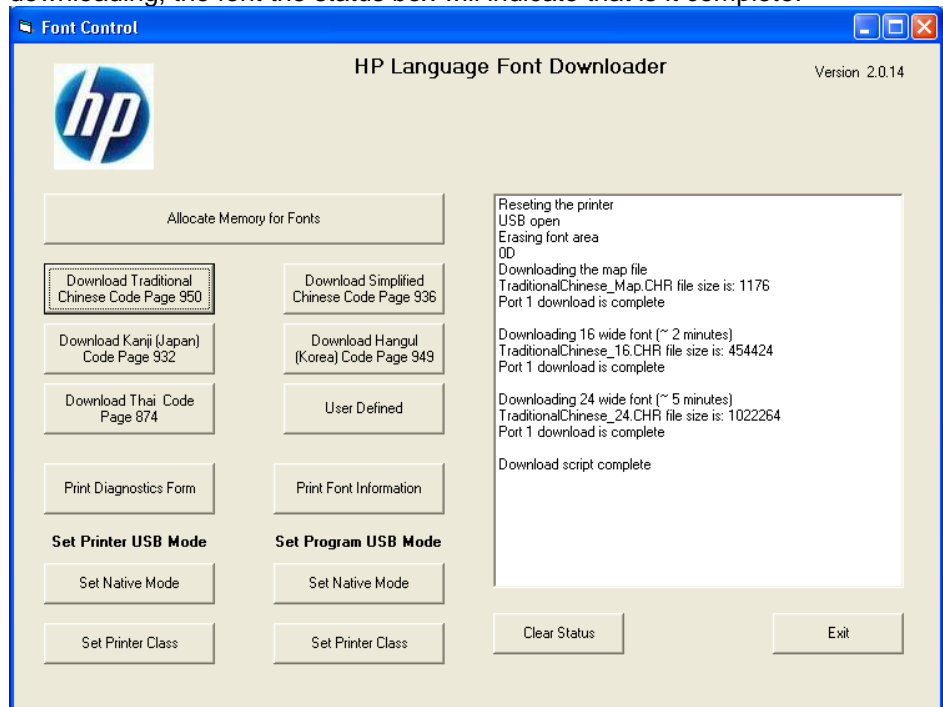

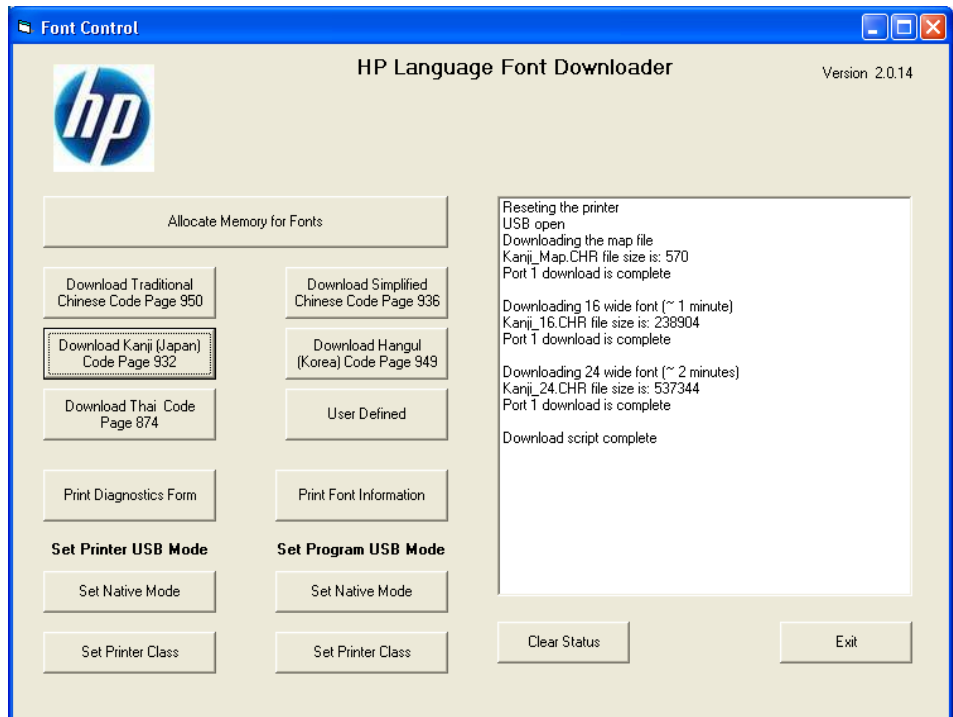
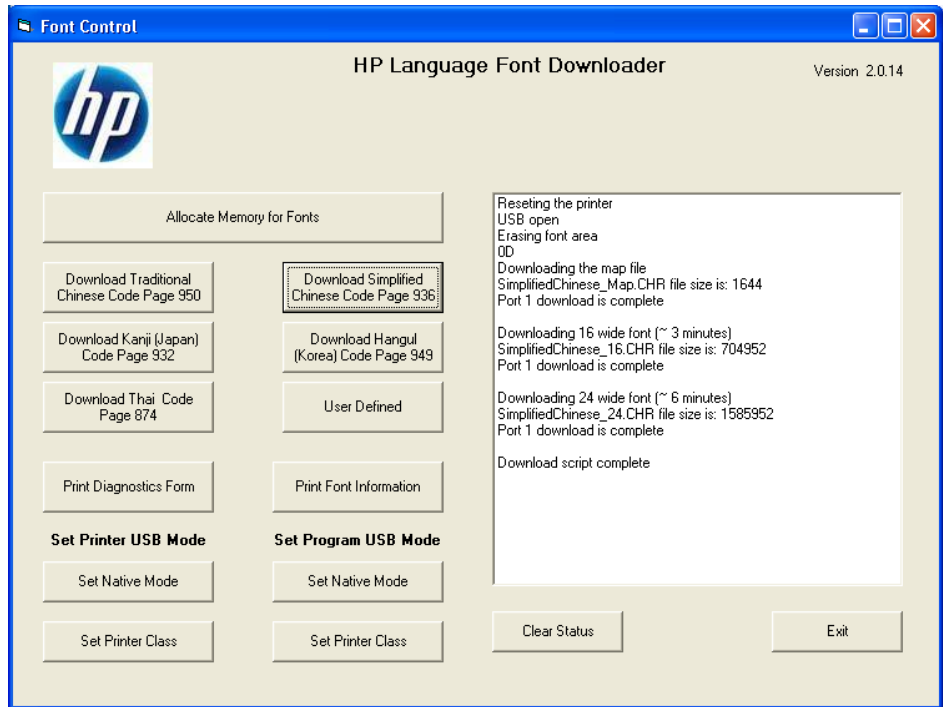

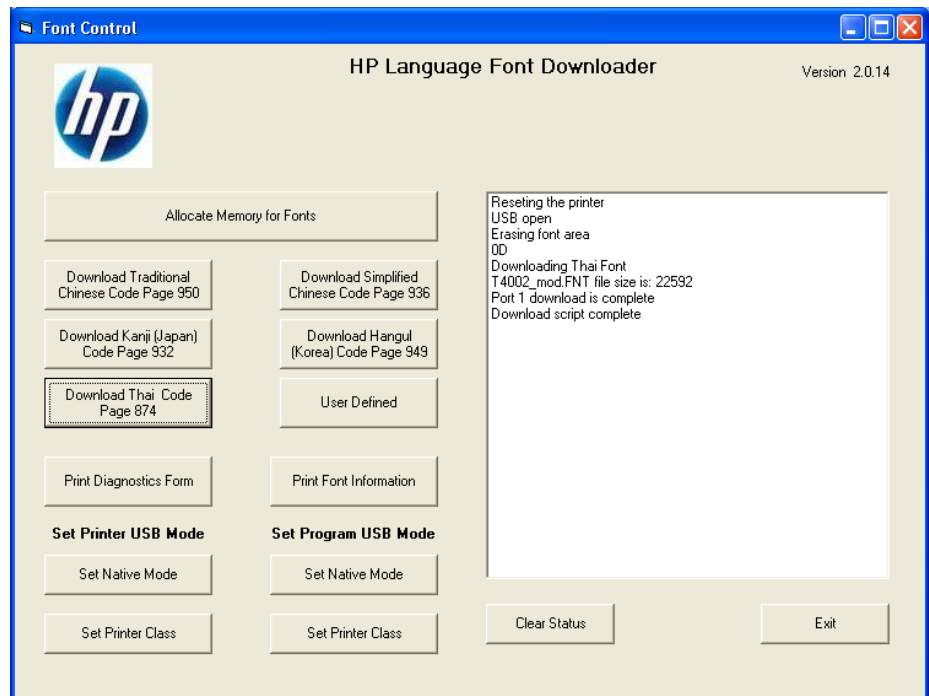
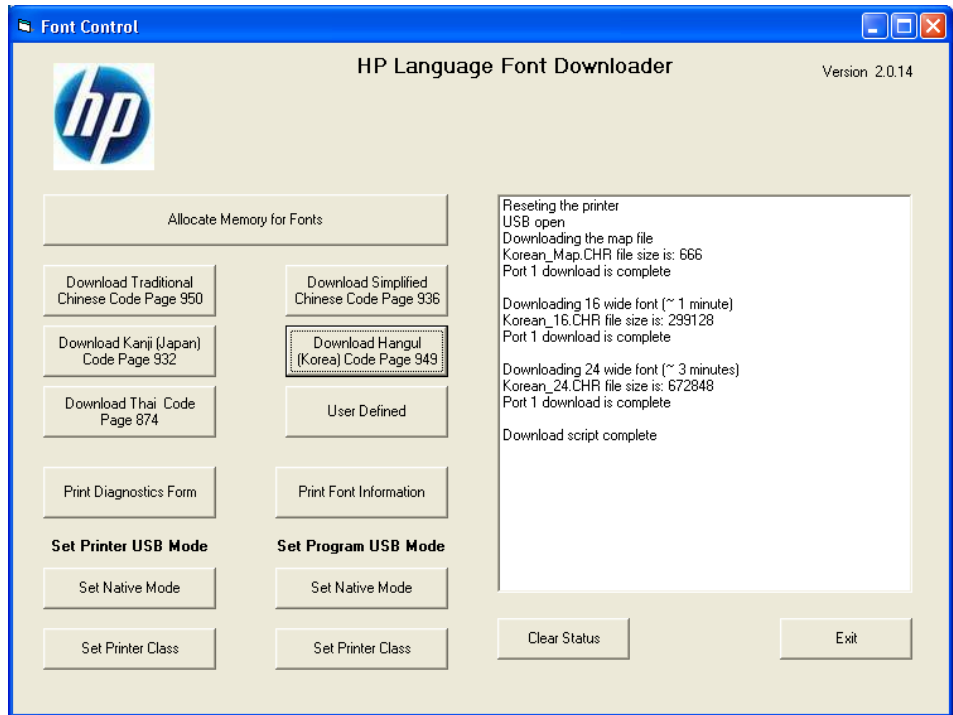

- Click on “Print Sample/Diagnostics” to confirm you are able to get a print out after the font download. Note that the print out will be in English.

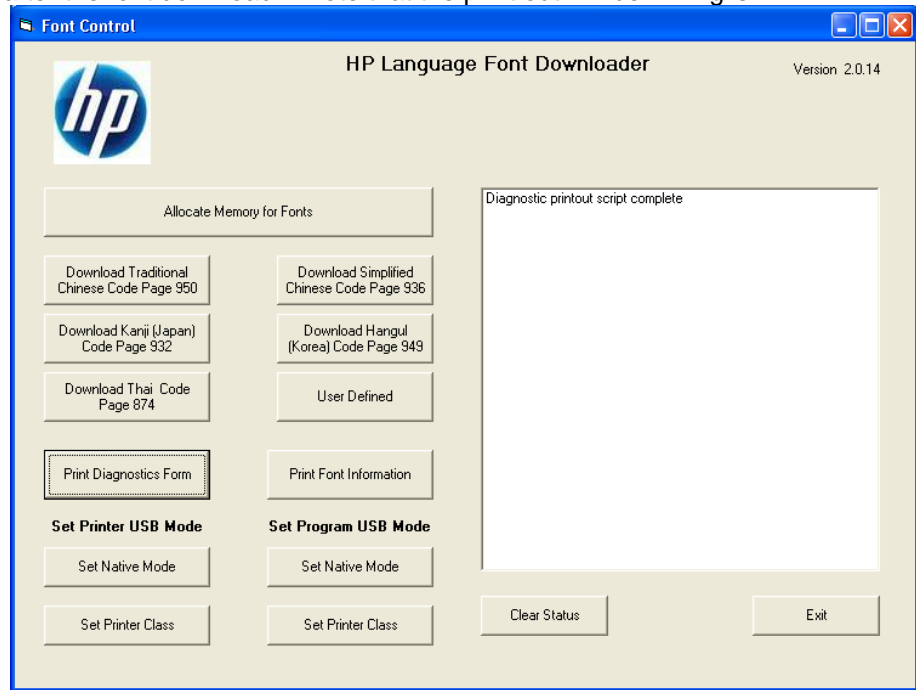

- Click on “Exit” to leave and close the application.

6.5 HP ap5000 MSR (Magnetic Stripe Reader)



6.5.1 Connection

The MSR on the HP ap5000 system is integrated into the system which is connected internally via serial interface; default is COM4. There is no user connection required for this device.

	ap5000 MSR
Port	COM4
Baud Rate	19200
Data Bit	8
Parity	None
Stop Bit	1
Flow Control	None

6.5.2 Windows Drivers for the HP ap5000 MSR

Windows operating system supports serial port COM4, so no extra drivers are needed to be installed.

6.5.3 OPOS Drivers for the HP ap5000 MSR

The HP ap5000 OPOS drivers are included in the HP factory image (C:\xxxx\Point of Sale\MSR HP ap5000\ap5000 MSR OPOS) and are also available from HP.COM.

6.5.4 Testing HP ap5000 MSR

6.5.4.1 Testing HP ap5000 MSR in non-OPOS mode

The following is overview of the steps to test the ap5000 MSR followed by detailed steps:

1. Start the non-OPOS test utility from Windows start menu.
2. Select the COM port from the drop down box or keep the default option of "Auto" which will search for the ap5000 MSR device. Click on the "Test Mode" button to start the test.

3. When the “Test Mode” has been selected the COM port will appear and in the GUI title bar “(Test Mode)” will appear. At this point when one swipes a card in the ap5000 MSR, the data will appear in the test utility.
4. To exit the application:
 - a. Click “Test Mode” so “(Test Mode)” does not appear in the title of the GUI.
 - b. Click on “Exit” to close test applet.

Detailed Steps

1. Start the non-OPOS test utility from Windows start menu.
2. Select the COM port from the drop down box or keep the default option of “Auto” which will search for the ap5000 MSR device. Click on the “Test Mode” button to start the test.

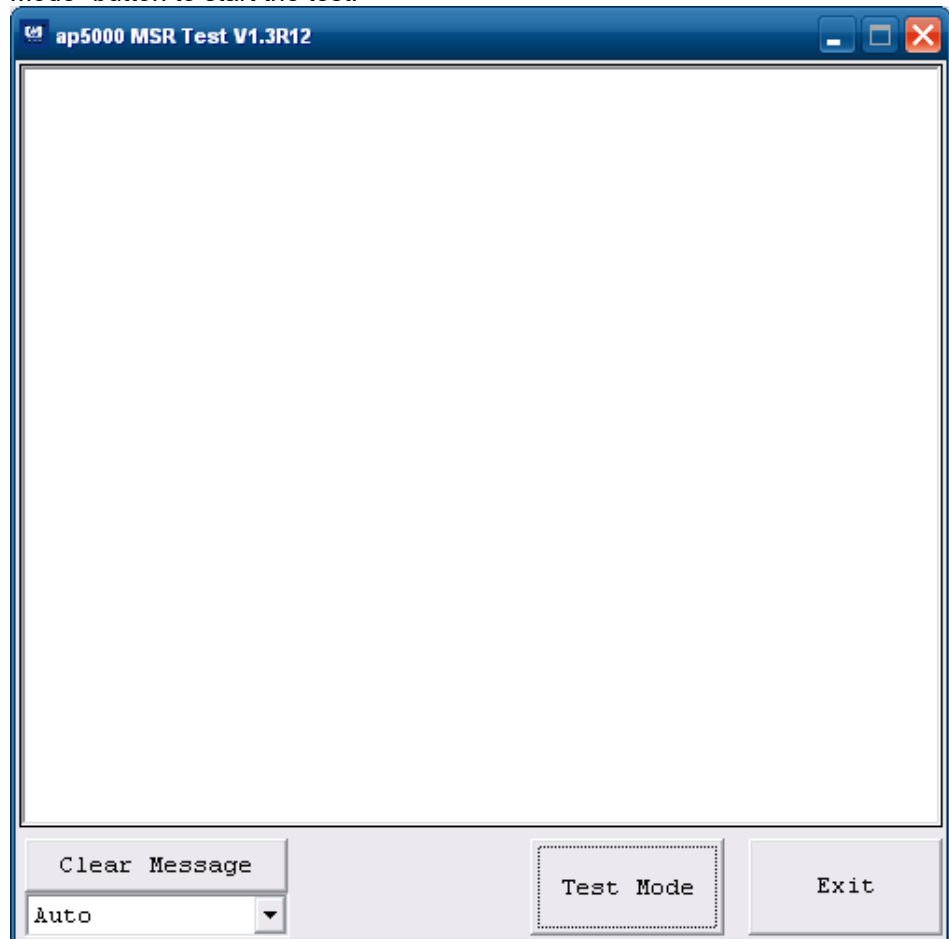

3. When the “Test Mode” has been selected the COM port will appear and in the GUI title bar “(Test Mode)” will appear. At this point when one swipes a card in the ap5000 MSR, the data will appear in the test utility.

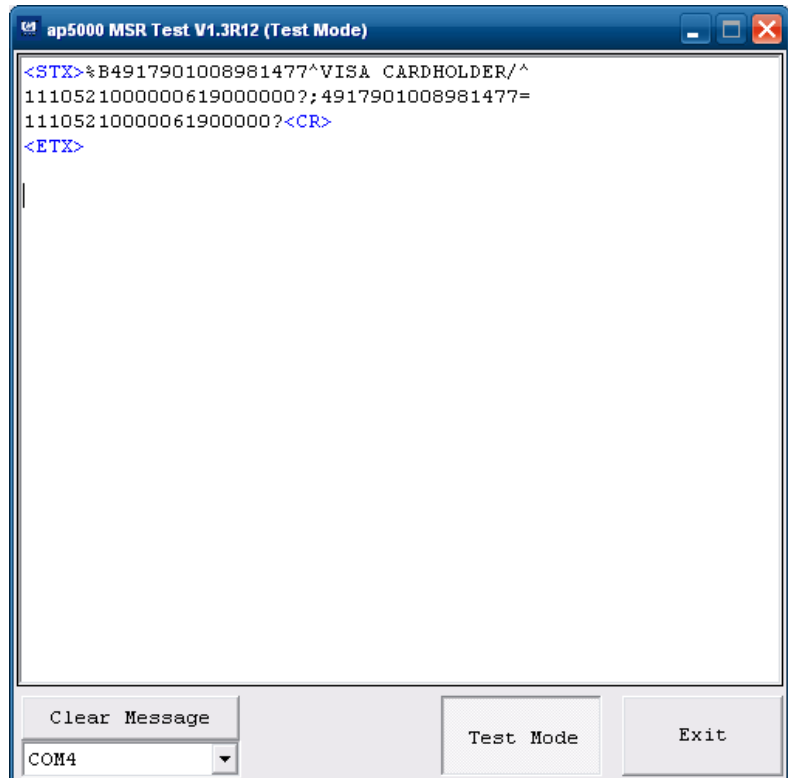
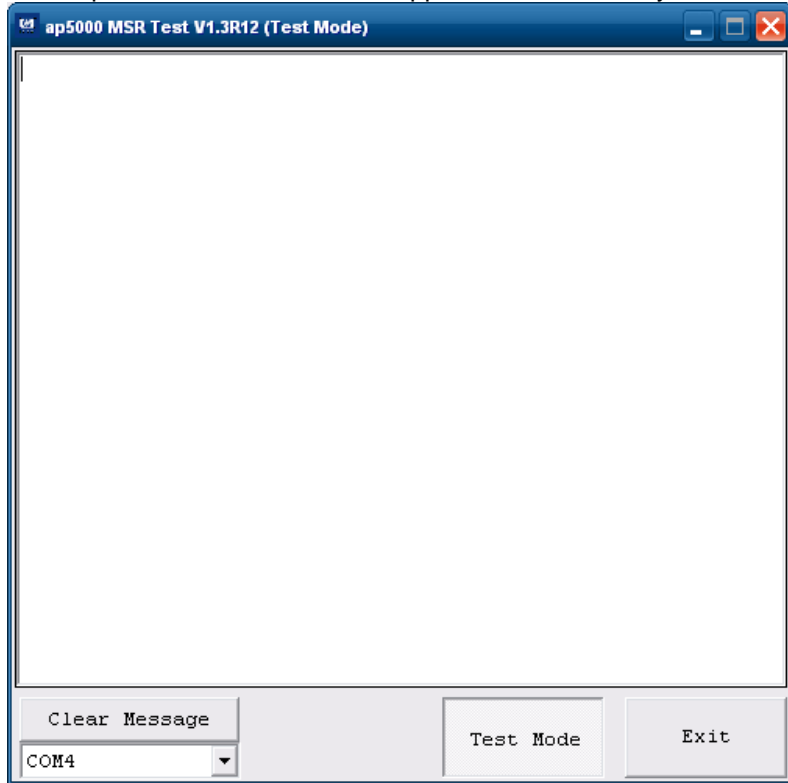

4. To exit the application:
 - a. Click "Test Mode" so "(Test Mode)" does not appear in the title of the GUI.

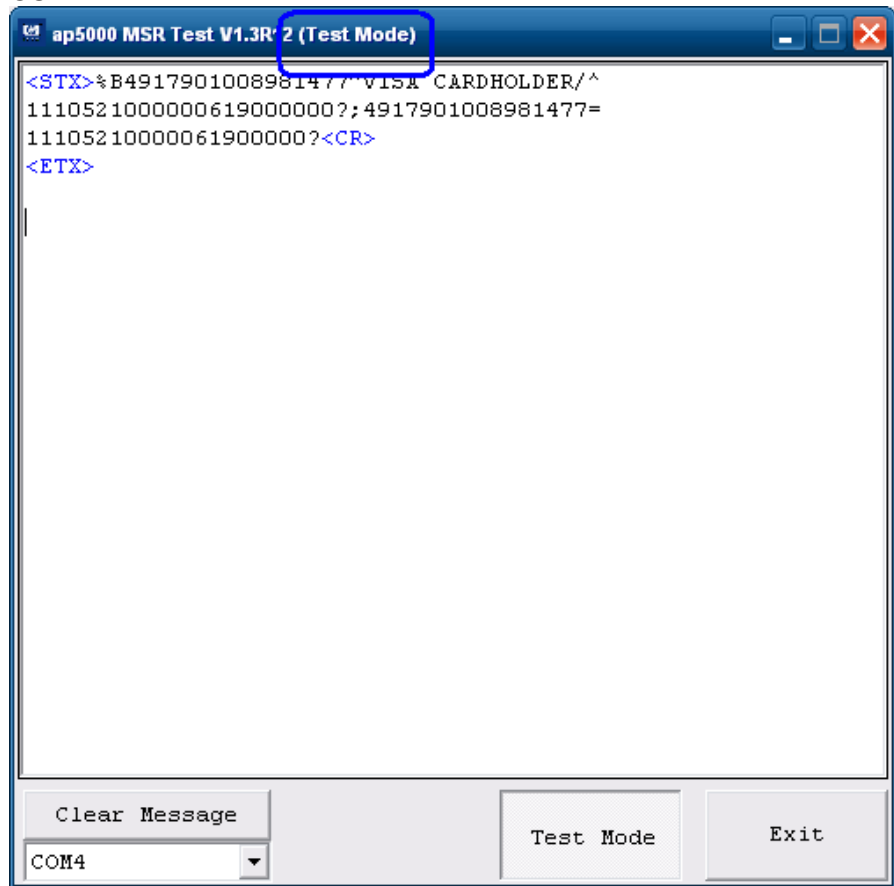

- b. Click on "Exit" to close test applet.

6.5.4.2 Testing HP ap5000 MSR in OPOS mode

The following is overview of the steps to test the ap5000 MSR followed by detailed steps:

1. Start the OPOS test utility from Windows start menu.
2. Click on the “OPEN” button to start the test, should receive “Open Success” status message.
3. When one swipes a valid card in the ap5000 MSR data should appear in the test utility. The “x” represent will be replaced by the data that is read from the card that is swiped.
4. To exit the application:
 - a. Click “CLOSE” button.
 - b. Click on “X” in the upper right hand corner to close the test applet.

Detailed Steps

1. Start the OPOS test utility from Windows start menu.

When the utility is opened the following is the GUI that will appear:

hp ap5000 MSR OPOS Test Utility V1.0.4

Please swipe a card.

Account number:

Expiration date:

First Name:

Surname:

Middle initials:

Track1:

Track2:

Track3:

Track4:

Clear Open Close

2. Click on the "OPEN" button to start the test, should receive "Open Success" status message.

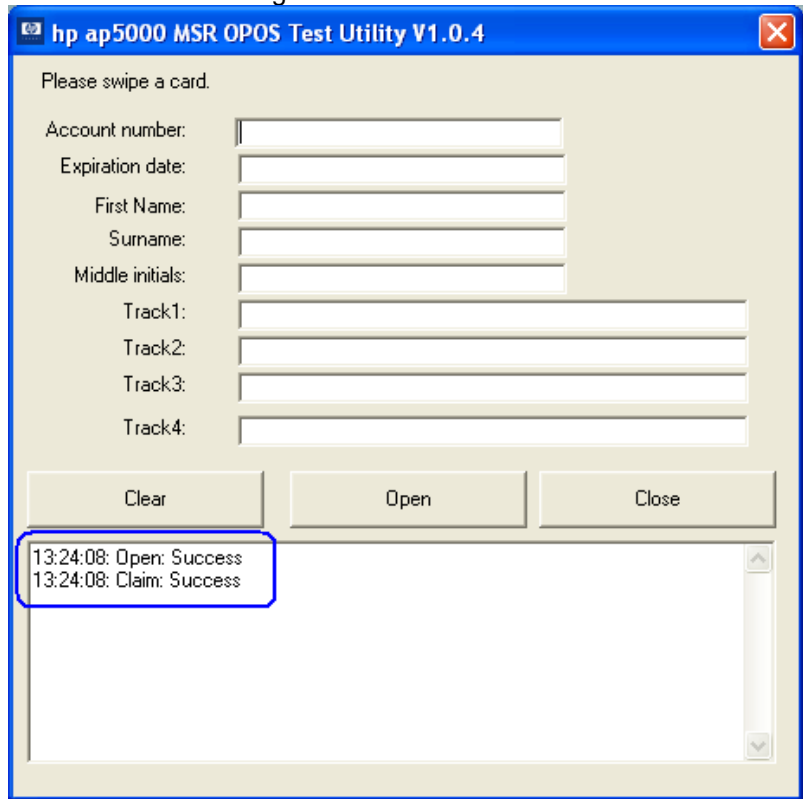

3. When one swipes a valid card in the ap5000 MSR data should appear in the test utility. The "x" represent will be replaced by the data that is read from the card that is swiped.

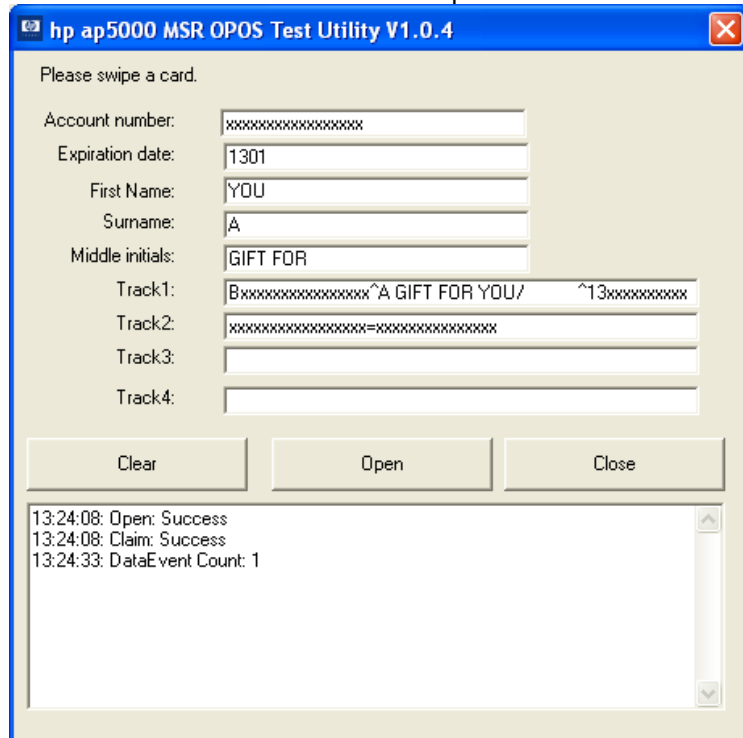

4. To exit the application:
 - a. Click "CLOSE" button.
 - b. Click on "X" in the upper right hand corner to close the test applet.

hp ap5000 MSR OPOS Test Utility V1.0.4

Please swipe a card.

Account number:

Expiration date:

First Name:

Surname:

Middle initials:

Track1:

Track2:

Track3:

Track4:

Clear Open Close

13:24:08: Open: Success
13:24:08: Claim: Success

6.5.5 **JPOS Drivers for the HP ap5000 MSR**

The HP ap5000 JPOS drivers are included in the HP factory image (C:\xxxxx\Point of Sale\MSR HP ap5000\ap5000 MSR JPOS) and are also available from HP.COM.

The following is overview of the steps to test the ap5000 MSR followed by detailed steps:

1. Start the JPOS test utility either using the link in the START MENU or by opening the POSTEST.BAT file locate in the JPOS folder in the ap5000 MSR folder.
2. Click on the “MSR” tab.
3. After clicking on the “MSR” tab.
4. Click on the “OPEN” button.
5. Click on the “CLAIM” button.
6. Check the “DATA EVENT ENABLED” so there is a check box.
7. Check the “DEVICE ENABLED” so there is a check box.
8. Swipe a credit card and text should appear in the field.
9. Click on “RELEASE” / “CLOSE” and then click “EXIT” to exit the JPOS test utility.

Detailed Steps

1. Start the JPOS test utility either using the link in the START MENU or by opening the POSTEST.BAT file that is located in the JPOS folder within the ap5000 MSR folder.

After a few seconds the JPOS test utility GUI will appear as shown below:

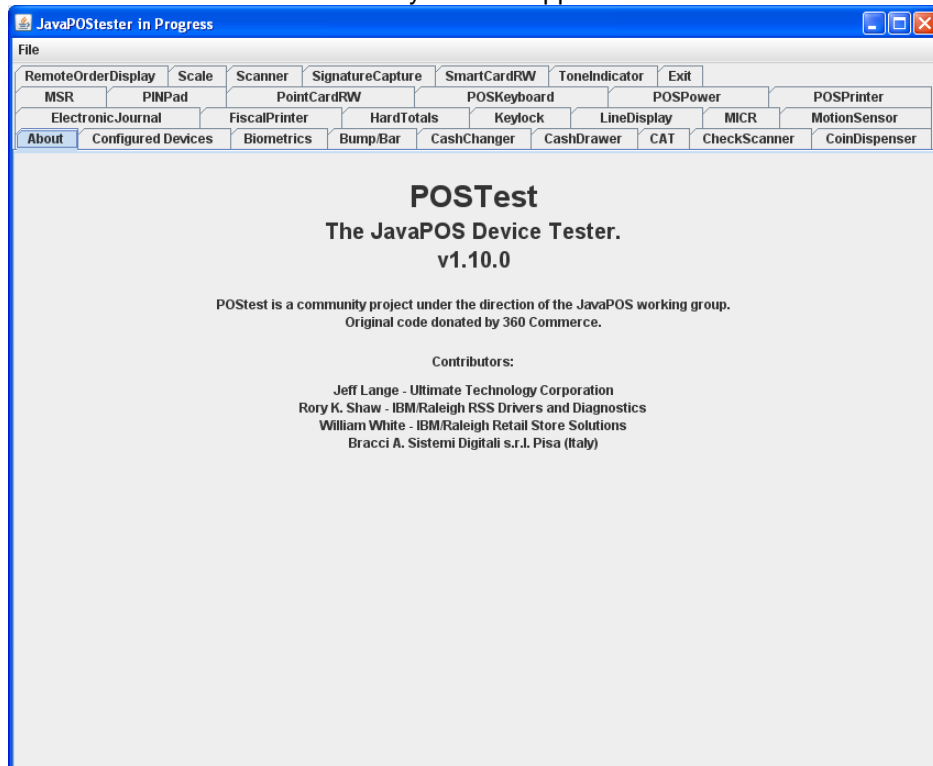

2. Click on the “MSR” tab:

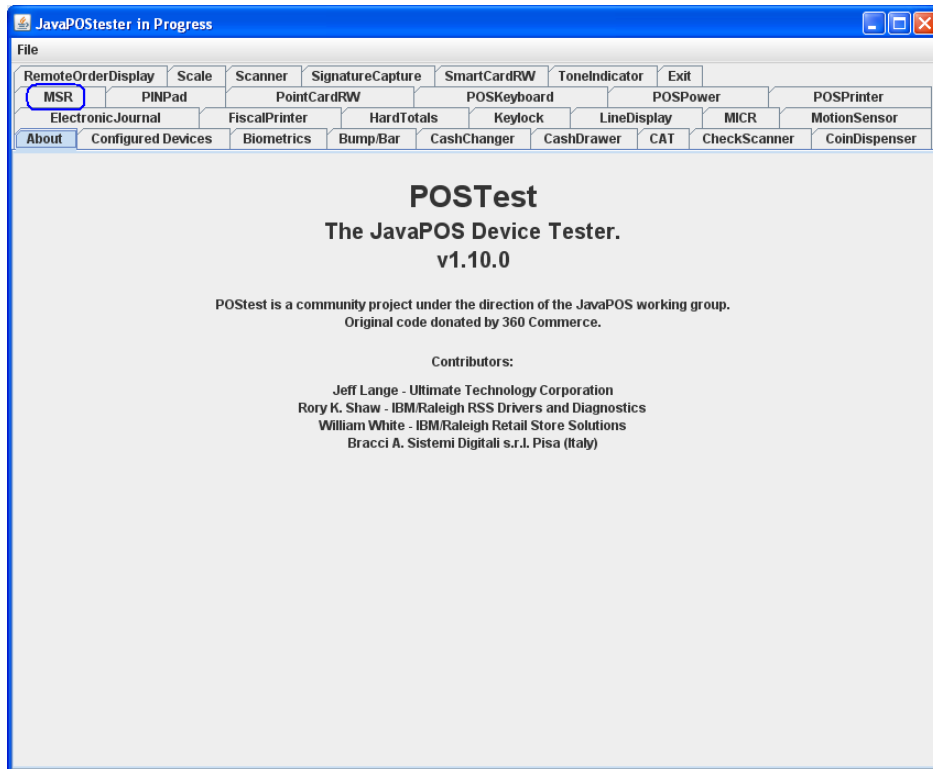

3. After clicking on the “MSR” tab the screen should look like:

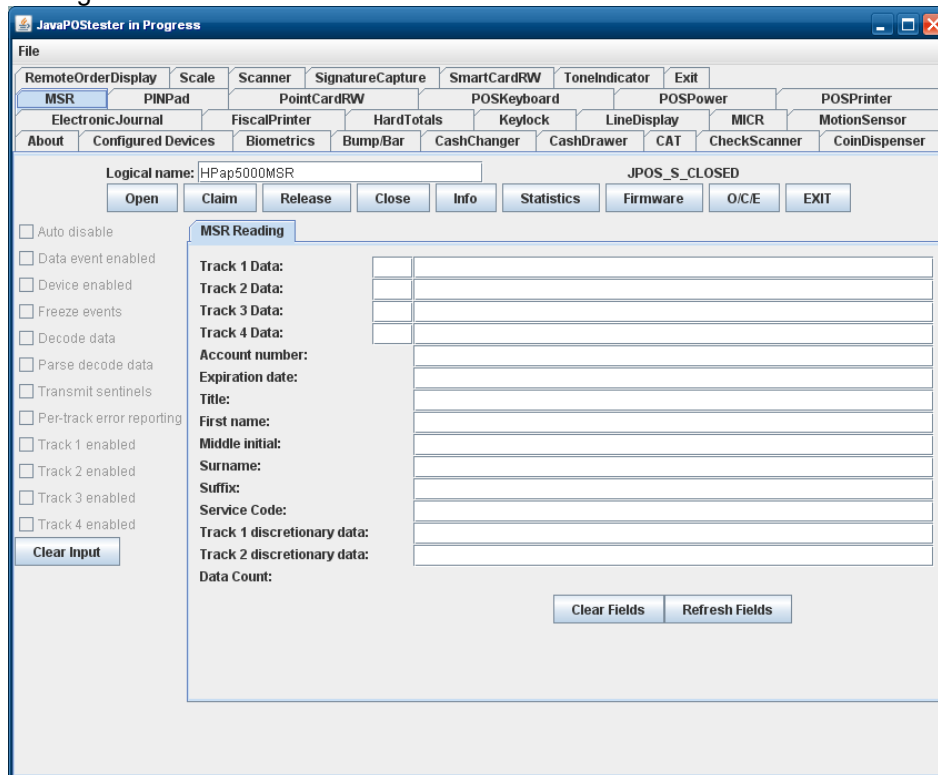

The logical name of the device is “HPap5000MSR” which should appear in the logical name field. If another name is present, change the logical name to “HPap5000MSR”. If one clicks on the “Configured Device” tab, the names for the device will appear that will be used in the test utility.

4. Click on the “OPEN” button.
5. Click on the “CLAIM” button.

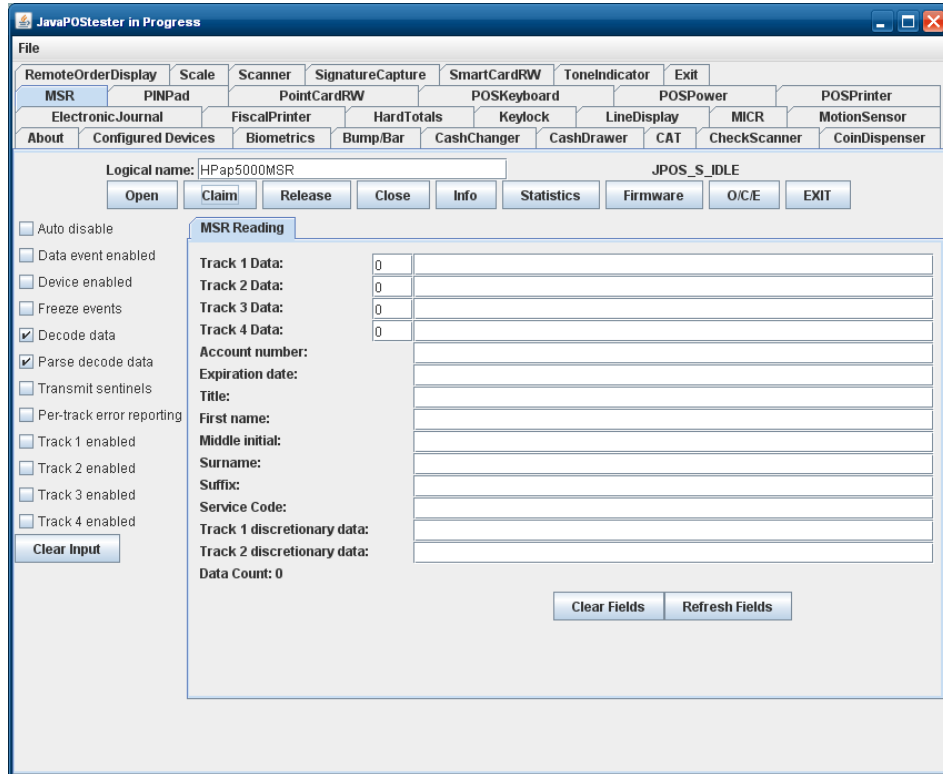

6. Check the "DATA EVENT ENABLED" so there is a check box.
7. Check the "DEVICE ENABLED" so there is a check box.

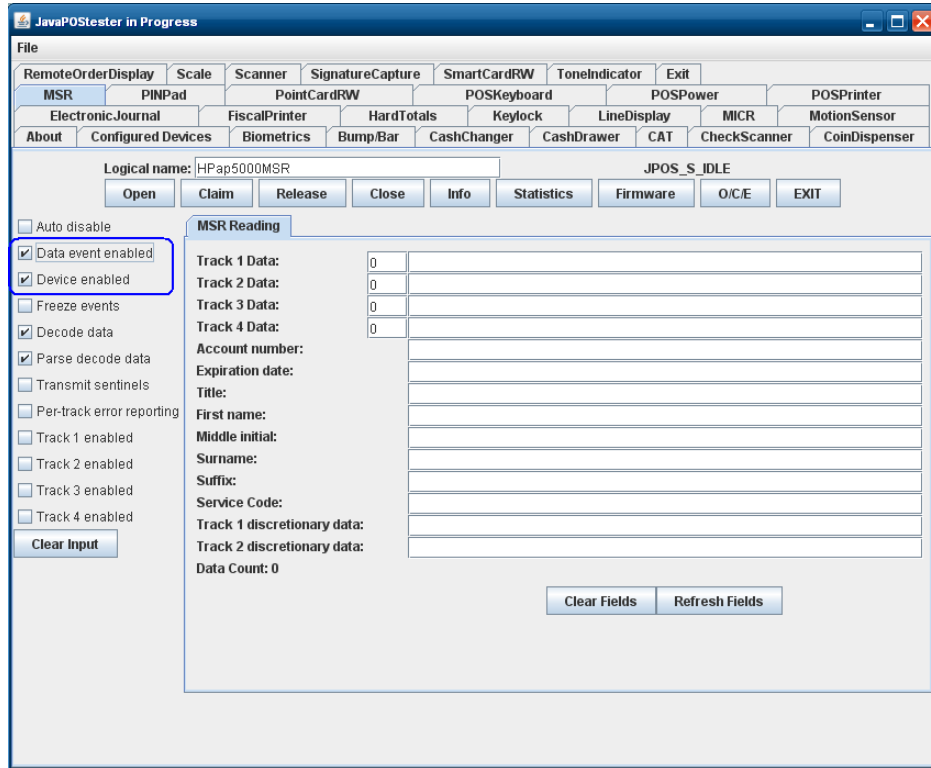

8. Swipe a credit card and text should appear in the field. Depending on the type of card there may or may not be information displayed in all of the track field.

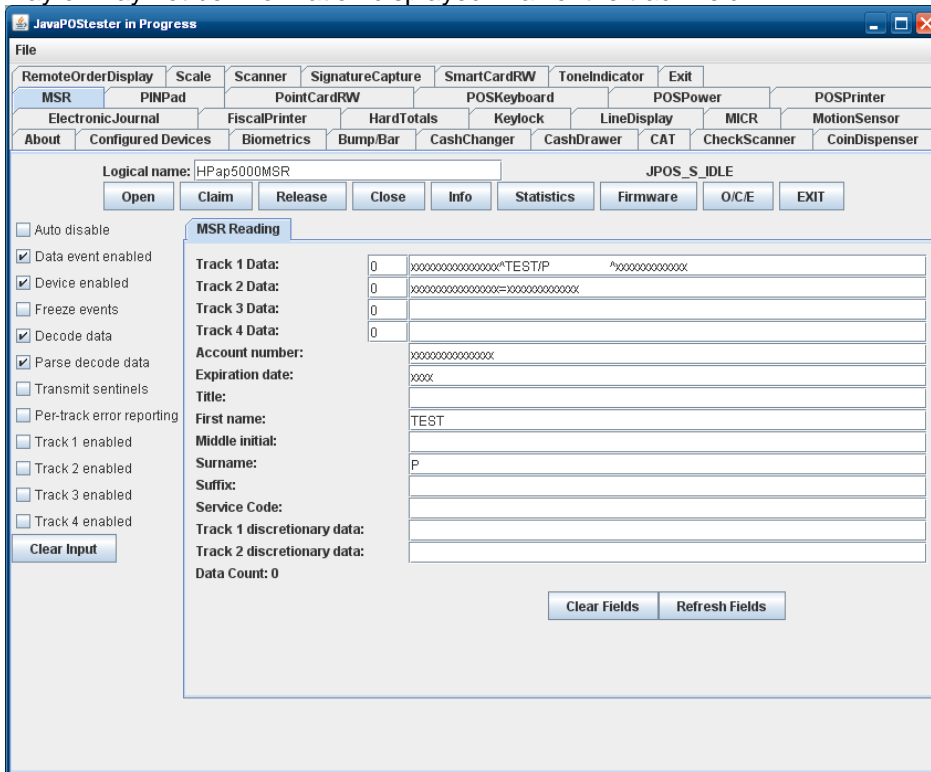

9. Click on "RELEASE" / "CLOSE" and then click "EXIT" to exit the JPOS test utility.

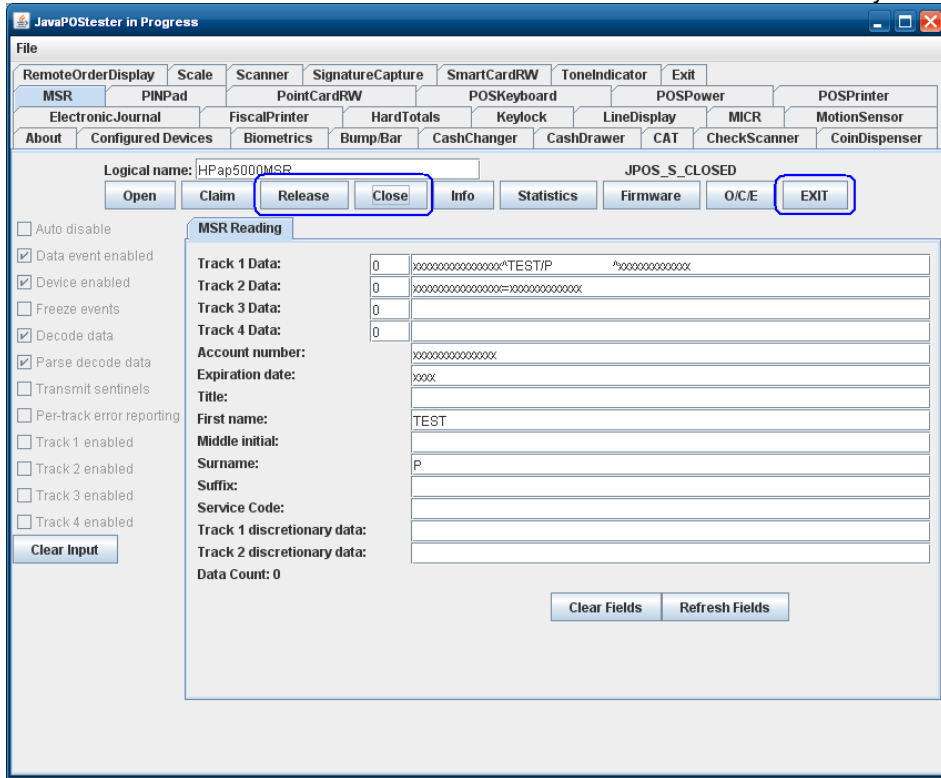

6.6 HP Magnetic Stripe Readers (MSR)

This section covers the following MSRs:

- HP ElitePOS MSR
- HP Retail Integrated Dual Head Magnetic Stripe Reader
- HP Retail Jacket for Elitepad MSR
- HP RP2 Integrated Single Head MSR w/o SRED
- HP RP7 Single Head Magnetic Stripe Reader w/o SRED
- HP RP9 Integrated Dual-Head MSR
- HP RP9 Integrated Single-Head MSR
- HP USB Mini Magnetic Stripe Reader with Brackets



HP ElitePOS MSR



HP RP9 Integrated Dual-Head MSR



HP RP9 Integrated Single-Head MSR



HP USB Mini Magnetic Stripe Reader with Brackets

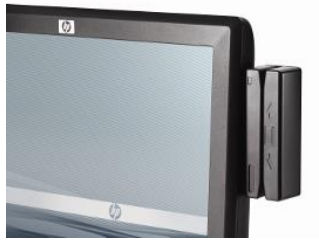

HP Retail Integrated Dual-Head Magnetic Stripe Reader



HP Retail Jacket for Elitepad MSR (two views)



HP RP2 Integrated Single Head MSR w/o SRED



HP RP7 Single Head Magnetic Stripe Reader w/o SRED

6.6.1 Connection

The MSR may be plugged into any free USB port, including powered USB ports. If a powered USB port is used, the powered portion is just not utilized. For All-in-One systems, the MSR may be plugged into any designated free USB port on the display.

6.6.2 Interfaces

The MSR supports the following interfaces:

- USB HID
- USB HID Keyboard (default)

Both interfaces are supported under OPOS.

6.6.3 Configuration

To change the MSR configuration settings such as interface, the HP MagSwipe Configuration Utility must be used, and is only available through a Softpaq download from HP.COM.

Changing Interface:

Click the Change Advanced Reader Settings button, make a selection, and click the Send to MSR button.

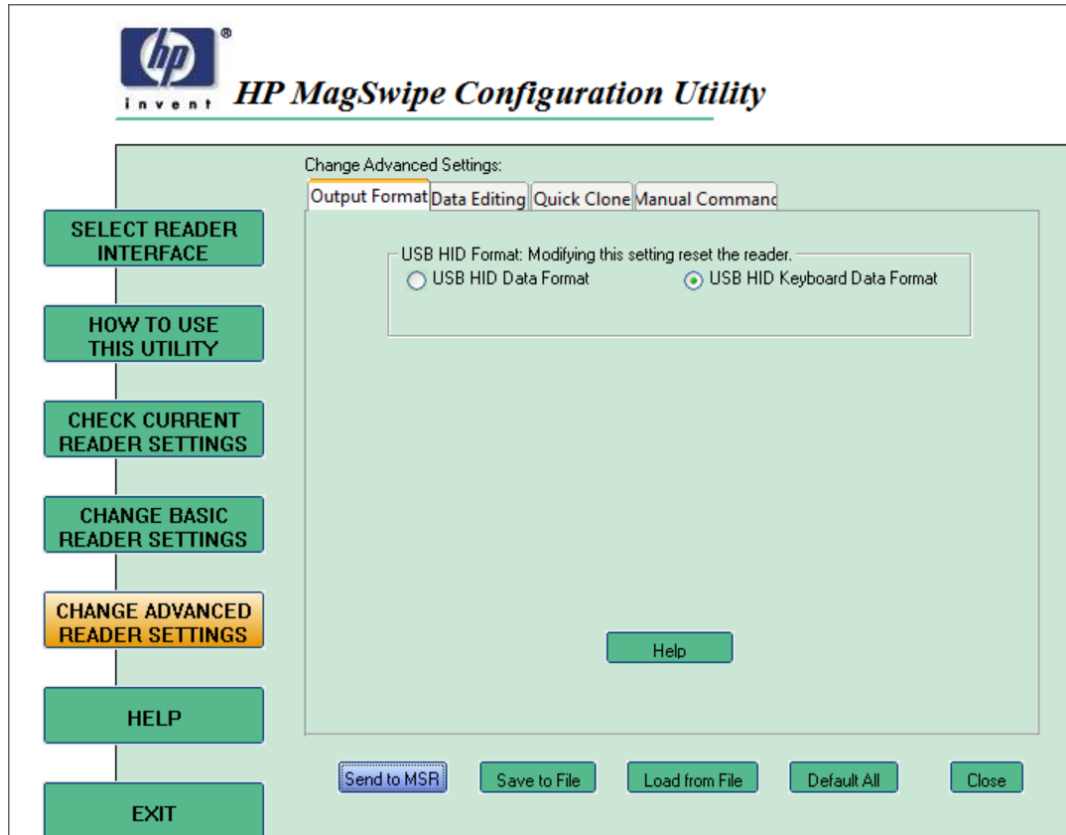

Changing Dual Head setting:



Click the Change Basic Reader Settings button, make a selection, and click the Send to MSR button.

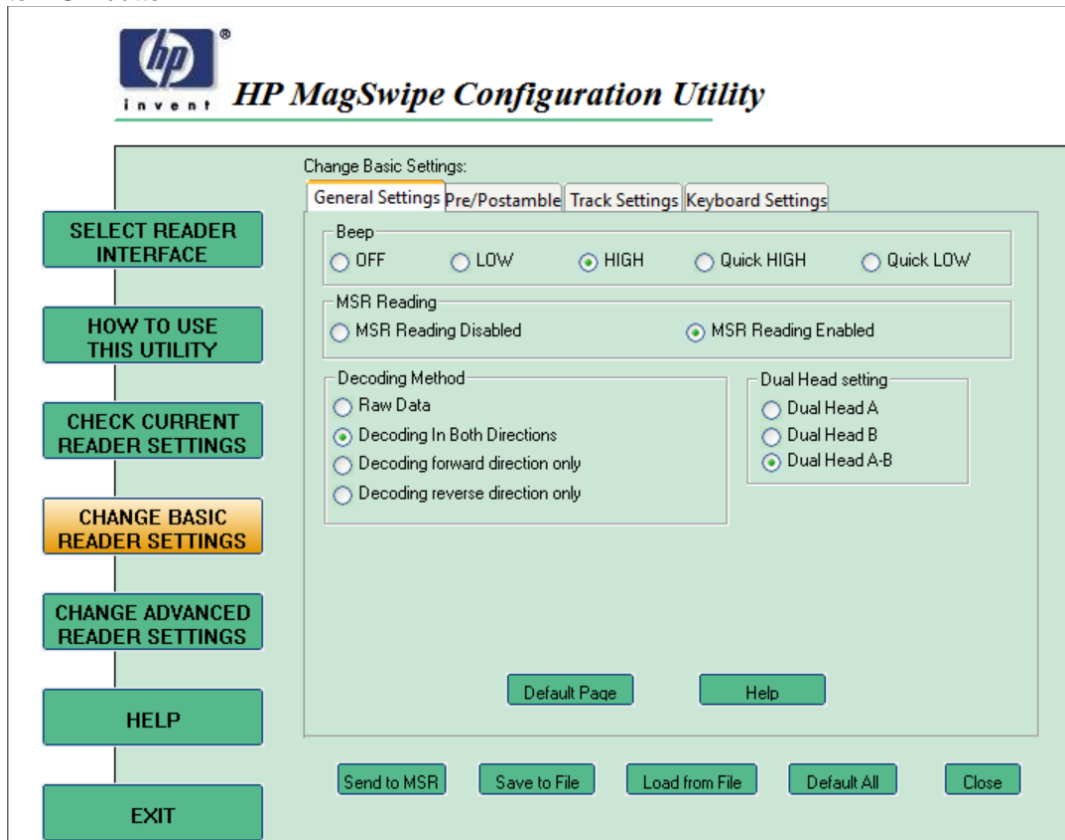

Changing Track Separator and Terminator:

Click the Change Basic Reader Settings button, click on the Track Settings tab, either make a selection from Non-Printable Char dropdown menu or type in the separator character to be used, and click the Send to MSR button.

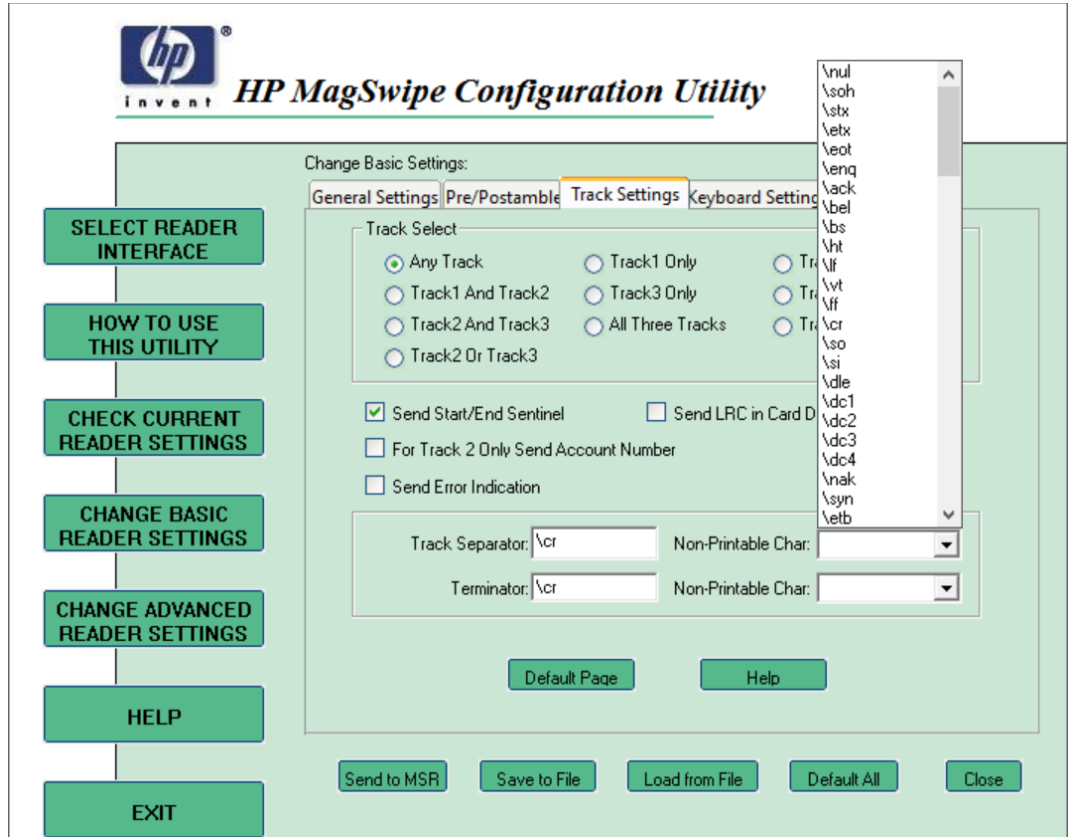

6.6.4 Windows Drivers

The MSR is natively supported by the Windows operating system as a Human Interface Device (HID). If during the driver installation Windows displays the new hardware wizard, the user needs to accept the defaults that appear during the hardware wizard GUI (for the first screen you may select the no option) and the native drivers will be loaded. Please refer to "[If prompted for native driver location \(New Hardware Wizard\)](#)" section.

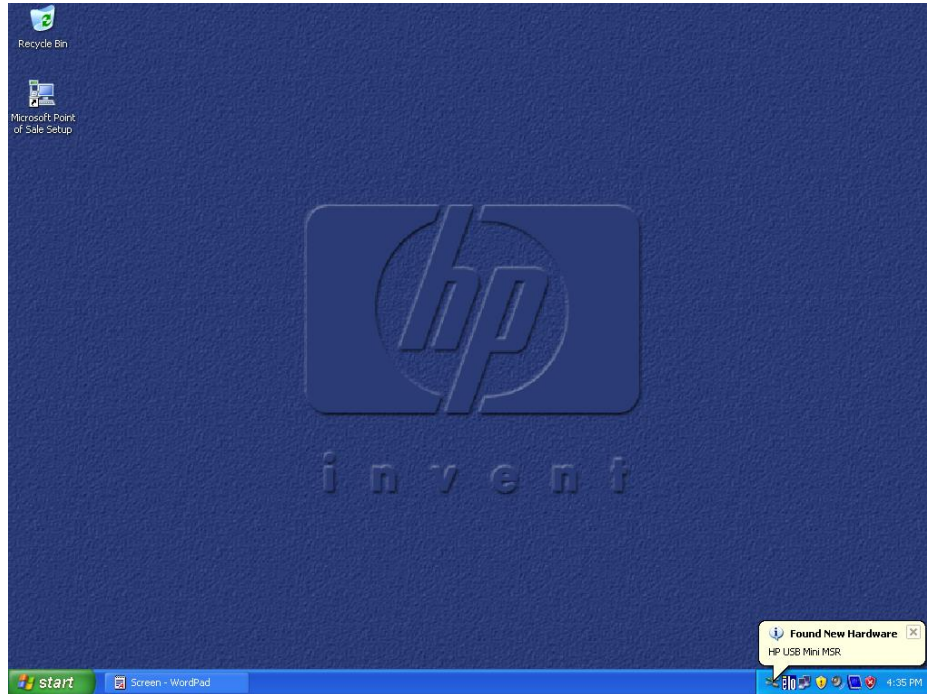

The following is the Windows Device Manager after all drivers are loaded for the MSR in:

USB HID interface

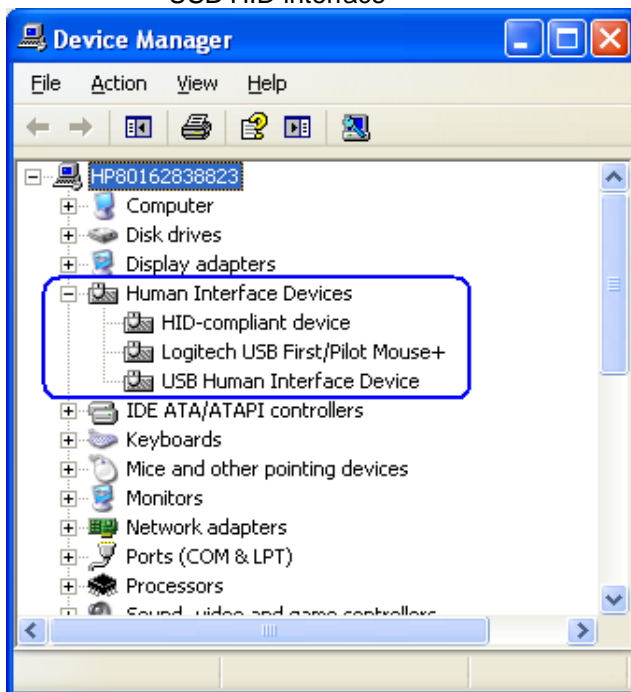

USB HID Keyboard interface

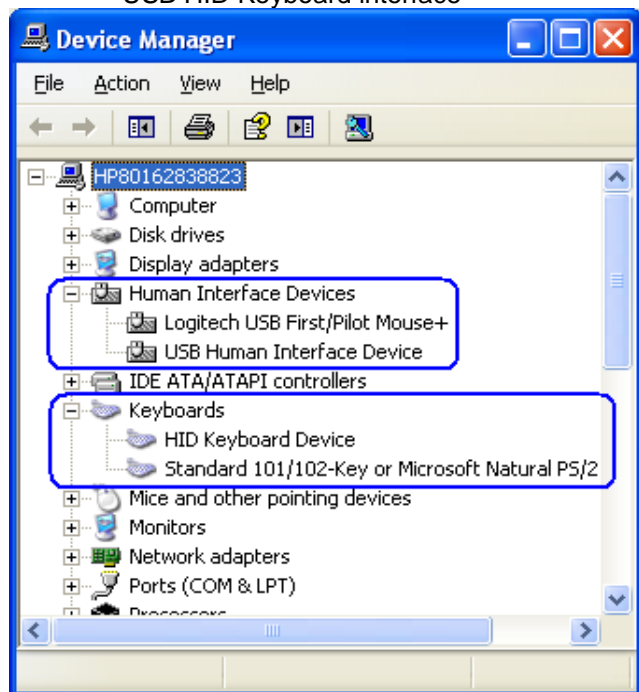

6.6.5 OPOS Drivers for the MSR

The MSR OPOS drivers included in the HP factory image and are also available from HP.COM.

6.6.6 Testing MSR

6.6.6.1 Testing MSR in USB HID Keyboard interface

Open Microsoft Notepad and swipe a card. If data appears as in the example below, this confirms that the MSR interface is USB HID Keyboard.

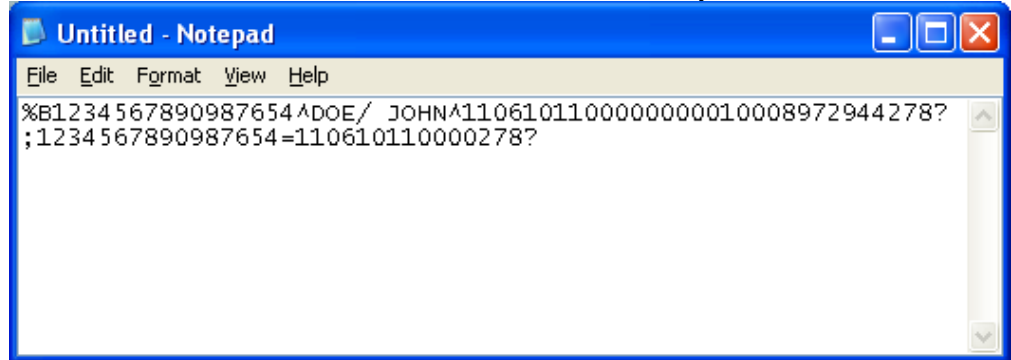

If nothing appears in Notepad, the MSR interface is likely set to USB HID. Use HP MagSwipe Configuration Utility to confirm the MSR interface and reconfigure as USB HID Keyboard if necessary.

6.6.6.2 Testing MSR in USB HID or USB HID Keyboard interface with OPOS

The OPOS drivers for the MSR will work with the MSR in either USB HID or USB HID Keyboard interface. In order to test the MSR, the OPOS for HP Mini MSR package must be installed. In order to test the MSR when it is in USB HID interface an OPOS aware application that interfaces with the MSR OPOS drivers is needed in order to confirm that MSR is able to read the data from a card.

The following is overview of the steps to test the MSR followed by detailed steps:

1. Open the **MSR OPOS Test Program**.
 - C:\xxxxx\Point of Sale\MSR (USB)\MSR OPOS Test Program\HP MSR OPOS Test Program.exe
2. Select the MSR OPOS logical name from the drop down menu that you wish to test.
3. Click "OPEN" button, if successful will receive and OPOS_SUCCESS message.
4. Click on "CLAIM" button, if successful will receive and OPOS_SUCCESS message.
5. Click on "Device Enabled" so there is a check in the box, if successful will receive and OPOS_SUCCESS message.
6. Swipe a credit card.
7. To close the MSR OPOS test application click on RELEASE / CLOSE / EXIT buttons in the order stated.

Detailed Steps

1. Open the **MSR OPOS Test Program**.
 - C:\xxxxx\Point of Sale\MSR (USB)\MSR OPOS Test Program\HP MSR OPOS Test Program.exe

2. Select the MSR OPOS logical name from the drop down menu that you wish to test.

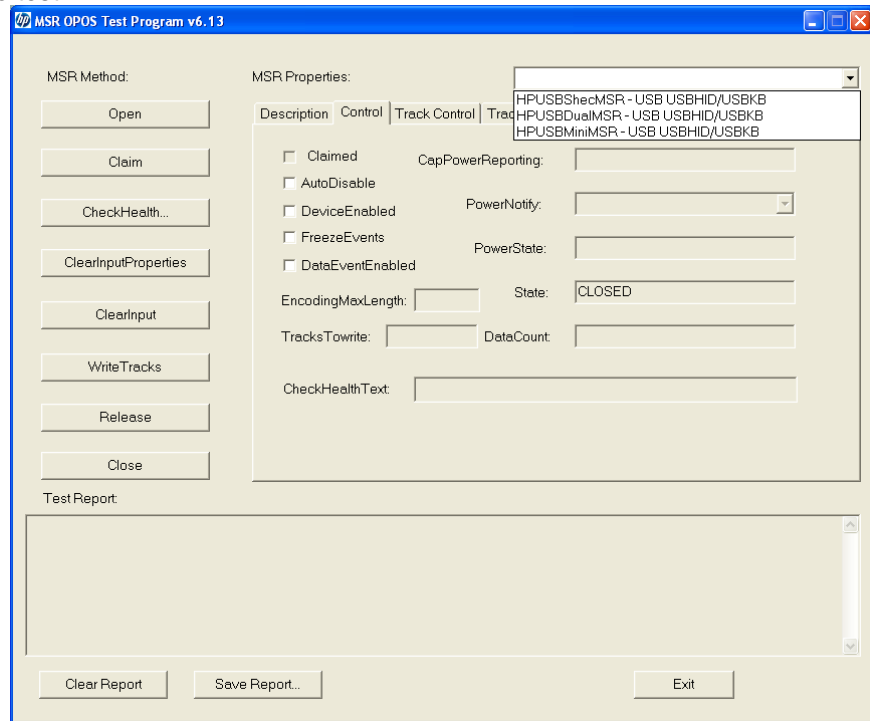

3. Click "OPEN" button, if successful will receive and OPOS_SUCCESS message.

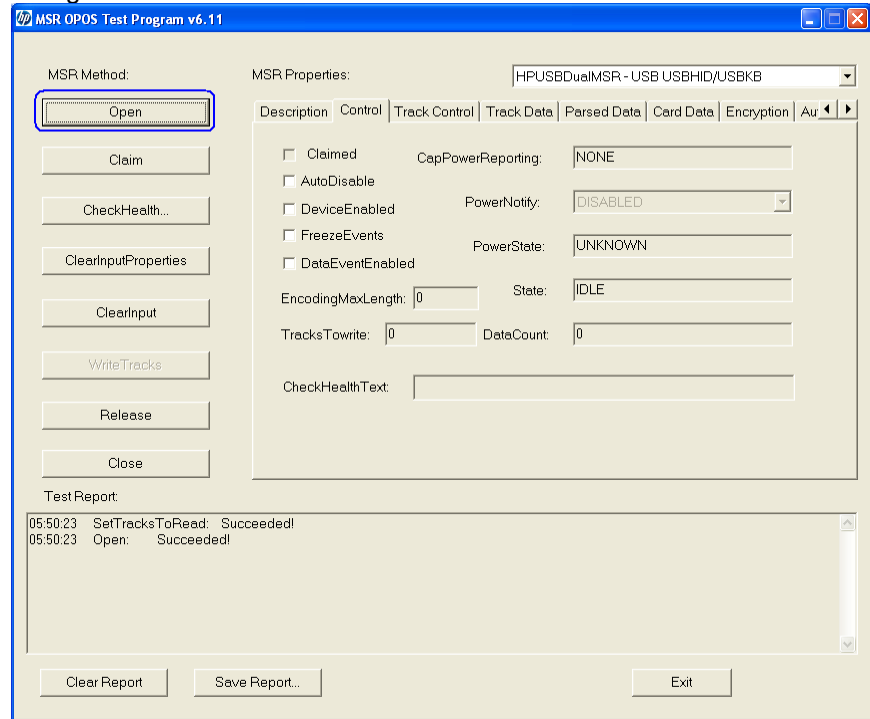

4. Click on “CLAIM” button, if successful will receive and OPOS_SUCCESS message.

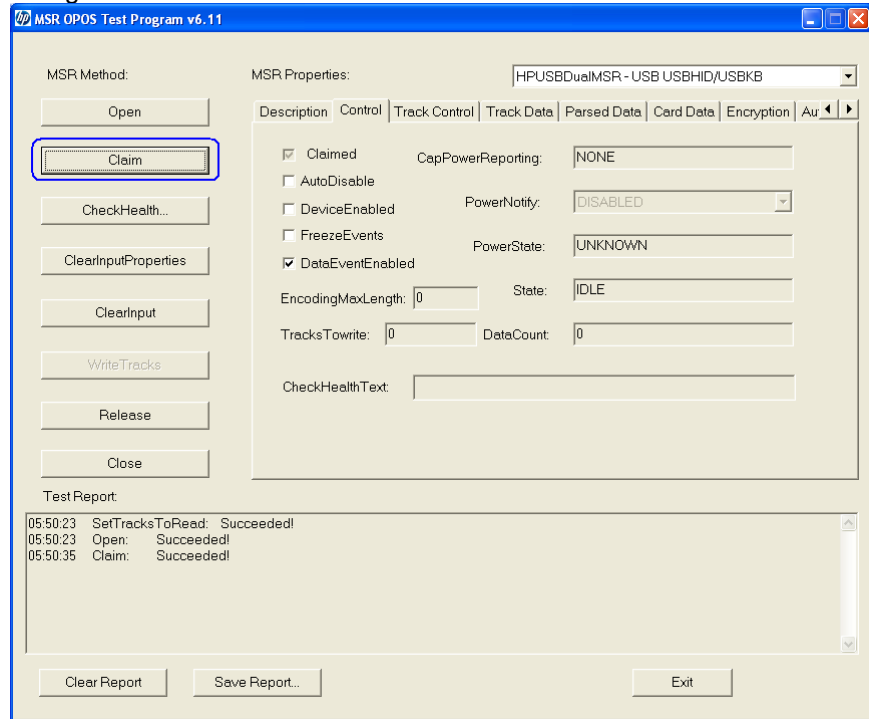

5. Click on “Device Enabled” so there is a check in the box, if successful will receive and OPOS_SUCCESS message.

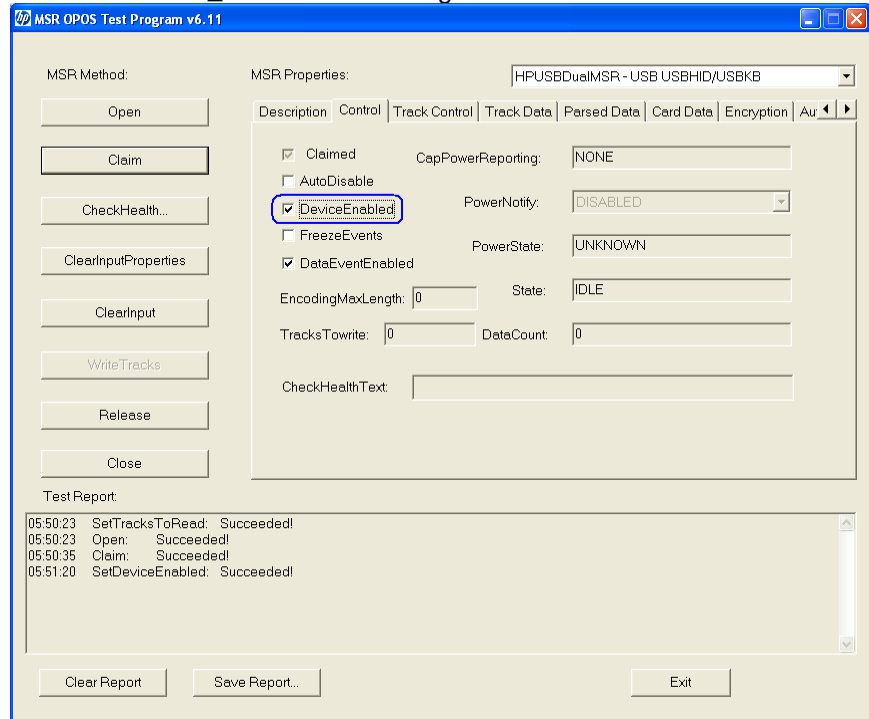

6. Swipe a credit card.

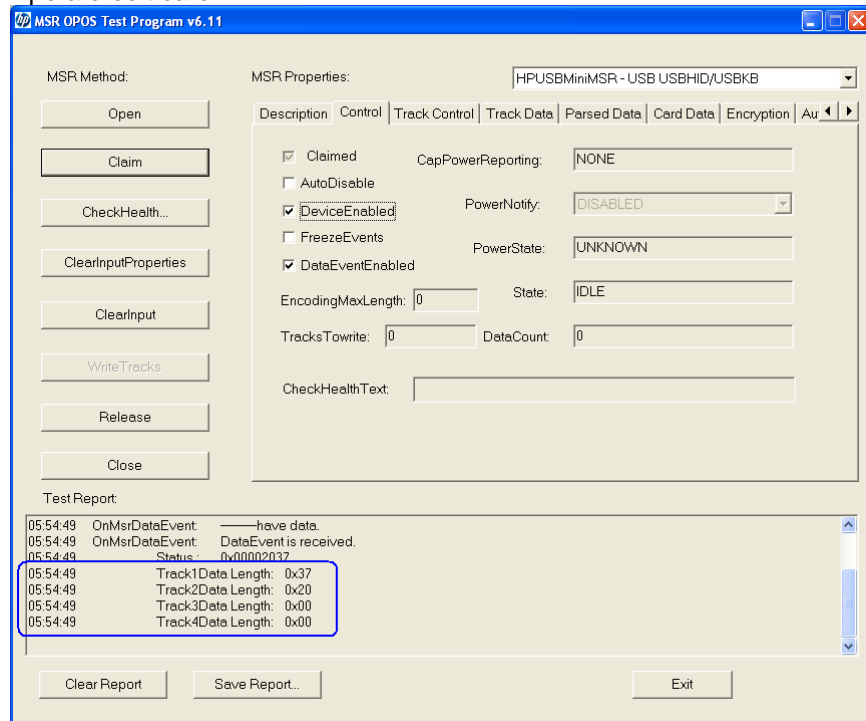

Click on "TRACK DATA" tab to see the data that was read.

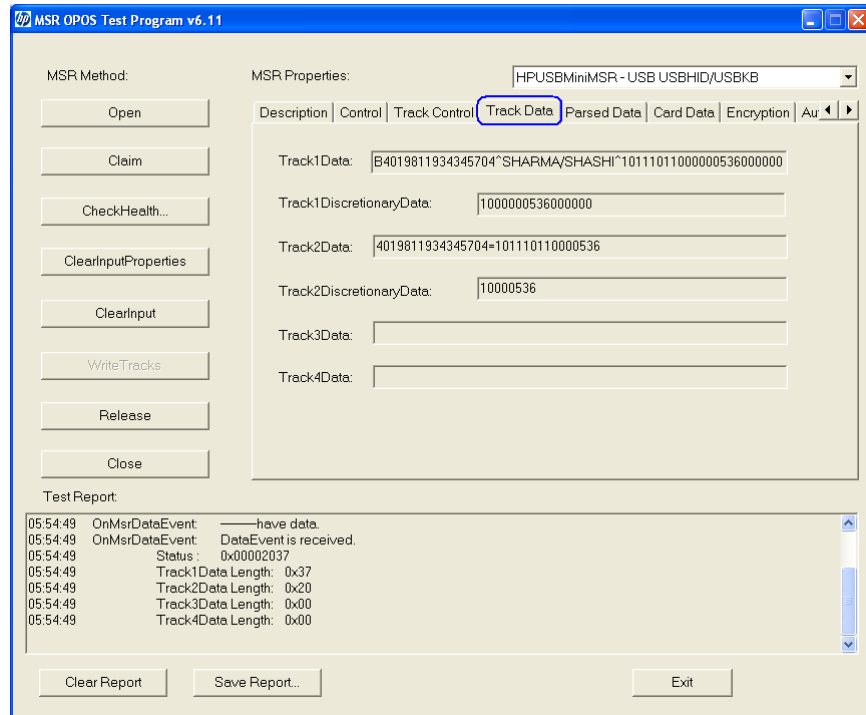

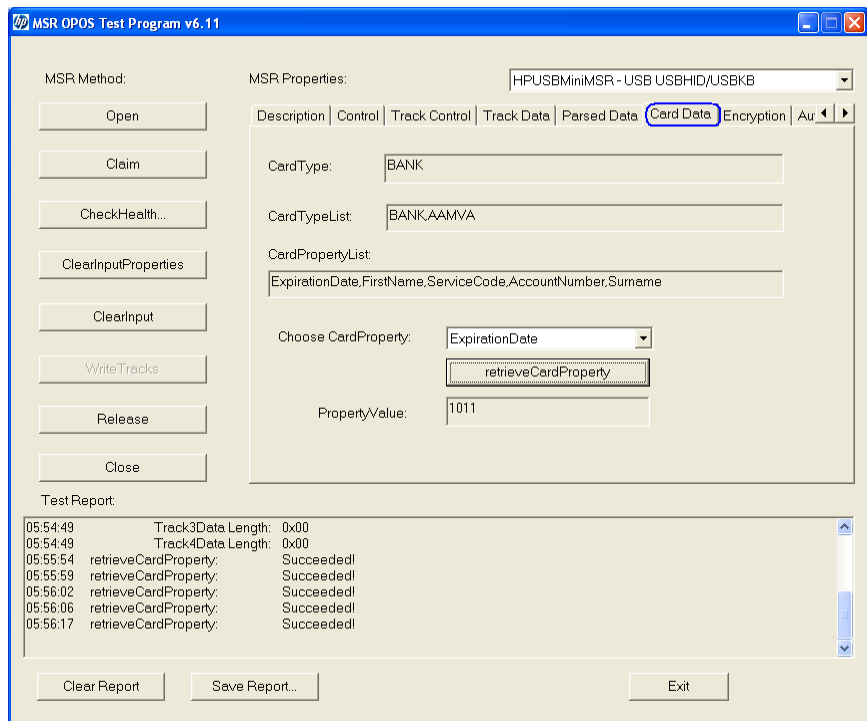
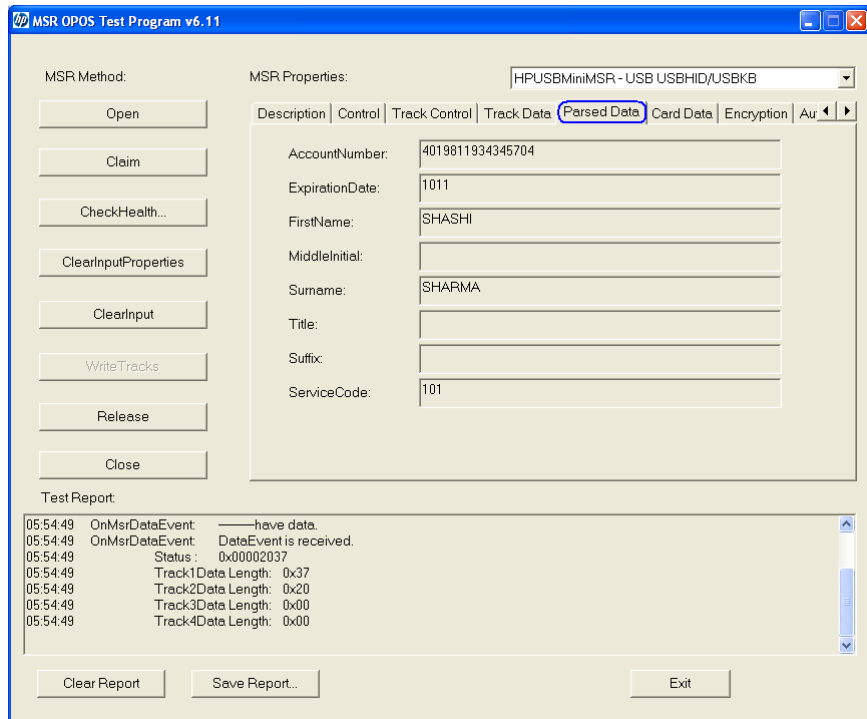

In order to test another card swipe it is recommended to click on the “ClearInputProperties” and “ClearInput” button to remove all the data that appears in the test application.

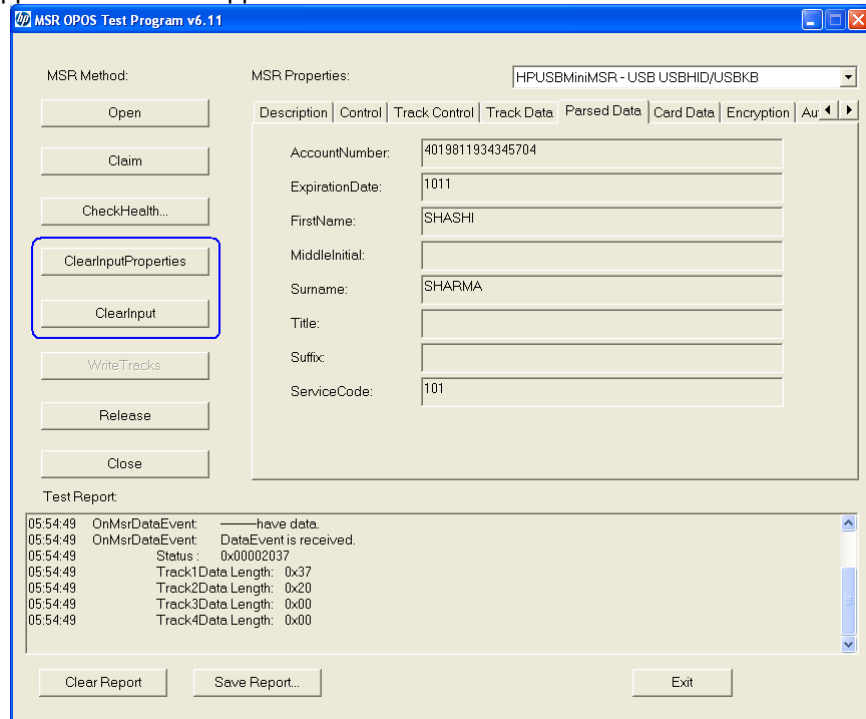

7. To close the MSR OPOS test application click on RELEASE / CLOSE / EXIT buttons in the order stated.

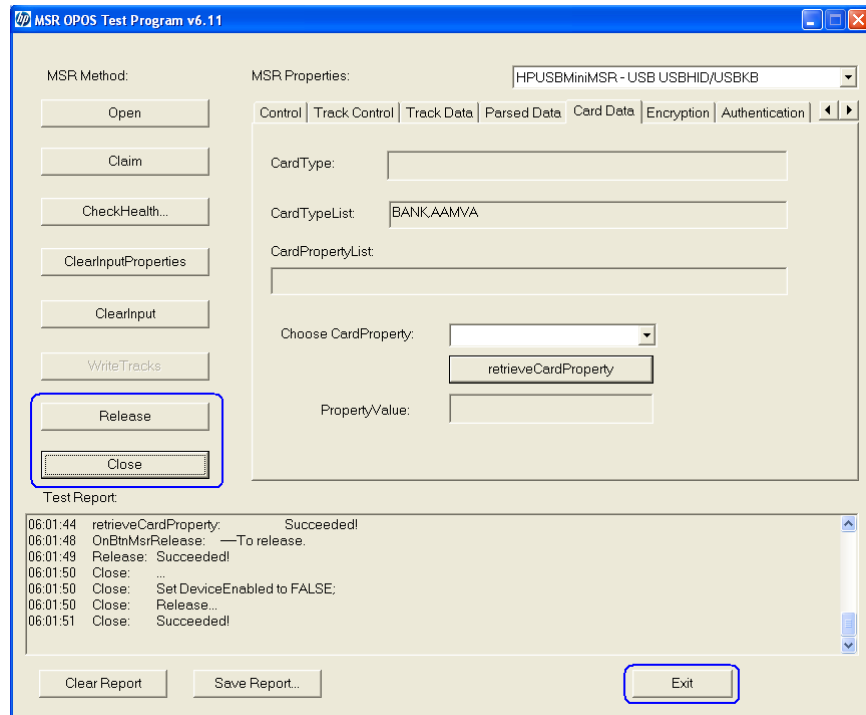

6.6.7 **JPOS Drivers for the MSR**

The JPOS drivers are included in the HP factory image and are also available from HP.COM.

The “MSR Keyboard Base Driver” must also be installed on the unit either via the standalone package (which is part of the JPOS softpaq / folder) or via the OPOS drivers installed on the unit.

The following is overview of the steps to test the MSR followed by detailed steps:

1. Open **JavaPOSTester**.
 - C:\xxxxx\Point of Sale\MSR (USB)\MSR JPOS\JPOS\POSTest\POSTest.bat.
2. Click on the “Configured Device” tab to obtain the device names.
3. Click on the “MSR” tab.
4. Enter the Logical Name for the MSR. (Note: This item is case sensitive).
5. Click on the “OPEN” button; the MSR will beep several times.
6. Click on the “CLAIM” button; the MSR will beep several times.
7. Check the “DATA EVENT ENABLED” and “DEVICE ENABLED” checkboxes.
8. Swipe a credit card and text should appear in the field. Depending on the type of card there may or may not be information displayed in all of the track fields.
9. Click the “RELEASE” button.
10. Click the “CLOSE” button and the click on “EXIT” to exit the JPOS test utility.

Detailed Steps

1. Open **JPOSTester**.
 - C:\xxxxx\Point of Sale\MSR (USB)\MSR JPOS\JPOS\POSTest\POSTest.bat.

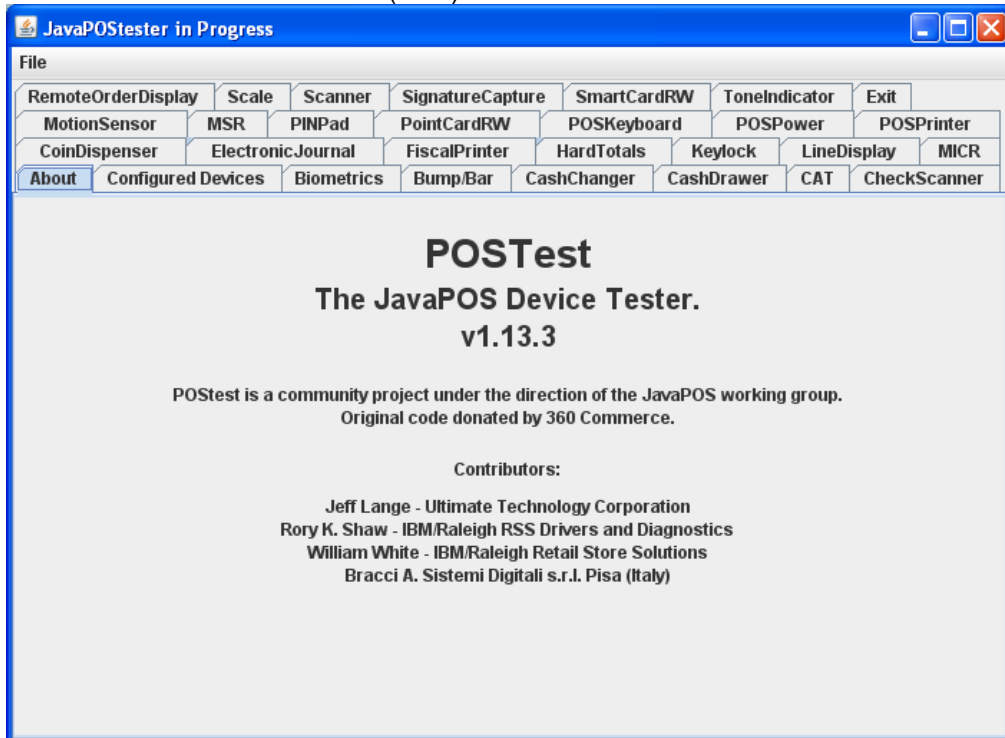

- Click on the "Configured Device" tab to obtain the device names.

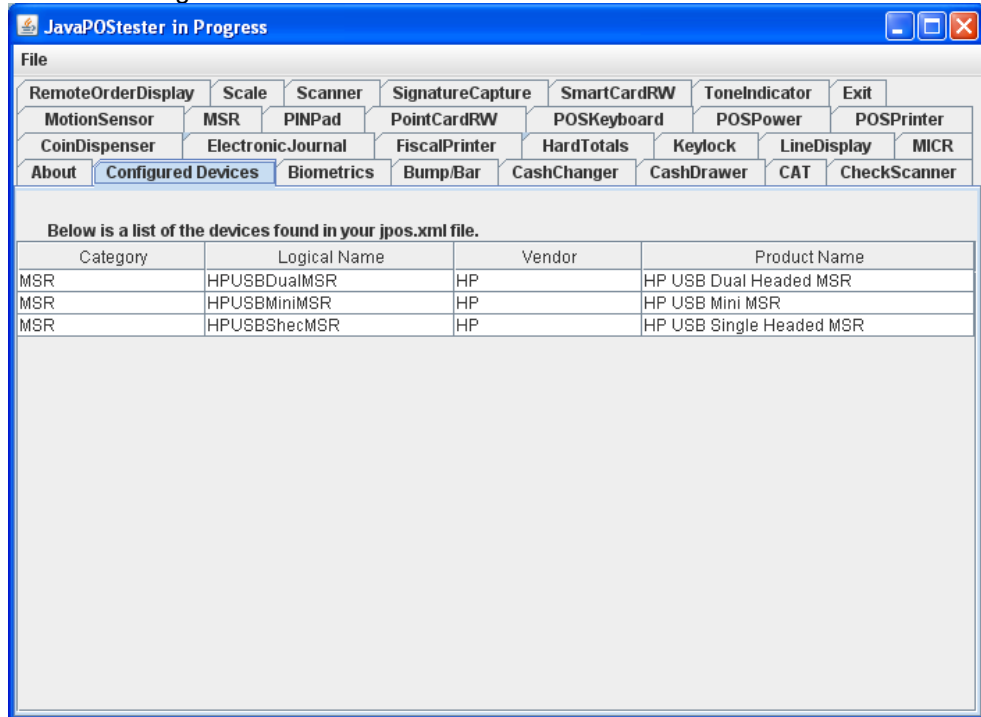

- Click on the "MSR" tab.

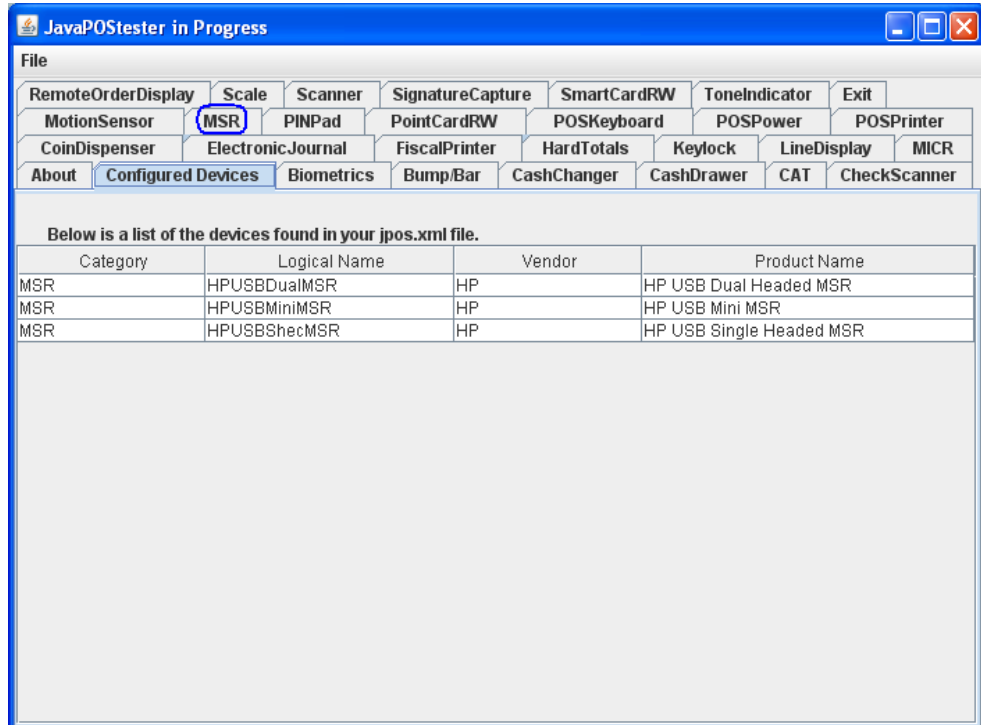

- Enter the Logical Name for the MSR. (**Note:** This item is case sensitive).

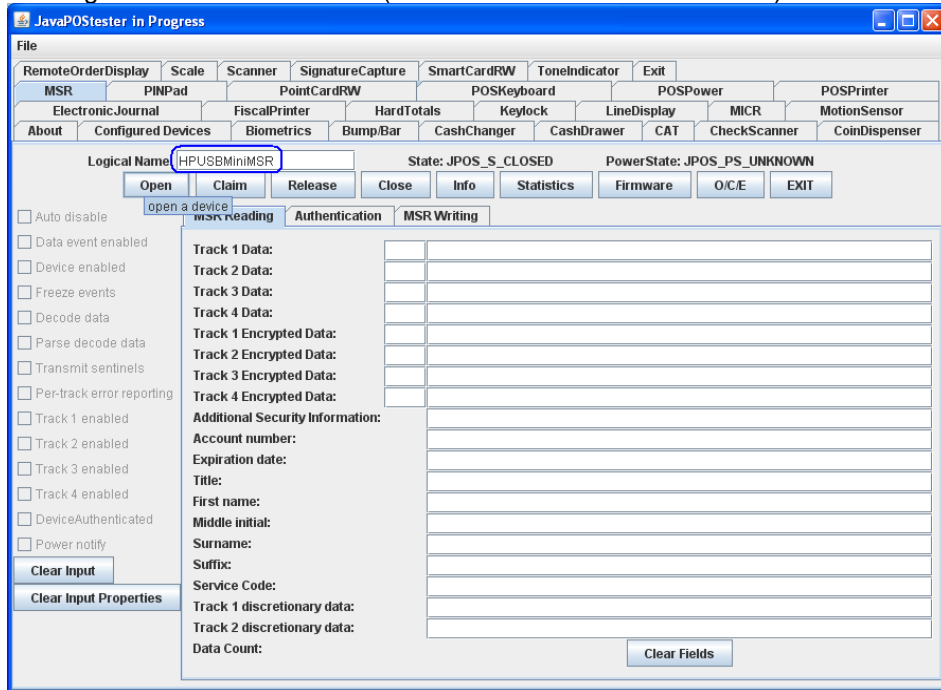

- Click on the "OPEN" button; the MSR will beep several times.

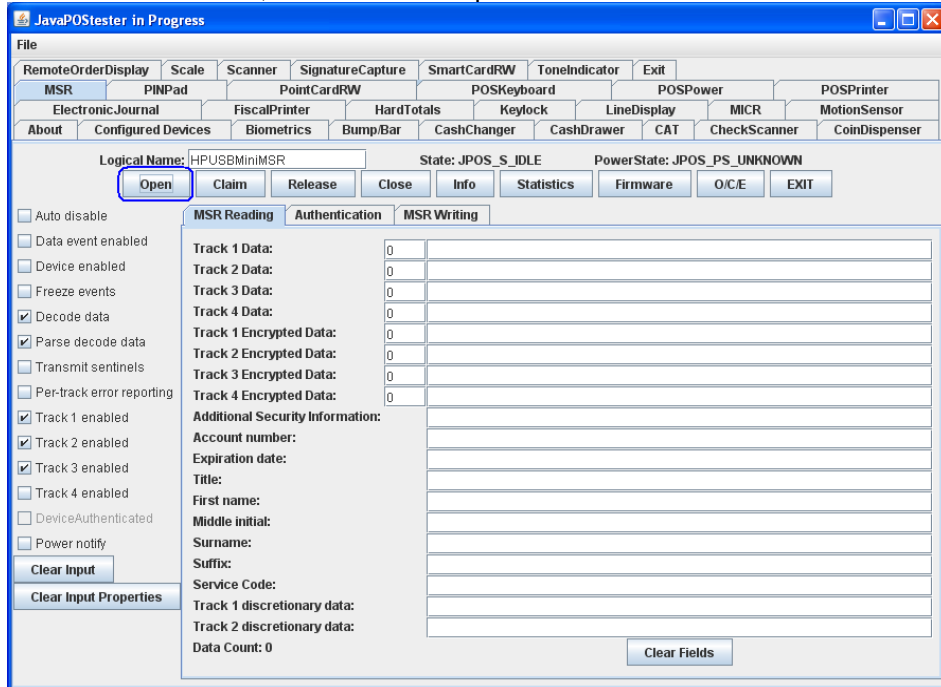

6. Click on the “CLAIM” button; the MSR will beep several times.

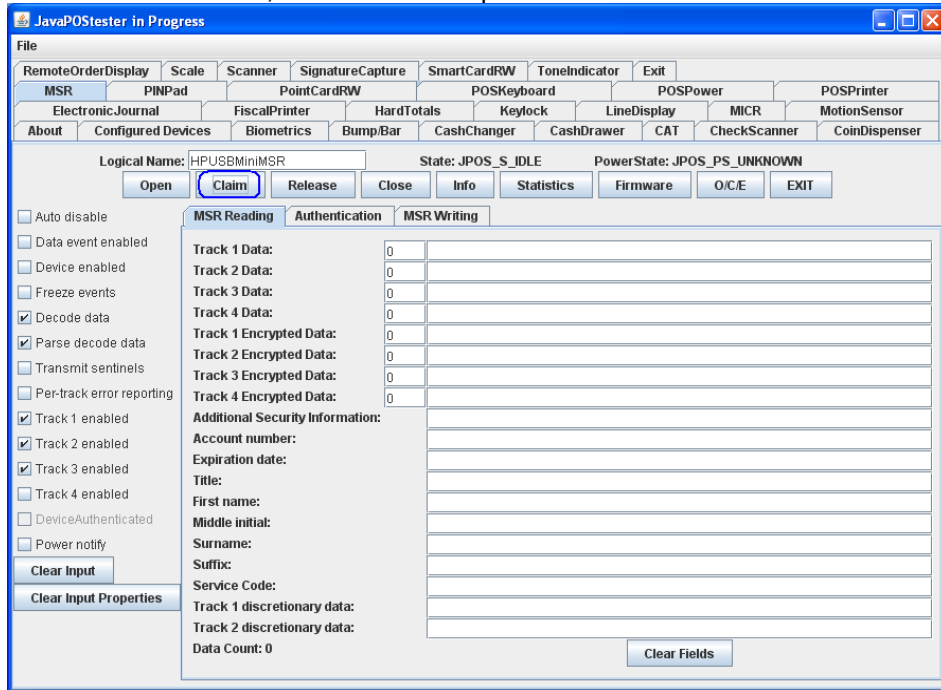

7. Check the “DATA EVENT ENABLED” and “DEVICE ENABLED” checkboxes.

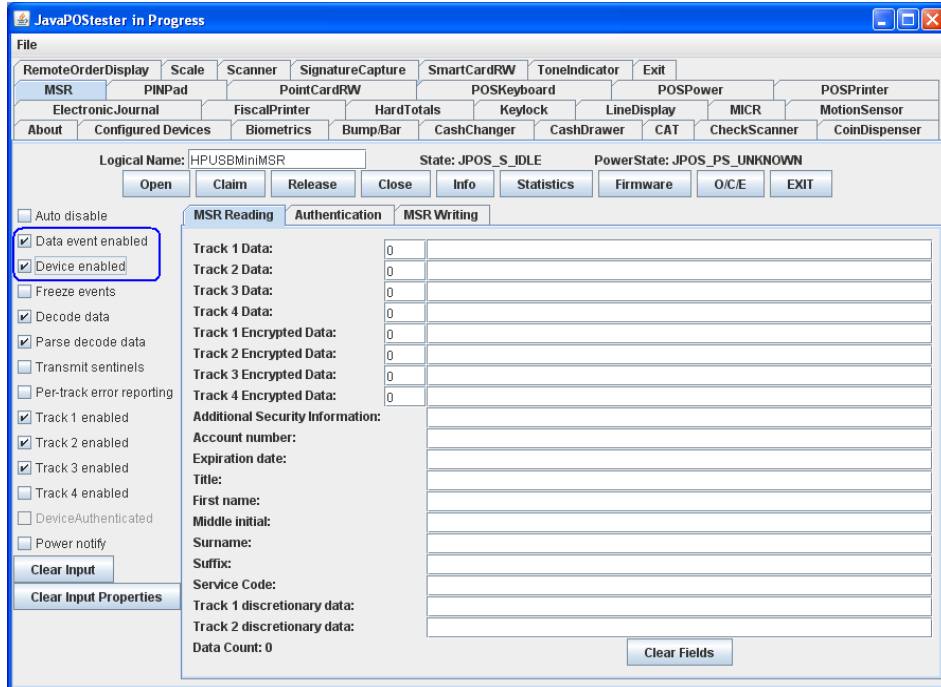

- Swipe a credit card and text should appear in the field. Depending on the type of card there may or may not be information displayed in all of the track fields.

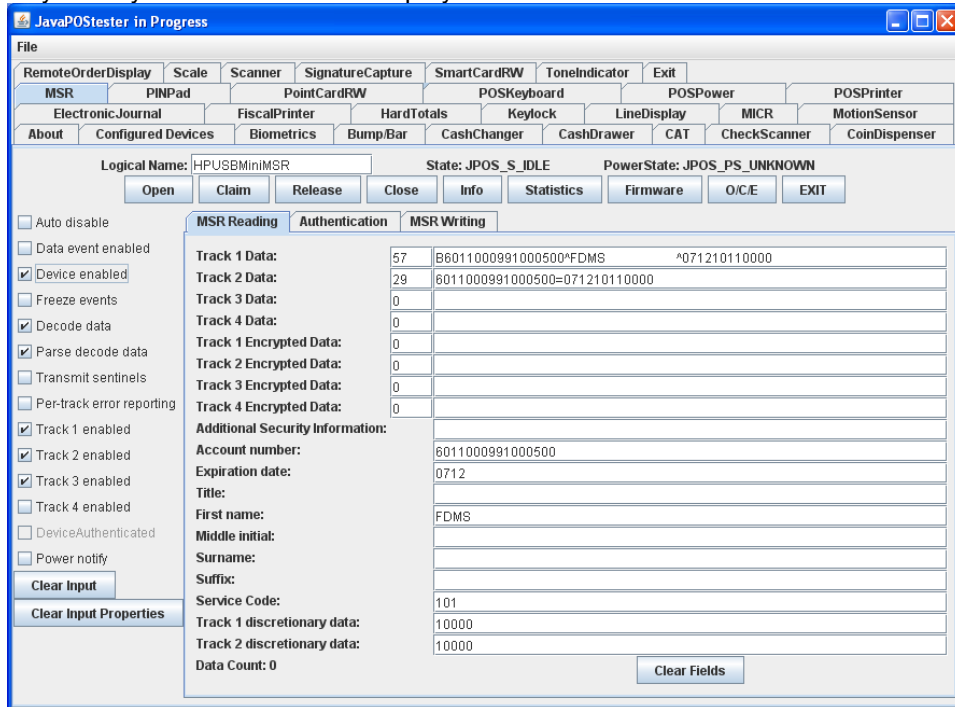

- Click the "RELEASE" button.

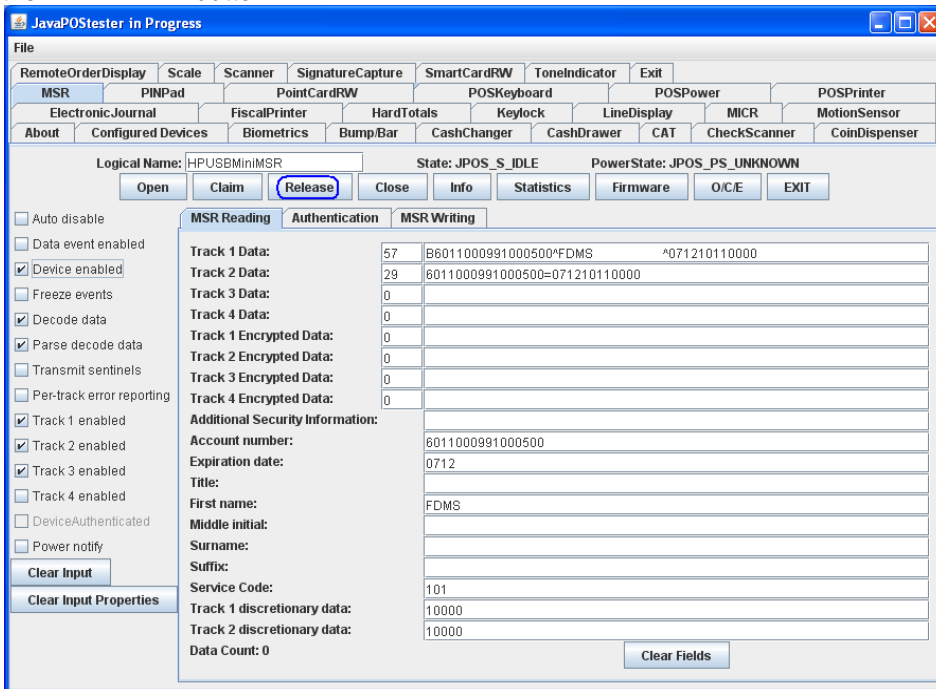

10. Click the “CLOSE” button and the click on “EXIT” to exit the JPOS test utility.

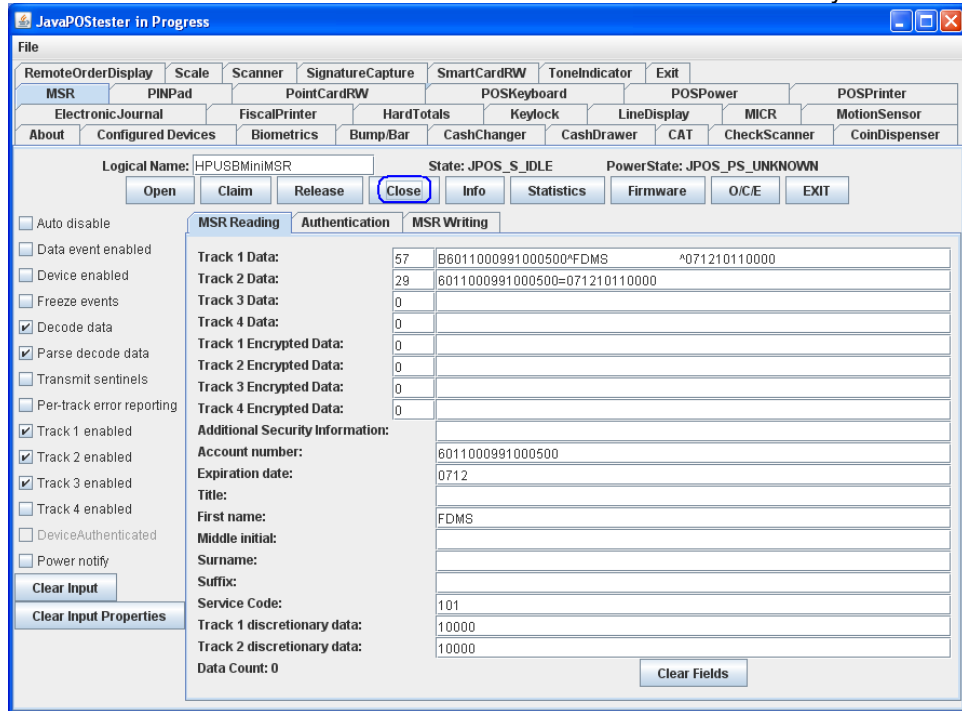

6.7 HP Barcode Scanner (Laser 1D)



6.7.1 Connection

The barcode scanner may be plugged into any free USB port. One may plug the barcode scanner into the power USB port in the 5V part of USB port, when plugged in this configuration the power portion of USB port is not utilized.

6.7.2 Windows Drivers for the Barcode Scanner

The HP POS scanner uses native drivers for Windows operating system. If during the driver installation Windows displays the new hardware wizard, the user needs to accept the defaults that appear during the hardware wizard GUI (for the first screen you may select the no option) and the native drivers will be loaded. Please refer to "[If prompted for native driver location \(New Hardware Wizard\)](#)" section.

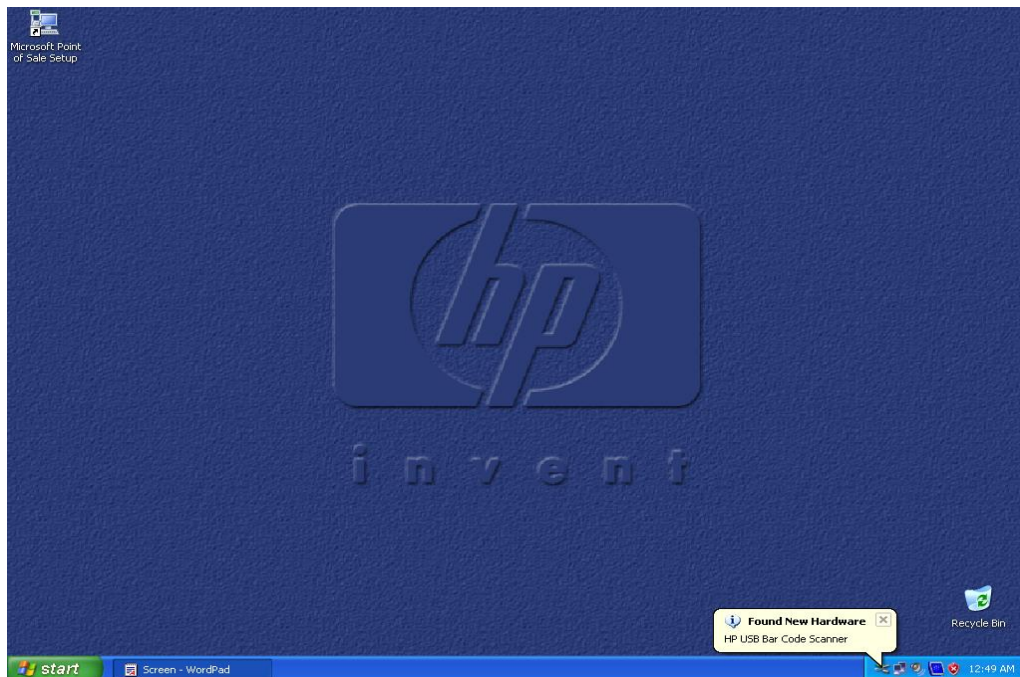

The following is the Device Manager window after all the drivers are loaded for the HP USB Barcode Scanner (default mode):

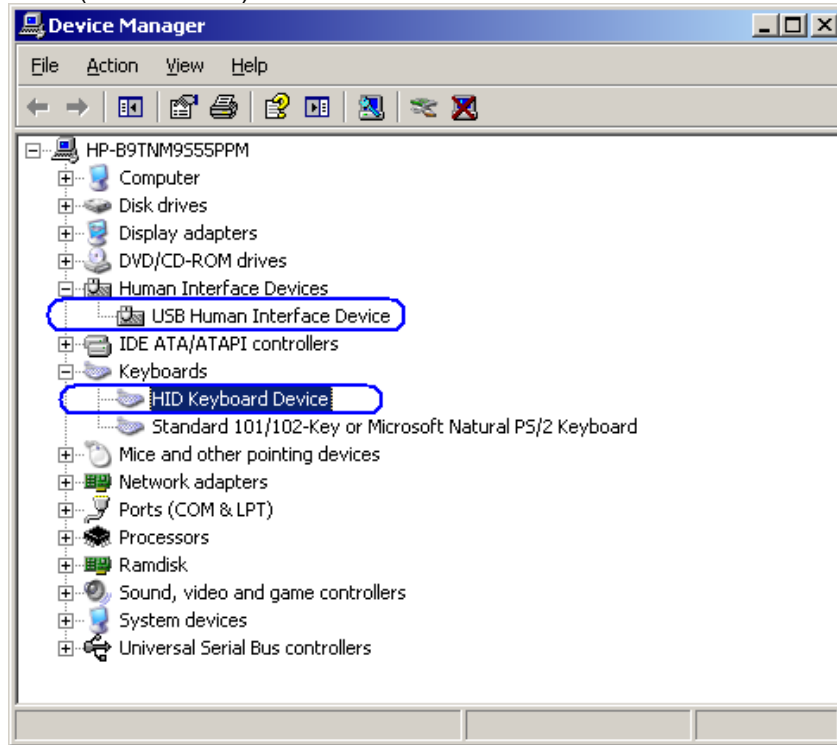

The following is the Device Manager window after all the drivers are loaded for the HP USB Barcode Scanner when it is in the OPOS mode:

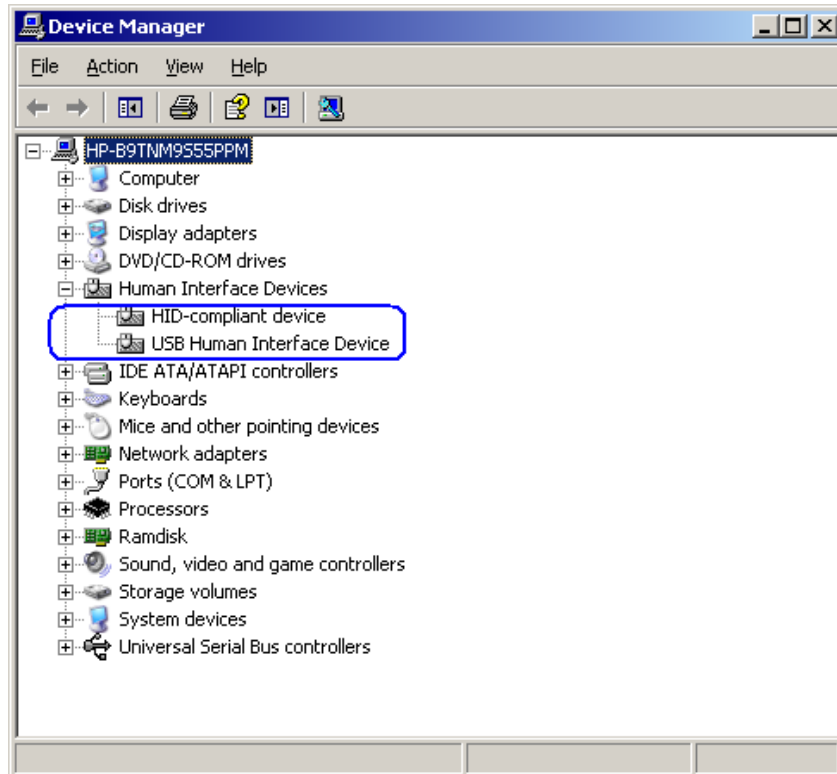

6.7.3 **OPOS Drivers for the Barcode Scanner**

There are no OPOS drivers needed for this device if the device is used in the human interface device (HID) keyboard emulation mode (default mode as shipped from the factory).

If the POS application needs the OPOS drivers, the barcode OPOS drivers can be found on HP.COM. The drivers are already installed in the HP factory image.

6.7.4 **Testing the Barcode Scanner**

6.7.4.1 **Testing Barcode Scanner in non-OPOS**

The default mode of the scanner is non-OPOS mode when shipped from HP. In order to test the scanner in non-OPOS mode one can open an application like Microsoft Notepad and scan a barcode when the scanner is in default scanner mode.

You may use one of the barcodes below for testing if you do not have an item with a barcode handy.



6.7.4.2 **Testing the Barcode Scanner in OPOS**

The Barcode Scanner must be in OPOS mode (IBM Hand-Held USB mode). If one is not sure what mode the scanner is in, open an application like notepad and scan a barcode. If the scanner is in OPOS mode, when you scan a barcode in Notepad nothing will appear in Notepad. If something appears in Notepad the scanner is HID Keyboard emulation mode.

To put the scanner in OPOS mode one needs to scan the barcode below:



IBM Hand-Held USB

The following is an overview of the steps to test the Barcode Scanner followed by detailed steps:

1. Open the barcode scanner OPOS Test utility from Windows start menu
2. Click "Open Service Object"
3. Click on OK after confirming "HP_USBSCANNER" is shown for the service object name.
4. Click on "Enable Scan"
5. Scan a barcode.
6. Click on "Disable Scan" to stop scanning with the OPOS test utility.
7. Click on "Close" to close the test application.

Detailed Steps

1. Open the barcode scanner OPOS Test utility from Windows start menu from the “HP USB Barcode Scanner” or from the “HP Point of Sale Information” menu.
2. Click “Open Service Object”

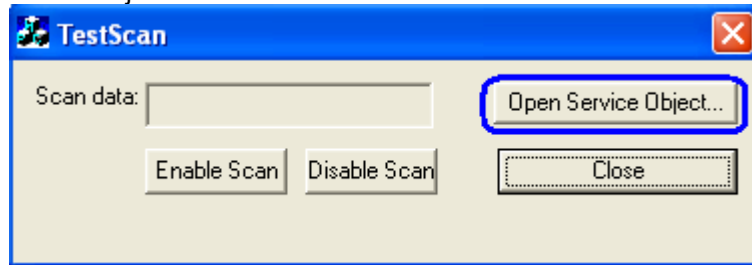

3. Click on OK after confirming “HP_USBSCANNER” is shown for the service object name.

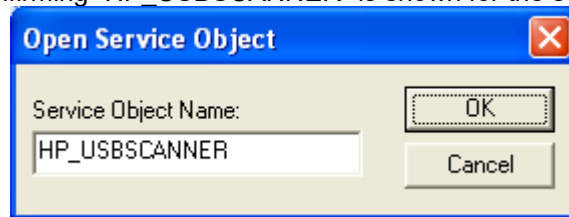

4. Click on “Enable Scan”

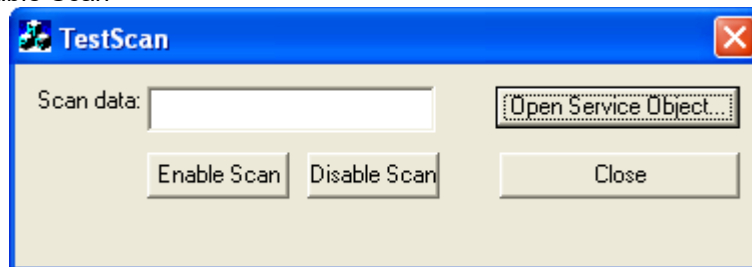

5. Scan a barcode.
6. Click on “Disable Scan” to stop scanning with the OPOS test utility.
7. Click on “Close” to close the test application.

6.7.5 **JPOS Drivers for the Barcode Scanner**

The JPOS drivers are included in the HP factory image (C:\xxxx\Point of Sale\Barcode Scanner\Barcode Scanner JPOS) and are also available from HP.COM.

In order for the scanner to work with JPOS driver, the scanner must be programmed into the "IBM HAND-HELD USB" / OPOS mode. In order to put the scanner into this mode, scan the barcode below:



IBM Hand-Held USB

Note: The HIDScanWin32.DLL is copied to working JAVA directory "C:\Program Files\Java\xxxx\bin" when the test utility is opened. An example of JAVA directory is "C:\Program Files\Java\jre1.6.0_01\bin", "jre1.6.0_01" reflects the version that is installed on the unit.

The following is overview of the steps to test the barcode scanner followed by detailed steps:
Start the JPOS test utility.

1. Start the JPOS test utility using the link in the START MENU:
2. Click on the "Scanner" tab.
3. Click on the "OPEN" button.
4. Click on the "CLAIM" button. After clicking on the "CLAIM" button a check should appear next to the "CLAIMED" box.
5. Check the "DEVICE ENABLED" so there is a check box.
6. Check the "AUTO DATA EVENT ENABLE" so there is a check box.
7. Check the "DATA EVENT ENABLED" so there is a check box.
8. Check the "DECODE DATA" so there is a check box.
9. Scan a bar code.
10. Click on "RELEASE" or "CLOSE" to exit the JPOS test utility.

Detailed Steps

1. Start the JPOS test utility either using the link in the START MENU or by opening the POSTEST.BAT file that is located in the JPOS folder for barcode scanner (C:\xxxxx\Point of Sale\Barcode Scanner\Barcode Scanner JPOS” folder). After a few seconds the JPOS test utility GUI will appear as shown below:



2. Click on the "Scanner" tab:

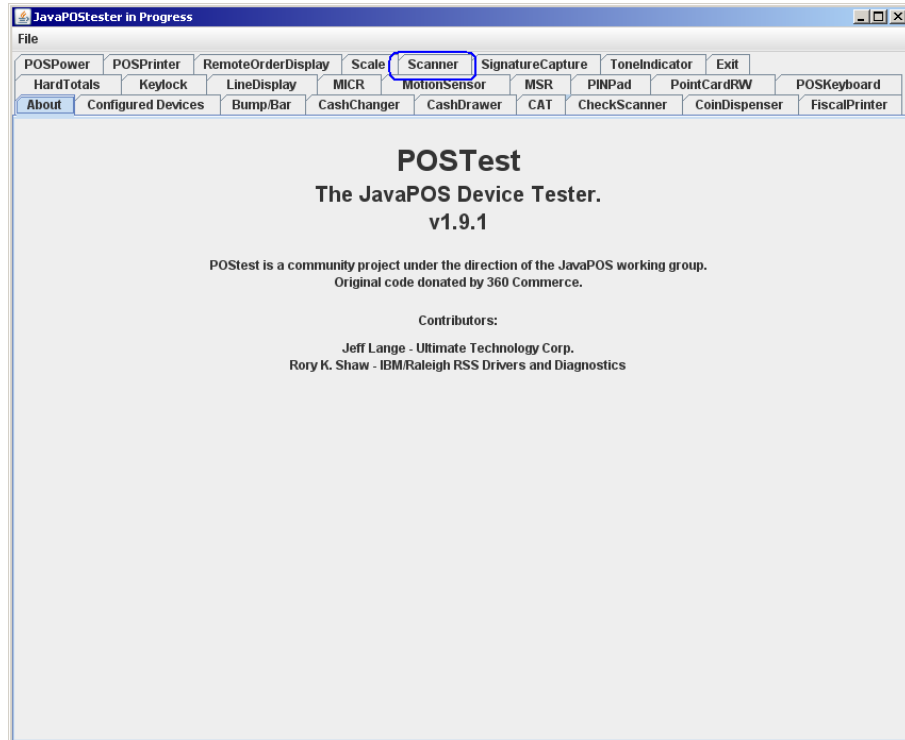

After clicking on the “Scanner” tab the screen should look like:

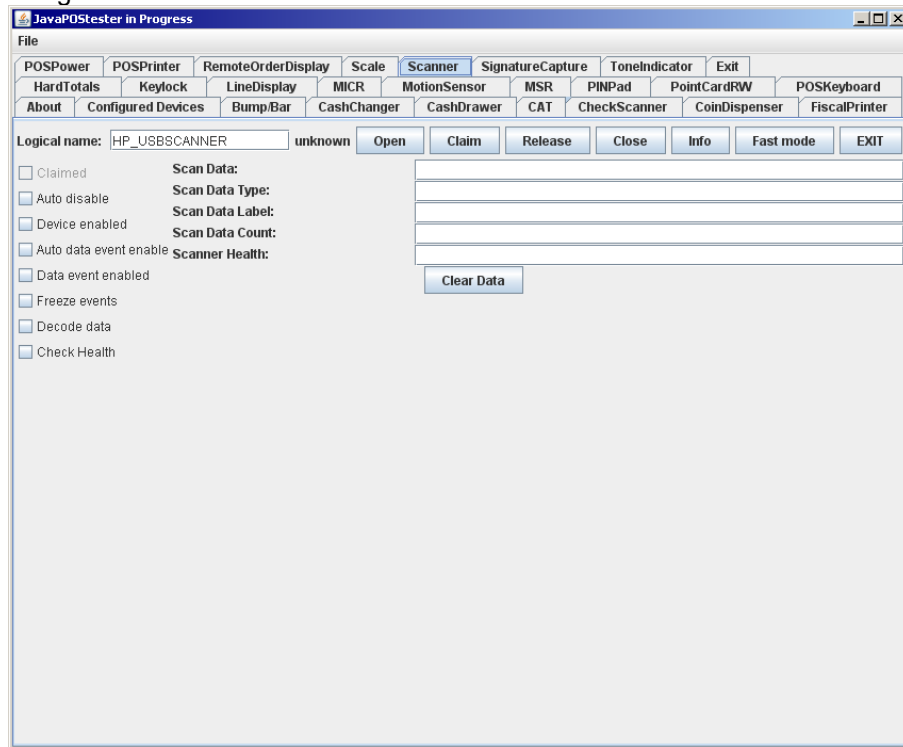

The logical name of the device is “HP_USBSCANNER”. If one clicks on the “Configured Device” tab, the names for the device will appear that will be used in the test utility.

3. Click on the “OPEN” button.

4. Click on the "CLAIM" button. A check should appear next to the "CLAIMED" box.

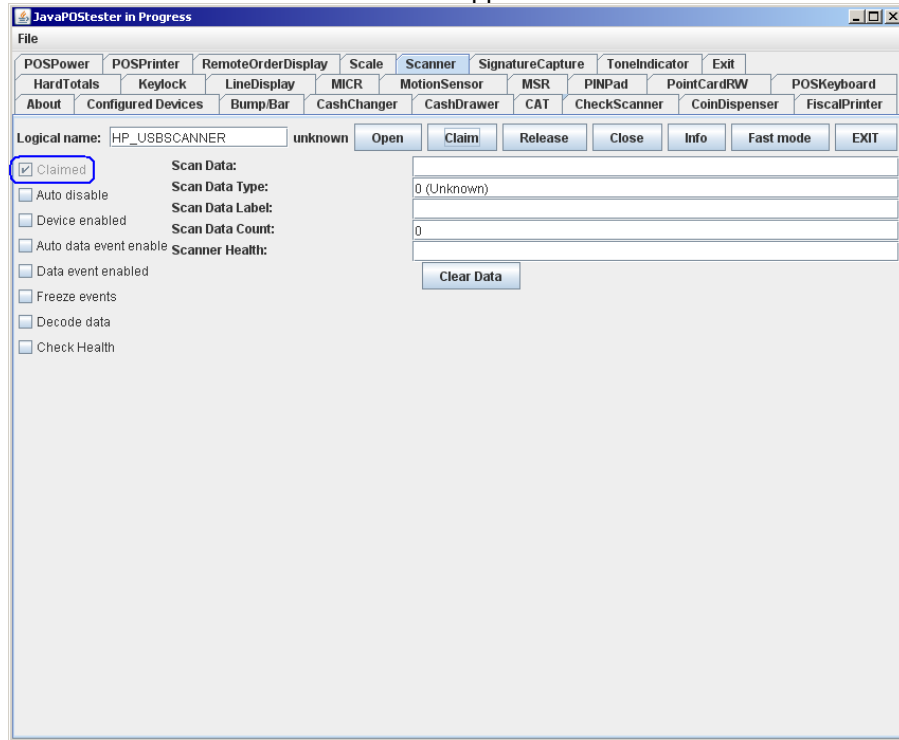

5. Check the "DEVICE ENABLED" so there is a check box.
6. Check the "AUTO DATA EVENT ENABLE" so there is a check box.
7. Check the "DATA EVENT ENABLED" so there is a check box.
8. Check the "DECODE DATA" so there is a check box.

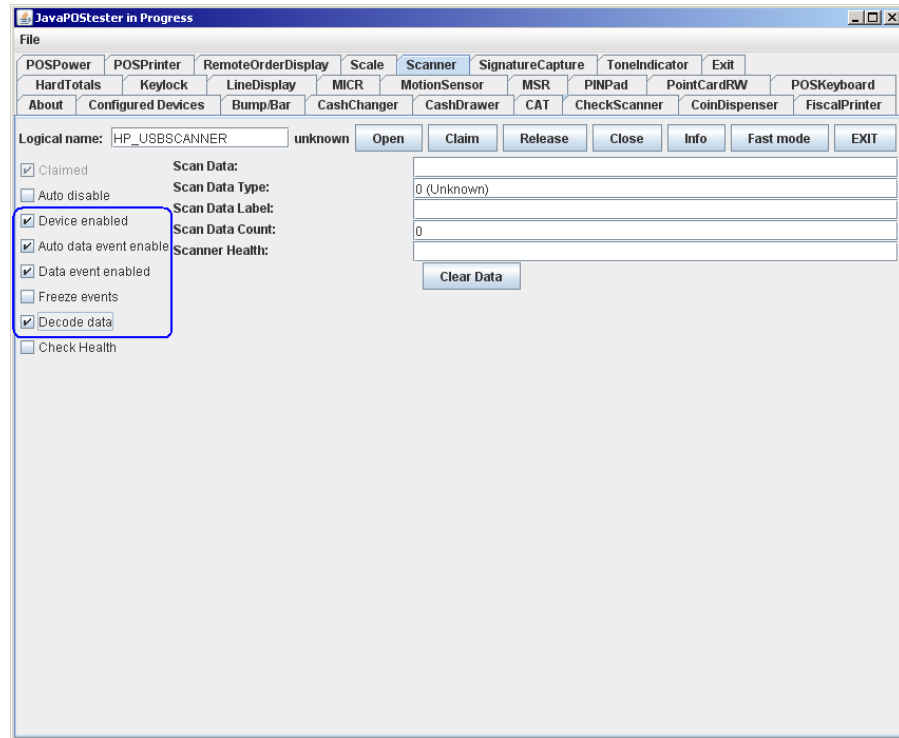

9. Scan a bar code:

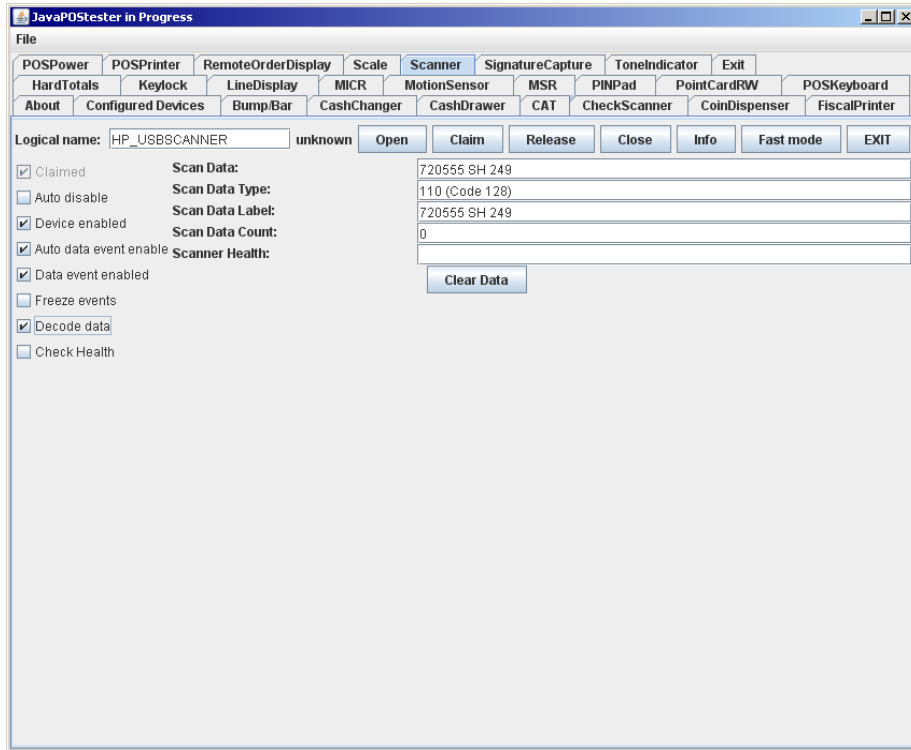

Depending on the fonts installed you may see some block character at the end of the "SCAN DATA" line, this is OK. An example

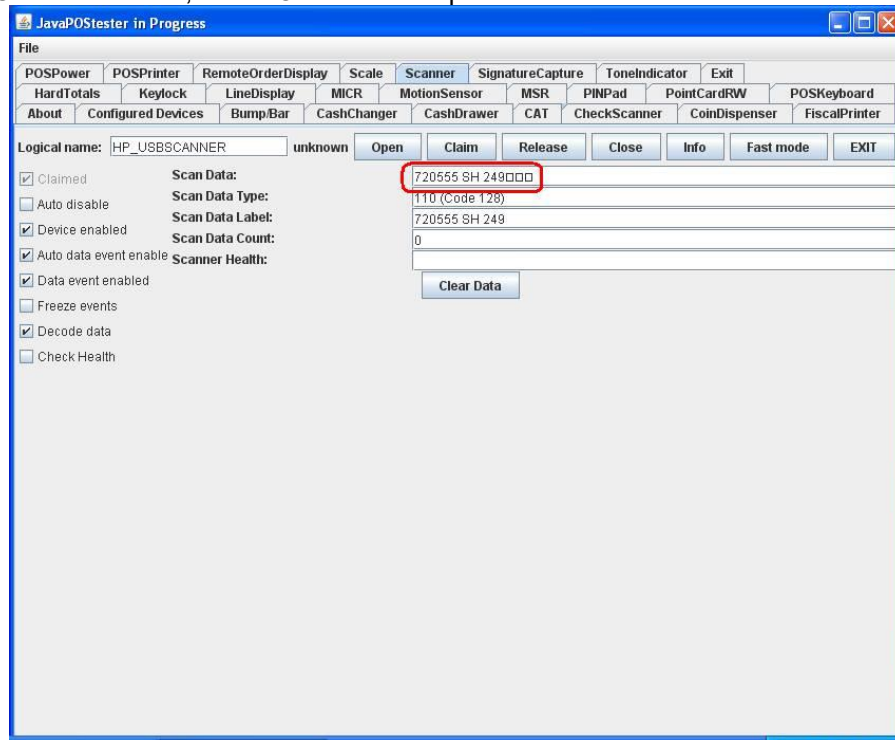

10. Click on "RELEASE" or "CLOSE" to exit the JPOS test utility.

6.8 **HP Barcode Scanner H-Series**

This section covers the following Barcode Scanner(s):

- HP ElitePOS 2D Barcode Scanner



HP ElitePOS 2D Barcode Scanner

6.8.1 **Connection**

The Barcode Scanner may be plugged into any free USB port, including powered USB ports. If a powered USB port is used, the powered portion is just not utilized.

6.8.2 **Interfaces**

The Barcode Scanner supports the following interfaces:

- USB COM
- USB Composite (default)
- USB HID POS

6.8.3 **Configuration**

To change the Barcode Scanner configuration settings such as interface, there are three methods available:

- Common configuration barcodes in this document.
- Programming Reference Guide available from HP.COM
- HP EZConfig (only available through a Softpaq download from HP.COM)

Common Configuration Barcodes:

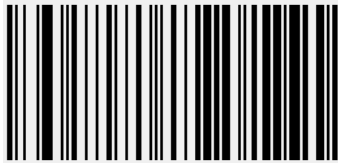

Default

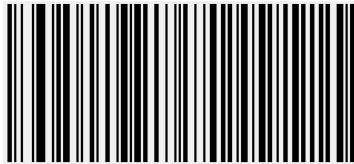

USB COM

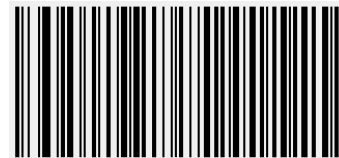

USB HID POS

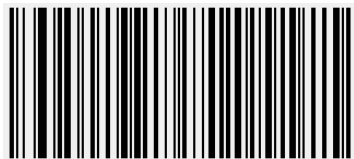

USB Composite

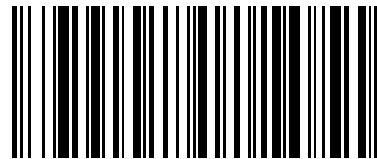

Show Software Revision



Presentation Mode

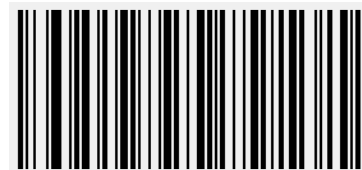

Manual Trigger Mode

HP EZConfig:

- Click the **CONNECTED DEVICE** button to begin configuring the device.

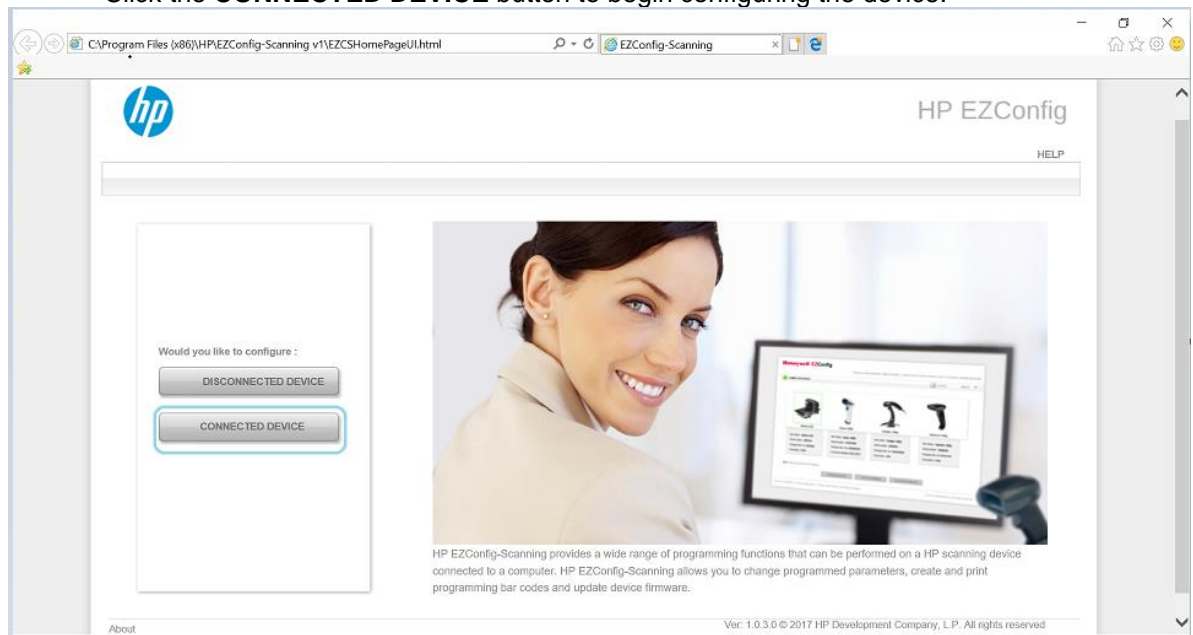

6.8.4 **Windows Drivers**

For USB Composite and USB HID POS interfaces, native Windows Operating System drivers are used. For USB COM interface, HP Barcode Scanner H-Series USB COM Driver is needed. It is included in the HP Factory image and can be found on HP.COM.

Device	Interface	Device Manager
HP ElitePOS 2D Barcode Scanner	USB COM	Ports (COM & LPT) HP ElitePOS 2D Barcode Scanner (COMx)
	USB Composite (default)	Keyboards HID Keyboard Device POS Barcode Scanner POS HID Barcode scanner
	USB HID POS	POS Barcode Scanner POS HID Barcode scanner

6.8.5 **OPOS Drivers**

HP Barcode Scanner H-Series OPOS is included in the HP factory image and can be found on HP.COM. OPOS can only be used with USB COM or USB HID POS interfaces.

6.8.6 **JPOS Drivers**

HP Barcode Scanner H-Series JPOS is included in the HP factory image and can be found on HP.COM. JPOS can only be used with USB COM or USB HID POS interfaces.

6.8.7 **Testing the Barcode Scanner**

6.8.7.1 **Testing in non-OPOS/JPOS**

Open Microsoft Notepad and scan a barcode. The data should appear in the Notepad window. If nothing appears, confirm that the interface is set to USB Composite.

6.8.7.2 **Testing in OPOS**

Steps

1. Open **OPOS Validation Utility**.
 - C:\<Program Files directory>\HP\HP Barcode Scanner H-Series OPOS\OPOS Validation Utility.exe
2. Click the **Advanced View** button.
3. Select the Device Name for your device (ex: N3680-HP).
4. Click the **Open** button.
5. Click the **Claim** button.
6. Click the **Enable Device** button.
7. Check the **Always Enable Data Event** checkbox.
8. Check the **Decode Data** checkbox.
9. Scan a barcode. The Scan Data will be displayed.
10. After testing is complete, click the **Disable Device** button.
11. Click the **Release** button.
12. Click the **Close** button.
13. Exit **OPOS Validation Utility**.

Detailed Steps

1. Open the **OPOS Validation Utility**.
 - C:\<Program Files directory>\HP\HP Barcode Scanner H-Series OPOS\OPOS Validation Utility.exe

2. Click the **Advanced View** button.

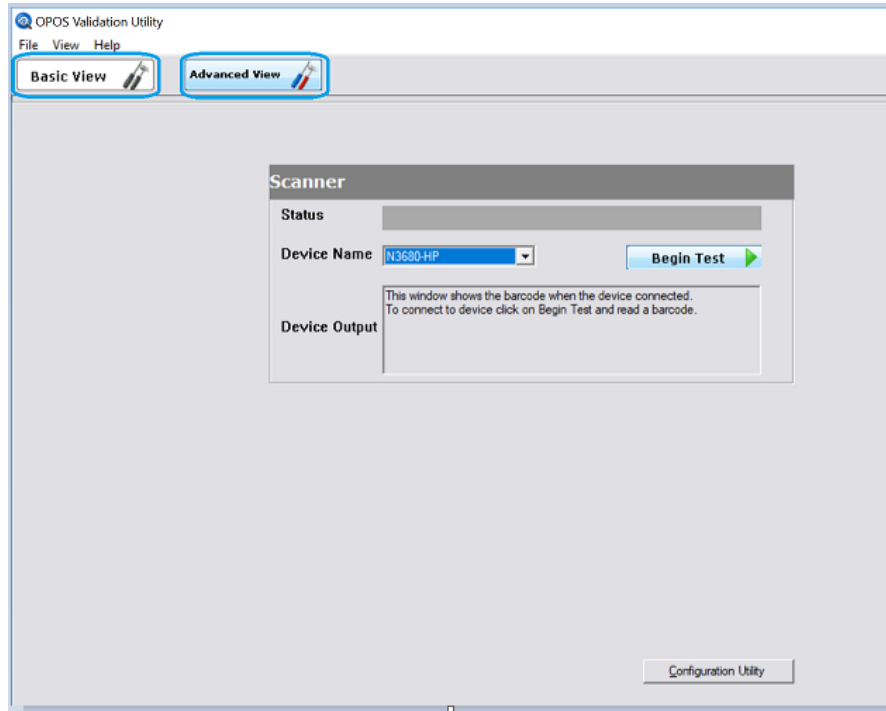

3. Select the Device Name for your device (ex: N3680-HP).

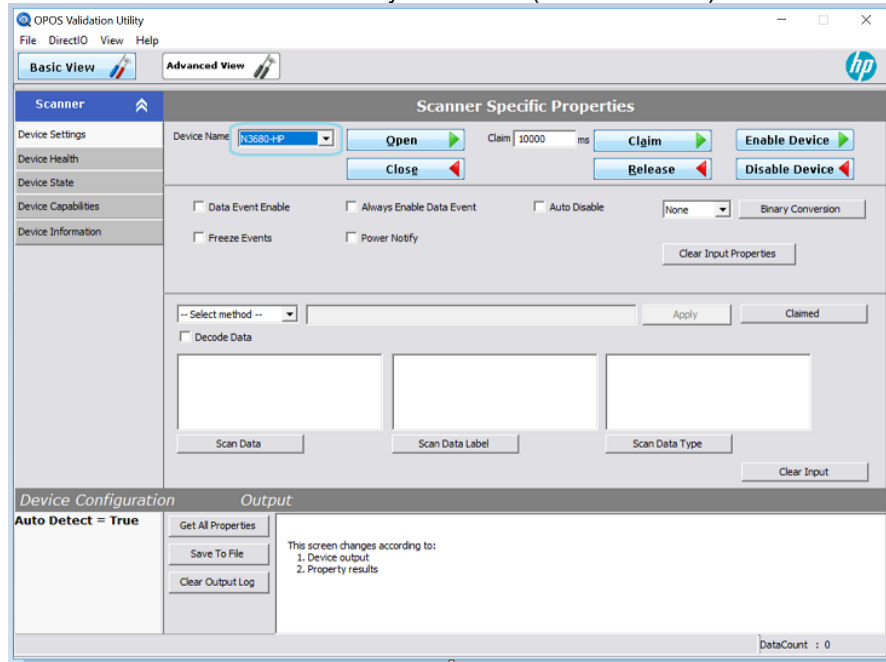

4. Click the **Open** button.

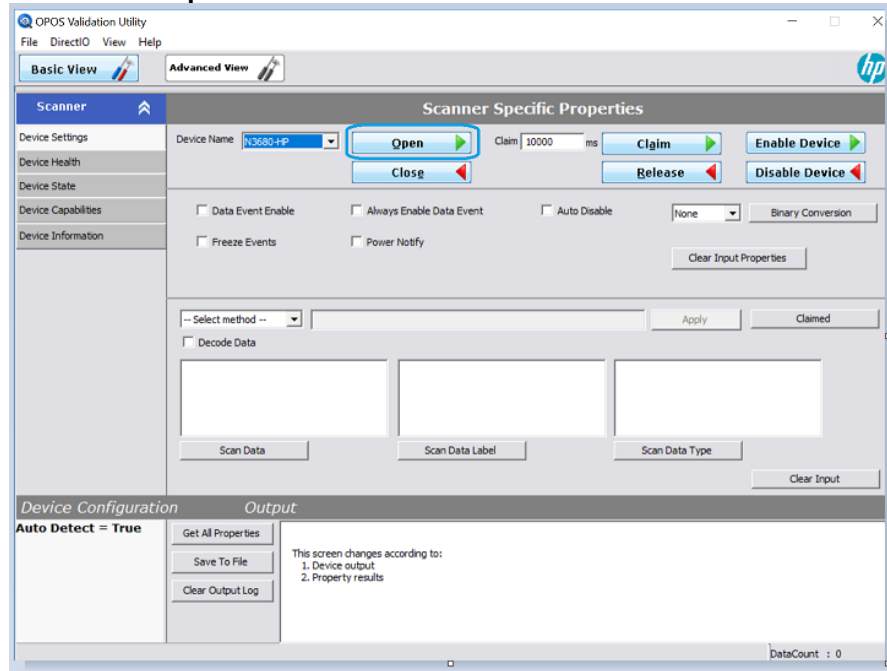

5. Click the **Claim** button.

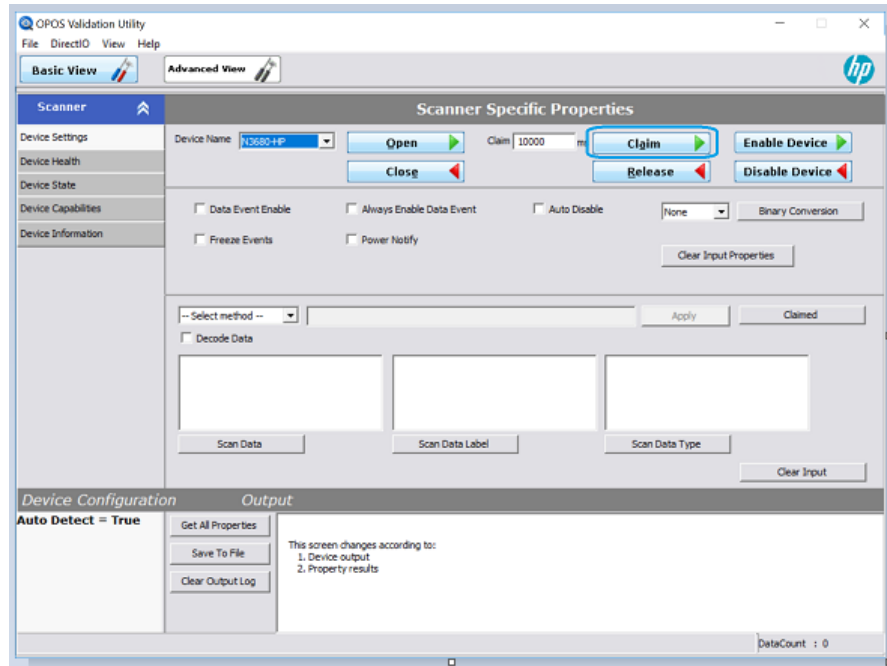

6. Click the **Enable Device** button.

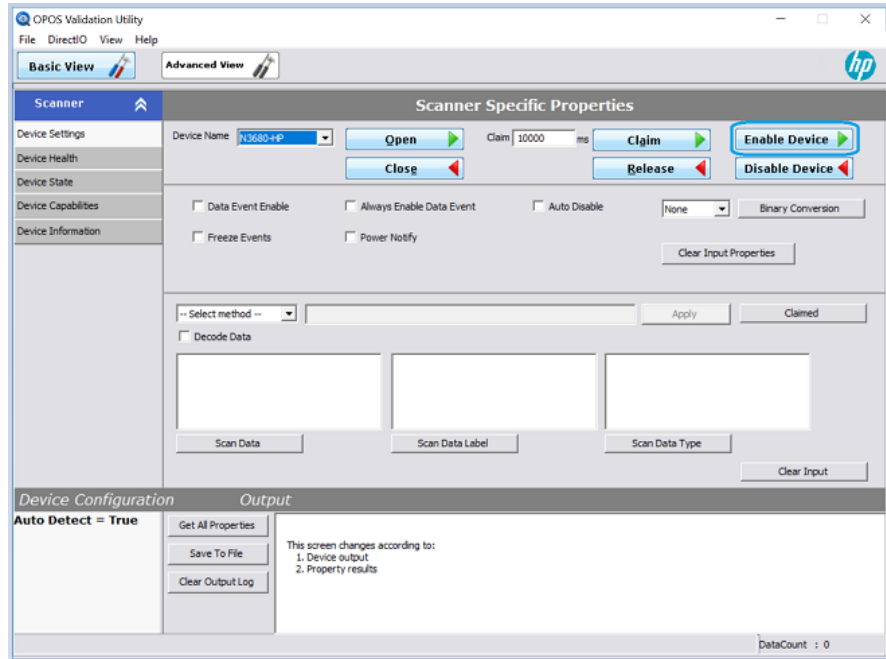

7. Check the **Always Enable Data Event** checkbox.

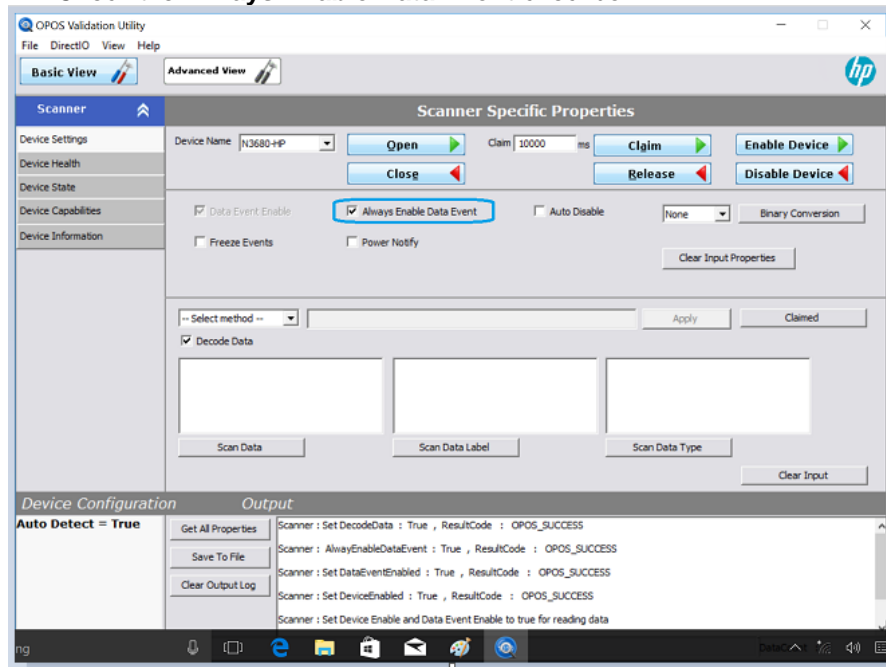

8. Check the **Decode Data** checkbox.

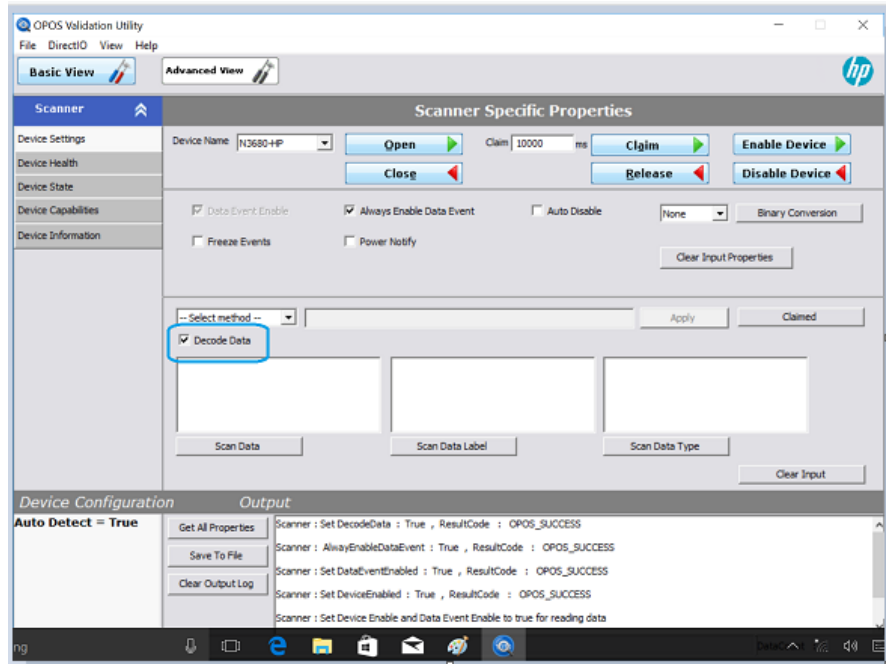

9. Scan a barcode. The Scan Data will be displayed.

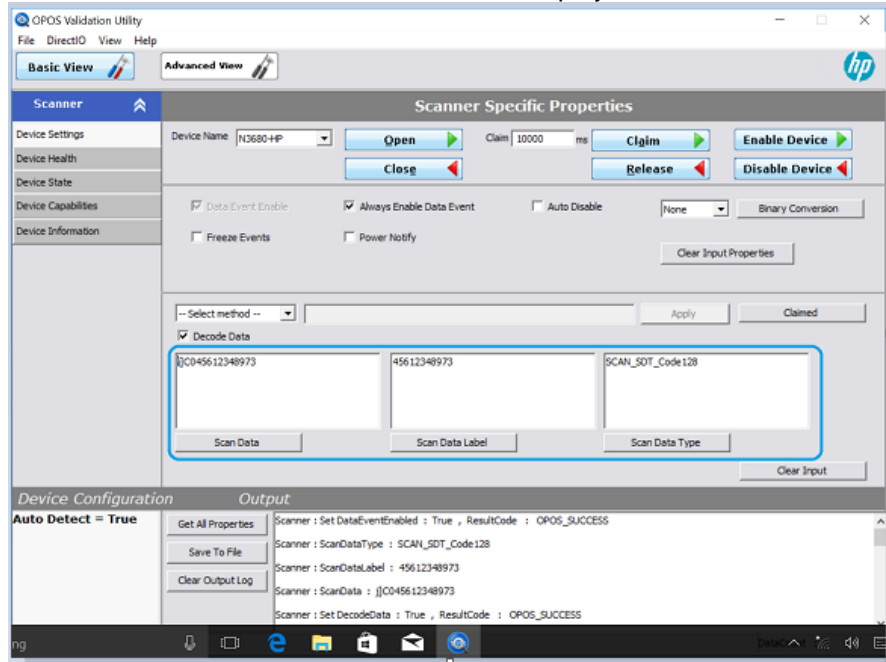

10. After testing is complete, click the **Disable Device** button.

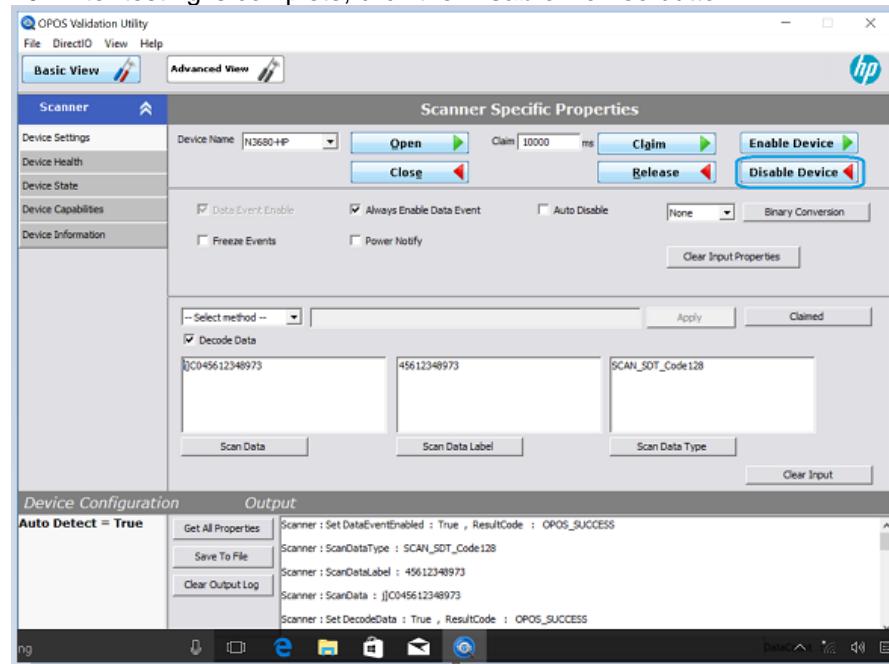

11. Click the **Release** button.

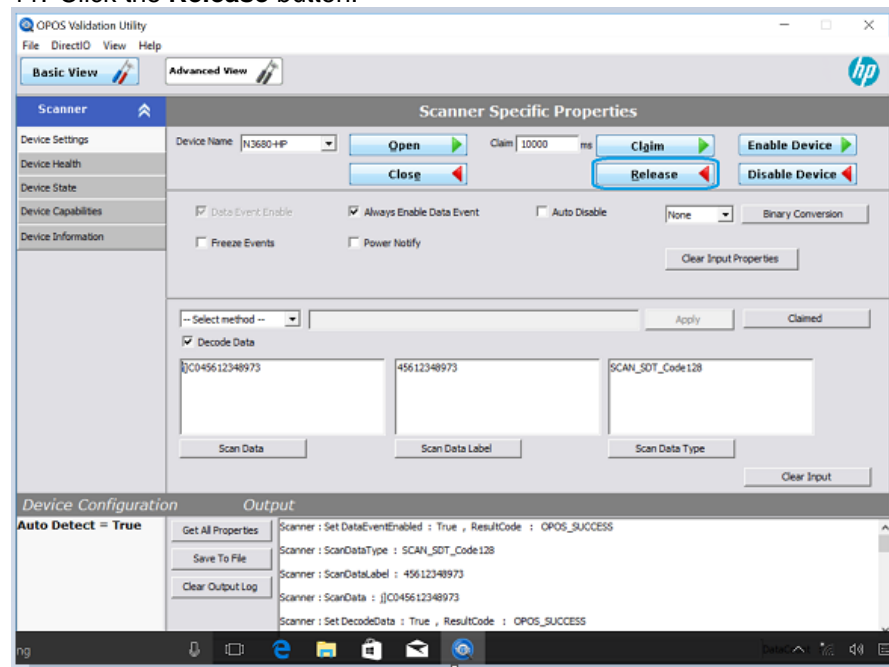

12. Click the **Close** button.

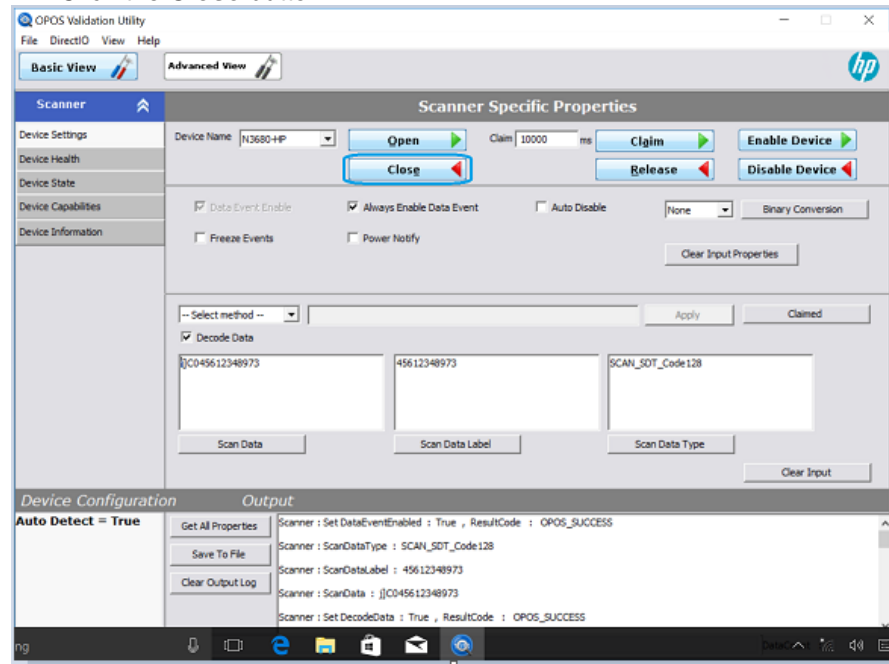

13. Exit **OPOS Validation Utility**.

6.8.7.3 Testing in JPOS

Steps

1. Open the **JPOS Validation Utility**.
 - C:\<Program Files directory>\HP\HP Barcode Scanner H-Series JPOS\JPOS Validation Utility.exe
2. Click the **Advanced View** button.
3. Select the Device Name for your device (ex: N3680-HP).
4. Click the **Open** button.
5. Click the **Claim** button.
6. Click the **Enable Device** button.
7. Check the **Always Enable Data Event** checkbox.
8. Check the **Decode Data** checkbox.
9. Scan a barcode. The Scan Data will be displayed.
10. After testing is complete, click the **Disable Device** button.
11. Click the **Release** button.
12. Click the **Close** button.
13. Exit **JPOS Validation Utility**.

Detailed Steps

1. Open the **JPOS Validation Utility**.
 - C:\<Program Files directory>\HP\HP Barcode Scanner H-Series JPOS\JPOS Validation Utility.exe
2. Click the **Advanced View** button.

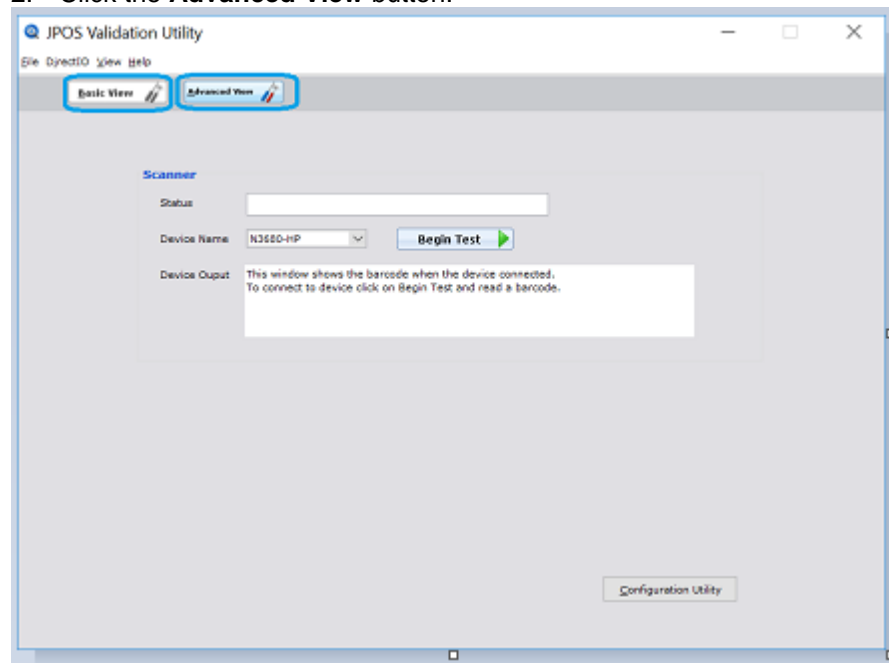

3. Select the Device Name for your device (ex: N3680-HP).

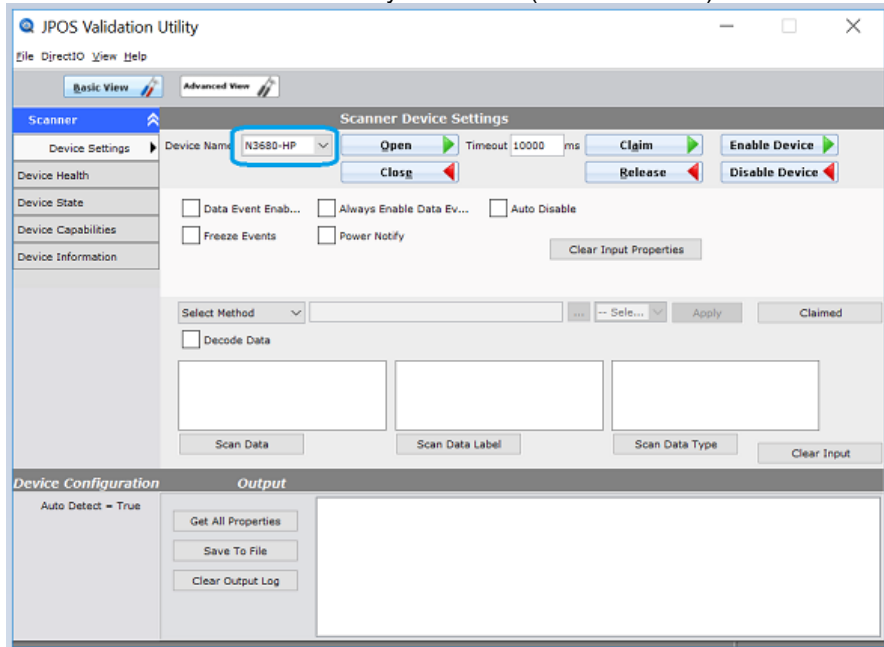

4. Click the **Open** button.

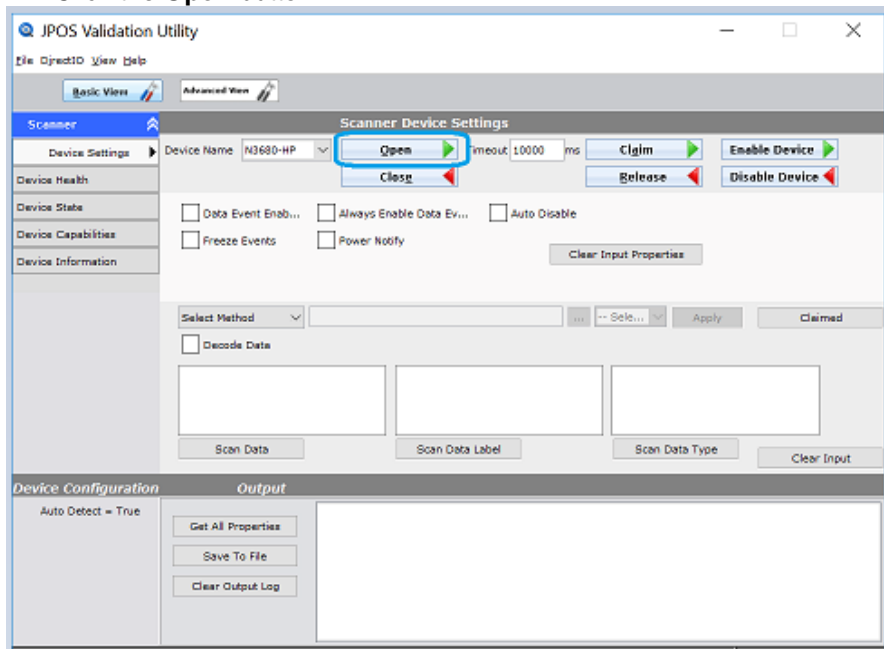

5. Click the **Claim** button.

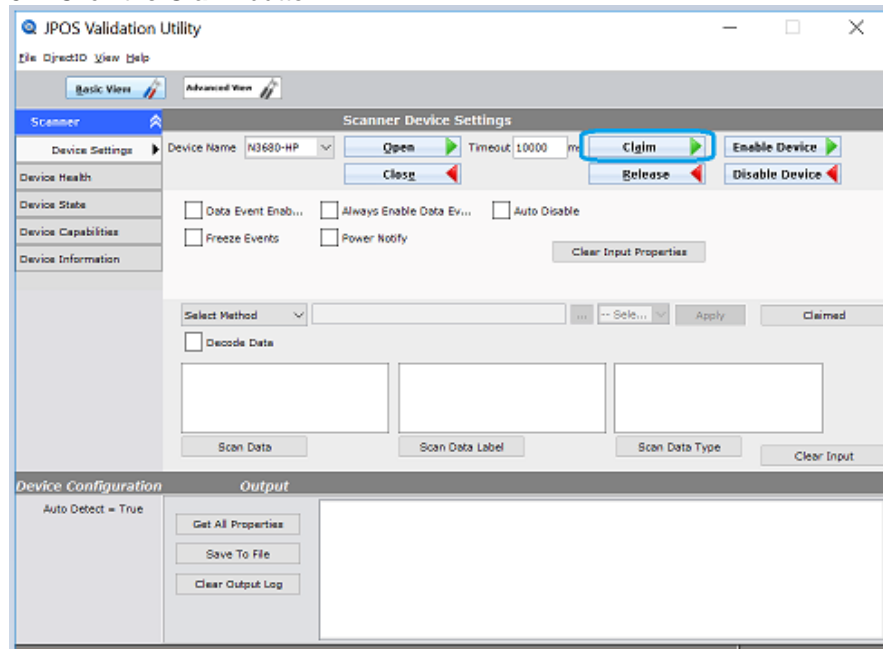

6. Click the **Enable Device** button.

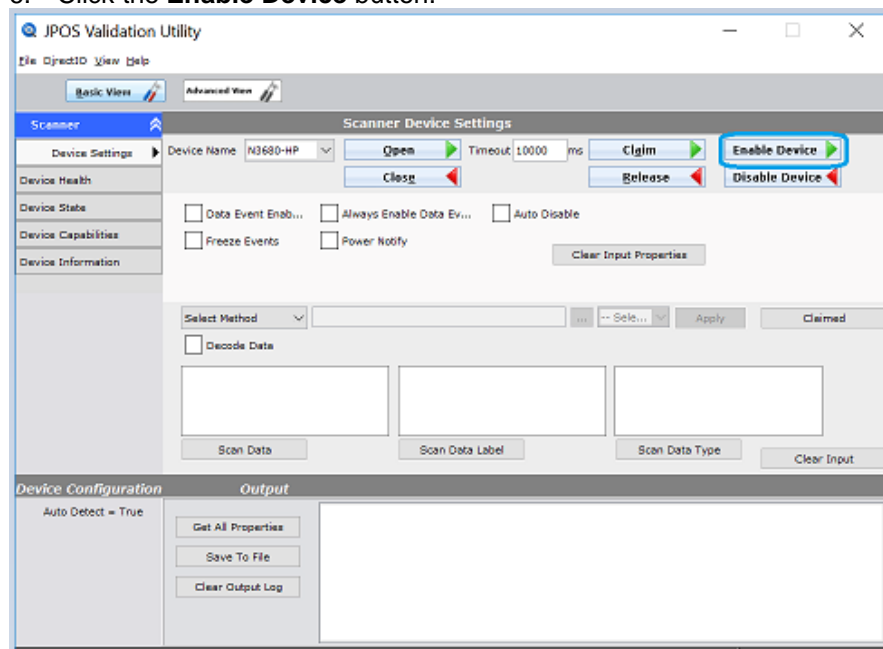

7. Check the **Always Enable Data Event** checkbox.

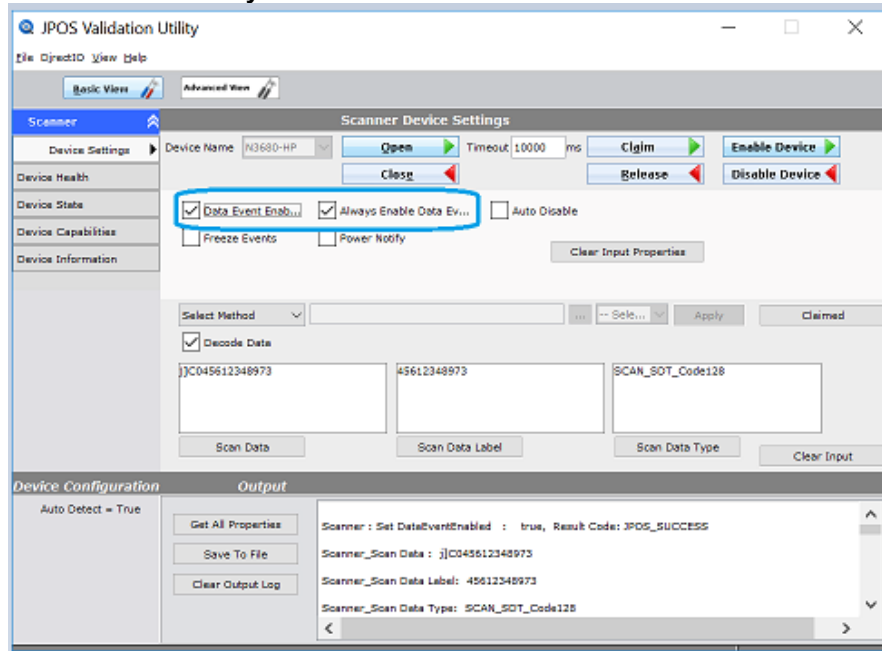

8. Check the **Decode Data** checkbox.

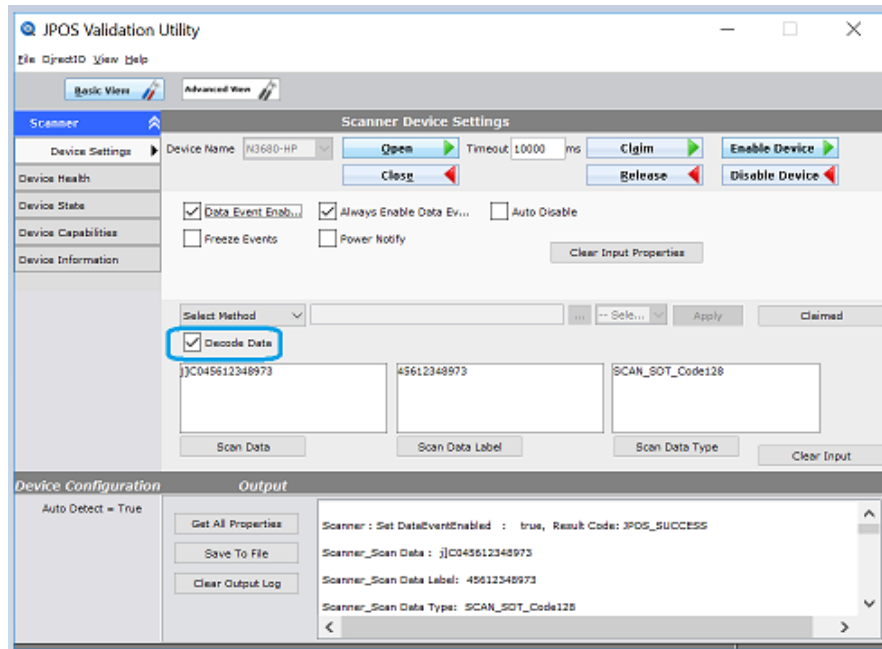

9. Scan a barcode. The Scan Data will be displayed.

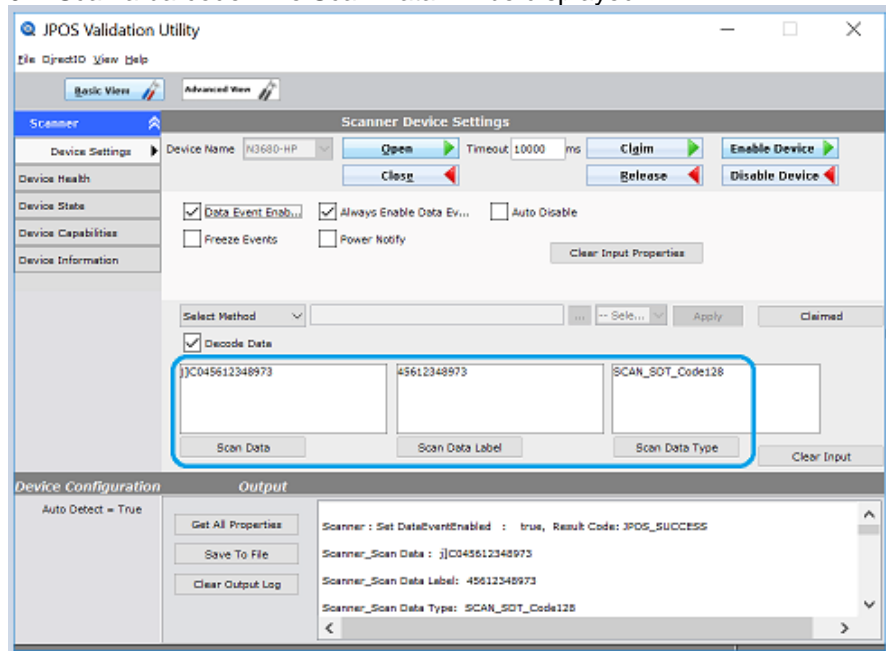

10. After testing is complete, click the **Disable Device** button.

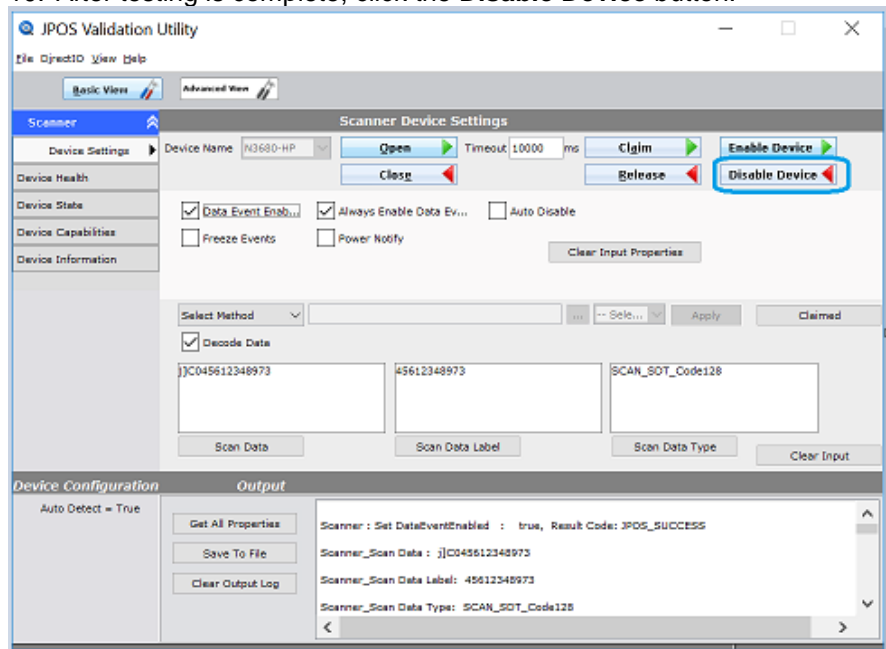

11. Click the **Release** button.

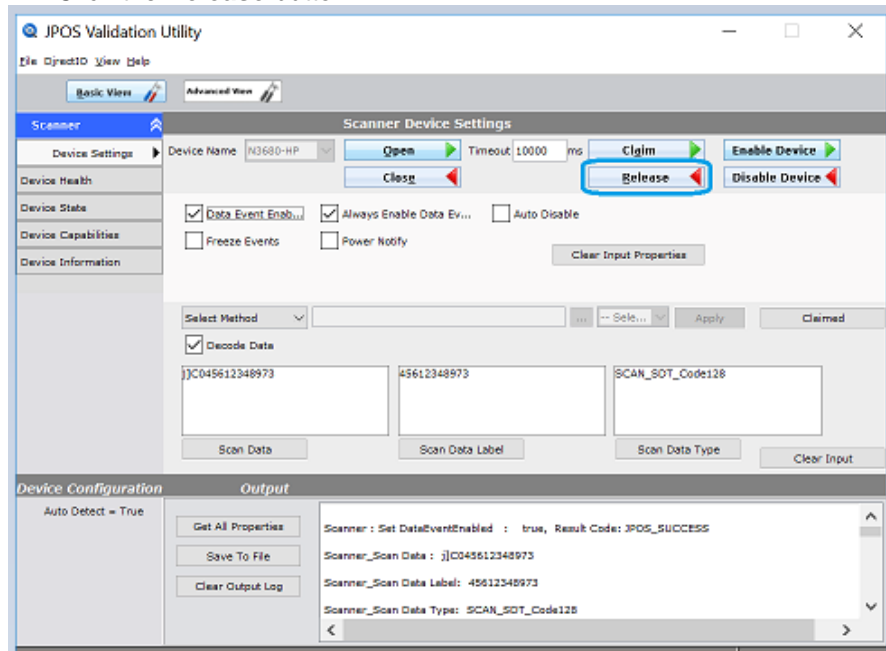

12. Click the **Close** button.

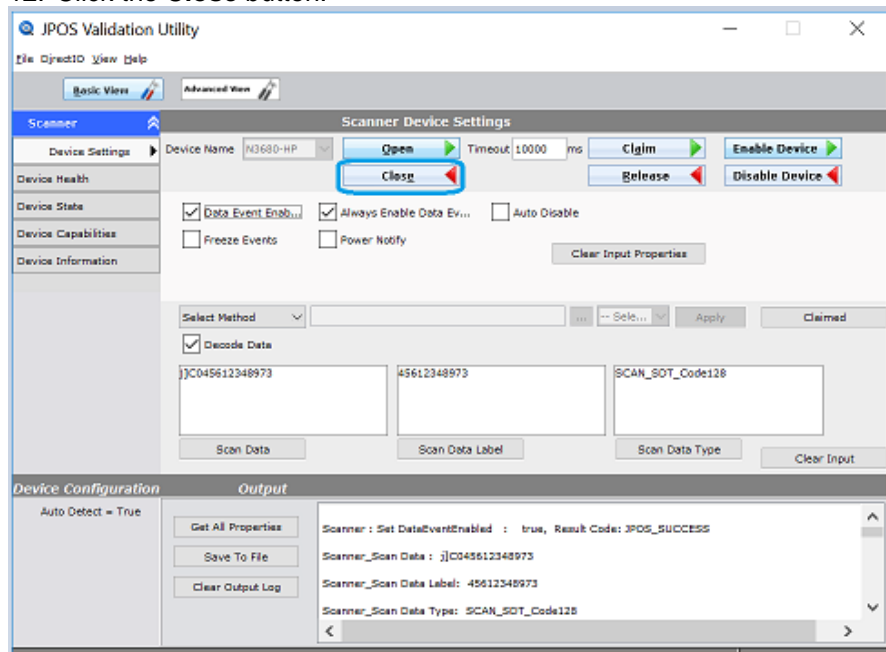

13. Exit JPOS Validation Utility.

6.9 HP USB Barcode Scanners

This section covers the following Barcode Scanner(s):



HP RP9 Integrated Bar Code Scanner-Side



HP RP9 Integrated Bar Code Scanner-Bottom



HP Retail Integrated Barcode Scanner



HP Laser Barcode Scanner



HP Wireless Barcode Scanner



HP Value 2D Wireless Scanner



HP Linear Barcode Scanner



HP Linear Barcode Scanner II



HP Presentation Barcode Scanner



HP KIOSK Scanner

6.9.1 **Connection**

The Barcode Scanner may be plugged into any free USB port, including powered USB ports. If a powered USB port is used, the powered portion is just not utilized.

6.9.2 **Windows Drivers for Scanners**

The HP Imaging / Linear / Presentation scanner uses native drivers for Windows operating system in USB HID-KBD mode. If during the driver installation Windows displays the new hardware wizard, the user needs to accept the defaults that appear during the hardware wizard GUI (for the first screen you may select the no option) and the native drivers will be loaded. Please refer to "[if prompted for native driver location \(New Hardware Wizard\)](#)" section.

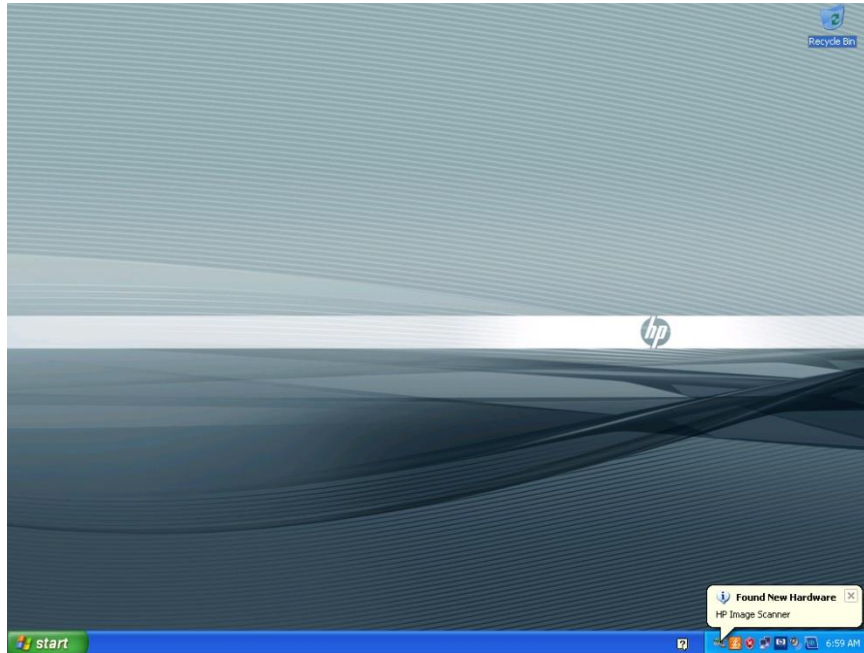

The following is the Device Manager window after all the drivers are loaded for the HP Imaging / Linear / Presentation Scanners in USB HID-KBD (default) mode:

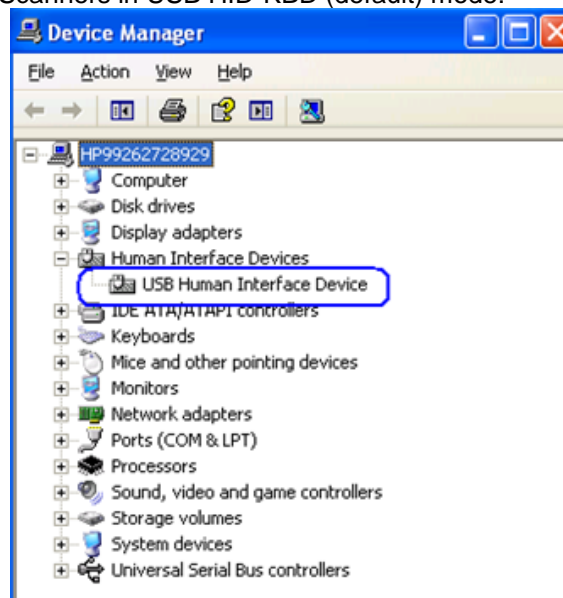

The following is the Device Manager window after all the drivers are loaded for the HP RP9 Integrated Barcode Scanners in USB HID-KBD mode:

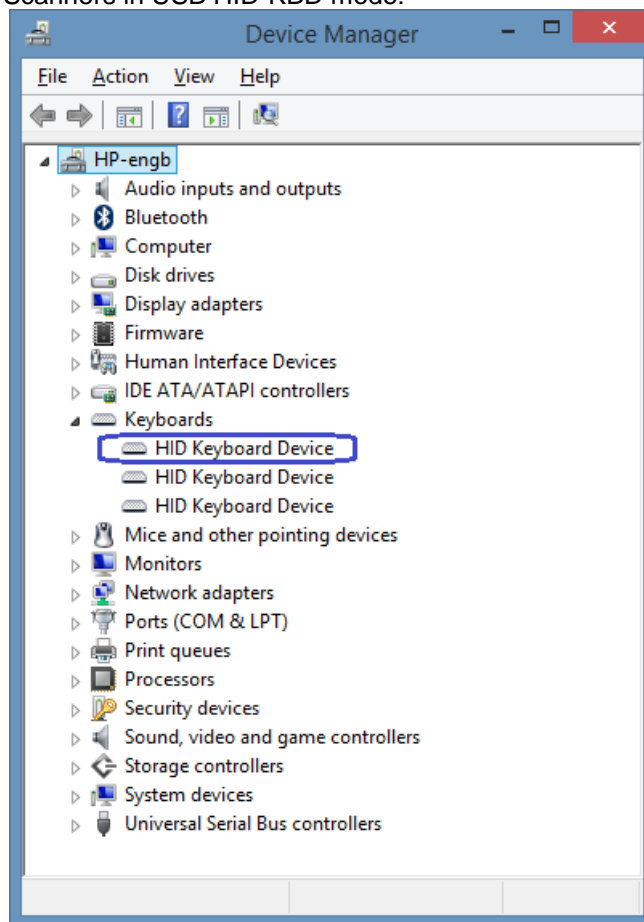

The following is the Device Manager window after all the drivers are loaded for the HP Imaging / Linear / Presentation Scanners when it is in the USB-COM mode (OPOS):

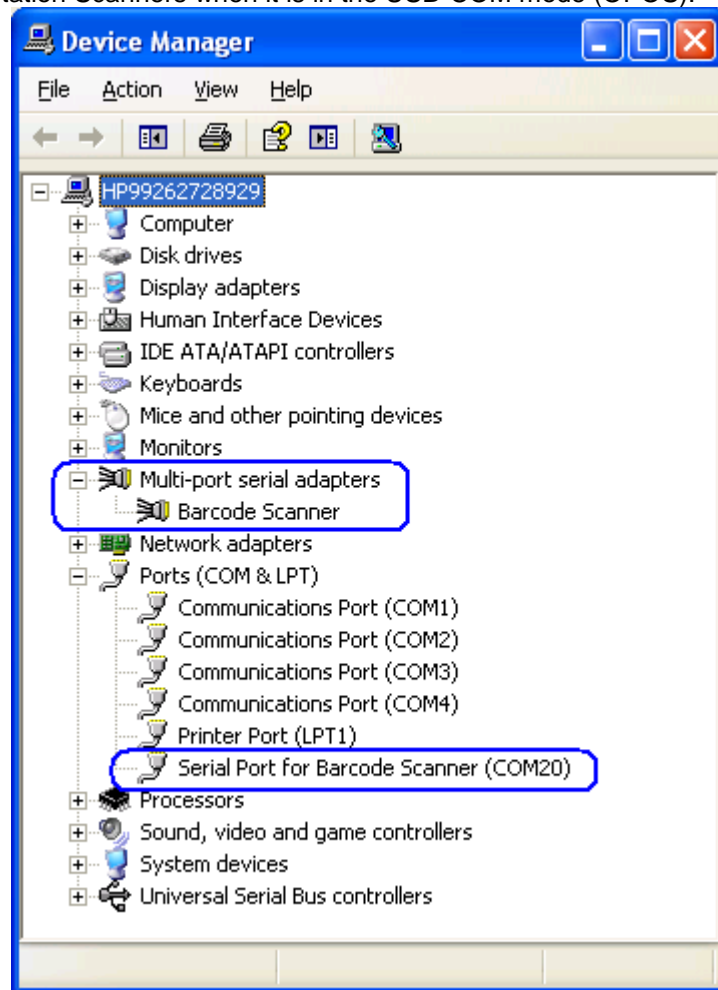

The following is the Device Manager window after all the drivers are loaded for the HP RP9 Integrated Barcode Scanners in USB-COM mode (OPOS):

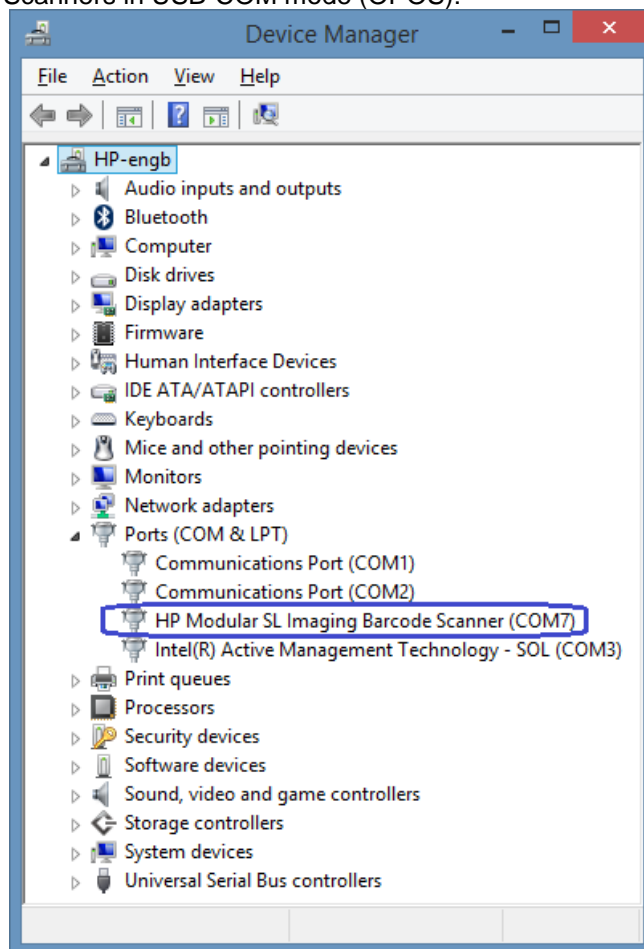

The following is the Device Manager window after all the drivers are loaded for the HP RP9 Integrated Barcode Scanners in USB-Composite (default) mode:

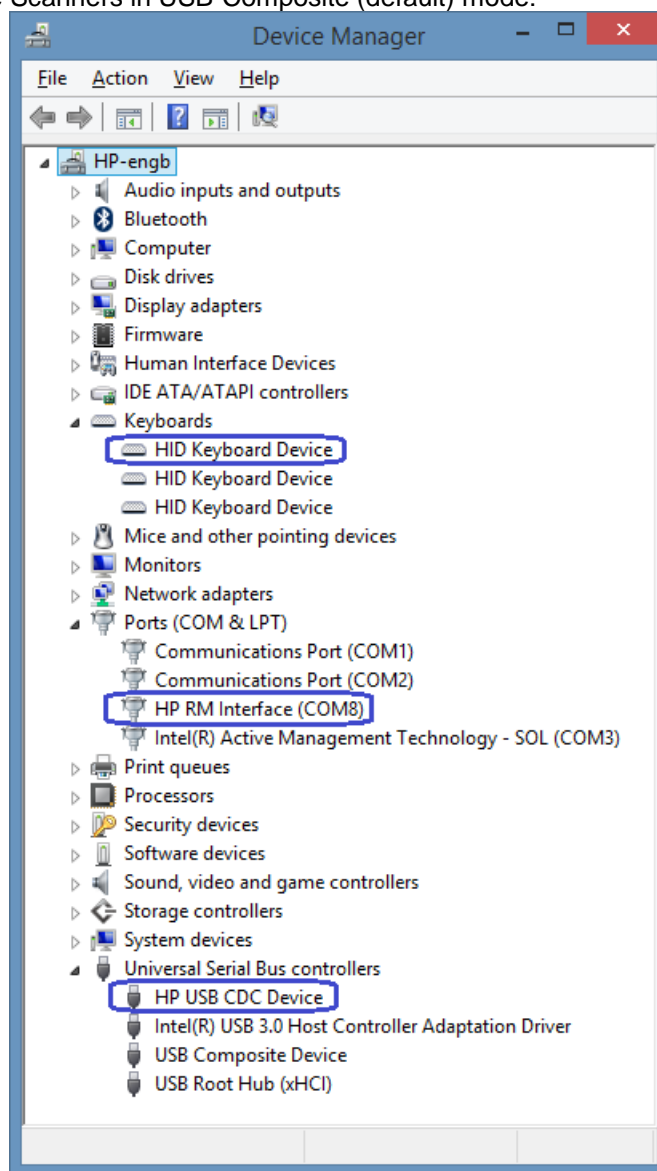

2D Imaging Barcode Scanner with driver 3.13.xx.xx

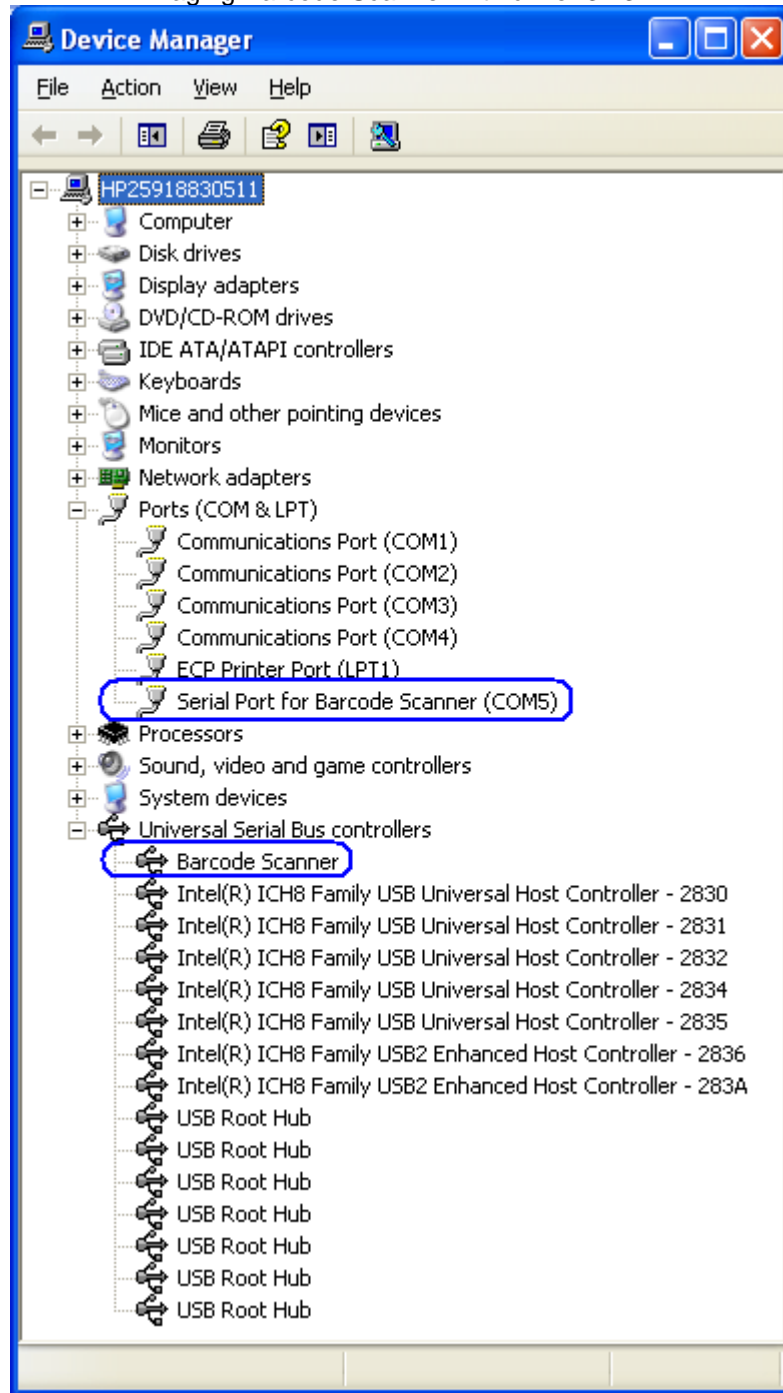

HP Linear Barcode Scanner with driver 3.13.xx.xx

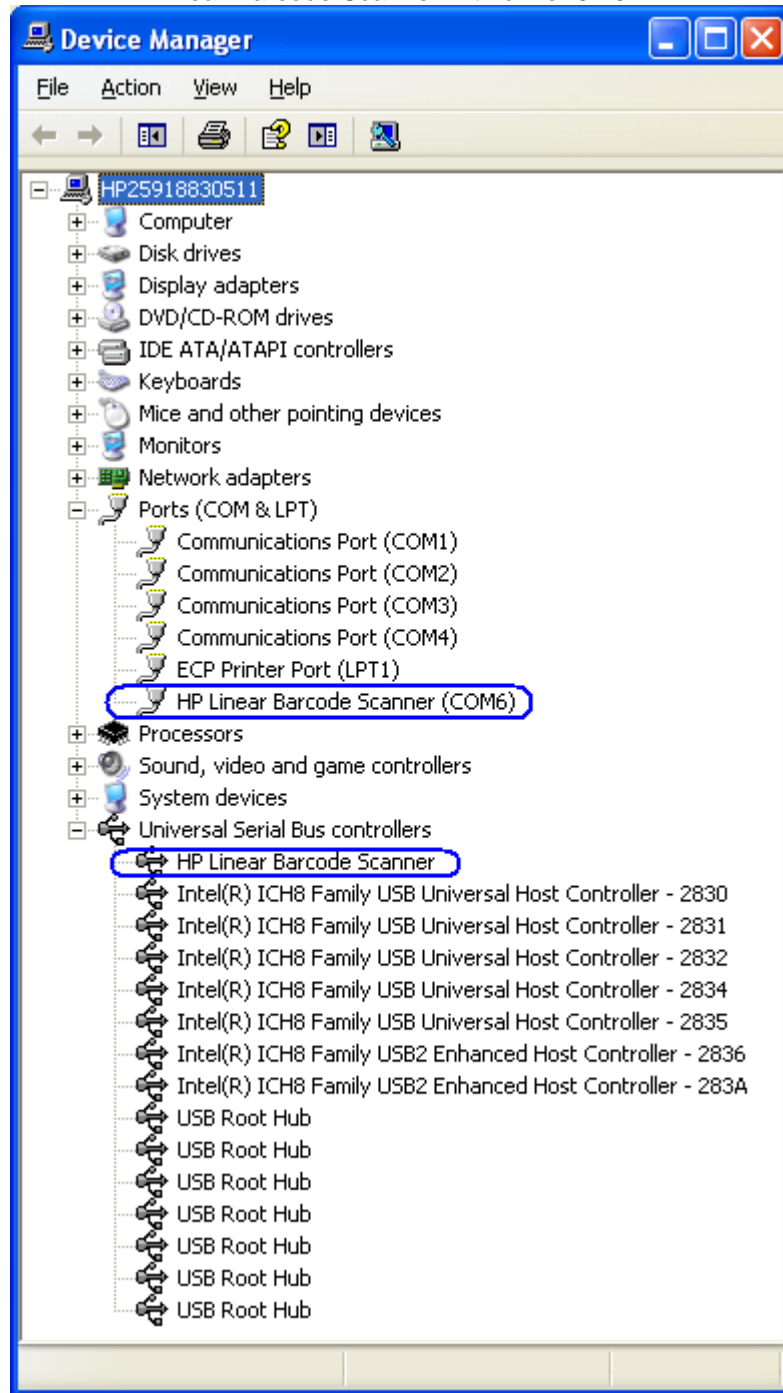

HP Presentation Scanner with driver 3.13.xx.xx

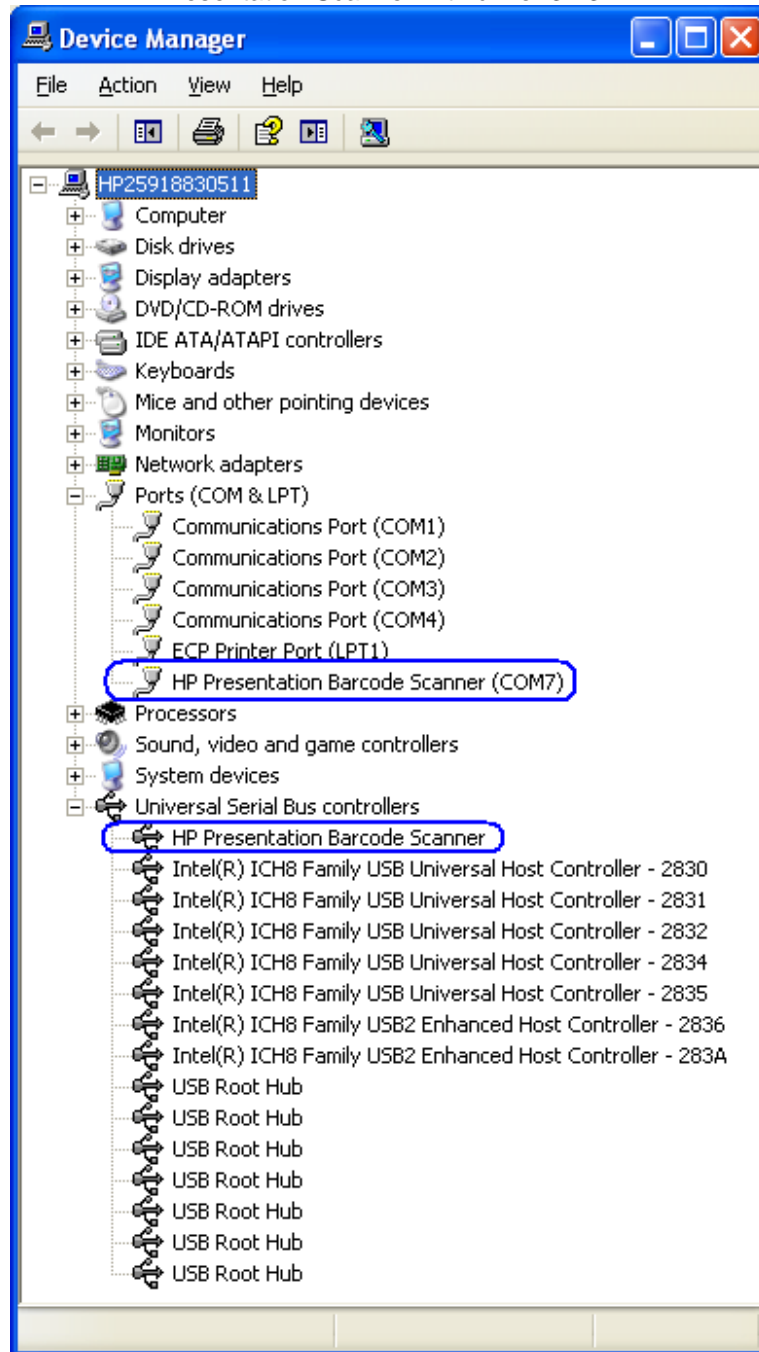

Note: For Windows XP Professional / WePOS / POSReady the virtual COM port for the scanner is assigned COM20 with version 3.0.1.32. Starting with version 3.12.0.32 the virtual COM port is not fixed at COM20 but assigned the next available COM port on the system. For Vista / Windows 7 the virtual COM port is assigned the next available COM port on the system. The virtual COM port assignment for the Imaging Barcode Scanner can be changed by going to the properties page of the scanner COM port.

With USB-COM driver version 3.13.xx.xx or later the "Multi-port serial adapters" will not appear for the scanner in device manager, it has moved to the USB section of device manager.

6.9.3 OPOS Drivers for the Scanners

There are no OPOS drivers needed for this device if the device is used in the human interface device (HID) keyboard emulation mode.

When the device is in USB-COM mode (OPOS) a Windows device driver is required. The required device drivers that support the scanner are included in the HP factory image and can be found on HP.COM.

6.9.4 Testing the Scanners

6.9.4.1 Testing scanners in non-OPOS

The default mode of the scanner is non-OPOS mode when shipped from HP. In order to test the scanner in non-OPOS mode one can open an application like Microsoft Notepad and scan a barcode when the scanner is in default scanner mode.

You may use one of the barcodes below for testing if you do not have an item with a barcode handy.



6.9.4.2 Testing the scanners in OPOS

The scanners must be in USB-COM mode (OPOS). If one is not sure what mode the scanner is in, open an application like notepad and scan a barcode. If the scanner is in OPOS mode, when you scan a barcode nothing will appear in Notepad. If something appears in Notepad, the scanner is in USB HID Keyboard emulation or USB-Composite mode.

In order for the scanner to work with OPOS driver, the scanner must be programmed into the USB-COM mode (OPOS).

All configuration barcodes can be found in the Programming Guide on HP.COM.

The following is an overview of the steps to test the scanners followed by more detailed steps:

1. Open **ScannerTest**.
 - C:\<Program Files directory>\HP\HPScannerOPOS\ScannerTest.exe.
2. Select the Scanner in the Scanners box.

3. Click the **Open Scanner** button.
4. Click the **Claim** button.
5. Click the **Enable** button.
6. Click the **Data Event Enable** button or select Auto Data Event Enable so the status states Ready to scan a label.
7. Scan a barcode.
8. After scan is complete click the **Disable** button.

Note: When the imaging scanner is disabled the LED on the scanner will blink to indicate that it has been disabled. When an OPOS application has been setup to use the imaging scanner in OPOS (USB COM) mode when the application is started the scanner will be enabled. When the application is exited then the imaging scanner will be disabled (LED on the scanner will blink).

9. Click the **Release** button.
10. Click the **Close Scanner** button.
11. Exit **ScannerTest**.

Detailed Steps

1. Open **ScannerTest**.
 - C:\<Program Files directory>\HP\HPScannerOPOS\ScannerTest.exe.
2. Select the Scanner in the Scanners box.
3. Click the **Open Scanner** button.

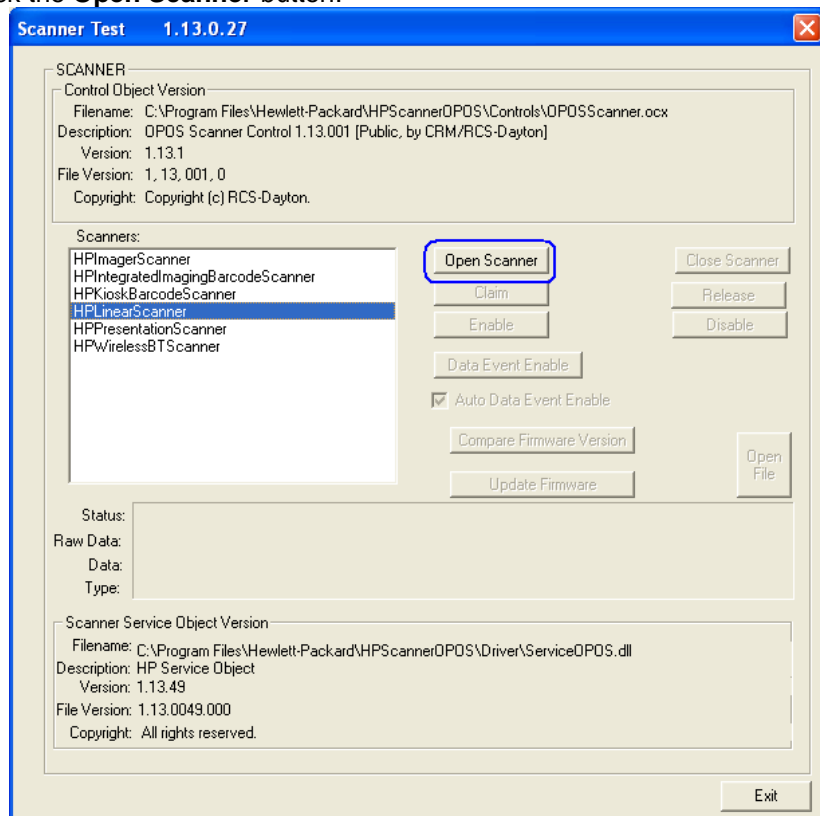

4. Click the **Claim** button.

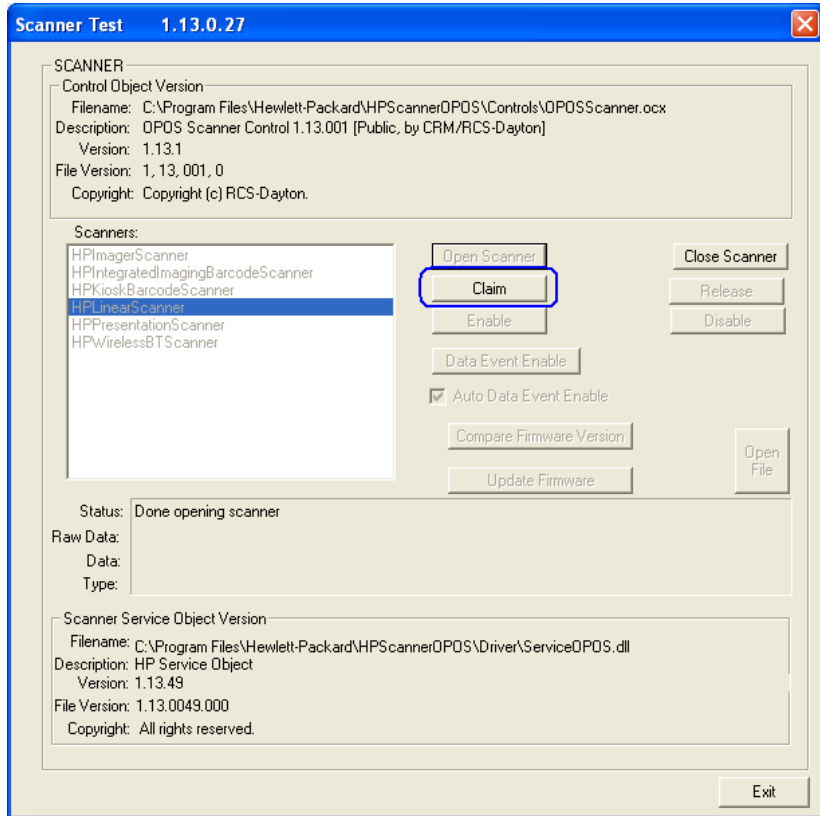

5. Click the **Enable** button.

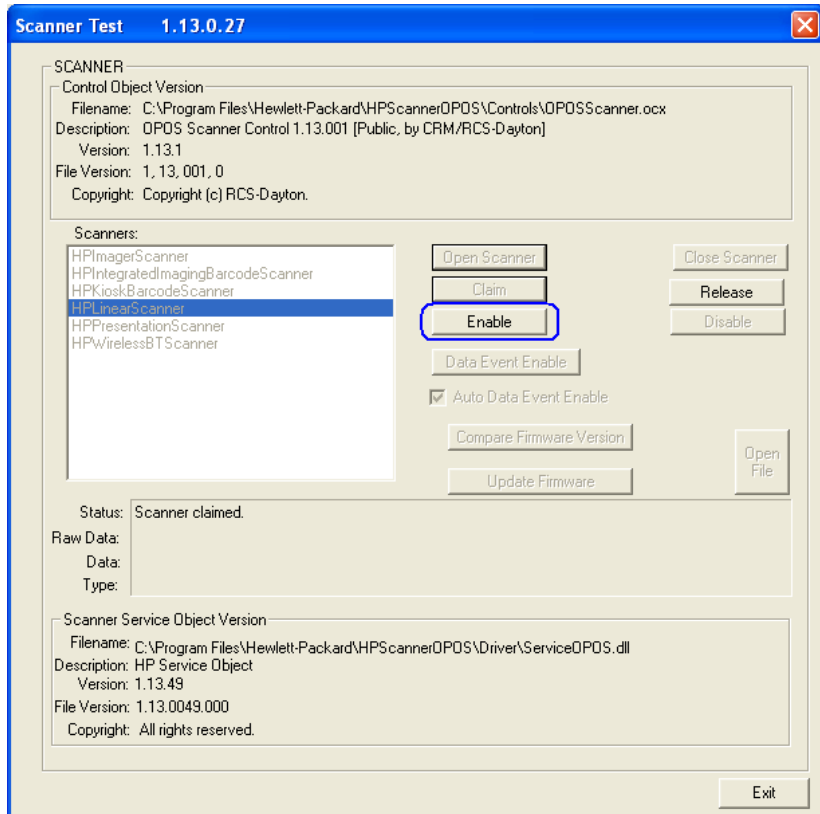

6. Click the **Data Event Enable** button or select Auto Data Event Enable so the status states Ready to scan a label.

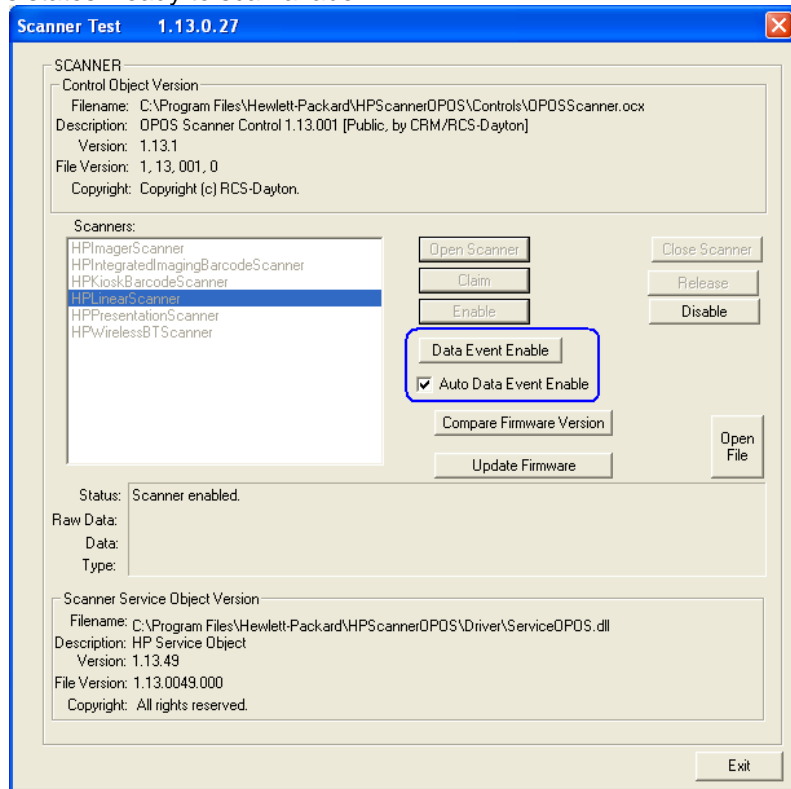

7. Scan a barcode and the data will appear in the dialog box.

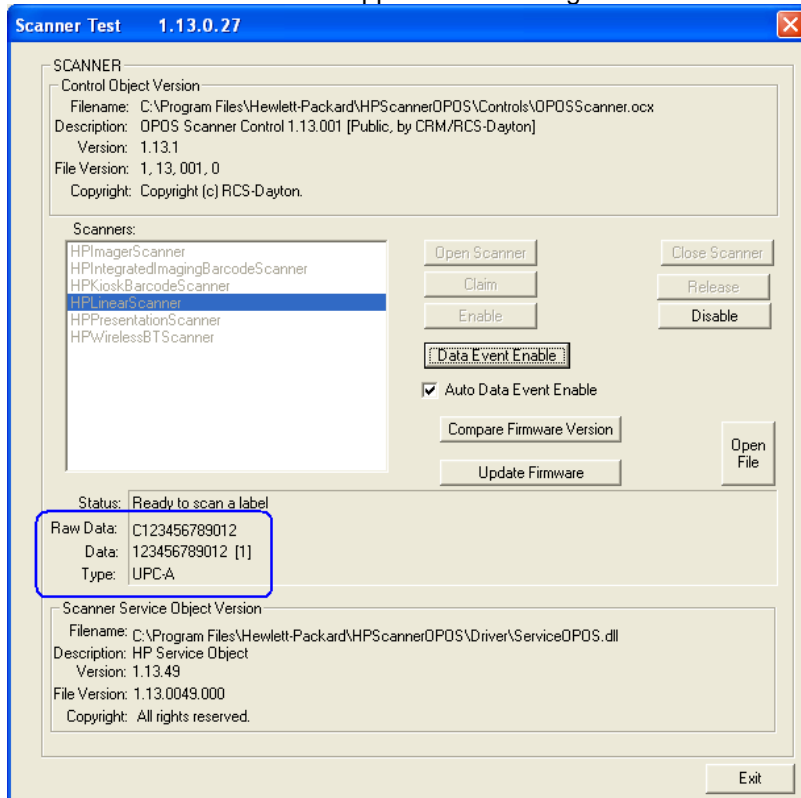

8. After scan is complete click on “Disable” button.

Note: When the imaging scanner is disabled the LED on the scanner will blink to indicate that it has been disabled. When an OPOS application has been setup to use the imaging scanner in OPOS (USB COM) mode when the application is started the scanner will be enabled. When the application is exited then the imaging scanner will be disabled (LED on the scanner will blink).

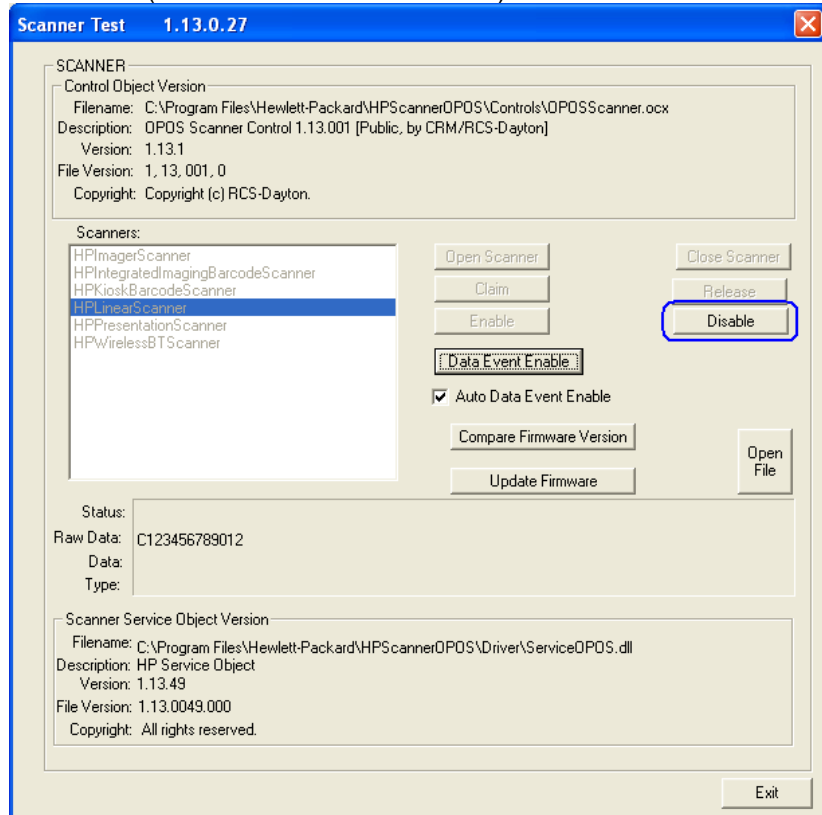

9. Click the **Release** button.

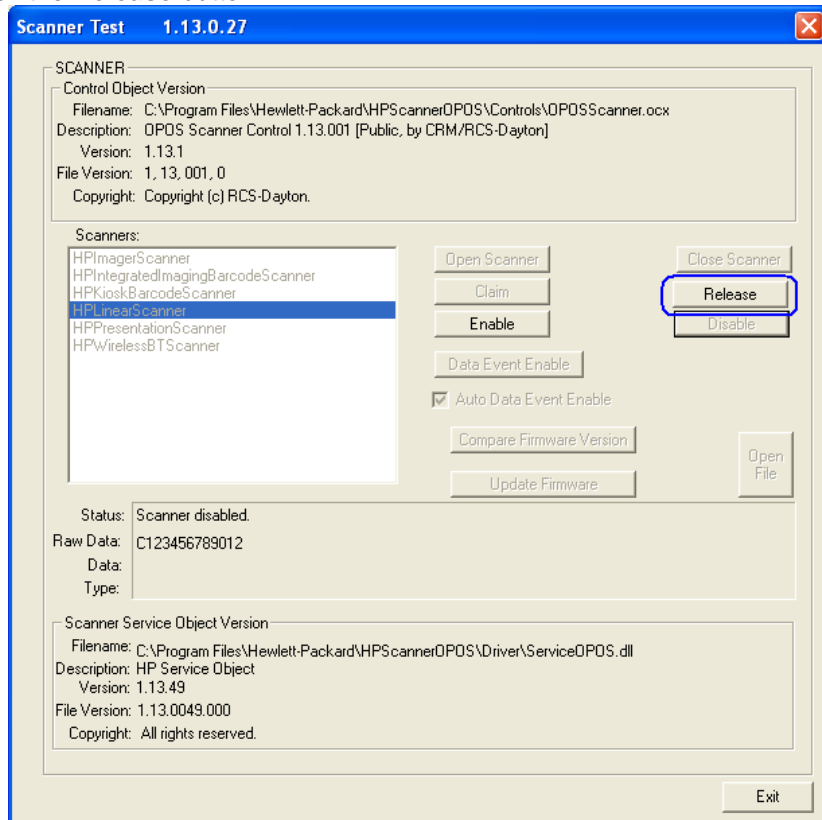

10. Click the **Close Scanner** button.

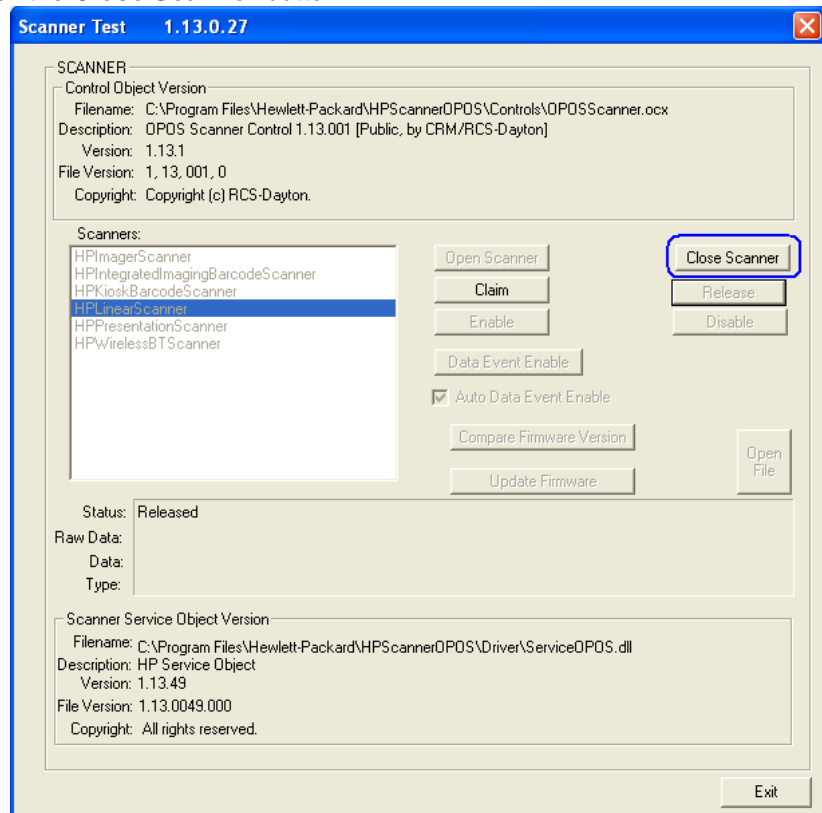

11. Exit ScannerTest.

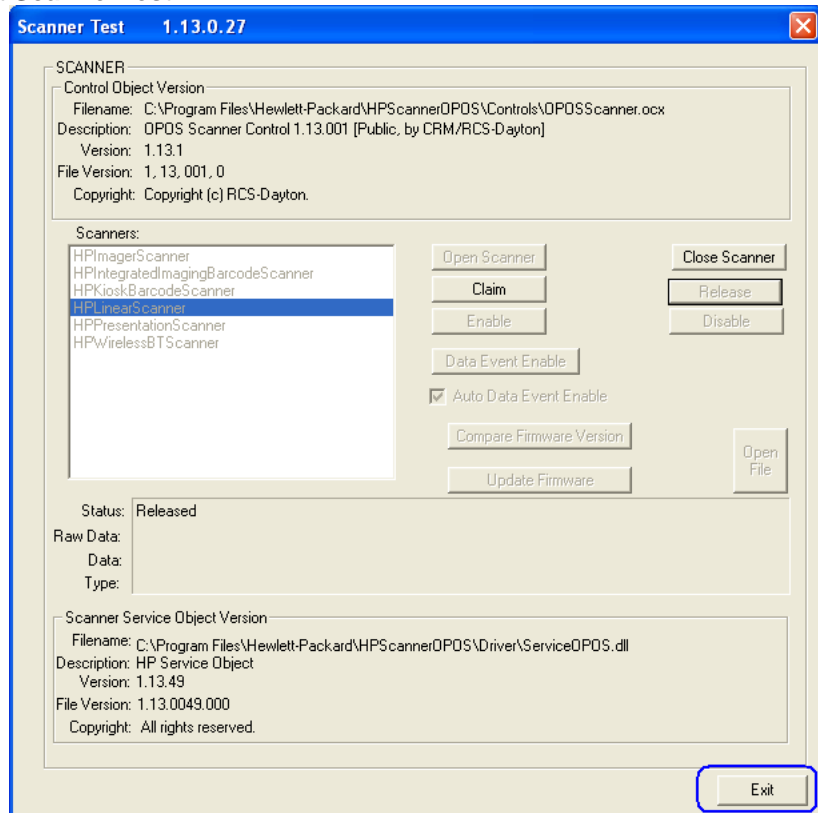

6.9.5 JPOS Drivers for the Scanners

The JPOS drivers are included in the HP factory image and are also available from HP.COM.

In order for the scanner to work with JPOS driver, the scanner must be programmed into the USB-COM mode.

The following is overview of the steps to test the imaging barcode scanner followed by detailed steps:

1. Open **JavaPOStester**.
 - C:\xxxxx\Point of Sale\Scanner (LED_Imager)\Img_LED JPOS\HPJPOSImagingScanner.bat.
2. Click on the Scanner tab.
3. Select the proper device from the dropdown menu.
4. Click the **Open** button. After the imaging scanner is opened a check will appear in the "Data event enabled" box.
5. Click the **Claim** button.
6. Check the "Device enabled" checkbox.
7. Check the "Decode Data" checkbox.
8. Scan a barcode and the data will appear in the "Scan Data" and "Scan Data Label" boxes.
9. After scan is complete click the **Release** button.
10. Click the **Close** button.
11. Click on "Exit" to close the test application.

Detailed Steps

1. Open **JavaPOStester**.
 - C:\xxxxx\Point of Sale\Scanner (LED_Imager)\Img_LED JPOS\HPJPOSImagingScanner.bat.
2. Click on the Scanner tab:

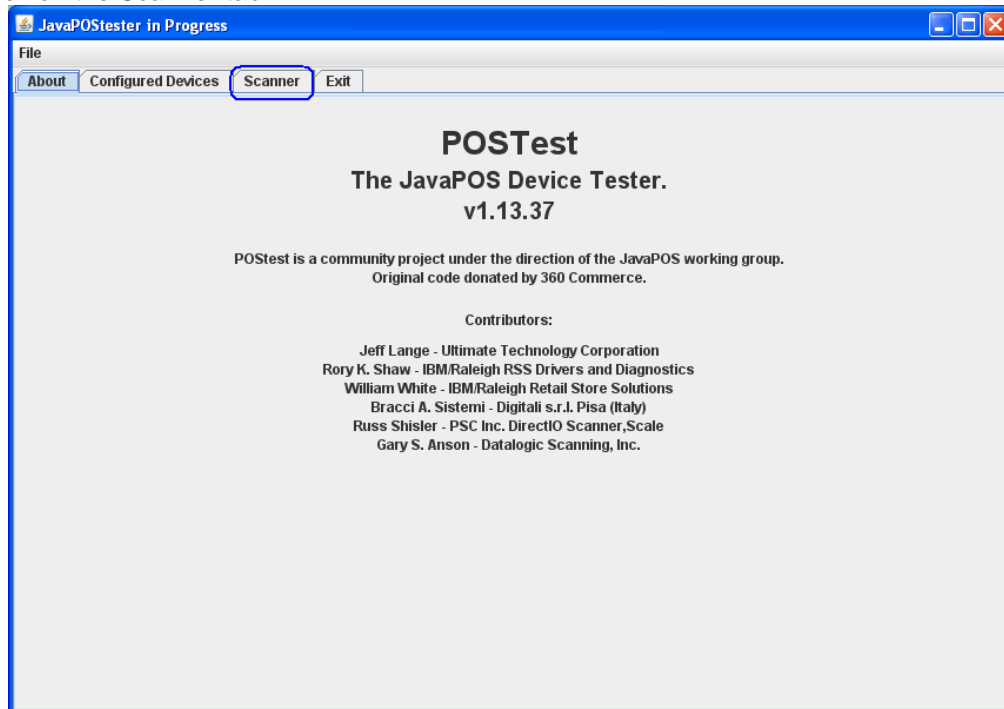

3. Select the proper device from the dropdown menu.

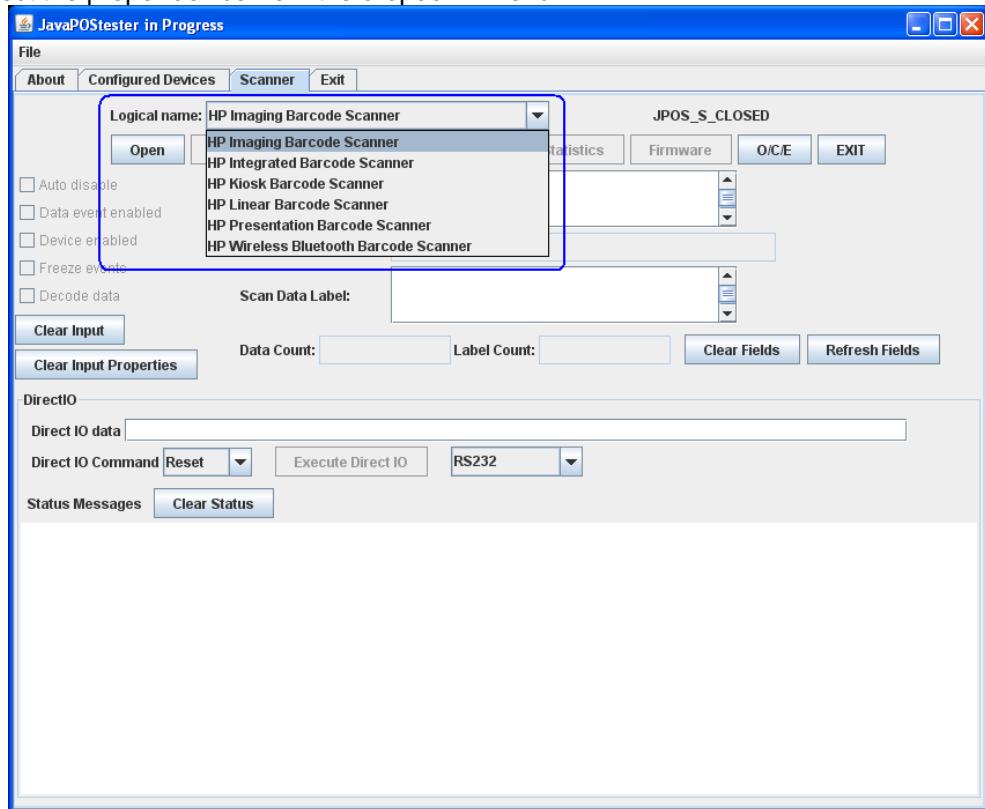

4. Click the **Open** button. After the imaging scanner is opened a check will appear in the "Data event enabled" box.

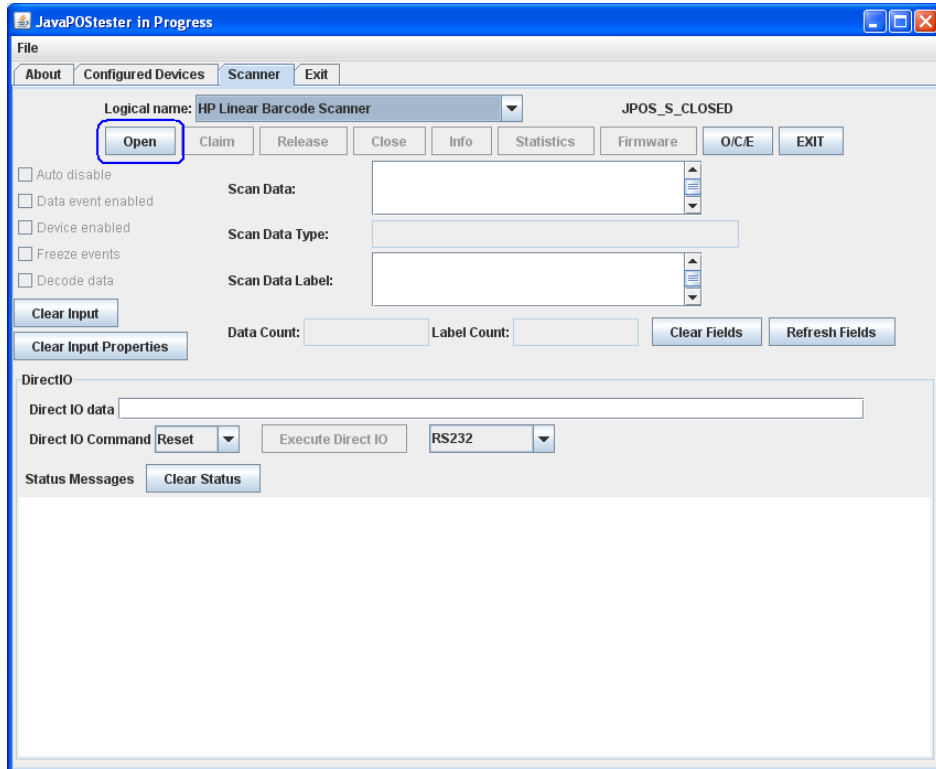

5. Click the **Claim** button.

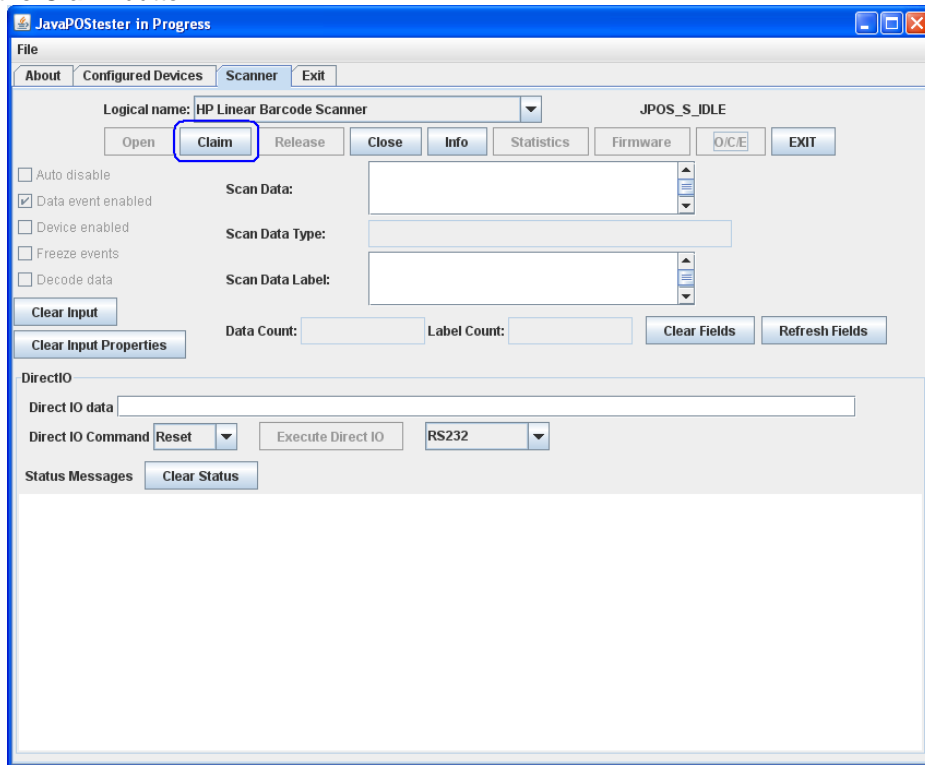

6. Check the **Device enabled** checkbox.

7. Check the Decode Data checkbox.

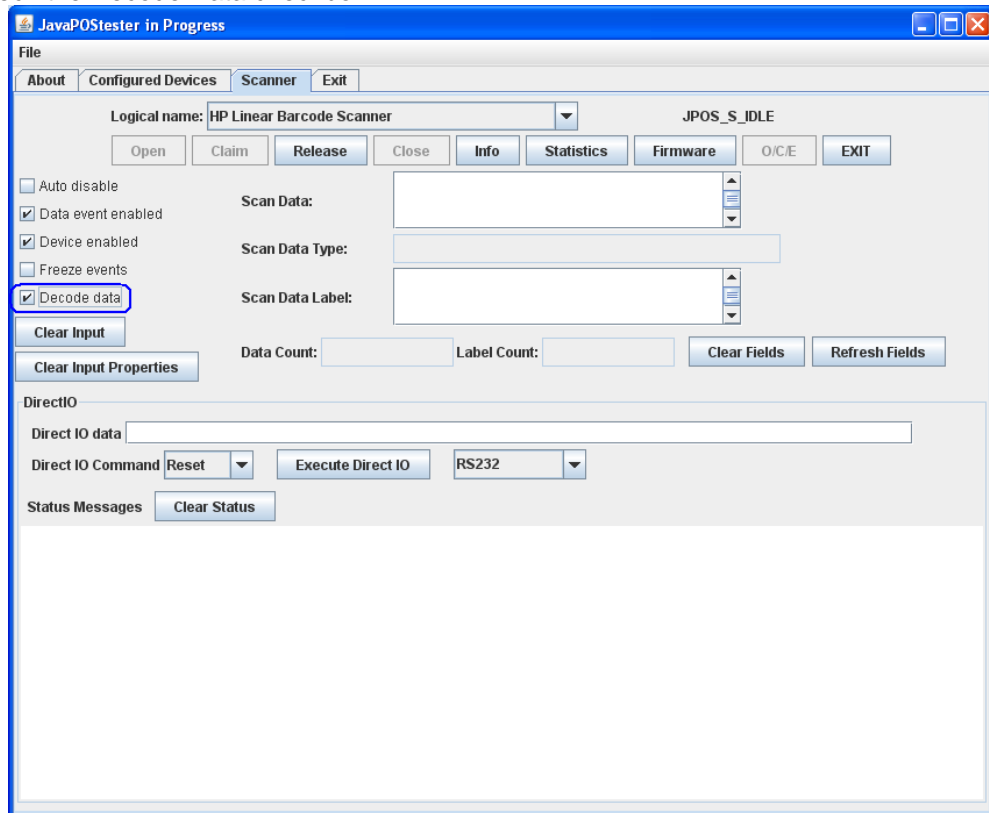

8. Scan a barcode and the data will appear in the “Scan Data” and “Scan Data Label” boxes.

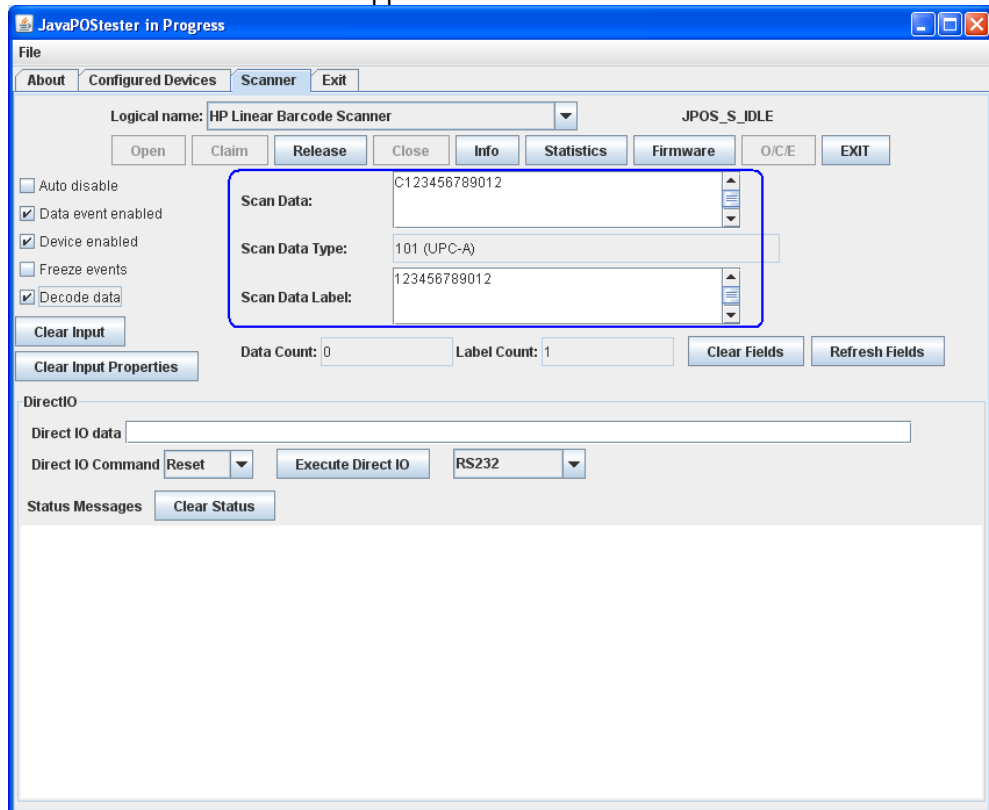

9. After scan is complete click the **Release** button.

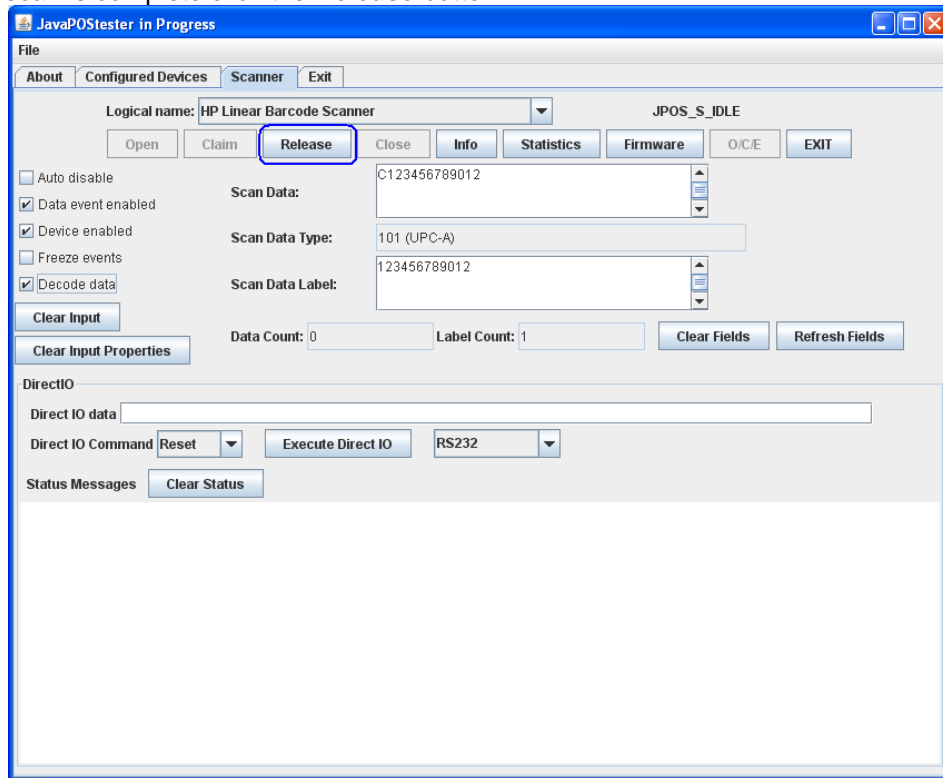

10. Click the **Close** button.

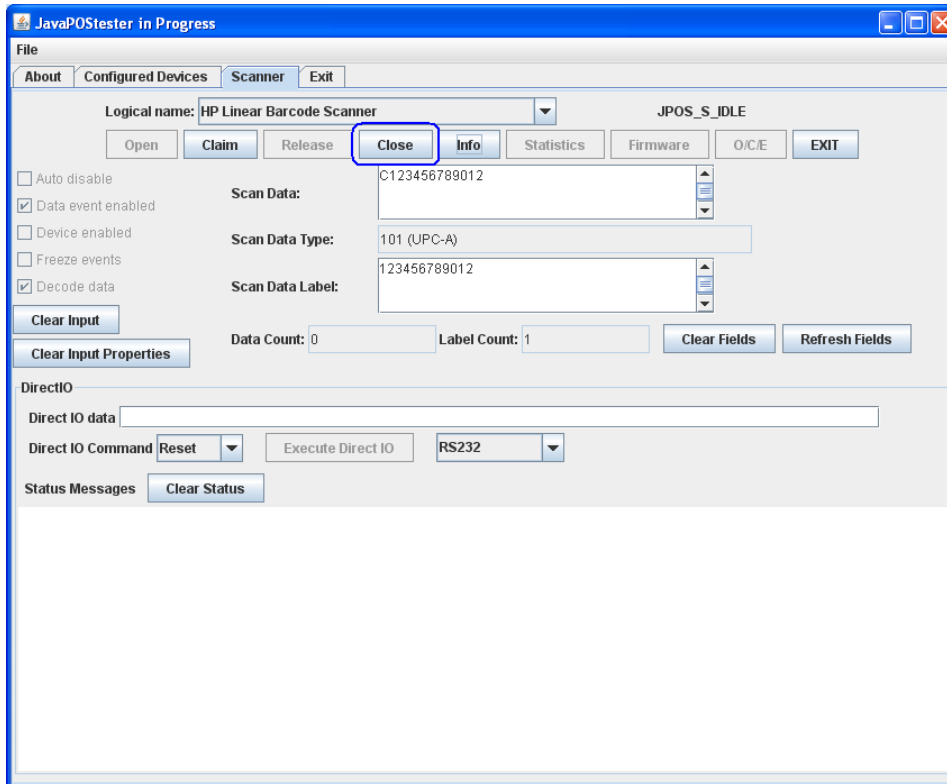

11. Click on "Exit" to close the test application.

6.9.6 **Imaging Testing**

In order for the scanner to capture an image, the scanner must be programmed into the USB-COM mode (OPOS). In order to put the scanner into this mode, scan the USB-COM barcode from the appropriate scanner folder (i.e. Imaging Scanner / Linear Scanner / Wireless BT scanner, etc.).

The following is overview of the steps to test the imaging barcode scanner followed by detailed steps:

1. Install **HP Imaging Scanner Configuration** on the system. This may be found on HP.COM.
2. After installation is complete open the **HP Imaging Scanner Configuration**.
3. Detect the scanner attached to the unit by selecting “Device Autodetection” option
4. Select on “Search On Connection” option.
5. Select the COM port that the scanner is attached to. If the scanner is not in USB-COM mode scan the barcode on the previous page or scan the barcode that appears on the screen and then select your COM port that the scanner is assigned to when in USB-COM mode:
6. Click on the scanner picture until the menu appears (will see a message that it is retrieving data from the scanner).
7. Click on the eyeglass icon (view image) in the menu bar to put the scanner into capture mode. When this option is selected the scanner will beep.
8. Select “Capture on Trigger” option located at the bottom of the screen.
9. Point the scanner to the item that one wishes to scan and pull the trigger to capture the image.
10. Exit the application.

Detailed Steps

1. Install **HP Imaging Scanner Configuration** on the system. This may be found on HP.COM.
2. After installation is complete open **HP Imaging Scanner Configuration**.
3. Detect the scanner attached to the unit by selecting “Device Autodetection” option

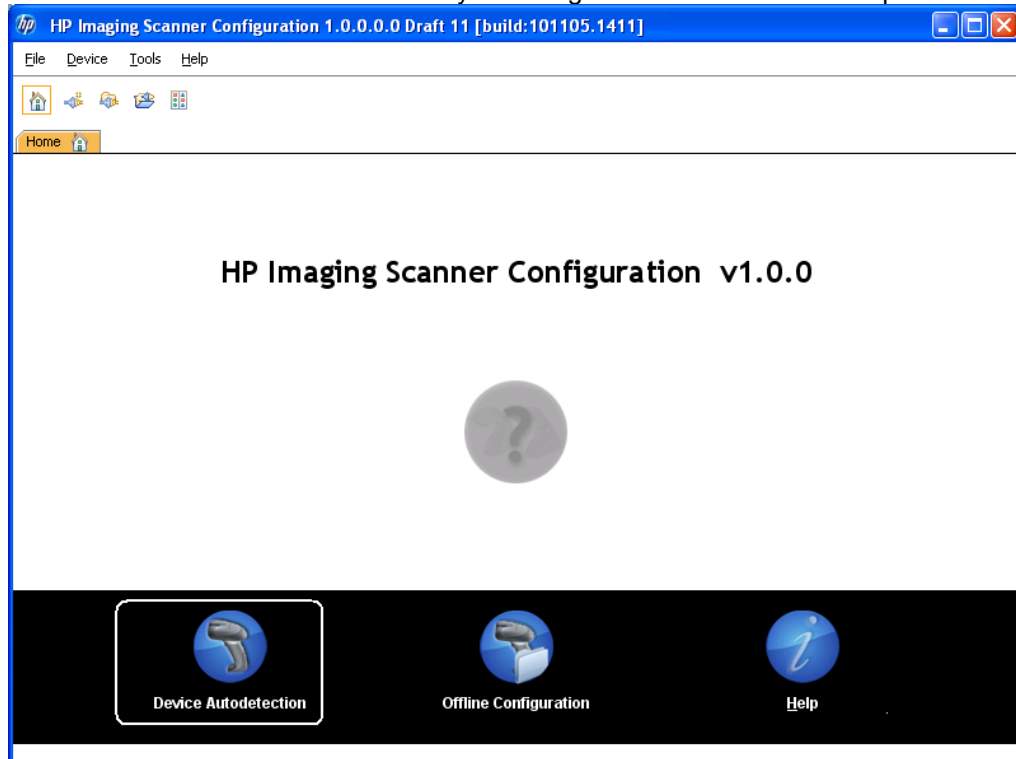

4. Select on “Search On Connection” option.

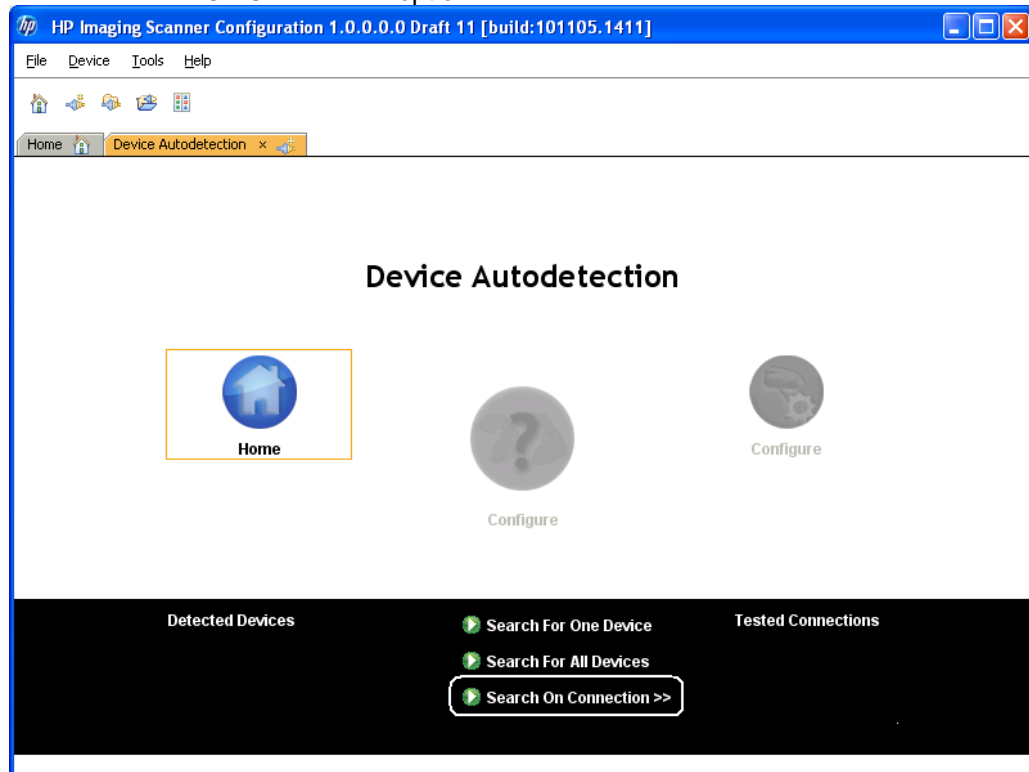

5. Select the COM port that the scanner is attached to. If the scanner is not in USB-COM mode scan the USB-COM barcode or scan the barcode that appears on the screen and then select your COM port that the scanner is assigned to when in USB-COM mode:



6. Click on the scanner picture until the menu appears (will see a message that it is retrieving data from the scanner).





7. Click on the eyeglass icon (view image) in the menu bar to put the scanner into capture mode. When this option is selected the scanner will beep.

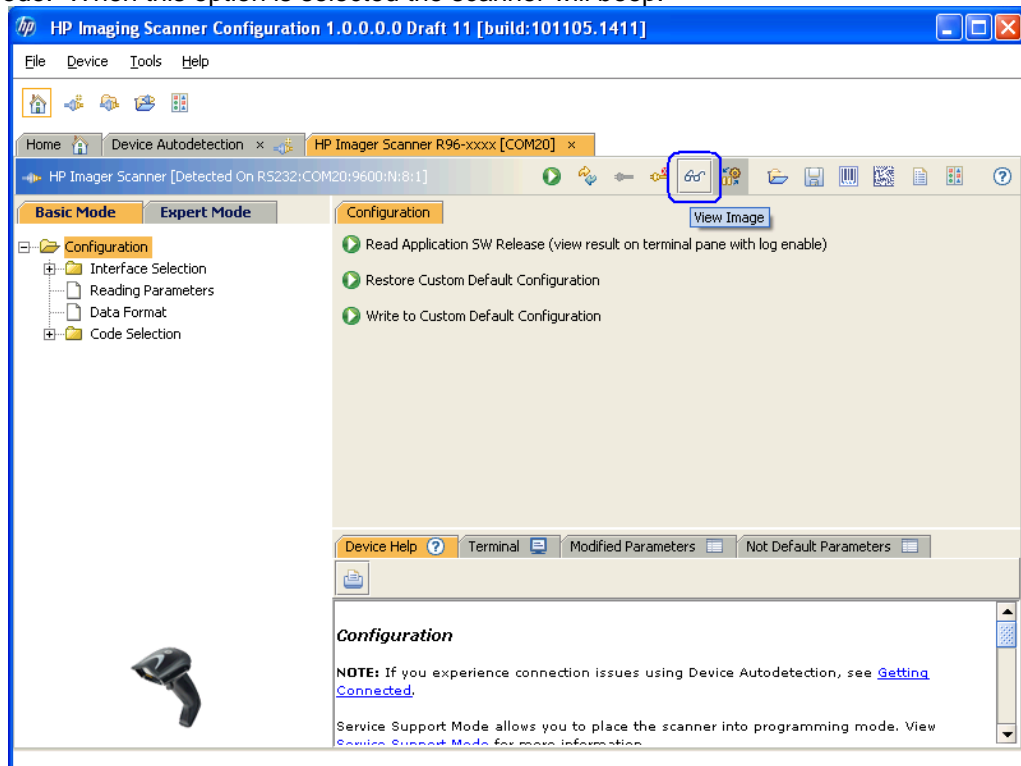

8. Select "Capture on Trigger" option located at the bottom of the screen.

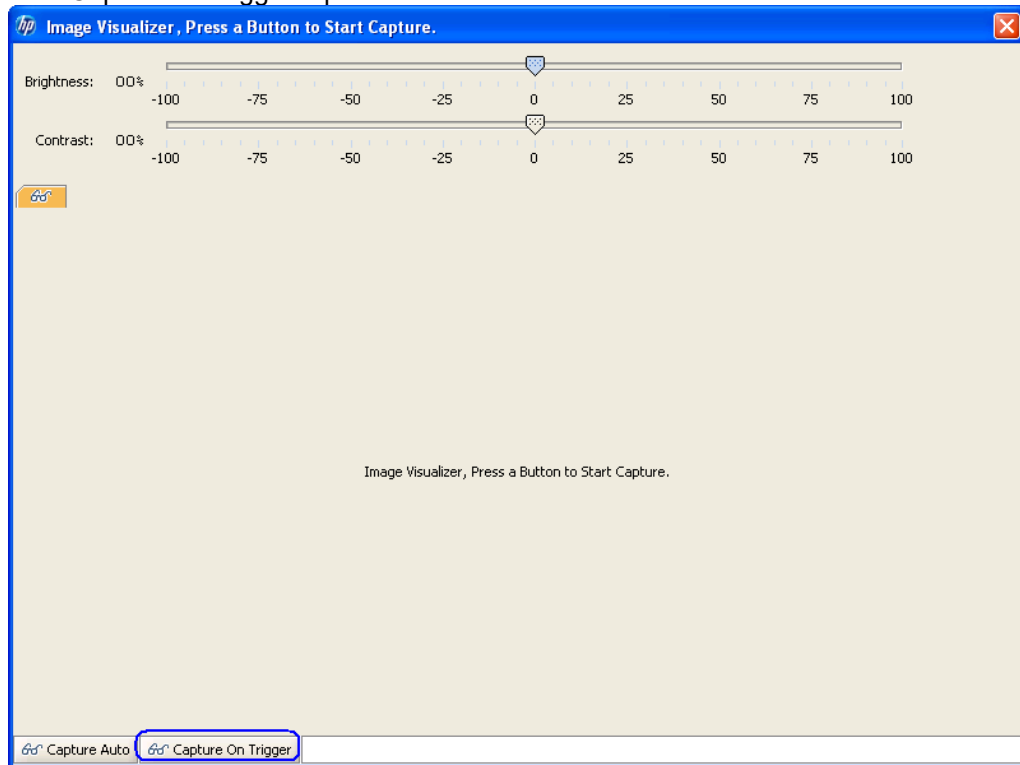

9. Point the scanner to the item that one wishes to scan and pull the trigger to capture the image.

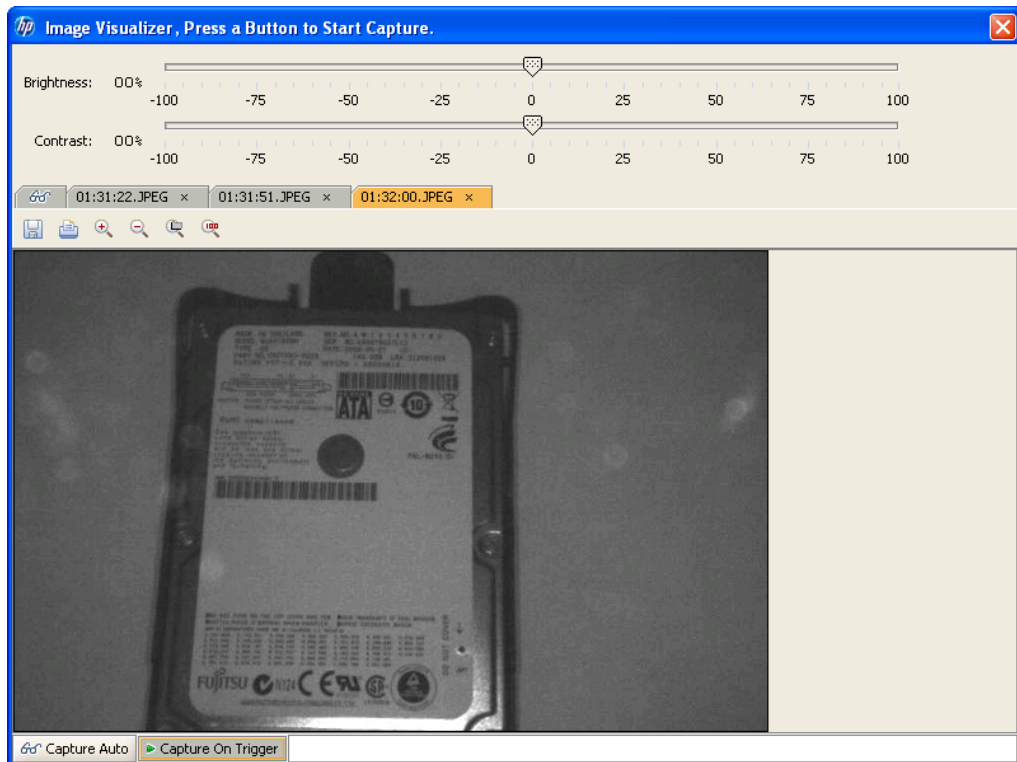
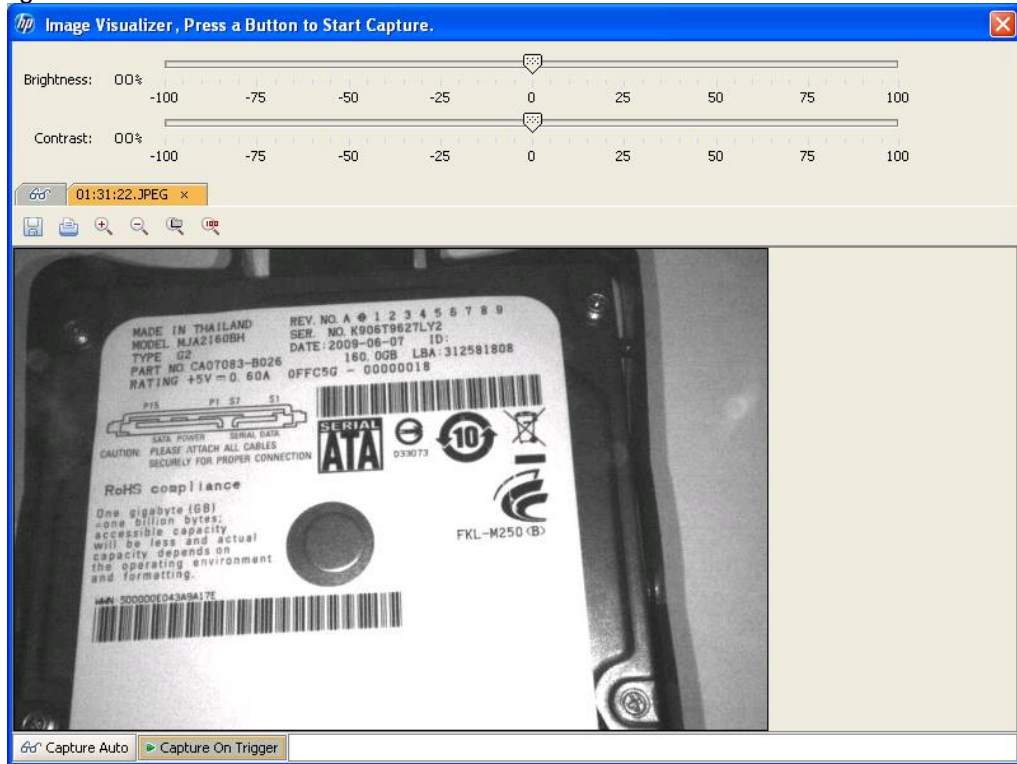

10. Exit the application.

6.10 HP Retail Jacket for ElitePad Barcode Scanner



6.10.1 Connection

The barcode scanner is connected by installing a supported tablet into the HP Retail Jacket for ElitePad:

- HP ElitePad 900 Tablet
- HP ElitePad 1000 Tablet

6.10.2 Operating Modes

The operating modes supported by the HP Retail Jacket for Elitepad barcode scanner are listed below along with their Windows Device Manager entries. The scanner by default is shipped in USB HID Keyboard mode; however, with scanner Firmware version 3.06.068 or newer this mode has been redefined as USB Composite (combines USB HID Keyboard and HID-POS) in order to support Firmware updates. If necessary, change the scanner mode for your environment by using the “HP Retail Jacket Scanner OPOS_NonOPOS Barcodes.pdf” file included in the HP factory image or the HP Retail Jacket for Elitepad Barcode Scanner Programming Reference Guide available on HP.COM.

HID-POS (available only with scanner Firmware version 3.06.068 or newer):

POS Barcode Scanner\POS HID Barcode scanner

- Hardware Id: HID\VID_03F0&PID_5539

USB COM:

Universal Serial Bus controllers\HP USB Mobile Barcode Scanner – COM

- Hardware Id: USB\VID_03F0&PID_2C39

USB HID Keyboard (default):

Scanner Firmware version 3.06.068 or newer:

Keyboards\HID Keyboard Device

- Hardware Id: HID\VID_03F0&PID_5739

POS Barcode Scanner\POS HID Barcode scanner

- Hardware Id: HID\VID_03F0&PID_5739

Universal Serial Bus controllers\USB Composite Device

- Hardware Id: USB\VID_03F0&PID_5739

Scanner Firmware version older than 3.06.068:

Keyboards\HID Keyboard Device

- Hardware Id: HID\VID_03F0&PID_2A39

6.10.3 Drivers

The drivers needed for each scanner operating mode are listed in the table below. All drivers are included in the HP factory image and are also available from HP.COM.

Operating mode	Windows driver	OPOS or JPOS driver
HID-POS	None (native)	Optional
USB COM	Required	Required
USB HID Keyboard (default)	None (native)	Not applicable

The OPOS and JPOS drivers are configured for USB COM mode by default. When switching the scanner operating mode between USB COM and HID-POS, the OPOS and JPOS drivers must be reconfigured to match:

Reconfiguring for OPOS is accomplished either by running the HP Scanner OPOS Setting utility (included and installed as part of the OPOS driver) in C:\<Program Files folder>\HP\HP Mobile Scanner OPOS\Scanner OPOS Configuration Utility or by uninstalling and reinstalling the OPOS driver itself. When opening the HP Scanner OPOS Setting utility and selecting the Device Type (ex: HPMobileScanner), the current scanner operating mode will be shown/selected under Communication Type.

Reconfiguring for JPOS is accomplished by editing jpos.xml in C:\xxxxx\Point of Sale\Scanner (Mobile Retail Jacket)\Mobile Retail Jacket Scanner JPOS\JposScanner. The Port value should be set to "COM" for USB COM mode or "HID" for HID-POS mode.

6.10.4 Testing the scanner

Sample barcodes that can be used for testing purposes are listed below.



6.10.4.1 Testing the scanner in HID-POS mode

There is currently no HID-POS test app available from HP.

6.10.4.2 Testing the scanner in USB HID Keyboard mode

To test the scanner in this mode open a text editor such as Microsoft Notepad, scan a barcode, and verify that a text entry is made.

6.10.4.3 Testing the scanner in USB COM mode with OPOS

The following is an overview of the steps to test the scanner followed by detailed steps:

1. Open **HP Mobile OPOS Scanner Test**.
 - C:\xxxx\Point of Sale\Scanner (Mobile Retail Jacket)\Mobile OPOS Test Utility folder.
2. Select appropriate scanner device from the drop down box.
3. Click "Open" button.
4. Click "Claim" button.
5. Click "Enable" button.
6. Scan a barcode and the data will appear in the dialog box.
7. After scan is complete click on "Disable" button.
8. Click "Release" button.
9. Click "Close Scanner" button.
10. Exit the application.

Detailed Steps

2. Open **HP Mobile OPOS Scanner Test**.
 - C:\xxxxx\Point of Sale\Scanner (Mobile Retail Jacket)\Mobile OPOS Test Utility folder.

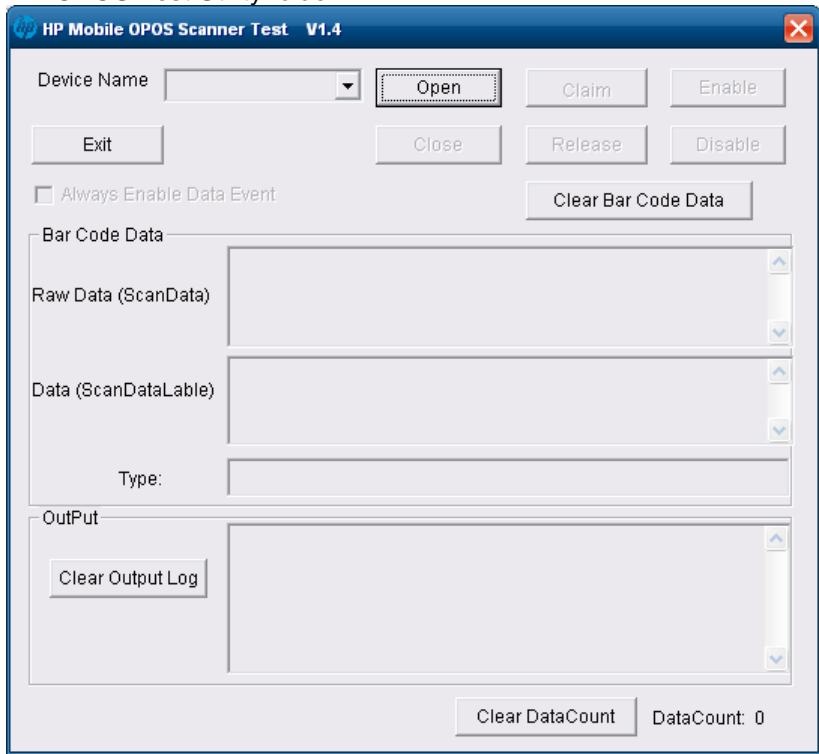

3. Select appropriate scanner device from the drop down box.

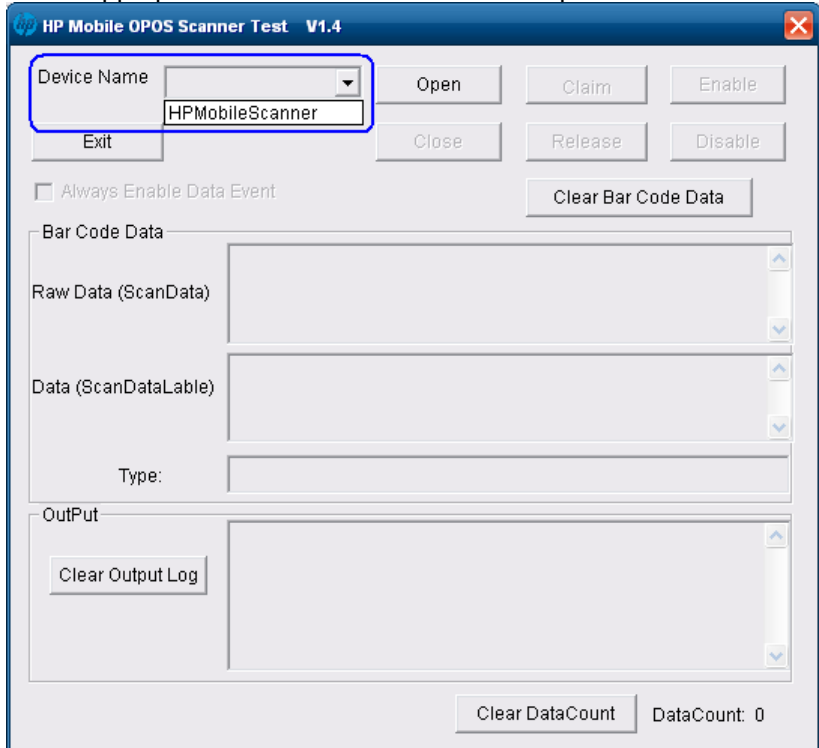

- Click "Open" button. In the OUTPUT section should see OPEN SUCCESS.

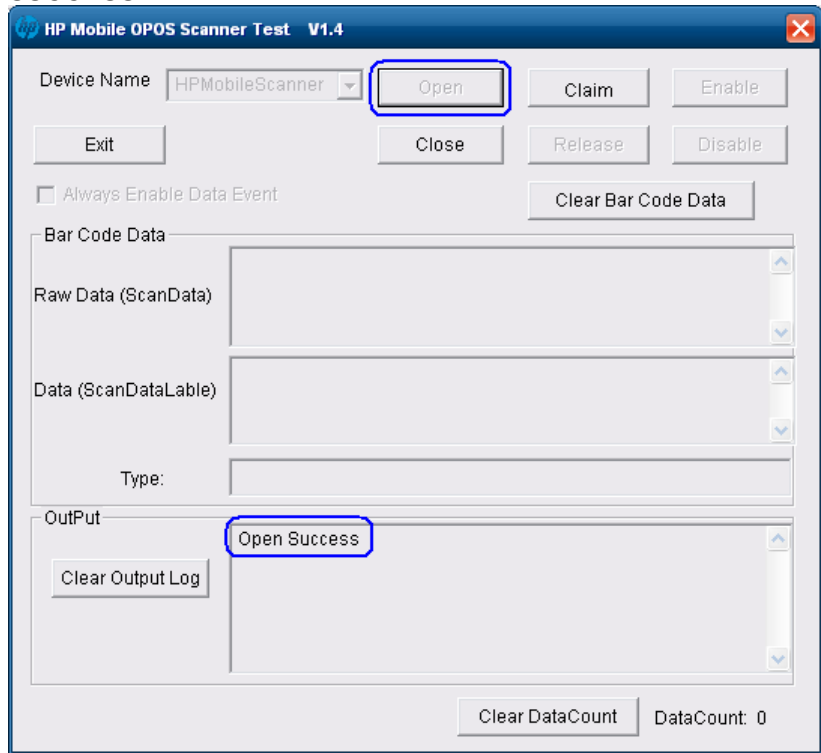

- Click "Claim" button. In the OUTPUT section should see CLAIM SUCCESS.

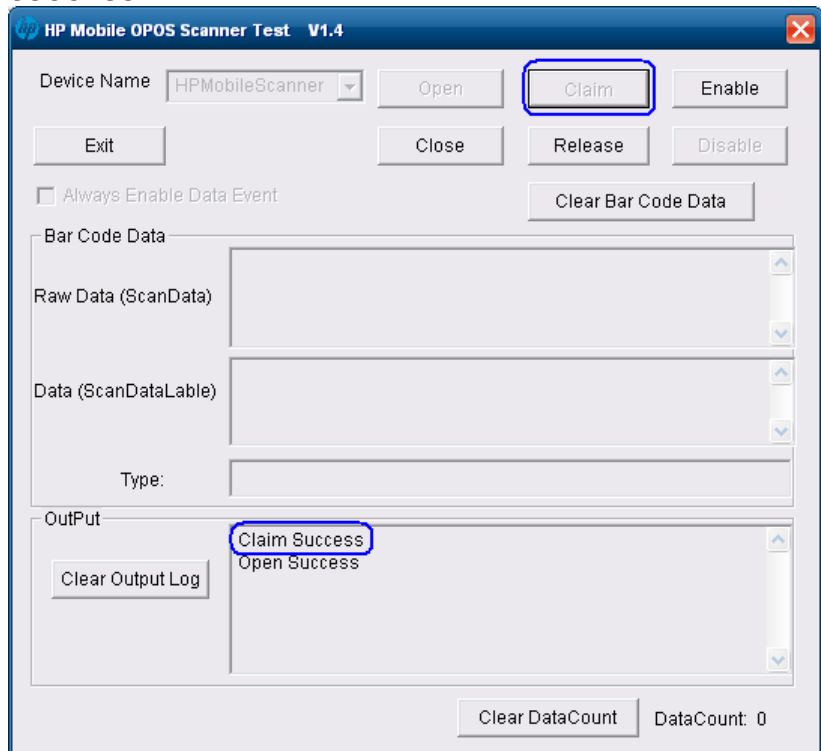

6. Click "Enable" button.
Make sure "Always Enable Data Event" has is checked.

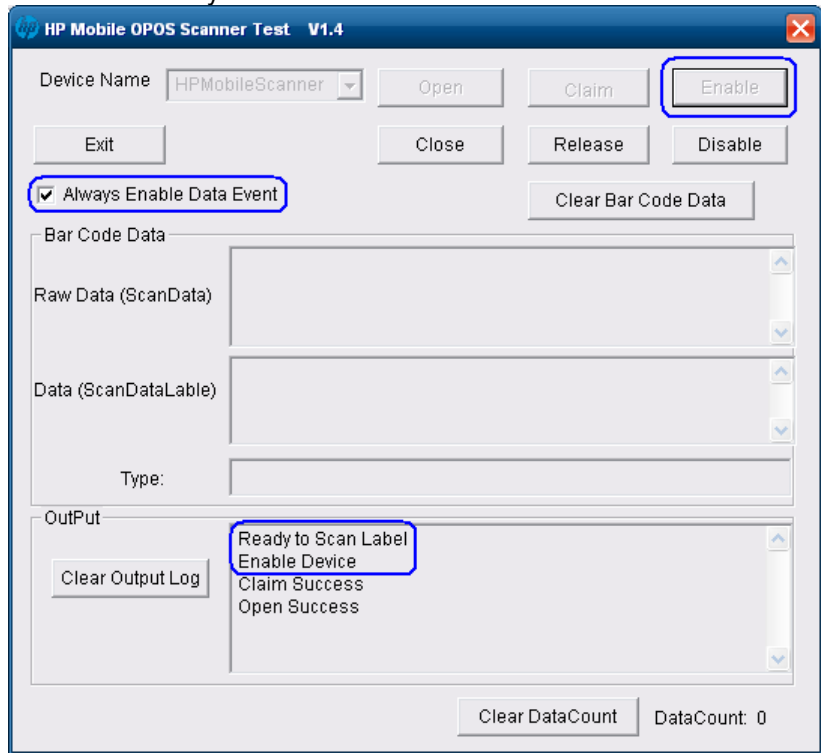

7. Scan a barcode and the data will appear in the dialog box.

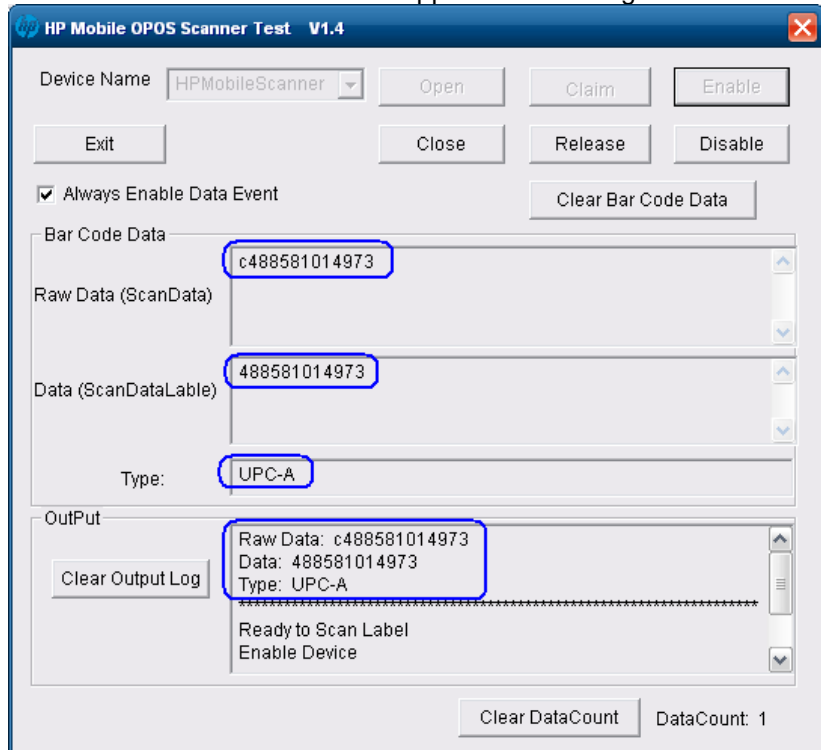

8. After scan is complete click on “Disable” button.

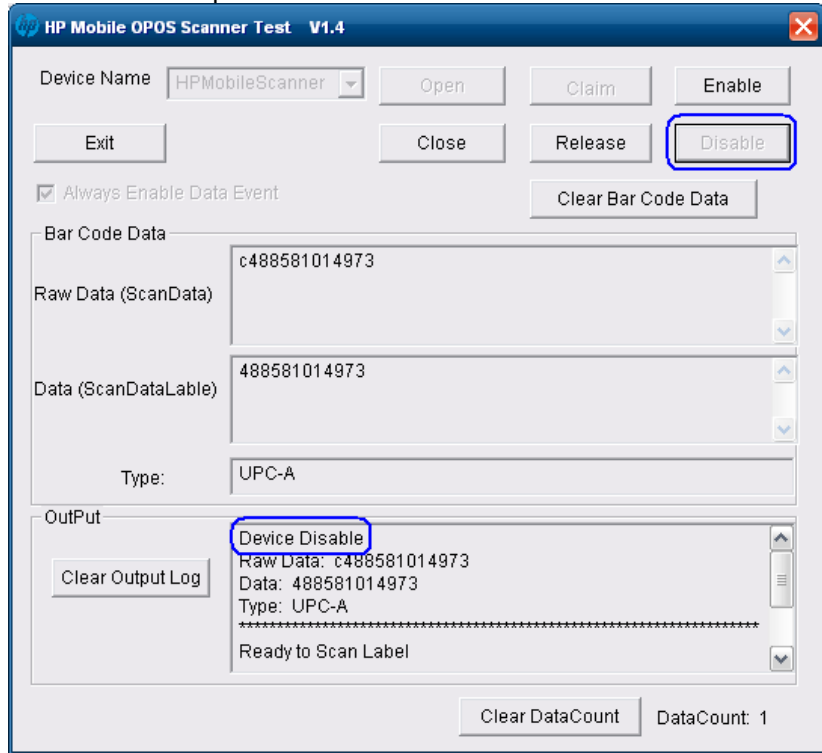

9. Click “Release” button.

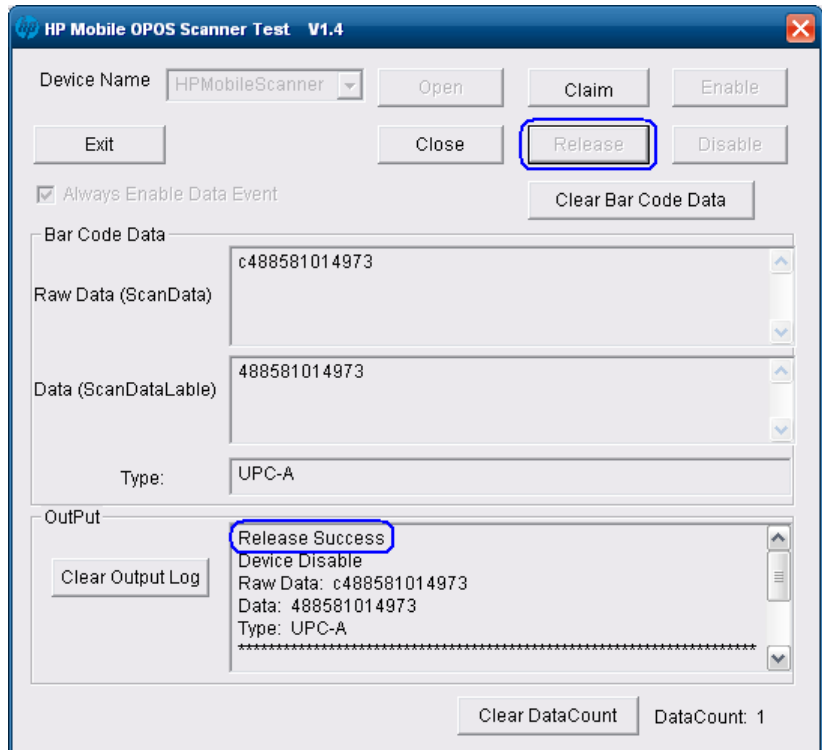

10. Click "Close Scanner" button.

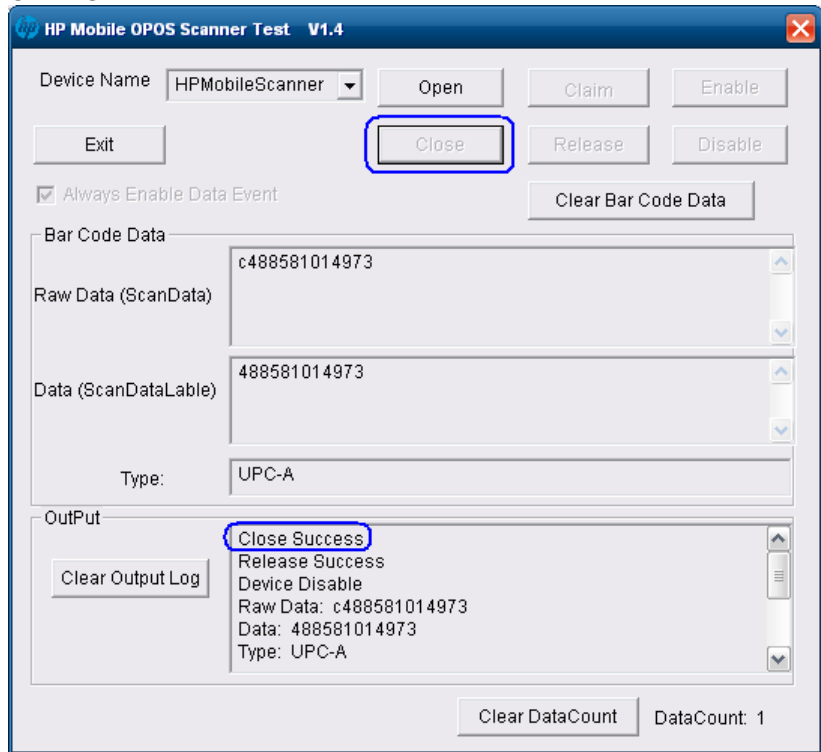

11. Exit the application.

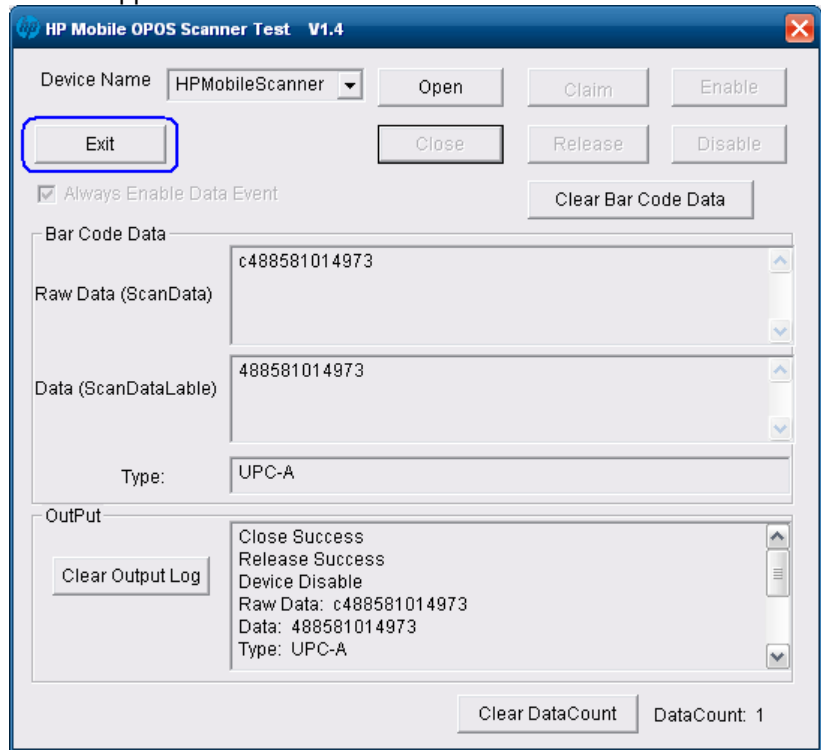

6.10.4.4 Testing the scanner in USB COM mode with JPOS

The JPOS drivers are located in "C:\xxxx\Point of Sale\Scanner (Mobile Retail Jacket)\ Mobile Retail Jacket Scanner JPOS" folder.

The following is an overview of the steps to test the scanner followed by detailed steps:

1. Open **JavaPOSTester**.
 - C:\xxxx\Point of Sale\Scanner (Mobile Retail Jacket)\ Mobile Retail Jacket Scanner JPOS\ HPJPOSMobileScanner.bat.
2. Click on the "Scanner" tab.
3. Select the proper device from the drop down menu.
4. Click on the "OPEN" button.
5. Click on the "CLAIM" button.
6. Scan a barcode and the data will appear in the "Scan Data" and "Scan Data Label" boxes.

Detailed Steps

1. Open **JavaPOSTester**.
 - C:\xxxx\Point of Sale\Scanner (Mobile Retail Jacket)\ Mobile Retail Jacket Scanner JPOS\ HPJPOSMobileScanner.bat.

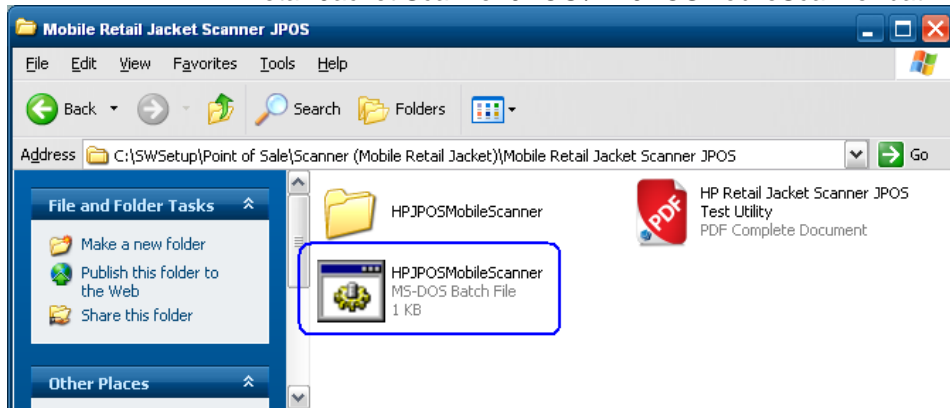

2. Click on the "Scanner" tab.



3. Select the proper device from the drop down menu.

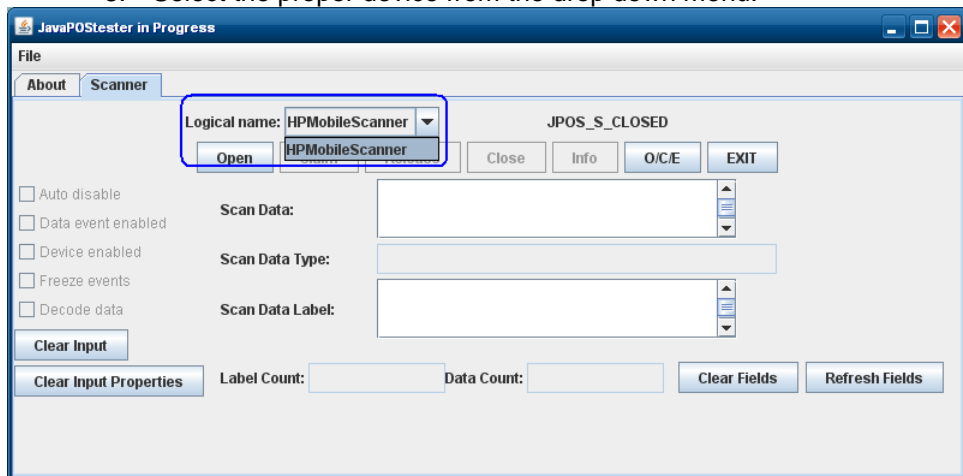

4. Click on the "OPEN" button.

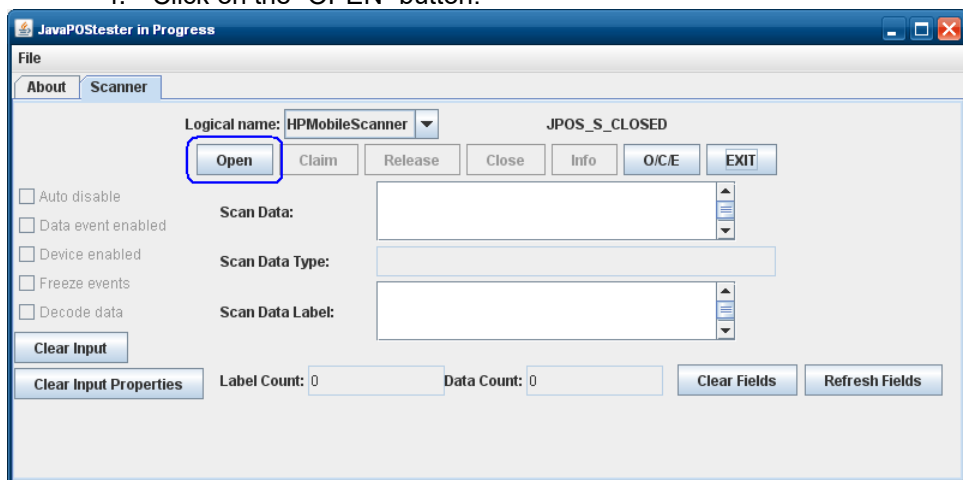

5. Click on the "CLAIM" button.

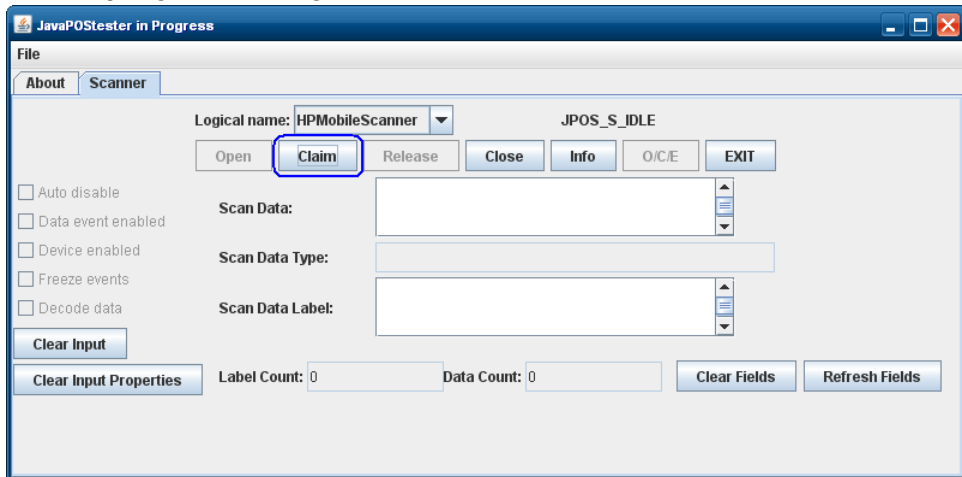

After clicking on the "CLAIM" button a few seconds later a check should appear next to the "Data event enabled / Device enabled / Decode data" boxes

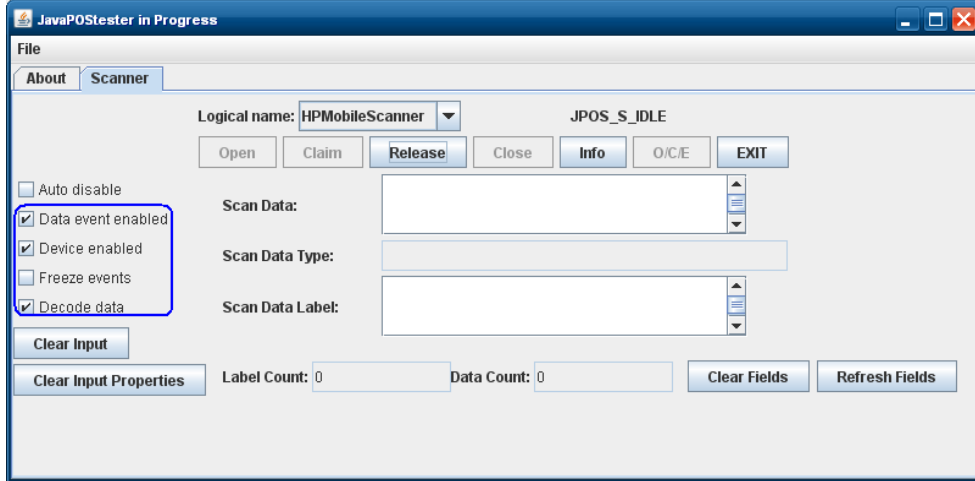

6. Scan a barcode and the data will appear in the "Scan Data" and "Scan Data Label" boxes.

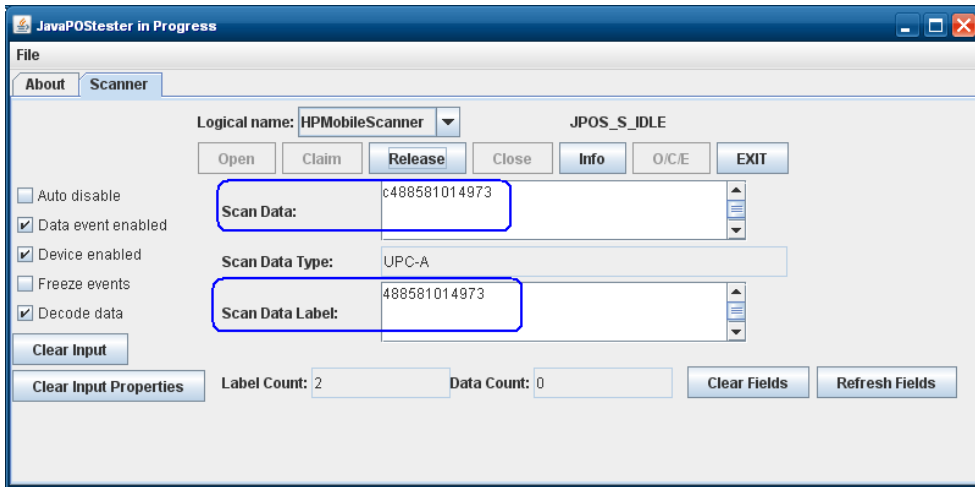

7. After scan is complete click on "Release" button.

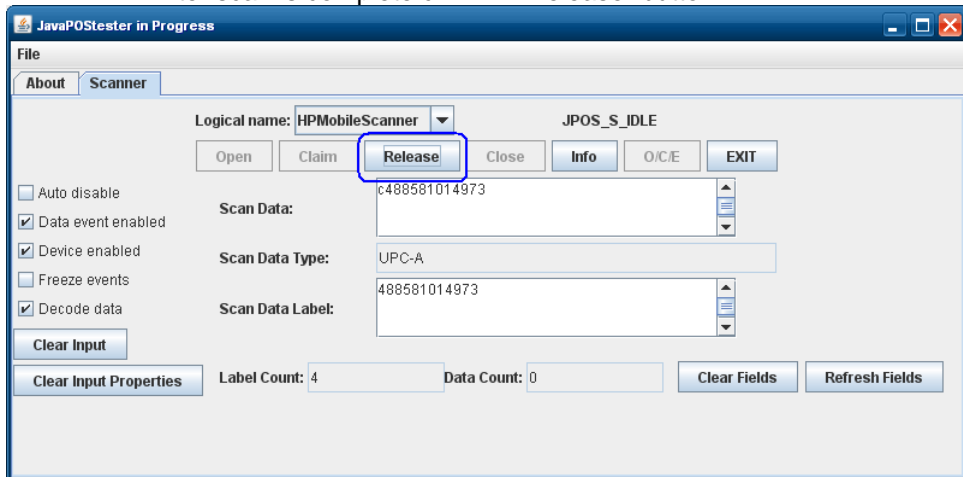

8. Click on "Close" button.

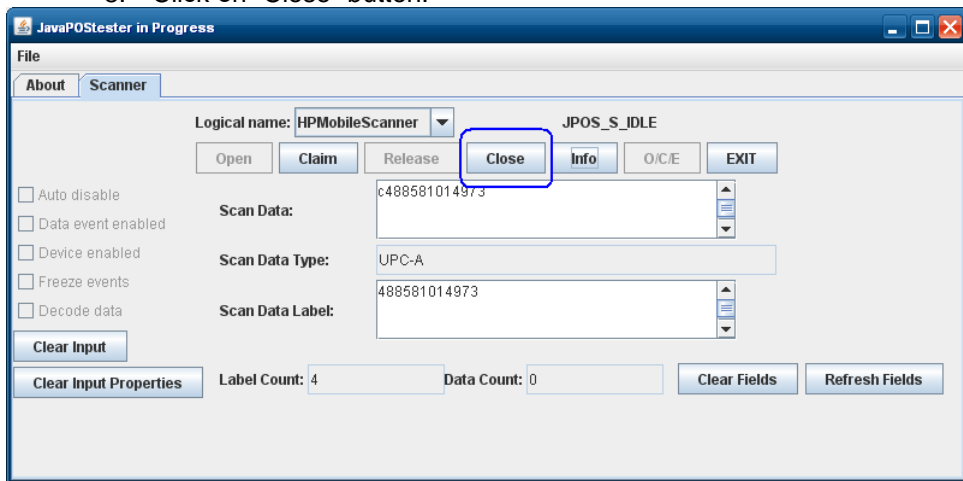

9. Click on "Exit" to close the test application.

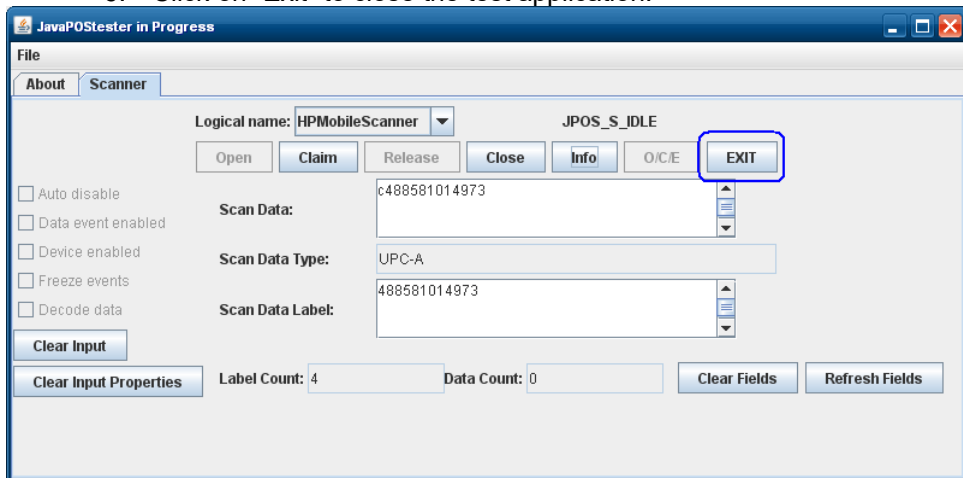

6.11 HP POS Keyboard



6.11.1 Connection

The HP POS Keyboard may be plugged into any free USB port, including powered USB ports. If a powered USB port is used, the powered portion is just not utilized.

6.11.2 Windows Drivers for the HP POS Keyboard

The HP POS Keyboard uses native drivers for Windows operating system. Windows will load several drivers for the keyboard and touch pad. If during the driver installation, Windows displays the new hardware wizard, the user needs to accept the defaults that appear during the hardware wizard GUI (for the first screen you may select the no option) and the native drivers will be loaded. Please refer to "[If prompted for native driver location \(New Hardware Wizard\)](#)" section. If prompted for the driver installation you may need to go through the new hardware wizard 5 or 6 times to load the Windows HID drivers.

The following shows some of the dialog boxes that will appear while Windows is installing the drivers for this device:

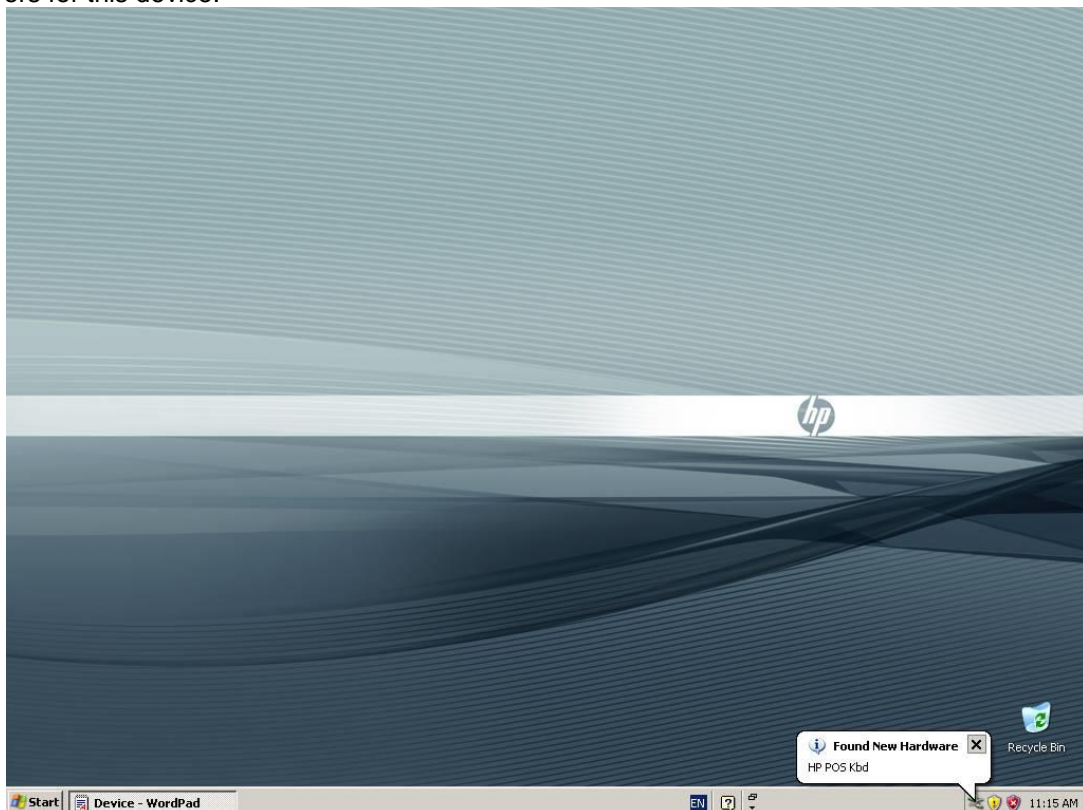

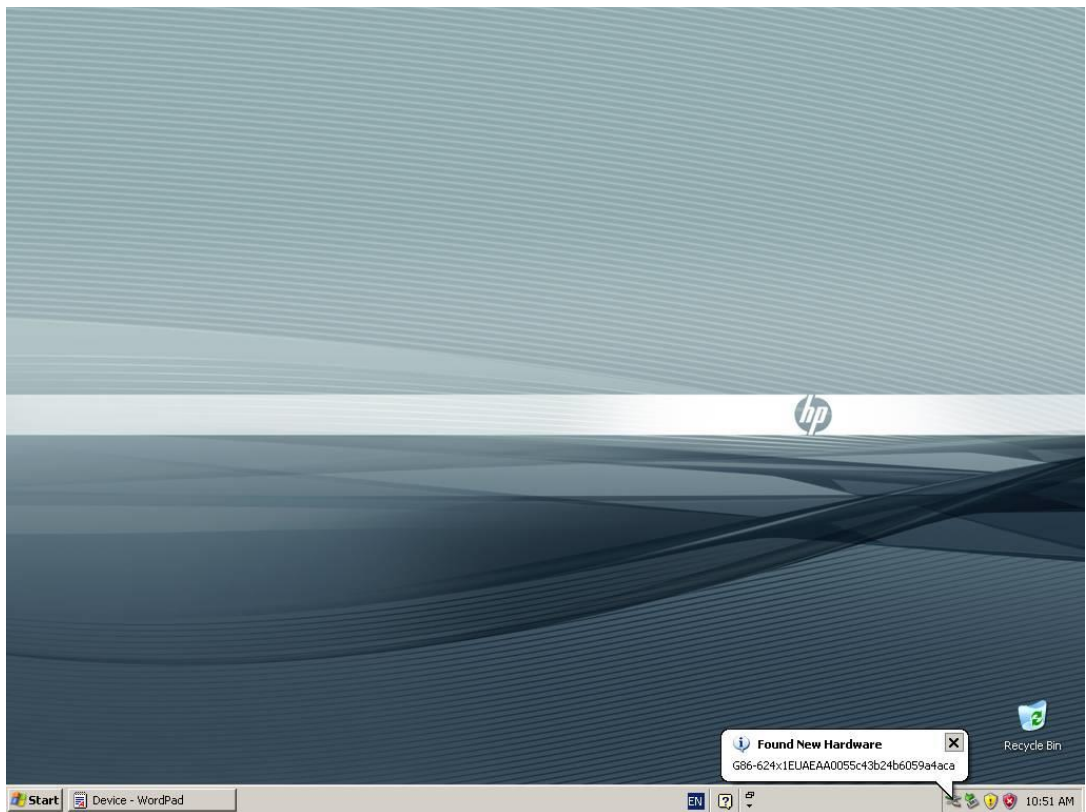
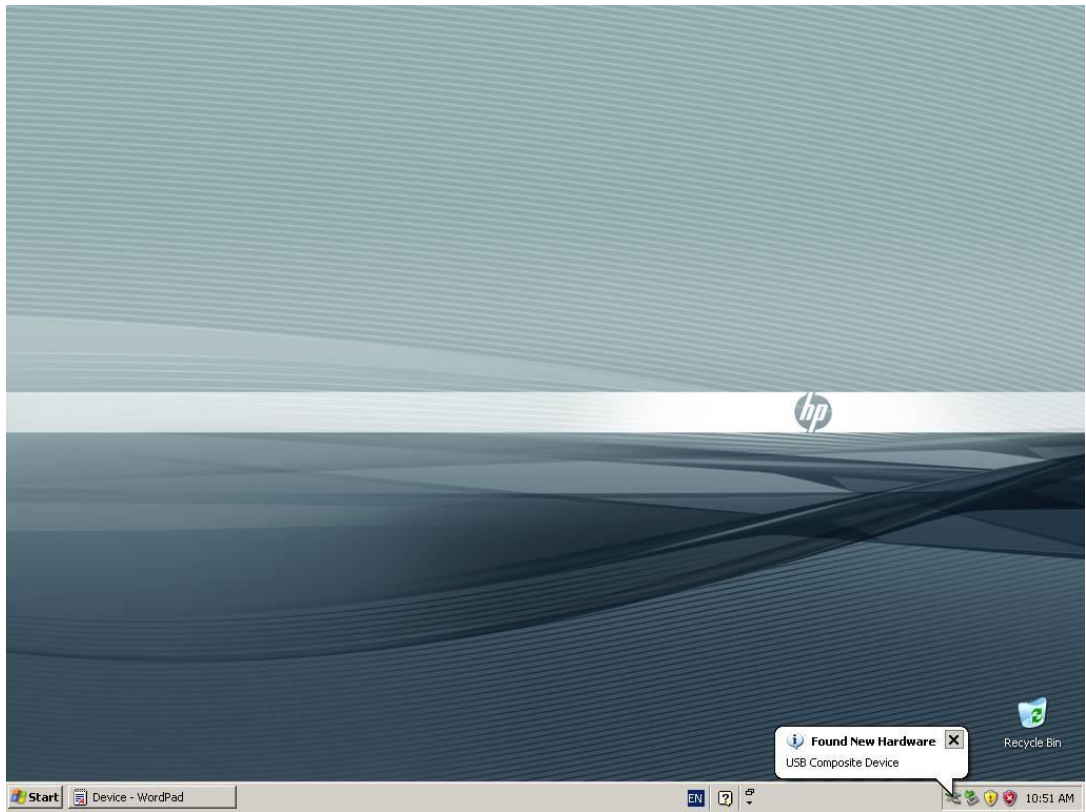

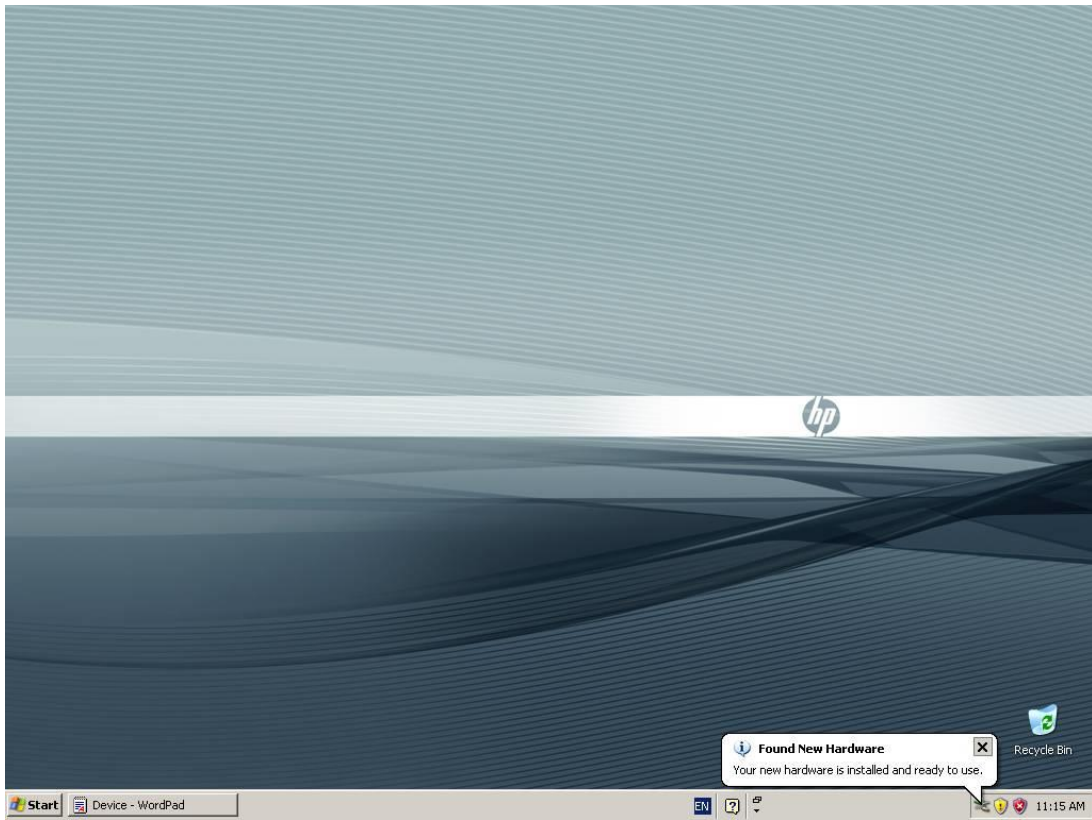

The following is the Device Manager window after all the drivers are loaded for the HP POS Keyboard:

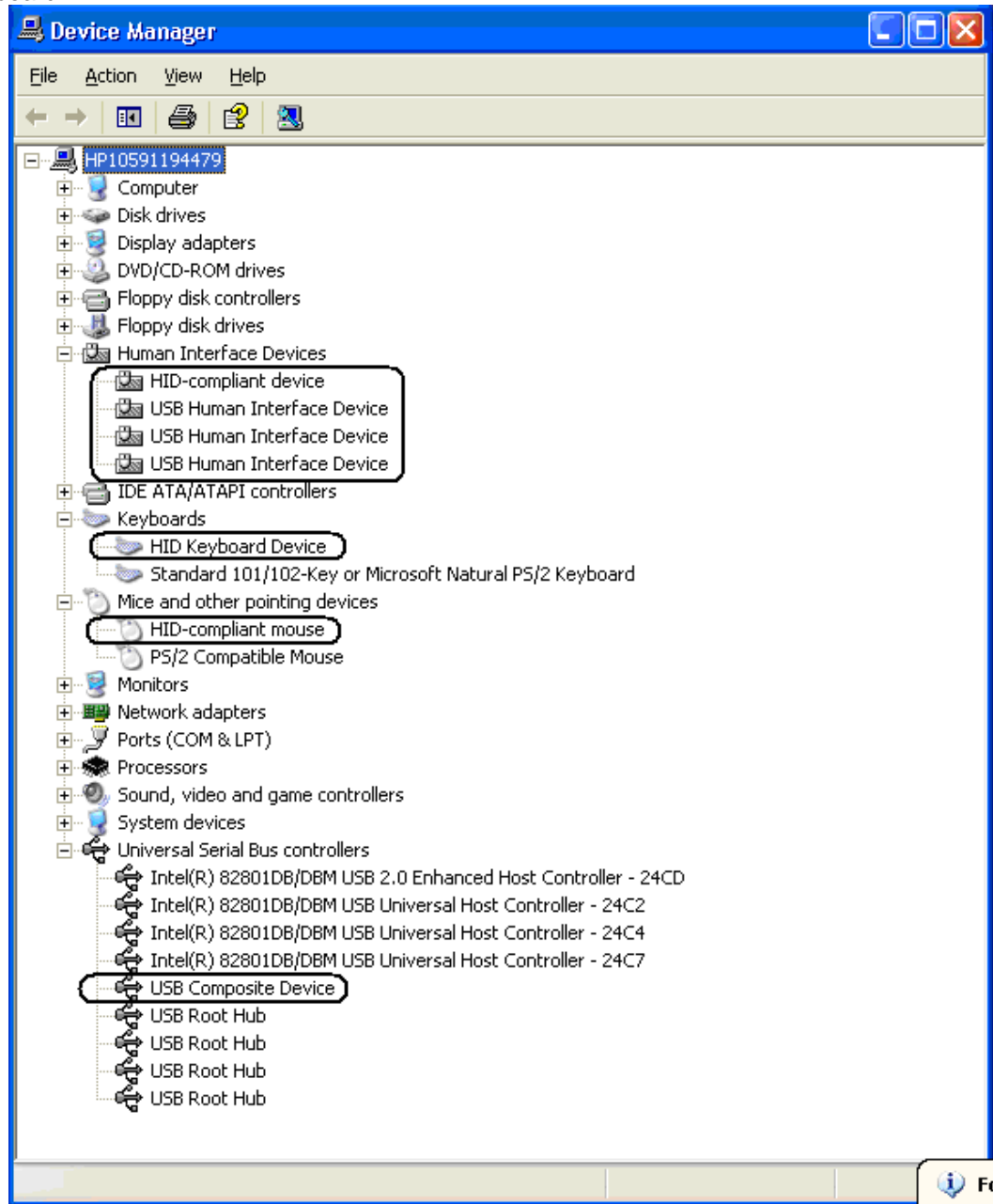

6.11.3 OPOS Drivers for the HP POS Keyboard

No OPOS drivers are needed for the keyboard.

6.11.4 Testing the HP POS Keyboard

Open Notepad, what is typed on the keyboard should appear in Notepad.

6.11.5 JPOS Drivers for the HP POS Keyboard

No JPOS drivers are needed for the keyboard.

6.12 HP USB POS Keyboard with Magnetic Stripe Reader



6.12.1 Connection

The HP USB POS Keyboard with Magnetic Stripe Reader may be plugged into any free USB port, including powered USB ports. If a powered USB port is used, the powered portion is just not utilized.

6.12.2 Windows Drivers for the HP USB POS Keyboard with Magnetic Stripe Reader

The HP USB POS Keyboard with Magnetic Stripe Reader uses native drivers for Windows operating system. Windows will load several drivers for the keyboard and touch pad. If during the driver installation, Windows displays the new hardware wizard, the user needs to accept the defaults that appear during the hardware wizard GUI (for the first screen you may select the no option) and the native drivers will be loaded. Please refer to [“If prompted for native driver location \(New Hardware Wizard\)”](#) section. If prompted for the driver installation you may need to go through the new hardware wizard 5 or 6 times to load the Windows HID drivers.

The following shows some of the dialog boxes that will appear while Windows is installing the drivers for this device:

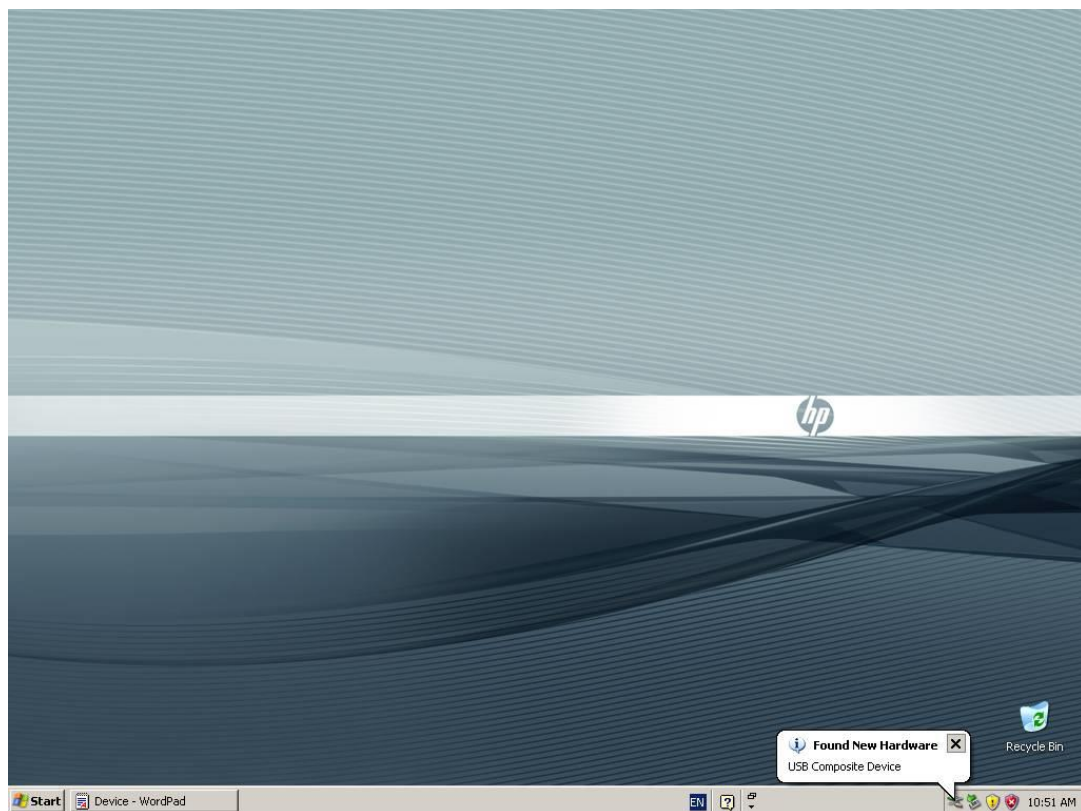
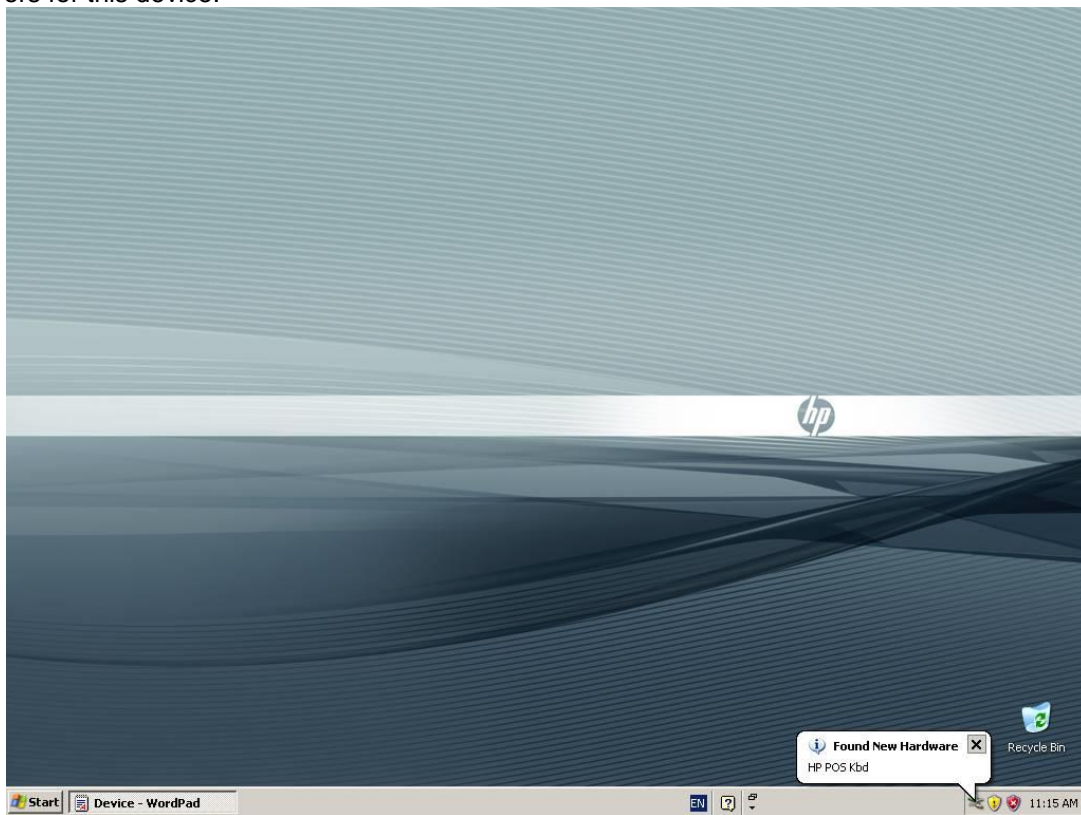

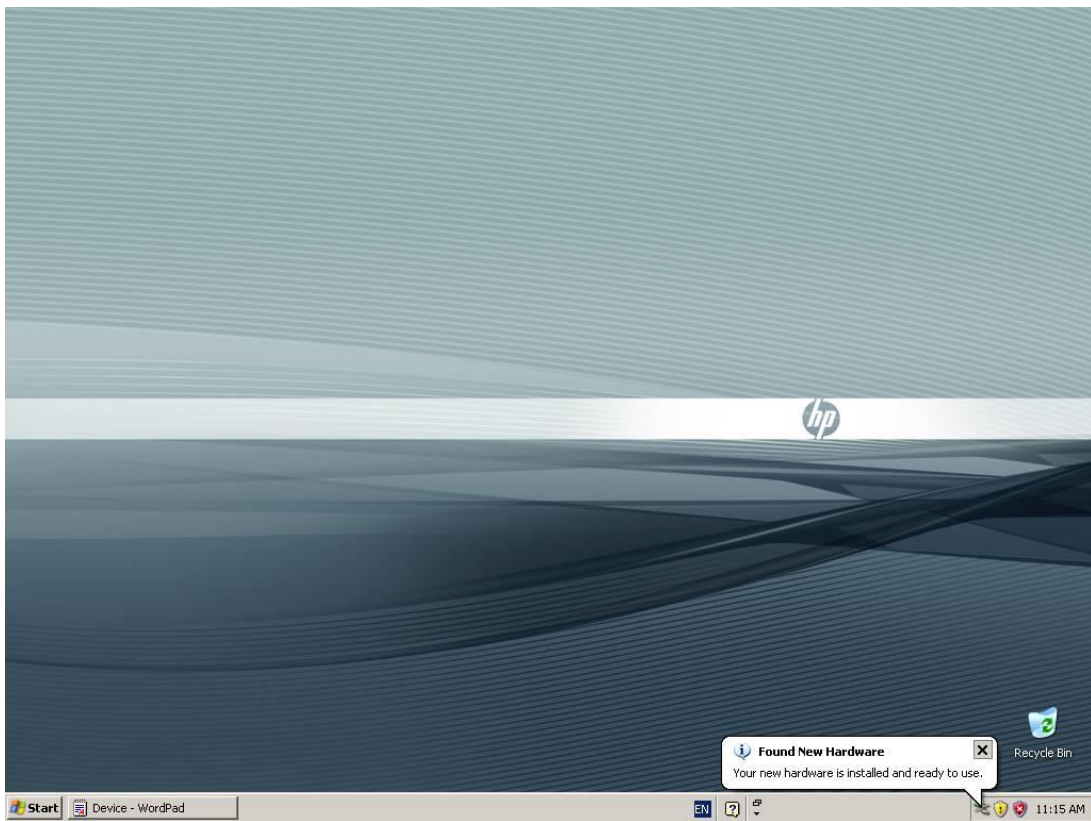
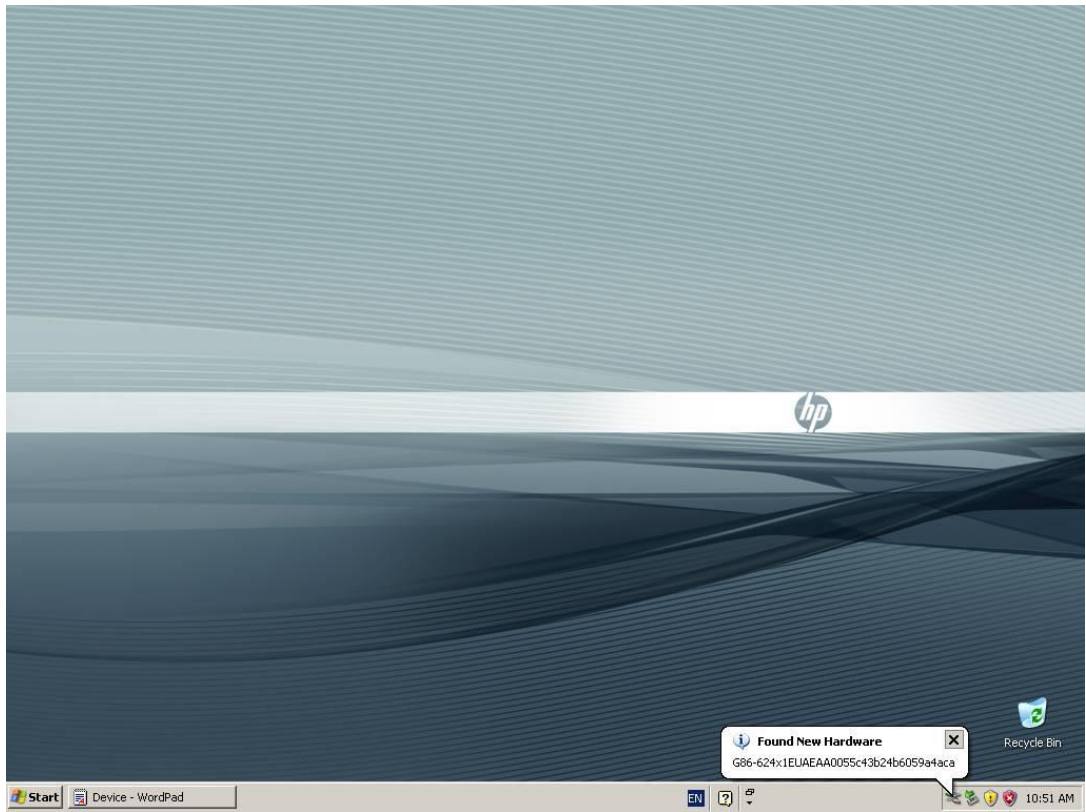

The following is the Device Manager window after all the drivers are loaded for the HP USB POS Keyboard with Magnetic Stripe Reader:

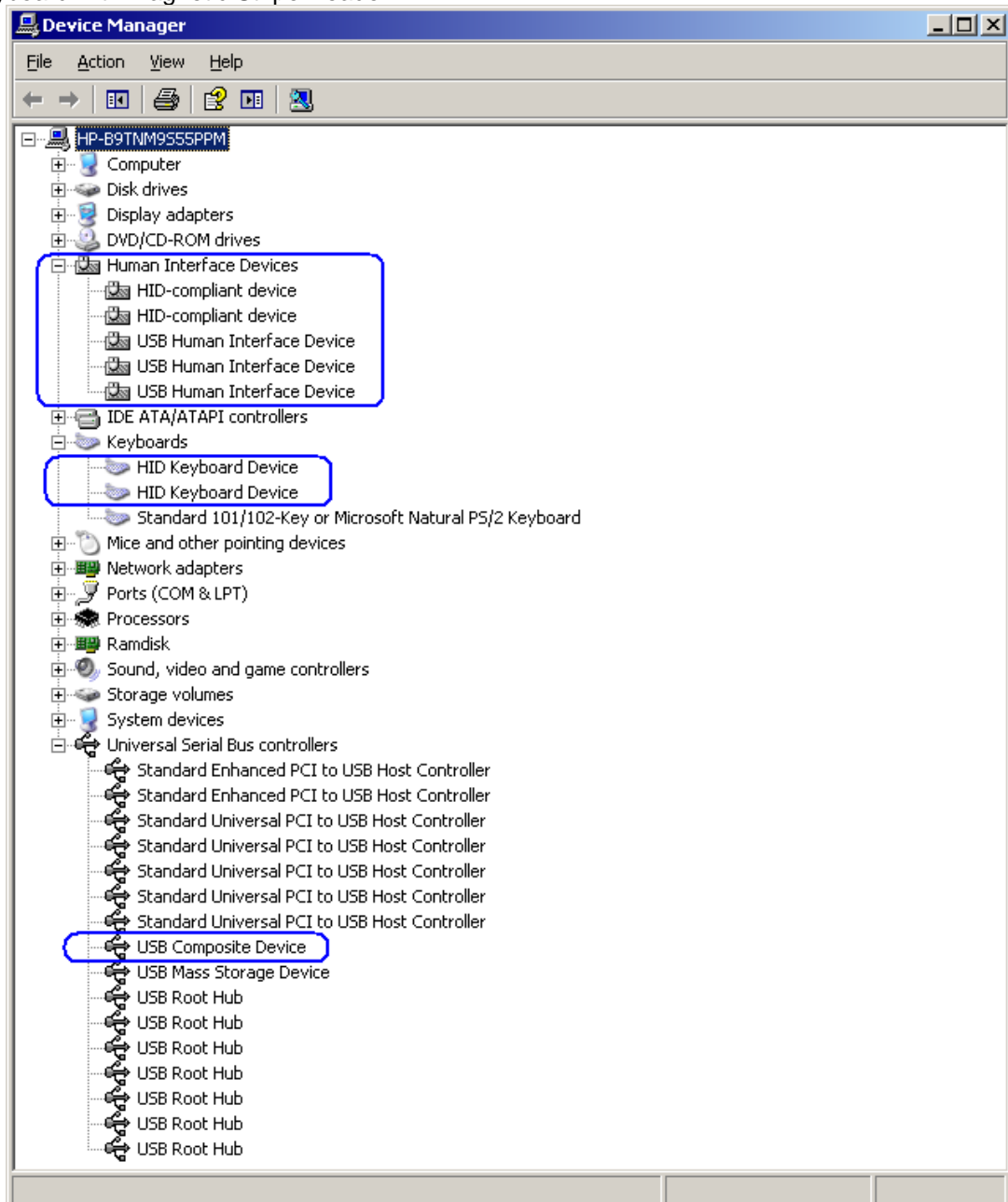

The following is the Device Manager window after all the drivers **and** the keyboard configuration software is installed on the unit for the HP USB POS Keyboard with Magnetic Stripe Reader:

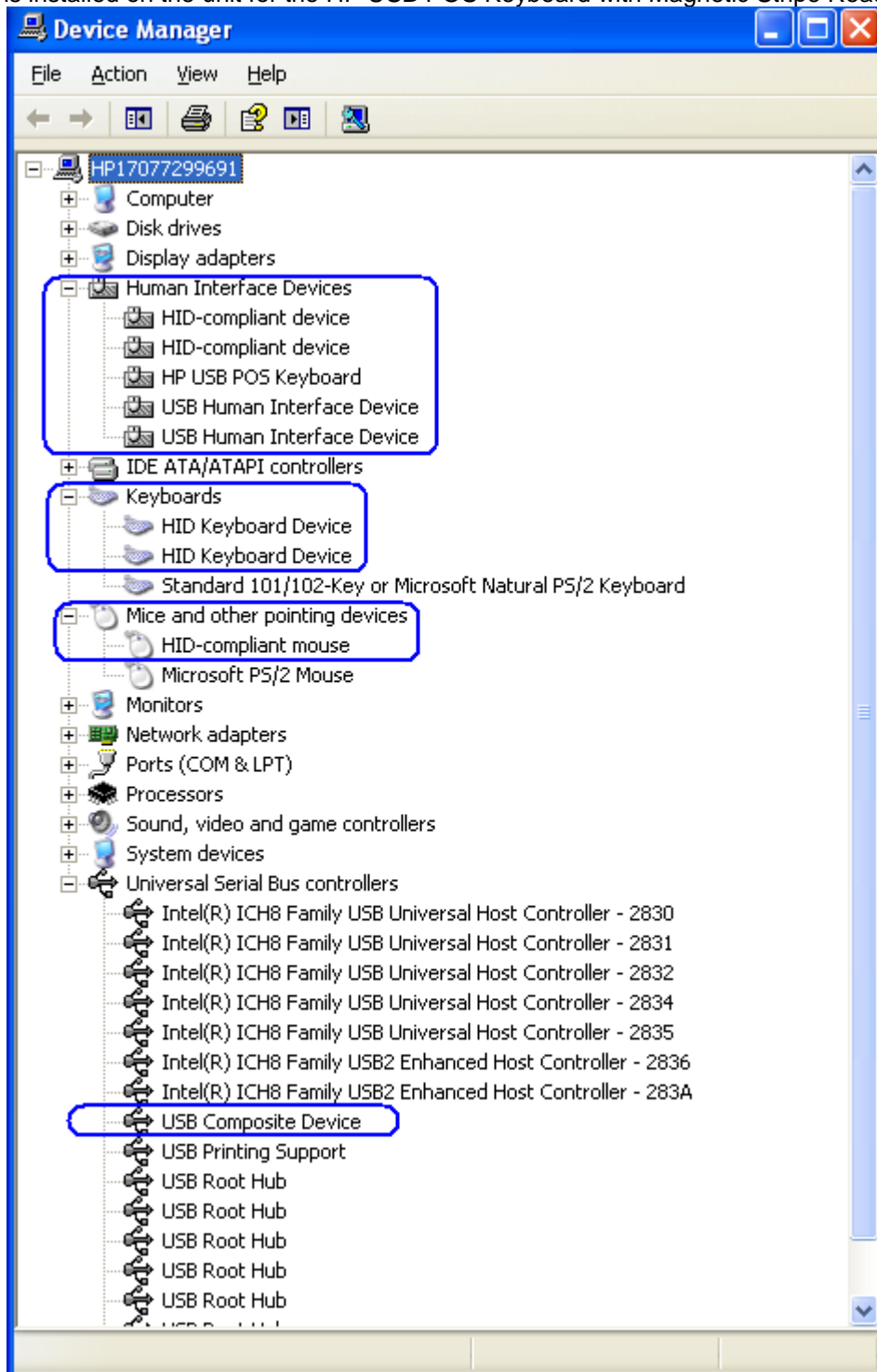

6.12.3 **Enable OPOS/JPOS for the MSR**

In order to use OPOS/JPOS drivers for the MSR on the HP USB POS Keyboard with Magnetic Stripe Reader one will need to enable this option.

Enable MSR OPOS/JPOS

The following is an overview of the steps to test the MSR followed by detailed steps:

1. Must have the HP POS Keyboard configuration utility package, run the EXE and the unit will need to be restarted after the utility has completed installation.

Note: In the HP factory image the HP POS Keyboard configuration utility is already installed so step 1 can be skipped, proceed to step 2. If the configuration utility is already installed on the unit and setup is opened one will be prompted to modify / repair / remove the version that is installed, cancel the installation process and proceed to step 2.

2. After the unit has completed the restart and is back at the Windows desktop, open “Designer” program which is located in the “HP POS Keyboard” folder.
3. Accept the default once “Designer” is opened.
4. Once the application has read the configuration you will see keyboard layout in the GUI and click on the MSR icon.
5. Click on the “Enable OPOS/JavaPOS settings:
6. Close the application and you will be prompted to save the setting to keyboard, click “YES”.

Enable MSR OPOS/JPOS Detailed Steps

1. Must have the HP POS Keyboard configuration utility package, run the EXE and the unit will need to be restarted after the utility has completed installation. This utility is already installed in the HP factory image (C:\xxxx\Point of Sale\Keyboard with MSR\Configuration Utility) and is also available from HP.COM.

Note: In the HP factory image the HP POS Keyboard configuration utility is already installed so step 1 can be skipped, proceed to step 2. If the configuration utility is already installed on the unit and setup is opened one will be prompted to modify / repair / remove the version that is installed, cancel the installation process and proceed to step 2.

2. After the unit has completed the restart and is back at the Windows desktop, open “Designer” program which is located in the “HP POS Keyboard” folder.
3. Accept the default once “Designer” is opened. The following are some screens that you will see:

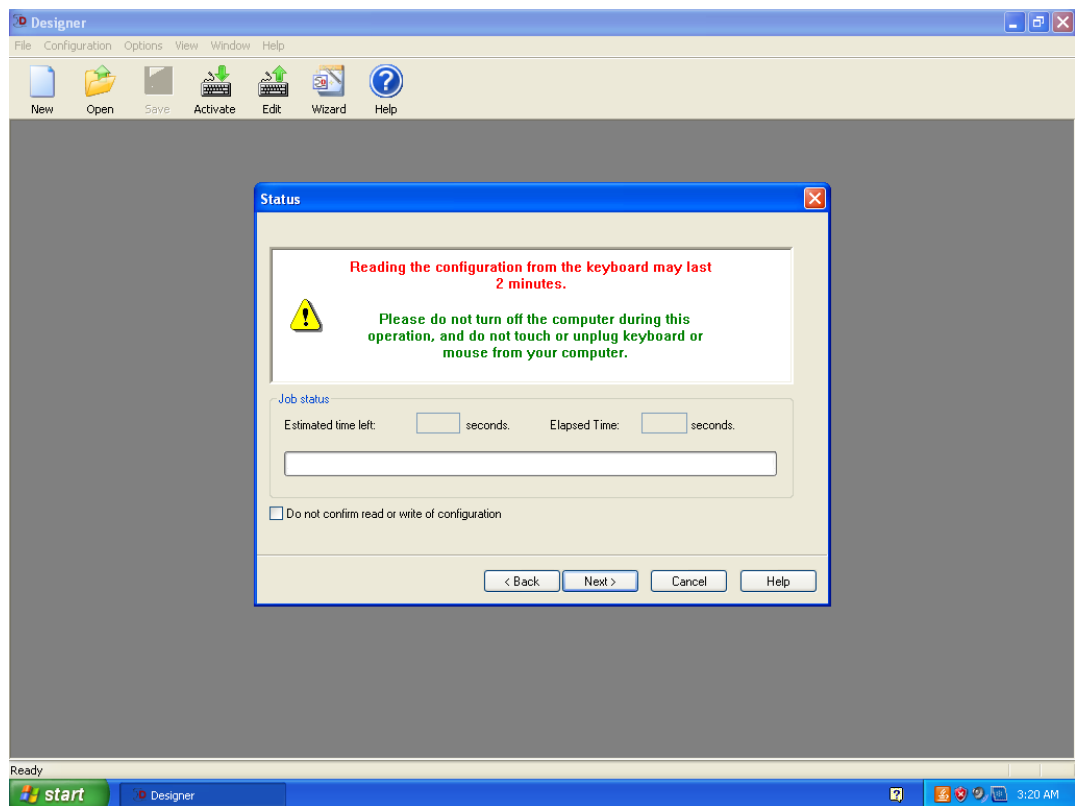
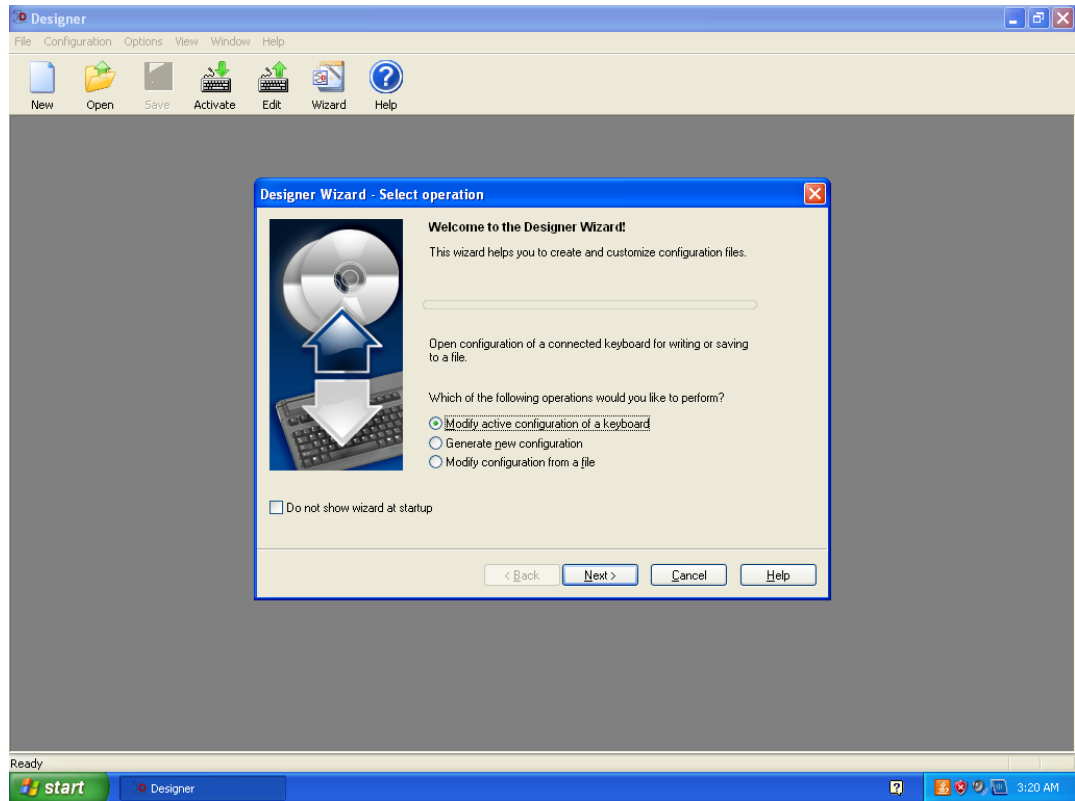

4. Once the application has read the configuration you will see keyboard layout in the GUI and click on the MSR icon:

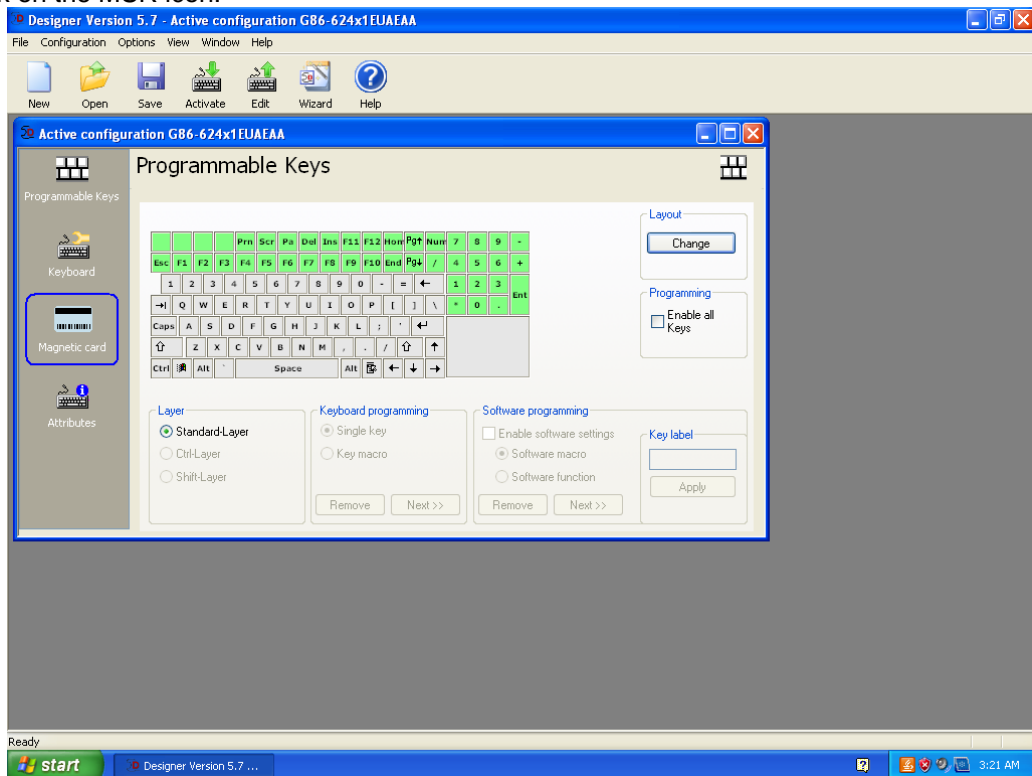

5. Click on the "Enable OPOS/JavaPOS settings":

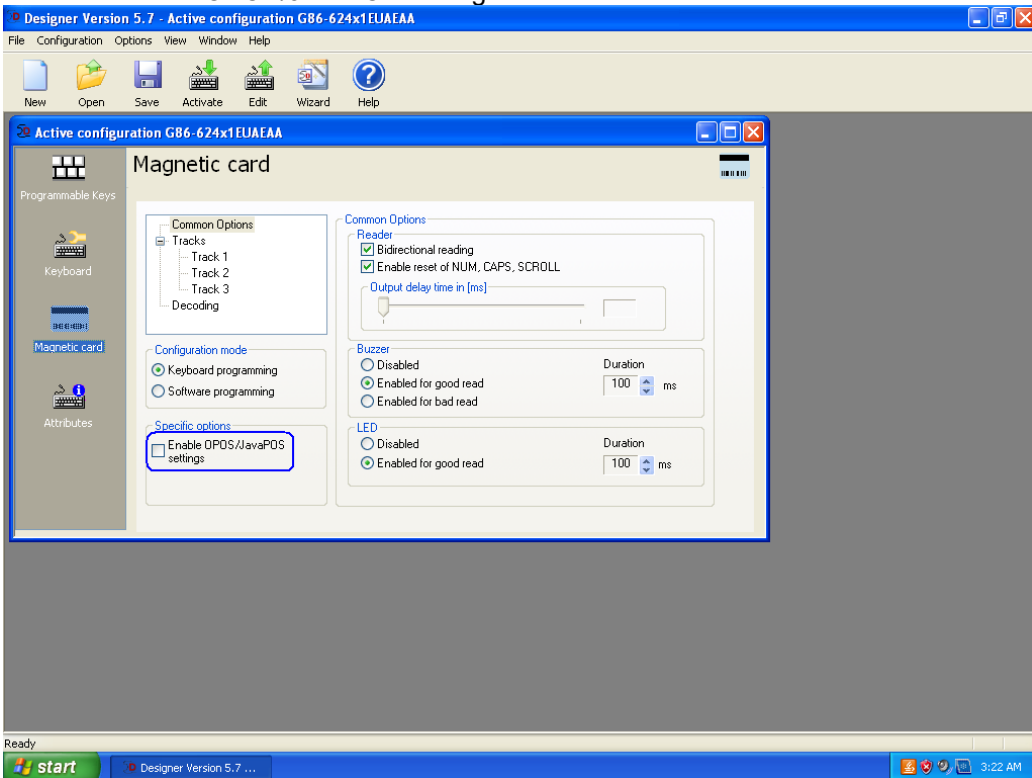

6. Close the application and you will be prompted to save the setting to keyboard, click "YES".

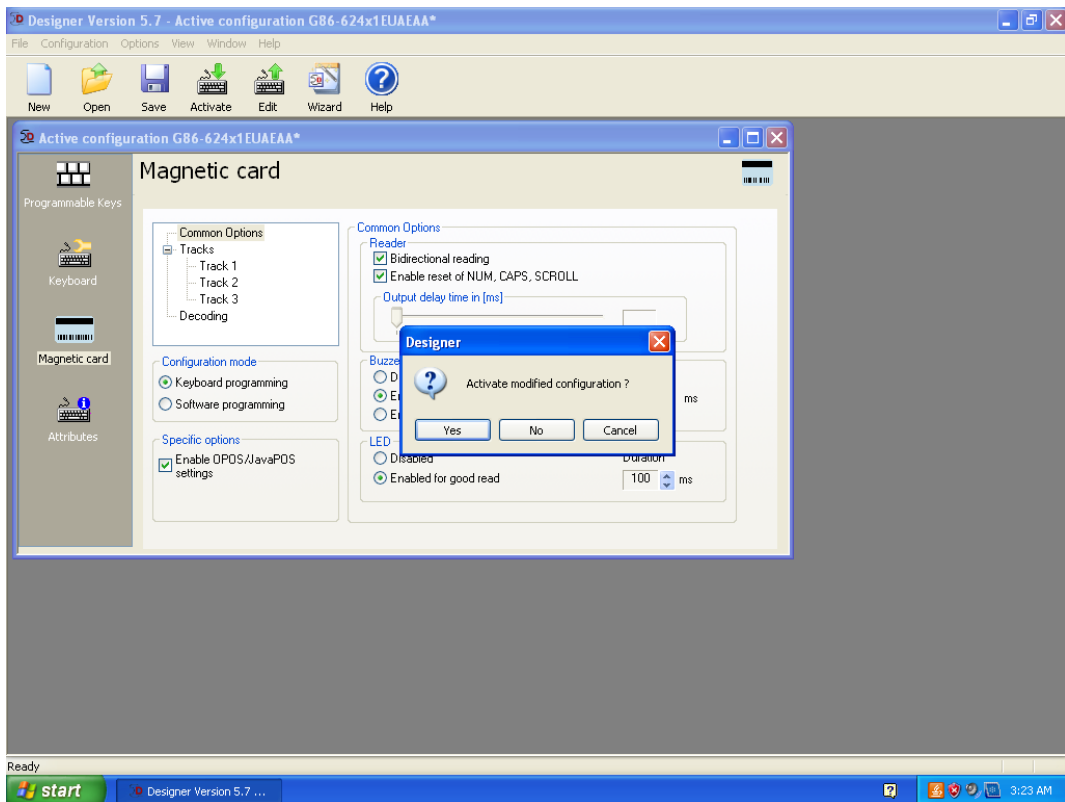
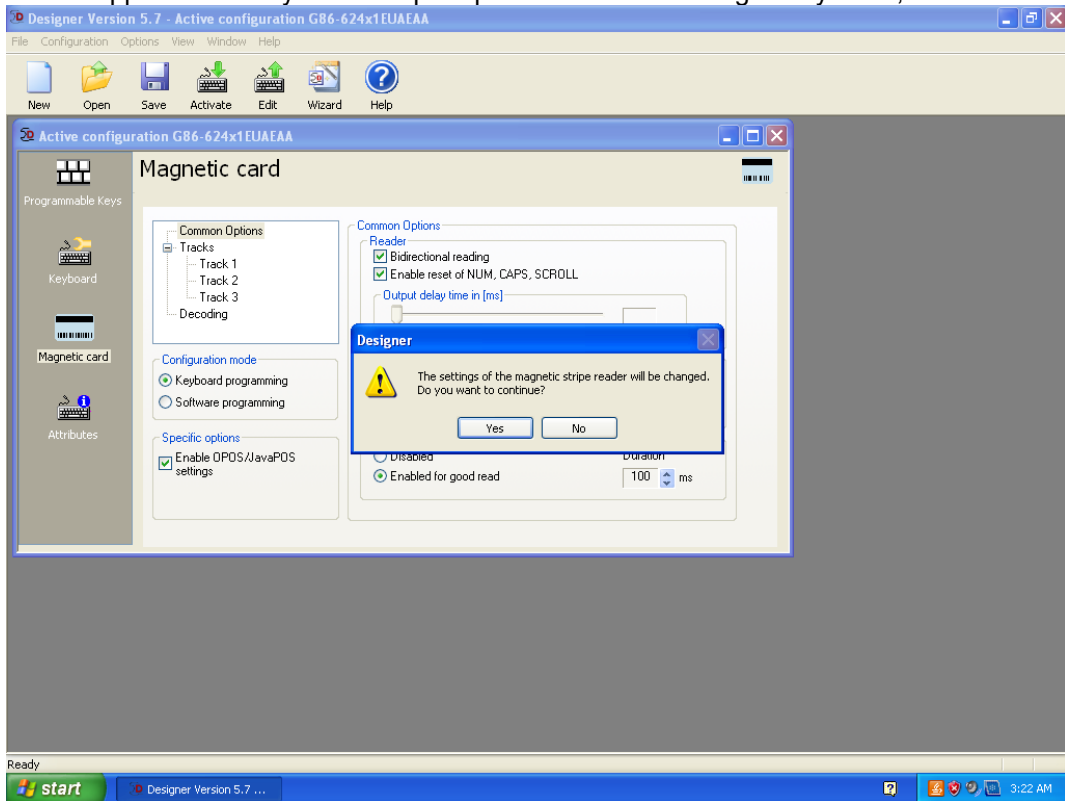

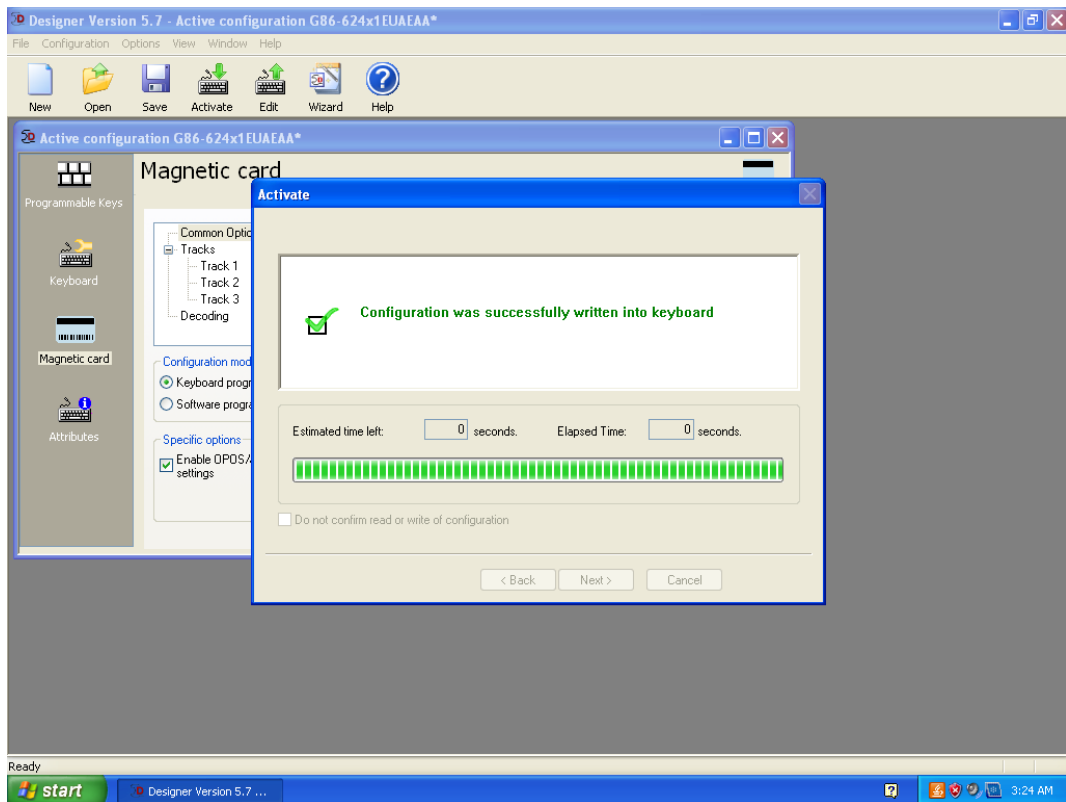
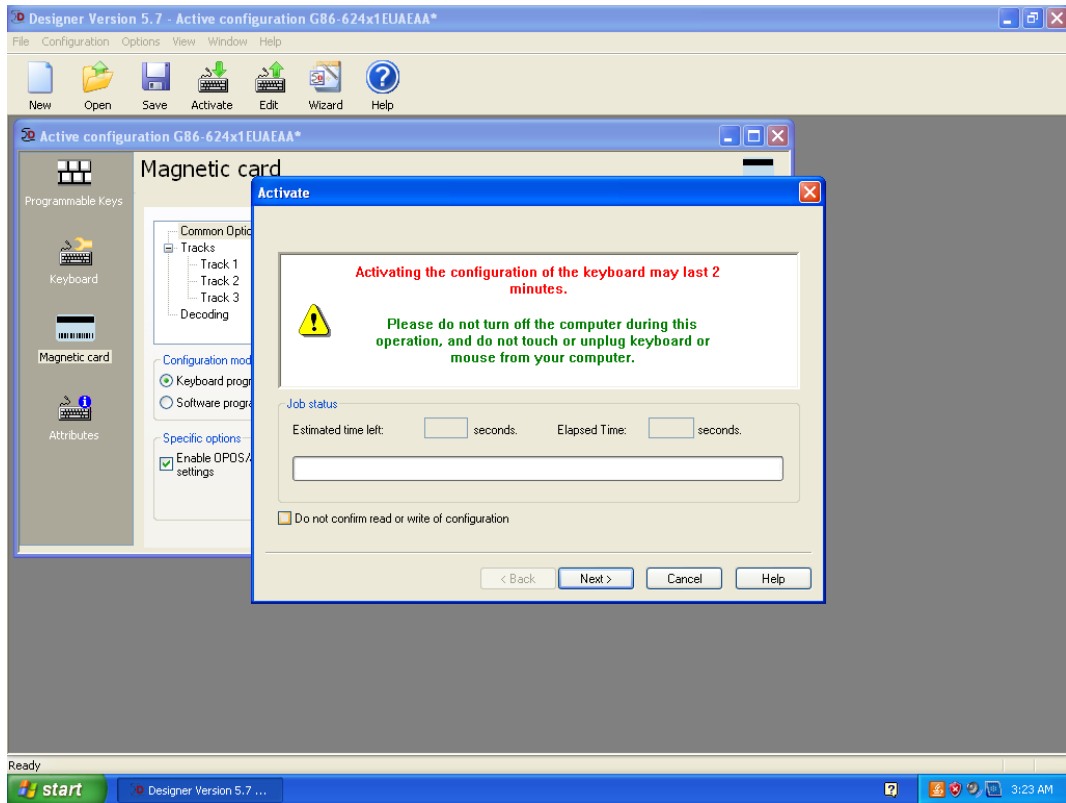

6.12.4 **OPOS Drivers for the HP USB POS Keyboard with Magnetic Stripe Reader - Keyboard**

No OPOS drivers are needed for the keyboard.

6.12.5 **OPOS Drivers for the HP USB POS Keyboard with Magnetic Stripe Reader - MSR**

The OPOS drivers are already installed in the HP factory image and are also available from HP.COM.

6.12.6 **Testing the HP USB POS Keyboard with Magnetic Stripe Reader**

6.12.6.1 **Keyboard**

Open Notepad, what is typed on the keyboard should appear in Notepad.

6.12.6.2 **MSR OPOS**

The following is overview of the steps to test the MSR followed by detailed steps:

1. Open **OPOS MagneticStripeReader Demo**.
 - C:\xxxxx\Point of Sale\Keyboard with MSR\OPOS Test Utility\oposmagnet.exe.
2. Select the device name, need to select "HPKBMSR" for the MSR that is located on the HP POS Keyboard with integrated MSR.
3. Click on "BEGIN" and swipe a card. After the card is swiped data should appear in the test applet.
4. Click on "END" button to exit the test application.

OR

1. Open **OPOS MagneticStripeReader Demo**.
 - C:\xxxxx\Point of Sale\Keyboard with MSR\OPOS Test Utility\oposmagnet.exe.
2. Select the device name, need to select "HPKBMSR" for the MSR that is located on the HP POS Keyboard with integrated MSR.
3. Click on "OPEN"
4. Click on "CLAIM"
5. Select "DataEventEnabled (R/W)" and "DeviceEnabled (R/W)"
6. Swipe a credit card and the data should appear in the test applet.
7. To exit the application:
 - Click on the RELEASE button.
 - Click on the CLOSE button.
 - Click on the EXIT button.

Detailed Steps

1. Open **OPOS MagneticStripeReader Demo**.
 - C:\xxxxx\Point of Sale\Keyboard with MSR\OPOS Test Utility\oposmagnet.exe.

2. Select the device name, need to select “HPKBMSR” for the MSR that is located on the HP USB POS Keyboard with Magnetic Stripe Reader.

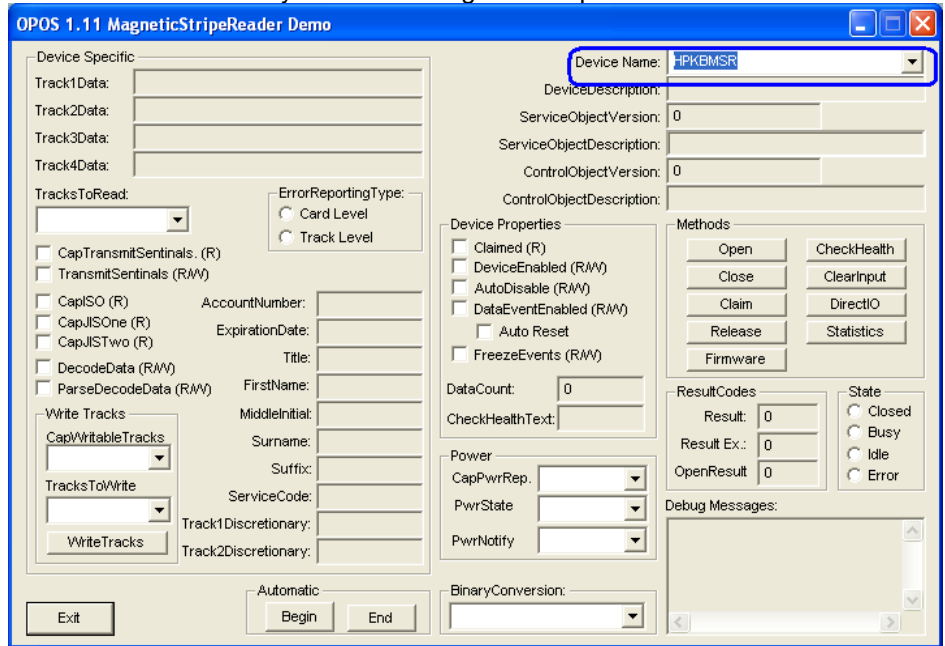

3. Click on “BEGIN” and swipe a card. After the card is swiped data should appear in the test applet.

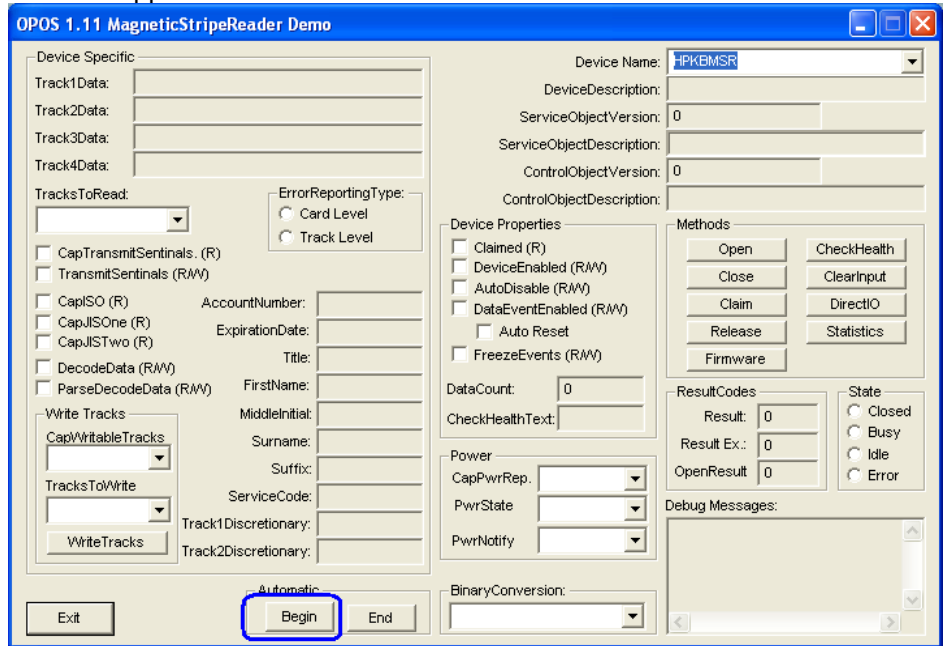

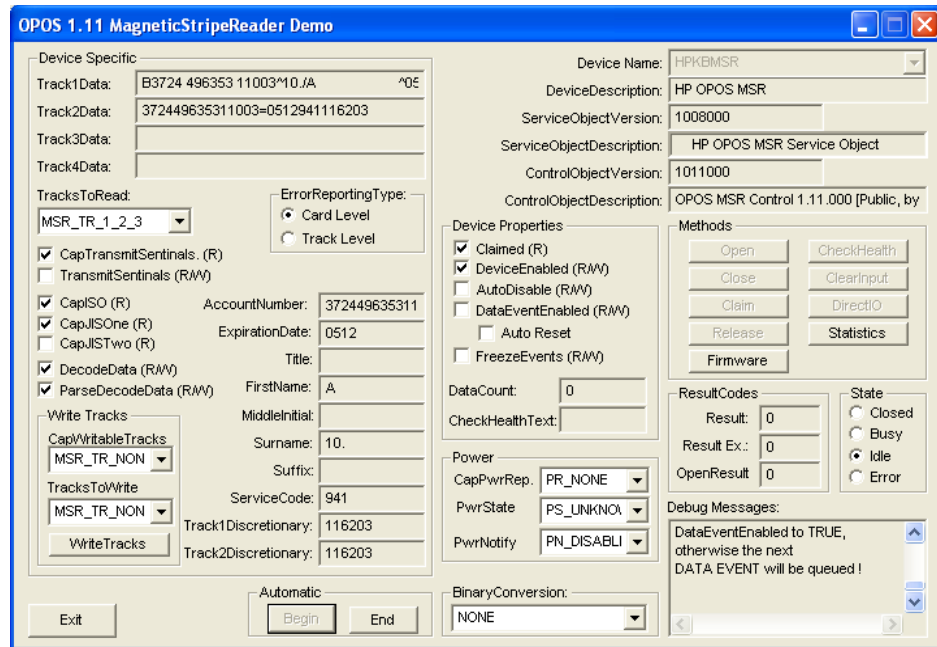

4. Click on “END” button to exit the test application.

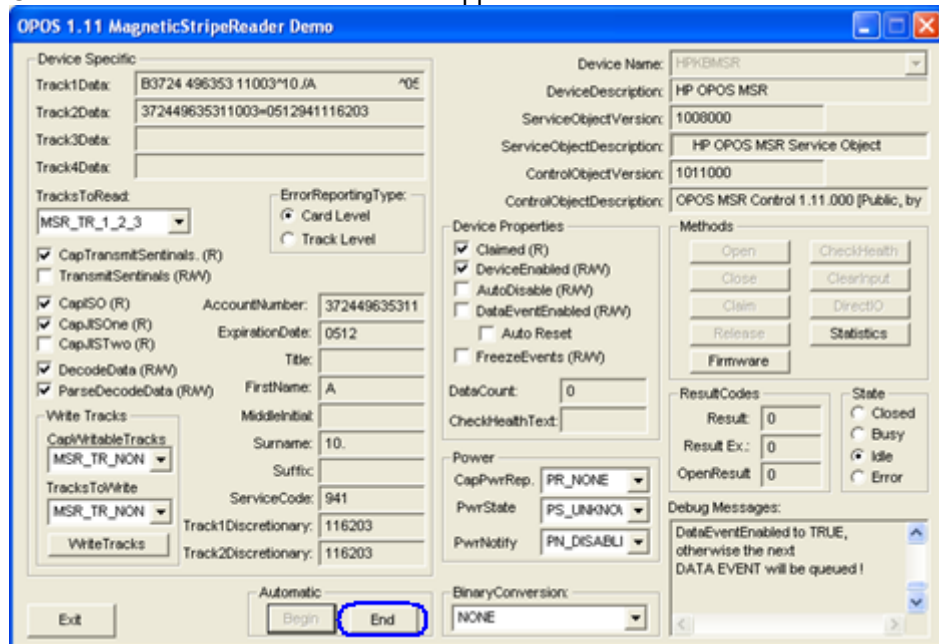

If one does not want to use the “AUTOMATIC” method, the following are the steps to use when manually test using the OPOS test applet.

1. Open **OPOS MagneticStripeReader Demo**.
 - C:\xxxx\Point of Sale\Keyboard with MSR\OPOS Test Utility\oposmagnet.exe.

2. Select the device name, need to select “HPKBMSR” for the MSR that is located on the HP USB POS Keyboard with Magnetic Stripe Reader.

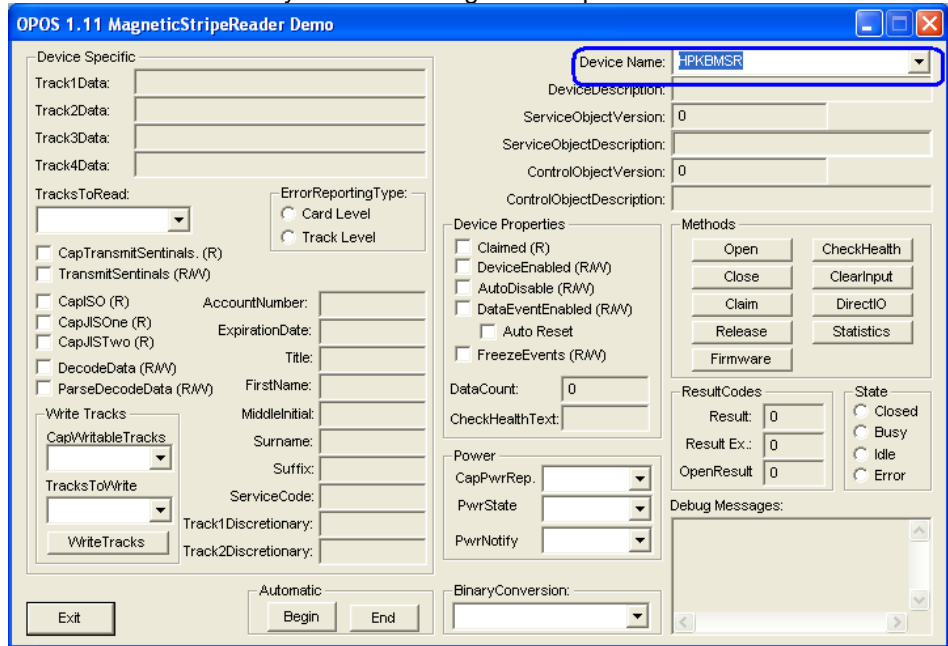

3. Click on “OPEN”
4. Click on “CLAIM”

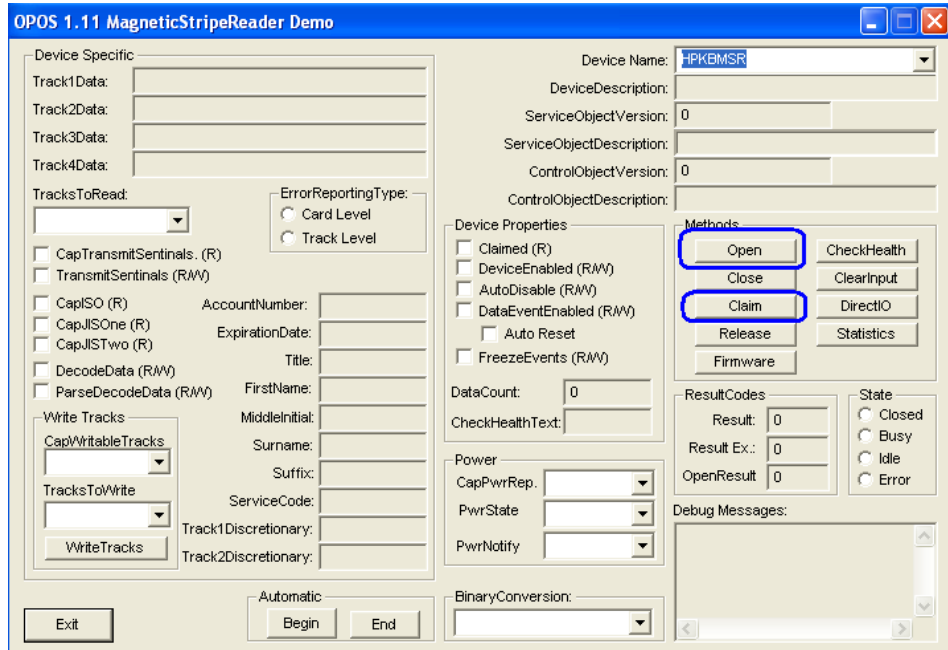

5. Select "DataEventEnabled (R/W)" and "DeviceEnabled (R/W)"

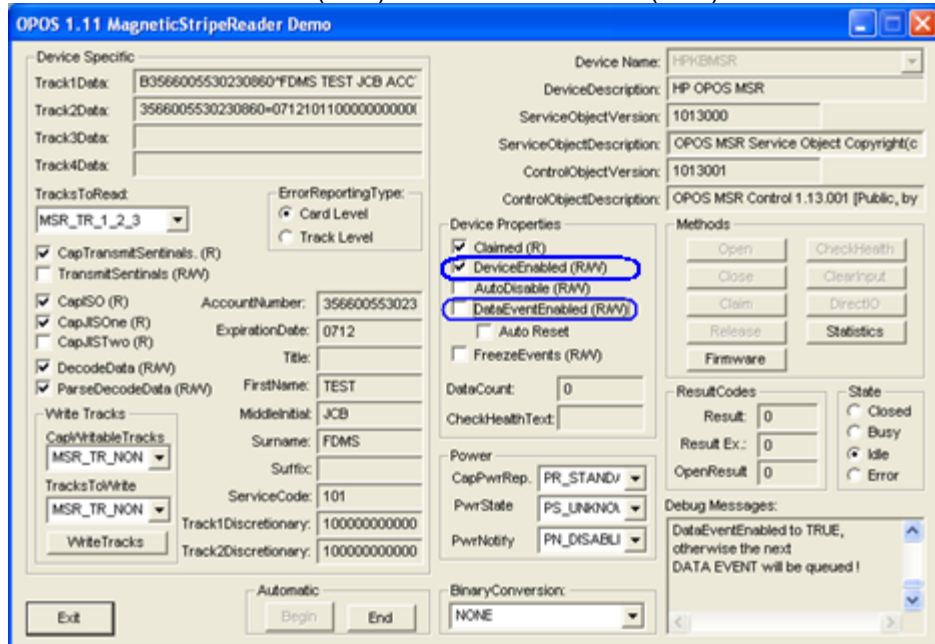

6. Swipe a credit card and the data should appear in the test applet.

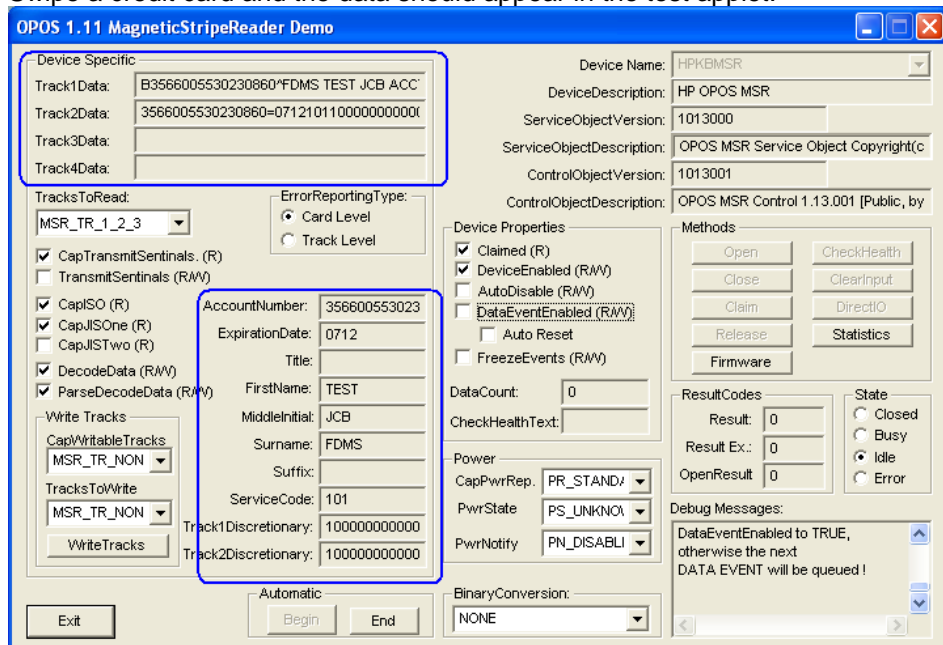

7. To exit the application:
- Click on the RELEASE button.
 - Click on the CLOSE button.
 - Click on the EXIT button.

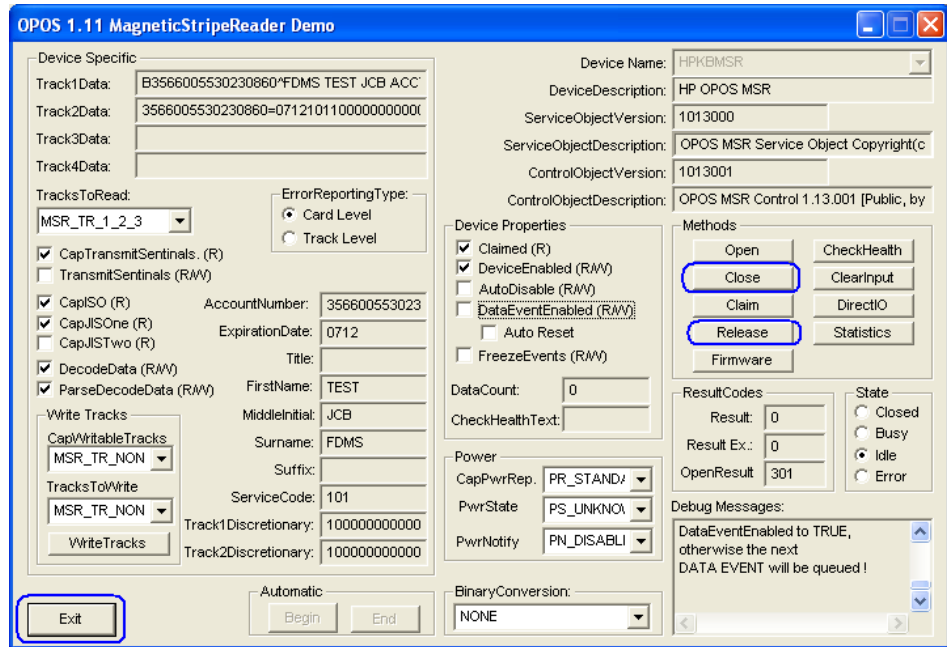

6.12.7 JPOS Drivers for the HP USB POS Keyboard with Magnetic Stripe Reader

6.12.7.1 Keyboard

No JPOS drivers are needed for the keyboard.

6.12.7.2 MSR JPOS

The following is overview of the steps to test the MSR followed by detailed steps:

1. Open **JPOS-Testsuite**.
 - C:\xxxxx\Point of Sale\Keyboard with MSR\JPOS Test Utility\TestSuite.bat
2. Select MSR from “TEST” drop down box.
3. Click “OPEN”
4. Click “CLAIM”
5. Click on “DataEventEnabled (R/W)”
6. Click on “DeviceEnabled (R/W)”
7. Swipe a card.
8. Select the Release / Close / Exit buttons to exit application.

Detailed Steps

1. Open **JPOS-Testsuite**.
 - C:\xxxxx\Point of Sale\Keyboard with MSR\JPOS Test Utility\TestSuite.bat
2. Select MSR from “TEST” drop down box.

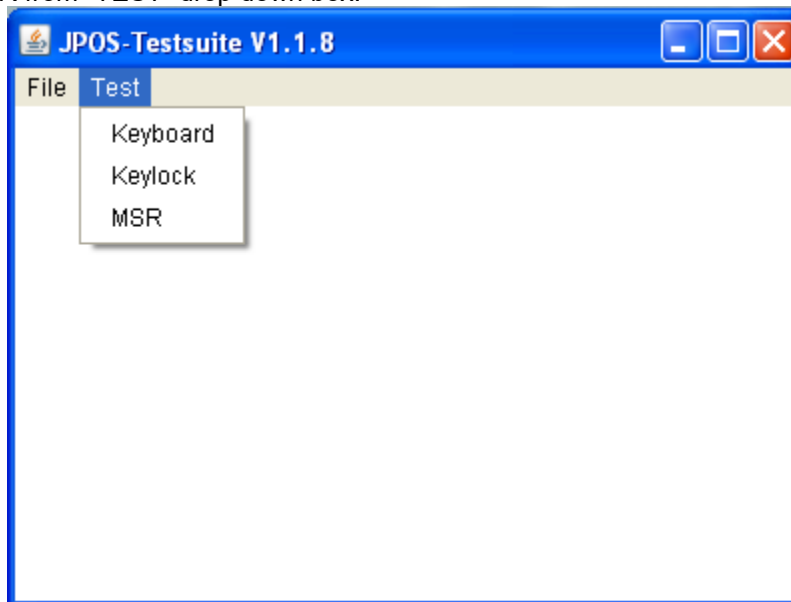

3. Click "OPEN"
4. Click "CLAIM"

POS MSR Test

Buttons: open, claim, clearInput, checkHealth, close, release, clearOutput, directIO

TracksToRead (R/W): MSR_TR_1_2_3_4

Track1Data, Track2Data, Track3Data, Track4Data

TransmitSentinels (R/W)

AutoDisable (R/W)

Claimed (R)

DataEventEnabled (R/W)

DeviceEnabled (R/W)

FreezeEvents (R/W)

PowerNotify (R/W)

CapPowerReporting: STANDARD

DataCount: 0

PowerState: PS_UNKNOWN

CheckHealthText:

State: Closed, Idle, Busy, Error

DeviceControlDescription: JavaPOS MSR Device Control

DeviceControlLabel: 1010000

DeviceServiceDescription: HP POS JPOS MSR Device Sen

DeviceServiceLabel: 11010001

PhysicalDeviceDescription: HP POS MSR-Device (HP-Keybo

PhysicalDeviceName: MSR

CapISO (R)

CapJISOne (R)

CapJISTwo (R)

CapTransmitSentinels (R)

DecodeData (R/W) CardLevel (Error R/W)

ParseDecodeData (R/W) TrackLevel (Error R/W)

AccountNumber, ExpirationDate, Title, FirstName, MiddleInitial, Surname, ServiceCode, Track1Discr.data, Track2Discr.data

End

5. Click on "DataEventEnabled (R/W)"
6. Click on "DeviceEnabled (R/W)"

POS MSR Test

Buttons: open, claim, clearInput, checkHealth, close, release, clearOutput, directIO

TracksToRead (R/W): MSR_TR_1_2_3_4

Track1Data, Track2Data, Track3Data, Track4Data

TransmitSentinels (R/W)

AutoDisable (R/W)

Claimed (R)

DataEventEnabled (R/W)

DeviceEnabled (R/W)

FreezeEvents (R/W)

PowerNotify (R/W)

CapPowerReporting: STANDARD

DataCount: 0

PowerState: PS_UNKNOWN

CheckHealthText:

State: Closed, Idle, Busy, Error

DeviceControlDescription: JavaPOS MSR Device Control

DeviceControlLabel: 1010000

DeviceServiceDescription: HP POS JPOS MSR Device Sen

DeviceServiceLabel: 11010001

PhysicalDeviceDescription: HP POS MSR-Device (HP-Keybo

PhysicalDeviceName: MSR

CapISO (R)

CapJISOne (R)

CapJISTwo (R)

CapTransmitSentinels (R)

DecodeData (R/W) CardLevel (Error R/W)

ParseDecodeData (R/W) TrackLevel (Error R/W)

AccountNumber, ExpirationDate, Title, FirstName, MiddleInitial, Surname, ServiceCode, Track1Discr.data, Track2Discr.data

End

7. Swipe a card. The data from the card should appear in the test applet.

The screenshot shows the 'POS MSR Test' application window. It features a control panel on the left with buttons for 'open', 'claim', 'clearInput', 'checkHealth', 'close', 'release', 'clearOutput', and 'directIO'. Below these are various checkboxes for device settings such as 'TransmitSentinels (R/W)', 'AutoDisable (R/W)', 'Claimed (R)', 'DataEventEnabled (R/W)', 'iDeviceEnabled (R/W)', 'FreezeEvents (R/W)', and 'PowerNotify (R/W)'. There are also input fields for 'DataCount' and 'PowerState'. On the right side, there are sections for 'TracksToRead (R/W)' (set to 'MSR_TR_1_2_3_4'), 'Track1Data' through 'Track4Data', and checkboxes for 'DecodeData (R/W)', 'CardLevel (Error R/W)', 'ParseDecodeData (R/W)', and 'TrackLevel (Error R/W)'. A large section on the right displays card data: 'AccountNumber' (372449635311003), 'ExpirationDate' (0512), 'Title', 'FirstName' (A), 'MiddleInitial', 'Surname' (10.), 'Suffix', 'ServiceCode' (941), 'Track1Discr.data' (116203), and 'Track2Discr.data' (116203). At the bottom left, there is a 'State' section with radio buttons for 'Closed', 'Idle' (selected), 'Busy', and 'Error', and a 'Cap' section with checkboxes for 'CapISO (R)', 'CapJISOne (R)', 'CapJISTwo (R)', and 'CapTransmitSentinels (R)'. An 'End' button is located at the bottom center.

To test another card, click on “DataEventEnabled (R/W)” so it is checked and then swipe the card that one wishes to test.

8. To exit the application:
 - a. Click on the RELEASE button.
 - b. Click on the CLOSE button.
 - c. Click on the EXIT button.

6.13 HP ap5000 VFD (Vacuum Fluorescent Display)



6.13.1 Connection

The VFD on the HP ap5000 system is connected via serial interface. When attached at the HP factory the VFD is installed on COM2 as the default location. The HP ap5000 VFD can be connected either on COM2 or COM1 on the ap5000 unit; it **cannot** be used on COM3.

If the VFD is moved to factory default location, please go into the BIOS and enable 5V on the COM2 and disable 5V on COM1.

	ap5000 VFD
Port	COM2 (default) or COM1
Baud Rate	38400
Data Bit	8
Parity	None
Stop Bit	1
Flow Control	None

6.13.2 Windows Drivers for the HP ap5000 VFD

Windows operating system supports serial port COM1/COM2, so no extra drivers are needed to be installed.

6.13.3 OPOS Drivers for the HP ap5000 VFD

The OPOS drivers are already installed in the HP factory image (C:\xxxxx\Point of Sale\VFD HP ap5000\ap5000 VFD OPOS) and are also available from HP.COM.

6.13.4 Testing HP ap5000 VFD

6.13.4.1 Testing HP ap5000 VFD in non-OPOS mode

The following is an overview of the steps to test the ap5000 VFD followed by detailed steps:

1. Start the Windows test utility from Windows start menu.
2. Select the COM port from the drop down box or keep the default option. The ap5000 VFD is shipped by default on COM2 from the HP factory.
3. Click on the “Test” button once “READY” appears in the status box.

4. To exit the application:
 - a. Click on "Exit" to close test applet.

Detailed Steps

1. Start the Windows test utility from Windows start menu.
2. Select the COM port from the drop down box or keep the default option. The ap5000 VFD is shipped by default on COM2 from the HP factory.

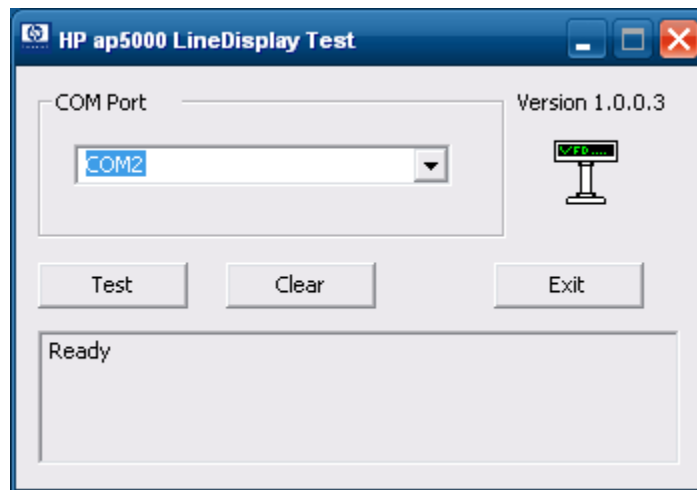
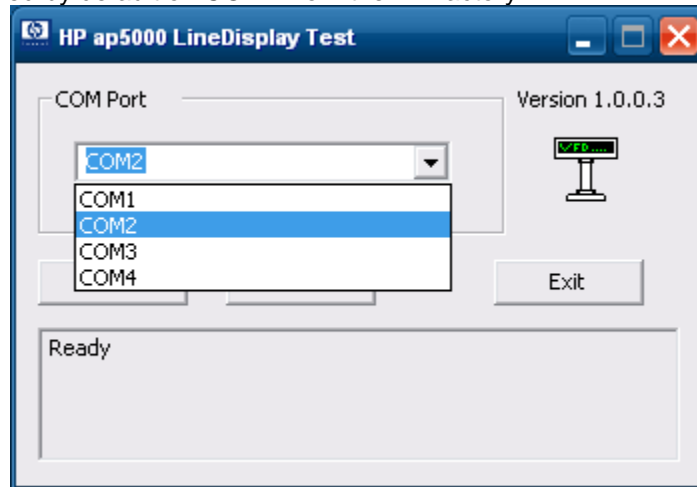

3. Click on the "Test" button once "READY" appears in the status box.

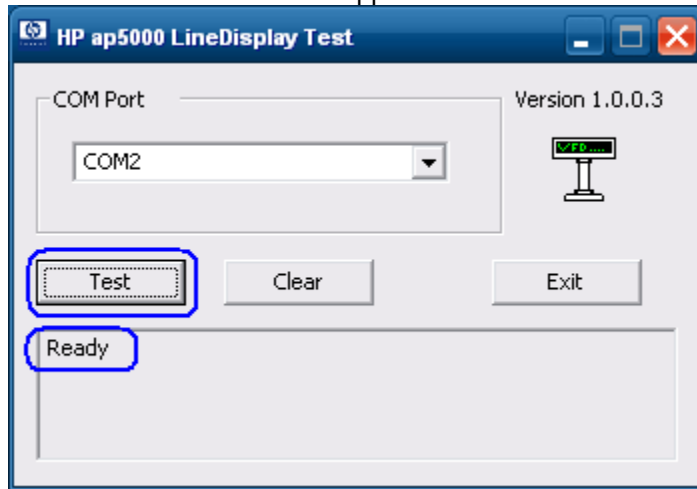

Once the test is complete and passes, the VFD will display "Test OK" and the test utility will provide some status information and the test results.

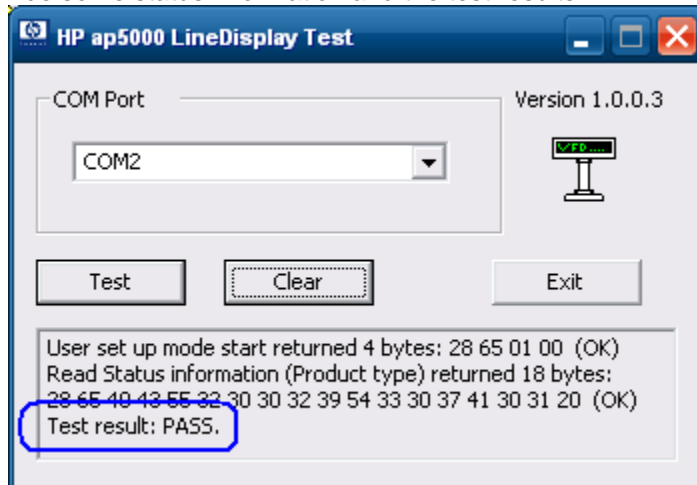

4. To exit the application:
 - a. Click on "Exit" to close test applet.

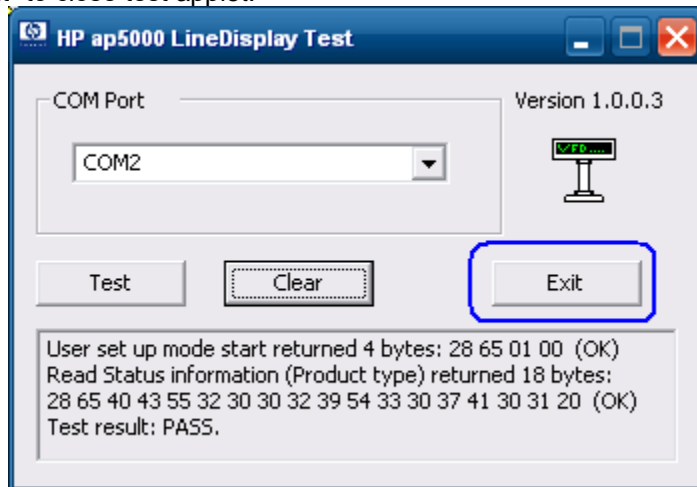

6.13.4.2 **Testing HP ap5000 VFD in OPOS mode**

The following is overview of the steps to test the ap5000 VFD followed by detailed steps:

1. Start the OPOS test utility.
2. Click on "Clear Text" to clear the text on the pole display. To display a test message on the pole, enter a message in the text box or use the default message that appear "Display this text" and click on "Display Text"
3. To blink a test message:
 - a. Enter the test message.
 - b. Check the "Blink" box
 - c. Click "Display Text" button.
4. To "Reverse" a test message:
 - a. Enter the test message.
 - b. Check the "Reverse" box
 - c. Click "Display Text" button.
5. To display a test message on different ROW or Column:
 - a. Enter the test message.
 - b. From the drop down menu select the column and row where you would like the message to be displayed.
 - c. Click "Display Text At" button.
6. To cause message to scroll (test #1):
 - a. Click on "Scrolling Text Test #1" button. The pole will scroll a message and the following message "Scrolling" appears on the VFD bottom line.
7. To cause message to scroll (test #2):
 - a. Click on "Scrolling Text Test #2" button. The pole will scroll a message and the following message "Longer scroll message (37 characters)" appears on the VFD bottom line.
8. To display a test message with delayed character appearing:
 - a. Enter different value (if so desired) for the delay time.
 - b. Click "Set CharacterDelayTime" button.
 - c. Enter a text message and click "Display Text" button.
9. To exit the OPOS test applet, click on the "EXIT" button or click on the "x" in the upper right corner of the test applet.

Detailed Steps

1. Start the OPOS test utility from the start menu or from "C:\xxxxx\Point of Sale\VFD HP ap5000\ap5000 VFD OPOS Test Program" folder.

When the HP Pole Display OPOS test applet has successfully established communication with the pole display, the following message will appear on the pole:

HPap5000LineDisplay
OPOS Test OK!

2. Click on "Clear Text" to clear the text on the pole display. To display a test message on the pole, enter a message in the text box or use the default message that appear "Display this text" and click on "Display Text".

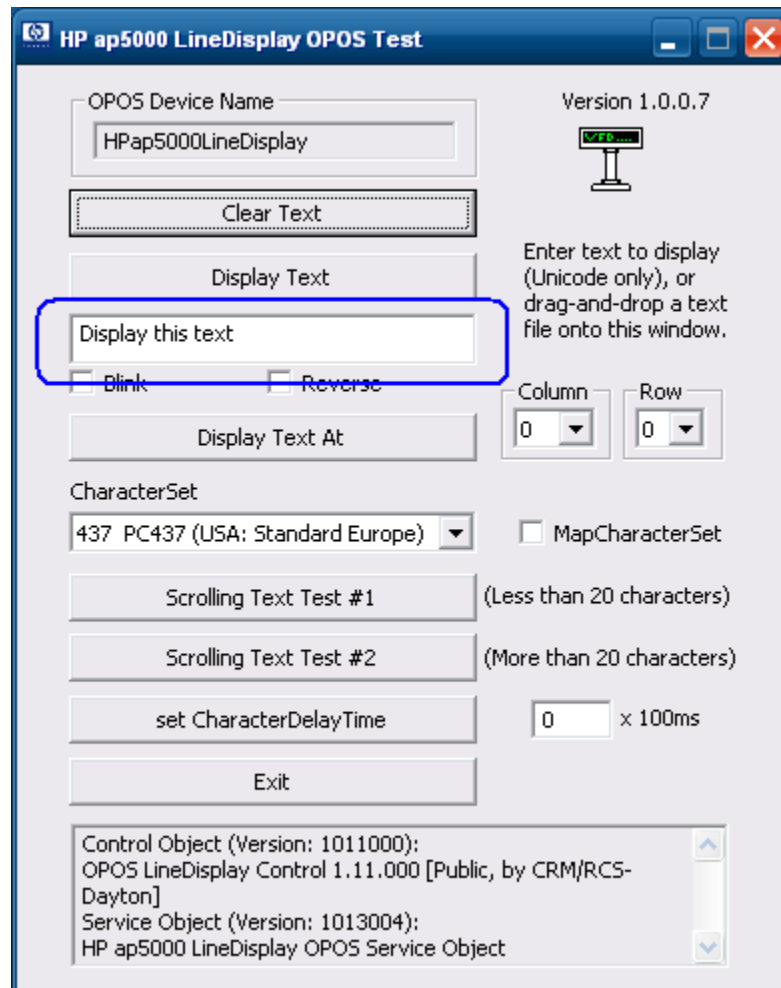

3. To blink a test message:
 - a. Enter the test message.
 - b. Check the "Blink" box
 - c. Click "Display Text" button.

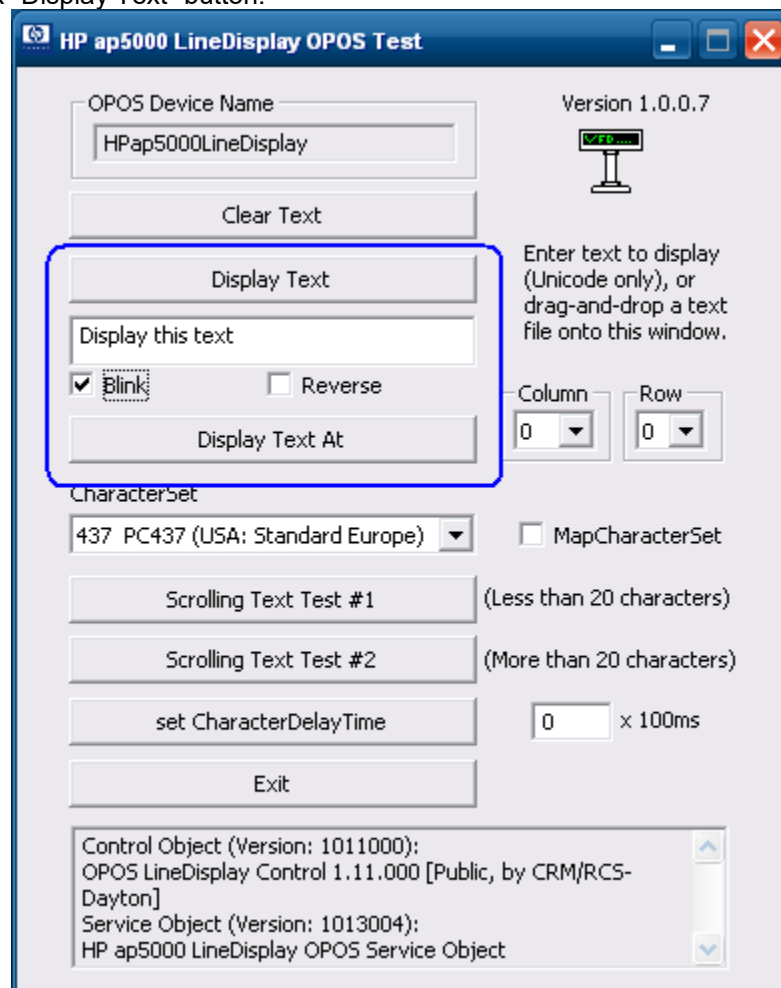

4. To “Reverse” a test message:
 - a. Enter the test message.
 - b. Check the “Reverse” box
 - c. Click “Display Text” button.

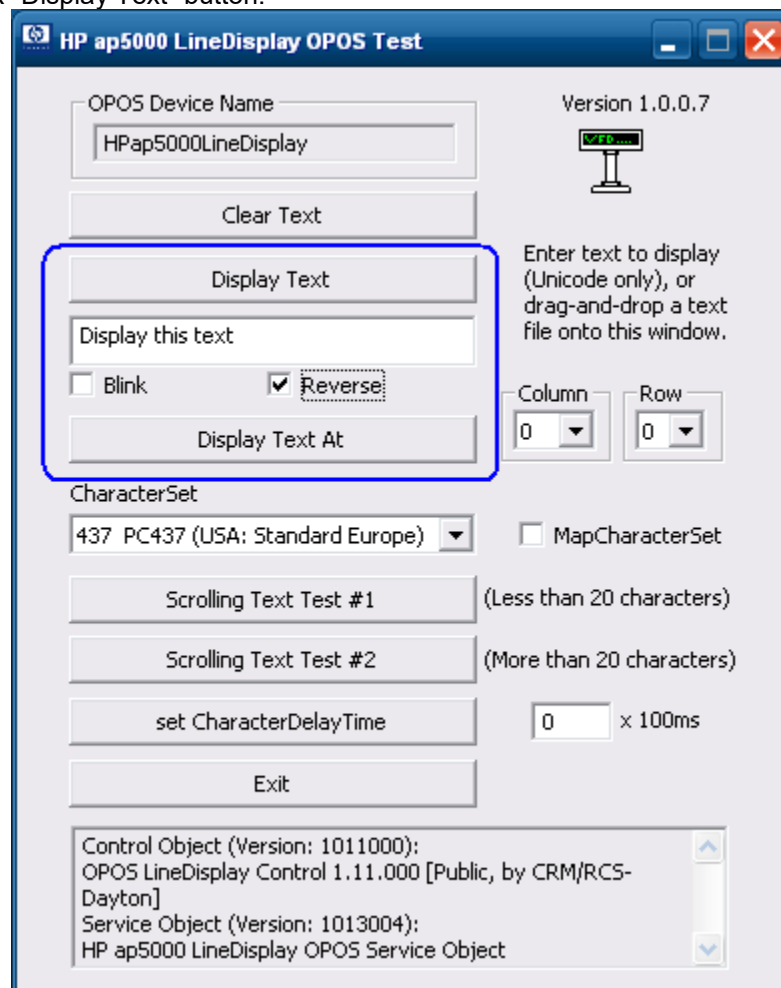

5. To display a test message on different ROW or Column:
 - a. Enter the test message.
 - b. From the drop down menu select the column and row where you would like the message to be displayed.
 - c. Click "Display Text At" button.

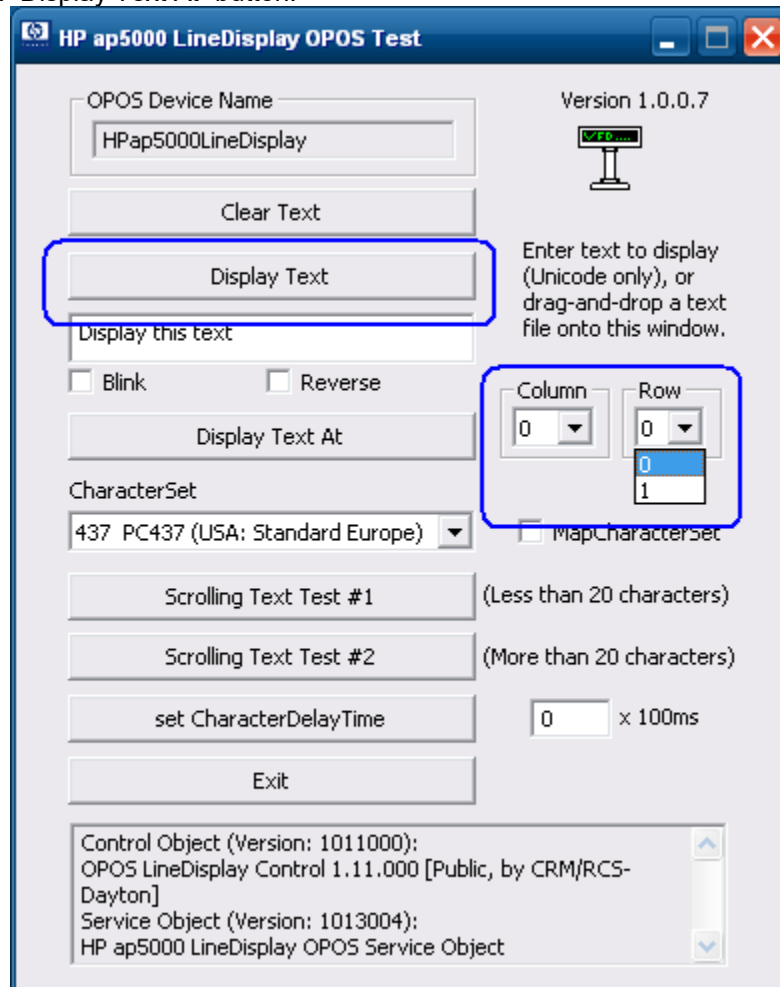

Note: In the column drop down box, the option shown are from 0 – 20 which is per the OPOS specification.

6. To cause message to scroll (test #1):
 - a. Click on “Scrolling Text Test #1” button. The pole will scroll a message and the following message “Scrolling” appears on the VFD bottom line.

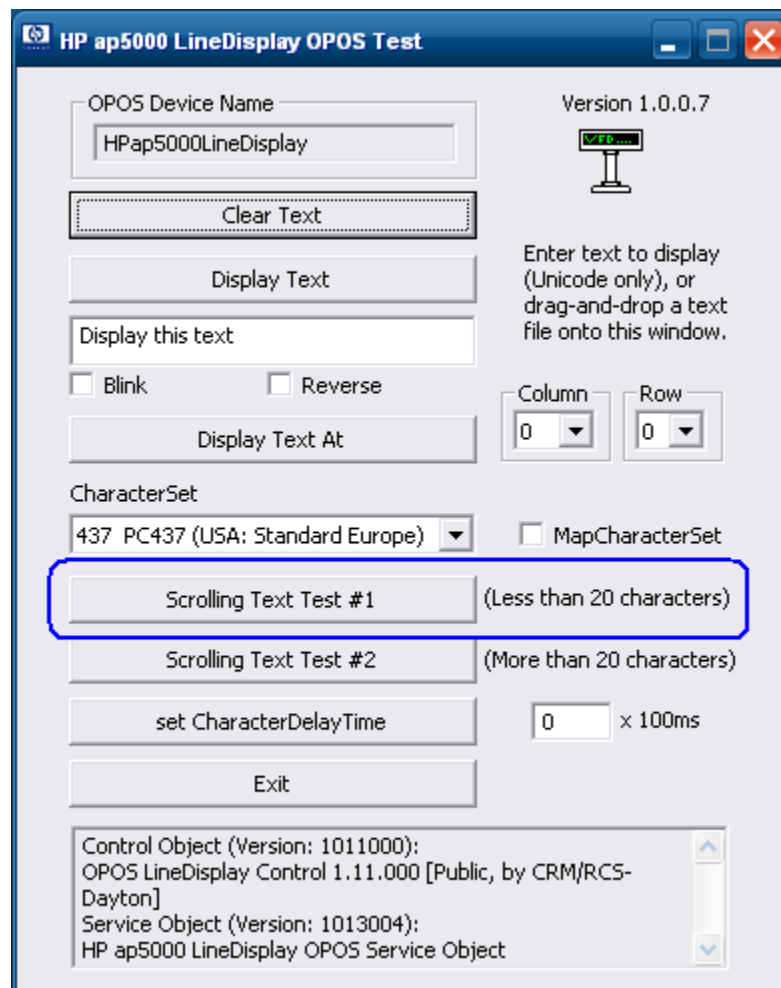

To stop the scrolling message click on the “OK” button on the following box:

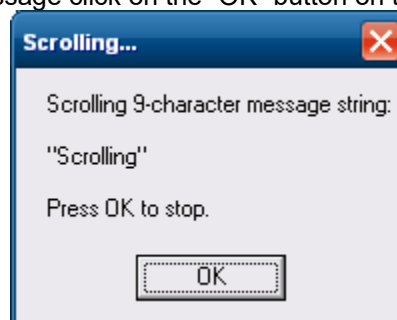

7. To cause message to scroll (test #2):
 - a. Click on “Scrolling Text Test #2” button. The pole will scroll a message and the following message “Longer scroll message (37 characters)” appears on the VFD bottom line.

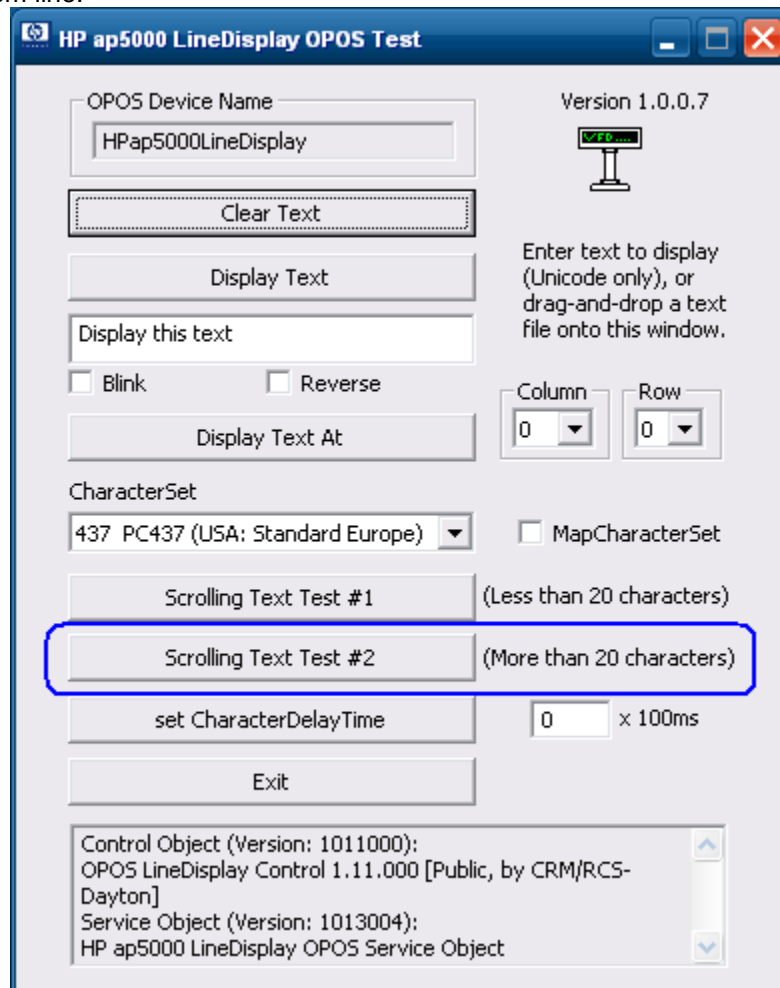

To stop the scrolling message click on the “OK” button on the following box:

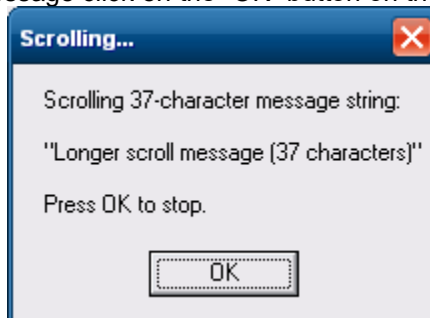

8. To display a test message with delayed character appearing:
 - a. Enter different value (if so desired) for the delay time.

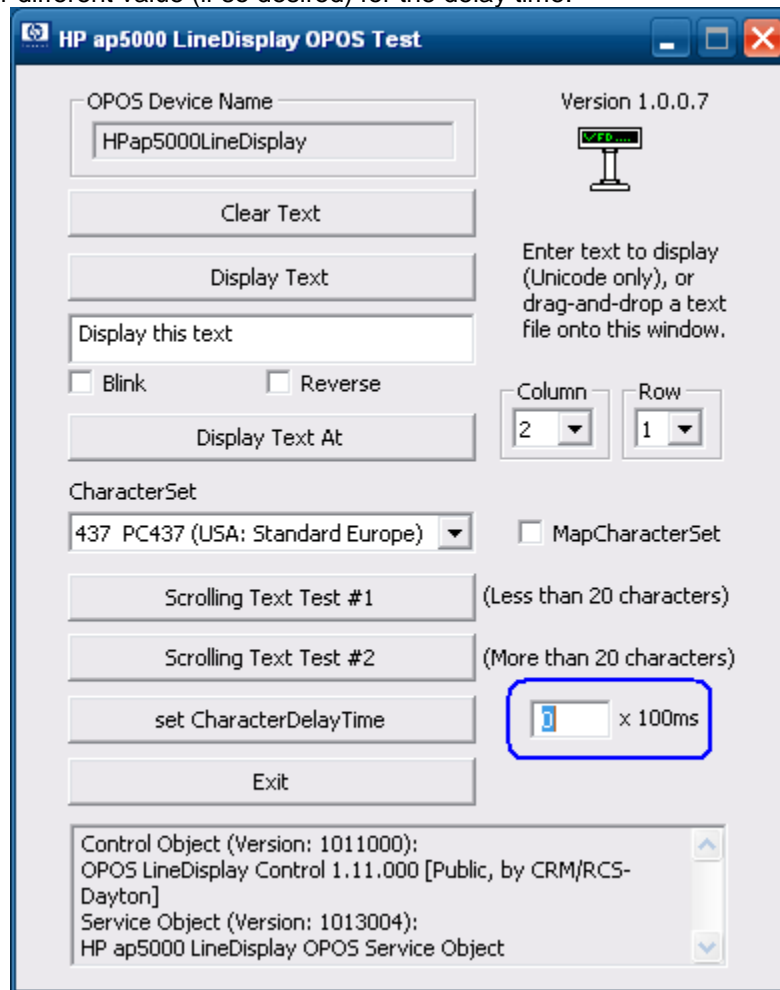

- b. Click “Set CharacterDelayTime” button.

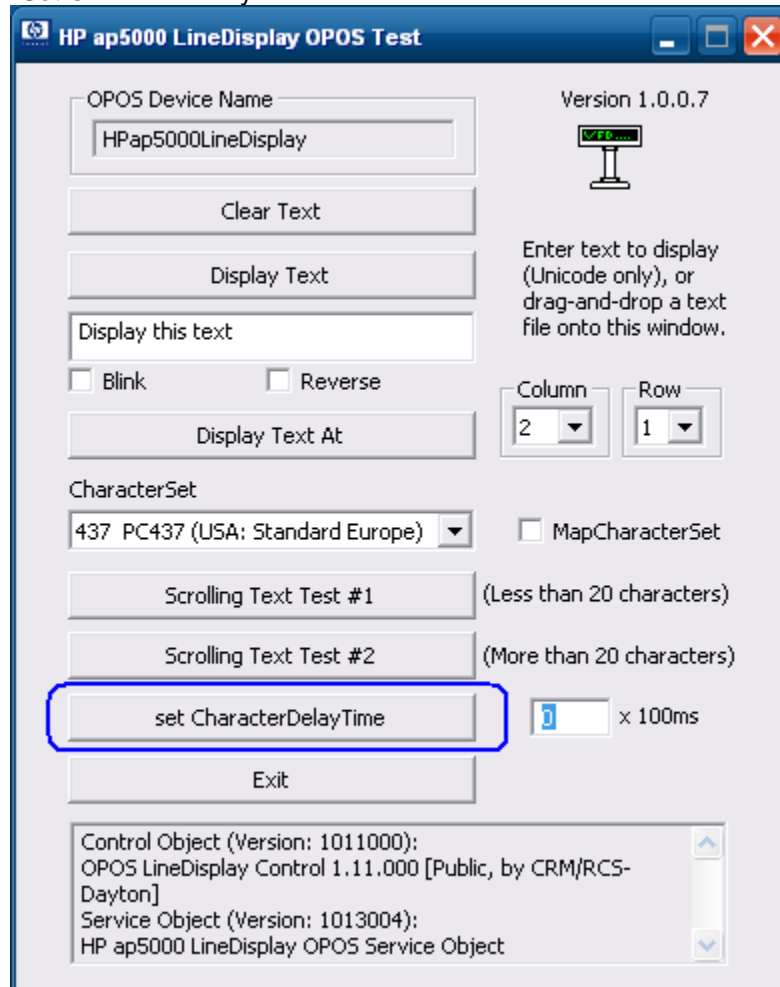

- c. Enter the test message and click “Display Text” button.

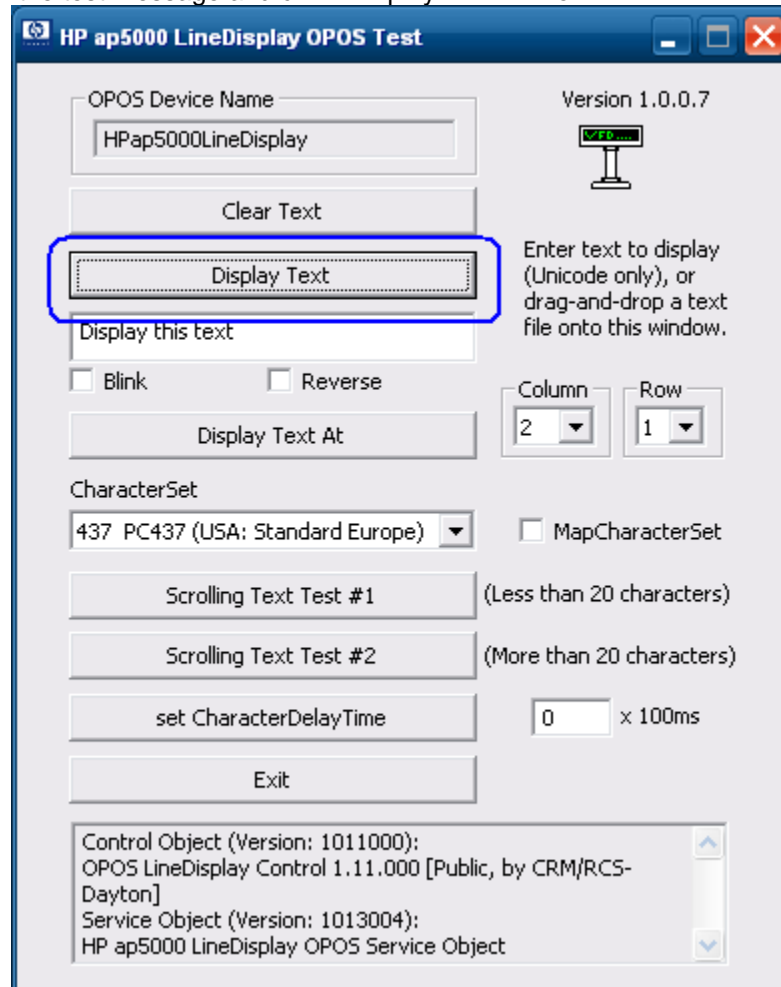

9. To exit the OPOS test applet, click on the “EXIT” button or click on the “x” in the upper right corner of the test applet.

6.13.5 JPOS Drivers for the HP ap5000 VFD

The JPOS drivers are already installed in the HP factory image (C:\xxxxx\Point of Sale\VFD HP ap5000\ap5000 VFD JPOS) and are also available from HP.COM.

The following is an overview of the steps to test the ap5000 VFD followed by detailed steps:

1. Start the JPOS test utility either using the link in the START MENU.
2. Click on the "LineDisplay" tab.
3. Replace the "defaultLineDisplay" that appears in the logical name box with "HPap5000LineDisplay".
4. Click on the "OPEN" button.
5. Click on the "CLAIM" button.
6. Check the "DEVICE ENABLED" so there is a check box.
7. Press the "CLEAR TEXT" button.
8. Type in the test message in the "Send to line display" box and click on "Display Text".
9. Click on "RELEASE" / "CLOSE" / "EXIT" to exit the JPOS test utility.

Detailed Steps

1. Start the JPOS test utility either using the link in the START MENU or by opening the POSTEST.BAT file that is located in the JPOS folder within the ap5000 VFD JPOS folder.

After a few seconds the JPOS test utility GUI will appear as shown below:

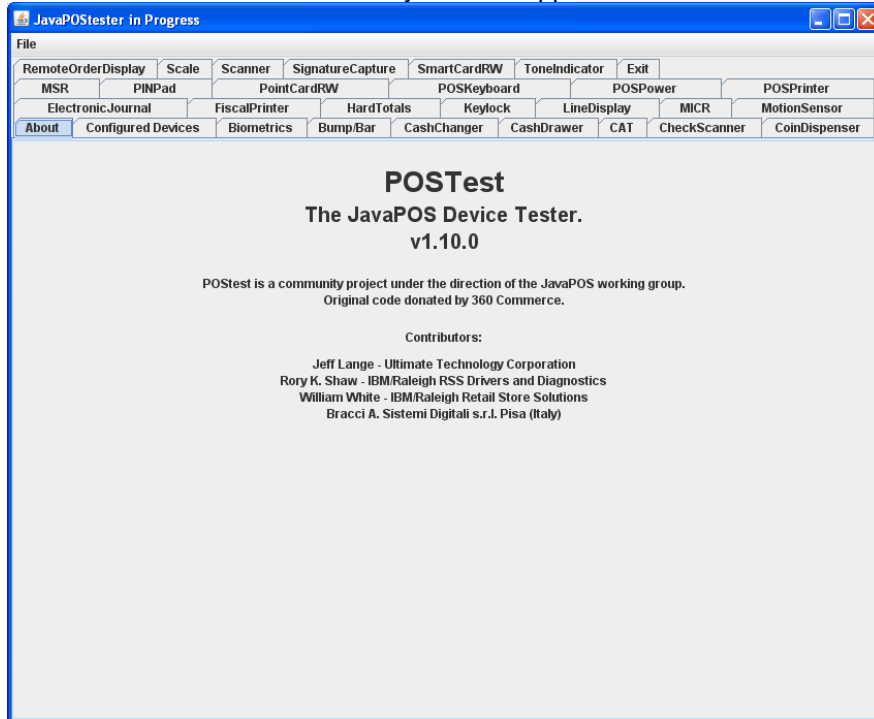

2. Click on the “LineDisplay” tab:

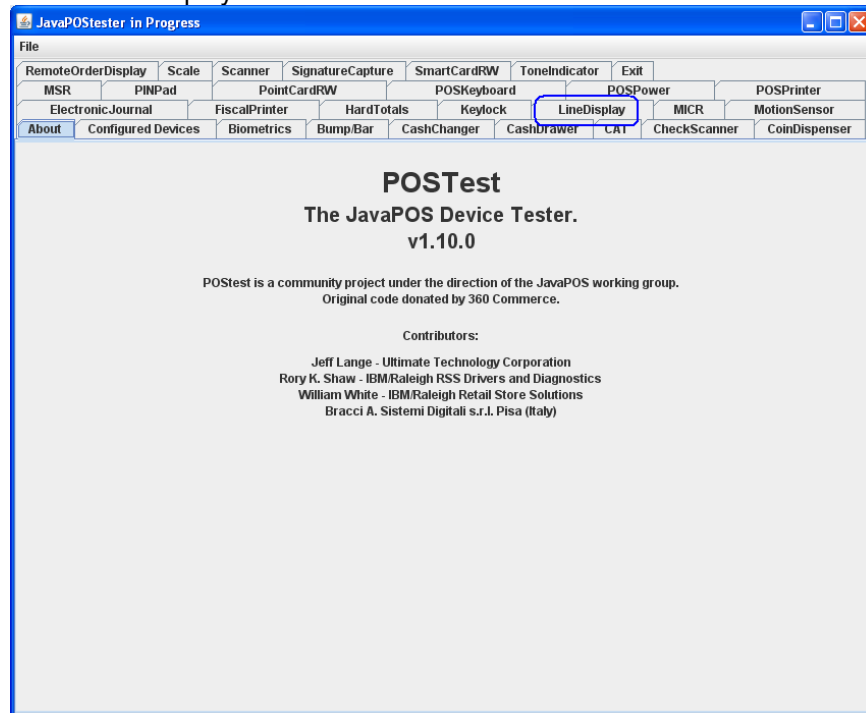

After clicking on the “LineDisplay” tab the screen should look like:

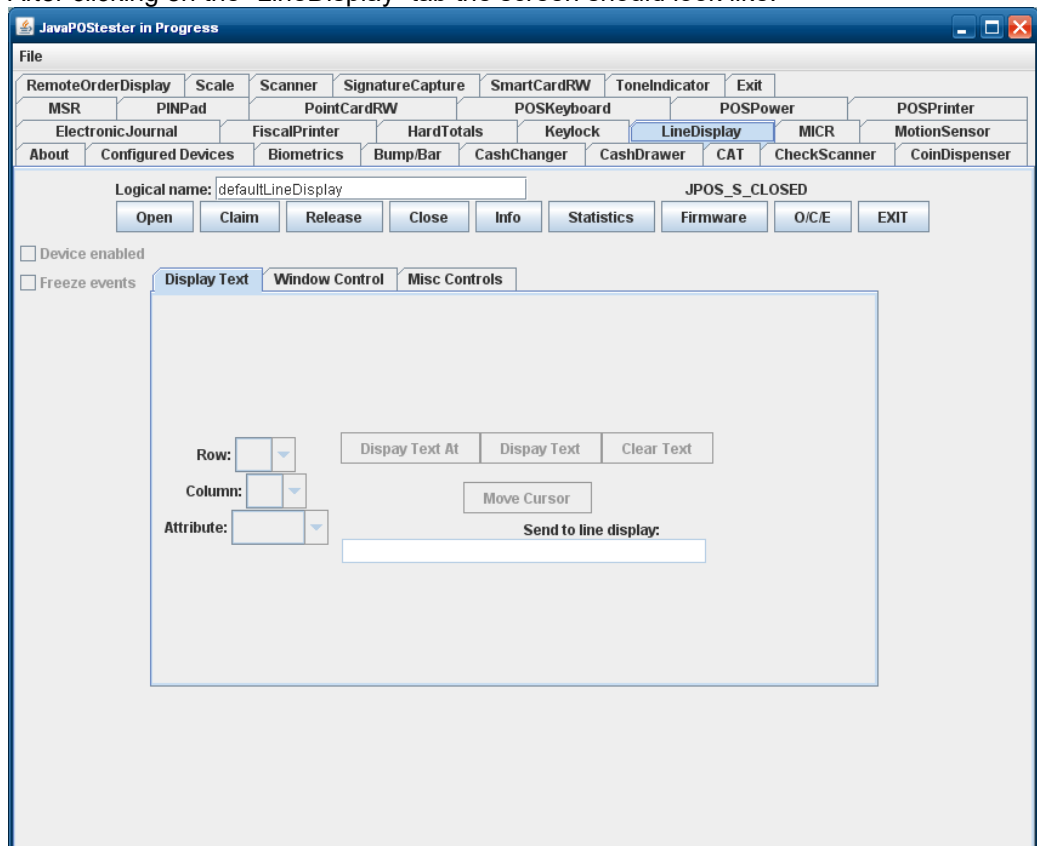

3. The logical name of the device is “HPap5000LineDisplay”. Replace the “defaultLineDisplay” that appears in the logical name box with “HPap5000LineDisplay”. If one clicks on the “Configured Device” tab, the names for the device will appear that will be used in the test utility.
4. Click on the “OPEN” button.
5. Click on the “CLAIM” button. After clicking the “CLAIM” button, the “Device Enabled” is available.

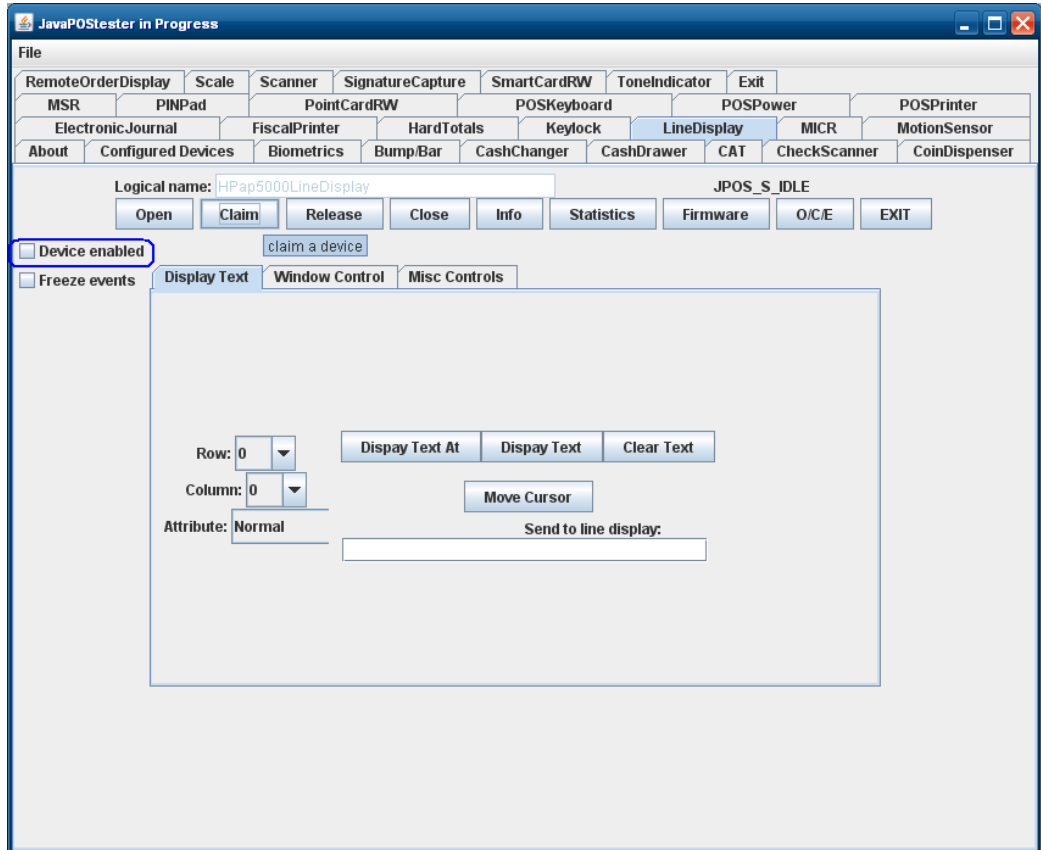

6. Check the "DEVICE ENABLED" so there is a check box.

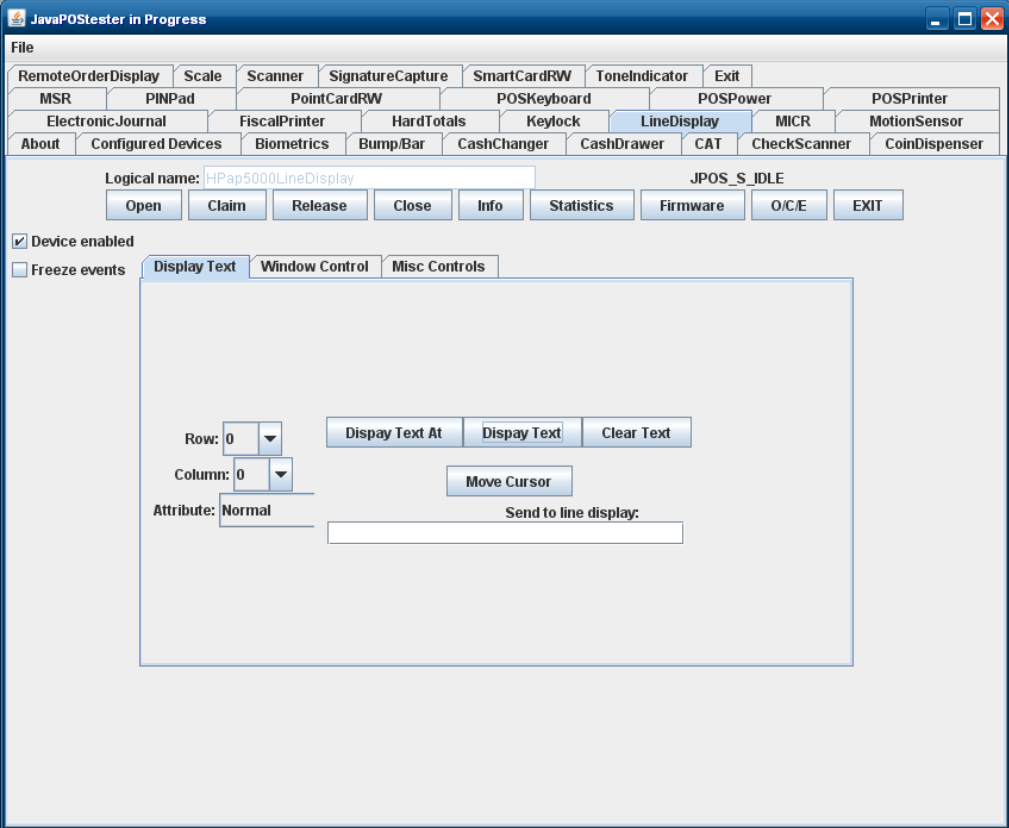

7. Press the “CLEAR TEXT” button.
8. Type in the test message in the “Send to line display” box and click on “Display Text”

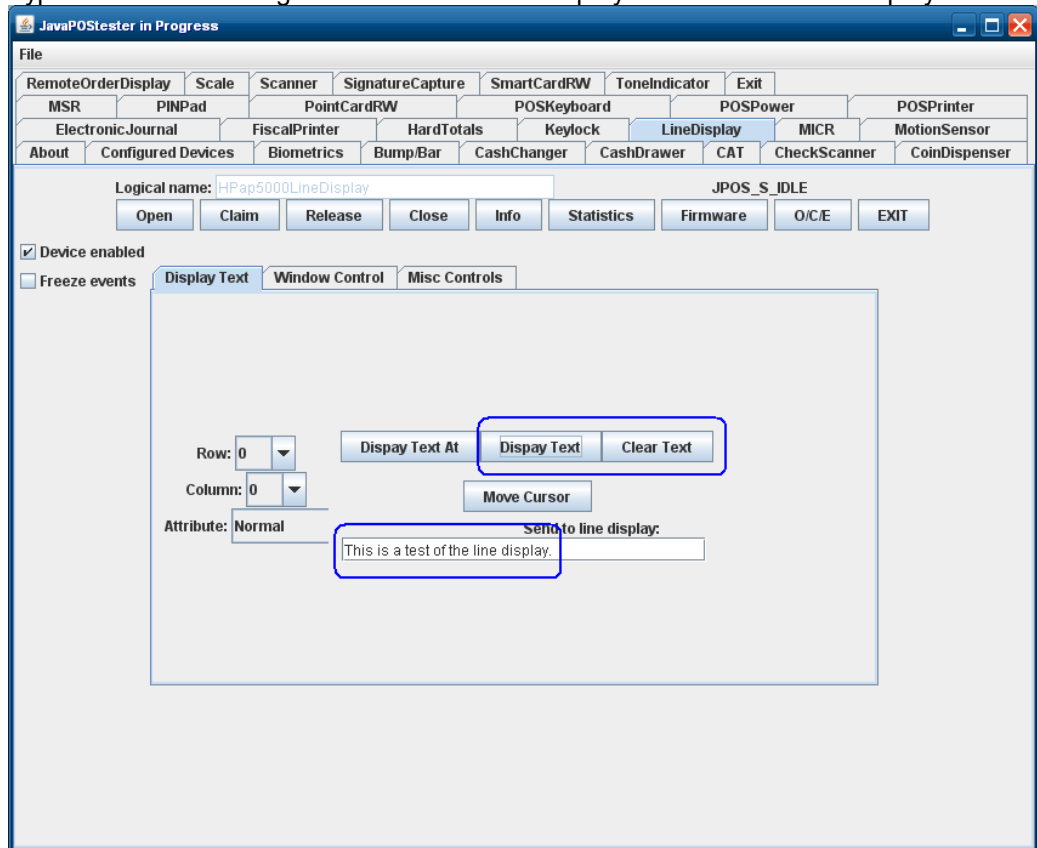

Note: On the JPOS tester utility when “INFO” button is pressed one will receive an exception. The exception error can be safely ignored; all the functions of the pole display under JPOS are working correctly.

9. Click on “RELEASE” / “CLOSE” / “EXIT” to exit the JPOS test utility.

6.13.6 Utility to change power-on message

When the HP ap5000 is powered on the following message is scrolled on the display until an application takes control the pole display. There are two lines that are scrolled, the default message that is scrolled on the display is:

HP ap5000 All-in-One Point of Sale System
.... Thank You and Have a Nice Day

If one wishes to change the power on message one may do so by running “HP ap5000 LineDisplay Startup Message” program. This program can be found on the “HP Point of Sale System Software and Documentation CD”. This utility is not included on the HP factory image.

Please note this only changes the scrolling message on the pole display; once the POS application has started, the POS application will control what is being displayed on the pole display.

6.13.6.1 Utility to Change Default Power-On Message

The following is an overview of the steps to test the power-on message utility followed by detailed steps:

1. Start the “HP ap5000 LineDisplay Startup Message” application which is available on “HP Point of Sale System Software and Documentation CD”. This utility is not included on the HP factory image.
2. Select the correct COM port where the ap5000 VFD is attached if the utility does not find the correct COM port. (COM2 is the factory default).
3. Enter the message(s) that one wishes to display on the VFD.
4. From the drop down box, select the scroll speed of the message.
5. Click on the “Write to VFD” to save the message to the pole.
6. Click on “Exit” to leave the application.

Detailed Steps

1. Start the “HP ap5000 LineDisplay Startup Message” application which is available on “HP Point of Sale System Software and Documentation CD”. This utility is not included on the HP factory image.
2. Select the correct COM port where the ap5000 VFD is attached if the utility does not find the correct COM port. (COM2 is the factory default).

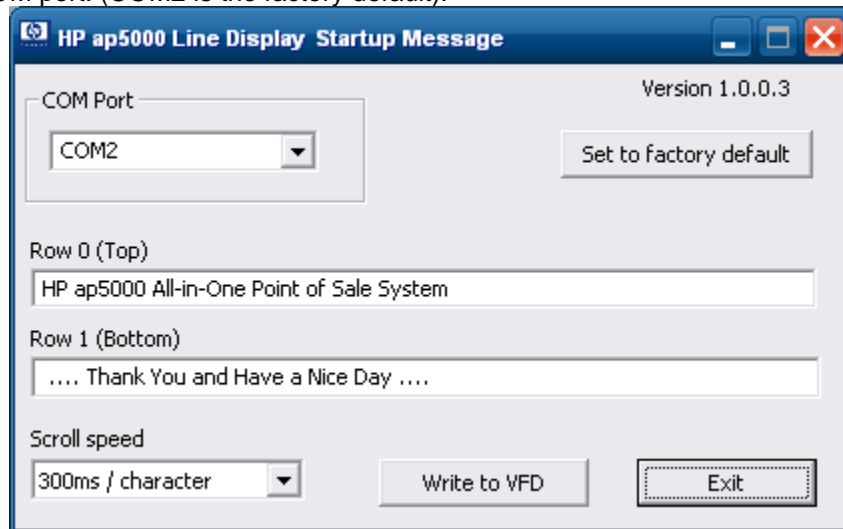

3. Enter the message(s) that one wishes to display on the VFD.

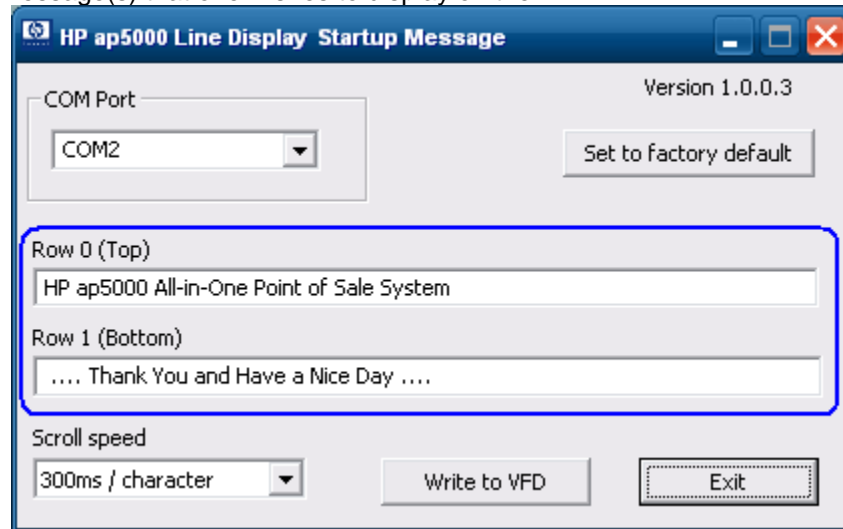

4. From the drop down box, select the scroll speed of the message.

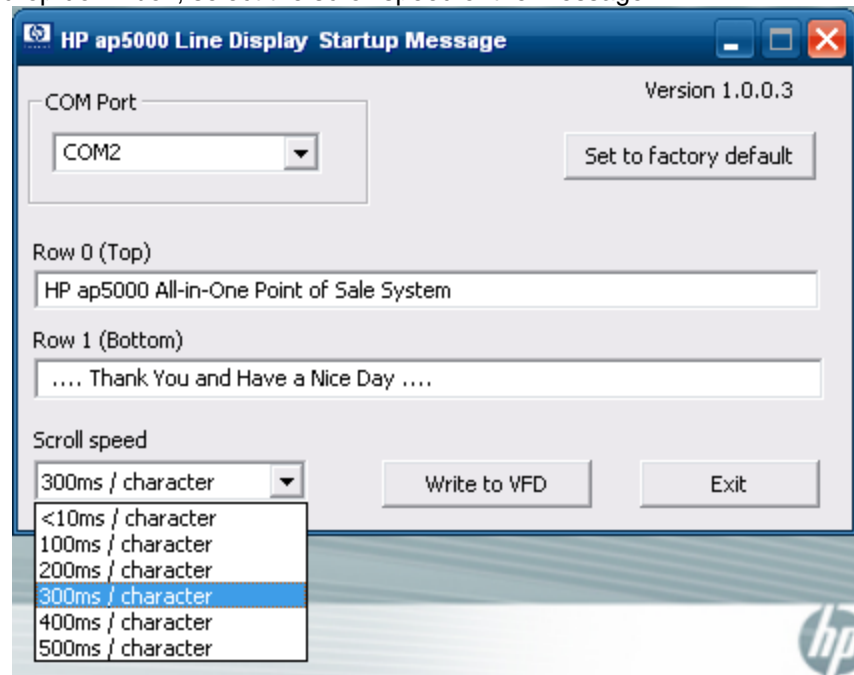

5. Click on the “Write to VFD” to save the message to the pole.

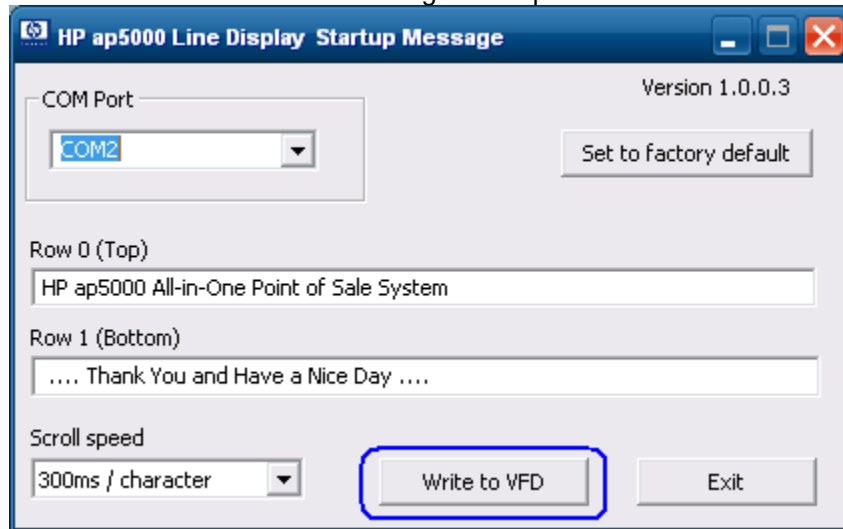

6. Click on “Exit” to leave the application.

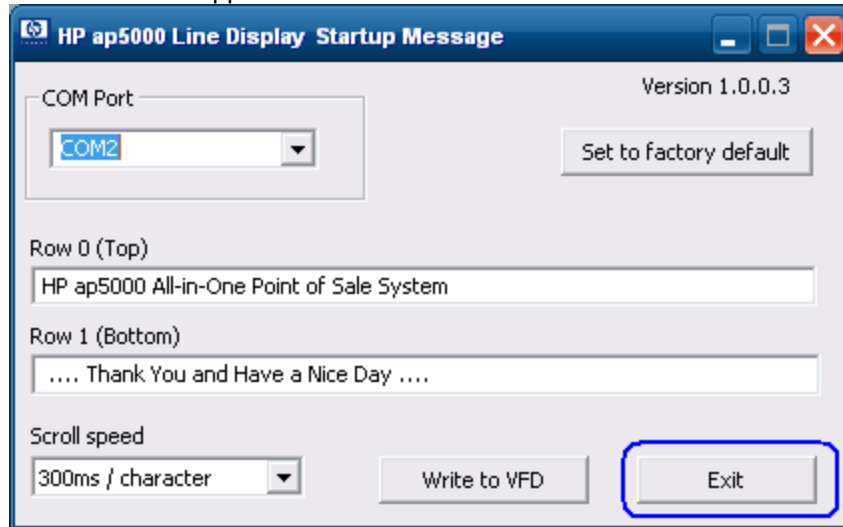

6.13.6.2 **Enable the VFD Default Power-On Message**

The following is an overview of the steps to test the power-on message utility followed by detailed steps:

1. Start the “HP ap5000 LineDisplay Startup Message” application which is available on “HP Point of Sale System Software and Documentation CD”. This utility is not included on the HP factory image.
2. When the utility is opened the default HP factory message appears in the GUI. One can either click on “Write to VFD” or click on “Set to factory default” button.
3. Click on “Exit” to leave the application.

Detailed Steps

1. Start the “HP ap5000 LineDisplay Startup Message” application which is available on “HP Point of Sale System Software and Documentation CD”. This utility is not included on the HP factory image.

- When the utility is opened the default HP factory message appears in the GUI. One can either click on "Write to VFD" or click on "Set to factory default" button.

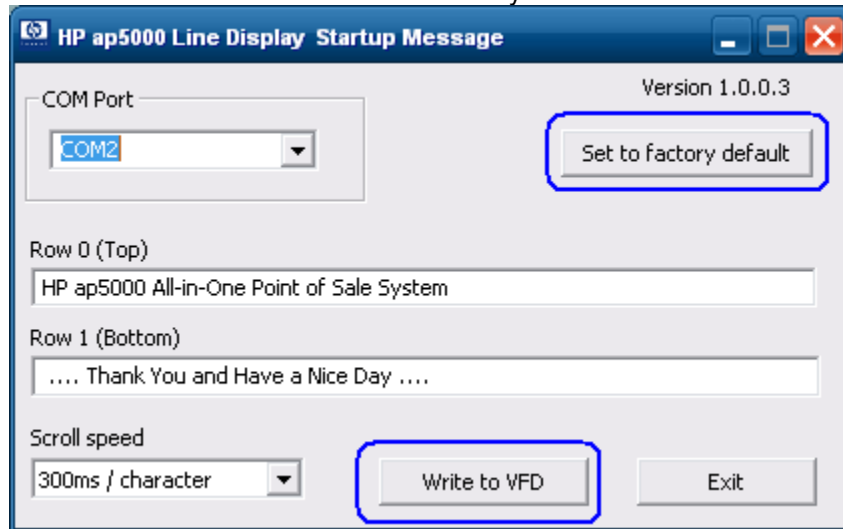

- Click on "Exit" to leave the application.

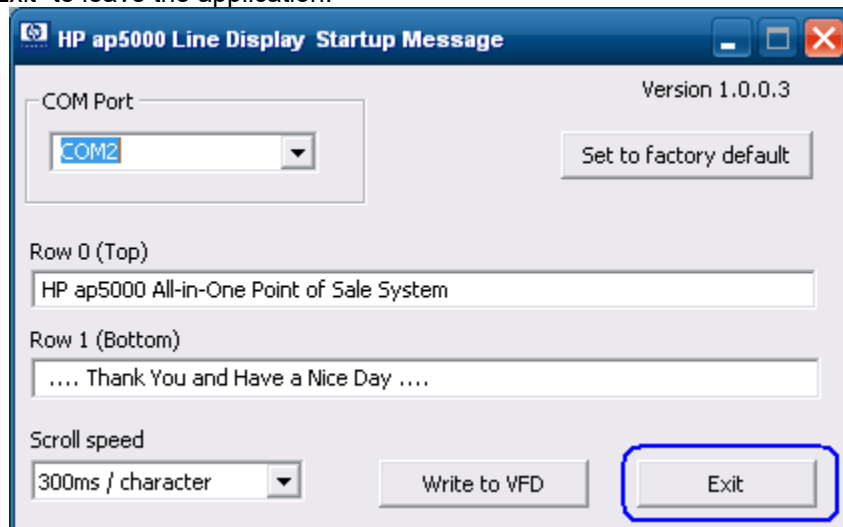

6.13.7 **HP ap5000 VFD BIOS Power Setting**

The 5 volt power that is needed for the HP ap5000 VFD is supplied via the serial port (pin 9). When the ap5000 VFD is attached to the unit on COM2 from the HP factory and a Windows operating system is installed, the 5 volt for COM2 will be enabled natively. If the user has the need to move the VFD from COM2 to COM1 then the 5 volt for COM1 will need to be enabled by the steps outlined below. In addition, it is recommended that the 5 volt for COM2 should be disabled. This will prevent any possible damage to future serial devices inserted into COM2 but not rated for 5 volt.

There are two ways one can enable the voltage on COM1 on the HP ap5000 unit. One method is to go into F10 BIOS and enable the voltage on the serial port. The second method under Windows is by using the graphical utility to change the setting.

6.13.7.1 **F10 BIOS Method**

- Press F10 to enter BIOS setup at the post screen. If power-on or password option is enabled, enter the password in order to continue.
- Press the right arrow key to highlight “Advanced” option.
- Press the down arrow key to highlight “SuperIO Configuration” option and press the “ENTER” key.
- Press the down arrow key to go the serial port that you wish to change the power setting and press the “ENTER” key.
- Once the menu appears select the setting the power option for the port to be set to. “Standard Mode” means no power on the serial port.

Note: The ap5000 VFD **cannot** be installed on COM3, it only be used on COM1 or COM2.

6.13.7.2 **Windows Graphical Method**

In order to use the Windows graphical utility no BIOS password (power-on or Setup) must be enabled and one must have administrator privilege.

Note: The ap5000 VFD **cannot** be installed on COM3, it only be used on COM1 or COM2

The following is an overview of the Windows graphical utility for the COM port setting:

1. Close any open application or document.
2. Open the “HP Com Port Utility.EXE” which is located on the “HP POS Software and Documentation CD” that is included in the peripherals after-market option kit.
3. Select the COM port that you wish to change.
4. Select the option that you wish for the COM port (Enable Power or Disable Power).
5. After the COM port setting is changed, restart Windows operating system for the BIOS changes to take effect.

Detailed Steps

1. Close any open application or document.

2. Open the “HP Com Port Utility.EXE” which is located on the “HP POS Software and Documentation CD” that is included in the peripherals after-market option kit. The following is the GUI that will appear when the utility is opened:

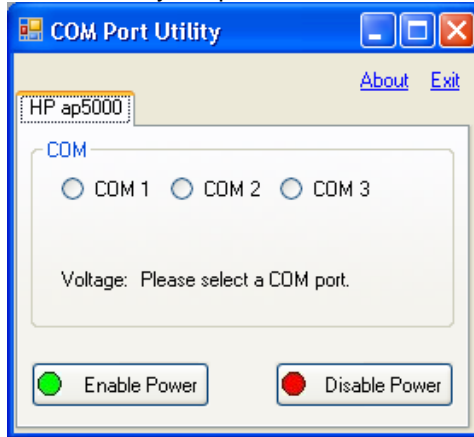

3. Select the COM port that you would like to change..

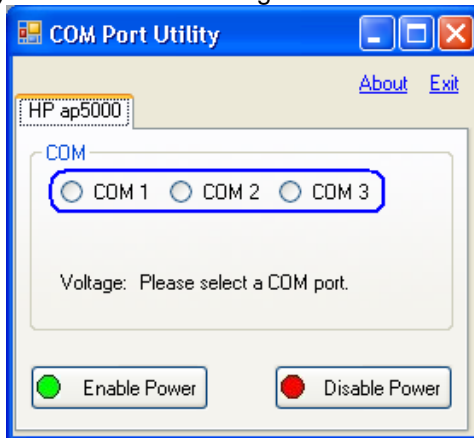

4. Select from the two options for the COM port (Enable Power or Disable Power).

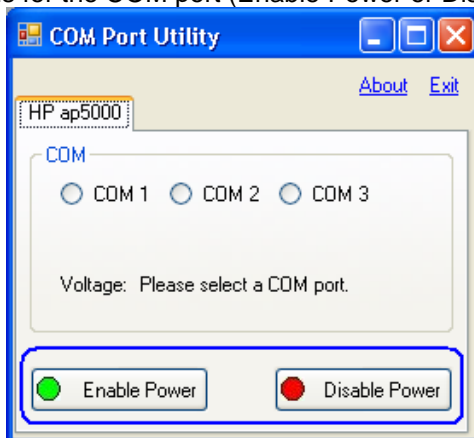

When power is enabled for COM1 or COM2, 5V will be enabled. When power is enabled for COM3, 12V will be enabled.

When “Enable Power” is selected, a prompt window to confirm the action will be shown.

The following is an example of the prompt screens that will appear when COM1 is enabled.

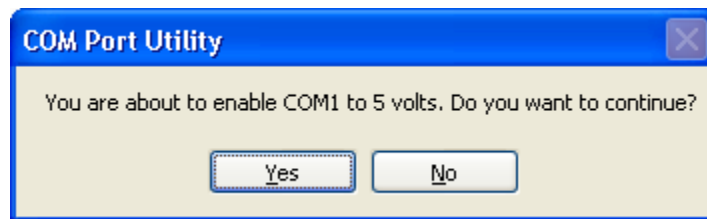
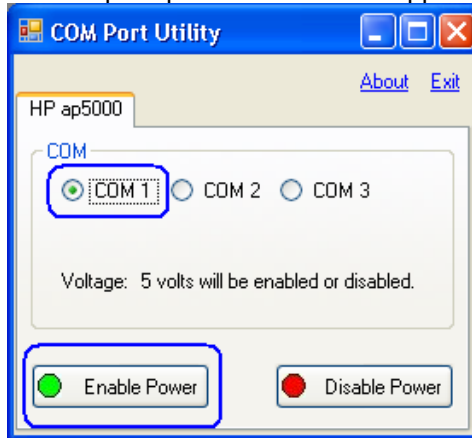

The following prompt appears when the “Disable Power” option is clicked:

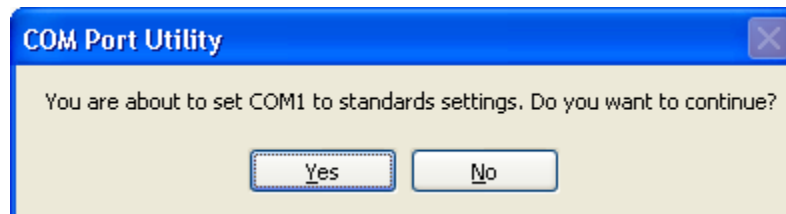
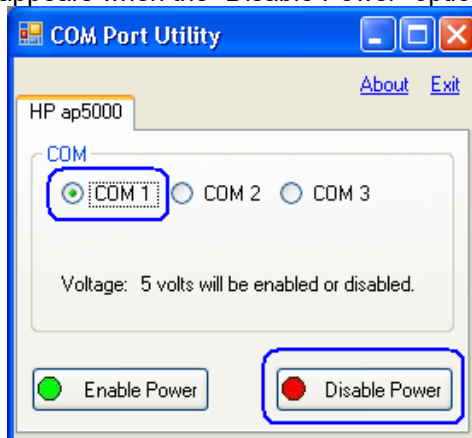

5. After the COM port setting is changed, restart Windows operating system for the BIOS changes to take effect.

Note: The ap5000 VFD **cannot** be installed on COM3, it only be used on COM1 or COM2.

6.14 HP Pole Display



6.14.1 Connection

The HP Pole Display may be plugged into any free USB port. One may plug the HP Pole Display into the power USB port in the 5V part of USB port, when plugged in this configuration the power portion of USB port is not utilized.

The standalone HP VFD display may be plugged into any free 12v powered USB port on the computer. The HP 7800 VFD display can be mounted on the back of the unit and is plugged in one of the 12v powered USB port on the HP 7800 unit.

6.14.2 Windows Drivers for the Pole Display

The HP Pole Display device drivers for Windows device manager may be installed using the Windows driver's package or by using the OPOS package for this device. The OPOS package will install both the Windows drivers for the device and the OPOS drivers for the device.

The following is the Windows Device Manager after all the drivers are loaded for the HP ElitePOS Top Mount 2 x 20 CFD:

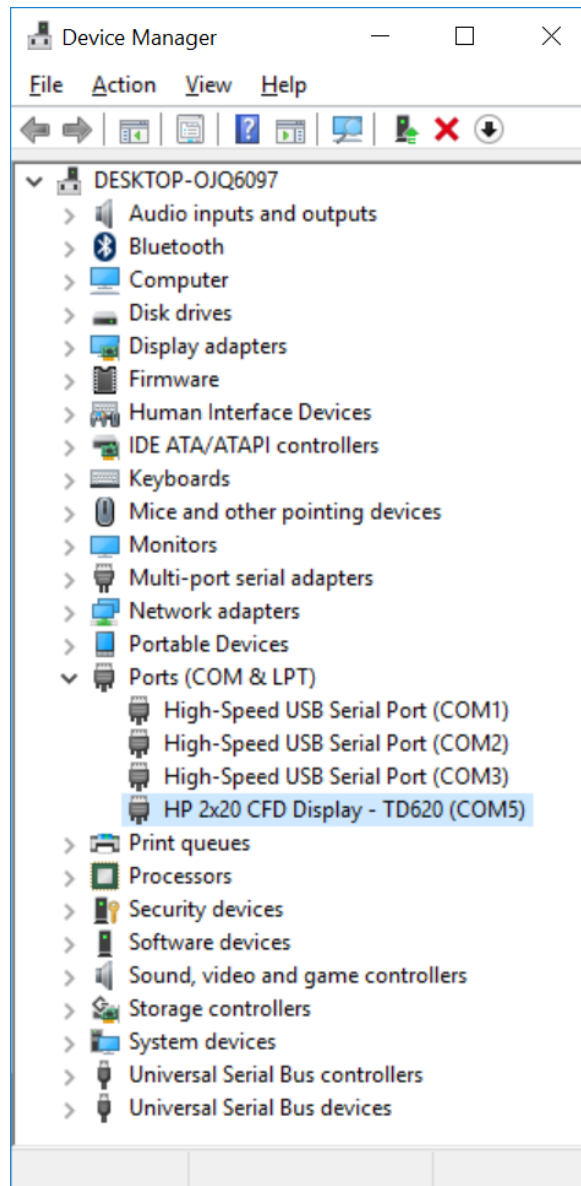

Note: The pole display driver will automatically assign the next available virtual port in the system.

The following is the Windows Device Manager after all the drivers are loaded for the HP USB Pole Display:

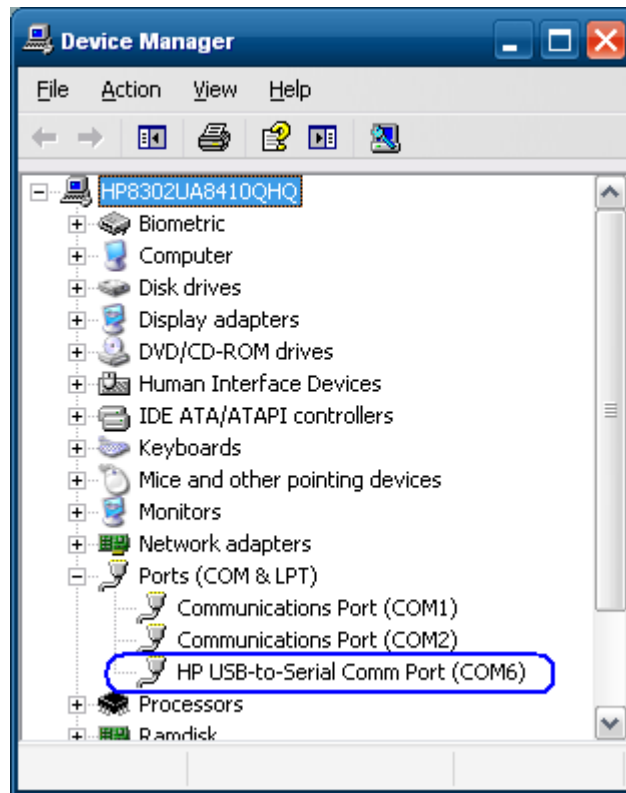

Note: The pole display driver will automatically assign the next available virtual port in the system.

The following is the Windows Device Manager after all the drivers are loaded for HP VFD Display:

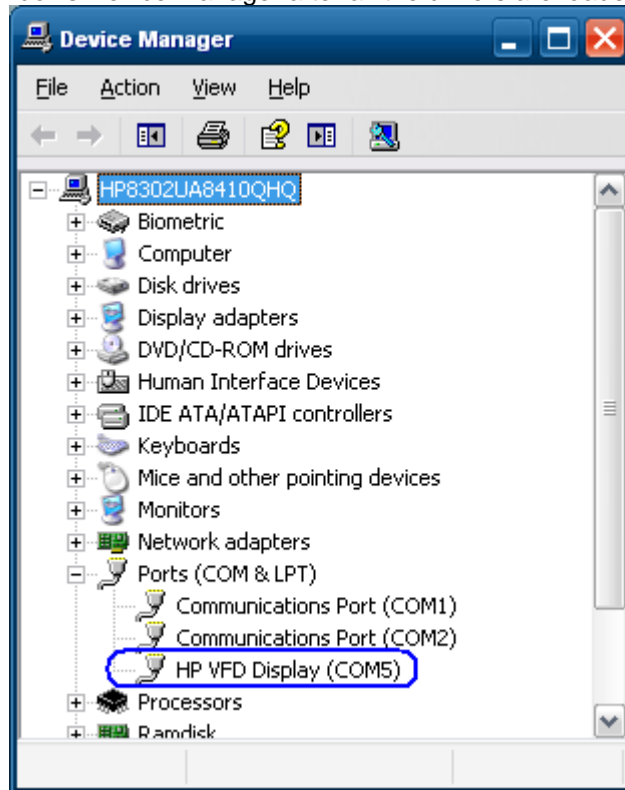

Note: The pole display driver will automatically assign the next available virtual port in the system.

The following is the Windows Device Manager after all the drivers are loaded for HP Integrated 2x20 Display (LCM220):

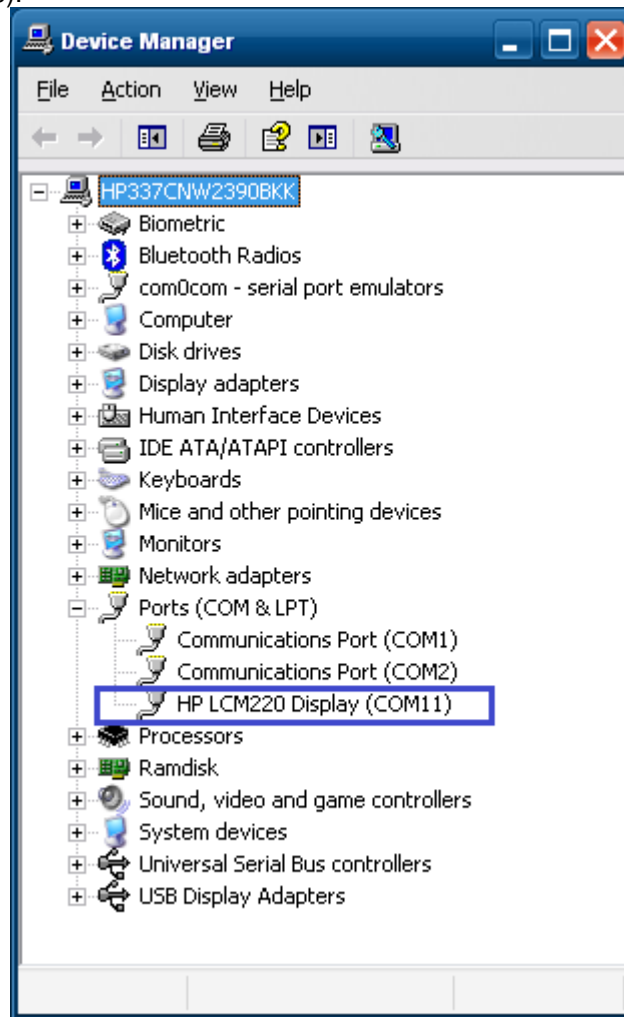

Note: The pole display driver will automatically assign the next available virtual port in the system.

The following is the Windows Device Manager after all the drivers are loaded for HP Integrated 2x20 Display Complex (LCM960):



The following is the Windows Device Manager after all the drivers are loaded for HP RP9 Integrated 2x20 Display (LM940):

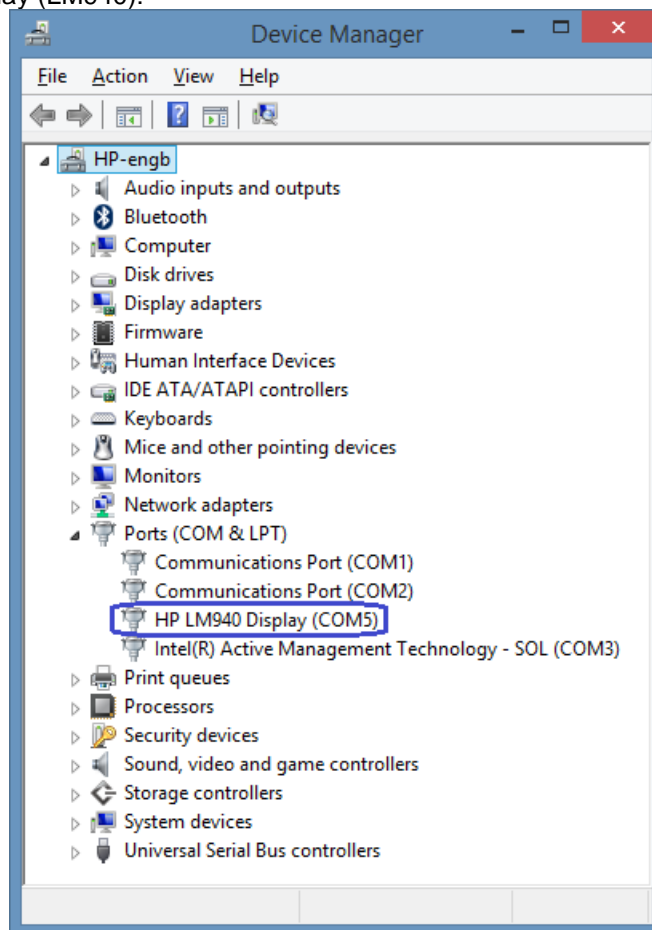

6.14.3 **Utility to change power-on message**

6.14.3.1 **HP USB Pole Display**

When the pole display has power the following message is scrolled on the display until an application takes control of the pole display. The HP USB Pole Display there are two lines that are scrolled at different speed, the default message that is scrolled on the display is:

** VFD DISPLAY LD220P**
** HAVE A NICE DAY AND THANK YOU**

If one wishes to change the power on message one may do so by running “HP Display Setup Utility” program. This program can be found on HP.COM. This utility is not included in the HP factory image.

Please note this only changes the power-on message on the pole display; once the POS application has started, the POS application will control what is being displayed on the pole display.

Utility to Change Default Power-On Message for HP USB Pole Display

The following is an overview of the steps to set the power-on message followed by detailed steps:

1. Open **HP Display Setup Utility**.
 - Only available from HP.COM.
2. Confirm the correct virtual COM port was automatically detected by the utility.
3. Click the **Obtain Setting from Display** button.
4. Click on the **Welcome Message** tab.
5. Enter the message that you wish to be displayed. Information that is entered on line1 and/or line 2 will automatically be converted to hex by the utility.
6. Click the **Download Setting to Display** button to save the message to the pole.
7. Once the message has been written successfully, a restart of the pole is required. The pole can be restarted by using the power button, by restarting the computer, or by unplugging and re-plugging the pole into the USB port.

Detailed Steps

1. Open **HP Display Setup Utility**.
 - Only available from HP.COM.

2. Confirm the correct virtual COM port was automatically detected by the utility. The COM port that has been assigned to the pole display can be obtained from Windows device manager.

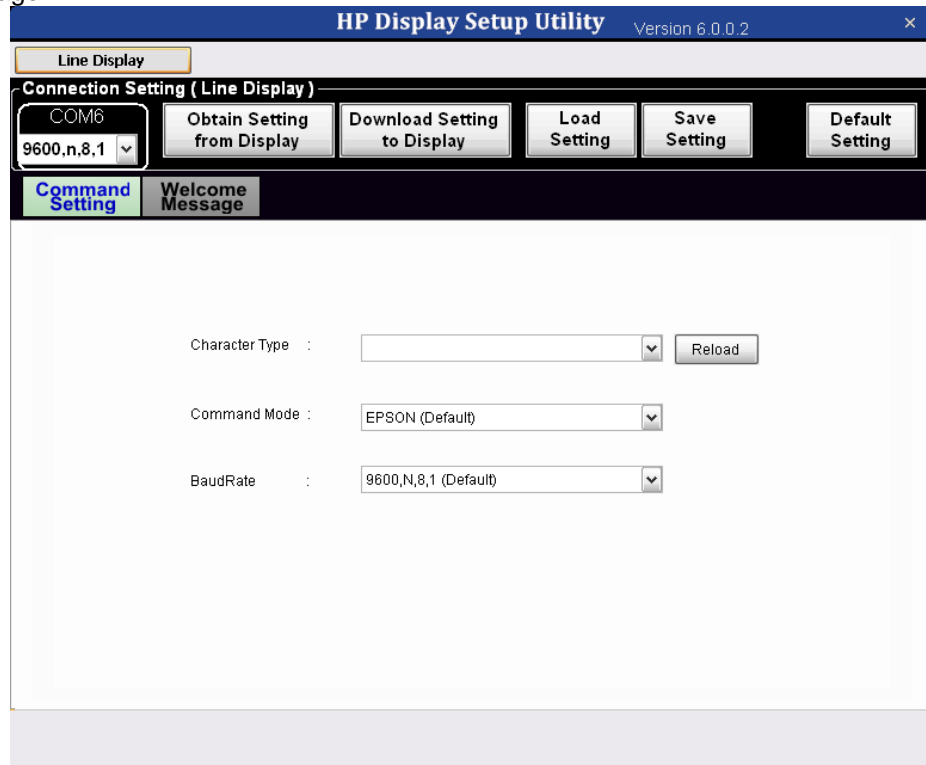

3. Click the **Obtain Setting from Display** button. The pole will go blank and message will appear indicating the information was successfully retrieved.

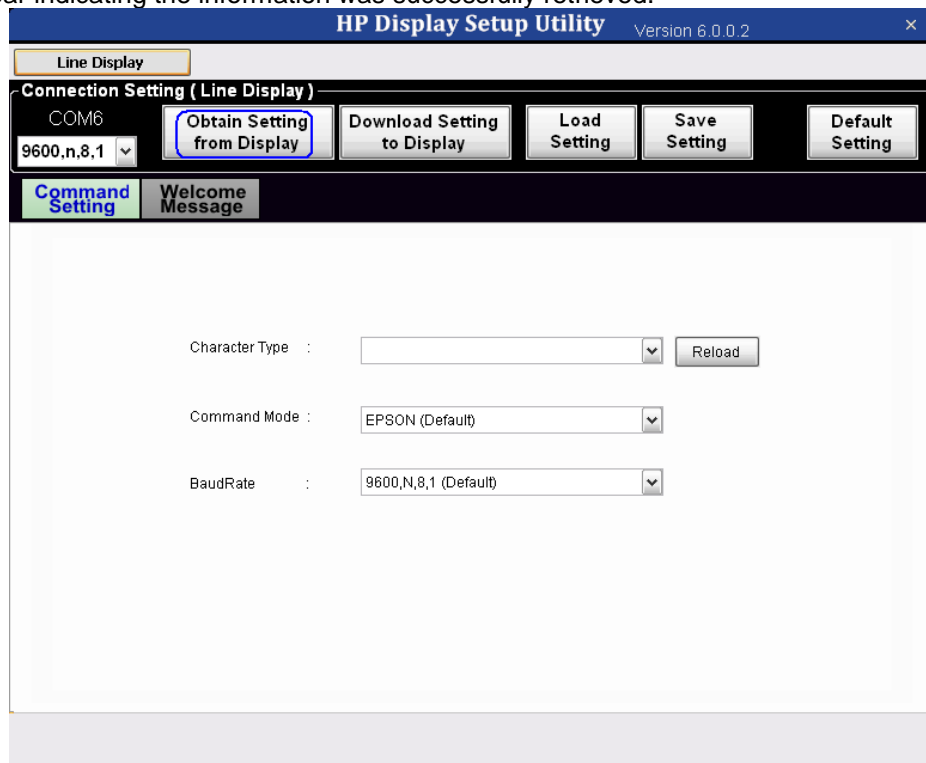

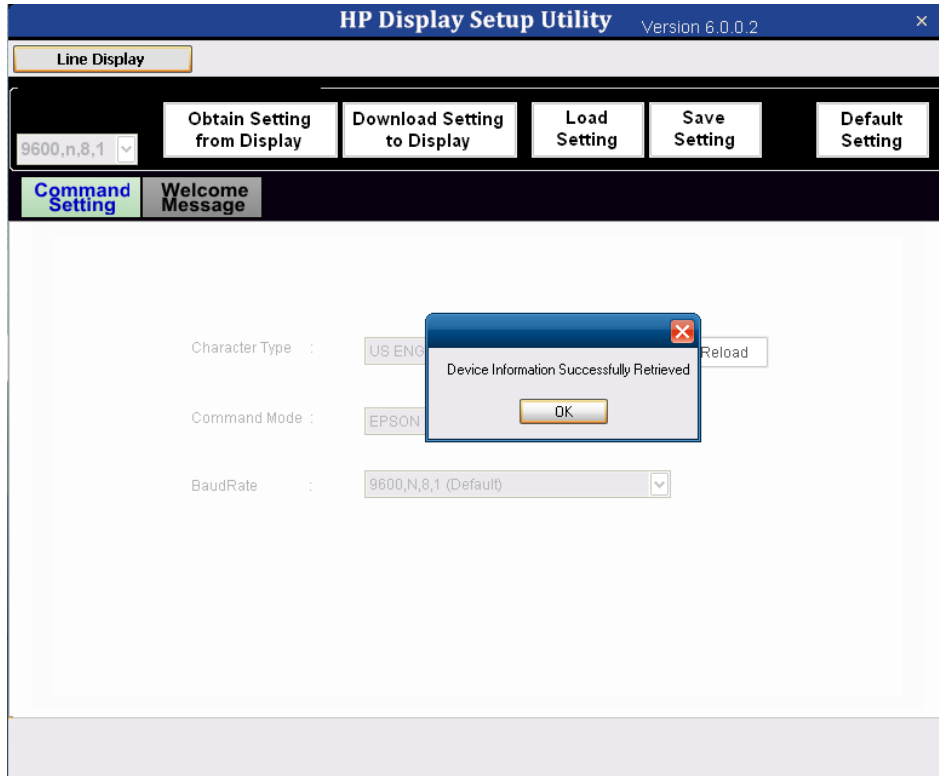

4. Click on the **Welcome Message** tab.

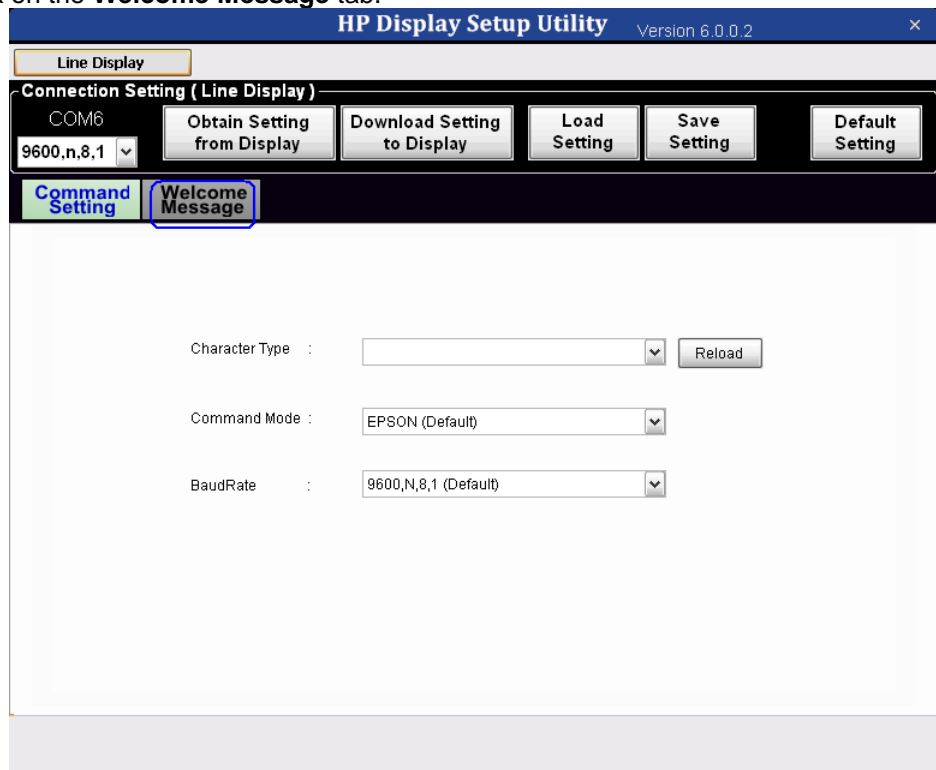

- Enter the message that you wish to be displayed. Information that is entered on line1 and/or line 2 will automatically be converted to hex by the utility.

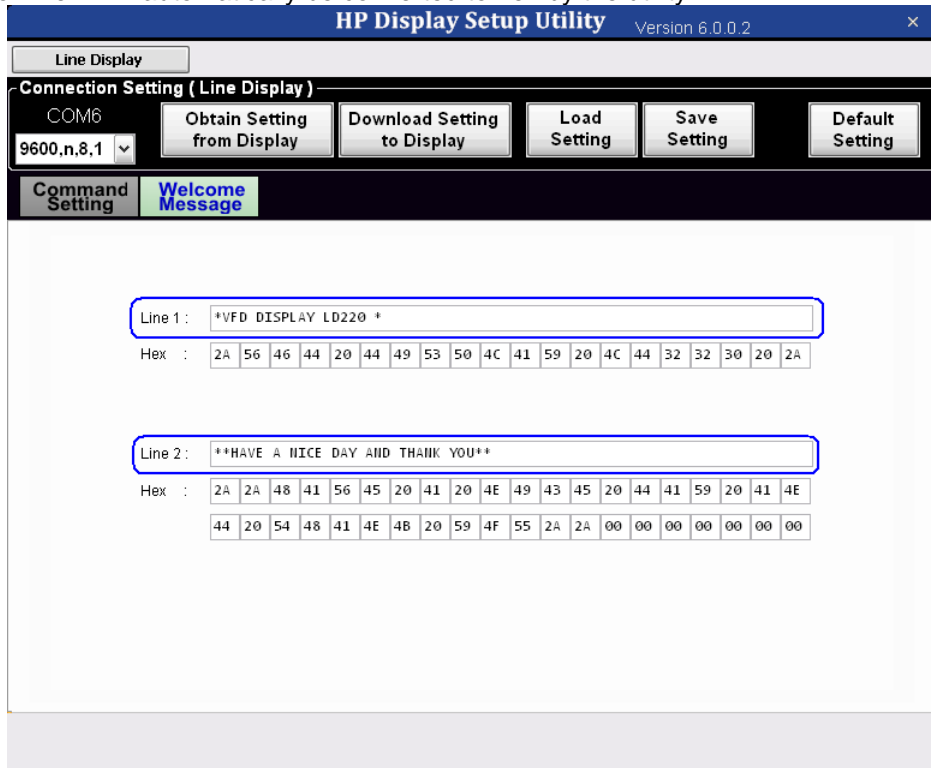

- Click the **Download Setting to Display** button to save the message to the pole.

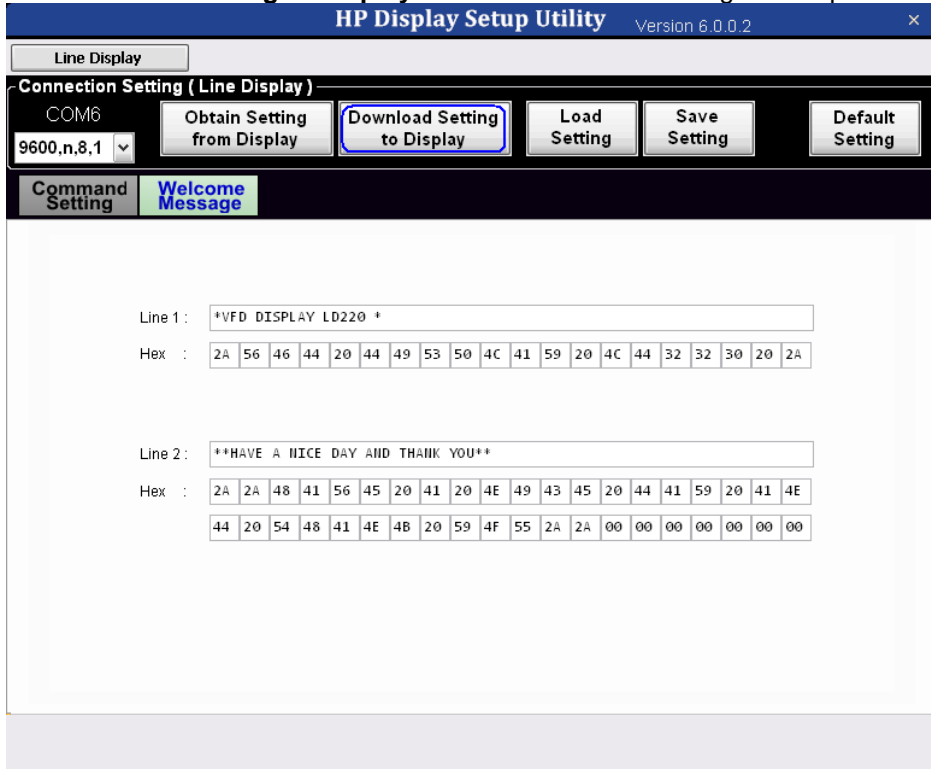

- Once the message has been written successfully, a restart of the pole is required. The pole can be restarted by using the power button, by restarting the computer, or by unplugging and re-plugging the pole into the USB port.

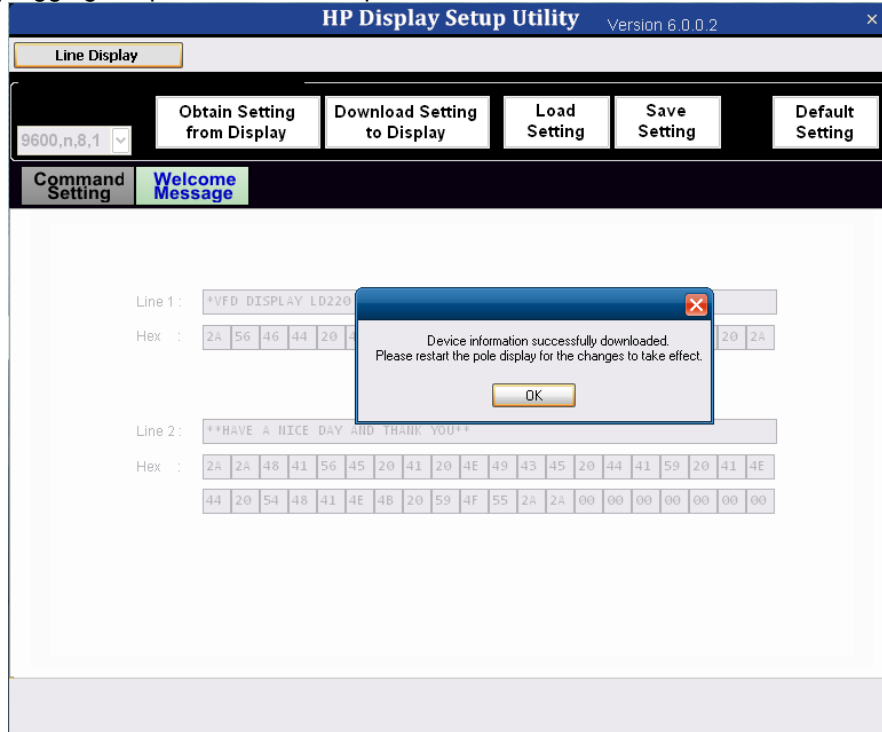

6.14.3.2 HP VFD Display

When the pole display has power the following message is scrolled on the display until an application takes control of the pole display. For the HP VFD Display there are two lines; the top line is centered and the bottom line will display a scrolling message. The default message that is displayed on the HP VFD Display is:

HP VFD Display
..... Thank You and Have a Nice Day

If one wishes to change the power on message one may do so by running “HP Display Setup Utility” program. This program can be found on HP.COM. This utility is not included in the HP factory image.

Please note this only changes the power-on message on the pole display; once the POS application has started, the POS application will control what is being displayed on the pole display.

Utility to Change Default Power-On Message for HP VFD Display

The following is an overview of the steps to test the power-on message utility followed by detailed steps:

1. Open **HP Display Setup Utility**.
 - Only available from HP.COM.
2. Confirm the correct virtual COM port was automatically detected by the utility.
3. Click the **Obtain Setting from Display** button.
4. Enter the message that you wish to be displayed. Information that is entered on line1 and/or line 2 will automatically be converted to hex by the utility.
5. Click the **Download Setting to Display** button to save the message to the pole.
6. Once the message has been written successfully, a restart of the pole is required. The pole can be restarted by using the power button, by restarting the computer, or by unplugging and re-plugging the pole into the USB port.

Detailed Steps

1. Open **HP Display Setup Utility**.
 - Only available from HP.COM.

2. Confirm the correct virtual COM port was automatically detected by the utility. The COM port that has been assigned to the pole display can be obtained from Windows device manager.



3. Click the **Obtain Setting from Display** button. The pole will go blank and message will appear indicating the information was successfully retrieved.

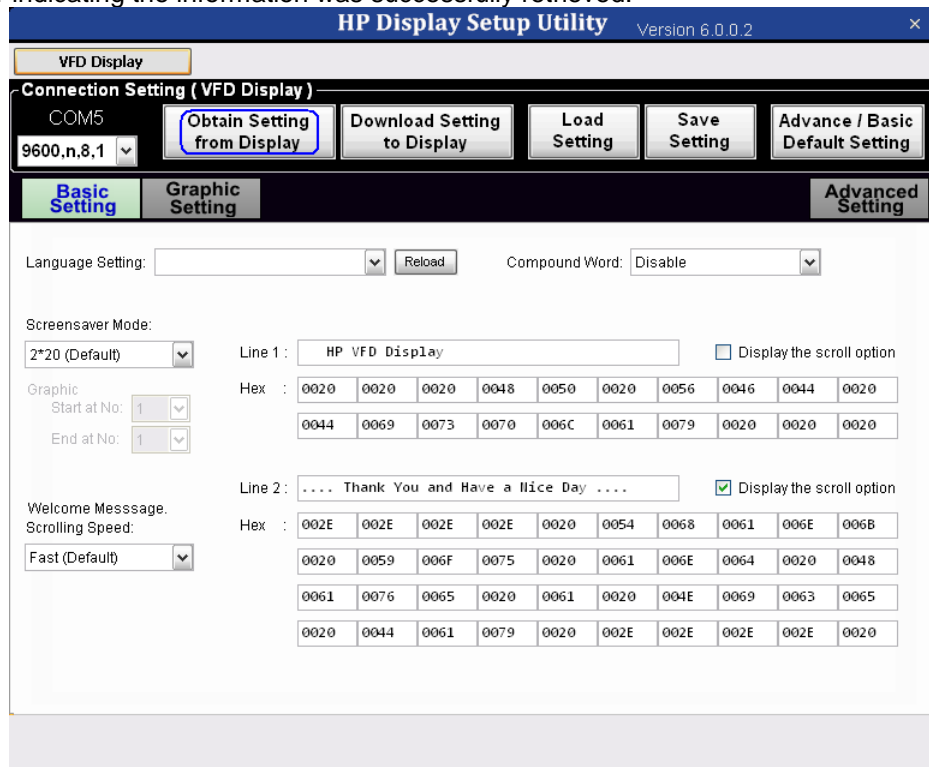

4. Enter the message that you wish to be displayed. Information that is entered on line1 and/or line 2 will automatically be converted to hex by the utility.

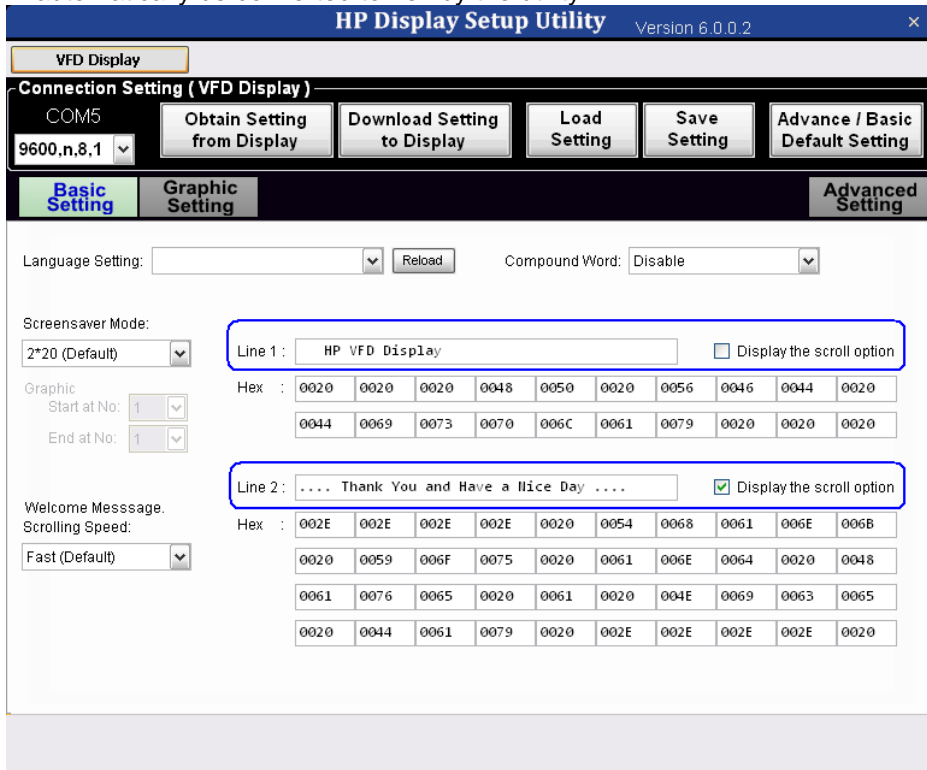

5. Click the **Download Setting to Display** button to save the message to the pole.

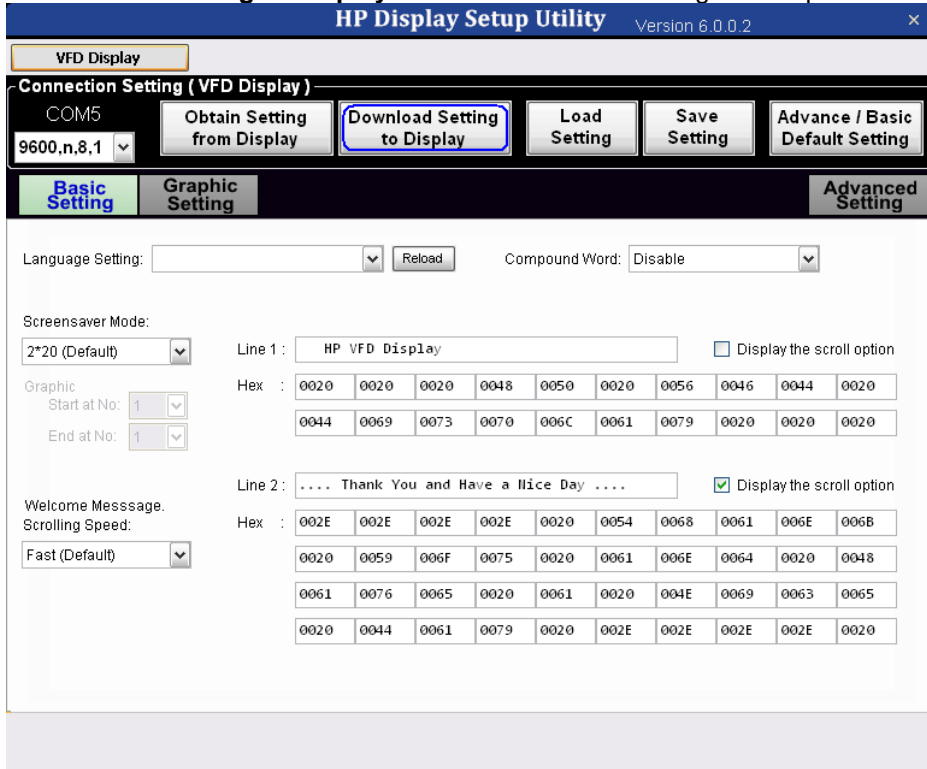

- Once the message has been written successfully, a restart of the pole is required. The pole can be restarted by using the power button, by restarting the computer, or by unplugging and re-plugging the pole into the USB port.

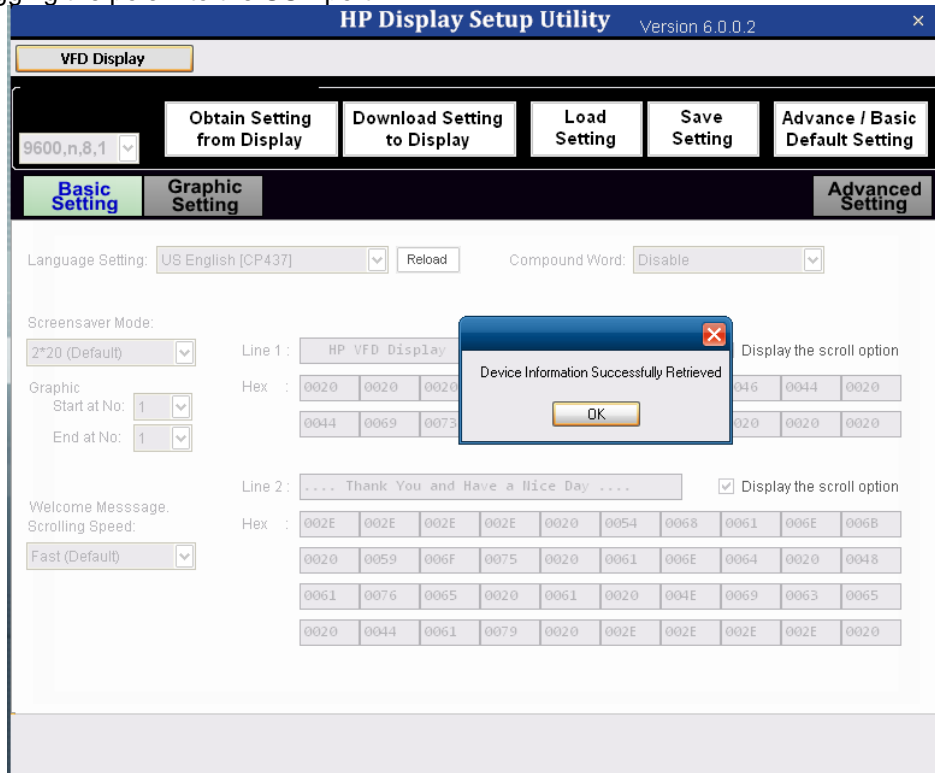

6.14.4 OPOS Drivers for the Pole Display

The HP Pole Display OPOS drivers are already installed in the HP factory image and are also available from HP.COM.

6.14.5 Testing Pole Display

6.14.5.1 Testing pole display in non-OPOS environment

There are two utilities available to test the display in non-OPOS environment: “HP USB Pole non-OPOS Test Utility” and “HP VFD Utility”

6.14.5.1.1 HP USB Pole non-OPOS Test Utility

The following is overview of the steps to test the pole display followed by detailed steps:

1. Open **HP Pole Display Test**.
 - C:\xxxxx\Point of Sale\Pole Display\Pole Test Utility (Non-OPOS)\HP Pole Test Utility\HP Pole Display Test.exe
2. After clicking on “Display Point Test” this message will appear on the pole display.
3. One can display other text for testing purpose by entering the text in the box. After entering the text in the box, click on “Display Text” and what is entered in the text box will be displayed on the pole display.
4. Click “Exit” to close the non-OPOS test applet.

Detailed Steps

1. Open **HP Pole Display Test**.
 - C:\xxxxx\Point of Sale\Pole Display\Pole Test Utility (Non-OPOS)\HP Pole Test Utility\HP Pole Display Test.exe
2. Several seconds will pass before the test GUI appears on the screen. After clicking on “Display Point Test” button this message will appear on the pole display with other block characters. When the test is complete the word “Finish...” will appear on the pole display.

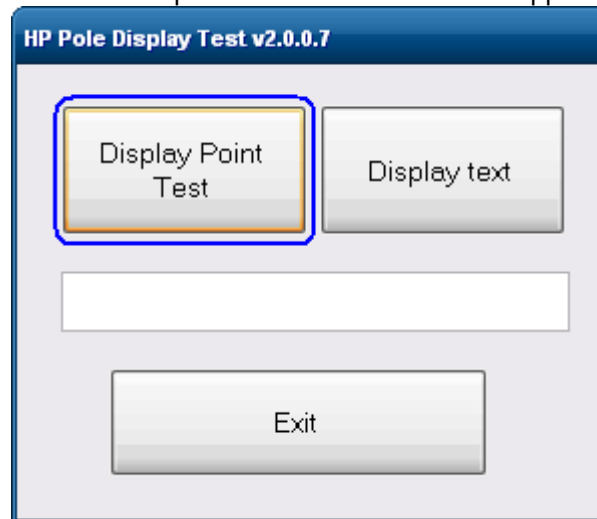

3. One can display other text for testing purpose by entering the text in the box. After entering the text in the box, click on “Display Text” and what is entered in the text box will be displayed on the pole display.

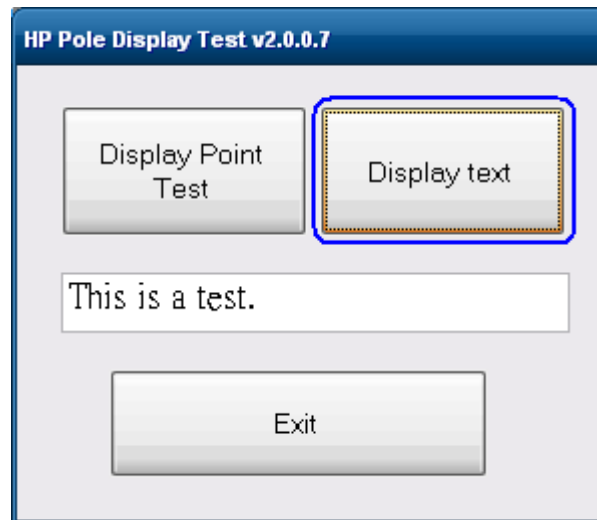
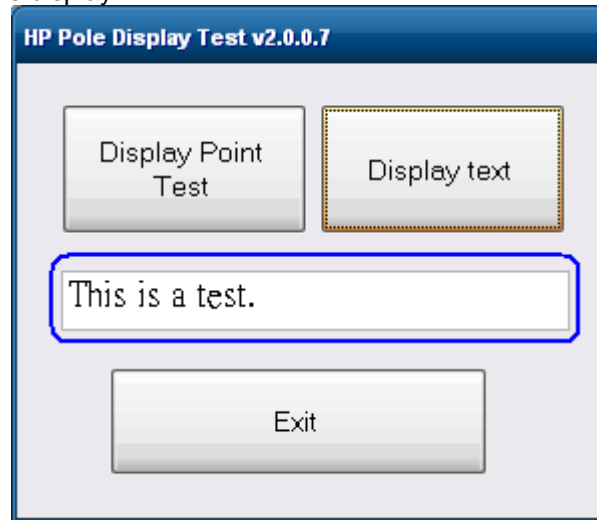

4. Click “Exit” to close the non-OPOS test applet.

6.14.5.1.2 HP VFD Utility for HP USB Pole Display

The following is overview of the steps to test the pole display followed by detailed steps:

1. Open **HP VFD Utility**.
 - C:\xxxxx\Point of Sale\Pole Display\Pole Test Utility (Non-OPOS)\HP VFD Utility\HP VFD Utility.exe.
2. Several seconds will pass before the test GUI appears on the screen. Confirm the device was detected on the proper COM port.
3. Click on the available buttons on the utility.
4. Click “x” in the upper right corner to exit the utility.

Detailed Steps

1. Open **HP VFD Utility**.
 - C:\xxxxx\Point of Sale\Pole Display\Pole Test Utility (Non-OPOS)\HP VFD Utility\HP VFD Utility.exe.
2. Several seconds will pass before the test GUI appears on the screen. Confirm the device was detected on the proper COM port.

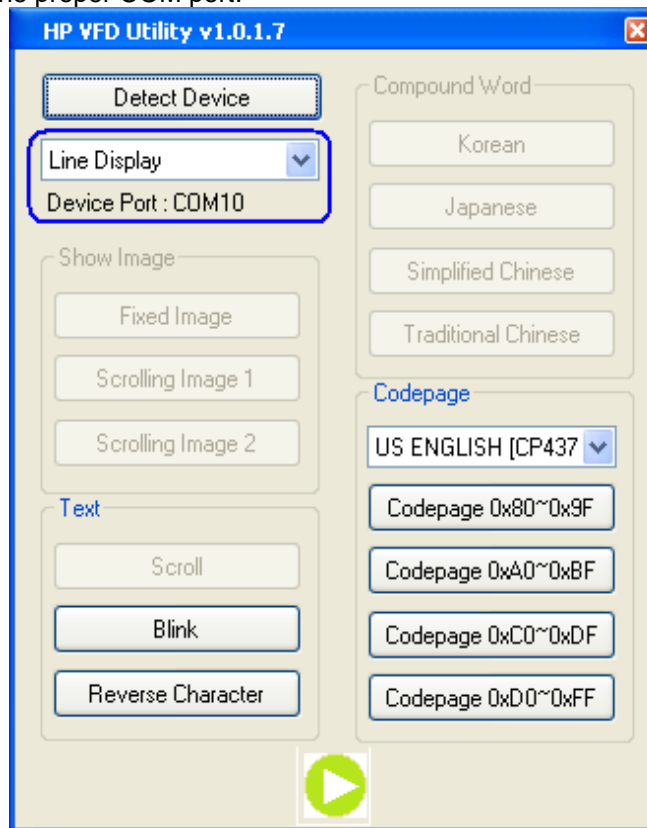

Note: Features that are not supported by this device will be grayed out.

3. Click on the available buttons on the utility. The following describe the function of the buttons in the utility.
 - **Blink** → Will cause the device to blink **ABCDEFGHIJ** on the display until another button is pressed or the utility is exited.

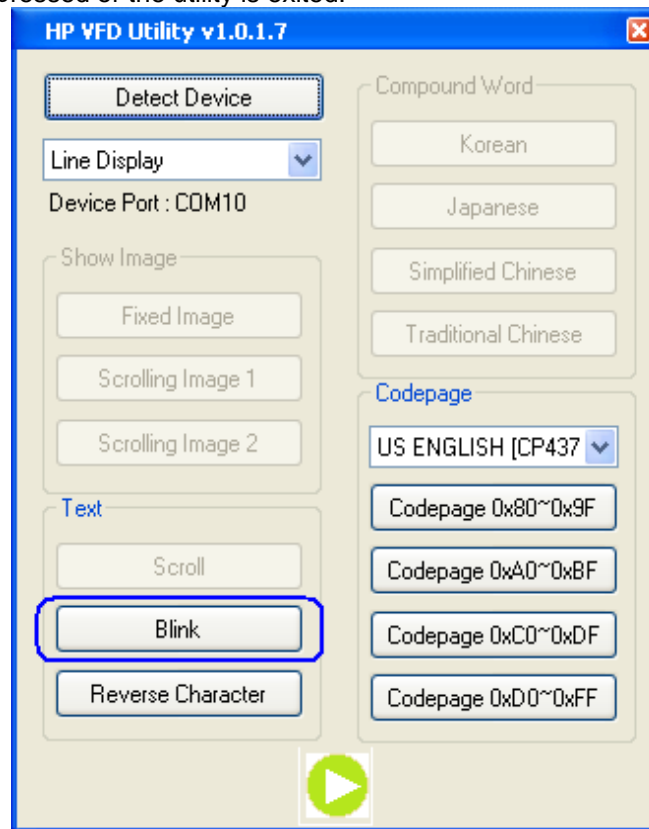

- **Reverse Characters** → Will cause the device to display lower case **abcdefghij** on the display in reverse characters until another button is pressed or the utility is exited.
If you close the pole it appears that as garbage characters; from a distance they are little more clear than close up.

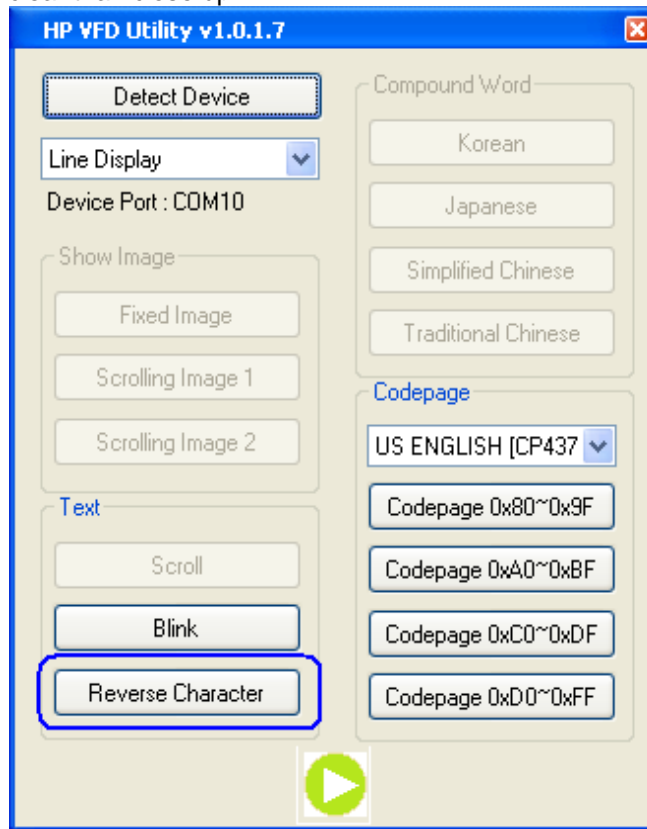

- **Code page** drop down → Allows one to select the code page/language to display on the pole.
 - The four code page button will let one display the down page that was selected in the drop down menu.

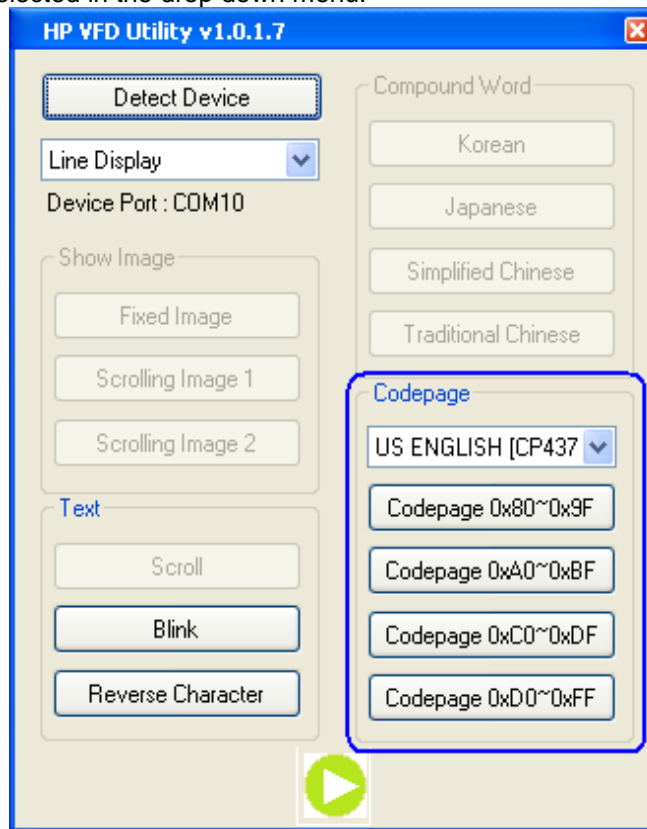

- **Play** → Will cause all the available option for the pole to be displayed automatically and continuously until the utility is stopped or exited. Only the selected cod page in the drop down box will be displayed in this mode.

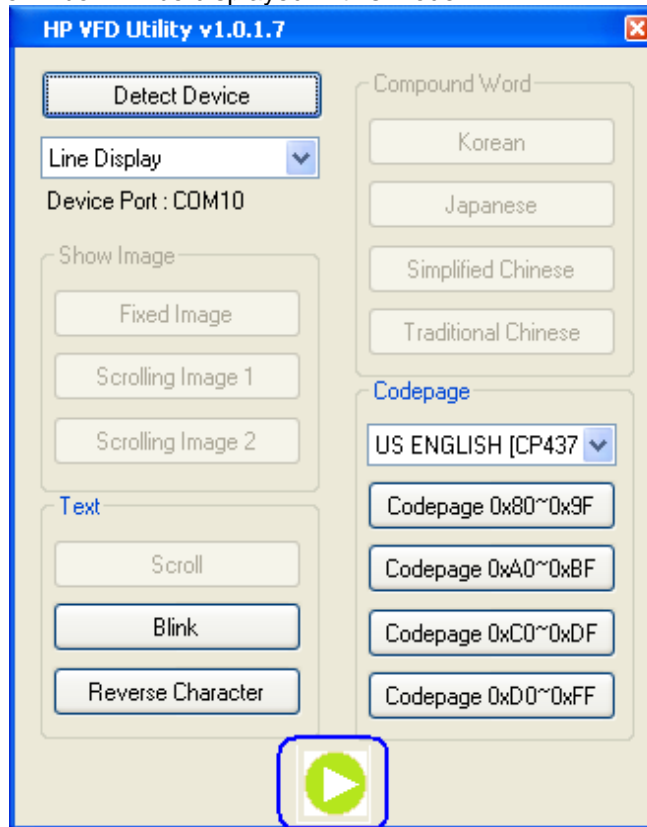

4. Click "x" in the upper right corner to exit the utility.

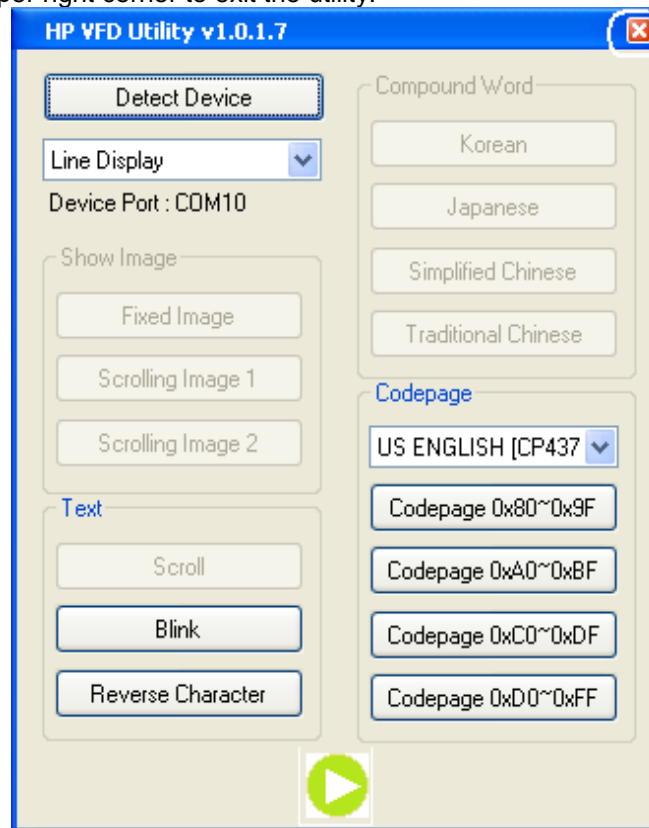

6.14.5.1.3 HP VFD Utility for HP VFD Display

The following is overview of the steps to test the pole display followed by detailed steps:

1. Open **HP VFD Utility**.
 - C:\xxxxx\Point of Sale\Pole Display\Pole Test Utility (Non-OPOS)\HP VFD Utility\HP VFD Utility.exe.
2. Several seconds will pass before the test GUI appears on the screen.
3. Click on the available buttons on the utility.
4. Click "x" in the upper right corner to exit the utility.

Detailed Steps

1. Open **HP VFD Utility**.
 - C:\xxxxx\Point of Sale\Pole Display\Pole Test Utility (Non-OPOS)\HP VFD Utility\HP VFD Utility.exe.
2. Several seconds will pass before the test GUI appears on the screen. Confirm the device was detected on the proper COM port.

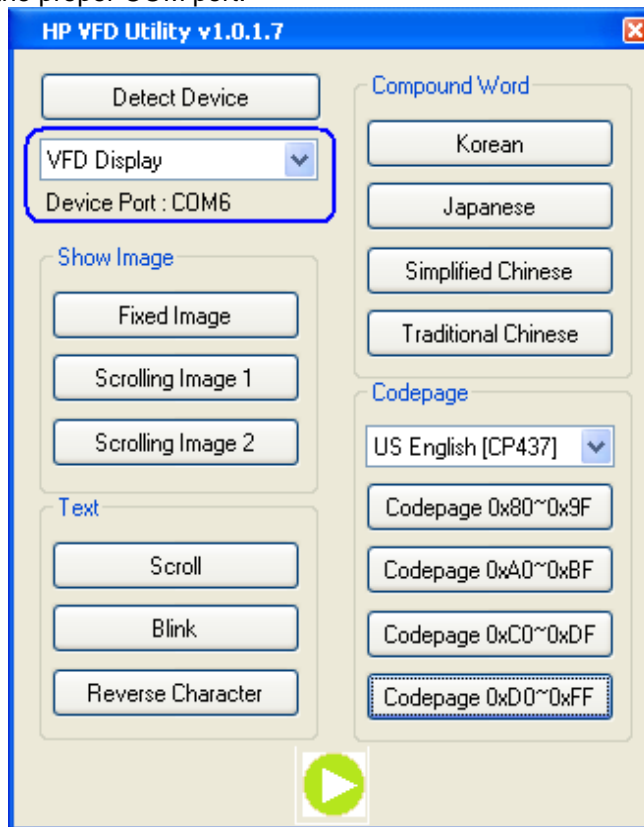

3. Click on the available buttons on the utility. The following describe the function of the buttons in the utility.
- **Fixed Image** → An image with geometric shapes (similar to what is shown below) will appear on the display.

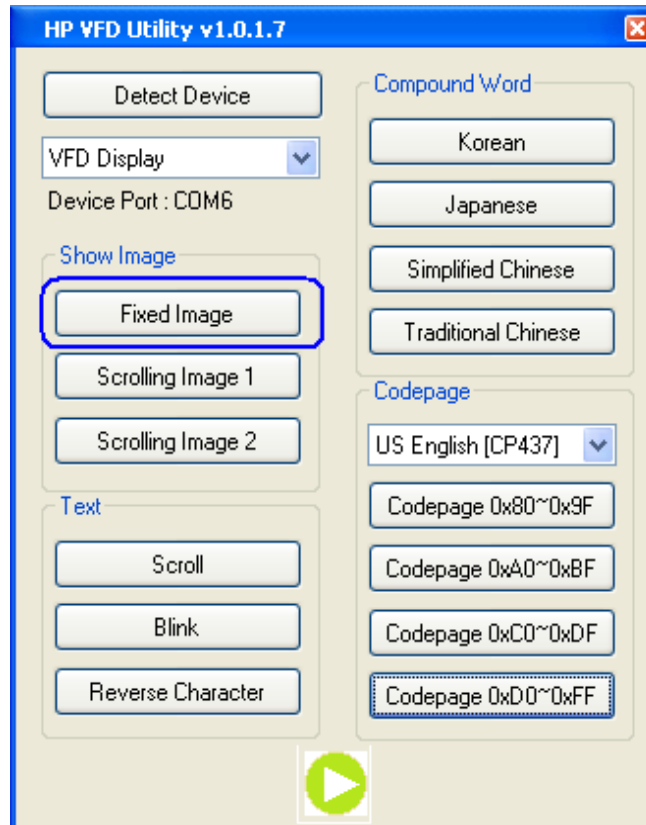

- [Scrolling Image 1](#) → Geometric shapes (similar to what is shown below) will scroll across the display. The same image that is in the fixed image except that it will be scrolling on the display.

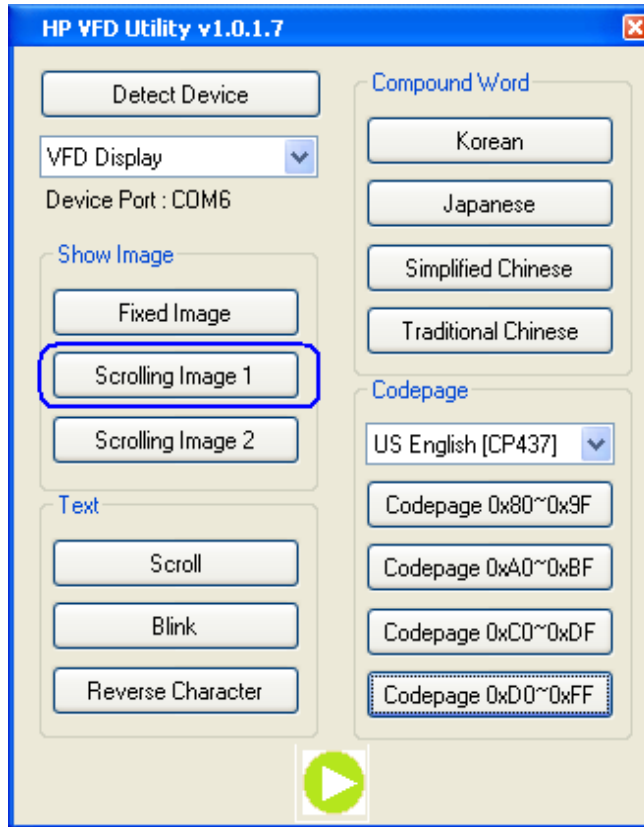

- **Scrolling Image 2** → Will cause two different images (similar to what is shown below) to scroll on the display; one after the other.



Enjoy your Shopping Here!

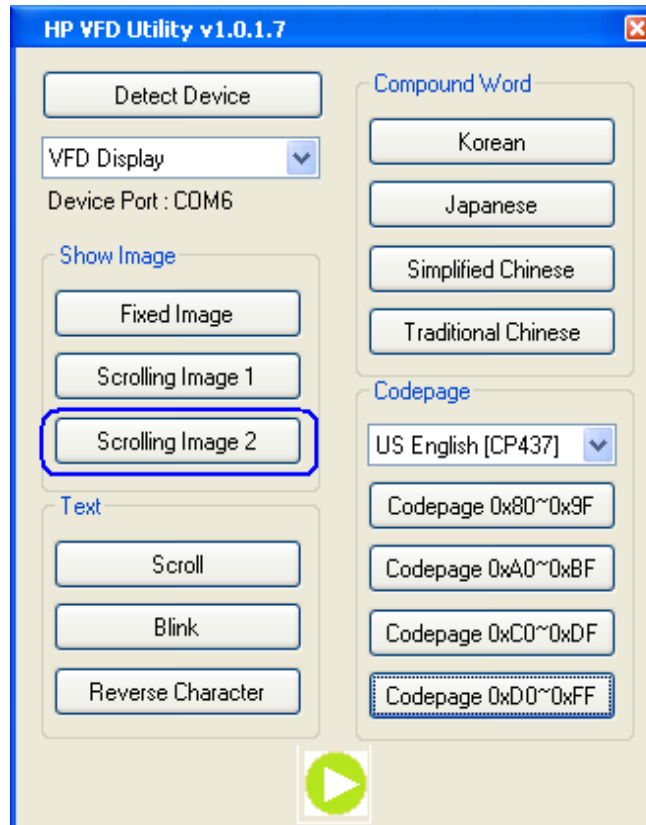

- **Scroll** → Will cause the device to scroll **1234567890** on the display until another button is pressed or the utility is exited.

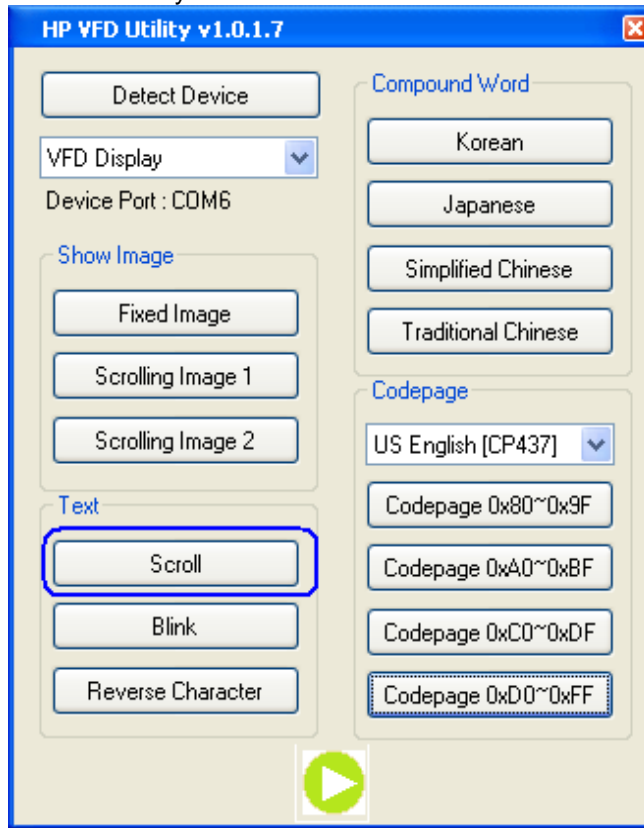

- **Blink** → Will cause the device to blink **ABCDEFGHIJ** on the display until another button is pressed or the utility is exited.

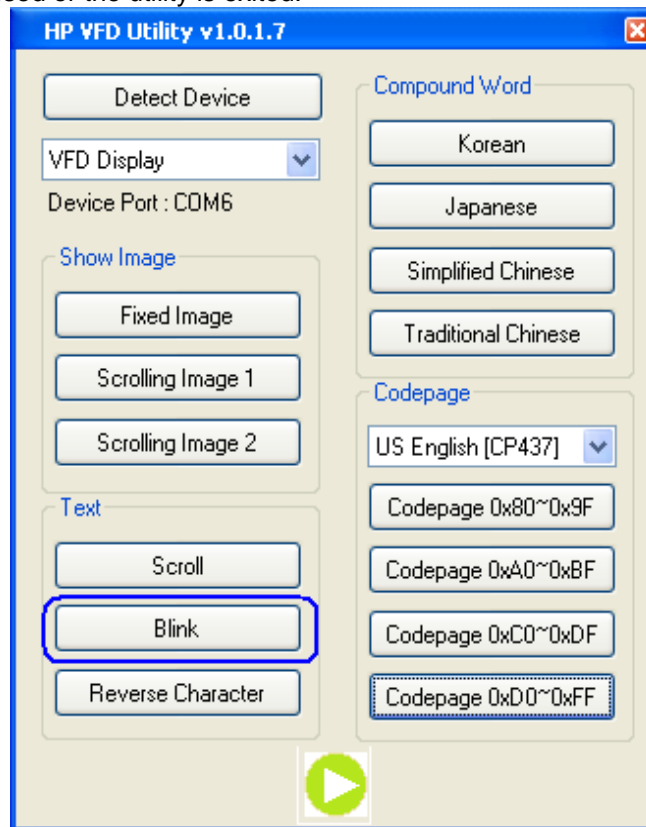

- **Reverse Characters** → Will cause the device to display lower case **abcdefghij** on the display in reverse characters until another button is pressed or the utility is exited.

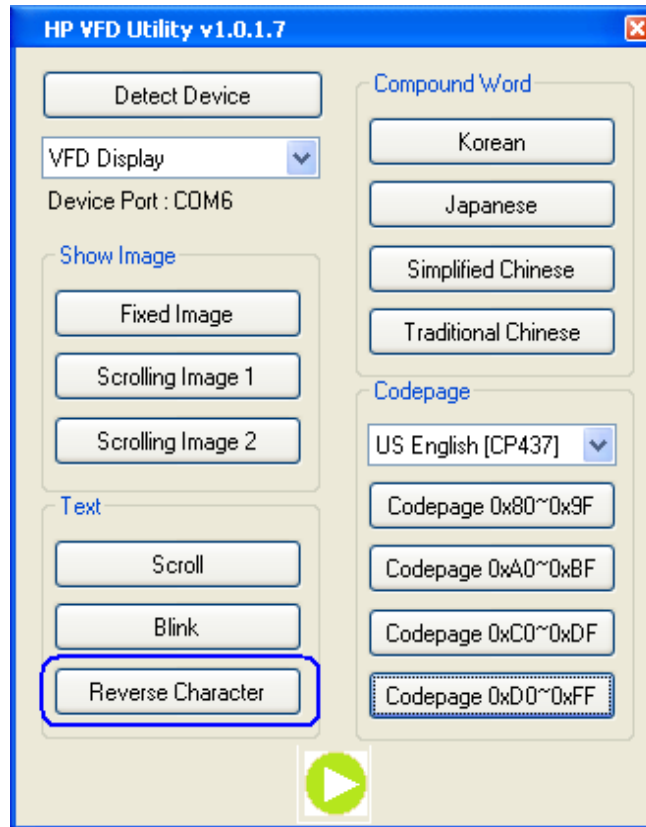

- **Code page** drop down → Allows one to select the code page/language to display on the pole.
 - The four code page button will let one display the down page that was selected in the drop down menu.

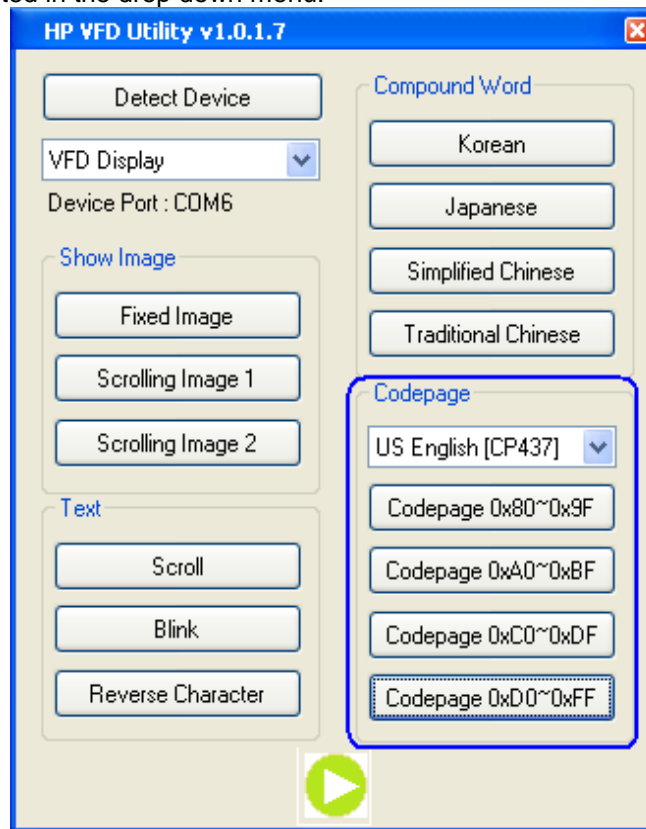

- **Compound Word** → When one clicks on the one of the four languages buttons (Korean / Japanese / Simplified Chinese / Traditional Chinese) two lines will be displayed on the HP VFD Display. The first line will display the welcome in the language button that was pressed and the second line will be “Welcome” in English. Sometimes “compound word” is referred to as complex characters.

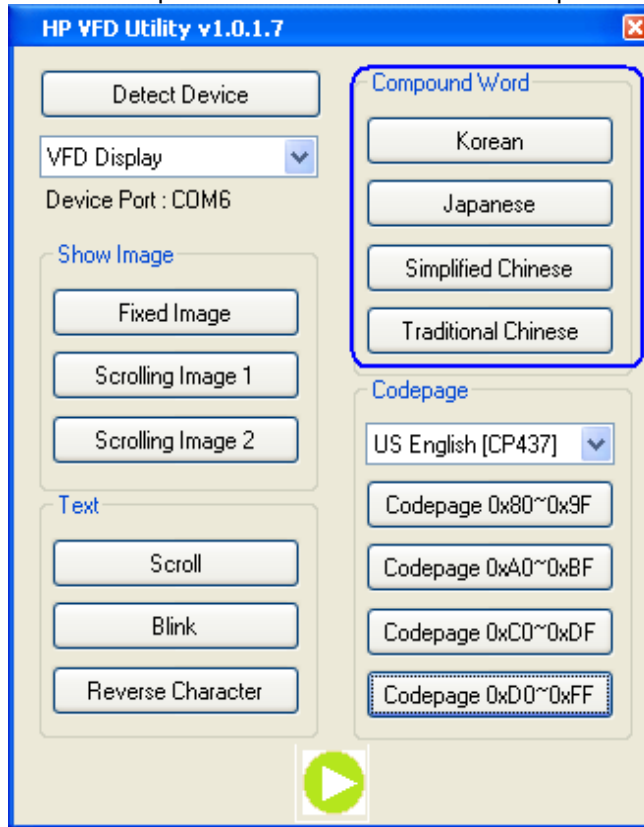

- **Play** → Will cause all the available option for the pole to be displayed automatically and continuously until the utility is stopped or exited. Only the selected cod page in the drop down box will be displayed in this mode.

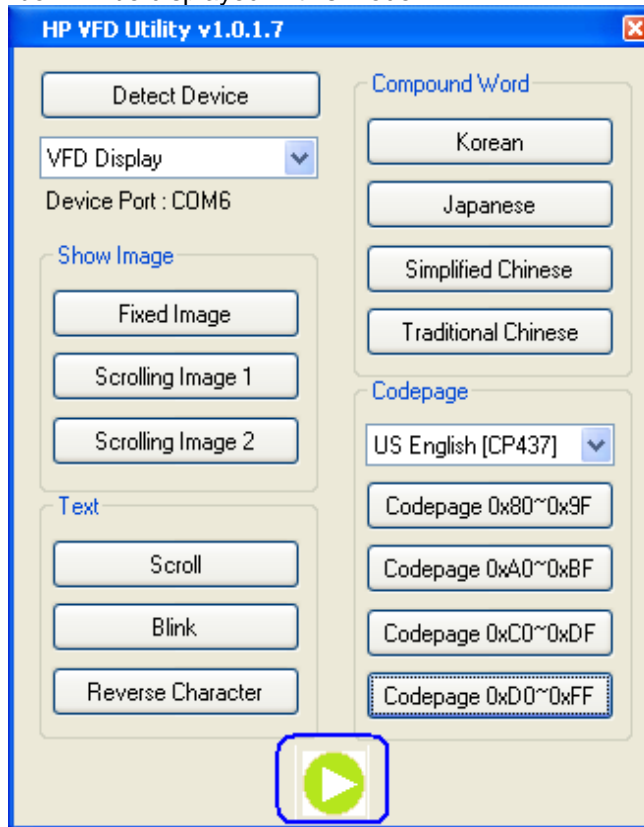

4. Click "x" in the upper right corner to exit the utility.

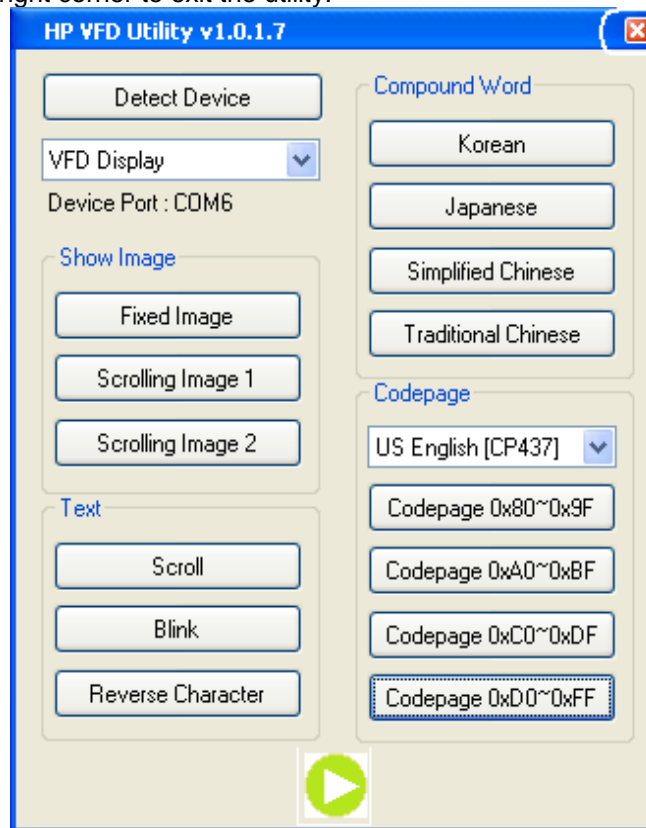

6.14.5.2 **Testing pole display in OPOS environment – HP USB Pole Display**

The following is overview of the steps to test the pole display followed by detailed steps:

1. Open **HP LineDisplay OPOS Demo Utility**.
 - C:\<Program Files directory>\HP\Line Display\OPOS\VFDTEST.exe
2. Select the device from the dropdown menu.
3. Click on “Clear Text” button to clear if there is any text on the pole display. To display a test message on the pole, enter a message in the text box and click on “Display Text”.
4. To display a test message on different ROW or Column:
 - a. Enter the test message.
 - b. Enter column and row supported by the display.
 - c. Click “Display Text At” button.
5. To cause a message to blink on the pole:
 - a. Click on the “Blink Characters” button which will cause “!!! Blinking !!!” to appear on the pole display.
6. To cause message to scroll (test #1):
 - a. Click on “Scrolling Text Line 1” button. The pole will scroll a message and the following message “Scrolling Text Line 1” appears on the pole until exiting the test applet or performing a different test function.
7. To cause message to scroll (test #2):
 - a. Click on “Scrolling Text Line 2” button. The pole will scroll a message and the following message “<<<Scrolling Text Line 2 >>> ...” appears on the pole until exiting the test applet or performing a different test function.
8. To display a message using different code page.
 - a. Click on “Clear Text” button.
 - b. Select Character Set from the drop down box.
 - c. Enable the character set by enabling the “MapCharacterSet” option on the utility.
 - d. Enter the appropriate text.
 - e. Click on the “Display Text” button.
 - f. The test message will display on the pole display using the code page specified.
9. To display a graphics on the HP VFD Display (this option will only be shown on the device that supports this feature):
 - a. Click on “Clear Text” button.
 - b. Click on “OPEN FILE” button and browse to the location of the BMP file.
 - In the OPOS folder there is “Sample BMP” folder with few BMP file that may be used with this utility.
 - Select the BITMAP file, now the file name and location should appear in the box to the left of the “OPEN FILE” button.
 - c. Click on “DISPLAYBITMAP” button to have the BMP appear on the VFD.
10. To exit the OPOS test applet, click on the “OK” button or click on the “x” in the upper right corner of the test applet.

Detailed Steps

1. Open **HP LineDisplay OPOS Demo Utility**.
 - C:\<Program Files directory>\HP\Line Display\OPOS\VFDTEST.exe

2. Select the device from the drop down menu:

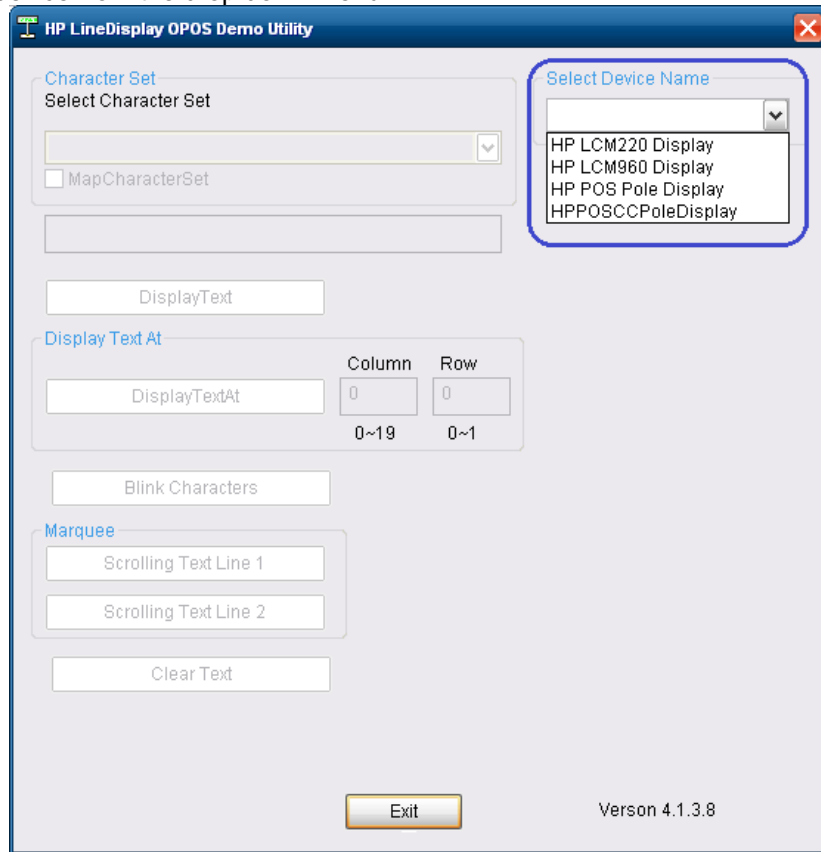

3. Click on “Clear Text” button to clear if there is any text on the pole display. To display a test message on the pole, enter a message in the text box and click on “Display Text”.

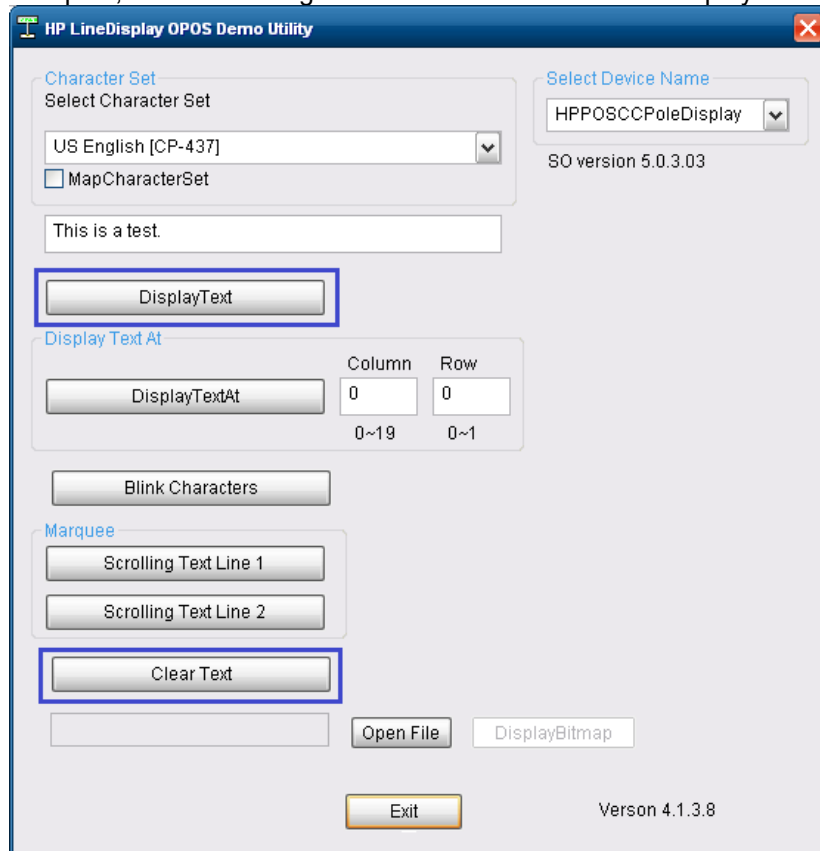

4. To display a test message on different ROW or Column:
 - a. Enter the test message.
 - b. Enter column and row supported by the display.
 - c. Click "Display Text At" button.

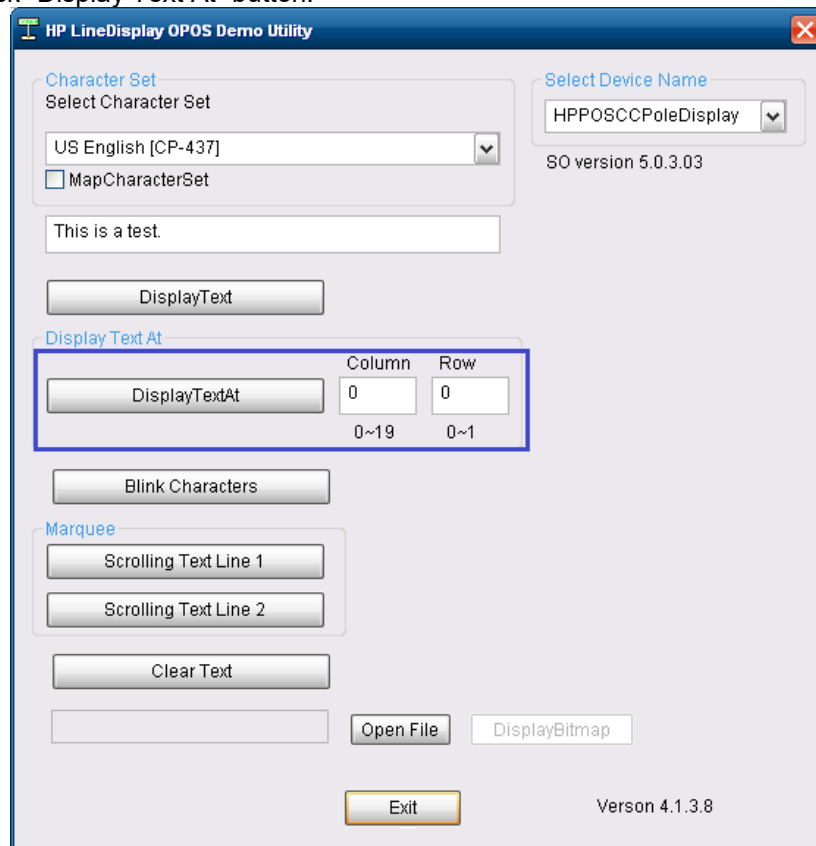

Note: If a numerical value is entered that is outside of the valid range, the value will default back to zero ("0").

5. To cause a message to blink on the pole:
 - a. Click on the “Blink Characters” button which will cause “!!! Blinking !!!” to appear on the pole display.

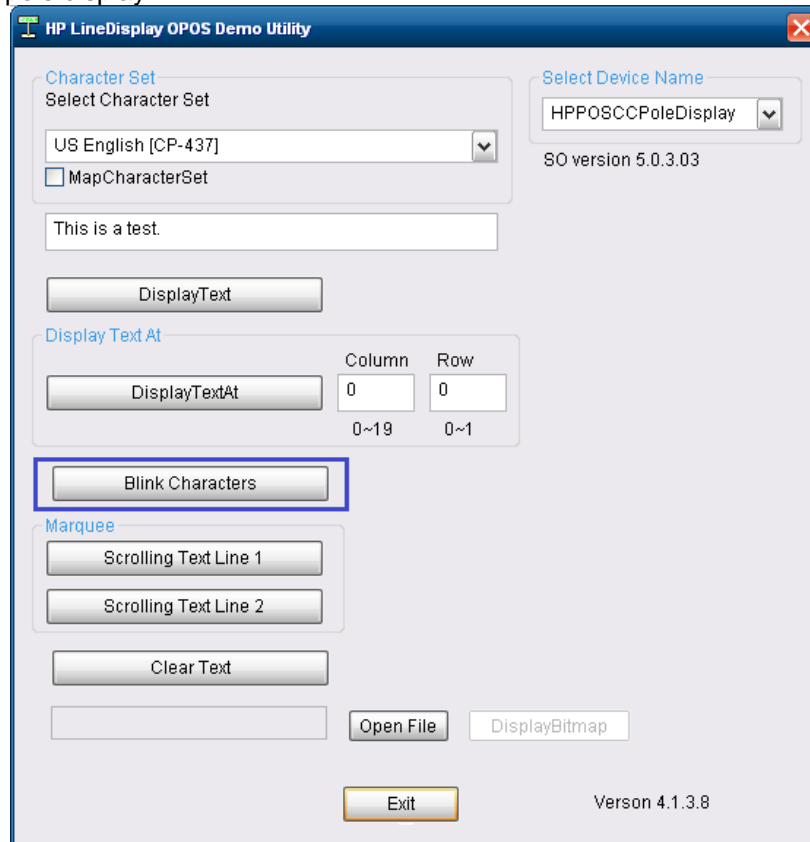

6. To cause message to scroll (test #1):
 - a. Click on “Scrolling Text Line 1” button. The pole will scroll a message and the following message “Scrolling Text Line 1” appears on the pole until exiting the test applet or performing a different test function.

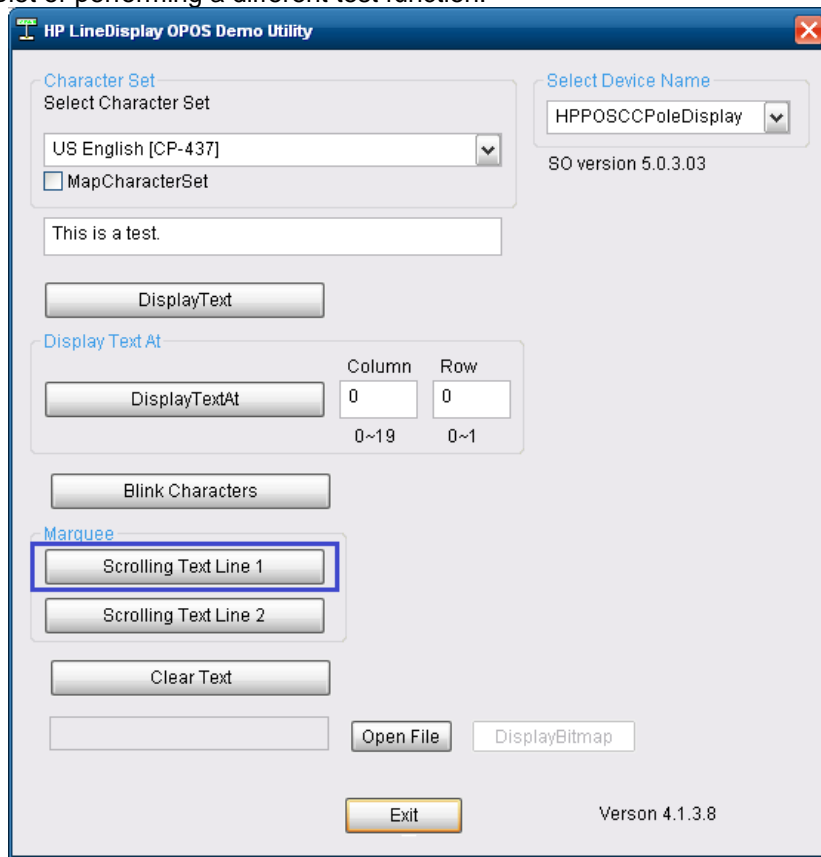

7. To cause message to scroll (test #2):
 - a. Click on “Scrolling Text Line 2” button. The pole will scroll a message and the following message “<<<Scrolling Text Line 2 >>> ...” appears on the pole until exiting the test applet or performing a different test function.

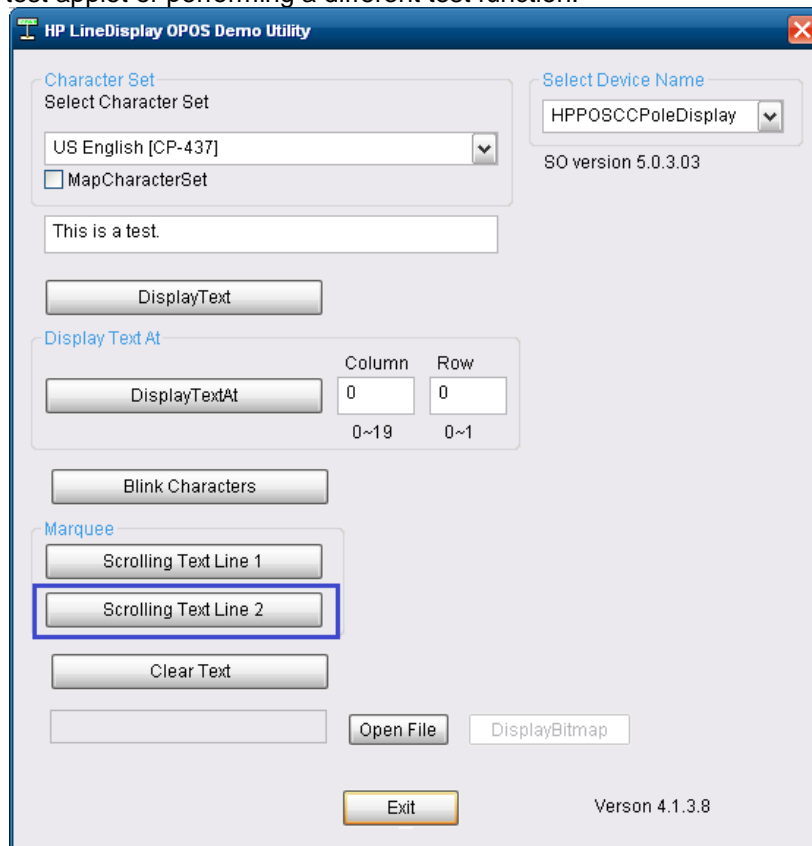

8. To display a message using different code page:
 - a. Click on “Clear Text” button.
 - b. Select Character Set from the dropdown box.
 - c. Enable the character set by enabling the “MapCharacterSet” option on the utility.
 - d. Enter the appropriate text.
 - e. Click on the “Display Text” button.
 - f. The test message will display on the pole display using the code page specified.

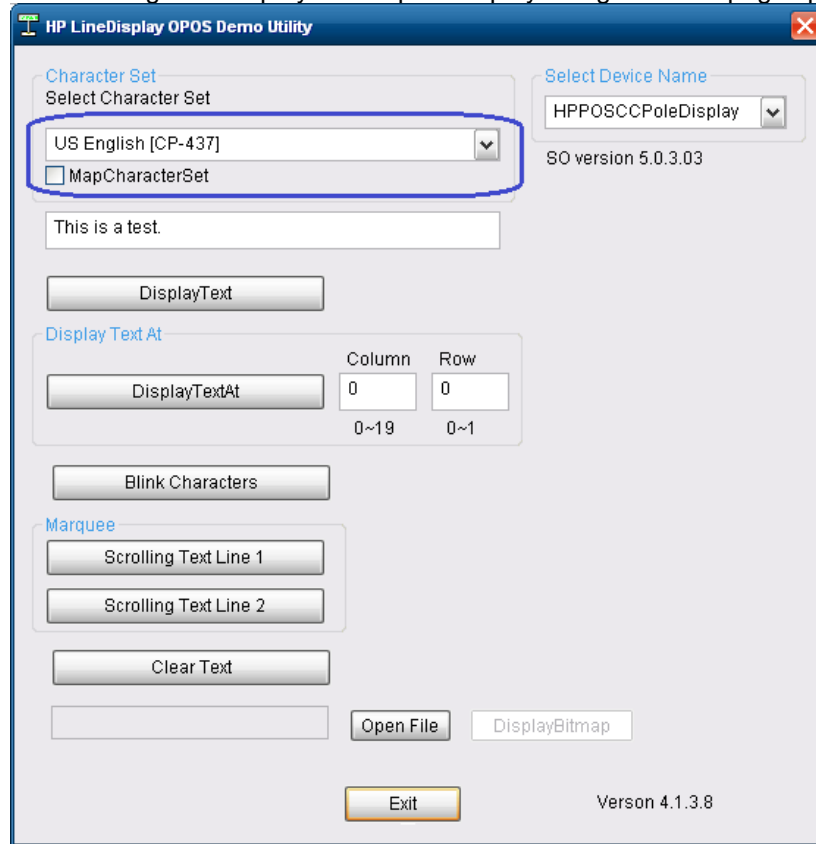

9. To display a graphics on the HP VFD Display (this option will only be shown on the device that supports this feature):
 - a. Click on “Clear Text” button.
 - b. Click on “OPEN FILE” button and browse to the location of the BMP file.
 - o In the OPOS folder there is “Sample BMP” folder with few BMP file that may be used with this utility.
 - o Select the BITMAP file, now the file name and location should appear in the box to the left of the “OPEN FILE” button.
 - c. Click on “DISPLAYBITMAP” button to have the BMP appear on the VFD.

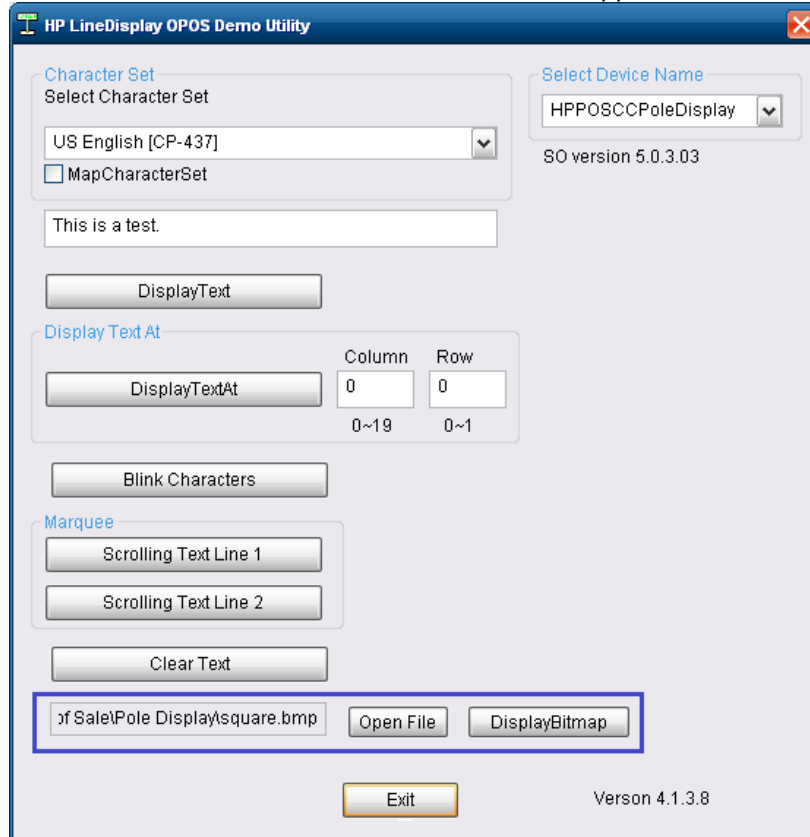

10. To exit the OPOS test applet, click on the “OK” button or click on the “x” in the upper right corner of the test applet.

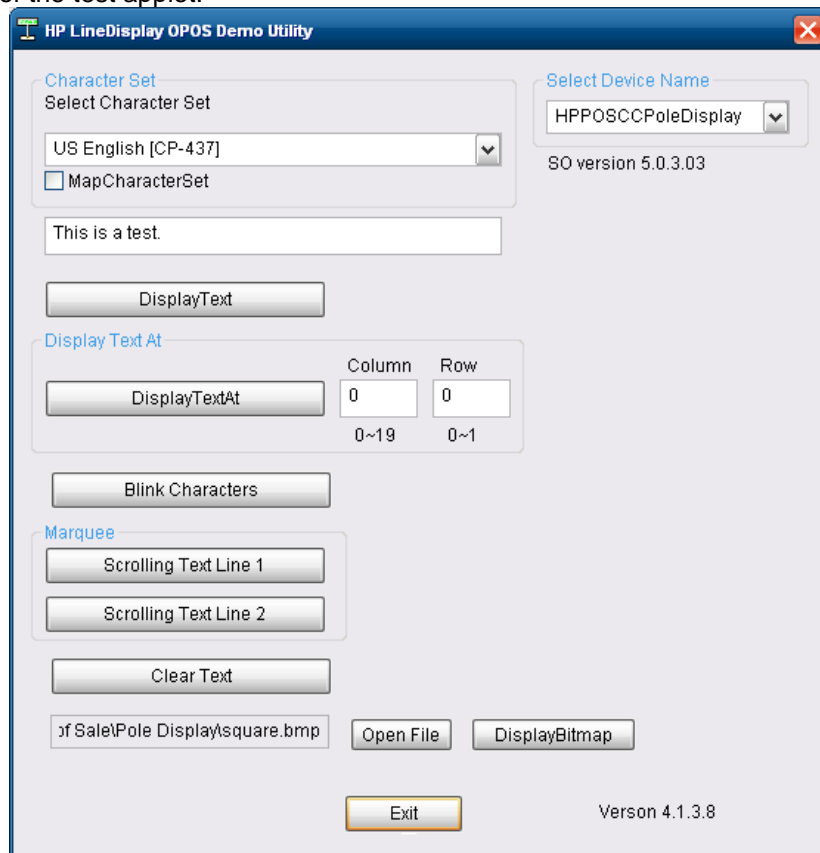

6.14.6 JPOS Drivers for the pole display

The HP Pole Display JPOS drivers are included in the HP factory image (C:\xxxxx\Point of Sale\Pole Display\Pole Display JPOS) and are also available from HP.COM.

The following is an overview of the steps to test the pole display followed by detailed steps:

1. Confirm/edit the JPOS.XML file that it has the correct COM port information for the pole that you are testing.
2. Open **JavaPOStester**.
 - C:\xxxxx\Point of Sale\Pole Display\Pole Display JPOS\postest.bat.
3. Click on the "LineDisplay" tab.
4. Click on the "OPEN" button.
5. Click on the "CLAIM" button.
6. Check the "DEVICE ENABLED" so there is a check box.
7. Press the "CLEAR TEXT" button.
8. Type in the test message in the "Send to line display" box and click on "Display Text"
9. Click on "RELEASE" / "CLOSE" / "EXIT" to exit the JPOS test utility.

Detailed Steps

1. Confirm/edit the JPOS.XML file that it has the correct COM port information for the pole that you are testing.

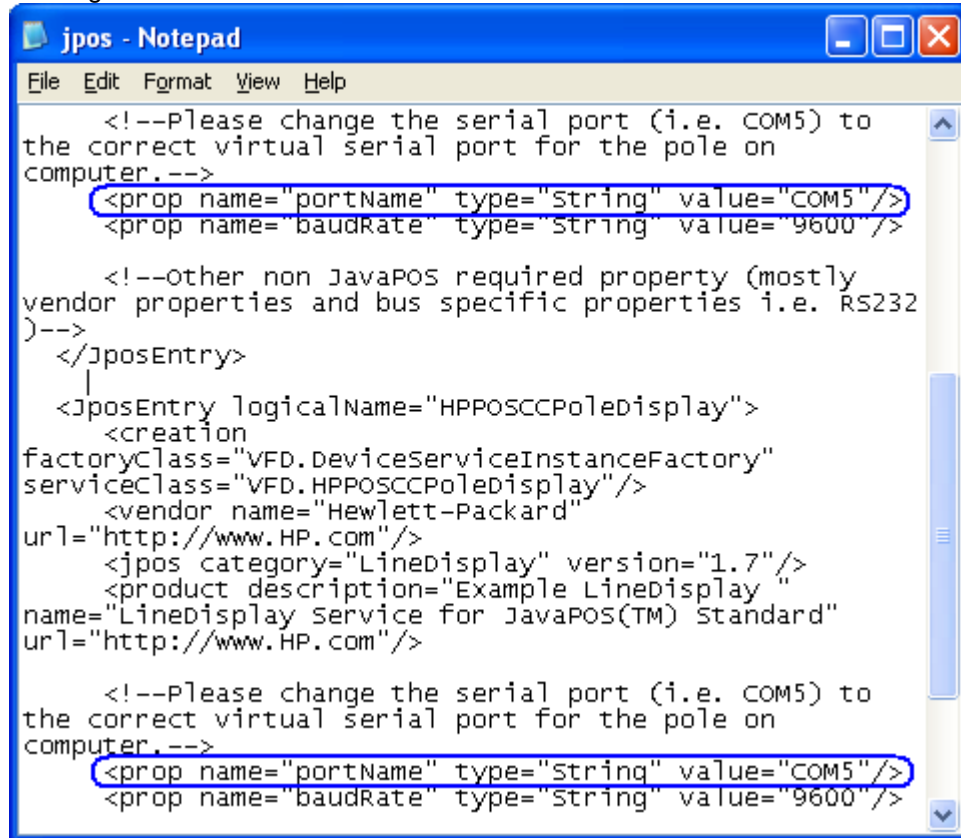

```
File Edit Format View Help
<!--Please change the serial port (i.e. COM5) to
the correct virtual serial port for the pole on
computer.-->
<prop name="portName" type="string" value="COM5"/>
<prop name="baudrate" type="string" value="9600"/>

<!--Other non JavaPOS required property (mostly
vendor properties and bus specific properties i.e. RS232
)-->
</JposEntry>
|
<JposEntry logicalName="HPPOSCCPoledisplay">
  <creation
factoryClass="VFD.DeviceServiceInstanceFactory"
serviceClass="VFD.HPPOSCCPoledisplay"/>
  <vendor name="Hewlett-Packard"
url="http://www.HP.com"/>
  <jpos category="LineDisplay" version="1.7"/>
  <product description="Example LineDisplay "
name="LineDisplay service for JavaPOS(TM) standard"
url="http://www.HP.com"/>

  <!--Please change the serial port (i.e. COM5) to
the correct virtual serial port for the pole on
computer.-->
  <prop name="portName" type="string" value="COM5"/>
  <prop name="baudrate" type="string" value="9600"/>
```

2. Open **JavaPOStester**.

- C:\xxxxx\Point of Sale\Pole Display\Pole Display JPOS\postest.bat.

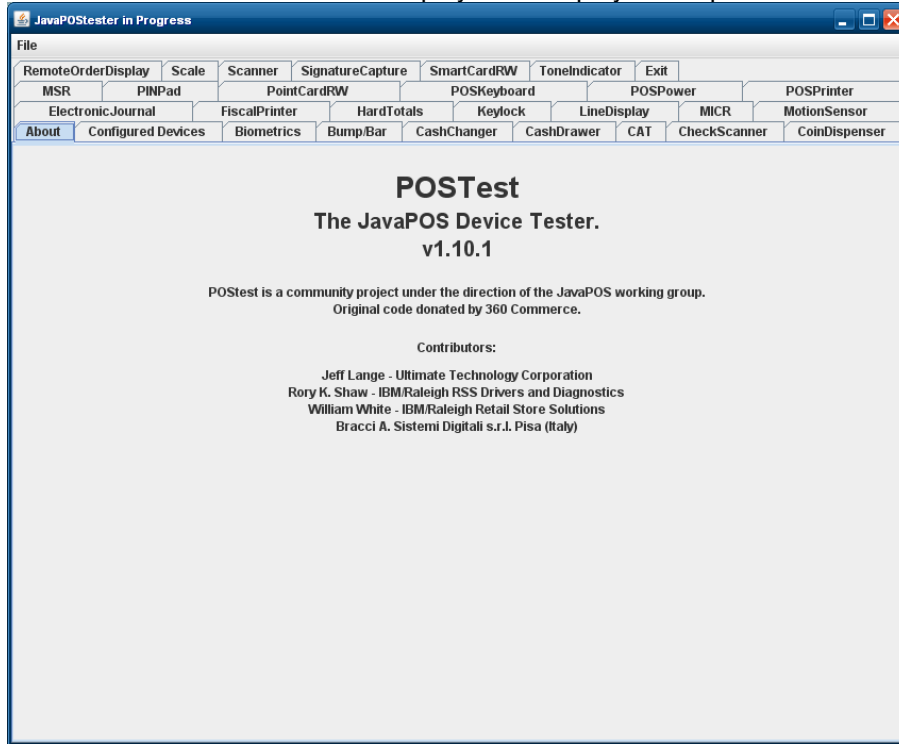

- Click on the “Configured Devices” tab to obtain the device names.

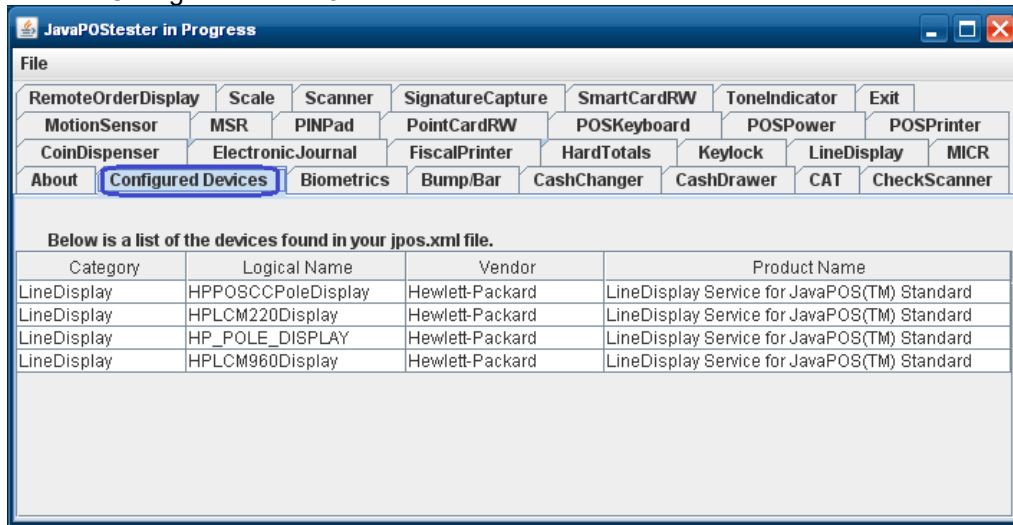

- Click on the “LineDisplay” tab to obtain the device logical name to use:

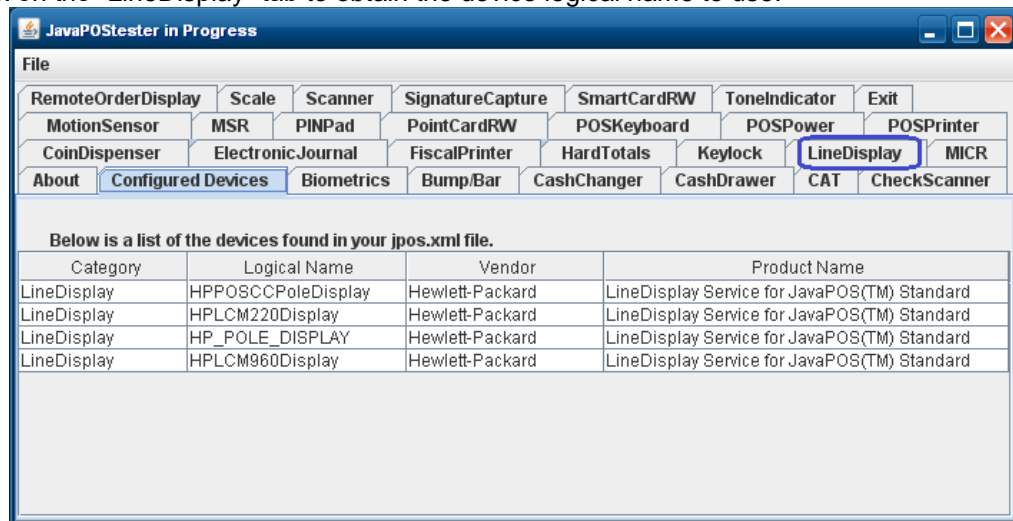

After clicking on the “LineDisplay” tab the screen should look like:

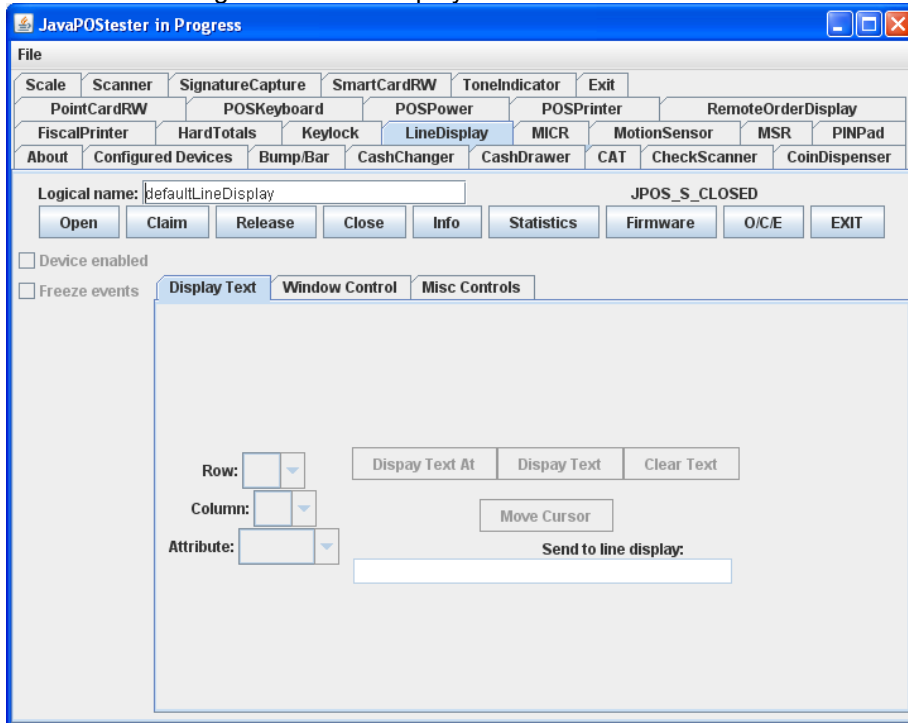

5. Enter the device logical name in the field.

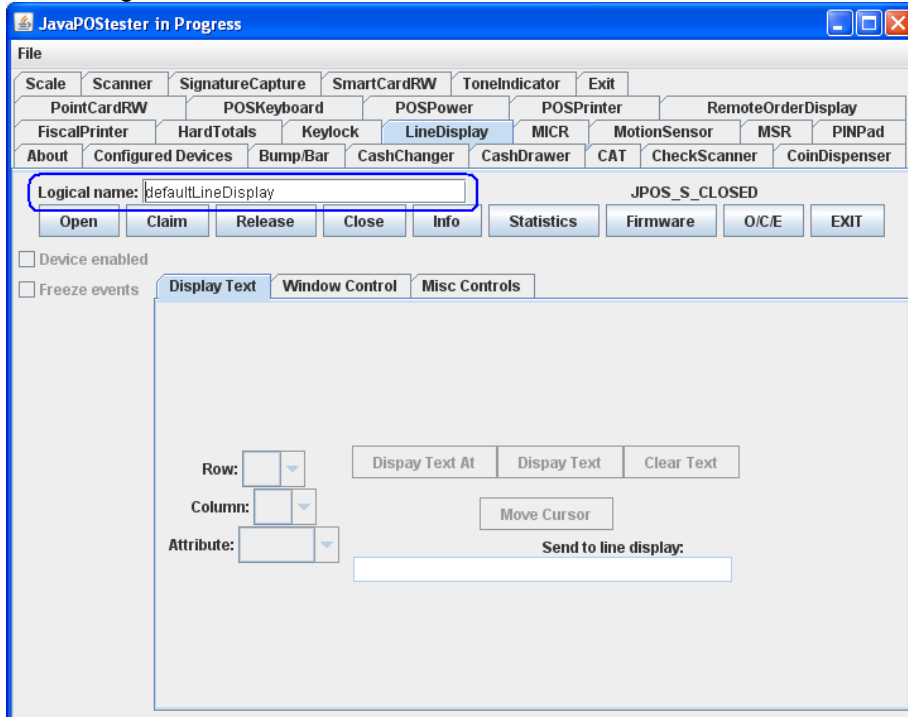

Note: If one clicks on the “Configured Device” tab, the names for the device will appear that will be used in the test utility.

- Click on the "OPEN" button. If the test applet has successfully established communication with the pole display, the pole display will be blank.

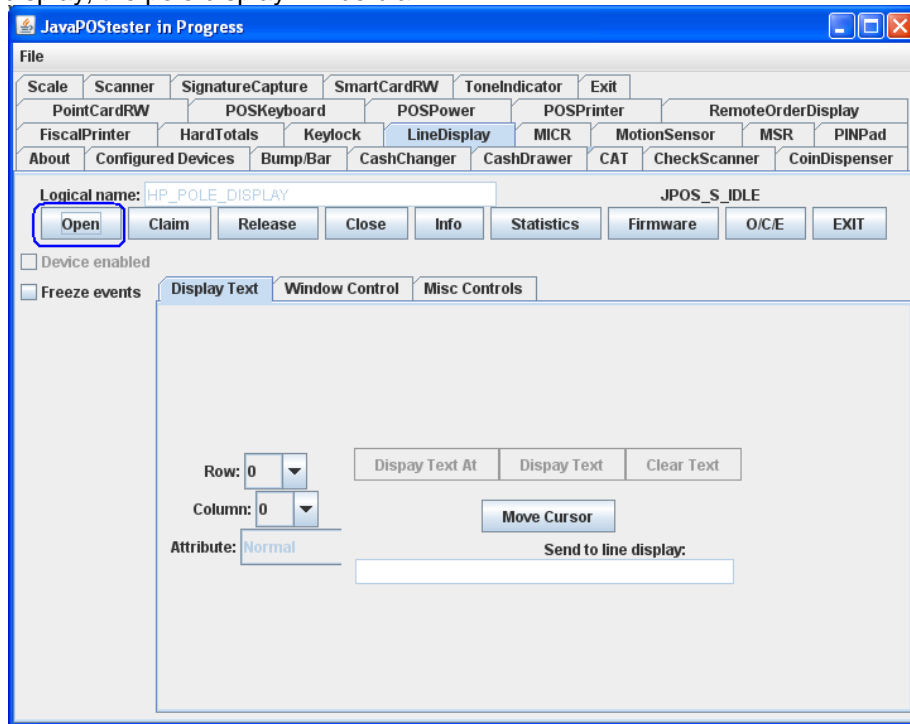

- Click on the "CLAIM" button. After clicking the "CLAIM" button, the "Device Enabled" is available.

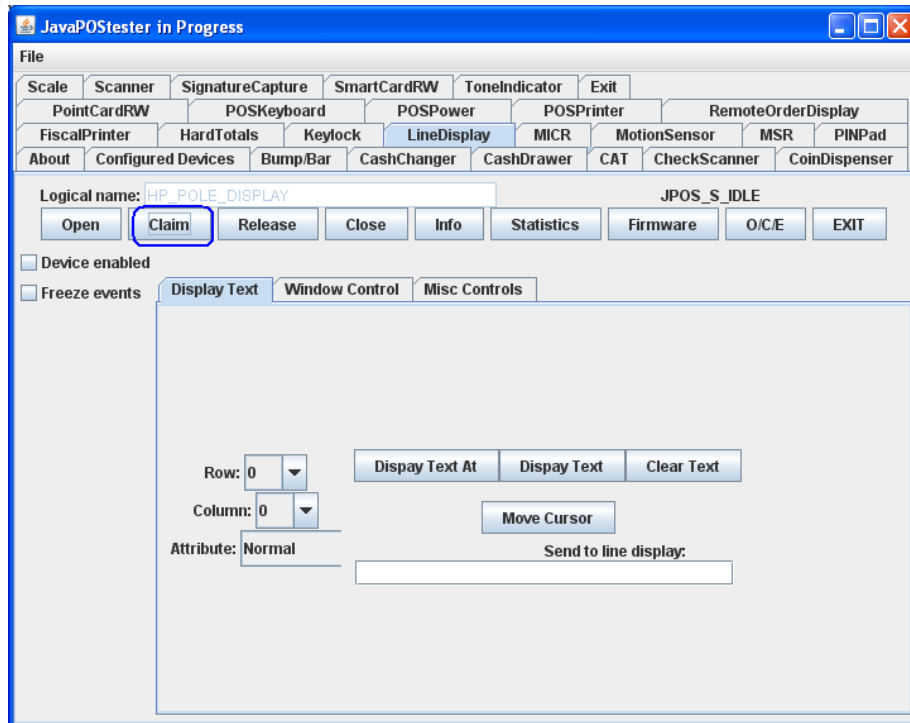

8. Check the “DEVICE ENABLED” so there is a check box.

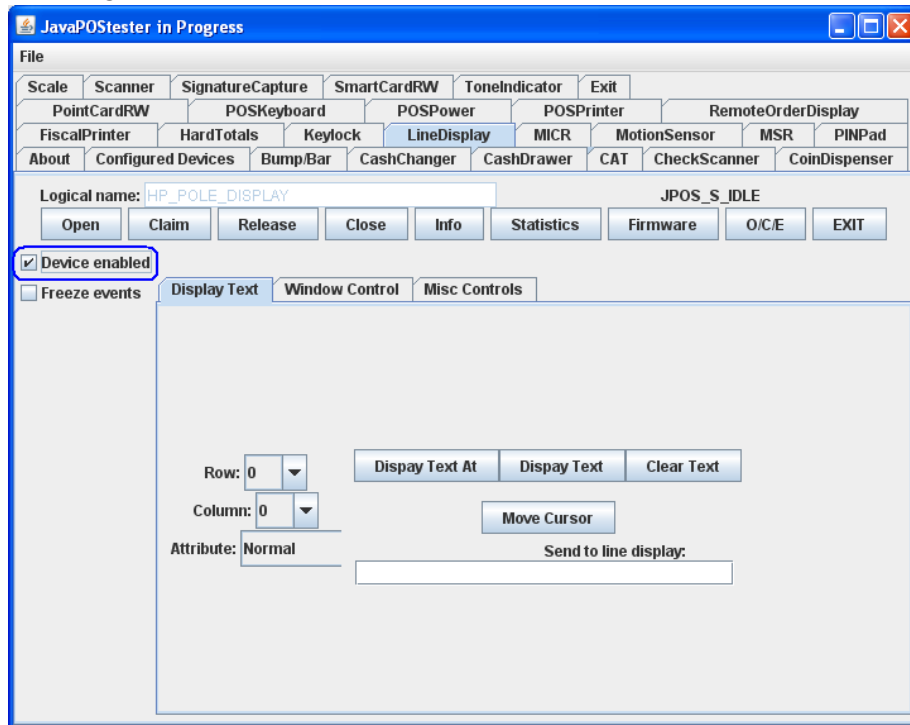

9. Press the “CLEAR TEXT” button.

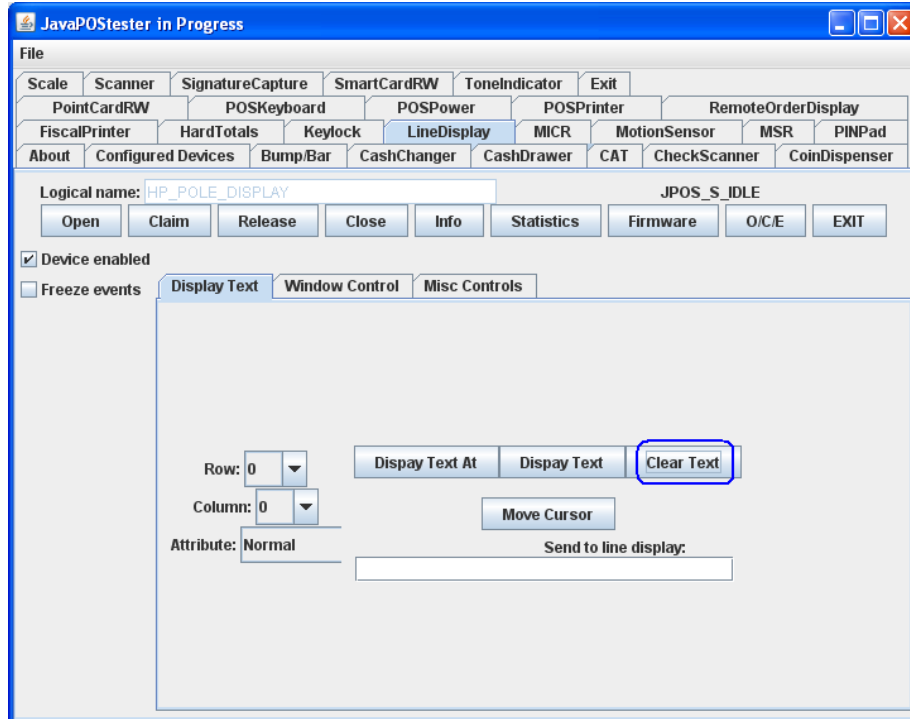

10. Type in the test message in the “Send to line display” box and click on “Display Text”

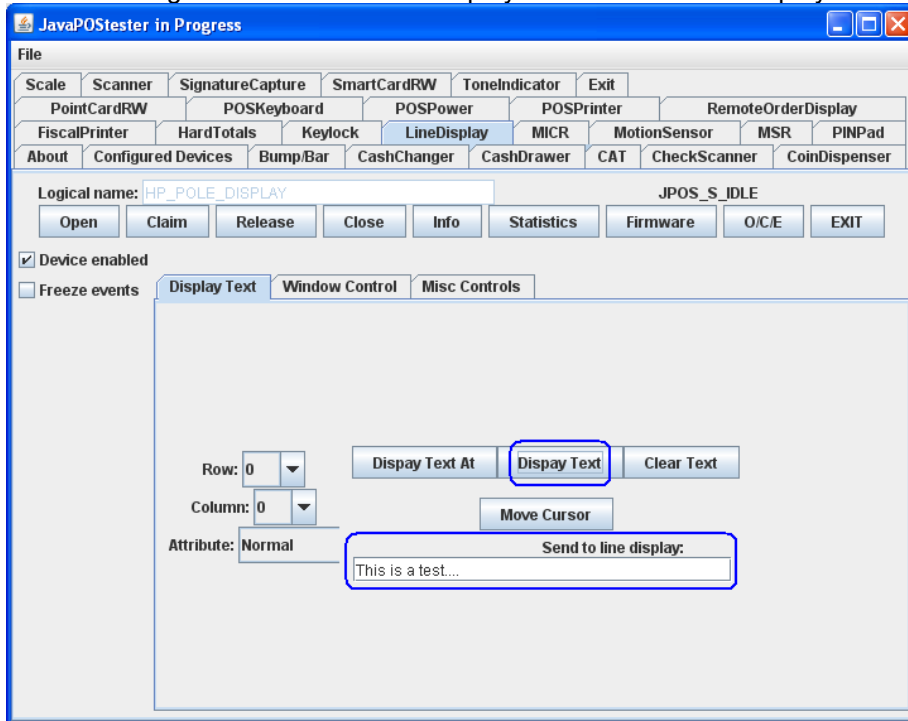

11. Click on “RELEASE” / “CLOSE” / “EXIT” to exit the JPOS test utility.

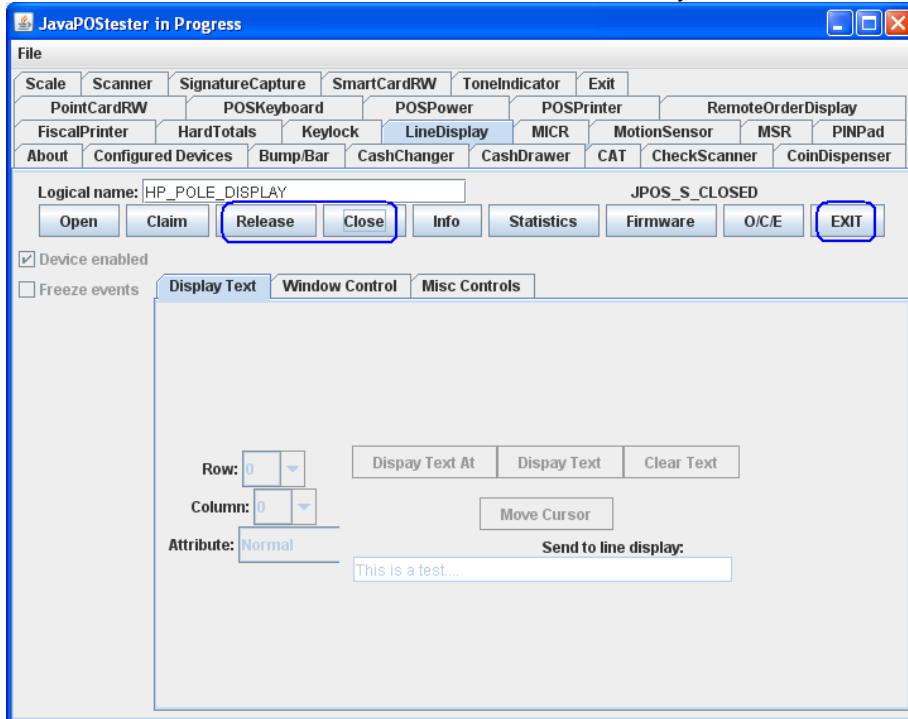

6.15 HP Biometric Fingerprint Readers



6.15.1 Connection

The fingerprint reader may be plugged into any designated free USB port for the specific device.

6.15.2 Windows Drivers for the HP Biometric Fingerprint Readers

The Biometric Fingerprint drivers are included in the HP factory image are also available from HP.COM.

The following is an example of Windows Device Manager after all the drivers are loaded for the HP Biometric Fingerprint Reader:

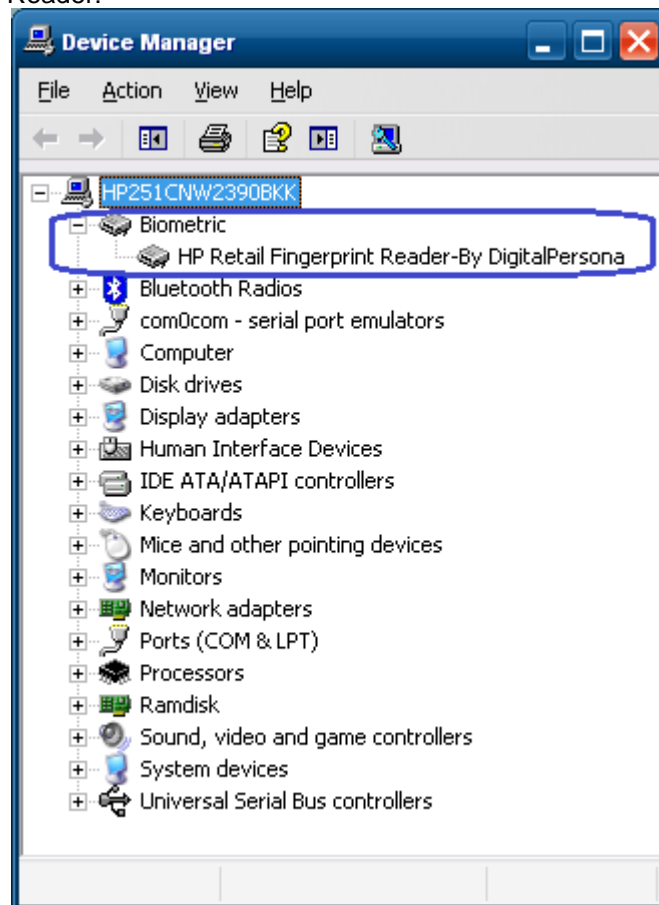

6.15.3 **OPOS Drivers / JPOS Drivers / SDK Kit**

Please contact your HP rep who will contact HP R&D to have arrangements made for the SDK kit for the HP Biometric device.

Recommended cleaning:

Apply the sticky side of a piece of adhesive cellophane tape on the window and peel it away. If necessary, gently wipe the window with a cloth (not paper) dampened with a mild ammonia-based glass cleaner to remove any milky haze.

Never do the following:

- Clean the reader window with paper
- Pour glass cleaner directly on the reader window
- Use alcohol-based cleaners
- Submerge the reader in liquid

7 HP Touch Screen

7.1 HP L5006tm

7.1.1 Connection

The HP L5006tm touch screen monitor has three (3) connections that need to be made on the back of the unit. One connector will plug into the VGA connector on the back of the unit, the second connection which is for the touch screen can be connected either via USB connector or serial connector and the third connection is for power to the monitor. The USB connection will plug into one of the free USB ports on the back of the unit. If the serial connection is chosen, please note which serial port on the back of the unit that you connect the monitor touch screen port; this information will be needed later.

View underneath the HP L5006tm monitor showing monitor connections:

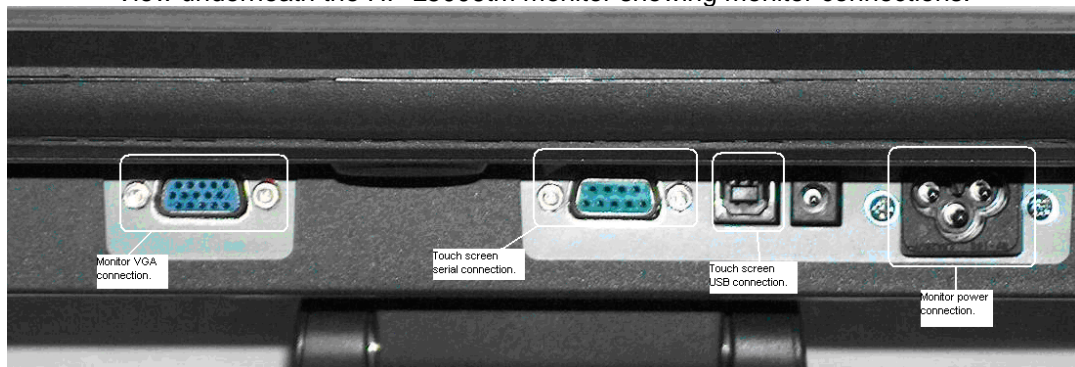

7.1.2 Windows Drivers for the Touch Screen

The drivers for HP touch screen may be obtained from HP.COM.

Note: The touch screen install process must be run with ADMINISTRATOR privileges.

The following is an overview of the steps to install the touch screen drivers and applets:

1. Start the touch screen installer.
2. Select your language.
3. Select the interface that you will use for the touch screen.
4. After the drivers are installed, please select the option to calibrate the touch screen monitor and follow the instructions on the screen.

For the L5006tm / L5009tm / L5015tm touch screen, after the drivers are installed please restart the operating system.

Detailed installation instructions

1. Start the touch screen installer and select your language:

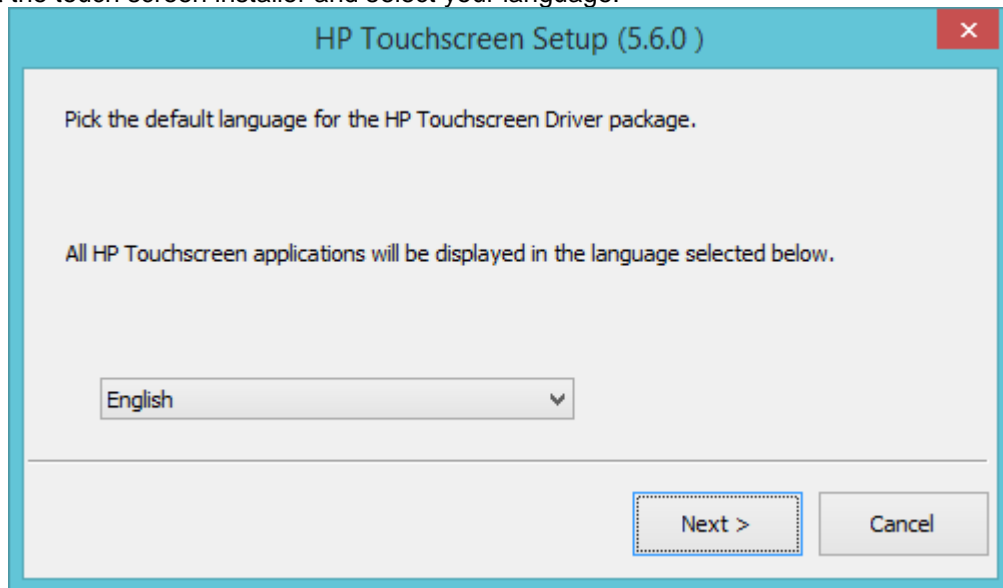

Selecting default will use the language that the operating system is running.

2. Make the appropriate selection for your model and interface:



USB Connection

If USB drivers are selected the installation package will search the USB ports for the monitor.

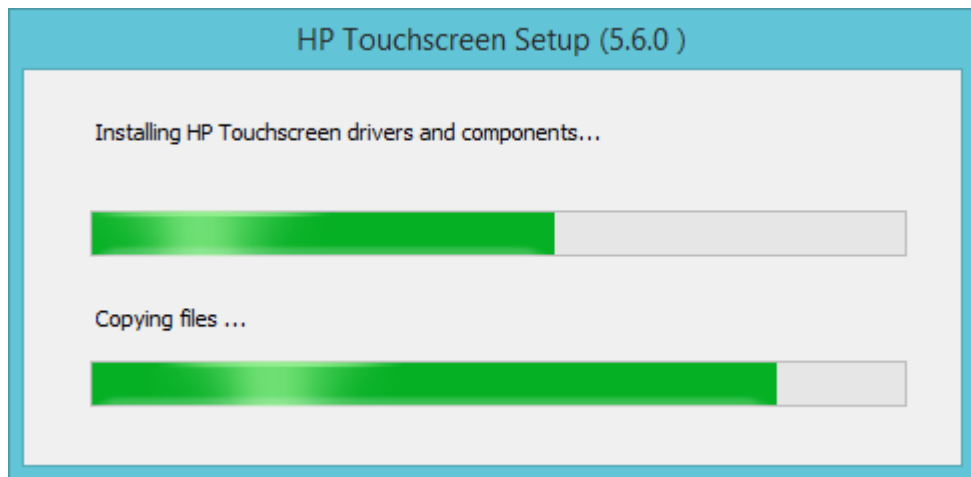
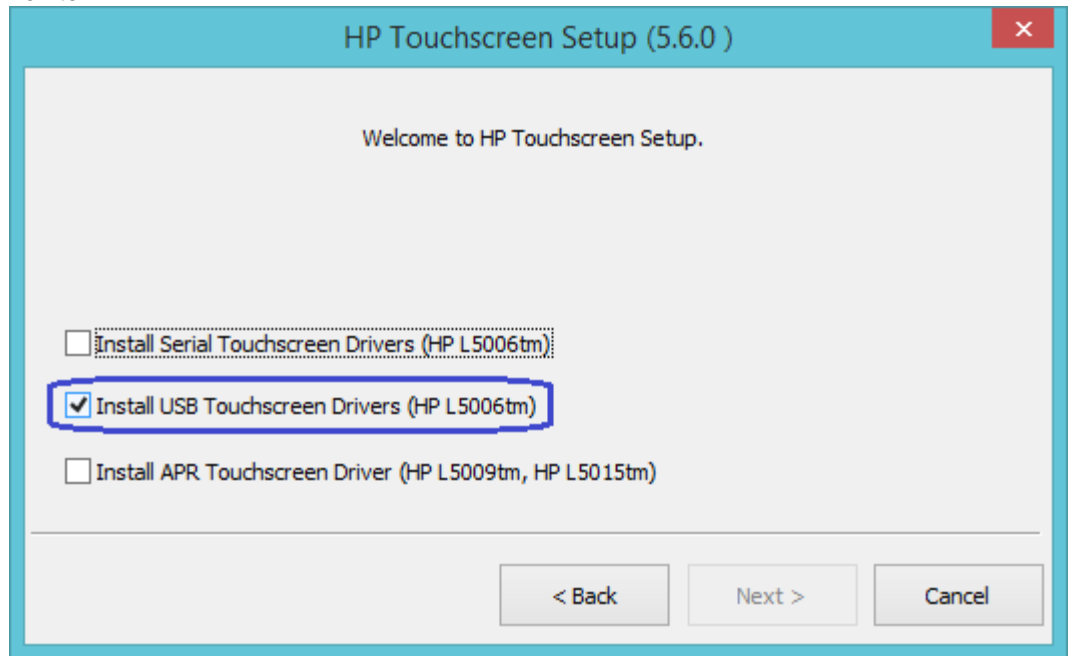

3. After the drivers are installed, please select the option to calibrate the touch screen monitor and follow the instructions on the screen.

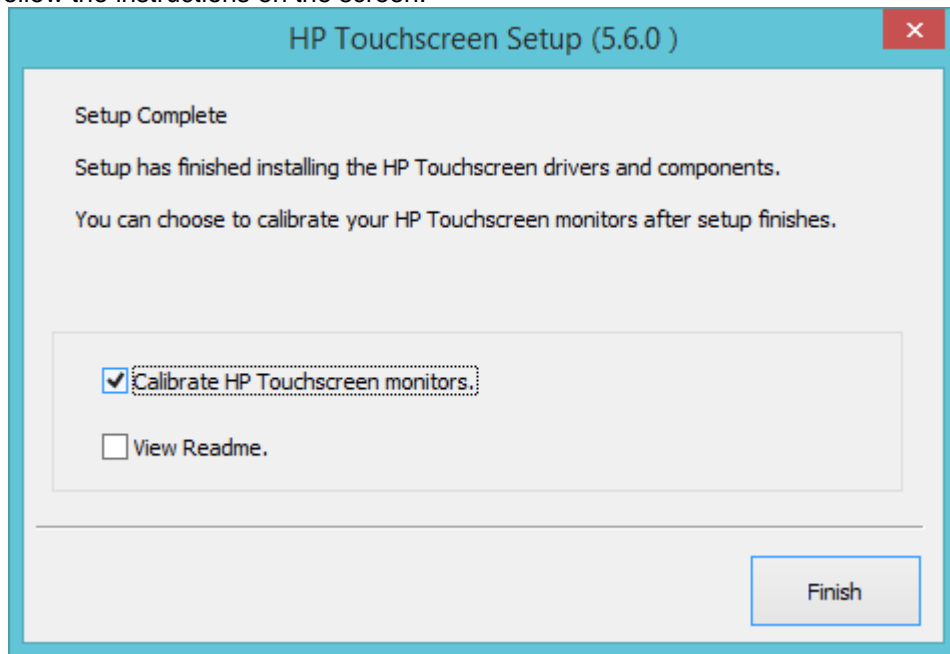

Serial Connection

If Serial Touchscreen drivers are selected you may have the installation package try to auto-detect which COM port the monitor is attached to.

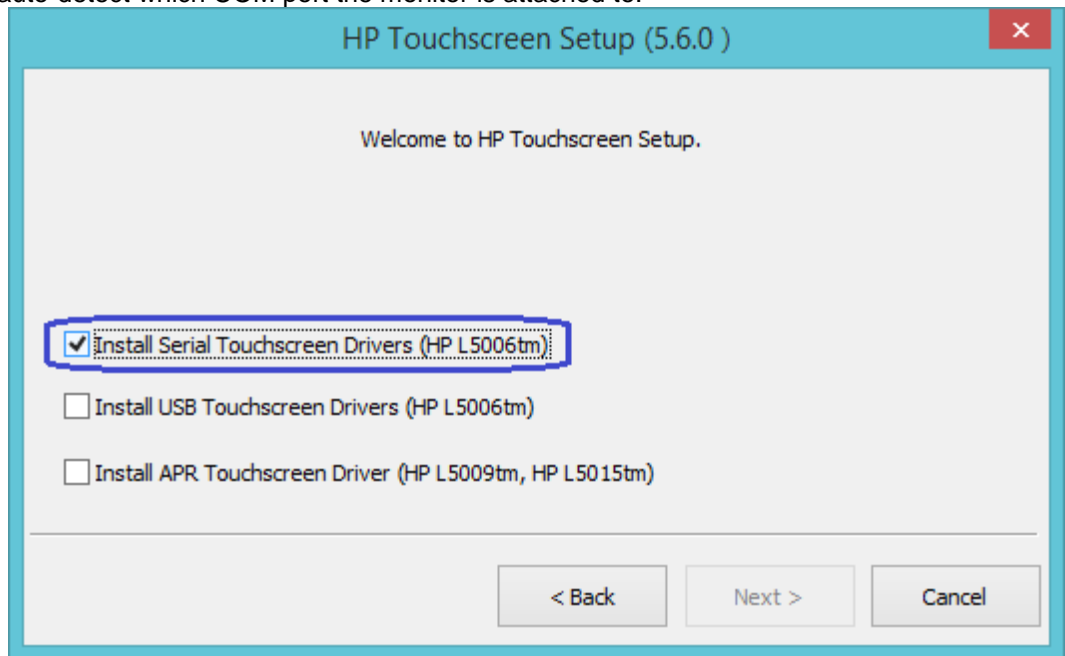

When the following box appears make sure that there is a check in the “Auto-detect HP Touchscreens” box.

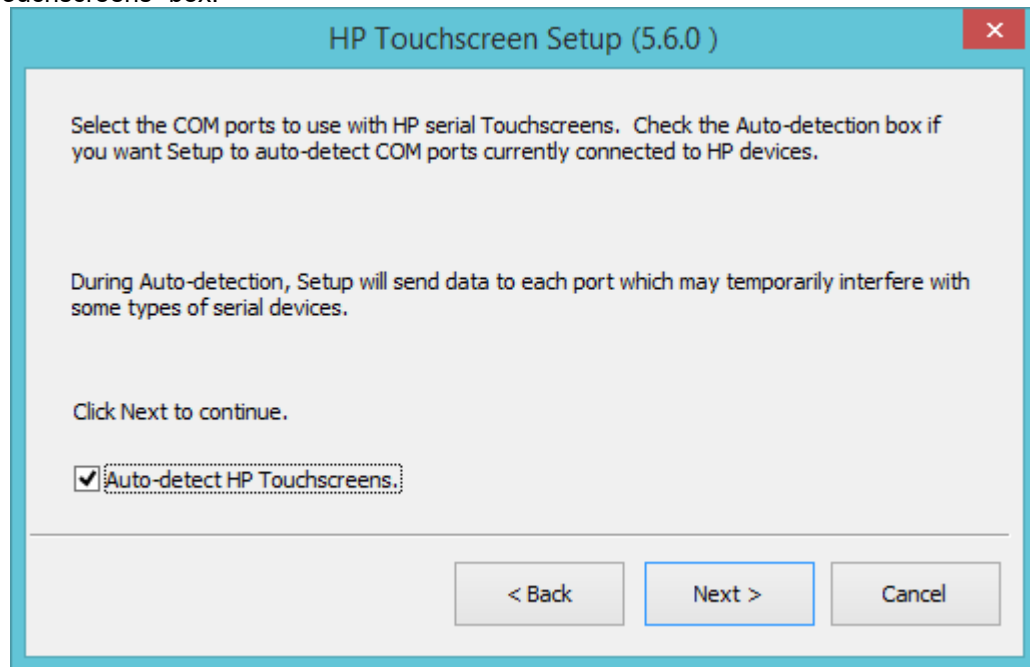

The following screen appears that shows the com ports that were found in unit. The COM port that is selected where were the utility found the touch screen monitor.

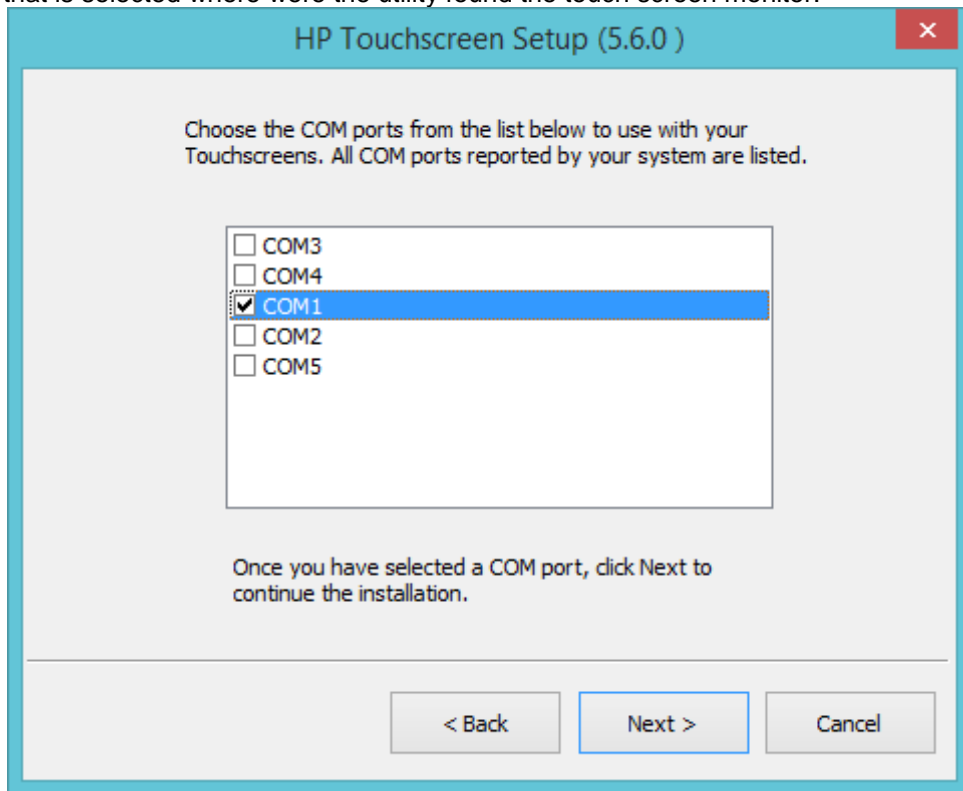

Note: The COM port listing on your unit may vary from the screen capture above.

You will be asked to confirm the COM port before the drivers are installed.

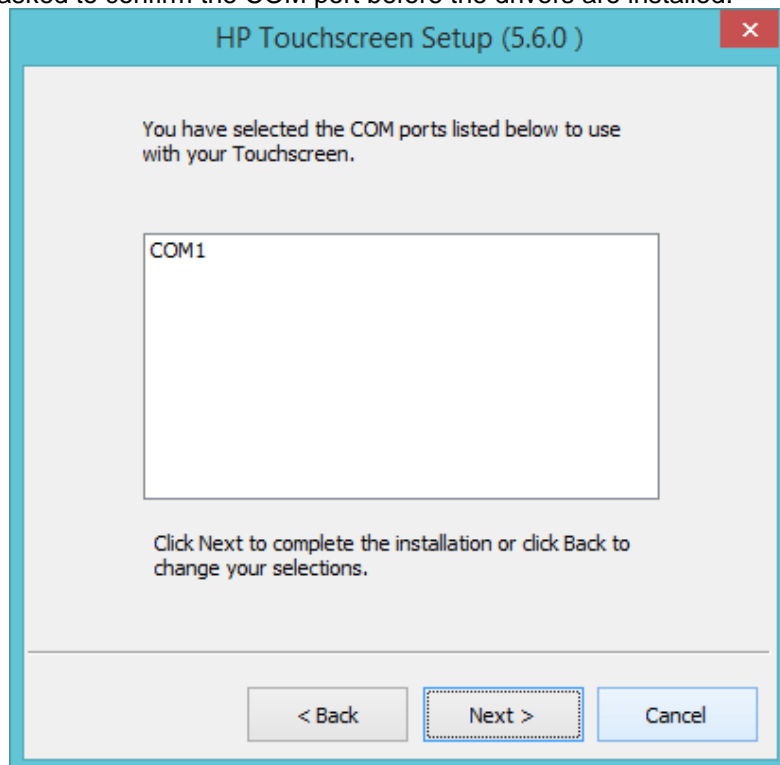

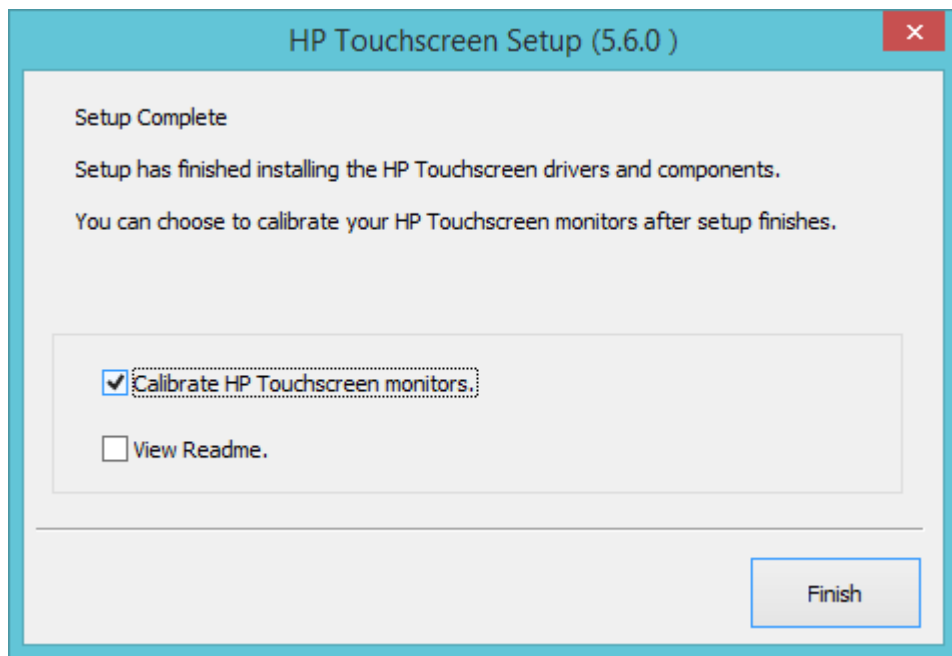
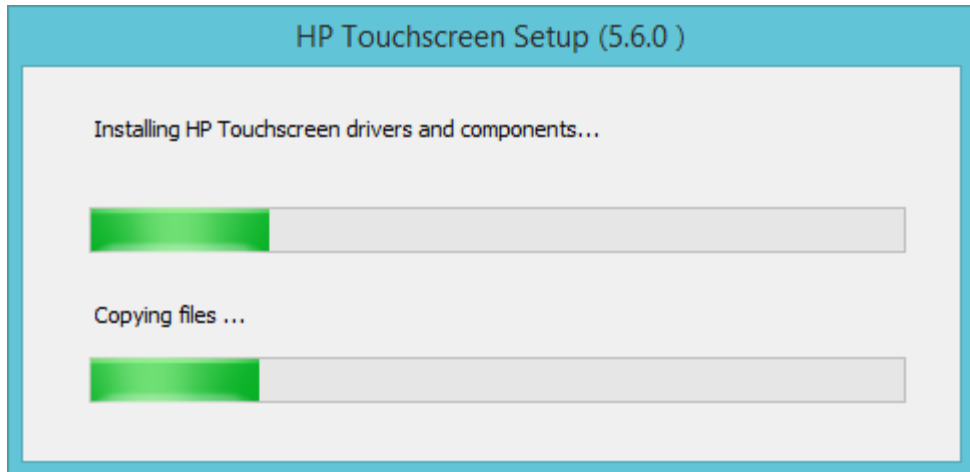

Would highly recommend after the drivers are installed please restart the operating system.

The following screen is showing Windows Device Manager when the touch screen is connected to the unit via the USB cable. After the Windows has loaded the device drivers for the touch screen there will be an entry in “Human Interface Devices” and “Mice and other pointing device” section in Device Manager as shown below:

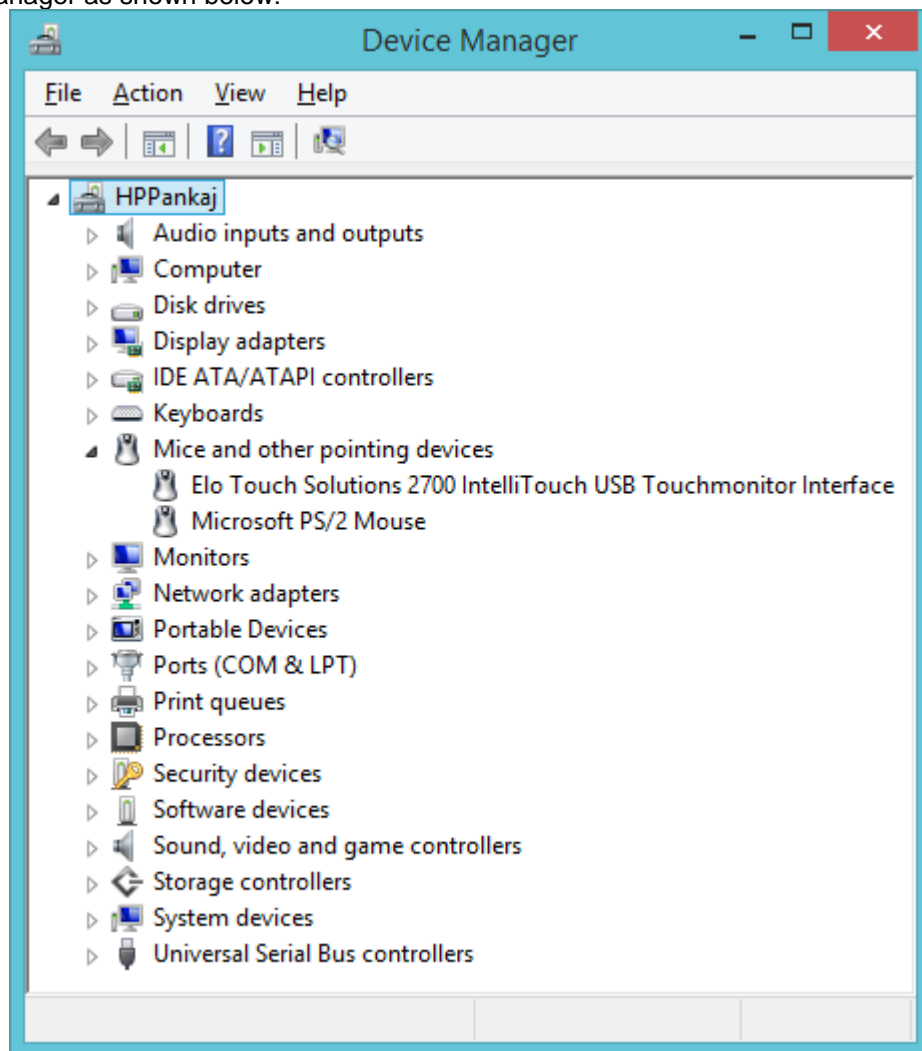

The following screen is showing Windows Device Manager when the touch screen is connected to the unit via the COM port. After the Windows has loaded the device drivers for the touch screen there will be an entry in "Mice and other pointing device" section in Device Manager as shown below:

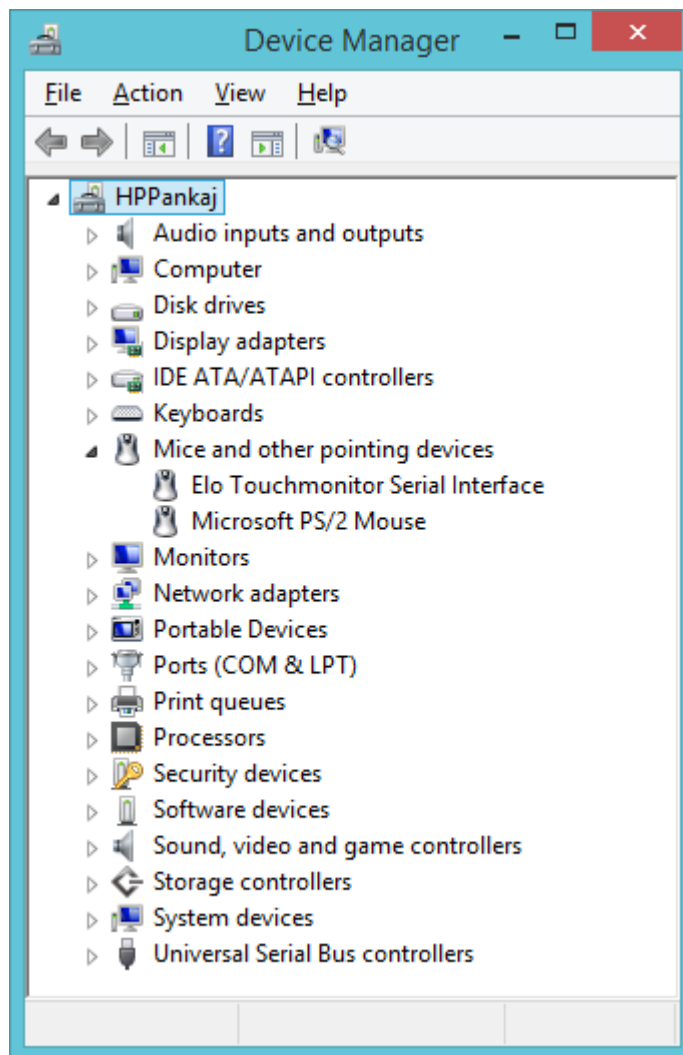

After Windows has loaded the device drivers for the touch screen there will be an Elo icon in the system tray:

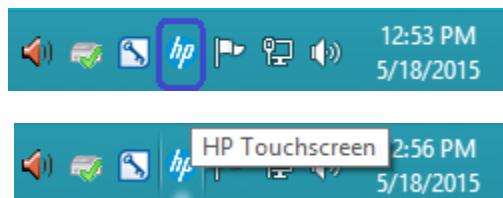

7.1.3 Touch Screen Alignment

You will need to run the touch screen alignment program the first time you use the touch screen.

There are couple methods to get to the alignment program for the touch screen. You can access this program either via the Elo ICON in the system tray or control panel.

Method1: On the Elo icon in the system tray, click on the icon and select “Align” Option:

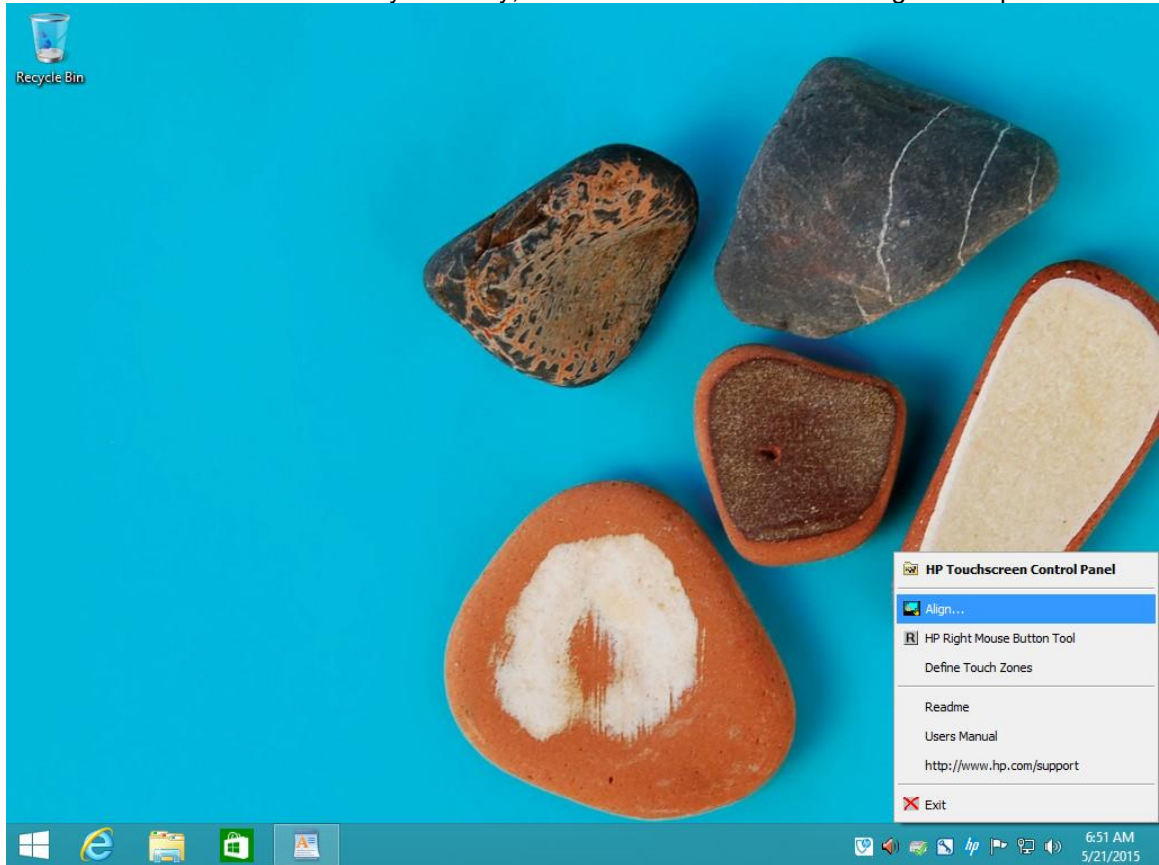

Note: The screen capture is example, what appears in the menu may vary by driver version.

Method 2: Need to switch to classic view or Large ICON / Small ICON view in control panel in order to see the HP Touch screen option.

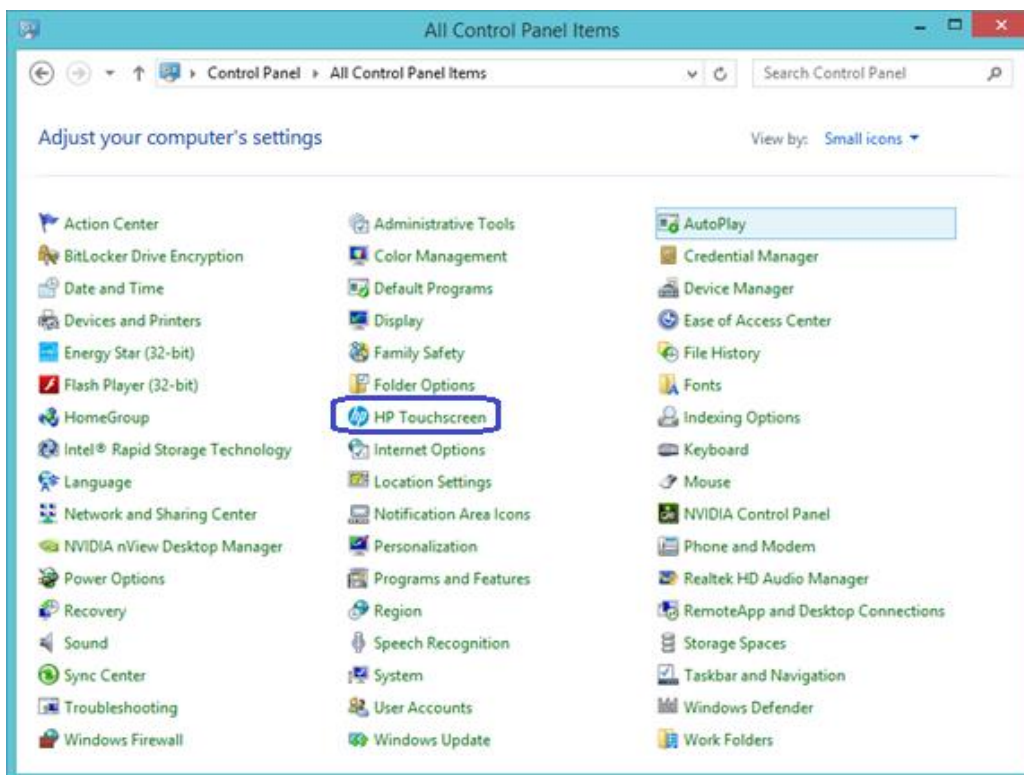
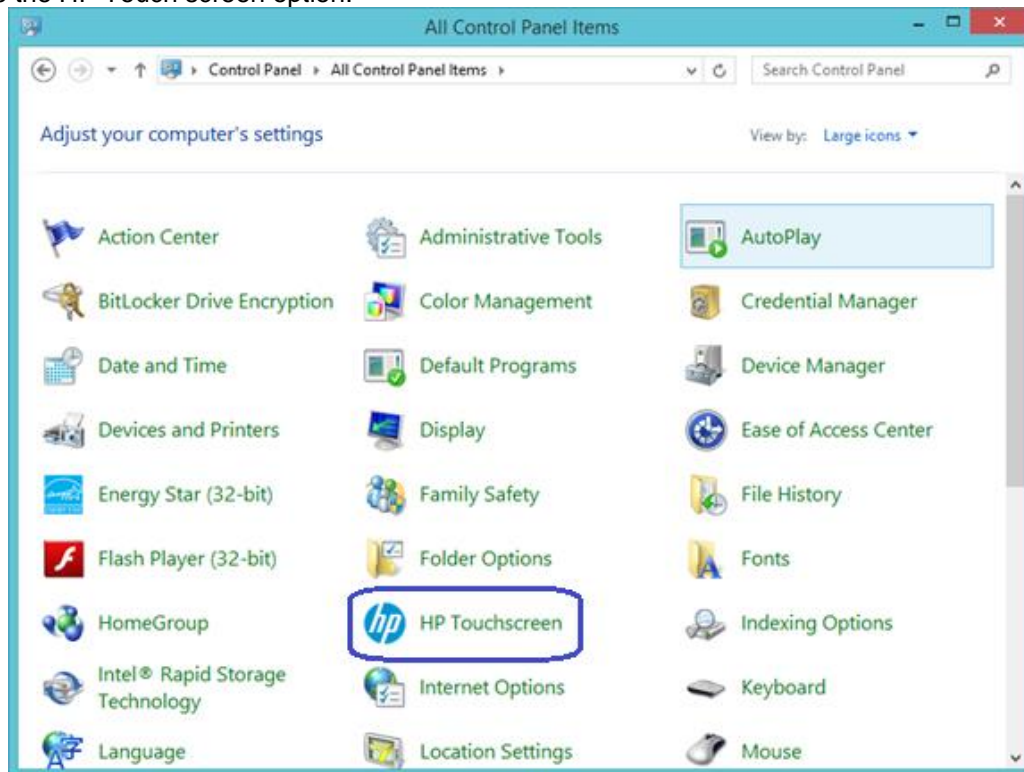

Select the align option; follow the on screen direction to align the touch screen:

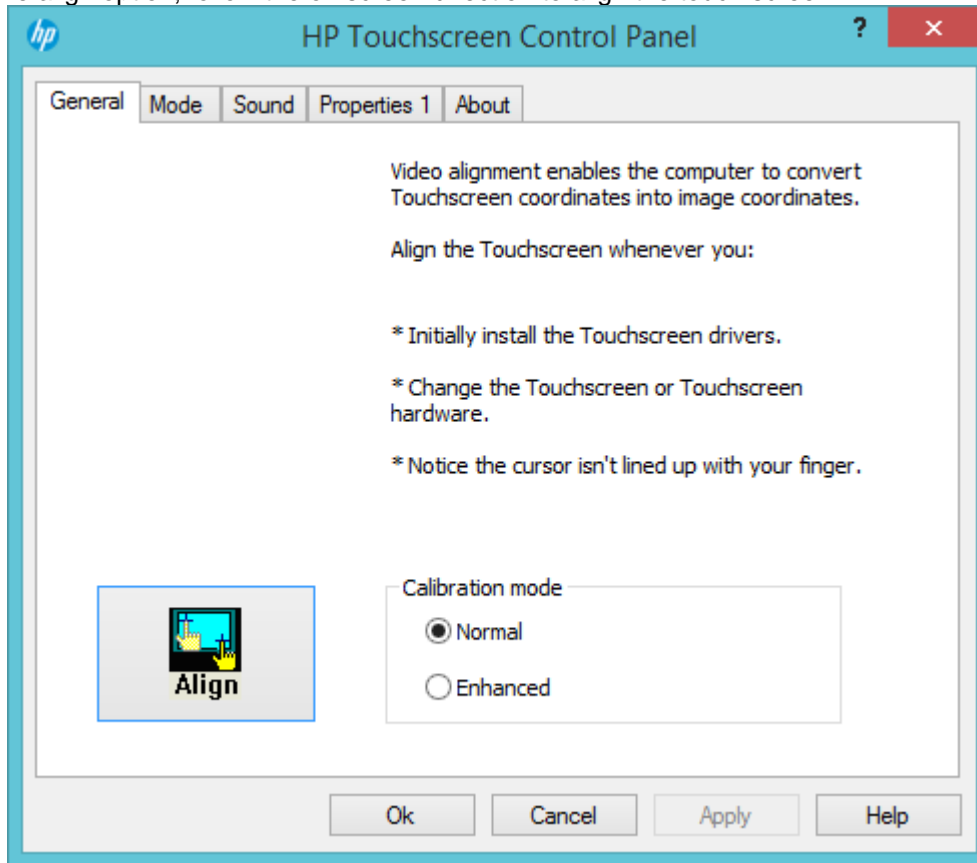

During the alignment of the touch screen you will be presented with three targets to press:

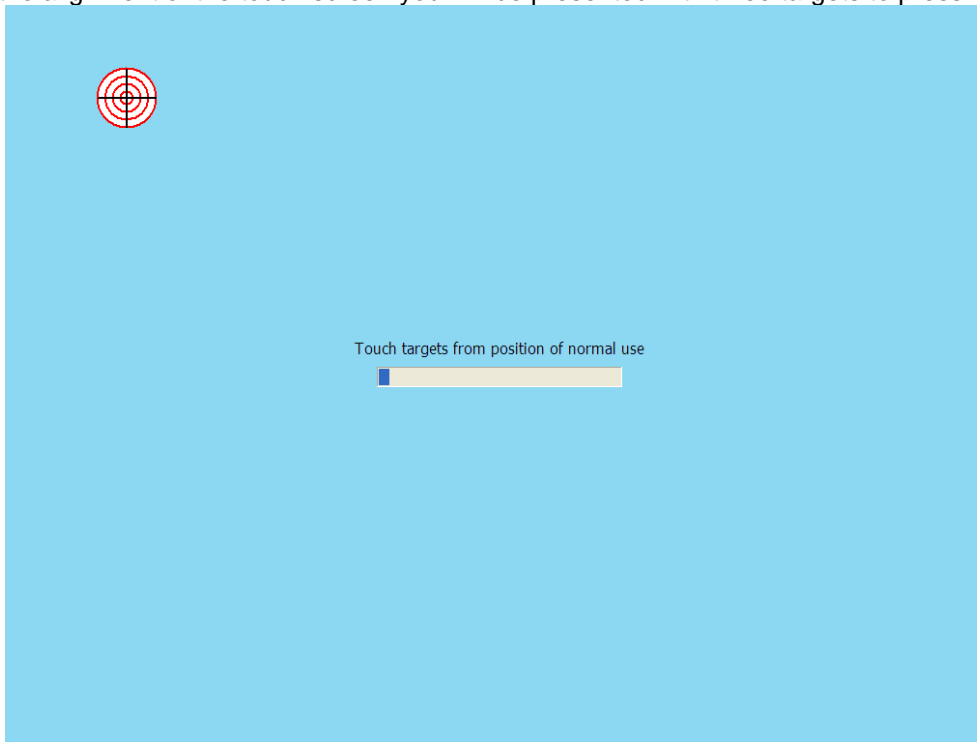

The fourth screen presented will accept the calibration that was performed:

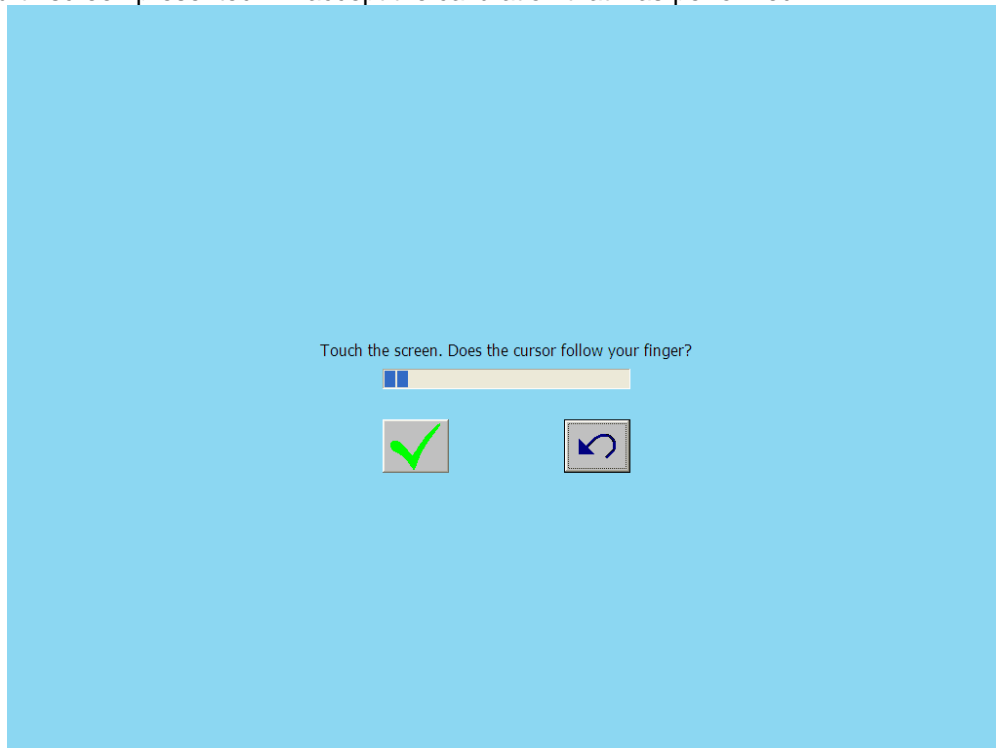

7.1.4 OPOS Drivers for the Touch Screen

No OPOS drivers are needed for the touch screen.

7.1.5 Testing the Touch Screen

Touch several places on the monitor screen and the mouse cursor should be present where the monitor was touched.

7.1.6 JPOS Drivers for the Touch Screen

No JPOS drivers are needed for the touch screen.

7.2 HP L5009tm / HP L5015tm

7.2.1 Connection

The HP L5009tm / HP L5015tm touch screen monitor has three (3) connections that need to be made on the back of the unit. One connector will plug into the VGA connector on the back of the unit, the second connection which is for the touch screen via USB connector and the third connection is for power to the monitor. The USB connection will plug into one of the free USB ports on the back of the unit.

View underneath the HP L5009tm monitor showing monitor connections:



View underneath the HP L5015tm monitor showing monitor connections:



Note: For the HP L5009tm / HP L5015tm, there is **no** serial connection for the touch screen, it is only USB.

7.2.2 Windows Drivers for the Touch Screen

The drivers for HP touch screen may be obtained from the HP.COM web or the HP factory image.

Note: When one attaches the USB cable for the touch screen on the HP L5009tm / HP L5015tm monitor, one may receive a Windows Hardware Wizard screen; select the CANCEL option on this screen. During the next few steps the drivers will be installed on the unit.

The touch screen install process must be run with ADMINISTRATOR privileges.

The following is overview of the steps to install the touch screen drivers and applets:

1. Start the touch screen installer.
2. Select your language.
3. Select the interface that you will use for the touch screen.
4. Agree to the license agreement.
5. Depending on whether the touch screen part of the monitor is attached to the unit or not, two different behaviors will be seen.

Detailed Steps

1. Start the touch screen installer and select your language:

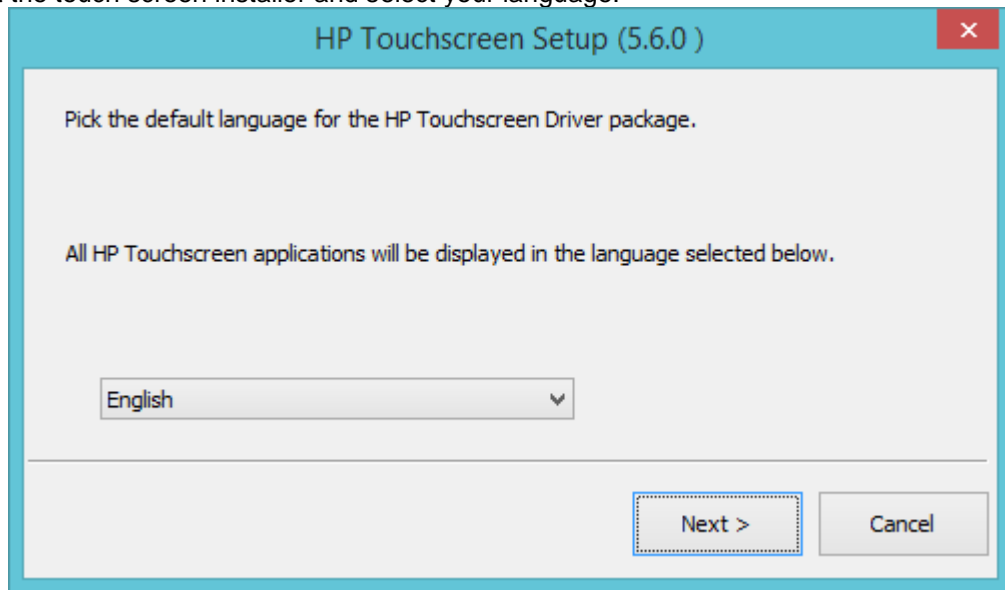

Selecting default will use the language that the operating system is running.

2. Select the "Install APR Touchscreen Driver" option and click on the NEXT button:

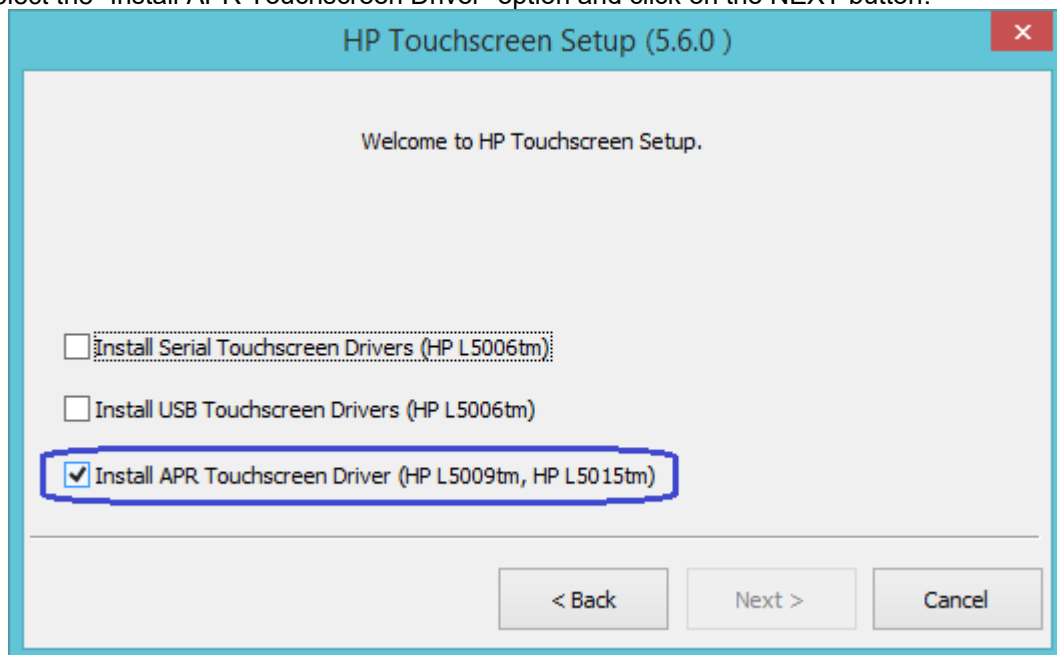

Note: The Serial Touchscreen Drivers option is not available for HP L5009tm / HP L5015tm.

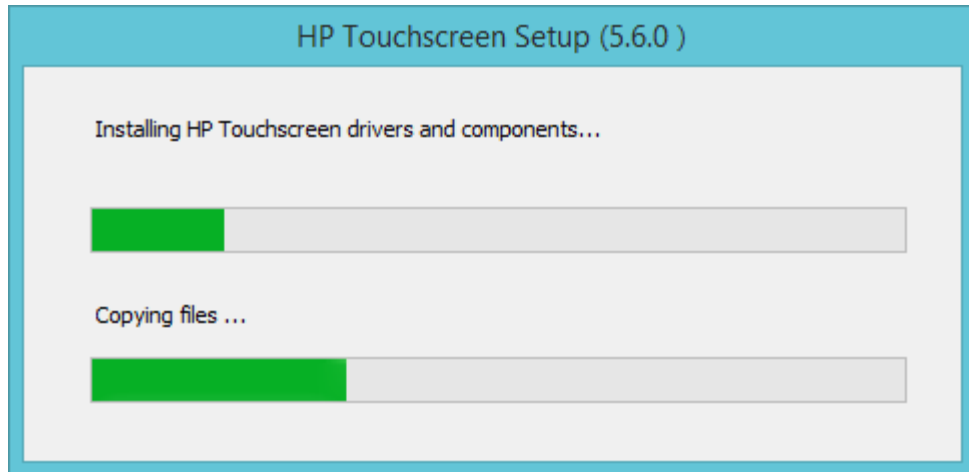

4. Depending if the touch screen USB cable is attached to the unit or not, one of the following behaviors will be seen:
 - a. After the drivers are installed and the HP L5009tm / HP L5015tm monitor touch screen USB cable is **not** attached to the unit, the installation process is complete as indicated below and the readme file may be viewed.

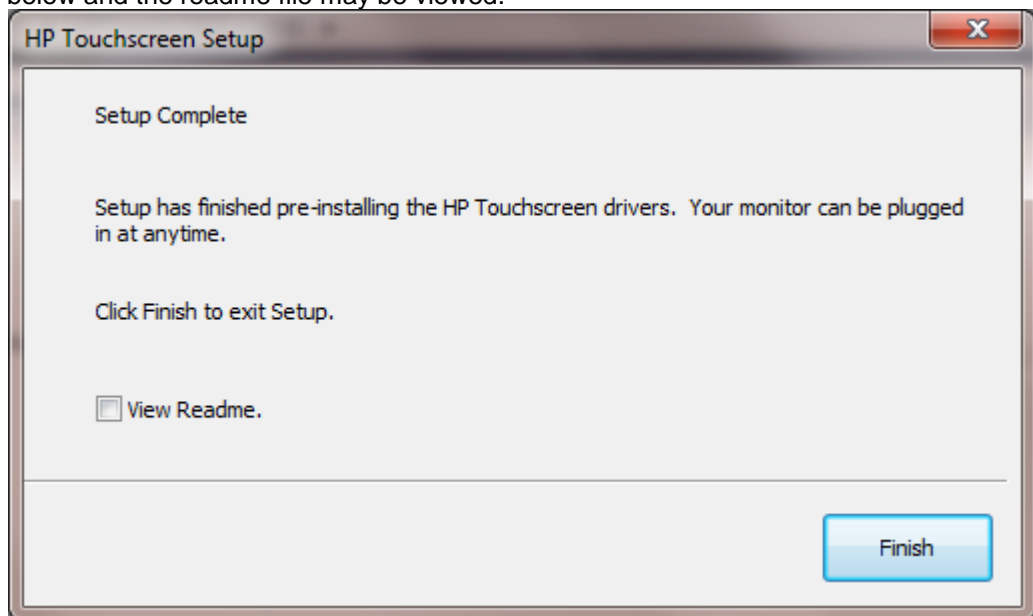

When one attaches the HP L5009tm / HP L5015tm monitor touch screen the APR configuration process will start, it will copy files to the hard drive (this process will take several minutes).

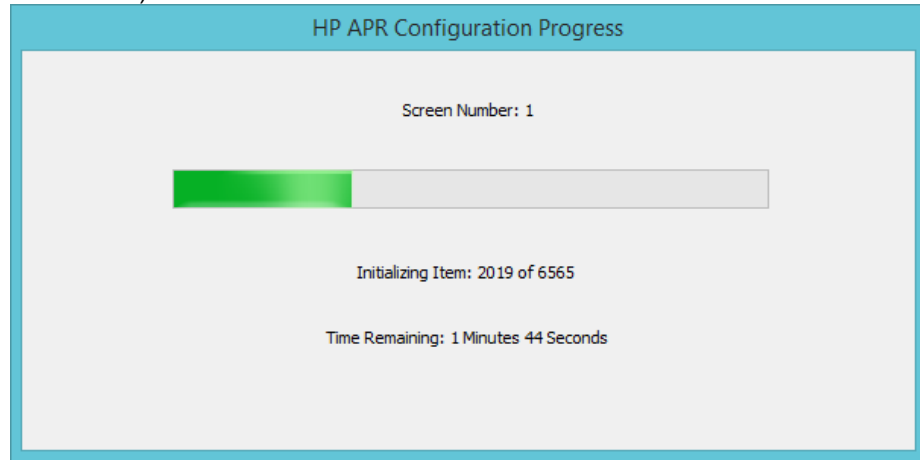

- b. With the HP L5009tm / HP L5015tm monitor touch screen (USB cable) attached to the unit and one has agreed to the license agreement the installation process for the driver will start and one will see some of the following screens:

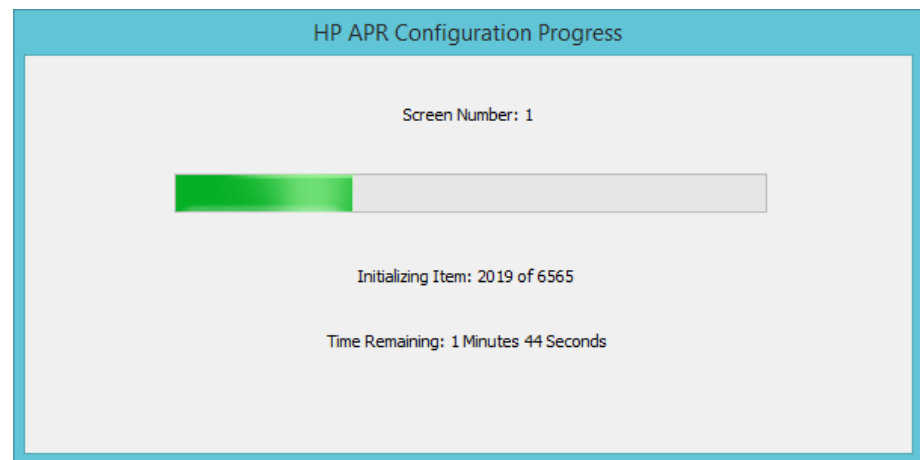
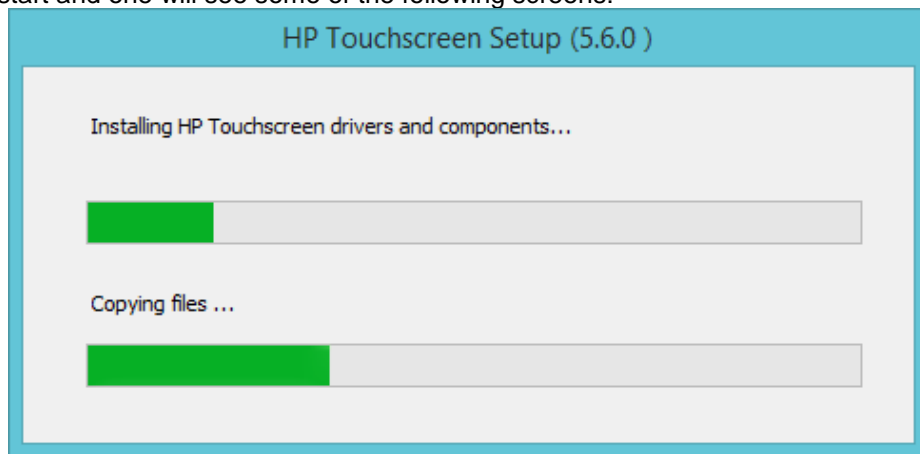

Select the option to “Calibrate HP Touchscreen monitors” and click on the “Finish” button:

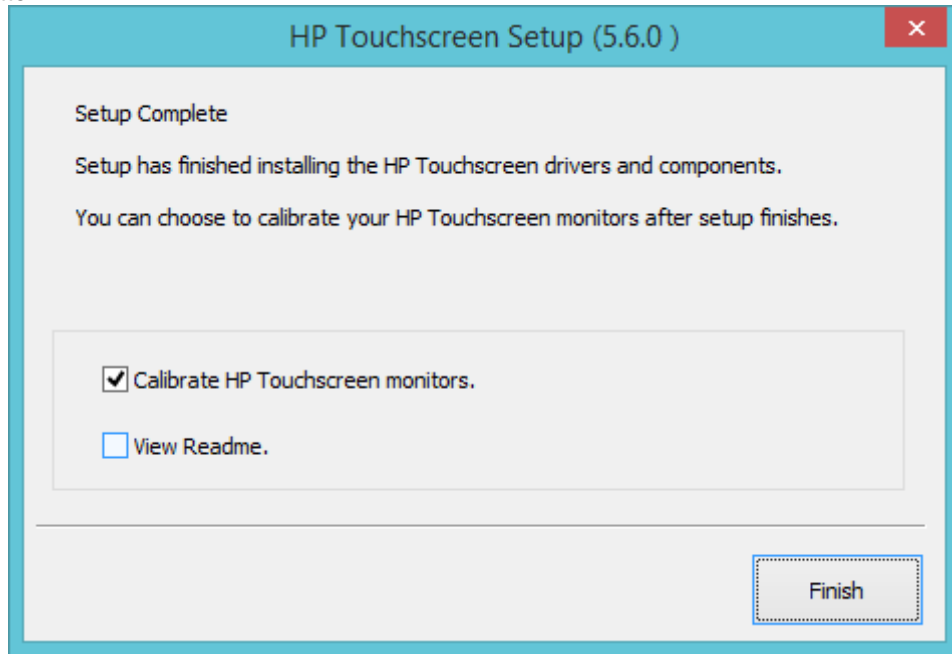

The calibrate option for HP L5009tm / HP L5015tm is a one point calibration, the screen during the calibration process looks like:

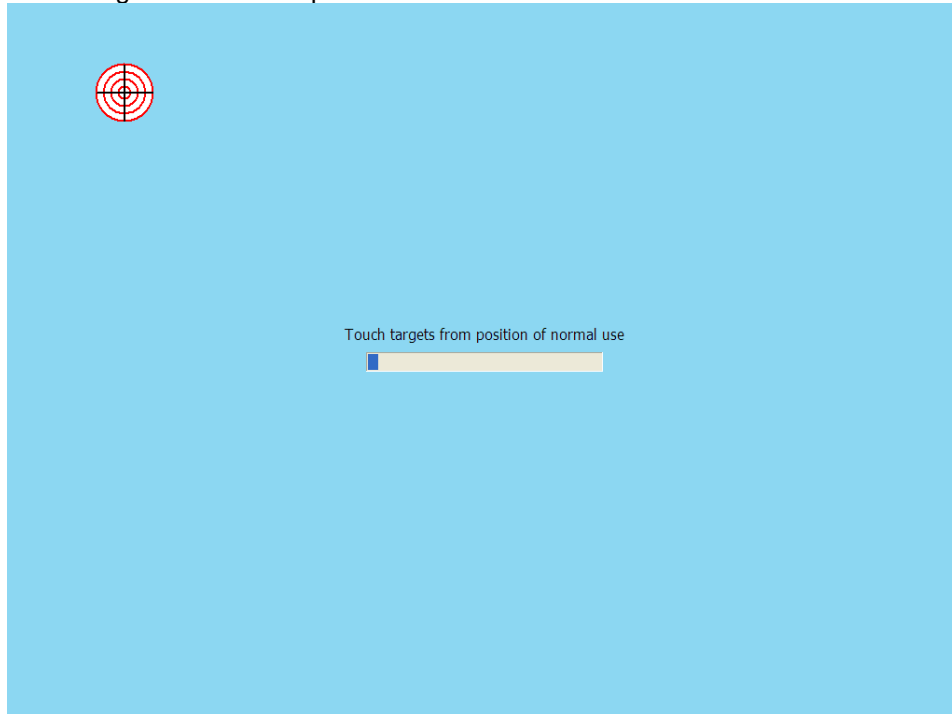

The following screen is showing Windows Device Manager after the HP L5009tm and HP L5015tm drivers are installed and when the touch screen is connected to the unit via the USB cable. After Windows has loaded the device drivers for the touch screen there will be an entry in “Human Interface Devices” and “Mice and other pointing devices” sections in Device Manager as shown below:

HP 5009tm attached to the unit.

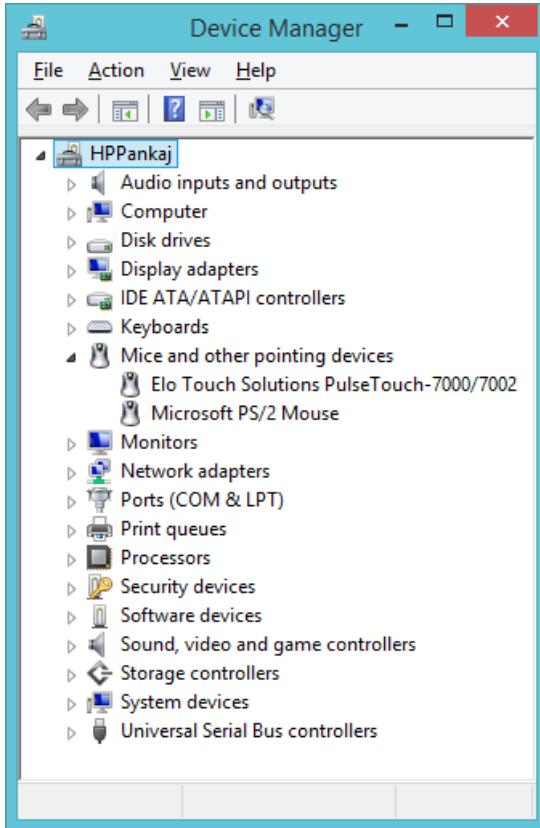

HP 5015tm attached to the unit.

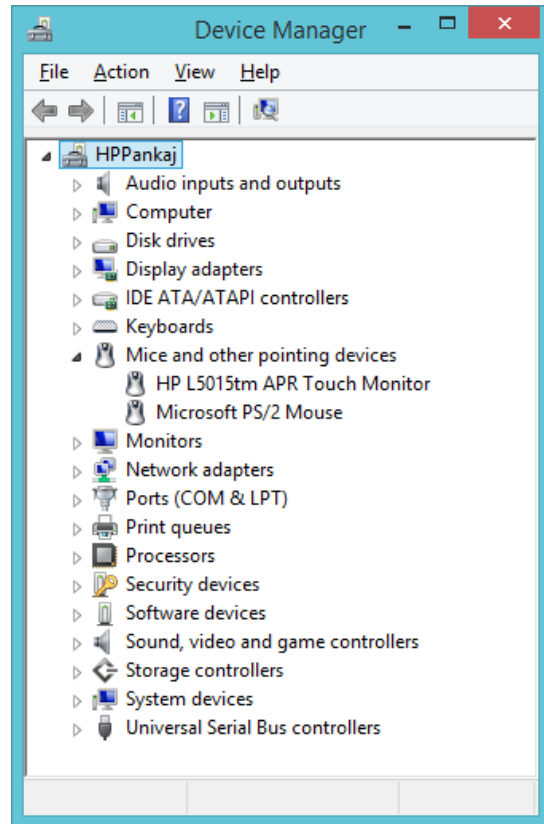

After Windows has loaded the device drivers for the touch screen there will be an HP icon in the system tray:

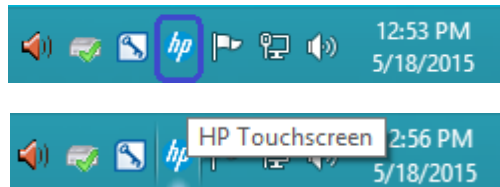

7.2.3 Touch Screen Alignment

You will need to run the touch screen alignment program the first time you use the touch screen.

There are couple of methods to get to the alignment program for the touch screen. You can access this program either via the HP ICON in the system tray or control panel.

Method1: On the HP icon in the system tray, click on the icon and select “Align” Option:

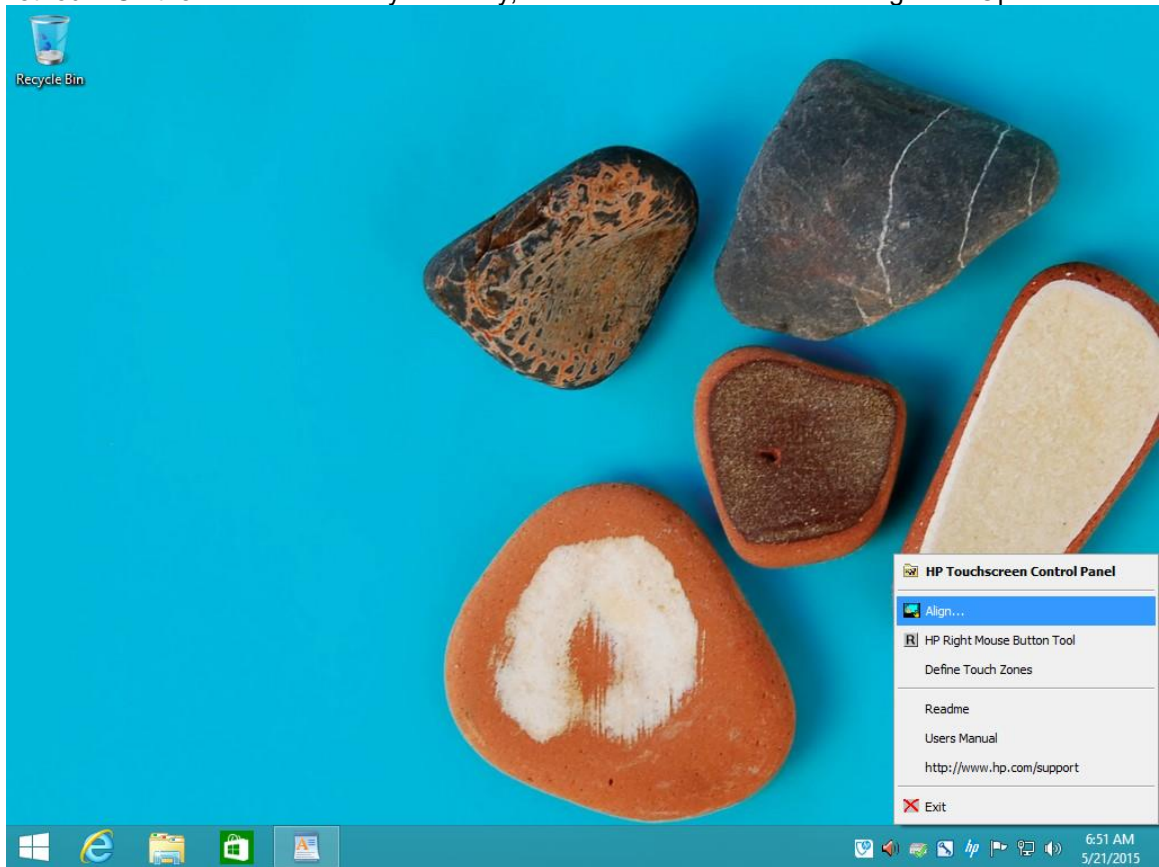

Note: The screen capture is example, what appears in the menu may vary by driver version.

Method 2: Need to switch to classic view or Large ICON / Small ICON view in control panel in order to see the HP Touch screen option.

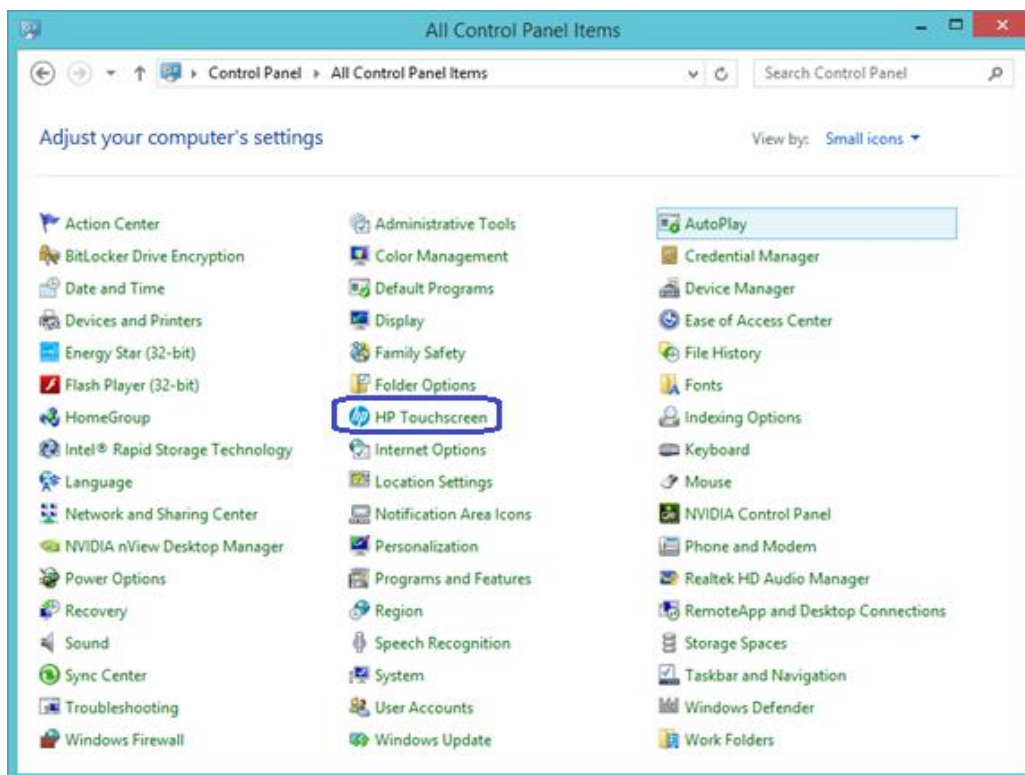
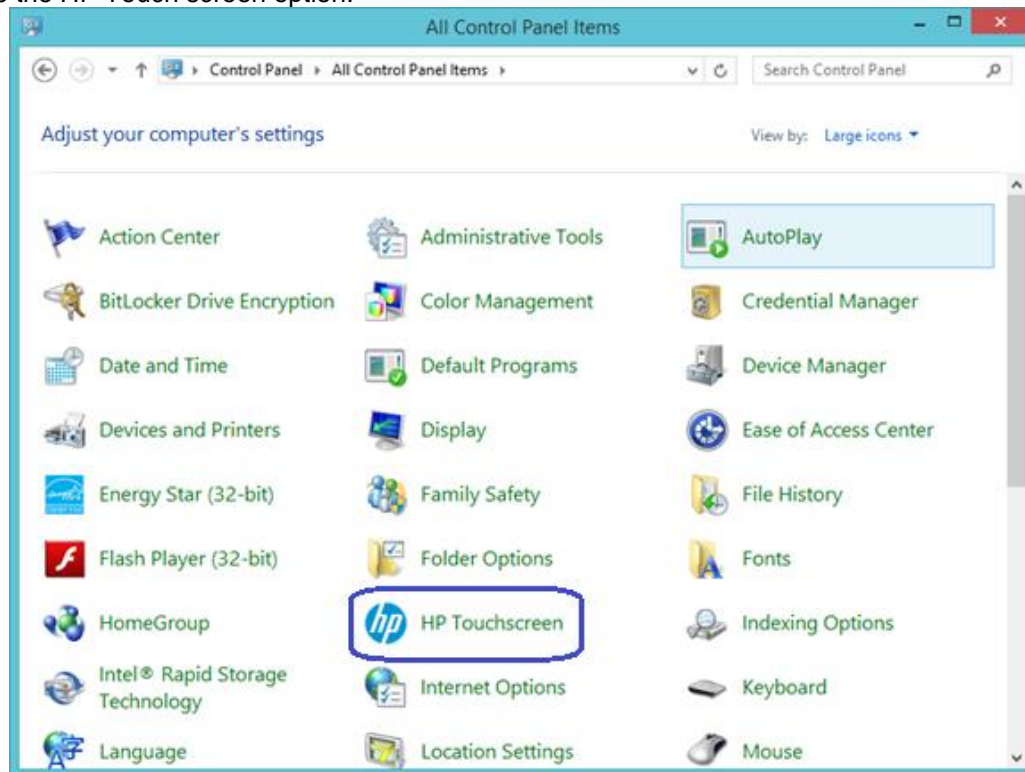

Select the align option; follow the on screen direction to align the touch screen:

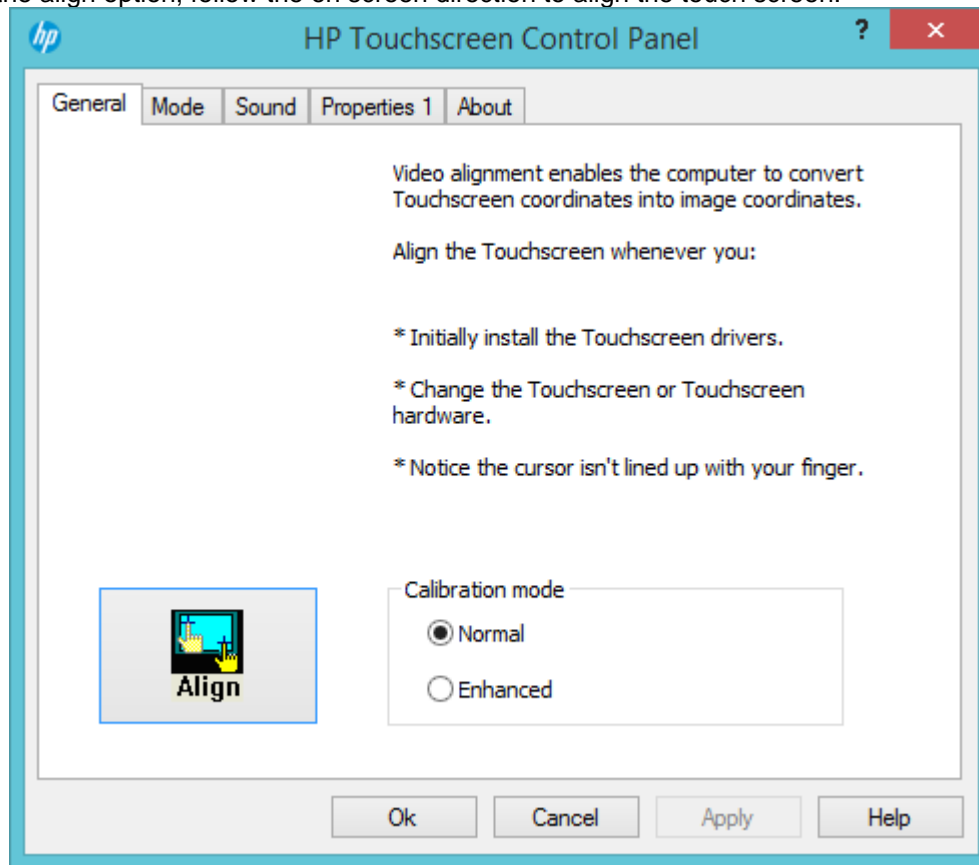

or

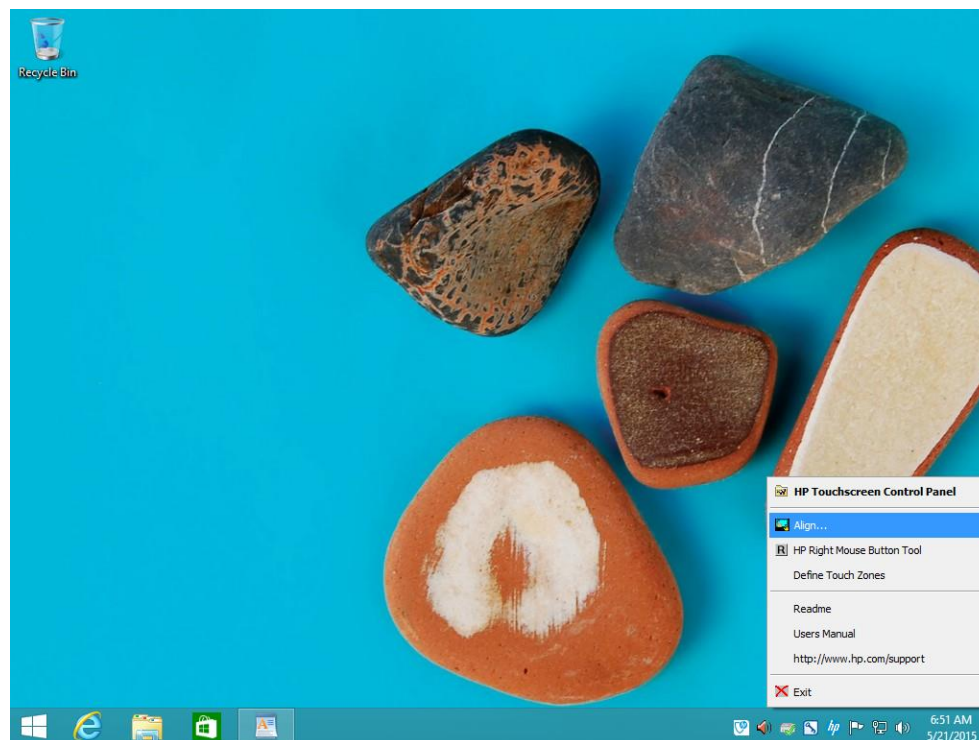

During the alignment of the touch screen you will be presented with one target to press:

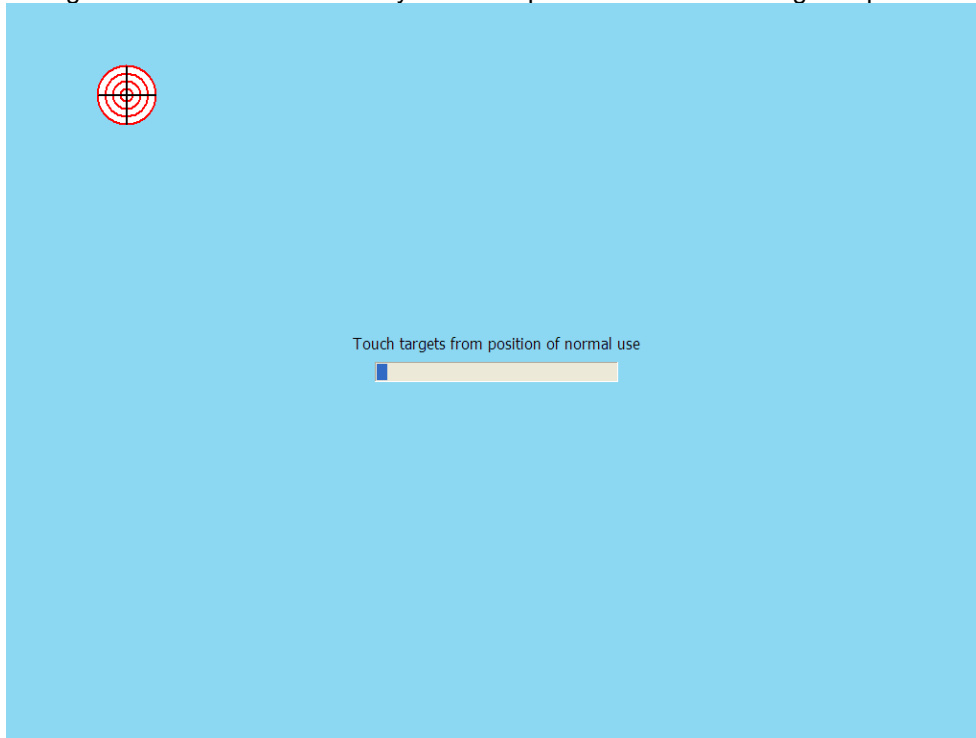

7.2.4 OPOS Drivers for the Touch Screen

No OPOS drivers are needed for the touch screen.

7.2.5 Testing the Touch Screen

Touch several places on the monitor screen and the mouse cursor should be present where the monitor was touched.

7.2.6 JPOS Drivers for the Touch Screen

No JPOS drivers are needed for the touch screen.

7.3 HP ap5000 Touch Screen



7.3.1 Connection

The touch screen on the HP ap5000 system is integrated into the system which is connected internally via PS/2 interface. There is no user connection required for this device.

7.3.2 Windows Drivers for the Touch Screen

The HP ap5000 touch screen drivers are already installed in the HP factory image (C:\xxxxx\ap5000 Touch Drivers) and are also available from HP.COM.

Note: Under Microsoft Vista, the touch screen install process must be run with ADMINISTRATOR privileges.

The following is an overview of the steps to install the touch screen drivers and applets:

1. Start the touch screen installer from the location that was mentioned in the beginning of this section.

Note: On the ap5000 unit with a Microsoft Windows image, the drivers for the ap5000 touch screen are pre-installed in the image.

2. Follow the prompts that appear on the screen.
3. After the drivers are installed, please select the option to calibrate the touch screen monitor and follow the instructions on the screen.

Detailed installation instructions

1. Start the touch screen installer from the location that was mentioned in the beginning of this section.

Note: On the ap5000 unit with a Microsoft Windows image, the drivers for the ap5000 touch screen are pre-installed in the image.

One must have ADMINISTRATOR privileges in order to install the drivers.

2. Follow the prompts that appear on the screen.

3. After the drivers are installed, please select the option to calibrate the touch screen monitor and follow the instructions on the screen by opening the calibration option in the start menu or from the system tray.

Calibration option from start menu

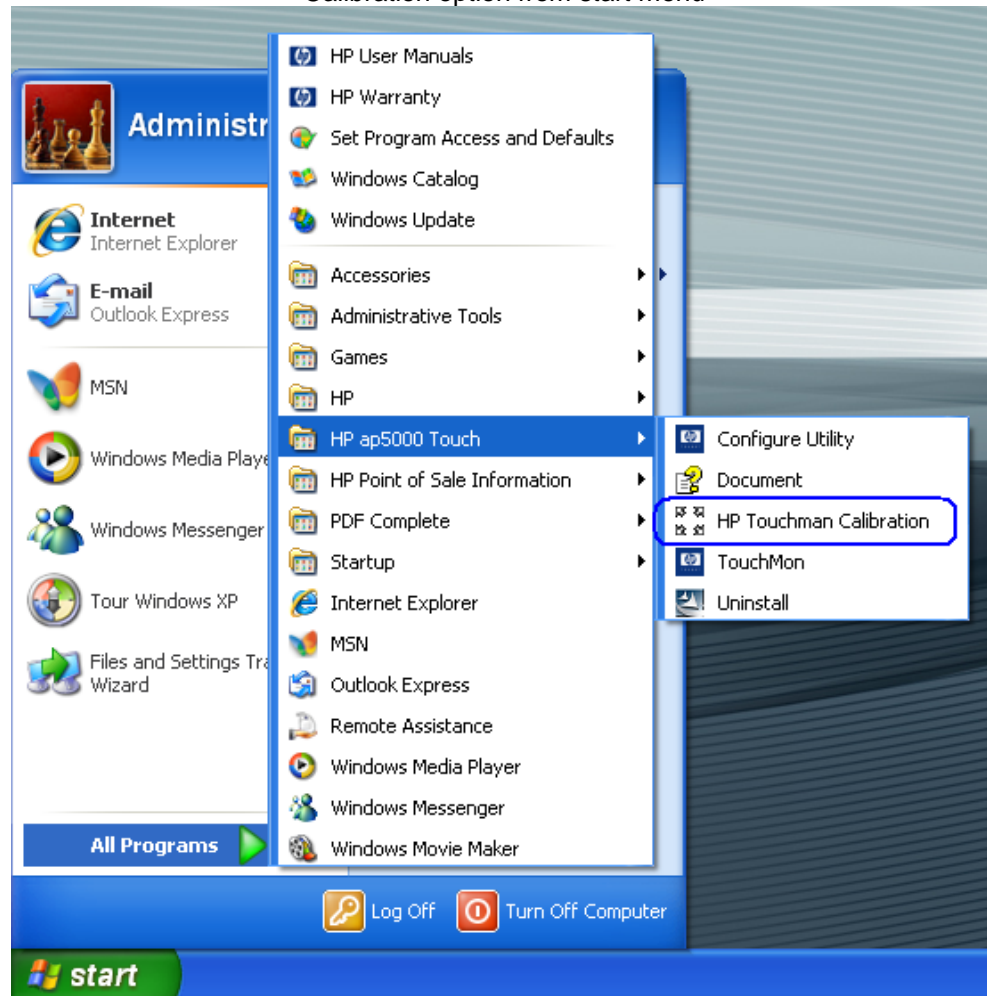

Calibration option from system tray menu

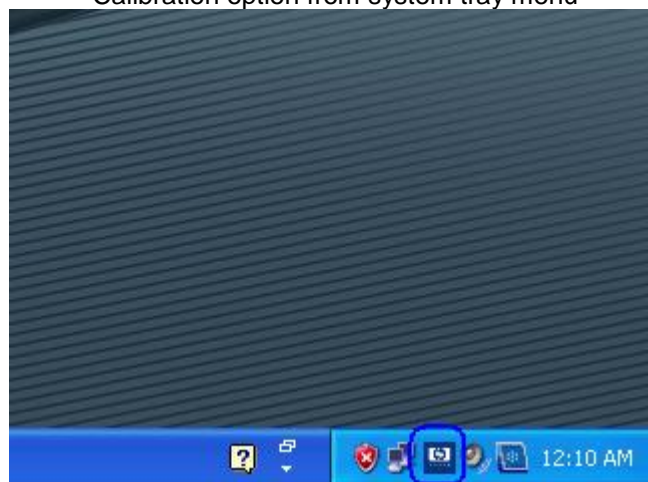

Right click on the touch screen option and select "4 Points Calibration"

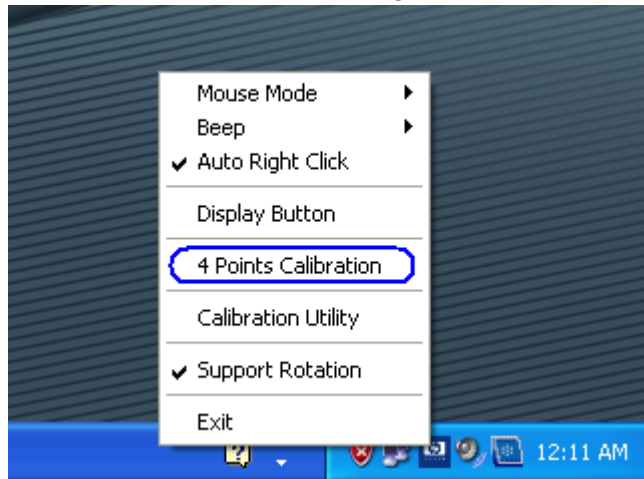

The calibrate option for HP ap5000 is four button calibration; one button appearing in each corner of the screen.

Note: When the red circle appear on the display, touch and hold the center of the red circle until it says OK.

The following screens appear during the calibration process:

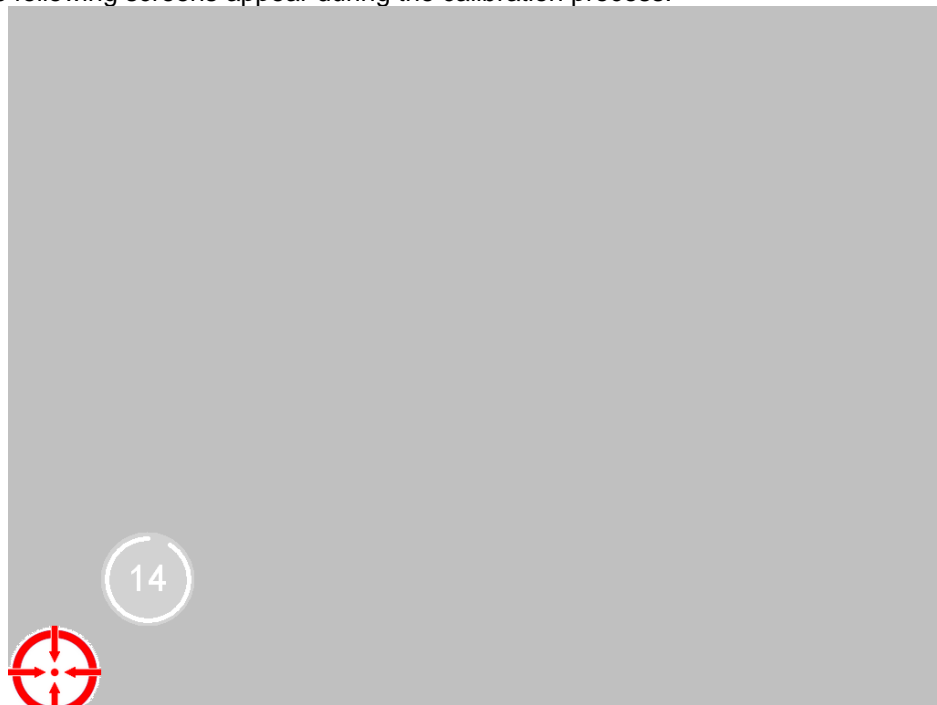

After the calibration point has been successfully accepted an "OK" appears:

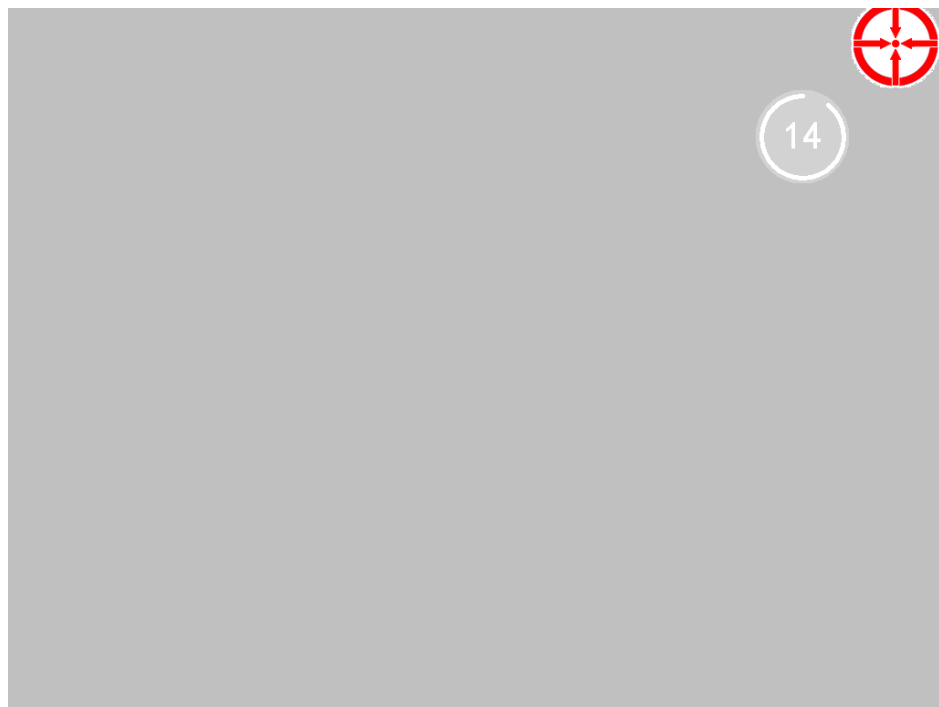
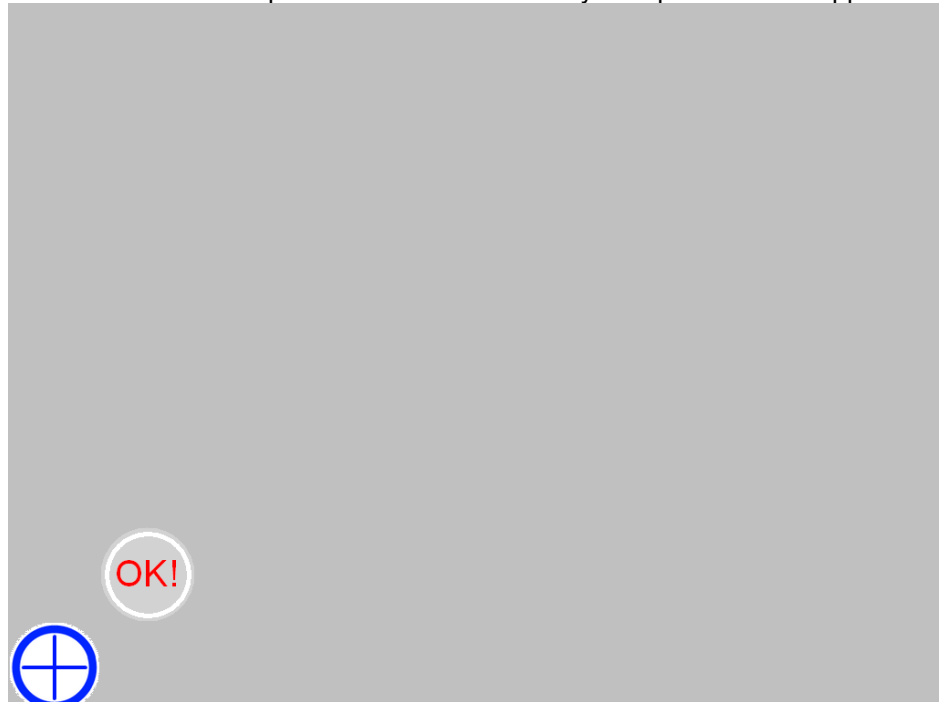

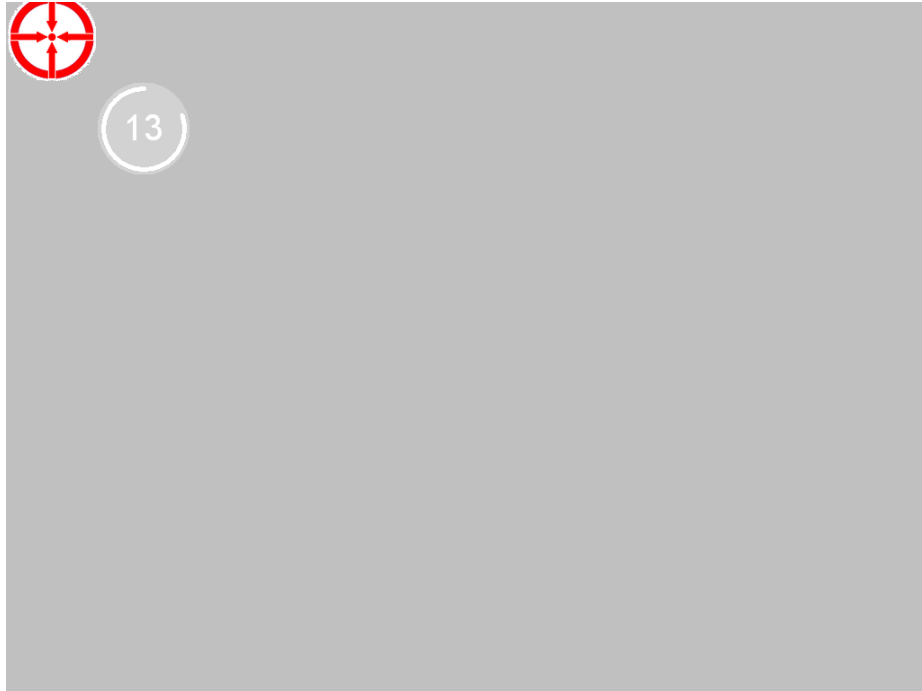

After all four points have been successfully calibrated, several screens will appear that read and write the calibration parameters. The following is a screen capture of the read screen that will appear:

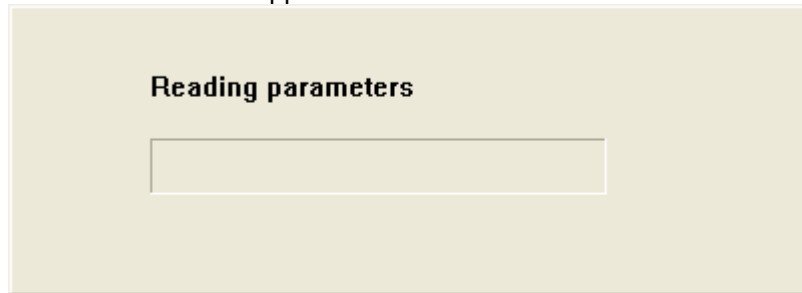

The following screen is showing Windows Device Manager after the HP ap5000 drivers are installed:

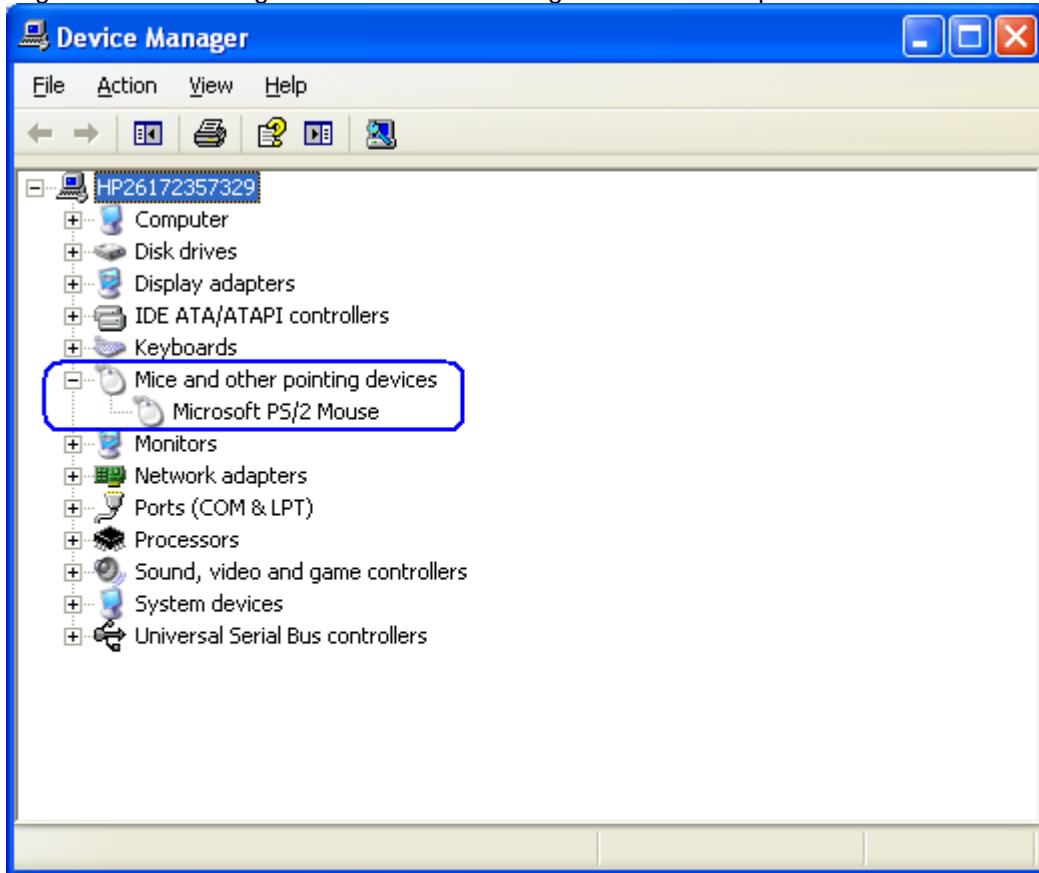

After Windows has loaded the device drivers for the touch screen there will be an HP icon in the system tray:

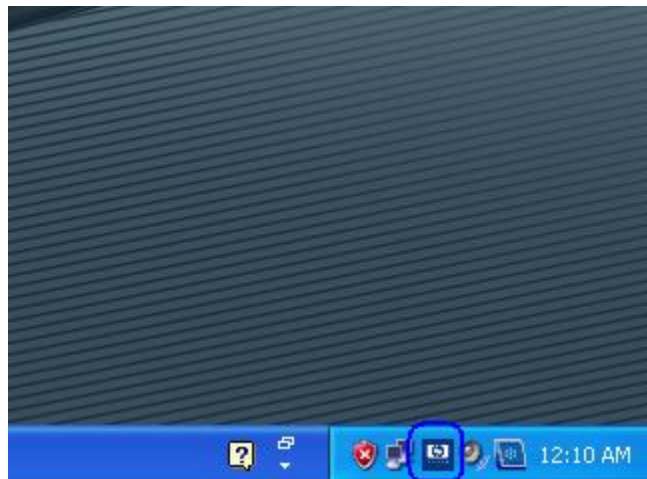

7.3.3 OPOS Drivers for the ap5000 Touch Screen

No OPOS drivers are needed for the touch screen.

7.3.4 Testing the Touch Screen

Touch several places on the monitor screen and the mouse cursor should be present where the monitor was touched.

7.3.5 JPOS Drivers for the ap5000 Touch Screen

No JPOS drivers are needed for the touch screen.

7.4 HP RP7 15inch Resistive (AFD)



Unit is shown down position with MSR / Biometric option.

7.4.1 Connection

The 15inch resistive AFD (Associate Facing Display) is part of the base unit thus require no external cables to be connected by the user.

7.4.2 Windows Drivers for the Touch Screen

For Windows 7 (32 and 64 bit) and POSReady 7 (32 and 64 bit) operating system, the touch is recognized by the operating system automatically.

For Microsoft POSReady 2009 operating system, the drivers for HP touch screen are already installed in the HP factory image and are also available from HP.COM.

After obtaining drivers, the following is overview of the steps to install the touch screen drivers and applets:

1. Start the touch screen installer by clicking on the SETUP.EXE file.
Note: The touch driver is installed in the HP factory for HP RP7 15inch resistive model.
2. Accept the default prompt prompts until the installation process is complete to install the drivers.
3. Once the installation is complete restart the operating system by selecting YES to the restart question or manually restart after other items installation are complete.
4. Run the calibration utility.

Detailed Steps

1. Start the touch screen installer by clicking on the "HP Resistive TouchScreen Driver.exe" file.
Note: The touch driver is installed in the HP factory for HP RP7 15inch resistive model.

2. Accept the default prompt prompts until the installation process is complete to install the drivers. Below are few screen that will be seen during the installation process:

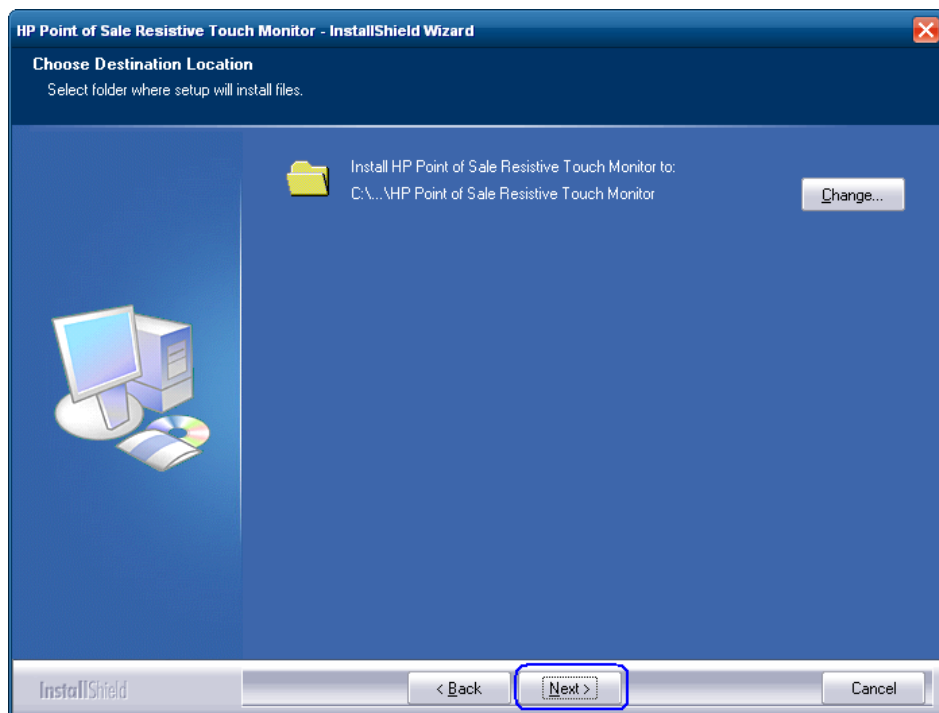
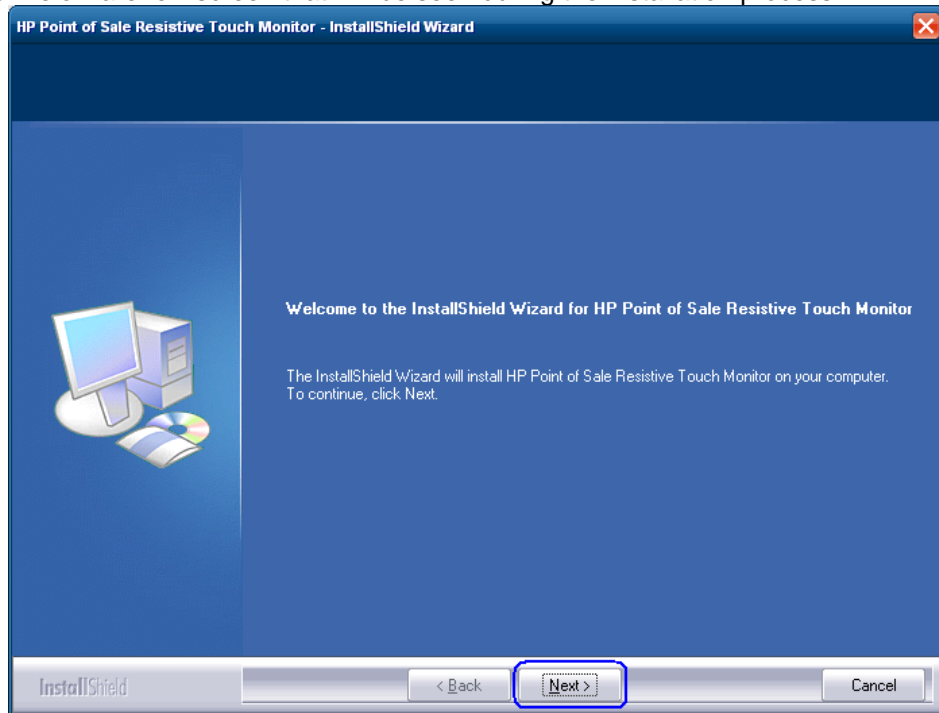

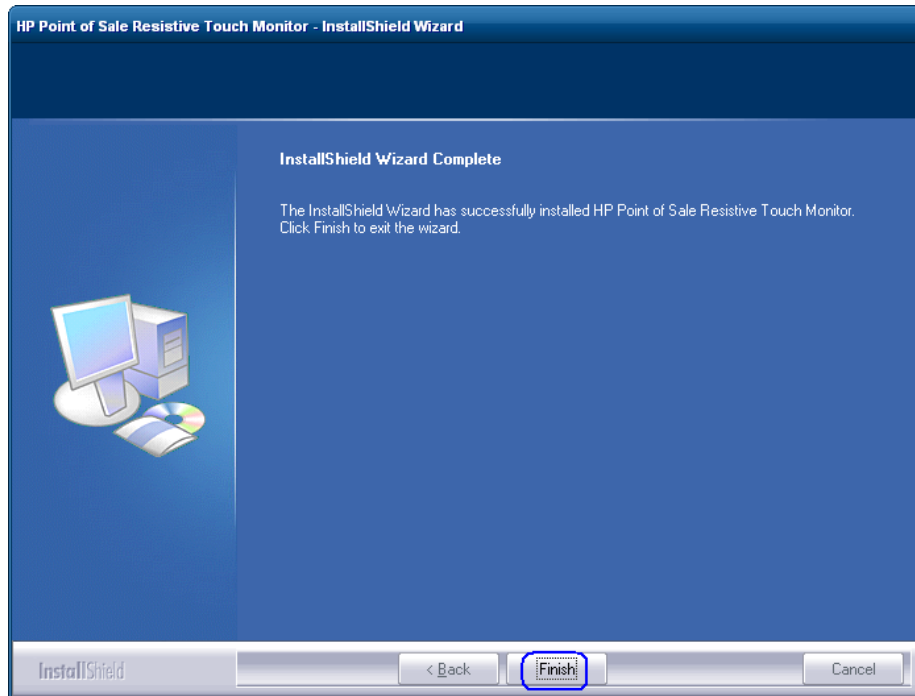

3. Once the installation is complete restart the operating system by selecting YES to the restart question or manually restart after other items installation are complete.

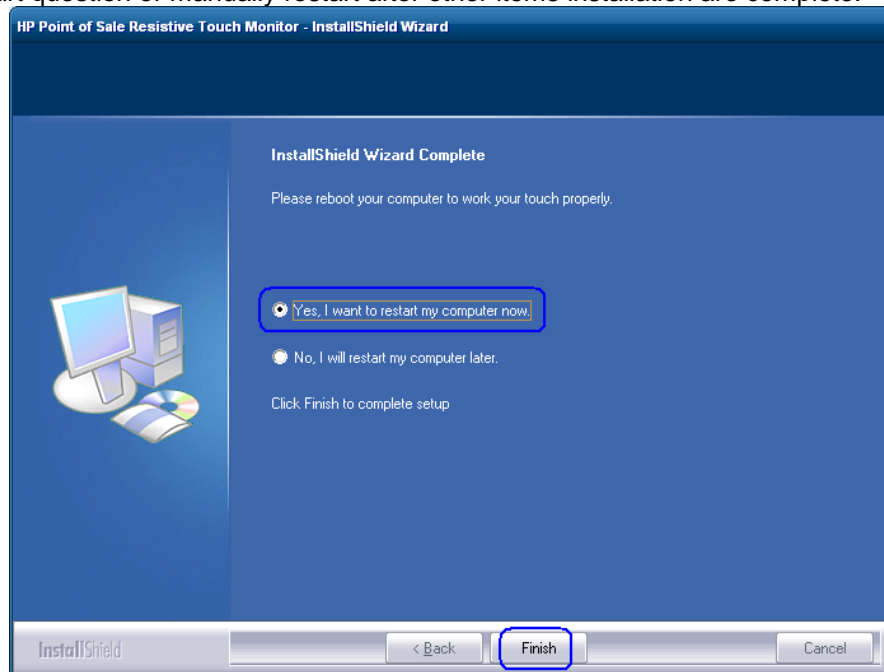

4. Run the calibration utility as mentioned in the touch screen calibration section.

7.4.3 Touch Screen calibration

For Windows 7 (32 and 64 bit) and POSReady 7 (32 and 64 bit) operating system:

1. Click on the START button.
2. Click on CONTROL PANEL.
3. In the search box type in "Tablet PC Setting" (without the quote) and in the list of results select "Table PC Settings".
4. On the DISPLAY tab under DISPLAY OPTION select CALIBRATE.

Note: When one calibrates for the screen for the first time, the screen uses 16 different reference points. If one selects the calibration option again only 4 points are used. To perform a 16-point calibration again, in the Tablet PC Properties window, tap the Reset button.

5. Follow the instructions on the screen and click YES to save your calibration settings.

For POSReady 2009 operating system:

1. Click on the START button.
2. Open "HP Point of Sale Resistive Touch Monitor" folder.
3. Select the TOUCH TOOL icon.



4. Select the 9 point calibration option and follow the prompts on the screen to calibrate the touch monitor. Press the target button that appears until the next target appears. The screen shot below represent the calibration screen that will appear during the process (the “x” represent the other 8 touch point that will appear during the calibration process.

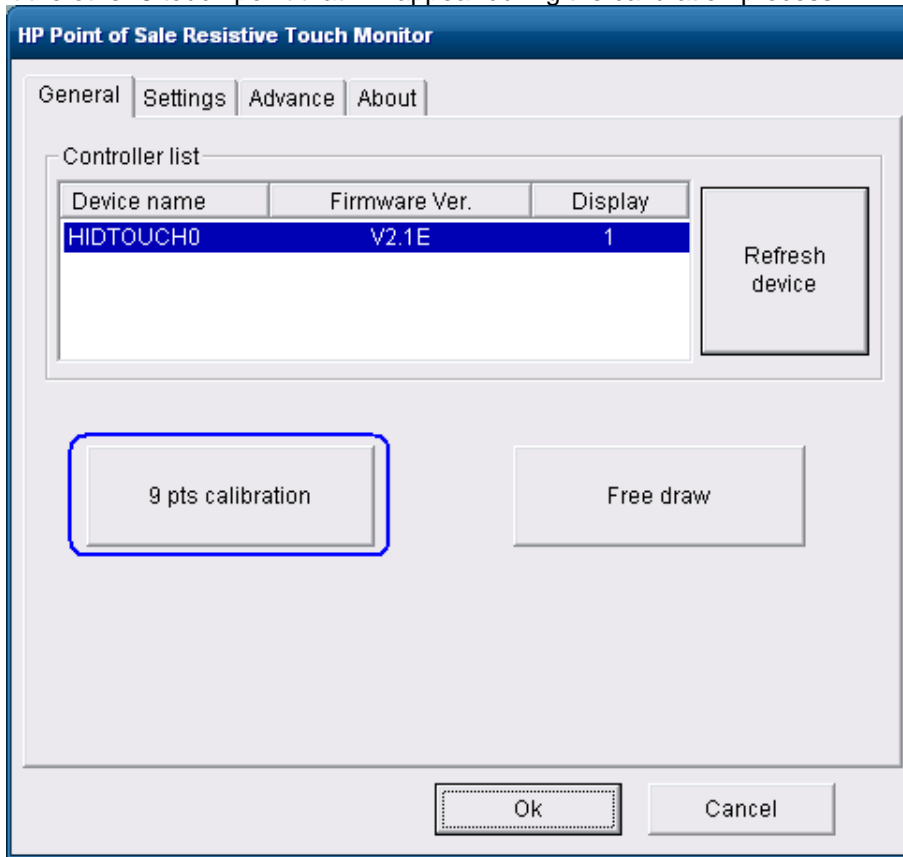

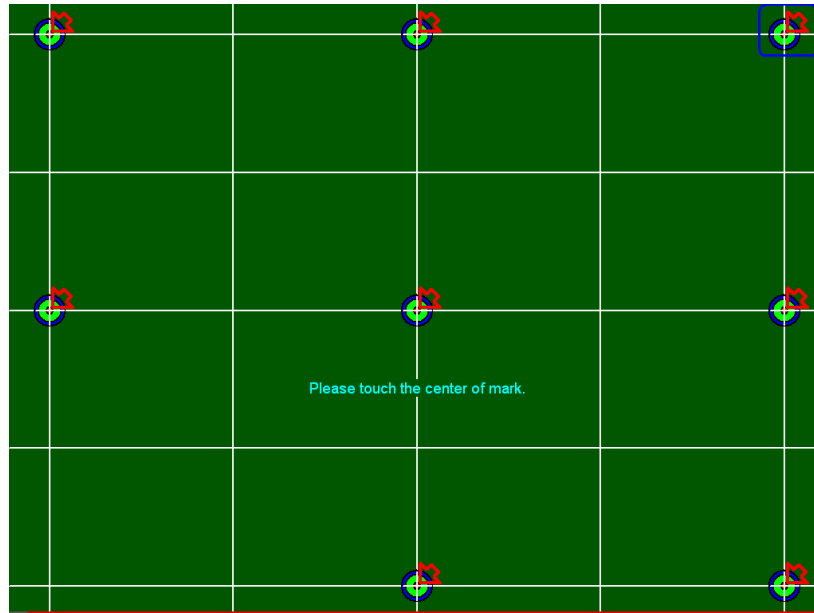

Note: The targets appear one at a time. The screen shot above represent the location where the 9 point calibration targets will appear.

5. Save the calibration setting.

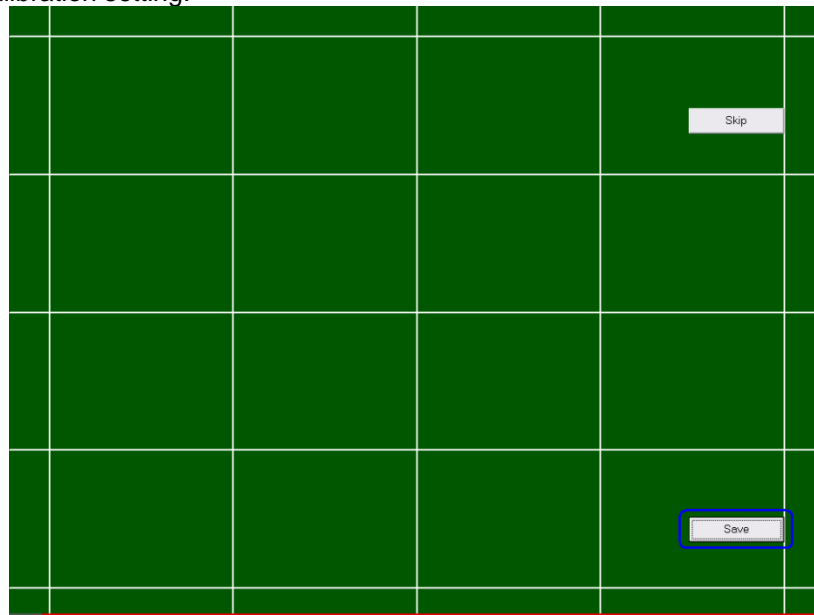

7.4.4 **OPOS Drivers for the Touch Screen**

No OPOS drivers are needed for the touch screen.

7.4.5 **Testing the Touch Screen**

Touch several places on the monitor screen and the mouse cursor should be present where the monitor was touched.

7.4.6 **JPOS Drivers for the Touch Screen**

No JPOS drivers are needed for the touch screen.

7.5 **HP RP7 15 /17 inch Projective Capacitive AFD (Associate Facing Display)**



Unit is shown down position with MSR option.

7.5.1 **Connection**

The 15 / 17 inch Projective Capacitive (PCap) AFD (Associate Facing Display) is part of the base unit thus require no external cables to be connected by the user.

7.5.2 **Windows Drivers for the Touch Screen**

For Windows 7 (32 and 64 bit) and POSReady 7 (32 and 64 bit) operating system, the touch is recognized by the operating system automatically.

For Microsoft POSReady 2009 operating system the drivers for HP touch screen are already installed in the HP factory image and are also available from HP.COM.

After obtaining drivers, the following is overview of the steps to install the touch screen drivers and applets:

1. Start the touch screen installer by clicking on the SETUP.EXE file.
Note: The touch driver is installed in the HP factory for HP RP7 15/17 inch projective capacitive model.
2. Click on the "OK" to start the installation process.
3. Once the installation is complete restart the operating system by selecting YES to the restart question. If one selects "NO" one will see a screen that indicates the driver was successfully installed; manually restart after other items installation are complete.

Detailed installation instructions for Windows XP/POSReady 2009

1. Start the touch screen installer by clicking on the SETUP.EXE file.
Note: The touch driver is installed in the HP factory for HP RP7 15/17 inch projective capacitive model.

2. Click on the "OK" to start the installation process.

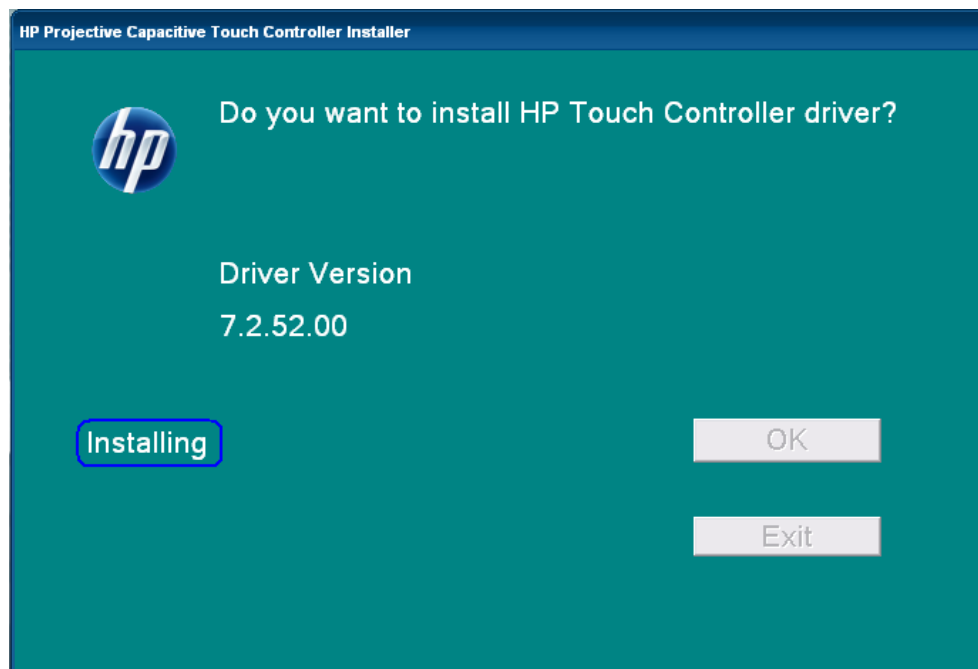
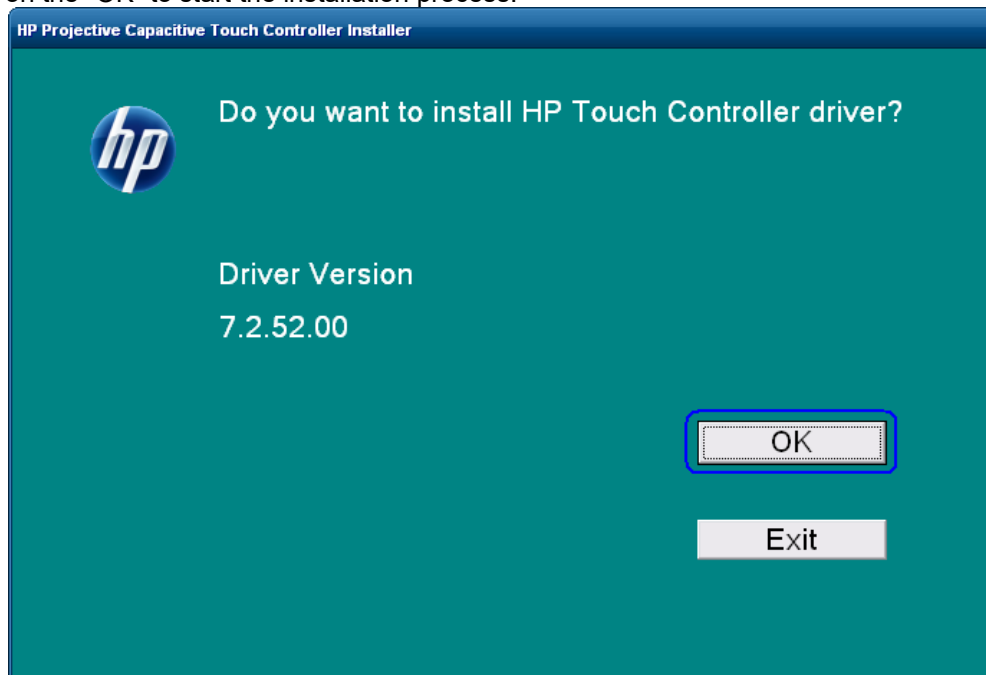

3. Once the installation is complete restart the operating system by selecting YES to the restart question. If one selects "NO" one will see a screen that indicates the driver was successfully installed; manually restart after other items installation are complete.

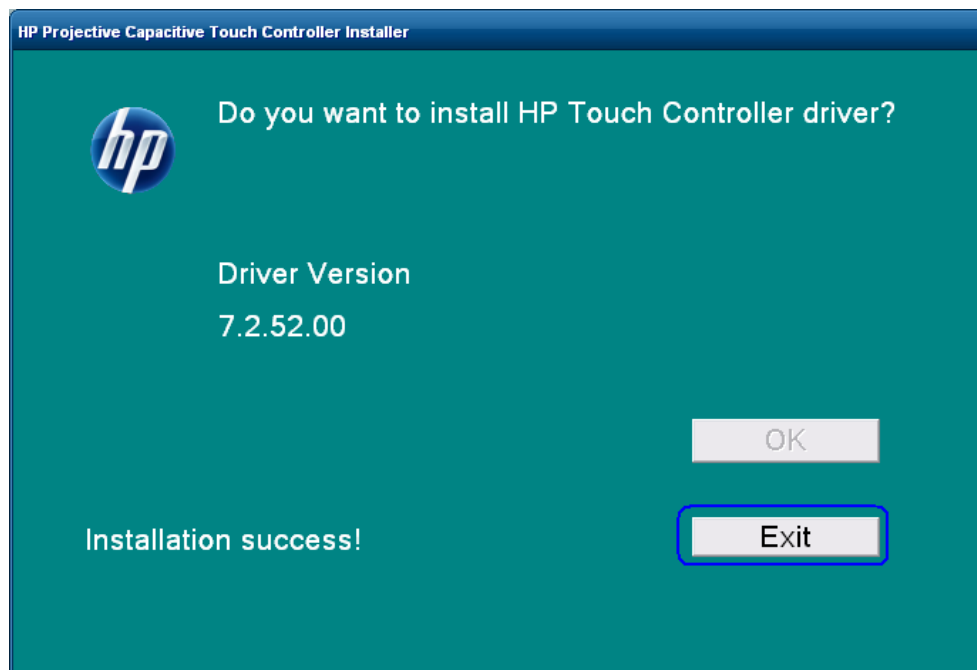
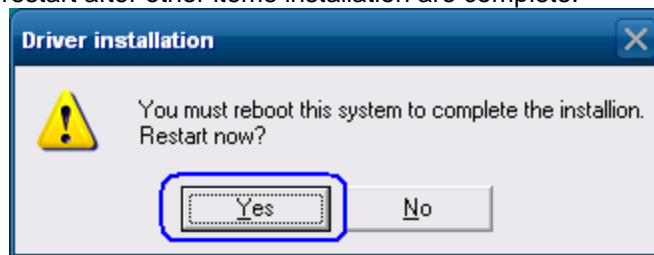

7.5.3 Touch Screen calibration

For Microsoft POSReady 2009 and Windows XP Professional operating system there is no calibration needed due to the projective capacitive technology therefore there is no calibration utility for the HP RP7 15/17 inch projective capacitive touch.

For Windows 7 (32 and 64 bit) and POSReady 7 (32 and 64 bit) operating system the following are the steps to open the calibration utility **BUT** it is not necessary for the HP RP7 15/17 inch projective capacitive touch:

1. Click on the START button.
2. Click on CONTROL PANEL.
3. In the search box type in "Tablet PC Setting" (without the quote) and in the list of results select "Table PC Settings".
4. On the DISPLAY tab under DISPLAY OPTION select CALIBRATE.

Note: When one calibrates for the screen for the first time, the screen uses 16 different reference points. If one selects the calibration option again only 4 points are used. To perform a 16-point calibration again, in the Tablet PC Properties window, tap the Reset button.

5. Follow the instructions on the screen and click YES to save your calibration settings.

7.5.4 Touch in Dual Monitor Configuration in POSReady 2009 or XP

This section and the touch drivers are for Microsoft POSReady 2009 and Microsoft Windows XP operating system.

In a dual touch PCAP monitor configuration, in order to have touch on both monitors one must have driver's version 7.5.52.00 or later which can be obtained on the HP.COM website. After the drivers are obtained the following is the process to install the drivers in dual touch PCAP configuration.

1. Go to the folder where the PCAP touch drivers have been downloaded and extracted.
2. Open the SETUP.EXE utility with "/dual" parameter (i.e. SETUP.EXE /dual) and follow the prompts on the screen.
3. After the drivers are installed and the unit is rebooted, need to identify the touch monitors to the touch drivers. In the system tray double click on the "Multi-mouse-daemon" icon to open the configuration of the touch monitors. This utility was installed in the system tray because of the "/dual" parameter.



Multi-mouse-daemon icon
in system tray.

4. Follow the prompts that appear when "Multi-mouse-daemon" utility is opened. The following are the screens that will appear.

Initial screen that appears when the utility is opened:

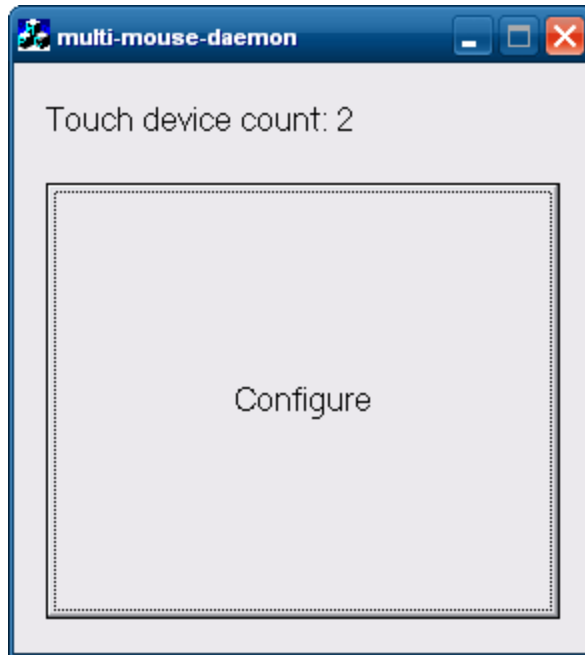

Once the "CONFIGURE" button is pressed on the primary monitor a screen appears that ask one to touch a box. After the box on primary monitor is touched then the similar screen appears on the secondary monitor. The boxes that will be similar to the box below:

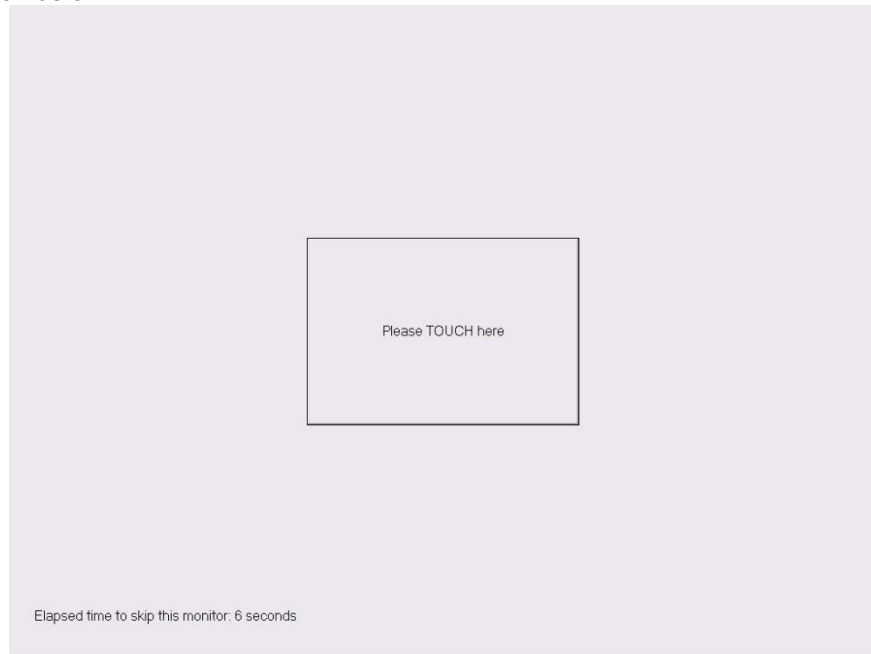

After the second monitor has been touched or timeout has occurred a message indicating that the process is complete appears:

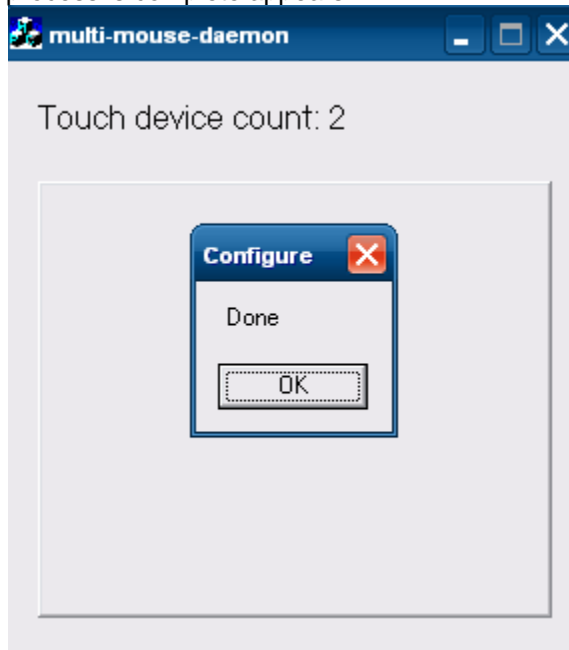

Click or press on the OK button to complete the process.

Note: The “Multi-mouse-daemon” information will be kept upon reboot of the operating system. If the driver is re-installed or different monitor PCAP monitor is installed on the unit the utility must be re-run in order to obtain the proper monitor information.

7.5.5 **Touch in Dual Monitor Setup in POSReady 7 or Windows 7**

For Windows 7 (32 and 64 bit) and POSReady 7 (32 and 64 bit) operating system the following are the steps to correctly identify the touch monitors:

1. Click on the START button.
2. Click on CONTROL PANEL.
3. In the search box type in “Tablet PC Setting” (without the quote) and in the list of results select “Table PC Settings”.

4. On the DISPLAY tab under CONFIGURE click on the SETUP button.

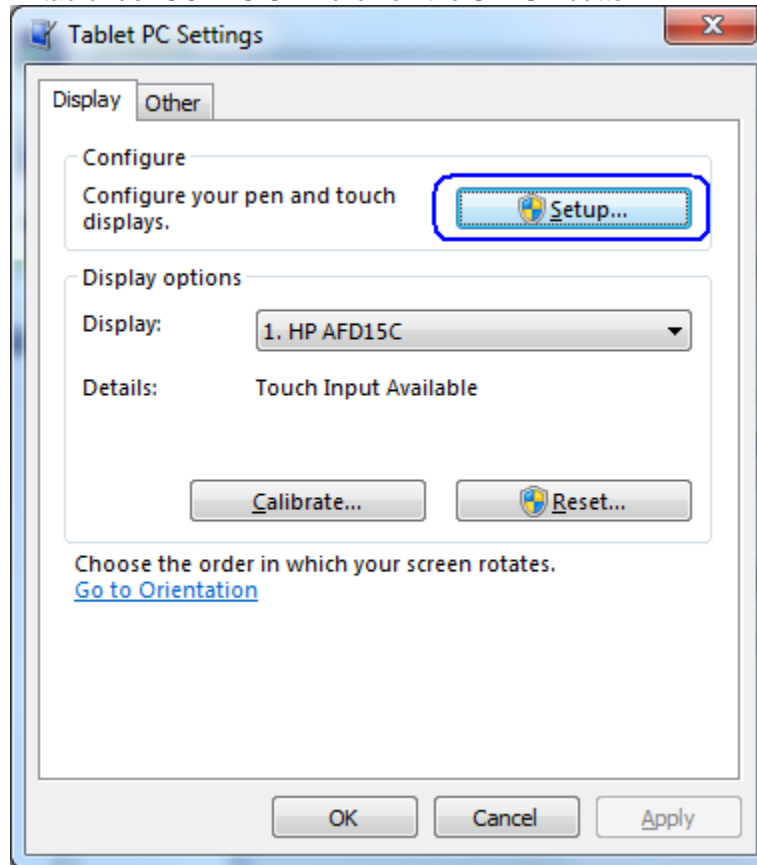

5. Follow the prompt that appears on the screen. The following is example of the prompt that appears on the screen:

Touch this screen to identify it as the touchscreen.

If this is not the Tablet PC screen, press Enter to move to the next screen. To close the tool, press Esc.

7.5.6 **OPOS Drivers for the Touch Screen**

No OPOS drivers are needed for the touch screen.

7.5.7 **Testing the Touch Screen**

Touch several places on the monitor screen and the mouse cursor should be present where the monitor was touched.

7.5.8 **JPOS Drivers for the Touch Screen**

No JPOS drivers are needed for the touch screen.

7.5.9 **Disable/Enable On-Screen Display (OSD)**

The OSD feature can be locked and unlocked. The monitor is shipped with the OSD menu in the unlocked position.

To lock the OSD menu and disable the OSD controls:

- Tap on the area where the OSD icons are located so that the icon become illuminated and active.
- Press the “MENU” icon for approximately 10 seconds until message appears indicating the OSD is locked.

To unlock the OSD menu and enable the OSD controls:

- Tap on the area where the OSD icons are located so that the icon become illuminated and active.
- Press the “MENU” icon for approximately 10 seconds until message appears indicating the OSD is unlocked.

7.6 Touch Screen – HP L6015tm / L6017tm Projective Capacitive (PCap)

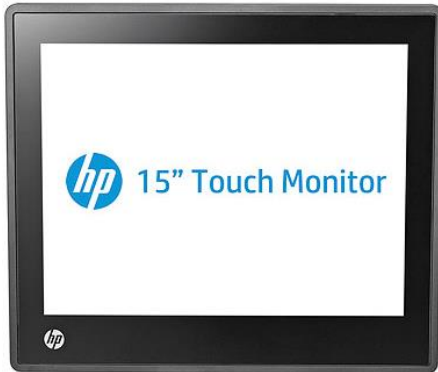

7.6.1 Connection

Please see the documentation that comes with the monitor for connection information.

7.6.2 Windows Drivers for the Touch Screen

For Windows 7 (32 and 64 bit) and POSReady 7 (32 and 64 bit) operating system, the touch is recognized by the operating system automatically.

For Microsoft POSReady 2009 operating system the drivers for HP touch screen are already installed in the HP factory image and are also available from HP.COM.

The following is overview of the steps to install the touch screen drivers and applets:

1. Start the touch screen installer by clicking on the SETUP.EXE file from the "Touchscreen" folder in the start menu.
2. Click on the "OK" to start the installation process.
3. Once the installation is complete restart the operating system by selecting YES to the restart question. If one selects "NO" one will see a screen that indicates the driver was successfully installed; manually restart after other items installation are complete.

Detailed Steps

1. Start the touch screen installer by clicking on the SETUP.EXE file from the "Touchscreen" folder in the start menu.

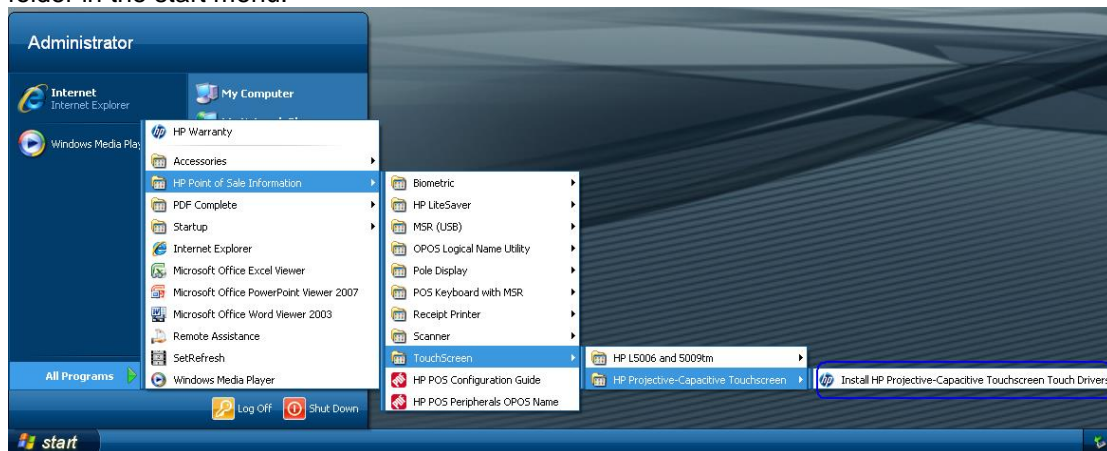

OR

The installation package can also be found at the following location on the HP image
“C:\xxxxx\Point of Sale\HP Projective-Capacitive Touchscreen”

2. Click on the “OK” to start the installation process.

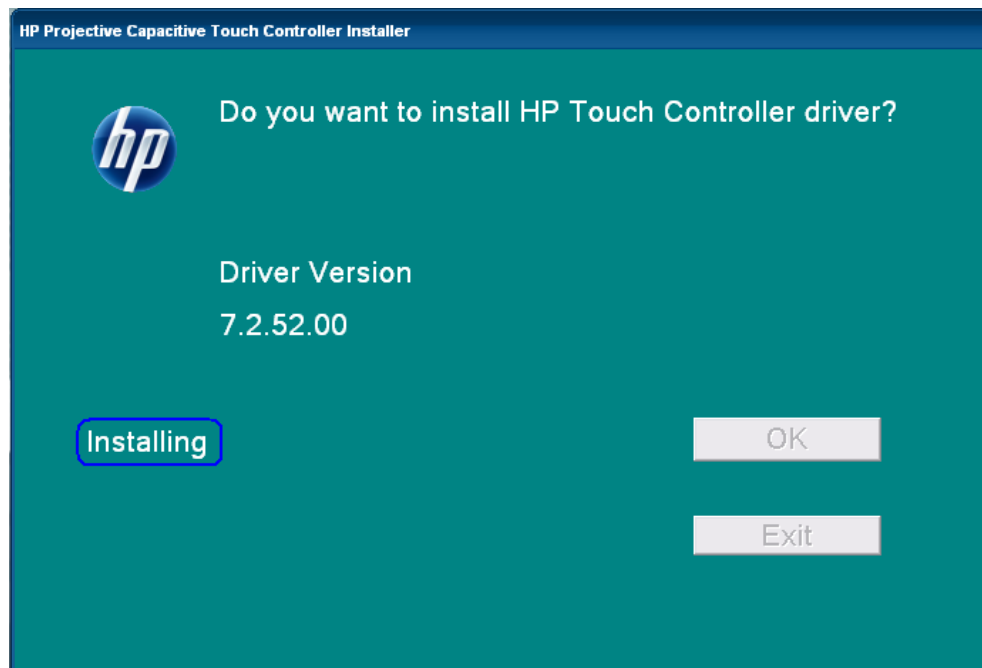
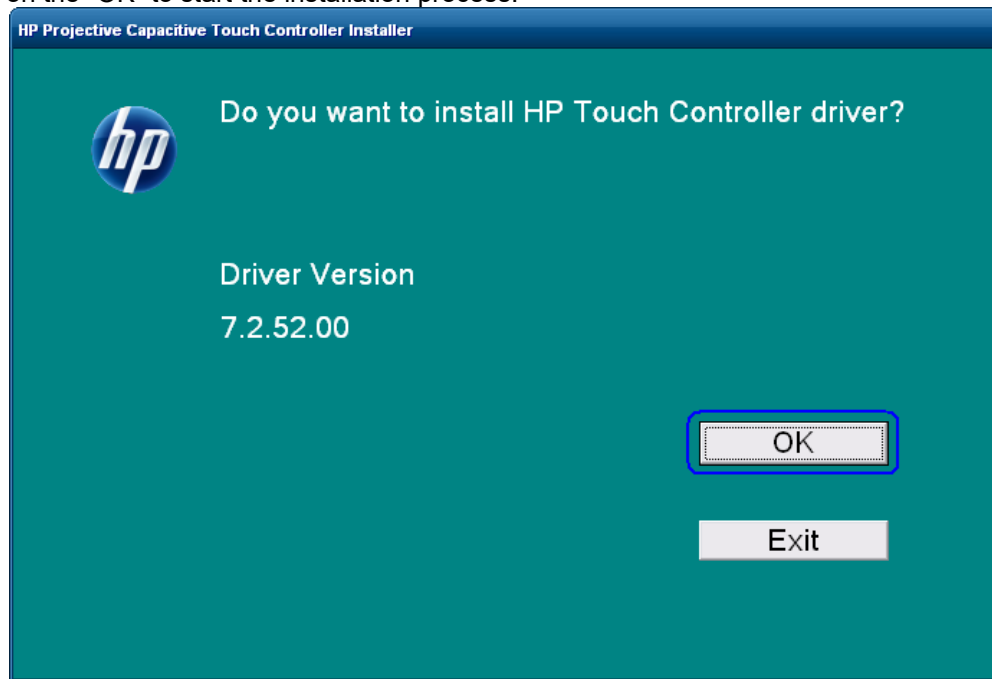

- Once the installation is complete restart the operating system by selecting YES to the restart question. If one selects "NO" one will see a screen that indicates the driver was successfully installed; manually restart after other items installation are complete.

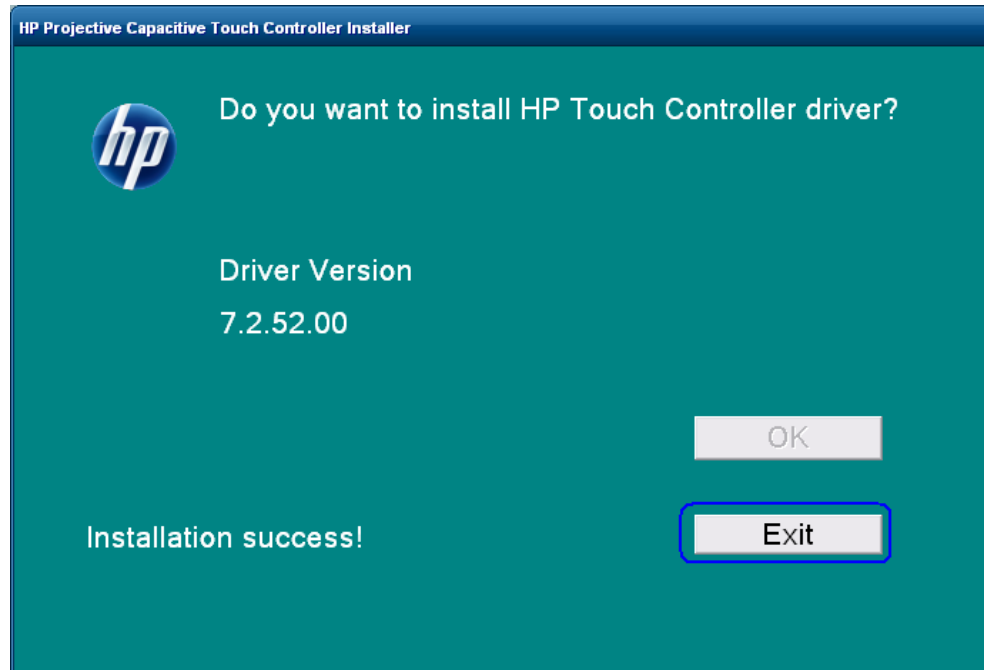
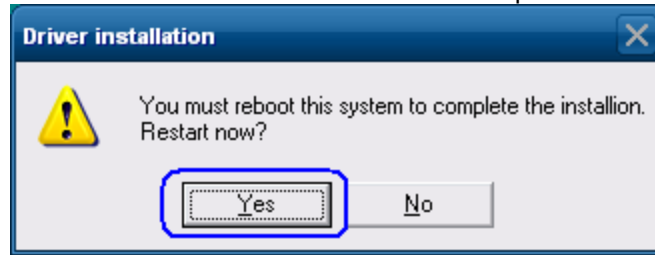

7.6.3 Touch Screen calibration

For Microsoft POSReady 2009 and Windows XP Professional operating system there is no calibration is needed due to the projective capacitive technology therefore there is no calibration utility for the HP RP7 15/17 inch projective capacitive touch.

For Windows 7 (32 and 64 bit) and POSReady 7 (32 and 64 bit) operating system the following are the steps to open the calibration utility **BUT** it is not necessary for the HP RP7 15/17 inch projective capacitive touch:

- Click on the START button.
- Click on CONTROL PANEL.
- In the search box type in "Tablet PC Setting" (without the quote) and in the list of results select "Table PC Settings".
- On the DISPLAY tab under DISPLAY OPTION select CALIBRATE.

Note: When one calibrates for the screen for the first time, the screen uses 16 different reference points. If one selects the calibration option again only 4 points are used. To perform a 16-point calibration again, in the Tablet PC Properties window, tap the Reset button.

- Follow the instructions on the screen and click YES to save your calibration settings.

7.6.4 **Touch in Dual Monitor Configuration in POSReady 2009 or XP**

This section and the touch drivers are for Microsoft POSReady 2009 and Microsoft Windows XP operating system.

In a dual touch PCAP monitor configuration, in order to have touch on both monitors one must have driver's version 7.5.52.00 or later which can be obtained on the HP.COM website. After the drivers are obtained the following is the process to install the drivers in dual touch PCAP configuration.

1. Go to the folder where the PCAP touch drivers have been downloaded and extracted.
2. Open the SETUP.EXE utility with "/dual" parameter (i.e. SETUP.EXE /dual) and follow the prompts on the screen.
3. After the drivers are installed and the unit is rebooted, need to identify the touch monitors to the touch drivers. In the system tray double click on the "Multi-mouse-daemon" icon to open the configuration of the touch monitors. This utility was installed in the system tray because of the "/dual" parameter.



Multi-mouse-daemon icon
in system tray.

4. Follow the prompts that appear when "Multi-mouse-daemon" utility is opened. The following are the screens that will appear.

Initial screen that appears when the utility is opened:

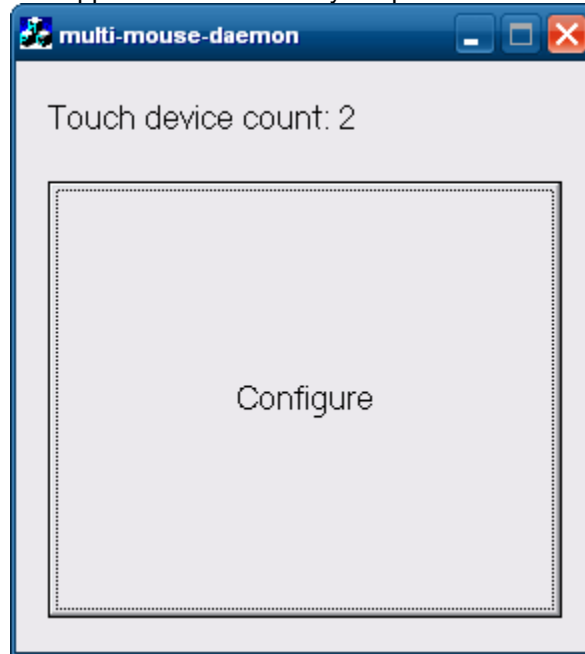

Once the "CONFIGURE" button is pressed on the primary monitor a screen appears that ask one to touch a box. After the box on primary monitor is touched then the similar screen appears on the secondary monitor. The boxes that will be similar to the box below:

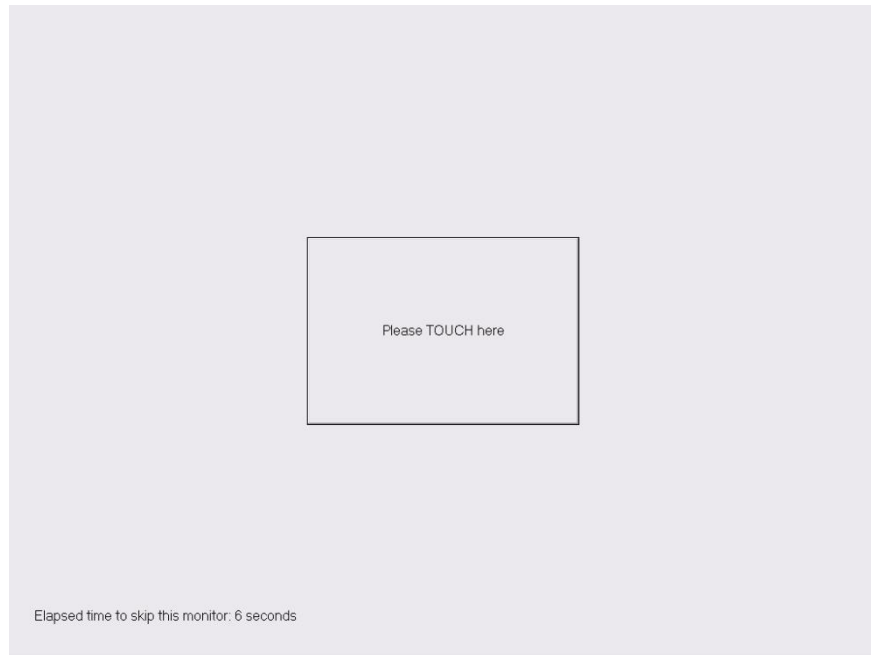

After the second monitor has been touched or timeout has occurred a message indicating that the process is complete appears:

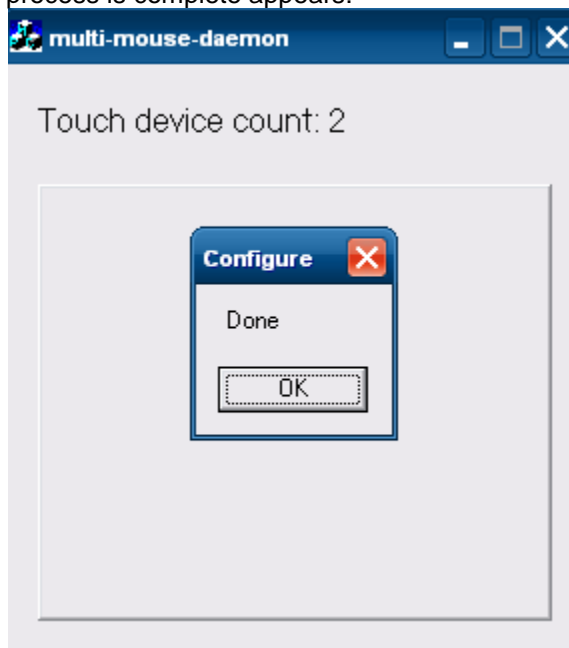

Click or press on the OK button to complete the process.

Note: The "Multi-mouse-daemon" information will be kept upon reboot of the operating system. If the driver is re-installed or different monitor PCAP monitor is installed on the unit the utility must be re-run in order to obtain the proper monitor information.

7.6.5 **Touch in Dual Monitor Setup in POSReady 7 or Windows 7**

For Windows 7 (32 and 64 bit) and POSReady 7 (32 and 64 bit) operating system the following are the steps to correctly identify the touch monitors:

1. Click on the START button.
2. Click on CONTROL PANEL.
3. In the search box type in "Tablet PC Setting" (without the quote) and in the list of results select "Table PC Settings".
4. On the DISPLAY tab under CONFIGURE click on the SETUP button.

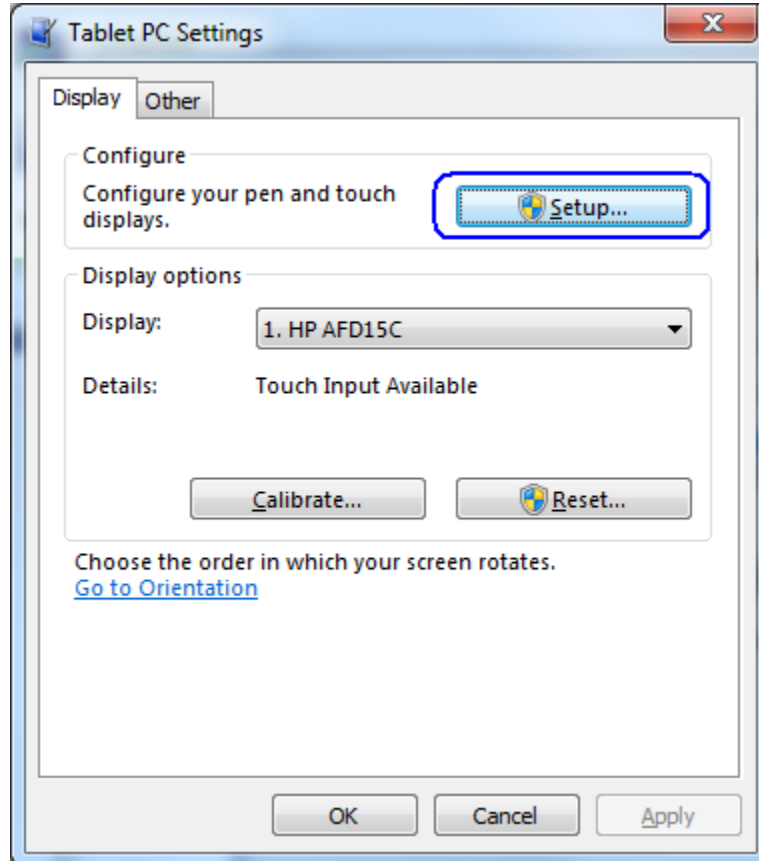

5. Follow the prompt that appears on the screen. The following is example of the prompt that appears on the screen:

Touch this screen to identify it as the touchscreen.

If this is not the Tablet PC screen, press Enter to move to the next screen. To close the tool, press Esc.

7.6.6 **OPOS Drivers for the Touch Screen**

No OPOS drivers are needed for the touch screen.

7.6.7 **Testing the Touch Screen**

Touch several places on the monitor screen and the mouse cursor should be present where the monitor was touched.

7.6.8 **JPOS Drivers for the Touch Screen**

No JPOS drivers are needed for the touch screen.

7.6.9 **Disable/Enable On-Screen Display (OSD)**

The OSD feature can be locked and unlocked. The monitor is shipped with the OSD menu in the unlocked position.

To lock the OSD menu and disable the OSD controls:

- Tap on the area where the OSD icons are located so that the icon become illuminated and active.
- Press the “MENU” icon for approximately 10 seconds until message appears indicating the OSD is locked.

To unlock the OSD menu and enable the OSD controls:

- Tap on the area where the OSD icons are located so that the icon become illuminated and active.
- Press the “MENU” icon for approximately 10 seconds until message appears indicating the OSD is unlocked.

7.6.10 **Disable/Enable Power Button**

The power button can be locked and unlocked. The monitor is shipped with the power button in the unlocked position.

To lock the power button menu:

- Press the power button for approximately 10 seconds until message appears indicating the power button is locked.

To unlock the power button menu:

- Press the power button for approximately 10 seconds until message appears indicating the power button is unlocked.

8 HP ap5000 Point of Sale System

8.1 HP ap5000 10" Display



8.1.1 Connection

The HP ap5000 10" display can be attached to the back of the ap5000 unit by replacing VFD. The ap5000 10" display is connected via VGA connector on the I/O panel of the unit.

8.1.2 Windows Drivers for the HP ap5000 10" display

No additional drivers are necessary. The Intel video drivers that are used for the ap5000 integrated (touch screen) video are drivers that are needed to drive the 10" display.

8.1.3 OPOS Drivers for the HP ap5000 10" Display

No OPOS drivers are needed for the touch screen.

8.1.4 Testing the HP ap5000 10" Display

Once the second monitor is enabled in the Windows operating system, video should appear on the 10" display.

8.1.5 JPOS Drivers for the HP ap5000 10" Display

No JPOS drivers are needed for the touch screen.



9.1.1 Connection

The HP 7" CFD can be connected to any USB port. The HP Integrated 7" CFD is designed to be attached on units and monitors that have the appropriate mounting receptacle (i.e. RP2, RP7, RP9, HP 6015tm, HP 6017tm).

The HP 7" CFD supports a single resolution of 1024x600. All other display options for the HP 7" CFD can be set either through the Control Panel or the DisplayLink System Tray icon depending on the OS and DisplayLink driver version being used. This device is not controlled by a video driver (i.e. Intel Video applet) even though it appears to applications as a monitor.

9.1.2 Windows Drivers for the HP 7" CFD display

The HP DisplayLink drivers may be included in the HP factory image and are also available from HP.COM.

If the HP DisplayLink drivers have been installed, the following will be present in Programs and Features:

Windows 10 and newer:

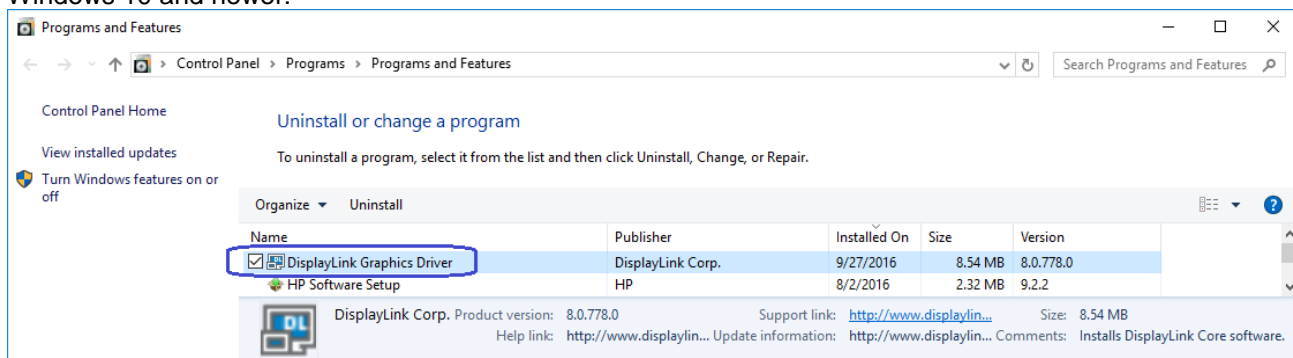

Windows 8.1 and older:

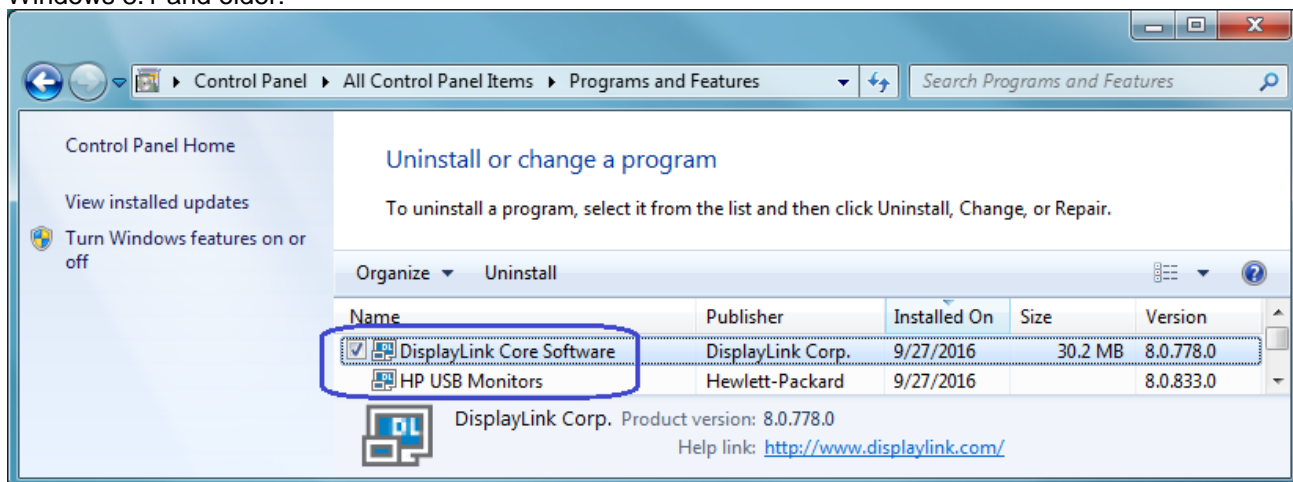

If the HP DisplayLink drivers have been installed and the HP 7" CFD is attached to the system, the following will be present in Device Manager:

Windows 10 and newer:

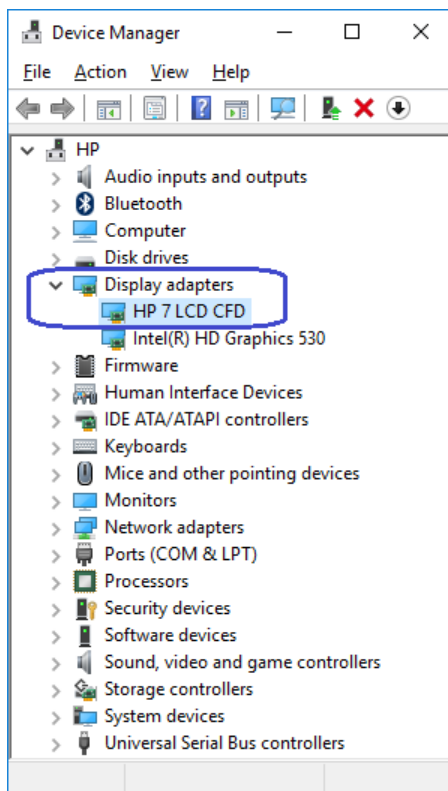

Windows 8.1 and older:

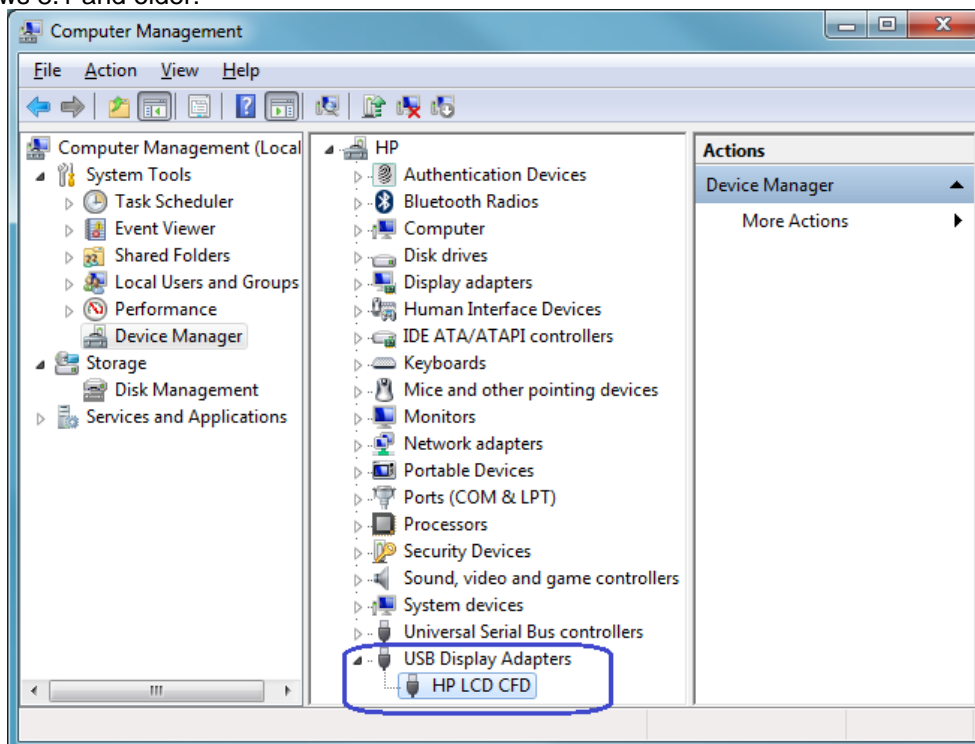

9.1.3 OPOS Drivers for the HP 7" CFD Display

No OPOS drivers are needed.

9.1.4 JPOS Drivers for the HP 7" CFD Display

No JPOS drivers are needed.

9.1.5 Testing the HP 7" CFD Display

Once the second monitor is enabled in the Windows operating system, video should appear on the HP 7" CFD display.

9.1.6 HP 7 CFD Options

If the HP DisplayLink drivers have been installed, a DisplayLink icon will be present in the System Tray:

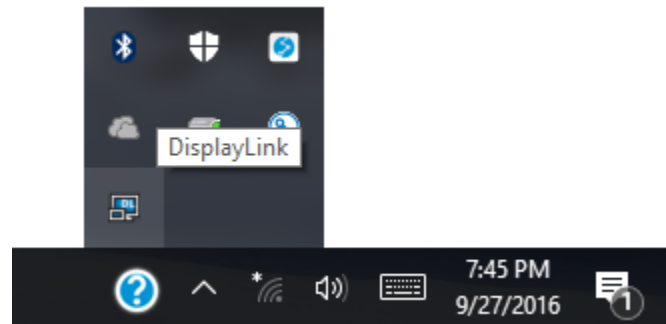

Clicking this icon will bring up the available configuration options. Depending on the OS installed, the icon may open the OS display properties directly instead of displaying menus as shown below:

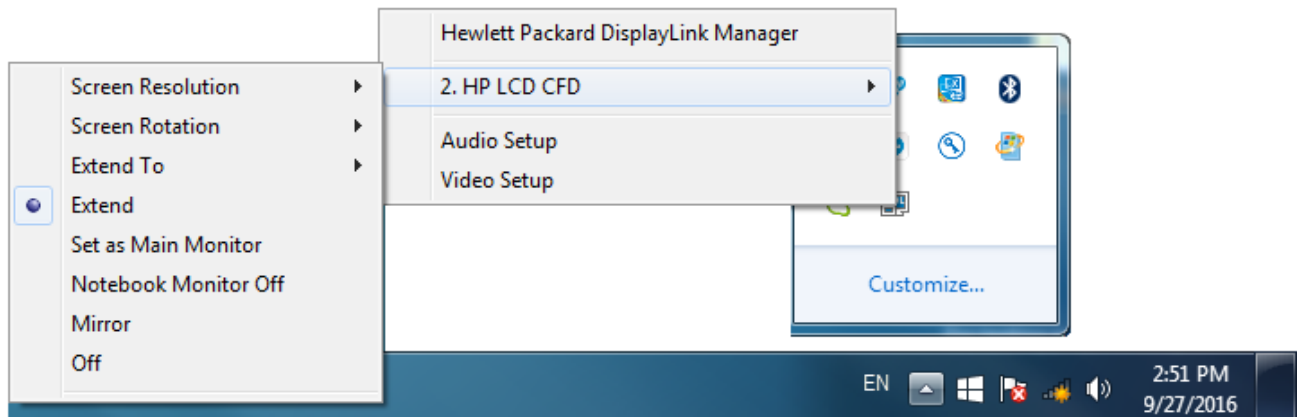

Note: The above screen is an example only. The HP LCD CFD may appear as different number depending on how many video monitors are attached and active.

Q & A

9.2 **General**

Question: What are the OPOS names for the HP Peripherals?

Answer: Please refer to section [OPOS Names for HP Point of Sale Peripherals](#) for the OPOS names.

Question: Where can I obtain the latest drivers?

Answer: The latest drivers are posted on the [HP.COM](#) web site.

9.3 HP Cash Drawer

Question: When I run the sample application I receive a message stating dependencies not correctly registered. How do I correct this?

Answer: If you run the cash drawer sample application and receive the following screen, it indicates that either the CCO or the OPOS drivers are not installed and registered. Install the CCO drivers and install the printer OPOS package. After the installation is complete, please restart Windows.

Cash Drawer Sample Application Error message:

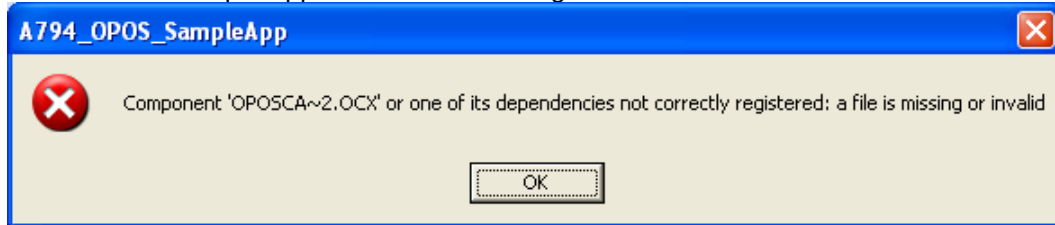

Printer Sample Application Error message when you click on cash drawer option

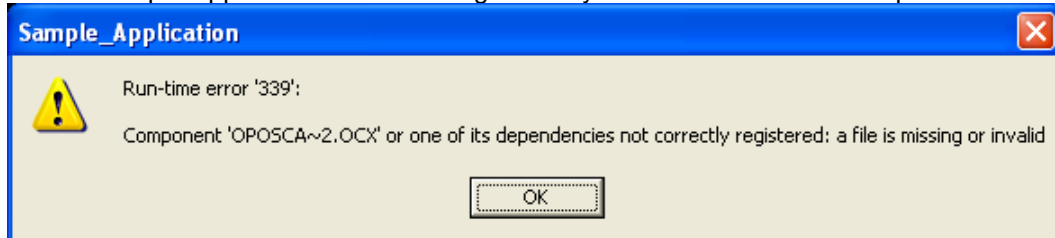

Question: In a dual cash drawer configuration both of my cash drawers are opening at the same time, why?

Answer: This is occurring because both the cash drawer have the same cash drawer cable. In a dual cash drawer configuration a different cash drawer cable is required for the second cash drawer.

Question: What are the ASCII codes to open the cash drawer?

Answer: The ASCII codes to open the cash drawer are:

Cash drawer 1	Cash Drawer 2
27 112 0 8 8	27 112 1 8 8

9.4 HP USB Cash Drawer

Question: With JPOS driver version 1.13.3 in dual cash drawer situation what used to be cash drawer 1 appears as USB0 before it was USB1, why?

Answer: JPOS driver prior to 1.13.3 used cashed drawer USB1 to define the first cash drawer mistakenly. With JPOS driver version 1.13.3 this was corrected to use USB0 for the first cash drawer. One can go into "C:\HP" folder and edit the JPOS XML file manually to define which cash drawer is the first cash drawer (will need the HID number on the bottom of the cash drawer).

9.5 HP Receipt Printer

Question: When I run the sample application I receive a message stating dependencies not correctly registered. How do I correct this?

Answer: If you run the cash drawer sample application and receive the following screen, it indicates that either the CCO or the OPOS drivers are not installed and registered. Install the CCO drivers and install the printer OPOS package. After the installation is complete, please restart Windows.

Printer Sample Application Error message when you click on printer option

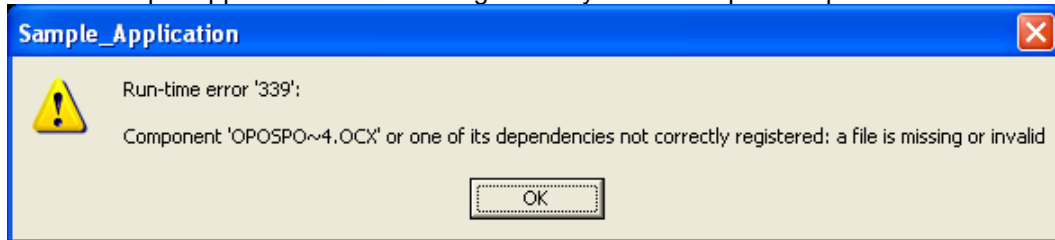

Question: What firmware version is required to be able to switch between native and printer class mode on the A794 printer?

Answer: The A794 printer must have firmware 3.48 or later. If the printer has firmware prior to 3.48, there is softpaq available on the HP.COM web site that will allow one to update the firmware.

Question: Can one switch the printer between native and printer class mode?

Answer: Yes, one may switch the printer between native and printer class mode. On the HP.COM web site there is firmware softpaq that may be obtained that has the option to switch the printer between printer class and native mode.

Question: How do I tell if the printer is in NATIVE or PRINTER CLASS mode?

Answer: One can obtain this information in one of two ways:

- 1 ... Print out the diagnostic form on the printer by holding down the form feed button when you close the printer cover. In the COMM. INTERFACE section of the print out see if the USB DRIVER TYPE states NATIVE or PRINTER CLASS.
- 2 ... Look in Windows device manager USB section. If it states HP USB Receipt printer, the printer is in NATIVE mode. If you it has USB PRINTING SUPPORT, the printer is in PRINTER CLASS mode.

Question: Downloaded an updated JAVA from the web site, now the JPOS test utility does not open?

Answer: The batch file sets the location where the runtime of JAVA folder is located. Need to change the location in the batch file to reflect the update JAVA folder.

Question: Why do I not see an option for “USB001 (Virtual USB Port) in the Windows mini-drivers setup?

Answer: In order for the port to appear, the printer must be attached to the unit AND the printer must be in printer class mode.

Question: What are the ASCII codes to open the cash drawer?

Answer: The ASCII codes to open the cash drawer are:

Cash drawer 1	Cash Drawer 2
27 112 0 8 8	27 112 1 8 8

Detailed explanation of the cash drawer command:

Generate pulse to open cash drawer

ASCII	ESC p	n p1 p2
Hexadecimal	1B 70	n p1 p2
Decimal	27 112	n p1 p2
Value of n:	00, 48 (Decimal) = Drawer 1; 01, 49 (Decimal) = Drawer 2	
Value of p1:	0-255	
Value of p2:	0-255	

Question: What are the ASCII codes to cut the paper (knife cut)?

Answer: The ASCII codes to cut the paper (knife cut) are:

Perform full knife cut

ASCII	EM	ESC i
Hexadecimal	19	1B 69
Decimal	25	27 105

Perform partial knife cut

ASCII	SUB	ESC m
Hexadecimal	1A	1B 6D
Decimal	26	27 109

The partial knife cut leaves 5mm (0.20 inch) of paper on the left edge.

Question: How do I obtain the baud rate that the serial printer is set to?

Answer: Perform the following steps to obtain a diagnostics printout which has the baud rate information:

- Open the printer cover.
- Pull the paper out slightly.
- Press and hold the form feed button on the printer.
- Close the printer cover.
- When the diagnostics form prints, let go of the form feed button. Close to the middle of the diagnostics print out is the baud rate of the printer. Below is an example of the diagnostics print out:

```
xxx A799 - Diagnostics Form xxx
ReceiptWare Enabled

Model number       : A799-C40W-HN00
Serial number      : K083100426

Boot Firmware
.....
.....
.....
.....
.....

Comm. Interface
RX Buffer Size     : 4096
Interface type    : RS232/USB
Parameters
  Baud Rate       : 115200
  Data Bits       : 8
  Stop Bit        : 1
  Parity          : NONE
  Flow Control    : DTR/DSR
  Reception Errors : Ignore
USB Driver Type   : Printer Class
USB Packet w/Error : Reject
```

Question: For the HP Hybrid printer, what is the ribbon number if I want to purchase them locally?

Answer: The following are the numbers for the ribbon for the HP Hybrid printer:

- A152-0041 Purple
- A152-0042 Black

Question: After installing the Windows mini-drivers in Windows 8.1 the print out on the receipt is small. This did not occur in previous operating system.

Answer: To resolve this issue, ensure you have Microsoft KB2911106 installed in your Windows 8.1 image.

Question: With the A799II printer when connected via serial connection, seeing garbage characters appear on the print out.

Answer: Make sure the baud rate setting in Windows for the COM port / the baud rate for the Windows mini-drivers make that baud rate on the printer.

Question: With the A799II printer receiving yellow bang in Windows device manager saying Cognitive TPGA795 but everything seems to work in OPOS/JPOS. How do I get rid of this yellow bang.

Answer: Point to the i386 folder that is located in the Windows mini-drivers. Will need to point to the 32bit or 64bit folder depending on your operating system in order to get the correct i386 folder.

Question: What version of OPOS driver do I need to support the Ethernet connection?

Answer: On the A799II Ethernet printer model need OPOS driver version 1.13.3.8 or later.

Question: What version of JPOS driver do I need to support the Ethernet connection?

Answer: On the A799II Ethernet printer model need OPOS driver version 1.13.0.3 or later.

Question: The A799II Ethernet printer will lockup with the OPOS test utility when I hot dock and undock the unit, I get an error message when I try to print or claim the printer.

Answer: Hot docking / undocking is not supported on the Ethernet printer since A799II Ethernet printer is not directly hooked up to the computer, Windows is not aware if the device is present or not. When using the Ethernet printer it is recommend to OPEN / CLAIM the network printer prior to printing a receipt and CLOSE the printer after the receipt is printed.

9.6 HP USB Barcode Scanner

Question: I am not sure the setting of the Barcode Scanner, how can I put the scanner back to the factory default setting?

Answer: You can put the scanner back to factory default setting by scanning the following bar code:



Set All Defaults

Question: After scanning an item, I have to press the “Enter” to accept what was scanned in my application.

Answer: You can change the behavior of the scan so that a carriage return is also transmitted after an item is scanned. In order to change the behavior of the scanner, scan the following bar codes in order that they appear below:



Scan Options

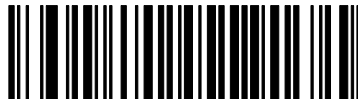

<Data><Suffix>



Enter

Question: After scanning an item my application needs a tab.

Answer: You can change the behavior of the scan so that a tab is also transmitted after an item is scanned. In order to change the behavior of the scanner, scan the following bar codes in order that they appear below:

Scan Options



<Data><Suffix>



Enter



Scan Suffix



7



0



0



9



Question: I need to use OPOS drivers with my application for the scanner, where can I obtain them from?

Answer: The OPOS drivers for the scanner may be obtained from the HP web site under the software/driver section for the product. You will also need to change the scanner from HID device (default) to IBM hand-held USB device by scanning the appropriate bar code below:

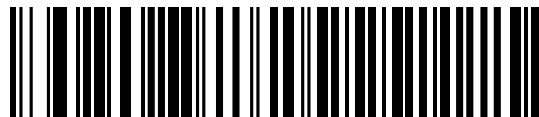

HID Keyboard Emulation



IBM Hand-Held USB

Question: The volume of the scanner is loud for my environment, how can I lower the volume on the scanner?

Answer: There are three volume setting for the scanner low / medium (default) / high. Scan one of the bar code below to set the volume on the scanner:



Low



Medium (Default)



High

Question: When I scan something in notepad it appears to garbage in non-English language?

Answer: The barcode scanner USB country keyboard type needs to change. Please use one of the following barcode to change to the country.



* North American Standard USB Keyboard



German Windows

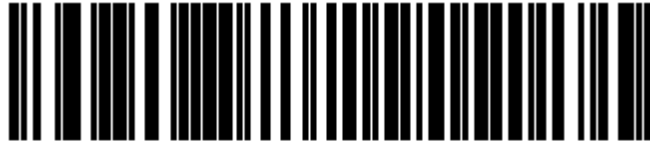

French Windows



French Canadian Windows 2000/XP



Spanish Windows

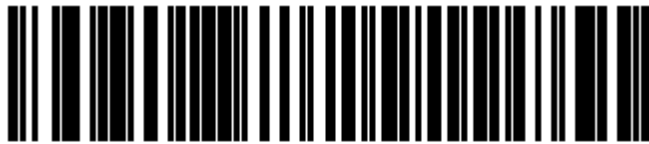

Italian Windows

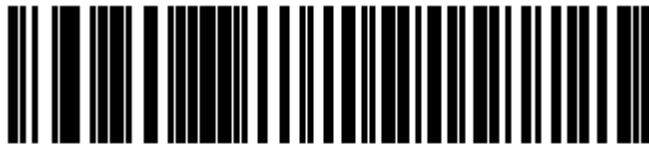

Swedish Windows



UK English Windows



Japanese Windows (ASCII)

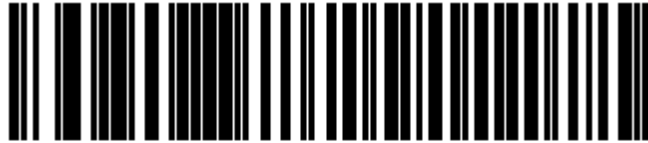

Portuguese-Brazilian Windows

9.7 HP Touch Screen (HP L5006tm / HP L5009tm / HP L5015tm)

Question: Someone else installed the HP touch screen, how do I know which port the touch screen is attached to?

Answer: In the touch screen properties it will inform you what if you are on the USB or serial interface. If you are using COM port it will tell you which com port the monitor is attached to.

Showing touch screen attached to USB port:

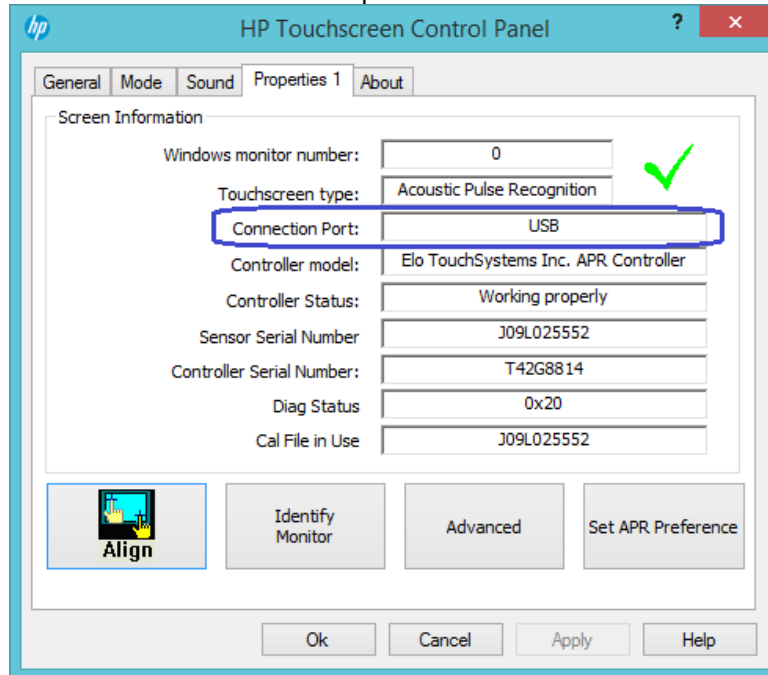

Showing touch screen attached to serial port on COM1:

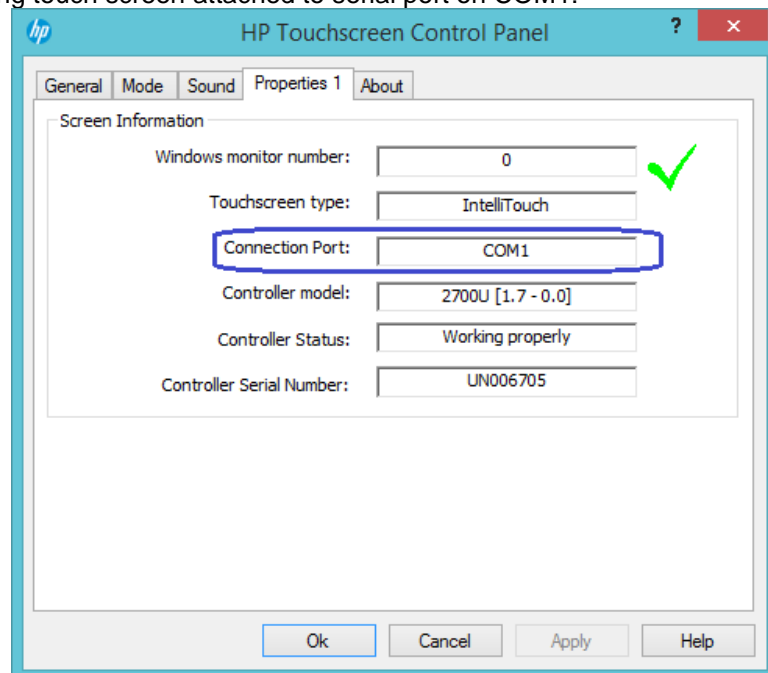

Question: In Microsoft Vista when I click on Elo ICON on control panel (classical view) I receive stating “No Elo touchscreen found” but the touch screen is attached to the unit.

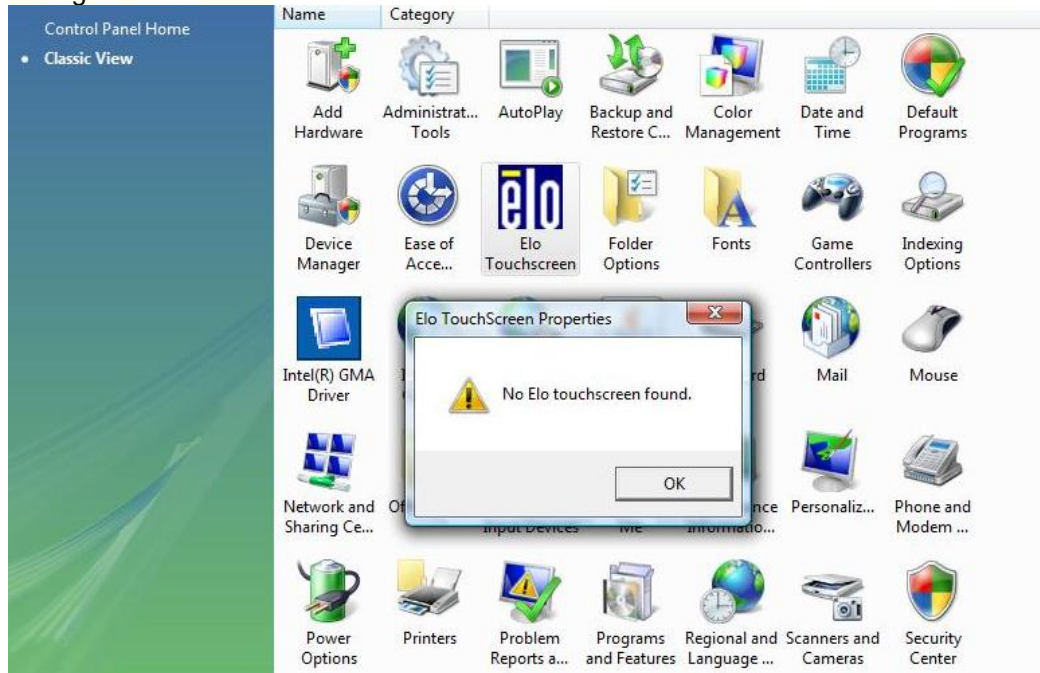

Answer: Re-run the install program from the start menu with administrator rights. Right click on the option to install and select “Run as administrator”.

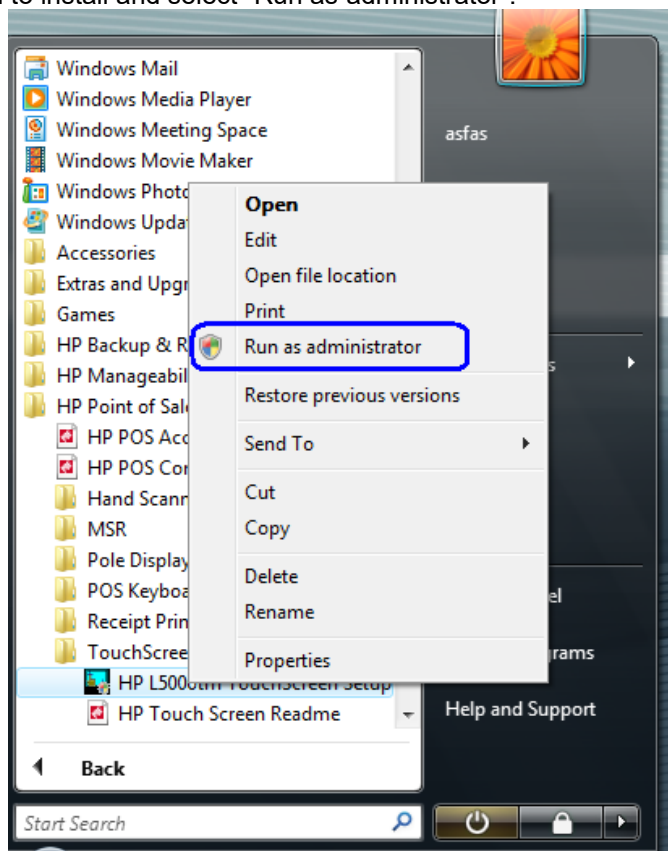

Question: I keep turning off the monitor or bringing up the on-screen display (OSD) when I put my hands on the side of the monitor. Is there a way to prevent this?

Answer: Yes, you can lock buttons on the monitor using the following procedure:

HP L5006tm and HP L5006tm:

OSD Lock/Unlock

1. Press the Menu button and down arrow button simultaneously until a window displays "OSD Unlock." Continue to hold the buttons down until "OSD Lock" displays.
2. To unlock the power button, repeat the above step until "OSD Unlock" is displayed.

Power Lock/Unlock

1. Press the Menu button and down arrow button simultaneously until a window displays "Power Unlock." Continue to hold the buttons down until "Power Lock" displays.
2. To unlock the power button, repeat the above step until "Power Unlock" is displayed.

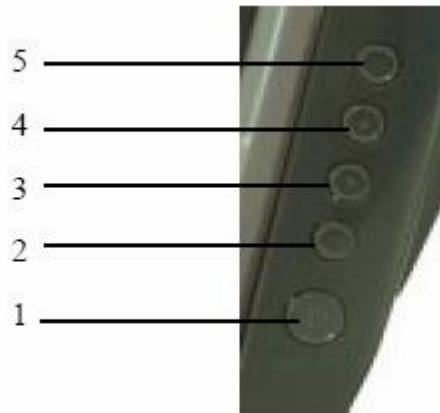

Monitor Front Panel Controls

- 1 - Power - Turns the monitor on or off.
- 2 - Select – Selects the adjustment items from the OSD menus.
- 3 - Decrease value of the adjustment item.
- 4 - Increase value of the adjustment item.
- 5 - Menu/Exit Displays or exits the OSD menus.

HP L5015tm:

OSD Lock/Unlock

1. To lock the OSD Press and hold the "Menu" and "Up" buttons for two seconds.
2. To unlock the OSD Press and hold the "Menu" and "Up" buttons for two seconds.
3. When the OSD Locking is enabled, pressing any of the Menu, Up, Down, or Select keys will have no effect on the system.

Power Lock/Unlock

1. Press the Menu button and down arrow button simultaneously until a window displays "Power Unlock." Continue to hold the buttons down until "Power Lock" displays.
2. To unlock the power button, repeat the above step until "Power Unlock" is displayed.

9.8 HP MSR

Question: How can I tell what mode the MSR is currently set to?

Answer: There are two ways to determine the mode the MSR is currently set to:

1. You can use the configuration utility and follow the steps that were outlined in ["Utility to switch MSR mode"](#) section of the document.
2. In Windows device manager see what drivers Microsoft Windows has loaded for the device.

When the MSR is in the USB HID-KB mode (default shipping mode) there will be one driver loaded for the MSR.*

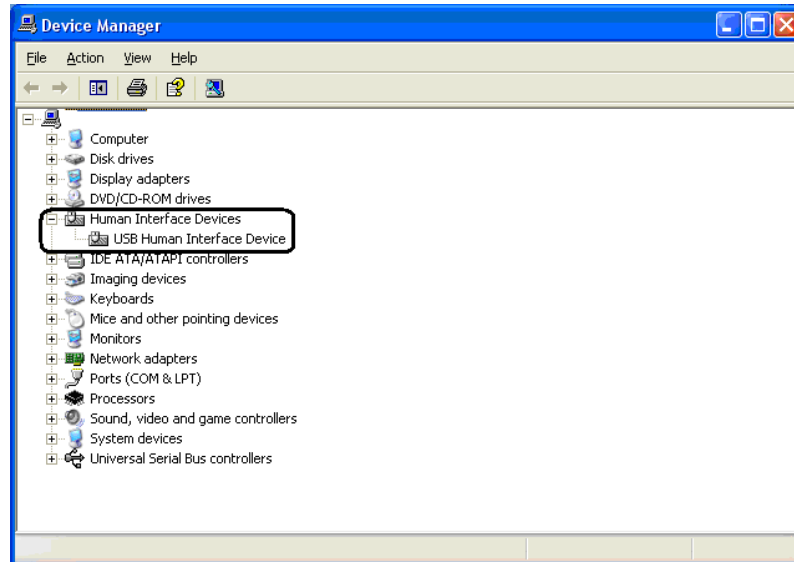

When the MSR is in the USB HID mode there will be two drivers loaded for the MSR.*

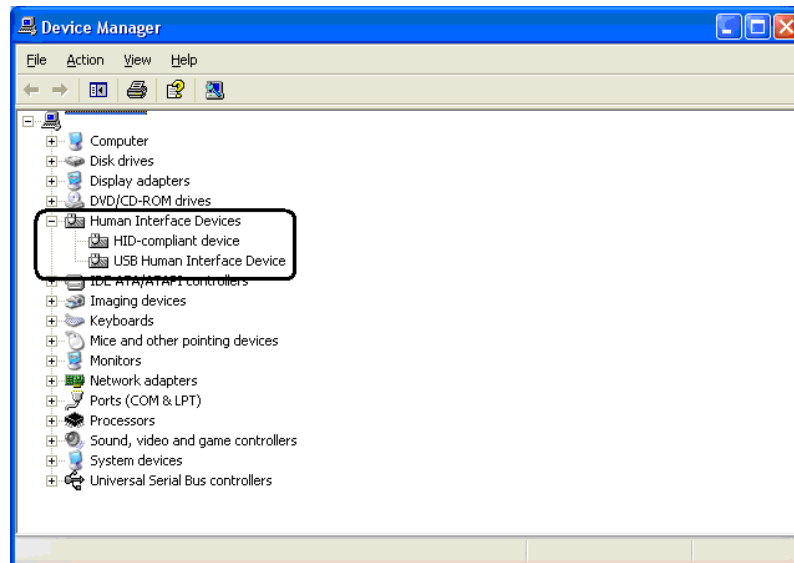

* If you have other USB device installed you may have more than two HID device loaded showing in the device manager.

Question: Can I switch the MSR between USB HID and USB HID-KB mode?

Answer: Yes, the MSR can be switched between the two modes. This can be accomplished either by using the MSR configuration utility which can be obtained on HP.COM web site or using the standalone MSR HID Utility to switch between the modes. The standalone utility is included in the HP Factory image and can also be obtained from HP.COM.

Question: I am trying to disable one of the read head on the dual head MSR but receive an error message, why can I not disable the read head?

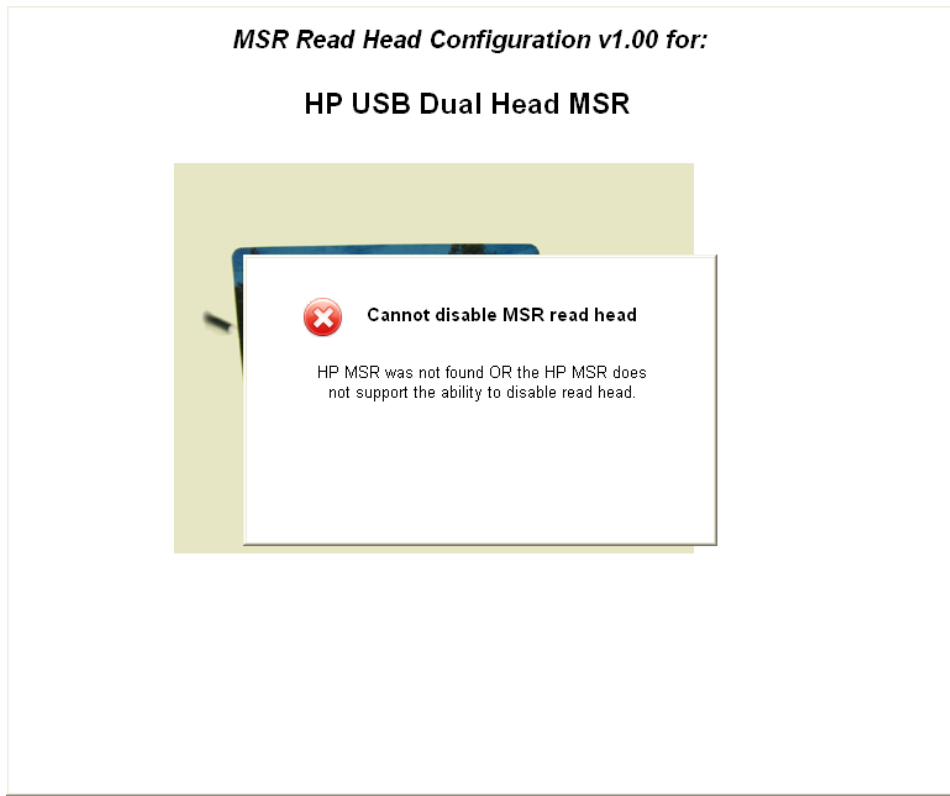

Answer: The MSR that is attached to the unit does not support the ability to disable the read head. The "-002" or later dual headed MSR has the ability to disable the read head; the "-001" does not have this ability.

Question: Can I disable the read head on the single headed MSR?

Answer: No, disabling the read head on the single headed MSR is not supported.

9.9 HP Font Loader

Question: When I open the font downloader utility, I receive an error message. How do I correct this?

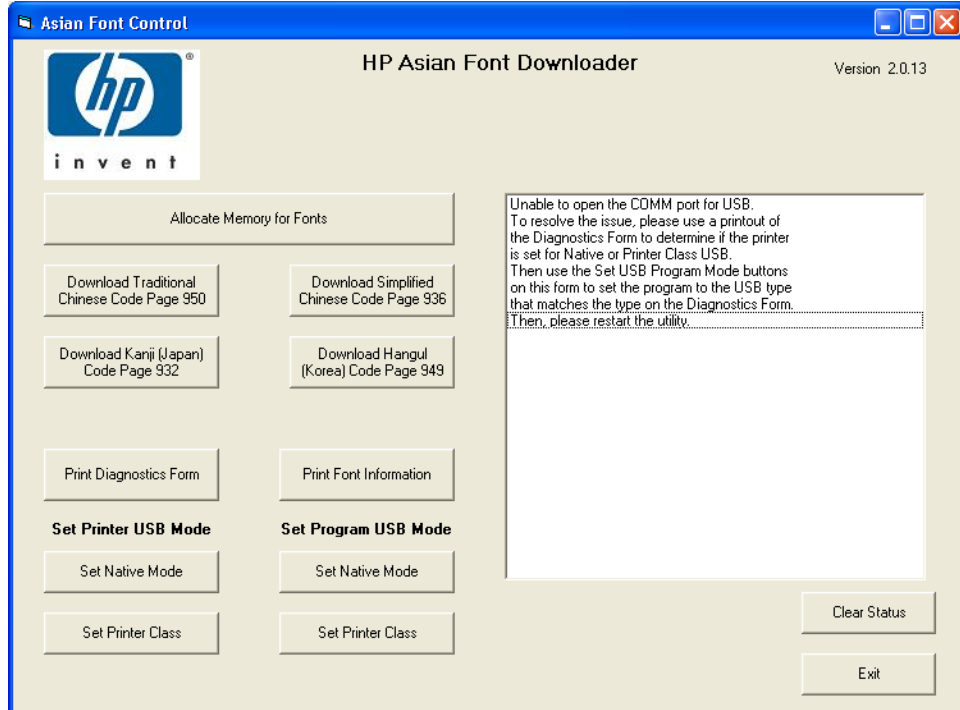

Answer: The printer is setup in a different mode then what utility is currently set to. In the "SET PROGRAM USB MODE" select the mode the printer is currently set and then restart the utility.

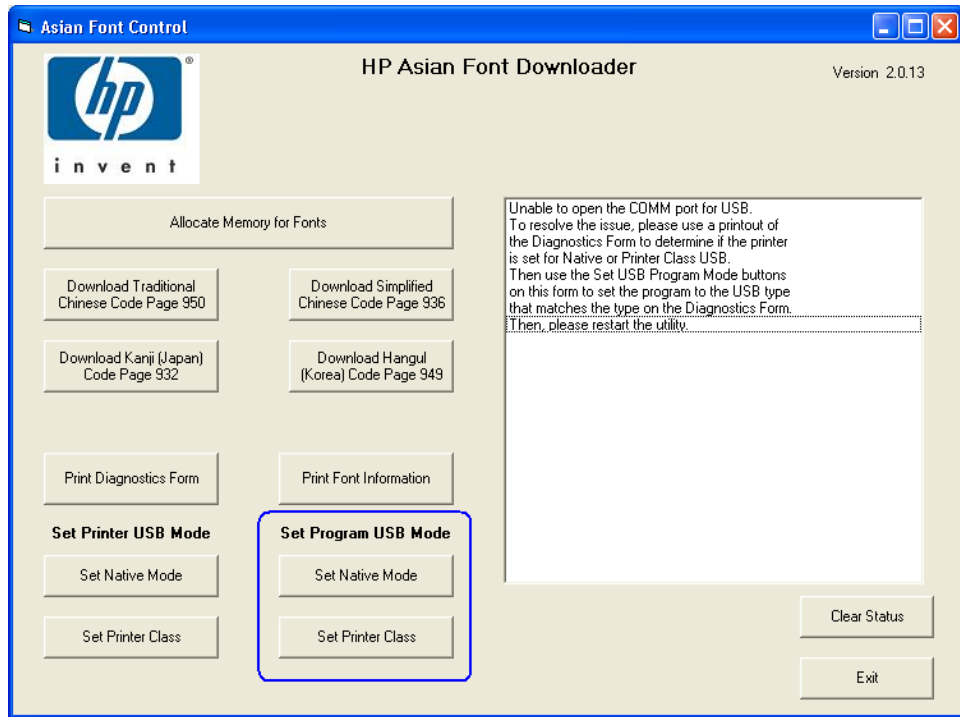

Question: After the font to the printer is complete, the LED on the printer is blinking?

Answer: Select the "PRINT Sample/Diagnostics" button on the utility or reset the printer in order to have the LED go back to solid state.

9.10 HP rp3000 Optical Door

Question: How does one start and stop the optical door utility service?

Answer: One must have administrator privileges in order to stop and start the service once it has been installed in the image. The following are the syntax:

- Syntax to enable "ODDDoorCoverMonitor.exe -install"
- Syntax to disable service "sc stop HPODDDoorCoverMonitor.exe"
 - Both enable and disable of the HPODDCoverMonitor service requires a reboot for the service to perform the action.

9.11 HP Pole Display

Question: When I run the non-OPOS test utility, I receive a run-time error message.

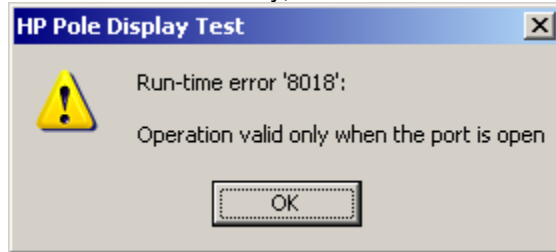

Answer: This error occurs when the utility is not able to talk to the pole display. Ensure the following on the pole display

- The pole display is attached to the unit
- The Windows device manager drivers for the pole display are installed.
- Confirm the pole display switch is turned on.

9.12 HP OPOS Logical Device Name Utility

Question: When the utility is opened it states “no OPOS drives have been detected”, what needs to be done to correct this?



Answer: Check with your POS application to see if application uses OPOS drivers. If the application does use OPOS drivers, for the HP branded peripherals the OPOS drivers can be obtained from HP.COM web site.

9.13 HP ap5000 VFD

Question: What is the default port that the VFD is attached to?

Answer: The ap5000 VFD as shipped from the HP factory is shipped on serial port 2 (COM2).

Question: Can the VFD be used on different COM port besides COM2?

Answer: Yes, the VFD may be used either on COM1 or COM2. The VFD cannot be attached to COM3 because of the power requirements.

Question: Does the VFD support emulation modes?

Answer: No emulation modes are supported BUT many of the same ESC commands are used that are used in Epson emulation mode.

9.14 HP ap5000 VFD (non-OPOS)

Question: When the “Test” button is selected I receive an error indicating a “WriteFile” error. How to fix this error?

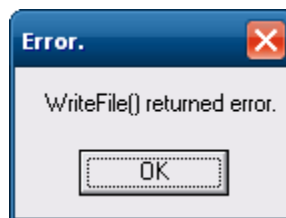
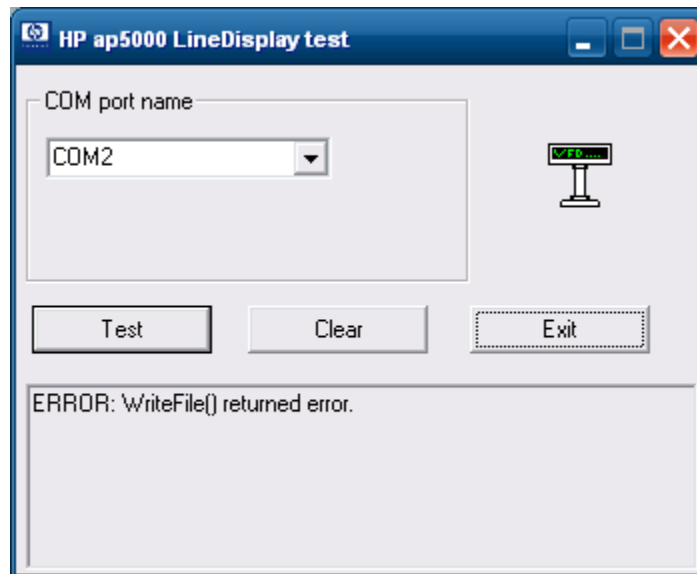

Answer: This error indicates that the utility is not able to find the ap5000 VFD attached to the unit. Checking the following items:

1. An ap5000 VFD is attached to the unit.
2. The ap5000 VFD is attached on either COM1 or COM2.

- In BIOS the port (COM1 or COM2) that the VFD is attached is set for “5V” for power instead of “Standard Mode”. Please refer to the [HP ap5000 VFD BIOS Power setting](#) section for details on how to enable the power on the serial ports.

9.15 **HP ap5000 VFD (JPOS)**

Question: In the JPOS test utility, after I click on the “OPEN” button I receive a failed message when the default name is used that appears in the JPOS test utility. How to fix this error?

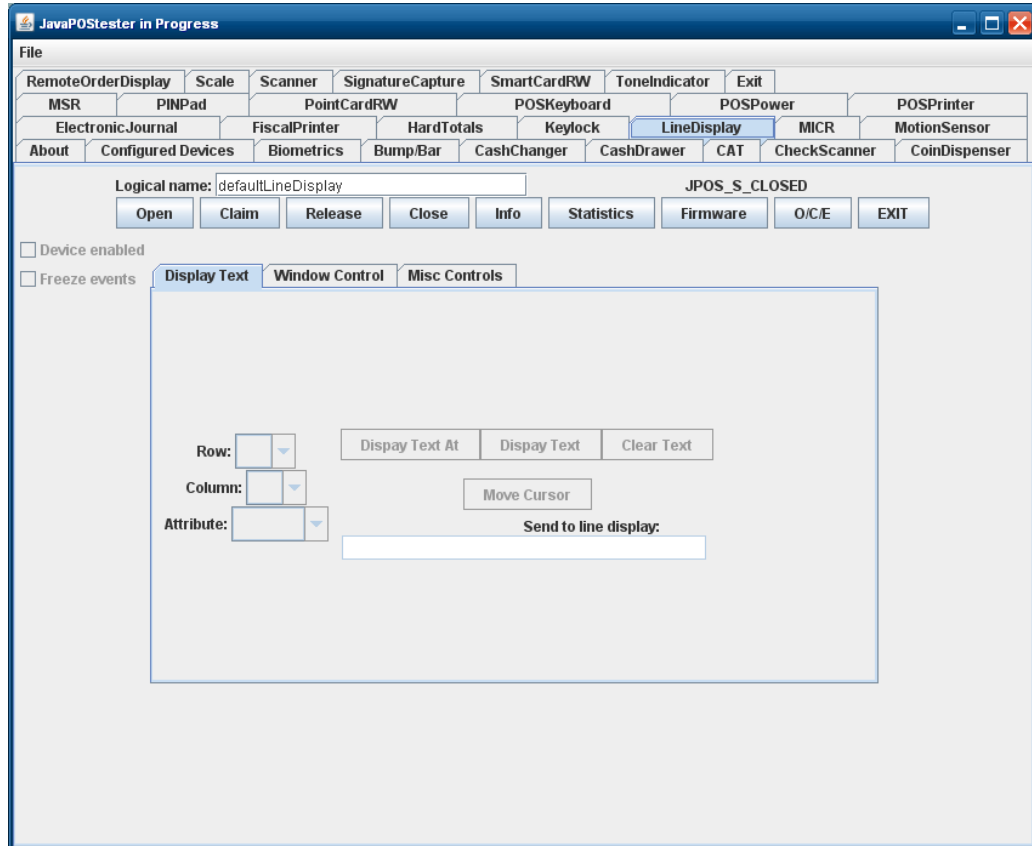

Answer: The logical name of the device is “HPap5000LineDisplay”. Replace the “defaultLineDisplay” that appears in the logical name box with “HPap5000LineDisplay”. If one clicks on the “Configured Device” tab, the names for the device will appear that will be used in the test utility.

9.16 HP ap5000 VFD (OPOS)

Question: When opening the OPOS test utility, I receive an error indicating a “FAILED”. How to fix this error?

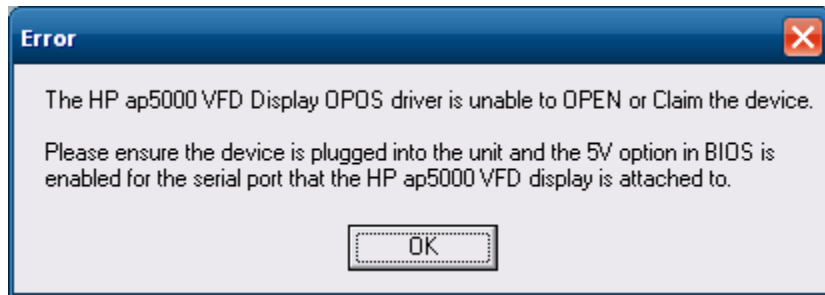
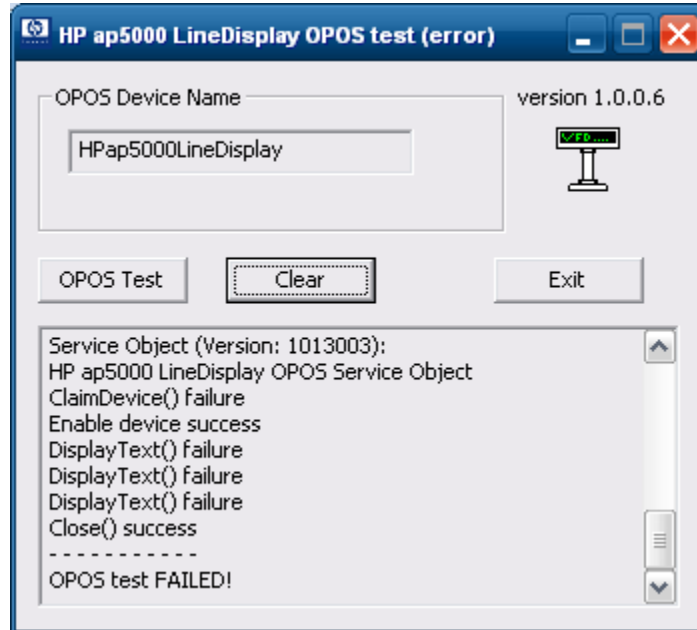

Answer: This error indicates that the utility is not able to find the ap5000 VFD attached to the unit. Checking the following items:

1. An ap5000 VFD is attached to the unit.
2. The ap5000 VFD is attached on either COM1 or COM2.
3. In BIOS the port (COM1 or COM2) that the VFD is attached is set for “5V” for power instead of “Standard Mode”. Please refer to the [HP ap5000 VFD BIOS Power setting](#) section for details on how to enable the power on the serial ports.

Question: When I exit my point of sale application that uses OPOS to control the VFD there is nothing displayed on the VFD. I would like to have my customized power-on message appear on the VFD, can this be accomplished?

Answer: The default behavior of the OPOS driver when exiting is to clear the screen. In order to have the power-on message appear when exiting a point of sale application a registry key value needs to be changed for the pole display. The registry key value that needs to be changed is “HKLM\Software\OLEforRetail\ServiceOPOS\LineDisplay\HPap5000LineDisplay”.

9.17 **HP ap5000 MSR**

Question: What port is the MSR attached to?

Answer: The ap5000 MSR as shipped from the HP factory is shipped on COM4.

Question: When I open Notepad and swipe a card nothing appears in Notepad, why?

Answer: The ap5000 MSR is attached to a serial port; it is not a USB HID keyboard (wedge) device. In order to have data appear in Notepad one may run a third party utility that takes data from the serial port and sends via keyboard. For XP / WePOS / POSReady there is serial key option that can be enabled, for Vista / Win7 a third party utility must be used. Please check with point of sale application if they support serial MSR which would be preferred over serial key option or third party application.

Question: My application needs a carriage return after track 2, how can I add carriage return after track 2?

Answer: One can use the ap5000 MSR configuration to enable a carriage return on track 2. The ap5000 MSR configuration utility may be obtained from HP.COM or from the HP Point of Sale Driver and Documentation CD.

9.18 **HP ap5000 MSR (JPOS/OPOS)**

Question: Why do I not need to configure any setting besides the device name when using OPOS / JPOS for the MSR like I need to for Windows?

Answer:

- For OPOS the drivers understand the settings for the MSR and communicate with it with the proper protocols.
- For JPOS the configuration file that is provided by HP already has proper protocol setting in the file.

9.19 Imaging Scanner - JPOS

Question: When I do a claim of the HP Imaging scanner in the JPOS utility I receive message stating the claim failed, what could be the cause?

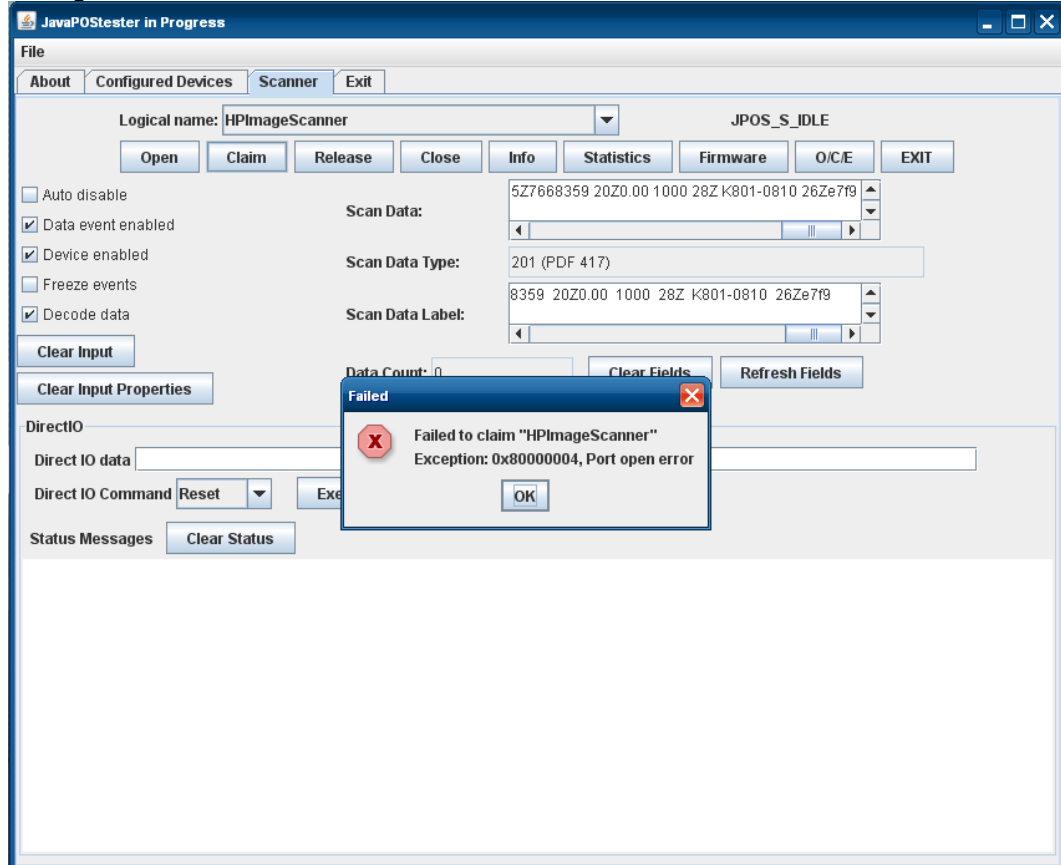

Answer: The above message will occur if the device has been released and then one tries to CLAIM the device again. Need to CLOSE the device and then reopen OPEN / CLAIM the device (see the [JPOS section of the Imaging Scanner](#) for details).

Question: In the JPOS test utility for the HP Imaging Barcode Scanner, the “Data Count” is always zero (0) regardless of how many barcodes I scan?

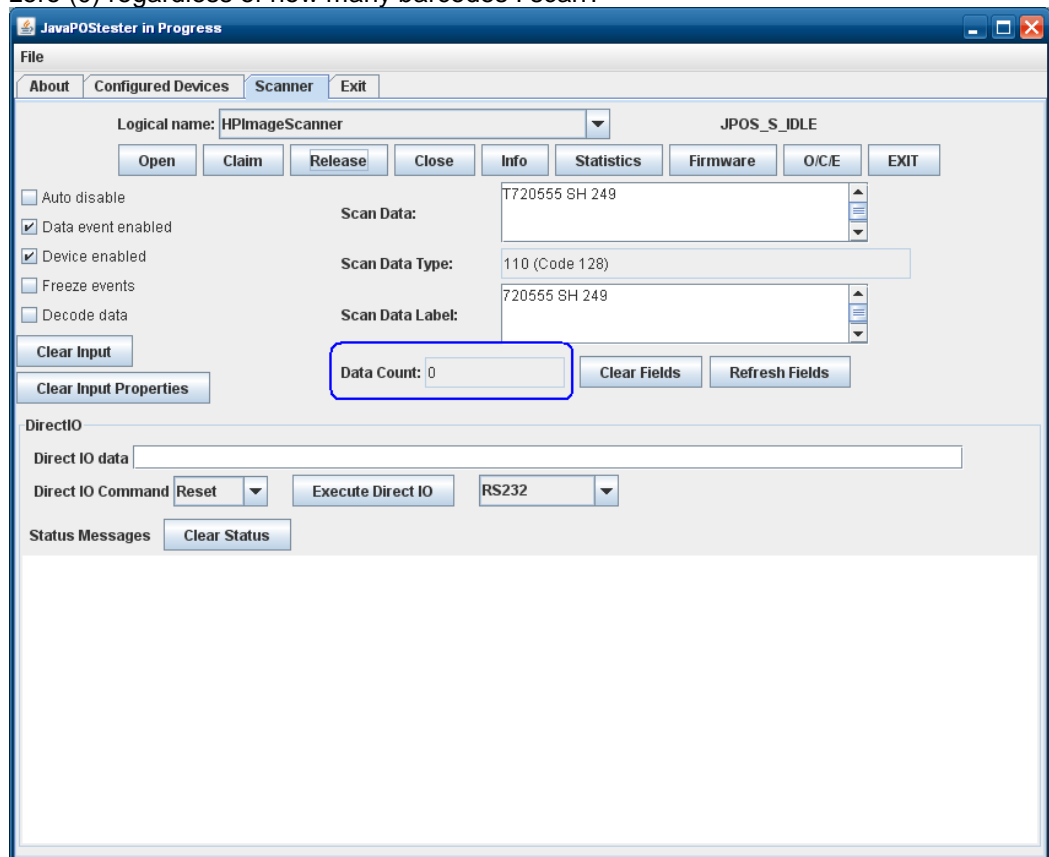

Answer: In the JPOS utility the “Data Count” field is not used to keep track of the number of barcode that have been scanned during the session of the JPOS utility like it is in the OPOS utility for the imaging scanner.

9.20 HP Imaging Barcode Scanner

Question: When I scan something in notepad it appears to garbage in non-English language?

Answer: The “country mode” needs to be changed on the imaging barcode scanner. The country mode barcode are available in the programming guide for the scanner or one can change this via the configuration utility for the scanner in the “USB Keyboard parameter” which is found in the “Interface selection” of the utility.

9.21 Multiple HP Barcode Scanner

Question: When I have multiple HP scanners installed on the unit (HP Imaging scanner / HP Linear Scanner / HP Presentation) the OPOS test utility will only test of one of the scanner. How can I have multiple scanners work on the unit in ((HP Imaging scanner / HP Linear Scanner / HP Presentation) OPOS?

Answer: One will need to disable the OPOS driver so it does not use the virtual port to find the scanner. When this feature is disabled the OPOS driver will use the COM port that is assigned to the scanner; the COM port setting can be obtained from Windows device manager. Change these settings for the other scanner (HP Imaging scanner / HP Linear Scanner / HP Presentation). The following shows the changes in the registry (scanner is on COM6):

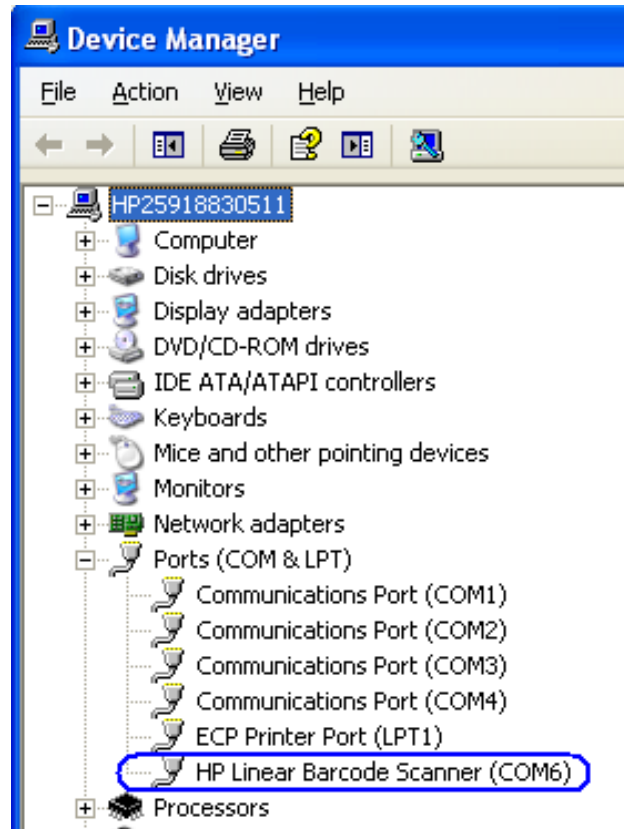

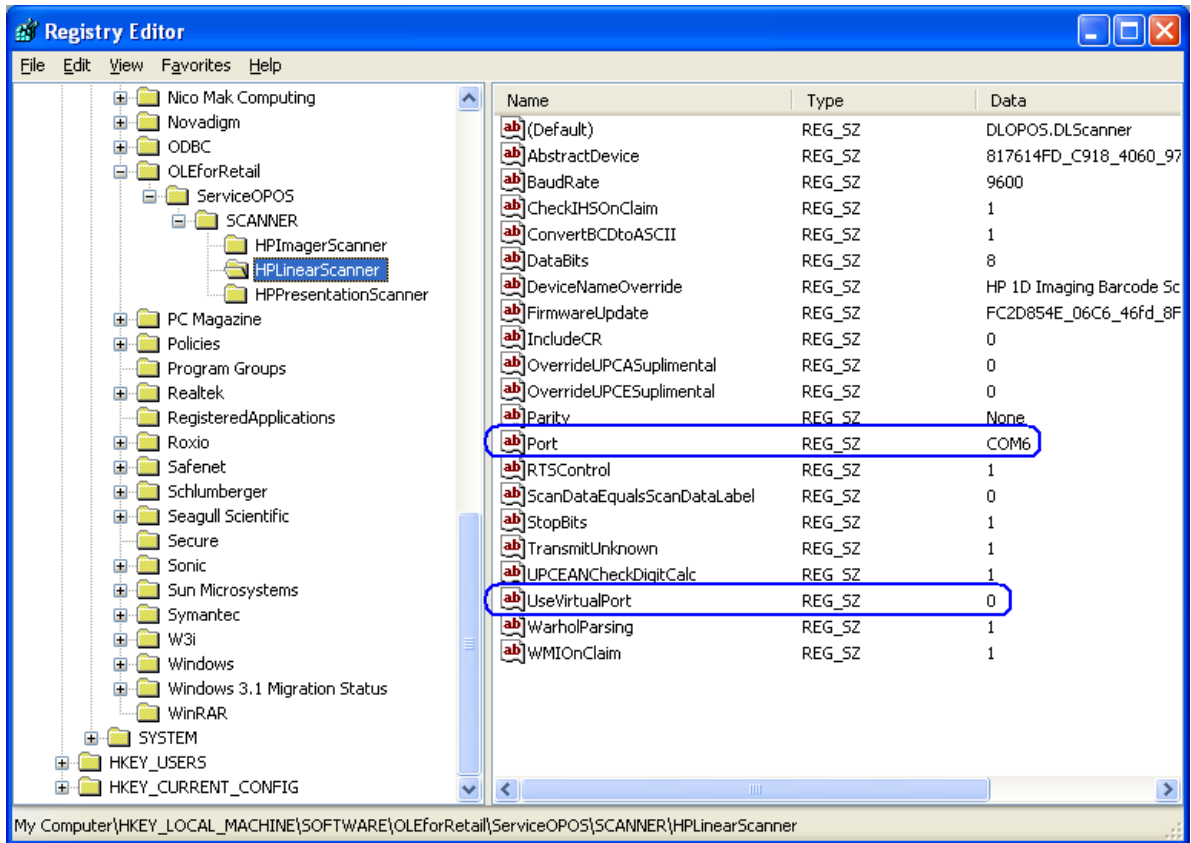

9.22 **HP Biometric Fingerprint Reader**

Question: Do I need to clean my reader to keep it working well?

Answer: Recommended cleaning:

Apply the sticky side of a piece of adhesive cellophane tape on the window and peel it away. If necessary, gently wipe the window with a cloth (not paper) dampened with a mild ammonia-based glass cleaner to remove any milky haze.

Never do the following:

- Clean the reader window with paper
- Pour glass cleaner directly on the reader window
- Use alcohol-based cleaners
- Submerge the reader in liquid

9.23 HP RP7 / RP3 Monitor

Question: How can I tell if I have Projective Capacitive or Resistive monitor on the RP7 or RP3 unit?

Answer: The Projective Capacitive display has flush glass on the front of the unit, the resistive display has a border around the touch.



Projective Capacitive



Resistive

Question: In Windows XP or POSReady 2009 environment I have dual Projective Capacitive display setup but the touch on the second monitor is registered on the primary monitor when I touch the screen.

Answer: The “Multi-mouse-daemon” utility needs to be run to provide the touch driver the monitor information. The “Multi-mouse-daemon” is found in driver’s version 7.5.52.00 or later and must be installed with the “/dual” parameter.

Question: In Windows 7 or POSReady 7 environment I have dual Projective Capacitive display setup but the touch one of the screens the mouse cursor is on the other screen.

Answer: The Windows 7 or POSReady 7 environment needs to be configured for the primary and secondary touch. Please refer to the “Touch in Dual Monitor Setup in POSReady 7 or Windows 7” section.

9.24 HP Retail Jacket for ElitePad Barcode Scanner

Question: How can I tell which COM port the scanner is assigned when it is USB-COM mode for OPOS/JPOS?

Answer: Open Windows Device Manager and open the “com0com – serial port emulators” device to see which COM port has been assigned.

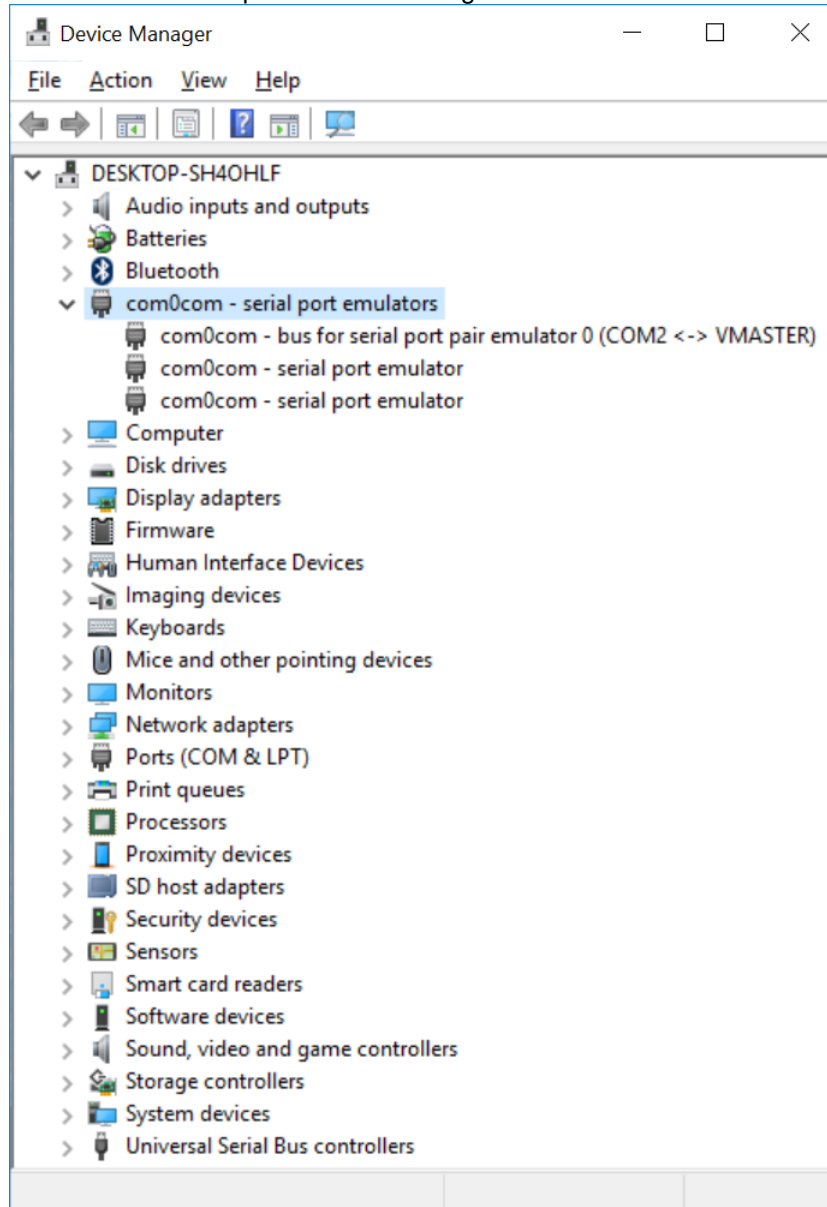

Note: The above screen capture show the scanner assigned as COM2, your system setup could vary.

Question: In JPOS when I click on the OPEN button, nothing seems to happen, what should I check?

Answer: Depending on the operating mode of the scanner:

- 1) If HID-POS mode is being used:
 - i. Make sure the Port value is set to "HID" in JPOS.XML.
- 2) If USB COM mode is being used:
 - i. Make sure the COM port drivers are installed.
 - ii. Make sure the Port value is set to "COM" in JPOS.XML.
 - iii. Make sure the Portno value is set to the COM# from Windows Device Manager in JPOS.XML.



```
jpos - Notepad
File Edit Format View Help
<?xml version="1.0" encoding="UTF-8"?>
<!DOCTYPE JposEntries PUBLIC "-//JavaPOS//DTD//EN"
                "jpos/res/jc1.dtd">

<JposEntries>

  <JposEntry logicalName="HPMobileScanner">
    <creation factoryClass="com.jpos.scanner.ScannerSvcInstanceFactory" serviceClass="com.jpos.scanner.ScannerSvc"/>
    <vendor name="HPScanner" url=""/>
    <jpos category="Scanner" version="1.13"/>
    <product description="Serial/USB Scanner" name="HPMobileScanner" url=""/>

    <!--
      -->
      <prop name="port" value="HID"/>
    <!-- The interface of Scanner, "HID" is HID POS Mode -->
    <prop name="port" value="COM"/>
    <prop name="portno" value="2"/>
    <!--See Scanner type define on the top-->
    <prop name="ScannerType" value="3"/>
    <!--Enable/disable the suffix code, default=0, close the suffix code-->
    <prop name="Suffix" value="0"/>
  </JposEntry>

</JposEntries>
```

9.25 HP 7" CFD

Question: What is the video resolution for this monitor?

Answer: The HP 7" CFD has one fixed video resolution which is 1024 x 600.

Question: I have dual touch screens on my system. When I attach the HP 7" CFD the touch on the second monitor does not seem to respond.

Answer: Multiple touch monitors need to be registered prior to attaching the HP 7" CFD to the unit. Below are the steps to register multiple touch monitors under Windows:

1. Click on the Start button.
2. In the search box, type "Tablet PC Settings" and select this option in the list of results.
 - i. You may be required to perform this search from the Control Panel on older OSs.
3. On the Display tab, click the Setup button under Configure.

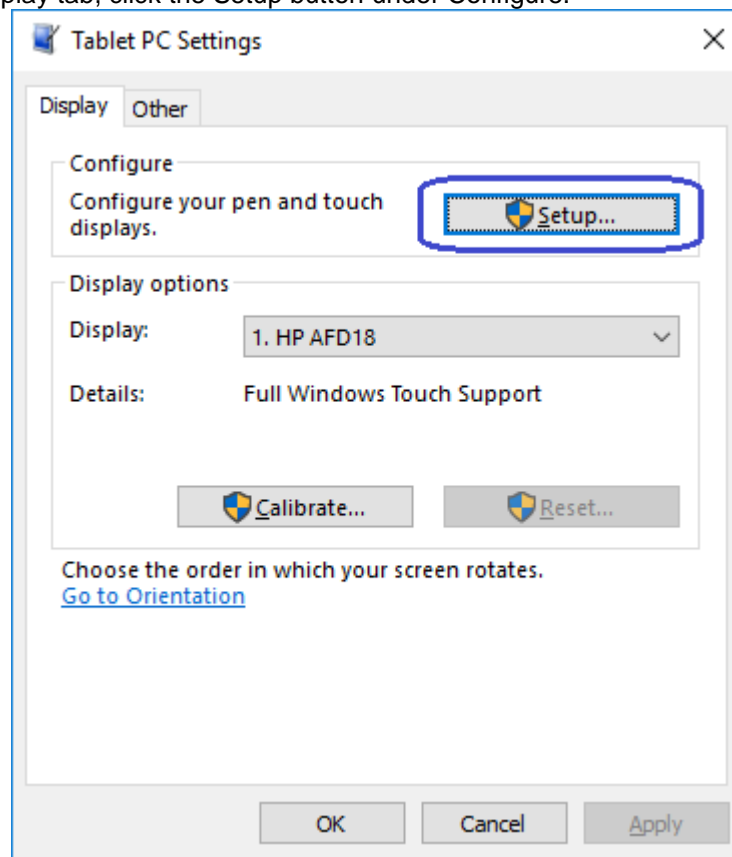

4. Follow the prompt that appears on the screen:

