

B2B/SCM Monitor for SAP

Company-wide End-to-End-Monitoring in SAP

Solution Extension
for SAP

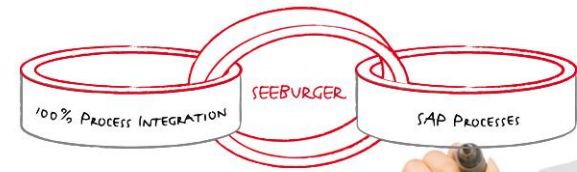



SEEBURGER B2B/SCM Monitor

The SEEBURGER supply chain management tool that provides transparency throughout the entire B2B supply chain.

- Secure
- Central Access
- Single Platform

Full Integration to SAP

SEEBURGER SCM Monitor - ORDERS									
Doc. Information		Schedule lines		Status		Tolerance check		Mes.Type	
Acct at cust	0000002020	Name	Customer for Orders	IDoc number	0000000000708053	Doc. date	20110223	Created on	20110223
Street	Order Street 1	Customer Material Number	OEM1-1000	Material	SUP2-1000				
Postl Code	12345	City	Order City	Part				Unloading Point	
Cty	DE	Receiving point		SOrg	2000	DChI	10	Pt of consump	00
Process definition	0250	Process description	Inbound Orders	SGrp		SOff	2000		
Internal status	I253	Text internal status	Application document posted						

IDoc number	Statu...	Receiver port	P...	Recipients	F...	Msg. ty...	Message Type	Ms...	Ms...	BasicType	Extension	Se
708053		2 SAPSGC	LI	2020	VN		ORDERS			ORDERS05		SA
708058		2 SAPSGC	LI	2020	VN		ORDERS			ORDERS05		SA
708254		2 SAPSGC	LI	2020	VN		ORDERS			ORDERS05		SA
708242		2 SAPSGC	LS	T90CLNT0...			ORDERS			ORDERS05		SE
708243		2 SAPSGC	LS	T90CLNT0...			ORDERS			ORDERS05		SE

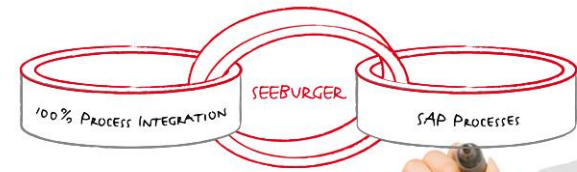

Background

- Global networks cause new forms of communication in B2B every day
- Rising number of EDI messages with external partners
- SAP only provides monitoring functionality for single processes, which makes a centralized, proactive monitoring for over 1800 IDOC types impossible

This Leads To:

- Processing delays – worst case production outage
- Increased costs (expedited shipments etc.)
- Strained relationships with business partners
- Numerous individual ad hoc solutions for isolated problems

SEEBURGER's innovative solution enables centralized monitoring and control of communication

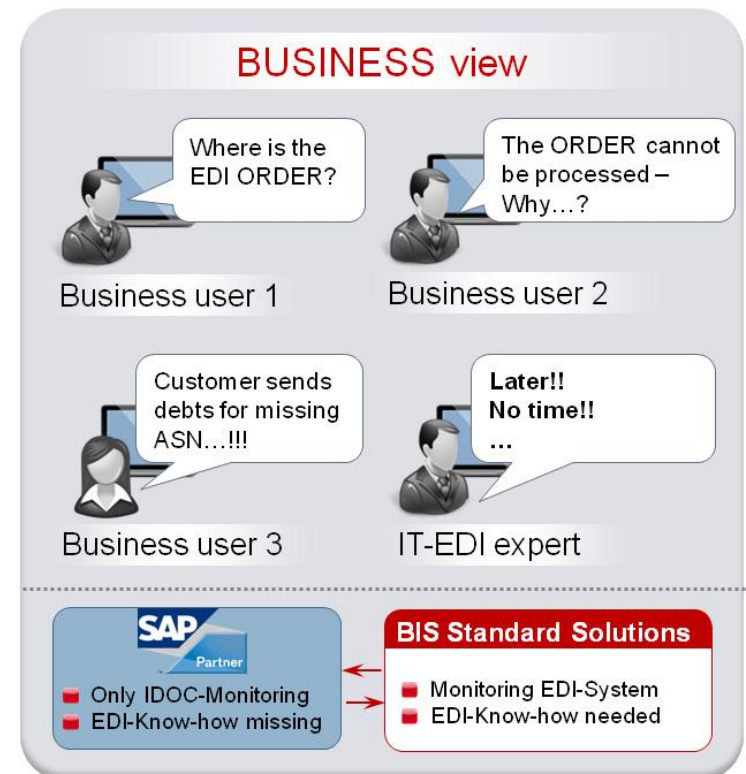

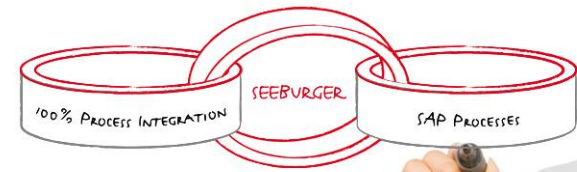

Analysts confirm the key value of centralized business visibility for B2B processes inside the ERP*

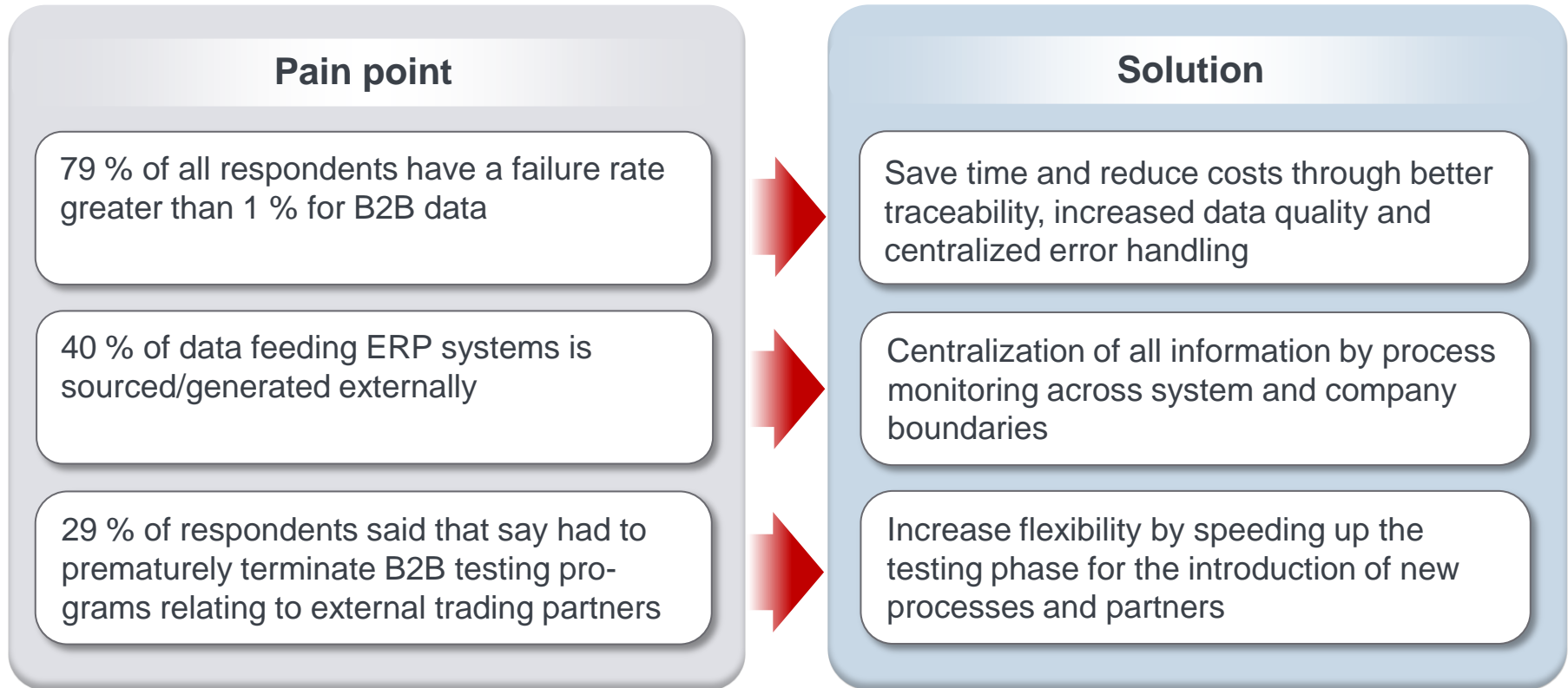

Increase efficiency & reduce costs

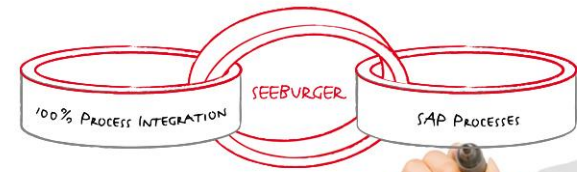

Pain-Point: Decentralized and complex business process monitoring with poor data quality

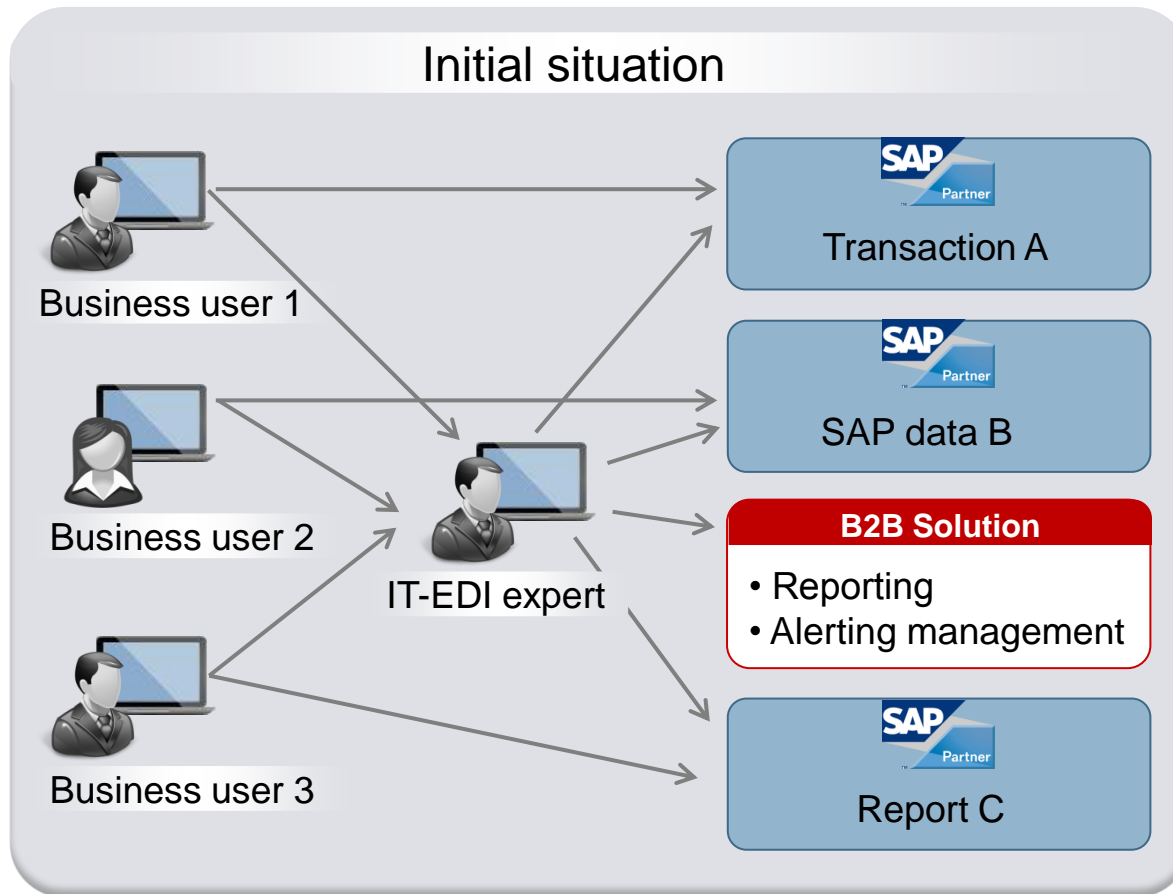

- Limited information available to departmental end users
- Difficult to obtain information when IT specialists are required.

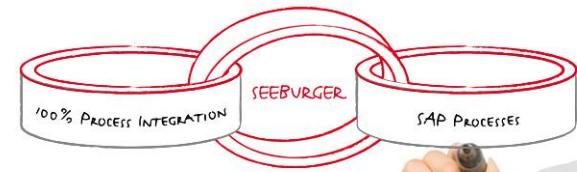

Pain-Point: Decentralized and complex business process monitoring with poor data quality

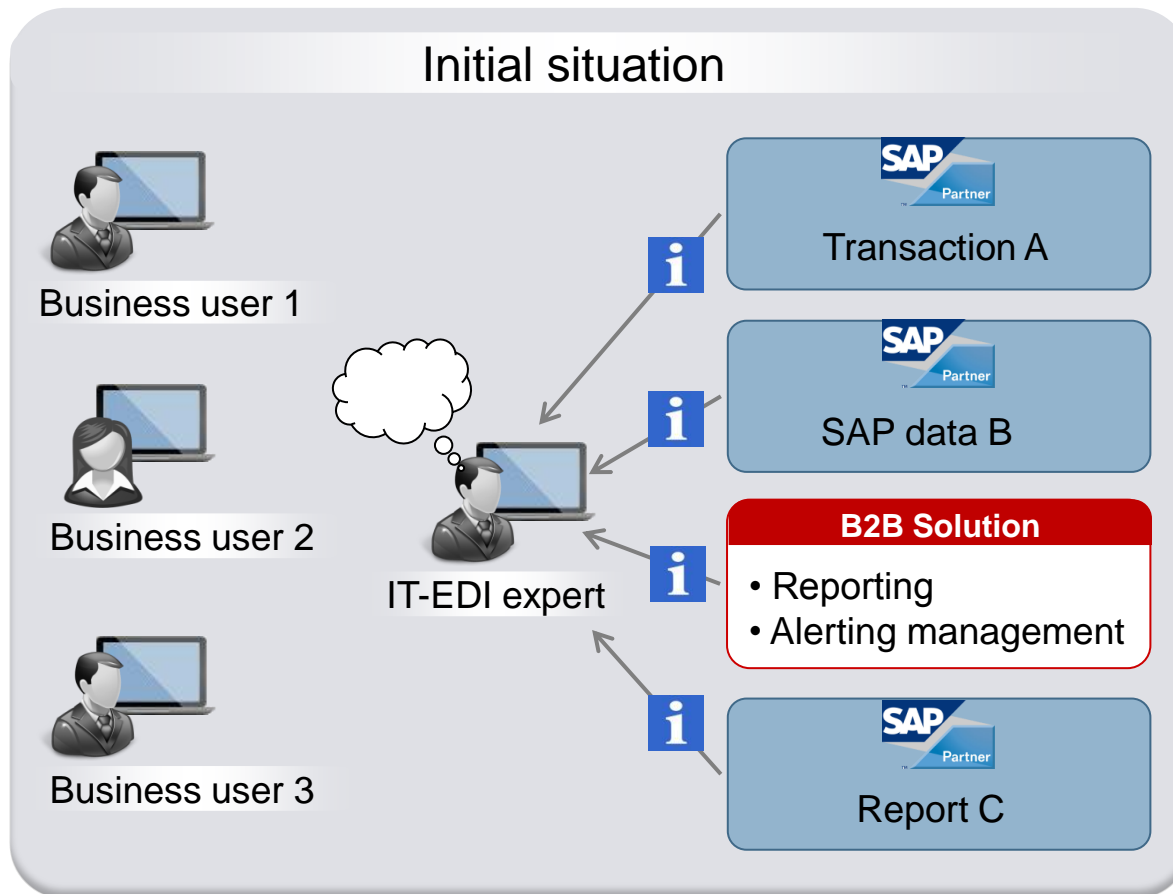

- Only IT specialists are authorized to access various sources of information
- Only IT specialists can provide departmental end users with the information regarding technical B2B communication

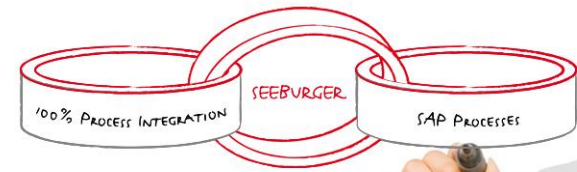

Pain-Point: Decentralized and complex business process monitoring with poor data quality

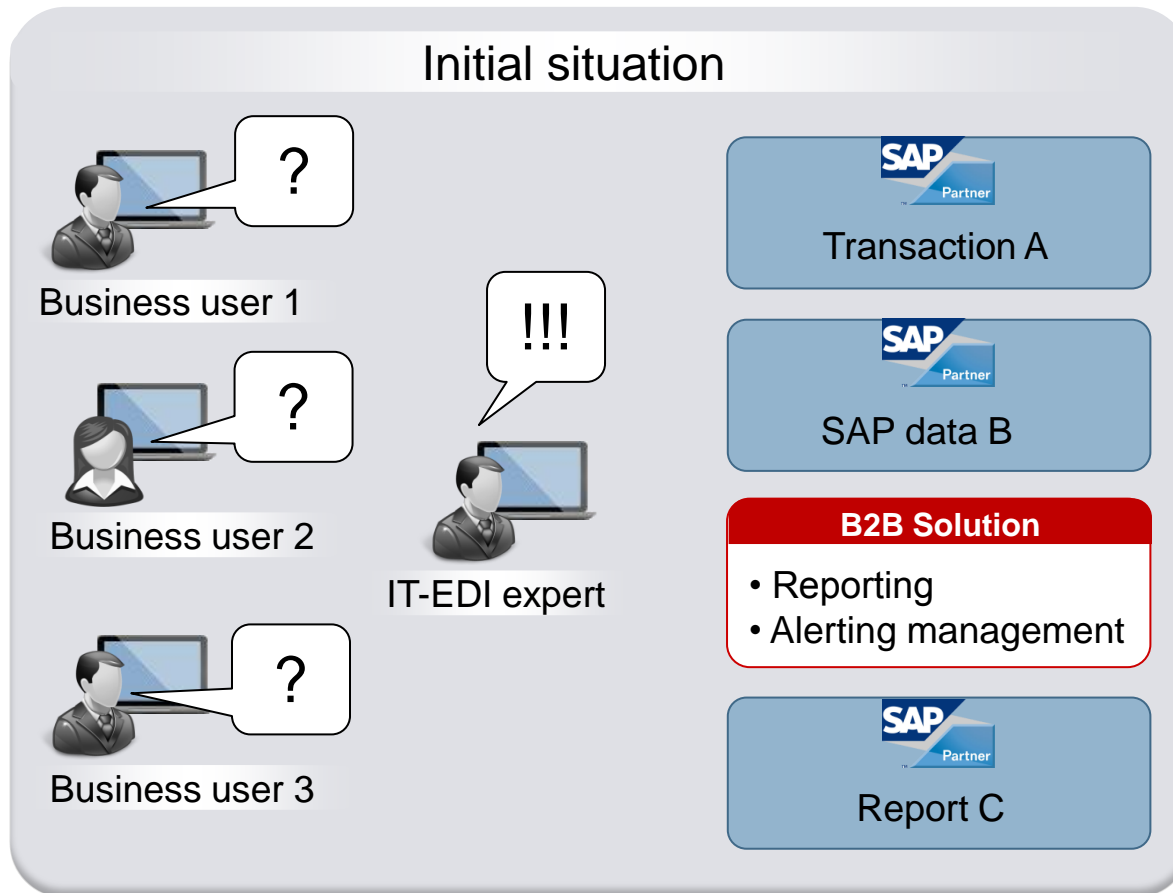

- Departmental end-users require IT support for analysis and troubleshooting
- The IT-EDI specialist becomes a bottleneck in the troubleshooting process
- The result: unnecessary delays and potential loss of important information

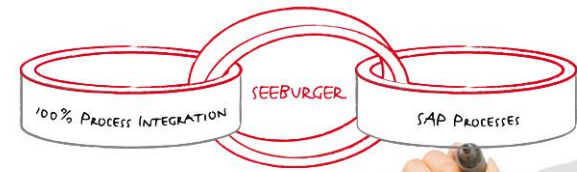

Solution: Transparent views and direct access to all information for business users

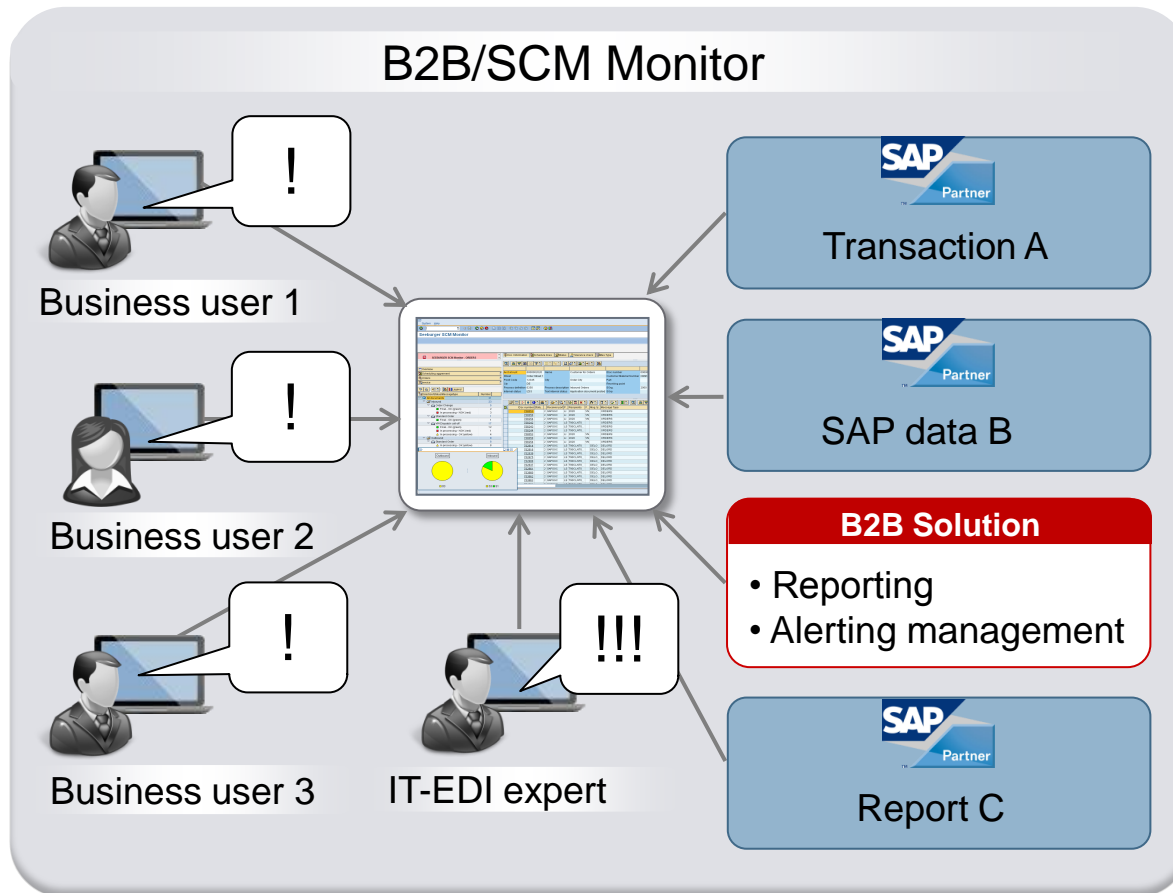

- Provide departmental users access to external sources of information in SAP
- Easy access to all documents associated with end-to-end business processes and communication.

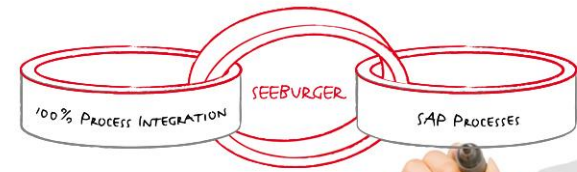

End-to-End-Monitoring in SAP across system boundaries

SEEBURGER Business Integration Suite

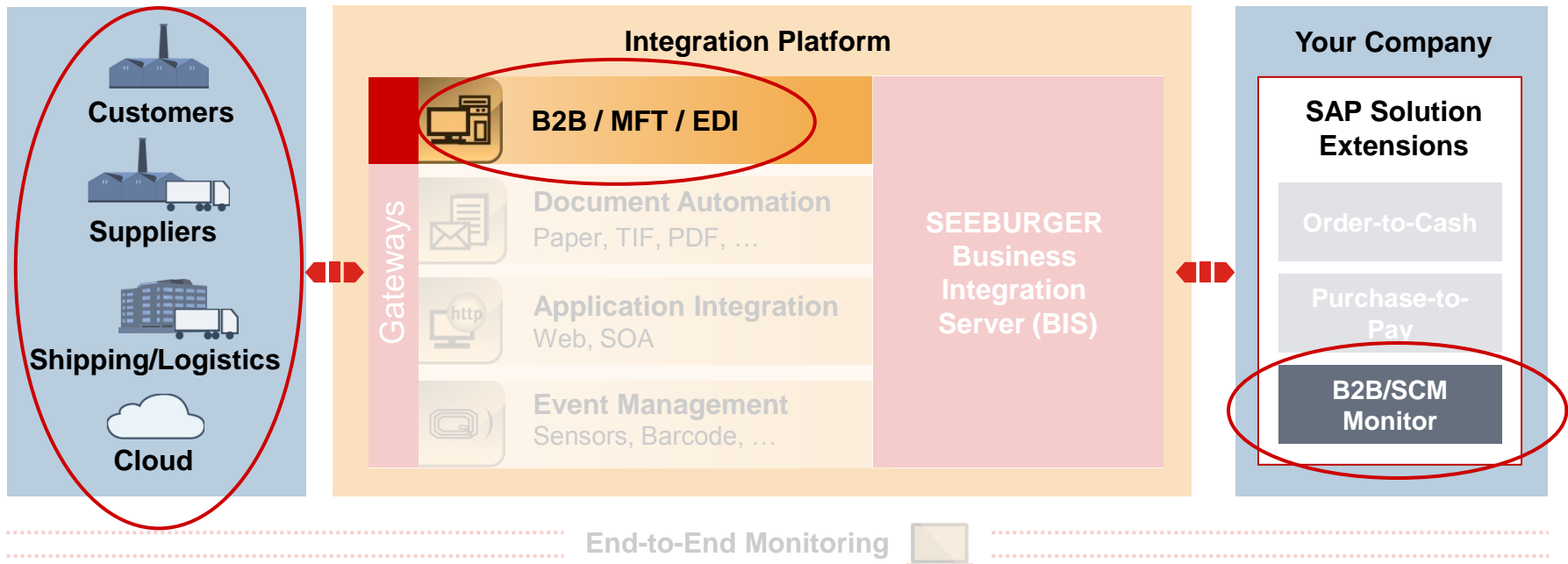

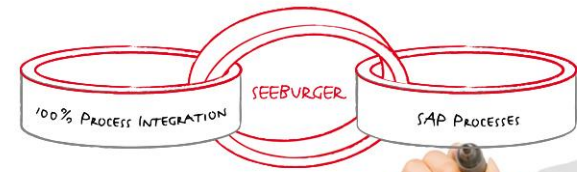

Transparency and Traceability for Business Users

B2B/SCM Monitor for SAP

- **Transparency:** Standardized display of heterogeneous content
- **Role concept:** extended role & authorization objects permit governance of data visibility
- **Acceleration:** Direct access to data and functions for trouble-free processing and display of follow-on-documents
- **Escalations management:** proactive notification of errors
- **Ready to Run:** fully integrated, preconfigured package for SAP



The screenshot displays the 'Seeburger SCM Monitor - ORDERS' window. It includes a navigation pane on the left with sections like 'Overview', 'Scheduling agreement', 'Orders', and 'Invoice'. The main area shows order details such as 'Acct at cust', 'Street', 'Postl Code', 'City', 'Process definition', and 'Internal status'. Below this is a table of document items with columns for IDoc number, Status, Receiver port, Recipients, and Message Type. At the bottom, there are two pie charts labeled 'Outbound' and 'Inbound' with a legend showing '03' and '53 51'.

IDoc number	Status	Receiver port	Recipients	F.	Msg. ty.	Message Type
708053	2	SAPSGC	LI 2020	VN		ORDERS
708058	2	SAPSGC	LI 2020	VN		ORDERS
708254	2	SAPSGC	LI 2020	VN		ORDERS
708242	2	SAPSGC	LS T90CLNT0...			ORDERS
708243	2	SAPSGC	LS T90CLNT0...			ORDERS
708244	2	SAPSGC	LS T90CLNT0...			ORDERS
708052	2	SAPSGC	LI 2020	VN		ORDERS
708058	2	SAPSGC	LI 2020	VN		ORDERS
708254	2	SAPSGC	LI 2020	VN		ORDERS
702814	2	SAPSGC	LS T90CLNT0...	DELO	DELO	DELO
702816	2	SAPSGC	LS T90CLNT0...	DELO	DELO	DELO
702828	2	SAPSGC	LS T90CLNT0...	DELO	DELO	DELO
702875	2	SAPSGC	LS T90CLNT0...	DELO	DELO	DELO
702808	2	SAPSGC	LS T90CLNT0...	DELO	DELO	DELO
702837	2	SAPSGC	LS T90CLNT0...	DELO	DELO	DELO
702861	2	SAPSGC	LS T90CLNT0...	DELO	DELO	DELO
703860	2	SAPSGC	LS T90CLNT0...	DELO	DELO	DELO
703862	2	SAPSGC	LS T90CLNT0...	DELO	DELO	DELO
703863	2	SAPSGC	LS T90CLNT0...	DELO	DELO	DELO

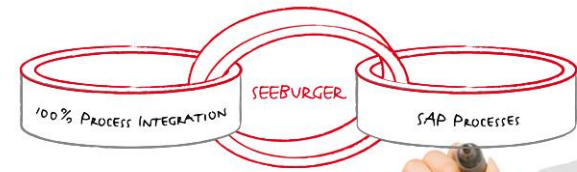

Compare / Contrast



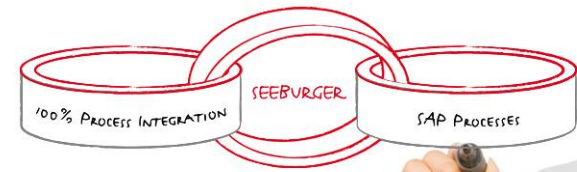

Comparison

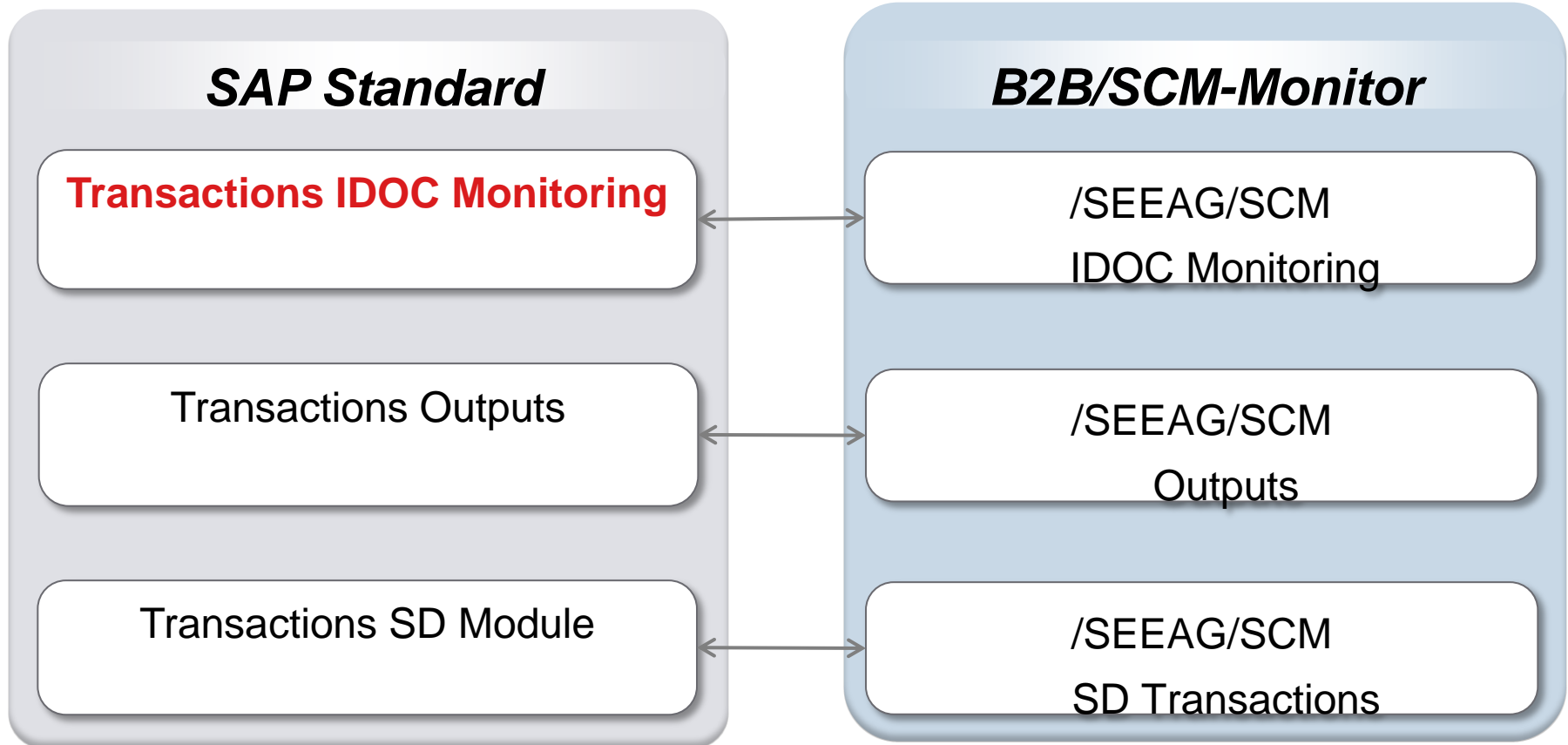

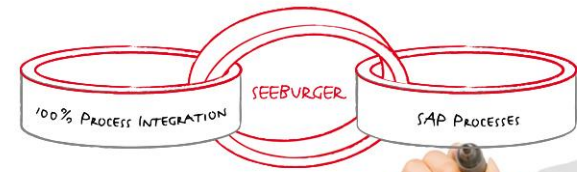

SAP-Standard – IDOC Monitoring

Transactions

- ☰ IDOC_EN
- ✳ WE02 - Display IDoc
- ✳ WE05 - IDoc Lists
- ✳ WE09 - Search for IDocs by Content
- ✳ BD87 - Status Monitor for ALE Messages
- ✳ BD84 - Post IDocs after ALE error
- ✳ WE19 - Test tool
- ✳ WE60 - Documentation for IDoc types

Display IDOC

IDocs	Numbr.										
Selected IDocs 013395											
Outbound IDocs 000797											
SEEAOMWRK	000011										
ADMAS	000005	12	53	000	KUJ/JOEM2011	DELFOR02	09/28/2010	19:41:59	DELINS	Inbox	SAPSGC
CREMAS	000077	18	53	000	LSI/RCV5	INVOIC01	09/29/2010	13:26:30	INVOIC	Inbox	TRFC
DEBMAS	000013	29	51	000	KUJAG/OEM2000	DELFOR02	09/29/2010	16:54:46	DELINS	Inbox	TRFC
DELFOR	000005	24	51	000	KUJAG/OEM2000	DELFOR02	09/29/2010	16:55:10	DELINS	Inbox	TRFC
DELINS	000208	39	51	000	KUJAG/OEM2000	DELFOR02	09/29/2010	16:55:10	DELINS	Inbox	TRFC
DESADV	000005	41	51	000	KUJAG/OEM2000	DELFOR02	09/29/2010	16:55:10	DELINS	Inbox	TRFC
INVOIC	000062	7	51	000	KUJAG/OEM2000	DELFOR02	09/29/2010	16:55:10	DELINS	Inbox	TRFC
MATMAS	000018	7	51	000	KUJAG/OEM2000	DELFOR02	09/29/2010	16:55:10	DELINS	Inbox	TRFC
ORDCHG	000006	7	51	000	KUJAG/OEM2000	DELFOR02	09/29/2010	16:55:10	DELINS	Inbox	TRFC
ORDERS	000017	7	51	000	KUJAG/OEM2000	DELFOR02	09/29/2010	16:55:10	DELINS	Inbox	TRFC
ORDRSP	000005	41	51	000	KUJAG/OEM2000	DELFOR02	09/29/2010	16:55:10	DELINS	Inbox	TRFC
PORDCR	000013	7	51	000	KUJAG/OEM2000	DELFOR02	09/29/2010	16:55:10	DELINS	Inbox	TRFC
RSINFO	000146	7	51	000	KUJAG/OEM2000	DELFOR02	09/29/2010	16:55:10	DELINS	Inbox	TRFC
SHPMNT	000143	59	51	000	KUJAG/OEM2000	DELFOR02	09/29/2010	16:55:27	DELINS	Inbox	TRFC
STPPOD	000063	29	51	000	KUJAG/OEM2000	DELFOR02	09/29/2010	16:55:27	DELINS	Inbox	TRFC
Inbound IDocs 012589											
SEEAOMWRK	000018	5	56	000	KUJAG/OEM2000	DELFOR02	09/29/2010	16:55:27	DELJIT	Inbox	TRFC
ACC_INVOIC	000032	7	53	000	LSI/RCV5	ACC_INVOL	10/01/2010	14:54:11	ACC_I	Inbox	TRFC
DELINS	007306	39	53	000	LSI/7306LNT090	DELFOR02	10/01/2010	16:17:13	DELINS	Inbox	SAPSGC
DELJIT	004006	3	53	000	LSI/RCV5	FIDCCP02	10/06/2010	09:14:59	FIDCC2	Inbox	TRFC
DELORD	000129	3	53	000	LSI/RCV5	FIDCCP02	10/06/2010	09:28:46	FIDCC2	Inbox	TRFC
DESADV	000084	3	53	000	LSI/RCV5	FIDCCP02	10/06/2010	09:25:02	FIDCC2	Inbox	TRFC
EMLNOT	000002	5	53	000	LSI/RCV5	FIDCCP02	10/06/2010	10:12:16	FIDCC2	Inbox	TRFC
FIDCC2	000012										
INVOIC	000136										
ORDCHG	000029										
ORDERS	000213										
ORDRSP	000035										
PORDCR	000003										
STATUS	000244										
STPPOD	000009										

Technical Monitoring of inbound and outbound IDOCs

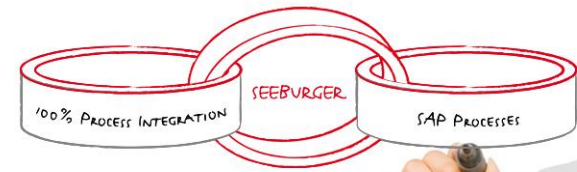

SAP-Standard – IDOC Monitoring

Transactions

- ▼ IDOC_EN
 - ✳ WE02 - Display IDoc
 - ✳ WE05 - IDoc Lists
 - ✳ WE09 - Search for IDocs by Content
 - ✳ BD87 - Status Monitor for ALE Messages
 - ✳ BD84 - Post IDocs after ALE error
 - ✳ WE19 - Test tool
 - ✳ WE60 - Documentation for IDoc types

Search for IDOCs by content

IDoc number	Date	Time	Direction	Partner	Status	Descr.
Number	Segment	Type	Number	Hier. Level		
000000000000093972	09/29/2010	16:55:27	2	KU/AG/0EN2000	51	Application document not posted
000000000000093973	09/29/2010	16:55:27	2	KU/AG/0EN2000	56	IDoc with errors added
000001	E1EDK09			1		
000002	E1EDK01			1	2	
000003	E1EDK01			1	2	
000004	E1EDP10			1	2	
000005	E1EDP10			4	3	
000000000000093974	10/01/2010	14:54:11	2	LS/ /ICV5	53	Application document posted
000000000000093975	10/01/2010	18:17:13	2	LS/ /T90CLNT090	53	Application document posted
000000000000093976	10/06/2010	09:14:59	2	LS/ /ICV5	53	Application document posted
000000000000093977	10/06/2010	09:28:46	2	LS/ /ICV5	53	Application document posted
000000000000093978	10/06/2010	09:55:02	2	LS/ /ICV5	53	Application document posted
000000000000093979	10/06/2010	10:12:16	2	LS/ /ICV5	53	Application document posted
000000000000093980	10/06/2010	10:24:03	2	LS/ /ICV5	53	Application document posted
000000000000093981	10/06/2010	10:34:40	2	KU/AG/0EN2000	51	Application document not posted
000000000000093982	10/06/2010	10:34:41	2	KU/AG/0EN2000	51	Application document not posted
000000000000093983	10/06/2010	11:05:38	2	LS/ /ICV5	53	Application document posted
000000000000093984	10/06/2010	11:59:26	2	LS/ /ICV5	53	Application document posted
000000000000093985	10/06/2010	12:04:35	2	KU/AG/0EN2000	51	Application document not posted
000000000000093986	10/06/2010	12:04:35	2	KU/AG/0EN2000	51	Application document not posted
000000000000093987	10/06/2010	14:42:50	2	KU/ /	56	IDoc with errors added
000000000000093988	10/06/2010	14:43:17	2	KU/ /0000001111	56	IDoc with errors added
000001	E1EDK01			1		
000002	E1EDK01			2		
000003	E1EDK01			2		

Monitoring of inbound and outbound IDOCs on Business Content

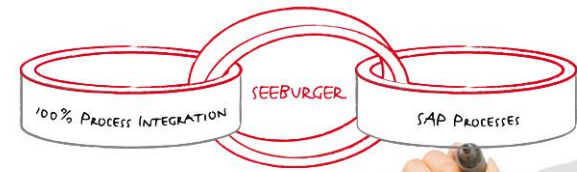

SAP-Standard – IDOC Monitoring

Transactions

- ▼ IDOC_EN
 - ✳ WE02 - Display IDoc
 - ✳ WE05 - IDoc Lists
 - ✳ WE09 - Search for IDocs by Content
 - ✳ BD87 - Status Monitor for ALE Messages
 - ✳ BD84 - Post IDocs after ALE error
 - ✳ WE19 - Test tool
 - ✳ WE60 - Documentation for IDoc types



Status Monitor

IDocs	IDoc status	Number
IDoc selection		
Changed on is in the range 09/28/2010 to 09/28/2011		
IDES ALE Central system (client 800)		13868
IDocs in outbound processing		1097
IDoc entries in IRFC queue		299
IDoc ready for dispatch (ALE service)	30	2
IDoc was edited	32	2
ADMAS		1
SHPMNT		1
Changed data record was saved		
Data passed to port OK	03	569
Interchange handling OK	10	153
Dispatch OK	12	1
Triggering EDI subsystem OK	18	47
Error - no further processing	31	2
Original of an IDoc which was edited	33	10
IDoc added incorrectly	37	12
IDoc in inbound processing		12771
Application document not posted	51	3565
IDoc with errors added	56	7901
(without name)		16
JSEEGAWRKFL		1
DELINS		3677
DELJIT		3849
DESADV		7
GSVERF		320
INVOIC		6
ORDERS		24
Changed data record was saved		
EDT: Partner profile not available		24
STATUS		1
Error passing IDoc to application	63	3
Error in ALE service	65	2
IDoc passed to application	62	78
IDoc ready to be transferred to application	64	135
Application document posted	53	1035
Error - no further processing	68	46

Monitoring of inbound and outbound IDOCs with status information and ability to restart processing

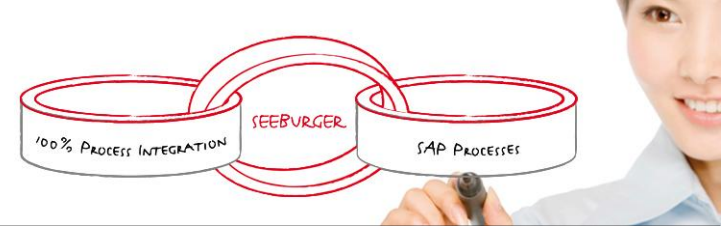

SAP-Standard – IDOC Monitoring

Transactions

IDOC_EN
WE02 - Display IDoc
WE05 - IDoc Lists
WE09 - Search for IDocs by Content
BD87 - Status Monitor for ALE Messages
BD84 - Post IDocs after ALE error
WE19 - Test tool
WE60 - Documentation for IDoc types

Test tool

Standard inbound	Inbound function module	Inbound file	Standard outbound processing
E1EDT20	0000001300ZNLK11014	HN-9-7651	EXT1
E1EDT22	VM NLK Transp. StraÙeladung	LKW	Direktlauf
E1EDT18	OR1		
E1ADRM4	SP 0000000000	ENHerr	Transporter
E1ADRM4	OTP 2000	DE	Heathrow / Hayes
E1ADRE4	3052000		
E1EDT10	001	0000000000000000000000000000	20110315211400 20110315211400
E1EDT10	004	0000000000000000000000000000	20110315212400 20110315212400
E1EDT10	005	2011011715300020110117220000	00000000000000 00000000000000
E1TXTH6	VTK 0000001300		ZAXNE EN
E1TXTP6	* 00000900		
E1TXTH6	VTK 0000001300		ZAXOE EN
E1TXTP6	* 2210242310001		
E1TXTH6	VTK 0000001300		ZAXNE EN
E1TXTP6	* 600201		
E1TXTH6	VTK 0000001300		ZTINE EN
E1TXTP6	*		
E1EDK33	00010001101 40.000	0.00 0.00 0 0 0 0	
E1EDT50	Transport	LKW	Direktlauf
E1EDT44	001	2000	
E1EDT49			Versandstelle Heathrow/Hayes
E1ADRM6			EN
E1EDT44	002	0000050643	00EN2000
E1ADRM6			DE
E1ADRM6			Aud1 A6
E1ADRM7	SP 0000000000	ENHerr	Transporter
E1EDT01	0000014665		
E1EDT57			00000000000000
E1EDL20	000001466520002000	JIT	EXVendor 600E010126 000

Test tool to change IDOCs with Standard inbound and outbound processing

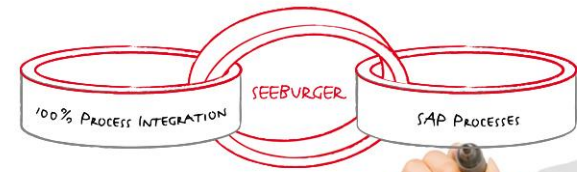

SAP-Standard – IDOC Monitoring

Transactions

▼ IDOC_EN

- ✳ WE02 - Display IDoc
- ✳ WE05 - IDoc Lists
- ✳ WE09 - Search for IDocs by Content
- ✳ BD87 - Status Monitor for ALE Messages
- ✳ BD84 - Post IDocs after ALE error
- ✳ WE19 - Test tool
- ✳ WE60 - Documentation for IDoc types

- EMFOR – IDOC Monitor for Inbound FRC/JIT
- EMORD – IDOC Monitor for Inbound ORDERS
- EMJIT – IDOC Monitor for Inbound SEQJIT
- EMASN – IDOC Monitor for Inbound ASN



IDOC Monitors

Status	IDoc number	Text	Ship-To	Party	Vendor	Sold-to	External	Delivery No	Message Text
PO number	Item	Customer	Q	Inb.	Deliv.	Receiving	Delivered	Quant	Sales Material No.
☐	000000000539748					41	5000117	0001	Inbound delivery/deliveries created (nos. 0180000072 t
4500015077	10	09.02.2003	180000872				1,000	PCE	R-2400-SUS
☐	000000000539753					41	5000122	0001	Inbound delivery/deliveries created (nos. 0180000073 t
☐	000000000539750					41	5000150	0001	Inbound delivery/deliveries created (nos. 0180000074 t
☐	000000000539762					41	5000153		Enter either delivery date or goods issue date
☐	000000000539764					41	5000155	0001	Inbound delivery/deliveries created (nos. 0180000075 t
☐	000000000539770	7800002				7800002	80005861	0001	Inbound delivery/deliveries created (nos. 0180000076 t
☐	000000000539785	7800002				7800002	80005862	0001	Inbound delivery/deliveries created (nos. 0180000077 t
☐	000000000539796	7800002				7800002	80005863	0001	Inbound delivery/deliveries created (nos. 0180000078 t
☐	000000000539801					41	5000168	0001	Inbound delivery/deliveries created (nos. 0180000079 t
☐	000000000539807					41	5000172		This function only possible for items with confirmation key
☐	000000000539808					41	5000174	0001	Inbound delivery/deliveries created (nos. 0180000080 t
☐	000000000567749						5000218	0001	Inbound delivery/deliveries created (nos. 0180000083 t
☐	000000000567751						5000218	0001	Inbound delivery/deliveries created (nos. 0180000084 t
☐	000000000579752						5000333	Item	00018 of purchasing document 4500015545 does not exist
4500015545	10						50,000	PCE	R-2400-SUS
☐	000000000579754						5000348	Item	00018 of purchasing document 4500015546 does not exist
☐	000000000737751	4130				4130	80015105	EDI:	Partner profile inbound not available
K-VMS-01							2,000	PCE	3500 3511
☐	000000000744757	4130				4130	80015140	EDI:	Partner profile inbound not available

Process-related IDOC Monitors for incoming messages with Display of segment content and processing status

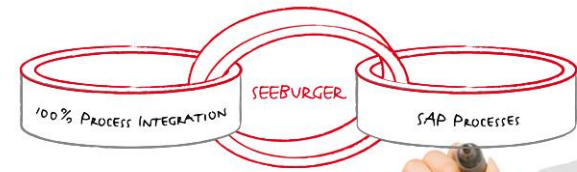

Agenda

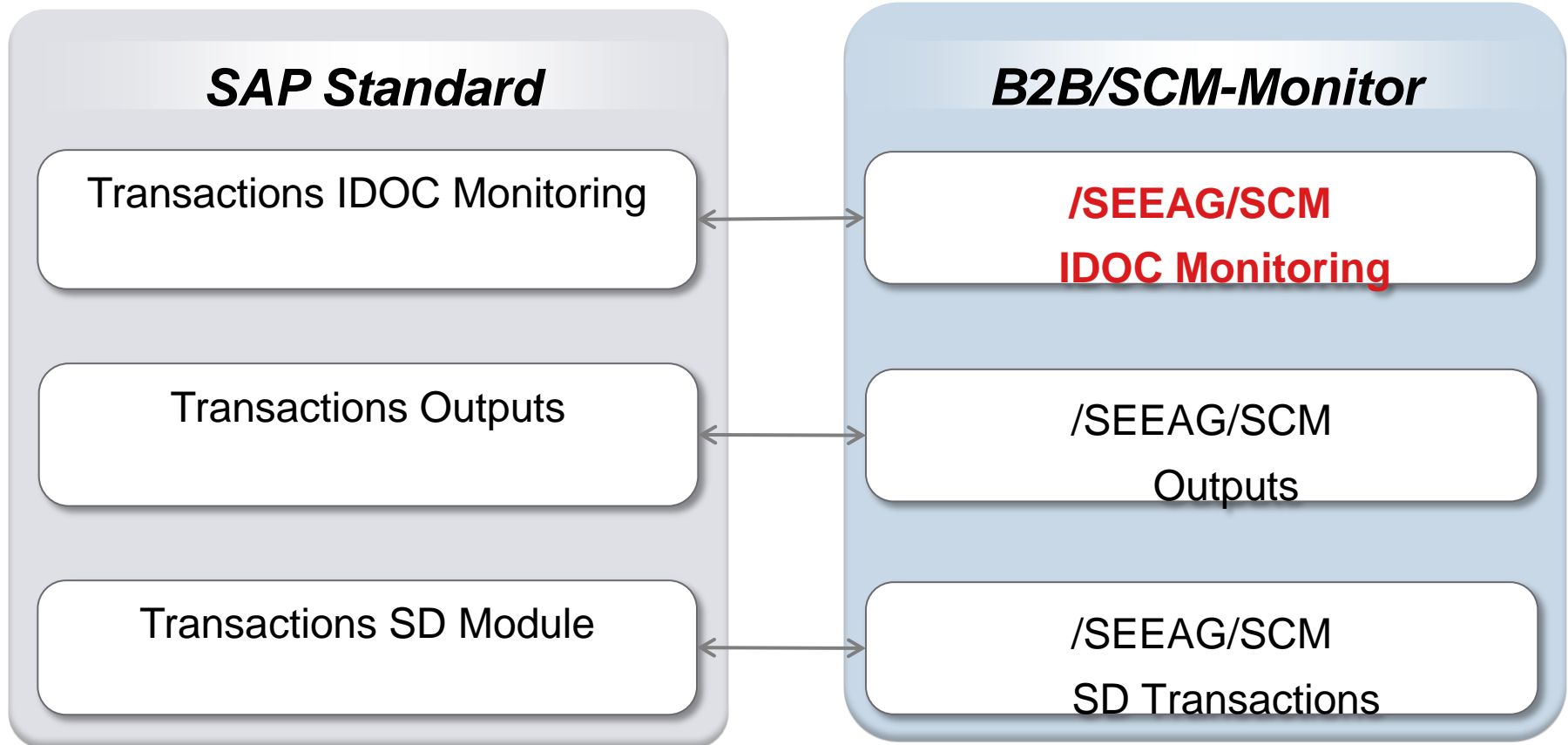

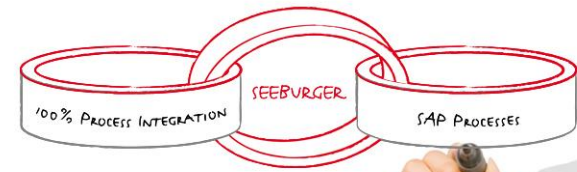

B2B/SCM Monitor – IDOC Monitoring

Change selection IMG

SEEBURGER SCM Monitor - SCHEDULING AGREEMENT

Overview

- Scheduling agreement
- Order Processing
- Invoice/Billing Document

Legend

Direction/Status/Message type Number

- All documents 540
 - Inbound 350
 - Standard ASN 49
 - Final - OK (green) 46
 - In processing - N 3
 - Standard FRC/JIT 262
 - VW Dispatch call off 39
 - Outbound 190
 - Standard ASN 37
 - Standard FRC/JIT 126
 - Final - OK (green) 78
 - In processing - OI 5
 - In processing - OI 41
 - In processing - OI 2
 - VW NLK PUS ASN 27

Doc. Information Schedule lines Status Tolerance check Mes. Type

Document data, Status, etc.

Direction	Msgg.Type	Number	Status 03	Status 10	Status 18	Status 51	Status 53	Status 62	Status 64	Status 68
1	DELFOR	5	5	0	0	0	0	0	0	0
1	DELINS	121	41	80	0	0	0	0	0	0
1	SHPMNT	37	14	23	0	0	0	0	0	0
1	SHPMNT	27	2	7	18	0	0	0	0	0
2	DELINS	232	0	0	0	68	138	5	8	13
2	DELINS	30	0	0	0	20	7	1	0	2
2	DELORD	39	0	0	0	1	38	0	0	0
2	DESADV	49	0	0	0	3	46	0	0	0

Display IDOCs

IDoc number	Statu...	Created on	Created at	Doc. date	Sold-to pt	Ship-to	Acct at cust.	Sales Doc.	Shipment	Docltn	Customer Material Number
702804		11/14/2010	10:31:01		OEM3011	OEM3011	0098A	30000067			2S6W 3B413AA
702805		11/14/2010	19:39:46		OEM3011	OEM3011	0098A	30000067			2S6W 3B413AA
702806		11/14/2010	19:58:50		OEM3011	OEM3011	0098A	30000067			2S6W 3B413AA
702811		11/16/2010	11:12:57	10/26/2010			000002022				
702812		11/16/2010	11:18:13	10/26/2010			000002022				
702814		11/16/2010	11:26:58	10/26/2010			000002022			0	
702816		11/16/2010	11:36:18	10/26/2010			000002022			0	4G8 853 855 D_Z3F
702816		11/16/2010	11:36:18	10/26/2010			000002022			1	4G8 853 856 D_Z3F
702817		11/16/2010	12:05:45								
702818		11/16/2010	12:28:32								
702819		11/16/2010	12:32:04								
702828		11/16/2010	13:55:41								
702831		11/16/2010	13:57:40								
702833		11/16/2010	13:58:04								
702836		11/16/2010	15:05:37		OEM3011	OEM3011	0098A	30000067			2S6W 3B413AA
702839		11/16/2010	15:32:14	10/26/2010			000002022			0	4G8 853 855 D_Z3F
702839		11/16/2010	15:32:14	10/26/2010			000002022			1	4G8 853 856 D_Z3F
702851		11/16/2010	17:20:35							1256	
702852		11/16/2010	17:26:47							1256	
702853		11/16/2010	17:35:22				0098A	30000067			2S6W 3B413AA
702854		11/16/2010	17:40:24							1256	

Message list with business content

- Message processing
- Message Control
- Segment Comparison

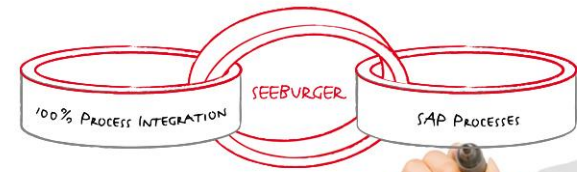

Agenda

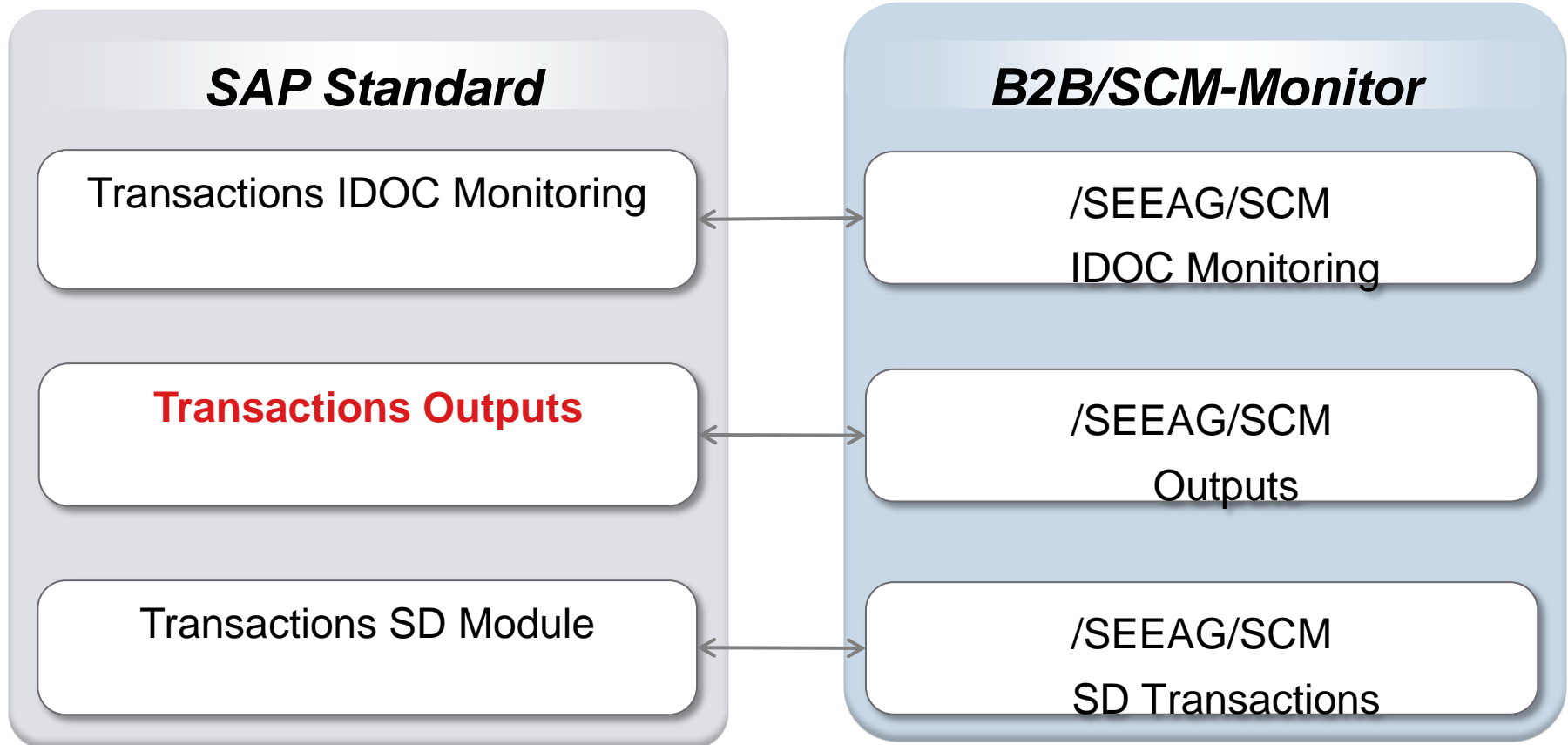

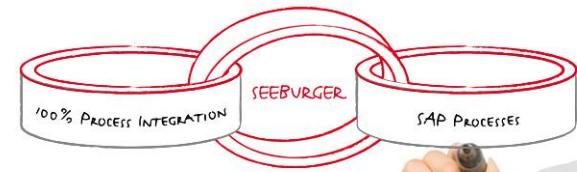

SAP-Standard – Outputs

Transactions

Outputs

- ✳ SP01 - Output Controller
- ✳ VT70 - Output for Shipments

3rd party addons

- ✳ /SEEAG/MENU - Transaction /SEEAG/MENU
- ✳ /SEEAG/DI_GTL_KLT - Print GTL or SLC with 2D-Barcode

Output Controller

Spool no.	Type	Date	Time	Status	Pages	Title
26397		09/21/2011	13:33	Waiting	1	SMART 259F SOWA
26303		09/05/2011	16:29	Compl	2	SMART LOCL SOWA
26302		09/05/2011	16:29	Compl	2	SMART LOCL SOWA
26301		09/05/2011	16:29	Compl	2	SMART LOCL SOWA
26300		09/05/2011	16:25	Compl	2	SMART LOCL SOWA
26299		09/05/2011	16:25	Compl	2	SMART LOCL SOWA
26298		09/05/2011	16:25	Compl	2	SMART LOCL SOWA
26297		09/05/2011	16:22	Compl	2	SMART LOCL SOWA
26296		09/05/2011	16:10	Compl	2	SMART LOCL SOWA
26295		09/05/2011	16:10	Compl	2	SMART LOCL SOWA
26294		09/05/2011	16:10	Compl	2	SMART LOCL SOWA
26293		09/05/2011	16:11	Compl	2	SMART LOCL SOWA

- Print EDIFACT
- Print EDIFACT - Smart Forms
- Print by R/3
 - Material Tags
 - Warenanhänger Global Label
 - Edit material tags
 - BMW Packstückliste
 - Delivery note
 - Delivery note Galia
 - Delivery note PSA
 - Sendungsbeleg VDA4939
 - Sendungsbeleg VDA4939 Position
 - Shipping order
 - CMR Shipping order
 - Invoice

Output or Display of Documents

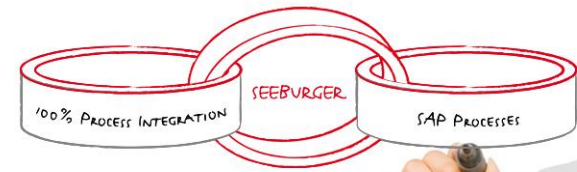

Agenda

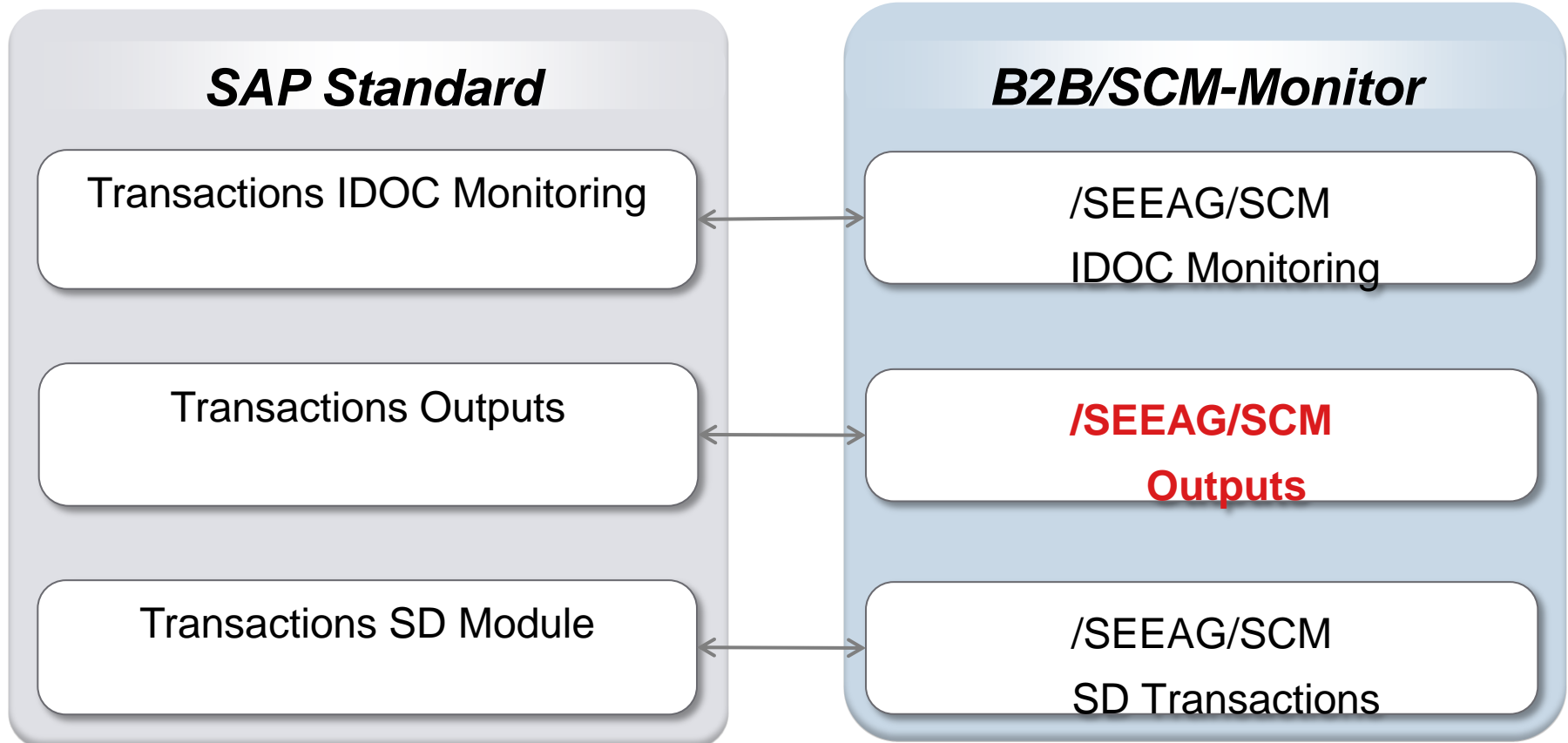

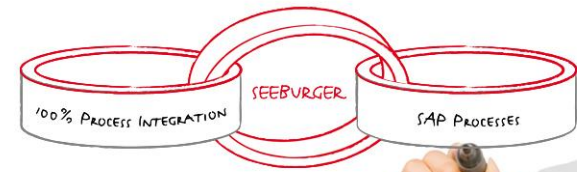

B2B/SCM Monitor – Outputs

Direction	Messg.Type	Number	Status 03	Status 10	Status 18	Status 51	Status 53	Status 62	Status 64	Status 68
1	DELFOR	5	5	0	0	0	0	0	0	0
1	DELINS	121	41	80	0	0	0	0	0	0
1	SHPMNT	37	14	23	0	0	0	0	0	0
1	SHPMNT	27	2	7	18	0	0	0	0	0
2	DELINS	232	0	0	0	68	138	5	8	1
2	DELINS	30	0	0	0	20	7	1	0	0
2	DELORD	39	0	0	0	1	20	0	0	0
2	DESADV	49	0	0	0	3	46	0	0	0

IDoc number	Statu...	Created on	Created on	Doc. date	Sold-to pt	Ship-to	Acct at cust.	Se
702804		11/14/2010	10:31:01		OEM3011	OEM3011	0098A	30
702805		11/14/2010	19:39:46		OEM3011	OEM3011	0098A	30
702806		11/14/2010	19:58:50		OEM3011	OEM3011	0098A	30
702811		11/16/2010	11:12:57	10/26/2010			000002022	
702812		11/16/2010	11:18:13	10/26/2010			000002022	
702814		11/16/2010	11:26:58	10/26/2010			000002022	
702816		11/16/2010	11:36:18	10/26/2010			000002022	
702816		11/16/2010	11:36:18	10/26/2010			000002022	
702817		11/16/2010	12:05:45					
702818		11/16/2010	12:28:32					
702819		11/16/2010	12:32:04					
702828		11/16/2010	13:55:41					
702831		11/16/2010	13:57:40					
702833		11/16/2010	13:58:04					
702836		11/16/2010	15:05:37		OEM3011	OEM3011	0098A	30
702839		11/16/2010	15:32:14	10/26/2010			000002022	
702839		11/16/2010	15:32:14	10/26/2010			000002022	
702851		11/16/2010	17:20:35					
702852		11/16/2010	17:26:47					
702853		11/16/2010	17:35:22				0098A	30
702854		11/16/2010	17:40:24					

- PDF view and output control

Transport
ZDIS
ZDMS
ZSMS

Shipment Document VDA 4939
DD 2010.12.07 T001 - M1(1) (01)

A1: Ship from / Supplier Shipping point IDES UK - Heathrow 3 Nobel Drive UB3 5EY Heathrow, Hayes	A2: Ship to / Receiver Audi AG Felix Wankel Strasse 74148 Neckarsulm	A3: Freight forwarder ID Forwarder:
Loading location / ID Supplier: 000002022	Ship to Location 001S3 ID Customer:	Carrier ID Carrier:

CT: Shipment data

Shipment no.	Receivers plant	Unloading points	Free.	No. load	Packaging	Gross
PUS			Units	weight KG	weight KG	
00000003	22	JIT	EX	2	24	88
W						

CT: Full Product

MASTER / MIXED PACKSTUECK- (HANDHABUNG-) INFORMATIONEN
ANZAHL X TYP PACKMITTEL (FUEHLANGE) (DE) PK. PACKSTUECKNR.

IS-NR. ... SACHNUMMER KUNDE. LIEFERMENGE NE. ABLAD. BESTELL-NR. BEZEICHN. DER LIEFERUNG
-DATUM. ... SACHNUMMER LIEFERANT. PACKSTUECK-HANDHABUNG-S- INFORMATIONEN

80014824	4GB 853 856 D Z3F	32	ST	JIT	00000003
18.06.10	SUP1-1000				
000010	1 X TTT 100 101	0,000	S		547 - 548
	BATCH NO:			POC:	
	USAGE: S				

80014824	4GB 853 856 D Z3F	32	ST	JIT	00000003
00.00.00	SUP2-2000				
000020	1 X TTT 100 102	0,000	S		548 - 547
	BATCH NO:			POC:	
	USAGE: S				

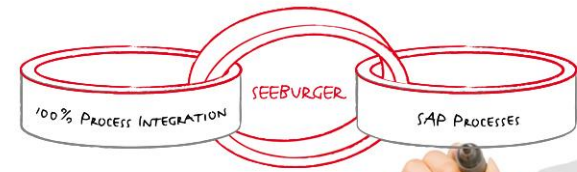

B2B/SCM Monitor – Attachment list

Direction	Messg.Type	Number	Status 03	Status 10	Status 18	Status 51	Status 53	Status 62	Status 64	Status 68
1	DELFOR	5	5	0	0	0	0	0	0	0
1	DELINS	121	41	80	0	0	0	0	0	0
1	SHPMNT	37	14	23	0	0	0	0	0	0
1	SHPMNT	27	2	7	18	0	0	0	0	0
2	DELINS	232	0	0	0	68	138	5	0	13
2	DELINS	30	0	0	0	20	7	1	0	2
2	DELORD	39	0	0	0	1	38	0	0	0
2	DESADV	49	0	0	0	3				

- Attachment of documents

The screenshot shows the SAP B2B/SCM Monitor interface. The main window displays a table of attachments for document 702804. A red box highlights the 'AttachmentFor0000001300' window, which shows a list of customer orders. Another red box highlights the 'Document Viewer' window, which displays a customer order document with a barcode and various fields.

IDoc number	Status	Created on	Created at	Doc. date	Sold-to pt
702804		11/14/2010	10:31:01		OEM3011
702805		11/14/2010	19:39:46		OEM3011
702806		11/14/2010	19:58:50		OEM3011
702811		11/16/2010	11:12:57	10/26/2010	
702812		11/16/2010	11:18:13	10/26/2010	
702814		11/16/2010	11:26:58	10/26/2010	
702816		11/16/2010	11:36:18	10/26/2010	
702816		11/16/2010	11:36:18	10/26/2010	
702817		11/16/2010	12:05:45		
702818		11/16/2010	12:28:32		
702819		11/16/2010	12:32:04		
702828		11/16/2010	13:55:41		
702831		11/16/2010	13:57:40		
702833		11/16/2010	13:58:04		
702836		11/16/2010	15:05:37		OEM3011
702839		11/16/2010	15:32:14	10/26/2010	
702839		11/16/2010	15:32:14	10/26/2010	
702851		11/16/2010	17:20:35		
702852		11/16/2010	17:26:47		
702853		11/16/2010	17:35:22		
702854		11/16/2010	17:40:24		

Document Viewer - Customer order

Supplier: IDES UK - Heathrow 3 Nobel Drive UB3 SEYHeathrow, UK
 To: Audi AG Felix Wankel Strasse DE 74148Neckarsulm, DE
 Plant: 22 JIT
 Order No: 13 / 1
 Ship Date: 03/16/2011
 Batch No:
 Supplier No: 2022
 Deliv. note No: 80014665
 Package: TTT 100 102
 City: 1PC
 Article Designation: 4G8 853 856 D Z3F
 Barcode: 1J UN 000002022 00002

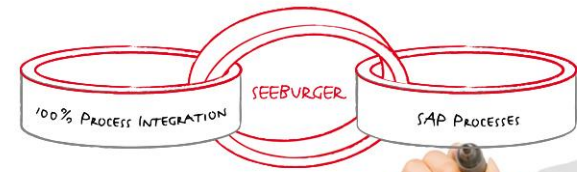

Agenda

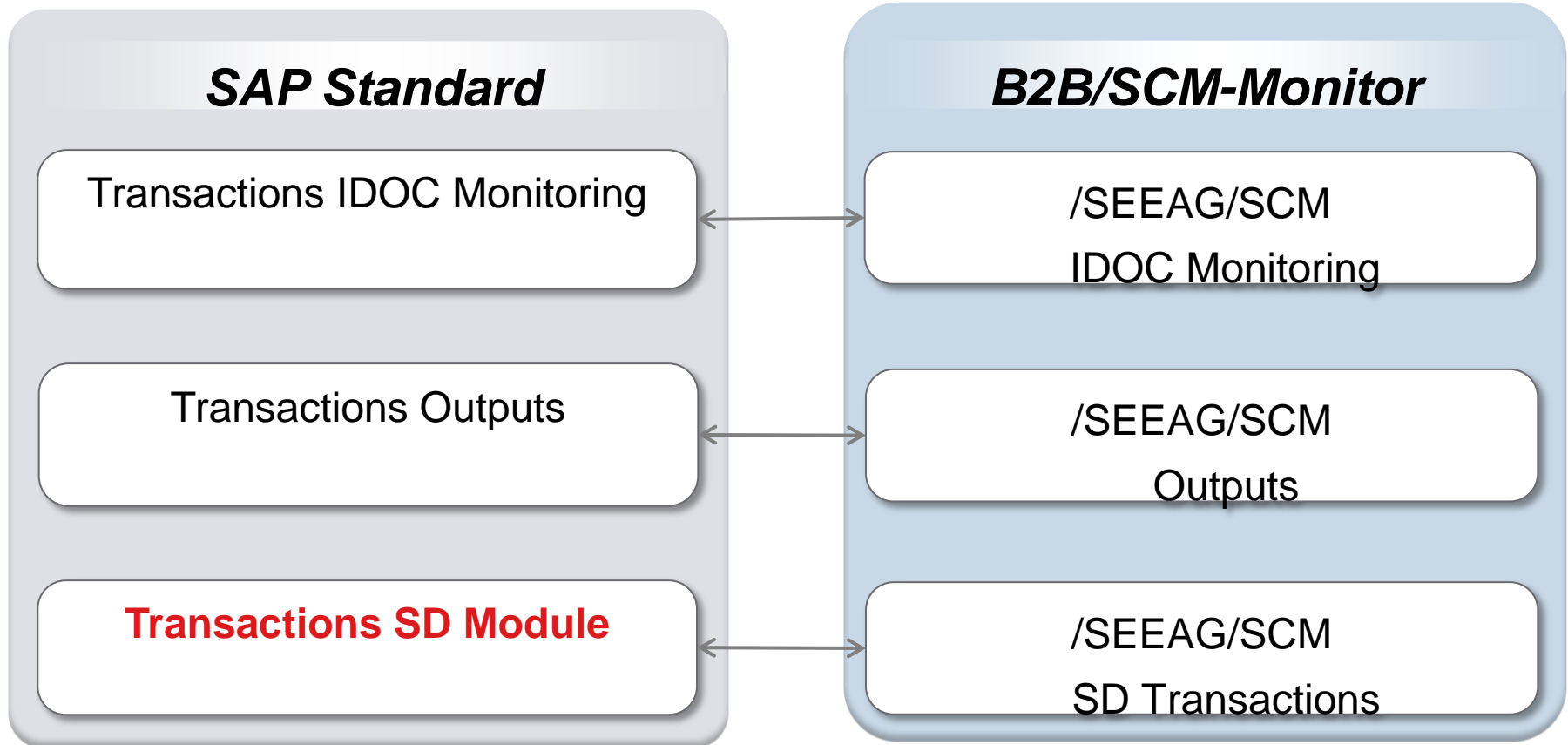

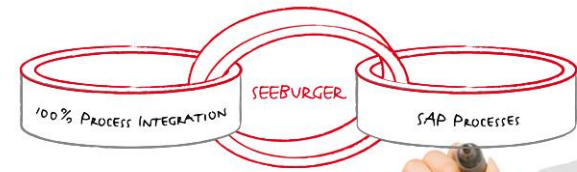

SAP-Standard – SD Module (extract)

Transactions

- ▼ SD_EN
- ✳️ VD02 - Change Customer (Sales)
- ✳️ VA02 - Change Sales Order
- ✳️ VA32 - Change Scheduling Agreement
- ✳️ VL10E - Order Schedule Lines due for Deliv.
- ✳️ VL02N - Change Outbound Delivery
- ✳️ VL36 - Change Picking Waves
- ✳️ VT02N - Change Shipment
- ✳️ VF02 - Change Billing Document

Change customer

General Data		Company Code Data		Sales Area Data		Assigned Object		Additional Data, Empties	
Customer	0EM2000	Audi AG		Neckarsulm					
<div style="display: flex; justify-content: space-between;"> Address Control data Marketing Unloading points Export data Contact persons </div>									
<div style="display: flex; justify-content: space-between;"> Preview Internet versions </div>									
Name Title: Company Name: Audi AG Name: NLK									
Search terms Search term 1/2: AUDI NLK									
Street address Street/House number: Felix Wankel Strasse Postal Code/City: 74148 Neckarsulm Country: DE Germany Region: 08 Baden-Wuertem... Transportation zone: 0000000002 Region south									
PO box address PO Box: Postal code:									
Communication Language: German Telephone: Extension: Fax: Extension: E-Mail: Data line:									

Control of logistic processes – Editing of master data

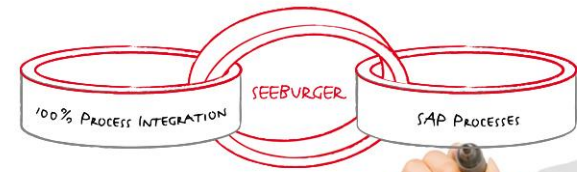

SAP-Standard – SD Module (extract)

Transactions

- SD_EN
- ✳️ VD02 - Change Customer (Sales)
- ✳️ VA02 - Change Sales Order
- ✳️ VA32 - Change Scheduling Agreement
- ✳️ VL10E - Order Schedule Lines due for Deliv.
- ✳️ VL02N - Change Outbound Delivery
- ✳️ VL36 - Change Picking Waves
- ✳️ VT02N - Change Shipment
- ✳️ VF02 - Change Billing Document

Change Outbound Delivery

Post goods issue

Outbound deliv. 88814677 Document Date 09/05/2011
 Ship-to party OEM2000 Audi AG / Felix Wankel Strasse / 74148 Neckarsulm

Item Overview Picking Loading Transport Status Overview Goods Movement Data

Planned GI 09/05/2011 00:00 Total Weight 36 KG
 Actual GI date No. of packages 1

Item	Material	Delivery quantity	SU	Description	B	ItCa	P	W	Batch
10	SUP1-1000	1		PC Schweller links		TAMA		C	
20	SUP2-2000	1		PC Schweller rechts		TAMA		C	
900001	B_SL_40	1		PC Rack Schweller links		HUPM			
900002	B_SR_40	1		PC Rack Schweller rechts		HUPM			
900003	BOX-01	1		PC Standardkarton		HUPM			

Batch split Main Items All Items

Control of logistic processes – Editing of Deliveries
(Packing / Batching)

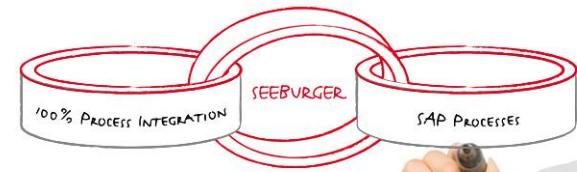

SAP-Standard – SD Module (extract)

Transactions

- SD_EN
- ✳️ VD02 - Change Customer (Sales)
- ✳️ VA02 - Change Sales Order
- ✳️ VA32 - Change Scheduling Agreement
- ✳️ VL10E - Order Schedule Lines due for Deliv.
- ✳️ VL02N - Change Outbound Delivery
- ✳️ VL36 - Change Picking Waves
- ✳️ VT02N - Change Shipment
- ✳️ VF02 - Change Billing Document

Change Shipment

Deliveries

Processing Identification Shipment cost cal Control Administr.

Shipment type: VW NLK Shpmt - Road TransportPlanPt: 2000 IDES UK
 Overall status: Shipment completion Tender status: Not offered to forwarding age...
 FwdAgent: 9090 Transporter / Bondstreet / GB - 12345 London
 Shipment route:
 Shipping type: 01 Truck Shp. Cond.:
 Service Level: Load Spec. Process.: SN60 NLK Process ASN
 Container ID: HN-B-7651 External ID 1: EXT1
 AlwdTotWgt: KG

Deadl. More Dates Stages Partner Texts Duration and distance Status Tender Addit. data

Planning			Execution			
Check-in		00:00	03/15/2011	21:14		✓ Planning
Loading start		00:00		00:00		Check-in
Loading end		00:00		00:00		Loading start
Shpmt completion		00:00	03/15/2011	21:24		✓ Shpmt completion
Shipment start	01/17/2011	15:30		00:00		Shipment start
Shipment end	01/17/2011	22:00		00:00		Shipment end

Control of logistic processes – Editing of shipments
(Define carrier / Planning / Completion / Creating messages)

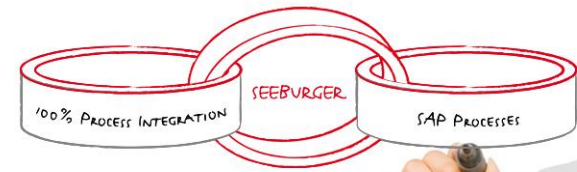

Agenda

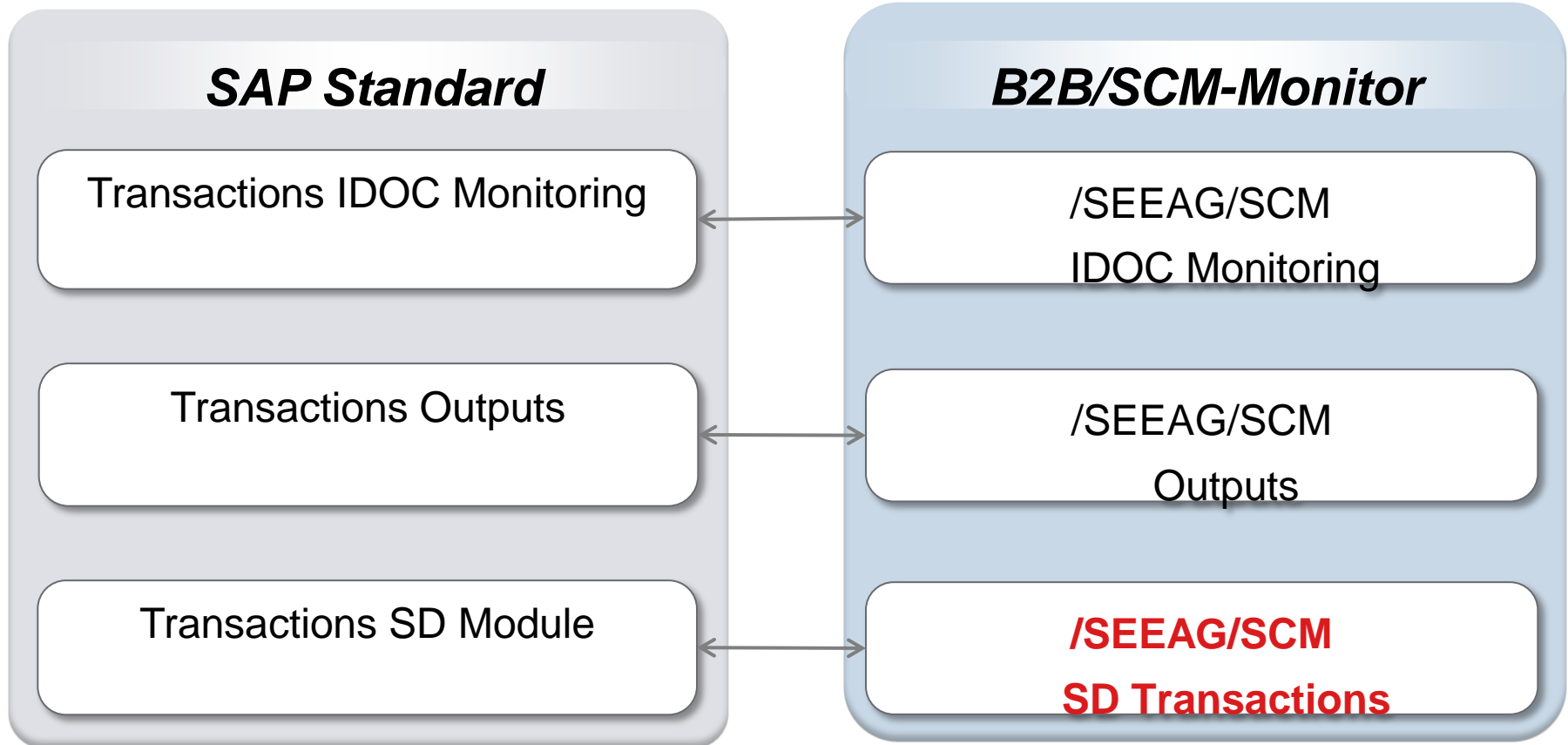

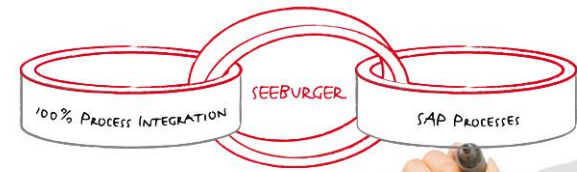

B2B/SCM Monitor – Hotspots in SD Transactions

Change selection IMG

SEEBURGER SCM Monitor - SCHEDULING AGREEMENT

Doc. Information Schedule lines Status Tolerance check Mes. Type

Overview

Scheduling agreement

Order Processing

Invoice/Billing Document

Legend

Direction/Status/Message type	Number
All documents	540
Inbound	350
Standard ASN	49
Final - OK (green)	46
In processing - N	3
Standard FRC/JIT	262
VW Dispatch call off	39
Outbound	190
Standard ASN	37
Standard FRC/JIT	126
Final - OK (green)	78
In processing - OI	5
In processing - OI	41
In processing - OI	2
VW NLK PUS ASN	27

Direction	Messg. Type	Number	Status 03	Status 10	Status 18	Status 51	Status 53	Status 62	Status 64	Status 68
1	DELFOR	5	5							
1	DELINS	121	41							
1	SHPMNT	37	14							
1	SHPMNT	27	2							
2	DELINS	232	0							
2	DELINS	30	0							
2	DELORD	39	0							
2	DESADV	49	0							

Deliveries

Processing Identification Shipment cost cal Control Administr.

Shipment type: VW NLK Shpmt - Road TransportPlanPt: 2000 IDES UK
 Overall status: Shipment completion Tender status: Not offered to forwarding age...
 FwdAgent: 9090 Transporter / Bondstreet / GB - 12345 London
 Shipment route:
 Shipping type: 01 Truck Shp. Cond.:
 Service Level: Load Spec. Process.: SN60 NLK Process ASN
 Container ID: HN-B-7651 External ID 1: EXT1
 AlwdTotWgt: K6

Deal. More Dates Stages Partner Texts Duration and distance Status Tender Addit. data

Planning		Execution		
Check-in	00:00	03/15/2011	21:14	✓ Planning
Loading start	00:00		00:00	✓ Loading start
Loading end	00:00		00:00	✓ Loading end
Shpmt completion	00:00	03/15/2011	21:24	✓ Shpmt completion
Shipment start	01/17/2011 15:30		00:00	✓ Shipment start
Shipment end	01/17/2011 22:00		00:00	✓ Shipment end

IDoc number	Status	Created on
702804		11/14/2010
702805		11/14/2010
702806		11/14/2010
702811		11/16/2010
702812		11/16/2010
702814		11/16/2010
702816		11/16/2010
702816		11/16/2010
702817		11/16/2010
702818		11/16/2010
702819		11/16/2010
702828		11/16/2010
702831		11/16/2010
702833		11/16/2010
702836		11/16/2010
702839		11/16/2010
702839		11/16/2010
702851		11/16/2010
702852		11/16/2010
702853		11/16/2010
702854		11/16/2010

Hotspots in SD Transactions to change master data, and documents (e.g. VT02N – Change Shipment)

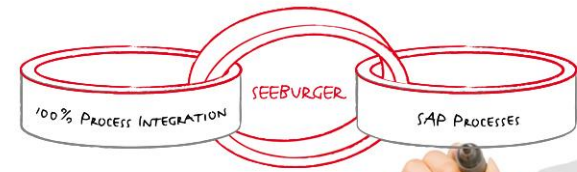

Benefits



- Full B2B-Integration with all B2B Solutions from SEEBURGER

- Maximum traceability and transparency for the entire Supply Chain: Central automatic End-to-End-Monitoring for all processes across system boundaries

- Easy error analysis via intuitive interface for business users: Central access to all SAP documents, transactions, and functions

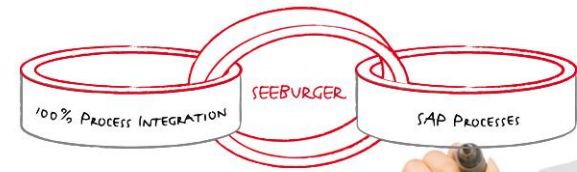

Benefits



- Reduce TCO – low project costs, seamless integration and no SAP industry solution required

- Increase customer satisfaction through process acceleration: more efficient and fast response to error messages

- Avoidance of a bottleneck in the supply chain and special charges for complaints or error reports

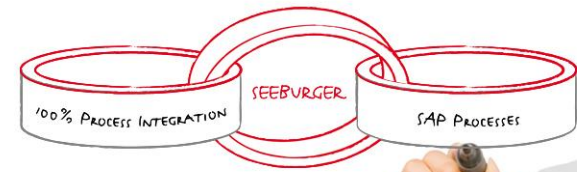

■ Contact Information: e.pearce@seeburger.com

or visit www.seeburger.com

Thank you for attending, and let us know if we can provide you with additional information.

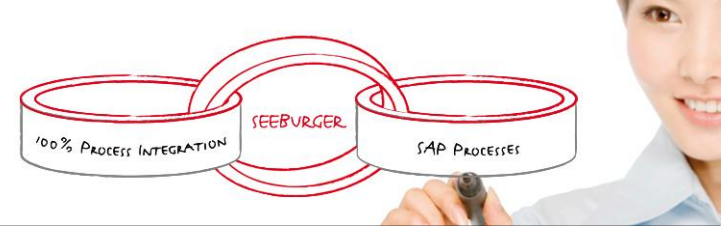

© Copyright 2012 SEEBURGER AG. All rights reserved.

The information in this document is proprietary to SEEBURGER. Neither any part of this document, nor the whole of it may be reproduced, copied, or transmitted in any form or purpose without the express prior written permission of SEEBURGER AG. Please note that this document is subject to change and may be changed by SEEBURGER at any time without notice. SEEBURGER's Software product, the ones of its business partners may contain software components from third parties.

SAP®, SAP® R/3®, SAP NetWeaver®, SAP® Exchange Infrastructure, ABAP™ are registered trade marks of the SAP AG or the SAP AG Deutschland (Germany), as well as Microsoft®, Windows®, Outlook®, NT®, Word®, EXCEL® and PowerPoint® are the ones of the Microsoft Corporation.

Oracle is a registered Mark of the Oracle Corporation as well as UNIX and X/Open are registered Marks of the Open Group.

HTML, XML, XHTML and W3C are Marks or registered Marks of W3C®, World Wide Web Consortium, Massachusetts Institute of Technology.

Java is a trade Mark of Sun Microsystems, Inc. JBOSS is a registered Mark of the JBOSS Inc.

4avis®, 4classification®, 4everything®, 4invoice®, 4invoice WEBflow®, 4order®, BIS:explore®, BIS:open®, BIS:open UX®, BIS:pdx®, BIS:plm®, FAX2XML®, Free Form Interpreter Kontierung Dialog Workflow®, FreeFormation®, FreiForm®, iMartOne®, Paper2ERP®, SEEBURGER®, SEEBURGER Business-Integration-Server®, SEEBURGER DocumentSuite®, SEEBURGER Logistic Solution Professional®, SEEBURGER Web Supplier Hub®, SEEBURGER Workflow®, SEEBURGER-CASEngine®, SEEBURGER-invoiceCONSOLE®, SEEBURGER-WEBflow®, SmartRetailConnector®, TRAVELinvoice®, WebVERA®, WinELKE® and other products or services of SEEBURGER which appear in this document as well as the according logos are marks or registered marks of the SEEBURGER AG in Germany and of other countries worldwide.

All other products and services names are marks of the mentioned companies. All contents of the present document are noncommittal and have a mere information intention. Produkts and services may be country-specific designed.

All other mentioned company and software designations are trade marks or unregistered trade marks of the respective organisations and are liable to the corresponding legal regulations.

- The information in this document is proprietary to SEEBURGER. No part of this document may be reproduced, copied, or transmitted in any form or purpose without the express prior written permission of SEEBURGER AG.
- This document is a preliminary version and not subject to your license agreement or any other agreement with SEEBURGER. This document contains only intended strategies, developments, and functionalities of the SEEBURGER product and is not intended to be binding upon SEEBURGER to any particular course of business, product strategy, and/or development. Please note that this document is subject to change and may be changed by SEEBURGER at any time without notice.
- SEEBURGER assumes no responsibility for errors or omissions in this document. SEEBURGER does not warrant the accuracy or completeness of the information, text, graphics, links, or other items contained within this material. This document is provided without a warranty of any kind, either express or implied, including but not limited to the implied warranties of merchantability, fitness for a particular purpose, or non-infringement.
- SEEBURGER shall have no liability for damages of any kind including without limitation direct, special, indirect, or consequential damages that may result from the use of these materials. This limitation shall not apply in cases of intent or gross negligence.
- The statutory liability for personal injury and defective products is not affected. SEEBURGER has no control over the information that you may access through the use of hot links contained in these materials and does not endorse your use of third-party web pages nor provide any warranty whatsoever relating to third-party web pages.