

Aspire 4530/4230 Series Service Guide

Service guide files and updates are available on the ACER/CSD web; for more information, please refer to <http://csd.acer.com.tw>

PRINTED IN TAIWAN

Revision History

Please refer to the table below for the updates made on Aspire 4530/4230 Series service guide.

Date	Chapter	Updates

Copyright

Copyright © 2008 by Acer Incorporated. All rights reserved. No part of this publication may be reproduced, transmitted, transcribed, stored in a retrieval system, or translated into any language or computer language, in any form or by any means, electronic, mechanical, magnetic, optical, chemical, manual or otherwise, without the prior written permission of Acer Incorporated.

Disclaimer

The information in this guide is subject to change without notice.

Acer Incorporated makes no representations or warranties, either expressed or implied, with respect to the contents hereof and specifically disclaims any warranties of merchantability or fitness for any particular purpose. Any Acer Incorporated software described in this manual is sold or licensed "as is". Should the programs prove defective following their purchase, the buyer (and not Acer Incorporated, its distributor, or its dealer) assumes the entire cost of all necessary servicing, repair, and any incidental or consequential damages resulting from any defect in the software.

Acer is a registered trademark of Acer Corporation.

Intel is a registered trademark of Intel Corporation.

Pentium and Pentium II/III are trademarks of Intel Corporation.

Other brand and product names are trademarks and/or registered trademarks of their respective holders.

Conventions

The following conventions are used in this manual:

SCREEN MESSAGES	Denotes actual messages that appear on screen.
NOTE	Gives bits and pieces of additional information related to the current topic.
WARNING	Alerts you to any damage that might result from doing or not doing specific actions.
CAUTION	Gives precautionary measures to avoid possible hardware or software problems.
IMPORTANT	Reminds you to do specific actions relevant to the accomplishment of procedures.

Preface

Before using this information and the product it supports, please read the following general information.

1. This Service Guide provides you with all technical information relating to the BASIC CONFIGURATION decided for Acer's "global" product offering. To better fit local market requirements and enhance product competitiveness, your regional office MAY have decided to extend the functionality of a machine (e.g. add-on card, modem, or extra memory capability). These LOCALIZED FEATURES will NOT be covered in this generic service guide. In such cases, please contact your regional offices or the responsible personnel/channel to provide you with further technical details.
2. Please note WHEN ORDERING FRU PARTS, that you should check the most up-to-date information available on your regional web or channel. If, for whatever reason, a part number change is made, it will not be noted in the printed Service Guide. For ACER-AUTHORIZED SERVICE PROVIDERS, your Acer office may have a DIFFERENT part number code to those given in the FRU list of this printed Service Guide. You MUST use the list provided by your regional Acer office to order FRU parts for repair and service of customer machines.

System Specifications	1
Features	1
System Block Diagram	4
Your Acer Notebook tour	5
Front View	5
Closed Front View	6
Left View	7
Right View	8
Rear View	8
Bottom View	9
Indicators	10
Easy-Launch Buttons	10
Touch Pad Basics (with fingerprint reader)	11
Using the Keyboard	12
Lock Keys and embedded numeric keypad	12
Windows Keys	13
Hot Keys	14
Special Key	15
Using the System Utilities	16
Acer GridVista (dual-display compatible)	16
Launch Manager	17
Hardware Specifications and Configurations	18
 System Utilities	 29
BIOS Setup Utility	29
Navigating the BIOS Utility	29
Information	30
Main	31
Advanced	32
Security	35
Boot	38
Power	39
Exit	41
BIOS Flash Utility	42
Remove HDD/BIOS Utility	43
 Machine Disassembly and Replacement	 47
Disassembly Requirements	47
General Information	48
Pre-disassembly Instructions	48
Disassembly Process	48
External Module Disassembly Process	49
External Modules Disassembly Flowchart	49
Removing the Battery Pack	50
Removing the Express Dummy Card	51
Removing the SD Dummy Card	52
Removing the Lower Cover	53
Removing the DIMM Module	54
Removing the WLAN Module	55
Removing the Hard Disk Drive Module	57
Removing the Optical Drive Module	59
Main Unit Disassembly Process	61
Main Unit Disassembly Flowchart	61
Removing the Switch Cover	63

Table of Contents

Removing the Keyboard	64
Removing the Antenna Cables	65
Removing the LCD Module	66
Removing the LED Board	68
Removing the Upper Cover	69
Removing the Launch Board	72
Removing the Speaker Module	73
Removing the Finger Print Reader	76
Removing the Touch Pad Module	77
Removing the Bluetooth board	78
Removing the Mainboard	80
Removing the Modem Module	81
Removing the I/O Board	82
Removing the Thermal/Fan Module	83
Removing the CPU	84
LCD Module Disassembly Process	85
LCD Module Disassembly Flowchart	85
Removing the LCD Bezel	86
Removing the Inverter Board	88
Removing the Camera Board	89
Removing the LCD Panel	90
Removing the LCD Brackets and FPC Cable	91
LCD Module Reassembly Procedure	92
Replacing the LCD Panel	92
Replacing the Camera Module	94
Replacing the Inverter Board	94
Replacing the LCD Bezel	95
Main Module Reassembly Procedure	96
Replacing the CPU	96
Replacing the Thermal/Fan Module	97
Replacing the I/O Board	98
Replacing the Modem Module	98
Replacing the Mainboard	99
Replacing the Bluetooth Board	99
Replacing the Touch Pad Module	100
Replacing the Finger Print Reader	101
Replacing the Speaker Module	101
Replacing the Launch Board	104
Replacing the Upper Cover	104
Replacing the LED Board	107
Replacing the LCD Module	107
Replacing the Antenna Cables	108
Replacing the Keyboard	109
Replacing the Switch Cover	110
Replacing the ODD Module	110
Replacing the Hard Disk Drive Module	111
Replacing the WLAN Module	112
Replacing the DIMM Modules	113
Replacing the Lower Cover	113
Replacing the SD Dummy Card	114
Replacing the ExpressCard Dummy Card	114
Replacing the Battery	114

Troubleshooting

115

Common Problems	115
---------------------------	-----

Table of Contents

Power On Issue	116
No Display Issue	117
Random Loss of BIOS Settings	118
LCD Failure	119
Built-In Keyboard Failure	119
Touch Pad Failure	120
Internal Speaker Failure	120
Internal Microphone Failure	122
HDD Not Operating Correctly	123
ODD Failure	124
USB Failure (Rightside)	127
Modem Function Failure	127
Wireless Function Failure	128
EasyTouch Button Failure	128
MediaTouch Button Failure	129
Fingerprint Reader Failure	129
Thermal Unit Failure	130
HDTV Switch Failure	130
External Mouse Failure	131
Other Failures	131
Intermittent Problems	132
Undetermined Problems	132
POST Codes Tables	133
Chipset POST Codes	133
Core POST Codes	135
Jumper and Connector Locations	143
Top View	143
Bottom View	144
Clearing Password Check and BIOS Recovery	145
Clearing Password Check	145
BIOS Recovery by Crisis Disk	146
FRU (Field Replaceable Unit) List	147
Aspire 4530/4230 Exploded Diagram	148
Main Assembly	148
LCD Assembly	149
Aspire 4530/4230 FRU List	150
Model Definition and Configuration	158
Aspire 4530/4230 Series	159
Test Compatible Components	183
Microsoft® Windows® Vista Environment Test	184
Online Support Information	187
Index	189

Table of Contents

System Specifications

Features

Below is a brief summary of the computer's many feature:

Operating System

- Windows® Vista™

Platform

- AMD Better By Design program, featuring:
 - AMD Turion™ 64 X2 dual-core mobile processor*
 - AMD Athlon™ 64 X2 dual-core mobile processor*
 - Mobile AMD Sempron™ processor*
 - NVIDIA® nForce® MCP77MH
 - Acer InviLink™ 802.11b/g

System Memory

- Dual-Channel DDR2 SDRAM support
- Up to 2 GB of DDR2 667 MHz memory, upgradeable to 4 GB using two soDIMM modules

Display and graphics

- 14.1" WXGA 1280 x 800
- NVIDIA® GeForce® 9100M G

Storage subsystem

- 2.5" hard disk drive
- Optical drive options:
 - DVD-Super Multi double-layer drive*
 - DVD/CD-RW combo drive*
- 5-in-1 card reader

Audio

- Two built-in Acer 3DSonic stereo speakers
- High-definition audio support
- S/PDIF (Sony/Philips Digital Interface) support for digital speakers
- MS-Sound compatible
- Built-in microphone

Communication

- Acer Video Conference, featuring:
 - Integrated Acer Crystal Eye webcam*
 - Optional Acer Xpress VoIP phone*
- WLAN: Acer InViLink™ 802.11b/g
- WPAN: Bluetooth® 2.0+EDR
- LAN: Gigabit Ethernet, Wake-on-LAN ready
- Modem: 56K ITU V.92

Privacy Control

- Acer Bio-Protection fingerprint solution*
- BIOS user, supervisor, HDD passwords
- Kensington lock slot

Dimensions

- 339 (W) x 243 (D) x 29/39 (H) mm (13.35 x 9.57 x 1.14/1.54 inches)
- 2.40 kg (5.29 lbs.)

Power Subsystem

- ACPI 3.0
- 48.8W 4400 mAh
- 3-pin 65 W AC adapter
- Energy Star 4.0

Special Keys and Controls

- 88-/89-/93-key keyboard
- Touch Pad pointing device

I/O Ports

- ExpressCard™/54 slot
- 5-in-1 card reader (SD™, MMC, MS, MS PRO, xD)
- 3 USB 2.0 ports
- External display (VGA) port
- Headphone/speaker/line-out jack with S/PDIF support
- Microphone-in jack
- Line-in jack
- Ethernet (RJ-45) port
- Modem (RJ-11) port
- DC-in jack for AC adapter

Environment

- Temperature:
 - Operating: 5 °C to 35 °C
 - Non-operating: -20 °C to 65 °C
- Humidity (non-condensing):
 - Operating: 20% to 80%
 - Non-operating: 20% to 80%

NOTE: Items marked with * denote only selected models.

System Block Diagram

- CPU CORE / VDDNB (SL6285A)
- NB CORE +1.1V (RT6202)
- +1.1V NB (RT6202)
- DDR II SMD DR. VTERM 1.8V(SUS)(TPS5116REG)
- SYSTEM POWER (SL4237)
- SYSTEM CHARGER (SL4251A)

- PCB STACK UP**
- LAYER 1 : TOP
 - LAYER 2 : GND
 - LAYER 3 : IN1
 - LAYER 4 : IN2
 - LAYER 5 : VCC
 - LAYER 6 : BOT

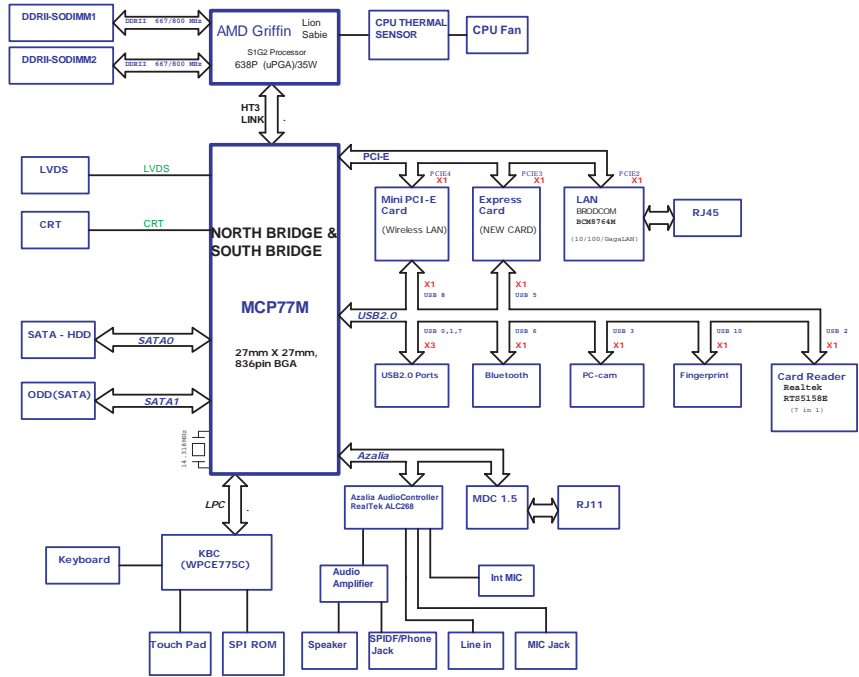



Your Acer Notebook tour

After knowing your computer features, let us show you around your new computer.

Front View





No.	Icon	Item	Description
1		Microphone	Internal microphone for sound recording.
2		Acer Crystal Eye	Web camera for video communication.
3		Display screen	Also called Liquid-Crystal Display (LCD), displays computer output.
4		Power button	Turns the computer on and off.
5		Empowering key	Launch Acer Empowering Technology
6		Easy-launch buttons	Buttons for launching frequently used program.
7		Palmrest	Comfortable support area for your hands when you use the computer.
8		Status indicators	Light-Emitting Diodes (LEDs) that light up to show the status of the computer's functions and components.

No.	Icon	Item	Description
9		Click buttons (left, center* and right)	The left and right buttons function like the left and right mouse buttons. *The center button serves as Acer Bio-Protection fingerprint reader supporting Acer FingerNav 4-way control function.
10		Touch Pad	Touch-sensitive pointing device which functions like a computer mouse.
11		Keyboard	For entering data into your computer.
12		Speakers	Left and right speakers deliver stereo audio output.









Closed Front View



No.	Icon	Item	Description
1		5-in-1 card reader	Accepts Secure Digital (SD), MultiMediaCard (MMC), Memory Stick (MS), Memory Stick PRO (MS PRO), xD-Picture Card (xD). Note: Only one card can operate at any given time.
2		Unlimited volume control wheel	Adjust the volume of the audio-out.
3		Latch	Locks and releases the lid



Left View



No.	Icon	Item	Description
1		External display (VGA) port	Connects to a display device (e.g. external monitor, LCD projector).
2		Ethernet (RJ-45) port	Connects to an Ethernet 10/100/1000-based network.
3		Modem (RJ-11) port	Connects to a phone line.
4		USB 2.0 ports	Connect to USB 2.0 devices (e.g. USB mouse, USB camera).
5		Headphones/speaker/line-out jack with S/PDIF support	Connects to audio line-out devices (e.g. speakers, headphones).
		Microphone-in jack	Accepts input from external microphones.
		Line-in jack	Accepts audio line-in devices (e.g. audio CD player, stereo walkman).
6		ExpressCard/54 slot	Accepts one ExpressCard/54 module.

Right View



No.	Icon	Item	Description
1		Optical drive	Internal optical drive; accepts CDs or DVDs.
2		Optical disk access indicator	Lights up when the optical drive is active.
3		Optical drive eject button	Ejects the optical disk from the drive.
4		Emergency eject hole	Ejects the optical drive tray when the computer is turned off. Note: Insert a paper clip into the emergency eject hole to eject the optical drive tray when the computer is off.
5		USB 2.0 port	Connect to USB 2.0 devices (e.g. USB mouse, USB camera).
6		DC-in jack	Connects to an AC adapter
7		Kensington lock slot	Connects to a Kensington-compatible computer security lock.





Rear View



No.	Icon	Item	Description
1		Ventilation slots	Enable the computer to stay cool, even after prolonged use.





Bottom View



No.	Icon	Item	Description
1		Battery bay	Houses the computer's battery pack.
2		Battery lock	Locks the battery in position.
3		Hard disk bay	Houses the computer's hard disk (secured with screws).
4		Memory compartment	Houses the computer's main memory.
5		Battery release latch	Releases the battery for removal.

Indicators

The computer has several easy-to-read status indicators. The front panel indicators are visible even when the computer cover is closed.







Icon	Function	Description
	Power	Indicates the computer's power status.
	Battery	Indicates the computer's battery status.
	HDD	Indicates when the hard disk drive is active.
	Num Lock	Lights up when Num Lock is activated.
	Caps Lock	Lights up when Caps Lock is activated.

NOTE: 1. **Charging:** The light shows amber when the battery is charging. 2. **Fully charged:** The light shows green when in AC mode.

Easy-Launch Buttons

Located beside the keyboard are application buttons. These buttons are called easy-launch buttons. They are: WLAN, Internet, email, Bluetooth, Arcade and Acer Empowering Technology.

The mail and Web browser buttons are pre-set to email and Internet programs, but can be reset by users. To set the Web browser, mail and programmable buttons, run the Acer Launch Manager.

Icon	Function	Description
	Empowering Technology	Launch Acer Empowering Technology. (user-programmable)
	Acer Arcade	Launch Acer Arcade utility
	Wireless communication button/indicator	Enables/disables the wireless function. Indicates the status of wireless LAN communication.
	Web browser	Internet browser (user-Programmable)
	Mail	Email application (user-Programmable)
	Bluetooth communication button/indicator	Enables/disables the Bluetooth function. Indicates the status of Bluetooth communication.

Touch Pad Basics (with fingerprint reader)

The following items show you how to use the Touch Pad with Acer Bio-Protection fingerprint reader:

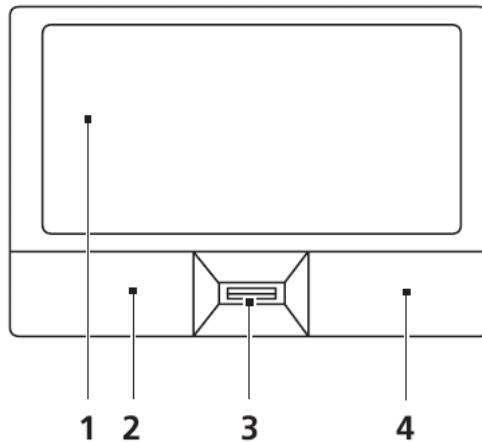

- Move your finger across the Touch Pad (2) to move the cursor.
- Press the left (1) and right (4) buttons located beneath the Touch Pad to perform selection and execution functions. These two buttons are similar to the left and right buttons on a mouse. Tapping on the Touch Pad is the same as clicking the left button.
- Use Acer Bio-Protection fingerprint reader (3) supporting Acer FingerNav 4-way control function (only for certain models) or the 4-way scroll (3) button (only for certain models) to scroll up or down and move left or right a page. This fingerprint reader or button mimics your cursor pressing on the right scroll bar of Windows applications.

Function	Left Button (1)	Right Button (3)	Main Touch Pad (2)
Execute	Quickly click twice.		Tap twice (at the same speed as double-clicking a mouse button).
Select	Click once.		Tap once.
Drag	Click and hold, then use finger on the Touch Pad to drag the cursor.		Tap twice (at the same speed as double-clicking a mouse button); rest your finger on the Touch Pad on the second tap and drag the cursor.
Access context menu		Click once.	

NOTE: When using the Touch Pad, keep it - and your fingers - dry and clean. The Touch Pad is sensitive to finger movement; hence, the lighter the touch, the better the response. Tapping too hard will not increase the Touch Pad's responsiveness.

Using the Keyboard

The keyboard has full-sized keys and an embedded numeric keypad, separate cursor, lock, Windows, function and special keys.

Lock Keys and embedded numeric keypad

The keyboard has three lock keys which you can toggle on and off.





















Lock key	Description
Caps Lock	When Caps Lock is on, all alphabetic characters typed are in uppercase.
Num Lock <Fn> + <F11>	When Num Lock is on, the embedded keypad is in numeric mode. The keys function as a calculator (complete with the arithmetic operators +, -, *, and /). Use this mode when you need to do a lot of numeric data entry. A better solution would be to connect an external keypad.
Scroll Lock <Fn> + <F12>	When Scroll Lock is on, the screen moves one line up or down when you press the up or down arrow keys respectively. Scroll Lock does not work with some applications.

The embedded numeric keypad functions like a desktop numeric keypad. It is indicated by small characters located on the upper right corner of the keycaps. To simplify the keyboard legend, cursor-control key symbols are not printed on the keys.

Desired access	Num Lock on	Num Lock off
Number keys on embedded keypad	Type numbers in a normal manner.	
Cursor-control keys on embedded keypad	Hold <Shift> while using cursor-control keys.	Hold <Fn> while using cursor-control keys.
Main keyboard keys	Hold <Fn> while typing letters on embedded keypad.	Type the letters in a normal manner.

Windows Keys

The keyboard has two keys that perform Windows-specific functions.

Key	Description
 Windows key	<p>Pressed alone, this key has the same effect as clicking on the Windows Start button; it launches the Start menu. It can also be used with other keys to provide a variety of functions:</p> <ul style="list-style-type: none"> <  >: Open or close the Start menu <  > + <D>: Display the desktop <  > + <E>: Open Windows Explore <  > + <F>: Search for a file or folder <  > + <G>: Cycle through Sidebar gadgets <  > + <L>: Lock your computer (if you are connected to a network domain), or switch users (if you're not connected to a network domain) <  > + <M>: Minimizes all windows <  > + <R>: Open the Run dialog box <  > + <T>: Cycle through programs on the taskbar <  > + <U>: Open Ease of Access Center <  > + <X>: Open Windows Mobility Center <  > + <BREAK>: Display the System Properties dialog box <  > + <SHIFT+M>: Restore minimized windows to the desktop <  > + <TAB>: Cycle through programs on the taskbar by using Windows Flip 3-D <  > + <SPACEBAR>: Bring all gadgets to the front and select Windows Sidebar <CTRL> + <  > + <F>: Search for computers (if you are on a network) <CTRL> + <  > + <TAB>: Use the arrow keys to cycle through programs on the taskbar by using Windows Flip 3-D <p>Note: Depending on your edition of Windows Vista, some shortcuts may not function as described.</p>
 Application key	<p>This key has the same effect as clicking the right mouse button; it opens the application's context menu.</p>

Hot Keys

The computer employs hotkeys or key combinations to access most of the computer's controls like screen brightness, volume output and the BIOS utility.

To activate hot keys, press and hold the <Fn> key before pressing the other key in the hotkey combination.



Hotkey	Icon	Function	Description
<Fn> + <F1>	?	Hotkey help	Displays help on hotkeys.
<Fn> + <F2>		Acer eSettings Management	Launches Acer eSettings Management in Acer Empowering Technology.
<Fn> + <F3>		Acer ePower Management	Launches Acer ePower Management in Acer Empowering Technology.
<Fn> + <F4>	Z ^z	Sleep	Puts the computer in Sleep mode.
<Fn> + <F5>		Display toggle	Switches display output between the display screen, external monitor (if connected) and both.
<Fn> + <F6>		Screen blank	Turns the display screen backlight off to save power. Press any key to return.
<Fn> + <F7>		Touch Pad toggle	Turns the internal Touch Pad on and off.
<Fn> + <F8>		Speaker toggle	Turns the speakers on and off.
<Fn> + <▷>		Brightness up	Increases the screen brightness.
<Fn> + <◁>		Brightness down	Decreases the screen brightness.
<Fn> + <F1>	?	Hotkey help	Displays help on hotkeys.
<Fn> + <F2>		Acer eSettings Management	Launches Acer eSettings Management in Acer Empowering Technology.

Special Key

You can locate the Euro symbol and the US dollar sign at the upper-center and/or bottom-right of your keyboard.



The Euro symbol

1. Open a text editor or word processor.
2. Hold <Alt Gr> and then press the <5> key at the upper-center of the keyboard.

NOTE: Note: Some fonts and software do not support the Euro symbol. Please refer to www.microsoft.com/typography/faq/faq12.htm for more information.

The US dollar sign

1. Open a text editor or word processor.
2. Hold <Shift> and then press the <4> key at the upper-center of the keyboard.

NOTE: This function varies by the operating system version.

Using the System Utilities

Acer Bio-Protection (only for certain models) Acer Bio-Protection Fingerprint Solution is a multi-purpose fingerprint software package integrated with the Microsoft Windows operating system. Utilizing the uniqueness of one's fingerprint features, Acer Bio-Protection Fingerprint Solution has incorporated protection against unauthorized access to your computer with centralized password management with Password Bank, easy music player launching with Acer MusicLaunch, secure Internet favorites via Acer MyLaunch, and fast application/website launching and login with Acer FingerLaunch, while Acer ProfileLaunch can launch up to three applications/websites from a single finger swipe.

Acer Bio-Protection Fingerprint Solution also allows you to navigate through web browsers and documents using Acer FingerNav. With Acer Bio-Protection Fingerprint Solution, you can now enjoy an extra layer of protection for your personal computer, as well as the convenience of accessing your daily tasks with a simple swipe of your finger!

For more information refer to the Acer Bio-Protection help files.

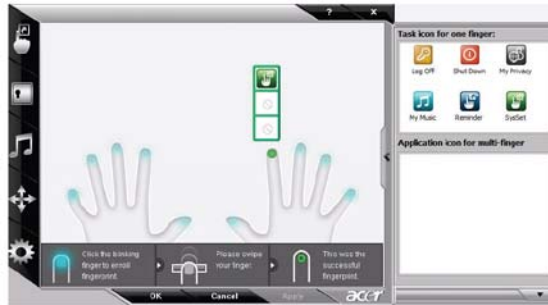

Acer GridVista (dual-display compatible)

NOTE: This feature is only available on certain models.

To enable the dual monitor feature of the notebook, first ensure that the second monitor is connected, then select **Start, Control Panel, Display** and click on **Settings**. Select the secondary monitor (**2**) icon in the display box and then click the check box **Extend my windows desktop onto this monitor**. Finally, click **Apply** to confirm the new settings and click **OK** to complete the process.

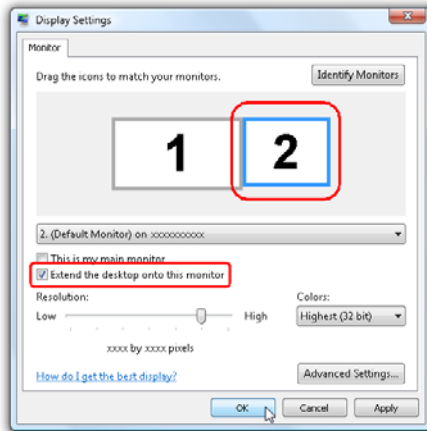

Acer GridVista is a handy utility that offers four pre-defined display settings so you can view multiple windows on the same screen. To access this function, please go to **Start → All Programs** and click on **Acer GridVista**. You may choose any one of the four display settings indicated below:



Double (vertical), Triple (primary at left), Triple (primary at right), or Quad Acer GridVista is dual-display compatible, allowing two displays to be partitioned independently.

Acer GridVista is dual-display compatible, allowing two displays to be partitioned independently.

AcerGridVista is simple to set up:

1. Run Acer GridVista and select your preferred screen configuration for each display from the task bar.
2. Drag and drop each window into the appropriate grid.
3. Enjoy the convenience of a well-organized desktop.

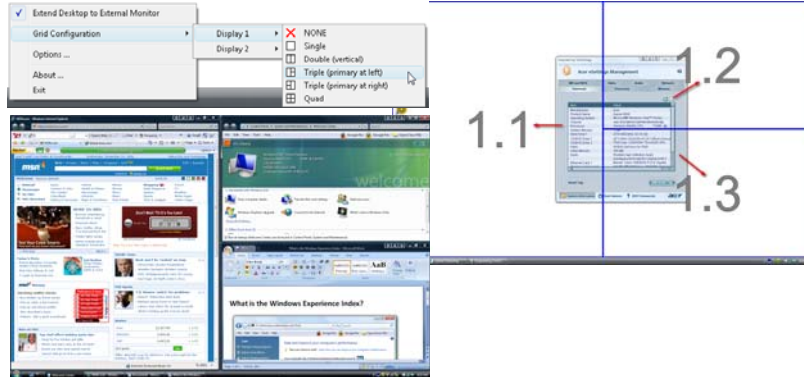

NOTE: Please ensure that the resolution setting of the second monitor is set to the manufacturer's recommended value.

Hardware Specifications and Configurations

Processor

Item	Specification
CPU type	AMD CPU S1g2 Processor (Griffin Series - Turion / Sempron); HT3 (1.2~2.6GT/s) (Bandwidth: 9.6GB/S to 20.8GB/s) 1.8GHz ~ 2.3GHz CPU Integrated 64bit or 128-bit DDR2 SDRAM controller One HyperTransport™ link to I/O devices One link, 16 bits in each direction, supporting speeds up to 800MHz (1.2GT/s) or 2.6Gigabytes/s in each direction L2 Cache 256Kb, 512Kb, or 1Mbytes The processor bus interfaces—HyperTransport 3 technology link and DDR2 memory—are both source-synchronous Supports up to 2 unbuffered SO-DIMMs 128-bit DDR2 SDRAM controller operating at up to 333MHz
Core logic	nVidia MCP77MH (North Bridge + South Bridge)
CPU package	638-Pin Lidless Micro PGA package (35mm x 35mm)
CPU core voltage	VCC_CORE0(based on CPU) VCC_CORE1(based on CPU) CPU)VDDNB(based on CPU) VLDT 1.2V_HT VDD I/O 1.8VSUS CPU Memory Interface SMDDR_VTEM(0.9V)

CPU Fan True Value Table

DTS (degree C°)	Active Fan Speed (rpm)
56-64	2900
65-74	3300
75-84	3700
>85	4000

BIOS

Item	Specification
BIOS vendor	Phoenix
BIOS Version	V1.3333
BIOS ROM type	W25X80VSSIG
BIOS ROM size	1Mbyte (8Mbit)
BIOS package	8-pin SOIC
Supported protocols	SPI
BIOS password control	Set by setup manual

Cache

Item	Specification
Cache controller	Non
Cache size	256Kb, 512kb, or 1Mbytes

System Memory

Item	Specification
Memory controller	Integrated with MCP77MH chipset
Memory size	0MB (no on-board memory)
DIMM socket number	2 sockets
Supports memory size per socket	2 GB
Supports maximum memory size	4GB for 64bit OS (with two 2 GB SODIMM)
Supports DIMM type	DDR 2 Synchronous DRAM
Supports DIMM Speed	533/667 MHz
Supports DIMM voltage	1.8V
Supports DIMM package	200-pin DDR2-533/667 soDIMM
Memory module combinations	You can install memory modules in any combinations as long as they match the above specifications.

Memory Combinations

Slot 1	Slot 2	Total Memory
0MB	512MB	512MB
0MB	1024MB	1024MB
0MB	2048MB	2048MB
512MB	512MB	1024MB
512MB	1024MB	1536MB
512MB	2048MB	2560MB
1024MB	0MB	1024MB
1024MB	512MB	1536MB
1024MB	1024MB	2048MB
1024MB	2048MB	3072MB
2048MB	0MB	2048MB
2048MB	512MB	2560MB
2048MB	1024MB	3072MB
2048MB	2048MB	4096MB

NOTE: Above table lists some system memory configurations. You may combine DIMMs with various capacities to form other combinations. On above table, the configuration of slot 1 and slot 2 could be reversed.

LAN Interface

Item	Specification
LAN Chipset	Broadcom BCM5764M / BCM5787M
Supports LAN protocol	10/100/1000 Mbps
LAN connector type	RJ45
LAN connector location	Left side
Features	PCIE v1.1 compliant Support Wake-On-Lan Self-boot feature, utilizing smaller EEPROM size Serial flash memory support SMBus interface supporting Alert Standard Format (ASF) v2.0 Hot plug support PCI Express CLKREQ support Energy Detect/Cable Sense Unbuffered serial flash memory support Integrated serial debug interface to ease system-level debugging

Bluetooth Interface

Item	Specification
Chipset	Broadcom BCN2045NMD <ul style="list-style-type: none"> • Internal Mini USB I/F solution with antenna • Bluetooth 2.0+EDR • 8 wires connector for system
Data throughput	Support 3Mbps enhanced data rate
Protocol	802.15.1
Interface	Universal Serial Bus(USB)
Connector type	SMT-S-F-0.8mm(SM08B-SURS-TF(CF) JST

Wireless Module 802.11b/g

Item	Specification
Chipset	Atheros AR2425
Data throughput	<ul style="list-style-type: none"> • 802.11b : 11Mbps with fall back rates of 5.5, 2, and 1Mbps • 802.11g : 54 Mbps with fall back rates of 48, 36, 24, 18, 1, 9, and 6Mbps
Protocol	802.11a/b/g
Interface	PCI-Express bus (mini PCI socket for wireless module)

Hard Disk Drive Interface

Item	Specifications				
Vendor & Model Name	Hitachi 5K250-250 5K250-160 5K250-120	Seagate ST9160827AS ST9120817AS	Toshiba MK2546GSX MK1646GSX MK1246GSX	WD WD2500BEVS WD1200BEVS	WD WD3200BEVT WD1600BEVT
Capacity (MB)	250, 160, 120	160, 120	250, 160, 120	250, 120	320,160
Bytes per sector	512	512	512	512	512
Data heads	4, 3, 2	3, 2	4, 3, 2	4, 2	4, 2

Item	Specifications				
Drive Format					
Disks	2, 2, 1	2, 1	2, 2, 1	2, 1	2, 1
Spindle speed (RPM)	5400	5400	5400	5400	5400
Performance Specifications					
Buffer size	8 MB	8 MB	8 MB	8 MB	8 MB
Interface	SATA	SATA	SATA	SATA	SATA
Internal transfer rate (Mbits/sec, max)	643 ~ 665	778	370 ~ 730 typical	850 Mbits/s maximum	850 Mbits/s maximum
I/O data transfer rate (Mbytes/sec max)	1.5 / 3.0	300	300	150 maximum	300 maximum
DC Power Requirements					
Voltage	5V ±5%	5V ±5%	5V ±5%	5V ±5%	5V ±5%

Combo Drive Module

Item	Specification	
Manufacturer and Model	Toshiba TS-L463A	Sony DL 24X CRX890S
Type	Drawer loading	Drawer loading
Interface	Serial ATA	Serial ATA
Data Transfer Mode	Gen1i 1.33 Gbits / sec	<ul style="list-style-type: none"> Ultra DMA mode5 Multi-word DMA mode 2 PIO mode 4
Buffer Memory Size	2 MB	2 MB
Maximum Write Speed	<ul style="list-style-type: none"> CD-Recordable 3,600 KB/sec CD-Rewritable (Include 32X Ultra Speed Plus) 3,600 KB/sec 	<ul style="list-style-type: none"> DVD: 8X (10.56 Mbytes/sec) CD: 24X (3,600 Kbytes/sec)

Item	Specification	
Maximum Read Speed	<ul style="list-style-type: none"> CD-DA (Audio Play) CAV 10X CD-DA (DAE) CAV 24X Mixed CD: <ul style="list-style-type: none"> Audio CAV 24X (DAE), CAV 10X (Audio Play) Data CAV 24X Video-CD CAV 16X DVD-Video Play CAV 4X (SINGLE, DUAL) DVD±R Read CAV 8X DVD±RW Read CAV 6X DVD±R DL Read CAV 6X TOC Read CLV 4X (CD), CAV 4X (DVD) Idle (pause) CAV 10X (CD), CAV 4X (DVD) Unbalanced: <ul style="list-style-type: none"> ~ 0.3gcm CAV 24X (CD), CAV 8X (DVD) 0.3 ~ 0.75gcm CAV 10X (CD), CAV 4X (DVD) Over 0.75gcm CAV 10X (CD), CAV 4X (DVD) 	<p>CD</p> <p>CD-ROM</p> <p>CD-R 5,000 rpm (10.8X ~ 24.8X CAV)</p> <p>CD-RW 4,200 rpm (9.1X ~ 21.1X CAV)</p> <p>CD-DA (DAE) 3,000 rpm (6.9X ~ 15.9X CAV)</p> <p>Video CD (Copy) 2,150 rpm (4.7X ~ 10.7X CAV)</p> <p>CD-DA (Playback) 2,150 rpm (4.7X ~ 10.7X CAV)</p> <p>Video CD (Playback) 2,150 rpm (4.7X ~ 10.7X CAV)</p> <p>DVD</p> <p>DVD-5 (Single Layer): 4,800 rpm (3.5X~8.3X CAV)</p> <p>DVD-R 3,600 rpm (2.6X ~ 6.2X CAV)</p> <p>DVD+R 2,400 rpm (1.7X ~ 4.2X CAV)</p> <p>DVD-9 (Dual Layer) 4,000 rpm (2.6X ~ 6.2X CAV)</p> <p>DVD+R DL 2,600 rpm (1.7X ~ 4.2X CAV)</p> <p>DVD-R DL</p> <p>DVD-RW 3,600 rpm (2.6X ~ 6.2X CAV)</p> <p>DVD+RW 2,400 rpm (1.7X ~ 4.2X CAV)</p> <p>DVD-5 (with CSS) 2,400 rpm (1.7X ~ 4.2X CAV)</p> <p>DVD-9 (with CSS) 2,600 rpm (1.7X ~ 4.2X CAV)</p> <p>DVD-RAM 2,900 rpm (1.7X ~ 4.0X CAV)</p>
Formats Supported	<ul style="list-style-type: none"> CD-DA (Red Book) - Standard Audio CD & CD-TEXT CD-ROM (Yellow Book Mode1 & 2) - Standard Data CD-ROM XA (Mode2 Form1 & 2) - Photo CD, Multi-Session CD-I (Green Book, Mode2 Form1 & 2, Ready, Bridge) CD-Extra/ CD-Plus (Blue Book) - Audio & Text/Video Video-CD (White Book) - MPEG1 Video CD-R (Orange Book Part II) CD-RW & HSRW (Orange Book Part III Volume1 & Volume2) Super Audio CD (SACD) Hybrid type US & US+ RW DVD-ROM (Book 1.02), DVD-Dual DVD-Video (Book 1.1) DVD-R (Book 1.0, 3.9G) DVD-R (Book 2.0, 4.7G) - General & Authoring DVD+R (Version 1.0) DVD-RW, DVD+RW DVD+R DL DVD-R DL Support CPRM (read) Support VCPS (read) 	<ul style="list-style-type: none"> CD-DA, CD-ROM Mode-1, CD-ROM/XA Mode-2 Form-1 and Mode-2 Form-2, CD-i, CD-i Bridge, Video-CD (MPEG-1), Karaoke CD, Photo-CD, Enhanced CD, CD Plus, CD Extra, itrax CD, CD-Text, UDF CD, CD-R, and CD-RW CD-DA, CD-ROM Mode-1, CD-ROM/XA Mode-2 Form-1 and Mode-2 Form-2, CD-i, Video-CD, CD-Text DVD-ROM (DVD-5, DVD-9, DVD-10, DVD-18), DVD-Video, DVD-Audio, SACD (Hybrid) UDF DVD, DVD-R, DVD-R DL, DVD-R 3.95 GB, DVD-R Authoring, DVD-R Multi-Border DVD-RW, DVD+R, DVD+R DL, DVD+R Multi-Session, DVD+RW, DVD-RAM V1.0, DVDRAM V2.1.
Power Supply	+5V	+5V
Voltage Allowance	±5% (operating) -8% (startup)	Ripple 100 mVp-p Max, 1 KHz~10 MHz

Super Multi Drive

Item	Specification	
Manufacturer and Model	Toshiba DL 8X TS-L633A	Hitachi GSA-T50N

Item	Specification	
Type	Drawer type	Drawer type
Interface	SATA	SATA
Data Transfer Modes	<ul style="list-style-type: none"> • PIO Mode4 • DMA Multiword Mode2 • ULTRA DMA Mode2 	<ul style="list-style-type: none"> • ATA PIO Mode 0-4 • ATA Multi Word DMA Modes 0-2 • ATA Ultra DMA Mode 0-6 • Default ATA Ultra DMA Modes 6
Buffer Memory Size	2 MB	
Maximum Write Speed	<ul style="list-style-type: none"> • CD-R Max. 24X (3,600 KB/sec) • DVD+RW Max 8X (10,800 KB/sec) 	<ul style="list-style-type: none"> • CD-R Max. 24X (2,400 KB/sec) • DVD+R Max 8X (11,080 KB/sec)
Maximum Read Speed	<ul style="list-style-type: none"> • CD 3,600 KB/sec • DVD 10,800 KB/sec 	<ul style="list-style-type: none"> • CD 3,600 KB/sec • DVD 11,080 KB/sec
Format Compatibility	<p>CD</p> <ul style="list-style-type: none"> • CD-DA (Red Book) - Standard Audio CD & CD-TEXT • CD-ROM (Yellow Book Mode1 & 2) - Standard Data • CD-ROM XA (Mode2 Form1 & 2) - Photo CD, Multi-Session • CD-I (Green Book, Mode2 Form1 & 2, Ready, Bridge) • CD-Extra/ CD-Plus (Blue Book) - Audio & Text/Video • Video-CD (White Book) - MPEG1 Video • CD-R (Orange Book Part 1) • CD-RW & HSRW (Orange Book Part IV Volume1 & Volume2) • Super Audio CD (SACD) Hybrid type • US & US+ RW <p>DVD</p> <ul style="list-style-type: none"> • DVD-ROM (Book 1.02), DVD-Dual • DVD-Video (Book 1.1) • DVD-R (Book 1.0, 3.9G) • DVD-R (Book 2.0, 4.7G) - General & Authoring • DVD+R (Version 1.0) • DVD+RW • DVD-RW (Non CPRM & CPRM) • DVD±R Dual • DVD-RAM 	<p>CD</p> <ul style="list-style-type: none"> • CD-ROM Mode-1 data disc • CD-ROM Mode-2 data disc <ul style="list-style-type: none"> • CD-ROM XA, CD-I, Photo-CD Multi-Session, Video CD • CD-Audio Disc • Mixed mode CD-ROM disc (data and audio) • CD-Extra • CD-Text • CD-R (Conforming to "Orange Book Part 2": read & write) • CD-RW (Conforming to "Orange Book Part 3": read & write) <p>DVD</p> <ul style="list-style-type: none"> • DVD-ROM: <ul style="list-style-type: none"> • 4.7GB (Single Layer) • 8.5GB (Dual Layer) • DVD-R: <ul style="list-style-type: none"> • 3.95GB (Ver. 1.0: read only) • 4.7GB (Ver. 2.0 for Authoring: read only) • 4.7GB (Ver. 2.1 for General: read & write) • (DL) 8.5GB (Ver. 3.0) • DVD-RW: <ul style="list-style-type: none"> • 4.7GB (Ver. 1.2/ Rev 1.0, 2.0, 3.0) • DVD-RAM: <ul style="list-style-type: none"> • 2.6GB/side (Ver. 1.0: read only) • 1.46GB/side, 4.7GB/side (Ver. 2.2) • DVD+R: <ul style="list-style-type: none"> • 4.7GB (Ver. 1.3) • (DL) 8.5GB (Ver. 1.1) • DVD+RW: <ul style="list-style-type: none"> • 4.7GB (Vol.1 Ver.1.3)

Item	Specification	
Power Supply	DC +5V / 1.3A	DC +5V
Voltage Allowance	DC +5V (5% (Operating), DC +5V(8% (Start Up))	±5% Ripple

Audio Interface

Item	Specification
Audio Controller	Realtek ALC268/ALC888S-VC Azadia Codec
Audio onboard or optional	Built-in
Mono or Stereo	Stereo
Resolution	2.1
Compatibility	<ul style="list-style-type: none"> Headphone-out with S/PDIF, Line-In and Microphone-In 2 stereo ADCs support 16/20/24-bit PCM format, one for mono microphone, one legacy mixer recording
Sampling rate	<ul style="list-style-type: none"> All DACs supports 16/20/24-bit, 44.1k/48k/96k/192kHz sample rate All ADCs supports 16/20/24-bit, 44.1k/48k/96k/192kHz sample rate One independent S/PDIF-OUT converters support 16/20/24-bit, 44.1k/48k/88.2k/96k/192kHz sample rate
Internal Microphone	Analog Microphone
Internal Speaker/Quantity	Two Med-High Speakers (2W/4 ohm)

Video Memory

Item	Specification
Chipset	Integrated with MCP77MH chipset
Memory size	64 - 256 MB

USB Interface

Item	Specification
Chipset	Integrated with MCP77MH chipset
USB Compliancy Level	2.0
OHCI	Dual USB 2.0 EHCI and USB 1.1
Number of USB port	3
Location	Two on the left side/one on the right side
Serial port function control	Enable/Disable by BIOS Setup

System Board Major Chips

Item	Controller
Core logic	AMD CPU S1g2 Processor (Griffin Series-Turion/Sempron)
VGA	Integrated with MCP77MH chipset
LAN	Broadcom BCM5764M / BCM5787M
USB 2.0	Integrated with MCP77MH chipset
Super I/O controller	N/A
MODEM	Lite-on T60M955.04(AD60M955002)
Bluetooth	Broadcom BCN2045NMD
Wireless 802.11 b+g	Atheros AR2425
5 in 1 Card Reader	Integrated with MCP77MH chipset
Audio Codec	Realtek ALC268/ALC888S-VC Azadia Codec

Keyboard

Item	Specification
Keyboard controller	Winbond WPC775LDG
Total number of keypads	88-key
Windows logo key	Yes
Internal & external keyboard work simultaneously	Plug USB keyboard to the USB port directly: Yes

Battery

Item	Specification
Vendor & model name	SANYO AS-2007A Li-Ion 3S2P SANYO 6 cell SONY AS-2007A Li-Ion 3S2P SONY 6 cell PANASONIC AS-2007A Li-Ion 3S2P PANASONIC 6 cell SIMPLO AS-2007A Li-Ion 3S2P PANASONIC 6 cell
Battery Type	Li-ion
Pack capacity	SANYO 6 cell 4400mAh Main COMMON Normal Type SONY 6 cell 4400mAh Main COMMON Normal Type PANASONIC 6 cell 4400mAh Main COMMON Normal Type SIMPLO 6 cell 4400mAh Main COMMON Normal Type
Number of battery cell	6
Package configuration	3 cells in series, 2 series in parallel
Normal voltage	11.1V
Charge voltage	12.6V

LCD 14.1”

Item	Specification
Vendor/model name	LG.Philips/LP141WX3, AUO/B141EW04 V4, Chimei/N14113 - L02, Samsung/LTN141W3-L01
Screen Diagonal	14.1 inches
Active Area (mm)	303.36 (H) x 189.6 (V)
Display Area	353.45 (H) x 198.72(V)
Display resolution (pixels)	WXGA (1280 x 800 Pixels)
Pixel Pitch	0.2370 (H) x 0.2370 (V) (TYP.)
Pixel Arrangement	RGB Vertical Stripe
Display Mode	Normally white
Typical White Luminance (cd/m ²) also called Brightness	200 cd/m2 (Typ.) 170 cd/m2 (Min.)
Luminance Uniformity	1.3 max (5 point)
Contrast Ratio	500:1(Typ.), 300:1(Min.)
Response Time (Optical Rise Time/Fall Time) msec	16 msec (Typ.), 25msec(Max.)
Normal Input Voltage	+3.3V
Typical Power Consumption (watt)	331mA x 3.3V = 1.09 W (Typ.)
Weight (with inverter)	400g (Typ.) 420g (Max.)
Physical Size (mm)	Horizontal (H): 320 (W) Vertical (V): 206 (H) Depth (D): 5.5 (T)
Electrical Interface	R/G/B Data, 3 Sync, signals Clock(4pairs LVDS)
Support Color	262,144 colors
Viewing Angle (degree)	Horizontal Right/Left : 45/45 degree Vertical Upper/Lower : 20/35 degree
Temperature Range (°C)	Storage: -20 ~ 60 °C Operating: 0 ~ 50 °C

LCD Inverter

Item	Specification
Vendor & model name	Foxconn/T18I095.00, Delta/DAC-08N035, SUMIDA/TWS-449-308, TDK/TBD485NR
Brightness conditions	PWM (10Level)
Input voltage (V)	8V~20V
Input current (mA)	7.5W (395 mA ~ 938 mA)
Output voltage (V, rms)	612 Vrms ~ 945 Vrms
Output current (mA, rms)	2.3 mArms ~ 6.5 mArms
Output voltage frequency (k Hz)	52 KHz ~ 64 KHz

AC Adapter

Item	Specification
Vendor & model name	Adapter DELTA 65W / SADP-65KB DFA LF level 4 Adapter Lite-ON 65W / PA-1650-02AC LF level 4 Adapter HIPRO 65W / HP-OK065B13 LED LF level 4
Input rating	90V ~ 240V
Maximum input AC current	1.5A ~ 1.6A
Inrush current	220A
Efficiency	>85%

System Power Management

ACPI mode	Power Management
Mech. Off (G3)	All devices in the system are turned off completely
Soft Off (G2/S5)	OS initiated shutdown. All devices in the system are turned off completely
Working (G0/S0)	Individual devices such as the CPU and hard disc may be power managed in this state
Suspend to RAM (S3)	CPU set power down VGA Suspend PCMCIA Suspend Audio Power Down Hard Disk Power Down CD-ROM Power Down Super I/O Low Power mode
Save to Disk (S4)	Also called Hibernation Mode. System saves all system states and data onto the disc prior to power off the whole system

System Utilities

BIOS Setup Utility

The BIOS Setup Utility is a hardware configuration program built into your computer's BIOS (Basic Input/Output System).

Your computer is already properly configured and optimized, and you do not need to run this utility. However, if you encounter configuration problems, you may need to run Setup. Please also refer to Chapter 4 Troubleshooting when problem arises.

To activate the BIOS Utility, press **F2** during POST (when "Press <F2> to enter Setup" message is prompted on the bottom of screen).

Press **F2** to enter setup. The default parameter of F12 Boot Menu is set to "disabled". If you want to change boot device without entering BIOS Setup Utility, please set the parameter to "enabled".

Press <F12> during POST to enter multi-boot menu. In this menu, user can change boot device without entering BIOS SETUP Utility.

Navigating the BIOS Utility

There are six menu options: Information, Main, Advanced, Security, Boot, and Exit.

Follow these instructions:

- To choose a menu, use the left and right arrow keys.
- To choose an item, use the up and down arrow keys.
- To change the value of a parameter, press **F5** or **F6**.
- A plus sign (+) indicates the item has sub-items. Press **Enter** to expand this item.
- Press **Esc** while you are in any of the menu options to go to the Exit menu.
- In any menu, you can load default settings by pressing **F9**. You can also press **F10** to save any changes made and exit the BIOS Setup Utility.

NOTE: You can change the value of a parameter if it is enclosed in square brackets. Navigation keys for a particular menu are shown on the bottom of the screen. Help for parameters are found in the Item Specific Help part of the screen. Read this carefully when making changes to parameter values. **Please note that system information is subject to different models.**

Information

The Information screen displays a summary of your computer hardware information.

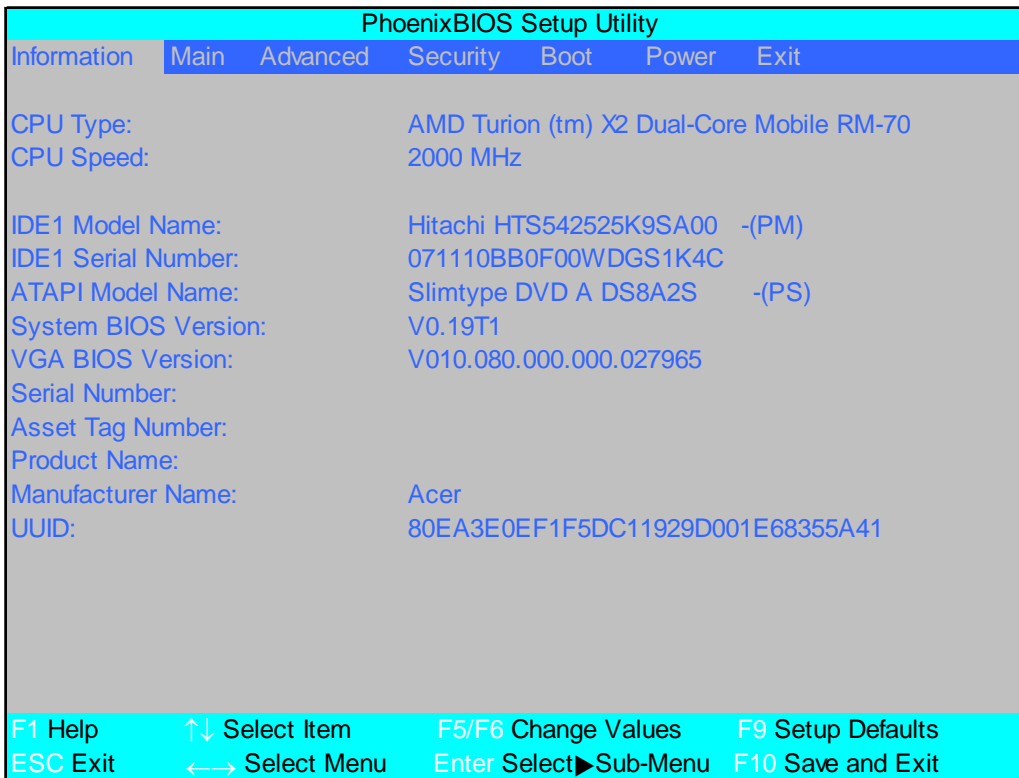

NOTE: The system information is subject to different models.

Parameter	Description
CPU Type	This field shows the CPU type and speed of the system.
CPU Speed	This field shows the speed of the CPU.
IDE1 Model Name	This field shows the model name of HDD installed on primary IDE master.
IDE1 Serial Number	This field displays the serial number of HDD installed on primary IDE master.
ATAPI Model Name	This field shows the model name of the Optical device installed in the system.
System BIOS Version	Displays system BIOS version.
VGA BIOS Version	This field displays the VGA firmware version of the system.
Serial Number	This field displays the serial number of this unit.
Asset Tag Number	This field displays the asset tag number of the system.
Product Name	This field shows product name of the system.
Manufacturer Name	This field displays the manufacturer of this system.
UUID Number	Universally Unique Identifier (UUID) is an identifier standard used in software construction, standardized by the Open Software Foundation (OSF) as part of the Distributed Computing Environment (DCE).

Main

The Main screen allows the user to set the system time and date as well as enable and disable boot option and recovery.

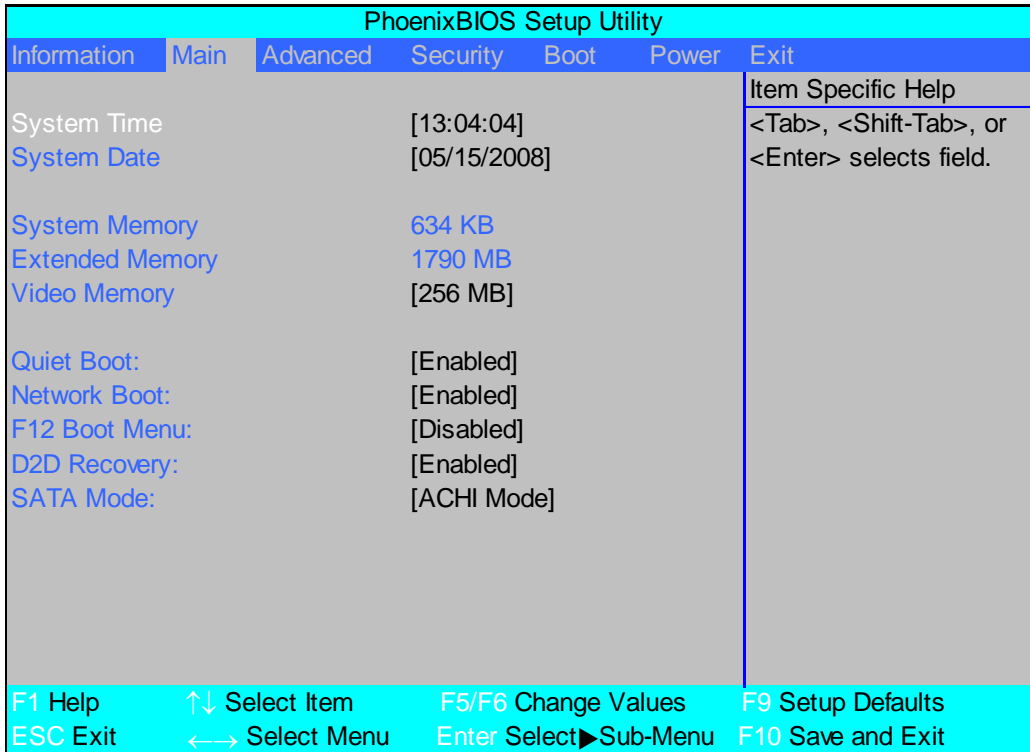

NOTE: The screen above is for your reference only. Actual values may differ.

The table below describes the parameters in this screen. Settings in **boldface** are the default and suggested parameter settings.

Parameter	Description	Format/Option
System Time	Sets the system time. The hours are displayed with 24-hour format.	Format: HH:MM:SS (hour:minute:second)
System Date	Sets the system date.	Format MM/DD/YYYY (month/day/year)
System Memory	This field reports the memory size of the system. Memory size is fixed to 3071 MB.	N/A
Extended Memory	This field reports the Extended Memory size. Memory size is fixed to 4094 MB.	N/A
Video Memory	Shows the video memory size. VGA Memory size=32 MB	N/A
Quiet Boot	Displays the logo screen while booting.	Option: Enabled or Disabled
Network Boot	Enables, disables the system boot from LAN (remote server).	Option: Enabled or Disabled
F12 Boot Menu	Enables, disables Boot Menu during POST.	Option: Disabled or Enabled
D2D Recovery	Enables, disables D2D Recovery function. The function allows the user to create a hidden partition on hard disc drive to store operation system and restore the system to factory defaults.	Option: Enabled or Disabled
SATA Mode	Control the mode in which the SATA controller should operate.	Option: AHCI Mode or IDE Mode

Advanced

The Advanced screen allows the user to configure the various advanced BIOS options.

IMPORTANT: Making incorrect settings to items on these pages may cause the system to malfunction. Unless you have experience adjusting these items, we recommend that you leave these settings at the default values. If making settings to items on these pages causes your system to malfunction or prevents the system from booting, open BIOS and choose Load Optimal Defaults in the Exit menu to boot up normally.

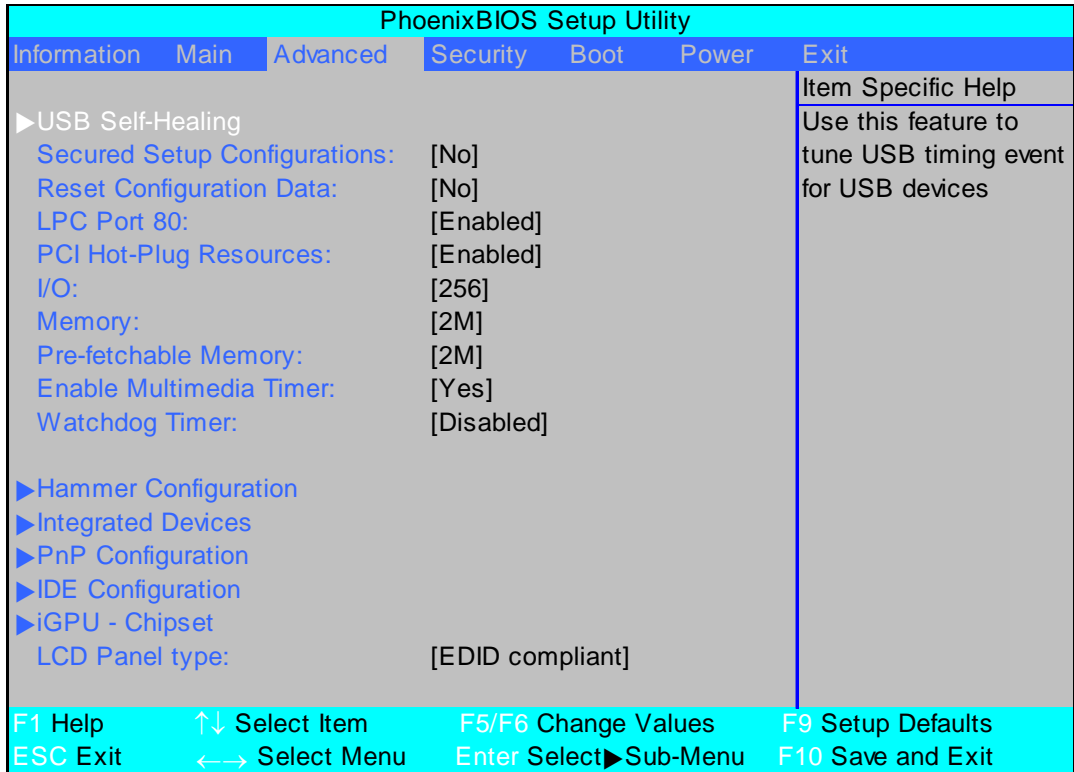

The table below describes the items, menus, and submenus in this screen. Settings in **boldface** are the default and suggested parameter settings.

Parameter	Description	Submenu Items
USB Self-Healing	Enter the USB Self-Healing menu.	<ul style="list-style-type: none"> • Self-Healing ▶ OCHI Self-Healing ▶ EHCI Self-Healing
Secured Setup Configuration	Prevents Plug and Play devices from changing system settings.	N/A
Reset Configuration Data	Clear the Extended System Configuration Data (ESCD) area using this option.	N/A
LPC Port 80	Enable or Disable LPC Port 80.	N/A
PCI Hot-Plug Resources	Enable or Disable Hot-Plug support.	N/A
I/O	Set the amount of I/O (in bytes) available to the Hot-Plug slots.	N/A
Memory	Set the amount of Memory (in bytes) available to Hot-Plug slots.	N/A
Pre-fetchable Memory	Set the amount of Pre-fetchable Memory (in bytes) available to the Hot-Plug slots.	N/A

Parameter	Description	Submenu Items
Enable Multimedia Timer	Enable [Yes] or Disable [No] Multimedia Timer support.	N/A
Watchdog Timer	Disable or Enable the OS Watchdog Timer using ACPI WDAT.	N/A
Hammer Configuration	Enter the Hammer Configuration menu.	<ul style="list-style-type: none"> • HT-LDT Frequency • HT-LDT Width • DDR2 Memory Frequency • LS Table loading • ISO Flow Control • Hi Priority Channel • Display Refresh • Sync Flood Detection
Integrated Devices	Enter the Integrated Devices menu.	<ul style="list-style-type: none"> • USB Control • USB2 Control • USB BIOS Legacy Support • MAC LAN • MAC Address • Azalia Codec • Integrated Codec • SATA Mode • SATA AHCI Mode • SATA Hotplug • Power on options • Interrupt Mode • PCI Express MSI • S5 WOL • Software Based PMU FW Loading • SMU • Dynamic Crush Voltage • PMU iGPU Stutter Mode • PMU System Stutter Mode • PMU LMM Mode • Dynamic FPCI Clock
PnP Configuration	Enter the PnP Configuration menu.	<ul style="list-style-type: none"> ▶ PCI Device, SLot #1 ▶ PCI/PNP ISA UMB Region Exclusion ▶ PCI/PNP IRQ UMB Resource Exclusion
IDE Configuration	Enter the IDE Configuration menu.	<ul style="list-style-type: none"> • Large Disk Access Mode • Local Bus IDE adapter ▶ Primary Master ▶ Primary Slave

Parameter	Description	Submenu Items
iGPU - Chipset	Enter the iGPU - Chipset menu.	<ul style="list-style-type: none">• Integrated Graphic• Video Memory• Hybrid Graphics• mGPU nPW• MXM LVDS/TV• MXM CRT/DVI• Panel Scaling• Boot Display• Preferred TV Connector• TV Format
LCD Panel type	Select the correct LCD panel type for testing purposes.	N/A

Security

The Security screen contains parameters that help safeguard and protect your computer from unauthorized use.

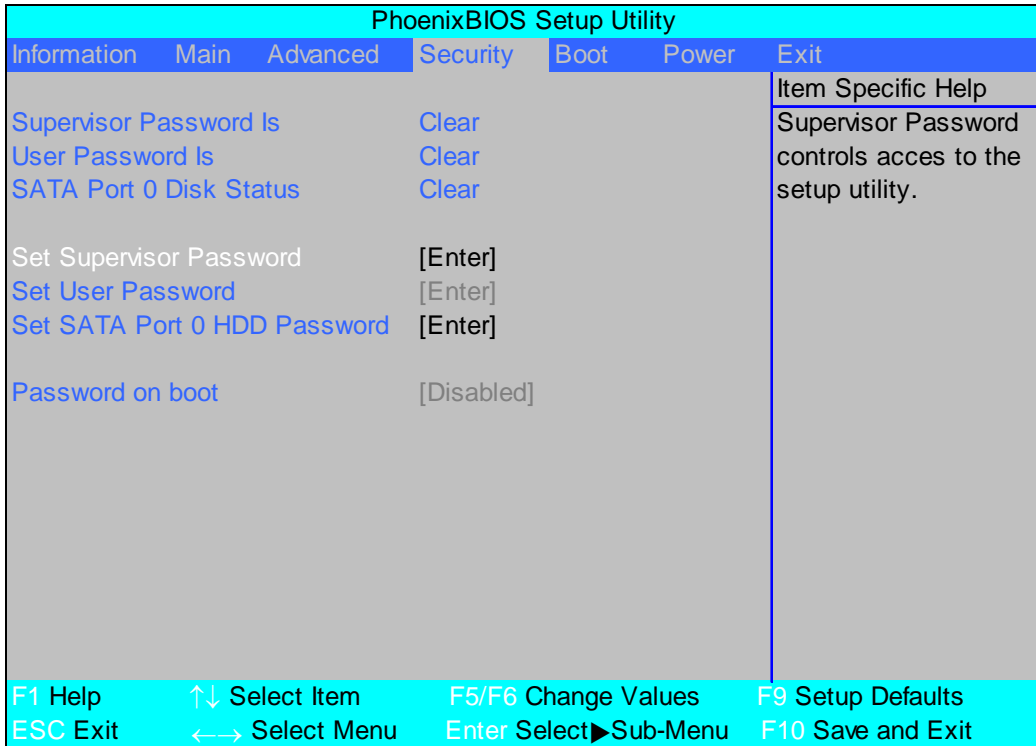

The table below describes the parameters in this screen. Settings in **boldface** are the default and suggested parameter settings.

Parameter	Description	Option
Supervisor Password Is	Shows the setting of the Supervisor password	Clear or Set
User Password Is	Shows the setting of the user password.	Clear or Set
SATA Port 0 Disk Status	Shows the setting of the hard disk password.	Clear or Set
Set Supervisor Password	Press Enter to set the supervisor password. When set, this password protects the BIOS Setup Utility from unauthorized access. The user can not either enter the Setup menu nor change the value of parameters.	N/A
Set User Password	Press Enter to set the user password. When user password is set, this password protects the BIOS Setup Utility from unauthorized access. The user can enter Setup menu only and does not have right to change the value of parameters.	N/A
Set SATA Port 0 HDD Password	Enter HDD Password.	N/A
Password on boot	Defines whether a password is required or not while the events defined in this group happened. The following sub-options are all requires the Supervisor password for changes and should be grayed out if the user password was used to enter setup.	Disabled or Enabled

NOTE: When you are prompted to enter a password, you have three tries before the system halts. Don't forget your password. If you forget your password, you may have to return your notebook computer to your dealer to reset it.

Setting a Password

Follow these steps as you set the user or the supervisor password:

1. Use the \uparrow and \downarrow keys to highlight the Set Supervisor Password parameter and press the **Enter** key. The Set Supervisor Password box appears:

Set Supervisor Password		
Enter New Password	[]
Confirm New Password	[]

2. Type a password in the "Enter New Password" field. The password length can not exceeds 8 alphanumeric characters (A-Z, a-z, 0-9, not case sensitive). Retype the password in the "Confirm New Password" field.

IMPORTANT: Be very careful when typing your password because the characters do not appear on the screen.

3. Press **Enter**. After setting the password, the computer sets the User Password parameter to "Set".
4. If desired, you can opt to enable the Password on boot parameter.
5. When you are done, press F10 to save the changes and exit the BIOS Setup Utility.

Removing a Password

Follow these steps:

1. Use the w and y keys to highlight the Set Supervisor Password parameter and press the **Enter** key. The Set Password box appears:

Set Supervisor Password		
Enter current password	[]
Enter New Password	[]
Confirm New Password	[]

2. Type the current password in the Enter Current Password field and press **Enter**.
3. Press e twice **without** typing anything in the Enter New Password and Confirm New Password fields. The computer then sets the Supervisor Password parameter to "Clear".
4. When you have changed the settings, press u to save the changes and exit the BIOS Setup Utility.

Changing a Password

1. Use the ↑ and ↓ keys to highlight the Set Supervisor Password parameter and press the **Enter** key. The Set Password box appears.

Set Supervisor Password		
Enter current password	[]
Enter New Password	[]
Confirm New Password	[]

2. Type the current password in the Enter Current Password field and press **Enter**.
3. Type a password in the Enter New Password field. Retype the password in the Confirm New Password field.
4. Press **Enter**. After setting the password, the computer sets the User Password parameter to “Set”.
5. If desired, you can enable the Password on boot parameter.
6. When you are done, press F10 to save the changes and exit the BIOS Setup Utility.

If the verification is OK, the screen will display as following.

Setup Notice
Changes have been saved.
[continue]

The password setting is complete after the user presses **Enter**.

If the current password entered does not match the actual current password, the screen will show you the Setup Warning.

Setup Warning
Invalid password
Re-enter Password
[continue]

If the new password and confirm new password strings do not match, the screen will display the following message.

Setup Warning
Password do not match
Re-enter Password

Power

The Power screen allows the user to configure various CPU and power management options and device wakeup behavior.

PhoenixBIOS Setup Utility						
Information	Main	Advanced	Security	Boot	Power	Exit
C1E Configuration [Griffin Mode] CPU Throttle: [Disabled] CPU Spread Spectrum: [Enabled] iGPU Spread Spectrum: [2.00% Triangular Centre] PCIE Spread Spectrum: [Disabled] SATA Spread Spectrum: [Linear Down] PState Configuration [Enabled] USB CSC Resume [Disabled] Cannot_Find_String [Disabled] HIPM [Disabled] SATA FPCI Clock: [133Mhz] PCI Clocks: [Enabled] AltVid [Disabled] ASPM (L0s/L1s) [Disabled L0s] PCIE Lane Swizzle: [Disabled]						Item Specific Help Enable or Disable C1E Dual-Core related CPU power State. Auto enables C1E if dual core is detected and disables C1E if single core is detected.
F1 Help ↑↓ Select Item F5/F6 Change Values F9 Setup Defaults ESC Exit ←→ Select Menu Enter Select▶Sub-Menu F10 Save and Exit						

The table below describes the items, menus, and submenus in this screen. Settings in **boldface** are the default and suggested parameter settings.

Parameter	Description	Option
C1E Configuration	Enable or Disable C1E Dual-Core related CPU power State.	Griffin Mode or Disabled
CPU Throttle	Enable or disable CPU Throttle.	Disabled or Enabled
CPU Spread Spectrum	Enable or disable CPU Spread Spectrum.	Disabled or Enabled
iGPU Spread Spectrum	Set the iGPU Spread Spectrum percentage.	1.00%, 2.00% , 3.00%, 4.00%, 5.00% or Disabled
PCIE Spread Spectrum	Enable or disable PCIE Spread Spectrum.	Disabled or Enabled
SATA Spread Spectrum	Enable or disable SATA Spread Spectrum.	Disabled or Linear Down
PState Configuration	Enable or disable ACPI PState Support	Enabled or Disabled
USB CSC Resume	Enable or disable wake up from S3 by USB plug or unplug.	Disabled or Enabled
Cannot_Find_String	Enable or disable the Cannot_Find_String message during boot.	Disabled or Enabled
HIPM	Enable or disable Aggressive Link Power Management (HIPM).	Disabled or Enabled
SATA FPCI Clock	Set the SATA low power control level.	133 MHz or 200 MHz
PCI Clocks	Enable all PCI clocks or lock down all PCI clocks to Port 80.	Enabled or Auto

Parameter	Description	Option
AltVid	Enable or disable AltVid functionality.	Disabled or Enabled
ASPM (L0s/L1s)	Enable or disable Active State Power Management (ASPM) states for L0s and L1.	Disable L0s , Disable L1, Enabled, or Disabled
PCIE Lane Swizzle	Enable or disable PCIE Lane Swizzle for PCIE x 16 slot.	Disabled or Enabled

Exit

The Exit screen allows you to save or discard any changes you made and quit the BIOS Utility.

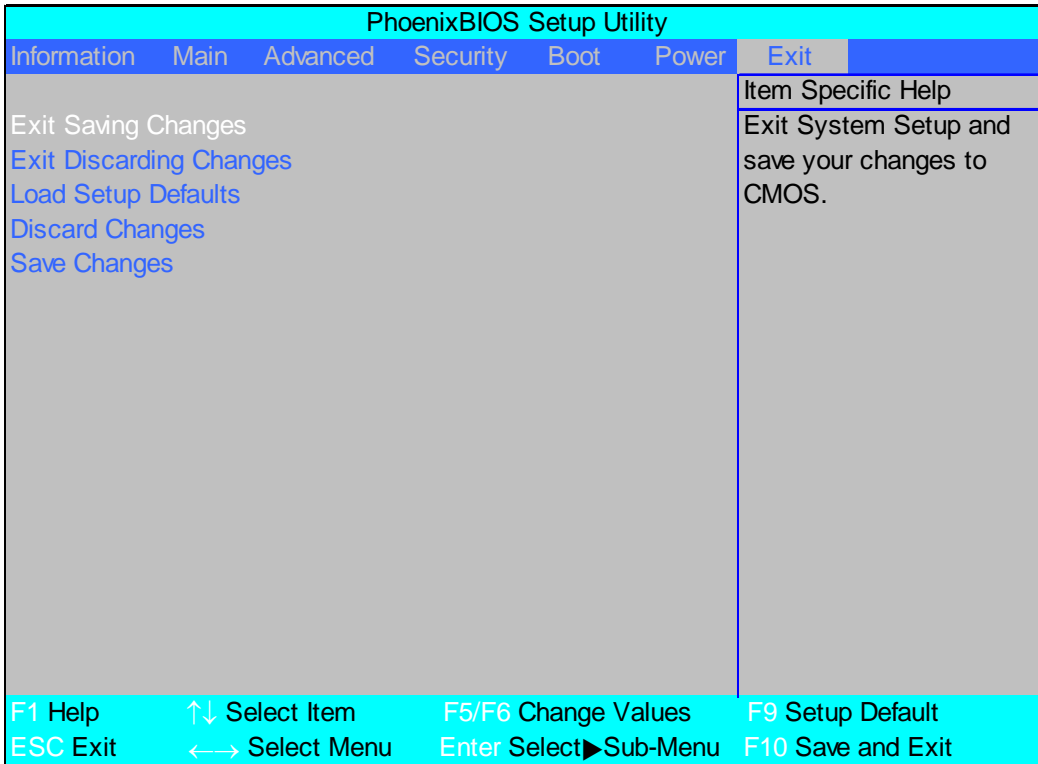

The table below describes the parameters in this screen.

Parameter	Description
Exit Saving Changes	Exit System Setup and save your changes to CMOS.
Exit Discarding Changes	Exit utility without saving setup data to CMOS.
Load Setup Default	Load default values for all SETUP item.
Discard Changes	Load previous values from CMOS for all SETUP items.
Save Changes	Save Setup Data to CMOS.

BIOS Flash Utility

The BIOS flash memory update is required for the following conditions:

- New versions of system programs
- New features or options
- Restore a BIOS when it becomes corrupted.

Use the Phlash utility to update the system BIOS flash ROM.

NOTE: If you do not have a crisis recovery diskette at hand, then you should create a **Crisis Recovery Diskette** before you use the Phlash utility.

NOTE: Do not install memory-related drivers (XMS, EMS, DPMI) when you use the Phlash.

NOTE: Please use the AC adaptor power supply when you run the Phlash utility. If the battery pack does not contain enough power to finish BIOS flash, you may not boot the system because the BIOS is not completely loaded.

Follow the steps below to run the Phlash.

1. Prepare a bootable diskette.
2. Copy the flash utilities to the bootable diskette.
3. Then boot the system from the bootable diskette. The flash utility has auto-execution function.

Remove HDD/BIOS Utility

This section provide you with removing HDD/BIOS method:

Remove HDD Password:

- If you key in wrong HDD password for three time, "HDD password error code" would display on the screen. See the image below.

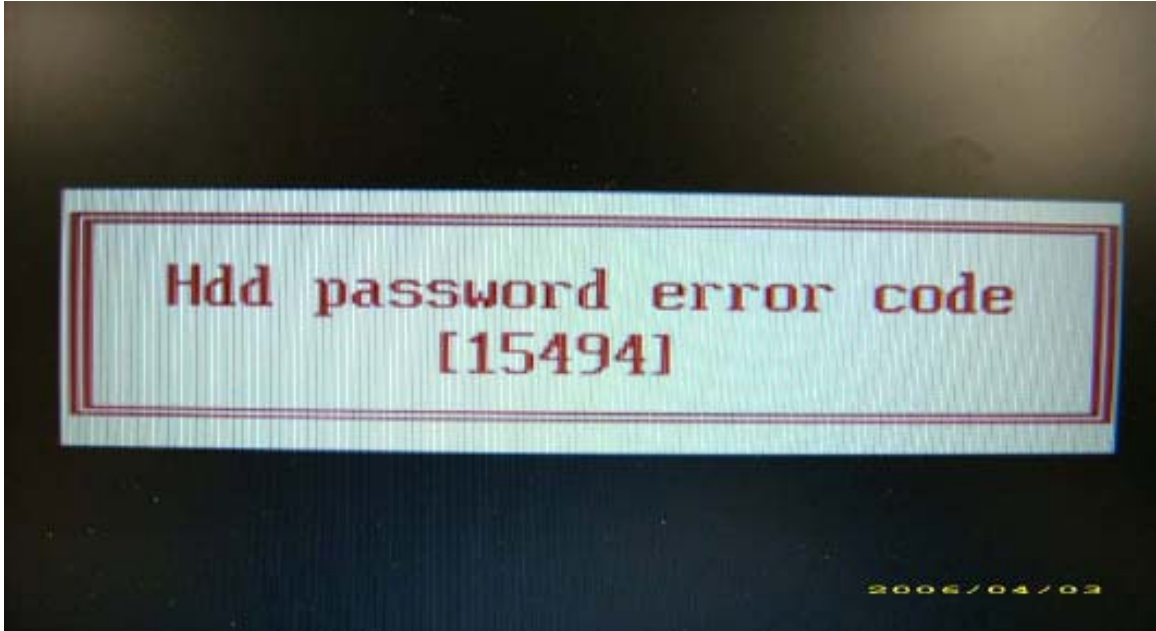

- If you need to solve HDD password locked problem, you can run HDD_PW.EXE
 1. Key in "hdd_pw 15494 0"
 2. Select "2"
 3. Choose one upper-case string



- Reboot system and key in "0KJFN42" or "UVEIQ96" to HDD user password.

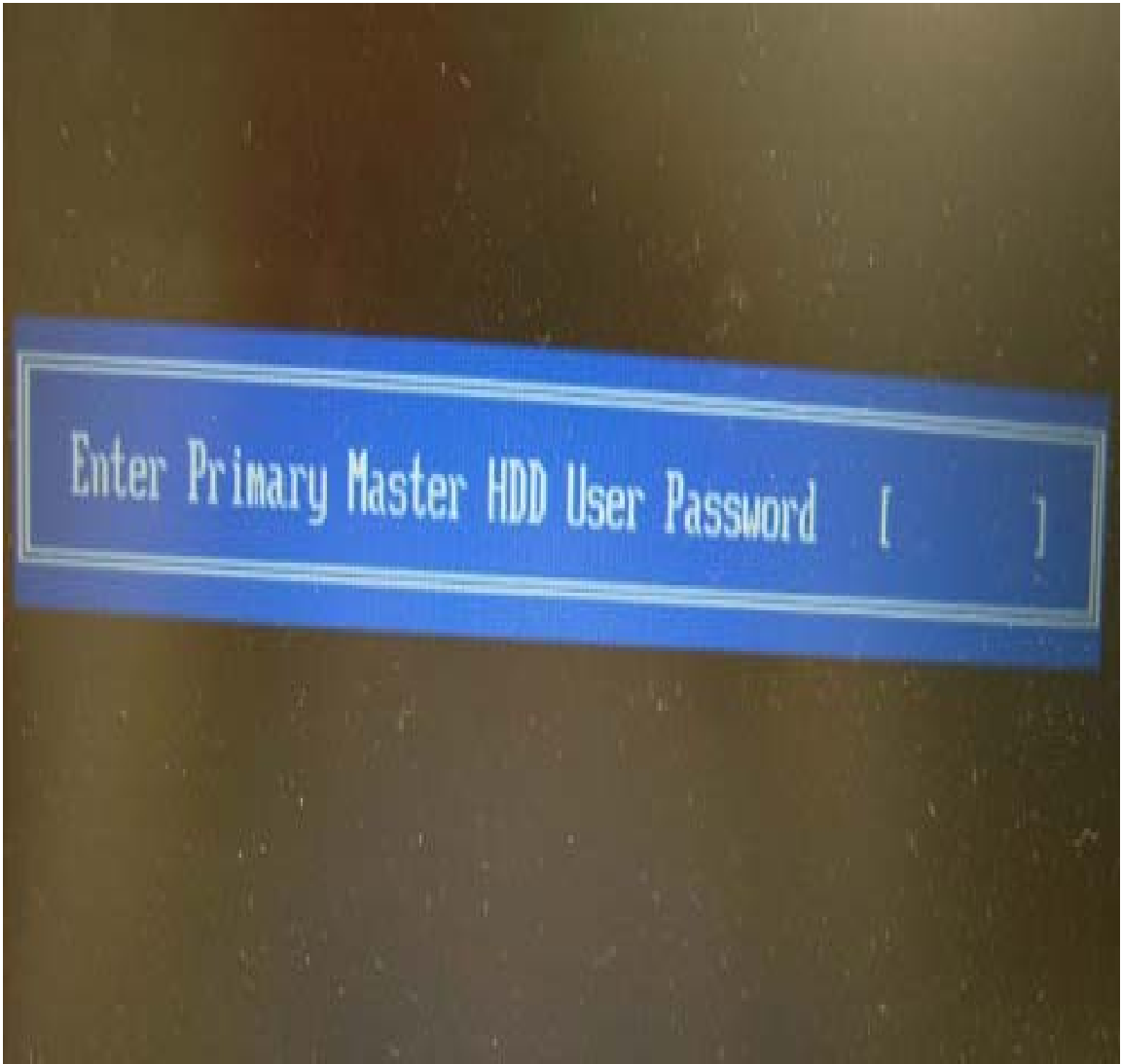

Remove BIOS Password:

- If you key in wrong Supervisor Password for three time, "System Disabled" would display on the screen. See the image below.

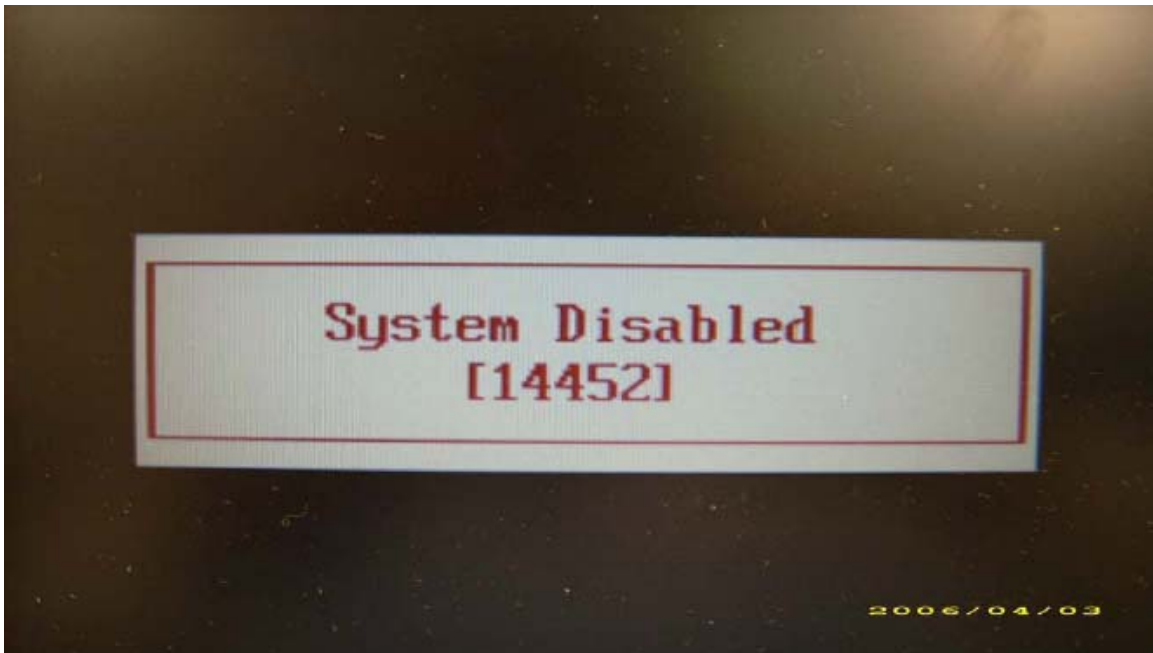

- If you need to solve BIOS password locked problem, you can run BIOS_PW.EXE
 1. Key in "bios_pw 14452 0"
 2. Choose one upper-case string

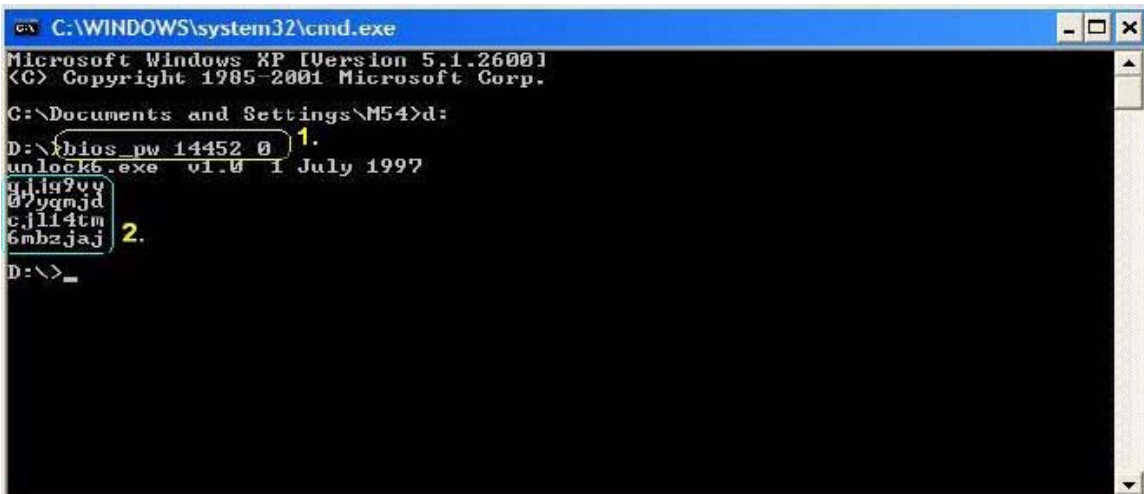

- Reboot the system and key in "qjjg9vy" or "07yqmjd" to BIOS user password.



Machine Disassembly and Replacement

This chapter contains step-by-step procedures on how to disassemble the notebook computer for maintenance and troubleshooting.

Disassembly Requirements

To disassemble the computer, you need the following tools:

- Wrist grounding strap and conductive mat for preventing electrostatic discharge
- Flat screwdriver
- Philips screwdriver
- Plastic flat screwdriver
- Plastic tweezers

NOTE: The screws for the different components vary in size. During the disassembly process, group the screws with the corresponding components to avoid mismatch when putting back the components.

General Information

Pre-disassembly Instructions

Before proceeding with the disassembly procedure, make sure that you do the following:

1. Turn off the power to the system and all peripherals.
2. Unplug the AC adapter and all power and signal cables from the system.



3. Place the system on a flat, stable surface.
4. Remove the battery pack.

Disassembly Process

The disassembly process is divided into the following stages:

- External module disassembly
- Main unit disassembly
- LCD module disassembly

The flowcharts provided in the succeeding disassembly sections illustrate the entire disassembly sequence. Observe the order of the sequence to avoid damage to any of the hardware components. For example, if you want to remove the mainboard, you must first remove the keyboard, then disassemble the inside assembly frame in that order.

Main Screw List

Screw	Quantity	Part Number
M2.5*4	28	86.T23V7.009
M2.5*6.5	15	86.ARE07.001
M2.5*5	12	86.ARE07.003
M2*3	11	86.A08V7.005
M3*3.5	4	86.TDY07.003
M2.5*3	9	86.A03V7.010

External Module Disassembly Process

External Modules Disassembly Flowchart

The flowchart below gives you a graphic representation on the entire disassembly sequence and instructs you on the components that need to be removed during servicing. For example, if you want to remove the mainboard, you must first remove the keyboard, then disassemble the inside assembly frame in that order.

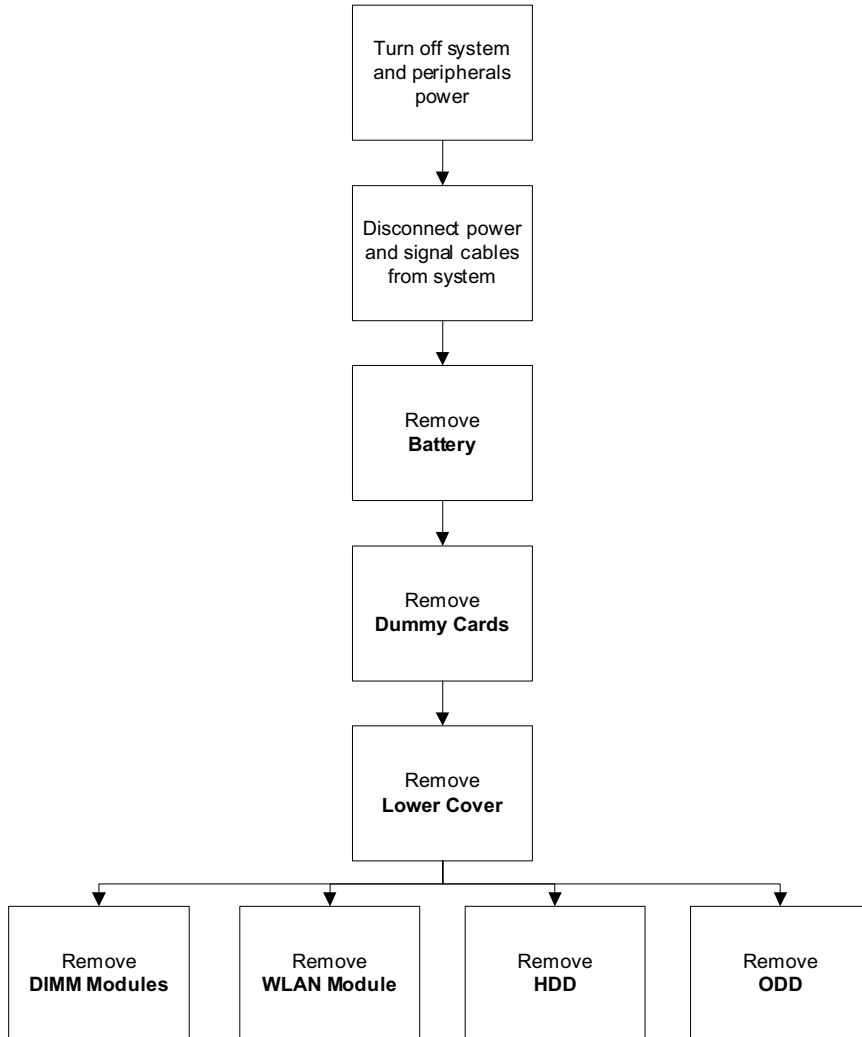

Screw List

Step	Screw	Quantity	Part No.
WLAN Module	M2.5*4	2	86.T23V7.009
HDD Module	M2.5*4	2	86.T23V7.009
HDD Carrier	M3*3.5	4	86.TDY07.003
ODD Bracket	M2*3	2	86.A08V7.005

Removing the Battery Pack

1. Turn computer over.
2. Slide the battery lock/unlock latch to the unlock position.



3. Slide and hold the battery release latch to the release position (1), then slide out the battery pack from the main unit (2).



Removing the Express Dummy Card

1. Push the Express Dummy Card all the way in to eject it.



2. Pull it out from the slot.



Removing the SD Dummy Card

1. Push the SD Dummy Card all the way in to eject it.



2. Pull it out from the slot.



Removing the Lower Cover

1. See “Removing the Battery Pack” on page 50.
2. See “Removing the Express Dummy Card” on page 51.
3. See “Removing the SD Dummy Card” on page 52.
4. Loosen the nine (captive) screws to allow access to memory, HDD, and WLAN bays.

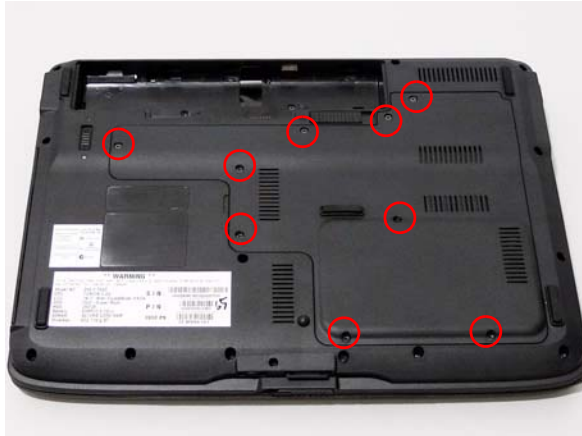

5. Carefully open the lower cover.



Removing the DIMM Module

1. See “Removing the Lower Cover” on page 53.
2. Push out the release securing clips on both sides of the DIMM socket to release the DIMM module.

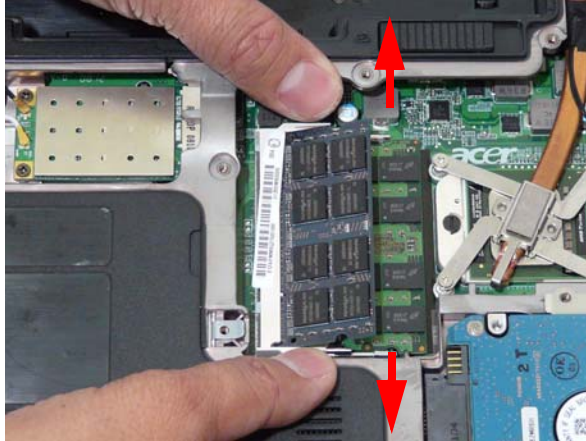

3. Remove the DIMM module.



4. Repeat steps for the second DIMM module.

Removing the WLAN Module

1. See "Removing the Lower Cover" on page 53.
2. Disconnect the antenna cables from the WLAN board.



3. Move the cables away and remove the two screws on the WLAN board to release the WLAN board.

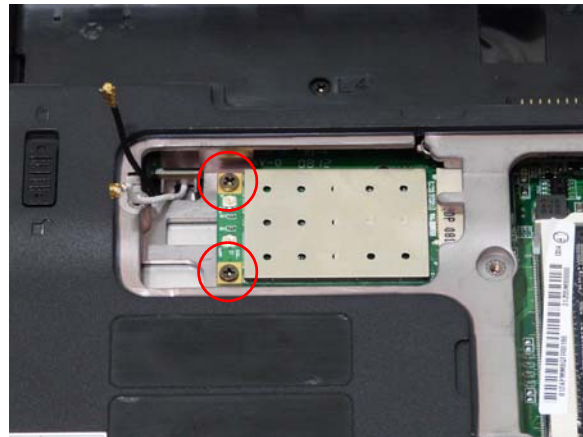

Step	Size	Quantity	Screw Type
WLAN Module	M2.5*4	2	

-
4. Detach the WLAN board from the WLAN socket.



NOTE: When attaching the antenna back to the WLAN board, make sure the cables are arranged properly.

Removing the Hard Disk Drive Module

1. See “Removing the Lower Cover” on page 53.
2. Remove the two securing screws.



Step	Size	Quantity	Screw Type
HDD	M2.5*4	2	

3. Use the pull-tab to slide and lift up the hard disk drive module to remove.



NOTE: To prevent damage to device, avoid pressing down on it or placing heavy objects on top of it.

4. Remove the four screws (two on each side of the bracket) securing the hard disk to the carrier.

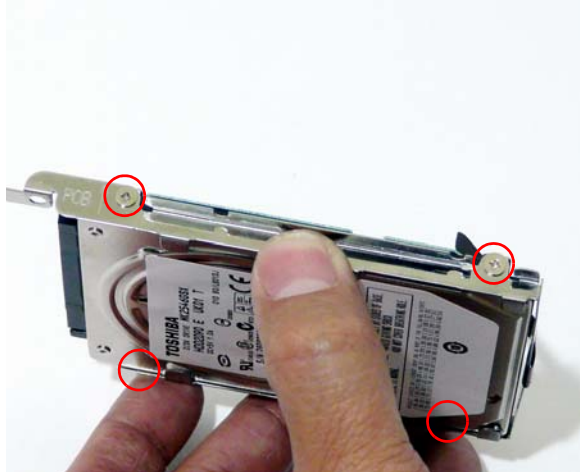

Step	Size	Quantity	Screw Type
HDD Carrier	M3*3.5	4	

5. Remove the HDD from the carrier.



Removing the Optical Drive Module

1. See “Removing the Lower Cover” on page 53.
2. Use a screw driver to push the module through the chassis.

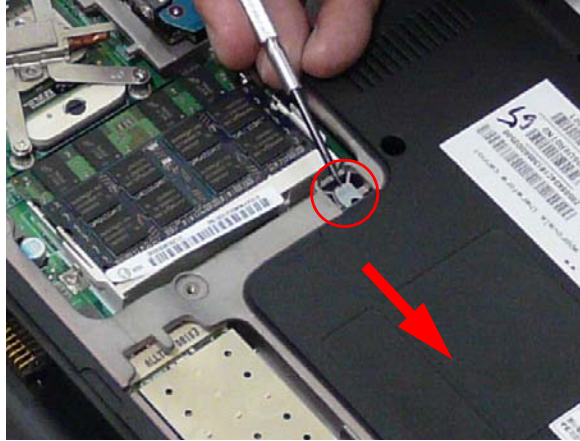

3. Pull the optical drive module out from the main unit.



4. Insert a pin in the eject hole of the ODD to eject the ODD tray.



5. Carefully press down on the locking catch to release the ODD cover. Remove the cover.

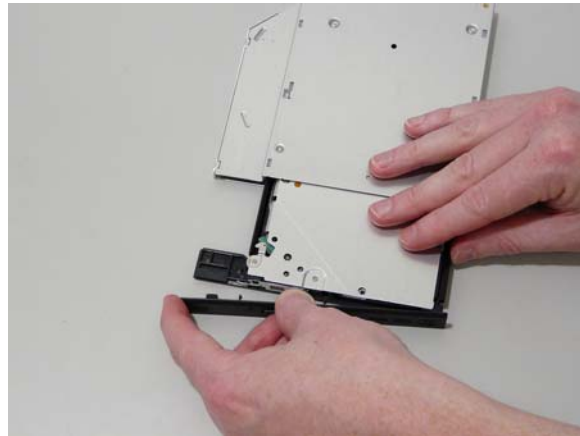

6. Remove the two screws securing the ODD bracket and remove the ODD bracket from the optical disk drive module.

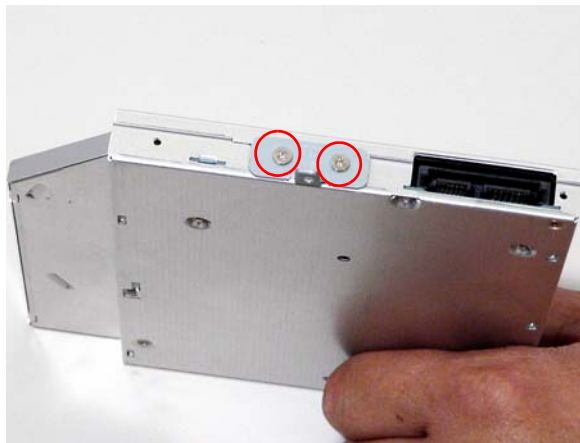

Step	Size	Quantity	Screw Type
ODD Bracket	M2*3	2	

Main Unit Disassembly Process

Main Unit Disassembly Flowchart

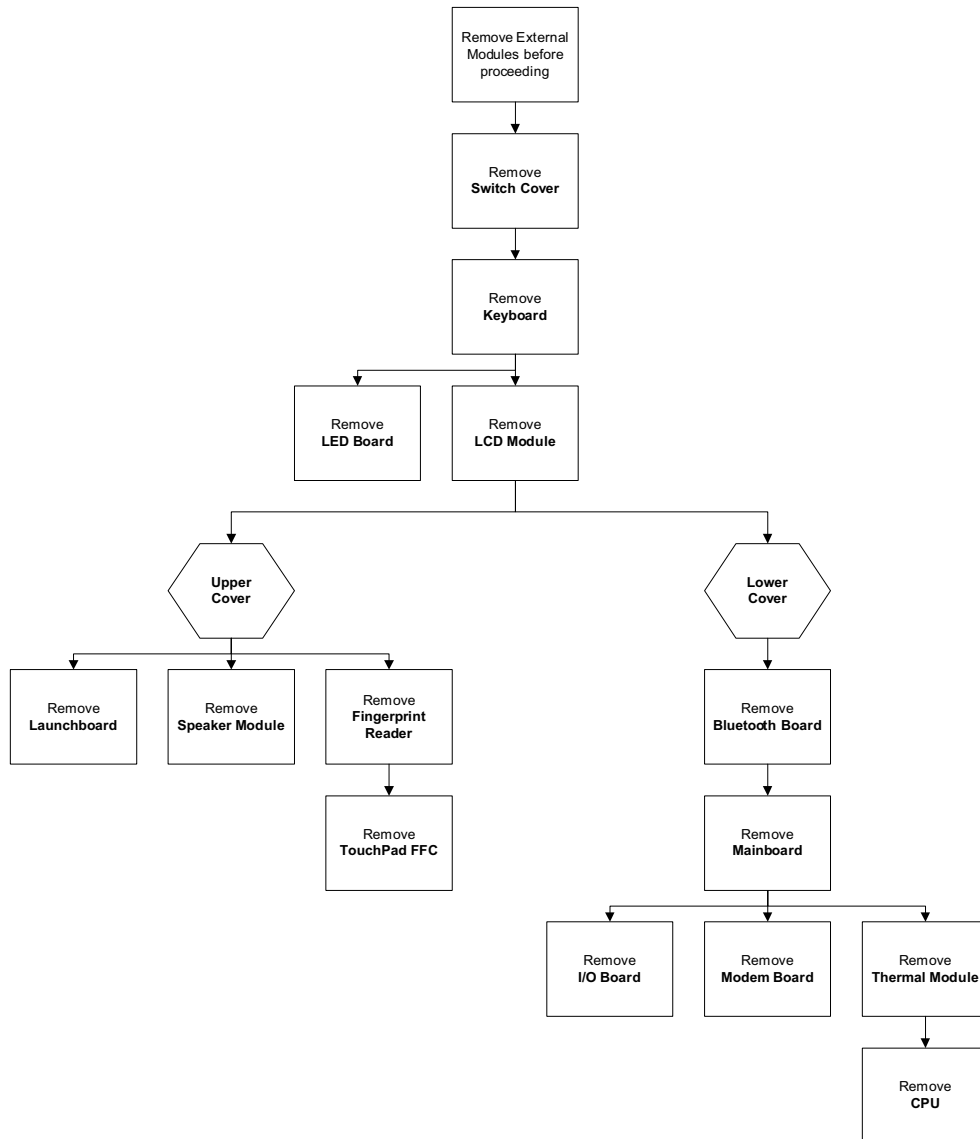

Screw List

Step	Size	Quantity	Acer Part No.
Switch Cover	M2.5*4	3	86.T23V7.009
LCD Module	M2.5*6.5	4	86.ARE07.001
	M2*3	4	86.A08V7.005
LED Board	M2.5*4	1	86.T23V7.009
Upper Cover	M2.5*6.5	11	86.ARE07.001
	M2.5*4	7	86.T23V7.009
Launch Board	M2.5*4	3	86.T23V7.009
Speaker Module	M2.5*4	4	86.T23V7.009
	M2.5*3	7	86.A03V7.010

Step	Size	Quantity	Acer Part No.
Finger Print Reader	M2.5*4	1	86.T23V7.009
Bluetooth Board	M2*3	1	86.A08V7.005
Mainboard	M2.5*4	2	86.T23V7.009
Modem Board	M2.5*4	2	86.T23V7.009
I/O Board	M2.5*3	2	86.A03V7.010
Thermal Module	N/A	4	N/A
	M2.5*4	1	86.T23V7.009

Removing the Switch Cover

CAUTION: Using tools to remove the Switch Cover may cause damage to the outer casing. It is recommended that only fingers are used to remove the Switch Cover.

1. See “Removing the Battery Pack” on page 50.
2. Locate and remove the three securing screws as shown.



Step	Size	Quantity	Screw Type
Switch Cover	M2.5*4	3	

3. Turn the computer over and open the LCD module fully to expose the Switch Cover.
4. Lift the Switch Cover as shown, leftside first.



5. Lift the Switch Cover clear of the chassis.

Removing the Keyboard

1. See "Removing the Switch Cover" on page 63.
2. Lift the keyboard up and turn over to expose the Touch Pad area.



3. Disconnect the keyboard FFC from the mainboard to remove the keyboard.

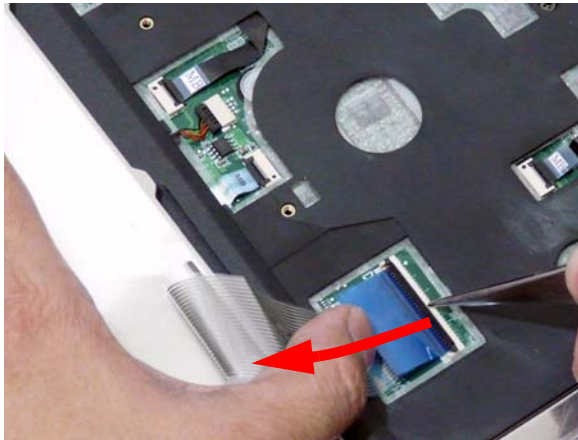

4. Lift and remove the keyboard.

Removing the Antenna Cables

1. See "Removing the Keyboard" on page 64.
2. Ensure the Antenna Cables are disconnected.

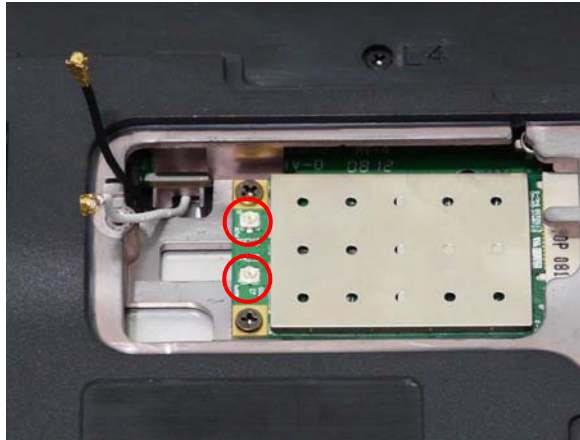

3. Turn the computer over. Use the tweezers to gently pull the cable through the chassis.

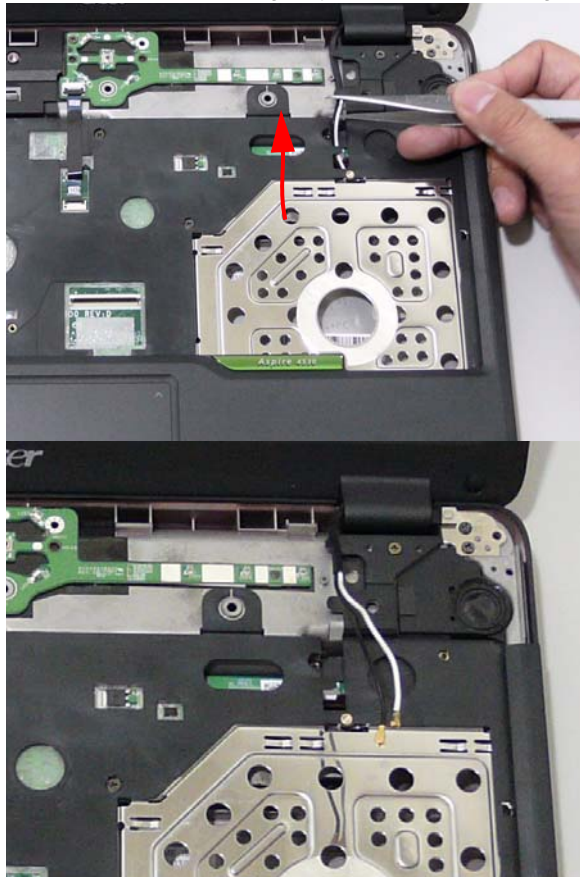

Removing the LCD Module

1. See "Removing the WLAN Module" on page 55.
2. See "Removing the Antenna Cables" on page 65.
3. Remove the two securing screws from the bottom of the chassis.



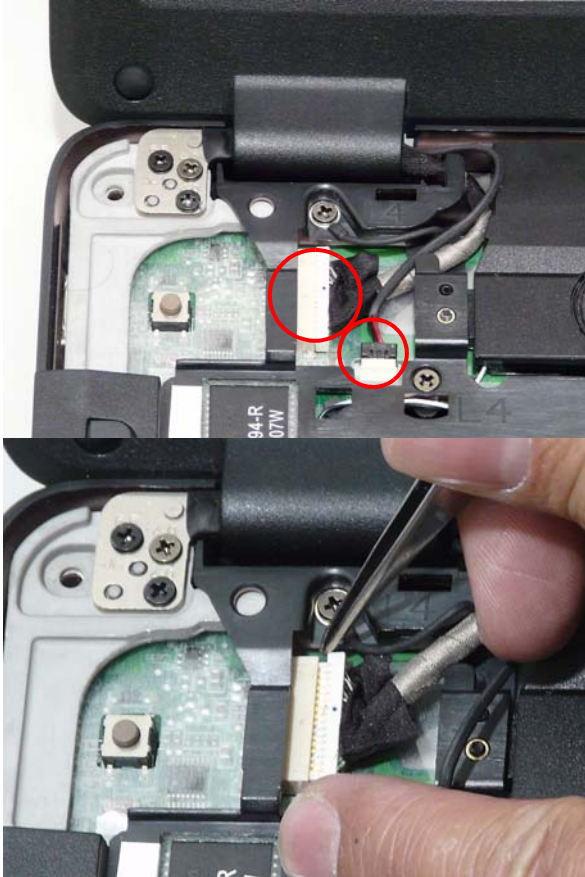

Step	Size	Quantity	Screw Type
LCD Module	M2.5*6.5	2	

4. Turn the computer over. Disconnect the following two cables from the chassis.

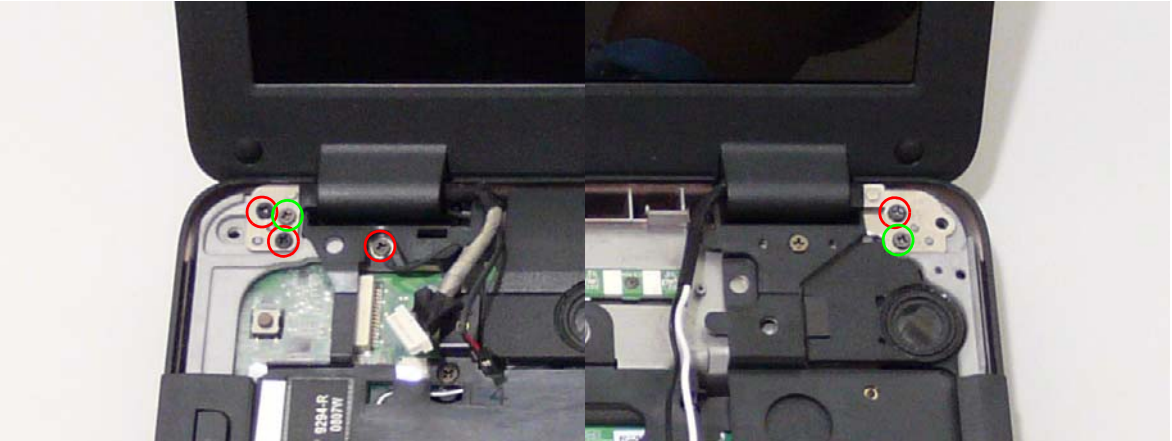

5. Remove the six securing screws (including the grounding wire screw) from the LCD module.



Step	Size	Quantity	Screw Type
LCD Module (red callout)	M2*3	4	
LCD Module (green callout)	M2.5*6.5	2	

6. Carefully remove the LCD module from the chassis.



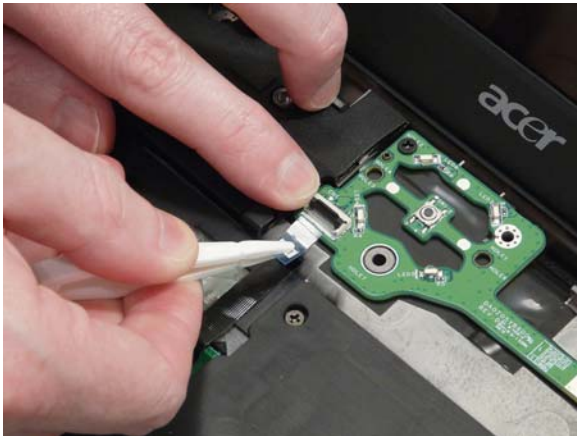

Removing the LED Board

1. See "Removing the Switch Cover" on page 63.
2. Remove the LED board FFC.

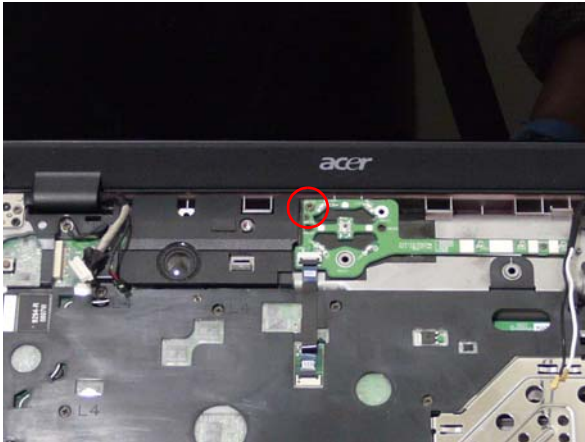

3. Remove the securing screw and lift the LED board.



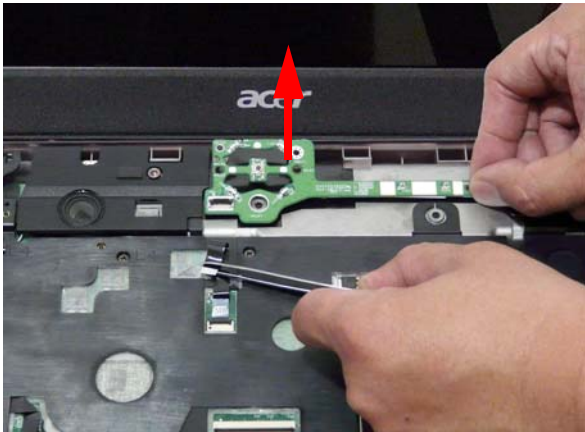

Step	Size	Quantity	Screw Type
LED Board	M2.5*4	1	

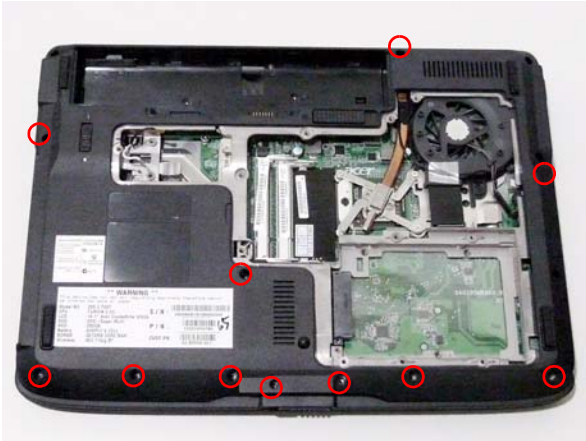

Removing the Upper Cover

1. See "Removing the Battery Pack" on page 50.
2. See "Removing the LCD Module" on page 66.
3. Turn the computer over. Remove the eleven screws on the bottom panel.



Step	Size	Quantity	Screw Type
Upper Cover	M2.5*6.5	11	

4. Turn the computer over. Remove the seven screws on the top panel.

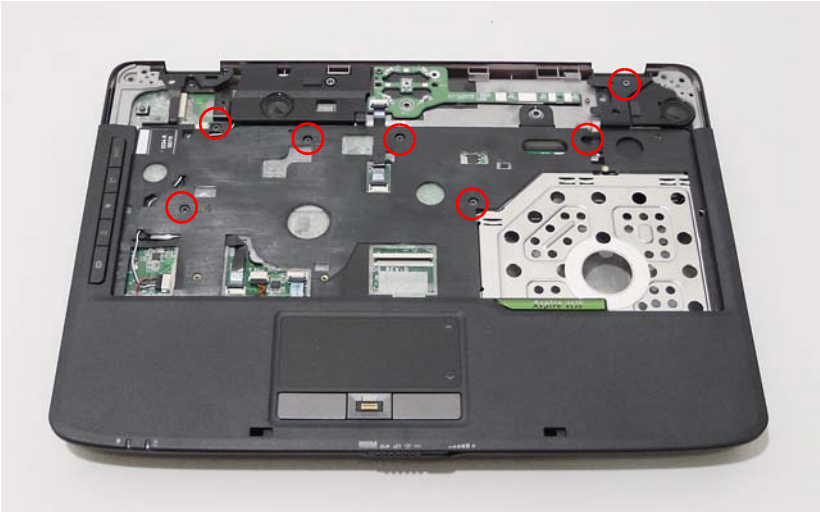

Step	Size	Quantity	Screw Type
Upper Cover	M2.5*4	7	

5. Locate the cables connecting the mainboard to the Upper Cover as shown.

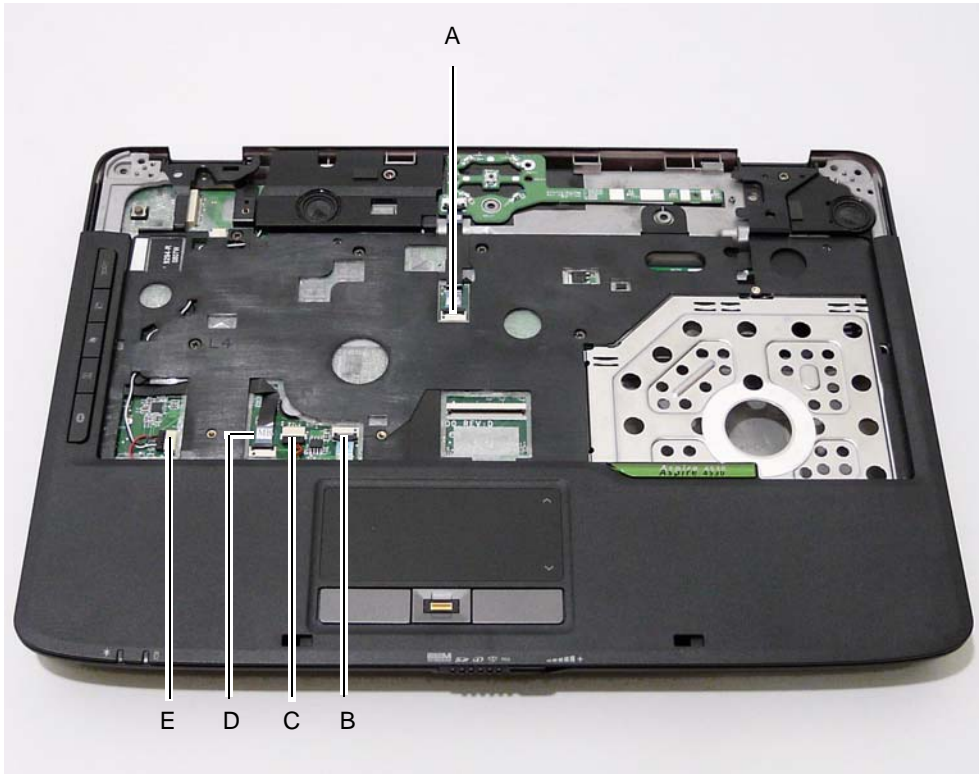

Release the securing latches and disconnect A as shown.

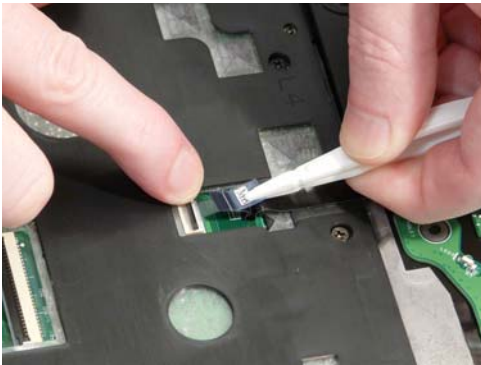

Release the securing latches and disconnect B as shown.



Disconnect C as shown.

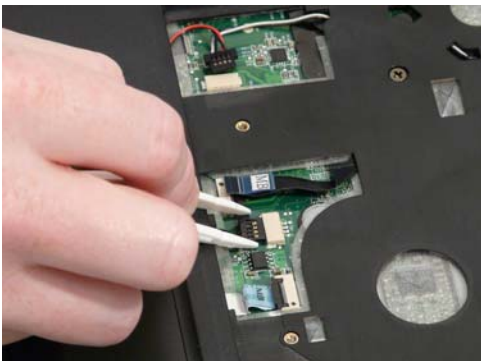

Release the securing latches and disconnect D as shown.



Disconnect E as shown.

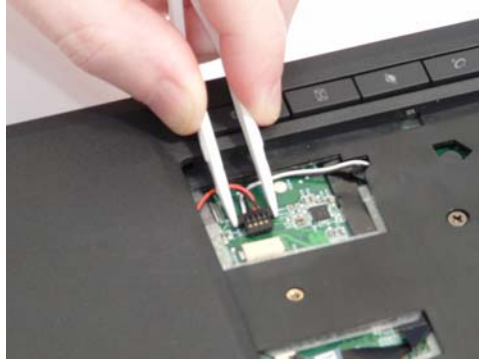



6. Remove the upper cover by lifting upward from the chassis.

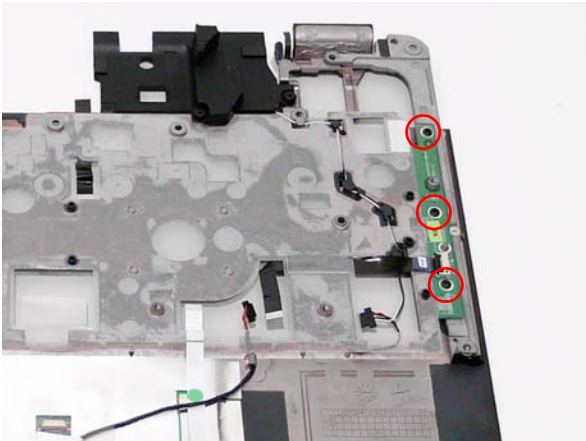

Removing the Launch Board

1. See "Removing the Upper Cover" on page 69.
2. Remove the three screws from the Launch Board.



Step	Size	Quantity	Screw Type
Launch Board	M2.5*4	3	

3. Disconnect the Launch Board FFC as shown

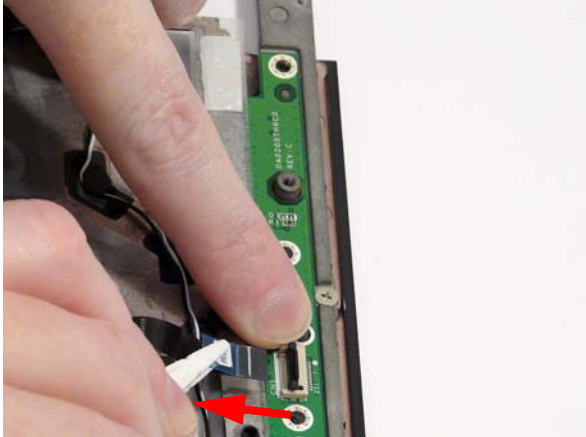

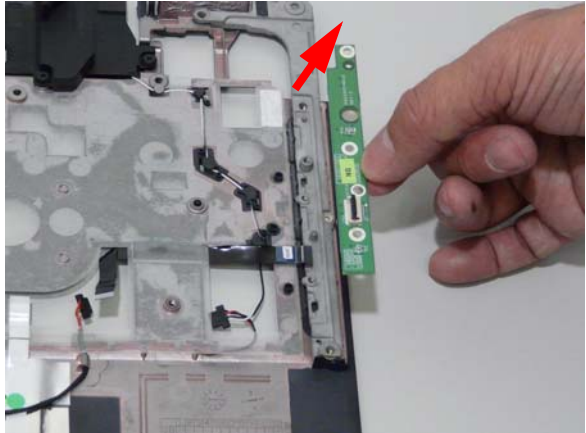

4. Lift the Launch Board clear of the Upper Cover.

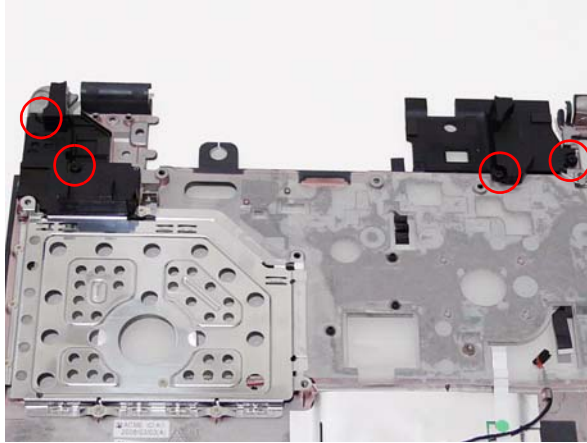

Removing the Speaker Module

1. See "Removing the Upper Cover" on page 69.
2. Turn the cover over and remove the four screws securing the Speakers to the Upper Cover.



Step	Size	Quantity	Screw Type
Speaker Module	M2.5*4	4	

3. Lift up the left speaker to allow access to the cables. Be careful not to pull damage the speaker cables.

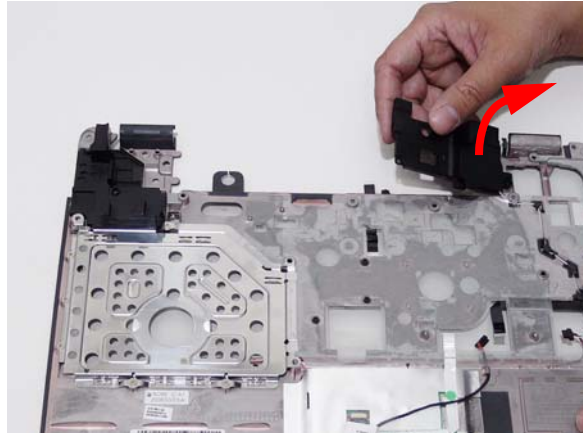

4. Carefully lift up the mylar cover to expose the cables. Do not remove mylar completely.

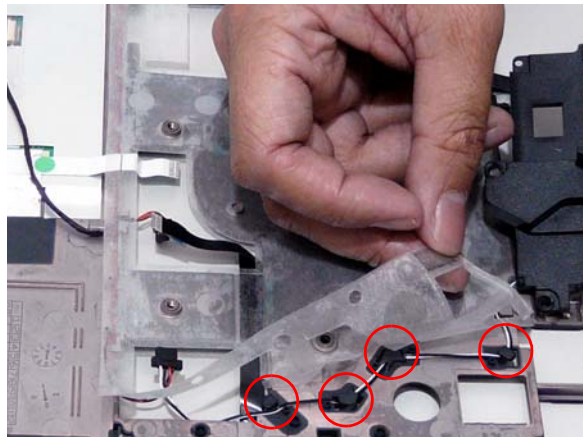

5. Remove the cable from the cable channel as shown.



6. While lifting the mylar cover, pull through the finger print reader cable and touchpad FFC to expose the speaker cable.

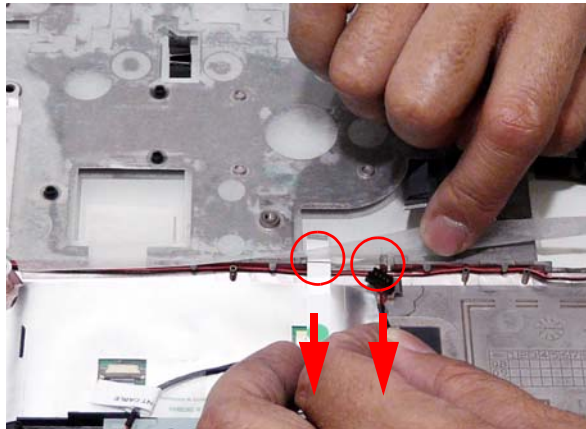

7. Remove the cable from the cable channel.

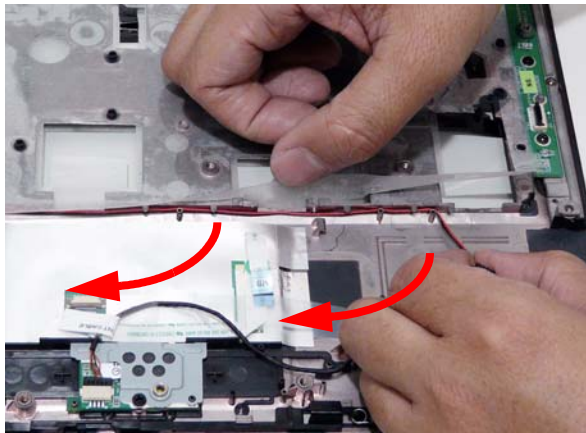

8. Remove the seven screws from the HDD plate.

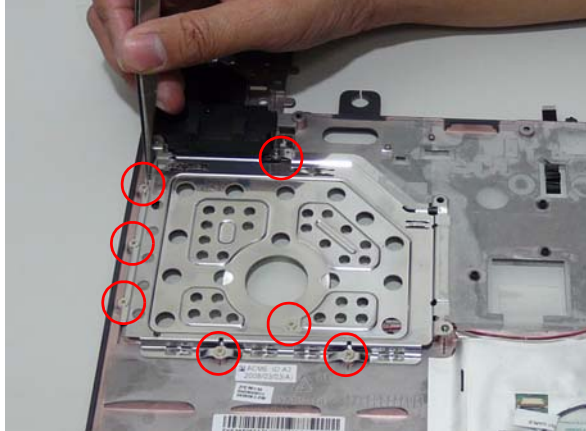

Step	Size	Quantity	Screw Type
Speaker Module	M2.5*3	7	

9. Lift the HDD plate and continue to pull out the speaker cable.

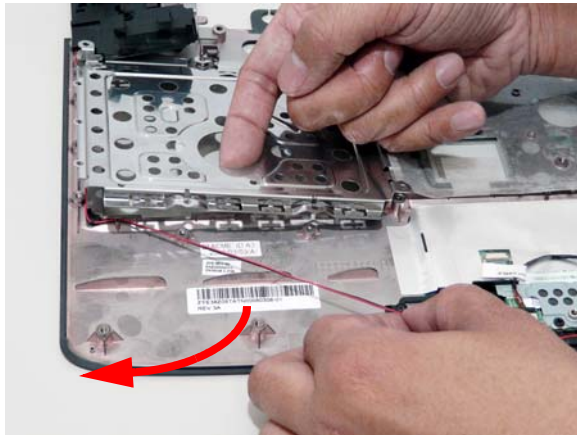

10. Ensure the speaker cable is removed from the cable channel and lift up the right speaker.

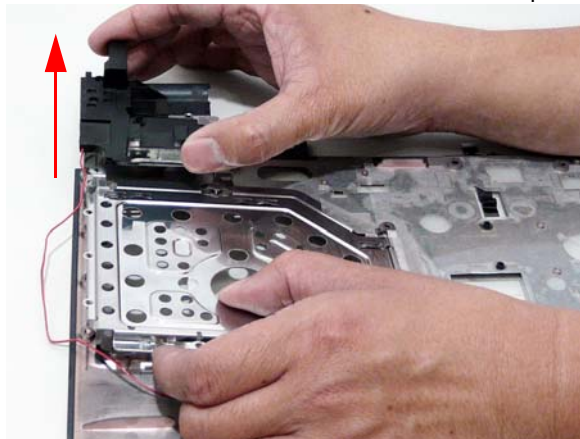

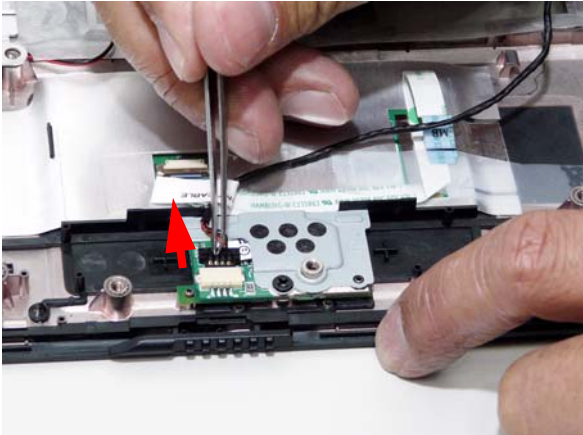

Removing the Finger Print Reader

1. See "Removing the Upper Cover" on page 69.
2. Disconnect the Finger Print Reader cable.

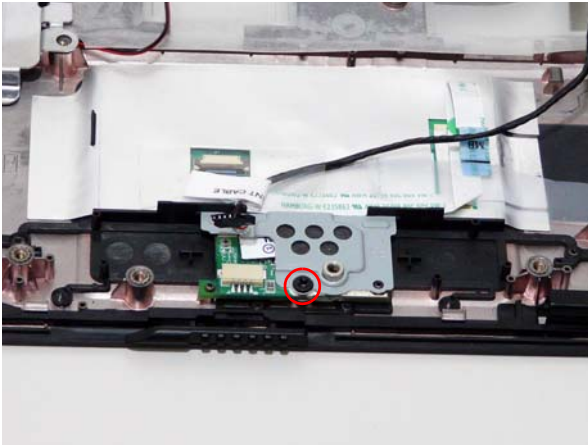

3. Remove the securing screw from the Finger Print Reader board.



Step	Size	Quantity	Screw Type
Finger Print Reader	M2.5*4	1	

4. Remove the bracket.

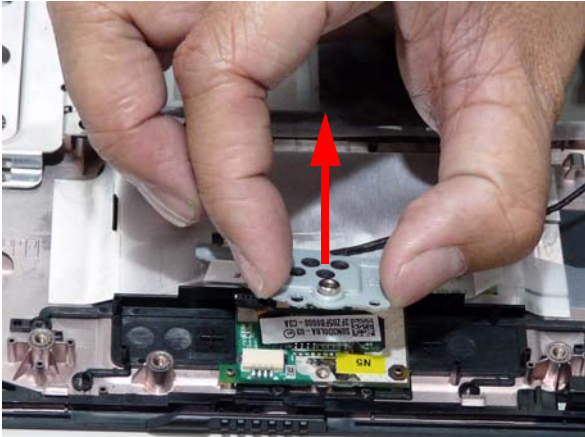

-
5. Remove the Finger Print Reader board.



Removing the Touch Pad Module

IMPORTANT:The Touch Pad is integrated into the design of the Upper Cover. To replace the Touch Pad, remove all components from the Upper Cover and install an entirely new Upper Cover.

1. See “Removing the Finger Print Reader” on page 76.
2. Disconnect the TouchPad cable from the TouchPad board.

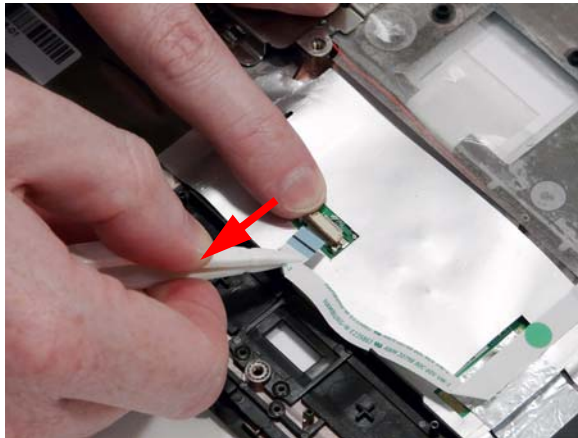



Removing the Bluetooth board

1. See "Removing the Upper Cover" on page 69.
2. Disconnect the Bluetooth cable from the mainboard.

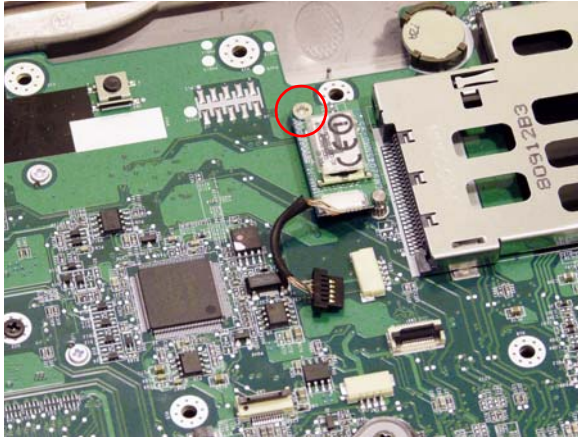

3. Remove the single securing screw from the Bluetooth board.



Step	Size	Quantity	Screw Type
Bluetooth Module	M2*3	1	

4. Carefully lift the Bluetooth board from the mainboard.

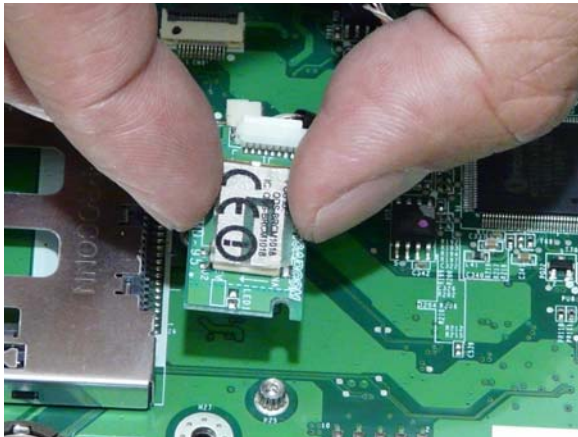

-
5. Disconnect the cable from the bluetooth board.

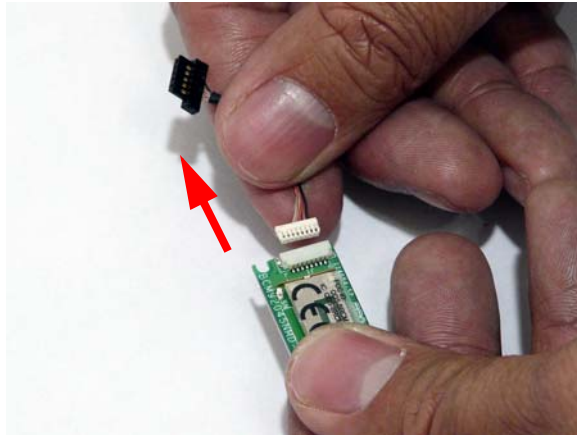

Removing the Mainboard

- 1. See "Removing the Upper Cover" on page 69.
- 2. Remove the two securing screws from the Mainboard.



Step	Size	Quantity	Screw Type
Mainboard	M2.5*4	2	

- 3. Ease the casing outward and remove the mainboard, rightside first, as shown.

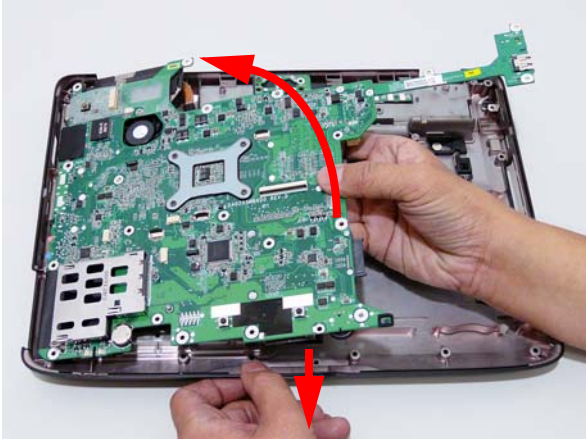

Removing the Modem Module

1. See "Removing the Mainboard" on page 80.
2. Remove the adhesive tape and two securing screws from the module.

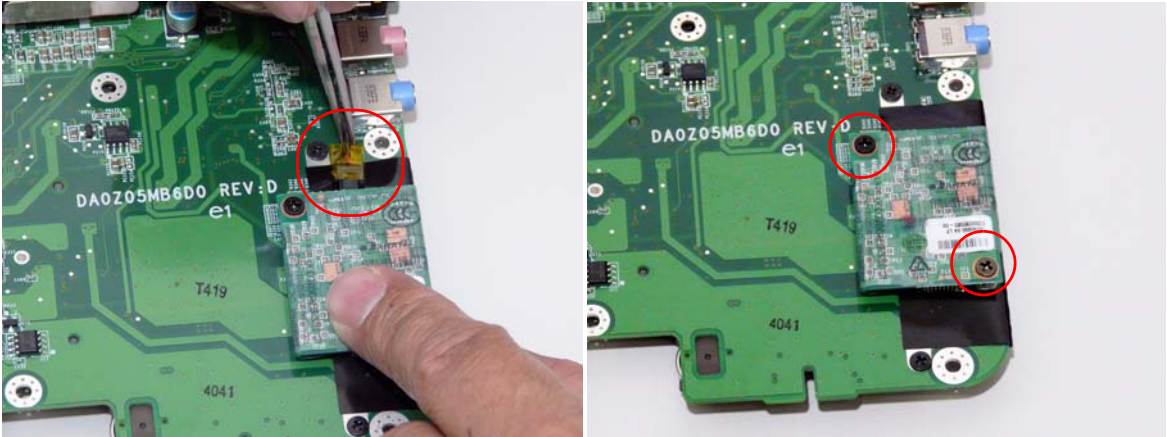

Step	Size	Quantity	Screw Type
Modem Module	M2.5*4	2	

3. Lift the Modem module from the Mainboard.



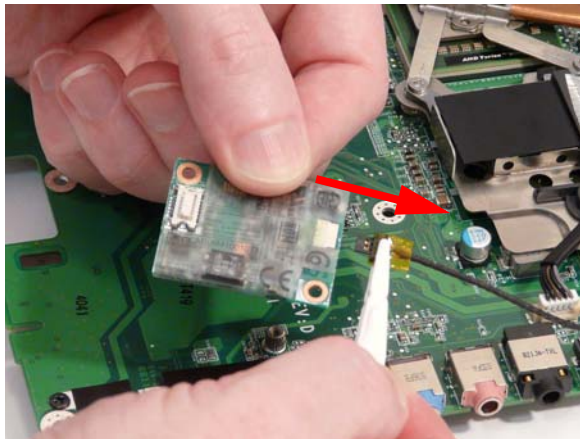

4. Turn the Modem module over and disconnect the modem cable from the board.

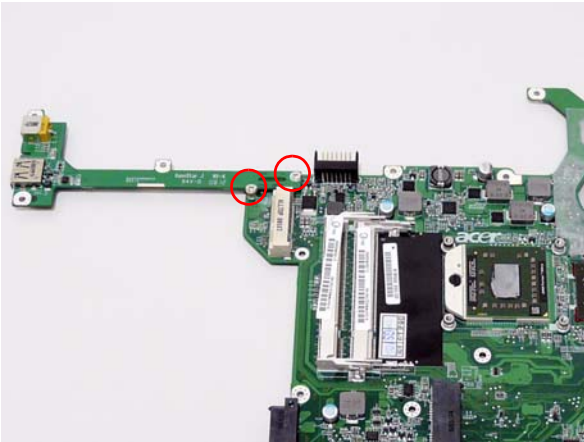

Removing the I/O Board

1. See "Removing the Mainboard" on page 80.
2. Turn the mainboard over, and remove the two securing screws from the I/O Board.



Step	Size	Quantity	Screw Type
I/O Board	M2.5*3	2	

3. Lift the I/O Board clear of the Lower cover.

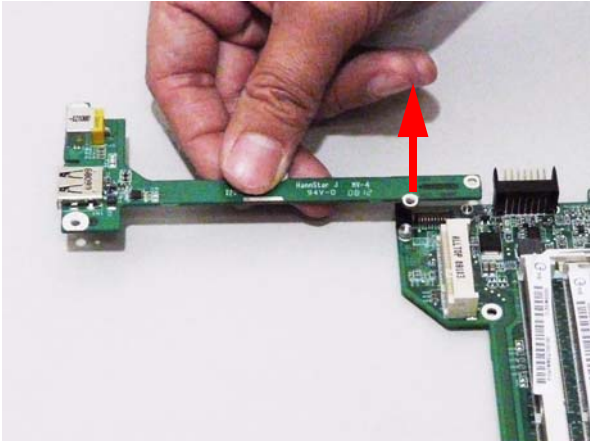

Removing the Thermal/Fan Module

1. See "Removing the Mainboard" on page 80.
2. Remove the five securing screws from the Fan module and heatsink.

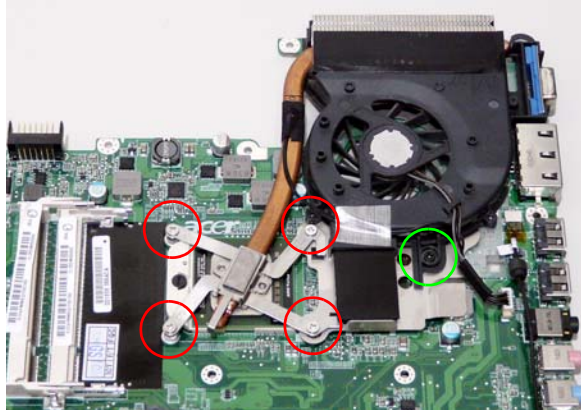

Step	Size	Quantity	Screw Type
Thermal Module (red callout)	N/A	4	N/A
Thermal Module (green callout)	M2.5*4	1	

3. Disconnect the Fan cable from the Mainboard.

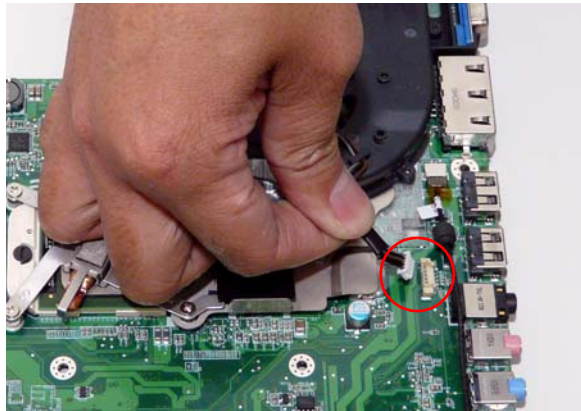

4. Lift the Thermal Module clear of the Mainboard.

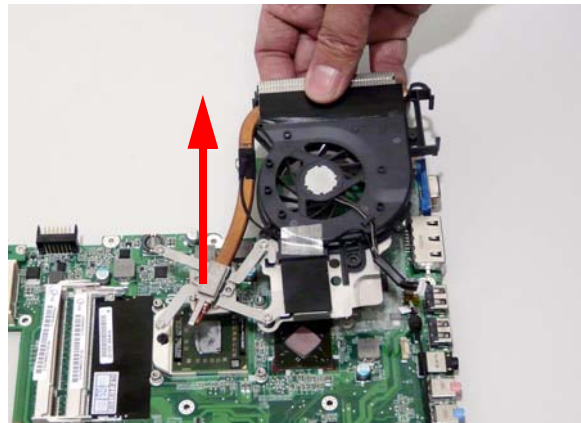

Removing the CPU

1. See “Removing the Thermal/Fan Module” on page 83.
2. Using a flat screwdriver, turn the CPU socket latch counter-clockwise to release the CPU.



3. Lift the CPU clear of the Mainboard.

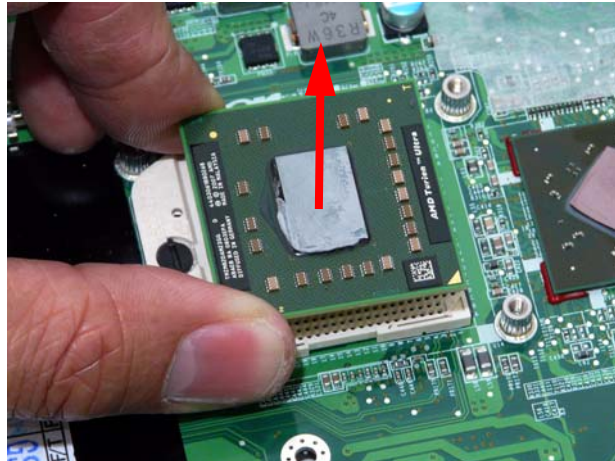

LCD Module Disassembly Process

LCD Module Disassembly Flowchart

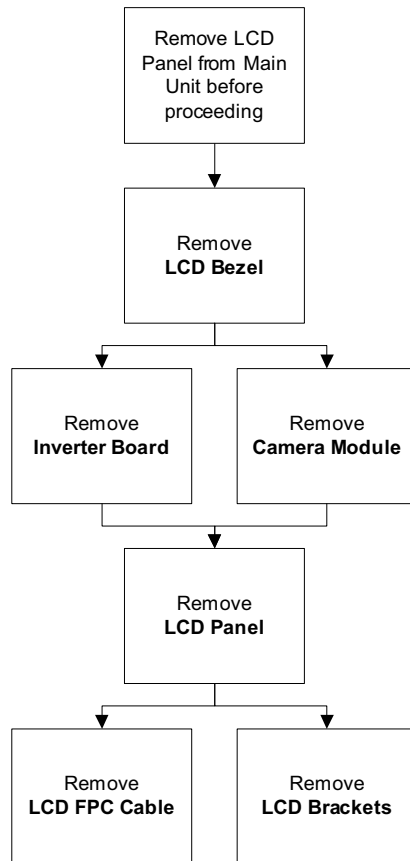



Screw List

Step	Size	Quantity	Acer Part No.
LCD Bezel	M2.5*5	6	86.ARE07.003
LCD Panel	M2.5*5	6	86.ARE07.003
LCD Brackets	M2*3	4	86.A08V7.005

Removing the LCD Bezel

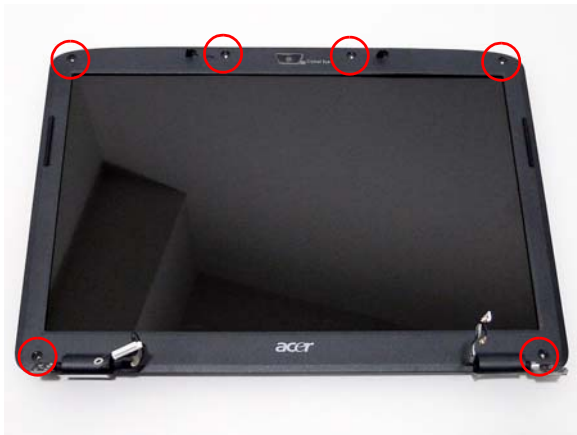
- 1. See "Removing the LCD Module" on page 66.
- 2. Remove the six rubber covers and screws.



Step	Size	Quantity	Screw Type
LCD Bezel	M2.5*5	6	

- 3. Start from the edges of the bezel, use your fingers to pry the bezel upward and outward from the LCD panel. If necessary, use a plastic pry to release the corners of the bezel.



4. Continue lifting the bezel as shown.

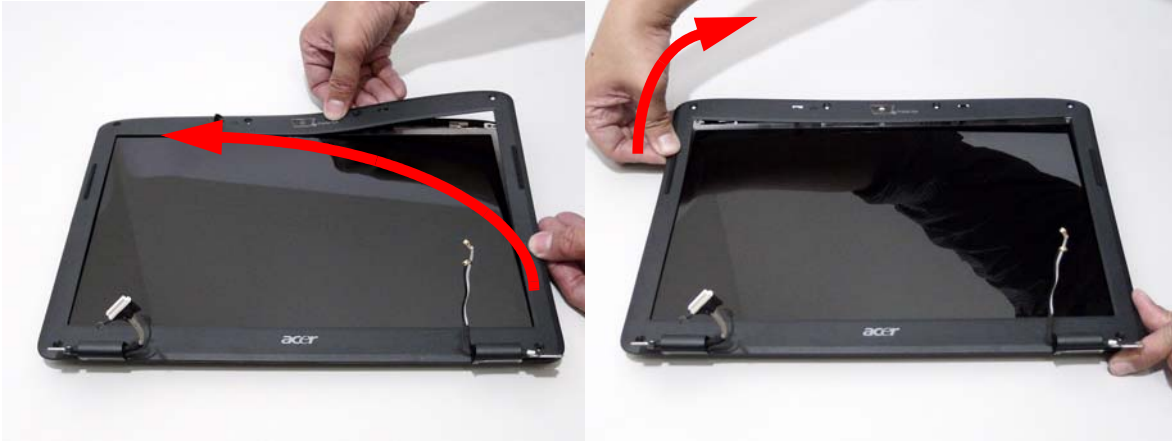

5. Use your fingers to pry the bottom of the bezel upwards and remove it from the LCD Module.



Removing the Inverter Board

1. See "Removing the LCD Bezel" on page 86.
2. Hold the Inverter board by both ends and lift up to clear the casing.



3. Disconnect the left and right Inverter board cables as shown.



Removing the Camera Board

1. See "Removing the LCD Bezel" on page 86.
2. Lift the camera board up and away from the back cover.

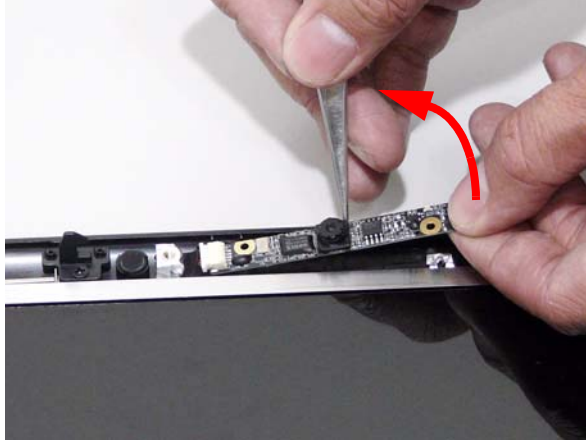

3. Disconnect the camera cable from the camera board.



Removing the LCD Panel

1. See “Removing the LCD Bezel” on page 86.
2. See “Removing the Inverter Board” on page 88.
3. Remove the six securing screws from the LCD Module.

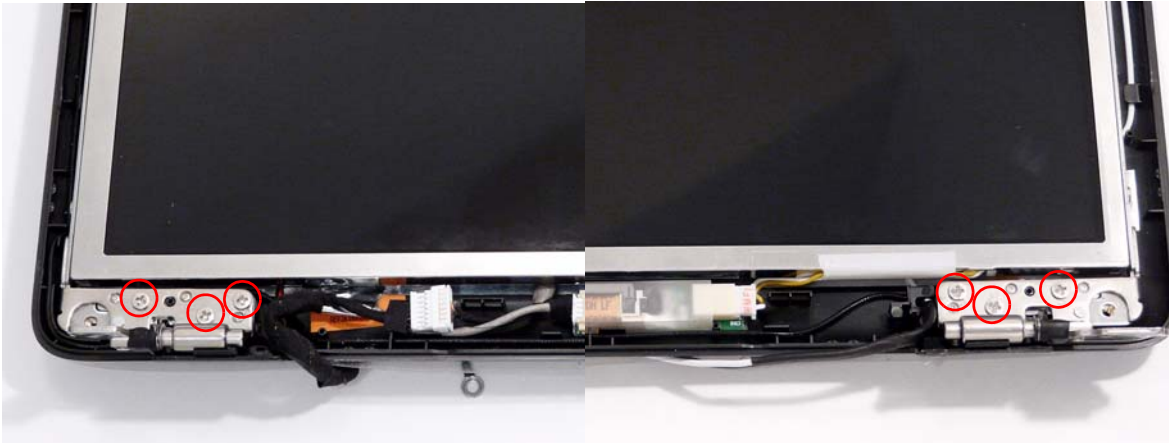

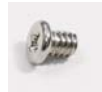
Step	Size	Quantity	Screw Type
LCD Panel	M2.5*5	6	

4. Lift the LCD Panel clear of the LCD Module.



IMPORTANT:The MIC and Antenna cables are part of the LCD Back Cover and cannot be replaced individually. To replace the MIC or Antenna, you must replace the entire LCD Back Cover. See “Aspire 4530/4230 FRU List” on page 150 for more details on replacement part numbers.

Removing the LCD Brackets and FPC Cable

1. See "Removing the LCD Panel" on page 90.
2. Turn the LCD panel over to expose the rear. Lift up the adhesive pads and detach the cables.

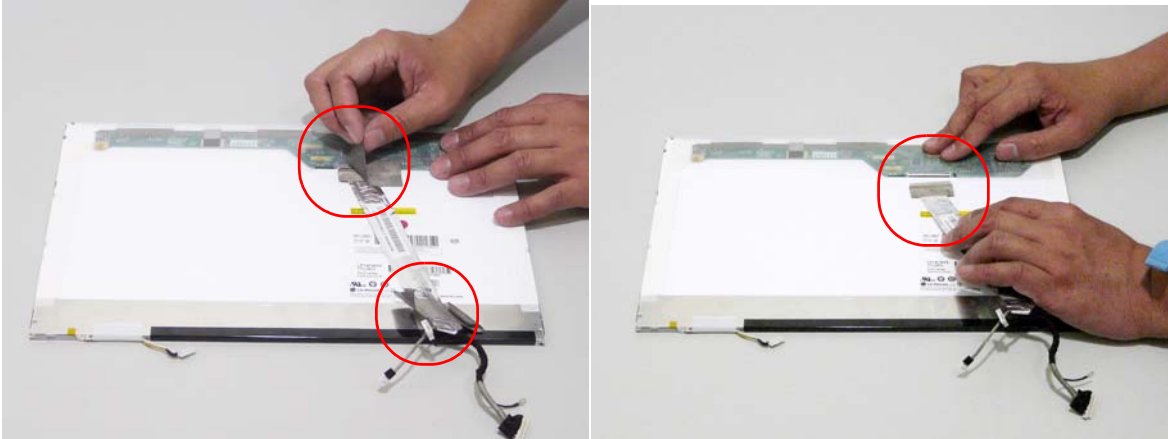

3. Remove the four securing screws (two on each side) from the LCD Panel brackets.

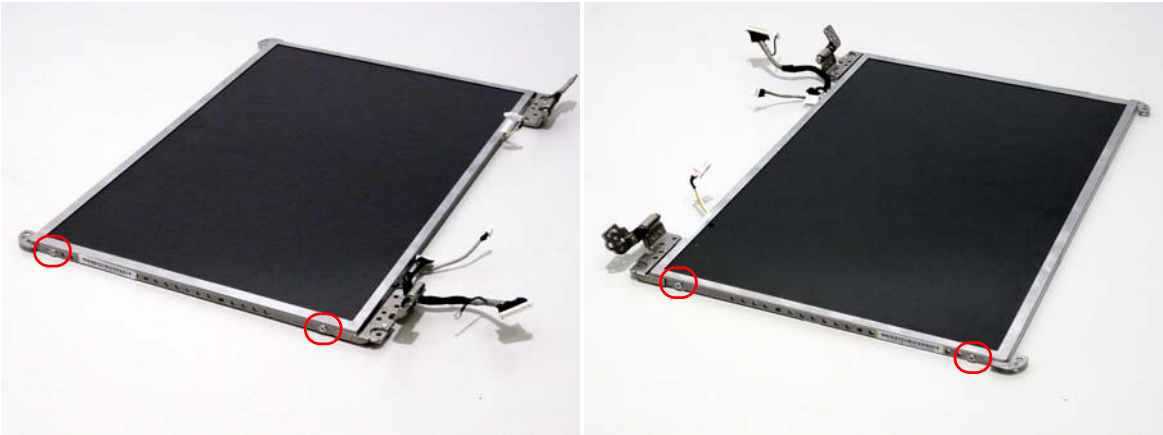

Step	Size	Quantity	Screw Type
LCD Panel	M2*3	4	

4. Remove the LCD brackets by pulling away from the LCD Panel as shown.



LCD Module Reassembly Procedure

Replacing the LCD Panel

1. Align the LCD brackets with the four screw holes (two on each side) on the LCD Panel as shown.



2. Secure the LCD brackets to the LCD panel.

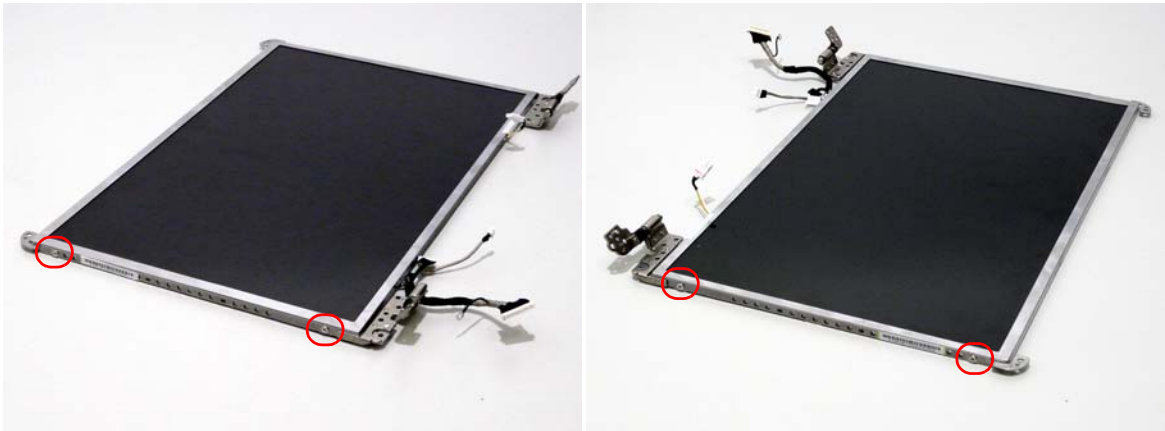

3. Turn the panel over. Insert the LCD Panel cable into the LCD Panel as shown.

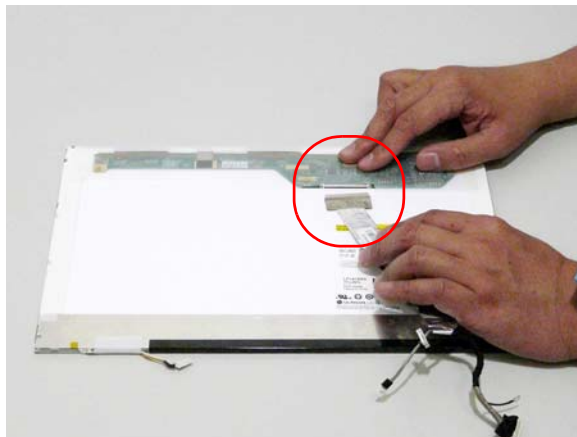

4. Align the LCD Panel cable as shown and re-attach the adhesive pads.

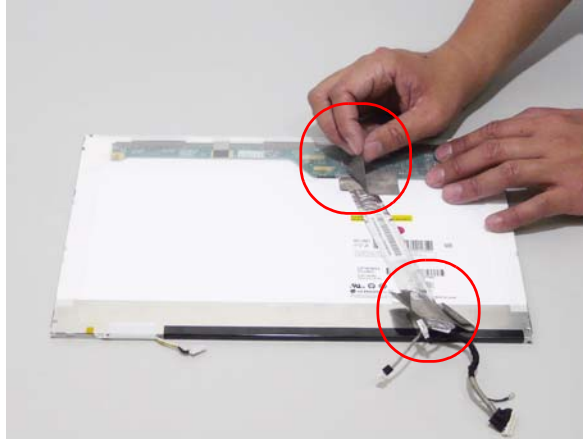

5. Turn the panel over and place it in the LCD casing as shown.



6. Replace the six securing screws.

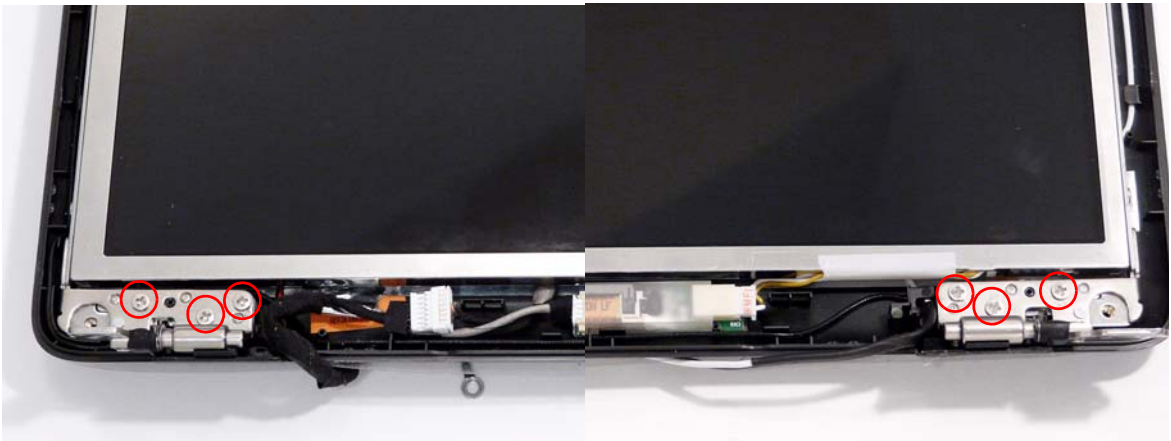

Replacing the Camera Module

1. Connect the camera cable to the camera board.
2. Replace the camera board in the LCD casing

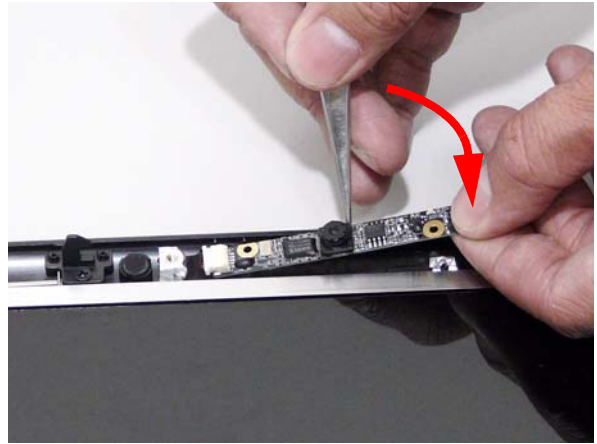
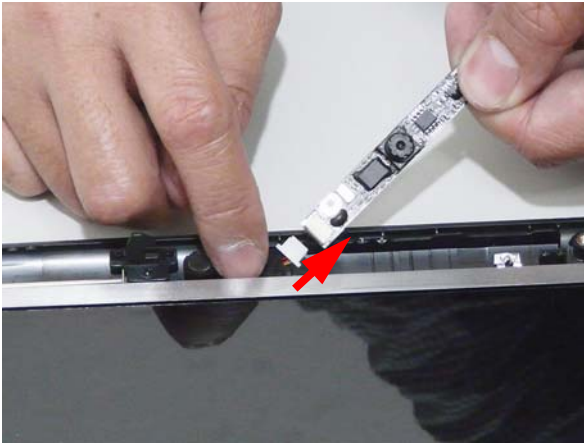

Replacing the Inverter Board

1. Connect the left and right inverter cables to the inverter board.

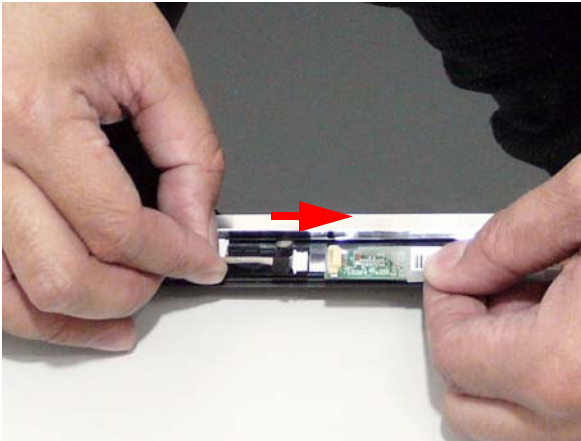

2. Replace the Inverter board in the LCD casing as shown.



Replacing the LCD Bezel

1. Locate the bezel correctly and press down the edges until there are no gaps between the bezel and the LCD Module.



2. Replace the six screws and the rubber screw caps provided.



Main Module Reassembly Procedure

Replacing the CPU

1. Align the CPU as shown and place the CPU in the socket.

IMPORTANT: Ensure that the Pin-1 corner of the CPU is correctly aligned with the Pin-1 locator on the socket.

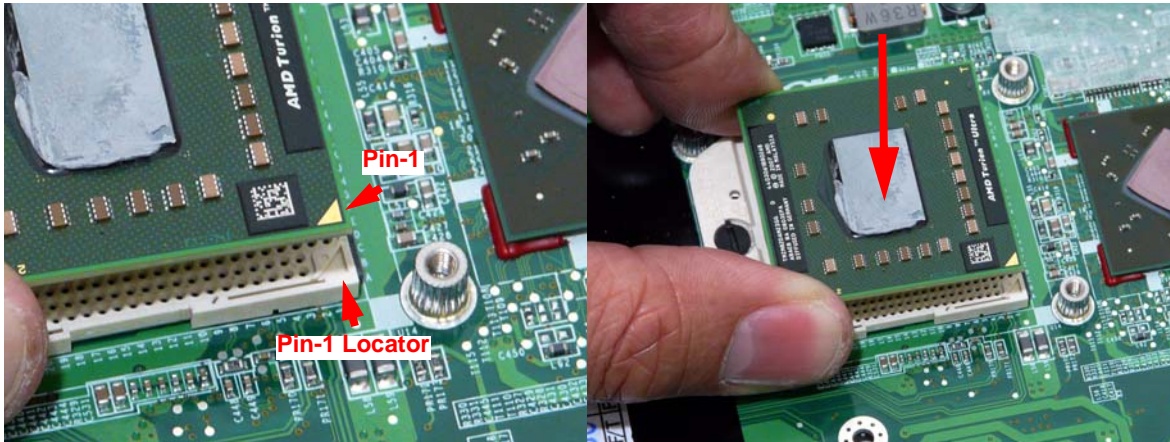

2. Using a plastic screw driver (recommended), lock the CPU in the socket as shown.

IMPORTANT: Do not force the lock. If any resistance is encountered, remove the CPU and check the alignment.

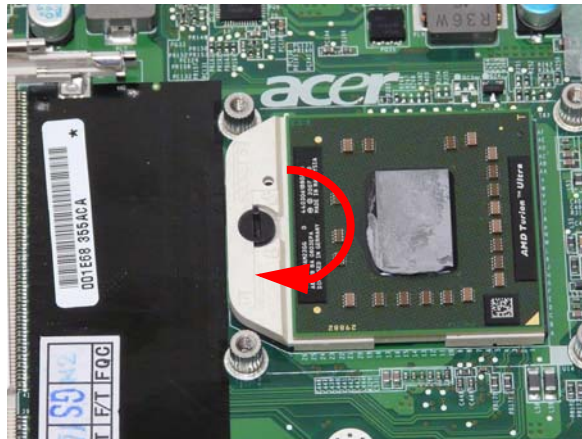

Replacing the Thermal/Fan Module

1. Align the Thermal Module with the screw holes around the CPU and replace the module.

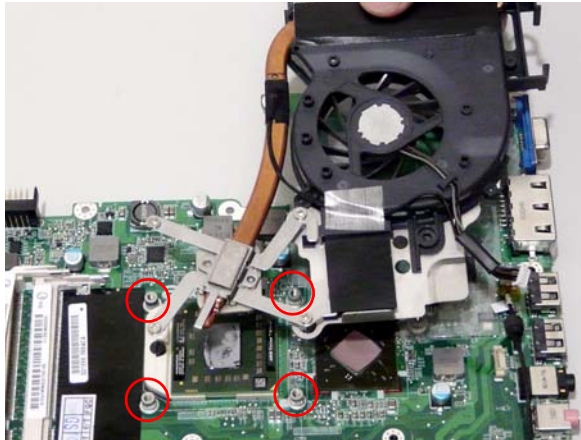

2. Replace the five securing screws in the Fan module and heatsink.

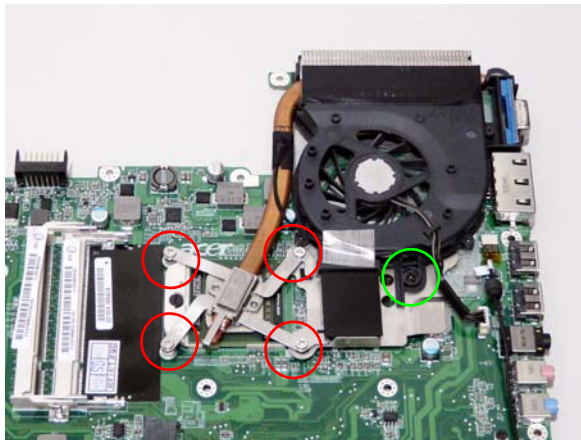

3. Connect the Fan cable to the Mainboard.

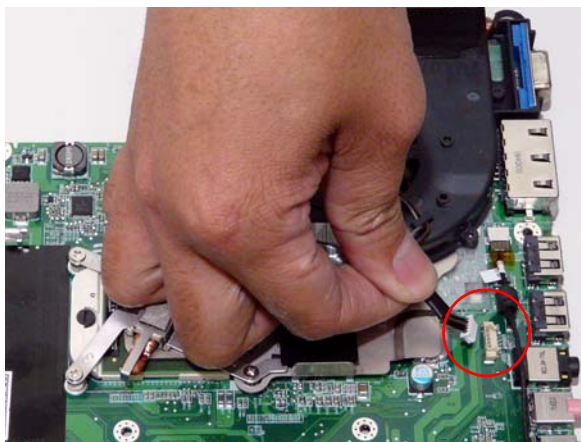

Replacing the I/O Board

1. Align the I/O Board with the mainboard screw holes and place it as shown.
2. Replace the two securing screws.

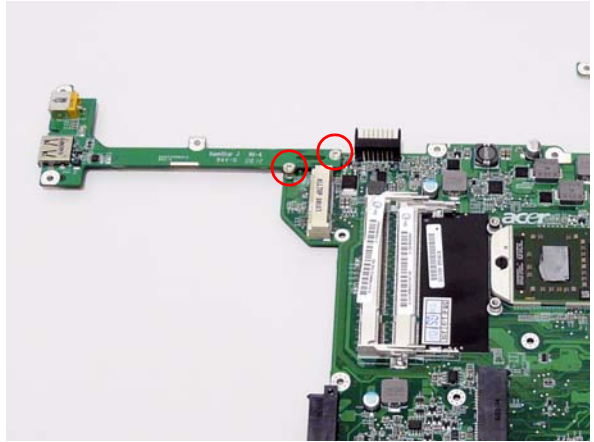
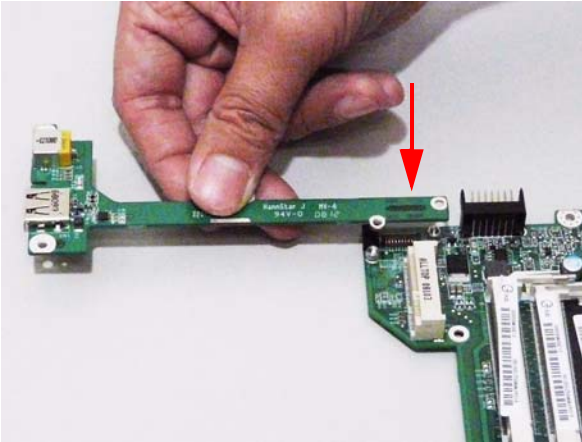

Replacing the Modem Module

1. Reconnect the modem cable to the module.
2. Align the Modem module as shown and push down to connect the interface.

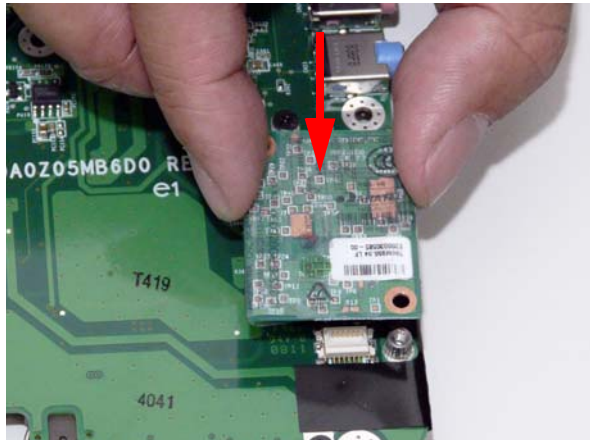

3. Replace the two securing screws.

4. Replace the adhesive tape securing the modem cable to the mainboard.

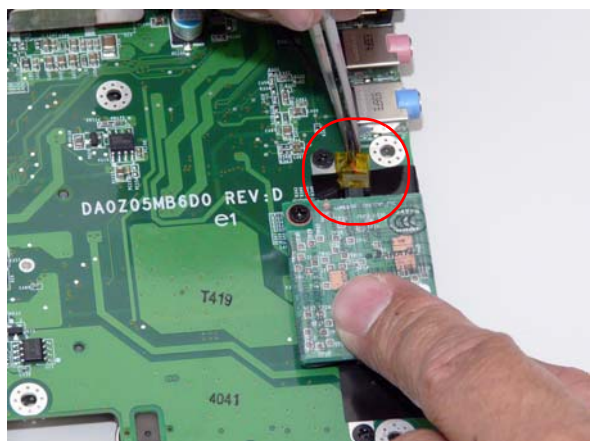
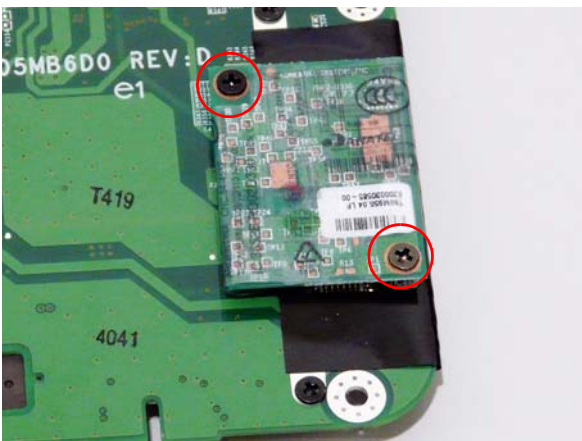

Replacing the Mainboard

1. Ensure that the Mainboard is face up (the Heatsink and CPU are not visible). Place the mainboard in the chassis, left side first, and press down to install.

IMPORTANT: Make sure the I/O ports are positioned correctly through the lower cover, and the screw sockets are visible through the mainboard.

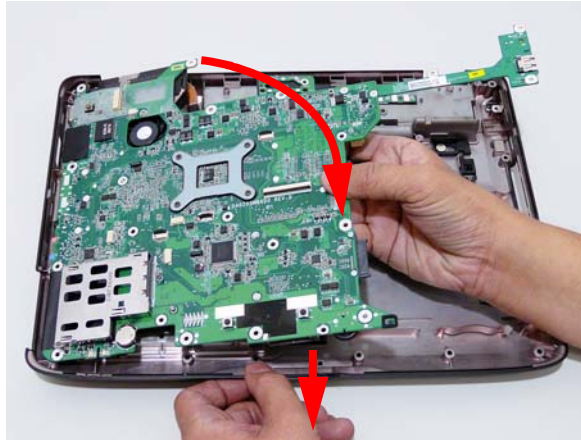

2. Replace the two securing screws as shown.



Replacing the Bluetooth Board

1. Connect the cable to the bluetooth board.
2. Align the Bluetooth board over the guide on the mainboard and gently press down.

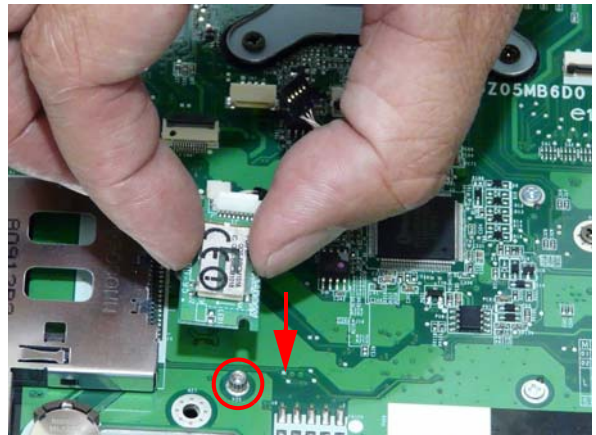
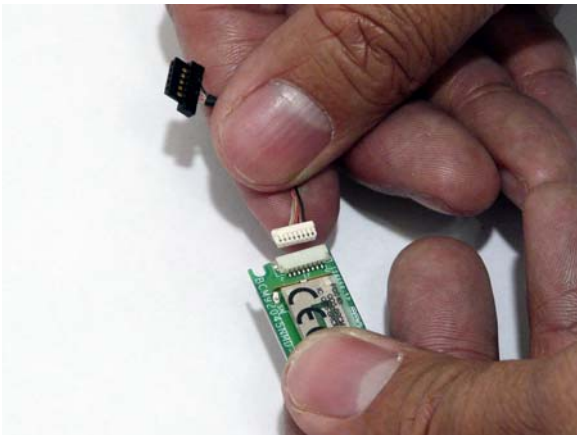

-
3. Connect the board to mainboard cable.

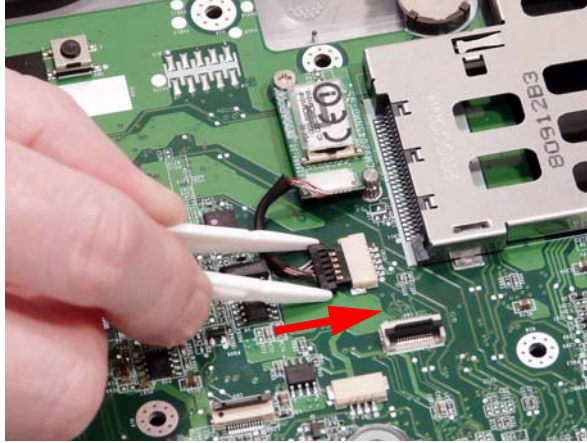

Replacing the Touch Pad Module

1. Connect the Touch Pad cable to the Touch Pad board.



NOTE: The Touch Pad is integrated into the design of the Upper Cover.

Replacing the Finger Print Reader

1. Replace the Finger Print Reader board.
2. Replace the Fingerprint Reader bracket.

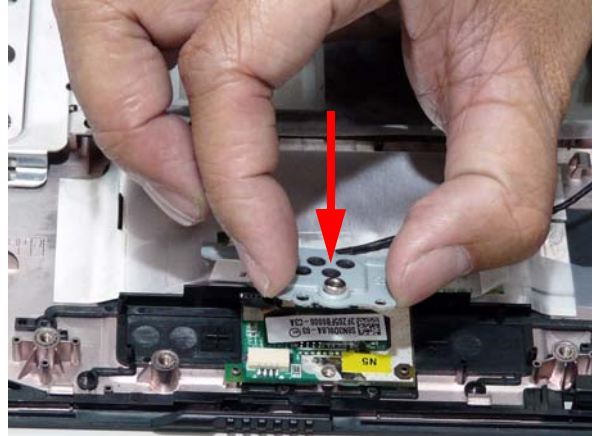

3. Replace the single securing screw.
4. Connect the Finger Print Reader cable.

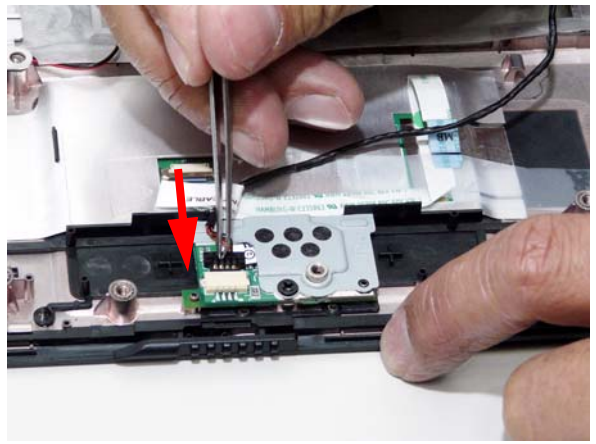
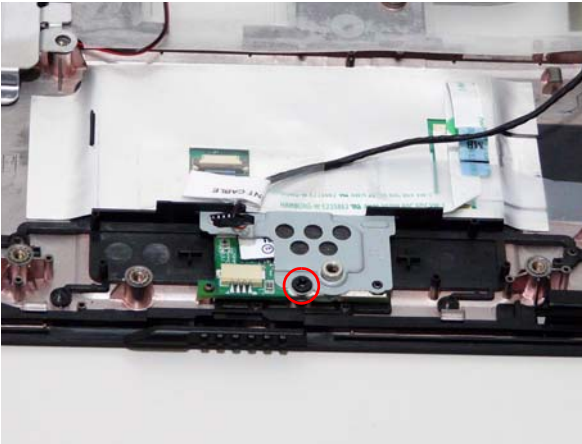

Replacing the Speaker Module

1. Replace the right speaker and align so that the screw sockets are visible.



2. Lift the HDD plate and insert the cable along the housing guides.



3. Replace the seven screws in the HDD plate.

4. With one hand carefully lift up the mylar cover and continue inserting the cable in place as shown.

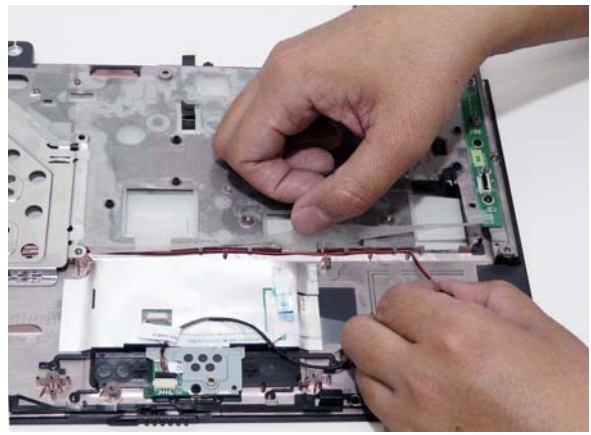
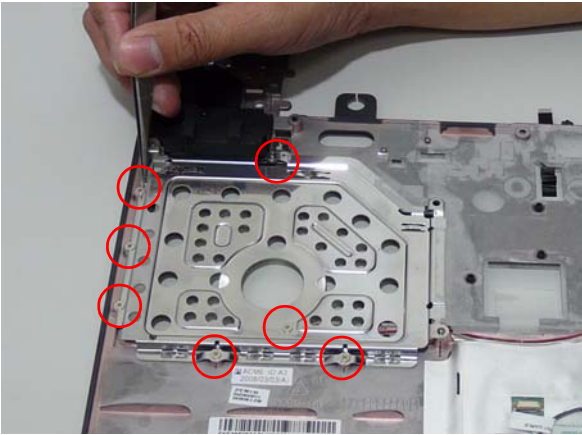

5. Lift up the mylar cover and replace the finger print reader cable and touchpad FFC over the speaker cable.

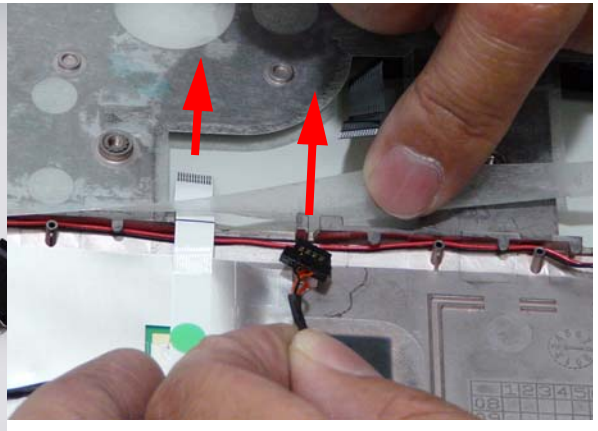
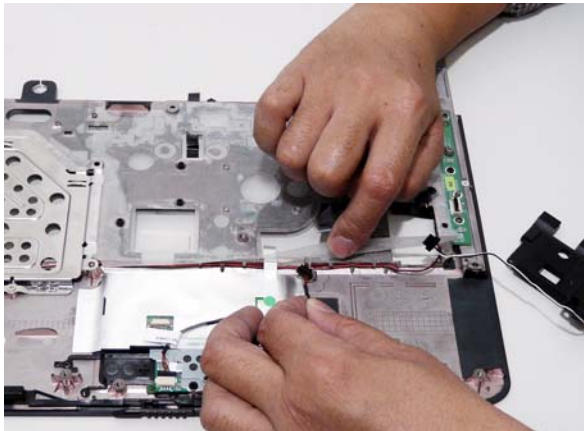

6. Carefully pull back mylar cover as shown.

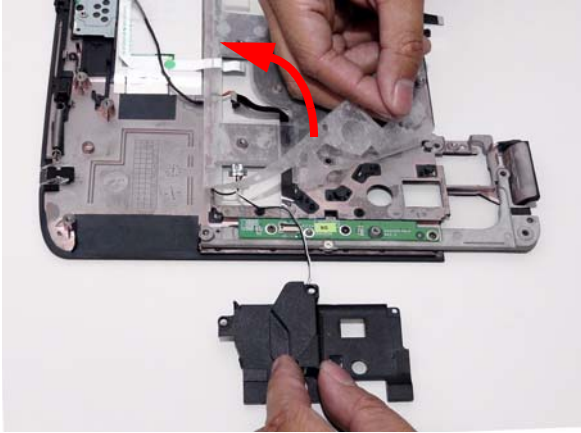

7. Insert the cable along its guides on the right side of the upper cover.

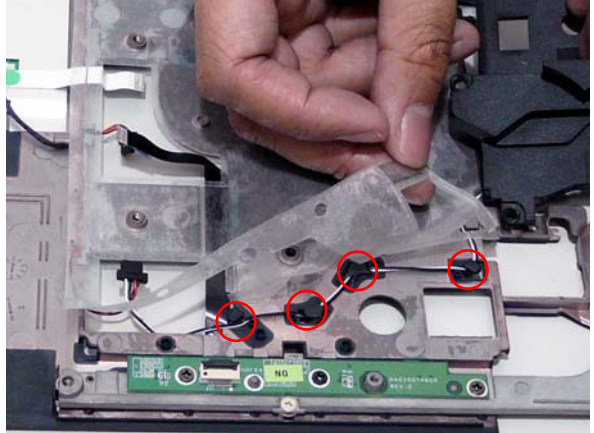

NOTE: Ensure that the cable is properly inserted inside the housing guides before replacing the mylar cover.

8. Replace the left speaker in the upper cover.

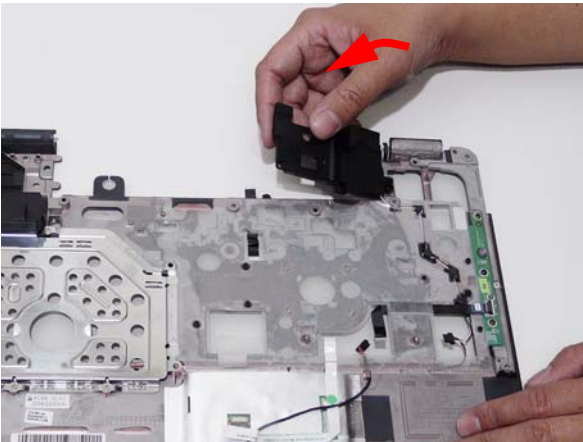

9. Replace the four securing screws as shown.

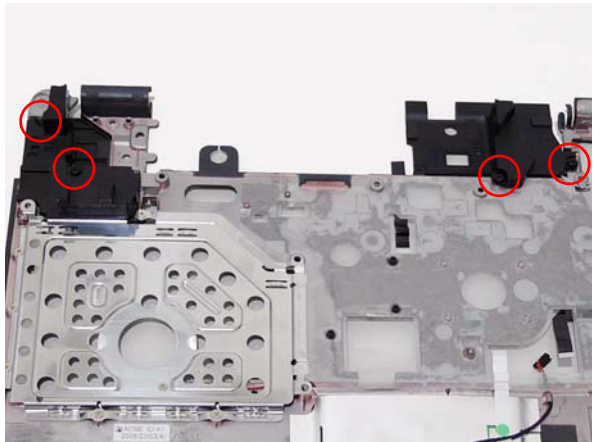

Replacing the Launch Board

1. Place the Launch board in the upper cover.
2. Replace the FFC and close the locking latch.

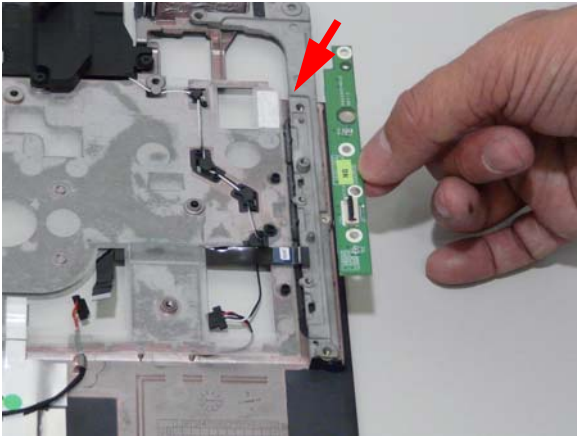

3. Replace the three securing screws.

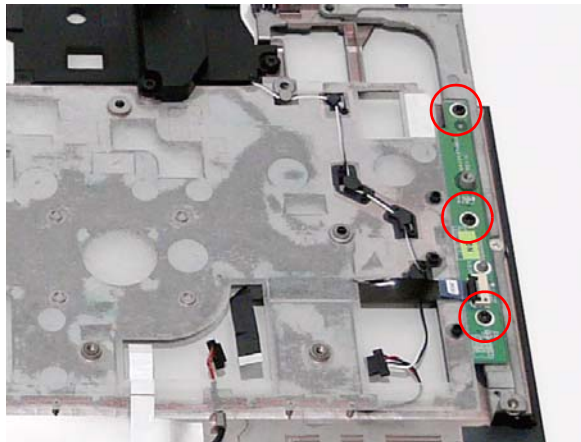

Replacing the Upper Cover

1. Place the Upper Cover on the lower cover as shown.



2. Press down around the edges of the casing to snap it into place.

3. Locate the following cables on the Upper Cover.

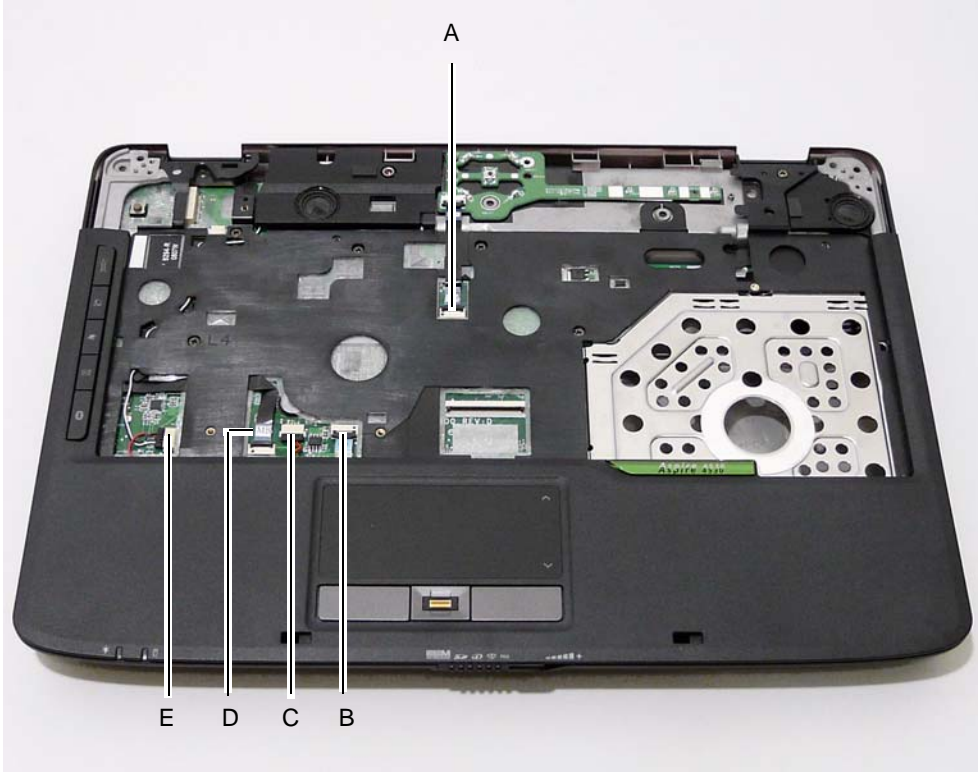

Replace A as shown and close the locking latch.

Replace B as shown and close the locking latch.

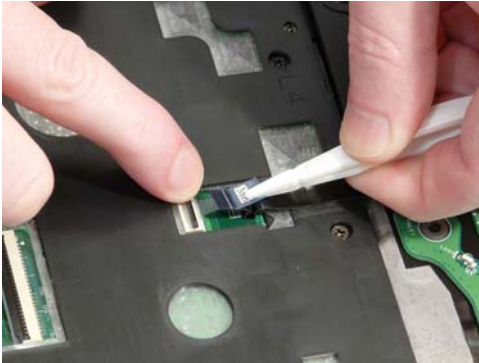

Connect C as shown.

Replace D as shown and close the locking latch.

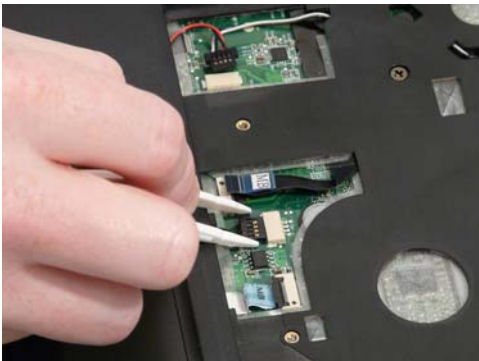

Connect E as shown.



4. Replace the seven screws securing the Upper Cover to the Lower Cover.

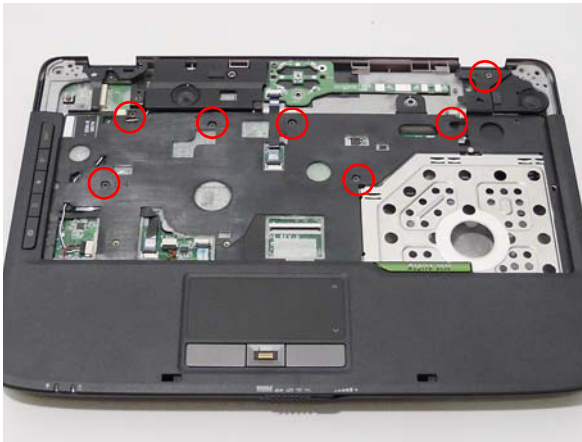

5. Turn the computer over and replace the eleven screws shown.

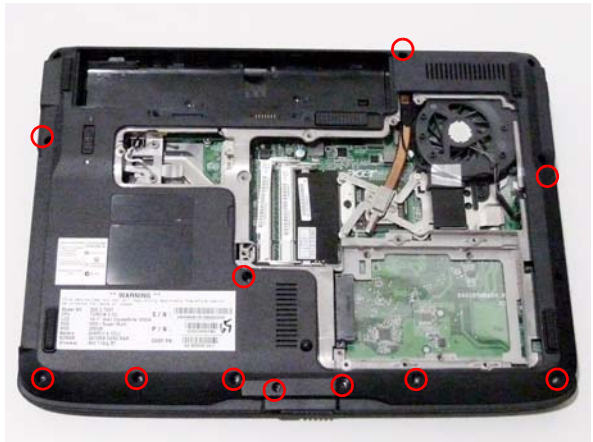

Replacing the LED Board

1. Place the LED Board on the Upper Cover as shown.
2. Connect the FFC and close the locking latch.

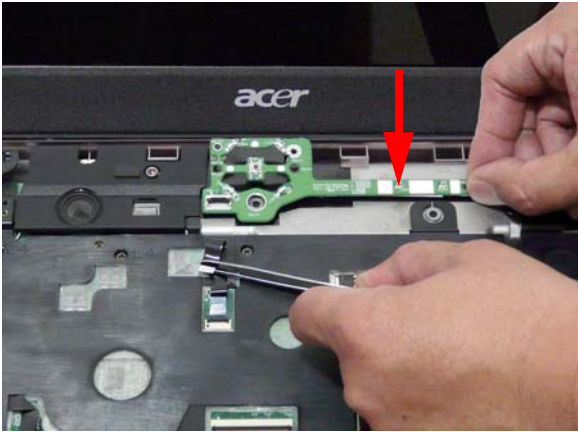

3. Replace the single securing screw.



Replacing the LCD Module

1. Align the LCD hinges as shown and place the hinges in the Upper Cover.
2. Replace the three securing screws in the left side hinge and secure the grounding cable.

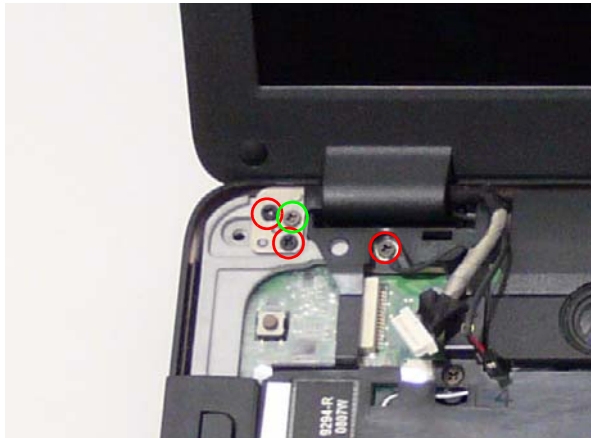
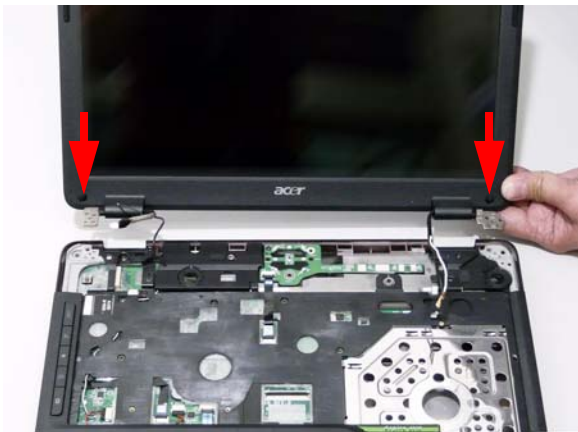

3. Replace the two securing screws in the right side hinge.



4. Connect the LCD cables as shown.

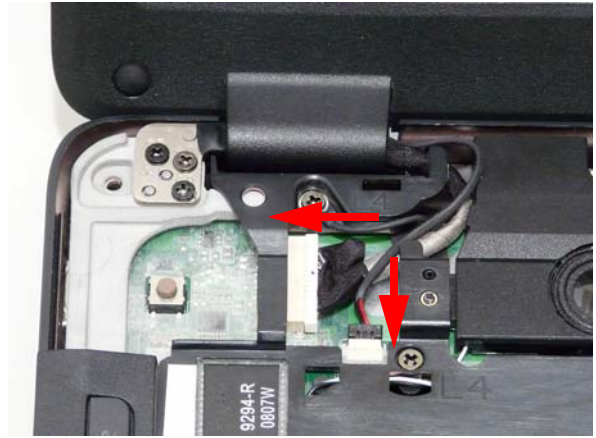

5. Ensure that the LCD cables follow the cable channel and use all the available clips.

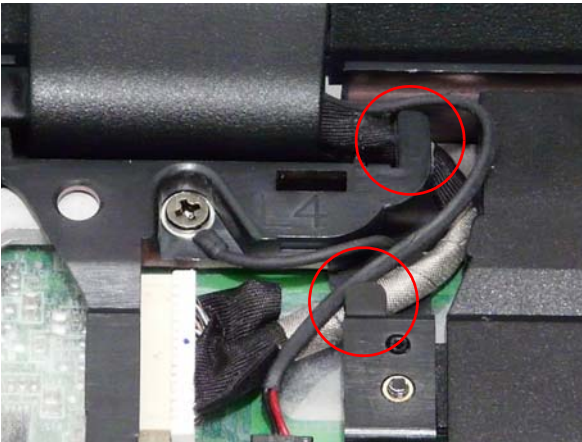

6. Turn the computer over and replace the two securing screws.



Replacing the Antenna Cables

IMPORTANT: Ensure that the antenna cables are not pinched under the LCD hinge.

1. Insert the antenna cables through the chassis and pull them completely through from the underside.

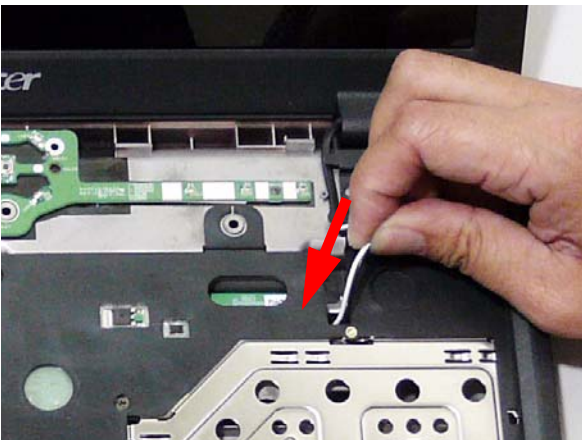

2. Place the Antenna cables in the cable channel using all available clips.

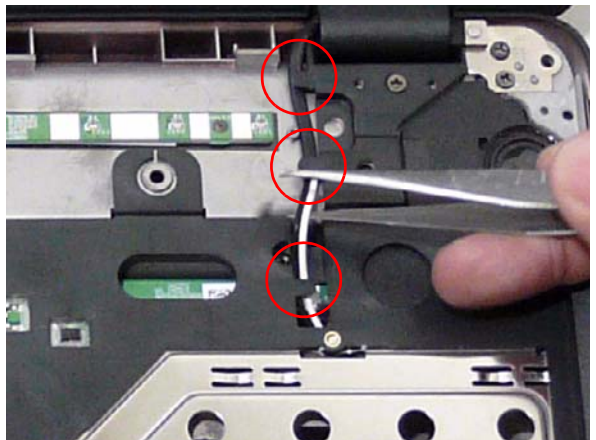

Replacing the Keyboard

1. Turn the keyboard over to expose the FFC, and use the pull-tab to insert the FFC into the connector.
2. Close the locking latch to secure the FFC in place.

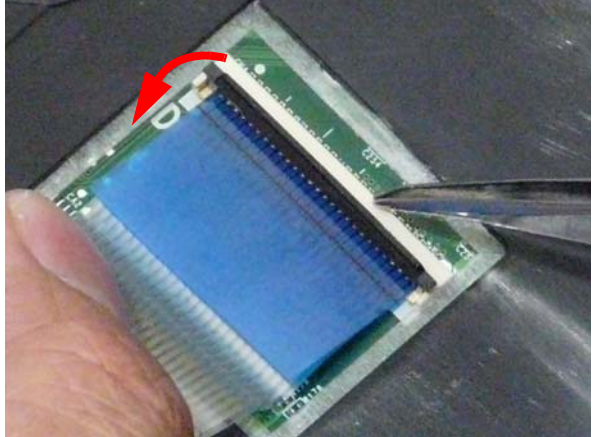
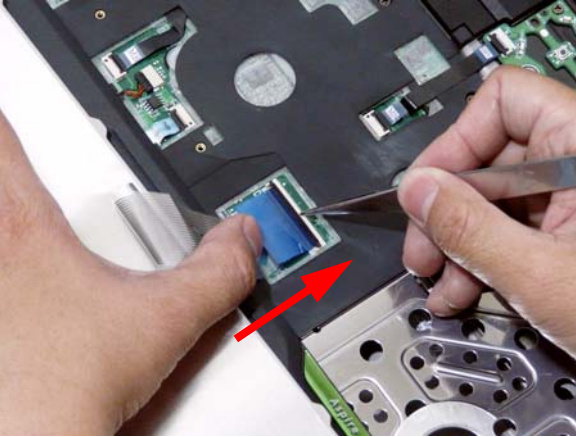

3. Turn the keyboard over, taking care not to detach the FFC from the Mainboard.
4. Insert the keyboard by sliding the keyboard tabs in place first as shown



5. Rotate the keyboard downward and rest it in place.

Replacing the Switch Cover

1. Place the Switch Cover into the Upper Cover, rear edge first, and rotate down into position.
2. Press down as shown to snap the centre of the cover into place.



3. Press down on the edges of the cover to snap it into place.
4. Turn over the computer and replace the three securing screws as shown.



Replacing the ODD Module

1. Replace the ODD bracket and secure with the two screws.
2. Replace the ODD bezel and ensure the locking catch is locked in place.

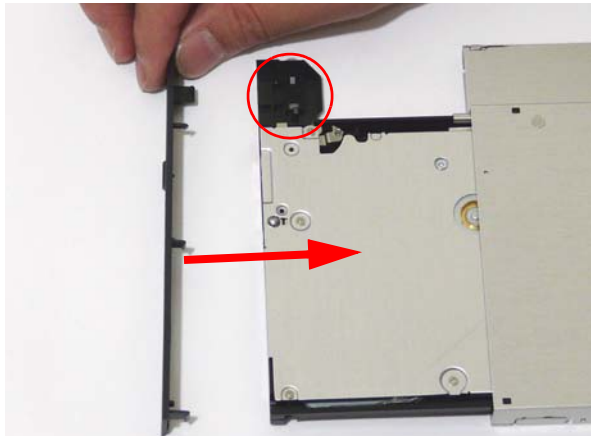
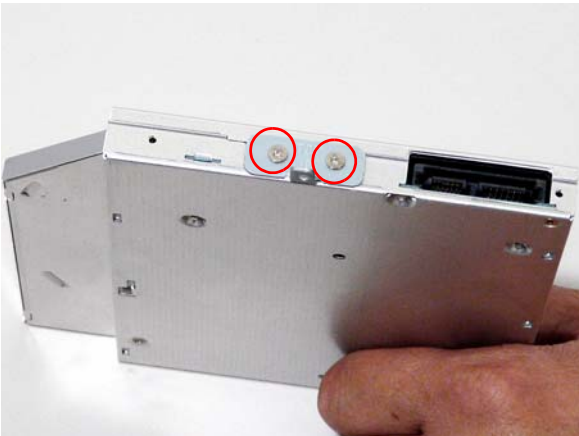

3. Push the ODD module into the ODD bay as shown.
4. Ensure that the ODD is flush with the chassis and the screw socket is aligned with the screw socket in the lower base.

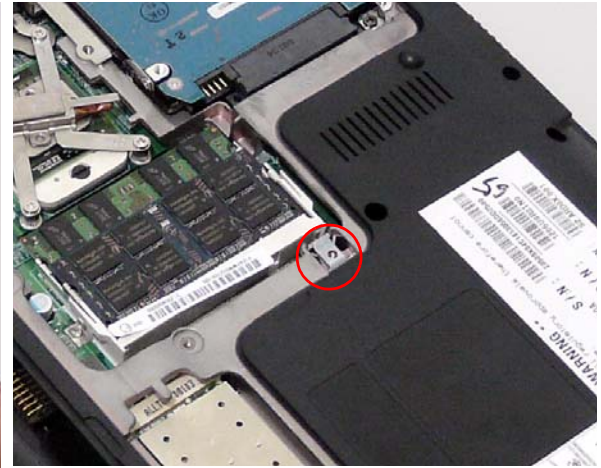

NOTE: Do not insert a screw to secure the ODD. The ODD is secured after replacing the lower cover and all captive screws are tightened.

Replacing the Hard Disk Drive Module

NOTE: To prevent damage to device, avoid pressing down on it or placing heavy objects on top of it.

1. Insert the HDD in to the carrier.
2. Replace the four screws to secure the carrier.

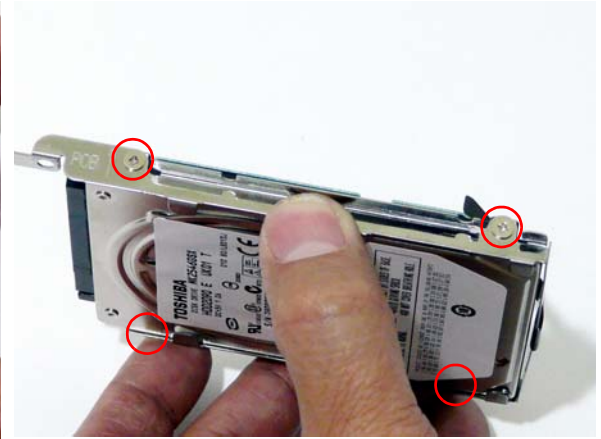

3. Place the HDD assembly in the HDD bay and push in the direction shown to connect the interface.
4. Replace the two securing screws.



Replacing the WLAN Module

1. Insert the WLAN board into the WLAN socket.
2. Replace the two securing screws.

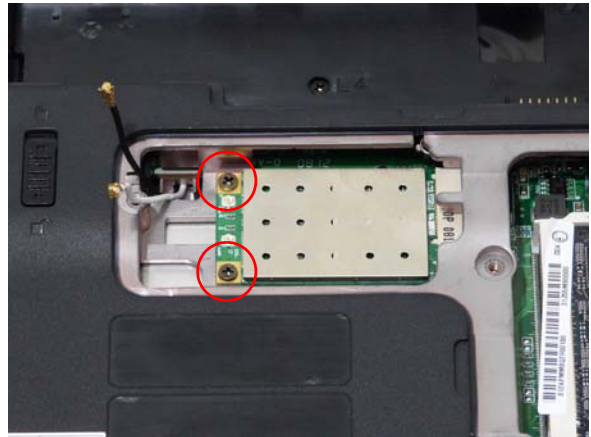

3. Connect the Antenna cables to the terminals as shown.



NOTE: The Antennas must be connected as shown, black to the upper terminal and white to the lower terminal.

Replacing the DIMM Modules

NOTE: If DIMM modules are not installed properly, the computer does not boot, and no service error is displayed.

1. Align the notch in the connector with the notch in the module and slide the DIMM module firmly in place.
2. Press down on the module until it clicks in place.

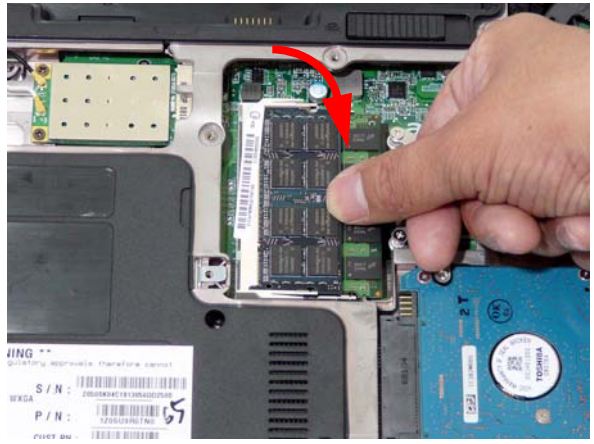

Replacing the Lower Cover

1. Insert the cover tabs as shown and press the lower cover in place.
2. Secure the nine captive screws to attach the Lower Cover.

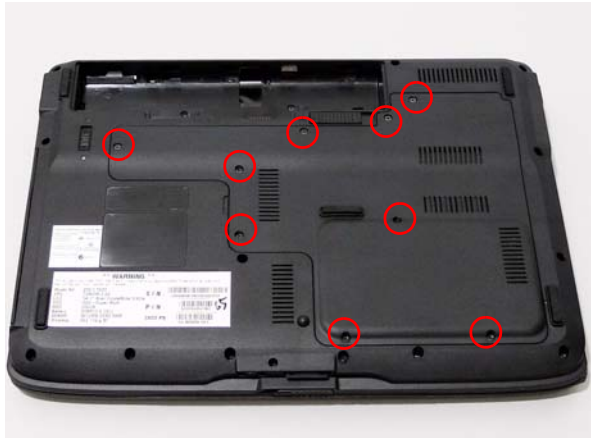

Replacing the SD Dummy Card

1. Insert the SD Dummy Card into the slot and press until it clicks in to place.



Replacing the ExpressCard Dummy Card

1. Insert the ExpressCard into the slot and press until it clicks in to place.



Replacing the Battery

1. Slide and hold the battery latch to the release position (1), then replace the battery pack (2).
2. Slide the battery lock/unlock latch to the lock position.



Troubleshooting

Common Problems

Use the following procedure as a guide for computer problems.

NOTE: The diagnostic tests are intended to test only Acer products. Non-Acer products, prototype cards, or modified options can give false errors and invalid system responses.

1. Obtain the failing symptoms in as much detail as possible.
2. Verify the symptoms by attempting to re-create the failure by running the diagnostic test or by repeating the same operation.
3. Use the following table with the verified symptom to determine which page to go to.

Symptoms (Verified)	Go To
Power On Issue	Page 116
No Display Issue	Page 117
LCD Failure	Page 119
Internal Keyboard Failure	Page 119
Touch Pad Failure	Page 120
Internal Speaker Failure	Page 120
Internal Microphone Failure	Page 122
ODD Failure	Page 124
Rightside USB Failure	Page 127
Modem Failure	Page 127
WLAN Failure	Page 128
Acer EasyLaunch Button Failure	Page 128
Acer MediaTouch Failure	Page 129
Fingerprint Reader Failure	Page 129
Thermal Unit Failure	Page 130
HDTV Switch Failure	Page 130
Other Functions Failure	Page 131
Intermittent Failures	Page 132
Undermined Failures	Page 132

4. If the Issue is still not resolved, see "Online Support Information" on page 187.

Power On Issue

If the system doesn't power on, perform the following actions one at a time to correct the problem. Do not replace a non-defective FRUs:

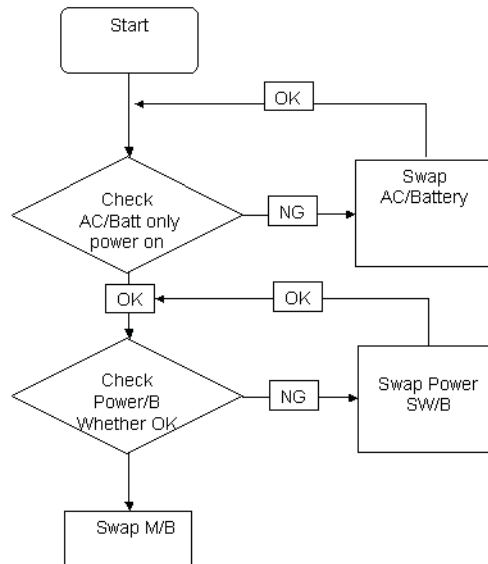

Computer Shutdown Intermittently

If the system powers off at intervals, perform the following actions one at a time to correct the problem.

1. Check the power cable is properly connected to the computer and the electrical outlet.
2. Remove any extension cables between the computer and the outlet.
3. Remove any surge protectors between the computer and the electrical outlet. Plug the computer directly into a known good electrical outlet.
4. Disconnect the power and open the casing to check the Thermal Unit (see "Thermal Unit Failure" on page 130) and fan airways are free of obstructions.
5. Disable the power management settings in the BIOS to ensure they are not the cause of the problem (see "Boot" on page 38).
6. Remove all external and non-essential hardware connected to the computer that are not necessary to boot the computer to the failure point.
7. Remove any recently installed software.
8. If the Issue is still not resolved, see "Online Support Information" on page 187.

No Display Issue

If the **Display** doesn't work, perform the following actions one at a time to correct the problem. Do not replace a non-defective FRUs:

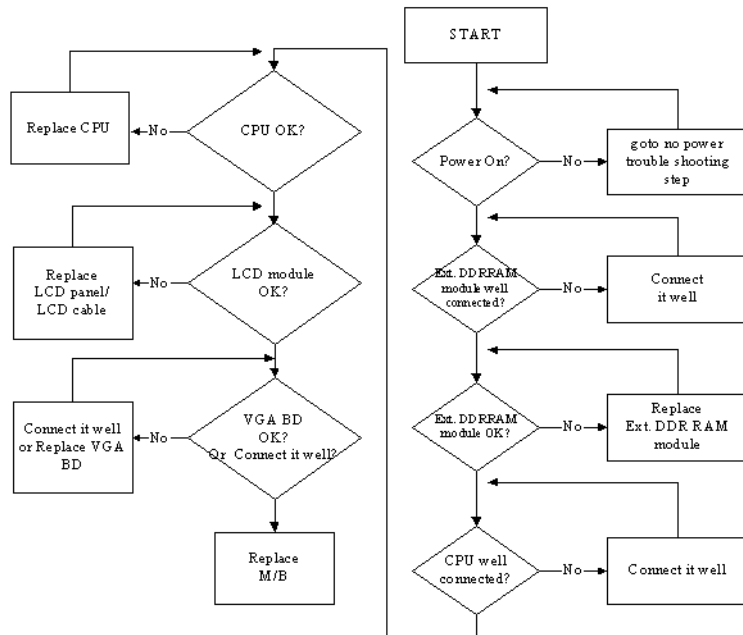

No POST or Video

If the POST or video doesn't display, perform the following actions one at a time to correct the problem.

1. Make sure that the internal display is selected. On this notebook model, switching between the internal display and the external display is done by pressing **Fn+F5**. Reference Product pages for specific model procedures.
2. Make sure the computer has power by checking at least one of the following occurs:
 - Fans start up
 - Status LEDs light up

If there is no power, see “Power On Issue” on page 116.

3. Drain any stored power by removing the power cable and battery and holding down the power button for 10 seconds. Reconnect the power and reboot the computer.
4. Connect an external monitor to the computer and switch between the internal display and the external display is by pressing **Fn+F5** (on this model).

If the POST or video appears on the external display, see “LCD Failure” on page 119.

5. Disconnect power and all external devices including port replicators or docking stations. Remove any memory cards and CD/DVD discs. Restart the computer.

If the computer boots correctly, add the devices one by one until the failure point is discovered.

6. Reseat the memory modules.
7. Remove the drives (see “Disassembly Process” on page 48).
8. If the Issue is still not resolved, see “Online Support Information” on page 187.

Abnormal Video Display

If video displays abnormally, perform the following actions one at a time to correct the problem.

1. Reboot the computer.
2. If permanent vertical/horizontal lines or dark spots display in the same location, the LCD is faulty and should be replaced. See “Disassembly Process” on page 48.
3. If extensive pixel damage is present (different colored spots in the same locations on the screen), the LCD is faulty and should be replaced. See “Disassembly Process” on page 48.
4. Adjust the brightness to its highest level. See the User Manual for instructions on adjusting settings.
NOTE: Ensure that the computer is not running on battery alone as this may reduce display brightness.
If the display is too dim at the highest brightness setting, the LCD is faulty and should be replaced. See “Disassembly Process” on page 48.
5. Check the display resolution is correctly configured:
 - a. Minimize or close all Windows.
 - b. If display size is only abnormal in an application, check the view settings and control/mouse wheel zoom feature in the application.
 - c. If desktop display resolution is not normal, right-click on the desktop and select **Personalize**→ **Display Settings**.
 - d. Click and drag the Resolution slider to the desired resolution.
 - e. Click **Apply** and check the display. Readjust if necessary.
6. Roll back the video driver to the previous version if updated.
7. Remove and reinstall the video driver.
8. Check the Device Manager to determine that:
 - The device is properly installed. There are no red Xs or yellow exclamation marks.
 - There are no device conflicts.
 - No hardware is listed under Other Devices.
9. If the Issue is still not resolved, see “Online Support Information” on page 187.
10. Run the Windows Memory Diagnostic from the operating system DVD and follow the onscreen prompts.
11. If the Issue is still not resolved, see “Online Support Information” on page 187.

Random Loss of BIOS Settings

If the computer is experiencing intermittent loss of BIOS information, perform the following actions one at a time to correct the problem.

1. If the computer is more than one year old, replace the CMOS battery.
2. Run a complete virus scan using up-to-date software to ensure the computer is virus free.
3. If the computer is experiencing HDD or ODD BIOS information loss, disconnect and reconnect the power and data cables between devices.
If the BIOS settings are still lost, replace the cables.
4. If HDD information is missing from the BIOS, the drive may be defective and should be replaced.
5. Replace the Motherboard.
6. If the Issue is still not resolved, see “Online Support Information” on page 187.

LCD Failure

If the **LCD** fails, perform the following actions one at a time to correct the problem. Do not replace a non-defective FRUs:

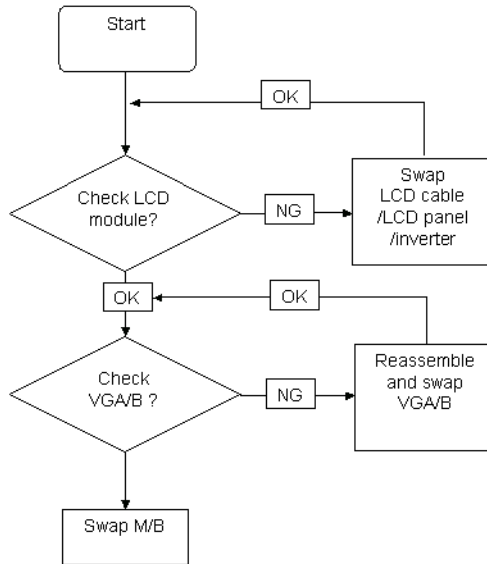

Built-In Keyboard Failure

If the built-in **Keyboard** fails, perform the following actions one at a time to correct the problem. Do not replace a non-defective FRUs:

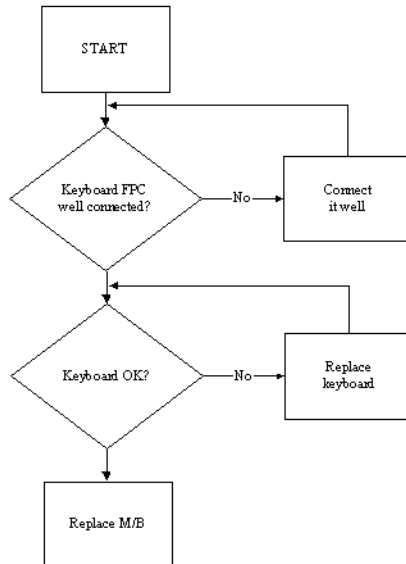

Touch Pad Failure

If the **Touch Pad** doesn't work, perform the following actions one at a time to correct the problem. Do not replace a non-defective FRUs:

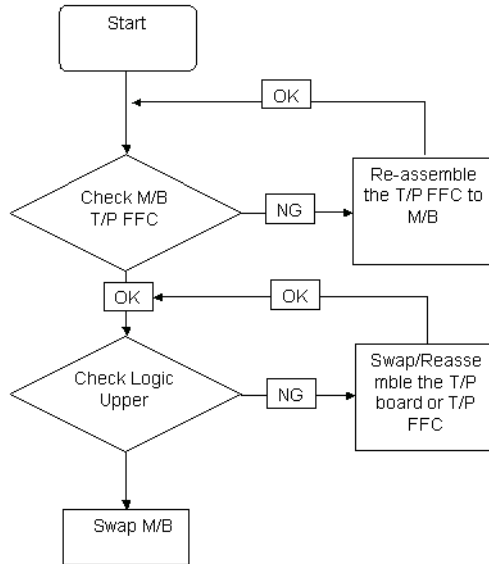

Internal Speaker Failure

If the internal **Speakers** fail, perform the following actions one at a time to correct the problem. Do not replace a non-defective FRUs:

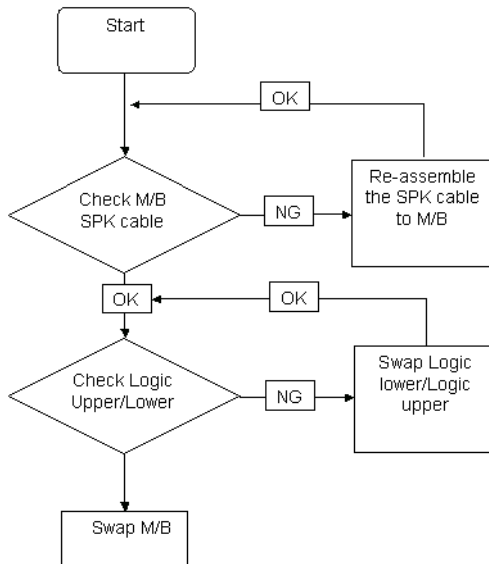

Sound Problems

If sound problems are experienced, perform the following actions one at a time to correct the problem.

1. Reboot the computer.
2. Navigate to **Start** → **Control Panel** → **System and Maintenance** → **System** → **Device Manager**. Check the Device Manager to determine that:
 - The device is properly installed.
 - There are no red Xs or yellow exclamation marks.
 - There are no device conflicts.
 - No hardware is listed under Other Devices.
3. Roll back the audio driver to the previous version, if updated recently.
4. Remove and reinstall the audio driver.
5. Ensure that all volume controls are set mid range:
 - a. Click the volume icon on the taskbar and drag the slider to 50. Ensure that the volume is not muted.
 - b. Click Mixer to verify that other audio applications are set to 50 and not muted.
6. Navigate to **Start** → **Control Panel** → **Hardware and Sound** → **Sound**. Ensure that Speakers are selected as the default audio device (green check mark).

NOTE: If Speakers does not show, right-click on the **Playback** tab and select **Show Disabled Devices** (clear by default).
7. Select Speakers and click **Configure** to start **Speaker Setup**. Follow the onscreen prompts to configure the speakers.
8. Remove and recently installed hardware or software.
9. Restore system and file settings from a known good date using **System Restore**.

If the issue is not fixed, repeat the preceding steps and select an earlier time and date.
10. Reinstall the Operating System.
11. If the Issue is still not resolved, see “Online Support Information” on page 187.

Internal Microphone Failure

If the internal **Microphone** fails, perform the following actions one at a time to correct the problem. Do not replace a non-defective FRUs:

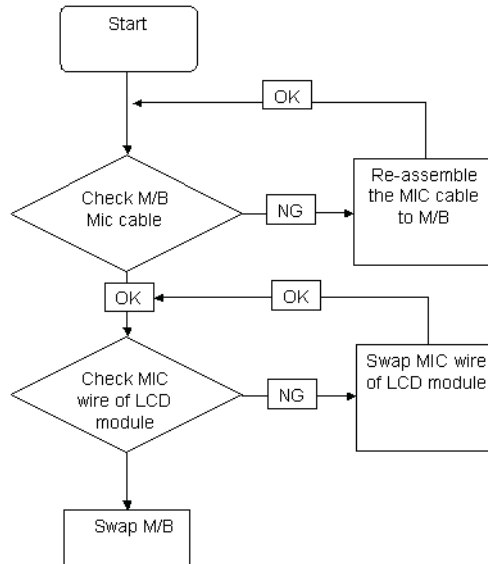

Microphone Problems

If internal or external **Microphones** do not operate correctly, perform the following actions one at a time to correct the problem.

1. Check that the microphone is enabled. Navigate to **Start** → **Control Panel** → **Hardware and Sound** → **Sound** and select the **Recording** tab.
2. Right-click on the **Recording** tab and select **Show Disabled Devices** (clear by default).
3. The microphone appears on the **Recording** tab.
4. Right-click on the microphone and select **Enable**.
5. Select the microphone then click **Properties**. Select the **Levels** tab.
6. Increase the volume to the maximum setting and click **OK**.
7. Test the microphone hardware:
 - a. Select the microphone and click **Configure**.
 - b. Select **Set up microphone**.
 - c. Select the microphone type from the list and click **Next**.
 - d. Follow the onscreen prompts to complete the test.
8. If the Issue is still not resolved, see "Online Support Information" on page 187.

HDD Not Operating Correctly

If the **HDD** does not operate correctly, perform the following actions one at a time to correct the problem.

1. Disconnect all external devices.
2. Run a complete virus scan using up-to-date software to ensure the computer is virus free.
3. Run the Windows Vista Startup Repair Utility:
 - a. insert the Windows Vista Operating System DVD in the ODD and restart the computer.
 - b. When prompted, press any key to start to the operating system DVD.
 - c. The **Install Windows** screen displays. Click **Next**.
 - d. Select **Repair your computer**.
 - e. The **System Recovery Options** screen displays. Click **Next**.
 - f. Select the appropriate operating system, and click **Next**.

NOTE: Click **Load Drivers** if controller drives are required.

- g. Select **Startup Repair**.
- h. Startup Repair attempts to locate and resolve issues with the computer.
- i. When complete, click **Finish**.

If an issue is discovered, follow the onscreen information to resolve the problem.

4. Run the Windows Memory Diagnostic Tool. For more information see Windows Help and Support.
5. Restart the computer and press F2 to enter the BIOS Utility. Check the BIOS settings are correct and that CD/DVD drive is set as the first boot device on the Boot menu.
6. Ensure all cables and jumpers on the HDD and ODD are set correctly.
7. Remove any recently added hardware and associated software.
8. Run the Windows Disk Defragmenter. For more information see Windows Help and Support.
9. Run Windows Check Disk by entering **chkdsk /r** from a command prompt. For more information see Windows Help and Support.
10. Restore system and file settings from a known good date using **System Restore**.

If the issue is not fixed, repeat the preceding steps and select an earlier time and date.
11. Replace the HDD. See "Disassembly Process" on page 48.

ODD Failure

If the **ODD** fails, perform the following actions one at a time to correct the problem. Do not replace a non-defective FRUs:

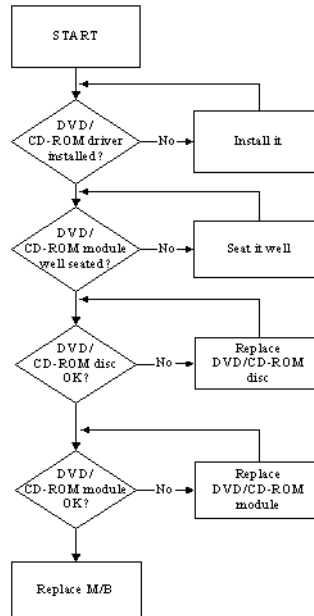

ODD Not Operating Correctly

If the **ODD** exhibits any of the following symptoms it may be faulty:

- Audio CDs do not play when loaded
- DVDs do not play when loaded
- Blank discs do not burn correctly
- DVD or CD play breaks up or jumps
- Optical drive not found or not active:
 - Not shown in My Computer or the BIOS setup
 - LED does not flash when the computer starts up
 - The tray does not eject
- Access failure screen displays
- The ODD is noisy

Perform the following general solutions one at a time to correct the problem.

1. Reboot the computer and retry the operation.
2. Try an alternate disc.
3. Navigate to **Start** → **Computer**. Check that the ODD device is displayed in the **Devices with Removable Storage** panel.
4. Navigate to **Start** → **Control Panel** → **System and Maintenance** → **System** → **Device Manager**.
 - a. Double-click **IDE ATA/ATAPI controllers**. If a device displays a down arrow, right-click on the device and click **Enable**.
 - b. Double-click **DVD/CD-ROM drives**. If the device displays a down arrow, right-click on the device and click **Enable**.

-
- c. Check that there are no yellow exclamation marks against the items in **IDE ATA/ATAPI controllers**. If a device has an exclamation mark, right-click on the device and uninstall and reinstall the driver.
 - d. Check that there are no yellow exclamation marks against the items in **DVD/CD-ROM drives**. If a device has an exclamation mark, right-click on the device and uninstall and reinstall the driver.
 - e. If the exclamation marker is not removed from the item in the lists, try removing any recently installed software and retrying the operation.

Discs Do Not Play

If discs do not play when inserted in the drive, perform the following actions one at a time to correct the problem.

1. Check that the disc is correctly seated in the drive tray and that the label on the disc is visible.
2. Check that the media is clean and scratch free.
3. Try an alternate disc in the drive.
4. Ensure that **AutoPlay** is enabled:
 - a. Navigate to **Start** → **Control Panel** → **Hardware and Sound** → **AutoPlay**.
 - b. Select **Use AutoPlay for all media and devices**.
 - c. In the Audio CD and DVD Movie fields, select the desired player from the drop down menu.
5. Check that the Regional Code is correct for the selected media:

IMPORTANT: Region can only be changed a limited number of times. After Changes remaining reaches zero, the region cannot be changed even Windows is reinstalled or the drive is moved to another computer.

- a. Navigate to **Start** → **Control Panel** → **System and Maintenance** → **System** → **Device Manager**.
- b. Double-click **DVD/CD-ROM drives**.
- c. Right-click **DVD drive** and click **Properties**, then click the **DVD Region** tab.
- d. Select the region suitable for the media inserted in the drive.

Discs Do Not Burn Properly

If discs can not be burned, perform the following actions one at a time to correct the problem.

1. Ensure that the default drive is record enabled:
 - a. Navigate to **Start** → **Computer** and right-click the writable ODD icon. Click **Properties**.
 - b. Select the **Recording** tab. In the **Desktop disc recording** panel, select the writable ODD from the drop down list.
 - c. Click **OK**.
2. Ensure that the software used for burning discs is the factory default. If using different software, refer to the software's user manual.

Playback is Choppy

If playback is choppy or jumps, perform the following actions one at a time to correct the problem.

1. Check that system resources are not running low:
 - a. Try closing some applications.
 - b. Reboot and try the operation again.
2. Check that the ODD controller transfer mode is set to DMA:
 - a. Navigate to **Start** → **Control Panel** → **System and Maintenance** → **System** → **Device Manager**.
 - b. Double-click **IDE ATA/ATAPI controllers**, then right-click ATA Device 0.
 - c. Click **Properties** and select the **Advanced Settings** tab. Ensure that the **Enable DMA** box is checked and click **OK**.

-
- d. Repeat for the other ATA Devices shown if applicable.

Drive Not Detected

If Windows cannot detect the drive, perform the following actions one at a time to correct the problem.

1. Restart the computer and press F2 to enter the BIOS Utility.
2. Check that the drive is detected in the **ATAPI Model Name** field on the Information page.
NOTE: Check that the entry is identical to one of the ODDs specified in “Hardware Specifications and Configurations” on page 18.
3. Turn off the power and remove the cover to inspect the connections to the ODD. See “Disassembly Process” on page 48.
 - a. Check for broken connectors on the drive, motherboard, and cables.
 - b. Check for bent or broken pins on the drive, motherboard, and cable connections.
 - c. Try an alternate cable, if available. If the drive works with the new cable, the original cable should be replaced.
4. Reseat the drive ensuring and all cables are connected correctly.
5. Replace the ODD. See “Disassembly Process” on page 48.

Drive Read Failure

If discs cannot be read when inserted in the drive, perform the following actions one at a time to correct the problem.

1. Remove and clean the failed disc.
2. Retry reading the CD or DVD.
 - d. Test the drive using other discs.
 - e. Play a DVD movie
 - f. Listen to a music CD

If the ODD works properly with alternate discs, the original disc is probably defective and should be replaced.

3. Turn off the power and remove the cover to inspect the connections to the ODD. See “Disassembly Process” on page 48.
 - a. Check for broken connectors on the drive, motherboard, and cables.
 - b. Check for bent or broken pins on the drive, motherboard, and cable connections.
 - c. Try an alternate cable, if available. If the drive works with the new cable, the original cable should be replaced.
4. Replace the ODD. See “Disassembly Process” on page 48.

USB Failure (Rightside)

If the rightside **USB** port fails, perform the following actions one at a time to correct the problem. Do not replace a non-defective FRUs:

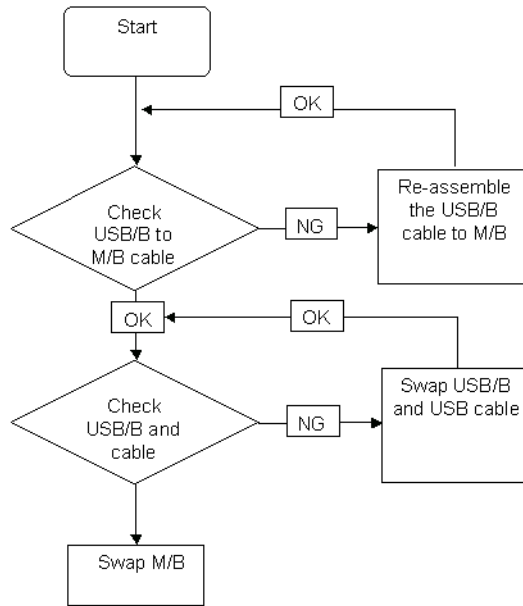

Modem Function Failure

If the internal **Modem** fails, perform the following actions one at a time to correct the problem. Do not replace a non-defective FRUs:

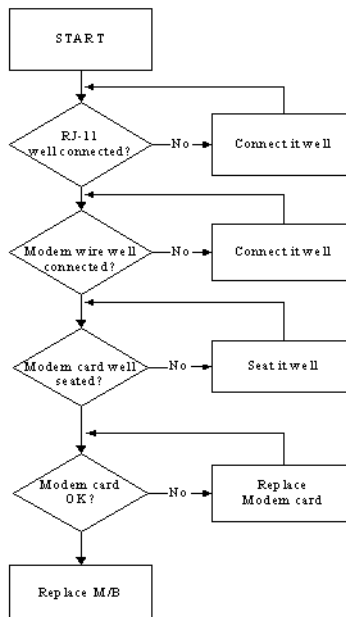

Wireless Function Failure

If the **WLAN** fails, perform the following actions one at a time to correct the problem. Do not replace a non-defective FRUs:

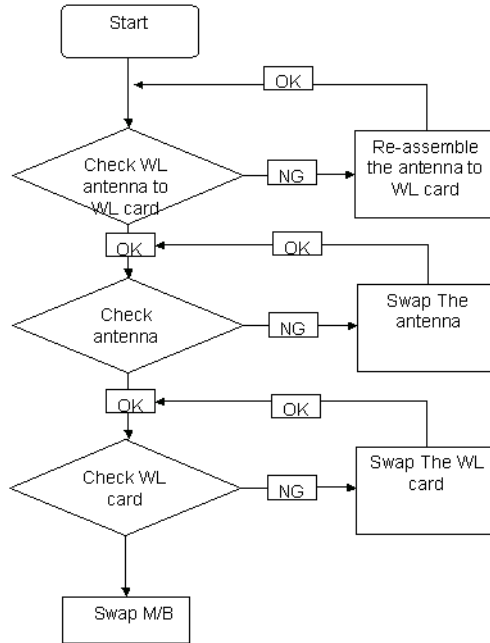

EasyTouch Button Failure

If the **Acer EasyTouch** buttons fail, perform the following actions one at a time to correct the problem. Do not replace a non-defective FRUs:

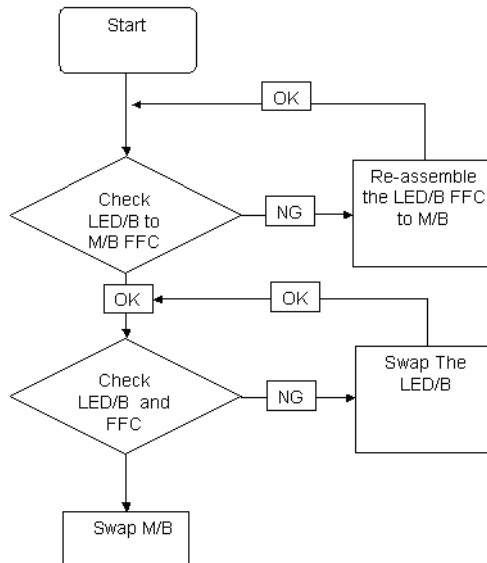

MediaTouch Button Failure

If the **Acer MediaTouch** buttons fail, perform the following actions one at a time to correct the problem. Do not replace a non-defective FRUs:

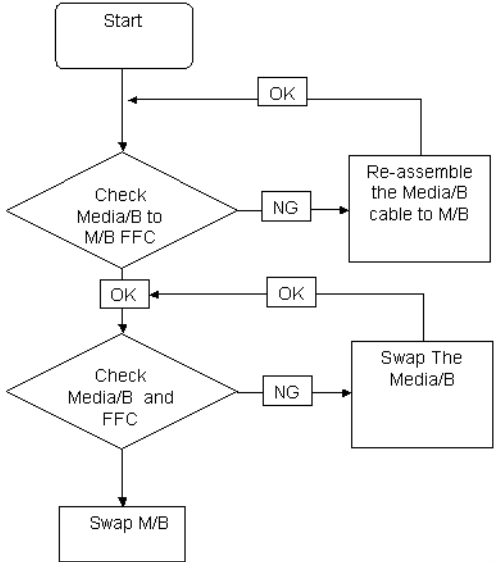

Fingerprint Reader Failure

If the **Fingerprint Reader** fails, perform the following actions one at a time to correct the problem. Do not replace a non-defective FRUs:

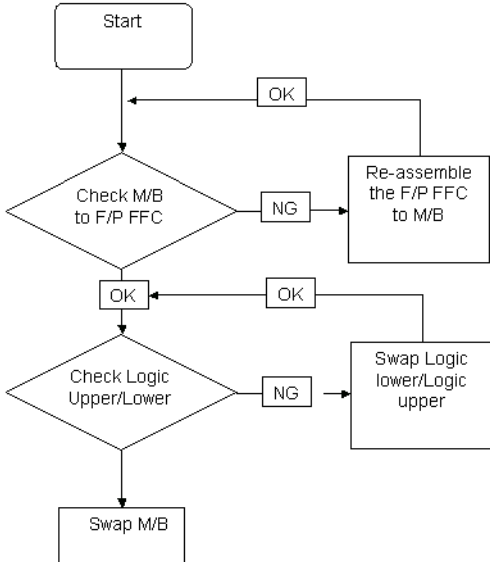

Thermal Unit Failure

If the **Thermal Unit** fails, perform the following actions one at a time to correct the problem. Do not replace a non-defective FRUs:

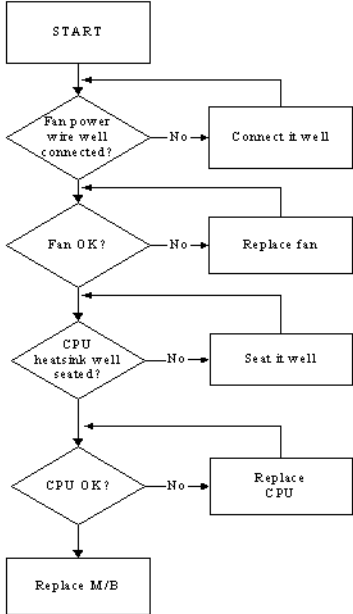

HDTV Switch Failure

If the **HDTV Switch** fails, perform the following actions one at a time to correct the problem. Do not replace a non-defective FRUs:

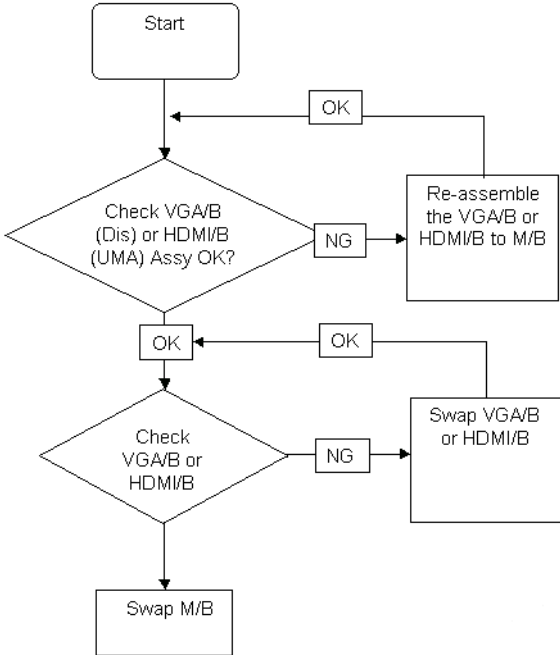

External Mouse Failure

If an external **Mouse** fails, perform the following actions one at a time to correct the problem.

1. Try an alternative mouse.
2. If the mouse uses a wireless connection, insert new batteries and confirm there is a good connection. See the mouse user manual.
3. If the mouse uses a USB connection, try an alternate USB port.
4. Try an alternative program to verify mouse operation. Reinstall the program experiencing mouse failure.
5. Restart the computer.
6. Remove any recently added hardware and associated software.
7. Remove any recently added software and reboot.
8. Restore system and file settings from a known good date using **System Restore**.
If the issue is not fixed, repeat the preceding steps and select an earlier time and date.
9. Run the Event Viewer to check the events log for errors. For more information see Windows Help and Support.
10. Roll back the mouse driver to the previous version if updated recently.
11. Remove and reinstall the mouse driver.
12. Check the Device Manager to determine that:
 - The device is properly installed. There are no red Xs or yellow exclamation marks.
 - There are no device conflicts.
 - No hardware is listed under Other Devices.
13. If the Issue is still not resolved, see "Online Support Information" on page 187.

Other Failures

If the CRT Switch, Dock, LAN Port, external MIC or Speakers, PCI Express Card, 5-in-1 Card Reader or Volume Wheel fail, perform the following general steps to correct the problem. Do not replace a non-defective FRUs:

1. Check Drive whether is OK.
2. Check Test Fixture is ok.
3. Swap M/B to Try.

Intermittent Problems

Intermittent system hang problems can be caused by a variety of reasons that have nothing to do with a hardware defect, such as: cosmic radiation, electrostatic discharge, or software errors. FRU replacement should be considered only when a recurring problem exists.

When analyzing an intermittent problem, do the following:

1. Run the advanced diagnostic test for the system board in loop mode at least 10 times.
2. If no error is detected, do not replace any FRU.
3. If any error is detected, replace the FRU. Rerun the test to verify that there are no more errors.

Undetermined Problems

The diagnostic problems does not identify which adapter or device failed, which installed devices are incorrect, whether a short circuit is suspected, or whether the system is inoperative.

Follow these procedures to isolate the failing FRU (do not isolate non-defective FRU).

NOTE: Verify that all attached devices are supported by the computer.

NOTE: Verify that the power supply being used at the time of the failure is operating correctly. (See “Power On Issue” on page 116.):

1. Power-off the computer.
2. Visually check them for damage. If any problems are found, replace the FRU.
3. Remove or disconnect all of the following devices:
 - Non-Acer devices
 - Printer, mouse, and other external devices
 - Battery pack
 - Hard disk drive
 - DIMM
 - CD-ROM/Diskette drive Module
 - PC Cards
4. Power-on the computer.
5. Determine if the problem has changed.
6. If the problem does not recur, reconnect the removed devices one at a time until you find the failing FRU.
7. If the problem remains, replace the following FRU one at a time. Do not replace a non-defective FRU:
 - System board
 - LCD assembly

POST Codes Tables

These tables describe the chipset and core POST codes, functions, phases, and components for the POST.

Chipset POST Codes

The following table details the chipset POST codes and functions used in the POST.

POST Code	Function	Phase	Component
0xA0	MRC Entry	PEI	chipset/MRC
0x01	Enable MCHBAR	PEI	chipset/MRC
0x02	Check ME existence	PEI	chipset/MRC
0x03	Check for DRAM initialization interrupt and reset fail	PEI	chipset/MRC
0x04	Determine the system Memory type based on first populated socket	PEI	chipset/MRC
0x05	Verify all DIMMs are DDR2 and SO-DIMMS, which are unbuffered	PEI	chipset/MRC
0x06	Verify all DIMMs are Non-ECC	PEI	chipset/MRC
0x07	Verify all DIMMs are single or double sided and not mixed	PEI	chipset/MRC
0x08	Verify all DIMMs are x8 or x16 width	PEI	chipset/MRC
0x09	Calculate number of Row and Column bits	PEI	chipset/MRC
0x10	Calculate number of banks for each DIMM	PEI	chipset/MRC
0x11	Determine raw card type	PEI	chipset/MRC
0x12	Find a common CAS latency between the DIMMS and the MCH	PEI	chipset/MRC
0x13	Determine the memory frequency and CAS latency to program	PEI	chipset/MRC
0x14	Determine the smallest common timing value for all DIMMS	PEI	chipset/MRC
0x17	Power management resume	PEI	chipset/MRC
0x18	Program DRAM type (DDR2/DDR3) and Power up sequence	PEI	chipset/MRC
0x19	Program the correct system memory frequency	PEI	chipset/MRC
0x20	Program the correct Graphics memory frequency	PEI	chipset/MRC
0x21	Early DRC initialization	PEI	chipset/MRC
0x22	Program the DRAM Row Attributes and DRAM Row Boundary registers PRE JEDEC.	PEI	chipset/MRC
0x23	Program the RCOMP SRAM registers	PEI	chipset/MRC
0x24	Program DRAM type (DDR2/DDR3) and Power up sequence	PEI	chipset/MRC
0x25	Program the DRAM Timing	PEI	chipset/MRC
0x26	Program the DRAM Bank Architecture register	PEI	chipset/MRC
0x27	Enable all clocks on populated rows	PEI	chipset/MRC
0x28	Program MCH ODT	PEI	chipset/MRC
0x29	Program tRD	PEI	chipset/MRC
0x30	Miscellaneous Pre JEDEC steps	PEI	chipset/MRC
0x31	Program clock crossing registers	PEI	chipset/MRC

POST Code	Function	Phase	Component
0x32	Program the Egress port timings	PEI	chipset/MRC
0x33	Program the Memory IO registers	PEI	chipset/MRC
0x34	Perform steps required before JEDEC	PEI	chipset/MRC
0x35	Perform JEDEC memory initialization for all memory rows	PEI	chipset/MRC
0x36	Setup DRAM control register for normal operation and enable	PEI	chipset/MRC
0x37	Do ZQ calibration for DDR3	PEI	chipset/MRC
0x38	Perform final Dra/Drb programming, Set the mode of operation for the memory channels	PEI	chipset/MRC
0x39	Set Enhanced addressing mode for each channel	PEI	chipset/MRC
0x40	Perform steps required after JEDEC init	PEI	chipset/MRC
0x41	Program the receive enable reference timing control register	PEI	chipset/MRC
0x42	Post receive enable initialization	PEI	chipset/MRC
0x43	Enable sense amps. Reset read/write DQS pointers	PEI	chipset/MRC
0x44	Perform ME steps	PEI	chipset/MRC
0x45	Clear DRAM initialization bit in the ICH.	PEI	chipset/MRC
0x46	Program Thermal Management	PEI	chipset/MRC
0x47	Program TS on DIMM	PEI	chipset/MRC
0x48	Program TS on Board	PEI	chipset/MRC
0xAF	Exit MRC	PEI	chipset/MRC
0xE0	#define MEM_ERR_BAD_DIMM (S11)	PEI	chipset/MRC
0xE1	#define MEM_ERR_ECC_DIMM (S06)	PEI	chipset/MRC
0xE2	#define MEM_ERR_SIDES (S07)	PEI	chipset/MRC
0xE3	#define MEM_ERR_WIDTH (S08, S10)	PEI	chipset/MRC
0xE4	#define MEM_ERR_TRFC (FindTrasTrpTrcd)	PEI	chipset/MRC
0xE5	#define MEM_ERR_CAS_LATENCY (S12, S13)	PEI	chipset/MRC
0xE6	#define MEM_ERR_REFRESH (ProgDrt)	PEI	chipset/MRC
0xE7	#define MEM_ERR_BL8 (S14)	PEI	chipset/MRC
0xE9	#define MEM_ERR_FREQUENCY (findTCLTacTCIk, S13, S12, ProgramGraphicsFrequency, ProgMchOdt, GetPlatformData)	PEI	chipset/MRC
0xEA	#define MEM_ERR_SIZE (S14)	PEI	chipset/MRC
0xEC	#define MEM_ERR_TRAS (FindTrasTrpTrcd)	PEI	chipset/MRC
0xED	#define MEM_ERR_TRP (FindTrasTrpTrcd)	PEI	chipset/MRC
0xEE	#define MEM_ERR_TRCD (FindTrasTrpTrcd)	PEI	chipset/MRC
0xEF	#define MEM_ERR_TWR (FindTrasTrpTrcd)	PEI	chipset/MRC
0xF0	#define MEM_ERR_RCVEN_FINDLOW (CalibrateRcvenForGroup)	PEI	chipset/MRC
0xF1	#define MEM_ERR_RCVEN_FINDEDGE (CalibrateRcvenForGroup)	PEI	chipset/MRC
0xF2	#define MEM_ERR_RCVEN_FINDPREAMBLE (CalibrateRcvenForGroup)	PEI	chipset/MRC
0xF6	#define MEM_ERR_RCVEN_PREAMBLEEDGE (CalibrateRcvenForGroup)	PEI	chipset/MRC

POST Code	Function	Phase	Component
0xF3	#define MEM_ERR_RCVEN_FINDCENTER (CalibrateRcvenForGroup)	PEI	chipset/MRC
0xFZ	#define MEM_ERR_TYPE (S11, S04)	PEI	chipset/MRC
0xF5	#define MEM_ERR_RAWCARD (S11)	PEI	chipset/MRC
0xFA	#define MEM_ERR_SFF (ProgWrioDll)	PEI	chipset/MRC
0xFB	#define MEM_ERR_THERMAL (ProgramThrottling)	PEI	chipset/MRC
0xA0xx	Launch BIOS ACMSclean	PEI	chipset/TXT
0xA4xx	Launch BIOS ACMScheck	PEI	chipset/TXT
0xE5	Wait for ME ready	DXE	HECI/iAMT
0xE6	ME Ready	DXE	HECI/iAMT

Core POST Codes

The following table details the core POST codes and functions used in the POST.

POST Code	Function	Phase	Component
0x00	Early Microcode update for CAR	CEI / SEC	Core
0x01	Enable CAR	CEI / SEC	Core
0x02	CAR Done, initial stack	CEI / SEC	Core
0xEE	unknown CPU ID to load uCode	CEI / SEC	CPU
0xEF	unknown DT CPU to load uCode	CEI / SEC	CPU
0xnn	File count found in a volume	PEI	Core
0x11	Debug Test driver for debug test PPI 1 (If install debugTest driver)	PEI	Core
0x22	Debug Test driver for debug test PPI 2 (If install debugTest driver)	PEI	Core
0x33	Debug Test driver for debug test PPI 3 (If install debugTest driver)	PEI	Core
0x44	Entry point of loadfile	PEI	Core
0x88	Entry point of apMuLoader	PEI	Core
0x80	A PEIM found	PEI	Core
0x82	PEIM not dispatched yet	PEI	Core
0x84	PEIM satisfies depex	PEI	Core
0x86	Image loaded but fail on security	PEI	Core
0x88	Executing a PEIM	PEI	Core
0x8A	Processing notify event for newly installed PPI	PEI	Core
0x8C	Handing off to next phase (DXE)	PEI	Core
0x8F	Fail to hand off to next phase, system halt	PEI	Core
0x90	All PEIM dispatched! Going to DxeIpl	PEI	Core
0xCC	AP Micro-code update	PEI	Core
0x20	S3 resume entry	S3 resume	Core
0x21	Start running Boot-time bootscripts	S3 resume	Core
0x22	Start running Run-time bootscripts	S3 resume	Core
0x23	End of S3 resume, jump back to Waking vector	S3 resume	Core
0x80	Initialize the chipset	Crisis Recovery	Core
0x81	Initialize the bridge	Crisis Recovery	Core

POST Code	Function	Phase	Component
0x82	Initialize the CPU	Crisis Recovery	Core
0x89	Set Huge Segment	Crisis Recovery	Core
0x83	Initialize system timer	Crisis Recovery	Core
0x84	Initialize system I/O	Crisis Recovery	Core
0x88	Initialize Multi Processor	Crisis Recovery	Core
0x8A	Initialize OEM special code	Crisis Recovery	Core
0x8B	Initialize PIC and DMA	Crisis Recovery	Core
0x8C	Initialize Memory type	Crisis Recovery	Core
0x8D	Initialize Memory size	Crisis Recovery	Core
0x8F	Initialize SMM	Crisis Recovery	Core
0x90	System memory test	Crisis Recovery	Core
0x91	Initialize interrupt vectors	Crisis Recovery	Core
0x92	Initialize Run Time Clock	Crisis Recovery	Core
0x99	Initialize security	Crisis Recovery	Core
0x93	Initialize video	Crisis Recovery	Core
0x94	Output one beep	Crisis Recovery	Core
0x98	USB Initialization	Crisis Recovery	Core
0x95	Initialize the installed boot devices	Crisis Recovery	Core
0x96	Clear Huge segment	Crisis Recovery	Core
0x97	Boot Crisis Disk	Crisis Recovery	Core
0x20	DXE starts	DXE	Core
0x30	BIOSPSM	DXE	Core
0x02	BIOSBlockIO	DXE	Core
0x00	BIOSPSM Exception Handler - Divide error	BIOSPSM	Core
0x38	Cannot locate LegacyRegion DXE	BIOSPSM	Core
0xB1	ACPISupport driver Installed	DXE	Core
0xE0	BDS Entry	DXE	Core
0x07	IA32 variable driver entry	DXE	Core
0x0D	conspliter driver entry	DXE	Core
0x10	partition driver entry	DXE	Core
0x49	pciRootBridge driver entry	DXE	Core
0xC6	pciBusDriver entry	DXE	Core
0xE0	Go to legacy BIOS or BDS Entry Point	DXE	Core
0x90	Start Image	DXE	Core
0x90	Start Image Successfully	DXE	Core
0x90	Start Image Failed	DXE	Core
0x33	Debug Test driver for debug test PPI 1	DXE	Core
0x22	Debug Test driver for debug test PPI 2	DXE	Core
0x11	Debug Test driver for debug test PPI 3	DXE	Core
0x02	Invalid event # for measuring Separator Event	DXE	TCG
0x02	Invalid event # for measuring Separator Event	DXE	TCG
0x02	PCR Index over limit (PCR > 23)	DXE	TCG
0x02	TCG copy memory failed	DXE	TCG

POST Code	Function	Phase	Component
0x09	TCG log event failed	DXE	TCG
0x09	Setup event log failed	DXE	TCG
0x12	TIS set active locality failed	DXE	TCG
0x12	TIS relinquish active locality failed	DXE	TCG
0x12	TIS wait command ready failed (prepare to send)	DXE	TCG
0x12	TIS abort 'send' command due to timeout	DXE	TCG
0x12	TIS abort 'sendAndGo' command due to timeout	DXE	TCG
0x04	TIS wait bit set failed before send last byte	DXE	TCG
0x12	TIS abort command due to timeout before send last byte	DXE	TCG
0x04	TIS wait bit clear failed when sending last byte	DXE	TCG
0x22	TCG Physical Presence execution	DXE	TCG
0xB1	TCG DXE common pass through	DXE	TCG
0xE3	First Legacy BIOS Task table for legacy reset	LBT	Core
0x20	Verify that DRAM refresh is operating by polling the refresh bit in PORTB.	LBT	Core
0xDA	Dummy PCIE Init entry, now handled by driver	LBT	Core
0x29	PMM (POST Memory Manager) init	LBT	Core
0xE5	WHEA init	LBT	Core
0x33	PDM (Post Dispatcher Manager) init	LBT	Core
0x01	IPMI init	LBT	Core
0xD8	ASF Init	LBT	Core
0x09	Set in-POST flag in CMOS that indicates we are in POST. If this bit is not cleared by postClearBootFlagJ (AEh), the TrustedCore on next boot determines that the current configuration caused POST to fail and uses default values for configuration.	LBT	Core
0x2B	Enhanced CMOS init	LBT	Core
0xE0	EFI Variable Init	LBT	Core
0xC1	PEM (Post Error Manager) init	LBT	Core
0x3B	Debug Service Init (ROM Polit)	LBT	Core
0xDC	POST Update Error	LBT	Core
0x3A	Autosize external cache and program cache size for enabling later in POST.	LBT	Core
0x0B	Enable CPU cache. Set bits in cmos related to cache.	LBT	Core
0x0F	Enable the local bus IDE as primary or secondary depending on other drives detected.	LBT	Core
0x10	Initialize Power Management.	LBT	Core
0x14	Verify that the 8742 keyboard controller is responding. Send a self-test command to the 8742 and wait for results. Also read the switch inputs from the 8742 and write the keyboard controller command byte.	LBT	Core

POST Code	Function	Phase	Component
0x1A	Initialize DMA command register with these settings: 1. Memory to memory disabled 2. Channel 0 hold address disabled 3. Controller enabled 4. Normal timing 5. Fixed priority 6. Late write selection 7. DREQ sense active 8. DACK sense active low.	LBT	Core
0x22	Reset the keyboard.	LBT	Core
0x40	Test A20 line	LBT	Core
0x67	Quick initialization of all Application Processors in a multi-processor system	LBT	Core
0x32	Compute CPU speed.	LBT	Core
0x69	Initialize the handler for SMM.	LBT	Core
0x6B	If CMOS is bad, load Custom Defaults from flash into CMOS. If successful, reboot.	LBT	Core
0x3C	If CMOS is valid, load chipset registers with values from CMOS, otherwise load defaults and display Setup prompt. If Auto Configuration is enabled, always load the chipset registers with the Setup defaults (Rel 6.0).	LBT	Core
0x3D	Load alternate registers with CMOS values	LBT	Core
0x42	Initialize interrupt vectors 0 thru 77h	LBT	Core
0x46	Verify the ROM copyright notice	LBT	Core
0x45	Initialize all motherboard devices.	LBT	Core
0x49	1. Size the PCI bus topology and set bridge bus numbers. 2. Set the system max bus number. 3. Write a 0 to the command register of every PCI device. 4. Write a 0 to all 6 base registers in every PCI device. 5. Write a -1 to the status register of every PC	LBT	Core
0xC6	Initialize note dock	LBT	Core
0xC5	PnPnd dual CMOS (optional)	LBT	Core
0x48	Verify that the equipment specified in the CMOS matches the hardware currently installed. If the monitor type is set to 00 then a video ROM must exist. If the monitor type is 1 or 2 set the video switch to CGA. If monitor type 3, set the video switch to m	LBT	Core
0xD1	Initialize BIOS stack	LBT	Core
0xD3	Setup E820h and WAD memory map	LBT	Core
0x24	Set segment-register addressability to 4 GB	LBT	Core
0xCC	Redirect Int 10h to enable target board to use a remote serial video (PICO BIOS).	LBT	Core
0x8A	Initialize Extended BIOS Data Area and initialize the mouse.	LBT	Core
0x9D	Initialize Security Engine.	LBT	Core
0x55	USB Initialization	LBT	Core
0x52	Verify keyboard reset.	LBT	Core
0x54	Initialize keystroke clicker if enabled in Setup.	LBT	Core
0x76	Check status bits for keyboard-related failures. Display error messages on the screen.	LBT	Core
0x4A	Initialize all video adapters in system	LBT	Core

POST Code	Function	Phase	Component
0x4C	Shadow video BIOS ROM if specified by Setup, and CMOS is valid and the previous boot was OK.	LBT	Core
0x59	Register POST Display Services, fonts, and languages with the POST Dispatch Manager.	LBT	Core
0x57	Initialize 1394 Firewire	LBT	Core
0xD6	Initialize PC card	LBT	Core
0x58	Test for unexpected interrupts. First do an STI for hot interrupts. Secondly, test the NMI for an unexpected interrupt. Thirdly, enable the parity checkers and read from memory, checking for an unexpected interrupt.	LBT	Core
0x3F	ROMPolit memory init	LBT	Core
0xC4	Install the IRQ vectors (Sever Hotkey)	LBT	Core
0x7C	Initialize the hardware interrupt vectors from 08 to 0F and from 70h to 77H. Also set the interrupt vectors from 60h to 66H to zero.	LBT	Core
0x41	ROM Pilot Init	LBT	Core
0x4B	Initialize QuietBoot if it is installed. Enable both keyboard and timer interrupts (IRQ0 and IRQ1). If your POST tasks require interrupts off, preserve them with a PUSHF and CLI at the beginning and a POPF at the end.	LBT	Core
0xDE	Initialize and UNDI ROM (fro remote flash)	LBT	Core
0xC6	Initial and install console for UCR	LBT	Core
0x4E	Display copyright notice.	LBT	Core
0xD4	Get CPU branding string	LBT	Core
0x50	Display CPU type and speed	LBT	Core
0xC9	pretask before EISA init	LBT	Core
0x51	EISA Init	LBT	Core
0x5A	Display prompt "Press F2 to enter SETUP"	LBT	Core
0x5B	Disable CPU cache.	LBT	Core
0x5C	Test RAM between 512K and 640K.	LBT	Core
0x60	Determine and test the amount of extended memory available. Determine if memory exists by writing to a few strategic locations and see if the data can be read back. If so, perform an address-line test and a RAM test on the memory.	LBT	Core
0x62	The amount of memory available. This test is dependent on the processor, since the test will vary depending on the width of memory (16 or 32 bits). This test will also use A20 as the skew address to prevent corruption of the system memory.	LBT	Core
0x64	Jump to UserPatch1.	LBT	Core
0x66	Set cache registers to their CMOS values if CMOS is valid, unless auto configuration is enabled, in which case load cache registers from the Setup default table.	LBT	Core
0x68	Enable external cache and CPU cache if present. Configure non-cacheable regions if necessary.	LBT	Core

POST Code	Function	Phase	Component
0x6A	Display external cache size on the screen if it is non-zero.	LBT	Core
0x6C	Display shadow message	LBT	Core
0xCA	post EISA init	LBT	Core
0x70	Check flags in CMOS and in the TrustedCore data area for errors detected during POST. Display error messages on the screen.	LBT	Core
0x72	Check status bits to see if configuration problems were detected. If so, display error messages on the screen.	LBT	Core
0x4F	Initialize MultiBoot. Allocate memory for old and new MultiBoot history tables.	LBT	Core
0xCD	Reclaim console vector after HW vectors initialized.	LBT	Core
0x7D	Initialize Intelligent System Monitoring.	LBT	Core
0x7E	The Coprocessor initialization test. Use the floating point instructions to determine if a coprocessor exists instead of the ET bit in CR0.	LBT	Core
0xC1	Check Boot Type (Server BIOS)	LBT	Core
0x80	Disable onboard COM and LPT ports before testing for presence of external I/O devices.	LBT	Core
0xCA	Redirect Int 15h to enable target board to use remote keyboard (PICO BIOS).	LBT	Core
0x88	Initialize interrupt controller.	LBT	Core
0x81	Run late device initialization routines.	LBT	Core
0x87	Initialize motherboard configurable devices.	LBT	Core
0x85	Display any ESCD read errors and configure all PnP ISA devices.	LBT	Core
0x82	Test and identify RS232 ports.	LBT	Core
0x84	Test and identify parallel ports.	LBT	Core
0x86	Initialize onboard I/O and BDA according to CMOS and presence of external devices.	LBT	Core
0x83	Configure Fisk Disk Controller.	LBT	Core
0xCE	Initialize digitizer device and display installed message if successful.	LBT	Core
0x89	Enable non-maskable interrupts.	LBT	Core
0x8C	Initialize both of the floppy disks and display an error message if failure was detected. Check both drives to establish the appropriate diskette types in the TrustedCore data area	LBT	Core
0xCB	Redirect Int 13h to Memory Technologies Devices such as ROM, RAM, PCMCIA, and serial disk (PICO BIOS).	LBT	Core
0xCD	Remap I/O and memory address space for PCMCIA (PICO BIOS).	LBT	Core
0x90	Initialize hard-disk controller. If the CMOS ram is valid and intact, and fixed disks are defined, call the fixed disk init routine to initialize the fixed disk system and take over the appropriate interrupt vectors.	LBT	Core

POST Code	Function	Phase	Component
0x8B	Setup interrupt vector and present bit in Equipment byte.	LBT	Core
0x95	1. Check CMOS for CD-ROM drive present 2. Activate the drive by checking for media present 3. Check sector 11h (17) for Boot Record Volume Descriptor 4. Check the boot catalog for validity 5. Pick a boot entry 6. Create a Specification Packet	LBT	Core
0x92	Jump to UserPatch2.	LBT	Core
0xB6	If password on boot is enabled, a call is made to Setup to check password. If the user does not enter a valid password, Setup does not return.	LBT	Core
0x98	Search for option ROMs. ROM scan the area from C800h for a length of BCP_ROM_Scan_Size (or to E000h by default) on every 2K boundary, looking for add on cards that need initialization.	LBT	Core
0x93	Build the MPTABLE for multi-processor boards	LBT	Core
0xD9	IPMI late init	LBT	Core
0x9C	Set up Power Management. Initiate power - management state machine.	LBT	Core
0xC7	Late note dock init	LBT	Core
0x9E	Enable hardware interrupts	LBT	Core
0xA0	Setup time tick for current date/time	LBT	Core
0xA2	Setup Numlock indicator. Display a message if key switch is locked.	LBT	Core
0xA4	Initialize typematic rate	LBT	Core
0xDB	StrongROM Test	LBT	Core
0xE2	OEM security key test	LBT	Core
0xC2	Write PEM errors.	LBT	Core
0xBA	Initialize the SMBIOS header and sub-structures.	LBT	Core
0xC3	Display PEM errors.	LBT	Core
0xA8	Overwrite the "Press F2 for Setup" prompt with spaces, erasing it from the screen.	LBT	Core
0xAA	Scan the key buffer to see if the F2 key was struck after keyboard interrupts were enabled. If an F2 keystroke is found, set a flag.	LBT	Core
0xE1	Start Periodic Timer (TC Subscribe)	LBT	Core
0xAC	Check if "Enter SETUP" is pressed.	LBT	Core
0x8F	Count the number of ATA drives in the system and update the number in bdaFdiskcount.	LBT	Core
0x91	Configure the local bus IDE timing register based on the drives attached to it.	LBT	Core
0x9F	Check the total number of Fast Disks (ATA and SCSI) and update the bdaFdiskCount.	LBT	Core
0xD7	Check if FirstWare HPA exists	LBT	Core
0xAE	Clear ConfigFailedBit and InPostBit in CMOS.	LBT	Core
0xB0	Check for errors and decide if needs to run Setup.	LBT	Core
0xB2	Change status bits in CMOS and/or the TrustedCore data area to reflect the fact that POST is complete.	LBT	Core

POST Code	Function	Phase	Component
0xB5	Fade out OEM Logo or post string	LBT	Core
0xC5	End hotkey detection (Server BIOS)	LBT	Core
0xBE	If BCP option is enabled, clear the screen before booting.	LBT	Core
0xB6	If password on boot is enabled, a call is made to Setup to check password. If the user does not enter a valid password, Setup does not return.	LBT	Core
0xBC	Clear parity-error latch	LBT	Core
0xB7	Initialize ACPI BIOS.	LBT	Core
0x9B	Enable CPU management (Geyserville I)	LBT	Core
0xBD	Display Boot First menu if MultiBoot is installed and hotkey pressed.	LBT	Core
0xBF	Check virus and backup reminders.	LBT	Core
0x97	Create pointer to MP table in Extended BDA.	LBT	Core
0x99	Check support status for Self-Monitoring Analysis Reporting Technology (disk-failure warning).	LBT	Core
0xB1	Unload ROM Pilot	LBT	Core
0xDD	Perform remote flash if requested	LBT	Core
0xC7	If UCR redirection is installed, remove display manager and unhook INT10	LBT	Core
0XDF	Shutdown the PXE UNDI code	LBT	Core
0xB3	Store enhanced CMOS values in non-volatile area	LBT	Core
0xE4	Last Legacy BIOS Task before hand off to UEFI/DXE	LBT	Core
0xB9	Clear all screen graphics before booting.	bootLegacy	Core
0xC0	INT19 entry for legacy boot	bootLegacy	Core
0xEF	Invalid AP #	SDXE	Core
0xEF	Non-Yohna and non-Morem class CPU found for SDXE (getTSCFreq)	SDXE	Core
0xEE	AP cannot synch BSP in SDXE (syncWithBSP)	SDXE	Core
0xEE	BSP cannot synch w/ AP in SDXE (syncWithAP)	SDXE	Core

Jumper and Connector Locations

Top View

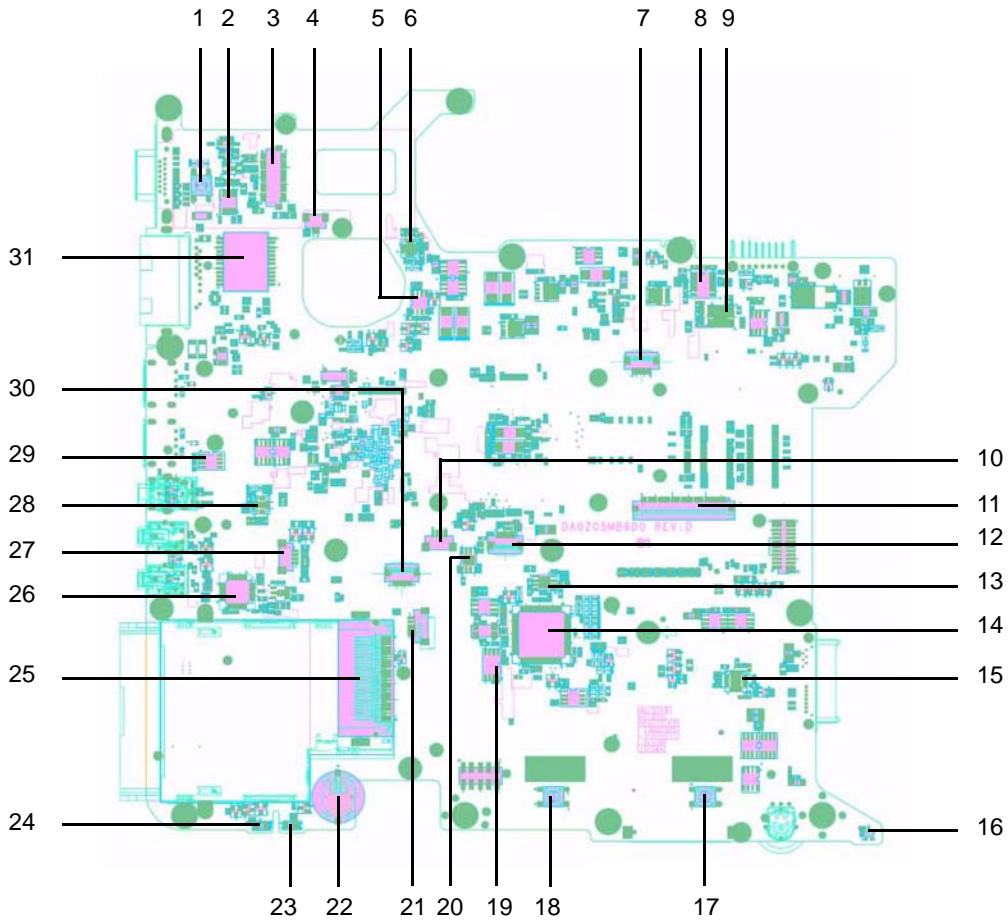

No.	Description	No.	Description	No.	Description
1	E-Key Switch	12	Touch Pad Connector	23	Charger LED
2	LCD Power IC	13	+2.5V Power IC	24	Power LED
3	LCD/CCD Connector	14	EC controller	25	NewCard Connector
4	Internal Microphone	15	+3V, +5V Converter IC	26	Audio Codec ALC888
5	CPU H/W MONITOR IC	16	LID switch (Hall Sensor)	27	Internal SPKS
6	+1.1V Converter IC	17	Touch Pad Right Switch	28	NB_Core Converter IC
7	SW Board Connector	18	Touch Pad Left Switch	29	FAN Power IC
8	Charger Converter IC	19	BIOS	30	Function Board Connector
9	+1.8V, 0.9V Converter IC	20	+1.2V Power IC	31	LAN Transformer
10	Finger Board Connector	21	Bluetooth Connector		
11	Keyboard Connector	22	RTC Battery		

Bottom View

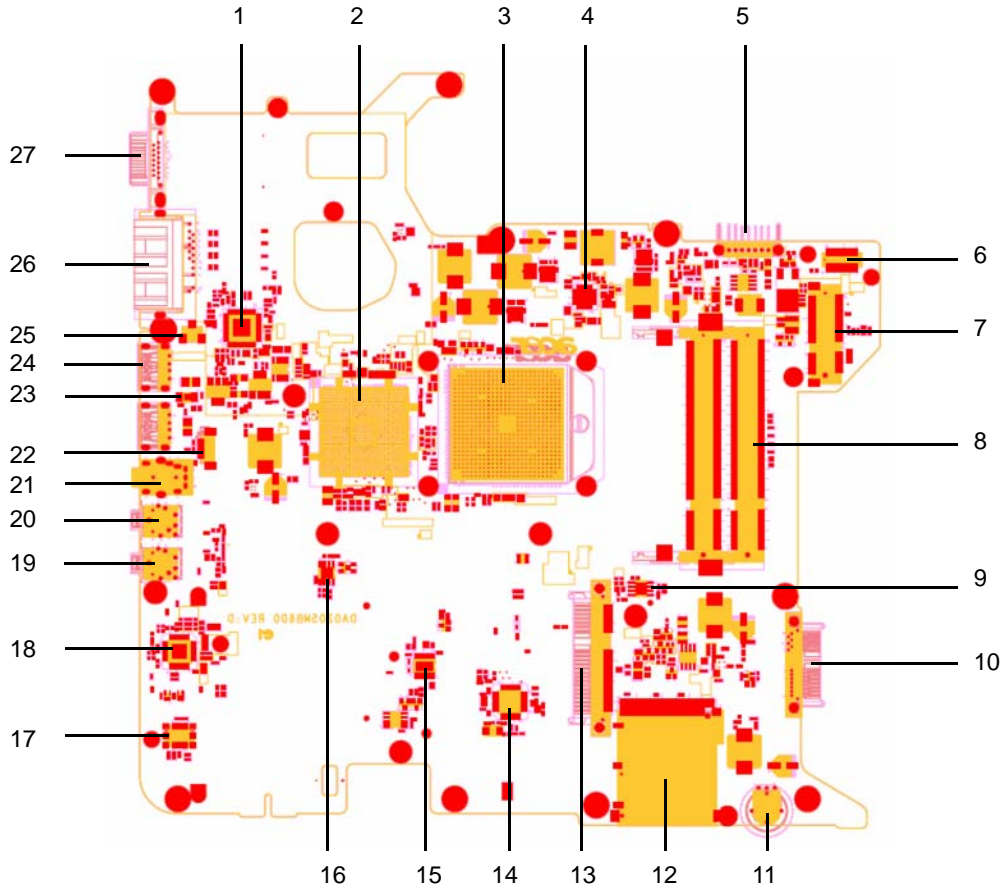

No.	Description	No.	Description
1	LAN Chipset	15	New Card Power IC
2	North Bridge MCP77MH	16	+1.1V_S5 Power IC
3	CPU Socket	17	MDC Connector
4	CPU Power IC	18	Amplifier IC
5	Battery Connector	19	Microphone Connector
6	Power Board Connector	20	Line In Connector
7	Mini Card Connector	21	HeadPhone/SPDIF Connector
8	DDRII SO-DIMM	22	FAN Connector
9	+1.5V Power IC	23	USB Power IC
10	CD-ROM Connector	24	USB Connector
11	Volume Control Dial	25	Modem Line-in
12	7 in1 CardReader Connector	26	RJ-45&RJ-11 Connector
13	SATA HDD Connector	27	VGA Connector
14	Card reader Controller		

Clearing Password Check and BIOS Recovery

This section provide you the standard operating procedures of clearing password and BIOS recovery for Aspire 4530/4230. Aspire 4530/4230 provide one Hardware Open Gap on main board for clearing password check, and one Hotkey for enabling BIOS Recovery.

Clearing Password Check

Hardware Open Gap Description

Item	Description
R347 (RTC_RST)	Clear CMOS Jumper



Steps for Clearing BIOS Password Check

If users set BIOS Password (Supervisor Password and/or User Password) for a security reason, BIOS will ask the password during systems POST or when systems enter to BIOS Setup menu. However, once it is necessary to bypass the password check, users need to short the HW Gap to clear the password by the following steps:

- Power Off a system, and remove HDD, AC and Battery from the machine.
- Open the back cover of the machine, and find out the HW Gap on M/B as picture.
- Use an electric conductivity tool to short the two points of the HW Gap.
- Plug in AC, keep the short condition on the HW Gap, and press Power Button to power on the system till BIOS POST finish. Then remove the tool from the HW Gap.
- Restart system. Press F2 key to enter BIOS Setup menu.
- If there is no Password request, BIOS Password is cleared. Otherwise, please follow the steps and try again.

NOTE: The steps are only for clearing BIOS Password (Supervisor Password and User Password).

BIOS Recovery by Crisis Disk

BIOS Recovery Boot Block:

BIOS Recovery Boot Block is a special block of BIOS. It is used to boot up the system with minimum BIOS initialization. Users can enable this feature to restore the BIOS firmware to a successful one once the previous BIOS flashing process failed.

BIOS Recovery Hotkey:

The system provides a function hotkey: **Fn+Esc**, for enable BIOS Recovery process when system is powered on during BIOS POST. To use this function, it is strongly recommended to have the AC adapter and Battery present. If this function is enabled, the system will force the BIOS to enter a special BIOS block, called Boot Block.

Steps for BIOS Recovery by Crisis Disk:

Before doing this, one Crisis Disk should be prepared ready in hand. The Crisis Disk could be made by executing the Crisis Disk program in another system with Windows XP OS.

Follow the steps below:

1. Power Off system.
2. Insert the Crisis Disk to a USB floppy drive which is attached to the BIOS flash failed machine.
3. In the power-off state, press **Fn+Esc** and hold them and then press Power Button. The system should be powered on with Crisis BIOS Recovery process.
4. BIOS Boot Block starts to restore the BIOS code from the Crisis floppy disk to BIOS ROM on the failed machine.
5. If the Crisis flashing process is finished, the system will restart.

If the Crisis Recovery process is finished, the system should be powered on with successful and workable BIOS. Then a person can update the latest version BIOS for this machine by regular BIOS flashing process.

FRU (Field Replaceable Unit) List

This chapter gives you the FRU (Field Replaceable Unit) listing in global configurations of Aspire 4530/4230. Refer to this chapter whenever ordering for parts to repair or for RMA (Return Merchandise Authorization).

Please note that WHEN ORDERING FRU PARTS, you should check the most up-to-date information available on your regional web or channel. For whatever reasons a part number change is made, it will not be noted on the printed Service Guide. For ACER AUTHORIZED SERVICE PROVIDERS, your Acer office may have a DIFFERENT part number code from those given in the FRU list of this printed Service Guide. You MUST use the local FRU list provided by your regional Acer office to order FRU parts for repair and service of customer machines.

NOTE: To scrap or to return the defective parts, you should follow the local government ordinance or regulations on how to dispose it properly, or follow the rules set by your regional Acer office on how to return it.

Aspire 4530/4230 Exploded Diagram

Main Assembly

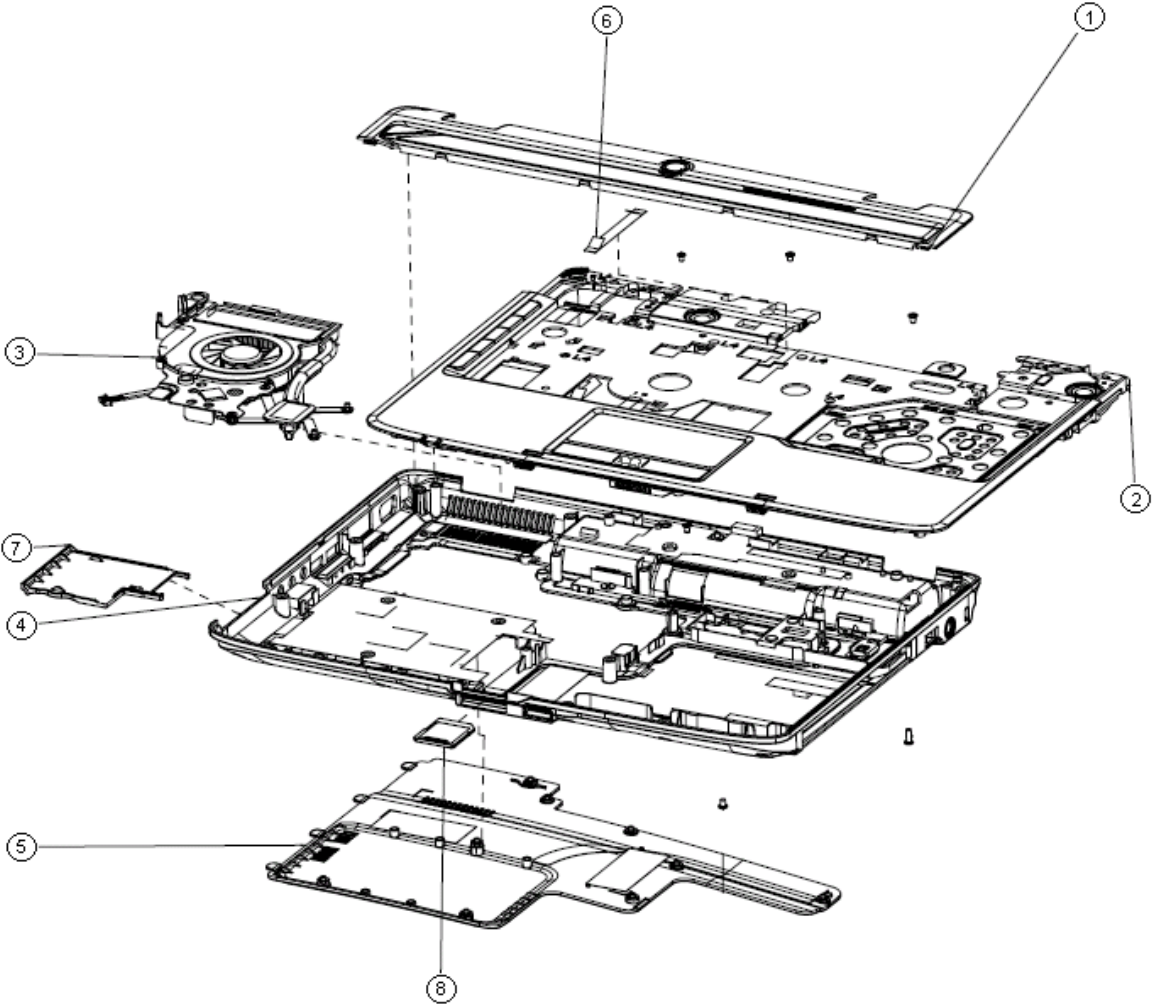

Item	Description	Part Number
1	Middle Cover	42.ARE07.001
2	Upper Cover	60.ARE07.001
3	Thermal Module	60.ARE07.008
4	Lower Cover	60.ARE07.003
5	Thermal Cover	42.ARE07.002
6	FFC Cable LED (3V, 58.5 MM, 12/12P)	50.ARE07.002
7	Express Card Dummy	42.ARE07.003
8	SD Card Dummy	42.TG607.005

LCD Assembly

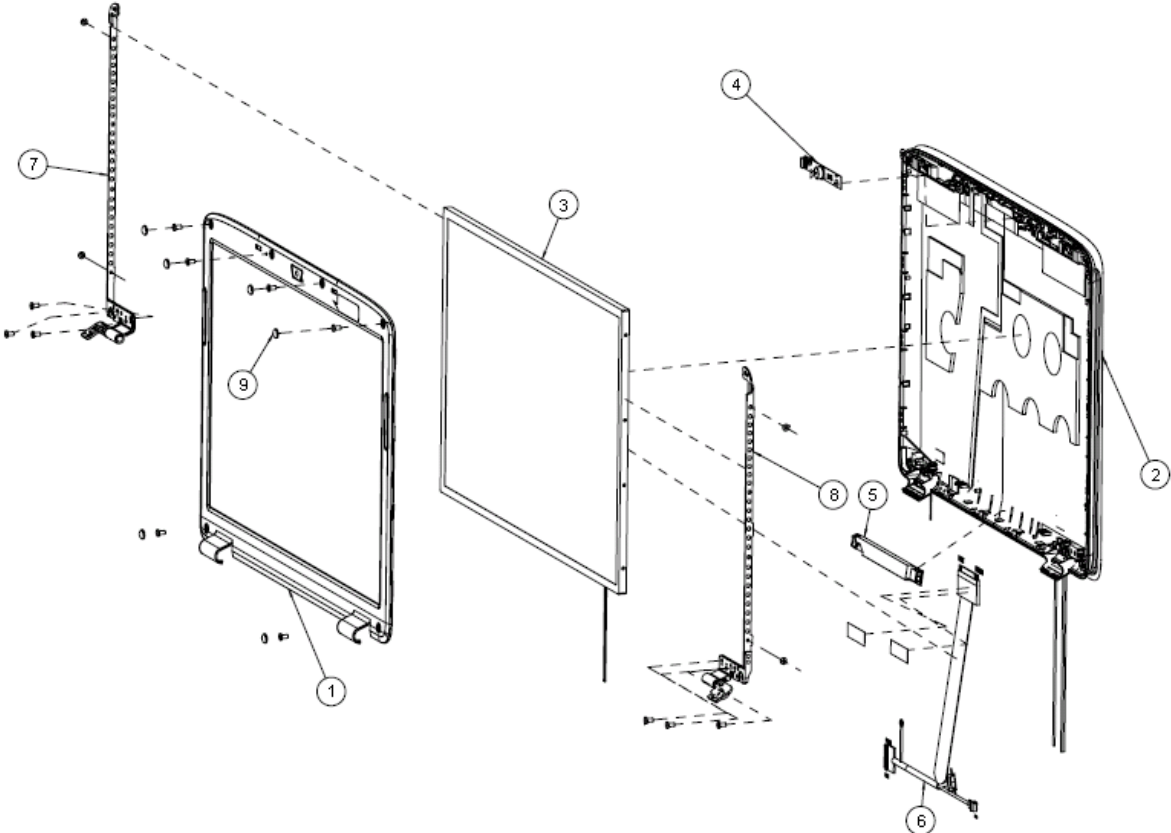



Item	Description	Part Number
1	LCD Bezel	60.ARE07.005
2	LCD Assy (IMR)	60.ARE07.004
3	LCD (TFT) 14.1" Panel	LK.14105.018
4	Camera Board	57.ARE07.001
5	Inverter	19.TPK07.001
6	LCD Cable Assy	50.ARE07.003
7	LCD Hinge_L	33.ARE07.005
8	LCD Hinge_R	33.ARE07.004
9	LCD Bezel Screw Cap	47.ARE07.001

Aspire 4530/4230 FRU List

Category	Description	Part Number
Adapter		
	ADAPTER 65W 3PIN DELTA SADP-65KB DFA	AP.06501.013
	ADAPTER 65W LITEON PA-1650-02AC LF	AP.06503.016
	ADAPTER 65W 3PIN HIPRO AC-OK065B13	AP.0650A.010
Battery		
	Battery SANYO AS-2007A Li-Ion 3S2P SANYO 6 cell 4400mAh Main COMMON Normal Type	BT.00603.041
	Battery SONY AS-2007A Li-Ion 3S2P SONY 6 cell 4400mAh Main COMMON Normal Type	BT.00604.024
	Battery PANASONIC AS-2007A Li-Ion 3S2P PANASONIC 6 cell 4400mAh Main COMMON PSS	BT.00605.020
	Battery SIMPLO AS-2007A Li-Ion 3S2P PANASONIC 6 cell 4400mAh Main COMMON PSS	BT.00607.015
Board		
	Foxconn Conexant -Unizion 1.5_3.3v AUS T60M955.04	FX.22500.025
	BLUETOOTH MODULE (T60H928.11)	BT.21100.005
	WIRELESS LAN CARD FOXCONN T60h976.00 MINI	54.AZL07.001
	WIRELESS LAN BOARD 802.11BG FOXCONN BCM4312 T77H030.00	NI.23600.029
	POWER BOARD W/USB	55.ARE07.001
	FUNCTION BOARD	55.ARE07.002
	LED BOARD	55.ARE07.003
	FP BOARD	55.ARE07.004

Category	Description	Part Number
Cable		
	PWR CORD V943B30001218008 DANISH 3P	27.A03V7.006
	PWR CORD(ISR)1.8M 3PBLK FZ010008-038	27.TATV7.005
	PWR CORD V50CB3T3012180QD TW-110V,3P	27.A99V7.002
	POWER CORD(SWI)1.8M 3PBLACK FZ010008-011	27.A99V7.004
	POWER CORD(IT) 1.8M 3PBLACK FZ010008-008	27.A99V7.005
	POWER CORD(S.A) 1.8M 3BLACK FZ010008-006	27.T48V7.001
	POWER CORD US 3PIN ROHS	27.TAXV7.001
	POWER CORD(EU) 1.8M 3PBLACK FM010008-010	27.TATV7.001
	POWER CORD(UK) 1.8M 3PBLACK FP010008-013	27.TATV7.003
	BLUETOOTH CABLE	50.TPK07.001
	MODEM CABLE	50.ARE07.001
	FFC LED CABLE	50.ARE07.002
Case/Cover/Bracket Assembly		
	MIDDLE COVER	42.ARE07.001
	UPPER CASE ASSY W/SPEAKER, TP, CABLES*2 FOR NON FP	60.ARE07.001
	UPPER CASE ASSY W/SPEAKER, TP, CABLES*3 FOR FP	60.ARE07.002
	LOWER CASE ASSY W/RUBBER	60.ARE07.003
	THERMAL COVER W/RUBBER	42.ARE07.002
	FP PLATE FOR NON FP	33.ARE07.001
	FP BRACKET	33.ARE07.002

Category	Description	Part Number
	DUMMY EXPRESS CARD	42.ARE07.003
	DUMMY 4 IN 1 CARD	42.TG607.005
CPU		
	CPU AMD Athlon64X2 QL60 PGA 1.9G 1M 638 35W Griffin B1	KC.AQL02.600
	CPU AMD TurionX2 RM70 PGA 2.0G 1M 638 35W Griffin B1	KC.TRM02.700
	CPU AMD TurionX2 ZM80 PGA 2.1G 2M 638 35W Griffin B1	KC.TZM02.800
	CPU AMD TurionX2 ZM82 PGA 2.2G 2M 638 35W Griffin B1	KC.TZM02.820
	CPU AMD TurionX2 ZM84 PGA 2.3G 2M 638 35W Griffin B1	KC.TZM02.840
	CPU AMD TurionX2 ZM86 PGA 2.4G 2M 638 35W Griffin B1	KC.TZM02.860
	CPU AMD SempronM SI40 PGA 2.0G 512K 638 25W Griffin B1	KC.SSI02.400
Combo Module		
	DVD/CDRW COMBO MODULE	6M.ARE07.001
	TOSHIBA COMBO Tray DL 24X TS-L463A LF W/O bezel SATA	KO.02401.006
	SONY COMBO Tray DL 24X CRX890S LF W/O bezel SATA	KO.0240E.009
	DVD/CDRW COMBO BEZEL	42.AHS07.004
	OPTICAL BRACKET	33.AHS07.002
Super Multi Drive		
	DVD/RW SUPER MULTI SATA MODULE	6M.ARE07.002
	TOSHIBA Super-Multi DRIVE Tray DL 8X TS-L633A LF W/O bezel SATA	KU.00801.021
	PIONEER Super-Multi DRIVE Tray DL 8X DVR-TD08RS LF W/O bezel SATA	KU.00805.044
	HLDS Super-Multi DRIVE Tray DL 8X GSA-T50N LF W/O bezel SATA Malaysia	KU.0080D.034
	ODD BEZEL - SUPER MULTI	42.AGW07.004

Category	Description	Part Number
	OPTICAL BRACKET	33.AHS07.002
HDD		
	HDD SEAGATE 2.5" 5400rpm 120GB ST9120817AS Corsair SATA LF F/W:3.AAA	KH.12001.032
	HDD HGST 5400rpm 120GB HTS542512K9SA00 Bronco-B SATA II LF F/W:C31P	KH.12007.014
	HDD(160G) ST9160827AS 9DG133-188 STN B/S SEAGATE F/W:3.AAA	KH.16001.029
	HDD TOSHIBA 5400rpm 160GB MK1646GSX Leo BS SATA I LF F/W:LB113J	KH.16004.002
	HDD HGST 2.5" 5400rpm 160GB HTS542516K9SA00 Bronco-B SATA II LF F/W:C31P	KH.16007.016
	HDD WD 2.5" 5400rpm 160GB WD1600BEVT-22ZCT0 ML160 SATA LF F/W:11.01A11	KH.16008.022
	HDD TOSHIBA 2.5" 5400rpm 250GB MK2546GSX Leo BS SATA I LF F/W:LB013J	KH.25004.001
	HDD 250GB 5400RPM SATA II HGST HTS542525K9SA00 LF F/W:C31P	KH.25007.011
HDD WD 2.5" 5400rpm 320GB WD3200BEVT-22ZCT0 ML160 SATA LF F/W:11.01A11	KH.32008.013	
	HDD BRACKET ASSY	33.ARE07.003

Category	Description	Part Number
Keyboard		
	Keyboard 14_15KB-FV3 Black 88KS US International (Aspire Black)	KB.INT00.442
	Keyboard 14_15KB-FV3 Black 88KS US International Hebrew (Aspire Black)	KB.INT00.443
	Keyboard 14_15KB-FV3 Black 89KS UK (Aspire Black)	KB.INT00.444
	Keyboard 14_15KB-FV3 Black 89KS Turkish (Aspire Black)	KB.INT00.445
	Keyboard 14_15KB-FV3 Black 88KS Thailand (Aspire Black)	KB.INT00.446
	Keyboard 14_15KB-FV3 Black 89KS Swiss/G (Aspire Black)	KB.INT00.447
	Keyboard 14_15KB-FV3 Black 89KS Swedish (Aspire Black)	KB.INT00.448
	Keyboard 14_15KB-FV3 Black 89KS Spanish (Aspire Black)	KB.INT00.449
	Keyboard 14_15KB-FV3 Black 89KS SLO/CRO (Aspire Black)	KB.INT00.451
	Keyboard 14_15KB-FV3 Black 88KS Russian (Aspire Black)	KB.INT00.452
	Keyboard 14_15KB-FV3 Black 89KS Portuguese (Aspire Black)	KB.INT00.453
	Keyboard 14_15KB-FV3 Black 89KS Norwegian (Aspire Black)	KB.INT00.455
	Keyboard 14_15KB-FV3 Black 88KS Korean (Aspire Black)	KB.INT00.457
	Keyboard 14_15KB-FV3 Black 93KS Japanese (Aspire Black)	KB.INT00.458
	Keyboard 14_15KB-FV3 Black 89KS Italian (Aspire Black)	KB.INT00.459
	Keyboard 14_15KB-FV3 Black 89KS Hungarian (Aspire Black)	KB.INT00.462
	Keyboard 14_15KB-FV3 Black 88KS Greek (Aspire Black)	KB.INT00.463
	Keyboard 14_15KB-FV3 Black 89KS German (Aspire Black)	KB.INT00.464
	Keyboard 14_15KB-FV3 Black 89KS French (Aspire Black)	KB.INT00.465
	Keyboard 14_15KB-FV3 Black 89KS Dutch (Aspire Black)	KB.INT00.467
	Keyboard 14_15KB-FV3 Black 89KS Danish (Aspire Black)	KB.INT00.468
	Keyboard 14_15KB-FV3 Black 89KS Czech (Aspire Black)	KB.INT00.469
	Keyboard 14_15KB-FV3 Black 88KS Traditional Chinese (Aspire Black)	KB.INT00.470
	Keyboard 14_15KB-FV3 Black 89KS Canadian French (Aspire Black)	KB.INT00.471
	Keyboard 14_15KB-FV3 Black 89KS Brazilian Portuguese (Aspire Black)	KB.INT00.472
Keyboard 14_15KB-FV3 Black 89KS Belgium (Aspire Black)	KB.INT00.473	
Keyboard 14_15KB-FV3 Black 88KS Arabic/English (Aspire Black)	KB.INT00.474	
Keyboard 14_15KB-FV3 Black 89KS Arabic/French (Aspire Black)	KB.INT00.475	
Keyboard 14_15KB-FV3 Black 89KS Slovak (Aspire Black)	KB.INT00.450	
LCD		
	LCD MODULE 14.1 IN. WXGAG ASSY W/ANTENNA CCD	6M.ARE07.003
	LCD 14.1" WXGA AU B141EW04-V4 LF GLARE 200NITS 16MS	LK.14105.018
	LCD SAMSUNG 14.1" WXGA Glare LTN141W3-L01-J L6 LF 200nit 16ms	LK.14106.014
	LCD LPL 14.1" WXGA Glare LP141WX3-TLN1 LF 200nit 16ms	LK.14108.014
	LCD 14.1" WXGA CMO N141I3-L02 LF GLARE 200NITS 16MS	LK.1410D.016

Category	Description	Part Number
	INVERTER BOARD	19.TPK07.001
	LCD CABLE	50.ARE07.003
	LCD COVER IMR W/MIC, CAMERA CABLE, ANTENNA	60.ARE07.004
	LCD BEZEL FOR CCD	60.ARE07.005
	LCD BRACKET W/HINGE - R	33.ARE07.004
	LCD BRACKET W/HINGE - L	33.ARE07.005
	CCD MODULE 0.3M	57.ARE07.001
	LCD MODULE 14.1 IN. WXGAG ASSY W/ANTENNA W/O CCD	6M.ARE07.004
	LCD 14.1" WXGA AU B141EW04-V4 LF GLARE 200NITS 16MS	LK.14105.018
	LCD SAMSUNG 14.1" WXGA Glare LTN141W3-L01-J L6 LF 200nit 16ms	LK.14106.014
	LCD LPL 14.1" WXGA Glare LP141WX3-TLN1 LF 200nit 16ms	LK.14108.014
	LCD 14.1" WXGA CMO N141I3-L02 LF GLARE 200NITS 16MS	LK.1410D.016
	INVERTER BOARD	19.TPK07.001
	LCD CABLE	50.ARE07.003
	LCD COVER IMR W/MIC, CAMERA CABLE, ANTENNA	60.ARE07.004
	LCD BEZEL W/O CCD	60.ARE07.007

Category	Description	Part Number
	LCD BRACKET W/HINGE - R	33.ARE07.004
	LCD BRACKET W/HINGE - L	33.ARE07.005
Mainboard		
	MAINBOARD UMA NVIDIA MCP77MH GIGA W/CARD READER, EXPRESS CARD W/O CPU RAM	MB.ARE06.001
Memory		
	SO-DIMM DDRII667 512MB NT512T64UH8B0FN-37C (0.09U)\NANYA	KN.51203.032
	Memory HYNIX SO-DIMM DDRII 667 512MB HYMP164S64CP6-Y5 LF	KN.5120G.024
	1GB NANYA DDRII 667 1GB NT1GT64U8HB0BN-3C (0.09U)	KN.1GB03.014
	Memory SAMSUNG SO-DIMM DDRII 667 1GB M470T2864DZ3-CE6 LF	KN.1GB0B.014
	Memory HYNIX SO-DIMM DDRII 667 1GB HYMP112S64CP6-Y5 LF	KN.1GB0G.012
	MEMORY HYNIX SO-DIMM DDRII 667 2GB HYMP125S64CP8-Y5 LF	KN.2GB0G.004
	Memory MICRON SO-DIMM DDRII 667 2GB MT16HTF25664HY-667E1 LF	KN.2GB04.001
	Memory SAMSUNG SO-DIMM DDRII 667 2GB M470T5663QZ3-CE6 LF	KN.2GB0B.003
Heatsink		
	THERMAL MODULE	60.ARE07.008
Miscellaneous		
	NAME PLATE - AS4530	40.ARE07.001
	NAME PLATE - AS4230	40.ARE07.002
	LCD BEZEL RUBBER	47.ARE07.001
	LOWER CASE RUBBER FOOT	47.ARE07.002

Screw List

Category	Description	Part Number
Screw List		
SCREW	M2.5*4	86.T23V7.009
SCREW	M2.5*6.5	86.ARE07.001
SCREW	M2.5*5	86.ARE07.003
SCREW	M2*3	86.A08V7.005
SCREW	M3*3.5	86.TDY07.003
SCREW	M2.5*3	86.A03V7.010

Model Definition and Configuration

Aspire 4530/4230 Series

Model	RO	Country	Acer Part no	Description
AS4230-401G12Mn	PA	ACLA-Portuguese	LX.APA0Y.010	AS4230-401G12Mn VHB32ATXC1 MC UMACÉ 1*1G/120/6L/5R/CB_bgn_0.3D_HG_XC21
AS4230-401G12Mn	PA	ACLA-Portuguese	LX.APA0Y.009	AS4230-401G12Mn EM VHB32ATXC2 MC UMACÉ 1*1G/120/6L/5R/CB_bgn_0.3D_HG_XC21
AS4230-401G12Mn	PA	ACLA-Portuguese	LX.APA0Y.008	AS4230-401G12Mn VHB32ATXC2 MC UMACÉ 1*1G/120/6L/5R/CB_bgn_0.3D_HG_XC22
AS4230-401G12Mn	PA	ACLA-Portuguese	LX.APA0Y.007	AS4230-401G12Mn EM VHB32ATXC1 MC UMACÉ 1*1G/120/6L/5R/CB_bgn_0.3D_HG_XC22
AS4230-401G16Mn	PA	ACLA-Portuguese	LX.APA0Y.018	AS4230-401G16Mn VHB32ATXC1 MC UMACÉ 1*1G/160/6L/5R/CB_bgn_0.3D_HG_XC21
AS4230-401G16Mn	PA	ACLA-Portuguese	LX.APA0Y.017	AS4230-401G16Mn EM VHB32ATXC2 MC UMACÉ 1*1G/160/6L/5R/CB_bgn_0.3D_HG_XC21
AS4230-401G16Mn	PA	ACLA-Portuguese	LX.APA0Y.016	AS4230-401G16Mn VHB32ATXC2 MC UMACÉ 1*1G/160/6L/5R/CB_bgn_0.3D_HG_XC22
AS4230-401G16Mn	PA	ACLA-Portuguese	LX.APA0Y.015	AS4230-401G16Mn EM VHB32ATXC1 MC UMACÉ 1*1G/160/6L/5R/CB_bgn_0.3D_HG_XC22
AS4230-401G16Mn	PA	ACLA-Portuguese	LX.APA0C.008	AS4230-401G16Mn LINPUSAXC1 UMACÉ 1*1G/160/6L/5R/CB_bgn_0.3D_HG_EN61
AS4230-401G16Mn	PA	ACLA-Portuguese	LX.APA0C.007	AS4230-401G16Mn LINPUSAXC2 UMACÉ 1*1G/160/6L/5R/CB_bgn_0.3D_HG_EN62
AS4230-401G16Mn	TWN	GCTWN	LX.APA0Y.002	AS4230-401G16Mn VHB32ATTW1 MC UMACÉ 1*1G/160/BT/6L/5R/CB_bgn_0.3D_HG_TC11
AS4230-401G12Mn	PA	ACLA-Spanish	LX.APA0Y.006	AS4230-401G12Mn EM VHB32ATEA1 MC UMACÉ 1*1G/120/6L/5R/CB_bgn_0.3D_HG_ES22
AS4230-401G12Mn	PA	ACLA-Spanish	LX.APA0Y.005	AS4230-401G12Mn VHB32ATEA3 MC UMACÉ 1*1G/120/6L/5R/CB_bgn_0.3D_HG_ES21
AS4230-401G12Mn	PA	ACLA-Spanish	LX.APA0Y.004	AS4230-401G12Mn EM VHB32ATEA3 MC UMACÉ 1*1G/120/6L/5R/CB_bgn_0.3D_HG_ES22
AS4230-401G12Mn	PA	ACLA-Spanish	LX.APA0Y.003	AS4230-401G12Mn VHB32ATEA1 MC UMACÉ 1*1G/120/6L/5R/CB_bgn_0.3D_HG_ES21
AS4230-401G16Mn	PA	ACLA-Spanish	LX.APA0Y.014	AS4230-401G16Mn EM VHB32ATEA1 MC UMACÉ 1*1G/160/6L/5R/CB_bgn_0.3D_HG_ES22
AS4230-401G16Mn	PA	ACLA-Spanish	LX.APA0Y.013	AS4230-401G16Mn VHB32ATEA3 MC UMACÉ 1*1G/160/6L/5R/CB_bgn_0.3D_HG_ES21
AS4230-401G16Mn	PA	ACLA-Spanish	LX.APA0Y.012	AS4230-401G16Mn EM VHB32ATEA3 MC UMACÉ 1*1G/160/6L/5R/CB_bgn_0.3D_HG_ES22
AS4230-401G16Mn	PA	ACLA-Spanish	LX.APA0Y.011	AS4230-401G16Mn VHB32ATEA1 MC UMACÉ 1*1G/160/6L/5R/CB_bgn_0.3D_HG_ES21
AS4230-401G16Mn	PA	ACLA-Spanish	LX.APA0C.006	AS4230-401G16Mn LINPUSAEA1 UMACÉ 1*1G/160/6L/5R/CB_bgn_0.3D_HG_EN61
AS4230-401G16Mn	PA	ACLA-Spanish	LX.APA0C.005	AS4230-401G16Mn LINPUSAEA2 UMACÉ 1*1G/160/6L/5R/CB_bgn_0.3D_HG_EN61
AS4230-401G16Mn	PA	ACLA-Spanish	LX.APA0C.004	AS4230-401G16Mn LINPUSAEA3 UMACÉ 1*1G/160/6L/5R/CB_bgn_0.3D_HG_EN61
AS4230-400516Mn	AAP	Singapore	LX.APA0C.001	AS4230-400516Mn LINPUSAG1 UMACÉ 1*512/160/BT/6L/5R/CB_bgn_0.3D_HG_EN11
AS4230-400525Mn	AAP	Singapore	LX.APA0C.002	AS4230-400525Mn LINPUSAG1 UMACÉ 1*512/250/BT/6L/5R/CB_bgn_0.3D_HG_EN11
AS4230-403G32Mn	AAP	Singapore	LX.APA0X.001	AS4230-403G32Mn VHP32ATSG1 MC UMACÉ 1G+2G/320/BT/6L/5R/CB_bgn_0.3D_HG_EN12
AS4230-401G12Cn	AAP	Philippines	LX.APA0C.003	AS4230-401G12Cn LINPUSAPH1 UMACÉ 1*1G/120/BT/6L/5R/CB_bgn_0.3D_HG_EN11

Model	RO	Country	Acer Part no	Description
AS4230-401G16Mn	PA	ACLA-Portuguese	LX.AP90Y.022	AS4230-401G16Mn EM VHB32ATXC2 MC UMAE 1*1G/160/6L/5R/CB_bgn_HG_XC21
AS4230-401G16Mn	PA	ACLA-Portuguese	LX.AP90Y.023	AS4230-401G16Mn VHB32ATXC2 MC UMAE 1*1G/160/6L/5R/CB_bgn_HG_XC22
AS4230-401G16Mn	PA	ACLA-Portuguese	LX.AP90Y.024	AS4230-401G16Mn EM VHB32ATXC1 MC UMAE 1*1G/160/6L/5R/CB_bgn_HG_XC22
AS4230-401G16Mn	PA	ACLA-Portuguese	LX.AP90C.010	AS4230-401G16Mn LINPUSAXC1 UMAE 1*1G/160/6L/5R/CB_bgn_HG_EN61
AS4230-401G16Mn	PA	ACLA-Portuguese	LX.AP90C.009	AS4230-401G16Mn LINPUSAXC2 UMAE 1*1G/160/6L/5R/CB_bgn_HG_EN62
AS4230-401G16Mn	PA	ACLA-Portuguese	LX.AP90Y.009	AS4230-401G16Mn VHB32ATXC1 MC UMAE 1*1G/160/6L/5R/CB_bgn_HG_XC21
AS4230-401G12Mn	PA	ACLA-Portuguese	LX.AP90Y.008	AS4230-401G12Mn VHB32ATXC1 MC UMAE 1*1G/120/6L/5R/CB_bgn_HG_XC21
AS4230-401G12Mn	PA	ACLA-Portuguese	LX.AP90Y.007	AS4230-401G12Mn EM VHB32ATXC2 MC UMAE 1*1G/120/6L/5R/CB_bgn_HG_XC21
AS4230-401G12Mn	PA	ACLA-Portuguese	LX.AP90Y.006	AS4230-401G12Mn VHB32ATXC2 MC UMAE 1*1G/120/6L/5R/CB_bgn_HG_XC22
AS4230-401G12Mn	PA	ACLA-Portuguese	LX.AP90Y.002	AS4230-401G12Mn EM VHB32ATXC1 MC UMAE 1*1G/120/6L/5R/CB_bgn_HG_XC22
AS4230-401G12Mn	PA	ACLA-Portuguese	LX.AP90C.005	AS4230-401G12Mn LINPUSAXC1 UMAE 1*1G/120/6L/5R/CB_bgn_HG_EN61
AS4230-401G12Mn	PA	ACLA-Portuguese	LX.AP90C.004	AS4230-401G12Mn LINPUSAXC2 UMAE 1*1G/120/6L/5R/CB_bgn_HG_EN62
AS4230-401G16Mn	PA	Canada	LX.AP90Y.018	AS4230-401G16Mn VHB32ATCA1 MC UMAE 1*1G/160/6L/5R/CB_bgn_HG_FR11
AS4230-401G16Mn	PA	Canada	LX.AP90Y.013	AS4230-401G16Mn VHB32ATCA1 MC UMAE 1*1G/160/6L/5R/CB_bgn_HG_FR12
AS4230-401G16Mn	PA	ACLA-Spanish	LX.AP90Y.021	AS4230-401G16Mn EM VHB32ATEA1 MC UMAE 1*1G/160/6L/5R/CB_bgn_HG_ES22
AS4230-401G16Mn	PA	ACLA-Spanish	LX.AP90Y.020	AS4230-401G16Mn VHB32ATEA3 MC UMAE 1*1G/160/6L/5R/CB_bgn_HG_ES21
AS4230-401G16Mn	PA	ACLA-Spanish	LX.AP90Y.019	AS4230-401G16Mn EM VHB32ATEA3 MC UMAE 1*1G/160/6L/5R/CB_bgn_HG_ES22
AS4230-401G16Mn	PA	ACLA-Spanish	LX.AP90Y.015	AS4230-401G16Mn VHB32ATEA1 MC UMAE 1*1G/160/6L/5R/CB_bgn_HG_ES21
AS4230-401G16Mn	PA	ACLA-Spanish	LX.AP90C.008	AS4230-401G16Mn LINPUSAEA1 UMAE 1*1G/160/6L/5R/CB_bgn_HG_EN61
AS4230-401G16Mn	PA	ACLA-Spanish	LX.AP90C.007	AS4230-401G16Mn LINPUSAEA2 UMAE 1*1G/160/6L/5R/CB_bgn_HG_EN61
AS4230-401G16Mn	PA	ACLA-Spanish	LX.AP90C.006	AS4230-401G16Mn LINPUSAEA3 UMAE 1*1G/160/6L/5R/CB_bgn_HG_EN61
AS4230-401G12Mn	PA	ACLA-Spanish	LX.AP90Y.003	AS4230-401G12Mn EM VHB32ATEA1 MC UMAE 1*1G/120/6L/5R/CB_bgn_HG_ES22
AS4230-401G12Mn	PA	ACLA-Spanish	LX.AP90Y.004	AS4230-401G12Mn VHB32ATEA3 MC UMAE 1*1G/120/6L/5R/CB_bgn_HG_ES21
AS4230-401G12Mn	PA	ACLA-Spanish	LX.AP90Y.005	AS4230-401G12Mn EM VHB32ATEA3 MC UMAE 1*1G/120/6L/5R/CB_bgn_HG_ES22
AS4230-401G12Mn	PA	ACLA-Spanish	LX.AP90Y.001	AS4230-401G12Mn VHB32ATEA1 MC UMAE 1*1G/120/6L/5R/CB_bgn_HG_ES21
AS4230-401G12Mn	PA	ACLA-Spanish	LX.AP90C.003	AS4230-401G12Mn LINPUSAEA1 UMAE 1*1G/120/6L/5R/CB_bgn_HG_EN61
AS4230-401G12Mn	PA	ACLA-Spanish	LX.AP90C.002	AS4230-401G12Mn LINPUSAEA2 UMAE 1*1G/120/6L/5R/CB_bgn_HG_EN61

Model	RO	Country	Acer Part no	Description
AS4230-401G12Mn	PA	ACLA-Spanish	LX.AP90C.001	AS4230-401G12Mn LIMPUSAEA3 UMAE 1*1G/120/6L/5R/CB_bgn_HG_EN61
AS4230-401G16Mn	PA	USA	LX.AP90Y.012	AS4230-401G16Mn VHB32ATUS1 MC UMAE 1*1G/160/6L/5R/CB_bgn_HG_EN33
AS4230-401G16Mn	PA	USA	LX.AP90Y.011	AS4230-401G16Mn VHB32ATUS1 MC UMAE 1*1G/160/6L/5R/CB_bgn_HG_EN34
AS4230-401G16Mn	PA	USA	LX.AP90Y.010	AS4230-401G16Mn VHB32ATUS1 MC UMAE 1*1G/160/6L/5R/CB_bgn_HG_EN32
AS4230-401G16Mn	PA	Canada	LX.AP90Y.017	AS4230-401G16Mn VHB32ATCA2 MC UMAE 1*1G/160/6L/5R/CB_bgn_HG_FR31
AS4230-401G16Mn	PA	Canada	LX.AP90Y.016	AS4230-401G16Mn VHB32ATCA2 MC UMAE 1*1G/160/6L/5R/CB_bgn_HG_FR32
AS4230-401G16Mn	PA	Canada	LX.AP90Y.014	AS4230-401G16Mn VHB32ATCA2 MC UMAE 1*1G/160/6L/5R/CB_bgn_HG_FR33
AS4530-601G16Mi	EMEA	Middle East	LX.ARE0X.028	AS4530-601G16Mi EM VHP32ATME2 MC UMACE 1*1G/160/6L/5R/CB_bg_0.3D_HG_AR23
AS4530-601G16Mi	EMEA	Middle East	LX.ARE0X.031	AS4530-601G16Mi EM VHP32ATME2 MC UMACE 1*1G/160/6L/5R/CB_bg_0.3D_HG_EN15
AS4530-601G16Mi	EMEA	Middle East	LX.ARE0X.032	AS4530-601G16Mi EM VHP32ATME2 MC UMACE 1*1G/160/6L/5R/CB_bg_0.3D_HG_AR13
AS4530-601G16Mi	EMEA	Belgium	LX.ARE0X.007	AS4530-601G16Mi VHP32ATBE1 MC UMACE 1*1G/160/6L/5R/CB_bg_0.3D_HG_NL13
AS4530-701G16Mn	PA	ACLA-Portuguese	LX.ARE0X.114	AS4530-701G16Mn EM VHP32ATXC2 MC UMACE 1*1G/160/6L/5R/CB_bgn_0.3D_HG_XC21
AS4530-702G16Mn	PA	ACLA-Portuguese	LX.ARE0X.111	AS4530-702G16Mn EM VHP32ATXC2 MC UMACE 2*1G/160/6L/5R/CB_bgn_0.3D_HG_XC21
AS4530-702G25Mn	PA	ACLA-Portuguese	LX.ARE0X.108	AS4530-702G25Mn EM VHP32ATXC2 MC UMACE 2*1G/250/6L/5R/CB_bgn_0.3D_HG_XC21
AS4530-702G25Mi	PA	ACLA-Portuguese	LX.ARE0X.069	AS4530-702G25Mi VHP32ATXC2 MC UMACE 1*2G/250/6L/5R/CB_bg_0.3D_HG_XC22
AS4530-702G25Mi	PA	ACLA-Portuguese	LX.ARE0X.068	AS4530-702G25Mi EM VHP32ATXC2 MC UMACE 1*2G/250/6L/5R/CB_bg_0.3D_HG_XC21
AS4530-702G25Mi	PA	ACLA-Portuguese	LX.ARE0X.067	AS4530-702G25Mi EM VHP32ATXC1 MC UMACE 1*2G/250/6L/5R/CB_bg_0.3D_HG_XC22
AS4530-702G25Mi	PA	ACLA-Portuguese	LX.ARE0X.066	AS4530-702G25Mi VHP32ATXC1 MC UMACE 1*2G/250/6L/5R/CB_bg_0.3D_HG_XC21
AS4530-601G16Mn	PA	ACLA-Portuguese	LX.ARE0X.088	AS4530-601G16Mn EM VHP32ATXC2 MC UMACE 1*1G/160/6L/5R/CB_bgn_0.3D_HG_XC21
AS4530-702G16Mn	PA	ACLA-Portuguese	LX.ARE0C.028	AS4530-702G16Mn LIMPUSAXC2 UMACE 2*1G/160/6L/5R/CB_bgn_0.3D_HG_EN62
AS4530-702G25Mn	PA	ACLA-Portuguese	LX.ARE0C.025	AS4530-702G25Mn LIMPUSAXC2 UMACE 2*1G/250/6L/5R/CB_bgn_0.3D_HG_EN62
AS4530-602G16Mn	PA	ACLA-Portuguese	LX.ARE0X.096	AS4530-602G16Mn EM VHP32ATXC2 MC UMACE 2*1G/160/6L/5R/CB_bgn_0.3D_HG_XC21
AS4530-602G16Mn	PA	ACLA-Portuguese	LX.ARE0C.036	AS4530-602G16Mn LIMPUSAXC2 UMACE 2*1G/160/6L/5R/CB_bgn_0.3D_HG_EN62
AS4530-601G16Mn	PA	ACLA-Portuguese	LX.ARE0C.022	AS4530-601G16Mn LIMPUSAXC2 UMACE 1*1G/160/6L/5R/CB_bgn_0.3D_HG_EN62
AS4530-602G12Mi	PA	Canada	LX.ARE0X.046	AS4530-602G12Mi VHP32ATCA1 MC UMACE 2*1G/120/6L/5R/CB_bg_0.3D_HG_FR11
AS4530-601G16Mi	EMEA	Eastern Europe	LX.ARE0X.013	AS4530-601G16Mi VHP32ATEU1 MC UMACE 1*1G/160/6L/5R/CB_bg_0.3D_HG_CS21
AS4530-602G16Mi	EMEA	Denmark	LX.ARE0X.053	AS4530-602G16Mi VHP32ATDK1 MC UMACE 2*1G/160/6L/5R/CB_bg_0.3D_HG_NO13

Model	RO	Country	Acer Part no	Description
AS4530-601G16Mi	EMEA	Denmark	LX.ARE0X.004	AS4530-601G16Mi VHP32ATDK1 MC UMACÉ 1*1G/160/6L/5R/CB_bg_0.3D_HG_NO13
AS4530-703G32Mi	EMEA	Denmark	LX.ARE0X.055	AS4530-703G32Mi VHP32ATDK1 MC UMACÉ 2G+1G/320/BT/6L/5R/CB_bg_0.3D_HG_NO13
AS4530-603G32Mi	EMEA	Denmark	LX.ARE0X.054	AS4530-603G32Mi VHP32ATDK1 MC UMACÉ 2G+1G/320/BT/6L/5R/CB_bg_0.3D_HG_NO13
AS4530-601G16Mi	EMEA	Middle East	LX.ARE0X.027	AS4530-601G16Mi EM VHP32ATME9 MC UMACÉ 1*1G/160/6L/5R/CB_bg_0.3D_HG_FR22
AS4530-601G16Mi	EMEA	Middle East	LX.ARE0X.030	AS4530-601G16Mi EM VHP32ATME3 MC UMACÉ 1*1G/160/6L/5R/CB_bg_0.3D_HG_FR23
AS4530-601G16Mi	EMEA	South Africa	LX.ARE0X.002	AS4530-601G16Mi EM VHP32ATZA1 MC UMACÉ 1*1G/160/6L/5R/CB_bg_0.3D_HG_FR23
AS4530-601G16Mi	EMEA	France	LX.ARE0X.005	AS4530-601G16Mi VHP32ATFR1 MC UMACÉ 1*1G/160/6L/5R/CB_bg_0.3D_HG_FR23
AS4530-601G16Mi	EMEA	Germany	LX.ARE0X.006	AS4530-601G16Mi VHP32ATDE1 MC UMACÉ 1*1G/160/6L/5R/CB_bg_0.3D_HG_DE13
AS4530-601G16Mi	EMEA	Greece	LX.ARE0X.022	AS4530-601G16Mi VHP32ATGR1 MC UMACÉ 1*1G/160/6L/5R/CB_bg_0.3D_HG_EL32
AS4530-601G16Mi	EMEA	Greece	LX.ARE0X.023	AS4530-601G16Mi VHP32ATGR1 MC UMACÉ 1*1G/160/6L/5R/CB_bg_0.3D_HG_EL22
AS4530-601G16Mi	EMEA	Hungary	LX.ARE0X.017	AS4530-601G16Mi VHP32ATHU1 MC UMACÉ 1*1G/160/6L/5R/CB_bg_0.3D_HG_HU11
AS4530-601G16Mi	EMEA	Italy	LX.ARE0X.025	AS4530-601G16Mi VHP32ATIT1 MC UMACÉ 1*1G/160/6L/5R/CB_bg_0.3D_HG_IT12
AS4530-601G16Mi	EMEA	Norway	LX.ARE0X.010	AS4530-601G16Mi VHP32ATNO1 MC UMACÉ 1*1G/160/6L/5R/CB_bg_0.3D_HG_NO12
AS4530-704G32Mi	EMEA	Norway	LX.ARE0X.079	AS4530-704G32Mi VHP32ATNO1 MC UMACÉ 2*2G/320/BT/6L/5R/CB_bg_0.3D_HG_NO12
AS4530-603G32Mi	EMEA	Norway	LX.ARE0X.060	AS4530-603G32Mi VHP32ATNO1 MC UMACÉ 2G+1G/320/6L/5R/CB_bg_0.3D_HG_NO12
AS4530-601G16Mi	EMEA	Portugal	LX.ARE0X.020	AS4530-601G16Mi VHP32ATPT1 MC UMACÉ 1*1G/160/6L/5R/CB_bg_0.3D_HG_PT12
AS4530-601G16Mi	EMEA	Russia	LX.ARE0X.003	AS4530-601G16Mi VHP32ATRU1 MC UMACÉ 1*1G/160/6L/5R/CB_bg_0.3D_HG_RU11
AS4530-601G16Mi	EMEA	Eastern Europe	LX.ARE0X.015	AS4530-601G16Mi VHP32ATEU3 MC UMACÉ 1*1G/160/6L/5R/CB_bg_0.3D_HG_RU21
AS4530-601G16Mi	EMEA	Eastern Europe	LX.ARE0X.018	AS4530-601G16Mi VHP32ATEU3 MC UMACÉ 1*1G/160/6L/5R/CB_bg_0.3D_HG_RU11
AS4530-603G25Mi	EMEA	Eastern Europe	LX.ARE0X.080	AS4530-603G25Mi VHP32ATEU3 MC UMACÉ 2G+1G/250/BT/6L/5R/CB_bg_0.3D_HG_RU21
AS4530-601G16Mi	EMEA	Slovenia/Croatia	LX.ARE0X.019	AS4530-601G16Mi VHP32ATSI1 MC UMACÉ 1*1G/160/6L/5R/CB_bg_0.3D_HG_EN12
AS4530-601G16Mi	EMEA	Spain	LX.ARE0X.021	AS4530-601G16Mi VHP32ATES1 MC UMACÉ 1*1G/160/6L/5R/CB_bg_0.3D_HG_ES22
AS4530-701G16Mn	PA	ACLA-Spanish	LX.ARE0X.113	AS4530-701G16Mn EM VHP32ATEA1 MC UMACÉ 1*1G/160/6L/5R/CB_bgn_0.3D_HG_ES22
AS4530-701G16Mn	PA	ACLA-Spanish	LX.ARE0X.112	AS4530-701G16Mn EM VHP32ATEA3 MC UMACÉ 1*1G/160/6L/5R/CB_bgn_0.3D_HG_ES22
AS4530-702G16Mn	PA	ACLA-Spanish	LX.ARE0X.110	AS4530-702G16Mn EM VHP32ATEA1 MC UMACÉ 2*1G/160/6L/5R/CB_bgn_0.3D_HG_ES22
AS4530-702G16Mn	PA	ACLA-Spanish	LX.ARE0X.109	AS4530-702G16Mn EM VHP32ATEA3 MC UMACÉ 2*1G/160/6L/5R/CB_bgn_0.3D_HG_ES22
AS4530-702G25Mn	PA	ACLA-Spanish	LX.ARE0X.107	AS4530-702G25Mn EM VHP32ATEA1 MC UMACÉ 2*1G/250/6L/5R/CB_bgn_0.3D_HG_ES22

Model	RO	Country	Acer Part no	Description
AS4530-702G25Mn	PA	ACLA-Spanish	LX.ARE0X.106	AS4530-702G25Mn EM VHP32ATEA3 MC UMACÉ 2*1G/250/6L/5R/CB_bgn_0.3D_HG_ES22
AS4530-702G25Mi	PA	ACLA-Spanish	LX.ARE0X.065	AS4530-702G25Mi VHP32ATEA3 MC UMACÉ 1*2G/250/6L/5R/CB_bg_0.3D_HG_ES21
AS4530-702G25Mi	PA	ACLA-Spanish	LX.ARE0X.064	AS4530-702G25Mi EM VHP32ATEA3 MC UMACÉ 1*2G/250/6L/5R/CB_bg_0.3D_HG_ES22
AS4530-702G25Mi	PA	ACLA-Spanish	LX.ARE0X.063	AS4530-702G25Mi EM VHP32ATEA1 MC UMACÉ 1*2G/250/6L/5R/CB_bg_0.3D_HG_ES22
AS4530-702G25Mi	PA	ACLA-Spanish	LX.ARE0X.062	AS4530-702G25Mi VHP32ATEA1 MC UMACÉ 1*2G/250/6L/5R/CB_bg_0.3D_HG_ES21
AS4530-601G16Mn	PA	ACLA-Spanish	LX.ARE0X.087	AS4530-601G16Mn EM VHP32ATEA3 MC UMACÉ 1*1G/160/6L/5R/CB_bgn_0.3D_HG_ES22
AS4530-601G16Mn	PA	ACLA-Spanish	LX.ARE0X.086	AS4530-601G16Mn EM VHP32ATEA1 MC UMACÉ 1*1G/160/6L/5R/CB_bgn_0.3D_HG_ES22
AS4530-702G16Mn	PA	ACLA-Spanish	LX.ARE0C.027	AS4530-702G16Mn LINPUSAE1 UMACÉ 2*1G/160/6L/5R/CB_bgn_0.3D_HG_EN61
AS4530-702G16Mn	PA	ACLA-Spanish	LX.ARE0C.026	AS4530-702G16Mn LINPUSAE3 UMACÉ 2*1G/160/6L/5R/CB_bgn_0.3D_HG_EN61
AS4530-702G25Mn	PA	ACLA-Spanish	LX.ARE0C.024	AS4530-702G25Mn LINPUSAE1 UMACÉ 2*1G/250/6L/5R/CB_bgn_0.3D_HG_EN61
AS4530-702G25Mn	PA	ACLA-Spanish	LX.ARE0C.023	AS4530-702G25Mn LINPUSAE3 UMACÉ 2*1G/250/6L/5R/CB_bgn_0.3D_HG_EN61
AS4530-602G16Mn	PA	ACLA-Spanish	LX.ARE0X.095	AS4530-602G16Mn EM VHP32ATEA3 MC UMACÉ 2*1G/160/6L/5R/CB_bgn_0.3D_HG_ES22
AS4530-602G16Mn	PA	ACLA-Spanish	LX.ARE0X.094	AS4530-602G16Mn EM VHP32ATEA1 MC UMACÉ 2*1G/160/6L/5R/CB_bgn_0.3D_HG_ES22
AS4530-602G16Mn	PA	ACLA-Spanish	LX.ARE0C.035	AS4530-602G16Mn LINPUSAE1 UMACÉ 2*1G/160/6L/5R/CB_bgn_0.3D_HG_EN61
AS4530-602G16Mn	PA	ACLA-Spanish	LX.ARE0C.034	AS4530-602G16Mn LINPUSAE3 UMACÉ 2*1G/160/6L/5R/CB_bgn_0.3D_HG_EN61
AS4530-601G16Mn	PA	ACLA-Spanish	LX.ARE0C.021	AS4530-601G16Mn LINPUSAE1 UMACÉ 1*1G/160/6L/5R/CB_bgn_0.3D_HG_EN61
AS4530-601G16Mn	PA	ACLA-Spanish	LX.ARE0C.020	AS4530-601G16Mn LINPUSAE3 UMACÉ 1*1G/160/6L/5R/CB_bgn_0.3D_HG_EN61
AS4530-601G16Mi	EMEA	Sweden/Finland	LX.ARE0X.011	AS4530-601G16Mi VHP32ATSE1 MC UMACÉ 1*1G/160/6L/5R/CB_bg_0.3D_HG_FI12
AS4530-601G16Mi	EMEA	Eastern Europe	LX.ARE0X.014	AS4530-601G16Mi VHP32ATEU4 MC UMACÉ 1*1G/160/6L/5R/CB_bg_0.3D_HG_FI12
AS4530-601G16Mi	EMEA	Switzerland	LX.ARE0X.033	AS4530-601G16Mi VHP32ATCH1 MC UMACÉ 1*1G/160/6L/5R/CB_bg_0.3D_HG_IT42
AS4530-601G16Mi	EMEA	Luxembourg	LX.ARE0X.009	AS4530-601G16Mi VHP32ATLU1 MC UMACÉ 1*1G/160/6L/5R/CB_bg_0.3D_HG_IT42
AS4530-601G16Mi	EMEA	Turkey	LX.ARE0X.026	AS4530-601G16Mi EM VHP32ATTR1 MC UMACÉ 1*1G/160/6L/5R/CB_bg_0.3D_HG_TR32
AS4530-601G16Mi	EMEA	UK	LX.ARE0X.034	AS4530-601G16Mi VHP32ATGB1 MC UMACÉ 1*1G/160/6L/5R/CB_bg_0.3D_HG_EN14
AS4530-700516Mn	AAP	Singapore	LX.ARE0C.002	AS4530-700516Mn LINPUSAG1 UMACÉ 1*512/160/BT/6L/5R/CB_bgn_0.3D_HG_EN11
AS4530-800516Mn	AAP	Singapore	LX.ARE0C.003	AS4530-800516Mn LINPUSAG1 UMACÉ 1*512/160/BT/6L/5R/CB_bgn_0.3D_HG_EN11
AS4530-820516Mn	AAP	Singapore	LX.ARE0C.004	AS4530-820516Mn LINPUSAG1 UMACÉ 1*512/160/BT/6L/5R/CB_bgn_0.3D_HG_EN11
AS4530-840516Mn	AAP	Singapore	LX.ARE0C.005	AS4530-840516Mn LINPUSAG1 UMACÉ 1*512/160/BT/6L/5R/CB_bgn_0.3D_HG_EN11

Model	RO	Country	Acer Part no	Description
AS4530-860516Mn	AAP	Singapore	LX.ARE0C.006	AS4530-860516Mn LINPUSASG1 UMACЕ 1*512/160/BT/6L/5R/CB_bgn_0.3D_HG_EN11
AS4530-600525Mn	AAP	Singapore	LX.ARE0C.007	AS4530-600525Mn LINPUSASG1 UMACЕ 1*512/250/BT/6L/5R/CB_bgn_0.3D_HG_EN11
AS4530-700525Mn	AAP	Singapore	LX.ARE0C.008	AS4530-700525Mn LINPUSASG1 UMACЕ 1*512/250/BT/6L/5R/CB_bgn_0.3D_HG_EN11
AS4530-600516Mn	AAP	Singapore	LX.ARE0C.001	AS4530-600516Mn LINPUSASG1 UMACЕ 1*512/160/BT/6L/5R/CB_bgn_0.3D_HG_EN11
AS4530-800525Mn	AAP	Singapore	LX.ARE0C.009	AS4530-800525Mn LINPUSASG1 UMACЕ 1*512/250/BT/6L/5R/CB_bgn_0.3D_HG_EN11
AS4530-820525Mn	AAP	Singapore	LX.ARE0C.010	AS4530-820525Mn LINPUSASG1 UMACЕ 1*512/250/BT/6L/5R/CB_bgn_0.3D_HG_EN11
AS4530-840525Mn	AAP	Singapore	LX.ARE0C.011	AS4530-840525Mn LINPUSASG1 UMACЕ 1*512/250/BT/6L/5R/CB_bgn_0.3D_HG_EN11
AS4530-860525Mn	AAP	Singapore	LX.ARE0C.012	AS4530-860525Mn LINPUSASG1 UMACЕ 1*512/250/BT/6L/5R/CB_bgn_0.3D_HG_EN11
AS4530-603G32Mn	AAP	Singapore	LX.ARE0X.037	AS4530-603G32Mn VHP32ATSG1 MC UMACЕ 1G+2G/320/BT/6L/5R/CB_bgn_0.3D_HG_EN12
AS4530-703G32Mi	AAP	Singapore	LX.ARE0X.038	AS4530-703G32Mi VHP32ATSG1 MC UMACЕ 1G+2G/320/BT/6L/5R/CB_bg_0.3D_HG_EN12
AS4530-700516Mi	AAP	Indonesia	LX.ARE0C.013	AS4530-700516Mi LINPUSAD1 UMACЕ 1*512/160/BT/6L/5R/CB_bg_0.3D_HG_ID21
AS4530-803G32Mn	AAP	Singapore	LX.ARE0X.039	AS4530-803G32Mn VHP32ATSG1 MC UMACЕ 1G+2G/320/BT/6L/5R/CB_bgn_0.3D_HG_EN12
AS4530-823G32Mi	AAP	Singapore	LX.ARE0X.040	AS4530-823G32Mi VHP32ATSG1 MC UMACЕ 1G+2G/320/BT/6L/5R/CB_bg_0.3D_HG_EN12
AS4530-843G32Mn	AAP	Singapore	LX.ARE0X.041	AS4530-843G32Mn VHP32ATSG1 MC UMACЕ 1G+2G/320/BT/6L/5R/CB_bgn_0.3D_HG_EN12
AS4530-863G32Mn	AAP	Singapore	LX.ARE0X.042	AS4530-863G32Mn VHP32ATSG1 MC UMACЕ 1G+2G/320/BT/6L/5R/CB_bgn_0.3D_HG_EN12
AS4530-601G25Mn	AAP	Vietnam	LX.ARE0C.015	AS4530-601G25Mn LINPUSAVN1 UMACЕ 1*1G/250/BT/6L/5R/CB_bgn_0.3D_HG_EN11
AS4530-701G25Mn	AAP	Vietnam	LX.ARE0C.016	AS4530-701G25Mn LINPUSAVN1 UMACЕ 1*1G/250/BT/6L/5R/CB_bgn_0.3D_HG_EN11
AS4530-702G12Mn	AAP	Philippines	LX.ARE0Y.002	AS4530-702G12Mn EM VHB32ATPH1 MC UMACЕ 2*1G/120/BT/6L/5R/CB_bgn_0.3D_HG_EN14
AS4530-701G12Mn	AAP	Philippines	LX.ARE0C.017	AS4530-701G12Mn LINPUSAPH1 UMACЕ 1*1G/120/BT/6L/5R/CB_bgn_0.3D_HG_EN11
AS4530-802G25Mn	AAP	Philippines	LX.ARE0X.043	AS4530-802G25Mn EM VHP32ATPH1 MC UMACЕ 2*1G/250/BT/6L/5R/CB_bgn_0.3D_HG_EN14
AS4530-843G32Mn	AAP	Philippines	LX.ARE0X.044	AS4530-843G32Mn EM VHP32ATPH1 MC UMACЕ 1G+2G/320/BT/6L/5R/CB_bgn_0.3D_HG_EN14
AS4530-701G16Mi	AAP	Malaysia	LX.ARE0C.014	AS4530-701G16Mi LINPUSAMY1 UMACЕ 1*1G/160/BT/6L/5R/CB_bg_0.3D_HG_EN11
AS4530-701G16Mi	AAP	Malaysia	LX.ARE0Y.001	AS4530-701G16Mi EM VHB32ATMY1 MC UMACЕ 1*1G/160/BT/6L/5R/CB_bg_0.3D_HG_EN14
AS4530-802G16Mn	AAP	Philippines	LX.ARE0X.045	AS4530-802G16Mn EM VHP32ATPH1 MC UMACЕ 2*1G/160/BT/6L/5R/CB_bgn_0.3D_HG_EN14
AS4530-802G16Mn	AAP	Singapore	LX.ARE0X.051	AS4530-802G16Mn VHP32ATSG1 MC UMACЕ 1*2G/160/6L/5R/CB_bgn_0.3D_HG_EN12
AS4530-802G32Mn	AAP	Singapore	LX.ARE0X.052	AS4530-802G32Mn VHP32ATSG1 MC UMACЕ 1*2G/320/6L/5R/CB_bgn_0.3D_HG_EN12
AS4530-602G16Mn	AAP	Singapore	LX.ARE0X.049	AS4530-602G16Mn VHP32ATSG1 MC UMACЕ 1*2G/160/BT/6L/5R/CB_bgn_0.3D_HG_EN12

Model	RO	Country	Acer Part no	Description
AS4530-601G12Mn	AAP	Singapore	LX.ARE0Y.003	AS4530-601G12Mn VHB32ATSG1 MC UMACÉ 1*1G/120/6L/5R/CB_bgn_0.3D_HG_EN12
AS4530-601G12Mn	AAP	Singapore	LX.ARE0C.018	AS4530-601G12Mn LINPUSASG1 UMACÉ 1*1G/120/6L/5R/CB_bgn_0.3D_HG_EN11
AS4530-602G25Mi	EMEA	Eastern Europe	LX.ARE0X.050	AS4530-602G25Mi VHP32ATEU5 MC UMACÉ 2*1G/250/BT/6L/5R/CB_bg_0.3D_HG_PL11
AS4530-601G16Mi	EMEA	Middle East	LX.ARE0X.029	AS4530-601G16Mi EM VHP32ATME6 MC UMACÉ 1*1G/160/6L/5R/CB_bg_0.3D_HG_EN15
AS4530-701G16Mi	PA	USA	LX.ARE0X.035	AS4530-701G16Mi VHP32ATUS1 MC UMACÉ 1*1G/160/6L/5R/CB_bg_0.3D_HG_EN32
AS4530-802G25Mi	PA	USA	LX.ARE0X.036	AS4530-802G25Mi VHP32ATUS1 MC UMACÉ 1*2G/250/6L/5R/CB_bg_0.3D_HG_EN32
AS4530-602G12Mi	PA	USA	LX.ARE0X.047	AS4530-602G12Mi VHP32ATUS1 MC UMACÉ 2*1G/120/6L/5R/CB_bg_0.3D_HG_EN32
AS4530-602G12Mi	PA	USA	LX.ARE0X.048	AS4530-602G12Mi VHP32ATUS1 MC UMACÉ 2*1G/120/6L/5R/CB_bg_0.3D_HG_EN33
AS4530-601G16Mi	EMEA	South Africa	LX.ARE0X.001	AS4530-601G16Mi EM VHP32ATZA2 MC UMACÉ 1*1G/160/6L/5R/CB_bg_0.3D_HG_EN16
AS4530-601G16Mi	EMEA	Holland	LX.ARE0X.008	AS4530-601G16Mi VHP32ATNL1 MC UMACÉ 1*1G/160/6L/5R/CB_bg_0.3D_HG_NL12
AS4530-601G16Mi	EMEA	Eastern Europe	LX.ARE0X.016	AS4530-601G16Mi VHP32ATEU5 MC UMACÉ 1*1G/160/6L/5R/CB_bg_0.3D_HG_PL11
AS4530-723G32Mn	AAP	Singapore	LX.ARE0X.099	AS4530-723G32Mn VHP32ATSG1 MC UMACÉ 1G+2G/320/BT/6L/5R/CB_bgn_0.3D_HG_ZH31
AS4530-703G32Mn	AAP	Singapore	LX.ARE0X.103	AS4530-703G32Mn VHP32ATSG1 MC UMACÉ 2G+1G/320/BT/6L/5R/CB_bgn_0.3D_HG_ZH31
AS4530-823G32Mn	AAP	Singapore	LX.ARE0X.102	AS4530-823G32Mn VHP32ATSG1 MC UMACÉ 2G+1G/320/BT/6L/5R/CB_bgn_0.3D_HG_ZH31
AS4530-602G16Mn	AAP	Singapore	LX.ARE0X.101	AS4530-602G16Mn VHP32ATSG1 MC UMACÉ 1*2G/160/BT/6L/5R/CB_bgn_0.3D_HG_ZH31
AS4530-701G16Mn	AAP	Malaysia	LX.ARE0C.038	AS4530-701G16Mn LINPUSAMY1 UMACÉ 1*1G/160/BT/6L/5R/CB_bgn_0.3D_HG_EN11
AS4530-701G16Mn	AAP	Malaysia	LX.ARE0Y.006	AS4530-701G16Mn EM VHB32ATMY1 MC UMACÉ 1*1G/160/BT/6L/5R/CB_bgn_0.3D_HG_EN14
AS4530-603G16Mn	PA	USA	LX.ARE0X.104	AS4530-603G16Mn VHP32ATUS1 MC UMACÉ 2G+1G/160/6L/5R/CB_bgn_0.3D_HG_EN32
AS4530-700516Mn	AAP	Indonesia	LX.ARE0C.037	AS4530-700516Mn LINPUSID1 UMACÉ 1*512/160/BT/6L/5R/CB_bgn_0.3D_HG_ID21
AS4530-721G16Mn	AAP	Malaysia	LX.ARE0C.039	AS4530-721G16Mn LINPUSAMY1 UMACÉ 1*1G/160/BT/6L/5R/CB_bgn_0.3D_HG_EN11
AS4530-721G16Mn	AAP	Malaysia	LX.ARE0Y.007	AS4530-721G16Mn EM VHB32ATMY1 MC UMACÉ 1*1G/160/BT/6L/5R/CB_bgn_0.3D_HG_EN14
AS4530-603G25Mi	EMEA	Eastern Europe	LX.ARE0X.081	AS4530-603G25Mi VHP32ATEU5 MC UMACÉ 2G+1G/250/BT/6L/5R/CB_bg_0.3D_HG_PL11
AS4530-704G32Mn	PA	USA	LX.ARE0X.083	AS4530-704G32Mn VHP64ATCA2 MC UMACÉ 2*2G/320/6L/5R/CB_bgn_0.3D_HG_EN11
AS4530-704G32Mn	PA	USA	LX.ARE0X.082	AS4530-704G32Mn VHP64ATCA2 MC UMACÉ 2*2G/320/6L/5R/CB_bgn_0.3D_HG_EN12
AS4530-601G16Mi	AAP	India	LX.ARE0C.019	AS4530-601G16Mi LINPUSAIN1 UMACÉ 1*1G/160/BT/6L/5R/CB_bg_0.3D_HG_EN11
AS4530-602G16Mi	AAP	Singapore	LX.ARE0X.061	AS4530-602G16Mi VHP32ATSG1 MC UMACÉ 1*2G/160/BT/6L/5R/CB_bg_0.3D_HG_ZH31
AS4530-823G32Mi	AAP	Singapore	LX.ARE0X.059	AS4530-823G32Mi VHP32ATSG1 MC UMACÉ 1G+2G/320/BT/6L/5R/CB_bg_0.3D_HG_ZH31

Model	RO	Country	Acer Part no	Description
AS4530-703G32Mi	AAP	Singapore	LX.ARE0X.058	AS4530-703G32Mi VHP32ATSG1 MC UMACÉ 1G+2G/320/BT/6L/5R/CB_bg_0.3D_HG_ZH31
AS4530-802G32Mn	AAP	Singapore	LX.ARE0X.057	AS4530-802G32Mn VHP32ATSG1 MC UMACÉ 1*2G/320/6L/5R/CB_bgn_0.3D_HG_ZH31
AS4530-802G16Mn	AAP	Singapore	LX.ARE0X.056	AS4530-802G16Mn VHP32ATSG1 MC UMACÉ 1*2G/160/6L/5R/CB_bgn_0.3D_HG_ZH31
AS4530-704G32Mi	PA	USA	LX.ARE0X.085	AS4530-704G32Mi VHP64ATCA2 MC UMACÉ 2*2G/320/6L/5R/CB_bg_0.3D_HG_EN11
AS4530-702G25Mi	PA	USA	LX.ARE0X.073	AS4530-702G25Mi VHP32ATUS1 MC UMACÉ 1*2G/250/6L/5R/CB_bg_0.3D_HG_EN33
AS4530-702G25Mi	PA	USA	LX.ARE0X.072	AS4530-702G25Mi VHP32ATUS1 MC UMACÉ 1*2G/250/6L/5R/CB_bg_0.3D_HG_EN35
AS4530-702G25Mi	PA	USA	LX.ARE0X.071	AS4530-702G25Mi VHP32ATUS1 MC UMACÉ 1*2G/250/6L/5R/CB_bg_0.3D_HG_EN32
AS4530-702G25Mi	PA	USA	LX.ARE0X.070	AS4530-702G25Mi VHP32ATUS1 MC UMACÉ 1*2G/250/6L/5R/CB_bg_0.3D_HG_EN34
AS4530-801G16Mn	AAP	Philippines	LX.ARE0C.031	AS4530-801G16Mn LIMPUSAPH1 UMACÉ 1*1G/160/BT/6L/5R/CB_bgn_0.3D_HG_EN11
AS4530-843G32Mn	AAP	Singapore	LX.ARE0X.091	AS4530-843G32Mn VHP32ATSG1 MC UMACÉ 1G+2G/320/BT/6L/5R/CB_bgn_0.3D_HG_ZH31
AS4530-863G32Mn	AAP	Singapore	LX.ARE0X.090	AS4530-863G32Mn VHP32ATSG1 MC UMACÉ 1G+2G/320/BT/6L/5R/CB_bgn_0.3D_HG_ZH31
AS4530-802G16Mn	AAP	Singapore	LX.ARE0X.089	AS4530-802G16Mn VHP32ATSG1 MC UMACÉ 1*2G/160/BT/6L/5R/CB_bgn_0.3D_HG_ZH31
AS4530-602G25Mn	PA	USA	LX.ARE0X.097	AS4530-602G25Mn VHP32ATUS1 MC UMACÉ 2*1G/250/6L/5R/CB_bgn_0.3D_HG_EN32
AS4530-602G16Mn	PA	USA	LX.ARE0C.033	AS4530-602G16Mn LIMPUSAUS1 UMACÉ 2*1G/160/6L/5R/CB_bgn_0.3D_HG_EN31
AS4530-601G12Mn	AAP	Philippines	LX.ARE0C.029	AS4530-601G12Mn LIMPUSAPH1 UMACÉ 1*1G/120/6L/5R/CB_bgn_0.3D_HG_EN11
AS4530-822G16Mn	AAP	Philippines	LX.ARE0C.030	AS4530-822G16Mn LIMPUSAPH1 UMACÉ 1*2G/160/6L/5R/CB_bgn_0.3D_HG_EN11
AS4530-822G16Mn	AAP	Philippines	LX.ARE0Y.005	AS4530-822G16Mn EM VHB32ATPH1 MC UMACÉ 1*2G/160/BT/6L/5R/CB_bgn_0.3D_HG_EN14
AS4530-602G16Mi	PA	USA	LX.ARE0X.092	AS4530-602G16Mi VHP32ATUS1 MC UMACÉ 2*1G/160/6L/5R/CB_bg_0.3D_HG_EN32
AS4530-601G16Mn	AAP	India	LX.ARE0Y.004	AS4530-601G16Mn VHB32ATIN1 MC UMACÉ 1*1G/160/BT/6L/5R/CB_bgn_0.3D_HG_EN12
AS4530-601G16Mn	AAP	Philippines	LX.ARE0C.032	AS4530-601G16Mn LIMPUSAPH1 UMACÉ 1*1G/160/6L/5R/CB_bgn_0.3D_HG_EN11
AS4530-601G16Mi	EMEA	Israel	LX.ARE0X.024	AS4530-601G16Mi VHP32ATIL1 MC UMACÉ 1*1G/160/6L/5R/CB_bg_0.3D_HG_HE11
AS4530-603G16Mn	PA	Canada	LX.ARE0X.105	AS4530-603G16Mn VHP32ATCA2 MC UMACÉ 2G+1G/160/6L/5R/CB_bgn_0.3D_HG_FR31
AS4530-704G32Mn	PA	Canada	LX.ARE0X.084	AS4530-704G32Mn VHP64ATCA2 MC UMACÉ 2*2G/320/6L/5R/CB_bgn_0.3D_HG_FR31
AS4530-702G25Mi	PA	Canada	LX.ARE0X.078	AS4530-702G25Mi VHP32ATCA2 MC UMACÉ 1*2G/250/6L/5R/CB_bg_0.3D_HG_FR35
AS4530-702G25Mi	PA	Canada	LX.ARE0X.077	AS4530-702G25Mi VHP32ATCA2 MC UMACÉ 1*2G/250/6L/5R/CB_bg_0.3D_HG_FR33
AS4530-702G25Mi	PA	Canada	LX.ARE0X.076	AS4530-702G25Mi VHP32ATCA2 MC UMACÉ 1*2G/250/6L/5R/CB_bg_0.3D_HG_FR32
AS4530-702G25Mi	PA	Canada	LX.ARE0X.075	AS4530-702G25Mi VHP32ATCA2 MC UMACÉ 1*2G/250/6L/5R/CB_bg_0.3D_HG_FR31

Model	RO	Country	Acer Part no	Description
AS4530-702G25Mi	PA	Canada	LX.ARE0X.074	AS4530-702G25Mi VHP32ATCA2 MC UMACE 1*2G/250/6L/5R/CB_bg_0.3D_HG_FR34
AS4530-602G25Mn	PA	Canada	LX.ARE0X.098	AS4530-602G25Mn VHP32ATCA2 MC UMACE 2*1G/250/6L/5R/CB_bgn_0.3D_HG_FR31
AS4530-602G16Mi	PA	Canada	LX.ARE0X.093	AS4530-602G16Mi VHP32ATCA2 MC UMACE 2*1G/160/6L/5R/CB_bg_0.3D_HG_FR31
AS4530-702G25Mi	PA	ACLA-Portuguese	LX.ARD0X.003	AS4530-702G25Mi EM VHP32ATXC1 MC UMACEF 1*2G/250/6L/5R/CB_bg_FP_0.3D_HG_XC22
AS4530-803G25Mi	PA	ACLA-Portuguese	LX.ARD0X.009	AS4530-803G25Mi EM VHP32ATXC1 MC UMACEF 2G+1G/250/BT/6L/5R/CB_bg_FP_0.3D_HG_XC22
AS4530-802G25Mi	PA	ACLA-Portuguese	LX.ARD0X.024	AS4530-802G25Mi VHP32ATXC2 MC UMACEF 1*2G/250/6L/5R/CB_bg_FP_0.3D_HG_XC22
AS4530-802G25Mi	PA	ACLA-Portuguese	LX.ARD0X.023	AS4530-802G25Mi EM VHP32ATXC2 MC UMACEF 1*2G/250/6L/5R/CB_bg_FP_0.3D_HG_XC21
AS4530-802G25Mi	PA	ACLA-Portuguese	LX.ARD0X.022	AS4530-802G25Mi EM VHP32ATXC1 MC UMACEF 1*2G/250/6L/5R/CB_bg_FP_0.3D_HG_XC22
AS4530-802G25Mi	PA	ACLA-Portuguese	LX.ARD0X.021	AS4530-802G25Mi VHP32ATXC1 MC UMACEF 1*2G/250/6L/5R/CB_bg_FP_0.3D_HG_XC21
AS4530-601G16Mi	TWN	GCTWN	LX.ARD0Y.001	AS4530-601G16Mi VHB32ATTW1 MC UMACEF 1*1G/160/BT/6L/5R/CB_bg_FP_0.3D_HG_TC11
AS4530-602G16Mn	TWN	GCTWN	LX.ARD0Y.035	AS4530-602G16Mn VHB32ATTW1 MC UMACEF 1*2G/160/BT/6L/5R/CB_bgn_FP_0.3D_HG_TC11
AS4530-702G16Mn	TWN	GCTWN	LX.ARD0X.036	AS4530-702G16Mn VHP32ATTW1 MC UMACEF 1*2G/160/BT/6L/5R/CB_bgn_FP_0.3D_HG_TC11
AS4530-601G16Mn	TWN	GCTWN	LX.ARD0Y.019	AS4530-601G16Mn VHB32ATTW1 MC UMACEF 1*1G/160/BT/6L/5R/CB_bgn_FP_0.3D_HG_TC11
AS4530-702G25Mi	PA	ACLA-Spanish	LX.ARD0X.005	AS4530-702G25Mi EM VHP32ATEA1 MC UMACEF 1*2G/250/6L/5R/CB_bg_FP_0.3D_HG_ES22
AS4530-702G25Mi	PA	ACLA-Spanish	LX.ARD0X.006	AS4530-702G25Mi EM VHP32ATEA3 MC UMACEF 1*2G/250/6L/5R/CB_bg_FP_0.3D_HG_ES22
AS4530-803G25Mi	PA	ACLA-Spanish	LX.ARD0X.010	AS4530-803G25Mi EM VHP32ATEA1 MC UMACEF 2G+1G/250/BT/6L/5R/CB_bg_FP_0.3D_HG_ES22
AS4530-803G25Mi	PA	ACLA-Spanish	LX.ARD0X.011	AS4530-803G25Mi EM VHP32ATEA3 MC UMACEF 2G+1G/250/BT/6L/5R/CB_bg_FP_0.3D_HG_ES22
AS4530-802G25Mi	PA	ACLA-Spanish	LX.ARD0X.020	AS4530-802G25Mi VHP32ATEA3 MC UMACEF 1*2G/250/6L/5R/CB_bg_FP_0.3D_HG_ES21
AS4530-802G25Mi	PA	ACLA-Spanish	LX.ARD0X.019	AS4530-802G25Mi EM VHP32ATEA3 MC UMACEF 1*2G/250/6L/5R/CB_bg_FP_0.3D_HG_ES22
AS4530-802G25Mi	PA	ACLA-Spanish	LX.ARD0X.018	AS4530-802G25Mi EM VHP32ATEA1 MC UMACEF 1*2G/250/6L/5R/CB_bg_FP_0.3D_HG_ES22
AS4530-802G25Mi	PA	ACLA-Spanish	LX.ARD0X.017	AS4530-802G25Mi VHP32ATEA1 MC UMACEF 1*2G/250/6L/5R/CB_bg_FP_0.3D_HG_ES21
AS4530-701G25Mi	AAP	Thailand	LX.ARD0X.014	AS4530-701G25Mi EM VHP32ATTH1 MC UMACEF 1*1G/250/BT/6L/5R/CB_bg_FP_0.3D_HG_TH22
AS4530-601G16Mi	AAP	Thailand	LX.ARD0X.015	AS4530-601G16Mi EM VHP32ATTH1 MC UMACEF 1*1G/160/BT/6L/5R/CB_bg_FP_0.3D_HG_TH22
AS4530-802G25Mn	AAP	Thailand	LX.ARD0X.016	AS4530-802G25Mn EM VHP32ATTH1 MC UMACEF 1*2G/250/BT/6L/5R/CB_bgn_FP_0.3D_HG_TH22
AS4530-721G25Mn	AAP	Thailand	LX.ARD0C.021	AS4530-721G25Mn LINPUSATH1 UMACEF 1*1G/250/BT/6L/5R/CB_bgn_FP_0.3D_HG_EN11
AS4530-702G25Mn	AAP	Vietnam	LX.ARD0Y.004	AS4530-702G25Mn EM VHB32ATVN1 MC UMACEF 2*1G/250/BT/6L/5R/CB_bgn_FP_0.3D_HG_EN13
AS4530-601G25Mi	CHINA	Hong Kong	LX.ARD0Y.012	AS4530-601G25Mi VHB32ATHK2 MC UMACEF 1*1G/250/BT/6L/5R/CB_bg_FP_0.3D_HG_ZH31

Model	RO	Country	Acer Part no	Description
AS4530-601G16C	CHINA	China	LX.ARD0C.004	AS4530-601G16C LINPUSACN1 UMACEF 1*1G/160/6L/5R/CB_FP_0.3D_HG_EN91
AS4530-702G25Mi	PA	USA	LX.ARD0X.002	AS4530-702G25Mi VHP32ATUS1 MC UMACEF 1*2G/250/6L/5R/CB_bg_FP_0.3D_HG_EN32
AS4530-803G25Mi	PA	USA	LX.ARD0X.007	AS4530-803G25Mi VHP32ATUS1 MC UMACEF 2G+1G/250/BT/6L/5R/CB_bg_FP_0.3D_HG_EN32
AS4530-824G25Mi	PA	USA	LX.ARD0X.012	AS4530-824G25Mi VHP64ATCA2 MC UMACEF 2*2G/250/BT/6L/5R/CB_bg_FP_0.3D_HG_EN11
AS4530-823G25Mi	PA	USA	LX.ARD0X.013	AS4530-823G25Mi VHP32ATUS1 MC UMACEF 2G+1G/250/BT/6L/5R/CB_bg_FP_0.3D_HG_EN32
AS4530-601G12C	CHINA	China	LX.ARD0C.002	AS4530-601G12C LINPUSACN1 UMACEF 1*1G/120/6L/5R/CB_FP_0.3D_HG_EN91
AS4530-601G16Mi	CHINA	Hong Kong	LX.ARD0Y.006	AS4530-601G16Mi VHB32ATHK2 MC UMACEF 1*1G/160/BT/6L/5R/CB_bg_FP_0.3D_HG_ZH31
AS4530-801G25Mi	CHINA	China	LX.ARD0Y.008	AS4530-801G25Mi VHB32ATCN1 MC UMACEF 1*1G/250/BT/6L/5R/CB_bg_FP_0.3D_HG_SC11
AS4530-701G16Ci	CHINA	China	LX.ARD0Y.009	AS4530-701G16Ci VHB32ATCN1 MC UMACEF 1*1G/160/6L/5R/CB_bg_FP_0.3D_HG_SC11
AS4530-701G25Mi	CHINA	China	LX.ARD0C.006	AS4530-701G25Mi LINPUSACN1 UMACEF 1*1G/250/6L/5R/CB_bg_FP_0.3D_HG_EN91
AS4530-700516Mn	AAP	Philippines	LX.ARD0C.022	AS4530-700516Mn LINPUSAPH1 UMACEF 1*512/160/BT/6L/5R/CB_bgn_FP_0.3D_HG_EN11
AS4530-601G16Mi	CHINA	China	LX.ARD0C.008	AS4530-601G16Mi LINPUSACN1 UMACEF 1*1G/160/6L/5R/CB_bg_FP_0.3D_HG_EN91
AS4530-702G25Mi	CHINA	China	LX.ARD0Y.015	AS4530-702G25Mi VHB32ATCN1 MC UMACEF 2*1G/250/BT/6L/5R/CB_bg_FP_0.3D_HG_SC11
AS4530-701G25Mi	CHINA	China	LX.ARD0C.007	AS4530-701G25Mi LINPUSACN1 UMACEF 1*1G/250/BT/6L/5R/CB_bg_FP_0.3D_HG_EN91
AS4530-802G25Mi	PA	USA	LX.ARD0X.028	AS4530-802G25Mi VHP32ATUS1 MC UMACEF 1*2G/250/6L/5R/CB_bg_FP_0.3D_HG_EN33
AS4530-802G25Mi	PA	USA	LX.ARD0X.027	AS4530-802G25Mi VHP32ATUS1 MC UMACEF 1*2G/250/6L/5R/CB_bg_FP_0.3D_HG_EN35
AS4530-802G25Mi	PA	USA	LX.ARD0X.026	AS4530-802G25Mi VHP32ATUS1 MC UMACEF 1*2G/250/6L/5R/CB_bg_FP_0.3D_HG_EN32
AS4530-802G25Mi	PA	USA	LX.ARD0X.025	AS4530-802G25Mi VHP32ATUS1 MC UMACEF 1*2G/250/6L/5R/CB_bg_FP_0.3D_HG_EN34
AS4530-604G25Mi	EMEA	Eastern Europe	LX.ARD0X.035	AS4530-604G25Mi VHP32ATEU5 MC UMACEF 2*2G/250/BT/6L/5R/CB_bg_FP_0.3D_HG_PL11
AS4530-604G32Mi	EMEA	Eastern Europe	LX.ARD0X.034	AS4530-604G32Mi VHP32ATEU5 MC UMACEF 2*2G/320/BT/6L/5R/CB_bg_FP_0.3D_HG_PL11
AS4530-701G16Mn	AAP	Philippines	LX.ARD0C.018	AS4530-701G16Mn LINPUSAPH1 UMACEF 1*1G/160/BT/6L/5R/CB_bgn_FP_0.3D_HG_EN11
AS4530-801G25Mn	CHINA	China	LX.ARD0Y.033	AS4530-801G25Mn VHB32ATCN1 MC UMACEF 1*1G/250/BT/6L/5R/CB_bgn_FP_0.3D_HG_SC11
AS4530-601G25Mn	CHINA	Hong Kong	LX.ARD0Y.031	AS4530-601G25Mn VHB32ATHK2 MC UMACEF 1*1G/250/BT/6L/5R/CB_bgn_FP_0.3D_HG_ZH31
AS4530-702G25Mn	CHINA	China	LX.ARD0Y.030	AS4530-702G25Mn VHB32ATCN1 MC UMACEF 2*1G/250/BT/6L/5R/CB_bgn_FP_0.3D_HG_SC11
AS4530-601G16Mn	CHINA	Hong Kong	LX.ARD0Y.029	AS4530-601G16Mn VHB32ATHK2 MC UMACEF 1*1G/160/BT/6L/5R/CB_bgn_FP_0.3D_HG_ZH31
AS4530-600512Cn	CHINA	China	LX.ARD0C.011	AS4530-600512Cn LINPUSACN1 UMACEF 1*512/120/6L/5R/CB_bgn_FP_0.3D_HG_EN91
AS4530-601G12Cn	CHINA	China	LX.ARD0C.010	AS4530-601G12Cn LINPUSACN1 UMACEF 1*1G/120/6L/5R/CB_bgn_FP_0.3D_HG_EN91

Model	RO	Country	Acer Part no	Description
AS4530-701G16Cn	CHINA	China	LX.ARD0Y.032	AS4530-701G16Cn VHB32ATCN1 MC UMACEF 1*1G/160/6L/5R/CB_bgn_FP_0.3D_HG_SC11
AS4530-700512Mn	AAP	Philippines	LX.ARD0C.020	AS4530-700512Mn LINPUSAPH1 UMACEF 1*512/120/6L/5R/CB_bgn_FP_0.3D_HG_EN11
AS4530-701G12Mn	AAP	Philippines	LX.ARD0C.019	AS4530-701G12Mn LINPUSAPH1 UMACEF 1*1G/120/6L/5R/CB_bgn_FP_0.3D_HG_EN11
AS4530-801G16Mn	AAP	Philippines	LX.ARD0C.017	AS4530-801G16Mn LINPUSAPH1 UMACEF 1*1G/160/6L/5R/CB_bgn_FP_0.3D_HG_EN11
AS4530-701G25Mn	CHINA	China	LX.ARD0C.014	AS4530-701G25Mn LINPUSACN1 UMACEF 1*1G/250/6L/5R/CB_bgn_FP_0.3D_HG_EN91
AS4530-801G16Mn	AAP	Philippines	LX.ARD0Y.034	AS4530-801G16Mn EM VHB32ATPH1 MC UMACEF 1*1G/160/BT/6L/5R/CB_bgn_FP_0.3D_HG_EN14
AS4530-801G16Mn	AAP	Philippines	LX.ARD0C.016	AS4530-801G16Mn LINPUSAPH1 UMACEF 1*1G/160/BT/6L/5R/CB_bgn_FP_0.3D_HG_EN11
AS4530-601G16Mn	AAP	Philippines	LX.ARD0C.015	AS4530-601G16Mn LINPUSAPH1 UMACEF 1*1G/160/BT/6L/5R/CB_bgn_FP_0.3D_HG_EN11
AS4530-701G25Mn	CHINA	China	LX.ARD0C.013	AS4530-701G25Mn LINPUSACN1 UMACEF 1*1G/250/BT/6L/5R/CB_bgn_FP_0.3D_HG_EN91
AS4530-601G16Mn	CHINA	China	LX.ARD0C.012	AS4530-601G16Mn LINPUSACN1 UMACEF 1*1G/160/6L/5R/CB_bgn_FP_0.3D_HG_EN91
AS4530-601G16Mn	CHINA	China	LX.ARD0C.009	AS4530-601G16Mn LINPUSACN1 UMACEF 1*1G/160/BT/6L/5R/CB_bgn_FP_0.3D_HG_EN91
AS4530-601G12Mn	CHINA	China	LX.ARD0Y.028	AS4530-601G12Mn VHB32ATCN1 MC UMACEF 1*1G/120/6L/5R/CB_bgn_FP_0.3D_HG_SC11
AS4530-601G12Mn	CHINA	Hong Kong	LX.ARD0Y.027	AS4530-601G12Mn VHB32ATHK2 MC UMACEF 1*1G/120/6L/5R/CB_bgn_FP_0.3D_HG_ZH31
AS4530-601G16Mn	CHINA	China	LX.ARD0Y.026	AS4530-601G16Mn VHB32ATCN1 MC UMACEF 1*1G/160/6L/5R/CB_bgn_FP_0.3D_HG_SC11
AS4530-802G32Mn	CHINA	China	LX.ARD0Y.025	AS4530-802G32Mn VHB32ATCN1 MC UMACEF 2*1G/320/BT/6L/5R/CB_bgn_FP_0.3D_HG_SC11
AS4530-821G32Mn	CHINA	China	LX.ARD0Y.024	AS4530-821G32Mn VHB32ATCN1 MC UMACEF 1*1G/320/BT/6L/5R/CB_bgn_FP_0.3D_HG_SC11
AS4530-822G32Mn	CHINA	China	LX.ARD0Y.023	AS4530-822G32Mn VHB32ATCN1 MC UMACEF 2*1G/320/BT/6L/5R/CB_bgn_FP_0.3D_HG_SC11
AS4530-802G25Mn	CHINA	China	LX.ARD0Y.022	AS4530-802G25Mn VHB32ATCN1 MC UMACEF 2*1G/250/BT/6L/5R/CB_bgn_FP_0.3D_HG_SC11
AS4530-824G32Mn	CHINA	China	LX.ARD0Y.021	AS4530-824G32Mn VHB32ATCN1 MC UMACEF 2*2G/320/BT/6L/5R/CB_bgn_FP_0.3D_HG_SC11
AS4530-804G32Mn	CHINA	China	LX.ARD0Y.020	AS4530-804G32Mn VHB32ATCN1 MC UMACEF 2*2G/320/BT/6L/5R/CB_bgn_FP_0.3D_HG_SC11
AS4530-702G32Mn	CHINA	China	LX.ARD0Y.018	AS4530-702G32Mn VHB32ATCN1 MC UMACEF 2*1G/320/BT/6L/5R/CB_bgn_FP_0.3D_HG_SC11
AS4530-704G32Mn	CHINA	China	LX.ARD0Y.017	AS4530-704G32Mn VHB32ATCN1 MC UMACEF 2*2G/320/6L/5R/CB_bgn_FP_0.3D_HG_SC11
AS4530-702G25Mi	PA	Canada	LX.ARD0X.004	AS4530-702G25Mi VHP32ATCA2 MC UMACEF 1*2G/250/6L/5R/CB_bg_FP_0.3D_HG_FR31
AS4530-803G25Mi	PA	Canada	LX.ARD0X.008	AS4530-803G25Mi VHP32ATCA2 MC UMACEF 2G+1G/250/BT/6L/5R/CB_bg_FP_0.3D_HG_FR31
AS4530-802G25Mi	PA	Canada	LX.ARD0X.033	AS4530-802G25Mi VHP32ATCA2 MC UMACEF 1*2G/250/6L/5R/CB_bg_FP_0.3D_HG_FR35
AS4530-802G25Mi	PA	Canada	LX.ARD0X.032	AS4530-802G25Mi VHP32ATCA2 MC UMACEF 1*2G/250/6L/5R/CB_bg_FP_0.3D_HG_FR33
AS4530-802G25Mi	PA	Canada	LX.ARD0X.031	AS4530-802G25Mi VHP32ATCA2 MC UMACEF 1*2G/250/6L/5R/CB_bg_FP_0.3D_HG_FR32

Model	RO	Country	Acer Part no	Description
AS4530-802G25Mi	PA	Canada	LX.ARD0X.030	AS4530-802G25Mi VHP32ATCA2 MC UMACEF 1*2G/250/6L/5R/CB_bg_FP_0.3D_HG_FR31
AS4530-802G25Mi	PA	Canada	LX.ARD0X.029	AS4530-802G25Mi VHP32ATCA2 MC UMACEF 1*2G/250/6L/5R/CB_bg_FP_0.3D_HG_FR34
AS4530-602G25Mn	PA	Canada	LX.AAL0X.004	AS4530-602G25Mn VHP32ATCA1 MC UMAE 2*1G/250/6L/5R/CB_bgn_HG_FR11
AS4530-602G25Mn	PA	USA	LX.AAL0X.002	AS4530-602G25Mn VHP32ATUS1 MC UMAE 2*1G/250/6L/5R/CB_bgn_HG_EN32
AS4530-602G25M	PA	USA	LX.AAL0X.001	AS4530-602G25MVHP32ATUS1 MC UMAE 2*1G/250/6L/5R/CB_HG_EN33
AS4530-602G12Mn	PA	USA	LX.AAL0X.005	AS4530-602G12Mn VHP32ATUS1 MC UMAE 2*1G/120/6L/5R/CB_bgn_HG_EN32
AS4530-602G25Mn	PA	Canada	LX.AAL0X.003	AS4530-602G25Mn VHP32ATCA2 MC UMAE 2*1G/250/6L/5R/CB_bgn_HG_FR33
AS4530-602G12Mn	PA	Canada	LX.AAL0X.006	AS4530-602G12Mn VHP32ATCA2 MC UMAE 2*1G/120/6L/5R/CB_bgn_HG_FR31
AS4530-602G16Mn	PA	Canada	LX.AAL0X.007	AS4530-602G16Mn VHP32ATCA2 MC UMAE 2*1G/160/6L/5R/CB_bgn_HG_FR35

Model	CPU	LCD	DIMM 1	DIMM2	HDD	ODD	WLAN	BT
AS4230-401G12Mn	SMPSI 4025W	N14.1 WXGAG	SO1GBII6	N	N120G B 5.4KS	NSM8XS	3rd WiFi 1x2 BGN	N
AS4230-401G12Mn	SMPSI 4025W	N14.1 WXGAG	SO1GBII6	N	N120G B 5.4KS	NSM8XS	3rd WiFi 1x2 BGN	N
AS4230-401G12Mn	SMPSI 4025W	N14.1 WXGAG	SO1GBII6	N	N120G B 5.4KS	NSM8XS	3rd WiFi 1x2 BGN	N
AS4230-401G12Mn	SMPSI 4025W	N14.1 WXGAG	SO1GBII6	N	N120G B 5.4KS	NSM8XS	3rd WiFi 1x2 BGN	N
AS4230-401G16Mn	SMPSI 4025W	N14.1 WXGAG	SO1GBII6	N	N160G B 5.4KS	NSM8XS	3rd WiFi 1x2 BGN	N
AS4230-401G16Mn	SMPSI 4025W	N14.1 WXGAG	SO1GBII6	N	N160G B 5.4KS	NSM8XS	3rd WiFi 1x2 BGN	N
AS4230-401G16Mn	SMPSI 4025W	N14.1 WXGAG	SO1GBII6	N	N160G B 5.4KS	NSM8XS	3rd WiFi 1x2 BGN	N
AS4230-401G16Mn	SMPSI 4025W	N14.1 WXGAG	SO1GBII6	N	N160G B 5.4KS	NSM8XS	3rd WiFi 1x2 BGN	N
AS4230-401G16Mn	SMPSI 4025W	N14.1 WXGAG	SO1GBII6	N	N160G B 5.4KS	NSM8XS	3rd WiFi 1x2 BGN	N
AS4230-401G16Mn	SMPSI 4025W	N14.1 WXGAG	SO1GBII6	N	N160G B 5.4KS	NSM8XS	3rd WiFi 1x2 BGN	N
AS4230-401G16Mn	SMPSI 4025W	N14.1 WXGAG	SO1GBII6	N	N160G B 5.4KS	NSM8XS	3rd WiFi 1x2 BGN	BT 2.0
AS4230-401G12Mn	SMPSI 4025W	N14.1 WXGAG	SO1GBII6	N	N120G B 5.4KS	NSM8XS	3rd WiFi 1x2 BGN	N
AS4230-401G12Mn	SMPSI 4025W	N14.1 WXGAG	SO1GBII6	N	N120G B 5.4KS	NSM8XS	3rd WiFi 1x2 BGN	N
AS4230-401G12Mn	SMPSI 4025W	N14.1 WXGAG	SO1GBII6	N	N120G B 5.4KS	NSM8XS	3rd WiFi 1x2 BGN	N
AS4230-401G12Mn	SMPSI 4025W	N14.1 WXGAG	SO1GBII6	N	N120G B 5.4KS	NSM8XS	3rd WiFi 1x2 BGN	N
AS4230-401G12Mn	SMPSI 4025W	N14.1 WXGAG	SO1GBII6	N	N120G B 5.4KS	NSM8XS	3rd WiFi 1x2 BGN	N
AS4230-401G16Mn	SMPSI 4025W	N14.1 WXGAG	SO1GBII6	N	N160G B 5.4KS	NSM8XS	3rd WiFi 1x2 BGN	N

Model	CPU	LCD	DIMM 1	DIMM2	HDD	ODD	WLAN	BT
AS4230-401G16Mn	SMPSI 4025W	N14.1 WYGAG	SO1GBII6	N	N160G B 5.4KS	NSM8XS	3rd WiFi 1x2 BGN	N
AS4230-401G16Mn	SMPSI 4025W	N14.1 WYGAG	SO1GBII6	N	N160G B 5.4KS	NSM8XS	3rd WiFi 1x2 BGN	N
AS4230-401G16Mn	SMPSI 4025W	N14.1 WYGAG	SO1GBII6	N	N160G B 5.4KS	NSM8XS	3rd WiFi 1x2 BGN	N
AS4230-401G16Mn	SMPSI 4025W	N14.1 WYGAG	SO1GBII6	N	N160G B 5.4KS	NSM8XS	3rd WiFi 1x2 BGN	N
AS4230-401G12Mn	SMPSI 4025W	N14.1 WYGAG	SO1GBII6	N	N120G B 5.4KS	NSM8XS	3rd WiFi 1x2 BGN	N
AS4230-401G12Mn	SMPSI 4025W	N14.1 WYGAG	SO1GBII6	N	N120G B 5.4KS	NSM8XS	3rd WiFi 1x2 BGN	N
AS4230-401G12Mn	SMPSI 4025W	N14.1 WYGAG	SO1GBII6	N	N120G B 5.4KS	NSM8XS	3rd WiFi 1x2 BGN	N
AS4230-401G12Mn	SMPSI 4025W	N14.1 WYGAG	SO1GBII6	N	N120G B 5.4KS	NSM8XS	3rd WiFi 1x2 BGN	N
AS4230-401G12Mn	SMPSI 4025W	N14.1 WYGAG	SO1GBII6	N	N120G B 5.4KS	NSM8XS	3rd WiFi 1x2 BGN	N
AS4230-401G12Mn	SMPSI 4025W	N14.1 WYGAG	SO1GBII6	N	N120G B 5.4KS	NSM8XS	3rd WiFi 1x2 BGN	N
AS4230-401G12Mn	SMPSI 4025W	N14.1 WYGAG	SO1GBII6	N	N120G B 5.4KS	NSM8XS	3rd WiFi 1x2 BGN	N
AS4230-401G16Mn	SMPSI 4025W	N14.1 WYGAG	SO1GBII6	N	N160G B 5.4KS	NSM8XS	3rd WiFi 1x2 BGN	N
AS4230-401G16Mn	SMPSI 4025W	N14.1 WYGAG	SO1GBII6	N	N160G B 5.4KS	NSM8XS	3rd WiFi 1x2 BGN	N
AS4230-401G16Mn	SMPSI 4025W	N14.1 WYGAG	SO1GBII6	N	N160G B 5.4KS	NSM8XS	3rd WiFi 1x2 BGN	N
AS4230-401G16Mn	SMPSI 4025W	N14.1 WYGAG	SO1GBII6	N	N160G B 5.4KS	NSM8XS	3rd WiFi 1x2 BGN	N
AS4230-401G16Mn	SMPSI 4025W	N14.1 WYGAG	SO1GBII6	N	N160G B 5.4KS	NSM8XS	3rd WiFi 1x2 BGN	N
AS4230-401G16Mn	SMPSI 4025W	N14.1 WYGAG	SO1GBII6	N	N160G B 5.4KS	NSM8XS	3rd WiFi 1x2 BGN	N
AS4230-401G16Mn	SMPSI 4025W	N14.1 WYGAG	SO1GBII6	N	N160G B 5.4KS	NSM8XS	3rd WiFi 1x2 BGN	N
AS4230-401G16Mn	SMPSI 4025W	N14.1 WYGAG	SO1GBII6	N	N160G B 5.4KS	NSM8XS	3rd WiFi 1x2 BGN	N
AS4530-601G16Mi	AAQL60	N14.1 WYGAG	SO1GBII6	N	N160G B 5.4KS	NSM8XS	3rd WiFi BG	N
AS4530-601G16Mi	AAQL60	N14.1 WYGAG	SO1GBII6	N	N160G B 5.4KS	NSM8XS	3rd WiFi BG	N
AS4530-601G16Mi	AAQL60	N14.1 WYGAG	SO1GBII6	N	N160G B 5.4KS	NSM8XS	3rd WiFi BG	N
AS4530-601G16Mi	AAQL60	N14.1 WYGAG	SO1GBII6	N	N160G B 5.4KS	NSM8XS	3rd WiFi BG	N
AS4530-701G16Mn	ATRM70	N14.1 WYGAG	SO1GBII6	N	N160G B 5.4KS	NSM8XS	3rd WiFi 1x2 BGN	N
AS4530-702G16Mn	ATRM70	N14.1 WYGAG	SO1GBII6	SO1GBII6	N160G B 5.4KS	NSM8XS	3rd WiFi 1x2 BGN	N
AS4530-702G25Mn	ATRM70	N14.1 WYGAG	SO1GBII6	SO1GBII6	N250G B 5.4KS	NSM8XS	3rd WiFi 1x2 BGN	N
AS4530-702G25Mi	ATRM70	N14.1 WYGAG	SO2GBII6	N	N250G B 5.4KS	NSM8XS	3rd WiFi BG	N
AS4530-702G25Mi	ATRM70	N14.1 WYGAG	SO2GBII6	N	N250G B 5.4KS	NSM8XS	3rd WiFi BG	N
AS4530-702G25Mi	ATRM70	N14.1 WYGAG	SO2GBII6	N	N250G B 5.4KS	NSM8XS	3rd WiFi BG	N

Model	CPU	LCD	DIMM 1	DIMM2	HDD	ODD	WLAN	BT
AS4530-702G25Mi	ATRM70	N14.1 WXGAG	SO2GBII6	N	N250G B 5.4KS	NSM8XS	3rd WiFi BG	N
AS4530-601G16Mn	AAQL60	N14.1 WXGAG	SO1GBII6	N	N160G B 5.4KS	NSM8XS	3rd WiFi 1x2 BGN	N
AS4530-702G16Mn	ATRM70	N14.1 WXGAG	SO1GBII6	SO1GBII6	N160G B 5.4KS	NSM8XS	3rd WiFi 1x2 BGN	N
AS4530-702G25Mn	ATRM70	N14.1 WXGAG	SO1GBII6	SO1GBII6	N250G B 5.4KS	NSM8XS	3rd WiFi 1x2 BGN	N
AS4530-602G16Mn	AAQL60	N14.1 WXGAG	SO1GBII6	SO1GBII6	N160G B 5.4KS	NSM8XS	3rd WiFi 1x2 BGN	N
AS4530-602G16Mn	AAQL60	N14.1 WXGAG	SO1GBII6	SO1GBII6	N160G B 5.4KS	NSM8XS	3rd WiFi 1x2 BGN	N
AS4530-601G16Mn	AAQL60	N14.1 WXGAG	SO1GBII6	N	N160G B 5.4KS	NSM8XS	3rd WiFi 1x2 BGN	N
AS4530-602G12Mi	AAQL60	N14.1 WXGAG	SO1GBII6	SO1GBII6	N120G B 5.4KS	NSM8XS	3rd WiFi BG	N
AS4530-601G16Mi	AAQL60	N14.1 WXGAG	SO1GBII6	N	N160G B 5.4KS	NSM8XS	3rd WiFi BG	N
AS4530-602G16Mi	AAQL60	N14.1 WXGAG	SO1GBII6	SO1GBII6	N160G B 5.4KS	NSM8XS	3rd WiFi BG	N
AS4530-601G16Mi	AAQL60	N14.1 WXGAG	SO1GBII6	N	N160G B 5.4KS	NSM8XS	3rd WiFi BG	N
AS4530-703G32Mi	ATRM70	N14.1 WXGAG	SO2GBII6	SO1GBII6	N320G B 5.4KS	NSM8XS	3rd WiFi BG	BT 2.0
AS4530-603G32Mi	AAQL60	N14.1 WXGAG	SO2GBII6	SO1GBII6	N320G B 5.4KS	NSM8XS	3rd WiFi BG	BT 2.0
AS4530-601G16Mi	AAQL60	N14.1 WXGAG	SO1GBII6	N	N160G B 5.4KS	NSM8XS	3rd WiFi BG	N
AS4530-601G16Mi	AAQL60	N14.1 WXGAG	SO1GBII6	N	N160G B 5.4KS	NSM8XS	3rd WiFi BG	N
AS4530-601G16Mi	AAQL60	N14.1 WXGAG	SO1GBII6	N	N160G B 5.4KS	NSM8XS	3rd WiFi BG	N
AS4530-601G16Mi	AAQL60	N14.1 WXGAG	SO1GBII6	N	N160G B 5.4KS	NSM8XS	3rd WiFi BG	N
AS4530-601G16Mi	AAQL60	N14.1 WXGAG	SO1GBII6	N	N160G B 5.4KS	NSM8XS	3rd WiFi BG	N
AS4530-601G16Mi	AAQL60	N14.1 WXGAG	SO1GBII6	N	N160G B 5.4KS	NSM8XS	3rd WiFi BG	N
AS4530-601G16Mi	AAQL60	N14.1 WXGAG	SO1GBII6	N	N160G B 5.4KS	NSM8XS	3rd WiFi BG	N
AS4530-601G16Mi	AAQL60	N14.1 WXGAG	SO1GBII6	N	N160G B 5.4KS	NSM8XS	3rd WiFi BG	N
AS4530-601G16Mi	AAQL60	N14.1 WXGAG	SO1GBII6	N	N160G B 5.4KS	NSM8XS	3rd WiFi BG	N
AS4530-601G16Mi	AAQL60	N14.1 WXGAG	SO1GBII6	N	N160G B 5.4KS	NSM8XS	3rd WiFi BG	N
AS4530-601G16Mi	AAQL60	N14.1 WXGAG	SO1GBII6	N	N160G B 5.4KS	NSM8XS	3rd WiFi BG	N
AS4530-601G16Mi	AAQL60	N14.1 WXGAG	SO1GBII6	N	N160G B 5.4KS	NSM8XS	3rd WiFi BG	N
AS4530-704G32Mi	ATRM70	N14.1 WXGAG	SO2GBII6	SO2GBII6	N320G B 5.4KS	NSM8XS	3rd WiFi BG	BT 2.0
AS4530-603G32Mi	AAQL60	N14.1 WXGAG	SO2GBII6	SO1GBII6	N320G B 5.4KS	NSM8XS	3rd WiFi BG	N
AS4530-601G16Mi	AAQL60	N14.1 WXGAG	SO1GBII6	N	N160G B 5.4KS	NSM8XS	3rd WiFi BG	N
AS4530-601G16Mi	AAQL60	N14.1 WXGAG	SO1GBII6	N	N160G B 5.4KS	NSM8XS	3rd WiFi BG	N

Model	CPU	LCD	DIMM 1	DIMM2	HDD	ODD	WLAN	BT
AS4530-601G16Mi	AAQL60	N14.1 WYGAG	SO1GBII6	N	N160G B 5.4KS	NSM8XS	3rd WiFi BG	N
AS4530-601G16Mi	AAQL60	N14.1 WYGAG	SO1GBII6	N	N160G B 5.4KS	NSM8XS	3rd WiFi BG	N
AS4530-603G25Mi	AAQL60	N14.1 WYGAG	SO2GBII6	SO1GBII6	N250G B 5.4KS	NSM8XS	3rd WiFi BG	BT 2.0
AS4530-601G16Mi	AAQL60	N14.1 WYGAG	SO1GBII6	N	N160G B 5.4KS	NSM8XS	3rd WiFi BG	N
AS4530-601G16Mi	AAQL60	N14.1 WYGAG	SO1GBII6	N	N160G B 5.4KS	NSM8XS	3rd WiFi BG	N
AS4530-701G16Mn	ATRM70	N14.1 WYGAG	SO1GBII6	N	N160G B 5.4KS	NSM8XS	3rd WiFi 1x2 BGN	N
AS4530-701G16Mn	ATRM70	N14.1 WYGAG	SO1GBII6	N	N160G B 5.4KS	NSM8XS	3rd WiFi 1x2 BGN	N
AS4530-702G16Mn	ATRM70	N14.1 WYGAG	SO1GBII6	SO1GBII6	N160G B 5.4KS	NSM8XS	3rd WiFi 1x2 BGN	N
AS4530-702G16Mn	ATRM70	N14.1 WYGAG	SO1GBII6	SO1GBII6	N160G B 5.4KS	NSM8XS	3rd WiFi 1x2 BGN	N
AS4530-702G25Mn	ATRM70	N14.1 WYGAG	SO1GBII6	SO1GBII6	N250G B 5.4KS	NSM8XS	3rd WiFi 1x2 BGN	N
AS4530-702G25Mn	ATRM70	N14.1 WYGAG	SO1GBII6	SO1GBII6	N250G B 5.4KS	NSM8XS	3rd WiFi 1x2 BGN	N
AS4530-702G25Mn	ATRM70	N14.1 WYGAG	SO1GBII6	SO1GBII6	N250G B 5.4KS	NSM8XS	3rd WiFi 1x2 BGN	N
AS4530-702G25Mi	ATRM70	N14.1 WYGAG	SO2GBII6	N	N250G B 5.4KS	NSM8XS	3rd WiFi BG	N
AS4530-702G25Mi	ATRM70	N14.1 WYGAG	SO2GBII6	N	N250G B 5.4KS	NSM8XS	3rd WiFi BG	N
AS4530-702G25Mi	ATRM70	N14.1 WYGAG	SO2GBII6	N	N250G B 5.4KS	NSM8XS	3rd WiFi BG	N
AS4530-702G25Mi	ATRM70	N14.1 WYGAG	SO2GBII6	N	N250G B 5.4KS	NSM8XS	3rd WiFi BG	N
AS4530-601G16Mn	AAQL60	N14.1 WYGAG	SO1GBII6	N	N160G B 5.4KS	NSM8XS	3rd WiFi 1x2 BGN	N
AS4530-601G16Mn	AAQL60	N14.1 WYGAG	SO1GBII6	N	N160G B 5.4KS	NSM8XS	3rd WiFi 1x2 BGN	N
AS4530-702G16Mn	ATRM70	N14.1 WYGAG	SO1GBII6	SO1GBII6	N160G B 5.4KS	NSM8XS	3rd WiFi 1x2 BGN	N
AS4530-702G16Mn	ATRM70	N14.1 WYGAG	SO1GBII6	SO1GBII6	N160G B 5.4KS	NSM8XS	3rd WiFi 1x2 BGN	N
AS4530-702G25Mn	ATRM70	N14.1 WYGAG	SO1GBII6	SO1GBII6	N250G B 5.4KS	NSM8XS	3rd WiFi 1x2 BGN	N
AS4530-702G25Mn	ATRM70	N14.1 WYGAG	SO1GBII6	SO1GBII6	N250G B 5.4KS	NSM8XS	3rd WiFi 1x2 BGN	N
AS4530-602G16Mn	AAQL60	N14.1 WYGAG	SO1GBII6	SO1GBII6	N160G B 5.4KS	NSM8XS	3rd WiFi 1x2 BGN	N
AS4530-602G16Mn	AAQL60	N14.1 WYGAG	SO1GBII6	SO1GBII6	N160G B 5.4KS	NSM8XS	3rd WiFi 1x2 BGN	N
AS4530-602G16Mn	AAQL60	N14.1 WYGAG	SO1GBII6	SO1GBII6	N160G B 5.4KS	NSM8XS	3rd WiFi 1x2 BGN	N
AS4530-602G16Mn	AAQL60	N14.1 WYGAG	SO1GBII6	SO1GBII6	N160G B 5.4KS	NSM8XS	3rd WiFi 1x2 BGN	N
AS4530-601G16Mn	AAQL60	N14.1 WYGAG	SO1GBII6	N	N160G B 5.4KS	NSM8XS	3rd WiFi 1x2 BGN	N
AS4530-601G16Mn	AAQL60	N14.1 WYGAG	SO1GBII6	N	N160G B 5.4KS	NSM8XS	3rd WiFi 1x2 BGN	N

Model	CPU	LCD	DIMM 1	DIMM2	HDD	ODD	WLAN	BT
AS4530-601G16Mi	AAQL60	N14.1 WXGAG	SO1GBII6	N	N160G B 5.4KS	NSM8XS	3rd WiFi BG	N
AS4530-601G16Mi	AAQL60	N14.1 WXGAG	SO1GBII6	N	N160G B 5.4KS	NSM8XS	3rd WiFi BG	N
AS4530-601G16Mi	AAQL60	N14.1 WXGAG	SO1GBII6	N	N160G B 5.4KS	NSM8XS	3rd WiFi BG	N
AS4530-601G16Mi	AAQL60	N14.1 WXGAG	SO1GBII6	N	N160G B 5.4KS	NSM8XS	3rd WiFi BG	N
AS4530-601G16Mi	AAQL60	N14.1 WXGAG	SO1GBII6	N	N160G B 5.4KS	NSM8XS	3rd WiFi BG	N
AS4530-601G16Mi	AAQL60	N14.1 WXGAG	SO1GBII6	N	N160G B 5.4KS	NSM8XS	3rd WiFi BG	N
AS4530-700516Mn	ATRM70	N14.1 WXGAG	SO512MBII6	N	N160G B 5.4KS	NSM8XS	3rd WiFi 1x2 BGN	BT 2.0
AS4530-800516Mn	ATUZM80	N14.1 WXGAG	SO512MBII6	N	N160G B 5.4KS	NSM8XS	3rd WiFi 1x2 BGN	BT 2.0
AS4530-820516Mn	ATUZM82	N14.1 WXGAG	SO512MBII6	N	N160G B 5.4KS	NSM8XS	3rd WiFi 1x2 BGN	BT 2.0
AS4530-840516Mn	ATUZM84	N14.1 WXGAG	SO512MBII6	N	N160G B 5.4KS	NSM8XS	3rd WiFi 1x2 BGN	BT 2.0
AS4530-860516Mn	ATUZM86	N14.1 WXGAG	SO512MBII6	N	N160G B 5.4KS	NSM8XS	3rd WiFi 1x2 BGN	BT 2.0
AS4530-600525Mn	AAQL60	N14.1 WXGAG	SO512MBII6	N	N250G B 5.4KS	NSM8XS	3rd WiFi 1x2 BGN	BT 2.0
AS4530-700525Mn	ATRM70	N14.1 WXGAG	SO512MBII6	N	N250G B 5.4KS	NSM8XS	3rd WiFi 1x2 BGN	BT 2.0
AS4530-600516Mn	AAQL60	N14.1 WXGAG	SO512MBII6	N	N160G B 5.4KS	NSM8XS	3rd WiFi 1x2 BGN	BT 2.0
AS4530-800525Mn	ATUZM80	N14.1 WXGAG	SO512MBII6	N	N250G B 5.4KS	NSM8XS	3rd WiFi 1x2 BGN	BT 2.0
AS4530-820525Mn	ATUZM82	N14.1 WXGAG	SO512MBII6	N	N250G B 5.4KS	NSM8XS	3rd WiFi 1x2 BGN	BT 2.0
AS4530-840525Mn	ATUZM84	N14.1 WXGAG	SO512MBII6	N	N250G B 5.4KS	NSM8XS	3rd WiFi 1x2 BGN	BT 2.0
AS4530-860525Mn	ATUZM86	N14.1 WXGAG	SO512MBII6	N	N250G B 5.4KS	NSM8XS	3rd WiFi 1x2 BGN	BT 2.0
AS4530-603G32Mn	AAQL60	N14.1 WXGAG	SO1GBII6	SO2GBII6	N320G B 5.4KS	NSM8XS	3rd WiFi 1x2 BGN	BT 2.0
AS4530-703G32Mi	ATRM70	N14.1 WXGAG	SO1GBII6	SO2GBII6	N320G B 5.4KS	NSM8XS	3rd WiFi BG	BT 2.0
AS4530-700516Mi	ATRM70	N14.1 WXGAG	SO512MBII6	N	N160G B 5.4KS	NSM8XS	3rd WiFi BG	BT 2.0
AS4530-803G32Mn	ATUZM80	N14.1 WXGAG	SO1GBII6	SO2GBII6	N320G B 5.4KS	NSM8XS	3rd WiFi 1x2 BGN	BT 2.0
AS4530-823G32Mi	ATUZM82	N14.1 WXGAG	SO1GBII6	SO2GBII6	N320G B 5.4KS	NSM8XS	3rd WiFi BG	BT 2.0
AS4530-843G32Mn	ATUZM84	N14.1 WXGAG	SO1GBII6	SO2GBII6	N320G B 5.4KS	NSM8XS	3rd WiFi 1x2 BGN	BT 2.0
AS4530-863G32Mn	ATUZM86	N14.1 WXGAG	SO1GBII6	SO2GBII6	N320G B 5.4KS	NSM8XS	3rd WiFi 1x2 BGN	BT 2.0
AS4530-601G25Mn	AAQL60	N14.1 WXGAG	SO1GBII6	N	N250G B 5.4KS	NSM8XS	3rd WiFi 1x2 BGN	BT 2.0
AS4530-701G25Mn	ATRM70	N14.1 WXGAG	SO1GBII6	N	N250G B 5.4KS	NSM8XS	3rd WiFi 1x2 BGN	BT 2.0

Model	CPU	LCD	DIMM 1	DIMM2	HDD	ODD	WLAN	BT
AS4530-702G12Mn	ATRM70	N14.1 WXGAG	SO1GBII6	SO1GBII6	N120G B 5.4KS	NSM8XS	3rd WiFi 1x2 BGN	BT 2.0
AS4530-701G12Mn	ATRM70	N14.1 WXGAG	SO1GBII6	N	N120G B 5.4KS	NSM8XS	3rd WiFi 1x2 BGN	BT 2.0
AS4530-802G25Mn	ATUZM80	N14.1 WXGAG	SO1GBII6	SO1GBII6	N250G B 5.4KS	NSM8XS	3rd WiFi 1x2 BGN	BT 2.0
AS4530-843G32Mn	ATUZM84	N14.1 WXGAG	SO1GBII6	SO2GBII6	N320G B 5.4KS	NSM8XS	3rd WiFi 1x2 BGN	BT 2.0
AS4530-701G16Mi	ATRM70	N14.1 WXGAG	SO1GBII6	N	N160G B 5.4KS	NSM8XS	3rd WiFi BG	BT 2.0
AS4530-701G16Mi	ATRM70	N14.1 WXGAG	SO1GBII6	N	N160G B 5.4KS	NSM8XS	3rd WiFi BG	BT 2.0
AS4530-802G16Mn	ATUZM80	N14.1 WXGAG	SO1GBII6	SO1GBII6	N160G B 5.4KS	NSM8XS	3rd WiFi 1x2 BGN	BT 2.0
AS4530-802G16Mn	ATUZM80	N14.1 WXGAG	SO2GBII6	N	N160G B 5.4KS	NSM8XS	3rd WiFi 1x2 BGN	N
AS4530-802G32Mn	ATUZM80	N14.1 WXGAG	SO2GBII6	N	N320G B 5.4KS	NSM8XS	3rd WiFi 1x2 BGN	N
AS4530-602G16Mn	AAQL60	N14.1 WXGAG	SO2GBII6	N	N160G B 5.4KS	NSM8XS	3rd WiFi 1x2 BGN	BT 2.0
AS4530-601G12Mn	AAQL60	N14.1 WXGAG	SO1GBII6	N	N120G B 5.4KS	NSM8XS	3rd WiFi 1x2 BGN	N
AS4530-601G12Mn	AAQL60	N14.1 WXGAG	SO1GBII6	N	N120G B 5.4KS	NSM8XS	3rd WiFi 1x2 BGN	N
AS4530-602G25Mi	AAQL60	N14.1 WXGAG	SO1GBII6	SO1GBII6	N250G B 5.4KS	NSM8XS	3rd WiFi BG	BT 2.0
AS4530-601G16Mi	AAQL60	N14.1 WXGAG	SO1GBII6	N	N160G B 5.4KS	NSM8XS	3rd WiFi BG	N
AS4530-701G16Mi	ATRM70	N14.1 WXGAG	SO1GBII6	N	N160G B 5.4KS	NSM8XS	3rd WiFi BG	N
AS4530-802G25Mi	ATUZM80	N14.1 WXGAG	SO2GBII6	N	N250G B 5.4KS	NSM8XS	3rd WiFi BG	N
AS4530-602G12Mi	AAQL60	N14.1 WXGAG	SO1GBII6	SO1GBII6	N120G B 5.4KS	NSM8XS	3rd WiFi BG	N
AS4530-602G12Mi	AAQL60	N14.1 WXGAG	SO1GBII6	SO1GBII6	N120G B 5.4KS	NSM8XS	3rd WiFi BG	N
AS4530-601G16Mi	AAQL60	N14.1 WXGAG	SO1GBII6	N	N160G B 5.4KS	NSM8XS	3rd WiFi BG	N
AS4530-601G16Mi	AAQL60	N14.1 WXGAG	SO1GBII6	N	N160G B 5.4KS	NSM8XS	3rd WiFi BG	N
AS4530-601G16Mi	AAQL60	N14.1 WXGAG	SO1GBII6	N	N160G B 5.4KS	NSM8XS	3rd WiFi BG	N
AS4530-723G32Mn	ATRM72	N14.1 WXGAG	SO1GBII6	SO2GBII6	N320G B 5.4KS	NSM8XS	3rd WiFi 1x2 BGN	BT 2.0
AS4530-703G32Mn	ATRM70	N14.1 WXGAG	SO2GBII6	SO1GBII6	N320G B 5.4KS	NSM8XS	3rd WiFi 1x2 BGN	BT 2.0
AS4530-823G32Mn	ATUZM82	N14.1 WXGAG	SO2GBII6	SO1GBII6	N320G B 5.4KS	NSM8XS	3rd WiFi 1x2 BGN	BT 2.0
AS4530-602G16Mn	AAQL60	N14.1 WXGAG	SO2GBII6	N	N160G B 5.4KS	NSM8XS	3rd WiFi 1x2 BGN	BT 2.0
AS4530-701G16Mn	ATRM70	N14.1 WXGAG	SO1GBII6	N	N160G B 5.4KS	NSM8XS	3rd WiFi 1x2 BGN	BT 2.0
AS4530-701G16Mn	ATRM70	N14.1 WXGAG	SO1GBII6	N	N160G B 5.4KS	NSM8XS	3rd WiFi 1x2 BGN	BT 2.0

Model	CPU	LCD	DIMM 1	DIMM2	HDD	ODD	WLAN	BT
AS4530-603G16Mn	AAQL60	N14.1 WXGAG	SO2GBII6	SO1GBII6	N160G B 5.4KS	NSM8XS	3rd WiFi 1x2 BGN	N
AS4530-700516Mn	ATRM70	N14.1 WXGAG	SO512MBII6	N	N160G B 5.4KS	NSM8XS	3rd WiFi 1x2 BGN	BT 2.0
AS4530-721G16Mn	ATRM72	N14.1 WXGAG	SO1GBII6	N	N160G B 5.4KS	NSM8XS	3rd WiFi 1x2 BGN	BT 2.0
AS4530-721G16Mn	ATRM72	N14.1 WXGAG	SO1GBII6	N	N160G B 5.4KS	NSM8XS	3rd WiFi 1x2 BGN	BT 2.0
AS4530-603G25Mi	AAQL60	N14.1 WXGAG	SO2GBII6	SO1GBII6	N250G B 5.4KS	NSM8XS	3rd WiFi BG	BT 2.0
AS4530-704G32Mn	ATRM70	N14.1 WXGAG	SO2GBII6	SO2GBII6	N320G B 5.4KS	NSM8XS	3rd WiFi 1x2 BGN	N
AS4530-704G32Mn	ATRM70	N14.1 WXGAG	SO2GBII6	SO2GBII6	N320G B 5.4KS	NSM8XS	3rd WiFi 1x2 BGN	N
AS4530-601G16Mi	AAQL60	N14.1 WXGAG	SO1GBII6	N	N160G B 5.4KS	NSM8XS	3rd WiFi BG	BT 2.0
AS4530-602G16Mi	AAQL60	N14.1 WXGAG	SO2GBII6	N	N160G B 5.4KS	NSM8XS	3rd WiFi BG	BT 2.0
AS4530-823G32Mi	ATUzM82	N14.1 WXGAG	SO1GBII6	SO2GBII6	N320G B 5.4KS	NSM8XS	3rd WiFi BG	BT 2.0
AS4530-703G32Mi	ATRM70	N14.1 WXGAG	SO1GBII6	SO2GBII6	N320G B 5.4KS	NSM8XS	3rd WiFi BG	BT 2.0
AS4530-802G32Mn	ATUzM80	N14.1 WXGAG	SO2GBII6	N	N320G B 5.4KS	NSM8XS	3rd WiFi 1x2 BGN	N
AS4530-802G16Mn	ATUzM80	N14.1 WXGAG	SO2GBII6	N	N160G B 5.4KS	NSM8XS	3rd WiFi 1x2 BGN	N
AS4530-704G32Mi	ATRM70	N14.1 WXGAG	SO2GBII6	SO2GBII6	N320G B 5.4KS	NSM8XS	3rd WiFi BG	N
AS4530-702G25Mi	ATRM70	N14.1 WXGAG	SO2GBII6	N	N250G B 5.4KS	NSM8XS	3rd WiFi BG	N
AS4530-702G25Mi	ATRM70	N14.1 WXGAG	SO2GBII6	N	N250G B 5.4KS	NSM8XS	3rd WiFi BG	N
AS4530-702G25Mi	ATRM70	N14.1 WXGAG	SO2GBII6	N	N250G B 5.4KS	NSM8XS	3rd WiFi BG	N
AS4530-702G25Mi	ATRM70	N14.1 WXGAG	SO2GBII6	N	N250G B 5.4KS	NSM8XS	3rd WiFi BG	N
AS4530-801G16Mn	ATUzM80	N14.1 WXGAG	SO1GBII6	N	N160G B 5.4KS	NSM8XS	3rd WiFi 1x2 BGN	BT 2.0
AS4530-843G32Mn	ATUzM84	N14.1 WXGAG	SO1GBII6	SO2GBII6	N320G B 5.4KS	NSM8XS	3rd WiFi 1x2 BGN	BT 2.0
AS4530-863G32Mn	ATUzM86	N14.1 WXGAG	SO1GBII6	SO2GBII6	N320G B 5.4KS	NSM8XS	3rd WiFi 1x2 BGN	BT 2.0
AS4530-802G16Mn	ATUzM80	N14.1 WXGAG	SO2GBII6	N	N160G B 5.4KS	NSM8XS	3rd WiFi 1x2 BGN	BT 2.0
AS4530-602G25Mn	AAQL60	N14.1 WXGAG	SO1GBII6	SO1GBII6	N250G B 5.4KS	NSM8XS	3rd WiFi 1x2 BGN	N
AS4530-602G16Mn	AAQL60	N14.1 WXGAG	SO1GBII6	SO1GBII6	N160G B 5.4KS	NSM8XS	3rd WiFi 1x2 BGN	N
AS4530-601G12Mn	AAQL60	N14.1 WXGAG	SO1GBII6	N	N120G B 5.4KS	NSM8XS	3rd WiFi 1x2 BGN	N
AS4530-822G16Mn	ATUzM82	N14.1 WXGAG	SO2GBII6	N	N160G B 5.4KS	NSM8XS	3rd WiFi 1x2 BGN	N
AS4530-822G16Mn	ATUzM82	N14.1 WXGAG	SO2GBII6	N	N160G B 5.4KS	NSM8XS	3rd WiFi 1x2 BGN	BT 2.0

Model	CPU	LCD	DIMM 1	DIMM2	HDD	ODD	WLAN	BT
AS4530-602G16Mi	AAQL60	N14.1 WXGAG	SO1GBII6	SO1GBII6	N160G B 5.4KS	NSM8XS	3rd WiFi BG	N
AS4530-601G16Mn	AAQL60	N14.1 WXGAG	SO1GBII6	N	N160G B 5.4KS	NSM8XS	3rd WiFi 1x2 BGN	BT 2.0
AS4530-601G16Mn	AAQL60	N14.1 WXGAG	SO1GBII6	N	N160G B 5.4KS	NSM8XS	3rd WiFi 1x2 BGN	N
AS4530-601G16Mi	AAQL60	N14.1 WXGAG	SO1GBII6	N	N160G B 5.4KS	NSM8XS	3rd WiFi BG	N
AS4530-603G16Mn	AAQL60	N14.1 WXGAG	SO2GBII6	SO1GBII6	N160G B 5.4KS	NSM8XS	3rd WiFi 1x2 BGN	N
AS4530-704G32Mn	ATRM70	N14.1 WXGAG	SO2GBII6	SO2GBII6	N320G B 5.4KS	NSM8XS	3rd WiFi 1x2 BGN	N
AS4530-702G25Mi	ATRM70	N14.1 WXGAG	SO2GBII6	N	N250G B 5.4KS	NSM8XS	3rd WiFi BG	N
AS4530-702G25Mi	ATRM70	N14.1 WXGAG	SO2GBII6	N	N250G B 5.4KS	NSM8XS	3rd WiFi BG	N
AS4530-702G25Mi	ATRM70	N14.1 WXGAG	SO2GBII6	N	N250G B 5.4KS	NSM8XS	3rd WiFi BG	N
AS4530-702G25Mi	ATRM70	N14.1 WXGAG	SO2GBII6	N	N250G B 5.4KS	NSM8XS	3rd WiFi BG	N
AS4530-702G25Mi	ATRM70	N14.1 WXGAG	SO2GBII6	N	N250G B 5.4KS	NSM8XS	3rd WiFi BG	N
AS4530-602G25Mn	AAQL60	N14.1 WXGAG	SO1GBII6	SO1GBII6	N250G B 5.4KS	NSM8XS	3rd WiFi 1x2 BGN	N
AS4530-602G16Mi	AAQL60	N14.1 WXGAG	SO1GBII6	SO1GBII6	N160G B 5.4KS	NSM8XS	3rd WiFi BG	N
AS4530-702G25Mi	ATRM70	N14.1 WXGAG	SO2GBII6	N	N250G B 5.4KS	NSM8XS	3rd WiFi BG	N
AS4530-803G25Mi	ATUZM80	N14.1 WXGAG	SO2GBII6	SO1GBII6	N250G B 5.4KS	NSM8XS	3rd WiFi BG	BT 2.0
AS4530-802G25Mi	ATUZM80	N14.1 WXGAG	SO2GBII6	N	N250G B 5.4KS	NSM8XS	3rd WiFi BG	N
AS4530-802G25Mi	ATUZM80	N14.1 WXGAG	SO2GBII6	N	N250G B 5.4KS	NSM8XS	3rd WiFi BG	N
AS4530-802G25Mi	ATUZM80	N14.1 WXGAG	SO2GBII6	N	N250G B 5.4KS	NSM8XS	3rd WiFi BG	N
AS4530-802G25Mi	ATUZM80	N14.1 WXGAG	SO2GBII6	N	N250G B 5.4KS	NSM8XS	3rd WiFi BG	N
AS4530-601G16Mi	AAQL60	N14.1 WXGAG	SO1GBII6	N	N160G B 5.4KS	NSM8XS	3rd WiFi BG	BT 2.0
AS4530-602G16Mn	AAQL60	N14.1 WXGAG	SO2GBII6	N	N160G B 5.4KS	NSM8XS	3rd WiFi 1x2 BGN	BT 2.0
AS4530-702G16Mn	ATRM70	N14.1 WXGAG	SO2GBII6	N	N160G B 5.4KS	NSM8XS	3rd WiFi 1x2 BGN	BT 2.0
AS4530-601G16Mn	AAQL60	N14.1 WXGAG	SO1GBII6	N	N160G B 5.4KS	NSM8XS	3rd WiFi 1x2 BGN	BT 2.0
AS4530-702G25Mi	ATRM70	N14.1 WXGAG	SO2GBII6	N	N250G B 5.4KS	NSM8XS	3rd WiFi BG	N
AS4530-702G25Mi	ATRM70	N14.1 WXGAG	SO2GBII6	N	N250G B 5.4KS	NSM8XS	3rd WiFi BG	N
AS4530-803G25Mi	ATUZM80	N14.1 WXGAG	SO2GBII6	SO1GBII6	N250G B 5.4KS	NSM8XS	3rd WiFi BG	BT 2.0
AS4530-803G25Mi	ATUZM80	N14.1 WXGAG	SO2GBII6	SO1GBII6	N250G B 5.4KS	NSM8XS	3rd WiFi BG	BT 2.0

Model	CPU	LCD	DIMM 1	DIMM2	HDD	ODD	WLAN	BT
AS4530-802G25Mi	ATUzM80	N14.1 WXGAG	SO2GBII6	N	N250G B 5.4KS	NSM8XS	3rd WiFi BG	N
AS4530-802G25Mi	ATUzM80	N14.1 WXGAG	SO2GBII6	N	N250G B 5.4KS	NSM8XS	3rd WiFi BG	N
AS4530-802G25Mi	ATUzM80	N14.1 WXGAG	SO2GBII6	N	N250G B 5.4KS	NSM8XS	3rd WiFi BG	N
AS4530-802G25Mi	ATUzM80	N14.1 WXGAG	SO2GBII6	N	N250G B 5.4KS	NSM8XS	3rd WiFi BG	N
AS4530-701G25Mi	ATRM70	N14.1 WXGAG	SO1GBII6	N	N250G B 5.4KS	NSM8XS	3rd WiFi BG	BT 2.0
AS4530-601G16Mi	AAQL60	N14.1 WXGAG	SO1GBII6	N	N160G B 5.4KS	NSM8XS	3rd WiFi BG	BT 2.0
AS4530-802G25Mn	ATUzM80	N14.1 WXGAG	SO2GBII6	N	N250G B 5.4KS	NSM8XS	3rd WiFi 1x2 BGN	BT 2.0
AS4530-721G25Mn	ATRM72	N14.1 WXGAG	SO1GBII6	N	N250G B 5.4KS	NSM8XS	3rd WiFi 1x2 BGN	BT 2.0
AS4530-702G25Mn	ATRM70	N14.1 WXGAG	SO1GBII6	SO1GBII6	N250G B 5.4KS	NSM8XS	3rd WiFi 1x2 BGN	BT 2.0
AS4530-601G25Mi	AAQL60	N14.1 WXGAG	SO1GBII6	N	N250G B 5.4KS	NSM8XS	3rd WiFi BG	BT 2.0
AS4530-601G16C	AAQL60	N14.1 WXGAG	SO1GBII6	N	N160G B 5.4KS	NCB24XS	N	N
AS4530-702G25Mi	ATRM70	N14.1 WXGAG	SO2GBII6	N	N250G B 5.4KS	NSM8XS	3rd WiFi BG	N
AS4530-803G25Mi	ATUzM80	N14.1 WXGAG	SO2GBII6	SO1GBII6	N250G B 5.4KS	NSM8XS	3rd WiFi BG	BT 2.0
AS4530-824G25Mi	ATUzM82	N14.1 WXGAG	SO2GBII6	SO2GBII6	N250G B 5.4KS	NSM8XS	3rd WiFi BG	BT 2.0
AS4530-823G25Mi	ATUzM82	N14.1 WXGAG	SO2GBII6	SO1GBII6	N250G B 5.4KS	NSM8XS	3rd WiFi BG	BT 2.0
AS4530-601G12C	AAQL60	N14.1 WXGAG	SO1GBII6	N	N120G B 5.4KS	NCB24XS	N	N
AS4530-601G16Mi	AAQL60	N14.1 WXGAG	SO1GBII6	N	N160G B 5.4KS	NSM8XS	3rd WiFi BG	BT 2.0
AS4530-801G25Mi	ATUzM80	N14.1 WXGAG	SO1GBII6	N	N250G B 5.4KS	NSM8XS	3rd WiFi BG	BT 2.0
AS4530-701G16Ci	ATRM70	N14.1 WXGAG	SO1GBII6	N	N160G B 5.4KS	NCB24XS	3rd WiFi BG	N
AS4530-701G25Mi	ATRM70	N14.1 WXGAG	SO1GBII6	N	N250G B 5.4KS	NSM8XS	3rd WiFi BG	N
AS4530-700516Mn	ATRM70	N14.1 WXGAG	SO512MBII6	N	N160G B 5.4KS	NSM8XS	3rd WiFi 1x2 BGN	BT 2.0
AS4530-601G16Mi	AAQL60	N14.1 WXGAG	SO1GBII6	N	N160G B 5.4KS	NSM8XS	3rd WiFi BG	N
AS4530-702G25Mi	ATRM70	N14.1 WXGAG	SO1GBII6	SO1GBII6	N250G B 5.4KS	NSM8XS	3rd WiFi BG	BT 2.0
AS4530-701G25Mi	ATRM70	N14.1 WXGAG	SO1GBII6	N	N250G B 5.4KS	NSM8XS	3rd WiFi BG	BT 2.0
AS4530-802G25Mi	ATUzM80	N14.1 WXGAG	SO2GBII6	N	N250G B 5.4KS	NSM8XS	3rd WiFi BG	N
AS4530-802G25Mi	ATUzM80	N14.1 WXGAG	SO2GBII6	N	N250G B 5.4KS	NSM8XS	3rd WiFi BG	N
AS4530-802G25Mi	ATUzM80	N14.1 WXGAG	SO2GBII6	N	N250G B 5.4KS	NSM8XS	3rd WiFi BG	N

Model	CPU	LCD	DIMM 1	DIMM2	HDD	ODD	WLAN	BT
AS4530-802G25Mi	ATUZM80	N14.1 WXGAG	SO2GBII6	N	N250G B 5.4KS	NSM8XS	3rd WiFi BG	N
AS4530-604G25Mi	AAQL60	N14.1 WXGAG	SO2GBII6	SO2GBII6	N250G B 5.4KS	NSM8XS	3rd WiFi BG	BT 2.0
AS4530-604G32Mi	AAQL60	N14.1 WXGAG	SO2GBII6	SO2GBII6	N320G B 5.4KS	NSM8XS	3rd WiFi BG	BT 2.0
AS4530-701G16Mn	ATRM70	N14.1 WXGAG	SO1GBII6	N	N160G B 5.4KS	NSM8XS	3rd WiFi 1x2 BGN	BT 2.0
AS4530-801G25Mn	ATUZM80	N14.1 WXGAG	SO1GBII6	N	N250G B 5.4KS	NSM8XS	3rd WiFi 1x2 BGN	BT 2.0
AS4530-601G25Mn	AAQL60	N14.1 WXGAG	SO1GBII6	N	N250G B 5.4KS	NSM8XS	3rd WiFi 1x2 BGN	BT 2.0
AS4530-702G25Mn	ATRM70	N14.1 WXGAG	SO1GBII6	SO1GBII6	N250G B 5.4KS	NSM8XS	3rd WiFi 1x2 BGN	BT 2.0
AS4530-601G16Mn	AAQL60	N14.1 WXGAG	SO1GBII6	N	N160G B 5.4KS	NSM8XS	3rd WiFi 1x2 BGN	BT 2.0
AS4530-600512Cn	AAQL60	N14.1 WXGAG	SO512MBII6	N	N120G B 5.4KS	NCB24XS	3rd WiFi 1x2 BGN	N
AS4530-601G12Cn	AAQL60	N14.1 WXGAG	SO1GBII6	N	N120G B 5.4KS	NCB24XS	3rd WiFi 1x2 BGN	N
AS4530-701G16Cn	ATRM70	N14.1 WXGAG	SO1GBII6	N	N160G B 5.4KS	NCB24XS	3rd WiFi 1x2 BGN	N
AS4530-700512Mn	ATRM70	N14.1 WXGAG	SO512MBII6	N	N120G B 5.4KS	NSM8XS	3rd WiFi 1x2 BGN	N
AS4530-701G12Mn	ATRM70	N14.1 WXGAG	SO1GBII6	N	N120G B 5.4KS	NSM8XS	3rd WiFi 1x2 BGN	N
AS4530-801G16Mn	ATUZM80	N14.1 WXGAG	SO1GBII6	N	N160G B 5.4KS	NSM8XS	3rd WiFi 1x2 BGN	N
AS4530-701G25Mn	ATRM70	N14.1 WXGAG	SO1GBII6	N	N250G B 5.4KS	NSM8XS	3rd WiFi 1x2 BGN	N
AS4530-801G16Mn	ATUZM80	N14.1 WXGAG	SO1GBII6	N	N160G B 5.4KS	NSM8XS	3rd WiFi 1x2 BGN	BT 2.0
AS4530-801G16Mn	ATUZM80	N14.1 WXGAG	SO1GBII6	N	N160G B 5.4KS	NSM8XS	3rd WiFi 1x2 BGN	BT 2.0
AS4530-601G16Mn	AAQL60	N14.1 WXGAG	SO1GBII6	N	N160G B 5.4KS	NSM8XS	3rd WiFi 1x2 BGN	BT 2.0
AS4530-701G25Mn	ATRM70	N14.1 WXGAG	SO1GBII6	N	N250G B 5.4KS	NSM8XS	3rd WiFi 1x2 BGN	BT 2.0
AS4530-601G16Mn	AAQL60	N14.1 WXGAG	SO1GBII6	N	N160G B 5.4KS	NSM8XS	3rd WiFi 1x2 BGN	N
AS4530-601G16Mn	AAQL60	N14.1 WXGAG	SO1GBII6	N	N160G B 5.4KS	NSM8XS	3rd WiFi 1x2 BGN	BT 2.0
AS4530-601G12Mn	AAQL60	N14.1 WXGAG	SO1GBII6	N	N120G B 5.4KS	NSM8XS	3rd WiFi 1x2 BGN	N
AS4530-601G12Mn	AAQL60	N14.1 WXGAG	SO1GBII6	N	N120G B 5.4KS	NSM8XS	3rd WiFi 1x2 BGN	N
AS4530-601G16Mn	AAQL60	N14.1 WXGAG	SO1GBII6	N	N160G B 5.4KS	NSM8XS	3rd WiFi 1x2 BGN	N
AS4530-802G32Mn	ATUZM80	N14.1 WXGAG	SO1GBII6	SO1GBII6	N320G B 5.4KS	NSM8XS	3rd WiFi 1x2 BGN	BT 2.0
AS4530-821G32Mn	ATUZM82	N14.1 WXGAG	SO1GBII6	N	N320G B 5.4KS	NSM8XS	3rd WiFi 1x2 BGN	BT 2.0
AS4530-822G32Mn	ATUZM82	N14.1 WXGAG	SO1GBII6	SO1GBII6	N320G B 5.4KS	NSM8XS	3rd WiFi 1x2 BGN	BT 2.0

Model	CPU	LCD	DIMM 1	DIMM2	HDD	ODD	WLAN	BT
AS4530-802G25Mn	ATUzM80	N14.1 WXGAG	SO1GBII6	SO1GBII6	N250G B 5.4KS	NSM8XS	3rd WiFi 1x2 BGN	BT 2.0
AS4530-824G32Mn	ATUzM82	N14.1 WXGAG	SO2GBII6	SO2GBII6	N320G B 5.4KS	NSM8XS	3rd WiFi 1x2 BGN	BT 2.0
AS4530-804G32Mn	ATUzM80	N14.1 WXGAG	SO2GBII6	SO2GBII6	N320G B 5.4KS	NSM8XS	3rd WiFi 1x2 BGN	BT 2.0
AS4530-702G32Mn	ATRM70	N14.1 WXGAG	SO1GBII6	SO1GBII6	N320G B 5.4KS	NSM8XS	3rd WiFi 1x2 BGN	BT 2.0
AS4530-704G32Mn	ATRM70	N14.1 WXGAG	SO2GBII6	SO2GBII6	N320G B 5.4KS	NSM8XS	3rd WiFi 1x2 BGN	N
AS4530-702G25Mi	ATRM70	N14.1 WXGAG	SO2GBII6	N	N250G B 5.4KS	NSM8XS	3rd WiFi BG	N
AS4530-803G25Mi	ATUzM80	N14.1 WXGAG	SO2GBII6	SO1GBII6	N250G B 5.4KS	NSM8XS	3rd WiFi BG	BT 2.0
AS4530-802G25Mi	ATUzM80	N14.1 WXGAG	SO2GBII6	N	N250G B 5.4KS	NSM8XS	3rd WiFi BG	N
AS4530-802G25Mi	ATUzM80	N14.1 WXGAG	SO2GBII6	N	N250G B 5.4KS	NSM8XS	3rd WiFi BG	N
AS4530-802G25Mi	ATUzM80	N14.1 WXGAG	SO2GBII6	N	N250G B 5.4KS	NSM8XS	3rd WiFi BG	N
AS4530-802G25Mi	ATUzM80	N14.1 WXGAG	SO2GBII6	N	N250G B 5.4KS	NSM8XS	3rd WiFi BG	N
AS4530-802G25Mi	ATUzM80	N14.1 WXGAG	SO2GBII6	N	N250G B 5.4KS	NSM8XS	3rd WiFi BG	N
AS4530-602G25Mn	AAQL60	N14.1 WXGAG	SO1GBII6	SO1GBII6	N250G B 5.4KS	NSM8XS	3rd WiFi 1x2 BGN	N
AS4530-602G25Mn	AAQL60	N14.1 WXGAG	SO1GBII6	SO1GBII6	N250G B 5.4KS	NSM8XS	3rd WiFi 1x2 BGN	N
AS4530-602G25M	AAQL60	N14.1 WXGAG	SO1GBII6	SO1GBII6	N250G B 5.4KS	NSM8XS	N	N
AS4530-602G12Mn	AAQL60	N14.1 WXGAG	SO1GBII6	SO1GBII6	N120G B 5.4KS	NSM8XS	3rd WiFi 1x2 BGN	N
AS4530-602G25Mn	AAQL60	N14.1 WXGAG	SO1GBII6	SO1GBII6	N250G B 5.4KS	NSM8XS	3rd WiFi 1x2 BGN	N
AS4530-602G12Mn	AAQL60	N14.1 WXGAG	SO1GBII6	SO1GBII6	N120G B 5.4KS	NSM8XS	3rd WiFi 1x2 BGN	N
AS4530-602G16Mn	AAQL60	N14.1 WXGAG	SO1GBII6	SO1GBII6	N160G B 5.4KS	NSM8XS	3rd WiFi 1x2 BGN	N

Test Compatible Components

This computer's compatibility is tested and verified by Acer's internal testing department. All of its system functions are tested under Windows® XP Home, Windows® XP Pro environment.

Refer to the following lists for components, adapter cards, and peripherals which have passed these tests. Regarding configuration, combination and test procedures, please refer to the Aspire 4530/4230 series Compatibility Test Report released by the Acer Mobile System Testing Department.

Microsoft® Windows® Vista Environment Test

Vendor	Type	Description
Adapter		
F0000183 DELTA CN	65W	Adapter DELTA 65W 1.7x5.5x11 SADP-65KB DFA LF level 4
10001023 LITE-ON	65W	Adapter LITE-ON 65W 1.7x5.5x11 PA-1650-02AC LF level 4
60002015 HIPRO	65W	Adapter HIPRO 65W 19V 1.7x5.5x11 Yellow HP-OK065B13 LED LF level 4
Battery		
60001921 SANYO	6CELL2.2	Battery SANYO AS-2007A Li-Ion 3S2P SANYO 6 cell 4400mAh Main COMMON Normal Type
10001063 SONY	6CELL2.2	Battery SONY AS-2007A Li-Ion 3S2P SONY 6 cell 4400mAh Main COMMON Normal Type
60001535 PANASONIC	6CELL2.2	Battery PANASONIC AS-2007A Li-Ion 3S2P PANASONIC 6 cell 4400mAh Main COMMON PSS
60002162 SIMPLO	6CELL2.2	Battery SIMPLO AS-2007A Li-Ion 3S2P PANASONIC 6 cell 4400mAh Main COMMON PSS
CPU		
22554573 AMD	AAQL60	CPU AMD Athlon64X2 QL60 PGA 1.9G 1M 638 35W Griffin B1
22554573 AMD	AAQL62	CPU AMD Athlon64X2 QL62 PGA 2.0G 1M 638 35W Griffin B1
22554573 AMD	ATRM70	CPU AMD TurionX2 RM70 PGA 2.0G 1M 638 31W Griffin B1
22554573 AMD	ATRM72	CPU AMD Turion RM72 PGA 2.1G 1M 638 35W Griffin B1
22554573 AMD	ATUZM80	CPU AMD TurionX2 ZM80 PGA 2.1G 2M 638 35W Griffin B1
22554573 AMD	ATUZM82	CPU AMD TurionX2 ZM82 PGA 2.2G 2M 638 35W Griffin B1
22554573 AMD	ATUZM84	CPU AMD TurionX2 ZM84 PGA 2.3G 2M 638 35W Griffin B1
22554573 AMD	ATUZM86	CPU AMD TurionX2 ZM86 PGA 2.4G 2M 638 35W Griffin B1
22554573 AMD	SMPSI4025W	CPU AMD SempronM SI40 PGA 2.0G 512K 638 25W Griffin B1
HDD		
60002036 SEAGATE	N120GB5.4KS	HDD SEAGATE 2.5" 5400rpm 120GB ST9120817AS Corsair SATA LF F/W:3.AAA
60001922 TOSHIBA DIGI	N120GB5.4KS	HDD TOSHIBA 2.5" 5400rpm 120GB MK1246GSX Leo BS SATA I LF F/W:LB213J
60002005 HGST SG	N120GB5.4KS	HDD HGST 2.5" 5400rpm 120GB HTS542512K9SA00 Bronco-B SATA II LF F/W:C31P
60001994 WD	N120GB5.4KS	HDD WD 2.5" 5400rpm 120GB WD1200BEVS-22UST0 ML125 SATA LF F/W:01.01A01
60002036 SEAGATE	N160GB5.4KS	HDD SEAGATE 2.5" 5400rpm 160GB ST9160827AS Corsair SATA LF F/W:3.AAA

Vendor	Type	Description
60001922 TOSHIBA DIGI	N160GB5.4KS	HDD TOSHIBA 2.5" 5400rpm 160GB MK1646GSX Leo BS SATA I LF F/W:LB113J
60002005 HGST SG	N160GB5.4KS	HDD HGST 2.5" 5400rpm 160GB HTS542516K9SA00 Bronco- B SATA II LF F/W:C31P
60001994 WD	N160GB5.4KS	HDD WD 2.5" 5400rpm 160GB WD1600BEVT-22ZCTO ML160 SATA LF F/W:11.01A11
60001922 TOSHIBA DIGI	N250GB5.4KS	HDD TOSHIBA 2.5" 5400rpm 250GB MK2546GSX Leo BS SATA I LF F/W:LB013J
60002005 HGST SG	N250GB5.4KS	HDD HGST 2.5" 5400rpm 250GB HTS542525K9SA00 Bronco- B SATA II LF F/W:C31P
60001994 WD	N250GB5.4KS	HDD WD 2.5" 5400rpm 250GB WD2500BEVS-22UST0 ML125 SATA LF F/W:01.01A01
60001994 WD	N320GB5.4KS	HDD WD 2.5" 5400rpm 320GB WD3200BEVT-22ZCT0 ML160 SATA LF F/W:11.01A11
LCD		
60003316 AUO	N14.1WXGAG	LCD AUO 14.1" WXGA Glare B141EW04-V4 LF 200nit 16ms
60002215 SAMSUNG	N14.1WXGAG	LCD SAMSUNG 14.1" WXGA Glare LTN141W3-L01-J L6 LF 200nit 16ms
60003089 LG	N14.1WXGAG	LCD LPL 14.1" WXGA Glare LP141WX3-TLN1 LF 200nit 16ms
10001038 CMO	N14.1WXGAG	LCD CMO 14.1" WXGA Glare N141I3-L02 LF 200nit 10ms
Memory		
60001993 NANYA	SO1GBII6	SO-DIMM DDRII 667 1GB NT1GT64U8HB0BN-3C (0.09U)
60002215 SAMSUNG	SO1GBII6	Memory SAMSUNG SO-DIMM DDRII 667 1GB M470T2864QZ3-CE6 LF
60002045 HYNIX	SO1GBII6	Memory HYNIX SO-DIMM DDRII 667 1GB HYMP112S64CP6- Y5 LF
60002215 SAMSUNG	SO2GBII6	Memory SAMSUNG SO-DIMM DDRII 667 2GB M470T5663QZ3-CE6 LF
60001993 NANYA	SO512MBII6	Memory NANYA SO-DIMM DDRII 667 512MB NT512T64UH8B0FN-3C LF 32*16 0.09um
60002215 SAMSUNG	SO512MBII6	Memory SAMSUNG SO-DIMM DDRII 667 512MB M470T6464QZ3-CE6 LF
60002045 HYNIX	SO512MBII6	Memory HYNIX SO-DIMM DDRII 667 512MB HYMP164S64CP6-Y5 LF 64*16 0.065um
ODD		
60001922 TOSHIBA DIGI	NCB24XS	ODD TOSHIBA COMBO 12.7mm Tray DL 24X TS-L463A LF W/O bezel SATA
10001063 SONY	NCB24XS	ODD SONY COMBO 12.7mm Tray DL 24X CRX890S LF W/O bezel SATA
60001922 TOSHIBA DIGI	NSM8XS	ODD TOSHIBA Super-Multi DRIVE 12.7mm Tray DL 8X TS- L633A LF W/O bezel SATA

Vendor	Type	Description
23418669 HLDS	NSM8XS	ODD HLDS Super-Multi DRIVE 12.7mm Tray DL 8X GSA-T50N LF W/O bezel SATA Malaysia
Keyboard		
820123 DARFON	14_15KB-FV3 Black	Keyboard 14_15KB-FV3 Black McKinley/Eiger Standard (Aspire Black)
LAN		
610112 BROADCOM	BCM5764	Broadcom BCM5764
Audio Codec		
9999995 ONE TIME VENDER	ALC888S	ALC888S
Bluetooth		
9999995 ONE TIME VENDER	BT 2.0	Foxconn Bluetooth FOX_BRM_2.0 F/W 300
Camera		
9999995 ONE TIME VENDER	0.3M DV	Suyin 0.3M DV Camellia_2
Card Reader		
9999995 ONE TIME VENDER	5 in 1-Build in	5 in 1-Build in MS, MS Pro, SD, SC, XD

Online Support Information

This section describes online technical support services available to help you repair your Acer Systems.

If you are a distributor, dealer, ASP or TPM, please refer your technical queries to your local Acer branch office. Acer Branch Offices and Regional Business Units may access our website. However some information sources will require a user i.d. and password. These can be obtained directly from Acer CSD Taiwan.

Acer's Website offers you convenient and valuable support resources whenever you need them.

In the Technical Information section you can download information on all of Acer's Notebook, Desktop and Server models including:

- Service guides for all models
- User's manuals
- Training materials
- Bios updates
- Software utilities
- Spare parts lists
- TABs (Technical Announcement Bulletin)

For these purposes, we have included an Acrobat File to facilitate the problem-free downloading of our technical material.

Also contained on this website are:

- Detailed information on Acer's International Traveler's Warranty (ITW)
- Returned material authorization procedures
- An overview of all the support services we offer, accompanied by a list of telephone, fax and email contacts for all your technical queries.

We are always looking for ways to optimize and improve our services, so if you have any suggestions or comments, please do not hesitate to communicate these to us.

A

AFLASH Utility 42

B

Battery Pack 50

BIOS

- package 18
- password control 18
- ROM size 18
- ROM type 18
- vendor 18
- Version 18

BIOS Supports protocol 18

BIOS Utility 29–42

- Advanced 32
- Boot 38
- Exit 41
- Navigating 29
- Onboard Device Configuration 36
- Power 38, 39
- Save and Exit 41
- Security 35
- System Security 41

Bluetooth board 78

Board Layout

Top View 143

brightness

hotkeys 14

C

Cache

- controller 18
- size 18

Camera Module 89

caps lock

on indicator 10

Chipset POST Codes 133

Common Problems 116

computer

on indicator 10

Core POST Codes 135

CPU 84

D

DIMM Module 54

Display 4

display

hotkeys 14

E

EasyTouch Failure 128

Euro 15

External Module Disassembly

Flowchart 49

F

Features 1

Fingerprint Reader Failure 129

Flash Utility 42

FPC Cable 91

FRU (Field Replaceable Unit) List 147

H

HDTV Switch Failure 130

Hibernation mode

hotkey 14

Hot Keys 12

I

Indicators 10

Intermittent Problems 132

Internal Microphone Failure 122

Internal Speaker Failure 120

inverter board 88

J

Jumper and Connector Locations 143

Top View 143

K

Keyboard 64

Keyboard Failure 119

L

- Launch Board 72
- LCD Bezel 86
- LCD Brackets 91
- LCD Failure 119
- LCD Module Disassembly
 - Flowchart 85
- LCD Panel 90
- lower cover 53

M

- Main Unit Disassembly
 - Flowchart 61
- Mainboard 80
- media access
 - on indicator 10
- MediaTouch Button Failure 129
- Memory Check 116
- Model Definition 158
- Modem Board 81
- Modem Failure 127

N

- No Display Issue 117
- Notebook Manager
 - hotkey 14
- num lock
 - on indicator 10

O

- ODD Failure 124
- Online Support Information 187
- optical drive module 59

P

- Panel 5
 - Bottom 9
 - left 5
- PC Card 10
- POST Codes
 - Chipset 133
 - Core 135
- POST Codes Tables 133
- Power On Failure 116

S

- Speaker Module 73
- speakers
 - hotkey 14
- System
 - Block Diagram 4

T

- Test Compatible Components 183
- Thermal Unit Failure 130
- Top 143
- touch pad
 - hotkey 14
- Touch Pad Board Plate 77
- Touch Pad Failure 120
- Troubleshooting
 - Built-in KB Failure 119
 - EasyTouch Buttons 128
 - Fingerprint Reader 129
 - HDTV Switch 130
 - Internal Microphone 122
 - Internal Speakers 120
 - LCD Failure 119
 - MediTouch Buttons 129
 - Modem 127
 - No Display 117
 - ODD 124
 - Other Failures 131
 - Power On 116
 - Thermal Unit 130
 - Touch Pad 120
 - USB 127
 - WLAN 128

U

- Undetermined Problems 132
- USB Failure (Rightside) 127
- utility
 - BIOS 29–42

W

- Windows 2000 Environment Test 184
- Wireless Function Failure 128
- WLAN Board 55