

TravelMate 6493 Series Service Guide

Service guide files and updates are available on the ACER/CSD web; for more information, please refer to <http://csd.acer.com.tw>

PRINTED IN TAIWAN

Revision History

Please refer to the table below for the updates made on TravelMate 6493 Series service guide.

Date	Chapter	Updates

Copyright

Copyright © 2008 by Acer Incorporated. All rights reserved. No part of this publication may be reproduced, transmitted, transcribed, stored in a retrieval system, or translated into any language or computer language, in any form or by any means, electronic, mechanical, magnetic, optical, chemical, manual or otherwise, without the prior written permission of Acer Incorporated.

Disclaimer

The information in this guide is subject to change without notice.

Acer Incorporated makes no representations or warranties, either expressed or implied, with respect to the contents hereof and specifically disclaims any warranties of merchantability or fitness for any particular purpose. Any Acer Incorporated software described in this manual is sold or licensed *as is*. Should the programs prove defective following their purchase, the buyer (and not Acer Incorporated, its distributor, or its dealer) assumes the entire cost of all necessary servicing, repair, and any incidental or consequential damages resulting from any defect in the software.

Acer is a registered trademark of Acer Corporation.

Intel is a registered trademark of Intel Corporation.

Pentium and Pentium II/III are trademarks of Intel Corporation.

Other brand and product names are trademarks and/or registered trademarks of their respective holders.

Conventions

The following conventions are used in this manual:

SCREEN MESSAGES	Denotes actual messages that appear on screen.
NOTE	Gives bits and pieces of additional information related to the current topic.
WARNING	Alerts you to any damage that might result from doing or not doing specific actions.
CAUTION	Gives precautionary measures to avoid possible hardware or software problems.
IMPORTANT	Reminds you to do specific actions relevant to the accomplishment of procedures.

Preface

Before using this information and the product it supports, please read the following general information.

1. This Service Guide provides you with all technical information relating to the BASIC CONFIGURATION decided for Acer's *global* product offering. To better fit local market requirements and enhance product competitiveness, your regional office MAY have decided to extend the functionality of a machine (e.g. add-on card, modem, or extra memory capability). These LOCALIZED FEATURES will NOT be covered in this generic service guide. In such cases, please contact your regional offices or the responsible personnel/channel to provide you with further technical details.
2. Please note WHEN ORDERING FRU PARTS, that you should check the most up-to-date information available on your regional web or channel. If, for whatever reason, a part number change is made, it will not be noted in the printed Service Guide. For ACER-AUTHORIZED SERVICE PROVIDERS, your Acer office may have a DIFFERENT part number code to those given in the FRU list of this printed Service Guide. You MUST use the list provided by your regional Acer office to order FRU parts for repair and service of customer machines.

System Specifications	1
Features	1
System Block Diagram	4
Your Acer Notebook tour	5
Front View	5
Closed Front View	6
Left View	7
Right View	7
Rear View	8
Bottom View	8
Indicators	10
Easy-Launch Buttons	10
Touchpad Basics (with fingerprint reader)	11
Using the Keyboard	12
Lock Keys and embedded numeric keypad	12
Windows Keys	13
Hot Keys	14
Special Key	15
Using the System Utilities	16
Acer GridVista (dual-display compatible)	16
Hardware Specifications and Configurations	18
 System Utilities	 29
BIOS Setup Utility	29
Navigating the BIOS Utility	29
Information	30
Main	31
Advanced	32
Intel	34
Security	36
Boot	39
Exit	40
BIOS Flash Utility	41
Remove HDD/BIOS Utility	43
 Machine Disassembly and Replacement	 47
Disassembly Requirements	47
General Information	48
Pre-disassembly Instructions	48
Disassembly Process	48
External Module Disassembly Process	49
External Modules Disassembly Flowchart	49
Removing the Battery Pack	50
Removing the SD dummy card	51
Removing the NewCard Dummy card	52
Removing the Lower Covers	53
Removing the DIMM Modules	55
Removing the 3G Module	56
Removing the Hard Disk Drive Module	57
Removing the Optical Drive Module	59
Main Unit Disassembly Process	62
Main Unit Disassembly Flowchart	62
Removing the Switch Cover	64
Removing the Keyboard	65

Table of Contents

Removing the eKey Board	67
Removing the Power Board	69
Removing the WLAN Module	71
Removing the 3G Antenna	72
Removing the WLAN Antenna and MIC Cable	73
Removing the LCD Module	75
Removing the Upper Cover	77
Removing the Card Reader Module	80
Removing the Finger Print Reader	81
Removing the TouchPad Bracket	83
Removing the Speaker Modules	85
Removing the Bluetooth Module	86
Removing the Modem Module	87
Removing the Mainboard	89
Removing the USB Board	91
Removing the Thermal Module	92
Removing the CPU Fan	93
Removing the CPU	94
LCD Module Disassembly Process	95
LCD Module Disassembly Flowchart	95
Removing the LCD Bezel	96
Removing the Camera Module	97
Removing the Inverter Board	98
Removing the LCD Panel	99
Removing the LCD Brackets and FPC Cable	100
Removing the Antennas	101
Removing the MIC Module	105
LCD Module Reassembly Procedure	106
Replacing the LCD Panel	106
Replacing the LCD Bezel	112
Main Module Reassembly Procedure	113
Replacing the CPU	113
Replacing the CPU Fan	113
Replacing the Thermal Module	114
Replacing the USB Board	114
Replacing the Mainboard	115
Replacing the Modem Module	116
Replacing the Bluetooth Board	117
Replacing the Speaker Modules	117
Replacing the TouchPad Bracket	119
Replacing the Finger Print Reader	120
Replacing the Card Reader Module	120
Replacing the Upper Cover	121
Replacing the LCD Module	123
Replacing the WLAN Module	124
Replacing the WLAN Antenna and MIC Cables	125
Replacing the 3G Antenna Cable	126
Replacing the Power Board	126
Replacing the eKey Board	127
Replacing the Keyboard	128
Replacing the Switch Cover	129
Replacing the ODD Module	130
Replacing the Hard Disk Drive Module	131
Replacing the 3G Module	131
Replacing the DIMM Modules	132

Table of Contents

Replacing the Lower Covers	133
Replacing the NewCard and SD Card Dummy Trays	134
Replacing the Battery Pack	134
Troubleshooting	135
Common Problems	135
Power On Issue	136
No Display Issue	137
Random Loss of BIOS Settings	138
LCD Failure	139
Built-In Keyboard Failure	139
Touchpad Failure	140
Internal Speaker Failure	140
Internal Microphone Failure	142
HDD Not Operating Correctly	143
ODD Failure	144
USB Failure (Rightside)	147
Modem Function Failure	147
Wireless Function Failure	148
3G Module Failure	149
EasyTouch Button Failure	149
Fingerprint Reader Failure	150
Thermal Unit Failure	150
External Mouse Failure	151
Other Failures	151
Intermittent Problems	152
Undetermined Problems	152
POST Codes Tables	153
Port 80 POST Codes	153
POST Keys and Messages	155
Jumper and Connector Locations	157
Top View	157
Bottom View	158
Clearing Password Check and BIOS Recovery	159
Clearing Password Check	159
BIOS Recovery by Crisis Disk	160
FRU (Field Replaceable Unit) List	161
TravelMate 6493 Exploded Diagrams	162
Upper Case	162
Lower Case	163
LCD Module	164
TravelMate 6493 FRU List	165
Model Definition and Configuration	178
TravelMate 6493 Series	178
Test Compatible Components	211
Microsoft® Windows® Vista Environment Test	212
Online Support Information	215
Index	217

Table of Contents

System Specifications

Features

Below is a brief summary of the computer's many features:

NOTE: Items marked with * denote only selected models.

Operating System

- Genuine Windows® Vista™
- Genuine Windows® XP

Platform

- Intel® Centrino® 2 with vPro™ technology, featuring:
 - Intel® Core™2 Duo processor
 - Mobile Intel® GM45 Express Chipset
 - Intel® 82566MM
 - Intel® Wireless WiFi Link 5100/5300*
 - Intel® Wireless WiFi Link 5150/5350 (Subject to availability)

System Memory

- Dual-Channel DDR3 support
- Up to 2 GB of DDR3 1066 MHz memory, upgradeable to 4 GB using two soDIMM modules*

Display and graphics

- 14.1" WXGA TFT LCD, 1280 x 800
- 14.1" WXGA+ TFT LCD, 1440 x 900
- Mobile Intel® GM45 Express Chipset (Intel® Graphics Media Accelerator X4500)

Storage subsystem

- 2.5" hard disk drive
- Intel® Turbo Memory supported*
- Optical drive options:
 - DVD-Super Multi double-layer drive*
 - DVD/CD-RW combo drive*
- 5-in-1 card reader

Audio

- Two built-in Acer 3DSonic stereo speakers
- High-definition audio support
- MS-Sound compatible
- Built-in microphone

Communication

- Acer Video Conference, featuring:
 - Integrated Acer Crystal Eye webcam
 - Optional Acer Bluetooth® VoIP phone
- WLAN: Intel® Wireless WiFi Link 5100/5300*
- WiFi®/WiMAX™: Intel® Wireless WiFi Link 5150/5350

NOTE: Subject to availability.

- WPAN: Bluetooth® 2.0+EDR
- LAN: Gigabit Ethernet, Wake-on-LAN ready
- WWAN: UMTS/HSDPA (High-Speed Downlink Packet Access) (3.5G) at 2100 MHz and quad-band GSM/ GPRS/EDGE (850/900/1800/1900 MHz*)
- Modem: 56K ITU V.92

Privacy control

- Enhanced Acer DASP (Disk Anti-Shock Protection)
- Acer Bio-Protection fingerprint solution
- TravelMate SmartCard solution
- TravelMate TPM (Trusted Platform Module) solution
- BIOS user, supervisor, HDD passwords
- Kensington lock slot

Dimensions and Weight

- 338 (W) x 245 (D) x 33.6/39.5 (H) mm (13.3 x 9.65 x 1.32/1.55 inches)
- 2.67 kg (5.89 lbs.) with 9-cell battery pack, Acer MediaBay 6-cell 2nd battery pack and 3G
- 2.56 kg (5.64 lbs.) with 9-cell battery pack, optical drive and 3G
- 2.51 kg (5.53 lbs.) with 6-cell battery pack, Acer MediaBay 6-cell 2nd battery pack and 3G
- 2.4 kg (5.29 lbs.) with 6-cell battery pack, optical drive and 3G
- 2.64 kg (5.82 lbs.) with 9-cell battery pack and Acer MediaBay 6-cell 2nd battery pack
- 2.53 kg (5.57 lbs.) with 9-cell battery pack and optical drive
- 2.48 kg (5.46 lbs.) with 6-cell battery pack and Acer MediaBay 6-cell 2nd battery pack
- 2.38 kg (5.24 lbs.) with 6-cell battery pack and optical drive

Power subsystem

- ACPI 3.0
- 79.9 W 4800 mAh
- 58.8 W 4400 mAh
- 3-pin 65W AC adapter
- Energy Star 4.0

Input Devices

- 88-/89-key keyboard
- Acer FineTrack™ with two FineTrack™ buttons
- Touchpad pointing device

I/O interface

- Acer ezDock II/ II+ connector
- PC Card slot (Type II)
- Acer Bio-Protection fingerprint reader*
- TravelMate SmartCard reader
- 5-in-1 card reader (SD™, MMC, MS, MS PRO, xD)
- Three USB 2.0 ports
- DVI-D port with HDCP support
- Fast infrared (FIR) port
- External display (VGA) port
- Headphone/speaker/line-out jack
- Microphone-in jack
- Ethernet (RJ-45) port
- Modem (RJ-11) port
- DC-in jack for AC adapter

Environment

- Temperature:
 - Operating: 5 °C to 35 °C
 - Non-operating: -20 °C to 65 °C
- Humidity (non-condensing):
 - Operating: 20% to 80%
 - Non-operating: 20% to 80%

NOTE: Items marked with * denote only selected models. The specifications listed above are for reference only. The exact configuration of your PC depends on the model purchased.

System Block Diagram

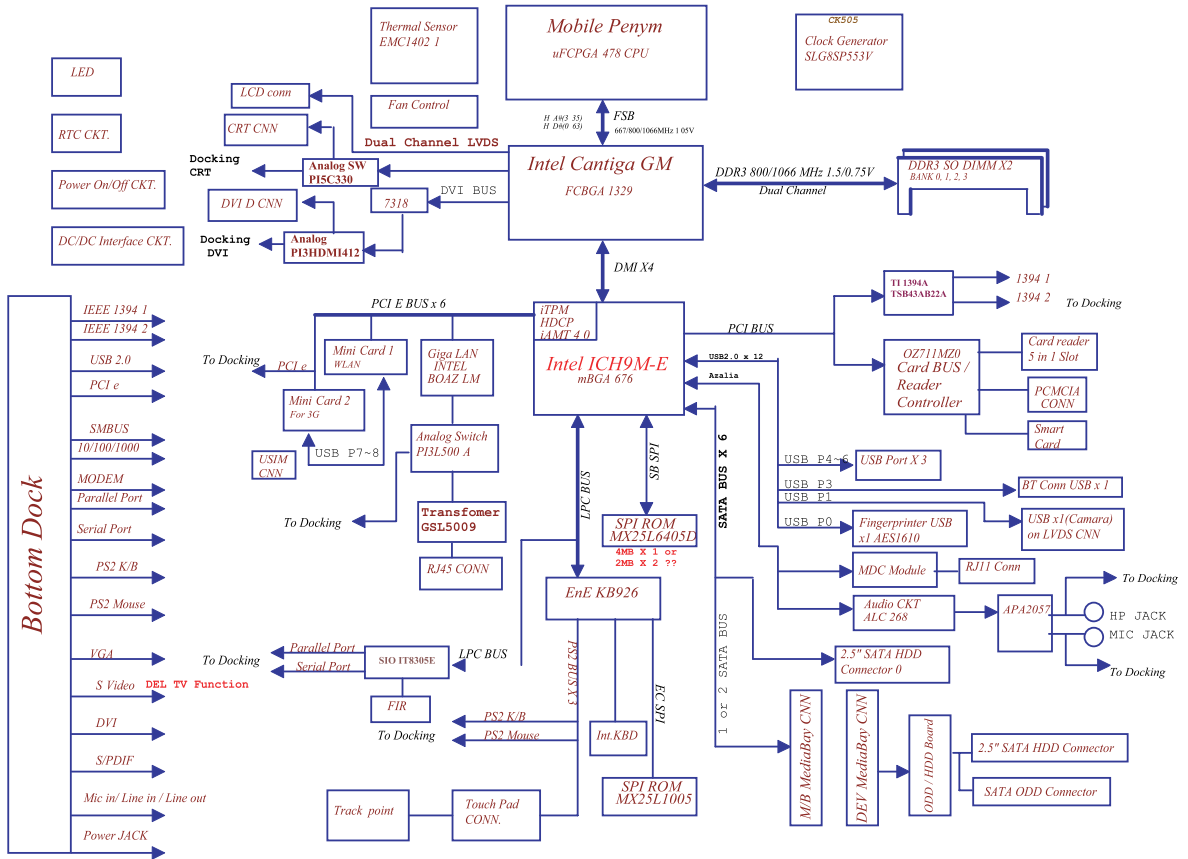

Your Acer Notebook tour

After knowing your computer features, let us show you around your new computer.

Front View







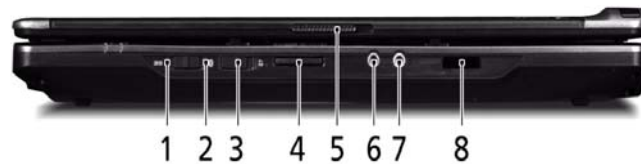

No.	Icon	Item	Description
1		Acer Crystal Eye	Web camera for video communication.
2		Display screen	Also called Liquid-Crystal Display (LCD), displays computer output.
3	<i>e</i>	Empowering key	Launch Acer Empowering Technology.
4		Productivity Keys	Three productivity keys give users one-touch access to protection and manageability features for a more secure, smarter and easier way to work.
5		Keyboard	For entering data into your computer.
6		Fine Track	Touch-sensitive pointing device which functions like a computer mouse when used together with the click buttons.
7		Fine Track buttons (left and right)	Function like the left and right mouse buttons when used together with the center-keyboard FineTrack.
8		Palmrest	Comfortable support area for your hands when you use the computer.

No.	Icon	Item	Description
9		TouchPad	Touch-sensitive pointing device which functions like a computer mouse.
10		Click buttons (left, center*, and right)	The left and right buttons function like the left and right mouse buttons. *The center button serves as Acer BioProtect fingerprint reader supporting Acer FingerNav 4-way control function (only for certain models).
11		Status indicators	Light-Emitting Diodes (LEDs) that light up to show the status of the computer's functions and components.
12		Speakers	Left and right speakers deliver stereo audio output.
13		Power button	Turns the computer on and off.
14		Easy-launch buttons	Buttons for launching frequently used programs.
15		Microphone	Internal microphone for sound recording.



Closed Front View



No.	Icon	Item	Description
1		3G switch/indicator	Enables/disables the 3G function. Indicates the status of 3G communication (only for certain models).
2		Bluetooth communication switch/indicator	Enables/disables the Bluetooth function. Indicates the status of Bluetooth communication.
3		Wireless communication switch/indicator	Enables/disables the wireless function. Indicates the status of wireless LAN communication.
4		5-in-1 card reader	Accepts Secure Digital (SD), MultiMediaCard (MMC), Memory Stick (MS), Memory Stick Pro (MS PRO), and xDPicture Card. Note: Push to remove/install the card. Only one card can operate at any given time.
5		Latch	Locks and releases the lid.
6		Microphone jack	Accepts inputs from external microphones.
7		Headphones/speaker/line-out jack	Connects to audio line-out devices (e.g., speakers, headphones).
8		Infrared port	Interfaces with infrared devices (e.g., infrared printer and IR-aware computer).

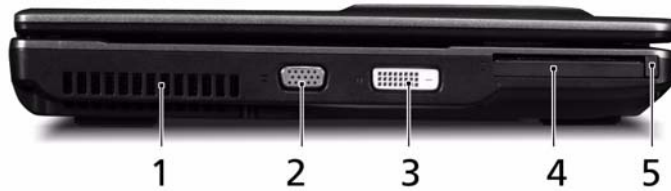

Left View



No.	Icon	Item	Description
1		Ventilation slots	Enable the computer to stay cool, even after prolonged use.
2		External display (VGA) port	Connects to a display device (e.g. external monitor, LCD projector).
3	DVI-D	Digital Video Interface -Digital port	Supports digital video connections.
4		PC Card slot	Accepts one Type II PC Card.
5		PC Card slot eject button	Ejects the PC Card from the slot.





Right View



No.	Icon	Item	Description
1		Optical drive	Internal optical drive; accepts CDs or DVDs.
2		Optical disk access indicator	Lights up when the optical drive is active.
3		Optical drive eject button	Ejects the optical disk from the drive.
4		Emergency eject hole	Ejects the optical drive tray when the computer is turned off. Note: Insert a paper clip into the emergency eject hole to eject the optical drive tray when the computer is off.
5		Two USB 2.0 ports	Connect to USB 2.0 devices (e.g. USB mouse, USB camera).
6		Kensington lock slot	Connects to a Kensington-compatible computer security lock.





Rear View

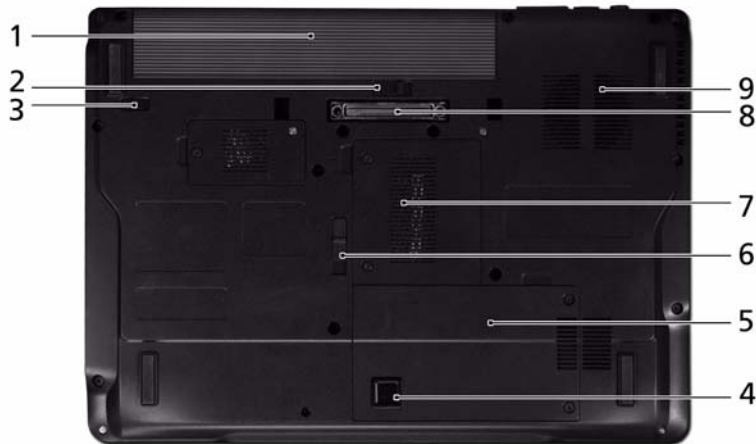

No.	Icon	Item	Description
1		Ethernet (RJ-45) port	Connects to an Ethernet 10/100/1000-based network.
2		Modem (RJ-11) port	Connects to a phone line.
3		USB 2.0 port	Connect to USB 2.0 devices (e.g. USB mouse, USB camera).
4		DC-in jack	Connects to an AC adapter

Bottom View









No.	Icon	Item	Description
1		Battery bay	Houses the computer's battery pack.
2		Battery release latch	Releases the battery for removal.
3		Battery lock	Locks the battery in position.
4		Acer DASP (Disk Anti-Shock Protection)	Protects the hard disk drive from shocks and bumps (only for certain models).
5		Hard disk bay	Houses the computer's hard disk (secured with screws).
6		Acer MediaBay release latch	Lock or unlock Acer MediaBay device.
7		Memory compartment	Houses the computer's main memory.

No.	Icon	Item	Description
8		Acer ezDock II/II+ connector	Connects to Acer ezDock II/II+.
9		Ventilation slots and cooling fan	Enable the computer to stay cool, even after prolonged use. Note: Do not cover or obstruct the opening of the fan.

Indicators

The computer has several easy-to-read status indicators:

The front panel indicators are visible even when the computer cover is closed.





Icon	Function	Description
	Bluetooth	Indicates the status of Bluetooth communication.
	WLAN	Indicates the status of wireless LAN communication.
	Power	Indicates the computer's power status.
	Battery	Indicates the computer's battery status.
	HDD	Indicates when the hard disk drive is active.
	Num Lock	Lights up when Num Lock is activated.
	Caps Lock	Lights up when Caps Lock is activated.

NOTE: 1. **Charging:** The battery light shows amber when the battery is charging. 2. **Fully charged:** The light shows green when in AC mode.

Easy-Launch Buttons

Located beside the keyboard are application buttons. These buttons are called easy-launch buttons. They are: WLAN, Internet, email, Bluetooth, Arcade and Acer Empowering Technology.

The mail and Web browser buttons are pre-set to email and Internet programs, but can be reset by users. To set the Web browser, mail and programmable buttons, run the Acer Launch Manager.

Icon	Function	Description
	Empowering Technology	Launch Acer Empowering Technology. (user-programmable)
	Web browser	Internet browser (user-Programmable)
	Mail	Email application (user-Programmable)
	Bluetooth communication switch	Enables/disables the Bluetooth function.
	Wireless communication switch	Enables/disables the wireless function.

Touchpad Basics (with fingerprint reader)

The following items show you how to use the touchpad with Acer Bio-Protection fingerprint reader:

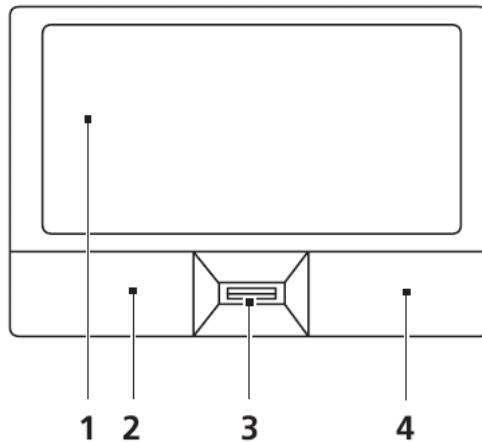

- Move your finger across the touchpad (1) to move the cursor.
- Press the left (2) and right (4) buttons located beneath the touchpad to perform selection and execution functions. These two buttons are similar to the left and right buttons on a mouse. Tapping on the touchpad is the same as clicking the left button.
- Use Acer Bio-Protection fingerprint reader (3) supporting Acer FingerNav 4-way control function (only for certain models) or the 4-way scroll (3) button (only for certain models) to scroll up or down and move left or right a page. This fingerprint reader or button mimics your cursor pressing on the right scroll bar of Windows applications.

Function	Left Button (2)	Right Button (4)	Main touchpad (1)
Execute	Quickly click twice.		Tap twice (at the same speed as double-clicking a mouse button).
Select	Click once.		Tap once.
Drag	Click and hold, then use finger on the touchpad to drag the cursor.		Tap twice (at the same speed as double-clicking a mouse button); rest your finger on the touchpad on the second tap and drag the cursor.
Access context menu		Click once.	

NOTE: When using the touchpad, keep it - and your fingers - dry and clean. The touchpad is sensitive to finger movement; hence, the lighter the touch, the better the response. Tapping too hard will not increase the touchpad's responsiveness.

Using the Keyboard

The keyboard has full-sized keys and an embedded numeric keypad, separate cursor, lock, Windows, function and special keys.

Lock Keys and embedded numeric keypad

The keyboard has three lock keys which you can toggle on and off.





















Lock key	Description
Caps Lock	When Caps Lock is on, all alphabetic characters typed are in uppercase.
Num Lock <Fn> + <F11>	When Num Lock is on, the embedded keypad is in numeric mode. The keys function as a calculator (complete with the arithmetic operators +, -, *, and /). Use this mode when you need to do a lot of numeric data entry. A better solution would be to connect an external keypad.
Scroll Lock <Fn> + <F12>	When Scroll Lock is on, the screen moves one line up or down when you press the up or down arrow keys respectively. Scroll Lock does not work with some applications.

The embedded numeric keypad functions like a desktop numeric keypad. It is indicated by small characters located on the upper right corner of the keycaps. To simplify the keyboard legend, cursor-control key symbols are not printed on the keys.

Desired access	Num Lock on	Num Lock off
Number keys on embedded keypad	Type numbers in a normal manner.	
Cursor-control keys on embedded keypad	Hold <Shift> while using cursor-control keys.	Hold <Fn> while using cursor-control keys.
Main keyboard keys	Hold <Fn> while typing letters on embedded keypad.	Type the letters in a normal manner.

Windows Keys

The keyboard has two keys that perform Windows-specific functions.

Key	Description
 Windows key	<p>Pressed alone, this key has the same effect as clicking on the Windows Start button; it launches the Start menu. It can also be used with other keys to provide a variety of functions:</p> <ul style="list-style-type: none"> <  >: Open or close the Start menu <  > + < D >: Display the desktop <  > + < E >: Open Windows Explore <  > + < F >: Search for a file or folder <  > + < G >: Cycle through Sidebar gadgets <  > + < L >: Lock your computer (if you are connected to a network domain), or switch users (if you're not connected to a network domain) <  > + < M >: Minimizes all windows <  > + < R >: Open the Run dialog box <  > + < T >: Cycle through programs on the taskbar <  > + < U >: Open Ease of Access Center <  > + < X >: Open Windows Mobility Center <  > + < BREAK >: Display the System Properties dialog box <  > + < SHIFT+M >: Restore minimized windows to the desktop <  > + < TAB >: Cycle through programs on the taskbar by using Windows Flip 3-D <  > + < SPACEBAR >: Bring all gadgets to the front and select Windows Sidebar < CTRL > + <  > + < F >: Search for computers (if you are on a network) < CTRL > + <  > + < TAB >: Use the arrow keys to cycle through programs on the taskbar by using Windows Flip 3-D <p>Note: Depending on your edition of Windows Vista, some shortcuts may not function as described.</p>
 Application key	<p>This key has the same effect as clicking the right mouse button; it opens the application's context menu.</p>

Hot Keys

The computer employs hotkeys or key combinations to access most of the computer's controls like screen brightness, volume output and the BIOS utility.

To activate hot keys, press and hold the <Fn> key before pressing the other key in the hotkey combination.



Hotkey	Icon	Function	Description
<Fn> + <F1>	?	Hotkey help	Displays help on hotkeys.
<Fn> + <F2>		Acer eSettings Management	Launches Acer eSettings Management in Acer Empowering Technology.
<Fn> + <F3>		Acer ePower Management	Launches Acer ePower Management in Acer Empowering Technology.
<Fn> + <F4>	Z ^Z	Sleep	Puts the computer in Sleep mode.
<Fn> + <F5>		Display toggle	Switches display output between the display screen, external monitor (if connected) and both.
<Fn> + <F6>		Screen blank	Turns the display screen backlight off to save power. Press any key to return.
<Fn> + <F7>		Touchpad toggle	Turns the internal touchpad on and off.
<Fn> + <F8>		Speaker toggle	Turns the speakers on and off.
<Fn> + <▷>		Brightness up	Increases the screen brightness.
<Fn> + <◁>		Brightness down	Decreases the screen brightness.

Special Key

You can locate the Euro symbol and the US dollar sign at the upper-center and/or bottom-right of your keyboard.



The Euro symbol

1. Open a text editor or word processor.
2. Hold <Alt Gr> and then press the <5> key at the upper-center of the keyboard.

NOTE: Note: Some fonts and software do not support the Euro symbol. Please refer to www.microsoft.com/typography/faq/faq12.htm for more information.

The US dollar sign

1. Open a text editor or word processor.
2. Hold <Shift> and then press the <4> key at the upper-center of the keyboard.

NOTE: This function varies by the operating system version.

Using the System Utilities

Acer Bio-Protection (only for certain models) Acer Bio-Protection Fingerprint Solution is a multi-purpose fingerprint software package integrated with the Microsoft Windows operating system. Utilizing the uniqueness of one's fingerprint features, Acer Bio-Protection Fingerprint Solution has incorporated protection against unauthorized access to your computer with centralized password management with Password Bank, easy music player launching with Acer MusicLaunch, secure Internet favorites via Acer MyLaunch, and fast application/website launching and login with Acer FingerLaunch, while Acer ProfileLaunch can launch up to three applications/websites from a single finger swipe.

Acer Bio-Protection Fingerprint Solution also allows you to navigate through web browsers and documents using Acer FingerNav. With Acer Bio-Protection Fingerprint Solution, you can now enjoy an extra layer of protection for your personal computer, as well as the convenience of accessing your daily tasks with a simple swipe of your finger!

For more information refer to the Acer Bio-Protection help files.



Acer GridVista (dual-display compatible)

NOTE: This feature is only available on certain models.

To enable the dual monitor feature of the notebook, first ensure that the second monitor is connected, then select **Start, Control Panel, Display** and click on **Settings**. Select the secondary monitor (**2**) icon in the display box and then click the check box **Extend my windows desktop onto this monitor**. Finally, click **Apply** to confirm the new settings and click **OK** to complete the process.

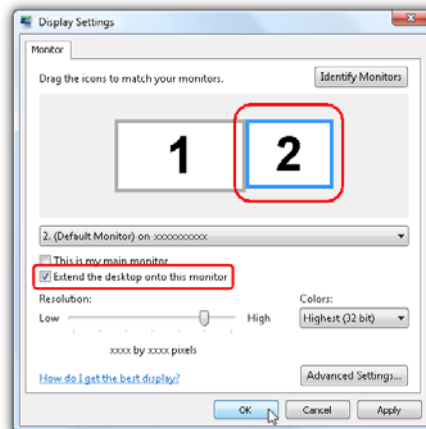

Acer GridVista is a handy utility that offers four pre-defined display settings so you can view multiple windows on the same screen. To access this function, please go to **Start → All Programs** and click on **Acer GridVista**. You may choose any one of the four display settings indicated below:



Double (vertical), Triple (primary at left), Triple (primary at right), or Quad Acer GridVista is dual-display compatible, allowing two displays to be partitioned independently.

Acer GridVista is dual-display compatible, allowing two displays to be partitioned independently.

AcerGridVista is simple to set up:

1. Run Acer GridVista and select your preferred screen configuration for each display from the task bar.
2. Drag and drop each window into the appropriate grid.
3. Enjoy the convenience of a well-organized desktop.

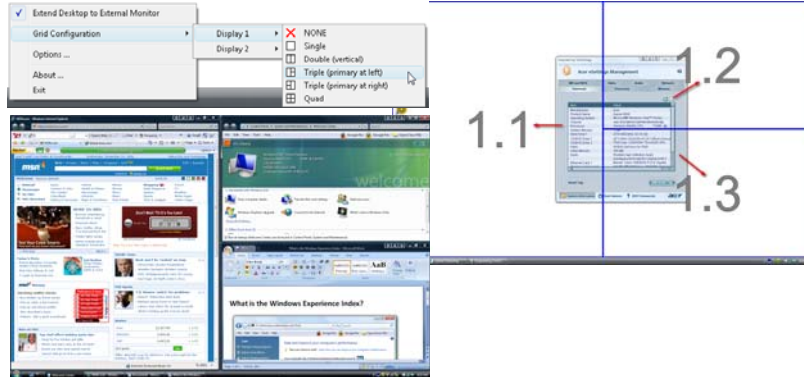

NOTE: Please ensure that the resolution setting of the second monitor is set to the manufacturer's recommended value.

Hardware Specifications and Configurations

Processor

Item	Specification
CPU type	Intel Mobile Montevina Centrino/PDC/Celeron FCPGA, Socket M, 6M L2, FSB 800/1066MHz
Core Logic	Intel® Cantiga-GM+ICH9M-E
CPU Package	Micro FC-PGA
CPU Core Voltage	1.0375V ~ 1.3V

CPU Fan True Value Table

Action	Lower Limit	Higher Limit	Fan Speed (RPM)	SPL Spec (dBA)
Fan Off	-	45	0	-
Fan Speed2	40	55	2900	31
Fan Speed3	50	65	3300	34
Fan Speed4	55	75	3600	37
Fan Speed5	70	100	3900	40
Throttling 50%	85	105	3900	40

- Throttling 50%: On= 100°C; OFF=85°C
- EC shut down (DTS) at 105°C; EC shut down (diode) at 105°C

BIOS

Item	Specification
BIOS vendor	Phoenix SecureCore
BIOS Version	v0.15A
BIOS ROM type	Flash
BIOS ROM size	1 MB
Features	<ul style="list-style-type: none"> • Support ISIPP • Support Acer UI • Support multi-boot • Suspend to RAM (S3)/Disk (S4) • Various hot-keys for system control • Support SMBIOS 2.3, PCI2.2. • ACPI 2.0 compliance with Intel SpeedStep Support C1, C2, C3, C4, C6 and S3, S4 for mobile CPU • DMI utility for BIOS serial number configurable/asset tag • Support INTEL IAMT4.0 & TXT & PXE & VPro • Support Y2K solution • Support WinFlash • Wake on LAN from S3 • Wake on LAN form S4 in AC mode • System information

Cache

Item	Specification
Cache controller	Built in
Cache size	6MB L2 Cache on CPU

System Memory

Item	Specification
Memory size	0 MB on board
DIMM socket number	2
Supports memory size per socket	2 GB
Supports maximum memory size	4 GB
Supports DIMM type	204-pin +1.5V DDRIII SO-DIMM
Supports DIMM Speed	800/1067 MHz

Memory Combinations

Slot 1	Slot 2	Total Memory
0MB	512MB	512MB
0MB	1024MB	1024MB
0MB	2048MB	2048MB
512MB	512MB	1024MB
512MB	1024MB	1536MB
512MB	2048MB	2560MB
1024MB	0MB	1024MB
1024MB	512MB	1536MB
1024MB	1024MB	2048MB
1024MB	2048MB	3072MB
2048MB	0MB	2048MB
2048MB	512MB	2560MB
2048MB	1024MB	3072MB
2048MB	2048MB	4096MB

NOTE: Above table lists some system memory configurations. You may combine DIMMs with various capacities to form other combinations. On above table, the configuration of slot 1 and slot 2 could be reversed.

Video Subsystem

Item	Specification
Chipset	Cantiga-GM Integrated Graphic
Features	<ul style="list-style-type: none"> • Intel Gen 5 integrated graphics engine with 10 fully programmable cores • Estimated 457-MHz core, render clock at 1.0-V core voltage • Estimated 533-MHz core, render clock at 1.1-V core voltage (Hi Def Playback only) • Supports TV-Out, LVDS, CRT and SDVO • Intel® Dynamic Video Memory Technology (Intel® DVMT 4.0) • Video Capture via x1 concurrent PCIe port • High performance MPEG-2 decoding • WMV9 (VC-1) and H.264 (AVC) support • Hardware acceleration for VLD/iDCT • Microsoft DirectX*10 support • Hardware motion compensation • Intermediate Z in classic rendering

Audio Subsystem

Item	Specification
Chipset	Realtek ALC268VC
Audio Onboard or Optional	Onboard
Mono or Stereo	Stereo
Resolution	<ul style="list-style-type: none"> • Two DACs channels support 16/20/24-bit PCM format playback • Two stereo ADCs support 16/20/24-bit PCM format recording
Compatibility	<ul style="list-style-type: none"> • Support hardware digital volume control for digital microphone input • Software programmable boost gain (+20/+40dB) for analog microphone input • Built-in headphone amplifiers for port-A and port-D. • Four GPIOs (General Purpose Input and Output) for customized applications • Supports Anti-pop mode when analog power AVDD is on and digital power is off • Integrates high pass filter to cancel DC offset generated from digital microphone (ALC 268B)
Sampling Rate	<ul style="list-style-type: none"> • All DACs supports 16/20/24-bit, 44.1k/48k/96k/192kHz sample rate • All ADCs supports 16/20/24-bit, 44.1k/48k/96k Hz sample rate • 16/20/24-bit S/PDIF-OUT support 44.1k/48k/88.2k/96k/192kHz sample rate
Internal Microphone	Support stereo digital microphone interface to improve voice quality
Internal Speaker/Quantity	2
Features	<ul style="list-style-type: none"> • High-performance DACs with 95dB SNR (A-Weighting), ADCs with 90dB SNR (A-Weighting) Meets premium performance requirements for Microsoft WLP 3.1 • High-quality analog differential CD input • Supports external PCBEEP input, built-in digital BEEP generator, and pass through function in D3 mode • Software selectable 2.5V/3.75V/4.2V VREFOUT • Two jack detection pins each designed to detect up to 4 jacks • 1dB resolution of analog output volume control • 48-pin LQFP 'Green' package • Support low voltage IO for HDA Link (1.5V~3.3V) (3.3 ~ 5 V) for analog power

LAN Interface

Item	Specification
LAN Chipset	INTEL 82567LM GIGA LAN
Features	<ul style="list-style-type: none"> • IEEE 802.3ab conformance • Line length > 140 m • Operates with worst-case cable • Supports carrier extension (half duplex) • Wake-on-LAN and remote wake-up support • Auto-negotiation with support for next page • Smart speed operation, for automatic speed reduction on faulty cable plants • Automatic MDI crossover capable • PMA loopback capable (No echo cancel) • Advanced power management: <ul style="list-style-type: none"> • Low power link up - differentiate between D0a/non-D0a • Auto Connect Battery Saver - link disconnect. • Advanced cable diagnostics: <ul style="list-style-type: none"> • TDR • Channel frequency response • Extended configuration load sequence • Automatic resolution of FDX/HDX mismatch in: <ul style="list-style-type: none"> • 10/100 forced configurations • Dual interconnect between MAC and PHY: <ul style="list-style-type: none"> • LCI for 10/100 Mb/s operation control traffic • GLCI for 1000 Mb/s operation • Three LED outputs
Power	<p>Multiple voltage regulation modes:</p> <ul style="list-style-type: none"> • External voltage regulation • Fully integrated linear regulator (nominal 1.0V programmable) • Discrete linear voltage regulator (nominal 1.8V programmable) • Reduced power consumption during normal operation and power down modes • Support GLCI K0s reduced power mode in 10/100/1000 full duplex operation

Card BUS/Reader

Item	Specification
Controller	OZ711MZ
Features	<ul style="list-style-type: none"> • Single-Slot PC Card (Card Bus) Controller <ul style="list-style-type: none"> • PC Card Standard Release 8.1 Compliant • Compliant with PCL Local Bus Specification Version 3.0 • Integrate Flash Media and SDIO Readers <ul style="list-style-type: none"> • SD Host Interface Specification V2.0 with DMA • Complies to MutilMediaCard Version 4.1 • Support SD/SDHC up to 50MHz Clock Rate • Support SD-CPRM and Panasonic SD-Jukebox • Supports MMCPlus Connectivity at 50MHz • Support Xd-Picture Card Type-M and Type-H • SDIO Version 1.10 Compliant with High-Speed Mode • Support Memory Stick PRO-HG up to 60MHz Clock • Support Memory Stick and Memory Stick PRO • Integrate Smart Card Reader <ul style="list-style-type: none"> • Smart Card available in NT package option • Provides an EMV L1 Certifiable Solution • O2 WDM Software Driver with CT-API Support • Power Interface Support Class A,AB,ABC Card • Fully Conform to ISO 7816-1/2/3/4 and PC/SC • Support T=0 and T=1 Smart Card Transmissions
Power Management	<ul style="list-style-type: none"> • Advanced Configuration and Power Interface Rev2.0 • PCI Bus Power Management Rev 1.1 Compliant • Provide PCI Clock Control Protocol via CLKRUN# • Support System Wake-UP via PME# Events • OZ-711MZ0 - 128-pin LQFP (Lead Free)

Item	Specification
Serial BUS Type	TI-TSB43AB22A 1394 Function
Features	<ul style="list-style-type: none"> • Fully compliant with provisions of IEEE Std 1394-1995 for a high-performance serial bus¹ and IEEE Std 1394a-2000 • Fully interoperable with FireWire and i.LINK implementations of IEEE Std 1394 • Compliant with Intel Mobile Power Guideline 2000 • Full IEEE Std 1394a-2000 support includes: connection debounce, arbitrated short reset, multispeed concatenation, arbitration acceleration, fly-by concatenation, and port disable/suspend/resume • Power-down features to conserve energy in battery-powered applications include: automatic device power down during suspend, PCI power management for link-layer, and inactive ports powered down • Ultralow-power sleep mode • Two IEEE Std 1394a-2000 fully compliant cable ports at 100M bits/s, 200M bits/s, and 400M bits/s • Cable power presence monitoring • Separate cable bias (TPBIAS) for each port • 1.8-V core logic with universal PCI interfaces compatible with 3.3-V and 5-V PCI signaling environments • Physical write posting of up to three outstanding transactions • PCI burst transfers and deep FIFOs to tolerate large host latency • PCI_CLKRUN protocol • External cycle timer control for customized synchronization • Extended resume signaling for compatibility with legacy DV components • PHY-Link logic performs system initialization and arbitration functions • PHY-Link encode and decode functions included for data-strobe bit level encoding • PHY-Link incoming data resynchronized to local clock • Low-cost 24.576-MHz crystal provides transmit and receive data at 100M bits/s, 200M bits/s, and 400M bits/s • Node power class information signaling for system power management • Serial ROM interface supports 2-wire serial EEPROM devices • Two general-purpose I/Os • Register bits give software control of contender bit, power class bits, link active control bit, and IEEE Std 1394a-2000 features • Fabricated in advanced low-power CMOS process • PCI and CardBus register support • Isochronous receive dual-buffer mode • Out-of-order pipelining for asynchronous transmit requests • Register access fail interrupt when the PHY SCLK is not active • PCI power-management D0, D1, D2, and D3 power states • Initial bandwidth available and initial channels available registers • PME support per 1394 Open Host Controller Interface Specification

Super I/O

Item	Specification
Type	ITE- 8305E Super IO chip
LPC Bus Interface	<ul style="list-style-type: none"> Supports I/O cycle Support DMA cycle Serial IRQ
Infrared Communications Controller	<ul style="list-style-type: none"> Support Fast IR Support Consumer IR
UART	16C550A Compatible
Parallel Port	<ul style="list-style-type: none"> Supports Standard Mode -SPP Support Enhanced Mode -EPP Support High-Speed Mode -ECP
GPIO	<ul style="list-style-type: none"> Each pin can be programmed independently Maximum 30 pins
Package	48 pin LQFP package

Hard Disk Drive Interface

Item	Specifications					
Vendor & Model Name	Hitachi 5K320-320 5K320-250 5K320-120	Segate ST9250827AS	Toshiba MK2546GSX MK1646GSX	Toshiba MK3252GSX	WD WD2500BEVS	WD WD3200BEVT
Capacity (MB)	320, 250, 120	250	250, 160	320	250	320
Bytes per sector	512	512	512	512	512	512
Data heads	4, 4 or 3, 2	4	4, 3	4	4	4
Drive Format						
Disks	2, 2, 1	2	2, 2	2	2	2
Spindle speed (RPM)	5400	5400	5400	5400	5400	5400
Performance Specifications						
Buffer size	8 MB	8 MB	8 MB	8 MB	8 MB	8 MB
Interface	SATA	SATA	SATA	SATA	SATA	SATA
Internal transfer rate (Mbits/sec, max)	674 ~ 775	778	370 ~ 720 typical	400 ~ 794 typical	850 Mbits/s maximum	850 Mbits/s maximum
I/O data transfer rate (Mbytes/sec max)	1.5 / 3.0	300	300	3000	150 maximum	300 maximum
DC Power Requirements						
Voltage tolerance	5V ±5%	5V ±5%	5V ±5%	5V ±5%	5V ±5%	5V ±5%

Super-Multi Combo Module

Item	Specification
Manufacturer and Model	Sony DL 8X AD-7560S Toshiba DL 8X TS-L633A
Type	Drawer type
Interface	SATA
Data Transfer Modes	<ul style="list-style-type: none"> • PIO Mode4 • DMA Multiword Mode2 • ULTRA DMA Mode2
Buffer Memory Size	2 MB
Maximum Write Speed	<ul style="list-style-type: none"> • CD-R Max. 24X (3,600 KB/sec) • DVD+RW Max 8X (10,800 KB/sec)
Maximum Read Speed	<ul style="list-style-type: none"> • CD 3,600 KB/sec • DVD 10,800 KB/sec
Format Compatibility	<p>CD</p> <ul style="list-style-type: none"> • CD-DA (Red Book) - Standard Audio CD & CD-TEXT • CD-ROM (Yellow Book Mode1 & 2) - Standard Data • CD-ROM XA (Mode2 Form1 & 2) - Photo CD, Multi-Session • CD-I (Green Book, Mode2 Form1 & 2, Ready, Bridge) • CD-Extra/ CD-Plus (Blue Book) - Audio & Text/Video • Video-CD (White Book) - MPEG1 Video • CD-R (Orange Book Part 1) • CD-RW & HSRW (Orange Book Part IV Volume1 & Volume2) • Super Audio CD (SACD) Hybrid type • US & US+ RW <p>DVD</p> <ul style="list-style-type: none"> • DVD-ROM (Book 1.02), DVD-Dual • DVD-Video (Book 1.1) • DVD-R (Book 1.0, 3.9G) • DVD-R (Book 2.0, 4.7G) - General & Authoring • DVD+R (Version 1.0) • DVD+RW • DVD-RW (Non CPRM & CPRM) • DVD±R Dual • DVD-RAM
Power Supply	DC +5V / 1.3A
Voltage Allowance	DC +5V (5% (Operating), DC +5V(8% (Start Up)))

Combo Drive Module

Item	Specification
Manufacturer and Model	Sony DL 24X CRX890S Toshiba DL 24X TS-L463A
Type	Drawer type
Interface	SATA
Data Transfer Mode	PIO Mode4
Buffer Memory Size	2 MB
Maximum Write Speed	• CD 3,600 KB/sec
Maximum Read Speed	• CD 3,600 KB/sec • DVD 10,800 KB/sec
Formats Supported	<p>CD</p> <ul style="list-style-type: none"> • CD-DA (Red Book) - Standard Audio CD & CD-TEXT • CD-ROM (Yellow Book Mode1 & 2) - Standard Data • CD-ROM XA (Mode2 Form1 & 2) - Photo CD, Multi-Session • CD-I (Green Book, Mode2 Form1 & 2, Ready, Bridge) • CD-Extra/ CD-Plus (Blue Book) - Audio & Text/Video • Video-CD (White Book) - MPEG1 Video • CD-R (Orange Book Part 1) • CD-RW & HSRW (Orange Book Part 2 Volume1 & Volume2) • Super Audio CD (SACD) Hybrid type • US & US+ RW <p>DVD</p> <ul style="list-style-type: none"> • DVD-ROM (Book 1.02), DVD-Dual • DVD-Video (Book 1.1) • DVD-R (Book 1.0, 3.9G) • DVD-R (Book 2.0, 4.7G) - General & Authoring • DVD+R (Version 1.0) • DVD-RW, DVD+RW • DVD+R DL • DVD-R DL • Support CPRM (read) • Support VCPS (read)
Power Supply	DC +5V / 1.3A
Voltage Allowance	DC +5V (5% (Operating), DC +5V(8% (Start Up))

Keyboard

Item	Specification
Keyboard controller	KB926
Number of keys	88-/89-key keyboard
Windows logo key	Yes
Internal & external keyboard work simultaneously	Yes

Battery

Item	Specification	
Vendor & model name	Sanyo/Sony/Panasonic/Simplo	Sony/Simplo
Battery Type	Li-ion	Li-ion
Pack capacity	4400 mAh	7200 mAh
Number of battery cell	6	9
Package configuration	3S2P	3S3P

LCD 14.1"

Item	Specification
Vendor/model name	AUO B141EW05 V0 AUO B141EW05 V1
Screen Diagonal (mm)	357.7 (14.1")
Active Area (mm)	303.36 x 189.6
Display resolution (pixels)	1280x3 (RGB) x 800
Pixel Pitch	0.237
Pixel Arrangement	R.G.B. Vertical Stripe
Display Mode	Normally White
Typical White Luminance (cd/m ²) also called Brightness	220 typ. (5 points average) 187 min. (5 points average)
Luminance Uniformity	1.25 max. (5 points)
Contrast Ratio	400 typ
Response Time (Optical Rise Time/Fall Time) msec	8 typ / 12 Max
Nominal Input Voltage VDD	+3.3 typ.
Typical Power Consumption (watt)	4.9 max./4.2 max. (Include Logic and Blu power)
Weight	375 max.
Physical Size (mm)	319 - 320 max. (L) x 205 - 206 max. (W)
Electrical Interface	1 channel LVDS
Support Color	262K colors (RGB 6-bit)
Viewing Angle (degree)	
Horizontal: Right/Left	40 - 45
Vertical: Upper/Lower	10 -15/30-35
Temperature Range (°C)	
Operating	0 to +50
Storage (shipping)	-20 to +65

System Utilities

BIOS Setup Utility

The BIOS Setup Utility is a hardware configuration program built into your computer's BIOS (Basic Input/Output System).

Your computer is already properly configured and optimized, and you do not need to run this utility. However, if you encounter configuration problems, you may need to run Setup. Please also refer to Chapter 4 Troubleshooting when problem arises.

To activate the BIOS Utility, press **F2** during POST (when "Press <F2> to enter Setup" message is prompted on the bottom of screen).

Press **F2** to enter setup. The default parameter of F12 Boot Menu is set to "disabled". If you want to change boot device without entering BIOS Setup Utility, please set the parameter to "enabled".

Press <F12> during POST to enter multi-boot menu. In this menu, user can change boot device without entering BIOS SETUP Utility.

Navigating the BIOS Utility

There are six menu options: Information, Main, Advanced, Security, Boot, and Exit.

Follow these instructions:

- To choose a menu, use the left and right arrow keys.
- To choose an item, use the up and down arrow keys.
- To change the value of a parameter, press **F5** or **F6**.
- A plus sign (+) indicates the item has sub-items. Press **Enter** to expand this item.
- Press **Esc** while you are in any of the menu options to go to the Exit menu.
- In any menu, you can load default settings by pressing **F9**. You can also press **F10** to save any changes made and exit the BIOS Setup Utility.

NOTE: You can change the value of a parameter if it is enclosed in square brackets. Navigation keys for a particular menu are shown on the bottom of the screen. Help for parameters are found in the Item Specific Help part of the screen. Read this carefully when making changes to parameter values. **Please note that system information is subject to different models.**

Information

The Information screen displays a summary of your computer hardware information.

Phoenix SecureCore(tm) Setup Utility						
Information	Main	Advanced	Intel	Security	Boot	Exit
CPU Type:			Intel (R) Core (TM)2 Duo CPU	T9400 @ 2.53GHz		
CPU Speed:			2530 MHz			
HDD Model Name:			WDCWD2500BEVS-22UST-(PM)			
HDD Serial Number:			WD-WXC208827525			
ATAPI Model Name:			OptiarcDVDRWAD-75-(SM)			
System BIOS Version:			v0.15A			
VGA BIOS Version:			Intel V1625			
Serial Number:						
Asset Tag Number:						
Product Name:			TravelMate 6493			
Manufacturer Name:			Acer			
UUID:			2A8D1752FA11A28D8E77001EEC42C73D			
F1 Help	↑↓ Select Item	F5/F6 Change Values	F9 Setup Defaults			
ESC Exit	←→ Select Menu	Enter Select▶ Sub-Menu	F10 Save and Exit			

NOTE: The system information is subject to different models.

Parameter	Description
CPU Type	This field shows the CPU type and speed of the system.
CPU Speed	This field shows the speed of the CPU.
HDD Model Name	This field shows the model name of HDD installed on primary IDE master.
HDD Serial Number	This field displays the serial number of HDD installed on primary IDE master.
ATAPI Model Name	This field shows the model name of the Optical device installed in the system.
System BIOS Version	Displays system BIOS version.
VGA BIOS Version	This field displays the VGA firmware version of the system.
Serial Number	This field displays the serial number of this unit.
Asset Tag Number	This field displays the asset tag number of the system.
Product Name	This field shows product name of the system.
Manufacturer Name	This field displays the manufacturer of this system.
UUID Number	Universally Unique Identifier (UUID) is an identifier standard used in software construction, standardized by the Open Software Foundation (OSF) as part of the Distributed Computing Environment (DCE).

Main

The Main screen allows the user to set the system time and date as well as enable and disable boot option and recovery.

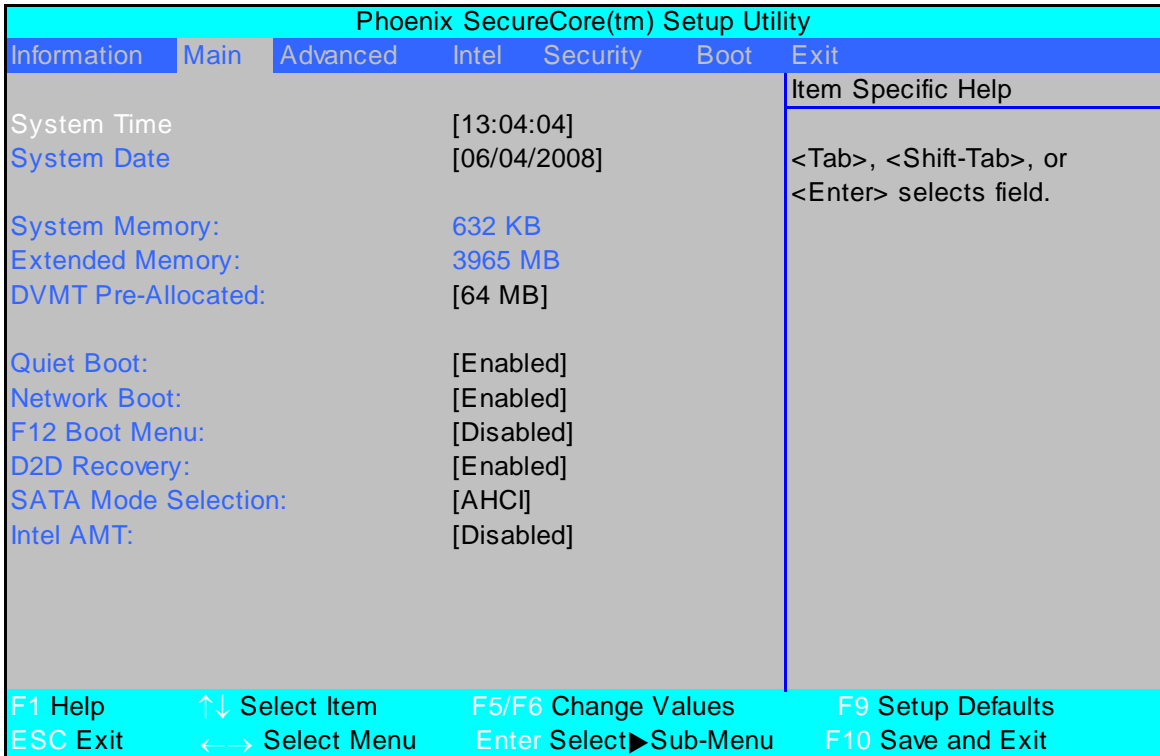

NOTE: The screen above is for your reference only. Actual values may differ.

Settings in **boldface** are the default and suggested parameter settings.

Parameter	Description	Format/Option
System Time	Sets the system time. The hours are displayed with 24-hour format.	Format: HH:MM:SS (hour:minute:second)
System Date	Sets the system date.	Format MM/DD/YYYY (month/day/year)
System Memory	This field reports the memory size of the system. Memory size is fixed to 632 KB.	N/A
Extended Memory	Shows the Extended memory size. Extended Memory size is fixed to 3965 MB	N/A
DVMT Pre-Allocated	Shows the DVMT Pre-Allocated memory size.	Option: 32, 64 , 128 MB
Quiet Boot	Select whether to display the logo screen during boot.	Option: Enabled or Disabled
Network Boot	Enables, disables the system boot from LAN (remote server).	Option: Enabled or Disabled
F12 Boot Menu	Enables, disables Boot Menu during POST.	Option: Disabled or Enabled
D2D Recovery	Enables, disables the Acer D2D Recovery function during POST by pressing Alt-F10 .	Option: Enabled or Disabled
SATA Mode Selection	Control the mode in which the SATA controller should operate.	Option: AHCI or IDE Mode
Intel AMT	Enable or disable the Intel Active Management Technology BIOS Extension.	Option: Disabled or Enabled

Advanced

The Advanced screen allows the user to configure the various advanced BIOS options.

IMPORTANT: Making incorrect settings to items on these pages may cause the system to malfunction. Unless you have experience adjusting these items, we recommend that you leave these settings at the default values. If making settings to items on these pages causes your system to malfunction or prevents the system from booting, open BIOS and choose Load Optimal Defaults in the Exit menu to boot up normally.

Phoenix SecureCore(tm) Setup Utility						
Information	Main	Advanced	Intel	Security	Boot	Exit
						Item Specific Help
Serial port:			[Auto]			
Parallel Port:			[Auto]	[Disabled] Serial port is not active.		
Infrared Port (FIR):			[Enabled]	[Enabled]		
Base I/O address:			[680/IRQ3/DMA1]	Serial port is active and is user configured.		
PS/2 Mouse			[Auto Detect]	[Auto]		
Installed O/S:			[Win XP]	Serial port is active and is automatically configured.		
Reset Configuration Data:			[No]			
Large Disk Access Mode:			[DOS]			
IDE Controller:			[Disabled]			
▶ Keyboard Features						
▶ Cache Memory						
F1 Help	↑↓ Select Item		F5/F6 Change Values		F9 Setup Defaults	
ESC Exit	←→ Select Menu		Enter Select▶ Sub-Menu		F10 Save and Exit	

The table below describes the items, menus, and submenus in this screen. Settings in **boldface** are the default and suggested parameter settings.

Parameter	Description	Submenu Items
Serial port	Determines serial port behavior, Disabled, Enabled, or Auto configure.	N/A
Parallel Port	Determines parallel port behavior, Disabled, Enabled, or Auto configure.	N/A
Infrared Port (FIR)	Determines FIR port behavior, Disabled or Enabled .	N/A
Base I/O address	Select the base I/O address for serial port A.	N/A
PS/2 Mouse	Determines PS/2 mouse port (IRQ12) behavior, Disabled, Enabled, or Auto Detect .	N/A
Installed O/S	Select the most commonly used O/S on the system from Win95, Win98, WinMe, Win2000, Win XP , or Other.	N/A
Reset Configured Data	Clear the Extended System Configuration Data (ESCD) area. Select No or Yes.	N/A
Large Disk Access Mode	For UNIX, Novell Netware, or other OS select Other. If installing new software and the drive fails, change this option and try again. Default setting is DOS .	N/A

Parameter	Description	Submenu Items
IDE Controller	Enable or disabled the Integrated local bus IDE Controller channels. Select Both (enabled), Primary (only), or Disabled .	N/A
Keyboard Features	Enter the Keyboard Features menu.	<ul style="list-style-type: none"> • NumLock • Key Click • Keyboard auto-repeat rate • Keyboard auto-repeat delay
Cache Memory	Enter the Cache Memory menu.	<ul style="list-style-type: none"> • Memory Cache • Cache System BIOS area • Cache Video BIOS area • Cache Base 0-512K • Cache Base 512-640K • Cache Extended Memory Area • Cache A000 - AFFF • Cache B000 - BFFF • Cache C800 - CBFF • Cache CC00 - CFFF • Cache D000 - D3FF • Cache D400 - D7FF • Cache D800 - DBFF • Cache DC00 - DFFF • Cache E000 - E3FF • Cache E400 - E7FF • Cache E800 - EBFF • Cache EC00 - EFFF

Intel

The Intel screen is used to access the Intel specific BIOS options.

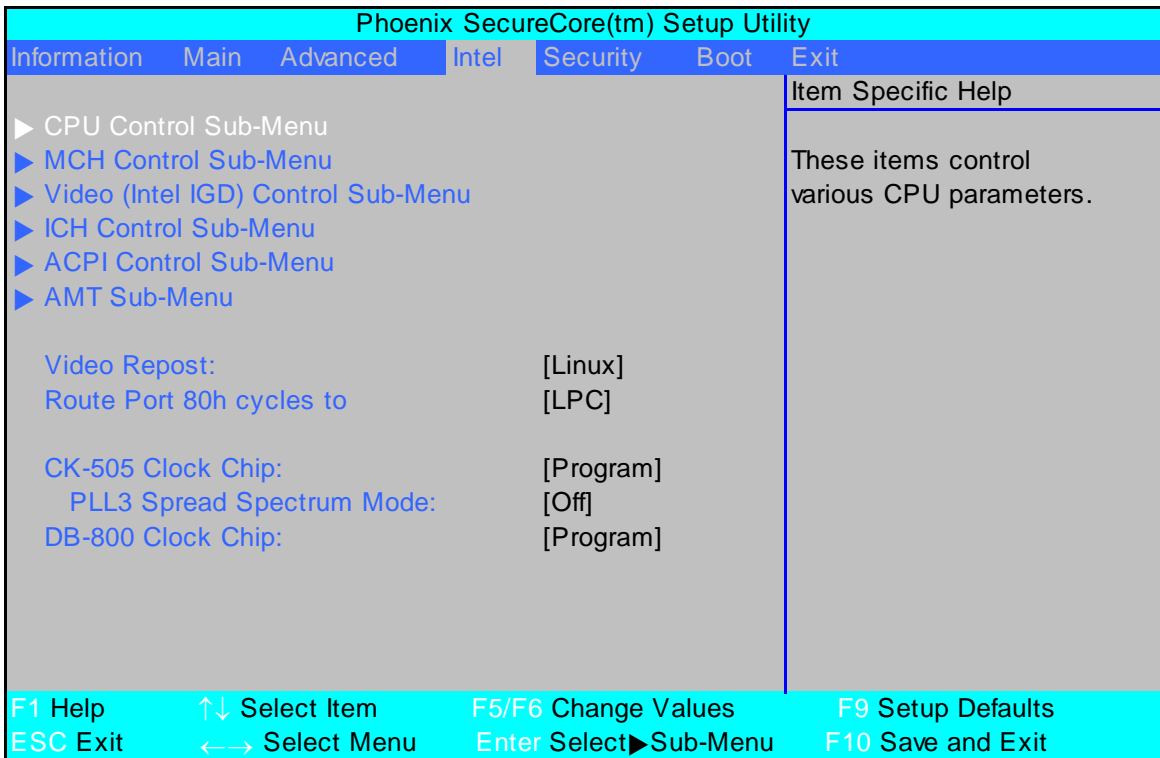

The table below describes the items, menus, and submenus in this screen. Settings in **boldface** are the default and suggested parameter settings.

Parameter	Description	Submenu Items
CPU Control Sub-Menu	Enter the CPU Control Sub-Menu.	<ul style="list-style-type: none"> • ►Penryn CPU Control Sub-Menu • Core Multi-Processing • Intel (R) SpeedStep (tm) • CX States • Enhanced C-states • Deep C4 • Hard C4 • C6 • No Execute Mode Mem Protection • Intel (R) Virtualization Technology • T States • Thermal Control Circuit • PROCHOT# Enable
MCH Control Sub-Menu	Enter the MCH Control Sub-Menu.	<ul style="list-style-type: none"> • PCI Express Size • PEG Port ASPM Support • MDA Support

Parameter	Description	Submenu Items
Video (Intel IGD) Control Sub-Menu	Enter the Video (Intel IGD) Control Sub-Menu.	<ul style="list-style-type: none"> • IGD - Device 2 • IGD - Boot Type • IGD - S3 Popup • Cantiga HDCP Mode • ►IGD - LCD Control Sub-Menu • ►IGD - TV Control Sub-Menu <ul style="list-style-type: none"> • DVM T 4.0 Mode • Total Graphics Memory • DVM T Graphics Memory • PAVP Mode
ICH Control Sub-Menu	Enter the ICH Control Sub-Menu.	<ul style="list-style-type: none"> • ►Integrated Device Control Sub-Menu • PCI Clock Run • Pop Up Mode Enable <ul style="list-style-type: none"> • Pop Down Mode Enable
ACPI Control Sub-Menu	Enter the ACPI Control Sub-Menu.	<ul style="list-style-type: none"> • Active Trip Point <ul style="list-style-type: none"> • High-Fan Trip Point • Passive Cooling Trip Point <ul style="list-style-type: none"> • Passive TC1 Value • Passive TC2 Value • Passive TSP Value • Critical Trip Point • FACP - RTC S4 Flag Value • FACP - PM Timer Flag Value • HPET Support <ul style="list-style-type: none"> • HPET Base Address • ALS Support • EMA Support • MEF Support
AMT Control Sub-Menu	Enter the AMT Control Sub-Menu.	<ul style="list-style-type: none"> • Intel AMT • Platform Manageability • Watch Dog Timer Config • OS Timer Config • BIOS Timer Config • AMT CIRA Request Trigger • AMT CIRA Timeout • ME IDE-R • ME KT • ►Console Redirection
Video Repost	Select IF a Video Repost is to be performed during resume from S3. Disabled, Linux , or Enabled.	N/A
Route Port 80h cycles to	Determines the Route Port 80h cycles to, either LPC or PCI.	N/A
CK-505 Clock Chip	Controls the programming of the CK-505 Clock Chip. Select Default or Program .	N/A
PLL3 Spread Spectrum Mode	Switch Spread Spectrum support for PLL3 in the CK-505 clock chip Off or On.	N/A
DB-800 Clock Chip	Controls the programming of the DB-800 Clock Chip. Select Default or Program .	N/A

Security

The Security screen contains parameters that help safeguard and protect your computer from unauthorized use.

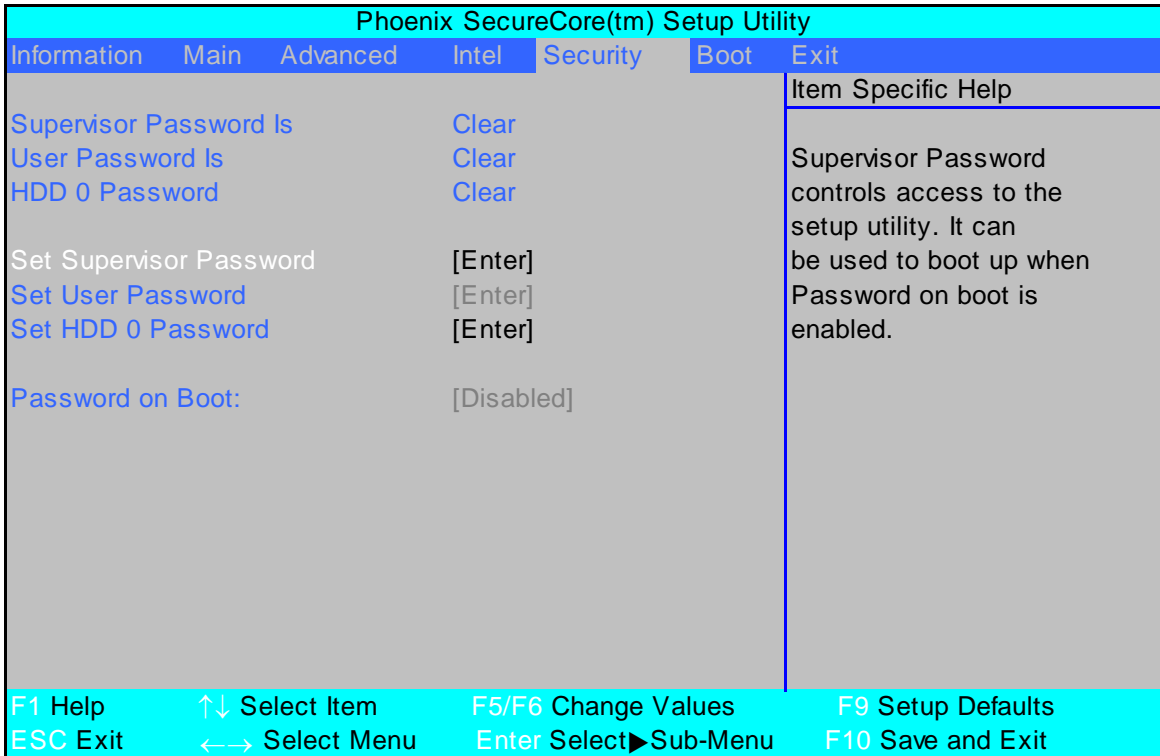

The table below describes the parameters in this screen. Settings in **boldface** are the default and suggested parameter settings.

Parameter	Description	Option
Supervisor Password Is	Shows the setting of the Supervisor password	Clear or Set
User Password Is	Shows the setting of the user password.	Clear or Set
HDD 0 Password	Shows the setting of the hard disk password.	Clear or Set
Set Supervisor Password	Press Enter to set the supervisor password. When set, this password protects the BIOS Setup Utility from unauthorized access. The user can not either enter the Setup menu nor change the value of parameters.	
Set User Password	Press Enter to set the user password. When user password is set, this password protects the BIOS Setup Utility from unauthorized access. The user can enter Setup menu only and does not have right to change the value of parameters.	
Set HDD 0 Password	Enter HDD Password.	
Password on Boot	Defines whether a password is required or not while the events defined in this group happened. The following sub-options are all requires the Supervisor password for changes and should be grayed out if the user password was used to enter setup.	Enabled or Disabled

NOTE: When you are prompted to enter a password, you have three tries before the system halts. Don't forget your password. If you forget your password, you may have to return your notebook computer to your dealer to reset it.

Setting a Password

Follow these steps as you set the user or the supervisor password:

1. Use the ↑ and ↓ keys to highlight the Set Supervisor Password parameter and press the **Enter** key. The Set Supervisor Password box appears:

Set Supervisor Password		
Enter New Password	[]
Confirm New Password	[]

2. Type a password in the “Enter New Password” field. The password length can not exceeds 8 alphanumeric characters (A-Z, a-z, 0-9, not case sensitive). Retype the password in the “Confirm New Password” field.

IMPORTANT: Be very careful when typing your password because the characters do not appear on the screen.

3. Press **Enter**. After setting the password, the computer sets the User Password parameter to “Set”.
4. If desired, you can opt to enable the Password on boot parameter.
5. When you are done, press F10 to save the changes and exit the BIOS Setup Utility.

Removing a Password

Follow these steps:

1. Use the ↑ and ↓ keys to highlight the Set Supervisor Password parameter and press the **Enter** key. The Set Password box appears:

Set Supervisor Password		
Enter current password	[]
Enter New Password	[]
Confirm New Password	[]

2. Type the current password in the Enter Current Password field and press **Enter**.
3. Press **Enter** twice **without** typing anything in the Enter New Password and Confirm New Password fields. The computer then sets the Supervisor Password parameter to “Clear”.
4. When you have changed the settings, press u to save the changes and exit the BIOS Setup Utility.

Changing a Password

1. Use the ↑ and ↓ keys to highlight the Set Supervisor Password parameter and press the **Enter** key. The Set Password box appears.

Set Supervisor Password		
Enter current password	[]
Enter New Password	[]
Confirm New Password	[]

2. Type the current password in the Enter Current Password field and press **Enter**.
3. Type a password in the Enter New Password field. Retype the password in the Confirm New Password field.
4. Press **Enter**. After setting the password, the computer sets the User Password parameter to “Set”.
5. If desired, you can enable the Password on boot parameter.
6. When you are done, press F10 to save the changes and exit the BIOS Setup Utility.

If the verification is OK, the screen will display as following.

Setup Notice
Changes have been saved.
[continue]

The password setting is complete after the user presses **Enter**.

If the current password entered does not match the actual current password, the screen will show you the Setup Warning.

Setup Warning
Invalid password
Re-enter Password
[continue]

If the new password and confirm new password strings do not match, the screen will display the following message.

Setup Warning
Password do not match
Re-enter Password

Boot

This menu allows the user to decide the order of boot devices to load the operating system. Bootable devices includes the USB diskette drives, the onboard hard disk drive and the DVD drive in the module bay.

Phoenix SecureCore(tm) Setup Utility						
Information	Main	Advanced	Intel	Security	Boot	Exit
Boot priority order:						Item Specific Help
1: IDE 0: WDC WD2500BEVS-22UST0-(PM)						Use <↑> or <↓> to select a device, then press <F6> to move it up the List, or <F5> to move it down the list. Press <Esc> to escape the menu.
2: IDE 1: Optiarc DVD RW AD-7560S-(PM)						
3: USB FDD:						
4: PCI LAN: IBA GE Slot 00C8 v1300						
5: USB HDD:						
6: USB KEY:						
7: USB CD/DVD ROM:						
F1 Help	↑↓ Select Item	F5/F6 Change Values		F9 Setup Defaults		
ESC Exit	←→ Select Menu	Enter Select▶ Sub-Menu		F10 Save and Exit		

Exit

The Exit screen allows you to save or discard any changes you made and quit the BIOS Utility.

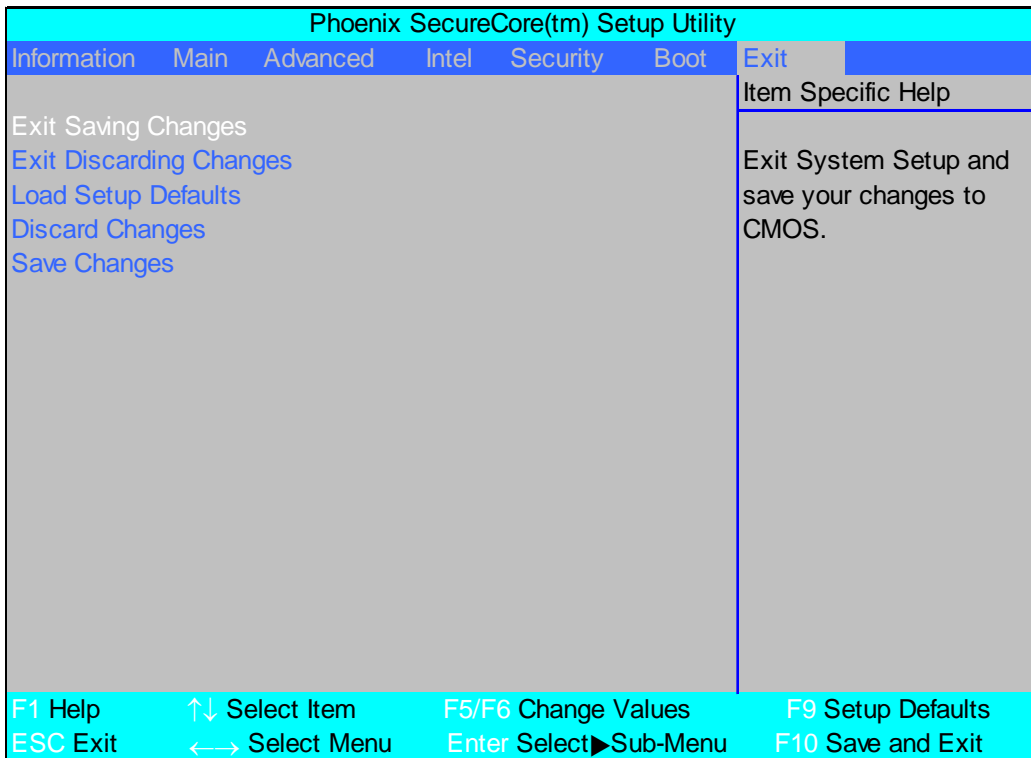

The table below describes the parameters in this screen.

Parameter	Description
Exit Saving Changes	Exit System Setup and save your changes to CMOS.
Exit Discarding Changes	Exit utility without saving setup data to CMOS.
Load Setup Default	Load default values for all SETUP item.
Discard Changes	Load previous values from CMOS for all SETUP items.
Save Changes	Save Setup Data to CMOS.

BIOS Flash Utility

The BIOS flash memory update is required for the following conditions:

- New versions of system programs
- New features or options
- Restore a BIOS when it becomes corrupted.

Use the Phlash utility to update the system BIOS flash ROM.

NOTE: Create a **Crisis Recovery Media** (such as USB HDD) before you use the Phlash utility.

NOTE: Do not install memory-related drivers (XMS, EMS, DPMI) when you use the Phlash.

NOTE: Please use the AC adaptor power supply when you run the Phlash utility. If the battery pack does not contain enough power to finish BIOS flash, the system will not boot as the BIOS is not loaded.

Perform the following steps to use the Flash Utility:

1. Press F2 during boot to enter the Setup Menu.
2. Select **Boot Menu** to modify the boot priority order, for example, if using USB HDD to Update BIOS, move USB HDD to position 1.

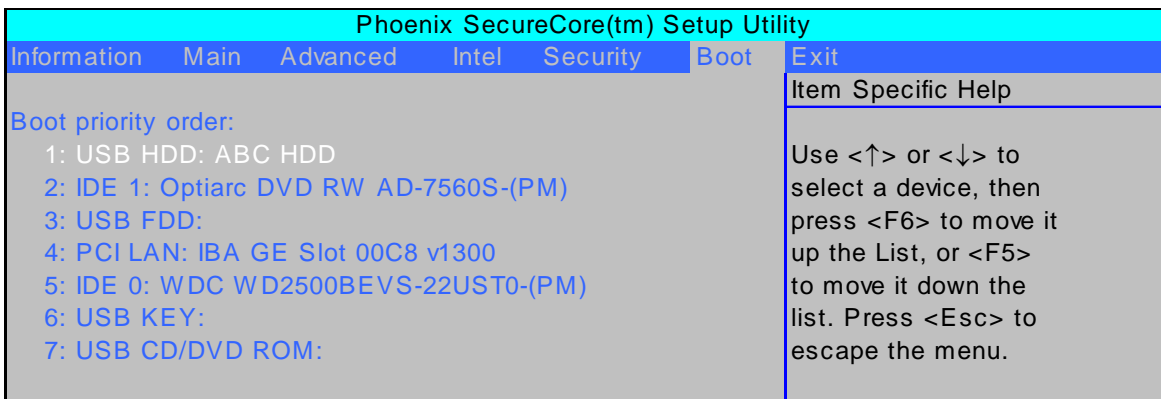

3. Execute the **IFLASH.BAT** batch file to update BIOS (Read xxxxx.fd to Memory).



4. In flash BIOS, the message **Please do not remove AC Power Source** displays.

NOTE: If the AC power is not connected, the following message displays.

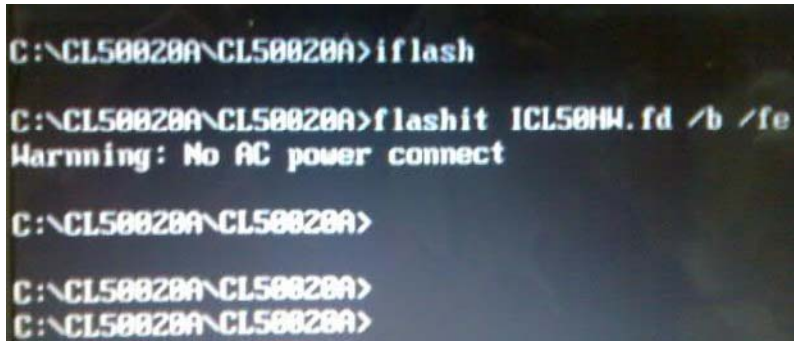

```
C:\CL50020A\CL50020A>iflash
C:\CL50020A\CL50020A>flashit ICL50HW.fd /b /fe
Warning: No AC power connect
C:\CL50020A\CL50020A>
C:\CL50020A\CL50020A>
C:\CL50020A\CL50020A>
```

Plug in the AC power to continue.

5. Flash is complete when the following message displays.

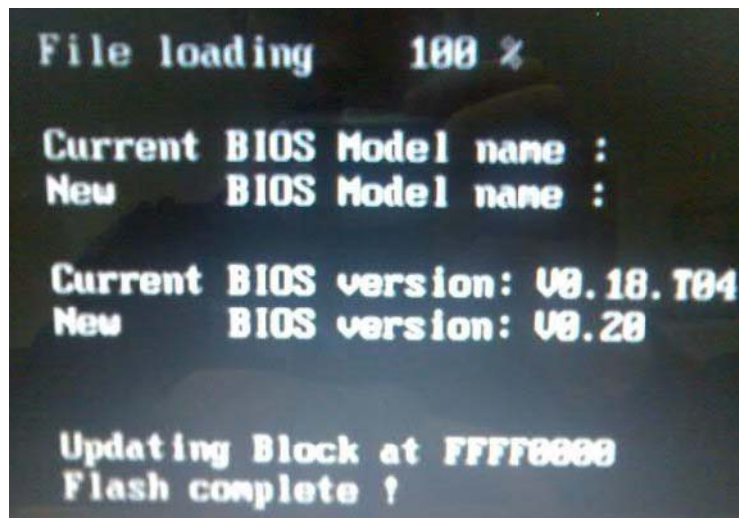

```
File loading 100 %
Current BIOS Model name :
New BIOS Model name :
Current BIOS version: V0.18.T04
New BIOS version: V0.20
Updating Block at FFFF0000
Flash complete !
```

6. Shutdown or reboot base on iflash.bat command.

Remove HDD/BIOS Utility

This section provide you with removing HDD/BIOS method:

Remove HDD Password:

- If you key in wrong HDD password three times, Hdd password error code displays. See the image below.



To reset the HDD password, run HDD_PW.EXE as follows:

1. Key in **hdd_pw 15494 0**
2. Press 2.
3. Select one upper-case string from the list.



4. Reboot system and key in the selected string (0KJFN42 or UVEIQ96) on the HDD User Password screen.



Remove BIOS Password:

If you key in the wrong Supervisor Password three times, System Disabled displays on the screen. See the image below.

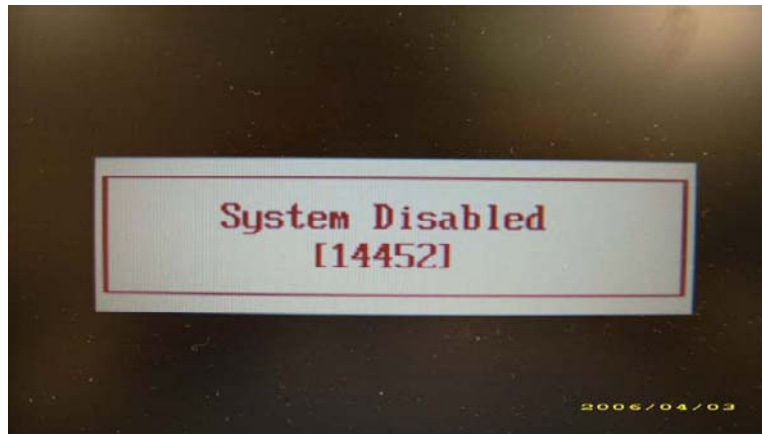

To reset the BIOS password, run BIOS_PW.EXE as follows:

1. Key in **bios_pw 14452 0**
2. Select one string from the list.

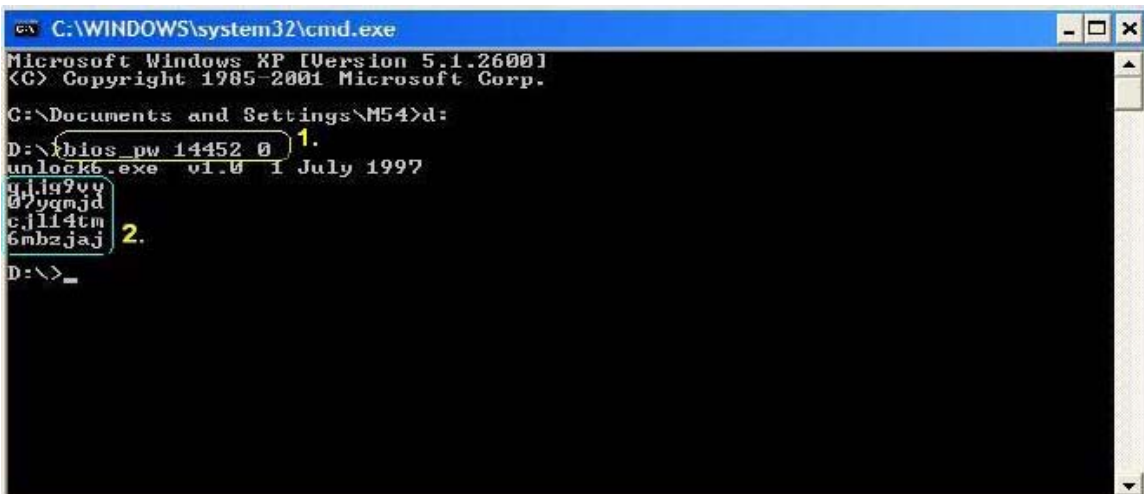

```
C:\WINDOWS\system32\cmd.exe
Microsoft Windows XP [Version 5.1.2600]
(C) Copyright 1985-2001 Microsoft Corp.
C:\Documents and Settings\M54>d:
D:\>bios_pw 14452 0
unlock6.exe v1.0 1 July 1997
qj119900
0?yqmjd
c.jl14tm
6mbzjaj
D:\>
```

-
3. Reboot the system and key in the selected string (qjjg9vy, 07yqmjd etc.) for the BIOS user password.



Machine Disassembly and Replacement

This chapter contains step-by-step procedures on how to disassemble the notebook computer for maintenance and troubleshooting.

Disassembly Requirements

To disassemble the computer, you need the following tools:

- Wrist grounding strap and conductive mat for preventing electrostatic discharge
- Flat screwdriver
- Philips screwdriver
- Plastic flat screwdriver
- Plastic tweezers

NOTE: The screws for the different components vary in size. During the disassembly process, group the screws with the corresponding components to avoid mismatch when putting back the components.

General Information

Pre-disassembly Instructions

Before proceeding with the disassembly procedure, make sure that you do the following:

1. Turn off the power to the system and all peripherals.
2. Unplug the AC adapter and all power and signal cables from the system.



3. Place the system on a flat, stable surface.
4. Remove the battery pack.

Disassembly Process

The disassembly process is divided into the following stages:

- External module disassembly
- Main unit disassembly
- LCD module disassembly

The flowcharts provided in the succeeding disassembly sections illustrate the entire disassembly sequence. Observe the order of the sequence to avoid damage to any of the hardware components. For example, if you want to remove the main board, you must first remove the keyboard, then disassemble the inside assembly frame in that order.

Main Screw List

Screw	Quantity	Part Number
M2*10 (NL)	15	86.TQ702.001
M2.5*4	6	86.TQ702.002
M2*3 (NL)	33	86.TQ702.003
M2*4 (NL)	19	86.TQ702.004
M2*5	2	86.TQ702.005
M3*3 (NI)	4	86.TQ702.006
M M 2.5D 3.2L K 6D NI +	4	86.TQ702.007

External Module Disassembly Process

External Modules Disassembly Flowchart

The flowchart below gives you a graphic representation on the entire disassembly sequence and instructs you on the components that need to be removed during servicing. For example, if you want to remove the main board, you must first remove the keyboard, then disassemble the inside assembly frame in that order.

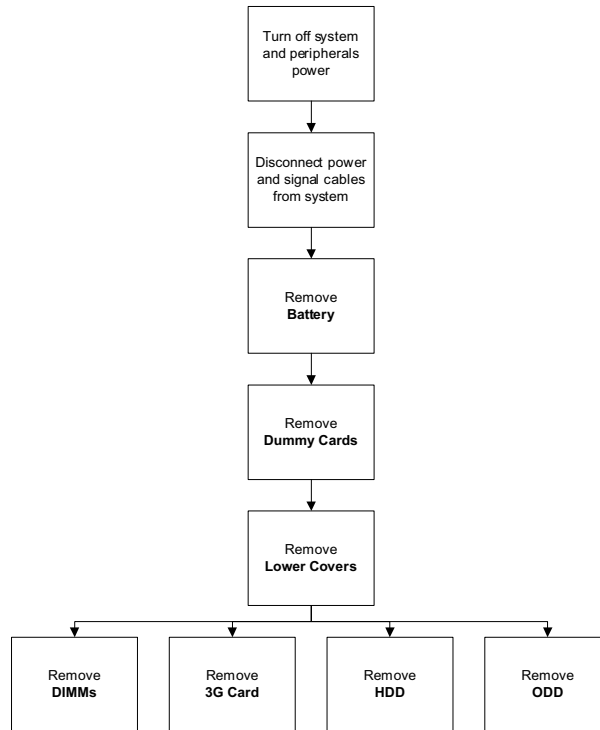

Screw List

Step	Screw	Quantity	Part No.
3G Module	M2*3	2	86.TQ702.003
HDD Carrier	M3*3	4	86.TQ702.006
ODD Bracket	M2*5	2	86.TQ702.005
	M2*3	2	86.TQ702.003

Removing the Battery Pack

1. Turn computer over.
2. Slide the battery lock/unlock latch to the unlock position.



3. Slide and hold the battery release latch to the release position (1), then slide out the battery pack from the main unit (2).

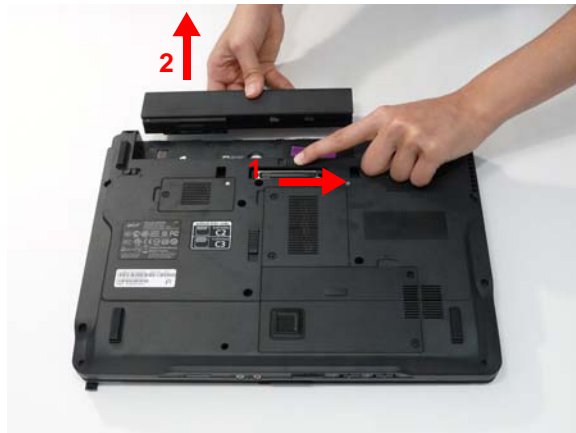

Removing the SD dummy card

1. Push the SD dummy card in to eject it.



2. Grasp the card and pull it out from the slot.



Removing the NewCard Dummy card

1. Push the NewCard eject button to eject it, then push it all the way in to eject the NewCard dummy.



2. Pull it out from the slot.



Removing the Lower Covers

1. See “Removing the Battery Pack” on page 50.
2. See “Removing the SD dummy card” on page 51.
3. See “Removing the NewCard Dummy card” on page 52.
4. Loosen the five captive screws in the Memory, HDD, and 3G bays as shown.

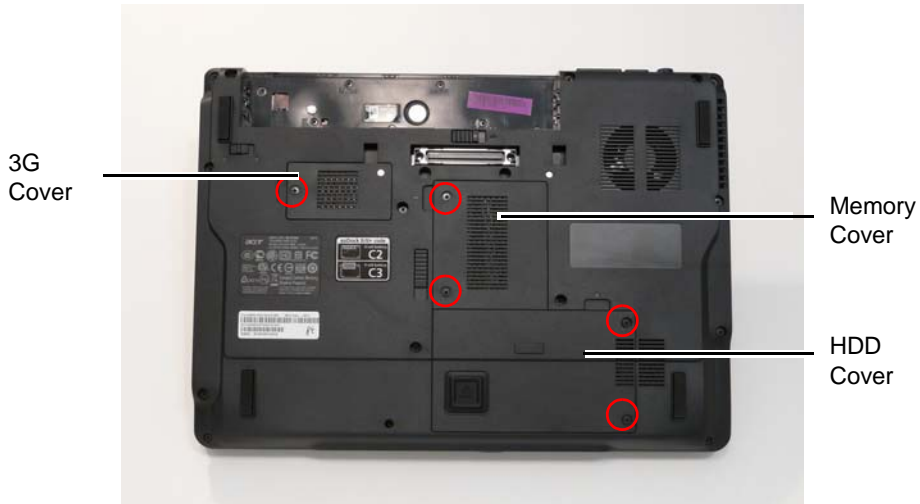

5. Carefully open the memory cover.



6. Remove the HDD cover as shown.



7. Remove the 3G cover as shown.



Removing the DIMM Modules

1. See “Removing the Battery Pack” on page 50.
2. Remove the Memory Module cover See “Removing the Lower Covers” on page 53.
3. Push out the release latches on both sides of the DIMM socket to release the DIMM module.

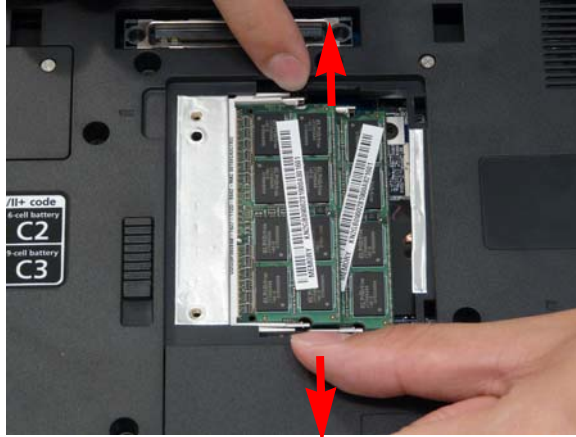

4. Remove the DIMM module.

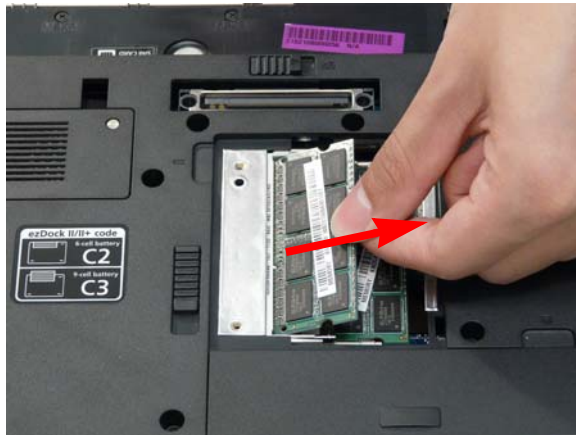

5. Repeat steps for the second DIMM module.

Removing the 3G Module

1. See “Removing the Battery Pack” on page 50.
2. Remove the 3G cover. See “Removing the Lower Covers” on page 53.
3. Disconnect the antenna cables from the 3G board.



4. Move the antenna cables away and remove the two screws to release the 3G board.



Step	Size	Quantity	Screw Type
3G Module	M2*3	2	

5. Detach the 3G board from the 3G socket.



Removing the Hard Disk Drive Module

1. See “Removing the Battery Pack” on page 50.
2. Remove the HDD cover, See “Removing the Lower Covers” on page 53.
3. Use the mylar tab to slide and lift up the hard disk drive module to remove.

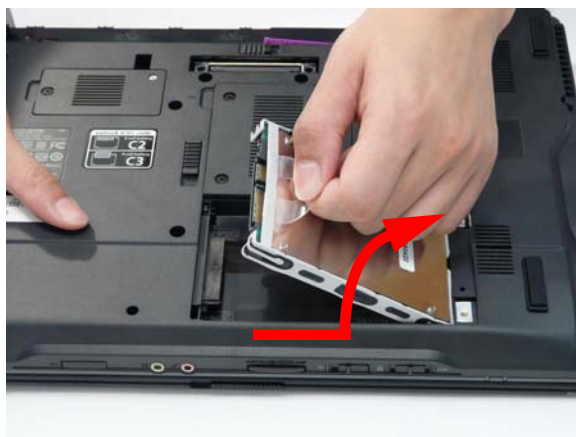



NOTE: To prevent damage to device, avoid pressing down on it or placing heavy objects on top of it.

4. Remove the HDD holder by easing the sides outward to clear the carrier.

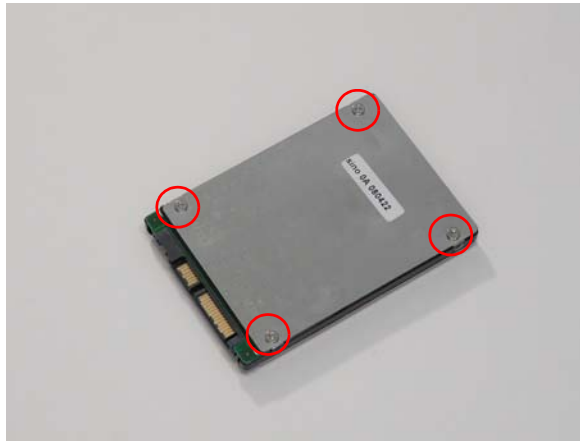

5. Remove the four screws securing the hard disk to the carrier.



Step	Size	Quantity	Screw Type
HDD Carrier	M3*3	4	

6. Remove the HDD from the carrier.



Removing the Optical Drive Module

1. See “Removing the Battery Pack” on page 50.
2. Remove the Memory cover. See “Removing the Lower Covers” on page 53.
3. Push the ODD release latch to eject the ODD module.





4. Pull the ODD module through the chassis to remove it from the main unit.



5. Remove the four screws securing the ODD bracket and remove it from the ODD module.



Step	Size	Quantity	Screw Type
ODD Bracket (red callout)	M2*5	2	
ODD Bracket (green callout)	M2*3	2	

6. Remove the ODD board from the ODD module by disconnecting the interface as shown.

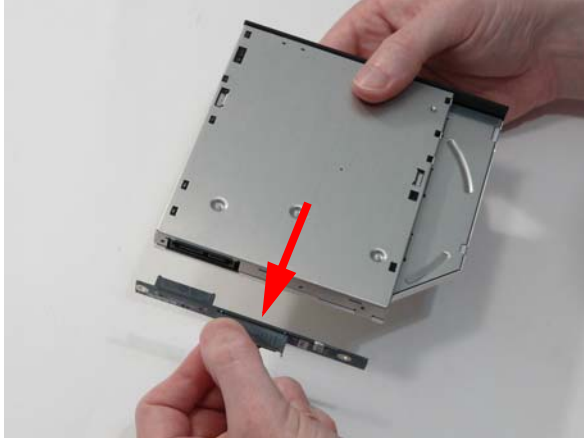

7. Insert a pin in the eject hole of the ODD to eject the ODD tray.



8. Press down on the locking catch to release the ODD cover and remove.

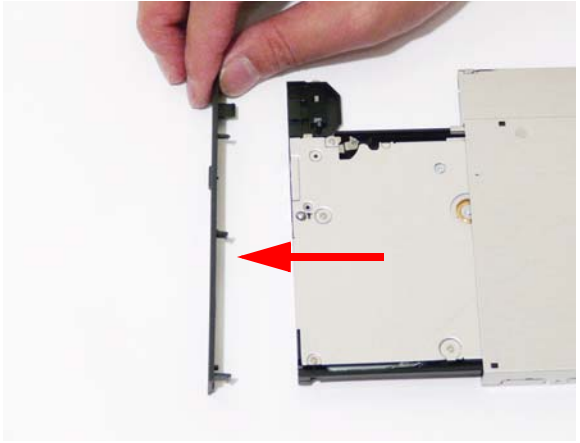
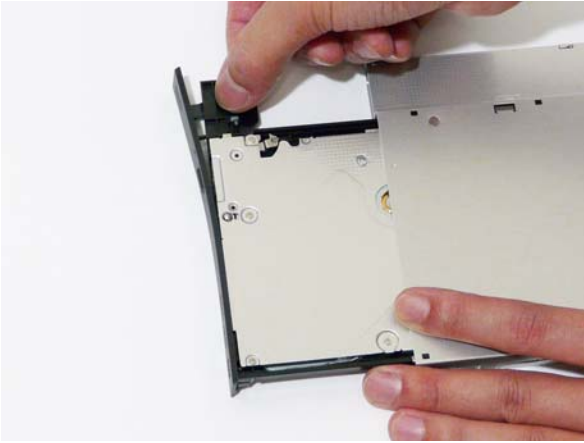

Main Unit Disassembly Process

Main Unit Disassembly Flowchart

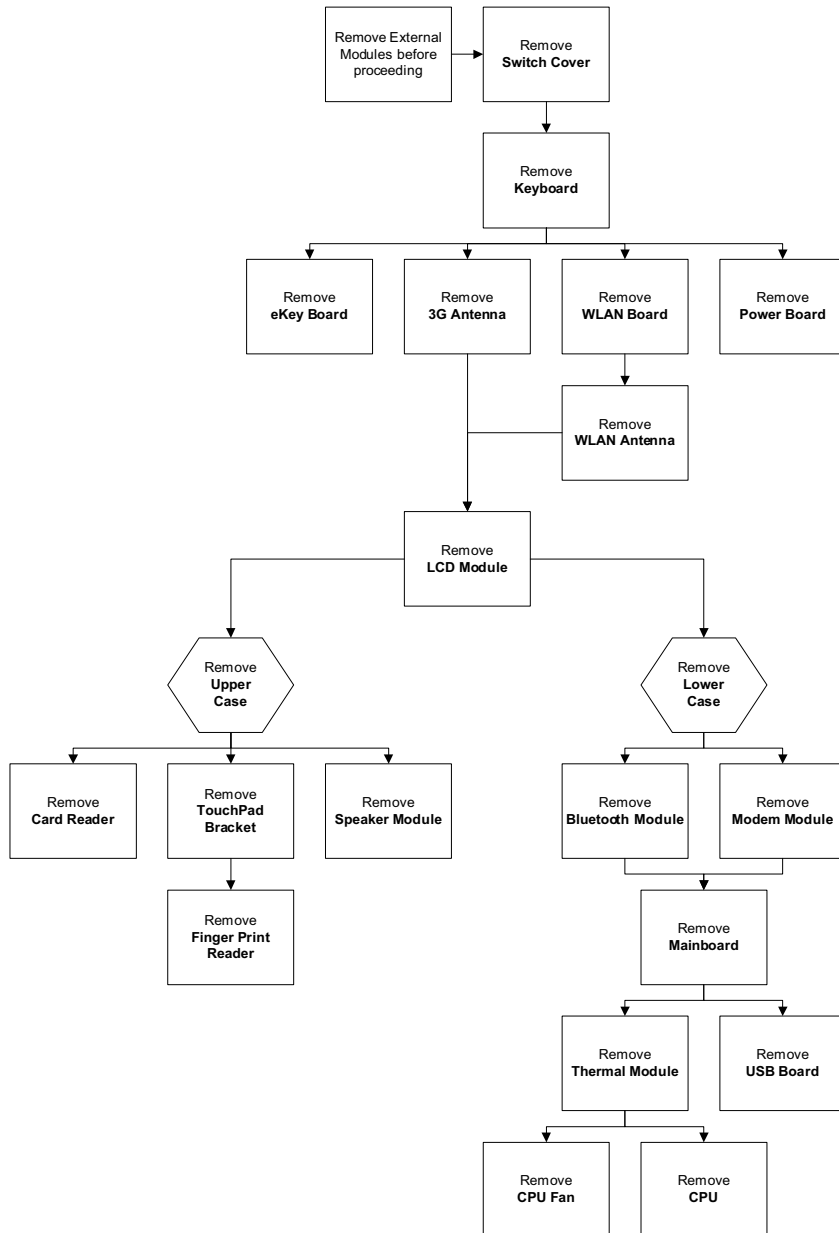

Screw List

Step	Screw	Quantity	Part No.
Switch Cover	M2*3	2	86.TQ702.003
Keyboard	M2*10	1	86.TQ702.001
	M2*3	2	86.TQ702.003
eKey Board	M2*3	2	86.TQ702.003
Power Board	M2*3	2	86.TQ702.003
WLAN Module	M2*3	2	86.TQ702.003

Step	Screw	Quantity	Part No.
LCD Module	M2*10	4	86.TQ702.001
	M2*4	2	86.TQ702.004
Upper Cover	M2*10	10	86.TQ702.001
	M2*4	6	86.TQ702.004
	M2.5*4	1	86.TQ702.002
Card Reader Module	M2*3	1	86.TQ702.003
F/P Reader	M2*3	1	86.TQ702.003
Touch Pad Bracket	M2*3	2	86.TQ702.003
Speaker (L and R)	M2*3	4	86.TQ702.003
Modem Module	M2*3	2	86.TQ702.003
Mainboard	M2.5*4	1	86.TQ702.002
USB Board	M2*3	2	86.TQ702.003
Thermal Module	M M 2.5D 3.2L K 6D NI +	4	86.TQ702.007
CPU Fan	M2*4	3	86.TQ702.004

Removing the Switch Cover

CAUTION: Using tools to remove the Switch Cover may cause damage to the outer casing. It is recommended that only fingers are used to remove the Switch Cover.

1. See "Removing the Battery Pack" on page 50.
2. Locate and remove the two securing screws as shown.



Step	Size	Quantity	Screw Type
Switch Cover	M2*3	2	

3. Turn the computer over and open the LCD module fully to expose the Switch Cover.
IMPORTANT:The LCD module must be fully open in the horizontal position to remove the switch cover.
4. Lift the Switch Cover as shown, rightside first.



5. Lift the Switch Cover clear of the chassis.

Removing the Keyboard

1. See "Removing the Battery Pack" on page 50.
2. See "Removing the Switch Cover" on page 64.
3. Turn the computer over. Remove the single securing screw as shown.



Step	Size	Quantity	Screw Type
Keyboard	M2*10	1	

4. Turn the computer over. Remove the two screws securing the keyboard to the upper case.



Step	Size	Quantity	Screw Type
Keyboard	M2*3	2	

5. Lift the keyboard and turn it over to expose the FFC cables.

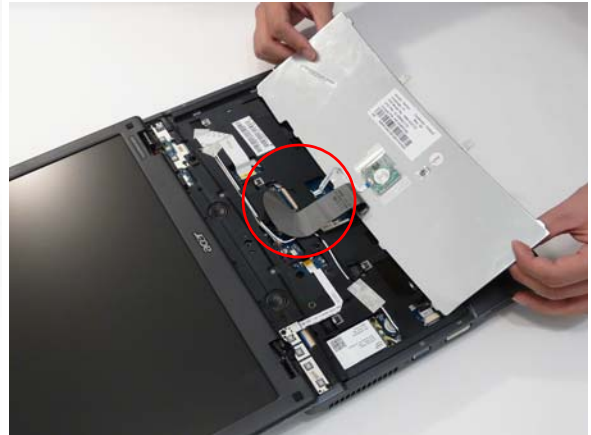

6. Release the keyboard FFC securing latch and disconnect the cable.

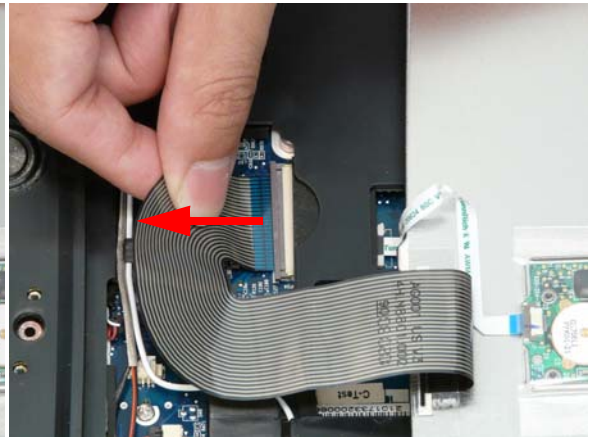
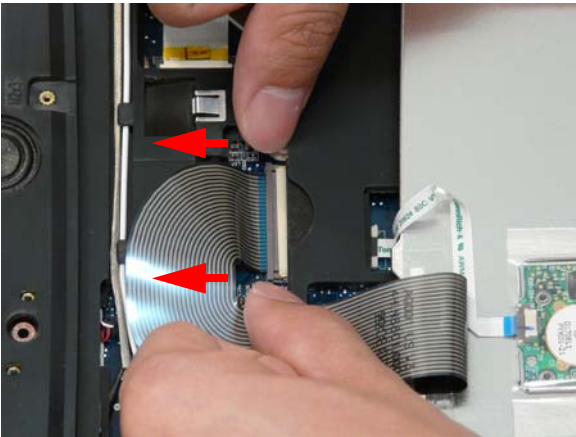

7. Release the Fine Track keyboard mouse FFC securing latch and disconnect the cable.

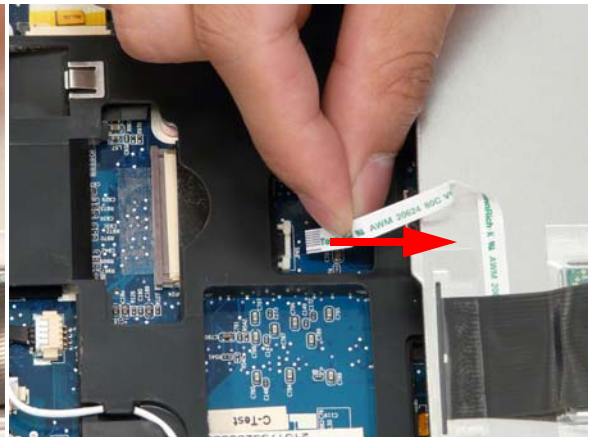
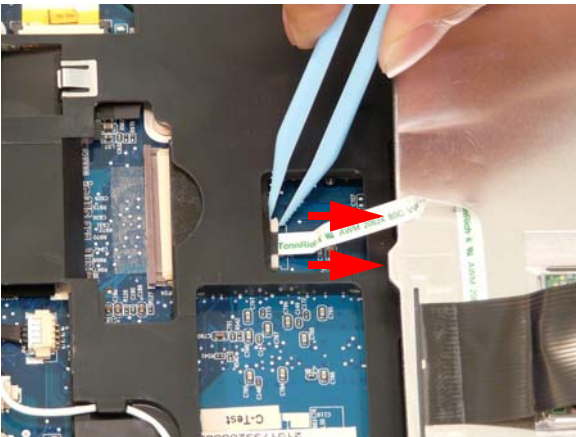

8. Remove the keyboard from the chassis.

Removing the eKey Board

1. See "Removing the Battery Pack" on page 50.
2. See "Removing the Keyboard" on page 65.
3. Disconnect the eKey Board cable from the mainboard.



4. Remove the two securing screws from the eKey Board.



Step	Size	Quantity	Screw Type
eKey Board	M2*3	2	

-
5. Carefully pull back the FFC to release the adhesive strips on the cable and remove the eKey Board from the upper case.

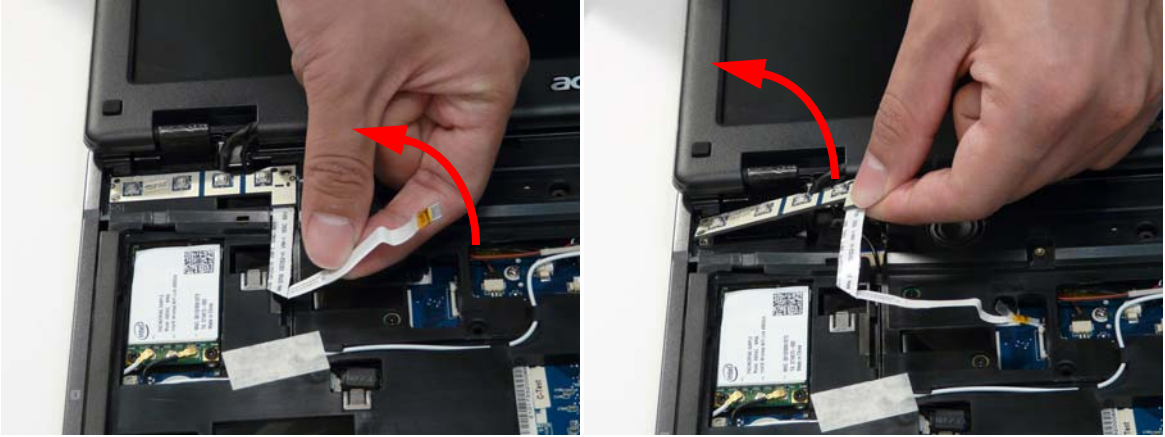

Removing the Power Board

1. See "Removing the Battery Pack" on page 50.
2. See "Removing the Keyboard" on page 65.
3. Disconnect the Power Board cable from the mainboard.



4. Remove the two securing screws from the Power Board.



Step	Size	Quantity	Screw Type
Power Board	M2*3	2	

5. Carefully pull back the FFC to release the adhesive strips on the cable and remove the Power Board from the upper case.

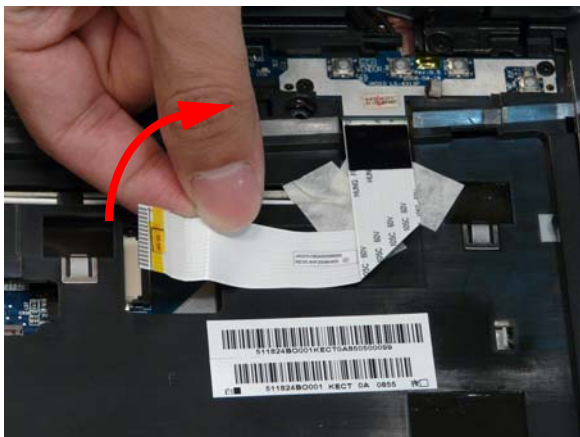

Removing the WLAN Module

1. See "Removing the Keyboard" on page 65.
2. Disconnect the antenna cables from the WLAN module.



3. Move the antenna cables away and remove the two screws to release the WLAN module.



Step	Size	Quantity	Screw Type
WLAN Module	M2*3	2	

4. Detach the WLAN Module from the mainboard.



Removing the 3G Antenna

1. See “Removing the 3G Module” on page 56.
2. Remove the adhesive tape from the 3G cable as shown.



3. Gently pull the 3G cables through the chassis, as shown, until the cable terminals are free from the case.

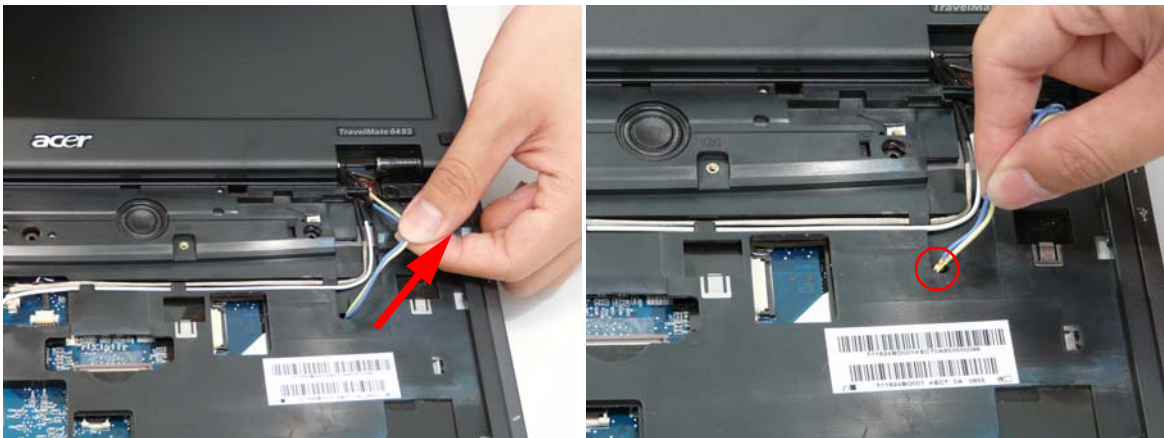

Removing the WLAN Antenna and MIC Cable

1. Disconnect the MIC cable from the mainboard.

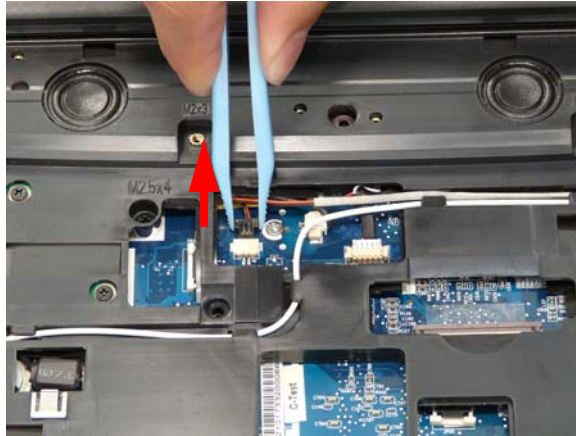

2. Remove the MIC cable from the cable channel as shown.



3. Remove the adhesive tape on the WLAN cable

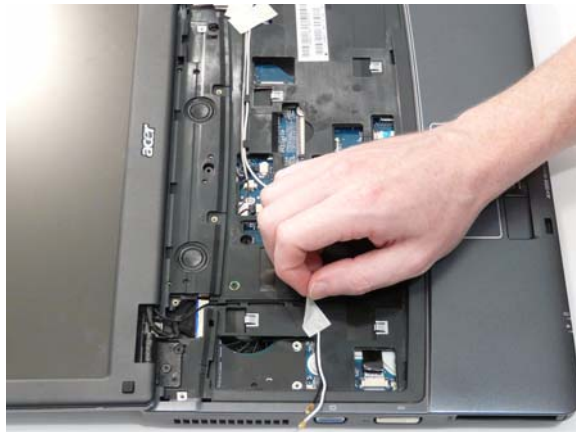

4. Remove the Antenna Cables from the housing well as shown.

NOTE: Place the cables to one side to avoid damage.

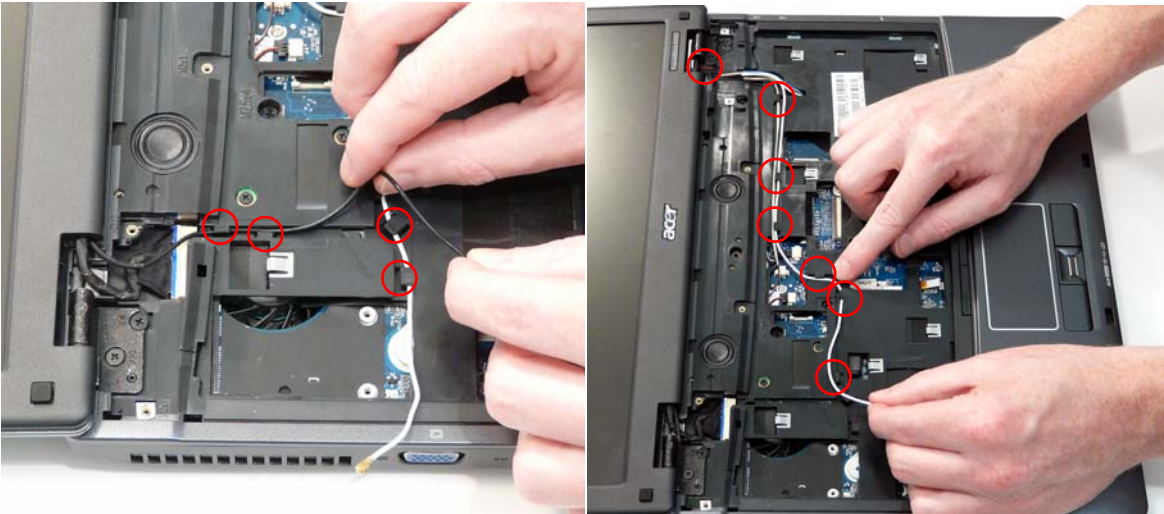
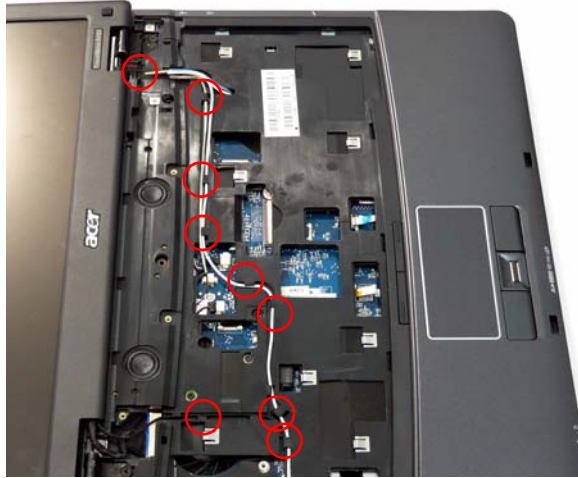



5. Ensure all cables are free of the right side cable channel as shown.

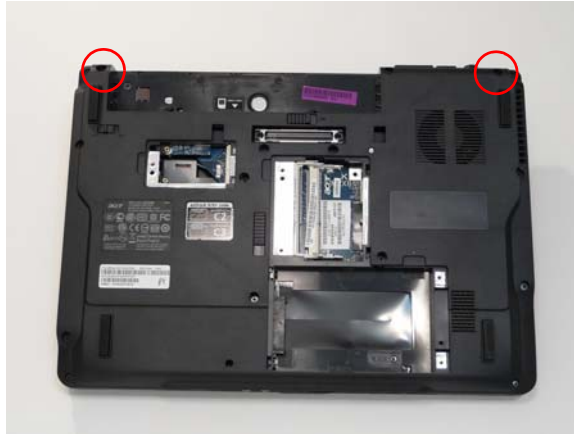

Removing the LCD Module

1. Remove the Battery Pack. See “Removing the Battery Pack” on page 50.
2. Remove the 3G Module. See “Removing the 3G Module” on page 56.
3. Remove the WLAN Module. See “Removing the WLAN Module” on page 71.
4. Remove the Antenna. See “Removing the 3G Antenna” on page 72.
5. Remove the two securing screws from the bottom of the chassis.





Step	Size	Quantity	Screw Type
LCD Module	M2*10	2	

6. Turn the computer over. Disconnect the LCD cable from the top cover.



7. Remove the four securing screws (two on each side) connecting the LCD module.



Step	Size	Quantity	Screw Type
LCD Module (red callout)	M2*10	2	
LCD Module (green callout)	M2*4	2	

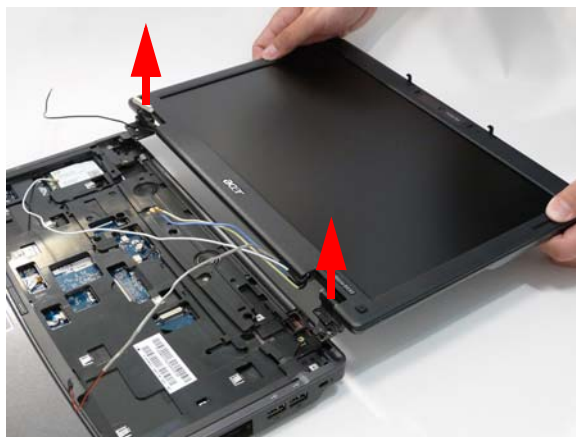

8. Carefully remove the LCD module from the chassis.

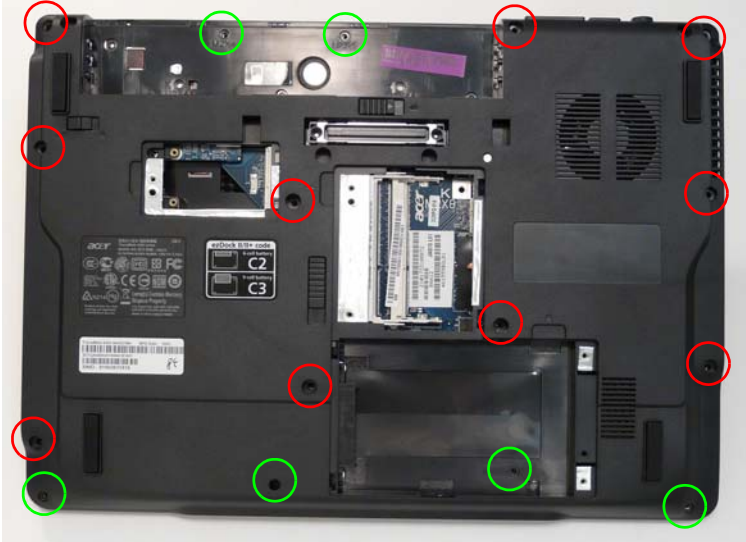

Removing the Upper Cover

1. See "Removing the Battery Pack" on page 50.
2. See "Removing the LCD Module" on page 75.
3. Turn the computer over. Remove the sixteen screws on the bottom panel.



Step	Size	Quantity	Screw Type
Upper Cover (red callout)	M2*10	10	
Upper Cover (green callout)	M2*4	6	

4. Turn the computer over and disconnect the four cables from the mainboard as shown.

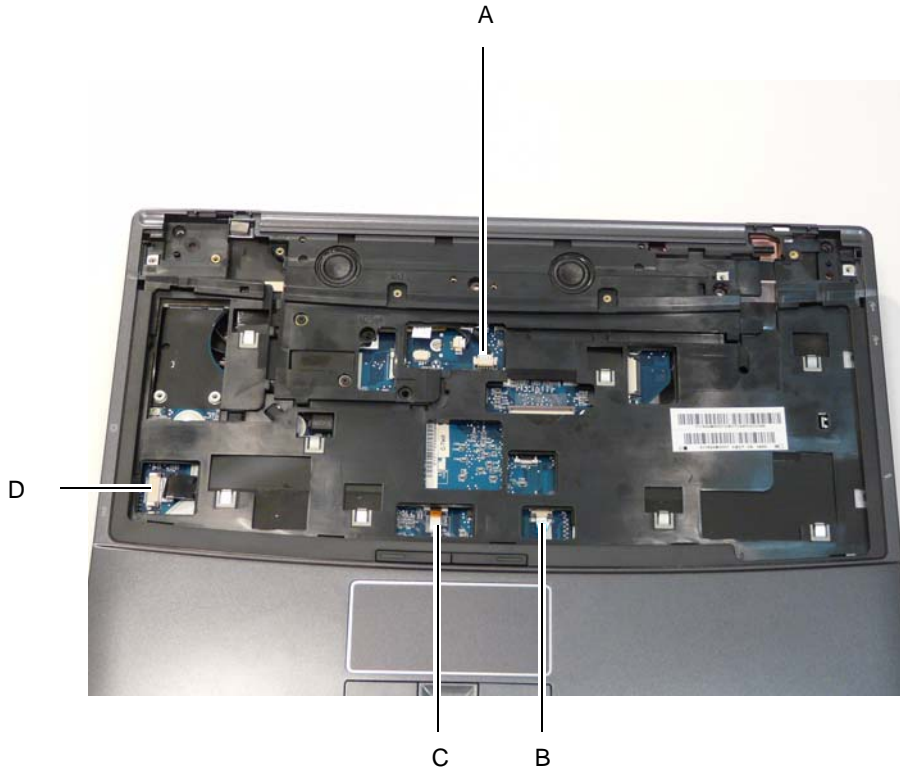

Disconnect A as shown.



Pull back the securing latch and disconnect B as shown.

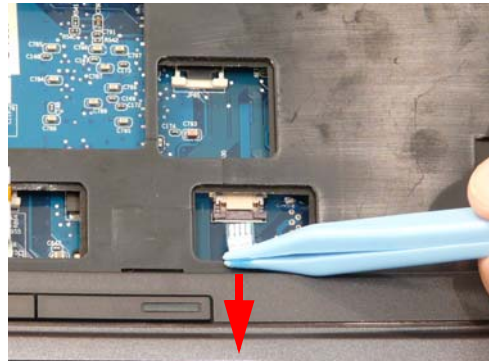

Pull back the securing latch and disconnect C as shown.

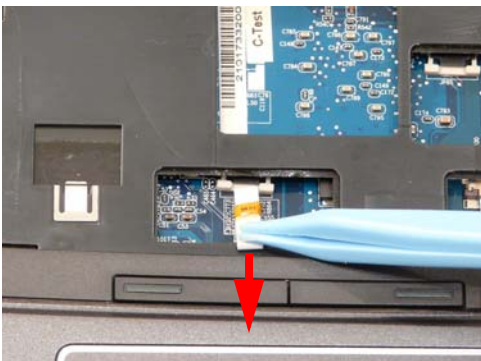

Pull back the securing latch and disconnect D as shown.

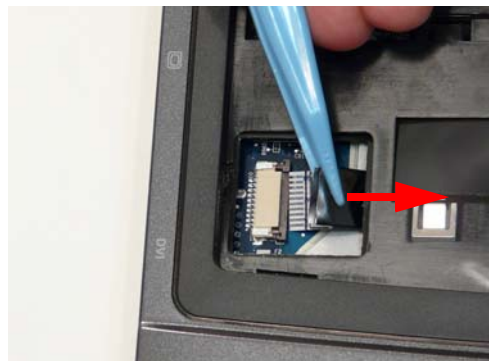

5. Remove the single screw on the top panel.



Step	Size	Quantity	Screw Type
Upper Cover	M2.5*4	1	

6. Lift the upper cover off the chassis, top edge first, as shown.

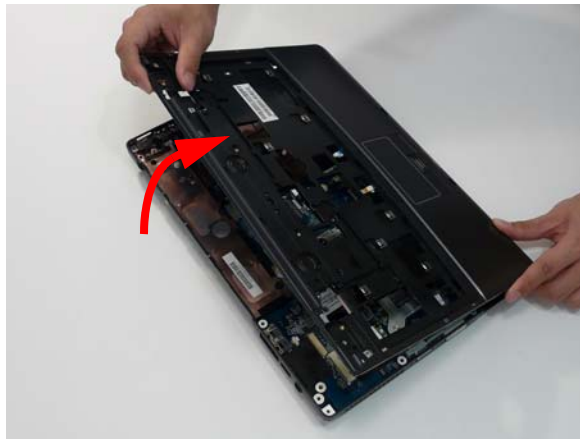



7. Moving from top to bottom, pry off the upper cover as shown.

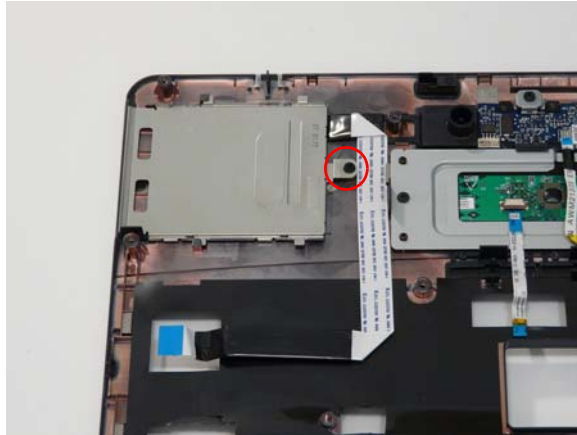

Removing the Card Reader Module

1. See "Removing the Upper Cover" on page 77.
2. Turn the Upper Cover over. Remove the single securing screw from the Card Reader.



Step	Size	Quantity	Screw Type
Card Reader Module	M2*3	1	

3. Slide the module in the direction shown to clear the securing clips.

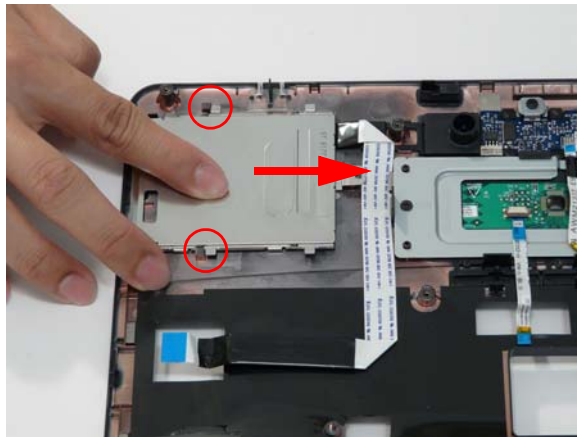

4. Lift the module and carefully remove the FFC cable from the adhesive pads, as shown, to remove the module.

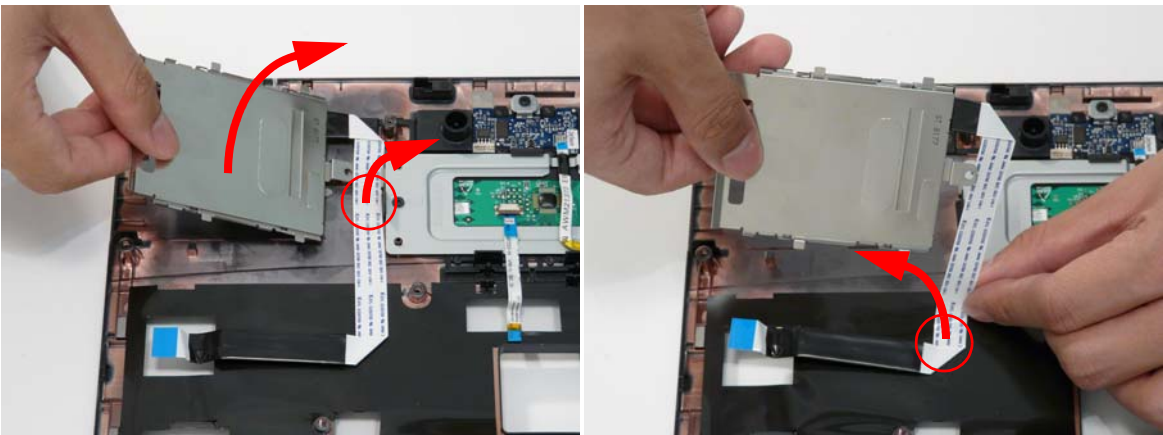

Removing the Finger Print Reader

1. See "Removing the Upper Cover" on page 77.
2. Remove the securing screw from the Finger Print Reader bracket.



Step	Size	Quantity	Screw Type
Finger Print Reader	M2*3	1	

3. Remove the bracket from the Upper Cover.

IMPORTANT: Do not discard the bracket. Remove and replace on the new Finger Print Board.

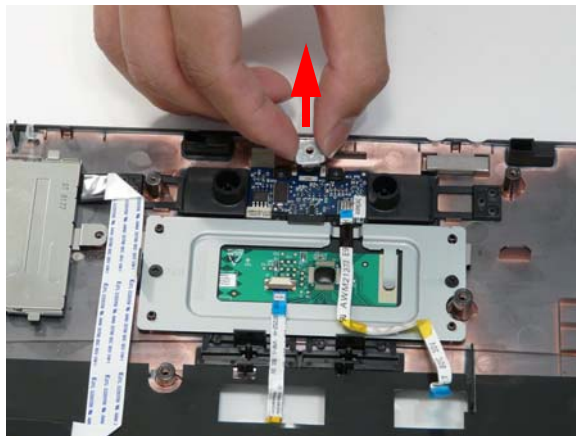

-
4. Lift up the adhesive pad holding the Finger Print Board in place and ensure the FFC is free of the Upper Cover.

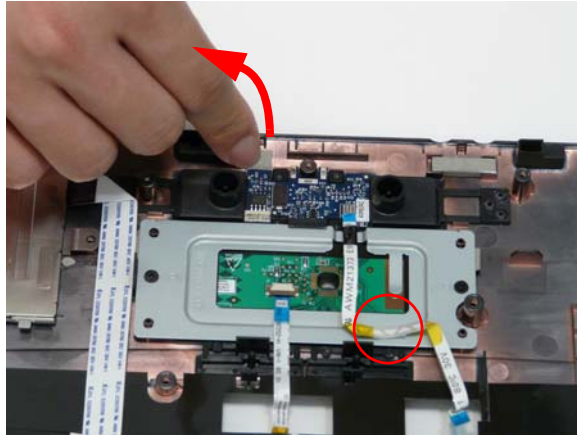

5. Remove the Finger Print Reader, top edge first, from the Upper Cover.

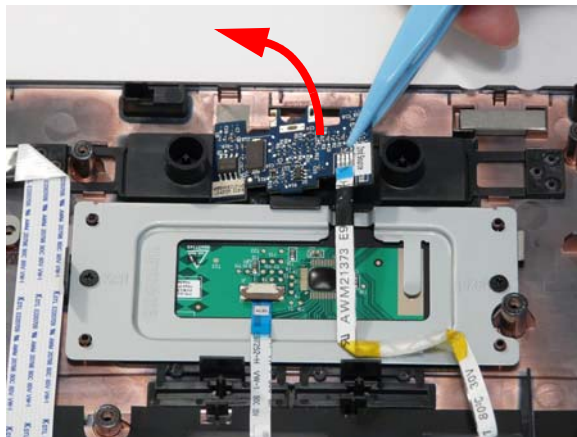

Removing the TouchPad Bracket

1. See “Removing the Finger Print Reader” on page 81.
2. Remove the two securing screws from the bracket.



Step	Size	Quantity	Screw Type
Touch Pad Bracket	M2*3	2	

3. Lift the FFC locking latch as shown.

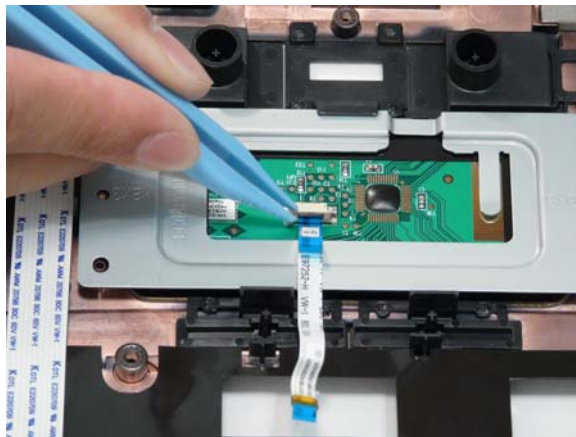

4. Remove the TouchPad FFC from the Upper Cover.

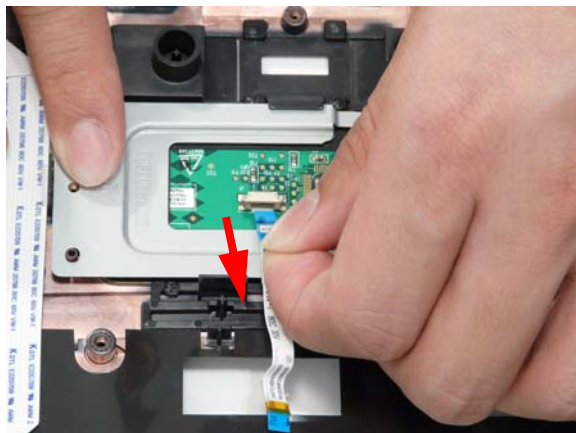

5. Rotate the TouchPad bracket upward as shown, and lift it clear of the Upper Cover.

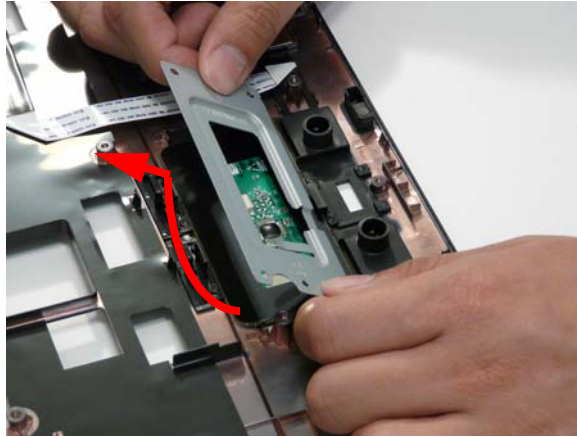

IMPORTANT: The TouchPad cannot be removed individually. To replace the TouchPad, replace the entire Upper Cover.

Removing the Speaker Modules

1. See "Removing the Upper Cover" on page 77.
2. Remove the four securing screws (two from each module).

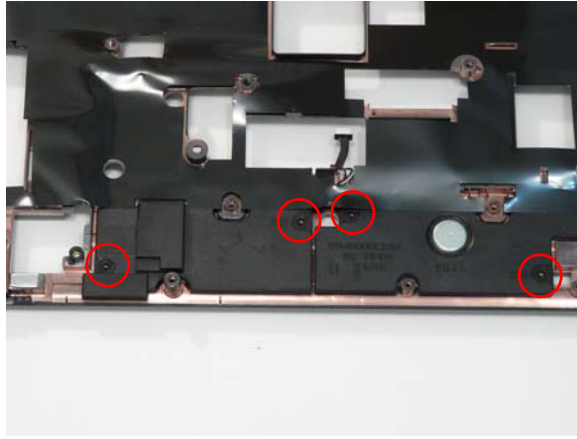

Step	Size	Quantity	Screw Type
Speaker Module	M2*3	4	

3. Grasp the mylar cover and carefully pull back to expose the speaker cable. Pull the cable through the cover until it is completely free of obstructions.

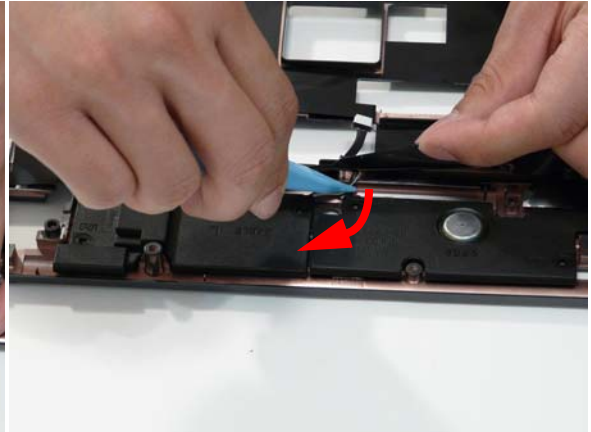
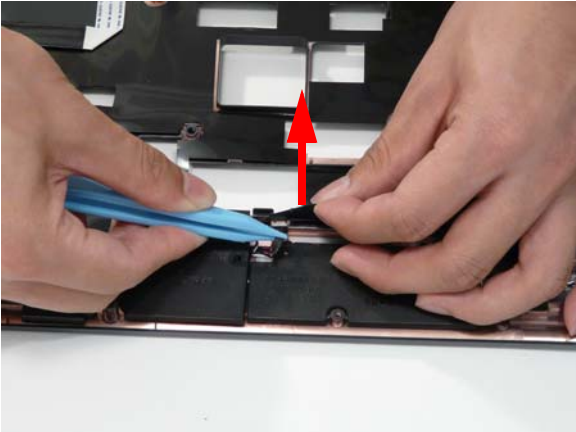

4. Remove the left and right speaker modules as shown.

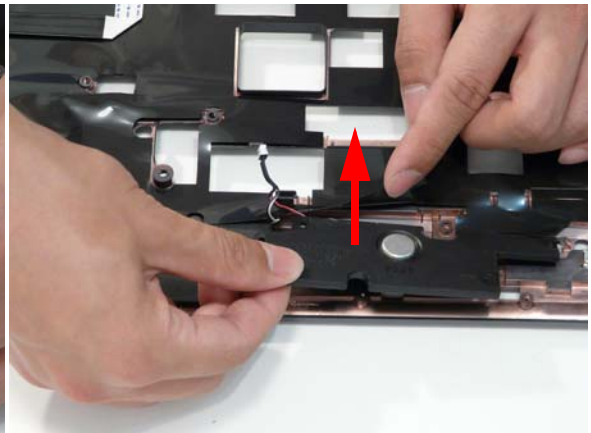
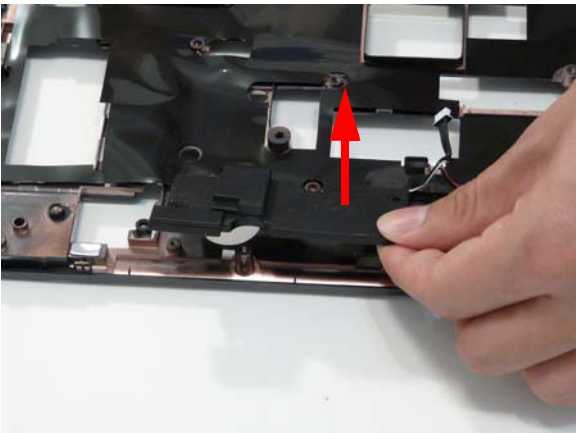

Removing the Bluetooth Module

1. See “Removing the Upper Cover” on page 77.
2. Disconnect the bluetooth cable from the mainboard as shown.



3. Using both hands, remove the Bluetooth module from the chassis.

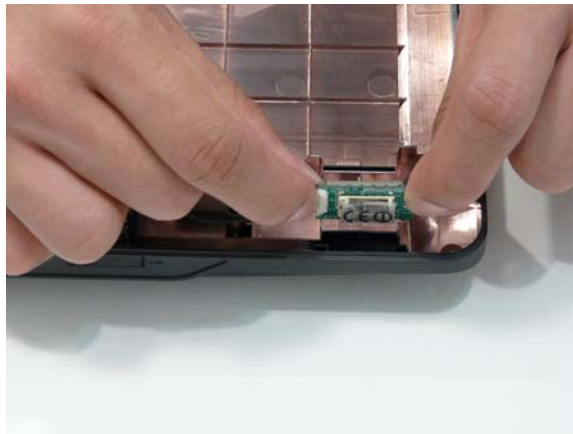

4. Disconnect the cable from the Bluetooth module.

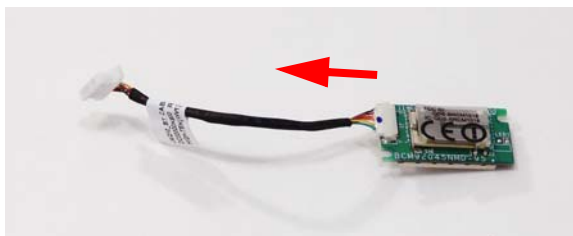

Removing the Modem Module

1. See “Removing the Upper Cover” on page 77.
2. Disconnect the cable from the mainboard as shown.



3. Disconnect the cable from the RJ-11 port.



4. Detach the adhesive pad on the modem cable as shown.

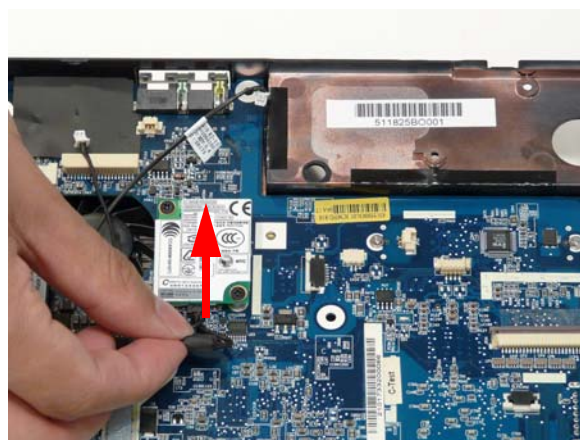

5. Disconnect the cable from the Modem module.

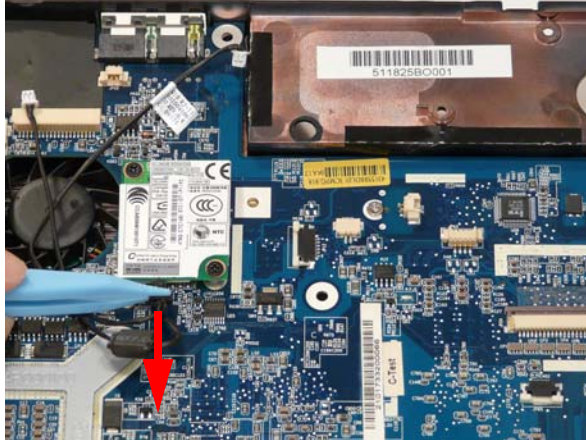

6. Remove the two securing screws from the Modem module.



Step	Size	Quantity	Screw Type
Modem Module	M2*3	2	

7. Remove the Modem from the mainboard.



Removing the Mainboard

1. See "Removing the LCD Module" on page 75.
2. See "Removing the Upper Cover" on page 77.
3. See "Removing the Modem Module" on page 87.
4. Remove the single securing screw from the mainboard.



Step	Size	Quantity	Screw Type
Mainboard	M2.5*4	1	

5. Disconnect the mainboard from the USB Board by lifting the top-right corner of the mainboard away from the chassis as shown.



6. Pull out the left side of the casing to clear the I/O ports as shown.



7. Lift the mainboard rear edge first, as shown, and remove from the chassis.

CAUTION: Ensure the I/O ports at the bottom of the mainboard are clear of the bottom base to prevent damage to the mainboard.

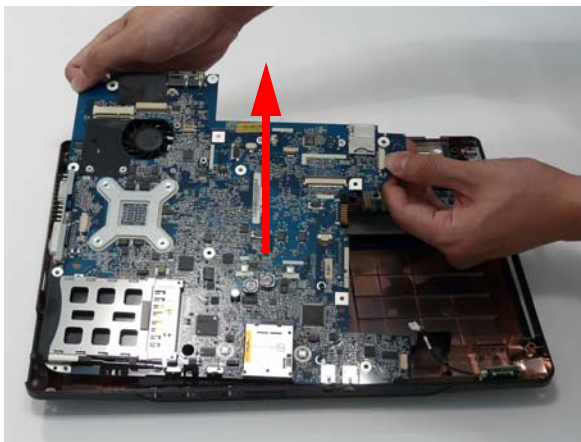

Removing the USB Board

1. Remove the mainboard. See “Removing the Mainboard” on page 89.
2. Remove the two securing screws from the USB board.

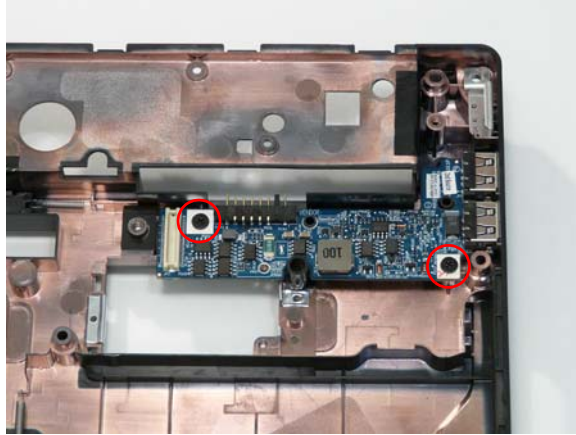

Step	Size	Quantity	Screw Type
USB Board	M2*3	2	

3. Lift the USB board clear of the chassis.



Removing the Thermal Module

1. See "Removing the Mainboard" on page 89.
2. Remove the four securing screws (in reverse numerical order from screw 4 to screw 1) from the Thermal Module.



Step	Size	Quantity	Screw Type
Thermal Module	M M 2.5D 3.2L K 6D NI +	4	

3. Using both hands, lift the Thermal Module clear of the Mainboard.

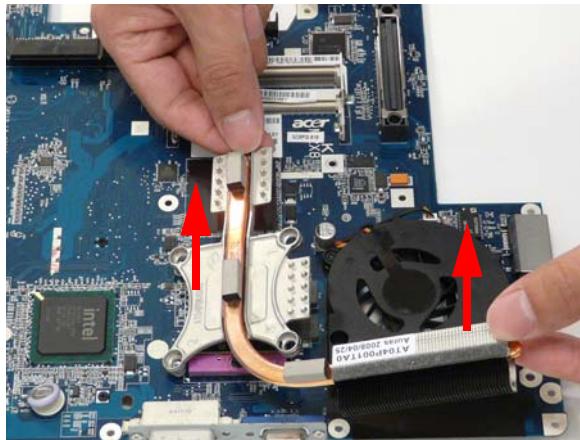

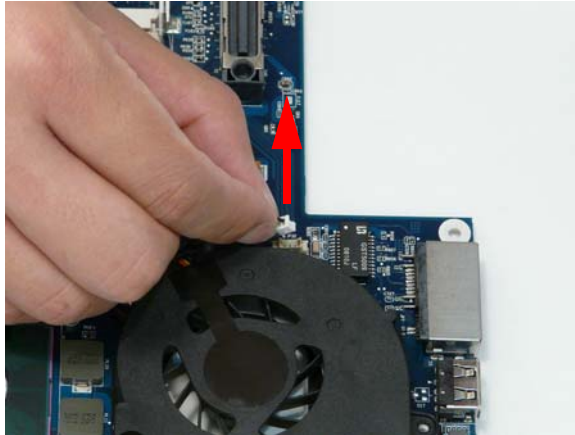

Removing the CPU Fan

1. See “Removing the Mainboard” on page 89.
2. Disconnect the fan cable from the mainboard.

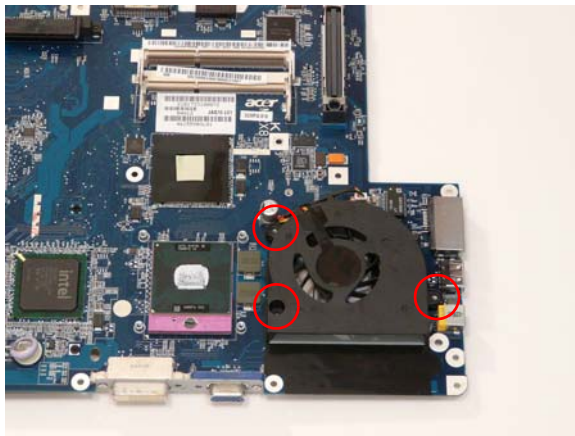

3. Remove the three securing screws from the CPU fan.



Step	Size	Quantity	Screw Type
CPU Fan Module	M2*4	3	

4. Lift the fan clear of the mainboard.

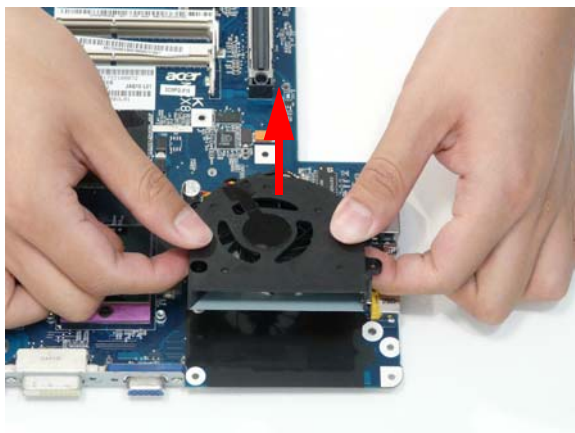

Removing the CPU

1. See “Removing the Thermal Module” on page 92.
2. Using a flat screwdriver, turn the CPU socket latch counter-clockwise 180° to release the CPU.

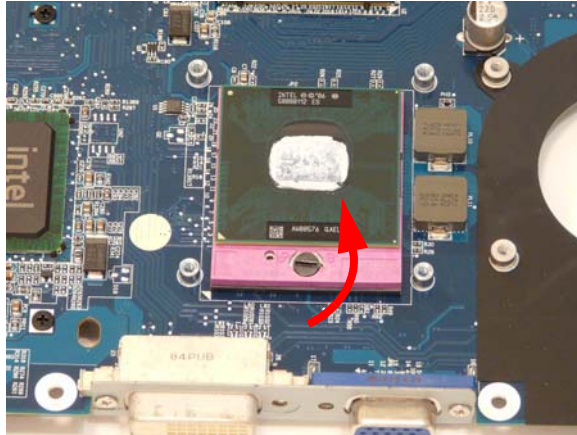

3. Lift the CPU clear of the Mainboard.

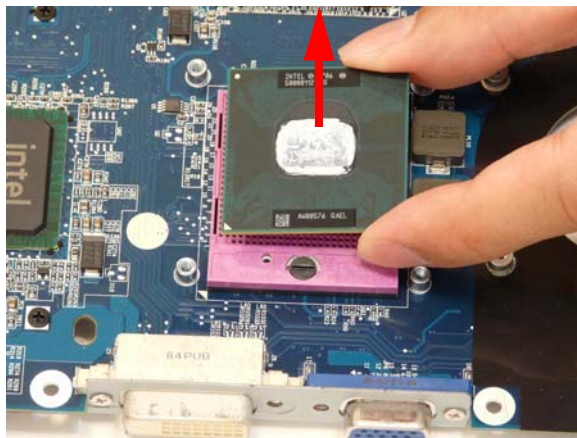

LCD Module Disassembly Process

LCD Module Disassembly Flowchart

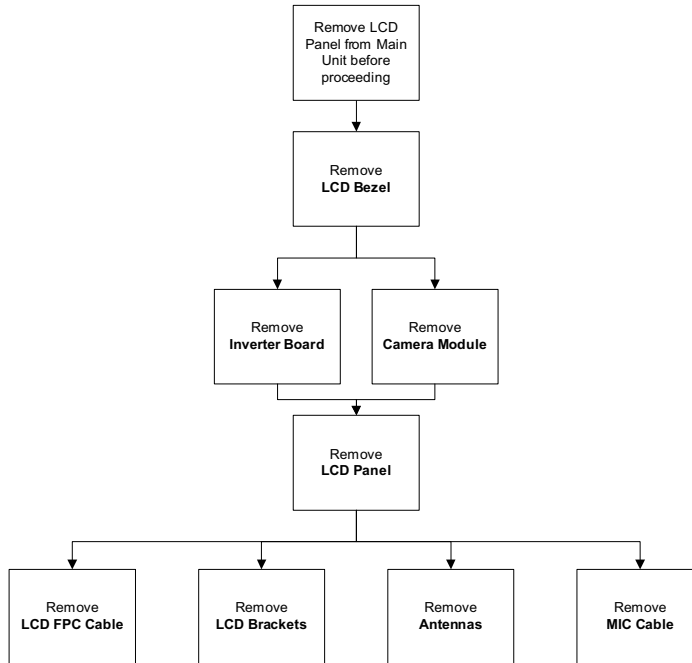

Screw List

Step	Screw	Quantity	Part No.
LCD Bezel	M2.5*4	4	86.TQ702.003
Inverter Board	M2*3	1	86.TQ702.003
LCD Panel	M2*3	2	86.TQ702.003
LCD Brackets	M2*4	8	86.TQ702.004
WLAN Antenna	M2*3	2	86.TQ702.003
3G Antenna	M2*3	2	86.TQ702.003

Removing the LCD Bezel

1. Remove the LCD module. See "Removing the LCD Module" on page 75.
2. Remove the two upper and two lower bezel screw caps. Remove the four securing screws from the LCD module.



Step	Size	Quantity	Screw Type
LCD Bezel	M2.5*4	4	

3. Lift up the bezel, left side first as shown followed by the bottom and right sides respectively.

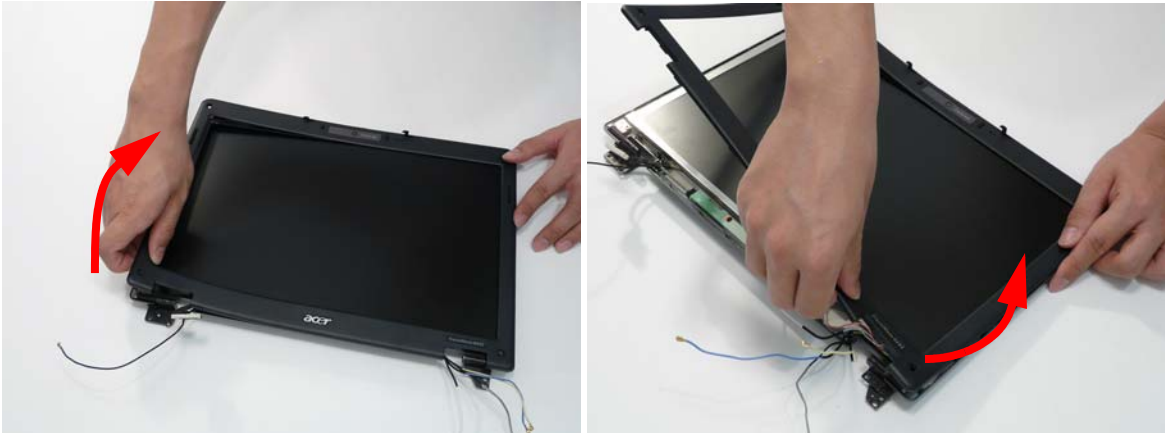

CAUTION: The LCD panel locking latches pass through the top of the bezel. Hold the lock in the open position to allow the latches to pass through the bezel when removing the top section.



Removing the Camera Module

1. Remove the LCD Bezel. See “Removing the LCD Bezel” on page 96.
2. Disconnect the Camera Module cable as shown.

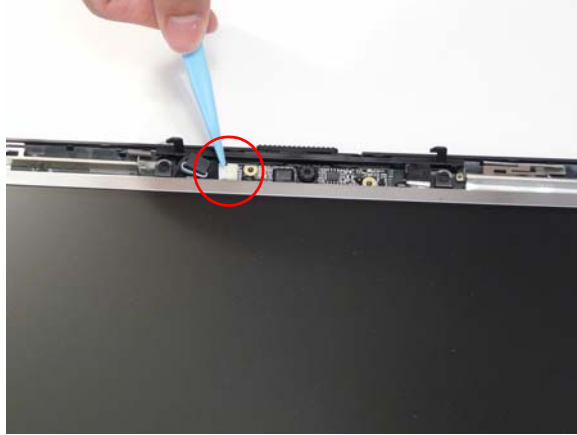

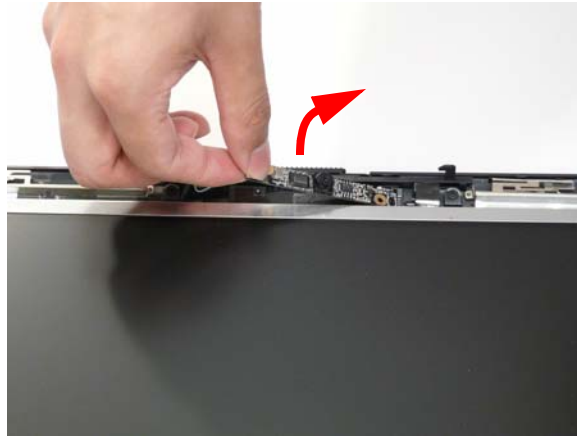

3. Lift the Camera upward to detach the adhesive strip and remove the module from the LCD assembly.

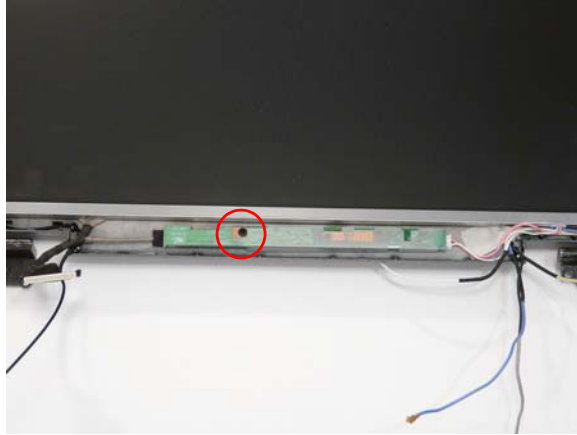

Removing the Inverter Board

1. Remove the LCD Bezel. See "Removing the LCD Bezel" on page 96.
2. Remove the single securing screw from the Inverter board as shown.



Step	Size	Quantity	Screw Type
Inverter Board	M2*3	1	

3. Lift the Inverter clear of the LCD module and remove the left and right inverter cables from the module.

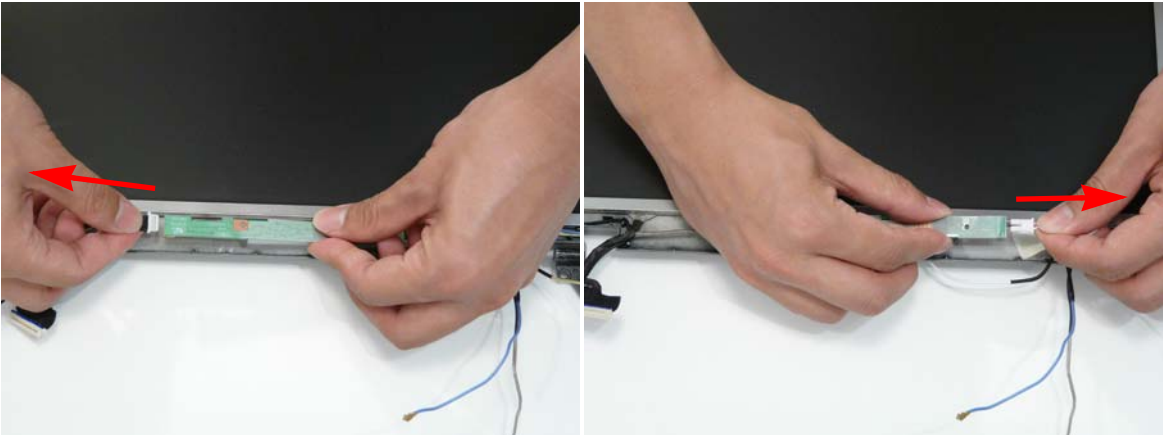

Removing the LCD Panel

1. See "Removing the Inverter Board" on page 98.
2. Remove the two securing screws from the panel as shown.



Step	Size	Quantity	Screw Type
LCD Panel	M2*3	2	

3. Lift the LCD Panel clear of the LCD Module, taking care to ensure the cables are free from the back cover.



Removing the LCD Brackets and FPC Cable

1. Remove the LCD panel. See “Removing the LCD Panel” on page 99.
2. Turn the LCD panel over to expose the rear. Detach the camera cable from the LCD panel as shown.



3. Lift the adhesive strip as shown, and disconnect the LCD cable interface.

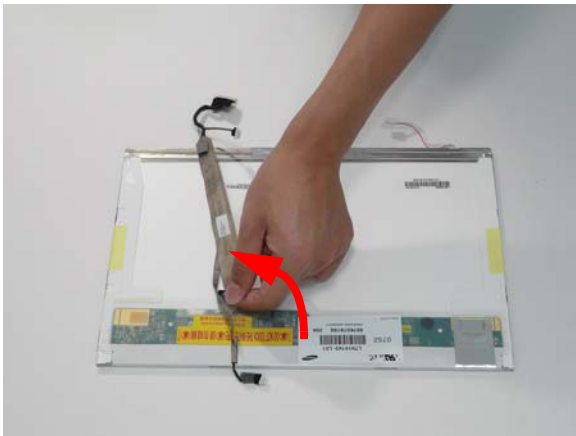

4. Grip the FPC cable and lift upward to detach the adhesive pads.
5. Remove the eight securing screws (four on each side) from the LCD Panel brackets. Remove the LCD brackets by pulling them away from the LCD Panel.



Step	Size	Quantity	Screw Type
LCD Brackets	M2*4	8	

Removing the Antennas

1. See "Removing the Battery Pack" on page 50.
2. See "Removing the 3G Module" on page 56.
3. See "Removing the WLAN Module" on page 71.
4. See "Removing the LCD Panel" on page 99.
5. Remove the strips holding the antenna cables in place. Ensure the cables are free from obstructions.

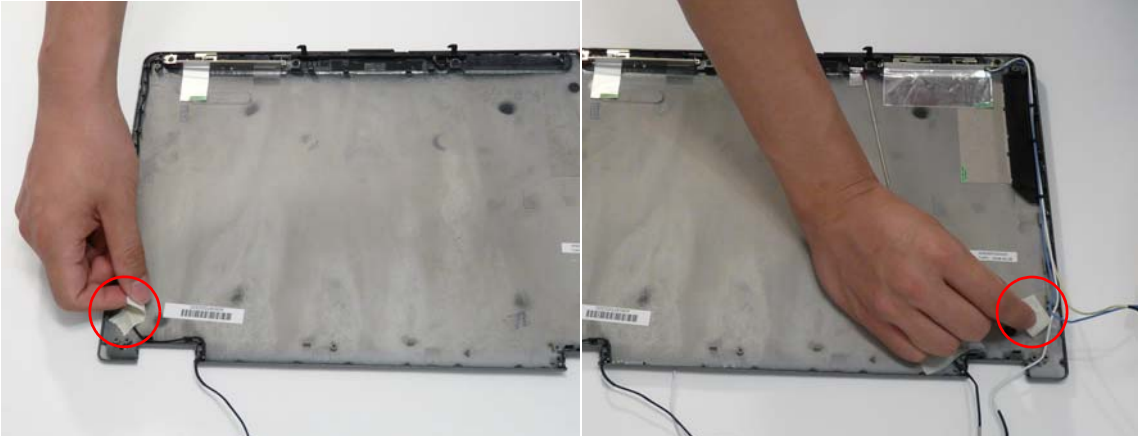

6. Remove the left side antenna cable from the cable channel.

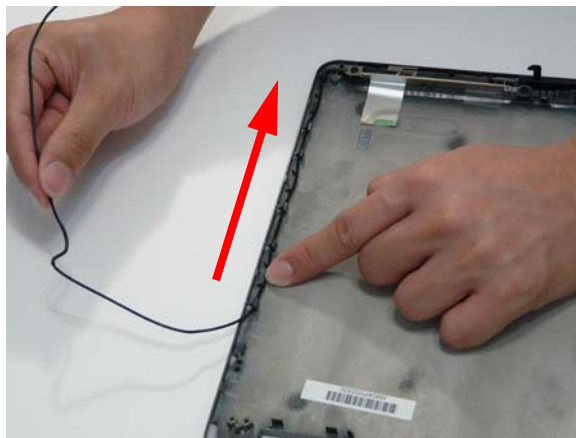

7. Detach the adhesive strips holding the antenna in place and remove the single securing screw.

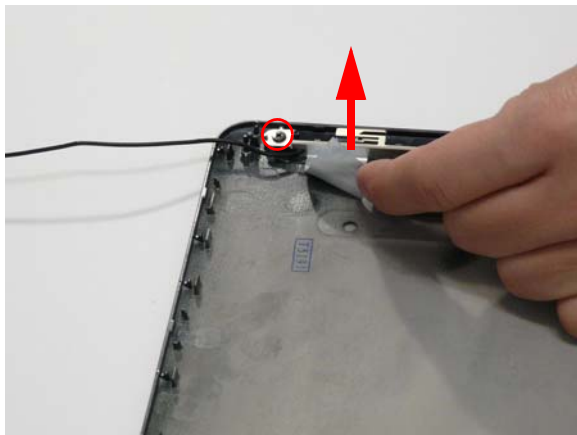

Step	Size	Quantity	Screw Type
WLAN Antenna	M2*3	1	

8. Lift the antenna away from the LCD module.

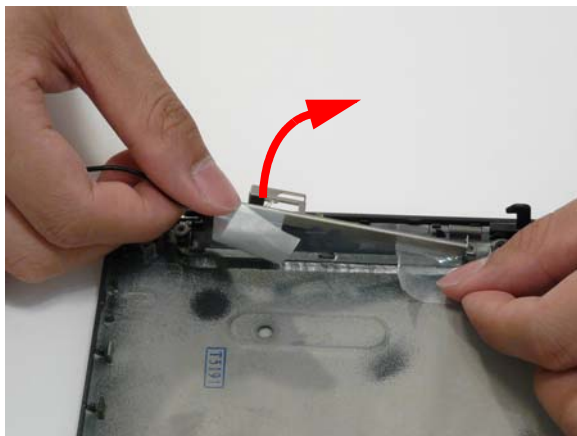

9. Remove the right side antenna cable from the cable channel.



10. Detach the adhesive strip holding the antenna in place.

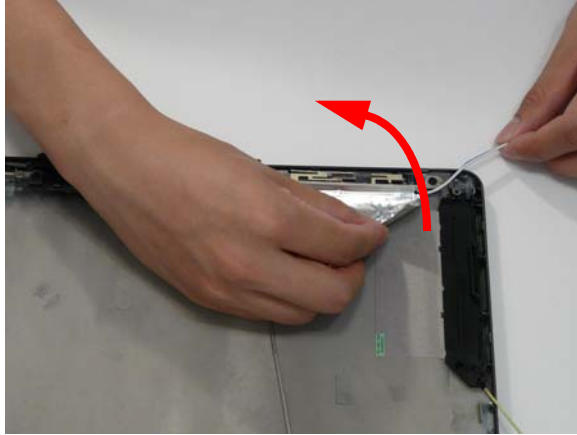

11. Remove the single securing screw from the antenna.

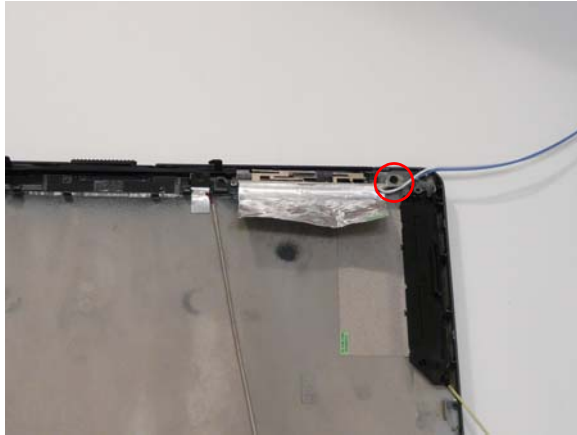

Step	Size	Quantity	Screw Type
WLAN Antenna	M2*3	1	

12. Remove the antenna from the LCD module.



13. Remove the 3G antenna cable from the cable channel.

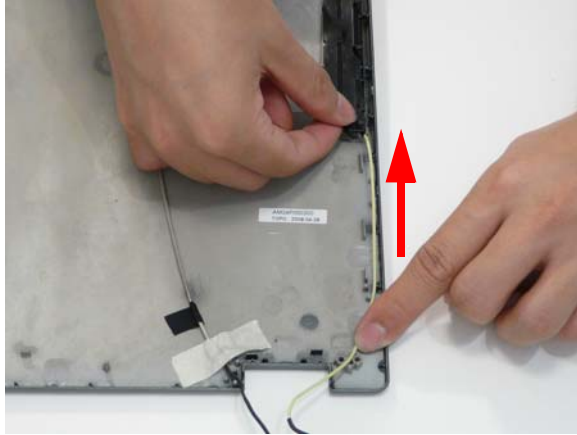

14. Remove the two securing screws from the 3G antenna as shown.



Step	Size	Quantity	Screw Type
3G Antenna	M2*3	2	

15. Remove the 3G antenna from the LCD module as shown, and gently remove the adhesive strip.

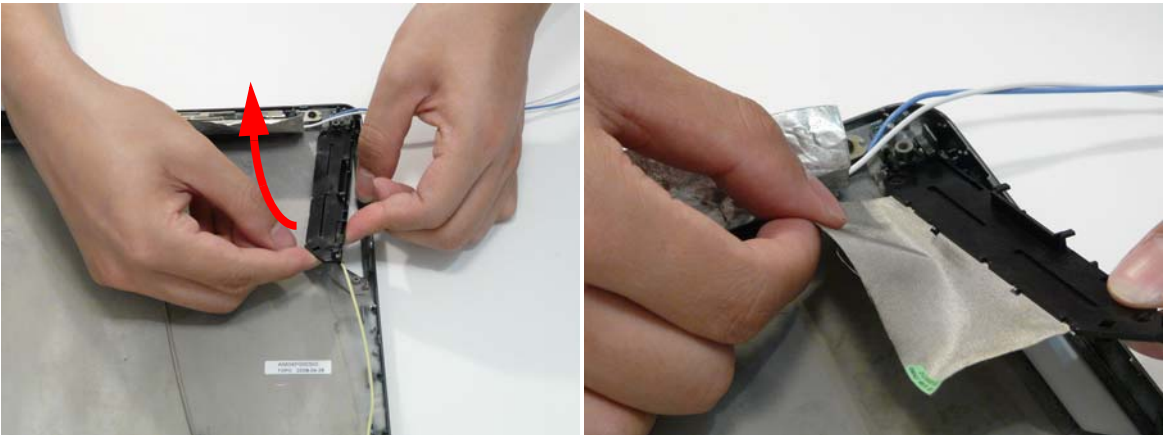

Removing the MIC Module

1. Remove the LCD panel. See “Removing the LCD Panel” on page 99.
2. Remove the strip holding the MIC Module cable in place. Ensure the cable is free from obstructions.



3. Remove the MIC cable and Module from the LCD module.

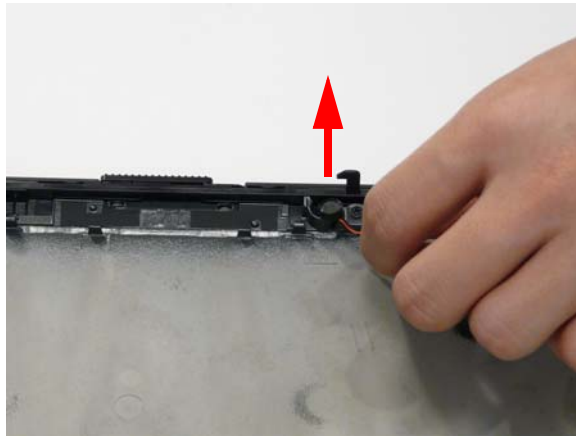

LCD Module Reassembly Procedure

Replacing the LCD Panel

1. Align the LCD brackets with the eight screw holes (four on each side) on the LCD Panel as shown.



2. Secure the LCD brackets to the LCD panel.
3. Turn the panel over. Insert the LCD Panel cable into the LCD Panel as shown. Secure the cable by pressing down on the securing strip.



4. Replace the camera cable and press down to engage the adhesive strip.

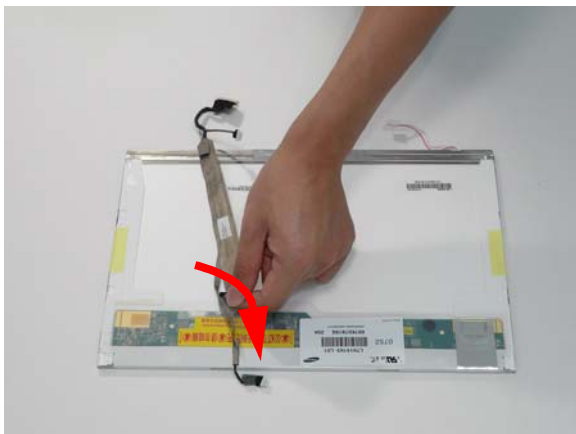

5. Replace the MIC as shown and secure the cable with the adhesive strips.

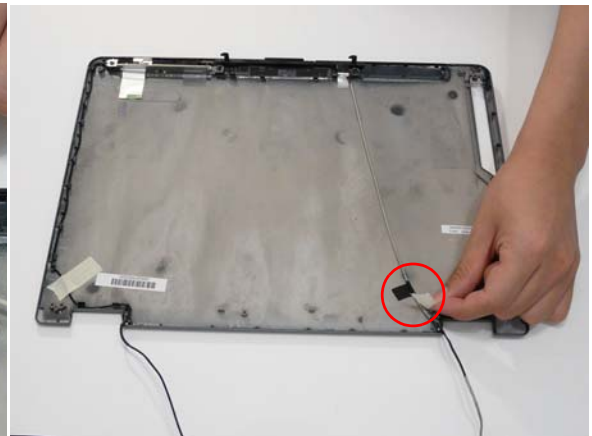
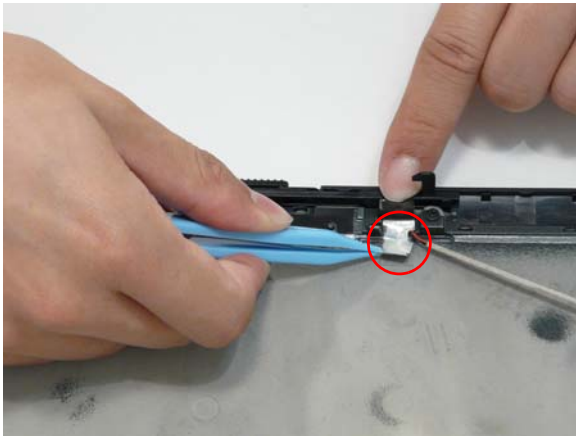
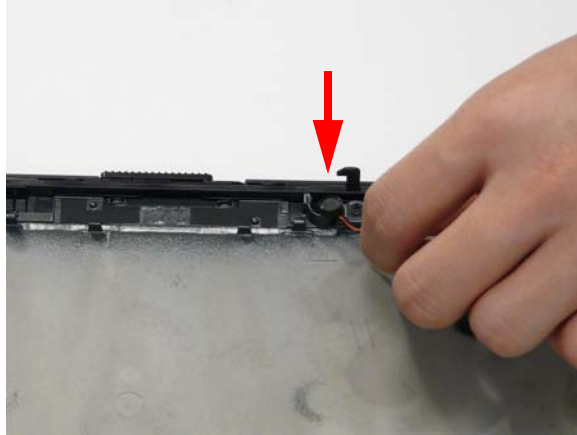

6. Align the 3G module and adhesive strip with the LCD module.



7. Replace the 3G antenna module and secure it in place with the adhesive strip and two screws provided.

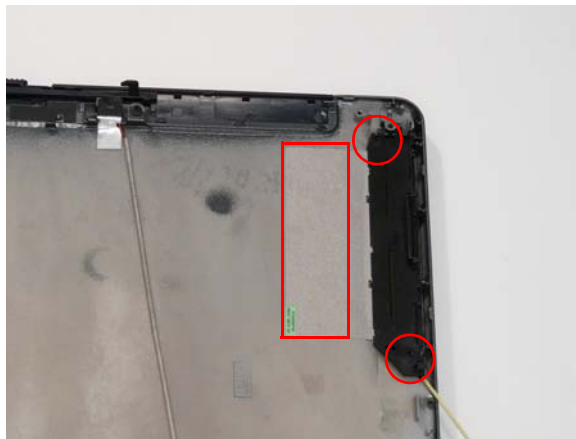

8. Replace the cable in the cable channel as shown.

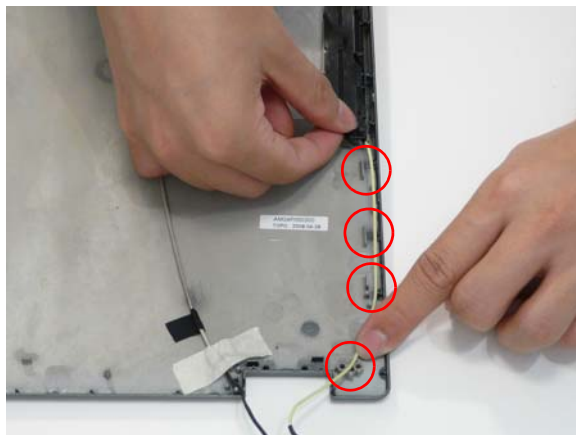

9. Replace the right side WLAN antenna module (left side first) and secure it in place with the screw.
NOTE: Ensure that the locating pin is correctly aligned during installation.

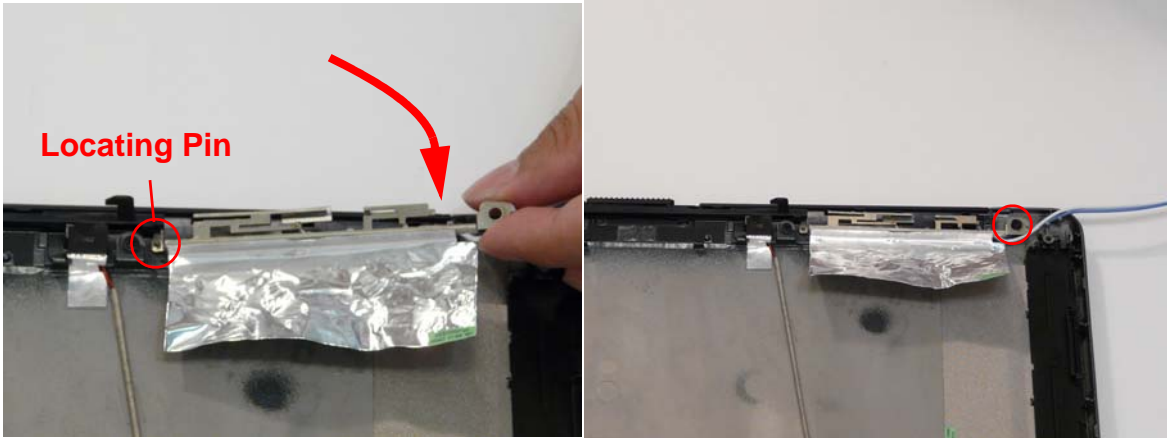

10. Press the adhesive strip down to secure the antenna.

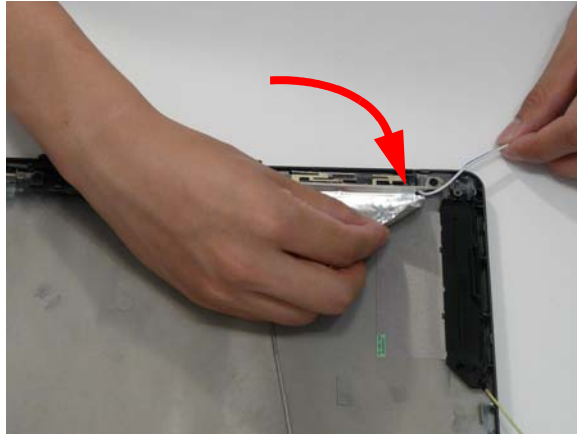

11. Run the antenna cables over the 3G antenna and down the cable channel using all the available cable clips. Replace the adhesive tape as shown.

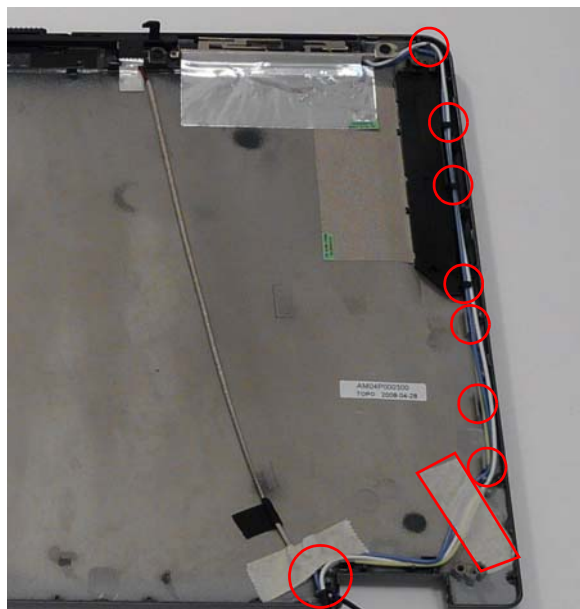

12. Replace the left side WLAN antenna module (right side first) and secure it in place with the screw and adhesive strip.

NOTE: Ensure that the locating pin is correctly aligned during installation.

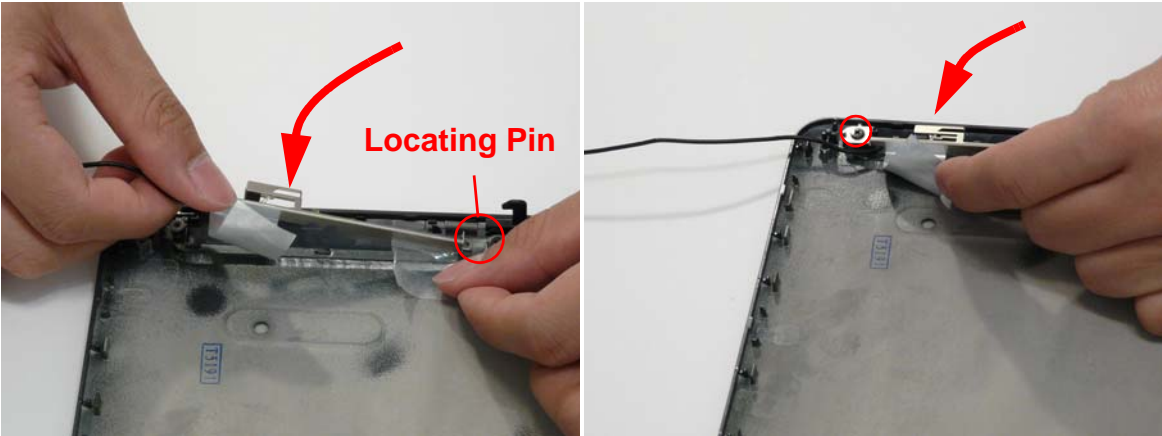

13. Run the antenna cable down the cable channel using all the available cable clips. Replace the adhesive tape as shown

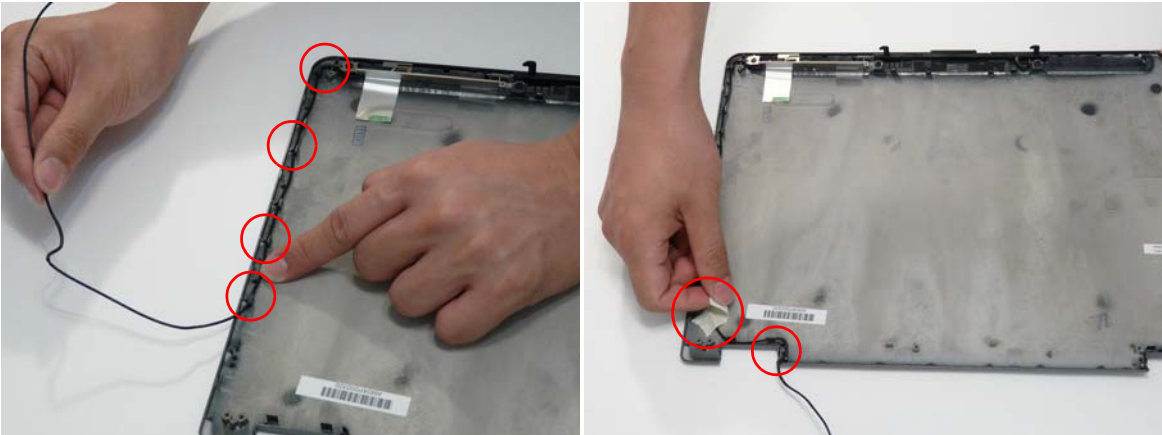

14. Align the hinges with the LCD back cover and replace the LCD panel. Replace the two securing screws.

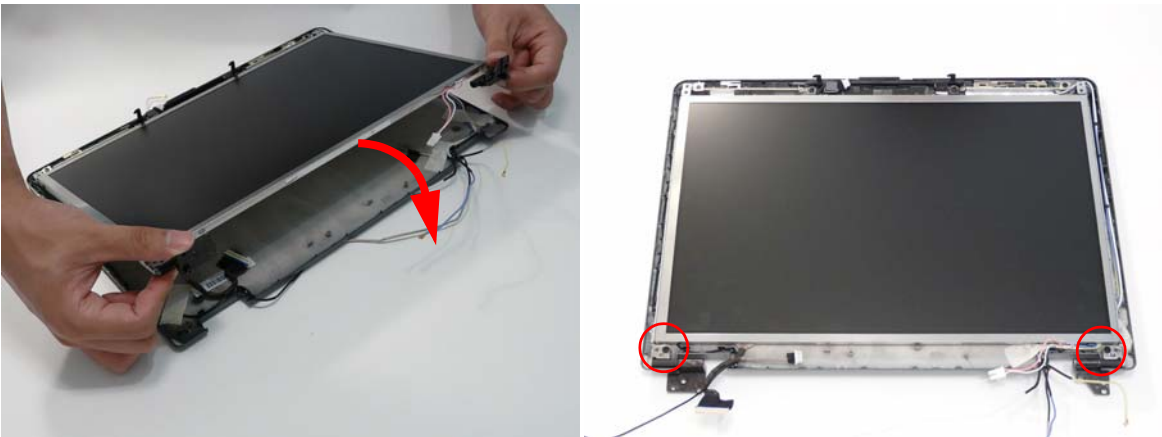

15. Replace the Camera Module in the LCD cover.



16. Connect the Camera Module cable as shown.

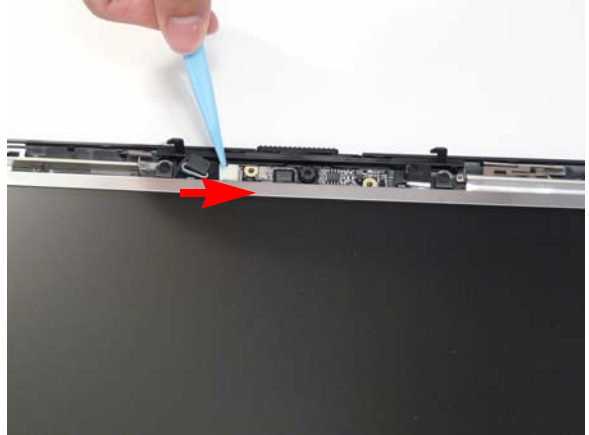

17. Connect the right Inverter board cable as shown.



18. Connect the left Inverter board cable as shown.

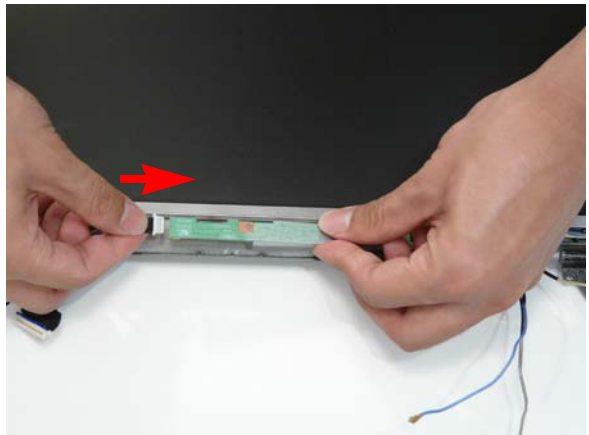

19. Replace the single securing screw as shown.

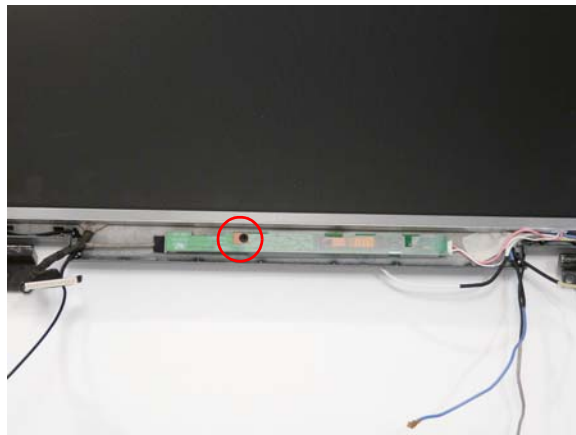

NOTE: Tuck the cables in securely to prevent damage to the cables or module.

Replacing the LCD Bezel

1. Ensure that the cables are correctly situated and that no trapping will occur when the bezel is replaced.



2. Hold the locking latch in the open position and place the LCD bezel over the latches as shown.



3. Press the bezel down around the edges to snap it into place.

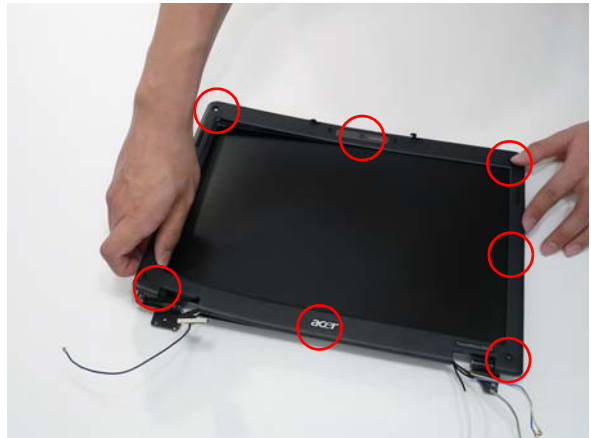

4. Replace the four securing screws and the four screw caps on the LCD module.



Main Module Reassembly Procedure

Replacing the CPU

1. Carefully turn the mainboard upside down (CPU side up), and insert the CPU into the CPU bracket as shown.
2. Using a flat-tipped screw driver, lock the CPU in to the socket as shown.

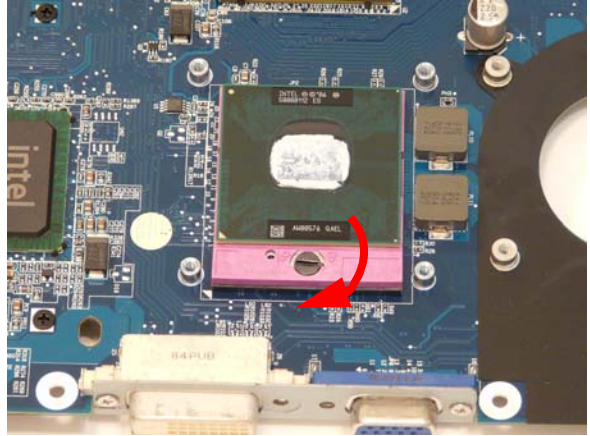
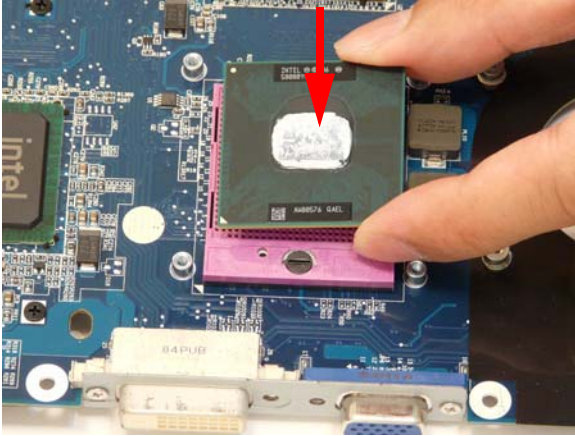

Replacing the CPU Fan

1. Place the CPU Fan on the mainboard as shown.
2. Replace the three securing screws as shown.

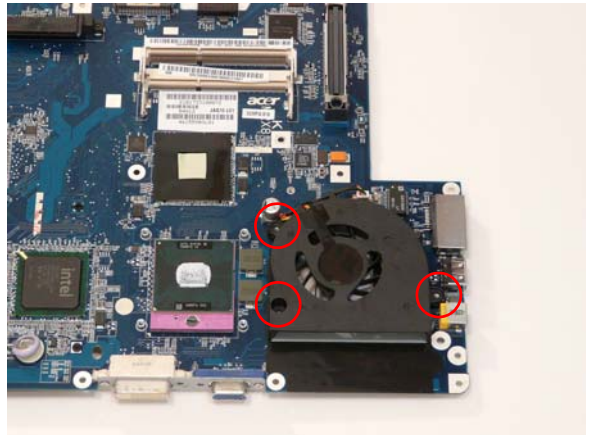
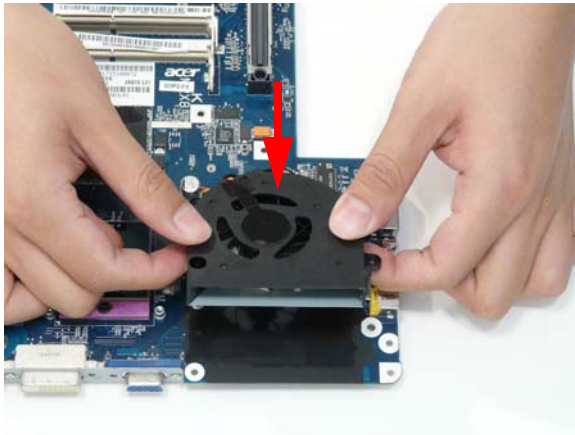

3. Reconnect the CPU Fan cable as shown.

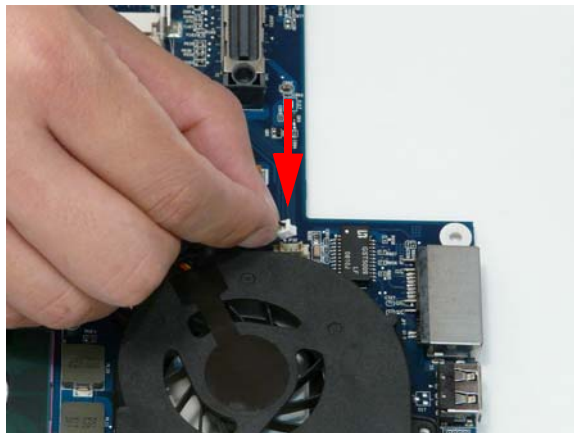

Replacing the Thermal Module

1. Align and place the Thermal Module on the mainboard as shown.
2. Replace the four securing screws (in numerical order from screw 1 to screw 4) in the Thermal Module.

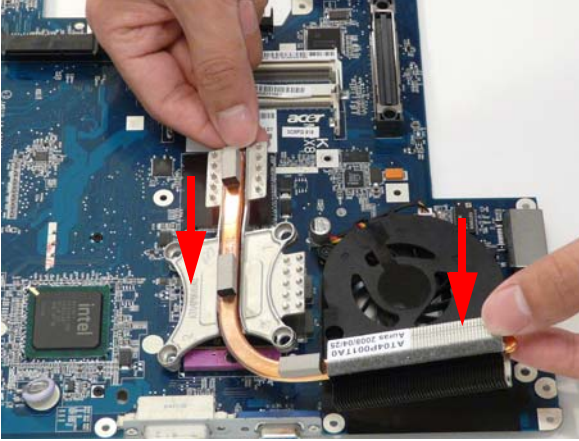

Replacing the USB Board

1. Place the USB Board in the chassis as shown.
2. Replace the two securing screws.

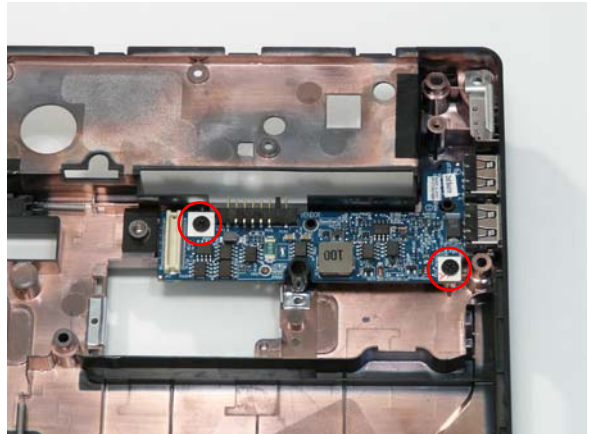

Replacing the Mainboard

1. Place the mainboard into the chassis, front edge first, ensuring that the I/O ports pass through the casing.

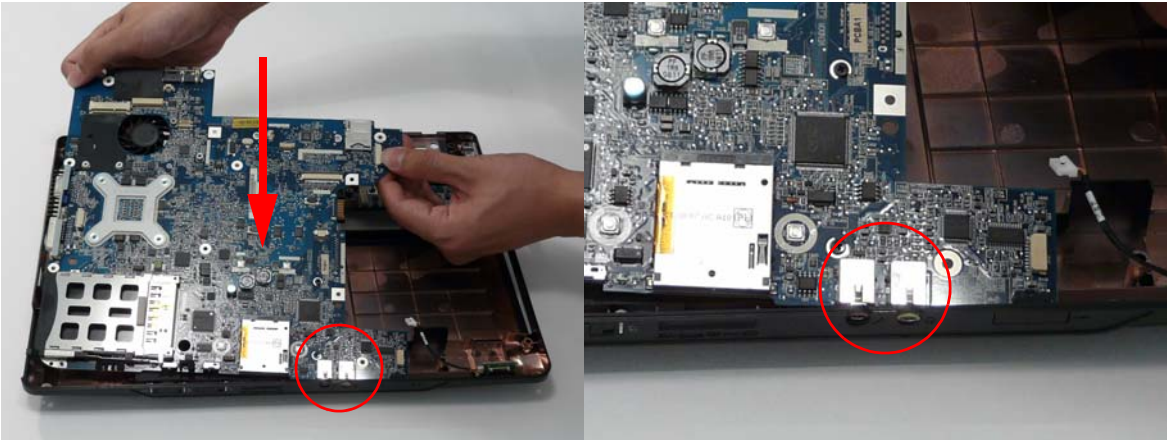

2. Pull out the left side of the casing to accommodate the left I/O ports as shown.
3. Reconnect the mainboard and USB Board by pinching them together in the area shown.



4. Replace the single securing screw.



NOTE: Make sure the I/O ports are positioned correctly through the lower cover, and the screw sockets are visible through the mainboard.

Replacing the Modem Module

1. Place the Modem module on the mainboard, ensuring the connection on the base of the module is well seated.



2. Replace the two securing screws.

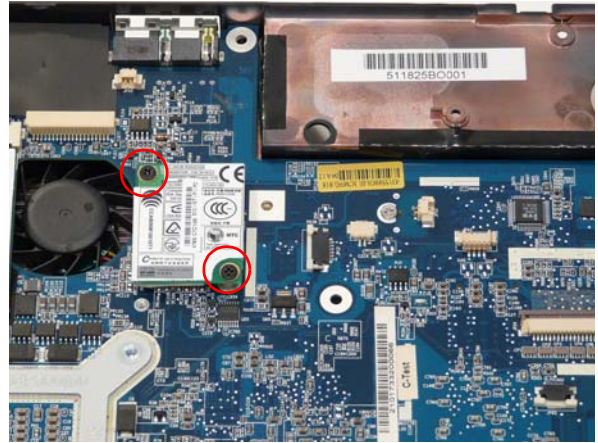

3. Reconnect the modem cable to the module.



4. Press down on the adhesive pad to reattach the cable to the mainboard.

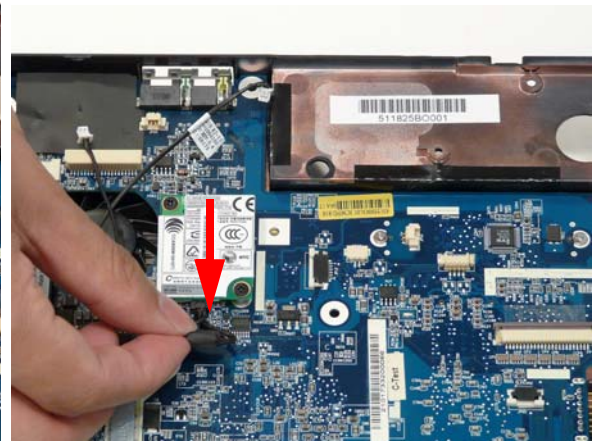

5. Reconnect the RJ-11 cable.



6. Route the remaining cable around the edge of the Modem module, as shown, and reconnect it to the mainboard.



Replacing the Bluetooth Board

1. Reconnect the cable to the Bluetooth module.

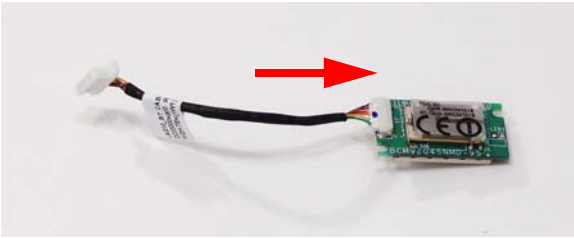

NOTE: The cable connector is right way up when the blue spot is visible.

2. Replace the Bluetooth module as shown.

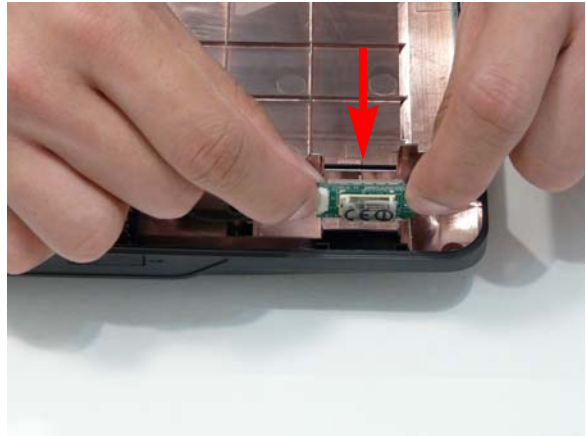

3. Reconnect the Bluetooth cable to the mainboard as shown.

NOTE: The cable connector is right way up when the blue spot is visible.

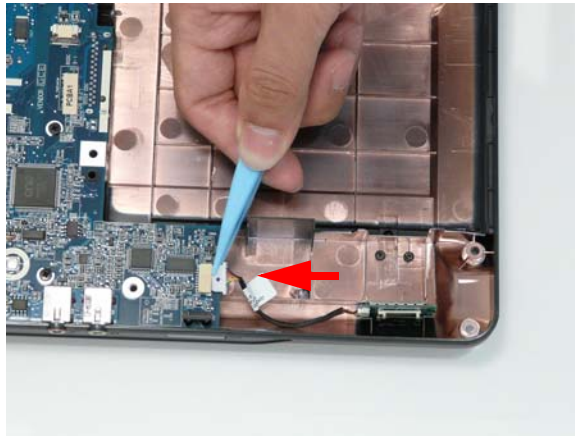

Replacing the Speaker Modules

1. Replace the left and right Speaker modules in the Upper Case.

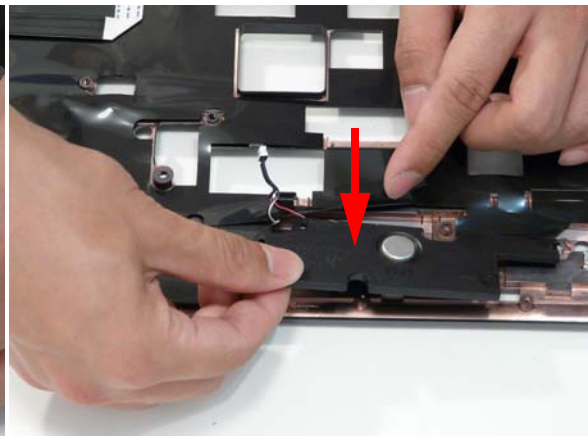
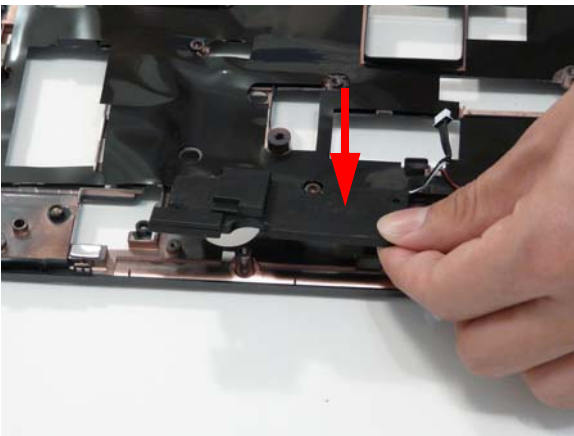

-
2. Lift the mylar covering and slide the speaker cable underneath into the cable channel.
 3. Replace the mylar and ensure the speaker cable is positioned as shown.

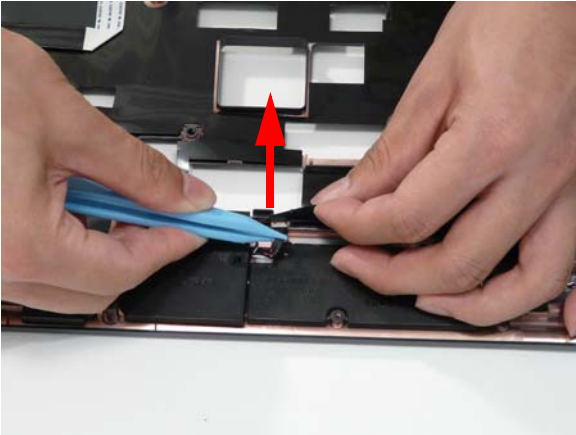

4. Replace the four securing screws as shown (two per module).

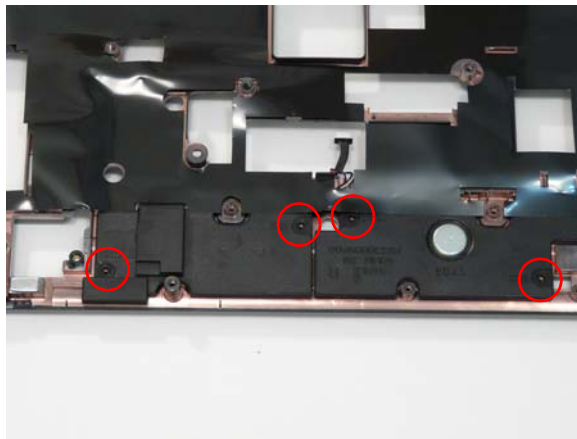

Replacing the TouchPad Bracket

IMPORTANT:The Touch Pad cannot be removed individually. To replace the Touch Pad, replace the entire Upper Cover.

1. Insert the bracket into the upper cover, top edge first, to engage the securing clip.
2. Rotate the bracket down into the upper cover as shown, ensuring that the four pins are located correctly.

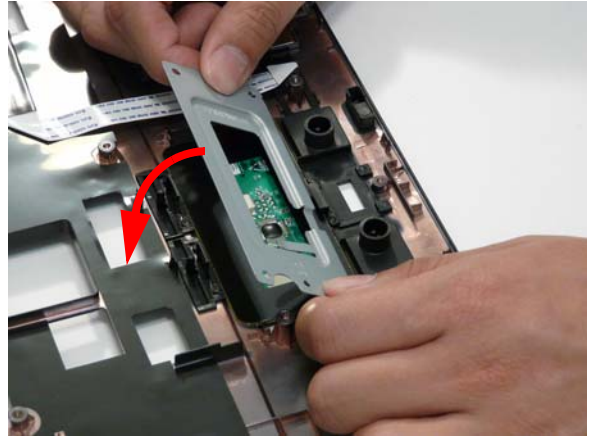
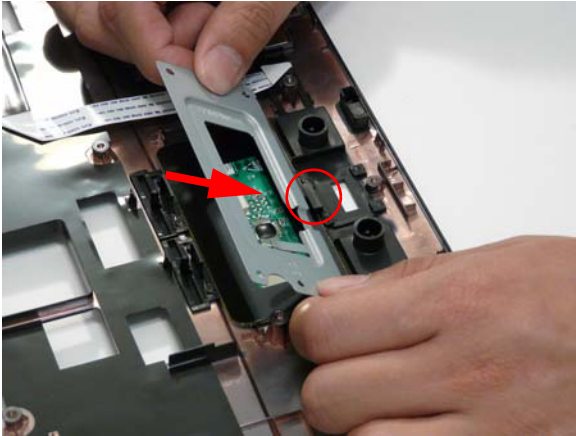

3. Replace the TouchPad FFC cable and lock it in place with the cable latch.

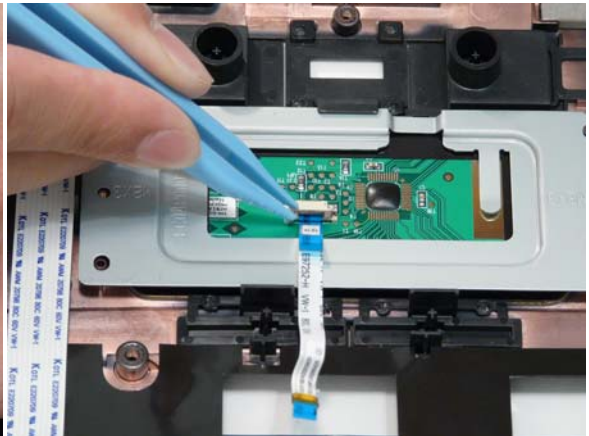
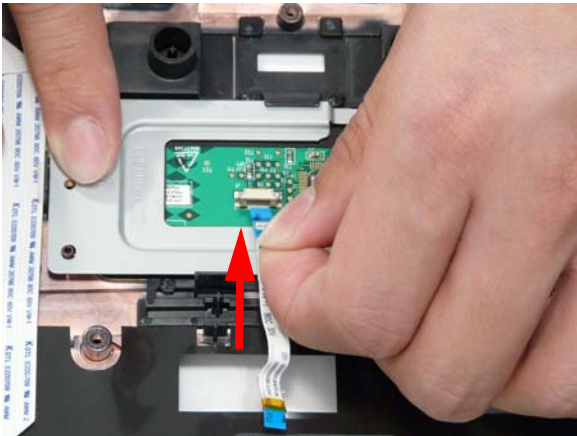

4. Replace the two securing screws.



Replacing the Finger Print Reader

1. Replace the Finger Print Reader board in the upper cover.
2. Press down on the adhesive pads to secure the module in place.

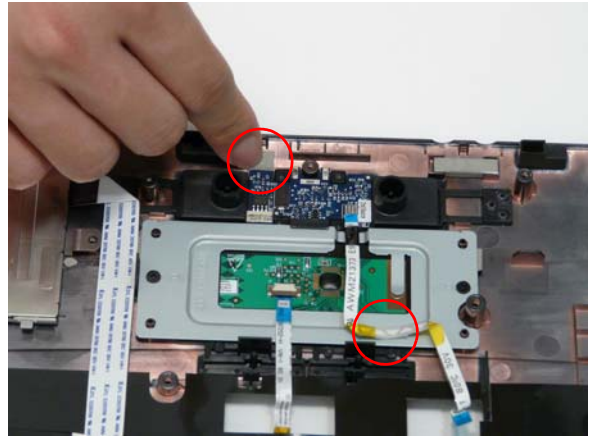
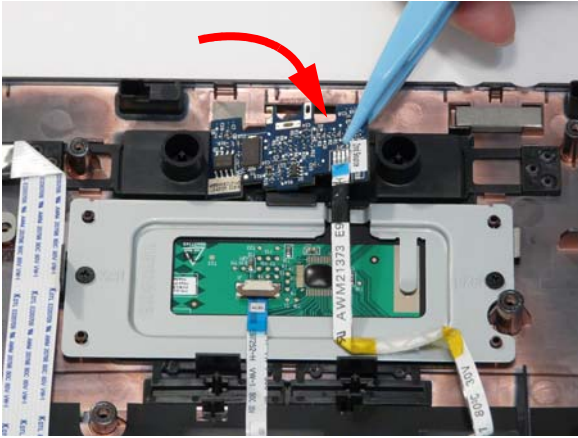

3. Replace the bracket as shown.

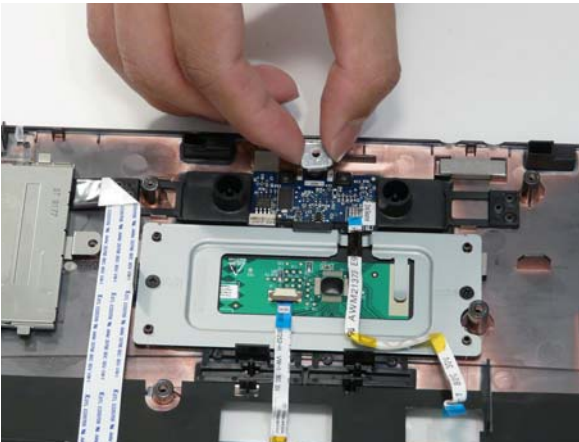

4. Replace the single securing screw.

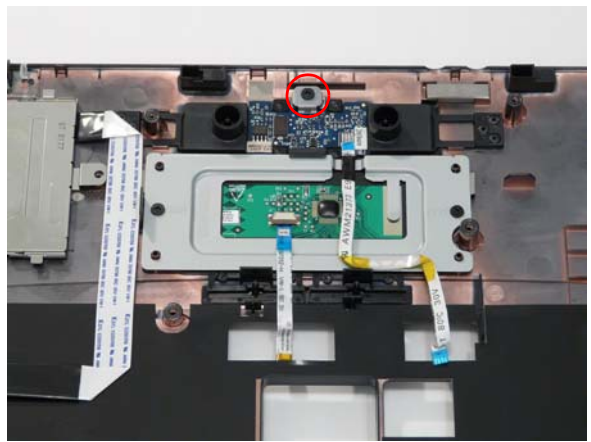

Replacing the Card Reader Module

1. Replace the module in the upper case as shown.
2. Slide the module in the direction shown to engage the securing clips.

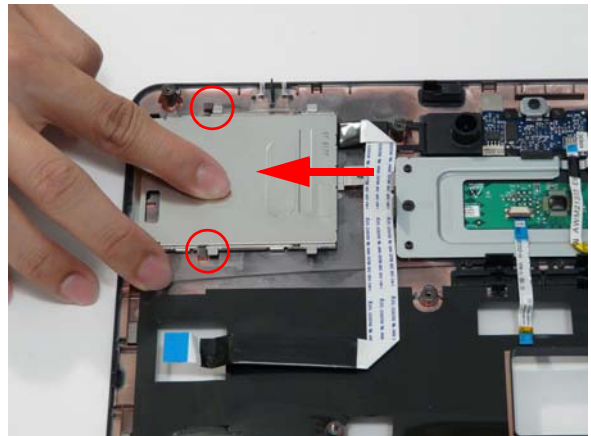
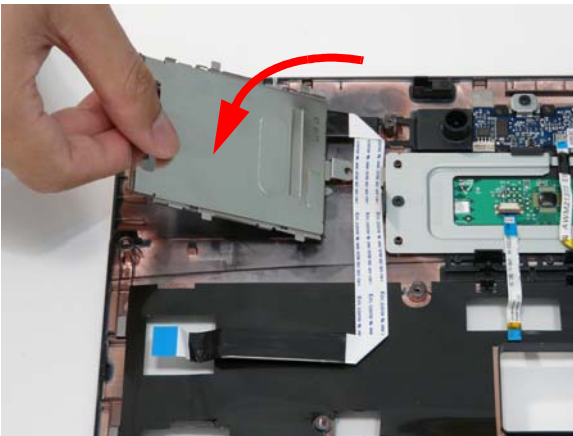

3. Replace the single securing screw.



4. Press down on the adhesive strips to secure the FFC in place.

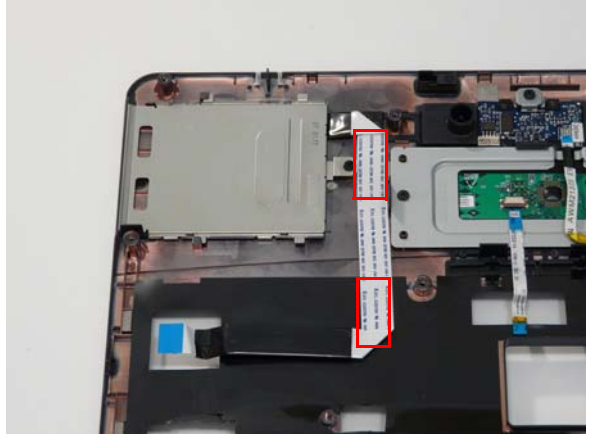

Replacing the Upper Cover

1. Replace the Upper Cover as shown, front edge first.



2. Rotate the cover downward and press around the edges, taking care not to force the cover closed.



3. Replace the single securing screw.



4. Connect the four cables on the mainboard as shown.

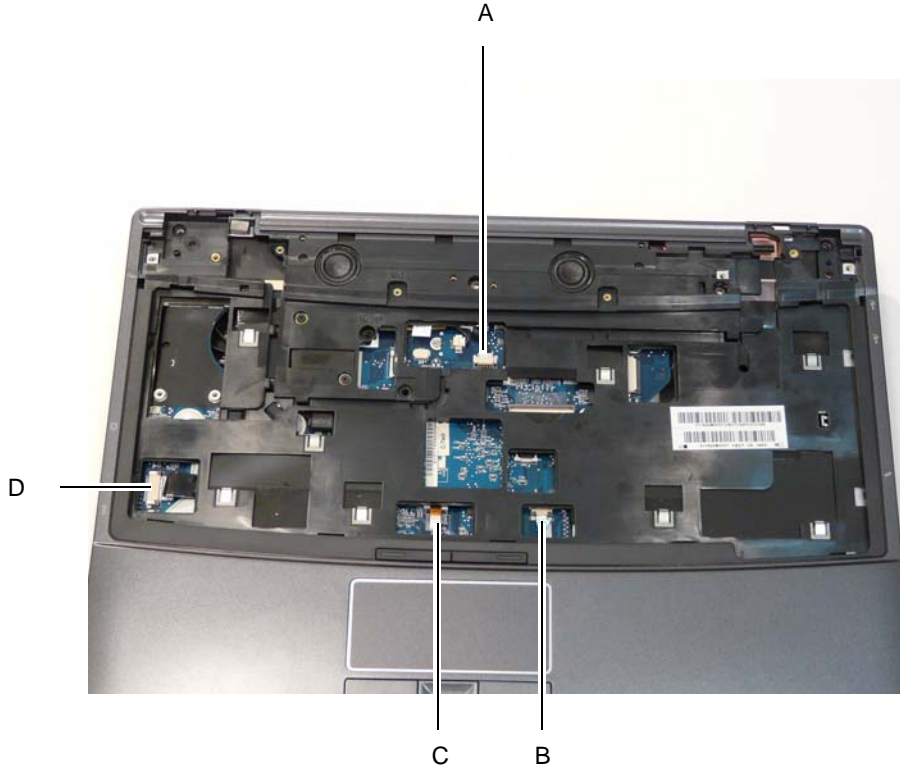

Connect A as shown.

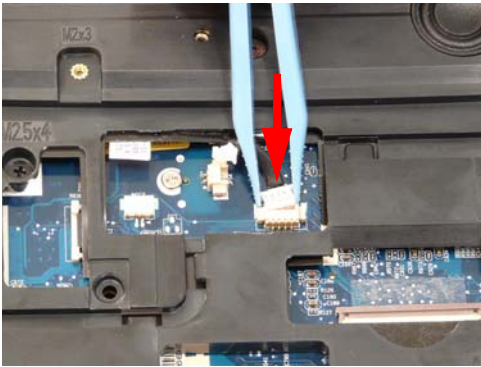

Connect B as shown and replace the securing latch.

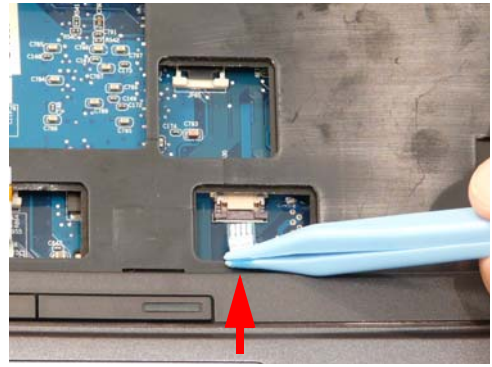

Connect C as shown and replace the securing latch. Connect D as shown and replace the securing latch.

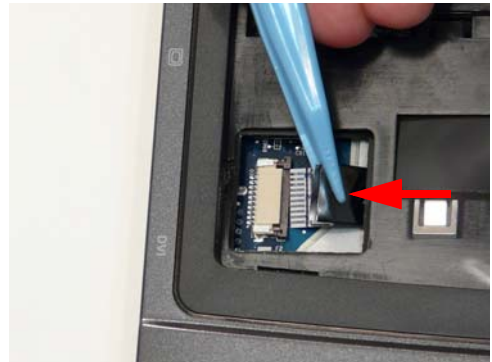
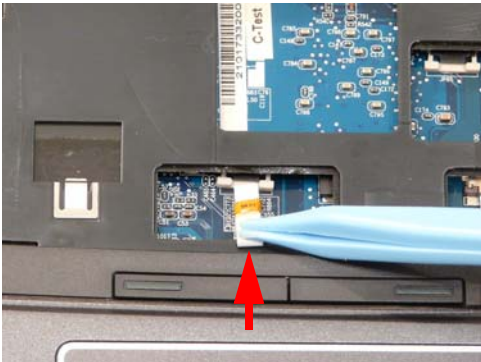

5. Turn the computer over. Replace the sixteen screws on the bottom panel.

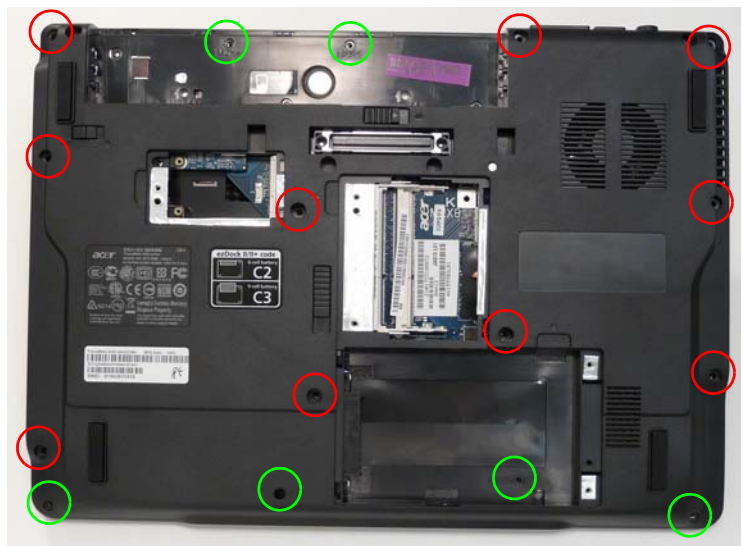

Replacing the LCD Module

1. Carefully align the LCD module over the hinge sockets and lower the module into the chassis.

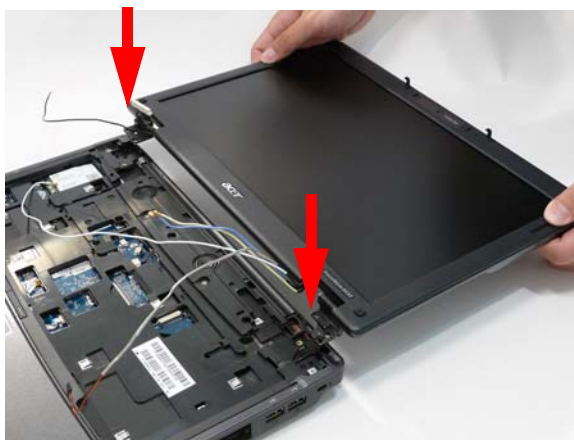

2. Replace the four securing screws (two on each side) securing the LCD module.



3. Connect the LCD cable as shown.

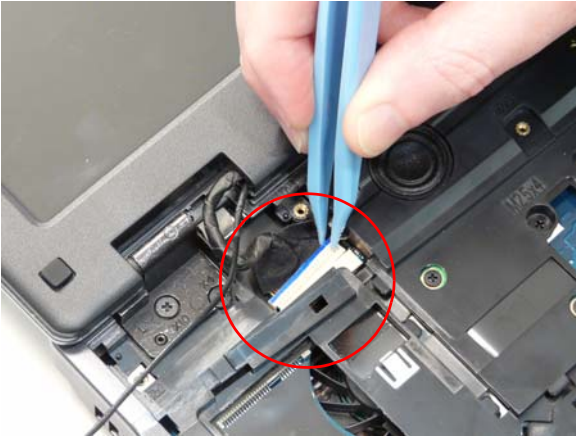

4. Turn the computer over and replace the two securing screws on the bottom of the chassis.



Replacing the WLAN Module

1. Insert the WLAN board into the mainboard socket as shown.



2. Replace the two securing screws.



Replacing the WLAN Antenna and MIC Cables

1. Replace all the LCD cables (WLAN, 3G, and MIC) in the right side housing well as shown.
2. Run the WLAN cable (white) along the cable channel using all available cable clips as shown.



3. Run the MIC cable along the cable channel as shown, using all the available cable clips.
4. Reconnect the MIC cable to the mainboard.

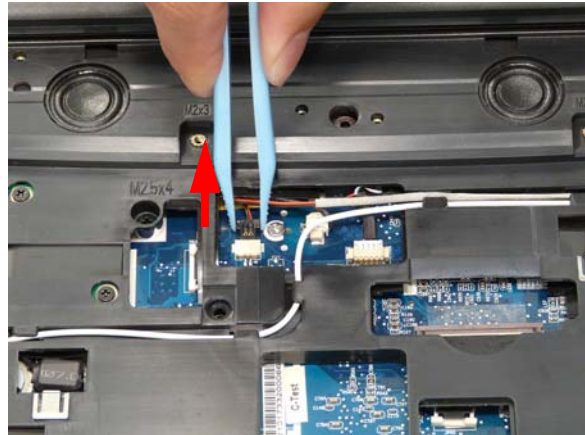
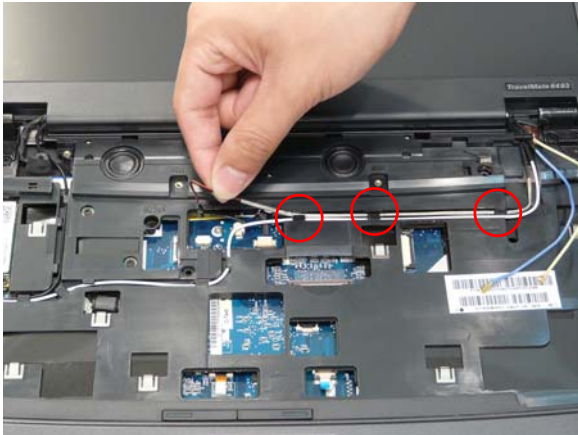

5. Run the WLAN cable (black) along the cable channel using all available cable clips as shown.
6. Reconnect the WLAN cables to the WLAN module as shown.

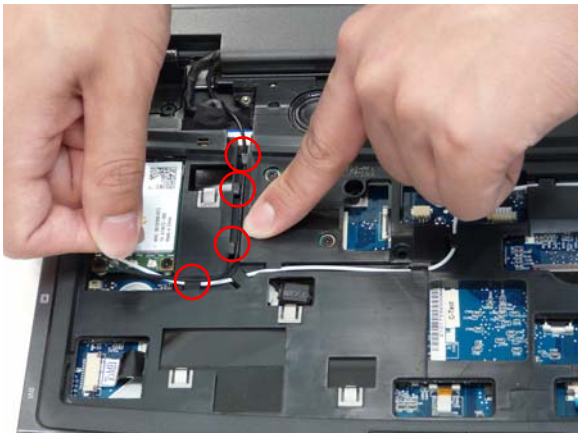

NOTE: The black cable terminates on the right and the white cable on the left.

Replacing the 3G Antenna Cable

1. Insert the 3G cables through the chassis.
2. Push the cables all the way through and place them in the cable channel.



3. Replace the adhesive tape to hold the cables in place.

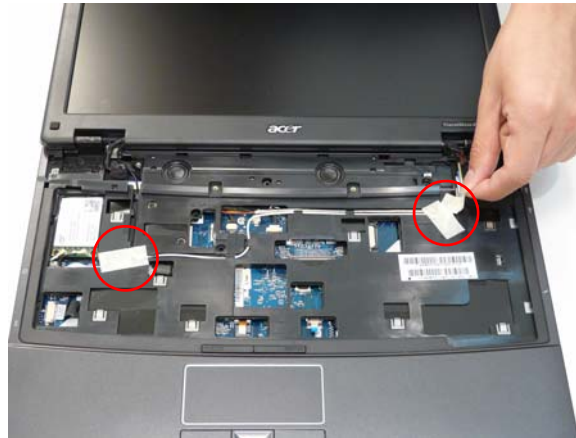

Replacing the Power Board

1. Place the Power Board in the chassis as shown.
2. Replace the two securing screws.



3. Press down on the FFC to attach the adhesive strip to the chassis.
4. Connect the FFC and close the locking latch.



Replacing the eKey Board

1. Place the eKey Board in the chassis as shown.
2. Press down on the FFC to attach the adhesive strip to the chassis.



3. Replace the two securing screws.
4. Connect the FFC and close the locking latch.



Replacing the Keyboard

1. Turn the keyboard over and place it on the chassis. Reconnect the Fine Track FFC and close the locking latch.
2. Reconnect the Keyboard FFC and close the locking latch.

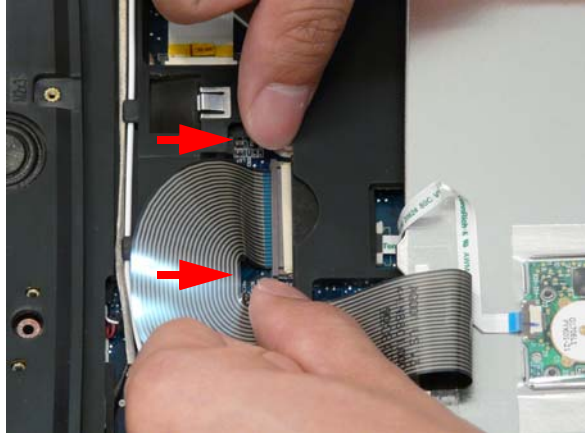
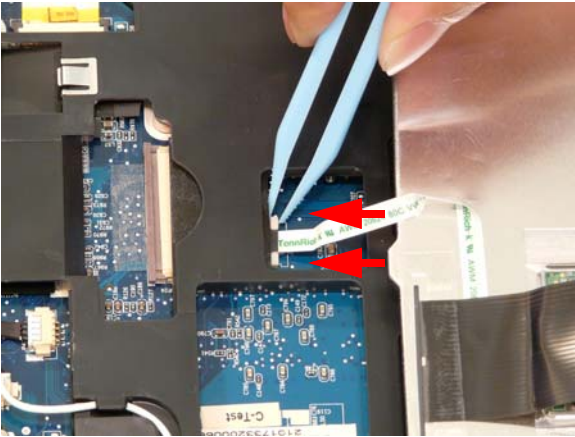

3. Turn the Keyboard over and place it in the chassis as shown. Push down in the areas indicated to locate the keyboard correctly.



4. Replace the two securing screws.
5. Turn the computer over and replace the single securing screw in the memory bay.



Replacing the Switch Cover

IMPORTANT:The LCD module must be fully open in the horizontal position to replace the switch cover.

1. Insert the left side of the Switch Cover as shown .
2. Lower the cover into place and press down from left to right to secure it.



3. Turn the computer over and replace the two securing screws.



Replacing the ODD Module

1. Align the ODD bezel with the ODD module and push it into place.
2. Replace the ODD board on the ODD module by reconnecting the interface as shown

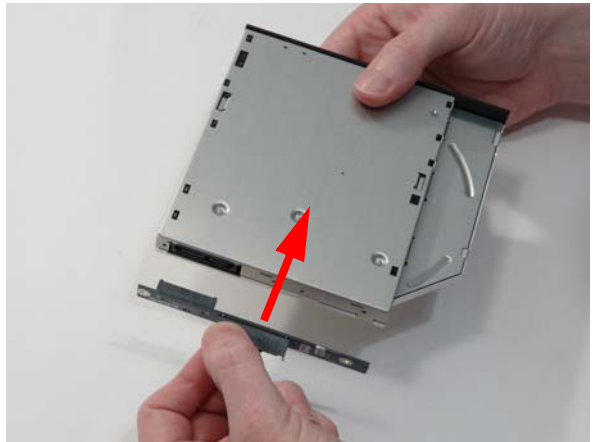
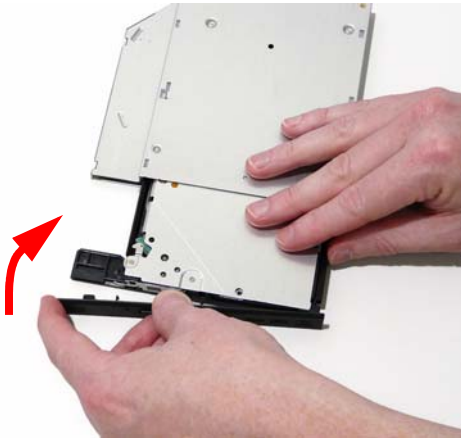

3. Replace the ODD bracket and secure it in place with the four screws.

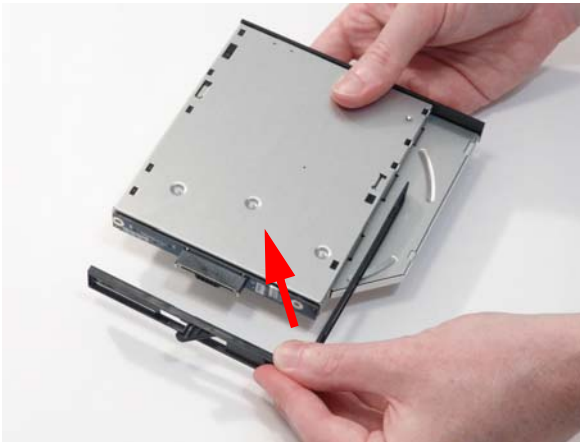

4. Slide the ODD module into the chassis until a click is heard and the module is flush with the casing.



Replacing the Hard Disk Drive Module

1. Place the HDD carrier on the HDD.



2. Replace the four screws to secure the carrier.



3. Replace the HDD holder over the HDD.

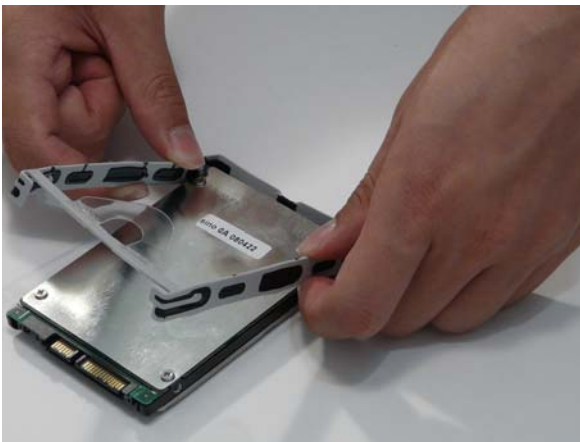

4. Insert the right side first and lower the HDD in to place. Slide the HDD left to connect the interface.



Replacing the 3G Module

1. Insert the 3G board into the 3G socket.



2. Replace the two screws to secure the module.



3. Connect the two antenna cables to the module.

NOTE: The yellow cable connects to the lower terminal and the blue cable to the upper terminal.



Replacing the DIMM Modules

NOTE: To replace DIMM Module 2, first remove DIMM Module 1. In this procedure, only DIMM Module 1 is shown.

1. Insert the DIMM Module flush with the connector and press down to lock in place.

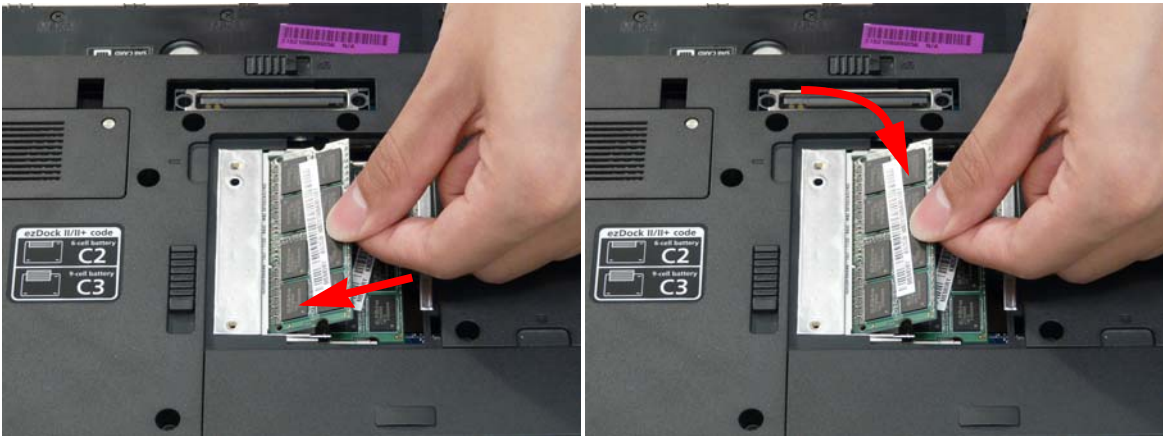

Replacing the Lower Covers

1. Replace the Memory Cover.



2. Tighten the captive screws to secure in place.

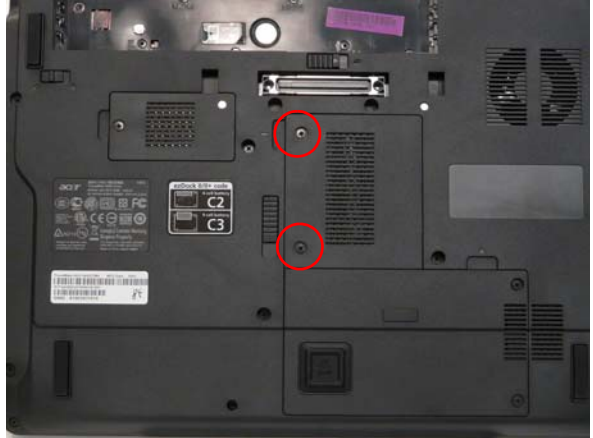

3. Replace the 3G Cover.



4. Tighten the captive screw to secure in place.

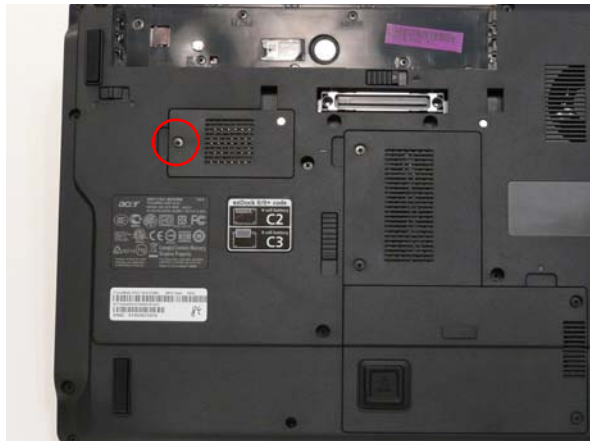

5. Replace HDD Cover.



6. Tighten the captive screws to secure in place.

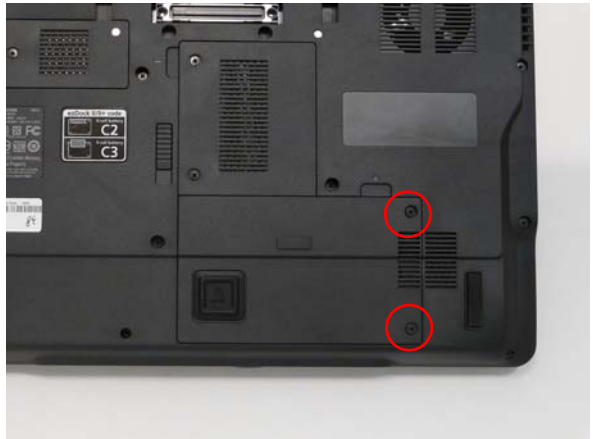

Replacing the NewCard and SD Card Dummy Trays

1. Insert the NewCard and push into the slot until flush with the chassis cover.



2. Insert the SD Card and push into the slot until flush with the chassis cover.



Replacing the Battery Pack

1. Slide and hold the battery release latch to the release position (1), then slide the battery pack into the main unit (2).

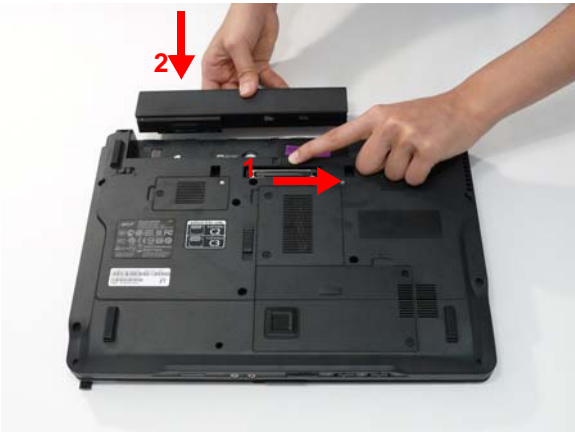

2. Slide the battery lock/unlock latch to the lock position.



Troubleshooting

Common Problems

Use the following procedure as a guide for computer problems.

NOTE: The diagnostic tests are intended to test only Acer products. Non-Acer products, prototype cards, or modified options can give false errors and invalid system responses.

1. Obtain the failing symptoms in as much detail as possible.
2. Verify the symptoms by attempting to re-create the failure by running the diagnostic test or by repeating the same operation.
3. Use the following table with the verified symptom to determine which page to go to.

Symptoms (Verified)	Go To
Power On Issue	Page 136
No Display Issue	Page 137
LCD Failure	Page 139
Internal Keyboard Failure	Page 139
Touchpad Failure	Page 140
Internal Speaker Failure	Page 140
Internal Microphone Failure	Page 142
ODD Failure	Page 144
Rightside USB Failure	Page 147
Modem Failure	Page 147
WLAN Failure	Page 148
3G Module Failure	Page 149
Acer EasyLaunch Button Failure	Page 149
Fingerprint Reader Failure	Page 150
Thermal Unit Failure	Page 150
Other Functions Failure	Page 151
Intermittent Failures	Page 152
Undetermined Failures	Page 152

4. If the Issue is still not resolved, see "Online Support Information" on page 215.

Power On Issue

If the system doesn't power on, perform the following actions one at a time to correct the problem. Do not replace a non-defective FRUs:

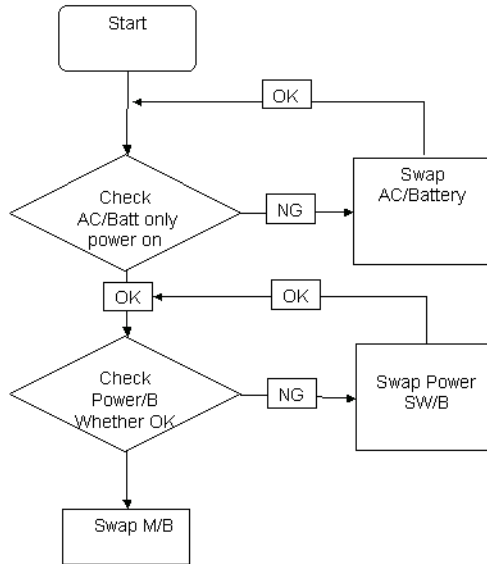

Computer Shutdown Intermittently

If the system powers off at intervals, perform the following actions one at a time to correct the problem.

1. Check the power cable is properly connected to the computer and the electrical outlet.
2. Remove any extension cables between the computer and the outlet.
3. Remove any surge protectors between the computer and the electrical outlet. Plug the computer directly into a known good electrical outlet.
4. Disconnect the power and open the casing to check the Thermal Unit (see "Thermal Unit Failure" on page 150) and fan airways are free of obstructions.
5. Remove all external and non-essential hardware connected to the computer that are not necessary to boot the computer to the failure point.
6. Remove any recently installed software.
7. If the Issue is still not resolved, see "Online Support Information" on page 215.

No Display Issue

If the **Display** doesn't work, perform the following actions one at a time to correct the problem. Do not replace a non-defective FRUs:

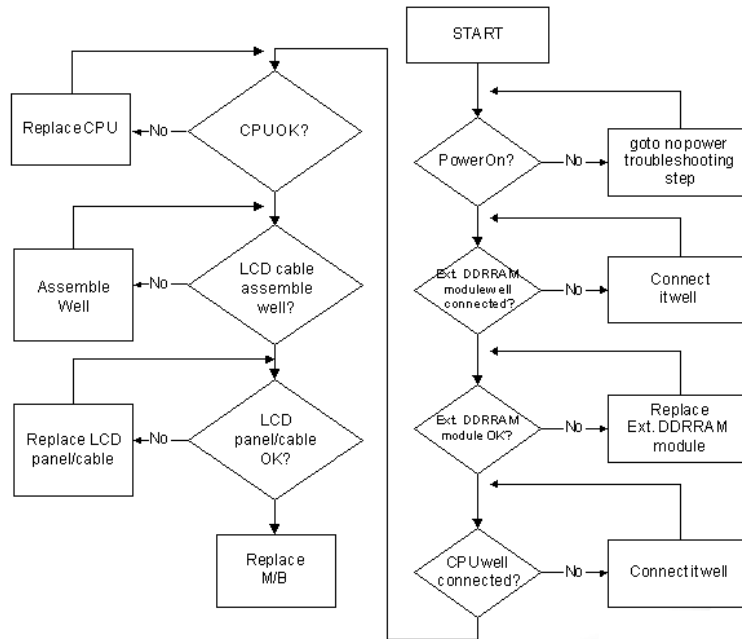

No POST or Video

If the POST or video doesn't display, perform the following actions one at a time to correct the problem.

1. Make sure that the internal display is selected. On this notebook model, switching between the internal display and the external display is done by pressing **Fn+F5**. Reference Product pages for specific model procedures.
2. Make sure the computer has power by checking at least one of the following occurs:
 - Fans start up
 - Status LEDs light up

If there is no power, see “Power On Issue” on page 136.

3. Drain any stored power by removing the power cable and battery and holding down the power button for 10 seconds. Reconnect the power and reboot the computer.
4. Connect an external monitor to the computer and switch between the internal display and the external display is by pressing **Fn+F5** (on this model).

If the POST or video appears on the external display, see “LCD Failure” on page 139.

5. Disconnect power and all external devices including port replicators or docking stations. Remove any memory cards and CD/DVD discs. Restart the computer.

If the computer boots correctly, add the devices one by one until the failure point is discovered.

6. Reseat the memory modules.
7. Remove the drives (see “Disassembly Process” on page 48).
8. If the Issue is still not resolved, see “Online Support Information” on page 215.

Abnormal Video Display

If video displays abnormally, perform the following actions one at a time to correct the problem.

1. Reboot the computer.
2. If permanent vertical/horizontal lines or dark spots display in the same location, the LCD is faulty and should be replaced. See “Disassembly Process” on page 48.
3. If extensive pixel damage is present (different colored spots in the same locations on the screen), the LCD is faulty and should be replaced. See “Disassembly Process” on page 48.
4. Adjust the brightness to its highest level. See the User Manual for instructions on adjusting settings.
NOTE: Ensure that the computer is not running on battery alone as this may reduce display brightness.
If the display is too dim at the highest brightness setting, the LCD is faulty and should be replaced. See “Disassembly Process” on page 48.
5. Check the display resolution is correctly configured:
 - a. Minimize or close all Windows.
 - b. If display size is only abnormal in an application, check the view settings and control/mouse wheel zoom feature in the application.
 - c. If desktop display resolution is not normal, right-click on the desktop and select **Personalize**→ **Display Settings**.
 - d. Click and drag the Resolution slider to the desired resolution.
 - e. Click **Apply** and check the display. Readjust if necessary.
6. Roll back the video driver to the previous version if updated.
7. Remove and reinstall the video driver.
8. Check the Device Manager to determine that:
 - The device is properly installed. There are no red Xs or yellow exclamation marks.
 - There are no device conflicts.
 - No hardware is listed under Other Devices.
9. If the Issue is still not resolved, see “Online Support Information” on page 215.
10. Run the Windows Memory Diagnostic from the operating system DVD and follow the onscreen prompts.
11. If the Issue is still not resolved, see “Online Support Information” on page 215.

Random Loss of BIOS Settings

If the computer is experiencing intermittent loss of BIOS information, perform the following actions one at a time to correct the problem.

1. If the computer is more than one year old, replace the CMOS battery.
2. Run a complete virus scan using up-to-date software to ensure the computer is virus free.
3. If the computer is experiencing HDD or ODD BIOS information loss, disconnect and reconnect the power and data cables between devices.
If the BIOS settings are still lost, replace the cables.
4. If HDD information is missing from the BIOS, the drive may be defective and should be replaced.
5. Replace the Motherboard.
6. If the Issue is still not resolved, see “Online Support Information” on page 215.

LCD Failure

If the **LCD** fails, perform the following actions one at a time to correct the problem. Do not replace a non-defective FRUs:

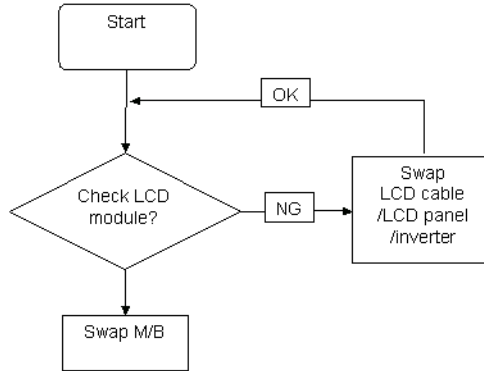

Built-In Keyboard Failure

If the built-in **Keyboard** fails, perform the following actions one at a time to correct the problem. Do not replace a non-defective FRUs:

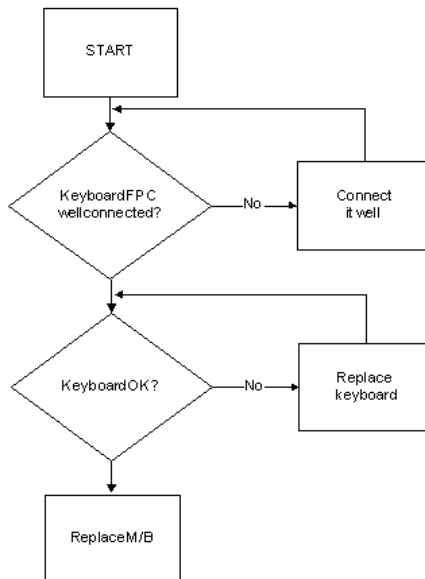

Touchpad Failure

If the **Touchpad** doesn't work, perform the following actions one at a time to correct the problem. Do not replace a non-defective FRUs:

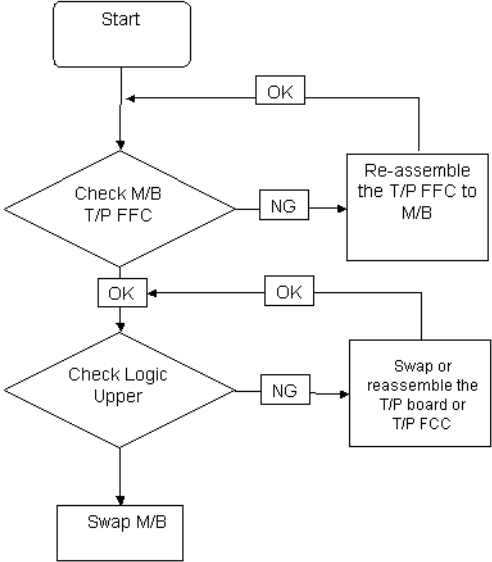

Internal Speaker Failure

If the internal **Speakers** fail, perform the following actions one at a time to correct the problem. Do not replace a non-defective FRUs:

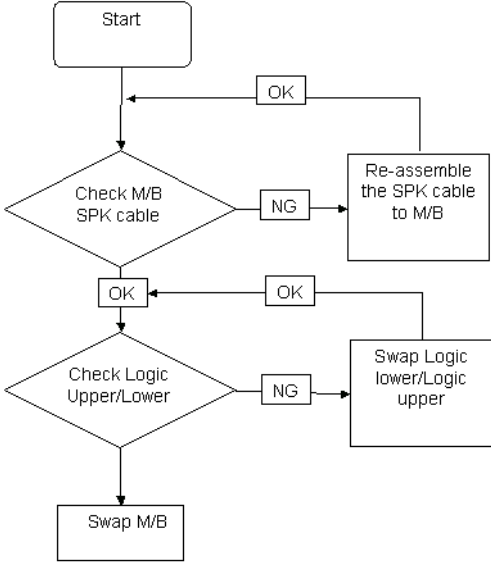

Sound Problems

If sound problems are experienced, perform the following actions one at a time to correct the problem.

1. Reboot the computer.
2. Navigate to **Start** → **Control Panel** → **System and Maintenance** → **System** → **Device Manager**. Check the Device Manager to determine that:
 - The device is properly installed.
 - There are no red Xs or yellow exclamation marks.
 - There are no device conflicts.
 - No hardware is listed under Other Devices.
3. Roll back the audio driver to the previous version, if updated recently.
4. Remove and reinstall the audio driver.
5. Ensure that all volume controls are set mid range:
 - a. Click the volume icon on the taskbar and drag the slider to 50. Ensure that the volume is not muted.
 - b. Click Mixer to verify that other audio applications are set to 50 and not muted.
6. Navigate to **Start** → **Control Panel** → **Hardware and Sound** → **Sound**. Ensure that Speakers are selected as the default audio device (green check mark).

NOTE: If Speakers does not show, right-click on the **Playback** tab and select **Show Disabled Devices** (clear by default).
7. Select Speakers and click **Configure** to start **Speaker Setup**. Follow the onscreen prompts to configure the speakers.
8. Remove and recently installed hardware or software.
9. Restore system and file settings from a known good date using **System Restore**.

If the issue is not fixed, repeat the preceding steps and select an earlier time and date.
10. Reinstall the Operating System.
11. If the Issue is still not resolved, see “Online Support Information” on page 215.

Internal Microphone Failure

If the internal **Microphone** fails, perform the following actions one at a time to correct the problem. Do not replace a non-defective FRUs:

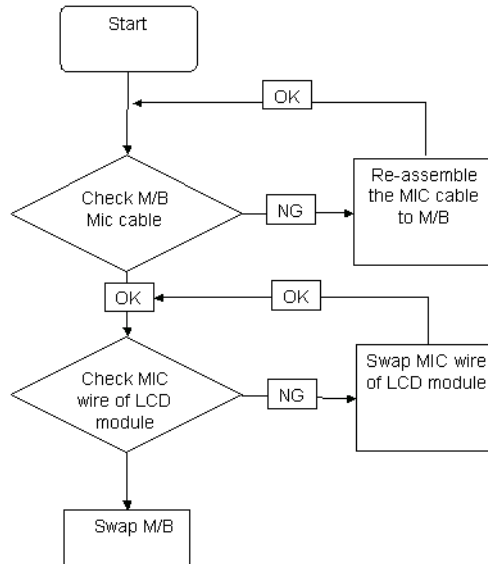

Microphone Problems

If internal or external **Microphones** do not operate correctly, perform the following actions one at a time to correct the problem.

1. Check that the microphone is enabled. Navigate to **Start** → **Control Panel** → **Hardware and Sound** → **Sound** and select the **Recording** tab.
2. Right-click on the **Recording** tab and select **Show Disabled Devices** (clear by default).
3. The microphone appears on the **Recording** tab.
4. Right-click on the microphone and select **Enable**.
5. Select the microphone then click **Properties**. Select the **Levels** tab.
6. Increase the volume to the maximum setting and click **OK**.
7. Test the microphone hardware:
 - a. Select the microphone and click **Configure**.
 - b. Select **Set up microphone**.
 - c. Select the microphone type from the list and click **Next**.
 - d. Follow the onscreen prompts to complete the test.
8. If the Issue is still not resolved, see "Online Support Information" on page 215.

HDD Not Operating Correctly

If the **HDD** does not operate correctly, perform the following actions one at a time to correct the problem.

1. Disconnect all external devices.
2. Run a complete virus scan using up-to-date software to ensure the computer is virus free.
3. Run the Windows Vista Startup Repair Utility:
 - a. insert the Windows Vista Operating System DVD in the ODD and restart the computer.
 - b. When prompted, press any key to start to the operating system DVD.
 - c. The **Install Windows** screen displays. Click **Next**.
 - d. Select **Repair your computer**.
 - e. The **System Recovery Options** screen displays. Click **Next**.
 - f. Select the appropriate operating system, and click **Next**.

NOTE: Click **Load Drivers** if controller drives are required.

- g. Select **Startup Repair**.
- h. Startup Repair attempts to locate and resolve issues with the computer.
- i. When complete, click **Finish**.

If an issue is discovered, follow the onscreen information to resolve the problem.

4. Run the Windows Memory Diagnostic Tool. For more information see Windows Help and Support.
5. Restart the computer and press F2 to enter the BIOS Utility. Check the BIOS settings are correct and that CD/DVD drive is set as the first boot device on the Boot menu.
6. Ensure all cables and jumpers on the HDD and ODD are set correctly.
7. Remove any recently added hardware and associated software.
8. Run the Windows Disk Defragmenter. For more information see Windows Help and Support.
9. Run Windows Check Disk by entering **chkdsk /r** from a command prompt. For more information see Windows Help and Support.
10. Restore system and file settings from a known good date using **System Restore**.

If the issue is not fixed, repeat the preceding steps and select an earlier time and date.
11. Replace the HDD. See "Disassembly Process" on page 48.

ODD Failure

If the **ODD** fails, perform the following actions one at a time to correct the problem. Do not replace a non-defective FRUs:

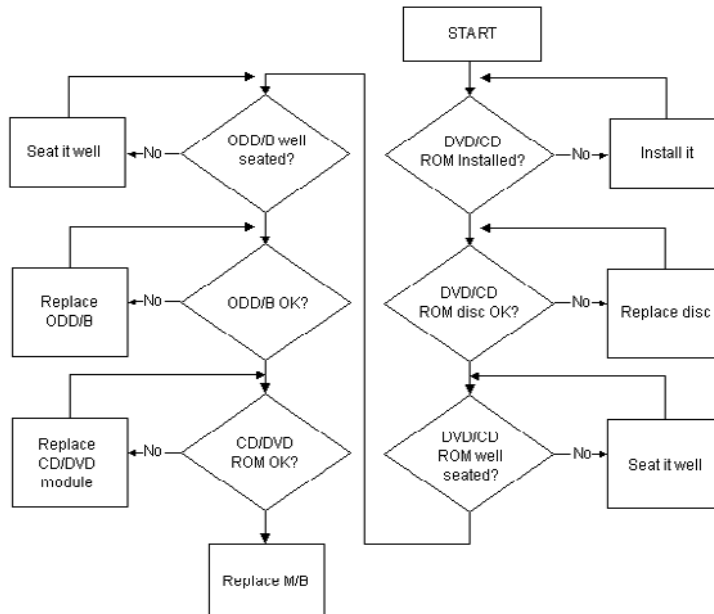

ODD Not Operating Correctly

If the **ODD** exhibits any of the following symptoms it may be faulty:

- Audio CDs do not play when loaded
- DVDs do not play when loaded
- Blank discs do not burn correctly
- DVD or CD play breaks up or jumps
- Optical drive not found or not active:
 - Not shown in My Computer or the BIOS setup
 - LED does not flash when the computer starts up
 - The tray does not eject
- Access failure screen displays
- The ODD is noisy

Perform the following general solutions one at a time to correct the problem.

1. Reboot the computer and retry the operation.
2. Try an alternate disc.
3. Navigate to **Start** → **Computer**. Check that the ODD device is displayed in the **Devices with Removable Storage** panel.
4. Navigate to **Start** → **Control Panel** → **System and Maintenance** → **System** → **Device Manager**.
 - a. Double-click **IDE ATA/ATAPI controllers**. If a device displays a down arrow, right-click on the device and click **Enable**.
 - b. Double-click **DVD/CD-ROM drives**. If the device displays a down arrow, right-click on the device and click **Enable**.

-
- c. Check that there are no yellow exclamation marks against the items in **IDE ATA/ATAPI controllers**. If a device has an exclamation mark, right-click on the device and uninstall and reinstall the driver.
 - d. Check that there are no yellow exclamation marks against the items in **DVD/CD-ROM drives**. If a device has an exclamation mark, right-click on the device and uninstall and reinstall the driver.
 - e. If the exclamation marker is not removed from the item in the lists, try removing any recently installed software and retrying the operation.

Discs Do Not Play

If discs do not play when inserted in the drive, perform the following actions one at a time to correct the problem.

1. Check that the disc is correctly seated in the drive tray and that the label on the disc is visible.
2. Check that the media is clean and scratch free.
3. Try an alternate disc in the drive.
4. Ensure that **AutoPlay** is enabled:
 - a. Navigate to **Start** → **Control Panel** → **Hardware and Sound** → **AutoPlay**.
 - b. Select **Use AutoPlay for all media and devices**.
 - c. In the Audio CD and DVD Movie fields, select the desired player from the drop down menu.
5. Check that the Regional Code is correct for the selected media:

IMPORTANT: Region can only be changed a limited number of times. After Changes remaining reaches zero, the region cannot be changed even Windows is reinstalled or the drive is moved to another computer.

- a. Navigate to **Start** → **Control Panel** → **System and Maintenance** → **System** → **Device Manager**.
- b. Double-click **DVD/CD-ROM drives**.
- c. Right-click **DVD drive** and click **Properties**, then click the **DVD Region** tab.
- d. Select the region suitable for the media inserted in the drive.

Discs Do Not Burn Properly

If discs can not be burned, perform the following actions one at a time to correct the problem.

1. Ensure that the default drive is record enabled:
 - a. Navigate to **Start** → **Computer** and right-click the writable ODD icon. Click **Properties**.
 - b. Select the **Recording** tab. In the **Desktop disc recording** panel, select the writable ODD from the drop down list.
 - c. Click **OK**.
2. Ensure that the software used for burning discs is the factory default. If using different software, refer to the software's user manual.

Playback is Choppy

If playback is choppy or jumps, perform the following actions one at a time to correct the problem.

1. Check that system resources are not running low:
 - a. Try closing some applications.
 - b. Reboot and try the operation again.
2. Check that the ODD controller transfer mode is set to DMA:
 - a. Navigate to **Start** → **Control Panel** → **System and Maintenance** → **System** → **Device Manager**.
 - b. Double-click **IDE ATA/ATAPI controllers**, then right-click ATA Device 0.
 - c. Click **Properties** and select the **Advanced Settings** tab. Ensure that the **Enable DMA** box is checked and click **OK**.
 - d. Repeat for the other ATA Devices shown if applicable.

Drive Not Detected

If Windows cannot detect the drive, perform the following actions one at a time to correct the problem.

1. Restart the computer and press F2 to enter the BIOS Utility.
2. Check that the drive is detected in the **ATAPI Model Name** field on the Information page.
NOTE: Check that the entry is identical to one of the ODDs specified in “Hardware Specifications and Configurations” on page 18.
3. Turn off the power and remove the cover to inspect the connections to the ODD. See “Disassembly Process” on page 48.
 - a. Check for broken connectors on the drive, motherboard, and cables.
 - b. Check for bent or broken pins on the drive, motherboard, and cable connections.
 - c. Try an alternate cable, if available. If the drive works with the new cable, the original cable should be replaced.
4. Reseat the drive ensuring and all cables are connected correctly.
5. Replace the ODD. See “Disassembly Process” on page 48.

Drive Read Failure

If discs cannot be read when inserted in the drive, perform the following actions one at a time to correct the problem.

1. Remove and clean the failed disc.
2. Retry reading the CD or DVD.
 - d. Test the drive using other discs.
 - e. Play a DVD movie
 - f. Listen to a music CD

If the ODD works properly with alternate discs, the original disc is probably defective and should be replaced.

3. Turn off the power and remove the cover to inspect the connections to the ODD. See “Disassembly Process” on page 48.
 - a. Check for broken connectors on the drive, motherboard, and cables.
 - b. Check for bent or broken pins on the drive, motherboard, and cable connections.
 - c. Try an alternate cable, if available. If the drive works with the new cable, the original cable should be replaced.
4. Replace the ODD. See “Disassembly Process” on page 48.

USB Failure (Rightside)

If the rightside **USB** port fails, perform the following actions one at a time to correct the problem. Do not replace a non-defective FRUs:

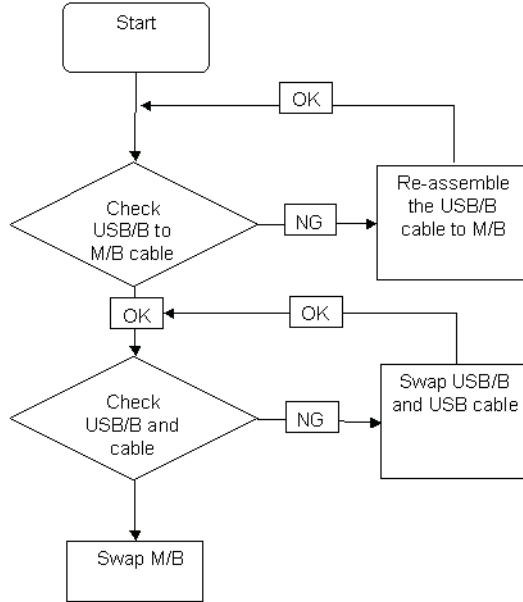

Modem Function Failure

If the internal **Modem** fails, perform the following actions one at a time to correct the problem. Do not replace a non-defective FRUs:

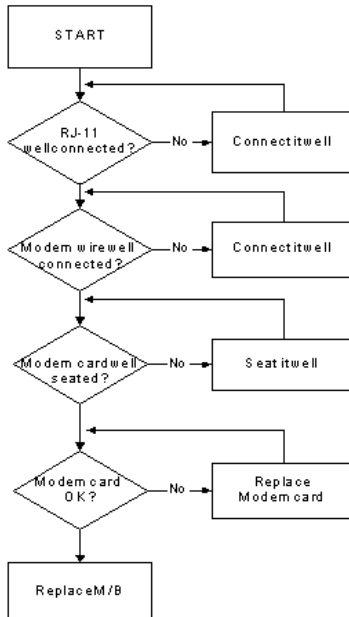

Wireless Function Failure

If the **WLAN** fails, perform the following actions one at a time to correct the problem. Do not replace a non-defective FRUs:

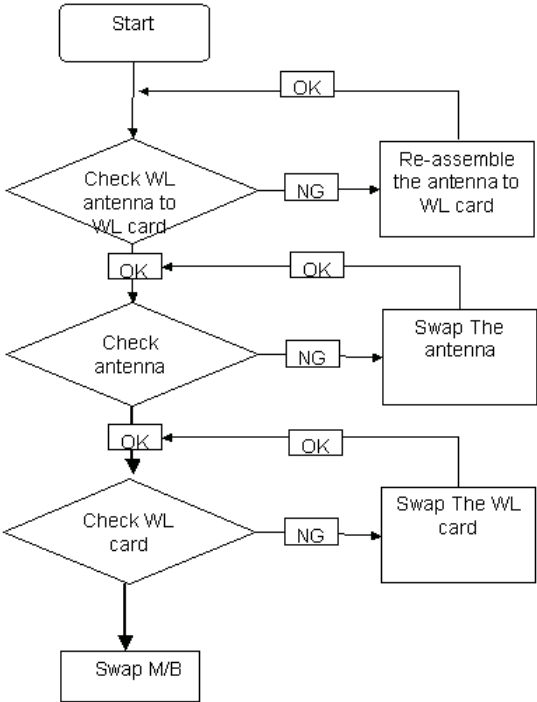

3G Module Failure

If the **3G Module** fails, perform the following actions one at a time to correct the problem. Do not replace a non-defective FRUs:

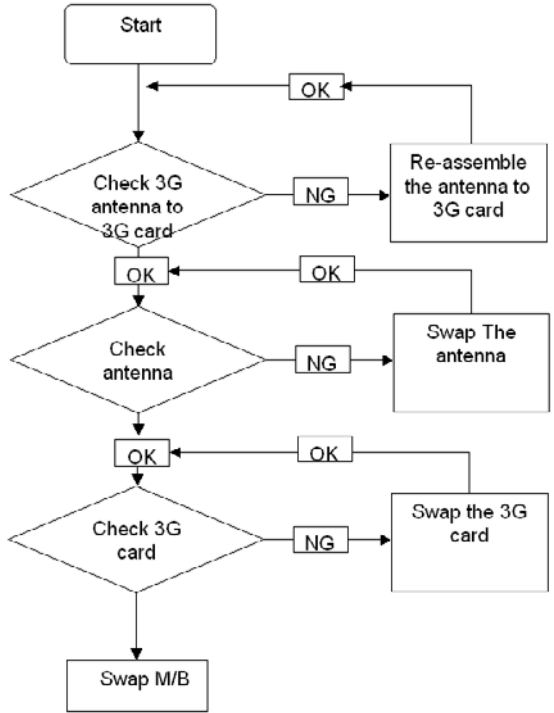

EasyTouch Button Failure

If the **Acer EasyTouch** buttons fail, perform the following actions one at a time to correct the problem. Do not replace a non-defective FRUs:

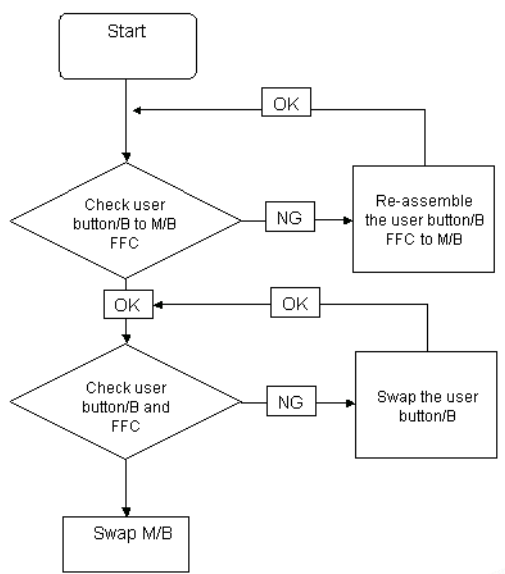

Fingerprint Reader Failure

If the **Fingerprint Reader** fails, perform the following actions one at a time to correct the problem. Do not replace a non-defective FRUs:

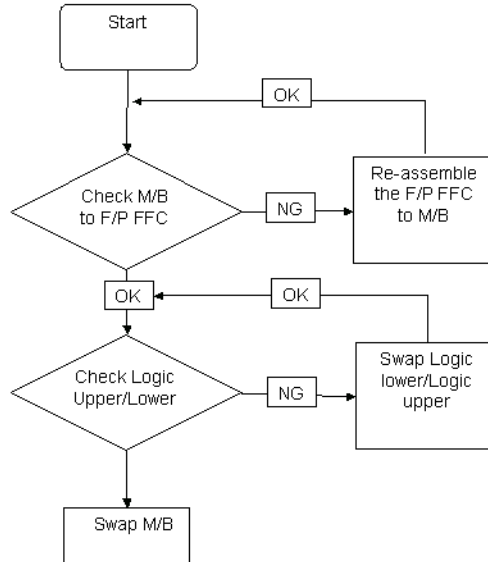

Thermal Unit Failure

If the **Thermal Unit** fails, perform the following actions one at a time to correct the problem. Do not replace a non-defective FRUs:

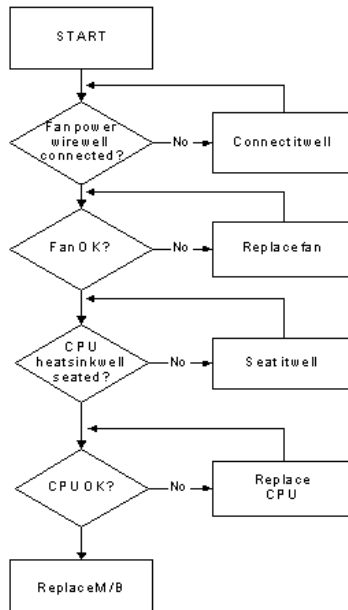

External Mouse Failure

If an external **Mouse** fails, perform the following actions one at a time to correct the problem.

1. Try an alternative mouse.
2. If the mouse uses a wireless connection, insert new batteries and confirm there is a good connection. See the mouse user manual.
3. If the mouse uses a USB connection, try an alternate USB port.
4. Try an alternative program to verify mouse operation. Reinstall the program experiencing mouse failure.
5. Restart the computer.
6. Remove any recently added hardware and associated software.
7. Remove any recently added software and reboot.
8. Restore system and file settings from a known good date using **System Restore**.
If the issue is not fixed, repeat the preceding steps and select an earlier time and date.
9. Run the Event Viewer to check the events log for errors. For more information see Windows Help and Support.
10. Roll back the mouse driver to the previous version if updated recently.
11. Remove and reinstall the mouse driver.
12. Check the Device Manager to determine that:
 - The device is properly installed. There are no red Xs or yellow exclamation marks.
 - There are no device conflicts.
 - No hardware is listed under Other Devices.
13. If the Issue is still not resolved, see "Online Support Information" on page 215.

Other Failures

If the CRT Switch, Dock, LAN Port, external MIC or Speakers, PCI Express Card, 5-in-1 Card Reader or Volume Wheel fail, perform the following general steps to correct the problem. Do not replace a non-defective FRUs:

1. Check Drive whether is OK.
2. Check Test Fixture is ok.
3. Swap M/B to Try.

Intermittent Problems

Intermittent system hang problems can be caused by a variety of reasons that have nothing to do with a hardware defect, such as: cosmic radiation, electrostatic discharge, or software errors. FRU replacement should be considered only when a recurring problem exists.

When analyzing an intermittent problem, do the following:

1. Run the advanced diagnostic test for the system board in loop mode at least 10 times.
2. If no error is detected, do not replace any FRU.
3. If any error is detected, replace the FRU. Rerun the test to verify that there are no more errors.

Undetermined Problems

The diagnostic problems does not identify which adapter or device failed, which installed devices are incorrect, whether a short circuit is suspected, or whether the system is inoperative.

Follow these procedures to isolate the failing FRU (do not isolate non-defective FRU).

NOTE: Verify that all attached devices are supported by the computer.

NOTE: Verify that the power supply being used at the time of the failure is operating correctly. (See “Power On Issue” on page 136.):

1. Power-off the computer.
2. Visually check them for damage. If any problems are found, replace the FRU.
3. Remove or disconnect all of the following devices:
 - Non-Acer devices
 - Printer, mouse, and other external devices
 - Battery pack
 - Hard disk drive
 - DIMM
 - CD-ROM/Diskette drive Module
 - PC Cards
4. Power-on the computer.
5. Determine if the problem has changed.
6. If the problem does not recur, reconnect the removed devices one at a time until you find the failing FRU.
7. If the problem remains, replace the following FRU one at a time. Do not replace a non-defective FRU:
 - System board
 - LCD assembly

POST Codes Tables

These tables describe the POST codes, drivers, and keys for the POST.

Port 80 POST Codes

The following table details the Port 80 POST codes and drivers used in the POST.

Driver Name	Port 80 Code	Driver Name	Port 80 Code
PeiEventLog	01	Cpulo	3E
OemServices	02	Cf9Reset	3F
Siolnit	03	PcRtc	40
MonoStatusCode	04	StatusCode	41
PentiumMCpuPeim	08	Variable	42
PlatformStage1	09	SmmVariable	CF
Variable	0A	EmuVariable	43
IchInit	0B	TcgDxe	A2
PlatformStage2	0D	PhysicalPresence	A3
IchSmbusArpDisabled	0E	TpmDriver	AE
ClockGen	12	TcgSmm	AE
OpPresence	13	PhysicalPresenceReadyToBoot	AE
TcgPei	14	DataHubRecordPolicy	AD
FindFv	15	Undi	86
DxeIpl	2F	SNP	90
LightMemoryInit	10	BC	91
S3ResumeSoftSmi	11	PxeDhcp4	92
Crc32SectionExtract	31	Ebc	93
OemServices	A4	IsaBus	4D
EventLog	A5	IsaSerial	4E
ScriptSave	32	Ps2Mouse	6D
AcpiS3Save	33	IdeBus	4F
SmartTimer	34	LightPciBus	50
JpegDecoder	35	UsbBot	6E
PcxDecoder	36	UsbCbi0	6F
PlatformBds	8A	UsbCbi1	70
MpCpu	37	UsbKb	71
LegacyMetronome	38	UsbMassStorage	72
FtwLite	39	UsbMouse	74
Runtime	3A	Ehci	8F
MonotonicCounter	3B	Uhci	73
WatchDogTimer	3C	UsbBus	75
SecurityStub	3D	SmmBase	C2

Driver Name	Port80 Code	Driver Name	Port80 Code
SmmDisp	C5	HiiDatabase	80
SmmReloc	C4	OemSetupBrowser	82
SmmRuntime	C7	Font(English)	7E
SmmThunk	C9	Font(French)	7F
OemServices	D8	Font(Chinese)	8D
ChipsetInit	44	UnicodeCollation	B1
SmmAccess	C0	ConPlatform	5A
PciHostBridge	46	ConSplitter	5D
PciExpress	47	GraphicsConsole	79
GmchMbi	CD	Terminal	7A
IchInit	48	VgaClass	5E
IdeController	49	SaveMemoryConfig	5B
SataController	4A	AcpiSupport	5C
IchSmbusLight	4B	AcpiPlatform	53
SmmControl	C1	DataHub	5F
Ich7MSmmDispatcher	C8	DataHubStdErr	7B
IsaAcpiDriver	4C	GenericMemoryTest	61
Fwh	52	Disklo	60
SmmFwh	CE	Fat	7C
PciHotPlug	54	Partition	7D
BootOptionPolicy	51	PciPlatform	6B
SetupUtility	76	AlertStandardForma	45
Platform	55	PciSerial	A8
PlatformIde	56	AsfInit	A7
Ppm	D9	IdeRController	A9
Platform	CC	Legacy8259	63
lhis	D0	LegacyRegion	64
SetupMouse	f9	LegacyInterrupt	65
Int15Microcode	D1	BiosKeyboard	66
SmmPnp	D2	BiosVideo	67
Smbios	57	MonitorKey	68
MemorySubClass	58	LegacyBios	69
MiscSubclassDriver	59	LegacyBiosPlatform	6A
SysPassword	AB	LegacyMouse	77
PswdConsole	AC	SmmUsbLegacy	78
HddPswdServiceBody	D7	AmbtxInvoke	AA
HddPswdService	A6	OemBadgingSupport	83

POST Keys and Messages

The following keys are available during POST.

Key	Function
F2	Enter into Setup Menu
F12	Enter into Boot Manager

The following messages display during POST:

Before press function key
CPUID: XXXXXX Press F2 go to Setup Utility Press F12 go to Boot Manager Press [PXE HOT KEY] go to PXE Setup Menu

After press function key
If user pressed F2 CPUID: XXXXXX F2 is pressed. Go to Setup Utility.
If user pressed F12 CPUID: XXXXXX F12 is pressed. Go to Boot Manager.
If user didn't press any key CPUID: XXXXXX Prepare Boot to OS
If user pressed PXE HOT KEY CPUID: XXXXXX [PXE HOT KEY] is pressed. Go to PXE Setup Menu.

Jumper and Connector Locations

Top View

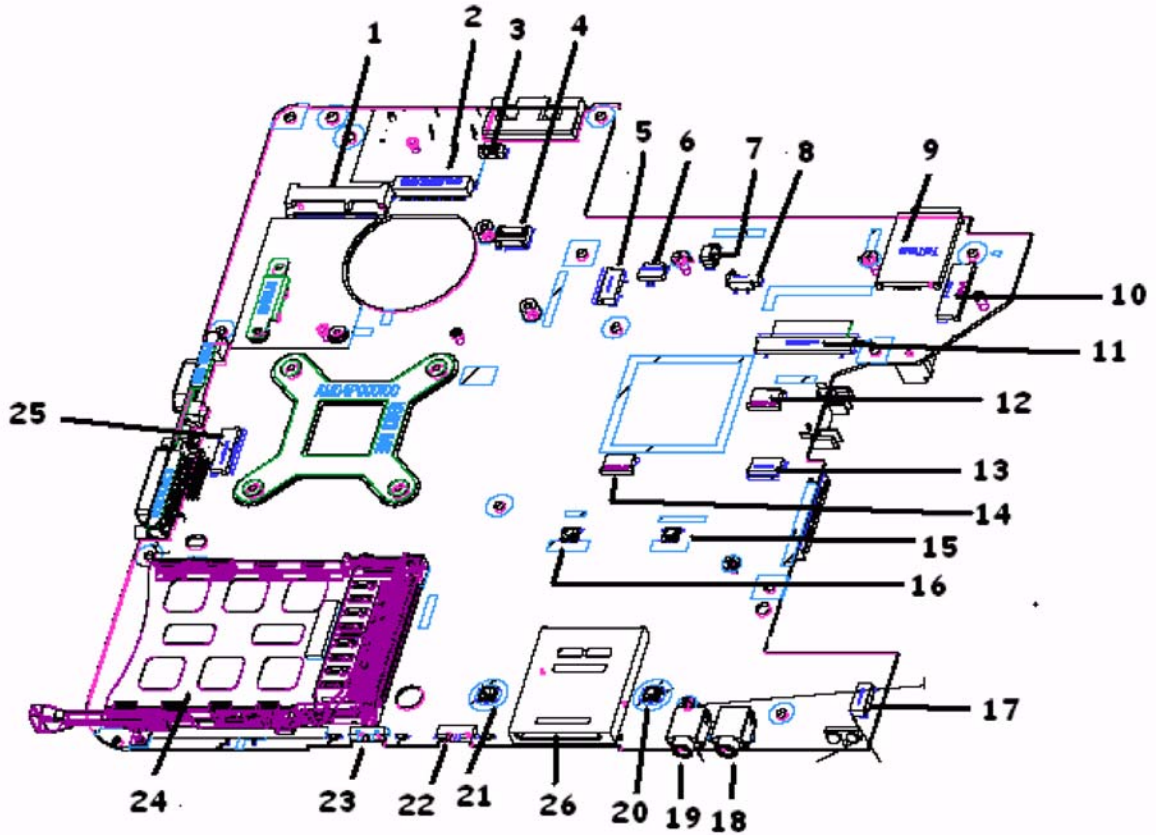

No.	Item	Description	No.	Item	Description
1	JP34	WLAN Connector	14	JP65	T/P Connector
2	JP33	LCD Connector	15	SW4	Right Switch button
3	JP55	RJ11 Connector	16	SW3	Left Switch button
4	JP39	MDC Connector	17	JP37	B/T Connector
5	JP12	Switch Board Connector	18	JHP1	Headphone Connector
6	JMIC2	MIC Connector	19	JMIC1	MIC JACK
7	JP34	RJ11 Connector	20	SW5	Right Switch button
8	JP43	SPK Connector	21	SW7	Left Switch button
9	JP62	SIN Connector	22	SW8	WL Switch
10	JP45	Function board Connector	23	SW9	BT & 3G Switch
11	JP24	K/B Connector	24	JP57	PCMCIA Connector
12	JP65	Track point Connector	25	JP64	Smart Card Connector
13	JP44	F/P Board Connector	26	JREAD1	5 in 1 Card Connector

Bottom View

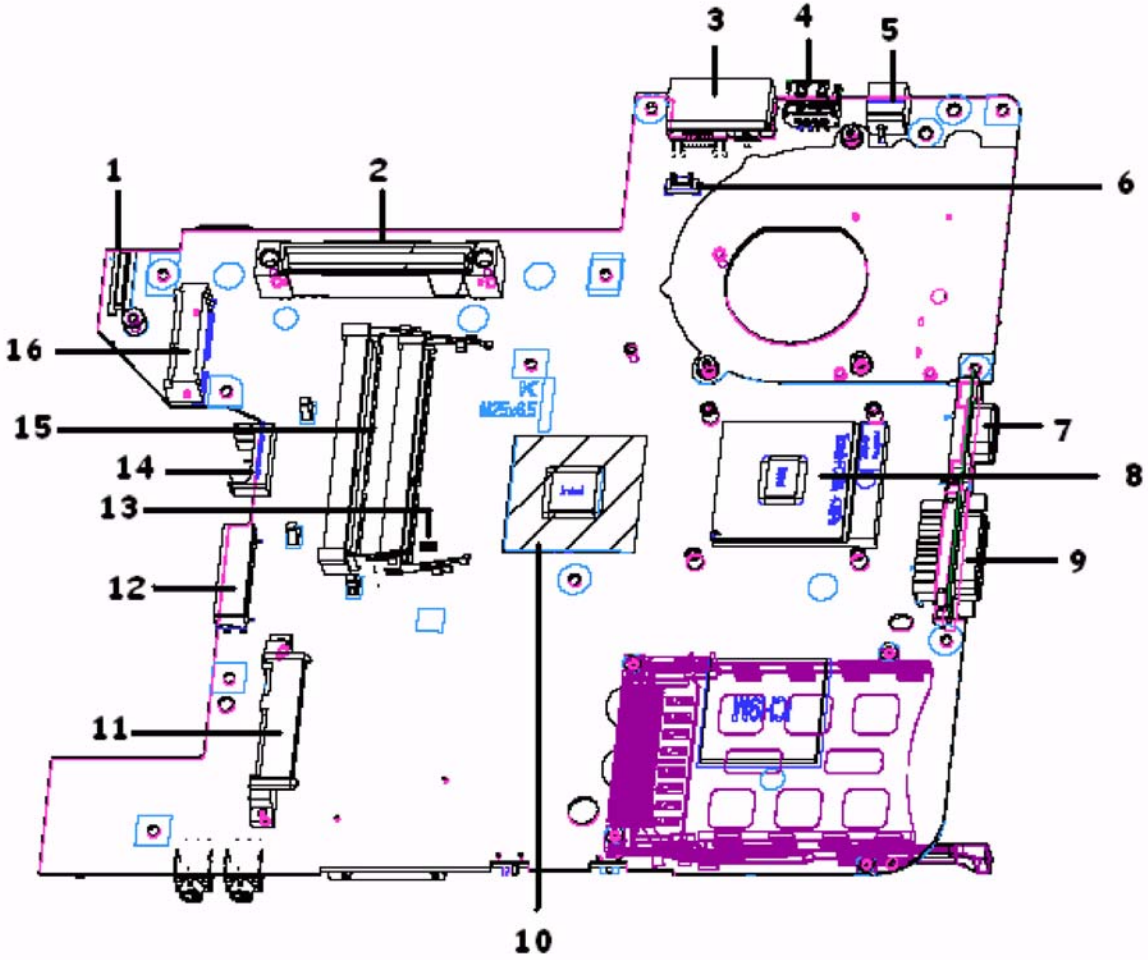

No.	Item	Description	No.	Item	Description
1	JP3	USB Board Connector	9	JP59	DVI Connector
2	JDOCK1	Docking Connector	10	U2	North Bridge
3	JP7	LAN Connector	11	JP9	HDD Connector
4	JP36	USB Connector	12	JP63	ODD Connector
5	PCN1	AC-IN Connector	13	CLRP2	CMOS clear
6	JP32	FAN Connector	14	PJP4	Battery Connector
7	JP6	CRT Connector	15	JP5	RAM Connector
8	JP2	CPU Connector	16	JP60	3G Connector

Clearing Password Check and BIOS Recovery

This section provide you the standard operating procedures of clearing password and BIOS recovery for TravelMate 6493. TravelMate 6493 provide one Hardware Open Gap on main board for clearing password check, and one Hotkey for enabling BIOS Recovery.

Clearing Password Check

Hardware Open Gap Description

Item	Description	Location
CLRP2	Clear CMOS Jumper	Memory bay



Steps for Clearing BIOS Password Check

If users set BIOS Password (Supervisor Password and/or User Password) for a security reason, BIOS will ask the password during systems POST or when systems enter to BIOS Setup menu. However, once it is necessary to bypass the password check, users need to short the HW Gap to clear the password by the following steps:

- Power Off a system, and remove HDD, AC and Battery from the machine.
- Open the back cover of the machine, and find out the HW Gap on M/B as picture.
- Use an electric conductivity tool to short the two points of the HW Gap.
- Plug in AC, keep the short condition on the HW Gap, and press Power Button to power on the system till BIOS POST finish. Then remove the tool from the HW Gap.
- Restart system. Press F2 key to enter BIOS Setup menu.
- If there is no Password request, BIOS Password is cleared. Otherwise, please follow the steps and try again.

NOTE: The steps are only for clearing BIOS Password (Supervisor Password and User Password).

BIOS Recovery by Crisis Disk

BIOS Recovery Boot Block:

BIOS Recovery Boot Block is a special block of BIOS. It is used to boot up the system with minimum BIOS initialization. Users can enable this feature to restore the BIOS firmware to a successful one once the previous BIOS flashing process failed.

BIOS Recovery Hotkey:

The system provides a function hotkey: **Fn+Esc**, for enable BIOS Recovery process when system is powered on during BIOS POST. To use this function, it is strongly recommended to have the AC adapter and Battery present. If this function is enabled, the system will force the BIOS to enter a special BIOS block, called Boot Block.

Steps for BIOS Recovery by Crisis Disk:

Before doing this, one Crisis Disk should be prepared ready in hand. The Crisis Disk could be made by executing the Crisis Disk program in another system with Windows XP OS.

Follow the steps below:

1. Power Off failed system.
2. Attach a USB floppy drive to the failed system.
3. Insert the Crisis Disk in to the USB floppy drive attached to the BIOS flash failed system.
4. In the power-off state, press and hold **Fn+Esc** then press the Power button.

The system powers on and the Crisis BIOS Recovery process begins.

BIOS Boot Block begins restoring the BIOS code from the Crisis floppy disk to BIOS ROM on the failed systems.

When the Crisis flash process is finished, the system restarts with a workable BIOS.

5. Update to the latest version BIOS for the system using the regular BIOS flashing process.

FRU (Field Replaceable Unit) List

This chapter gives you the FRU (Field Replaceable Unit) listing in global configurations of TravelMate 6493. Refer to this chapter whenever ordering for parts to repair or for RMA (Return Merchandise Authorization).

Please note that WHEN ORDERING FRU PARTS, you should check the most up-to-date information available on your regional web or channel. For whatever reasons a part number change is made, it will not be noted on the printed Service Guide. For ACER AUTHORIZED SERVICE PROVIDERS, your Acer office may have a DIFFERENT part number code from those given in the FRU list of this printed Service Guide. You MUST use the local FRU list provided by your regional Acer office to order FRU parts for repair and service of customer machines.

NOTE: To scrap or to return the defective parts, you should follow the local government ordinance or regulations on how to dispose it properly, or follow the rules set by your regional Acer office on how to return it.

TravelMate 6493 Exploded Diagrams

Upper Case

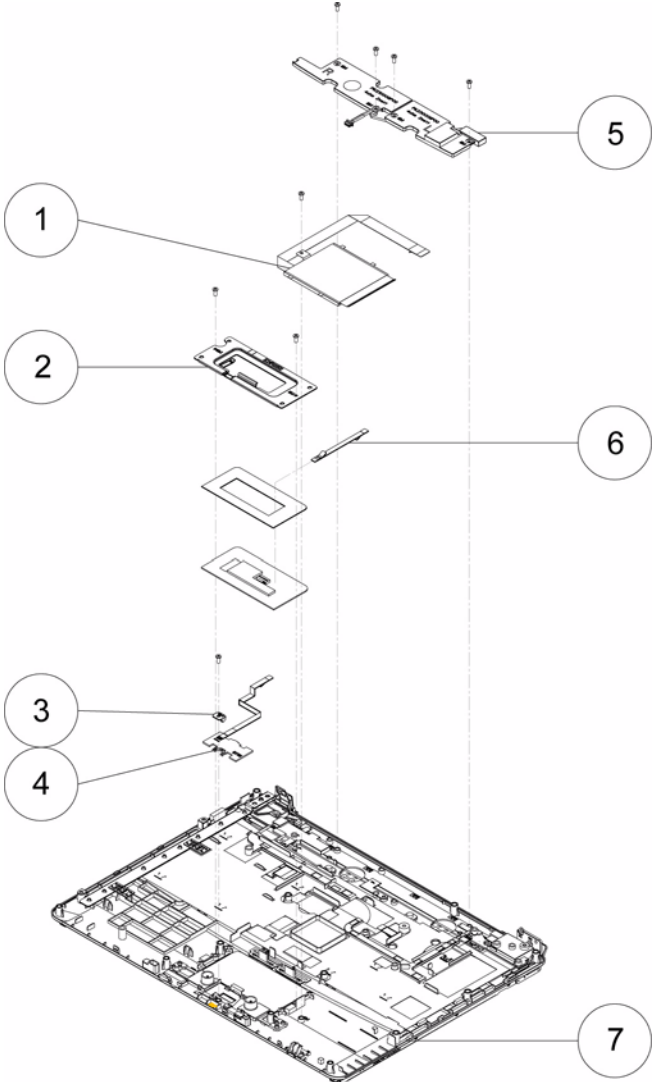

Item	Description	Part No.	Item	Description	Part No.
1	Smart Card Reader	55.TQ702.007	5	Speaker Set (R+L)	23.TQ702.002
2	TouchPad Bracket	33.TQ702.001	6	TouchPad FFC	50.TQ702.006
3	F/P Reader Bracket	42.TQ702.001	7	Upper Case Assy	60.TQ702.002
4	F/P Reader	55.TQ702.003			

Lower Case

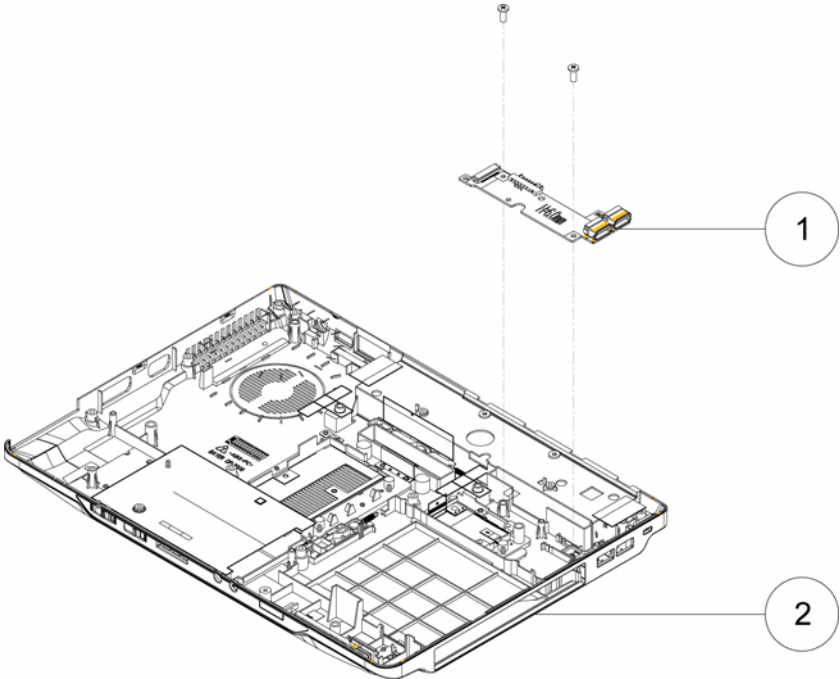

Item	Description	Part No.
1	USB Board	55.TQ702.005
2	Lower Case Assy	60.TQA02.001 (w/3G) 60.TQ702.003 (w/o 3G)

LCD Module

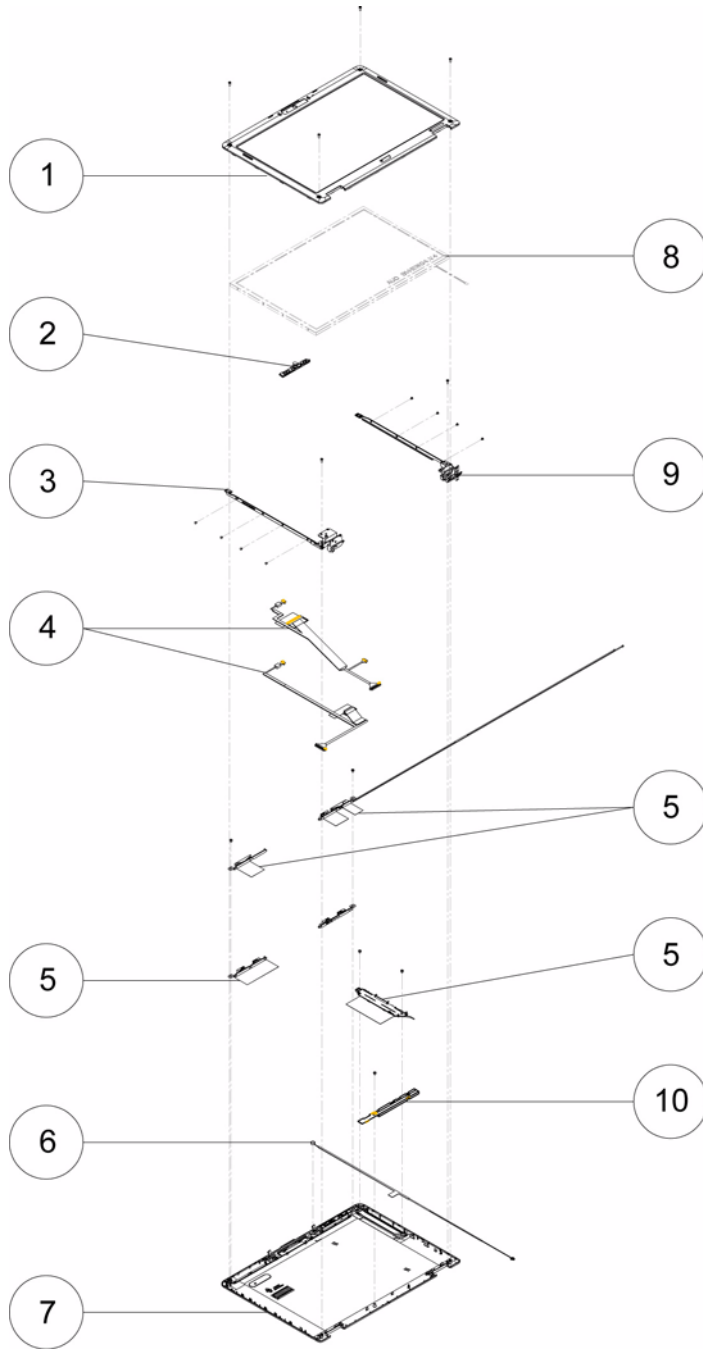

Item	Description	Part No.	Item	Description	Part No.
1	LCD Bezel	60.TQ702.004	6	Mic Set	23.TQ702.003
2	Camera Module	55.TQ702.010	7	LCD Assy	6M.TQA02.001
3	LCD Bracket (L)	33.TQ702.005	8	LCD Panel	LK.14105.019
4	LCD Cable	50.TQ702.007	9	LCD Bracket (R)	33.TQ702.005
5	Antennas	50.TQA02.001 50.TQA02.002 50.TQA02.003	10	Inverter Board	55.TQ702.009







TravelMate 6493 FRU List

Category	Description	Acer Part No.
Adapter		
	ADAPTER 65W 3PIN DELTA SADP-65KB DFA	AP.06501.013
	ADAPTER 65W 3PIN LITEON PA-1650-02AC	AP.06503.016
	ADAPTER 65W 3PIN HIPRO AC-OK065B13 LF	AP.0650A.010
Battery		
	BATTERY LI-ION 6CELLS 4.4KAH SANYO 3S2P	BT.00603.044
	BATTERY LI-ION 6CELLS 4.4KAH SONY 3S2P	BT.00604.027
	BATTERY LI-ION 6CELLS 4.4KAH SIMPLO 3S2P	BT.00607.018
	BATTERY LI-ION 6CELLS 4.4KAH PANASONIC 3S2P	BT.00605.024
	BATTERY LI-ION 9CELLS 7.2KAH SONY 3S3P	BT.00904.003
	BATTERY LI-ION 9CELLS 7.2KAH SIMPLO 3S3P	BT.00907.003
Board		
	EKEY BOARD	55.TQ702.001
	POWER BOARD	55.TQ702.002
	FINGER PRINT BOARD	55.TQ702.003
	BLUETOOTH BOARD	55.TQ702.004
	USB BOARD	55.TQ702.005
	MODEM BOARD LITEON 1.5_3.3V AUS RD02-D330	FX.22500.021
	2ND HDD BOARD	55.TQ702.006

Category	Description	Acer Part No.
	MINI CARD WLAN AGN 1x2 512AN_MMWG INTEL NON-FCC/IC	KI.SPM01.006
	MINI CARD WLAN AGN 3x3 533AN_MMWG INTEL W FCC/IC	KI.SPM01.001
	MINI CARD WLAN AGN 3x3 533AN_MMWG NON FCC/IC	KI.SPM01.007
	HALF MINI CARD AGN 1x2 512AN_HMWG INTEL	KI.SPH01.003
	HALF MINI CARD WLAN AGN 3x3 533AN_HMWG INTEL	KI.SPH01.001
	WLAN CARD 3G (3G GTM380E)	LC.21300.004
Cable		
	BLUE TOOTH CABLE	50.TQ702.001
	RJ11 CABLE	50.TQ702.002
	3G ANTENNA L(3*3)	50.TQA02.001
	3G ANTENNA L(1*2)	50.TQA02.002
	3G ANTENNA R	50.TQA02.003
	WLAN ANTENNA R(3*3)	50.TQ702.003
	WLAN ANTENNA R(1*2)	50.TQ702.004
	WLAN ANTENNA L	50.TQ702.005
	TOUCHPAD FFC	50.TQ702.006

Category	Description	Acer Part No.
	POWER CORD US 3 PIN	27.TAVV5.001
	POWER CORD EU 3 PIN	27.TAVV5.002
	POWER CORD AUS 3 PIN	27.TAVV5.003
	POWER CORD UK 3 PIN	27.TAVV5.004
	POWER CORD CHINA 3 PIN	27.TAVV5.005
	POWER CORD SWISS 3 PIN	27.TAVV5.006
	POWER CORD ITALIAN 3 PIN	27.TAVV5.007
	POWER CORD DENMARK 3 PIN	27.TAVV5.008
	POWER CORD JP 3 PIN	27.TAVV5.009
	POWER CORD SOUTH AFRICA 3 PIN	27.TAVV5.010
	POWER CORD KOERA 3 PIN	27.TAVV5.011
	POWER CORD ISRAEL 3 PIN	27.TAVV5.012
	POWER CORD INDIA 3 PIN	27.TAVV5.013
	POWER CORD TWN 3 PIN	27.TAVV5.014
	POWER CORD ARGENTINA 3 PIN	27.APV02.001
Case/Cover/Bracket Assembly		
	MIDDLE COVER	60.TQ702.001
	UPPER CASE ASSY	60.TQ702.002
	LOWER CASE ASSY W/3G FUNCTION	60.TQA02.001
	LOWER CASE ASSY W/O 3G FUNCTION	60.TQ702.003
	FINGER PRINT BRACKET	42.TQ702.001
	SMART CARD READER	55.TQ702.007
	TOUCH PAD BRACKET	33.TQ702.001
	MINI PCI PLATE	33.TQ702.002

Category	Description	Acer Part No.
	RAM DOOR	42.TQ702.002
	HDD DOOR	42.TQ702.003
	3G DOOR	42.TQA02.001
	2ND HDD PLATE	33.TQ702.003
	2ND HDD CARRIER ASSY	42.TQ702.004
	PCMCIA DUMMY CARD	42.TQ702.005
	CARD READER DUMMY CARD	42.TQ702.006
CPU/Processor		
	INTEL CPU T9600 2.8G AW80576GH0726M SLB47 C0	KC.96001.DTP
	INTEL CPU T9400 2.53G AW80576GH0616M SLB46 C0	KC.94001.DTP
	INTEL CPU P9500 2.53 AW80576SH0616M SLB4E C0	KC.95001.DPP
	INTEL CPU P8600 2.4G AW80577SH0563M SLB3S M0	KC.86001.DPP
	INTEL CPU P8400 2.26G AW80577SH0513M SLB3R M0	KC.84001.DPP
Combo Drive		
	DVD/CDRW COMBO MODULE TRAY IN	6M.TQ702.001
	DVD/CDRW COMBO DRIVE TOSHIBA TS-L463A LF W/O bezel	KO.02401.006
	DVD/CDRW COMBO DRIVE SONY CRX890S LF W/O bezel	KO.0240E.009
	ODD BEZEL-COMBO	42.TQ702.007
	ODD SUPPORT	42.TQ702.008

Category	Description	Acer Part No.
	ODD BOARD	55.TQ702.008
Multi Drive		
	DVD SUPER MULTI MODULE TRAY IN	6M.TQ702.002
	DVD SUPER MULTI DRIVE SONY AD-7560S LF W/O bezel	KU.0080E.009
	DVD SUPER MULTI DRIVE TSST TS-L633A LF W/O bezel	KU.00801.021
	ODD BEZEL-SUPER MULTI	42.TQ702.009
	ODD SUPPORT	42.TQ702.008
	ODD BOARD	55.TQ702.008
HDD		
	HDD SATA 120G 5400RPM HGST HT542512K9SA00	KH.12007.014
	HDD SATA 120G 5400RPM TOSHIBA MK1246GSX	KH.12004.007
	HDD SATA 120G 5400RPM SEAGATE ST9120817AS (-188)	KH.12001.032
	HDD SATA 120G 5400RPM WD WD1200BEVS-22UST0	KH.12008.019
	HDD SATA 160G 5400RPM HGST HTS542516K9SA00	KH.16007.016
	HDD SATA 160G 5400RPM HGST HTS543216L9A300 Falcon-B	KH.16007.019
	HDD SATA 160G 5400RPM TOSHIBA MK1646GSX	KH.16004.002
	HDD SATA 160G 5400RPM TOSHIBA MK1652GSX Virgo	KH.16004.003
	HDD SATA 160G 5400RPM SEAGATE ST9160827AS (-188)	KH.16001.029
	HDD SATA 160G 5400RPM WD WD1600BEVS-22ZCT0	KH.16008.022
	HDD SATA 250G 5400RPM HGST HTS542525K9SA00	KH.25007.011
	HDD SATA 250G 5400RPM TOSHIBA MK2546GSX	KH.25004.001
	HDD SATA 250G 5400RPM SEAGATE ST9250827AS (-188)	KH.25001.011
	HDD SATA 250G 5400RPM WD WD2500BEVS-22UST0	KH.25008.018
	HDD SATA 320G 5400RPM WD WD3200BEVT-22ZCT0	KH.32008.013
HDD SATA 320G 5400RPM HGST HTS543232L9A300 Falcon-B	KH.32007.004	
HDD SATA 320G 5400RPM TOSHIBA MK3252GSX Virgo BS	KH.32004.001	
	HDD HOLDER	42.TQ702.010









Category	Description	Acer Part No.
	HDD SHIELD	33.TQ702.004
Keyboard		
	KEYBOARD INTE(UI) W/TP TM	KB.INT00.070
	KEYBOARD ARABIC W/TP TM	KB.INT00.104
	KEYBOARD BELGIAN W/TP TM	KB.INT00.103
	KEYBOARD BRAZILIAN W/TP TM	KB.INT00.102
	KEYBOARD CANADIAN/FRENCH W/TP TM	KB.INT00.101
	KEYBOARD CHINESE W/TP TM	KB.INT00.099
	KEYBOARD CZECH W/TP TM	KB.INT00.098
	KEYBOARD DENMARK W/TP TM	KB.INT00.097
	KEYBOARD NETHERLANDS W/TP TM	KB.INT00.096
	KEYBOARD FRENCH W/TP TM	KB.INT00.094
	KEYBOARD GERMAN W/TP TM	KB.INT00.093
	KEYBOARD GREEK W/TP TM	KB.INT00.092
	KEYBOARD HUNGARY W/TP TM	KB.INT00.091
	KEYBOARD ITALY W/TP TM	KB.INT00.088
	KEYBOARD KOREAN W/TP TM	KB.INT00.086
	KEYBOARD NORWEGIAN W/TP TM	KB.INT00.084
	KEYBOARD PORTUGUESE W/TP TM	KB.INT00.082
	KEYBOARD RUSSIAN W/TP TM	KB.INT00.081
	KEYBOARD SLOVENIAN W/TP TM(SLO/CRO)	KB.INT00.080
	KEYBOARD SLOVAKIAN W/TP TM	KB.INT00.079
	KEYBOARD SPANISH W/TP TM	KB.INT00.077
	KEYBOARD SWEDISH W/TP TM	KB.INT00.076
	KEYBOARD SWITZERLAND W/TP TM	KB.INT00.075
	KEYBOARD THAILAND W/TP TM	KB.INT00.074
KEYBOARD TURKISH W/TP TM	KB.INT00.073	
KEYBOARD UK W/TP TM	KB.INT00.072	
KEYBOARD HEBREW W/TP TM	KB.INT00.071	
KEYBOARD JP W/TP TM	KB.INT00.087	
LCD		
	ASSY LCD MODULE 14.1 IN. WXGA N-GLARE CCD 0.3M 3G	6M.TQA02.001
	LCD PANEL NG 14.1" WXGA AUO B141EW04-V3 LF	LK.14105.019
	LCD PANEL NG 14.1" WXGA SAMSUNG LTN141W3-L01-2 L6 LF	LK.14106.013
	LCD PANEL NG 14.1" WXGA CMO N141I3-L01 LF	LK.1410D.015
	LCD PANEL NG 14.1" WXGA LGL LP141WX3-TLP1 LF	LK.14108.013

Category	Description	Acer Part No.
	INVERTER BOARD	55.TQ702.009
	LCD CABLE-WXGA	50.TQ702.007
	LCD COVER ASSY W/3G FUNCTION	60.TQA02.002
	LCD BEZEL WITH CCD FUNCTION	60.TQ702.004
	LCD BRACKET-R&L	33.TQ702.005
	3G ANTENNA L(3*3)	50.TQA02.001
	3G ANTENNA L(1*2)	50.TQA02.002
	3G ANTENNA R	50.TQA02.003
	CAMERA BOARD 0.3M	55.TQ702.010
	ASSY LCD MODULE 14.1 IN. WLED GLARE CCD 0.3M 3G	6M.TQA02.002
	LCD PANEL G 14.1" WLED AUO B141EW05 V0 LF	LK.14105.025
	INVERTER BOARD	55.TQ702.009
	LCD COVER ASSY W/3G FUNCTION	60.TQA02.002
	LCD BEZEL WITH CCD FUNCTION	60.TQ702.004
	LCD CABLE-WLED	50.TQ702.008

Category	Description	Acer Part No.
	LCD BRACKET-R&L	33.TQ702.005
	3G ANTENNA L(3*3)	50.TQA02.001
	3G ANTENNA L(1*2)	50.TQA02.002
	3G ANTENNA R	50.TQA02.003
	CAMERA BOARD 0.3M	55.TQ702.010
	ASSY LCD MODULE 14.1 IN. WLED N-GLARE CCD 0.3M 3G	6M.TQA02.003
	LCD PANEL NG 14.1" WLED AUO B141EW05 V1 LF	LK.14105.026
	INVERTER BOARD	55.TQ702.009
	LCD COVER ASSY W/3G FUNCTION	60.TQA02.002
	LCD BEZEL WITH CCD FUNCTION	60.TQ702.004
	LCD CABLE-WLED	50.TQ702.008
	LCD BRACKET-R&L	33.TQ702.005
	3G ANTENNA L(3*3)	50.TQA02.001
	3G ANTENNA L(1*2)	50.TQA02.002
	3G ANTENNA R	50.TQA02.003
	CAMERA BOARD 0.3M	55.TQ702.010

Category	Description	Acer Part No.
	ASSY LCD MODULE 14.1 IN. WXGA N-GLARE CCD 0.3M	6M.TQ702.003
	LCD PANEL NG 14.1" WXGA AUO B141EW04-V3 LF	LK.14105.019
	LCD PANEL NG 14.1" WXGA SAMSUNG LTN141W3-L01-2 L6 LF	LK.14106.013
	LCD PANEL NG 14.1" WXGA CMO N141I3-L01 LF	LK.1410D.015
	LCD PANEL NG 14.1" WXGA LGL LP141WX3-TLP1 LF	LK.14108.013
	INVERTER BOARD	55.TQ702.009
	LCD COVER ASSY W/O 3G FUNCTION	60.TQ702.005
	LCD BEZEL WITH CCD FUNCTION	60.TQ702.004
	LCD CABLE-WXGA	50.TQ702.007
	LCD BRACKET-R&L	33.TQ702.005
	WLAN ANTENNA R(3*3)	50.TQ702.003
	WLAN ANTENNA R(1*2)	50.TQ702.004
	WLAN ANTENNA L	50.TQ702.005
	CAMERA BOARD 0.3M	55.TQ702.010
	ASSY LCD MODULE 14.1 IN. WLED GLARE CCD 0.3M	6M.TQ702.004
	LCD PANEL G 14.1" WLED AUO B141EW05 V0 LF	LK.14105.025
	INVERTER BOARD	55.TQ702.009
	LCD COVER ASSY W/O 3G FUNCTION	60.TQ702.005

Category	Description	Acer Part No.
	LCD BEZEL WITH CCD FUNCTION	60.TQ702.004
	LCD CABLE-WLED	50.TQ702.008
	LCD BRACKET-R&L	33.TQ702.005
	WLAN ANTENNA R(3*3)	50.TQ702.003
	WLAN ANTENNA R(1*2)	50.TQ702.004
	WLAN ANTENNA L	50.TQ702.005
	CAMERA BOARD 0.3M	55.TQ702.010
	ASSY LCD MODULE 14.1 IN. WLED N-GLARE CCD 0.3M	6M.TQ702.005
	LCD PANEL NG 14.1" WLED AUO B141EW05 V1 LF	LK.14105.026
	INVERTER BOARD	55.TQ702.009
	LCD COVER ASSY W/O 3G FUNCTION	60.TQ702.005
	LCD BEZEL WITH CCD FUNCTION	60.TQ702.004
	LCD CABLE-WLED	50.TQ702.008
	LCD BRACKET-R&L	33.TQ702.005

Category	Description	Acer Part No.
	WLAN ANTENNA R(3*3)	50.TQ702.003
	WLAN ANTENNA R(1*2)	50.TQ702.004
	WLAN ANTENNA L	50.TQ702.005
	CAMERA BOARD 0.3M	55.TQ702.010
Mainboard		
	MAINBOARD TM6493_3G INTEL GM45 ICH9 GIGABIT ETHERNET, SUPPORTING INTEL R AMT 4.0 MC3Z MDC1.5_AZALIA P	MB.TQA02.001
	MAINBOARD TM6493 INTEL GM45 ICH9 GIGABIT ETHERNET, SUPPORTING INTEL R AMT 4.0 MC3Z MDC1.5_AZALIA PROP	MB.TQ702.001
Memory		
	RAM 1GB DDRIII 1066 MICRON MT8JSF12864HY-1G1D1 LF	KN.1GB04.003
	RAM 1GB DDRIII 1066 ELPIDA EBJ11UE6BAU0-AE-E LF	KN.1GB09.009
	RAM 1GB DDRIII 1066 SAMSUNG M471B2874DZ1-CF8 LF	KN.1GB0B.019
	RAM 2GB DDRIII 1066 MICRON MT16JSF25664HY-1G1D1 LF	KN.2GB04.004
	RAM 2GB DDRIII 1066 ELPIDA EBJ21UE8BAU0-AE-E LF	KN.2GB09.002
	RAM 2GB DDRIII 1066 SAMSUNG M471B5673DZ1-CF8 LF	KN.2GB0B.005
Fan		
	FAN	23.TQ702.001
Heatsink		
	CPU THERMAL MODULE	60.TQ702.006
Speaker		
	SPEAKER SET R+L	23.TQ702.002

Category	Description	Acer Part No.
	MIC SET	23.TQ702.003
Miscellaneous		
	NAME PLATE-TM6493	47.TQ702.001

Screw List

Category	Description	Acer Part No.
SCREW	M2.5*10 (NL)	86.TQ702.001
SCREW	M2.5*4	86.TQ702.002
SCREW	M2*3 (NL)	86.TQ702.003
SCREW	M2*4 (NL)	86.TQ702.004
SCREW	M2*5	86.TQ702.005
SCREW	M3*3 (NI)	86.TQ702.006
SCREW	M M 2.5D 3.2L K 6D NI +	86.TQ702.007

Model Definition and Configuration

TravelMate 6493 Series

Model	RO	Country	Acer Part no	Description	CPU
TM6493-844G32Mn	EMEA	South Africa	LX.TQA0Z.144	TM6493-844G32Mn EM VB32TRZA2 MC UMAGCF 2*2G/320_7.2K/BT/6L/5R/n3_FP_0.3D_3G_MA_EN17	C2DP8400
TM6493-844G32Mn	EMEA	South Africa	LX.TQA0Z.143	TM6493-844G32Mn EM VB32TRZA1 MC UMAGCF 2*2G/320_7.2K/BT/6L/5R/n3_FP_0.3D_3G_MA_FR24	C2DP8400
TM6493-844G32Mn	EMEA	South Africa	LX.TQA0Z.142	TM6493-844G32Mn EM VB32TZA1 MC UMAGCF 2*2G/320_7.2K/BT/6L/5R/n3_FP_0.3D_3G_MA_FR24	C2DP8400
TM6493-844G32Mn	EMEA	South Africa	LX.TQA0Z.141	TM6493-844G32Mn EM VB32TZA2 MC UMAGCF 2*2G/320_7.2K/BT/6L/5R/n3_FP_0.3D_3G_MA_EN18	C2DP8400
TM6493-844G32Mn	EMEA	South Africa	LX.TQA0Z.140	TM6493-844G32Mn EM VB32TZA2 MC UMAGCF 2*2G/320_7.2K/BT/6L/5R/n3_FP_0.3D_3G_MA_EN17	C2DP8400
TM6493-844G32Mn	EMEA	South Africa	LX.TQA0Z.139	TM6493-844G32Mn EM VB32TRZA2 MC UMAGCF 2*2G/320_7.2K/BT/6L/5R/n3_FP_0.3D_3G_MA_EN18	C2DP8400
TM6493-844G32Mn	EMEA	Eastern Europe	LX.TQA0Z.128	TM6493-844G32Mn VB32TREU6 MC UMAGCF 2*2G/320_7.2K/BT/6L/5R/n3_FP_0.3D_3G_MA_CS21	C2DP8400
TM6493-844G32Mn	EMEA	Eastern Europe	LX.TQA0Z.129	TM6493-844G32Mn VB32TREU3 MC UMAGCF 2*2G/320_7.2K/BT/6L/5R/n3_FP_0.3D_3G_MA_RU12	C2DP8400
TM6493-844G32Mn	EMEA	Eastern Europe	LX.TQA0Z.127	TM6493-844G32Mn VB32TEU5 MC UMAGCF 2*2G/320_7.2K/BT/6L/5R/n3_FP_0.3D_3G_MA_PL11	C2DP8400
TM6493-844G32Mn	EMEA	Eastern Europe	LX.TQA0Z.126	TM6493-844G32Mn VB32TREU2 MC UMAGCF 2*2G/320_7.2K/BT/6L/5R/n3_FP_0.3D_3G_MA_HU21	C2DP8400
TM6493-844G32Mn	EMEA	Eastern Europe	LX.TQA0Z.125	TM6493-844G32Mn VB32TREU4 MC UMAGCF 2*2G/320_7.2K/BT/6L/5R/n3_FP_0.3D_3G_MA_FI12	C2DP8400
TM6493-844G32Mn	EMEA	Eastern Europe	LX.TQA0Z.121	TM6493-844G32Mn VB32TEU2 MC UMAGCF 2*2G/320_7.2K/BT/6L/5R/n3_FP_0.3D_3G_MA_HU21	C2DP8400
TM6493-844G32Mn	EMEA	Eastern Europe	LX.TQA0Z.122	TM6493-844G32Mn VB32TEU4 MC UMAGCF 2*2G/320_7.2K/BT/6L/5R/n3_FP_0.3D_3G_MA_FI12	C2DP8400
TM6493-844G32Mn	EMEA	Eastern Europe	LX.TQA0Z.123	TM6493-844G32Mn VB32TEU3 MC UMAGCF 2*2G/320_7.2K/BT/6L/5R/n3_FP_0.3D_3G_MA_RU11	C2DP8400
TM6493-844G32Mn	EMEA	Hungary	LX.TQA0Z.124	TM6493-844G32Mn VB32THU1 MC UMAGCF 2*2G/320_7.2K/BT/6L/5R/n3_FP_0.3D_3G_MA_HU11	C2DP8400
TM6493-844G32Mn	EMEA	Hungary	LX.TQA0Z.118	TM6493-844G32Mn VB32TRHU1 MC UMAGCF 2*2G/320_7.2K/BT/6L/5R/n3_FP_0.3D_3G_MA_HU11	C2DP8400

Model	RO	Country	Acer Part no	Description	CPU
TM6493-844G32Mn	EMEA	Slovenia/ Croatia	LX.TQA0Z.119	TM6493-844G32Mn VB32TSI1 MC UMAGCF 2*2G/320_7.2K/BT/6L/5R/ n3_FP_0.3D_3G_MA_EN11	C2DP8400
TM6493-844G32Mn	EMEA	Slovenia/ Croatia	LX.TQA0Z.120	TM6493-844G32Mn VB32TRS11 MC UMAGCF 2*2G/320_7.2K/BT/6L/5R/ n3_FP_0.3D_3G_MA_EN11	C2DP8400
TM6493-844G32Mn	EMEA	Slovenia/ Croatia	LX.TQA0Z.117	TM6493-844G32Mn VB32TRS11 MC UMAGCF 2*2G/320_7.2K/BT/6L/5R/ n3_FP_0.3D_3G_MA_EN12	C2DP8400
TM6493-844G32Mn	EMEA	Slovenia/ Croatia	LX.TQA0Z.116	TM6493-844G32Mn VB32TSI1 MC UMAGCF 2*2G/320_7.2K/BT/6L/5R/ n3_FP_0.3D_3G_MA_EN12	C2DP8400
TM6493-844G32Mn	EMEA	Portugal	LX.TQA0Z.115	TM6493-844G32Mn VB32TRPT1 MC UMAGCF 2*2G/320_7.2K/BT/6L/5R/ n3_FP_0.3D_3G_MA_PT12	C2DP8400
TM6493-844G32Mn	EMEA	Portugal	LX.TQA0Z.111	TM6493-844G32Mn VB32TPT1 MC UMAGCF 2*2G/320_7.2K/BT/6L/5R/ n3_FP_0.3D_3G_MA_PT12	C2DP8400
TM6493-844G32Mn	EMEA	Spain	LX.TQA0Z.112	TM6493-844G32Mn VB32TES1 MC UMAGCF 2*2G/320_7.2K/BT/6L/5R/ n3_FP_0.3D_3G_MA_ES22	C2DP8400
TM6493-844G32Mn	EMEA	Spain	LX.TQA0Z.113	TM6493-844G32Mn VB32TRES1 MC UMAGCF 2*2G/320_7.2K/BT/6L/5R/ n3_FP_0.3D_3G_MA_ES22	C2DP8400
TM6493-844G32Mn	EMEA	Spain	LX.TQA0Z.114	TM6493-844G32Mn VB32TRES1 MC UMAGCF 2*2G/320_7.2K/BT/6L/5R/ n3_FP_0.3D_3G_MA_ES23	C2DP8400
TM6493-844G32Mn	EMEA	Spain	LX.TQA0Z.108	TM6493-844G32Mn VB32TES1 MC UMAGCF 2*2G/320_7.2K/BT/6L/5R/ n3_FP_0.3D_3G_MA_ES23	C2DP8400
TM6493-844G32Mn	EMEA	Greece	LX.TQA0Z.109	TM6493-844G32Mn VB32TGR1 MC UMAGCF 2*2G/320_7.2K/BT/6L/5R/ n3_FP_0.3D_3G_MA_EL32	C2DP8400
TM6493-844G32Mn	EMEA	Greece	LX.TQA0Z.110	TM6493-844G32Mn VB32TRGR1 MC UMAGCF 2*2G/320_7.2K/BT/6L/5R/ n3_FP_0.3D_3G_MA_EL32	C2DP8400
TM6493-844G32Mn	EMEA	Israel	LX.TQA0Z.107	TM6493-844G32Mn VB32TIL1 MC UMAGCF 2*2G/320_7.2K/BT/6L/5R/ n3_FP_0.3D_3G_MA_HE31	C2DP8400
TM6493-844G32Mn	EMEA	Israel	LX.TQA0Z.106	TM6493-844G32Mn VB32TRIL1 MC UMAGCF 2*2G/320_7.2K/BT/6L/5R/ n3_FP_0.3D_3G_MA_HE31	C2DP8400
TM6493-844G32Mn	EMEA	Israel	LX.TQA0Z.105	TM6493-844G32Mn VB32T IL1 MC UMAGCF 2*2G/320_7.2K/BT/6L/5R/ n3_FP_0.3D_3G_MA_HE31	C2DP8400
TM6493-844G32Mn	EMEA	Italy	LX.TQA0Z.101	TM6493-844G32Mn VB32TIT1 MC UMAGCF 2*2G/320_7.2K/BT/6L/5R/ n3_FP_0.3D_3G_MA_IT14	C2DP8400
TM6493-844G32Mn	EMEA	Italy	LX.TQA0Z.102	TM6493-844G32Mn VB32TIT1 MC UMAGCF 2*2G/320_7.2K/BT/6L/5R/ n3_FP_0.3D_3G_MA_IT12	C2DP8400
TM6493-844G32Mn	EMEA	Italy	LX.TQA0Z.103	TM6493-844G32Mn VB32TRIT1 MC UMAGCF 2*2G/320_7.2K/BT/6L/5R/ n3_FP_0.3D_3G_MA_IT12	C2DP8400
TM6493-844G32Mn	EMEA	Italy	LX.TQA0Z.104	TM6493-844G32Mn VB32TRIT1 MC UMAGCF 2*2G/320_7.2K/BT/6L/5R/ n3_FP_0.3D_3G_MA_IT14	C2DP8400

Model	RO	Country	Acer Part no	Description	CPU
TM6493-844G32Mn	EMEA	Turkey	LX.TQA0Z.098	TM6493-844G32Mn EM VB32TRTR1 MC UMAGCF 2*2G/320_7.2K/BT/6L/5R/ n3_FP_0.3D_3G_MA_TR12	C2DP8400
TM6493-844G32Mn	EMEA	Turkey	LX.TQA0Z.099	TM6493-844G32Mn EM VB32TRTR1 MC UMAGCF 2*2G/320_7.2K/BT/6L/5R/ n3_FP_0.3D_3G_MA_TR42	C2DP8400
TM6493-844G32Mn	EMEA	Turkey	LX.TQA0Z.100	TM6493-844G32Mn EM VB32TTR1 MC UMAGCF 2*2G/320_7.2K/BT/6L/5R/ n3_FP_0.3D_3G_MA_TR41	C2DP8400
TM6493-844G32Mn	EMEA	Turkey	LX.TQA0Z.097	TM6493-844G32Mn EM VB32TTR1 MC UMAGCF 2*2G/320_7.2K/BT/6L/5R/ n3_FP_0.3D_3G_MA_TR12	C2DP8400
TM6493-844G32Mn	EMEA	Middle East	LX.TQA0Z.096	TM6493-844G32Mn EM VB32TRME2 MC UMAGCF 2*2G/320_7.2K/BT/6L/5R/ n3_FP_0.3D_3G_MA_AR24	C2DP8400
TM6493-844G32Mn	EMEA	Middle East	LX.TQA0Z.095	TM6493-844G32Mn EM VB32TME3 MC UMAGCF 2*2G/320_7.2K/BT/6L/5R/ n3_FP_0.3D_3G_MA_FR25	C2DP8400
TM6493-844G32Mn	EMEA	Middle East	LX.TQA0Z.091	TM6493-844G32Mn EM VB32TME9 MC UMAGCF 2*2G/320_7.2K/BT/6L/5R/ n3_FP_0.3D_3G_MA_FR23	C2DP8400
TM6493-844G32Mn	EMEA	Middle East	LX.TQA0Z.092	TM6493-844G32Mn EM VB32TRME3 MC UMAGCF 2*2G/320_7.2K/BT/6L/5R/ n3_FP_0.3D_3G_MA_FR25	C2DP8400
TM6493-844G32Mn	EMEA	Middle East	LX.TQA0Z.093	TM6493-844G32Mn EM VB32TRME9 MC UMAGCF 2*2G/320_7.2K/BT/6L/5R/ n3_FP_0.3D_3G_MA_FR24	C2DP8400
TM6493-844G32Mn	EMEA	Middle East	LX.TQA0Z.094	TM6493-844G32Mn EM VB32TME2 MC UMAGCF 2*2G/320_7.2K/BT/6L/5R/ n3_FP_0.3D_3G_MA_AR13	C2DP8400
TM6493-844G32Mn	EMEA	Middle East	LX.TQA0Z.088	TM6493-844G32Mn EM VB32TRME2 MC UMAGCF 2*2G/320_7.2K/BT/6L/5R/ n3_FP_0.3D_3G_MA_AR13	C2DP8400
TM6493-844G32Mn	EMEA	Middle East	LX.TQA0Z.089	TM6493-844G32Mn EM VB32TME6 MC UMAGCF 2*2G/320_7.2K/BT/6L/5R/ n3_FP_0.3D_3G_MA_EN17	C2DP8400
TM6493-844G32Mn	EMEA	Middle East	LX.TQA0Z.090	TM6493-844G32Mn EM VB32TRME6 MC UMAGCF 2*2G/320_7.2K/BT/6L/5R/ n3_FP_0.3D_3G_MA_EN17	C2DP8400
TM6493-844G32Mn	EMEA	Middle East	LX.TQA0Z.087	TM6493-844G32Mn EM VB32TRME9 MC UMAGCF 2*2G/320_7.2K/BT/6L/5R/ n3_FP_0.3D_3G_MA_FR23	C2DP8400
TM6493-844G32Mn	EMEA	Middle East	LX.TQA0Z.086	TM6493-844G32Mn EM VB32TME9 MC UMAGCF 2*2G/320_7.2K/BT/6L/5R/ n3_FP_0.3D_3G_MA_FR22	C2DP8400
TM6493-844G32Mn	EMEA	Middle East	LX.TQA0Z.085	TM6493-844G32Mn EM VB32TME2 MC UMAGCF 2*2G/320_7.2K/BT/6L/5R/ n3_FP_0.3D_3G_MA_AR25	C2DP8400
TM6493-844G32Mn	EMEA	Middle East	LX.TQA0Z.081	TM6493-844G32Mn EM VB32TME6 MC UMAGCF 2*2G/320_7.2K/BT/6L/5R/ n3_FP_0.3D_3G_MA_EN16	C2DP8400
TM6493-844G32Mn	EMEA	Middle East	LX.TQA0Z.082	TM6493-844G32Mn EM VB32TRME2 MC UMAGCF 2*2G/320_7.2K/BT/6L/5R/ n3_FP_0.3D_3G_MA_AR25	C2DP8400
TM6493-844G32Mn	EMEA	Middle East	LX.TQA0Z.083	TM6493-844G32Mn EM VB32TRME6 MC UMAGCF 2*2G/320_7.2K/BT/6L/5R/ n3_FP_0.3D_3G_MA_EN16	C2DP8400

Model	RO	Country	Acer Part no	Description	CPU
TM6493-844G32Mn	EMEA	Middle East	LX.TQA0Z.084	TM6493-844G32Mn EM VB32TME3 MC UMAGCF 2*2G/320_7.2K/BT/6L/5R/ n3_FP_0.3D_3G_MA_FR24	C2DP8400
TM6493-844G32Mn	EMEA	Middle East	LX.TQA0Z.078	TM6493-844G32Mn EM VB32TRME3 MC UMAGCF 2*2G/320_7.2K/BT/6L/5R/ n3_FP_0.3D_3G_MA_FR24	C2DP8400
TM6493-844G32Mn	EMEA	Middle East	LX.TQA0Z.079	TM6493-844G32Mn EM VB32TME2 MC UMAGCF 2*2G/320_7.2K/BT/6L/5R/ n3_FP_0.3D_3G_MA_AR24	C2DP8400
TM6493-844G32Mn	EMEA	Switzerland	LX.TQA0Z.080	TM6493-844G32Mn VB32TCH1 MC UMAGCF 2*2G/320_7.2K/BT/6L/5R/ n3_FP_0.3D_3G_MA_IT42	C2DP8400
TM6493-844G32Mn	EMEA	Switzerland	LX.TQA0Z.077	TM6493-844G32Mn VB32TRCH1 MC UMAGCF 2*2G/320_7.2K/BT/6L/5R/ n3_FP_0.3D_3G_MA_IT42	C2DP8400
TM6493-844G32Mn	EMEA	UK	LX.TQA0Z.076	TM6493-844G32Mn VB32TGB1 MC UMAGCF 2*2G/320_7.2K/BT/6L/5R/ n3_FP_0.3D_3G_MA_EN14	C2DP8400
TM6493-844G32Mn	EMEA	UK	LX.TQA0Z.075	TM6493-844G32Mn VB32TRGB1 MC UMAGCF 2*2G/320_7.2K/BT/6L/5R/ n3_FP_0.3D_3G_MA_EN15	C2DP8400
TM6493-844G32Mn	EMEA	UK	LX.TQA0Z.048	TM6493-844G32Mn VB32TRGB1 MC UMAGCF 2*2G/320_7.2K/BT/6L/5R/ n3_FP_0.3D_3G_MA_EN14	C2DP8400
TM6493-844G32Mn	EMEA	South Africa	LX.TQA0Z.138	TM6493-844G32Mn EM VB32TZA1 MC UMAGCF 2*2G/320_7.2K/BT/6L/5R/ n3_FP_0.3D_3G_MA_FR25	C2DP8400
TM6493-844G32Mn	EMEA	South Africa	LX.TQA0Z.137	TM6493-844G32Mn EM VB32TRZA1 MC UMAGCF 2*2G/320_7.2K/BT/6L/5R/ n3_FP_0.3D_3G_MA_FR25	C2DP8400
TM6493-844G32Mn	EMEA	Denmark	LX.TQA0Z.136	TM6493-844G32Mn VB32TDK1 MC UMAGCF 2*2G/320_7.2K/BT/6L/5R/ n3_FP_0.3D_3G_MA_NO13	C2DP8400
TM6493-844G32Mn	EMEA	Denmark	LX.TQA0Z.135	TM6493-844G32Mn VB32TRDK1 MC UMAGCF 2*2G/320_7.2K/BT/6L/5R/ n3_FP_0.3D_3G_MA_NO13	C2DP8400
TM6493-844G32Mn	EMEA	France	LX.TQA0Z.134	TM6493-844G32Mn VB32TFR1 MC UMAGCF 2*2G/320_7.2K/BT/6L/5R/ n3_FP_0.3D_3G_MA_FR23	C2DP8400
TM6493-844G32Mn	EMEA	France	LX.TQA0Z.133	TM6493-844G32Mn VB32TRFR1 MC UMAGCF 2*2G/320_7.2K/BT/6L/5R/ n3_FP_0.3D_3G_MA_FR24	C2DP8400
TM6493-844G32Mn	EMEA	France	LX.TQA0Z.132	TM6493-844G32Mn VB32TFR1 MC UMAGCF 2*2G/320_7.2K/BT/6L/5R/ n3_FP_0.3D_3G_MA_FR24	C2DP8400
TM6493-844G32Mn	EMEA	France	LX.TQA0Z.131	TM6493-844G32Mn VB32TRFR1 MC UMAGCF 2*2G/320_7.2K/BT/6L/5R/ n3_FP_0.3D_3G_MA_FR23	C2DP8400
TM6493-844G32Mn	EMEA	Germany	LX.TQA0Z.130	TM6493-844G32Mn VB32TDE1 MC UMAGCF 2*2G/320_7.2K/BT/6L/5R/ n3_FP_0.3D_3G_MA_DE13	C2DP8400
TM6493-844G32Mn	EMEA	Germany	LX.TQA0Z.074	TM6493-844G32Mn VB32TRDE1 MC UMAGCF 2*2G/320_7.2K/BT/6L/5R/ n3_FP_0.3D_3G_MA_DE14	C2DP8400
TM6493-844G32Mn	EMEA	Germany	LX.TQA0Z.073	TM6493-844G32Mn VB32TRDE1 MC UMAGCF 2*2G/320_7.2K/BT/6L/5R/ n3_FP_0.3D_3G_MA_DE13	C2DP8400

Model	RO	Country	Acer Part no	Description	CPU
TM6493-844G32Mn	EMEA	Germany	LX.TQA0Z.072	TM6493-844G32Mn VB32TDE1 MC UMAGCF 2*2G/320_7.2K/BT/6L/5R/ n3_FP_0.3D_3G_MA_DE14	C2DP8400
TM6493-844G32Mn	EMEA	Belgium	LX.TQA0Z.071	TM6493-844G32Mn VB32TBE1 MC UMAGCF 2*2G/320_7.2K/BT/6L/5R/ n3_FP_0.3D_3G_MA_NL13	C2DP8400
TM6493-844G32Mn	EMEA	Belgium	LX.TQA0Z.070	TM6493-844G32Mn VB32TRBE1 MC UMAGCF 2*2G/320_7.2K/BT/6L/5R/ n3_FP_0.3D_3G_MA_NL13	C2DP8400
TM6493-844G32Mn	EMEA	Holland	LX.TQA0Z.069	TM6493-844G32Mn VB32TNL1 MC UMAGCF 2*2G/320_7.2K/BT/6L/5R/ n3_FP_0.3D_3G_MA_NL12	C2DP8400
TM6493-844G32Mn	EMEA	Holland	LX.TQA0Z.068	TM6493-844G32Mn VB32TRNL1 MC UMAGCF 2*2G/320_7.2K/BT/6L/5R/ n3_FP_0.3D_3G_MA_NL12	C2DP8400
TM6493-844G32Mn	EMEA	Luxembourg	LX.TQA0Z.067	TM6493-844G32Mn VB32TRLU1 MC UMAGCF 2*2G/320_7.2K/BT/6L/5R/ n3_FP_0.3D_3G_MA_IT42	C2DP8400
TM6493-844G32Mn	EMEA	Norway	LX.TQA0Z.066	TM6493-844G32Mn VB32TRNO1 MC UMAGCF 2*2G/320_7.2K/BT/6L/5R/ n3_FP_0.3D_3G_MA_NO12	C2DP8400
TM6493-844G32Mn	EMEA	Russia	LX.TQA0Z.065	TM6493-844G32Mn VB32TRRU1 MC UMAGCF 2*2G/320_7.2K/BT/6L/5R/ n3_FP_0.3D_3G_MA_RU11	C2DP8400
TM6493-844G32Mn	EMEA	Russia	LX.TQA0Z.061	TM6493-844G32Mn VB32TRRU1 MC UMAGCF 2*2G/320_7.2K/BT/6L/5R/ n3_FP_0.3D_3G_MA_RU12	C2DP8400
TM6493-844G32Mn	EMEA	Sweden/ Finland	LX.TQA0Z.056	TM6493-844G32Mn VB32TRSE1 MC UMAGCF 2*2G/320_7.2K/BT/6L/5R/ n3_FP_0.3D_3G_MA_FI12	C2DP8400
TM6493-844G32Mn	EMEA	Czech	LX.TQA0Z.059	TM6493-844G32Mn VB32TRCZ2 MC UMAGCF 2*2G/320_7.2K/BT/6L/5R/ n3_FP_0.3D_3G_MA_SK11	C2DP8400
TM6493-844G32Mn	EMEA	Eastern Europe	LX.TQA0Z.054	TM6493-844G32Mn VB32TREU1 MC UMAGCF 2*2G/320_7.2K/BT/6L/5R/ n3_FP_0.3D_3G_MA_CS21	C2DP8400
TM6493-844G32Mn	EMEA	Eastern Europe	LX.TQA0Z.055	TM6493-844G32Mn VB32TREU3 MC UMAGCF 2*2G/320_7.2K/BT/6L/5R/ n3_FP_0.3D_3G_MA_RU11	C2DP8400
TM6493-844G32Mn	EMEA	Eastern Europe	LX.TQA0Z.052	TM6493-844G32Mn VB32TREU5 MC UMAGCF 2*2G/320_7.2K/BT/6L/5R/ n3_FP_0.3D_3G_MA_PL11	C2DP8400
TM6493-844G32Mn	EMEA	Sweden/ Finland	LX.TQA0Z.029	TM6493-844G32Mn VB32TRSE1 MC UMAGCF 2*2G/320/BT/6L/ 5R_n3_FP_0.3D_GG7_MA_FI12	C2DP8400
TM6493-844G32Mn	EMEA	Czech	LX.TQA0Z.008	TM6493-844G32Mn VB32TRCZ2 MC UMAGCF 2*2G/320/BT/6L/ 5R_n3_FP_0.3D_3G_GG7_MA_SK11	C2DP8400
TM6493-844G32Mn	EMEA	Eastern Europe	LX.TQA0Z.030	TM6493-844G32Mn VB32TREU1 MC UMAGCF 2*2G/320/BT/6L/ 5R_n3_FP_0.3D_GG7_MA_CS21	C2DP8400
TM6493-844G32Mn	EMEA	Belgium	LX.TQA0Z.009	TM6493-844G32Mn VB32TRBE1 MC UMAGCF 2*2G/320/BT/6L/ 5R_n3_FP_0.3D_GG7_MA_NL13	C2DP8400
TM6493-844G32Mn	EMEA	Eastern Europe	LX.TQA0Z.031	TM6493-844G32Mn VB32TREU4 MC UMAGCF 2*2G/320/BT/6L/ 5R_n3_FP_0.3D_GG7_MA_FI12	C2DP8400

Model	RO	Country	Acer Part no	Description	CPU
TM6493-844G32Mn	EMEA	Eastern Europe	LX.TQA0Z.032	TM6493-844G32Mn VB32TREU3 MC UMAGCF 2*2G/320/BT/6L/ 5R_n3_FP_0.3D_GG7_MA_RU11	C2DP8400
TM6493-844G32Mn	EMEA	Eastern Europe	LX.TQA0Z.033	TM6493-844G32Mn VB32TREU2 MC UMAGCF 2*2G/320/BT/6L/ 5R_n3_FP_0.3D_GG7_MA_HU21	C2DP8400
TM6493-844G32Mn	EMEA	Eastern Europe	LX.TQA0Z.034	TM6493-844G32Mn VB32TREU5 MC UMAGCF 2*2G/320/BT/6L/ 5R_n3_FP_0.3D_GG7_MA_PL11	C2DP8400
TM6493-844G32Mn	EMEA	Hungary	LX.TQA0Z.035	TM6493-844G32Mn VB32TRHU1 MC UMAGCF 2*2G/320/BT/6L/ 5R_n3_FP_0.3D_GG7_MA_HU11	C2DP8400
TM6493-844G32Mn	EMEA	Eastern Europe	LX.TQA0Z.036	TM6493-844G32Mn VB32TREU3 MC UMAGCF 2*2G/320/BT/6L/ 5R_n3_FP_0.3D_GG7_MA_RU12	C2DP8400
TM6493-844G32Mn	EMEA	Slovenia/ Croatia	LX.TQA0Z.037	TM6493-844G32Mn VB32TRS11 MC UMAGCF 2*2G/320/BT/6L/ 5R_n3_FP_0.3D_GG7_MA_EN11	C2DP8400
TM6493-844G32Mn	EMEA	Slovenia/ Croatia	LX.TQA0Z.038	TM6493-844G32Mn VB32TRS11 MC UMAGCF 2*2G/320/BT/6L/ 5R_n3_FP_0.3D_GG7_MA_EN12	C2DP8400
TM6493-844G32Mn	EMEA	Portugal	LX.TQA0Z.039	TM6493-844G32Mn VB32TRPT1 MC UMAGCF 2*2G/320/BT/6L/ 5R_n3_FP_0.3D_GG7_MA_PT12	C2DP8400
TM6493-844G32Mn	EMEA	Spain	LX.TQA0Z.040	TM6493-844G32Mn VB32TRES1 MC UMAGCF 2*2G/320/BT/6L/ 5R_n3_FP_0.3D_GG7_MA_ES22	C2DP8400
TM6493-844G32Mn	EMEA	Spain	LX.TQA0Z.041	TM6493-844G32Mn VB32TRES1 MC UMAGCF 2*2G/320/BT/6L/ 5R_n3_FP_0.3D_GG7_MA_ES23	C2DP8400
TM6493-844G32Mn	EMEA	Greece	LX.TQA0Z.042	TM6493-844G32Mn VB32TRGR1 MC UMAGCF 2*2G/320/BT/6L/ 5R_n3_FP_0.3D_GG7_MA_EL32	C2DP8400
TM6493-844G32Mn	EMEA	Israel	LX.TQA0Z.043	TM6493-844G32Mn VB32TRIL1 MC UMAGCF 2*2G/320/BT/6L/ 5R_n3_FP_0.3D_GG7_MA_HE31	C2DP8400
TM6493-844G32Mn	EMEA	Italy	LX.TQA0Z.044	TM6493-844G32Mn VB32TRIT1 MC UMAGCF 2*2G/320/BT/6L/ 5R_n3_FP_0.3D_GG7_MA_IT12	C2DP8400
TM6493-844G32Mn	EMEA	Italy	LX.TQA0Z.045	TM6493-844G32Mn VB32TRIT1 MC UMAGCF 2*2G/320/BT/6L/ 5R_n3_FP_0.3D_GG7_MA_IT14	C2DP8400
TM6493-844G32Mn	EMEA	Turkey	LX.TQA0Z.010	TM6493-844G32Mn EM VB32TRTR1 MC UMAGCF 2*2G/320/BT/6L/ 5R_n3_FP_0.3D_GG7_MA_TR12	C2DP8400
TM6493-844G32Mn	EMEA	Turkey	LX.TQA0Z.011	TM6493-844G32Mn EM VB32TRTR1 MC UMAGCF 2*2G/320/BT/6L/ 5R_n3_FP_0.3D_GG7_MA_TR42	C2DP8400
TM6493-844G32Mn	EMEA	Middle East	LX.TQA0Z.012	TM6493-844G32Mn EM VB32TRME2 MC UMAGCF 2*2G/320/BT/6L/ 5R_n3_FP_0.3D_GG7_MA_AR24	C2DP8400
TM6493-844G32Mn	EMEA	Middle East	LX.TQA0Z.013	TM6493-844G32Mn EM VB32TRME3 MC UMAGCF 2*2G/320/BT/6L/ 5R_n3_FP_0.3D_GG7_MA_FR24	C2DP8400
TM6493-844G32Mn	EMEA	Middle East	LX.TQA0Z.014	TM6493-844G32Mn EM VB32TRME6 MC UMAGCF 2*2G/320/BT/6L/ 5R_n3_FP_0.3D_GG7_MA_EN16	C2DP8400

Model	RO	Country	Acer Part no	Description	CPU
TM6493-844G32Mn	EMEA	Middle East	LX.TQA0Z.015	TM6493-844G32Mn EM VB32TRME2 MC UMAGCF 2*2G/320/BT/6L/ 5R_n3_FP_0.3D_GG7_MA_AR25	C2DP8400
TM6493-844G32Mn	EMEA	Middle East	LX.TQA0Z.016	TM6493-844G32Mn EM VB32TRME9 MC UMAGCF 2*2G/320/BT/6L/ 5R_n3_FP_0.3D_GG7_MA_FR23	C2DP8400
TM6493-844G32Mn	EMEA	Middle East	LX.TQA0Z.017	TM6493-844G32Mn EM VB32TRME6 MC UMAGCF 2*2G/320/BT/6L/ 5R_n3_FP_0.3D_GG7_MA_EN17	C2DP8400
TM6493-844G32Mn	EMEA	Middle East	LX.TQA0Z.018	TM6493-844G32Mn EM VB32TRME2 MC UMAGCF 2*2G/320/BT/6L/ 5R_n3_FP_0.3D_GG7_MA_AR13	C2DP8400
TM6493-844G32Mn	EMEA	Middle East	LX.TQA0Z.019	TM6493-844G32Mn EM VB32TRME9 MC UMAGCF 2*2G/320/BT/6L/ 5R_n3_FP_0.3D_GG7_MA_FR24	C2DP8400
TM6493-844G32Mn	EMEA	Middle East	LX.TQA0Z.020	TM6493-844G32Mn EM VB32TRME3 MC UMAGCF 2*2G/320/BT/6L/ 5R_n3_FP_0.3D_GG7_MA_FR25	C2DP8400
TM6493-844G32Mn	EMEA	Switzerland	LX.TQA0Z.021	TM6493-844G32Mn VB32TRCH1 MC UMAGCF 2*2G/320/BT/6L/ 5R_n3_FP_0.3D_GG7_MA_IT42	C2DP8400
TM6493-844G32Mn	EMEA	UK	LX.TQA0Z.046	TM6493-844G32Mn VB32TRGB1 MC UMAGCF 2*2G/320/BT/6L/ 5R_n3_FP_0.3D_GG7_MA_EN14	C2DP8400
TM6493-844G32Mn	EMEA	UK	LX.TQA0Z.047	TM6493-844G32Mn VB32TRGB1 MC UMAGCF 2*2G/320/BT/6L/ 5R_n3_FP_0.3D_GG7_MA_EN15	C2DP8400
TM6493-844G32Mn	EMEA	South Africa	LX.TQA0Z.001	TM6493-844G32Mn EM VB32TRZA2 MC UMAGCF 2*2G/320/BT/6L/ 5R_n3_FP_0.3D_GG7_MA_EN17	C2DP8400
TM6493-844G32Mn	EMEA	South Africa	LX.TQA0Z.002	TM6493-844G32Mn EM VB32TRZA1 MC UMAGCF 2*2G/320/BT/6L/ 5R_n3_FP_0.3D_GG7_MA_FR24	C2DP8400
TM6493-844G32Mn	EMEA	South Africa	LX.TQA0Z.003	TM6493-844G32Mn EM VB32TRZA2 MC UMAGCF 2*2G/320/BT/6L/ 5R_n3_FP_0.3D_GG7_MA_EN18	C2DP8400
TM6493-844G32Mn	EMEA	South Africa	LX.TQA0Z.004	TM6493-844G32Mn EM VB32TRZA1 MC UMAGCF 2*2G/320/BT/6L/ 5R_n3_FP_0.3D_GG7_MA_FR25	C2DP8400
TM6493-844G32Mn	EMEA	Denmark	LX.TQA0Z.005	TM6493-844G32Mn VB32TRDK1 MC UMAGCF 2*2G/320/BT/6L/ 5R_n3_FP_0.3D_GG7_MA_NO13	C2DP8400
TM6493-844G32Mn	EMEA	France	LX.TQA0Z.022	TM6493-844G32Mn VB32TRFR1 MC UMAGCF 2*2G/320/BT/6L/ 5R_n3_FP_0.3D_GG7_MA_FR23	C2DP8400
TM6493-844G32Mn	EMEA	France	LX.TQA0Z.023	TM6493-844G32Mn VB32TRFR1 MC UMAGCF 2*2G/320/BT/6L/ 5R_n3_FP_0.3D_GG7_MA_FR24	C2DP8400
TM6493-844G32Mn	EMEA	Germany	LX.TQA0Z.006	TM6493-844G32Mn VB32TRDE1 MC UMAGCF 2*2G/320/BT/6L/ 5R_n3_FP_0.3D_GG7_MA_DE13	C2DP8400
TM6493-844G32Mn	EMEA	Germany	LX.TQA0Z.007	TM6493-844G32Mn VB32TRDE1 MC UMAGCF 2*2G/320/BT/6L/ 5R_n3_FP_0.3D_GG7_MA_DE14	C2DP8400
TM6493-844G32Mn	EMEA	Holland	LX.TQA0Z.024	TM6493-844G32Mn VB32TRNL1 MC UMAGCF 2*2G/320/BT/6L/ 5R_n3_FP_0.3D_GG7_MA_NL12	C2DP8400

Model	RO	Country	Acer Part no	Description	CPU
TM6493-844G32Mn	EMEA	Luxembourg	LX.TQA0Z.025	TM6493-844G32Mn VB32TRLU1 MC UMAGCF 2*2G/320/BT/6L/ 5R_n3_FP_0.3D_GG7_MA_IT42	C2DP8400
TM6493-844G32Mn	EMEA	Norway	LX.TQA0Z.026	TM6493-844G32Mn VB32TRNO1 MC UMAGCF 2*2G/320/BT/6L/ 5R_n3_FP_0.3D_GG7_MA_NO12	C2DP8400
TM6493-844G32Mi	EMEA	Russia	LX.TQA0Z.027	TM6493-844G32Mi VB32TRRU1 MC UMAGCF 2*2G/320/BT/6L/5R/ abg_FP_0.3D_3G_GG7_MA_RU11	C2DP8400
TM6493-844G32Mi	EMEA	Russia	LX.TQA0Z.028	TM6493-844G32Mi VB32TRRU1 MC UMAGCF 2*2G/320/BT/6L/5R/ abg_FP_0.3D_3G_GG7_MA_RU12	C2DP8400
TM6493-844G32Mn	EMEA	Luxembourg	LX.TQA0Z.223	TM6493-844G32Mn VB32TRLU1 MC UMAGCF 2*2G/320_7.2K/BT/6L/5R/ n3_FP_0.3D_3G_GG7_MA_IT43	C2DP8400
TM6493-844G32Mn	EMEA	Luxembourg	LX.TQA0Z.222	TM6493-844G32Mn VB32TRLU1 MC UMAGCF 2*2G/320_7.2K/BT/6L/5R/ n3_FP_0.3D_3G_GG7_MA_IT44	C2DP8400
TM6493-844G32Mn	EMEA	Norway	LX.TQA0Z.221	TM6493-844G32Mn VB32TRNO1 MC UMAGCF 2*2G/320_7.2K/BT/6L/5R/ n3_FP_0.3D_3G_GG7_MA_NO13	C2DP8400
TM6493-844G32Mn	EMEA	Norway	LX.TQA0Z.220	TM6493-844G32Mn VB32TRNO1 MC UMAGCF 2*2G/320_7.2K/BT/6L/5R/ n3_FP_0.3D_3G_GG7_MA_NO14	C2DP8400
TM6493-844G32Mi	EMEA	Russia	LX.TQA0Z.219	TM6493-844G32Mi VB32TRRU1 MC UMAGCF 2*2G/320_7.2K/BT/6L/5R/ abg_FP_0.3D_3G_GG7_MA_RU13	C2DP8400
TM6493-844G32Mi	EMEA	Russia	LX.TQA0Z.218	TM6493-844G32Mi VB32TRRU1 MC UMAGCF 2*2G/320_7.2K/BT/6L/5R/ abg_FP_0.3D_3G_GG7_MA_RU14	C2DP8400
TM6493-844G32Mn	EMEA	Sweden/ Finland	LX.TQA0Z.217	TM6493-844G32Mn VB32TRSE1 MC UMAGCF 2*2G/320_7.2K/BT/6L/5R/ n3_FP_0.3D_3G_GG7_MA_FI13	C2DP8400
TM6493-844G32Mn	EMEA	Sweden/ Finland	LX.TQA0Z.203	TM6493-844G32Mn VB32TRSE1 MC UMAGCF 2*2G/320_7.2K/BT/6L/5R/ n3_FP_0.3D_3G_GG7_MA_FI14	C2DP8400
TM6493-844G32Mn	EMEA	Czech	LX.TQA0Z.202	TM6493-844G32Mn VB32TRCZ2 MC UMAGCF 2*2G/320_7.2K/BT/6L/5R/ n3_FP_0.3D_3G_GG7_MA_SK12	C2DP8400
TM6493-844G32Mn	EMEA	Czech	LX.TQA0Z.201	TM6493-844G32Mn VB32TRCZ1 MC UMAGCF 2*2G/320_7.2K/BT/6L/5R/ n3_FP_0.3D_3G_GG7_MA_SK12	C2DP8400
TM6493-844G32Mn	EMEA	Czech	LX.TQA0Z.199	TM6493-844G32Mn VB32TRCZ1 MC UMAGCF 2*2G/320_7.2K/BT/6L/5R/ n3_FP_0.3D_3G_GG7_MA_SK13	C2DP8400
TM6493-844G32Mn	EMEA	Czech	LX.TQA0Z.195	TM6493-844G32Mn VB32TRCZ2 MC UMAGCF 2*2G/320_7.2K/BT/6L/5R/ n3_FP_0.3D_3G_GG7_MA_SK13	C2DP8400
TM6493-844G32Mn	EMEA	Eastern Europe	LX.TQA0Z.196	TM6493-844G32Mn VB32TREU7 MC UMAGCF 2*2G/320_7.2K/BT/6L/5R/ n3_FP_0.3D_3G_GG7_MA_ENG2	C2DP8400
TM6493-844G32Mn	EMEA	Eastern Europe	LX.TQA0Z.197	TM6493-844G32Mn VB32TREU2 MC UMAGCF 2*2G/320_7.2K/BT/6L/5R/ n3_FP_0.3D_3G_GG7_MA_HU23	C2DP8400
TM6493-844G32Mn	EMEA	Eastern Europe	LX.TQA0Z.198	TM6493-844G32Mn VB32TREU5 MC UMAGCF 2*2G/320_7.2K/BT/6L/5R/ n3_FP_0.3D_3G_GG7_MA_PL13	C2DP8400

Model	RO	Country	Acer Part no	Description	CPU
TM6493-844G32Mn	EMEA	Eastern Europe	LX.TQA0Z.192	TM6493-844G32Mn VB32TREU6 MC UMAGCF 2*2G/320_7.2K/BT/6L/5R/n3_FP_0.3D_3G_GG7_MA_CS23	C2DP8400
TM6493-844G32Mn	EMEA	Eastern Europe	LX.TQA0Z.193	TM6493-844G32Mn VB32TREU7 MC UMAGCF 2*2G/320_7.2K/BT/6L/5R/n3_FP_0.3D_3G_GG7_MA_ENG3	C2DP8400
TM6493-844G32Mn	EMEA	Eastern Europe	LX.TQA0Z.194	TM6493-844G32Mn VB32TREU2 MC UMAGCF 2*2G/320_7.2K/BT/6L/5R/n3_FP_0.3D_3G_GG7_MA_HU22	C2DP8400
TM6493-844G32Mn	EMEA	Eastern Europe	LX.TQA0Z.191	TM6493-844G32Mn VB32TREU4 MC UMAGCF 2*2G/320_7.2K/BT/6L/5R/n3_FP_0.3D_3G_GG7_MA_FI13	C2DP8400
TM6493-844G32Mn	EMEA	Eastern Europe	LX.TQA0Z.190	TM6493-844G32Mn VB32TREU1 MC UMAGCF 2*2G/320_7.2K/BT/6L/5R/n3_FP_0.3D_3G_GG7_MA_CS22	C2DP8400
TM6493-844G32Mn	EMEA	Eastern Europe	LX.TQA0Z.189	TM6493-844G32Mn VB32TREU3 MC UMAGCF 2*2G/320_7.2K/BT/6L/5R/n3_FP_0.3D_3G_GG7_MA_RU13	C2DP8400
TM6493-844G32Mn	EMEA	Eastern Europe	LX.TQA0Z.185	TM6493-844G32Mn VB32TREU5 MC UMAGCF 2*2G/320_7.2K/BT/6L/5R/n3_FP_0.3D_3G_GG7_MA_PL12	C2DP8400
TM6493-844G32Mn	EMEA	Eastern Europe	LX.TQA0Z.186	TM6493-844G32Mn VB32TREU1 MC UMAGCF 2*2G/320_7.2K/BT/6L/5R/n3_FP_0.3D_3G_GG7_MA_CS23	C2DP8400
TM6493-844G32Mn	EMEA	Eastern Europe	LX.TQA0Z.187	TM6493-844G32Mn VB32TREU4 MC UMAGCF 2*2G/320_7.2K/BT/6L/5R/n3_FP_0.3D_3G_GG7_MA_FI14	C2DP8400
TM6493-844G32Mn	EMEA	Eastern Europe	LX.TQA0Z.188	TM6493-844G32Mn VB32TREU3 MC UMAGCF 2*2G/320_7.2K/BT/6L/5R/n3_FP_0.3D_3G_GG7_MA_RU14	C2DP8400
TM6493-844G32Mn	EMEA	Eastern Europe	LX.TQA0Z.182	TM6493-844G32Mn VB32TREU6 MC UMAGCF 2*2G/320_7.2K/BT/6L/5R/n3_FP_0.3D_3G_GG7_MA_CS22	C2DP8400
TM6493-844G32Mn	EMEA	Hungary	LX.TQA0Z.183	TM6493-844G32Mn VB32TRHU1 MC UMAGCF 2*2G/320_7.2K/BT/6L/5R/n3_FP_0.3D_3G_GG7_MA_HU12	C2DP8400
TM6493-844G32Mn	EMEA	Hungary	LX.TQA0Z.184	TM6493-844G32Mn VB32TRHU1 MC UMAGCF 2*2G/320_7.2K/BT/6L/5R/n3_FP_0.3D_3G_GG7_MA_HU13	C2DP8400
TM6493-844G32Mn	EMEA	Slovenia/Croatia	LX.TQA0Z.181	TM6493-844G32Mn VB32TRS11 MC UMAGCF 2*2G/320_7.2K/BT/6L/5R/n3_FP_0.3D_3G_GG7_MA_EN13	C2DP8400
TM6493-844G32Mn	EMEA	Slovenia/Croatia	LX.TQA0Z.180	TM6493-844G32Mn VB32TRS11 MC UMAGCF 2*2G/320_7.2K/BT/6L/5R/n3_FP_0.3D_3G_GG7_MA_EN14	C2DP8400
TM6493-844G32Mn	EMEA	Portugal	LX.TQA0Z.179	TM6493-844G32Mn VB32TRPT1 MC UMAGCF 2*2G/320_7.2K/BT/6L/5R/n3_FP_0.3D_3G_GG7_MA_PT13	C2DP8400
TM6493-844G32Mn	EMEA	Portugal	LX.TQA0Z.175	TM6493-844G32Mn VB32TRPT1 MC UMAGCF 2*2G/320_7.2K/BT/6L/5R/n3_FP_0.3D_3G_GG7_MA_PT14	C2DP8400
TM6493-844G32Mn	EMEA	Spain	LX.TQA0Z.176	TM6493-844G32Mn VB32TRES1 MC UMAGCF 2*2G/320_7.2K/BT/6L/5R/n3_FP_0.3D_3G_GG7_MA_ES24	C2DP8400
TM6493-844G32Mn	EMEA	Spain	LX.TQA0Z.177	TM6493-844G32Mn VB32TRES1 MC UMAGCF 2*2G/320_7.2K/BT/6L/5R/n3_FP_0.3D_3G_GG7_MA_ES25	C2DP8400

Model	RO	Country	Acer Part no	Description	CPU
TM6493-844G32Mn	EMEA	Greece	LX.TQA0Z.178	TM6493-844G32Mn VB32TRGR1 MC UMAGCF 2*2G/320_7.2K/BT/6L/5R/n3_FP_0.3D_3G_GG7_MA_EL33	C2DP8400
TM6493-844G32Mn	EMEA	Greece	LX.TQA0Z.172	TM6493-844G32Mn VB32TRGR1 MC UMAGCF 2*2G/320_7.2K/BT/6L/5R/n3_FP_0.3D_3G_GG7_MA_EL34	C2DP8400
TM6493-844G32Mn	EMEA	Israel	LX.TQA0Z.173	TM6493-844G32Mn VB32TRIL1 MC UMAGCF 2*2G/320_7.2K/BT/6L/5R/n3_FP_0.3D_3G_GG7_MA_HE32	C2DP8400
TM6493-844G32Mn	EMEA	Israel	LX.TQA0Z.174	TM6493-844G32Mn VB32TRIL1 MC UMAGCF 2*2G/320_7.2K/BT/6L/5R/n3_FP_0.3D_3G_GG7_MA_HE35	C2DP8400
TM6493-844G32Mn	EMEA	Israel	LX.TQA0Z.171	TM6493-844G32Mn VB32TRIL1 MC UMAGCF 2*2G/320_7.2K/BT/6L/5R/n3_FP_0.3D_3G_GG7_MA_HE33	C2DP8400
TM6493-844G32Mn	EMEA	Israel	LX.TQA0Z.170	TM6493-844G32Mn VB32TRIL1 MC UMAGCF 2*2G/320_7.2K/BT/6L/5R/n3_FP_0.3D_3G_GG7_MA_HE34	C2DP8400
TM6493-844G32Mn	EMEA	Italy	LX.TQA0Z.169	TM6493-844G32Mn VB32TRIT1 MC UMAGCF 2*2G/320_7.2K/BT/6L/5R/n3_FP_0.3D_3G_GG7_MA_IT15	C2DP8400
TM6493-844G32Mn	EMEA	Italy	LX.TQA0Z.165	TM6493-844G32Mn VB32TRIT1 MC UMAGCF 2*2G/320_7.2K/BT/6L/5R/n3_FP_0.3D_3G_GG7_MA_IT16	C2DP8400
TM6493-844G32Mn	EMEA	Turkey	LX.TQA0Z.166	TM6493-844G32Mn EM VB32TRTR1 MC UMAGCF 2*2G/320_7.2K/BT/6L/5R/n3_FP_0.3D_3G_GG7_MA_TR43	C2DP8400
TM6493-844G32Mn	EMEA	Turkey	LX.TQA0Z.167	TM6493-844G32Mn EM VB32TRTR1 MC UMAGCF 2*2G/320_7.2K/BT/6L/5R/n3_FP_0.3D_3G_GG7_MA_TR14	C2DP8400
TM6493-844G32Mn	EMEA	Turkey	LX.TQA0Z.168	TM6493-844G32Mn EM VB32TRTR1 MC UMAGCF 2*2G/320_7.2K/BT/6L/5R/n3_FP_0.3D_3G_GG7_MA_TR44	C2DP8400
TM6493-844G32Mn	EMEA	Turkey	LX.TQA0Z.162	TM6493-844G32Mn EM VB32TRTR1 MC UMAGCF 2*2G/320_7.2K/BT/6L/5R/n3_FP_0.3D_3G_GG7_MA_TR13	C2DP8400
TM6493-844G32Mn	EMEA	Middle East	LX.TQA0Z.163	TM6493-844G32Mn EM VB32TRME2 MC UMAGCF 2*2G/320_7.2K/BT/6L/5R/n3_FP_0.3D_3G_GG7_MA_AR14	C2DP8400
TM6493-844G32Mn	EMEA	Middle East	LX.TQA0Z.164	TM6493-844G32Mn EM VB32TRME9 MC UMAGCF 2*2G/320_7.2K/BT/6L/5R/n3_FP_0.3D_3G_GG7_MA_FR25	C2DP8400
TM6493-844G32Mn	EMEA	Middle East	LX.TQA0Z.161	TM6493-844G32Mn EM VB32TRME2 MC UMAGCF 2*2G/320_7.2K/BT/6L/5R/n3_FP_0.3D_3G_GG7_MA_AR26	C2DP8400
TM6493-844G32Mn	EMEA	Middle East	LX.TQA0Z.160	TM6493-844G32Mn EM VB32TRME9 MC UMAGCF 2*2G/320_7.2K/BT/6L/5R/n3_FP_0.3D_3G_GG7_MA_FR26	C2DP8400
TM6493-844G32Mn	EMEA	Middle East	LX.TQA0Z.159	TM6493-844G32Mn EM VB32TRME3 MC UMAGCF 2*2G/320_7.2K/BT/6L/5R/n3_FP_0.3D_3G_GG7_MA_FR28	C2DP8400
TM6493-844G32Mn	EMEA	Middle East	LX.TQA0Z.155	TM6493-844G32Mn EM VB32TRME2 MC UMAGCF 2*2G/320_7.2K/BT/6L/5R/n3_FP_0.3D_3G_GG7_MA_AR27	C2DP8400
TM6493-844G32Mn	EMEA	Middle East	LX.TQA0Z.156	TM6493-844G32Mn EM VB32TRME6 MC UMAGCF 2*2G/320_7.2K/BT/6L/5R/n3_FP_0.3D_3G_GG7_MA_EN19	C2DP8400

Model	RO	Country	Acer Part no	Description	CPU
TM6493-844G32Mn	EMEA	Middle East	LX.TQA0Z.157	TM6493-844G32Mn EM VB32TRME2 MC UMAGCF 2*2G/320_7.2K/BT/6L/5R/ n3_FP_0.3D_3G_GG7_MA_AR15	C2DP8400
TM6493-844G32Mn	EMEA	Middle East	LX.TQA0Z.158	TM6493-844G32Mn EM VB32TRME3 MC UMAGCF 2*2G/320_7.2K/BT/6L/5R/ n3_FP_0.3D_3G_GG7_MA_FR27	C2DP8400
TM6493-844G32Mn	EMEA	Middle East	LX.TQA0Z.152	TM6493-844G32Mn EM VB32TRME6 MC UMAGCF 2*2G/320_7.2K/BT/6L/5R/ n3_FP_0.3D_3G_GG7_MA_EN18	C2DP8400
TM6493-844G32Mn	EMEA	Middle East	LX.TQA0Z.153	TM6493-844G32Mn EM VB32TRME3 MC UMAGCF 2*2G/320_7.2K/BT/6L/5R/ n3_FP_0.3D_3G_GG7_MA_FR26	C2DP8400
TM6493-844G32Mn	EMEA	Switzerland	LX.TQA0Z.154	TM6493-844G32Mn VB32TRCH1 MC UMAGCF 2*2G/320_7.2K/BT/6L/5R/ n3_FP_0.3D_3G_GG7_MA_IT43	C2DP8400
TM6493-844G32Mn	EMEA	Switzerland	LX.TQA0Z.151	TM6493-844G32Mn VB32TRCH1 MC UMAGCF 2*2G/320_7.2K/BT/6L/5R/ n3_FP_0.3D_3G_GG7_MA_IT44	C2DP8400
TM6493-844G32Mn	EMEA	UK	LX.TQA0Z.150	TM6493-844G32Mn VB32TRGB1 MC UMAGCF 2*2G/320_7.2K/BT/6L/5R/ n3_FP_0.3D_3G_GG7_MA_EN16	C2DP8400
TM6493-844G32Mn	EMEA	UK	LX.TQA0Z.149	TM6493-844G32Mn VB32TRGB1 MC UMAGCF 2*2G/320_7.2K/BT/6L/5R/ n3_FP_0.3D_3G_GG7_MA_EN17	C2DP8400
TM6493-844G32Mn	EMEA	South Africa	LX.TQA0Z.216	TM6493-844G32Mn EM VB32TRZA1 MC UMAGCF 2*2G/320_7.2K/BT/6L/5R/ n3_FP_0.3D_3G_GG7_MA_FR26	C2DP8400
TM6493-844G32Mn	EMEA	South Africa	LX.TQA0Z.215	TM6493-844G32Mn EM VB32TRZA2 MC UMAGCF 2*2G/320_7.2K/BT/6L/5R/ n3_FP_0.3D_3G_GG7_MA_EN19	C2DP8400
TM6493-844G32Mn	EMEA	South Africa	LX.TQA0Z.214	TM6493-844G32Mn EM VB32TRZA1 MC UMAGCF 2*2G/320_7.2K/BT/6L/5R/ n3_FP_0.3D_3G_GG7_MA_FR27	C2DP8400
TM6493-844G32Mn	EMEA	Denmark	LX.TQA0Z.213	TM6493-844G32Mn VB32TRDK1 MC UMAGCF 2*2G/320_7.2K/BT/6L/5R/ n3_FP_0.3D_3G_GG7_MA_NO14	C2DP8400
TM6493-844G32Mn	EMEA	Denmark	LX.TQA0Z.212	TM6493-844G32Mn VB32TRDK1 MC UMAGCF 2*2G/320_7.2K/BT/6L/5R/ n3_FP_0.3D_3G_GG7_MA_NO15	C2DP8400
TM6493-844G32Mn	EMEA	France	LX.TQA0Z.211	TM6493-844G32Mn VB32TRFR1 MC UMAGCF 2*2G/320_7.2K/BT/6L/5R/ n3_FP_0.3D_3G_GG7_MA_FR25	C2DP8400
TM6493-844G32Mn	EMEA	France	LX.TQA0Z.210	TM6493-844G32Mn VB32TRFR1 MC UMAGCF 2*2G/320_7.2K/BT/6L/5R/ n3_FP_0.3D_3G_GG7_MA_FR26	C2DP8400
TM6493-844G32Mn	EMEA	Germany	LX.TQA0Z.209	TM6493-844G32Mn VB32TRDE1 MC UMAGCF 2*2G/320_7.2K/BT/6L/5R/ n3_FP_0.3D_3G_GG7_MA_DE15	C2DP8400
TM6493-844G32Mn	EMEA	Germany	LX.TQA0Z.208	TM6493-844G32Mn VB32TRDE1 MC UMAGCF 2*2G/320_7.2K/BT/6L/5R/ n3_FP_0.3D_3G_GG7_MA_DE16	C2DP8400
TM6493-844G32Mn	EMEA	Belgium	LX.TQA0Z.207	TM6493-844G32Mn VB32TRBE1 MC UMAGCF 2*2G/320_7.2K/BT/6L/5R/ n3_FP_0.3D_3G_GG7_MA_NL14	C2DP8400
TM6493-844G32Mn	EMEA	Belgium	LX.TQA0Z.206	TM6493-844G32Mn VB32TRBE1 MC UMAGCF 2*2G/320_7.2K/BT/6L/5R/ n3_FP_0.3D_3G_GG7_MA_NL15	C2DP8400

Model	RO	Country	Acer Part no	Description	CPU
TM6493-844G32Mn	EMEA	Holland	LX.TQA0Z.205	TM6493-844G32Mn VB32TRNL1 MC UMAGCF 2*2G/320_7.2K/BT/6L/5R/n3_FP_0.3D_3G_GG7_MA_NL13	C2DP8400
TM6493-844G32Mn	EMEA	Holland	LX.TQA0Z.204	TM6493-844G32Mn VB32TRNL1 MC UMAGCF 2*2G/320_7.2K/BT/6L/5R/n3_FP_0.3D_3G_GG7_MA_NL14	C2DP8400
TM6493-844G25Mn	EMEA	Eastern Europe	LX.TQA0Z.146	TM6493-844G25Mn VB32TREU5 MC UMAGCF 2*2G/250_7.2K/BT/9L/5R/n3_FP_0.3D_3G_MA_PL12	C2DP8400
TM6493-844G32Mn	EMEA	South Africa	LX.TQA0Z.147	TM6493-844G32Mn EM VB32TRZA2EN MC UMAGCF 2*2G/320_7.2K/BT/6L/5R/n3_FP_0.3D_3G_GG7_MA_1_10	C2DP8400
TM6493-862G32Mn	AAP	Australia/ New Zealand	LX.TQA0Z.148	TM6493-862G32Mn VB32TRAU1 MC UMAGCF 1*2G/320/BT/6L/5R/n3_FP_0.3D_3G_MA_EN13	C2DP8600
TM6493-864G32Mn	EMEA	Eastern Europe	LX.TQA0Z.145	TM6493-864G32Mn VB32TREU5 MC UMAGCF 2*2G/320_7.2K/BT/9L/5R/n3_FP_0.3D_3G_MA_PL11	C2DP8600
TM6493-842G16Mn	AAP	Australia/ New Zealand	LX.TQ70Z.048	TM6493-842G16Mn VB32TRAU1 MC UMACF 1*2G/160/BT/6L/5R_n3_FP_0.3D_MA_EN13	C2DP8400
TM6493-862G25Mn	AAP	Australia/ New Zealand	LX.TQ70Z.049	TM6493-862G25Mn VB32TRAU1 MC UMACF 1*2G/250/BT/6L/5R_n3_FP_0.3D_MA_EN13	C2DP8600
TM6493-942G25Mn	AAP	Thailand	LX.TQ70Z.051	TM6493-942G25Mn EM VB32TRTH1 MC UMACF 2*1G/250/BT/6L/5R_n3_FP_0.3D_MA_TH23	C2DT9400
TM6493-844G32Mn	EMEA	UK	LX.TQ70Z.076	TM6493-844G32Mn VB32TRGB1 MC UMACF 2*2G/320_7.2K/BT/6L/5R/n3_FP_0.3D_MA_EN14	C2DP8400
TM6493-864G25Mn	PA	USA	LX.TQ70Z.053	TM6493-864G25Mn VB32TRUS1 MC UMACF 2*2G/250/BT/9L/5R/n2_FP_0.3D_MA_EN34	C2DP8600
TM6493-844G32Mn	EMEA	South Africa	LX.TQ70Z.102	TM6493-844G32Mn EM VB32TRZA2 MC UMACF 2*2G/320_7.2K/BT/6L/5R/n3_FP_0.3D_MA_EN17	C2DP8400
TM6493-844G32Mn	EMEA	South Africa	LX.TQ70Z.101	TM6493-844G32Mn EM VB32TRZA1 MC UMACF 2*2G/320_7.2K/BT/6L/5R/n3_FP_0.3D_MA_FR24	C2DP8400
TM6493-844G32Mn	EMEA	South Africa	LX.TQ70Z.100	TM6493-844G32Mn EM VB32TRZA2 MC UMACF 2*2G/320_7.2K/BT/6L/5R/n3_FP_0.3D_MA_EN18	C2DP8400
TM6493-844G32Mn	EMEA	South Africa	LX.TQ70Z.099	TM6493-844G32Mn EM VB32TRZA1 MC UMACF 2*2G/320_7.2K/BT/6L/5R/n3_FP_0.3D_MA_FR25	C2DP8400
TM6493-844G32Mn	EMEA	Denmark	LX.TQ70Z.098	TM6493-844G32Mn VB32TRDK1 MC UMACF 2*2G/320_7.2K/BT/6L/5R/n3_FP_0.3D_MA_NO13	C2DP8400
TM6493-844G32Mn	EMEA	France	LX.TQ70Z.097	TM6493-844G32Mn VB32TRFR1 MC UMACF 2*2G/320_7.2K/BT/6L/5R/n3_FP_0.3D_MA_FR24	C2DP8400
TM6493-844G32Mn	EMEA	France	LX.TQ70Z.096	TM6493-844G32Mn VB32TRFR1 MC UMACF 2*2G/320_7.2K/BT/6L/5R/n3_FP_0.3D_MA_FR23	C2DP8400
TM6493-844G32Mn	EMEA	Germany	LX.TQ70Z.095	TM6493-844G32Mn VB32TRDE1 MC UMACF 2*2G/320_7.2K/BT/6L/5R/n3_FP_0.3D_MA_DE14	C2DP8400

Model	RO	Country	Acer Part no	Description	CPU
TM6493-844G32Mn	EMEA	Germany	LX.TQ70Z.094	TM6493-844G32Mn VB32TRDE1 MC UMACF 2*2G/320_7.2K/BT/6L/5R/ n3_FP_0.3D_MA_DE13	C2DP8400
TM6493-844G32Mn	EMEA	Belgium	LX.TQ70Z.093	TM6493-844G32Mn VB32TRBE1 MC UMACF 2*2G/320_7.2K/BT/6L/5R/ n3_FP_0.3D_MA_NL13	C2DP8400
TM6493-844G32Mn	EMEA	Holland	LX.TQ70Z.092	TM6493-844G32Mn VB32TRNL1 MC UMACF 2*2G/320_7.2K/BT/6L/5R/ n3_FP_0.3D_MA_NL12	C2DP8400
TM6493-844G32Mn	EMEA	Luxembourg	LX.TQ70Z.091	TM6493-844G32Mn VB32TRLU1 MC UMACF 2*2G/320_7.2K/BT/6L/5R/ n3_FP_0.3D_MA_IT42	C2DP8400
TM6493-844G32Mn	EMEA	Norway	LX.TQ70Z.090	TM6493-844G32Mn VB32TRNO1 MC UMACF 2*2G/320_7.2K/BT/6L/5R/ n3_FP_0.3D_MA_NO12	C2DP8400
TM6493-844G32Mi	EMEA	Russia	LX.TQ70Z.089	TM6493-844G32Mi VB32TRRU1 MC UMACF 2*2G/320_7.2K/BT/6L/5R/ abg_FP_0.3D_MA_RU11	C2DP8400
TM6493-844G32Mi	EMEA	Russia	LX.TQ70Z.088	TM6493-844G32Mi VB32TRRU1 MC UMACF 2*2G/320_7.2K/BT/6L/5R/ abg_FP_0.3D_MA_RU12	C2DP8400
TM6493-844G32Mn	EMEA	Sweden/ Finland	LX.TQ70Z.087	TM6493-844G32Mn VB32TRSE1 MC UMACF 2*2G/320_7.2K/BT/6L/5R/ n3_FP_0.3D_MA_FI12	C2DP8400
TM6493-844G32Mn	EMEA	Czech	LX.TQ70Z.086	TM6493-844G32Mn VB32TRCZ2 MC UMACF 2*2G/320_7.2K/BT/6L/5R/ n3_FP_0.3D_MA_SK11	C2DP8400
TM6493-844G32Mn	EMEA	Eastern Europe	LX.TQ70Z.085	TM6493-844G32Mn VB32TREU1 MC UMACF 2*2G/320_7.2K/BT/6L/5R/ n3_FP_0.3D_MA_CS21	C2DP8400
TM6493-844G32Mn	EMEA	Eastern Europe	LX.TQ70Z.084	TM6493-844G32Mn VB32TREU3 MC UMACF 2*2G/320_7.2K/BT/6L/5R/ n3_FP_0.3D_MA_RU11	C2DP8400
TM6493-844G32Mn	EMEA	Eastern Europe	LX.TQ70Z.083	TM6493-844G32Mn VB32TREU5 MC UMACF 2*2G/320_7.2K/BT/6L/5R/ n3_FP_0.3D_MA_PL11	C2DP8400
TM6493-844G32Mn	EMEA	Eastern Europe	LX.TQ70Z.082	TM6493-844G32Mn VB32TREU6 MC UMACF 2*2G/320_7.2K/BT/6L/5R/ n3_FP_0.3D_MA_CS21	C2DP8400
TM6493-844G32Mn	EMEA	Eastern Europe	LX.TQ70Z.081	TM6493-844G32Mn VB32TREU3 MC UMACF 2*2G/320_7.2K/BT/6L/5R/ n3_FP_0.3D_MA_RU12	C2DP8400
TM6493-844G32Mn	EMEA	Eastern Europe	LX.TQ70Z.080	TM6493-844G32Mn VB32TREU2 MC UMACF 2*2G/320_7.2K/BT/6L/5R/ n3_FP_0.3D_MA_HU21	C2DP8400
TM6493-844G32Mn	EMEA	Eastern Europe	LX.TQ70Z.079	TM6493-844G32Mn VB32TREU4 MC UMACF 2*2G/320_7.2K/BT/6L/5R/ n3_FP_0.3D_MA_FI12	C2DP8400
TM6493-844G32Mn	EMEA	Hungary	LX.TQ70Z.078	TM6493-844G32Mn VB32TRHU1 MC UMACF 2*2G/320_7.2K/BT/6L/5R/ n3_FP_0.3D_MA_HU11	C2DP8400
TM6493-844G32Mn	EMEA	Slovenia/ Croatia	LX.TQ70Z.077	TM6493-844G32Mn VB32TRS11 MC UMACF 2*2G/320_7.2K/BT/6L/5R/ n3_FP_0.3D_MA_EN11	C2DP8400
TM6493-844G32Mn	EMEA	Slovenia/ Croatia	LX.TQ70Z.075	TM6493-844G32Mn VB32TRS11 MC UMACF 2*2G/320_7.2K/BT/6L/5R/ n3_FP_0.3D_MA_EN12	C2DP8400

Model	RO	Country	Acer Part no	Description	CPU
TM6493-844G32Mn	EMEA	Portugal	LX.TQ70Z.074	TM6493-844G32Mn VB32TRPT1 MC UMACF 2*2G/320_7.2K/BT/6L/5R/ n3_FP_0.3D_MA_PT12	C2DP8400
TM6493-844G32Mn	EMEA	Spain	LX.TQ70Z.073	TM6493-844G32Mn VB32TRES1 MC UMACF 2*2G/320_7.2K/BT/6L/5R/ n3_FP_0.3D_MA_ES22	C2DP8400
TM6493-844G32Mn	EMEA	Spain	LX.TQ70Z.072	TM6493-844G32Mn VB32TRES1 MC UMACF 2*2G/320_7.2K/BT/6L/5R/ n3_FP_0.3D_MA_ES23	C2DP8400
TM6493-844G32Mn	EMEA	Greece	LX.TQ70Z.071	TM6493-844G32Mn VB32TRGR1 MC UMACF 2*2G/320_7.2K/BT/6L/5R/ n3_FP_0.3D_MA_EL32	C2DP8400
TM6493-844G32Mn	EMEA	Israel	LX.TQ70Z.070	TM6493-844G32Mn VB32TRIL1 MC UMACF 2*2G/320_7.2K/BT/6L/5R/ n3_FP_0.3D_MA_HE31	C2DP8400
TM6493-844G32Mn	EMEA	Italy	LX.TQ70Z.069	TM6493-844G32Mn VB32TRIT1 MC UMACF 2*2G/320_7.2K/BT/6L/5R/ n3_FP_0.3D_MA_IT12	C2DP8400
TM6493-844G32Mn	EMEA	Italy	LX.TQ70Z.068	TM6493-844G32Mn VB32TRIT1 MC UMACF 2*2G/320_7.2K/BT/6L/5R/ n3_FP_0.3D_MA_IT14	C2DP8400
TM6493-844G32Mn	EMEA	Turkey	LX.TQ70Z.067	TM6493-844G32Mn EM VB32TRTR1 MC UMACF 2*2G/320_7.2K/BT/6L/5R/ n3_FP_0.3D_MA_TR12	C2DP8400
TM6493-844G32Mn	EMEA	Turkey	LX.TQ70Z.066	TM6493-844G32Mn EM VB32TRTR1 MC UMACF 2*2G/320_7.2K/BT/6L/5R/ n3_FP_0.3D_MA_TR42	C2DP8400
TM6493-844G32Mn	EMEA	Middle East	LX.TQ70Z.065	TM6493-844G32Mn EM VB32TRME2 MC UMACF 2*2G/320_7.2K/BT/6L/5R/ n3_FP_0.3D_MA_AR24	C2DP8400
TM6493-844G32Mn	EMEA	Middle East	LX.TQ70Z.064	TM6493-844G32Mn EM VB32TRME3 MC UMACF 2*2G/320_7.2K/BT/6L/5R/ n3_FP_0.3D_MA_FR25	C2DP8400
TM6493-844G32Mn	EMEA	Middle East	LX.TQ70Z.063	TM6493-844G32Mn EM VB32TRME9 MC UMACF 2*2G/320_7.2K/BT/6L/5R/ n3_FP_0.3D_MA_FR24	C2DP8400
TM6493-844G32Mn	EMEA	Middle East	LX.TQ70Z.062	TM6493-844G32Mn EM VB32TRME6 MC UMACF 2*2G/320_7.2K/BT/6L/5R/ n3_FP_0.3D_MA_EN17	C2DP8400
TM6493-844G32Mn	EMEA	Middle East	LX.TQ70Z.061	TM6493-844G32Mn EM VB32TRME9 MC UMACF 2*2G/320_7.2K/BT/6L/5R/ n3_FP_0.3D_MA_FR23	C2DP8400
TM6493-844G32Mn	EMEA	Middle East	LX.TQ70Z.060	TM6493-844G32Mn EM VB32TRME2 MC UMACF 2*2G/320_7.2K/BT/6L/5R/ n3_FP_0.3D_MA_AR13	C2DP8400
TM6493-844G32Mn	EMEA	Middle East	LX.TQ70Z.059	TM6493-844G32Mn EM VB32TRME2 MC UMACF 2*2G/320_7.2K/BT/6L/5R/ n3_FP_0.3D_MA_AR25	C2DP8400
TM6493-844G32Mn	EMEA	Middle East	LX.TQ70Z.058	TM6493-844G32Mn EM VB32TRME6 MC UMACF 2*2G/320_7.2K/BT/6L/5R/ n3_FP_0.3D_MA_EN16	C2DP8400
TM6493-844G32Mn	EMEA	Middle East	LX.TQ70Z.057	TM6493-844G32Mn EM VB32TRME3 MC UMACF 2*2G/320_7.2K/BT/6L/5R/ n3_FP_0.3D_MA_FR24	C2DP8400
TM6493-844G32Mn	EMEA	Switzerland	LX.TQ70Z.056	TM6493-844G32Mn VB32TRCH1 MC UMACF 2*2G/320_7.2K/BT/6L/5R/ n3_FP_0.3D_MA_IT42	C2DP8400

Model	RO	Country	Acer Part no	Description	CPU
TM6493-844G32Mn	EMEA	UK	LX.TQ70Z.055	TM6493-844G32Mn VB32TGB1 MC UMACF 2*2G/320_7.2K/BT/6L/5R/ n3_FP_0.3D_MA_EN14	C2DP8400
TM6493-844G32Mn	EMEA	UK	LX.TQ70Z.054	TM6493-844G32Mn VB32TRGB1 MC UMACF 2*2G/320_7.2K/BT/6L/5R/ n3_FP_0.3D_MA_EN15	C2DP8400
TM6493-844G32Mn	EMEA	South Africa	LX.TQ70Z.002	TM6493-844G32Mn EM VB32TRZA1 MC UMACF 2*2G/320/BT/6L/ 5R_n3_FP_0.3D_MA_FR24	C2DP8400
TM6493-844G32Mn	EMEA	South Africa	LX.TQ70Z.003	TM6493-844G32Mn EM VB32TRZA2 MC UMACF 2*2G/320/BT/6L/ 5R_n3_FP_0.3D_MA_EN18	C2DP8400
TM6493-844G32Mn	EMEA	South Africa	LX.TQ70Z.004	TM6493-844G32Mn EM VB32TRZA1 MC UMACF 2*2G/320/BT/6L/ 5R_n3_FP_0.3D_MA_FR25	C2DP8400
TM6493-844G32Mn	EMEA	Denmark	LX.TQ70Z.005	TM6493-844G32Mn VB32TRDK1 MC UMACF 2*2G/320/BT/6L/ 5R_n3_FP_0.3D_MA_NO13	C2DP8400
TM6493-844G32Mn	EMEA	France	LX.TQ70Z.024	TM6493-844G32Mn VB32TRFR1 MC UMACF 2*2G/320/BT/6L/ 5R_n3_FP_0.3D_MA_FR23	C2DP8400
TM6493-844G32Mn	EMEA	France	LX.TQ70Z.025	TM6493-844G32Mn VB32TRFR1 MC UMACF 2*2G/320/BT/6L/ 5R_n3_FP_0.3D_MA_FR24	C2DP8400
TM6493-844G32Mn	EMEA	Germany	LX.TQ70Z.006	TM6493-844G32Mn VB32TRDE1 MC UMACF 2*2G/320/BT/6L/ 5R_n3_FP_0.3D_MA_DE13	C2DP8400
TM6493-844G32Mn	EMEA	Holland	LX.TQ70Z.026	TM6493-844G32Mn VB32TRNL1 MC UMACF 2*2G/320/BT/6L/ 5R_n3_FP_0.3D_MA_NL12	C2DP8400
TM6493-844G32Mn	EMEA	Luxembourg	LX.TQ70Z.027	TM6493-844G32Mn VB32TRLU1 MC UMACF 2*2G/320/BT/6L/ 5R_n3_FP_0.3D_MA_IT42	C2DP8400
TM6493-844G32Mn	EMEA	Norway	LX.TQ70Z.028	TM6493-844G32Mn VB32TRNO1 MC UMACF 2*2G/320/BT/6L/ 5R_n3_FP_0.3D_MA_NO12	C2DP8400
TM6493-844G32Mi	EMEA	Russia	LX.TQ70Z.029	TM6493-844G32Mi VB32TRRU1 MC UMACF 2*2G/320/BT/6L/5R/ abg_FP_0.3D_MA_RU11	C2DP8400
TM6493-844G32Mi	EMEA	Russia	LX.TQ70Z.030	TM6493-844G32Mi VB32TRRU1 MC UMACF 2*2G/320/BT/6L/5R/ abg_FP_0.3D_MA_RU12	C2DP8400
TM6493-844G32Mn	EMEA	Sweden/ Finland	LX.TQ70Z.031	TM6493-844G32Mn VB32TRSE1 MC UMACF 2*2G/320/BT/6L/ 5R_n3_FP_0.3D_MA_FI12	C2DP8400
TM6493-844G32Mn	EMEA	Czech	LX.TQ70Z.007	TM6493-844G32Mn VB32TRCZ2 MC UMACF 2*2G/320/BT/6L/ 5R_n3_FP_0.3D_MA_SK11	C2DP8400
TM6493-844G32Mn	EMEA	Germany	LX.TQ70Z.008	TM6493-844G32Mn VB32TRDE1 MC UMACF 2*2G/320/BT/6L/ 5R_n3_FP_0.3D_MA_DE14	C2DP8400
TM6493-844G32Mn	EMEA	Belgium	LX.TQ70Z.009	TM6493-844G32Mn VB32TRBE1 MC UMACF 2*2G/320/BT/6L/ 5R_n3_FP_0.3D_MA_NL13	C2DP8400
TM6493-844G32Mn	EMEA	Eastern Europe	LX.TQ70Z.033	TM6493-844G32Mn VB32TREU4 MC UMACF 2*2G/320/BT/6L/ 5R_n3_FP_0.3D_MA_FI12	C2DP8400

Model	RO	Country	Acer Part no	Description	CPU
TM6493-844G32Mn	EMEA	Eastern Europe	LX.TQ70Z.034	TM6493-844G32Mn VB32TREU3 MC UMACF 2*2G/320/BT/6L/ 5R_n3_FP_0.3D_MA_RU11	C2DP8400
TM6493-844G32Mn	EMEA	Eastern Europe	LX.TQ70Z.035	TM6493-844G32Mn VB32TREU2 MC UMACF 2*2G/320/BT/6L/ 5R_n3_FP_0.3D_MA_HU21	C2DP8400
TM6493-844G32Mn	EMEA	Eastern Europe	LX.TQ70Z.036	TM6493-844G32Mn VB32TREU5 MC UMACF 2*2G/320/BT/6L/ 5R_n3_FP_0.3D_MA_PL11	C2DP8400
TM6493-844G32Mn	EMEA	Hungary	LX.TQ70Z.037	TM6493-844G32Mn VB32TRHU1 MC UMACF 2*2G/320/BT/6L/ 5R_n3_FP_0.3D_MA_HU11	C2DP8400
TM6493-844G32Mn	EMEA	Eastern Europe	LX.TQ70Z.038	TM6493-844G32Mn VB32TREU3 MC UMACF 2*2G/320/BT/6L/ 5R_n3_FP_0.3D_MA_RU12	C2DP8400
TM6493-844G32Mn	EMEA	Slovenia/ Croatia	LX.TQ70Z.039	TM6493-844G32Mn VB32TRS11 MC UMACF 2*2G/320/BT/6L/ 5R_n3_FP_0.3D_MA_EN11	C2DP8400
TM6493-844G32Mn	EMEA	Slovenia/ Croatia	LX.TQ70Z.040	TM6493-844G32Mn VB32TRS11 MC UMACF 2*2G/320/BT/6L/ 5R_n3_FP_0.3D_MA_EN12	C2DP8400
TM6493-844G32Mn	EMEA	Portugal	LX.TQ70Z.041	TM6493-844G32Mn VB32TRPT1 MC UMACF 2*2G/320/BT/6L/ 5R_n3_FP_0.3D_MA_PT12	C2DP8400
TM6493-844G32Mn	EMEA	Spain	LX.TQ70Z.010	TM6493-844G32Mn VB32TRES1 MC UMACF 2*2G/320/BT/6L/ 5R_n3_FP_0.3D_MA_ES22	C2DP8400
TM6493-844G32Mn	EMEA	Spain	LX.TQ70Z.011	TM6493-844G32Mn VB32TRES1 MC UMACF 2*2G/320/BT/6L/ 5R_n3_FP_0.3D_MA_ES23	C2DP8400
TM6493-844G32Mn	EMEA	Greece	LX.TQ70Z.042	TM6493-844G32Mn VB32TRGR1 MC UMACF 2*2G/320/BT/6L/ 5R_n3_FP_0.3D_MA_EL32	C2DP8400
TM6493-844G32Mn	EMEA	Israel	LX.TQ70Z.043	TM6493-844G32Mn VB32TRIL1 MC UMACF 2*2G/320/BT/6L/ 5R_n3_FP_0.3D_MA_HE31	C2DP8400
TM6493-844G32Mn	EMEA	Italy	LX.TQ70Z.044	TM6493-844G32Mn VB32TRIT1 MC UMACF 2*2G/320/BT/6L/ 5R_n3_FP_0.3D_MA_IT12	C2DP8400
TM6493-844G32Mn	EMEA	Italy	LX.TQ70Z.045	TM6493-844G32Mn VB32TRIT1 MC UMACF 2*2G/320/BT/6L/ 5R_n3_FP_0.3D_MA_IT14	C2DP8400
TM6493-844G32Mn	EMEA	Turkey	LX.TQ70Z.012	TM6493-844G32Mn EM VB32TRTR1 MC UMACF 2*2G/320/BT/6L/ 5R_n3_FP_0.3D_MA_TR12	C2DP8400
TM6493-844G32Mn	EMEA	Turkey	LX.TQ70Z.013	TM6493-844G32Mn EM VB32TRTR1 MC UMACF 2*2G/320/BT/6L/ 5R_n3_FP_0.3D_MA_TR42	C2DP8400
TM6493-844G32Mn	EMEA	Middle East	LX.TQ70Z.014	TM6493-844G32Mn EM VB32TRME2 MC UMACF 2*2G/320/BT/6L/ 5R_n3_FP_0.3D_MA_AR24	C2DP8400
TM6493-844G32Mn	EMEA	Middle East	LX.TQ70Z.015	TM6493-844G32Mn EM VB32TRME3 MC UMACF 2*2G/320/BT/6L/ 5R_n3_FP_0.3D_MA_FR24	C2DP8400
TM6493-844G32Mn	EMEA	Middle East	LX.TQ70Z.016	TM6493-844G32Mn EM VB32TRME6 MC UMACF 2*2G/320/BT/6L/ 5R_n3_FP_0.3D_MA_EN16	C2DP8400

Model	RO	Country	Acer Part no	Description	CPU
TM6493-844G32Mn	EMEA	Middle East	LX.TQ70Z.017	TM6493-844G32Mn EM VB32TRME2 MC UMACF 2*2G/320/BT/6L/ 5R_n3_FP_0.3D_MA_AR25	C2DP8400
TM6493-844G32Mn	EMEA	Middle East	LX.TQ70Z.018	TM6493-844G32Mn EM VB32TRME9 MC UMACF 2*2G/320/BT/6L/ 5R_n3_FP_0.3D_MA_FR23	C2DP8400
TM6493-844G32Mn	EMEA	Middle East	LX.TQ70Z.019	TM6493-844G32Mn EM VB32TRME6 MC UMACF 2*2G/320/BT/6L/ 5R_n3_FP_0.3D_MA_EN17	C2DP8400
TM6493-844G32Mn	EMEA	Middle East	LX.TQ70Z.020	TM6493-844G32Mn EM VB32TRME2 MC UMACF 2*2G/320/BT/6L/ 5R_n3_FP_0.3D_MA_AR13	C2DP8400
TM6493-844G32Mn	EMEA	Middle East	LX.TQ70Z.021	TM6493-844G32Mn EM VB32TRME9 MC UMACF 2*2G/320/BT/6L/ 5R_n3_FP_0.3D_MA_FR24	C2DP8400
TM6493-844G32Mn	EMEA	Middle East	LX.TQ70Z.022	TM6493-844G32Mn EM VB32TRME3 MC UMACF 2*2G/320/BT/6L/ 5R_n3_FP_0.3D_MA_FR25	C2DP8400
TM6493-844G32Mn	EMEA	Switzerland	LX.TQ70Z.023	TM6493-844G32Mn VB32TRCH1 MC UMACF 2*2G/320/BT/6L/ 5R_n3_FP_0.3D_MA_IT42	C2DP8400
TM6493-844G32Mn	EMEA	UK	LX.TQ70Z.046	TM6493-844G32Mn VB32TRGB1 MC UMACF 2*2G/320/BT/6L/ 5R_n3_FP_0.3D_MA_EN14	C2DP8400
TM6493-844G32Mn	EMEA	UK	LX.TQ70Z.047	TM6493-844G32Mn VB32TRGB1 MC UMACF 2*2G/320/BT/6L/ 5R_n3_FP_0.3D_MA_EN15	C2DP8400
TM6493-864G16Mn	CHINA	China	LX.TQ70Y.001	TM6493-864G16Mn VHB32TRCN1 MC UMACF 2*2G/160/BT/6L/ 5R_n3_FP_0.3D_MA_SC11	C2DP8600
TM6493-864G25Mn	CHINA	China	LX.TQ70Y.002	TM6493-864G25Mn VHB32TRCN1 MC UMACF 2*2G/250/BT/6L/ 5R_n3_FP_0.3D_MA_SC11	C2DP8600
TM6493-841G16Mn	AAP	Thailand	LX.TQ70Z.050	TM6493-841G16Mn EM VB32TRTH1 MC UMACF 1*1G/160/BT/6L/ 5R_n3_FP_0.3D_MA_TH23	C2DP8400
TM6493-844G32Mn	EMEA	South Africa	LX.TQ70Z.001	TM6493-844G32Mn EM VB32TRZA2 MC UMACF 2*2G/320/BT/6L/ 5R_n3_FP_0.3D_MA_EN17	C2DP8400
TM6493-944G32Mn	AAP	Thailand	LX.TQ70Z.052	TM6493-944G32Mn EM VB32TRTH1 MC UMACF 2*2G/320/BT/6L/5R/ n3_FP_0.3D_MA_TH23	C2DT9400
TM6493-952G32Mi	AAP	Indonesia	LX.TQ70Z.106	TM6493-952G32Mi EM VB32TRID1 MC UMACF 1*2G/320_7.2K/BT/6L/5R/ abg_FP_0.3D_MA_ID24	C2DP9500
TM6493-842G25Mn	EMEA	Italy	LX.TQ70Z.121	TM6493-842G25Mn VB32TRIT1 MC UMACF 1*2G/250/BT/6L/5R/ n3_FP_0.3D_MA_IT16	C2DP8400
TM6493-862G32Mn	AAP	Australia/ New Zealand	LX.TQ70Z.125	TM6493-862G32Mn VB32TRAU1 MC UMACF 1*2G/320/BT/6L/5R/ n3_FP_0.3D_MA_EN13	C2DP8600
TM6493-842G25Mn	AAP	Malaysia	LX.TQ70Z.113	TM6493-842G25Mn EM VB32TRMY1 MC UMACF 1*2G/250/BT/6L/5R/ n2_FP_0.3D_MA_EN16	C2DP8400
TM6493-864G32Mn	CHINA	China	LX.TQ70Y.003	TM6493-864G32Mn VHB32TRCN1 MC UMACF 2*2G/320/BT/6L/5R/ n3_FP_0.3D_MA_SC11	C2DP8600

Model	RO	Country	Acer Part no	Description	CPU
TM6493-844G25Mn	EMEA	South Africa	LX.TQ70Z.124	TM6493-844G25Mn EM VB32TRZA2EN MC UMACF 2*2G/250_7.2K/BT/6L/5R/n3_FP_0.3D_MA_1_10	C2DP8400
TM6493-863G32Mn	AAP	Singapore	LX.TQ70Z.126	TM6493-863G32Mn VB32TRSG1 MC UMACF 2G+1G/320/BT/6L/5R/n3_FP_0.3D_MA_ZH32	C2DP8600
TM6493-842G12Mn	AAP	Australia/ New Zealand	LX.TQ70Z.104	TM6493-842G12Mn VB32TRAU1 MC UMACF 1*2G/120/BT/6L/5R/n3_FP_0.3D_MA_EN13	C2DP8400
TM6493-862G16Mn	AAP	Australia/ New Zealand	LX.TQ70Z.103	TM6493-862G16Mn VB32TRAU1 MC UMACF 1*2G/160/BT/6L/5R/n3_FP_0.3D_MA_EN13	C2DP8600
TM6493-942G25Mn	AAP	Thailand	LX.TQ70Z.105	TM6493-942G25Mn EM VB32TRTH1 MC UMACF 2*1G/250_7.2K/BT/6L/5R/n3_FP_0.3D_MA_TH23	C2DT9400
TM6493-862G25Mn	AAP	Vietnam	LX.TQ70Z.123	TM6493-862G25Mn EM VB32TRVN1 MC UMACF 1*2G/250/BT/6L/5R/n3_FP_0.3D_MA_EN14	C2DP8600
TM6493-842G25Mn	AAP	Malaysia	LX.TQ70Z.122	TM6493-842G25Mn EM VB32TRMY1 MC UMACF 1*2G/250_7.2K/BT/6L/5R/n2_FP_0.3D_MA_EN16	C2DP8400
TM6493-842G25Mn	EMEA	Switzerland	LX.TQ70Z.120	TM6493-842G25Mn VB32TRCH1 MC UMACF 1*2G/250/BT/6L/5R/n3_FP_0.3D_MA_IT44	C2DP8400
TM6493-862G25Mn	EMEA	Switzerland	LX.TQ70Z.119	TM6493-862G25Mn VB32TRCH1 MC UMACF 1*2G/250/BT/6L/5R/n3_FP_0.3D_MA_IT44	C2DP8600
TM6493-842G32Mn	TWN	GCTWN	LX.TQ70Z.109	TM6493-842G32Mn VB32TRTW1 MC UMACF 1*2G/320_7.2K/BT/6L/5R/n3_FP_0.3D_MA_TC12	C2DP8400
TM6493-842G32Mn	CHIN A	China	LX.TQ70Z.108	TM6493-842G32Mn VB32TRCN1 MC UMACF 1*2G/320_7.2K/BT/6L/5R/n3_FP_0.3D_MA_SC12	C2DP8400
TM6493-842G32Mn	CHIN A	Hong Kong	LX.TQ70Z.107	TM6493-842G32Mn VB32TRHK2 MC UMACF 1*2G/320_7.2K/BT/6L/5R/n3_FP_0.3D_MA_ZH32	C2DP8400
TM6493-942G16Mn	AAP	Singapore	LX.TQ70Z.112	TM6493-942G16Mn VB32TRSG1 MC UMACF 1*2G/160/BT/6L/5R/n3_FP_0.3D_MA_ZH32	C2DT9400
TM6493-942G16Mn	AAP	Thailand	LX.TQ70Z.111	TM6493-942G16Mn EM VB32TRTH1 MC UMACF 1*2G/160/BT/6L/5R/n3_FP_0.3D_MA_TH23	C2DT9400
TM6493-952G25Mn	EMEA	Switzerland	LX.TQ70Z.118	TM6493-952G25Mn VB32TRCH1 MC UMACF 1*2G/250/BT/6L/5R/n3_FP_0.3D_MA_IT44	C2DP9500
TM6493-952G25Mn	EMEA	Switzerland	LX.TQ70Z.117	TM6493-952G25Mn VB32TRCH1 MC UMACF 1*2G/250/BT/9L/5R/n3_FP_0.3D_MA_IT44	C2DP9500
TM6493-964G25Mn	EMEA	Switzerland	LX.TQ70Z.116	TM6493-964G25Mn VB32TRCH1 MC UMACF 2*2G/250_7.2K/BT/9L/5R/n3_FP_0.3D_MA_IT44	C2DT9600
TM6493-862G32Mn	TWN	GCTWN	LX.TQ70Z.115	TM6493-862G32Mn VB32TRTW1 MC UMACF 1*2G/320_7.2K/BT/6L/5R/n3_FP_0.3D_MA_TC12	C2DP8600
TM6493-862G16Mn	AAP	Thailand	LX.TQ70Z.114	TM6493-862G16Mn EM VB32TRTH1 MC UMACF 2*1G/160/BT/6L/5R/n3_FP_0.3D_MA_TH23	C2DP8600

Model	LCD	Memory 1	Memory 2	HDD 1 (GB)	ODD	Wireless LAN	Finger Print
TM6493-844G32Mn	NLED14.1W XGA	SO2GBIII10	SO2GBIII10	N320GB5.4KS	NSM8XS	SP3x3MMW	TCS4E
TM6493-844G32Mn	NLED14.1W XGA	SO2GBIII10	SO2GBIII10	N320GB5.4KS	NSM8XS	SP3x3MMW	TCS4E
TM6493-844G32Mi	NLED14.1W XGA	SO2GBIII10	SO2GBIII10	N320GB5.4KS	NSM8XS	SP1x2MAB G	TCS4E
TM6493-844G32Mi	NLED14.1W XGA	SO2GBIII10	SO2GBIII10	N320GB5.4KS	NSM8XS	SP1x2MAB G	TCS4E
TM6493-844G32Mn	NLED14.1W XGA	SO2GBIII10	SO2GBIII10	N320GB7.2KS	NSM8XS	SP3x3MMW	TCS4E
TM6493-844G32Mn	NLED14.1W XGA	SO2GBIII10	SO2GBIII10	N320GB7.2KS	NSM8XS	SP3x3MMW	TCS4E
TM6493-844G32Mn	NLED14.1W XGA	SO2GBIII10	SO2GBIII10	N320GB7.2KS	NSM8XS	SP3x3MMW	TCS4E
TM6493-844G32Mn	NLED14.1W XGA	SO2GBIII10	SO2GBIII10	N320GB7.2KS	NSM8XS	SP3x3MMW	TCS4E
TM6493-844G32Mi	NLED14.1W XGA	SO2GBIII10	SO2GBIII10	N320GB7.2KS	NSM8XS	SP3x3MMW	TCS4E
TM6493-844G32Mi	NLED14.1W XGA	SO2GBIII10	SO2GBIII10	N320GB7.2KS	NSM8XS	SP3x3MMW	TCS4E
TM6493-844G32Mn	NLED14.1W XGA	SO2GBIII10	SO2GBIII10	N320GB7.2KS	NSM8XS	SP3x3MMW	TCS4E
TM6493-844G32Mn	NLED14.1W XGA	SO2GBIII10	SO2GBIII10	N320GB7.2KS	NSM8XS	SP3x3MMW	TCS4E
TM6493-844G32Mn	NLED14.1W XGA	SO2GBIII10	SO2GBIII10	N320GB7.2KS	NSM8XS	SP3x3MMW	TCS4E
TM6493-844G32Mn	NLED14.1W XGA	SO2GBIII10	SO2GBIII10	N320GB7.2KS	NSM8XS	SP3x3MMW	TCS4E
TM6493-844G32Mn	NLED14.1W XGA	SO2GBIII10	SO2GBIII10	N320GB7.2KS	NSM8XS	SP3x3MMW	TCS4E
TM6493-844G32Mn	NLED14.1W XGA	SO2GBIII10	SO2GBIII10	N320GB7.2KS	NSM8XS	SP3x3MMW	TCS4E
TM6493-844G32Mn	NLED14.1W XGA	SO2GBIII10	SO2GBIII10	N320GB7.2KS	NSM8XS	SP3x3MMW	TCS4E
TM6493-844G32Mn	NLED14.1W XGA	SO2GBIII10	SO2GBIII10	N320GB7.2KS	NSM8XS	SP3x3MMW	TCS4E
TM6493-844G32Mn	NLED14.1W XGA	SO2GBIII10	SO2GBIII10	N320GB7.2KS	NSM8XS	SP3x3MMW	TCS4E
TM6493-844G32Mn	NLED14.1W XGA	SO2GBIII10	SO2GBIII10	N320GB7.2KS	NSM8XS	SP3x3MMW	TCS4E
TM6493-844G32Mn	NLED14.1W XGA	SO2GBIII10	SO2GBIII10	N320GB7.2KS	NSM8XS	SP3x3MMW	TCS4E
TM6493-844G32Mn	NLED14.1W XGA	SO2GBIII10	SO2GBIII10	N320GB7.2KS	NSM8XS	SP3x3MMW	TCS4E
TM6493-844G32Mn	NLED14.1W XGA	SO2GBIII10	SO2GBIII10	N320GB7.2KS	NSM8XS	SP3x3MMW	TCS4E
TM6493-844G32Mn	NLED14.1W XGA	SO2GBIII10	SO2GBIII10	N320GB7.2KS	NSM8XS	SP3x3MMW	TCS4E
TM6493-844G32Mn	NLED14.1W XGA	SO2GBIII10	SO2GBIII10	N320GB7.2KS	NSM8XS	SP3x3MMW	TCS4E
TM6493-844G32Mn	NLED14.1W XGA	SO2GBIII10	SO2GBIII10	N320GB7.2KS	NSM8XS	SP3x3MMW	TCS4E

Model	LCD	Memory 1	Memory 2	HDD 1 (GB)	ODD	Wireless LAN	Finger Print
TM6493-844G25Mn	NLED14.1W XGA	SO2GBIII10	SO2GBIII10	N250GB7.2KS	NSM8XS	SP3x3MMW	TCS4E
TM6493-844G32Mn	NLED14.1W XGA	SO2GBIII10	SO2GBIII10	N320GB7.2KS	NSM8XS	SP3x3MMW	TCS4E
TM6493-862G32Mn	NLED14.1W XGA	SO2GBIII10	N	N320GB5.4KS	NSM8XS	SP3x3MMW	TCS4E
TM6493-864G32Mn	NLED14.1W XGA	SO2GBIII10	SO2GBIII10	N320GB7.2KS	NSM8XS	SP3x3MMW	TCS4E
TM6493-842G16Mn	NLED14.1W XGA	SO2GBIII10	N	N160GB5.4KS	NSM8XS	SP3x3MMW	TCS4E
TM6493-862G25Mn	NLED14.1W XGA	SO2GBIII10	N	N250GB5.4KS	NSM8XS	SP3x3MMW	TCS4E
TM6493-942G25Mn	NLED14.1W XGA	SO1GBIII10	SO1GBIII10	N250GB5.4KS	NSM8XS	SP3x3MMW	TCS4E
TM6493-844G32Mn	NLED14.1W XGA	SO2GBIII10	SO2GBIII10	N320GB7.2KS	NSM8XS	SP3x3MMW	TCS4E
TM6493-864G25Mn	N14.1WXGA	SO2GBIII10	SO2GBIII10	N250GB5.4KS	NSM8XS	SP1x2HMW	TCS4E
TM6493-844G32Mn	NLED14.1W XGA	SO2GBIII10	SO2GBIII10	N320GB7.2KS	NSM8XS	SP3x3MMW	TCS4E
TM6493-844G32Mn	NLED14.1W XGA	SO2GBIII10	SO2GBIII10	N320GB7.2KS	NSM8XS	SP3x3MMW	TCS4E
TM6493-844G32Mn	NLED14.1W XGA	SO2GBIII10	SO2GBIII10	N320GB7.2KS	NSM8XS	SP3x3MMW	TCS4E
TM6493-844G32Mn	NLED14.1W XGA	SO2GBIII10	SO2GBIII10	N320GB7.2KS	NSM8XS	SP3x3MMW	TCS4E
TM6493-844G32Mn	NLED14.1W XGA	SO2GBIII10	SO2GBIII10	N320GB7.2KS	NSM8XS	SP3x3MMW	TCS4E
TM6493-844G32Mn	NLED14.1W XGA	SO2GBIII10	SO2GBIII10	N320GB7.2KS	NSM8XS	SP3x3MMW	TCS4E
TM6493-844G32Mn	NLED14.1W XGA	SO2GBIII10	SO2GBIII10	N320GB7.2KS	NSM8XS	SP3x3MMW	TCS4E
TM6493-844G32Mn	NLED14.1W XGA	SO2GBIII10	SO2GBIII10	N320GB7.2KS	NSM8XS	SP3x3MMW	TCS4E
TM6493-844G32Mn	NLED14.1W XGA	SO2GBIII10	SO2GBIII10	N320GB7.2KS	NSM8XS	SP3x3MMW	TCS4E
TM6493-844G32Mn	NLED14.1W XGA	SO2GBIII10	SO2GBIII10	N320GB7.2KS	NSM8XS	SP3x3MMW	TCS4E
TM6493-844G32Mn	NLED14.1W XGA	SO2GBIII10	SO2GBIII10	N320GB7.2KS	NSM8XS	SP3x3MMW	TCS4E
TM6493-844G32Mi	NLED14.1W XGA	SO2GBIII10	SO2GBIII10	N320GB7.2KS	NSM8XS	SP1x2MAB G	TCS4E
TM6493-844G32Mi	NLED14.1W XGA	SO2GBIII10	SO2GBIII10	N320GB7.2KS	NSM8XS	SP1x2MAB G	TCS4E
TM6493-844G32Mn	NLED14.1W XGA	SO2GBIII10	SO2GBIII10	N320GB7.2KS	NSM8XS	SP3x3MMW	TCS4E
TM6493-844G32Mn	NLED14.1W XGA	SO2GBIII10	SO2GBIII10	N320GB7.2KS	NSM8XS	SP3x3MMW	TCS4E

Model	LCD	Memory 1	Memory 2	HDD 1 (GB)	ODD	Wireless LAN	Finger Print
TM6493-844G32Mn	NLED14.1W XGA	SO2GBIII10	SO2GBIII10	N320GB7.2KS	NSM8XS	SP3x3MMW	TCS4E
TM6493-844G32Mn	NLED14.1W XGA	SO2GBIII10	SO2GBIII10	N320GB7.2KS	NSM8XS	SP3x3MMW	TCS4E
TM6493-844G32Mn	NLED14.1W XGA	SO2GBIII10	SO2GBIII10	N320GB7.2KS	NSM8XS	SP3x3MMW	TCS4E
TM6493-844G32Mn	NLED14.1W XGA	SO2GBIII10	SO2GBIII10	N320GB7.2KS	NSM8XS	SP3x3MMW	TCS4E
TM6493-844G32Mn	NLED14.1W XGA	SO2GBIII10	SO2GBIII10	N320GB7.2KS	NSM8XS	SP3x3MMW	TCS4E
TM6493-844G32Mn	NLED14.1W XGA	SO2GBIII10	SO2GBIII10	N320GB5.4KS	NSM8XS	SP3x3MMW	TCS4E
TM6493-844G32Mn	NLED14.1W XGA	SO2GBIII10	SO2GBIII10	N320GB5.4KS	NSM8XS	SP3x3MMW	TCS4E
TM6493-844G32Mn	NLED14.1W XGA	SO2GBIII10	SO2GBIII10	N320GB5.4KS	NSM8XS	SP3x3MMW	TCS4E
TM6493-844G32Mn	NLED14.1W XGA	SO2GBIII10	SO2GBIII10	N320GB5.4KS	NSM8XS	SP3x3MMW	TCS4E
TM6493-844G32Mn	NLED14.1W XGA	SO2GBIII10	SO2GBIII10	N320GB5.4KS	NSM8XS	SP3x3MMW	TCS4E
TM6493-844G32Mn	NLED14.1W XGA	SO2GBIII10	SO2GBIII10	N320GB5.4KS	NSM8XS	SP3x3MMW	TCS4E
TM6493-844G32Mn	NLED14.1W XGA	SO2GBIII10	SO2GBIII10	N320GB5.4KS	NSM8XS	SP3x3MMW	TCS4E
TM6493-844G32Mn	NLED14.1W XGA	SO2GBIII10	SO2GBIII10	N320GB5.4KS	NSM8XS	SP3x3MMW	TCS4E
TM6493-844G32Mn	NLED14.1W XGA	SO2GBIII10	SO2GBIII10	N320GB5.4KS	NSM8XS	SP3x3MMW	TCS4E
TM6493-844G32Mi	NLED14.1W XGA	SO2GBIII10	SO2GBIII10	N320GB5.4KS	NSM8XS	SP1x2MAB G	TCS4E
TM6493-844G32Mi	NLED14.1W XGA	SO2GBIII10	SO2GBIII10	N320GB5.4KS	NSM8XS	SP1x2MAB G	TCS4E
TM6493-844G32Mn	NLED14.1W XGA	SO2GBIII10	SO2GBIII10	N320GB5.4KS	NSM8XS	SP3x3MMW	TCS4E
TM6493-844G32Mn	NLED14.1W XGA	SO2GBIII10	SO2GBIII10	N320GB5.4KS	NSM8XS	SP3x3MMW	TCS4E
TM6493-844G32Mn	NLED14.1W XGA	SO2GBIII10	SO2GBIII10	N320GB5.4KS	NSM8XS	SP3x3MMW	TCS4E
TM6493-844G32Mn	NLED14.1W XGA	SO2GBIII10	SO2GBIII10	N320GB5.4KS	NSM8XS	SP3x3MMW	TCS4E
TM6493-844G32Mn	NLED14.1W XGA	SO2GBIII10	SO2GBIII10	N320GB5.4KS	NSM8XS	SP3x3MMW	TCS4E
TM6493-844G32Mn	NLED14.1W XGA	SO2GBIII10	SO2GBIII10	N320GB5.4KS	NSM8XS	SP3x3MMW	TCS4E
TM6493-844G32Mn	NLED14.1W XGA	SO2GBIII10	SO2GBIII10	N320GB5.4KS	NSM8XS	SP3x3MMW	TCS4E
TM6493-844G32Mn	NLED14.1W XGA	SO2GBIII10	SO2GBIII10	N320GB5.4KS	NSM8XS	SP3x3MMW	TCS4E
TM6493-844G32Mn	NLED14.1W XGA	SO2GBIII10	SO2GBIII10	N320GB5.4KS	NSM8XS	SP3x3MMW	TCS4E
TM6493-844G32Mn	NLED14.1W XGA	SO2GBIII10	SO2GBIII10	N320GB5.4KS	NSM8XS	SP3x3MMW	TCS4E

Model	LCD	Memory 1	Memory 2	HDD 1 (GB)	ODD	Wireless LAN	Finger Print
TM6493-841G16Mn	NLED14.1W XGA	SO1GBIII10	N	N160GB5.4KS	NSM8XS	SP3x3MMW	TCS4E
TM6493-844G32Mn	NLED14.1W XGA	SO2GBIII10	SO2GBIII10	N320GB5.4KS	NSM8XS	SP3x3MMW	TCS4E
TM6493-944G32Mn	NLED14.1W XGA	SO2GBIII10	SO2GBIII10	N320GB5.4KS	NSM8XS	SP3x3MMW	TCS4E
TM6493-952G32Mi	NLED14.1W XGA	SO2GBIII10	N	N320GB7.2KS	NSM8XS	SP1x2MAB G	TCS4E
TM6493-842G25Mn	NLED14.1W XGA	SO2GBIII10	N	N250GB5.4KS	NSM8XS	SP3x3MMW	TCS4E
TM6493-862G32Mn	NLED14.1W XGA	SO2GBIII10	N	N320GB5.4KS	NSM8XS	SP3x3MMW	TCS4E
TM6493-842G25Mn	NLED14.1W XGA	SO2GBIII10	N	N250GB5.4KS	NSM8XS	SP1x2MMW	TCS4E
TM6493-864G32Mn	NLED14.1W XGA	SO2GBIII10	SO2GBIII10	N320GB5.4KS	NSM8XS	SP3x3MMW	TCS4E
TM6493-844G25Mn	NLED14.1W XGA	SO2GBIII10	SO2GBIII10	N250GB7.2KS	NSM8XS	SP3x3MMW	TCS4E
TM6493-863G32Mn	NLED14.1W XGA	SO2GBIII10	SO1GBIII10	N320GB5.4KS	NSM8XS	SP3x3MMW	TCS4E
TM6493-842G12Mn	NLED14.1W XGA	SO2GBIII10	N	N120GB5.4KS	NSM8XS	SP3x3MMW	TCS4E
TM6493-862G16Mn	NLED14.1W XGA	SO2GBIII10	N	N160GB5.4KS	NSM8XS	SP3x3MMW	TCS4E
TM6493-942G25Mn	NLED14.1W XGA	SO1GBIII10	SO1GBIII10	N250GB7.2KS	NSM8XS	SP3x3MMW	TCS4E
TM6493-862G25Mn	NLED14.1W XGA	SO2GBIII10	N	N250GB5.4KS	NSM8XS	SP3x3MMW	TCS4E
TM6493-842G25Mn	NLED14.1W XGA	SO2GBIII10	N	N250GB7.2KS	NSM8XS	SP1x2MMW	TCS4E
TM6493-842G25Mn	NLED14.1W XGA	SO2GBIII10	N	N250GB5.4KS	NSM8XS	SP3x3MMW	TCS4E
TM6493-862G25Mn	NLED14.1W XGA	SO2GBIII10	N	N250GB5.4KS	NSM8XS	SP3x3MMW	TCS4E
TM6493-842G32Mn	NLED14.1W XGA	SO2GBIII10	N	N320GB7.2KS	NSM8XS	SP3x3MMW	TCS4E
TM6493-842G32Mn	NLED14.1W XGA	SO2GBIII10	N	N320GB7.2KS	NSM8XS	SP3x3MMW	TCS4E
TM6493-842G32Mn	NLED14.1W XGA	SO2GBIII10	N	N320GB7.2KS	NSM8XS	SP3x3MMW	TCS4E
TM6493-842G32Mn	NLED14.1W XGA	SO2GBIII10	N	N320GB7.2KS	NSM8XS	SP3x3MMW	TCS4E
TM6493-942G16Mn	NLED14.1W XGA	SO2GBIII10	N	N160GB5.4KS	NSM8XS	SP3x3MMW	TCS4E
TM6493-942G16Mn	NLED14.1W XGA	SO2GBIII10	N	N160GB5.4KS	NSM8XS	SP3x3MMW	TCS4E
TM6493-952G25Mn	NLED14.1W XGA	SO2GBIII10	N	N250GB5.4KS	NSM8XS	SP3x3MMW	TCS4E
TM6493-952G25Mn	NLED14.1W XGA	SO2GBIII10	N	N250GB5.4KS	NSM8XS	SP3x3MMW	TCS4E
TM6493-964G25Mn	NLED14.1W XGA	SO2GBIII10	SO2GBIII10	N250GB7.2KS	NSM8XS	SP3x3MMW	TCS4E
TM6493-862G32Mn	NLED14.1W XGA	SO2GBIII10	N	N320GB7.2KS	NSM8XS	SP3x3MMW	TCS4E

Model	LCD	Memory 1	Memory 2	HDD 1 (GB)	ODD	Wireless LAN	Finger Print
TM6493-862G16Mn	NLED14.1W XGA	SO1GBIII10	SO1GBIII10	N160GB5.4KS	NSM8XS	SP3x3MMW	TCS4E

Test Compatible Components

This computer's compatibility is tested and verified by Acer's internal testing department. All of its system functions are tested under Windows® XP Home, Windows® XP Pro environment.

Refer to the following lists for components, adapter cards, and peripherals which have passed these tests. Regarding configuration, combination and test procedures, please refer to the TravelMate 6493 series Compatibility Test Report released by the Acer Mobile System Testing Department.

Microsoft® Windows® Vista Environment Test

Vendor	Type	Description
Adapter Test		
F0000183 DELTA CN	65W	Adapter DELTA 65W 1.7x5.5x11 SADP-65KB DFA LF level 4
10001023 LITE-ON	65W	Adapter LITE-ON 65W 1.7x5.5x11 PA-1650-02AC LF level 4
60002015 HIPRO	65W	Adapter HIPRO 65W 19V 1.7x5.5x11 Yellow HP-OK065B13 LED LF level 4
Battery Test		
60001921 SANYO	6CELL2.2	Battery SANYO TM-2007A Li-Ion 3S2P SANYO 6 cell 4400mAh Main COMMON Normal Type
10001063 SONY	6CELL2.2	Battery SONY TM-2007A Li-Ion 3S2P SONY 6 cell 4400mAh Main COMMON Normal Type
60001535 PANASONI C	6CELL2.2	Battery PANASONIC TM-2007A Li-Ion 3S2P PANASONIC 6 cell 4400mAh Main COMMON PSS
60002162 SIMPLO	6CELL2.2	Battery SIMPLO TM-2007A Li-Ion 3S2P PANASONIC 6 cell 4400mAh Main COMMON PSS
10001063 SONY	9CELL2.4	Battery SONY TM-2007A Li-Ion 3S3P SONY 9 cell 7200mAh Main COMMON
60002162 SIMPLO	9CELL2.4	Battery SIMPLO TM-2007B Li-Ion 3S3P PANASONIC 9 cell 7200mAh Main COMMON
CPU Test		
10001067 INTEL	C2DP8400	CPU Intel Core2Dual P8400 PGA 2.26G 3M 1066 25W
10001067 INTEL	C2DP8600	CPU Intel Core2Dual P8600 PGA 2.4G 1066 25W 3M
10001067 INTEL	C2DT9400	CPU Intel Core2Dual T9400 PGA 2.53G 6M 1066 35W
10001067 INTEL	C2DT9600	CPU Intel Core2Dual T9600 PGA 2.8G 6M 1066 35W
HDD Test		
60002005 HGST SG	N120GB5.4KS	HDD HGST 2.5" 5400rpm 120GB HTS542512K9SA00 Bronco-B SATA II LF F/W:C31P
60001922 TOSHIBA DIGI	N160GB5.4KS	HDD TOSHIBA 2.5" 5400rpm 160GB MK1646GSX Leo BS SATA I LF F/W:LB113J
60002036 SEAGATE	N250GB5.4KS	HDD SEAGATE 2.5" 5400rpm 250GB ST9250827AS Corsair SATA LF F/W:3.AAA
60001922 TOSHIBA DIGI	N250GB5.4KS	HDD TOSHIBA 2.5" 5400rpm 250GB MK2546GSX Leo BS SATA I LF F/W:LB013J
60002005 HGST SG	N250GB5.4KS	HDD HGST 2.5" 5400rpm 250GB HTS542525K9SA00 Bronco-B SATA II LF F/W:C31P
60001994 WD	N250GB5.4KS	HDD WD 2.5" 5400rpm 250GB WD2500BEVS-22UST0 ML125 SATA LF F/W:01.01A01
60001922 TOSHIBA DIGI	N320GB5.4KS	HDD TOSHIBA 2.5" 5400rpm 320GB MK3252GSX Virgo BS SATA LF F/W:LV010J

Vendor	Type	Description
60002005 HGST SG	N320GB5.4KS	HDD HGST 2.5" 5400rpm 320GB HTS543232L9A300 Falcon-B SATA LF F/W:C40C
60001994 WD	N320GB5.4KS	HDD WD 2.5" 5400rpm 320GB WD3200BEVT- 22ZCT0 ML160 SATA LF F/W:11.01A11
LCD Test		
60003316 AUO	NLED14.1WXGA	LED LCD AUO 14.1" WXGA None Glare B141EW05 V1 LF 220nit 8ms 500:1
60003316 AUO	NLED14.1WXGAG	LED LCD AUO 14.1" WXGA Glare B141EW05 V0 LF 220nit 8ms 500:1
Memory Test		
16081942 MICRON	SO1GBIII10	Memory MICRON SO-DIMM DDRIII 1066 1GB MT8JSF12864HY-1G1D1 LF 64*16 0.07um
60002214 ELPIDA	SO1GBIII10	Memory ELPIDA SO-DIMM DDRIII 1066 1GB EBJ11UE6BAU0-AE-E LF 64*16 0.07um
16081942 MICRON	SO2GBIII10	Memory MICRON SO-DIMM DDRIII 1066 2GB MT16JSF25664HY-1G1D1 LF 128*8 0.07um
60002214 ELPIDA	SO2GBIII10	Memory ELPIDA SO-DIMM DDRIII 1066 2GB EBJ21UE8BAU0-AE-E LF 128*8 0.07um
ODD Test		
60001922 TOSHIBA DIGI	NCB24XS	ODD TOSHIBA COMBO 12.7mm Tray DL 24X TS- L463A LF W/O bezel SATA
10001063 SONY	NCB24XS	ODD SONY COMBO 12.7mm Tray DL 24X CRX890S LF W/O bezel SATA
60001922 TOSHIBA DIGI	NSM8XS	ODD TOSHIBA Super-Multi DRIVE 12.7mm Tray DL 8X TS-L633A LF W/O bezel SATA
10001063 SONY	NSM8XS	ODD SONY Super-Multi DRIVE 12.7mm Tray DL 8X AD-7560S LF W/O bezel SATA
Northbridge Chipset Test		
10001067 INTEL	GM45	NB Chipset Intel CS GM45NB
Southbridge Chipset Test		
10001067 INTEL	ICH9M-E	SB Chipset Intel CS ICH9M-E
Keyboard Test		
820123 DARFON	14_15KB-EV2T	Keyboard 14_15KB-EV2T Michigan/Pantanal Ergo (Change+*/location)
LAN Test		
10001067 INTEL	Boazman LM	Intel Boazman LM
3G Test		
9999995 ONE TIME VENDER	GTM380E	3G GTM380E
Audio Codec Test		
9999995 ONE TIME VENDER	ALC268	ALC268

Vendor	Type	Description
Bluetooth Test		
9999995 ONE TIME VENDER	BT 2.0	Foxconn Bluetooth FOX_BRM_2.0 F/W 300
Card Reader Test		
9999995 ONE TIME VENDER	5 in 1-Build in	5 in 1-Build in MS, MS Pro, SD, SC, XD
Finger Print Reader Test		
9999995 ONE TIME VENDER	TCS4E	Upek Finger Print TCS4E
Modem Test		
10001023 LITE-ON	Lite+Con MC4Z 1.5_3.3V Aus	Lite-On Conexant -Unizion 1.5_3.3v AUS RD02-D330
WLAN Test		
10001067 INTEL	SP1x2HMW	Lan Intel WLAN 512AN_HMWG Shirley Peak 5100 MM#895373

Online Support Information

This section describes online technical support services available to help you repair your Acer Systems.

If you are a distributor, dealer, ASP or TPM, please refer your technical queries to your local Acer branch office. Acer Branch Offices and Regional Business Units may access our website. However some information sources will require a user i.d. and password. These can be obtained directly from Acer CSD Taiwan.

Acer's Website offers you convenient and valuable support resources whenever you need them.

In the Technical Information section you can download information on all of Acer's Notebook, Desktop and Server models including:

- Service guides for all models
- User's manuals
- Training materials
- Bios updates
- Software utilities
- Spare parts lists
- TABs (Technical Announcement Bulletin)

For these purposes, we have included an Acrobat File to facilitate the problem-free downloading of our technical material.

Also contained on this website are:

- Detailed information on Acer's International Traveler's Warranty (ITW)
- Returned material authorization procedures
- An overview of all the support services we offer, accompanied by a list of telephone, fax and email contacts for all your technical queries.

We are always looking for ways to optimize and improve our services, so if you have any suggestions or comments, please do not hesitate to communicate these to us.

A

AFLASH Utility 41
Antennas 101

B

Battery Pack 50
BIOS
 ROM size 18
 ROM type 18
 vendor 18
 Version 18
BIOS Utility 29–41
 Advanced 32
 Boot 39
 Exit 40
 Intel 34
 Navigating 29
 Onboard Device Configuration 37
 Save and Exit 40
 Security 36
 System Security 40
Bluetooth module 86
Board Layout
 Top View 157
brightness
 hotkeys 14

C

Cache
 controller 18
 size 18
Camera Module 97
caps lock
 on indicator 10
Common Problems 136
computer
 on indicator 10
CPU 94

D

DIMM Module 55
Display 4
display

hotkeys 14

E

EasyTouch Failure 149
Euro 15
External Module Disassembly
 Flowchart 49

F

Features 1
Fingerprint Reader Failure 150
Flash Utility 41
FPC Cable 100
FRU (Field Replaceable Unit) List 161

H

Hard Disk Drive Module 57
Hibernation mode
 hotkey 14
Hot Keys 12

I

Indicators 10
Intermittent Problems 152
Internal Microphone Failure 142
Internal Speaker Failure 140
inverter board 98

J

Jumper and Connector Locations 157
 Top View 157

K

Keyboard 65
Keyboard Failure 139

L

LCD Bezel 96
LCD Brackets 100
LCD Failure 139

LCD Module Disassembly
 Flowchart 95
LCD Panel 99
lower cover 53

M

Main Unit Disassembly
 Flowchart 62
Mainboard 89
media access
 on indicator 10
MediaTouch Button Failure 150
Memory Check 136
Model Definition 178
Modem Failure 147
Modem Module 87

N

No Display Issue 137
Notebook Manager
 hotkey 14
num lock
 on indicator 10

O

ODD Failure 144
Online Support Information 215
optical drive module 59

P

Panel 5
 Bottom 8
 left 5
PC Card 10
Port 80 POST Codes 153
POST Codes
 Port 80 153
Power On Failure 136

S

speakers
 hotkey 14
System

Block Diagram 4

T

Test Compatible Components 211
Thermal Unit Failure 150
Top 157
Touch Pad Bracket 83
touchpad
 hotkey 14
Touchpad Failure 140
Troubleshooting
 Built-in KB Failure 139
 EasyTouch Buttons 149
 Fingerprint Reader 150
 Internal Microphone 142
 Internal Speakers 140
 LCD Failure 139
 MediTouch Buttons 150
 Modem 147
 No Display 137
 ODD 144
 Other Failures 151
 Power On 136
 Thermal Unit 150
 Touchpad 140
 USB 147
 WLAN 148
TV tuner 56

U

Undetermined Problems 152
USB Failure (Rightside) 147
utility
 BIOS 29–41

W

Windows 2000 Environment Test 212
Wireless Function Failure 148
WLAN Board 56