

acer

DRAFT



TravelMate 7730/7730A
Service Guide

Revision History

Please refer to the table below for the updates made on Travelmate 7730/7730G Series service guide.

Date	Chapter	Updates

Service guide files and updates are available on the ACER/CSD web. For more information, refer to <http://csd.acer.com.tw>

Copyright

Copyright © 2008 by Acer Incorporated. All rights reserved. No part of this publication may be reproduced, transmitted, transcribed, stored in a retrieval system, or translated into any language or computer language, in any form or by any means, electronic, mechanical, magnetic, optical, chemical, manual or otherwise, without the prior written permission of Acer Incorporated.

Disclaimer

The information in this guide is subject to change without notice.

Acer Incorporated makes no representations or warranties, either expressed or implied, with respect to the contents hereof and specifically disclaims any warranties of merchantability or fitness for any particular purpose. Any Acer Incorporated software described in this manual is sold or licensed "as is". Should the programs prove defective following their purchase, the buyer (and not Acer Incorporated, its distributor, or its dealer) assumes the entire cost of all necessary servicing, repair, and any incidental or consequential damages resulting from any defect in the software.

Acer is a registered trademark of Acer Corporation.

Intel is a registered trademark of Intel Corporation.

Pentium and Pentium II/III are trademarks of Intel Corporation.

Other brand and product names are trademarks and/or registered trademarks of their respective holders.

PRINTED IN TAIWAN

Conventions

The following conventions are used in this manual:

SCREEN MESSAGES	Denotes actual messages that appear on screen.
NOTE	Gives bits and pieces of additional information related to the current topic.
WARNING	Alerts you to any damage that might result from doing or not doing specific actions.
CAUTION	Gives precautionary measures to avoid possible hardware or software problems.
IMPORTANT	Reminds you to do specific actions relevant to the accomplishment of procedures.

Preface

Before using this information and the product it supports, please read the following general information.

- 1 This Service Guide provides you with all technical information relating to the BASIC CONFIGURATION decided for Acer's "global" product offering. To better fit local market requirements and enhance product competitiveness, your regional office MAY have decided to extend the functionality of a machine (such as add-on cards, modems, or extra memory capabilities). These LOCALIZED FEATURES are NOT covered in this generic service guide. In such cases, contact your regional offices or the responsible personnel/channel to provide you with further technical details.
- 2 Please note WHEN ORDERING FRU PARTS, that you should check the most up-to-date information available on your regional web or channel. If, for whatever reason, a part number change is made, it will not be noted in the printed Service Guide. For ACER-AUTHORIZED SERVICE PROVIDERS, your Acer office may have a DIFFERENT part number code to those given in the FRU list of this printed Service Guide. You MUST use the list provided by your regional Acer office to order FRU parts for repair and service of customer machines.

Contents

Chapter 1: System specifications	1
Features	2
System block diagram	5
The Acer notebook tour	6
LCD panel	6
Palm rest	7
Front	8
Left	9
Right	10
Rear	10
Bottom view	11
Indicators	12
Easy-launch buttons	13
Touchpad basics	14
Using the keyboard	14
Hardware specifications and configurations	18
CPU	18
Controllers	18
BIOS	18
Memory	19
Hard Disk Drive	20
DVD-CDRW drive	22
DVD burner	23
Blu-ray drive	25
LCD	25
Inverter	28
Video subsystem	28
Keyboard	29
Pointing device	29
Memory card reader	29
PCMCIA	29
ExpressCard (NewCard)	29
Audio	30
Wired LAN	30
Bluetooth	30
Wireless LAN	31
Modem	31
USB	31
Buttons/Indicators/Ports	31
Fingerprint reader	32
Camera	32
Fan	32
Battery	33
Power supply	33
Power savings	33
Chapter 2: System utilities	35
BIOS Setup Utility	36
Navigating the BIOS Setup Utility	36
BIOS Setup Utility screens	37
Information screen	37
Main screen	38
Advanced screen	40

Security screen41
Boot45
Exit46
BIOS Flash utility47
Removing a password lock48
Removing a HDD password lock48
Removing a Supervisor password lock48

Chapter 3: Replacing notebook components 51

Preventing static electricity discharge52
Tape52
Preparing your work space53
Tools required54
Preparing the notebook55
Remove a PC Card55
Removing an ExpressCard55
Removing a memory card56
Removing the battery56
Adding or replacing memory modules57
Replacing the graphics card61
Replacing the primary hard drive64
Replacing the IEEE 802.11 wireless card67
Replacing the CMOS battery71
Replacing the secondary hard drive73
Replacing the optical drive76
Replacing the keyboard cover78
Replacing the keyboard80
Replacing the power button board82
Replacing the LCD assembly84
Replacing the inverter87
Replacing the LCD panel89
Replacing the LCD panel hinges92
Replacing the web cam94
Replacing the palm rest96
Replacing the microphone and speakers103
Replacing the touchpad button board/fingerprint assembly106
Replacing the button board109
Replacing the ExpressCard (NewCard) assembly112
Replacing the Bluetooth card114
Replacing the modem117
Replacing the system board120
Replacing the cooling assembly124
Replacing the processor129

Chapter 4: Troubleshooting 135

Diagnosing problems136
System test procedures137
Testing the external diskette drive137
Testing the external CD-ROM drive137
Testing the keyboard or auxiliary input device137
Testing the memory138
Testing the power system138
Testing the touchpad139
Power-On Self-Test (POST) error message140

Contents

Index of error messages	141
Error codes	141
Error messages	141
No-beep error messages	143
Phoenix BIOS beep codes	144
Symptom-to-FRU error messages.	148
LCD.	148
Indicator	148
Power	148
ExpressCard (NewCard).	149
Memory	149
Sound	149
Power management	149
Devices	150
Keyboard and touchpad	151
Modem.	151
Intermittent problems	152
Undetermined problems	153
Chapter 5: Jumper and connector locations	155
System board top connectors	156
System board bottom connectors	157
Clearing password check and BIOS recovery	158
Clearing the password check.	158
BIOS Recovery by Crisis Diskette	159
Chapter 6: FRU (Field-Replaceable Unit) list	161
Introduction	162
Travelmate 7730/7730G exploded diagram.	163
Notebook chassis	163
Notebook LCD panel.	164
Travelmate 7730/7730G FRU list.	165
Appendix A: Model definition and configuration	173
Appendix B: Test compatible components	235
Microsoft® Windows® Vista Environment Test.	236
Appendix C: Online support information	239
Index	241

Chapter 1

System specifications

- Features
- System block diagram
- The Acer notebook tour
- Using the keyboard
- Hardware specifications and configurations

Features

Platform

For TravelMate 7730

- Intel® Centrino® 2 processor technology, featuring:
 - Intel® Core™2 Duo processor T9400/P9500 (6 MB L2 cache, 2.53 GHz, 1066 MHz FSB, 35 W/25 W), T9600 (6 MB L2 cache, 2.80 GHz, 1066 MHz FSB, 35 W) or higher, or P8400/P8600 (3 MB L2 cache, 2.26/2.40 GHz, 1066 MHz FSB, 25 W), supporting Intel® 64 architecture
 - Mobile Intel® GM45 Express Chipset
 - Intel® Wireless WiFi Link 5100/5300 (dual-band quad-mode 802.11a/b/g/Draft-N) Wi-Fi CERTIFIED® network connection, featuring 1x2 or 3x3 MIMO technology, supporting Acer SignalUp™ with Nplify™2, 3 wireless technology

For TravelMate 7730G

- Intel® Centrino® 2 processor technology, featuring:
 - Intel® Core™2 Duo processor T9400/P9500 (6 MB L2 cache, 2.53 GHz, 1066 MHz FSB, 35 W/25 W), T9600 (6 MB L2 cache, 2.80 GHz, 1066 MHz FSB, 35 W) or higher, or P8400/P8600 (3 MB L2 cache, 2.26/2.40 GHz, 1066 MHz FSB, 25 W), supporting Intel® 64 architecture
 - Mobile Intel® PM45 Express Chipset
 - Intel® Wireless WiFi Link 5100/5300 (dual-band quad-mode 802.11a/b/g/Draft-N) Wi-Fi CERTIFIED® network connection, featuring MIMO technology, supporting Acer SignalUp™ with Nplify™2, 3 wireless technology

System Memory

- Dual-Channel DDR2 SDRAM support
- Up to 2 GB of DDR2 667 MHz memory, upgradeable to 4 GB using two SO-DIMM modules

Display and graphics

- 17" WXGA+ high-brightness (220 nit), 1440 × 900 pixel resolution, supporting simultaneous multi-window viewing via Acer GridVista™
- 17" WXGA+ high-brightness (220 nit) Acer CrystalBrite™ TFT LCD, 1440 × 900 pixel resolution, supporting simultaneous multi-window viewing via Acer GridVista™ (for selected models)
- Mobile Intel® GM45 Express Chipset with integrated 3D graphics, featuring Intel® Graphics Media Accelerator X4500 (Intel® GMA X4500) with up to 3587 MB of Intel® Dynamic Video Memory Technology 4.0 (8 MB of dedicated system memory, up to 350 MB of shared system memory), supporting Microsoft® DirectX® 10
- NVIDIA® GeForce® 9600M GT with up to 23037 MB of TurboCache™ (512 MB of dedicated GDDR3 VRAM, up to 1791 MB of shared system memory), supporting NVIDIA® PureVideo™ HD technology, OpenEXR High Dynamic-Range (HDR) technology, Shader Model 4.0, Microsoft® DirectX® 10 (for selected models)

-
- ❑ NVIDIA® GeForce® 9300M GS with up to 20477 MB of TurboCache™ (256 MB of dedicated DDR2 VRAM, up to 1791 MB of shared system memory), supporting NVIDIA® PureVideo™ HD technology, OpenEXR High Dynamic-Range (HDR) technology, Shader Model 4.0, Microsoft® DirectX® 10 (for selected models)
 - ❑ Dual independent display support
 - ❑ 16.7 million colors
 - ❑ MPEG-2/DVD hardware-assisted capability (acceleration)
 - ❑ MPEG-2/DVD decoding (for selected models)
 - ❑ WMV9 (VC-1) support (acceleration)
 - ❑ WMV9 (VC-1) and H.264 (AVC) decoding (for selected models)
 - ❑ HDMI™ (High-Definition Multimedia Interface) with HDCP (High-bandwidth Digital Content Protection) support

Storage subsystem

- ❑ One or two 120/160/250/320 GB or larger hard disk drives
- ❑ Intel® Turbo Memory 2 GB supported
- ❑ Optical drive options:
 - ❑ Blu-ray Disc™/DVD-Super Multi double-layer drive
 - ❑ DVD-Super Multi double-layer drive
 - ❑ DVD/CD-RW combo drive
- ❑ 5-in-1 card reader, supporting Secure Digital™ (SD), MultiMediaCard (MMC), Memory Stick® (MS), Memory Stick PRO™ (MS PRO), xD-Picture Card™ (xD)

Input devices

- ❑ 105-/106-key keyboard with inverted “T” cursor layout, 2.5 mm (minimum) key travel
- ❑ Touchpad pointing device
- ❑ 12 function keys, four cursor keys, two Windows® keys, hotkey controls, standard numeric keypad, international language support, independent US dollar and Euro symbol keys
- ❑ Media keys (printed on keyboard): play/pause, stop, previous, next
- ❑ Empowering Key
- ❑ Easy-launch buttons: WLAN, Internet, Bluetooth, email, programmable
- ❑ Productivity keys: Lock, Presentation, Sync

Audio

- ❑ Two built-in Acer 3DSonic stereo speakers
- ❑ High-definition audio support
- ❑ MS-Sound compatible
- ❑ Built-in microphone

Communication

- ❑ Acer Video Conference, featuring:
 - ❑ Integrated Acer Crystal Eye webcam, supporting enhanced Acer PrimaLite™ technology
 - ❑ Optional Acer Xpress VoIP phone
- ❑ WLAN: Intel® Wireless WiFi Link 5100/5300 (dual-band quad-mode 802.11a/b/g/Draft-N) Wi-Fi CERTIFIED® network connection, featuring MIMO technology, supporting Acer SignalUp™ with Nplify™2 wireless technology
- ❑ WPAN: Bluetooth® 2.0+EDR (Enhanced Data Rate)
- ❑ LAN: Gigabit Ethernet supporting ASF (Alert Standard Format) 2.0, Wake-on-LAN ready
- ❑ Modem: 56K ITU V.92 with PTT approval¹⁰, Wake-on-Ring ready

I/O Ports

- ❑ 68-pin Acer EasyPort IV connector
- ❑ ExpressCard™/54 slot
- ❑ PC Card slot (Type II)
- ❑ Acer Bio-Protection fingerprint reader¹
- ❑ 5-in-1 card reader (SD™, MMC, MS, MS PRO, xD)
- ❑ Four USB 2.0 ports
- ❑ HDMI™ port with HDCP support
- ❑ External display (VGA) port
- ❑ Headphone/speaker/line-out jack
- ❑ Microphone in jack
- ❑ Line in jack
- ❑ Ethernet (RJ-45) port
- ❑ Modem (RJ-11) port
- ❑ DC in jack for AC adapter

Environment

- ❑ Temperature:
 - ❑ Operating: 41 °F to 95 °F (5 °C to 35 °C)
 - ❑ Non-operating: -4 °F to 149 °F (20 °C to 65 °C)
- ❑ Humidity (non-condensing):
 - ❑ Operating: 20% to 80%
 - ❑ Non-operating: 20% to 80%

System block diagram

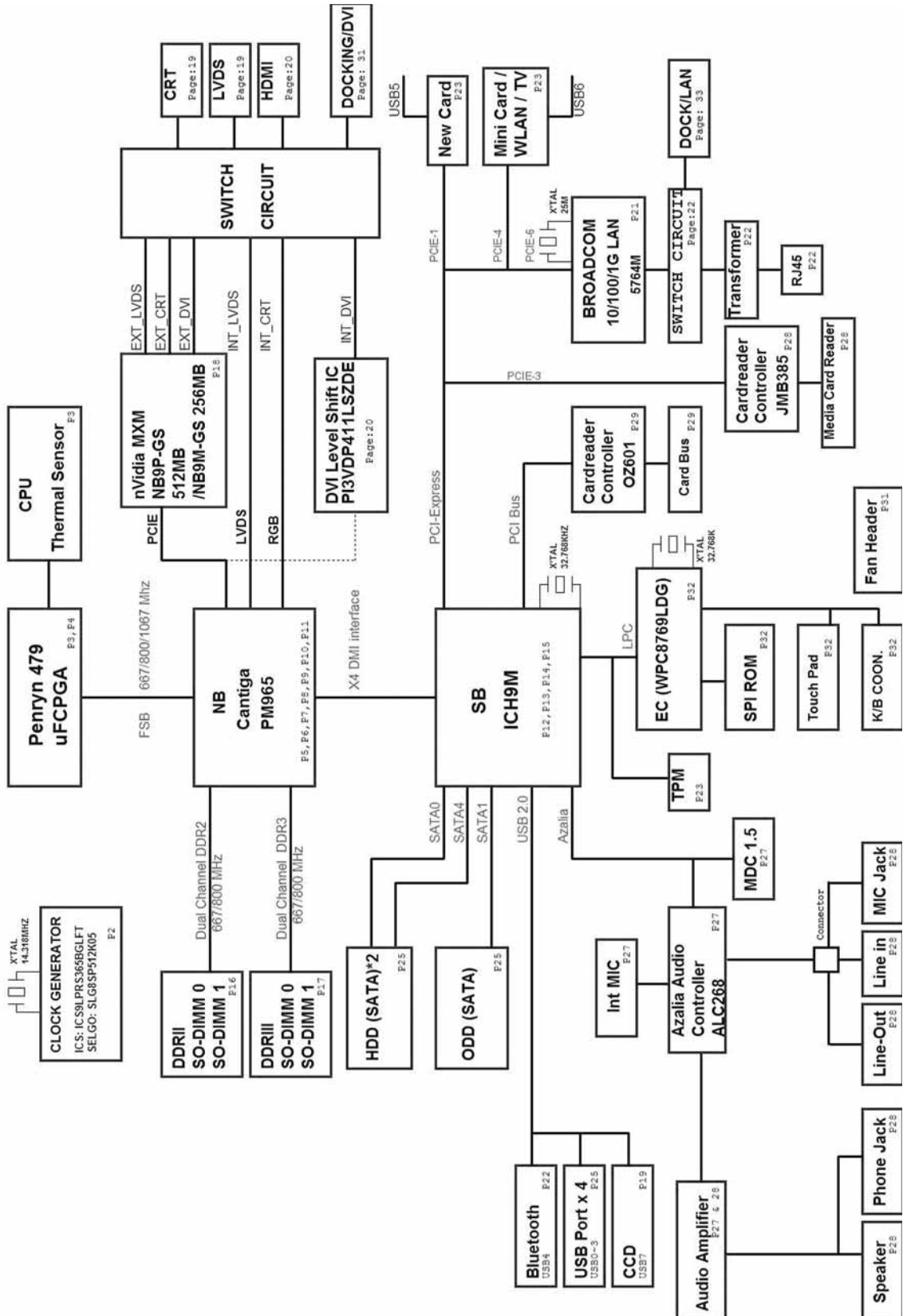

The Acer notebook tour

LCD panel

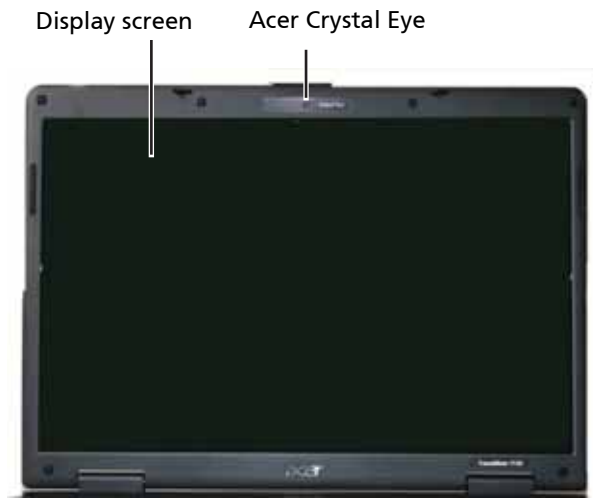

Item	Description
Display screen	Also called Liquid-Crystal Display (LCD), displays video output.
Acer Crystal Eye	Web camera for video communication. (Available on select models only.)

Palm rest



Item	Description
Speakers	Left and right speakers deliver stereo audio output.
Status indicators	Light-Emitting Diodes (LEDs) that light up to show the status of the notebook's functions and components. Refer to the <i>Generic User Guide</i> for more details.
Microphone	Internal microphone for sound recording. (Available on select models only.)
Easy-launch buttons	Buttons for launching frequently used programs. Refer to the <i>Generic User Guide</i> for more details.
Touchpad	Touch-sensitive pointing device which functions like a computer mouse.
Status indicators	Light-Emitting Diodes (LEDs) that light up to show the status of the notebook's functions and components.
Click buttons (left, center, and right)	The left and right buttons function like the left and right mouse buttons. Note: The center button serves as Acer BioProtect fingerprint reader supporting Acer FingerNav 4-way control function. (Available on select models only.)
Keyboard	For entering data into your notebook.
Palm rest	Comfortable support area for your hands when you use the notebook.
Power button	Turns the notebook on and off.
Empowering key	Launch Acer Empowering Technology.
Productivity keys	Three productivity keys give users one-touch access to protection and manageability features for a more secure, smarter, and easier way to work. Refer to the <i>Generic User Guide</i> for more details.

Front

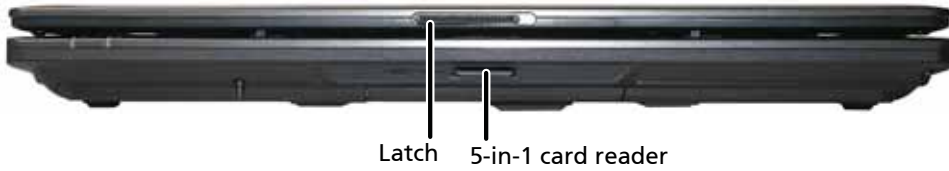

Item	Icon	Description
Latch		Locks and releases the lid.
5-in-1 card reader		Accepts Secure Digital (SD), MultiMediaCard (MMC), Memory Stick (MS), Memory Stick Pro (MS PRO), and xD-Picture Card. Note: Push to remove or install a card. Only one card can operate at any given time.



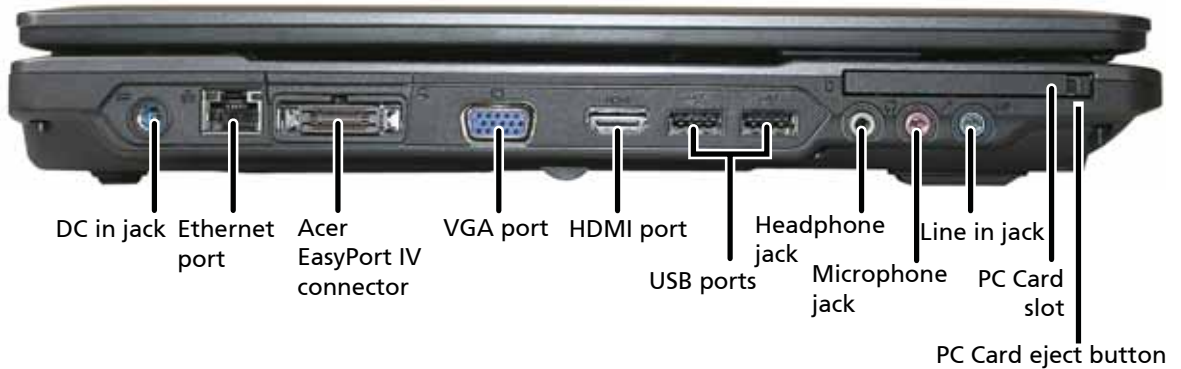

Left

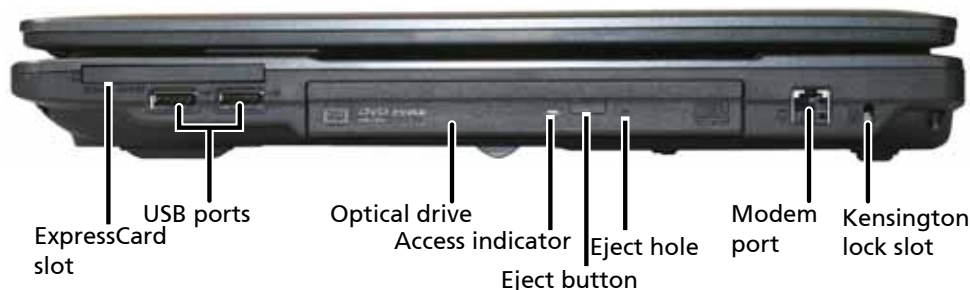

Item	Icon	Description
DC in jack		Connects to an AC adapter.
Ethernet (RJ-45) port		Connects to an Ethernet 10/100/1000-based network.
Acer EasyPort IV connector		Connects to an Acer EasyPort IV. (Available on select models only.)
External display (VGA) port		Connects to a display device (such as an external monitor or LCD projector).
HDMI port	HDMI	Connects to a high definition digital video device. (Available on select models only.)
Two USB 2.0 ports		Connects to USB 2.0 devices (such as a USB mouse, keyboard, printer, or camera).
Headphones/speaker/line-out jack.		Connects to audio line-out devices (such as speakers or headphones).
Microphone jack		Connects to an external microphone.
Line in jack		Connects to an audio line in device (such as an audio CD player, stereo walkman, or mp3 player).
PC Card slot		Accepts one Type II PC Card.
PC Card slot eject button		Ejects the PC Card from the slot.

Right



Item	Icon	Description
Type 54 ExpressCard slot		Accepts one Type 54 ExpressCard module. Note: Push to remove or install the card.
USB 2.0 ports		Connects to USB 2.0 devices (such as a USB mouse, keyboard, printer, or camera).
Optical drive		Internal optical drive. Accepts CDs, DVDs, or Blu-ray discs. (Blu-ray available on select models only.)
Optical disc access indicator		Lights up when the optical drive is active.
Optical drive eject button		Ejects the optical disc from the drive.
Emergency eject hole		Ejects the optical drive tray when the notebook is turned off. Note: Insert a paper clip to the emergency eject hole to eject the optical drive tray when the notebook is turned off.
Modem (RJ-11) port		Connects to a telephone line.
Kensington lock slot		Connects to a Kensington-compatible computer security lock.







Rear

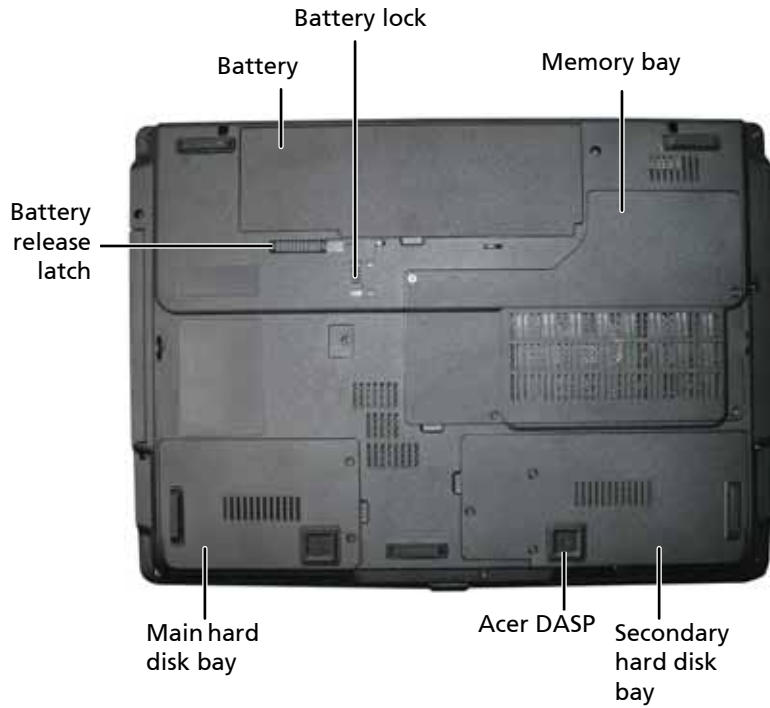

Item	Description
Ventilation slots	Helps cool internal components. Warning: Do not work with the notebook resting on your lap. If the air vents are blocked, the notebook may become hot enough to harm your skin. Caution: Do not block or insert objects into these slots. If these slots are blocked, your notebook may overheat resulting in unexpected shutdown or permanent damage to the notebook. Caution: Provide adequate space around your notebook so air vents are not obstructed. Do not use the notebook on a bed, sofa, rug, or other similar surface.

Bottom view







Item	Icon	Description
Battery bay		Houses the notebook's battery pack.
Battery release latch		Releases the battery to remove the battery pack.
Hard disk bay-Main		Houses the notebook's hard disk (secured with screws)
Acer DASP (Disk Anti-Shock Protection)		Protects the hard disk drive from shocks and bumps. (Available on select models only.)
Hard disk bay-Secondary		Houses the notebook's hard disk (secured with screws). (Available on select models only.)
Memory bay		Houses the notebook's main memory.
Battery lock		Locks the battery in position.

Indicators

The notebook has several easy-to-read status indicators:



The front panel indicators are visible even when the notebook cover is closed.







Icon	Function	Description
	Power	Indicates the notebook's power status.
	Battery	Indicates the notebook's battery status. <ul style="list-style-type: none">• Amber—battery is charging.• Green—battery is charged and AC adapter is plugged in.
	Hard Disk Drive (HDD)	Indicates when the hard disk drive is active.
	Num Lock	Lights up when Num Lock is activated.
	Caps Lock	Lights up when Caps Lock is activated.

Easy-launch buttons

Located beside the keyboard are application buttons. These buttons are called easy-launch buttons. They are: WLAN, Internet, email, Bluetooth, Arcade and Acer Empowering Technology.

The mail and Web browser buttons are pre-set to email and Internet programs, but can be reset by the user. To set the Web browser, mail, and programmable buttons, run the Acer Launch Manager.



Icon	Function	Description
	Empowering Technology	Launches Acer Empowering Technology. (This button is user-programmable.)
	Acer Arcade	Launches the Acer Arcade utility.
	Wireless communication button/indicator	Enables/disables the wireless function. Indicates the status of wireless LAN communication.
	Web browser	Launches the Internet browser. (This button is user-programmable.)
	Mail	Launches the Email application. (This button is user-programmable.)
	Bluetooth communication button/indicator	Enables/disables the Bluetooth function. Indicates the status of Bluetooth communication.

Touchpad basics

The following teaches you how to use the touchpad:

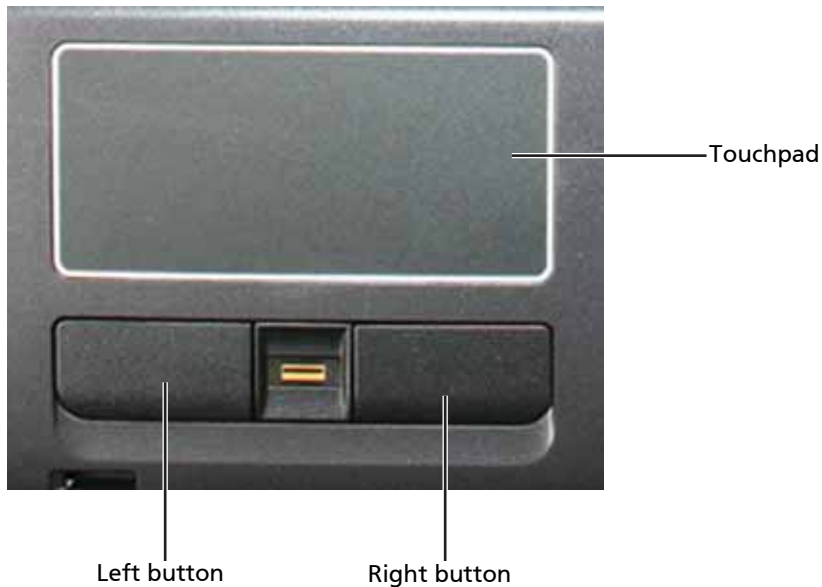

- ❑ Move your finger across the touchpad to move the cursor.
- ❑ Press the left and right buttons located beneath the touchpad to perform selection and execution functions. These two buttons are similar to the left and right buttons on a mouse. Tapping on the touchpad is the same as clicking the left button.

Function	Left Button	Right Button	Main touchpad
Execute	Quickly click twice.		Tap twice (at the same speed as double-clicking a mouse button).
Select	Click once.		Tap once.
Drag	Click and hold, then use finger on the touchpad to drag the cursor.		Tap twice (at the same speed as double-clicking a mouse button); rest your finger on the touchpad on the second tap and drag the cursor.
Access context menu		Click once.	

Note: When using the touchpad, keep it—and your fingers—dry and clean. The touchpad is sensitive to finger movement. The lighter the touch, the better the response. Tapping too hard does not increase the touchpad's responsiveness.

Using the keyboard

The keyboard has full-sized keys and an embedded numeric keypad, separate cursor, lock, Windows, function and special keys.

Lock keys

The keyboard has three lock keys which you can toggle on and off.

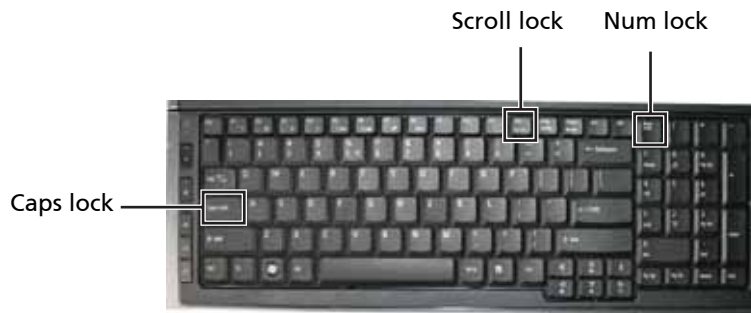



Lock key	Description
Caps Lock	When Caps Lock is on, all alphabetic characters typed are in uppercase.
Scroll Lock <Fn> + <F12>	When Scroll Lock is on, the screen moves one line up or down when you press the up or down arrow keys respectively. Scroll Lock does not work with some applications.
Num Lock	When Num Lock is on, the numeric keypad is in numeric mode. The keys function as a calculator (complete with the arithmetic operators +, -, *, and /). Use this mode when you need to do a lot of numeric data entry.

Windows keys

The keyboard has two keys that perform Windows-specific functions.



Key	Description
 Windows key	<p>Pressed alone, this key has the same effect as clicking on the Windows Start button. It launches the Start menu. It can also be used with other keys to provide a variety of functions:</p> <ul style="list-style-type: none"> <⊞>: Open or close the Start menu <⊞> + <D>: Display the desktop <⊞> + <E>: Open Windows Explore <⊞> + <F>: Search for a file or folder <⊞> + <G>: Cycle through Sidebar gadgets <⊞> + <L>: Lock your notebook (if you are connected to a network domain), or switch users (if you're not connected to a network domain) <⊞> + <M>: Minimizes all windows <⊞> + <R>: Open the <i>Run</i> dialog box <⊞> + <T>: Cycle through programs on the taskbar <⊞> + <U>: Open Ease of Access Center <⊞> + <X>: Open Windows Mobility Center <⊞> + <BREAK>: Display the <i>System Properties</i> dialog box <⊞> + <SHIFT+M>: Restore minimized windows to the desktop <⊞> + <TAB>: Cycle through programs on the taskbar by using Windows Flip 3-D <⊞> + <SPACEBAR>: Bring all gadgets to the front and select Windows Sidebar <CTRL> + <⊞> + <F>: Search for computers (if you are on a network) <CTRL> + <⊞> + <TAB>: Use the arrow keys to cycle through programs on the taskbar by using Windows Flip 3-D <p>Note: Depending on your edition of Windows Vista, some shortcuts may not function as described.</p>
 Application key	<p>This key has the same effect as clicking the right mouse button. It opens the application's context menu.</p>

Hotkeys

The notebook employs hotkeys or key combinations to access most of the notebook's controls like screen brightness, volume output, and the BIOS Setup Utility.

To activate hotkeys, press and hold the <Fn> key before pressing the other key in the hotkey combination.

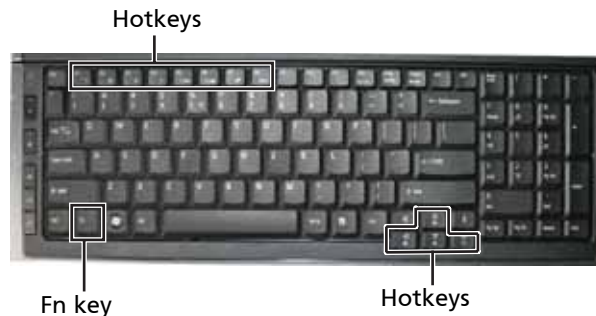

Hotkey	Icon	Function	Description
<Fn> + <F1>	?	Hotkey help	Displays help on hotkeys.
<Fn> + <F2>		Acer eSettings Management	Launches Acer eSettings Management in Acer Empowering Technology.
<Fn> + <F3>		Acer ePower Management	Launches Acer ePower Management in Acer Empowering Technology.
<Fn> + <F4>	Z ^z	Sleep	Puts the notebook in Sleep mode.
<Fn> + <F5>		Display toggle	Switches display output between the display screen, external monitor (if connected) and both.
<Fn> + <F6>		Screen blank	Turns the display screen backlight off to save power. Press any key to return.
<Fn> + <F7>		Touchpad toggle	Turns the internal touchpad on and off.
<Fn> + <F8>		Speaker toggle	Turns the speakers on and off.
<Fn> + <D>		Brightness up	Increases the screen brightness.
<Fn> + <Q>		Brightness down	Decreases the screen brightness.
<Fn> + <Δ>		Volume up	Increases the volume.
<Fn> + <∇>		Volume down	Decreases the volume.

Hardware specifications and configurations

CPU

Item	Specification
CPU type	Intel® Core™2 Duo processor supporting Intel® 64 architecture: <ul style="list-style-type: none">• T9400/P9500 (6 MB L2 cache, 2.53 GHz, 1066 MHz FSB, 35 W/25 W)• T9600 (6 MB L2 cache, 2.80 GHz, 1066 MHz FSB, 35 W) or higher• P8400/P8600 (3 MB L2 cache, 2.26/2.40 GHz, 1066 MHz FSB, 25 W)
Core logic	Intel Crestline PM965 + ICH9M chipset
CPU package	Intel 479 pin Micro-FCPGA
CPU core voltage	1.05V

Controllers

Item	Controller
Core logic	Intel Crestline PM965 + ICH9M chipset
VGA	<ul style="list-style-type: none">• Nvidia NB9M-GS• Nvidia NB9P-GS
LAN	Broadcom 5764M
USB 2.0	Intel ICH9M
Super I/O controller	N/A
MODEM	LSI
Bluetooth	Foxconn TT60H928.11
Wireless 802.11 b+g	Intel
PCMCIA	O2 Mirco OZ601
5 in 1 Card Reader	JMicron JMB385
Audio Codec	Realtek 268 Azadia codec and Amplifier GMT G1412+G1411

BIOS

Item	Specification
BIOS vendor	Phoenix
BIOS Version	1.XX (MP version) <Athena: what is the final shipping vers  >
BIOS ROM type	Serial Flash Memory
BIOS ROM size	2 MB
BIOS package	8 pin SOIC

Item	Specification
Supported protocols	<ul style="list-style-type: none"> • ACPI 1.0b/2.0/3.0 compliance • PCI 2.2 or later • System/HDD Password Security Control • INT 13H Extensions • PnP BIOS 1.0a • SMBIOS 2.4 or later • BIOS Boot Specification • Simple Boot Flag 1.0 • Boot Block • PCI Bus Power Management Interface Specification • USB Specification 1.1/2.0 • USB/1394 CD-ROM Boot Up support • PC Card Standard 1995 (PCMCIA 3.0 Compliant Device) • Support HD audio • WfM 2.0, PXE 2.1 • Preboot Execution Environment (PXE) 2.1 • Boot Integrity Service Application Program Interface (BIS) 1.0 • PC2002/2005 compliant • Intel Enhanced Speedstep Technology • ASF 2.0 • AHCI support
BIOS password control	Manually set Supervisor and User passwords.

Memory

Item	Specification
Memory controller	Built-in
Memory size	0 MB (no on-board memory)
SO-DIMM socket number	2 sockets
Supports memory size per socket	<ul style="list-style-type: none"> • 1024 MB for 32 bit OS • 2048 MB for 65 bit OS
Supports maximum memory size	<ul style="list-style-type: none"> • 2G for 32 bit OS (with two 1GB SO-DIMM) • 4G for 64 bit OS (with two 2GB SO-DIMM)
Supports SO-DIMM type	<ul style="list-style-type: none"> • DDR 2 Synchronous DRAM • DDR 3 Synchronous DRAM
Supports SO-DIMM Speed	<ul style="list-style-type: none"> • 667 MHz DDR 2 • 1066 MHz DDR3
Supports SO-DIMM voltage	<ul style="list-style-type: none"> • 1.8 V for DDR 2 • 1.5 V for DDR 3
Supports SO-DIMM package	<ul style="list-style-type: none"> • 200-pin SO-DIMM for DDR 2 • 204-pin SO-DIMM for DDR 3
Memory module combinations	You can install memory modules in any combinations as long as they match the above specifications.

Slot 1	Slot 2	Total Memory
0MB	256MB	256MB
0MB	512MB	512MB
0MB	1024MB	1024MB
0MB	2048MB	2048MB
256MB	256MB	512MB
256MB	512MB	768MB
256MB	1024MB	1280MB
256MB	2048MB	2304MB
512MB	256MB	768MB
512MB	512MB	1024MB
512MB	1024MB	1536MB
512MB	2048MB	2560MB
1024MB	0MB	1024MB
1024MB	256MB	1280MB
1024MB	512MB	1536MB
1024MB	1024MB	2048MB
1024MB	2048MB	3072MB
2048MB	0MB	2048MB
2048MB	256MB	2304MB
2048MB	512MB	2560MB
2048MB	1024MB	3072MB
2048MB	2048MB	4096MB

Note: Above table lists some system memory configurations. You may combine SO-DIMMs with various capacities to form other combinations. On above table, the configuration of slot 1 and slot 2 can be reversed.

Hard Disk Drive

Item	Specification			
Vendor & Model Name	Seagate ST9250827AS	Seagate ST9200827AS	Seagate ST9160827AS	Seagate ST9120817AS
Capacity	250 GB	200 GB	160 GB	120 GB
Bytes per sector	512	512	512	512
Data heads	4	4	3	2
Drive Format				
Disks	2	2	2	1
Spindle speed	5400 RPM	5400 RPM	5400 RPM	5400 RPM
Performance Specifications				
Buffer size	8 MB	8 MB	8 MB	8 MB
Interface	SATA	SATA	SATA	SATA
Max. media transfer rate (disk-buffer)	778 Mbits/sec	778 Mbits/sec	778 Mbits/sec	778 Mbits/sec

Item	Specification			
Data transfer rate (host~buffer)	300 Mbit/sec Ultra DMA mode 6	300 Mbit/sec Ultra DMA mode 6	300 Mbit/sec Ultra DMA mode 6	300 Mbit/sec Ultra DMA mode 6
DC Power Requirements				
Input Voltage	5 V	5 V	5 V	5 V

Item	Specification			
Vendor & Model Name	Toshiba MK2546GSX	Toshiba MK1646GSX	Toshiba MK1246GSX	Toshiba MK8046GSX
Capacity	250 GB	160 GB	120 GB	80 GB
Bytes per sector	512	512	512	512
Data heads	4	3	2	2
Drive Format				
Disks	2	2	1	1
Spindle speed	5400 RPM	5400 RPM	5400 RPM	5400 RPM
Performance Specifications				
Buffer size	8 MB	8 MB	8 MB	8 MB
Interface	SATA	SATA	SATA	SATA
Max. media transfer rate (disk-buffer)	730 Mbits/sec	730 Mbits/sec	730 Mbits/sec	730 Mbits/sec
Data transfer rate (host~buffer)	300 Mbit/sec Ultra DMA mode 6	300 Mbit/sec Ultra DMA mode 6	300 Mbit/sec Ultra DMA mode 6	300 Mbit/sec Ultra DMA mode 6
DC Power Requirements				
Input Voltage	5 V	5 V	5 V	5 V

Item	Specification		
Vendor & Model Name	Western Digital WD2500BEVT	Western Digital WD2500BEVS	Western Digital WD1200BEVS
Capacity	250 GB	250 GB	120 GB
Bytes per sector	512	512	512
Data heads	3	4	2
Drive Format			
Disks	2	2	1
Spindle speed	5400 RPM	5400 RPM	5400 RPM
Performance Specifications			
Buffer size	8 MB	8 MB	8 MB
Interface	SATA	SATA	SATA
Max. media transfer rate (disk-buffer)	850 Mbits/sec	850 Mbits/sec	850 Mbits/sec
Data transfer rate (host~buffer)	3 Gbit/sec Ultra DMA mode 6	1.5 Gbit/sec Ultra DMA mode 6	1.5 Gbit/sec Ultra DMA mode 6
DC Power Requirements			
Input Voltage	5 V	5 V	5 V

DVD-CDRW drive

Item	Specification	
Vendor & model name	Sony CRX890S	
Performance Specification	With CD Disc	With DVD Disc
Transfer rate	XX	XX 
Buffer Memory	2 MB	
Interface	SATA	
Applicable disc format	Applicable CD Formats: Read: <ul style="list-style-type: none"> • CD-Audio • CD-DA • CD-Extra/CD-Plus • CD-I • CD-ROM • CD-ROM XA • CD-TEXT • Karaoke CD • Photo CD • Video CD Write: <ul style="list-style-type: none"> • CD-R • CD-RW 	Applicable DVD formats: Read: <ul style="list-style-type: none"> • DVD±R • DVD±RW • DVD-RAM • DVD-ROM • DVD-Video
Loading mechanism	Tray	
Power Requirement		
Input Voltage	5 V	

Item	Specification	
Vendor & model name	Toshiba TS-L463A	
Performance Specification	With CD Disc	With DVD Disc
Transfer rate	3600 KB/s	8–10 MB/s
Buffer Memory	2 MB	
Interface	SATA	
Applicable disc format	Applicable CD Formats: Read: <ul style="list-style-type: none"> • CD-Audio • CD-DA • CD-Extra/CD-Plus • CD-I • CD-ROM • CD-ROM XA • CD-TEXT • Photo CD • Video CD Write: <ul style="list-style-type: none"> • CD-R • CD-RW 	Applicable DVD formats: Read: <ul style="list-style-type: none"> • DVD±R • DVD±RW • DVD-ROM • DVD-Video

Item	Specification
Loading mechanism	Tray
Power Requirement	
Input Voltage	5 V

DVD burner

Item	Specification	
Vendor & model name	HLDS GSA-T50N	
Performance Specification	With CD Disc	With DVD Disc
Transfer rate	3600 KB/s	11 MB/s
Buffer Memory	2 MB	
Interface	SATA	
Applicable disc format	Applicable CD Formats: Read: <ul style="list-style-type: none"> • CD-Audio • CD-DA • CD-Extra/CD-Plus • CD-I • CD-ROM • CD-ROM XA • CD-TEXT • Photo CD • Video CD Write: <ul style="list-style-type: none"> • CD-R • CD-RW 	Applicable DVD formats: Read: <ul style="list-style-type: none"> • DVD±R • DVD±RW • DVD-RAM • DVD-ROM • DVD-Video Write: <ul style="list-style-type: none"> • DVD+R • DVD+R Double Layer • DVD+RW • DVD-R • DVD-R DL • DVD-RW • DVD-RAM
Loading mechanism	Tray	
Power Requirement		
Input Voltage	5 V	

Item	Specification	
Vendor & model name	Pioneer DVR-TD08RS	
Performance Specification	With CD Disc	With DVD Disc
Transfer rate	3600 KB/s	10 MB/s
Buffer Memory	2 MB	
Interface	SATA	

Item	Specification	
Applicable disc format	Applicable CD Formats: Read: <ul style="list-style-type: none"> • CD-Audio • CD-DA • CD-Extra/CD-Plus • CD-ROM • CD-ROM XA • CD-TEXT • Photo CD • Video CD Write: <ul style="list-style-type: none"> • CD-R • CD-RW 	Applicable DVD formats: Read: <ul style="list-style-type: none"> • DVD±R • DVD±RW • DVD-RAM • DVD-ROM • DVD-Video Write: <ul style="list-style-type: none"> • DVD+R • DVD+R Double Layer • DVD+RW • DVD-R • DVD-R DL • DVD-RW • DVD-RAM
Loading mechanism	Tray	
Power Requirement		
Input Voltage	5 V	

Item	Specification	
Vendor & model name	Toshiba TS-L633A	
Performance Specification	With CD Disc	With DVD Disc
Transfer rate	3600 KB/s	10 MB/s
Buffer Memory	2 MB	
Interface	SATA	
Applicable disc format	Applicable CD Formats: Read: <ul style="list-style-type: none"> • CD-Audio • CD-DA • CD-Extra/CD-Plus • CD-I • CD-ROM • CD-ROM XA • CD-TEXT • Photo CD • Video CD Write: <ul style="list-style-type: none"> • CD-R • CD-RW 	Applicable DVD formats: Read: <ul style="list-style-type: none"> • DVD±R • DVD±RW • DVD-RAM • DVD-ROM • DVD-Video Write: <ul style="list-style-type: none"> • DVD+R • DVD+R Double Layer • DVD+RW • DVD-R • DVD-R DL • DVD-RW • DVD-RAM
Loading mechanism	Tray	
Power Requirement		
Input Voltage	5 V	

Blu-ray drive

Item	Specification		
Vendor & model name	Sony NEC Optiarc BC-5500S-AR		
Performance Specification	With CD Disc	With DVD Disc	With Blu-ray Disc
Transfer rate	600–3600 KB/sec	2.2–11 MB/sec	9 MB/sec
Buffer Memory	4.5 MB		
Interface	SATA		
Applicable disc format	Applicable CD Formats: Read: <ul style="list-style-type: none"> • CD-Audio • CD Extra • CD-I (FMV) • CD-ROM • CD-ROM XAQ • CD-TEXT • Photo CD • Video CD Write: <ul style="list-style-type: none"> • CD-R • CD-RW 	Applicable DVD formats: Read: <ul style="list-style-type: none"> • DVD±R • DVD±RW • DVD-ROM • DVD-Video • Multi-Border • Multi-session Write: <ul style="list-style-type: none"> • DVD+R • DVD+R Double Layer • DVD+RW • DVD-R • DVD-R DL • DVD-RW • DVD-RAM 	Applicable BD formats: <ul style="list-style-type: none"> • BD-ROM • BD-ROM-DL • BD-R • BD-R DL • BD-RE • BD-RE DL
Loading mechanism	Tray		
Power Requirement			
Input Voltage	5 V		

LCD

Item	Specification	
Vendor & model name	AUO B170PW06 V2	AUO B170PW06 V3
Screen Diagonal	17 inches (431.8 mm)	17 inches (431.8 mm)
Active Area (horizontal × vertical)	14.45 × 9.03 inches (367.2 × 229.5 mm)	14.45 × 9.03 inches (367.2 × 229.5 mm)
Display resolution (pixels)	1440 × 900 WXGA+	1440 × 900 WXGA+
Pixel Pitch	0.01 × 0.01 inches (0.255 × 0.255 mm)	0.01 × 0.01 inches (0.255 × 0.255 mm)
Pixel Arrangement	R.G.B. Vertical Stripe	R.G.B. Vertical Stripe
Display Mode	Normally White	Normally White
Typical White Luminance (also called Brightness)	220 cd/m ² typical 187 cd/m ² minimum	220 cd/m ² typical 187 cd/m ² minimum
Luminance Uniformity	1.2 max	1.2 max
Contrast Ratio	500 typical	400 typical
Response Time (Optical Rise Time/Fall Time)	8 ms	8 ms

Item	Specification	
Nominal Input Voltage VDD	+3.3 typical	+3.3 typical
Typical Power Consumption	8 Watt maximum	8 Watt maximum
Weight (without inverter)	700 grams maximum	700 grams maximum
Physical Size	15.0 × 9.6 × 0.25 inches (382.7 × 247.0 × 6.7 mm)	15.0 × 9.6 × 0.25 inches (382.7 × 245.0 × 6.7 mm)
Electrical Interface	2 channel LVDS	2 channel LVDS
Surface	Glare	Anti-glare
Support Color	262K colors (RGB 6-Bit)	262K colors (RGB 6-Bit)
Viewing Angle	Horizontal: 45° Right / 45° Left Vertical: 20° Upper/ 30° Lower	Horizontal: 45° Right / 45° Left Vertical: 20° Upper/ 30° Lower
Temperature Range	Operating: 32—122°F (0—50°C) Storage: -4—140°F (-20—60°C)	Operating: 32—122°F (0—50°C) Storage: -4—140°F (-20—60°C)

Item	Specification	
Vendor & model name	CMO N170C2	LG LP171WP4
Screen Diagonal	17 inches (431.8 mm)	17.1 inches (434 mm)
Active Area (horizontal × vertical)	14.45 × 9.03 inches (367.2 × 229.5 mm)	14.45 × 9.03 inches (367.2 × 229.5 mm)
Display resolution (pixels)	1440 × 900 WXGA+	1440 × 900 WXGA+
Pixel Pitch	0.01 × 0.01 inches (0.255 × 0.255 mm)	0.01 × 0.01 inches (0.255 × 0.255 mm)
Pixel Arrangement	R.G.B. Vertical Stripe	R.G.B. Vertical Stripe
Display Mode	Normally White	Normally White
Typical White Luminance (also called Brightness)	200 cd/m ² typical 160 cd/m ² minimum	220 cd/m ² typical
Luminance Uniformity	1.4 max	1.7 max
Contrast Ratio	400 typical	500 typical
Response Time (Optical Rise Time/Fall Time)	10 ms	8 ms
Nominal Input Voltage VDD	+3.3 typical	+3.3 typical
Typical Power Consumption	XX 	6.7 Watt maximum
Weight (without inverter)	700 grams maximum	705 grams maximum
Physical Size	15.0 × 9.6 × 0.25 inches (382.2 × 244.5 × 6.2 mm)	15.0 × 9.6 × 0.25 inches (382.2 × 244.5 × 6.5 mm)
Electrical Interface	2 channel LVDS	2 channel LVDS
Surface	Glare	Glare
Support Color	262K colors (RGB 6-Bit)	262K colors (RGB 6-Bit)
Viewing Angle (degree)	XX	Horizontal: 45° Right / 45° Left Vertical: 15° Upper/ 35° Lower
Temperature Range	Operating: 32—122°F (0—50°C) Storage: -4—140°F (-20—60°C)	Operating: 32—122°F (0—50°C) Storage: -4—140°F (-20—60°C)

Item	Specification	
Vendor & model name	LG 60003089	SAMSUNG 60002215
Screen Diagonal (mm)		
Active Area (horizontal x vertical)		
Display resolution (pixels)		
Pixel Pitch		
Pixel Arrangement		
Display Mode		
Typical White Luminance (also called Brightness)		
Luminance Uniformity		
Contrast Ratio		
Response Time (Optical Rise Time/Fall Time)		
Nominal Input Voltage VDD		
Typical Power Consumption		
Weight (without inverter)		
Physical Size		
Electrical Interface		
Surface		
Support Color		
Viewing Angle		
Temperature Range		

Item	Specification
Vendor & model name	SAMSUNG 60002215
Screen Diagonal	
Active Area (horizontal x vertical)	
Display resolution (pixels)	
Pixel Pitch	
Pixel Arrangement	
Display Mode	
Typical White Luminance (also called Brightness)	
Luminance Uniformity	
Contrast Ratio	
Response Time (Optical Rise Time/Fall Time)	
Nominal Input Voltage VDD	
Typical Power Consumption (watt)	
Weight (without inverter)	

Item	Specification
Physical Size	
Electrical Interface	
Surface	
Support Color	
Viewing Angle	
Temperature Range	

Inverter

Item	Specification
Vendor & model name	Sumida TWS-449-308
Brightness conditions	3.3V duty 20%—80%
Input voltage (V)	8V—20V
Input current (mA)	950 mA (max)
Output voltage (V, rms)	612V, rms—945V, rms
Output current (mA, rms)	6.2 mA, rms—6.8 mA, rms
Output voltage frequency (k Hz)	50—60 kHz

Video subsystem

Item	Specification
Chipset	<ul style="list-style-type: none"> • Nvidia NB9M-GS • Nvidia NB9P-GS
Memory size	<ul style="list-style-type: none"> • 256 MB VRAM (NB9M-GS) • 512 MB VRAM (NB9P-GS)
Features	<ul style="list-style-type: none"> • Unified Shader Architecture • Support Microsoft® DirectX® 10 Shader Model 4 • Geometry Instancing 2.0 • SGI OpenGL® 2.0 Optimizations and support • Adaptive PCI Express Interface • High efficiency integrated adaptable and programmable Video Processor (VP2) • Integrated Bit Stream Processor (BSP) • NVIDIA PureVideo/Pure Video HD Technology • Industry Video codec standard hardware acceleration • Advanced Spatial Temporal De-Interlacing • Vibrant Color Temperature Correction • LCD Overdrive • High-Quality Real-Time Video Recording • Best quality 10-bit display pipeline • NVIDIA nView Multi Display Technology • SmartDimmer Technology • Integrated HDMI Support • Support for integrated HDCP • NVIDIA Digital Vibrance Control Technology • Integrate HDTV Encoder • Dual 400MHz RAMDACs
Core voltage	<ul style="list-style-type: none"> • 1.0V

Keyboard

Item	Specification
Keyboard controller	WINBOND WPCE775CA0DG
Total number of keypads	105-/106-key
Windows logo key	Yes
Internal & external keyboard work simultaneously	Plug USB keyboard to the USB port directly: Yes

Pointing device

Item	Specification
Type	Touchpad
Buttons	Left/Right
Scrolling	4-way scroll button

Memory card reader

Item	Specification
Controller	JMicron JMB385
Cards supported	Support 5-in-1 Card Reader (MS,MS pro, SD, MMC, xD)
Compliance	<ul style="list-style-type: none">• SD Memory Card Specification Version 2.0• MultiMediaCard Specification Version 4.1• Memory Stick Standard Format Specification Version 1.4• Memory Stick PRO Format Specification Version 1.00• xD Picture Card Specification Version 1.20• xD Picture Card Host Guideline Version 1.20

PCMCIA

Item	Specification
PCMCIA controller	O2 Mirco OZ601
Supports card type	Type-II
Number of slots	One type-II
Access location	Left panel
Supports ZV (Zoomed Video) port	No ZV support
Supports 32 bit CardBus	Yes

ExpressCard (NewCard)

Item	Specification
Controller	Intel ICH 9M
Supports card type	Type 54
Number of slots	One

Item	Specification
Access location	Right panel

Audio

Item	Specification
Audio Controller	Realtek 268 Azadia codec and Amplifier GMT G1412+G1411
Audio onboard or optional	Built-in
Mono or Stereo	Stereo
Resolution	<ul style="list-style-type: none"> Ten DAC channels support 16/20/24-bit PCM format for 7.1 sound playback, plus 2 channels of independent stereo sound output (multiple streaming) through the front panel output Two stereo ADCs support 16/20/24-bit PCM format, one for stereo microphone, one for legacy mixer recording
Compatibility	<ul style="list-style-type: none"> HD Audio
Sampling rate	<ul style="list-style-type: none"> All DACs supports 44.1k/48k/96k/192kHz sample rate All ADCs support 44.1k/48k/96k sample rate
Internal microphone	Yes
Internal speaker / Quantity	Yes/2 (2 W speakers)
Features	<ul style="list-style-type: none"> 97dB SNR DACs & 90dB SNR ADCs Enable VoIP function

Wired LAN

Item	Specification
LAN Chipset	Broadcom 5764M
Supports LAN protocol	10/100/1000 Mbps
LAN connector type	RJ45
LAN connector location	Left side
Features	<ul style="list-style-type: none"> Integrated 10/100/1000 BASE-T transceiver PCIe v1.1 compliant Wake on LAN support meeting ACPI requirements Supports Alert Standard Format (ASF) v2.0 64 pin-QFN package

Bluetooth

Item	Specification
Chipset	Foxconn TT60H928.11
Data throughput	723 bps (full speed data rate)
Protocol	Bluetooth 1.1 (Upgradeable to Bluetooth 1.2 when SIG specification is ratified).
Interface	USB 1.1
Connector type	USB

Wireless LAN

Item	Specification
Chipset	Intel
Data throughput	11~54 Mbps, up to 270 Mbps for Draft-N
Protocol	<ul style="list-style-type: none">• IEEE 802.11a• IEEE 802.11b• IEEE 802.11g• IEEE 802.11 Draft-N• WiMax
Interface	PCI-E (mini card socket for wireless modules)

Modem

Item	Specification
Chipset	LSI
Protocol	<ul style="list-style-type: none">• ITU-T V.92, V.90 Data Mode with auto-fallback to, V.34, V.32terbo, and V.32bis.• V.42 LAPM and MNP 2-4 error correction.• V.44, V.42bis, and MNP 5 data compression.• Send and receive rates up to 14400bps, support ITU-T V.17, V.29, V.27ter, and V.21 Ch2 fax.• TIA/EIA 602 Standard for AT command set, and Fax TIA/EIA 578 Class 1 command set.
Interface	RJ11

USB

Item	Specification
Chipset	ICH9M
USB Compliancy Level	2.0
OHCI	USB 1.1 and USB 2.0 Host controller
Number of USB port	4
Location	<ul style="list-style-type: none">• Two on the left side• Two on the right side
Serial port function control	Enable/Disable by BIOS Setup

Buttons/Indicators/Ports

Item	Specification
Buttons	<ul style="list-style-type: none">• 6 Media buttons• Wireless on/off button• Bluetooth on/off button• Empowering button• Power button• E-mail button• WWW button

Item	Specification
Indicators	<ul style="list-style-type: none"> • 2 keyboard indicators (CAPS Lock and NUM Lock) • HDD/CD-ROM active LED • Power On Status LED • Battery with two-color (visible when lid closed) • Power on/Suspend (visible when lid closed) • Wireless (visible when lid closed) • Bluetooth (visible when lid closed) • E-mail (embedded in QSB) • AC IN • WWW • 6 Media buttons have LEDs
Ports & Slots	<ul style="list-style-type: none"> • Color-coded connectors • VGA port, 15 pins • Microphone-in • Line-in • Headphone out • 4 External USB 2.0 connectors • DC in jack (blue color) • RJ-11 jack for modem • RJ-45 jack for LAN • Express card (New Card) slot • 2 MINI card slots • HDMI port • 5 in 1 card reader • PCMCIA CardBus Slot • Docking

Fingerprint reader

Item	Specification
Interface	USB 2.0 Full Speed Interface
Resolution	High-definition 128 × 8 Pixel Array
Technology	TruePrint® and TrueMatch® Technology. TrueNav® Cursor and Menu Navigation Technology
Power	Multiple battery-friendly operating modes @ 3.3V Built-in low power Finger Detection w/ remote wakeup capability

Camera

Item	Specification
Interface	USB
Resolution	0.3 M pixel <Athena: Is this correct 

Fan

CPU Temperature	Fan Speed (rpm)	Acoustic Level (dBA)
113°F (45°C)	0	26.5db
122°F (50°C)	3200±100	30.3db
149°F (65°C)	3700±100	33db

CPU Temperature	Fan Speed (rpm)	Acoustic Level (dBA)
172°F (78°C)	4100±100	37db
194°F (90°C)	4400±100	39.5db

Throttling 50%: On= 105° C; OFF=95° C

OS shut down at 110° C; H/W shut down at 110°C

Battery

Item	Specification
Vendor	Panasonic Sanyo Simple Sony
Battery Type	Li-ion
Pack capacity	4000mAh–4800mAh
Number of battery cell	6 or 8
Package configuration	<ul style="list-style-type: none"> 3 cells in series, 2 series in parallel 4 cells in series, 2 series in parallel
Normal voltage	10.8V–14.8V
Charge voltage	12.3V–16.8V

Power supply

Item	Specification
Input rating	100–240V (under 50–60Hz)
Maximum input AC current	1.5mA
Inrush current	N/A
Efficiency	85%

Power savings

ACPI mode	Power Management
Mech. Off (G3)	All devices in the notebook are turned off completely.
Soft Off (G2/S5)	OS initiated shutdown. All devices in the notebook are turned off completely.
Working (G0/S0)	Individual devices such as the CPU and hard disc may be power managed in this state.
Suspend to RAM (S3)	CPU set power down VGA Suspend PCMCIA Suspend Audio Power Down Hard Disk Power Down CD-ROM Power Down Super I/O Low Power mode
Save to Disk (S4)	Also called Hibernation Mode. System saves all system states and data onto the disc prior to power off the whole system.

Chapter 2

System utilities

- BIOS Setup Utility
- BIOS Flash utility
- Removing a password lock

BIOS Setup Utility

The BIOS Setup Utility is a hardware configuration program built into the notebook's BIOS (Basic Input/Output System). The notebook was shipped already properly configured and optimized. However, if the user encounters configuration problems, you may need to run Setup.

Note: Also see Chapter 4 "Troubleshooting" on page 135 and Chapter 5 "Clearing password check and BIOS recovery" on page 158 when problems arise.

To run the BIOS Setup Utility:

- 1 Turn on the notebook. You will see `Press <F2> to enter Setup` at the bottom of the screen.
- 2 Press **F2**. The BIOS Setup Utility opens.

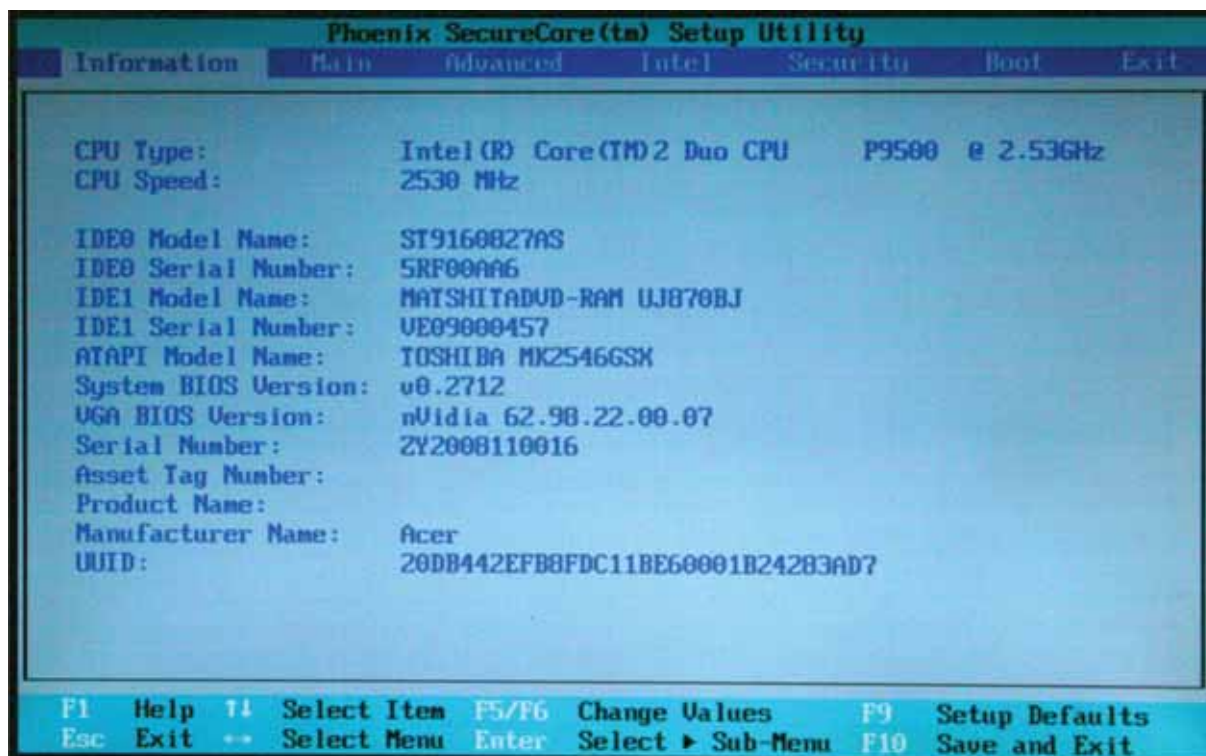

Navigating the BIOS Setup Utility

There are six menu options in the BIOS Setup Utility: Information, Main, Advanced, Intel, Security, Boot, and Exit.

To use the BIOS Setup Utility:

- To choose a menu, use the left ← and right → arrow keys.
- To choose an item, use the up ↑ and down ↓ arrow keys.
- To change the value of a parameter, press **F5** or **F6**.
- A plus sign (+) indicates the item has sub-items. Press **Enter** to expand this item.
- Press **Esc** while you are in any of the menu options to go to the Exit menu.

- In any menu, you can load default settings by pressing **F9**. You can also press **F10** to save any changes made and exit the BIOS Setup Utility.

Note: You can change the value of a parameter if it is enclosed in square brackets. Navigation keys for a particular menu are shown on the bottom of the screen. Help for parameters are found in the Item Specific Help part of the screen. Read this information carefully when making changes to parameter values. **System information differs by model.**

BIOS Setup Utility screens

Note: The screens shown in this section are for informational purposes only. Screen information varies by model, features ordered, and location.

Information screen

The Information screen displays a summary of your notebook hardware information.

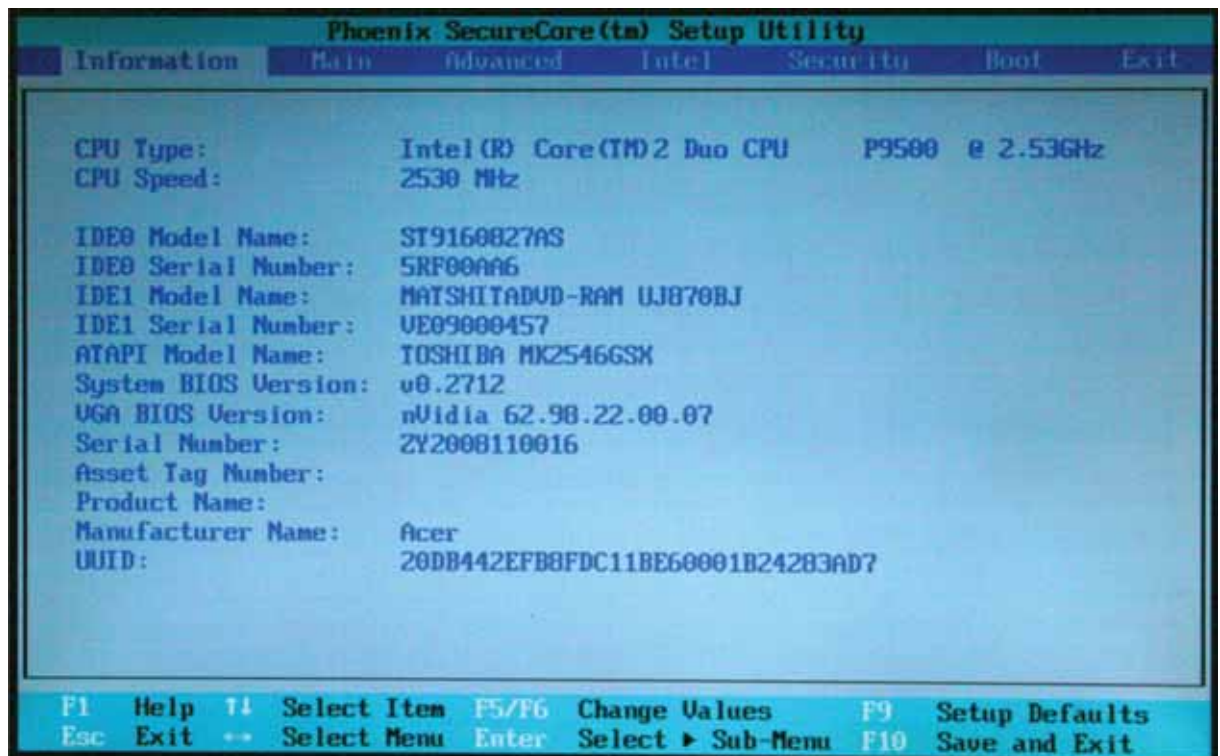

Parameter	Description
CPU Type	Shows the CPU type and speed.
CPU Speed	Shows the CPU speed.
IDE0 Model Name	Shows the model name of the Hard Disk Drive (HDD) installed on the primary IDE master.
IDE0 Serial Number	Shows the serial number of the HDD installed on the primary IDE master.
IDE1 Model Name	Shows the model name of the HDD installed on the secondary IDE master.
IDE1 Serial Number	Shows the serial number of the HDD installed on the secondary IDE master.
ATAPI Model Name	Shows the model name of the optical device installed in the notebook.
System BIOS Version	Shows the version of the system BIOS.
VGA BIOS Version	Shows the VGA firmware version of the system.

Parameter	Description
Serial Number	Shows the notebook's serial number.
Asset Tag Number	Shows the notebook's asset tag number.
Product Name	Shows the notebook's product name.
Manufacturer Name	Shows the notebook's manufacturer.
UUID Number	Shows the notebook's Universally Unique Identifier number. The UUID is an identifier standard used in software construction. It is standardized by the Open Software Foundation (OSF) as part of the Distributed Computing Environment (DCE).

Main screen

The Main screen allows the user to set the system time and date as well as enable and disable the boot option and recovery.

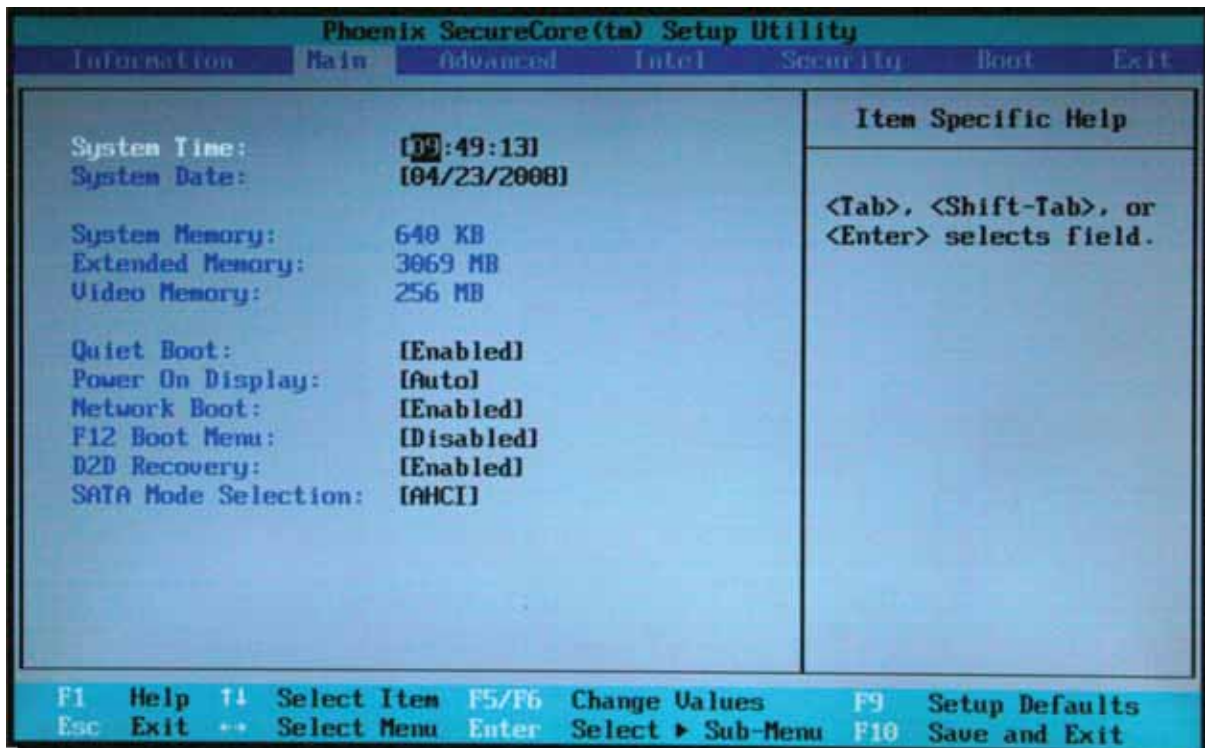

The table below describes the parameters found on this screen. Settings in **boldface** are the default and suggested parameter settings.

Parameter	Description	Format/Option
System Time	Sets the system time. The hours are displayed in a 24-hour format.	Format: HH:MM:SS (hour:minute:second) System Time
System Date	Sets the system date.	Format MM/DD/YYYY (month/day/year) System Date
Total Memory Size	Shows the notebook's memory size.	
Video Memory	Shows the VGA memory size. VGA Memory size= 256 or 512 MB	
Quiet Boot	Determines if the Acer logo will be displayed or not. Also determines if the Summary Screen is disabled or enabled. Enabled: The Acer logo is displayed and the Summary Screen is not displayed. Disabled: The Acer logo is not displayed, and the Summary Screen is displayed.	Option: Enabled or Disabled
Power On Display	XX 	
Network Boot	Enables or disables the system boot from LAN (remote server).	Option: Enabled or Disabled
F12 Boot Menu	Enables or disables the Boot Menu during POST. Note: The default parameter is set to Disabled . If you want to change the boot device without entering the BIOS Setup Utility, set the parameter to Enabled. Press <F12> during POST to enter the multi-boot menu. In this menu, the user can change the boot device without entering the BIOS Setup Utility.	Option: Disabled or Enabled
D2D Recovery	Enables or disables the D2D Recovery function. The function allows the user to create a hidden partition on the hard disc drive to store the operating system and other files used to restore the notebook to factory defaults.	Option: Enabled or Disabled
SATA Mode Selection	Controls the mode in which the SATA controller operates.	Option: AHCI Mode or IDE Mode

Note: Sub-items under each device will not be shown if the device control is set to Disabled or Auto. This is because the user is not allowed to control the settings in these cases.

Advanced screen

The Advanced screen allows the user to configure the Alert Standard Format parameters.

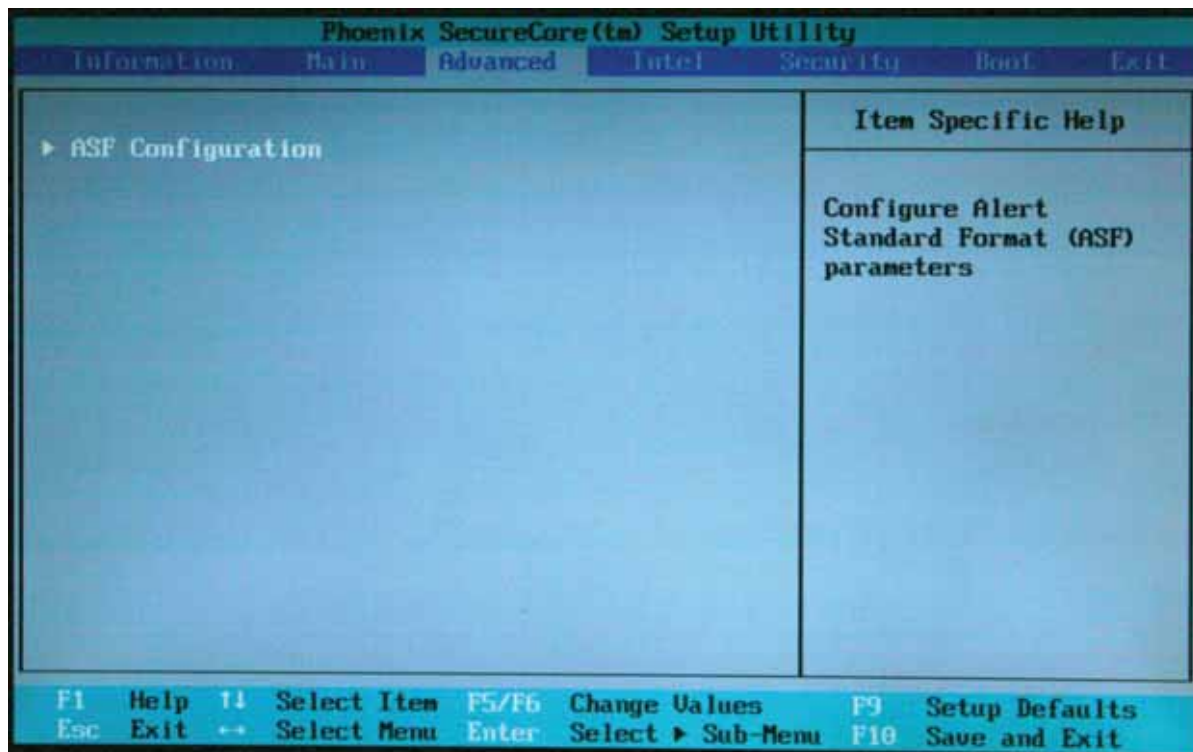

The table below describes the parameters found on the ASF Configuration sub menu screen.

Parameter	Description
Minimum WatchDog Timeout	Time for BIOS to stop the WatchDog timer after a reset has occurred.
BIOS Boot Timeout	Time, in seconds, for BIOS to boot before the system is reset.
SO Boot Timeout	Time, in seconds, for OS to boot before the system is reset.
Power-on wait time	Maximum time, in seconds, for Alert Sending Device (ASD) to establish connection with its transport media.

Security screen

The Security screen contains parameters that help safeguard and protect your notebook from unauthorized use.

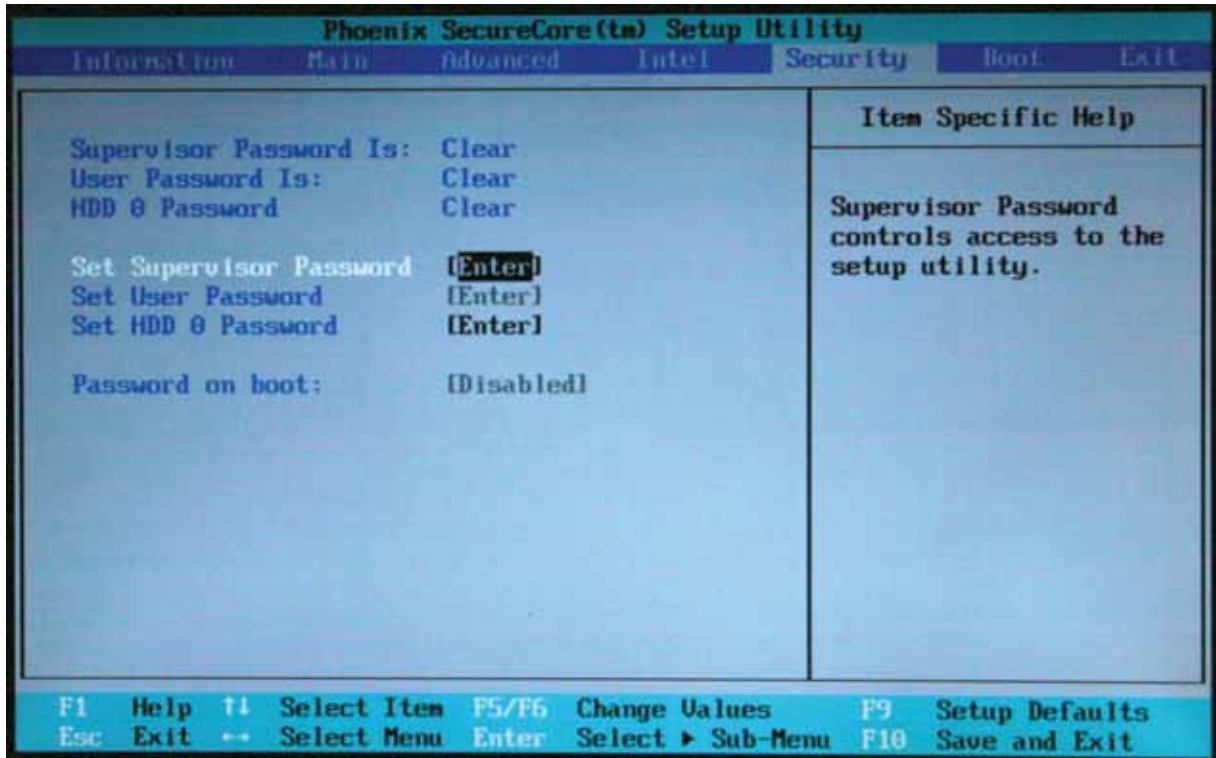

Note: Refer to ["Removing a password lock"](#) on page 48 if you need to know how to remove a Hard Drive or BIOS Password.

The table below describes the parameters in this screen. Settings in **boldface** are the default and suggested parameter settings.

Parameter	Description	Option
Supervisor Password Is	Shows the setting of the Supervisor password	Clear or Set
User Password Is	Shows the setting of the User password.	Clear or Set
HDD Password Is	Shows the setting of the hard disk password.	Clear or Set
Set Supervisor Password	Press Enter to set the supervisor password. When set, this password protects the BIOS Setup Utility from unauthorized access. The user cannot enter the Setup Utility without entering this password.	
Set User Password	Press Enter to set the user password. When a user password is set, this password protects the BIOS Setup Utility from unauthorized changes. The user can enter the Setup Utility only and does not have the right to change the value of any parameters. If Password on Boot is enabled, the user must enter the user password each time the notebook is turned on or wakes from Sleep.	
Set HDD Password	Press Enter to set the HDD password.	
Password on Boot	Defines whether a password is required or not while the events defined in this group happened. The sub-options all require the Supervisor password for changes and should be grayed out if the User password was used to enter the Setup Utility.	Disabled or Enabled

Caution: When you are prompted to enter a password, you have three tries before the system halts. Don't forget your password. If you forget your password, you may have to return your notebook to your dealer to reset it.

Setting a Password

Note: You must set a Supervisor password before you can set a User password.

To set the Supervisor password:

- 1 Press **↑** or **↓** to highlight **Set Supervisor Password**, then press **ENTER**. The *Set Supervisor Password* box opens.

Set Supervisor Password

Enter New Password []

Confirm New Password []

- 2 Type a password in the **Enter New Password** field. The password length cannot exceed eight alphanumeric characters (A-Z, a-z, 0-9). The password is not case sensitive.
- 3 Retype the password in the **Confirm New Password** field.

Caution: Be very careful when typing your password because the characters do not appear on the screen.
- 4 Press **ENTER**. After setting the password, the value of **Supervisor Password** changes to **Set**.

- 5 Optional: you can enable the **Password on Boot** parameter.
- 6 When you are done, press F10 to save your password and exit the BIOS Setup Utility or you can proceed to setting the User password.

To set the User password:

- 1 Press ↑ or ↓ to highlight **Set User Password**, then press ENTER. The *Set User Password* box opens.
- 2 Type a password in the **Enter New Password** field. The password length cannot exceed eight alphanumeric characters (A-Z, a-z, 0-9). The password is not case sensitive.
- 3 Retype the password in the **Confirm New Password** field.
Caution: Be very careful when typing your password because the characters do not appear on the screen.
- 4 Press ENTER. After setting the password, the value of **User Password** changes to **Set**.
- 5 When you are done, press F10 to save your password and exit the BIOS Setup Utility.

Removing a Password

To remove a password:

- 1 Press ↑ or ↓ to highlight **Set Supervisor Password** or **Set User Password**, then press ENTER. The *Set Supervisor Password* or *Set User Password* box opens.

Set Supervisor Password	
Enter Current Password []
Enter New Password []
Confirm New Password []

- 2 Type the current password in the **Enter Current Password** field, then press ENTER.
- 3 Press ENTER twice **without** typing anything in the **Enter New Password** and **Confirm New Password** fields. After removing the password, the value of **Supervisor Password** changes to **Clear**.
- 4 When you are done, press F10 to save your password and exit the BIOS Setup Utility.

Changing a Password

To change a password:

- 1 Press ↑ or ↓ to highlight **Set Supervisor Password** or **Set User Password**, then press ENTER. The *Set Supervisor Password* or *Set User Password* box opens.

Set Supervisor Password	
Enter Current Password []
Enter New Password []
Confirm New Password []

-
- 2 Type the current password in the **Enter Current Password** field, then press ENTER.

Note: If you enter an incorrect current password, the screen displays the following.

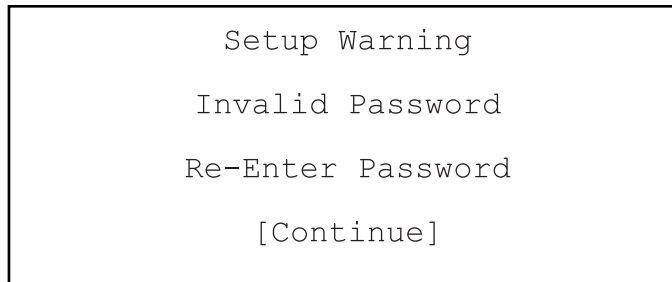

Setup Warning
Invalid Password
Re-Enter Password
[Continue]

Press ENTER, then re-enter the current password.

- 3 Type a password in the **Enter New Password** field.
- 4 Retype the password in the **Confirm New Password** field.

Note: If you do not enter the same new password and confirm new password, the screen displays the following.

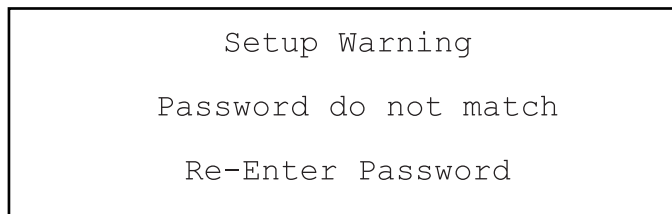

Setup Warning
Password do not match
Re-Enter Password

Press ENTER, then re-enter the new password and confirmation password.

- 5 Press ENTER. The screen displays the following.

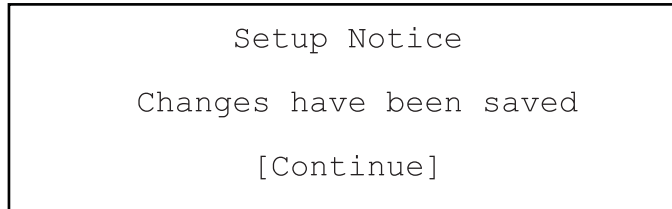

Setup Notice
Changes have been saved
[Continue]

- 6 Press ENTER.
- 7 When you are done, press F10 to save your password and exit the BIOS Setup Utility.

Boot

This menu allows the user to decide the order of boot devices to load the operating system. Bootable devices include the onboard hard disk drive and the optical drive. Follow the instructions in Item Specific Help to change to boot order of the notebook devices.

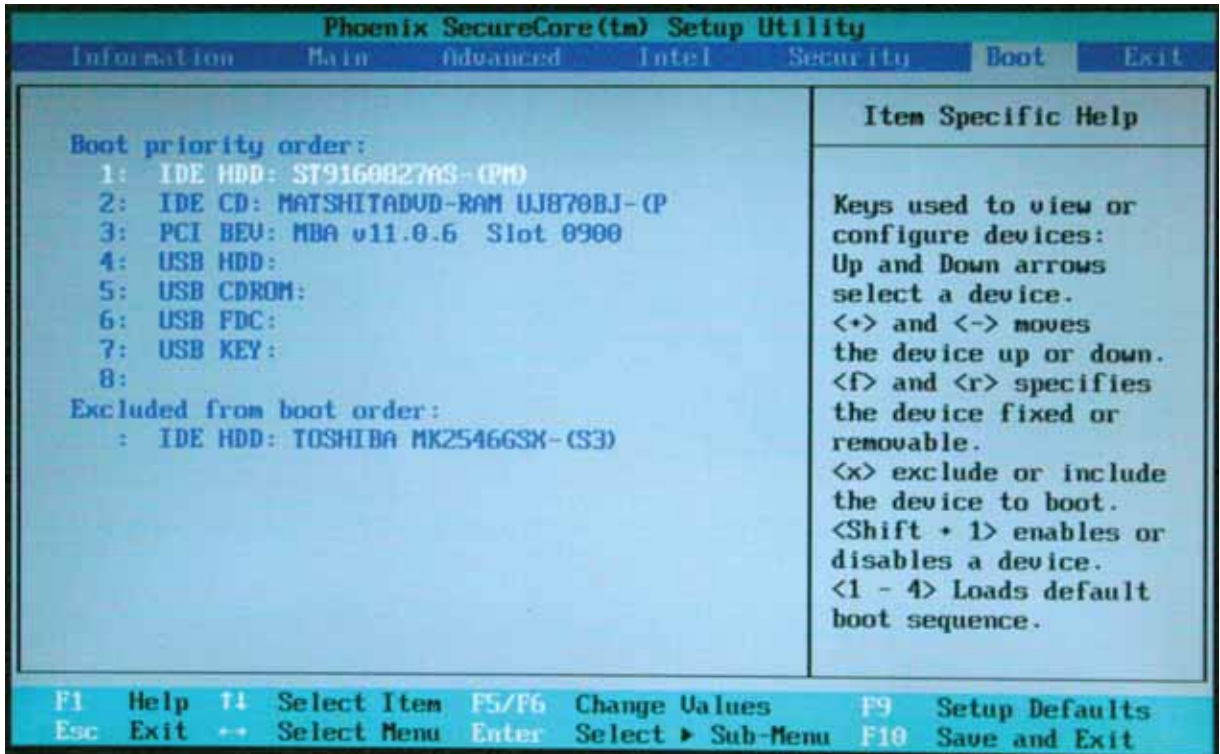

Exit

The Exit screen contains options for leaving the BIOS Setup Utility and starting Windows.

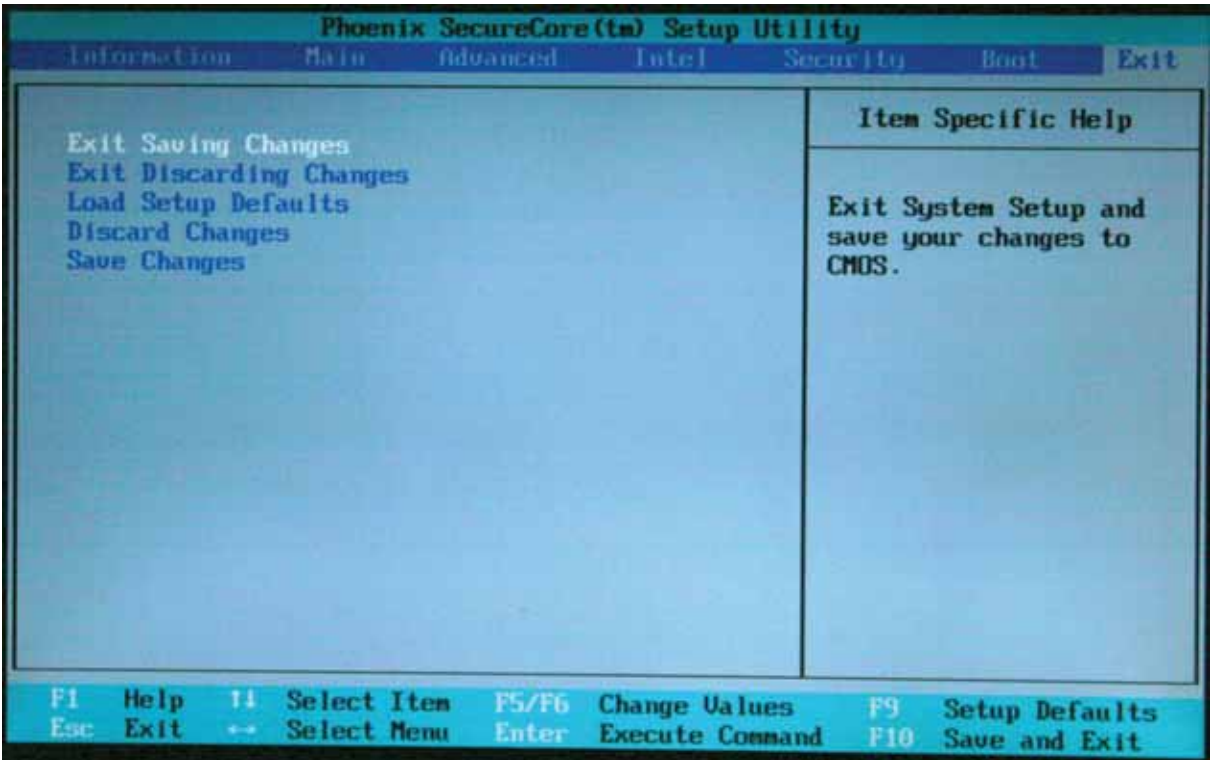

The table below describes the options on this screen.

Option	Description
Exit Saving Changes	Exit the BIOS Setup Utility and save your changes to CMOS.
Exit Discarding Changes	Exit the BIOS Setup Utility without saving your changes to CMOS.
Load Setup Default	Load default values for all SETUP items.
Discard Changes	Load previous values from CMOS for all SETUP items.
Save Changes	Save your changes to CMOS.

BIOS Flash utility

Use the BIOS flash memory update for the following conditions:

- ❑ New versions of system programs (such as HDD_PW or bios_pw).
- ❑ New BIOS features or options.
- ❑ Restore a BIOS when it becomes corrupted.

Use the Phlash utility to update the system BIOS flash ROM.

Note: If you do not have a crisis recovery diskette at hand, then you should create a **Crisis Recovery Diskette** before you use the Phlash utility. For more information about creating a Crisis Recovery Diskette, see ["Creating a Crisis Diskette" on page 159](#)

Note: Do not install memory-related drivers (XMS, EMS, DPMS) when using Phlash.

Caution: Use the AC adapter power supply when you run the Phlash utility. If the battery pack does not contain enough power to finish flashing the BIOS, the notebook may not boot because the BIOS was not completely loaded.

To use Phlash:

- 1 Create a bootable diskette.
- 2 Copy the flash utilities to the bootable diskette.
- 3 Boot the notebook from the bootable diskette. The pflash utility runs automatically.

Removing a password lock

This section provides you with instructions to remove a hard drive or Supervisor password lock.

Note: For more information about removing a password lock, see [“Clearing password check and BIOS recovery” on page 158](#).

Removing a HDD password lock

If you type the wrong HDD password three times in a row, the error message `Hdd password error code` is displayed on the screen and the HDD is locked. If you need to solve a HDD password locked problem, you can run `HDD_PW.EXE`.

To remove the HDD password:

- 1 On a working Acer notebook, click **Start**, then **Run**. The *Run* dialog box opens.
- 2 Type `cmd` in the **Open** field, then click **OK**.
- 3 Type `hdd_pw 15494 0`.
- 4 Select **2 Upper case ASCII Code**.



```
C:\WINDOWS\system32\cmd.exe
F:\>cd password
F:\password>dir/w
Volume in drive F has no label.
Volume Serial Number is D4F6-B236

Directory of F:\password

[.]                [..]                BIOS_PW.EXE    HDD_PW.EXE
 1.                2 File(s)        35,354 bytes
                  2 Dir(s)         487,895,848 bytes free

F:\password>hdd_pw 15494 0
unlock6.exe v1.1 2 May 2003

Choice what kind of the password to be generated:
0.) Exit...
1.) Scan Code
2.) Upper case ASCII Code
3.) Lower case ASCII Code
Enter your choice: 2
0KJFN42
UVEIQ96
F:\password>
```

- 5 Choose one of the upper-case strings. In this example you can choose either `0KJFN42` or `UVEIQ96`.
- 6 Reboot the notebook that is locked, then enter either `0KJFN42` or `UVEIQ96` for the HDD user password.

Removing a Supervisor password lock

If you type the wrong Supervisor password three times in a row, the error message `System Disabled` appears on the screen and the notebook is locked. If you need to solve a BIOS password locked problem, you can run `BIOS_PW.EXE`.

To remove the Supervisor password:

- 1 On a working Acer notebook, click **Start**, then **Run**. The *Run* dialog box opens.
- 2 Type `cmd` in the **Open** field, then click **OK**.

3 Type **bios_pw 14452 0**.



```
C:\WINDOWS\system32\cmd.exe
Microsoft Windows XP [Version 5.1.2600]
(C) Copyright 1985-2001 Microsoft Corp.
C:\Documents and Settings\M54>d:
D:\>bios_pw 14452 0
unlock6.exe v1.0 1 July 1997
qjig9vy
07yqmjd
cjl14tm
6nbzjaJ
```

4 Choose one of the strings. In this example you can choose either **qjig9vy** or **07yqmjd**.

5 Reboot the notebook that is locked, then enter either **qjig9vy** or **07yqmjd** for the Supervisor password.

Chapter 3

Replacing notebook components

- ❑ Preventing static electricity discharge
- ❑ Preparing your work space
- ❑ Tools required
- ❑ Preparing the notebook
- ❑ Adding or replacing memory modules
- ❑ Replacing the graphics card
- ❑ Replacing the primary hard drive
- ❑ Replacing the IEEE 802.11 wireless card
- ❑ Replacing the CMOS battery
- ❑ Replacing the secondary hard drive
- ❑ Replacing the optical drive
- ❑ Replacing the keyboard cover
- ❑ Replacing the keyboard
- ❑ Replacing the power button board
- ❑ Replacing the LCD assembly
- ❑ Replacing the inverter
- ❑ Replacing the LCD panel
- ❑ Replacing the LCD panel hinges
- ❑ Replacing the web cam
- ❑ Replacing the palm rest
- ❑ Replacing the microphone and speakers
- ❑ Replacing the touchpad button board/fingerprint assembly
- ❑ Replacing the button board
- ❑ Replacing the ExpressCard (NewCard) assembly
- ❑ Replacing the Bluetooth card
- ❑ Replacing the modem
- ❑ Replacing the system board
- ❑ Replacing the cooling assembly
- ❑ Replacing the processor

Preventing static electricity discharge

Warning: To avoid exposure to dangerous electrical voltages and moving parts, turn off your notebook, remove the battery, and unplug the power cord, modem cable, and network cable before opening the case.

Warning: To prevent risk of electric shock, do not insert any object into the vent holes of the notebook.

Important: Before performing maintenance on the notebook, you should read and understand the information in this section.

The components inside your notebook are extremely sensitive to static electricity, also known as *electrostatic discharge* (ESD).

Before performing maintenance on the notebook, follow these guidelines:

- ❑ Avoid static-causing surfaces such as carpeted floors, plastic, and packing foam.
- ❑ Remove components from their antistatic bags only when you are ready to use them. Do not lay components on the outside of antistatic bags because only the inside of the bags provide electrostatic protection.
- ❑ Always hold components by their edges. Avoid touching the edge connectors. Never slide components over any surface.
- ❑ Wear a grounding wrist strap (available at most electronics stores) and attach it to a bare metal part of your workbench or other grounded connection.
- ❑ Touch a bare metal surface on your workbench or other grounded object.

Tape

Some of the procedures in this guide involve removing tape that holds cables or components. Two types of tape are used in this notebook:

- ❑ Mylar, non-conductive tape is typically transparent, with a red or brown tint.
- ❑ Conductive tape is typically grey or silver.

If the existing tape cannot be reused, replace it with the same type (conductivity) of tape. Both types of replacement tape should be non-ESD generating tape.

Do not use cellophane tape.

Preparing your work space

Before performing maintenance on the notebook, make sure that your work space and the notebook are correctly prepared.

- ❑ Wear a grounding (ESD) wrist strap, and use a grounded or dissipative work mat.
- ❑ Use a stable and strong table, and make sure that the table top is large enough to hold each component as you remove it.
- ❑ Use bright lighting to make part identification easier.
- ❑ Keep your work surface free from clutter and dust that may damage components.
- ❑ Use a magnetized screwdriver for removing screws.
- ❑ When removing components that are attached to the notebook by a cable, unplug the cable before removing the screws, when possible, to avoid damaging the cable.
- ❑ As you remove components and screws, lay them toward the rear of your work surface (behind the notebook) or far enough to the side that your arms do not accidentally brush them onto the floor.
- ❑ To help keep track of screws, try the following:
 - ❑ Place each component's screws in their own section of a parts sorter.
 - ❑ Place each component's screws next to the component on your work surface.
 - ❑ Print the first page of each task, then place the page toward the rear of your work surface. As you remove screws, place the screws in their respective boxes on the page.
 - ❑ After loosening screws that are deeply recessed in a hole (for example, on the bottom of the base assembly), you can leave the screws in the holes if you place small pieces of masking tape over the hole openings. When reassembling the component, just remove the tape and tighten the screws.
 - ❑ When you place flat-headed screws on your work surface, stand them on their heads to prevent the screws from rolling off the table.

Tools required

To disassemble the notebook, you need the following tools:

- ❑ Wrist grounding strap and conductive mat for preventing electrostatic discharge



- ❑ Flat screwdriver



- ❑ Philips screwdriver



- ❑ Scribe or non-marring tool



- ❑ Tweezers



Preparing the notebook

To prepare the notebook for maintenance:

- 1 Make sure that the disc drive is empty.
- 2 Turn off the notebook.
- 3 Close the LCD panel
- 4 Disconnect the AC adapter, modem cable, and network cable.
- 5 Disconnect all peripheral devices connected to the notebook and remove any PC Cards, Express Cards, and memory cards.
- 6 Remove the battery.

Remove a PC Card

To remove a PC Card:

- 1 Release the eject button by pressing the PC Card eject button once.



- 2 Eject the PC Card by pressing the eject button again.



Removing an ExpressCard

To remove an ExpressCard:

- 1 Push the ExpressCard all the way into the notebook.



- 2 Pull the ExpressCard all the way out of the notebook.



Removing a memory card

To remove a memory card:

- 1 Push the memory card all the way into the notebook.



- 2 Pull the memory card all the way out of the notebook.



Removing the battery

To remove the battery:

- 1 Turn the notebook over so the bottom is facing up.
- 2 Slide the battery lock to the unlocked position.

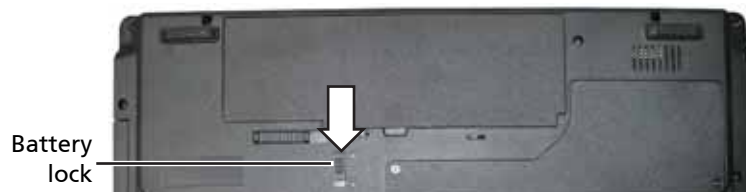

- 3 Slide the battery release latch, then lift the battery out of the notebook.



Adding or replacing memory modules

Important: Use only memory modules designed for this notebook.

Tools you need to complete this task:



Locating components:

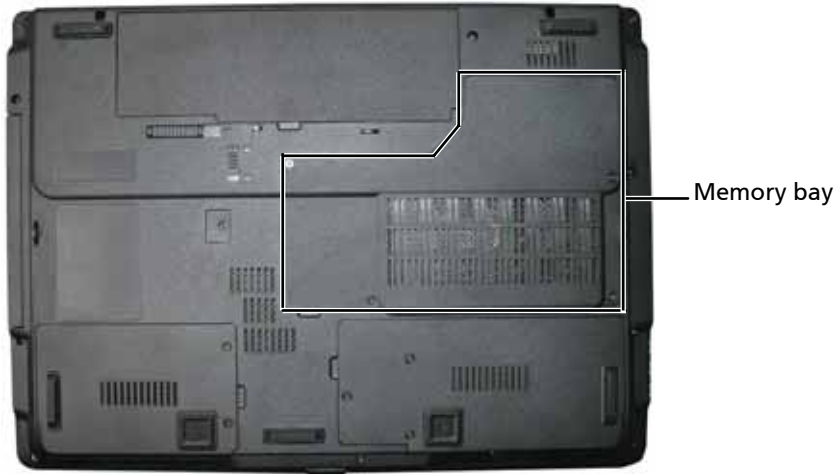

To add or replace memory modules:

- 1 Complete the steps in [“Preparing the notebook” on page 55](#).
- 2 Loosen the memory bay cover screws (these screws cannot be removed).

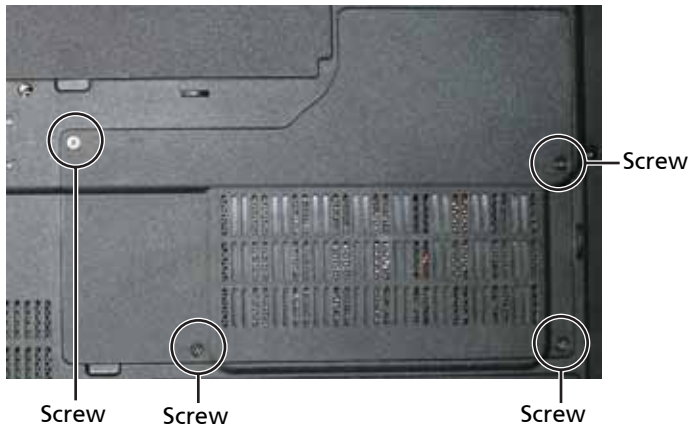

- 3 Use the thumb notch to lift the memory bay cover, then remove it. Be careful not to break off the tabs located on the end of the cover opposite the thumb notch.



Thumb notch

- 4 If you are removing a module, gently press outward on the clip at each end of the memory module until the module tilts upward.



Clip

Clip

- 5 Pull the memory module out of the slot.

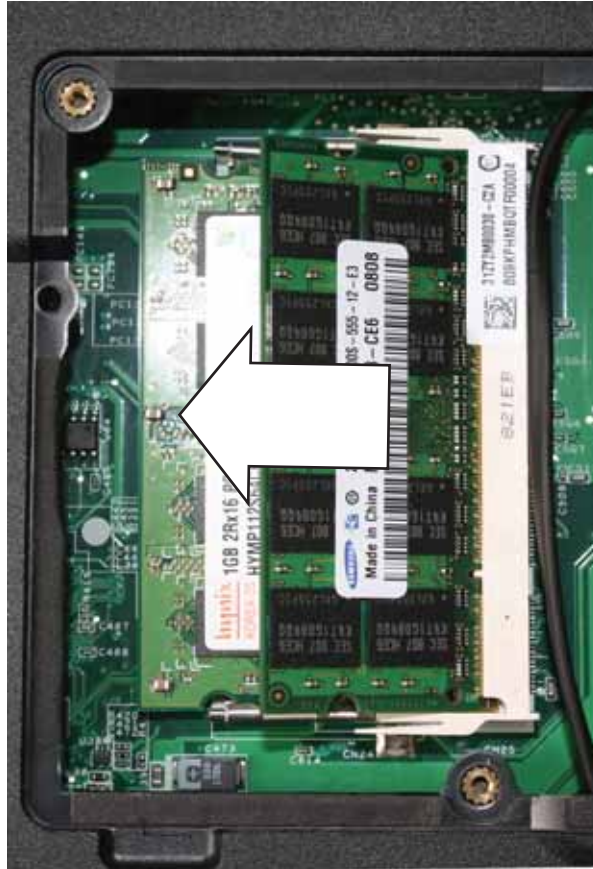

- 6 Hold the new or replacement module at a 30-degree angle and press it into the empty memory slot. This module is keyed so it can only be inserted in one direction. If the module does not fit, make sure that the notch in the module lines up with the tab in the memory slot.



- 7 Press the card down until it click into place.
- 8 Replace the memory bay cover, then tighten the cover screws.

Replacing the graphics card

Important: Use only graphics cards designed for this notebook.

Tools you need to complete this task:



Additional materials you need to complete this task:

- X-23-7762 thermal grease [<Athena: Is this the right grease?>](#)

Screws removed during this task:

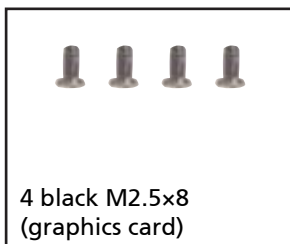

Locating components:



To replace the graphics card:

- 1 Complete the steps in ["Preparing the notebook"](#) on page 55.

- 2 Loosen the graphics card bay cover screws (these screws cannot be removed).

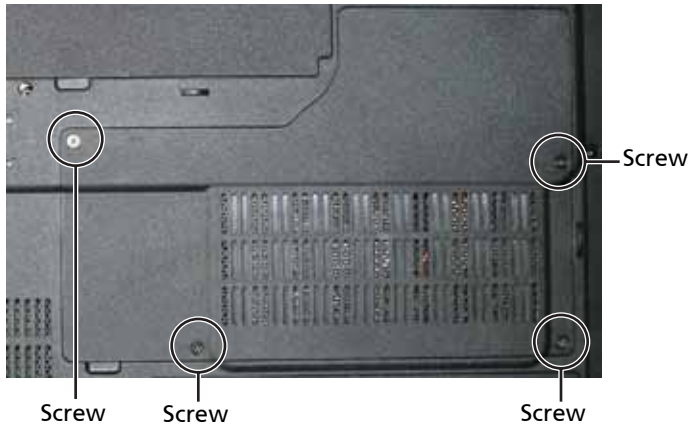

- 3 Use the thumb notch to lift the graphics card bay cover, then remove it. Be careful not to break off the tabs located on the end of the cover opposite the thumb notch.

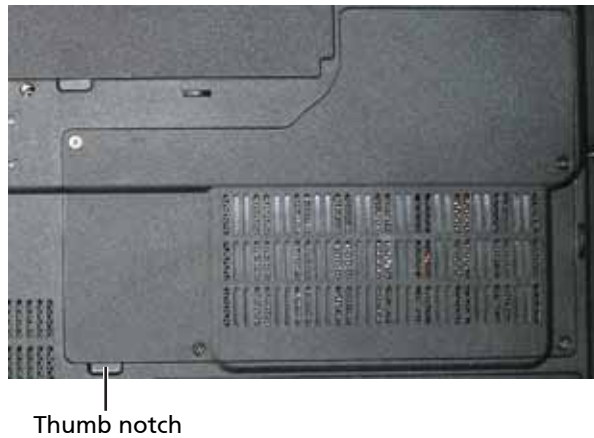

- 4 Remove the graphics card screws.

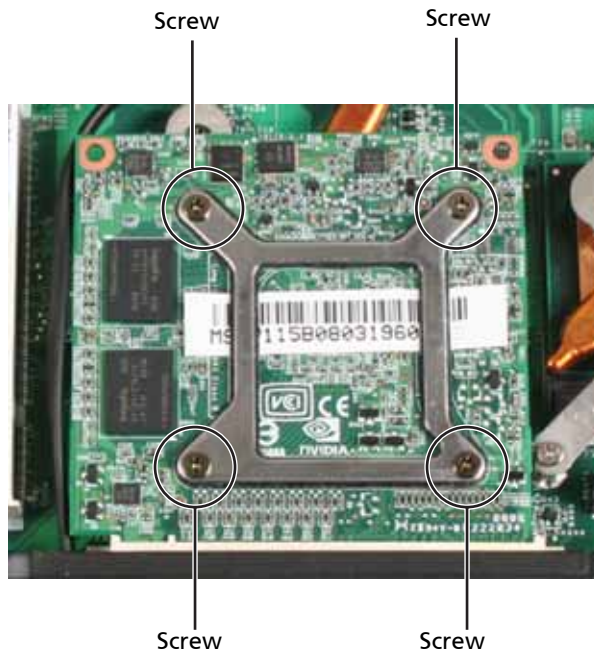

- 5 Pull the card out of the slot.



- 6 Remove any thermal grease residue from the cooling assembly using a soft cloth and isopropyl alcohol.



- 7 Place new thermal grease on the graphics card. Use only enough to cover the graphics processor die.
- 8 Hold the new card at a 30-degree angle and slide it into the empty slot. This card is keyed so it can only be inserted in one direction. If the card does not fit, make sure that the notch in the card lines up with the tab in the card slot.
- 9 Replace the screws removed in [Step 4](#).
- 10 Replace the graphics card bay cover, then tighten the cover screws.

Replacing the primary hard drive

Tools you need to complete this task:



Phillips #0 screwdriver

Screws removed during this task:

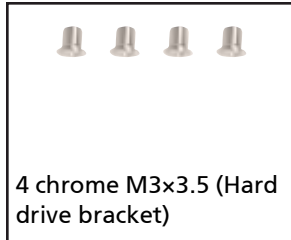

Locating components:

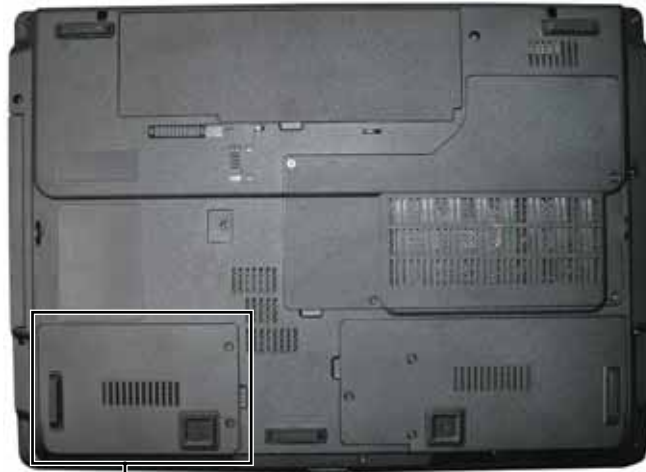

Primary hard drive bay

To replace the primary hard drive:

- 1 Complete the steps in [“Preparing the notebook” on page 55](#).
- 2 Loosen the hard drive bay cover screws (these screws cannot be removed).



- 3 Use the thumb notch to lift the hard drive bay cover, then remove it. Be careful not to break off the tabs located on the end of the cover opposite the thumb notch.

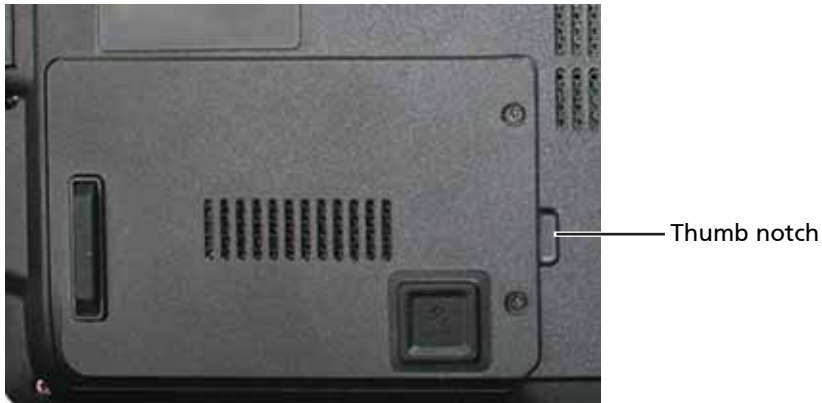

- 4 Using the plastic tab, lift straight up on the hard drive, then remove it.

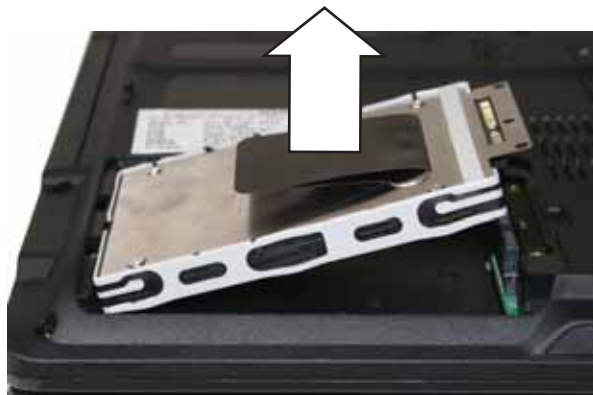

- 5 If your new hard drive already includes the hard drive bracket, go to step [Step 10](#).
-OR-
If you need to move the hard drive bracket from your old hard drive to your new hard drive, go to step [Step 6](#).
- 6 Remove the screws that secure the hard drive to the hard drive bracket.

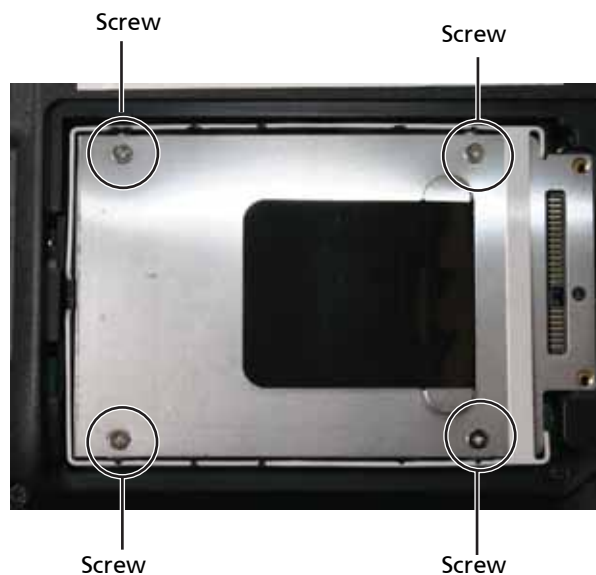

-
- 7 Remove the bracket from the old drive.



- 8 Insert the new drive label side up onto the bracket so the screw holes line up.
- 9 Replace the screws that secure the bracket to the drive.
- 10 Slide the new hard drive kit into your notebook.
- 11 Replace the cover, then tighten the screws.

Replacing the IEEE 802.11 wireless card

Important: Use only wireless cards designed for this notebook.

Tools you need to complete this task:



Screws removed during this task:

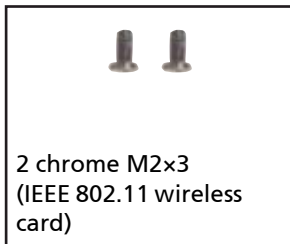

Locating components:

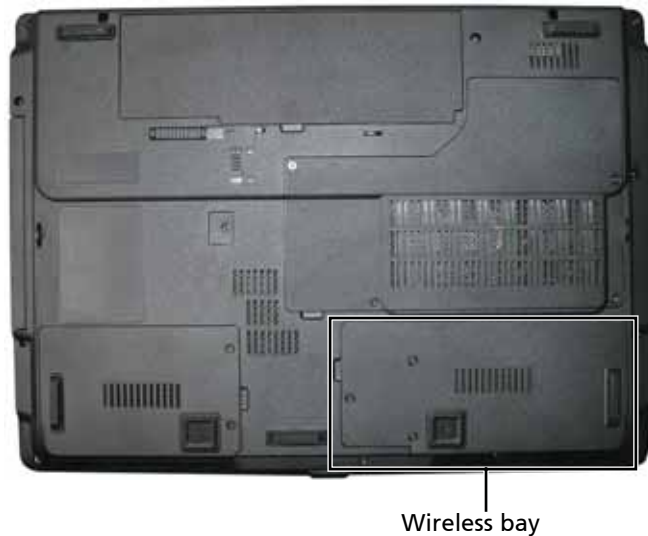

To replace the IEEE 802.11 wireless card:

- 1 Complete the steps in ["Preparing the notebook"](#) on page 55.
- 2 Loosen the wireless bay cover screws (these screws cannot be removed).



- 3 Use the thumb notch to lift the wireless bay cover, then remove it. Be careful not to break off the tabs located on the end of the cover opposite the thumb notch.

Thumb notch



- 4 Unplug the antenna cables. Note which color cable is connected to each of the connectors.

Important: The number of antenna cables varies by the type of wireless network used by the notebook. IEEE 802.11N cards typically have three antenna cables. Other types of wireless network cards typically have two antenna cables.



- 5 Remove the wireless card screws.



- 6 Pull the card out of the slot.



- 7 Move the antenna cables out of the way.
- 8 Hold the new card at a 30-degree angle and slide it into the empty slot. This card is keyed so it can only be inserted in one direction. If the card does not fit, make sure that the notch in the card lines up with the tab in the card slot.

- 9 Replace the screws removed in [Step 5](#).
- 10 Reattach the antenna cables to the connectors.



- 11 Replace the wireless bay cover, then tighten the cover screws.

Replacing the CMOS battery

Important: Use only CMOS batteries designed for this notebook.

Tools you need to complete this task:

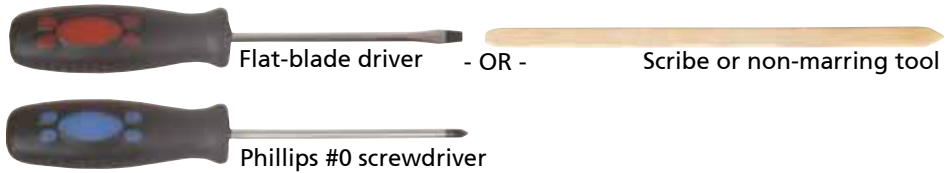

Screws removed during this task:

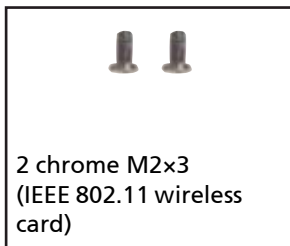

Locating components:

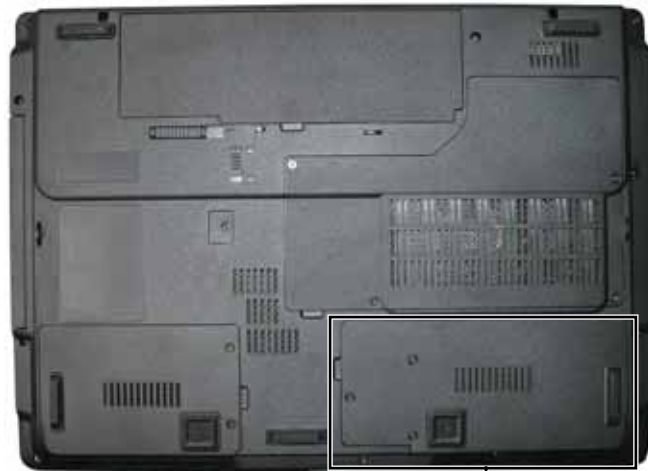

CMOS battery bay

To replace the CMOS battery:

- 1 Complete the steps in [“Preparing the notebook”](#) on page 55.
- 2 Remove the optional IEEE 802.11 wireless card by following the instructions in [“Replacing the IEEE 802.11 wireless card”](#) on page 67.

- 3 Insert the small flat-blade screwdriver or non-marring tool under the old battery and gently pry it up until it pops out of the socket.



- 4 Make sure that the positive (+) side of the new battery is facing up, then press the battery into the socket until it snaps into place.
- 5 Replace the optional IEEE 802.11 wireless card by following the instructions in ["Replacing the IEEE 802.11 wireless card" on page 67](#).

Replacing the secondary hard drive

Tools you need to complete this task:



Screws removed during this task:

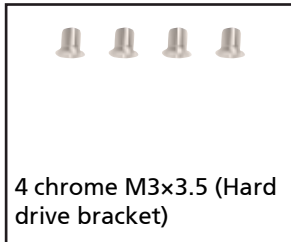

Locating components:

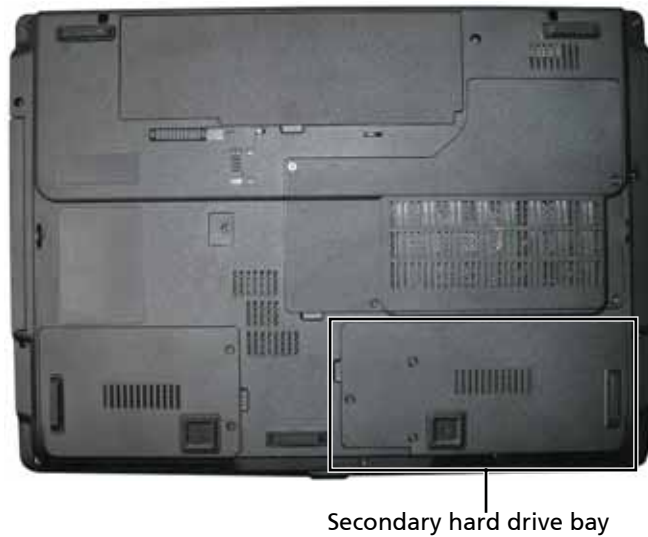

To replace the secondary hard drive:

- 1 Complete the steps in ["Preparing the notebook"](#) on page 55.
- 2 Loosen the hard drive bay cover screws (these screws cannot be removed).



- 3 Use the thumb notch to lift the hard drive bay cover, then remove it. Be careful not to break off the tabs located on the end of the cover opposite the thumb notch.

Thumb notch



- 4 Using the plastic tab, lift straight up on the hard drive, then remove it.

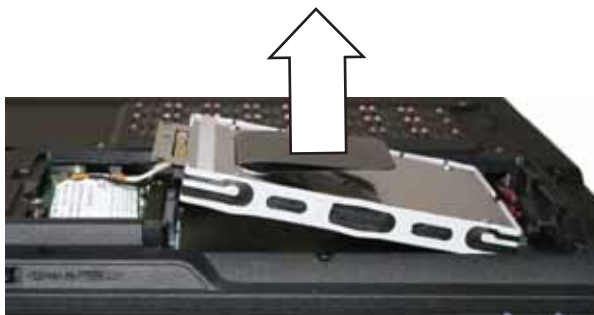

- 5 If your new hard drive already includes the hard drive bracket, go to step [Step 10](#).
-OR-

If you need to move the hard drive bracket from your old hard drive to your new hard drive, go to step [Step 6](#).

- 6 Remove the screws that secure the hard drive to the hard drive bracket.

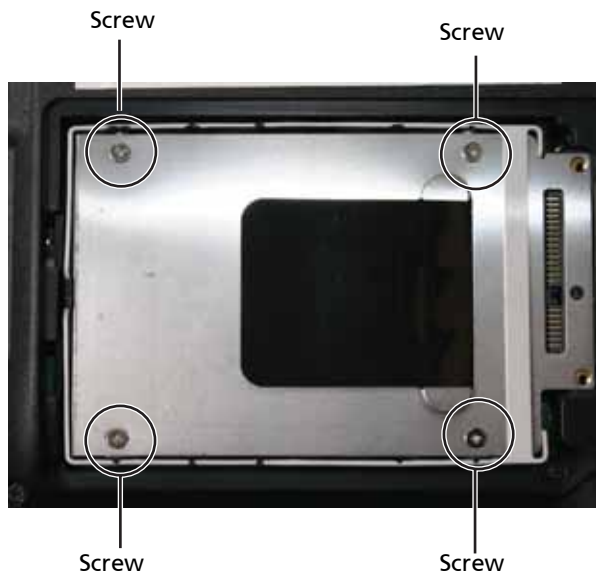

-
- 7 Remove the bracket from the old drive.



- 8 Insert the new drive label side up onto the bracket so the screw holes line up.
- 9 Replace the screws that secure the bracket to the drive.
- 10 Slide the new hard drive kit into your notebook.
- 11 Replace the cover, then tighten the screws.

Replacing the optical drive

Tools you need to complete this task:

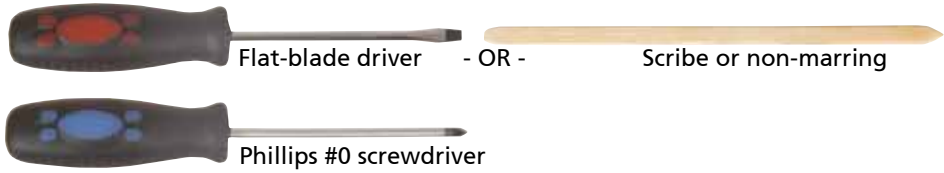

Locating components:



To replace the optical drive:

- 1 Complete the steps in ["Preparing the notebook" on page 55](#).
- 2 Remove the screw and cover that secures the DVD drive to your notebook.

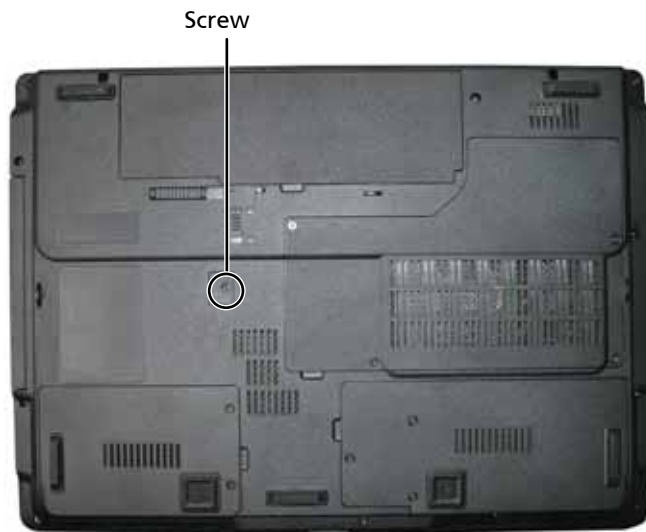

3 Carefully slide the drive out of the drive bay.

Important: Use a small screwdriver or other pointed tool to push on the DVD bracket and slide the drive out of the bay.

DVD bracket

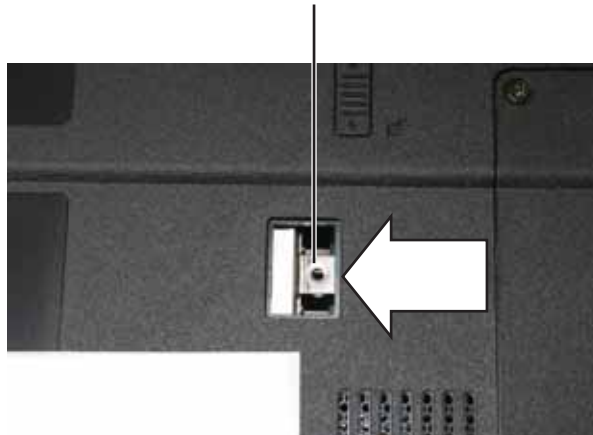

- 4** Slide the new DVD drive into the drive bay. Make sure that the drive fits securely in the bay.
- 5** Replace the screw and cover removed in [Step 2](#).

Replacing the keyboard cover

Tools you need to complete this task

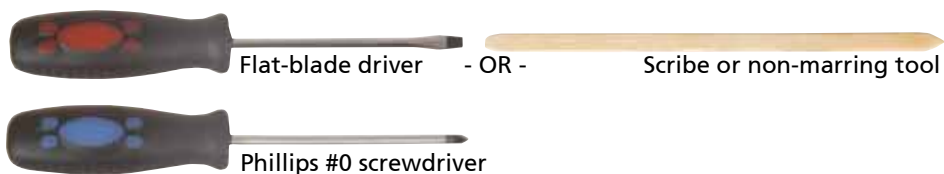

Screws removed during this task:



To replace the keyboard cover:

- 1 Complete the steps in ["Preparing the notebook"](#) on page 55.
- 2 Remove the two keyboard cover screws from the inside of the battery compartment.



- 3 Turn your notebook over so the top is facing up.
- 4 Open the LCD panel to the fully opened position.
- 5 Insert the small flat-blade screwdriver under each of the hinge covers and gently pry them up.



-
- 6 Insert the small flat-blade screwdriver under each end of the keyboard cover and gently pry it up.



- 7 Pull the cover off the notebook by lifting the back corners of the cover. Be careful to not damage the LCD panel.



- 8 Replace the keyboard cover by first inserting the tabs located on the front of the cover into the slots provided, then pressing down on the back. Press down on the cover in several places until it clicks in place. The cover is correctly mounted when you can run your finger along the cover and find no loose spots. The cover should be flat all the way across.

Caution: If the cover is not correctly replaced, your notebook could be damaged when you try to close the LCD panel.

- 9 Close the LCD panel.
- 10 Turn your notebook over so the bottom is facing up.
- 11 Replace the screws removed in [Step 2](#).

Replacing the keyboard

Tools you need to complete this task:

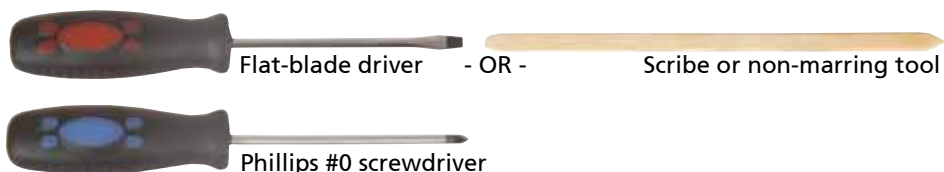

Screws removed during this task:



To replace the keyboard:

- 1 Complete the steps in ["Preparing the notebook" on page 55](#).
- 2 Remove the keyboard cover by following the steps in ["Replacing the keyboard cover" on page 78](#).
- 3 Lift the center of the back edge of the keyboard slightly and, at the same time, press inward on the left side and then the right side. This will release the keyboard from the side tabs.
- 4 Slowly slide the keyboard toward the LCD panel to release the keyboard retaining tabs located on the front edge of the keyboard.



- 5 Carefully rotate the keyboard toward you so it lies **keys-down** on top of your notebook. Be careful not to damage the LCD panel.



- 6 Swing the keyboard connector clip upward, then slide the cable out of the clip. Be careful not to touch or damage any other components.

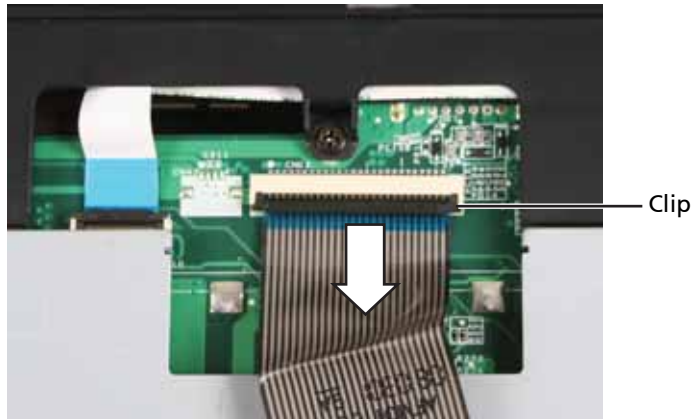

- 7 Place the new keyboard **keys-down** on your notebook with the space bar away from you.
- 8 Make sure the keyboard connector clip is fully lifted up, insert the cable into the connector, then swing the clip downward to lock the connector in place.
Important: The keyboard cable is correctly oriented if it is not twisted and the blue band is facing up.
- 9 Insert the tabs on the front edge of the keyboard into the slots under the palm rest. You may need to press down on the keyboard keys along the front edge of the keyboard to seat the retaining tabs into their corresponding slots.



- 10 Gently press the keyboard down until it is flat all the way across. Be careful to not damage the LCD panel.
- 11 Press down on the right side and left side of the keyboard to make sure that the side tabs secure the keyboard.
- 12 Replace the keyboard cover by following the steps in [“Replacing the keyboard cover” on page 78](#).

Replacing the power button board

Tools you need to complete this task:

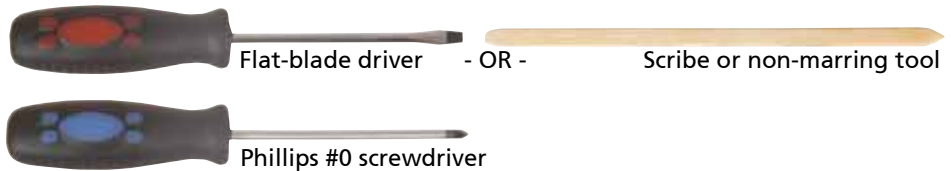

Screws removed during this task:

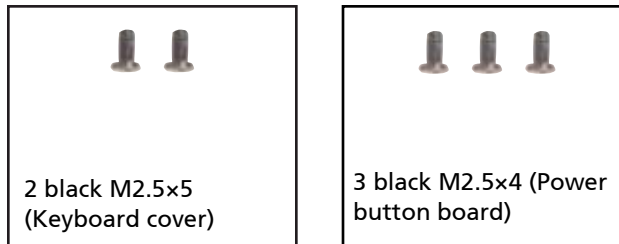

To replace the status indicator board:

- 1 Complete the steps in [“Preparing the notebook”](#) on page 55.
- 2 Remove the keyboard cover by following the steps in [“Replacing the keyboard cover”](#) on page 78.
- 3 Open the keyboard compartment by following the steps in [“Replacing the keyboard”](#) on page 80.
Important: You do not need to disconnect the keyboard cable from the system board to complete this procedure.
- 4 Swing the black connector clip upward, then lift the cable out of the connector. Be careful not to touch or damage any other components.

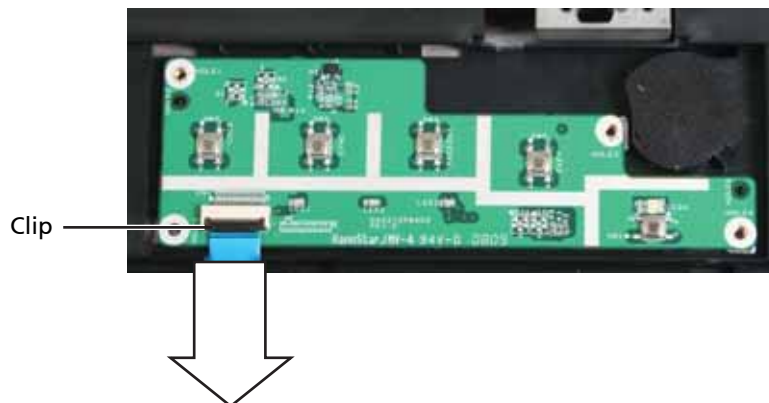

- 5 Remove the screws connecting the power button board to the notebook.

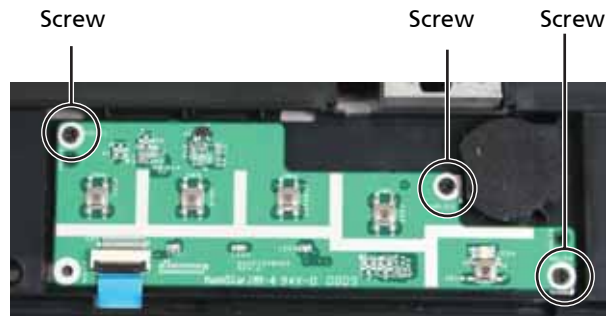

- 6 Replace the power button board, then replace the screws removed in [Step 5](#).
- 7 Make sure the black connector clip on the new power button board is swung upward, insert the cable into the connector, then swing the clip down to lock the connector in place.

Important: The cable is correctly oriented if it is not twisted and the blue band is facing up.
- 8 Close the keyboard compartment by following the steps in [“Replacing the keyboard” on page 80](#).
- 9 Replace the keyboard cover by following the steps in [“Replacing the keyboard cover” on page 78](#).

Replacing the LCD assembly

Tools you need to complete this task:

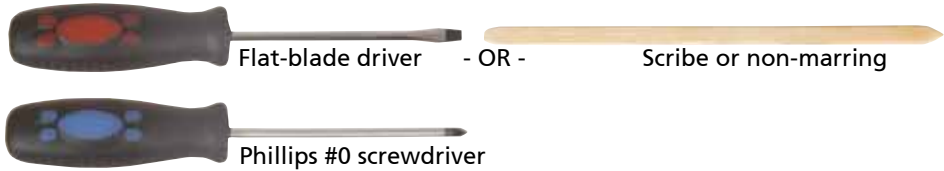

Screws removed during this task:



To replace the LCD assembly:

- 1 Complete the steps in [“Preparing the notebook”](#) on page 55.
- 2 Open the memory bay by following the steps in [“Adding or replacing memory modules”](#) on page 57.
- 3 Open the wireless bay by following the steps in [“Replacing the IEEE 802.11 wireless card”](#) on page 67.
- 4 If the notebook has wireless networking built in, unplug the wireless antennas by following the steps in [“Replacing the IEEE 802.11 wireless card”](#) on page 67.
- 5 Taking care to note the cables’ routing and positions as they are installed from Acer, slide the antenna cables out of the wireless bay.



- 6 Remove the screws on the bottom that secure the LCD panel hinges to the chassis.



- 7 Remove the keyboard cover by following the steps in ["Replacing the keyboard cover" on page 78](#).
- 8 Remove the keyboard by following the steps in ["Replacing the keyboard" on page 80](#).
- 9 Detach the LCD cable from the system board. Use a scribe or other non-marring tool to gently push the plug out of the connector.

Caution: The LCD video cable connector is fragile.

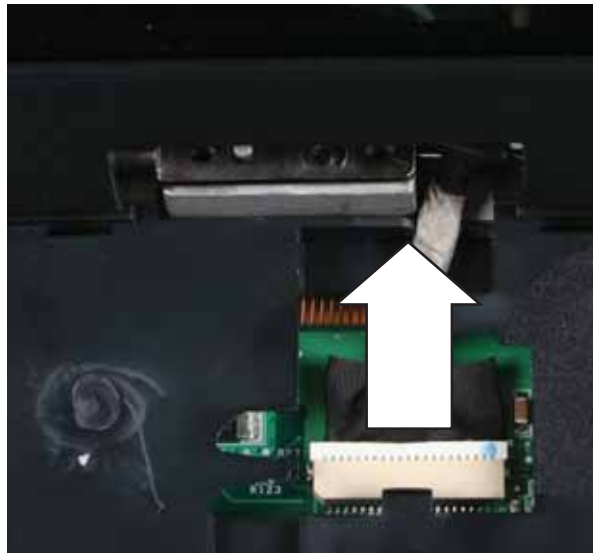

- 10 Taking care to note the cables' routing and positions as they are installed from Acer, pull the antenna cables out from under the system board, then slide the antenna cables and LCD cables out from under the retaining clips.

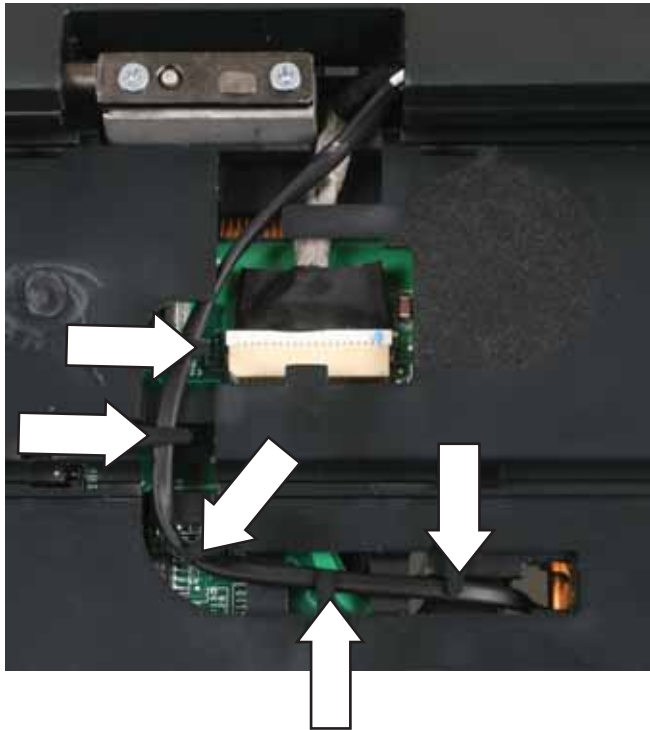

- 11 Remove the screws on the top that secure the LCD panel hinge to the chassis.



- 12 Lift the LCD panel assembly up and away from the notebook.
- 13 Place the new LCD panel assembly onto the notebook, then replace the hinge screws removed in [Step 11](#).
- 14 Slide the antenna cables through the retaining clips, then under the system board.
- 15 Slide the LCD cable through the retaining clip, then plug it into the notebook.
- 16 Replace the keyboard by following the steps in ["Replacing the keyboard" on page 80](#).
- 17 Replace the keyboard cover by following the steps in ["Replacing the keyboard cover" on page 78](#).
- 18 Close the LCD panel, turn the notebook over so the bottom is facing up, then replace the bottom hinge screws removed in [Step 6](#).
- 19 Route the antenna cables into the wireless bay, then reconnect the antenna wires to the wireless card by following the steps in ["Replacing the IEEE 802.11 wireless card" on page 67](#).
- 20 Replace the wireless bay cover by following the steps in ["Replacing the IEEE 802.11 wireless card" on page 67](#).
- 21 Replace the memory bay cover by following the steps in ["Adding or replacing memory modules" on page 57](#).

Replacing the inverter

Tools you need to complete this task:

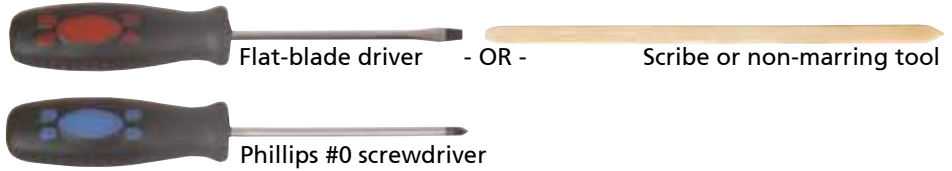

Screws removed during this task:

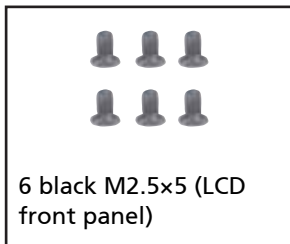

To replace the inverter:

- 1 Complete the steps in ["Preparing the notebook"](#) on page 55.
- 2 Remove the LCD panel by following the steps in ["Replacing the LCD assembly"](#) on page 84.
- 3 Remove the rubber inserts from the front of the LCD panel assembly.

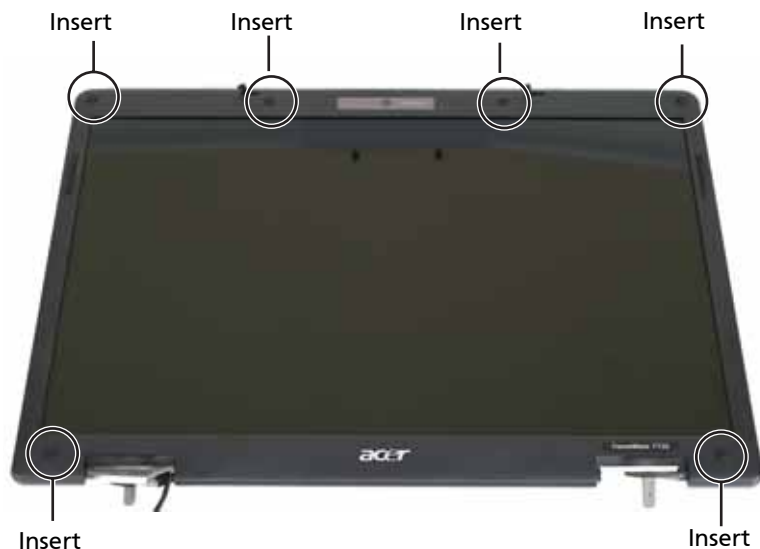

- 4 Remove the screws from the front of the LCD panel assembly.



- 5 Carefully separate the front and back of the LCD panel assembly.



- 6 Lift the inverter from the LCD panel assembly.
- 7 Disconnect the connectors from the old inverter and connect them to the new inverter.



- 8 Align the holes in new inverter with the pegs in the LCD lid, then press the inverter into place.
- 9 Press the LCD panel front and back together. Press the two halves together in several places until they click in place. You should find no loose spots or spots where the two halves do not meet.
- 10 Replace the LCD panel assembly screws removed in [Step 4](#).
- 11 Replace the rubber inserts removed in [Step 3](#).
- 12 Replace the LCD panel by following the steps in ["Replacing the LCD assembly" on page 84](#).

Replacing the LCD panel

Tools you need to complete this task:

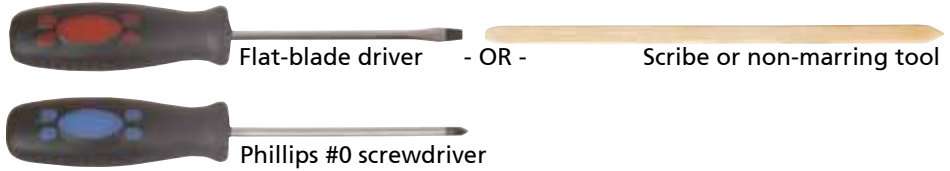

Screws removed during this task: [<Athena, what screw size the grounding screw?>](#)

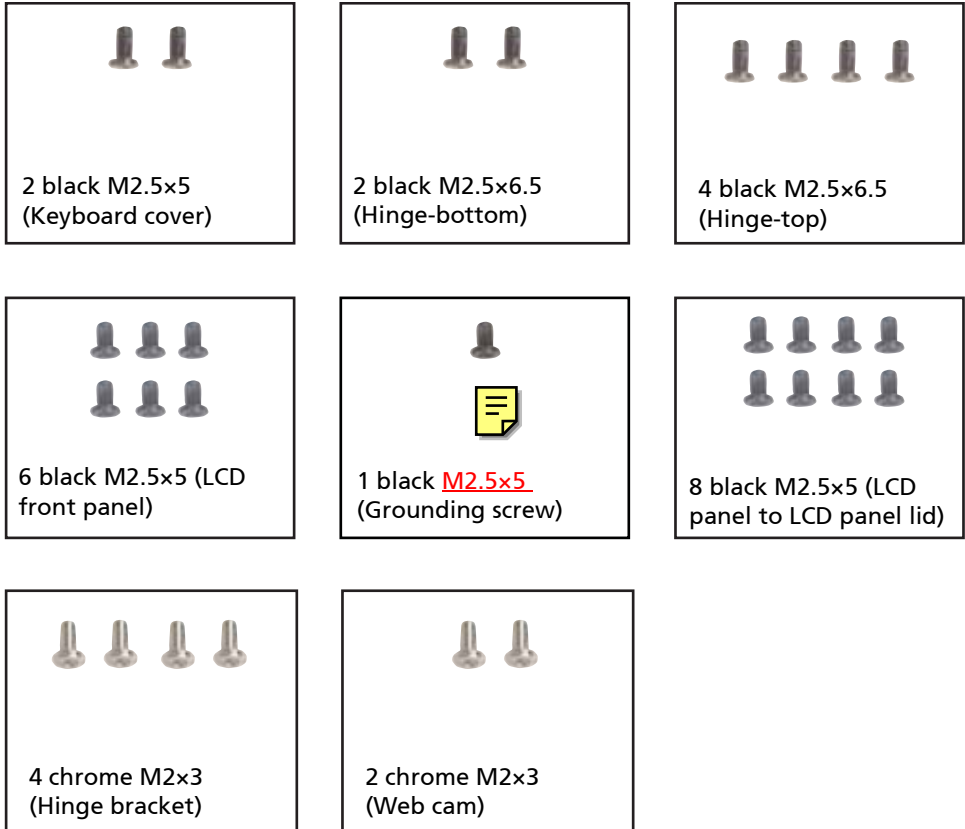

► To replace the LCD panel:

- 1 Complete the steps in [“Preparing the notebook” on page 55.](#)
- 2 Remove the LCD panel by following the steps in [“Replacing the LCD assembly” on page 84.](#)

- 3 Remove the rubber inserts from the front of the LCD panel assembly.



- 4 Remove the screws from the front of the LCD panel assembly.



- 5 Carefully separate the front and back of the LCD panel assembly.



- 6 Remove the grounding screw from the LCD panel lid.



- 7 Remove the screws that secure the LCD panel to the LCD panel lid.



- 8 Remove the inverter by following the steps in ["Replacing the inverter" on page 87](#).
- 9 Remove the old LCD panel from the LCD panel lid.
- 10 Remove the hinges from the old LCD panel and install them on the new panel by following the steps in ["Replacing the LCD panel hinges" on page 92](#).
- 11 Remove the web cam from the old LCD panel and install it on the new panel by following the steps in ["Replacing the web cam" on page 94](#).
- 12 Place the new LCD panel into the LCD panel lid.
- 13 Replace the inverter by following the steps in ["Replacing the inverter" on page 87](#).
- 14 Feed the wiring back into the hinge channels.
- 15 Replace the screws that were removed in [Step 7](#).
- 16 Press the LCD panel front and back together. Press the two halves together in several places until they click in place. You should find no loose spots or spots where the two halves do not meet.
- 17 Replace the LCD panel assembly screws removed in [Step 4](#).
- 18 Replace the rubber inserts removed in [Step 3](#).
- 19 Replace the LCD assembly by following the steps in ["Replacing the LCD assembly" on page 84](#).

Replacing the LCD panel hinges

Tools you need to complete this task:

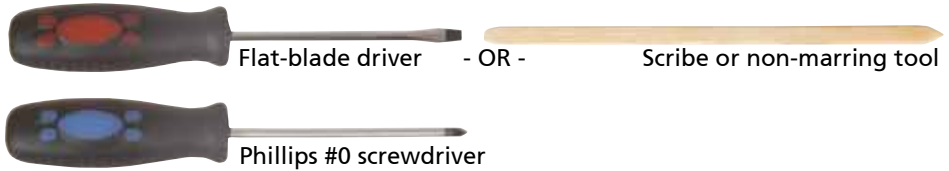

Screws removed during this task:

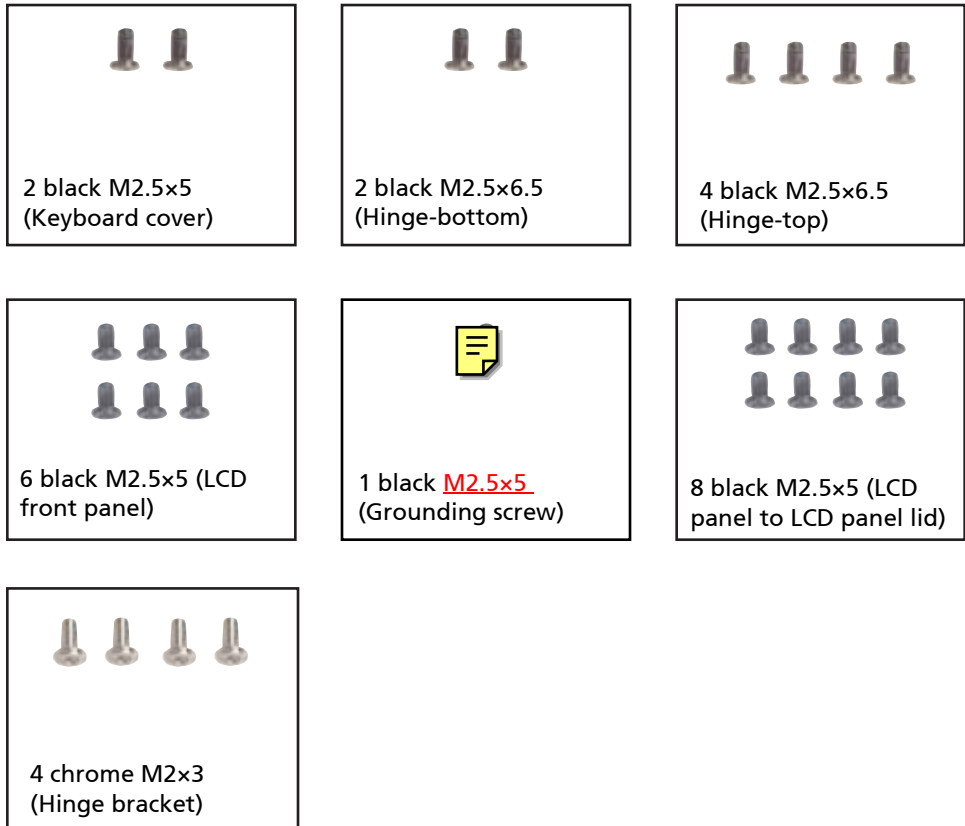

► To replace the LCD panel hinges:

- 1 Complete the steps in [“Preparing the notebook”](#) on page 55.
- 2 Remove the LCD panel assembly by following the steps in [“Replacing the LCD assembly”](#) on page 84.
- 3 Remove the LCD panel by following the steps in [“Replacing the LCD panel”](#) on page 89.
- 4 Remove the screws that secure the hinge bracket to the LCD panel.



- 5 Place the new hinge bracket onto the LCD panel.

-
- 6 Replace the screws that were removed in [Step 4](#).
 - 7 Replace the LCD panel by following the steps in [“Replacing the LCD panel” on page 89](#).
 - 8 Replace the LCD assembly by following the steps in [“Replacing the LCD assembly” on page 84](#).

Replacing the web cam

Tools you need to complete this task:

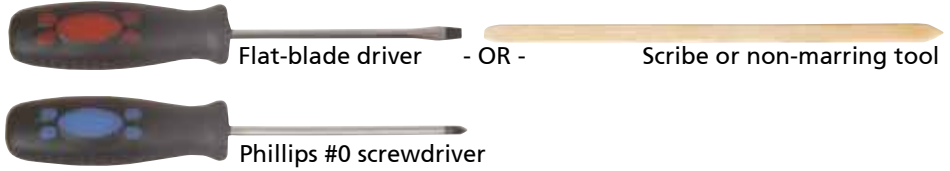

Screws removed during this task:

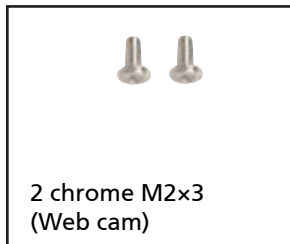
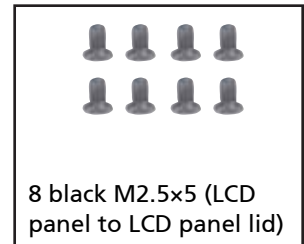
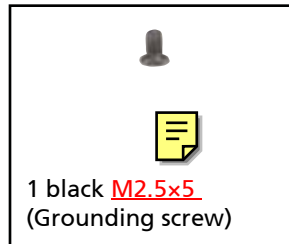
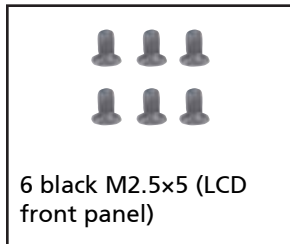
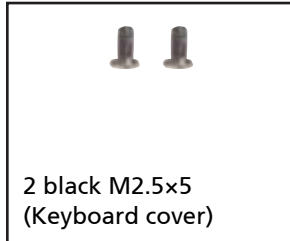

► To replace the web cam:

- 1 Complete the steps in [“Preparing the notebook”](#) on page 55.
- 2 Remove the LCD panel by following the steps in [“Replacing the LCD assembly”](#) on page 84.
- 3 Remove the LCD panel by following the steps in [“Replacing the LCD panel”](#) on page 89.
- 4 Disconnect the connector from the web cam.



-
- 5 Remove the screws that secure the LCD panel to the LCD panel lid.



- 6 Replace the screws that were removed in [Step 5](#).
- 7 Reconnect the connector from the web cam.
- 8 Replace the LCD panel by following the steps in ["Replacing the LCD panel" on page 89](#).
- 9 Replace the LCD assembly by following the steps in ["Replacing the LCD assembly" on page 84](#).









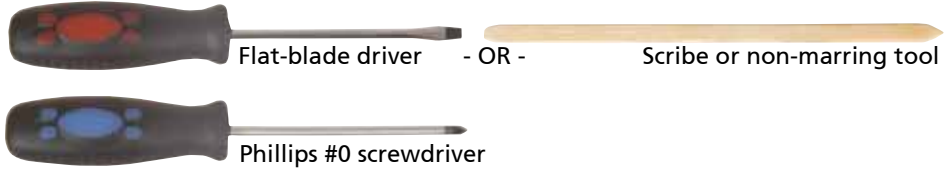







Replacing the palm rest

Tools you need to complete this task:



Screws removed during this task: [<Athena, what screw size is the screw in step 8?>](#)

 <p>2 black M2.5x5 (Keyboard cover)</p>	 <p>2 black M2.5x6.5 (Hinge-bottom)</p>	 <p>4 chrome M2.5x6.5 (Hinge-top)</p>
 <p>1 black M2.5x8 (Keyboard plate)</p>	 <p>4 black M2.5x4 (Palm Rest-top)</p>	 <p>16 black M2.5x6.5 (Palm rest-bottom)</p>
 <p>3 black M2.5x5 (Palm rest-bottom)</p>	 <p>2 black M2.5x3 (Palm rest-bottom)</p>	 <p>3 black M2.5x5 (Speaker-Right)</p>
 <p>2 black M2.5x8 (Speaker-Left)</p>	 <p>2 black M2.5x4 (Touchpad button board/fingerprint assembly)</p>	 <p>4 chrome M3x3 (Touchpad cover)</p>
 <p>3 black M2.5x4 (Button board)</p>		

To replace the palm rest:

- 1 Complete the steps in [“Preparing the notebook”](#) on page 55.
- 2 Remove the memory bay cover by following the steps in [“Adding or replacing memory modules”](#) on page 57.
- 3 If the notebook has wireless networking built in, unplug the wireless antennas by following the steps in [“Replacing the IEEE 802.11 wireless card”](#) on page 67.
- 4 Remove the hard drive(s) by following the steps in [“Replacing the primary hard drive”](#) on page 64 and [“Replacing the secondary hard drive”](#) on page 73.
- 5 Remove the keyboard cover by following the steps in [“Replacing the keyboard cover”](#) on page 78.
- 6 Remove the keyboard by following the steps in [“Replacing the keyboard”](#) on page 80.
- 7 Remove the LCD assembly by following the steps in [“Replacing the LCD assembly”](#) on page 84.
- 8 Remove the screw holding the keyboard plate to the notebook, then lift and remove the keyboard plate.



- 9 Swing the black touchpad connector clip upward, then lift the touchpad cable out of the connector. Be careful not to touch or damage any other components.



- 10 Disconnect the finger print reader cable from the system board. Use a scribe or other non-marring tool to gently push the plug out of the connector.
- 11 Swing the black power button board connector clip upward, then lift the power button cable out of the connector. Be careful not to touch or damage any other components.

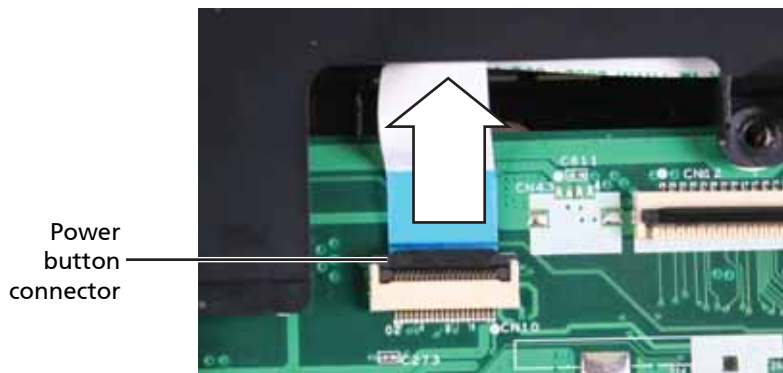

- 12 Swing the black button board connector clip upward, then lift the button board cable out of the connector. Be careful not to touch or damage any other components.

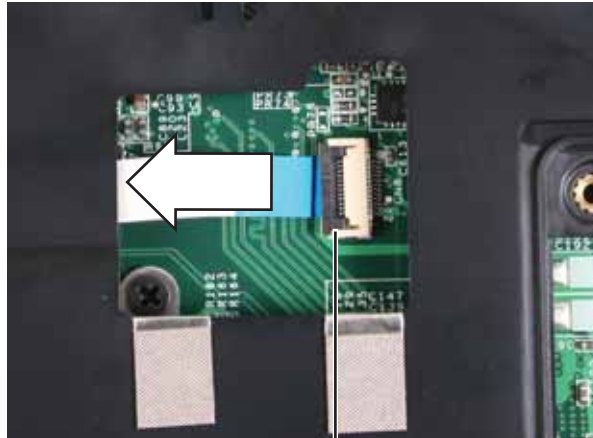

Button board connector

- 13 Remove the screws from the top of the palm rest.

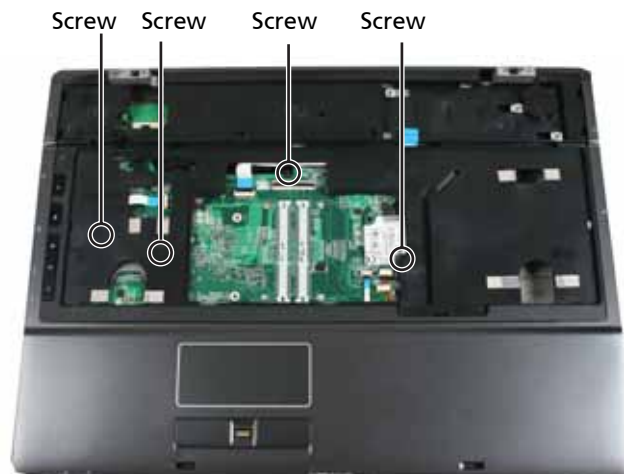

- 14 Turn the notebook over so the bottom is facing up.

-
- 15** Disconnect the microphone and speaker cables from the system board. Use a scribe or other non-marring tool to gently lift the plugs out of the connectors.

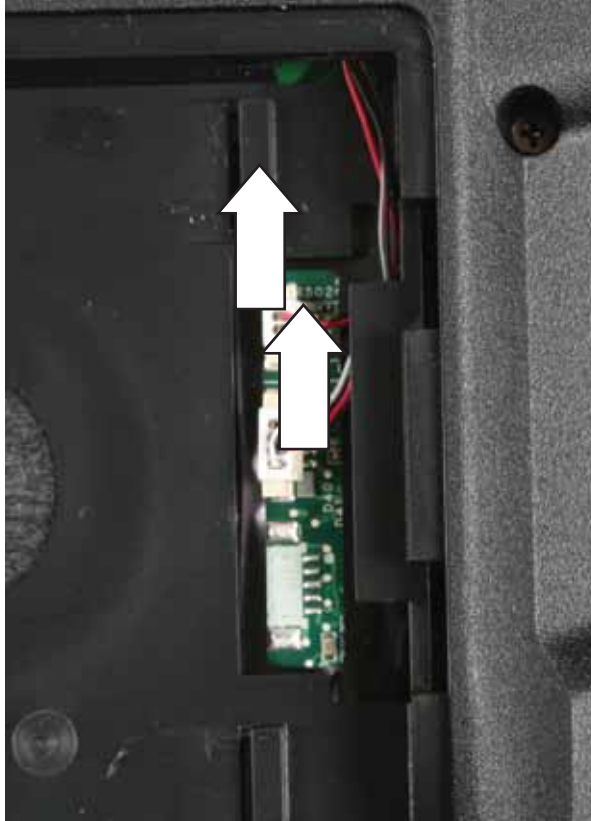

- 16 Taking care to note the cables' routing and positions as they are installed from Acer, slide the microphone and speaker cables out of the wireless bay.



- 17 Remove the screws from the bottom of the notebook.

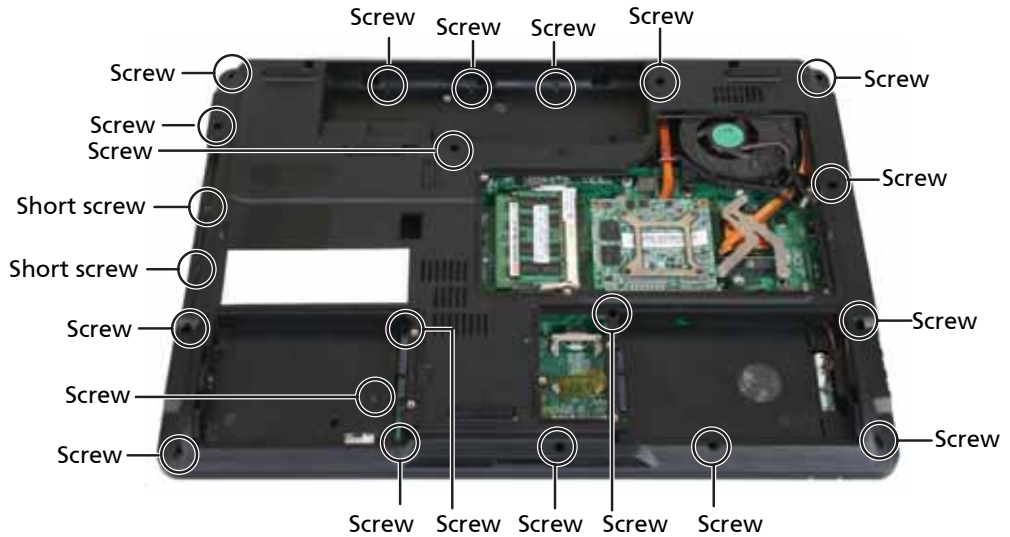

- 18 Turn the notebook over so the top is facing up.
- 19 Taking care to note the cables' routing and positions as they are installed from Acer, pull the microphone and speaker cables out from under the system board.

- 20 Lift the palm rest assembly up from the notebook.



- 21 Remove the speakers and microphone from the old palm rest and install them on the new palm rest by following the instructions in [“Replacing the microphone and speakers”](#) on page 103.
- 22 Remove the touchpad button board/fingerprint assembly from the old palm rest and install it on the new palm rest by following the instructions in [“Replacing the touchpad button board/fingerprint assembly”](#) on page 106.

[<Athena: Do we transfer the green square touchpad board that is on the back side of the touchpad area?>](#)

- 23 Remove the button board from the old palm rest and install it on the new palm rest by following the instructions in [“Replacing the button board”](#) on page 109.
- 24 Route the microphone and speaker cables under the system board.
- 25 Place the new palm rest assembly onto the notebook, then snap the assembly into place.
- 26 Replace the screws removed in [Step 13](#).
- 27 Make sure the black power button board connector clip is swung upward, insert the cable into the connector, then swing the clip down to lock the connector in place.

Important: The cable is correctly oriented if it is not twisted and the blue band is facing up.

- 28 Make sure the black button board connector clip is swung upward, insert the cable into the connector, then swing the clip down to lock the connector in place.

Important: The cable is correctly oriented if it is not twisted and the blue band is facing up.

- 29 Make sure the black touchpad cable connector clip is swung upward, insert the cable into the connector, then swing the clip down to lock the connector in place.

Important: The cable is correctly oriented if it is not twisted and the blue band is facing up.

- 30 Connect the finger print reader cable to the system board.
- 31 Replace the keyboard plate removed in [Step 8](#).
- 32 Turn the notebook over so the bottom is facing up.
- 33 Replace the screws removed in [Step 17](#).
- 34 Connect the microphone and speaker cables to the system board.
- 35 Replace the LCD assembly by following the steps in [“Replacing the LCD assembly”](#) on page 84.
- 36 Replace the keyboard by following the steps in [“Replacing the keyboard”](#) on page 80.
- 37 Replace the keyboard cover by following the steps in [“Replacing the keyboard cover”](#) on page 78.
- 38 Replace the hard drive(s) by following the steps in [“Replacing the primary hard drive”](#) on page 64 and [“Replacing the secondary hard drive”](#) on page 73.
- 39 If the notebook has wireless networking built in, reconnect the wireless antennas by following the steps in [“Replacing the IEEE 802.11 wireless card”](#) on page 67.
- 40 Replace the wireless bay cover by following the steps in [“Replacing the IEEE 802.11 wireless card”](#) on page 67.

Replacing the microphone and speakers

<Athena, do speakers and microphone get replaced? The screws are pt in the Screw BOM. The microphone and speakers are listed in the Replacement Parts List.>

Tools you need to complete this task:

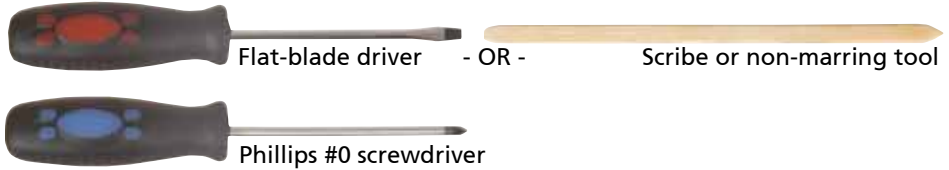

Screws removed during this task:

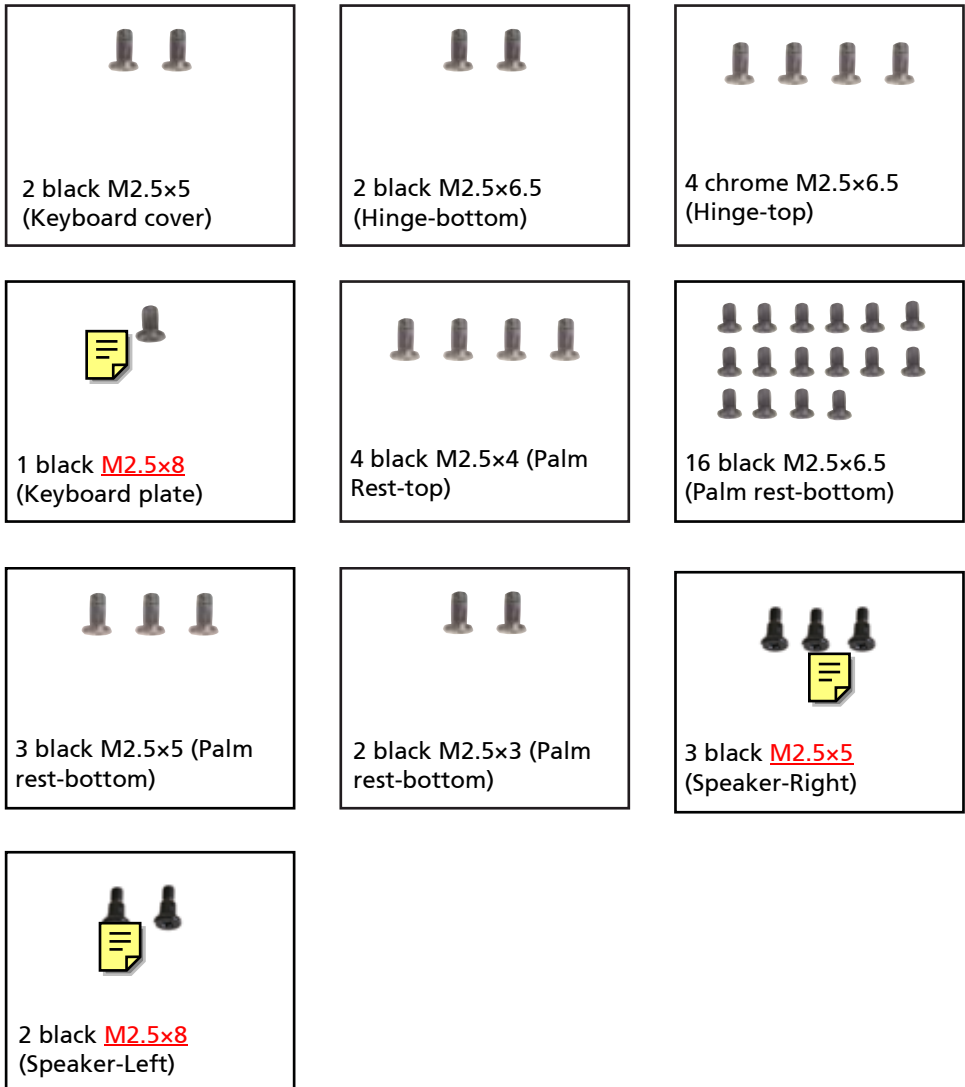

To replace the microphone and speakers:

- 1 Complete the steps in [“Preparing the notebook” on page 55.](#)
- 2 Remove the memory bay cover by following the steps in [“Adding or replacing memory modules” on page 57.](#)

- 3 If the notebook has wireless networking built in, unplug the wireless antennas by following the steps in [“Replacing the IEEE 802.11 wireless card” on page 67](#).
- 4 Remove the hard drive(s) by following the steps in [“Replacing the primary hard drive” on page 64](#) and [“Replacing the secondary hard drive” on page 73](#).
- 5 Remove the keyboard cover by following the steps in [“Replacing the keyboard cover” on page 78](#).
- 6 Remove the keyboard by following the steps in [“Replacing the keyboard” on page 80](#).
- 7 Remove the LCD assembly by following the steps in [“Replacing the LCD assembly” on page 84](#).
- 8 Remove the palm rest by following the instructions in [“Replacing the palm rest” on page 96](#).
- 9 Remove the screws securing the right speaker to the palm rest.

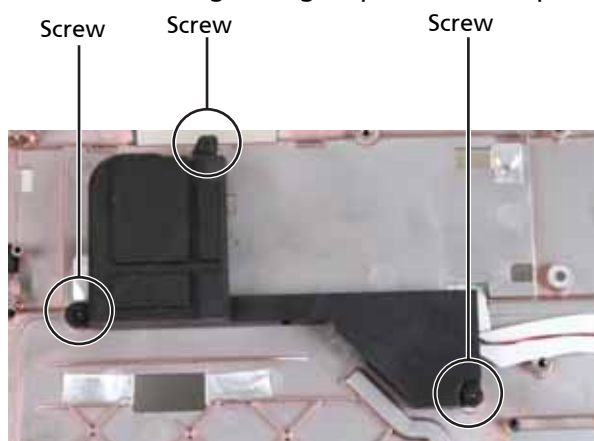

- 10 Remove the screws securing the left speaker to the palm rest.

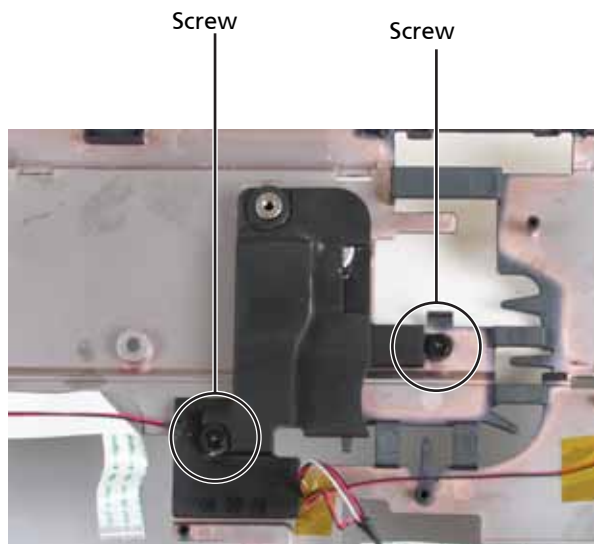

- 11 Carefully lift the microphone out of its holder and put the new microphone in its place.

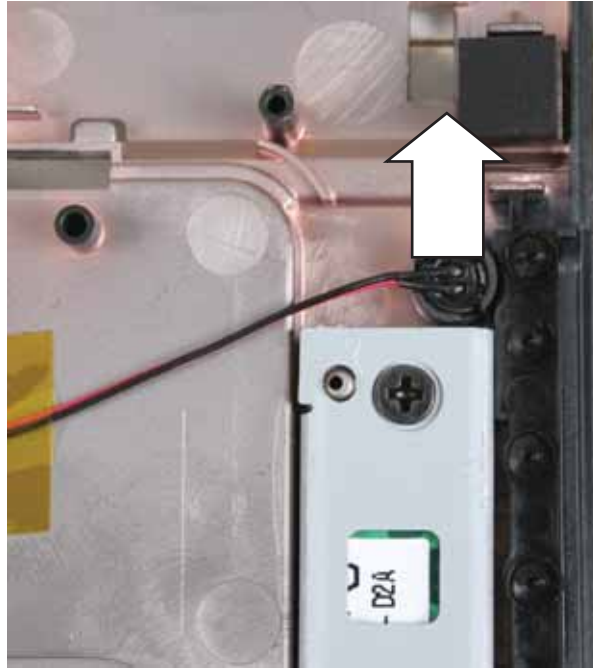

- 12 Replace the left speaker, then replace the screws removed in [Step 10](#).
- 13 Replace the right speaker, then replace the screws removed in [Step 9](#).
- 14 Replace the palm rest by following the steps in ["Replacing the palm rest" on page 96](#).
- 15 Replace the LCD assembly by following the steps in ["Replacing the LCD assembly" on page 84](#).
- 16 Replace the keyboard by following the steps in ["Replacing the keyboard" on page 80](#).
- 17 Replace the keyboard cover by following the steps in ["Replacing the keyboard cover" on page 78](#).
- 18 Replace the hard drive(s) by following the steps in ["Replacing the primary hard drive" on page 64](#) and ["Replacing the secondary hard drive" on page 73](#).
- 19 If the notebook has wireless networking built in, reconnect the wireless antennas by following the steps in ["Replacing the IEEE 802.11 wireless card" on page 67](#).
- 20 Replace the wireless bay cover by following the steps in ["Replacing the IEEE 802.11 wireless card" on page 67](#).

Replacing the touchpad button board/ fingerprint assembly

Tools you need to complete this task:

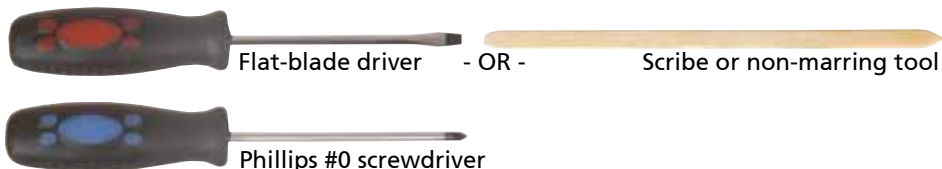

Screws removed during this task:

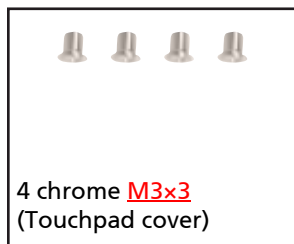
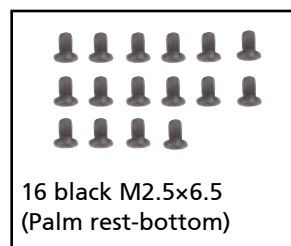
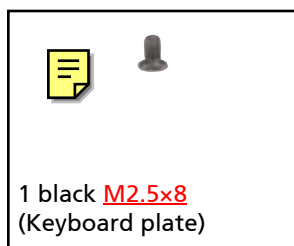
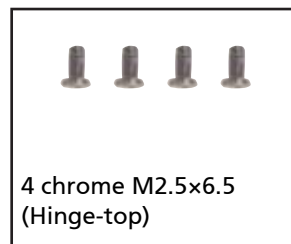

To replace the touchpad button board/fingerprint assembly:

- 1 Complete the steps in [“Preparing the notebook” on page 55](#).
- 2 Remove the memory bay cover by following the steps in [“Adding or replacing memory modules” on page 57](#).
- 3 If the notebook has wireless networking built in, unplug the wireless antennas by following the steps in [“Replacing the IEEE 802.11 wireless card” on page 67](#).

- 4 Remove the hard drive(s) by following the steps in ["Replacing the primary hard drive"](#) on page 64 and ["Replacing the secondary hard drive"](#) on page 73.
- 5 Remove the keyboard cover by following the steps in ["Replacing the keyboard cover"](#) on page 78.
- 6 Remove the keyboard by following the steps in ["Replacing the keyboard"](#) on page 80.
- 7 Remove the LCD assembly by following the steps in ["Replacing the LCD assembly"](#) on page 84.
- 8 Remove the palm rest by following the instructions in ["Replacing the palm rest"](#) on page 96.
- 9 Swing the black touchpad connector clip upward, then lift the touchpad cables out of the connectors. Be careful not to touch or damage any other components.

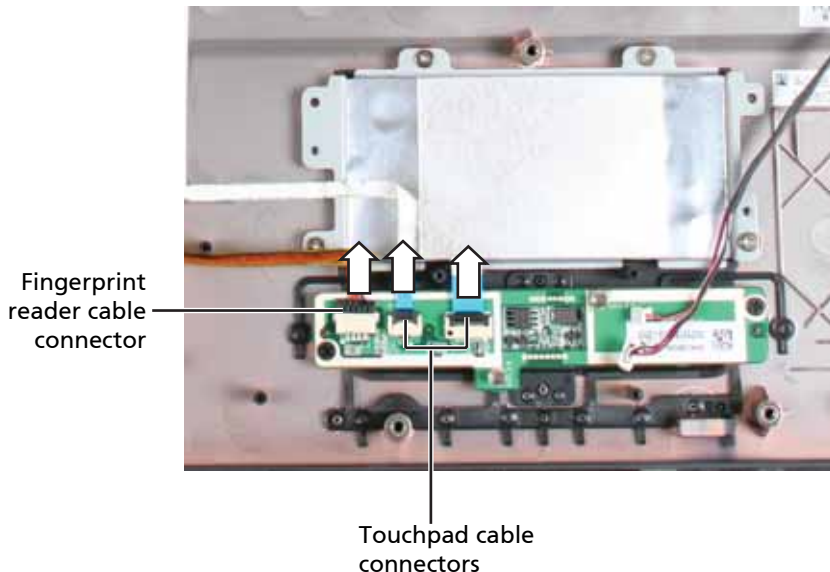

- 10 Disconnect the finger print reader cable from the assembly. Use a scribe or other non-marring tool to gently push the plug out of the connector.
- 11 Remove the screws securing the touchpad button board/fingerprint assembly to the palm rest, then lift the assembly out of the notebook.



<Athena: Does the green square touchpad board get replaced in the procedure, another procedure, or not at all? I do not see it on the Replacement Parts List and I do not see the bracket screws in the Screw Specs.>

- 12 Replace the touchpad button board/fingerprint assembly, then replace the screws removed in [Step 5](#).
- 13 Make sure the black touchpad connector clip is swung upward, insert the cable into the connector, then swing the clip down to lock the connector in place.

Important: The cable is correctly oriented if it is not twisted and the blue band is facing up.
- 14 Connect the finger print reader cable to the touchpad button board/fingerprint assembly.

-
- 15 Replace the palm rest by following the steps in [“Replacing the palm rest”](#) on page 96.
 - 16 Replace the LCD assembly by following the steps in [“Replacing the LCD assembly”](#) on page 84.
 - 17 Replace the keyboard by following the steps in [“Replacing the keyboard”](#) on page 80.
 - 18 Replace the keyboard cover by following the steps in [“Replacing the keyboard cover”](#) on page 78.
 - 19 Replace the hard drive(s) by following the steps in [“Replacing the primary hard drive”](#) on page 64 and [“Replacing the secondary hard drive”](#) on page 73.
 - 20 If the notebook has wireless networking built in, reconnect the wireless antennas by following the steps in [“Replacing the IEEE 802.11 wireless card”](#) on page 67.
 - 21 Replace the wireless bay cover by following the steps in [“Replacing the IEEE 802.11 wireless card”](#) on page 67.

Replacing the button board

Tools you need to complete this task:

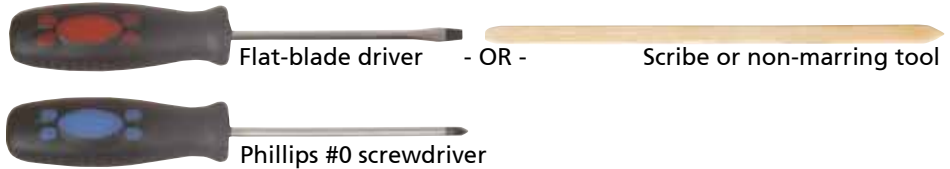

Screws removed during this task:

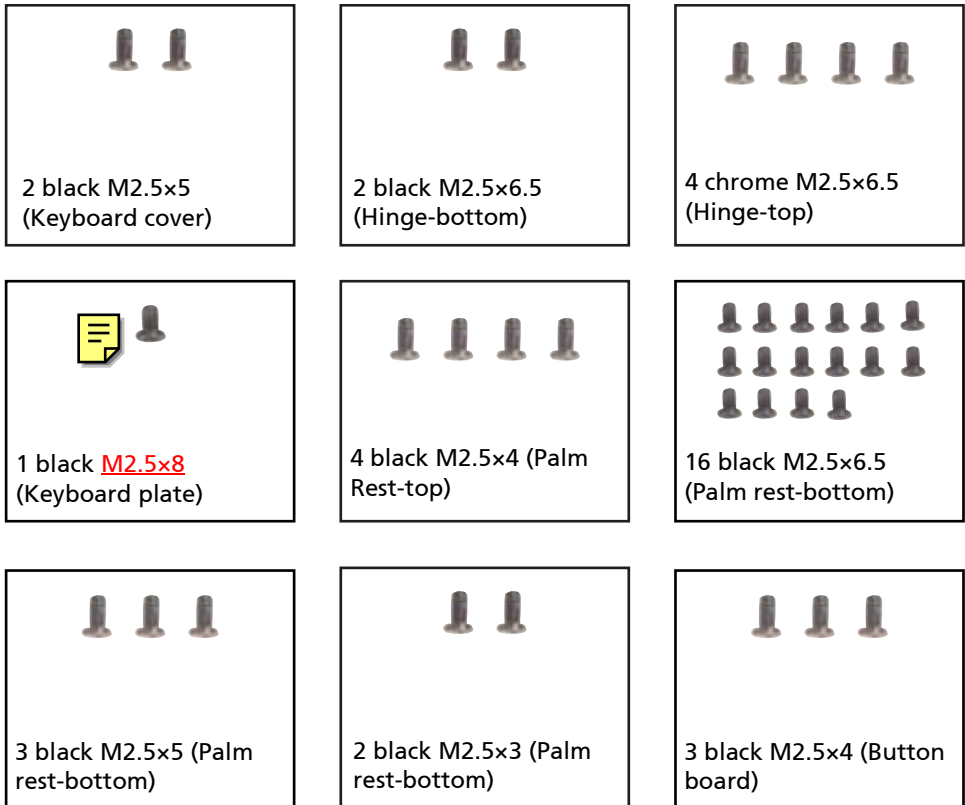

To replace the button board:

- 1 Complete the steps in [“Preparing the notebook”](#) on page 55.
- 2 Remove the memory bay cover by following the steps in [“Adding or replacing memory modules”](#) on page 57.
- 3 If the notebook has wireless networking built in, unplug the wireless antennas by following the steps in [“Replacing the IEEE 802.11 wireless card”](#) on page 67.
- 4 Remove the hard drive(s) by following the steps in [“Replacing the primary hard drive”](#) on page 64 and [“Replacing the secondary hard drive”](#) on page 73.
- 5 Remove the keyboard cover by following the steps in [“Replacing the keyboard cover”](#) on page 78.
- 6 Remove the keyboard by following the steps in [“Replacing the keyboard”](#) on page 80.
- 7 Remove the LCD assembly by following the steps in [“Replacing the LCD assembly”](#) on page 84.
- 8 Remove the palm rest by following the instructions in [“Replacing the palm rest”](#) on page 96.

-
- 9 Swing the black button board connector clip upward, then lift the button board cable out of the connector. Be careful not to touch or damage any other components.

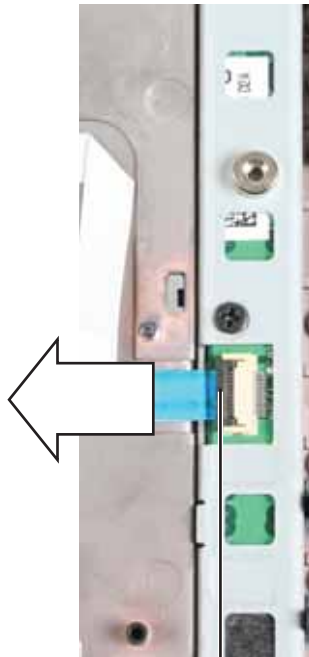

Button board
cable connector

- 10 Remove the screws securing the button board assembly to the palm rest.

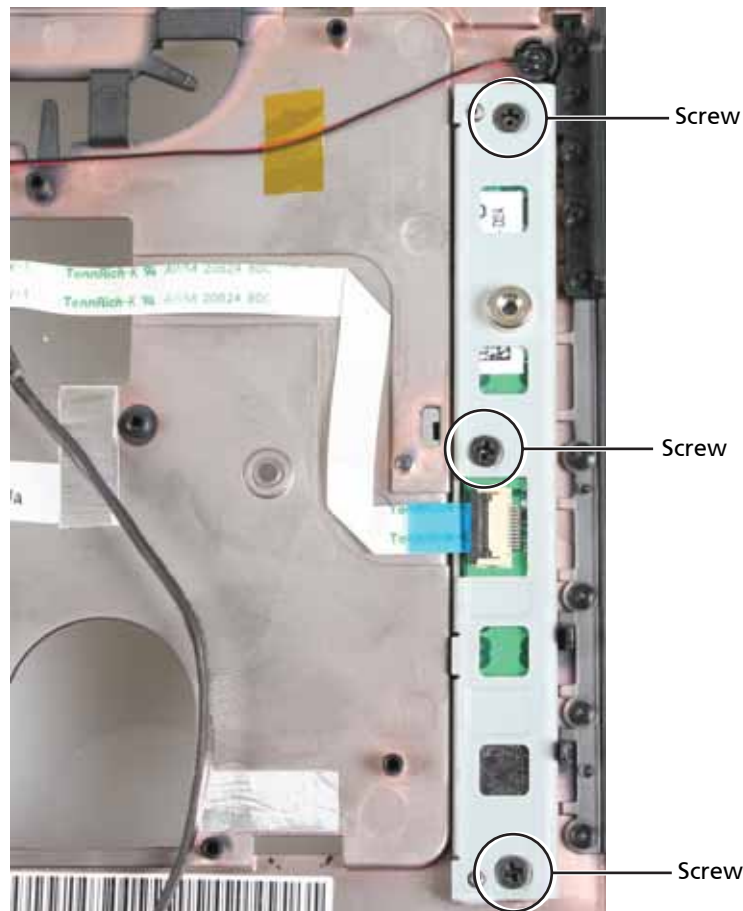

- 11 Separate the old button board from the metal bracket and install the new board into the bracket.
- 12 Replace the button board assembly, then replace the screws removed in [Step 10](#).
- 13 Make sure the black button board connector clip is swung upward, insert the cable into the connector, then swing the clip down to lock the connector in place.
Important: The cable is correctly oriented if it is not twisted and the blue band is facing up.
- 14 Replace the palm rest by following the steps in [“Replacing the palm rest” on page 96](#).
- 15 Replace the LCD assembly by following the steps in [“Replacing the LCD assembly” on page 84](#).
- 16 Replace the keyboard by following the steps in [“Replacing the keyboard” on page 80](#).
- 17 Replace the keyboard cover by following the steps in [“Replacing the keyboard cover” on page 78](#).
- 18 Replace the hard drive(s) by following the steps in [“Replacing the primary hard drive” on page 64](#) and [“Replacing the secondary hard drive” on page 73](#).
- 19 If the notebook has wireless networking built in, reconnect the wireless antennas by following the steps in [“Replacing the IEEE 802.11 wireless card” on page 67](#).
- 20 Replace the wireless bay cover by following the steps in [“Replacing the IEEE 802.11 wireless card” on page 67](#).

Replacing the ExpressCard (NewCard) assembly

Tools you need to complete this task:

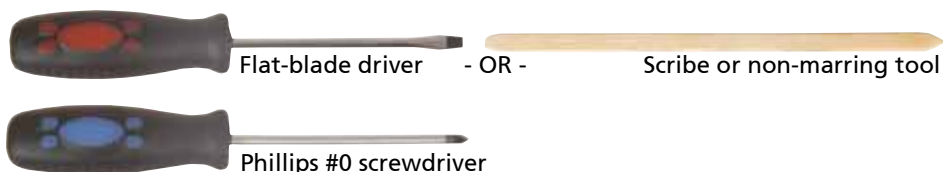

Screws removed during this task:

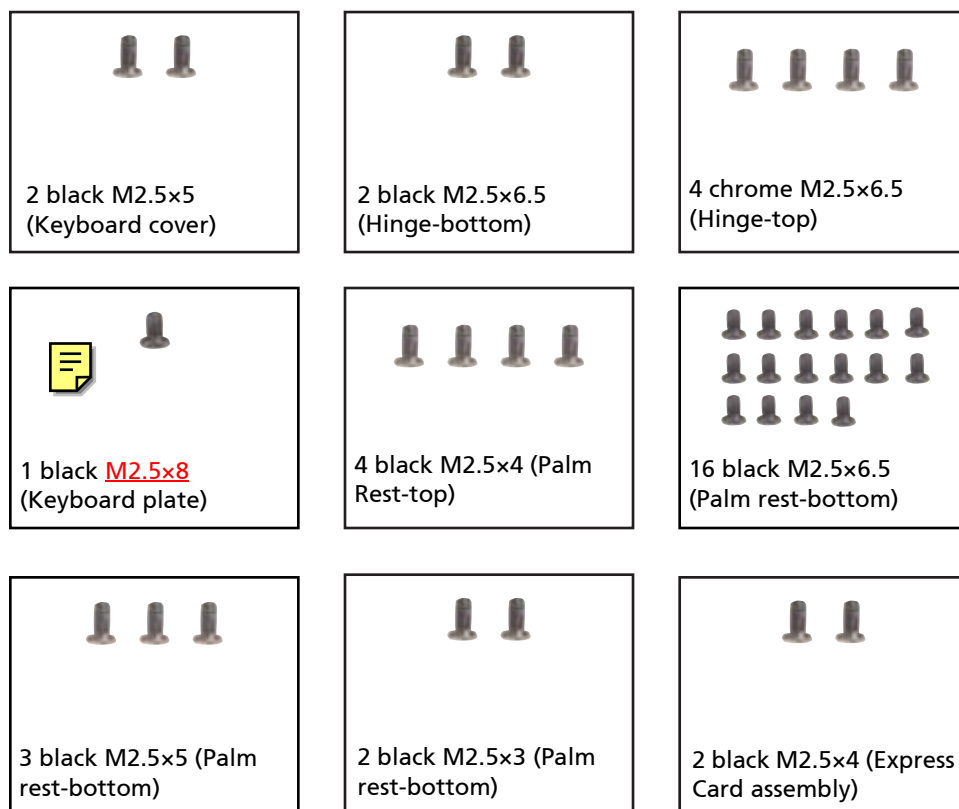

To replace the Express Card assembly:

- 1 Complete the steps in [“Preparing the notebook”](#) on page 55.
- 2 Remove the memory bay cover by following the steps in [“Adding or replacing memory modules”](#) on page 57.
- 3 If the notebook has wireless networking built in, unplug the wireless antennas by following the steps in [“Replacing the IEEE 802.11 wireless card”](#) on page 67.
- 4 Remove the hard drive(s) by following the steps in [“Replacing the primary hard drive”](#) on page 64 and [“Replacing the secondary hard drive”](#) on page 73.
- 5 Remove the keyboard cover by following the steps in [“Replacing the keyboard cover”](#) on page 78.
- 6 Remove the keyboard by following the steps in [“Replacing the keyboard”](#) on page 80.
- 7 Remove the LCD assembly by following the steps in [“Replacing the LCD assembly”](#) on page 84.

- 8 Remove the palm rest by following the instructions in [“Replacing the palm rest” on page 96](#).
- 9 Disconnect the cable from the Express Card assembly. Use a scribe or other non-marring tool to gently push the plug out of the connector.



Express Card
cable connector

- 10 Remove the screws securing the old Express Card assembly to the notebook.

Screw



Screw

- 11 Replace the Express Card assembly, then replace the screws removed in [Step 10](#).
- 12 Connect the Express Card cable to the Express Card assembly.
- 13 Replace the palm rest by following the steps in [“Replacing the palm rest” on page 96](#).
- 14 Replace the LCD assembly by following the steps in [“Replacing the LCD assembly” on page 84](#).
- 15 Replace the keyboard by following the steps in [“Replacing the keyboard” on page 80](#).
- 16 Replace the keyboard cover by following the steps in [“Replacing the keyboard cover” on page 78](#).
- 17 Replace the hard drive(s) by following the steps in [“Replacing the primary hard drive” on page 64](#) and [“Replacing the secondary hard drive” on page 73](#).
- 18 If the notebook has wireless networking built in, reconnect the wireless antennas by following the steps in [“Replacing the IEEE 802.11 wireless card” on page 67](#).
- 19 Replace the wireless bay cover by following the steps in [“Replacing the IEEE 802.11 wireless card” on page 67](#).

Replacing the Bluetooth card

Tools you need to complete this task:

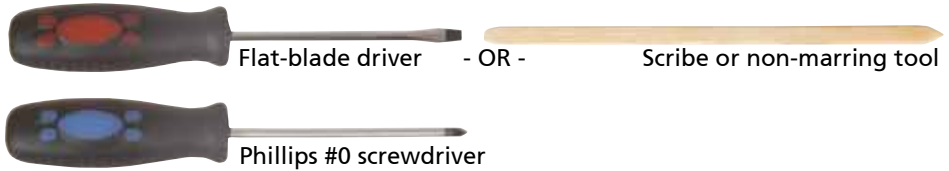

Screws removed during this task:

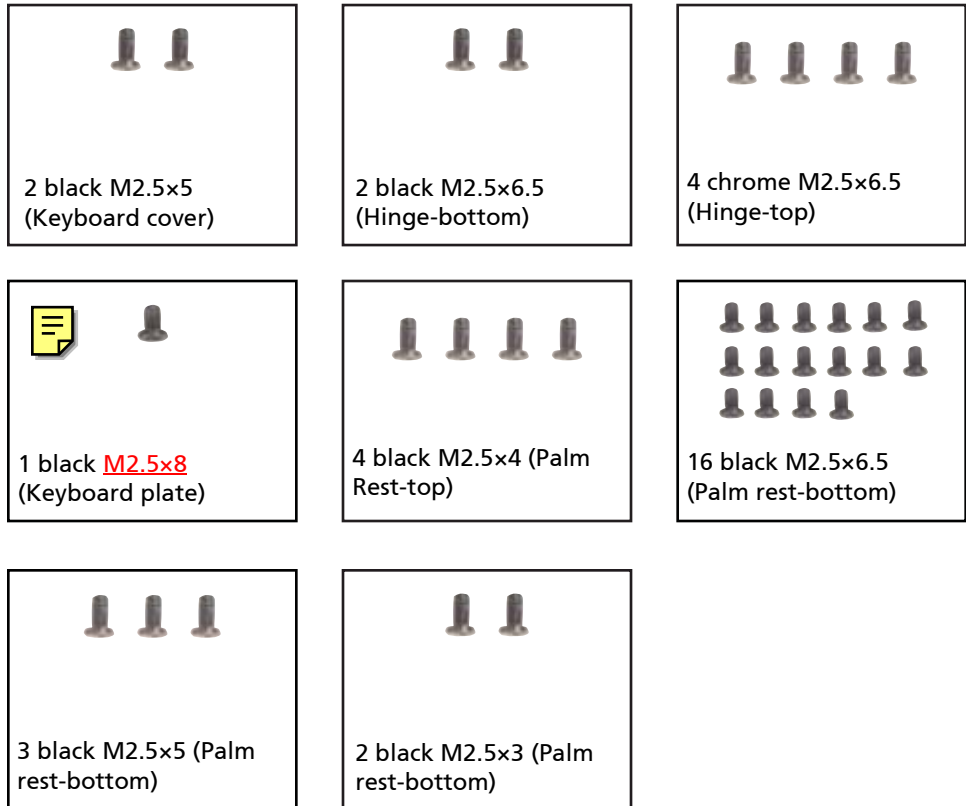

To replace the Bluetooth card:

- 1 Complete the steps in [“Preparing the notebook”](#) on page 55.
- 2 Remove the memory bay cover by following the steps in [“Adding or replacing memory modules”](#) on page 57.
- 3 If the notebook has wireless networking built in, unplug the wireless antennas by following the steps in [“Replacing the IEEE 802.11 wireless card”](#) on page 67.
- 4 Remove the hard drive(s) by following the steps in [“Replacing the primary hard drive”](#) on page 64 and [“Replacing the secondary hard drive”](#) on page 73.
- 5 Remove the keyboard cover by following the steps in [“Replacing the keyboard cover”](#) on page 78.
- 6 Remove the keyboard by following the steps in [“Replacing the keyboard”](#) on page 80.
- 7 Remove the LCD assembly by following the steps in [“Replacing the LCD assembly”](#) on page 84.

- 8 Remove the palm rest by following the instructions in [“Replacing the palm rest” on page 96](#).
- 9 Disconnect the cable from the Bluetooth card. Use a scribe or other non-marring tool to gently push the plug out of the connector.

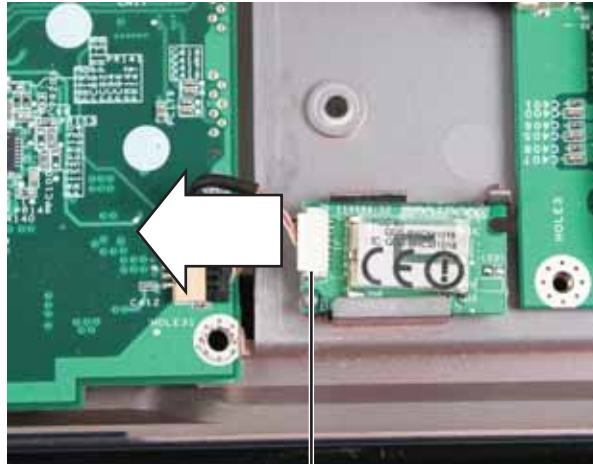

Bluetooth card connector

- 10 Remove the old Bluetooth card from the notebook.

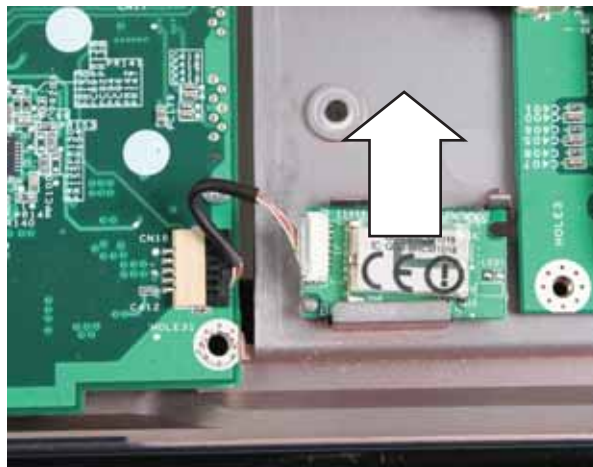

- 11 Insert the new Bluetooth card.
- 12 Connect the Bluetooth cable to the Bluetooth card.
- 13 Replace the palm rest by following the steps in [“Replacing the palm rest” on page 96](#).
- 14 Replace the LCD assembly by following the steps in [“Replacing the LCD assembly” on page 84](#).
- 15 Replace the keyboard by following the steps in [“Replacing the keyboard” on page 80](#).
- 16 Replace the keyboard cover by following the steps in [“Replacing the keyboard cover” on page 78](#).
- 17 Replace the hard drive(s) by following the steps in [“Replacing the primary hard drive” on page 64](#) and [“Replacing the secondary hard drive” on page 73](#).
- 18 If the notebook has wireless networking built in, reconnect the wireless antennas by following the steps in [“Replacing the IEEE 802.11 wireless card” on page 67](#).

-
- 19 Replace the wireless bay cover by following the steps in [“Replacing the IEEE 802.11 wireless card”](#) on page 67.

Replacing the modem

Tools you need to complete this task:

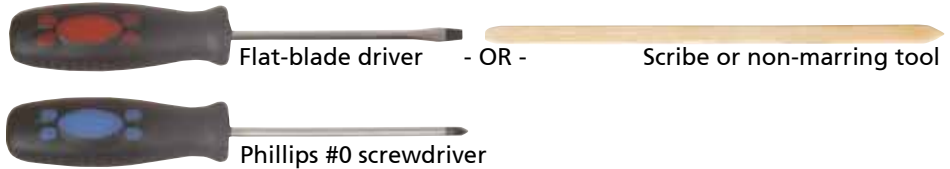

Screws removed during this task:

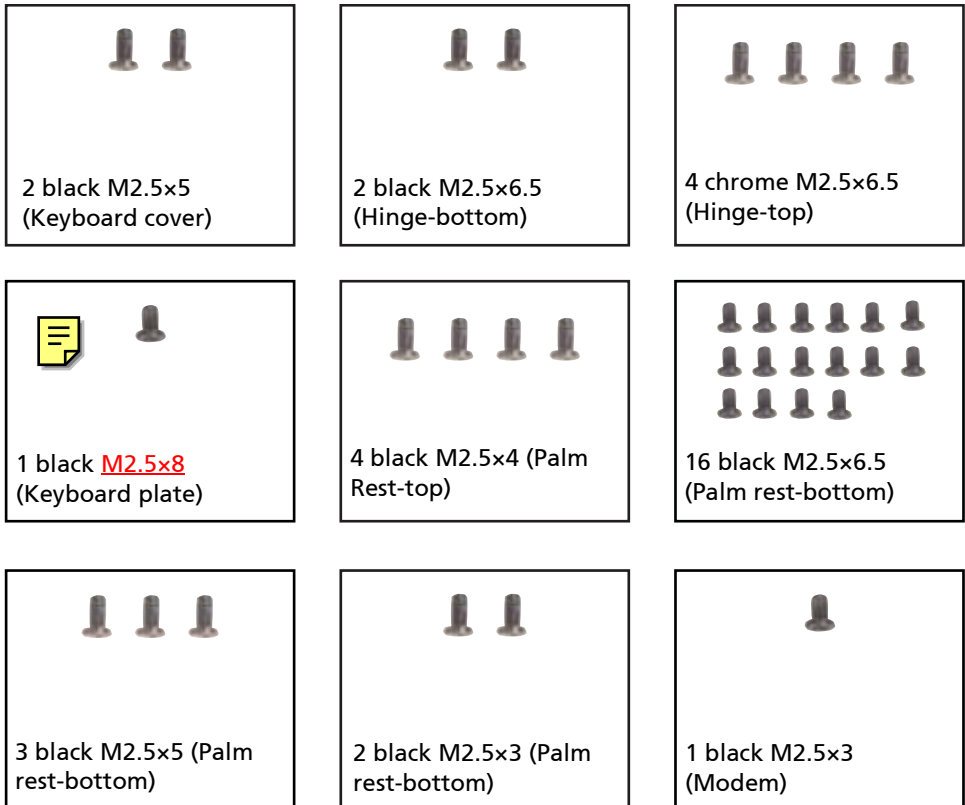

To replace the modem:

- 1 Complete the steps in [“Preparing the notebook”](#) on page 55.
- 2 Remove the memory bay cover by following the steps in [“Adding or replacing memory modules”](#) on page 57.
- 3 If the notebook has wireless networking built in, unplug the wireless antennas by following the steps in [“Replacing the IEEE 802.11 wireless card”](#) on page 67.
- 4 Remove the hard drive(s) by following the steps in [“Replacing the primary hard drive”](#) on page 64 and [“Replacing the secondary hard drive”](#) on page 73.
- 5 Remove the keyboard cover by following the steps in [“Replacing the keyboard cover”](#) on page 78.
- 6 Remove the keyboard by following the steps in [“Replacing the keyboard”](#) on page 80.
- 7 Remove the LCD assembly by following the steps in [“Replacing the LCD assembly”](#) on page 84.
- 8 Remove the palm rest by following the instructions in [“Replacing the palm rest”](#) on page 96.

- 9 Remove the screw securing the old modem to the system board.

Screw



- 10 Carefully lift the old modem off of the system board.

- 11 Disconnect the cable from the modem. Use a scribe or other non-marring tool to gently push the plug out of the connector.

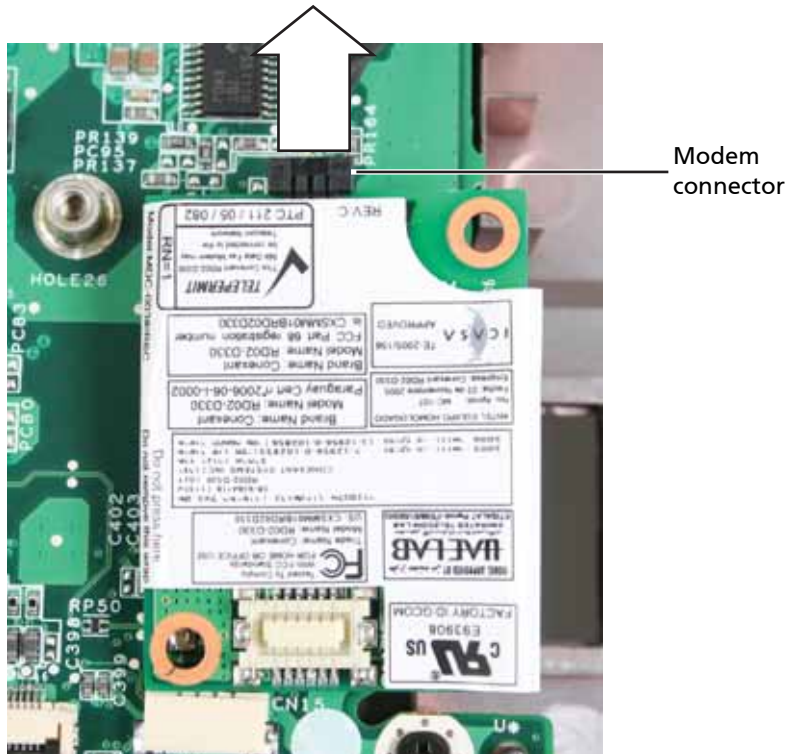

- 12 Connect the modem cable to the modem.
- 13 Insert the new modem into the socket on the system board.
- 14 Replace the screw removed in [Step 9](#).
- 15 Replace the palm rest by following the steps in [“Replacing the palm rest” on page 96](#).
- 16 Replace the LCD assembly by following the steps in [“Replacing the LCD assembly” on page 84](#).
- 17 Replace the keyboard by following the steps in [“Replacing the keyboard” on page 80](#).
- 18 Replace the keyboard cover by following the steps in [“Replacing the keyboard cover” on page 78](#).
- 19 Replace the hard drive(s) by following the steps in [“Replacing the primary hard drive” on page 64](#) and [“Replacing the secondary hard drive” on page 73](#).
- 20 If the notebook has wireless networking built in, reconnect the wireless antennas by following the steps in [“Replacing the IEEE 802.11 wireless card” on page 67](#).
- 21 Replace the wireless bay cover by following the steps in [“Replacing the IEEE 802.11 wireless card” on page 67](#).

Replacing the system board



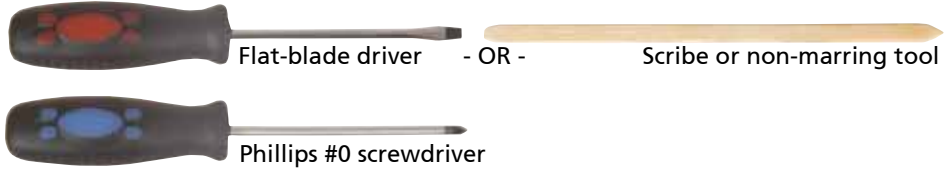









Tools you need to complete this task:



Additional materials you need to complete this task:

- X-23-7762 thermal grease [<Athena: Is this the right grease?>](#)

Screws removed during this task:

 <p>4 black M2.5x8 (graphics card)</p>	 <p>2 chrome M2x3 (IEEE 802.11 wireless card)</p>	 <p>2 black M2.5x5 (Keyboard cover)</p>
 <p>2 black M2.5x6.5 (Hinge-bottom)</p>	 <p>4 chrome M2.5x6.5 (Hinge-top)</p>	 <p>1 black M2.5x8 (Keyboard plate)</p>
 <p>4 black M2.5x4 (Palm Rest-top)</p>	 <p>16 black M2.5x6.5 (Palm rest-bottom)</p>	 <p>3 black M2.5x5 (Palm rest-bottom)</p>
 <p>2 black M2.5x3 (Palm rest-bottom)</p>	 <p>1 black M2.5x3 (Modem)</p>	 <p>2 black M2.5x6.5 (System board)</p>
 <p>2 black M2.5x6.5 (Cooling assembly)</p>		

To replace the system board:

- 1 Complete the steps in [“Preparing the notebook”](#) on page 55.
- 2 Remove the memory from the old system board and install it on the new system board by following the steps in [“Adding or replacing memory modules”](#) on page 57.
- 3 Remove the graphics card by following the steps in [“Replacing the graphics card”](#) on page 61.
- 4 Remove the hard drive(s) by following the steps in [“Replacing the primary hard drive”](#) on page 64 and [“Replacing the secondary hard drive”](#) on page 73.
- 5 If the notebook has wireless networking built in, remove the wireless card from the old system board and install it on the new system board by following the steps in [“Replacing the IEEE 802.11 wireless card”](#) on page 67.
- 6 Remove the keyboard cover by following the steps in [“Replacing the keyboard cover”](#) on page 78.
- 7 Remove the keyboard by following the steps in [“Replacing the keyboard”](#) on page 80.
- 8 Remove the LCD assembly by following the steps in [“Replacing the LCD assembly”](#) on page 84.
- 9 Remove the palm rest by following the instructions in [“Replacing the palm rest”](#) on page 96.
- 10 Remove the modem by following the instructions in [“Replacing the modem”](#) on page 117.
- 11 Disconnect the Bluetooth and Express Card cables. Use a scribe or other non-marring tool to gently push the plugs out of the connectors.

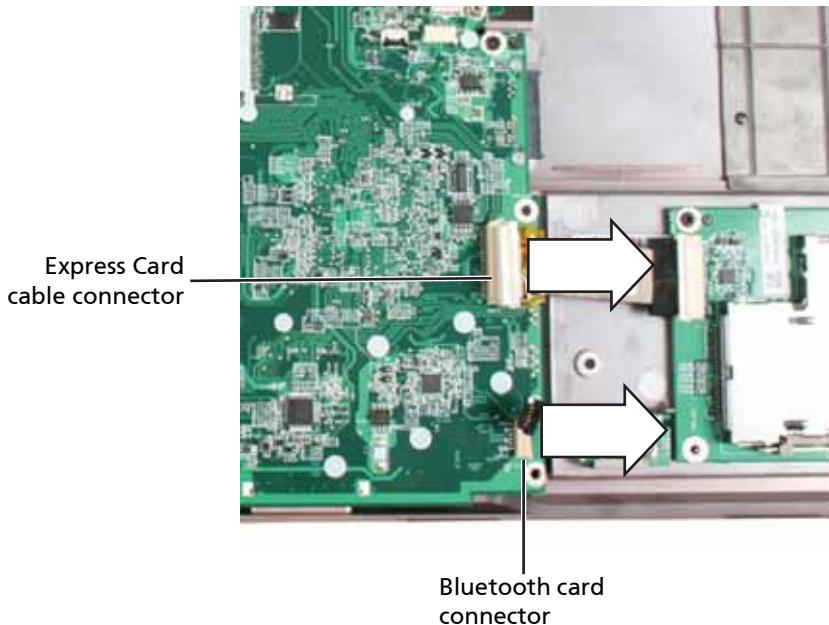

- 12 Remove the screws securing the old system board to the notebook.

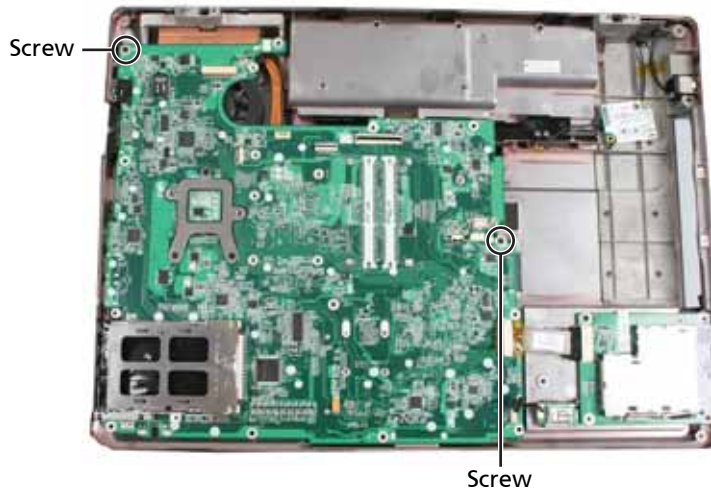

- 13 Remove the system board from the notebook.

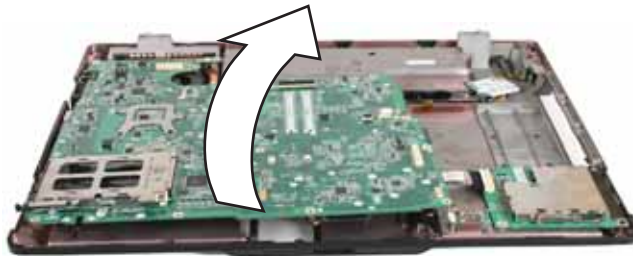

- 14 Turn the system board so the bottom is facing up.
- 15 Remove the cooling assembly from the system board by following the steps in ["Replacing the cooling assembly" on page 124](#).
- 16 Remove the processor from the old system board and install it on the new system board by following the steps in ["Replacing the processor" on page 129](#).
- 17 Replace the cooling assembly by following the steps in ["Replacing the cooling assembly" on page 124](#).
- 18 Insert the new system board into the notebook.
- 19 Replace the screws removed in [Step 12](#).
- 20 Connect the Bluetooth and Express Card cables.
- 21 Replace the modem by following the instructions in ["Replacing the modem" on page 117](#).
- 22 Replace the palm rest by following the steps in ["Replacing the palm rest" on page 96](#).
- 23 Replace the LCD assembly by following the steps in ["Replacing the LCD assembly" on page 84](#).
- 24 Replace the keyboard by following the steps in ["Replacing the keyboard" on page 80](#).
- 25 Replace the keyboard cover by following the steps in ["Replacing the keyboard cover" on page 78](#).
- 26 Replace the hard drive(s) by following the steps in ["Replacing the primary hard drive" on page 64](#) and ["Replacing the secondary hard drive" on page 73](#).
- 27 Replace the graphics card by following the steps in ["Replacing the graphics card" on page 61](#).

-
- 28 If the notebook has wireless networking built in, reconnect the wireless antennas by following the steps in [“Replacing the IEEE 802.11 wireless card”](#) on page 67.
 - 29 Replace the wireless bay cover by following the steps in [“Replacing the IEEE 802.11 wireless card”](#) on page 67.

Replacing the cooling assembly



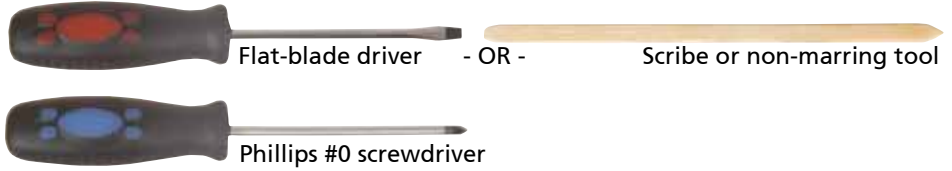









Tools you need to complete this task:



Additional materials you need to complete this task:

- X-23-7762 thermal grease

Screws removed during this task:

 <p>4 black M2.5x8 (graphics card)</p>	 <p>2 chrome M2x3 (IEEE 802.11 wireless card)</p>	 <p>2 black M2.5x5 (Keyboard cover)</p>
 <p>2 black M2.5x6.5 (Hinge-bottom)</p>	 <p>4 chrome M2.5x6.5 (Hinge-top)</p>	 <p>1 black M2.5x8 (Keyboard plate)</p>
 <p>4 black M2.5x4 (Palm Rest-top)</p>	 <p>16 black M2.5x6.5 (Palm rest-bottom)</p>	 <p>3 black M2.5x5 (Palm rest-bottom)</p>
 <p>2 black M2.5x3 (Palm rest-bottom)</p>	 <p>1 black M2.5x3 (Modem)</p>	 <p>2 black M2.5x6.5 (System board)</p>
 <p>2 black M2.5x6.5 (Cooling assembly)</p>		

To replace the cooling assembly:

- 1 Complete the steps in [“Preparing the notebook”](#) on page 55.
- 2 Remove the memory from the old system board and install it on the new system board by following the steps in [“Adding or replacing memory modules”](#) on page 57.
- 3 Remove the graphics card by following the steps in [“Replacing the graphics card”](#) on page 61.
- 4 Remove the hard drive(s) by following the steps in [“Replacing the primary hard drive”](#) on page 64 and [“Replacing the secondary hard drive”](#) on page 73.
- 5 If the notebook has wireless networking built in, remove the wireless card from the old system board and install it on the new system board by following the steps in [“Replacing the IEEE 802.11 wireless card”](#) on page 67.
- 6 Remove the keyboard cover by following the steps in [“Replacing the keyboard cover”](#) on page 78.
- 7 Remove the keyboard by following the steps in [“Replacing the keyboard”](#) on page 80.
- 8 Remove the LCD assembly by following the steps in [“Replacing the LCD assembly”](#) on page 84.
- 9 Remove the palm rest by following the instructions in [“Replacing the palm rest”](#) on page 96.
- 10 Remove the modem by following the instructions in [“Replacing the modem”](#) on page 117.
- 11 Remove the system board by following the instructions in [“Replacing the system board”](#) on page 120.
- 12 Turn the system board so the bottom is facing up.
- 13 Disconnect the fan from the system board. Use a scribe or other non-marring tool to gently push the plugs out of the connectors.

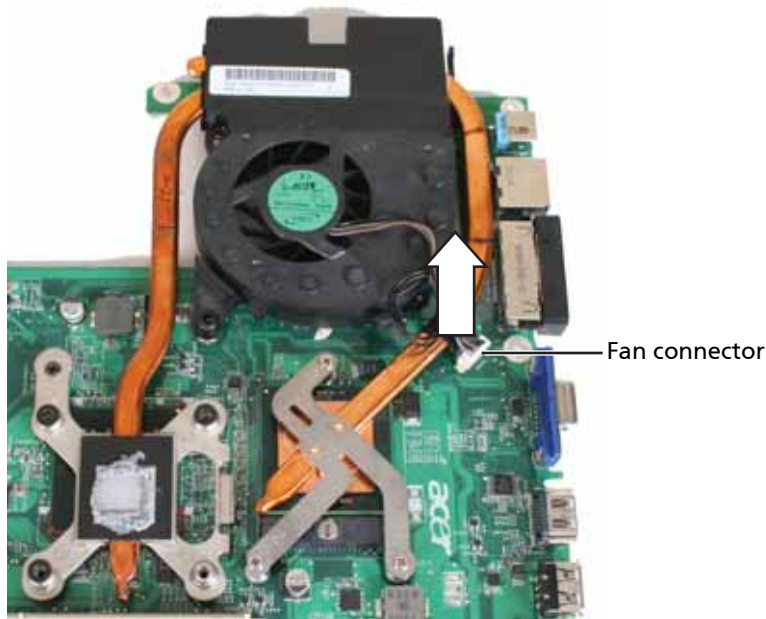

- 14 Remove the screws as shown and loosen the captive screws that secure the cooling assembly to the system board.

Caution: When loosening or removing the cooling assembly's screws in the numbered holes, loosen them in reverse numerical order.

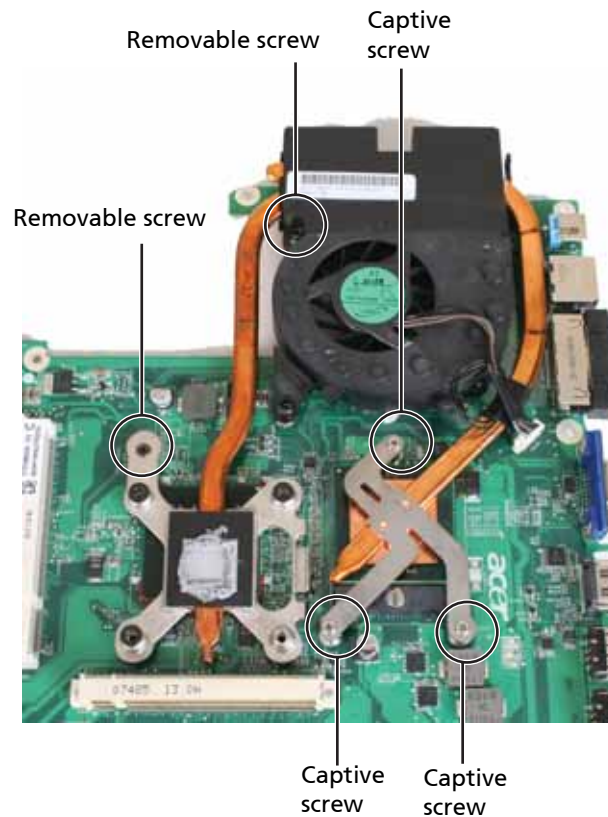

- 15 Remove the old cooling assembly.
- 16 Remove any thermal grease residue from the processor using a soft cloth and isopropyl alcohol.
- 17 Place new thermal grease on the processor. Use only enough to cover the CPU die.

- 18 Make sure a thermal pad is placed between the new cooling assembly and other components as shown.



- 19 Insert the new cooling assembly into the notebook.
- 20 Tighten the captive screws that secure the cooling assembly to the system board. Use the numbers stamped in the metal next to each screw and tighten the screws in numerical order (start with 1, then 2, then 3).

Caution: When tightening the cooling assembly's screws into the numbered holes, tighten them in numerical order.
- 21 Replace the other cooling assembly screws removed in [Step 14](#).

-
- 22 Replace the system board by following the instructions in [“Replacing the system board” on page 120](#).
 - 23 Replace the modem by following the instructions in [“Replacing the modem” on page 117](#).
 - 24 Replace the palm rest by following the steps in [“Replacing the palm rest” on page 96](#).
 - 25 Replace the LCD assembly by following the steps in [“Replacing the LCD assembly” on page 84](#).
 - 26 Replace the keyboard by following the steps in [“Replacing the keyboard” on page 80](#).
 - 27 Replace the keyboard cover by following the steps in [“Replacing the keyboard cover” on page 78](#).
 - 28 Replace the hard drive(s) by following the steps in [“Replacing the primary hard drive” on page 64](#) and [“Replacing the secondary hard drive” on page 73](#).
 - 29 Replace the graphics card by following the steps in [“Replacing the graphics card” on page 61](#).
 - 30 If the notebook has wireless networking built in, reconnect the wireless antennas by following the steps in [“Replacing the IEEE 802.11 wireless card” on page 67](#).
 - 31 Replace the wireless bay cover by following the steps in [“Replacing the IEEE 802.11 wireless card” on page 67](#).

Replacing the processor



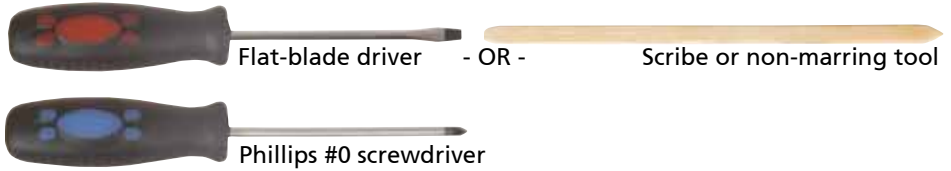









Tools you need to complete this task:



Additional materials you need to complete this task:

- X-23-7762 thermal grease

Screws removed during this task:

 <p>4 black M2.5x8 (graphics card)</p>	 <p>2 chrome M2x3 (IEEE 802.11 wireless card)</p>	 <p>2 black M2.5x5 (Keyboard cover)</p>
 <p>2 black M2.5x6.5 (Hinge-bottom)</p>	 <p>4 chrome M2.5x6.5 (Hinge-top)</p>	 <p>1 black M2.5x8 (Keyboard plate)</p>
 <p>4 black M2.5x4 (Palm Rest-top)</p>	 <p>16 black M2.5x6.5 (Palm rest-bottom)</p>	 <p>3 black M2.5x5 (Palm rest-bottom)</p>
 <p>2 black M2.5x3 (Palm rest-bottom)</p>	 <p>1 black M2.5x3 (Modem)</p>	 <p>2 black M2.5x6.5 (System board)</p>
 <p>2 black M2.5x6.5 (Cooling assembly)</p>		

To replace the processor:

- 1 Complete the steps in [“Preparing the notebook”](#) on page 55.
- 2 Remove the memory from the old system board and install it on the new system board by following the steps in [“Adding or replacing memory modules”](#) on page 57.
- 3 Remove the graphics card by following the steps in [“Replacing the graphics card”](#) on page 61.
- 4 Remove the hard drive(s) by following the steps in [“Replacing the primary hard drive”](#) on page 64 and [“Replacing the secondary hard drive”](#) on page 73.
- 5 If the notebook has wireless networking built in, remove the wireless card from the old system board and install it on the new system board by following the steps in [“Replacing the IEEE 802.11 wireless card”](#) on page 67.
- 6 Remove the keyboard cover by following the steps in [“Replacing the keyboard cover”](#) on page 78.
- 7 Remove the keyboard by following the steps in [“Replacing the keyboard”](#) on page 80.
- 8 Remove the LCD assembly by following the steps in [“Replacing the LCD assembly”](#) on page 84.
- 9 Remove the palm rest by following the instructions in [“Replacing the palm rest”](#) on page 96.
- 10 Remove the modem by following the instructions in [“Replacing the modem”](#) on page 117.
- 11 Remove the system board by following the instructions in [“Replacing the system board”](#) on page 120.
- 12 Turn the system board so the bottom is facing up.
- 13 Remove the cooling assembly by following the instructions in [“Replacing the cooling assembly”](#) on page 124.
- 14 Use a flat-blade screwdriver to turn the processor lock screw 1/2-turn counter-clockwise.



- 15 Remove the old processor from the system board.

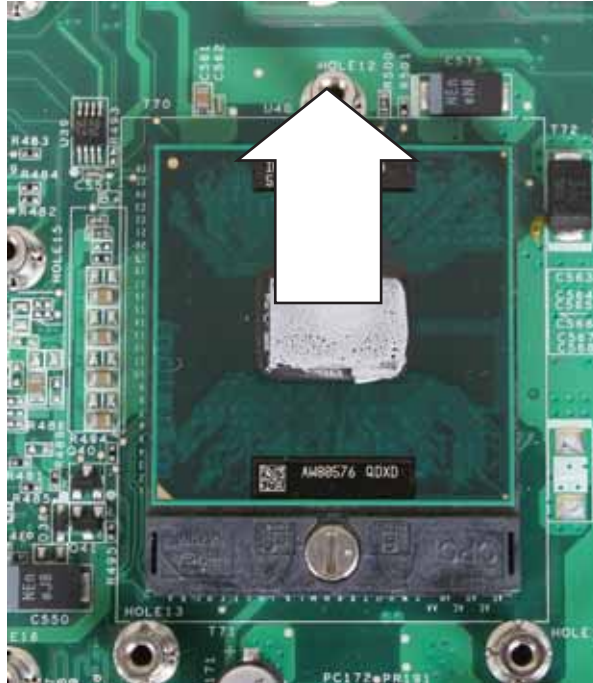

- 16 Install the new processor onto the system board making sure that Pin 1 on the processor (indicated by the silk-screened arrow on the corner of the processor) aligns with Pin 1 on the processor socket (indicated by the absence of a pin hole in the processor socket), then use a flat-blade screwdriver to turn the processor lock screw 1/2-turn clockwise.
- 17 Remove any thermal grease residue from the cooling assembly using a soft cloth and isopropyl alcohol.
- 18 Place new thermal grease on the processor. Use only enough to cover the CPU die.

- 19 Make sure a thermal pad is placed between the new cooling assembly and other components as shown.

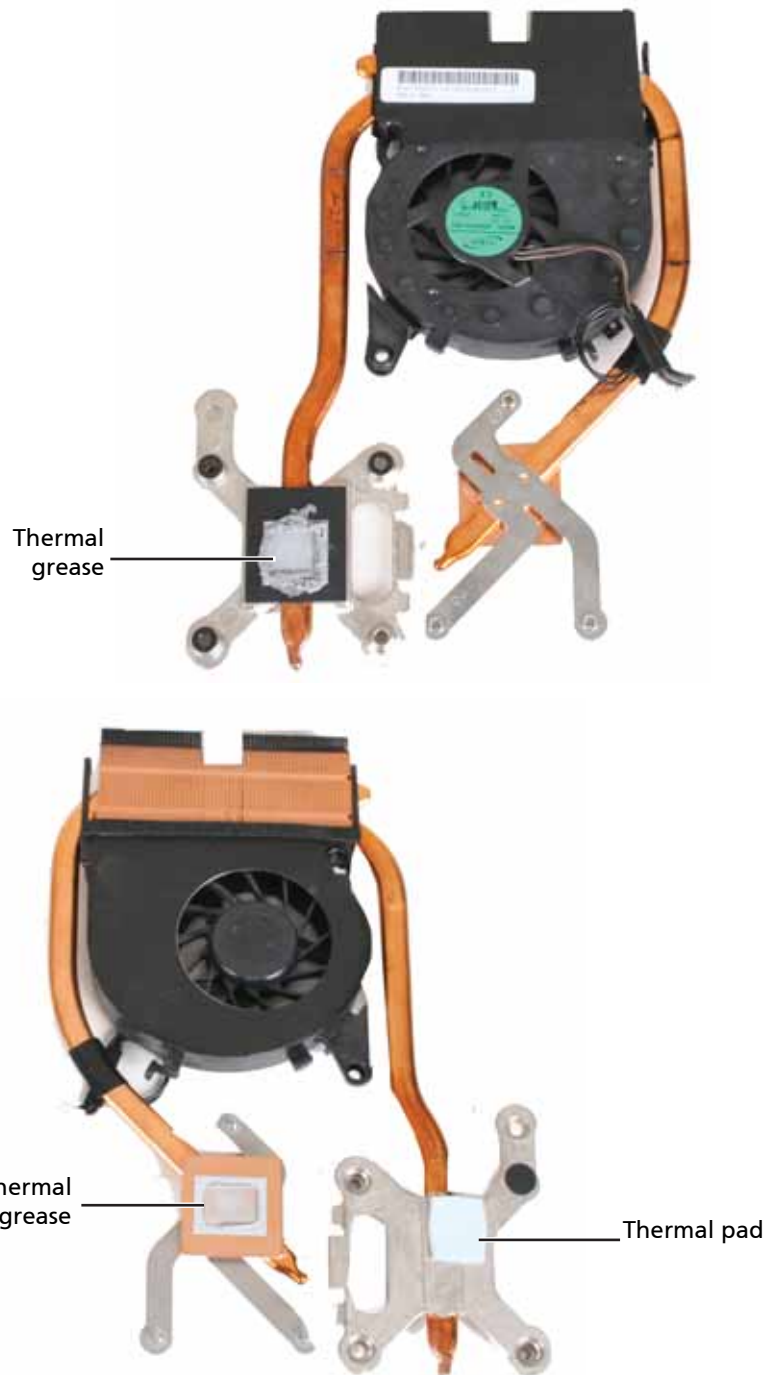

- 20 Replace the cooling assembly by following the instructions in ["Replacing the cooling assembly" on page 124.](#)
- 21 Replace the system board by following the instructions in ["Replacing the system board" on page 120.](#)
- 22 Replace the modem by following the instructions in ["Replacing the modem" on page 117.](#)

-
- 23 Replace the palm rest by following the steps in [“Replacing the palm rest”](#) on page 96.
 - 24 Replace the LCD assembly by following the steps in [“Replacing the LCD assembly”](#) on page 84.
 - 25 Replace the keyboard by following the steps in [“Replacing the keyboard”](#) on page 80.
 - 26 Replace the keyboard cover by following the steps in [“Replacing the keyboard cover”](#) on page 78.
 - 27 Replace the hard drive(s) by following the steps in [“Replacing the primary hard drive”](#) on page 64 and [“Replacing the secondary hard drive”](#) on page 73.
 - 28 Replace the graphics card by following the steps in [“Replacing the graphics card”](#) on page 61.
 - 29 If the notebook has wireless networking built in, reconnect the wireless antennas by following the steps in [“Replacing the IEEE 802.11 wireless card”](#) on page 67.
 - 30 Replace the wireless bay cover by following the steps in [“Replacing the IEEE 802.11 wireless card”](#) on page 67.

Chapter 4

Troubleshooting

- ❑ Diagnosing problems
- ❑ System test procedures
- ❑ Power-On Self-Test (POST) error message
- ❑ Index of error messages
- ❑ Phoenix BIOS beep codes
- ❑ Symptom-to-FRU error messages
- ❑ Intermittent problems
- ❑ Undetermined problems

Diagnosing problems

Use the following procedure as a guide for diagnosing notebook problems.

Note: The diagnostic tests are intended to test only Acer products. Non-Acer products, prototype cards, or modified options can give false errors and invalid system responses.

- 1 Obtain the failing symptoms in as much detail as possible.
- 2 Verify the symptoms by attempting to re-create the failure by running the diagnostic test or by repeating the same operation.
- 3 Use the following table with the verified symptom to determine which page to go to.

Symptoms (Verified)	Go To
Power failure. (The power indicator does not go on or stay on.)	"Testing the power system" on page 138
POST does not complete. No beep or error codes are indicated.	"Power-On Self-Test (POST) error message" on page 140 "Undetermined problems" on page 153
POST detects an error and displayed messages on screen.	"Index of error messages" on page 141
Other symptoms (LCD display problems or others).	"Power-On Self-Test (POST) error message" on page 140
Symptoms cannot be re-created (intermittent problems).	Use the customer-reported symptoms and go to "Power-On Self-Test (POST) error message" on page 140 "Intermittent problems" on page 152 "Undetermined problems" on page 153

System test procedures

Testing the external diskette drive

Use the following procedure to isolate a problem in a diskette controller, driver, or drive. You must have a write-enabled, diagnostic diskette to complete this test.

Note: Make sure that the diskette does not have more than one label attached to it. Multiple labels can cause damage to the drive or cause the drive to fail.

To test the external diskette drive:

- 1 Boot from the diagnostics diskette and start the diagnostics program.
- 2 Run the FDD Test and see if the test completes successfully.
- 3 Follow any instructions in the message window.

If the error still remains:

- 1 Reconnect the external diskette drive/DVD-ROM module to a USB jack.
- 2 Replace the external diskette drive/CD-ROM module.
- 3 Replace the system board.

Testing the external CD-ROM drive

Use the following procedure to isolate a problem in a CD-ROM controller, driver, or drive.

Note: Make sure that the CD-ROM does not have any label attached to it. The label can cause damage to the drive or can cause the drive to fail.

To test the external CD-ROM drive:

- 1 Boot from the diagnostics diskette and start the diagnostics program.
- 2 Run the CD-ROM Test and see if the test completes successfully.
- 3 Follow the instructions in the message window.

If an error occurs, reconnect the connector on the system board.

If the error still remains:

- 1 Reconnect the external diskette drive/CD-ROM module to a USB jack.
- 2 Replace the external diskette drive/CD-ROM module.
- 3 Replace the system board.

Testing the keyboard or auxiliary input device

If the internal keyboard does not work or an unexpected character appears, make sure that the flexible cable extending from the keyboard is correctly seated in the connector on the system board. If the keyboard cable is connected correctly, run the Keyboard Test.

Note: Disconnect any external keyboards before testing the built-in keyboard.

If the tests detect a keyboard problem, do the following one at a time to correct the problem.

- 1 Reconnect the keyboard cable to the system board.
- 2 Replace the keyboard.
- 3 Replace the system board.

Important: Do not replace a non-defective FRU.

The following auxiliary input devices are supported by this notebook:

- ❑ Numeric keypad
- ❑ External keyboard

If any of these devices do not work, reconnect the cable connector and repeat the failing operation.

Testing the memory

Memory errors can stop your programs, show error messages on the screen, or hang the system.

To test the memory:

- 1 Boot from the diagnostics diskette and start the diagnostics program.
- 2 Run the Memory Test and see if the test completes successfully.
- 3 Press F2 in the test items.
- 4 Follow the instructions in the message window.

Note: Make sure that each memory card is fully installed into the connector. A loose connection can cause an error.

Testing the power system

To test for a power problem:

- 1 Turn on the notebook using each of the following power sources:
 - ❑ Remove the battery pack, connect the power adapter, then make sure that the notebook turns on using AC power.
 - ❑ Disconnect the power adapter, install a charged battery pack, then make sure that power is supplied by the battery pack.

If you suspect a power problem, complete the appropriate power supply check:

- ❑ ["Check the power adapter" on page 138](#)
- ❑ ["Check the battery pack" on page 139](#)

Check the power adapter

Unplug the power adapter cable from the notebook and measure the output voltage at the power adapter cable plug. See the following figure.

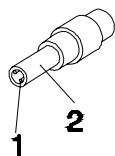

Pin 1: +19 to +20.5V
Pin 2: 0V, Ground

- 1 If the voltage is not correct, replace the power adapter.
- 2 If the voltage is within the range, do the following:
 - ❑ Replace the system board.
 - ❑ If the problem is not corrected, see ["Undetermined problems" on page 153](#).
 - ❑ If the voltage is not correct, go to [Step 3](#).

Note: An audible noise from the power adapter does not always indicate a defect.

-
- 3 If the power-on indicator does not light up, check the power adapter's power cord for correct continuity and installation.
 - 4 If the operational charge does not work, see ["Check the battery pack" on page 139](#).

Check the battery pack

To check the battery pack using software:

- 1 Open Power Management in the Windows Control Panel.
- 2 In Power Meter, make sure that the parameters shown for **Current Power Source** and **Total Battery Power Remaining** are correct.
- 3 Repeat the steps 1 and 2, for both battery and adapter. This helps you identify first the problem is on recharging or discharging.

To check the battery pack using hardware:

- 1 Turn off the notebook.
- 2 Remove the battery pack and measure the voltage between battery terminals 1 (+) and 6 (ground).
- 3 If the voltage is still less than 7.5 Vdc after recharging, replace the battery.

Note: To check the battery charge operation, use a discharged battery pack or a battery pack that has less than 50% of the total power remaining when installed in the notebook.

If the battery status indicator does not light up, remove the battery pack and let it return to room temperature. Re-install the battery pack.

If the charge indicator still does not light up, replace the battery pack. If the charge indicator still does not light up, replace the DC/DC charger board.

Testing the touchpad

If the touchpad doesn't work, do the following actions one at a time to correct the problem.

- 1 Reconnect the touchpad cables.
- 2 Replace the touchpad.
- 3 Replace the system board.

Important: Do not replace a non-defective FRU.

After you use the touchpad, the pointer may drift on the screen for a short time. This self-acting pointer movement can occur when a slight, steady pressure is applied to the touchpad pointer. This symptom is not a hardware problem. No service actions are necessary if the pointer movement stops in a short period of time.

Power-On Self-Test (POST) error message

The POST error message index lists the error message and their possible causes. The most likely cause is listed first.

Note: Perform the FRU replacement or actions in the sequence shown in the FRU/Action column. If the FRU replacement does not solve the problem, put the original part back in the notebook. Do not replace a non-defective FRU.

This index can also help you determine the next possible FRU to be replaced when servicing a notebook.

If the symptom is not listed, [see “Undetermined problems” on page 153](#).

The following lists the error messages that the BIOS displays on the screen and the error symptoms classified by function.

Note: Most of the error messages occur during POST. Some of them display information about a hardware device, such as the amount of memory installed. Others may indicate a problem with a device, such as the way it has been configured.

Note: If the system fails after you make changes in the BIOS Setup Utility menus, reset the notebook, enter Setup, and install Setup defaults or correct the error.

Index of error messages

Error codes

Error Codes	Error Messages
006	Equipment Configuration Error Causes: 1. CPU BIOS Update Code Mismatch 2. IDE Primary Channel Master Drive Error (The causes are shown before "Equipment Configuration Error")
010	Memory Error at xxxx:xxxx:xxxxh (R:xxxxh, W:xxxxh)
070	Real Time Clock Error
071	CMOS Battery Bad
072	CMOS Checksum Error
110	System is disabled. An incorrect password was entered.
<No error code>	Battery is critically low. In this situation BIOS issues four short beeps, then shuts the system down. No message is displayed.
<No error code>	Temperature is critically high. In this situation BIOS shuts the system down. No message is displayed.

Error messages

Error Messages	FRU/Action Sequence
Stuck Key	See "Testing the keyboard or auxiliary input device" on page 137.
Keyboard error	See "Testing the keyboard or auxiliary input device" on page 137.
Keyboard Controller Failed	See "Testing the keyboard or auxiliary input device" on page 137.
Keyboard locked - Unlock key switch	Unlock the external keyboard.
Monitor type does not match CMOS - Run Setup	Run "Load Setup Defaults" using the BIOS Setup Utility, then reboot the notebook.
Shadow RAM Failed at offset: nnnn	<ul style="list-style-type: none"> • Test or replace the BIOS ROM. • Test or replace the system board.
System RAM Failed at offset: nnnn	<ul style="list-style-type: none"> • Test or replace the SO-DIMM. • Test or replace the system board.
Extended RAM Failed at offset: nnnn	<ul style="list-style-type: none"> • Test or replace the SO-DIMM. • Test or replace the system board.
System battery is dead - Replace and run Setup	Replace the CMOS battery, run the BIOS Setup Utility to reconfigure system time, then reboot the system.
System CMOS checksum bad - Default configuration used	Replace the CMOS battery, run the BIOS Setup Utility to reconfigure system time, then reboot the system.
System timer error	<ul style="list-style-type: none"> • Replace the CMOS battery, run the BIOS Setup Utility to reconfigure system time, then reboot the system. • Test or replace the system board.
Real time clock error	<ul style="list-style-type: none"> • Replace the CMOS battery, run the BIOS Setup Utility to reconfigure system time, then reboot the system. • Test or replace the system board.

Error Messages	FRU/Action Sequence
Previous boot incomplete - Default configuration used	<ul style="list-style-type: none"> • Run "Load Setup Defaults" using the BIOS Setup Utility, then reboot the notebook. • Replace the CMOS battery, run the BIOS Setup Utility to reconfigure system time, then reboot the system. • Test or replace the system board.
Memory size found by POST differed from CMOS	<ul style="list-style-type: none"> • Run "Load Setup Defaults" using the BIOS Setup Utility, then reboot the notebook. • Test or replace the SO-DIMM. • Test or replace the system board.
Diskette drive A error	<ul style="list-style-type: none"> • Make sure that the drive is defined with the proper diskette type in the BIOS Setup Utility • See "Testing the external diskette drive" on page 137.
Incorrect Drive A type - run SETUP	Make sure that the drive is defined with the proper diskette type in the BIOS Setup Utility
System cache error - Cache disabled	Test or replace the system board.
CPU ID:	Test or replace the system board.
DMA Test Failed	<ul style="list-style-type: none"> • Test or replace the SO-DIMM. • Test or replace the system board.
Software NMI Failed	<ul style="list-style-type: none"> • Test or replace the SO-DIMM. • Test or replace the system board.
Fail-Safe Timer NMI Failed	<ul style="list-style-type: none"> • Test or replace the SO-DIMM. • Test or replace the system board.
Device Address Conflict	<ul style="list-style-type: none"> • Run "Load Setup Defaults" using the BIOS Setup Utility, then reboot the notebook. • Replace the CMOS battery, run the BIOS Setup Utility to reconfigure system time, then reboot the system. • Test or replace the system board.
Allocation Error for device	<ul style="list-style-type: none"> • Run "Load Setup Defaults" using the BIOS Setup Utility, then reboot the notebook. • Replace the CMOS battery, run the BIOS Setup Utility to reconfigure system time, then reboot the system. • Test or replace the system board.
Failing Bits: nnnn	<ul style="list-style-type: none"> • Test or replace the SO-DIMM. • Test or replace the BIOS ROM. • Test or replace the system board.
Fixed Disk n	None
Invalid System Configuration Data	<ul style="list-style-type: none"> • Test or replace the BIOS ROM. • Test or replace the system board.
I/O device IRQ conflict	<ul style="list-style-type: none"> • Run "Load Setup Defaults" using the BIOS Setup Utility, then reboot the notebook. • Replace the CMOS battery, run the BIOS Setup Utility to reconfigure system time, then reboot the system. • Test or replace the system board.
Operating system not found	<ul style="list-style-type: none"> • Run the BIOS Setup Utility and see if fixed disk and drive A: are properly identified. • Test or replace the diskette drive • Test or replace the hard disk drive • Test or replace the system board

No-beep error messages

No-beep Error Messages	FRU/Action in Sequence
No beep, power-on indicator turns off and LCD is blank.	<ul style="list-style-type: none"> • Test the power source (battery pack and power adapter). See "Testing the power system" on page 138. • Make sure that every connector is connected tightly and correctly. • Reconnect the SO-DIMM. • Test or replace the LED board. • Test or replace the system board.
No beep, power-on indicator turns on and LCD is blank.	<ul style="list-style-type: none"> • Test the power source (battery pack and power adapter). See "Testing the power system" on page 138. • Reconnect the LCD connector • Check the hard disk drive. • Check the LCD inverter ID. • Check the LCD cable. • Test or replace the LCD inverter. • Test or replace the LCD. • Test or replace the system board.
No beep, power-on indicator turns on and LCD is blank. But you can see POST on an external CRT.	<ul style="list-style-type: none"> • Reconnect the LCD connectors. • Check the LCD inverter ID. • Check the LCD cable. • Test or replace the LCD inverter. • Test or replace the LCD. • Test or replace the system board.
No beep, power-on indicator turns on and a blinking cursor shown on LCD during POST.	<ul style="list-style-type: none"> • Make sure that every connector is connected tightly and correctly. • Test or replace the system board.
No beep during POST but system runs correctly.	<ul style="list-style-type: none"> • Test or replace the speaker. • Test or replace the system board.

Phoenix BIOS beep codes

Code	Beeps	POST Routine Description
02h		Verify Real Mode
03h		Disable Non-Maskable Interrupt (NMI)
04h		Get CPU type
06h		Initialize system hardware
08h		Initialize chipset with initial POST values
09h		Set IN POST flag
0Ah		Initialize CPU registers
0Bh		Enable CPU cache
0Ch		Initialize caches to initial POST values
0Eh		Initialize I/O component
0Fh		Initialize the local bus IDE
10h		Initialize Power Management
11h		Load alternate registers with initial POST values
12h		Restore CPU control word during warm boot
13h		Initialize PCI Bus Mastering devices
14h		Initialize keyboard controller
16h	1-2-2-3	BIOS ROM checksum
17h		Initialize cache before memory autosize
18h		8254 timer initialization
1Ah		8237 DMA controller initialization
1Ch		Reset Programmable Interrupt Controller
20h	1-3-1-1	Test DRAM refresh
22h	1-3-1-3	Test 8742 Keyboard Controller
24h		Set ES segment register to 4 GB
26h		Enable A20 line
28h		Autosize DRAM
29h		Initialize POST Memory Manager
2Ah		Clear 215 KB base RAM
2Ch	1-3-4-1	RAM failure on address line xxxx
2Eh	1-3-4-3	RAM failure on data bits xxxx of low byte of memory bus
2Fh		Enable cache before system BIOS shadow
30h	1-4-1-1	RAM failure on data bits xxxx of high byte of memory bus
32h		Test CPU bus-clock frequency
33h		Initialize Phoenix Dispatch Manager
36h		Warm start shut down
38h		Shadow system BIOS ROM
3Ah		Autosize cache
3Ch		Advanced configuration of chipset registers
3Dh		Load alternate registers with CMOS values
42h		Initialize interrupt vectors
45h		POST device initialization

Code	Beeps	POST Routine Description
46h	2-1-2-3	Check ROM copyright notice
48h		Check video configuration against CMOS
49h		Initialize PCI bus and devices
4Ah		Initialize all video adapters in system
4Bh		QuietBoot start (optional)
4Ch		Shadow video BIOS ROM
4Eh		Display BIOS copyright notice
50h		Display CPU type and speed
51h		Initialize EISA board
52h		Test keyboard
54h		Set key click if enabled
58h	2-2-3-1	Test for unexpected interrupts
59h		Initialize POST display service
5Ah		Display prompt "Press F2 to enter SETUP"
5Bh		Disable CPU cache
5Ch		Test RAM between 512 and 640 KB
60h		Test extended memory
62h		Test extended memory address lines
64h		Jump to User Patch1
66h		Configure advanced cache registers
67h		Initialize Multi Processor APIC
68h		Enable external and CPU caches
69h		Setup System Management Mode (SMM) area
6Ah		Display external L2 cache size
6Bh		Load custom defaults (optional)
6Ch		Display shadow-area message
6Eh		Display possible high address for UMB recovery
70h		Display error messages
72h		Check for configuration errors
76h		Check for keyboard errors
7Ch		Set up hardware interrupt vectors
7Eh		Initialize coprocessor if present
80h		Disable onboard Super I/O ports and IRQs
81h		Late POST device initialization
82h		Detect and install external RS232 ports
83h		Configure non-MCD IDE controllers
84h		Detect and install external parallel ports
85h		Initialize PC-compatible PnP ISA devices
86h		Re-initialize onboard I/O ports
87h		Configure Motherboard Configurable Devices (optional)
88h		Initialize BIOS Area
89h		Enable Non-Maskable Interrupts (NMIs)
8Ah		Initialize Extended BIOS Data Area

Code	Beeps	POST Routine Description
8Bh		Test and initialize PS/2 mouse
8Ch		Initialize floppy controller
8Fh		Determine number of ATA drives (optional)
90h		Initialize hard-disk controllers
91h		Initialize local-bus hard-disk controllers
92h		Jump to UserPatch2
93h		Build MPTABLE for multi-processor boards
95h		Install CD ROM for boot
96h		Clear huge ES segment register
97h		Fixup Multi Processor table
98h	1-2	Search for option ROMs. One long, two short beeps on checksum failure.
99h		Check for SMART drive (optional)
9Ah		Shadow option ROMs
9Ch		Set up Power Management
9Dh		Initialize security engine (optional)
9Eh		Enable hardware interrupts
9Fh		Determine number of ATA and SCSI drives
A0h		Set time of day
A2h		Check key lock
A4h		Initialize Typematic rate
A8h		Erase F2 prompt
AAh		Scan for F2 key stroke
ACh		Enter SETUP
A Eh		Clear Boot flag
B0h		Check for errors
B2h		POST done- prepare to boot operating system
B4h	1	One short beep before boot
B5h		Terminate QuietBoot (optional)
B6h		Check password (optional)
B9h		Prepare Boot
BAh		Initialize DMI parameters
BBh		Initialize PnP Option ROMs
BCh		Clear parity checkers
BDh		Display MultiBoot menu
BEh		Clear screen (optional)
BFh		Check virus and backup reminders
C0h		Try to boot with INT 19
C1h		Initialize POST Error Manager (PEM)
C2h		Initialize error logging
C3h		Initialize error display function
C4h		Initialize system error handler
C5h		PnPnd dual CMOS (optional)
C6h		Initialize notebook docking (optional)

Code	Beeps	POST Routine Description
C7h		Initialize notebook docking late
C8h		Force check (optional)
C9h		Extended checksum (optional)
D2h		Unknown interrupt

Code	Beeps	
E0h		Initialize the chipset
E1h		Initialize the bridge
E2h		Initialize the CPU
E3h		Initialize the system timer
E4h		Initialize system I/O
E5h		Check force recovery boot
E6h		Checksum BIOS ROM
E7h		Go to BIOS
E8h		Set Huge Segment
E9h		Initialize Multi Processor
EAh		Initialize OEM special code
EBh		Initialize PIC and DMA
ECh		Initialize Memory type
EDh		Initialize Memory size
EEh		Shadow Boot Block
EFh		System memory test
F0h		Initialize interrupt vectors
F1h		Initialize Run Time Clock
F2h		Initialize video
F3h		Initialize System Management Mode
F4h	1	Output one beep before boot
F5h		Boot to Mini DOS
F6h		Clear Huge Segment
F7h		Boot to Full DOS

Symptom-to-FRU error messages

LCD

Symptom / Error	Action in Sequence
<ul style="list-style-type: none"> The LCD backlight doesn't work. The LCD is too dark. The LCD brightness cannot be adjusted. The LCD contrast cannot be adjusted. 	<ul style="list-style-type: none"> Run "Load Setup Defaults" using the BIOS Setup Utility, then reboot the notebook. Reconnect the LCD connectors. Test or replace the keyboard (if contrast and brightness function key doesn't work). Check the LCD inverter ID. Test or replace the LCD cable. Test or replace the LCD inverter. Test or replace the LCD. Test or replace the system board.
<ul style="list-style-type: none"> The LCD screen is unreadable. Missing pixels in characters. The screen appears abnormal. The wrong color is displayed. 	<ul style="list-style-type: none"> Reconnect the LCD connector. Check the LCD inverter ID. Test or replace the LCD cable. Test or replace the LCD inverter. Test or replace the LCD. Test or replace the system board.
The LCD is displaying extra horizontal or vertical lines.	<ul style="list-style-type: none"> Check the LCD inverter ID. Test or replace the LCD cable. Test or replace the LCD inverter. Test or replace the LCD. Test or replace the system board.

Indicator

Symptom / Error	Action in Sequence
Indicator incorrectly remains off or on, but system runs correctly. <Athena: What indicator? What relationship does it have to the inverter?>	<ul style="list-style-type: none"> Reconnect the inverter board. Test or replace the LCD inverter. Test or replace the system board.

Power

Symptom / Error	Action in Sequence
The notebook shuts down during operation.	<ul style="list-style-type: none"> Test the power source (battery pack and power adapter). See "Testing the power system" on page 138. Replace the battery pack. Test or replace the power adapter. Test or replace the system board.
The notebook doesn't turn on.	<ul style="list-style-type: none"> Test the power source (battery pack and power adapter). See "Testing the power system" on page 138. Replace the battery pack. Test or replace the power adapter. Test or replace the system board.

Symptom / Error	Action in Sequence
The notebook doesn't turn off.	<ul style="list-style-type: none"> • Test the power source (battery pack and power adapter). See "Testing the power system" on page 138. • Press and hold the power button for more than four seconds. • Test or replace the system board.
The battery can't be charged.	<ul style="list-style-type: none"> • Test the battery pack. See "Check the battery pack" on page 139. • Replace the battery pack. • Test or replace the system board.

ExpressCard (NewCard)

Symptom / Error	Action in Sequence
The notebook cannot detect the ExpressCard	<ul style="list-style-type: none"> • Test or replace the ExpressCard assembly. See "Replacing the ExpressCard (NewCard) assembly" on page 112. • Test or replace the system board.
ExpressCard slot pin is damaged.	<ul style="list-style-type: none"> • Test or replace the ExpressCard assembly. See "Replacing the ExpressCard (NewCard) assembly" on page 112.

Memory



Symptom / Error	Action in Sequence
Memory count (size) appears different from actual size.	<ul style="list-style-type: none"> • Run "Load Setup Defaults" using the BIOS Setup Utility, then reboot the notebook. • Test or replace the SO-DIMM. • Test or replace the system board.

Sound

Symptom / Error	Action in Sequence
No sound comes from the notebook when running Windows multimedia programs.	<ul style="list-style-type: none"> • Reinstall the audio driver. • Test or replace the speakers. • Test or replace the system board.
The internal speakers make noise or emit no sound.	<ul style="list-style-type: none"> • Test or replace the speakers. • Test or replace the system board.

Power management

Symptom / Error	Action in Sequence
The notebook will not hibernate.	<ul style="list-style-type: none"> • <Athena: Why are they looking at a spec?> See "Save to Disk (S4)" on page 33.  • Test or replace the keyboard (if control is from the keyboard). • Test or replace the hard disk drive. • Test or replace the system board.

Symptom / Error	Action in Sequence
The system doesn't hibernate and emits four short beeps every minute.	<ul style="list-style-type: none"> • Press Fn+O and see if the notebook enters hibernation mode. • Test or replace the touchpad. • Test or replace the keyboard. • Check the hard disk connection to the system board. • Test or replace the hard disk drive. • Test or replace the system board.
The notebook doesn't enter standby mode after closing the LCD.	<ul style="list-style-type: none"> • <Athena: Why are they looking at a spec?> See "Save to Disk (S4)" on page 33.  • Test or replace the system board.
The system doesn't resume from hibernation mode.	<ul style="list-style-type: none"> • <Athena: Why are they looking at a spec?> See "Save to Disk (S4)" on page 33.  • Check the hard disk connection to the system board. • Test or replace the hard disk drive. • Test or replace the system board.
The system doesn't resume from standby mode after opening the LCD.	<ul style="list-style-type: none"> • <Athena: Why are they looking at a spec?> See "Save to Disk (S4)" on page 33.  • Test or replace the system board.
The battery fuel gauge in Windows doesn't go higher than 90%.	<ul style="list-style-type: none"> • Remove the battery pack and let it cool for two hours. • Refresh the battery (use only battery power until the notebook turns off, then charge the battery). • Test or replace the battery pack. • Test or replace the system board.
The system hangs intermittently.	<ul style="list-style-type: none"> • Reconnect the hard disk drive and optical drive. • Check the hard disk connection to the system board. • Test or replace the system board.

Devices

Symptom / Error	Action in Sequence
System configuration does not match the installed devices.	<ul style="list-style-type: none"> • Run "Load Setup Defaults" using the BIOS Setup Utility, then reboot the notebook. • Reconnect the hard disk drive and optical drive.
The external display does not work correctly.	<ul style="list-style-type: none"> • Press Fn+F5 repeatedly to switch between LCD, external display, and both displays. • Test or replace the system board.
USB does not work correctly.	<ul style="list-style-type: none"> • Test or replace the ExpressCard assembly. See "Replacing the ExpressCard (NewCard) assembly" on page 112. • Test or replace the system board.
Printer problems.	<ul style="list-style-type: none"> • Run the printer self-test. • Reinstall the printer driver. • Test or replace the printer cable. • Test or replace the printer. • Test or replace the system board.
Serial or parallel port device problems.	<ul style="list-style-type: none"> • Reinstall the device driver. • Test or replace the device cable. • Test or replace the device. • Test or replace the system board.

Keyboard and touchpad

Symptom / Error	Action in Sequence
The keyboard (one or more keys) does not work.	<ul style="list-style-type: none">• Reconnect the keyboard cable.• Test or replace the keyboard.• Test or replace the system board.
The touchpad does not work.	<ul style="list-style-type: none">• Reconnect the touchpad cable.• Test or replace the touchpad board.• Test or replace the system board.

Modem

Symptom / Error	Action in Sequence
The internal modem does not work correctly.	<ul style="list-style-type: none">• Test the modem phone port.• Test or replace the modem card.• Test or replace the system board.

Note: If you cannot find a symptom or an error in this list and the problem remains, see [“Undetermined problems” on page 153](#).

Intermittent problems

Intermittent system hang problems can be caused by a variety of reasons that have nothing to do with a hardware defect. These reasons include: cosmic radiation, electrostatic discharge, or software errors. FRU replacement should be considered only when a recurring problem exists.

To analyze an intermittent problem:

- 1 Run the advanced diagnostic test for the system board in loop mode at least ten times.
 - If any error is detected, replace the FRU.
 - If no error is detected, do not replace any FRU.
- 2 Rerun the test to verify that there are no more errors.

Undetermined problems

If the diagnostic test may not identify which adapter or device failed, which installed devices are incorrect, whether a short circuit is suspected, or whether the system is inoperative. Use these procedures to isolate the failing FRU (do not isolate a non-defective FRU).

Note: Verify that all attached devices are supported by the notebook.

Note: Verify that the power supply being used at the time of the failure is operating correctly. (See ["Testing the power system" on page 138](#).)

To isolate a failing FRU:

- 1 Turn off the notebook.
- 2 Visually check FRU parts for damage. If you identify any damage, replace the FRU.
- 3 Remove or disconnect all of the following devices:
 - ❑ Non-Acer devices
 - ❑ Printer, mouse, and other external devices
 - ❑ Battery pack
 - ❑ Hard disk drive(s)
 - ❑ SO-DIMM
 - ❑ Optical drive
 - ❑ PC Cards and Type 54 ExpressCards
- 4 Turn on the notebook.
- 5 Determine if the problem has changed.
 - ❑ If the problem does not recur, reconnect the removed devices one at a time until you find the failing FRU.
 - ❑ If the problem does recur, replace the following FRUs one at a time:
 - ❑ System board
 - ❑ LCD assembly

Important: Do not replace a non-defective FRU.

Chapter 5

Jumper and connector locations

- System board top connectors
- System board bottom connectors
- Clearing password check and BIOS recovery

System board top connectors

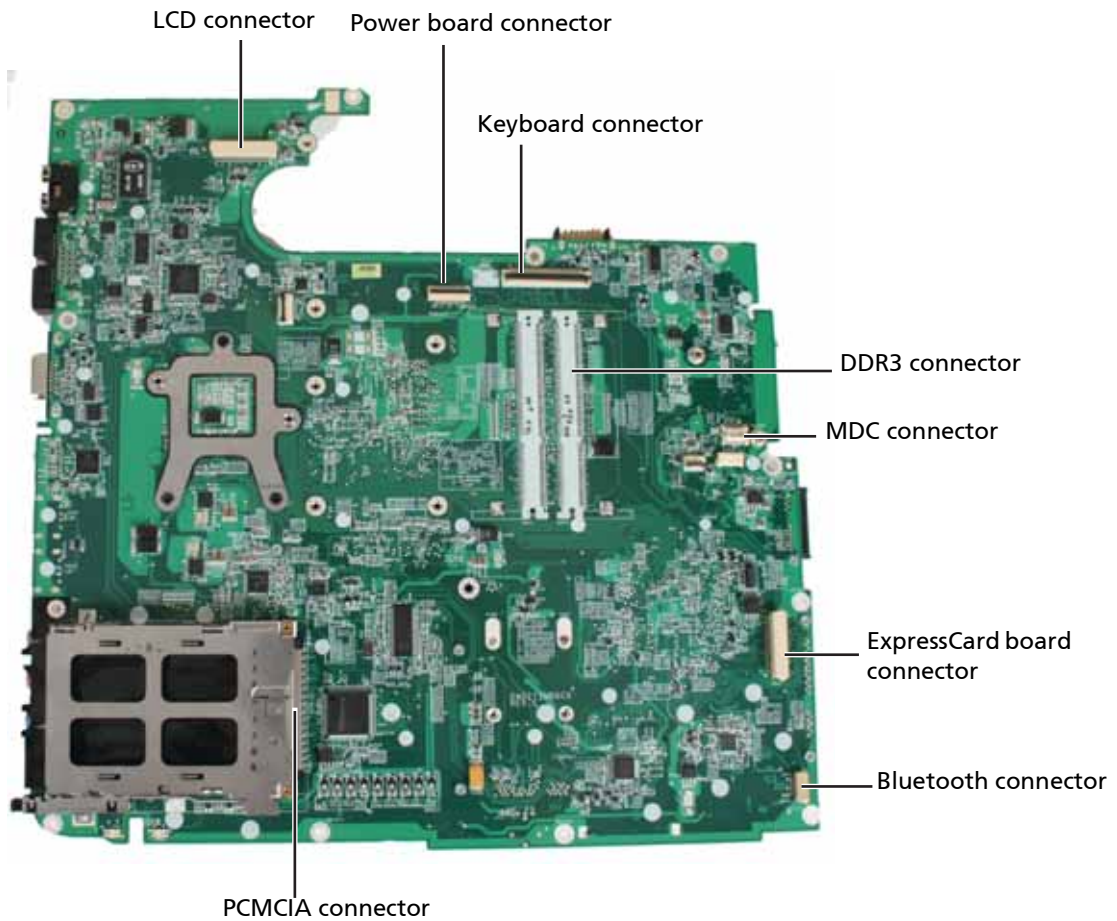

System board bottom connectors

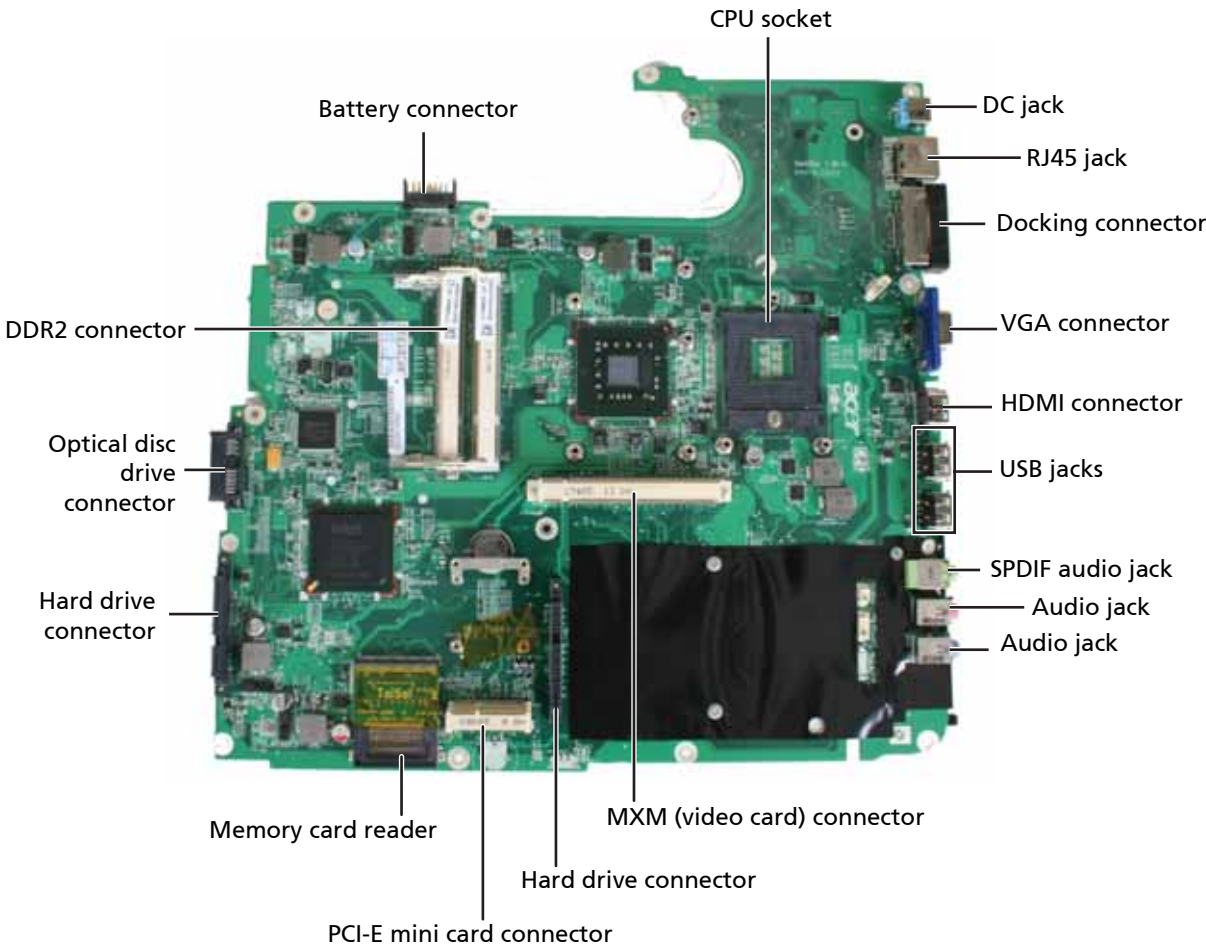

Clearing password check and BIOS recovery

This section provides you with the standard operating procedures of clearing password and BIOS recovery for Travelmate 7730/7730G. The system board has one Hardware Open Gap for clearing the password check, and one Hotkey for enabling BIOS recovery.

Clearing the password check

Hardware Open Gap Description:

Hardware	Default Setting	Operation Description
Gap	Open (Normal)	Short (Clearing Password Check)

Locating the hardware gap on the system board

Gap name in Travelmate 7730/7730G is G71

Steps for Clearing BIOS Password Check

If users set the BIOS password (Supervisor password and/or User password) for a security reason, BIOS will ask the password during system POST or when the system enters the BIOS Setup Utility. To bypass the password check, users need to short the hardware gap to clear the password.

To clear the BIOS password:

- 1 Disconnect the power adapter and remove the battery from the notebook.
- 2 Turn off the notebook and remove hard disk drive. [<Athena: both hard drives?>](#)
For more information, see ["Replacing the primary hard drive" on page 64](#) and ["Replacing the secondary hard drive" on page 73](#).
- 3 Open the [<Athena: which cover?>](#) cover of the machine.
- 4 Locate the hardware gap. [<Athena: can you help me find it on the system board?>](#)
[Richard: Need to shoot new pic once we know where the gap is.>](#)

- 5 Use the blade of a flat screwdriver to short the two points of the gap.

-
- 6 Plug in the power adapter while keeping the screwdriver on the gap, and press the power button to turn on the notebook.
 - 7 After the BIOS POST has finished, remove the tool from the gap.
 - 8 Restart the notebook. Press the F2 key to enter the BIOS Setup Utility.
If are not prompted for a password, then the BIOS passwords have been cleared.
If you are prompted for a password, repeat the procedure.

Note: This procedure only clears the BIOS password (Supervisor password and User password). It does not clear a hard drive password.
 - 9 Reassemble the notebook.

BIOS Recovery by Crisis Diskette

BIOS Recovery Boot Block

BIOS Recovery Boot Block is a special block of BIOS. It is used to boot up the notebook with minimum BIOS initialization. Users can enable this feature to restore the BIOS firmware to a successful one once the previous BIOS flashing process failed.

BIOS Recovery Hotkey

The notebook provides a function hotkey: **Fn+Esc**, to enable BIOS Recovery process when notebook is powered on during BIOS POST. If this function is enabled, the notebook forces the BIOS to enter a special BIOS block, called Boot Block.

Important: To use this function, it is strongly recommended that you have the AC adapter plugged in and a charged battery in the battery bay.

Creating a Crisis Diskette

Before completing this procedure you should prepare a Crisis Diskette. The Crisis Diskette could be made by executing the Crisis Disk program in another notebook [<Athena: Can it be any notebook or does it need to be an Acer notebook? Does it need to have a similar BIOS?>](#) with Windows XP OS.

BIOS Recovery using a Crisis Diskette

To complete a BIOS Recovery using a Crisis Diskette:

- 1 Turn off the notebook.
- 2 Connect a USB diskette drive to the notebook, then insert the Crisis Diskette into the drive.
- 3 With the notebook turned off, press and hold **Fn+Esc**, then press the power button. The notebook should start with Crisis BIOS Recovery process running.
BIOS Boot Block restores the BIOS code from the Crisis Diskette to the BIOS ROM on the notebook.
- 4 The notebook automatically restarts after the Crisis flashing process is finished. The notebook should have a working BIOS. At this point, a user can update the BIOS to the latest version using the regular BIOS flashing process.

Chapter 6

FRU (Field-Replaceable Unit) list

- Introduction
- Travelmate 7730/7730G exploded diagram
- Travelmate 7730/7730G FRU list

Introduction

This chapter gives you the FRU (field-replaceable-unit) listing in global configurations of Travelmate 7730/7730G. Refer to this chapter whenever ordering for parts to repair or for RMA (Return Merchandise Authorization).

Please note that **WHEN ORDERING FRU PARTS**, you should check the most up-to-date information available on your regional web or channel. For whatever reasons a part number change is made, it will not be noted on the printed Service Guide. For **ACER AUTHORIZED SERVICE PROVIDERS**, your Acer office may have a **DIFFERENT** part number code from those given in the FRU list of this printed Service Guide. You **MUST** use the local FRU list provided by your regional Acer office to order FRU parts for repair and service of customer machines.

Note: To scrap or to return the defective parts, you should follow the local government ordinance or regulations on how to dispose it properly, or follow the rules set by your regional Acer office on how to return it.

Travelmate 7730/7730G exploded diagram

Notebook chassis

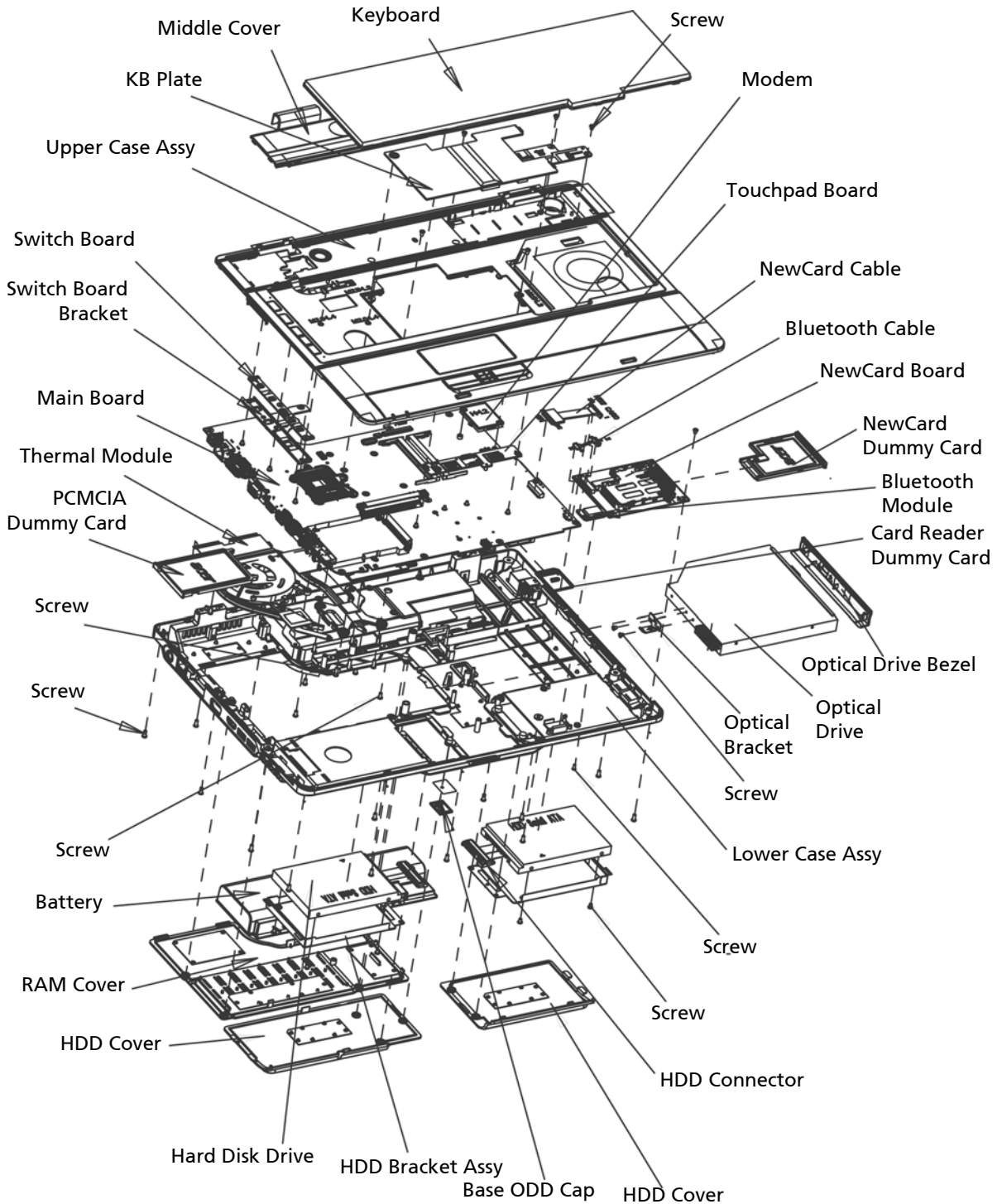

Notebook LCD panel

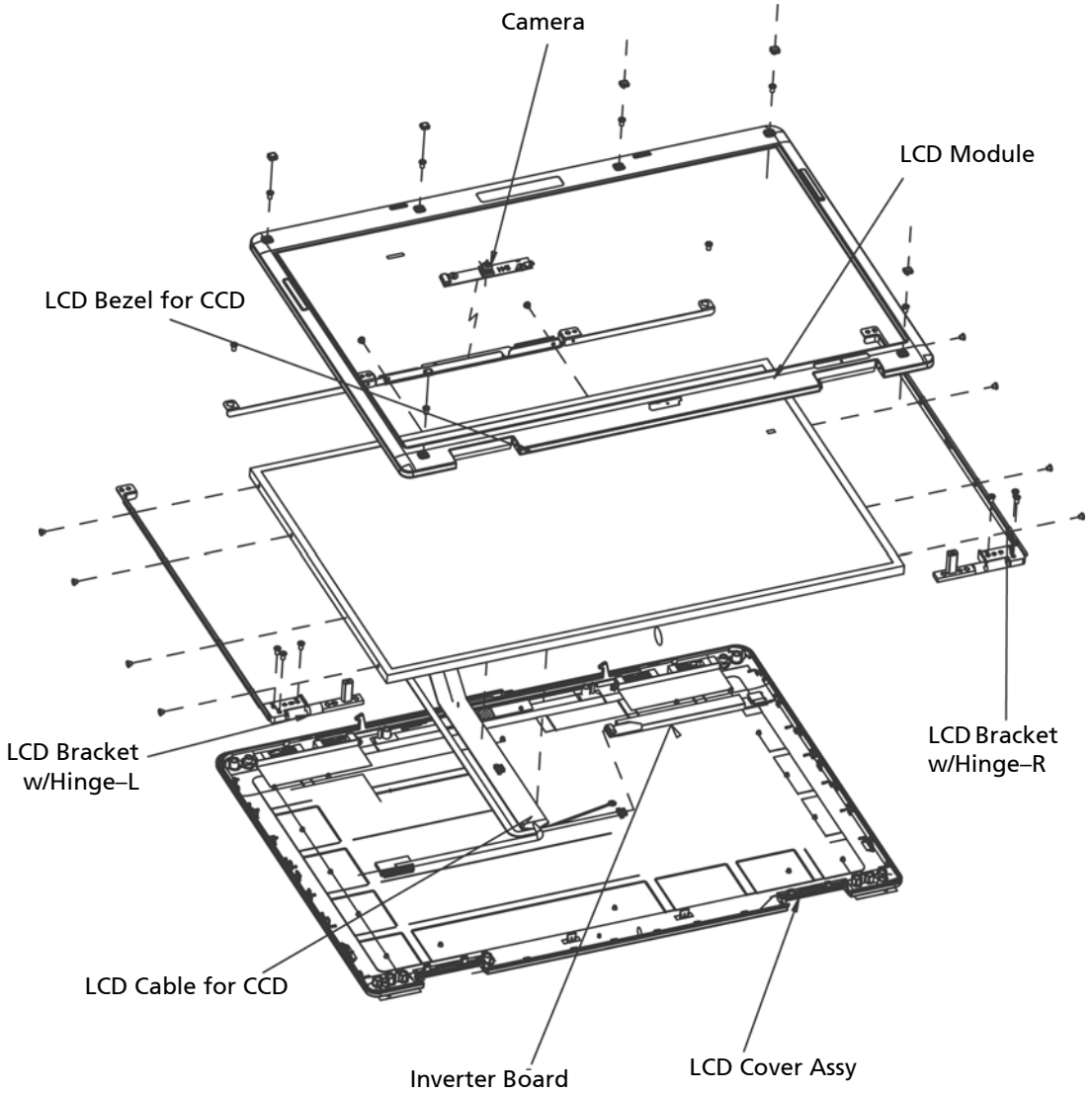



Travelmate 7730/7730G FRU list

Category	Part Name and Description	Acer Part No.
Adapters		
	ADAPTER 65W 3PIN DELTA SADP-65KB DFA	AP.06501.013
	ADAPTER 65W LITEON PA-1650-02AC LF	AP.06503.016
	ADAPTER 65W 3PIN HIPRO AC-OK065B13	AP.0650A.010
	ADAPTER DELTA 90W ADP-90SB BBEA LF	AP.09001.013
	ADAPTER LITE-ON 90W 19V BLUE PA-1900-24AR LED LF	AP.09003.011
	ADAPTER HIPRO 90W 19V BLUE HP-OL093B13P LED LF LEVEL 4	AP.0900A.001
Batteries		
	Battery SANYO AS-2007B Li-Ion 3S2P SANYO 6 cell 4400mAh Main COMMON Normal Type	BT.00603.042
	Battery SONY AS-2007B Li-Ion 3S2P SONY 6 cell 4400mAh Main COMMON Normal Type	BT.00604.025
	Battery SIMPLO AS-2007B Li-Ion 3S2P PANASONIC 6 cell 4400mAh Main COMMON PSS	BT.00607.016
	Battery SANYO AS-2007B Li-Ion 4S2P SANYO 8 cell 4800mAh Main COMMON	BT.00803.024
	Battery SONY AS-2007B Li-Ion 4S2P SONY 8 cell 4800mAh Main COMMON	BT.00804.020
	Battery PANASONIC AS-2007B Li-Ion 4S2P PANASONIC 8 cell 4800mAh Main COMMON	BT.00805.011
	Battery SIMPLO AS-2007B Li-Ion 4S2P PANASONIC 8 cell 4800mAh Main COMMON PSS	BT.00807.015
Blue Ray Disc Combo Modules		
	BLUE RAY COMBO MODULE	6M.TPL07.001
	BLUE RAY COMBO TRAY 2X SONY BC-5500S-AR	KO.0020E.002
Boards		
	Lite-On Conexant -Unizion 1.5_3.3v AUS RD02-D330 B85247600G	FX.22500.021
	BLUETOOTH MODULE (T60H928.11)	BT.21100.005
	WIRELESS LAN CARD FOXCONN T60h976.00 MINI	54.AZL07.001
	WIRELESS LAN BOARD 802.11BG FOXCONN BCM4312 T77H030.00	NI.23600.029
	Lan Intel WLAN 512AN_HMWG Shirley Peak 5100 MM#895373	KI.SPH01.003
	Lan Intel WLAN 533AN_HMWG Shirley Peak MM#895401	KI.SPH01.001
	Lan Intel WLAN 533AN_MMWG Shirley Peak MM#895362	KI.SPM01.001





Category	Part Name and Description	Acer Part No.
	TOUCHPAD BOARD W/O FP	55.TQ407.001
	TOUCHPAD BOARD W/ FP	55.TPK07.001
	POWER BOARD	55.TPK07.002
	SWITCH BOARD	55.TPK07.003
	NEWCARD BOARD	55.TPK07.004
	MSI VGA Card nVidia NB9P-GS DDRIII 512M 800MHz 32*32 MXM II w/ HDCP w/ Intersil PowerIC	VG.9PG06.002
	MSI VGA Card nVidia NB9M-GS DDRII 256M 400MHz 32*16 MXM I w/ HDCP w/ Intersil PowerIC	VG.9MG06.001
	INVERTER BOARD	19.TPK07.001
Cables		
	BLUETOOTH CABLE	50.TPK07.001
	NEW CARD CABLE	50.TPK07.002
<Richard: Need Graphic>	LCD CABLE FOR CCD	50.TPK07.003
<Richard: Need Graphic>	CCD CABLE	50.TPK07.004
	PWR CORD V943B30001218008 DANISH 3P	27.A03V7.006
	PWR CORD(ISR)1.8M 3PBLK FZ0I0008-038	27.TATV7.005
	PWR CORD V50CB3T3012180QD TW-110V,3	27.A99V7.002
	POWER CORD(SWI)1.8M 3PBLACK FZ0I0008-011	27.A99V7.004
	POWER CORD(IT) 1.8M 3PBLACK FZ0I0008-008	27.A99V7.005
	POWER CORD(S.A) 1.8M 3BLACK FZ0I0008-006	27.T48V7.001
	POWER CORD US 3PIN ROHS	27.TAXV7.001
	POWER CORD(EU) 1.8M 3PBLACK FM0I0008-010	27.TATV7.001
POWER CORD(UK) 1.8M 3PBLACK FP0I0008-013	27.TATV7.003	
Cameras		
	CAMERA CN0314-SN30-OV03 SUYIN	57.TPK07.001
	CAMERA CNF701721004971L CNY	57.TPK07.002
Cases/Covers/Brackets/Assemblies		
	MIDDLE COVER	42.TPK07.001



Category	Part Name and Description	Acer Part No.
	UPPER CASE ASSY W/TP,SPEAKER,MIC,FFC CABLE W/O FP	60.TQ407.001
	UPPER CASE ASSY W/TP,SPEAKER,MIC,FFC CABLE FOR FP	60.TPK07.001
	LOWER CASE ASSY W/RJ11	60.TPK07.002
	RAM COVER	42.TPK07.002
	KB PLATE FOR DDR3	33.TPK07.006
	KB PLATE FOR DDR2	33.TPK07.007
	SWITCH BOARD BRACKET	33.TPK07.008
	BASE ODD CAP	42.TG607.002
<Richard: Need Graphic>	VGA SUPPORT BRACKET <Athena: What is this bracket?>	33.AHS07.007
	OPTICAL BRACKET	33.TPK07.001
	BD COMBO BEZEL	42.TPL07.001
	DVD/CDRW COMBO BEZEL	42.TPK07.005
	ODD BEZEL - SUPER MULTI	42.TPK07.006
	HDD BRACKET ASSY	33.TPK07.002
	HDD COVER-1 ASSY W/RUBBER	42.TPK07.003
	HDD COVER-2 ASSY W/RUBBER	42.TPK07.004
<Richard: Need Graphic>	HDD CONNECTOR	20.TPK07.001

Category	Part Name and Description	Acer Part No.
	LCD COVER ASSY W/ANTENNA * 3	60.TPK07.003
	LCD COVER ASSY W/ANTENNA * 2	60.TPK07.005
	LCD BEZEL FOR CCD	60.TPK07.004
	LCD BRACKET W/HINGE - R	33.TPK07.003
	LCD BRACKET W/HINGE - L	33.TPK07.004
	CCD BRACKET	33.TPK07.005
CPUs/Processors		
	CPU Intel Core2Dual T9600 PGA 2.8G 6M 1066 35W	KC.96001.DTP
	CPU Intel Core2Dual T9400 PGA 2.53G 6M 1066 35W	KC.94001.DTP
	CPU Intel Core2Dual P8600 PGA 2.4G 1066 25W 3M	KC.86001.DPP
	CPU Intel Core2Dual P8400 PGA 2.26G 3M 1066 25W	KC.84001.DPP
	CPU Intel Core2Dual P9500 PGA 2.53G 6M 1066 25W	KC.95001.DPP
DVD/CDRW Combo Modules		
	DVD/CDRW COMBO MODULE	6M.TPK07.001
	TOSHIBA COMBO Tray DL 24X TS-L463A LF W/O bezel SATA	KO.02401.006
	SONY COMBO Tray DL 24X CRX890S LF W/O bezel SATA	KO.0240E.009
DVD-RW Drives		
	DVD/RW SUPER MULTI SATA MODULE	6M.TPK07.002
	TOSHIBA Super-Multi DRIVE Tray DL 8X TS-L633A LF W/O bezel SATA	KU.00801.021
	PIONEER Super-Multi DRIVE Tray DL 8X DVR-TD08RS LF W/O bezel SATA	KU.00805.044
	PANASONIC Super-Multi DRIVE 12.7mm Tray DL 8X UJ-870A LF W/O bezel SATA	TBD
	ODD HLDS Super-Multi DRIVE 12.7mm Tray DL 8X GSA-T50N LF W/O bezel SATA FW:RP05	KU.0080D.029
	ODD HLDS Super-Multi DRIVE 12.7mm Tray DL 8X GSA-T50N LF W/O bezel SATA Malaysia FW:RP05	KU.0080D.034

Category	Part Name and Description	Acer Part No.
HDDs/Hard Disk Drives		
	HDD SEAGATE 2.5" 5400rpm 120GB ST9120817AS Corsair SATA LF F/W:3.AAA	KH.12001.032
	HDD TOSHIBA 5400rpm 120GB MK1246GSX Leo BS SATA I LF F/W:LB213J	KH.12004.007
	HDD HGST 5400rpm 120GB HTS542512K9SA00 Bronco-B SATA II LF F/W:C31P	KH.12007.014
	HDD WD 5400rpm 120GB WD1200BEVS-22UST0 ML125 SATA LF F/W:01.01A01	KH.12008.019
	HDD(160G) ST9160827AS 9DG133-188 STN B/S SEAGATE F/W:3.AAA	KH.16001.029
	HDD TOSHIBA 5400rpm 160GB MK1646GSX Leo BS SATA I LF F/W:LB113J	KH.16004.002
	HDD HGST 2.5" 5400rpm 160GB HTS542516K9SA00 Bronco-B SATA II LF F/W:C31P	KH.16007.016
	HDD SEAGATE 2.5" 5400rpm 250GB ST9250827AS Corsair SATA LF F/W:3.AAA	KH.25001.011
	HDD TOSHIBA 2.5" 5400rpm 250GB MK2546GSX Leo BS SATA I LF F/W:LB013J	KH.25004.001
	HDD 250GB 5400RPM SATA II HGST HTS542525K9SA00 LF F/W:C31P	KH.25007.011
	HDD WD 2.5 IN. 5400rpm 250GB WD2500BEVS-22UST0 ML125 SATA LF F/W:01.01A01	KH.25008.018
	HDD WD 2.5" 5400rpm 320GB WD3200BEVT-22ZCT0 ML160 SATA LF F/W:11.01A11	KH.32008.013
	HDD TOSHIBA 2.5" 5400rpm 320GB MK3252GSX Virgo BS SATA LF F/W:LV010J	KH.32004.001
Heatsinks		
	THERMAL MODULE	60.TPK07.006

Category	Part Name and Description	Acer Part No.
Keyboards		
	Keyboard 17KB-FV4 Black Monserrat 104KS Black US International	KB.INT00.627
	Keyboard 17KB-FV4 Black Monserrat 104KS Black US International Hebrew	KB.INT00.628
	Keyboard 17KB-FV4 Black Monserrat 105KS Black UK	KB.INT00.629
	Keyboard 17KB-FV4 Black Monserrat 105KS Black Turkish	KB.INT00.630
	Keyboard 17KB-FV4 Black Monserrat 104KS Black Thailand	KB.INT00.631
	Keyboard 17KB-FV4 Black Monserrat 105KS Black Swiss/G	KB.INT00.632
	Keyboard 17KB-FV4 Black Monserrat 105KS Black Swedish	KB.INT00.633
	Keyboard 17KB-FV4 Black Monserrat 105KS Black Spanish	KB.INT00.634
	Keyboard 17KB-FV4 Black Monserrat 105KS Black Slovak	KB.INT00.635
	Keyboard 17KB-FV4 Black Monserrat 105KS Black SLO/CRO	KB.INT00.636
	Keyboard 17KB-FV4 Black Monserrat 104KS Black Russian	KB.INT00.637
	Keyboard 17KB-FV4 Black Monserrat 105KS Black Portuguese	KB.INT00.638
	Keyboard 17KB-FV4 Black Monserrat 105KS Black Polish	KB.INT00.639
	Keyboard 17KB-FV4 Black Monserrat 105KS Black Norwegian	KB.INT00.640
	Keyboard 17KB-FV4 Black Monserrat 104KS Black Korean	KB.INT00.642
	Keyboard 17KB-FV4 Black Monserrat 104KS Black Japanese	KB.INT00.643
	Keyboard 17KB-FV4 Black Monserrat 105KS Black Italian	KB.INT00.644
	Keyboard 17KB-FV4 Black Monserrat 105KS Black Hungarian	KB.INT00.647
	Keyboard 17KB-FV4 Black Monserrat 104KS Black Greek	KB.INT00.648
	Keyboard 17KB-FV4 Black Monserrat 105KS Black German	KB.INT00.649
	Keyboard 17KB-FV4 Black Monserrat 105KS Black French	KB.INT00.650
	Keyboard 17KB-FV4 Black Monserrat 105KS Black Danish	KB.INT00.653
	Keyboard 17KB-FV4 Black Monserrat 105KS Black Czech	KB.INT00.654
	Keyboard 17KB-FV4 Black Monserrat 104KS Black Traditional Chinese	KB.INT00.655
	Keyboard 17KB-FV4 Black Monserrat 105KS Black Canadian French	KB.INT00.656
	Keyboard 17KB-FV4 Black Monserrat 105KS Black Brazilian Portuguese	KB.INT00.657
Keyboard 17KB-FV4 Black Monserrat 105KS Black Belgium	KB.INT00.658	
Keyboard 17KB-FV4 Black Monserrat 104KS Black Arabic/English	KB.INT00.659	
Keyboard 17KB-FV4 Black Monserrat 105KS Black Luxembourgish	KB.INT00.641	
Keyboard 17KB-FV4 Black Monserrat 104KS Black Israel	KB.INT00.645	
Keyboard 17KB-FV4 Black Monserrat 105KS Black Irish	KB.INT00.646	

Category	Part Name and Description	Acer Part No.
	Keyboard 17KB-FV4 Black Monserrat 105KS Black Finnish	KB.INT00.651
	Keyboard 17KB-FV4 Black Monserrat 105KS Black Dutch	KB.INT00.652
	Keyboard 17KB-FV4 Black Monserrat 105KS Black Arabic/French	KB.INT00.660
	Keyboard 17KB-FV4 Black Monserrat 105KS Black Nordic	KB.INT00.661
	Keyboard 17KB-FV4 Black Monserrat 105KS Black English/Canadian French	KB.INT00.662
	Keyboard 17KB-FV4 Black Monserrat 109KS Black Japanese	KB.INT00.663
LCD Modules		
	LCD MODULE ASSY MIMO (3WIRE) GLARE W/CCD	6M.TPK07.003
	LCD AUO 17.1" WXGA+ Glare B170PW06 V2 LF 220nit 8ms	LK.17105.009
	LCD SAMSUNG 17.1" WXGA+ Glare LTN170BT07-G01 LF 220nit 8ms 500:1	LK.17106.004
	LCD LPL 17.1" WXGA+ Glare LP171WP4-TLR1 LF 220nit 8ms	LK.17108.011
	LCD MODULE ASSY MIMO (3WIRE) NON-GLARE W/CCD	6M.TPK07.004
	LCD AUO 17.1" WXGA+ None Glare B170PW06 V3 LF 220nit 8ms	LK.17105.008
	LCD LPL 17.1" WXGA+ None Glare LP171WP4-TLR2 LF 220nit 8ms	LK.17108.012
	LCD MODULE ASSY MIMO (2WIRE) NON-GLARE W/CCD	6M.TPK07.005
Main Boards		
	MAINBOARD DIS PM45 ICH9 GL DDR2 W/CARD REEADER W/O CPU RAM LF	MB.TQ506.001
	MAINBOARD UMA GM45 ICH9 GL DDR2 W/CARD REEADER W/O CPU RAM LF	MB.TQ406.001
	MAINBOARD DIS PM45 ICH9 GL DDR3 W/CARD REEADER W/O CPU RAM LF	MB.TQ506.002
Memory Cards		
	SO-DIMM DDRII667 512MB NT512T64UH8B0FN-37C (0.09U)NANYA	KN.51203.032
	Memory HYNIX SO-DIMM DDRII 667 512MB HYMP164S64CP6-Y5 LF	KN.5120G.024
	Memory SAMSUNG SO-DIMM DDRII 667 1GB M470T2864QZ3-CE6 LF	KN.1GB0B.016
	Memory HYNIX SO-DIMM DDRII 667 1GB HYMP112S64CP6-Y5 LF	KN.1GB0G.012
	MEMORY HYNIX SO-DIMM DDRII 667 2GB HYMP125S64CP8-Y5 LF	KN.2GB0G.004
	Memory SAMSUNG SO-DIMM DDRII 667 2GB M470T5663QZ3-CE6 LF	KN.2GB0B.003
	Memory ELPIDA SO-DIMM DDRIII 1066 1GB EBJ11UE6BAU0-AE-E LF	KN.1GB09.009
	Memory SAMSUNG SO-DIMM DDRIII 1066 1GB M471B2874DZ1-CF8 LF	KN.1GB0B.019
	Memory SAMSUNG SO-DIMM DDRIII 1066 2GB M471B5673DZ1-CF8 LF	KN.2GB0B.005

Category	Part Name and Description	Acer Part No.
Miscellaneous		
<Richard: Need Graphic>	NAME PLATE TM7730	40.TPK07.001
	LCD RUBBER-1	47.TPK07.001
	LCD RUBBER-2	47.TPK07.002
<Richard: Need Graphic>	LOWER CASE FOOT STAND	47.AGW07.004
Screws		
	SCREW M2.0*2.5-I(BUWZN)	86.TPK07.001
	SCREW M3.0*3.5-I(BUWZN) IRON	86.TPK07.002
	SCREW M3*0.5+3.5I	86.A03V7.006
	SCREW M2.5*6.5-I(BZN(NYLOK-RED))	86.ARE07.001
	SCREW M2.5*5.0-I(BZN)	86.ARE07.003
	SCREW M2.5*3.0-I(BZN)	86.TPK07.003
	SCREW M2.5*8-I BNI NYLOK	86.T48V7.001
Speakers		
<Richard: Need Graphic>	SPEAKER	23.TPK07.001
<Richard: Need Graphic>	MIC	23.TPK07.002

Appendix A

Model definition and configuration

Model	TM7730-843G50Mi
RO	PA
Country	USA
Acer Part No.	LX.TPK0Z.001
Description	TM7730-843G50Mi VB32TRUS1 MC UMACF 2G+1G/250+250/8L/5R_i2_FP_0.3D_EN33
CPU	C2DP8400
LCD	N17WXGA+
SO-DIMM 1	SO2GBII6
SO-DIMM 2	SO1GBII6
HDD 1 (GB)	N250GB5.4KS
HDD 2 (GB)	N250GB5.4KS
ODD	NSM8XS
Wireless LAN	SP1x2MMW
Bluetooth	N

Model	TM7730-843G50Mi
RO	PA
Country	USA
Acer Part No.	LX.TPK0Z.002
Description	TM7730-843G50Mi VB32TRUS1 MC UMACF 2G+1G/250+250/8L/5R_i2_FP_0.3D_EN34
CPU	C2DP8400
LCD	N17WXGA+
SO-DIMM 1	SO2GBII6
SO-DIMM 2	SO1GBII6
HDD 1 (GB)	N250GB5.4KS
HDD 2 (GB)	N250GB5.4KS
ODD	NSM8XS
Wireless LAN	SP1x2MMW
Bluetooth	N

Model	TM7730-843G50Mi
RO	PA
Country	Canada
Acer Part No.	LX.TPK0Z.003
Description	TM7730-843G50Mi VB32TRCA1 MC UMACF 2G+1G/250+250/8L/5R_i2_FP_0.3D_FR31
CPU	C2DP8400
LCD	N17WXGA+
SO-DIMM 1	SO2GBII6
SO-DIMM 2	SO1GBII6
HDD 1 (GB)	N250GB5.4KS
HDD 2 (GB)	N250GB5.4KS
ODD	NSM8XS
Wireless LAN	SP1x2MMW
Bluetooth	N

Model	TM7730-843G50Mi
RO	PA
Country	ACLA-Spanish
Acer Part No.	LX.TPK0Z.004
Description	TM7730-843G50Mi EM VB32TREA3 MC UMACF 2G+1G/250+250/8L/5R_i2_FP_0.3D_ES22
CPU	C2DP8400
LCD	N17WXGA+
SO-DIMM 1	SO2GBII6
SO-DIMM 2	SO1GBII6
HDD 1 (GB)	N250GB5.4KS
HDD 2 (GB)	N250GB5.4KS
ODD	NSM8XS
Wireless LAN	SP1x2MMW
Bluetooth	N

Model	TM7730-843G50Mi
RO	PA
Country	Canada
Acer Part No.	LX.TPK0Z.005
Description	TM7730-843G50Mi VB32TRCA1 MC UMACF 2G+1G/250+250/8L/5R_i2_FP_0.3D_FR32
CPU	C2DP8400
LCD	N17WXGA+
SO-DIMM 1	SO2GBII6
SO-DIMM 2	SO1GBII6
HDD 1 (GB)	N250GB5.4KS
HDD 2 (GB)	N250GB5.4KS
ODD	NSM8XS
Wireless LAN	SP1x2MMW
Bluetooth	N

Model	TM7730-843G50Mi
RO	PA
Country	ACLA-Spanish
Acer Part No.	LX.TPK0Z.006
Description	TM7730-843G50Mi EM VB32TREA1 MC UMACF 2G+1G/250+250/8L/5R_i2_FP_0.3D_ES23
CPU	C2DP8400
LCD	N17WXGA+
SO-DIMM 1	SO2GBII6
SO-DIMM 2	SO1GBII6
HDD 1 (GB)	N250GB5.4KS
HDD 2 (GB)	N250GB5.4KS
ODD	NSM8XS
Wireless LAN	SP1x2MMW
Bluetooth	N

Model	TM7730-843G50Mi
RO	PA
Country	ACLA-Portuguese
Acer Part No.	LX.TPK0Z.007
Description	TM7730-843G50Mi EM VB32TRXC1 MC UMACF 2G+1G/250+250/8L/5R_i2_FP_0.3D_XC25
CPU	C2DP8400
LCD	N17WXGA+
SO-DIMM 1	SO2GBII6
SO-DIMM 2	SO1GBII6
HDD 1 (GB)	N250GB5.4KS
HDD 2 (GB)	N250GB5.4KS
ODD	NSM8XS
Wireless LAN	SP1x2MMW
Bluetooth	N

Model	TM7730-843G50Mi
RO	PA
Country	USA
Acer Part No.	LX.TPK0X.001
Description	TM7730-843G50Mi VHP32TRUS1 MC UMACF 2G+1G/250+250/8L/5R/CB_i2_FP_0.3D_EN32
CPU	C2DP8400
LCD	N17WXGA+G
SO-DIMM 1	SO2GBII6
SO-DIMM 2	SO1GBII6
HDD 1 (GB)	N250GB5.4KS
HDD 2 (GB)	N250GB5.4KS
ODD	NSM8XS
Wireless LAN	SP1x2MMW
Bluetooth	N

Model	TM7730-843G50Mi
RO	PA
Country	Canada
Acer Part No.	LX.TPK0X.002
Description	TM7730-843G50Mi VHP32TRCA2 MC UMACF 2G+1G/250+250/8L/5R/CB_i2_FP_0.3D_FR31
CPU	C2DP8400
LCD	N17WXGA+G
SO-DIMM 1	SO2GBII6
SO-DIMM 2	SO1GBII6
HDD 1 (GB)	N250GB5.4KS
HDD 2 (GB)	N250GB5.4KS
ODD	NSM8XS
Wireless LAN	SP1x2MMW
Bluetooth	N

Model	TM7730-843G50Mi
RO	PA
Country	ACLA-Portuguese
Acer Part No.	LX.TPK0X.003
Description	TM7730-843G50Mi EM VHP32TRXC1 MC UMACF 2G+1G/250+250/8L/5R/CB_i2_FP_0.3D_XC22
CPU	C2DP8400
LCD	N17WXGA+G
SO-DIMM 1	SO2GBII6
SO-DIMM 2	SO1GBII6
HDD 1 (GB)	N250GB5.4KS
HDD 2 (GB)	N250GB5.4KS
ODD	NSM8XS
Wireless LAN	SP1x2MMW
Bluetooth	N

Model	TM7730-843G50Mi
RO	PA
Country	ACLA-Spanish
Acer Part No.	LX.TPK0X.004
Description	TM7730-843G50Mi EM VHP32TREA1 MC UMACF 2G+1G/250+250/8L/5R/CB_i2_FP_0.3D_ES22
CPU	C2DP8400
LCD	N17WXGA+G
SO-DIMM 1	SO2GBII6
SO-DIMM 2	SO1GBII6
HDD 1 (GB)	N250GB5.4KS
HDD 2 (GB)	N250GB5.4KS
ODD	NSM8XS
Wireless LAN	SP1x2MMW
Bluetooth	N

Model	TM7730-843G50Mi
RO	PA
Country	ACLA-Spanish
Acer Part No.	LX.TPK0X.005
Description	TM7730-843G50Mi EM VHP32TREA3 MC UMACF 2G+1G/250+250/8L/5R/CB_i2_FP_0.3D_ES21
CPU	C2DP8400
LCD	N17WXGA+G
SO-DIMM 1	SO2GBII6
SO-DIMM 2	SO1GBII6
HDD 1 (GB)	N250GB5.4KS
HDD 2 (GB)	N250GB5.4KS
ODD	NSM8XS
Wireless LAN	SP1x2MMW
Bluetooth	N

Model	TM7730G-843G64Mi
RO	PA
Country	USA
Acer Part No.	LX.TPLOX.001
Description	TM7730G-843G64Mi VHP32TRUS1 MC 9MGSHM256CF 2G+1G/320+320/8L/5R/CB_i2_FP_0.3D_EN32
CPU	C2DP8400
LCD	N17WXGA+G
SO-DIMM 1	SO2GBII6
SO-DIMM 2	SO1GBII6
HDD 1 (GB)	N320GB5.4KS
HDD 2 (GB)	N320GB5.4KS
ODD	NSM8XS
Wireless LAN	SP1x2MMW
Bluetooth	N

Model	TM7730G-843G64Mi
RO	PA
Country	Canada
Acer Part No.	LX.TPLOX.002
Description	TM7730G-843G64Mi VHP32TRCA2 MC 9MGSHM256CF 2G+1G/320+320/8L/5R/CB_i2_FP_0.3D_FR31
CPU	C2DP8400
LCD	N17WXGA+G
SO-DIMM 1	SO2GBII6
SO-DIMM 2	SO1GBII6
HDD 1 (GB)	N320GB5.4KS
HDD 2 (GB)	N320GB5.4KS
ODD	NSM8XS
Wireless LAN	SP1x2MMW
Bluetooth	N

Model	TM7730G-843G64Mi
RO	PA
Country	ACLA-Portuguese
Acer Part No.	LX.TPLOX.003
Description	TM7730G-843G64Mi EM VHP32TRXC1 MC 9MGSHM256CF 2G+1G/320+320/8L/5R/CB_i2_FP_0.3D_XC22
CPU	C2DP8400
LCD	N17WXGA+G
SO-DIMM 1	SO2GBII6
SO-DIMM 2	SO1GBII6
HDD 1 (GB)	N320GB5.4KS
HDD 2 (GB)	N320GB5.4KS
ODD	NSM8XS
Wireless LAN	SP1x2MMW
Bluetooth	N

Model	TM7730G-843G64Mi
RO	PA
Country	ACLA-Spanish
Acer Part No.	LX.TPL0X.004
Description	TM7730G-843G64Mi EM VHP32TREA1 MC 9MGSHM256CF 2G+1G/320+320/8L/5R/CB_i2_FP_0.3D_ES22
CPU	C2DP8400
LCD	N17WXGA+G
SO-DIMM 1	SO2GBII6
SO-DIMM 2	SO1GBII6
HDD 1 (GB)	N320GB5.4KS
HDD 2 (GB)	N320GB5.4KS
ODD	NSM8XS
Wireless LAN	SP1x2MMW
Bluetooth	N

Model	TM7730G-843G64Mi
RO	PA
Country	ACLA-Spanish
Acer Part No.	LX.TPL0X.005
Description	TM7730G-843G64Mi EM VHP32TREA3 MC 9MGSHM256CF 2G+1G/320+320/8L/5R/CB_i2_FP_0.3D_ES21
CPU	C2DP8400
LCD	N17WXGA+G
SO-DIMM 1	SO2GBII6
SO-DIMM 2	SO1GBII6
HDD 1 (GB)	N320GB5.4KS
HDD 2 (GB)	N320GB5.4KS
ODD	NSM8XS
Wireless LAN	SP1x2MMW
Bluetooth	N

Model	TM7730G-843G64Mi
RO	PA
Country	USA
Acer Part No.	LX.TPL0Z.001
Description	TM7730G-843G64Mi VB32TRU51 MC 9MGSHM256CF 2G+1G/320+320/8L/5R_i2_FP_0.3D_EN33
CPU	C2DP8400
LCD	N17WXGA+
SO-DIMM 1	SO2GBII6
SO-DIMM 2	SO1GBII6
HDD 1 (GB)	N320GB5.4KS
HDD 2 (GB)	N320GB5.4KS
ODD	NSM8XS
Wireless LAN	SP1x2MMW
Bluetooth	N

Model	TM7730G-843G64Mi
RO	PA
Country	Canada
Acer Part No.	LX.TPL0Z.002
Description	TM7730G-843G64Mi VB32TRCA1 MC 9MGSHM256CF 2G+1G/320+320/8L/5R_i2_FP_0.3D_FR31
CPU	C2DP8400
LCD	N17WXGA+
SO-DIMM 1	SO2GBII6
SO-DIMM 2	SO1GBII6
HDD 1 (GB)	N320GB5.4KS
HDD 2 (GB)	N320GB5.4KS
ODD	NSM8XS
Wireless LAN	SP1x2MMW
Bluetooth	N

Model	TM7730G-843G64Mi
RO	PA
Country	Canada
Acer Part No.	LX.TPL0Z.003
Description	TM7730G-843G64Mi VB32TRCA1 MC 9MGSHM256CF 2G+1G/320+320/8L/5R_i2_FP_0.3D_FR32
CPU	C2DP8400
LCD	N17WXGA+
SO-DIMM 1	SO2GBII6
SO-DIMM 2	SO1GBII6
HDD 1 (GB)	N320GB5.4KS
HDD 2 (GB)	N320GB5.4KS
ODD	NSM8XS
Wireless LAN	SP1x2MMW
Bluetooth	N

Model	TM7730G-843G64Mi
RO	PA
Country	ACLA-Spanish
Acer Part No.	LX.TPL0Z.004
Description	TM7730G-843G64Mi EM VB32TREA3 MC 9MGSHM256CF 2G+1G/320+320/8L/5R_i2_FP_0.3D_ES22
CPU	C2DP8400
LCD	N17WXGA+
SO-DIMM 1	SO2GBII6
SO-DIMM 2	SO1GBII6
HDD 1 (GB)	N320GB5.4KS
HDD 2 (GB)	N320GB5.4KS
ODD	NSM8XS
Wireless LAN	SP1x2MMW
Bluetooth	N

Model	TM7730G-843G64Mi
RO	PA
Country	ACLA-Spanish
Acer Part No.	LX.TPL0Z.005
Description	TM7730G-843G64Mi EM VB32TREA1 MC 9MGSHM256CF 2G+1G/320+320/8L/5R_i2_FP_0.3D_ES23
CPU	C2DP8400
LCD	N17WXGA+
SO-DIMM 1	SO2GBII6
SO-DIMM 2	SO1GBII6
HDD 1 (GB)	N320GB5.4KS
HDD 2 (GB)	N320GB5.4KS
ODD	NSM8XS
Wireless LAN	SP1x2MMW
Bluetooth	N

Model	TM7730G-843G64Mi
RO	PA
Country	ACLA-Portuguese
Acer Part No.	LX.TPL0Z.006
Description	TM7730G-843G64Mi EM VB32TRXC1 MC 9MGSHM256CF 2G+1G/320+320/8L/5R_i2_FP_0.3D_XC25
CPU	C2DP8400
LCD	N17WXGA+
SO-DIMM 1	SO2GBII6
SO-DIMM 2	SO1GBII6
HDD 1 (GB)	N320GB5.4KS
HDD 2 (GB)	N320GB5.4KS
ODD	NSM8XS
Wireless LAN	SP1x2MMW
Bluetooth	N

Model	TM7730-864G32Mi
RO	PA
Country	USA
Acer Part No.	LX.TPK0Z.008
Description	TM7730-864G32Mi VB32TRUS1 MC UMACF 2*2G/320/BT/8L/5R/CB_i3_FP_0.3D_EN33
CPU	C2DP8600
LCD	N17WXGA+G
SO-DIMM 1	SO2GBII6
SO-DIMM 2	SO2GBII6
HDD 1 (GB)	N320GB5.4KS
HDD 2 (GB)	N
ODD	NSM8XS
Wireless LAN	SP3x3MMW
Bluetooth	BT 2.0

Model	TM7730G-864G32Mi
RO	PA
Country	USA
Acer Part No.	LX.TPLOZ.007
Description	TM7730G-864G32Mi VB32TRUS1 MC 9MGSHM256CF 2*2G/320/BT/6L/5R/CB_i3_FP_0.3D_EN33
CPU	C2DP8600
LCD	N17WXGA+G
SO-DIMM 1	SO2GBII6
SO-DIMM 2	SO2GBII6
HDD 1 (GB)	N320GB5.4KS
HDD 2 (GB)	N
ODD	NSM8XS
Wireless LAN	SP3x3MMW
Bluetooth	BT 2.0

Model	TM7730G-844G50Bi
RO	EMEA
Country	Norway
Acer Part No.	LX.TPLOX.006
Description	TM7730G-844G50Bi VHP32TRNO1 MC 9MGSHM256CF 2*2G/250+250/BT/6L/5R/CB_i2_FP_0.3D_NO12
CPU	C2DP8400
LCD	N17WXGA+G
SO-DIMM 1	SO2GBII6
SO-DIMM 2	SO2GBII6
HDD 1 (GB)	N250GB5.4KS
HDD 2 (GB)	N250GB5.4KS
ODD	NBDCB2XS
Wireless LAN	SP1x2MMW
Bluetooth	BT 2.0

Model	TM7730G-844G50Bi
RO	EMEA
Country	Russia
Acer Part No.	LX.TPLOX.007
Description	TM7730G-844G50Bi VHP32TRRU1 MC 9MGSHM256CF 2*2G/250+250/BT/6L/5R/CB_i2_FP_0.3D_RU11
CPU	C2DP8400
LCD	N17WXGA+G
SO-DIMM 1	SO2GBII6
SO-DIMM 2	SO2GBII6
HDD 1 (GB)	N250GB5.4KS
HDD 2 (GB)	N250GB5.4KS
ODD	NBDCB2XS
Wireless LAN	SP1x2MMW
Bluetooth	BT 2.0

Model	TM7730G-844G50Bi
RO	EMEA
Country	Sweden/Finland
Acer Part No.	LX.TPL0X.008
Description	TM7730G-844G50Bi VHP32TRSE1 MC 9MGSHM256CF 2*2G/250+250/BT/6L/5R/CB_i2_FP_0.3D_F12
CPU	C2DP8400
LCD	N17WXGA+G
SO-DIMM 1	SO2GBII6
SO-DIMM 2	SO2GBII6
HDD 1 (GB)	N250GB5.4KS
HDD 2 (GB)	N250GB5.4KS
ODD	NBDCB2XS
Wireless LAN	SP1x2MMW
Bluetooth	BT 2.0

Model	TM7730G-844G50Bi
RO	EMEA
Country	Slovenia/Croatia
Acer Part No.	LX.TPL0X.009
Description	TM7730G-844G50Bi VHP32TRS11 MC 9MGSHM256CF 2*2G/250+250/BT/6L/5R/CB_i2_FP_0.3D_EN12
CPU	C2DP8400
LCD	N17WXGA+G
SO-DIMM 1	SO2GBII6
SO-DIMM 2	SO2GBII6
HDD 1 (GB)	N250GB5.4KS
HDD 2 (GB)	N250GB5.4KS
ODD	NBDCB2XS
Wireless LAN	SP1x2MMW
Bluetooth	BT 2.0

Model	TM7730G-844G50Bi
RO	EMEA
Country	Portugal
Acer Part No.	LX.TPL0X.010
Description	TM7730G-844G50Bi VHP32TRPT1 MC 9MGSHM256CF 2*2G/250+250/BT/6L/5R/CB_i2_FP_0.3D_PT12
CPU	C2DP8400
LCD	N17WXGA+G
SO-DIMM 1	SO2GBII6
SO-DIMM 2	SO2GBII6
HDD 1 (GB)	N250GB5.4KS
HDD 2 (GB)	N250GB5.4KS
ODD	NBDCB2XS
Wireless LAN	SP1x2MMW
Bluetooth	BT 2.0

Model	TM7730-842G25Mi
RO	EMEA
Country	South Africa
Acer Part No.	LX.TPK0X.006
Description	TM7730-842G25Mi EM VHP32TRZA2 MC UMACF 1*2G/250/BT/6L/5R/CB_i2_FP_0.3D_EN16
CPU	C2DP8400
LCD	N17WXGA+G
SO-DIMM 1	SO2GBII6
SO-DIMM 2	N
HDD 1 (GB)	N250GB5.4KS
HDD 2 (GB)	N
ODD	NSM8XS
Wireless LAN	SP1x2MMW
Bluetooth	BT 2.0

Model	TM7730-842G25Mi
RO	EMEA
Country	South Africa
Acer Part No.	LX.TPK0X.007
Description	TM7730-842G25Mi EM VHP32TRZA1 MC UMACF 1*2G/250/BT/6L/5R/CB_i2_FP_0.3D_FR23
CPU	C2DP8400
LCD	N17WXGA+G
SO-DIMM 1	SO2GBII6
SO-DIMM 2	N
HDD 1 (GB)	N250GB5.4KS
HDD 2 (GB)	N
ODD	NSM8XS
Wireless LAN	SP1x2MMW
Bluetooth	BT 2.0

Model	TM7730-842G25Mi
RO	EMEA
Country	Denmark
Acer Part No.	LX.TPK0X.008
Description	TM7730-842G25Mi VHP32TRDK1 MC UMACF 1*2G/250/BT/6L/5R/CB_i2_FP_0.3D_NO13
CPU	C2DP8400
LCD	N17WXGA+G
SO-DIMM 1	SO2GBII6
SO-DIMM 2	N
HDD 1 (GB)	N250GB5.4KS
HDD 2 (GB)	N
ODD	NSM8XS
Wireless LAN	SP1x2MMW
Bluetooth	BT 2.0

Model	TM7730-842G25Mi
RO	EMEA
Country	France
Acer Part No.	LX.TPK0X.009
Description	TM7730-842G25Mi VHP32TRFR1 MC UMACF 1*2G/250/BT/6L/5R/CB_i2_FP_0.3D_FR23
CPU	C2DP8400
LCD	N17WXGA+G
SO-DIMM 1	SO2GBII6
SO-DIMM 2	N
HDD 1 (GB)	N250GB5.4KS
HDD 2 (GB)	N
ODD	NSM8XS
Wireless LAN	SP1x2MMW
Bluetooth	BT 2.0

Model	TM7730-842G25Mi
RO	EMEA
Country	Germany
Acer Part No.	LX.TPK0X.010
Description	TM7730-842G25Mi VHP32TRDE1 MC UMACF 1*2G/250/BT/6L/5R/CB_i2_FP_0.3D_DE13
CPU	C2DP8400
LCD	N17WXGA+G
SO-DIMM 1	SO2GBII6
SO-DIMM 2	N
HDD 1 (GB)	N250GB5.4KS
HDD 2 (GB)	N
ODD	NSM8XS
Wireless LAN	SP1x2MMW
Bluetooth	BT 2.0

Model	TM7730-842G25Mi
RO	EMEA
Country	Belgium
Acer Part No.	LX.TPK0X.011
Description	TM7730-842G25Mi VHP32TRBE1 MC UMACF 1*2G/250/BT/6L/5R/CB_i2_FP_0.3D_NL13
CPU	C2DP8400
LCD	N17WXGA+G
SO-DIMM 1	SO2GBII6
SO-DIMM 2	N
HDD 1 (GB)	N250GB5.4KS
HDD 2 (GB)	N
ODD	NSM8XS
Wireless LAN	SP1x2MMW
Bluetooth	BT 2.0

Model	TM7730-842G25Mi
RO	EMEA
Country	Holland
Acer Part No.	LX.TPK0X.012
Description	TM7730-842G25Mi VHP32TRNL1 MC UMACF 1*2G/250/BT/6L/5R/CB_i2_FP_0.3D_NL12
CPU	C2DP8400
LCD	N17WXGA+G
SO-DIMM 1	SO2GBII6
SO-DIMM 2	N
HDD 1 (GB)	N250GB5.4KS
HDD 2 (GB)	N
ODD	NSM8XS
Wireless LAN	SP1x2MMW
Bluetooth	BT 2.0

Model	TM7730-842G25Mi
RO	EMEA
Country	Luxembourg
Acer Part No.	LX.TPK0X.013
Description	TM7730-842G25Mi VHP32TRLU1 MC UMACF 1*2G/250/BT/6L/5R/CB_i2_FP_0.3D_IT42
CPU	C2DP8400
LCD	N17WXGA+G
SO-DIMM 1	SO2GBII6
SO-DIMM 2	N
HDD 1 (GB)	N250GB5.4KS
HDD 2 (GB)	N
ODD	NSM8XS
Wireless LAN	SP1x2MMW
Bluetooth	BT 2.0

Model	TM7730-842G25Mi
RO	EMEA
Country	Norway
Acer Part No.	LX.TPK0X.014
Description	TM7730-842G25Mi VHP32TRNO1 MC UMACF 1*2G/250/BT/6L/5R/CB_i2_FP_0.3D_NO12
CPU	C2DP8400
LCD	N17WXGA+G
SO-DIMM 1	SO2GBII6
SO-DIMM 2	N
HDD 1 (GB)	N250GB5.4KS
HDD 2 (GB)	N
ODD	NSM8XS
Wireless LAN	SP1x2MMW
Bluetooth	BT 2.0

Model	TM7730-842G25Mi
RO	EMEA
Country	Sweden/Finland
Acer Part No.	LX.TPK0X.015
Description	TM7730-842G25Mi VHP32TRSE1 MC UMACF 1*2G/250/BT/6L/5R/CB_i2_FP_0.3D_FI12
CPU	C2DP8400
LCD	N17WXGA+G
SO-DIMM 1	SO2GBII6
SO-DIMM 2	N
HDD 1 (GB)	N250GB5.4KS
HDD 2 (GB)	N
ODD	NSM8XS
Wireless LAN	SP1x2MMW
Bluetooth	BT 2.0

Model	TM7730-842G25Mi
RO	EMEA
Country	Czech
Acer Part No.	LX.TPK0X.016
Description	TM7730-842G25Mi VHP32TRCZ1 MC UMACF 1*2G/250/BT/6L/5R/CB_i2_FP_0.3D_SK11
CPU	C2DP8400
LCD	N17WXGA+G
SO-DIMM 1	SO2GBII6
SO-DIMM 2	N
HDD 1 (GB)	N250GB5.4KS
HDD 2 (GB)	N
ODD	NSM8XS
Wireless LAN	SP1x2MMW
Bluetooth	BT 2.0

Model	TM7730-842G25Mi
RO	EMEA
Country	Russia
Acer Part No.	LX.TPK0X.017
Description	TM7730-842G25Mi VHP32TRRU1 MC UMACF 1*2G/250/BT/6L/5R/CB_i2_FP_0.3D_RU11
CPU	C2DP8400
LCD	N17WXGA+G
SO-DIMM 1	SO2GBII6
SO-DIMM 2	N
HDD 1 (GB)	N250GB5.4KS
HDD 2 (GB)	N
ODD	NSM8XS
Wireless LAN	SP1x2MMW
Bluetooth	BT 2.0

Model	TM7730-842G25Mi
RO	EMEA
Country	Eastern Europe
Acer Part No.	LX.TPK0X.018
Description	TM7730-842G25Mi VHP32TREU1 MC UMACF 1*2G/250/BT/6L/5R/CB_i2_FP_0.3D_CS21
CPU	C2DP8400
LCD	N17WXGA+G
SO-DIMM 1	SO2GBII6
SO-DIMM 2	N
HDD 1 (GB)	N250GB5.4KS
HDD 2 (GB)	N
ODD	NSM8XS
Wireless LAN	SP1x2MMW
Bluetooth	BT 2.0

Model	TM7730-842G25Mi
RO	EMEA
Country	Eastern Europe
Acer Part No.	LX.TPK0X.019
Description	TM7730-842G25Mi VHP32TREU4 MC UMACF 1*2G/250/BT/6L/5R/CB_i2_FP_0.3D_FI12
CPU	C2DP8400
LCD	N17WXGA+G
SO-DIMM 1	SO2GBII6
SO-DIMM 2	N
HDD 1 (GB)	N250GB5.4KS
HDD 2 (GB)	N
ODD	NSM8XS
Wireless LAN	SP1x2MMW
Bluetooth	BT 2.0

Model	TM7730-842G25Mi
RO	EMEA
Country	Eastern Europe
Acer Part No.	LX.TPK0X.020
Description	TM7730-842G25Mi VHP32TREU3 MC UMACF 1*2G/250/BT/6L/5R/CB_i2_FP_0.3D_RU21
CPU	C2DP8400
LCD	N17WXGA+G
SO-DIMM 1	SO2GBII6
SO-DIMM 2	N
HDD 1 (GB)	N250GB5.4KS
HDD 2 (GB)	N
ODD	NSM8XS
Wireless LAN	SP1x2MMW
Bluetooth	BT 2.0

Model	TM7730-842G25Mi
RO	EMEA
Country	Eastern Europe
Acer Part No.	LX.TPK0X.021
Description	TM7730-842G25Mi VHP32TREU5 MC UMACF 1*2G/250/BT/6L/5R/CB_i2_FP_0.3D_PL11
CPU	C2DP8400
LCD	N17WXGA+G
SO-DIMM 1	SO2GBII6
SO-DIMM 2	N
HDD 1 (GB)	N250GB5.4KS
HDD 2 (GB)	N
ODD	NSM8XS
Wireless LAN	SP1x2MMW
Bluetooth	BT 2.0

Model	TM7730-842G25Mi
RO	EMEA
Country	Hungary
Acer Part No.	LX.TPK0X.022
Description	TM7730-842G25Mi VHP32TRHU1 MC UMACF 1*2G/250/BT/6L/5R/CB_i2_FP_0.3D_HU11
CPU	C2DP8400
LCD	N17WXGA+G
SO-DIMM 1	SO2GBII6
SO-DIMM 2	N
HDD 1 (GB)	N250GB5.4KS
HDD 2 (GB)	N
ODD	NSM8XS
Wireless LAN	SP1x2MMW
Bluetooth	BT 2.0

Model	TM7730-842G25Mi
RO	EMEA
Country	Eastern Europe
Acer Part No.	LX.TPK0X.023
Description	TM7730-842G25Mi VHP32TREU3 MC UMACF 1*2G/250/BT/6L/5R/CB_i2_FP_0.3D_RU11
CPU	C2DP8400
LCD	N17WXGA+G
SO-DIMM 1	SO2GBII6
SO-DIMM 2	N
HDD 1 (GB)	N250GB5.4KS
HDD 2 (GB)	N
ODD	NSM8XS
Wireless LAN	SP1x2MMW
Bluetooth	BT 2.0

Model	TM7730-842G25Mi
RO	EMEA
Country	Slovenia/Croatia
Acer Part No.	LX.TPK0X.024
Description	TM7730-842G25Mi VHP32TRS11 MC UMACF 1*2G/250/BT/6L/5R/CB_i2_FP_0.3D_EN12
CPU	C2DP8400
LCD	N17WXGA+G
SO-DIMM 1	SO2GBII6
SO-DIMM 2	N
HDD 1 (GB)	N250GB5.4KS
HDD 2 (GB)	N
ODD	NSM8XS
Wireless LAN	SP1x2MMW
Bluetooth	BT 2.0

Model	TM7730-842G25Mi
RO	EMEA
Country	Portugal
Acer Part No.	LX.TPK0X.025
Description	TM7730-842G25Mi VHP32TRPT1 MC UMACF 1*2G/250/BT/6L/5R/CB_i2_FP_0.3D_PT12
CPU	C2DP8400
LCD	N17WXGA+G
SO-DIMM 1	SO2GBII6
SO-DIMM 2	N
HDD 1 (GB)	N250GB5.4KS
HDD 2 (GB)	N
ODD	NSM8XS
Wireless LAN	SP1x2MMW
Bluetooth	BT 2.0

Model	TM7730-842G25Mi
RO	EMEA
Country	Spain
Acer Part No.	LX.TPK0X.026
Description	TM7730-842G25Mi VHP32TRES1 MC UMACF 1*2G/250/BT/6L/5R/CB_i2_FP_0.3D_ES22
CPU	C2DP8400
LCD	N17WXGA+G
SO-DIMM 1	SO2GBII6
SO-DIMM 2	N
HDD 1 (GB)	N250GB5.4KS
HDD 2 (GB)	N
ODD	NSM8XS
Wireless LAN	SP1x2MMW
Bluetooth	BT 2.0

Model	TM7730-842G25Mi
RO	EMEA
Country	Greece
Acer Part No.	LX.TPK0X.027
Description	TM7730-842G25Mi VHP32TRGR1 MC UMACF 1*2G/250/BT/6L/5R/CB_i2_FP_0.3D_EL32
CPU	C2DP8400
LCD	N17WXGA+G
SO-DIMM 1	SO2GBII6
SO-DIMM 2	N
HDD 1 (GB)	N250GB5.4KS
HDD 2 (GB)	N
ODD	NSM8XS
Wireless LAN	SP1x2MMW
Bluetooth	BT 2.0

Model	TM7730-842G25Mi
RO	EMEA
Country	Greece
Acer Part No.	LX.TPK0X.028
Description	TM7730-842G25Mi VHP32TRGR1 MC UMACF 1*2G/250/BT/6L/5R/CB_i2_FP_0.3D_EL22
CPU	C2DP8400
LCD	N17WXGA+G
SO-DIMM 1	SO2GBII6
SO-DIMM 2	N
HDD 1 (GB)	N250GB5.4KS
HDD 2 (GB)	N
ODD	NSM8XS
Wireless LAN	SP1x2MMW
Bluetooth	BT 2.0

Model	TM7730-842G25Mi
RO	EMEA
Country	Israel
Acer Part No.	LX.TPK0X.029
Description	TM7730-842G25Mi VHP32TRIL1 MC UMACF 1*2G/250/BT/6L/5R/CB_i2_FP_0.3D_HE11
CPU	C2DP8400
LCD	N17WXGA+G
SO-DIMM 1	SO2GBII6
SO-DIMM 2	N
HDD 1 (GB)	N250GB5.4KS
HDD 2 (GB)	N
ODD	NSM8XS
Wireless LAN	SP1x2MMW
Bluetooth	BT 2.0

Model	TM7730-842G25Mi
RO	EMEA
Country	Italy
Acer Part No.	LX.TPK0X.030
Description	TM7730-842G25Mi VHP32TRIT1 MC UMACF 1*2G/250/BT/6L/5R/CB_i2_FP_0.3D_IT12
CPU	C2DP8400
LCD	N17WXGA+G
SO-DIMM 1	SO2GBII6
SO-DIMM 2	N
HDD 1 (GB)	N250GB5.4KS
HDD 2 (GB)	N
ODD	NSM8XS
Wireless LAN	SP1x2MMW
Bluetooth	BT 2.0

Model	TM7730-842G25Mi
RO	EMEA
Country	Turkey
Acer Part No.	LX.TPK0X.031
Description	TM7730-842G25Mi EM VHP32TRTR1 MC UMACF 1*2G/250/BT/6L/5R/CB_i2_FP_0.3D_TR22
CPU	C2DP8400
LCD	N17WXGA+G
SO-DIMM 1	SO2GBII6
SO-DIMM 2	N
HDD 1 (GB)	N250GB5.4KS
HDD 2 (GB)	N
ODD	NSM8XS
Wireless LAN	SP1x2MMW
Bluetooth	BT 2.0

Model	TM7730-842G25Mi
RO	EMEA
Country	Turkey
Acer Part No.	LX.TPK0X.032
Description	TM7730-842G25Mi EM VHP32TRTR1 MC UMACF 1*2G/250/BT/6L/5R/CB_i2_FP_0.3D_TR32
CPU	C2DP8400
LCD	N17WXGA+G
SO-DIMM 1	SO2GBII6
SO-DIMM 2	N
HDD 1 (GB)	N250GB5.4KS
HDD 2 (GB)	N
ODD	NSM8XS
Wireless LAN	SP1x2MMW
Bluetooth	BT 2.0

Model	TM7730-842G25Mi
RO	EMEA
Country	Middle East
Acer Part No.	LX.TPK0X.033
Description	TM7730-842G25Mi EM VHP32TRME3 MC UMACF 1*2G/250/BT/6L/5R/CB_i2_FP_0.3D_FR23
CPU	C2DP8400
LCD	N17WXGA+G
SO-DIMM 1	SO2GBII6
SO-DIMM 2	N
HDD 1 (GB)	N250GB5.4KS
HDD 2 (GB)	N
ODD	NSM8XS
Wireless LAN	SP1x2MMW
Bluetooth	BT 2.0

Model	TM7730-842G25Mi
RO	EMEA
Country	Middle East
Acer Part No.	LX.TPK0X.034
Description	TM7730-842G25Mi EM VHP32TRME2 MC UMACF 1*2G/250/BT/6L/5R/CB_i2_FP_0.3D_AR23
CPU	C2DP8400
LCD	N17WXGA+G
SO-DIMM 1	SO2GBII6
SO-DIMM 2	N
HDD 1 (GB)	N250GB5.4KS
HDD 2 (GB)	N
ODD	NSM8XS
Wireless LAN	SP1x2MMW
Bluetooth	BT 2.0

Model	TM7730-842G25Mi
RO	EMEA
Country	Middle East
Acer Part No.	LX.TPK0X.035
Description	TM7730-842G25Mi EM VHP32TRME6 MC UMACF 1*2G/250/BT/6L/5R/CB_i2_FP_0.3D_EN15
CPU	C2DP8400
LCD	N17WXGA+G
SO-DIMM 1	SO2GBII6
SO-DIMM 2	N
HDD 1 (GB)	N250GB5.4KS
HDD 2 (GB)	N
ODD	NSM8XS
Wireless LAN	SP1x2MMW
Bluetooth	BT 2.0

Model	TM7730-842G25Mi
RO	EMEA
Country	Middle East
Acer Part No.	LX.TPK0X.036
Description	TM7730-842G25Mi EM VHP32TRME9 MC UMACF 1*2G/250/BT/6L/5R/CB_i2_FP_0.3D_FR22
CPU	C2DP8400
LCD	N17WXGA+G
SO-DIMM 1	SO2GBII6
SO-DIMM 2	N
HDD 1 (GB)	N250GB5.4KS
HDD 2 (GB)	N
ODD	NSM8XS
Wireless LAN	SP1x2MMW
Bluetooth	BT 2.0

Model	TM7730-842G25Mi
RO	EMEA
Country	Middle East
Acer Part No.	LX.TPK0X.037
Description	TM7730-842G25Mi EM VHP32TRME2 MC UMACF 1*2G/250/BT/6L/5R/CB_i2_FP_0.3D_AR13
CPU	C2DP8400
LCD	N17WXGA+G
SO-DIMM 1	SO2GBII6
SO-DIMM 2	N
HDD 1 (GB)	N250GB5.4KS
HDD 2 (GB)	N
ODD	NSM8XS
Wireless LAN	SP1x2MMW
Bluetooth	BT 2.0

Model	TM7730-842G25Mi
RO	EMEA
Country	Middle East
Acer Part No.	LX.TPK0X.038
Description	TM7730-842G25Mi EM VHP32TRME2 MC UMACF 1*2G/250/BT/6L/5R/CB_i2_FP_0.3D_EN15
CPU	C2DP8400
LCD	N17WXGA+G
SO-DIMM 1	SO2GBII6
SO-DIMM 2	N
HDD 1 (GB)	N250GB5.4KS
HDD 2 (GB)	N
ODD	NSM8XS
Wireless LAN	SP1x2MMW
Bluetooth	BT 2.0

Model	TM7730-842G25Mi
RO	EMEA
Country	Switzerland
Acer Part No.	LX.TPK0X.039
Description	TM7730-842G25Mi VHP32TRCH1 MC UMACF 1*2G/250/BT/6L/5R/CB_i2_FP_0.3D_IT42
CPU	C2DP8400
LCD	N17WXGA+G
SO-DIMM 1	SO2GBII6
SO-DIMM 2	N
HDD 1 (GB)	N250GB5.4KS
HDD 2 (GB)	N
ODD	NSM8XS
Wireless LAN	SP1x2MMW
Bluetooth	BT 2.0

Model	TM7730-842G25Mi
RO	EMEA
Country	UK
Acer Part No.	LX.TPK0X.040
Description	TM7730-842G25Mi VHP32TRGB1 MC UMACF 1*2G/250/BT/6L/5R/CB_i2_FP_0.3D_EN14
CPU	C2DP8400
LCD	N17WXGA+G
SO-DIMM 1	SO2GBII6
SO-DIMM 2	N
HDD 1 (GB)	N250GB5.4KS
HDD 2 (GB)	N
ODD	NSM8XS
Wireless LAN	SP1x2MMW
Bluetooth	BT 2.0

Model	TM7730G-844G32Mi
RO	EMEA
Country	South Africa
Acer Part No.	LX.TPL0X.011
Description	TM7730G-844G32Mi EM VHP32TRZA2 MC 9MGSHM256CF 2*2G/320/BT/6L/5R/CB_i2_FP_0.3D_EN16
CPU	C2DP8400
LCD	N17WXGA+G
SO-DIMM 1	SO2GBII6
SO-DIMM 2	SO2GBII6
HDD 1 (GB)	N320GB5.4KS
HDD 2 (GB)	N
ODD	NSM8XS
Wireless LAN	SP1x2MMW
Bluetooth	BT 2.0

Model	TM7730G-844G32Mi
RO	EMEA
Country	South Africa
Acer Part No.	LX.TPLOX.012
Description	TM7730G-844G32Mi EM VHP32TRZA1 MC 9MGSHM256CF 2*2G/320/BT/6L/5R/CB_i2_FP_0.3D_FR23
CPU	C2DP8400
LCD	N17WXGA+G
SO-DIMM 1	SO2GBII6
SO-DIMM 2	SO2GBII6
HDD 1 (GB)	N320GB5.4KS
HDD 2 (GB)	N
ODD	NSM8XS
Wireless LAN	SP1x2MMW
Bluetooth	BT 2.0

Model	TM7730G-844G32Mi
RO	EMEA
Country	Denmark
Acer Part No.	LX.TPLOX.013
Description	TM7730G-844G32Mi VHP32TRDK1 MC 9MGSHM256CF 2*2G/320/BT/6L/5R/CB_i2_FP_0.3D_NO13
CPU	C2DP8400
LCD	N17WXGA+G
SO-DIMM 1	SO2GBII6
SO-DIMM 2	SO2GBII6
HDD 1 (GB)	N320GB5.4KS
HDD 2 (GB)	N
ODD	NSM8XS
Wireless LAN	SP1x2MMW
Bluetooth	BT 2.0

Model	TM7730G-844G32Mi
RO	EMEA
Country	Denmark
Acer Part No.	LX.TPLOX.026
Description	TM7730G-844G32Mi VHP32TRFR1 MC 9MGSHM256CF 2*2G/320/BT/6L/5R/CB_i2_FP_0.3D_FR23
CPU	C2DP8400
LCD	N17WXGA+G
SO-DIMM 1	SO2GBII6
SO-DIMM 2	SO2GBII6
HDD 1 (GB)	N320GB5.4KS
HDD 2 (GB)	N
ODD	NSM8XS
Wireless LAN	SP1x2MMW
Bluetooth	BT 2.0

Model	TM7730G-844G32Mi
RO	EMEA
Country	Germany
Acer Part No.	LX.TPL0X.014
Description	TM7730G-844G32Mi VHP32TRDE1 MC 9MGSHM256CF 2*2G/320/BT/6L/5R/CB_i2_FP_0.3D_DE13
CPU	C2DP8400
LCD	N17WXGA+G
SO-DIMM 1	SO2GBII6
SO-DIMM 2	SO2GBII6
HDD 1 (GB)	N320GB5.4KS
HDD 2 (GB)	N
ODD	NSM8XS
Wireless LAN	SP1x2MMW
Bluetooth	BT 2.0

Model	TM7730G-844G32Mi
RO	EMEA
Country	Belgium
Acer Part No.	LX.TPL0X.015
Description	TM7730G-844G32Mi VHP32TRBE1 MC 9MGSHM256CF 2*2G/320/BT/6L/5R/CB_i2_FP_0.3D_NL13
CPU	C2DP8400
LCD	N17WXGA+G
SO-DIMM 1	SO2GBII6
SO-DIMM 2	SO2GBII6
HDD 1 (GB)	N320GB5.4KS
HDD 2 (GB)	N
ODD	NSM8XS
Wireless LAN	SP1x2MMW
Bluetooth	BT 2.0

Model	TM7730G-844G32Mi
RO	EMEA
Country	Holland
Acer Part No.	LX.TPL0X.027
Description	TM7730G-844G32Mi VHP32TRNL1 MC 9MGSHM256CF 2*2G/320/BT/6L/5R/CB_i2_FP_0.3D_NL12
CPU	C2DP8400
LCD	N17WXGA+G
SO-DIMM 1	SO2GBII6
SO-DIMM 2	SO2GBII6
HDD 1 (GB)	N320GB5.4KS
HDD 2 (GB)	N
ODD	NSM8XS
Wireless LAN	SP1x2MMW
Bluetooth	BT 2.0

Model	TM7730G-844G32Mi
RO	EMEA
Country	Czech
Acer Part No.	LX.TPLOX.016
Description	TM7730G-844G32Mi VHP32TRCZ1 MC 9MGSHM256CF 2*2G/320/BT/6L/5R/CB_i2_FP_0.3D_SK11
CPU	C2DP8400
LCD	N17WXGA+G
SO-DIMM 1	SO2GBII6
SO-DIMM 2	SO2GBII6
HDD 1 (GB)	N320GB5.4KS
HDD 2 (GB)	N
ODD	NSM8XS
Wireless LAN	SP1x2MMW
Bluetooth	BT 2.0

Model	TM7730G-844G32Mi
RO	EMEA
Country	Luxembourg
Acer Part No.	LX.TPLOX.028
Description	TM7730G-844G32Mi VHP32TRLU1 MC 9MGSHM256CF 2*2G/320/BT/6L/5R/CB_i2_FP_0.3D_IT42
CPU	C2DP8400
LCD	N17WXGA+G
SO-DIMM 1	SO2GBII6
SO-DIMM 2	SO2GBII6
HDD 1 (GB)	N320GB5.4KS
HDD 2 (GB)	N
ODD	NSM8XS
Wireless LAN	SP1x2MMW
Bluetooth	BT 2.0

Model	TM7730G-844G32Mi
RO	EMEA
Country	Norway
Acer Part No.	LX.TPLOX.029
Description	TM7730G-844G32Mi VHP32TRNO1 MC 9MGSHM256CF 2*2G/320/BT/6L/5R/CB_i2_FP_0.3D_NO12
CPU	C2DP8400
LCD	N17WXGA+G
SO-DIMM 1	SO2GBII6
SO-DIMM 2	SO2GBII6
HDD 1 (GB)	N320GB5.4KS
HDD 2 (GB)	N
ODD	NSM8XS
Wireless LAN	SP1x2MMW
Bluetooth	BT 2.0

Model	TM7730G-844G32Mi
RO	EMEA
Country	Sweden/Finland
Acer Part No.	LX.TPL0X.030
Description	TM7730G-844G32Mi VHP32TRSE1 MC 9MGSHM256CF 2*2G/320/BT/6L/5R/CB_i2_FP_0.3D_FI12
CPU	C2DP8400
LCD	N17WXGA+G
SO-DIMM 1	SO2GBII6
SO-DIMM 2	SO2GBII6
HDD 1 (GB)	N320GB5.4KS
HDD 2 (GB)	N
ODD	NSM8XS
Wireless LAN	SP1x2MMW
Bluetooth	BT 2.0

Model	TM7730G-844G32Mi
RO	EMEA
Country	Sweden/Finland
Acer Part No.	LX.TPL0X.030
Description	TM7730G-844G32Mi VHP32TRSE1 MC 9MGSHM256CF 2*2G/320/BT/6L/5R/CB_i2_FP_0.3D_FI12
CPU	C2DP8400
LCD	N17WXGA+G
SO-DIMM 1	SO2GBII6
SO-DIMM 2	SO2GBII6
HDD 1 (GB)	N320GB5.4KS
HDD 2 (GB)	N
ODD	NSM8XS
Wireless LAN	SP1x2MMW
Bluetooth	BT 2.0

Model	TM7730G-844G32Mi
RO	EMEA
Country	Russia
Acer Part No.	LX.TPL0X.031
Description	TM7730G-844G32Mi VHP32TRRU1 MC 9MGSHM256CF 2*2G/320/BT/6L/5R/CB_i2_FP_0.3D_RU11
CPU	C2DP8400
LCD	N17WXGA+G
SO-DIMM 1	SO2GBII6
SO-DIMM 2	SO2GBII6
HDD 1 (GB)	N320GB5.4KS
HDD 2 (GB)	N
ODD	NSM8XS
Wireless LAN	SP1x2MMW
Bluetooth	BT 2.0

Model	TM7730G-844G50Bi
RO	EMEA
Country	South Africa
Acer Part No.	LX.TPLOX.047
Description	TM7730G-844G50Bi EM VHP32TRZA1 MC 9MGSHM256CF 2*2G/250+250/BT/6L/5R/CB_i2_FP_0.3D_FR23
CPU	C2DP8400
LCD	N17WXGA+G
SO-DIMM 1	SO2GBII6
SO-DIMM 2	SO2GBII6
HDD 1 (GB)	N250GB5.4KS
HDD 2 (GB)	N250GB5.4KS
ODD	NBDCB2XS
Wireless LAN	SP1x2MMW
Bluetooth	BT 2.0

Model	TM7730G-844G50Bi
RO	EMEA
Country	Denmark
Acer Part No.	LX.TPLOX.048
Description	TM7730G-844G50Bi VHP32TRDK1 MC 9MGSHM256CF 2*2G/250+250/BT/6L/5R/CB_i2_FP_0.3D_NO13
CPU	C2DP8400
LCD	N17WXGA+G
SO-DIMM 1	SO2GBII6
SO-DIMM 2	SO2GBII6
HDD 1 (GB)	N250GB5.4KS
HDD 2 (GB)	N250GB5.4KS
ODD	NBDCB2XS
Wireless LAN	SP1x2MMW
Bluetooth	BT 2.0

Model	TM7730G-844G32Mi
RO	EMEA
Country	Middle East
Acer Part No.	LX.TPLOX.020
Description	TM7730G-844G32Mi EM VHP32TRME2 MC 9MGSHM256CF 2*2G/320/BT/6L/5R/CB_i2_FP_0.3D_AR23
CPU	C2DP8400
LCD	N17WXGA+G
SO-DIMM 1	SO2GBII6
SO-DIMM 2	SO2GBII6
HDD 1 (GB)	N320GB5.4KS
HDD 2 (GB)	N
ODD	NSM8XS
Wireless LAN	SP1x2MMW
Bluetooth	BT 2.0

Model	TM7730G-844G32Mi
RO	EMEA
Country	Middle East
Acer Part No.	LX.TPL0X.021
Description	TM7730G-844G32Mi EM VHP32TRME6 MC 9MGSHM256CF 2*2G/320/BT/6L/5R/CB_i2_FP_0.3D_EN15
CPU	C2DP8400
LCD	N17WXGA+G
SO-DIMM 1	SO2GBII6
SO-DIMM 2	SO2GBII6
HDD 1 (GB)	N320GB5.4KS
HDD 2 (GB)	N
ODD	NSM8XS
Wireless LAN	SP1x2MMW
Bluetooth	BT 2.0

Model	TM7730G-844G32Mi
RO	EMEA
Country	Middle East
Acer Part No.	LX.TPL0X.022
Description	TM7730G-844G32Mi EM VHP32TRME9 MC 9MGSHM256CF 2*2G/320/BT/6L/5R/CB_i2_FP_0.3D_FR22
CPU	C2DP8400
LCD	N17WXGA+G
SO-DIMM 1	SO2GBII6
SO-DIMM 2	SO2GBII6
HDD 1 (GB)	N320GB5.4KS
HDD 2 (GB)	N
ODD	NSM8XS
Wireless LAN	SP1x2MMW
Bluetooth	BT 2.0

Model	TM7730G-844G32Mi
RO	EMEA
Country	Middle East
Acer Part No.	LX.TPL0X.023
Description	TM7730G-844G32Mi EM VHP32TRME2 MC 9MGSHM256CF 2*2G/320/BT/6L/5R/CB_i2_FP_0.3D_AR13
CPU	C2DP8400
LCD	N17WXGA+G
SO-DIMM 1	SO2GBII6
SO-DIMM 2	SO2GBII6
HDD 1 (GB)	N320GB5.4KS
HDD 2 (GB)	N
ODD	NSM8XS
Wireless LAN	SP1x2MMW
Bluetooth	BT 2.0

Model	TM7730G-844G32Mi
RO	EMEA
Country	Middle East
Acer Part No.	LX.TPLOX.024
Description	TM7730G-844G32Mi EM VHP32TRME2 MC 9MGSHM256CF 2*2G/320/BT/6L/5R/CB_i2_FP_0.3D_EN15
CPU	C2DP8400
LCD	N17WXGA+G
SO-DIMM 1	SO2GBII6
SO-DIMM 2	SO2GBII6
HDD 1 (GB)	N320GB5.4KS
HDD 2 (GB)	N
ODD	NSM8XS
Wireless LAN	SP1x2MMW
Bluetooth	BT 2.0

Model	TM7730G-844G32Mi
RO	EMEA
Country	Switzerland
Acer Part No.	LX.TPLOX.025
Description	TM7730G-844G32Mi VHP32TRCH1 MC 9MGSHM256CF 2*2G/320/BT/6L/5R/CB_i2_FP_0.3D_IT42
CPU	C2DP8400
LCD	N17WXGA+G
SO-DIMM 1	SO2GBII6
SO-DIMM 2	SO2GBII6
HDD 1 (GB)	N320GB5.4KS
HDD 2 (GB)	N
ODD	NSM8XS
Wireless LAN	SP1x2MMW
Bluetooth	BT 2.0

Model	TM7730G-844G32Mi
RO	EMEA
Country	UK
Acer Part No.	LX.TPLOX.045
Description	TM7730G-844G32Mi VHP32TRGB1 MC 9MGSHM256CF 2*2G/320/BT/6L/5R/CB_i2_FP_0.3D_EN14
CPU	C2DP8400
LCD	N17WXGA+G
SO-DIMM 1	SO2GBII6
SO-DIMM 2	SO2GBII6
HDD 1 (GB)	N320GB5.4KS
HDD 2 (GB)	N
ODD	NSM8XS
Wireless LAN	SP1x2MMW
Bluetooth	BT 2.0

Model	TM7730G-844G50Bi
RO	EMEA
Country	South Africa
Acer Part No.	LX.TPL0X.046
Description	M7730G-844G50Bi EM VHP32TRZA2 MC 9MGSHM256CF 2*2G/250+250/BT/6L/5R/CB_i2_FP_0.3D_EN16
CPU	C2DP8400
LCD	N17WXGA+G
SO-DIMM 1	SO2GBII6
SO-DIMM 2	SO2GBII6
HDD 1 (GB)	N250GB5.4KS
HDD 2 (GB)	N250GB5.4KS
ODD	NBDCB2XS
Wireless LAN	SP1x2MMW
Bluetooth	BT 2.0

Model	TM7730G-844G32Mi
RO	EMEA
Country	Eastern Europe
Acer Part No.	LX.TPL0X.032
Description	TM7730G-844G32Mi VHP32TREU1 MC 9MGSHM256CF 2*2G/320/BT/6L/5R/CB_i2_FP_0.3D_CS21
CPU	C2DP8400
LCD	N17WXGA+G
SO-DIMM 1	SO2GBII6
SO-DIMM 2	SO2GBII6
HDD 1 (GB)	N320GB5.4KS
HDD 2 (GB)	N
ODD	NSM8XS
Wireless LAN	SP1x2MMW
Bluetooth	BT 2.0

Model	TM7730G-844G32Mi
RO	EMEA
Country	Eastern Europe
Acer Part No.	LX.TPL0X.033
Description	TM7730G-844G32Mi VHP32TREU4 MC 9MGSHM256CF 2*2G/320/BT/6L/5R/CB_i2_FP_0.3D_F112
CPU	C2DP8400
LCD	N17WXGA+G
SO-DIMM 1	SO2GBII6
SO-DIMM 2	SO2GBII6
HDD 1 (GB)	N320GB5.4KS
HDD 2 (GB)	N
ODD	NSM8XS
Wireless LAN	SP1x2MMW
Bluetooth	BT 2.0

Model	TM7730G-844G32Mi
RO	EMEA
Country	Eastern Europe
Acer Part No.	LX.TPLOX.034
Description	TM7730G-844G32Mi VHP32TREU3 MC 9MGSHM256CF 2*2G/320/BT/6L/5R/CB_i2_FP_0.3D_RU21
CPU	C2DP8400
LCD	N17WXGA+G
SO-DIMM 1	SO2GBII6
SO-DIMM 2	SO2GBII6
HDD 1 (GB)	N320GB5.4KS
HDD 2 (GB)	N
ODD	NSM8XS
Wireless LAN	SP1x2MMW
Bluetooth	BT 2.0

Model	TM7730G-844G32Mi
RO	EMEA
Country	Eastern Europe
Acer Part No.	LX.TPLOX.035
Description	TM7730G-844G32Mi VHP32TREU5 MC 9MGSHM256CF 2*2G/320/BT/6L/5R/CB_i2_FP_0.3D_PL11
CPU	C2DP8400
LCD	N17WXGA+G
SO-DIMM 1	SO2GBII6
SO-DIMM 2	SO2GBII6
HDD 1 (GB)	N320GB5.4KS
HDD 2 (GB)	N
ODD	NSM8XS
Wireless LAN	SP1x2MMW
Bluetooth	BT 2.0

Model	TM7730G-844G32Mi
RO	EMEA
Country	Hungary
Acer Part No.	LX.TPLOX.036
Description	TM7730G-844G32Mi VHP32TRHU1 MC 9MGSHM256CF 2*2G/320/BT/6L/5R/CB_i2_FP_0.3D_HU11
CPU	C2DP8400
LCD	N17WXGA+G
SO-DIMM 1	SO2GBII6
SO-DIMM 2	SO2GBII6
HDD 1 (GB)	N320GB5.4KS
HDD 2 (GB)	N
ODD	NSM8XS
Wireless LAN	SP1x2MMW
Bluetooth	BT 2.0

Model	TM7730G-844G32Mi
RO	EMEA
Country	Eastern Europe
Acer Part No.	LX.TPL0X.037
Description	TM7730G-844G32Mi VHP32TREU3 MC 9MGSHM256CF 2*2G/320/BT/6L/5R/CB_i2_FP_0.3D_RU11
CPU	C2DP8400
LCD	N17WXGA+G
SO-DIMM 1	SO2GBII6
SO-DIMM 2	SO2GBII6
HDD 1 (GB)	N320GB5.4KS
HDD 2 (GB)	N
ODD	NSM8XS
Wireless LAN	SP1x2MMW
Bluetooth	BT 2.0

Model	TM7730G-844G32Mi
RO	EMEA
Country	Slovenia/Croatia
Acer Part No.	LX.TPL0X.038
Description	TM7730G-844G32Mi VHP32TRS1 MC 9MGSHM256CF 2*2G/320/BT/6L/5R/CB_i2_FP_0.3D_EN12
CPU	C2DP8400
LCD	N17WXGA+G
SO-DIMM 1	SO2GBII6
SO-DIMM 2	SO2GBII6
HDD 1 (GB)	N320GB5.4KS
HDD 2 (GB)	N
ODD	NSM8XS
Wireless LAN	SP1x2MMW
Bluetooth	BT 2.0

Model	TM7730G-844G32Mi
RO	EMEA
Country	Portugal
Acer Part No.	LX.TPL0X.039
Description	TM7730G-844G32Mi VHP32TRPT1 MC 9MGSHM256CF 2*2G/320/BT/6L/5R/CB_i2_FP_0.3D_PT12
CPU	C2DP8400
LCD	N17WXGA+G
SO-DIMM 1	SO2GBII6
SO-DIMM 2	SO2GBII6
HDD 1 (GB)	N320GB5.4KS
HDD 2 (GB)	N
ODD	NSM8XS
Wireless LAN	SP1x2MMW
Bluetooth	BT 2.0

Model	TM7730G-844G32Mi
RO	EMEA
Country	Spain
Acer Part No.	LX.TPLOX.040
Description	TM7730G-844G32Mi VHP32TRES1 MC 9MGSHM256CF 2*2G/320/BT/6L/5R/CB_i2_FP_0.3D_ES22
CPU	C2DP8400
LCD	N17WXGA+G
SO-DIMM 1	SO2GBII6
SO-DIMM 2	SO2GBII6
HDD 1 (GB)	N320GB5.4KS
HDD 2 (GB)	N
ODD	NSM8XS
Wireless LAN	SP1x2MMW
Bluetooth	BT 2.0

Model	TM7730G-844G32Mi
RO	EMEA
Country	Greece
Acer Part No.	LX.TPLOX.041
Description	TM7730G-844G32Mi VHP32TRGR1 MC 9MGSHM256CF 2*2G/320/BT/6L/5R/CB_i2_FP_0.3D_EL32
CPU	C2DP8400
LCD	N17WXGA+G
SO-DIMM 1	SO2GBII6
SO-DIMM 2	SO2GBII6
HDD 1 (GB)	N320GB5.4KS
HDD 2 (GB)	N
ODD	NSM8XS
Wireless LAN	SP1x2MMW
Bluetooth	BT 2.0

Model	TM7730G-844G32Mi
RO	EMEA
Country	Greece
Acer Part No.	LX.TPLOX.042
Description	TM7730G-844G32Mi VHP32TRGR1 MC 9MGSHM256CF 2*2G/320/BT/6L/5R/CB_i2_FP_0.3D_EL22
CPU	C2DP8400
LCD	N17WXGA+G
SO-DIMM 1	SO2GBII6
SO-DIMM 2	SO2GBII6
HDD 1 (GB)	N320GB5.4KS
HDD 2 (GB)	N
ODD	NSM8XS
Wireless LAN	SP1x2MMW
Bluetooth	BT 2.0

Model	TM7730G-844G32Mi
RO	EMEA
Country	Israel
Acer Part No.	LX.TPL0X.043
Description	TM7730G-844G32Mi VHP32TRIL1 MC 9MGSHM256CF 2*2G/320/BT/6L/5R/CB_i2_FP_0.3D_HE11
CPU	C2DP8400
LCD	N17WXGA+G
SO-DIMM 1	SO2GBII6
SO-DIMM 2	SO2GBII6
HDD 1 (GB)	N320GB5.4KS
HDD 2 (GB)	N
ODD	NSM8XS
Wireless LAN	SP1x2MMW
Bluetooth	BT 2.0

Model	TM7730G-844G32Mi
RO	EMEA
Country	Italy
Acer Part No.	LX.TPL0X.044
Description	TM7730G-844G32Mi VHP32TRIT1 MC 9MGSHM256CF 2*2G/320/BT/6L/5R/CB_i2_FP_0.3D_IT12
CPU	C2DP8400
LCD	N17WXGA+G
SO-DIMM 1	SO2GBII6
SO-DIMM 2	SO2GBII6
HDD 1 (GB)	N320GB5.4KS
HDD 2 (GB)	N
ODD	NSM8XS
Wireless LAN	SP1x2MMW
Bluetooth	BT 2.0

Model	TM7730G-844G32Mi
RO	EMEA
Country	Turkey
Acer Part No.	LX.TPL0X.017
Description	TM7730G-844G32Mi EM VHP32TRTR1 MC 9MGSHM256CF 2*2G/320/BT/6L/5R/CB_i2_FP_0.3D_TR22
CPU	C2DP8400
LCD	N17WXGA+G
SO-DIMM 1	SO2GBII6
SO-DIMM 2	SO2GBII6
HDD 1 (GB)	N320GB5.4KS
HDD 2 (GB)	N
ODD	NSM8XS
Wireless LAN	SP1x2MMW
Bluetooth	BT 2.0

Model	TM7730G-844G32Mi
RO	EMEA
Country	Turkey
Acer Part No.	LX.TPLOX.018
Description	TM7730G-844G32Mi EM VHP32TRTR1 MC 9MGSHM256CF 2*2G/320/BT/6L/5R/CB_i2_FP_0.3D_TR32
CPU	C2DP8400
LCD	N17WXGA+G
SO-DIMM 1	SO2GBII6
SO-DIMM 2	SO2GBII6
HDD 1 (GB)	N320GB5.4KS
HDD 2 (GB)	N
ODD	NSM8XS
Wireless LAN	SP1x2MMW
Bluetooth	BT 2.0

Model	TM7730G-844G32Mi
RO	EMEA
Country	Middle East
Acer Part No.	LX.TPLOX.019
Description	TM7730G-844G32Mi EM VHP32TRME3 MC 9MGSHM256CF 2*2G/320/BT/6L/5R/CB_i2_FP_0.3D_FR23
CPU	C2DP8400
LCD	N17WXGA+G
SO-DIMM 1	SO2GBII6
SO-DIMM 2	SO2GBII6
HDD 1 (GB)	N320GB5.4KS
HDD 2 (GB)	N
ODD	NSM8XS
Wireless LAN	SP1x2MMW
Bluetooth	BT 2.0

Model	TM7730G-844G50Bi
RO	EMEA
Country	France
Acer Part No.	LX.TPLOX.049
Description	TM7730G-844G50Bi VHP32TRFR1 MC 9MGSHM256CF 2*2G/250+250/BT/6L/5R/CB_i2_FP_0.3D_FR23
CPU	C2DP8400
LCD	N17WXGA+G
SO-DIMM 1	SO2GBII6
SO-DIMM 2	SO2GBII6
HDD 1 (GB)	N250GB5.4KS
HDD 2 (GB)	N250GB5.4KS
ODD	NBDCB2XS
Wireless LAN	SP1x2MMW
Bluetooth	BT 2.0

Model	TM7730G-844G50Bi
RO	EMEA
Country	Germany
Acer Part No.	LX.TPL0X.050
Description	TM7730G-844G50Bi VHP32TRDE1 MC 9MGSHM256CF 2*2G/250+250/BT/6L/5R/CB_i2_FP_0.3D_DE13
CPU	C2DP8400
LCD	N17WXGA+G
SO-DIMM 1	SO2GBII6
SO-DIMM 2	SO2GBII6
HDD 1 (GB)	N250GB5.4KS
HDD 2 (GB)	N250GB5.4KS
ODD	NBDCB2XS
Wireless LAN	SP1x2MMW
Bluetooth	BT 2.0

Model	TM7730G-844G50Bi
RO	EMEA
Country	Luxembourg
Acer Part No.	LX.TPL0X.053
Description	TM7730G-844G50Bi VHP32TRLU1 MC 9MGSHM256CF 2*2G/250+250/BT/6L/5R/CB_i2_FP_0.3D_IT42
CPU	C2DP8400
LCD	N17WXGA+G
SO-DIMM 1	SO2GBII6
SO-DIMM 2	SO2GBII6
HDD 1 (GB)	N250GB5.4KS
HDD 2 (GB)	N250GB5.4KS
ODD	NBDCB2XS
Wireless LAN	SP1x2MMW
Bluetooth	BT 2.0

Model	TM7730G-844G50Bi
RO	EMEA
Country	Belgium
Acer Part No.	LX.TPL0X.051
Description	TM7730G-844G50Bi VHP32TRBE1 MC 9MGSHM256CF 2*2G/250+250/BT/6L/5R/CB_i2_FP_0.3D_NL13
CPU	C2DP8400
LCD	N17WXGA+G
SO-DIMM 1	SO2GBII6
SO-DIMM 2	SO2GBII6
HDD 1 (GB)	N250GB5.4KS
HDD 2 (GB)	N250GB5.4KS
ODD	NBDCB2XS
Wireless LAN	SP1x2MMW
Bluetooth	BT 2.0

Model	TM7730G-844G50Bi
RO	EMEA
Country	Holland
Acer Part No.	LX.TPLOX.052
Description	TM7730G-844G50Bi VHP32TRNL1 MC 9MGSHM256CF 2*2G/250+250/BT/6L/5R/CB_i2_FP_0.3D_NL12
CPU	C2DP8400
LCD	N17WXGA+G
SO-DIMM 1	SO2GBII6
SO-DIMM 2	SO2GBII6
HDD 1 (GB)	N250GB5.4KS
HDD 2 (GB)	N250GB5.4KS
ODD	NBDCB2XS
Wireless LAN	SP1x2MMW
Bluetooth	BT 2.0

Model	TM7730G-844G50Bi
RO	EMEA
Country	Spain
Acer Part No.	LX.TPLOX.061
Description	TM7730G-844G50Bi VHP32TRES1 MC 9MGSHM256CF 2*2G/250+250/BT/6L/5R/CB_i2_FP_0.3D_ES22
CPU	C2DP8400
LCD	N17WXGA+G
SO-DIMM 1	SO2GBII6
SO-DIMM 2	SO2GBII6
HDD 1 (GB)	N250GB5.4KS
HDD 2 (GB)	N250GB5.4KS
ODD	NBDCB2XS
Wireless LAN	SP1x2MMW
Bluetooth	BT 2.0

Model	TM7730G-844G50Bi
RO	EMEA
Country	Eastern Europe
Acer Part No.	LX.TPLOX.060
Description	TM7730G-844G50Bi VHP32TREU3 MC 9MGSHM256CF 2*2G/250+250/BT/6L/5R/CB_i2_FP_0.3D_RU11
CPU	C2DP8400
LCD	N17WXGA+G
SO-DIMM 1	SO2GBII6
SO-DIMM 2	SO2GBII6
HDD 1 (GB)	N250GB5.4KS
HDD 2 (GB)	N250GB5.4KS
ODD	NBDCB2XS
Wireless LAN	SP1x2MMW
Bluetooth	BT 2.0

Model	TM7730G-844G50Bi
RO	EMEA
Country	Greece
Acer Part No.	LX.TPL0X.062
Description	TM7730G-844G50Bi VHP32TRGR1 MC 9MGSHM256CF 2*2G/250+250/BT/6L/5R/CB_i2_FP_0.3D_EL32
CPU	C2DP8400
LCD	N17WXGA+G
SO-DIMM 1	SO2GBII6
SO-DIMM 2	SO2GBII6
HDD 1 (GB)	N250GB5.4KS
HDD 2 (GB)	N250GB5.4KS
ODD	NBDCB2XS
Wireless LAN	SP1x2MMW
Bluetooth	BT 2.0

Model	TM7730G-844G50Bi
RO	EMEA
Country	Greece
Acer Part No.	LX.TPL0X.063
Description	TM7730G-844G50Bi VHP32TRGR1 MC 9MGSHM256CF 2*2G/250+250/BT/6L/5R/CB_i2_FP_0.3D_EL22
CPU	C2DP8400
LCD	N17WXGA+G
SO-DIMM 1	SO2GBII6
SO-DIMM 2	SO2GBII6
HDD 1 (GB)	N250GB5.4KS
HDD 2 (GB)	N250GB5.4KS
ODD	NBDCB2XS
Wireless LAN	SP1x2MMW
Bluetooth	BT 2.0

Model	TM7730G-844G50Bi
RO	EMEA
Country	Israel
Acer Part No.	LX.TPL0X.064
Description	TM7730G-844G50Bi VHP32TRIL1 MC 9MGSHM256CF 2*2G/250+250/BT/6L/5R/CB_i2_FP_0.3D_HE11
CPU	C2DP8400
LCD	N17WXGA+G
SO-DIMM 1	SO2GBII6
SO-DIMM 2	SO2GBII6
HDD 1 (GB)	N250GB5.4KS
HDD 2 (GB)	N250GB5.4KS
ODD	NBDCB2XS
Wireless LAN	SP1x2MMW
Bluetooth	BT 2.0

Model	TM7730G-844G50Bi
RO	EMEA
Country	Italy
Acer Part No.	LX.TPLOX.065
Description	TM7730G-844G50Bi VHP32TRIT1 MC 9MGSHM256CF 2*2G/250+250/BT/6L/5R/CB_i2_FP_0.3D_IT12
CPU	C2DP8400
LCD	N17WXGA+G
SO-DIMM 1	SO2GBII6
SO-DIMM 2	SO2GBII6
HDD 1 (GB)	N250GB5.4KS
HDD 2 (GB)	N250GB5.4KS
ODD	NBDCB2XS
Wireless LAN	SP1x2MMW
Bluetooth	BT 2.0

Model	TM7730G-844G50Bi
RO	EMEA
Country	Czech
Acer Part No.	LX.TPLOX.054
Description	TM7730G-844G50Bi VHP32TRCZ1 MC 9MGSHM256CF 2*2G/250+250/BT/6L/5R/CB_i2_FP_0.3D_SK11
CPU	C2DP8400
LCD	N17WXGA+G
SO-DIMM 1	SO2GBII6
SO-DIMM 2	SO2GBII6
HDD 1 (GB)	N250GB5.4KS
HDD 2 (GB)	N250GB5.4KS
ODD	NBDCB2XS
Wireless LAN	SP1x2MMW
Bluetooth	BT 2.0

Model	TM7730G-844G50Bi
RO	EMEA
Country	Eastern Europe
Acer Part No.	LX.TPLOX.055
Description	TM7730G-844G50Bi VHP32TREU1 MC 9MGSHM256CF 2*2G/250+250/BT/6L/5R/CB_i2_FP_0.3D_CS21
CPU	C2DP8400
LCD	N17WXGA+G
SO-DIMM 1	SO2GBII6
SO-DIMM 2	SO2GBII6
HDD 1 (GB)	N250GB5.4KS
HDD 2 (GB)	N250GB5.4KS
ODD	NBDCB2XS
Wireless LAN	SP1x2MMW
Bluetooth	BT 2.0

Model	TM7730G-844G50Bi
RO	EMEA
Country	Eastern Europe
Acer Part No.	LX.TPL0X.056
Description	TM7730G-844G50Bi VHP32TREU4 MC 9MGSHM256CF 2*2G/250+250/BT/6L/5R/CB_i2_FP_0.3D_FI12
CPU	C2DP8400
LCD	N17WXGA+G
SO-DIMM 1	SO2GBII6
SO-DIMM 2	SO2GBII6
HDD 1 (GB)	N250GB5.4KS
HDD 2 (GB)	N250GB5.4KS
ODD	NBDCB2XS
Wireless LAN	SP1x2MMW
Bluetooth	BT 2.0

Model	TM7730G-844G50Bi
RO	EMEA
Country	Eastern Europe
Acer Part No.	LX.TPL0X.057
Description	TM7730G-844G50Bi VHP32TREU3 MC 9MGSHM256CF 2*2G/250+250/BT/6L/5R/CB_i2_FP_0.3D_RU21
CPU	C2DP8400
LCD	N17WXGA+G
SO-DIMM 1	SO2GBII6
SO-DIMM 2	SO2GBII6
HDD 1 (GB)	N250GB5.4KS
HDD 2 (GB)	N250GB5.4KS
ODD	NBDCB2XS
Wireless LAN	SP1x2MMW
Bluetooth	BT 2.0

Model	TM7730G-844G50Bi
RO	EMEA
Country	Eastern Europe
Acer Part No.	LX.TPL0X.058
Description	TM7730G-844G50Bi VHP32TREU5 MC 9MGSHM256CF 2*2G/250+250/BT/6L/5R/CB_i2_FP_0.3D_PL11
CPU	C2DP8400
LCD	N17WXGA+G
SO-DIMM 1	SO2GBII6
SO-DIMM 2	SO2GBII6
HDD 1 (GB)	N250GB5.4KS
HDD 2 (GB)	N250GB5.4KS
ODD	NBDCB2XS
Wireless LAN	SP1x2MMW
Bluetooth	BT 2.0

Model	TM7730G-844G50Bi
RO	EMEA
Country	Hungary
Acer Part No.	LX.TPLOX.059
Description	TM7730G-844G50Bi VHP32TRHU1 MC 9MGSHM256CF 2*2G/250+250/BT/6L/5R/CB_i2_FP_0.3D_HU11
CPU	C2DP8400
LCD	N17WXGA+G
SO-DIMM 1	SO2GBII6
SO-DIMM 2	SO2GBII6
HDD 1 (GB)	N250GB5.4KS
HDD 2 (GB)	N250GB5.4KS
ODD	NBDCB2XS
Wireless LAN	SP1x2MMW
Bluetooth	BT 2.0

Model	TM7730G-844G50Bi
RO	EMEA
Country	Turkey
Acer Part No.	LX.TPLOX.066
Description	TM7730G-844G50Bi EM VHP32TRTR1 MC 9MGSHM256CF 2*2G/250+250/BT/6L/5R/CB_i2_FP_0.3D_TR22
CPU	C2DP8400
LCD	N17WXGA+G
SO-DIMM 1	SO2GBII6
SO-DIMM 2	SO2GBII6
HDD 1 (GB)	N250GB5.4KS
HDD 2 (GB)	N250GB5.4KS
ODD	NBDCB2XS
Wireless LAN	SP1x2MMW
Bluetooth	BT 2.0

Model	TM7730G-844G50Bi
RO	EMEA
Country	Turkey
Acer Part No.	LX.TPLOX.067
Description	TM7730G-844G50Bi EM VHP32TRTR1 MC 9MGSHM256CF 2*2G/250+250/BT/6L/5R/CB_i2_FP_0.3D_TR32
CPU	C2DP8400
LCD	N17WXGA+G
SO-DIMM 1	SO2GBII6
SO-DIMM 2	SO2GBII6
HDD 1 (GB)	N250GB5.4KS
HDD 2 (GB)	N250GB5.4KS
ODD	NBDCB2XS
Wireless LAN	SP1x2MMW
Bluetooth	BT 2.0

Model	TM7730G-844G50Bi
RO	EMEA
Country	Middle East
Acer Part No.	LX.TPL0X.068
Description	TM7730G-844G50Bi EM VHP32TRME3 MC 9MGSHM256CF 2*2G/250+250/BT/6L/5R/CB_i2_FP_0.3D_FR23
CPU	C2DP8400
LCD	N17WXGA+G
SO-DIMM 1	SO2GBII6
SO-DIMM 2	SO2GBII6
HDD 1 (GB)	N250GB5.4KS
HDD 2 (GB)	N250GB5.4KS
ODD	NBDCB2XS
Wireless LAN	SP1x2MMW
Bluetooth	BT 2.0

Model	TM7730G-844G50Bi
RO	EMEA
Country	Middle East
Acer Part No.	LX.TPL0X.069
Description	TM7730G-844G50Bi EM VHP32TRME2 MC 9MGSHM256CF 2*2G/250+250/BT/6L/5R/CB_i2_FP_0.3D_AR23
CPU	C2DP8400
LCD	N17WXGA+G
SO-DIMM 1	SO2GBII6
SO-DIMM 2	SO2GBII6
HDD 1 (GB)	N250GB5.4KS
HDD 2 (GB)	N250GB5.4KS
ODD	NBDCB2XS
Wireless LAN	SP1x2MMW
Bluetooth	BT 2.0

Model	TM7730G-844G50Bi
RO	EMEA
Country	Middle East
Acer Part No.	LX.TPL0X.070
Description	TM7730G-844G50Bi EM VHP32TRME6 MC 9MGSHM256CF 2*2G/250+250/BT/6L/5R/CB_i2_FP_0.3D_EN15
CPU	C2DP8400
LCD	N17WXGA+G
SO-DIMM 1	SO2GBII6
SO-DIMM 2	SO2GBII6
HDD 1 (GB)	N250GB5.4KS
HDD 2 (GB)	N250GB5.4KS
ODD	NBDCB2XS
Wireless LAN	SP1x2MMW
Bluetooth	BT 2.0

Model	TM7730G-844G50Bi
RO	EMEA
Country	Middle East
Acer Part No.	LX.TPLOX.071
Description	TM7730G-844G50Bi EM VHP32TRME9 MC 9MGSHM256CF 2*2G/250+250/BT/6L/5R/CB_i2_FP_0.3D_FR22
CPU	C2DP8400
LCD	N17WXGA+G
SO-DIMM 1	SO2GBII6
SO-DIMM 2	SO2GBII6
HDD 1 (GB)	N250GB5.4KS
HDD 2 (GB)	N250GB5.4KS
ODD	NBDCB2XS
Wireless LAN	SP1x2MMW
Bluetooth	BT 2.0

Model	TM7730G-844G50Bi
RO	EMEA
Country	Middle East
Acer Part No.	LX.TPLOX.072
Description	TM7730G-844G50Bi EM VHP32TRME2 MC 9MGSHM256CF 2*2G/250+250/BT/6L/5R/CB_i2_FP_0.3D_AR13
CPU	C2DP8400
LCD	N17WXGA+G
SO-DIMM 1	SO2GBII6
SO-DIMM 2	SO2GBII6
HDD 1 (GB)	N250GB5.4KS
HDD 2 (GB)	N250GB5.4KS
ODD	NBDCB2XS
Wireless LAN	SP1x2MMW
Bluetooth	BT 2.0

Model	TM7730G-844G50Bi
RO	EMEA
Country	Middle East
Acer Part No.	LX.TPLOX.073
Description	TM7730G-844G50Bi EM VHP32TRME2 MC 9MGSHM256CF 2*2G/250+250/BT/6L/5R/CB_i2_FP_0.3D_EN15
CPU	C2DP8400
LCD	N17WXGA+G
SO-DIMM 1	SO2GBII6
SO-DIMM 2	SO2GBII6
HDD 1 (GB)	N250GB5.4KS
HDD 2 (GB)	N250GB5.4KS
ODD	NBDCB2XS
Wireless LAN	SP1x2MMW
Bluetooth	BT 2.0

Model	TM7730G-844G50Bi
RO	EMEA
Country	Switzerland
Acer Part No.	LX.TPL0X.074
Description	TM7730G-844G50Bi VHP32TRCH1 MC 9MGSHM256CF 2*2G/250+250/BT/6L/5R/CB_i2_FP_0.3D_IT42
CPU	C2DP8400
LCD	N17WXGA+G
SO-DIMM 1	SO2GBII6
SO-DIMM 2	SO2GBII6
HDD 1 (GB)	N250GB5.4KS
HDD 2 (GB)	N250GB5.4KS
ODD	NBDCB2XS
Wireless LAN	SP1x2MMW
Bluetooth	BT 2.0

Model	TM7730G-844G50Bi
RO	EMEA
Country	UK
Acer Part No.	LX.TPL0X.075
Description	TM7730G-844G50Bi VHP32TRGB1 MC 9MGSHM256CF 2*2G/250+250/BT/6L/5R/CB_i2_FP_0.3D_EN14
CPU	C2DP8400
LCD	N17WXGA+G
SO-DIMM 1	SO2GBII6
SO-DIMM 2	SO2GBII6
HDD 1 (GB)	N250GB5.4KS
HDD 2 (GB)	N250GB5.4KS
ODD	NBDCB2XS
Wireless LAN	SP1x2MMW
Bluetooth	BT 2.0

Model	TM7730-863G32Mi
RO	AAP
Country	Australia/New Zealand
Acer Part No.	LX.TPK0Z.009
Description	TM7730-863G32Mi VB32TRAU1 MC UMACF 2G+1G/320/BT/6L/5R/CB_i3_FP_0.3D_EN13
CPU	C2DP8600
LCD	N17WXGA+G
SO-DIMM 1	SO2GBII6
SO-DIMM 2	SO1GBII6
HDD 1 (GB)	N320GB5.4KS
HDD 2 (GB)	N
ODD	NSM8XS
Wireless LAN	SP3x3MMW
Bluetooth	BT 2.0

Model	TM7730-863G32Mi
RO	AAP
Country	Australia/New Zealand
Acer Part No.	LX.TPK0X.041
Description	TM7730-863G32Mi VHP32TRAU1 MC UMACF 2G+1G/320/BT/6L/5R/CB_i3_FP_0.3D_EN12
CPU	C2DP8600
LCD	N17WXGA+G
SO-DIMM 1	SO2GBII6
SO-DIMM 2	SO1GBII6
HDD 1 (GB)	N320GB5.4KS
HDD 2 (GB)	N
ODD	NSM8XS
Wireless LAN	SP3x3MMW
Bluetooth	BT 2.0

Model	TM7730G-944G50Mi
RO	AAP
Country	Australia/New Zealand
Acer Part No.	LX.TQ30X.001
Description	TM7730G-944G50Mi VHP32TRAU1 MC 9PGSHM512CF 2*2G/250+250/BT/8L/5R/CB_i3_FP_0.3D_EN12
CPU	C2DT9400
LCD	N17WXGA+G
SO-DIMM 1	SO2GBII6
SO-DIMM 2	SO2GBII6
HDD 1 (GB)	N250GB5.4KS
HDD 2 (GB)	N250GB5.4KS
ODD	NSM8XS
Wireless LAN	SP3x3MMW
Bluetooth	BT 2.0

Model	TM7730G-944G50Mi
RO	AAP
Country	Australia/New Zealand
Acer Part No.	LX.TQ30Z.001
Description	TM7730G-944G50Mi VB32TRAU1 MC 9PGSHM512CF 2*2G/250+250/BT/8L/5R/CB_i3_FP_0.3D_EN13
CPU	C2DT9400
LCD	N17WXGA+G
SO-DIMM 1	SO2GBII6
SO-DIMM 2	SO2GBII6
HDD 1 (GB)	N250GB5.4KS
HDD 2 (GB)	N250GB5.4KS
ODD	NSM8XS
Wireless LAN	SP3x3MMW
Bluetooth	BT 2.0

Model	TM7730-842G25Mi
RO	EMEA
Country	South Africa
Acer Part No.	LX.TPK0Z.010
Description	TM7730-842G25Mi EM VB32TRZA2 MC UMACF 1*2G/250/BT/6L/5R_i2_FP_0.3D_EN17
CPU	C2DP8400
LCD	N17WXGA+
SO-DIMM 1	SO2GBII6
SO-DIMM 2	N
HDD 1 (GB)	N250GB5.4KS
HDD 2 (GB)	N
ODD	NSM8XS
Wireless LAN	SP1x2MMW
Bluetooth	BT 2.0

Model	TM7730-842G25Mi
RO	EMEA
Country	South Africa
Acer Part No.	LX.TPK0Z.011
Description	TM7730-842G25Mi EM VB32TRZA1 MC UMACF 1*2G/250/BT/6L/5R_i2_FP_0.3D_FR24
CPU	C2DP8400
LCD	N17WXGA+
SO-DIMM 1	SO2GBII6
SO-DIMM 2	N
HDD 1 (GB)	N250GB5.4KS
HDD 2 (GB)	N
ODD	NSM8XS
Wireless LAN	SP1x2MMW
Bluetooth	BT 2.0

Model	TM7730-842G25Mi
RO	EMEA
Country	Holland
Acer Part No.	LX.TPK0Z.012
Description	TM7730-842G25Mi VB32TRNL1 MC UMACF 1*2G/250/BT/6L/5R_i2_FP_0.3D_NL12
CPU	C2DP8400
LCD	N17WXGA+
SO-DIMM 1	SO2GBII6
SO-DIMM 2	N
HDD 1 (GB)	N250GB5.4KS
HDD 2 (GB)	N
ODD	NSM8XS
Wireless LAN	SP1x2MMW
Bluetooth	BT 2.0

Model	TM7730-842G25Mi
RO	EMEA
Country	South Africa
Acer Part No.	LX.TPK0Z.013
Description	TM7730-842G25Mi EM VB32TRZA2 MC UMACF 1*2G/250/BT/6L/5R_i2_FP_0.3D_EN18
CPU	C2DP8400
LCD	N17WXGA+
SO-DIMM 1	SO2GBII6
SO-DIMM 2	N
HDD 1 (GB)	N250GB5.4KS
HDD 2 (GB)	N
ODD	NSM8XS
Wireless LAN	SP1x2MMW
Bluetooth	BT 2.0

Model	TM7730-842G25Mi
RO	EMEA
Country	South Africa
Acer Part No.	LX.TPK0Z.014
Description	TM7730-842G25Mi EM VB32TRZA1 MC UMACF 1*2G/250/BT/6L/5R_i2_FP_0.3D_FR25
CPU	C2DP8400
LCD	N17WXGA+
SO-DIMM 1	SO2GBII6
SO-DIMM 2	N
HDD 1 (GB)	N250GB5.4KS
HDD 2 (GB)	N
ODD	NSM8XS
Wireless LAN	SP1x2MMW
Bluetooth	BT 2.0

Model	TM7730-842G25Mi
RO	EMEA
Country	Denmark
Acer Part No.	LX.TPK0Z.015
Description	TM7730-842G25Mi VB32TRDK1 MC UMACF 1*2G/250/BT/6L/5R_i2_FP_0.3D_NO13
CPU	C2DP8400
LCD	N17WXGA+
SO-DIMM 1	SO2GBII6
SO-DIMM 2	N
HDD 1 (GB)	N250GB5.4KS
HDD 2 (GB)	N
ODD	NSM8XS
Wireless LAN	SP1x2MMW
Bluetooth	BT 2.0

Model	TM7730-842G25Mi
RO	EMEA
Country	France
Acer Part No.	LX.TPK0Z.016
Description	TM7730-842G25Mi VB32TRFR1 MC UMACF 1*2G/250/BT/6L/5R_i2_FP_0.3D_FR23
CPU	C2DP8400
LCD	N17WXGA+
SO-DIMM 1	SO2GBII6
SO-DIMM 2	N
HDD 1 (GB)	N250GB5.4KS
HDD 2 (GB)	N
ODD	NSM8XS
Wireless LAN	SP1x2MMW
Bluetooth	BT 2.0

Model	TM7730-842G25Mi
RO	EMEA
Country	France
Acer Part No.	LX.TPK0Z.017
Description	TM7730-842G25Mi VB32TRFR1 MC UMACF 1*2G/250/BT/6L/5R_i2_FP_0.3D_FR24
CPU	C2DP8400
LCD	N17WXGA+
SO-DIMM 1	SO2GBII6
SO-DIMM 2	N
HDD 1 (GB)	N250GB5.4KS
HDD 2 (GB)	N
ODD	NSM8XS
Wireless LAN	SP1x2MMW
Bluetooth	BT 2.0

Model	TM7730-842G25Mi
RO	EMEA
Country	Germany
Acer Part No.	LX.TPK0Z.018
Description	TM7730-842G25Mi VB32TRDE1 MC UMACF 1*2G/250/BT/6L/5R_i2_FP_0.3D_DE13
CPU	C2DP8400
LCD	N17WXGA+
SO-DIMM 1	SO2GBII6
SO-DIMM 2	N
HDD 1 (GB)	N250GB5.4KS
HDD 2 (GB)	N
ODD	NSM8XS
Wireless LAN	SP1x2MMW
Bluetooth	BT 2.0

Model	TM7730-842G25Mi
RO	EMEA
Country	Germany
Acer Part No.	LX.TPK0Z.019
Description	TM7730-842G25Mi VB32TRDE1 MC UMACF 1*2G/250/BT/6L/5R_i2_FP_0.3D_DE14
CPU	C2DP8400
LCD	N17WXGA+
SO-DIMM 1	SO2GBII6
SO-DIMM 2	N
HDD 1 (GB)	N250GB5.4KS
HDD 2 (GB)	N
ODD	NSM8XS
Wireless LAN	SP1x2MMW
Bluetooth	BT 2.0

Model	TM7730-842G25Mi
RO	EMEA
Country	Belgium
Acer Part No.	LX.TPK0Z.020
Description	TM7730-842G25Mi VB32TRBE1 MC UMACF 1*2G/250/BT/6L/5R_i2_FP_0.3D_NL13
CPU	C2DP8400
LCD	N17WXGA+
SO-DIMM 1	SO2GBII6
SO-DIMM 2	N
HDD 1 (GB)	N250GB5.4KS
HDD 2 (GB)	N
ODD	NSM8XS
Wireless LAN	SP1x2MMW
Bluetooth	BT 2.0

Model	TM7730-842G25Mi
RO	EMEA
Country	Luxembourg
Acer Part No.	LX.TPK0Z.021
Description	TM7730-842G25Mi VB32TRLU1 MC UMACF 1*2G/250/BT/6L/5R_i2_FP_0.3D_IT42
CPU	C2DP8400
LCD	N17WXGA+
SO-DIMM 1	SO2GBII6
SO-DIMM 2	N
HDD 1 (GB)	N250GB5.4KS
HDD 2 (GB)	N
ODD	NSM8XS
Wireless LAN	SP1x2MMW
Bluetooth	BT 2.0

Model	TM7730-842G25Mi
RO	EMEA
Country	Norway
Acer Part No.	LX.TPK0Z.022
Description	TM7730-842G25Mi VB32TRNO1 MC UMACF 1*2G/250/BT/6L/5R_i2_FP_0.3D_NO12
CPU	C2DP8400
LCD	N17WXGA+
SO-DIMM 1	SO2GBII6
SO-DIMM 2	N
HDD 1 (GB)	N250GB5.4KS
HDD 2 (GB)	N
ODD	NSM8XS
Wireless LAN	SP1x2MMW
Bluetooth	BT 2.0

Model	TM7730-842G25Mi
RO	EMEA
Country	Russia
Acer Part No.	LX.TPK0Z.023
Description	TM7730-842G25Mi VB32TRRU1 MC UMACF 1*2G/250/BT/6L/5R_i2_FP_0.3D_RU11
CPU	C2DP8400
LCD	N17WXGA+
SO-DIMM 1	SO2GBII6
SO-DIMM 2	N
HDD 1 (GB)	N250GB5.4KS
HDD 2 (GB)	N
ODD	NSM8XS
Wireless LAN	SP1x2MMW
Bluetooth	BT 2.0

Model	TM7730-842G25Mi
RO	EMEA
Country	Russia
Acer Part No.	LX.TPK0Z.024
Description	TM7730-842G25Mi VB32TRRU1 MC UMACF 1*2G/250/BT/6L/5R_i2_FP_0.3D_RU12
CPU	C2DP8400
LCD	N17WXGA+
SO-DIMM 1	SO2GBII6
SO-DIMM 2	N
HDD 1 (GB)	N250GB5.4KS
HDD 2 (GB)	N
ODD	NSM8XS
Wireless LAN	SP1x2MMW
Bluetooth	BT 2.0

Model	TM7730-842G25Mi
RO	EMEA
Country	Sweden/Finland
Acer Part No.	LX.TPK0Z.025
Description	TM7730-842G25Mi VB32TRSE1 MC UMACF 1*2G/250/BT/6L/5R_i2_FP_0.3D_FI12
CPU	C2DP8400
LCD	N17WXGA+
SO-DIMM 1	SO2GBII6
SO-DIMM 2	N
HDD 1 (GB)	N250GB5.4KS
HDD 2 (GB)	N
ODD	NSM8XS
Wireless LAN	SP1x2MMW
Bluetooth	BT 2.0

Model	TM7730-842G25Mi
RO	EMEA
Country	Czech
Acer Part No.	LX.TPK0Z.026
Description	TM7730-842G25Mi VB32TRCZ1 MC UMACF 1*2G/250/BT/6L/5R_i2_FP_0.3D_SK11
CPU	C2DP8400
LCD	N17WXGA+
SO-DIMM 1	SO2GBII6
SO-DIMM 2	N
HDD 1 (GB)	N250GB5.4KS
HDD 2 (GB)	N
ODD	NSM8XS
Wireless LAN	SP1x2MMW
Bluetooth	BT 2.0

Model	TM7730-842G25Mi
RO	EMEA
Country	Eastern Europe
Acer Part No.	LX.TPK0Z.027
Description	TM7730-842G25Mi VB32TREU1 MC UMACF 1*2G/250/BT/6L/5R_i2_FP_0.3D_CS21
CPU	C2DP8400
LCD	N17WXGA+
SO-DIMM 1	SO2GBII6
SO-DIMM 2	N
HDD 1 (GB)	N250GB5.4KS
HDD 2 (GB)	N
ODD	NSM8XS
Wireless LAN	SP1x2MMW
Bluetooth	BT 2.0

Model	TM7730-842G25Mi
RO	EMEA
Country	Eastern Europe
Acer Part No.	LX.TPK0Z.028
Description	TM7730-842G25Mi VB32TREU4 MC UMACF 1*2G/250/BT/6L/5R_i2_FP_0.3D_F112
CPU	C2DP8400
LCD	N17WXGA+
SO-DIMM 1	SO2GBI16
SO-DIMM 2	N
HDD 1 (GB)	N250GB5.4KS
HDD 2 (GB)	N
ODD	NSM8XS
Wireless LAN	SP1x2MMW
Bluetooth	BT 2.0

Model	TM7730-842G25Mi
RO	EMEA
Country	Eastern Europe
Acer Part No.	LX.TPK0Z.029
Description	TM7730-842G25Mi VB32TREU3 MC UMACF 1*2G/250/BT/6L/5R_i2_FP_0.3D_RU11
CPU	C2DP8400
LCD	N17WXGA+
SO-DIMM 1	SO2GBI16
SO-DIMM 2	N
HDD 1 (GB)	N250GB5.4KS
HDD 2 (GB)	N
ODD	NSM8XS
Wireless LAN	SP1x2MMW
Bluetooth	BT 2.0

Model	TM7730-842G25Mi
RO	EMEA
Country	Eastern Europe
Acer Part No.	LX.TPK0Z.030
Description	TM7730-842G25Mi VB32TREU2 MC UMACF 1*2G/250/BT/6L/5R_i2_FP_0.3D_HU21
CPU	C2DP8400
LCD	N17WXGA+
SO-DIMM 1	SO2GBI16
SO-DIMM 2	N
HDD 1 (GB)	N250GB5.4KS
HDD 2 (GB)	N
ODD	NSM8XS
Wireless LAN	SP1x2MMW
Bluetooth	BT 2.0

Model	TM7730-842G25Mi
RO	EMEA
Country	Eastern Europe
Acer Part No.	LX.TPK0Z.031
Description	TM7730-842G25Mi VB32TREU5 MC UMACF 1*2G/250/BT/6L/5R_i2_FP_0.3D_PL11
CPU	C2DP8400
LCD	N17WXGA+
SO-DIMM 1	SO2GBII6
SO-DIMM 2	N
HDD 1 (GB)	N250GB5.4KS
HDD 2 (GB)	N
ODD	NSM8XS
Wireless LAN	SP1x2MMW
Bluetooth	BT 2.0

Model	TM7730-842G25Mi
RO	EMEA
Country	Hungary
Acer Part No.	LX.TPK0Z.032
Description	TM7730-842G25Mi VB32TRHU1 MC UMACF 1*2G/250/BT/6L/5R_i2_FP_0.3D_HU11
CPU	C2DP8400
LCD	N17WXGA+
SO-DIMM 1	SO2GBII6
SO-DIMM 2	N
HDD 1 (GB)	N250GB5.4KS
HDD 2 (GB)	N
ODD	NSM8XS
Wireless LAN	SP1x2MMW
Bluetooth	BT 2.0

Model	TM7730-842G25Mi
RO	EMEA
Country	Eastern Europe
Acer Part No.	LX.TPK0Z.033
Description	TM7730-842G25Mi VB32TREU3 MC UMACF 1*2G/250/BT/6L/5R_i2_FP_0.3D_RU12
CPU	C2DP8400
LCD	N17WXGA+
SO-DIMM 1	SO2GBII6
SO-DIMM 2	N
HDD 1 (GB)	N250GB5.4KS
HDD 2 (GB)	N
ODD	NSM8XS
Wireless LAN	SP1x2MMW
Bluetooth	BT 2.0

Model	TM7730-842G25Mi
RO	EMEA
Country	Slovenia/Croatia
Acer Part No.	LX.TPK0Z.034
Description	TM7730-842G25Mi VB32TRS11 MC UMACF 1*2G/250/BT/6L/5R_i2_FP_0.3D_EN11
CPU	C2DP8400
LCD	N17WXGA+
SO-DIMM 1	SO2GB1I6
SO-DIMM 2	N
HDD 1 (GB)	N250GB5.4KS
HDD 2 (GB)	N
ODD	NSM8XS
Wireless LAN	SP1x2MMW
Bluetooth	BT 2.0

Model	TM7730-842G25Mi
RO	EMEA
Country	Slovenia/Croatia
Acer Part No.	LX.TPK0Z.035
Description	TM7730-842G25Mi VB32TRS11 MC UMACF 1*2G/250/BT/6L/5R_i2_FP_0.3D_EN12
CPU	C2DP8400
LCD	N17WXGA+
SO-DIMM 1	SO2GB1I6
SO-DIMM 2	N
HDD 1 (GB)	N250GB5.4KS
HDD 2 (GB)	N
ODD	NSM8XS
Wireless LAN	SP1x2MMW
Bluetooth	BT 2.0

Model	TM7730-842G25Mi
RO	EMEA
Country	Portugal
Acer Part No.	LX.TPK0Z.036
Description	TM7730-842G25Mi VB32TRPT1 MC UMACF 1*2G/250/BT/6L/5R_i2_FP_0.3D_PT12
CPU	C2DP8400
LCD	N17WXGA+
SO-DIMM 1	SO2GB1I6
SO-DIMM 2	N
HDD 1 (GB)	N250GB5.4KS
HDD 2 (GB)	N
ODD	NSM8XS
Wireless LAN	SP1x2MMW
Bluetooth	BT 2.0

Model	TM7730-842G25Mi
RO	EMEA
Country	Spain
Acer Part No.	LX.TPK0Z.037
Description	TM7730-842G25Mi VB32TRES1 MC UMACF 1*2G/250/BT/6L/5R_i2_FP_0.3D_ES22
CPU	C2DP8400
LCD	N17WXGA+
SO-DIMM 1	SO2GBII6
SO-DIMM 2	N
HDD 1 (GB)	N250GB5.4KS
HDD 2 (GB)	N
ODD	NSM8XS
Wireless LAN	SP1x2MMW
Bluetooth	BT 2.0

Model	TM7730-842G25Mi
RO	EMEA
Country	UK
Acer Part No.	LX.TPK0Z.056
Description	TM7730-842G25Mi VB32TRGB1 MC UMACF 1*2G/250/BT/6L/5R_i2_FP_0.3D_EN15
CPU	C2DP8400
LCD	N17WXGA+
SO-DIMM 1	SO2GBII6
SO-DIMM 2	N
HDD 1 (GB)	N250GB5.4KS
HDD 2 (GB)	N
ODD	NSM8XS
Wireless LAN	SP1x2MMW
Bluetooth	BT 2.0

Model	TM7730-842G25Mi
RO	EMEA
Country	Middle East
Acer Part No.	LX.TPK0Z.052
Description	TM7730-842G25Mi EM VB32TRME9 MC UMACF 1*2G/250/BT/6L/5R_i2_FP_0.3D_FR24
CPU	C2DP8400
LCD	N17WXGA+
SO-DIMM 1	SO2GBII6
SO-DIMM 2	N
HDD 1 (GB)	N250GB5.4KS
HDD 2 (GB)	N
ODD	NSM8XS
Wireless LAN	SP1x2MMW
Bluetooth	BT 2.0

Model	TM7730-842G25Mi
RO	EMEA
Country	Middle East
Acer Part No.	LX.TPK0Z.053
Description	TM7730-842G25Mi EM VB32TRME3 MC UMACF 1*2G/250/BT/6L/5R_i2_FP_0.3D_FR25
CPU	C2DP8400
LCD	N17WXGA+
SO-DIMM 1	SO2GBII6
SO-DIMM 2	N
HDD 1 (GB)	N250GB5.4KS
HDD 2 (GB)	N
ODD	NSM8XS
Wireless LAN	SP1x2MMW
Bluetooth	BT 2.0

Model	TM7730-842G25Mi
RO	EMEA
Country	Switzerland
Acer Part No.	LX.TPK0Z.054
Description	TM7730-842G25Mi VB32TRCH1 MC UMACF 1*2G/250/BT/6L/5R_i2_FP_0.3D_IT42
CPU	C2DP8400
LCD	N17WXGA+
SO-DIMM 1	SO2GBII6
SO-DIMM 2	N
HDD 1 (GB)	N250GB5.4KS
HDD 2 (GB)	N
ODD	NSM8XS
Wireless LAN	SP1x2MMW
Bluetooth	BT 2.0

Model	TM7730-842G25Mi
RO	EMEA
Country	UK
Acer Part No.	LX.TPK0Z.055
Description	TM7730-842G25Mi VB32TRGB1 MC UMACF 1*2G/250/BT/6L/5R_i2_FP_0.3D_EN14
CPU	C2DP8400
LCD	N17WXGA+
SO-DIMM 1	SO2GBII6
SO-DIMM 2	N
HDD 1 (GB)	N250GB5.4KS
HDD 2 (GB)	N
ODD	NSM8XS
Wireless LAN	SP1x2MMW
Bluetooth	BT 2.0

Model	TM7730-842G25Mi
RO	EMEA
Country	Spain
Acer Part No.	LX.TPK0Z.038
Description	TM7730-842G25Mi VB32TRES1 MC UMACF 1*2G/250/BT/6L/5R_i2_FP_0.3D_ES23
CPU	C2DP8400
LCD	N17WXGA+
SO-DIMM 1	SO2GBII6
SO-DIMM 2	N
HDD 1 (GB)	N250GB5.4KS
HDD 2 (GB)	N
ODD	NSM8XS
Wireless LAN	SP1x2MMW
Bluetooth	BT 2.0

Model	TM7730-842G25Mi
RO	EMEA
Country	Greece
Acer Part No.	LX.TPK0Z.039
Description	TM7730-842G25Mi VB32TRGR1 MC UMACF 1*2G/250/BT/6L/5R_i2_FP_0.3D_EL32
CPU	C2DP8400
LCD	N17WXGA+
SO-DIMM 1	SO2GBII6
SO-DIMM 2	N
HDD 1 (GB)	N250GB5.4KS
HDD 2 (GB)	N
ODD	NSM8XS
Wireless LAN	SP1x2MMW
Bluetooth	BT 2.0

Model	TM7730-842G25Mi
RO	EMEA
Country	Israel
Acer Part No.	LX.TPK0Z.040
Description	TM7730-842G25Mi VB32TRIL1 MC UMACF 1*2G/250/BT/6L/5R_i2_FP_0.3D_HE31
CPU	C2DP8400
LCD	N17WXGA+
SO-DIMM 1	SO2GBII6
SO-DIMM 2	N
HDD 1 (GB)	N250GB5.4KS
HDD 2 (GB)	N
ODD	NSM8XS
Wireless LAN	SP1x2MMW
Bluetooth	BT 2.0

Model	TM7730-842G25Mi
RO	EMEA
Country	Italy
Acer Part No.	LX.TPK0Z.041
Description	TM7730-842G25Mi VB32TRIT1 MC UMACF 1*2G/250/BT/6L/5R_i2_FP_0.3D_IT12
CPU	C2DP8400
LCD	N17WXGA+
SO-DIMM 1	SO2GBII6
SO-DIMM 2	N
HDD 1 (GB)	N250GB5.4KS
HDD 2 (GB)	N
ODD	NSM8XS
Wireless LAN	SP1x2MMW
Bluetooth	BT 2.0

Model	TM7730-842G25Mi
RO	EMEA
Country	Italy
Acer Part No.	LX.TPK0Z.042
Description	TM7730-842G25Mi VB32TRIT1 MC UMACF 1*2G/250/BT/6L/5R_i2_FP_0.3D_IT14
CPU	C2DP8400
LCD	N17WXGA+
SO-DIMM 1	SO2GBII6
SO-DIMM 2	N
HDD 1 (GB)	N250GB5.4KS
HDD 2 (GB)	N
ODD	NSM8XS
Wireless LAN	SP1x2MMW
Bluetooth	BT 2.0

Model	TM7730-842G25Mi
RO	EMEA
Country	Turkey
Acer Part No.	LX.TPK0Z.043
Description	TM7730-842G25Mi EM VB32TRTR1 MC UMACF 1*2G/250/BT/6L/5R_i2_FP_0.3D_TR12
CPU	C2DP8400
LCD	N17WXGA+
SO-DIMM 1	SO2GBII6
SO-DIMM 2	N
HDD 1 (GB)	N250GB5.4KS
HDD 2 (GB)	N
ODD	NSM8XS
Wireless LAN	SP1x2MMW
Bluetooth	BT 2.0

Model	TM7730-842G25Mi
RO	EMEA
Country	Turkey
Acer Part No.	LX.TPK0Z.044
Description	TM7730-842G25Mi EM VB32TRTR1 MC UMACF 1*2G/250/BT/6L/5R_i2_FP_0.3D_TR42
CPU	C2DP8400
LCD	N17WXGA+
SO-DIMM 1	SO2GBII6
SO-DIMM 2	N
HDD 1 (GB)	N250GB5.4KS
HDD 2 (GB)	N
ODD	NSM8XS
Wireless LAN	SP1x2MMW
Bluetooth	BT 2.0

Model	TM7730-842G25Mi
RO	EMEA
Country	Middle East
Acer Part No.	LX.TPK0Z.045
Description	TM7730-842G25Mi EM VB32TRME2 MC UMACF 1*2G/250/BT/6L/5R_i2_FP_0.3D_AR24
CPU	C2DP8400
LCD	N17WXGA+
SO-DIMM 1	SO2GBII6
SO-DIMM 2	N
HDD 1 (GB)	N250GB5.4KS
HDD 2 (GB)	N
ODD	NSM8XS
Wireless LAN	SP1x2MMW
Bluetooth	BT 2.0

Model	TM7730-842G25Mi
RO	EMEA
Country	Middle East
Acer Part No.	LX.TPK0Z.046
Description	TM7730-842G25Mi EM VB32TRME3 MC UMACF 1*2G/250/BT/6L/5R_i2_FP_0.3D_FR24
CPU	C2DP8400
LCD	N17WXGA+
SO-DIMM 1	SO2GBII6
SO-DIMM 2	N
HDD 1 (GB)	N250GB5.4KS
HDD 2 (GB)	N
ODD	NSM8XS
Wireless LAN	SP1x2MMW
Bluetooth	BT 2.0

Model	TM7730-842G25Mi
RO	EMEA
Country	Middle East
Acer Part No.	LX.TPK0Z.047
Description	TM7730-842G25Mi EM VB32TRME6 MC UMACF 1*2G/250/BT/6L/5R_i2_FP_0.3D_EN16
CPU	C2DP8400
LCD	N17WXGA+
SO-DIMM 1	SO2GBII6
SO-DIMM 2	N
HDD 1 (GB)	N250GB5.4KS
HDD 2 (GB)	N
ODD	NSM8XS
Wireless LAN	SP1x2MMW
Bluetooth	BT 2.0

Model	TM7730-842G25Mi
RO	EMEA
Country	Middle East
Acer Part No.	LX.TPK0Z.048
Description	TM7730-842G25Mi EM VB32TRME2 MC UMACF 1*2G/250/BT/6L/5R_i2_FP_0.3D_AR25
CPU	C2DP8400
LCD	N17WXGA+
SO-DIMM 1	SO2GBII6
SO-DIMM 2	N
HDD 1 (GB)	N250GB5.4KS
HDD 2 (GB)	N
ODD	NSM8XS
Wireless LAN	SP1x2MMW
Bluetooth	BT 2.0

Model	TM7730-842G25Mi
RO	EMEA
Country	Middle East
Acer Part No.	LX.TPK0Z.049
Description	TM7730-842G25Mi EM VB32TRME9 MC UMACF 1*2G/250/BT/6L/5R_i2_FP_0.3D_FR23
CPU	C2DP8400
LCD	N17WXGA+
SO-DIMM 1	SO2GBII6
SO-DIMM 2	N
HDD 1 (GB)	N250GB5.4KS
HDD 2 (GB)	N
ODD	NSM8XS
Wireless LAN	SP1x2MMW
Bluetooth	BT 2.0

Model	TM7730-842G25Mi
RO	EMEA
Country	Middle East
Acer Part No.	LX.TPK0Z.050
Description	TM7730-842G25Mi EM VB32TRME6 MC UMACF 1*2G/250/BT/6L/5R_i2_FP_0.3D_EN17
CPU	C2DP8400
LCD	N17WXGA+
SO-DIMM 1	SO2GBII6
SO-DIMM 2	N
HDD 1 (GB)	N250GB5.4KS
HDD 2 (GB)	N
ODD	NSM8XS
Wireless LAN	SP1x2MMW
Bluetooth	BT 2.0

Model	TM7730-842G25Mi
RO	EMEA
Country	Middle East
Acer Part No.	LX.TPK0Z.051
Description	TM7730-842G25Mi EM VB32TRME2 MC UMACF 1*2G/250/BT/6L/5R_i2_FP_0.3D_AR13
CPU	C2DP8400
LCD	N17WXGA+
SO-DIMM 1	SO2GBII6
SO-DIMM 2	N
HDD 1 (GB)	N250GB5.4KS
HDD 2 (GB)	N
ODD	NSM8XS
Wireless LAN	SP1x2MMW
Bluetooth	BT 2.0

Appendix B

Test compatible components

This notebook's compatibility is tested and verified by Acer's internal testing department. All of its system functions are tested under Windows® XP Home, Windows® XP Pro environment.

Refer to the following lists for components, adapter cards, and peripherals which have passed these tests. Regarding configuration, combination and test procedures, please refer to the Travelmate 7730/7730G series Compatibility Test Report released by the Acer Mobile System Testing Department.

Microsoft® Windows® Vista Environment Test

<Athena: Is this the correct test environment list?>

Item	Specification
CRT Port Test	
CRT Monitor	Acer 211c 21", ViewSonic G220F, ViewSonic PF790 19"
LCD Monitor	Acer FP751 17" TFT LCD, Acer AL1521, Acer AL1721, ViewSonic VD201b, Westinghouse W37G, HP LP2065, HP S9500
Projector	Dell 3300MP
USB Port Test	
USB Keyboard/Mouse	Microsoft Natural Keyboard Pro Dell USB Keyboard Logitech USB Mouse (OWCM-USB) Logitech USB Wheel Mouse Logitech First Wheel Mouse Dell Dell by Logitech Dell Internet Navigator Keyboard Dell Smart Card Keyboard HP USB Optical Austin Mouse Belkin Miniglow Optical USB Mouse HP USB Optical Mouse (RB129AA)
USB Speaker/Joystick	Aiwa Multimedia Digital Speaker (SC-UC78) Panasonic USB Speaker EAB-MPC57USB
USB Storage Drive	Iomega USB Zip 250MB Transcend 80G HDD Plextor DVD+R/RW LG DVD+R/RW Sony DVD+R/RW
USB Camera	Intel Easy PC Camera (A20953-001) Orange Micro USB 2.0 Web Cam
USB HUB and Others	A TEN UH-204 IOGEAR 4-Port Hub Corega CG-WLUSBST11
USB Printer/Scanner	HP 450WBT Deskjet Printer
USB Flash Drive	Sony Memory Key 128MB Sony Micro Vault Pro USD-5G IBM 128MB Memory Key IBM 512MB Memory Key Apacer Handy Drive Apacer The USB Flash Drive 256MB
USB ODD	Logitec CDRW+DVDROM combo LG DVD+R/RW Sony DVD+R/RW
1394 Camera	Sony DV-TRV10
Access Point 802.11a	Intel Pro/Wireless 5000 NetGear HE 102
Access Point 802.11g	D-Link Building Networks People WiFi Certified a/b/g Wireless 108AG
Access Point 802.11n	Belkin N1MIMO Wireless Router High Performance wireless 802.11n
Bluetooth Device	Sony Ericsson Wireless Headset Sony Ericsson T610 X Bridge Bluetooth Access Point BT300

Item	Specification
PCMCIA Test	
LAN/Modem Card	TDK CardBus Ethernet 10/100 32-Bit CBE-10/100BTX
Storage Card	Hitachi Microdrive 4G
1394 Card	Buffalo 1394 Interface Cardbus (IFC-ILCB/DV)
USB2.0 Card	IBM EtherJet CardBus Adapter 10/100
Wireless Lan Card (Not recommended for wireless ready model)	Cisco Wireless LAN Card 802.11a NETGEAR Wireless LAN card 802.11a
ISDN Card	Toshiba Type B for Bluetooth 128K ISDN Card
GPRS Card	Vodafone QL1ACC-21581 3G/GPRS card Sony Ericsson GC83 GPRS card Sony Ericsson GC89 GPRS card
ExpressCard Test	
Express Card	Abcom 5-in-1 Adapter ExpressCard Reader Abcom GigaLan ExpressCard Sunix ECF2400 2 Ports 1394A ExpressCard
Memory Card Test (SD/MS/MMC/SM/CF/Microdrive/XD)	
SD Card	Apacer 128/256MB SanDisk 256MB Apacer 2GB (150x Hi-Speed) KINGMAX 1GB (66x Hi-Speed) SanDisk 1GB RiDATA 4GB SD PRO Memory Card
MS Card	Sony 512 MS PRO Lexar 512MB MS PRO Lexar 1GB MS PRO Sony 2GB MS PRO
MMC Card	SanDisk 32MB Transcend 64/128MB Transcend 256MB SanDisk RS-MMC 128MB PQI RS-MMC 256MB Transcend 512MB A-DATA Turbo 200X 2GB MMC Card
XD Card	Apacer 256/512MB SanDisk 2GB Olympus 512MB
CF Card	Apacer 256/512 SanDisk 2GB

Appendix C

Online support information

This section describes online technical support services available to help you repair your Acer Systems.

If you are a distributor, dealer, ASP or TPM, please refer your technical queries to your local Acer branch office. Acer Branch Offices and Regional Business Units may access our website. However some information sources will require a user i.d. and password. These can be obtained directly from Acer CSD Taiwan.

Acer's Website offers you convenient and valuable support resources whenever you need them. In the Technical Information section you can download information on all of Acer's Notebook, Desktop and Server models including:

- Service guides for all models
- User's manuals
- Training materials
- BIOS updates
- Software utilities
- Spare parts lists
- TABs (Technical Announcement Bulletin)

For these purposes, we have included an Acrobat File to facilitate the problem-free downloading of our technical material. Also contained on this website are:

- Detailed information on Acer's International Traveller's Warranty (ITW)
- Returned material authorization procedures
- An overview of all the support services we offer, accompanied by a list of telephone, fax and email contacts for all your technical queries.

We are always looking for ways to optimize and improve our services, so if you have any suggestions or comments, please do not hesitate to communicate these to us.

A

AFLASH Utility 47

B

BIOS

- package 18
- password control 19
- ROM size 18
- ROM type 18
- supported protocols 19
- vendor 18
- version 18

BIOS Utility 36, 47

- navigating 36
- onboard device configuration 42, 43
- security 41
- system security 46

brightness

- hotkeys 17

C

Caps Lock

- on indicator 12

computer

- on indicator 12, 13

D

display 5

- hotkeys 17

E

error symptom-to-spare part index 140

external CD-ROM drive check 137

F

features 2

flash utility 47

FRU (field-replaceable unit) list 161

H

Hibernation mode

- hotkey 17

hotkeys 14

I

indicators 12

intermittent problems 152

J

jumper and connector locations 155

- top view 156

K

keyboard or auxiliary input device check 137

M

media access

- on indicator 12

memory check 138

model definition 173

N

Notebook Manager

- hotkey 17

Num Lock

- on indicator 12

O

online support 239

P

panel 6

- bottom 11
- left 7

PC Card 12

power system check 138

- battery pack 139
- power adapter 138

S

speakers

- hotkey 17

support 239

system

- block diagram 5
- check procedures 137
- utilities 35

T

technical support 239

test compatible components 235

top 156

touchpad

- check 139
- hotkey 17

troubleshooting 135

U

undetermined problems 153

utility

BIOS 36, 47

Flash Utility 47

Notebook Manager 17

system 35

W

Windows 2000 environment test 236

acer

MAN MONSERRAT SVC GDE R0 06/08



8513189