



The end of the boring door™  
**SUPADOORS**®  
*Environmentally Kind Stile + Rail MDF Doors*



***The Georgica***



As we approach our 20th anniversary at SUPA DOORS, we are humbled and also proud to think of how many prestigious projects have chosen to use our doors, from beautiful custom homes, to exquisite condominiums, to world famous Hotels. We are excited to be broadening the line of options we offer, from great new designs, to in house custom color factory finishing, to pre hanging in both pine and hardwood jambs. With a passion for heroic customer service and excellently crafted doors, we hope to have the opportunity to work with you on your next project as well. Thank YOU for choosing SUPA DOORS!

*Ian and Dave Fisher*



## Table of Contents

<i>The Mayflower</i> .....	2
<i>Tailored Doors</i> .....	3
<i>Standard Door Designs</i> .....	4-5
<i>Sticking &amp; Panel Options</i> .....	6-7
<i>R&amp;T Series</i> .....	8-9
<i>O&amp;B Series</i> .....	10-11
<i>E&amp;S Series</i> .....	12-13
<i>Raised Moulding</i> .....	14-15
<i>V-Groove</i> .....	16
<i>Louver</i> .....	17
<i>Power of One</i> .....	18
<i>Cascadelli</i> .....	19
<i>Modern Series</i> .....	20-23
<i>Glass Series</i> .....	24-25
<i>Common Arches&amp;Clipped Corners</i> .	26
<i>Stain Grade</i> .....	26
<i>Pre-Finishing</i> .....	27
<i>Fire Rated / STC Rated</i> .....	28-29
<i>Large Projects / Case Studies</i> ....	30-31
<i>Environmentally Kind/LEED</i> .....	32
<i>Jambs</i> .....	33
<i>Packaging, and Freight</i> .....	34
<i>Handling, Finishing &amp; Pre-drilling</i> ....	35
<i>Routed Doors Compared to Supa</i> ....	36

## The Supa Difference...

**Design Flexibility** Every Supa Door is **Built to Order**. This allows you to have a door YOU design, not one that the manufacturer dictates for you. A door that is constructed in an architecturally correct manner, built by hand using sophisticated machinery in quick lead times. Use this brochure to customize your door, or create your own design using the Door Designer program at [www.supadoor.com](http://www.supadoor.com).

**Product Reliability** Supa Doors Inc. has been manufacturing solid MDF doors for 20 years, making Supa Doors one of the most field-tested MDF doors in the world. We use the highest quality double-refined material and each door is hand-checked before shipping. All are made in the USA.

**Lifetime Warranty** With 20 years and over a million doors of experience, we are confident your MDF doors will stand the test of time.

**Commercial & Hotel Applicability** Aside from single family residences, Supa Doors are ideal for Hotel, Assisted Living, Religious, Historic, Large-Scale Residential, and Speciality Projects. Supa Doors has a rich history in creating stylish doors at competitive prices.

**Environmental Sustainability** MDF is, at its core, recycled wood. We use 100% recycled wood fiber. We use low VOC primer and glue, and offer No Added Formaldehyde (NAUF) and FSC Certified material. All Supa Doors have been tested to minimize noise.

**Patented Technology** Supa Doors are manufactured to a patented stile and rail laminated process to ensure no weak joints. Blending a traditional stile and rail door with modern manufacturing method of laminated construction, provides several advantages including interlocking wood edges.

S U P A D O O R S

## Patented Construction

*This unique process creates stile and rail constructed doors where every piece of the door is laminated to each other simultaneously, creating a continuous lamination. This process ensures that there are no weak joints where the stiles meet the rails. There is no other door that is made this way.*

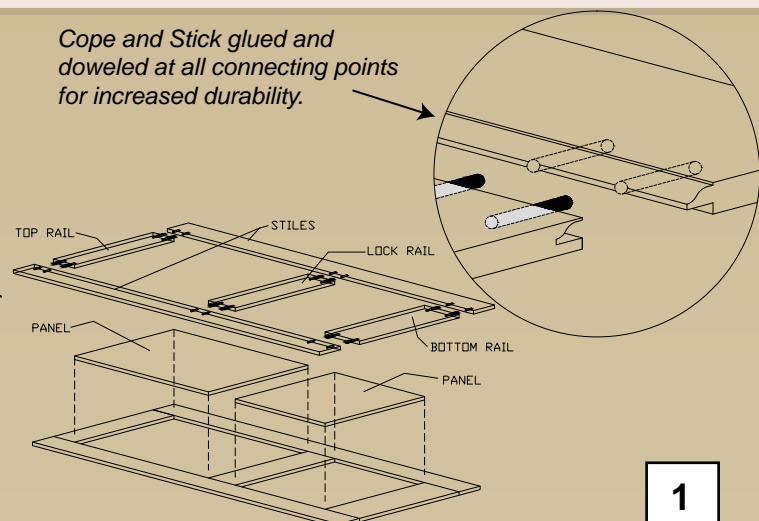

# The Mayflower

"15 CPW - THE KING OF CENTRAL PARK WEST" - VANITY FAIR, SEPTEMBER 2008



15 Central Park West - Manhattan



Robert A.M. Stern Architects

Custom designed for 15 Central Park West, the Mayflower combines 3 panels in a classic traditional layout with a full thickness, convex panel.



MAYFLOWER DETAIL  
1-3/4" ONLY

# Tailor-make your own door

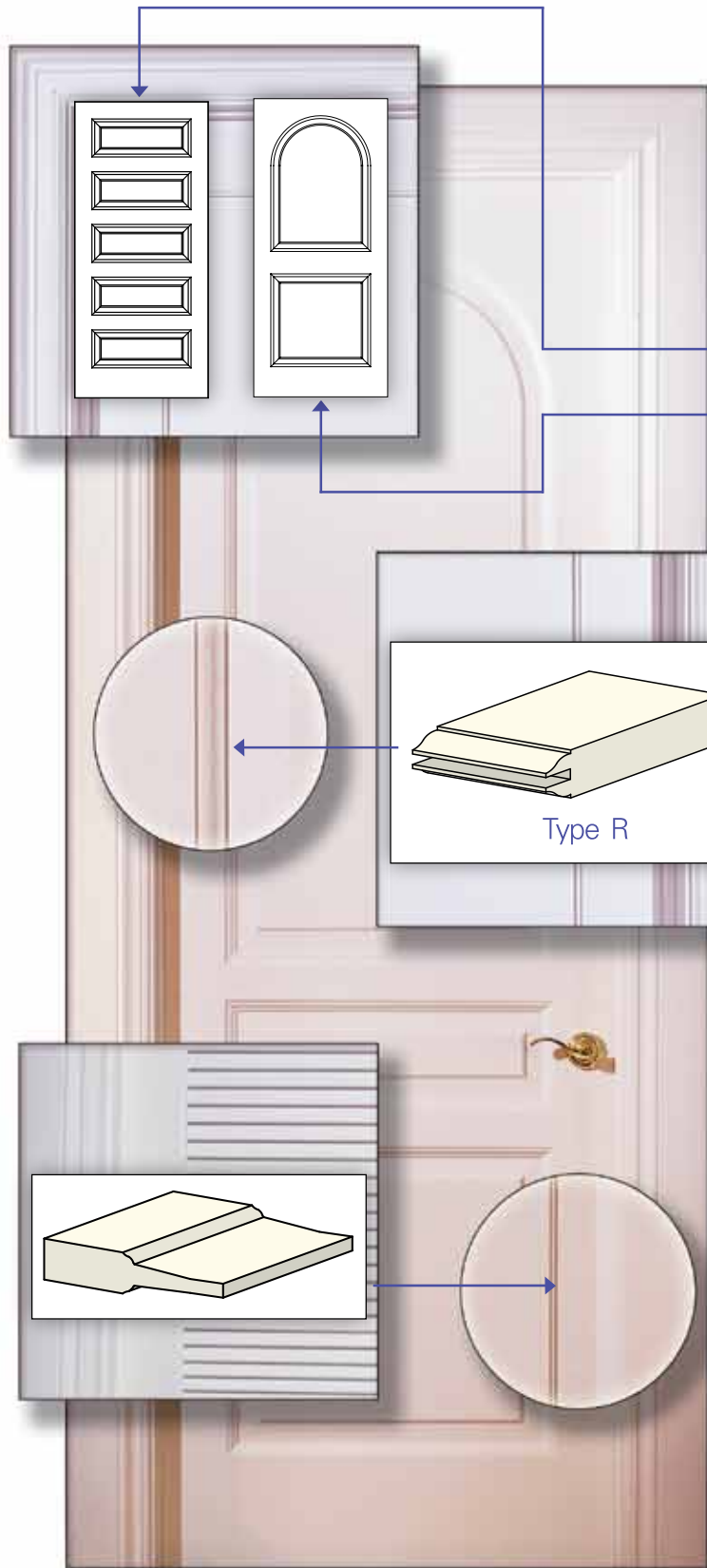

one.

Choose the number of panels  
and the shape of the door you prefer

two.

Choose the Sticking  
(The sticking is the profile of  
the door itself, not the panel)

three.

Choose the Panel  
(The panel option is the profile  
of the edge of the panel)

# Easy as 1,2,3.

## Step 1 *Choose your design.*

The layouts shown on these pages present the standard Supa Door elevations. However, Supa Doors are available with custom stile and rail dimensions, and therefore, customized panels. This differentiates Supa Doors from molded skin doors which have fixed elevation dimensions.

## Standard Door Designs

All doors are available in standard heights of 6'8", 7'0", and 8'0" and standard widths between 1'0" and 3'6" (all door elevations below are shown as 3'0" x 6'8"). Custom heights and widths are available upon request (note that certain sizes will fall outside the standard lifetime limited warranty). Door thicknesses are available in 1-3/8", 1-3/4", and 2-1/4". All MDF Panel doors may be fire rated. Glass may be substituted for all MDF panels and some glass doors. please inquire for your specific request.

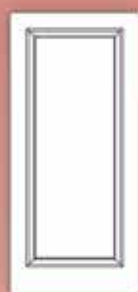

# 100

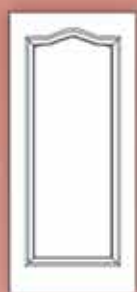

# 110



# 120



# 130



# 140



# 150



# 150A

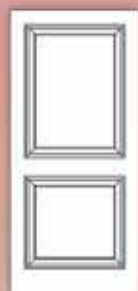

2 panel



2 panel Colonial



2 panel Victorian

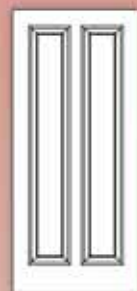

# 200

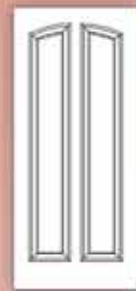

# 213



# 225



# 250



# 270



3 panel



# 300

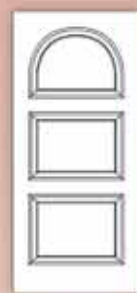

# 305



# 311

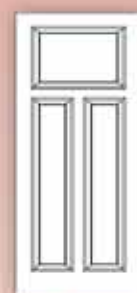

# 312



# 325



# 330



# 340

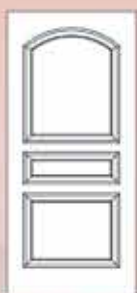

# 350



# 355

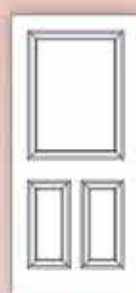

# 360



# 361



# 370

ALL STILE AND RAIL DIMENSIONS ARE ADJUSTABLE



# 380



# 392



4 panel



# 400



# 420



# 430

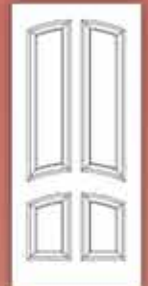

# 450



# 470



# 490



5 panel



# 500



# 520



# 530

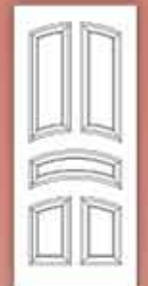

# 550



6 panel



# 600



# 605



# 610



# 660



# 800



# 310 Madrid

All tile doors and tile over panel doors shown below are true divided tile construction



# 510 Madrid  
No grills are available

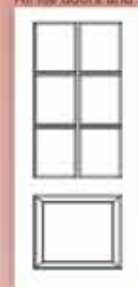

# 6 Lite Over Panel

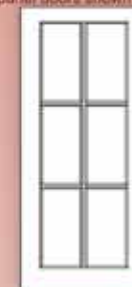

# 6 Lite

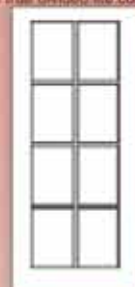

# 8 Lite



# 8 Lite Over Panel



# 9 Lite Over Panel

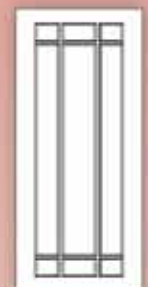

# 9 Lite Prairie

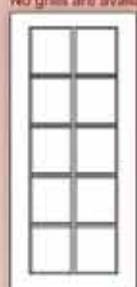

# 10 Lite

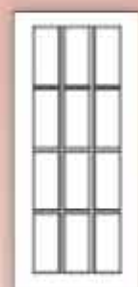

# 12 Lite

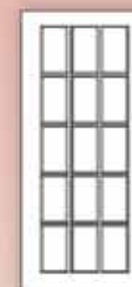

# 15 Lite

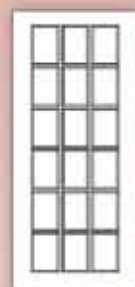

# 18 Lite



Bifold 2 panel











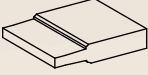
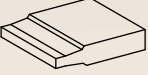

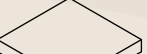

Bifold 4 Panel

# Step 2&3

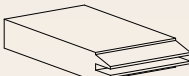
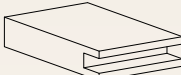
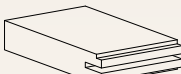
## Sticking & Panel Options

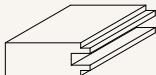
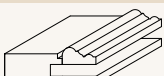

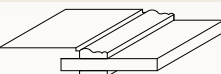



### Panels

Sticking	Panels						
	 B Double Hip	 T Single Hip	 SC Scoop	 F Flat	 V Groove	 Full Thickness Double Hip	 Arch Panel Available
 R	✓	✓	✓	✓	1 3/4" ONLY		✓
 T	✓	✓	✓	✓	1 3/4" ONLY		✓
 B	✓	✓	✓	✓	1 3/4" ONLY		✓
 S	✓	✓	✓	✓	✓		✓
 E	✓	✓	✓	✓	1 3/4" ONLY		✓
 O	✓	✓	✓	✓	1 3/4" ONLY		✓
 Oval O	✓	✓	✓	✓	1 3/4" ONLY		✓
 Modified E	✓	✓	✓	✓	1 3/4" ONLY		✓
 Heavy Bollection				✓		✓	✓ Semi Arch Only
 Nuline				✓		✓	✓
 M	✓	✓	✓	✓	1 3/4" ONLY		✓
 C				✓	1 3/4" ONLY		

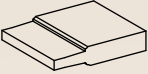
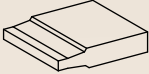

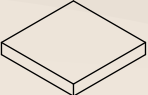
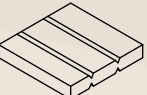
# Sticking & Panel Options

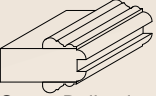
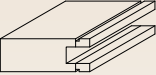
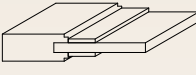
## Panels

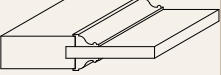
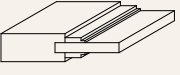
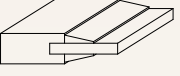
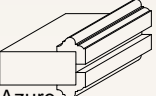
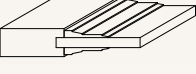
Sticking							
	B Double Hip	T Single Hip	SC Scoop	F Flat	V Groove	Full Thickness Double Hip	Arch Panel Available
 Super Bollection	✓	✓	✓	✓	1 3/4" ONLY		
 Tivoli				✓			
 Cascadelli				✓			
 Venetian	✓	✓	✓	✓	1 3/4" ONLY		✓
 Vintage				✓			
 Escala				✓			
 Classic				✓			
 Azure				✓		✓	✓
 Triple Crown				✓			

### Standard Panel Thickness

#### For 1 3/4" Doors

All raised panels are 1 1/4"  
All flat panels are 5/8"  
other than "S" sticking which is 7/8"

#### For 1 3/8" Doors

All raised panels are 7/8"  
All flat panels are 1/4"  
other than "S" sticking which is 11/16"

### Interlocking Keyed Wood Edge

Our hardwood Keyed Woodedge interlocks itself into the edge of the door for increased durability and runs the full length of both stiles. For POCKET doors and SLIDERS, the woodedge is available across the top rail, when requested.

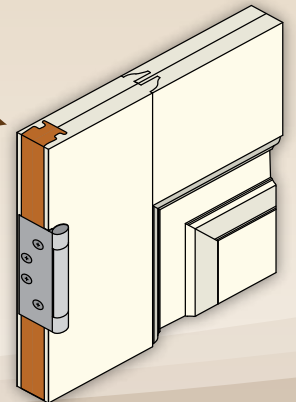

The use of **arched** panels in the door introduces a whole **new** feel to the room.



style # 370 door with full radius top panel with type "R" sticking and "B" panels

examples of type "R" sticking and panel options



type "R" sticking with "B" panel  
see page 6 for all panel options



type "R" sticking with "B" panel



type "R" sticking with "F" panel



type "R" sticking with "SC" panel



optional type "M" plant on moulding (available for doors with "R" sticking)

*Supa Doors' designs  
bring elegance and  
sophistication to your home.*



*common arched pair of 2 Panel Victorian doors*

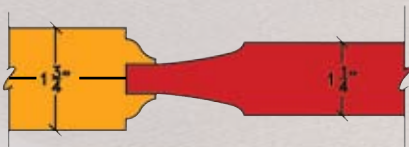

type "T" sticking with "T" panel  
see page 6 for all panel options

examples of type "T" sticking and panel options



type "T" sticking  
with "T" panel



type "T" sticking  
with "B" panel



type "T" sticking  
with "F" panel

# ovaloffice

*Style, quality  
and elegance  
in every room.*



*pair of style # 300 doors with type "O" sticking and "SC" panels*

## examples of type "O" sticking and panel options

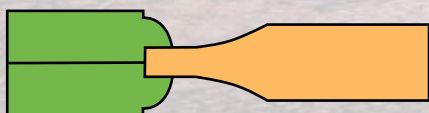

type "O" sticking with "SC" panel  
see page 6 for all panel options



type "O" sticking  
with "SC" panel



type "O" sticking  
with "B" panel

# modernslant

A modern slant on traditional profiles.  
**Bold, Sharp & Distinct.**



Anaheim Marriott

*sliding door with type "B" sticking and white laminated glass*

## examples of type "B" sticking and panel options

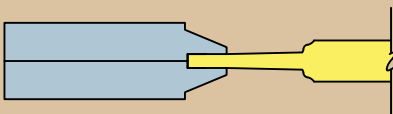

type "B" sticking with "B" panel  
see page 6 for all panel options



type "B" sticking with "B" panel



type "B" sticking with "F" panel



type "B" sticking with "SC" panel



type "B" sticking with "T" panel

# contemporaryclass

*Tasteful, uncluttered style  
with a touch of finesse.*



style #100 door with type "E" sticking and "F" panel

## examples of type "E" sticking and panel options



type "E" sticking with "F" panel  
see page 6 for all panel options



optional molding type "C"  
for "E" sticking with "F" panels



type "E" sticking  
with "B" panel



type "E" sticking  
with "F" panel



type "E" sticking with  
H/B moulding on "F" panels

# shakerseries

*Chic simplicity.  
Classic, clean lines.  
Simple in theme.*

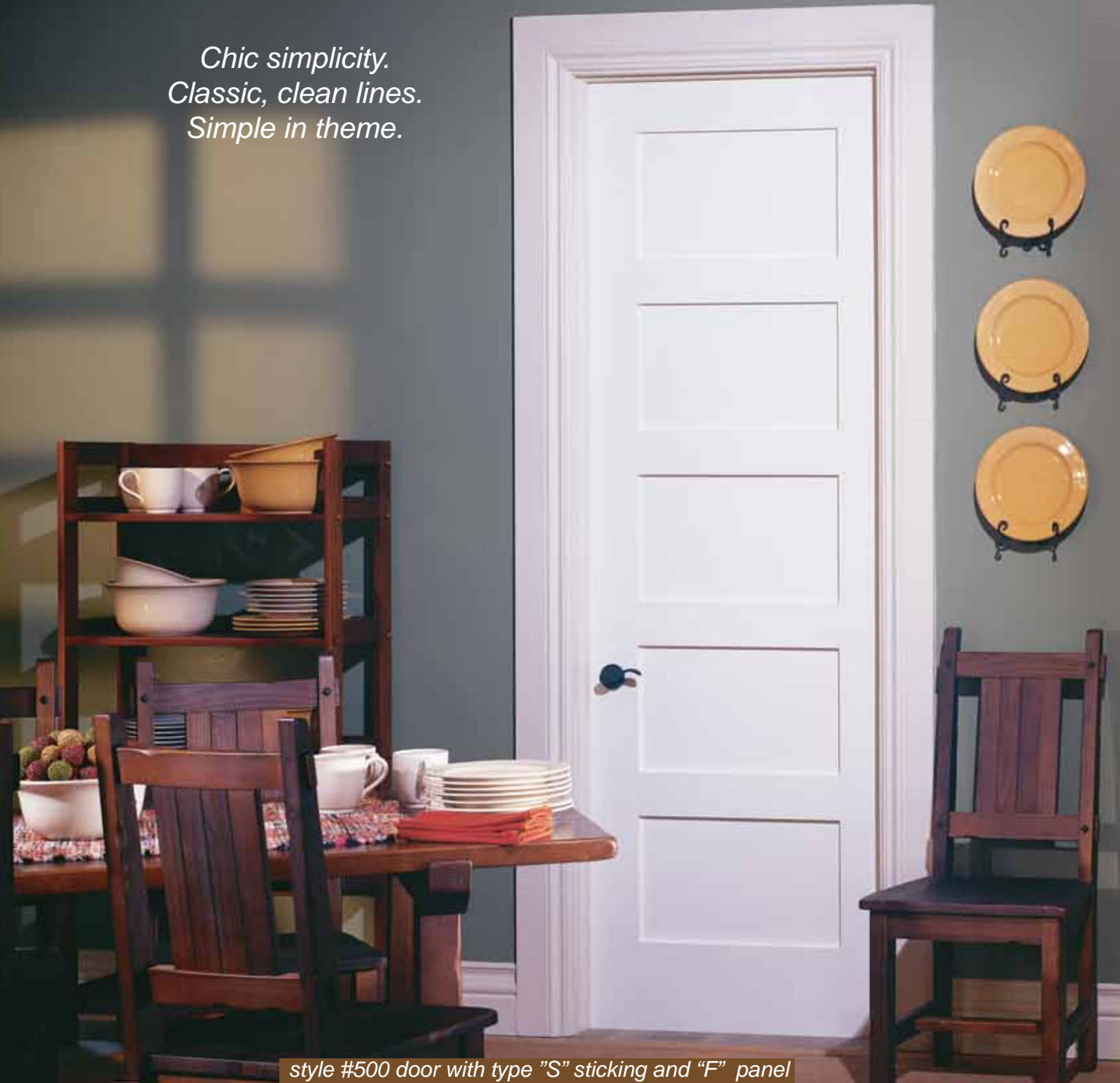

style #500 door with type "S" sticking and "F" panel

## examples of type "S" sticking and panel options



type "S" sticking with "F" panel  
see page 6 for all panel options



type "S" sticking with "F" panel



type "S" sticking with "B" panel



type "S" sticking with "SC" panel



type "S" sticking with "F" panel and H/B moulding



type "S" sticking with "C" moulding and "F" panel

**Nuline Moulding**

*Sophistication and grace.*



*Suggested Designs  
but not limited to*

*style #250 with "S" Sticking and Nuline Moulding*



Nuline moulding detail



Nuline pocket moulding detail

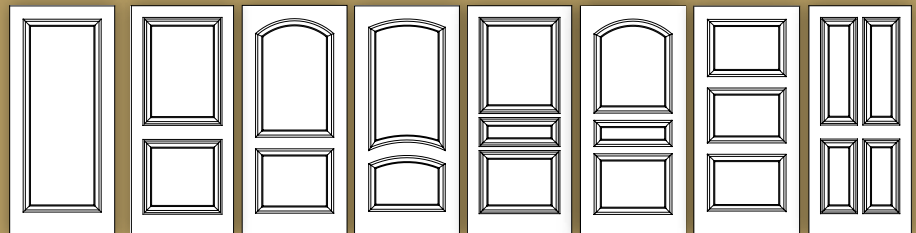

#100

2 panel

2 panel  
Victorian

#250

3 panel

#350

#300

4 panel



# formalclass

*Raised Moulding Series*

Heavy  
Bollection  
Moulding



*Sophistication  
and formality.*



All shown with  
Full Thickness panel



"S" sticking with Heavy  
Bollection Moulding



"S" sticking with Heavy  
Bollection Pocket Moulding



"E" sticking with  
Heavy Bollection Moulding



"E" sticking with Heavy  
Bollection Pocket Moulding

*Suggested Designs  
but not limited to*

*2 panel with "E" sticking and HB Moulding and a full thickness panel*

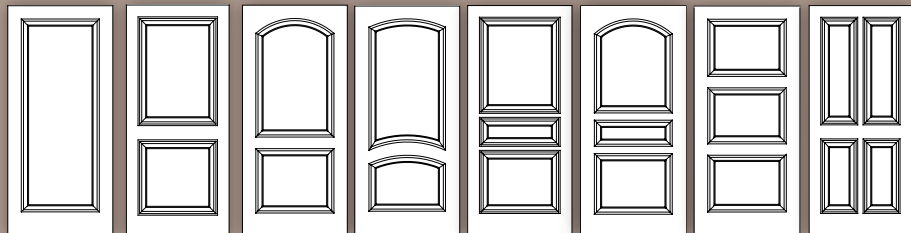

#100

2 panel  
Victorian

2 panel

#250

3 panel

#350

#300

4 panel

# southwest style

*Country Living.  
Beautiful, uncomplicated doors to lend a rustic air to your down-to-earth lifestyle.*



**Suggested Designs**  
but not limited to

"V1" door with "S" sticking and V Groove panel.

examples of type "S" sticking with v-groove panels



type "S" sticking with V GROOVE panels

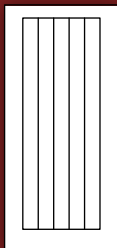

V1

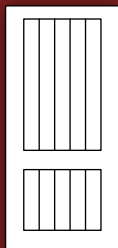

V2

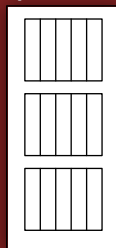

V3

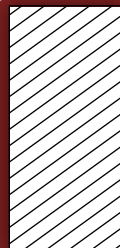

V45

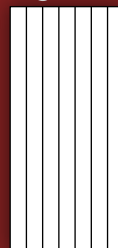

VV1

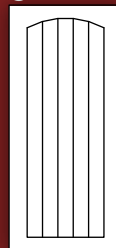

V1-V

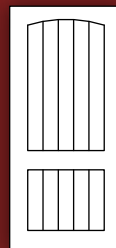

V2-V

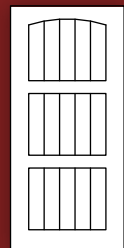

V3-V

# louverdoors



*Relax in airy, breezy rooms, with true(vented) louvers or achieve a similar look with false (non-vented) louvers*

*Suggested Designs but not limited to*

*full true louver door with "E" sticking*

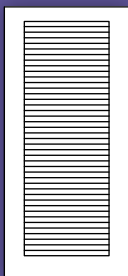

full louver



louver/louvers

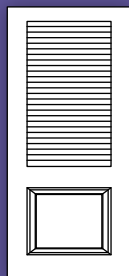

louver/panel

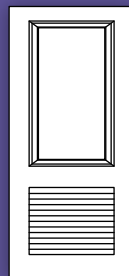

panel/louvers

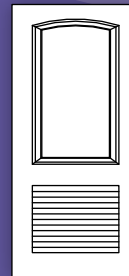

victorian panel/louvers

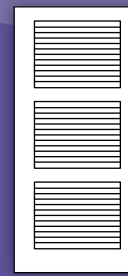

#300 louver



true louver

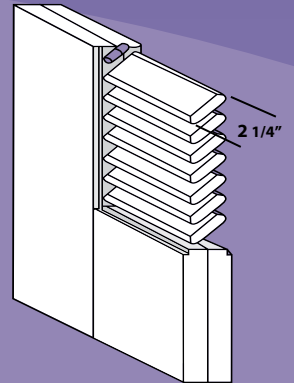

true louver section



false louver

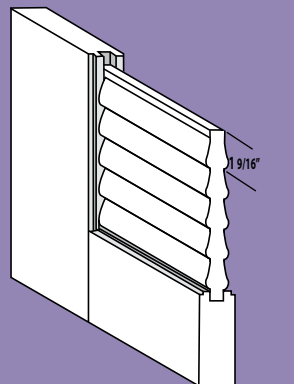

false louver section

# "The power of one" - One Panel Options

## Tivoli



Subtle, with a statement. Slightly modifying the simple and clean lines of a single panel door can be a clever and effective way of differentiating your project. By incorporating specially designed knives to shape profiles and panels, each door in the collection enjoys a truly unique and special feel. Several have been designed for some of the highest profile projects across the nation and are now available for your special project.

### The Rushmore - NY



#### Milano



#### Venetian



#### Tuscany



#### Cascadelli



#### Tivoli



#### Milano



#### Venetian



#### Tuscany



#### Cascadelli



# *Cascadelli*



#225 Cascadelli

## *Classic & Modern*

The Cascadelli has quickly become an instant classic with its special tiered, stair-stepped profile. When used in a #225 design layout, it blends clean, sharp lines with a  $\frac{3}{4}$  length top panel which provides the ultimate exclusive look for upscale homes and apartments.



# MODERN *BY* SUPA



# AZIA

with white laminated glass





L100 with Frosted Glass and Natural Unfinished MDF

# The Enclave

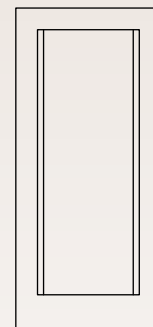

ENCLAVE





Available thickness  
 $1\frac{3}{8}$ ",  $1\frac{3}{4}$ ",  $2\frac{1}{4}$ "

Custom Designs  
 Available

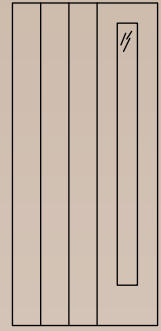

AZIA

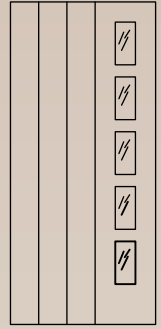

AZIA5

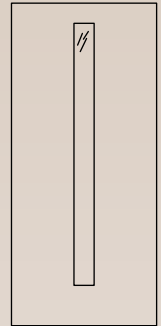

INFINITY 1

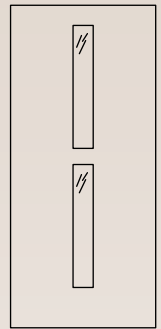

INFINITY 2

Designs available with a  
 Square groove or V groove

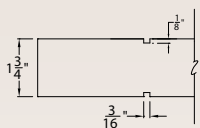

SQ.-GROOVED

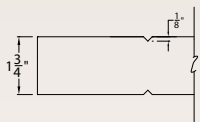

V-GROOVED

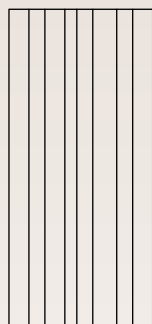

VV1-RANDOM

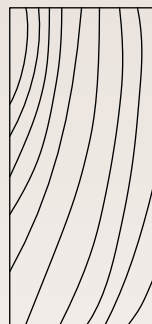

REVEL



H2

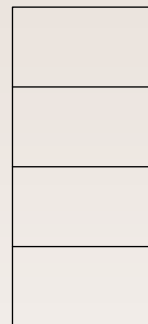

H3

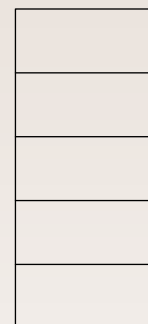

H4

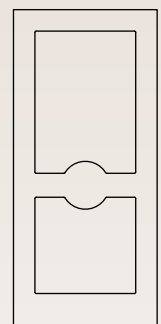

#212

# lighten up

## The LITE Series



Glass is available in all panel door layouts. Any number of panels may be substituted with glass. Textures include clear, frosted, white laminated, or textures as shown below. Leaded glass is also available in any custom design with lead or brass came. Mirrors may also be substituted on one or both sides of a door.

In addition to panel substitutions, glass is available in true divided light doors as shown on page 5 & 22. Standard face dimensions of muntin bars is 5/8". No light grills are available. Glass thickness standard is 1/4".



the use of glass introduces a whole new feel to the room



Oversize Barn Slider  
L300 with Frosted Glass



L300



18 Lite Common Arch pair



Pair of style # 100 pocket doors shown with clear, tempered glass and modified "E" sticking.



Style # 600 with clear tempered glass and "S" sticking and matching # 100 side lites.



Style # 400 shown with white laminated glass and modified "E" sticking.



4 panel clipped corner door

common arched pairs, radius top, semi-arch top, and clipped corner options

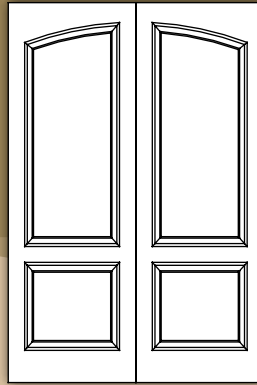

2 panel Victorian pair with common arched (semi arched) panels specify "CAP"

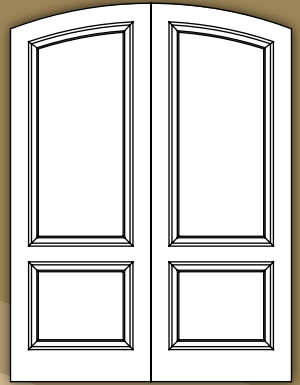

common arched pair with semi arched top when specify "CAP-SA"

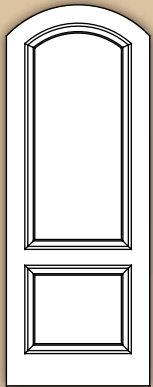

semi arched top specify "SAT"

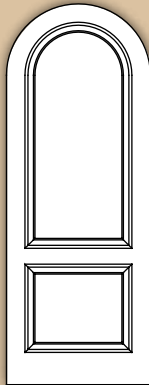

radius top specify "RT"

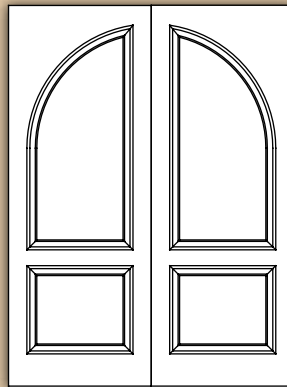

square 2 panel doors with full radius common arch panels specify "CAP-RTP"

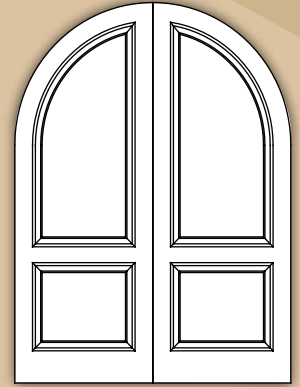

common arched pair with full radius top panels specify "CAP-RTP-RT"

## stain grade doors

*A Solid Proposition*

While many manufacturers offer a paper-thin veneer overlay, Supa now offers SOLID wood doors to augment our MDF doors. Most designs can be identically matched and are manufactured from a range of SOLID hardwoods, including Red Oak, Honduras or African Mahogany, Hard Maple, Birch, and more (Please inquire for species). Choosing a Single Source Provider creates a consistent, uniform look across your home, and with Supa Doors, you know the quality will be through-and-through.



SSW 355



SSW 300



SSW Victorian



SSW 312

\*Matching frames as K.D. or pre-hung are also currently available.

*In response to many requests from hospitality and hotel groups for a pre-finished solution for painted doors, we began investigating key criteria for a durable coating.*

# pre-finishing

## **CRITERIA FOR A GREAT DURABLE PAINTED PRE-FINISH**

1. To achieve a professional factory finish and a phenomenal look.
2. To be easily repairable in the field by the hotel maintenance crew.
3. To provide an easy to clean surface so as to resist the daily wear doors in the hospitality field face from luggage, cleaning carts, etc.
4. To meet independent tests for durability and a stain resistant surface.

What resulted was the **Supa Water Based Acrylic Factory Finish**. The look was reviewed and approved by three major hotel flags, and has been used on multiple high profile, full service hotels in gateway cities such as New York, Chicago, and San Diego. The Supa Durable painted pre-finish is applied in house, which is important for the following reasons.

## **BENEFITS OF FACTORY FINISHING**

1. We **Maintain** our extreme **quality standards** over the product.
2. In-house factory finishing **Eliminates** any passed through secondary **transport costs** to a third party vendor.
3. We are able to **Decrease the lead time** since primer and a finish coat can be applied concurrently.
4. **We are able to** properly package **the doors so that they are transported** to the job site in pristine condition.



*pair of 2'6" x 8'0" 3 panel doors with "R" sticking and "B" panels*

Premium  
Pre-finishing

This process is applied in a clean environment and provides a premium finish. Pre-Finishing is offered in any Sherwin Williams color as well as custom match. This option is ideal for Hospitality, Assisted Living, and Commercially oriented projects. We will entertain other projects on a case by case basis.



# all fired up | Fire Door Details

### Standard 20 Min.

Stile and rail, raised or flat panel 20 minute doors using our traditional method of manufacture, Supa laminates a 3/8" MDF core into our construction to achieve the exact match to any of our standard or custom designs. Thickness 1 3/4" or 2 1/4"

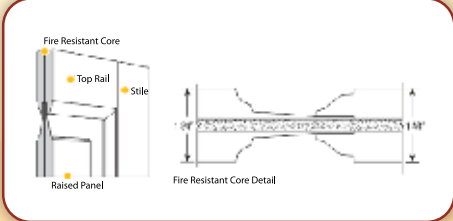

### Standard 45/60/90 Min.

Stile and rail, raised or flat panel 45, 60, or 90 minute rated doors. Using our traditional method of manufacture, Supa laminates a fire rated core between our MDF to achieve the exact match to any of our standard or custom designs. Thickness 1 3/4" or 2 1/4"

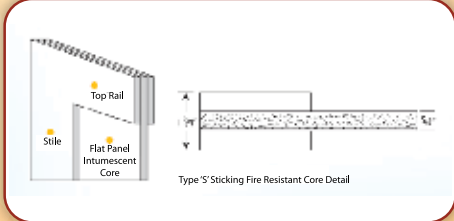

### Mineral Core Option

By using flush rated mineral core doors, Supa is licensed to apply mouldings and panels to flush doors and achieve a "raised panel effect". Thickness 1 3/4" or 2 1/4".

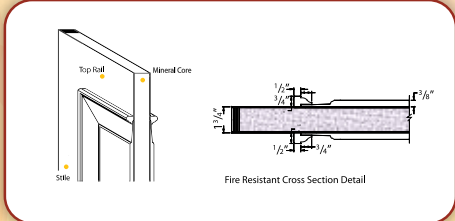

Holiday Inn Sunspree Orlando



Marriott Chicago O'Hare

DOOR TYPE	MINIMUM THICKNESS	MAX WIDTH SINGLE	MAX WIDTH PR	MAX HEIGHT	Max Glass Size (sq.in.)	Wood Fire Frames Max Size
20 MIN. CAT A/CAT B POSITIVE PRESSURE	1-3/4"	4'-0"	8'-0"	8'-0"	1296"sq. in.	4'-0" x 9'-0" Singles 8'-0" x 8'-0" Pairs
45/60 MIN. CAT A POSITIVE PRESSURE	1-3/4"	4'-0"	7'-0"	8'-0"	1296" sq.in.	4'-0" x 9'-0" Singles 8'-0" x 8'-0" Pairs
90 MIN. CAT A POSITIVE PRESSURE	1-3/4"	4'-0"	7'-0"	8'-0"	100" sq.in.	4'-0" x 8'-0" Singles 8'-0" x 8'-0" Pairs
Mineral Core Option	1-3/4"	4'-0"	7'-0"	8'-0"	100" Sq.in.	

### Standard Fire Core Construction Example

*Fire doors can be manufactured with any profile and configuration*

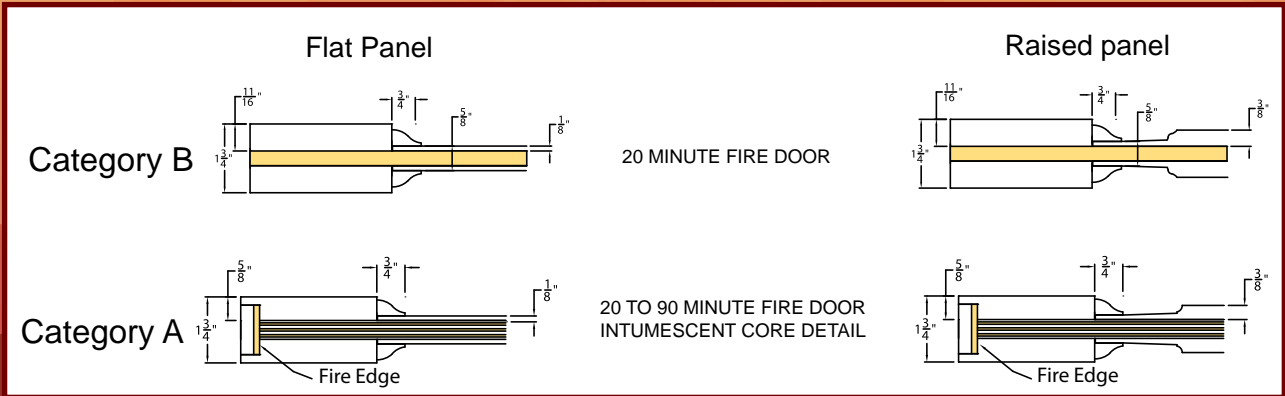

# low sound

Since noise is one of the more frequent complaints hotels/condos face, STC ratings are now a key criteria in choosing doors. Supa Doors have always been considered a “quiet” door due to its solid nature, high density, and patented construction and have been independently tested to determine STC ratings.

## STC RATINGS (Sound Transmission Coefficient)

STC Rating	Door Type	Door Thickness	Seals	Door bottom Threshold	Secondary Seals
37	60/90 Min Fire Door	1¾”	Zero #475	Zero #564	Not Necessary
36	45 Min	1¾”	Pemko S773	Pemko 434	Not Necessary
34-36	20 Min	1¾”	Pemko S773	Pemko 434	Not Necessary
32	Non-rated	1¾”	Pemko S773	Pemko 434	Not Necessary



### Guest Reviews of Hotels with SUPA DOORS *Marriott Marina - San Diego (1356 Rooms)*

I am a light sleeper, but was never awakened...I was also right next to the vending room and elevators, and **the noise from them were also not a bother.**”

TripAdvisor Review June 2011

### *Embassy Suites Houston (262 All Suite Rooms)*

“I am in LOVE with this hotel!!.... What we loved best was the great night sleep, **not hearing any outside/hallway noise**”

Hotels.com guest review March 2011

### *Sheraton New York Hotel and Towers (1750 Rooms)*

“i have expected much more noise from outside but can say the noise isolation is good:)”

TripAdvisor Review Aug 2011

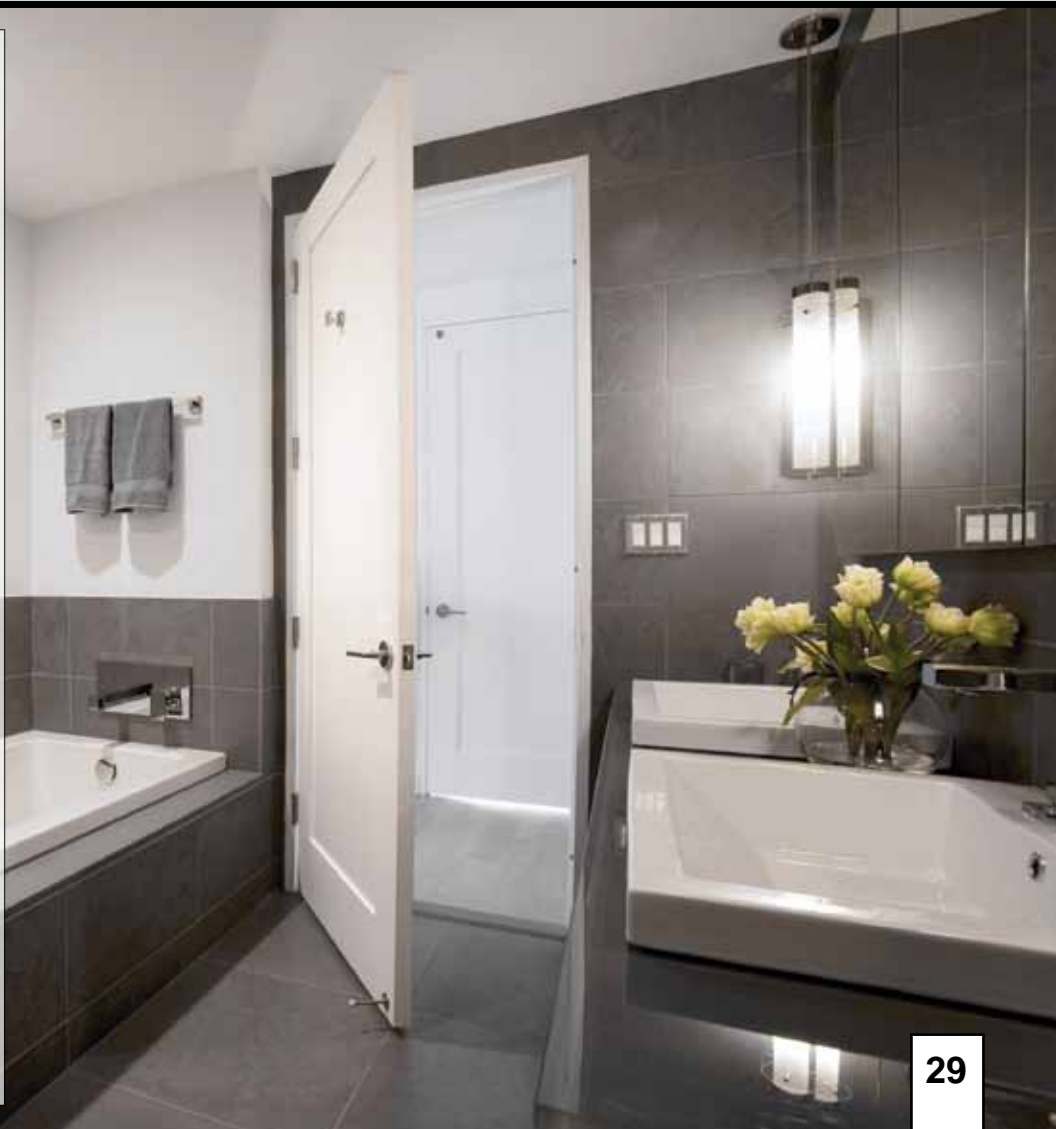

# commercial applicability

HOSPITALITY

ASSISTED LIVING

RESIDENTIAL TOWERS

RELIGIOUS INSTITUTIONS

HISTORIC PRESERVATION

SPECIALTY PROJECTS

*Supa is proud to offer the ability to customize the look and design of your doors for any project. We encourage you to create your own signature door.*

## Did you know?

**Supa Doors, Inc.**

is officially approved on many hotel brand specification lists, including **Hilton Worldwide** and **Marriott International**.

## Large projects have special needs. Supa Doors offers the following:

- Full Sample Doors for approvals
- Tagging Doors by floor and unit number
- Machining including mortise pockets, all hinge preps, channel grooves, exit device preps, and other requirements
- Packing by unit / floor / or other considerations
- Ship to a customer specified destination
- Pre-finishing
- Upscale louvered closet doors
- Custom panel and profiles
- Ideal for offshore properties
- Flexibility in meeting tight delivery schedules
- Mirrored doors





## Case Study I

## Renovation to the Max

### HOSPITALITY



*Sheraton Times Square*

When the Sheraton New York Hotel and Towers, one of New York City's largest and most legendary hotels, began its \$150 million renovation, they faced a common challenge; many guest room entry doors were sized slightly differently! Supa was able to customize the order at no extra cost to provide multiple door heights and widths, staged by floor, to ensure an accurate and timely installation schedule. Supa Doors collaborated with the design team to create a well thought-through, design in which we believe will serve as a perfect invitation for decades to come.



## Case Study II

## Aging in Elegance

### ASSISTED LIVING



Photo courtesy of Mark Shelton, AIA

*Parkside Health Care Building  
at Beth Shalom Assisted Living*

For the latest addition to the Beth Shalom Assisted Living campus, the architect aimed at creating a more comfortable, non-institutional feel for the future residents of The Parkside Health Care Building. By avoiding the use of flush doors and the commodity look of 6 panel doors, they successfully achieved the upscale residential touch they sought. The 2 Panel Victorian design added a "little more elegance" to the project and also worked well as a 3'8" wide entry door, which will allow the building to adapt for future nursing home opportunities.



## Case Study III

## Where Custom is Standard

### RESIDENTIAL



*The Chelsea Enclave*

Here at Supa Doors, we always preach, "The End of the Boring Door." The interior design team for the Chelsea Enclave, took that concept to the extreme. Their door incorporates two unique channels, and has artistically challenged the status quo of how a door must look.



Photo courtesy of Peter M. Hosier

# environmentally kind doors



## Every SUPA Door

Uses 100% pre consumer recycled wood fibers.

- Made in the United States- saving transport emissions
- Uses double-refined MDF
- Qualifies as an Environmental Preferred Product(EPP)
- Accepted by the City of NY Dept. of Buildings (MEA 36-08-M)
- Contains less than 0.11 parts per million (PPM) of formaldehyde conforming with CARB 2 and ANSI standards
- Primed with a non-hazardous water based primer

## No Added Formaldehyde Option (NAUF)

- All designs and profiles including louver doors
- SCS certified to contain NO ADDED urea formaldehyde
- Same lead times and features as our standard MDF doors

## FSC Certified Option

- Chain of custody SCS-COC- 002211

### Battery Park



Millenium Towers supplied with No-Added Formaldehyde options to help achieve **LEED credits**.

## LEED CREDIT

### MATERIALS & RESOURCES

MR Credit 4.1: Recycled content 10%  
 MR Credit 4.2: Recycled content 20%  
 MR Credit 5.1: Regional materials 10%  
 MR Credit 5.2: Regional materials 20%  
 MR Credit 7.0: Certified Wood

### PRODUCT QUALIFICATIONS

All SUPA Doors  
 All SUPA Doors  
 Qualify for most Texas - based projects  
 Qualify for most Texas - based projects-  
 Specify FSC - Certified SUPA Doors

### INDOOR ENVIRONMENTAL QUALITY

EQ Credit 4.4: Low emitting materials

### PRODUCT QUALIFICATIONS

Specify No Added Urea Formaldehyde SUPA Doors

All SUPA Doors



**Recycled Content**  
Minimum 86%

All SUPA Doors

**Low VOC Primer and Glue**

All SUPA Doors

Environmentally Preferred Product



CARB Compliant

Upon Request



SCS-COC-002211

All SUPA Doors

**Qualifies for LEED Credit**

Upon Request

**No added Formaldehyde Material**

# Knocked Down or Prehung Jamb Units

Supa Doors supplies machined K.D. jambs or Prehung Door Units to certain markets.

# in a jamb

## Jamb options

- Pine: 1 1/16" or 3/4" x 4-5/8", 4-3/4", 6-9/16" and wider
- Poplar: 3/4" or 1" x 4-5/8" and wider
- Red Oak and other hardwoods upon request
- Wood fire rated jambs 20,45,60 and 90 minutes rated

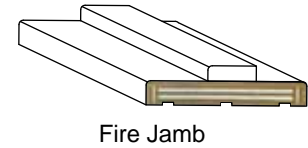
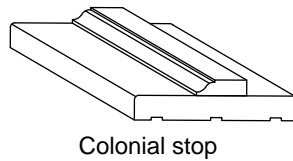
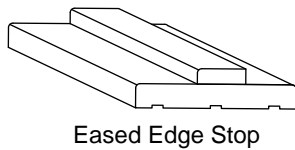
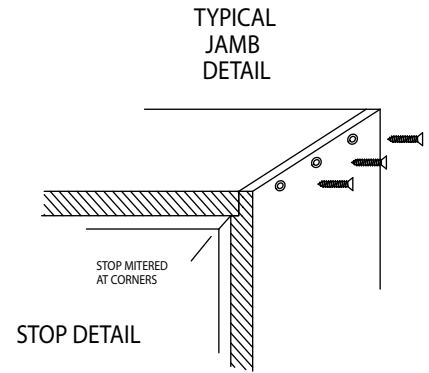

## Hinges

Available in the following colors

- US 3 - Polished Brass
- US 10B - Oil Rubbed Bronze
- US 26D - Brushed Chrome
- US 15 - Satin Nickel
- Other sizes and colors available upon request

Square or Radius Corners

- 3-1/2" x 3-1/2"
- 4" x 4"
- 4-1/2" x 4-1/2"

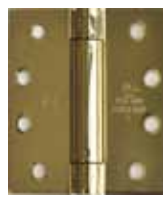

## Door sills

Bronze



Mill (aluminum)



## door machining

Supa Doors has full capabilities to machine for nearly all types of hardware from basic hinge preps to concealed hinges; from cylinder lock preps to full card lock mortise bodies, from bottom tracks to concealed closers. Please contact Supa Doors with your specific needs and machining sheets.



## beveling & chamfering

Our fully automated door sizing line accurately ensures that all Supa Doors are exactly sized. It also bevels and chamfers them at the same time.



## freight & packaging

We pack our doors onto a pallet before shrinkwrapping and adding corner protection on all four sides. After this is done, we strap them down with high tensile metal banding over 3 equally spaced 2 x 4's on top of the doors. This ensures that your doors will arrive in factory condition.

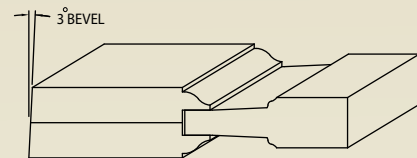

BEVELED EDGE

Doors can be supplied with a 3 degree bevel on one or both sides.

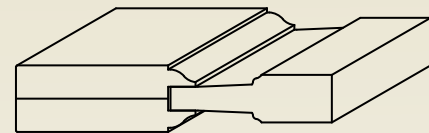

CHAMFERED CORNERS

All Supa® Doors slabs are supplied with both stiles chamfered.

# priming

Our state of the art, fully automated priming line enables us to supply the most consistent top quality doors, ready primed to accept final coats of paint to the color of your choice. All primers are water based acrylic paint.



## important pre-drilling & screw information

### handling

Supa<sup>®</sup> Doors should be handled in the same way you would a good quality lumber door. Here are some basic instructions that may be helpful in handling our product.

1. Doors should not be delivered to a job site or installed until concrete floors, foundations and plaster or drywall are completely dry.
2. Doors should be stored flat on at least three equally spaced 2 X 4's in a dry, well ventilated area. Do NOT lean up against walls.

### finishing

1. Doors supplied primed should be well sanded with 150 grit sandpaper, then wiped clean and finished with two coats of good quality oil based or latex paint.
2. To properly seal and finish doors, use a high grade product and apply in strict compliance with the manufacturers specifications. If you are using latex-paint do not over dilute or water down.
3. Door ends must be sealed before hanging.
4. Doors should be finished on all six sides before hanging or immediately thereafter.
5. When finishing doors, finish both sides at the same time, do not leave one side unfinished for a prolonged period of time.

1. Screw Type - Preferably single thread parallel core screws are recommended for use with all M.D.F. doors (including wood edge doors).
2. Pre-drilling - It is imperative that you pre-drill pilot holes and do NOT over tighten screws. M.D.F. is a fiber board and if not pre-drilled the fibers stretch on either side of the screw hole, which is unsightly but does not effect the integrity of the door. If this splitting occurs fill with vinyl spackle.
3. The pilot hole should be 90-95% of the screw core diameter. You should also make sure that the pilot hole is drilled approximately 1/8" deeper than the length of the screw being used.
4. Do not over-tighten screws - set clutch on drill to minimum. Over-tightening of screws causes a wedge effect and creates minor splits approximately 1/16" on either side of the screw. If splits appear loosen screw slightly and fill split with vinyl spackle. The integrity of the door will not be compromised and the full lifetime warranty will stay in place.
5. We recommend #8 X 1-1/4" screws for 1-3/8" doors and #10 or 12 X 1-1/4" screws for 1-3/4" doors. 6'8" doors require 3 hinges and 8 ft. doors 4 hinges.

## Limited Lifetime Warranty

*Supa Doors proudly stands behind your purchase of our doors and offers a Limited Lifetime Warranty. Some conditions and restrictions apply which can be found on our website. We encourage you to read the Warranty sheet on any building product you purchase.*

## Patented Construction

*This unique process creates stile and rail constructed doors where every piece of the door is laminated to each other simultaneously, creating a continuous lamination. This process ensures that there are no weak joints where the stiles meet the rails. There is no other door that is made this way.*

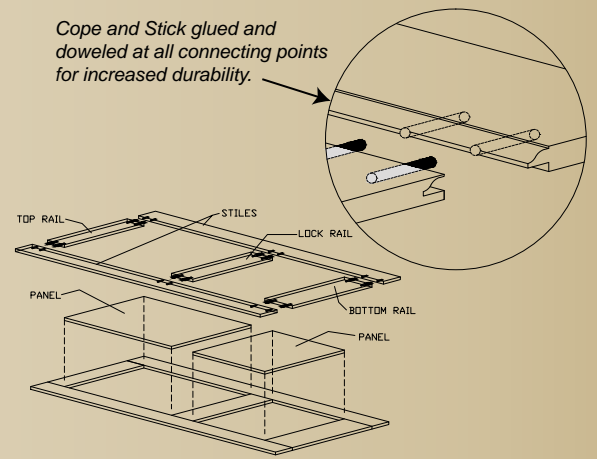

### Routed doors compared to the patented stile & rail Supa Door



Supa Door

100% solid MDF Supa® Door  
with patented stile and rail  
manufacturing process.  
Patent number 5771656.

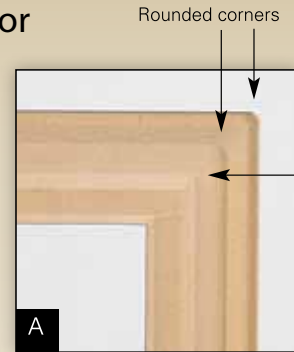

Routed Door

### Why Supa Doors?

- Supa Doors are constructed by means of a continuous laminated process using stile and rail components. This process ensures stability and integrity while minimizing warping, cracking or bowing.
- Stile and rail construction promotes architectural integrity of proportion in design. In other words, this method facilitates different possibilities in panel design (raised or flat) and panel thickness.
- Using stile and rail construction ensures all corners are sharp and have clean lines.
- Supa Doors are constructed using only the best double refined western softwoods which provides the smoothest machined finish. By comparison, routed doors facilitate only full thickness panels, create rounded corners, and rougher textures (see figure A).
- Supa Doors has supplied top quality doors to prestigious homes, high rise condos, hospitality projects, assisted living, and religious institutions across the nation.
- Supa Doors are backed by a LIMITED LIFETIME WARRANTY and are shipped in short lead times.

**Residential • Hospitality • Commercial • Assisted Living • Religious Institutions • Historical Matches**



*The Plaza Hotel - New York*



The **Plaza Hotel**, New York City - 2006 complete renovation included **Supa Doors** throughout. Pictured below - The Versace Apartment.



*Interior photo courtesy of Gal Nauer Architectural and Design, Inc.*

*1 panel interior door with type "R" sticking and "F" panel*

# THE EVOLUTION of the DOOR



## Stile and rail doors compared to the patented SUPADOOR method.

Traditional stile and rail doors are assembled as shown in the diagram on the right. Glue is placed between the joints where the stiles meet the rails, these are the only spots where the glue is placed and these spots of glue hold the entire door together

stile & rail door

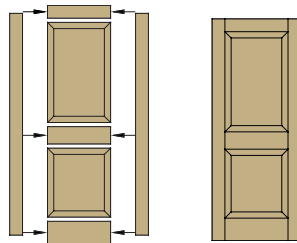

SUPA Doors being pressed



With the SUPA DOORS patented method, the door is manufactured in two glued and nailed halves. Glue is spread over the whole surface of one half of the door which is then pressed together with the other half under pressure creating a continuous lamination over the whole door, ensuring no weak joints.

patented stile and rail SUPA DOOR

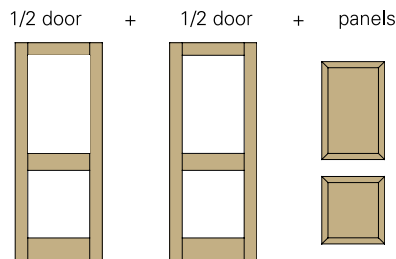

"Blending tradition with technology"

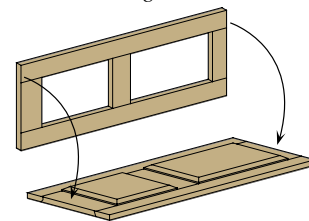

two halves face glued together then placed in the press to form a door

**Limited Lifetime Warranty!**

## SUPA DOORS, INC.

1732 Universal City Blvd. Universal City, TX 78148  
 Toll Free: 1.888.SupaDoor (787.2366) 210-698-8500  
 Toll Free Fax: 1.888.SupaFax (787.2399) 210-698-8507  
[www.SupaDoor.com](http://www.SupaDoor.com)