

Service Manual

Digital Camera

LUMIX

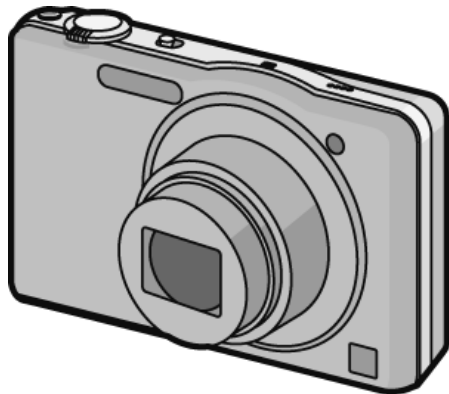

Model No. **DMC-SZ1P**
DMC-SZ1PC
DMC-SZ1PU
DMC-SZ1EB
DMC-SZ1EE
DMC-SZ1EF
DMC-SZ1EG
DMC-SZ1EP
DMC-SZ1GA
DMC-SZ1GC
DMC-SZ1GD
DMC-SZ1GF
DMC-SZ1GH
DMC-SZ1GK
DMC-SZ1GN
DMC-SZ1GT
DMC-SZ02P

Colour

[DMC-SZ1]

(S).....Silver Type (except PC/EF/GD)

(K).....Black Type

(A).....Blue Type (except EE/GC/GD/GH/GT)

(R).....Red Type (except EE/GD/GT)

(V).....Violet Type (only EB/EF/EG/EP)

[DMC-SZ02]

(K).....Black Type

Panasonic[®]

© Panasonic Corporation 2012 Unauthorized copying and distribution is a violation of law.

WARNING

This service information is designed for experienced repair technicians only and is not designed for use by the general public. It does not contain warnings or cautions to advise non-technical individuals of potential dangers in attempting to service a product. Products powered by electricity should be serviced or repaired only by experienced professional technicians. Any attempt to service or repair the product or products dealt with in this service information by anyone else could result in serious injury or death.

TABLE OF CONTENTS

	PAGE		PAGE
1 Safety Precautions	3	11 Block Diagram	40
1.1. General Guidelines	3	11.1. Overall Block Diagram.....	40
1.2. Leakage Current Cold Check	3	11.2. System Control Block Diagram	41
1.3. Leakage Current Hot Check (See Figure. 1).....	3	11.3. Video/Audio Process Block Diagram	42
1.4. How to Discharge the E.Capacitor on Flash Top P.C.B.	4	11.4. Sensor Block Diagram	43
2 Warning	5	11.5. Lens Drive Block Diagram.....	44
2.1. Prevention of Electrostatic Discharge (ESD) to Electrostatically Sensitive (ES) Devices	5	11.6. Power Block Diagram.....	45
2.2. How to Recycle the Lithium Ion Battery (U.S. Only).....	5	12 Wiring Connection Diagram	46
2.3. How to Replace the Lithium Battery.....	6	12.1. Interconnection Diagram.....	46
3 Service Navigation	7		
3.1. Introduction	7		
3.2. Important Notice	7		
3.3. General Description About Lead Free Solder (PbF)	7		
3.4. Important Notice 1:(Other than U.S.A. and Canadian Market).....	7		
3.5. How to Define the Model Suffix (NTSC or PAL model).....	8		
4 Specifications	13		
5 Location of Controls and Components	14		
6 Service Mode	16		
6.1. Error Code Memory Function	16		
7 Service Fixture & Tools	19		
7.1. Service Fixture and Tools	19		
7.2. When Replacing the Main P.C.B.	20		
7.3. Service Position	20		
8 Disassembly and Assembly Instructions	21		
8.1. Disassembly Flow Chart.....	21		
8.2. P.C.B. Location	21		
8.3. Disassembly Procedure	21		
8.4. Lens Disassembly Procedure.....	27		
8.5. Removal of the Focus Motor	29		
8.6. The Application of Grease Method	29		
8.7. Removal of the CCD Unit	30		
9 Measurements and Adjustments	31		
9.1. Introduction	31		
9.2. Before Disassembling the unit	31		
9.3. Details of Electrical Adjustment.....	33		
9.4. After Adjustment.....	38		
10 Maintenance	39		
10.1. Cleaning Lens and LCD Panel	39		

1 Safety Precautions

1.1. General Guidelines

1. IMPORTANT SAFETY NOTICE

There are special components used in this equipment which are important for safety. These parts are marked by

 in the Schematic Diagrams, Circuit Board Layout, Exploded Views and Replacement Parts List. It is essential that these critical parts should be replaced with manufacturer's specified parts to prevent X-RADIATION, shock, fire, or other hazards. Do not modify the original design without permission of manufacturer.

2. An Isolation Transformer should always be used during the servicing of AC Adaptor whose chassis is not isolated from the AC power line. Use a transformer of adequate power rating as this protects the technician from accidents resulting in personal injury from electrical shocks. It will also protect AC Adaptor from being damaged by accidental shorting that may occur during servicing.
3. When servicing, observe the original lead dress. If a short circuit is found, replace all parts which have been overheated or damaged by the short circuit.
4. After servicing, see to it that all the protective devices such as insulation barriers, insulation papers shields are properly installed.
5. After servicing, make the following leakage current checks to prevent the customer from being exposed to shock hazards.

1.2. Leakage Current Cold Check

1. Unplug the AC cord and connect a jumper between the two prongs on the plug.
2. Measure the resistance value, with an ohmmeter, between the jumpered AC plug and each exposed metallic cabinet part on the equipment such as screwheads, connectors, control shafts, etc. When the exposed metallic part has a return path to the chassis, the reading should be between $1\text{ M}\Omega$ and $5.2\text{ M}\Omega$. When the exposed metal does not have a return path to the chassis, the reading must be infinity.

1.3. Leakage Current Hot Check (See Figure. 1)

1. Plug the AC cord directly into the AC outlet. Do not use an isolation transformer for this check.
2. Connect a $1.5\text{ k}\Omega$, 10 W resistor, in parallel with a $0.15\text{ }\mu\text{F}$ capacitor, between each exposed metallic part on the set and a good earth ground, as shown in Figure. 1.
3. Use an AC voltmeter, with $1\text{ k}\Omega/\text{V}$ or more sensitivity, to measure the potential across the resistor.
4. Check each exposed metallic part, and measure the voltage at each point.
5. Reverse the AC plug in the AC outlet and repeat each of the above measurements.
6. The potential at any point should not exceed 0.75 V RMS . A leakage current tester (Simpson Model 229 or equivalent) may be used to make the hot checks, leakage current must not exceed $1/2\text{ mA}$. In case a measurement is outside of the limits specified, there is a possibility of a shock hazard, and the equipment should be repaired and rechecked before it is returned to the customer.

Hot-Check Circuit

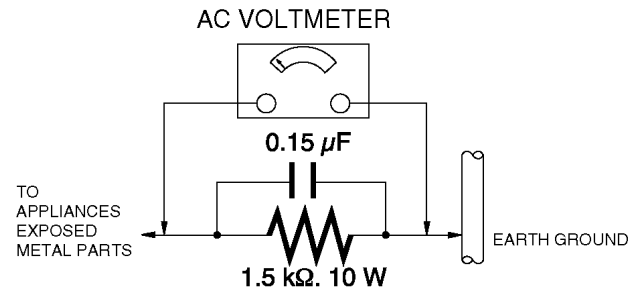

Figure. 1

1.4. How to Discharge the E.Capacitor on Flash Top P.C.B.

CAUTION:

1. Be sure to discharge the E.capacitor on FLASH TOP P.C.B..
2. Be careful of the high voltage circuit on FLASH TOP P.C.B. when servicing.

[Discharging Procedure]

1. Refer to the disassemble procedure and remove the necessary parts/unit.
2. Install the insulation tube onto the lead part of resistor (ERG5SJ102:1k Ω /5W).
(An equivalent type of resistor may be used.)
3. Place a resistor between both terminals of E.capacitor on the FLASH TOP P.C.B. for approx. 5 seconds.
4. After discharging, confirm that the E.capacitor voltage is lower than 10V by using a voltmeter.

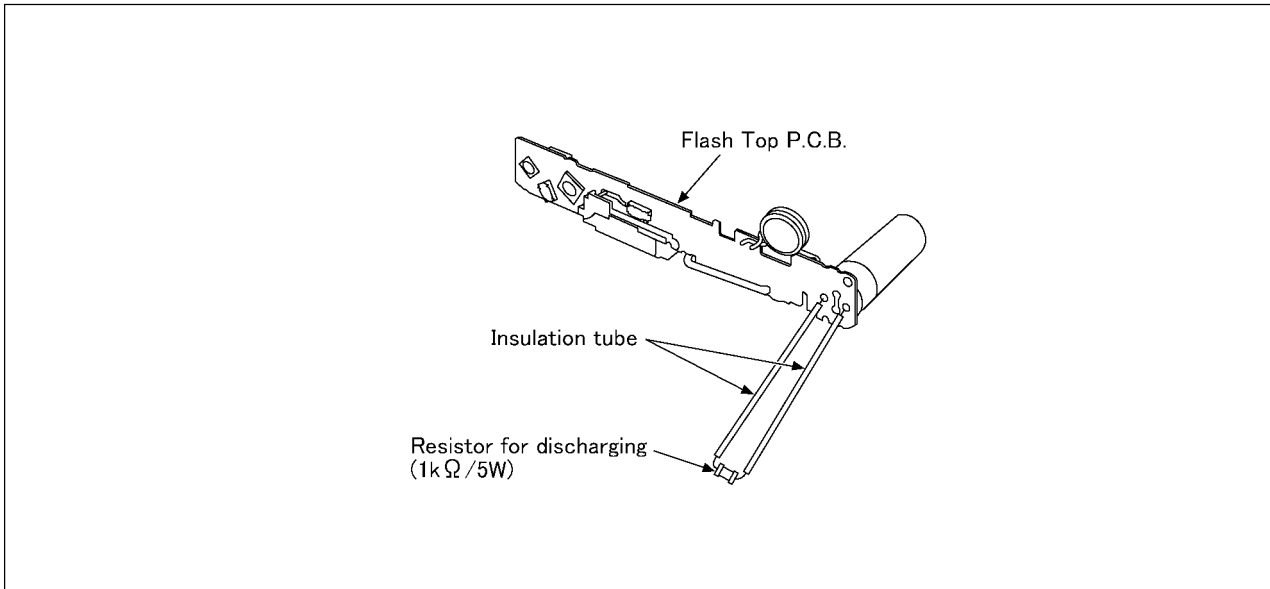

Fig. F1

2 Warning

2.1. Prevention of Electrostatic Discharge (ESD) to Electrostatically Sensitive (ES) Devices

Some semiconductor (solid state) devices can be damaged easily by static electricity. Such components commonly are called Electrostatically Sensitive (ES) Devices.

Examples of typical ES devices are CCD image sensor, IC (integrated circuits) and some field-effect transistors and semiconductor "chip" components.

The following techniques should be used to help reduce the incidence of component damage caused by electrostatic discharge (ESD).

1. Immediately before handling any semiconductor component or semiconductor-equipped assembly, drain off any ESD on your body by touching a known earth ground. Alternatively, obtain and wear a commercially available discharging ESD wrist strap, which should be removed for potential shock reasons prior to applying power to the unit under test.
2. After removing an electrical assembly equipped with ES devices, place the assembly on a conductive surface such as aluminum foil, to prevent electrostatic charge buildup or exposure of the assembly.
3. Use only a grounded-tip soldering iron to solder or unsolder ES devices.
4. Use only an antistatic solder removal device. Some solder removal devices not classified as "antistatic (ESD protected)" can generate electrical charge sufficient to damage ES devices.
5. Do not use freon-propelled chemicals. These can generate electrical charges sufficient to damage ES devices.
6. Do not remove a replacement ES device from its protective package until immediately before you are ready to install it. (Most replacement ES devices are packaged with leads electrically shorted together by conductive foam, aluminum foil or comparable conductive material).
7. Immediately before removing the protective material from the leads of a replacement ES device, touch the protective material to the chassis or circuit assembly into which the device will be installed.

CAUTION :

Be sure no power is applied to the chassis or circuit, and observe all other safety precautions.

8. Minimize bodily motions when handling unpackaged replacement ES devices. (Otherwise harmless motion such as the brushing together of your clothes fabric or the lifting of your foot from a carpeted floor can generate static electricity (ESD) sufficient to damage an ES device).

2.2. How to Recycle the Lithium Ion Battery (U.S. Only)

ENGLISH



A lithium ion battery that is recyclable powers the product you have purchased. Please call 1-800-8-BATTERY for information on how to recycle this battery.

FRANÇAIS



L'appareil que vous vous êtes procuré est alimenté par une batterie au lithium-ion recyclable. Pour des renseignements sur le recyclage de la batterie, veuillez composer le 1-800-8-BATTERY.

2.3. How to Replace the Lithium Battery

2.3.1. Replacement Procedure

1. Remove the SUB OPERATION P.C.B.. (Refer to Disassembly Procedures.)
2. Unsolder the each soldering point of electric lead terminal for Lithium battery (Ref. No. "B9501" at component side of SUB OPERATION P.C.B.) and remove the Lithium battery together with electric lead terminal. Then replace it into new one.

NOTE:

The Type No. ML421 includes electric lead terminals.

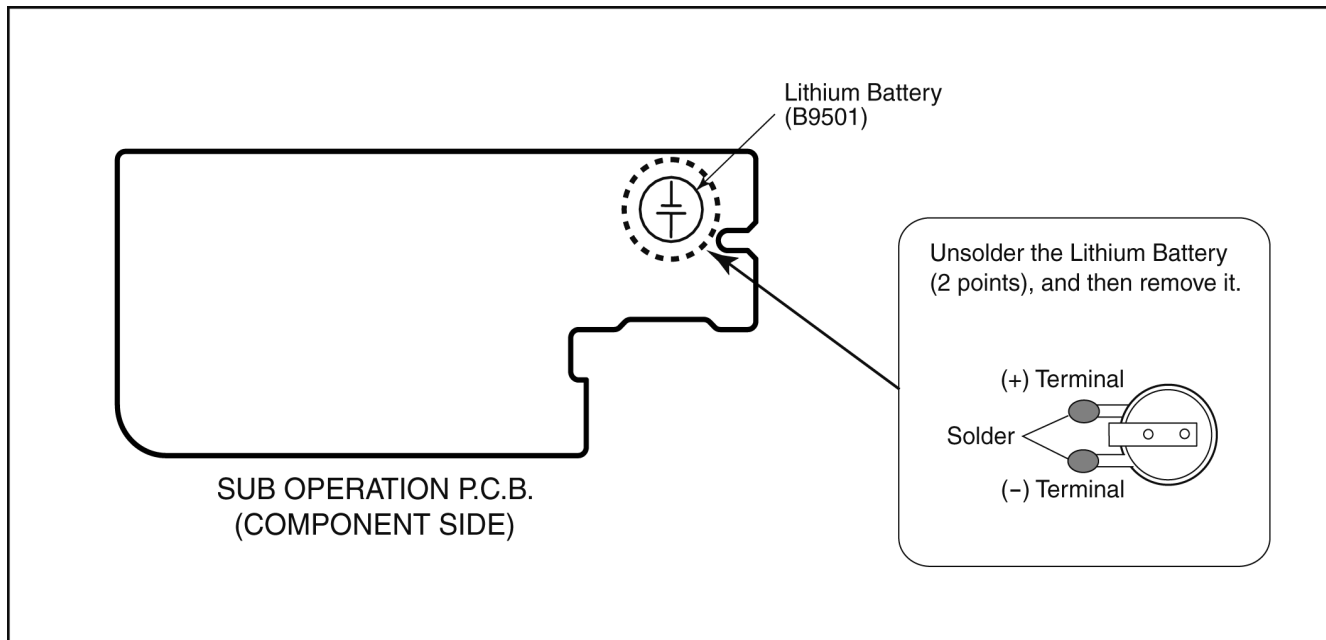

NOTE:

This Lithium battery is a critical component.

(Type No.: ML421 **Manufactured by Energy Company, Panasonic Corporation.**)

It must never be subjected to excessive heat or discharge.

It must therefore only be fitted in requirement designed specifically for its use.

Replacement batteries must be of same type and manufacture.

They must be fitted in the same manner and location as the original battery, with the correct polarity contacts observed.

Do not attempt to re-charge the old battery or re-use it for any other purpose.

It should be disposed of in waste products destined for burial rather than incineration.

(For English)

CAUTION

- Danger of explosion if battery is incorrectly replaced. Replace only with the type recommended by the manufacturer.
- When disposing the batteries, please contact your local authorities or dealer and ask for the correct method of disposal.

(For German)

ACHTUNG

- Explosionsgefahr bei falschem Anbringen der Batterie. Ersetzen Sie die Batterie nur durch den vom Hersteller empfohlenen Typ.
- Wenden Sie sich zur Entsorgung der Batterien an die lokalen Behörden oder erfragen Sie die richtige Vorgehensweise zur Entsorgung.

(For French)

MISE EN GARDE

- Il y a un danger d'explosion si la batterie n'est pas correctement remplacée. Remplacez-la uniquement par le type recommandé par le fabricant.
- Pour vous débarrasser des batteries, veuillez contacter les autorités locales ou votre revendeur afin de connaître la procédure d'élimination à suivre.

NOTE:

Above caution is applicable for a battery pack which is for DMC-SZ1/SZ02 series, as well.

3 Service Navigation

3.1. Introduction

This service manual contains technical information, which allow service personnel's to understand and service this model. Please place orders using the parts list and not the drawing reference numbers. If the circuit is changed or modified, the information will be followed by service manual to be controlled with original service manual.

3.2. Important Notice

3.2.1. CCD UNIT:

- The image sensor (CCD) unit which are connected to the lens unit with 3 screws. These screws are locked with the screw locking glue, after performing the Optical tilt adjustment. During servicing, if one of CCD fixing screws are loosened, the Optical tilt adjustment must be performed. About the Optical tilt adjustment, refer to the "9.3.2 Adjustment Specifications" for details.

3.2.2. About Flexible Cable and Connector

Do not touch carelessly so that the foreign body should not adhere to the terminal part of flexible cable and connector. Wipe off with a clean cloth and the cotton bud, etc. when the terminal part is dirty.

3.3. General Description About Lead Free Solder (PbF)

The lead free solder has been used in the mounting process of all electrical components on the printed circuit boards used for this equipment in considering the globally environmental conservation.

The normal solder is the alloy of tin (Sn) and lead (Pb). On the other hand, the lead free solder is the alloy mainly consists of tin (Sn), silver (Ag) and Copper (Cu), and the melting point of the lead free solder is higher approx.30°C (86°F) more than that of the normal solder.

Distinction of P.C.B. Lead Free Solder being used

The letter of "PbF" is printed either foil side or components side on the P.C.B. using the lead free solder.(See right figure)	PbF
--	------------

Service caution for repair work using Lead Free Solder (PbF)

- The lead free solder has to be used when repairing the equipment for which the lead free solder is used. (Definition: The letter of "PbF" is printed on the P.C.B. using the lead free solder.)
- To put lead free solder, it should be well molten and mixed with the original lead free solder.
- Remove the remaining lead free solder on the P.C.B. cleanly for soldering of the new IC.
- Since the melting point of the lead free solder is higher than that of the normal lead solder, it takes the longer time to melt the lead free solder.
- Use the soldering iron (more than 70W) equipped with the temperature control after setting the temperature at 350±30°C (662±86°F).

Recommended Lead Free Solder (Service Parts Route.)

- The following 3 types of lead free solder are available through the service parts route.
 - RFKZ03D01KS----- (0.3mm 100g Reel)
 - RFKZ06D01KS----- (0.6mm 100g Reel)
 - RFKZ10D01KS----- (1.0mm 100g Reel)

Note

* Ingredient: tin (Sn) 96.5%, silver (Ag) 3.0%, Copper (Cu) 0.5%, Cobalt (Co) / Germanium (Ge) 0.1 to 0.3%

3.4. Important Notice 1:(Other than U.S.A. and Canadian Market)

1. The service manual does not contain the following information because of issues servicing to component level without necessary equipment/facilities.
 - a. Schematic diagram, Block Diagram and P.C.B. layout of MAIN P.C.B. and SUB OPERATION P.C.B..
 - b. Parts list for individual parts for MAIN P.C.B. and SUB OPERATION P.C.B..
 When a part replacement is required for repairing MAIN P.C.B. and/or SUB OPERATION P.C.B., replace as an assembled parts. (MAIN P.C.B./SUB OPERATION P.C.B.)
2. The following category is/are recycle module part. please send it/them to Central Repair Center.
 - MAIN P.C.B. (VEP56149A)
 - SUB OPERATION P.C.B. (VEP59108A): Excluding replacement of Lithium Battery.

3.5. How to Define the Model Suffix (NTSC or PAL model)









There are nine kinds of DMC-SZ1 and SZ02, regardless of the colours.

- a) DMC-SZ1P/PC
- b) DMC-SZ02P
- c) DMC-SZ1EB/EF/EG/EP
- d) DMC-SZ1EE
- e) DMC-SZ1GD
- f) DMC-SZ1GK
- g) DMC-SZ1GN
- h) DMC-SZ1GT
- i) DMC-SZ1PU/GA/GC/GF/GH

What is the difference is that the "INITIAL SETTINGS" data which is stored in Flash-ROM mounted on MAIN P.C.B..

3.5.1. Defining methods:

To define the model suffix to be serviced, refer to the nameplate which is putted on the bottom side of the Unit.

<p>a) DMC-SZ1P/PC The nameplate for these models show the following Safety registration mark.</p> 
<p>b) DMC-SZ02P The nameplate for this model shows the following Safety registration mark.</p> 
<p>c) DMC-SZ1EB/EF/EG/EP The nameplate for these models show the following Safety registration mark.</p> 
<p>d) DMC-SZ1EE The nameplate for this model shows the following Safety registration mark.</p> 
<p>e) DMC-SZ1GD The nameplate for this model shows the following Safety registration mark.</p> 
<p>f) DMC-SZ1GK The nameplate for this model shows the following Safety registration mark.</p> 
<p>g) DMC-SZ1GN The nameplate for this model shows the following Safety registration mark.</p> 
<p>h) DMC-SZ1GT The nameplate for this model shows the following Safety registration mark.</p> 
<p>i) DMC-SZ1PU/GA/GC/GF/GH The nameplate for these models do not show any above Safety registration mark.</p>

NOTE:

After replacing the MAIN P.C.B., be sure to achieve adjustment.

The service software is available at "TSN Website". To download, click on "Support Information from NWBG/VDBG-AVC".

3.5.2. INITIAL SETTINGS:

After replacing the MAIN P.C.B., make sure to perform the initial settings after achieving the adjustment by ordering the following procedure in accordance with model suffix of the unit.

1. IMPORTANT NOTICE:

Before proceeding Initial settings, make sure to read the following CAUTIONS.

CAUTION 1:(INITIAL SETTINGS)

---AFTER REPLACING THE MAIN P.C.B. and/or FLASH-ROM ---

- *.The model suffix can be chosen **JUST ONE TIME.**
- *.Once one of the model suffix has been chosen, the model suffix lists will not be displayed, thus, it can not be changed.

CAUTION 2:(Stored picture image data in the unit)

This unit employs "Built-in Memory" for picture image data recording. (Approx.70MB)
After proceeding "INITIAL SETTINGS", the picture image data stored in the unit is erased.

2. PROCEDURES:

- Precautions: Read the above "CAUTION 1" and "CAUTION 2", carefully.
- Preparation:
 - Attach the Battery or AC Adaptor with a DC coupler to the unit.
(Since this unit has built-in memory, it can be performed without inserting SD memory card.)
 - 1. Set the REC/PLAY switch to "[REC] (Camera mark)", and then turn the Power on.
 - 2. Press the [MODE] button, and select the [NORMAL PICTURE] mode by Cursor buttons, then press the [MENU/SET] button.
 - 3. Turn the Power off.
(If the unit is other than [NORMAL PICTURE] mode, it does not display the initial settings menu.)
- **Step 1. The temporary cancellation of "INITIAL SETTINGS":**
Set the REC/PLAY switch to "[REC] (Camera mark)".
While pressing "[UP] of Cursor button" and [MOTION PICTURE] button simultaneously, turn the Power on.
- **Step 2. The cancellation of "INITIAL SETTINGS":**
Set the REC/PLAY switch to "[PLAY]".
Press "[UP] of Cursor button" and [MOTION PICTURE] button simultaneously, turn the Power off.

The LCD displays the " ! " mark before the unit powers down.

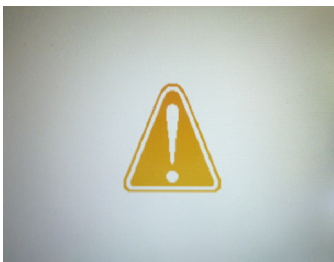

- **Step 3. Turn the Power on:**
Set the REC/PLAY switch to "[REC] (Camera mark)", and then turn the Power on.

• **Step 4. Display the INITIAL SETTING:**

While pressing [MENU/SET] button and “[RIGHT] of Cursor button” simultaneously, turn the Power off.

The “INITIAL SETTINGS” menu is displayed.

There are two kinds of “INITIAL SETTINGS” menu form as follows:

[CASE 1. After replacing MAIN P.C.B.]

When MAIN P.C.B. has just been replaced, all of the model suffixes is displayed as follows. (six pages in total)

The following table summarizes the content of the six screenshots in Case 1:

Screenshot	Model Suffixes	Excluded Models
1/6	NONE(JAPAN), P, EG, PU, GD	(No "JAPAN" model), DMC-SZ1P, SZ02P, DMC-SZ1EG, DMC-SZ1PU, DMC-SZ1GD
2/6	GC, GT, GK, EF, EB	DMC-SZ1GC, DMC-SZ1GT, DMC-SZ1GK, DMC-SZ1EF, DMC-SZ1EB
3/6	EE, GN, PC, PR, GJ	DMC-SZ1EE, DMC-SZ1GN, DMC-SZ1PC, (No "PR" model), (No "GJ" model)
4/6	SG, LB, EC, GH, EP	(No "SG" model), (No "LB" model), (No "EC" model), DMC-SZ1GH, DMC-SZ1EP
5/6	EN, GF, GM, GA, PB	(No "EN" model), DMC-SZ1GF, (No "GM" model), DMC-SZ1GA, (No "PB" model)
6/6	JPC	(No "JPC" model)

[CASE 2. Other than “After replacing MAIN P.C.B.”]

Case 2 shows two variations of the INITIAL SETTINGS menu:

- <Other than “EG/EF/EB/EP” models>**: Shows 'GC' selected as the model suffix.
- <Only “EG/EF/EB/EP” models>**: Shows 'EG' selected as the model suffix, with other options (EF, EB, EC, EP) listed below.

• **Step 5. Choose the model suffix in “INITIAL SETTINGS”: (Refer to “CAUTION 1”)**

[Caution: After replacing MAIN P.C.B.]

The model suffix can be chosen, **JUST ONE TIME**.

Once one of the model suffix have been chosen, the model suffix lists will not be displayed, thus, it can not be changed.

Therefore, select the area carefully.

Select the area with pressing “[UP] / [DOWN] of Cursor buttons”.

• **Step 6. Choose the model number in "INITIAL SETTINGS": (Only for "P" model.)**

This step is necessary only for "P".

Only for model suffix with "P", there is two kind of model; (DMC-SZ1 and DMC-SZ02), due to difference of sales channel. Therefore, not only model suffix, but also model number (SZ1 or SZ02) has to be set up in the "INITIAL SETTINGS". (The "SZ1" is displayed as default status.)

When the model number is one of the "DMC-SZ02P", change the model number with the following procedure:

Press the [Q.MENU]/[(Delete/Cancel)] button in order to change the indication from "SZ1" into "SZ02".

(Each time one presses the [Q.MENU]/[(Delete/Cancel)] button, model indication is changed from "SZ1" to "SZ02" (Toggle switch))

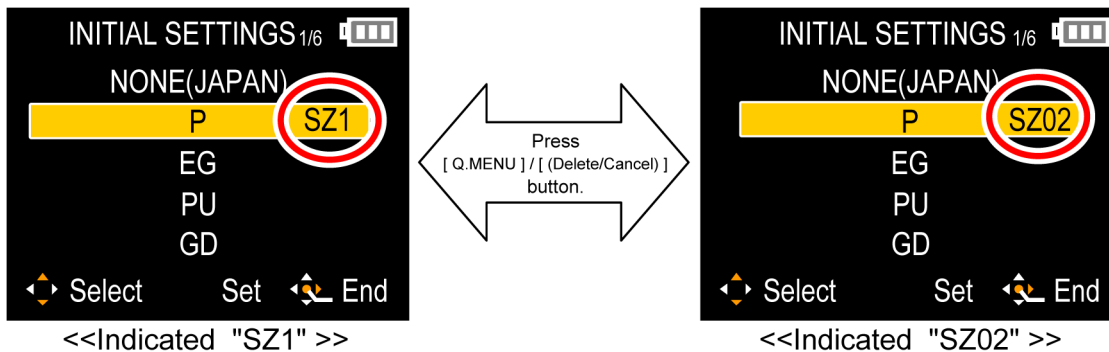

• **Step 7. Set the model suffix in "INITIAL SETTINGS":**

Press the "[RIGHT] of Cursor buttons".

The only set area is displayed, and then press the "[RIGHT] of Cursor buttons" after confirmation.

(The unit is powered off automatically.)

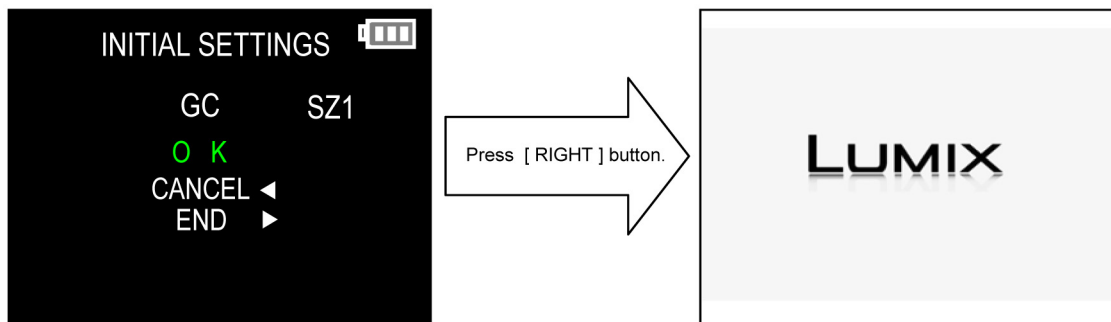

• **Step 8. CONFIRMATION:**

Confirm the display of “PLEASE SET THE CLOCK” in concerned language when the unit is turned on again.

When the unit is connected to PC with USB cable, it is detected as removable media.

(When the “GT” or “GK” model suffix is selected, the display shows “PLEASE SET THE CLOCK” in Chinese.)

1) As for your reference, major default setting condition is as shown in the following table.

• **Default setting (After “INITIAL SETTINGS”)**

	MODEL	VIDEO OUTPUT	LANGUAGE	DATE	REMARKS
a)	DMC-SZ1P/SZ02P	NTSC	English	Month/Date/Year	
b)	DMC-SZ1PC	NTSC	English	Month/Date/Year	
c)	DMC-SZ1PU	NTSC	Spanish	Month/Date/Year	
d)	DMC-SZ1EG	PAL	English	Date/Month/Year	
e)	DMC-SZ1EP	PAL	English	Date/Month/Year	
f)	DMC-SZ1EF	PAL	French	Date/Month/Year	
g)	DMC-SZ1EB	PAL	English	Date/Month/Year	
h)	DMC-SZ1EE	PAL	Russian	Date/Month/Year	
i)	DMC-SZ1GC	PAL	English	Date/Month/Year	
j)	DMC-SZ1GD	NTSC	Korean	Year/Month/Date	
k)	DMC-SZ1GF	PAL	English	Date/Month/Year	
l)	DMC-SZ1GA	PAL	English	Date/Month/Year	
m)	DMC-SZ1GK	PAL	Chinese (simplified)	Year/Month/Date	
n)	DMC-SZ1GT	NTSC	Chinese (traditional)	Year/Month/Date	
o)	DMC-SZ1GH	PAL	English	Date/Month/Year	
p)	DMC-SZ1GN	PAL	English	Date/Month/Year	

4 Specifications

Digital Camera:
Information for your safety

Power Source:	DC 5.1 V	
Power Consumption:	1.1 W (When recording) 0.6 W (When playing back)	
Camera effective pixels	16,100,000 pixels	
Image sensor	1/2.33" CCD, total pixel number 16,600,000 pixels, Primary color filter	
Lens	Optical 10× zoom, f=4.5 mm to 45 mm (35 mm film camera equivalent: 25 mm to 250 mm)/F3.1 (Wide) to F5.9 (Tele)	
Image stabilizer	Optical method	
Focus range	Normal	50 cm (1.6 feet) (Wide)/1.5 m (4.9 feet) (Tele) to ∞ [9× is 2 m (6.6 feet) to ∞]
	Macro/ Intelligent auto/ Motion picture	5 cm (0.16 feet) (Wide)/1.5 m (4.9 feet) (Tele) to ∞ [9× is 2 m (6.6 feet) to ∞]
	Scene Mode	There may be differences in the above settings.
Shutter system	Electronic shutter+Mechanical shutter	
Minimum Illumination	[NTSC areas] Approx. 10 lx (when i-low light is used, the shutter speed is 1/30th of a second) [PAL areas] Approx. 10 lx (when i-low light is used, the shutter speed is 1/25th of a second)	
Shutter speed	8 seconds to 1/1600th of a second	
Exposure (AE)	Auto (Program AE)	
Metering mode	Multiple	
LCD monitor	3.0" TFT LCD (4:3) (Approx. 230,000 dots) (field of view ratio about 100%)	
Microphone	Monaural	
Speaker	Monaural	
Recording media	Built-in Memory (Approx. 70 MB)/SD Memory Card/ SDHC Memory Card/SDXC Memory Card	
Recording file format		
Still Picture	JPEG (based on "Design rule for Camera File system", based on "Exif 2.3" standard)/DPOF corresponding	
Motion pictures	MP4	
Audio compression format	AAC	

Interface	
Digital	"USB 2.0" (High Speed)
Analog video	[NTSC areas] NTSC [PAL areas] NTSC/PAL Composite (Switched by menu)
Audio	Audio line output (monaural)
Terminal	
[AV OUT/DIGITAL]	Dedicated jack (8 pin)
Dimensions (excluding the projecting parts)	Approx. 99.0 mm (W)×59.4 mm (H)×21.0 mm (D) [3.9"(W)×2.4"(H)×0.9"(D)]
Mass (weight)	Approx. 131 g/0.29 lb (with card and battery) Approx. 114 g/0.25 lb (excluding card and battery)
Operating temperature	0 °C to 40 °C (32 °F to 104 °F)
Operating humidity	10%RH to 80%RH

AC Adaptor:
Information for your safety

Input:	~ 110 V to 240 V, 50/60 Hz, 0.2 A
Output:	=== 5 V, 800 mA

Battery Pack (lithium-ion):
Information for your safety

Voltage/capacity:	3.6 V/680 mAh
--------------------------	---------------

NOTE:(Only for "EB/EF/EG/EP" models)

- Data from the PC can not be written to the camera using the USB connection cable.

5 Location of Controls and Components

- 1 Flash
- 2 Lens
- 3 Self-timer indicator
- AF Assist Lamp

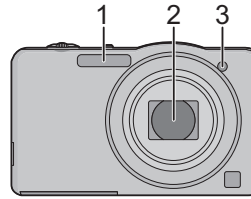

- 4 LCD monitor
- 5 [MENU/SET] button
- 6 [DISP.] button
- 7 [Q.MENU]/[/☑] (Delete/Cancel) button
- 8 [MODE] button
- 9 REC/PLAY switch
- 10 Charging lamp

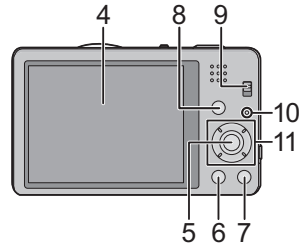

- 11 Cursor buttons
 - Ⓐ: ▲/Exposure compensation
 - Ⓑ: ▼/Macro Mode
AF Tracking
 - Ⓒ: ◀/Self-timer
 - Ⓓ: ▶/Flash setting

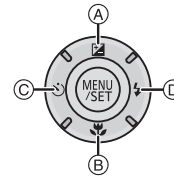

- 12 Strap eyelet
 - Be sure to attach the strap when using the camera to ensure that you will not drop it.
- 13 Lens barrel
- 14 [AV OUT/DIGITAL] socket

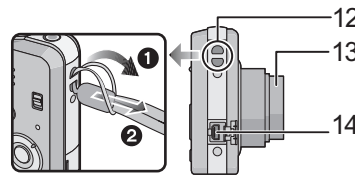

- 15 Speaker
 - Be careful not to cover the speaker with your finger. Doing so may make sound difficult to hear.
- 16 Camera ON/OFF switch
- 17 Zoom lever
- 18 Microphone
- 19 Shutter button
- 20 Motion picture button
- 21 Tripod receptacle
- 22 Card/Battery door
- 23 Release lever

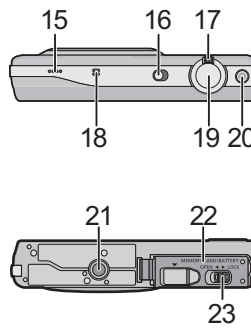

Selecting the Recording Mode

1 Slide the REC/PLAY switch to [📷].

2 Press [MODE].

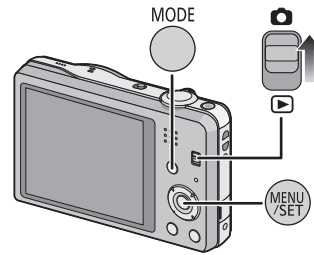

3 Press ▲/▼/◀/▶ to select the Recording Mode.



4 Press [MENU/SET].

List of Recording Modes

iA Intelligent Auto Mode
The subjects are recorded using settings automatically selected by the camera.
📷 Normal Picture Mode
The subjects are recorded using your own settings.
📷 Miniature Effect Mode
This is an imaging effect which defocuses the surroundings to make it look like a diorama. (also known as Tilt Shift Focus)
SCN Scene Mode
This allows you to take pictures that match the scene being recorded.

Note

- When the mode has been switched from Playback Mode to Recording Mode, the previously set Recording Mode will be set.

6 Service Mode

6.1. Error Code Memory Function

1. General description

This unit is equipped with history of error code memory function, and can be memorized 16 error codes in sequence from the latest. When the error is occurred more than 16, the oldest error is overwritten in sequence.

The error code is not memorized when the power supply is shut down forcibly (i.e., when the unit is powered on by the battery, the battery is pulled out) The error code is memorized to FLASH-ROM when the unit has just before powered off.

2. How to display

The error code can be displayed by ordering the following procedure:

• Preparation

- Attach the Battery or AC Adaptor with a DC coupler to the unit.

(Since this unit has built-in memory, it can be performed without inserting SD memory card.)

1. Set the REC/PLAY switch to "[REC] (Camera mark)", and then turn the Power on.

2. Press the [MODE] button, and select the [NORMAL PICTURE] mode by Cursor buttons, then press the [MENU/SET] button.

3. Turn the Power off.

(If the unit is other than [NORMAL PICTURE] mode, it does not display the initial settings menu.)

• Step 1. The temporary cancellation of "INITIAL SETTINGS":

Set the REC/PLAY switch to "[REC] (Camera mark)".

While pressing "[UP] of Cursor button" and [MOTION PICTURE] button simultaneously, turn the Power on.

• Step 2. Execute the error code display mode:

Press the "[RIGHT] of Cursor button", [MENU/SET] button and [MOTION PICTURE] button simultaneously.

The display is changed as shown below when the above buttons are pressed simultaneously.

Normal display → Error code display → Operation history display → Normal display →.....

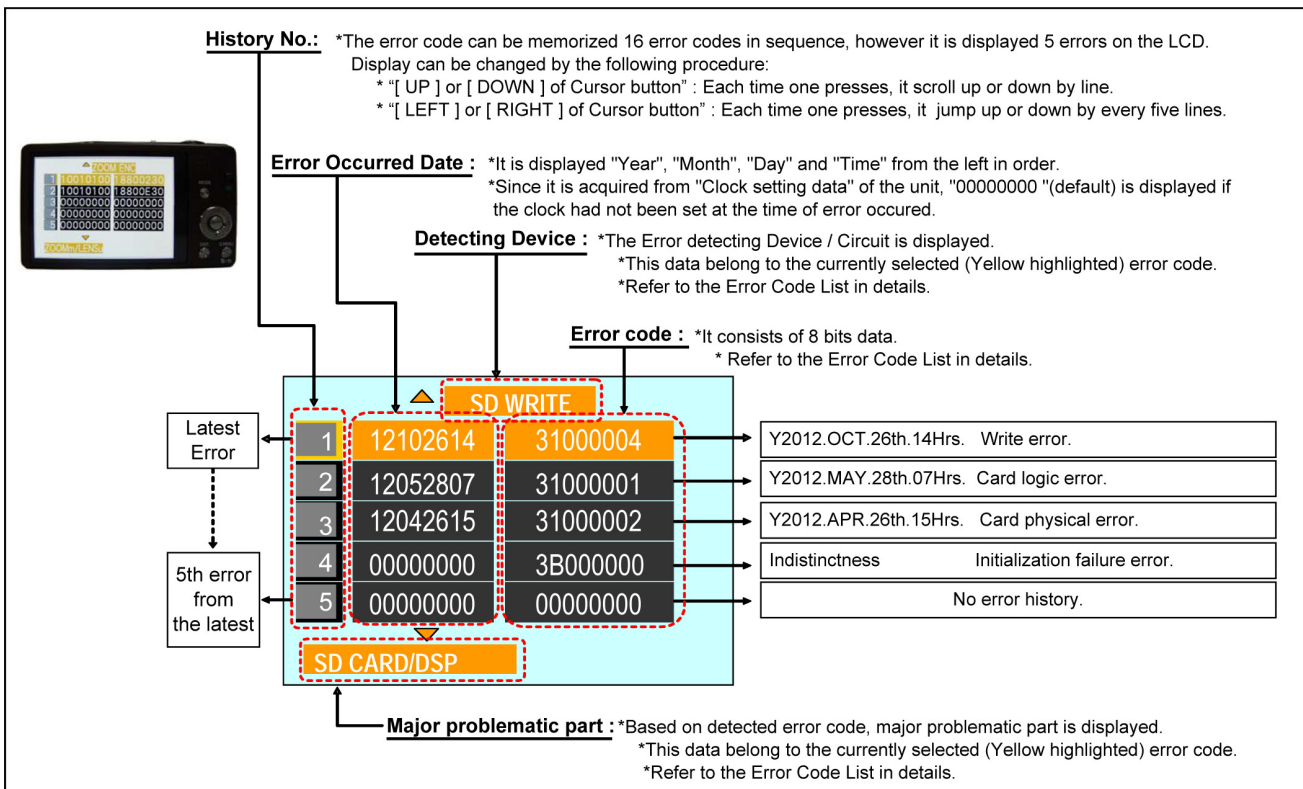

Example of Error Code Display

• 3. Error Code List

The error code consists of 8 bits data and it shows the following information.

Attribute	Main item	Sub item	Error code		Contents (Upper line)		Error Indication					
			High 4 bits	Low 4 bits	Problematic Part & Check point (Lower line)		Detecting device	Problematic Part/Circuit				
LENS	Lens drive	OIS	18*0	1000	PSD (X) error. Hall element (X axis) position detect error in OIS unit. OIS Unit	OIS X	LENSu NG					
				2000	PSD (Y) error. Hall element (Y axis) position detect error in OIS unit. OIS Unit	OIS Y						
				3000	GYRO (X) error. Gyro (IC7101: X axis) detect error on Sub P.C.B.. IC7101 (Gyro element) or IC6001 (VENUS ENGINE)	GYRO X	GYRO NG					
				4000	GYRO (Y) error. Gyro (IC7101: Y axis) detect error on Sub P.C.B.. IC7101 (Gyro element) or IC6001 (VENUS ENGINE)	GYRO Y						
				5000	MREF error (Reference voltage error). IC9101 (SYSTEM) or IC6001 (VENUS ENGINE)	OIS REF	LENSSd/DSP NG					
				6000	Drive voltage (X) error. LENS Unit, LENS flex breaks, IC6001 (VENUS ENGINE) AD value error,	OISX REF	LENSu/LENS FPC					
				7000	Drive voltage (Y) error. LENS Unit, LENS flex breaks, IC6001 (VENUS ENGINE) AD value error,	OISY REF						
			Zoom	0710	Collapsible barrel Low detect error (Collapsible barrel encoder always detects Low.) Mechanical lock, FP9002-(40) signal line or IC6001 (VENUS ENGINE)	ZOOM L	ZOOMm/LENSu					
					0720	Collapsible barrel High detect error (Collapsible barrel encoder always detects High.) Mechanical lock, FP9002-(40) signal line or IC6001 (VENUS ENGINE)		ZOOM H				
					0730	Zoom motor sensor error. Mechanical lock, FP9002-(34), (37) signal line or IC6001 (VENUS ENGINE)		ZOOM ENC				
				0740	Zoom motor sensor error. (During monitor mode.) Mechanical lock, FP9002-(34), (37) signal line or IC6001 (VENUS ENGINE)							
				0750	Zoom motor sensor error. (During monitor mode with slow speed.) Mechanical lock, FP9002-(34), (37) signal line or IC6001 (VENUS ENGINE)							
				Focus	0701	HP Low detect error (Focus encoder always detects High, and not becomes Low) Mechanical lock, FP9002-(40) signal line or IC6001 (VENUS ENGINE)			FOCUS L	LENS FPC/DSP		
					0702	HP High detect error (Focus encoder always detects Low, and not becomes High) Mechanical lock, FP9002-(40) signal line or IC6001 (VENUS ENGINE)		FOCUS H				
		Lens	18*1	0000	Power ON time out error. Lens drive system	LENS DRV	LENSu					
				18*2	0000			Power OFF time out error. Lens drive system				
		Adj. History	OIS	19*0	2000	OIS adj. Yaw direction amplitude error (small)	OIS ADJ	OIS ADJ				
					3000	OIS adj. Pitch direction amplitude error (small)						
					4000	OIS adj. Yaw direction amplitude error (large)						
					5000	OIS adj. Pitch direction amplitude error (large)						
					6000	OIS adj. MREF error						
					7000	OIS adj. time out error						
					8000	OIS adj. Yaw direction off set error						
					9000	OIS adj. Pitch direction off set error						
					A000	OIS adj. Yaw direction gain error						
					B000	OIS adj. Pitch direction gain error						
					C000	OIS adj. Yaw direction position sensor error						
D000	OIS adj. Pitch direction position sensor error											
E000	OIS adj. other error											
HARD	VENUS A/D				Flash	28*0			0000	Flash charging error. IC6001-(AC16) signal line or Flash charging circuit	STRB CHG	STRB PCB/FPC
	FLASH ROM (EEPROM Area)				FLASH ROM (EEPROM Area)	2B*0			0001	EEPROM read error IC6002 (FLASH ROM)	FROM RE	FROM
									0002	EEPROM write error IC6002 (FLASH ROM)	FROM WR	FROM
									0005	Firmware version up error. Replace the firmware file in the SD memory card.	(No indication)	(No indication)
		0008	SDRAM error									
	SYSTEM	RTC	2C*0	0001	SYSTEM IC initialize failure error Communication between IC6001 (VENUS ENGINE) and IC9101 (SYSTEM)	SYS INIT	MAIN PCB					
				0009	SDRAM Mounting defective							
SOFT	CPU	Reset	30*0	0001	NMI reset Non Mask-able Interrupt (30000001-30000007 are caused by factors)	NMI RST	MAIN PCB					
		Card	Card	31*0	0001	Card logic error SD memory card data line or IC6001 (VENUS ENGINE)	SD CARD	SD CARD/DSP				
	0002				Card physical error SD memory card data line or IC6001 (VENUS ENGINE)							
	0004				Write error SD memory card data line or IC6001 (VENUS ENGINE)	SD WRITE						
	39*0				0005	Format error	INMEMORY		FROM			
	CPU, ASIC hard	Stop	38*0	0001	Camera task finish process time out. Communication between Lens system and IC6001 (VENUS ENGINE)	LENS COM	LENSu/DSP					
				0002	Camera task invalid code error. IC6001 (VENUS ENGINE)	DSP	DSP					
				0100	File time out error in recording motion image IC6001 (VENUS ENGINE)							
				0200	File data cue send error in recording motion image IC6001 (VENUS ENGINE)							
				0300	Single or burst recording brake time out.							
				Memory area	3A*0	0008	USB work area partitioning failure USB dynamic memory securing failure when connecting	(No indication)	(No indication)			
	Operation	Power on	3B*0			0000	FLASH ROM processing early period of camera during movement.	INIT	(No indication)			
	Zoom	Zoom	3C*0	0000	Inperfect zoom lens processing Zoom lens	ZOOM	ZOOMm/LENSu					
				35*0	0000	Software error (0-7bit : command, 8-15bit : status)	DSP	DSP				
				35*1	0000	Though record preprocessing is necessary, it is not called.						
35*2				0000	Though record preprocessing is necessary, it is not completed.	(No indication)	(No indication)					

Important notice about "Error Code List"

1) About "*" indication:

The third digit from the left is different as follows.

- In case of 0 (example: 18001000)

When the third digit from the left shows "0", this error occurred under the condition of INITIAL SETTINGS has been completed.

It means that this error is occurred basically at user side.

- In case of 8 (example: 18801000)

When the third digit from the left shows "8", this error occurred under the condition of INITIAL SETTINGS has been released.

(Example; Factory assembling-line before unit shipment, Service mode etc.)

It means that this error is occurred at service side.

2) About "?" indication: ("18*0 0?01" to "18*0 0?60"):

The third digit from the right shows one of the hexadecimal ("0" to "F") character.

• 4. How to exit from Error Code display mode:

Simply, turn the power off. (Since Error code display mode is executed under the condition of temporary cancellation of "INITIAL SETTINGS", it wake up with normal condition when turn off the power.)





NOTE:

The error code can not be initialized.

7 Service Fixture & Tools

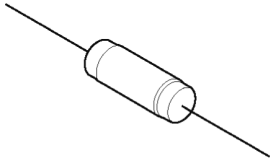
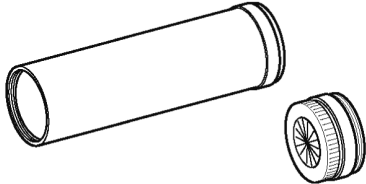
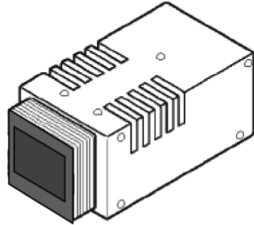
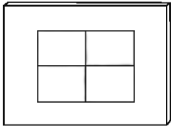
7.1. Service Fixture and Tools

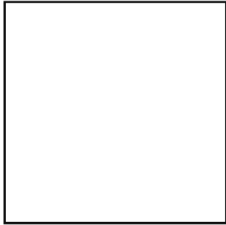
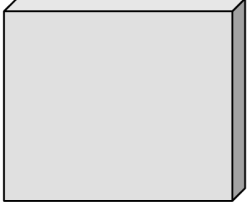
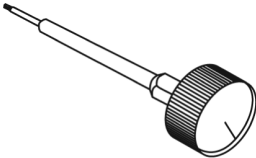
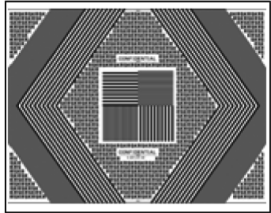
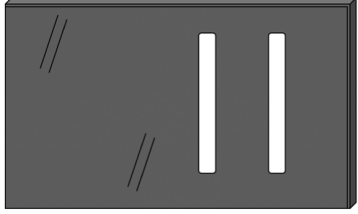
The following Service Fixture and tools are used for checking and servicing this unit.

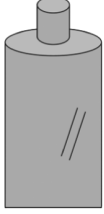
<p>Resistor for Discharging (1kΩ/5W) ERG5SJ102</p>	<p>Collimator (with Focus Chart) VFK1164TCM02</p>	<p>LIGHT BOX (with DC Cable) RFKZ0523</p>
 <p>An equivalent type of Resistor may be used.</p>	 <p>*VFK1164TCM03 can be used. *RFKZ0422 can be used.</p>	 <p>*VFK1164TDVLB can be used.</p>
<p>TR Chart RFKZ0443</p>	<p>Lens Cleaning Kit (BK) VFK1900BK</p>	<p>ND Filter (ND0.3) RFKZ0513</p>
	 <p>*Only supplied 10 set/box.</p>	
<p>Diffuser RFKZ0591</p>	<p>Driver (for optical axis adjustment) RFKZ0569</p>	<p>Optical axis adjustment chart RFKZ0570</p>
		
<p>Camera stand RFKZ0333J</p>	<p>Driver (for Lens) VFK1390</p>	<p>Grease (for Lens) RFKZ0472</p>
		
<p>Screw locking glue RFKZ0573</p>		
		

7.2. When Replacing the Main P.C.B.

After replacing the MAIN P.C.B., be sure to achieve adjustment.

The service software is available at "TSN Website". To download, click on "Support Information from NWBG/VDBG-AVC".

7.3. Service Position

This Service Position is used for checking and replacing parts. Use the following Extension cables for servicing.

Table S1 Extension Cable List

No.	Parts No.	Connection	Form
1	RFKZ0494	FP9001(MAIN) - CCD UNIT	45PIN 0.3FFC
2	RFKZ0354	FP9002(MAIN) - LENS UNIT	41PIN 0.3FFC
3	RFKZ0553	PS9001(MAIN) - PP9501(SUB OPERATION)	16PIN B to B
4	RFKZ0418	PP9001(MAIN) - PS8001(FLASH TOP)	30PIN B to B

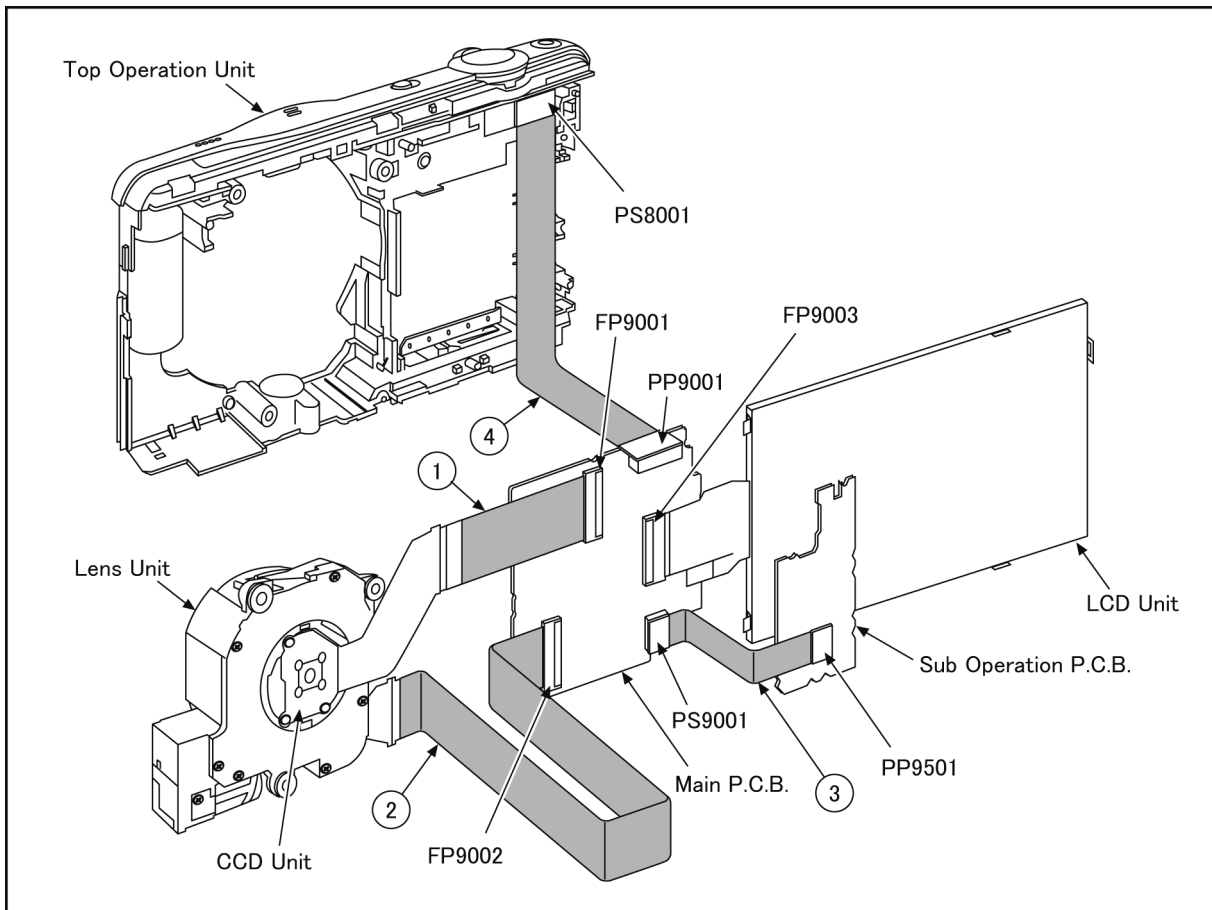

CAUTION-1. (When servicing FLASH TOP P.C.B.)

1. Be sure to discharge the E.capacitor on FLASH TOP P.C.B..

Refer to "HOW TO DISCHARGE THE E.CAPACITOR ON FLASH TOP P.C.B..".

The E.capacitor voltage is not lowered soon even if the AC Cord is unplugged or the battery is removed.

2. Be careful of the high voltage circuit on FLASH TOP P.C.B..
3. DO NOT allow other parts to touch the high voltage circuit on FLASH TOP P.C.B..

8 Disassembly and Assembly Instructions

8.1. Disassembly Flow Chart

This is a disassembling chart.

When assembling, perform this chart conversely.

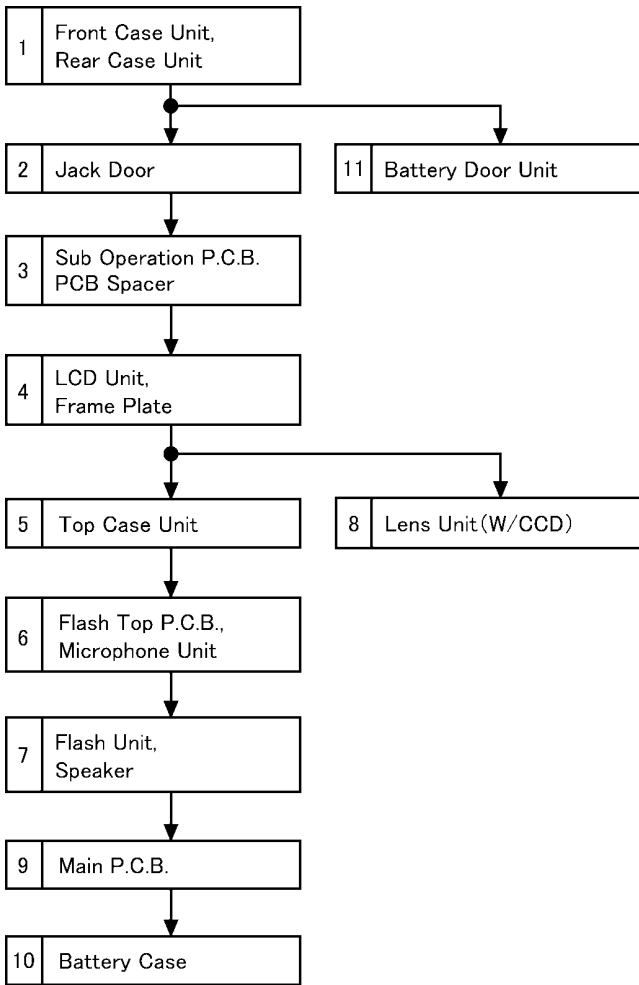

8.2. P.C.B. Location

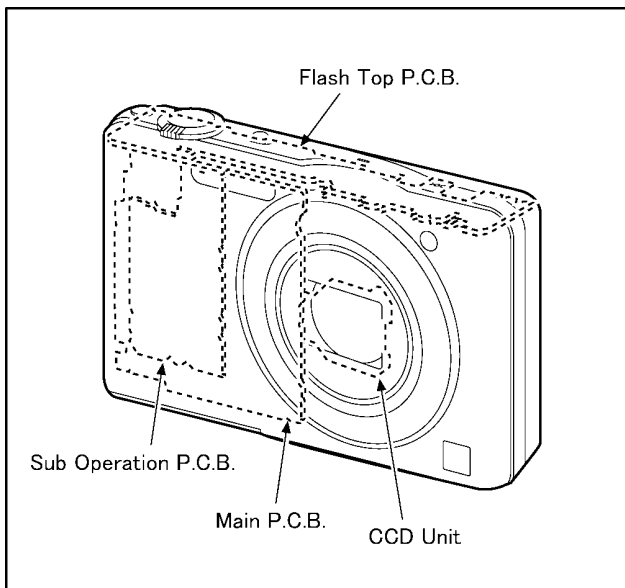

8.3. Disassembly Procedure

No.	Item	Fig	Removal
1	Front Case Unit Rear Case Unit	(Fig. D1)	Card Battery 3 Screws (A) 1 Screw (B) 2 Screws (C)
		(Fig. D2)	4 Locking tabs Front Case Unit 4 Locking tabs Rear Case Unit
2	Jack Door	(Fig. D3)	1 Groove 1 Locking tab Side Ornament(R) 2 Locking tabs Side Ornament(L) Jack Door
3	Sub Operation P.C.B. PCB Spacer	(Fig. D4)	PP9501 (Connector) Sub Operation P.C.B. 2 Locking tabs PCB Spacer
4	LCD Unit Frame Plate	(Fig. D5)	1 Locking tab FP9003 (Flex) LCD Unit 3 Locking tabs Frame Plate
5	Top Case Unit	(Fig. D6)	PS8001 (Connector) AF Panel Light Top Case Unit
6	Flash Top P.C.B. Microphone Unit	(Fig. D7)	2 Screws (D) FP8051 (Flex) 3 Locking tabs Flash Top P.C.B. 2 Locking tabs Power Knob 2 Convexes REC Button Microphone Unit
		(Fig. D8)	Discharge the E.capacitor
7	Flash Unit Speaker	(Fig. D9)	3 Solders Flash Unit 2 Solders Speaker
8	Lens Unit (W/CCD)	(Fig. D10)	DPR Sheet FP9001 (Flex) FPC Tape FP9002 (Flex) Lens Unit (W/CCD)
9	Main P.C.B.	(Fig. D11)	1 Screw (E) 1 Convex Main P.C.B.
10	Battery Case	(Fig. D12)	1 Locking tab Battery Out Spring 4 Locking tabs Battery Case
11	Battery Door Unit	(Fig. D13)	Battery Lock Knob Battery Lock Spring Battery Door Unit

8.3.1. Removal of the Front Case Unit and Rear Case Unit

NOTE:

When servicing and reassembling, remove the card and battery from the unit.

- Card
- Battery
- Screw(A) × 3
- Screw(B) × 1
- Screw(C) × 2

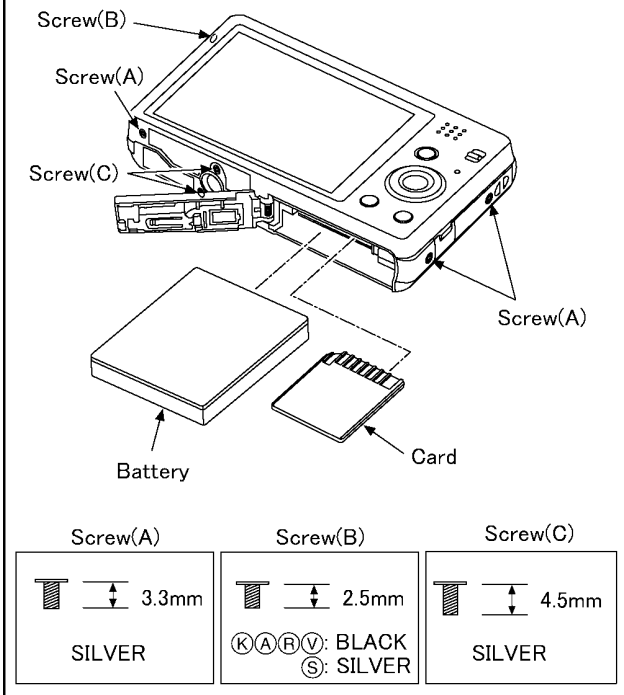

(Fig. D1)

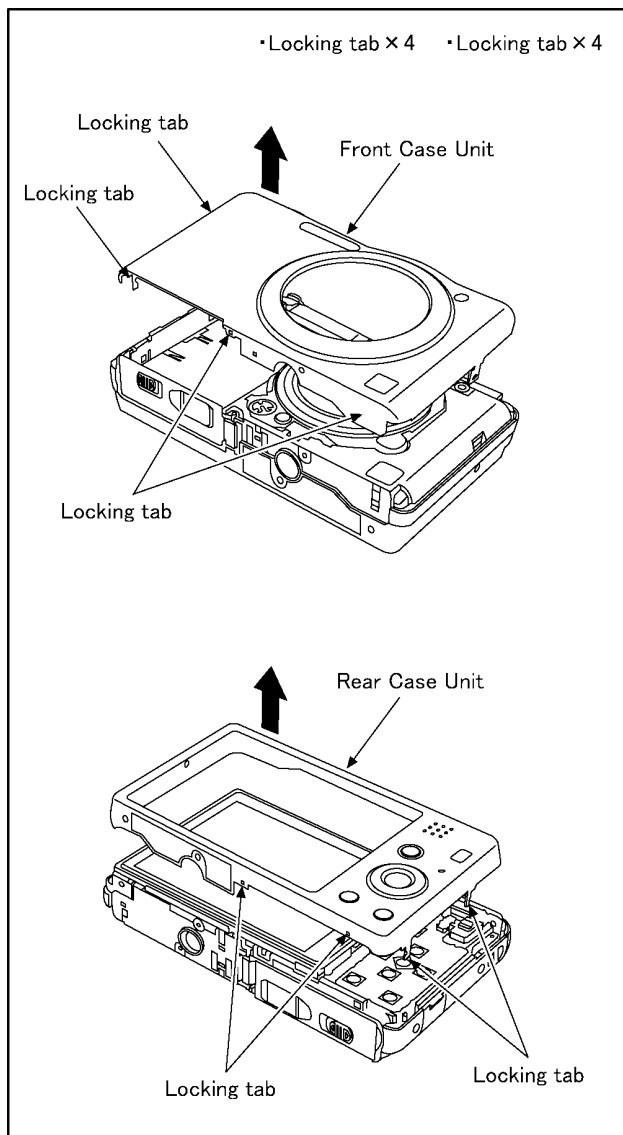

(Fig. D2)

8.3.2. Removal of the Jack Door

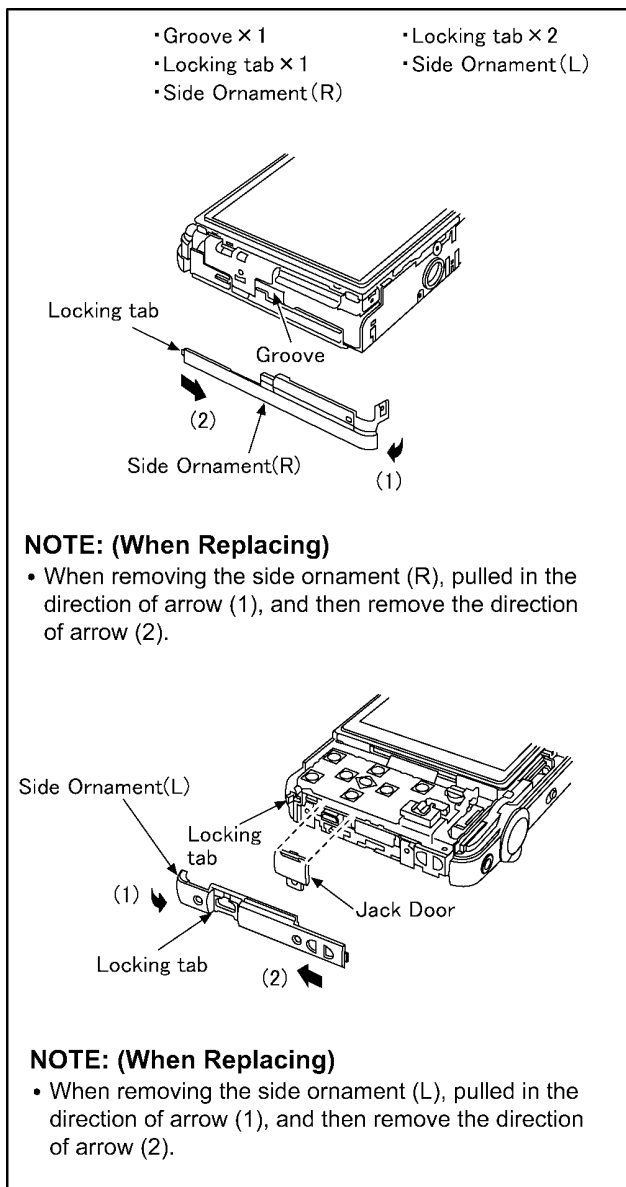

(Fig. D3)

8.3.3. Removal of the Sub Operation P.C.B. and PCB Spacer

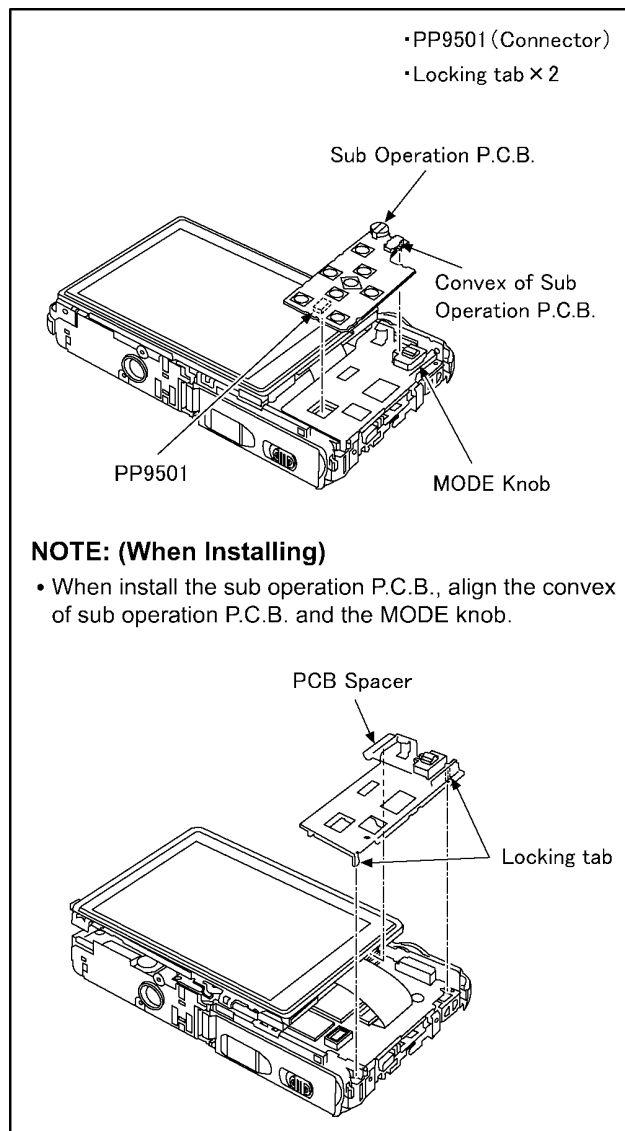

(Fig. D4)

8.3.4. Removal of the LCD Unit and Frame Plate

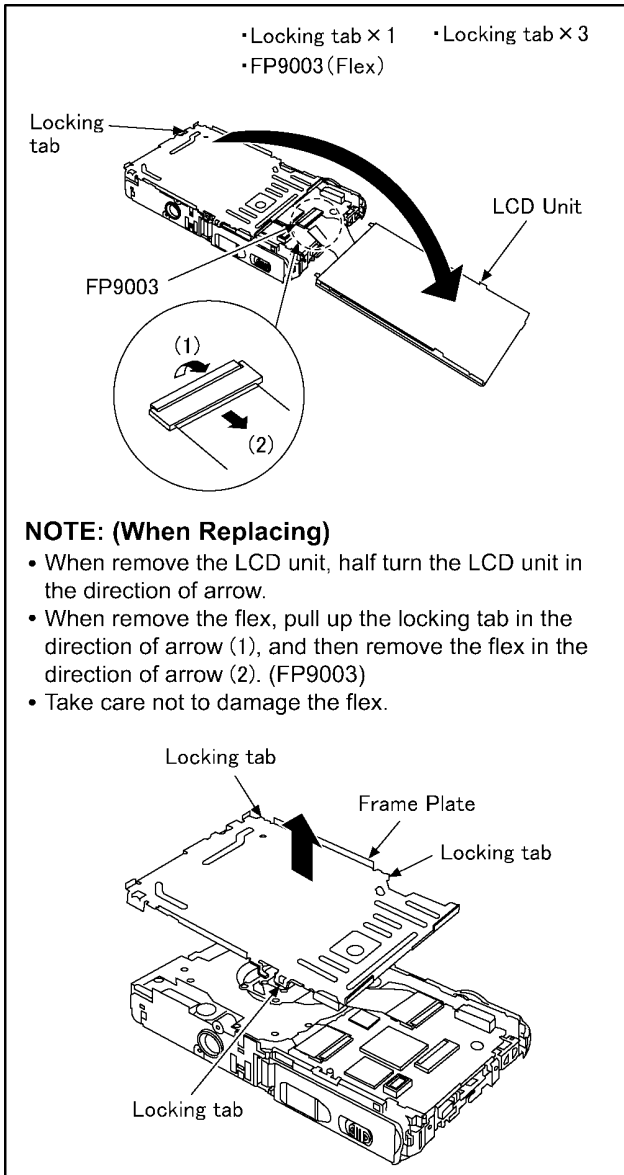

(Fig. D5)

8.3.5. Removal of the Top Case Unit

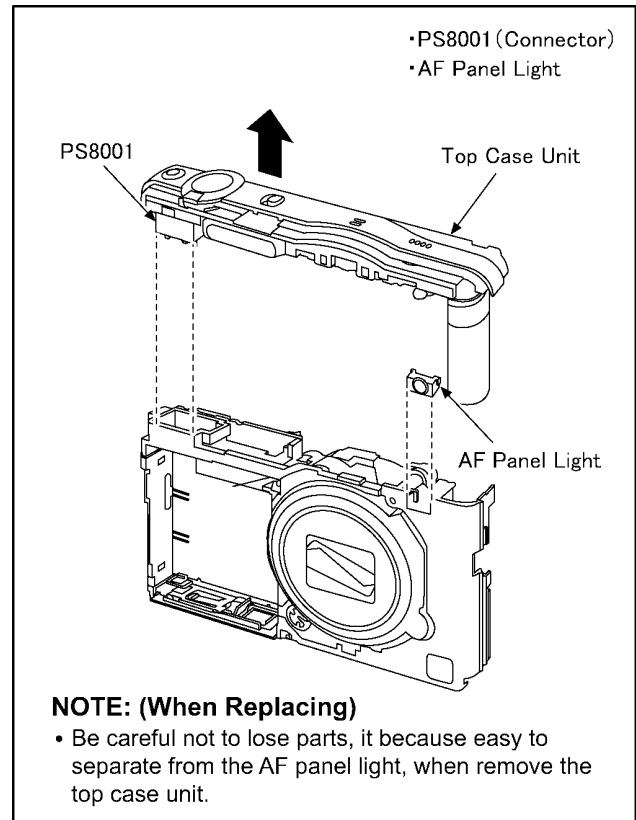

(Fig. D6)

8.3.6. Removal of the Flash Top P.C.B. and Microphone Unit

IMPORTANT NOTICE:

Take care not apply any bending load to the charging E.capacitor. It brings about the possibility of P.C.B. and/or component damage on the Flash Top P.C.B..

- Screw(D) × 2
- FP8051 (Flex)
- Locking tab × 3
- Locking tab × 2
- Power Knob
- Convex × 2
- REC Button

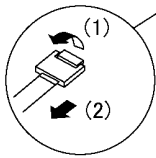
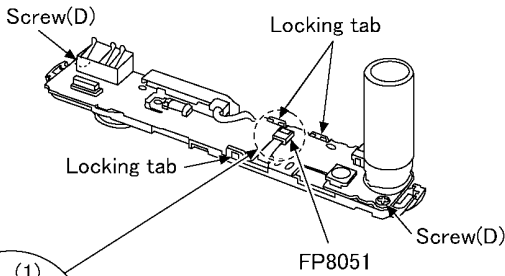

NOTE: (When Replacing)

- When remove the flex, pull up the locking tab in the direction of arrow (1), and then remove the flex in the direction of arrow (2). (FP8051)
- Take care not to damage the flex.

Screw(D)

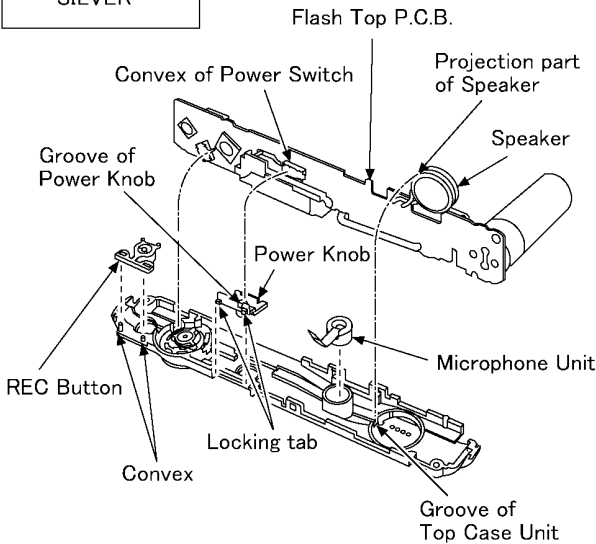
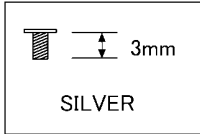

NOTE: (When Installing)

1. Align the convex of power switch and groove of power knob.
2. Insert the projection part of speaker to the groove of top case unit.

(Fig. D7)

IMPORTANT NOTICE:

Take care not apply any bending load to the charging E.capacitor. It brings about the possibility of P.C.B. and/or component damage on the Flash Top P.C.B..

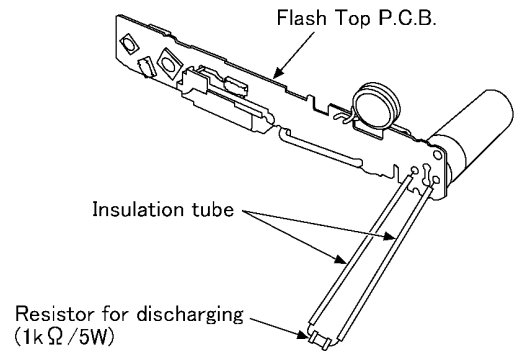

CAUTION

Be sure to discharge the E.capacitor on Flash Top P.C.B. before disassembling.

1. Put the insulation tube on the lead part of resistor (ERG5SJ102: 1kΩ/5W).
2. Put the resistor between both terminals of E.capacitor unit for approx. 5 seconds.

(Fig. D8)

8.3.7. Removal of the Flash Unit and Speaker

IMPORTANT NOTICE:

Take care not apply any bending load to the charging E.capacitor. It brings about the possibility of P.C.B. and/or component damage on the Flash Top P.C.B..

- Sloder × 3 points
- Sloder × 2 points

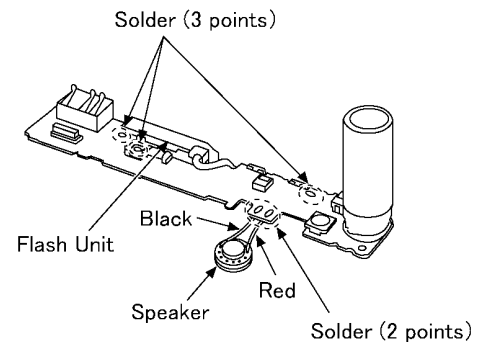

(Fig. D9)

8.3.8. Removal of the Lens Unit (W/CCD)

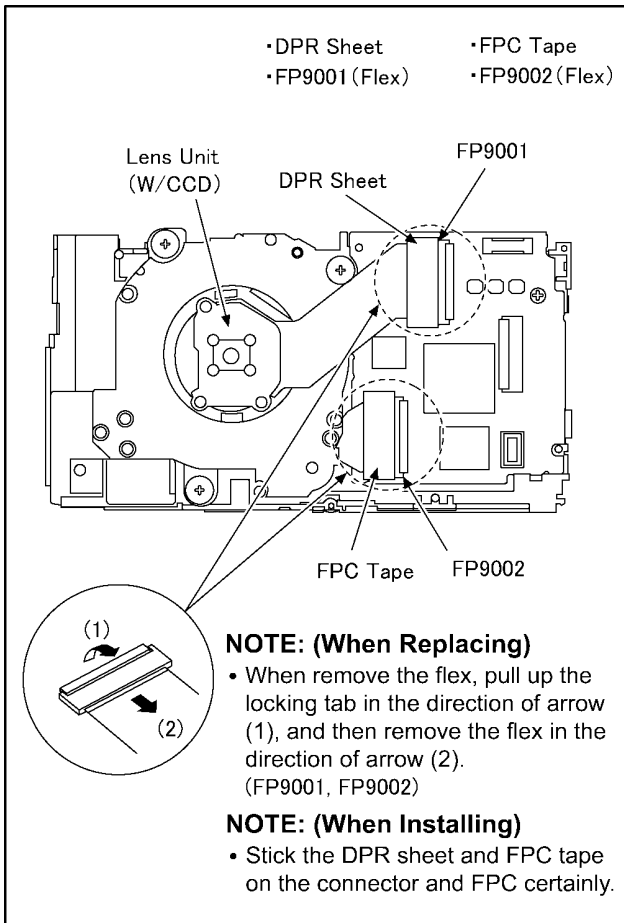

(Fig. D10)

8.3.9. Removal of the Main P.C.B.

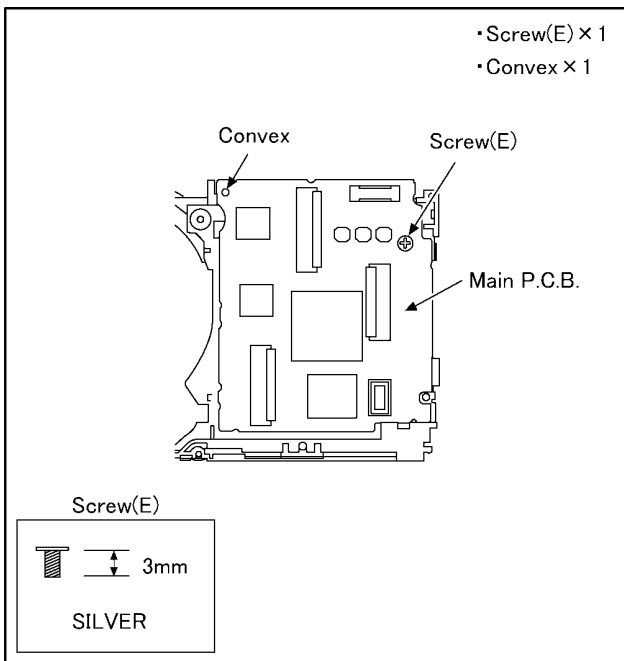

(Fig. D11)

8.3.10. Removal of the Battery Case

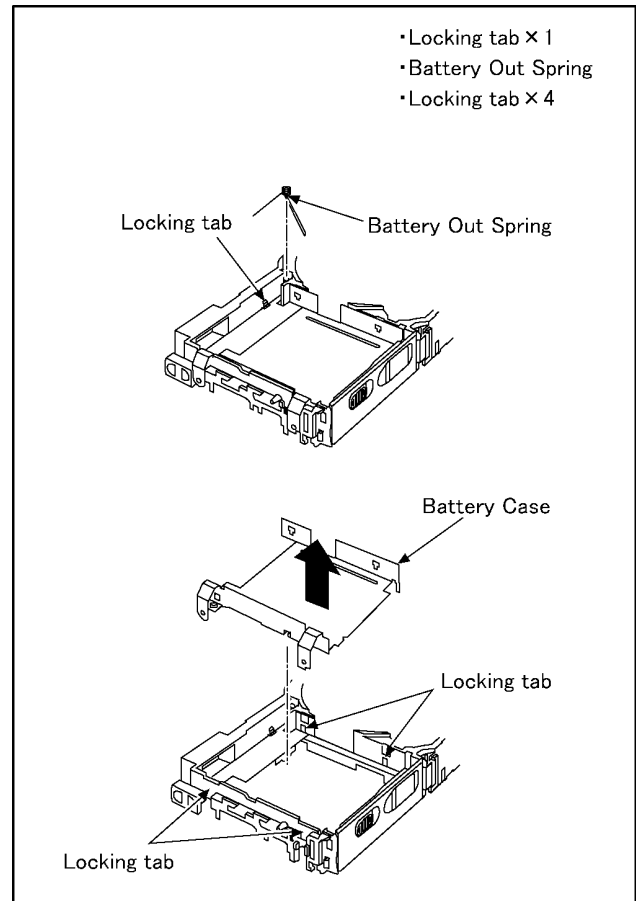

(Fig. D12)

8.3.11. Removal of the Battery Door Unit

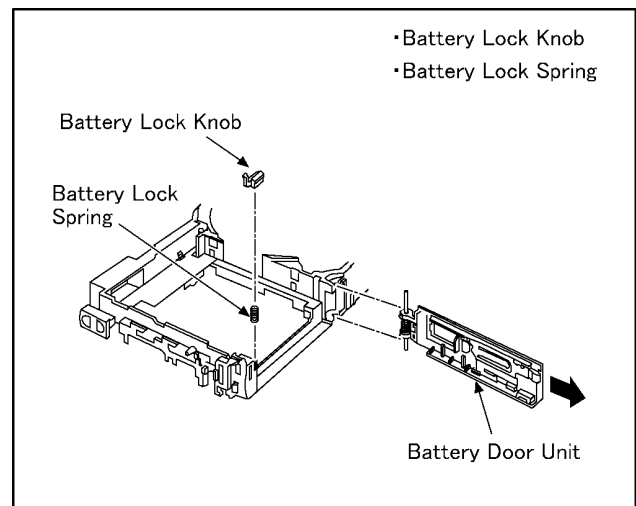

(Fig. D13)

NOTE: (When Installing)

Make sure to confirm the following points when installing:

- The Screw is tightened enough.
- Installing conditions are fine. (No distortion, no abnormal-space.)
- No dust and/or dirt on Lens surfaces.
- LCD image is fine. (No dust and dirt on it, and no gradient images.)

8.4. Lens Disassembly Procedure

Precaution:

1. Do not remove the CCD unit when disassembling or reassembling the lens in order to maintain it clean.
The screw fitting the CCD unit to the master flange unit is fixed by the bond lock with the adjustment of the installation angle of the CCD unit against the lens (optical axis adjustment) finished.
When remove it, refer to item "8.7."
2. Keep dust or dirt away from the lens.
To remove dirt or dust from the lens, blow with dry air.
3. Do not touch the lens surface.
4. Use lens cleaning KIT (VFK1900BK).
5. Apply grease (RFKZ0472) as shown on "THE APPLICATION OF GREASE METHOD" in the figure.

8.4.1. Removal of the Zoom Motor Unit and Lens FPC Unit

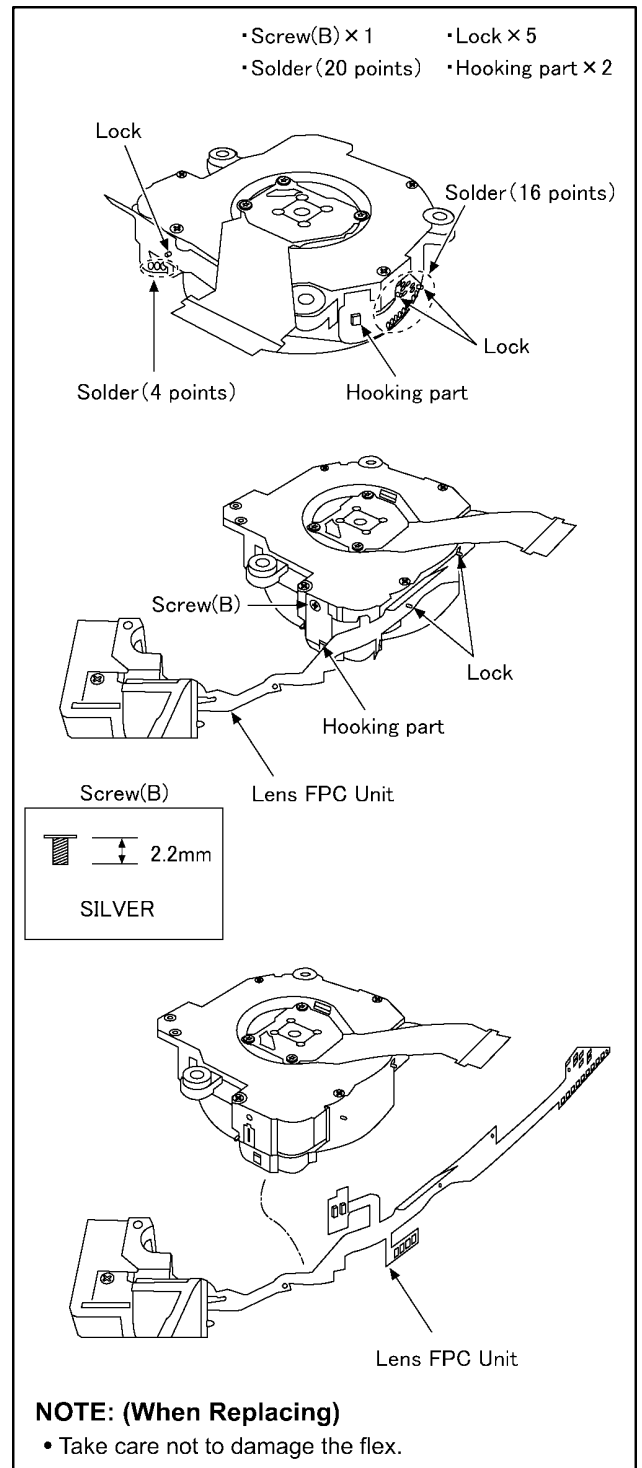
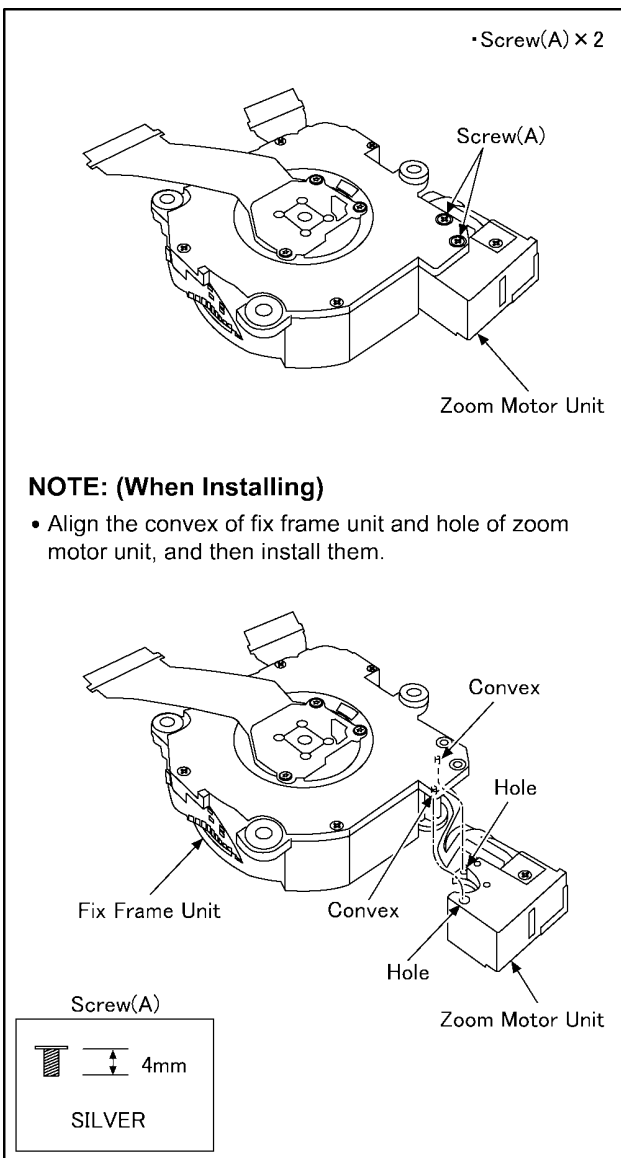

8.4.2. Removal of the Master Flange Unit

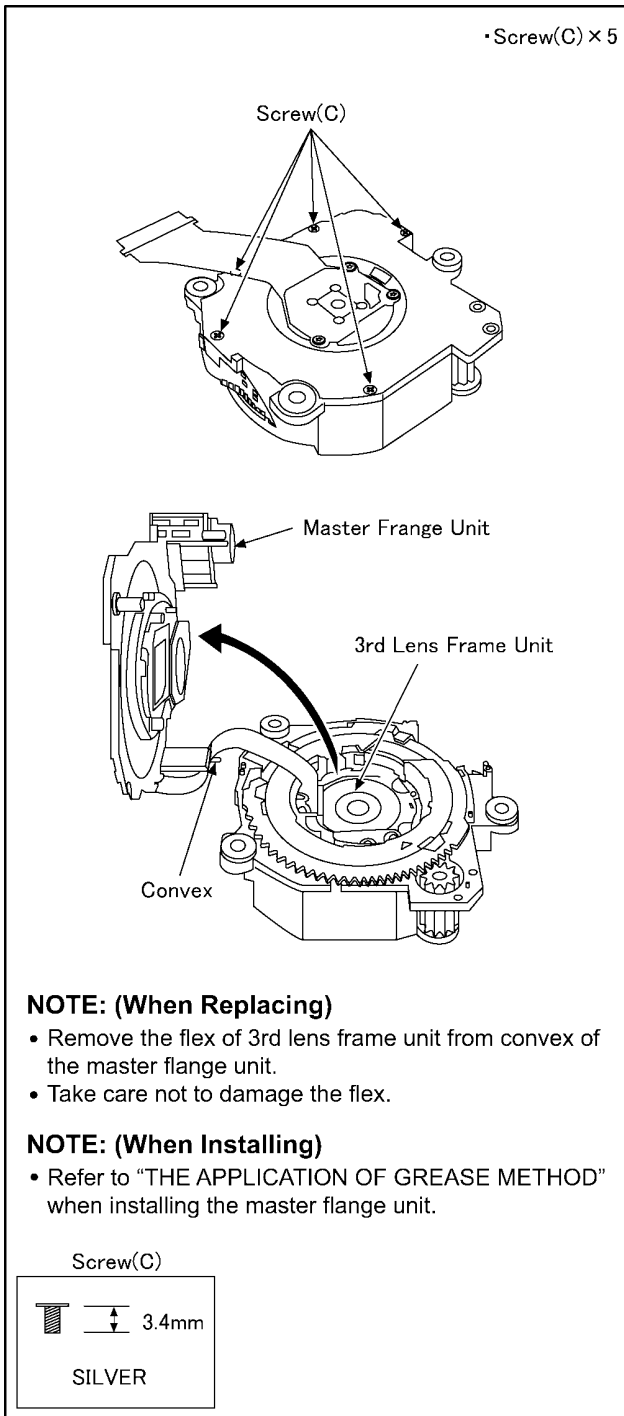

8.4.3. Removal of the Outside Direct Frame Unit / 1st-3rd Lens Frame Unit

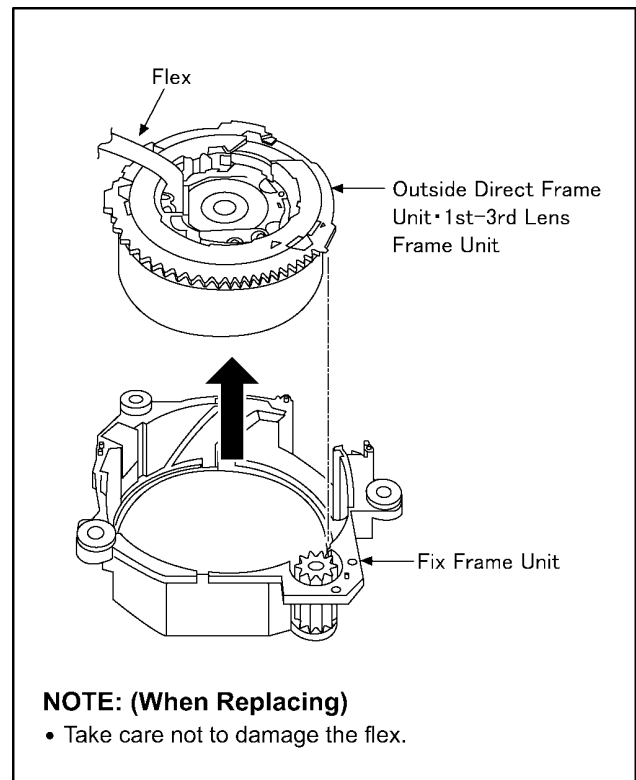

8.4.4. 1st-3rd Lens Frame Unit

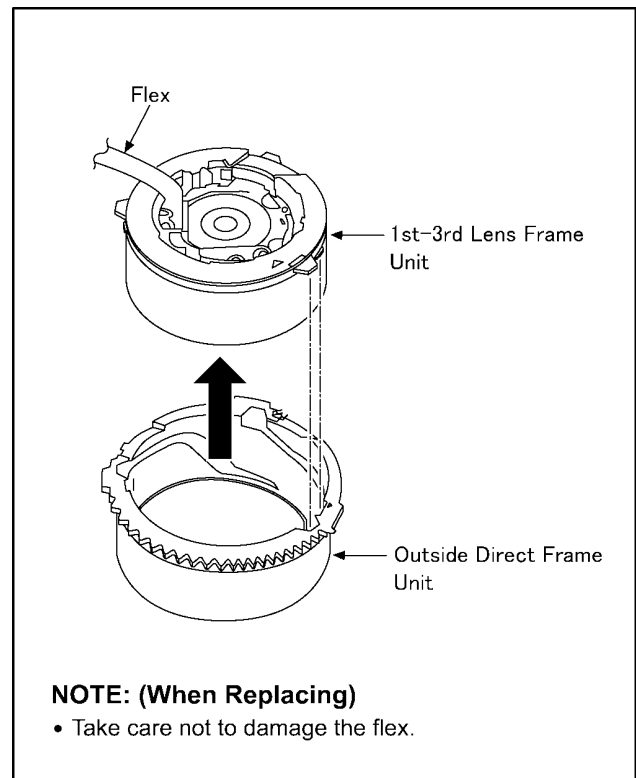

8.5. Removal of the Focus Motor

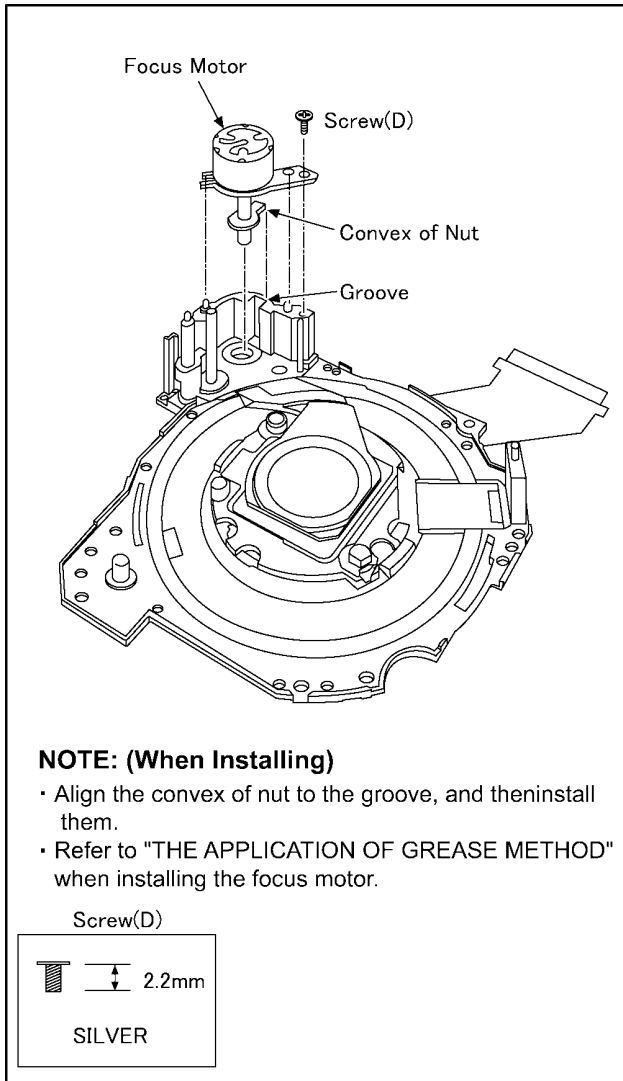

8.6. The Application of Grease Method

The grease application parts of lens unit are as follows. Apply grease additionally in the specified position if necessary. When the grease is applied, use a toothpick and apply thinly.

- Focus motor nut sliding part
 - Grease: RFKZ0472
 - Amount of application: 1.5 - 2 mg
- 4th Lens Frame sub shaft
 - Grease: RFKZ0472
 - Amount of application: 0.5 - 1 mg
- Lead screw
 - Grease: RFKZ0472
 - Amount of application: 2 - 4 mg
- 4th Lens Frame spindle guide
 - Grease: RFKZ0472
 - Amount of application: 1 - 2 mg

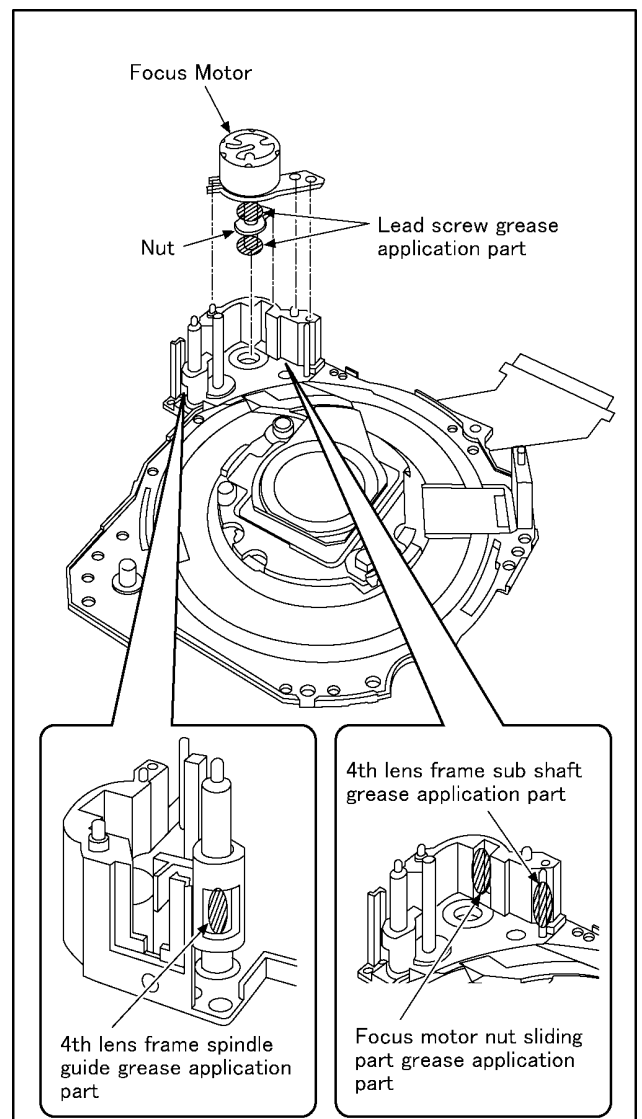

8.7. Removal of the CCD Unit

When remove the CCD unit once (the screw(E) is loosened even a little), the optical tilt adjustment is required.

When loosen the screw(E), necessary the optical tilt adjustment at the end of assembling. (Refer to item "9.3.2.")

To prevent the CCD unit from catching the dust and dirt, do not remove the CCD unit except for replacing.

CAUTION

- The screw(E) is fixed by the screw locking glue with the optical tilt adjustment finished. When remove the CCD unit, wipe the screw locking glue away carefully.
- Don't reuse the screw(E) that the screw locking glue adheres to keep dust or dirt away from the CCD unit. (When installing, use new screw(E).)

- Screw (E) × 3
- Tilt Spring × 2

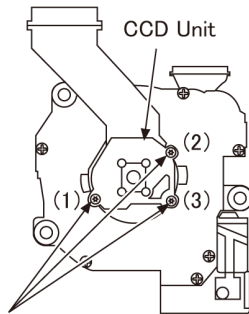

Screw(E)

- Screws(1)(2) are for adjustment, screw(3) is for fix.

Screw(E)

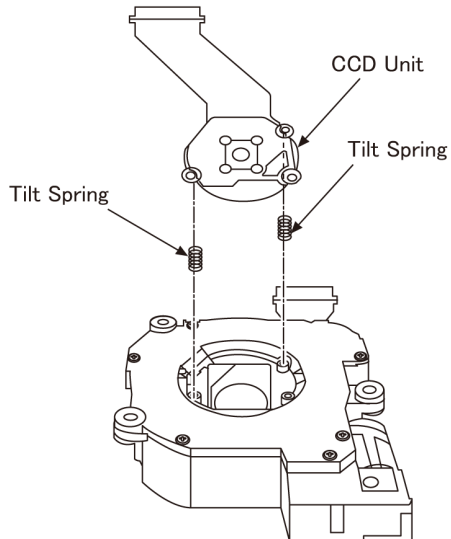

NOTE: (When Installing)

- Take new screw.
(Don't reuse the screw that the screw locking glue adheres.)
- Be sure to execute the optical tilt adjustment with the screw (1) and (2).
- Tighten the 3 special screws in order (1)→(2)→(3).
- Screw torque: 5 N·cm.
- After the adjustment is finished, apply the screw locking glue as shown on the next item in the figure.

- Remove screw locking glue for services to clean the bond curing UV, so as to straddle the place of the original application.
(Do not adhere locking glue to the head of tilt screw)

(Example)

This is the case where the screw locking glue is applied to inside of the broken line.

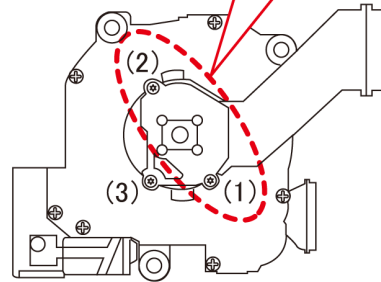
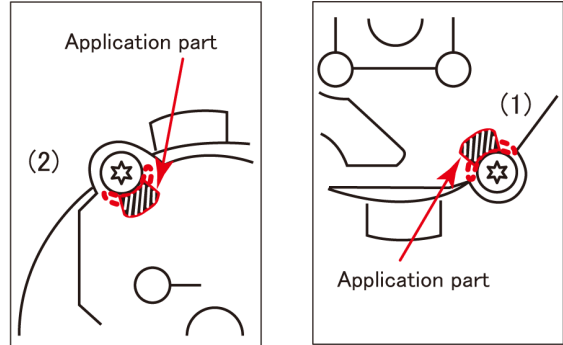

9 Measurements and Adjustments

9.1. Introduction

When servicing this unit, make sure to perform the adjustments necessary based on the part(s) replaced. Before disassembling the unit, it is recommended to back up the camera data stored in flash-rom as a data file.

IMPORTANT NOTICE (After replacing the MAIN P.C.B.)

After replacing the MAIN P.C.B., it is necessary to use the "DIAS" software to allow the release of adjustment flag(s). The Adjustment software "DIAS" is available at "TSN Website". To download, click on "Support Information from NWBG/VDBG-AVC".

*DIAS (DSC Integrated Assist Software)

NOTE: (When replacing the Lens unit and CCD unit)

- When the CCD unit is unavoidably removed for Lens unit, Master Flange unit and CCD unit replaced, an optical tilt adjustment is necessary after parts are exchanged.
- The adjustment software (DSC_Tilt) is necessary to execute an optical tilt adjustment.
- The adjustment software "DSC_Tilt" is available at "TSN Website", therefore, access to "TSN Website" at "Support Information from NWBG/VDBG-AVC".

9.2. Before Disassembling the unit

9.2.1. Initial Setting Release

The cameras specification are initially set in accordance with model suffix (such as EB, EG, GK, GC, and so on.). Unless the initial setting is not released, an automatic alignment software in the camera is not able to be executed when the alignment is carried out.

Note:

The initial setting should be again done after completing the alignment. Otherwise, the camera may not work properly. Therefore as a warning, the camera display a warning symbol "!" on the LCD monitor every time the camera is turned off. Refer to the procedure described in "3.5.2 INITIAL SETTINGS" for details.

[How to Release the camera initial setting]

Preparation:

- Attach the Battery or AC Adaptor with a DC coupler to the unit.
 1. Set the REC/PLAY switch to "[REC] (Camera mark)", and then turn the Power on.
 2. Press the [MODE] button, and select the [NORMAL PICTURE] mode by Cursor buttons, then press the [MENU/SET] button.
 3. Turn the Power off.
(If the unit is other than [NORMAL PICTURE] mode, it does not display the initial settings menu.)

Step 1. The temporary cancellation of "INITIAL SETTINGS":

Set the REC/PLAY switch to "[REC] (Camera mark)".

While pressing "[UP] of Cursor button" and [MOTION PICTURE] button simultaneously, turn the Power on.

Step 2. Cancellation of "INITIAL SETTINGS":

Set the REC/PLAY switch to "[PLAY]".

Press "[UP] of Cursor button" and [MOTION PICTURE] button simultaneously, turn the Power off.

The LCD displays the "!" mark before the unit powers down.

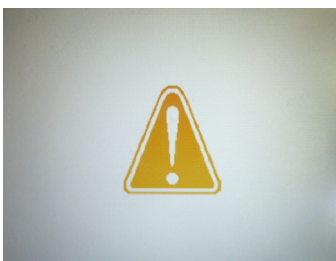

9.2.2. Flash-Rom Data Backup

When trouble occurs, it is recommended to backup the Flash-rom data before disassembling the unit.

There are two kinds of Flash-rom data backup methods:

[ROM_BACKUP (Method of Non-PC backup)]

1. Insert the SD-card into the camera.
2. Set the camera to "Temporary cancellation of the initial settings".
3. Select the "SETUP" menu.

From the "SETUP" menu, select "ROM BACKUP".

NOTE:

This item is not listed on the customer's "SETUP" menu.

4. When this "ROM_BACKUP" item is selected, the following submenus are displayed.



Fig.2-1

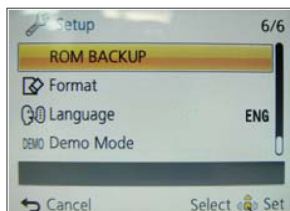

Fig.2-2

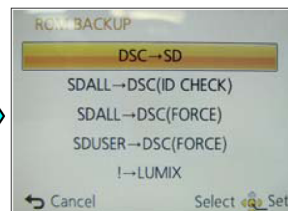

Fig.2-3

Item	Function	Details
DSC → SD	Save all the DSC's Flash-rom data to SD-CARD	*DSC's Flash-rom data is saved to the SD-CARD as a data file by the same format as the TATSUJIN software for the previous models. (DATA BACKUP) -File location: ROOT DIRECTORY in SD-CARD. -File Name: 1) User Setup Information data: <Model Number>U.txt [Example: DMC-FX66 : "FX66U.txt"] 2) Optical Adjustment data: <Model Number>F.txt [Example: DMC-FX66 : "FX66F.txt"] *If the concerned file already exists, "OVERWRITE?" message is displayed.
SDALL→ DSC (ID CHECK)	Write the all data to DSC's Flash-rom from SD-CARD	*The backup data being stored in the SD card is transferred to DSC unit. *ID CHECK: When the model ID is different, data is not transferred.
SDALL→ DSC (FORCE)	Write the all data to DSC's Flash-rom from SD-CARD	*FORCE: Even if the model ID is different, data is transferred. ※If the main PCB is replaced, select "SDALL → DSC (FORCE)".
SDUSER→DSC (FORCE)	Only "User setup information" is written from the saved file in the SD-CARD to DSC's Flash-rom.	*Only the user's "setup" setting condition is transferred to DSC unit. *FORCE: Even if the model ID is different, the data is transferred.
!→LUMIX	Shipping set without initializing "User setup information"	*Initial setting is executed without initializing the user's set up setting condition. ※ The initial setting must be perform while the Self-timer LED is blinking, ※ The picture data stored in the built-in memory of the DSC is not erased, with this operation.

[DSC Integrated Assist Software (Method of Using PC)]

Same as TATSUJIN software for previous models.

9.2.3. Light Box

If using VFK1164TDVLB Light Box, remove the lens connection ring by loosening three hexagonal screws.

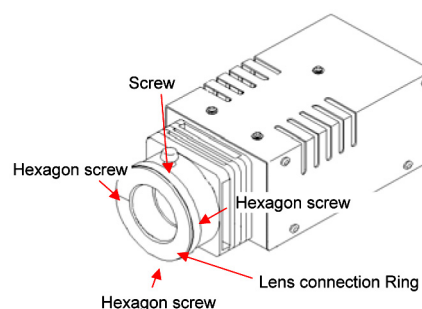

9.3. Details of Electrical Adjustment

9.3.1. How to execute the Electrical Adjustment

It is not necessary to connect the camera to a PC to perform adjustments.

“Flag reset operation” and “Initial setting operation” are required when carrying out the alignment, follow the procedure below.

9.3.1.1. Startup Electrical Adjustment mode

1. Release the initial settings.
2. Insert a recordable SD card.
(Without a SD card, the automatic adjustment can not executed.)
3. Procedure to set the camera into adjustment mode:
 - a. Set the REC/PLAY switch to “[REC] (Camera mark)”, and then turn the Power on.
 - b. Press the [MODE] button, and select the [NORMAL PICTURE] mode by Cursor button, then press the [MENU/SET] button.
 - c. Set the REC/PLAY switch to “[REC] (Camera mark)”, and then turn the Power off.
 - d. Turn the Power on pressing [MENU/SET] and [MOTION PICTURE] simultaneously.
LCD monitor displays “SERVICE MODE”.(Refer to Fig. 3-1)

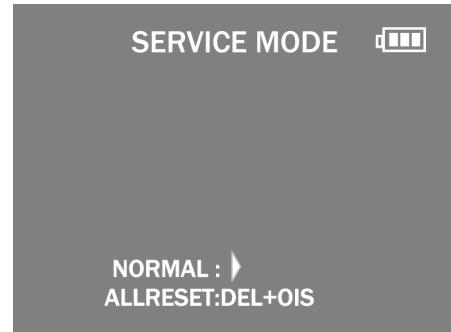

Fig.3-1

9.3.1.2. Status Adjustment Flag Setting

Reset (Not yet adjusted) the status flag condition.

1. After pressing the [DISP.] button, the LCD monitor displays the Flag status screen (Refer to Fig.3-2)
2. Select item by pressing the Cursor buttons. (Gray cursor is moved accordingly.)
3. Press the [Q.MENU]/[(Delete/Cancel)] button.

NOTE:

The selected item's flag has been changed from “F (green)” to “0 (yellow)”.

*Flag conditions:

F (green)

means that the alignment has been completed and the status flag condition is set. In this case, the flag condition should be reset, if you try to carry out the automatic alignment.

0 (yellow)

means that the alignment has been not “completed” and the status flag condition is “reset”. In this case, automatic alignment is available.

- In case of setting the status flag into set condition again without completion of the alignment, the status flag should be SET by using PC, or UNDO by using ROM BACKUP function.

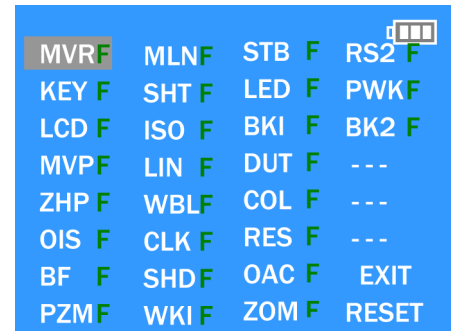

Fig.3-2

9.3.1.3. Execute Adjustment (In case of “OIS Adjustment”)

1. Perform step “9.3.1.1.” to “9.3.1.2.”, to reset the OIS flag status “F” (Set) to “0” (Reset)
2. Press [DISP.] button after Flag reset.
OIS Adjustment screen is displayed on the LCD panel.
(Refer to Fig.3-3)
3. Press the [Shutter] button.
The adjustment will start automatically.



Fig.3-3

4. When the adjustment is completed successfully, adjustment report menu appears with Green OK on the LCD monitor. (Refer to Fig.3-4)

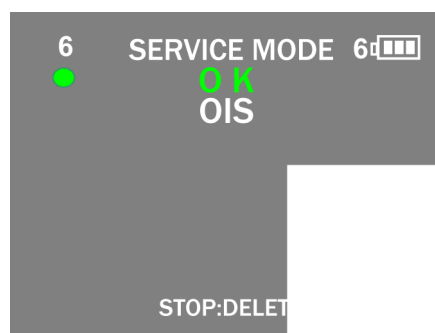

Fig.3-4

9.3.1.4. Attention point during Adjustment

1. Step “9.3.1.3.” procedure shows OIS adjustment as an example. To perform the adjustment, refer to the “9.3.2. Adjustment Specifications” table which shows key point for each adjustment.
2. Do not move the light box, the camera or the chart while adjusting. If one of these is moved accidentally, start the adjustment again.
3. Do not press any buttons/keys until the default menu (Fig.3-5) is displayed on the LCD monitor. Otherwise, adjustment data may not be stored properly.
4. If the adjustment is interrupted accidentally, the alignment data may not be properly saved in the Flash-rom.

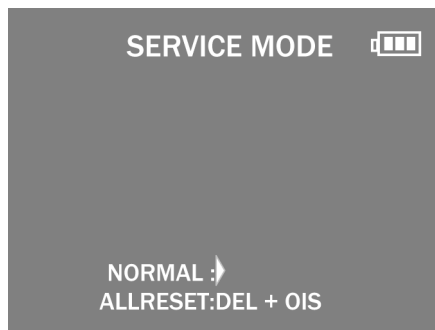

Fig.3-5

9.3.1.5. Finalizing the Adjustment

1. Several adjustment flags can be reset (“F” into “0”) at the same time. In this case, when the adjustment has been completed, the screen will change showing the adjustment for the next item until all reset items are completed.
Also, when the [Shutter] button is pressed, the screen jump to the next adjustment item.
2. To cancel the adjustment mode while in the process of performing the adjustment, follow this procedures.
 - (1) Press “[Q.MENU]/[(Delete/Cancel)] of Cursor button”.
 - (2) Press “[RIGHT] of Cursor button”.

NOTE:

- If adjustment is cancelled with above procedure, adjustment is not completed. Make sure to adjust it later.
- Adjustment software “DIAS” is able to control the status of the adjustment flags.

9.3.2. Adjustment Specifications

The following matrix table shows the relation between the replaced part and the Necessary Adjustment.

When a part is replaced, make sure to perform the necessary adjustment(s) in the order indicated.

The table below shows all the information necessary to perform each adjustment.

Adjustment order	Adjustment Item	FLAG	Purpose	Replacing Parts				JIG/TOOLS	SET UP	How to Operate	
				MAIN P.C.B./F.ROM/VENUS	Lens part (Include CCD U)	MIC	Flash Part				LCD
1	Optical Tilt Adjustment		Adjustment of image sensor installation angle to lens	-	○	-	-	-	Please execute the adjustment by using optical tilt adjustment software "DSC_Tilt" for DMC-SZ1/SZ02. The adjustment software "DSC_Tilt" is available at "TSN Website", therefore, access to "TSN Website" at "Support Information from NNBG/VDBG-AVC".		
2	LCD Flicker adjustment	LCD	LCD Flicker adjustment	-	-	-	-	○	NONE	NONE	1)Set in the mode which presses the right-and-left key and screen flicker chooses the fewest mode. 2)Press Shutter Button (Do not apply any shock and vibration for the camera while adjusting) 3)After completed, the "OK" message appears.
3	Zoom Home Position and Microphone check	ZHP	Zoom Home Position adjustment	○	○	○	-	-	NONE	NONE	1)Press Shutter Button (Do not apply any shock and vibration for the camera while adjusting) 2)Voice is uttered for 5 seconds into the microphone, waiting 5 seconds after pushing a shutter release. ※Comparatively high voice is ideal. (Standard: 1Khz) 3)After completed, the "OK" message appears.
4	OIS sensor	OIS	OIS sensor output level adjustment	○	○	-	-	-	NONE	NONE	1)Press Shutter Button (Do not apply any shock and vibration for the camera while adjusting) 2)After completed, the "OK" message appears.
5	Backfocus / GYRO	BF	To have the focus tracking curve be appropriate shape and GYRO sensor adjustment	○	○※1	-	-	-	•COLLIMATOR (VFK1164TCM02 or VFK1164TCM03 or RFKZ0422)	1)Set the camera in front of collimator so that the distance between collimator and camera becomes about 4 cm as shown in Fig.A. 【NOTE】 Please note that "NG" might happen while auto adjusting. - Do not put the black colored stuff at the back side of collimator near hunching chart to get some certain brightness. - Make sure the hunting chart has no dust and dirty condition. - Not connect the USB cable at this stage.	1)A star chart changes into the state where it is reflected to the center. Press Shutter Button (Do not apply any shock and vibration for the camera while adjusting) (Green ● mark is displayed on LCD). 2)A star chart changes into the state where it is reflected to the center. 3)Press shutter button. 4)After completed, the "OK" message appears.
6	Venus Zoom	PZM	Venus Zoom Inspection	○	-	-	-	-	NONE	NONE	1)Press Shutter Button (Do not apply any shock and vibration for the camera while adjusting) 2)After completed, the "OK" message appears.
7	Monitor Linearity	MLN	Monitor Linearity adjustment	○	○	-	-	-	•LIGHT BOX RFKZ0523 (VFK1164TDVLB)	1)Set the camera in front of LIGHT BOX so that the distance between Light box and camera becomes about 4 cm as shown in Fig.B. 【NOTE】 - Not connect the USB cable at this stage.	1)Press Shutter Button (Do not apply any shock and vibration for the camera while adjusting) 2)After completed, the "OK" message appears.
8	Shutter	SHT	Shutter speed adjustment	○	○	-	-	-	•LIGHT BOX RFKZ0523 (VFK1164TDVLB)	1)Set the camera in front of LIGHT BOX so that the distance between Light box and camera becomes about 12 cm as shown in Fig.B. 【NOTE】 - Not connect the USB cable at this stage.	1)Press Shutter Button (Do not apply any shock and vibration for the camera while adjusting) 2)After completed, the "OK" message appears.
9	ISO	ISO	ISO sensitivity adjustment	○	○	-	-	-	•LIGHT BOX RFKZ0523 (VFK1164TDVLB)	1) Set the ND FILTER (RFKZ0513) to the LIGHT BOX. (The LIGHT BOX "VFK1164TDVLB" can be used if the front hood of VFK1164TDVLB is removed.) 2) Set the camera in front of LIGHT BOX so that the distance between ND FILTER and camera becomes about 9 cm as shown in Fig.C. 【NOTE】 - Not connect the USB cable at this stage.	1)Press Shutter Button (Do not apply any shock and vibration for the camera while adjusting) 2)After completed, the "OK" message appears.
10	High brightness coloration	LIN	High brightness coloration adjustment	○	○	-	-	-	•ND FILTER (RFKZ0513)(ND0.3)	1)Press Shutter Button (Do not apply any shock and vibration for the camera while adjusting) 2)After completed, the "OK" message appears.	1)Press Shutter Button (Do not apply any shock and vibration for the camera while adjusting) 2)After completed, the "OK" message appears.
11	White Balance	WBL	White balance adjustment under various color temperature	○	○	-	-	-	•LIGHT BOX RFKZ0523 (VFK1164TDVLB) •TR CHART (RFKZ0443)	1)Insert the TR chart into the slot of light box as shown in Fig.E. 2)Set the camera in front of LIGHT BOX so that the distance between Light box and camera becomes about 15 cm as shown in Fig.B. 【NOTE】 - Not connect the USB cable at this stage.	1)Press Shutter Button (Do not apply any shock and vibration for the camera while adjusting) 2)After completed, the "OK" message appears.
12	CCD Missing Pixels (White)※2	WKI	Compensation of CCD Missing Pixels (White)	○	○※1	-	-	-	NONE	NONE	1)Press Shutter Button (Do not apply any shock and vibration for the camera while adjusting) 2)After completed, the "OK" message appears.

Adjustment order	Adjustment Item	FLAG	Purpose	Replacing Parts				JIG/TOOLS	SET UP	How to Operate	
				MAIN P.C.B.	Lens part (include CCD U)	MIC	Flash Part				LCD
13	Flash adjustment	STB	Flash adjustment	O	-	-	O	-	NONE	NONE	1) Press Shutter Button (Do not apply any shock and vibration for the camera while adjusting) 2) Check that a flash shines. (It is different for every mode how many times it shines.) ※When a flash does not shine, there is a possibility that the flash unit is out of order. 3) Check a test result. ※Results of the tests are usually NG. (When a result is OK, it is the completion of an inspection.) 4) When a result is NG, rewrite STB flag to an adjustment using DIAS. ※STB is an item which checks shines operation of a flash automatically at a Manufacturing facility. For this reason, Except environment for exclusive use, a result will be NG, but it is no problem if shines operation can be checked visually.
14	Color reproduction inspection and Microphone check	COL	Color reproduction inspection and Microphone check	O	O	-	-	-	NONE	NONE	1) Press Shutter Button (Do not apply any shock and vibration for the camera while adjusting) 2) After completed, the "OK" message appears.
		BK1	Do not use "BK1" adjustment flag for this unit. Use "BK2" adjustment flag, instead. (In case of most DSC models, the adjustment flag for CCD Missing Pixels is "BK1". But, in this model, "BK2" the adjustment flag for CCD Missing Pixels.)								
15	MOS Missing Pixels (Black)※3	BK2	Compensation of MOS Missing Pixels (Black)	O	O	※1	-	-	-	- LIGHT BOX RFKZ0523 (VFK1164TDVLB) - DIFFUSER (RFKZ0591) 1) Prepare the LIGHT BOX (RFKZ0523). (The LIGHT BOX "VFK1164TDVLB" can be used if the front hood of VFK1164TDVLB is removed.) 2) Set the Diffuser (RFKZ0591) to the LIGHT BOX. 3) Set the camera in front of LIGHT BOX so that the distance between Diffuser and camera becomes about 4 cm as shown in Fig.D. 【NOTE】 - Do not use "BK1" adjustment flag for this unit. Use "BK2" adjustment flag, instead.	1) Press Shutter Button after SET UP. (Green ● mark is displayed on LCD). 2) Press Shutter Button. (The 1st adjustment is executed, and then green ● mark is displayed on LCD). 3) Press Shutter Button. (Green ● mark is displayed on LCD). 4) Press Shutter Button. (The 2nd adjustment is executed, and then green ● mark is displayed on LCD). 5) Press Shutter Button. (Green ● mark is displayed on LCD). 6) Press Shutter Button. (The 3rd adjustment is executed, and then "OK" mark is displayed on LCD when the adjustment has been completed successfully.)
16	OIS Act adjustment	OAC	OIS performance/Lens flare/ghost adjustment	O	O	-	-	-	NONE	1) Set the camera on plane.	1) Press Shutter Button (Do not apply any shock and vibration for the camera while adjusting) 2) After completed, the "OK" message appears.

- ※1: This adjustment must be performed not only replacing the CCD unit, but also simply removing the CCD unit.
 ※2: The pixel that always lights while shaded is called a white wound.
 ※3: The pixel that does not light while complete exposed is called a black wound.

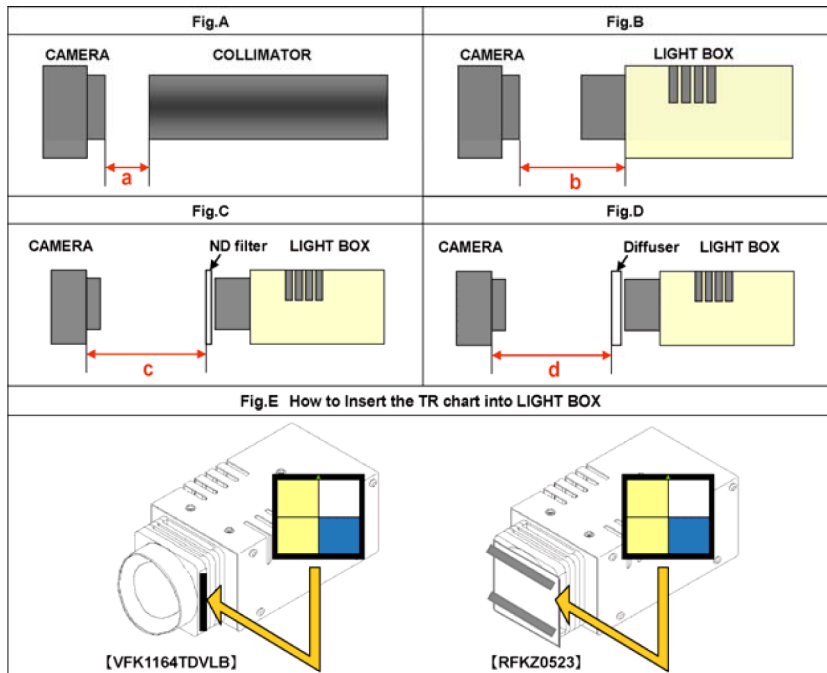

■ **IMPORTANT NOTICE** (After replacing the MAIN P.C.B.)
 After replacing the MAIN P.C.B., make sure to perform the "INITIAL SETTINGS" first, then release the "INITIAL SETTINGS" in order to proceed the electrical adjustment.

NOTE:

- 1). If electrical adjustment or data re-writing is executed before "INITIAL SETTINGS", suffix code list is never displayed, and it cannot be chosen suitable suffix code.
- 2). Never remove the battery during initial setting in process.

9.4. After Adjustment

9.4.1. Initial Setting

Since the initial setting has been released to execute the built-in adjustment software, it should be set up again before shipping the camera to the customer.

Refer to the procedure described in “3.5.2. INITIAL SETTINGS” for details.

[IMPORTANT]

1. The initial setting should be done again after completing the alignment. Otherwise, the camera will not work properly.
Therefore as a warning, the camera display a warning symbol “ ! ” on the LCD monitor every time the camera is turned off.
2. Confirm that status of all adjustment flag show “F”. Even if one of the adjustment flag shows “0”, initial setting programmed is never executed.

10 Maintenance

10.1. Cleaning Lens and LCD Panel

Do not touch the surface of lens and LCD Panel with your hand.

When cleaning the lens, use air-Blower to blow off the dust.

When cleaning the LCD Panel, dampen the lens cleaning paper with lens cleaner, and the gently wipe the its surface.

Note:

The Lens Cleaning KIT ; VFK1900BK (Only supplied as 10 set/Box) is available as Service Aid.

11 Block Diagram

11.1. Overall Block Diagram

OVERALL BLOCK DIAGRAM

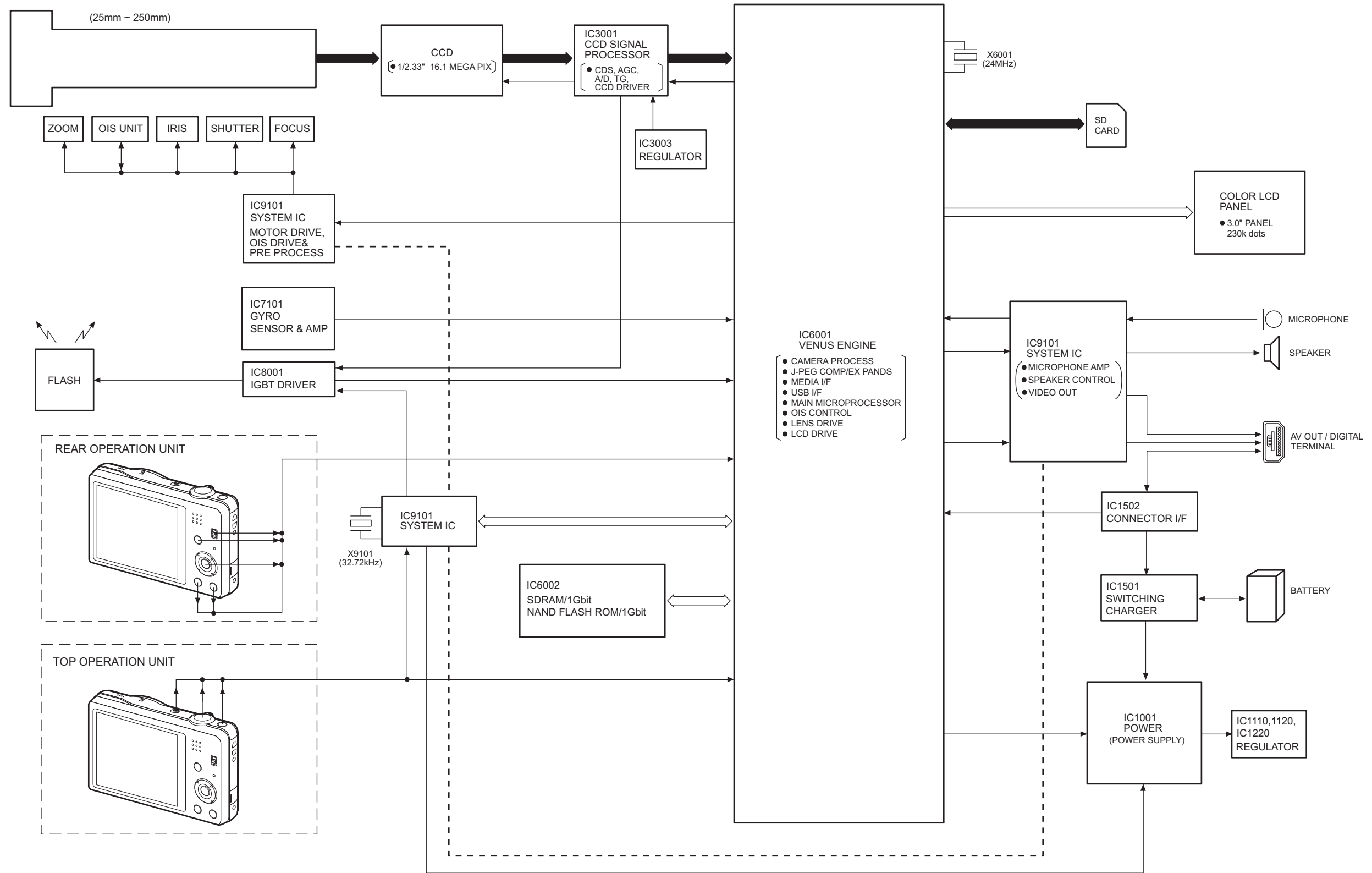

11.2. System Control Block Diagram

SYSTEM CONTROL BLOCK DIAGRAM

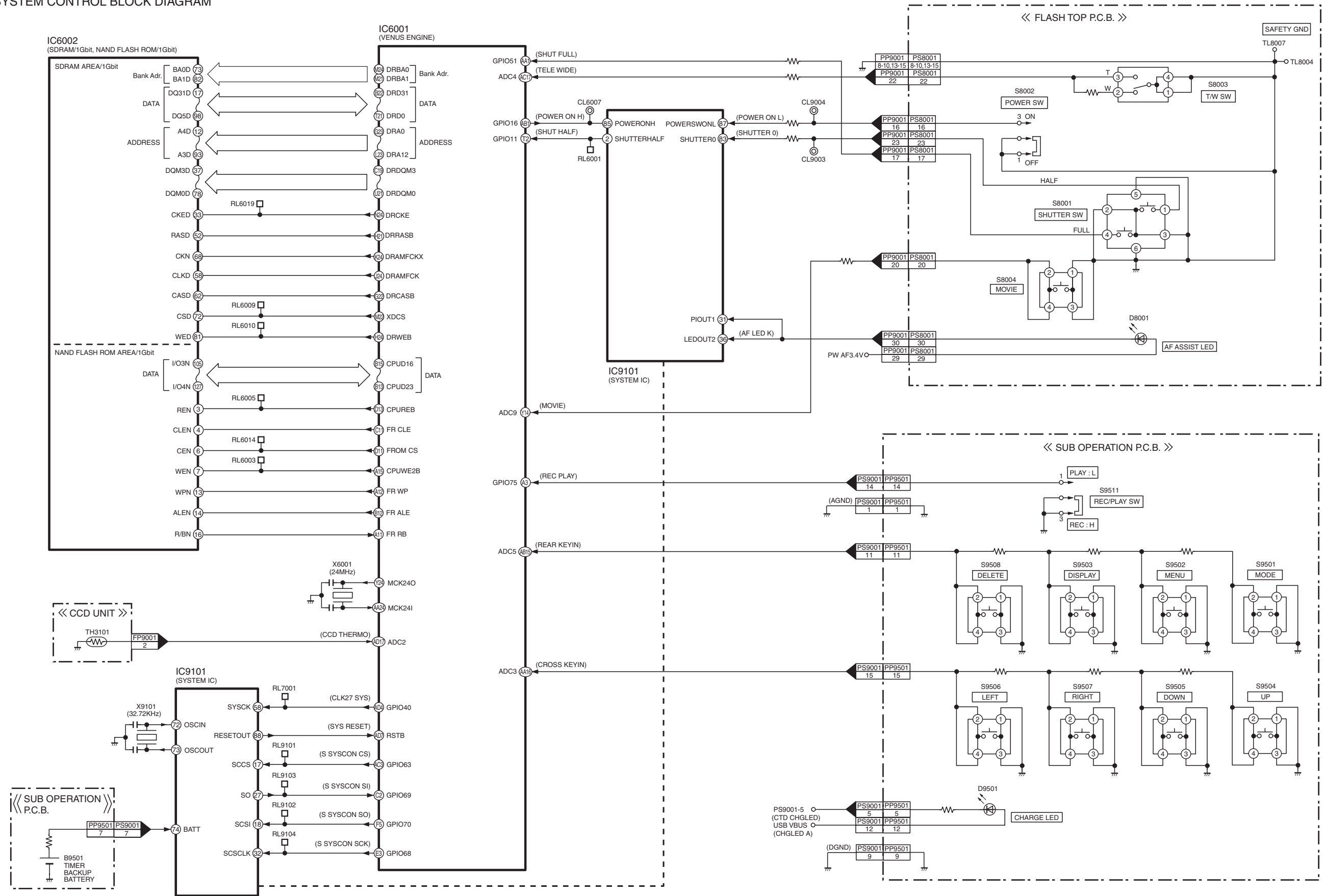

DMC-SZ1/SZ02 SYSTEM CONTROL BLOCK DIAGRAM

11.3. Video/Audio Process Block Diagram

VIDEO/AUDIO PROCESS BLOCK DIAGRAM

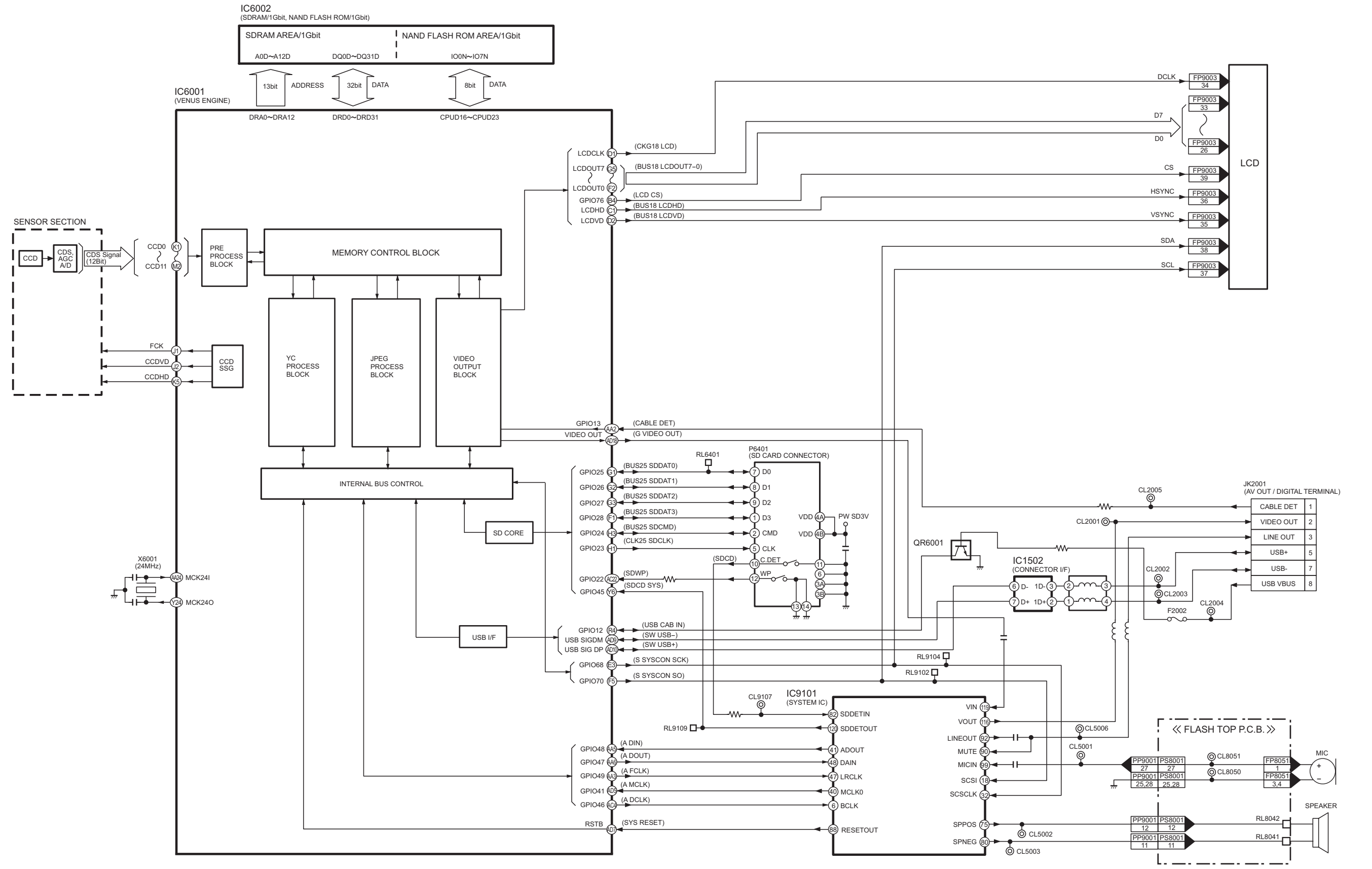

DMC-SZ1/SZ02 VIDEO/AUDIO PROCESS BLOCK DIAGRAM

11.4. Sensor Block Diagram

◆ SENSOR BLOCK DIAGRAM

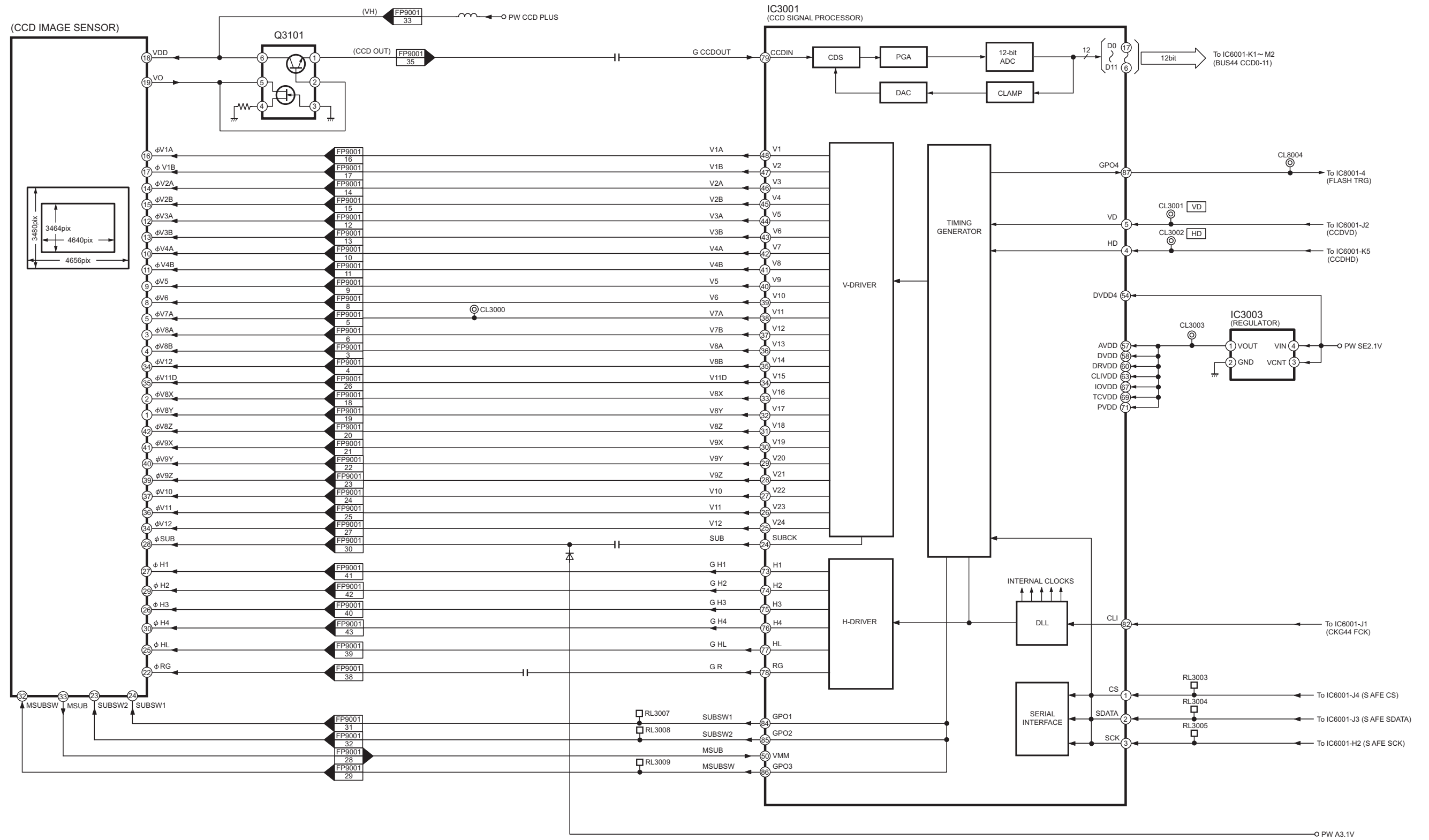

11.5. Lens Drive Block Diagram

LENS DRIVE BLOCK DIAGRAM

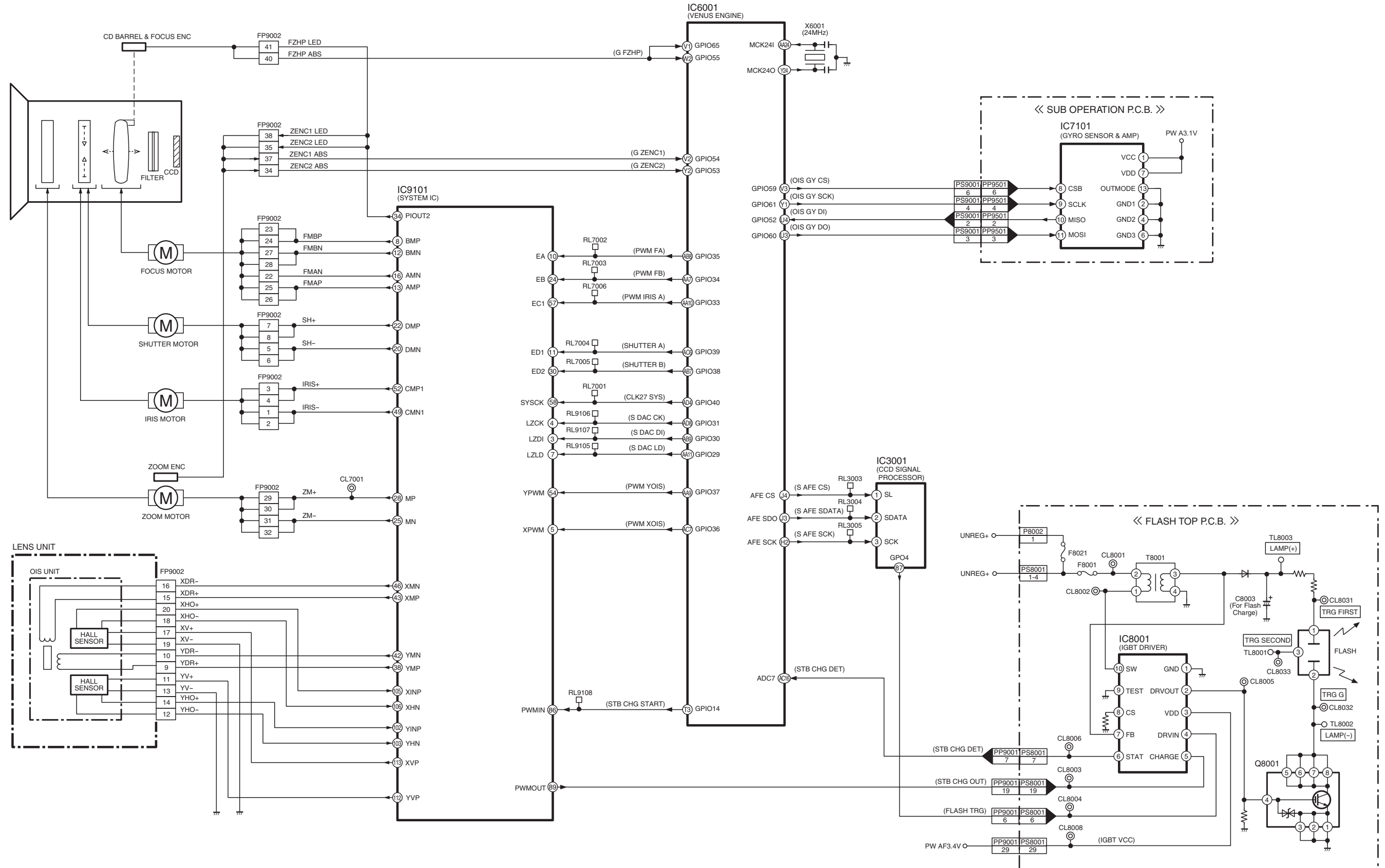

DMC-SZ1/SZ02 LENS DRIVE BLOCK DIAGRAM

11.6. Power Block Diagram

POWER BLOCK DIAGRAM

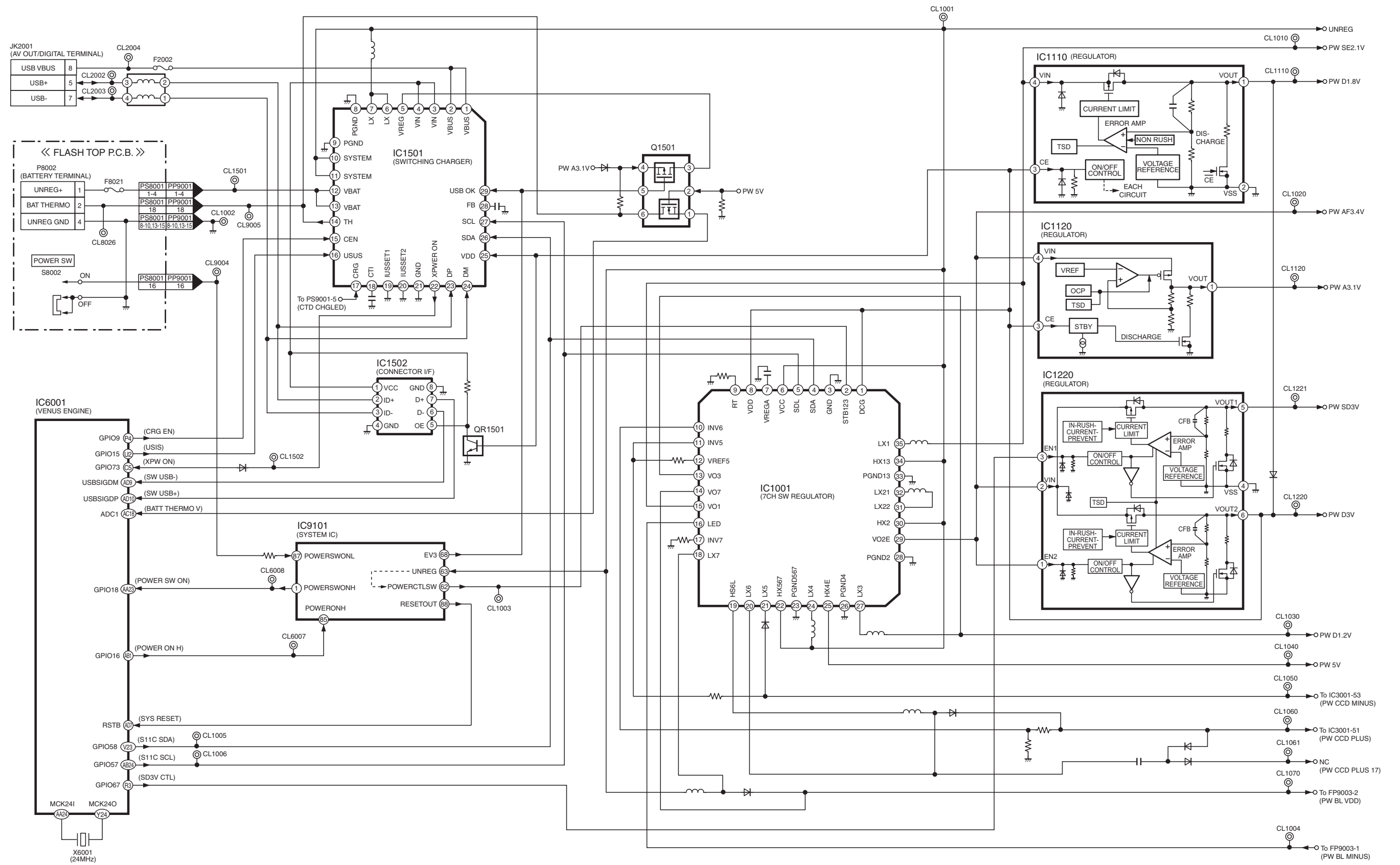

DMC-SZ1/SZ02 POWER BLOCK DIAGRAM

12 Wiring Connection Diagram

12.1. Interconnection Diagram

◆ INTERCONNECTION DIAGRAM

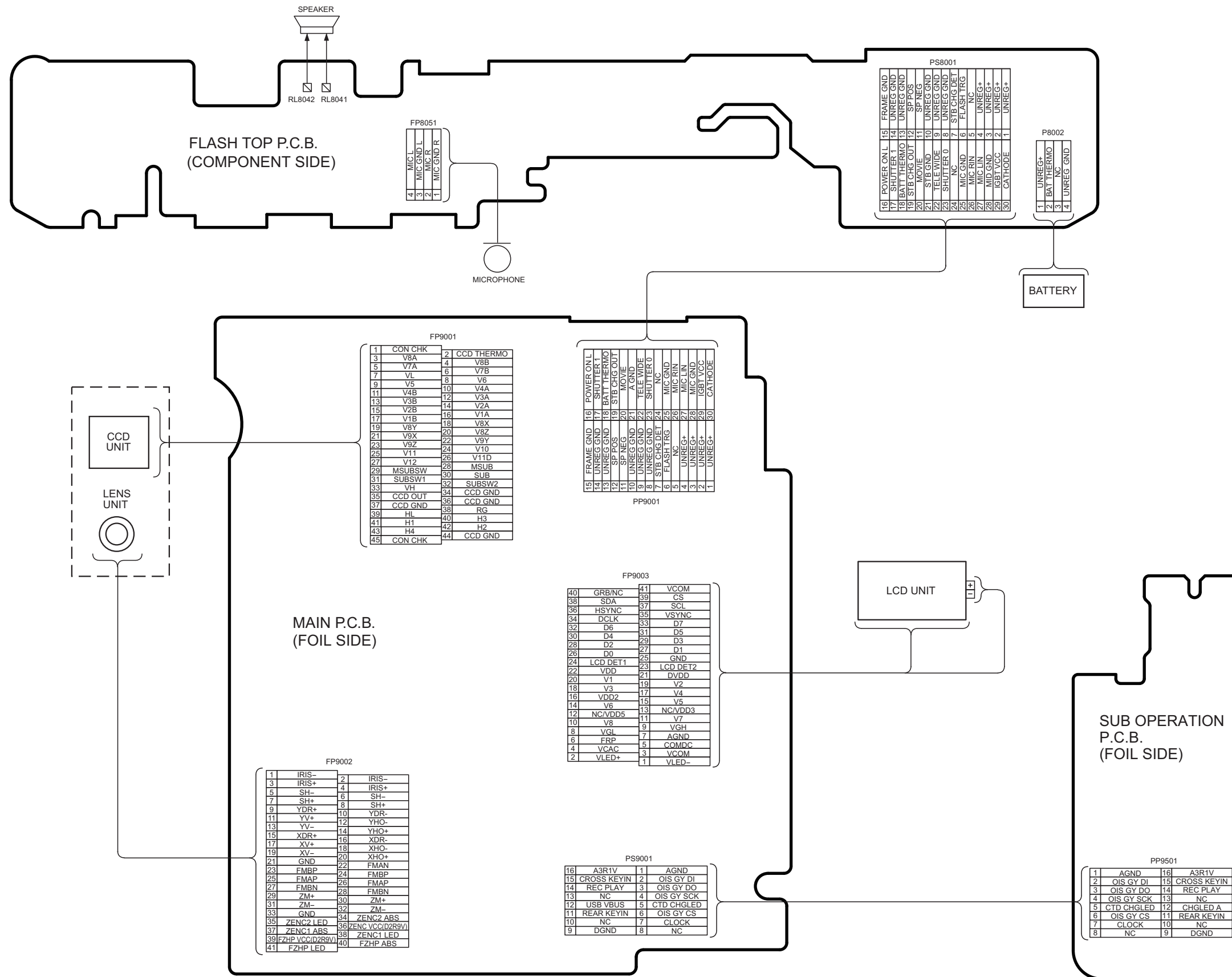

IMPORTANT SAFETY NOTICE:

COMPONENTS IDENTIFIED WITH THE MARK  HAVE THE SPECIAL CHARACTERISTICS FOR SAFETY. WHEN REPLACING ANY OF THESE COMPONENTS USE ONLY THE SAME TYPE.

1. Although reference number of the parts is indicated on the P.C.B. drawing and/or schematic diagrams, it is NOT mounted on the P.C.B. when it is displayed with "\$" mark.
2. It is only the "Test Round" and no terminal (Pin) is available on the P.C.B. when the TP (Test Point) indicated as "●" mark.
3. Use the parts number indicated on the Replacement Parts List .
4. Indication on Schematic diagrams:

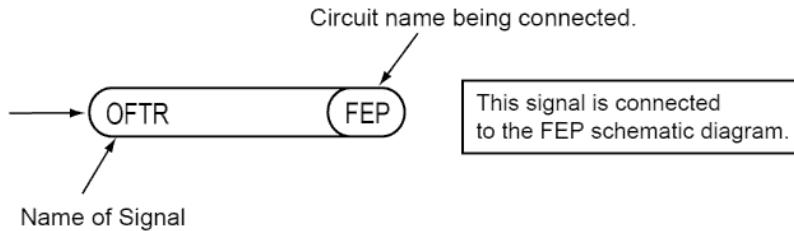

5. It might be taking time for display and/or access of the Schematic Diagrams & P. C. B. having the heavy data volume.

- Note:
1. * Be sure to make your orders of replacement parts according to this list.
 2. **IMPORTANT SAFETY NOTICE**
Components identified with the mark \triangle have the special characteristics for safety.
When replacing any of these components, use only the same type.
 3. Unless otherwise specified,
All resistors are in OHMS, K=1,000 OHMS. All capacitors are in MICRO-FARADS (uf), P=uuF.
 4. The marking (RTL) indicates the retention time is limited for this item. After the discontinuation of this assembly in production, it will no longer be available.
 5. Supply of CD-ROM, in accordance with license protection, is allowable as replacement parts only for customers who accidentally damaged or lost their own.

E.S.D. standards for Electrostatically Sensitive Devices, refer to PREVENTION OF ELECTROSTATIC DISCHARGE (ESD) TO ELECTROSTATICALLY SENSITIVE (ES) DEVICES section.

Definition of Parts supplier:

1. Parts marked with [ENERGY] in the remarks column are supplied from Panasonic Corporation Energy Company.
2. Parts marked with [SPC] in the remarks column are supplied from AVC-CSC-SPC. Others are supplied from PAVCX.

Model No. : DMC-SZ1/SZ02 Power (P) (Main P.C.B.)

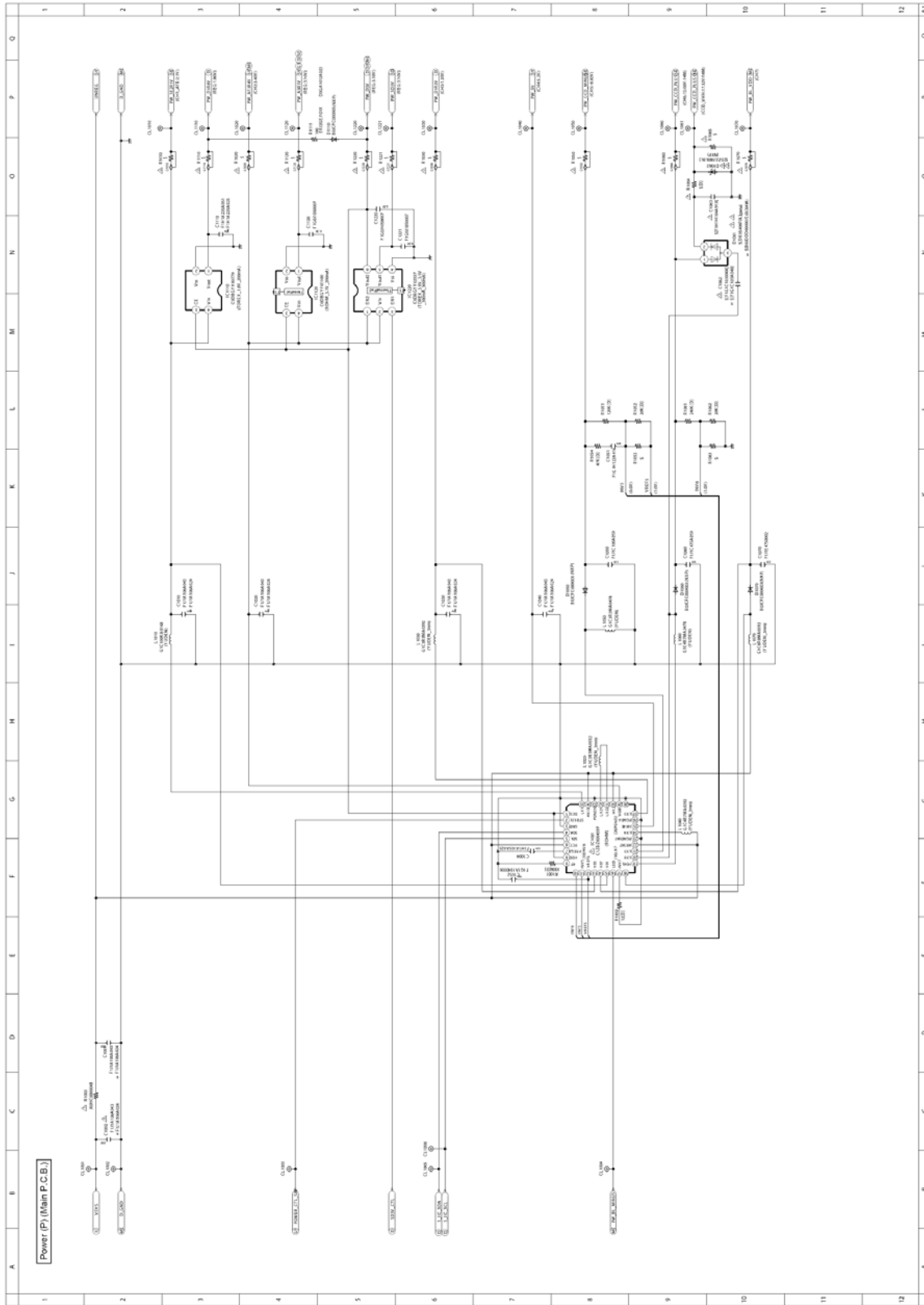

Model No. : DMC-SZ1/SZ02 Jack (J) (Main P.C.B.)

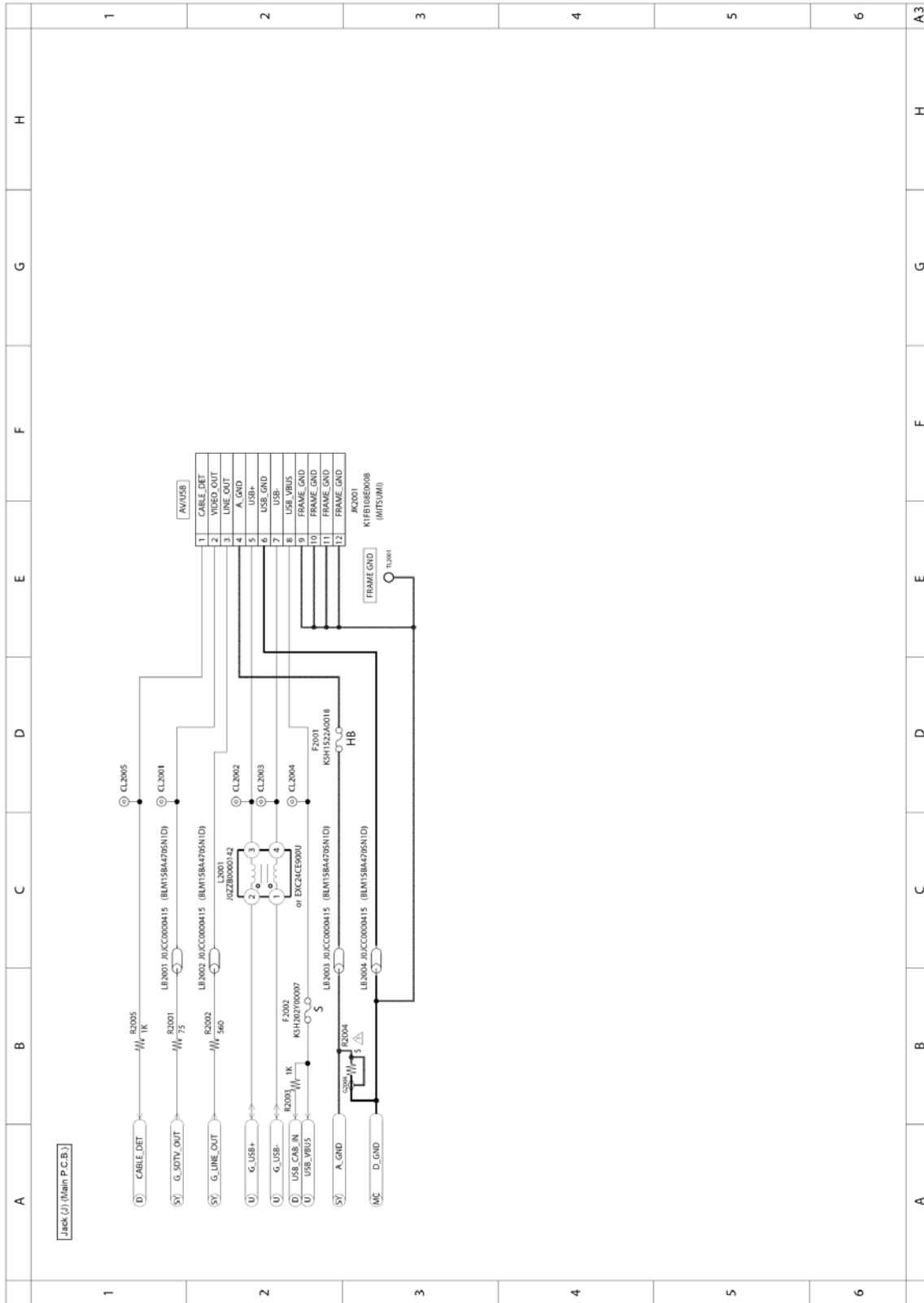

Model No. : DMC-SZ1/SZ02 SENSOR (SE) (Main P.C.B.)

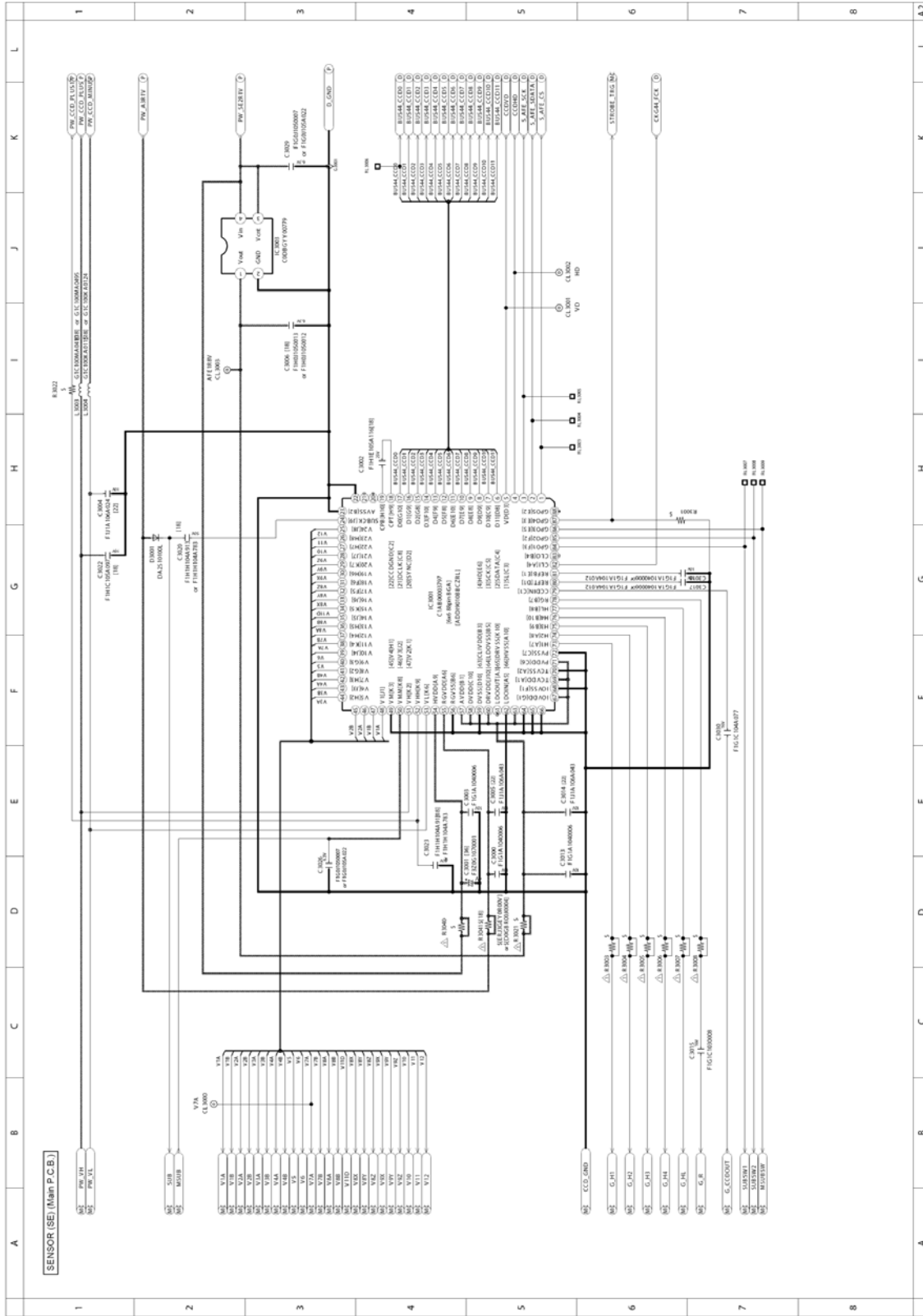

Model No. : DMC-SZ1/SZ02 LCD (L) (Main P.C.B.)

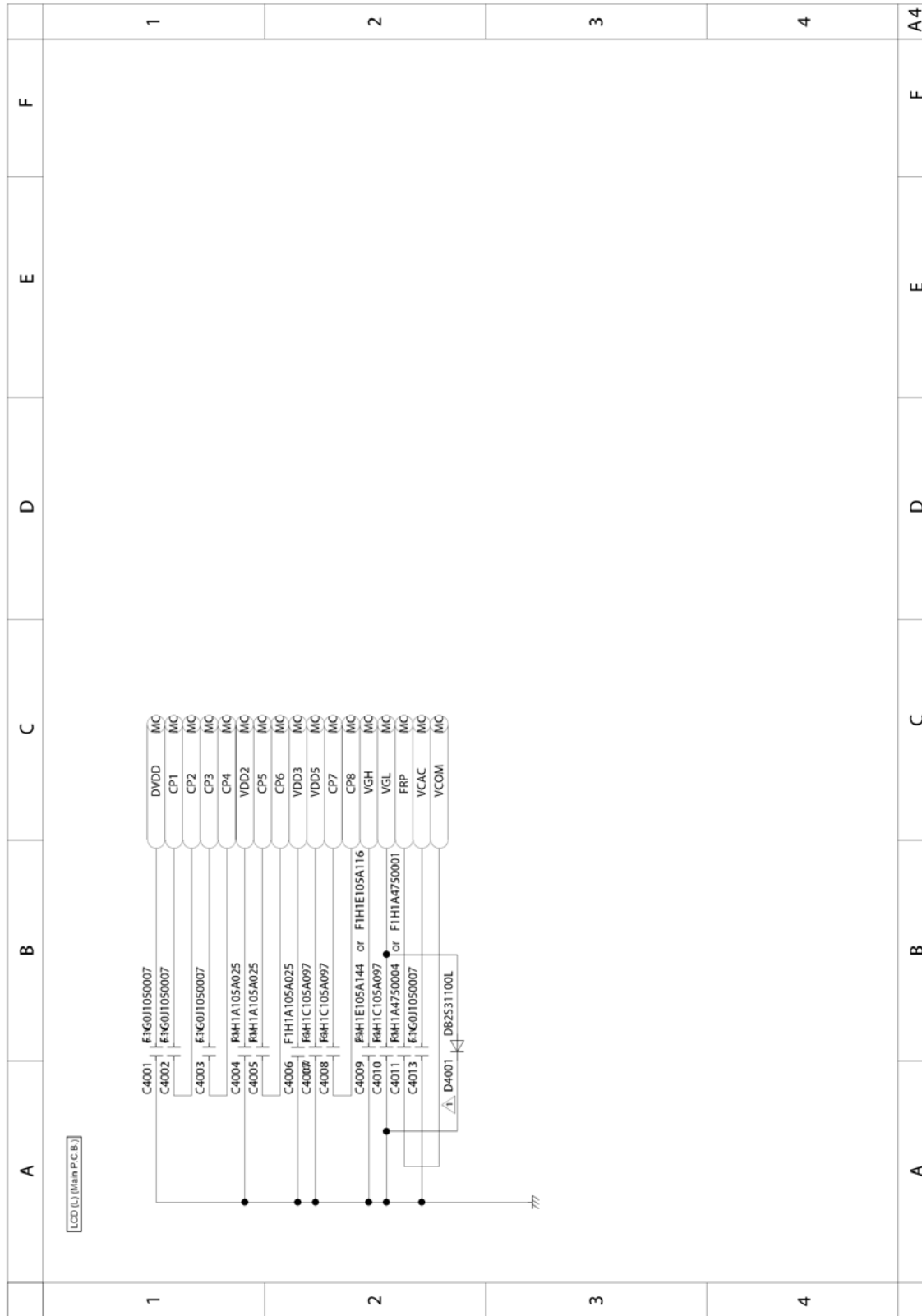

Model No. : DMC-SZ1/SZ02 Digital (D) (Main P.C.B.)

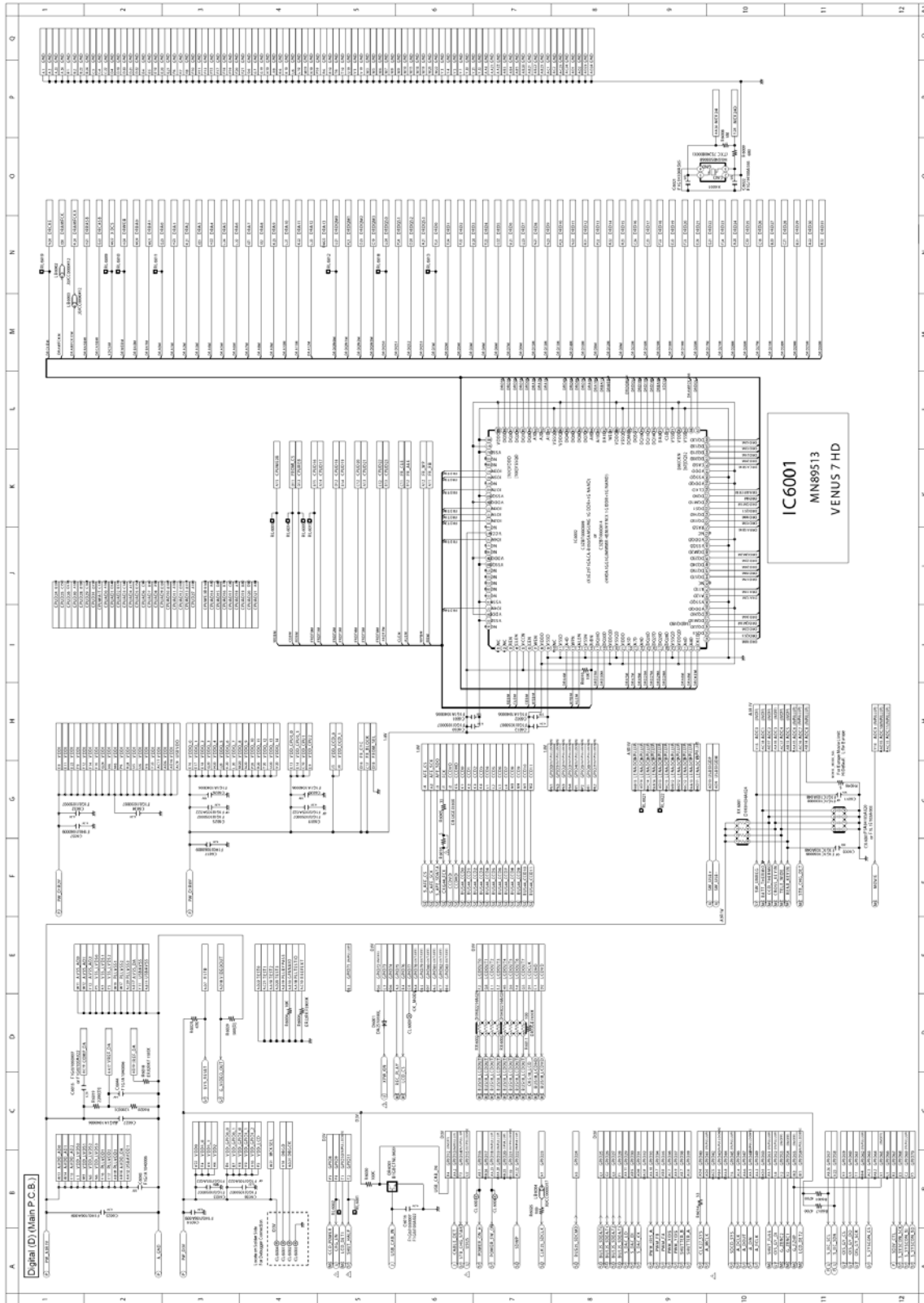

Model No. : DMC-SZ1/SZ02 SD Card (SD) (Main P.C.B.)

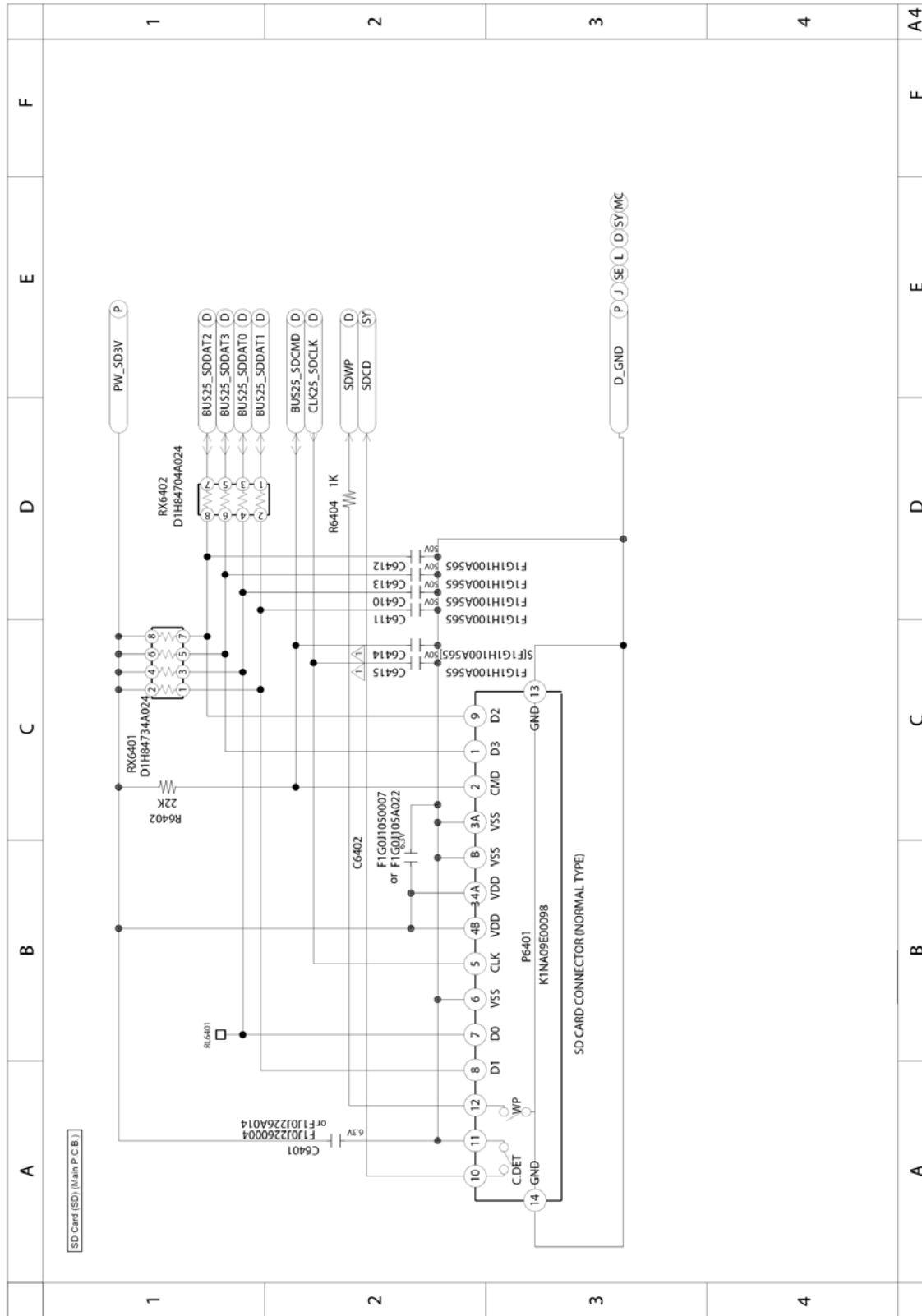

Model No. : DMC-SZ1/SZ02 System Driver (SY) (Main P.C.B.)

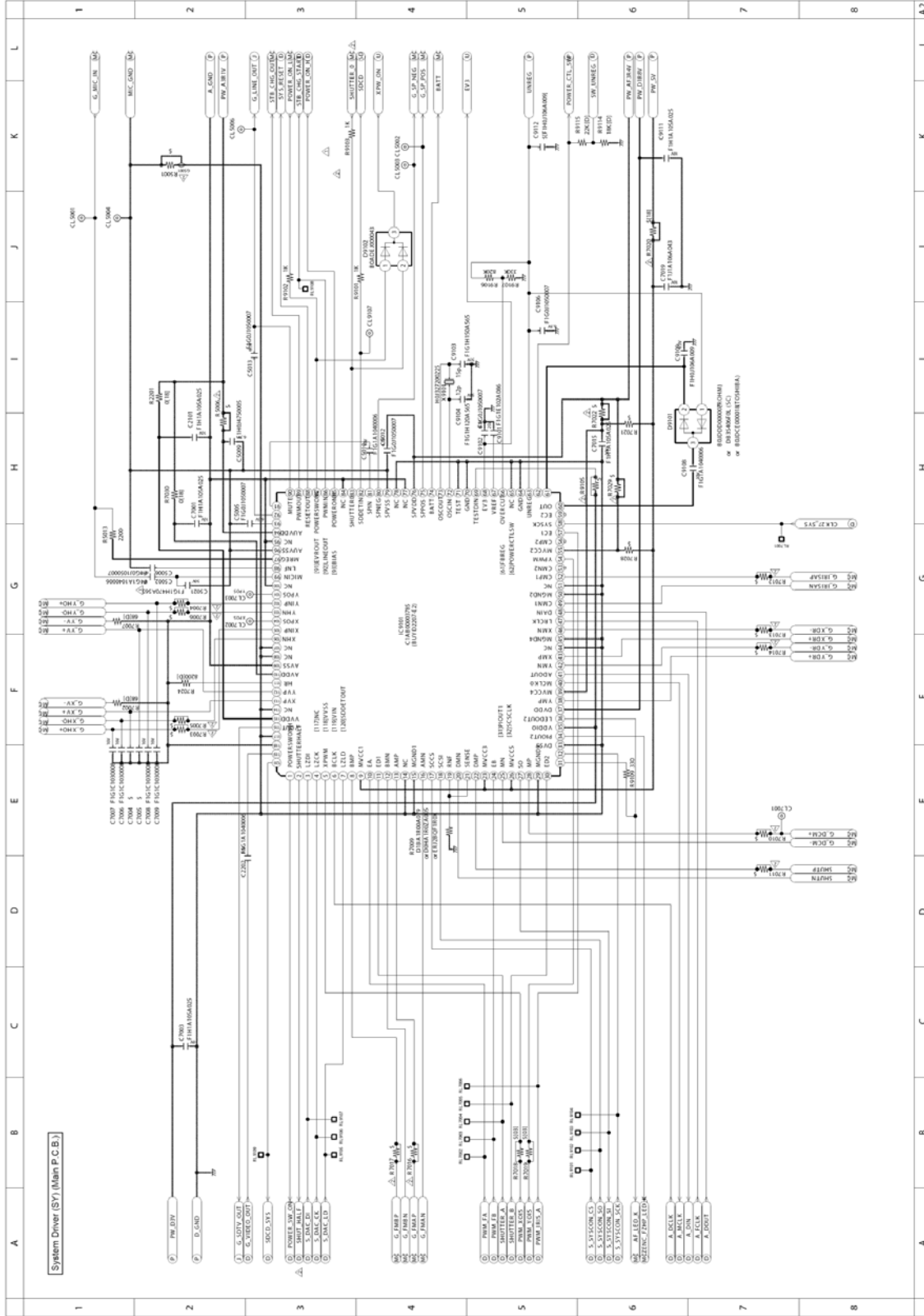

Model No. : DMC-SZ1/SZ02 Main Connection (MC) (Main P.C.B.)

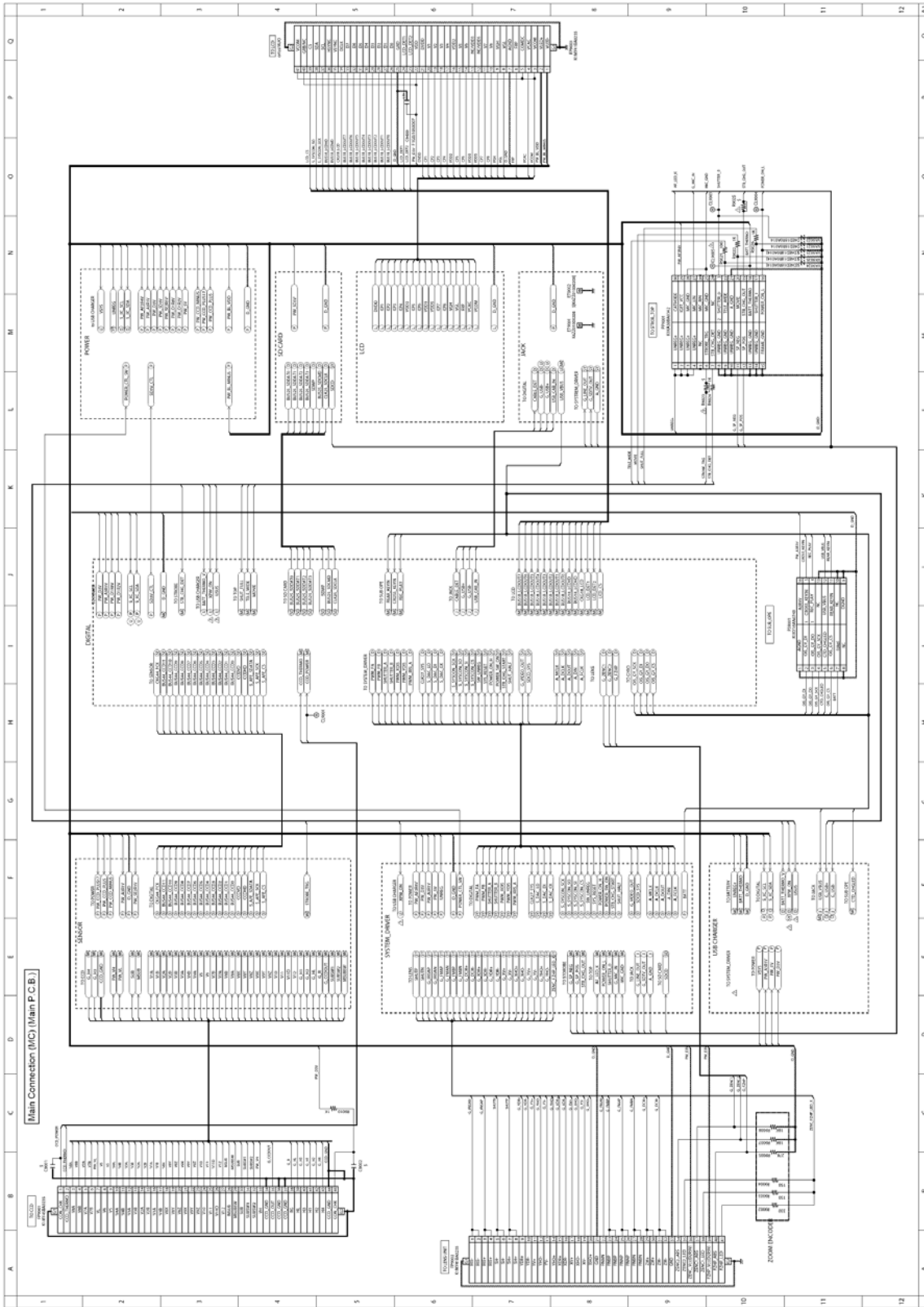

Model No. : DMC-SZ1/SZ02 Sub Operation (R) (Sub Operation P.C.B.)

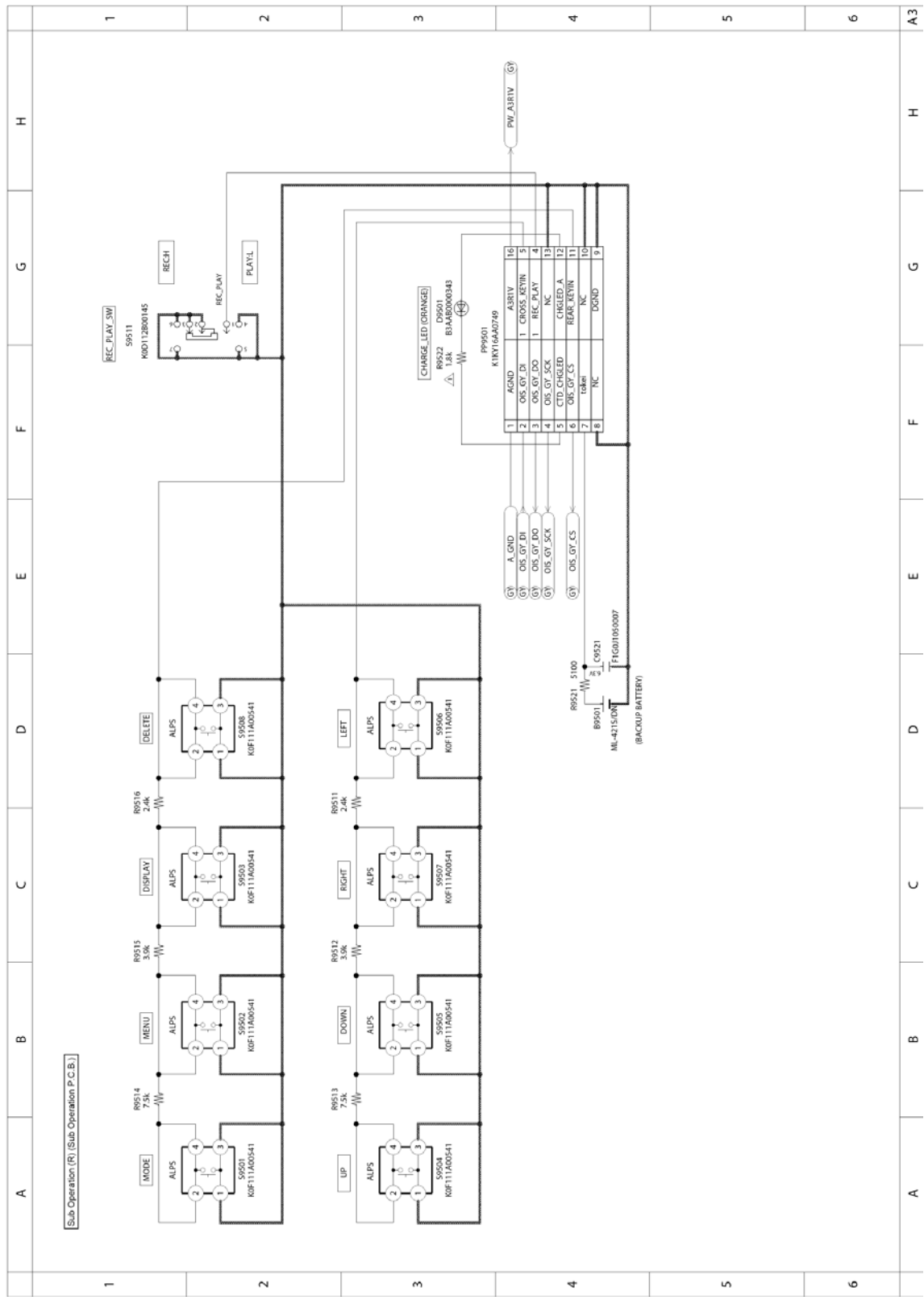

Model No. : DMC-SZ1/SZ02 Flash Top (Flash Top P.C.B.)

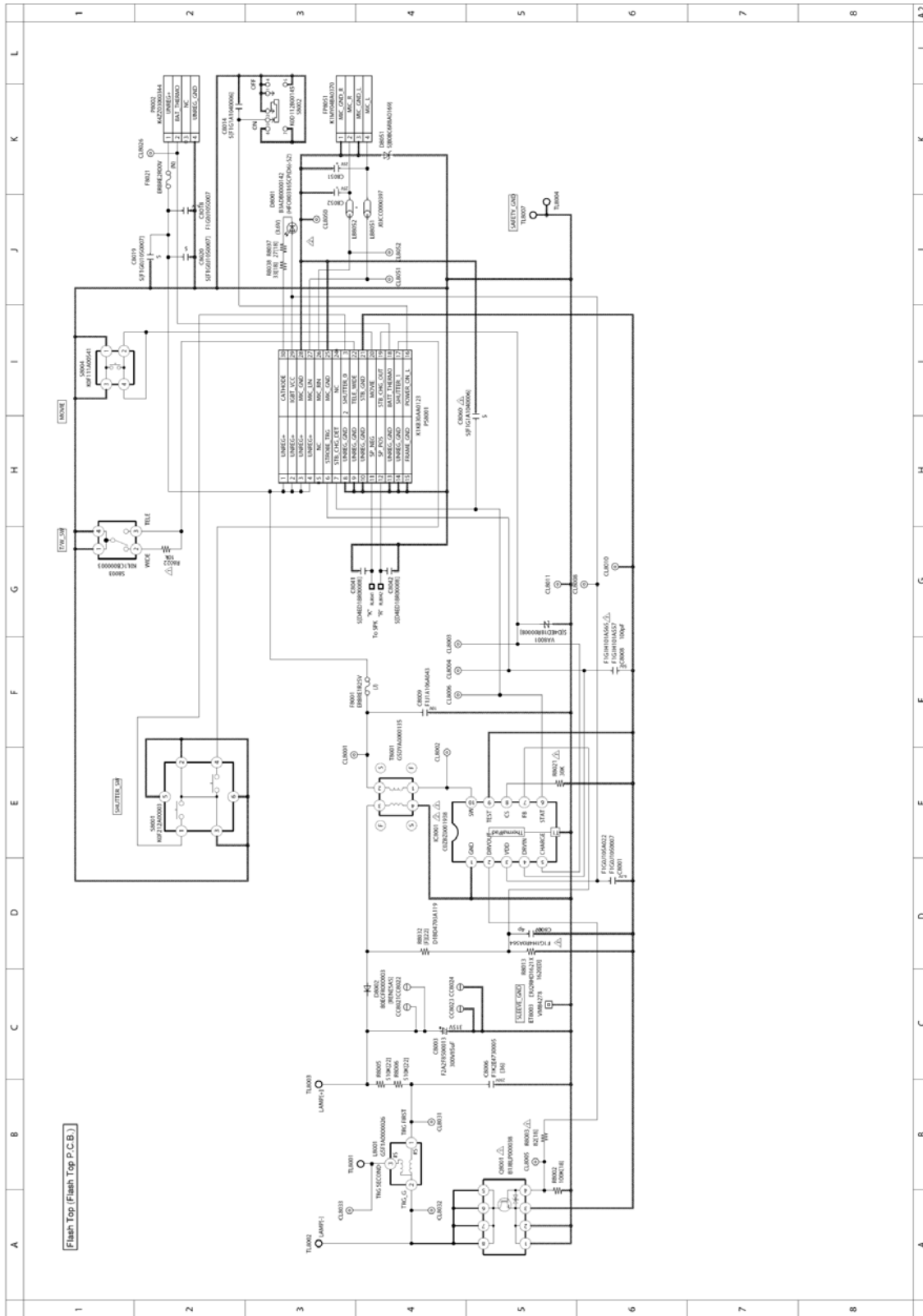

Model No. : DMC-SZ1/SZ02 CCD (CCD Flex P.C.B.)

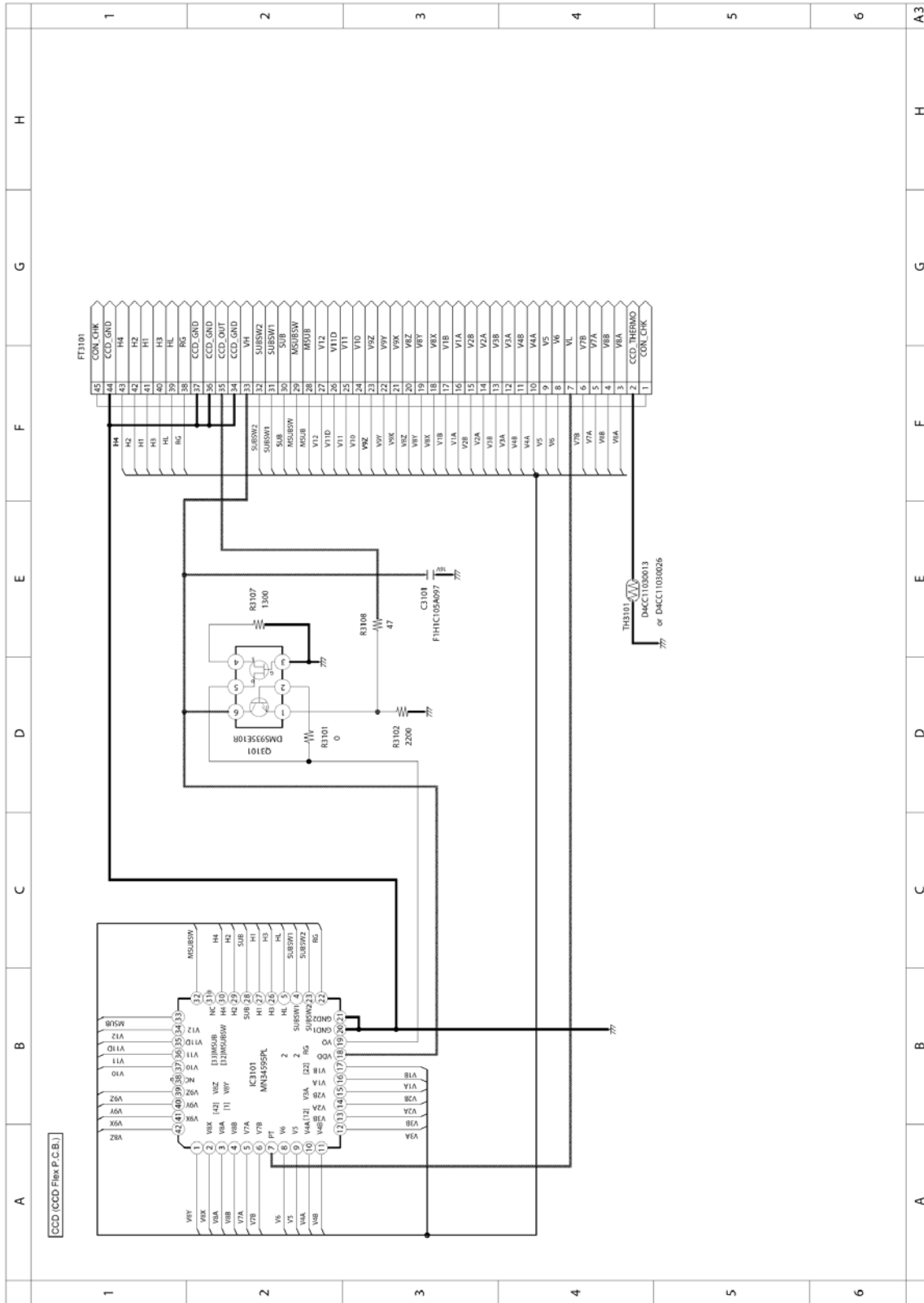

[CCD (CCD Flex P.C.B.)]

A B C D E F G H A3
1 2 3 4 5 6

Lens Flex (Lens Flex P.C.B.)

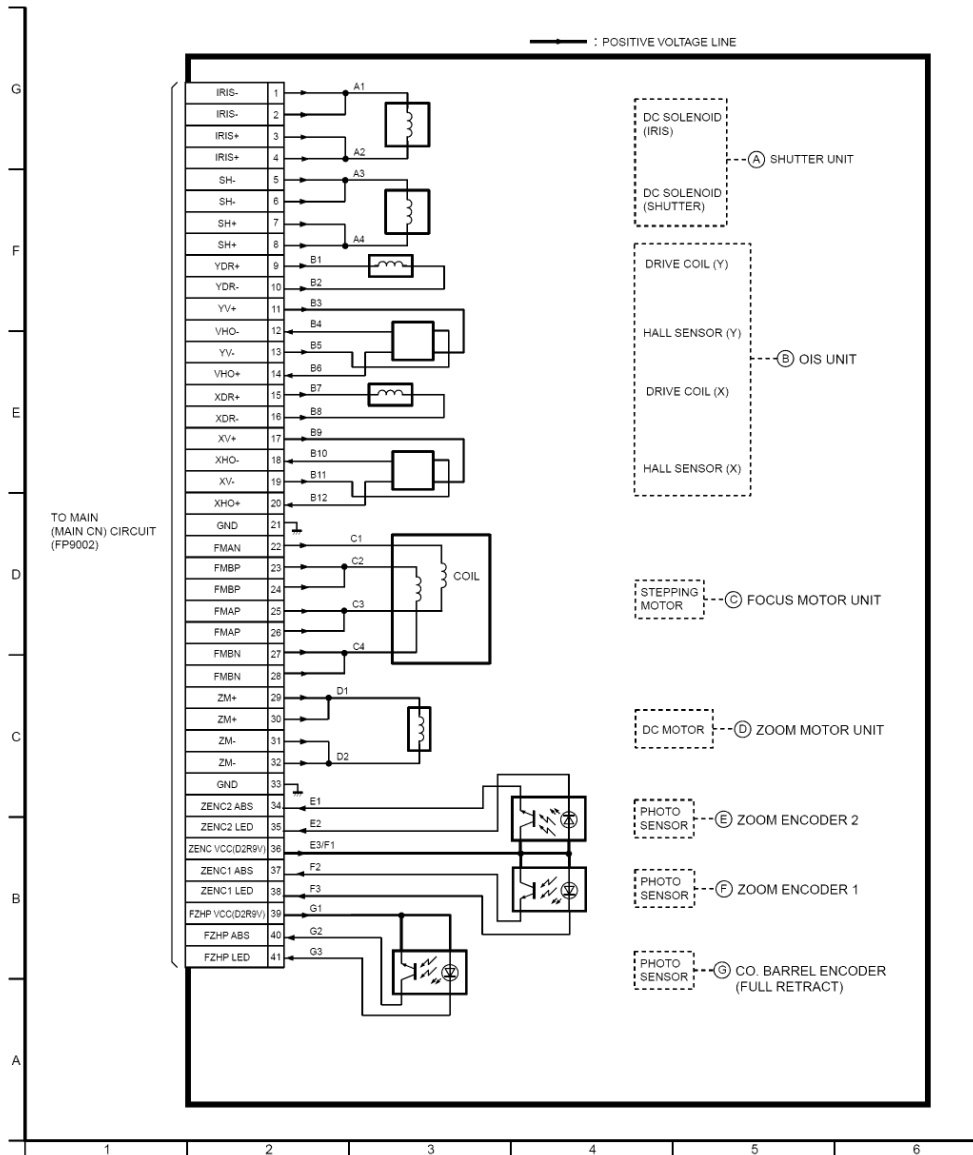

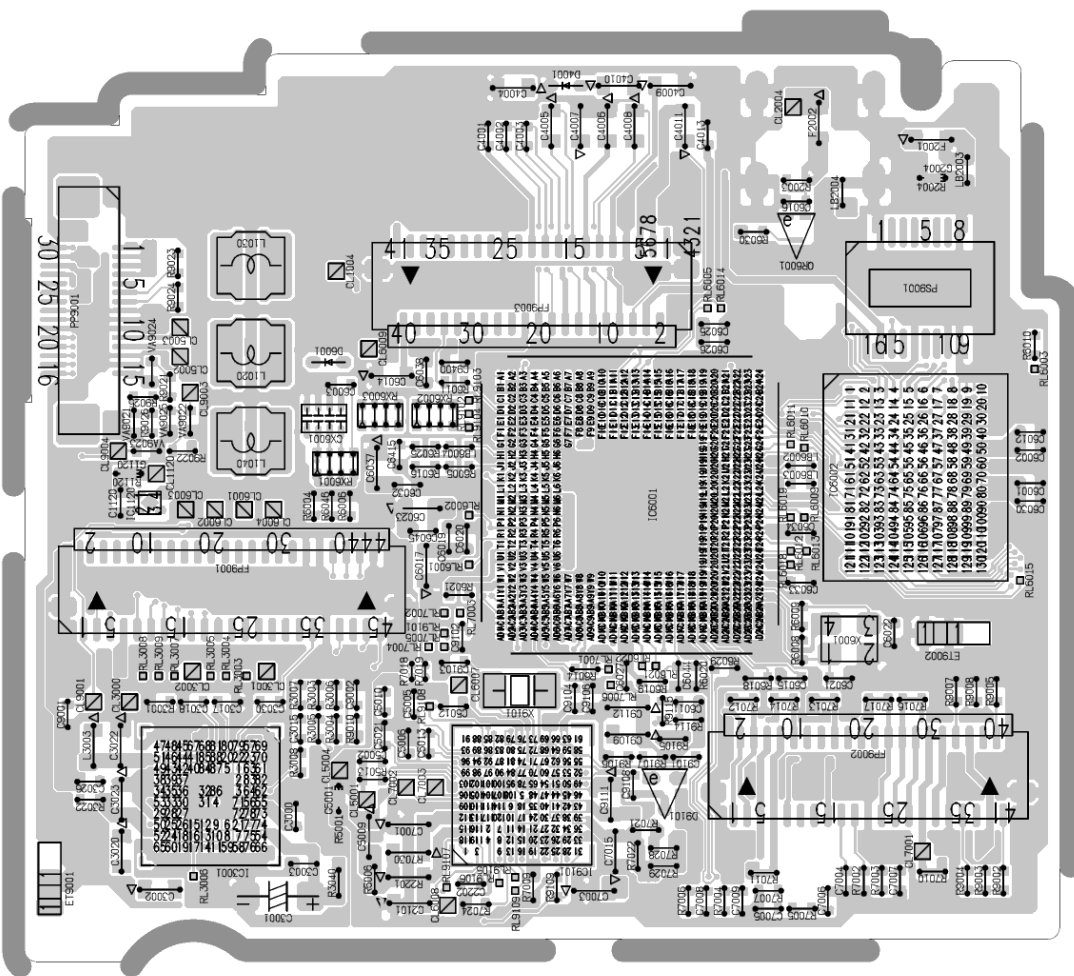

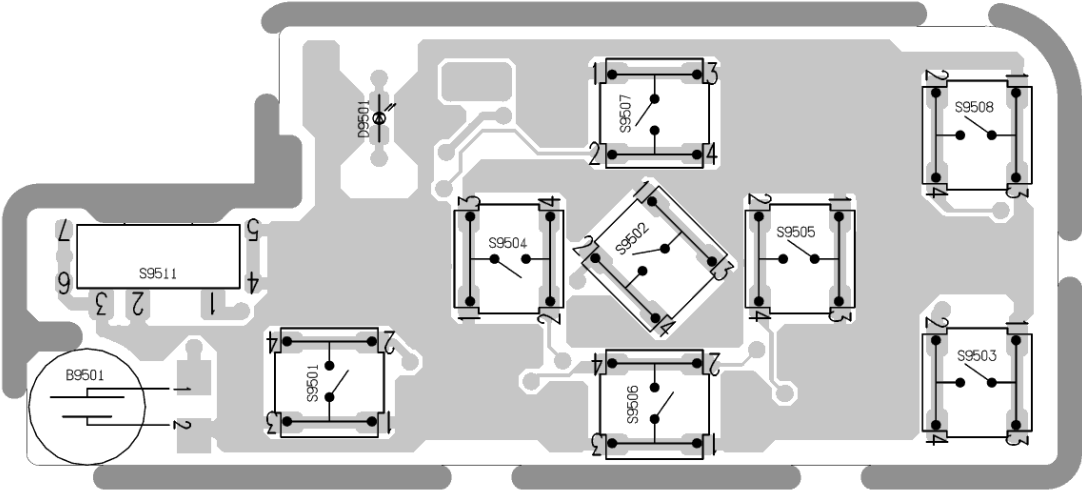

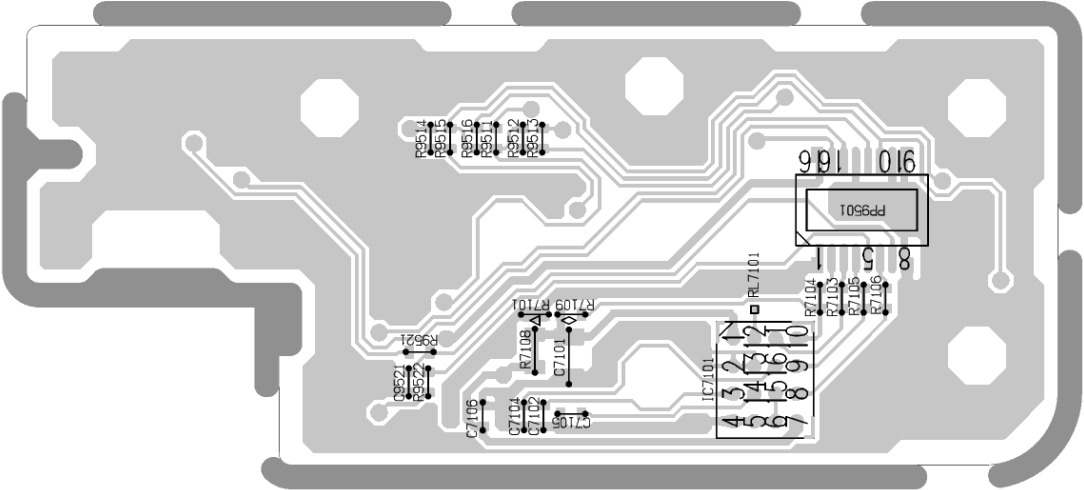

Model No. : DMC-SZ1/SZ02 Flash Top P.C.B. (Component Side)

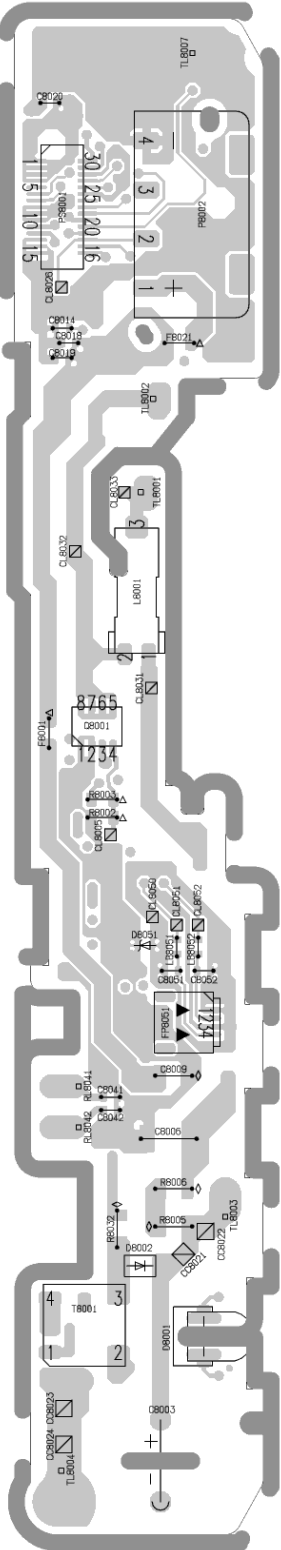

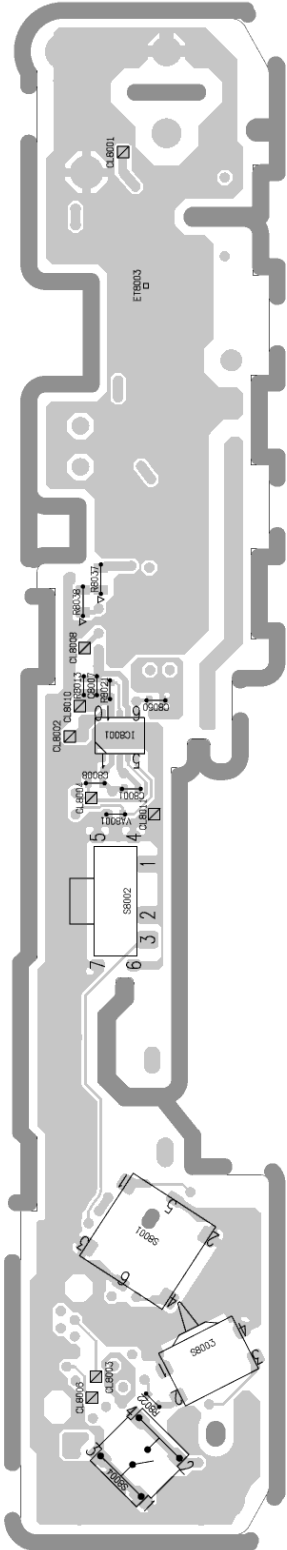

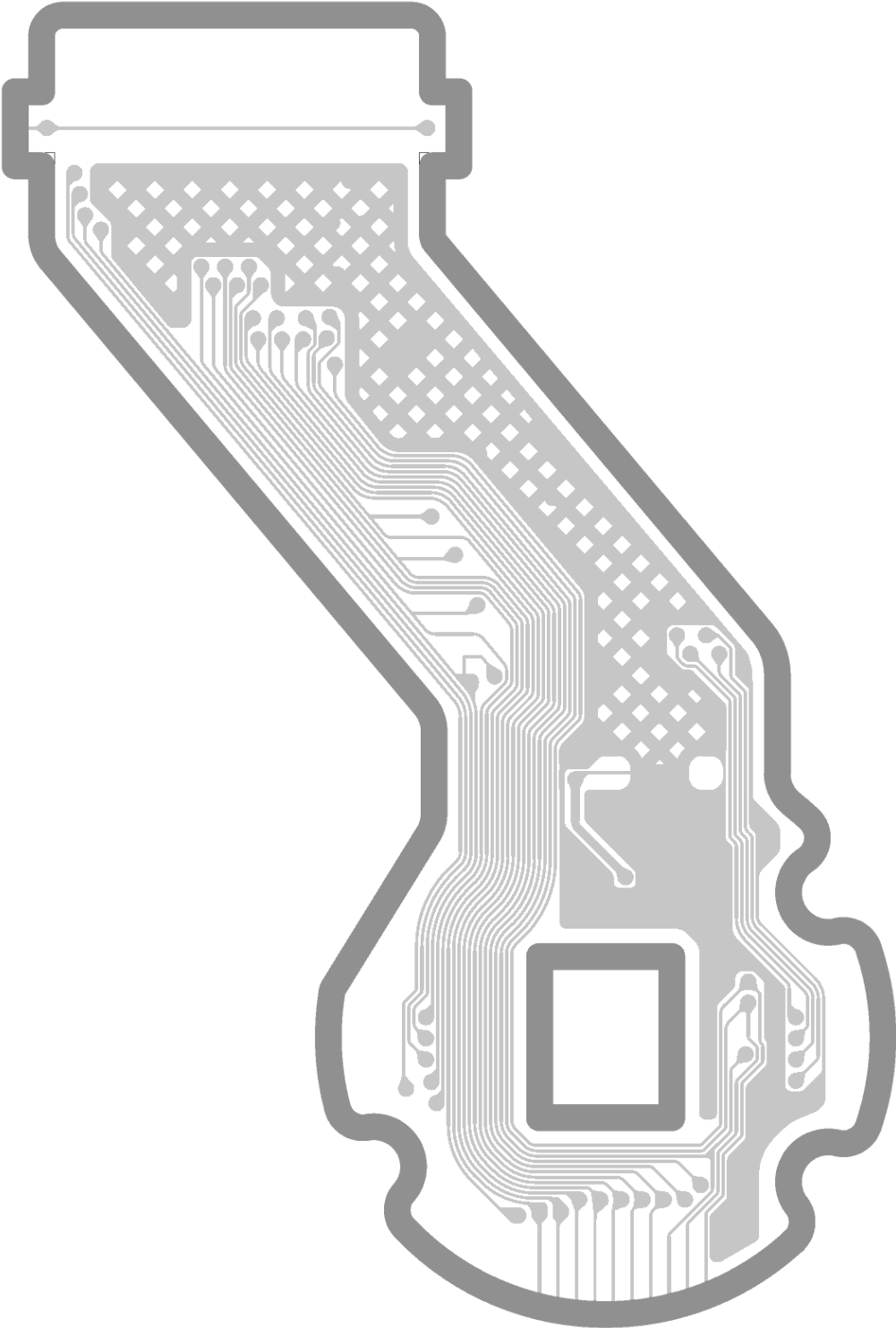

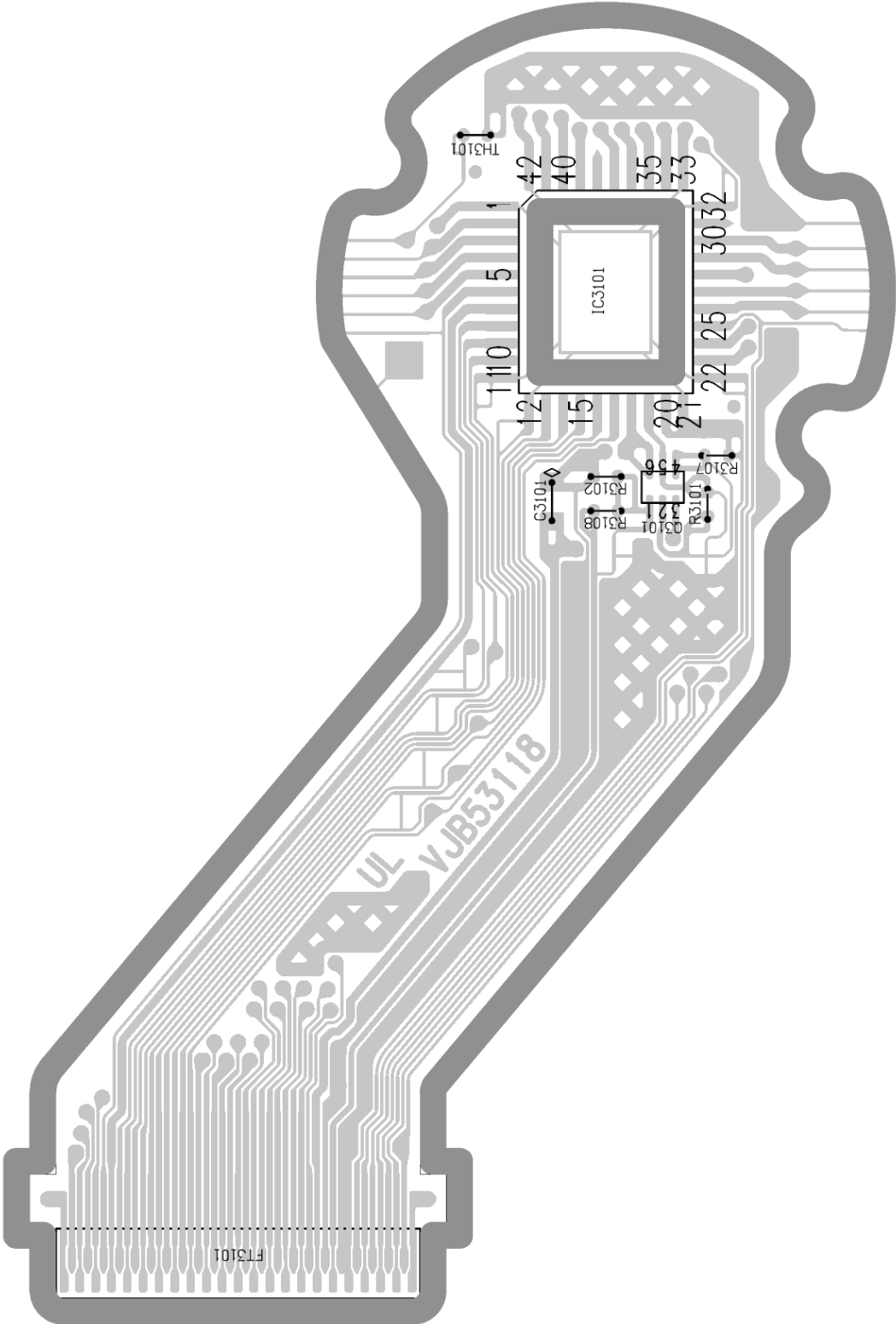

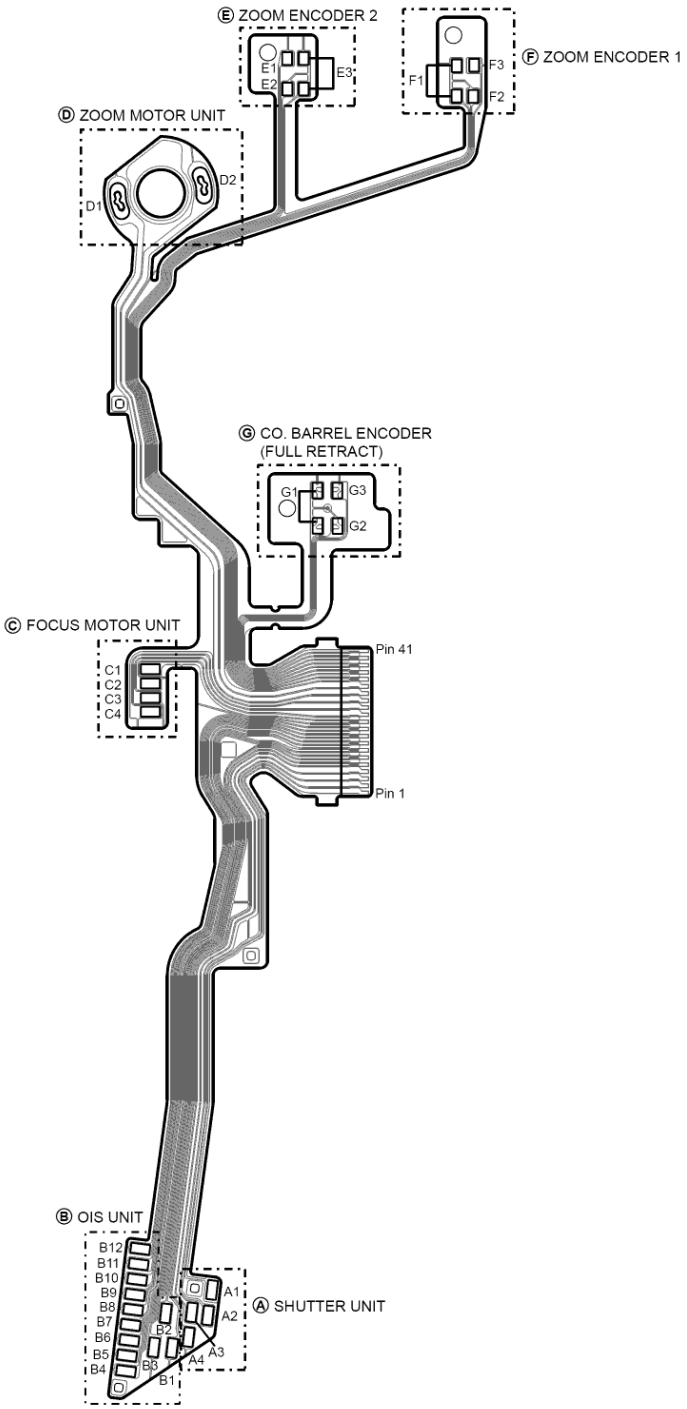





Model No. : DMC-SZ1/SZ02 Parts List

Safety	Ref. No.	Part No.	Part Name & Description	Q'ty	Remarks
	C1001	FLJ1A106A024	C.CAPACITOR CH 10V 10U	1	
	C1002	FLJ1A106A024	C.CAPACITOR CH 10V 10U	1	
	C1004	FLH1A105A025	C.CAPACITOR CH 10V 1U	1	
	C1010	FLJ1A106A024	C.CAPACITOR CH 10V 10U	1	
	C1020	FLJ1A106A024	C.CAPACITOR CH 10V 10U	1	
	C1030	FLJ1A106A024	C.CAPACITOR CH 10V 10U	1	
	C1040	FLJ1A106A024	C.CAPACITOR CH 10V 10U	1	
	C1050	FLJ1C106A059	C.CAPACITOR CH 16V 10U	1	
	C1051	FLG1H122A416	C.CAPACITOR CH 50V 1200P	1	
	C1052	FLG1A1040006	C.CAPACITOR CH 10V 0.1U	1	
	C1060	FLJ1C475A059	C.CAPACITOR CH 16V 4.7U	1	
	C1070	FLJ1E4750002	C.CAPACITOR CH 25V 4.7U	1	
	C1110	FLH1A225A051	C.CAPACITOR CH 10V 2.2U	1	
	C1120	FLG0J1050007	C.CAPACITOR CH 6.3V 1U	1	
	C1220	FLG0J1050007	C.CAPACITOR CH 6.3V 1U	1	
	C1221	FLG0J1050007	C.CAPACITOR CH 6.3V 1U	1	
	C1501	FLJ1A106A024	C.CAPACITOR CH 10V 10U	1	
	C1502	FLH1A4750001	C.CAPACITOR CH 10V 4.7U	1	
	C1503	FLH1A4750001	C.CAPACITOR CH 10V 4.7U	1	
	C1504	FLH1A105A025	C.CAPACITOR CH 10V 1U	1	
	C1505	FLG1H1020008	C.CAPACITOR CH 50V 1000P	1	
	C1506	FLG0J1050007	C.CAPACITOR CH 6.3V 1U	1	
	C1507	FLG0J1050007	C.CAPACITOR CH 6.3V 1U	1	
	C2101	FLH1A105A025	C.CAPACITOR CH 10V 1U	1	
	C2202	FLG1A1040006	C.CAPACITOR CH 10V 0.1U	1	
	C3000	FLG1A1040006	C.CAPACITOR CH 10V 0.1U	1	
	C3001	F3Z0E1070001	CHIP CAPACITOR	1	
	C3002	FLH1E105A116	C.CAPACITOR CH 25V 1U	1	
	C3003	FLG1A1040006	C.CAPACITOR CH 10V 0.1U	1	
	C3004	FLJ1A106A024	C.CAPACITOR CH 10V 10U	1	
	C3005	FLJ1A106A043	C.CAPACITOR CH 10V 10U	1	
	C3006	FLH0J1050013	C.CAPACITOR CH 6.3V 1U	1	
	C3013	FLG1A1040006	C.CAPACITOR CH 10V 0.1U	1	
	C3014	FLJ1A106A043	C.CAPACITOR CH 10V 10U	1	
	C3015	FLG1C1030008	C.CAPACITOR CH 16V 0.01U	1	
	C3017	FLG1A1040006	C.CAPACITOR CH 10V 0.1U	1	
	C3018	FLG1A1040006	C.CAPACITOR CH 10V 0.1U	1	
	C3020	FLH1H104A913	C.CAPACITOR CH 50V 0.1U	1	
	C3022	FLH1C105A097	C.CAPACITOR CH 16V 1U	1	
	C3023	FLH1H104A913	C.CAPACITOR CH 50V 0.1U	1	
	C3026	FLG0J1050007	C.CAPACITOR CH 6.3V 1U	1	
	C3029	FLG0J1050007	C.CAPACITOR CH 6.3V 1U	1	
	C3030	FLG1C104A077	C.CAPACITOR CH 16V 0.1U	1	
	C3101	FLH1C105A097	C.CAPACITOR CH 16V 1U	1	
	C4001	FLG0J1050007	C.CAPACITOR CH 6.3V 1U	1	
	C4002	FLG0J1050007	C.CAPACITOR CH 6.3V 1U	1	
	C4003	FLG0J1050007	C.CAPACITOR CH 6.3V 1U	1	
	C4004	FLH1A105A025	C.CAPACITOR CH 10V 1U	1	
	C4005	FLH1A105A025	C.CAPACITOR CH 10V 1U	1	
	C4006	FLH1A105A025	C.CAPACITOR CH 10V 1U	1	
	C4007	FLH1C105A097	C.CAPACITOR CH 16V 1U	1	
	C4008	FLH1C105A097	C.CAPACITOR CH 16V 1U	1	
	C4009	FLH1E105A144	C.CAPACITOR CH 25V 1U	1	
	C4010	FLH1C105A097	C.CAPACITOR CH 16V 1U	1	
	C4011	FLH1A4750004	C.CAPACITOR CH 10V 4.7U	1	
	C4013	FLG0J1050007	C.CAPACITOR CH 6.3V 1U	1	
	C5002	FLG1A1040006	C.CAPACITOR CH 10V 0.1U	1	
	C5005	FLG0J1050007	C.CAPACITOR CH 6.3V 1U	1	
	C5006	FLG0J1050007	C.CAPACITOR CH 6.3V 1U	1	
	C5009	FLH0J4750005	C.CAPACITOR CH 6.3V 4.7U	1	
	C5010	FLG1A1040006	C.CAPACITOR CH 10V 0.1U	1	
	C5012	FLG0J1050007	C.CAPACITOR CH 6.3V 1U	1	

Model No. : DMC-SZ1/SZ02 Parts List

Safety	Ref. No.	Part No.	Part Name & Description	Q'ty	Remarks
	C5013	F1G0J1050007	C.CAPACITOR CH 6.3V 1U	1	
	C5021	F1G1H470A565	C.CAPACITOR CH 50V 47P	1	
	C6001	F1G1A1040006	C.CAPACITOR CH 10V 0.1U	1	
	C6002	F1G1A1040006	C.CAPACITOR CH 10V 0.1U	1	
	C6003	F1G1C1030008	C.CAPACITOR CH 16V 0.01U	1	
	C6011	F1G1C1030008	C.CAPACITOR CH 16V 0.01U	1	
	C6012	F1G0J1050007	C.CAPACITOR CH 6.3V 1U	1	
	C6014	F1H0J106A009	C.CAPACITOR CH 6.3V 10U	1	
	C6015	F1G0J1050007	C.CAPACITOR CH 6.3V 1U	1	
	C6016	F1G0J1050007	C.CAPACITOR CH 6.3V 1U	1	
	C6017	F1H0J1060009	C.CAPACITOR CH 6.3V 10U	1	
	C6019	F1G0J1050007	C.CAPACITOR CH 6.3V 1U	1	
	C6020	F1G1A1040006	C.CAPACITOR CH 10V 0.1U	1	
	C6021	F1G1H100A565	C.CAPACITOR CH 50V 10P	1	
	C6022	F1G1H100A565	C.CAPACITOR CH 50V 10P	1	
	C6023	F1H0J106A009	C.CAPACITOR CH 6.3V 10U	1	
	C6025	F1G0J1050007	C.CAPACITOR CH 6.3V 1U	1	
	C6026	F1G1A1040006	C.CAPACITOR CH 10V 0.1U	1	
	C6027	F1G1A1040006	C.CAPACITOR CH 10V 0.1U	1	
	C6030	F1G0J1050007	C.CAPACITOR CH 6.3V 1U	1	
	C6032	F1G0J1050007	C.CAPACITOR CH 6.3V 1U	1	
	C6033	F1G0J1050007	C.CAPACITOR CH 6.3V 1U	1	
	C6034	F1G0J1050007	C.CAPACITOR CH 6.3V 1U	1	
	C6037	F1H0J1060009	C.CAPACITOR CH 6.3V 10U	1	
	C6038	F1G0J1050007	C.CAPACITOR CH 6.3V 1U	1	
	C6044	F1G1A1040006	C.CAPACITOR CH 10V 0.1U	1	
	C6045	F1G1A1040006	C.CAPACITOR CH 10V 0.1U	1	
	C6401	F1J0J2260004	C.CAPACITOR CH 6.3V 22U	1	
	C6402	F1G0J1050007	C.CAPACITOR CH 6.3V 1U	1	
	C6410	F1G1H100A565	C.CAPACITOR CH 50V 10P	1	
	C6411	F1G1H100A565	C.CAPACITOR CH 50V 10P	1	
	C6412	F1G1H100A565	C.CAPACITOR CH 50V 10P	1	
	C6413	F1G1H100A565	C.CAPACITOR CH 50V 10P	1	
	C6415	F1G1H100A565	C.CAPACITOR CH 50V 10P	1	
	C7001	F1H1A105A025	C.CAPACITOR CH 10V 1U	1	
	C7003	F1H1A105A025	C.CAPACITOR CH 10V 1U	1	
	C7006	F1G1C1030008	C.CAPACITOR CH 16V 0.01U	1	
	C7007	F1G1C1030008	C.CAPACITOR CH 16V 0.01U	1	
	C7008	F1G1C1030008	C.CAPACITOR CH 16V 0.01U	1	
	C7009	F1G1C1030008	C.CAPACITOR CH 16V 0.01U	1	
	C7015	F1H1A105A025	C.CAPACITOR CH 10V 1U	1	
	C7019	F1J1A106A043	C.CAPACITOR CH 10V 10U	1	
	C7101	F1J0J1060009	C.CAPACITOR CH 6.3V 10U	1	
	C7102	F1G1A1040006	C.CAPACITOR CH 10V 0.1U	1	
	C7104	F1G1A1040006	C.CAPACITOR CH 10V 0.1U	1	
	C7105	F1G1A1040006	C.CAPACITOR CH 10V 0.1U	1	
	C7106	F1G1A1040006	C.CAPACITOR CH 10V 0.1U	1	
	C8001	F1G0J1050007	C.CAPACITOR CH 6.3V 1U	1	
	C8006	F1K2E4730005	C.CAPACITOR 250V 0.047U	1	
	C8007	F1G1H220A557	C.CAPACITOR CH 50V 22P	1	
	C8009	F1J1A106A043	C.CAPACITOR CH 10V 10U	1	
	C8018	F1G0J1050007	C.CAPACITOR CH 6.3V 1U	1	
	C9101	F1G1E102A086	C.CAPACITOR CH 25V 1000P	1	
	C9102	F1G0J1050007	C.CAPACITOR CH 6.3V 1U	1	
	C9103	F1G1H150A565	C.CAPACITOR CH 50V 15P	1	
	C9104	F1G1H120A565	C.CAPACITOR CH 50V 12P	1	
	C9106	F1G0J1050007	C.CAPACITOR CH 6.3V 1U	1	
	C9108	F1G1A1040006	C.CAPACITOR CH 10V 0.1U	1	
	C9109	F1H0J106A009	C.CAPACITOR CH 6.3V 10U	1	
	C9111	F1H1A105A025	C.CAPACITOR CH 10V 1U	1	
	C9400	F1G0J1050007	C.CAPACITOR CH 6.3V 1U	1	
	C9521	F1G0J1050007	C.CAPACITOR CH 6.3V 1U	1	

Model No. : DMC-SZ1/SZ02 Parts List

Safety	Ref. No.	Part No.	Part Name & Description	Q'ty	Remarks
	CX6001	F5A84103A020	CAPACITOR NETWORKS	1	
	D1050	B0JCF0000003	DIODE	1	E.S.D.
	D1060	B0JCF0000003	DIODE	1	E.S.D.
	D1070	B0JCF0000003	DIODE	1	E.S.D.
	D1110	B0JCF0000003	DIODE	1	E.S.D.
	D1501	B0JCF0000003	DIODE	1	E.S.D.
	D3001	DA2S10100L	DIODE	1	E.S.D.
	D4001	DB2S31100L	DIODE	1	E.S.D.
	D6001	DA2S10100L	DIODE	1	E.S.D.
	D8001	B3ADB0000142	DIODE	1	E.S.D.
	D8002	B0ECFR000003	DIODE	1	E.S.D.
	D9101	DB3S406F0L	DIODE	1	E.S.D.
	D9102	B0ADEJ000054	DIODE	1	E.S.D.
	D9501	B3AAB0000343	LED	1	E.S.D.
	ET9001	K4ZZ01000208	EARTH TERMINAL	1	
	ET9002	K4ZZ01000208	EARTH TERMINAL	1	
	F2001	K5H1522A0018	FUSE 32V 1.5A	1	
	F2002	K5H202Y00007	FUSES	1	
	F8001	ERBRE1R25V	FUSE 32V 1.25A	1	
	F8021	ERBRE2R00V	FUSE	1	
	FP8051	K1MY04BA0370	CONNECTOR 4P	1	
	FP9001	K1MY45BA0235	CONNECTOR 45P	1	
	FP9002	K1MY41BA0235	CONNECTOR 41P	1	
	FP9003	K1MY41BA0235	CONNECTOR 41P	1	
	IC1001	C1ZBZ0004597	IC	1	E.S.D.
	IC1110	C0DBGYY00779	IC	1	E.S.D.
	IC1120	C0DBGYY01180	IC	1	E.S.D.
	IC1220	C0DBGYY02557	IC	1	E.S.D.
	IC1501	C1ZBZ0004582	IC	1	E.S.D.
	IC1502	C1CB00003709	IC	1	E.S.D.
	IC3001	C1AB00003797	IC	1	E.S.D.
	IC3003	C0DBGYY00779	IC	1	E.S.D.
	IC6001	MN89513	IC	1	E.S.D.
	IC6002	RS10310	IC	1	E.S.D.
	IC7101	EWTS9PSL1A	IC	1	[SPC], E.S.D.
	IC8001	C0ZBZ0001710	IC	1	E.S.D.
	IC9101	C1AB00003785	IC	1	E.S.D.
	JK2001	K1FB108E0008	JACK, AV/USB	1	
	L1010	G1C100KA0148	CHIP INDUCTOR 10UH	1	
	L1020	G1C3R3MA0392	CHIP INDUCTOR 3.3UH	1	
	L1030	G1C3R3MA0392	CHIP INDUCTOR 3.3UH	1	
	L1040	G1C4R7MA0392	CHIP INDUCTOR 4.7UH	1	
	L1050	G1C3R3MA0478	CHIP INDUCTOR 3.3UH	1	
	L1060	G1C4R7MA0478	CHIP INDUCTOR 4.7UH	1	
	L1070	G1C6R8MA0392	CHIP INDUCTOR 6.8UH	1	
	L1501	G1C4R7MA0428	CHIP INDUCTOR 4.7UH	1	
	L2001	J0ZZB0000142	FILTER	1	
	L3003	G1C100MA0410	CHIP INDUCTOR 10UH	1	
	L3004	G1C100KA0115	CHIP INDUCTOR 10UH	1	
	L8001	G5F1A0000026	CHIP INDUCTOR	1	
	LB2001	J0JCC0000415	FILTER	1	
	LB2002	J0JCC0000415	FILTER	1	
	LB2003	J0JCC0000415	FILTER	1	
	LB2004	J0JCC0000415	FILTER	1	
	LB6002	J0JCC0000412	FILTER	1	
	LB6003	J0JCC0000412	FILTER	1	
	LB6004	J0JCC0000317	FILTER	1	
	LB8051	J0JCC0000397	FILTER	1	
	P6401	K1NA09E00098	SD CARD CONNECTOR	1	
	P8002	K4ZZ03000344	OTHER TERMINALS	1	
	PP9001	K1KA30BA0342	CONNECTOR 30P	1	
	PP9501	K1KY16AA0749	CONNECTOR 16P	1	

Model No. : DMC-SZ1/SZ02 Parts List

Safety	Ref. No.	Part No.	Part Name & Description	Q'ty	Remarks
	PS8001	K1KB30AA0123	CONNECTOR 30P	1	
	PS9001	K1KY16AA0748	CONNECTOR 16P	1	
	Q1501	FG6943010R	TRANSISTOR	1	E.S.D.
	Q3101	DMS935E10R	TRANSISTOR	1	E.S.D.
	Q8001	BJJBLP000038	TRANSISTOR	1	E.S.D.
	QR1501	DRC3114E0L	TRANSISTOR-RESISTOR	1	E.S.D.
	QR6001	B1GBCFNL0020	TRANSISTOR-RESISTOR	1	E.S.D.
	R1001	ERJ2RHD104X	M.RESISTOR CH 1/16W 100K	1	
	R1002	ERJ2RKD120X	M.RESISTOR CH 1/16W 12	1	
	R1003	J0JHC0000048	FILTER	1	
	R1051	ERJ2RKD124X	M.RESISTOR CH 1/16W 120K	1	
	R1052	ERJ2RHD203X	M.RESISTOR CH 1/16W 20K	1	
	R1054	ERJ2RHD473X	M.RESISTOR CH 1/16W 47K	1	
	R1061	ERJ2RKD244X	M.RESISTOR CH 1/16W 240K	1	
	R1062	ERJ2RHD203X	M.RESISTOR CH 1/16W 20K	1	
	R1111	DOGA101JA023	CHIP RESISTOR	1	
	R1501	ERJ2RHD103X	M.RESISTOR CH 1/16W 10K	1	
	R1502	DOGA104JA023	CHIP RESISTOR	1	
	R1503	DOGA103JA023	CHIP RESISTOR	1	
	R1504	J0JHC0000048	FILTER	1	
	R1507	DOGA104JA023	CHIP RESISTOR	1	
	R1508	DOGA472JA023	CHIP RESISTOR	1	
	R2001	DOGA750JA023	CHIP RESISTOR	1	
	R2002	DOGA561JA023	CHIP RESISTOR	1	
	R2003	DOGA102JA023	CHIP RESISTOR	1	
	R2005	DOGA102JA023	CHIP RESISTOR	1	
	R2201	D0GBR00J0004	CHIP RESISTOR	1	
	R3101	ERJ2GE0R00X	M.RESISTOR CH 1/10W 0	1	
	R3102	ERJ2GEJ222X	M.RESISTOR CH 1/16W 2.2K	1	
	R3107	ERJ2GEJ132X	M.RESISTOR CH 1/16W 1.3K	1	
	R3108	ERJ2GEJ470X	M.RESISTOR CH 1/16W 47	1	
	R5013	ERJ2GEJ222X	M.RESISTOR CH 1/16W 2.2K	1	
	R6001	DOGA472JA023	CHIP RESISTOR	1	
	R6004	DOGA103JA023	CHIP RESISTOR	1	
	R6005	DOGA330JA023	CHIP RESISTOR	1	
	R6006	ERJ2RKF5901X	M.RESISTOR CH 1/16W 5.9K	1	
	R6008	DOGA105JA023	CHIP RESISTOR	1	
	R6009	DOGA681JA023	CHIP RESISTOR	1	
	R6010	DOGA103JA023	CHIP RESISTOR	1	
	R6011	DOGA101JA023	CHIP RESISTOR	1	
	R6014	DOGA330JA023	CHIP RESISTOR	1	
	R6017	DOGA472JA023	CHIP RESISTOR	1	
	R6018	ERJ2RKF1183X	M.RESISTOR CH 1/16W 118K	1	
	R6019	ERJ2RHD222X	M.RESISTOR CH 1/16W 2.2K	1	
	R6020	ERJ2RHD122X	M.RESISTOR CH 1/16W 1.2K	1	
	R6021	DOGA473JA023	CHIP RESISTOR	1	
	R6025	DOGA101JA023	CHIP RESISTOR	1	
	R6029	ERJ2RHD561X	M.RESISTOR CH 1/16W 560	1	
	R6030	DOGA104JA023	CHIP RESISTOR	1	
	R6402	DOGA223JA023	CHIP RESISTOR	1	
	R6404	DOGA102JA023	CHIP RESISTOR	1	
	R7002	ERJ2RKD680X	M.RESISTOR CH 1/16W 68	1	
	R7007	ERJ2RKD680X	M.RESISTOR CH 1/16W 68	1	
	R7009	D1BA1R00A079	CHIP RESISTOR	1	
	R7024	ERJ2RHD822X	M.RESISTOR CH 1/16W 8.2K	1	
	R7030	D0GBR00J0004	CHIP RESISTOR	1	
	R7109	DOGA473JA023	CHIP RESISTOR	1	
	R8002	D0GB104JA065	CHIP RESISTOR	1	
	R8003	D0GB820JA065	CHIP RESISTOR	1	
	R8005	ERJ6GEYJ514V	M.RESISTOR CH 1/8W 510K	1	
	R8006	ERJ6GEYJ514V	M.RESISTOR CH 1/8W 510K	1	
	R8013	ERJ2RHD1621X	M.RESISTOR CH 1/16W 1620	1	

Model No. : DMC-SZ1/SZ02 Parts List

Safety	Ref. No.	Part No.	Part Name & Description	Q'ty	Remarks
	R8021	D0GA513JA023	CHIP RESISTOR	1	
	R8022	D0GA103JA023	CHIP RESISTOR	1	
	R8032	D1BD4703A119	CHIP RESISTOR	1	
	R8037	ERJ3GEYJ270V	M.RESISTOR CH 1/10W 27	1	
	R8038	D0GB330JA065	CHIP RESISTOR	1	
	R9002	D0GA331JA023	CHIP RESISTOR	1	
	R9003	D0GA151JA023	CHIP RESISTOR	1	
	R9004	D0GA151JA023	CHIP RESISTOR	1	
	R9005	D0GA273JA023	CHIP RESISTOR	1	
	R9007	D0GA183JA023	CHIP RESISTOR	1	
	R9008	D0GA183JA023	CHIP RESISTOR	1	
	R9010	D0GA102JA023	CHIP RESISTOR	1	
	R9021	D0GA101JA023	CHIP RESISTOR	1	
	R9022	D0GA102JA023	CHIP RESISTOR	1	
	R9024	D0GA102JA023	CHIP RESISTOR	1	
	R9026	D0GA102JA023	CHIP RESISTOR	1	
	R9101	D0GA102JA023	CHIP RESISTOR	1	
	R9102	D0GA102JA023	CHIP RESISTOR	1	
	R9103	D0GA102JA023	CHIP RESISTOR	1	
	R9106	ERJ2GEJ824X	M.RESISTOR CH 1/16W 820K	1	
	R9107	D0GA334JA023	CHIP RESISTOR	1	
	R9109	D0GA331JA023	CHIP RESISTOR	1	
	R9114	ERJ2RHD183X	M.RESISTOR CH 1/16W 18K	1	
	R9115	ERJ2RHD223X	M.RESISTOR CH 1/16W 22K	1	
	R9511	D0GA242JA023	CHIP RESISTOR	1	
	R9512	D0GA392JA023	CHIP RESISTOR	1	
	R9513	D0GA752JA023	CHIP RESISTOR	1	
	R9514	D0GA752JA023	CHIP RESISTOR	1	
	R9515	D0GA392JA023	CHIP RESISTOR	1	
	R9516	D0GA242JA023	CHIP RESISTOR	1	
	R9521	D0GA512JA023	CHIP RESISTOR	1	
	R9522	D0GA182JA023	CHIP RESISTOR	1	
	RX6001	D1H81034A024	RESISTOR NETWORKS	1	
	RX6002	D1H82214A024	RESISTOR NETWORKS	1	
	RX6003	D1H82214A024	RESISTOR NETWORKS	1	
	RX6401	D1H84734A024	RESISTOR NETWORKS	1	
	RX6402	D1H84704A024	RESISTOR NETWORKS	1	
	S8001	K0F212A00003	SWITCH	1	
	S8002	K0D112B00145	SWITCH	1	
	S8003	K0L1CB000003	SWITCH	1	
	S8004	K0F111A00541	SWITCH	1	
	S9501	K0F111A00541	SWITCH	1	
	S9502	K0F111A00541	SWITCH	1	
	S9503	K0F111A00541	SWITCH	1	
	S9504	K0F111A00541	SWITCH	1	
	S9505	K0F111A00541	SWITCH	1	
	S9506	K0F111A00541	SWITCH	1	
	S9507	K0F111A00541	SWITCH	1	
	S9508	K0F111A00541	SWITCH	1	
	S9511	K0D112B00145	SWITCH	1	
	T8001	G5DYA0000135	TRANSFORMER	1	
	TH3101	D4CC11030013	NTC THERMISTORS	1	
	VA9021	D4ED18R0A014	VARISTOR	1	
	VA9022	D4ED18R0A014	VARISTOR	1	
	X6001	H0J240500068	CRYSTAL OSCILLATOR	1	
	X9101	H0J327200225	CRYSTAL OSCILLATOR	1	

Model No. : DMC-SZ1/SZ02 Frame and Casing Section

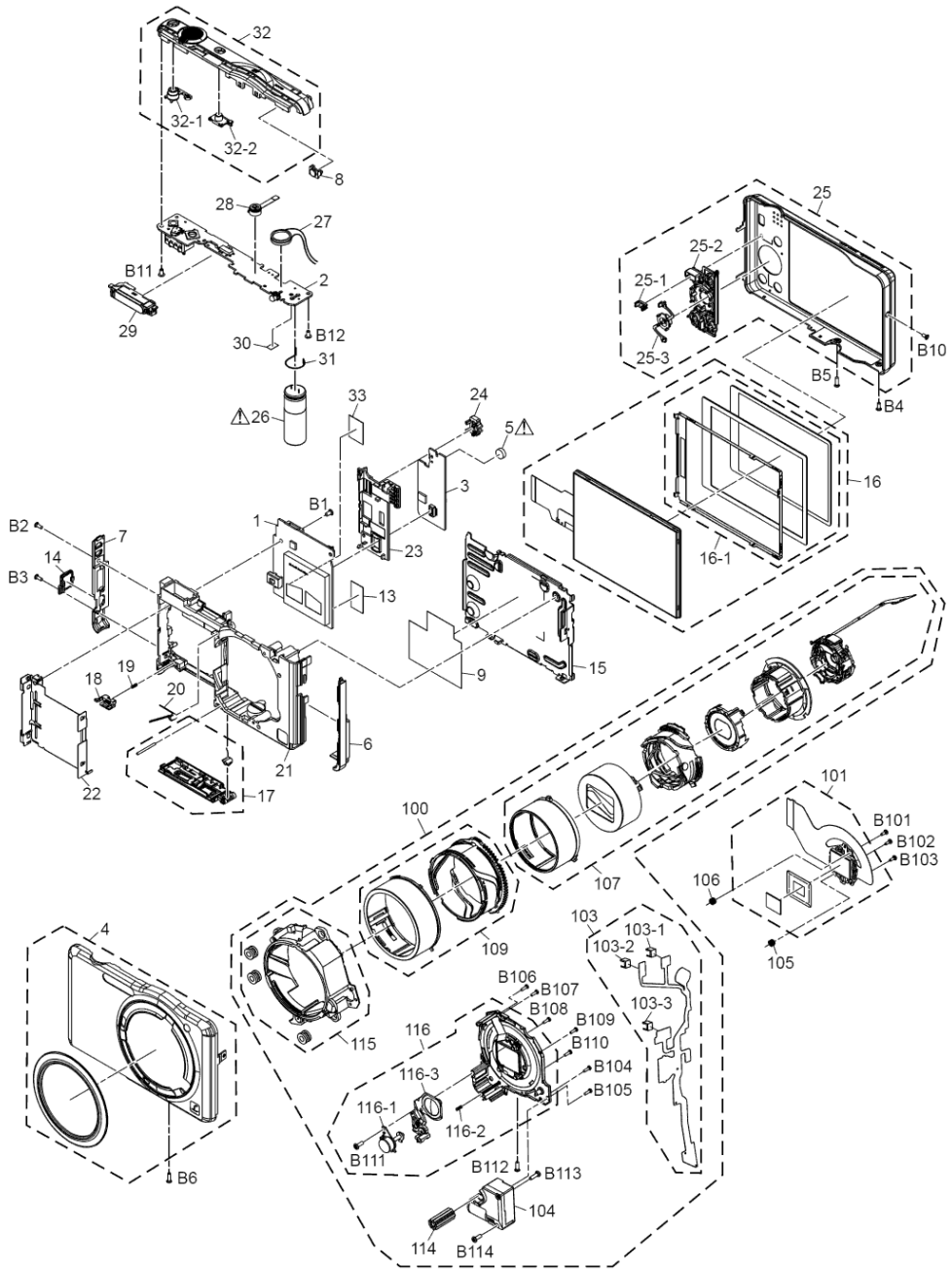

Model No. : DMC-SZ1/SZ02 Packing Parts and Accessories Section (1)

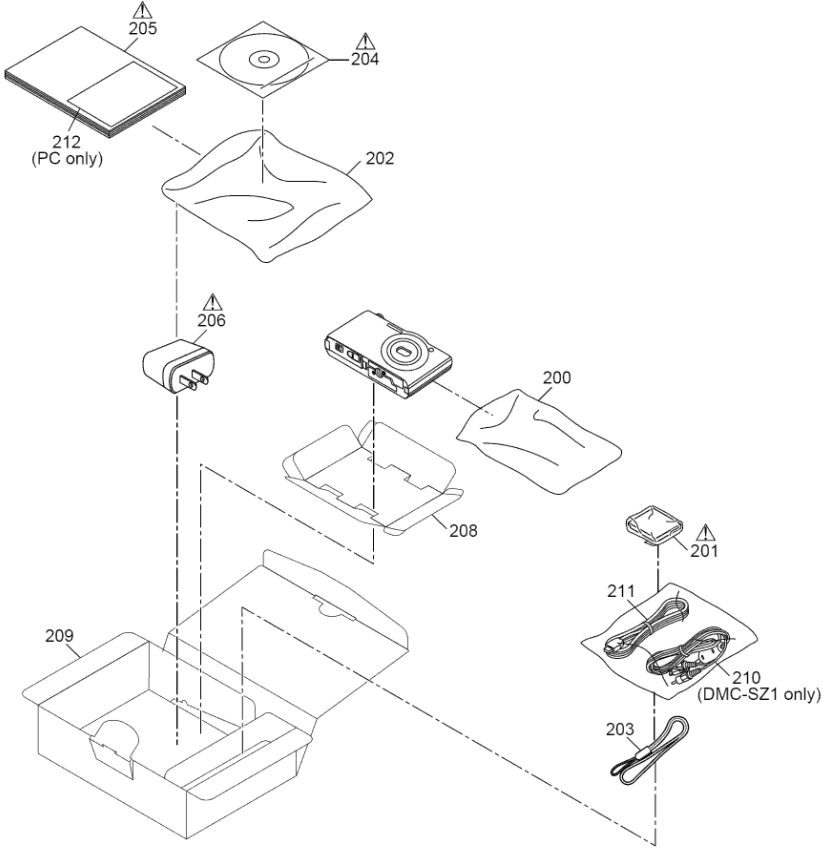

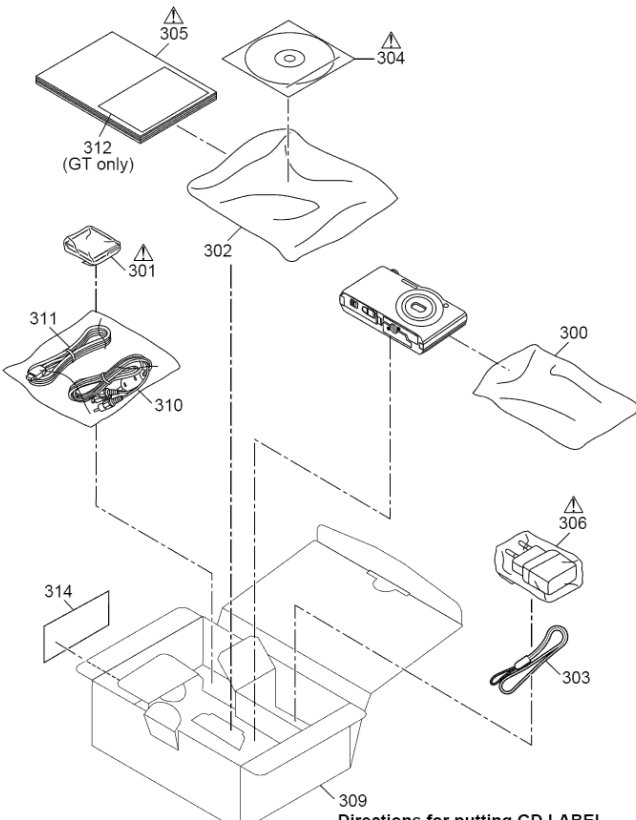

Model No. : DMC-SZ1/SZ02 Packing Parts and Accessories Section (2)









Directions for putting GD LABEL .
* Stick the GD LABEL (Ref. No.314) for [GD] mdel on the original printed place.

Model No. : DMC-SZ1/SZ02 Parts List

Safety	Ref. No.	Part No.	Part Name & Description	Q'ty	Remarks
	1	VEP56149A	MAIN P.C.B.	1	(RTL), E.S.D.
	2	VEP58166B	FLASH TOP P.C.B.	1	(RTL), E.S.D.
	3	VEP59108A	SUB OPERATION P.C.B.	1	(RTL), E.S.D.
	4	VYK5M51	FRONT CASE UNIT	1	1P-S
	4	VYK5M52	FRONT CASE UNIT	1	1P-K, 02P-K
	4	VYK5M54	FRONT CASE UNIT	1	1P-A
	4	VYK5M53	FRONT CASE UNIT	1	1P-R
	4	VYK5M32	FRONT CASE UNIT	1	1PC-K,PU-K,EG-K,EP-K,EF-K, EB-K,EE-K, GC-K, GH-K,GF-K, GA-K,GT-K,GK-K,GN-K,GD-K
	4	VYK5M17	FRONT CASE UNIT	1	1PC-A,PU-A,EG-A,EP-A,EF-A, EB-A,GF-A,GA-A,GK-A,GN-A
	4	VYK5M16	FRONT CASE UNIT	1	1PC-R,PU-R,EG-R,EP-R,EF-R, EB-R,GC-R,GH-R,GF-R,GA-R, GK-R,GN-R
	4	VYK5M15	FRONT CASE UNIT	1	1PU-S,EG-S,EP-S,EB-S,EE-S, GC-S,GH-S,GF-S,GA-S,GT-S, GK-S,GN-S
	4	VYK5S72	FRONT CASE UNIT	1	(-V)
	5	ML-421S/DN	BUTTON BATTERY	1	(B9501), [ENERGY]
	6	VGK3883	SIDE ORNAMENT(R)	1	
	7	VGK3853	SIDE ORNAMENT(L)	1	
	8	VGL1365	AF PANEL LIGHT	1	
	9	VGQ1C32	PLATE SHEET	1	
	13	VGQ1D49	FPC TAPE	1	
	14	VKF5093	JACK DOOR	1	
	15	VMP0B91	FRAME PLATE	1	
	16	VYK5M97	LCD UNIT	1	
	16-1	VYQ7890	LCD PANEL UNIT	1	
	17	VYK5M22	BATTERY DOOR UNIT	1	(-S)
	17	VYK5R08	BATTERY DOOR UNIT	1	(-K)
	17	VYK5M24	BATTERY DOOR UNIT	1	(-A)
	17	VYK5R26	BATTERY DOOR UNIT	1	(-R)
	17	VYK5S70	BATTERY DOOR UNIT	1	(-V)
	18	VGU0H52-A	BATTERY LOCK KNOB	1	
	19	VMB4152-A	BATTERY LOCK SPRING	1	
	20	VMB4530	BATTERY OUT SPRING	1	
	21	VMP0B89	FRAME	1	
	22	VMP0B92	BATTERY CASE	1	
	23	VGQ1A46	PCB SPACER	1	
	24	VGU0L26	MODE KNOB	1	(-S, -A, -R, -V)
	24	VGU0L29	MODE KNOB	1	(-K)
	25	VYK5M37	REAR CASE UNIT	1	(-S)
	25	VYK5M38	REAR CASE UNIT	1	(-K)
	25	VYK5M40	REAR CASE UNIT	1	(-A)
	25	VYK5M39	REAR CASE UNIT	1	(-R)
	25	VYK5S71	REAR CASE UNIT	1	(-V)
	25	VYK5U39	REAR CASE UNIT	1	02P-K
	25-1	VGL1421	REAR PANEL LIGHT	1	
	25-2	VGU0K98	CURSOR BUTTON	1	
	25-3	VGU0K99	MENU/SET BUTTON	1	
	26	F2A2F8500013	E.CAPACITOR	1	(C8003)
	27	L0AA01A00098	SPEAKER	1	
	28	L0CBAY000141	MICROPHONE UNIT	1	
	29	VEK0S64	FLASH UNIT	1	
	30	VGQ1C30	TOP PCB SHEET	1	
	31	VMB4604	EARTH SPRING	1	(ET8003)
	32	VYK5M46	TOP CASE UNIT	1	
	32-1	VGU0L25	REC BUTTON	1	
	32-2	VGU0L27	POWER KNOB	1	
	33	VGQ1D02	DPR SHEET	1	1P,PC,PU, EG,EP,EF,EB,EE, GH,GF,GA,GT,GK,GN,GD, 02P
	100	VXW1432	LENS UNIT (W/O CCD)	1	
	101	VEK0T14	CCD UNIT	1	E.S.D.
	103	VEK0S66	LENS FPC UNIT	1	

Model No. : DMC-SZ1/SZ02 Parts List

Safety	Ref. No.	Part No.	Part Name & Description	Q'ty	Remarks
	103-1	B3NBA0000011	PHOTO SENSOR	1	
	103-2	B3NBA0000011	PHOTO SENSOR	1	
	103-3	B3NBA0000018	PHOTO SENSOR	1	
	104	L6DAYYYD0005	ZOOM MOTOR UNIT	1	
	105	VMB4603	TILT SPRING	1	
	106	VMB4603	TILT SPRING	1	
	107	VXP3818	1ST-3RD LENS FRAME UNIT	1	
	109	VXP3761	OUTSIDE DIRECT FRAME UNIT	1	
	114	VDG1781	DRIVE GEAR	1	
	115	VXQ2221	FIX FRAME UNIT	1	
	116	VXQ2222	MASTER FLANGE UNIT	1	
	116-1	L6HAYYYD0047	FOCUS MOTOR UNIT	1	
	116-2	VMB4593	FOCUS SPRING	1	
	116-3	VXP3768	4TH LENS FRAME UNIT	1	
	B1	VHD2004	SCREW	1	
	B2	VHD2205	SCREW	1	
	B3	VHD2205	SCREW	1	
	B4	VHD2205	SCREW	1	
	B5	VHD2290	SCREW	1	
	B6	VHD2290	SCREW	1	
	B10	VHD2409	SCREW	1	(-S)
	B10	VHD2408	SCREW	1	(-K, -A, -R, -V)
	B11	XQN16+BJ3FN	SCREW	1	
	B12	XQN16+BJ3FN	SCREW	1	
	B101	VHD2388	SCREW	1	
	B102	VHD2388	SCREW	1	
	B103	VHD2388	SCREW	1	
	B104	VHD2430	SCREW	1	
	B105	VHD2430	SCREW	1	
	B106	VHD2390	SCREW	1	
	B107	VHD2390	SCREW	1	
	B108	VHD2390	SCREW	1	
	B109	VHD2390	SCREW	1	
	B110	VHD2390	SCREW	1	
	B111	VHD2400	SCREW	1	
	B112	VHD2400	SCREW	1	
	B113	VHD2400	SCREW	1	
	B114	VHD2400	SCREW	1	
	200	VPF1372-A	CAMERA BAG	1	1EG, EP, EF, EB, EE, GH, GF, GA, GT, GK, GN, GD
	201	-----	BATTERY	1	1P, PC, PU, 02P
	202	VPF1378	BAG, POLYETHYLENE	1	1P, PC, PU, 02P
	203	VFC4297-B	HAND STRAP	1	1P, PC, PU, 02P
	204	VFF0940-S	CD-ROM	1	1P, PC, PU, 02P [SPC] See "Notes"
	205	VQT3Z30	BASIC O/I (ENGLISH/SPANISH)	1	1P, 02P
	205	VQT3Z31	BASIC O/I (ENGLISH/CANADIAN FRENCH)	1	1PC
	205	VQT3Z32	BASIC O/I (SPANISH/PORTUGUESE)	1	1PU
	206	VSK0768	AC ADAPTOR	1	1P, PC, PU, 02P
	208	VPN7381	PAD	1	1P, PC, PU, 02P
	209	VYQ7446	PACKING CASE	1	1P-S
	209	VYQ7452	PACKING CASE	1	1P-K, PC-K
	209	VYQ7459	PACKING CASE	1	1P-A, PC-A
	209	VYQ7464	PACKING CASE	1	1P-R, PC-R
	209	VYQ7447	PACKING CASE	1	1PU-S
	209	VYQ7453	PACKING CASE	1	1PU-K
	209	VYQ7460	PACKING CASE	1	1PU-A
	209	VYQ7465	PACKING CASE	1	1PU-R
	210	K1HY08YY0026	AV CABLE W/PLUG	1	1P, PC, PU
	211	K1HY08YY0025	USB CABLE W/PLUG	1	1P, PC, PU, 02P
	212	VQL2C67-1A	OPERATING LABEL	1	1PC
	300	VPF1372	CAMERA BAG	1	1GC [SPC]
	300	VPF1372-A	CAMERA BAG	1	1P, PC, PU, 02P
	301	-----	BATTERY	1	EXCEPT 1P, PC, PU, 02P

Model No. : DMC-SZ1/SZ02 Parts List

Safety	Ref. No.	Part No.	Part Name & Description	Q'ty	Remarks
	302	VPF1378	BAG, POLYETHYLENE	1	EXCEPT 1P,PC,PU, 02P
	303	VFC4297-B	HAND STRAP	1	EXCEPT 1P,PC,PU, 02P
⚠	304	VFF0941-S	CD-ROM	1	1EG [SPC] See "Notes"
⚠	304	VFF0942-S	CD-ROM	1	1EP,EF,EB [SPC] See "Notes"
⚠	304	VFF0943-S	CD-ROM	1	1EE [SPC] See "Notes"
⚠	304	VFF0944-S	CD-ROM	1	1GH,GF,GA,GN [SPC] See "Notes"
⚠	304	VFF0945-S	CD-ROM	1	1GT,GD [SPC] See "Notes"
⚠	304	VFF0946-S	CD-ROM	1	1GK [SPC] See "Notes"
⚠	304	VFF0947-S	CD-ROM	1	1GC [SPC] See "Notes"
⚠	305	VQT3Z34	BASIC O/I (GERMAN/FRENCH)	1	1EG
⚠	305	VQT3Z35	BASIC O/I (ITALIAN/DUTCH)	1	1EG
⚠	305	VQT3Z36	BASIC O/I (SPANISH/PORTUGUESE)	1	1EG
⚠	305	VQT3Z37	BASIC O/I (TURKISH)	1	1EG
⚠	305	VQT3Z38	BASIC O/I (SWEDISH/DANISH)	1	1EP
⚠	305	VQT3Z39	BASIC O/I (POLISH/CZECH)	1	1EP
⚠	305	VQT3Z40	BASIC O/I (HUNGARIAN/FINNISH)	1	1EP
⚠	305	VQT3Z41	BASIC O/I (FRENCH)	1	1EF
⚠	305	VQT3Z42	BASIC O/I (ENGLISH)	1	1EB
⚠	305	VQT3Z43	BASIC O/I (RUSSIAN/UKRAINIAN)	1	1EE
⚠	305	VQT3Z44	BASIC O/I (ENGLISH/CHINESE(TRADITIONAL))	1	1GH,GF,GA,GC
⚠	305	VQT3Z45	BASIC O/I (ARABIC/PERSIAN)	1	1GF,GC
⚠	305	VQT3Z46	BASIC O/I (VIETNAMESE)	1	1GA
⚠	305	VQT3Z47	BASIC O/I (CHINESE(TRADITIONAL))	1	1GT
⚠	305	VQT3Z48	BASIC O/I (CHINESE(SIMPLIFIED))	1	1GK
⚠	305	VQT3Z49	BASIC O/I (ENGLISH)	1	1GN
⚠	305	VQT3Z50	BASIC O/I (KOREAN)	1	1GD
⚠	306	VSK0772	AC ADAPTOR	1	1EG,EP,EF,EE,GF,GA
⚠	306	VSK0775	AC ADAPTOR	1	1EB,GC,GH
⚠	306	VSK0769	AC ADAPTOR	1	1GT
⚠	306	VSK0770	AC ADAPTOR	1	1GK
⚠	306	VSK0776	AC ADAPTOR	1	1GN
⚠	306	VSK0773	AC ADAPTOR	1	1GD
	309	VYQ7454	PACKING CASE	1	1EG-K,EP-K,EF-K, EB-K, EE-K, GH-K,GA-K,G T-K,GN-K,GD-K
	309	VYQ7448	PACKING CASE	1	1EG-S,EP-S,EB-S,EE-S, GH-S, GA-S,GT-S,GN -S
	309	VYQ7461	PACKING CASE	1	1EG-A,EP-A,EF-A,EB-A, GA-A, GN-A
	309	VYQ7466	PACKING CASE	1	1EG-R,EP-R,EF-R,EB-R,GH-R, GA-R,GN-R
	309	VYQ7630	PACKING CASE	1	(-V)
	309	VYQ7450	PACKING CASE	1	1GF-S
	309	VYQ7457	PACKING CASE	1	1GF-K
	309	VYQ7462	PACKING CASE	1	1GF-A
	309	VYQ7467	PACKING CASE	1	1GF-R
	309	VYQ7451	PACKING CASE	1	1GK-S
	309	VYQ7458	PACKING CASE	1	1GK-K
	309	VYQ7463	PACKING CASE	1	1GK-A
	309	VYQ7468	PACKING CASE	1	1GK-R
	309	VYQ7803	PACKING CASE	1	02P-K
	309	VPK5305	PACKING CASE	1	1GC-S [SPC]
	309	VPK5304	PACKING CASE	1	1GC-K [SPC]
	309	VPK5306	PACKING CASE	1	1GC-R [SPC]
	310	K1HY08YY0026	AV CABLE W/PLUG	1	1EG,EP,EF,EB,EE,GH,GF,GA, GT,GK,GN,GD
	311	K1HY08YY0025	USB CABLE W/PLUG	1	EXCEPT 1P,PC,PU, 02P
	312	VQL2C68-1A	OPERATING LABEL	1	1GT
	314	VQL2J61	GD LABEL	1	1GD-K