

Service Manual

Digital Camera

Model No. **DMC-FT5EB**

DMC-FT5EE

DMC-FT5EF

DMC-FT5EG

DMC-FT5EP

DMC-FT5GC

DMC-FT5GA

DMC-FT5GN

DMC-FT5EA

DMC-TS5P

DMC-TS5PC

DMC-TS5PU

DMC-TS5GH

DMC-TS5GT

DMC-TS5GD

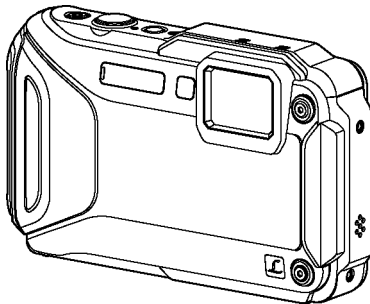

Colours

- (A).....Blue Type (Except DMC-FT5EE/EA,
DMC-TS5GH/GT/GD)
- (D).....Orange Type
- (S).....Silver Type (Except DMC-FT5EF/EA,
DMC-TS5PC/PU)
- (K).....Black Type (Except DMC-FT5EE/GN/EA,
DMC-TS5PC/GH/GT/GD)

WARNING

This service information is designed for experienced repair technicians only and is not designed for use by the general public. It does not contain warnings or cautions to advise non-technical individuals of potential dangers in attempting to service a product. Products powered by electricity should be serviced or repaired only by experienced professional technicians. Any attempt to service or repair the product or products dealt with in this service information by anyone else could result in serious injury or death.

Panasonic®

© Panasonic Corporation 2013.
Unauthorized copying and distribution is a violation
of law.

TABLE OF CONTENTS

	PAGE	PAGE
1 Safety Precautions	3	
1.1. General Guidelines	3	
1.2. Leakage Current Cold Check	3	
1.3. Leakage Current Hot Check (See Figure 1).....	3	
1.4. How to Discharge the Capacitor on Flash P.C.B.....	4	
2 Warning	5	
2.1. Prevention of Electrostatic Discharge (ESD) to Electrostatic Sensitive (ES) Devices	5	
2.2. How to Recycle the Lithium Ion Battery (U.S. Only).....	5	
2.3. Caution for AC Cord (For EB/GC/GH).....	6	
2.4. How to Replace the Lithium Battery.....	7	
3 Service Navigation	9	
3.1. Introduction	9	
3.2. Service Navigation.....	9	
3.3. Service Notes	11	
3.4. General Description About Lead Free Solder (PbF)	12	
3.5. How to Define the Model Suffix (NTSC or PAL model).....	13	
4 Specifications	17	
5 Location of Controls and Components	18	
6 Service Mode	19	
6.1. Error Code Memory Function	19	
7 Troubleshooting Guide	23	
7.1. Service and Check Procedures (Air-leak Test) ---	23	
7.2. Failure Diagnosis of GPS	27	
7.3. Checking Method of compass, altimeter, & barometer	28	
7.4. Failure Diagnosis of Wi-Fi.....	32	
7.5. Failure Diagnosis of NFC	33	
8 Service Fixture & Tools	34	
8.1. Service Fixture and Tools	34	
8.2. When Replacing the Main P.C.B.	35	
8.3. Service Position	35	
9 Disassembly and Assembly Instructions	36	
9.1. Disassembly Flow Chart.....	36	
9.2. P.C.B. Location	36	
9.3. Disassembly Procedures.....	37	
10 Measurements and Adjustments	48	
10.1. Introduction	48	
10.2. Before Disassembling the unit.....	48	
10.3. Details of Electrical Adjustment.....	50	
10.4. After Adjustment.....	54	
11 Maintenance	55	
11.1. Cleaning Lens and LCD Panel	55	
12 Block Diagram	57	
12.1. Overall Block Diagram	57	
12.2. System Control Block Diagram.....	58	
12.3. Video/Audio Signal Process Block Diagram.....	59	
12.4. Lens Drive Block Diagram	60	
12.5. Power Block Diagram	61	
13 Wiring Connection Diagram	62	
13.1. Interconnection Schematic Diagram	62	

1 Safety Precautions

1.1. General Guidelines

1. IMPORTANT SAFETY NOTICE

There are special components used in this equipment which are important for safety. These parts are marked by  in the Schematic Diagrams, Circuit Board Layout, Exploded Views and Replacement Parts List. It is essential that these critical parts should be replaced with manufacturer's specified parts to prevent X-RADIATION, shock fire, or other hazards. Do not modify the original design without permission of manufacturer.

2. An Isolation Transformer should always be used during the servicing of AC Adaptor whose chassis is not isolated from the AC power line. Use a transformer of adequate power rating as this protects the technician from accidents resulting in personal injury from electrical shocks. It will also protect AC Adaptor from being damaged by accidental shorting that may occur during servicing.
3. When servicing, observe the original lead dress. If a short circuit is found, replace all parts which have been overheated or damaged by the short circuit.
4. After servicing, see to it that all the protective devices such as insulation barriers, insulation papers shields are properly installed.
5. After servicing, make the following leakage current checks to prevent the customer from being exposed to shock hazards.

1.2. Leakage Current Cold Check

1. Unplug the AC cord and connect a jumper between the two prongs on the plug.
2. Measure the resistance value, with an ohmmeter, between the jumpered AC plug and each exposed metallic cabinet part on the equipment such as screwheads, connectors, control shafts, etc. When the exposed metallic part has a return path to the chassis, the reading should be between $1M\Omega$ and $5.2M\Omega$. When the exposed metal does not have a return path to the chassis, the reading must be infinity.

1.3. Leakage Current Hot Check (See Figure 1)

1. Plug the AC cord directly into the AC outlet. Do not use an isolation transformer for this check.
2. Connect a $1.5k\Omega$, 10 W resistor, in parallel with a $0.15\mu F$ capacitor, between each exposed metallic part on the set and a good earth ground, as shown in Figure 1.
3. Use an AC voltmeter, with $1 k\Omega/V$ or more sensitivity, to measure the potential across the resistor.
4. Check each exposed metallic part, and measure the voltage at each point.
5. Reverse the AC plug in the AC outlet and repeat each of the above measurements.
6. The potential at any point should not exceed 0.75 V RMS. A leakage current tester (Simpson Model 229 or equivalent) may be used to make the hot checks, leakage current must not exceed $1/2$ mA. In case a measurement is outside of the limits specified, there is a possibility of a shock hazard, and the equipment should be repaired and rechecked before it is returned to the customer.

Hot-Check Circuit

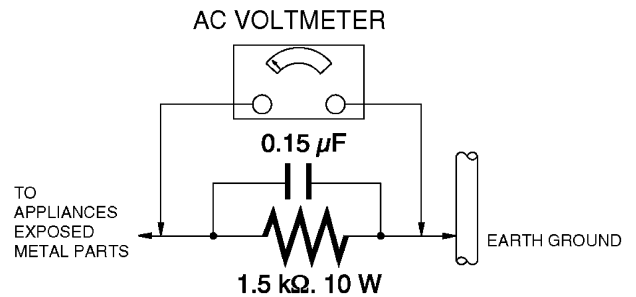

Figure 1

1.4. How to Discharge the Capacitor on Flash P.C.B.

CAUTION:

1. Be sure to discharge the capacitor on Flash P.C.B.
2. Be careful of the high voltage circuit on Flash P.C.B. when servicing.

[Discharging Procedure]

1. Refer to the disassemble procedure and remove the necessary parts/unit.
2. Put the insulation tube onto the lead part of Resistor (ERG5SJ102:1k Ω /5W).
(An equivalent type of resistor may be used.)
3. Put the resistor between both terminals of capacitor on Flash P.C.B. for approx. 5 seconds.
4. After discharging confirm that the capacitor voltage is lower than 10V using a voltmeter.

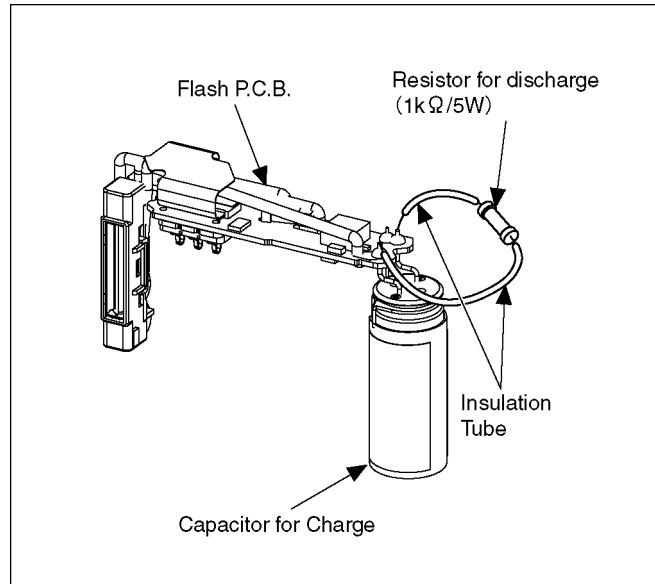

Fig. F1

2 Warning

2.1. Prevention of Electrostatic Discharge (ESD) to Electrostatic Sensitive (ES) Devices

Some semiconductor (solid state) devices can be damaged easily by static electricity. Such components commonly are called Electrostatically Sensitive (ES) Devices.

Examples of typical ES devices are MOS image sensor, IC (integrated circuits) and some field-effect transistors and semiconductor "chip" components.

The following techniques should be used to help reduce the incidence of component damage caused by electrostatic discharge (ESD).

1. Immediately before handling any semiconductor component or semiconductor-equipped assembly, drain off any ESD on your body by touching a known earth ground. Alternatively, obtain and wear a commercially available discharging ESD wrist strap, which should be removed for potential shock reasons prior to applying power to the unit under test.
2. After removing an electrical assembly equipped with ES devices, place the assembly on a conductive surface such as aluminum foil, to prevent electrostatic charge buildup or exposure of the assembly.
3. Use only a grounded-tip soldering iron to solder or unsolder ES devices.
4. Use only an antistatic solder removal device. Some solder removal devices not classified as **antistatic (ESD protected)** can generate electrical charge sufficient to damage ES devices.
5. Do not use freon-propelled chemicals. These can generate electrical charges sufficient to damage ES devices.
6. Do not remove a replacement ES device from its protective package until immediately before you are ready to install it. (Most replacement ES devices are packaged with leads electrically shorted together by conductive foam, aluminum foil or comparable conductive material).
7. Immediately before removing the protective material from the leads of a replacement ES device, touch the protective material to the chassis or circuit assembly into which the device will be installed.

CAUTION:

Be sure no power is applied to the chassis or circuit, and observe all other safety precautions.

8. Minimize bodily motions when handling unpackaged replacement ES devices. (Otherwise harmless motion such as the brushing together of your clothes fabric or the lifting of your foot from a carpeted floor can generate static electricity (ESD) sufficient to damage an ES device).

2.2. How to Recycle the Lithium Ion Battery (U.S. Only)

ENGLISH



A lithium ion/polymer battery that is recyclable powers the product you have purchased. Please call 1-800-8-BATTERY for information on how to recycle this battery.

FRANÇAIS



L'appareil que vous vous êtes procuré est alimenté par une batterie au lithium-ion/polymère recyclable. Pour des renseignements sur le recyclage de la batterie, veuillez composer le 1-800-8-BATTERY.

2.3. Caution for AC Cord (For EB/GC/GH)

2.3.1. Information for Your Safety

IMPORTANT

Your attention is drawn to the fact that recording of pre-recorded tapes or discs or other published or broadcast material may infringe copyright laws.

WARNING

To reduce the risk of fire or shock hazard, do not expose this equipment to rain or moisture.

CAUTION

To reduce the risk of fire or shock hazard and annoying interference, use the recommended accessories only.

FOR YOUR SAFETY

DO NOT REMOVE THE OUTER COVER

To prevent electric shock, do not remove the cover. No user serviceable parts inside. Refer servicing to qualified service personnel.

2.3.2. Caution for AC Mains Lead

For your safety, please read the following text carefully.

This appliance is supplied with a moulded three-pin mains plug for your safety and convenience.

A 5-ampere fuse is fitted in this plug.

Should the fuse need to be replaced please ensure that the replacement fuse has a rating of 5 amperes and it is approved by ASTA or BSI to BS1362

Check for the ASTA mark or the BSI mark on the body of the fuse.



If the plug contains a removable fuse cover you must ensure that it is refitted when the fuse is replaced.

If you lose the fuse cover, the plug must not be used until a replacement cover is obtained.

A replacement fuse cover can be purchased from your local Panasonic Dealer.

If the fitted moulded plug is unsuitable for the socket outlet in your home then the fuse should be removed and the plug cut off and disposed of safely.

There is a danger of severe electrical shock if the cut off plug is inserted into any 13-ampere socket.

If a new plug is to be fitted please observe the wiring code as shown below.

If in any doubt, please consult a qualified electrician.

2.3.2.1. Important

The wires in this mains lead are coloured in accordance with the following code:

Blue	Neutral
Brown	Live

As the colours of the wires in the mains lead of this appliance may not correspond with the coloured markings identifying the terminals in your plug, proceed as follows:

The wire which is coloured BLUE must be connected to the terminal in the plug which is marked with the letter N or coloured BLACK.

The wire which is coloured BROWN must be connected to the terminal in the plug which is marked with the letter L or coloured RED.

Under no circumstances should either of these wires be connected to the earth terminal of the three pin plug, marked with the letter E or the Earth Symbol.

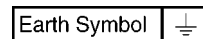

2.3.2.2. Before Use

remove the Connector Cover as follows.

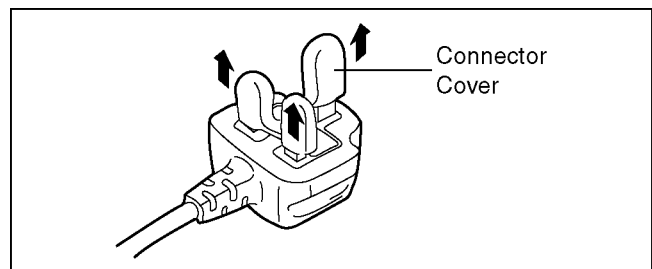

2.3.2.3. How to Replace the Fuse

1. Remove the Fuse Cover with a screwdriver.

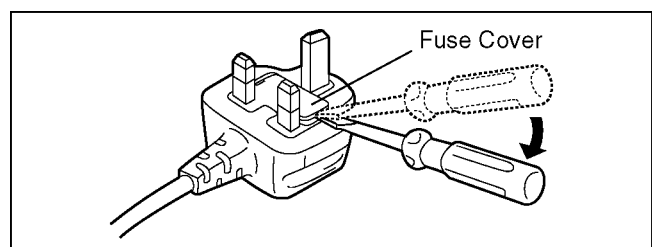

2. Replace the fuse and attach the Fuse cover.

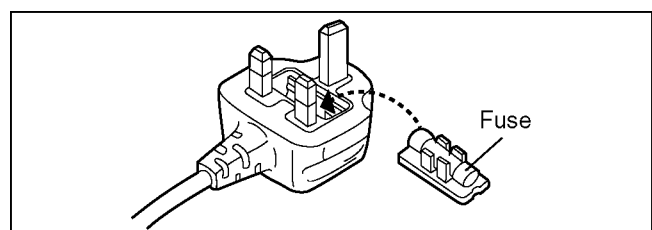

2.4. How to Replace the Lithium Battery

2.4.1. Replacement Procedure

1. Remove the Top FPC P.C.B. (Top FPC Unit) (Refer to Disassembly Procedures.)
2. Unsolder the Lithium battery (Ref. No. **B6301**) at foil side of Top FPC P.C.B. (Top FPC Unit) and then replace it into new one.

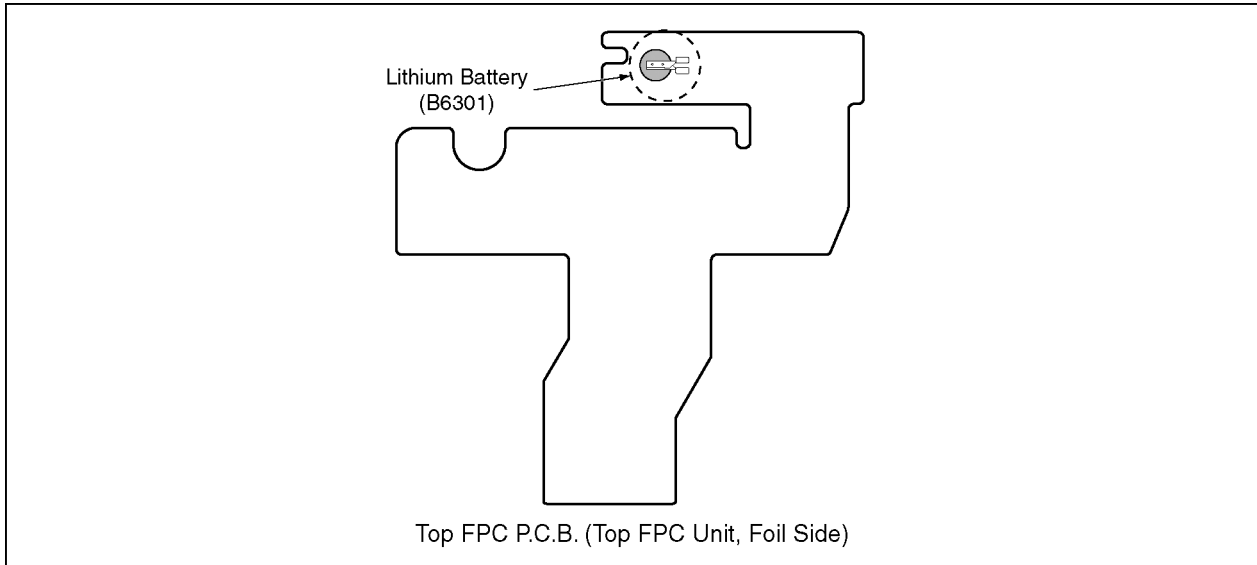

CAUTION

Danger of explosion if battery is incorrectly replaced.
Replace only with the same or equivalent type.

CAUTION

The battery used in this device may present a risk of fire or chemical burn if mistreated.
Do not recharge, disassemble, heat above 100 °C (212 °F), or incinerate.
Replace battery with Panasonic part number ML-421S/DN only.
Use of another battery may present a risk of fire or explosion.
Dispose of used battery promptly.
Keep away from children.
Do not disassemble and do not dispose of in fire.

Note:

The lithium battery is a critical component.

(Type No.: ML-421S/DN **Manufactured by Energy Company, Panasonic Corporation**)

It must never be subjected to excessive heat or discharge.

It must therefore only be fitted in equipment designed specifically for its use.

Replacement batteries must be of the same type and manufacture.

They must be fitted in the same manner and location as the original battery, with the correct polarity contacts observed.

Do not attempt to re-charge the old battery or re-use it for any other purpose.

It should be disposed of in waste products destined for burial rather than incineration.

(For English)

CAUTION

Danger of explosion if battery is incorrectly replaced.
Replace only with the same or equivalent type recommended by the manufacturer.
Dispose of used batteries according to the manufacturer's instructions.

(For German)

ACHTUNG

Explosionsgefahr bei falschem Anbringen der Batterie. Ersetzen Sie nur mit einem äquivalentem vom Hersteller empfohlenem Typ.
Behandeln Sie gebrauchte Batterien nach den Anweisungen des Herstellers.

(For French)

MISE EN GARDE

Une batterie de remplacement inappropriée peut exploser. Ne remplacez qu'avec une batterie identique ou d'un type recommandé par le fabricant. L'élimination des batteries usées doit être faite conformément aux instructions du fabricant.

Note:

Above caution is applicable for a battery pack which is for DMC-FT5 and DMC-TS5 series, as well.

Danger of explosion if battery is incorrectly replaced.

Replace only with the same or equivalent type recommended by the manufacturer.

Dispose of used batteries according to the manufacturer's instructions.

3 Service Navigation

3.1. Introduction

This service manual contains technical information, which will allow service personnel's to understand and service this model. Please place orders using the parts list and not the drawing reference numbers.

If the circuit is changed or modified, the information will be followed by service manual to be controlled with original service manual.

3.2. Service Navigation

3.2.1. Air-leak test (inspection)

Waterproof/Dustproof Performance

This camera's waterproof/dustproof rating complies with the "IPX8" and "IP6X" ratings. Provided the care and maintenance guidelines described in this document are strictly followed, this camera can operate underwater, to a depth not exceeding 13 m (43 feet) for a time not exceeding 60 minutes. (*1)

Anti-shock Performance

This camera also complies with "MIL-STD 810F Method 516.5-Shock". The camera has cleared a drop test from a height of 2 m (6.6 feet) onto 3 cm (0.10 feet) thick plywood. In most cases this camera should not sustain any damage if dropped from a height not exceeding 2 m (6.6 feet). (*2)

Withstand Load Performance

This camera complies with 100 kgf/220.5 lbf load tests. (*3)

This does not guarantee no destruction, no malfunction, or waterproofing in all conditions.

*1 This means that the camera can be used underwater for specified time in specified pressure in accordance with the handling method established by Panasonic.

*2 "MIL-STD 810F Method 516.5-Shock" is the test method standard of the U.S. Defense Department, which specifies performing drop tests from a height of 122 cm (4.0 feet), at 26 orientations (8 corners, 12 ridges, 6 faces) using 5 sets of devices, and passing the 26 orientation drops within 5 devices. (If failure occurs during the test, a new set is used to pass the drop orientation test within a total of 5 devices)

Panasonic's test method is based on the above "MIL-STD 810F Method 516.5-Shock". However, the drop height was changed from 122 cm (4.0 feet) to 200 cm (6.6 feet) dropping onto 3 cm (0.10 feet) thick plywood. This drop test was passed. (Disregarding appearance change such as loss of paint or distortion of the part where drop impact is applied.)

*3 According to the test conditions specified by Panasonic.

- Due to the above characteristics of the products, perform the air-leak test (inspection) using Air -leak tester (Part No.:RFKZ0528) before/after servicing including assembly and/or assembly process.

Note:

The purpose of the air-leak test before servicing is that whether the malfunction occurred due to air-leak or not.

- When servicing, refer to the "7.Troubleshooting Guide" section for details.

3.2.2. Replacing the waterproof packing (waterproof seal)

- The integrity of the waterproof packing may decrease about 1 year, with use and age.
- (We recommend end users to replace the waterproof packing (waterproof seal) at least once each year described in the operating instructions.)
- As for replacement procedure, refer to the 7.1.2. Periodical maintenance (Packing replacement) flow for details.

3.2.3. Lens Unit

- Since the lens unit for this model is assembled with high accuracy manufacturing technologies, it is not allowed to disassemble/assemble the lens unit, in terms of performance retention.

When servicing, it has to be handled the "Lens with MOS unit" as the smallest part size.

Confirm the replacement part list and exploded views for details.

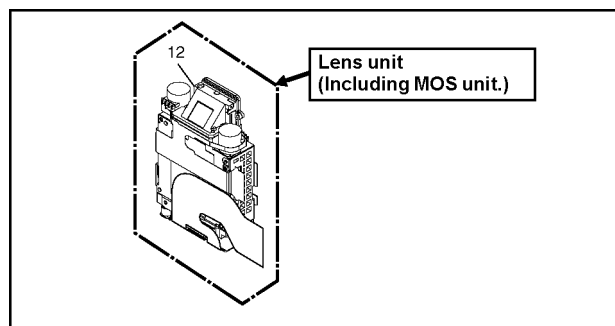

3.2.4. About IC6301 (COMPASS) [On the TOP FPC UNIT]

When IC6301 is defects and necessary to be replaced, replace with whole TOP FPC UNIT as a unit.

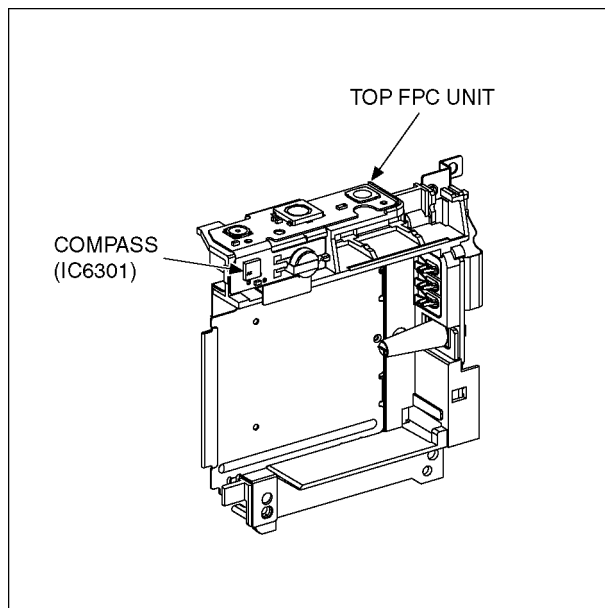

3.2.5. About VENUS ENGINE (IC6001) < Located on the Main P.C.B. >

- The VENUS ENGINE (IC6001) consists of two IC chips, which are fixed together with solder. (It is so called, "Package On Package" type of IC.)

Caution:

- During servicing, do not press down hard on the surface of IC6001.

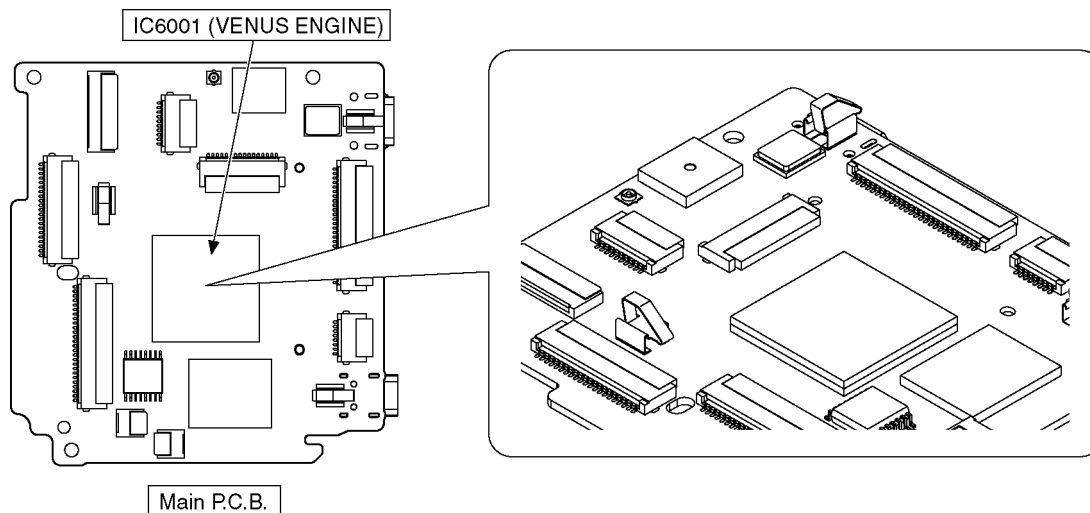





3.3. Service Notes

The page number in the section does not show the page number of this service manual.

3.3.1. About Wi-Fi Function

Linking with the Wi-Fi compatible equipment allows you to remotely operate the camera, or share pictures with people in distant places even during recording or playing back.

<p style="text-align: center;">Remote Shooting (P176)</p>  <p>Linking with a smartphone/tablet enables the following:</p> <ul style="list-style-type: none"> • Remote recording (P178) • Playing back the pictures in the camera (P178) • Saving the pictures in the camera to the smartphone/tablet, or sending them to WEB services. (P178) • Sending the acquired location information to the camera. (P178) 	<p style="text-align: center;">Playback on TV (P188)</p>  <p>By linking with the DLNA compatible TV, you can display pictures on TV right after taking them or display them on TV later by playing them back on the camera.</p>
<p style="text-align: center;">Send Images While Recording (P190)</p>  <p>Every time you take a picture, the picture can be automatically sent to a specified location. You can play back the picture on the smartphone/tablet, or save and edit it on PC.</p> <p>• Send to:</p> <ul style="list-style-type: none"> - [Smartphone] (P190)/[PC] (P193)/[Cloud Sync. Service] (P195)/[Web service] (P196)/[AV device] (P197) 	<p style="text-align: center;">Send Images Stored in the Camera (P198)</p>  <p>You can select and send recorded images.</p> <p>• Send to:</p> <ul style="list-style-type: none"> - [Smartphone] (P198)/[PC] (P201)/[Cloud Sync. Service] (P202)/[Web service] (P203)/[AV device] (P204)/[Printer] (P205)

3.3.2. Important Notice of Servicing

This Camera unit has the personal information of wireless LAN connection the customer has registered.

For the protection of private information, please erase the personal information after the completion of repair by "INITIAL SETTING".

In addition, please print out the following documents, and pass to the customer with the Camera unit.

Printing Material [Leaflet for Customer]

Printing Material [Leaflet for Customer]

[For The Customer]

Before using your camera please check the Wi-Fi settings.
Depending on what was serviced, the settings may have been reset to the factory defaults.

1. If the settings were reset you will need to reenter your Lumix Club login ID and password.

If you have forgotten the login ID and/or Password, please connect to the Lumix Club web site and create a new ones.
2. You may also have to reenter the settings for your local Wi-Fi network settings.

We recommend consulting the operating manual if you have any questions.

3.4. General Description About Lead Free Solder (PbF)

The lead free solder has been used in the mounting process of all electrical components on the printed circuit boards used for this equipment in considering the globally environmental conservation.

The normal solder is the alloy of tin (Sn) and lead (Pb). On the other hand, the lead free solder is the alloy mainly consists of tin (Sn), silver (Ag) and Copper (Cu), and the melting point of the lead free solder is higher approx.30 °C (86 °F) more than that of the normal solder.

Definition of P.C.B. Lead Free Solder being used

The letter of PbF is printed either foil side or components side on the P.C.B. using the lead free solder. (See right figure)

PbF

Service caution for repair work using Lead Free Solder (PbF)

- The lead free solder has to be used when repairing the equipment for which the lead free solder is used.
- (Definition: The letter of **PbF** is printed on the P.C.B. using the lead free solder.)
- To put lead free solder, it should be well molten and mixed with the original lead free solder.
- Remove the remaining lead free solder on the P.C.B. cleanly for soldering of the new IC.
- Since the melting point of the lead free solder is higher than that of the normal lead solder, it takes the longer time to melt the lead free solder.
- Use the soldering iron (more than 70W) equipped with the temperature control after setting the temperature at 350±30 degrees C (662±86 °F).

Recommended Lead Free Solder (Service Parts Route.)

- The following 3 types of lead free solder are available through the service parts route.
 - RFKZ03D01KS----- (0.3mm 100g Reel)
 - RFKZ06D01KS----- (0.6mm 100g Reel)
 - RFKZ10D01KS----- (1.0mm 100g Reel)

Note

* Ingredient: tin (Sn) 96.5%, silver (Ag) 3.0%, Copper (Cu) 0.5%, Cobalt (Co) / Germanium (Ge) 0.1 to 0.3%

3.5. How to Define the Model Suffix (NTSC or PAL model)









There are eight kinds of DMC-FT5/TS5, regardless of the colours.

- a) DMC-FT5 (Japan domestic model.)
- b) DMC-TS5P/PC
- c) DMC-FT5EB/EF/EG/EP
- d) DMC-FT5EA/EE
- e) DMC-TS5GT
- f) DMC-FT5GN
- g) DMC-TS5GD
- h) DMC-FT5GA/GC, DMC-TS5GH/PU

What is the difference is that the "INITIAL SETTINGS" data which is stored in Flash ROM mounted on Main P.C.B.

3.5.1. Defining methods

To define the model suffix to be serviced, refer to the nameplate which is putted on the bottom side of the Unit.

<p>a) DMC-FT5 (Japan domestic model) The nameplate for this model shows the following Safety registration mark.</p>	 <p>Safety registration mark</p>
	
<p>b) DMC-TS5P/PC The nameplate for these models show the following Safety registration mark.</p>	
	
<p>c) DMC-FT5EB/EF/EG/EP The nameplate for these models show the following Safety registration mark.</p>	
	
<p>d) DMC-FT5EA/EE The nameplate for this model show the following Safety registration mark.</p>	
	
<p>e) DMC-TS5GT The nameplate for this model show the following Safety registration mark.</p>	
	
<p>f) DMC-FT5GN The nameplate for this model show the following Safety registration mark.</p>	
	
<p>g) DMC-TS5GD The nameplate for this model show the following Safety registration mark.</p>	
	
<p>h) DMC-FT5GA/GC, DMC-TS5GH/PU The nameplate for these models do not show any above safety registration mark.</p>	

Note:

After replacing the Main P.C.B., be sure to achieve adjustment.

3.5.2. INITIAL SETTINGS:

After replacing the Main P.C.B., be sure to perform the initial settings after achieving the adjustment by ordering the following procedure in accordance with model suffix of the unit.

1. IMPORTANT NOTICE:

Before proceeding Initial settings, be sure to read the following CAUTIONS.

CAUTION 1:(INITIAL SETTINGS)

--- AFTER REPLACING THE MAIN P.C.B. and/or FLASH ROM ---

[Except "EG, EF, EB and EP" models]

*.The model suffix can be chosen **JUST ONE TIME**.

(Effective model suffix : DMC-FT5 " EE/GC/GA/GN and EA",
DMC-TSS " P/PC/PU/GH/GT and GD")

*.Once one of the model suffix has been chosen, the model suffix lists will not be displayed,
thus, it can not be changed.

CAUTION 2:(Stored picture image data in the unit)

This unit employs "Built-in Memory" for picture image data recording.(Approx.10MB)
After proceeding "INITIAL SETTINGS", the picture image data stored in the unit is erased.

2. PROCEDURES:

- Precautions: Read the above "CAUTION 1" and "CAUTION 2", carefully

- Preparation:

1. Attach the Battery to the unit.
2. Set to P(Program AE) mode by operating the mode button.

Note:

If the picture mode is other than P(Program AE) mode, it does not display the initial settings menu.

- **Step 1. The temporary cancellation of "INITIAL SETTINGS":**

While keep pressing "UP of Cursor button" and MOTION PICTURE button simultaneously, turn the Power on.

- **Step 2. The cancellation of "INITIAL SETTINGS":**

Press the PLAYBACK button.

Press "UP of Cursor button" and MOTION PICTURE button simultaneously, then turn the Power off.

- **Step 3. Turn the Power on:**

Turn the Power on.

- **Step 4. Display the "INITIAL SETTINGS" menu:**

While keep pressing MENU/SET and "RIGHT of Cursor button" simultaneously, turn the Power off.

The "INITIAL SETTINGS" menu is displayed.

There are two kinds of "INITIAL SETTINGS" menu form as follows:

[CASE 1. After replacing Main P.C.B.]

[Except "EG, EF, EB and EP" models : (VEP56172A is used as a Main P.C.B.)]

When Main P.C.B. has just been replaced, the following model suffix list is displayed as follows. (Four pages in total)

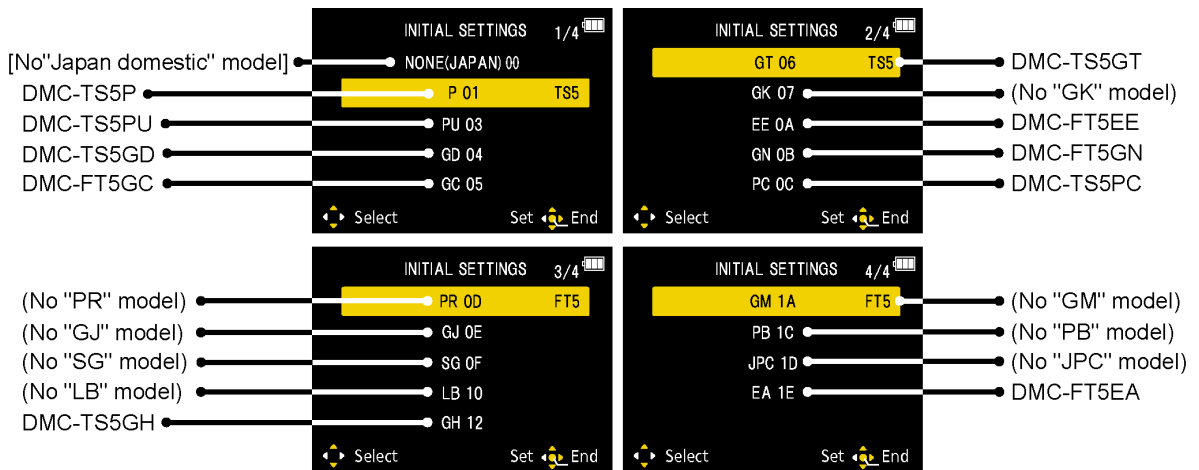

[Only for "EG, EF, EB and EP" models : (VEP56172B is used as a Main P.C.B.)]

When Main P.C.B. has just been replaced, only 8 model suffix list is displayed as follows. (Two pages in total)

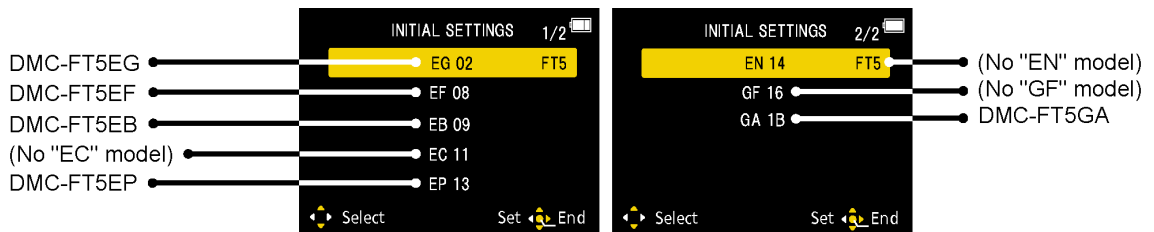

[CASE 2. Other than "After replacing Main P.C.B."]

< Other than "EG/EF/EB/EC/EP" models >

< Only "EG/EF/EB/EC/EP" models >

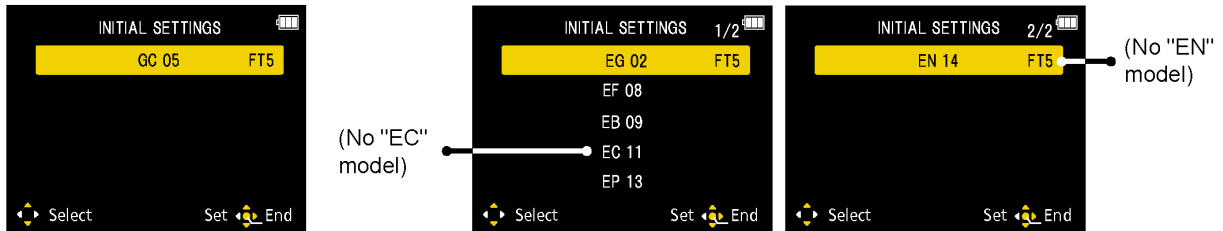

• Step 5. Choose the model suffix in "INITIAL SETTINGS": (Refer to "CAUTION 1")

[Caution: After replacing Main P.C.B.]

(Especially, other than "EG, EF, EB and EP" models)

The model suffix can be chosen, JUST ONE TIME.

Once one of the model suffix have been chosen, the model suffix lists will not be displayed, thus, it can be changed.

Therefore, select the area carefully.

Select the area with pressing "UP / DOWN" of Cursor buttons".

• Step 6. Set the model suffix at "INITIAL SETTINGS":

Press the "RIGHT" of Cursor buttons".

The only set area is displayed. Press the "RIGHT" of Cursor buttons" after confirmation.

(The unit is powered off automatically.)

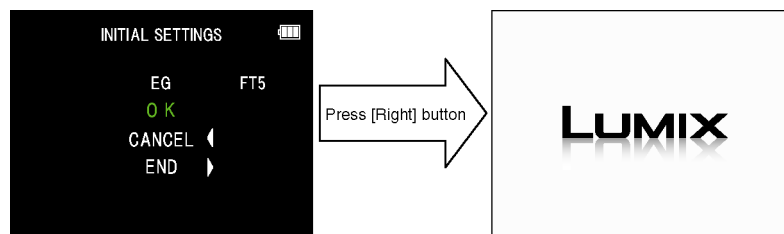

• **Step 7. CONFIRMATION:**

Confirm the display of "PLEASE SET THE CLOCK" in concerned language when the unit is turned on again.

When the unit is connected to PC with USB cable, it is detected as removable media.

1) As for your reference, major default setting condition is as shown in the following table.

• **Default setting (After "INITIAL SETTINGS")**

	MODEL	VIDEO OUTPUT	LANGUAGE	DATE	REMARKS
a)	DMC-FT5(Japan domestic model)	NTSC	Japanese	Year/Month/Date	
b)	DMC-FT5EB	PAL	English	Date/Month/Year	
c)	DMC-FT5EE	PAL	Russian	Date/Month/Year	
d)	DMC-FT5EF	PAL	French	Date/Month/Year	
e)	DMC-FT5EG	PAL	English	Date/Month/Year	
f)	DMC-FT5EP	PAL	English	Date/Month/Year	
g)	DMC-FT5GC	PAL	English	Date/Month/Year	
h)	DMC-FT5GA	PAL	English	Date/Month/Year	
i)	DMC-FT5GN	PAL	English	Date/Month/Year	
j)	DMC_FT5EA	PAL	Russian	Date/Month/Year	
k)	DMC-TS5GH	PAL	English	Date/Month/Year	
l)	DMC-TS4GT	NTSC	Chinese (Traditional)	Year/Month/Date	
m)	DMC-TS5GD	NTSC	Korean	Year/Month/Date	
n)	DMC-TS5P	NTSC	English	Date/Month/Year	
o)	DMC-TS5PC	NTSC	English	Date/Month/Year	
p)	DMC-TS5PU	NTSC	Spanish	Date/Month/Year	

4 Specifications

The following specification is for DMC-TS5P.

Some specifications may differ depending on model suffix.

Digital Camera:

Information for your safety

Power Source:	DC 5.1 V	
Power Consumption:	1.5 W (When recording) 1.1 W (When playing back)	
Camera effective pixels	16,100,000 pixels	
Image sensor	1/2.33" MOS sensor, total pixel number 17,500,000 pixels, Primary color filter	
Lens	Optical 4.6× zoom, f=4.9 mm to 22.8 mm (35 mm film camera equivalent: 28 mm to 128 mm)/F3.3 (Wide) to F5.9 (Tele)	
Image stabilizer	Optical method	
Focus range	Normal	30 cm (0.98 feet) to ∞
	Macro/ Intelligent auto/ Motion Picture	5 cm (0.16 feet) (Wide)/30 cm (0.98 feet) (Tele) to ∞
	Scene Mode	There may be differences in the above settings.
Shutter system	Electronic shutter + Mechanical shutter	
Minimum illumination	Approx. 12 lx (when i-low light is used, the shutter speed is 1/30th of a second)	
Shutter speed	4 seconds to 1/1300th of a second [Starry Sky] Mode: 15 seconds, 30 seconds	
Exposure	Program AE (P)/Manual Exposure (M)	
Metering mode	Multiple	

LCD monitor	3.0" TFT LCD (4:3) (Approx. 460,000 dots) (field of view ratio about 100%)	
Microphones	Stereo	
Speaker	Monaural	
Recording media	Built-in Memory (Approx. 10 MB)/SD Memory Card/ SDHC Memory Card/SDXC Memory Card	
Recording file format		
Still Picture	JPEG (based on "Design rule for Camera File system", based on "Exif 2.3" standard, DPOF corresponding)/MPO	
Motion pictures	AVCHD/MP4	
Audio compression format	AVCHD: Dolby® Digital (2 ch) MP4: AAC (2 ch)	
Interface		
Digital	"USB 2.0" (High Speed)	
Analog video	NTSC	
Audio	Audio line output (monaural)	
Terminal		
[AV OUT/DIGITAL]	Dedicated jack (8 pin)	
[HDMI]	MicroHDMI TypeD	
Dimensions (excluding the projecting parts)	Approx. 109.2 mm (W)×67.4 mm (H)×28.9 mm (D) [4.30"(W)×2.65"(H)×1.14"(D)]	
Mass (weight)	Approx. 214 g/0.471 lb (with card and battery) Approx. 188 g/0.414 lb (excluding card and battery)	
Operating temperature	-10 °C* to 40 °C (14 °F* to 104 °F) * The performance of the battery (number of recordable pictures/operating time) may decrease temporarily when using in a temperature between -10 °C and 0 °C (14 °F and 32 °F) (cold places such as ski resorts or places at high altitude).	
Operating humidity	10%RH to 80%RH	
Language select	[ENGLISH]/[ESPAÑOL]	

Bearing sensor	16 bearing detection (with angular position correction function by the 3 axes acceleration sensor, with automatic declination correction, and with automatic offset adjustment function)
Atmospheric pressure/altitude sensor	
Atmospheric pressure	Measurement range 300 hPa to 1100 hPa, with 24 hour memory function in 1 hPa unit (every 1.5 hours)
Altitude	Convert atmospheric pressure to altitude using ISA [International Standard Atmosphere], accuracy: -5 m (-16 feet) to +5 m (16 feet)
Depth	Displays in 3 levels [displays 0 m (0 feet) to 13 m (43 feet) in 3 levels]
Waterproof performance	Equivalent to IEC 60529 "IPX8". [Usable for 60 minutes in 13 m (43 feet) water depth]
Crash resistance performance	The test method of the camera is in compliance with "MIL-STD 810F Method 516.5-Shock"*. * "MIL-STD 810F Method 516.5-Shock" is the test method standard of the U.S. Defense Department, which specifies performing drop tests from a height of 122 cm (4 feet), at 26 orientations (8 corners, 12 ridges, 6 faces) using 5 sets of devices, and passing the 26 orientation drops within 5 devices. (If failure occurs during the test, a new set is used to pass the drop orientation test within a total of 5 devices) • Panasonic's test method is based on the above "MIL-STD 810F Method 516.5-Shock". However, the drop height was changed from 122 cm (4 feet) to 200 cm (6.6 feet) dropping onto 3 cm (0.1 feet) thick plywood. This drop test was passed. (Disregarding appearance change such as loss of paint or distortion of the part where drop impact is applied.) There is no guarantee of not breaking or malfunctioning under all conditions.
Withstand Load Performance	100 kgf/220.5 lbf (According to the test conditions specified by Panasonic)
Dustproof performance	Equivalent to IEC 60529 "IP6X".

Wireless transmitter

Compliance standard	IEEE 802.11b/g/n (standard wireless LAN protocol)
Frequency range used (central frequency)	2412 MHz to 2462 MHz (1 to 11ch)
Encryption method	Wi-Fi compliant WPA™/WPA2™
Access method	Infrastructure mode

Battery Charger (Panasonic VSK0800):

Information for your safety

Input:	~ 110 V to 240 V, 50/60 Hz, 0.2 A
Output:	== 4.2 V, 0.65 A
Operating temperature:	0 °C* to 40 °C (32 °F* to 104 °F) * The battery cannot be recharged in a temperature less than 0 °C (32 °F). (The [CHARGE] indicator blinks when the battery cannot be recharged.)

Equipment mobility:

Movable

Battery Pack (lithium-ion) (Panasonic DMW-BCM13PP):

Information for your safety

Voltage/capacity:	3.6 V/1250 mAh
--------------------------	----------------

5 Location of Controls and Components

The following specification is for DMC-TS5P.

Some specifications may differ depending on model suffix.

- 1 Flash
 - 2 Self-timer indicator/
AF Assist Lamp/
LED light
 - 3 Lens
 - 4 Speaker
- Be careful not to cover the speaker with your finger. Doing so may make sound difficult to hear.

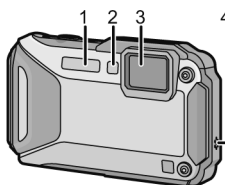

- 5 LCD monitor
 - 6 [Wi-Fi] button
 - 7 Wi-Fi® connection lamp
 - 8 Zoom button
 - 9 [▶] (Playback) button
 - 10 Strap eyelet
- Be sure to attach the strap when using the camera to ensure that you will not drop it.
- Be sure to attach the strap to the strap eyelet.
- 11 Decorative hole
 - 12 [MODE] button
 - 13 [Q.MENU/↵] button/[⏏] (Delete) button
 - 14 [DISP.] button
 - 15 [MENU/SET] button
 - 16 Cursor buttons

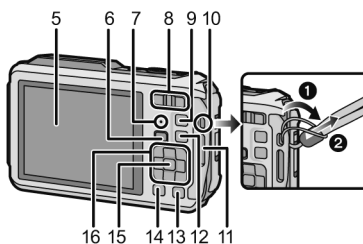

- 17 Microphones
- 18 GPS antenna
- 19 Camera [ON/OFF] button
- 20 GPS status indicator
- 21 Shutter button
- 22 Motion picture button

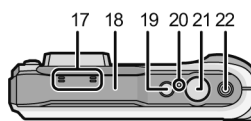

- 23 Tripod mount
- A tripod with a screw length of 5.5 mm (0.22 inch) or more may damage this unit if attached.
- 24 NFC antenna [NFC]

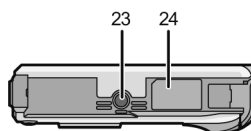

- 25 [HDMI] socket
- Do not connect with any cable other than an HDMI micro cable (RP-CHEU15: optional). Doing so may cause malfunction.
- 26 Card slot
 - 27 Battery slot
- When using an AC adaptor, ensure that the Panasonic DC coupler (DMW-DCC14: optional) and AC adaptor (DMW-AC5PP: optional) are used.
- Always use a genuine Panasonic AC adaptor (DMW-AC5PP: optional).
- When using an AC adaptor, use the AC cable supplied with the AC adaptor.
- 28 [AV OUT/DIGITAL] socket
 - 29 Release lever
 - 30 [LOCK] switch
 - 31 Side door

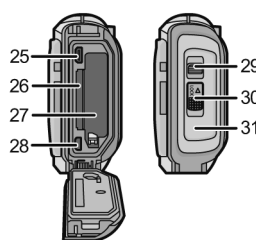

6 Service Mode

6.1. Error Code Memory Function

1. General description

This unit is equipped with history of error code memory function, and can be memorized 16 error codes in sequence from the latest. When the error is occurred more than 16, the oldest error is overwritten in sequence.

The error code is not memorized when the power supply is shut down forcibly (i.e., when the unit is powered on by the battery, the battery is pulled out) The error code is memorized to FLASH ROM when the unit has just before powered off.

2. How to display

The error code can be displayed by ordering the following procedure:

• Preparation:

1. Attach the Battery to the unit.

Note:

*Since this unit has built-in memory, it can be performed without inserting Memory Card.

• Step 1. The temporary cancellation of "INITIAL SETTINGS":

While keep pressing "UP" of Cursor button" and MOTION PICTURE button simultaneously, turn the Power on.

• Step 2. Execute the error code display mode:

Press the "LEFT" of Cursor button", MENU/SET button and MOTION PICTURE button simultaneously.

The display is changed as shown below when the above buttons are pressed simultaneously.

Normal display → Error code display → CAMERA INFO → Normal display →

Example of Error Code Display

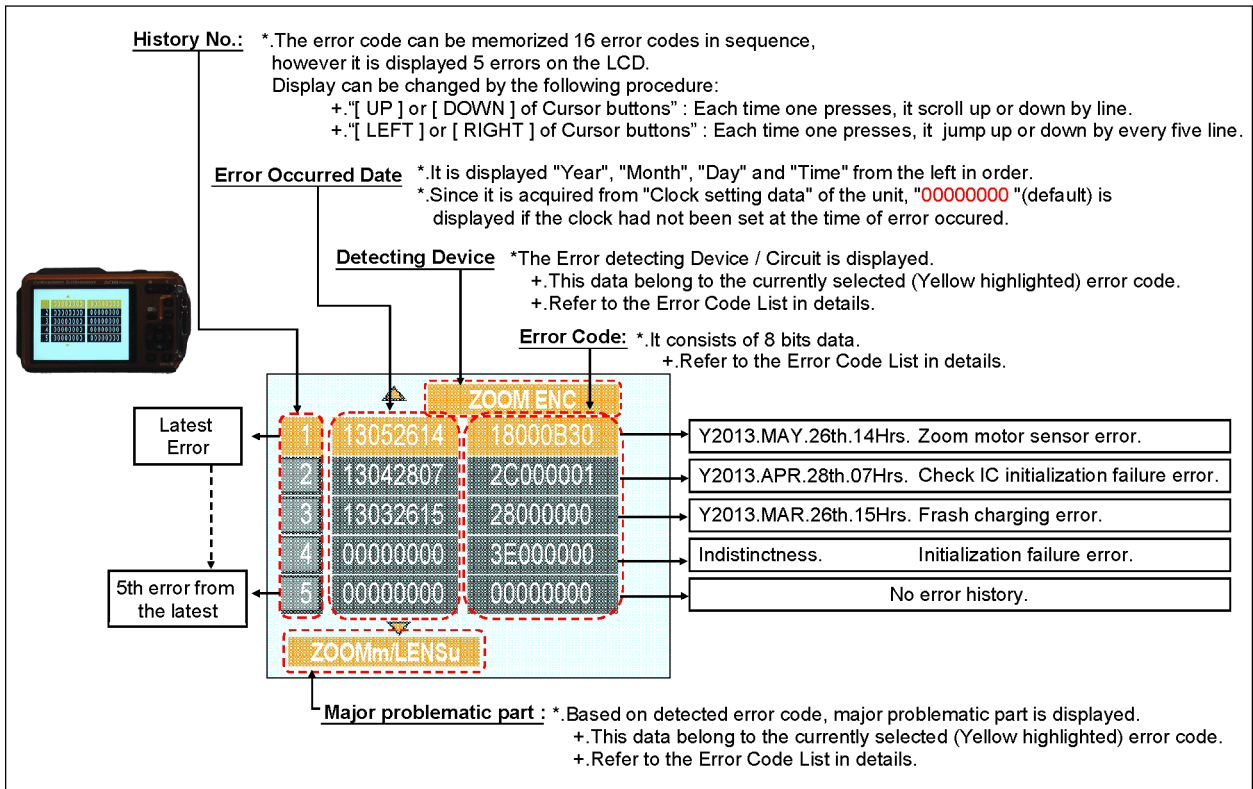

3. Error Code List

The error code consists of 8 bits data and it shows the following information.

Attribute	Main item	Sub item	Error code		Contents (Upper)	Error Indication	
			High 4bits	Low 4 bits	Check point (Lower)	Detecting device	Part/Circuit
LENS	Lens drive	OIS	18*0	1000	PSD (X) error. Hall element (X axis) position detect error in OIS unit. OIS Unit	OIS X	LENSu NG
				2000	PSD (Y) error. Hall element (Y axis) position detect error in OIS unit. OIS Unit	OIS Y	
			3000	GYRO (X) error. Gyro (IC7101) detect error on Main P.C.B. IC7101 (Gyro element) or IC6001 (VENUS ENGINE)	GYRO X	GYRO NG	
			4000	GYRO (Y) error. Gyro (IC7101) detect error on Main P.C.B. IC7101 (Gyro element) or IC6001 (VENUS ENGINE)	GYRO Y		
			5000	GYRO (R) error. Gyro (IC7101) detect error on Main P.C.B. IC7101 (Gyro element) or IC6001 (VENUS ENGINE)	GYRO R		
			6000	Drive voltage (X) error. LENS Unit, LENS flex breaks, IC6001(VENUS ENGINE) AD value error, etc.	OISX REF	LENSu/LENS FPC	
			7000	Drive voltage (Y) error. LENS Unit, LENS flex breaks, IC6001(VENUS ENGINE) AD value error, etc.	OISY REF		
			8000	OIS GYRO - Digital communication error. IC7101 (Gyro element) or IC6001 (VENUS ENGINE)	(No indication)	(No indication)	
			Zoom	0?10	Collapsible barrel Low detect error (Collapsible barrel encoder always detects Low.) Mechanical lock, FP9002-(40) signal line or IC6001 (VENUS ENGINE)	ZOOM L	ZOOMm/ LENSu
					0?20	Collapsible barrel High detect error (Collapsible barrel encoder always detects High.) Mechanical lock, FP9002-(40) signal line or IC6001 (VENUS ENGINE)	
				0?30	Zoom motor encoder error. Mechanical lock or IC6001 (VENUS ENGINE)	ZOOM ENC	
					0?40		
		0?50		Zoom motor encoder error. (During monitor mode with slow speed.) Mechanical lock or IC6001 (VENUS ENGINE)			
				0?60			The zoom position jump is detected due to the impact (i.e. drop.) to the camera occurs. Lens unit
		Focus		0?01	HP High detect error (Focus encoder always detects High, and not becomes Low) Mechanical lock, FP9002-(40) signal line or IC6001 (VENUS ENGINE)	FOCUS L	LENS FPC/ DSP
					0?02	HP Low detect error (Focus encoder always detects Low, and not becomes High) Mechanical lock, FP9002-(40) signal line or IC6001 (VENUS ENGINE)	
		Lens		10*8	Lens cap error	(No indication)	(No indication)
					Zoom motor, zoom pulse encoder 2		
			18*1	0000	Power ON time out error. Lens drive system	LENS DRV	LENSu
		18*2		0000	Power OFF time out error. Lens drive system		

Attribute	Main item	Sub item	Error code		Contents (Upper)	Error Indication		
			High 4bits	Low 4 bits	Check point (Lower)	Detecting device	Part/Circuit	
	Adj.History	OIS	19*0	2000	OIS adj. Yaw direction amplitude error (small)	OIS ADJ	OIS ADJ	
				3000	OIS adj. Pitch direction amplitude error (small)			
				4000	OIS adj. Yaw direction amplitude error (large)			
				5000	OIS adj. Pitch direction amplitude error (large)			
				8000	OIS adj. Yaw direction off set error			
				9000	OIS adj. Pitch direction off set error			
				A000	OIS adj. Yaw direction gain error			
				B000	OIS adj. Pitch direction gain error			
				C000	OIS adj. Yaw direction position sensor error			
				D000	OIS adj. Pitch direction position sensor error			
				E000	OIS adj. other error			
HARD	VENUS A/D	Flash	28*0	0000	Flash charging error. IC6001-(AC16) signal line or Flash charging circuit	STRB CHG	STRB P.C.B./ FPC	
				2000	0000			Flash charging error. IC6001-(AC16) signal line or Flash charging circuit
	FLASH ROM (EEPROM Area)	FLASH ROM (EEPROM Area)	2B*0	0001	EEPROM read error IC6005 (FLASH ROM)	FROM RE	FROM	
				0002	EEPROM write error IC6005 (FLASH ROM)	FROM WR	FROM	
				0005	Firmware version up error Replace the firmware file in the Memory Card.	(No indication)	(No indication)	
	SYSTEM	RTC	2C*0	0001	SYSTEM IC initialize failure error Communication between IC6001 (VENUS ENGINE) and IC9101 (SYSTEM)	SYS INIT	Main P.C.B.	
	SOFT	CPU	Reset	30*0	0000 0007	NMI reset Non Mask-able Interrupt (30000001-30000007 are caused by factors)	NMI RST	Main P.C.B.
		CPU, ASIC hard	Stop	38*0	0001	Camera task finish process time out. Communication between Lens system and IC6001 (VENUS ENGINE)	LENS COM	LENSu/DSP
					0002	Camera task invalid code error. IC6001 (VENUS ENGINE)	DSP	DSP
					0100	File time out error in recording motion image IC6001 (VENUS ENGINE)		
0200					File data cue send error in recording motion image IC6001 (VENUS ENGINE)			
0300					Single or burst recording brake time out.			
0008					USB work area partitioning failure USB dynamic memory securing failure when connecting	(No indication)	(No indication)	
Operation		Power on	3B*0	0000	FLASHROM processing early period of camera during movement.	INIT	(No indication)	
Zoom		Zoom	3C*0	0000	Imperfect zoom lens processing Zoom lens	ZOOM	ZOOMm/ LENSu	
				35*0	0000 FFFF	Software error (0-7bit : command, 8-15bit : status)	DSP	DSP
				35*1	0000	Though record preprocessing is necessary, it is not called.		
				35*2	0000	Though record preprocessing is necessary, it is not completed.	(No indication)	(No indication)
Wi-Fi				3211 3214	0001 FFFF	Wi-Fi related errors: *Generally, above are unable to specified the, which cannot be used for malfunction diagnosis.		

1) About "*" indication:

The third digit from the left is different as follows.

In case of 0 (example: 18 **0** 01000)

When the third digit from the left shows "0", this error occurred under the condition of INITIAL SETTINGS has been completed.

It means that this error is occurred basically at user side.

In case of 8 (example: 18 **8** 01000)

When the third digit from the left shows "8", this error occurred under the condition of INITIAL SETTINGS has been released.

(Example; Factory assembling-line before unit shipment, Service mode etc.)

It means that this error is occurred at service side.

2) About "?" indication: ("18*0 0?01" to "18*0 0?50"):

The third digit from the right shows one of the hexadecimal ("0" to "F") character.

4. How to returned to Normal Display:

Turn the power off and on, to exit from Error code display mode.

Note:

The error code can not be initialized.

7.1.2. Periodical maintenance (Packing replacement) flow

- The integrity of the waterproof packings may decrease about 1 year, with use and age.
(We recommend end-users to replace the waterproof packing at least once each year described in the operating instructions.)
- Please use waterproof packing kit (Part No.: VUMG2076). (5 types, 6 packings in total are included)
- Do not touch the waterproof packings directly by the hand.
- Do not perform cleaning of waterproof packings by the solvent of alcohol etc. or by blowing air.
- Take care not to put any foreign objects (garbage and dust).
- As for the air-leak test, refer to "7.1.3. Air-leak Test".

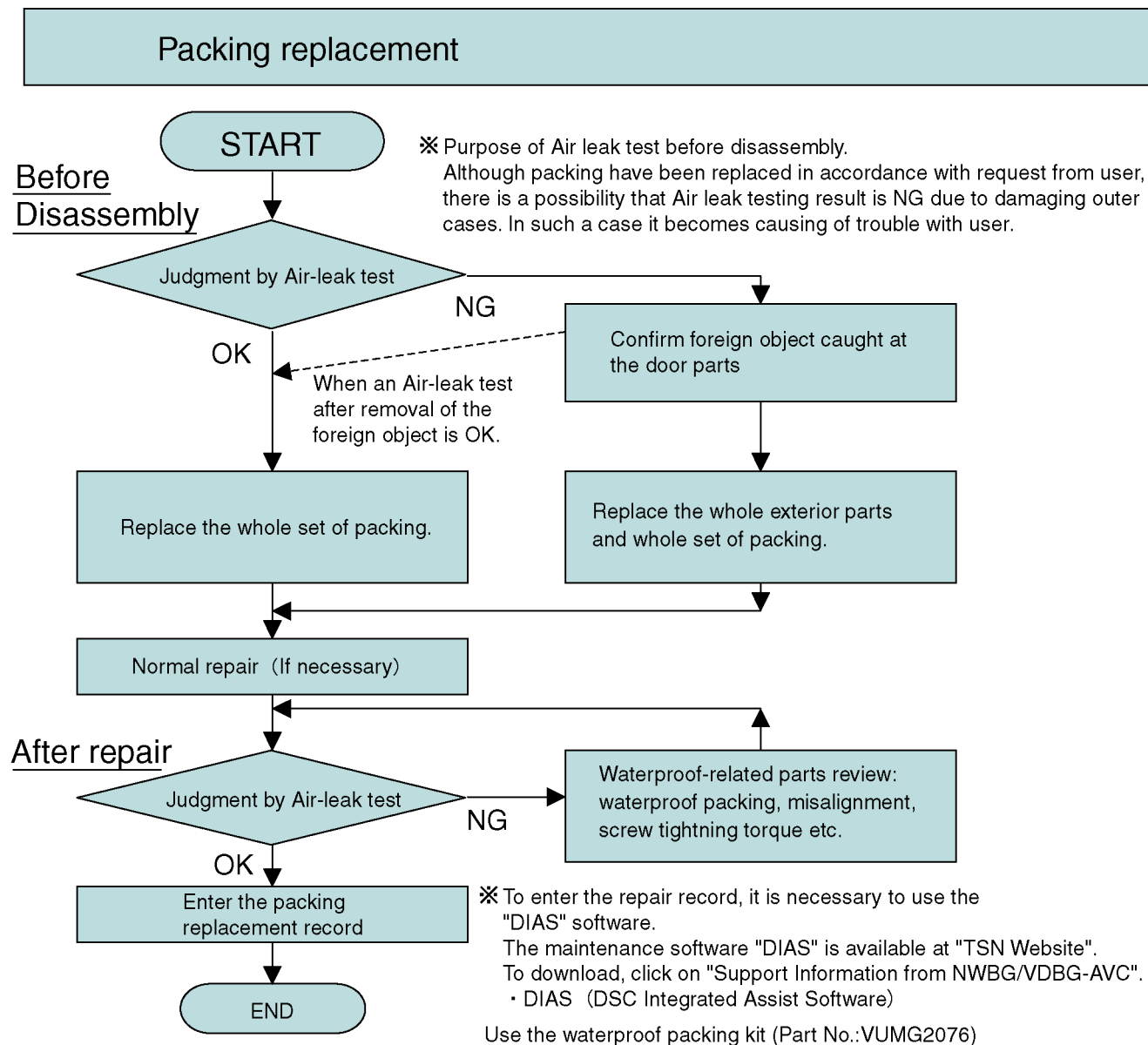

Replacing the waterproof packing

- The location of waterproof packing are shown at right. (5 types, 6 packings in total)
- Waterproof packings are supplied as Waterproof packing kit (Part No.: VUMG2076).

< Note for replacement >

- Do not touch the waterproof packings directly by the hand.
- Do not perform cleaning of waterproof packings by the solvent of alcohol etc. or by blowing air.
- Take care not to put any foreign objects (garbage and dust).
- Use the silicon chips (Part No.: RFKZ0478) when replacing the Case O-ring.

From Ref No.
"P-1,P-2,P-5,P-6,P-7,P-8" are
supplied only as
a "waterproof packing kit"
(Part No. VUMG2076)

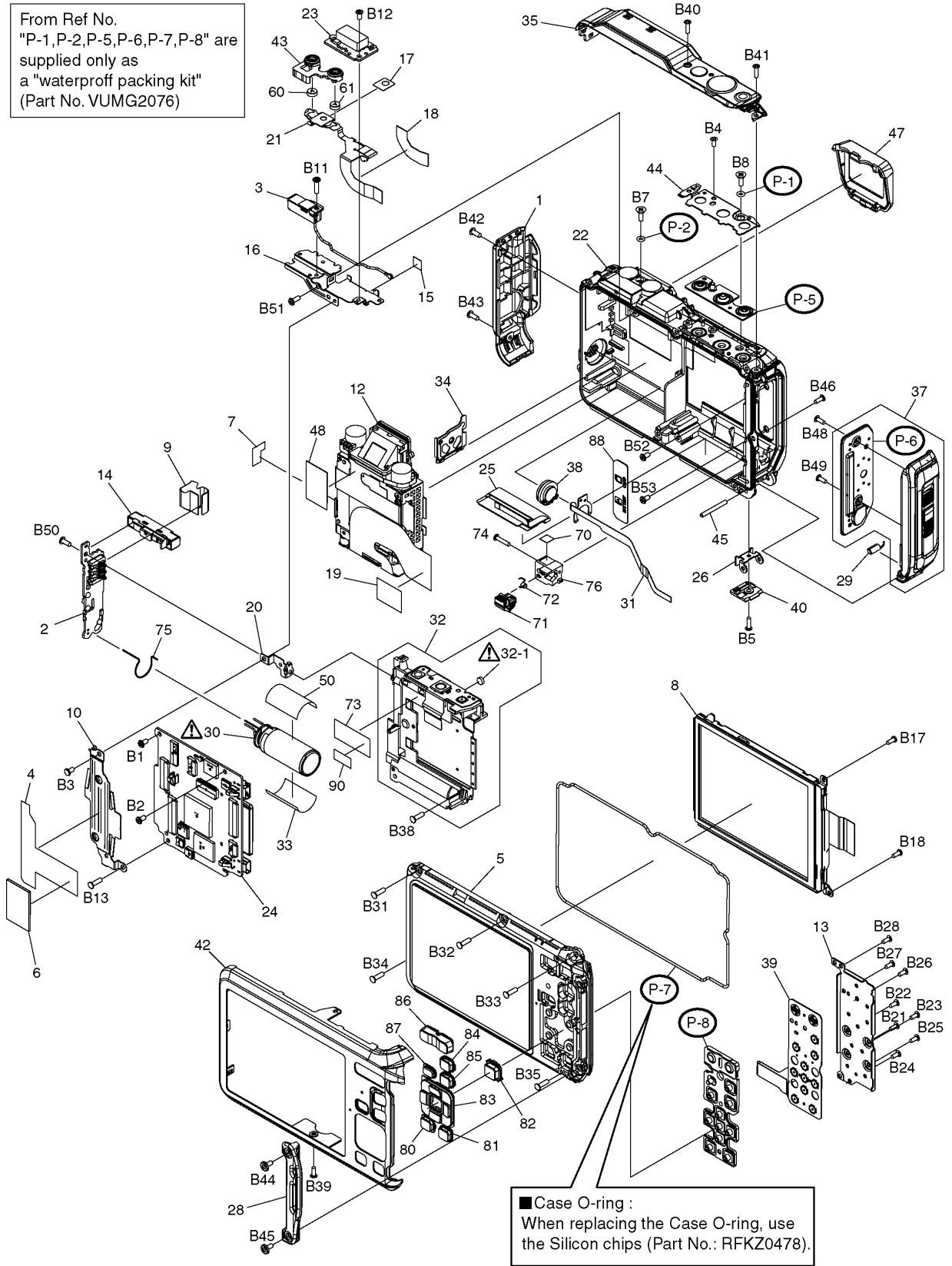

■ Case O-ring :
When replacing the Case O-ring, use
the Silicon chips (Part No.: RFKZ0478).

7.1.3. Air-leak Test

Due to the waterproof performance retention, perform the air-leak test using Air-leak tester (Part No.:RFKZ0528) before/after servicing when disassembling and assembling the unit.

*The Air-leak test before servicing is necessary to be performed to check whether the malfunction occurred due to air-leak or not.

1. Preparation:

- 1) By referring the "9.3. Disassembly procedures", remove the side ornament unit.
- 2) Confirm that no foreign objects at the side door, and it is firmly closed.



2. Air-leak Test (Inspection):

*Perform the air-leak test by referring the following procedure.

Note:

As for the detail instruction of air-leak tester, refer to the operating guide (attached to the product).

[Preparation]

1. Put the camera with the top case facing upward condition.
2. Set the following measurement pressure value on the air-leak tester. (Part No.:RFKZ0528).

[Measurement pressure value] :- 33 k P a

*About the Setting methods, refer to the operating guide for air-leak tester.

3. Attach "L" size of absorption pad to the tip of the hose of the air-leak tester.
4. Put the absorption pad of air-leak tester vertically on the Microphone part.

Note:

- Keep firmly hold above condition until the measurement is completed.
- Once pad is tilted/misaligned from the test hole during testing process, start it from this step.

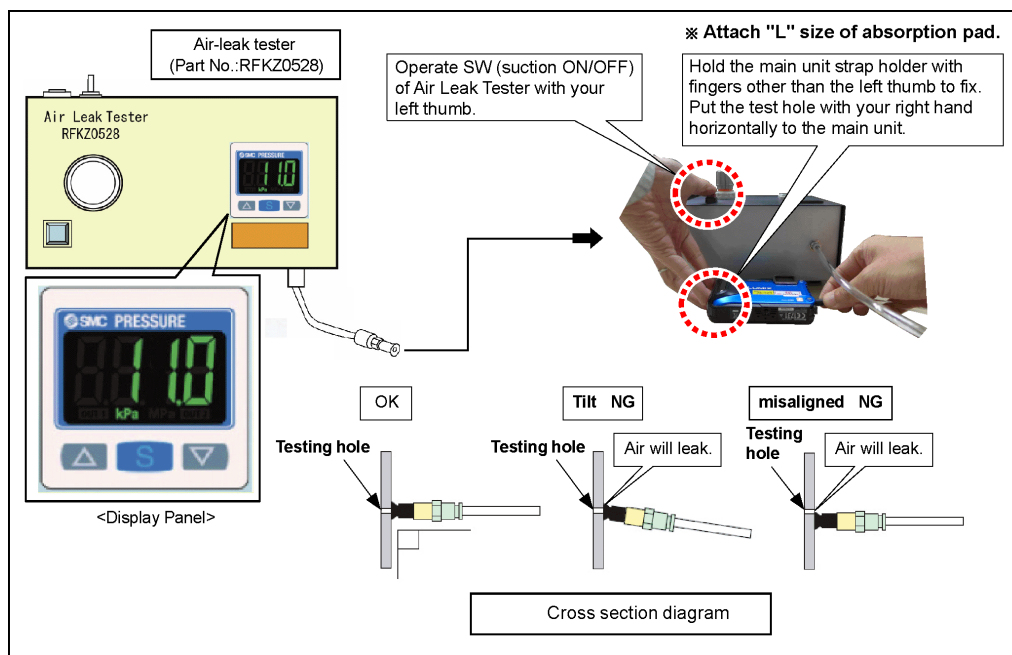

■ Measuring condition (For DMC-FT5, DMC-TS5)

Item	Specifications	Remarks
Setting pressure	-33kPa	
Setting stand value	more than -30kPa	
Exhausted period	more than 210sec.	
Stand-by period	15sec.	
Measuring time*1 (Period)	30sec.	
Testing*1 Specification	Stabilization Deviation	Between -30kPa and -33kPa ±0.2kPa
		*1 It must be stabilized between -30kPa and -33kPa, with a deviation of +/- 0.2kPa, within 30 seconds.

*Attach "L" size of absorption pad.

[Exhaust Air]

5. Operate the measurement switch of the air-leak tester to exhaust air inside the product for more than 210 seconds.

[Stand-by]

6. After a laps of 15 seconds, take a note (Record) that the pressure value indicated on the indication panel.

[Measurement]

7. Confirm that the pressure value fluctuations during measurement process are within the testing specifications

[Measuring time] :30 seconds
 [Testing Specification] :Stabilization :Between -30kPa and -33kPa
 Deviation : ± 0.2kPa

The air-leak test is now completed.

3. Packing replacement record input:

- To enter the repair record, it is necessary to use the "DIAS" software. The maintenance software "DIAS" is available at "TSN Website".
 To download, click on "Support Information from NWBG/VDBG-AVC".
 *DIAS (DSC Integrated Assist Software)

7.2. Failure Diagnosis of GPS

7.2.1. Checking Method of GPS failure

1. GENERAL DESCRIPTION

About the location name information of this unit

Be sure to read the "User License Agreement for Location Name data".

When [GPS Setting] is set to [ON], GPS function will operate even when this unit is turned off.

- When you bring the camera on an airplane or to a hospital, etc., set [Airplane Mode] to [ON], and turn off the camera because electromagnetic waves, etc. emitted by the camera may interfere with gauges.
- Battery power is consumed even if this unit is turned off when [GPS Setting] is set to [ON].

About the information of recording location

- Location names of the recording locations or landmarks (such as name of the building, etc.) are as of October 2012. Information will not be updated.
- Depending on the country or the region, there may be less information for location names and landmark names.

About the positioning

- It will take longer for positioning in an environment where it is harder to receive the radio waves from the GPS satellites.
- **Even if the receiving condition of the radio waves is excellent, it may take approx. 2 to 3 minutes to complete the positioning when performing positioning for the first time or when you perform positioning after turning this unit on again after turning the unit off with the [GPS Setting] set to [OFF] or [Airplane Mode] set to [ON].**
 Using GPS assist data can reduce the time required for positioning.
- The positions of the GPS satellites are changing constantly, so positioning may not be performed or the information may have errors depending on the recording location or conditions.
- For details on how to perform positioning smoothly, read "Receiving signals from GPS satellites".

When used during overseas travel etc.

- The GPS may not operate in China or close to the Chinese border in neighbouring countries. (As of January 2013)
- The usage of GPS etc., may be restricted depending on the country or the region. This camera has a GPS function, so check with the embassies or travel agencies etc. prior to your overseas travel regarding any restrictions on cameras with a built-in GPS function.

7.2.1.1. Checking flowchart of GPS failure

The checking flowchart of GPS failure is as follows:

- Note:**
- *Perform the GPS communication test, even if the repair being carried out is not related with GPS function.
 - *The GPS function in this unit is performed communication between GPS module (Mic GPS FPC Unit) and VENUS (IC6001: on the Main P.C.B.).

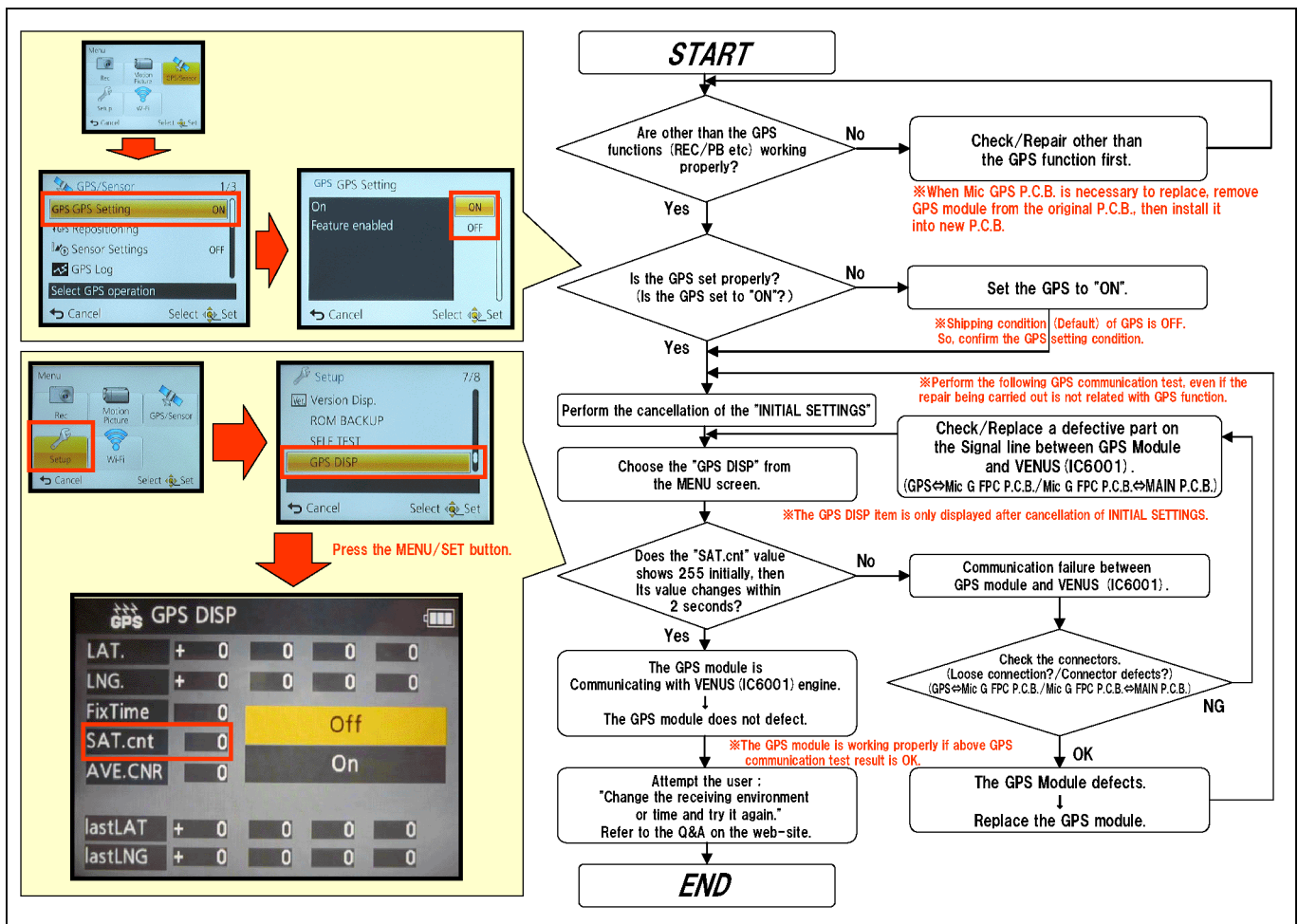

7.3. Checking Method of compass, altimeter, & barometer

This unit is possible to display or store in recorded pictures the environmental information of the recording location utilizing the built-in compass, altimeter, and barometer. (To display the compass, altimeter, and barometer, set [GPS Setting] to [ON]).

- (A) Compass
- (B) Altimeter
- (C) Latitude
- (D) Longitude
- (E) Time positioning was performed
- (F) Barometer

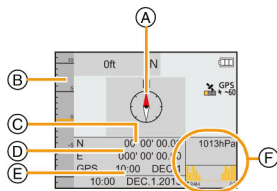

7.3.1. COMPASS

7.3.1.1. General description

Applicable modes: 

16 bearings are measured based on the direction the lens of the camera is pointing in.

- The colored portion of the compass needle points north.
- When [GPS Setting] is set to [OFF], magnetic declination is not corrected.

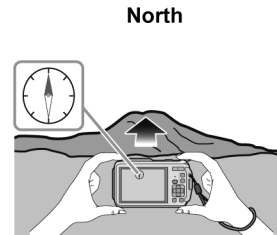

About the declination adjustment

Earth is a giant magnet with the South Pole at the Geographic North Pole and the North Pole at the Geographic South Pole, and the magnetism the Earth has is called "geomagnetism". There is a difference between the angle of the "magnetic north" that a magnetic compass points to and the geographical "true north" due to the effect of the "geomagnetism". The difference between these angles is called "declination".

The compass in this unit points "true north", when it corrects "magnetic declination" based on the latitude and longitude acquired in the GPS positioning.

- **The size of the magnetic declination can change as you move to different locations, so we recommend that you set [GPS Setting] to [ON] and perform positioning regularly to update your latitude/longitude.**

- It may not measure correctly when you measure with this unit upside down.
- The bearing measurement value may be affected in locations with weak geomagnetism.
- It may not measure accurately if close to the following objects:
 - Permanent magnets (metals in magnetic necklaces, etc.)/metallic objects (steel desks, lockers, etc.)/high-voltage lines or overhead wires/household appliances (TVs, PCs, mobile phones, speakers, etc.)
- It may not measure accurately in the following locations:
 - Inside cars/trains/ships/airplanes/rooms (when the steel beams are magnetised)

7.3.1.2. Failure diagnosis of Compass

The Compass sensor unit is IC6301 which is located on TOP FPC unit.

Since the IC6301 does not supply as a spare parts, replace as a TOP FPC unit if necessary.

Settings/Condition:

1. Release the initial settings to be forcefully turned off the declination adjustment:
2. Turn on the GPS setting.
3. Press the Display button to display the compass, altimeter, & barometer.
4. Select [Calibrate compass] on the [GPS/Sensor] menu, and then press [MENU/SET].
5. Securely hold the unit vertically, and adjust by turning it in a figure 8 a few times rolling your wrist.

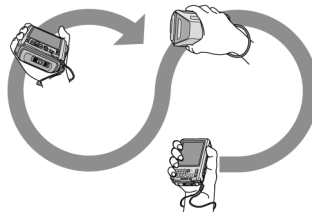

The "Calibration successful" is displayed when the adjustment is successful.

Diagnosis:

1. When both of the red arrow of compass unit and camera unit's one point same direction, the built-in compass unit works fine.

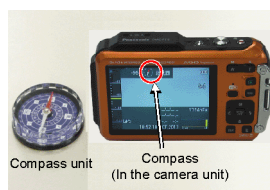

7.3.2. ALTIMETER

7.3.2.1. General description

Applicable modes: 

You can check the altitude of the current location.

Altimeter is not adjusted at the time of purchase.

- Displaying range is -600 m (-2000 feet) to 9000 m (30000 feet).
- A depth meter will be displayed instead of the altimeter in Beach & Snorkeling mode.

For details about the depth meter.

(A) Altitude

(B) Current altitude

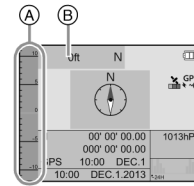

■ About altitude conversion

The displayed altitude is a relative altitude^{*1}. The altitude is a value calculated by converting an atmospheric pressure within the unit to an altitude with 0 m (0 feet) (sea level) = 1013 hPa^{*2} as a reference.

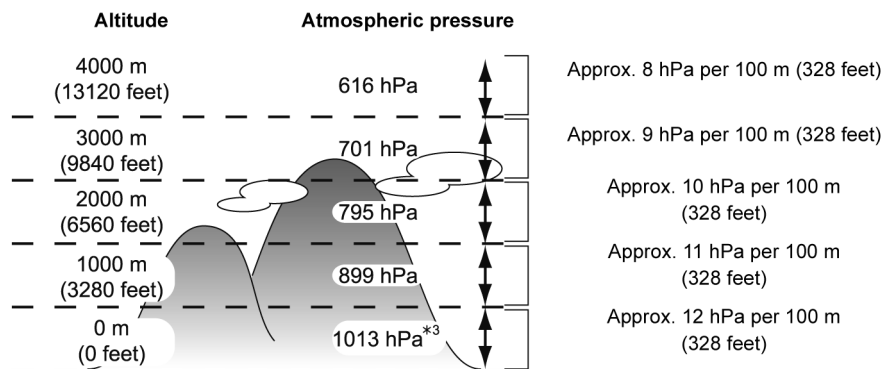

*1 Altitude can be expressed in two forms — as an altitude above sea level (absolute height from sea surface) or as a relative altitude (difference in altitude between two locations). This unit displays a relative altitude estimated by a method which uses the relationship between the altitude and atmospheric pressure in the ISA [International Standard Atmosphere], as specified by the ICAO [International Civil Aviation Organization].

*2 "hPa (hectopascal)" is a unit used to represent atmospheric pressure.

*3 Readings fluctuate with the weather. Adjust frequently with [Adjust] in [Altimeter].

7.3.2.2. Failure diagnosis of Altimeter.

The Altimeter sensor unit is IC6202 which is located on Main PCB.

(It detects direction of gravitation.)

Settings/Condition:

1. After performing the compass failure diagnosis, face down (the LCD side up) the camera unit, gradually.

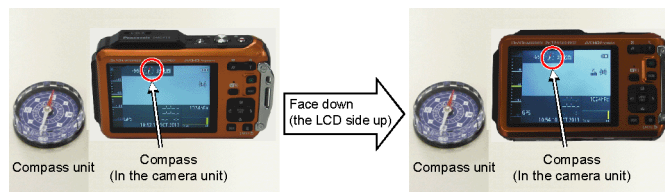

Diagnosis:

1. When the compass in the camera unit points same direction before and after above condition, the built-in altimeter unit works fine.

7.3.3. BAROMETER (ACCELEROMETER)

7.3.3.1. General description

Applicable modes: 

With the current atmospheric pressure as a reference, it is displayed on the graph within the range of -10 hPa to +10 hPa.

(Atmospheric pressure out of range cannot be displayed in details)

- Ⓐ 24 hours earlier
- Ⓑ Current
- Ⓒ Time periods for which history was not recorded (white portion)
- Ⓓ Atmospheric pressure information in 90 minute intervals

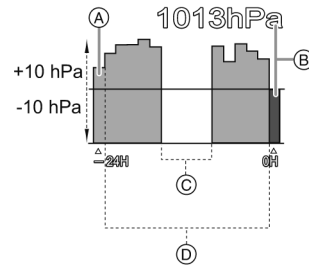

- The barometer is an indicator of changes between fine weather and rain.
 - When the atmospheric pressure rises: Weather tends to recover
 - When the atmospheric pressure drops: Weather tends to worsen

- In the following cases, atmospheric pressure is not recorded on the graph.
 - When [Sensor Settings] is set to [ON], the battery is low, and this unit is turned off
 - When [Airplane Mode] is set to [ON] and this unit is turned off
 - When [Sensor Settings] is set to [OFF]
- When the displayable range (current atmospheric pressure of -10 hPa to +10 hPa from the reference pressure) is exceeded, the atmospheric pressure will not be displayed correctly.

7.3.3.2. Failure diagnosis of Barometer

The barometer sensor unit is IC6201 which is located on Main P.C.B.

Settings/Condition:

1. After performing the altimeter failure diagnosis, take a note that the altimeter which is currently indicated on the LCD.

Diagnosis:

1. Do not turn off the power, but simply open the side door.
In this case, the altimeter value is increased.
2. Close the side door again.
In this case, the altimeter value is decreased.
After a while the value becomes closer to original value, the built-in barometer unit works fine.

7.4. Failure Diagnosis of Wi-Fi

7.4.1. How to Remove Wi-Fi Password Protection

To prevent incorrect operation or use of the Wi-Fi function by a third party and to protect saved personal information, this unit protects the Wi-Fi function with a password.

It is unable to service with password locked condition. When accepting for repair, the unit has been set the Wi-Fi password by customer, run the [Reset Wi-Fi Settings] for removing Wi-Fi password, then check the operation.

[Reset Procedure of Wi-Fi Settings]

1. Press the [MENU/SET] button, and select the [SETUP] mode by Cursor buttons, then press the [MENU/SET] button.
2. Select [Reset Wi-Fi Settings] by Cursor buttons, then press the [MENU/SET] button.
3. Select [YES] and press the [MENU/SET] button in several times.

(The [Reset Wi-Fi Settings] performs not only resetting Wi-Fi Password but also resetting other all Wi-Fi Settings.)

7.4.2. Checking of trouble caused by Wi-Fi Circuit on Main P.C.B. or not

(Primary Confirmation)

Confirm that the wireless access point (broadband router) works properly.

(Procedure)

- 1) Select [Access Point] in [Wi-Fi Setup] menu.
- 2) Select [Add] in [Access Point] menu.
- 3) Select [Manual Connection] in [Register Access Point] menu.
- 4) The Wi-Fi Circuit on Main P.C.B. works properly if the wireless access point (broadband router) in use is displayed.
 - ✘ When Wi-Fi Circuit has a defect, replace the Main P.C.B.

7.5. Failure Diagnosis of NFC

7.5.1. Checking flowchart of NFC failure

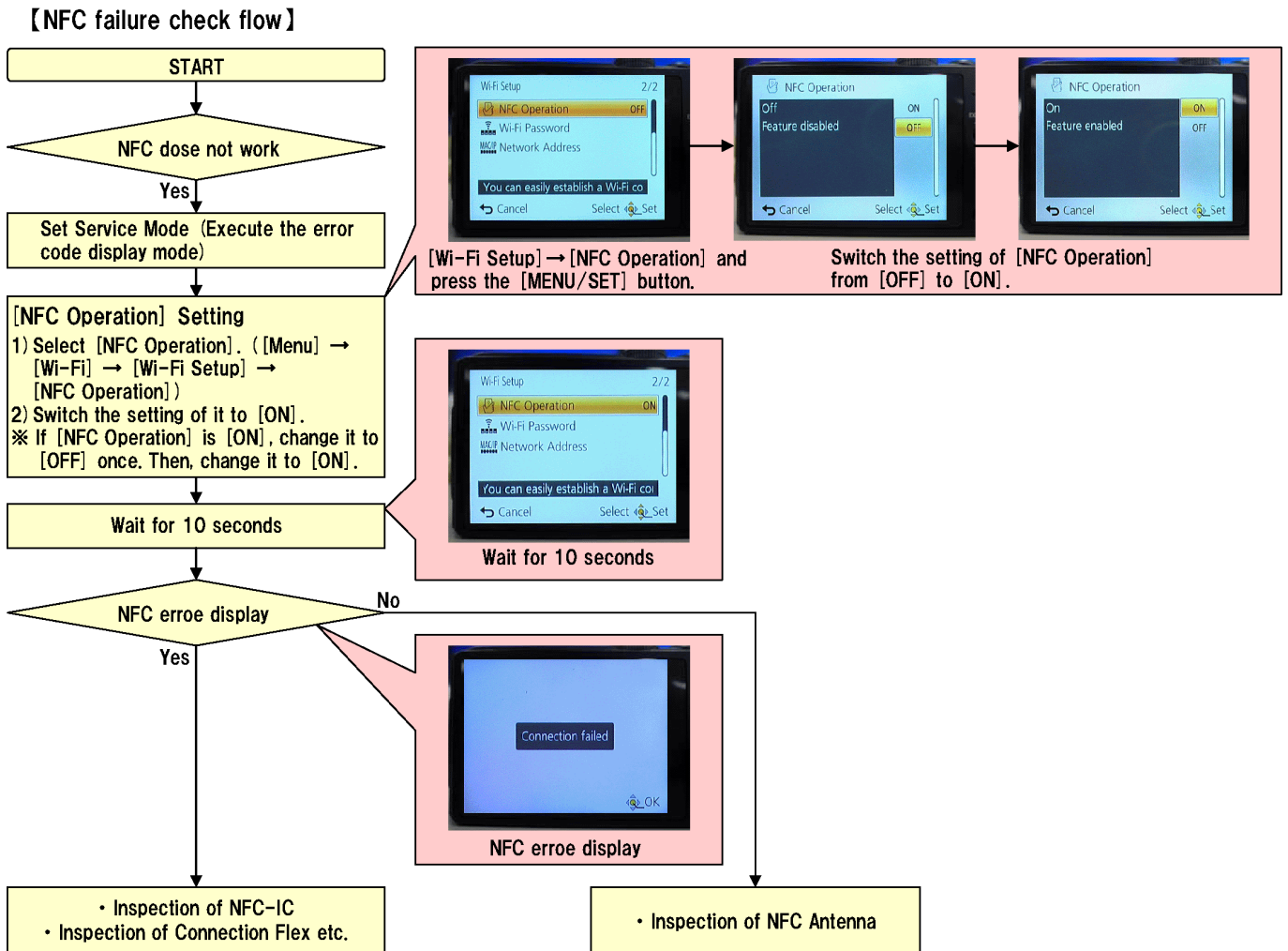

7.5.2. Initial Setting of NFC

【NFC initial setting procedure when repair work complete.】

After repair, make sure to perform the following ① and ②. (Initial Setting of NFC)
Then, the initialization data is written to NFC-IC.

- ① [NFC Operation] Setting
 - 1) Select [NFC Operation]. ([Menu] → [Wi-Fi] → [Wi-Fi Setup] → [NFC Operation])
 - 2) Switch the setting of it to [ON].
 - ※ If [NFC Operation] is [ON], change it to [OFF] once. Then, change it to [ON].
 - ※ If NFC-IC is defective, an error message will be displayed. (Mentioned Above)
- ② Initial Setting

Perform the initial setting operation. (Refer to 3.5.2. INITIAL SETTINGS)

- ※ The default setting of NFC operation is [ON].

Notes:

- NFC-IC and MAIN P.C.B. have no initialization data of NFC.
So, make sure to perform Initial Setting of NFC.
- NFC-IC may lose the initialization data due to heat during repair process.
Therefore, make sure to perform Initial Setting of NFC when the component parts on MAIN P.C.B. are replaced.

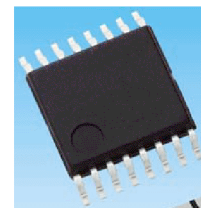





【NFC-IC】

8 Service Fixture & Tools

8.1. Service Fixture and Tools

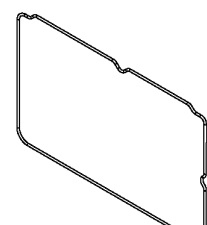
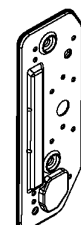
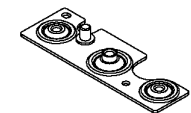
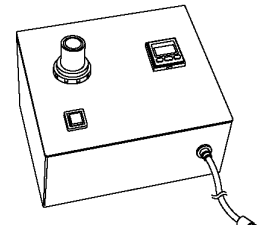
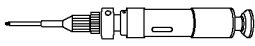
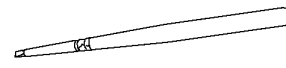
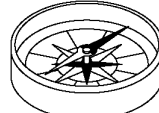
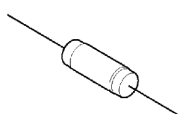
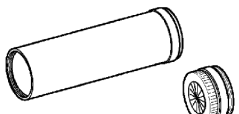
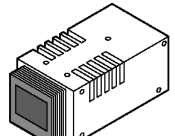
The following Service Fixture and tools are used for checking and servicing this unit.

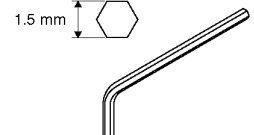
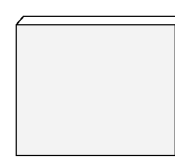
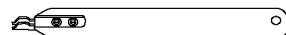
Related to waterproof					
Waterproof packing kit (For waterproof packing replacement) VUMG2076					
 Screw O-ring		 Rear Button Packing		 Case O-ring	
			 Battery Door Packing	 Top Button Packing	
Air-leak test jig (For Waterproof property test) RFKZ0528					
		Part No.	Usage	Spec.	Remarks
		RFKZ0536	DC/banana conversion cable	For power supply	Optional goods (1 piece supplied with RFKZ0528)
		RFKZ0533	Vacuum pad (2 included)	For power supply	Optional goods (1 piece supplied with RFKZ0528)
		RFKZ0537	Air-leak test tube (without pad)	For air-leak test	Optional goods (1 piece supplied with RFKZ0528)
Torque driver RFKZ0542		Silicon chips RFKZ0478		Compass Goods on market	
 (For tightening screws with the torque) RFKZ0456 (Shorter shank version) may be used.		 (For replacing the packings/ For prevention sticking of dust when replacing the packings)			
Resistor for Discharging (1kΩ/5W) ERG5SJ102		COLLIMATOR (with Focus Chart) VFK1164TCM02		LIGHT BOX (with DC Cable) RFKZ0523	
 An equivalent type of Resistor may be used.		 ※ RFKZ0422 may be used. ※ VFK1164TCM03 may be used.		 ※ VFK1164TDVLB may be used.	
ND Filter RFKZ0513		Lens Cleaning Kit VFK1900BK		Hex Wrench (Please purchase it, locally) Goods on market	
				 1.5 mm	
Diffuser RFKZ0591		Cable Jig RFKZ0608			
					

8.2. When Replacing the Main P.C.B.

After replacing the Main P.C.B., be sure to achieve adjustment.

8.3. Service Position

This Service Position is used for checking and replacing parts. Use the original cables for servicing.

8.3.1. Extension Cable Connections

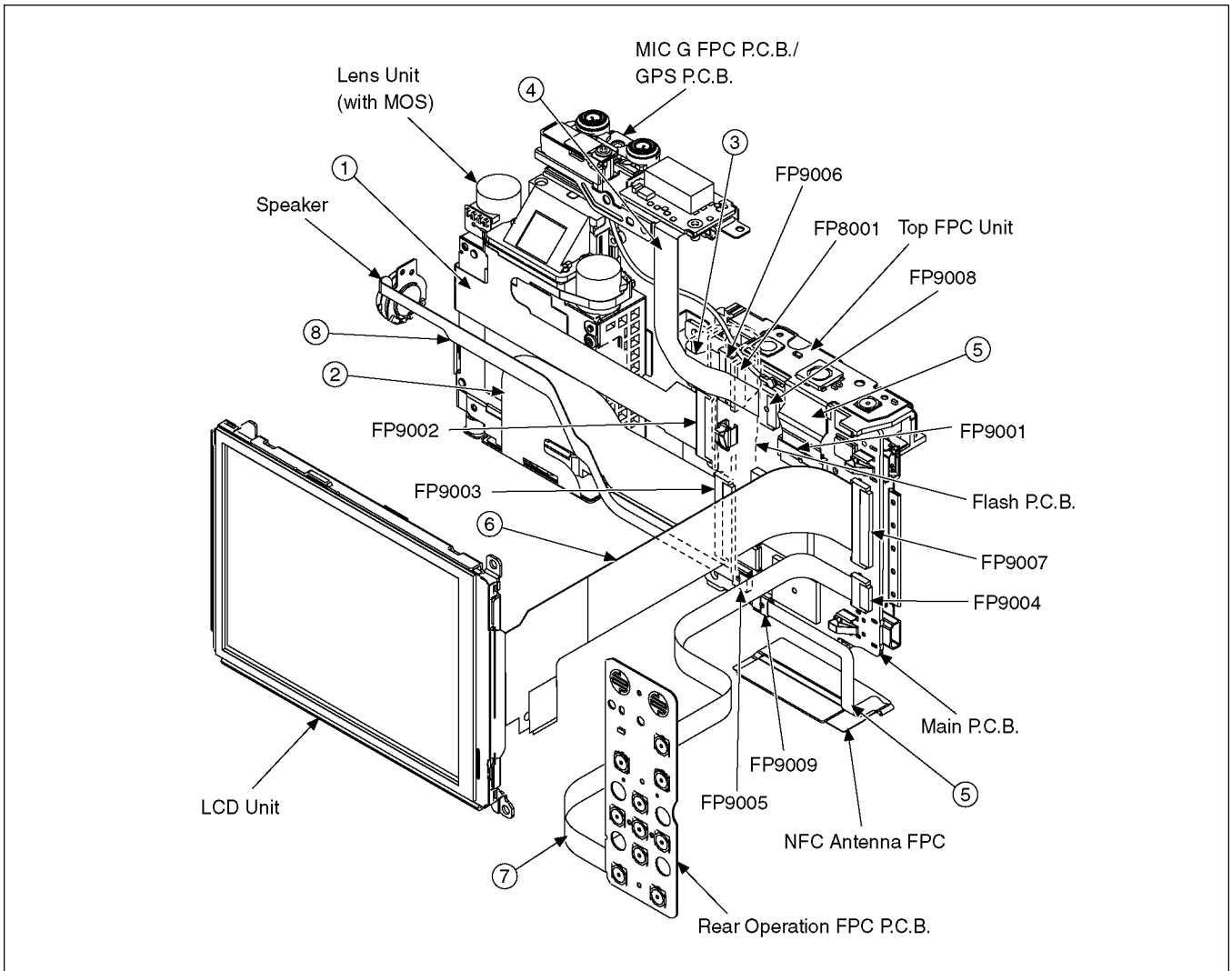

CAUTION-1. (When servicing Flash P.C.B.)

1. Be sure to discharge the capacitor on Flash P.C.B.
Refer to "HOW TO DISCHARGE THE CAPACITOR ON FLASH P.C.B.".
The capacitor voltage is not lowered soon even if the AC Cord is unplugged or the battery is removed.
2. Be careful of the high voltage circuit on Flash P.C.B.
3. DO NOT allow other parts to touch the high voltage circuit on Flash P.C.B.

9 Disassembly and Assembly Instructions

9.1. Disassembly Flow Chart

- Make sure to perform air-leak test (refer to "7.1. Service and Check Procedures (Air-leak Test)" before disassembly and after assembly for check of waterproof property.
- Do not touch the waterproof packings directly by the hand.
- Do not perform cleaning of waterproof packings by the solvent of alcohol etc. or by blowing air .
- Take care not to put any foreign object (garbage and dust).
- When replacing the case O-ring, use Silicon chips (RFKZ0478).
- When tightening screws, follow the specifications when the torque is specified .

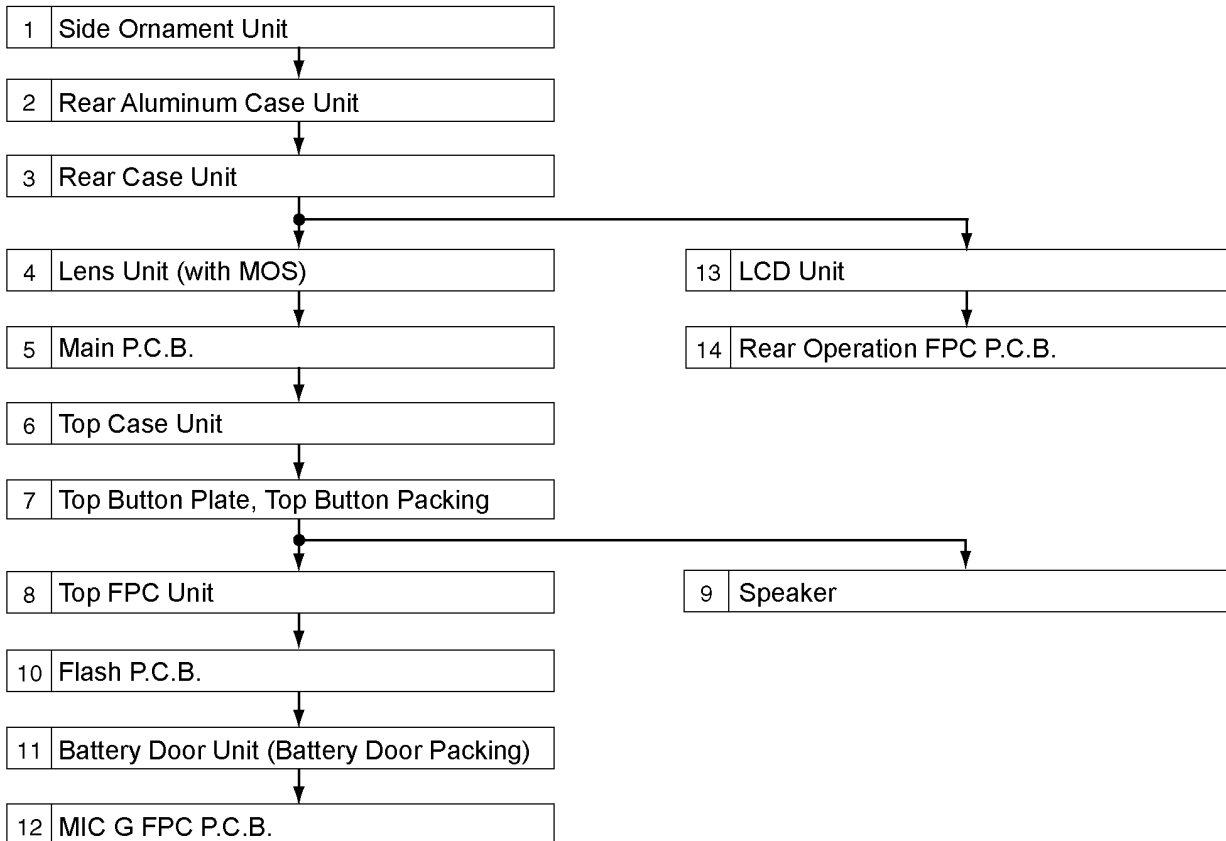

9.2. P.C.B. Location

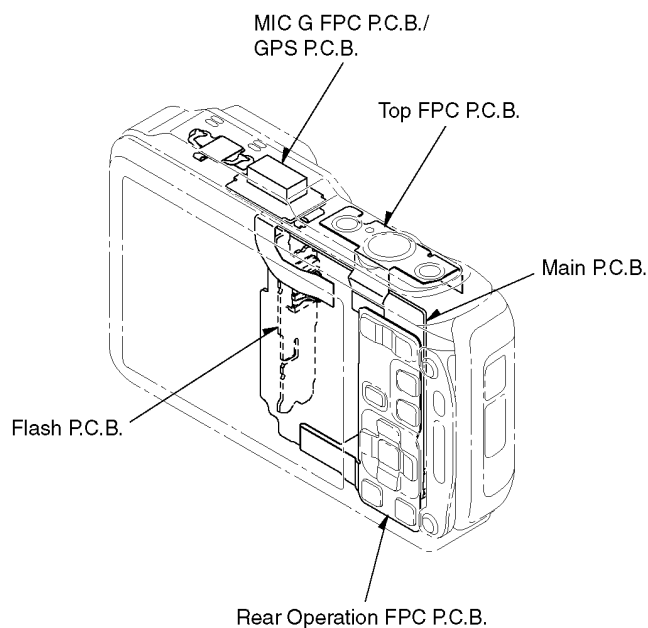

9.3. Disassembly Procedures

No.	Item	Fig.	Removal			
1	Side Ornament Unit	Fig. D1	Memory Card			
			Battery			
			2 Screws (A)			
			2 Locking tabs Side Ornament Unit			
2	Rear Aluminum Case Unit	Fig. D2	1 Screw (B)			
			2 Hex. Screws (C)			
			2 Screws (D)			
			1 Locking tab			
			Rear Aluminum Case Unit			
3	Rear Case Unit	Fig. D3	5 Screws (E)			
			2 Locking tabs			
			FP9004 (Flex)			
			FP9007 (Flex)			
		Fig. D4	Note: When attaching the Rear case Unit			
4	Lens Unit (with MOS)	Fig. D5	EMC Sheet (C)			
			Graphite Sheet, Venus Cushion			
			1 Screw (F)			
			1 Screw (G)			
			Lens Plate			
			LCD FPC Sheet			
			FP9005 (Flex)			
			FP9002 (Flex)			
			FP9003 (Flex)			
			Lens Unit (with MOS)			
			Fig. D6	As for attaching position of EMC Sheet (C), Graphite Sheet and Venus Cushion.		
			5	Main P.C.B.	Fig. D7	FP9001 (Flex)
						Wi-Fi Coaxial Cable
		5	Main P.C.B.	Fig. D8	FP9006 (Flex)	
FP9008 (Flex)						
FP9009 (Flex)						
2 Screws (H)						
Main P.C.B.						
5	Main P.C.B.	Fig. D9	Processing of Wi-Fi Coaxial Cable			
			Fig. D10	Note: Processing of Wi-Fi Coaxial Cable		
				Fig. D11	Insertion Procedures of Cable and Flex	
6	Top Case Unit	Fig. D12	1 Screw (I)			
			1 Locking tab (A)			
			2 Locking tabs (B)			
			Top Case Unit			
7	Top Button Plate, Top Button Packing	Fig. D13	1 Screw (J)			
			1 Screw (K)			
			1 Screw O-ring			
			Top Button Plate			
			Top Button Packing			
8	Top FPC Unit	Fig. D14	1 Screw (L)			
			Top FPC Unit			
9	Speaker	Fig. D15	Speaker Plate			
			Speaker			
10	Flash P.C.B.	Fig. D16	1 Screw (M)			
			2 Locking tabs			
			FL Earth Plate			
			Flash P.C.B.			

No.	Item	Fig.	Removal
11	Battery Door Unit (Battery Door Packing)	Fig. D17	2 Screws (N)
			Door shaft
			Battery Door Spring
			Battery Door Unit (Battery Door Packing)
12	MIC G FPC P.C.B.	Fig. D18	1 Screw (O)
			1 Screw (P)
			1 Screw (Q)
			1 Screw (R)
			1 Screw O-ring
			Wi-Fi Antenna Module
			GPS Module
			GPS MIC Plate
			MIC G FPC P.C.B.
13	LCD Unit	Fig. D19	2 Screws (S)
			2 Locking tabs
			LCD Unit
14	Rear Operation FPC P.C.B.	Fig. D20	8 Screws (T)
			Rear FPC Plate
		Fig. D21	Rear Button Packing
			Rear Operation FPC P.C.B.

9.3.1. Removal of Side Ornament Unit

- Memory Card
- Battery
- Screw (A) × 2
- Locking Tab × 2

NOTE:
When servicing and disassembling, remove the Memory Card and Battery from the Unit.

Fig. D1

9.3.2. Removal of Rear Aluminum Case Unit

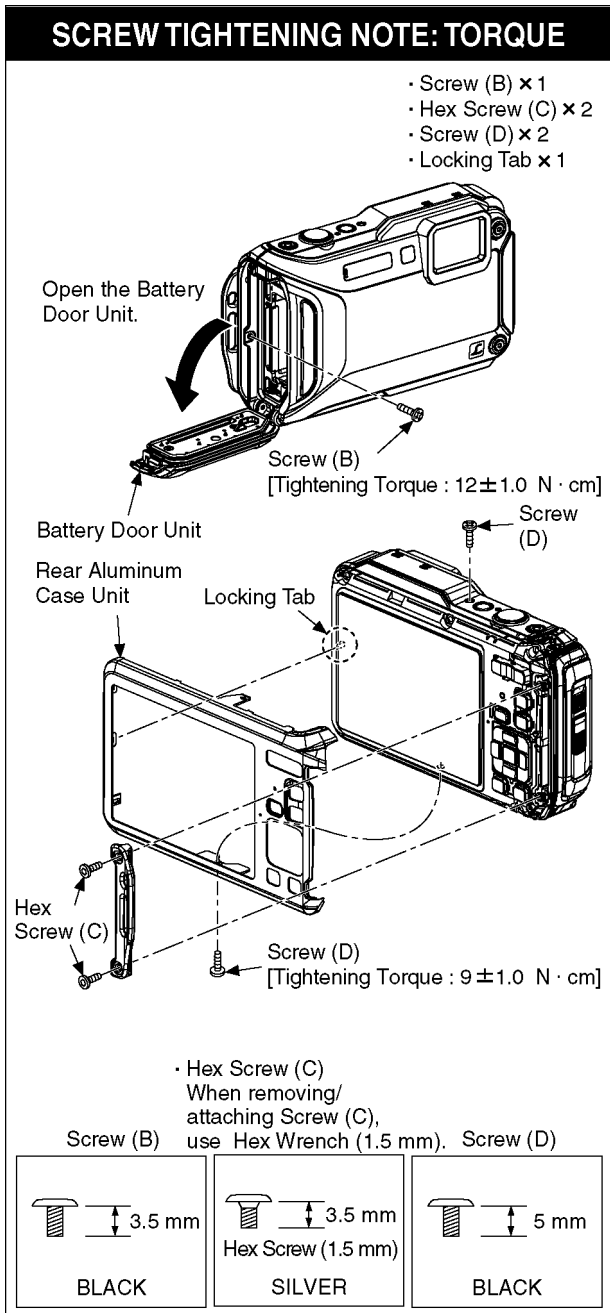

Fig. D2

9.3.3. Removal of Rear Case Unit

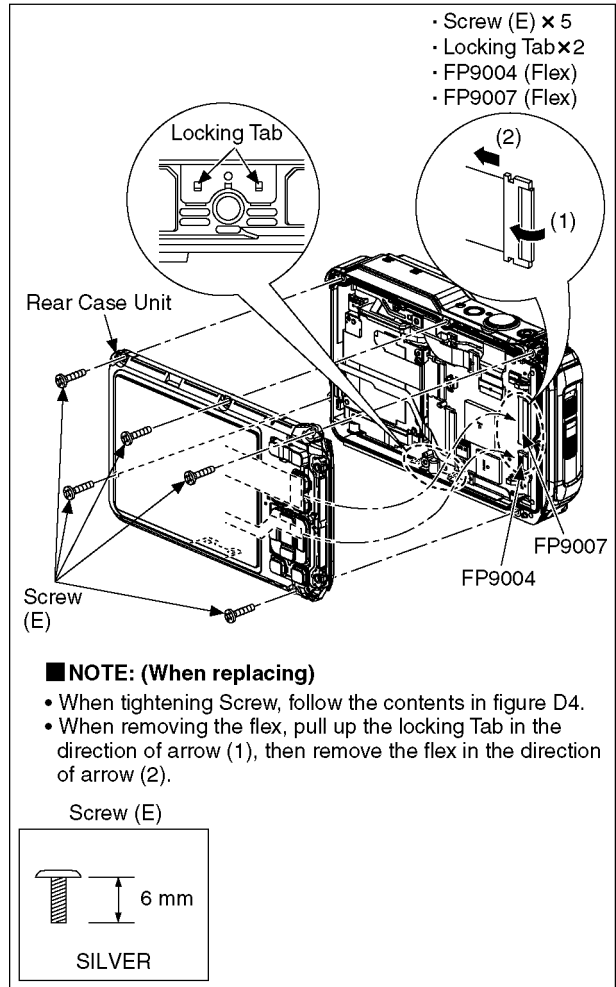
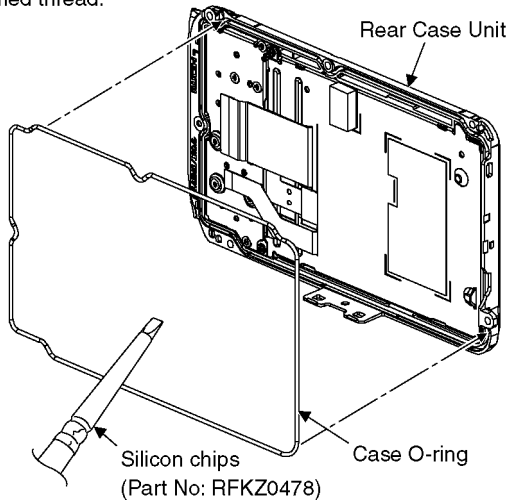

Fig. D3

SCREW TIGHTENING NOTE: TAPE/ORDER/TORQUE

NOTE: (When attaching the rear case unit)

- Do not insert the Flex from any slanted angle.
- Make sure the connector is firmly locked.
- When attaching case O-ring, use Silicon chips (Part No. : RFKZ0478).
- Make sure the O-ring of rear case dose not come off.
- Make sure foreign objects are not attached to the O-ring the waterproof lib of the front case.
- When tighten the screws, use Torque screwdriver (Part No. RFKZ0542) and tighten by the specified torque.
- Tighten the screws in the order of (1) to (5) as shown below.
- To keep waterproof property, not to be stripped thread or stuffed thread.



< Order of tightening screws/ tightening torque >

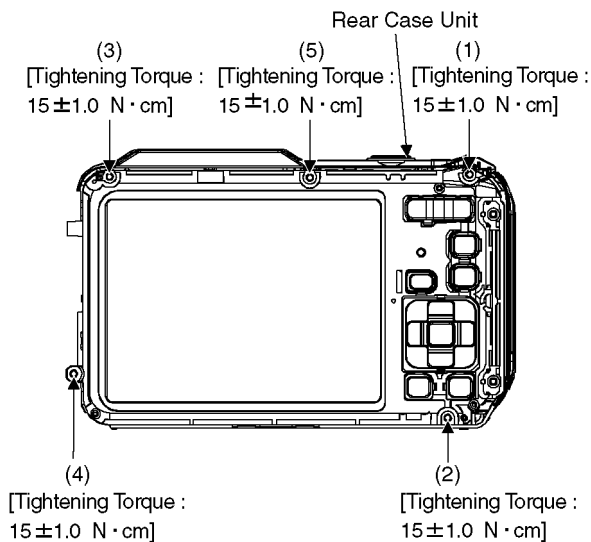

Fig. D4

9.3.4. Removal of Lens Unit (with MOS)

Note: (When Disassembling/Assembling)

1. When dust stuck, use air-Blower to blow off the dust.
2. Do not touch the surface of lens by your hand.
3. Use Lens Cleaning KIT; VFK1900BK (Only supplied as 10 set/Box) is available as Service Aid.

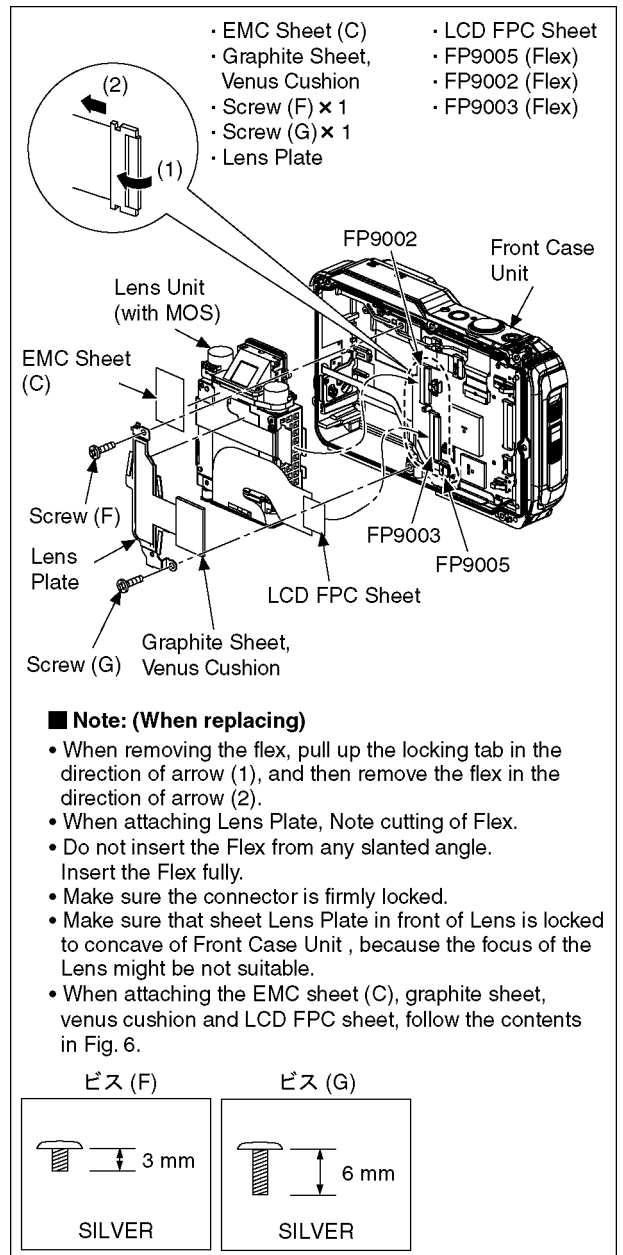

Fig. D5

EMC Sheet (C) Graphite Sheet, Venus Cushion and LCD FPC Sheet attaching position

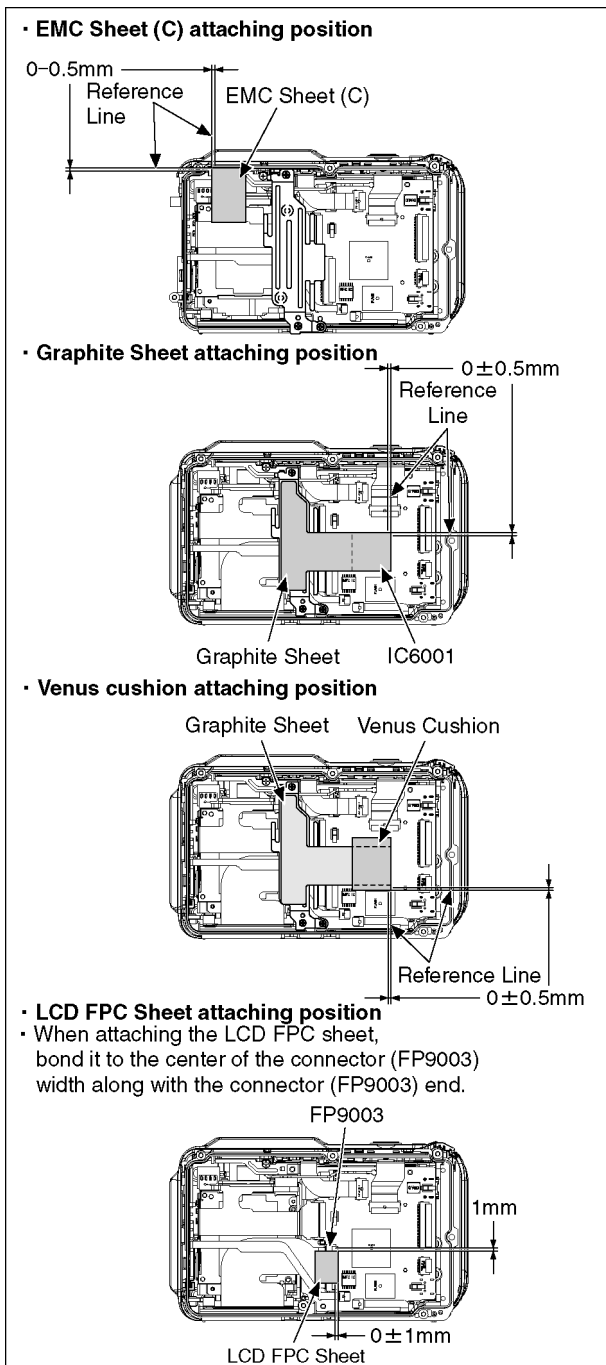

Fig. D6

9.3.5. Removal of Main P.C.B.

When attaching/removing the Wi-Fi Coaxial Cable, use the cable jig (RFKZ0608).

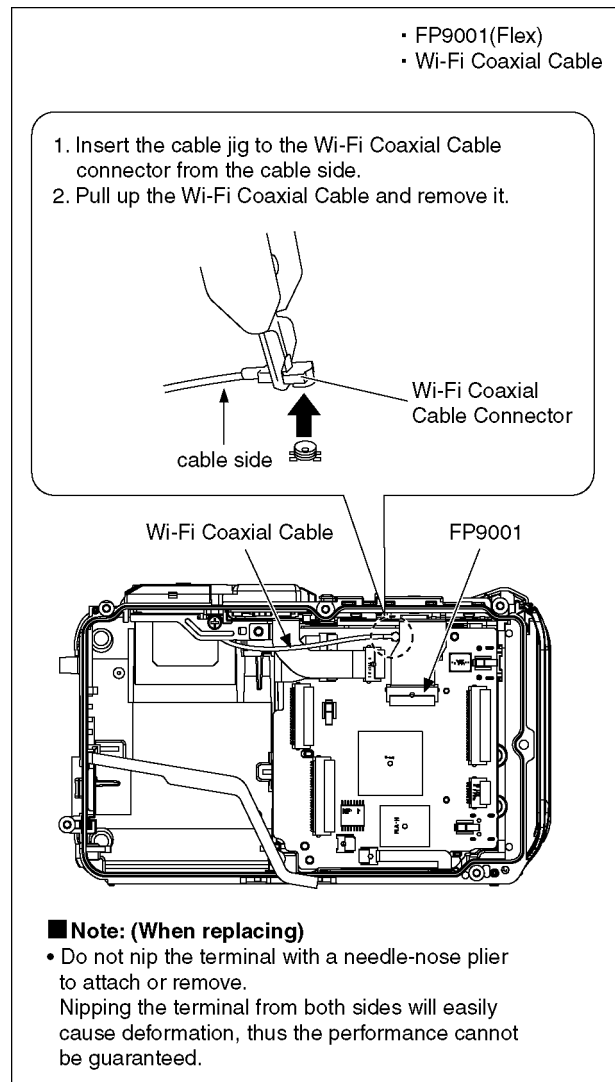

Fig. D7

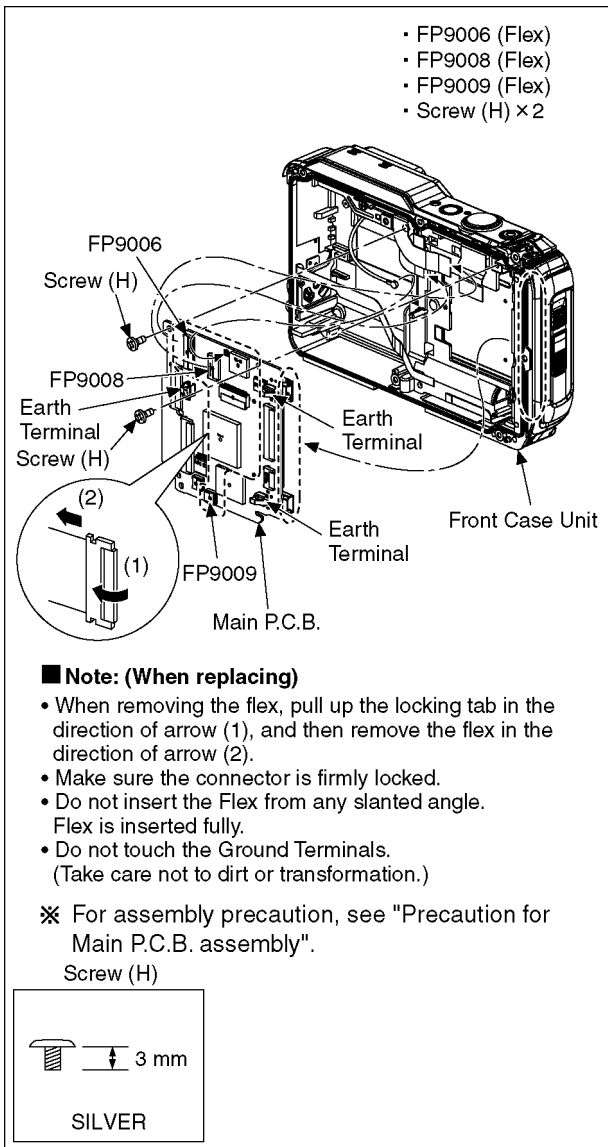

Fig. D8

Precaution for Main P.C.B. assembly

1. Refer to the following figure for the state of MIC G FPC P.C.B. and Wi-Fi Coaxial Cable.

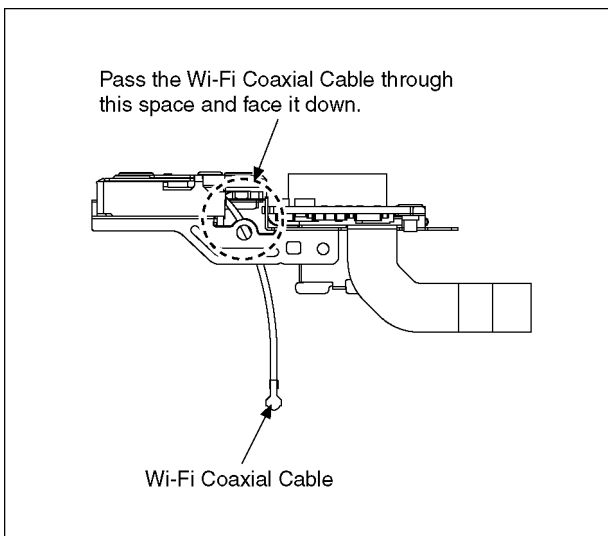

Fig. D9

2. When attaching the MIC G FPC P.C.B. to the front case unit, do not catch the Wi-Fi Coaxial Cable.

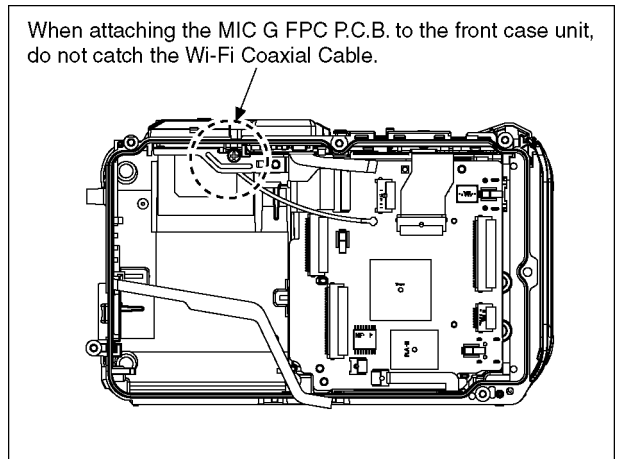
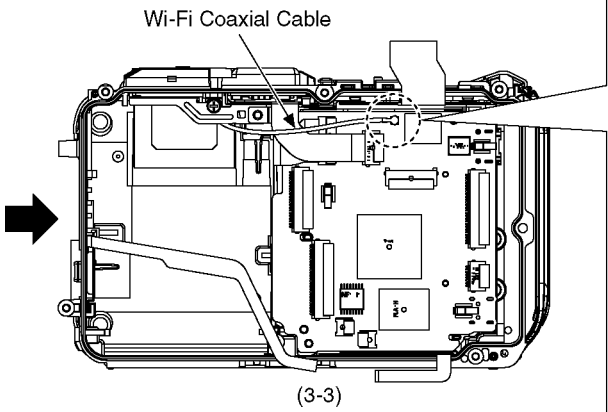
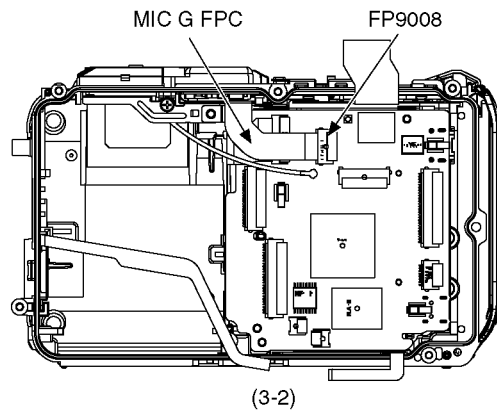
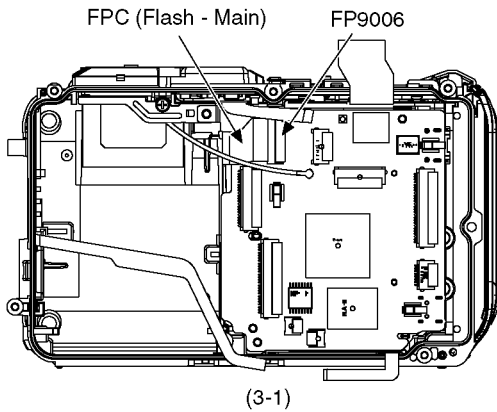

Fig. D10

3. Insert the FPC (Flex) and cable into the Main P.C.B. with the following order.

- 3-1. FPC (Flash - Main)
- 3-2. MIC G FPC
- 3-3. Wi-Fi Coaxial Cable
- 3-4. Top FPC
- 3-5. NFC Antenna FPC

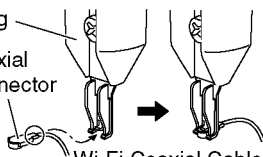

Precaution for Wi-Fi Coaxial Cable assembly

1. Insert the cable jig to the Wi-Fi Coaxial Cable connector from the cable side.
 

Cable Jig
Wi-Fi Coaxial Cable connector

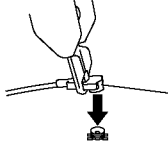
Wi-Fi Coaxial Cable jig setting complete.
2. Adjust the Wi-Fi coaxial cable connector position and push from above. (Push in until a clicking sound is heard.)
 

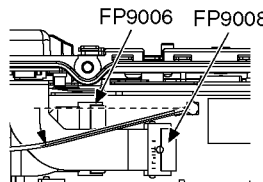
Wi-Fi Coaxial Cable connector
3.
 - The Wi-Fi Coaxial Cable must be lower than the upper end of the STROBE (FP9006) connector.
 - Avoid running over the GPS MIC FPC (FP9008) connector.

FP9006 FP9008

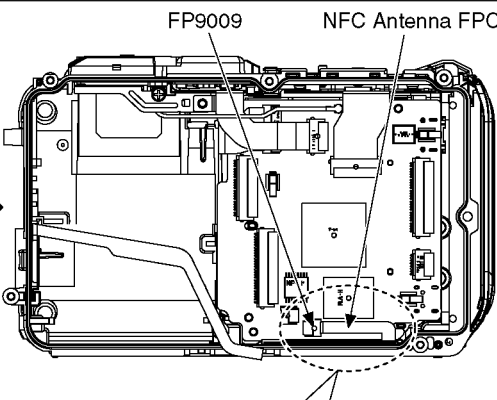
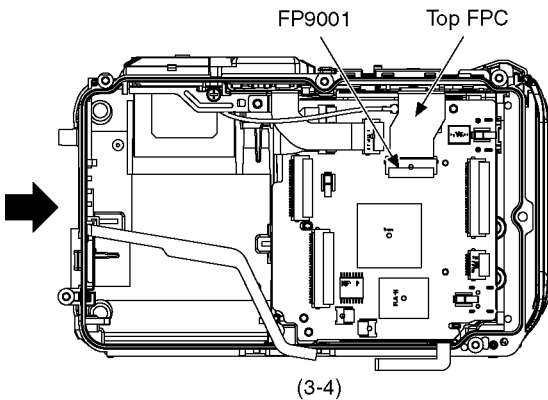

Before assembling the Main P.C.B., put the NFC antenna FPC outside the front case unit.

Fig. D11

9.3.6. Removal of Top Unit

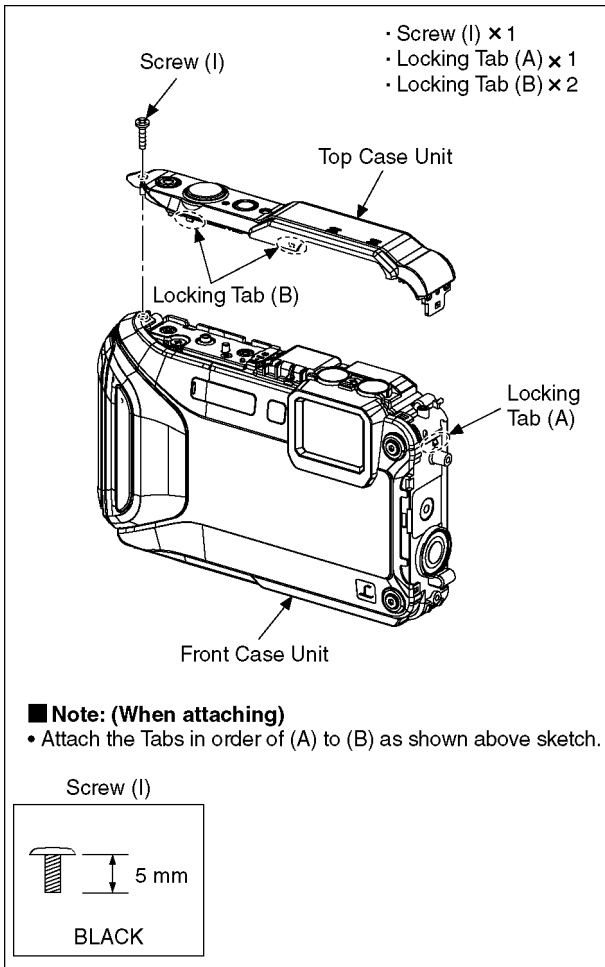

Fig. D12

9.3.7. Removal of Top Button Plate/Top Button Packing

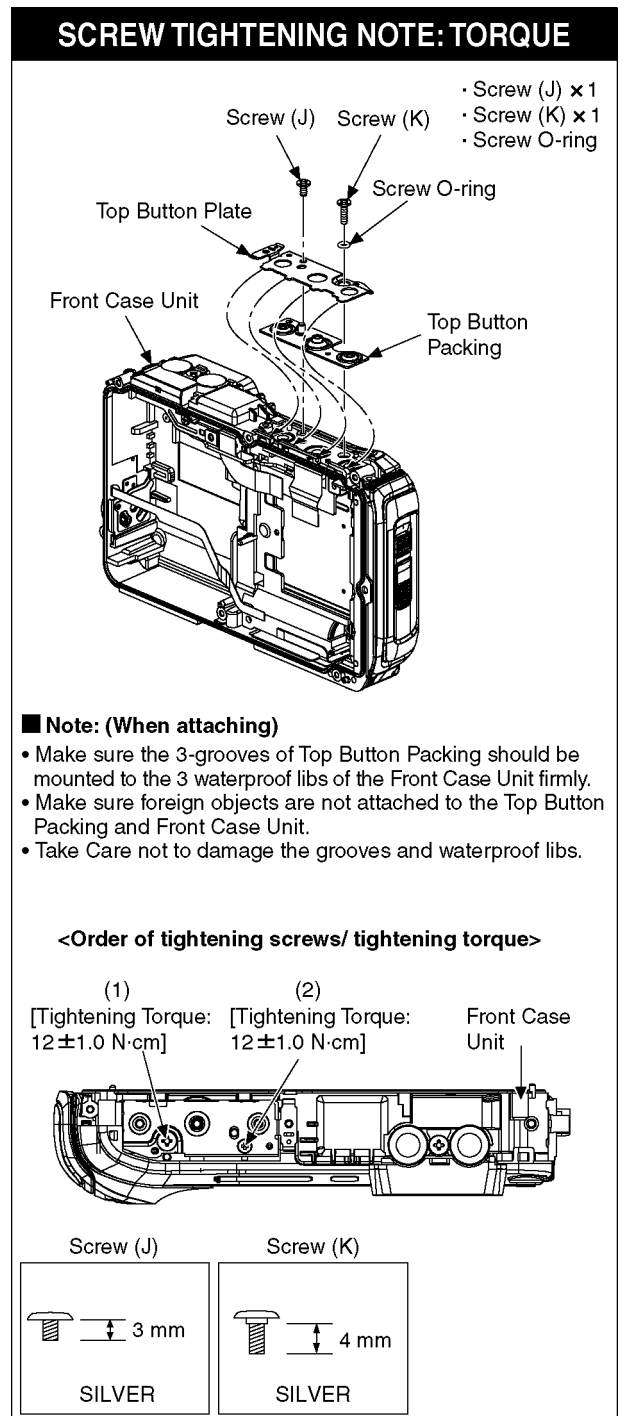

Fig. D13

9.3.8. Removal of Top FPC Unit

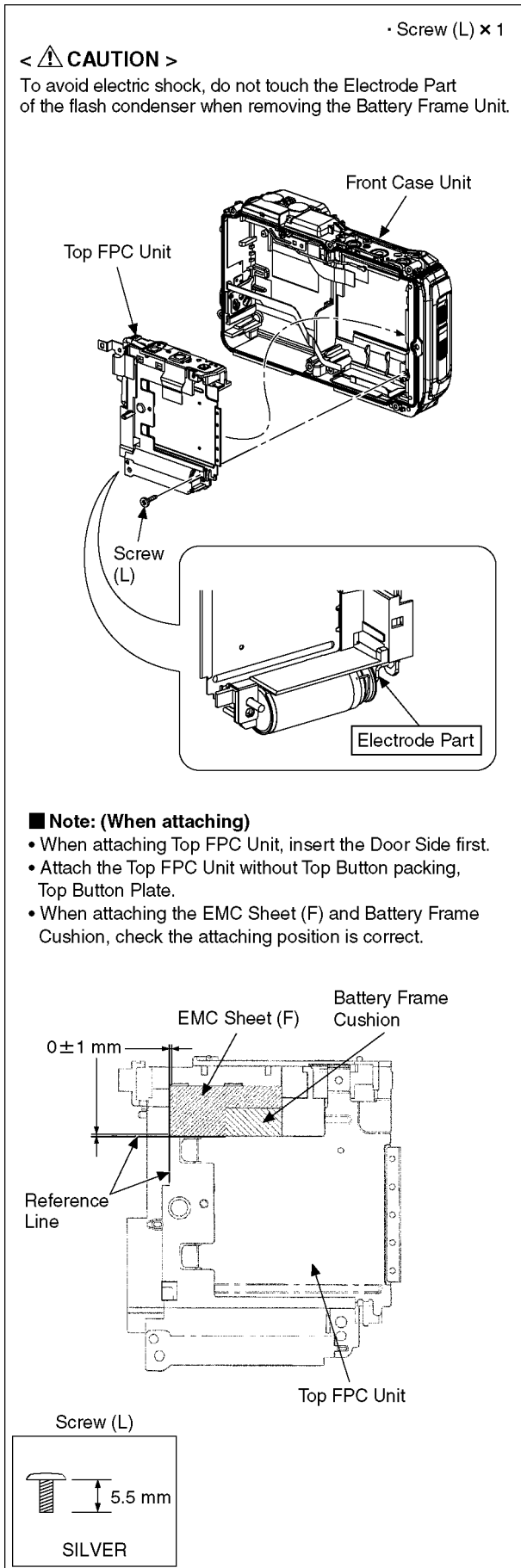

Fig. D14

9.3.9. Removal of Speaker

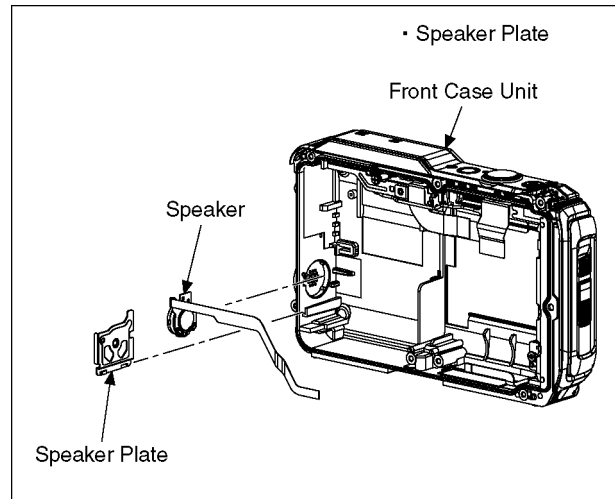

Fig. D15

9.3.10. Removal of Flash P.C.B.

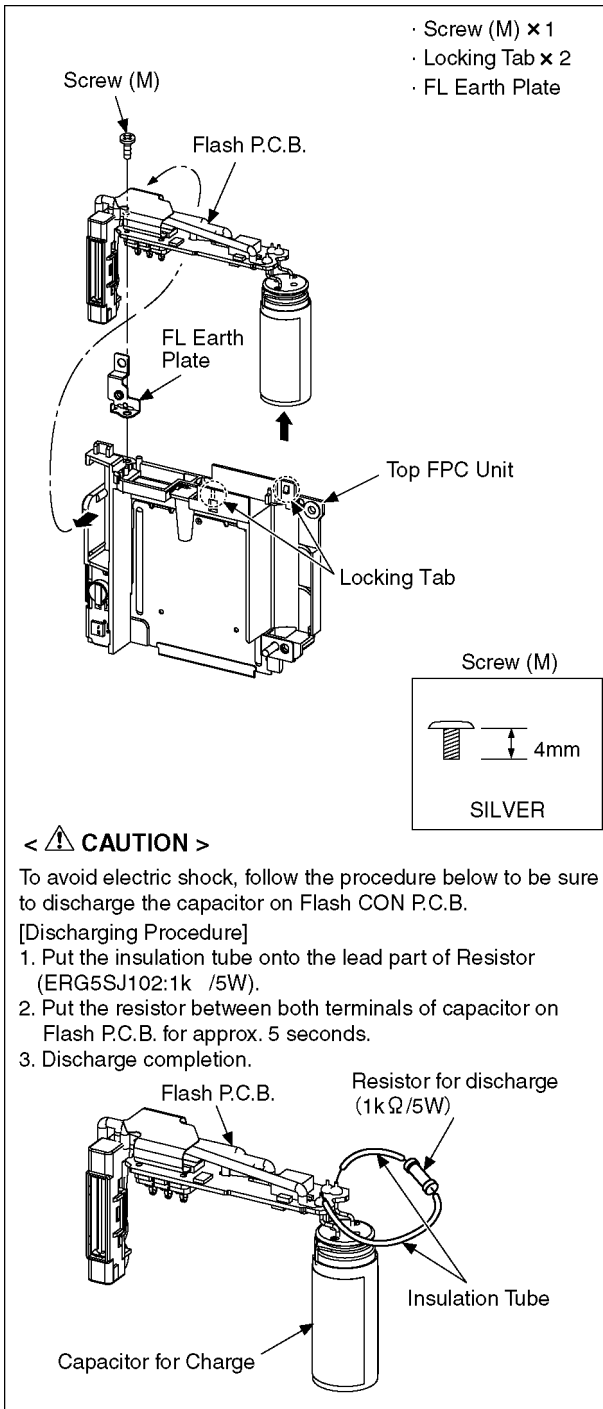

Fig. D16

9.3.11. Removal of Battery Door Unit (Battery Door Packing)

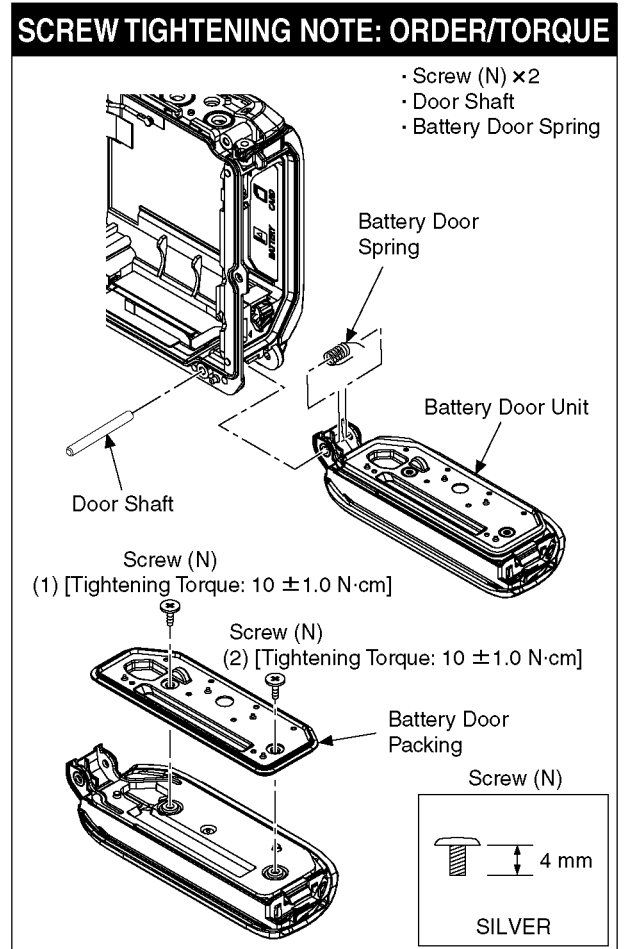

Fig. D17

9.3.12. Removal of MIC G FPC P.C.B.

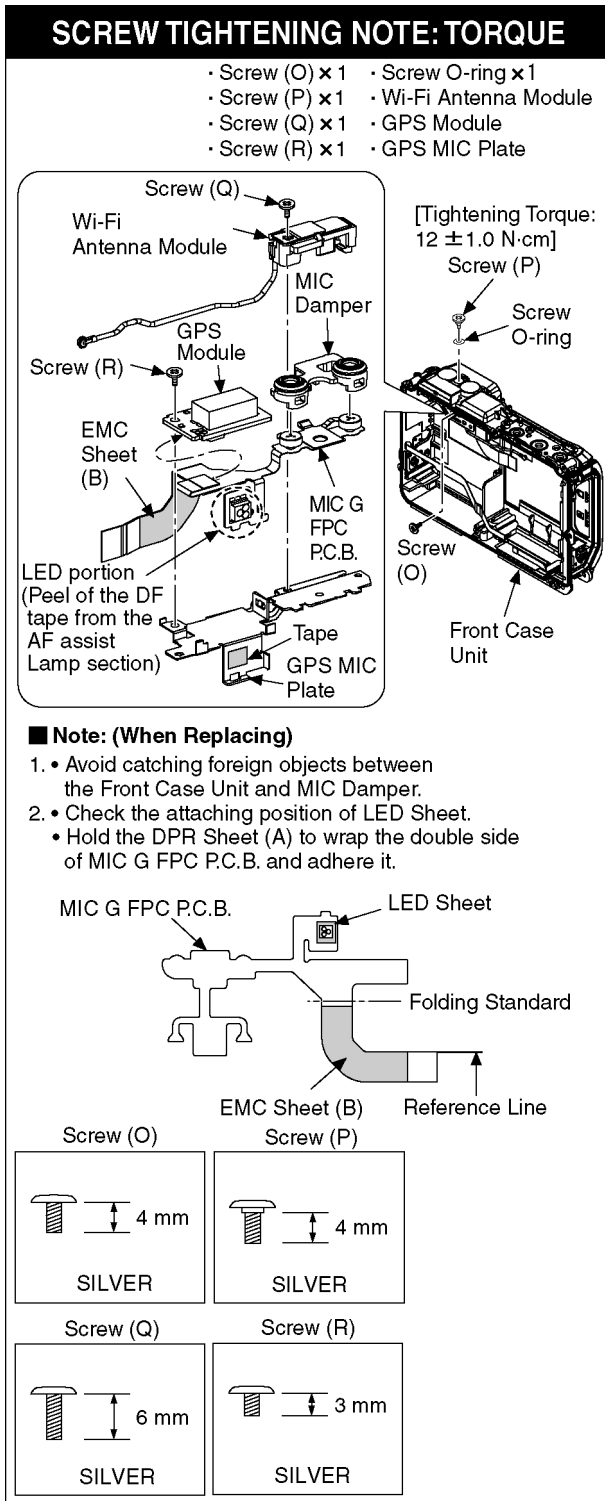

Fig. D18

9.3.13. Removal of LCD Unit

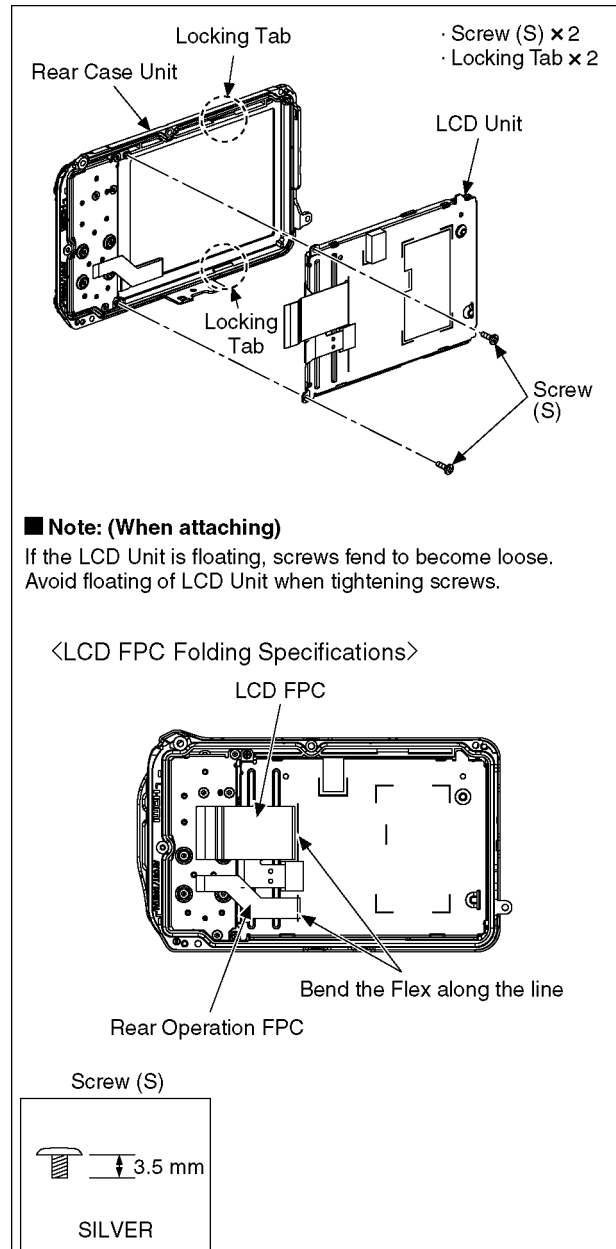
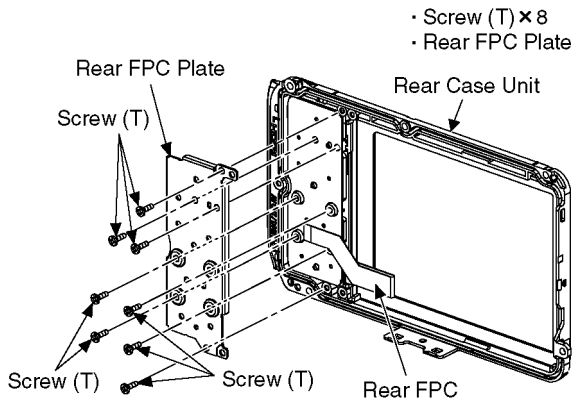

Fig. D19

9.3.14. Removal of Rear Operation FPC P.C.B.

SCREW TIGHTENING NOTE: TORQUE



Note: (When attaching)

- If the Rear FPC Plate is floating, screws tend to become loose. Avoid floating of Rear FPC Plate when tightening screws.
- Bend the Rear Operation FPC along the line. (Refer to Fig.19)

<Order of tightening screws/ tightening torque>

(1)-(8) : [Tightening Torque : 15±1.0 N-cm]

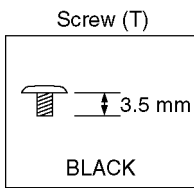
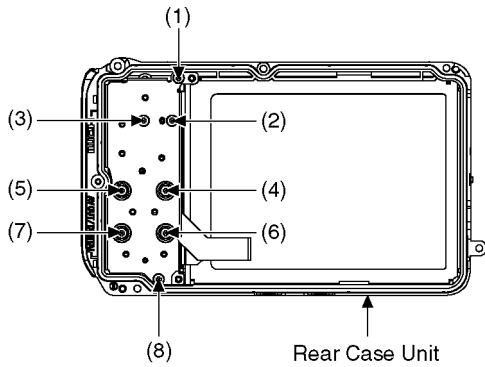
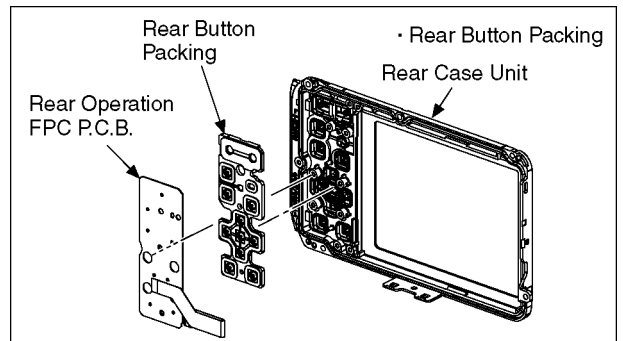

Fig. D20



Note: (When attaching Rear Buttons)

- Make sure that each Rear Button Pin is securely inserted into the screw holes of Rear Button Packing.
- Note that the Rear Button has a direction.
- Make sure that the Waterproof Lib of Rear Case is securely inserted in the groove of Rear Button Packing.
- Avoid catching foreign objects between the Rear Button Packing and the Rear Case (1).

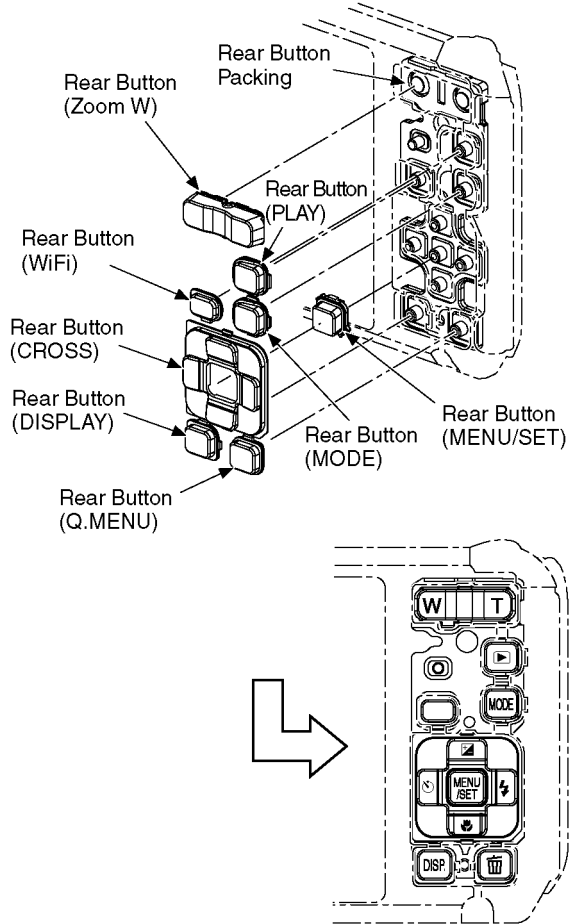

Fig. D21

10 Measurements and Adjustments

10.1. Introduction

When servicing this unit, make sure to perform the adjustments necessary based on the part(s) replaced.
Before disassembling the unit, it is recommended to back up the camera data stored in flash-rom as a data file.

NOTICE (When Main P.C.B. is exchanged)

Number of necessary adjustment items decreases by copying the backup data to new Main P.C.B. when adjustment data in old Main P.C.B. can be read by ROM_BACKUP "DSC → SD" in "10.2.2. Flash-Rom Data Backup".

For more details, please refer an item "MAIN PCB (to which the backup data was copied)" in the table of "10.3.2. Adjustment Specifications".

IMPORTANT NOTICE (After replacing the Main P.C.B.)

After replacing the Main P.C.B., it is necessary to achieve adjustment.

10.2. Before Disassembling the unit

10.2.1. Initial Setting Release

The cameras specification are initially set in accordance with model suffix (such as EB, EG, GC, and so on.).
Unless the initial setting is not released, an automatic alignment software in the camera is not able to be executed when the alignment is carried out.

Note:

The initial setting should be again done after completing the alignment. Otherwise, the camera may not work properly.

Therefore as a warning, the camera display a warning symbol " ! " on the LCD monitor every time the camera is turned off.

Refer to the procedure described in "3.5.2. INITIAL SETTINGS" for details.

[How to Release the camera initial setting]

Preparation:

Attach the Battery to the unit.

Set to P(Program AE) mode by operating the mode button.

Step 1. Temporary cancellation of "INITIAL SETTINGS":

While pressing the UP of Cursor button and MOTION PICTURE button simultaneously, turn the Power on.

Step 2. Cancellation of "INITIAL SETTINGS":

Press the PLAYBACK switch.

While pressing UP of Cursor button and MOTION PICTURE button simultaneously, turn the Power off. (The warning symbol " ! " is displayed on the LCD monitor.)

10.2.2. Flash-Rom Data Backup

Number of necessary adjustment items decreases by copying the backup data to new Main P.C.B. when adjustment data in old Main P.C.B. can be read by ROM_BACKUP "DSC → SD".

It is recommended to backup the Flash-rom data as the way of return when trouble occurs before disassembling the unit depending on each case.

[ROM_BACKUP (Method of Non-PC backup)]

1. Insert the Memory Card into the camera.
2. Set the camera to "Temporary cancellation of the initial settings".
3. Select the "SETUP" menu.

From the "SETUP" menu, select "ROM BACKUP".

Note:

This item is not listed on the customer's "SET UP" menu.

4. When this "ROM_BACKUP" item is selected, the following submenus are displayed.

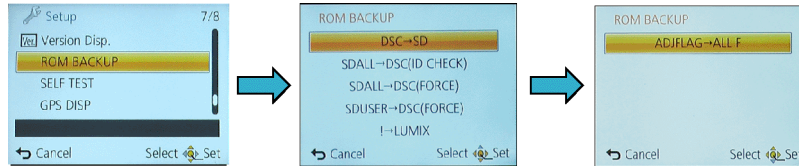

Item	Function	Details
DSC → SD	Save all the DSC's Flash-rom data to Memory Card	<ul style="list-style-type: none"> • DSC's Flash-rom data is saved to the Memory Card as a data file. (DATA BACKUP) -File location: ROOT DIRECTORY in Memory Card. -File Name: <ol style="list-style-type: none"> 1) User Setup Information data: <Model No.>U.txt [Depending on the model, more than one file may be generated (e.g. <Model No.>U.TXT and <Model No.>U3.TXT).] 2) Electrical Adjustment data: <Model No.>F.txt [Depending on the model, more than one file may be generated (e.g. <Model No.>F.TXT and <Model No.>F3.TXT).] • If the concerned file already exists, "OVERWRITE?" message is displayed.
SDALL → DSC (ID CHECK)	Write the all data to DSC's Flash-rom from Memory Card	<ul style="list-style-type: none"> • The backup data stored in the Memory Card is transferred to DSC unit. • ID CHECK: When the model ID is different, data is not transferred.
SDALL → DSC (FORCE)	Write the all data to DSC's Flash-rom from Memory Card	<ul style="list-style-type: none"> • FORCE: Even if the model ID is different, data is transferred. * If the main PCB is replaced, select "SDALL → DSC(FORCE)".
SDUSER → DSC (FORCE)	Only "User setup information" is written from the saved file in the Memory Card to DSC's Flash-rom.	<ul style="list-style-type: none"> • Only the user's "setup" setting condition is transferred to DSC unit. • FORCE: Even if the model ID is different, the data is transferred.
I → LUMIX	Shipping set without initializing "User setup information"	<ul style="list-style-type: none"> • Initial setting is executed without initializing the user's set up setting condition. * The initial setting must be performed while the Self-timer LED is blinking, * The picture data stored in the built-in memory of the DSC is not erased, with this operation.
ADJFLAG → ALL F	Set all adjustment flags completion	<ul style="list-style-type: none"> • Status of the all adjustment flags are changed to "F"(completion).

10.2.3. Light Box

If using VFK1164TDVLB Light Box, remove the lens connection ring by loosening three hexagon screws.

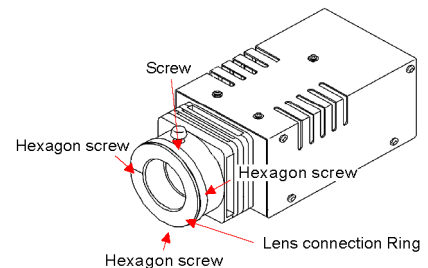

10.3. Details of Electrical Adjustment

10.3.1. How to execute the Electrical Adjustment

It is not necessary to connect the camera to a PC to perform adjustments.

"Flag reset operation" and "Initial setting operation" are required when carrying out the alignment, follow the procedure below.

10.3.1.1. Startup Electrical Adjustment mode

1. Release the initial settings.
2. Insert a recordable Memory Card.
(Without a Memory Card, the automatic adjustment can not executed.)
3. Procedure to set the camera into adjustment mode:
 - a. Set to P(Program AE) mode by operating the mode button.
 - b. Turn the Power off.
 - c. Turn the Power on pressing MOTION PICTURE and MENU/SET simultaneously.
LCD monitor displays "SERVICE MODE".
(Refer to Fig.F3-1)

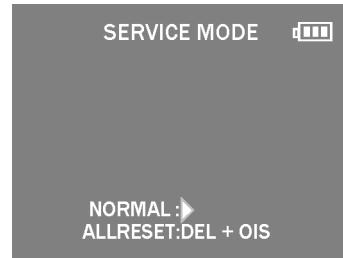

Fig. 3-1

10.3.1.2. Status Adjustment Flag Setting

Reset (Not yet adjusted) the status flag condition.

1. After pressing the DISPLAY button, the LCD monitor displays the Flag status screen (Refer to Fig.3-2.)
2. Select item by pressing the cross keys. (Gray cursor is moved accordingly.)
3. Press the DELETE button.

Note:

The selected item's flag has been changed from "F (green)" to "0 (yellow)".

*(Refer to Fig. 3-3)

*Flag conditions:

F (green)

means that the alignment has been completed and the status flag condition is set. In this case, the flag condition should be reset, if you try to carry out the automatic alignment.

0 (yellow)

means that the alignment has been not "completed" and the status flag condition is "reset". In this case, automatic alignment is available.

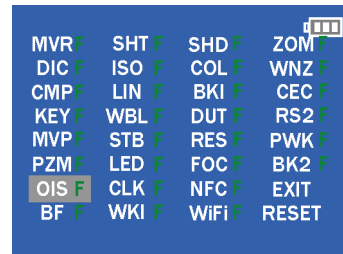

Fig. 3-2



Fig. 3-3

< Example: OIS flag is reset. >

- In case of setting the status flag into set condition again without completion of the alignment, the status flag should be SET by using PC, or UNDO by using ROM BACKUP function.

10.3.1.3. Execute Adjustment

1. Perform step "10.3.1.1." to "10.3.1.2.", to reset the OIS flag status "F" (Set) to "0" (Reset).
2. Press DISPLAY button after Flag reset.
OIS Adjustment screen is displayed on the LCD panel.
(Refer to Fig.3-4)
3. Press the shutter button. The adjustment will start automatically.
4. When the adjustment is completed successfully, adjustment report menu appears with Green OK on the LCD monitor. (Refer to Fig.3-5)



Fig. 3-4

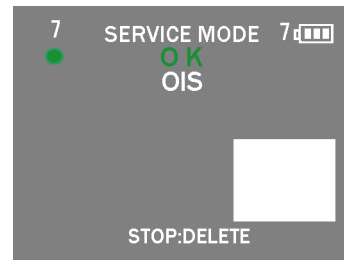

Fig. 3-5

10.3.1.4. Attention point during Adjustment

1. Step "10.3.1.3." procedure shows OIS adjustment as an example. To perform the adjustment, refer to the "10.3.2. Adjustment Specifications" table which shows key point for each adjustment.
2. Do not move the light box, the camera or the chart while adjusting. If one of these is moved accidentally, start the adjustment again.
3. Do not press any buttons/keys until the default menu (Fig.3-6) is displayed on the LCD monitor. Otherwise, adjustment data may not be stored properly.
4. If the adjustment is interrupted accidentally, the alignment data may not be properly saved in the Flash-rom.

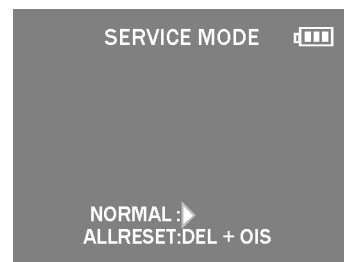

Fig. 3-6

10.3.1.5. Finalizing the Adjustment

1. Several adjustment flags can be reset ("F" into "0") at the same time. In this case, when the adjustment has been completed, the screen will change showing the adjustment for the next item until all reset items are completed.
Also, when the shutter button is pressed, the screen jump to the next adjustment item.
2. To cancel the adjustment mode while in the process of performing the adjustment, follow this procedures.
(1) Press "Right of cross key" button.

Note:

*.If adjustment is cancelled with above procedure, adjustment is not completed. Make sure to adjust it later.

10.3.2. Adjustment Specifications

The following matrix table shows the relation between the replaced part and the Necessary Adjustment.

When a part is replaced, make sure to perform the necessary adjustment(s) in the order indicated.

The table below shows all the information necessary to perform each adjustment.

Adjustment order	Adjustment Item	FLAG	Purpose	Replacing Parts						JIG/TOOLS	SET UP	How to Operate
				MAIN P.C.B./ VENUS ENGINE (IC6001)/ F.ROM (IC6005)	MAIN P.C.B. (to which the backup data was copied)	Lens Parts (include MOS U)	MIC UNIT	FLASH UNIT	Component parts excluding VENUS-F.ROM on MAIN P.C.B.			
1	Venus Zoom *4	PZM	Venus Zoom Inspection	○	○	-	-	-	-	NONE	NONE	1) Press Shutter Button. 2) After completed, the "OK" menu appears.
2	OIS sensor	OIS	OIS sensor output level adjustment	○	-	○	-	-	-	NONE	NONE	1) Press Shutter Button. (Do not apply any shock and vibration for the camera while adjusting) 2) After completed, the "OK" menu appears.
3	Backfocus / GYRO *4	BF	To have the focus tracking curve be appropriate shape and GYRO sensor adjustment	○	○	○ *1	-	-	-	-COLLIMATOR (VFK1164TCM02 or VFK1164TCM03 or RFKZ0422)	Set the camera in front of collimator so that the distance from collimator to camera becomes about 1 cm as shown in Fig. A. [IMPORTANT] The adjustment "NG" might be happened with the following conditions: - Do not put the black colored stuff at the back side of collimator near hunching chart. It needs to get some certain brightness. - Make sure the hunching chart has no dust and dirty condition.	1) Set up the main unit so that the chart can be seen in the center and press the Shutter Button. ※ Stop the zooming operation and display green ● on the LCD. 2) Confirm the chart is seen in the center and press the shutter button. 3) After completed, the "OK" menu appears
4	Shutter	SHT	Shutter speed adjustment	○	-	○	-	-	-	-LIGHT BOX (RFKZ0523 or VFK1164TDVLB)	1) Set the camera in front of LIGHT BOX so that the distance from LIGHT BOX to camera becomes about 7 cm as shown in Fig. B. 2) Aim the LIGHTBOX so that the entire LCD screen becomes fully "white". (No dark area).	1) Press Shutter Button 2) After completed, the "OK" menu appears.
5	High brightness coloration	LIN	High brightness coloration adjustment	○	-	○	-	-	-	-LIGHT BOX (RFKZ0523 or VFK1164TDVLB) -ND FILTER (RFKZ0513 (ND0.3))	1) Prepare the LIGHTBOX (RFKZ0523). (The LIGHTBOX "VFK1164TDVLB" can be used if the front hood of VFK1164TDVLB is removed.) 2) Set ND FILTER (RFKZ0513 (ND0.3)) to the LIGHTBOX. 3) Set ND FILTER and Camera unit so that distance becomes about 7 cm (Fig. B) 4) Aim the LIGHTBOX so that the entire LCD screen becomes fully "white". (No dark area).	1) Press Shutter Button. 2) After completed, the "OK" menu appears.
6	Flash *4	STB	Flash Inspection	○	○	-	-	○	-	NONE	NONE	1) Press Shutter Button and check that Flash is emitted. (The number of emissions differs depending on the model.) If Flash is not emitted, Flash Unit may be damaged. 2) If the inspection result shows "NG", use "ROM_BACKUP" and rewrite STB to confirm it is adjusted. The result may show "NG" if the inspection is performed on sites other than the specific environment (factory). However, if the flash emission is visible, there is no problem. 3) After completed, the "OK" menu appears.
7	MOS Missing Pixels (White) *2	WKI	Compensation of MOS Missing Pixels (White)	○	-	○ *1	-	-	-	NONE	NONE	1) Press Shutter Button. 2) After completed, the "OK" menu appears.
8	Color reproduction inspection and Microphone check	COL	Color reproduction inspection and Microphone check	○	-	○	○	-	-	NONE	No need to enter the continuous sounds (voice) to the microphone as usual.	1) Press Shutter Button. 2) After completed, the "OK" menu appears.
		BKI	Do not use "BKI" adjustment flag for this unit. Use "BK2" adjustment flag, instead. (In case of most DSC models, the adjustment flag for MOS Missing Pixels is "BKI". But, in this model, "BK1" the adjustment flag for MOS Missing Pixels.)									

Adjustment order	Adjustment Item	FLAG	Purpose	Replacing Parts						JIG/TOOLS	SET UP	How to Operate
				MAIN P.C.B./ VENUS ENGINE (IC6001)/ F-ROM (IC6005)	MAIN P.C.B. (to which the backup data was copied)	Lens Parts (Include MOS U)	MIC UNIT	FLASH UNIT	Component parts excluding VENUS-F-ROM on MAIN P.C.B.			
9	MOS Missing Pixels (Black) *3	BK2	Compensation of MOS Missing Pixels (Black)	○	-	*1 ○	-	-	-	<ul style="list-style-type: none"> • LIGHT BOX (RFKZ0523 or VFK1164TDVLB) • DIFFUSER (RFKZ0591) 	<ol style="list-style-type: none"> 1) Prepare the LIGHTBOX (RFKZ0523). (The LIGHTBOX "VFK1164TDVLB" can be used if the front hood of VFK1164TDVLB is removed.) 2) Set the Diffuser (RFKZ0591) to the LIGHTBOX. 3) Set the LIGHTBOX and Camera unit so that distance becomes about 2 cm in Fig. B. 4) Aim the LIGHTBOX and make the frame detail alignment so that the entire LCD screen becomes fully "white". (No dark area). Press the Shutter Button. <p>NOTE Do not use "BK1" adjustment flag for this unit. Use "BK2" adjustment flag, instead.</p>	<ol style="list-style-type: none"> 1) Set the LIGHTBOX and Camera unit so that the distance becomes about 2 cm (Refer to Fig.B) • Press Shutter Button. (The green●mark is displayed on LCD). 2) Press Shutter Button. (1st) (The adjustment is executed, and then green●mark is displayed on LCD). 3) Press Shutter Button. (The green●mark is displayed on LCD). 4) Press Shutter Button. (2nd) (The adjustment is executed, and then green●mark is displayed on LCD). 5) Press Shutter Button. (The green●mark is displayed on LCD). 6) Press Shutter Button. (3rd) (The adjustment is executed, then "OK" mark is displayed on LCD when the adjustment has been completed successfully.)
10	Initialization data of NFC	NFC	Initial Setting of NFC	○	○	-	-	-	○	<p>■ Make sure to perform the following ① and ②. (Initial Setting of NFC)</p> <p>※NFC-IC and MAIN P.C.B. have no initialization data of NFC. So, make sure to perform Initial Setting of NFC.</p> <p>※NFC-IC may lose the initialization data due to heat during repair process. Therefore, make sure to perform Initial Setting of NFC when the component parts on MAIN P.C.B. are replaced.</p> <p><Initial Setting of NFC></p> <p>① [NFC Operation] Setting 1) Select [NFC Operation]. ([Menu] → [Wi-Fi] → [Wi-Fi Setup] → [NFC Operation]) 2) Switch the setting of it to [ON]. ※ If [NFC Operation] is [ON], change it to [OFF] once. Then, change it to [ON].</p> <p>② Initial Setting Perform the initial setting operation. (Refer to 3.5.2. INITIAL SETTINGS) ※ The default setting of NFC operation is [ON].</p>		

*1 :This adjustment must be performed not only replacing the Lens Parts (Include MOS Unit), but also simply removing the Lens Parts (Include MOS Unit).

*2 :White missing pixels means that the pixel which is always active (lit) although shading (Dark) condition.

*3 :Black missing pixels means that the pixel which is always non-active (off) although high-intensity light is coming.

*4 :If the adjusted data is backed up from the main board before replacement or repair, write the data to the new main board.
If parts other than the main board are not replaced, adjustment is not necessary for items other than "Venus Zoom (PZM)/ Backfocus/GYRO(BF)/Flash(STB)".

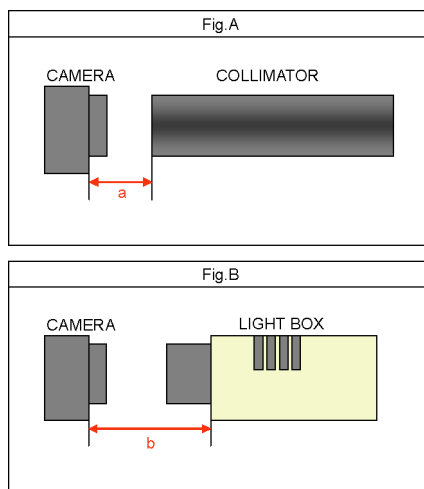

■ **IMPORTANT NOTICE (After replacing the Main P.C.B.)**
After replacing the MAIN P.C.B., make sure to perform the "INITIAL SETTINGS" first, then release the "INITIAL SETTINGS" in order to proceed the electrical adjustment.

Note:

1. If electrical adjustment or data re-writing is executed before "INITIAL SETTINGS", suffix code list is never displayed, and it cannot be chosen suitable suffix code.
2. Never remove the battery during initial setting in process.

10.4. After Adjustment

10.4.1. Initial Setting

Since the initial setting has been released to execute the built-in adjustment software, it should be set up again before shipping the camera to the customer.

Refer to the procedure described in "3.5.2. INITIAL SETTINGS" for details.

[IMPORTANT]

1. The initial setting should be done again after completing the alignment. Otherwise, the camera will not work properly.
Therefore as a warning, the camera display a warning symbol " ! " on the LCD monitor every time the camera is turned off.
2. Confirm that status of all adjustment flag show "F". Even if one of the adjustment flag shows "0", initial setting programmed is never executed.

11 Maintenance

11.1. Cleaning Lens and LCD Panel

Do not touch the surface of lens and LCD Panel with your hand.

When cleaning the lens, use air-Blower to blow off the dust.

When cleaning the LCD Panel, dampen the lens cleaning paper with lens cleaner, and the gently wipe the their surface.

Note:

The Lens Cleaning KIT; VFK1900BK (Only supplied as 10 set/Box) is available as Service Aid.

12 Block Diagram

12.1. Overall Block Diagram

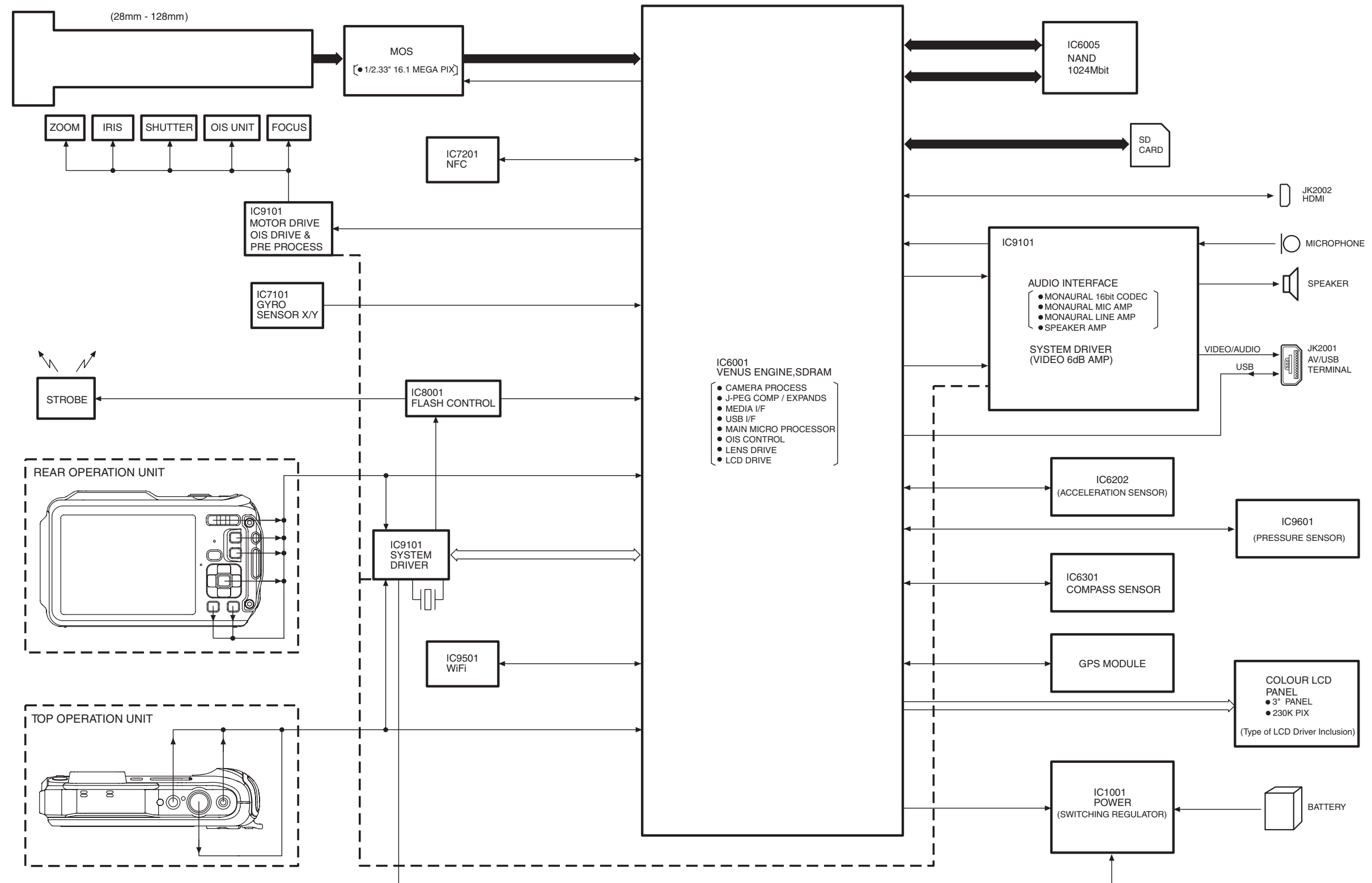

DMC-FT5/TS5 OVERALL BLOCK DIAGRAM

12.2. System Control Block Diagram

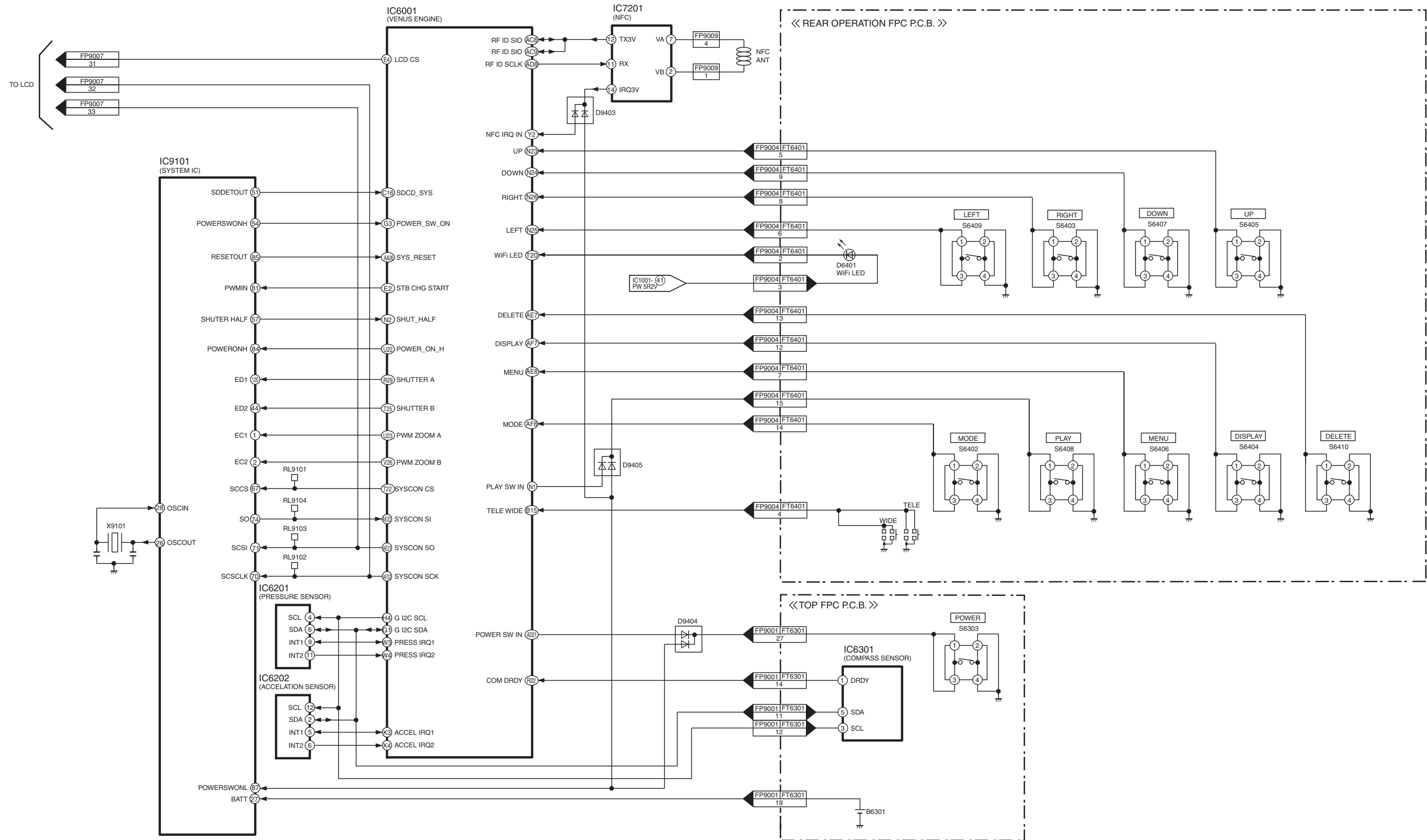

DMC-FT5/TS5 SYSTEM CONTROL BLOCK DIAGRAM

12.3. Video/Audio Signal Process Block Diagram

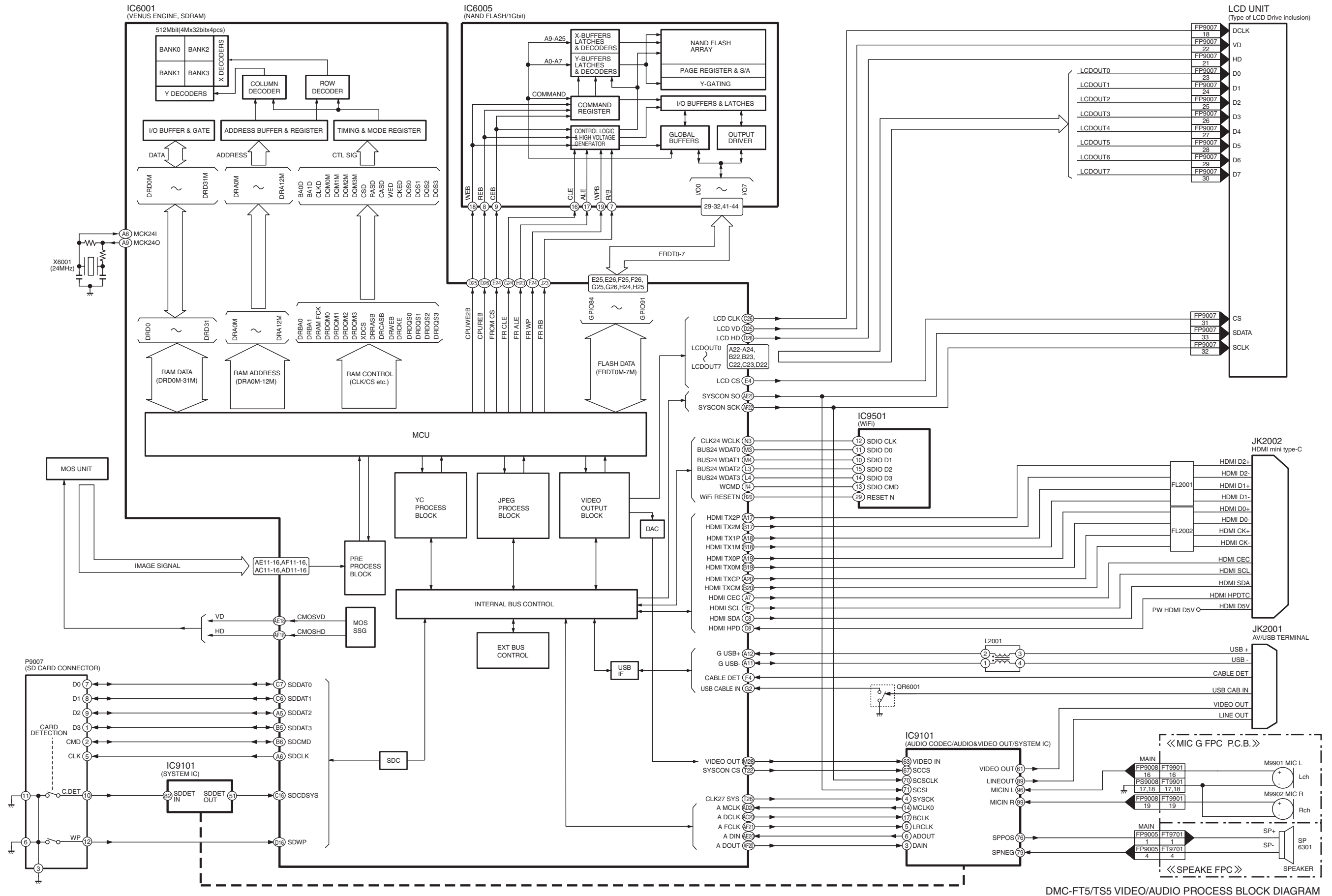

DMC-FT5/TS5 VIDEO/AUDIO PROCESS BLOCK DIAGRAM

12.4. Lens Drive Block Diagram

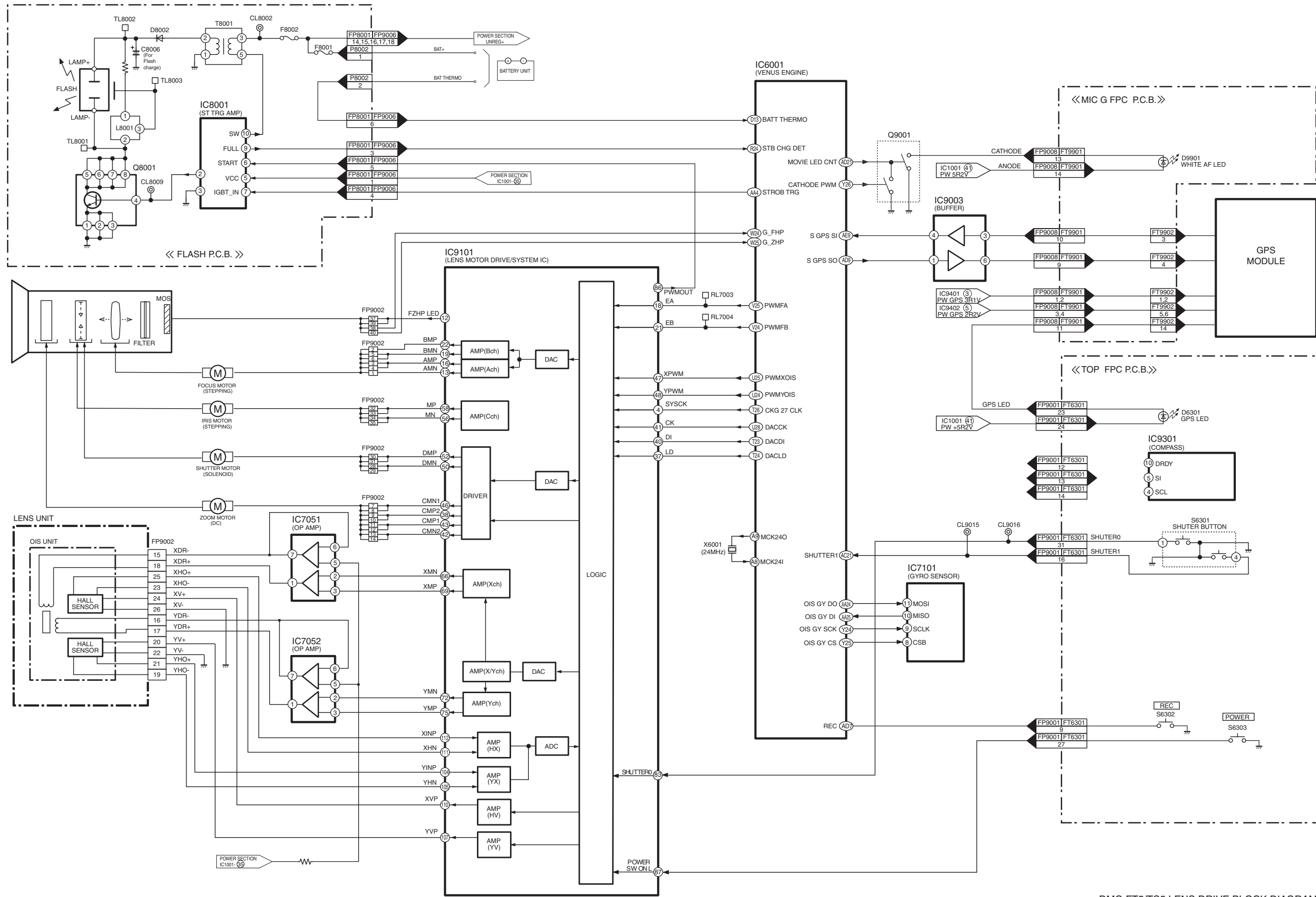

DMC-FT5/TS5 LENS DRIVE BLOCK DIAGRAM

12.5. Power Block Diagram

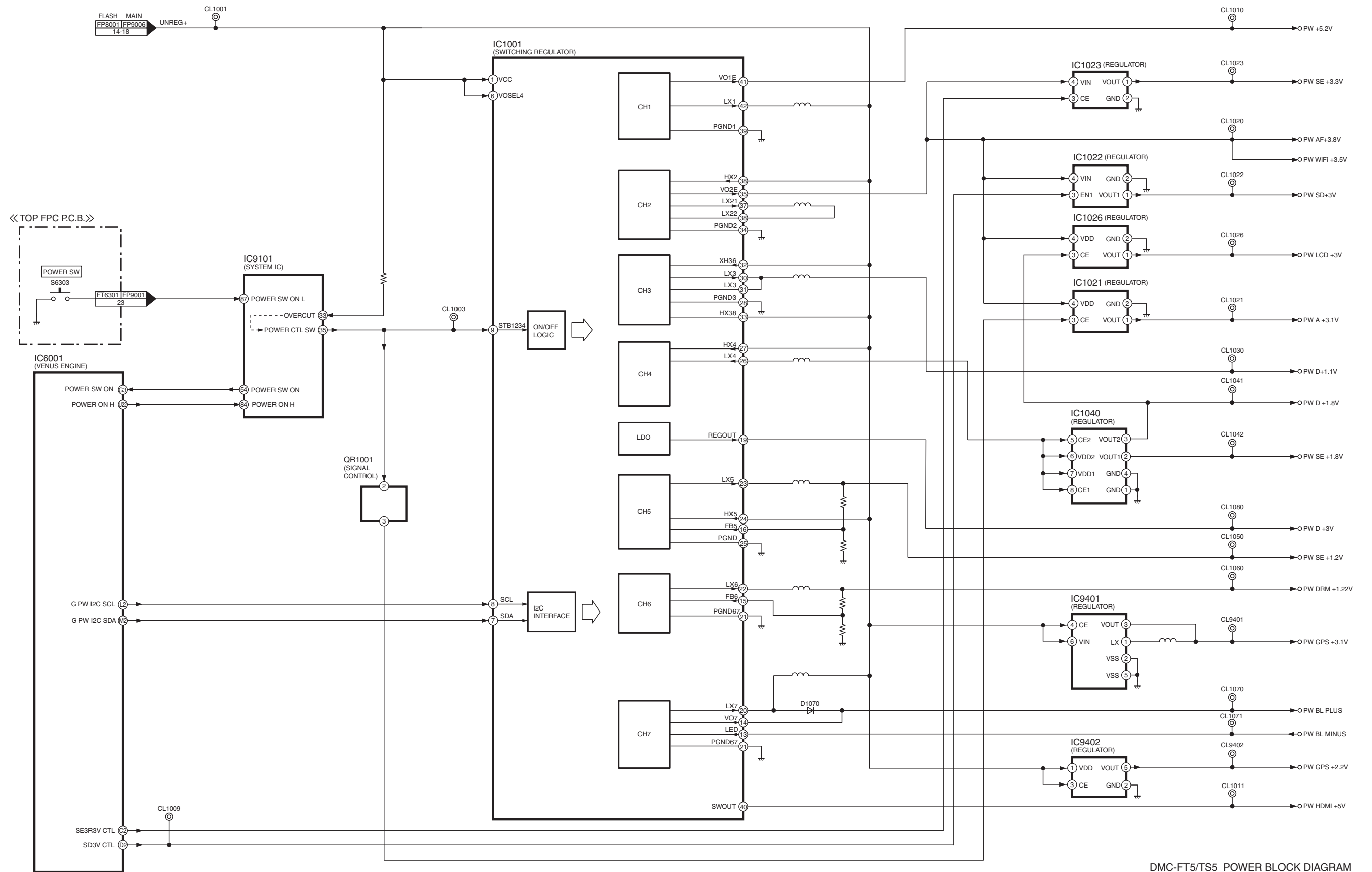

DMC-FT5/TS5 POWER BLOCK DIAGRAM

13 Wiring Connection Diagram

13.1. Interconnection Schematic Diagram

