

**daum
electronic**
best for your fitness

cardio pro

User Manual

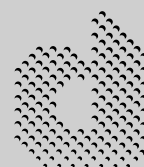

דאום
אלקטרוניקס
best for your fitness

This ergometer is specially designed for health and endurance training. High quality manufacturing, a user friendly dashboard, ease of use and maintenance all contribute to make this appliance an ideal training device for sport and fitness purposes. Also note that the complete equipment and the wide performance range should appeal to sport or fitness conscious persons of every age group.

Please Note



Read this user manual thoroughly before using the device.

Please follow the recommendations about your health.

You should undergo a general medical examination before you start a training program.

You should interrupt immediately the training session if you feel uncomfortable, dizzy or in any way ill during a training session.

Always start a training with a low load and then increase the load gradually. At the end of the training reduce the load. After the training you should execute a few stretching and gymnastics exercises to relax your muscles.

Recommendations about the training location

Install your training device on a level ground. The device may damage wooden floors. We therefore recommend the installation of a protective underlay on wooden floors. We also recommend not to install the device on white or light-coloured carpets or mats because they could be stained by the black colour of the device's feet.

We recommend that the training location be properly aerated to provide enough fresh air, but nevertheless avoid draught.

You can use this device in a temperature range from +10°C to +35°C.

Safety notes

Children should only use this device under supervision and they must be provided with a proper explanation of its operating principles. This device is not a toy.

Please make sure the device is in working order. You should never train on a defective device.

The device may only be used by one person at a time.

You should wear appropriate clothing and shoes while training.

The device may only be used if all the parts are firmly attached and no part is loose.

You may only execute the repair operations described in this user manual. Other repair and service operations may only be carried out by qualified specialists.

Do not press the buttons with the fingernails, always use the fingertips to avoid scratching the button.

Avoid wetting the dashboard. If during a training session your dashboard is wetted by sweat you should wipe it with a soft cloth after training.

The device surface should not come into contact with corrosive or strong chemicals.

The maximum allowable user weight is 120kg.

Daum electronic gmbh provides a 24 months warranty for the device for private use, and a three (3) months warranty for commercial use.

The warranty is voided in the case of improper utilisation.

Setting Up



The On/Off switch is located on the rear of the device.



When the device is switched On, the LCD screen displays a big "d" and the system plays a start-up tune.



After this the system displays the program last used. The manual program is displayed on the first start-up.

The Dashboard

1. Heart rate display
2. Dissipated energy and time display
3. RPM display
4. Speed and distance display
5. Load in watt display
6. Graphic screen
7. Control button
8. Pulse sensor connector
9. Relax sensor connector
10. Menu key
11. Info key
12. Fitness key
13. Function key
14. Reset key (recessed)
15. PC connector

14
(Underside)

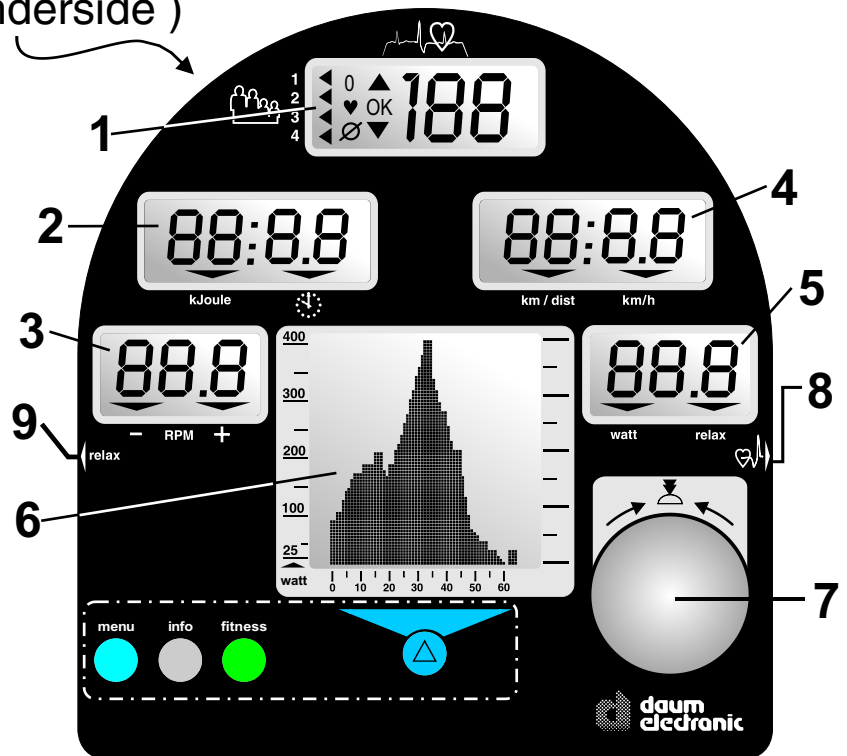

15
(Underside)

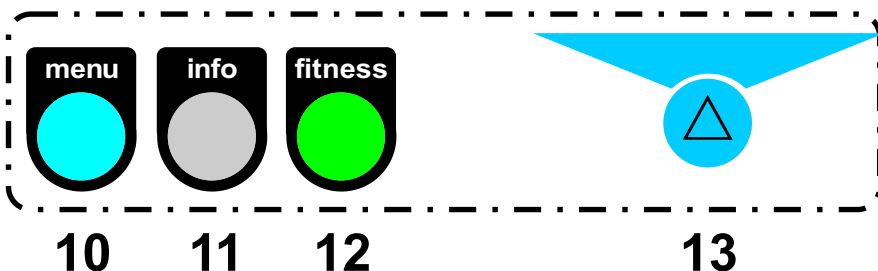

Dashboard Displays

The graphic screen displays the programs. The load (in watt) is shown on the scale on the left side of the screen. The training time is shown on the lower axis.

Note: the illustrations may be changed without notice!

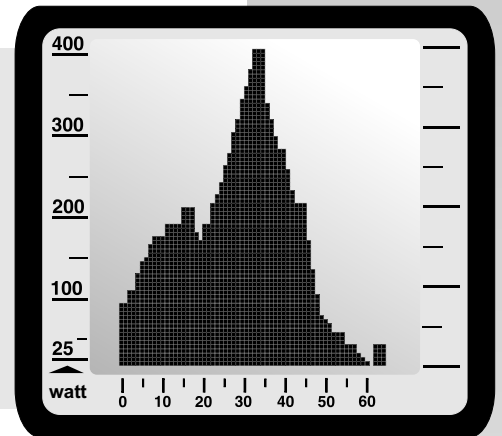

The heart rate window displays the heart rate of the user (1 to 4). When only the upward pointing arrow is displayed in the middle, then this means that the heart rate is too low to ensure an effective training. Inversely, when only the downward pointing arrow is displayed then the heart rate is too high. If the arrow starts blinking then the load is too high and the user should moderate the training. The arrows pointing to the left indicate the user currently selected.



Dissipated energy (in kJoule) and elapsed time display: this window shows the time elapsed since starting training or how many kJoule have been dissipated. Press the Info key to switch between the two values. When the device is unused for an extended period of time this window displays the local time.



The RPM window indicates the speed in revolution per minute. If the downward pointing arrow on the right side is displayed then the user should pedal faster, the user should pedal slower if the left arrow is displayed. (+ = pedal faster, - = pedal slower)



Speed and distance window: this window shows the actual speed and distance covered. Press the Info key to switch between these two values.



The watt window shows the load in watt. It also shows the relax value with relaxation exercises.



Using the Menu and Language Selection

Use the Menu key to call and leave the menu. Use the function key to move back one step in the menu.

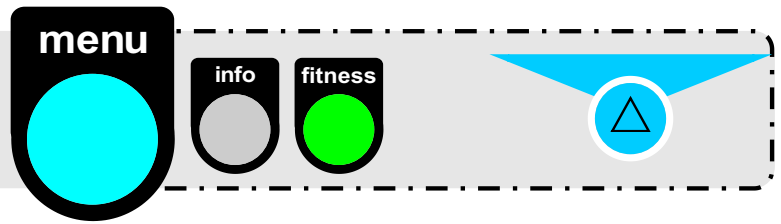

Turn the control button to move up or down in the menu. Press the control button to open the selected option, e.g. language selection.

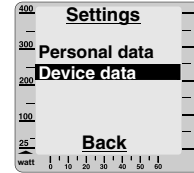
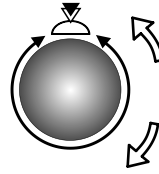
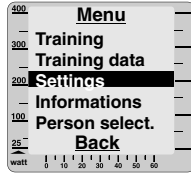
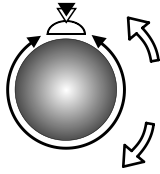
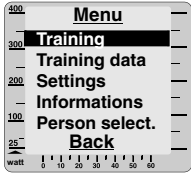

1. Press the **menu** key
2. Turn the control button to select "Setting"

3. Press the control button
4. Turn and press the control button to select "Device Data"

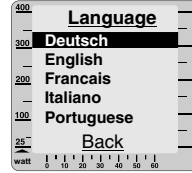
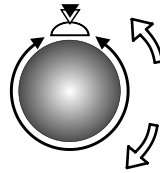
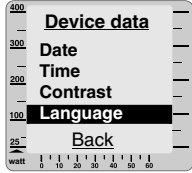
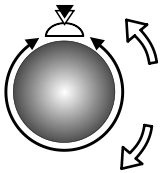

7. Press the Menu key to return to your training program, Press the function key to return to "Device Data"

5. Turn and press the control button to select "Language"

6. Turn and press the control button to select required language

Choosing the User

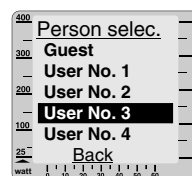
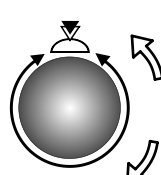
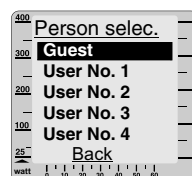
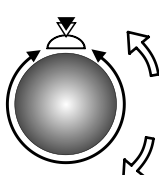

1. Press the menu key
2. Turn the control button to select "User"
3. Press the control button

4. Turn and press the control button to select a user from 1 to 4 or Guest
5. The selected user is then indicated on the left side of the heart rate window
6. Press the menu key to return to the start.



The device will store the training data of four users. It is therefore important that each user selects his own "number" when training. Guest data are not stored.

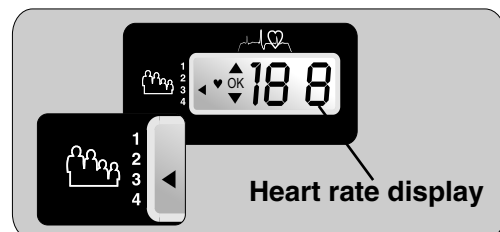

Heart rate display

The following is an example of a possible number attribution scheme in a family:

Mother
User 1

Father
User 2

Daughter
User 3

Son
User 4

Stand-By Mode

The device switches automatically to stand-by mode if it is left switched on and unused for two hours. This is indicated by the display of "SLP" on the dissipated energy/elapsed time window. (the stand-by mode is deactivated when using ergo_memo or ergo_win.).

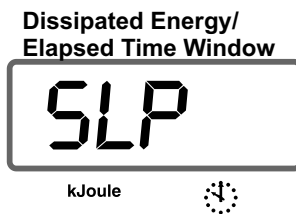

Press the control button to restart the device from stand-by mode.

System Settings

1

User's data

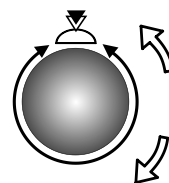
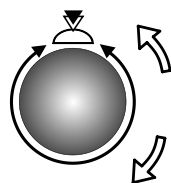
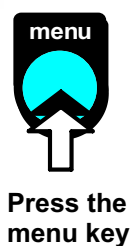

If you want to change the user's data you should always note the presently selected user. This information will always be shown in heart rate window. (see Choosing the User p. 4)

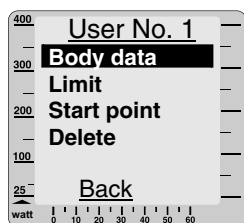
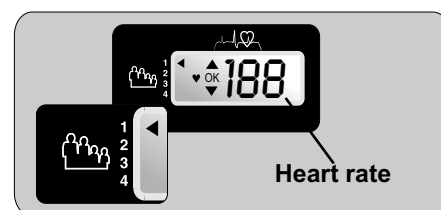

Turn and press the control button to enter and store your physical data.

- Age → enter your age.
- Gender → choose M or F to enter your gender.
- Height → enter you height in cm.
- Weight → enter your weight in kg.
- Fat content → enter your body fat content (if available).
- Evaluation → select the value most appropriate for you.
- Frequency → enter the number of times you want to train per week

You can also enter your own limit values. If one of these values is exceeded the system plays an signal melody.

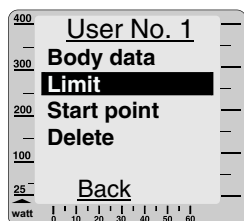

- Watt → you can select here the maximal load (between 25 and 400 watts). If you choose e.g. 180W the load will not exceed this value
- Heart rate → when the actual heart rate exceeds the entered limit value the system reduces automatically the applied load.
- Time → a signal melody plays when the time limit is exceeded.
- Km → a signal melody plays when the distance limit is exceeded.
- kJoule → a signal melody plays when the kJoule limit is dissipated.

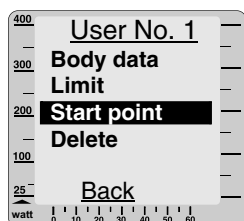

You can set the system to confirm the starting point of the training before every training program. If the "Start Point" option is turned on, you can choose the starting point of the course. If it is turned off then the program begins always at the start of the course.

System Settings

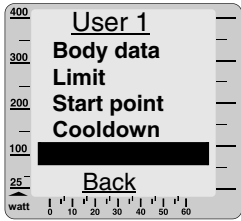

Use the delete function to reset all the data of the selected user back to the factory settings.

2 Device data



Press the menu key

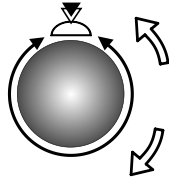

Turn to select "Settings"



Press the control button

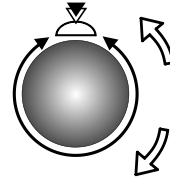

Turn to select "Device data"



Press the control button

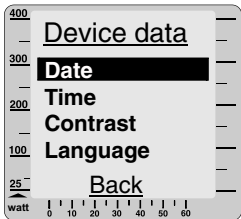

Date entry

1. turn and press the control button to set the day.
2. turn and press the control button to set the month.
3. turn and press the control button to set the year.
(DD/MM/YYYY)

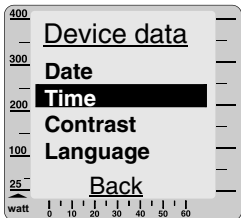

Setting the time

1. turn and press the control button to set the hour.
2. turn and press the control button to set the minute.
3. turn and press the control button to set the seconds.
(HH:MM:SS)

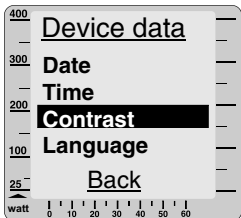

Contrast

You can choose a value for the contrast from 16 to 31. The optimal value lies normally around 25.

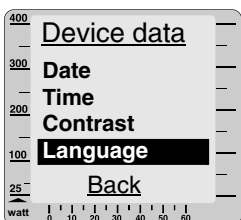

Language

Choose the appropriate language:
German, English, French, Italian, Portuguese, Finnish.

Monitoring the Heart Rate



Please take serious care to watch your heart rate while training and not to exceed the limits.

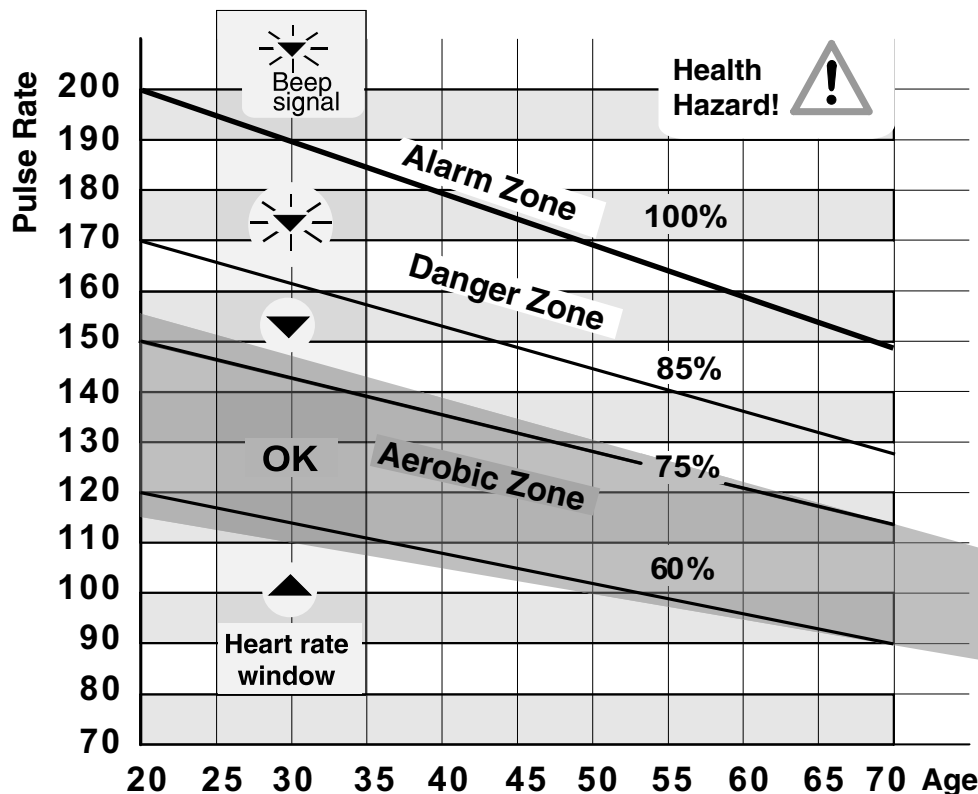

Example
for a person 50 years old

Alarm Zone
Heart rate above 171

Danger Zone
Heart rate 145 - 170
Heart rate 128 - 144

Aerobic Zone
Heart rate 102 - 127
Heart rate 40 - 101

Whenever the actual heart rate exceeds that of the alarm zone the system will give a beep signal and the load will be automatically reduced.



For beginner: the widely accepted recommendation is to train at 55% to 65% of the maximum heart rate. This zone is very well suited for weight loss or for returning users after an extended interruption due to illness.

Training in the aerobic zone will always be safe and good for your health. This zone is located at 60% to 75% of the maximum heart rate.

You will always achieve your training target optimally if you train in the appropriate zone, whether your target is the improvement of your fitness level, the reduction of your body fat content or the development of muscular mass.



A very high heart rate can be very dangerous!

Heart rate measure using the ear clip

Plug the connector on the right side of the dashboard, attach the clip on the other end of the cable to your ear. The heart rate window will then display your heart rate after a short delay.

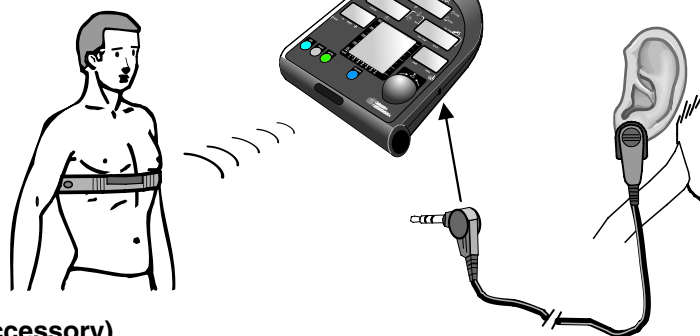

Heart rate measure using the chest band (optional accessory)

Apply some water on the inner side of the band to the left and right side of the serration and then fasten it to your chest firmly to prevent it from sliding off and insuring the electrodes are in direct contact with the skin.

If you have in the room many devices that may interfere with the signals of a wireless heart rate measuring device, then these devices must be located at a distance of at least 1.5m from the heart rate measuring device. If more than one wireless heart rate measuring systems are used in the same room then only one of these systems may be located close to the training device.



Warning! If you have a heart pacemaker you should consult your physician to find out if you can safely use the chest band transmitter!

1

Programs



Press the menu key

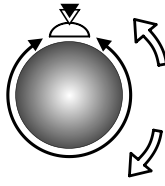

Turn to select "Training"



Press the control button

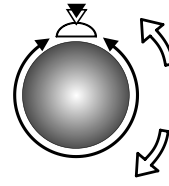

Turn to select "Programs"



Press the control button

The programs are grouped in five categories.

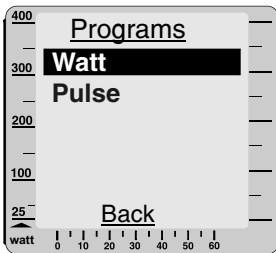

Watt controlled programs: the applied load is independent of the speed.

Pulse controlled programs: when the heart rate increases the load is decreased and vice versa.

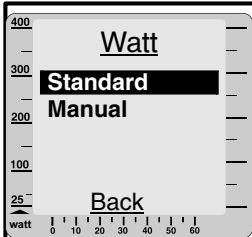

Standard programs: you can choose from 38 programs already stored in the machine. (you can increase or decrease the difficulty level of these programs by turning the control button). The actual training position is indicated on the screen.

Manual: you can here increase or decrease the load by turning the control button.

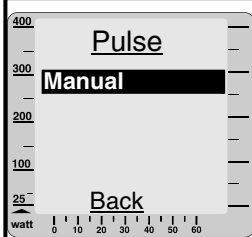

Manual pulse program: you decide what heart rate you want in beats per minute and the device will adjust the load so that this value is maintained.

2 Built-in programs

You will find below a presentation of the course of these programs.

Standard programs
Watt controlled

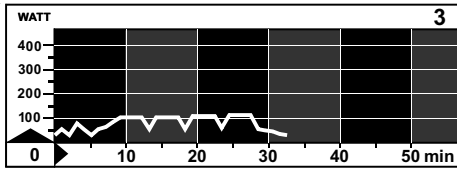

Program 3
Interval training "Low"
33 Min. / max 110 Watt
Light load training for women and men
with little training experience

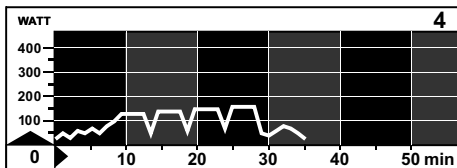

Program 4
Interval training "Mid"
35 Min. / max 160 Watt
for women and men
with little training experience

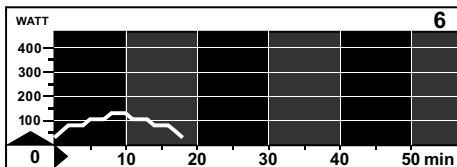

Program 6
Pyramid "Low"
19 Min. / max 115 Watt
for untrained women and men
age up to 35 years

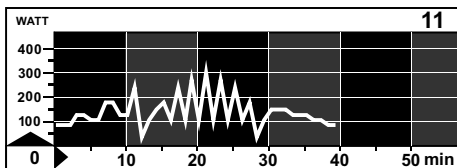

Program 11
Mount Everest
40 Min. / max. 300 watts
for trained users

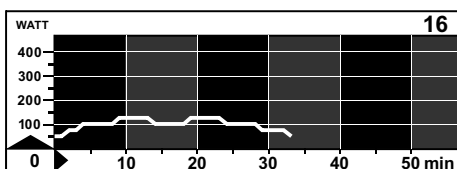

Program 16
Body Watching 1
34 Min. / max 125 watts
for trained women up to 30 years of age

3 Training data

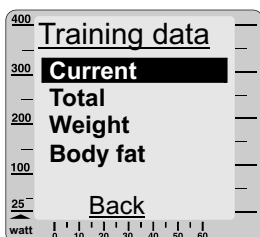

You review the training data of the selected user:

- Current: the training values of the last training
- Total: the values of all the training units together
- Weight: the distribution over a period of 60 days and of 1 year
- Body fat: the distribution over a period of 60 days and of 1 year

4

Fitness mark

The *ergo_bike* can carry out an evaluation your **fitness**. The measurement principle is based on the fact that the pulse rate falls faster within the first minute following a load period for healthy, well-trained users than for healthy, less trained users.

If the user presses the Fitness key during a training session, the present training will be interrupted and the load will be lowered to **25 Watt within 3 to 4 sec.** The graphical screen will display the message "Fitness mark determination". The drop in pulse rate **within 60sec** will be measured (see window no. 2) and the mark computed according to the following scheme and displayed

The fitness mark F1 is awarded for a pulse rate drop of more than 25.0% within 60 sec
The fitness mark F2 is awarded for a pulse rate drop of 20.0% to 24.9% within 60 sec
The fitness mark F3 is awarded for a pulse rate drop of 16.0% to 19.9% within 60 sec
The fitness mark F4 is awarded for a pulse rate drop of 12.0% to 15.9% within 60 sec
The fitness mark F5 is awarded for a pulse rate drop of 8.0% to 11.9% within 60 sec
The fitness mark F6 is awarded when the pulse rate drop is less than 8% within 60 sec

The mark of "F0" is awarded if no usable result can be measured

The training program resumes at the actual position after the evaluation process. The load in Watt is raised within 3 to 4 seconds to its value just before the evaluation and the training can be continued.
A fitness evaluation is not possible after the training session is finished.

Fitness evaluation process

- ! A pulse measuring device (pulse sensor / ear clip or the cardio sensor chest band) must be connected and functional during the whole fitness evaluation process.

The measuring process takes one minute and its progress is displayed.

1. Train at least **15 minutes** in the **OK-area**.
2. Continue pedalling "loosely" at the load of 25 Watt during the 60 sec measurement process.

3.  Press the fitness key only when the two dots in display **window no. 2** are blinking.

4. **Window No. 2** displays an "F", and a timer from **1 to 60 seconds** during the measurement process.

5.  **After one minute window no 2** displays the **F mark** and the system plays a short melody.

Graphic window



Window no. 2



The two dots blink during the training!

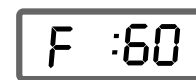

Example of the display of fitness mark 2

Your perseverance will be rewarded

Take part in the



Team Award



Team Award awarding levels

1.000 km	5.000 km	10.000 km	20.000 km
----------	----------	-----------	-----------



Press the menu key

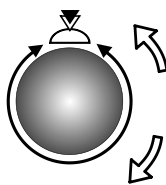

Turn to select "Training"



Press the control button

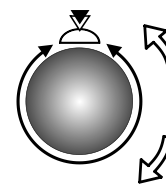

Select "Team Award"



Press the control button

If you send us the code number displayed in window no. 6, together with your name, your address, your email address, the serial number of your device (on the name plate), and the serial number of your dashboard (see "Menu", "Information", "Version Data", "Serial Number"); we will send you an award for your performance. **Give us a chance to surprise you!**

And you will be admitted in the "Hall of Fame" of the *ergo_bike* users

Grafic display

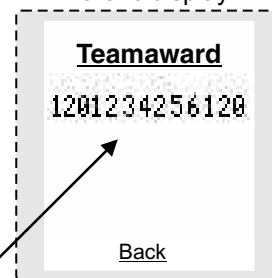

Serial Number for Team Award

You can enter the required information directly to our web page at www.daum-electronic.de, under the heading "Team Award" (the simplest possibility), or send us an email to "TeamAward@daum-electronic.de", or send us a fax to +49 / (0) 911 753714 or write to us to

daum electronic GmbH,
Team Award department
Flugplatzstr. 100,
D-90768 Fürth

The Relaxation funktion

The Relaxation funktion

The relaxation funktion is a **Biofeedback-process** that is carried out by measuring the electrical resistance of the skin. The measured values are indicated by means of optical and audio signals. Biofeedback is thus the translation into perceptible signals of physiological processes occurring in our body, which our senses can barely, or not at all, perceive. The relaxation funktion is the **ergo_bike**'s way of helping you relax and eliminate stress. You should use this option particularly after a physical endurance training.

Connecting the relaxation sensor

1. Take the Velcro bands of the fingers' sensor out of the package and open them.
2. Place the open tape on one of your fingertip. Make sure there is good contact between the silver buttons and your skin. The wires from the tape should lead away from the back of your hand.
3. Put down the side of the Velcro tape with the sensor button on your finger and wrap the other side around it and press it firmly in place.
4. Wrap the other tape around your middle finger in the same fashion.
5. Plug the connector of the relaxation sensor into the "relax" input socket no. 9 on the dashboard.

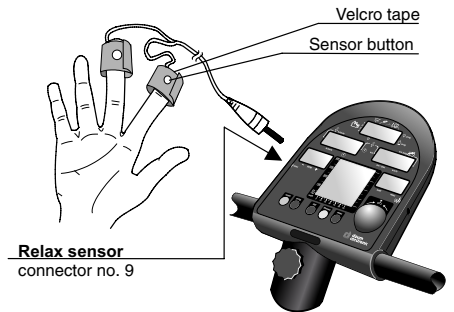

Relaxing

Relax program / process description

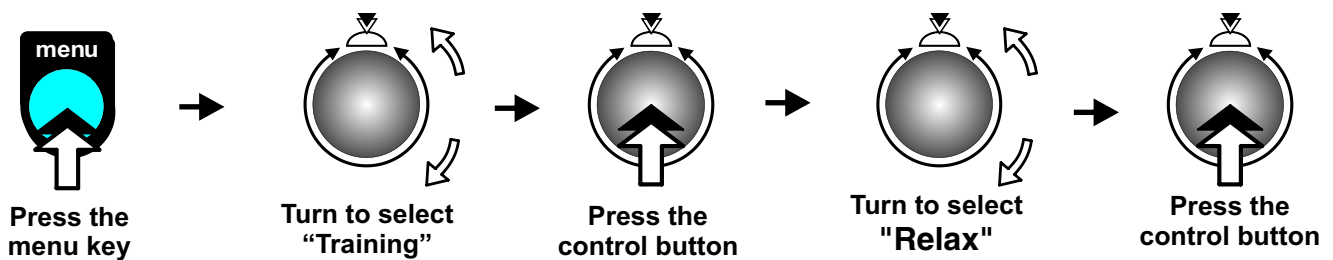

The wide down pointing arrow  in **window no. 5** switches from Watt to Relax. A value is displayed, which **starts at 199**.



The displayed value drops gradually as you relax after training, and increases with the stress level.

Watt display

The **Relax-value** can drop all the way to almost **zero**. The user should therefore contribute to his/her relaxing and avoid any other stress. You can support this process by getting off the device and sitting in a relaxed position, or laying down close to the **ergo_bike** and calm down.



The graphic screen displays a representation of the relaxation process. The displayed line shows the transition from the maximal value (199) to the minimum relax value (0). This process is also visible in window no. 5. The same process is presented in a graphical form in window no. 6 (see illustration to the right).

The actual relax level is indicated by a blinking bar in the display window

The complete relaxing process is divided into 25 levels. A short beep sound signals when each level is achieved. The successive beeps are each lower in tonality.

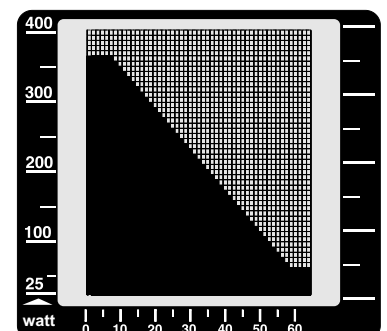

Transport and storage

Transport

The rear standard feet are equipped with roller casters to ease moving the device.

Hold the handlebars column with one hand and grab and raise the foot with the other hand, this way will ensure you have a good grip. Please take care to keep your back straight and to avoid injuries.

Also move the device on flat floors to avoid damaging the bearings.

Storage

Store the device in dry and warm rooms, at a temperature range of 0 to +25°C. The humidity ratio should not exceed 70%. If you store the device for an extended period in a cold room you should let it warm up again before using it.

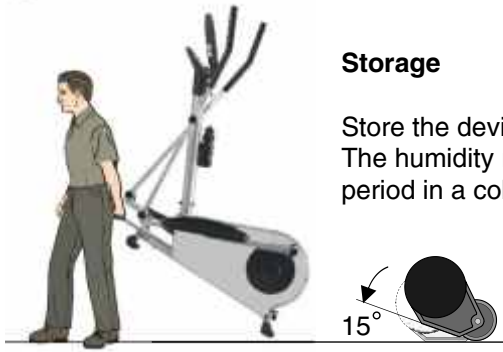

Accessories (sold separately)

The wireless ergo_bike chest band

We recommend using the wireless chest band to achieve a better and more precise heart rate measurement. The corresponding receiver is built into the device.

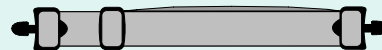

Multifunction memory card reader

Training data will automatically be stored in full details on the ergo_memo-card through the reader attached to the PC interface of the dashboard. The 32MB version of the card permits storage and evaluation of up to 2000 hours of training.



You will find more accessories on our Internet site at www.daum-electronic.de

Specifications

Braking system: Computer-controlled, full electronic eddy current brake operating in the speed ranges shown in the diagram to the right.

Load range: 25 to 400 Watt

Speed range: 0 to 199 RPM

Load precision +/- 10%

Loading levels: In 5-Watt increments, manually adjustable

Drive: Single-stage, maintenance-free steel-ribbed belt drive in a spring supported drive unit.

Flywheel: Machined

Programming system: Single button programming

Bio Feedback Function: Bio feedback based on the electrical resistance of the skin, measurement via finger electrodes, approx. 100 KOhm to 3 MOhm, self calibrating, display on LCD Panel in 255 levels and audible time controlled relaxing melody.

Fitness level: Six age-related fitness levels grading, displayed on LCD panel and through 6 commendation melodies.

Displays: 5 liquid crystal panels for pulse, distance, speed, average speed, load in Watt, kJoule burned, pedal speed (RPM) and training time. 1 graphic display / 76 x 64 pixels / total of 4864 pixels

Heart rate measurement: On the ear, measuring range 50 to 199 beats/min., telemetric using Cardio sensor chest band (optional accessory)

Limit values setting: Heart rate, distance, training time, kJoule, maximum load in watt.

Alarm signals: Acoustic and optical

Weight: About 75 kg

Dimensions: W x H x L 55 cm x 155 cm x 105 cm

Power supply: 230 V alternating current, 50 Hz, 50 W

Safety standards: CE

Safety class: 2

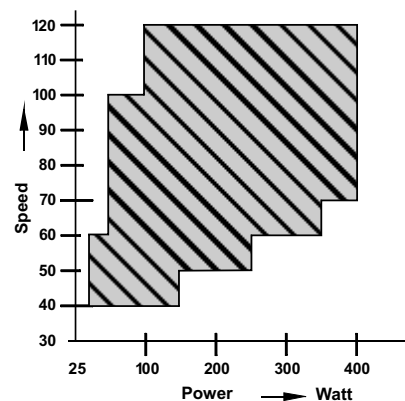

Conformity To The Technical Plant And Equipment Act



hereby declares that this product complies with the following provisions regarding electromagnetic compatibility and electrical safety:

- EN60335-1 edition of July 2003, Specification for safety of household and similar electrical appliances. (part 1: General requirements)
- 89 / 336 / EEC of May 3, 1989 including subsequent changes (Recommendation 92 / 31 / EEC of April 28, 1992 and recommendation 93 /68 / EEC of July 22, 1993)
- 73 / 23 / EEC of February 19, 1973 including subsequent changes (Recommendation 93 / 68 / EEC of August 30, 1993)
- EN55014-1 edition of September 2003, Electromagnetic compatibility. Requirements for household appliances, electric tools and similar apparatus. Part 1: Emission
- EN55014-2 edition of August 2002, Electromagnetic compatibility. Requirements for household appliances, electric tools and similar apparatus. (Part 2: Immunity. Product family standard)

Technical safety recommendation:

Compare the supply voltage on the nameplate on the housing with your local supply voltage prior to plugging the power cord to the power supply. Contact you dealer If the values are not the same.

The device is completely disconnected from the power supply by pulling out the power cord, therefore it should always be plugged into an easily accessible socket.

If the dashboard were subject to operational troubles due to static electricity turn the device OFF and then back ON again using the main switch.

Area of application:

The device is suitable for therapeutic utilisation at home.
(it is manufactured in compliance with DIN EN 957-1/9 Class A)

it does not meet the requirements of medical diagnostic applications (clinical use).

Glossary

Aching muscles Painful phenomenon of the muscles tissues, occurring when the aerobic zone is exceeded leading to an overproduction of lactic acid. In order to avoid it, the ergo_bike compares measured data, input parameters and statistical values and displays the resulting aerobic zone status.

Aerobic zone The training phase during which the load on the muscles is enough to keep them supplied with oxygen, but not enough to cause an overproduction of lactic acid (aching muscles). Aerobics also makes use of the aerobic zone.

Bio-Feedback Acoustic and/or optical feedback on the metabolism and condition of the body.

BMI Body-Mass-Index

Calorie (abbr.: cal) Energy measurement unit. Officially obsolete, but still in common use. It refers to thermal energy in particular. The conversion factor to the unit in use today (J): 1 cal = 4.1868 J, or the other way around 1 J = 0.2388 cal

Coaching Automatic training control oriented towards training objectives.

Eddy current brake Uses the fact that electric currents induced in a conductor by a fluctuating magnetic field produce joule-type energy which can be used for an electronically controlled brake.

Energy balance The balance between energy intake and energy usage. There can only be a balance if intake and output are the same. For example, in Germany every person consumes on average 400 - 500 Kcal more than he or she can use.

Joule (abbr.: J)

1 kJoule = 1000 Joules Energy measurement unit, named after the british physicist James Prescott Joule. (see calorie)

Lactic acid (aching muscles)

LED Light Emitting Diode: when current is passed through a LED it emits light, either visible or invisible. It is used for indicator lamps or remote controls.

Physical kJoule Represents only the mechanical work done on the ergometer; it is computed by mean of the following formula:

$$\text{Power [Watt]} * \text{Time [Sec]} = \text{Work [Joule]}$$

Exemple 100 Watt * 60s = 6000 Joule = 6 kJoule

This value does not cover the energy needed by the body to maintain its vital functions (e.g. respiration, blood circulation, metabolism).

Physiology The science of life processes

Realistic kJoule Using the data of the height, the weight, the age, and the sex, the system computes the approximate basic and total quantity of burned energy. The system will then display the approximate amount of kJoule actually burned during the training on the ergometer.

RPM Revolutions per Minute.

Self test When switched on, the *ergo_lyps* computer checks the electronic circuits it uses to make sure every thing functions properly.

Virtual Reality An illusion of reality generated by technical means that is influenced by external impulses or gives impulses to its surrounding. The *ergo_lyps* uses these possibilities through an optional accessory set. This way, you can travel through beautiful landscapes while training, or experience competition circuits.

Watt (abbr.: W) Unit of measure of the work done per unit time:

$$1 \text{ W} = 1 \text{ J} / \text{s} = 1 \text{ Nm} / \text{s} = 1 \text{ VA}$$

WHO World Health Organisation



In the case of a failure what to do if...?

All **ergo_lyps** ergometer bikes undergo a detailed test before they are shipped.

Should you, in spite of this, face a functional failure, the following recommendations should tell you what to do.

General procedure to identify the cause of a failure

The **ergo_lyps** bikes consist essentially of two functional units

- the dashboard and the drive unit.

The drive unit is located inside the device, before the crank/pulley. It contains the power supply, the eddy current brake and the related electronic circuits.

The dashboard contains the electronic circuits used for system control, display and data processing. The dashboard and the drive unit communicate via a cable, which is routed through the dashboard support column, via a connector in the area of the receptacle of the dashboard support column.

Should the assembled **ergo_lyps** fail to function, the defect would generally be found either on the dashboard, the drive unit or the cable connecting them.

The most frequent cause of complaint turns out to be jamming the connecting cable during the assembly process of the ergo_lyps, or not properly plugging the cable connector.

In the event of a failure, check carefully first if

- The cable connector found on the lower end of the dashboard support column is properly connected, and that the cable was not jammed or cut when the dashboard support column was mounted on the frame. To do this you need to disassemble the dashboard support column.
- The cable was not jammed or cut while mounting the dashboard on the support column, or if the cable connector to the circuit board inside the dashboard is loose. To do this you need to disassemble the dashboard.

Fastening screws

All the fastening screws must be tightened from time to time. We recommend tightening them at least after the first 50 km and then once every 500 km.

Contacting your dealer or the service department of the ergo_lyps

If the cause of the failure could not be identified, you should contact your dealer or the repair hotline of daum electronic gmbh (telephone number ++49 / (0) 911 / 97 536-0).

We need the following information:

1. The **device number** (this number is on the silver label on the rear lower part of the frame).
2. The **dashboard version number** (you can access this number under the "Menu", "Information", "Version Data", "Serial Number" on the graphic display).
3. The **proof of purchase and the device reference sheet**.
4. **ergo_lyps** ergometers have a built-in failure diagnostic system, which signals device functionality using a red and a yellow LED.

These LEDs are located on the small circuit board located on the drive unit inside the device. You can see this board from above through the metal frame (to the right side looking in the front direction). It is located on the front part of the drive unit before the big tensing spring. With the device switched on, the yellow LED should blink when pedalling or turning the crank wheel slowly, and blink faster when pedalling fast.

With the device switched on, the red LED should light with high intensity when pedalling against a low load, and decrease in intensity as the load increases.

Please inform us of the status of these LEDs for all complaints concerning "the device is not braking" or "the device is not braking properly." This enables us to draw relatively concrete conclusions about the cause of the failure.

If you wish to obtain more information on your device, please visit our service and repair hints web site on Internet (www.daum-electronic.de). You can also call our service and repair hotline

(telephone number ++49 / (0) 911 / 97 536-0).

Software Failure / Loss of Dashboard Control

All computer controlled appliances have one undesirable characteristic in common that is that the normal software operation can sometime fail for generally unknown reasons. This situation is generally described by the expression “the system has frozen”. Should the dashboard operation fail and cannot be restored by means of normal keys operations, then the solution would be to press the recessed RESET key (No. 14) underneath the dashboard with a pointed tool (e.g. A pencil or ball pen).

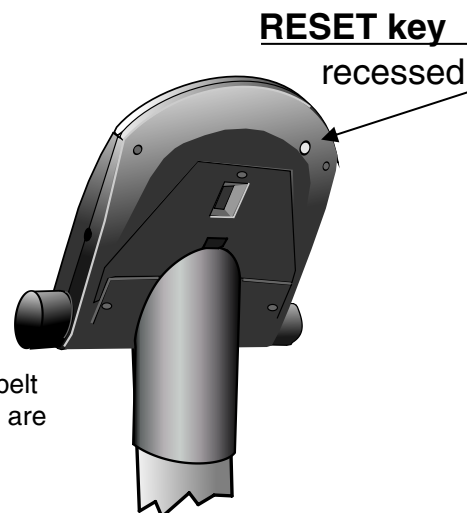

Noises

ergo_lyps ergometers are equipped with quality ball bearings and a silent belt drive. However, it cannot be avoided that remaining noises be heard, which are in the range of LpA 52 dB (decibel).

The squeaking or other disturbing noises generally originate from:

- Wear of the V-belt
- Wear of the slipping coupling
- Wear of the bearings

or also

- Loosening of the crank arm fastening screws!
- The bearings of the oscillating poles.
- The fastening screws of the feet or dashboard support column!

These screws must be tightened from time to time, but in any cases every 500 km!!

Notes about the pulse alarm

If you enter the age of the user under “**Age**”, and a heart rate limit value that should not be exceeded under “**heart rate**” in the “**limit values**” menu (see page 5), then the alarm will always sound whenever

- the aerobic zone corresponding to the age of the user is exceeded (see page 7)
- and
- the value entered under heart rate higher limit is reached (see page 5)

If you want the alarm to sound only when the heart rate limit value entered under “heart rate higher limit” is reached, you should enter 10 as the user age under “Age”!!

Drive / Braking unit (eddy current brake)

If a major failure is detected on the **drive unit**, it is possible to replace the complete unit. The braking unit, which consists of the flywheel, a transformer, a belt tensioning device and the mounting plate, is mounted with only three screws.

You can order an exchange unit from **daum electronic GmbH**. The defective unit can then be relatively easily replaced with the new one, without requiring any adjustment, by your dealer or a bike mechanic.

The flywheel of the *ergo_lyps* is equipped with two journal bearings. These bearings continue to run for a little while after you stop pedalling. Feeling a light drag on the foot rods is then normal. The journal bearings should be lubricated with Klüberplex BEM 34-132 grease every about 3000km (if the drag on the foot rods increases and becomes uncomfortable), depending on the load.

Warranty conditions

Please consult your dealer/retailer in the case of a failure or trouble. The manufacturer **daum electronic GmbH** provides the warranty to your retailer according to the following conditions:

1. We guarantee that our products are free of manufacturing and/or material defects.
2. We will correct any problem pertaining to the above categories, with the exclusion of customer claims not related to those categories through upgrading services provided by us. We reserve the right, upon returning of the product in question, to exchange it with another product of the same type and value or, at our own discretion, to take it back against repayment of the amount paid by the customer (deducting overhead costs).
3. Our warranty covers a period of two years for parts and labour in the case of private utilisation of the product, and a period of three months, for parts and labour, in the case of commercial utilisation of the product, in both cases starting on the manufacturing date.

We will fulfil this warranty service provided the customer will pay all freight and transport costs, including those for spare parts, and the cost of any packaging material we should possibly need to use.

Returned devices will only be accepted if in the original packaging.

(see illustration on page 22)

Advance replacement of parts under warranty will be invoiced and delivered against payment (COD). The amount paid will be immediately refunded upon reception of the returned old part by us.

4. All other warranty claims, specially claims for the compensation of direct or indirect damages, or damage to a third party, or damages to other objects, as well as of damages due to failure, and of labour costs, are expressly excluded to the extend authorised by law. Should the repair fail within a reasonable delay, the customer has the right to demand a price reduction or the cancellation (modification) of the contract at his discretion.
5. We decline any responsibility for any wear occurring through normal utilisation. The warranty will be considered null and void if our instructions for mounting and utilising the device are not respected, or if the chemical products we recommend and deliver are not used, or if any modification was made to the device without our prior approval.
6. It is the customer's responsibility to check each one of our deliveries immediately upon reception. Any complaints about missing or defective parts must each be immediately transmitted in writing.
7. We do not guarantee that the delivered product will be suitable for the usage intended by our customer. Extended agreements need to be expressly confirmed in writing.
8. Any technical advice provided by us is formulated according to the best of our knowledge and in good faith, based on our own experience and testing. We do not assume any responsibility for this service, unless serious negligence can be proven on our part.

If you wish to obtain more information on your device, you can visit our service and repair hints web site on Internet (www.daum-electronic.de). You can also call us on our repair hotline at daum electronic gmbh

(telephone number ++49 / (0) 911 / 97 536 - 0).

daum electronic gmbh, Fürth

Menu Diagram

menu

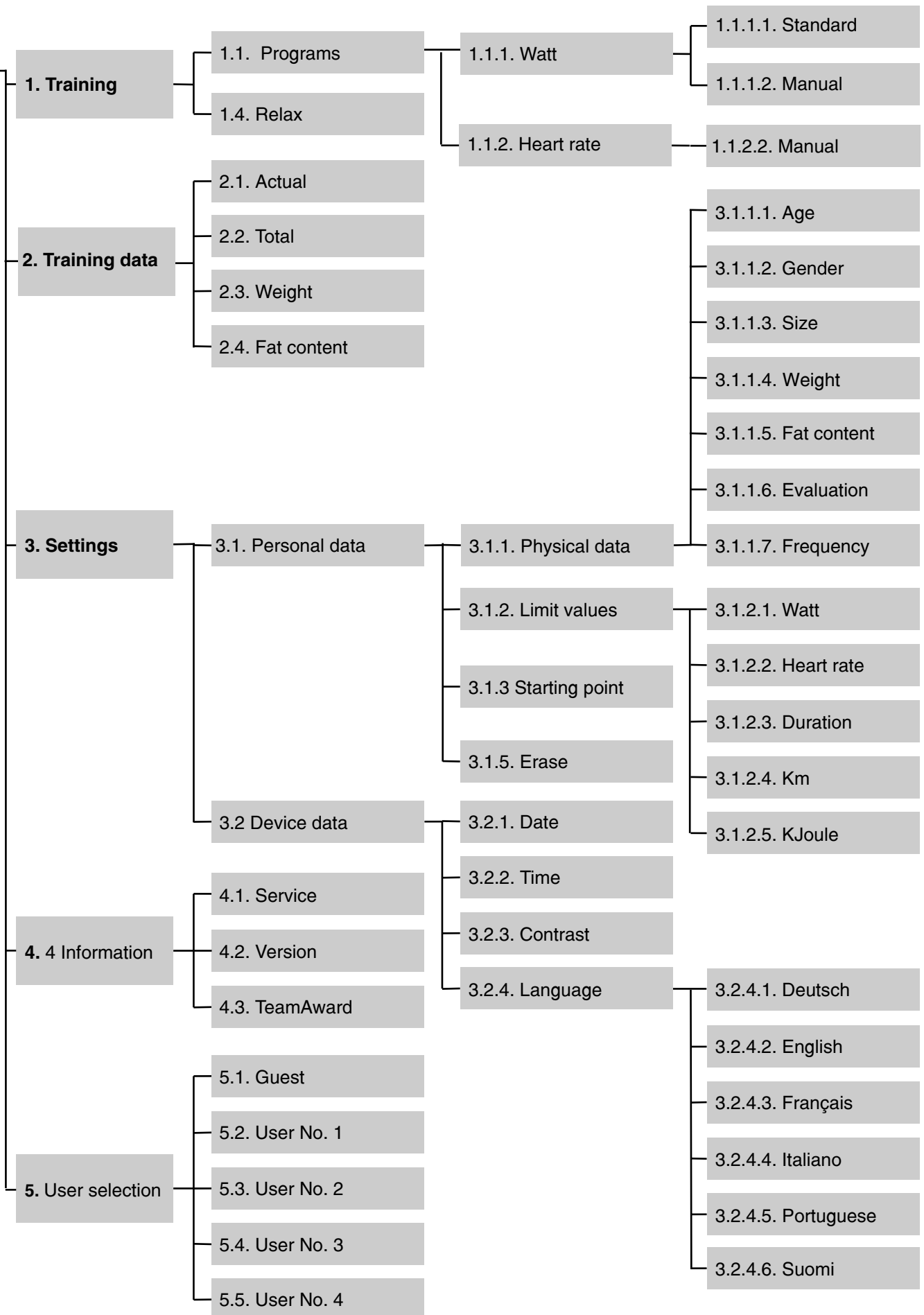

Installation hints

Miscellaneous

Install the **ergo_lyps** on a level floor. The manufacturer will not be held responsible for any damage done to the floor. We thus recommend installing the device on a protective base.

The **ergo_lyps** is not intended for use in damp rooms. Rust could develop, which would damage parts of the device and impair both the operating functions and the safety features.

The **ergo_lyps** uses a mains voltage of 230 Volt, 50/60 Hz and has a power consumption of 50 Watt. The power supply you wish to use must fulfil these requirements!

Any fault or defect on the device that have an impact on safety must be repaired. Defective or broken parts must be replaced immediately (see spare parts list page 30). The device is not to be used until the repair is complete.

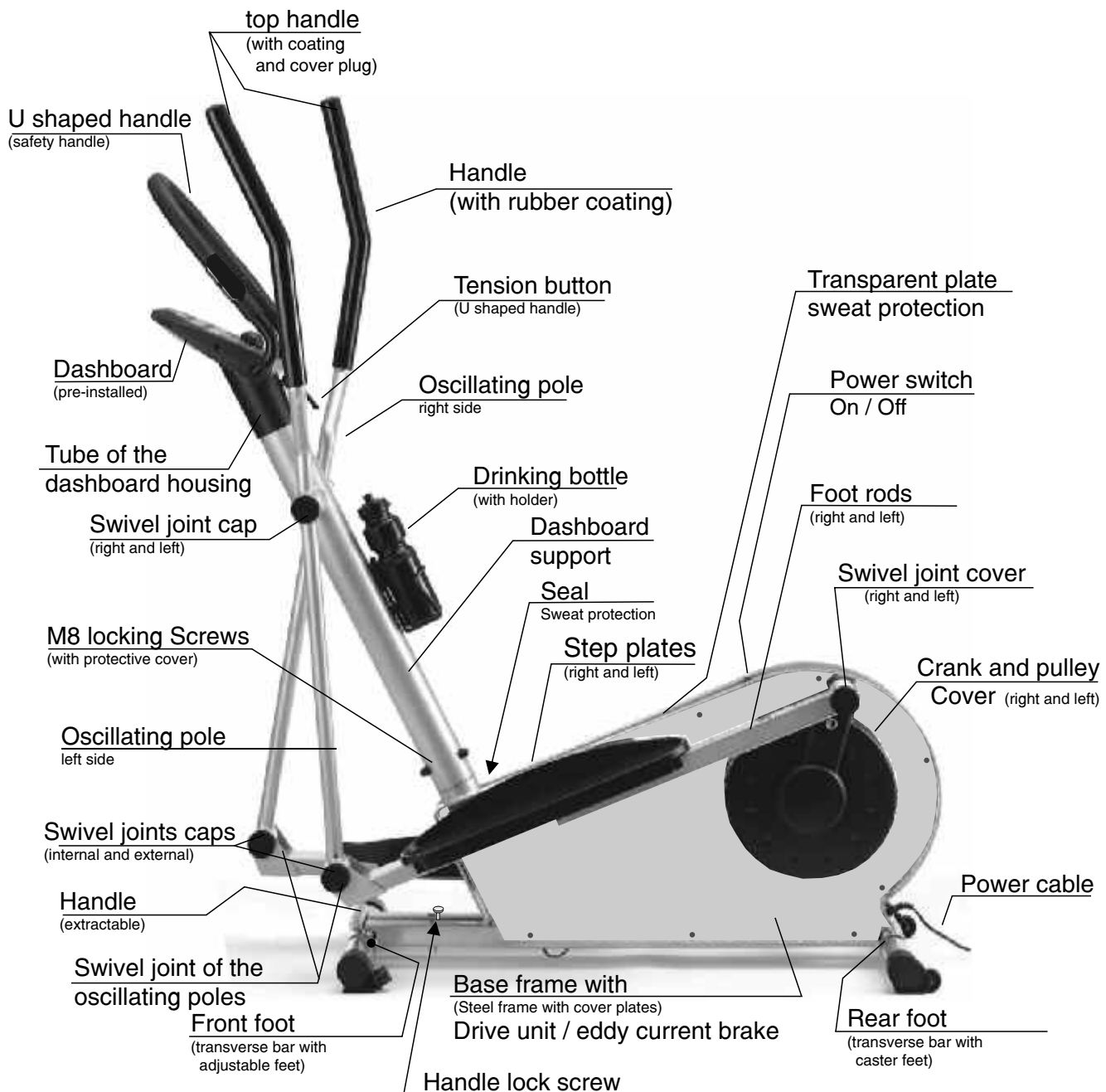

Package Contents

The ergo_lyps can be assembled easily and swiftly by two persons.

The device:

- 1 ergo_lyps base frame with drive unit
- 1 dashboard stand with dashboard & U shaped handle
- 2 feet set
- 2 Oscillating poles / right and left
- 2 Top handle with coating and caps
- 2 Foot rods / right and left
- 2 Step plates with corresponding screws
- 2 Bearing shafts for the oscillating poles (right and left)
- 2 Bearing shafts / crank lever (right and left)
- 1 Drinking bottle with holder and screws

Mounting hardware:

- 4 Recessed head screws M 8x50 (A)
- 4 Spacer sleeves 12 Ø x 37.5 mm (B)
- 11 Hexagonal head screws M8 x 20 (C)
- 7 Spring washers DIN 127 - 8.1 (D)
- 4 Washers DIN 9021 8.4 (E)
- 4 Flat head screws M5 x 40 (F)
- 4 Washers DIN 125 5.3 (G)
- 4 Hexagonal nuts M5 (H)
- 3 Dome nut f. hex. head screws M8 (J)
- 4 Curved spring washers ET3159 (K)
- 2 Screws 3.5 x 25 (L)
- 2 Foot stopper (M)
- 8 Swivel joint caps (N)

Tools

- 1 Wrench 8 mm
- 1 Wrench 13/17 mm
- 1 Allen wrench SW 6

Accessories

- 1 Pulse sensor Ear clip
- 1 Relaxation sensor
- 1 Software update cable
- 1 User manual

Small parts box

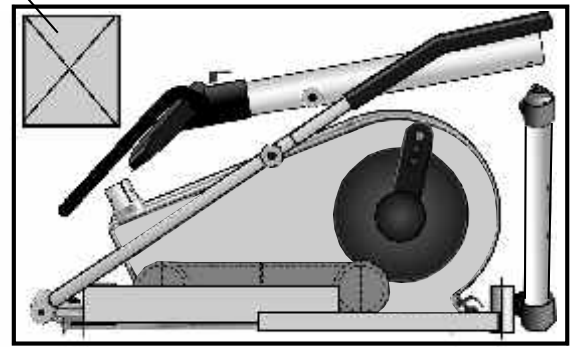

ergo_lyps package contents

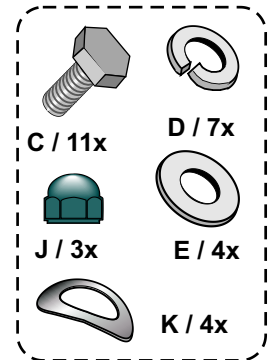
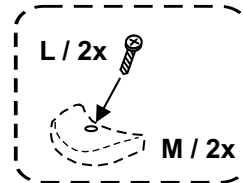
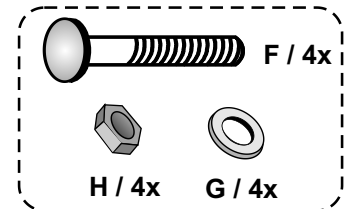
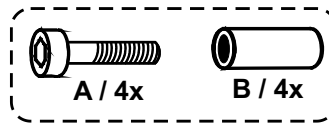

Assembling the feet

Insert the four recessed head screws with spacer sleeves (1) through the two holes and tighten them firmly.

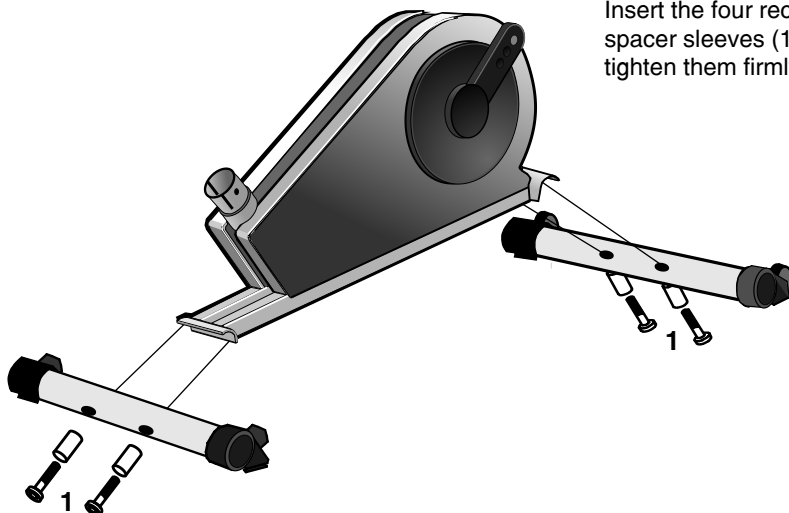
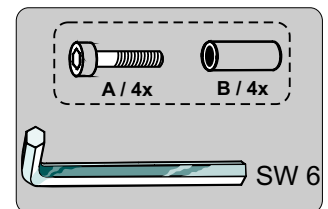

Foot with caster roller to the rear.

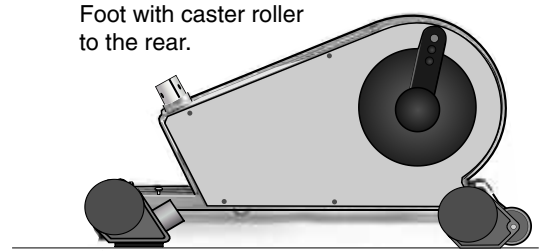

Please respect the proper positioning of the feet.

Installing the dashboard

Connect the two cables X and Y by means of the connector. Then raise the dashboard into position. Take care in doing so not to get the cables jammed or even severed. This assembly step is more easily executed with the help of a second person since the dashboard support column is heavy.

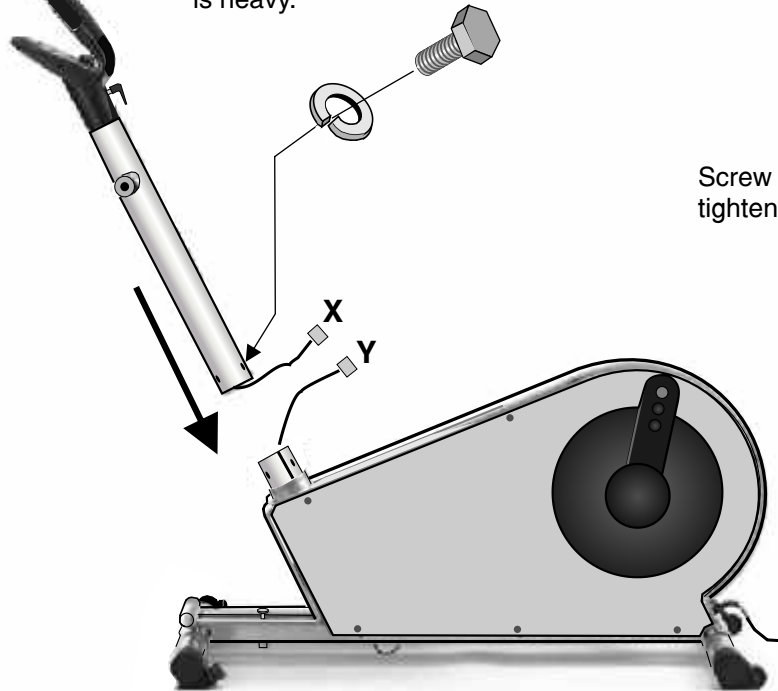
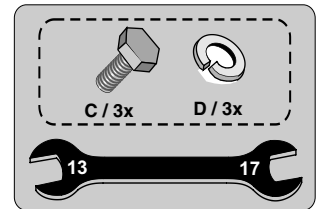

Screw in the screws with the washers without tightening them for now.



Be careful! Avoid jamming or separating the dashboard cable in the receptacle.

Assembling the handles

1

Pull together the two halves of the handle's extensions and insert the extension in the oscillating poles.

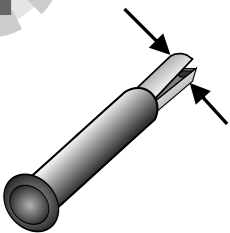

2

Use a hammer, with a shock absorber (a piece of soft wood or plastic) between the handle and the hammer, to insert the handle into the oscillating pole until the pole's sleeve is even with the handle's extension. Repeat the procedure with the other handle.

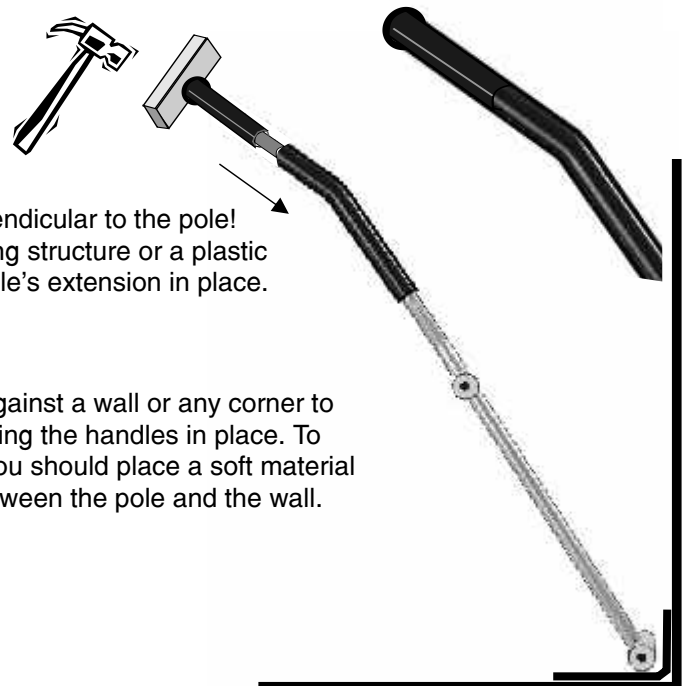

Be careful to hammer the handle perpendicular to the pole! It is mandatory to use a shock absorbing structure or a plastic or rubber hammer to hammer the handle's extension in place.

You should lean the oscillating poles against a wall or any corner to keep them from slipping while hammering the handles in place. To further protect the poles and the wall you should place a soft material like e.g. a carpet or a piece of cloth between the pole and the wall.

Installing the oscillating poles

1

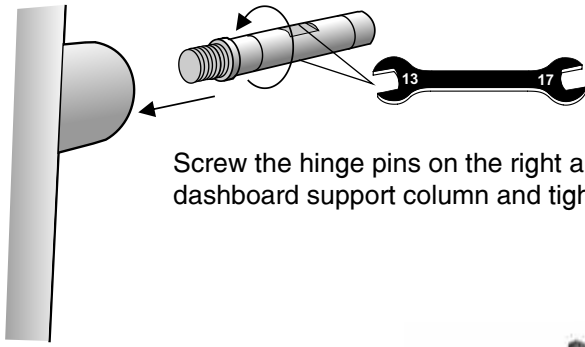

Screw the hinge pins on the right and left sides of the dashboard support column and tighten them in place.

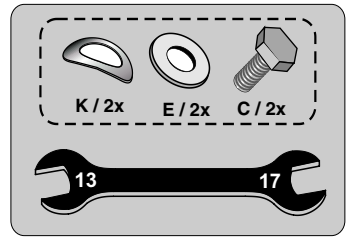

2

Attach the oscillating pole with the screw with washer and the curved spring washer without tightening them at this moment.

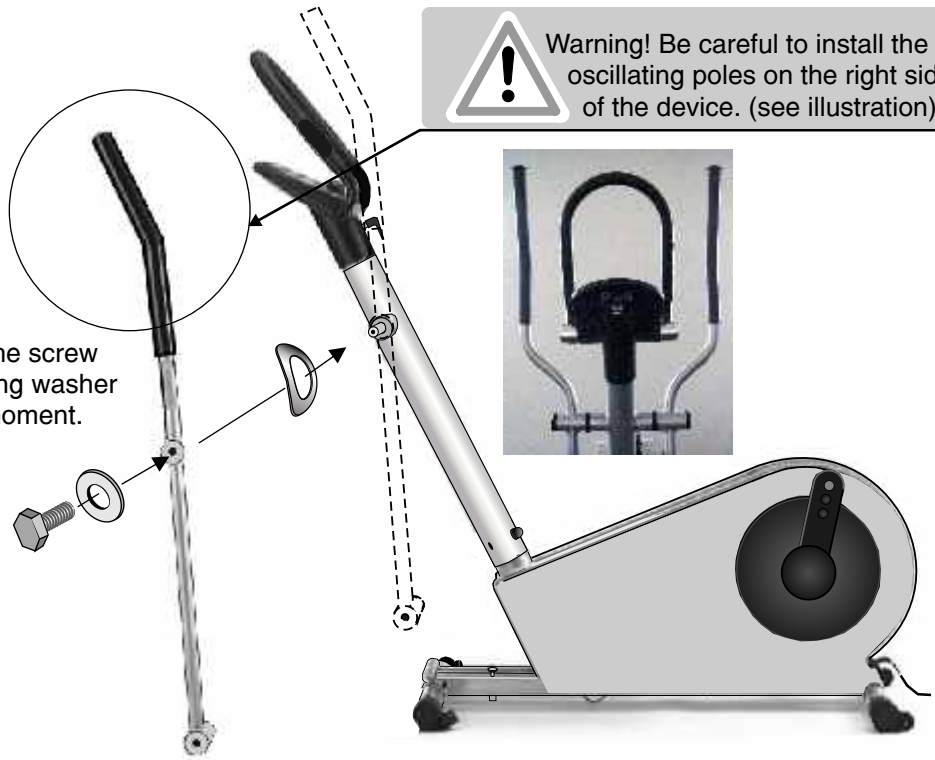

Installing the foot rods (front)

Attach the foot rods to the oscillating poles by means of the screws. Do not tighten the screws at this moment.

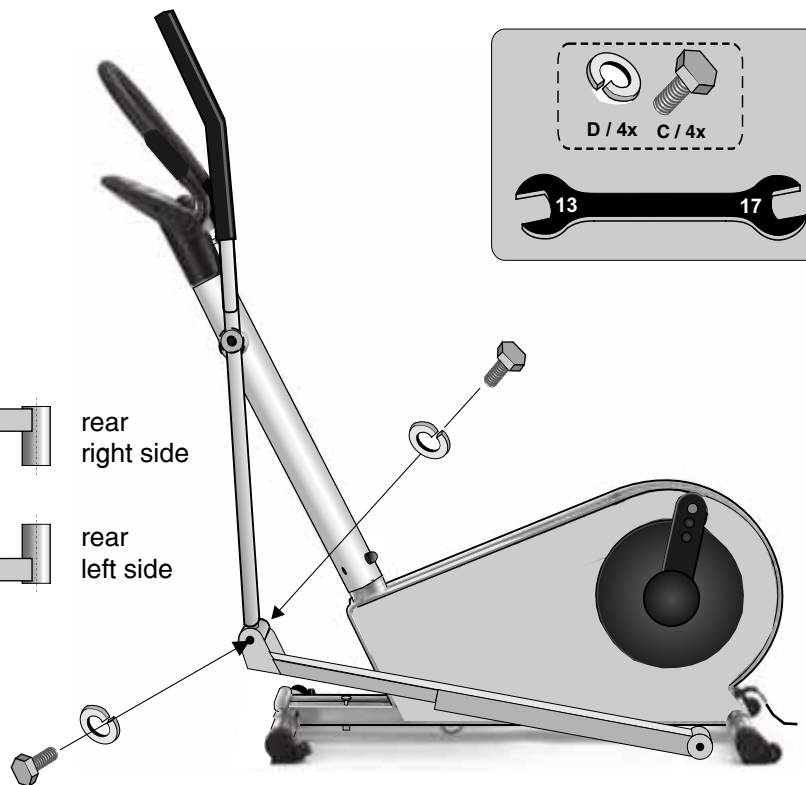
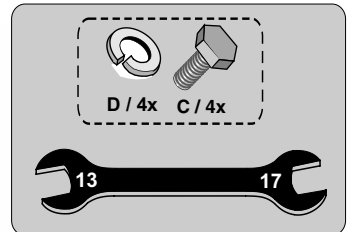
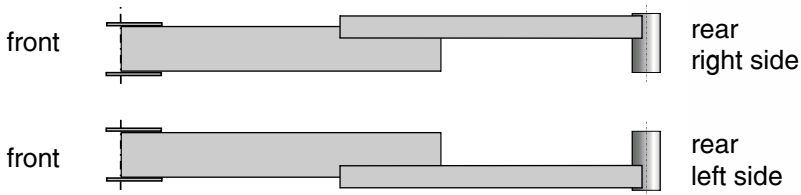

Installing the foot rods (rear)

1

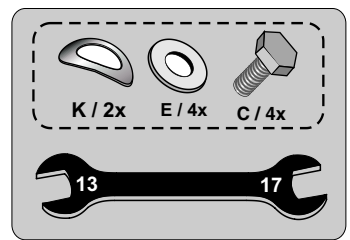
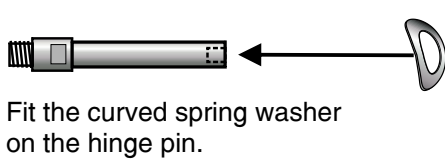

Hinge pin of the crank lever

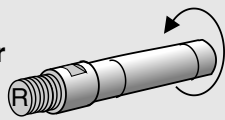

Watch for the left/L and right/R thread on the pin!!

Right Bearing carrier

2

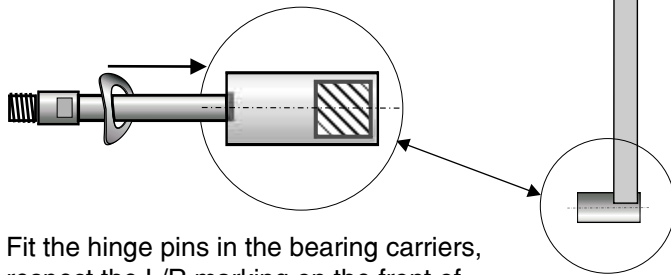

3

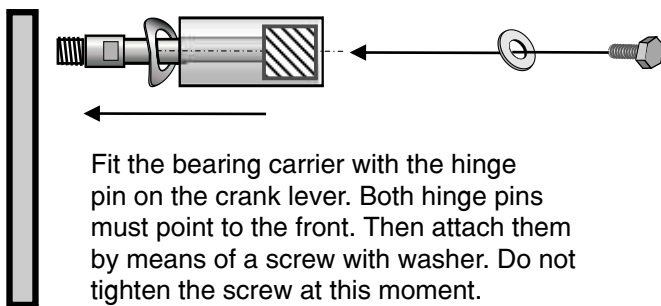

Installing the step plates

1

The foot plates are attached with two flat head screws. The side retaining wall must be located to the side of the device and the line of adjusting holes must point to the front.

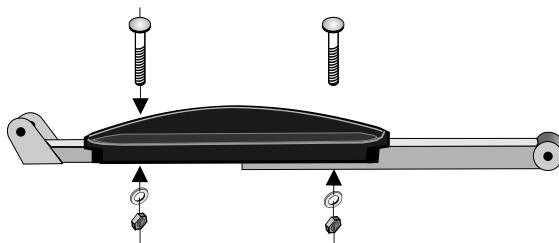
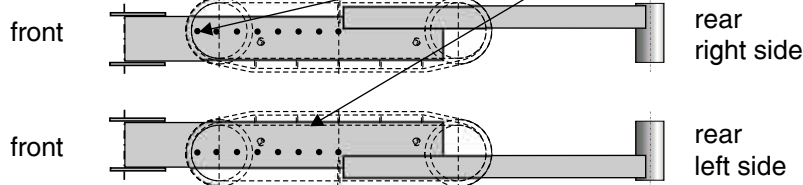
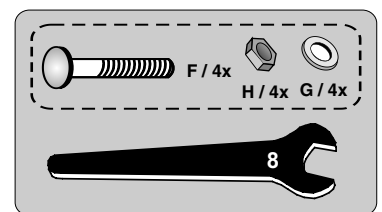

2

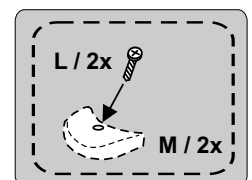
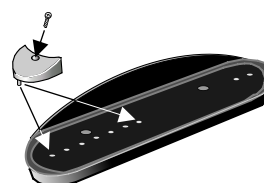
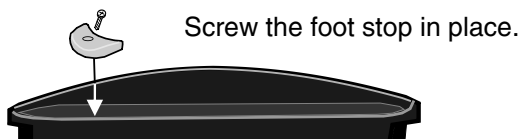

Installing the bottle holder



Mount the bottle holder to the dashboard column using the supplied screws.

Installing the covers on the joints.

At this point in the assembly process it is possible to test the movement of the ellipse trainer by hand to evaluate the adjustment of the parts to one-another. If no visible defect and no unexpected friction or squeak noises are detected then you should firmly tighten all swivel joints and attachment screws, including those of the hinge pins (13mm or 17mm), and double check their seating position.

Once you are sure that all the screws are firmly tightened, you can put on the corresponding joint covers.

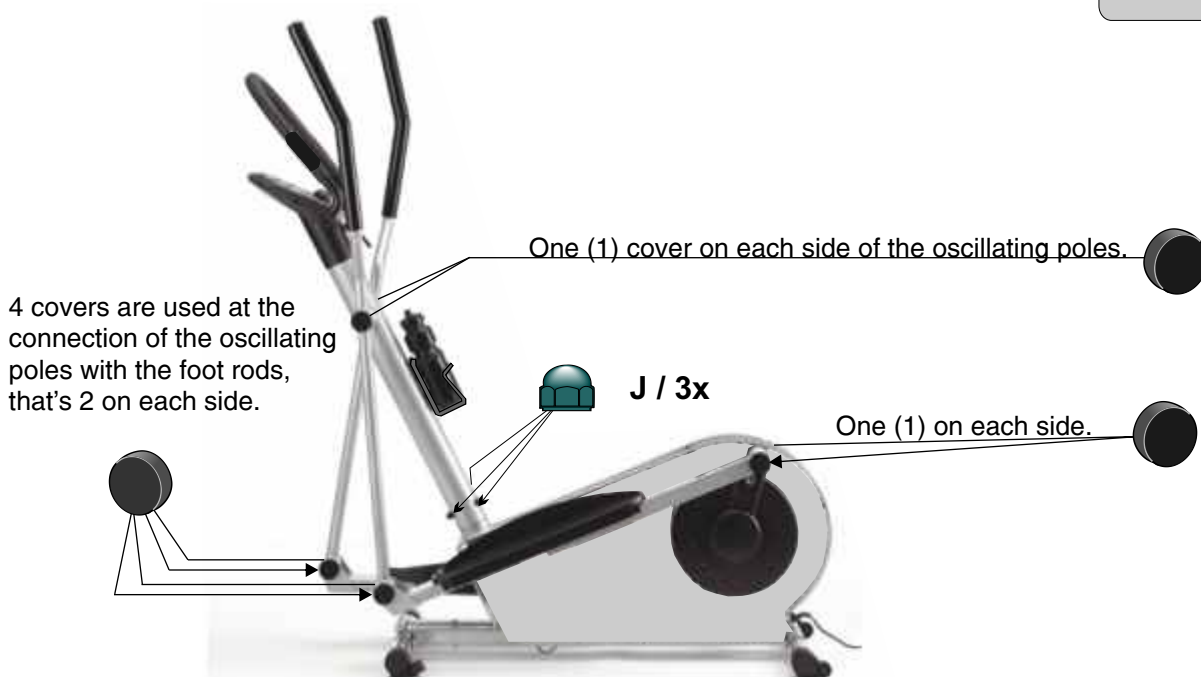
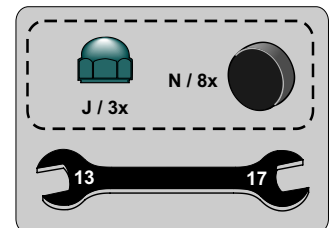

Changing the position of the crank hinge pin

The height of the foot rods can be adjusted, and thus the radius of the pedalling circle, by moving the hinge pin on the crank lever.



1



Remove the cover of the hinge pin position you wish to use.

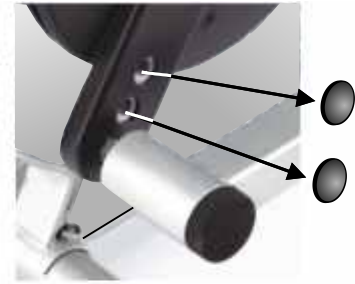

2

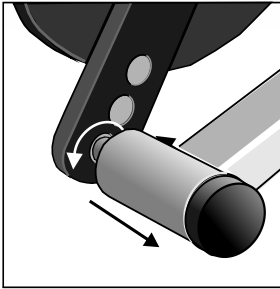

Remove the hinge pin by turning it backwards.

3

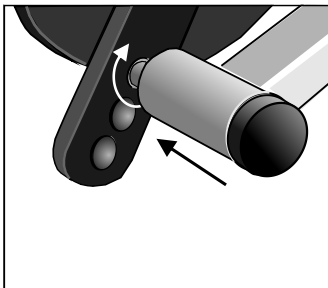

Move the hinge pin to the new position and mount it by turning it.

4

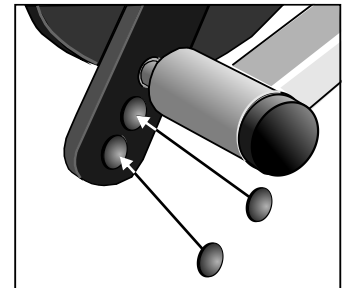

Reinstall the covers on the unused positions.

Stand foot

If the *ergo_lyps* is installed on an uneven floor, use a screwdriver to adjust the compensation setting in the front feet to ensure a stable stand.

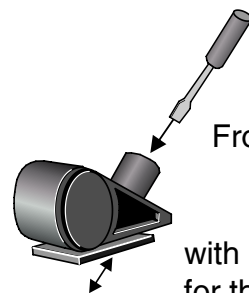

Front Foot

with compensation setting for the floor distance

Adjusting the handlebars

Loosen the **tensing button** on the dashboard to change the inclination angle of the handlebars. After you bring the handlebars to the required inclination retighten the tensing button back again.

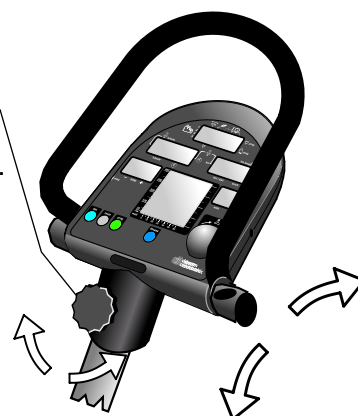

Simple Maintenance and Service Activities

Miscellaneous

Every 500 km of cumulated running distance you should check whether all the screws are still firmly set. Tighten them back as needed.

Care should be taken to remove sweat from the dashboard and the frame after every training session to protect the paint against rust. Rust damage caused by sweat is not covered by the warranty!

Use a soft cloth wetted with water to clean the outer surface of the device. A light soap solution may also be used to wet the cloth.

Procedure to replace the V-belt

Unplug the power cable from the main power supply before opening the device!

Take particular care to avoid damaging the internal parts of your ergo_lyps while you are working.



The manufacturer will not be liable for any damages arising as a result of negligence while changing the V-belt!

V-belts are wearable parts and as such are not covered by the warranty.

The V-belt is located on the right side of the device.

1. Remove the foot rod on the right side. Use the wrench (17mm) to loosen the hinge pin.
2. Remove the screws (9 units) fastening the side cover.
3. Remove the side cover.
4. The driving parts on the carrier plate /drive unit are now freely accessible. Press on the belt tension lever and the tension spring (9h) to release the V-belt tension, and then pull the belt from the pulley (9a).

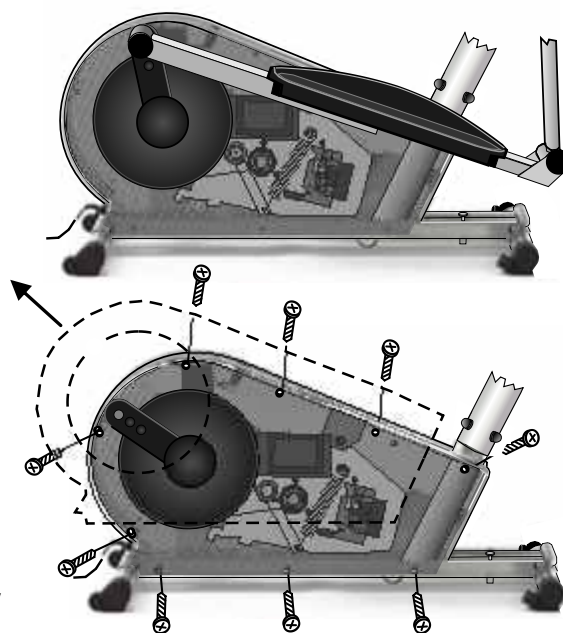

Follow the same steps (1 to 4) as described above in reverse sequence to install the new V-belt.

Before installing the new V-belt, you should clean the belt slipping surfaces of the pulley and the drive shaft, as well as the belt itself, with alcohol or cleaning petrol to remove the grease.

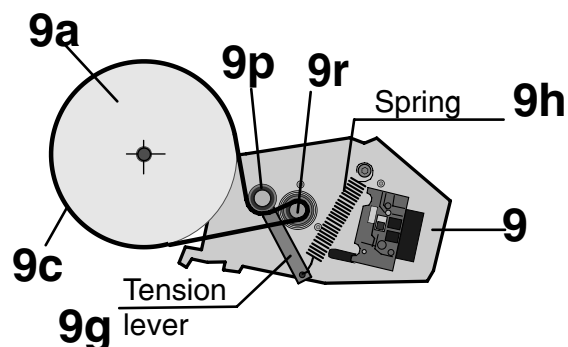

Exchanging the Dashboard / Replacing the Battery

Required tools: Phillips screwdriver / Blade 1 x 70 mm

1. Unplug the power cord!

(For your personal safety and to protect the sensitive electronic parts inside the dashboard)

2. The top part of the dashboard is secured to the bottom part by mean of 4 Phillips screws (A, B, C, D). Use an appropriate screwdriver to unscrew these screws from underneath the dashboard. (See the figure to the right) Please note that the screws C & D are located toward the outward border and are deeply recessed in the dashboard bottom part. Do not unscrew the nearby located screws (X)!

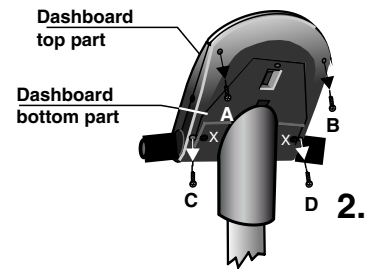

3. Then you can remove the top part of the dashboard very carefully. First open the dashboard housing by raising it from the higher side slightly and grasp (hold) with both hands underneath the top shell of the dashboard. Raise the higher part of the dashboard top shell further until the lower side separates from the dashboard support. Be careful to raise the top shell of the dashboard housing only until you feel a slight resistance from the cables that are connected from underneath, and until you can reach the connectors on the circuit board with your thumb and index finger.

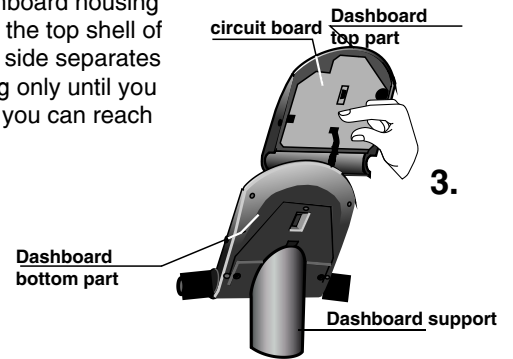

4. You must unplug both connectors.

Never pull on the cables to unplug them!! This would tear them off!



**Never pull the cable!
It could tear off!**

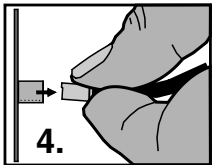

4.

Be careful when pulling the connector in order to avoid damaging the circuit board and the electronic parts!

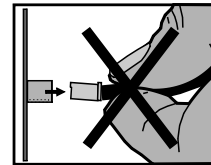

5. Plug the dashboard connector and the hand pulse connector to the female connector of the corresponding colour until they lock in position. Then pull carefully the two cables through the opening of the bottom part of the dashboard and the dashboard support and take care not to jam the cables when you reinstall the top part of the dashboard on the bottom part.

6. Screw the removed housing screws (A, B, C, D) from underneath the dashboard and tighten them.

7. You can now plug the power cord, turn on the device and test its operation.

Replacing the dashboard battery

A button cell battery (CR 2032) is located on the underside of the dashboard circuit board. This battery must be replaced when the time and date keeping function fails. Problems when turning on the machine and display failures are also signs of an empty battery.

Warning: The device must be switched OFF when replacing the battery. Afterward you must set the date and time.

Unscrew and remove the 4 screws on the lower part of the dashboard. Then tilt the upper part of the dashboard up carefully.

Take care not to separate any cable connection.

Never touch the electronic parts of the dashboard with your fingers! Charges of static electricity can destroy the sensitive parts.

Press the clip holder outward with a pin to replace the battery, remove the battery and insert a new one with the plus symbol up.

Reassemble the upper part of the dashboard carefully.

Caution! Do not pinch any cable!

Notes about used button cell batteries

- Keep batteries away from children, and do not swallow them!
- Do not recharge empty batteries and do not throw them in fire.

Please recycle used batteries by bringing them to the appropriate collect point, or return them to your dealer.



CAUTION!
**Failure to correctly
replace the battery
may create an
explosion risk.**

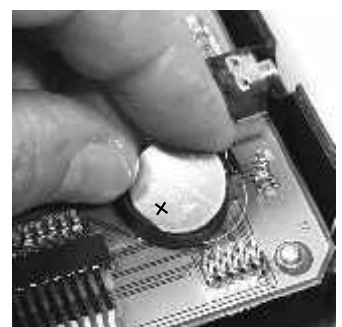

Spare Parts List

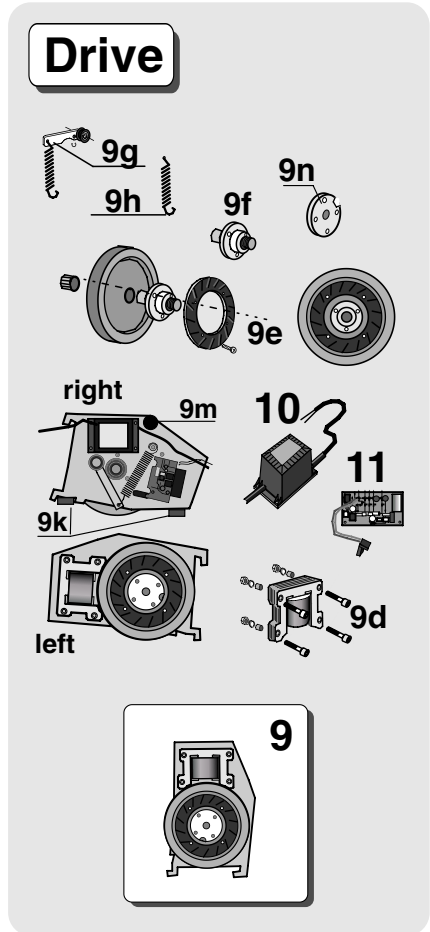
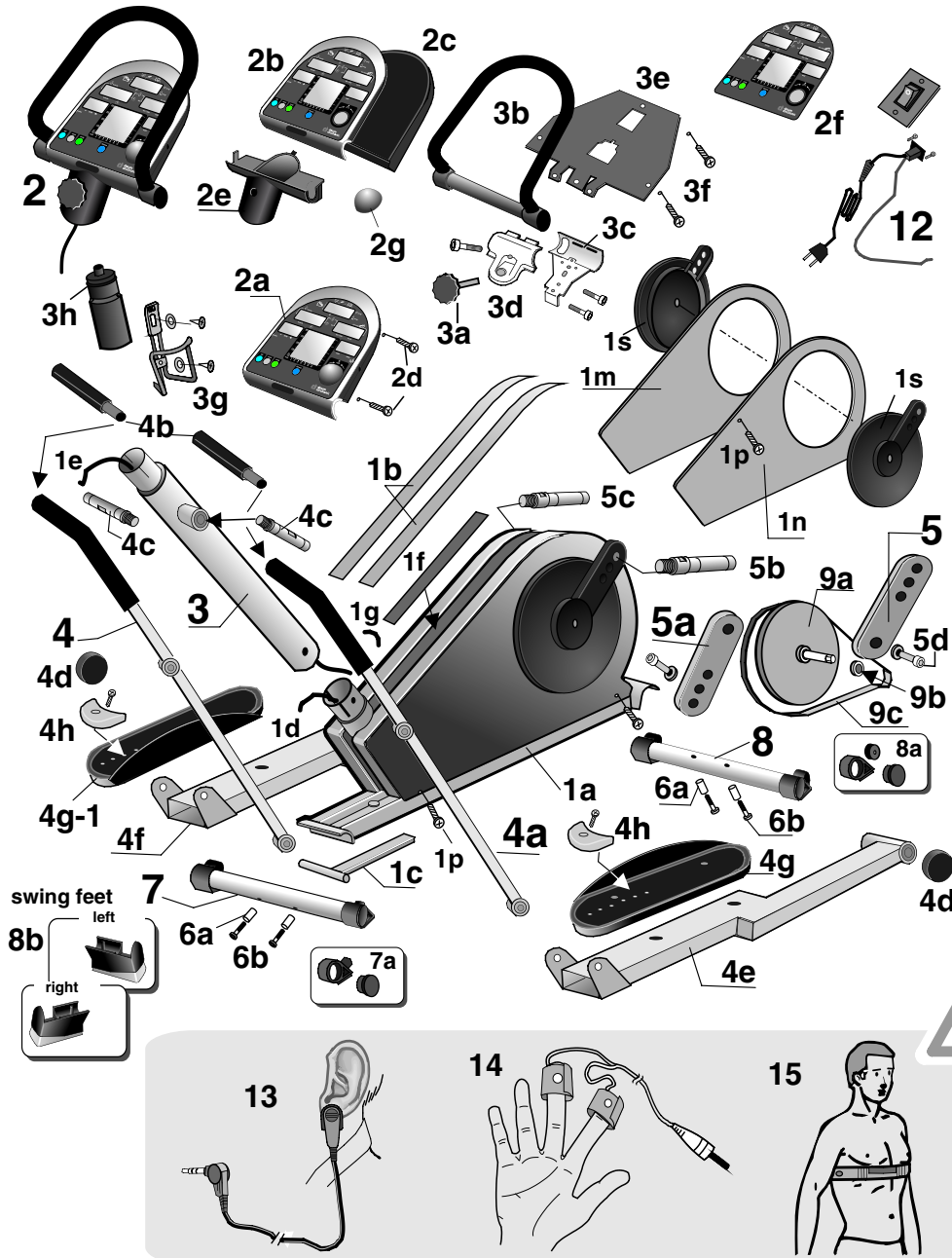

When ordering parts, please include the device serial number with the part number. You will find the device serial number on the specifications plate located at the front on the lower frame cross bar on the left side.

No.	Spare part	ergo_lyps cardio pro	No.	Spare part	ergo_lyps cardio pro
1	ergo_lyps complete body	M80 55 182 A	4d	Set of swivel joint caps	00 37 510
1a	Frame	00 38 950 A	4e	Foot rod / left	00 38 120
1b	Decoration self sticking strips	06 50 949	4f	Foot rod / right	00 38 125
1c	Carrying handle	00 37 155	4g	Step plate left (step plate right /4g-1 order no. 00 37 131)	00 37 130 / 00 37 131
1d	Frame cable	12 10 801	4h	Position stopper	00 37 345
1e	Dashboard - frame connection cable	12 10 803	5	Crank lever / left	00 38 150 A
1f	Transparent sweat protection cover	00 37 351	5a	Crank lever / right	00 38 155 A
1g	Sealing / Sweat protection	07 05 186	5b	Shaft / Crank lever / left	00 37 100
1h	Mounting base for locking strip FTH 15	03 00 035	5c	Shaft / Crank lever / right	00 37 105
1k	Locking strip 2,5 100	07 50 090	5d	Crank lever screw (washer / 00 05 571)	00 30 571
1m	Right side cover	00 38 412	6	Hardware bag	00 37 461
1n	Left side cover	00 38 411	6a	Spacer sleeve for fastening the foot	00 09 535
1p	Fastening screws for the side cover	00 21 412	6b	Screw for fastening the foot	00 21 850
1s	Cover of the crank and pulley	00 37 150	7	Complete front foot	M 80 90 197
2	Dashboard unit (Dashboard, U-shaped handle and cable)	M 60 55 182 A	7a	Foot with adjustable height (front)	00 17 418
2a	Dashboard housing including electronic parts	M 70 55 182	8	Complete rear foot	M 80 90 198
2b	Dashboard upper part	00 17 436	8a	Foot with roller caster (rear)	00 17 419
2c	Dashboard lower part	00 17 437	8b	Set SF = "swing feet" upgrade kit	00 17 635
2d	Dashboard housing screws	00 21 510	9	Complete drive unit for the ergo_lyps	M 80 50 000
2e	Dashboard housing tube / Bottom cover	00 37 404	9a	Pulley with shaft and ball bearing	M 80 50 200 A
2f	Dashboard foil	06 50 790	9b	Ball bearing	00 09 316 A
2g	Control button	00 17 422	9c	Driving belt (V-belt)	00 31 070
3	Dashboard column	00 38 160	9d	Brake magnet	M 80 50 050
3a	Locking lever / Handle positioning	00 17 317	9e	Flywheel complete	M 80 50 060
3b	U-shaped handle complete	00 17 494 A	9f	Bearing carrier with pulley shaft and ball bearing	M 80 50 070
3c	Handle carrier complete (rear)	00 17 232 A	9g	Belt tensing unit complete	M 80 50 080
3d	Handle clamp (front)	00 17 233 A	9h	Pulley tensing spring	00 09 233
3e	Dashboard protective plate / carrier plate	00 17 138	9k	Rubber pad D 25 x 10	00 07 320
3f	Screws for the protective plate / housing	00 24 406	9m	Rubber pad M6*18 25x30	00 07 335
3g	Drinking bottle holder with fastening screws	01 00 050	9n	Sliding joint	M 60 50 100
3h	Drinking bottle	01 00 045	10	Power transformer / 230 V, 50 - 60 Hz	18 20 150
4	Oscillating pole / right side with ball bearing	00 38 105	11	Power part / Version 2002	E 80 90 025
4a	Oscillating pole / left side with ball bearing	00 38 100	12	Power switch	M 80 50 150
4b	Handle set / oscillating poles extensions	M 80 50 800 A	13	Pulse sensor	00 17 900
4c	Pin bearing flange	00 37 120	14	Relaxation sensor	E 80 90 080
			15	Cardio Sensor chest band	E 90 91 015



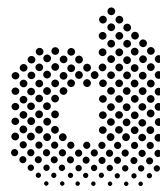

daum
electronic
best for your fitness

daum electronic gmbH
Flugplatzstr. 100
D - 90768 Fürth

Tel. ++49 / (0) 911 / 97 536 - 0
Fax. ++49 / (0) 911 / 75 37 14
www.daum-electronic.de

ergo lyps
Fitness PRO
Order Nr. 90 55 382

© daum electronic;
Copying or using the contents
of this manual, as a whole or
in parts, is not authorised without
the written permission of daum
electronic GmbH.

Index-06-4