



ELECTRONICS
FOR SPECIAL ORIGINAL
EQUIPMENT



Energy Management



Drive Train



Components



Lighting electronics

ELECTRONIC MADE FOR INDIVIDUAL CHALLENGES



HELLA ELECTRONIC COMPONENTS

You, too, can profit from our rich experience gathered over decades and from our innovations!

We offer a wide selection of specific electronic parts for all the following areas: energy management, drive trains, components and lighting electronics. These are designed for use in a complete system or they can also be intended for a specific application. And they even fulfill the more demanding requirements of commercial and/or special vehicles. Hallmarks of our products include the way they are extremely robust, temperature-resistant and also heat-resistant.

And our application specialists will always offer you support with the integration of the latest technologies and functions. It makes no difference how specific your requirements seem, HELLA faces such challenges head on and ensures that an individual solution is found and implemented.

Sales, Product Management and the Development departments all focus on your electronics projects, offering a wealth of flexibility and technical support in and around the product application concerned.

Reliable, intensive and indeed personal customer care: HELLA works hand in hand with you.



INFORMATIVE, COMPACT, INTERACTIVE. Information on our electronics range.

The purpose of our online information is to give you more ways to efficiently and conveniently identify the latest HELLA products and obtain important information about them.

No matter what you are looking for, we are sure to have the right part in our range:

- Product information
- Product videos
- Animations
- Configuration tools for many applications
- Online catalogs

You will find everything you need to know about our electronics portfolio here.

www.hella.com/soe-electronics

This brochure shows you an extract from the HELLA electronics product range and is aimed at manufacturers of special vehicles and it is also designed for sub-suppliers.



Agricultural Vehicles
www.hella.com/agriculture



Construction machinery
www.hella.com/construction



Mining
www.hella.com/mining



Truck and Trailers
www.hella.com/truck
www.hella.com/trailer



City buses and coaches
www.hella.com/bus



Municipal Vehicles and Special Bodywork
www.hella.com/municipal



Emergency vehicles
www.hella.com/emergency



Motor Homes
www.hella.com/caravan



Motorbikes and quads
www.hella.com/powersports



E-cars
www.hella.com/ecars



Some of our products are likewise also relevant for Tier X customers.
www.hella.com/tierx



Sports cars and premium vehicles
www.hella.com/premiumcars



THE NEW ROCKER SWITCH CONFIGURATOR

Just a few steps away from the switch you really want to have! It is now even easier and more straightforward to put your individual switches together thanks to the new HELLA rocker switch configurator.

With just a few clicks, choose from various criteria and switch accessories for the 3100 or 4100 series - it has never been more convenient! You do not have to miss out on our proven basic range, the 4570/7832 series, either, thanks to the range overview – including the part number, of course, for your next order.

www.hella.com/switch

PRODUCT DIVISION

Energy Management	Drive Train	Components	Lighting electronics
			
<p>Careful use of energy by appropriately influencing the consumer:</p> <p>These electronic systems make it possible to monitor and plan the energy budget and maintain the power supply.</p>	<p>Increasing the safety and efficiency of the overall system and preventing failures:</p> <p>These electronic systems make it possible to precisely measure and record values in the engine compartment and drive train.</p>	<p>Provide added convenience with compact solutions in a variety of areas:</p> <p>These electronic systems are generally invisible little helpers for the various automatic processes within the vehicle.</p>	<p>Provide added convenience with compact solutions in a variety of areas:</p> <p>These electronic systems are generally invisible little helpers for the various automatic processes within the vehicle.</p>
 <p>Intelligent battery sensors</p>  <p>Voltage stabilisers</p>	 <p>Oil pressure sensors</p>  <p>Oil level sensors</p>	 <p>Angular position sensors</p>  <p>Air quality monitor</p>	 <p>LED flasher unit towing vehicle</p>  <p>LED light control unit</p>
 <p>Pedal sensors</p>  <p>Pedal sensors</p>	 <p>Turbo actuators</p>	 <p>Remote controls</p>  <p>Rain/light sensors</p>	 <p>Control unit for flashing side marker lights</p>
 <p>Rocker switches</p>	 <p>Actuators</p>  <p>Temperature sensors</p>	 <p>Current monitoring control unit</p>  <p>Simulation device for cold checking</p>	 <p>Current monitoring control unit</p>  <p>Simulation device for cold checking</p>

TABLE OF CONTENTS

Energy Management



from page 10

Overview mating connectors.....	6
IP protection classes.....	8
Intelligent battery sensors.....	12
Voltage stabilisers.....	20

Drive Train



from page 25

Level sensors.....	26
Recording the liquid level (static and dynamic).....	26
Measuring the oil pressure and oil temperature.....	36
Pedal sensors.....	40
Floor-mounted pedals.....	40
Pendant pedals.....	44
Turbo actuators.....	48
Universal Turbo Actuator (UTA).....	50

Components



from page 52

Remote Control System.....	54
Switching on and off and/or opening and locking.....	54
Actuators.....	58
Electromotive actuators.....	58
Sensors.....	94
Temperature sensors.....	94
Air quality monitor.....	96
Rain/light sensors.....	98
Angular position sensors.....	106
Rocker switches.....	130



Lighting electronics



from page 136

LED lighting	
Failure monitor and electrical connection.....	138
LED flasher unit: towing vehicle.....	140
LED flasher unit: for LED direction indicators	
12 V and 24 V.....	141
LED light control unit.....	142
Control unit for flashing side marker lights.....	144
Control unit for current monitoring.....	146
Simulation device for cold checking.....	147

OVERVIEW OF MATING CONNECTORS

PRODUCT	PRODUCT DESCRIPTION	PART NUMBER	ASSOCIATED MATING CONNECTORS
 ENERGY MANAGEMENT			
Intelligent battery sensors	Sensor 1	6PK 010 842-001	Hirschmann 872-858-565
	Sensor 2	6PK 010 842-011	Hirschmann 872-858-565
	24 V	6PK 011 700-001	Hirschmann 872-858-546
	24 V	6PK 011 700-317	Hirschmann 872-858-546
	12 V, for motor homes	6PK 013 824-001	Hirschmann 872-857-565
	12 V, for agricultural and construction machinery	on request	Hirschmann 872-858-546
Voltage stabilisers	DC / DC 200 W	on request	TE Connectivity 156333-1
	DC / DC 400 W	8ES 312 331-101	Mating connector 1: TE Connectivity 1473672-1, Mating connector 2: TE Connectivity 1897519-1
 DRIVE TRAIN			
Level sensors	Recording the liquid level	6PR 007 968-041	TE Connectivity 1-967644-1
	Recording the liquid level (static or dynamic)	6PR 232 000-001 6PR 232 000-011	Delphi ZFW2-141, Bosch ZFW2-83
	Recording the liquid level (static and dynamic)	6PR 010 497-501 6PR 010 497-511	Kostal 09 44 13 82
	Measuring the oil pressure and oil temperature	6PR 010 378-101	Hirschmann Automotive 872-597-501, 872-597-506, coding A
Pedal sensors	Floor-mounted pedals	6PV 312 010-107	TE Connectivity 1-967616-1
	Pendant pedals	6PV 009 591-011	Yazaki 7283-1968-30
Turbo actuators	Universal Turbo Actuator (UTA)	on request	Kostal, 09 4415 82, coding B
 COMPONENTS			
Remote control systems	Switching on and off and/or opening and locking	on request	Lear 17848 000 000
Actuators electric motor actuators	Electrical locking/unlocking, space-saving, electrical forward and reverse rotation	6NW 011 122-017	Hirschmann Automotive 3-pin MLK coupler ELA 872-858-541
	Electrical locking/unlocking, space-saving, with micro-switch, electrical forward and reverse rotation, with micro-switch	6NW 011 122-027	Hirschmann Automotive 3-pin MLK coupler ELA 872-858-...KA
	Electrical locking/unlocking, space-saving, with micro-switch, electrical forward rotation, reverse rotation via return spring, with soft touch button	6NW 011 122-047	Hirschmann Automotive 3-pin MLK coupler ELA 872-858-541
	Electrical locking/unlocking and closing (medium force), electrical retraction and extension	6NW 009 203-401	TE Connectivity 282080-1
		6NW 009 203-411	TE Connectivity 1355390-1
6NW 009 203-421		TE Connectivity 282080-1	
6NW 009 203-431			
6NW 009 203-441			
6NW 009 203-451			
6NW 009 203-557			

PRODUCT	PRODUCT DESCRIPTION	PART NUMBER	ASSOCIATED MATING CONNECTORS
	Electrical locking/unlocking and closing (medium force), electrical retraction, extension with mainspring	6NW 009 203-461	TE Connectivity 1355390-1
	Electrical locking/unlocking and closing (medium force), electrical retraction, extension with mainspring	6NW 009 203-471 6NW 009 203-541	TE Connectivity 282080-1
	Electrical locking/unlocking and closing (medium force), electrical extension, retraction with mainspring	6NW 009 203-491	TE Connectivity 1355390-1
	Electrical locking/unlocking and closing (medium force), electrical extension, retraction with mainspring	6NW 009 203-501 6NW 009 203-521	TE Connectivity 282080-1
	Electrical locking/unlocking and closing (high force), electrical rotation left, reset per spring right	6NW 009 424-781	TE Connectivity 1355390-1
	Electrical locking/unlocking and closing (high force), electrical rotation right and left	6NW 009 424-791	TE Connectivity 1355390-1
	Smart URA – Power locking/unlocking and closing, power rotational movement to right and left, with position feedback via CIPOS technology	6NW 011 303-701	TE Connectivity 1-1456426-1, coding A
Sensors	Temperature sensors Measurement of air temperatures	6PT 009 522-011	TE Connectivity 2-1437712-5
	Rain/light sensors Recording environmental properties	on request	TE Connectivity 114 18063-18, coding D
	Rain/light sensors For vehicles with steeply sloped windshields Recording environmental properties	on request	TE Connectivity 114 18063-18, coding A
Angular position sensors	Single sensors 1st generation	6PM 011 081-001 6PM 008 161-241 6PD 009 583-101 6PM 008 161-251 6PD 009 583-111 6PM 008 161-121 6PM 008 161-131 6PM 008 161-141 6PM 008 161-151	TE Connectivity 1-967616-1 TE Connectivity 1394416-1 TE Connectivity 1-967616-1 TE Connectivity 1394416-1 TE Connectivity 1-967616-1
	Single sensors 2nd generation	on request	Sigma 2
	Double sensors (redundant angle measurement for safety-critical applications) 1st generation	6PD 009 583-001 6PD 009 583-011 6PD 009 580-017 6PD 009 584-017	TE Connectivity 1394416-1



LIGHTING ELECTRONICS

LED light control unit	Basic variant 12 V 24 V	5DS 227 488-001 5DS 227 488-101	Amphenol AT06-6S
	Premium variant 12 V (1 stop light channel) 12 V (2 stop light channels) 24 V (1 stop light channel)	5DS 227 489-001 5DS 227 489-011 5DS 227 489-101	OUT, B coding: Amphenol AT06-08SB IN, A coding: Amphenol AT06-08SA 6-pin: Amphenol AT06-06S

IP PROTECTION CLASS

IP stands for International Protection. The IP level of protection is determined according to DIN 40050 Part 9. The purpose of the standard is the exact definition against the penetration of solid foreign objects including dust and against water penetration. The adjacent overview of the IP levels of protection and the explanation of their meanings should serve to help you select the correct components to meet the respective requirements of your application.

EXAMPLE

Code letters

IP 6K5





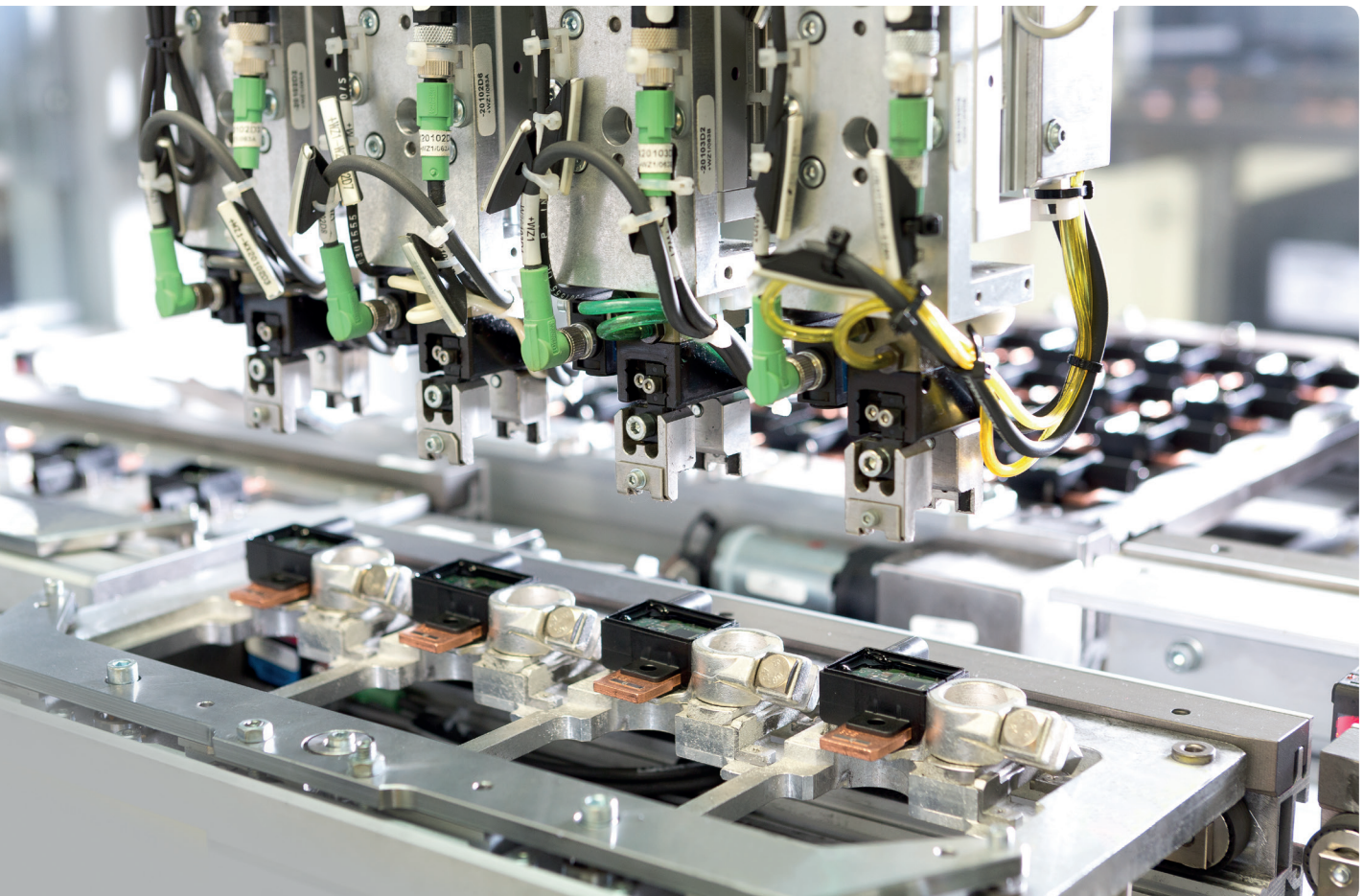

First digit:
Protection against penetration of foreign objects

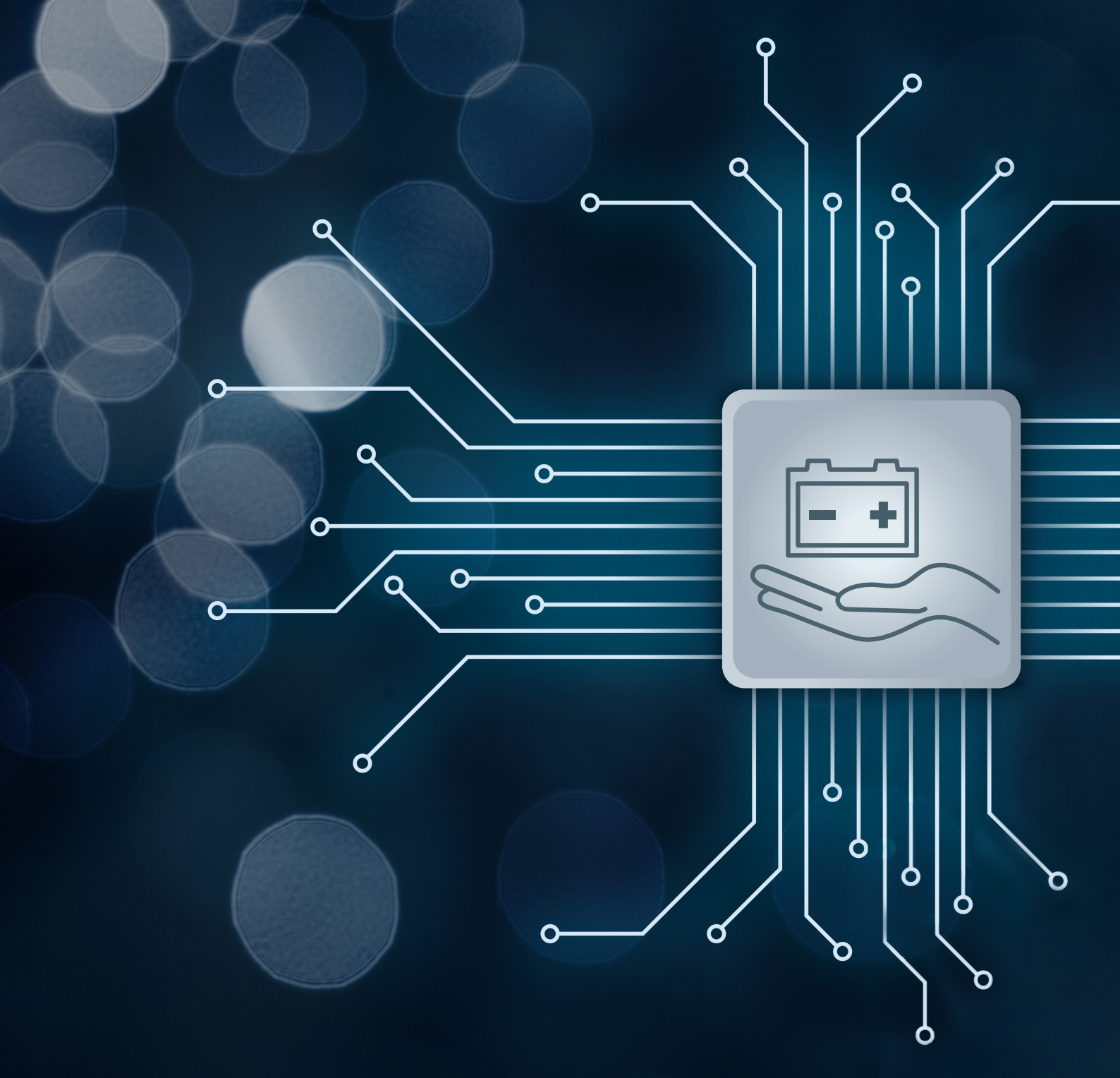
Second index:
Protected against liquid



LEVEL OF PROTECTION AGAINST SOLID FOREIGN OBJECTS (DUST)			LEVEL PROTECTION AGAINST WATER		
First digit	Brief Description	Definition	Second digit	Brief Description	Definition
0	Not protected	No requirements	0	Not protected	No requirements
1	Protected against solid foreign objects > 50 mm	The object probe, a sphere of 50 mm diameter, must not be able to penetrate completely	1	Protected against drops of water	Vertically falling drops must not have any effect
2	Protected against solid foreign objects with diameter > 12.5 mm	The object probe, 12.5 mm diameter, must not be able to penetrate at all	2	Protected against drops of water when the housing is tilted by up to 15°	Vertically falling drops must not have any harmful effects when the housing is tilted by an angle of up to 15° on both sides of its normal position
3	Protected against solid foreign objects with diameter > 2.5 mm	The object probe, 2.5 mm diameter, must not be able to penetrate at all	3	Protected against spraying water	Water, which is sprayed at an angle of up to 60° on both sides of the normal position must not have any harmful effects
4	Protected against solid foreign objects with diameter > 1.0 mm	The object probe, 1.0 mm diameter, must not be able to penetrate at all	4	Protected against spraying water	Water, which is sprayed from one direction against the housing, must not have any harmful effects
			4K	Protected against splashwater at increased pressure	Water, which is sprayed against the casing from any direction at increased pressure, must not have any harmful effects
5K	Dust protected	Penetration of dust is not entirely prevented, but dust must not be able to penetrate in such quantities that will impair the satisfactory operation of the equipment or its safety	5	Protected against sprayed water	Water, which is sprayed against the casing from any direction as a jet, must not have any harmful effects
6K	Dustproof	No ingress of dust	6	Protected against powerful water jets	Water, which is sprayed against the casing from any direction as a jet, must not have any harmful effects
			6K	Protected against powerful sprayed water with increased pressure	Water projected in powerful jets at increased pressure against the housing from any direction shall have no harmful effect
			7	Protected against the effect of temporary immersion in water	Water must not penetrate in quantities which will cause harmful effects when the casing is temporarily immersed under water under pressure and time conditions
			8	Continuous immersion in water	Water must not penetrate in quantities which will cause harmful effects when the casing is continuously immersed under water under defined conditions
			9	Protected against the effects of continuous immersion in water	Water must not penetrate in quantities which will cause harmful effects when the casing is continuously immersed under water
			9K	Protected against water during high pressure/ steam jet cleaning	Water, which is sprayed against the casing from any direction under strong pressure, must not have any harmful effects



ENERGY MANAGEMENT	AREA OF APPLICATION
Intelligent battery sensors	
	Intelligent battery sensors 12 V 
Measuring battery capacity and aging	Intelligent battery sensors 24 V 
	Intelligent battery sensors 12 V, for motorhomes 
	Intelligent battery sensors 12 V for agricultural and construction machines 
DC/DC voltage stabilisers	
System stabiliser for short-term voltage drop	DC / DC voltage stabilizer, 200 W 
	DC / DC voltage stabilizer, 400 W 



ENERGY MANAGEMENT

Careful use of energy by appropriately influencing the consumer:

These electronic systems make it possible to monitor and plan the energy budget and maintain the power supply.

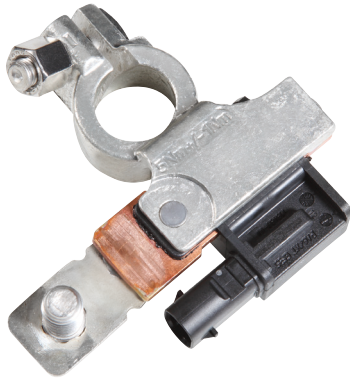

Intelligent battery sensors

PRODUCT FEATURES

- Accurate measurement of voltage, current and temperature battery parameters
- Determining the battery condition parameters State of Charge (SOC), State of Health (SOH) and State of Function (SOF)
- Simple electrical and mechanical integration

APPLICATION

The intelligent battery sensor (IBS) from HELLA is the key element of vehicle energy management.

The IBS reliably and accurately measures the battery parameters: voltage, current and temperature. Information about the battery's state of charge (SOC), state of health (SOH) and state of function (SOF) is calculated algorithmically from the measurements. The IBS is designed for use in starter, gel and AGM batteries to monitor in-vehicle starter or consumer batteries. The IBS can be directly integrated into the vehicle's electrical system with the standardised LIN protocol.

DESIGN AND FUNCTION

The IBS is attached directly to the negative pole of the battery via the pole terminal(4).

In addition to the terminal, the mechanical portion of the battery sensor consists of shunt (1) and ground bolt (5) components. The shunt is attached to the vehicle's load path and is used as a measuring resistor to measure the current indirectly. On the ground bolt (5), the existing ground cable can be conveniently attached, for example, to the optionally available battery pole adapter.

The electronics are located in molded casing (3) with plug connector (2), functioning as the interface to the energy management system. The communication interface to the higher-level control unit is the LIN protocol. The supply voltage, used simultaneously as the reference voltage for voltage measurement, is provided by the connection to the positive pole of the battery.

The ASIC is the main electronics component used to record and process measured values. Measured value acquisition in the ASIC, as a precision sensor, is the core function of the intelligent battery sensor and is used to record the physical parameters of current, voltage and temperature.

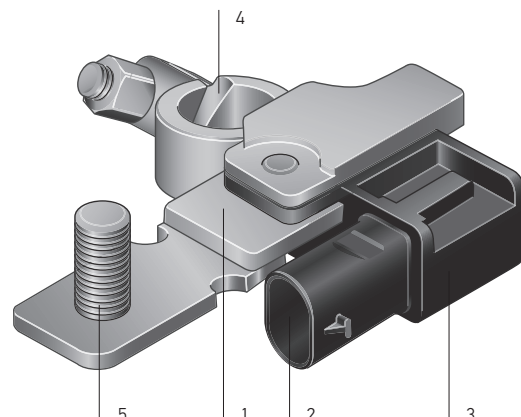

BATTERY STATUS ALGORITHMS:

The intelligent battery sensor calculates and monitors the following battery conditions

State of charge:

The state of charge (SOC) describes the current charge status of the battery.

The SOC is defined as:

$$\text{SOC [\%]} = \frac{\text{extractable capacity}}{\text{rated capacity}}$$

State of health (SOH):

Indicates the ageing status of the battery.

The (SOH) is defined as:

$$\text{SOH [\%]} = \frac{\text{available capacity}}{\text{nominal capacity}}$$

Typically, the available capacity of the battery falls with age and long use.

State of Function (SoF):

Describes the future starting ability of the motor based on the actual measured current and the voltage

Monitoring of different battery states

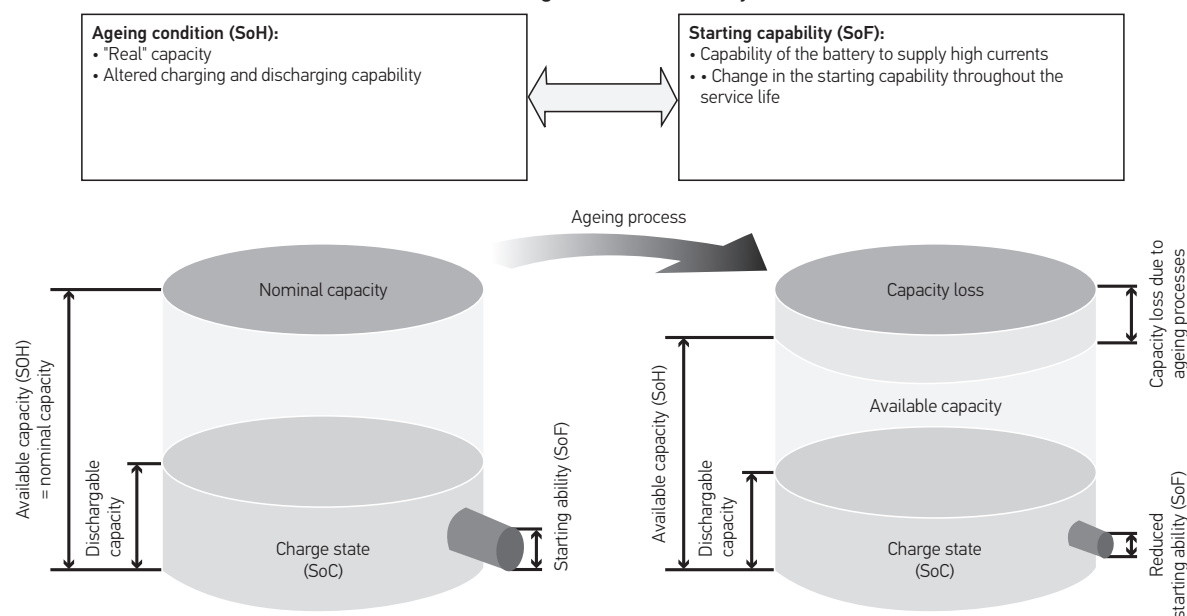

OVERVIEW OF VARIANTS

There are six variants of the intelligent battery sensor available. Sensor 1 is the basic version. When monitoring a second battery, sensor 2 is used in the same communication network. The third and fourth variants are used in 24V applications. They vary in the form of the cable lug. The fifth variant is especially designed for use in motorhomes. Here, for example, two 12 V series-connected batteries (24 V vehicle electrical system) can be monitored. The sixth variant is intended for vehicles with high starting currents (e.g. agricultural and construction vehicles) as well as those with higher ground cable cross sections (> 70 mm²).

Operating voltage	Type	Mating connector	PART NUMBER	Page reference
6 – 16.5 V	Sensor 1	Hirschmann 872-858-565	6PK 010 842-001	14
6 – 16.5 V	Sensor 2	Hirschmann 872-858-565	6PK 010 842-011	14
7.5 – 32 V	Cable lug, straight	Hirschmann 872-858-546	6PK 011 700-001	15
7.5 – 32 V	Cable lug, right-angled	Hirschmann 872-858-546	6PK 011 700-317	16
6 – 18 V	for motorhomes	Hirschmann 872-857-561	6PK 013 824-001	17
6 – 16.5 V	For agricultural and construction machinery	Hirschmann 872-858-546	on request	18

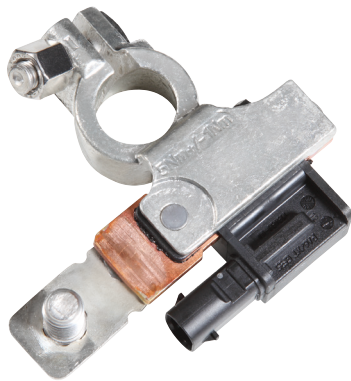

Intelligent battery sensors
Part number 6PK 010 842-001 (Sensor 1)
6PK 010 842-011 (Sensor 2)

TECHNICAL DATA

Operating voltage	6 – 16.5 V
Reverse-polarity voltage	- 16,5 V / 60 s
Test voltage	13,8 – 14,2 V
Operating current ¹⁾	≤ 15 mA (normal mode)
Idle current ¹⁾	≤ 120 µA (sleep mode)
Nominal resistance (shunt)	100 µΩ
Permanent load current ²⁾	± 155 A
Maximum current ²⁾	± 1,500 A (500 ms)
Operating temperature	- 40°C to + 115°C
Re-heating temperature	+ 105°C to + 120°C
Storage temperature	- 20°C to + 55°C
Defined charge controller	18 V / 60 min
Jump start	27 V / 1 min
Load Dump	35 V / 400 ms
Output signal	LIN 2.0 or higher
Protection class	IP 6K7
Permissible pole terminal tightening torque	5 Nm +/- 1 Nm
Threaded bolt, ground connection	M8
Weight	125 g
Max. battery capacity ³⁾	249 Ah
Mating connector ⁴⁾	Hirschmann 872-858-565

¹⁾ Condition: $T_a \leq 40^\circ\text{C}$; $U_b = 14\text{ V}$
²⁾ Typical condition: $T_a \leq 105^\circ\text{C}$; $U_b = 14\text{ V}$
 Typical ground cable: 35 mm²
 Approved for max. 500 ms.
 Other configurations upon request.
³⁾ Expandable upon request.
⁴⁾ This accessory is not included.
 Available from Hirschmann Automotive and/or TE Connectivity.

TECHNICAL DRAWING

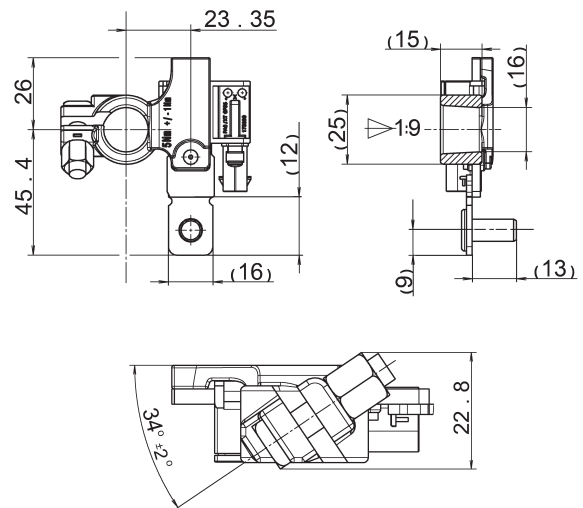

Bolt tightening torque (terminal) 5 ± 1 Nm

PIN ASSIGNMENT

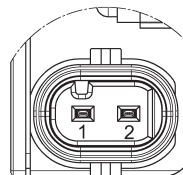

Pin 1: supply voltage
 Pin 2: connection for LIN bus

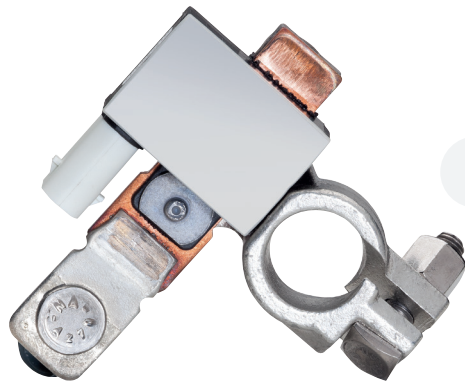

Intelligent battery sensors Part number 6PK 011 700-001

TECHNICAL DATA

Operating voltage	7,5 – 32 V
Reverse-polarity voltage	- 28 V / 60 s
Test voltage	27,8 – 28,2 V
Operating current ¹⁾	≤ 16 mA (normal mode)
Idle current ¹⁾	≤ 230 μA (sleep mode)
Nominal resistance (shunt)	68 μΩ
Permanent load current ²⁾	± 200 A
Maximum current ²⁾	± 2,000 A (20 ms)
Operating temperature	- 40°C to + 80°C
Re-heating temperature	+ 105°C to + 120°C
Storage temperature	- 20°C to + 50°C
Defined charge controller	36 V / 120 min
Jump start	48 V / 2 min
Load Dump	58 V / 500 ms
Output signal	LIN 2.0 or higher
Protection class	IP 6K7
Permissible pole terminal tightening torque	5 Nm +/- 1 Nm
Threaded bolt, ground connection	M8
Weight	119 g
Max. battery capacity ³⁾	255 Ah
Mating connector ⁴⁾	Hirschmann 872-858-546

¹⁾ Condition: $T_a \leq 40^\circ\text{C}$; $U_{bq} = 24\text{ V}$; $U_{brun} = 28\text{ V}$

²⁾ Typical condition: $T_a \leq 80^\circ\text{C}$; $U_b = 24\text{ V}$
Typical ground cable: $\geq 70\text{ mm}^2$
Approved for max. 500 ms.

Other configurations upon request.

³⁾ Expandable upon request.

⁴⁾ This accessory is not included.
Available from Hirschmann Automotive.

TECHNICAL DRAWING

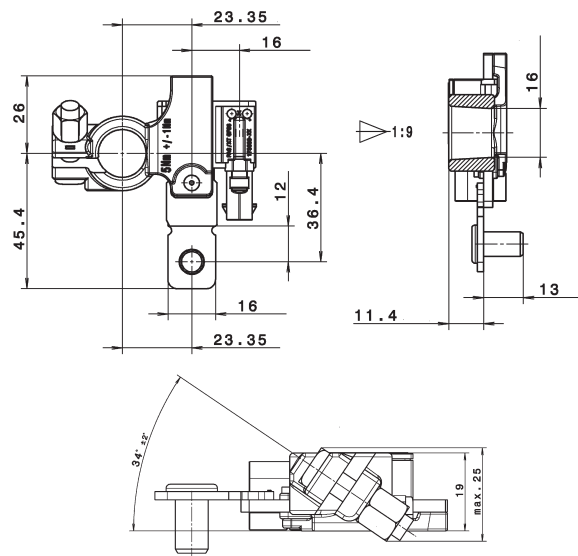

Bolt tightening torque (terminal) $5 \pm 1\text{ Nm}$

PIN ASSIGNMENT

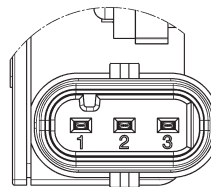

Pin 1: partial voltage 12 V
Pin 2: connection for LIN bus
Pin 3: supply voltage 24 V.

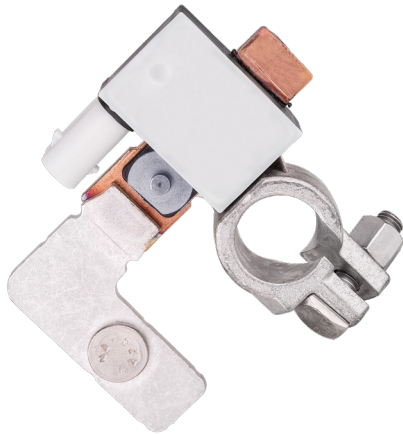

Intelligent battery sensors
Part number 6PK 011 700-317

TECHNICAL DATA

Operating voltage	7.5 – 32 V
Reverse-polarity voltage	- 28 V / 60 s
Test voltage	27,8 – 28,2 V
Operating current ¹⁾	≤ 16 mA (normal mode)
Idle current ¹⁾	≤ 230 µA (sleep mode)
Nominal resistance (shunt)	68 µΩ
Permanent load current ²⁾	± 200 A
Maximum current ²⁾	± 2,000 A (20 ms)
Operating temperature	- 40°C to + 80°C
Re-heating temperature	+ 105°C to + 120°C
Storage temperature	- 20°C to + 50°C
Defined charge controller	36 V / 120 min
Jump start	48 V / 2 min
Load Dump	58 V / 500 ms
Output signal	LIN 2.0 or higher
Protection class	IP 6K7
Permissible pole terminal tightening torque	5 Nm +/- 1 Nm
Threaded bolt, ground connection	M8
Weight	119 g
Max. battery capacity ³⁾	255 Ah
Mating connector ⁴⁾	Hirschmann 872-858-546

¹⁾ Condition: $T_a \leq 40^\circ\text{C}$; $U_{\text{bat}} = 24\text{ V}$; $U_{\text{brun}} = 28\text{ V}$

²⁾ Typical condition: $T_a \leq 80^\circ\text{C}$; $U_b = 24\text{ V}$
Typical ground cable: $\geq 70\text{ mm}^2$
Approved for max. 500 ms.

Other configurations upon request.

³⁾ Expandable upon request.

⁴⁾ This accessory is not included.
Available from Hirschmann Automotive.

TECHNICAL DRAWING

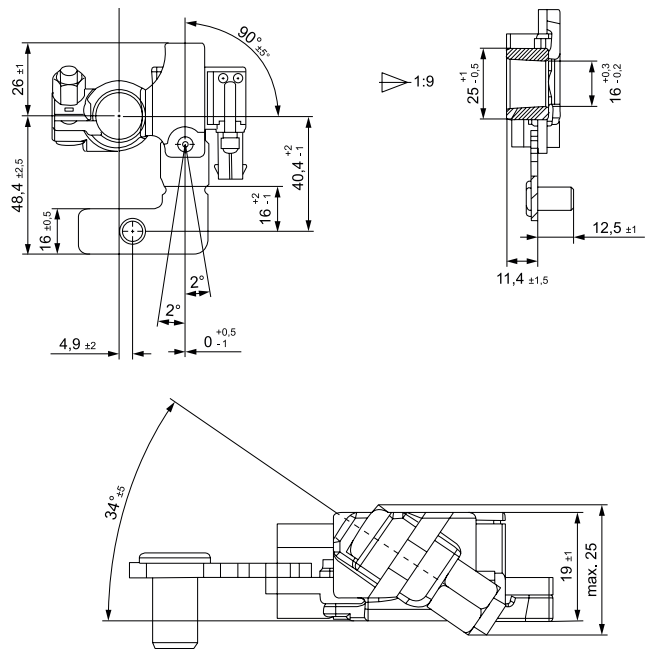

Bolt tightening torque (terminal) 5 ± 1 Nm

PIN ASSIGNMENT

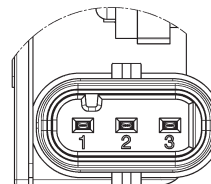

Pin 1: partial voltage 12 V
Pin 2: connection for LIN bus
Pin 3: supply voltage 24 V.

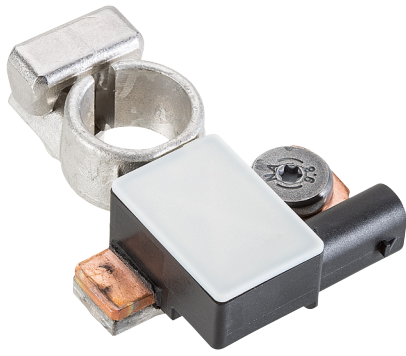

Intelligent battery sensors
12 V, for motor homes
6PK 013 824-001

TECHNICAL DATA

Operating voltage	6 – 18 V
Reverse-polarity voltage	- 16,5 V / 60 s
Test voltage	13,8 – 14,2 V
Operating current ¹⁾	10 mA
Idle current ¹⁾	≤ 200 µA
Nominal resistance (shunt)	68 µΩ
Permanent load current ²⁾	± 200 A
Maximum current ²⁾	1,500 A
Operating temperature	- 40°C to + 115°C
Re-heating temperature	+ 105°C to + 120°C
Storage temperature	- 20°C to + 55°C
Defined charge controller	18 V / 60 min
Jump start	27 V / 1 min
Load Dump	35 V / 400 ms
Protocol	LIN 2.0 or higher
Protection class	IP 6K7
Permissible pole terminal tightening torque	5 Nm +/- 1 Nm
Threaded bolt, ground connection	M6
Weight	70 g
Mating connector ³⁾	Hirschmann 872-857-565
Max. battery capacity ⁴⁾	500 Ah
Optional accessories	Battery pole adapter for Plug-and-Play installation 9MK 230 836-007

¹⁾ Condition: $T_a \leq 40^\circ\text{C}$; $U_b = 14\text{ V}$

²⁾ Typical condition: $T_a \leq 105^\circ\text{C}$; $U_b = 14\text{ V}$
Typical ground cable: 35 mm²
Approved for max. 500 ms.
Other configurations upon request.

³⁾ This accessory is not included.
Available from Hirschmann Automotive.

⁴⁾ Expandable upon request.

Description

Unlike its predecessors, the IBS generation II boasts the following advantages: The sensor is now also able to monitor larger batteries. Thanks to the higher and adjustable nominal capacity, this battery sensor can also be used to monitor several series-connected batteries. Instead of 250 ampere hours, this type can be configured for up to 500 ampere hours (Ah). This is particularly important in view of the growing energy requirements of motorhomes and caravans. And what is more, these new IBS generation II units are particularly robust and can reliably detect short-term, high current consumption – for example when bow thrusters are used. The package space has been optimized in such a way that installation even in locations with difficult access, e.g. under a seat, is easily possible. Furthermore, this product variant has the latest algorithms for battery condition detection. Reliable statements on charge condition and aging are therefore possible even with higher quiescent currents such as can occur, for example, in mobile homes.

TECHNICAL DRAWING

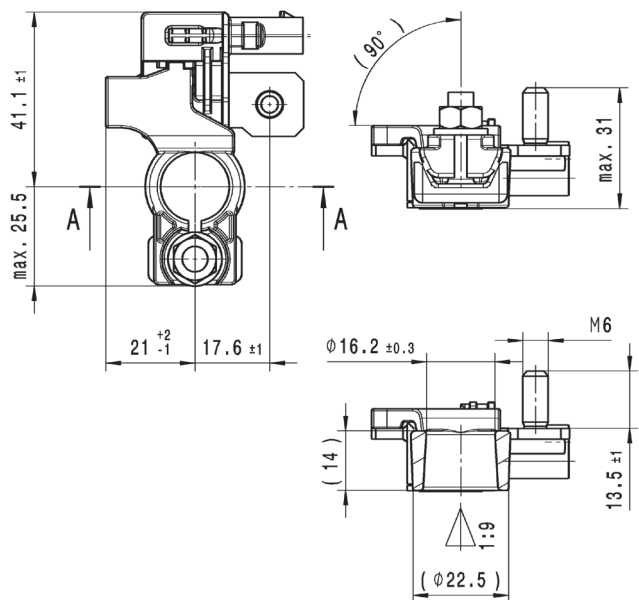

PIN ASSIGNMENT

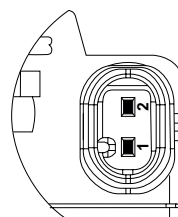

Pin 1: connection for LIN bus
Pin 2: connection for B+

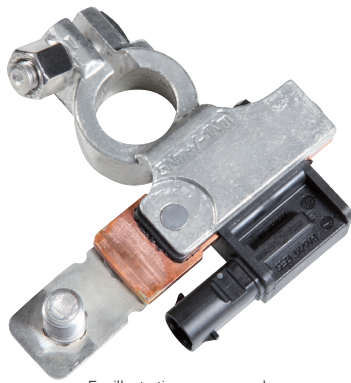

For illustrative purposes only

Intelligent battery sensors
12 V, for agricultural and construction machines
on request

TECHNICAL DATA

Operating voltage	6 – 16.5 V
Reverse-polarity voltage	- 16,5 V / 60 s
Test voltage	13,8 – 14,2 V
Operating current ¹⁾	≤ 15 mA
Idle current ¹⁾	≤ 120 µA
Nominal resistance (shunt)	68 µΩ
Permanent load current ²⁾	± 200 A
Maximum current ²⁾	2,000 A
Operating temperature	- 40°C to + 115°C
Re-heating temperature	+ 105°C to + 120°C
Storage temperature	- 20°C to + 55°C
Defined charge controller	18 V / 60 min
Jump start	27 V / 1 min
Load Dump	35 V / 400 ms
Protocol	LIN 2.0 or higher
Protection class	IP 6K7
Permissible pole terminal tightening torque	5 Nm +/- 1 Nm
Threaded bolt, ground connection	M10
Weight	145 g
Mating connector ³⁾	Hirschmann 872-858-546
Max. battery capacity ⁴⁾	249 Ah

¹⁾ Condition: $T_a \leq 40^\circ\text{C}$; $U_b = 14\text{ V}$
²⁾ Typical condition: $T_a \leq 105^\circ\text{C}$; $U_b = 14\text{ V}$
 Typical ground cable: 35 mm²
 Approved for max. 500 ms.
 Other configurations upon request.
³⁾ This accessory is not included.
 Available from Hirschmann Automotive.
⁴⁾ Expandable upon request.

TECHNICAL DRAWING

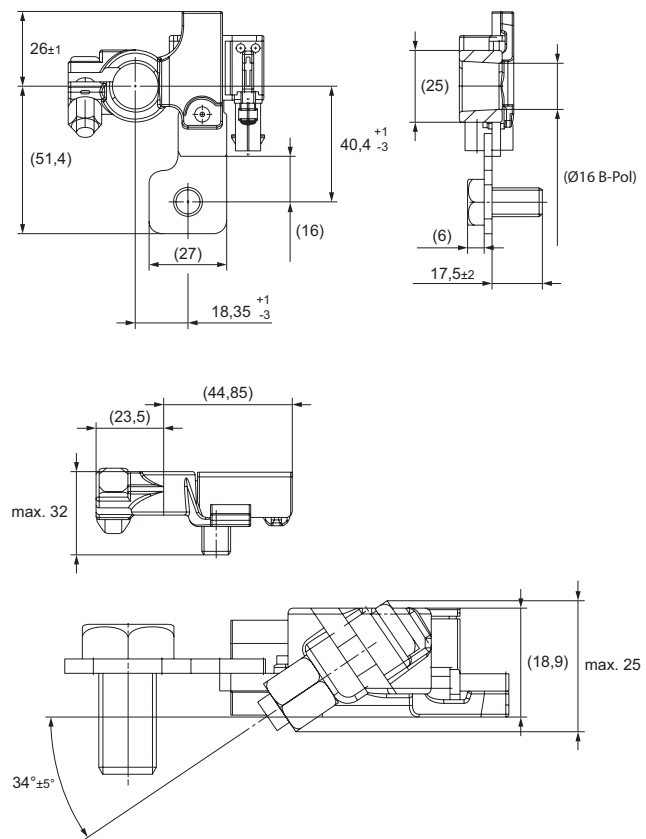

Bolt tightening torque (terminal) 5 ± 1 Nm

PIN ASSIGNMENT

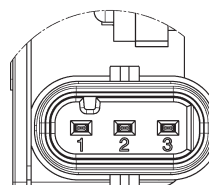

Pin 1: supply voltage 12 V
 Pin 2: connection for LIN bus
 Pin 3: not assigned



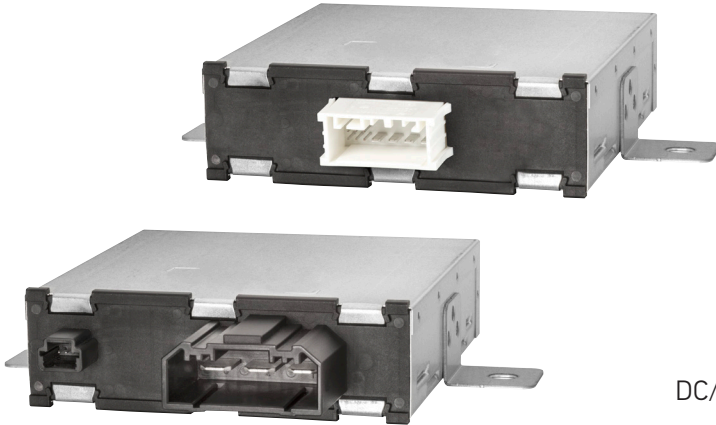

DC/DC voltage stabiliser

PRODUCT FEATURES

- For 12 V Systems
- Output power 200–400 W
- System stabiliser for short-term voltage drop

DESIGN AND FUNCTION

The voltage stabiliser is activated by ignition. As long as no stabilisation is required, the sub-system of the vehicle electric system is coupled with the main system via a low-impedance cable.

The voltage drop when starting the engine is signalled via the start signal. This leads to the sub-system and the main network being decoupled from each other and stabilisation is carried out.

Optionally, the device can be equipped with an LIN diagnostic interface.

APPLICATION

The DC/DC converter is also referred to as a voltage stabiliser. In the case of a short-term voltage drop (when starting the engine), it maintains the output voltage to the electrical sub-system (e.g. for the start/stop system).

This essentially concerns the elements of the vehicle electric system which the vehicle driver perceives and which are not safety-critical. The radio and navigation (infotainment system are part of this), but also various terminals (e.g. for agricultural and construction machines) and information systems (e.g. in buses).

FUNCTIONAL DIAGRAM

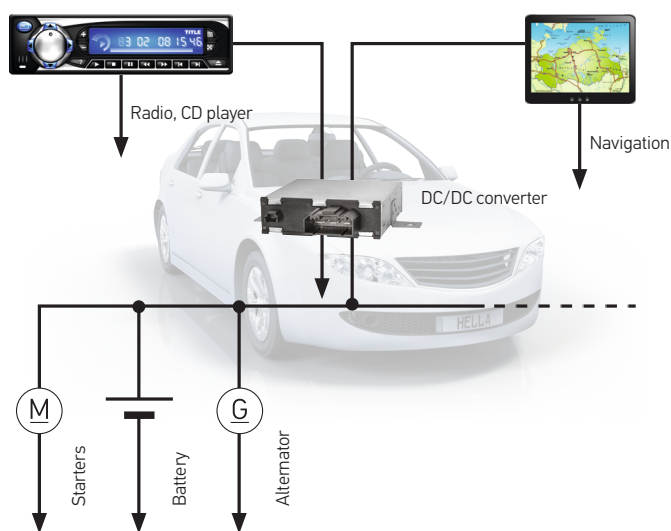

The voltage stabiliser is logically connected between the current supply of the vehicle electric system and the (sub-) vehicle electric system to be stabilised. Stabilisation is activated as soon as the start information is available from the starter (terminal 50). Stabilisation (boost mode) is limited to 5 seconds.

OVERVIEW OF VARIANTS

Power	Output current	Type and mating connector	Page reference
200 W	17 A	TE Connectivity 156333-1	22
400 W	34 A	Mating connector 1: TE 1473672-1 Mating connector 2: TE 1897519-1	23

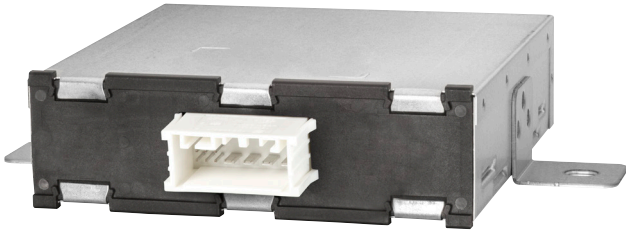

DC/DC voltage stabiliser 200 W
on request

TECHNICAL DATA

Operating temperature	-40 to +85°C (-40 °C to -20 °C bypass mode)
Supply voltage	+6.0 V to +18 V
Stabilization range	+6.0 V to +12 V
Output voltage	(boost mode) 12 V +/- 0.5 V Rippel < 200 mV
Power	200 W
Storage temperature	-40 to +105 °C
Cooling	Convection
Weight	approx. 370 g
Mating connector ¹⁾	156333-1
Output current	17 A
Efficiency	boost mode 85 % @ U > 8 V bypass mode > 99 %
Protection class	IP 5K0

¹⁾ This accessory is not included.
Available from TE Connectivity.

TECHNICAL DRAWING

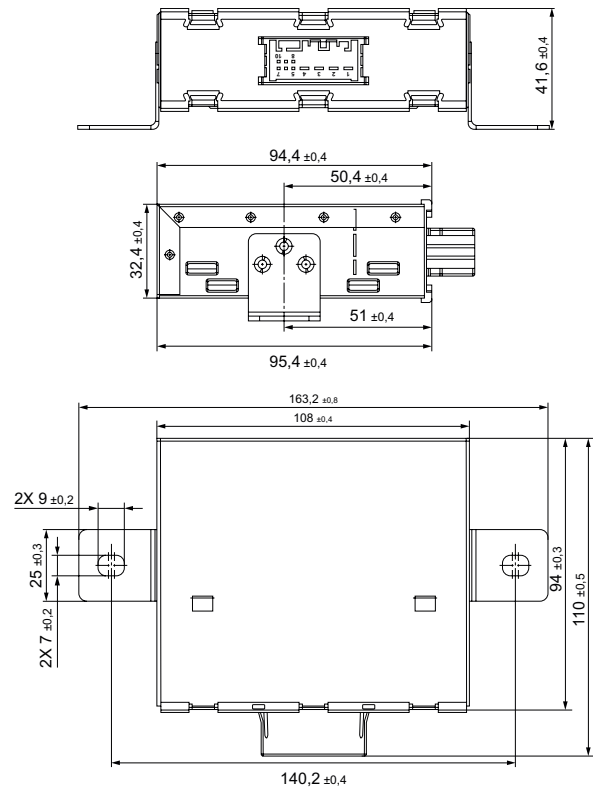

PIN ASSIGNMENT

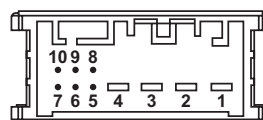

- Pin 1: KL 30
- Pin 2: KL 31
- Pin 3: NA
- Pin 4: KL 30_STABLE
- Pin 5: NA
- Pin 6: NA
- Pin 7: NA
- Pin 8: KL 15
- Pin 9: KL 50
- Pin 10: LIN

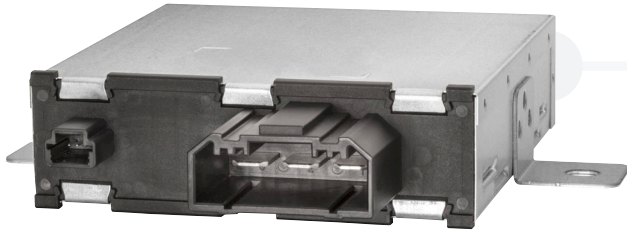

DC/DC voltage stabiliser 400 W
8ES 312 331-101

TECHNICAL DATA

Operating temperature	-40 to +85°C (-40 °C to -20 °C bypass mode)
Supply voltage	+6.0 V to +18 V
Stabilization range	+6.0 V to +12 V
Output voltage	(boost mode) 12 V +/- 0.5 V Rippel < 200 mV
Power	400 W
Storage temperature	-40 to +105 °C
Cooling	Convection
Weight	approx. 370 g
Mating connector ¹⁾	Mating connector 1: 1473672-1 Mating connector 2: 1897519-1
Output current	34 A
Efficiency	boost mode 85 % @ U > 8 V bypass mode > 99 %
Protection class	IP 5K0

¹⁾ This accessory is not included.
Available from TE Connectivity.

TECHNICAL DRAWING

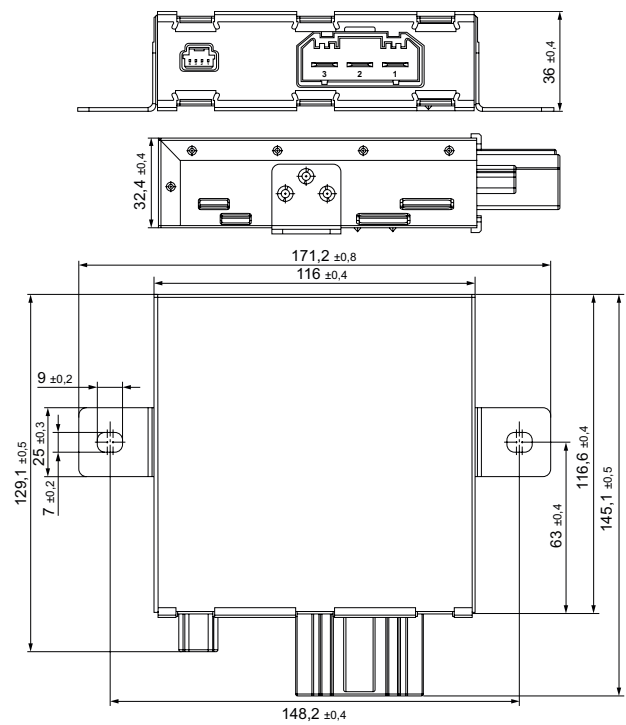

PIN ASSIGNMENT

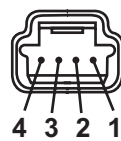



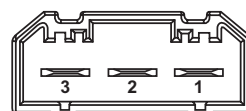















Pin 1: LIN
Pin 2: NC
Pin 3: KL 15 (IGN)
Pin 4: KL 50 (RE-CRANK)



Pin 1: KL 30 (VIN)
Pin 2: KL 31 (GND)
Pin 3: KL 30_stab (VOUT)



DRIVE TRAIN		AREA OF APPLICATION	
Level sensors			
Recording or measuring of levels	Recording the liquid level	  	Motor manufacturer
	Recording the liquid level (static or dynamic)	  	Motor manufacturer
	Recording the liquid level (static and dynamic)	   	Motor manufacturer
Relative pressure measurement of liquids and gases	Measuring the oil pressure and oil temperature	  	Motor manufacturer
Pedal sensors			
Floor-mounted and suspended pedal sensors	Floor-mounted pedals	  	
	Pendant pedals	  	



DRIVE TRAIN

Increasing the safety and efficiency of the overall system and preventing failures:

These electronic systems make it possible to precisely measure and record values in the engine compartment and drive train.

DRIVE TRAIN	AREA OF APPLICATION
Turbo actuators	
Universal Turbo Actuator (UTA)	



Level sensors
Recording the liquid level (static and dynamic)

PRODUCT FEATURES

- Continuous measurement of the engine oil level in the static and dynamic range
- Compact sensor architecture with a multi-chip module
- Integrated temperature sensor
- Immediate measurement after switch-on

DESIGN AND FUNCTION

The sensor architecture of the PULS (Packed Ultrasonic Level Sensor) oil level sensor consists of one single multi-chip module that integrates the ultrasonic sensor, the temperature sensor and an ASIC (Application Specific Integrated Circuit). The compactness of our sensors increases their impact and vibration resistance compared with sensors that are fitted with numerous electronic components. The ultrasonic sensor integrated in the multi-chip module transmits a signal that is reflected by the bounding surface between the motor oil and the air.

The signal's running time is measured and the filling level is calculated depending on the speed of sound in the medium. The attenuation cup attached above the multi-chip module serves to calm the medium (particularly) in the dynamic measuring range. The damping cap has openings at the base and at the tip, which allow permanent oil flow.

APPLICATION

In vehicles, oil sensors ensure that the engine cannot work unnoticed with too little oil. The tried-and-trusted technology of the ultrasonic sensors works on the delay time principle and records the filling level continuously during the trip. During engine operation (dynamic measuring range) the filling level is significantly lower than when the engine is at a standstill (static measuring range). An oil dipstick only records the oil level in the static range. This oil level sensor can measure the oil level continuously, i.e. both in the dynamic and in the static range. It thus provides information about the oil level throughout the period of time the engine is operated, which can often be a number of hours in the case of construction machinery, tractors and fork lift trucks.

The sensor provides continuous monitoring of the oil level throughout the period of time the engine is operated, thus preventing the oil level falling below the minimum level during operation and interrupting the oil film (which would cause engine damage).

Marginal influences such as an inclined position of the vehicle and lateral and longitudinal acceleration are compensated by an averaging out in the vehicle's electronic control unit.

Use of the oil level sensor with special media, e.g. transmission and hydraulic oils require prior testing and approval by HELLA.

INSTALLATION

The sensor has been designed for vertical installation from below, directly into the bottom of an oil pan. The oil level sensor is usually located on a ledge in the oil pan to protect the sensor sub-structure. This installation position, combined with the openings which make a permanent flow of oil possible, prevent sludge forming within the damping cup.

SCHEMATIC DIAGRAM

Optimum sensor position in the oil pan for dynamic measurements

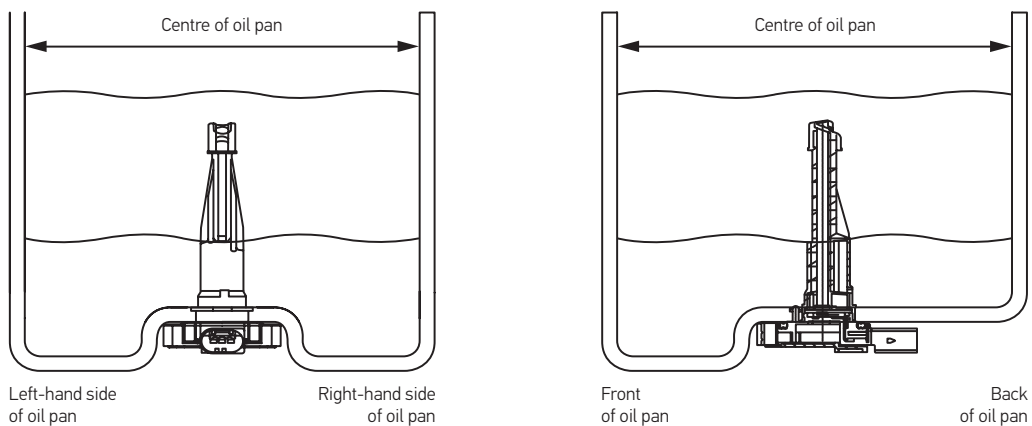

CIRCUIT DIAGRAM

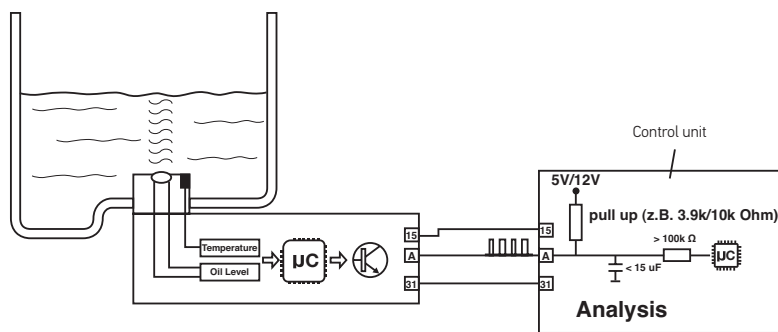

OVERVIEW OF VARIANTS

Length of damping cup	Supply voltage	Measurement range	PART NUMBER	Page reference
132 mm	12 V	static and dynamic 18 – 118.8 mm	6PR 010 497-501	30–31
109 mm	12 V	Static and dynamic 18 – 95.8 mm	6PR 010 497-511	32–33
88 mm	12 V	Static and dynamic 18 – 74 mm	6PR 010 497-521	34–35



Level sensors
Recording the liquid level
(static and dynamic)

T₁: TEMPERATURE EVALUATION (T₁ TEMP)

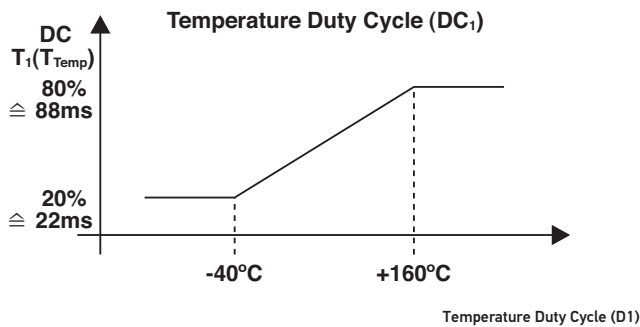

20% of the PWM block duration T₁ (22 ms) corresponds to the lowest measuring point of the measuring range, equal to -40 °C

80% of the PWM block duration T₁ (88 ms) corresponds to the highest measuring point of the measuring range, equal to 160 °C

T₁/T = DC = 0.2 (20%) => -40°C
T₁/T = DC = 0.8 (80%) => 160°C

T₂: LEVEL EVALUATION (T₂ LEVEL)

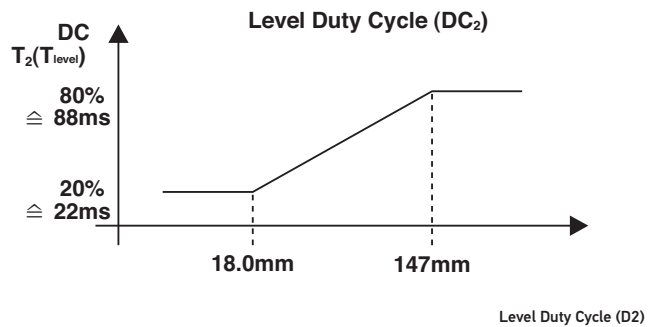

20 % of the PWM block duration T₂ (22 ms) corresponds to the lowest measuring point of the measuring range of 18 mm

80% of the PWM block duration T₂ (88 ms) corresponds to the highest measuring point of the measuring range, equal to 147 mm

T₂/T = DC = 0.2 (20%) => 18 mm
T₂/T = DC = 0.8 (80%) => 147 mm

T₃: DIAGNOSTIC EVALUATION

Diagnosics duty cycle (DC3)	T3 (ms) for T = 110ms	Diagnosics information	Signal transmission priority*
0,2 (20 %)	22	PULS ok	Prio 5
0,3 (30 %)	33	Voltage outside the tolerance (<8.5 V ± 0.5 V; > 16.5 V ± 0.5 V)	Prio 1
0,4 (40 %)	44	Open / short-circuited (signal converter)	Prio 2
0,5 (50 %)	55	Temperature outside the tolerance (-48°C > temp. > 168°C)	Prio 3
0,6 (60 %)	66	Level outside the tolerance DC ₃ 0,6 and Level 18 mm = Level under 18 mm or temperature under -10°C DC ₃ 0,6 and Level 147 mm = Level over 147 mm DC ₃ 0,6 and Level L-14 mm = Noise filter active, i.e. foam entry detected	Prio 4

* Signal with the highest priority is transmitted

BASIC INFORMATION ABOUT THE SIGNAL DURATION

Startup checksum = 920 ms
 PWM block duration $T = 110 \text{ ms} \pm 10 \text{ ms}$
 PWM block duration $T_3 = 68.2 \text{ ms}$ (fixed)
 Total PWM block duration $T_{\text{Signal}} = 1,000 \text{ ms} \pm 100 \text{ ms}$
 Brake signal $670 \text{ ms} \pm 40 \text{ ms}$

All the calculation data only apply for standard motor oil on account of the dependence between ultrasonic speed and density of the medium. Hence, the above calculation only applies to standard engine oils (e.g. Castrol 10W30). In the case of other measurable, non-conductive media, the calculation must be checked in the respective application.

$$\text{Temperature } [^{\circ}\text{C}] = \frac{(T_1/T - 0,32)}{0,003}$$

$$\text{Level}_{\text{Camp}} [\text{mm}] = [(T_2/T - 0,2) \cdot 215 + 13,95] \cdot \frac{T[\text{ms}]}{110} + 4,05$$

$$\text{Diagnostics} = [T_3/T]$$

OUTPUT CHARACTERISTICS

Name	Symbol	Min.	Typically	Max.	Unit
Output voltage low	V_{ol}	–	–	$0,1 \times V_{bat}$	V
Output voltage high ¹⁾	V_{oh}	$0,9 \times V_{bat}$	–	–	V
Output current at low level	I_{ol}	0,6	–	10	mA
Output current at high level	I_{oh}	-20	0	20	μA
PWM Open Collector resistor ²⁾	R_{pullup}	1,6	–	10	kOhm
Peak output current short-circuit detection	$I_{ol\text{peak}}$	80	–	–	mA
RMS output current short-circuit detection	$I_{ol\text{RMS}}$	80	100	–	mA
Capacitive load ³⁾	C_{load}	–	–	40	nF

¹⁾ Open collector with output capacitance = 1 nF (flank gradient to be observed with external capacitive loads).

²⁾ To be implemented in on-board computer.

³⁾ Capacitive load at pulse communication output.

STARTING BEHAVIOUR AFTER POWER-ON

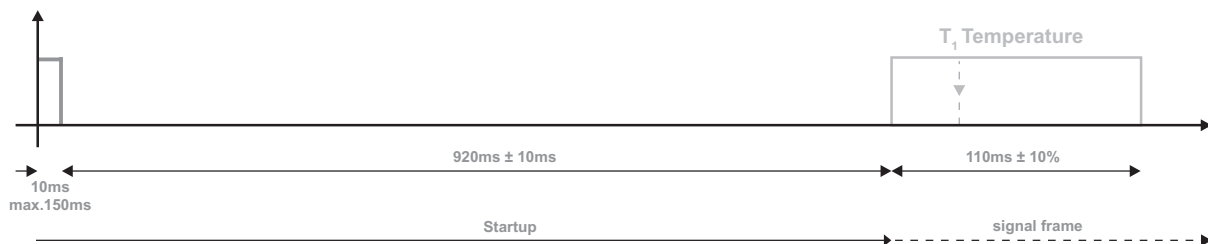

PWM (OPEN COLLECTOR) SIGNAL EVALUATION

The PWM output signal consists of three pulses that are repeated cyclically every 1,000 ms $\pm 10\%$. The pulses contain encoded information on the oil temperature, oil level and diagnosis.

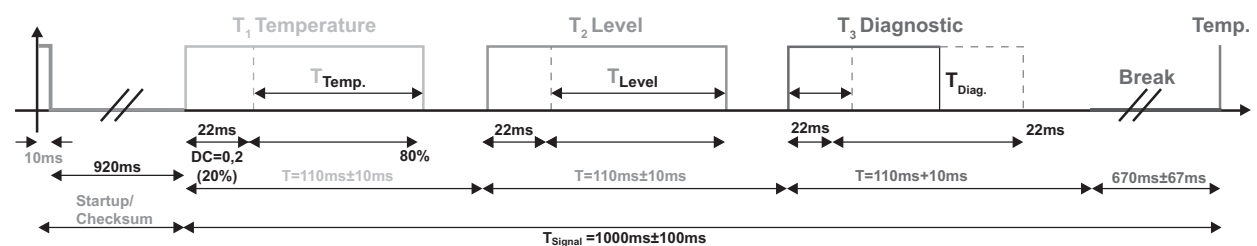



Level sensors
Recording the liquid level (static and dynamic)
6PR 010 497-501

TECHNICAL DATA

Operating voltage (for oil level measurement)	9 – 16 V
Operating voltage (for temperature measurement)	6 – 16 V
Reverse-polarity voltage	- 14 V / 60 s
Overvoltage	15 s at 28 V 250 ms at 32 V
Measuring range (static and dynamic)	18 – 118,8 mm
Operating temperature	- 40 °C to + 160 °C
Operating temperature (for oil level measurement) ¹⁾	- 10 °C to + 150 °C
Re-heating temperature	Max. 5,700 h at 125 °C Max. 240 h at 145 °C Max. 60 h at 160 °C
Storage temperature	- 40 °C to + 150 °C
Current consumption	4 mA
Max. power consumption during measurement	50 mA
Report ²⁾	PWM
Mating connector ³⁾	09 44 13 82
Protection class	IP 6K9K
Weight	88 g
Viscosities	1 mm ² /s to 1,300 mm ² /s

¹⁾ Level output above - 10 °C. At temperatures below -10 °C, an "empty" signal is sent (18 mm) together with the diagnostic signal "out of tolerance".

²⁾ LIN available upon request.

³⁾ This accessory is not included.
Available from Kostal.

NEW GENERATION OF SENSORS

This sensor has an improved meander structure for optimised behaviour under dynamic conditions in oil as well as improved response times.

Tolerance of level measurement

Oil level	Temperature range	Operating voltage	Tolerance
18 to 118.8 mm	-10 °C ≤ T < 30 °C	9 to 16 V	± 4 mm
18 to 118.8 mm	30 °C ≤ T < 150 °C	9 to 16 V	+ 2 mm

Tolerance of temperature measurement

Oil level	Temperature range	Operating voltage	Tolerance
All	60 °C ≤ T < 120 °C	6 to 16 V	± 4 K
All	-40 °C ≤ T < 60 °C	6 to 16 V	± 3 K
All	120 °C ≤ T < 160 °C	6 to 16 V	± 3 K

PIN ASSIGNMENT

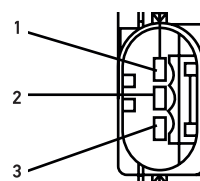

Pin 1: KL 15 V_{BAT}
Pin 2: KL 31 GND
Pin 3: OUTPUT

TECHNICAL DRAWING

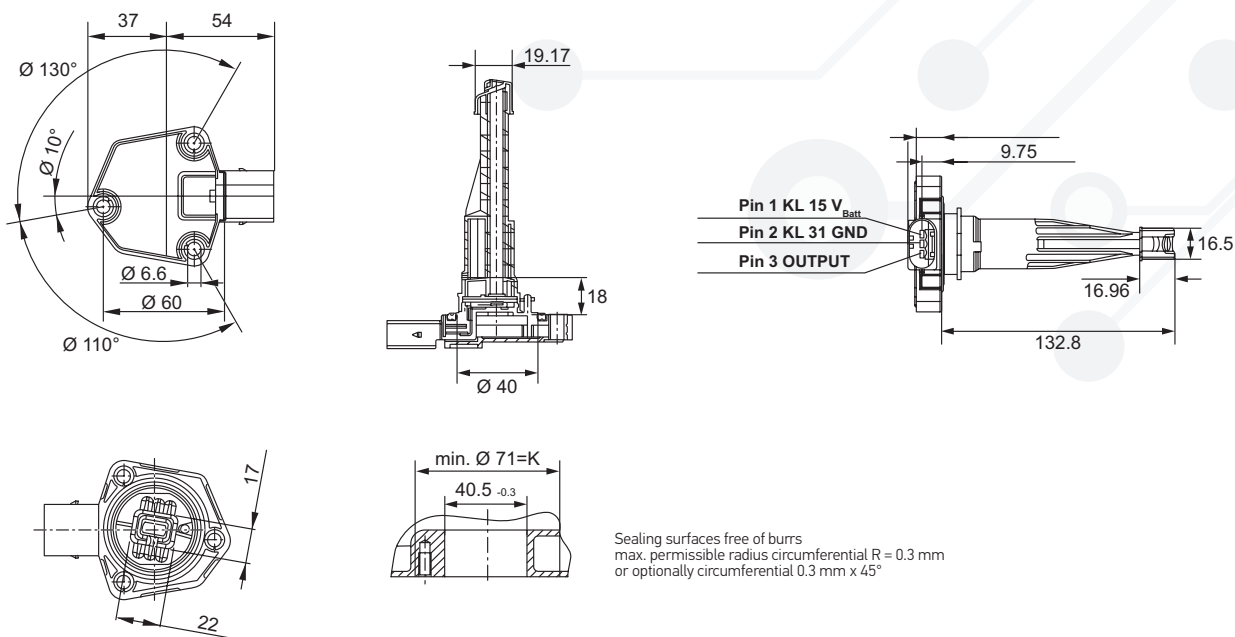

DYNAMIC MEASUREMENT OF THE ENGINE OIL

For dynamic measurement (during operation of the engine), an evaluation algorithm in the control unit must be developed that compensates for the marginal influences of the engine (oil volume, oil temperature, engine speed) and of the vehicle (longitudinal and transversal acceleration, ascending and descending). As a result of subsequent averaging, the influences brought about by driving conditions cancel out over longer periods. Hence, either a warning can be triggered with respect to the minimum oil volume reached or the oil volume that is actually still available can be calculated.

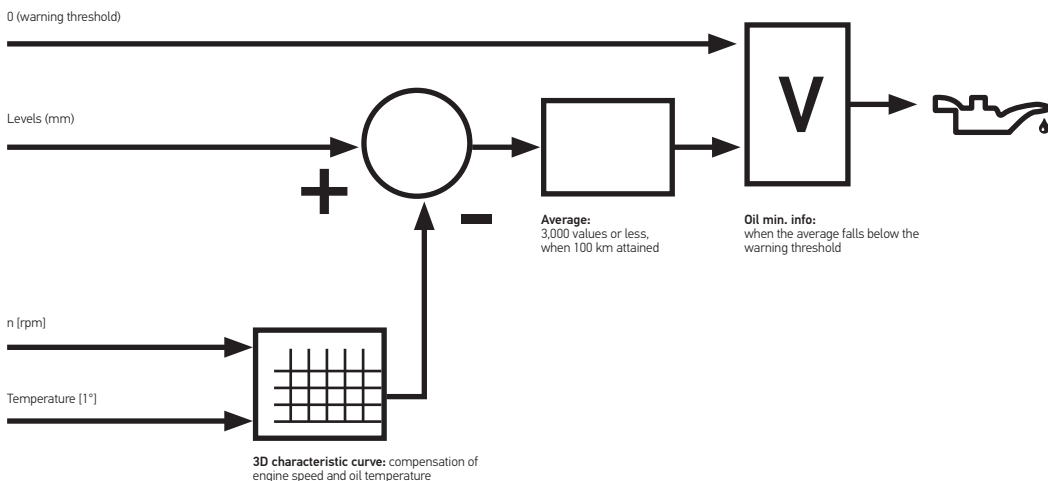
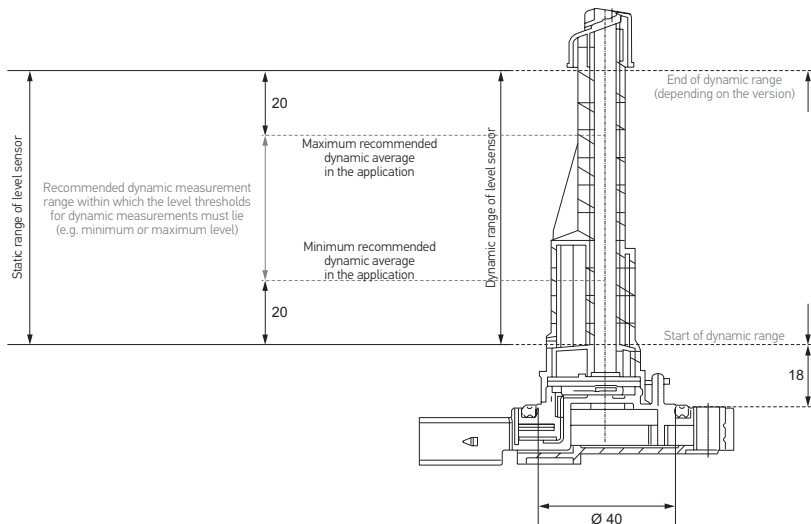



Level sensors
Recording the liquid level (static and dynamic)
6PR 010 497-511

TECHNICAL DATA

Operating voltage (for oil level measurement)	9 – 16 V
Operating voltage (for temperature measurement)	6 – 16 V
Reverse-polarity voltage	- 14 V / 60 s
Overvoltage	15 s at 28 V 250 ms at 32 V
Measuring range (static and dynamic)	18 – 95,8 mm
Operating temperature	- 40 °C to + 160 °C
Operating temperature (for oil level measurement) ¹⁾	- 10 °C to + 150 °C
Re-heating temperature	Max. 5,700 h at 125 °C Max. 240 h at 145 °C Max. 60 h at 160 °C
Storage temperature	- 40 °C to + 150 °C
Current consumption	4 mA
Max. power consumption during measurement	50 mA
Report ²⁾	PWM
Mating connector ³⁾	09 44 13 82
Protection class	IP 6K9K
Weight	80 g
Viscosities	1 mm ² /s to 1,300 mm ² /s

¹⁾ Level output above - 10 °C. At temperatures below -10 °C, an "empty" signal is sent (18 mm) together with the diagnostic signal "out of tolerance".

²⁾ LIN available upon request.

³⁾ This accessory is not included.
Available from Kostal.

NEW GENERATION OF SENSORS

This sensor has an improved meander structure for optimised behaviour under dynamic conditions in oil as well as improved response times.

Tolerance of level measurement

Oil level	Temperature range	Operating voltage	Tolerance
18 to 95.8 mm	-10 °C ≤ T < 30 °C	9 to 16 V	± 4 mm
18 to 95.8 mm	30 °C ≤ T < 150 °C	9 to 16 V	+ 2 mm

Tolerance of temperature measurement

Oil level	Temperature range	Operating voltage	Tolerance
All	60 °C ≤ T < 120 °C	6 to 16 V	± 4 K
All	-40 °C ≤ T < 60 °C	6 to 16 V	± 3 K
All	120 °C ≤ T < 160 °C	6 to 16 V	± 3 K

PIN ASSIGNMENT

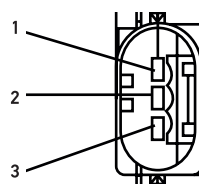

Pin 1: KL 15 V_{BAT}
Pin 2: KL 31 GND
Pin 3: OUTPUT

TECHNICAL DRAWING

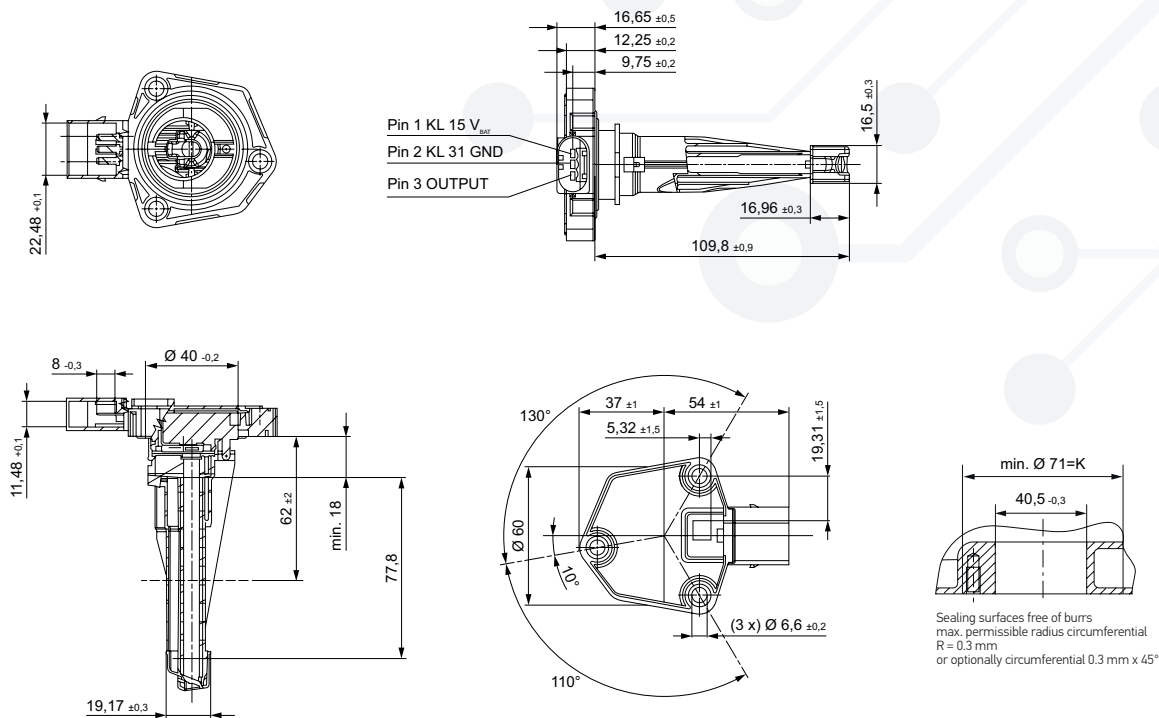

DYNAMIC MEASUREMENT OF THE ENGINE OIL

For dynamic measurement (during operation of the engine), an evaluation algorithm in the control unit must be developed that compensates for the marginal influences of the engine (oil volume, oil temperature, engine speed) and of the vehicle (longitudinal and transversal acceleration, ascending and descending). As a result of subsequent averaging, the influences brought about by driving conditions cancel out over longer periods. Hence, either a warning can be triggered with respect to the minimum oil volume reached or the oil volume that is actually still available can be calculated.

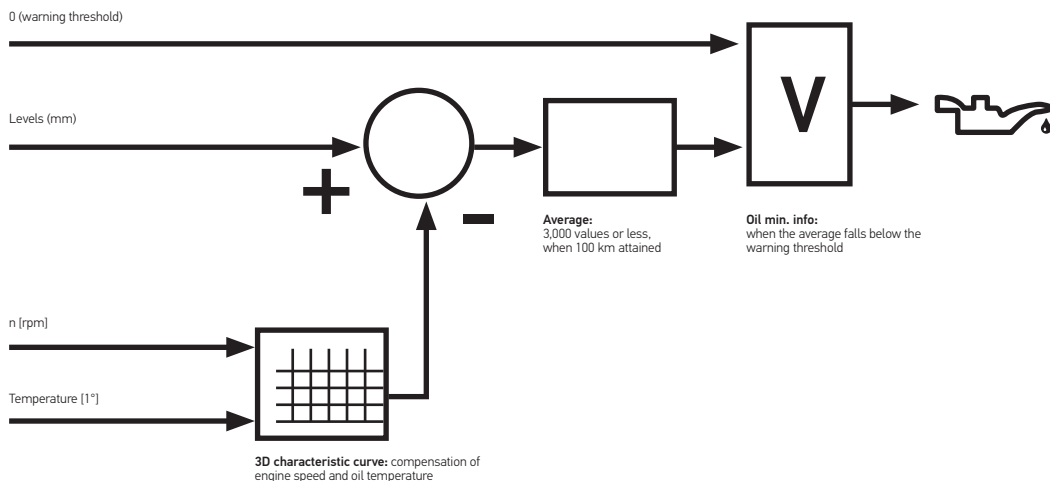
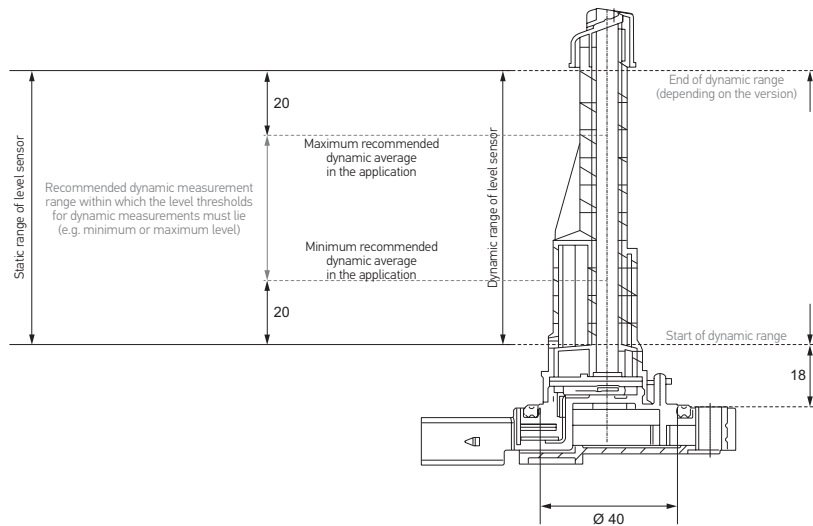



Level sensors
Recording the liquid level (static and dynamic)
6PR 010 497-521

TECHNICAL DATA

Operating voltage (for oil level measurement)	9 – 16 V
Operating voltage (for temperature measurement)	6 – 16 V
Reverse-polarity voltage	- 14 V / 60 s
Overvoltage	15 s at 28 V 250 ms at 32 V
Measuring range (static and dynamic)	18 – 74 mm
Operating temperature	- 40 °C to + 160 °C
Operating temperature (for oil level measurement) ¹⁾	- 10 °C to + 150 °C
Re-heating temperature	Max. 5,700 h at 125 °C Max. 240 h at 145 °C Max. 60 h at 160 °C
Storage temperature	- 40 °C to + 150 °C
Current consumption	4 mA
Max. power consumption during measurement	50 mA
Report ²⁾	PWM
Mating connector ³⁾	09 44 13 82
Protection class	IP 6K9K
Weight	78 g
Viscosities	1 mm ² /s to 1,300 mm ² /s

¹⁾ Level output above - 10 °C. At temperatures below -10 °C, an "empty" signal is sent (18 mm) together with the diagnostic signal "out of tolerance".

²⁾ LIN available upon request.

³⁾ This accessory is not included.
Available from Kostal.

NEW GENERATION OF SENSORS

This sensor has an improved meander structure for optimised behaviour under dynamic conditions in oil as well as improved response times.

Tolerance of level measurement

Oil level	Temperature range	Operating voltage	Tolerance
18 to 74 mm	-10 °C ≤ T < 30 °C	9 to 16 V	± 4 mm
18 to 74 mm	30 °C ≤ T < 150 °C	9 to 16 V	+ 2 mm

Tolerance of temperature measurement

Oil level	Temperature range	Operating voltage	Tolerance
All	60 °C ≤ T < 120 °C	6 to 16 V	± 4 K
All	-40 °C ≤ T < 60 °C	6 to 16 V	± 3 K
All	120 °C ≤ T < 160 °C	6 to 16 V	± 3 K

PIN ASSIGNMENT

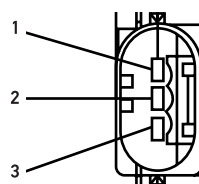

Pin 1: KL 15 V_{BAT}
Pin 2: KL 31 GND
Pin 3: OUTPUT

TECHNICAL DRAWING

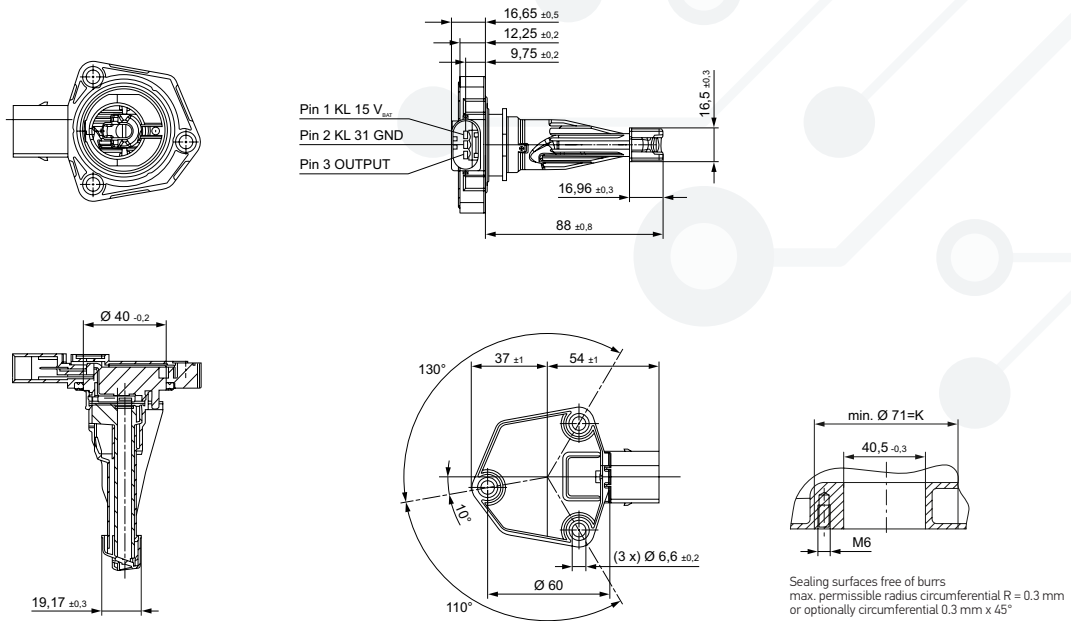

For dynamic measurement (during operation of the engine), an evaluation algorithm in the control unit must be developed that compensates for the marginal influences of the engine (oil volume, oil temperature, engine speed) and of the vehicle (longitudinal and transversal acceleration, ascending and descending). As a result of subsequent averaging, the influences brought about by driving conditions cancel out over longer periods. Hence, either a warning can be triggered with respect to the minimum oil volume reached or the oil volume that is actually still available can be calculated.

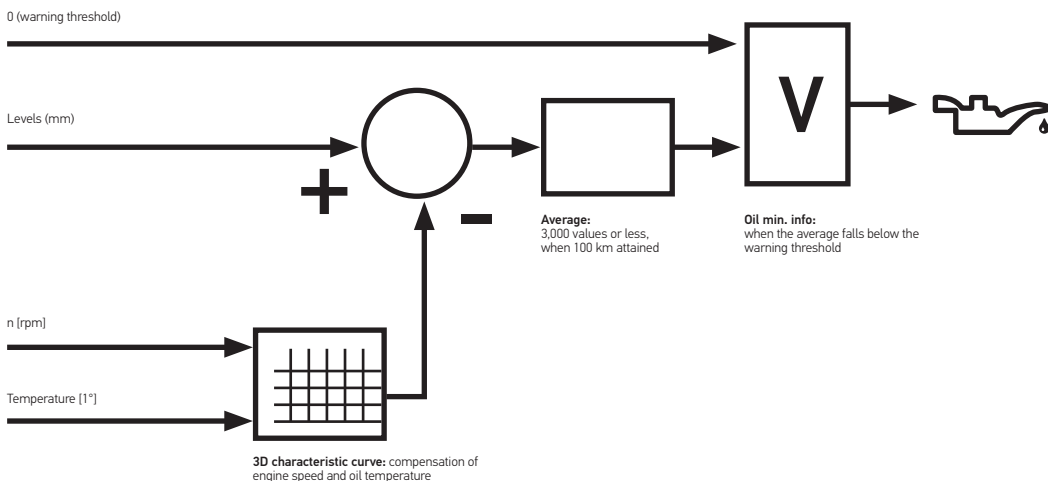
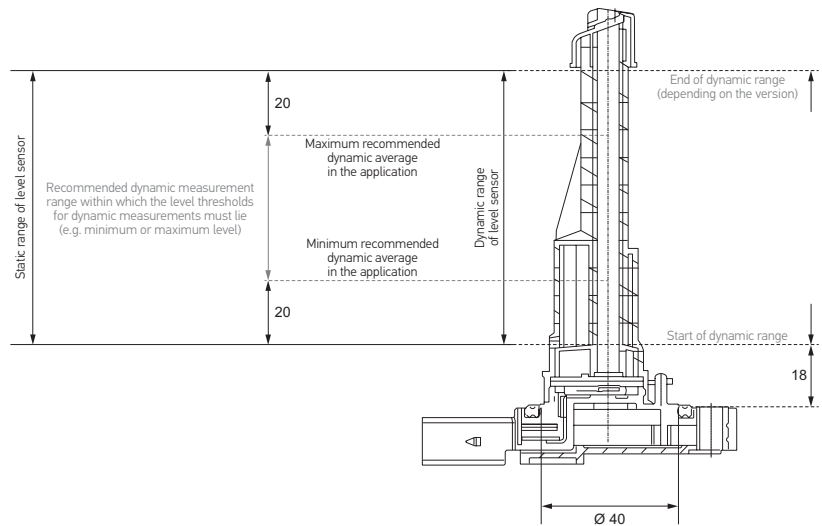



Level sensors
Measuring the oil pressure and oil temperature

PRODUCT FEATURES

- Continuous measurement of oil pressure
- Continuous measurement of the oil temperature
- Robust and reliable design

DESIGN AND FUNCTION

The OPS+T bases on a multi-chip module (MCM), consisting of a piezoresistive cell for measuring the absolute pressure and an ASIC for digital evaluation and to further process the information. The oil temperature can also be determined via a diode integrated into the MCM. Both the oil pressure and the oil temperature are transferred via the PWM output signal. The engine control unit (ECU) evaluates the PWM output signal of the sensor. The patented technology guarantees tightness compared to oils.

APPLICATION

The oil pressure and temperature sensor OPS+T is used to measure the absolute oil pressure and the oil temperature directly in the main oil channel behind the oil filter.

It uses the pressure value to properly control mechanical or electrical oil pumps. This lowers the CO₂ emissions and reduces the fuel consumption. Recording the temperature serves as input information for the engine's thermal management. The evaluation of both signals occurs in superordinate control unit.

Usable in harsh environments thanks to the integration of the multi-chip module.

EXTERNAL CONVERTER IN THE CONTROL UNIT

A 10k pull-up resistor should be integrated into the ECU of the vehicle to define the idle mode.

In order to optimally read the PWM signal, a capacity of max. 2.2 nF should be integrated to compensate for vibration oscillations.

For an ECU with 3.3 V

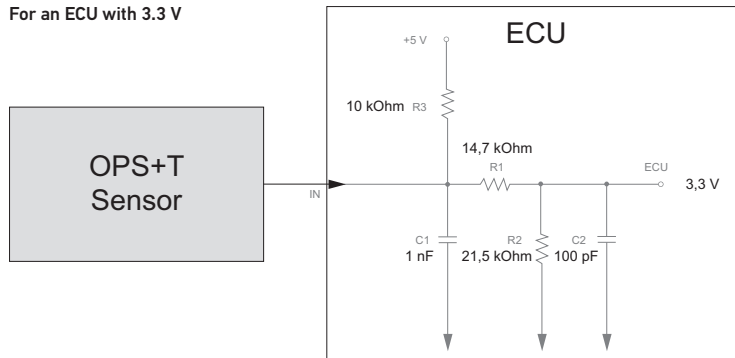

For an ECU with 5 V

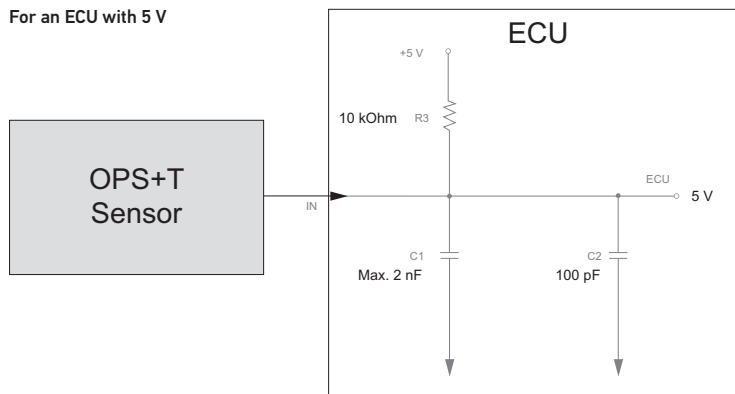

OVERVIEW OF VARIANTS

Mounting	Supply voltage	Measurement range	PART NUMBER	Page reference
Screw sensor, M12 x 1.5	4,75–5,25 V	Pressure 0.5–10.5 bar, temperature -40°C to +160°C	6PR 010 378-101	38–39



Level sensors
Measuring the oil pressure and oil temperature
Part number 6PR 010 378-101

TECHNICAL DATA

Temperature range	-40°C to +150°C
Max. temperature	160°C (max. 100 h)
Supply voltage	4,75 – 5,25 V
Output signal	PWM
Response time	2 ms
Sampling frequency	< 3 kHz
Max. operating pressure	40 bar
Overpressure	60 bar
Pressure measuring range	0.5 to 10.5 bar
Temperature measuring range	-40 °C to +160 °C
Protection class	IP 69K
Mating connector ¹⁾	872-597-501, 872-597-506, Coding A

¹⁾ This accessory is not included.
Available from Hirschmann Automotive.

RANGE OF TOLERANCE FOR PRESSURE MEASUREMENT

Temperature	0,50 – 3,00 bar	3,00 – 5,50 bar	5,50 – 10,50 bar
70 to 160 °C	+/- 0,15 bar	+/- 0,20 bar	+/- 0,30 bar
20 to 70 °C	+/- 0,15 bar	+/- 0,20 bar	+/- 0,30 bar
0 to 20 °C	+/- 0,20 bar	+/- 0,25 bar	+/- 0,35 bar
-40 to 0°C	+/- 0,40 bar	+/- 0,40 bar	+/- 0,50 bar

RANGE OF TOLERANCE FOR TEMPERATURE MEASUREMENT

Temperature	Accuracy
135 to 160 °C	+/- 1 K
20 to 135 °C	+/- 2 K
-40 to 20°C	+/- 3 K

TECHNICAL DRAWING

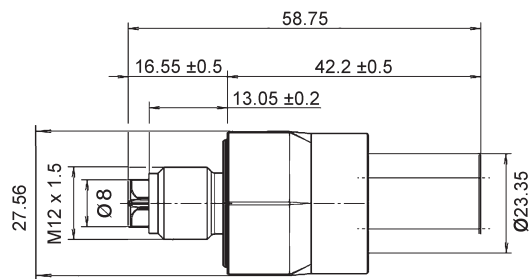

INSTALLATION SPACE

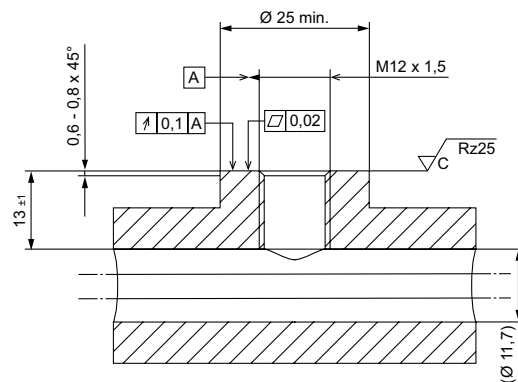

PIN ASSIGNMENT

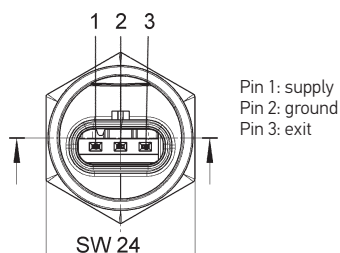

Pin 1: supply
Pin 2: ground
Pin 3: exit

Output signal

A pulse width modulation signal (PWM) is used to communicate the temperature, pressure and diagnostic information. The entire information is sent every 9.216 μs and receives the temperature, pressure and diagnostic signals. The higher-level control unit must be able to measure the different pulse widths of the three square wave signals which can vary from 128 μs to 3.958 μs . The control unit must have a suitable sampling frequency and logic for measuring and recording the signals available.

General information on the evaluation of the PWM communication:

Due to the setting accuracy of the oscillator and its temperature dependency, the length of a PWM frame is subject to a maximum tolerance of $\pm 10\%$. Serious hardware errors in the program design of the ASIC lead to an interruption of the PWM communication and are detectable on the control unit by a permanent high level.

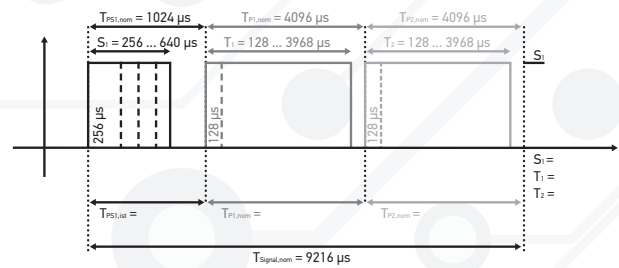

S₁: Signal
T₁: Temperature
T₂: Pressure

S₁: DIAGNOSTIC SIGNAL

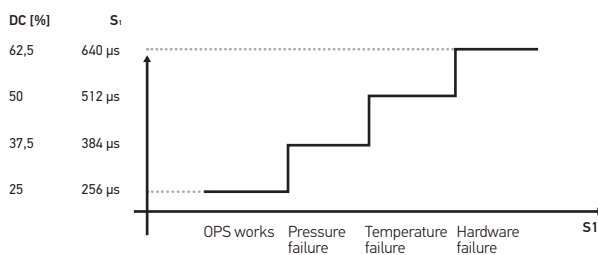

DC = 0.25 (S₁ = 256 $\mu\text{s} \pm 25 \mu\text{s}$) => OPS functional status
DC = 0.375 (S₁ = 384 $\mu\text{s} \pm 25 \mu\text{s}$) => pressure failure
DC = 0.5 (S₁ = 512 $\mu\text{s} \pm 25 \mu\text{s}$) => temperature failure
DC = 0.625 (S₁ = 640 $\mu\text{s} \pm 25 \mu\text{s}$) => hardware failure

T₁: TEMPERATURE EVALUATION

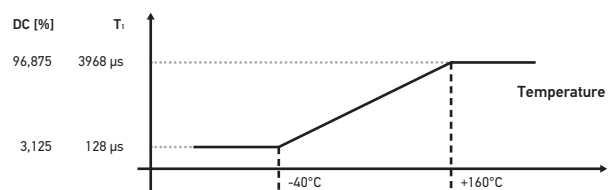

96.9% of the PWM block duration T₁ (3968 ms) corresponds to the highest measuring point of the measuring range, equal to 160°C.
3.1% of the PWM block duration T₁ (128 ms) corresponds to the lowest measuring point of the measuring range, equal to -40°C.

$$T_{1|\mu\text{s}} = 19.2 \frac{\mu\text{s}}{^\circ\text{C}} \cdot \text{Temp} + 896 \mu\text{s}$$

T₂: PRESSURE EVALUATION (T₂ LEVEL)

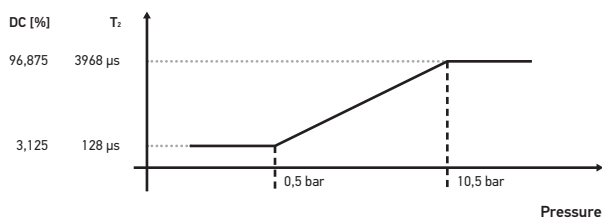

96.9% of the PWM block duration T₂ (3968 ms) corresponds to the highest measuring point of the measuring range, equal to 10.5 bar.
3.1% of the PWM block duration T₂ (128 ms) corresponds to the lowest measuring point of the measuring range, equal to 0.5 bar.

$$T_{2|\mu\text{s}} = 384 \frac{\mu\text{s}}{\text{bar}} \cdot \text{Pressure} - 64 \mu\text{s}$$

ECU CALCULATION

$$\text{Temperature} = \left(\frac{4096 \mu\text{s}}{T_{P1, \text{est}|\mu\text{s}}} \cdot T_{1|\mu\text{s}} - 128 \mu\text{s} \right) \cdot \frac{1}{19.2} \frac{^\circ\text{C}}{\mu\text{s}} - 40^\circ\text{C}$$

$$\text{Pressure} = \left(\frac{4096 \mu\text{s}}{T_{P2, \text{est}|\mu\text{s}}} \cdot T_{2|\mu\text{s}} - 128 \mu\text{s} \right) \cdot \frac{1}{384} \frac{\text{bar}}{\mu\text{s}} + 0.5 \text{ bar}$$

$$\text{Diagnosis} = \left(\frac{1024 \mu\text{s}}{T_{PS1, \text{est}|\mu\text{s}}} \cdot S_{1|\mu\text{s}} \right)$$



Floor-mounted pedals

PRODUCT FEATURES

- Contact-free measuring principle
- Slim and sturdy design
- Simple mechanical connection
- Redundant output signal
- High measurement precision
- No programming or "teaching" in the vehicle is necessary
- High interference immunity against electrical and magnetic fields

DESIGN AND FUNCTION

Casing and the pedal plate are made completely of recyclable glass fibre reinforced plastic. The sensor is completely waterproof, enclosed in casing within the overall dimensions of the device. The actuating force is generated by two springs, each of which is sufficient to safely return the pedal to its original position. The electrical output signal is obtained using the CIPOS® measurement principle. For this purpose, a sheet metal cursor is routed from the pedal arm to a guide rod via sensor conductor paths on the measuring board. Two output signals are generated by two galvanically isolated sensors.

APPLICATION

The HELLA accelerator pedals designed for floor-mounted or suspended installation can be used in a wide variety of vehicles - ranging from automotive applications, such as sports cars and electric vehicles, right up to robust applications in agricultural vehicles and construction machinery. Thanks to the wear-free measurement principle of the CIPOS® sensor developed in-house at HELLA (see description of design and function of the angular position sensors) and its extremely low level of mechanical wear, this version is particularly preferable to contact-type pedals in the case of frequent small movements.



OVERVIEW OF VARIANTS

Pedal material	PART NUMBER	Page reference
Plastic	On request	42 – 43



Floor-mounted pedals
Part number on request

TECHNICAL DATA

Operating voltage	5 V ± 6 %
Power consumption per channel	max. 10 mA
Overtoltage resistance, duration $t \rightarrow \infty$	16 V
Initial force	15 N
Final force	25 N
Actuation angle	17°
Resolution	0,04°
Output signal	2 x analog ratiometric, 2nd channel half pitch
Linearity	≤ 1,5 %
Synchronisation	≤ 3 %
Idling voltage	15 % / 7,5 %
Full throttle voltage	80 % / 40 %
Load resistor	typ. 10 kΩ to 100 kΩ
Load capacity	max. 100 nF
Filter constant in the control unit	1 ms ± 5 %
Signal output current	max. 1 mA
Operating temperature	-40°C to +85°C
Storage temperature	-40°C to +105°C
Degree of protection (electronic)	IP 6K9K
Housing material	PBT, PP GF30; PA, GF 40
Mating connector ¹⁾	1-967616-1
Weight	≤ 500 g
Vibration resistance	4,4 g
Actuations	at least 3,5 m.
EMC	CISPR 25, Class 5; electrical and magnetic fields
ESD	4 kV, 8 kV, 15 kV

¹⁾ This accessory is not included.
Available from TE Connectivity.
Gold-plated contacts and the individual wire seal are required.

TECHNICAL DRAWING

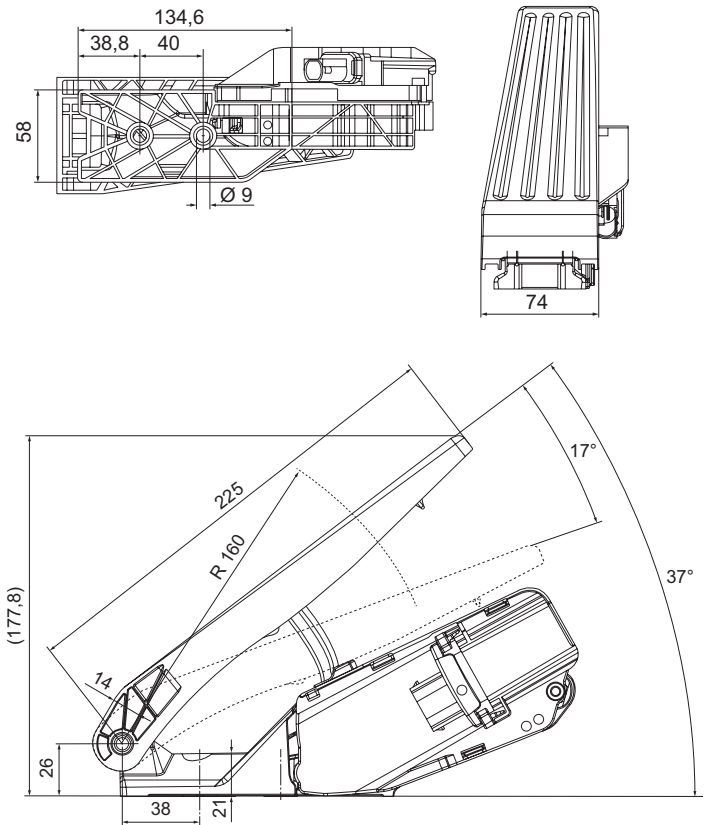

RECOMMENDED CONVERTER IN THE CONTROL UNIT

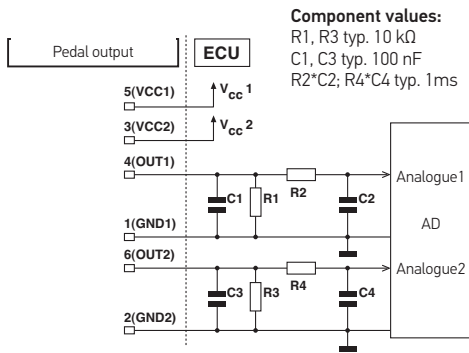

PIN ASSIGNMENT

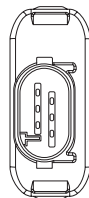

- Pin 1: Ground: sensor 1
- Pin 2: Logic earth: sensor 2
- Pin 3: Supply 5 V: sensor 2
- Pin 4: Analogue signal: sensor 1
- Pin 5: Supply 5 V: Sensor 1
- Pin 6: Analogue signal: sensor 2

MECHANICAL CHARACTERISTIC CURVE

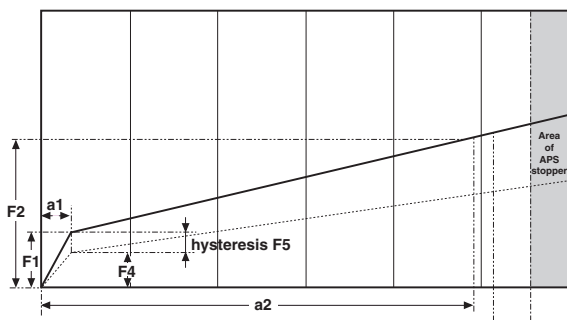

RATED VALUES

R	[mm]	160,0
F1	[N]	15,0 ± 3,5
F2	[N]	25 ± 4,5
F4	[N]	> 4,0
F5	[N]	> 1,5
a1	[degrees]	< 1,5
a2	[degrees]	15,5

ELECTRICAL CHARACTERISTIC CURVE

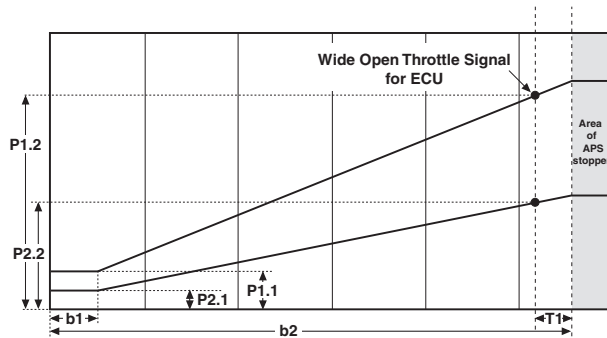

RATED VALUES

b2	[degrees]	17 ± 1,0
P1.1	[%]	15,0 ± 1,0
P2.1	[%]	7,5 ± 1,0
P1 _{max}	[%]	< 81,8
P2 _{max}	[%]	< 40,9
P1.2	[%]	76,8
P2.2	[%]	38,4
T1	[degrees]	< 2,0
b1	[degrees]	< 1,2



Pendant pedals

PRODUCT FEATURES

- Contact-free measuring principle
- Slim and sturdy design
- Simple mechanical connection
- Redundant output signal
- High measurement precision
- No programming or "teaching" in the vehicle is necessary
- High interference immunity against electrical and magnetic fields

DESIGN AND FUNCTION

Casing and the operating lever are made completely of recyclable glass fibre reinforced plastic. The sensor is completely waterproof, enclosed in casing within the overall dimensions of the device. The actuating force is generated by two springs, each of which is sufficient to safely return the pedal to its original position. The electrical output signal is obtained using the CIPOS® measurement principle. For this purpose, a sheet metal cursor is routed from the pedal arm via sensor conductor paths on the measuring board. Two output signals are generated by two galvanically isolated sensors. Different output signals can be generated depending on the measuring board used. In addition, individual characteristic curves can be programmed on request.

APPLICATION

The HELLA accelerator pedals designed for floor-mounted or suspended installation can be used in a wide variety of vehicles - ranging from automotive applications, such as sports cars and electric vehicles, right up to robust applications in agricultural vehicles and construction machinery. Thanks to the wear-free measurement principle of the CIPOS® sensor developed in-house at HELLA (see description of design and function of the angular position sensors) and its extremely low level of mechanical wear, this version is particularly preferable to contact-type pedals in the case of frequent small movements.



OVERVIEW OF VARIANTS

Pedal material	PART NUMBER	Page reference
Plastic	On request	46 – 47



Pendant pedals
Part number on request

TECHNICAL DATA

Operating voltage	5 V ± 6 %
Power consumption per channel	max. 10 mA
Oversvoltage resistance, duration $t \rightarrow \infty$	16 V
Initial force	24 N
Final force	42 N
Actuation angle	17°
Resolution	0,04°
Output signal	2 x analog ratiometric, 2nd channel half pitch
Linearity	≤ 1,5 %
Synchronisation	≤ 3 %
Idling voltage	10 % / 5 %
Full throttle voltage	90 % / 45 %
Load resistor	typ. 10 kΩ to 100 kΩ
Load capacity	max. 100 nF
Filter constant in the control unit	1 ms ± 5 %
Signal output current	max. 1 mA
Operating temperature	-40°C to +85°C
Storage temperature	-40°C to +105°C
Degree of protection (electronic)	IP 6K9K
Housing material	PA; PBT; GF30 to GF 50
Mating connector ¹⁾	7283-1968-30
Weight	≤ 400 g
Vibration resistance	4,4 g
Actuations	at least 3.5 m.
EMC	CISPR 25, Class 5; electrical and magnetic fields
ESD	4 kV, 8 kV, 15 kV

¹⁾ This accessory is not included.
Available from Yazaki.
Gold-plated contacts and the individual wire seal are required.

TECHNICAL DRAWING

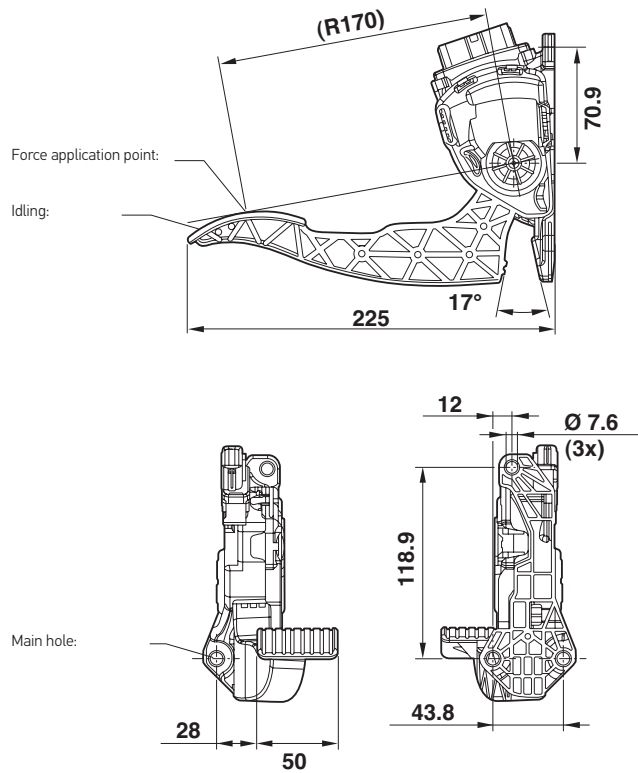

RECOMMENDED CONVERTER IN THE CONTROL UNIT

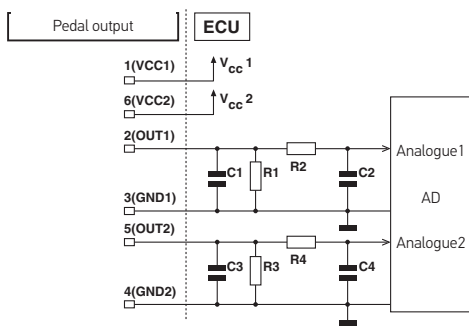

PIN ASSIGNMENT

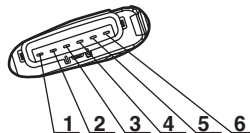

- Pin 1: 5 V supply: sensor 1
- Pin 2: Analog signal: sensor 1
- Pin 3: Ground: sensor 1
- Pin 4: Ground: sensor 2
- Pin 5: Analog signal: sensor 2
- Pin 6: 5 V supply: sensor 2

MECHANICAL CHARACTERISTIC CURVE

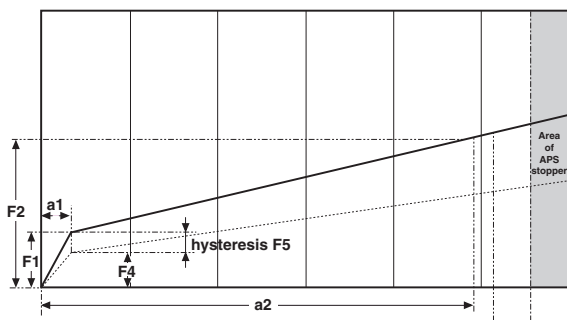

RATED VALUES

R	[mm]	170,0
F1	[N]	24,0 ± 6,0
F2	[N]	42,0 ± 8,0
F4	[N]	> 5,0
F5	[N]	> 4,0
a1	[degrees]	< 1,2
a2	[degrees]	15,5

ELECTRICAL CHARACTERISTIC CURVE

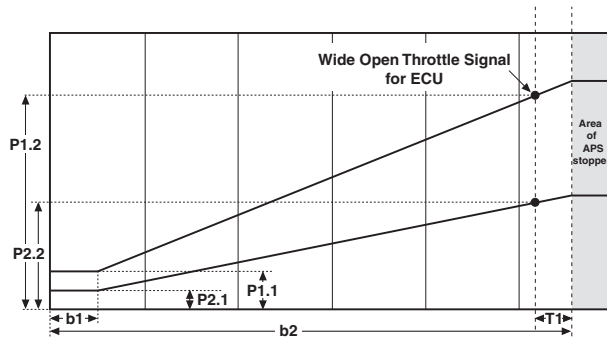

RATED VALUES

b2	[degrees]	17,0 ± 1,2
P1.1	[%]	10,0 ± 1,0
P2.1	[%]	5,0 ± 1,0
P1.max	[%]	< 90,0
P2.max	[%]	< 45,0
P1.2	[%]	84,0
P2.2	[%]	42,0
T1	[degrees]	< 2,0
b1	[degrees]	< 1,5



Turbo actuators

PRODUCT FEATURES

- Integrated electronics consisting of CIPOS (Contactless Inductive Position Sensor) position sensor, motor control and error diagnosis
- Short response time
- Self-blocking transmission and low current consumption for holding position

DESIGN AND FUNCTION

The UTA's main function consists in placing the shaft into the position defined by the control unit. Thanks to the CIPOS sensor, the shaft's position is continuously calculated and actively updated. The integrated electronics incorporate engine control and error diagnosis in addition to the CIPOS sensor responsible for precise position detection. This enables the finding of errors, their updating and the automatic deducing of the correct reactions to any given situation. Errors are then stored in a memory.

APPLICATION

The Universal Turbo Actuator is mostly used for VNT /VTG (Variable Nozzle Turbine / Variable Turbine Geometry) turbocharger technology for the purpose of determining reliable and precise positions. It is especially the insensitivity to magnetic fields and the high level of temperature stability that are the characteristic qualities of the CIPOS technology used in conjunction with the UTA. Angles are measured inductively using a contact-free and hence wear-free method, thus guaranteeing a high measuring precision throughout the entire service life.



OVERVIEW OF VARIANTS

Voltage range	Working angle	Torque	PART NUMBER	Page reference
10.5 V – 16 V	100°	> 55 Ncm	On request	50 – 51



Universal Turbo Actuator (UTA)
Part number on request

TECHNICAL DATA

Rated voltage	14 V
Operating voltage	10.5 V – 16 V
Operating temperature	-40°C to +125°C
Short-term maximum temperature	up to 150°C
Operating angle range	100°
Angular velocity (@ 20 Ncm)	> 0.35°/ms
Max. current consumption	< 9 A
Min. torque (@ 14 V, 0,1° / ms)	> 55 Ncm
Sensor resolution	0.125°
Position tolerance over full angle	±2%
Protection class	IP 6K9K
Protocol	CAN or PWM
Mating connector	Kostal, 09 4415 82, coding B

TECHNICAL DRAWING

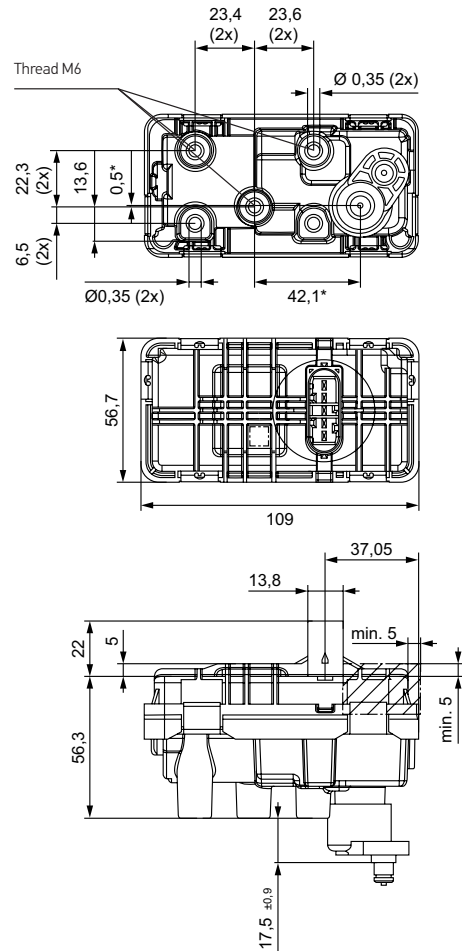

* Only relating to housing dome.

PIN ASSIGNMENT

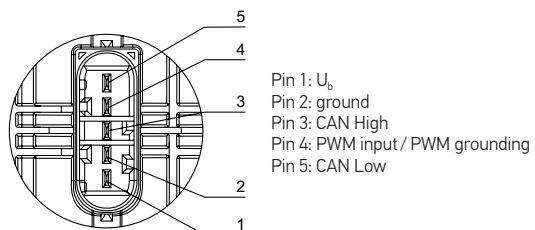

EXAMPLE OF A CONNECTING ELEMENT

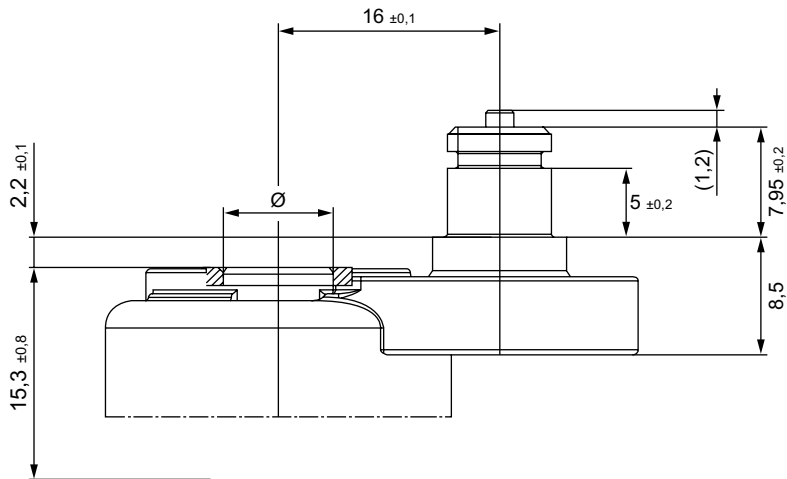

VIEW OF AN ALTERNATIVE CONNECTING ELEMENT

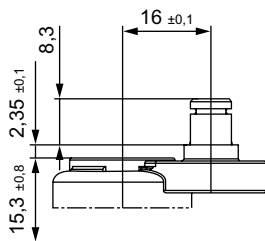

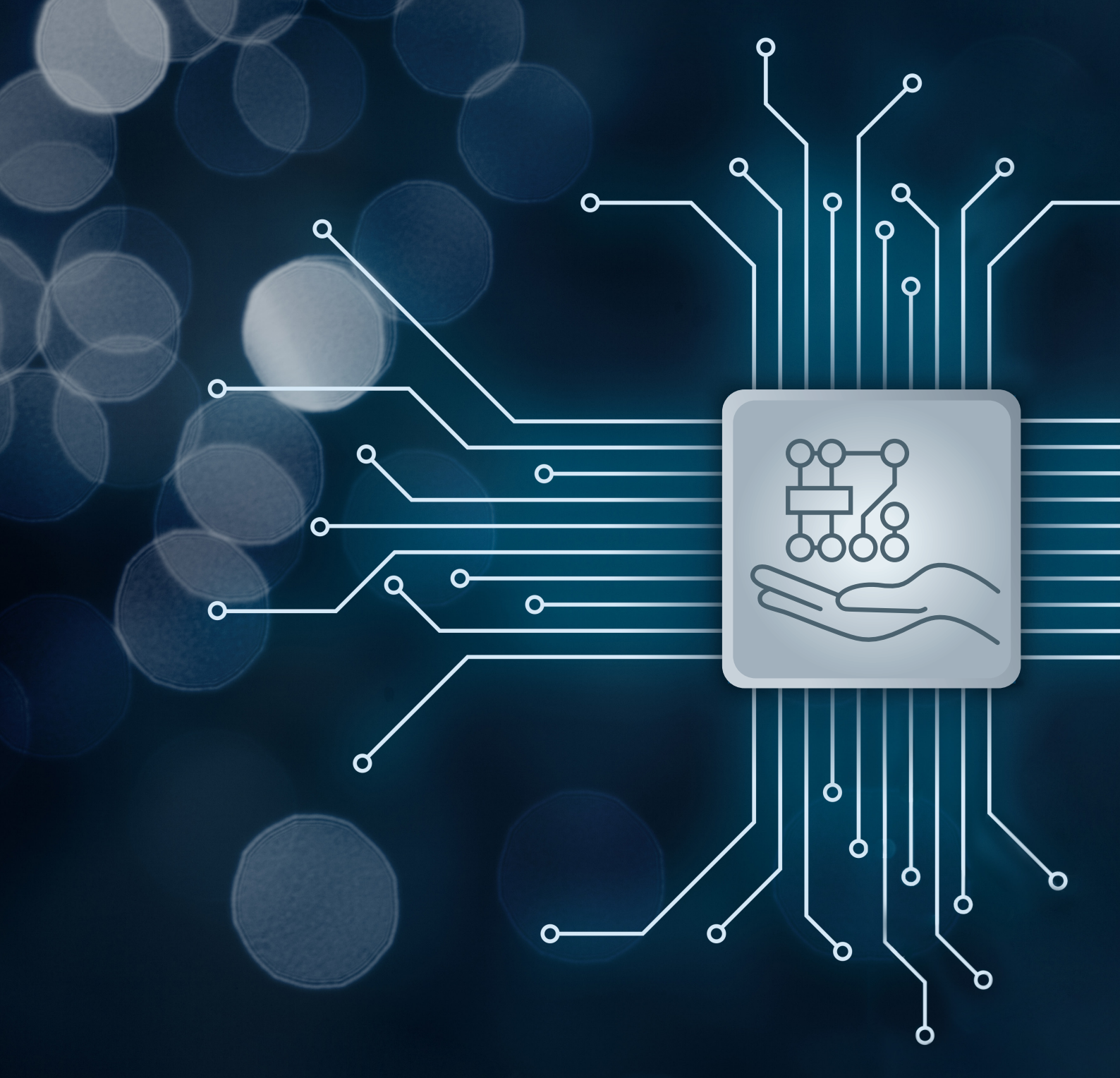



















COMPONENTS		AREA OF APPLICATION
Remote Control Systems		
Switching on and off and/or opening and locking	Remote control	
Actuators		
Electrical locking and/or unlocking, pull/push function of closing and opening mechanisms	Electromotive actuators	
Sensors		
Measurement of air temperatures	Temperature sensors	
Measurement of air properties	Air quality monitor	

COMPONENTS

Provide added convenience with compact solutions in a variety of areas:

These electronic systems are generally invisible little helpers for the various automatic processes within the vehicle.

COMPONENTS		AREA OF APPLICATION
Sensors		
Recording environmental properties	Rain/light sensor, PC (passenger car)	
	Rain/light sensor, vehicles with special windshields	  
Precise and reliable measurement of angle settings and their changes.	Angular Position Sensors	  
Rocker switches		
Series 4570 / 7832		    
Series 3100		  
Series 4100		   



Remote Control Systems
Switching on and off and/or opening and locking

PRODUCT FEATURES

- Electronic remote key:
- Unlocking cab doors /covers
 - Controlling lamps/work lights
 - Activating/deactivating an electronic immobilizer via a transponder
 - Robust design

APPLICATION

The remote control transmitter system was specially developed under hard operating conditions (agricultural, construction machines, commercial vehicles). The system enables the driver to conveniently unlock the cabin door. The remote control can be equipped with one or two buttons, depending on the customer's requirements. The rugged design has been specially developed for use with agricultural and construction machinery. An additional control unit with up to four output signals also makes it possible to control lights, e.g. worklights or beacons. The HELLA wireless remote system makes it easy to activate the flashers as well as opening and locking of compartments, e.g. the engine compartment and tool containers. The design can be customised on request, e.g. to incorporate customer-specific logos.

DESIGN AND FUNCTION

In terms of its electronic function, the radio control transmitter consists of the "radio control transmitter electronics" and the "transponder."

The transponder responsible for the immobiliser function is independent from the radio control transmitter electronics and can be customised.

The transmitter is mounted to a double-sided populated PCB. In addition to the actual transmitter electronics, the printed circuit board contains the locking/unlocking button and depending on the variant a further button (additional function). The printed circuit board and the battery are electrically connected by the spring contact elements. By pressing a button, the remote control sends data packages provided with a roll code and an up-to-date 128 bit encryption. If the data are positively decoded by the receiving control unit of the remote control, this will activate the output signal of the control unit.

The remote control system can be used in every European country and also in North America (USA + Canada) and India without limitations. System remote approvals outside Europe can be carried out in consultation with HELLA.

The remote control is equipped with a holder for a mechanical key bit. The remote transmission electronics device does not include the mechanical key bit. The key bit is usually mounted at the customer or manufacturer of the key bit (using a special mounting device).

Two remote keys are "taught-in" and assigned to the device during production of the remote receiver. Teaching additional remote keys in the field requires at least one functioning, taught-in key. For remote controls with two buttons, up to 7 remote keys can be taught in. If the maximum number of remote keys has already been taught in, the last key place is overwritten when teaching in another key. If the remote control only has one button, no keys can be subsequently taught in.

FUNCTIONAL DIAGRAM

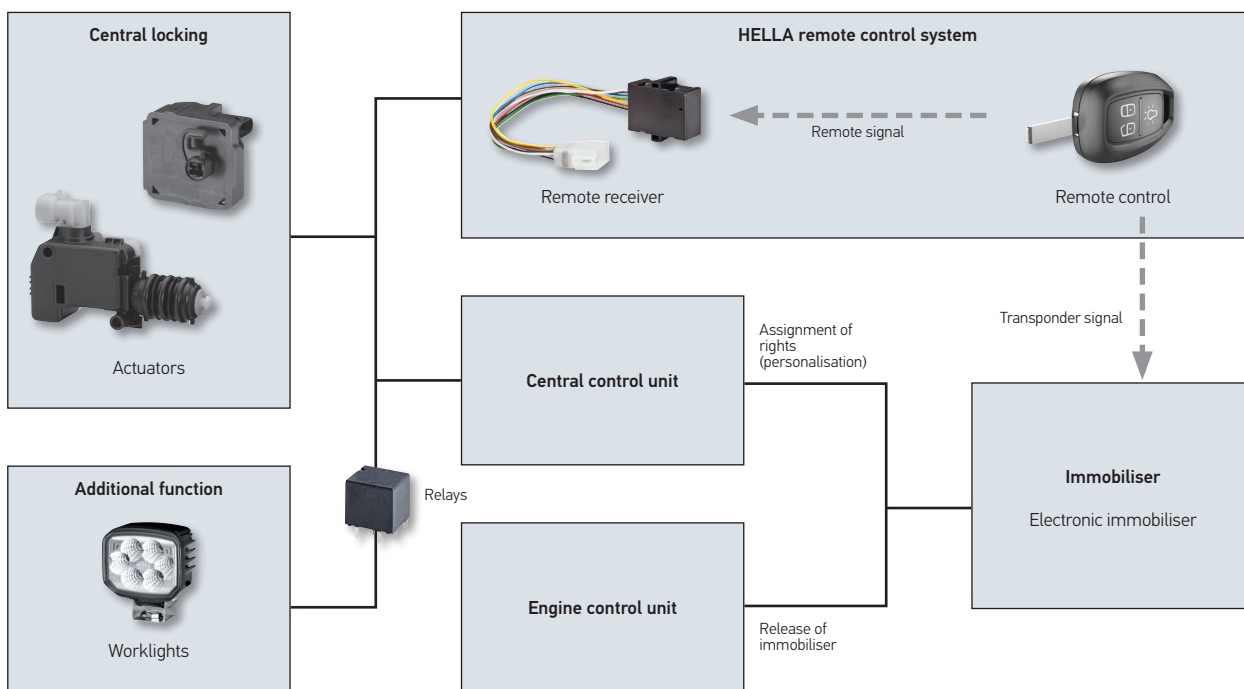

OVERVIEW OF VARIANTS

There are two variants of the receiver control unit available: The basic variant and the enhanced variant. Customer-specific output signal characteristics are available upon request. If a customer-specific emblem is to be included, a new part number is created for this. Each device variant includes two blind plugs made from hard plastic. This enables the remote control transmitters to also be operated without a key bit.

Variants	PART NUMBER	Page reference
2 remote control transmitters and receivers, enhanced variant	5FA 012 485-817	56 – 57
Replacement key for 5FA 012 485-817	5FA 012 485-201	56 – 57
2 remote control transmitters with light symbol button and receivers, enhanced variant	on request	56 – 57

Further variants and configurations available upon request.
 Details on the basic variant and extended variants can be found on page 55.



Remote Control System
 Switching on and off and/or opening and locking
Basic variant on request
Extended version Part number 5FA 012 485-817
Replacement key 5FA 012 485-201

TECHNICAL SPECIFICATIONS RADIO CONTROL TRANSMITTER

Key bit – joining force	max. 350 N
Key bit – extraction force	> 180 N
Torque around the key roll axis	3 Nm
Torque around key width axis	4 Nm
Separation of housing parts, joining/ separating force:	110 N (in new condition)
Housing cover	PA66+PA6I/X-GF50 and TPU
Housing base	PA6-GF30
Contact elements	X10CrNi 18-8
Customer emblem	PU emblem, customized
Button field	Hytrel black
Transmission frequency	434.42 MHz
Transmission power	30 μW ERP
Battery type ¹⁾	CR2032
Service life of battery	100,000 key activations (corresponds to approx. 3 years)
Max. range ²⁾	119 m
Min. range ²⁾	51 m
Average range ²⁾	70.5 m
Operating temperature	-20°C to +60°C
Storage temperature	-20°C to +60°C
Protection class	IP 6K7 and IP X5

¹⁾ A battery comes with the radio control transmitter.

²⁾ Ranges are dependent on installation location and interference factors.
 The values specified are merely examples and must be validated for each new application.

TECHNICAL DRAWING

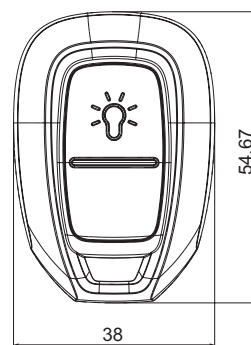
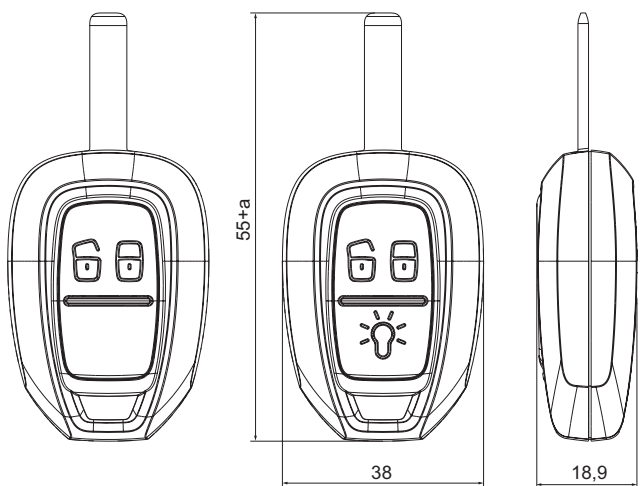

Interface to key bit
 (a, b and c dimensions are customer-specific)

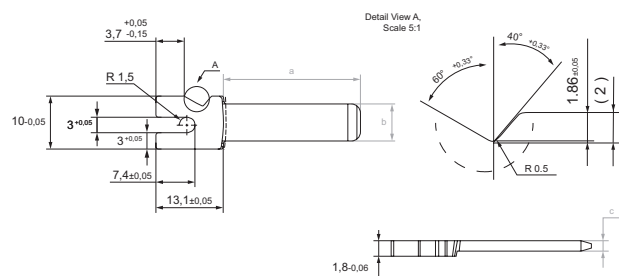

Blind plug

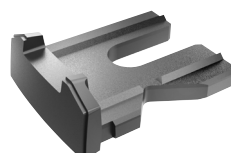

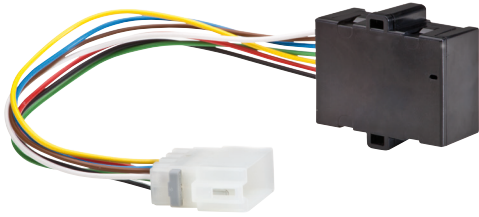

Receiver control unit

TECHNICAL SPECIFICATIONS REMOTE RECEIVER

Operating voltage	6–32 V
Power consumption	11 mA (signal output not activated)
Idling current	< 2 mA
Min. voltage:	6 V
Max. voltage	58 V for 250 ms
Nominal voltage	12/24 V
Test voltage	27,6 ± 0,4 V
Overvoltage	36 V (at 40°C, 1 hour)
Housing cover	Recycled PC
Housing base	Recycled PC
Male connector housing	PBT-GF20, V0
Operating temperature	-40°C to +80°C
Storage temperature	-40°C to +90°C
Protection class	IP 5K0
Length	51 mm
Width	45 mm
Height	21,5 mm
Mating connector ¹⁾	17848 000 000

¹⁾ This accessory is not included.
Available from Lear.

BASIC VARIANT

Pin configuration	Function	DESCRIPTION
1 Positive pole	Input	Power supply (+ 12/24 V)
2 GND	Input	Power supply (ground)
3 Door control module	Output	Low-active (< 300 mA) signal duration 3.5 s when pressing button 1
4		Not assigned
5 Reserve	Output	High-active (< 300 mA) signal duration 0.5 s when pressing button 2
6		Not assigned
7		Not assigned
8		Not assigned

TECHNICAL DRAWING

Receiver control unit

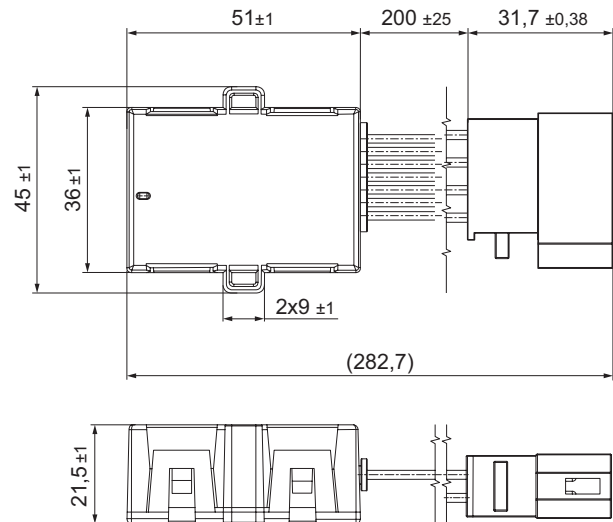

EXTENDED VARIANT

Pin configuration	Function	DESCRIPTION
1 Positive pole	Input	Power supply (+ 12/24 V)
2 GND	Input	Power supply (ground)
3 Mode:	Input signal	mode = low or mode = high (high at 70% of vehicle electrical system voltage)
4		Not assigned
5 Door 1	Output	High-active (< 300 mA) when pressing button 1 mode = low: signal duration 3 s, mode = high: signal duration 0.5 s
6 door 2	Output	High-active (< 300 mA) when pressing button 2 mode = low: signal duration 3 s, mode = high: signal duration 0.5 s
7 Wake-up function	Output	High-active (< 300 mA), signal duration 3.5 s
8 Reserve	Output	High-active (< 300 mA) signal duration 3 s when pressing button 2



Electromotive actuators
 Electric locking / unlocking, space-saving,
 with or without micro-switch
 Low Force

PRODUCT FEATURES

- Compact, space-saving design
- Electrical resetting or automatic resetting (without current)
- Easy to fix in place thanks to snap-fit mounting
- Spray water protected
- With or without micro-switch
- Explosion report for tank modules

APPLICATION

This actuator's extremely compact design makes it particularly suitable for locking and unlocking applications in dry and wet areas (including via remote control, for example) where the available space is tight.

Examples include:

- Tank modules
- Service flaps
- Glove compartments
- Locking of the charging plug (e-mobility)

FUNCTION

- When a voltage is applied, the motor integrated in the electromotive actuator moves the locking lever attached to the motor shaft. A

Two product variants are available in the product range. The first actuator variant with power locking and unlocking function is particularly well suited to conventional applications in which the locking lever locks a hinge arm connected to the locking system by applying voltage and unlocks it when polarity is reversed. The stability of the open/closed locking positions is achieved after short-circuiting the motor following successful actuation. The position of the locking element can also be defined via an integrated micro-switch.

A return spring and a micro-switch are integrated in the second actuator variant. Lightly move the locking lever e.g. by pressing a service flap to actuate the micro-switch. The actuator is then energized by a control unit. The locking lever is subsequently fully retracted so that the locking system is open and the service flap also opens via a spring action. The actuator is then switched off and the locking lever returns to the locking position de-energized via the integrated return spring. Press the service flap shut to lock it; the hinge arm of the flap then engages in the locking lever of the actuator.

EXAMPLES OF THE MOUNTING INTERFACE

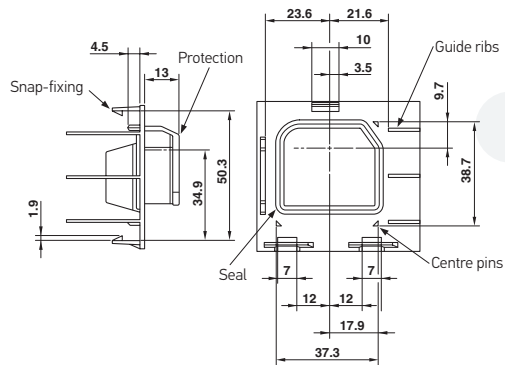

LOCKING INTERFACE (VARIANT -017 and -027)

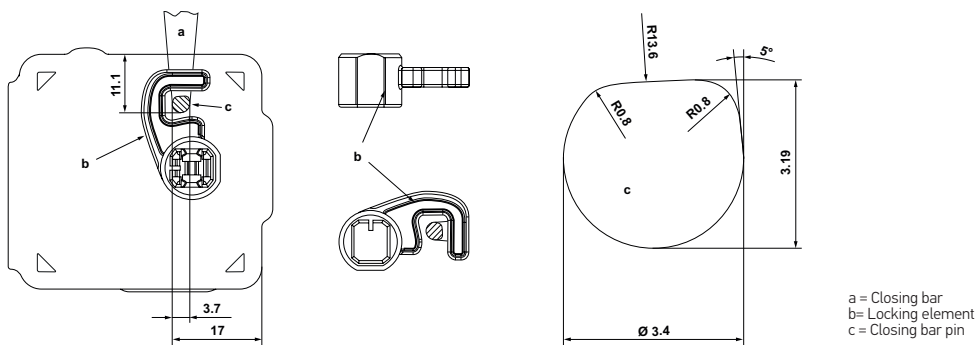

LOCKING INTERFACE (VARIANT -047)

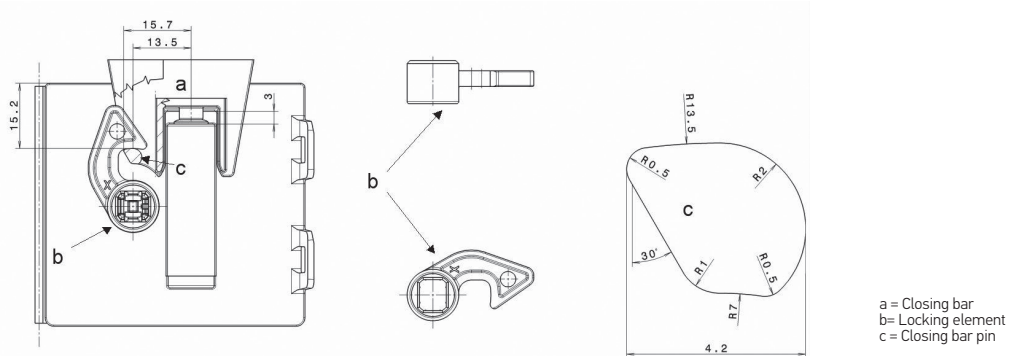

OVERVIEW OF VARIANTS

Function	Voltage	Actuating force	Manual adjustment	Protection class	PART NUMBER	Page reference
Forward and reverse rotation electrical						
	12 V	-	Yes	IP 5K4	6NW 011 122-017	60
With micro-switch	12 V	-	Yes	IP 5K4	6NW 011 122-027	62-63
Electrical forward rotation and reverse rotation via return spring, with soft touch button						
	12 V	-	Yes	IP 5K4	6NW 011 122-047	64-65



Electric motor actuators
 electrical locking/unlocking, space-saving,
 electrical forward and reverse rotation
Part number 6NW 011 122-017

TECHNICAL DATA

Function	Forward and reverse rotation electrical
Weight	60 g
Rated voltage	12 V
Voltage range	9 – 15.5 V
Maximum current consumption (blocking current)	3,2 A
Idling current	≤ 250 mA
Locking lever retention force	> 75 N (after design life > 50 N)
Locking lever breaking force	≥ 300 N
Functional angle	≤ 78°
Stellzeit für 78° über Funktionswinkel ¹⁾	max. 200 ms
Triggering time	0,2 s < t < 10 s
Thermal overload protection	not available
Operating temperature	-40°C to +85°C
Storage temperature	-40°C to +90°C
Design life ²⁾	100,000 cycles
Conducted interference	DIN ISO 7637, SAE J1113-42
Interference suppression CISPR 25, SAE J-1113-41	Intensity level 1 + 10 dB µV
Final position stability with motor short circuit	≤ 6°
Protection class	IP 5K4
Salt spray test according to DIN 50 021 SS	96 h
Vibration resistance according to IEC 68-2-64	2,7 g
Housing material	PP-GF30
Sealing ring	NBR 70 Shore A
Locking lever material	PAA GF60
Resistant to	Petrol, diesel, bio-diesel, ozone
Pin coating	tin-plated
Connector	Hirschmann, 3-pin
Mating connector ³⁾	3-pin MLK coupling ELA 872-858-541

¹⁾ 1) Over the operating voltage and temperature range.

²⁾ 2) One switching cycle equals one forward and one reverse rotation.

³⁾ 3) This accessory is not included.
 Available from Hirschmann Automotive.

TECHNICAL DRAWING

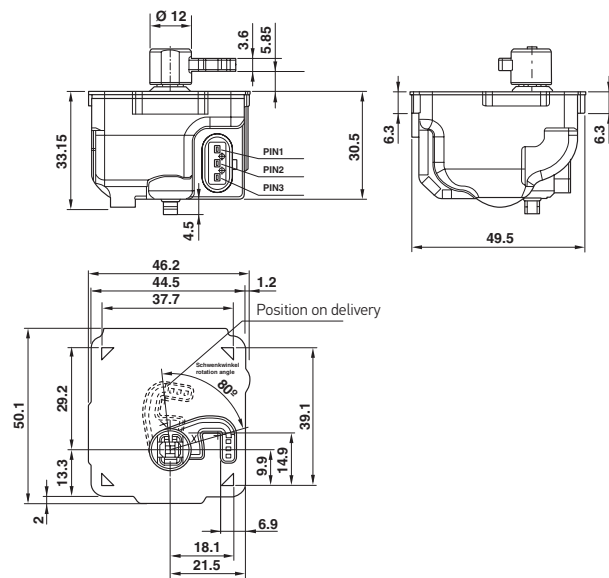

ELECTRICAL CONNECTION / PIN ASSIGNMENT

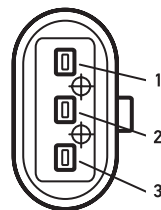

Hirschmann, 3-pin MLK plug

Unlock central locking system
 Lock central locking system

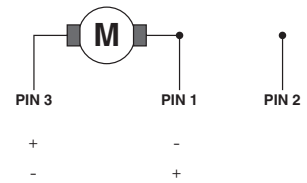





Electric motor actuators
 electrical locking/unlocking, space-saving with
 micro-switch, electrical forward and reverse rotation
Part number 6NW 011 122-027

TECHNICAL DATA

Function	Forward and reverse rotation electrical with micro-switch
Weight	60 g
Rated voltage	12 V
Voltage range	9 – 15.5 V
Maximum current consumption (blocking current)	3.2 A
Idling current	≤ 250 mA
Locking lever retention force	≥ 75 N
Locking lever breaking force	≥ 300 N
Functional angle	≤ 78°
Actuating time 78° over functional angle ¹⁾	40 ms < t < 200 ms
Triggering time	0,2 s < t < 10 s
Thermal overload protection	not available
Operating temperature	-40°C to +85°C
Storage temperature	-40°C to +90°C
Design life ²⁾	60,000 cycles
Conducted interference	Level 2
Interference suppression CISPR 25, SAE J-1113-41	≤ 18 mm Intensity level 1 + 10 dB µV
Micro-switch switching angle	8° to 18°
Final position stability with motor short-circuit	≤ 6°
Protection class	IP 5K4
Salt spray test according to DIN 50 021 SS	96 h
Vibration resistance according to IEC 68-2-64	2,7 g
Housing material	PP-GF30
Sealing ring	NBR 70 Shore A black
Locking lever material	PAA GF60
Resistant to	Petrol, diesel, bio-diesel, ozone
Pin coating	tin-plated
Connector	Hirschmann, 3-pin
Mating connector ³⁾	3-pin MLK coupler ELA 872-858-...KA

¹⁾ Over the operating voltage and temperature range.

²⁾ One switching cycle equals one forward and one reverse rotation.

³⁾ This accessory is not included.
 Available from Hirschmann Automotive.

OTHER VARIANTS

On request: 6NW 011 122-031

(same as version -021 but without operating and locking elements)

On request: 6NW 011 122-051

(without locking element, with operating element)

TECHNICAL DRAWING

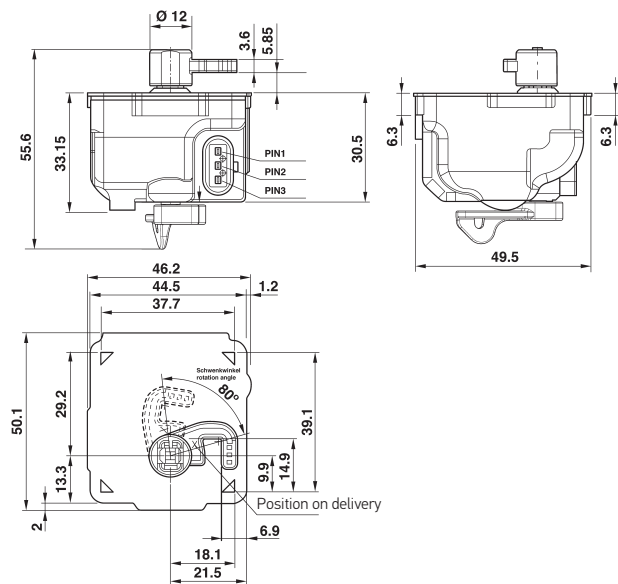

ELECTRICAL CONNECTION / PIN ASSIGNMENT

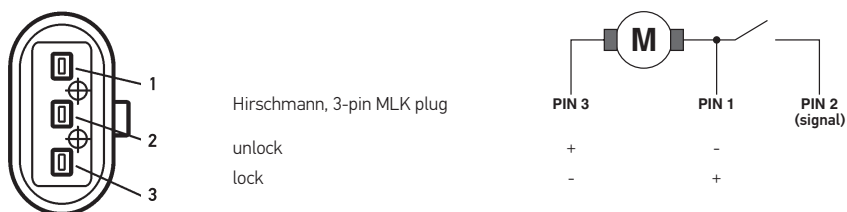

MICRO-SWITCH TRIGGER

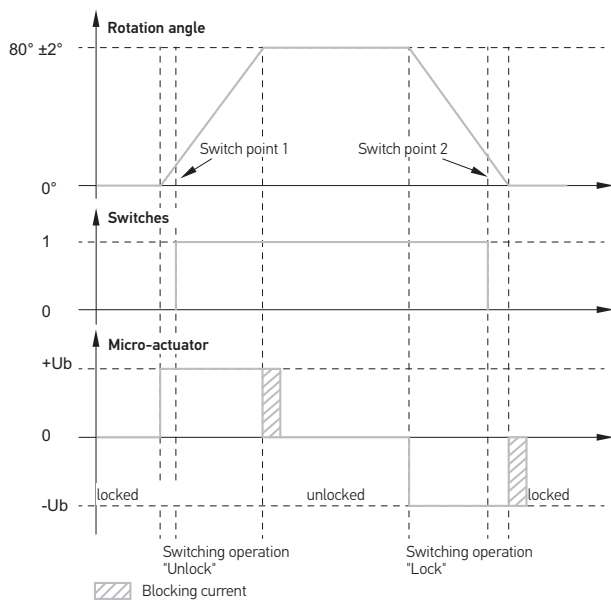



Electromotive actuators
 Electrical locking/unlocking, space-saving,
 with micro-switch, electrical forward rotation,
 reverse rotation via return spring, with soft touch
 button

Part number 6NW 011 122-047

TECHNICAL DATA

Function	Power open rotation; return rotation via return spring
Weight	60 g
Rated voltage	12 V
Voltage range	9 – 15.5 V
Maximum current consumption (blocking current)	5,1 A
Idling current	≤ 700 mA
Locking lever retention force	75 N
Locking lever breaking force	300 N
Micro-switch triggering force	≤ 24 N
Functional angle	≤ 78°
Actuating time 78° over functional angle ¹⁾	max. 4 sec
Triggering time	0,3 s < t < 4 s
Thermal overload protection	not available
Operating temperature	-40°C to +85°C
Storage temperature	-40°C to +90°C
Design life ²⁾	7,500 cycles
Conducted interference	DIN ISO 7637, SAE J1113-42
Interference suppressing CISPR 25, SAE J-1113-41	Intensity level 1 + 10 dB µV
Micro-switch switching angle	8° – 18°
Final position stability with motor short-circuit	≤ 6°
Protection class	IP 5K4
Salt spray test according to DIN 50 021 SS	96 h
Vibration resistance according to IEC 68-2-64	2,7 g
Housing material	PP-GF30
Sealing ring	NBR 70 Shore A
Locking lever material	PAA GF60
Resistant to	Petrol, diesel, bio-diesel, ozone
Pin coating	CuSn6, bronze plate, galvanically tin-plated
Connector	Hirschmann, 3-pin
Mating connector ³⁾	3-pin MLK coupling ELA 872-858-541

¹⁾ 1) Over the operating voltage and temperature range.
²⁾ 2) One switching cycle equals one forward and one reverse rotation.
³⁾ This accessory is not included.
 Available from Hirschmann Automotive.

TECHNICAL DRAWING

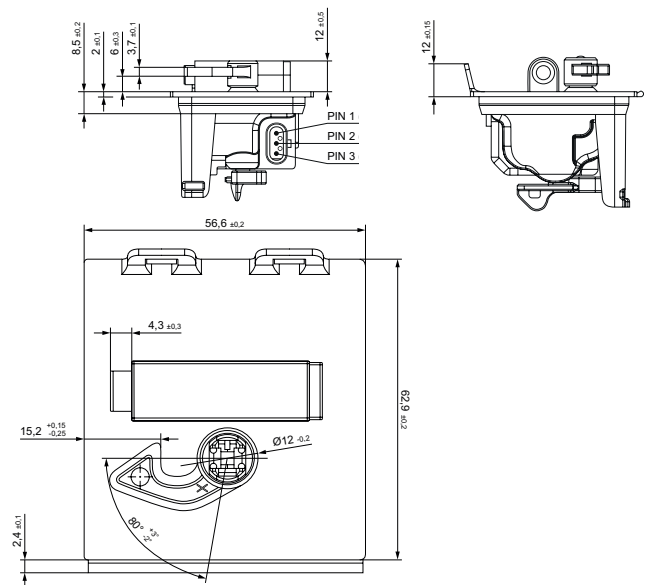

ELECTRICAL CONNECTION / PIN ASSIGNMENT

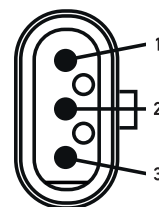

Hirschmann, 3-pin MLK plug

Softtouch unlocking
 Softtouch locking

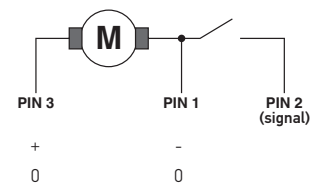

SWITCHING OPERATION FUNCTION SEQUENCE

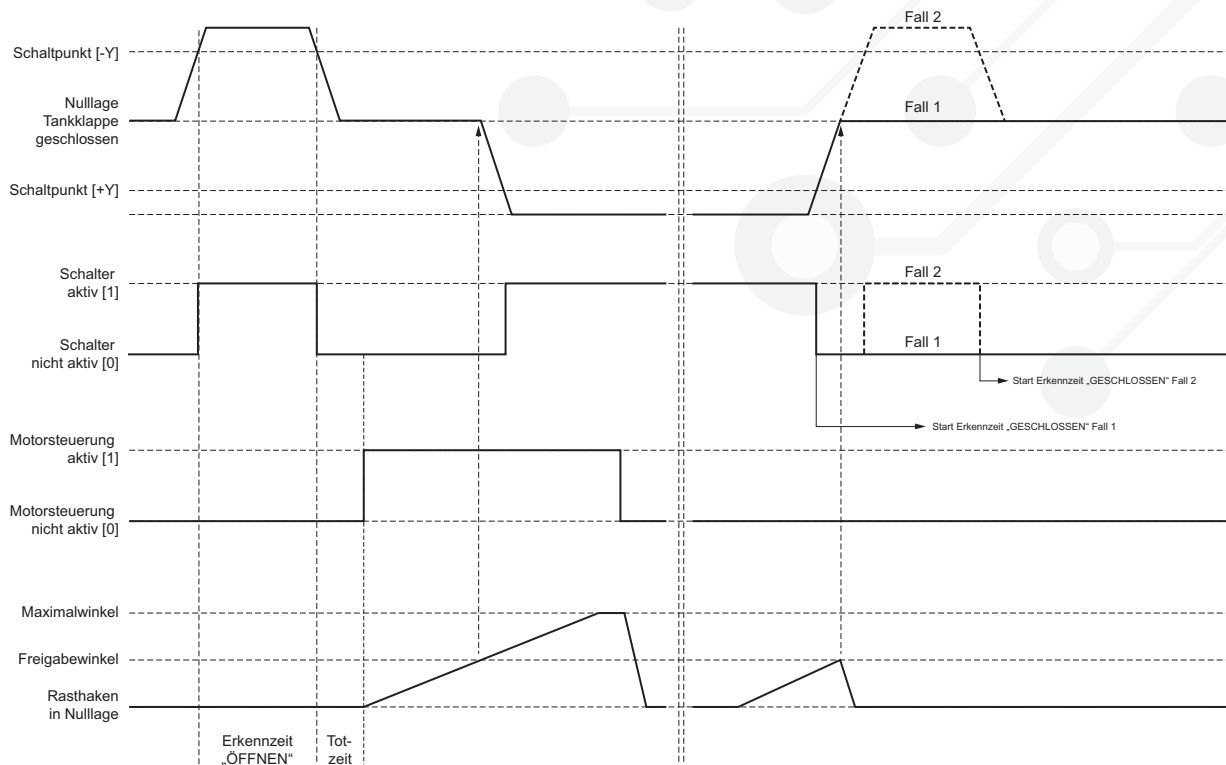

Detection time "OPEN"

Description:
Minimum time that the operator has to hold the operating element depressed for opening.

Explanation:
In order that short pulses do not lead to unintentional opening, the "OPEN" detection time starts with the switch change from [0] to [1]. If the state [1] "Switch active" is detected for longer than the preset value, opening is initiated at the switch change from [1] to [0].

Dead time

Description:
Time between switch change to [0] and activation of the motor controller [1] when an opening is initiated.

Explanation:
On the electronic side there is a system reaction time comprising the switch debouncing time and the system runtime. This can lead to a delay of up to 70 ms, delaying the nonparameterisable (actual) dead time of the opening operation.

Detection time "CLOSED"

Description:
Minimum time that the application has to be closed before a new opening operation can be initiated by the operator.

Explanation:
When the application is open, the switch signal is active [1]. As soon as the operator closes the application, the switch signal changes to not active [0]. The switch change to not active [0] starts the "CLOSED" detection time. Two cases are possible during closing (see case examples).

Case examples

Case 1:
The operator does not press down to the end stop during closing of the application. The signal then changes from Switch active [1] to Switch not active [0] and the "CLOSED" detection time starts. As soon as the preset time has expired, the application can be opened again.

Case 2:
The operator presses down to the end stop during closing of the application. The signal first changes from Switch active [1] to Switch not active [0] and the "CLOSED" detection time starts. When pressing down to the end stop, the signal changes again to Switch active [1] and the "CLOSED" detection time that has not yet expired is reset. As soon as the operator releases the application, the signal changes to Switch not active [0] and the "CLOSED" detection time starts again.

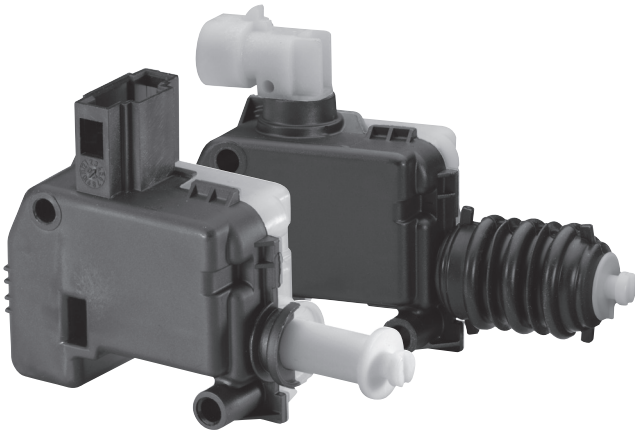

Electromotive actuators
Electrical locking / unlocking and closing
(medium force)

PRODUCT FEATURES

- High actuating force
- High-accuracy, laser-welded housing
- Three versions
- Dust- and waterproof
- With or without manual adjustment
- Thermal overload protection through PTC (PolySwitch)
- Multifunctional
- Various connecting elements available

FUNCTION

An electric motor is installed in the two laser-welded polyamide housing halves. Energised by pins 1 and 2, the electric motor moves a spindle gear that extends or retracts a tappet, depending on the direction of rotation. The tappet is extended with plus at pin 1 and minus at pin 2.

The tappet is retracted with minus at pin 1 and plus at pin 2. The stability of the retracted/extended locking positions is achieved by the short-circuited motor following successful actuation. A PolySwitch (PTC) is integrated in the motor for thermal overload protection. It is also possible to equip the actuators with an automatic reset function (retract or extend) by way of a mainspring.

APPLICATION

The motor-driven actuator is used for electrical locking and unlocking or closing of locking and flap systems in vehicles and industrial applications.

Examples of applications in mechanisms include:

- Electrical locking and unlocking,
- Electrical shutting,
- Power opening and closing of all doors (locking systems), flaps, roof windows, seats, covers, hoods, glove boxes, etc.

ACCESSORIES

The comprehensive range of accessories for the electrical actuator includes a wide variety of different connection elements, which enable the actuator to be integrated into your application easily without additional development costs.

DEPENDENCIES OF ACTUATING FORCE CHARACTERISTIC CURVES

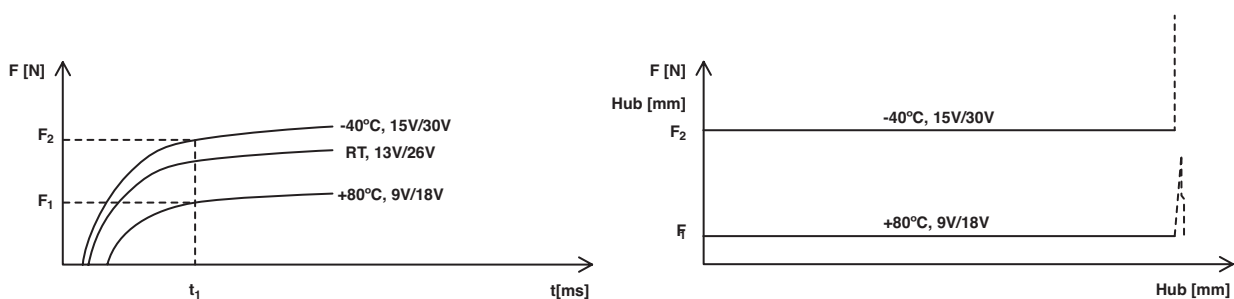

With a controller time of t_1 , the actuator has an actuating force of $F_1 < F < F_2$. The constant actuating force at the ram over the nominal stroke is dependent on the operating voltage and ambient temperature. If the actuator does not have to move a load over the stroke, the actuator force is converted into a higher actuator speed, resulting in the dynamic impact pulses that are a multiple of the constant actuating force.

OVERVIEW OF VARIANTS

Function	Voltage	Positioning force*	Manual adjustment	Protection class	PART NUMBER	Page reference
Power extension and retraction						
	12 V	30 – 130 N	Yes	IP 5K0	6NW 009 203-401	68
	12 V	30 – 140 N	No	IP 5K0	6NW 009 203-411	69
	12 V	30 – 130 N	Yes	IP 5K4	6NW 009 203-421	70
	12 V	30 – 140 N	No	IP 5K4	6NW 009 203-431	71
	24 V	30 – 130 N	Yes	IP 5K4	6NW 009 203-441	72
	24 V	30 – 140 N	No	IP 5K4	6NW 009 203-451	73
	12 V	30 – 140 N	No	IP 5K4	6NW 009 203-557	74
Electrical retraction, extension with clockwork spring						
	12 V	30 – 170 N	No	IP 5K0	6NW 009 203-461	75
	12 V	30 – 170 N	No	IP 5K4	6NW 009 203-471	76
	24 V	30 – 170 N	Yes	IP 5K4	6NW 009 203-541	77
Electrical extension, retraction with clockwork spring						
	12 V	30 – 130 N	No	IP 5K0	6NW 009 203-491	78
	12 V	30 – 130 N	No	IP 5K4	6NW 009 203-501	79
	24 V	40 – 150 N	No	IP 5K4	6NW 009 203-521	80

* Dependent on the operating voltage and ambient temperature

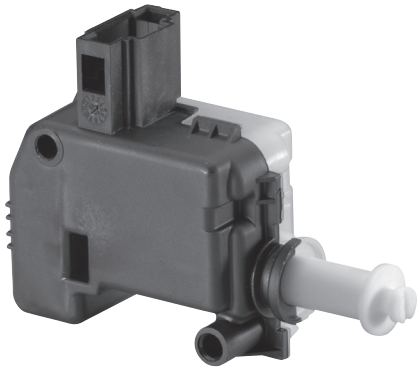

Electromotive actuators
 Electrical locking / unlocking and closing
 (medium force)
 Power extension and retraction
Part number 6NW 009 203-401

TECHNICAL DATA

Position on delivery	retracted
Mainspring reset	none
Weight	90 g
Rated voltage	12 V
Voltage range	9 – 15 V
Maximum current consumption (blocking current)	6,7 A
Idling current	350 mA
Actuating force for ram stroke over Operating voltage range and operating temperature range	30 – 130 N
Manual adjustment	≤ 15 N
Actuating time for 18 mm stroke ¹⁾	max. 400 ms
Thermal overload protection	via PolySwitch (PTC)
Operating temperature	-40°C to +80°C
Storage temperature	-40°C to +90°C
Lifetime	100,000 switching cycles
Conducted interference	< 75 V
Interference suppression (in all ranges)	Intensity level 1 + 10 dB μ V
Functional stroke	≤ 18 mm
Protection class	IP 5K0
Vibration resistance	2,7 g _{eff.}
Casing material (upper side)	Polyamide 6 GF15
Casing material (bottom side)	Polyamide 6 M25 GF15
Pin coating	Tin
Mating connector ²⁾	1355390-1

¹⁾ At the positioning mechanism over the operating voltage and temperature range.

²⁾ This accessory is not included. Available from TE Connectivity.

TECHNICAL DRAWING

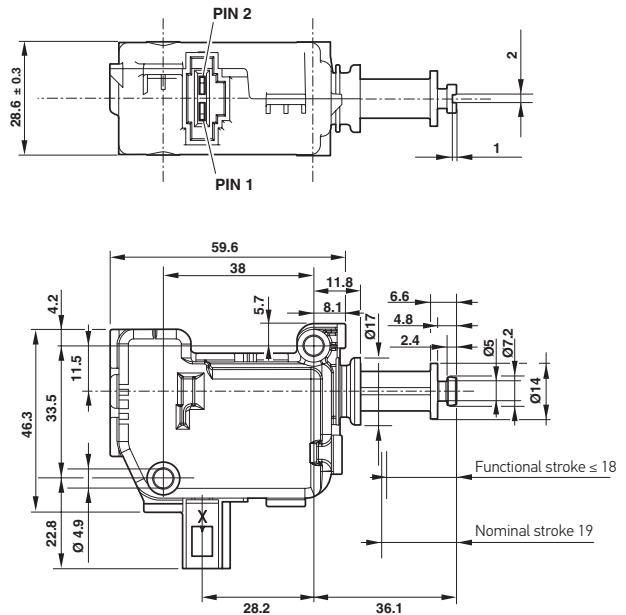

ELECTRICAL CONNECTION / PIN ASSIGNMENT

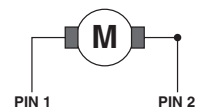
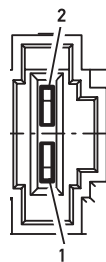

Electrical extension	+	-
Electrical retraction	-	+

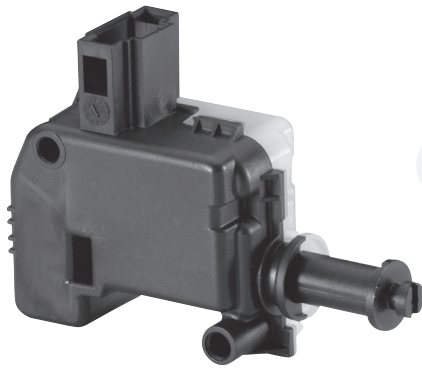

Electromotive actuators
 Electrical locking / unlocking and closing
 (medium force)
 Power extension and retraction
Part number 6NW 009 203-411

TECHNICAL DATA

Position on delivery	retracted
Mainspring reset	none
Weight	90 g
Rated voltage	12 V
Voltage range	9 – 15 V
Maximum current consumption (blocking current)	6,7 A
Idling current	350 mA
Actuating force for ram stroke over Operating voltage range and operating temperature range	30 – 140 N
Manual adjustment	none
Actuating time for 18 mm stroke ¹⁾	max. 400 ms
Thermal overload protection	via PolySwitch (PTC)
Operating temperature	-40°C to +80°C
Storage temperature	-40°C to +90°C
Lifetime	100,000 switching cycles
Conducted interference	< 75 V
Interference suppression (in all ranges)	Intensity level 1 + 10 dB μ V
Functional stroke	\leq 18 mm
Protection class	IP 5K0
Vibration resistance	2,7 g _{Eff.}
Casing material (upper side)	Polyamide 6 GF15
Casing material (bottom side)	Polyamide 6 M25 GF15
Pin coating	Tin
Mating connector ²⁾	1355390-1

¹⁾ At the positioning mechanism over the operating voltage and temperature range.

²⁾ This accessory is not included.
 Available from TE Connectivity.

TECHNICAL DRAWING

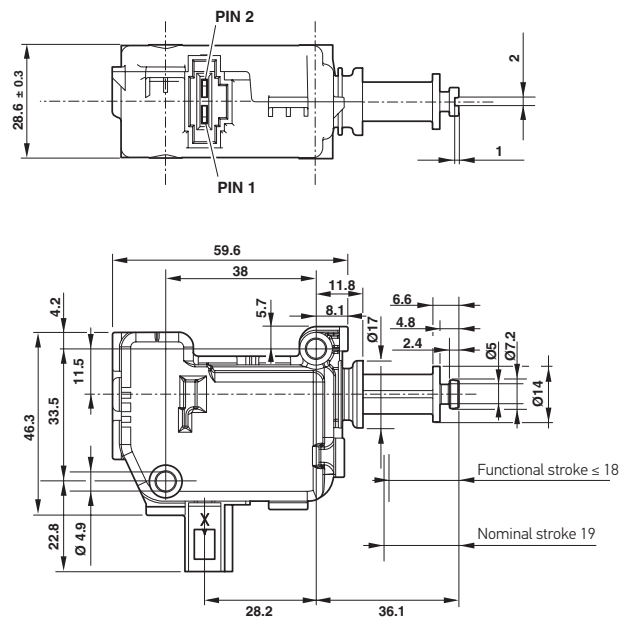

ELECTRICAL CONNECTION / PIN ASSIGNMENT

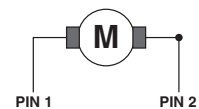
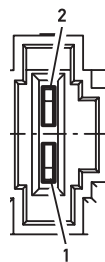

Electrical extension +
 Electrical retraction -

+ -
 - +

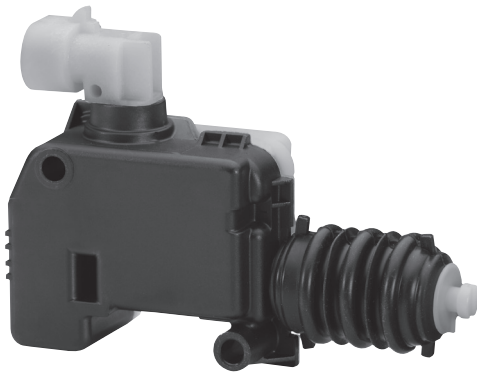

Electromotive actuators
 Electrical locking / unlocking and closing
 (medium force)
 Power extension and retraction
Part number 6NW 009 203-421

TECHNICAL DATA

Position on delivery	extended
Mainspring reset	none
Weight	90 g
Rated voltage	12 V
Voltage range	9 – 15 V
Maximum current consumption (blocking current)	6,7 A
Idling current	350 mA
Actuating force for ram stroke over Operating voltage range and operating temperature range	30 – 130 N
Manual adjustment	≤ 15 N
Actuating time for 18 mm stroke ¹⁾	max. 400 ms
Thermal overload protection	via PolySwitch (PTC)
Operating temperature	-40°C to +80°C
Storage temperature	-40°C to +90°C
Lifetime	100,000 switching cycles
Conducted interference	< 75 V
Interference suppression (in all ranges)	Intensity level 1 + 10 dB μ V
Functional stroke	≤ 18 mm
Protection class	IP 5K4
Vibration resistance	2,7 g _{eff.}
Casing material (upper side)	Polyamide 6 GF15
Casing material (bottom side)	Polyamide 6 M25 GF15
Pin coating	Tin
Mating connector ²⁾	282080-1

¹⁾ At the positioning mechanism over the operating voltage and temperature range.

²⁾ This accessory is not included.
 Available from TE Connectivity.

TECHNICAL DRAWING

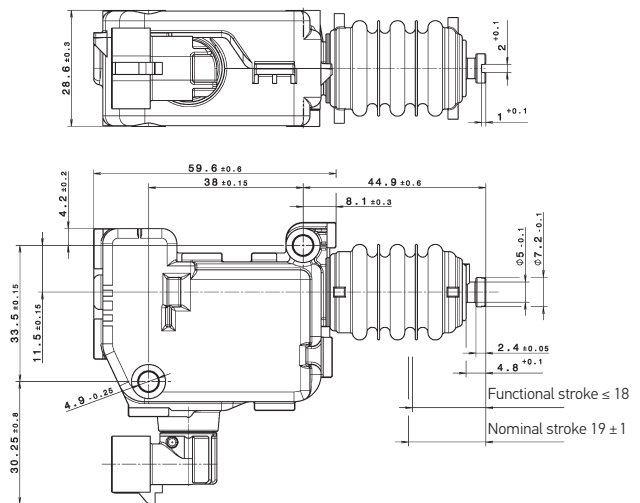

ELECTRICAL CONNECTION / PIN ASSIGNMENT

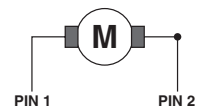
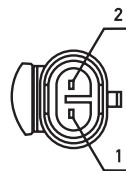

Electrical extension
 Electrical retraction

+ -
 - +

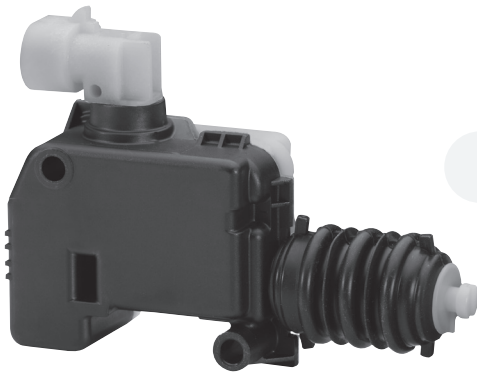

Electromotive actuators
 Electrical locking / unlocking and closing
 (medium force)
 Power extension and retraction
Part number 6NW 009 203-431

TECHNICAL DATA

Position on delivery	extended
Mainspring reset	none
Weight	90 g
Rated voltage	12 V
Voltage range	9 – 15 V
Maximum current consumption (blocking current)	6,7 A
Idling current	350 mA
Actuating force for ram stroke over Operating voltage range and operating temperature range	30 – 140 N
Manual adjustment	none
Actuating time for 18 mm stroke ¹⁾	max. 400 ms
Thermal overload protection	via PolySwitch (PTC)
Operating temperature	-40°C to +80°C
Storage temperature	-40°C to +90°C
Lifetime	100,000 switching cycles
Conducted interference	< 75 V
Interference suppression (in all ranges)	Intensity level 1 + 10 dB μ V
Functional stroke	\leq 18 mm
Protection class	IP 5K4
Vibration resistance	2,7 g _{Eff.}
Casing material (upper side)	Polyamide 6 GF15
Casing material (bottom side)	Polyamide 6 M25 GF15
Pin coating	Tin
Mating connector ²⁾	282080-1

¹⁾ At the positioning mechanism over the operating voltage and temperature range.

²⁾ This accessory is not included.
 Available from TE Connectivity.

TECHNICAL DRAWING

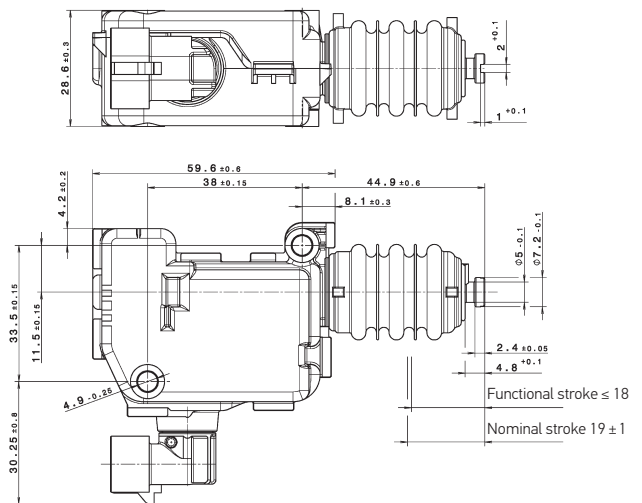

ELECTRICAL CONNECTION / PIN ASSIGNMENT

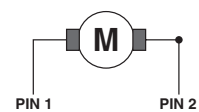

Electrical extension +
 Electrical retraction -

+ -
 - +

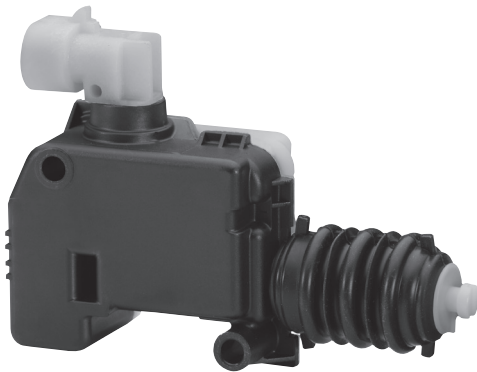

Electromotive actuators
 Electrical locking / unlocking and closing
 (medium force)
 Power extension and retraction
Part number 6NW 009 203-441

TECHNICAL DATA

Position on delivery	extended
Mainspring reset	none
Weight	90 g
Rated voltage	24 V
Voltage range	18 – 30 V
Maximum current consumption (blocking current)	4,2 A
Idling current	185 mA
Actuating force for ram stroke over Operating voltage range and operating temperature range	30 – 130 N
Manual adjustment	≤ 15 N
Actuating time for 18 mm stroke ¹⁾	max. 400 ms
Thermal overload protection	via PolySwitch (PTC)
Operating temperature	-40°C to +80°C
Storage temperature	-40°C to +90°C
Lifetime	50,000 switching cycles
Conducted interference	< 75 V
Interference suppression (in all ranges)	Intensity level 1 + 10 dB µV
Functional stroke	≤ 18 mm
Protection class	IP 5K4
Vibration resistance	2,7 g _{eff.}
Casing material (upper side)	Polyamide 6 GF15
Casing material (bottom side)	Polyamide 6 M25 GF15
Pin coating	Tin
Mating connector ²⁾	282080-1

¹⁾ At the positioning mechanism over the operating voltage and temperature range.

²⁾ This accessory is not included.
 Available from TE Connectivity.

TECHNICAL DRAWING

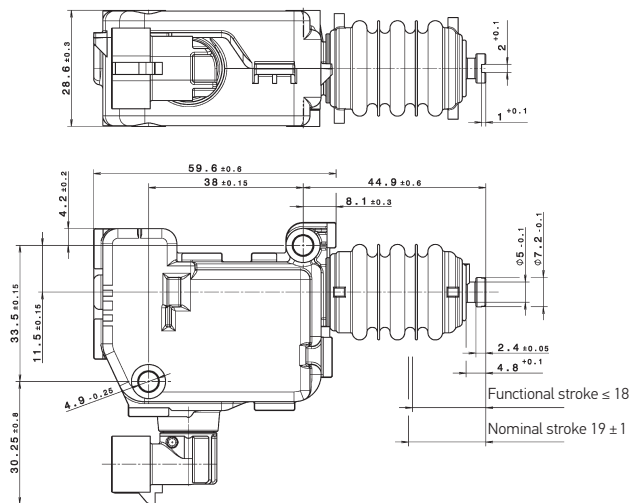

ELECTRICAL CONNECTION / PIN ASSIGNMENT

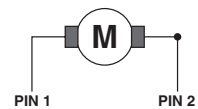
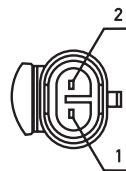

Electrical extension	+	-
Electrical retraction	-	+

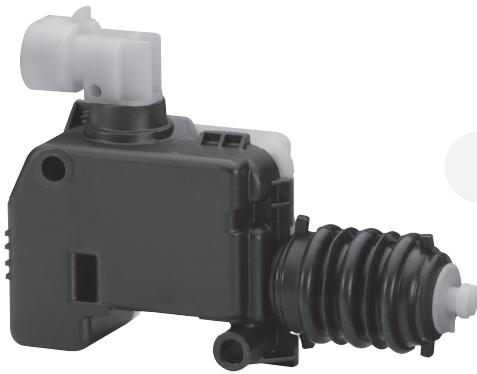

Electromotive actuators
 Electrical locking / unlocking and closing
 (medium force)
 Power extension and retraction
Part number 6NW 009 203-451

TECHNICAL DATA

Position on delivery	extended
Mainspring reset	none
Weight	90 g
Rated voltage	24 V
Voltage range	18 – 30 V
Maximum current consumption (blocking current)	4,2 A
Idling current	185 mA
Actuating force for ram stroke over Operating voltage range and operating temperature range	40 – 140 N
Manual adjustment	none
Actuating time for 18 mm stroke ¹⁾	max. 400 ms
Thermal overload protection	via PolySwitch (PTC)
Operating temperature	-40°C to +80°C
Storage temperature	-40°C to +90°C
Lifetime	20,000 switching cycles
Conducted interference	< 75 V
Interference suppression (in all ranges)	Intensity level 1 + 10 dB μ V
Functional stroke	\leq 18 mm
Protection class	IP 5K4
Vibration resistance	2,7 g _{Eff.}
Casing material (upper side)	Polyamide 6 GF15
Casing material (bottom side)	Polyamide 6 M25 GF15
Pin coating	Tin
Mating connector ²⁾	282080-1

¹⁾ At the positioning mechanism over the operating voltage and temperature range.

²⁾ This accessory is not included.
 Available from TE Connectivity.

TECHNICAL DRAWING

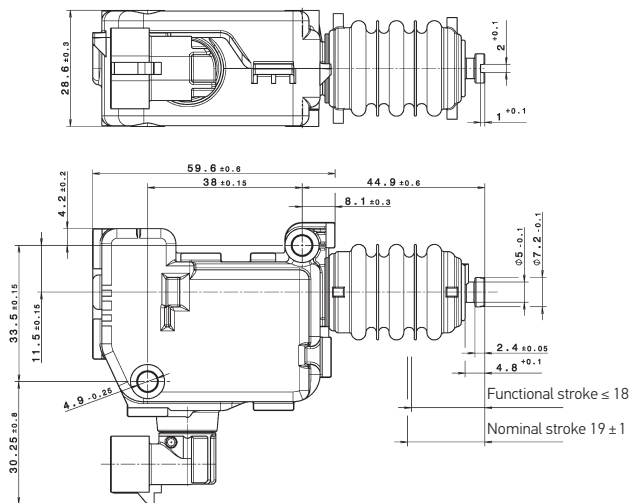

ELECTRICAL CONNECTION / PIN ASSIGNMENT

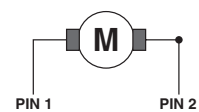

Electrical extension +
 Electrical retraction -

+ -
 - +



Electromotive actuators
 Electrical locking / unlocking and closing
 (medium force)
 Power extension and retraction
 With cable

Part number 6NW 009 203-557

TECHNICAL DATA

Position on delivery	extended
Mainspring reset	none
Weight	90 g
Rated voltage	12 V
Voltage range	9 – 15 V
Maximum current consumption (blocking current)	6,7 A
Idling current	350 mA
Actuating force for ram stroke over Operating voltage range and operating temperature range	30 – 140 N
Manual adjustment	none
Actuating time for 18 mm stroke ¹⁾	max. 400 ms
Thermal overload protection	via PolySwitch (PTC)
Operating temperature	-40°C to +80°C
Storage temperature	-40°C to +90°C
Lifetime	70,000 switching cycles
Conducted interference	< 75 V
Interference suppression (in all ranges)	Intensity level 1 + 10 dB μ V
Functional stroke	\leq 18 mm
Protection class	IP 5K4
Vibration resistance	2,7 g _{eff.}
Casing material (upper side)	Polyamide 6 GF15
Casing material (bottom side)	Polyamide 6 M25 GF15
Pin coating	Tin
Mating connector ²⁾	282080-1

¹⁾ At the positioning mechanism over the operating voltage and temperature range.

²⁾ This accessory is not included.
 Available from TE Connectivity.

TECHNICAL DRAWING

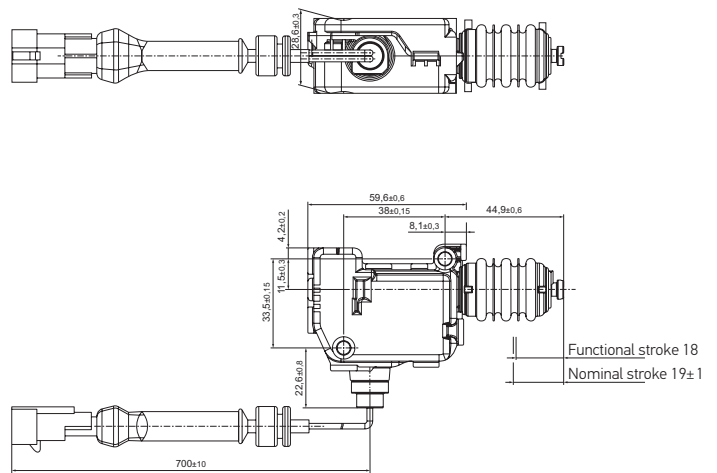

ELECTRICAL CONNECTION / PIN ASSIGNMENT

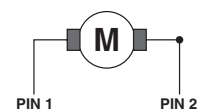
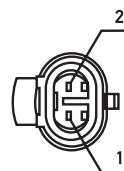

Electrical extension +
 Electrical retraction -

PIN 1 +
 PIN 2 -

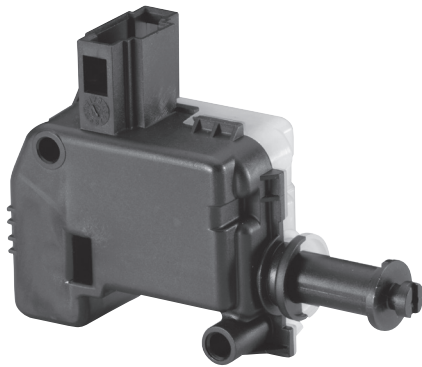

Electromotive actuators
 Electrical locking / unlocking and closing
 (medium force)
 Electrical retraction, extension with clockwork spring
Part number 6NW 009 203-461

TECHNICAL DATA

Position on delivery	extended
Mainspring reset	extend
Weight	90 g
Rated voltage	12 V
Voltage range	9 – 15 V
Maximum current consumption (blocking current)	10,5 A
Idling current	545 mA
Actuating force for ram stroke over Operating voltage range and operating temperature range	30 – 170 N
Manual adjustment	none
Actuating time for 18 mm stroke ¹⁾	max. 400 ms
Thermal overload protection	via PolySwitch (PTC)
Operating temperature	-40°C to +80°C
Storage temperature	-40°C to +90°C
Lifetime	50,000 switching cycles
Conducted interference	< 75 V
Interference suppression (in all ranges)	Intensity level 1 + 10 dB µV
Functional stroke	≤ 18 mm
Protection class	IP 5K0
Vibration resistance	2,7 g _{eff.}
Casing material (upper side)	Polyamide 6 GF15
Casing material (bottom side)	Polyamide 6 M25 GF15
Pin coating	Tin
Mating connector ²⁾	1355390-1

¹⁾ At the positioning mechanism over the operating voltage and temperature range.

²⁾ This accessory is not included.
 Available from TE Connectivity.

TECHNICAL DRAWING

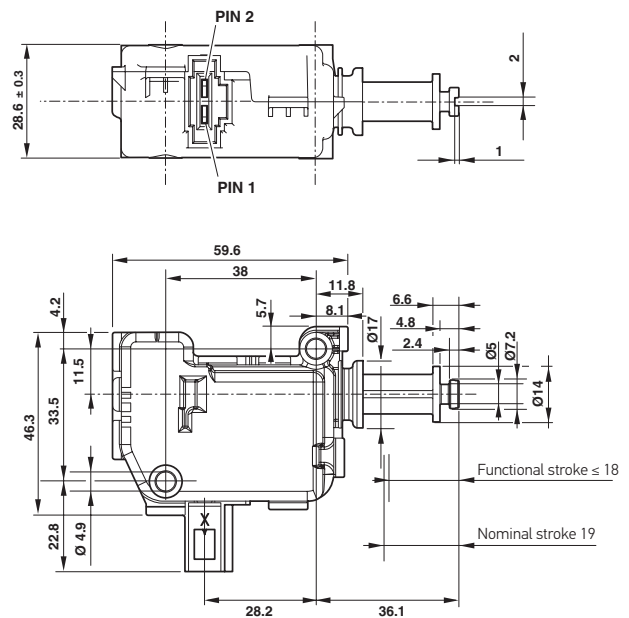

ELECTRICAL CONNECTION / PIN ASSIGNMENT

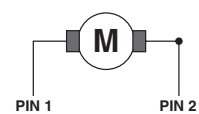
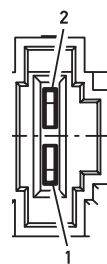

Electrical extension with clockwork spring	0	0
Electrical retraction	-	+

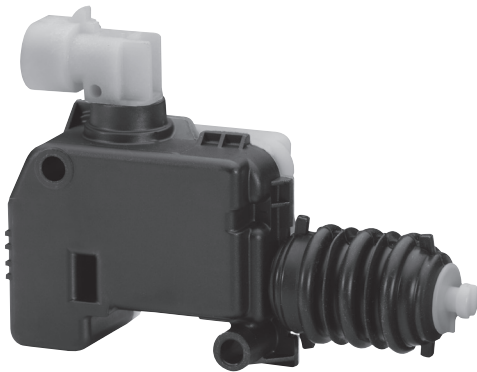

Electromotive actuators
 Electrical locking / unlocking and closing
 (medium force)
 Electrical retraction, extension with clockwork spring
Part number 6NW 009 203-471

TECHNICAL DATA

Position on delivery	extended
Mainspring reset	extend
Weight	90 g
Rated voltage	12 V
Voltage range	9 – 15 V
Maximum current consumption (blocking current)	10,5 A
Idling current	545 mA
Actuating force for ram stroke over Operating voltage range and operating temperature range	30 – 170 N
Manual adjustment	none
Actuating time for 18 mm stroke ¹⁾	max. 400 ms
Thermal overload protection	via PolySwitch (PTC)
Operating temperature	-40°C to +80°C
Storage temperature	-40°C to +90°C
Lifetime	50,000 switching cycles
Conducted interference	< 75 V
Interference suppression (in all ranges)	Intensity level 1 + 10 dB μ V
Functional stroke	\leq 18 mm
Protection class	IP 5K4
Vibration resistance	2,7 g _{eff.}
Casing material (upper side)	Polyamide 6 GF15
Casing material (bottom side)	Polyamide 6 M25 GF15
Pin coating	Tin
Mating connector ²⁾	282080-1

¹⁾ At the positioning mechanism over the operating voltage and temperature range.

²⁾ This accessory is not included.
 Available from TE Connectivity.

TECHNICAL DRAWING

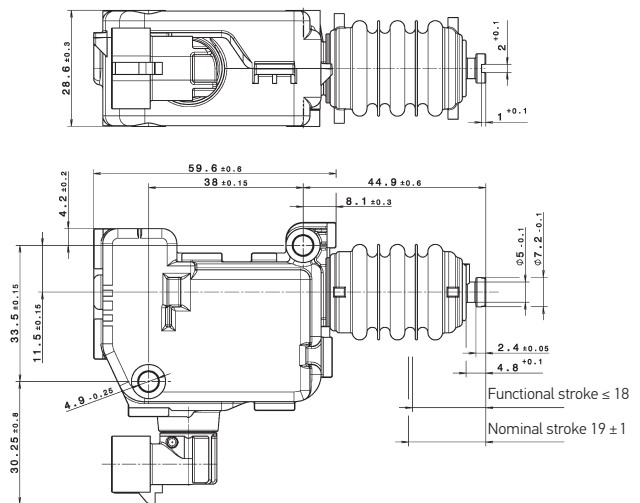

ELECTRICAL CONNECTION / PIN ASSIGNMENT

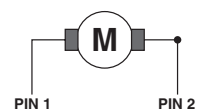

Electrical extension with clockwork spring	0	0
Electrical retraction	-	+

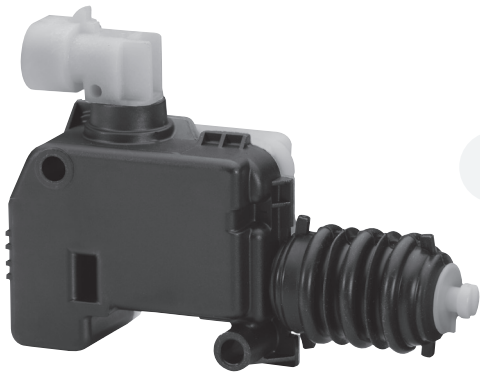

Electromotive actuators
 Electrical locking / unlocking and closing
 (medium force)
 Electrical retraction, extension with clockwork spring
Part number 6NW 009 203-541

TECHNICAL DATA

Position on delivery	extended
Mainspring reset	extend
Weight	90 g
Rated voltage	24 V
Voltage range	18 – 30 V
Maximum current consumption (blocking current)	4,2 A
Idling current	185 mA
Actuating force for ram stroke over Operating voltage range and operating temperature range	30 – 170 N
Manual adjustment	< 35 N
Actuating time for 18 mm stroke ¹⁾	max. 400 ms
Thermal overload protection	via PolySwitch (PTC)
Operating temperature	-40°C to +80°C
Storage temperature	-40°C to +90°C
Lifetime	50,000 switching cycles
Conducted interference	< 75 V
Interference suppression (in all ranges)	Intensity level 1 + 10 dB μ V
Functional stroke	\leq 18 mm
Protection class	IP 5K4
Vibration resistance	2,7 g _{Eff.}
Casing material (upper side)	Polyamide 6 GF15
Casing material (bottom side)	Polyamide 6 M25 GF15
Pin coating	Tin
Mating connector ²⁾	282080-1

¹⁾ At the positioning mechanism over the operating voltage and temperature range.

²⁾ This accessory is not included.
Available from TE Connectivity.

TECHNICAL DRAWING

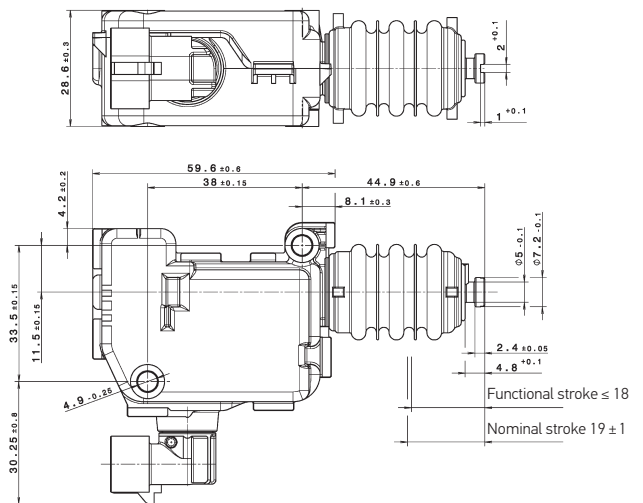

ELECTRICAL CONNECTION / PIN ASSIGNMENT

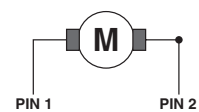

Electrical extension with clockwork spring	0	0
Electrical retraction	-	+

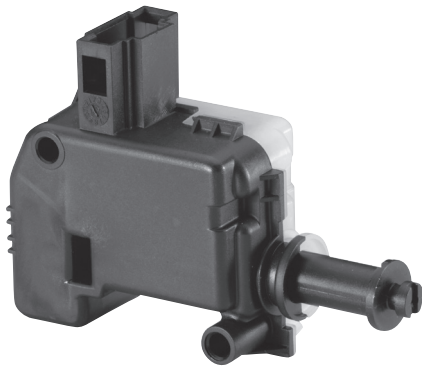

Electromotive actuators
 Electrical locking / unlocking and closing
 (medium force)
 Electrical extension, retraction with clockwork spring
Part number 6NW 009 203-491

TECHNICAL DATA

Position on delivery	retracted
Mainspring reset	retract
Weight	90 g
Rated voltage	12 V
Voltage range	9 – 15 V
Maximum current consumption (blocking current)	10,5 A
Idling current	577 mA
Actuating force for ram stroke over Operating voltage range and operating temperature range	30 – 120 N
Manual adjustment	none
Actuating time for 18 mm stroke ¹⁾	max. 400 ms
Thermal overload protection	via PolySwitch (PTC)
Operating temperature	-40°C to +80°C
Storage temperature	-40°C to +90°C
Lifetime	50,000 switching cycles
Conducted interference	< 75 V
Interference suppression (in all ranges)	Intensity level 1 + 10 dB μ V
Functional stroke	\leq 18 mm
Protection class	IP 5K0
Vibration resistance	2,7 g _{eff.}
Casing material (upper side)	Polyamide 6 GF15
Casing material (bottom side)	Polyamide 6 M25 GF15
Pin coating	Tin
Mating connector ²⁾	1355390-1

¹⁾ At the positioning mechanism over the operating voltage and temperature range.

²⁾ This accessory is not included.
 Available from TE Connectivity.

TECHNICAL DRAWING

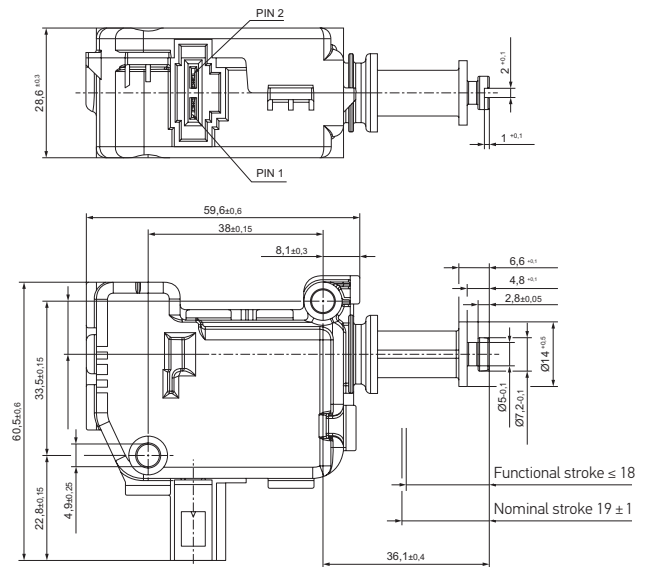

ELECTRICAL CONNECTION / PIN ASSIGNMENT

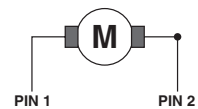
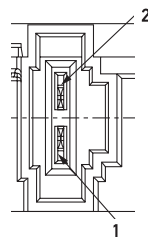

Electrical extension	+	-
Electrical retraction with clockwork spring	0	0

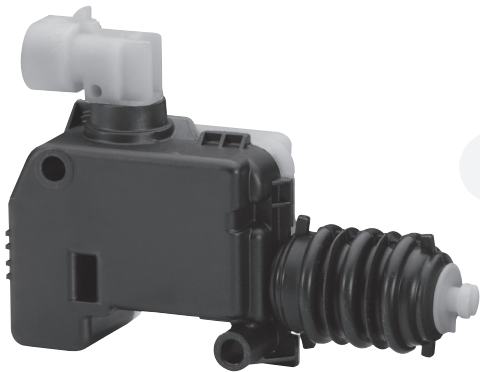

Electromotive actuators
 Electrical locking / unlocking and closing
 (medium force)
 Electrical extension, retraction with clockwork spring
Part number 6NW 009 203-501

TECHNICAL DATA

Position on delivery	retracted
Mainspring reset	retract
Weight	90 g
Rated voltage	12 V
Voltage range	9 – 15 V
Maximum current consumption (blocking current)	10,5 A
Idling current	577 mA
Actuating force for ram stroke over Operating voltage range and operating temperature range	30 – 120 N
Manual adjustment	none
Actuating time for 18 mm stroke ¹⁾	max. 400 ms
Thermal overload protection	via PolySwitch (PTC)
Operating temperature	-40°C to +80°C
Storage temperature	-40°C to +90°C
Lifetime	50,000 switching cycles
Conducted interference	< 75 V
Interference suppression (in all ranges)	Intensity level 1 + 10 dB μ V
Functional stroke	\leq 18 mm
Protection class	IP 5K4
Vibration resistance	2,7 g _{Eff.}
Casing material (upper side)	Polyamide 6 GF15
Casing material (bottom side)	Polyamide 6 M25 GF15
Pin coating	Tin
Mating connector ²⁾	282080-1

¹⁾ At the positioning mechanism over the operating voltage and temperature range.

²⁾ This accessory is not included.
 Available from TE Connectivity.

TECHNICAL DRAWING

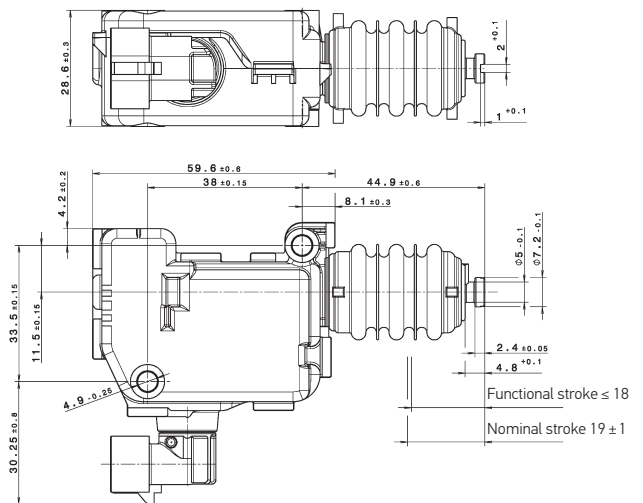

ELECTRICAL CONNECTION / PIN ASSIGNMENT

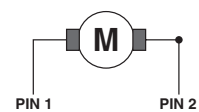

Electrical extension	0	0
Electrical retraction with clockwork spring	-	+



Electromotive actuators
 Electrical locking / unlocking and closing
 (medium force)
 Electrical extension, retraction with clockwork spring
Part number 6NW 009 203-521

TECHNICAL DATA

Position on delivery	retracted
Mainspring reset	retract
Weight	90 g
Rated voltage	24 V
Voltage range	18 – 30 V
Maximum current consumption (blocking current)	4,2 A
Idling current	185 mA
Actuating force for ram stroke over Operating voltage range and operating temperature range	40 – 150 N
Manual adjustment	none
Actuating time for 18 mm stroke ¹⁾	max. 400 ms
Thermal overload protection	via PolySwitch (PTC)
Operating temperature	-40°C to +80°C
Storage temperature	-40°C to +90°C
Lifetime	50,000 switching cycles
Conducted interference	< 75 V
Interference suppression (in all ranges)	Intensity level 1 + 10 dB μ V
Functional stroke	\leq 18 mm
Protection class	IP 5K4
Vibration resistance	2,7 g _{eff.}
Casing material (upper side)	Polyamide 6 GF15
Casing material (bottom side)	Polyamide 6 M25 GF15
Pin coating	Tin
Mating connector ²⁾	282080-1

¹⁾ At the positioning mechanism over the operating voltage and temperature range.

²⁾ This accessory is not included.
 Available from TE Connectivity.

TECHNICAL DRAWING

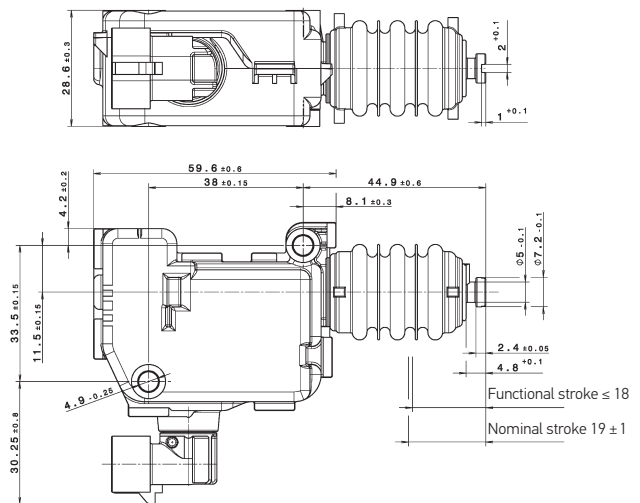

ELECTRICAL CONNECTION / PIN ASSIGNMENT

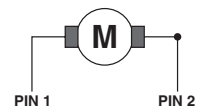
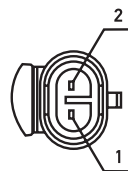

Electrical extension	+	-
Electrical retraction with clockwork spring	0	0





Electromotive actuators
 Electrical locking / unlocking and closing
 (medium force)
 Connecting element for retraction and extension
 actuator function

TECHNICAL DATA

Storage temperature	-40°C to +90°C
Material	POM white

Part number 9XD 860 912-001



TECHNICAL DRAWING

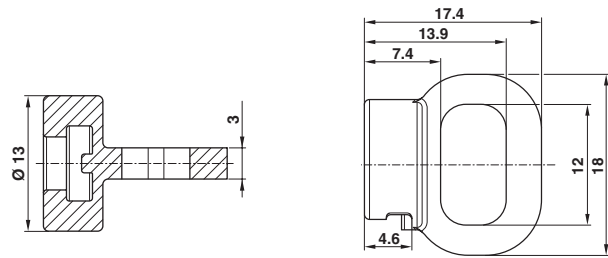

Part number 9XD 862 354-001



TECHNICAL DRAWING

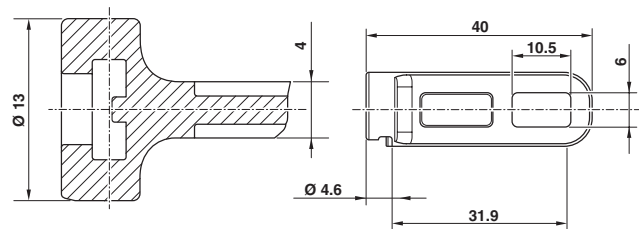

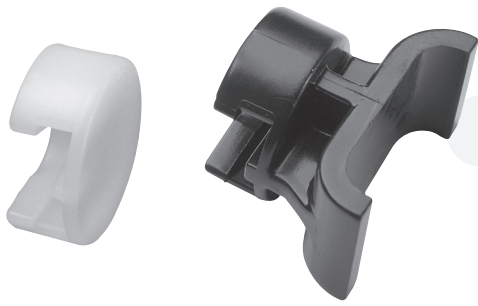

Electromotive actuators
 Electrical locking / unlocking and closing
 (medium force)
 Connecting element for retraction and extension
 actuator function

TECHNICAL DATA

Storage temperature	-40°C to +90°C
Material	POM white

Part number 9XD 862 098-001



TECHNICAL DRAWING

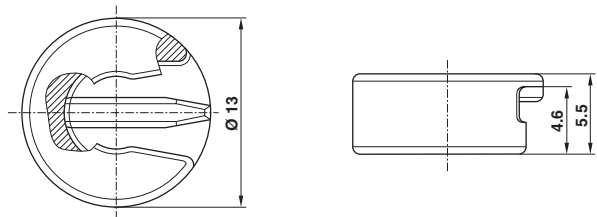

TECHNICAL DATA

Storage temperature	-40°C to +90°C
Material	POM black

Part number 9XD 861 450-001



TECHNICAL DRAWING

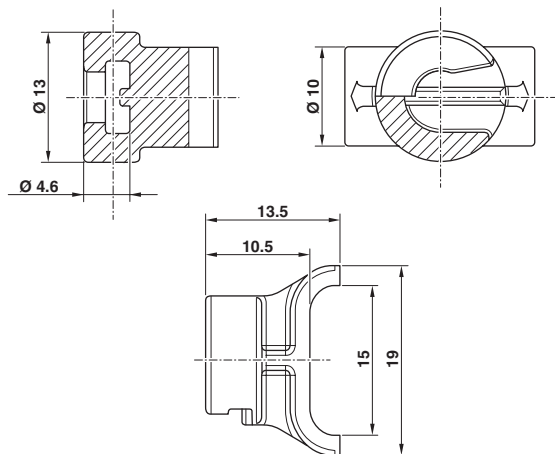

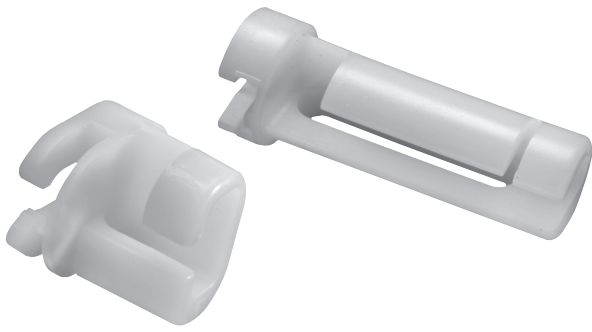

Electromotive actuators
 Electrical locking / unlocking and closing
 (medium force)
 Connecting element for retraction and extension
 actuator function with rod

TECHNICAL DATA

Storage temperature	-40°C to +90°C
Material	POM white

Part number 9XD 861 771-001



TECHNICAL DRAWING

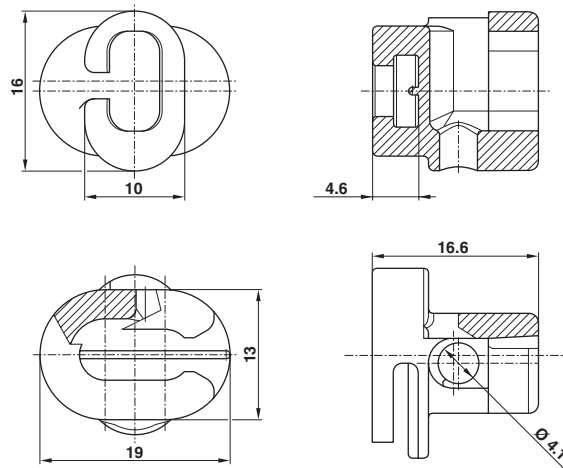

Part number 9XD 862 516-001

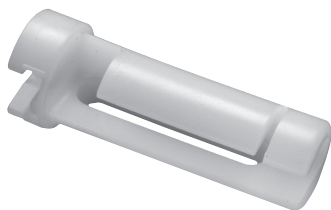

TECHNICAL DRAWING

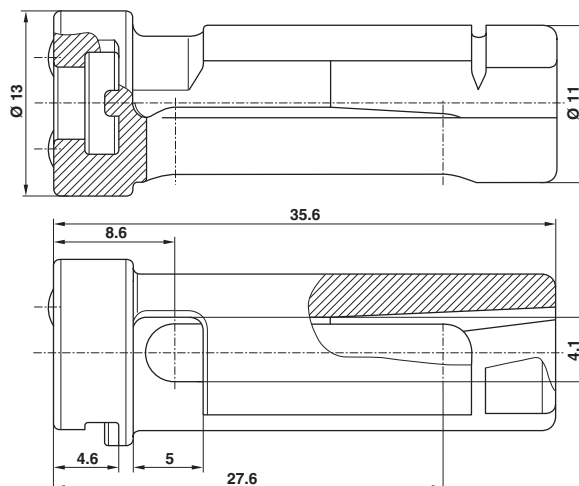



Electromotive actuators
Electrical locking / unlocking and closing
(medium force)
Connecting element for retraction and extension
actuator function with rod

TECHNICAL DATA

Storage temperature	-40°C to +90°C
Material	POM white

Part number 9XD 860 913-001



TECHNICAL DRAWING

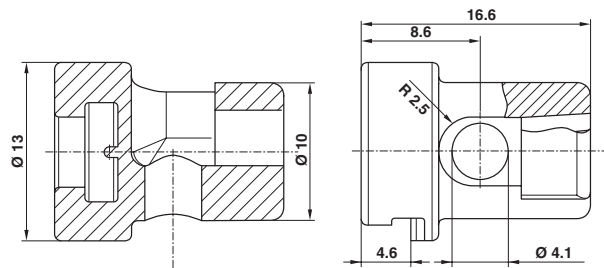

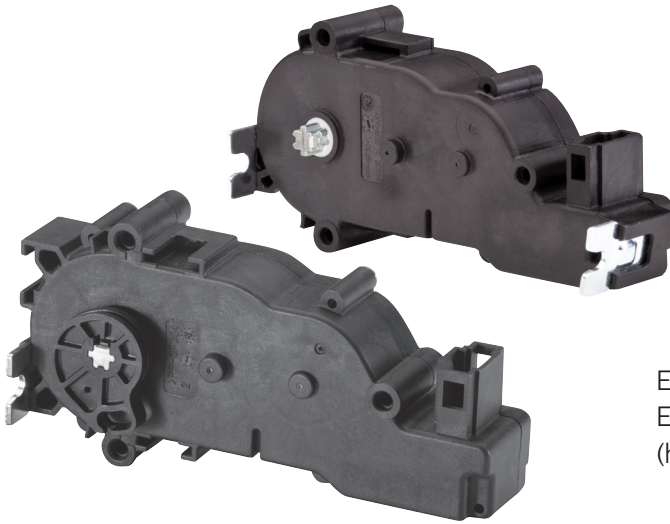

Electromotive actuators
Electrical locking / unlocking and pull / push
(high force)

PRODUCT FEATURES

- Very high positioning forces
- Sturdy and compact design
- Interference suppression class 3
- Universal interface for Bowden cable
- For universal use

FUNCTION

- This electromotive actuator is an actuator with rotary output driven by a DC motor. The actuator is operated by applying a voltage via a two-pin plug with contacts "+" and "ground". The return action is carried out by simply reversing the polarity or automatically via a spring. The direction of rotation and runtime are defined by the control unit. The actuator can be attached to three connecting points.

APPLICATION REQUIREMENTS:

No mechanical restriction or limitation of the actuator by the application is permitted.
The high impact pulse (approx. 7 to 8 Nm) can damage the application, bracket or bowden cable.

APPLICATION

The actuator is particularly suitable for locking and pull/push applications for which high forces are required.

Examples include:

- Large locks and
- Large flaps
- Seat release

When a Bowden cable is used, the actuator can also operate without being attached to the body as it is attached to the application via the Bowden cable sheath and can be embedded in a foam body for noise dampening.

The customer application must ensure that in the rest position (end position following ccw rotation), no load is acting on the actuator to avoid damaging the internal limit stop.

A motor short circuit is necessary during mainspring return (only 6CSA 009 424-781). This short circuit takes place using an 1N 4005 diode during the service life test. The short-circuited motor has a braking effect that protects the internal limit stop. Without this, the dynamism in the system can damage the limit stop during the return action, which can cause the device to become blocked.



OVERVIEW OF VARIANTS

Function	Voltage	Torque	Manual adjustment	Protection class	PART NUMBER	Page reference
Retraction with spring, electrical extension	12 V	150 Ncm	No	IP 5K0	6NW 009 424-781	88
Power extension and retraction	12 V	300 Ncm	No	IP 5K0	6NW 009 424-791	89



Electromotive actuators
 Electrical locking / unlocking and pull / push
 (high force)
 Electrical rotation left,
 reset per spring right
Part number 6NW 009 424-781

TECHNICAL DATA

Mainspring reset	Available
Weight	181 g
Rated voltage	12 V
Voltage range	9 – 16 V
Maximum current consumption (blocking current)	7 A
Idling current	150 mA
Nominal torque	150 Ncm
Functional angle	0° to 198°
Gauge	approx. 45 mm
Rated torque (at rated load and room temperature)	32 min ⁻¹
Manual adjustment	none
Thermal overload protection	Available
Operating temperature	-40°C to +85°C
Lifetime	8,000 switching cycles
Conducted interference	< -75 V
Interference suppression (in all ranges)	Level 3
Protection class	IP 5K0
Vibration resistance (IEC 68-2-64)	3 g _{eff.}
Casing material (upper side)	PP-GF30
Casing material (bottom side)	PP-GF30
Pin coating	Tin
Mating connector ¹⁾	1355390-1

¹⁾ This accessory is not included.
 Available from TE Connectivity.

TECHNICAL DRAWING

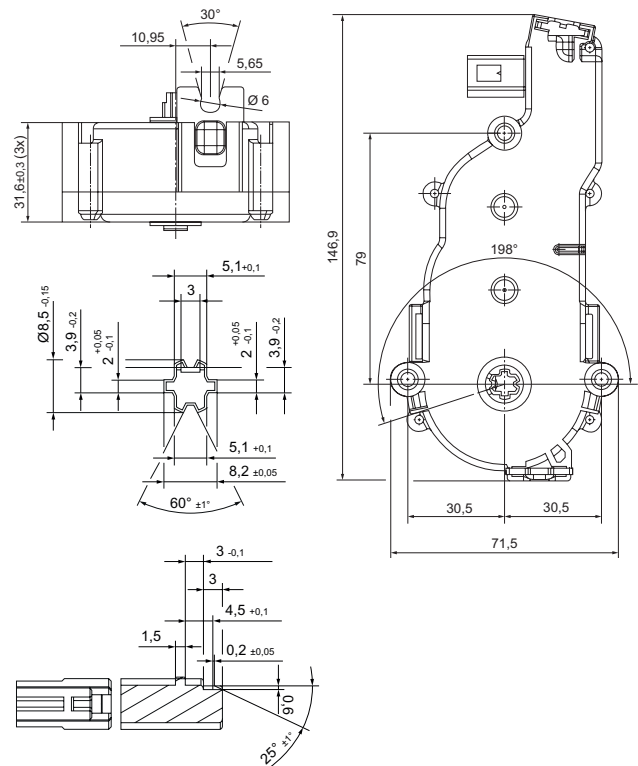

ELECTRICAL CONNECTION / PIN ASSIGNMENT

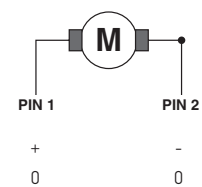
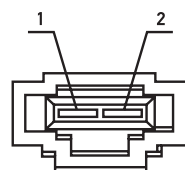

Electrical rotation to the left
 Reset with spring, to the right

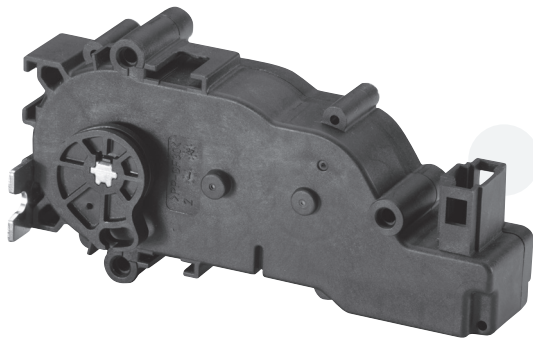

Electromotive actuators
 Electrical locking / unlocking and pull / push
 (high force)
 Electrical rotation to right and left
Part number 6NW 009 424-791

TECHNICAL DATA

Mainspring reset	none
Weight	181 g
Rated voltage	12 V
Voltage range	9 – 16 V
Maximum current consumption (blocking current)	6 A
Idling current	150 mA
Nominal torque	300 Ncm
Functional angle	0° to 198°
Gauge	approx. 45 mm
Rated torque (at rated load and room temperature)	15 min ⁻¹ at RT and 13 V
Manual adjustment	none
Thermal overload protection	not available
Operating temperature	-40°C to +85°C
Lifetime	50,000 switching cycles
Conducted interference	< -75 V
Interference suppression (in all ranges)	Level 3
Protection class	IP 5K0
Vibration resistance (IEC 68-2-64)	3 g _{eff}
Casing material (upper side)	PP-GF30
Casing material (bottom side)	PP-GF30
Pin coating	Tin
Mating connector ¹⁾	1355390-1

¹⁾ This accessory is not included.
 Available from TE Connectivity.

TECHNICAL DRAWING

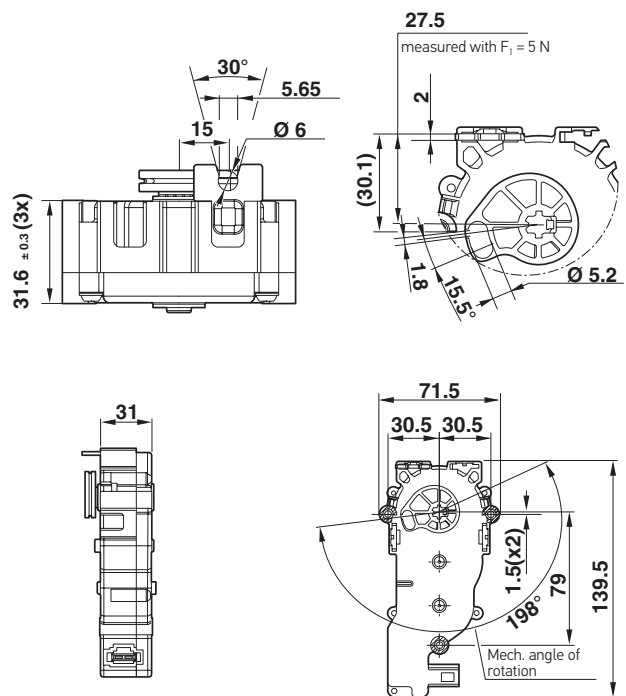

ELECTRICAL CONNECTION / PIN ASSIGNMENT

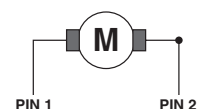
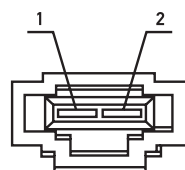

Electrical rotation to the right
 Electrical rotation to the left

+	-
-	+



Electromotive actuators
 Electrical locking / unlocking and closing
 (Smart URA)
 Electrical rotation, left, right,
 with high torque
 Flexible operating angle range
Part number 6NW 011 303-701

PRODUCT FEATURES

- Actuator controls the position of its output gear wheel in accordance with the target position
- Precise position control with HELLA CIPOS® technology
- Electrical rotation (right / left) with high torque
- Flexible operating angle range with up to eight complete revolutions
- "True Power On" function for angular ranges < 180°
- Integrated electronics monitor actuator function
- Error feedback and error memory
- Self-locking transmission

FUNCTION

The smart URA monitors the position of the output gear wheel and the integrated electronics continually calculate the position using an ASIC (Application Specific Integrated Circuit). The actuator offers the "True Power On" function for angles under 180°, i.e. it enables direct startup without calibration. In operation, the actuator carries out controlled movement to the programmable "soft stops". The self-locking transmission minimises current consumption (< 25 mA), which is required to maintain a defined position.

APPLICATION

The smart URA can be used in a broad range of applications involving harsh environmental conditions, and can perform precise and reliable positionings. The insensitivity to magnetic fields and the high level of temperature stability, in particular, are the characteristic qualities of the CIPOS technology used in conjunction with the smart URA. Angles are measured inductively using a contact-free and hence wear-free method, thus guaranteeing a high measuring precision throughout the entire service life. An error memory records errors and the actuator is able to react differently to all the various kinds of errors.

APPLICATION EXAMPLES

- Seed metering/singling
- Delivery air/exhaust air flaps
- Control of valves in the cooling circuit
- Control of the radiator grille chokes

PWM INTERFACE – INPUT SIGNAL

A PWM signal can be used as input signal for the communication of the actuator with the controller. This PWM signal must be supplied by the external controller as a low-side driver (open collector). The PWM input signal is defined by the periods and the cyclic duration factor. The period duration starts (and ends) with a rising flank. The cyclic duration factor is defined as the ratio between the time with high signal and the total period duration.

PWM FEEDBACK AND PWM GROUNDING

In order to transmit errors by PWM grounding, the PWM input signal is set to Low for a defined time and then set to High again. The time for which the PWM signal is set to Low depends on the error group.

LIN INTERFACE / LIN BUS SPECIFICATIONS:

A LIN signal can be used by the control unit as an input/output signal for the communication with the actuator. The smart URA functions here as a LIN slave. The smart URA operates with the LIN 2.0 protocol without a diagnostic function (diagnostic function and 2.1 or 2.2 are possible). The hardware is compatible with the LIN 2.2 protocol. The typical baud rate is 19.2 kbps (+/- 10%).

PWM SIGNAL: DEFINITION

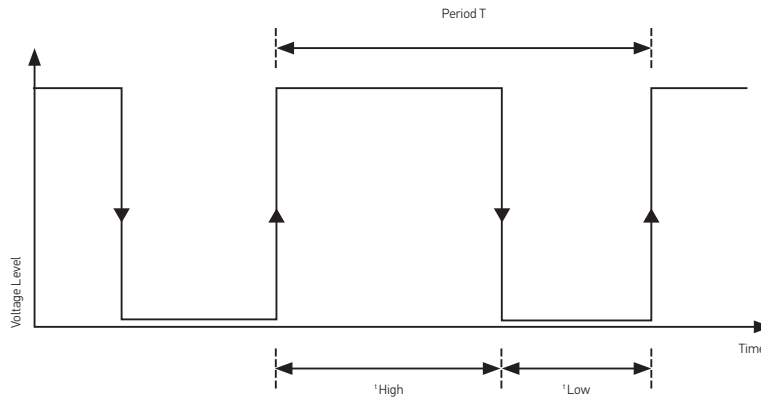

INTERFACE CIRCUIT PWM-INPUT

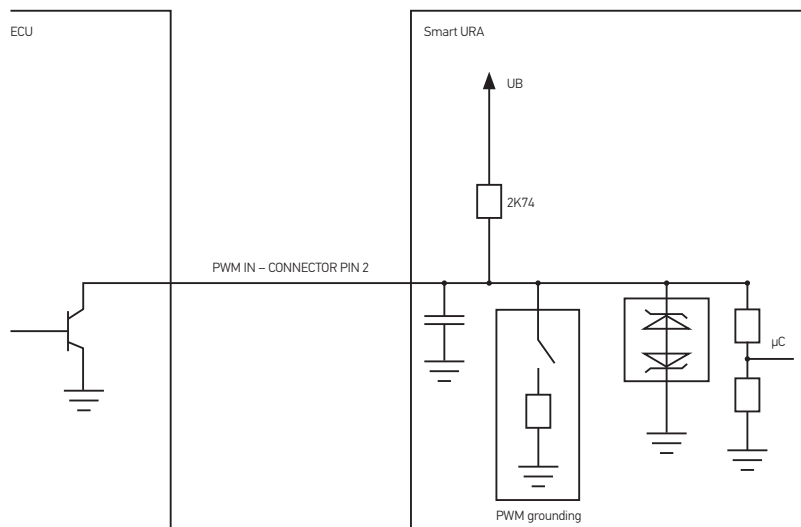

OVERVIEW OF VARIANTS

Function	Voltage	Torque	Manual adjustment	Protection class	PART NUMBER	Page reference
Power locking/unlocking and closing, power rotational movement to right and left, with position feedback via CIPOS technology	12 V	Up to 300 Ncm	No	IP 6K9K or IP 6K7 ¹ (¹ depends on the connector classification)	6NW 011 303-701	92–93



Electrical locking/unlocking and closing, electrical rotation right and left with position feedback via CIPOS technology

Part number 6NW 011 303-701

TECHNICAL DATA

Weight	106 g
Rated voltage	13.5 V
Voltage range	9 - 16 V
Rated current	0.5 A
Maximum current consumption (stall current)	3.7 A
No-load current in idle mode	<100 µA (type 20 µA)
Nominal torque (at 13.5 V and RT)	60 Ncm
Maximum torque after lifetime (at 13.5 V and RT)	200 Ncm
Working angle	> 360° (< 180° true power on)
Actuating time 0°-90°	< 2 s (no load; 13.5 V and RT)
Thermal overload protection	Self-protection by self-diagnosis
Operating temperature	-40 °C to +85 °C
Storage temperature	-40 °C to +105 °C
Lifetime	250,000 cycles (1 cycle = angle of 90° open - closed)
EMC	CISPR25 class 5*
Protocol	LIN 2.0 and PWM
Protection class	IP 6K9K; IP 6K7 ¹ (¹ depends on the connector classification)
Vibration resistance	9.6 g
Housing material	PPA-GF40
Pin coating	Tin
Manual adjustment	No
Mating connector	TE Connectivity 1-1456426-1, Coding A

PIN ASSIGNMENT

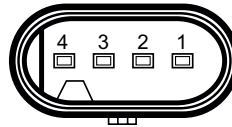

Pin 1: U_{bat}
 Pin 2: PWM input
 Pin 3: LIN / PWM output
 Pin 4: Ground

* Limit values can be exceeded in the frequency range of 3 – 4 MHz.

TECHNICAL DRAWING

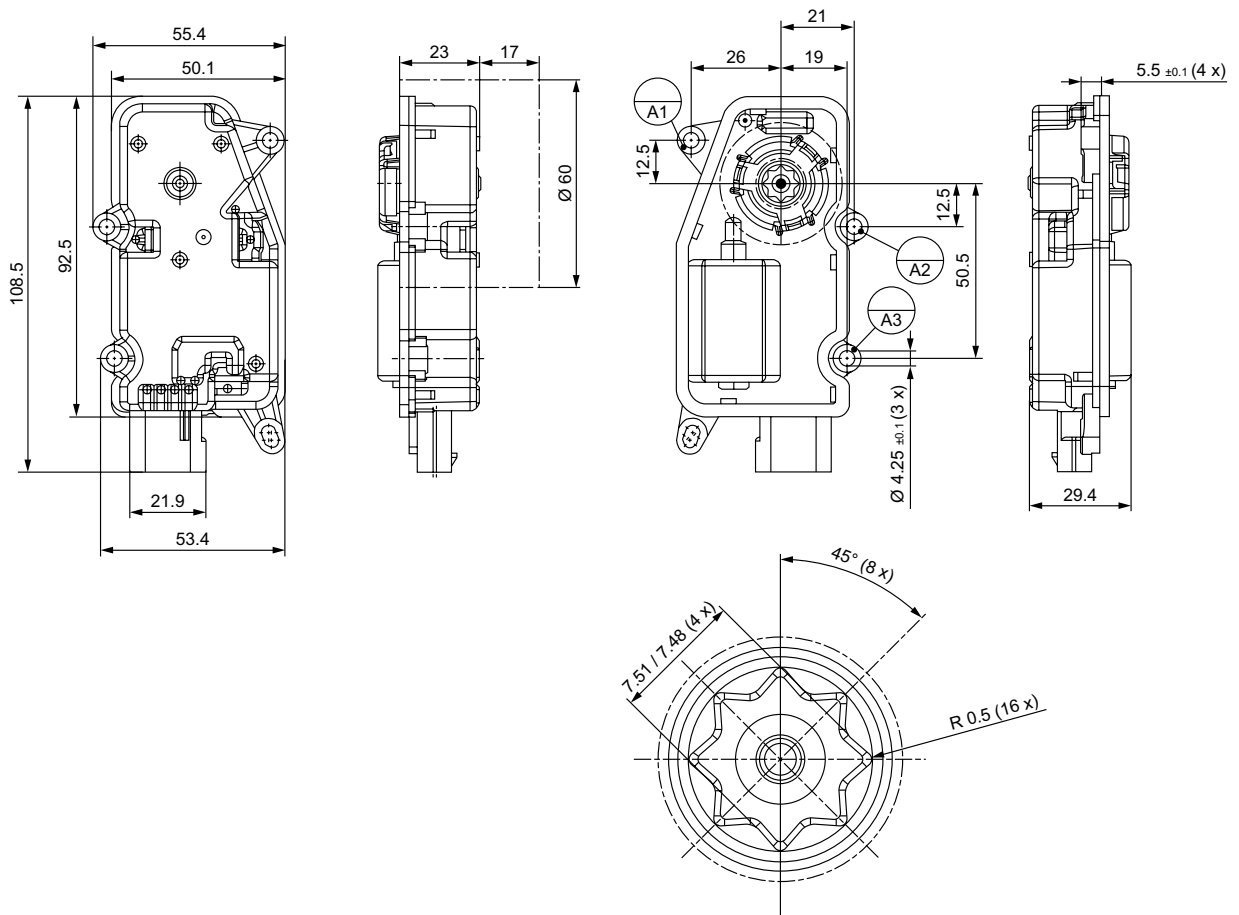

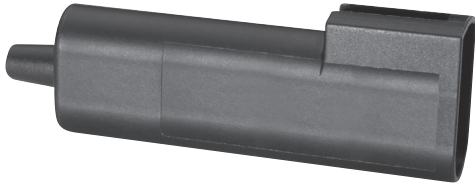

Temperature sensors
Measurement of air temperatures

PRODUCT FEATURES

- EMC stable
- Quick response times

APPLICATION

The air temperature sensors measure temperatures in the air flow of the air conditioning system. Furthermore, this version for measuring the outside temperature can be implemented while keeping in mind the relevant response times and protection classes in the various industrial spheres.

- Examples include air-conditioning systems in:
- Vehicles
 - Heating and sanitary equipment and facilities

DESIGN AND FUNCTION

The basic design of this sensor variant consists of an NTC resistor. NTC resistors have a negative temperature coefficient and increase in conductivity as temperatures increase.

The basic wiring diagram consists of the sensor and a constant resistor wired in series. By means of the voltage drop on the resistor or on the sensor, it is possible to apply the voltage divider law to calculate the resistance of the NTC temperature sensor. The resistance curve can be used to match the temperature to the resistance of the NTC sensor.

The fourth version (part no.: 6PT 009 522-011) has been designed as an outdoor temperature sensor and is protected against splashing water. The temperature curve is linearised using a resistor connected in parallel. A parallel capacitor improves the electromagnetic compatibility of this version.

SCHEMATIC SENSOR DESIGN

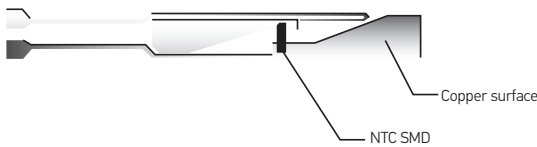

CIRCUIT DIAGRAM

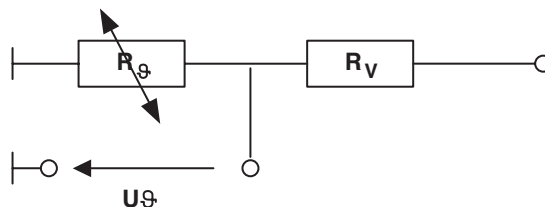

OVERVIEW OF VARIANTS

Temperature range	Areas of use	Time constant	Mating connector	Encased	Protection class	PART NUMBER	Page reference
-40°C to +65°C	Outdoor temperature sensor	< 35 s (water / alcohol bath)	2-1437712-5	Yes	IP 67	6PT 009 522-011	95

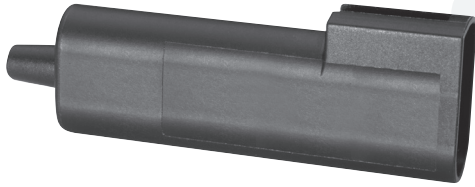

Temperature sensors
Measurement of air temperatures
Part number 6PT 009 522-011

TECHNICAL DATA

Nominal voltage	5 V
Temperature measurement range	-40°C to +65°C
Time constant	< 35 s (in water / alcohol bath)
Vibration resistance	1 g, frequency cycle 10 Hz to 100 Hz up to 10 Hz, change in frequency 1 Hz/s, test time of 94 hours pro direction (flat), in three test directions
Storage temperature	-40°C to +90°C
Protection class	IP 67
Corrosion tested in accordance with	ASTM 13117, 96 h
Lifetime	15 years
Housing material	PA6 GF30
Contact pin	CuSn6, gold-plated
Pin coating	NiAu and NiSn, solderable
Mating connector ¹⁾	2-1437712-5
Weight	5,9 g

¹⁾ This accessory is not included.
Available from TE Connectivity.

TECHNICAL DRAWING

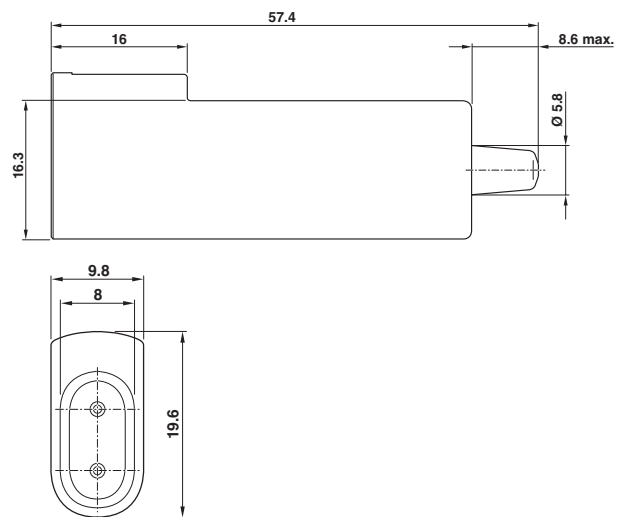

CHARACTERISTIC RESISTANCE VALUES

Temperature	Resistance (R nom.)	Percentage deviation (±)
-40°C	9,820 k Ω	1,5%
-20°C	7,931 k Ω	1,5%
0°C	5,179 k Ω	0,5%
+4°C	4,632 k Ω	0,5%
+25°C	2,354 k Ω	1,0%
+65°C	0,588 k Ω	1,0%

PIN ASSIGNMENT

No fixed pin assignment



Air quality monitor
Measurement of air properties
on request

PRODUCT FEATURES

- Greater driving comfort due to continual optimisation of the interior air quality in the inside of the vehicle
- The intelligent software automatically provides pre-processed information for the air conditioning system while taking into account the respective environmental conditions (e.g. city traffic, overland, motorway)

APPLICATION

The air quality is assessed on the basis of the recorded changes in concentration of CO and NO₂ and divided into levels from 0 to 4. In order to give consideration to the environmental conditions, as they are present e.g. in the city compared to country areas, the air quality monitor has an autonomous sensitivity adjustment for different gas concentrations and occurrences.

Example: With an increasing number of gas occurrences (air quality level ≥ 2) recorded, the sensitivity of the device is lowered to reach an average rate of 0.25 event recordings per minute.

DESIGN AND FUNCTION

During the trip the AQM air quality monitor from HELLA records all occurrences that could have an effect on the air quality in the inside of the vehicle (e.g. driving through a tunnel or driving past vehicles with high exhaust emissions).

The AQM is located on the vehicle to enable the air quality outside the vehicle to be recorded quickly in all driving situations. A possible installation location could, for example be the water tank.

The AQM activates the air conditioning system which regulates its air circulation automatically according to the outside air quality. If there is a high exhaust concentration in the external environment of the vehicle, it switches automatically to air circulation mode. This prevents exhaust fumes getting into the vehicle.

PIN ASSIGNMENT

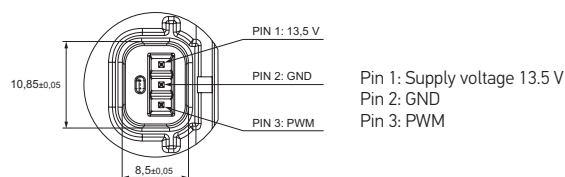

TECHNICAL DATA

Rated voltage	9 – 16 V
Recorded gases	CO, NO ₂
Min. concentrated change recorded	CO: 7ppm, NO ₂ : 75ppb
Response time	CO: 5s, NO ₂ : 10s
Chemical resistance	Typical vehicle media
Operating temperature	-40°C to +85°C
Storage temperature	-40°C to +95°C
Protection rating	IP 26 (with sealed connector: IP 5K9K)
Lifetime	241,350 km (150,000 miles), 10 years
Material	Casing: PA 66 GF25, membrane: Teflon
Contact pin material	C19010
Contact pin coating	Ni 1 – 2 µm, zinc-plated pin, matt final coating 5 ± 2,5 µm Sn to Ni
Electrical connector	EWCAP Nr. 064-S-003-1-Z01 (Option A)
Mechanical interface	Receptacle with Delphi clip
Alignment at installation	Plug and air inlet point downwards
Weight	21 g

TECHNICAL DRAWING

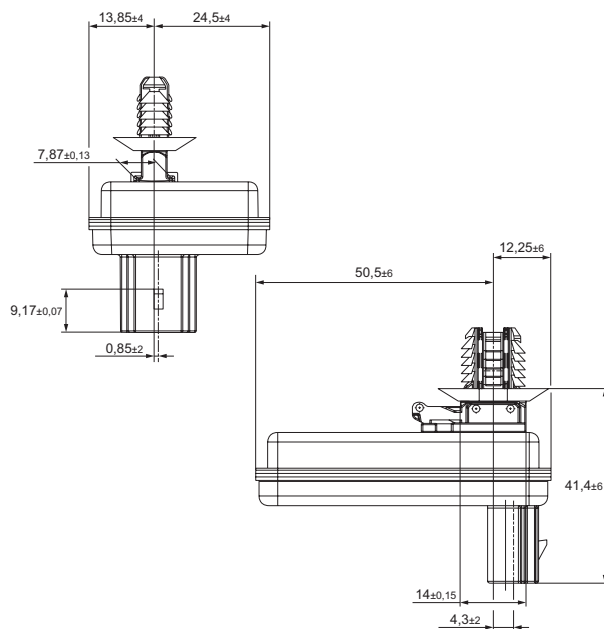

PWM DUTY CYCLE

Unit	Min.	Typically	Max.	Signal content/comment
%	0	–	5	Not in operation, not ready
%	7	12,5	18	Not in use
%	22	27,5	33	Air quality level 4
%	37	42,5	48	Air quality level 3
%	52	57,5	63	Air quality level 2
%	67	72,5	78	Air quality level 1
%	82	87,5	93	Air quality level 0
%	95	–	100	Not in operation, not ready



Rain/light sensors
Recording environmental properties

PRODUCT FEATURES

- Fourth generation of the long-established rain sensors by HELLA
- Five functions in one product: rain, light solar and humidity measurement and adjustment of the light intensity of the head-up display
- Optimised design – extremely compact package space

APPLICATION

The full range of functions of the rain/light sensor (five functions: rain sensor, light sensor, solar sensor, humidity measurement, and head-up display) can only be used for passenger vehicle applications. This sensor can only be used to a limited extent in vehicles with special windshields (thick, slanted, transmission).

The optics of the second sensor are specially designed for vehicles with steep windshields and combines the rain and light recognition functions (environment and tunnel recognition).

DESIGN AND FUNCTION

This new sensor offers the user five functions in one product:

Rain sensor

The rain sensor is used to recognise different rain situations in the sensor range and activates the front windshield wiper accordingly. Thus, manual intervention by the driver is now more or less unnecessary.

Light sensor

As a light sensor, it activates the switching on and off of the dimmed headlights in different light conditions or in special situations e.g. tunnels.

Head-Up-Display

If it is used for the Head-Up-Display, the sensor detects the brightness in the vehicle's immediate vicinity and adjusts the light intensity of the display based on the current light conditions.

Solar sensor

As a solar sensor, it measures insolation and thus supports air conditioning control.

Humidity measurement

The humidity measurement is used to control the air conditioning control unit for the air conditioning in the vehicle interior, such as automatic ventilation of the windshield.

FUNCTIONAL DIAGRAM

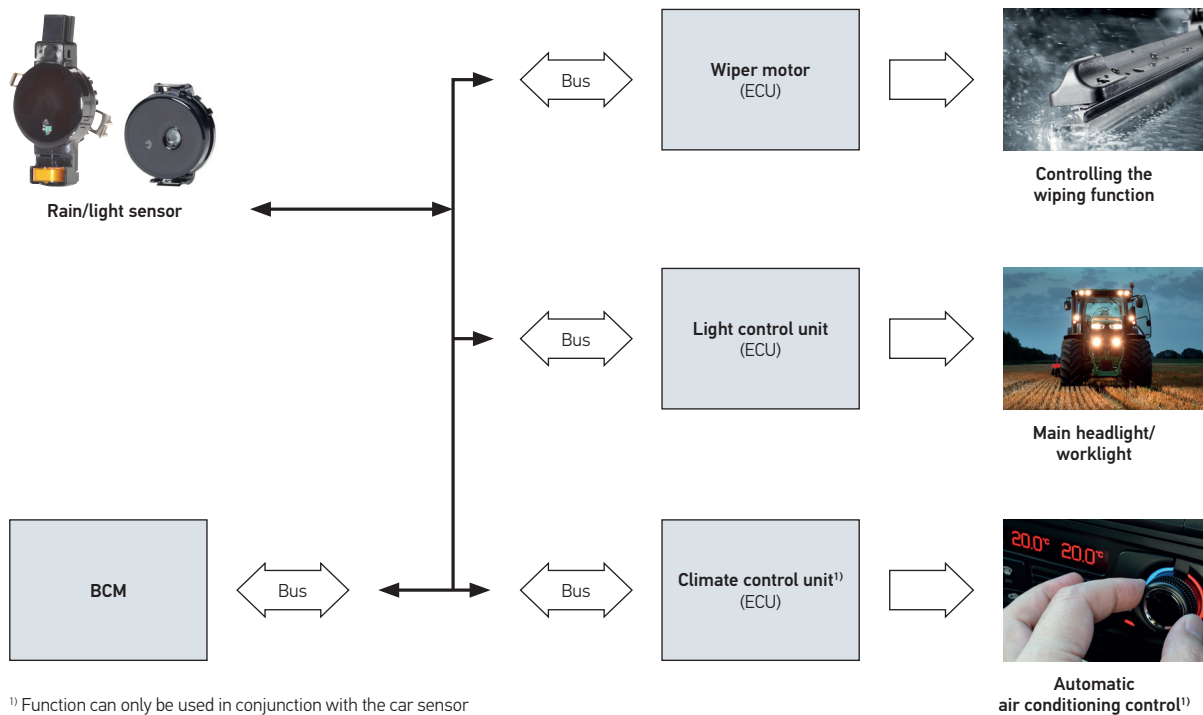

OVERVIEW OF VARIANTS

The sensors have to be specially adapted to suit each vehicle type. All part numbers are therefore assigned on a customer-specific basis.

Areas of use	Permissible glass thickness	Permissible glass tilt	PART NUMBER	Page reference
Passenger vehicles	4–6 mm	22°–32°	on request	100
Passenger car (van)	4–6 mm	32°–54°	on request	100
Vehicles with steeply sloped windshields	6–9 mm	80°–90°	on request	102



Rain/light sensors
Recording environmental properties
on request

TECHNICAL DATA

Operating temperature	-40 to +85°C
Storage temperature	-40°C to +100°C
Protection class	IP 50
Protection class (in the area of fogging sensors)	IP 20
Operating voltage	9 – 16 V
Overtoltage	24 V
Rated current consumption	< 50 mA
Communication interface	LIN 2.0
Weight	< 17 g
Mating connector ¹⁾	114 18063-18, coding D

Windshield requirements

Spectral working range	400 – 1,050 nm
Permissible transmission of the windshield	20 – 80 % (at 950 nm)
Permissible glass thickness	4 – 6 mm
Permissible glass tilt	22° – 32° or 32° – 54°
Permissible radius in the area of the sensor	R => 1,400 mm
Diameter of the black print section	28 +/- 0.2 mm

¹⁾ This accessory is not included.
Available from TE Connectivity.

TECHNICAL DRAWING

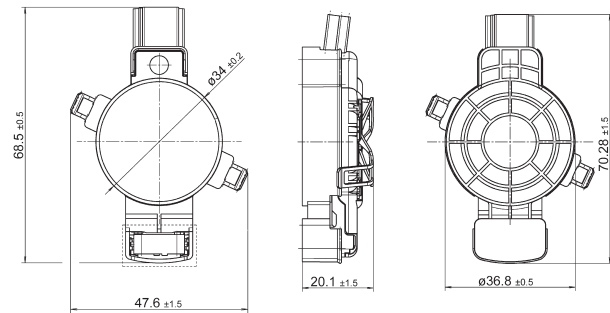
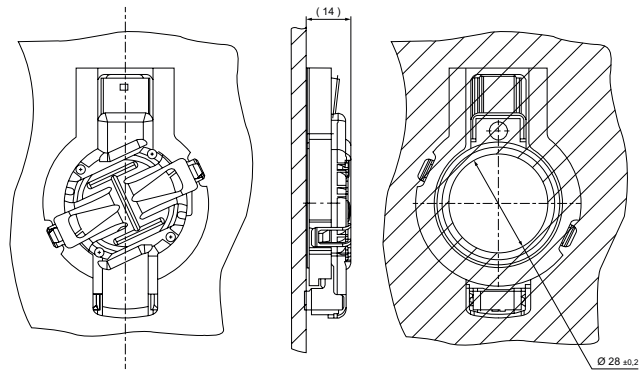
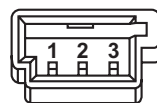

ILLUSTRATION OF INSTALLATION ON THE WINDSHIELD



PIN ASSIGNMENT



Pin 1: VCC
Pin 2: LIN
Pin 3: GND

Rain/light sensors Bracket

Accessories¹⁾

Part number	
on request	For fixing with 3 m adhesive tape Plastic
9XD 420 747-502	For fixing with PUR liquid adhesive Plastic



TECHNICAL DRAWING

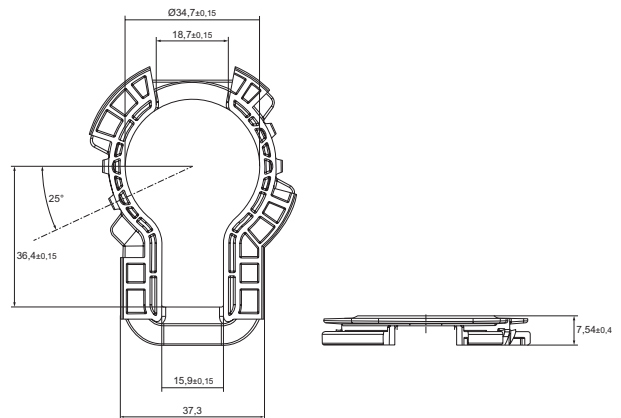

Accessories¹⁾

Part number	
9XD 420 747-007	For fixing with 3 m adhesive tape Sintered metal
on request	For fixing with PUR liquid adhesive Sintered metal



TECHNICAL DRAWING

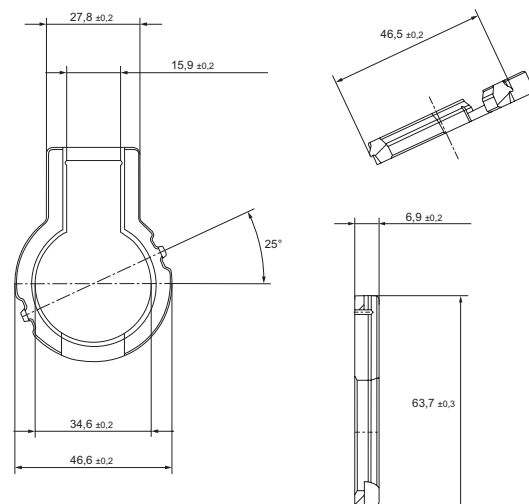

¹⁾ This accessory is not included.



Rain/light sensors
for vehicles with high-angled windshields
Recording environmental properties
on request

TECHNICAL DATA

Operating temperature	-40 to +85°C
Storage temperature	-40°C to +100°C
Protection class	IP 50
Operating voltage	9 – 16 V
Rated voltage	12 V
Overtoltage	24 V
Rated current consumption	< 50 mA
Communication interface	LIN 2.1
Weight	≤ 42 g
Mating connector ¹⁾	114 18063-18, coding A
Windshield requirements²⁾	
Spectral working range	400 – 1,050 nm
Permissible transmission of the windshield	23 – 80 % (at 800 – 1,100 nm)
Permissible glass thickness	6 – 9 mm
Permissible glass tilt	80° – 90°
Permissible radius in the area of the sensor	R => 1,400 mm
Diameter of the black print section	40 +/- 0.2 mm

¹⁾ This accessory is not included.
Available from TE Connectivity.
²⁾ Other windshield configurations available upon request.

TECHNICAL DRAWING

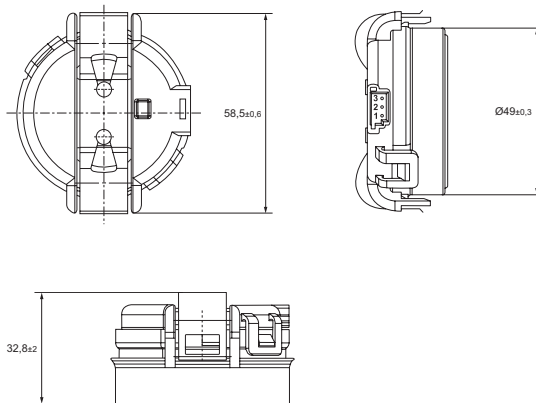
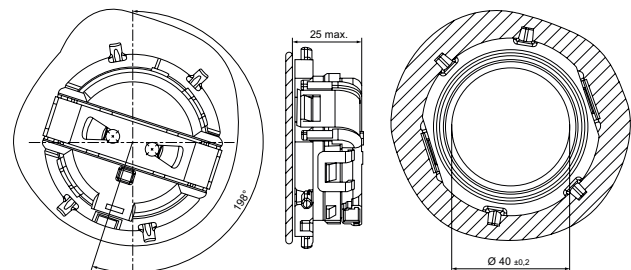

ILLUSTRATION OF INSTALLATION ON THE WINDSHIELD



PIN ASSIGNMENT



Pin 1: 12 V
Pin 2: LIN
Pin 3: GND



Rain/light sensors
Bracket

Accessories¹⁾

Part number	
9XD 420 696-101	For fixing with PUR liquid adhesive Sintered metal



TECHNICAL DRAWING

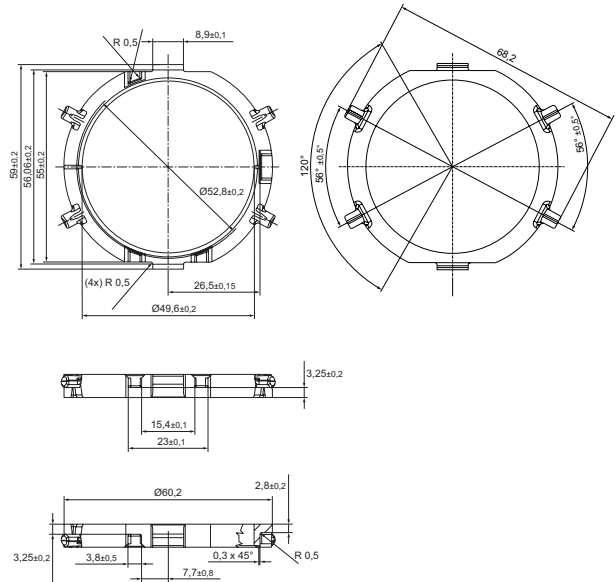

Accessories¹⁾

Part number	
on request	For fixing with 3 m adhesive tape Sintered metal



TECHNICAL DRAWING

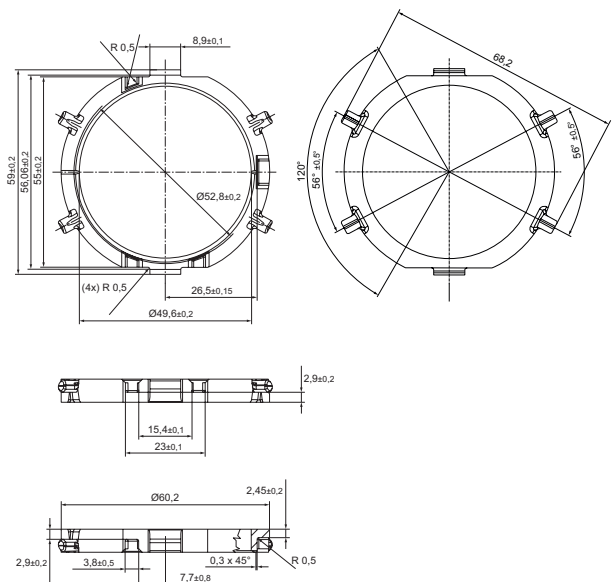

¹⁾ This accessory is not included.



Rain/light sensors
Bracket

Accessories

Part number

9XD 748 921-017 For fixing with PUR liquid adhesive
Sintered metal

TECHNICAL DRAWING



This bracket can be used together with a design cover (9HB 748 851-107).

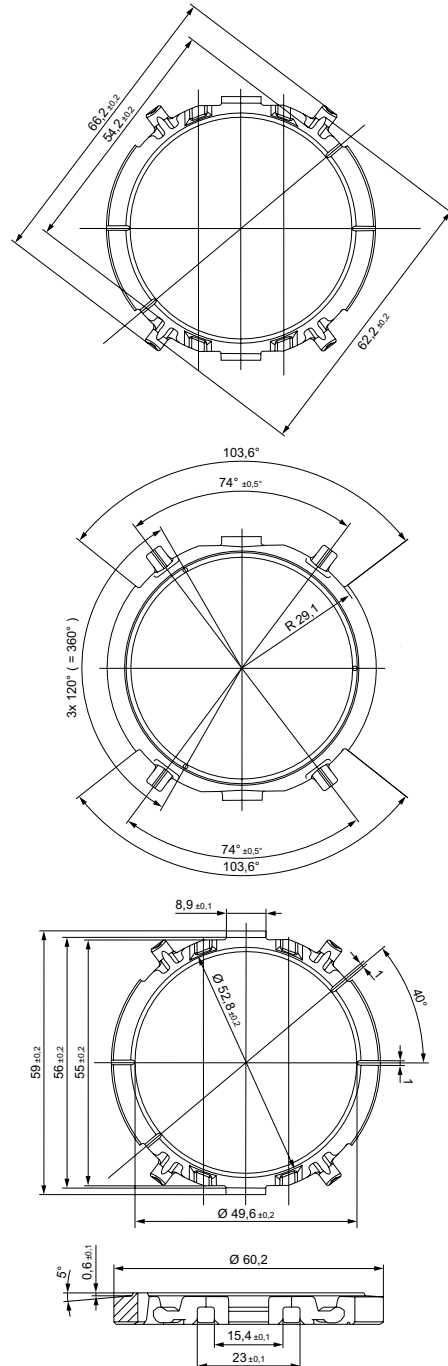

Accessories

Part number

9HB 748 851-107

Design cover

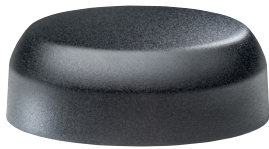

TECHNICAL DRAWING

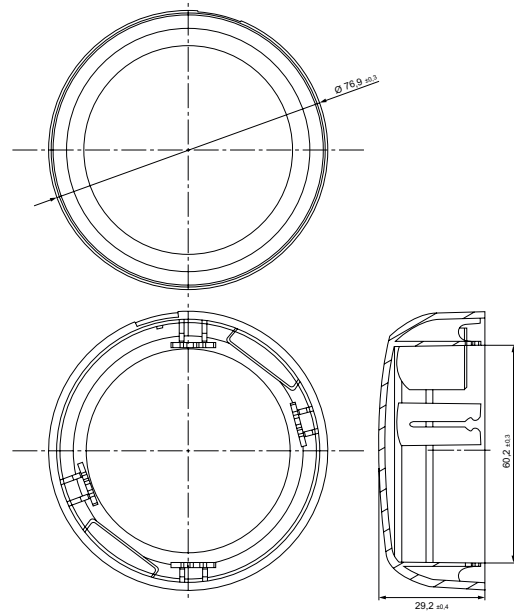

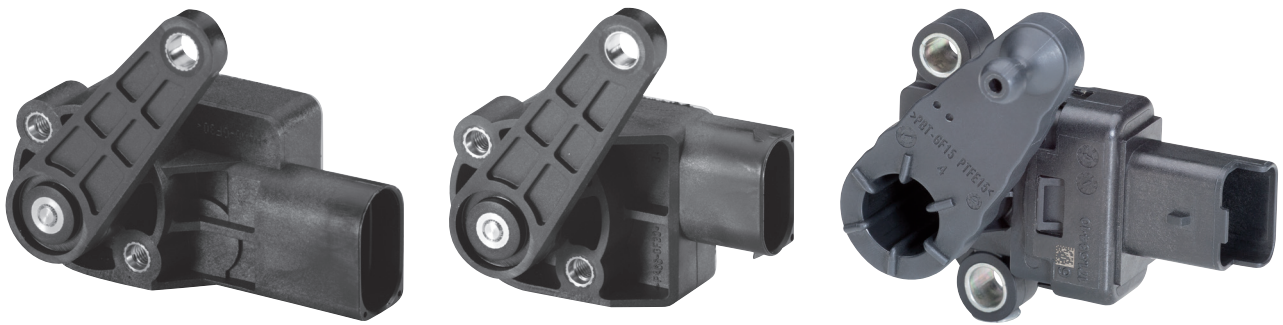

Angular Position Sensors
Single and double sensors

PRODUCT FEATURES

- Single or redundant sensors
- High precision due to internal 14 bit resolution
- High thermal stability and linearity
- High insensitivity to magnetic fields
- Zero position can be individually programmed
- Various connecting elements available

APPLICATION

These CIPOS[®] angular position sensors (contactless inductive position sensors) can be used in many different applications to return accurate and reliable angular measurements even in tough environments. In particular, insensitivity to magnetic fields and a high degree of thermal stability are characteristic of the CIPOS[®] technology used in all these angular position sensors. Angles are measured inductively using a contact-free and hence wear-free method. This guarantees a high degree of precision throughout the entire life of the sensor. The redundant sensors (double sensors) are especially designed for failure detection, thus improving the reliability of the overall system.

FUNCTION

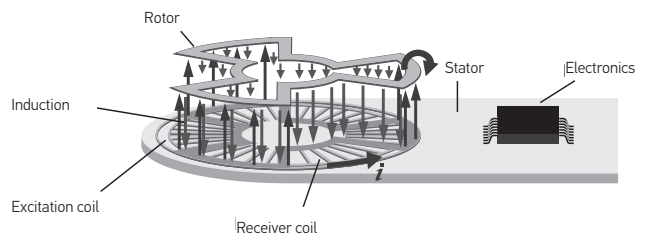

Inside the laser-welded polyamide housing PA 66, the rotation of the lever arm is transferred to the rotor and measured by induction. An ASIC (Application Specific Integrated Circuit) accurately calculates the rotor position. Various mounting positions are possible thanks to the repeating characteristic curve of the output signal (depending on the sensor structure used). This increases the flexible options for use of the sensor.

ANALOGUE OUTPUT

At a supply voltage of 5 V DC, the angle measured is rendered as the ratio of the output voltage (U_{out}) and operating voltage (U_s) (ratiometric to power supply). This signal is output by a high-side driver (HSD). At a supply voltage between 9 V and 32 V (multivoltage), the angle measured is rendered as a voltage between 0.5 V and 4.5 V.

PWM OUTPUT (DIGITAL)

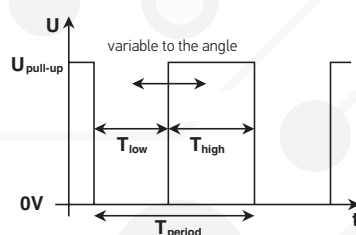

When the PWM signal is used, the actual position of the angular position sensor is equivalent to the ratio of the low time of the PWM signal (T_{low}) and the period (T_{period}). The absolute duration of the high or low level is not indicative of the angle. The PWM signal is output by a low-side driver (LSD). You can of course also choose to evaluate the ratio between high time (T_{high}) and period (T_{period}). This will invert the course with reference to the analogue signal.

OVERVIEW OF VARIANTS

Mechanical connection	Angle range	Supply voltage	Output signal	Zero position	Lever arm	PART NUMBER	Page reference
Single sensors							
Socket	-30° to +30°	5 V	0.5–4.5 V ratiometric and PWM	0° / 120° / 240°	50 mm	6PM 008 161-241	110
Socket	-51° to +51°	5 V	0.5–4.5 V ratiometric and PWM	0° / 120° / 240°	50 mm	6PM 008 161-251	111
Socket	-54° to +54°	5 V	0.25 - 4.75 V ratiometric and PWM	0° / 120° / 240°	70 mm	6PM 008 161-121	112
Socket	-54° to +54°	5 V	0.25 - 4.75 V ratiometric and PWM	60° / 180° / 300°	70 mm	6PM 008 161-131	113
Socket	-54° to +54°	5 V	0.25 - 4.75 V ratiometric and PWM	30° / 150° / 270°	50 mm	6PM 008 161-141	114
Socket	-54° to +54°	5 V	0.25 - 4.75 V ratiometric and PWM	90° / 210° / 330°	50 mm	6PM 008 161-151	115
Basic sensors – Compact design							
Ball, top	-54° to +54°	5 V	0.5–4.5 V ratiometric	0° / 120° / 240°	39 mm	6PM 010 200-501	116
Ball, bottom	-54° to +54°	5 V	0.5–4.5 V ratiometric	0° / 120° / 240°	39 mm	6PM 010 200-511	117
Ball, bottom	-54° to +54°	5 V	0.5–4.5 V ratiometric	0° / 120° / 240°	51 mm	6PM 010 200-521	118
Ball, top	-54° to +54°	5 V	0.5–4.5 V ratiometric	0° / 120° / 240°	64 mm	6PM 010 200-531	119
Double sensors							
Socket	-30° to +30°	5 V or 9 - 32 V	0.5–4.5 V ratiometric/ absolute	0° / 120° / 240°	50 mm	6PD 009 583-001	120–121
Socket	-54 to +54°	5 V or 9 - 32 V	0.5–4.5 V ratiometric/ absolute	0° / 120° / 240°	50 mm	6PD 009 583-011	122–123
Socket	-54 to +54°	5 V	0.5–4.5 V ratiometric	0° / 120° / 240°	70 mm	6PD 009 580-017	124–125
Ball, top	-54 to +54°	5 V or 9 - 32 V	0.5–4.5 V ratiometric/ absolute	0° / 120° / 240°	90 mm	6PD 009 584-017	126–127

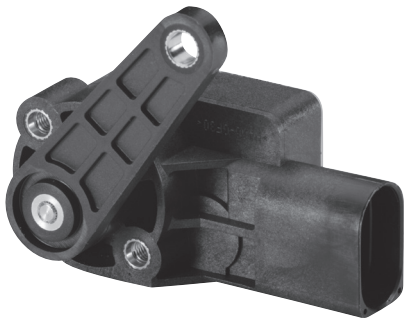

Housing version A

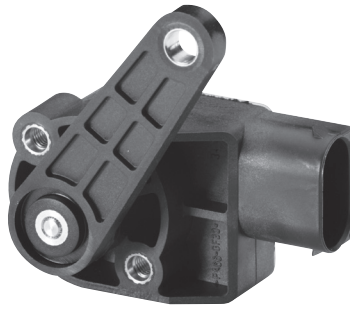

Housing version B

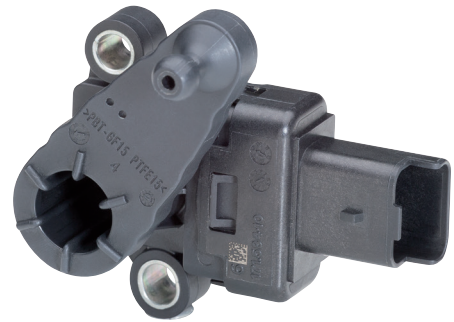

Housing version C

TECHNICAL DRAWING OF HOUSING TYPE A

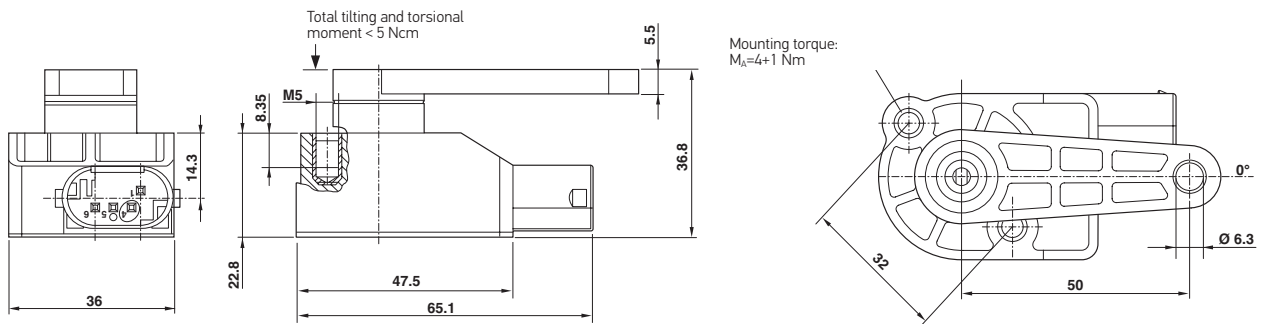

TECHNICAL DRAWING, HOUSING VARIANT B

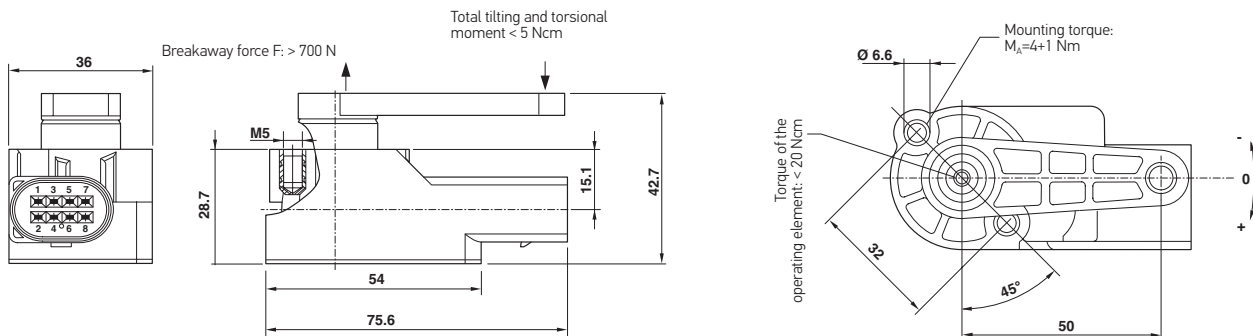

TECHNICAL DRAWING, HOUSING VARIANT C

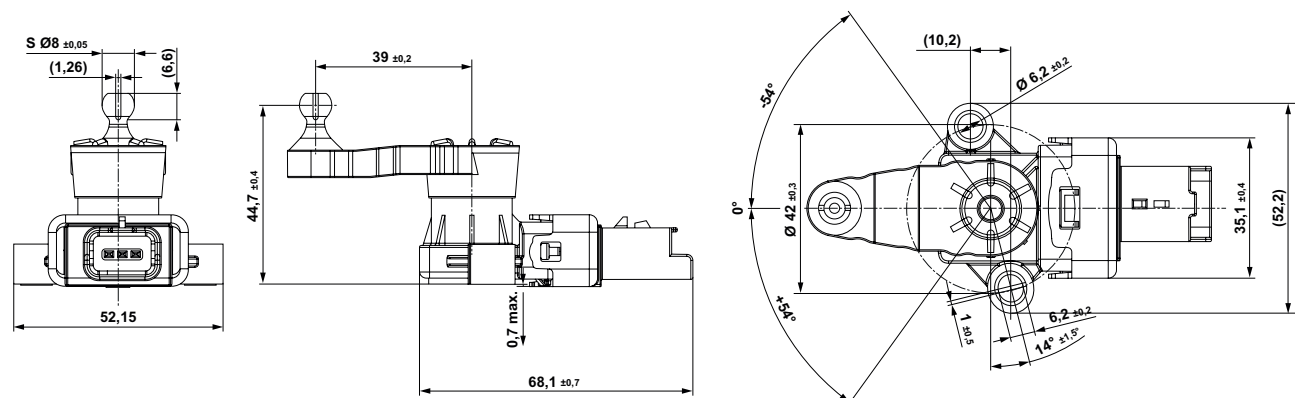

ENVIRONMENTAL TEST

Humidity / heat	DIN EN 60068-2-38,-Z/AD $T_0 = +65^\circ\text{C} \pm 2^\circ\text{C}$, $T_U = -10^\circ\text{C} \pm 2^\circ\text{C}$ $F_{\text{rel}} = 93\% \pm 3\%$, number of cycles: 10
Salt spray	IEC 60068-2-11 Ka, duration of test: 168 h
Vibration resistance	Broadband noise with reference to ISO 16750-3, section 4.1.3.2.3, DIN EN 60068-2-64, temperature overlapping DIN EN 60068-2-14 Nb, test period per axis: 8 h, $T_{\text{min}} = -40^\circ\text{C}$, $T_{\text{max}} = +85^\circ\text{C}$
Shock resistance	ISO 16750-3, section 4.2.2, DIN EN 60068-2-29, test method: semi-sine Acceleration 500 m/s ² , duration 6 ms Number of shocks 10 in every direction
Conducted interference	according to IEC-CISPR 25, Class 5
Radiated electromagnetic interference	according to IEC-CISPR 25, Class 5
Other EMC tests	ISO 7637-2, 3 / ISO 11452-2,-5 / ISO TR 10605
Protection class	DIN 40050, Part 9 IP6K5 and IP6K9K
Salt spray	according to IEC 60068-2-11 Ka and duration 168 h
Surge voltage withstand capability	ISO 16750-2, section 4.2 (where applicable)
Short-circuit resistance	ISO 16750-2, section 4.8.2 (where applicable)
Insulation resistance	With reference to ISO 16750-2, section 4.10 $T_{\text{amb}} = 35^\circ\text{C} \pm 5^\circ\text{C}$, $F_{\text{rel}} = 50\% \pm 5\%$ $U = 500\text{ V DC}$, duration = 60 s \pm 6 s
Breakdown strength	With reference to ISO 16750-2, section 4.9 $T_{\text{amb}} = 35^\circ\text{C} \pm 5^\circ\text{C}$, $F_{\text{rel}} = 50\% \pm 5\%$ $U = 500\text{ Veff. AC}$, $f = 50$ to 60 Hz Duration 60 s

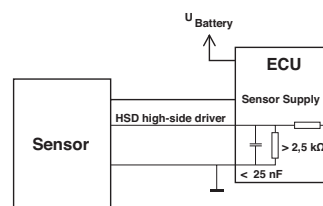

WIRING FOR RATIOMETRIC (10% to 90%) OR FIXED-VOLTAGE OUTPUT (0.5 V - 4.5 V)

This version requires an external pull-down resistor. If 5 V are supplied, e.g. select 2.7 kΩ to 10 kΩ. The max. output current of the analogue output should not exceed 2 mA. The output voltage is relative to the supply voltage, because the high-side driver (HSD) is used as the analogue output.

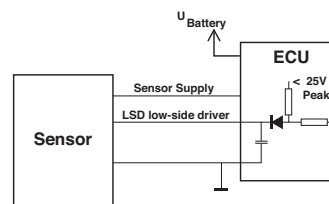

WIRING FOR PWM OUTPUT AT THE LOW-SIDE DRIVER (LSD)

The maximum current through the pull-up resistor is set by the external ECU, because an LSD is used as the PWM output. HELLA recommends using 10 kΩ to keep the output current as low as possible. The pull-up resistor also limits the current output of the sensor, which should not exceed 5 mA. The voltage and transients at the pull-up resistor must not exceed 25 V.

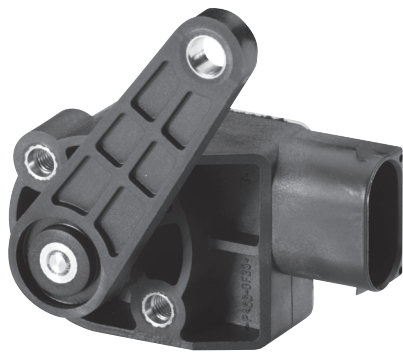

Angular Position Sensors
Single sensors
Part number 6PM 008 161-241

TECHNICAL DATA

Angle range	-30° to +30°
Mechanical angle range	unlimited (full 360° circle)
Supply voltage	U_s 5 V \pm 10 %
Output signal 1	0.5–4.5 V ratiometric
Output signal 2	PWM
Resolution	0,12°
Linearity error including temperature drift	\pm 0,6°
Current consumption	< 15 mA
Max. current (analogue output)	< 2 mA
Max. current (PWM output)	< 5 mA
PWM frequency	200 Hz
Casing type	A
Zero position	0° / 120° / 240°
Lever arm	50 mm
Protection class	IP 6K5, IP 6K9K
Operating temperature	-40°C to +125°C
Lifetime	5 million cycles
Polarity reversal protection	none, mechanical protection only
Mating connector ¹⁾	1-967616-1
Pin coating	Sn

¹⁾ This accessory is not included.
Available from TE Connectivity.

This special variant outputs two different signals, i.e. a voltage indicating the angle measured (analogue) and a PWM signal (pulse width modulated digital signal), ensuring this angular position sensor can be used universally.

PIN ASSIGNMENT FOR CASING TYPE A

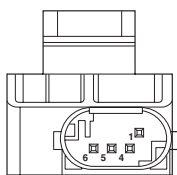

- Pin 1: Ground
- Pin 4: Output signal 0.5–4.5 V ratiometric
- Pin 5: 5 V DC supply
- Pin 6: PWM output

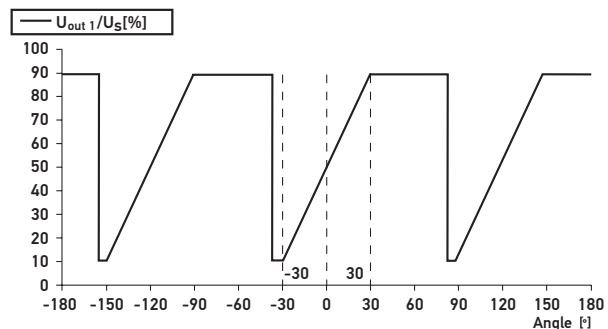
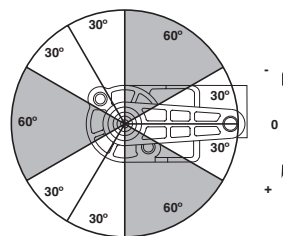

CHARACTERISTIC CURVE OF THE ROTATION ANGLE SENSOR

The characteristic curve of the rotation angle sensor repeats every 120°. The sensor does not therefore have to be installed in the mounting position shown, but can be installed at any offset angle that is a multiple of 120°. This will not affect the behaviour of the connected system in any way. The measuring angle range is 60°. If the signal continues to fall or rise up to 82.5° in the positive direction of rotation or 7.5° in the negative direction of rotation, the output signal remains at the limit value of the measuring range. If exceeded further, the next section of the characteristic curve is applied. The resulting measuring ranges and zero positions are shown on the graph. The segments of the circle shown in grey represent the angles that cannot be measured.

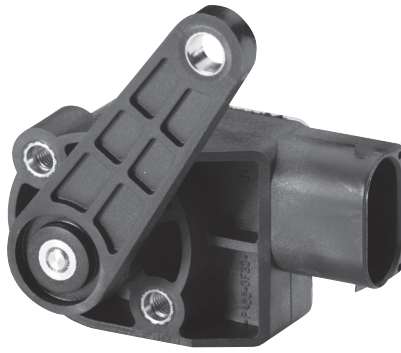

Angular Position Sensors Single sensors Part number 6PM 008 161-251

TECHNICAL DATA

Angle range	-51° to +51°
Mechanical angle range	unlimited (full 360° circle)
Supply voltage	U_s 5 V \pm 10 %
Output signal 1	0.5–4.5 V ratiometric
Output signal 2	PWM
Resolution	0,12°
Linearity error including temperature drift	\pm 0,6°
Current consumption	< 15 mA
Max. current (analogue output)	< 2 mA
Max. current (PWM output)	< 5 mA
PWM frequency	200 Hz
Casing type	A
Zero position	0° / 120° / 240°
Lever arm	50 mm
Protection class	IP 6K5, IP 6K9K
Operating temperature	-40°C to +125°C
Lifetime	5 million cycles
Polarity reversal protection	none, mechanical protection only
Mating connector ¹⁾	1-967616-1
Pin coating	Sn

¹⁾ This accessory is not included.
Available from TE Connectivity.

This special variant outputs two different signals, i.e. a voltage indicating the angle measured (analogue) and a PWM signal (pulse width modulated digital signal), ensuring this angular position sensor can be used universally.

PIN ASSIGNMENT FOR CASING TYPE A

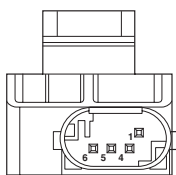

Pin 1: Ground
Pin 4: Output signal 0.5–4.5 V ratiometric
Pin 5: 5 V DC supply
Pin 6: PWM output

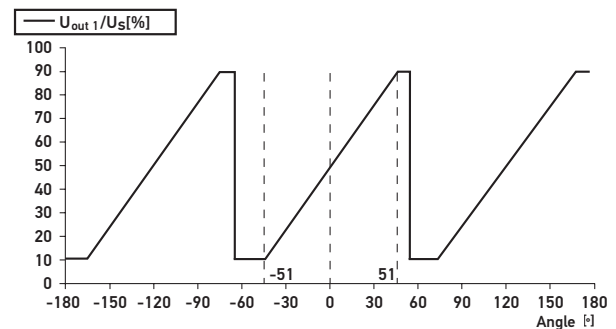
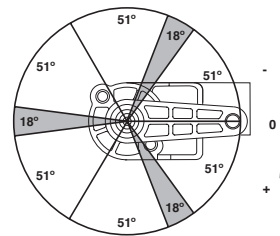

CHARACTERISTIC CURVE OF THE ROTATION ANGLE SENSOR

The characteristic curve of the rotation angle sensor repeats every 120°. The sensor does not therefore have to be installed in the mounting position shown, but can be installed at any offset angle that is a multiple of 120°. This will not affect the behaviour of the connected system in any way. The measuring angle range is 102°. If the signal continues to fall or rise up to 5.25° in the positive direction of rotation or 12.75° in the negative direction of rotation, the output signal remains at the limit value of the measuring range. If exceeded further, the next section of the characteristic curve is applied. The resulting measuring ranges and zero positions are shown on the graph. The segments of the circle shown in grey represent the angles that cannot be measured.



Angular Position Sensors
Single sensors
Part number 6PM 008 161-121

TECHNICAL DATA

Angle range	-54° to +54°
Mechanical angle range	unlimited (full 360° circle)
Supply voltage	U _s 5 V ± 10 %
Output signal 1	0.25 – 4.75 V ratiometric
Output signal 2	PWM
Resolution	0,12°
Linearity error including temperature drift	± 0,6°
Current consumption	< 15 mA
Max. current (analogue output)	< 2 mA
Max. current (PWM output)	< 5 mA
PWM frequency	200 Hz
Casing type	A
Zero position	0° / 120° / 240°
Lever arm	70 mm
Protection class	IP 6K5, IP 6K9K
Operating temperature	- 40°C to + 125°C
Lifetime	5 million cycles
Polarity reversal protection	none, mechanical protection only
Mating connector ¹⁾	1-967616-1
Pin coating	Sn

¹⁾ This accessory is not included.
Available from TE Connectivity.

This special variant outputs two different signals, i.e. a voltage indicating the angle measured (analogue) and a PWM signal (pulse width modulated digital signal), ensuring this angular position sensor can be used universally.

PIN ASSIGNMENT FOR CASING TYPE A

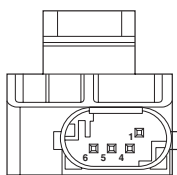

- Pin 1: Ground
- Pin 4: Output signal 0.25 – 4.75 V ratiometric
- Pin 5: 5 V DC supply
- Pin 6: PWM output

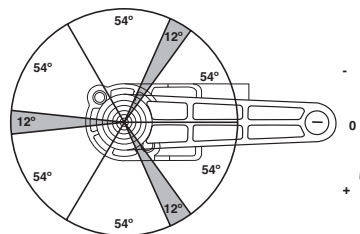

— U_{out 1} / U_s [%]

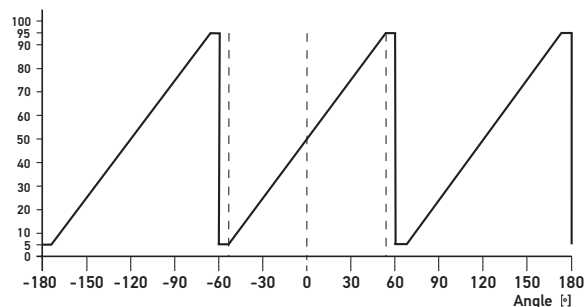

CHARACTERISTIC CURVE OF THE ROTATION ANGLE SENSOR

The characteristic curve of the angular position sensor repeats every 120°. The sensor does not therefore have to be installed in the mounting position shown, but can be installed at any offset angle that is a multiple of 120°. The behaviour of the connected system does not change in any way. The measuring angle range is 108°. If it is exceeded by up to 6°, the output signal remains limited to the measuring range final value. For further exceedance, the next characteristic curve section is run through. The resulting measuring ranges and zero positions can also be obtained from the graphic representation. The segments of the circle shown in grey represent the angles that cannot be measured.

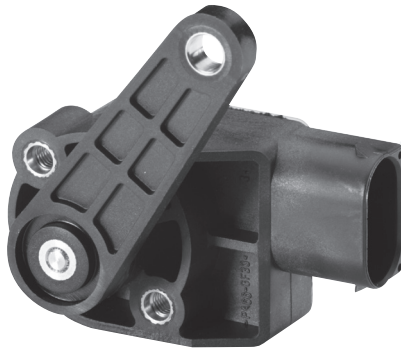

Angular Position Sensors Single sensors Part number 6PM 008 161-131

TECHNICAL DATA

Angle range	-54° to +54°
Mechanical angle range	unlimited (full 360° circle)
Supply voltage	U_s 5 V \pm 10 %
Output signal 1	0.25–4.75 V ratiometric
Output signal 2	PWM
Resolution	0,12°
Linearity error including temperature drift	\pm 0,6°
Current consumption	< 15 mA
Max. current (analogue output)	< 2 mA
Max. current (PWM output)	< 5 mA
PWM frequency	200 Hz
Casing type	A
Zero position	60° / 180° / 300°
Lever arm	70 mm
Protection class	IP 6K5, IP 6K9K
Operating temperature	-40°C to +125°C
Lifetime	5 million cycles
Polarity reversal protection	none, mechanical protection only
Mating connector ¹⁾	1-967616-1
Pin coating	Sn

¹⁾ This accessory is not included.
Available from TE Connectivity.

This special variant outputs two different signals, i.e. a voltage indicating the angle measured (analogue) and a PWM signal (pulse width modulated digital signal), ensuring this angular position sensor can be used universally.

PIN ASSIGNMENT FOR CASING TYPE A

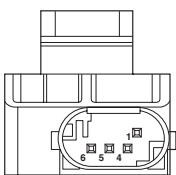

Pin 1: Ground
Pin 4: Output signal 0.25–4.75 V ratiometric
Pin 5: 5 V DC supply
Pin 6: PWM output

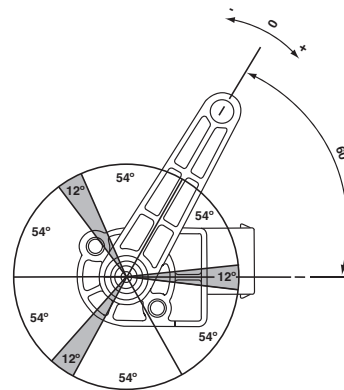

— U_{out1}/U_s [%]

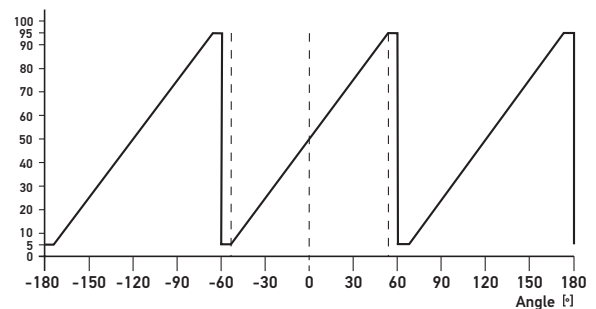

CHARACTERISTIC CURVE OF THE ROTATION ANGLE SENSOR

The characteristic curve of the angular position sensor repeats every 120°. The sensor does not therefore have to be installed in the mounting position shown, but can be installed at any offset angle that is a multiple of 120°. The behaviour of the connected system does not change in any way. The measuring angle range is 108°. If it is exceeded by up to 6°, the output signal remains limited to the measuring range final value. For further exceedance, the next characteristic curve section is run through. The resulting measuring ranges and zero positions can also be obtained from the graphic representation. The segments of the circle shown in grey represent the angles that cannot be measured.



Angular Position Sensors
Single sensors
Part number 6PM 008 161-141

TECHNICAL DATA

Angle range	-54° to +54°
Mechanical angle range	unlimited (full 360° circle)
Supply voltage	U_s 5 V \pm 10 %
Output signal 1	0.25–4.75 V ratiometric
Output signal 2	PWM
Resolution	0,12°
Linearity error including temperature drift	\pm 0,6°
Current consumption	< 15 mA
Max. current (analogue output)	< 2 mA
Max. current (PWM output)	< 5 mA
PWM frequency	200 Hz
Casing type	A
Zero position	30° / 150° / 270°
Lever arm	50 mm
Protection class	IP 6K5, IP 6K9K
Operating temperature	-40°C to +125°C
Lifetime	5 million cycles
Polarity reversal protection	none, mechanical protection only
Mating connector ¹⁾	1-967616-1
Pin coating	Sn

¹⁾ This accessory is not included.
Available from TE Connectivity.

This special variant outputs two different signals, i.e. a voltage indicating the angle measured (analogue) and a PWM signal (pulse width modulated digital signal), ensuring this angular position sensor can be used universally.

PIN ASSIGNMENT FOR CASING TYPE A

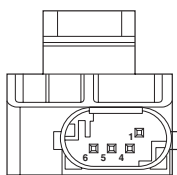

- Pin 1: Ground
- Pin 4: Output signal 0.25–4.75 V ratiometric
- Pin 5: 5 V DC supply
- Pin 6: PWM output

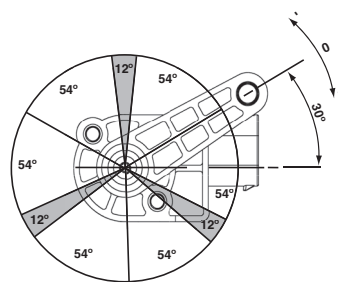

$U_{out 1} / U_s$ [%]

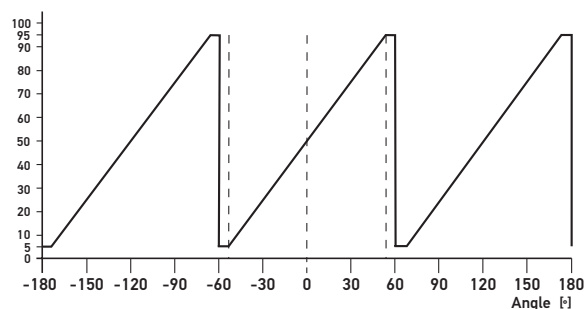

CHARACTERISTIC CURVE OF THE ROTATION ANGLE SENSOR

The characteristic curve of the angular position sensor repeats every 120°. The sensor does not therefore have to be installed in the mounting position shown, but can be installed at any offset angle that is a multiple of 120°. The behaviour of the connected system does not change in any way. The measuring angle range is 108°. If it is exceeded by up to 6°, the output signal remains limited to the measuring range final value. For further exceedance, the next characteristic curve section is run through. The resulting measuring ranges and zero positions can also be obtained from the graphic representation. The segments of the circle shown in grey represent the angles that cannot be measured.



Angular Position Sensors Single sensors Part number 6PM 008 161-151

TECHNICAL DATA

Angle range	-54° to +54°
Mechanical angle range	unlimited (full 360° circle)
Supply voltage	U_s 5 V \pm 10 %
Output signal 1	0.25–4.75 V ratiometric
Output signal 2	PWM
Resolution	0,12°
Linearity error including temperature drift	\pm 0,6°
Current consumption	< 15 mA
Max. current (analogue output)	< 2 mA
Max. current (PWM output)	< 5 mA
PWM frequency	200 Hz
Casing type	A
Zero position	90° / 210° / 330°
Lever arm	50 mm
Protection class	IP 6K5, IP 6K9K
Operating temperature	-40°C to +125°C
Lifetime	5 million cycles
Polarity reversal protection	none, mechanical protection only
Mating connector ¹⁾	1-967616-1
Pin coating	Sn

¹⁾ This accessory is not included.
Available from TE Connectivity.

This special variant outputs two different signals, i.e. a voltage indicating the angle measured (analogue) and a PWM signal (pulse width modulated digital signal), ensuring this angular position sensor can be used universally.

PIN ASSIGNMENT FOR CASING TYPE A

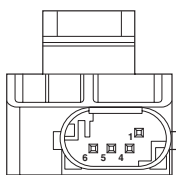

Pin 1: Ground
Pin 4: Output signal 0.25–4.75 V ratiometric
Pin 5: 5 V DC supply
Pin 6: PWM output

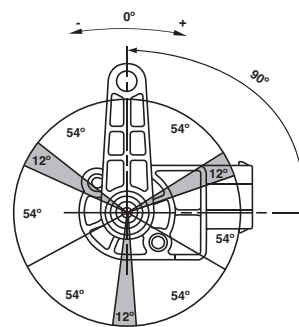

— U_{out1}/U_s [%]

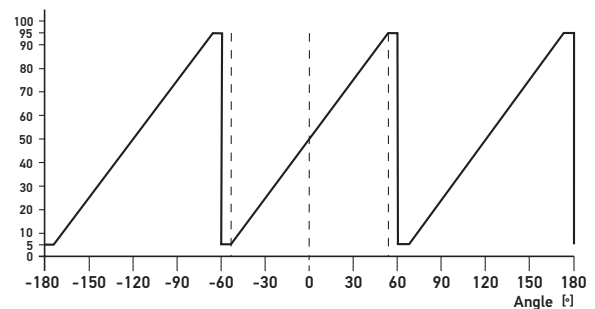

CHARACTERISTIC CURVE OF THE ROTATION ANGLE SENSOR

The characteristic curve of the angular position sensor repeats every 120°. The sensor does not therefore have to be installed in the mounting position shown, but can be installed at any offset angle that is a multiple of 120°. The behaviour of the connected system does not change in any way. The measuring angle range is 108°. If it is exceeded by up to 6°, the output signal remains limited to the measuring range final value. For further exceedance, the next characteristic curve section is run through. The resulting measuring ranges and zero positions can also be obtained from the graphic representation. The segments of the circle shown in grey represent the angles that cannot be measured.



Angular Position Sensors
Basic sensors – Compact design
6PM 010 200-501

TECHNICAL DATA

Angle range	-54° to +54°
Mechanical angle range	unlimited (full 360° circle)
Supply voltage	U_s 5 V ± 0,5 V
Output signal	0.5–4.5 V ratiometric
Resolution	12 bit
Linearity error including temperature drift	1 % of the supply voltage
Current consumption	10 mA
PWM frequency	1000 Hz ± 20 %
Zero position	0° / 120° / 240°
Lever arm	50 mm
Protection class	IP 6K9K according to DIN 40050
Operating temperature	-40°C to +125°C
Lifetime	6.75 million cycles
Polarity reversal protection	mechanical only
Mating connector ¹⁾	Sigma 2
Pin coating	CuNiSi, Au

¹⁾ This accessory is not included.
Available from Sigma.

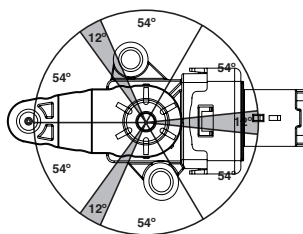

U_{out} / U_s [%]

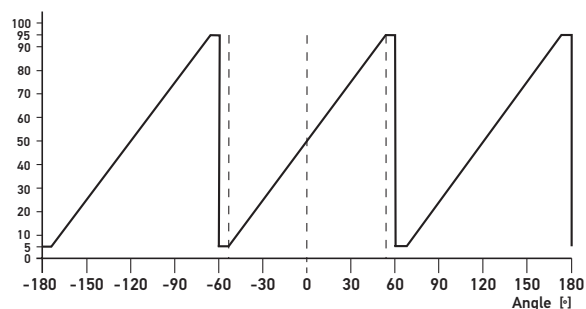

PIN ASSIGNMENT FOR SINGLE SENSORS 2ND GENERATION

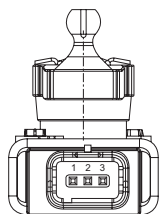

- Pin 1: Ground
- Pin 2: Output signal 0.5–4.5 V ratiometric
- Pin 3: 5 V DC supply

CHARACTERISTIC CURVE OF THE ROTATION ANGLE SENSOR

The characteristic curve of the angular position sensor repeats every 120°. The sensor does not therefore have to be installed in the mounting position shown, but can be installed at any offset angle that is a multiple of 120°. The behaviour of the connected system does not change in any way. The measuring angle range is 108°. If it is exceeded by up to 6°, the output signal remains limited to the measuring range final value. For further exceedance, the next characteristic curve section is run through. The resulting measuring ranges and zero positions can also be obtained from the graphic representation. The segments of the circle shown in grey represent the angles that cannot be measured.

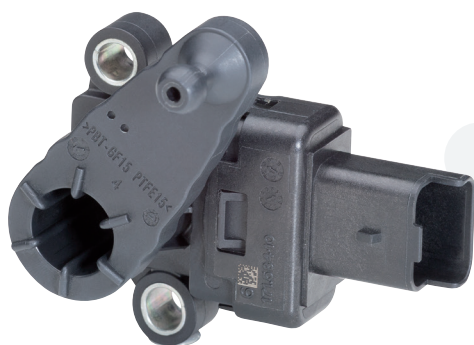

Angular Position Sensors Basic sensors – Compact design 6PM 010 200-511

TECHNICAL DATA

Angle range	-54° to +54°
Mechanical angle range	unlimited (full 360° circle)
Supply voltage	$U_s 5\text{ V} \pm 0,5\text{ V}$
Output signal	0.5–4.5 V ratiometric
Resolution	12 bit
Linearity error including temperature drift	1 % of the supply voltage
Current consumption	10 mA
PWM frequency	1000 Hz $\pm 20\%$
Zero position	0° / 120° / 240°
Lever arm	50 mm
Protection class	IP 6K9K according to DIN 40050
Operating temperature	-40°C to +125°C
Lifetime	6.75 million cycles
Polarity reversal protection	mechanical only
Mating connector ¹⁾	Sigma 2
Pin coating	CuNiSi, Au

¹⁾ This accessory is not included.
Available from Sigma.

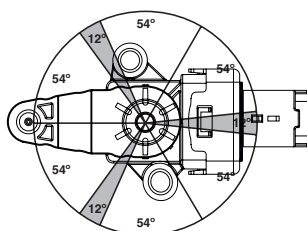

— $U_{out1}/U_s[\%]$

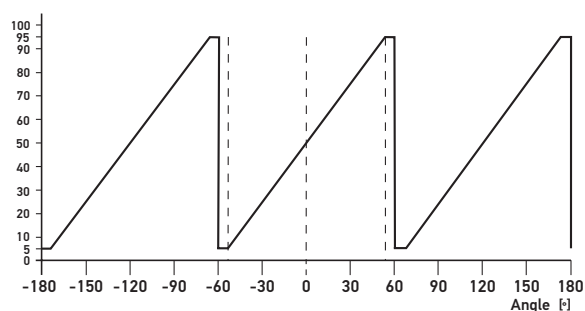

PIN ASSIGNMENT FOR SINGLE SENSORS 2ND GENERATION

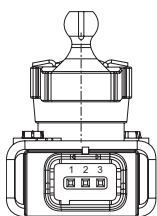

Pin 1: Ground
Pin 2: Output signal 0.5–4.5 V ratiometric
Pin 3: 5 V DC supply

CHARACTERISTIC CURVE OF THE ROTATION ANGLE SENSOR

The characteristic curve of the angular position sensor repeats every 120°. The sensor does not therefore have to be installed in the mounting position shown, but can be installed at any offset angle that is a multiple of 120°. The behaviour of the connected system does not change in any way. The measuring angle range is 108°. If it is exceeded by up to 6°, the output signal remains limited to the measuring range final value. For further exceedance, the next characteristic curve section is run through. The resulting measuring ranges and zero positions can also be obtained from the graphic representation. The segments of the circle shown in grey represent the angles that cannot be measured.



Angular Position Sensors
Basic sensors – Compact design
6PM 010 200-521

TECHNICAL DATA

Angle range	-54° to +54°
Mechanical angle range	unlimited (full 360° circle)
Supply voltage	U_s 5 V ± 0,5 V
Output signal	0.5–4.5 V ratiometric
Resolution	12 bit
Linearity error including temperature drift	1 % of the supply voltage
Current consumption	10 mA
PWM frequency	1000 Hz ± 20 %
Zero position	0° / 120° / 240°
Lever arm	70 mm
Protection class	IP 6K9K according to DIN 40050
Operating temperature	-40°C to +125°C
Lifetime	6.75 million cycles
Polarity reversal protection	mechanical only
Mating connector ¹⁾	Sigma 2
Pin coating	CuNiSi, Au

¹⁾ This accessory is not included.
Available from Sigma.

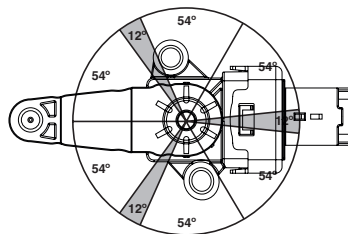

$U_{out 1} / U_s$ [%]

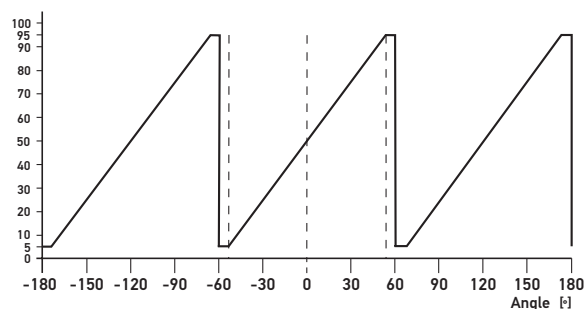

PIN ASSIGNMENT FOR SINGLE SENSORS 2ND GENERATION

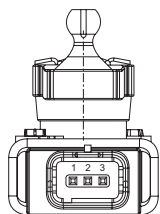

Pin 1: Ground
Pin 2: Output signal 0.5–4.5 V ratiometric
Pin 3: 5 V DC supply

CHARACTERISTIC CURVE OF THE ROTATION ANGLE SENSOR

The characteristic curve of the angular position sensor repeats every 120°. The sensor does not therefore have to be installed in the mounting position shown, but can be installed at any offset angle that is a multiple of 120°. The behaviour of the connected system does not change in any way. The measuring angle range is 108°. If it is exceeded by up to 6°, the output signal remains limited to the measuring range final value.

For further exceedance, the next characteristic curve section is run through. The resulting measuring ranges and zero positions can also be obtained from the graphic representation. The segments of the circle shown in grey represent the angles that cannot be measured.

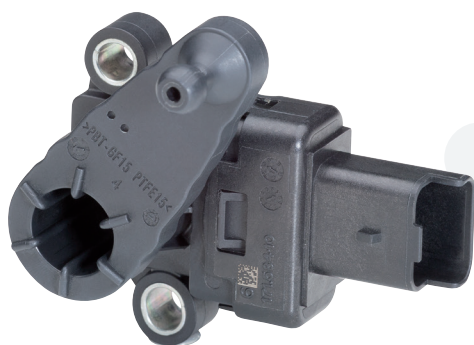

Angular Position Sensors Basic sensors – Compact design 6PM 010 200-531

TECHNICAL DATA

Angle range	-54° to +54°
Mechanical angle range	unlimited (full 360° circle)
Supply voltage	U_s 5 V \pm 0,5 V
Output signal	0.5–4.5 V ratiometric
Resolution	12 bit
Linearity error including temperature drift	1 % of the supply voltage
Current consumption	10 mA
PWM frequency	1000 Hz \pm 20 %
Zero position	0° / 120° / 240°
Lever arm	90 mm
Protection class	IP 6K9K according to DIN 40050
Operating temperature	-40°C to +125°C
Lifetime	6.75 million cycles
Polarity reversal protection	mechanical only
Mating connector ¹⁾	Sigma 2
Pin coating	CuNiSi, Au

¹⁾ This accessory is not included.
Available from Sigma.

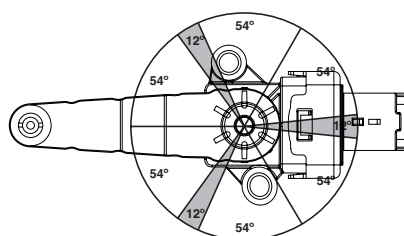

— U_{out} / U_s [%]

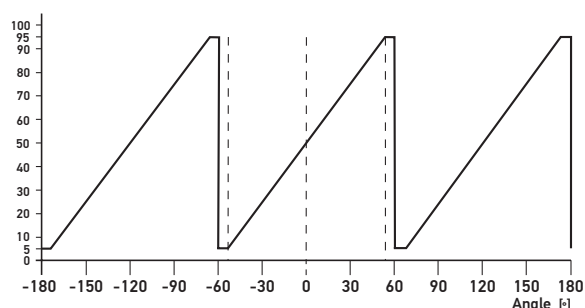

PIN ASSIGNMENT FOR SINGLE SENSORS 2ND GENERATION

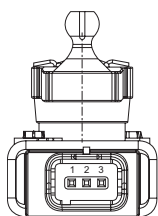

Pin 1: Ground
Pin 2: Output signal 0.5–4.5 V ratiometric
Pin 3: 5 V DC supply

CHARACTERISTIC CURVE OF THE ROTATION ANGLE SENSOR

The characteristic curve of the angular position sensor repeats every 120°. The sensor does not therefore have to be installed in the mounting position shown, but can be installed at any offset angle that is a multiple of 120°. The behaviour of the connected system does not change in any way. The measuring angle range is 108°. If it is exceeded by up to 6°, the output signal remains limited to the measuring range final value. For further exceedance, the next characteristic curve section is run through. The resulting measuring ranges and zero positions can also be obtained from the graphic representation. The segments of the circle shown in grey represent the angles that cannot be measured.

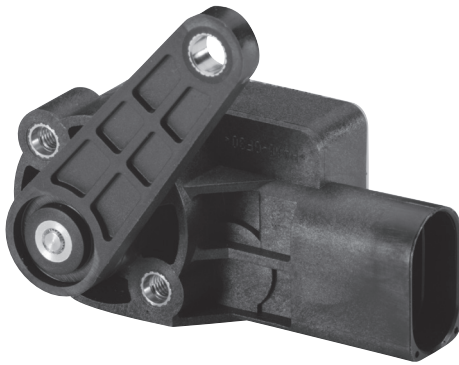

Angular Position Sensors
 Double sensors (redundant angle measurement for safety-critical applications)
Part number 6PD 009 583-001

TECHNICAL DATA

Angle range	-30° to +30°
Mechanical angle range	unlimited (full 360° circle)
Supply voltage	5 V ± 10% or 9–32 V
"Crossed Scale" output signal	
Power Supply	U _s 5 V Output U _{out 1} 0.5–4.5 V ratiometric Output U _{out 2} 4.5–0.5 V ratiometric
Power Supply	U _s 9–32 V Output U _{out 1} 0.5–4.5 V Output U _{out 2} 4.5–0.5 V
Resolution	0,06°
Linearity error including temperature drift	± 0,3°
Current consumption	< 15 mA
Max. current (analogue output)	< 2 mA
Casing type	B
Zero position	0° / 120° / 240°
Lever arm	50 mm
Protection class	IP 6K9K
Operating temperature	-40°C to +85°C
Lifetime	5 million cycles
Polarity reversal protection	none, mechanical protection only
Mating connector ¹⁾	1394416-1
Pin coating	Sn

¹⁾ This accessory is not included.
 Available from TE Connectivity.

PIN ASSIGNMENT FOR CASING TYPE B

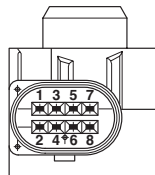

Power supply with 5 V DC²⁾

- Pin 1: 5 V DC sensor 2
- Pin 2: Output U_{out 1} 0.5–4.5 V ratiometric
- Pin 3: not assigned
- Pin 4: 5 V DC sensor 1
- Pin 5: Output U_{out 2} 4.5–0.5 V ratiometric
- Pin 6: Not assigned
- Pin 7: Ground sensor 2
- Pin 8: Ground sensor 1

²⁾ The power supply (pin 1 and pin 4) and the ground supply (pin 7 and pin 8) can be bridged externally (e.g. in the mating connector) in order to reduce the number of cables.

Power supply with 9–32 V DC³⁾

- Pin 1: Bridge to pin 4 (external)
- Pin 2: Output U_{out 1} 0.5–4.5 V
- Pin 3: 9–32 V DC sensor 1 and 2
- Pin 4: Bridge to pin 1 (external)
- Pin 5: Output U_{out 2} 4.5–0.5 V
- Pin 6: Not assigned
- Pin 7: Ground sensor 2
- Pin 8: Ground sensor 1

³⁾ The bridge between pin 1 and pin 4 must be set up externally (e.g. in the mating connector). The power supply (pin 7 and pin 8) can be bridged externally (e.g. in the mating connector) in order to reduce the number of cables.

CHARACTERISTIC CURVE OF THE ROTATION ANGLE SENSOR

The characteristic curve of the angular position sensor repeats every 120°. The sensor does not therefore have to be installed in the mounting position shown, but can be installed at any offset angle that is a multiple of 120°. This will not affect the behaviour of the connected system in any way. The measuring angle range is 60°. If it is exceeded by up to 30°, the output signal remains at the limit value of the measuring range. If exceeded further, the next section of the characteristic curve is applied. The resulting measuring ranges and zero positions are shown on the graph. The segments of the circle shown in grey represent the angles that cannot be measured.

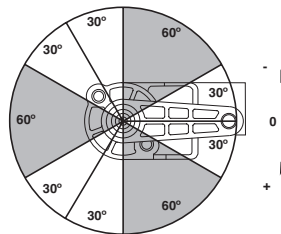

Ratiometric output signal $U_{out 1}$ with power supply 5 V

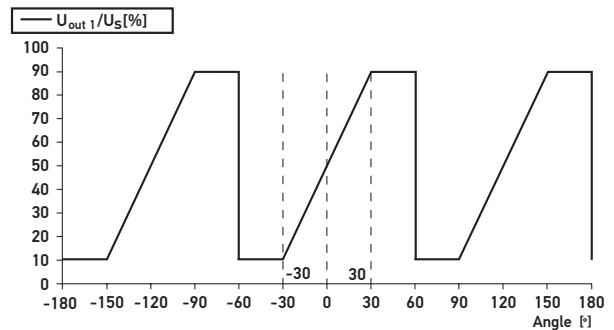

Output signal $U_{out 2} = 100\% - U_{out 1} / U_s$ [%] (opposite curve)

Absolute output signal $U_{out 1}$ with power supply 9–32 V

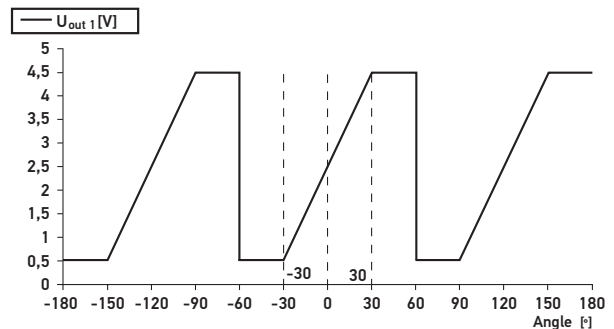

Output signal $U_{out 2} = 5 V - U_{out 1}$ [V] (opposite curve)

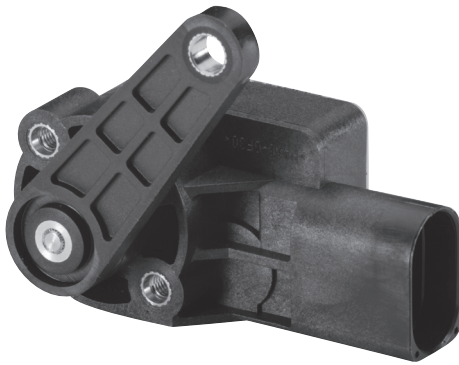

Angular Position Sensors
 Double sensors (redundant angle measurement for safety-critical applications)
Part number 6PD 009 583-011

TECHNICAL DATA

Angle range	-54° to +54°
Mechanical angle range	unlimited (full 360° circle)
Supply voltage	U_s 5 V ± 10% or 9–32 V
"Crossed Scale" output signal	
Power Supply	U_s 5 V Output U_{out1} 0.5–4.5 V ratiometric Output U_{out2} 4.5–0.5 V ratiometric
Power Supply	U_s 9–32 V Output U_{out1} 0.5–4.5 V Output U_{out2} 4.5–0.5 V
Resolution	0,06°
Linearity error including temperature drift	±0,3°
Current consumption	< 15 mA
Max. current (analogue output)	< 2 mA
Casing type	B
Zero position	0° / 120° / 240°
Lever arm	50 mm
Protection class	IP 6K9K
Operating temperature	-40°C to +85°C
Lifetime	5 million cycles
Polarity reversal protection	none, mechanical protection only
Mating connector ¹⁾	1394416-1
Pin coating	Sn

¹⁾ This accessory is not included.
 Available from TE Connectivity.

PIN ASSIGNMENT FOR CASING TYPE B

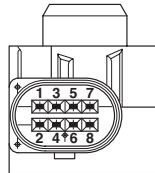

Power supply with 5 V DC²⁾

- Pin 1: 5 V DC sensor 2
- Pin 2: Output U_{out1} 0.5–4.5 V ratiometric
- Pin 3: not assigned
- Pin 4: 5 V DC sensor 1
- Pin 5: Output U_{out2} 4.5–0.5 V ratiometric
- Pin 6: Not assigned
- Pin 7: Ground sensor 2
- Pin 8: Ground sensor 1

²⁾ The power supply (pin 1 and pin 4) and the ground supply (pin 7 and pin 8) can be bridged externally (e.g. in the mating connector) in order to reduce the number of cables.

Power supply with 9–32 V DC³⁾

- Pin 1: Bridge to pin 4 (external)
- Pin 2: Output U_{out1} 0.5–4.5 V
- Pin 3: 9–32 V DC sensor 1 and 2
- Pin 4: Bridge to pin 1 (external)
- Pin 5: Output U_{out2} 4.5–0.5 V
- Pin 6: Not assigned
- Pin 7: Ground sensor 2
- Pin 8: Ground sensor 1

³⁾ The bridge between pin 1 and pin 4 must be set up externally (e.g. in the mating connector). The power supply (pin 7 and pin 8) can be bridged externally (e.g. in the mating connector) in order to reduce the number of cables.

CHARACTERISTIC CURVE OF THE ROTATION ANGLE SENSOR

The characteristic curve of the angular position sensor repeats every 120°. The sensor does not therefore have to be installed in the mounting position shown, but can be installed at any offset angle that is a multiple of 120°. This will not affect the behaviour of the connected system in any way. The measuring angle range is 108°. If it is exceeded by up to 6°, the output signal remains at the limit value of the measuring range. If exceeded further, the next section of the characteristic curve is applied. The resulting measuring ranges and zero positions are shown on the graph. The segments of the circle shown in grey represent the angles that cannot be measured.

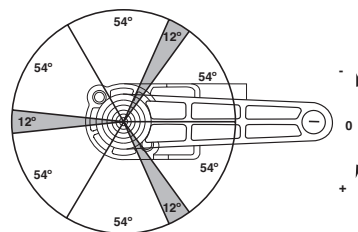

Ratiometric output signal $U_{out 1}$ with power supply 5 V

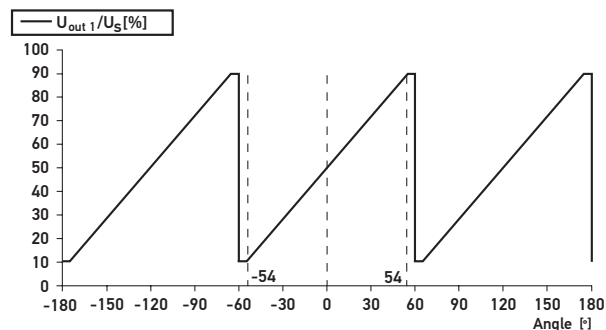

Output signal $U_{out 2} = 100\% - U_{out 1} / U_s$ [%] (opposite curve)

Absolute output signal $U_{out 1}$ with power supply 9–32 V

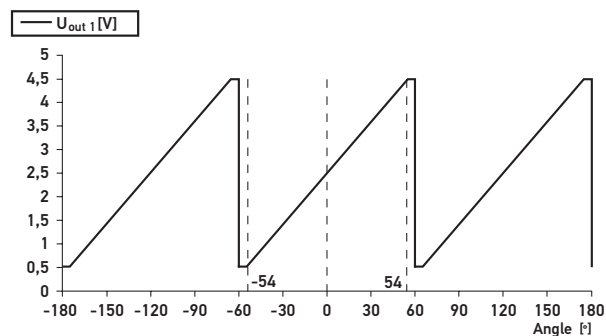

Output signal $U_{out 2} = 5 V - U_{out 1}$ [V] (opposite curve)

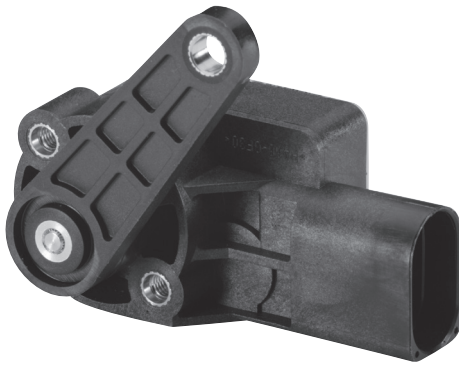

For illustrative purposes only

Angular Position Sensors
 Double sensors (redundant angle measurement for safety-critical applications)

Part number 6PD 009 580-017

TECHNICAL DATA

Angle range	-54° to +54°
Mechanical angle range	unlimited (full 360° circle)
Supply voltage	U_s 5 V \pm 10 %
"Crossed Scale" output signal	
Power Supply	U_s 5 V Output U_{out1} 0.5–4.5 V ratiometric Output U_{out2} 4.5–0.5 V ratiometric
Resolution	0,06°
Linearity error including temperature drift	\pm 0,3°
Current consumption	< 15 mA
Max. current (analogue output)	< 2 mA
Casing type	B
Zero position	0° / 120° / 240°
Lever arm	70 mm
Protection class	IP 6K9K
Operating temperature	-40°C to +85°C
Lifetime	5 million cycles
Polarity reversal protection	none, mechanical protection only
Mating connector ¹⁾	1394416-1
Pin coating	Sn

¹⁾ This accessory is not included.
 Available from TE Connectivity.

PIN ASSIGNMENT FOR CASING TYPE B

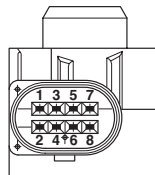

Power supply with 5 V DC²⁾

- Pin 1: 5 V DC sensor 2
- Pin 2: Output U_{out1} 0.5–4.5 V ratiometric
- Pin 3: not assigned
- Pin 4: 5 V DC sensor 1
- Pin 5: Output U_{out2} 4.5–0.5 V ratiometric
- Pin 6: Not assigned
- Pin 7: Ground sensor 2
- Pin 8: Ground sensor 1

²⁾ The power supply (pin 1 and pin 4) and the ground supply (pin 7 and pin 8) can be bridged externally (e.g. in the mating connector) in order to reduce the number of cables.

CHARACTERISTIC CURVE OF THE ROTATION ANGLE SENSOR

The characteristic curve of the angular position sensor repeats every 120°. The sensor does not therefore have to be installed in the mounting position shown, but can be installed at any offset angle that is a multiple of 120°. This will not affect the behaviour of the connected system in any way. The measuring angle range is 108°. If it is exceeded by up to 6°, the output signal remains at the limit value of the measuring range. If exceeded further, the next section of the characteristic curve is applied. The resulting measuring ranges and zero positions are shown on the graph. The segments of the circle shown in grey represent the angles that cannot be measured.

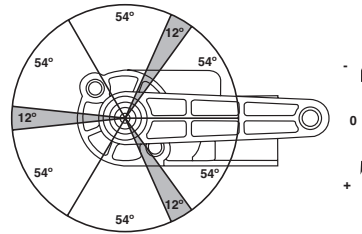

Ratiometric output signal $U_{out 1}$ with power supply 5 V

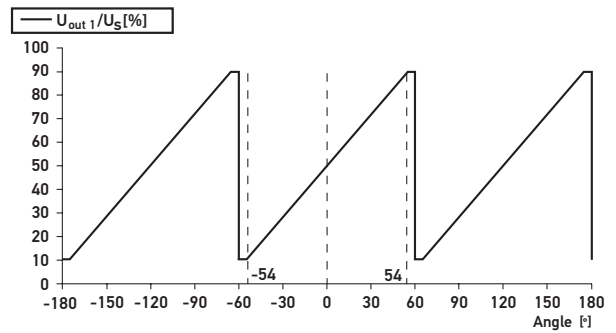

Output signal $U_{out 2} = 100\% - U_{out 1} / U_s$ [%] (opposite curve)



Angular Position Sensors
 Double sensors (redundant angle measurement for safety-critical applications)
Part number 6PD 009 584-017

TECHNICAL DATA

Angle range	-54° to +54°
Mechanical angle range	unlimited (full 360° circle)
Supply voltage	U_s 5 V \pm 10% or 9–32 V
"Crossed Scale" output signal	
Power Supply	U_s 5 V Output U_{out1} 0.5–4.5 V ratiometric Output U_{out2} 4.5–0.5 V ratiometric
Power Supply	U_s 9–32 V Output U_{out1} 0.5–4.5 V Output U_{out2} 4.5–0.5 V
Resolution	0,06°
Linearity error including temperature drift	\pm 0,3°
Current consumption	< 15 mA
Max. current (analogue output)	< 2 mA
Casing type	B
Zero position	0° / 120° / 240°
Lever arm	90 mm
Protection class	IP 6K9K
Operating temperature	-40°C to +85°C
Lifetime	5 million cycles
Polarity reversal protection	none, mechanical protection only
Mating connector ¹⁾	1394416-1
Pin coating	Sn

¹⁾ This accessory is not included.
 Available from TE Connectivity.

PIN ASSIGNMENT FOR CASING TYPE B

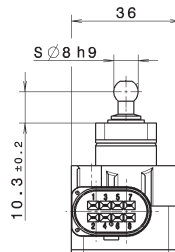

Power supply with 5 V DC²⁾

- Pin 1: 5 V DC sensor 2
- Pin 2: Output U_{out1} 0.5–4.5 V ratiometric
- Pin 3: not assigned
- Pin 4: 5 V DC sensor 1
- Pin 5: Output U_{out2} 4.5–0.5 V ratiometric
- Pin 6: Not assigned
- Pin 7: Ground sensor 2
- Pin 8: Ground sensor 1

²⁾ The power supply (pin 1 and pin 4) and the ground supply (pin 7 and pin 8) can be bridged externally (e.g. in the mating connector) in order to reduce the number of cables.

Power supply with 9–32 V DC³⁾

- Pin 1: Bridge to pin 4 (external)
- Pin 2: Output U_{out1} 0.5–4.5 V
- Pin 3: 9–32 V DC sensor 1 and 2
- Pin 4: Bridge to pin 1 (external)
- Pin 5: Output U_{out2} 4.5–0.5 V
- Pin 6: Not assigned
- Pin 7: Ground sensor 2
- Pin 8: Ground sensor 1

³⁾ The bridge between pin 1 and pin 4 must be set up externally (e.g. in the mating connector). The power supply (pin 7 and pin 8) can be bridged externally (e.g. in the mating connector) in order to reduce the number of cables.

CHARACTERISTIC CURVE OF THE ROTATION ANGLE SENSOR

The characteristic curve of the angular position sensor repeats every 120°. The sensor does not therefore have to be installed in the mounting position shown, but can be installed at any offset angle that is a multiple of 120°. This will not affect the behaviour of the connected system in any way. The measuring angle range is 108°. If it is exceeded by up to 6°, the output signal remains at the limit value of the measuring range. If exceeded further, the next section of the characteristic curve is applied. The resulting measuring ranges and zero positions are shown on the graph. The segments of the circle shown in grey represent the angles that cannot be measured.

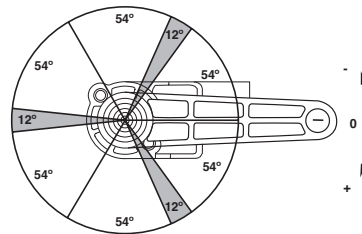

Ratiometric output signal $U_{out 1}$ with power supply 5 V

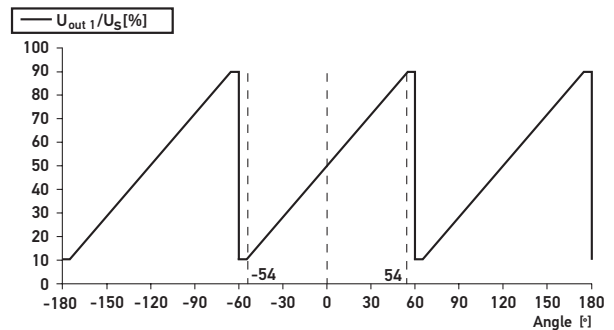

Output signal $U_{out 2} = 100\% - U_{out 1} / U_s$ [%] (opposite curve)

Absolute output signal $U_{out 1}$ with power supply 9–32 V

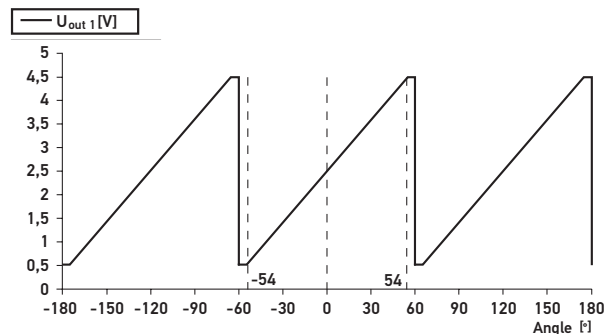

Output signal $U_{out 2} = 5 V - U_{out 1}$ [V] (opposite curve)

Angular Position Sensors
Connecting elements

CONNECTING ELEMENT WITH TWO BALL HEAD SCREW

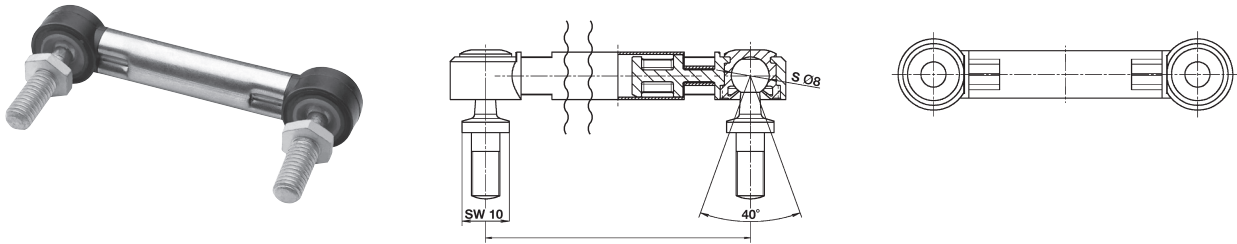

CONNECTING ELEMENT WITH TWO BALL HEAD SCREWS, ONE OF WHICH TURNED BY 180°

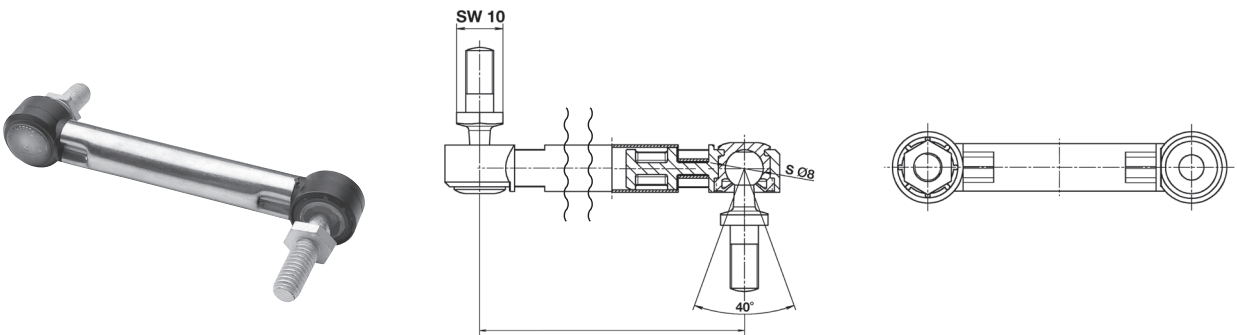

CONNECTING ELEMENT WITH COVER CAP AND ONE BALL HEAD SCREW

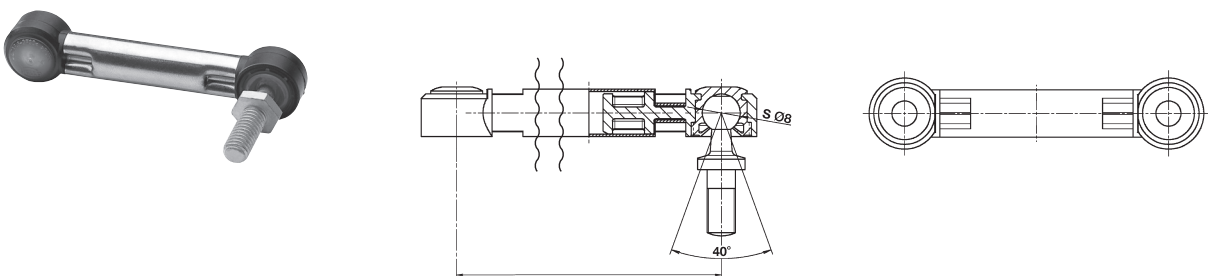

Head section, left
Type A – ball head screw
Rotated 180°



Head section, left
Type A – ball head screw

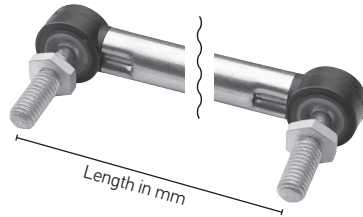

Head section, right
Type A – ball head screw

Head section, left
Type B – cover cap

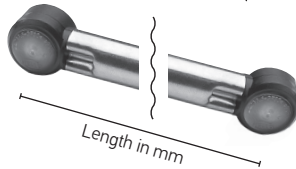

Head section, right
Type B – cover cap

OVERVIEW OF VARIANTS

Head section – left	Rotation	Length of connection element	Head section – right	Part number
A	0°	56 mm	A	9XB 732 588-207
A	0°	78.2 mm	A	9XB 732 588-197
A	0°	90 mm	A	9XB 732 588-167
B	0°	120 mm	A	9XB 732 588-237
B	180°	56 mm	A	9XX 732 603-167
A	180°	70 mm	A	9XX 732 603-107
A	180°	90 mm	B	9XX 732 603-117

Part no. 9NS 740 413-317

TECHNICAL DATA

Length (total)	29.5 mm ± 0.6
Length (screw)	14 mm ± 0.3
Placement	M6

TECHNICAL DRAWING

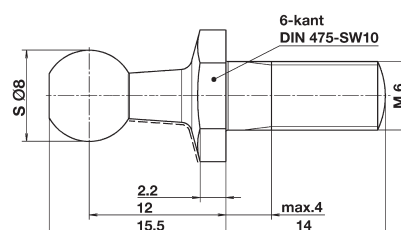



Rocker switches
Choose from 3 different series

PRODUCT FEATURES

Rocker switches:

- Modular structure covering individual applications right up to complete vehicle equipment
- Multifaceted applications
- High degree of coverage as regards standard functions
- Clear allocation of switch functions, even under extreme conditions
- Timeless design
- High abrasion resistance of lasered symbols
- Replacement and retrofitting through standardised mounting hole and mounting frame

APPLICATION

The HELLA rocker switch range, which boasts four series, offers the right configuration for every application thanks to its wide range of functions and countless symbols.

Series 4570 / 7832: Basic range for simple electrical systems that has been tried and tested for more than 20 years. The snap-in symbol buttons are available in accordance with DIN or in different colours upon customer request. The symbols are lit by bulbs or LEDs, which can be ordered as accessories. Replacement and retrofitting possible through standardised mounting hole and mounting frame.

Series 3100 – for tough and waterproof applications:

It meets the requirements of protection class IP 68 (dustproof and waterproof). The series is ideal for use in agricultural and construction vehicles because of its high degree of reliability under extreme conditions. It is also simple to install either directly in the mounting hole or using a modular mounting frame. Choose from a wide variety of standard and customer-specific symbols. These abrasion-resistant, lasered symbols are illuminated by integrated LEDs.

Series 4100 – for interior applications and safe switching of low currents:

The modular switch series with a self-cleaning microswitch is suitable for modern electrical and electronic systems. This also ensures reliable switching of small currents without any contamination of contacts taking place. The series stands out from the crowd with its timeless design. Its abrasion-resistant, lasered symbols are illuminated by integrated LEDs. A wide range of standard and customer-specific symbols can similarly be found on offer for this series, too.

DESIGN AND FUNCTION

The switches are modular and can be individually configured to suit customer requirements – starting with a single application right through to complete vehicle equipment. The following models are available: On / off switch (0-I), changeover switch (0-I-II, I-0-II), hazard warning switch, locking switch.

In addition to a large selection of switches and functions, we offer individualised and abrasion-resistant laser marking in addition to the standard characters. Customers can thus select their own personalised symbols themselves. And always all inclusive: the high-class HELLA quality.

Safe switching is guaranteed, even under difficult conditions. This is ensured by means of precise feedback, unambiguous symbols and the integrated orientation and functional lighting. A disable mode is also available as an option.

The rocker switches are mounted as snap-on fixtures on a pre-determined installation opening either directly or by means of an installation frame. In addition to individual frames, modular intermediate and end pieces that can be combined together are available, which means that switch rows can be created. Matching mating connectors, display lights and disassembly tools round off the range of accessories.



OVERVIEW OF VARIANTS



The HELLA switch configurator
Configure your custom switch at
www.hella.com/switch.

Select switching functions, symbol combinations and accessories with just a few clicks.



Switch series 4570 / 7832

Basic range for simple electrical systems with snap-on symbol buttons

TECHNICAL DATA

Mounting hole, without installation frame	44.1 x 22.1 mm
Mounting hole, with installation frame	51.3 x 48.1 mm (for two units)
Dashboard thickness for direct installation	1 to 2.5 mm
Dashboard thickness with installation frame	1 to 2.5 mm
Switching functions	Normally open contact, changeover contact, combination switch, normally open contact with lock, changeover contact with lock, hazard/warning light, display/warning light
Switch principle	Bridge switch
Actuation mode	Pushbutton, toggle
Circuits	Max. 2
Switching steps	0-1, 0-1-2, 1-0-2
Protection class	IP 5
Rated switching current, resistive load, 12 V	16 A
Rated switching current, resistive load, 24 V	8 A
Electrical service life, resistive load, 12 V	20,000, 16 A
Electrical service life, resistive load, 24 V	20,000, 8 A
Mechanical design life	250,000
Blade terminals	6.3 x 0.8 mm
Operating temperature	-35 to +65°C
Housing material	PA6
Rocker switch material	PA6
Function check	Yes, partially
Location lighting	Yes
Light source	LED / bulb
Type of symbols	Symbol button, coloured
Configurable online?	No
Part numbers	
12 V	On request
24 V	On request

TECHNICAL DRAWING

On and off switch

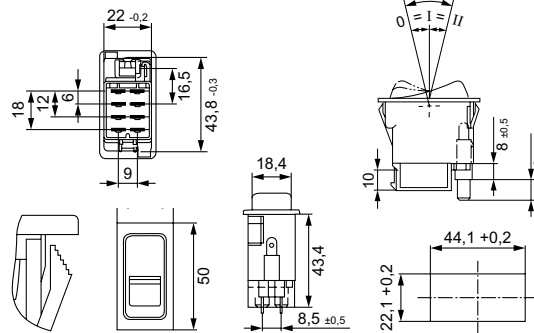

Switches

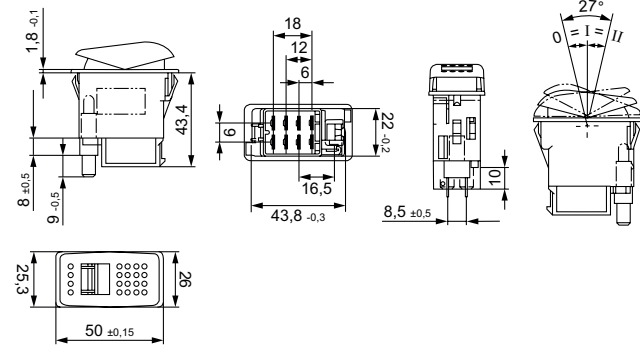

ACCESSORIES

Display/warning lights

	Part number	VPE*
For switch series 007 832 with 12 V bulb	2AA 713 628-021	10
For switch series 007 832 with 24 V bulb	2AA 713 628-031	10
For switch series 007 832 with LED, 12 V and 24 V	2AA 713 628-041	10
For switch series 004 570 with 12 V bulb	2AA 713 628-001	10
For switch series 004 570 with 24 V bulb	2AA 713 628-011	10
For switch series 004 570 with LED, 12 V and 24 V	2AA 713 628-051	10
Spare parts: W5/1.2 bulb, 12 V 1.2 W	8GP 002 095-121	10
Spare parts: W5/1.2 bulb, 24 V 1.2 W	8GP 002 095-241	10

* Packaging unit



Switch series 3100

Changeover switch with zero position for warning signal mode suitable for robust and waterproof applications

TECHNICAL DATA

Mounting hole, without installation frame	37.0 x 21.1 mm
Mounting hole, with installation frame	51.3 x 48.3 mm (for two units)
Dashboard thickness for direct installation	1.6 to 6.3 mm
Dashboard thickness with installation frame	2.5 to 6.5 mm
Switching functions	Normally open contact, changeover contact, Normally open contact with lock, Changeover contact with lock, Hazard/warning light, display/ warning light
Switch principle	Bridge switch
Actuation mode	Pushbutton, toggle
Circuits	Max. 2
Switching steps	0-1, 0-2, 0-1-2, 1-0-2
Protection class	IP 68, connector side: IP 66
Rated switching current, resistive load, 12 V	20 A
Rated switching current, resistive load, 24 V	15 A
Electrical service life, resistive load, 12 V	50,000, 20 A
Electrical service life, resistive load, 24 V	50,000, 15 A
Mechanical design life	150,000
Blade terminals	6.3 x 0.8 mm
Operating temperature	-40 °C to +85 °C
Housing material	PBT
Rocker switch material	PC transparent, painted
Function check	Yes, partially
Location lighting	Yes
Light source	LED
Type of symbols	Laser
Configurable online?	Yes
Part numbers	
12 V	Our switch configurator can be found at: www.hella.com/switch
24 V	

TECHNICAL DRAWING

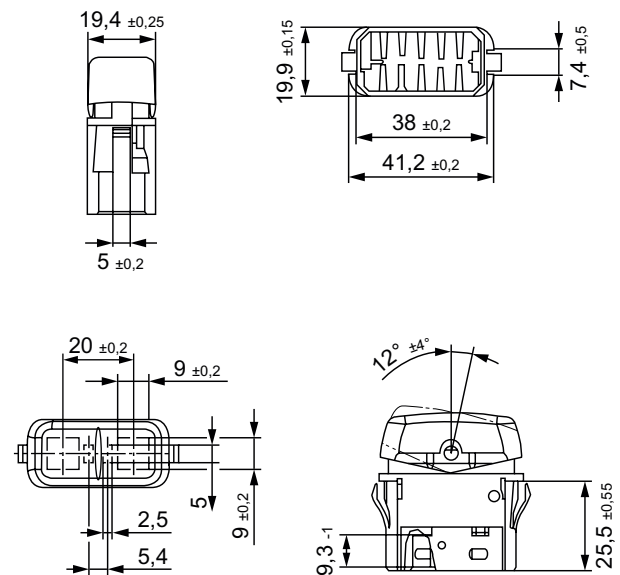

ACCESSORIES

Display/warning lights

	Part number	VPE*
For switch series 007 832 with 12 V bulb	2AA 713 628-021	10
For switch series 007 832 with 24 V bulb	2AA 713 628-031	10
For switch series 007 832 with LED, 12 V and 24 V	2AA 713 628-041	10
For switch series 004 570 with 12 V bulb	2AA 713 628-001	10
For switch series 004 570 with 24 V bulb	2AA 713 628-011	10
For switch series 004 570 with LED, 12 V and 24 V	2AA 713 628-051	10
Spare parts: W5 /1.2 bulb, 12 V 1.2 W	8GP 002 095-121	10
Spare parts: W5 /1.2 bulb, 24 V 1.2 W	8GP 002 095-241	10

* Packaging unit



Switch series 4100

Interior applications and safe switching of low currents

TECHNICAL DATA

Mounting hole, without installation frame	41.8 x 19.8 mm
Mounting hole, with installation frame	44.1 x 22.1 (for one unit) mm
Dashboard thickness for direct installation	2 (+ / - 0.3) mm
Dashboard thickness with installation frame	3 to 4 mm
Switching functions	Normally open contact, changeover contact, changeover contact with lock, hazard/warning light, display/warning light
Switch principle	Microswitch with self-cleaning contacts
Actuation mode	Pushbutton, toggle
Circuits	Max. 2
Switching steps	0-1, 0-1-2, 1-0-2
Protection class	IP 52
Rated switching current, resistive load, 12 V	10 A
Rated switching current, resistive load, 24 V	10 A
Electrical service life, resistive load, 12 V	50,000, 10 A
Electrical service life, resistive load, 24 V	50,000, 10 A
Mechanical design life	450,000
Blade terminals	2.8 x 0.8 mm
Operating temperature	- 40 °C to + 85 °C
Housing material	PA
Rocker switch material	PC transparent, painted
Function check	Yes, partially
Location lighting	Yes
Light source	LED
Type of symbols	Laser
Configurable online?	Yes

Part numbers

12 V	Our switch configurator can be found at: www.hella.com/switch
24 V	

TECHNICAL DRAWING

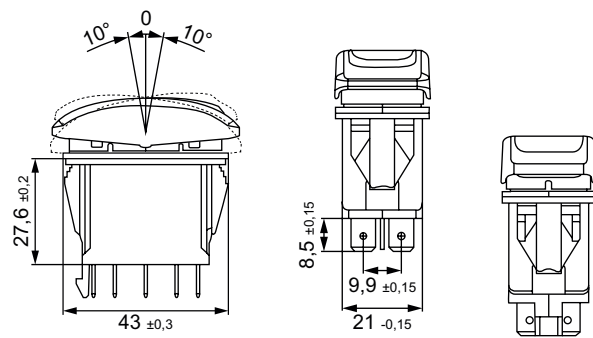

ACCESSORIES

Display/warning lights

	Part number	VPE*
For switch series 007 832 with 12 V bulb	2AA 713 628-021	10
For switch series 007 832 with 24 V bulb	2AA 713 628-031	10
For switch series 007 832 with LED, 12 V and 24 V	2AA 713 628-041	10
For switch series 004 570 with 12 V bulb	2AA 713 628-001	10
For switch series 004 570 with 24 V bulb	2AA 713 628-011	10
For switch series 004 570 with LED, 12 V and 24 V	2AA 713 628-051	10
Spare parts: W5/1.2 bulb, 12 V 1.2 W	8GP 002 095-121	10
Spare parts: W5/1.2 bulb, 24 V 1.2 W	8GP 002 095-241	10







* Packaging unit

Accessories

	4570- / 7832-	VPE*	3100-	VPE*	4100-	VPE*
Installation strips						
Installation strip for 6 switches	8HG 713 626-001	12	-	-	-	-
Installation strip for 3 switches	8HG 714 504-001	24	-	-	-	-
Installation frame insertion system						
Single frame	-	-	-	-	9AR 168 396-002	10
Single frame	-	-	-	-	9AR 168 396-007	200
End piece, left	8HG 716 734-001	10	9AR 169 209-102	10	9AR 169 209-002	10
End piece, left	8HG 716 734-007	200	9AR 169 209-107	100	9AR 169 209-007	100
Intermediate piece	8HG 716 735-001	1	9AR 169 208-102	10	9AR 169 208-002	10
Intermediate piece	8HG 716 735-007	200	9AR 169 208-107	200	9AR 169 208-007	200
End piece, right	8HG 716 734-001	10	9AR 169 209-102	10	9AR 169 210-002	10
End piece, right	8HG 716 734-007	200	9AR 169 209-107	100	9AR 169 210-007	200
Dummy cover	9HB 713 629-001	10	9HB 172 229-101	10	9HB 172 229-002	10
Dummy cover	-	-	9HB 172 229-107	10	9HB 172 229-007	52
Female connector housing						
Female connector housing, type 1	8JA 713 631-001	10	8JD 010 076-102	10	8JD 010 076-002	10
Female connector housing, type 1	8JA 713 631-007	1000	8JD 010 076-107	50	8JD 010 076-007	440
Female connector housing, type 2	-	-	8JD 010 076-112	10	-	-
Female connector housing, type 2	-	-	8JD 010 076-117	50	-	-
Female connector housing, type 3	-	-	8JD 010 076-122	10	-	-
Female connector housing, type 3	-	-	8JD 010 076-127	50	-	-
Female connector housing, bulb holder	8JA 715 600-001	10	-	-	-	-
Dismantling tool	-	-	8PE 197 631-001	1	-	-
Flat receptacles/ Junior Power Timer						
Flat receptacle CuSn/ Sn, Cross section: 0.5 – 1.0 mm ²	-	-	8KW 744 882-003	100	8KW 863 934-003	50
Flat receptacle CuSn/ Sn, Cross section: 1.0 – 2.5 mm ²	-	-	8KW 744 825-003	100	8KW 863 934-023	50
Flat receptacle CuSn/ Sn, Cross section: 1.0 – 2.5 mm ²	-	-	-	-	8KW 863 934-003	1000
Bulb-sockets						
Bulb holders for display/warning lights with 12 V bulb	9FF 713 627-001	10	-	-	-	-
Bulb holders for display/warning lights with 24 V bulb	9FF 713 627-011	10	-	-	-	-
Spare parts: W5/1.2 bulb, 12 V 1.2 W	8GP 002 095-121	10	-	-	-	-
Spare parts: W5/1.2 bulb, 24 V 1.2 W	8GP 002 095-241	10	-	-	-	-
Bulb holders with LED, 12 V and 24 V	9FF 713 627-031	10	-	-	-	-

* Packaging unit



LIGHTING ELECTRONICS	AREA OF APPLICATION
LED lighting: Failure monitor and electrical connection	
LED flasher unit: towing vehicle	
LED flasher unit: for LED direction indicators 12 V and 24 V	
LED light control unit	
Control unit for flashing side marker lights	
Control unit for current monitoring	
Simulation device for cold checking	



LIGHTING ELECTRONICS

The focus here is on the control of the lighting function.

These electronic products offer solutions for "communication" between the LED lamps and the vehicle and for monitoring the function. They ensure that the lighting electronics or the flasher unit can be matched to the connected lighting.



LED lighting
Failure monitor and electrical connection

LED LIGHT FAILURE MONITOR

A defined standard such as for bulbs cannot be used for the monitoring of LED lights. Every LED light is different in its technical design and its energy consumption:

- Due to the number of LEDs,
- the intensity with which they are driven,
- and also due to the electronic ballast necessary for their operation.

Monitoring of the lamp failure is therefore no longer as simple as it once was with bulbs. HELLA has various approaches as solutions to this problem that are summarised here under the heading "Lighting Electronics".

FUNCTIONAL DIAGRAM

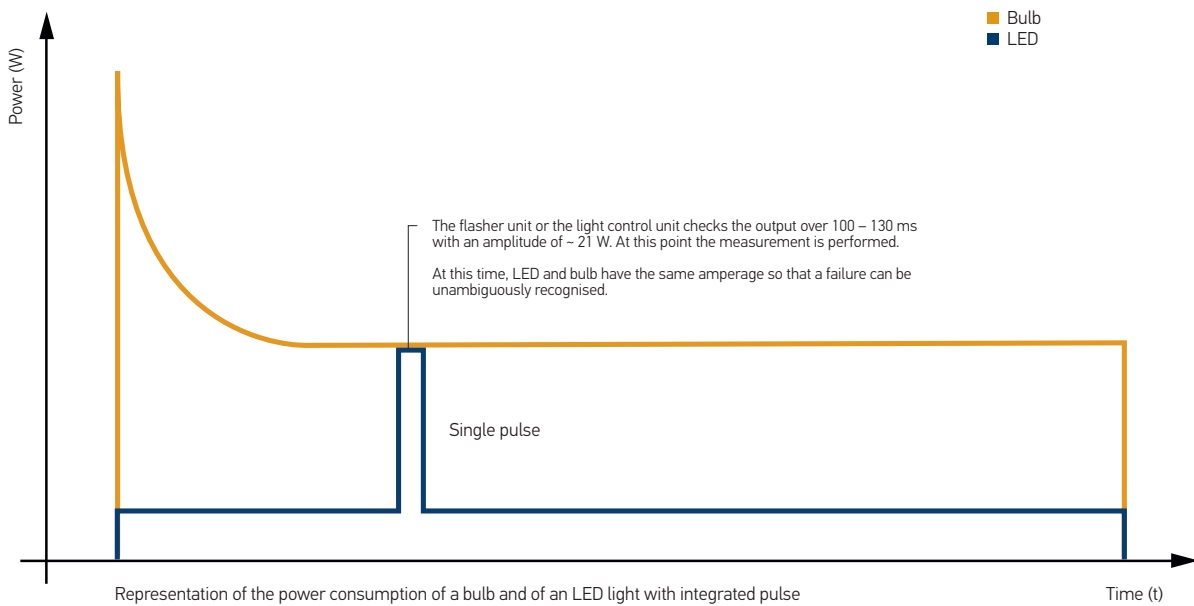



WHAT IS DEMANDED BY LAW?

ECE R48 defines that direction indicator lamps/flashers showing the direction of travel have to be monitored and that their failure has to be signaled optically.

THERE ARE TWO POSSIBILITIES:

- The LED light either has to be able to "communicate" with the vehicle
- The "communication" is the better approach here, but is not always possible, e.g. between towing vehicle and trailer.

SOLUTIONS:

The optimum solution is to match the lighting electronics or the flasher unit to the connected lighting. This is only possible in the most seldom of cases, however, as either a towing vehicle or trailer is involved or the vehicle electronics have already been stipulated by third parties.

Flasher units

ISO 13207-conformant LED flashers can "communicate" with the flasher unit. The flasher unit checks for a defined energy consumption at a defined point in time: Exactly 21 W for 100-130 ms after each switching on of the direction indicator. The energy consumption or "pulse" corresponds here to that of a bulb, so that the flasher unit notices no difference between a bulb and an ISO 13207-conformant LED lamp.

If the intelligent ISO 13207-conformant LED light detects a defect or only a partial defect, this "pulse" is switched off and the flasher unit can interpret this as a failure. ISO 13207-compliant LED lights and ISO 13207-compliant flasher units are required for this method.

Advantage:

Bulbs and ISO LED lights can be operated in any combination on an ISO 13207-conformant flasher unit. This is relevant both for vehicles that are frequently operated with different trailers and for manufacturers who wish to offer several variants of the lighting system without having to modify the underlying electronics.

LED lamp control units for use with third-party electronics

If the vehicle electronics have already been stipulated by third parties, HELLA offers LED control units that monitor the LED lights on the one hand, and on the other hand simulate to the vehicle that bulbs are connected. This allows LED lights to be used without any problems.

Current monitoring

Another possibility is to measure the average energy consumption of the headlamp or the LED light.

Disadvantage:

In most cases, however, partial defects cannot be detected in this way: With very efficient LED lights, it is possible that their energy consumption is so low that they are detected as defective even when functioning correctly. Or in the worst case: The electronic ballast of the LED light requires so much energy that a failure cannot be detected even if all the LEDs are defective.



LED lighting
Failure monitor and electrical connection
LED flasher unit: towing vehicle

ISO 13207-conformant LED direction indicators can "communicate" with the flasher unit. The flasher unit checks for a defined energy requirement at a defined point in time: exactly 21 W for 100-130 ms after each activation of the direction indicator. The energy consumption or "pulse" corresponds here to that of a bulb, so that the flasher unit notices no difference between a bulb and an ISO 13207-conformant LED light.

Benefit: Bulbs and ISO LED lamps can be operated in any combination on an ISO 13207-conformant flasher unit. This is relevant both for vehicles that are frequently operated with different trailers and for manufacturers who wish to offer several variants of the lighting system without having to modify the underlying electronics.

TECHNICAL DATA – 12 V

Operating voltage	10 – 15 V
Functional voltage	11 – 14 V
Operating temperature	-40 to +85 °C
Protection class	IP 53 (contacts underneath)
Contacting	Blade terminal DIN 46244 A6, 3 x 0.8

TECHNICAL DATA – 24 V

Operating voltage	18 – 32 V
Functional voltage	20 – 28 V
Operating temperature	-40 to +85 °C
Protection class	IP 53 (contacts underneath)
Contacting	Blade terminal DIN 46244 A6, 3 x 0.8



12 V, LED flasher unit 3+1

3 Indicators on the vehicle / tractor vehicle
1 direction indicator on optional trailer

Minimum switching power	18 W
Maximum switching power	171 W
Error threshold towing vehicle	58 W
Error threshold towing vehicle + trailer	77 W

4DW 009 492-111



24 V, LED flasher unit 3+1

3 Indicators on the vehicle / tractor vehicle
1 direction indicator on optional trailer

Minimum switching power	18 W
Maximum switching power	171 W
Error threshold towing vehicle	59 W
Error threshold towing vehicle + trailer	82 W

4DW 009 492-011

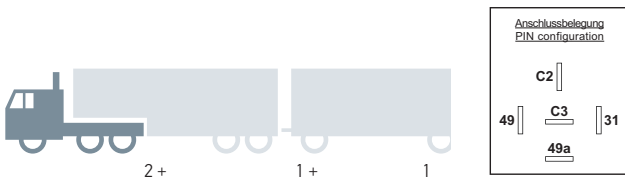

12 V, LED flasher unit 2+1+1

2 indicators on the vehicle / traction vehicle
1 direction indicator at max. 2 optional trailers

Minimum switching power	18 W
Maximum switching power	171 W
Error threshold towing vehicle	39 W
Error threshold towing vehicle + trailer	59 W
Error threshold towing vehicle + 2 trailers	80 W

4DN 009 492-101



24 V, LED flasher unit 2+1

2 indicators on the vehicle / traction vehicle
1 direction indicator on optional trailer

Minimum switching power	18 W
Maximum switching power	129 W
Error threshold towing vehicle	33 W
Error threshold towing vehicle + trailer	59 W

4DM 009 492-001

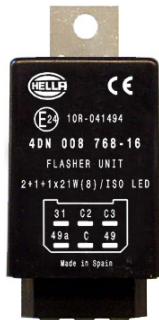

LED lighting LED flasher unit: for LED direction indicators 12 V and 24 V

PRODUCT FEATURES

- Controls flashing function in the vehicle
- Switches the warning display and the control/indicator lamp on and off
- For vehicles fitted with a trailer coupling, the unit takes over the indicator function for the trailer and triggers the additional indicator control lamp
- Universal connection of LED direction indicator lamps, that do not have an electronic pulse

TECHNICAL DRAWING

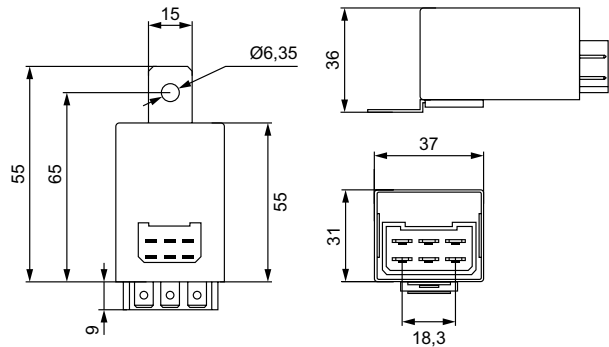

12 V, LED flasher unit 2+1+1

2 indicators on the vehicle / traction vehicle
1 direction indicator at max. 2 optional trailers

4DN 008 768-161

TECHNICAL DATA

Rated voltage	12 V DC
Operating voltage	10,5–16 V
Rated load	2 + 1 + 1 x 21 W (8 x 21 W) or comparable LED cluster to ISO standard
Frequency	95 ± 20 c/m (at 14 V – 23°C)
Failure monitor	Increased frequency (min. 150 c/m, max. 200 c/m; at 14 V – 23°C)
Bright-light time	40–60 %
Operating temperature	-40 to +85 °C
Storage temperature	-40 to +85 °C
Contacting	Blade terminal DIN 46244 A6, 3 x 0.8

PIN ASSIGNMENT

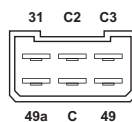

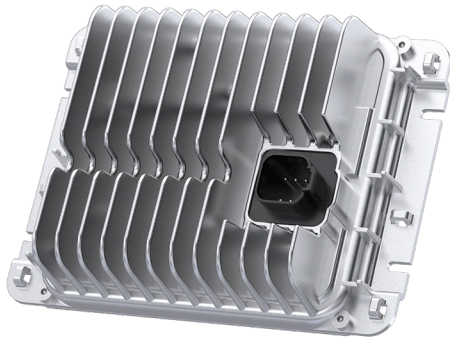

LED lighting
Failure monitor and electrical connection
LED light control unit

HELLA offers two different types of LED light control units designed to monitor lighting functions.

- Basic version: This only monitors the direction indicator
- Premium Version: This monitors all lighting functions

Only one control unit is required for the left and the right side.

- The DEUTSCH connector, itself integrated in the housing, enables easy integration in the vehicle architecture
- Active thermal management, including overheating protection, for a long service life
- Completely watertight and dust-proof for maximum functioning safety
- Electromagnetic compatibility (EMC) for trouble-free use of, for example, radio

System representation: Basic

Control unit is responsible **only** for monitoring the direction indicators.

TECHNICAL DATA

Operating temperature	-40 to +50 °C
Protection class	IP 6K9K

BASIC CONTROL UNIT

12 V Basis	5DS 227 488-001
24 V Basis	5DS 227 488-101

TECHNICAL DRAWING

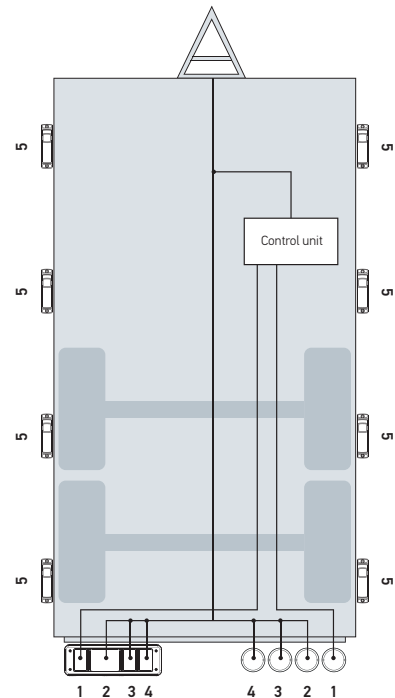
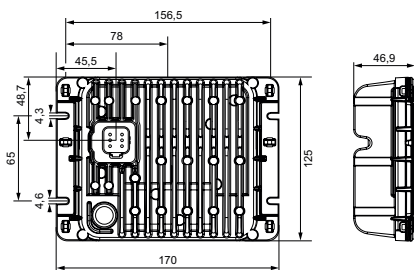

- Legend
- 1 - Direction indicator
 - 2 - Stop-tail lamp
 - 3 - Reverse light
 - 4 - Rear fog light
 - 5 - Side marker light

PIN ASSIGNMENT

- 1 Input Direction indicator, right
- 2 Input Ground
- 3 Input Direction indicator, left
- 4 Output Direction indicator, left
- 5 Output Ground
- 6 Output Direction indicator, right

System representation: Premium

Control unit is responsible for monitoring the **whole** rear lighting (tail lights, brake lights, direction indicators, reversing light and rear fog light).

TECHNICAL DATA

Operating temperature	-40 to +50 °C
Protection class	IP 6K9K

PREMIUM CONTROL UNIT

12 V Premium (1 stop light channel)	5DS 227 489-001
12 V Premium (2 stop light channels)	5DS 227 489-011
24 V Premium (1 stop light channel)	5DS 227 489-101

TECHNICAL DRAWING

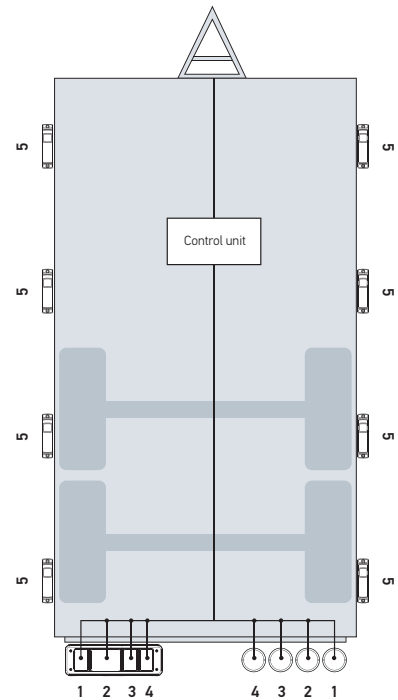
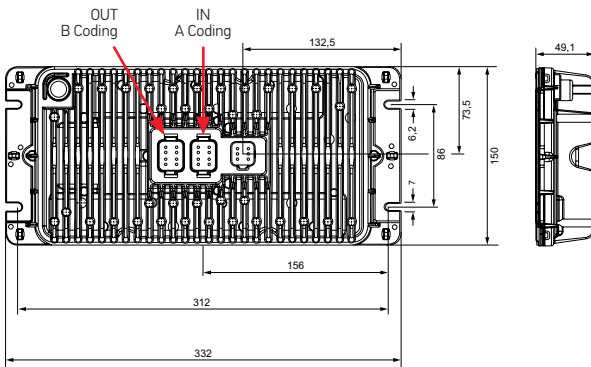

Legend

- 1 – Direction indicator
- 2 – Stop-tail lamp
- 3 – Reverse light
- 4 – Rear fog light
- 5 – Side marker light

PIN ASSIGNMENT 12 V

- 1 Input Stop light, left
- 2 Input Tail light, right
- 3 Input Tail light, left
- 4 Input Stop light, right
- 5 Input Reversing light
- 6 Input Rear fog light
- 7 Input Ground
- 8 free

PIN ASSIGNMENT 12 V / 24 V

- 1 Input/output Stop light
- 2 Input Tail light, right
- 3 Input Tail light, left
- 4 free
- 5 Input Reversing light
- 6 Input Rear fog light
- 7 Input Ground
- 8 free

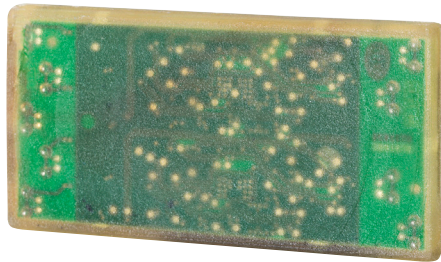

LED lighting
Control unit for flashing side marker lights

In order to increase the safety of trailers, the side marker lights can flash synchronously with the direction indicators.

PRODUCT FEATURES

The control unit monitors functioning of the rear direction indicator. In the event of a fault, it switches off the flasher function of the side marker lights to ensure that the failure monitor of the towing vehicle conforms to the law.

- Only one control unit is required
- The compact design permits installation in a distribution box
- Extremely robust and watertight thanks to full encapsulation
- High degree of EMC protection for use in very challenging environments
- Suitable for use with all LED side marker lights

TECHNICAL DATA

Operating temperature	-40 to +65 °C
Protection class	IP 6K9K
Contacting	Blade terminal DIN 46244 A6, 3 x 0.8

This control unit can be connected to any side marker light and allows it to flash, if necessary.

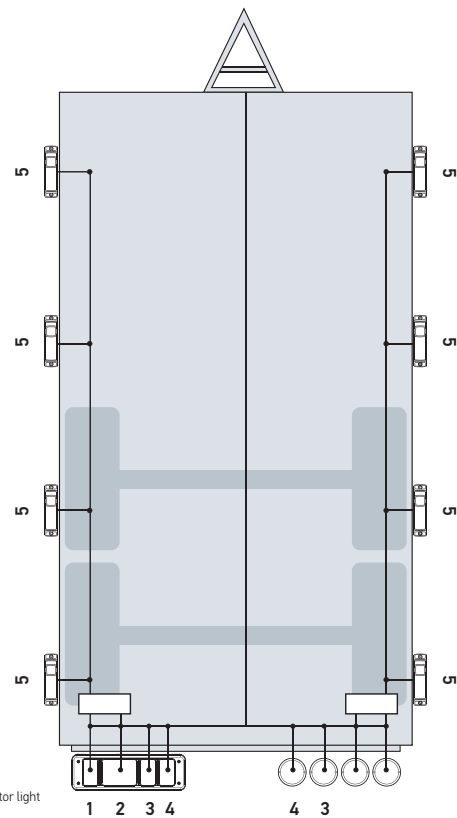

- Legend
- - Control unit
 - 1 - Direction indicator
 - 2 - Stop-tail lamp
 - 3 - Reverse light
 - 4 - Rear fog light
 - 5 - Side marker / indicator light

CONTROL UNIT FOR FLASHING SIDE MARKER LIGHTS

ECE-R48 Kategorie 6, 24 V SDS 223 544-001

PIN ASSIGNMENT

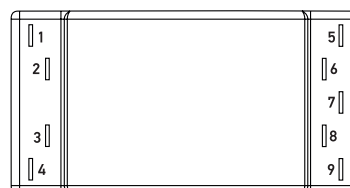

- 1 Output Side marker, left
- 2 Output Direction indicator, left
- 3 Output Side marker, right
- 4 Output Direction indicator, right
- 5 Input Tail light, left
- 6 Input Direction indicator, left
- 7 Mass
- 8 Input Tail light, right
- 9 Input Direction indicator, right

ECE-R48 REVISION 6

Mandatory: The vehicle **must** be equipped with a side flasher function.

Option 1: On a vehicle with side marker lights, direction indicators belonging to CAT 5 are operated.



OR

Option 2: On the vehicle, the existing side marker lights are switched on / off together with the direction indicator light. The existing side marker lights are switched on / off together with the direction indicator light (in phase), i.e. all side marker lights on one side must flash (except for combination lamps such as rubber arm lights). All yellow lights perform the the flasher function synchronously.



FAILURE MONITOR

If the side marker lights flash together (in phase) with the rear direction indicator light, they obtain their energy from the same supply line. If the rear direction indicator light is defective, this may have the result that the failure monitor fitted in the towing vehicle no longer functions in conformity with the law and does not identify a failure. The control electronics developed by HELLA ensure the necessary safety here. A fault in the rear direction indicator light is reliably identified, and the towing vehicle is able to inform the driver.



In order to test LED low beam headlamps or LED beacons, the average energy consumption is determined by measuring the current. The current monitors are matched to the HELLA products and allow very reliable monitoring.

LED lighting
Failure monitor and electrical connection
Control unit for current monitoring

PIN ASSIGNMENT

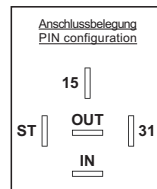

CIRCUIT DIAGRAM

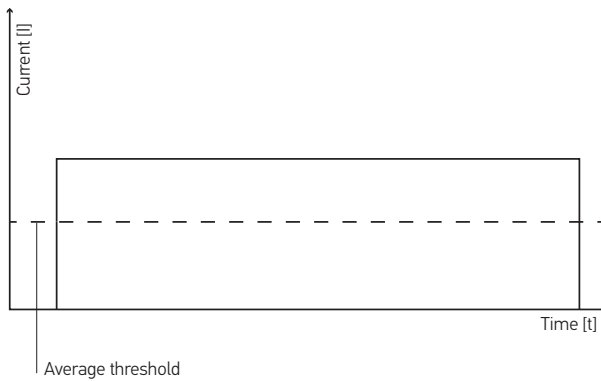

Control unit for current monitoring
Direct reading
Example 90 mm LED module headlight L 4060



Variant	Voltage	SCHWELLE
5DS 011 630-001	12 V	500 mA
5DS 011 630-211	24 V	350 mA

TECHNICAL DATA

Operating temperature	-40 to +85 °C
Protection class	IP 5KX
Contacting	Blade terminal DIN 46244 A6, 3 x 0.8

CIRCUIT DIAGRAM

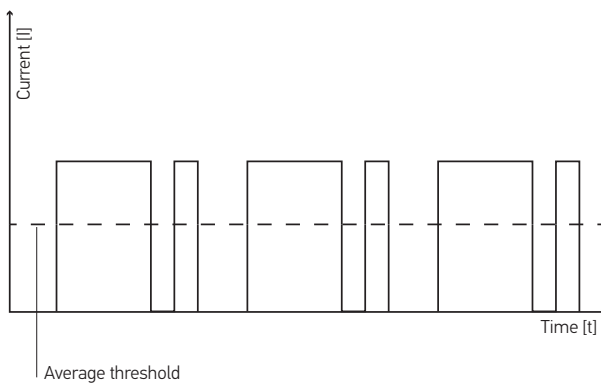

Control unit for current monitoring
Integrated reading over time
Example K-LED 2.0 beacon



Variant	Voltage
5KG 011 630-101	12 V

TECHNICAL DATA

Operating temperature	-40 to +85 °C
Protection class	IP 5KX
Contacting	Blade terminal DIN 46244 A6, 3 x 0.8



LED lighting
 Failure monitor and electrical connection
Simulation device for cold checking

If the existing vehicle electrical system is programmed to monitor the lighting even when it is not in operation, we speak of a cold check. During a cold check, a small test pulse is transmitted to the light while switched off to see whether this pulse is discharged via the bulb to ground. The energy here is so low that the bulb does not light up.

As LED lights are essentially not suitable for this form of monitoring, HELLA offers an electronic system for "simulation of the cold check" to ensure operation.

12 V	
Operating voltage	9 – 16 V
Rated current	1.5 A
Operating temperature	-40 to +85 °C
Protection class	IP 54 (contacts below)
Contacting	Blade terminal DIN 46244 A6, 3 x 0.8
PART NUMBER	5DS 009 602-011



24 V	
Operating voltage	18 – 32 V
Rated current	1.5 A
Operating temperature	-40 to +85 °C
Protection class	IP 54 (contacts below)
Contacting	Blade terminal DIN 46244 A6, 3 x 0.8
PART NUMBER	5DS 009 602-001

HELLA GmbH & Co. KGaA

Rixbecker Straße 75
59552 Lippstadt, Germany
Tel.: +49 2941 38-0
Fax: +49 2941 38-7133
Internet: www.hella.com

© HELLA GmbH & Co. KGaA, Lippstadt
922 999 141-715 J01517/FR/02.19/1.6
Printed in Germany

Subject to technical and price modifications..