

Service Manual

Digital Imaging Systems

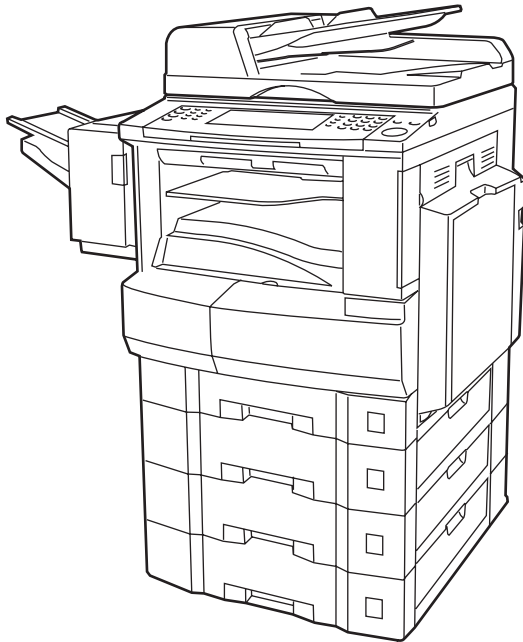

DP-8032 / 8025

[Version 1.2]

WARNING

This service information is designed for experienced repair technicians only and is not intended for use by the general public. It does not contain warnings or cautions to advise non-technical individuals of potential dangers in attempting to service a product. Products powered by electricity should be serviced or repaired only by experienced professional technicians. Any attempt to service or repair the product or products dealt within this service information by anyone else could result in serious injury or death.

IMPORTANT SAFETY NOTICE

There are special components used in this equipment which are important for safety. These parts are marked by  in the Schematic Diagrams, Circuit Board Diagrams, Exploded Views and Replacement Parts List. It is essential that these critical parts should be replaced with manufacturer's specified parts to prevent shock, fire or other hazards. Do not modify the original design without permission of manufacturer.

Panasonic[®]

© Panasonic Communications Co., Ltd. 2008.
Unauthorized copying and distribution is a violation of law.

General Annotations

1. Panasonic Communications Company of North America, and other Panasonic Sales Companies reserve the right to change any information enclosed herein without prior notification. (This includes, but is not limited to, parts pricing, availability, and text)
2. Electrical parts supplied may include previously used components.
3. **⚠ Important Safety Notice**
Components identified by a **⚠** mark, have special characteristics important for safety. When replacing any of these components, use only manufacturer's specified parts.
4. In New Parts column, "**N**" indicates part is used only in DP-8032 Series, "**C**" indicates part is used in previous models.
5. In Remarks column, "**PM**" indicates "Preventive Maintenance Part".
6. In Remarks column, "**RTL**" indicates that the Retention Time is limited for this item. After the discontinuation of this assembly in production, the item will continue to be available for a specific period of time. The retention period of availability is dependent on the type of assembly, and in accordance with the laws governing part and product retention. After the end of this period, the assembly will no longer be available.
7. This "Unit" which includes other itemized parts is provided as "Limited Availability" for your convenience, and will only be offered for up to 3 years after the production of the unit ceases. However, the individual contents of the assembly will be available for the standard period.
8. **This Product Uses Lead (Pb) Free Solder Printed Circuit Boards (PCBs).**
Information regarding Lead-Free (PbF) solder;

Distinction of PbF PCB:

PCBs (manufactured) using lead free solder will have a **PbF** mark following the PCB part numbers in a label on the PCB.

Caution:

- Pb free solder has a higher melting point than standard solder; typically the melting point is 50 - 70 °F (30 - 40 °C) higher. Please use a soldering iron with temperature control and adjust it to 700 ± 20 °F (370 ± 10 °C). Exercise care while using higher temperature soldering irons, do not heat the PCB for too long to prevent solder splash or damage to the PCB.
- Pb free solder will tend to splash when heated too high (about 1112 °F/600 °C).
- ECO SOLDER M705 (available from Senju Metal Industry Co., Ltd.;
[URL: http://www.senju-m.co.jp](http://www.senju-m.co.jp)) is recommended when repairing PbF PCBs.

General Annotations

9. Important Notice

(Especially for countries belonging to the European Union):

This product is fully compliant with the national laws transposed from the EU Directive on the restriction of the use of certain hazardous substances (RoHS) in electrical and electronic equipment, effective July 1, 2006 in the EU countries.

In order for the product to comply with the RoHS Directive, the six particular substances (lead, mercury, cadmium, hexavalent chromium, polybrominated biphenyls, and polybrominated diphenyl ethers) have been either totally eliminated or limited to the concentration level below maximum allowed. Consequently spare parts have been changed to RoHS-compliant parts where applicable.

Due to spare parts application of RoHS legislation, non-compliant spare parts cannot be used to repair compliant products put on the EU market on or after July 1, 2006. Therefore, please make sure to order and use only RoHS-compliant spare parts listed in this manual.

The contents of this Manual, and the Specifications are subject to change without notice.

Panasonic Communications Co., Ltd. reserves the right to make improvements in the product design without reservation, and without notice.

Published in Japan.

Important Notice

Please read this notice completely **BEFORE** installing any optional accessories. As failure to properly install the additional board or connector with the power ON (only the front power switch Off) could damage the copier's SPC or SC board.

Please follow the instructions below:

1. It is essential that you turn OFF power to the Main Power Switch located in the rear of the copier.
2. It is essential that you unplug the Main AC Power Cord from the wall outlet.
3. Please carefully read the installation instructions and follow each step.

< Example >

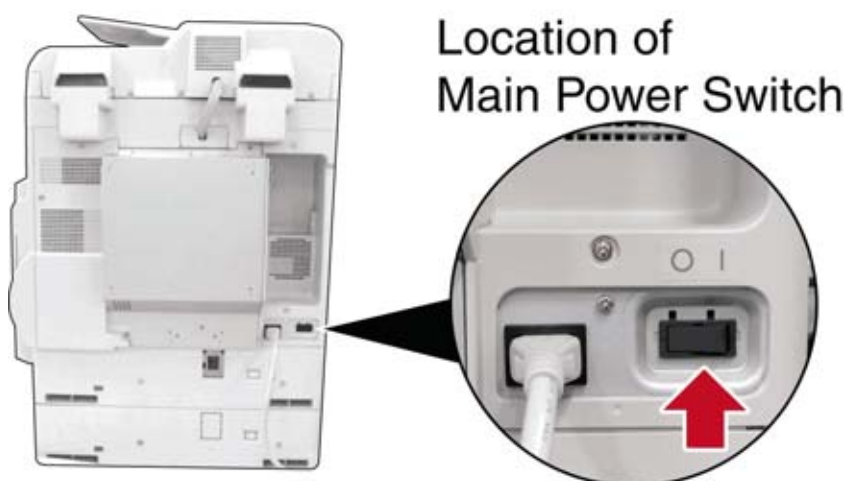

Note:

If the Hard Disk Drive Unit is installed, to prevent a Disk Scan Function from being performed (similar to Windows OS when the power is abruptly interrupted), it is important to follow the step sequence below when turning OFF the Power Switches on the machine.

1. Turn the Power Switch on the Left Side of the machine to the OFF position first.
2. Wait approximately 10 seconds while the machine writes the closing status onto the Hard Disk Drive Unit.
3. Turn the Main Power Switch on the Back of the machine to the OFF position.
(This interrupts all the power to the machine)
4. Unplug the AC Power Cord.

* The specifications are subject to change without notice. Panasonic Communications Co., Ltd. reserves the right to make improvements in the product design without reservation and without notice.

Wichtiger Hinweis

Diesen Hinweis bitte ganz durchlesen, BEVOR optionales Zubehör installiert wird. Ansonsten bei inkorrektem Einbau bzw. Anschluss der zusätzlichen Leiterplatte, wenn die Netzspannung zugeschaltet ist, die SPC- oder SC- Leiterplatte der Maschine beschädigt werden könnte.

Bitte die Anweisungen unten beachten:

1. Unbedingt den Betriebsschalter auf der rechten Seite der Maschine ausschalten.
2. Unbedingt das Netzkabel aus der Wandsteckdose ziehen. (Falls die Fax-Option installiert ist, sollte bei einem Gewitter das Telefonkabel entfernt werden, bevor das Netzkabel gezogen wird, um einen elektrischen Schlag zu vermeiden.)
3. Die Installationsanleitung sorgfältig durchlesen und genau befolgen.

< Beispiel >

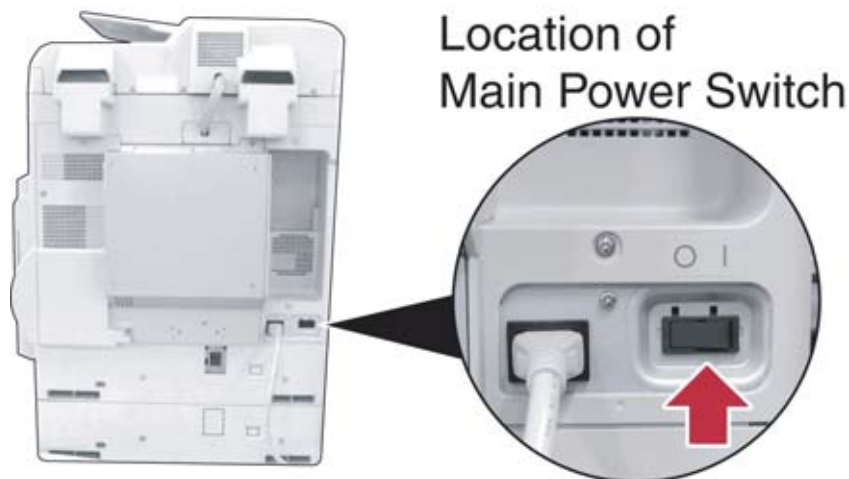

Hinweis:

Um zu verhindern, daß nach dem Einbau des Festplattenlaufwerks ein Disk-Scan ausgeführt wird (ähnlich dem Windows-BS, wenn die Spannung plötzlich unterbrochen wird), ist es wichtig, beim Ausschalten der Netzschalter an der Maschine gemäß untenstehender Schrittfolge vorzugehen.

1. Zuerst den Betriebsschalter auf der linken Seite der Maschine auf OFF stellen.
2. Ca 10 Sekunden warten, während die Maschine den Endstatus auf die Festplatte schreibt.
3. Den Hauptnetzschalter auf der Rückseite der Maschine auf OFF stellen.
(Dadurch wird die gesamte Stromzufuhr zur Maschine unterbrochen)
4. Das Netzkabel abziehen.

* Technische Änderungen jederzeit vorbehalten. Panasonic Communications Co., Ltd. behält sich das Recht vor, jederzeit und ohne Mitteilung Verbesserungen des Produkt-Design durchzuführen.

Precautions

For Your Safety

To prevent severe injury and loss of life, read this section carefully before servicing the Panasonic machine to ensure proper, and safe operation of your machine.

Please ensure that the machine is installed near a wall outlet, and is easily accessible.

- This section explains the Warnings and Cautions used in the machine and/or this manual.



WARNING: Denotes a potential hazard that could result in serious injury or death.



CAUTION: Denotes hazards that could result in minor injury or damage to the machine.

- This section also explains the Warnings and Cautions used in the machine and/or this manual.



These symbols are used to alert operators to a specific operating procedure that must not be performed.



These symbols are used to alert operators to a specific operating procedure that must be emphasized in order to operate the machine safely.



WARNING

Power and Ground Connection Cautions



Ensure that the plug connection is free of dust. In a damp environment, a contaminated connector can draw a significant amount of current that can generate heat and eventually cause fire if left unattended over an extended period of time.



Always use the power cord provided with your machine. When an extension power cord is required, always use a properly rated cord.

- 120 V/15 A or AC 220 - 240V/10 A

If you use a cord with an unspecified current rating, it may be underrated, and the machine, or plug may emit smoke, or become hot to the touch.



Do not attempt to repair, pull, bend, chafe or otherwise damage the power cord. Do not place a heavy object on the cord. A damaged cord can cause fire or electric shocks.



Never touch a power cord with wet hands. Danger of electric shock exists.



If the power cord is damaged, or insulated wires are exposed, contact the authorized Panasonic dealer for a replacement. Using a damaged cord can cause fire or electric shocks.



Stop operation immediately if your machine emits smoke, excessive heat, unusual noise, or abnormal smell, or if water is spilt onto the machine. These conditions can cause fire. Immediately switch Off and unplug the machine, and contact the authorized Panasonic dealer.



Do not disconnect or reconnect the machine while the power switch is in the On position. Disconnecting a live connector can cause arcing, consequently deforming the plug and cause fire.



When disconnecting the machine, grasp the plug instead of the cord. Pulling on a cord forcibly can damage it, and cause fire, or an electric shock.



When the machine is not used over an extended period of time, switch it Off and unplug it. If an unused machine is left connected to a power source for a long period, degraded insulation can cause electric shocks, current leakage or fire.



Be sure to switch Off, and unplug the machine before accessing the interior of the machine for cleaning, maintenance or fault clearance. Access to a live machine's interior can cause an electric shock.



Once a month, unplug the machine and check the power cord for the following. If you notice any unusual condition, contact your authorized Panasonic dealer

- The power cord is plugged firmly into the receptacle.
- The plug is not excessively heated, rusted, or bent.
- The plug and receptacle are free of dust.
- The cord is not cracked or frayed.

Operating Safeguards



Do not touch areas where these caution labels are attached to, the surface may be very hot and may cause severe burns.



Do not place any liquid container such as a vase, or coffee cup on the machine. Spilt water can cause fire or shock hazard.



Do not place any metal parts such as staples or clips on the machine. If metal and flammable parts get into the machine, they can short-circuit internal components, and cause fire or electric shocks.



If debris (metal or liquid) gets into the machine, switch Off and unplug the machine immediately. Operating a debris-contaminated machine can cause fire or electric shock.



Do not try to alter the machine configuration or modify any parts. An unauthorized modification can cause smoke or fire.

Consumable Safeguards



Never dispose of toner, toner cartridge, or a waste toner container into an open flame. Toner remaining in the cartridge/bottle can cause an explosion, burns and/or injuries.



Keep button batteries/stamp out of the reach of children to prevent choking or poisoning. If a button battery/verification stamp is swallowed accidentally, get medical treatment immediately.

Notice: California only:

This product contains a CR Coin Cell Lithium Battery which contains Perchlorate Material - special handling may apply. See www.dtsc.ca.gov/hazardouswaste/perchlorate



CAUTION

Installation and Relocation Cautions



Do not place the machine near heaters or volatile, flammable, or combustible materials such as curtains that may catch fire.



Do not place the machine in a hot, humid, dusty, or poorly ventilated environment. Prolonged exposure to these adverse conditions can cause fire or electric shocks.



Place the machine on a level and sturdy surface that can withstand the weight of the machine. Refer to the Specifications section for the weight of the machine. If tilted, the machine may tip-over and cause injuries.



When relocating the machine, remove the toner and/or developer, and pack the machine with proper packing materials for shipping.













When moving the machine, be sure to unplug the power cord from the outlet. If the machine is moved with the power cord attached, it can cause damage to the cord which could result in fire or electric shock.





CAUTION

Operating Safeguards

-  Do not place a magnet near the safety switch of the machine. A magnet can activate the machine accidentally, resulting in injuries.
-  Do not use a highly flammable spray, or solvent near the machine. It can cause fire.
-  When copying a thick document, do not use excessive force to press it against the scanning glass. The glass may break and cause injuries.
-  Never touch a labelled area found on, or near the heat roller. You can get burnt. If a sheet of paper is wrapped around the heat roller, do not try to remove it yourself to avoid injuries or burns. Switch Off the machine immediately, and wait until it cools down.
-  Do not use conductive paper, e.g. folding paper, carbon paper and coated paper. When a paper jam occurs, they can cause a short circuit and fire.
-  Do not place any heavy object on the machine. An off-balance machine can tip-over, or the heavy object can fall, causing damage and/or injuries.
-  Keep the room ventilated when using the machine for an extended period of time to minimize the ozone density in the air.
-  When copying with the document cover open, do not look directly at the exposure lamp. Direct eye exposure can cause eye fatigue or eye injury.
-  Pull the paper trays out slowly to prevent injuries.
-  When removing jammed paper, make sure that no pieces of torn paper are left in the machine. A piece of paper remaining in the machine can cause fire. If a sheet of paper is wrapped around the heat roller, or when clearing a jammed paper that is difficult or impossible to see, do not try to remove it by yourself. Doing so can cause injuries or burns. Switch Off the machine immediately, and wait until it cools down.

Consumable Safeguards

-  Never heat the drum cartridge, or scratch its surface. A heated, or scratched drum can be hazardous to your health.
-  Do not mix new and old batteries together, as they can burst or leak, causing a fire or injuries. Be sure to use the specified type of batteries only.
-  Ensure that batteries are installed with correct polarity. Incorrectly installed batteries can burst or leak, resulting in spillage or injuries.

Others

- When clearing a paper jam or other fault, follow the appropriate procedure given in this manual.
- The machine has a built-in circuit for protection against lightning-induced surge current. If lightning strikes in your neighborhood, maintain an ample distance from the machine, and do not touch it until the lightning stops.
- If you notice flickering, distorted images, or noises on your audio-visual units, your machine may be causing radio interference. Switch it Off, and if the interference disappears, the machine is the cause of the radio interference. Perform the following procedure until the interference is corrected.
 - Move the machine, and the TV and/or radio away from each other.
 - Reposition or reorient the machine, and the TV and/or radio.
 - Unplug the machine, TV and/or radio, and replug them into outlets operating on different circuits.
 - Reorient the TV and/or radio antennas, and cables until the interference stops. For an outdoor antenna, ask your local electrician for support.
 - Use a coaxial cable antenna.



Einmal im Monat die Maschine vom Netz trennen und das Netzkabel auf Folgendes prüfen. Wenn ein ungewöhnlicher Zustand vorgefunden wird, wenden Sie sich an Ihren Panasonic-Fachhändler.

- Das Netzkabel ist fest in die Steckdose eingesteckt.
- Der Stecker ist nicht stark erhitzt, verrostet oder verbogen.
- Stecker und Steckdose sind frei von Staub.
- Das Kabel ist nicht gerissen oder aufgefasert.

Bedienungs-Schutzmaßnahmen



Berühren Sie nicht Bereiche, wo diese Vorsichtsaufkleber an der Oberfläche angebracht sind, da diese sehr heiß sein können und zu schweren Verbrennungen führen können.



Stellen Sie keine Flüssigkeitsbehälter wie eine Vase oder Kaffeekanne auf die Maschine. Verschüttetes Wasser kann zu Bränden oder elektrischen Schlägen führen.



Legen Sie keine Metallgegenstände wie Heft- oder Büroklammern auf die Maschine. Falls Metall- oder brennbare Teile in die Maschine geraten, können sie zu Kurzschlüssen an internen Bauteilen führen und Brände oder elektrische Schläge verursachen.



Falls Fremdkörper (Metall oder Flüssigkeiten) in die Maschine geraten, sofort ausschalten und den Stecker abziehen. Den Panasonic-Fachhändler anrufen. Bedienung einer durch Fremdkörper verschmutzten Maschine kann zu Bränden oder elektrischen Schlägen führen.



Niemals die Maschinenabdeckungen öffnen, die mit Schrauben festgeschraubt sind, wenn nicht spezifisch in der "Bedienungsanleitung" angegeben. Ein Hochspannungsbauenteil kann zu elektrischen Schlägen führen.



Versuchen Sie nicht, die Maschinenkonfiguration zu ändern oder Teile zu modifizieren. Eine unbefugte Modifikation kann zu Rauch oder Bränden führen.

Verbrauchsmaterialien Schutzmaßnahmen



Niemals Toner, Tonerkassette oder Tonerabfallbehälter in offenes Feuer werfen. In der Kassette verbleibender Toner kann eine Explosion verursachen und zu Verbrennungen und/oder Verletzungen führen.



Halten Sie Knopfbatterien/Stempel außer Reichweite von Kindern. Wenn eine Knopfbatterie/Stempel versehentlich verschluckt wird, sofort ärztliche Hilfe aufsuchen.

ACHTUNG

Vorsichtsmaßregeln zu Aufstellung und Transport



Platzieren Sie die Maschine nicht in der Nähe von Heizkörpern oder flüchtigen, entflammaren oder brennbaren Materialien wie Vorhänge, die Feuer fangen können.



Stellen Sie die Maschine nicht in einer heißen, feuchten, staubigen oder schlecht belüfteten Umgebung auf. Längerer Betrieb unter diesen Bedingungen kann zu Bränden oder elektrischen Schlägen führen.



Die Maschine auf eine ebene und feste Oberfläche stellen

Wenn sie geneigt wird, kann die Maschine umkippen und Verletzungen verursachen.



Beim Aufstellungsänderung des Geräts wenden Sie sich an Ihren Panasonic-Fachhändler.



Beim Transport der Maschine ziehen Sie den Netzstecker von der Steckdose ab. Wenn die Maschine bei eingestecktem Netzkabel und -stecker bewegt wird, kann das Netzkabel beschädigt werden, was zu Bränden oder elektrischen Schlägen führen kann.

Bedienungs-Schutzmaßnahmen



Bringen Sie keinen Magneten in die Nähe des Sicherheitsschalters der Maschine. Ein Magnet kann die Maschine versehentlich aktivieren, was zu Verletzungen führen kann.





Verwenden Sie keine leicht entflammaren Sprays oder Lösungsmittel in der Nähe der Maschine. Dadurch können Brände verursacht werden.



Für Ihre Sicherheit

Um schwere Verletzungen, möglicherweise mit Todesfolge, zu vermeiden, lesen Sie diesen Abschnitt sorgfältig durch, bevor Sie den Panasonic verwenden, um richtige und sichere Verwendung Ihrer Maschine sicherzustellen.

■ Dieser Abschnitt erklärt die Warnungen und Vorsichtsmaßnahmen, die in dieser Bedienungsanleitung verwendet werden.

	WARNUNG Weist auf eine potenzielle Gefahr hin, die zu schweren Verletzungen oder Tod führen kann.
	Achtung beschreibt Gefahren, die zu leichten Verletzungen oder Schäden an der Maschine führen können.









■ Dieser Abschnitt erklärt auch die grafischen Symbole, die in dieser Bedienungsanleitung verwendet werden.

	Diese Symbole werden verwendet, um Bediener auf spezifische Bedienverfahren hinzuweisen, die vermieden werden müssen.
	Diese Symbole werden verwendet, um Bediener auf spezifische Bedienverfahren hinzuweisen, die genutzt werden müssen, um die Maschine sicher zu betreiben.
	Dieses Symbol dient dazu, die Bediener darauf aufmerksam zu machen, dass eine heiße Oberfläche vorhanden ist, die Verbrennungen verursachen kann.

WARNUNG

Vorsichtsmaßnahmen zu Strom- und Erdungsverbindungen

-  Stellen Sie sicher, dass die Steckerverbindung staubfrei ist. In einer feuchten Umgebung kann ein verschmutzter Stecker eine beträchtliche Menge Strom aufnehmen, die Hitze erzeugen und nach längerer Zeit in diesem Zustand zu Bränden führen kann.
-  Verwenden Sie immer das mit dem Gerät mitgelieferte Netzkabel. Wenn ein Verlängerungskabel erforderlich ist, verwenden Sie immer ein Kabel mit geeigneter Stärke.
 - 120-240V/6.5AWenn Sie ein Kabel mit einer nichtspezifizierten Stromstärke verwenden, kann die Maschine Rauch abgeben oder sich außen stark erhitzen.
-  Versuchen Sie nicht, das Netzkabel zu modifizieren und vermeiden Sie Ziehen, Biegen, Scheuern oder anderweitige Beschädigung. Stellen Sie keine schweren Gegenstände auf das Netzkabel. Ein beschädigtes Netzkabel kann zu Bränden oder elektrischen Schlägen führen.
-  Niemals ein Netzkabel mit nassen Händen berühren. Dabei besteht die Gefahr elektrischer Schläge.
-  Wenn das Netzkabel beschädigt ist oder isolierte Drähte freiliegen, wenden Sie sich wegen Ersatz an Ihren Panasonic-Fachhändler. Verwendung eines beschädigten Netzkabels kann zu Bränden oder elektrischen Schlägen führen.
-  Sofort den Betrieb stoppen, wenn Ihre Maschine Rauch, starke Hitze, ungewöhnliche Geräusche oder Geruch abgibt, oder wenn Wasser auf die Maschine geschüttet wurde. Durch diese Bedingungen können Brände verursacht werden. Schalten Sie die Maschine sofort aus, ziehen Sie den Stecker ab, und wenden Sie sich an Ihren Panasonic-Fachhändler.
-  Versuchen Sie nicht, die Maschine abzutrennen oder neu anzuschließen, während der Netzschalter auf Ein steht. Durch Abziehen eines stromführenden Steckers kann ein Lichtbogen entstehen, durch den Verformungen und Brände verursacht werden.
-  Beim Abtrennen des Netzsteckers immer am Stecker und nicht am Kabel ziehen. Wenn ein Stecker gewaltsam abgezogen wird, kann er beschädigt werden und Brände oder elektrische Schläge verursachen.
-  Wenn die Maschine längere Zeit über nicht verwendet wird, schalten Sie sie aus und ziehen den Netzstecker ab. Wenn eine nichtverwendete Maschine längere Zeit an einer Stromquelle angeschlossen bleibt, kann beeinträchtigte Isolierung zu elektrischen Schlägen, Stromlecks oder Feuer führen.
-  Schalten Sie die Maschine immer aus und ziehen Sie den Stecker ab, bevor Sie auf das Innere der Maschine zugreifen, um Reinigung, Wartung oder Fehlerbehebung auszuführen. Zugriff zu Teilen im Maschineninneren kann zu elektrischen Schlägen führen.

-  Beim Kopieren eines dicken Originals nicht starke Kraft verwenden, um es gegen das Originalauflageglas zu drücken. Das Glas kann brechen und Verletzungen verursachen.
-  Niemals den markierten Bereich in der Nähe der Heizwalze berühren. Dabei besteht die Gefahr von Verbrennungen. Wenn ein Blatt Papier um die Heizwalze gewickelt ist, versuchen Sie nicht, es selber zu entfernen, um Verletzungen oder Verbrennungen zu vermeiden. Schalten Sie das Gerät sofort aus und wenden Sie sich an Ihren Panasonic-Fachhändler.
-  Verwenden Sie kein leitendes Papier, wie z.B. Faltpapier, Karbonpapier oder beschichtetes Papier. Wenn ein Fehleinzug auftritt, kann dies zu Kurzschlüssen und Bränden führen.
-  Stellen Sie keine schweren Gegenstände auf die Maschine. Eine unbalancierte Maschine kann umkippen, oder schwere Gegenstände können herunterfallen, was zu Schäden und/oder Verletzungen führen kann.
-  Halten Sie den Raum gut gelüftet, wenn Sie die Maschine längere Zeit über verwenden, um die Ozondichte in der Luft zu minimieren.
-  Beim Kopieren mit offener Originalauflage-Abdeckung nicht direkt in die Belichtungslampe blicken. Direkte Bestrahlung des Auges kann zu Augenermüdung oder sogar zu Augenschäden führen.
-  Die Papierfächer langsam ziehen, um Verletzungen zu vermeiden.
-  Beim Entfernen von fehleingezogenem Papier stellen Sie sicher, dass keine abgerissenen Papierreste in der Maschine verbleiben. Ein in der Maschine verbleibendes Stück Papier kann Feuer fangen. Wenn ein Blatt Papier um die Heizwalze gewickelt ist oder wenn ein besonders schwieriger Papierfehleinzug behoben werden muss, versuchen Sie nicht, es selber zu entfernen. Dabei besteht die Gefahr von Verletzungen oder Verbrennungen. Schalten Sie das Gerät sofort aus und wenden Sie sich an Ihren Panasonic-Fachhändler.
-  Beim Zugriff auf Innenteile des Geräts zum Beheben von Papierfehleinzug usw. immer darauf achten, nicht heiße Stellen zu berühren; sonst besteht die Gefahr von Verbrennungen.



Sonstiges

- Beim Beheben eines Papierstaus oder einer anderen Störung das geeignete Verfahren entsprechend der Bedienungsanleitung befolgen.

Für Ihre Sicherheit

 **ACHTUNG**

VerbrauchsmaterialienSchutzmaßnahmen

-  Verwenden Sie immer nur Batterien des vorgeschriebenen Typs.
-  Stellen Sie sicher, dass die Batterien mit richtiger Polung eingelegt sind. Falsch eingelegte Batterien können bersten oder leck werden, was zu Bränden oder Verletzungen führen kann.

Sonstiges

- Die Maschine hat eine eingebaute Schaltung zum Schutz gegen Stromspitzen durch Blitzschlag. Falls in der Nähe ein Gewitter mit Blitzschlägen auftritt, sorgen Sie für ausreichenden Abstand vom Gerät und berühren Sie das Gerät nicht, bevor das Gewitter beendet ist.
- Wenn Sie Flackern oder verzerrte Bilder oder Rauschen in Audio/Video-Geräten in der Nähe feststellen, kann es sein, dass die Maschine elektromagnetische Störungen erzeugt. Schalten Sie sie aus, und wenn die Störungen verschwinden ist die Maschine die Ursache der Störungen. Führen Sie das folgende Verfahren aus, bis die Störungen beseitigt sind.
 - Die Maschine und das Fernsehgerät und/oder Radio weiter voneinander entfernt aufstellen.
 - Die Maschine und das Fernsehgerät und/oder Radio anders aufstellen oder ausrichten.
 - Ziehen Sie den Netzstecker der Maschine, von Fernsehgerät und/oder Radio ab und stecken sie in Steckdosen ein, die zu getrennten Stromkreisen gehören.
 - Die Fernseh- und/oder Rundfunkantennen und -kabel anders ausrichten, bis die Störungen aufhören. Bei einer Außenantenne den örtlichen Elektriker um Unterstützung bitten.
 - Verwenden Sie eine Koaxkabelantenne.

memo

Table of Contents

Specifications Table	15	System Description	225
1.1. Copy Function.....	15	6.1. Printing Process	225
1.2. Fax, Printer and Internet Fax Functions	24	6.2. Precaution with Consumables.....	226
1.3. System Combination.....	32	6.3. New Image Stabilizing Technology	227
1.4. Options List.....	33	6.4. Mechanical Operation	230
1.5. External View.....	34	6.5. Automatic Document Feeder	232
1.6. Control Panel.....	37	6.6. Receive Mechanism.....	235
1.7. Fans and Motors.....	37	Installation	243
1.8. Clutches and Switches	38	7.1. Precautions During Set Up.....	243
1.9. PC Boards	38	7.2. Unpacking	245
Disassembly Instructions	39	7.3. Installation Procedure	246
2.1. General Disassembly.....	39	Options and Supplies	257
2.2. Disassembly Instructions	40	8.1. Service Notes “Firmware Update” for PCL or PS Option Installation	257
2.3. Screw Identification Template.....	82	8.2. Installing the Printer Controller Module for PCL6 (DA-PC302)	260
Maintenance, Adjustments and Check Points	85	8.3. Installing the Printer Controller Module for PS/PCL6 (DA-MC302)	262
3.1. Preventive Maintenance	85	8.4. Installing the Fax Communication Board (DA-FG300)	264
3.2. Required Tools	87	8.5. Installing the Hard Disk Drive Unit (DA-HD31)	272
3.3. Preventive Maintenance Points	88	8.6. Installing the Accounting Software (DA-WA10).....	278
3.4. Preventive Maintenance Check List	89	8.7. Installing the Expansion F-ROM Board (DA-EM600).....	279
3.5. Resetting the P/M (Preventive Maintenance) Counter	91	8.8. Installing the Sorting Image Memory 16 / 64 / 128 MB (DA-SM16B / 64B / 28B)	281
3.6. Lubrication Point List	92	8.9. Installing the Expansion Flash Memory Card 4/8 MB (UE-410047/410048).....	283
3.7. Updating the Firmware	95	8.10. Installing the 3rd Paper Tray (DA-DS305) / 4th Paper Tray (DA-DS306) and the Stand for 4-Paper Tray Configuration (DA-DA230-PA)	284
3.8. Adjusting the Printer Registration, LSU Image Side to Side	103	8.11. Installing the Deluxe Stand (DA-DA310 / DA320) for USA Only.....	288
3.9. Calibrating the LCD	105	8.12. Installing the Stand (DA-DA310-PA / DA320-PA).....	290
3.10. Glossary of Electrical Abbreviations	106	8.13. Installing the Stand (DA-DA311-PA / DA321-PA)	292
Troubleshooting	113	8.14. Installing the 1-Bin Finisher (DA-FS300)	294
4.1. Initial Troubleshooting Flowchart	113	8.15. Installing the Exit Tray [Inner] (DA-XN201)	300
4.2. Improper LCD Display	114	8.16. Installing the Exit Tray [Outer] (DA-XT200)	302
4.3. Printed Copy Quality Problems.....	115		
4.4. Document Feeder (ADF)	132		
4.5. Troubleshooting the LAN Interface	137		
4.6. Error Codes (For Copier).....	144		
4.7. Information Codes Table (For Facsimile).....	156		
4.8. Diagnostic Codes (For Facsimile).....	162		
4.9. Troubleshooting (For Printer).....	169		
Service Modes	171		
5.1. Service Modes (For Copier).....	171		
5.2. Service Modes (For Facsimile).....	199		

Table of Contents

8.17. Installing the Automatic Document Feeder (DA-AS201) and the Inverting Automatic Document Feeder (DA-AR251)	304
8.18. Installing the Platen Cover (DA-UC200)	310
8.19. Installing the Key Counter Harness Kit (DA-KH200)	311
8.20. Installing the Dehumidifier Heater Kit (DZTQ000048R)	314
8.21. Installing the Dehumidifier Heater Kit (DZTQ000049R)	322
8.22. Replacing the OPC Drum	334
8.23. Replacing the Laser Unit (LSU)	337
Network Information	341
9.1. Programming or Retrieving Parameters via Email	341
Schematic Diagram	349
10.1. General Circuit Diagram	349
10.2. Finisher Circuit Diagram	350
Finisher Option (DA-FS300)	351
11.1. General Description	351
11.2. Maintenance and Inspection	354
11.3. Operation and System Description	364

1 Specifications Table

1.1. Copy Function

Items	Description		Remarks
	DP-8032	DP-8025	
Basic Specifications			
1	Type	Desktop	
2	Platen	Fixed	
3	Original Position		
	Platen	Left / Rear	
	ADF / i-ADF	Left / Center	
4	Recording Paper Path	Center	
5	Face Up / Face Down	Face Down	
6	Drum	Organic Photo Conductor (OPC)	
7	Copy Process	Dry Electrostatic System	
8	Developing Process	Dry Dual Components	
9	Toner Recycle	No	
10	Fusing System	Heat & Pressure	
11	Max Original Size	Ledger (11 x 17 in) / A3 (297 x 420 mm)	
12	Paper Size		
	Paper Tray	LDR, LGL, LTR, LTR-R, INV-R	For USA and Canada
		A3, A4, A4-R, A5, A5-R, B4, FLS	For EU FLS = 8 x 13 in, 8.5 x 13 in
		A3, B4, A4, A4-R, B5, B5-R	For Other Destinations
	Bypass	LDR, LGL, LTR, LTR-R, INV-R	For USA and Canada
		A3, A4, A4-R, A5, A5-R, B4, FLS	For EU FLS = 8 x 13 in, 8.5 x 13 in
		A3, B4, A4, A4-R, B5, B5-R	For Other Destinations
	Bypass Envelope	No	
13	Warm-up Time	Approx. 35 sec	
14	First Copy Time	Less than 4.5 sec	
		From Platen/ Letter/ A4 Portrait/ 1st Paper Tray. Period between Start Key is pressed and Paper exits to the lower Inner tray. When LSU is ready.	
15	Copy Speed		
	Ledger / A3	18 / 19 cpm	15 / 16 cpm
	Legal / B4 / FLS	21 / 21 / 23 cpm	17 / 17 / 18 cpm
	Letter-R / A4-R	25 / 24 cpm	20 / 19 cpm
	Letter / A4	32 cpm	25 cpm
	Invoice-R / A5 / A5-R	32 cpm	25 cpm
		From 1st Paper Tray, exit to Lower Inner Tray and Continuous Copy.	
16	Zoom		
	Enlargement	Selected Original size / Copy size	
	Reduction	Selected Original size / Copy size	
	Zoom	25 - 400%	
		1% Step	
17	Paper Feed	Front Loading Universal Paper Tray	
	Paper Tray		

Items		Description		Remarks
		DP-8032	DP-8025	
	Capacity	550 sheets x 2		USA and Canada LTR : 20 lb (75 g/m ²) Other Destinations A4 : 80 g/m ²
	Auto Size Setting	No		
	Low Level Warning	Empty Only		
	Bypass			
	Capacity	50 sheets		
	Auto Size Setting	Yes		
	Paper Capacity (Std. Configuration)	1,150 sheets		
18 Acceptable Paper Weight				
	Paper Tray	16-24 lb / 60-90 g/m ²		
	Sheet Bypass	15-35 lb / 55-133 g/m ²		
19 Multi Copy Range		999 sheets		
20 Gradation				
	Text	Bi-Level		
	Text / Photo	256 steps		Halftone by Error Diffusion
	Photo	256 steps		
21 Resolution		600 dpi		Scanning and Printing.
22 Standard Sorting Memory Size		16 MB		
23 Standard Page Memory Size		32 MB		
24 Exit Tray Capacity		Standard: 250 sheets		
25 Color		No		
26 Dimensions				
	(W x D x H)	23.58 x 27.83 x 27.44 in (599 x 707 x 697 mm)		H: To Platen Glass.
27 Operating Space				
	(W x D)	38.50 x 27.83 in (978 x 707 mm)		Includes Bypass Paper Tray.
28 Weight		158.73 lb (72 kg)		Main Unit
		180.78 lb (82 kg)		Main Unit with i-ADF mounted
Options				
1 Paper Feed System		Max. 550 sheets x 4		
	550 sheets 3rd Paper Feed Module		Yes	Motor is mounted.
	Paper Size Detection		Manual	Control Panel Selectable
	Low Level Paper Warning		Empty Only	
	550 sheets 4th Paper Feed Module		Yes	Motor is not mounted.
	Paper Size Detection		Manual	Control Panel Selectable
	Low Level Paper Warning		Empty Only	
Max. Paper Capacity		2,250 sheets		USA and Canada LTR : 20 lb (75 g/m ²) Other Destinations A4 : 80 g/m ²
2 Cabinet				
	Stand for 4-Paper Tray Configuration	Option		Base Plate with Casters

Items		Description		Remarks
		DP-8032	DP-8025	
	Stand for 3-Paper Tray Configuration	Option		Low Plain Stand
	Stand for 2-Paper Tray Configuration	Option		High Plain Stand
3	Platen Cover	Option		For EU and Other Destinations
	Free Stop	Yes		From 30 to 70 degrees.
4	ADF			
	Single Side Type	Option		For EU and Other Destinations
	Original Set	Face Up		
	Scanning Method	Sheet Through		
	Capacity (Original)	50 sheets		USA and Canada LTR : 20 lb (75 g/m ²) Other Destinations A4 : 80 g/m ²
	SADF Mode	Yes		
	Free Stop	Yes		From 30 to 70 degrees.
5	Inverting ADF (i-ADF)			
	Duplex Type	Standard		For USA and Canada
		Option		For EU and Other Destinations
	Original Set	Face Up		
	Scanning Method	Sheet Through		
	Capacity (Original)	50 sheets		USA and Canada LTR : 20 lb (75 g/m ²) Other Destinations A4 : 80 g/m ²
	SADF Mode	Yes		
	Free Stop	Yes		From 30 to 70 degrees.
6	Exit Tray (Inner)			
	Tray Position	Inner		
	Number of Bins	1		
	Face Up / Face Down	Face Down		
	Bin Capacity	Upper / Lower Bins: 250 sheets		
	Multi Tray Function	Option (Inner 2-way)		Requires the Optional Exit Tray (Inner). Max. 3 way using Optional Exit Tray (Outer) or Finisher.
	Shift Tray Function	No		
7	Finisher	Option		Not available with Exit Tray (Outer).
	Tray Position	Outer		
	Number of Bins	1		
	Face Up / Face Down	Face Down		
	Bin Capacity	500 sheets		LTR, LTR-R, A4, A4-R, B5
		250 sheets		LDR, LGL, A3, B4, FLS

Items		Description		Remarks
		DP-8032	DP-8025	
	Multi Tray Function	Yes		Max. 3 way using Optional Exit Tray (Inner) and Exit Tray (Outer) or Finisher.
	Shift Tray Function	Yes		
	Staple Function	Yes		No Manual Stapling. Not available with Rotation. Not available with INV, INV-R, A5, A5-R or B5-R.
	Stapler Capacity	3,000 pins		
	Max. Number of Pages Stapled	30 sheets / set		LTR, LTR-R, A4, A4-R, B5 : 30 sheets LDR, LGL, A3, B4, FLS: 20 sheets
	Staple Position	Rear / Upper		1 Position
	Punch Function	No		
8	Exit Tray (Outer)	Option		Not available with Finisher.
	Tray Position	Outer		
	Number of Bins	1		
	Face Up / Face Down	Face Down		
	Bin Capacity	250 sheets		LTR / A4
	Multi Tray Function	Yes		Max. 3 way using Optional Exit Trays (Inner and Outer).
	Shift Tray Function	No		
9	Dual-Path Exit Guide Unit	Standard		For Exit Tray (Inner or Outer), Finisher and Duplex printing.
10	Paper Transport Unit	Standard		To be used for Exit Tray (Outer), Finisher and Duplex printing.
11	Automatic Duplex Unit	Standard		
12	Counter			
	Key Counter Capability	Option		The Harness Kit contains only Harnesses, Bracket and a Screw.
13	Dehumidifier	Option		Supplied as a Service Part.
14	Sorting Image Memory			
	Optional Image Memory 1 (16MB)	Yes		Unit comes standard with 16MB. 1-Slot available for an Optional Image Memory module.
	Optional Image Memory 2 (64MB)	Yes		
	Optional Image Memory 3 (128MB)	Yes		
15	Hard Disk Drive	Option		Additional Optional Sorting Image Memory (Minimum 16 MB) is required for the Hard Disk Drive to function. (For Tandem, Remote Copy, etc.)
Features				
1	Automatic Features			
	Auto Magnification Selection	Yes		
	Auto Paper Selection	Yes		

Items	Description		Remarks
	DP-8032	DP-8025	
Auto Paper Tray Selection	Yes		
Auto Start	Yes		Reservation while Power On Initial
Energy Saver			Automatically enters the Sleep or Shutdown Mode after 15 minutes from the Standby or Energy Saver Mode. Manually enters the Energy Saver Mode by pressing the Energy Saver key. Sleep or Shutdown mode is controlled by the General Functions setting.
Standby Mode	Yes (140Wh)		
Energy Saver Mode	Yes (28W)		
Sleep Mode	Yes (18W)		
Shutdown Mode	Yes (3W)		
	Yes (4W)		
Remote Diagnostic	Yes		Requires the Fax Communication Board (DA-FG300) option or the Internet Fax / E-MAIL Module (DA-NF600) option.
Machine Stops when Out of Toner	Yes		PPC Function
2 Additional Features			
Low Level Paper Warning	Empty Only		
Photo Mode	Yes		256 steps
Original Detection Release	Yes		Manually overridden when using the Original Size keys.
Edit / Effects			
Book Mode	Yes		
Edge Mode	Yes		
Margin Mode	Yes		
X-Y Zoom	Yes		25 - 400%
Stamping			
Page, Date, Issue	Yes		Available only when using the ADF.
2-Sided Copy	Yes		
Inverse Mode (Negative / Positive)	Yes		
Centering Mode	Yes		With Digital Sky Shot
Mirror Mode	No		
Image Repeat	Yes		
Others (Inverting ADF & ADU)			
2-Page Copy Mode	Yes		LDR → LTR x 2 (A3 → A4 x 2, B4 → B5 x 2)
2 in 1	Yes		

Items	Description		Remarks
	DP-8032	DP-8025	
4 in 1	Yes		
6 in 1	Yes		For USA and Canada
8 in 1	Yes		For EU and Other Destinations
Booklet Mode	Yes		Copy from four 1-Sided pages to 1 Booklet Mode sheet.
Duplex Copy			
1→2	Yes		
2→1	Yes		Available only when using the i-ADF.
2→2	Yes		
Book→2	Yes		
1st Page BLANK	Yes		1 → 2/2 → 1/2 → 2
1st Page IMAGE	Yes		Book → 2
Image Rotation (90 or 270 °)	Yes		
Electronic Sorting	Yes		
Rotation Sorting	Yes		
Insertion Job			
Cover Mode	Yes		
Page Insertion Mode	Yes		Available when using the ADF or i-ADF.
OHP Interleave Mode	Yes		
Presentation Mode	Yes		
Department Counter	Yes		
Security Enhancement (CC)	Yes (OP)		Default Password: 0000000
ADF			
Multi Size Feed	Yes		LDR and LTR, LGL and LTR-R, A3 and A4, B4 and B5, A4-R and A5
JOB Build and SADF Mode	Yes		
Original Counter	No		
Job Memory	Yes		5 Jobs in Memory
Job Time Display	Yes		
Concurrent Copy	Yes		12 Concurrent Copy Jobs
Tandem Copy Mode	Yes		
Remote Copy Mode	Yes		
Scan Once Print Many Mode	Yes		
Job Complete Notice	Yes		
Trial Copy Mode	Yes		
Weekly Timer	Yes		
Function Mode	Yes		
Interrupt	Yes		
Electronic Counter	Yes		
Digital Sky Shot Mode	Yes		
Check / Slip Mode	Yes		

Items	Description		Remarks
	DP-8032	DP-8025	
3 Control Panel			
Display	Wide Touch Panel LCD		
Status Lamp	Yes		GREEN : Scanning / Printing RED : Alarm / Warning
Key			
Original Size	Yes		
Copy Size	Yes		
Keypad	Yes		
Clear	Yes		
Stop	Yes		
Start	Yes		
Energy Saver	Yes		
Multi Size Feed	No		
Sort / Finish	No		
Function Mode	Yes		
Original Detection Release	No		
Interrupt	Yes		
Reset	Yes		
One-Touch key	No		
Mode Change	Yes		Copier / Printer / NW Scanner / Fax and Internet Fax Mode
LCD Main Indication			
Message Language (Default)	English (American)		For USA and Canada
	Specified Language		For EU and Other Destinations
Original Size / Image Indication	Yes (without Image)		
Paper Size / Image Indication	Yes (without Image)		
Paper Tray Selection	Yes		
Selected Paper Tray / Tray Status	Yes		
Original Mode Selection	Yes		Text / Text-Photo / Photo
Copy Density Selection	Yes		
Setting Confirmation	Yes		
Function Classification	Yes		
Zoom Magnification	Yes		
Number of Copies	Yes		
JOB Build and SADF / Multi Size Feed Mode	Yes		
Error Code	Yes		
Finishing	Yes		
Warning Indicators	Yes		
Add Toner	Yes		
Toner Waste Container Full	Yes		
Add Paper (No Paper)	Yes		

Items		Description		Remarks
		DP-8032	DP-8025	
	Add Paper (Under 50 sheets)	No		
	Paper Jam Indication	Yes		
	Paper Jam Location	Yes		
	Service Alert Call	Yes		
	User Error	Yes		
	Machine Error	Yes		
	History of Jam Errors	Yes		
4 Main Unit				
	Total Counter	Yes (Standard)		Mechanical Counter
	Max. Weight of Documents on the Platen Glass	11.02 lb (5 kg)		
	ADF with Document Guide	Yes		
	Clip Pocket	Yes		
	Operating Instructions Pocket	No		
	Warning / Caution Label	Specified Language		
5 Optical System				
	Original Detection Method	Reflective Photo Sensor Type		
	Scanning Method	600 dpi CCD		
	Dehumidifier	Yes		Supplied as a Service Part
	Mechanical Multi Copy Mode	No		
6 Process System				
	Type	Separate OPC Unit and Developer Unit Type		
	Toner	15 k		
	Drum Life	60 k		
	Developer Life	120 k		
	Toner Waste Container	Yes		
	Dehumidifier	Yes		Supplied as a Service Part
	Manual Add Toner	Yes		Manually adds toner to the developer (up to TDC threshold)
Efficiency				
1 Productivity				
	ADF Productivity (LTR / A4)			
	ADF	100%		
	Inverting ADF	100%		
	ADU Copy Productivity (LTR / A4)			Throughput
	Transport Method	Stack less		When exiting to lower Inner Tray from 1st Tray. When LSU is ready.
	1→2			
	10 copies	81%	93%	
PM Cycle				
1 PM Cycle				
	Major PM	120 k		
	Minor PM (Cleaning)	60 k		

Items	Description		Remarks
	DP-8032	DP-8025	
Packing Configuration			
1	Packing Dimension	28.58 x 32.91 x 42.91 in (726 x 836 x 1090 mm)	
2	Packing Weight	218.26 lb (99 kg)	
3	Accessories		
	Process Unit	Yes	
	Developer	No	
	Toner	No	
	Toner Waste Container	No	
	Outer Tray	No	Option
	Operating Instructions	Yes	
Power Supply			
1	Power Requirement	99 - 138 VAC 47 - 63 Hz Single phase	100 VAC Power Supply
		180 - 264 VAC 47 - 63 Hz Single phase	220 VAC Power Supply
2	Power Consumption	Less than 1500 W	
Ambient Conditions			
1	Temperature	50 - 80 °F / 10 - 30 °C	
2	Relative Humidity	30 - 80%	
3	Safety	UL1950 / CSA C22.2 No.950	For USA and Canada
		EN60950	For EU and Other Destinations
4	Energy Saver	Energy Star Compliant	
5	EMI	Class A computing device in FCC Rules Part 15	For USA and Canada
6	Lead Free Solder (PbF)	This Product uses Lead Free (PbF) PCBs	Refer to the Parts Manual for details

1.2. Fax, Printer and Internet Fax Functions

1.2.1. Fax Function

Items	Description		Remarks
	DP-8032	DP-8025	
Main Specifications			
1 Compatibility	G3		ITU-T Std & Non-Std
2 PSTN Line Port	Yes		1-Line Only
3 Leased Line Port	No		
4 V.24 Line Port	No		
5 Modem Speed	33.6 - 2.4kbps		T.30/V.34/V.17/V.29/V.27ter
6 Coding Scheme	JBIG/MMR/MR/MH		
7 ECM	Yes		Conforms to ITU-T Rec. T.30 ECM
8 Short Protocol	Yes (B, D)		
9 Transmission Speed	Approx. 3 sec		ITU-T Image No. 1 (A4, Std Resolution)
10 Communication Resolution dpi x lpi (pels/mm x lines/mm)	Transmission Std. 203 x 98 (8 x 3.85) Fine 203 x 196 (8 x 7.7) S-Fine 203 x 391 (8 x 15.4) 406 x 391 (16 x 15.4) 600dpi 600 x 600 dpi Reception Std. 203 x 98 (8 x 3.85) Fine 203 x 196 (8 x 7.7) S-Fine 203 x 391 (8 x 15.4) 406 x 391 (16 x 15.4) 600dpi 600 x 600 dpi		600 dpi communication is only available between T.30 compliant machines.
Scanner Mechanism			
1 Scanning Device	CCD (ADF / Platen)		
2 Scanning Speed (ADF)			
	Resolution	Vertical Horizontal	A4, Scanned in Vertical or Horizontal Direction. Excluding Initializing Time and ADF slipping factor.
	Std: 203 x 98 (8 x 3.85) dpi x lpi (pels/mm x lines/mm)	0.6 sec 0.4 sec	
	Fine: 203 x 196 (8 x 7.7) dpi x lpi (pels/mm x lines/mm)		
	S-Fine: 406 x 391 (16 x 15.4) dpi x lpi (pels/mm x lines/mm)	1.1 sec 0.8 sec	
	600dpi: 600 x 600	1.7 sec 1.2 sec	
	Scanning Speed (Platen)		
	Resolution	Vertical Horizontal	
	600dpi: 600 x 600	1.7 sec 1.2 sec	
3 Scanning Resolution dpi x lpi (pel/mm x lines/mm)	Std 203 x 98 (8 x 3.85) Fine 203 x 196 (8 x 7.7) S-Fine 203 x 391 (8 x 15.4) 406 x 391 (16 x 15.4) 600dpi 600 x 600 dpi		
4 Document Size (Max.)	ADF: Ledger / A3		

Items	Description		Remarks
	DP-8032	DP-8025	
5 Effective Scanning Width	LDR (10.7 in) / A3 (292 mm)		
6 A3 Size TX/RX	Yes		Conforms to ITU-T A3
7 Reduction XMT	Yes		A3 to B4 / A3 to A4 / B4 to A4
8 ADF Capacity	50 sheets		Face-Up, feed from top page
9 Collation Stack	Yes		Face Down
Printer Mechanism			
1 Recording Method	LP		
2 Recording Speed	25 / 32 ppm (A4 Horizontal)		Recording Speed attained after the 1st copy.
3 Recording Resolution Fax	600 x 600 dpi		
4 Recording Paper Size	Ledger / Legal / Letter / A3 / B4 / A4 / A5		Invoice : Not supported. Ledger size is transmitted as A3 size for N. American models. If A3 is received, approx. 1" of image on both edges are not printed on Ledger size paper.
5 Effective Printing Width	LDR (10.6 in) / A3 (289 mm)		
6 Recording Paper Capacity	1,150 sheets		Optional max. 2250 sheets
7 Collation Stack	Yes		Face Down
8 Consumable	Toner Bottle, Developer, OPC Drum and Staples		
Fax Memory			
1 Standard Memory	3 MB (180 pages)		Flash ROM, ITU-T Image No.1 (A4, Std Resolution)
2 Optional Memory	4 MB (+320 additional pages) 8 MB (+640 additional pages)		Expansion Flash Memory Card, using ITU-T Image No.1 (A4, Std Resolution)
Dual Operation			
1 Multi Task Operation	Yes		
2 Direct XMT Reserve	Yes		
3 Memory XMT Reserve	Yes		
4 Number of Memory Job Files	Yes		Max. 50 files
Dialing/Telephone Features			
1 Auto Dialers	200 Stations		Plus an additional 800 stations available to select from, when the optional Hard Disk Drive (DA-HD31) is installed.
2 Phone Book Directory Search Dialing	Yes		
3 Total Auto Dialers	270 Stations		200 Address Book + 70 Full Number Dialing
4 Program Dials	12		
5 Max. Tel Number Digits	36		
6 Max. Station Name Characters	15		
7 Full Number Dialing (Buffered Dialing)	Yes		Max. 70 stations

Items	Description		Remarks
	DP-8032	DP-8025	
8 Direct Dialing (Monitor Dialing)	Yes		Voice mode
9 Automatic Redialing	Yes		Up to 15 times at 0 to 15 min. intervals
10 Manual Redialing	Yes		Pressing the REDIAL/PAUSE button
11 Line Monitor Speaker	Yes		
12 Chain Dialing (Hybrid Dial)	Yes		In Monitor Dialing mode only
13 Pulse / Tone Dialing	Yes		10 pps / DTMF
14 Pulse to Tone Change	No		
15 Flash Key	Yes		
16 Handset	No		
Transmission Features			
1 Direct Transmission	Yes		
2 Memory Transmission	Yes		Page Retransmission
3 Quick Memory Transmission	Yes		
4 Multi-Station Transmission (Sequential Broadcasting)	Yes		Max. 270 stations
5 Direct Deferred Transmission	No		ADF Deferred Transmission
6 Deferred Transmission	Yes		Max. 50 timers
7 Deferred Multi-Station Transmission	Yes		
8 Priority Direct Transmission	Yes		Priority ADF Transmission
9 Priority Memory Transmission	No		
10 Batch Transmission	Yes		Real Time (up to 5 Files)
11 90 Degree Rotation Transmission	Yes		
12 Cover Sheet	Yes		
13 Confidential Mail Box	No		
14 Multi-Copy Transmission	No		
15 Memory Back-Up	Yes		FAX : Back-up with Flash Memory. Copy / Printer : No Back-up with D-RAM
16 Duplex Scanning	Yes		With Inverting ADF (i-ADF)
Reception Features			
1 Substitute Reception	Yes		
2 Fixed Reduction	Yes		LTR/A4/LGL: 70 - 100% (in 1% Steps), Top & Left Alignment
3 Auto Reduction	Yes		LTR/A4/LGL: 70 - 100% (in 1% Steps), Top & Left Alignment
4 Overlap Printing	Yes		Page End Approx. 0.51 in (13 mm)
5 Receive to Memory	Yes		
6 Distinctive Ring Detector (DRD)	No		

Items	Description		Remarks
	DP-8032	DP-8025	
7 90 Degree Rotation Reception	Yes		
8 Duplex Printing	Yes		
Polling			
1 Polling	Yes		
2 Turnaround Polling	No		
3 Multi-Station Polling	Yes		Max. 270 stations
4 Deferred Polling	Yes		Max. 50 timers
5 Deferred Multi-Station Polling	Yes		Max. 50 timers / 270 stations
6 Direct Polling Tx	No		
7 Memory Polling Tx	Yes		1 File
8 Preset Polling Password	Yes		
9 Temporary Polling Password	Yes		
10 Continuous Polling	Yes		
Convenience			
1 Panel Display	Wide Touch Panel Display		
2 Voice Contact	No		
3 Edit File Mode	Yes		With View Mode
4 Incomplete File Save	Yes		With View Mode
5 Automatic Cover Sheet	Yes		
Certainty			
1 Verification Stamp	Yes		
2 Header / Total Page Print	Yes		
3 Transaction Journal	Yes		200 Transactions / with View Mode
4 Comm. Journal	Yes		With Image Data
5 Last Ind. XMT Journal	Yes		
List Printouts			
1 One-Touch List	-		
2 ABBR. No. List	-		
3 Program List	Yes		
4 Address Book Search List	Yes		Auto Dialer List
5 Fax Parameter List	Yes		
6 File List	Yes		With View Mode
7 Ind. XMT Journal	Yes		
8 Directory Sheet	No		
Identifications			
1 Logo	Yes		25 Characters
2 Multiple Logo	No		
3 Character ID	Yes		16 Characters
4 Numeric ID	Yes		20 Digits
Special Communications			
1 Password XMT / RCV	No		
2 Selective Reception	No		TSI Check
3 Relay XMT Request	No		
4 Relay XMT Center	No		

Items	Description		Remarks
	DP-8032	DP-8025	
5 Confidential XMT / Polling	No		
6 Confidential Center	No		
7 Mailbox XMT / Polling	No		
8 Mailbox Center	No		
9 File XMT	No		
10 Fax Forward	Yes		Received File Transfer (Only with Internet FAX Option)
11 Sub-Address XMT	Yes		T. Routing
12 Sub-address RCV	No		
13 OMR-XMT	No		
Standards			
1 PSTN	FCC Part 68: Industry Canada No. CS-03: Issue 9		
Others			
1 Fax Access Code	Yes		
2 PIN Code Access	Yes		For USA and Canada only
3 Intelligent Redial (AI)	Yes		5 Files
4 Department Code	Yes		300 Departmental Codes
5 Power Saver Mode	Yes		
6 Self Diagnostic Function	Yes		
7 Remote Diagnostic Function	Yes		
8 Check & Call Function	Yes		
9 V.24 / Encryption Interface	No		

1.2.2. Printer Function

Items	Description		Remarks
	DP-8032	DP-8025	
Interface			
1 Centronics Parallel I/F	No		
2 LAN (Network)	Ethernet 10Base-T/100Base-TX		
3 USB Port	Yes		USB
4 IEEE-1394	No		
Printer Function			
1 Printing Size	LDR, LGL, LTR, LTR-R, INV-R		For USA and Canada
	A3, A4, A4-R, A5, A5-R, B4, FLS		For EU
	A3, B4, A4, A4-R, B5, B5-R		For Other Destinations
2 Bypass	Yes		
3 Stapling	Yes		Requires Optional Finisher
4 Printing Resolution (dpi)	600 x 600 (with Smoothing)		Selectable 600 dpi, with Smoothing, the results are similar to PS3 / PCL6 Printers (1200 dpi Interpolated).
5 Interface	USB / Ethernet		
6 Applicable PC	IBM PC / AT or Compatible		MAC is PS only.
7 OS	Win 2000 / Win XP / Server 2003 / Vista / MAC 8.6-10.5		MAC 8.6-10.5 is PS only.
8 GDI	Yes		

Items	Description		Remarks
	DP-8032	DP-8025	
9 PDL (PCL6)	Yes		Requires Optional PCL6 Emulation Kit.
10 PDL (PS3)	Yes		Requires Optional PS / PCL6 Emulation Kit
11 Duplex Printing	Yes		Custom Size/Post Card Size is not available.
12 Collation Stack	Yes		
13 Network Printing	Yes		
14 Device Monitor	Yes		
15 Smoothing	Yes		
16 Multi-Task Operation			
	Printing while Fax-XMT from Memory	Yes	
	Printing while Fax-RCV into Memory	Yes	
	Fax-XMT from Memory while Printing	Yes	
	Fax-RCV into Memory while Printing	Yes	
17 Output to separate tray for Printing, Fax, Copy	Yes		
18 Font	Yes		Requires Optional PCL6 or PS / PCL6 Emulation Kit
19 Security Print	Yes		Requires Optional HDD Unit Max. 100 Boxes

1.2.3. Network Scanner Function

Items	Description		Remarks
	DP-8032	DP-8025	
Interface			
1 Centronics Parallel I/F	No		
2 LAN (Network)	Ethernet 10Base-T/ 100Base-TX		
3 USB Port	No		
4 IEEE-1394	No		Firewire
Network Scanning Function			
1 Scanning Device	CCD (i-ADF / Platen)		
2 Scanning Speed (ADF)	30 opm		ITU-T Image No. 1 (A4, Std Resolution), JBIG, 600 dpi Excluding Data XMT Time.
3 Halftone	256 Halftone Shades		With Error Diffusion
4 Max. Document Size	Ledger, A3		
5 Scanning Resolution (dpi)	600 x 600 300 x 300 150 x 150		Selectable, 600 dpi Optical Scanner
6 OS	Win 2000 / Win XP / Server 2003 / Vista		
7 2-Sided Scanning	Yes		With i-ADF.

Items	Description		Remarks
	DP-8032	DP-8025	
8 File Format	Mult-page TIFF / PDF		TIFF can also be converted to PDF with the PDMS Software
9 Completion Notice	Yes		Auto Pop-up on the PC Screen (requires Network Status Monitor - installed with PDMS Software)
10 Protocol	TCP/IP, Non-Std		

1.2.4. Internet Fax Function

Items	Description		Remarks
	DP-8032	DP-8025	
Main Specifications			
1 Communication Protocols	SMTP / POP3 / MIME		
2 Max. Modem Speed	NA		
3 Coding Scheme	JBIG/MMR/MR/MH		
4 File Format	TIFF / PDF		Selectable (PDF format can be used for Scan-to-Email when sending to a PC. However, since current Internet Fax standards do not support this file format, it cannot be used for sending to another Internet Fax machine)
5 Line Interface	RJ-45		Ethernet LAN
Scanner Mechanism			
1 Max. Document Size	Ledger / A3		
2 Effective Scanning Width	LDR (10.7 in) / A3 (292 mm)		
3 Scanning Resolution dpi x lpi (pel/mm x lines/mm)	Std 203 x 98 (8 x 3.85) Fine 203 x 196 (8 x 7.7) S-Fine 203 x 391 (8 x 15.4) 406 x 391 (16 x 15.4) 600dpi 600 x 600 dpi		LAN: 600 dpi, 16 x 15.4 Scanning Resolution is available with Parameter setting
Printer Mechanism			
1 Printing Resolution	600 dpi		
2 Effective Printing Width	LDR (10.6 in) / A3 (289 mm)		
Transmission Features			
1 Multi-Task Operation	Yes		Simultaneous operation of G3 Fax and LAN is available.
2 Memory Transmission	Yes		
3 Sequential Multi-Station Transmission	Yes		
4 Simultaneous Multi-Station Transmission	Yes		Max. 270 stations (200 Address Book + 70 Full Number Dialing)
5 Sender Selection	Yes		
6 G3 / Email Mixed Broadcasting	Yes		
7 Deferred Transmission	Yes		

Items	Description		Remarks
	DP-8032	DP-8025	
8 Fax Forward	Yes		Received File Transfer, only with Internet FAX Option
9 Sub-address RCV	Yes		Inbound Routing, only with Internet FAX Option
10 Mail Header			
Email Header Print Selection	Yes		All or From / To / Subject only
Subject Line	Random Entry		
LAN Features			
1 Internet Fax Communication	Yes		A3 Communication is available with Parameter setting.
2 Internet Mail Reception	Yes		
3 Internet Fax Server Features			
Internet Fax Relay XMT	Yes		Internet Fax → Internet Fax → G3FAX
Email Relay MXT	Yes		PC → Internet Fax → G3FAX
Received Fax / Email Forward	Yes		Local print available
PC to FAX Transmission	No		
Inbound Routing	Yes		Using Sub-Address. Local print available
Phone Book Registration from PC	Yes		Via Email
4 Internet Fax Parameters Registration via Email	Yes		
5 Internet Delivery Confirmation	Yes		With MDN
6 DHCP Client	Yes		
7 LDAP	Yes		Lightweight Directory Access Protocol
8 TIFF Viewer	Yes		Selectable, PDMS / TIFF Viewer
Certainty			
1 Comm. Journal (w / Image)	Yes		Email from RCV side to Panasonic Internet FAX's only
ID			
1 Email Address	Yes		

1.3. System Combination

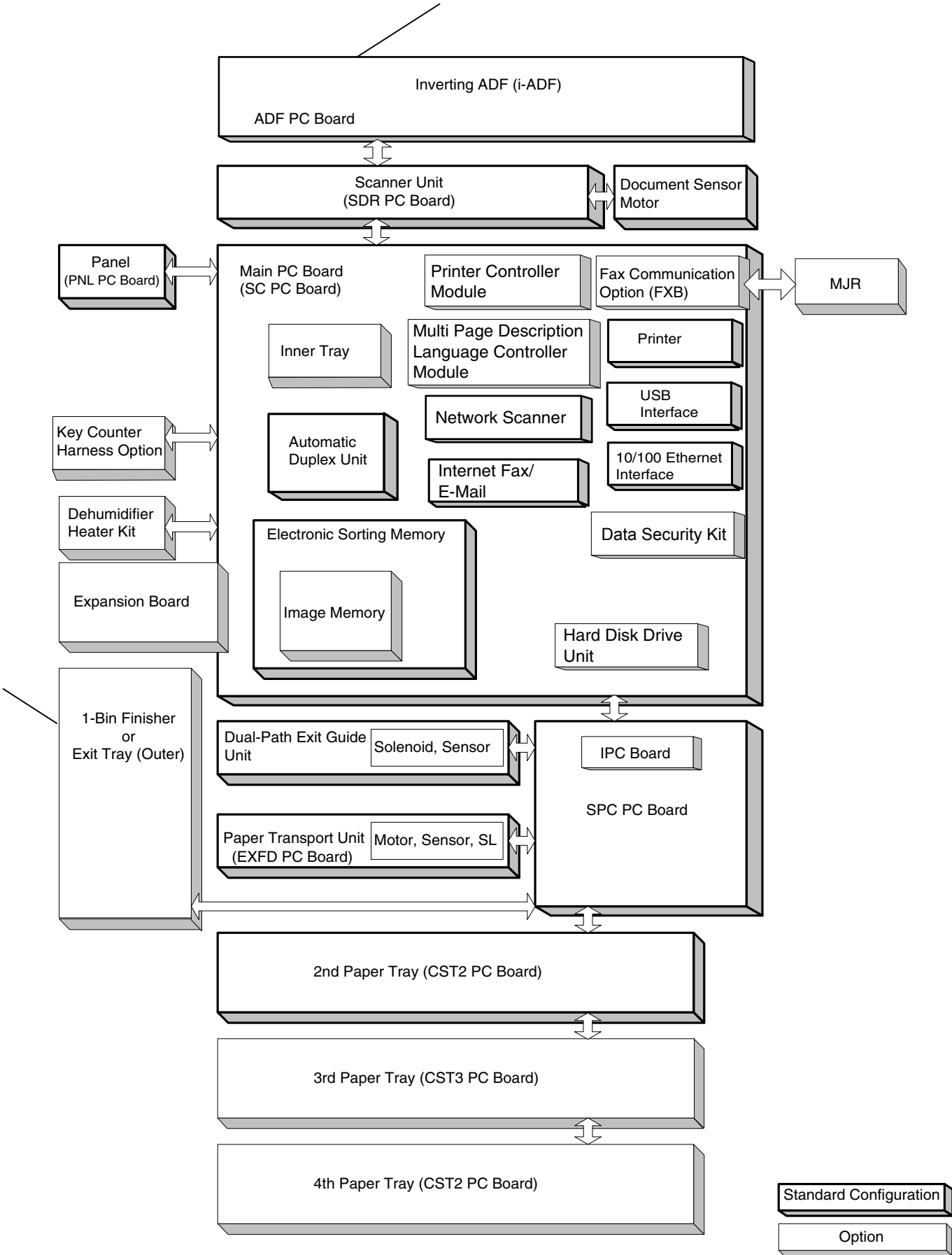

Note:

Depict a DP-8032 with the USA/Canada standard configuration. The configuration may differ depending on the destinations.

1.4. Options List

1. Options

Option Name	Option Number	Remarks
Printer Controller Module for PCL6	DA-PC302	
Multi Page Description Language Controller Module for PS/PCL6	DA-MC302	
Document Distribution System	DA-WR10	
Fax Communication Board	DA-FG300	G3 Fax Communication
Hard Disk Drive Unit	DA-HD31	Additional Optional Sorting Image Memory (Minimum 16 MB) is required for the Hard Disk Drive to function. (For Tandem, Remote Copy, etc.)
Expansion Board	DA-EM600	F-ROM Board (8 MB)
Expansion Flash Memory Card, 4 MB	UE-410047	Additional Memory for Fax / Internet Fax
Expansion Flash Memory Card, 8MB	UE-410048	
Image Memory (16MB)	DA-SM16B	For Electronic Sorting
Image Memory (64 MB)	DA-SM64B	
Image Memory (128MB)	DA-SM28B	
Accounting Software	DA-WA10	For Accounting Function
Data Security Kit	DA-SC06	For Specified Destinations
1-Bin Finisher	DA-FS300	
Exit Tray (Outer)	DA-XT200	
Exit Tray (Inner)	DA-XN201	
Platen Cover	DA-UC200	Available in Specified Destinations
Automatic Document Feeder	DA-AS201	
Inverting Automatic Document Feeder	DA-AR251	
3rd Paper Tray	DA-DS305	
4th Paper Tray	DA-DS306	
Stand (High)	DA-DA310	Available in Specified Destinations
Stand (Low)	DA-DA320	
Stand (High)	DA-DA311	Available in Specified Destinations
Stand (Low)	DA-DA321	
Base Plate with Casters	DA-DA230	Available in Specified Destinations
Key Counter Harness Kit	DA-KH200*	DZTY000161 is not available by Supply rout / policy change.

2. Supplies

Part Name	Part Number	Remarks
Toner	DQ-TU15E	15 k
Staple Cartridge	FQ-SS32	
OPC Drum	DQ-H60E	
Developer	DQ-Z120E	

Note:

PCL6 is a Page Description Language of the Hewlett-Packard Company.

PS3 is a Page Description Language of the Adobe Systems Company.

The Part Number(s) may differ for other than PU (USA/Canada, etc.) destinations. Please ask your sales company for details.

1.5. External View

1. Standard Configuration

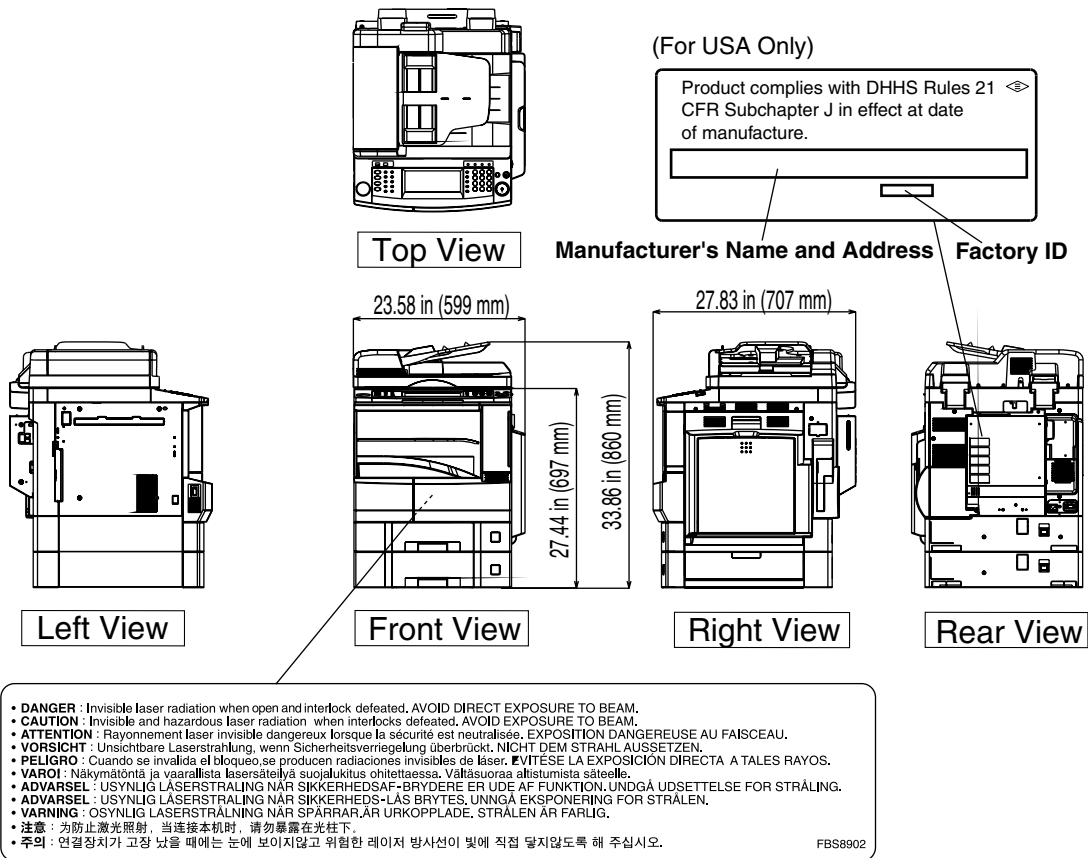

2. With Optional System Console Configuration

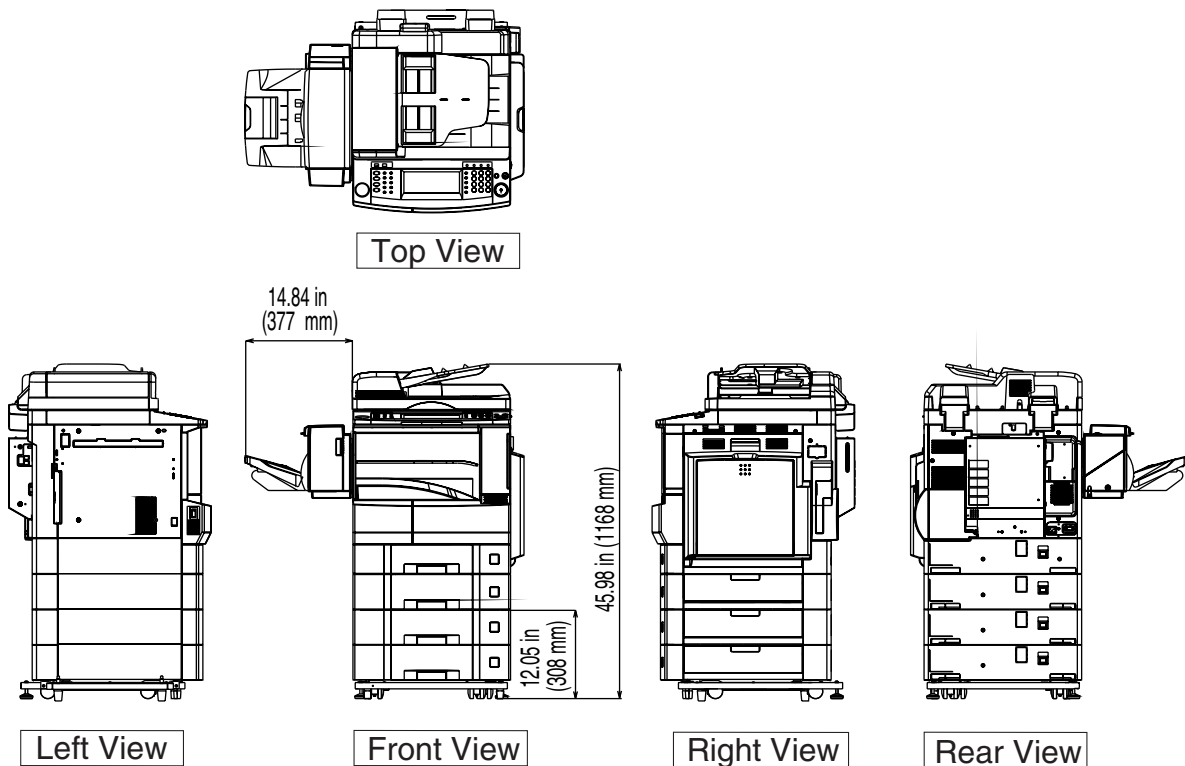

3. Space Requirements With Options

Main Unit

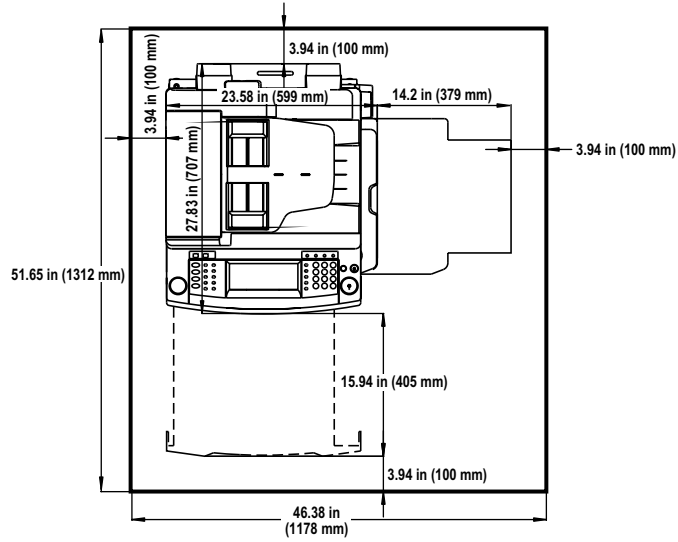

Main Unit + Outer Exit Tray

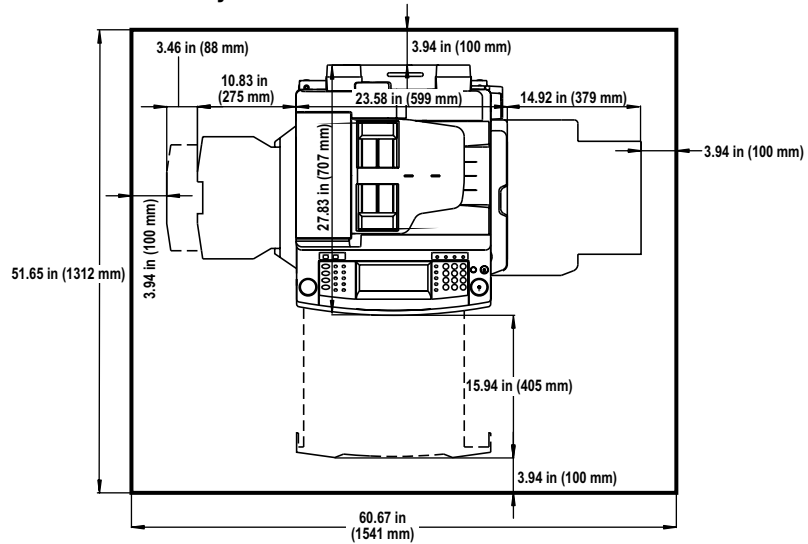

Main Unit + Finisher

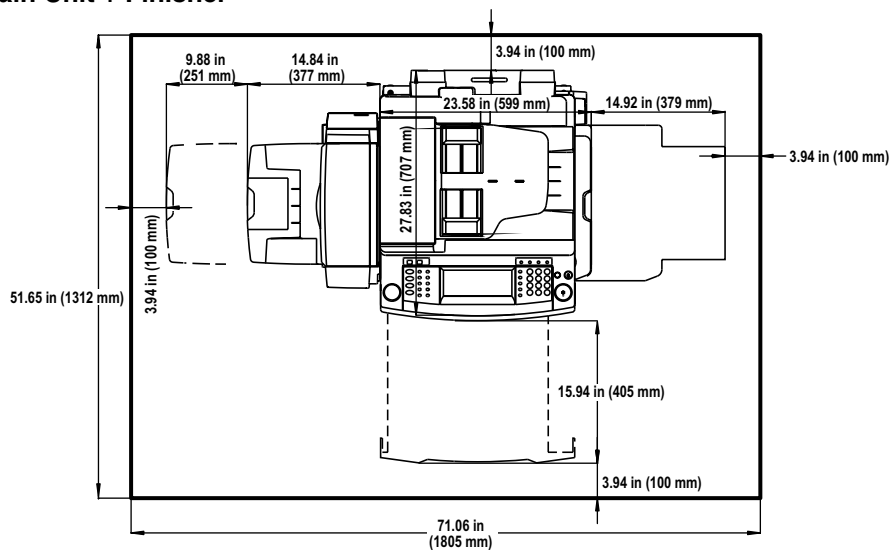

1.5.1. Serial Number Contents

The contents of the 11-digit Serial Number is as follows:

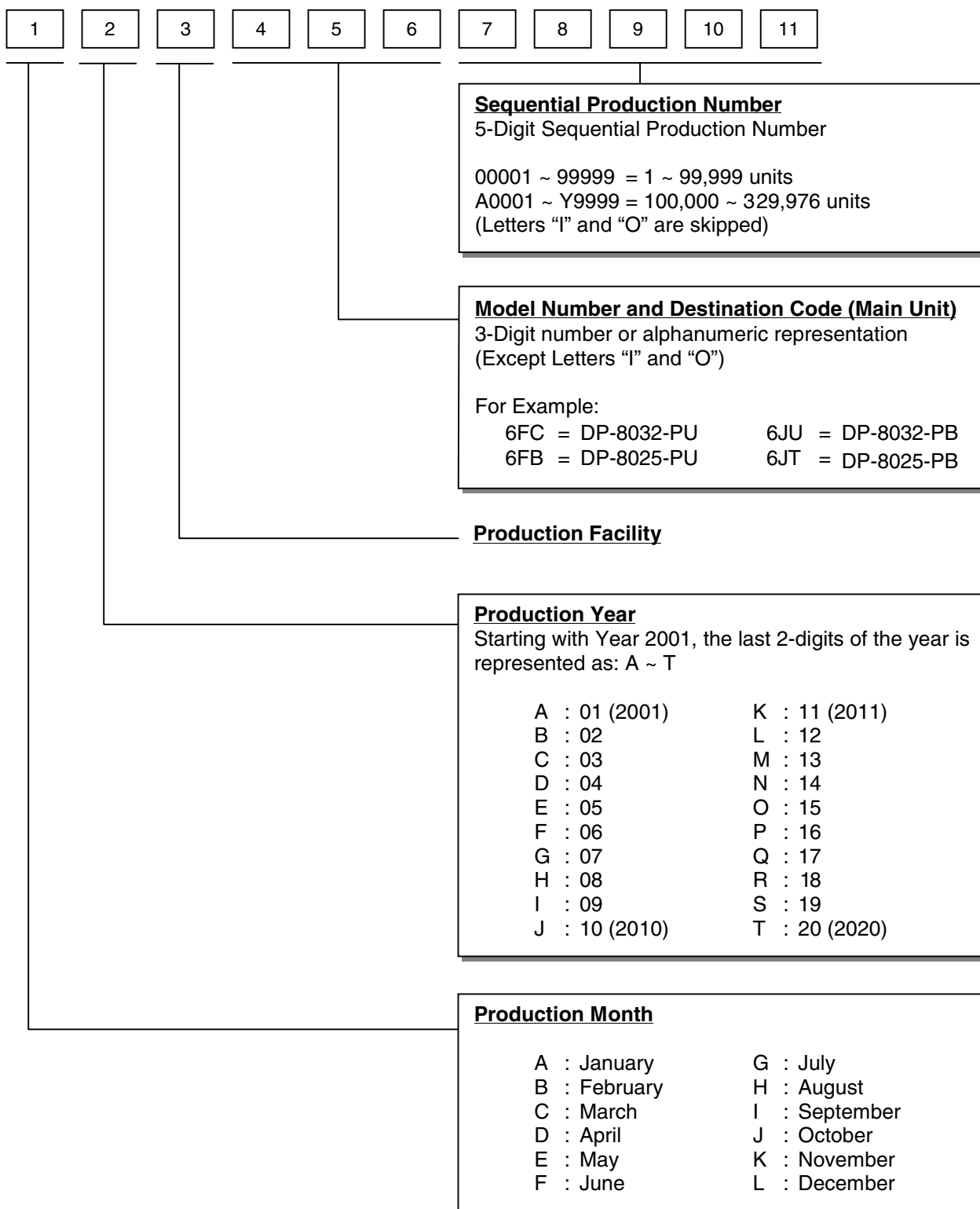

1.6. Control Panel



1.7. Fans and Motors

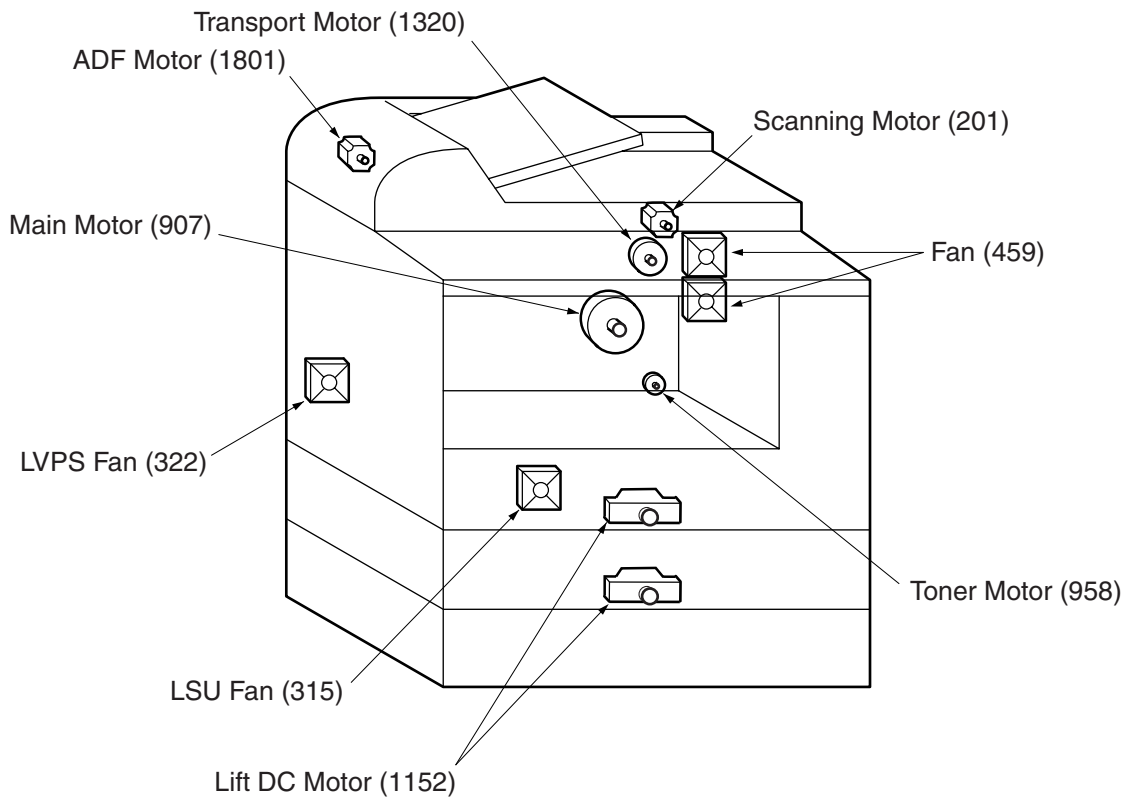

1.8. Clutches and Switches

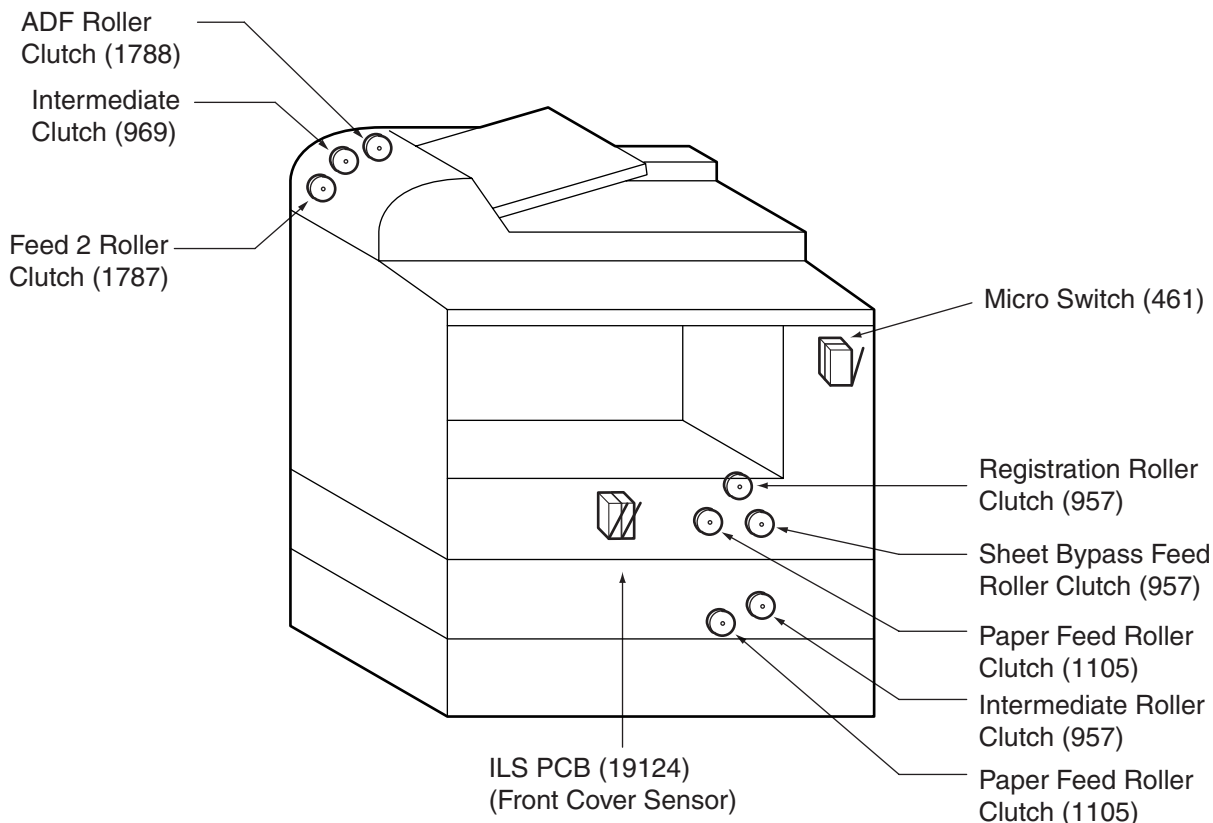

1.9. PC Boards

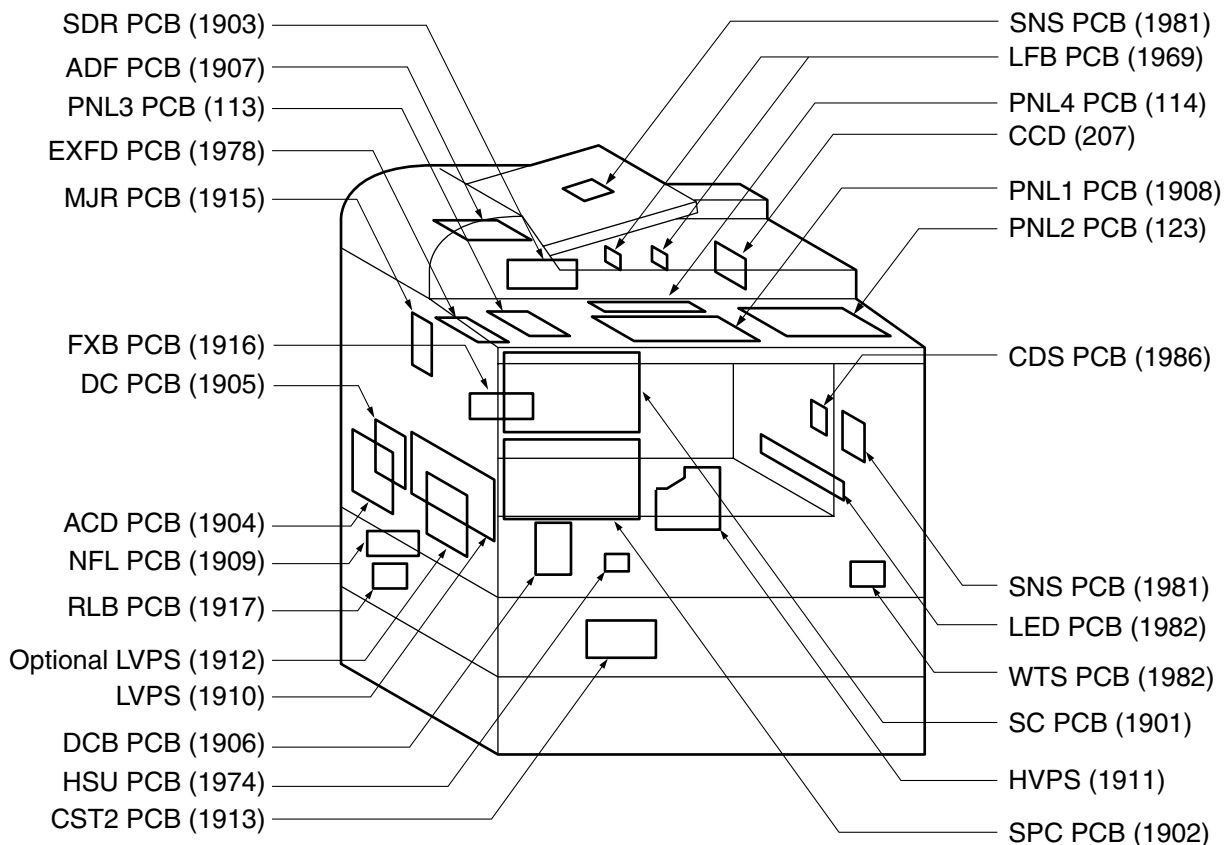

2 Disassembly Instructions

2.1. General Disassembly

Pertinent Disassembly Instruction sections are shown below.

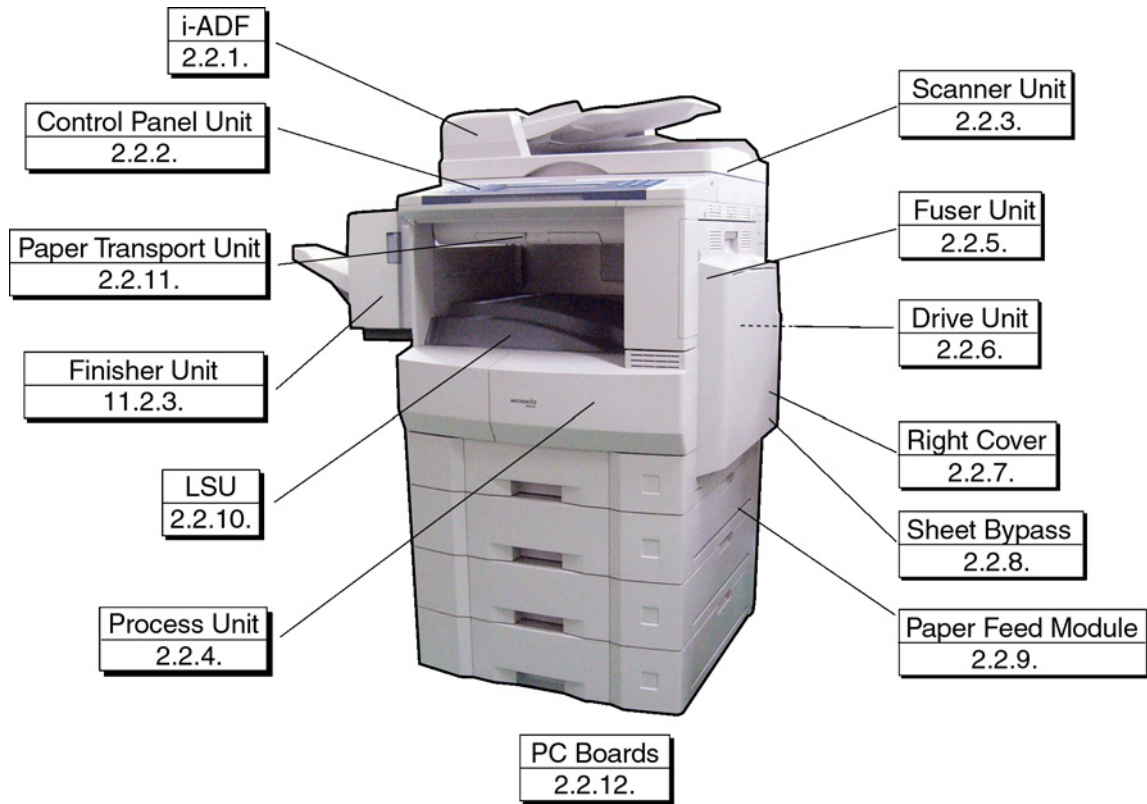

2.2. Disassembly Instructions

2.2.1. Inverting-Automatic Document Feeder (i-ADF) Unit

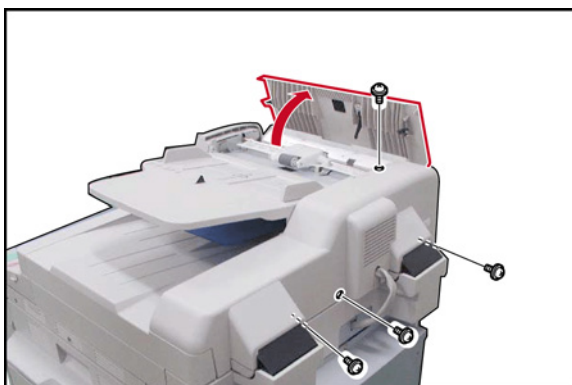

- (1) Open the **ADF Cover** (1831).
- (2) Remove 4 **Silver Screws** (B1).

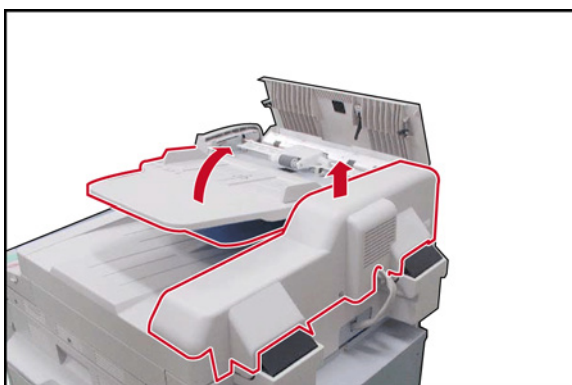

- (3) Lift the **ADF Input Tray** (1604).
- (4) Slightly pull the right edge of the ADF Rear Cover upward.
- (5) Release the **Latch Hooks**.
- (6) Remove the **ADF Rear Cover** (1601).

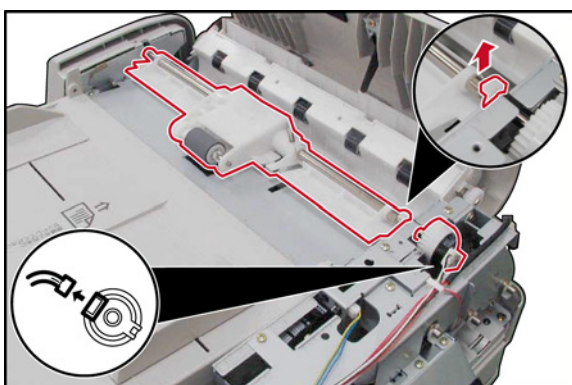

- (7) Lower the ADF Input Tray back in place.
- (8) Disconnect the **AMT Harness** (1951) from the Clutch.
- (9) Remove the **Snap Ring** (S9).
- (10) Remove the **ADF Roller** (1728) Assembly.

Caution:

When reinstalling, make sure that the Harness is secured with the Clamp to prevent nipping the Harness.

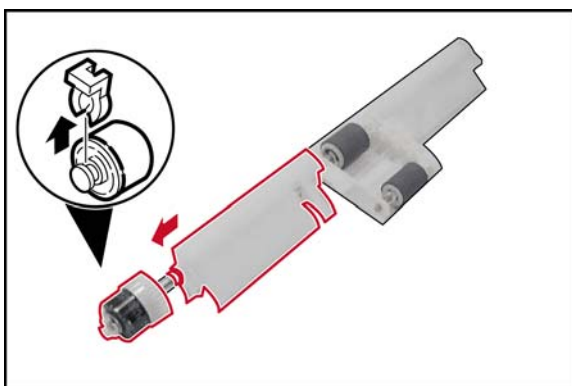

- (11) Remove the **Snap Ring** (S9).
- (12) Remove the **Clutch** (1788).
- (13) Remove the **Bushing** (1621).
- (14) Remove the **Rear ADF Guide** (1725).

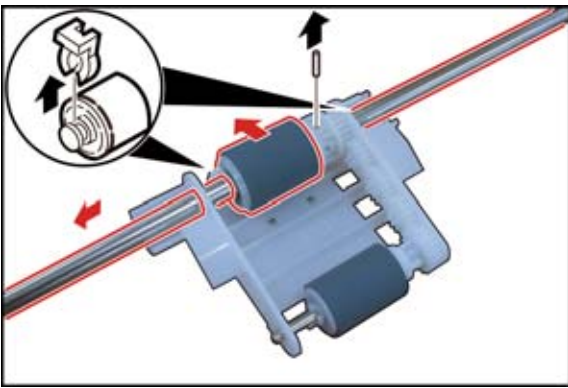

- (15) Remove the **Snap Ring (S9)**.
- (16) Remove the **Pin (744)**.
- (17) Remove the **ADF Shaft (1724)**.
- (18) Remove the **ADF Roller (1728)**.

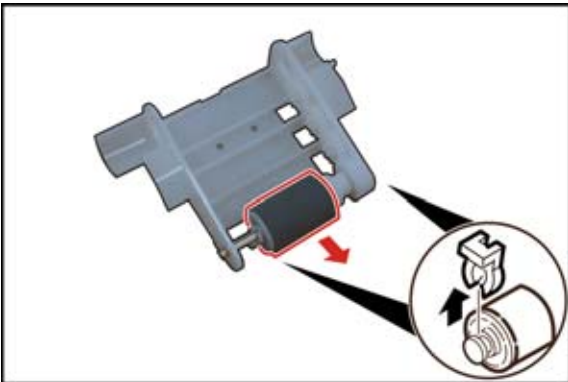

- (19) Remove the **Snap Ring (S9)**.
- (20) Remove the **Pre-Feed Roller Shaft (1730)**.
- (21) Remove the **Pre-Feed Roller (1731)**.

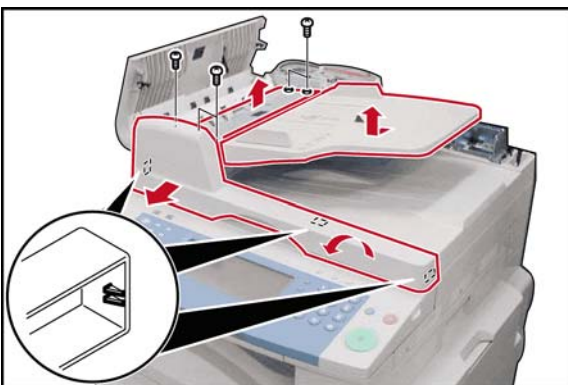

- (22) Remove 1 **Silver Screw (B1)**.
- (23) Remove the **ADF Front Cover (1637)**.

Note:

Release 3 Latch Hooks in alphabetical order and in the direction as shown by each arrow.

- (24) Remove 4 **Screws (19)**.
- (25) Remove the **Upper ADF Guide (1723)**.

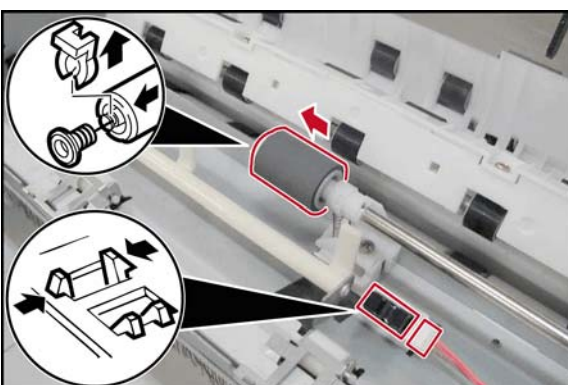

- (26) Remove the **Snap Ring (S9)**.
- (27) Remove the **Torque Limiter Bushing (1741)** and **Torque Limiter Spring (1742)**.

Note:

When reinstalling the Torque Limiter Assembly, ensure that the Torque Limiter Spring is placed into the deeper slot of the Separation Roller.

- (28) Remove the **Separation Roller (1740)**.
- (29) Disconnect the **APNT Harness (1956)** and remove **Sensor (1045)** (Original Detection Sensor).

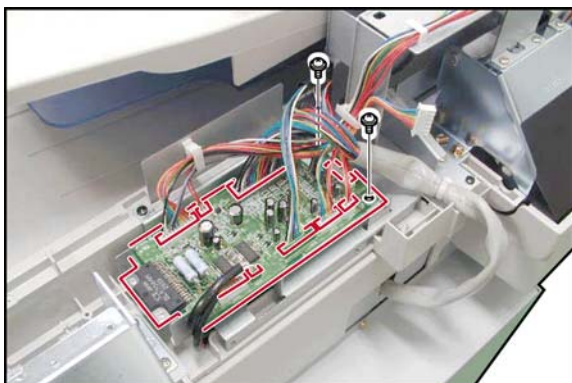

- (30) Disconnect all **Connectors** on the ADF PC Board.
- (31) Remove 2 **Screws** (19).
- (32) Remove the **ADF PC Board** (1907).

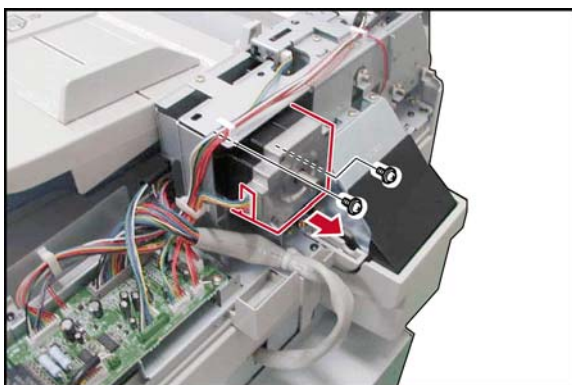

- (33) Remove 2 **Screws** (24).
- (34) Remove the **ADF Motor** (1801).

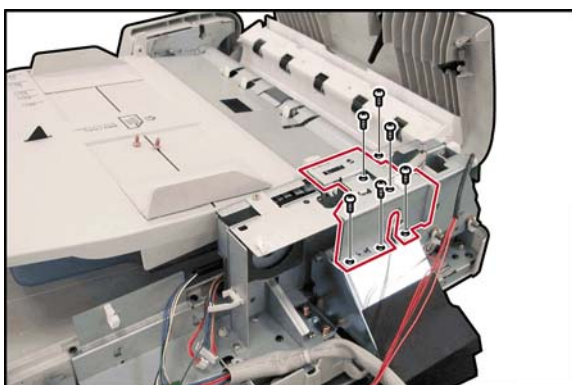

- (35) Remove 6 **Screws** (19).
- (36) Remove the **Sensor Bracket** (1663).

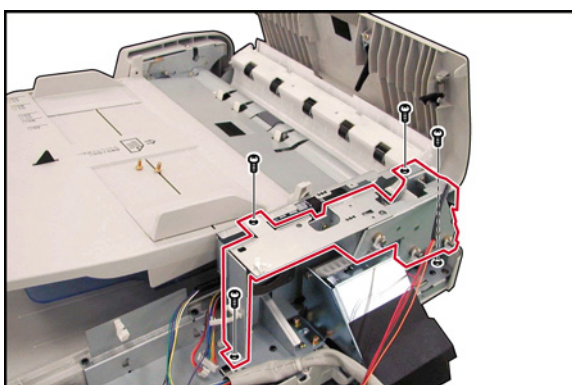

- (37) Remove 4 **Screws** (19).
- (38) Remove the **Motor Bracket** (1811) and **Gear Bracket** (1802) Assemblies.

Note:

Apply Molykote EM-50L Grease to all Gears and Shafts except to the following: E26S35 Drive Gear (1805), E26S35 Gear F (3305), ADF Motor (1801), and the shafts of Drive Shaft 2 (1817) and Exit Roller (1751).

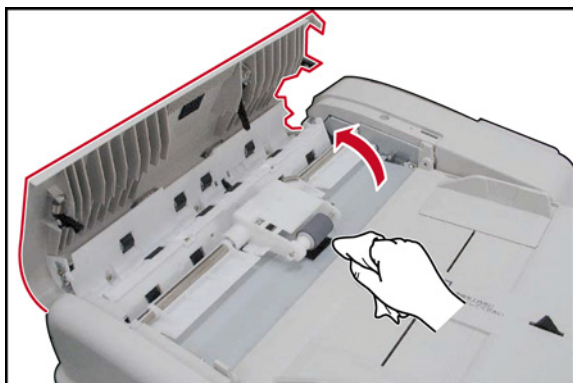

< Cleaning ADF Roller, Pre-Feed Roller, Drive Roller and Feed 2 Roller >

- (1) Open the **ADF Cover** (1831).
- (2) Clean the **ADF Roller** (1728), **Pre-Feed Roller** (1731), **Drive Roller** (1872) and the **Feed 2 Roller** (1753) with a soft cloth, saturated with isopropyl alcohol.

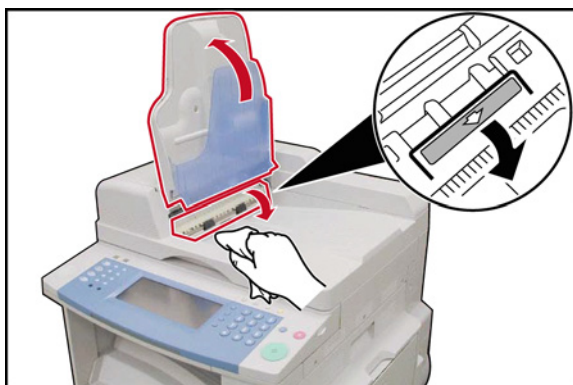

< Cleaning Exit Roller and Inverting Feed Roller >

- (3) Lift the **ADF Input Tray** (1604).
- (4) Open the **ADF Exit Cover** (1854).
- (5) Clean the **Exit Roller** (1751) and the **Inverting Feed Roller** (1853) with a soft cloth, saturated with isopropyl alcohol.

2.2.2. Control Panel Unit



- (1) Pull the **Battery Holder** (104) part of the way out.
- (2) Release the Latch, and remove the **Battery Holder** (104) out.

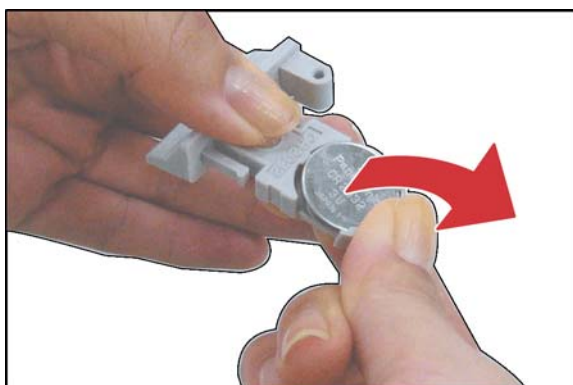

Note:

- (a) Replace the **Battery**.
- (b) Reinstall the **Battery Holder**.

⚠ CAUTION

Denotes hazards that could result in minor injury or damage to the machine.

* THIS PRODUCT CONTAINS A LITHIUM BATTERY. REPLACE ONLY WITH THE SAME OR EQUIVALENT TYPE. IMPROPER USE OR REPLACEMENT MAY CAUSE OVERHEATING, RUPTURE OR EXPLOSION RESULTING IN INJURY OR FIRE. DISPOSE OF USED BATTERIES ACCORDING TO THE INSTRUCTIONS OF YOUR LOCAL SOLID WASTE OFFICIALS AND LOCAL REGULATIONS.

Note: The service life of the Battery is approximately 1 year under normal use.

⚠ Avertissement

CE PRODUIT CONTIENT UNE PILE AU LITHIUM. REMPLACEZ UNIQUEMENT AVEC LE MÊME TYPE DE PILE OU UN TYPE ÉQUIVALENT. UNE UTILISATION OU UN REMPLACEMENT IMPROPRE POURRAIT CAUSER UNE SURCHARGE, UNE RUPTURE OU UNE EXPLOSION RÉSUANT EN DES BLESSURES OU UN INCENDIE. DÉBARASSEZ-VOUS DES PILES USÉES EN RESPECTANT LA RÉGLEMENTATION LOCALE SUR LA MISE AU REBUT DES DÉCHETS SOLIDES.

⚠ VORSICHT

● DIESES PRODUKT IST MIT EINER LITHIUM-BATTERIE BESTÜCKT. ERSETZEN SIE DIE BATTERIE DURCH EINE IDENTISCHE ODER GLEICHWERTIGE. EINE NICHT BESTIMMUNGSGEMÄSSE VERWENDUNG ODER DIE VERWENDUNG EINES ANDEREN BATTERIETYPUS KANN ZU ÜBERHITZUNG, BRUCH ODER EXPLOSION FÜHREN UND VERLETZUNGEN ODER EINEN BRAND VERURSACHEN. ENTSORGEN SIE VERBRAUCHTE BATTERIEN GEMÄSS DEN ANWEISUNGEN DER ZUSTÄNDIGEN STELLEN SOWIE DEN ÖRTLICHEN UMWELTSCHUTZBESTIMMUNGEN.

- Verwenden Sie ausschließlich den angegebenen Batterietyp.
- Setzen Sie die Batterie korrekt ein (beachten Sie die Polarität).

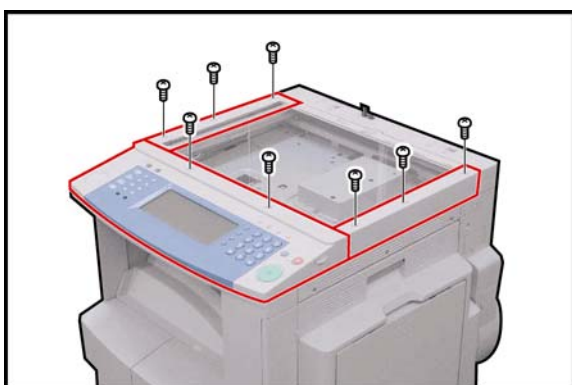

- (3) Remove 6 **Silver Screws** (B1).
- (4) Remove the **Left Platen Cover** (514) and the **Right Platen Cover** (516).
- (5) Remove 2 **Silver Screws** (B1).

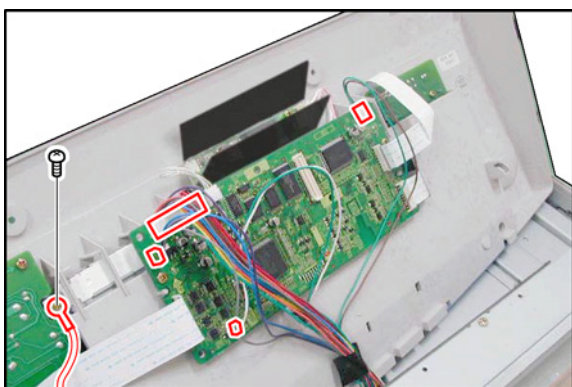

- (6) Slightly lift the **Control Panel** Assembly.
- (7) Disconnect 4 **Harnesses** on the PNL1 PC Board (CN220, CN221, CN222 and CN224).
- (8) Remove 1 **Screw** (21) to disconnect the **Ground Connector**.
- (9) Remove the **Control Panel** Assembly.

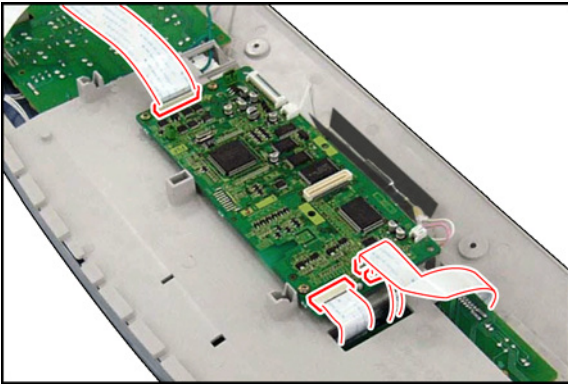

(10) Disconnect 4 **Harnesses** on the PNL1 PC Board (CN223, CN225, CN229 and CN230).

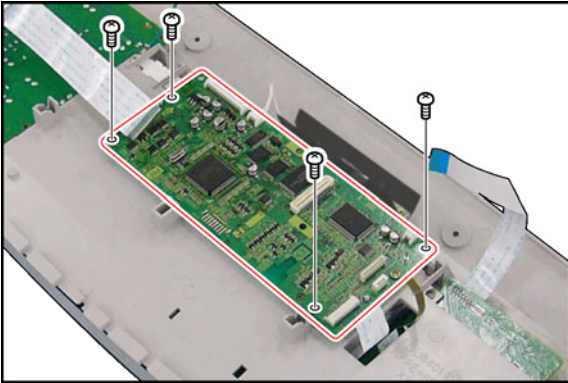

(11) Remove 4 **Screws** (F10).
 (12) Remove the **PNL1 PC Board** (1908).

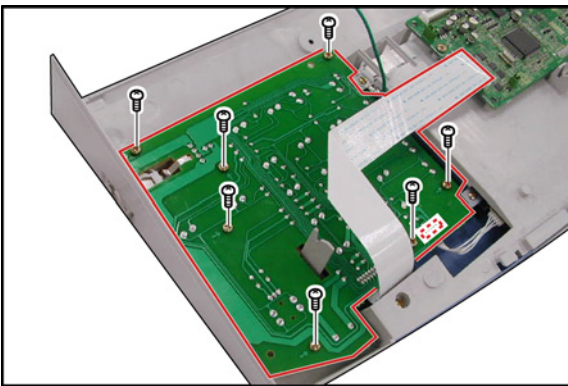

(13) Remove 7 **Screws** (F10).
 (14) Disconnect the **Harness** on the PNL2 PC Board (CN251).
 (15) Remove the **PNL2 PC Board** (123).

Note:

After reassembling the Control PNL2 PC Board, make sure that the Battery Holder is reinstalled.

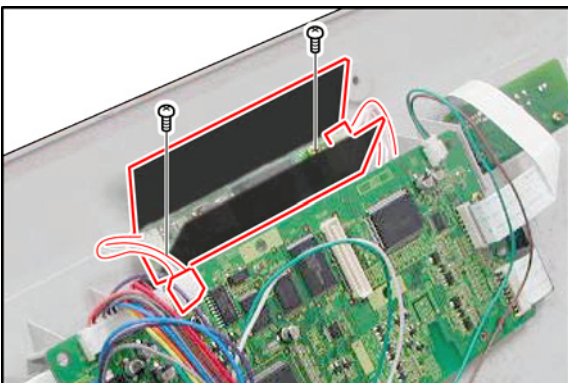

(16) Disconnect the **Harness** on the INV PC Board (CN2).
 (17) Remove 2 **Screws** (P5).
 (18) Remove the **INV PC Board** (129) and the Sheet.

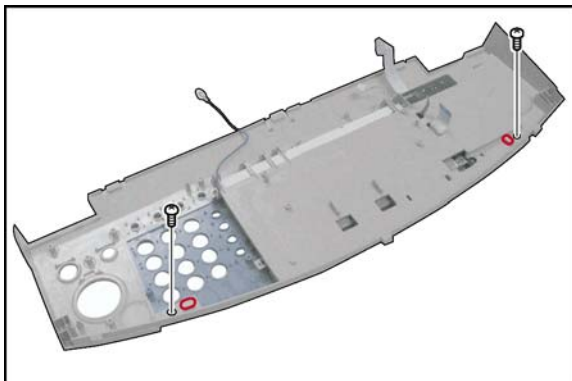

- (19) Remove 2 **Screws** (P5).
 (20) Release 2 **Latch Hooks** and remove the **Upper Control Panel Cover** (122).

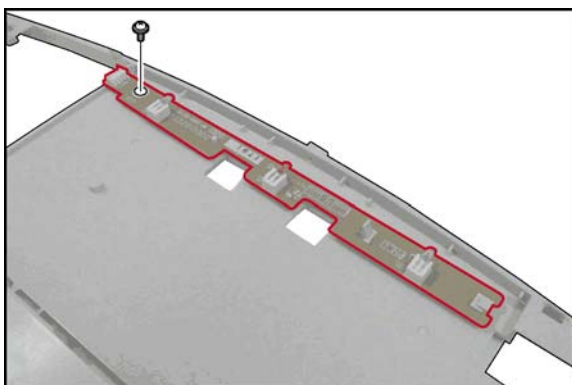

- (21) Remove 1 **Screw** (P5).
 (22) Remove the **PNL4 PC Board** (114).

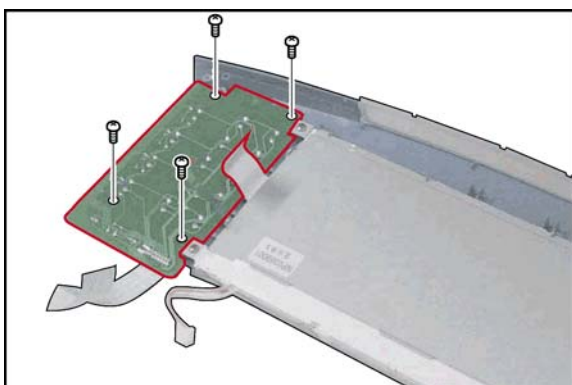

- (23) Remove 4 **Screws** (P5).
 (24) Remove the **PNL3 PC Board** (113).

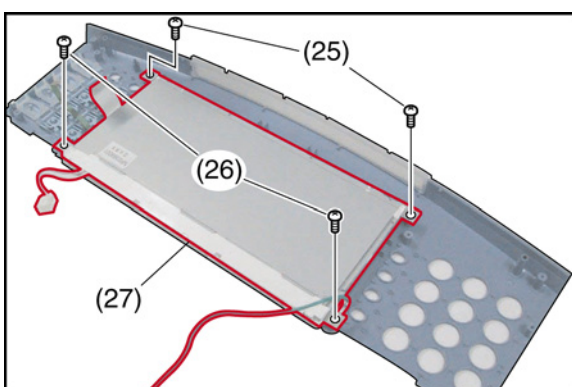

- (25) Remove 2 **Screws** (H4).
 (26) Remove 2 **Screws** (H4).
 (27) Remove the **LCD Module** (128).

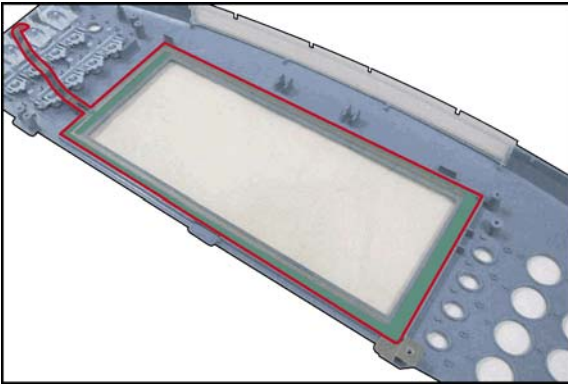

(28) Remove the **Touch Panel** (127).

2.2.3. Scanner Unit

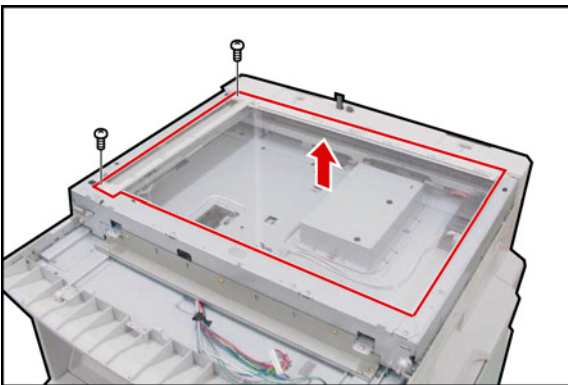

- (1) Remove the **Left and Right Platen Covers** (514, 516) and the **Control Panel Assembly**. (Refer to 2.2.2.)
- (2) Remove 2 **Screws** (19).
- (3) Remove the **Glass Assembly** (557).

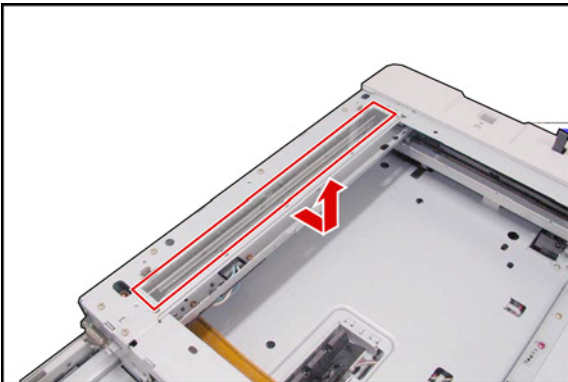

- (4) Remove the **Glass S** (559).

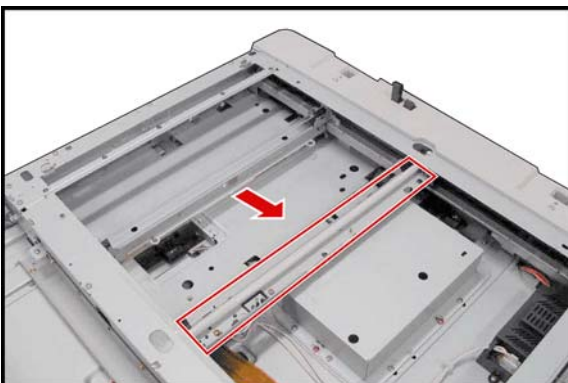

- (5) Holding by the center, slowly move the **Lamp Base Assembly** to the center of the Scanner Base Frame in the direction shown by the arrow.

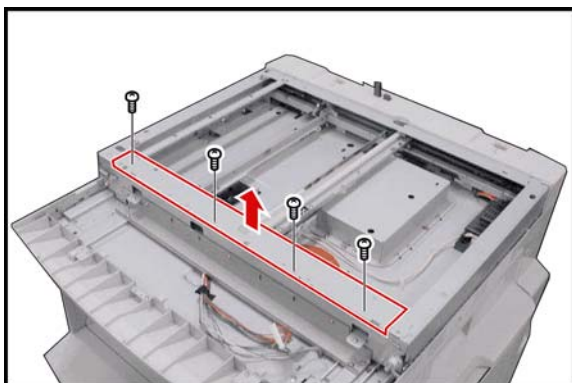

- (6) Remove 4 **Screws** (19).
 (7) Remove the **F/R Scanner Frame** (240).

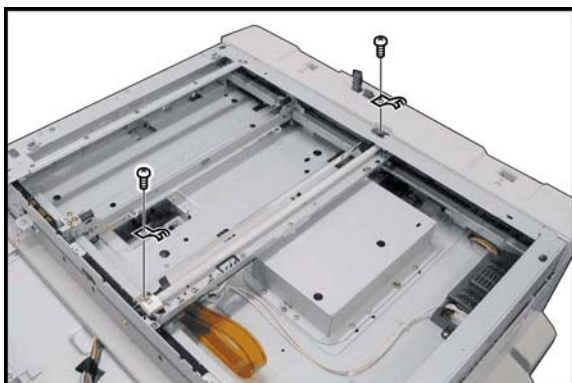

- (8) Remove 2 **Screws** (19).
 (9) Remove the 2 **Lamp Plate Springs** (232).
 (10) Disconnect the **Harness** on the LFB PC Board (CN181).
 (11) Remove the **Scanning Lamp** (204).

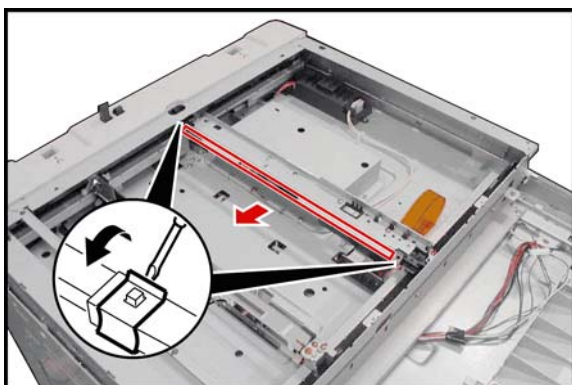

- (12) Remove 2 **Mirror Plate Springs** (230).
 (13) Remove **Mirror 1** (264).

Note:

Observe the position of the Mirror 1 before removing it. The Black Mark on the Mirror, indicates non-reflective side. When reinstalling, make sure the smooth side of Mirror 1 with the Black Mark is pointing downwards.

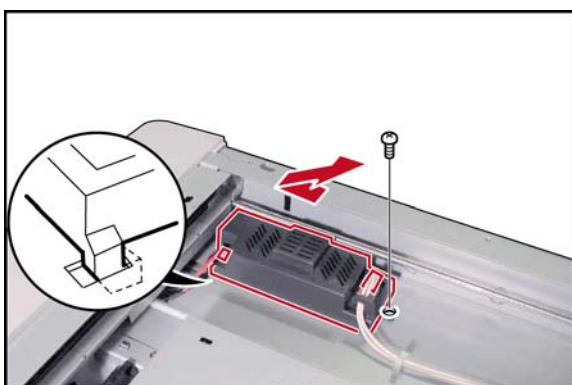

- (14) Disconnect 2 **Harnesses** on the Inverter PC Board (CN1 and CN2).
 (15) Remove 1 **Screw** (19).
 (16) Remove the **Inverter Upper Cover** (212).

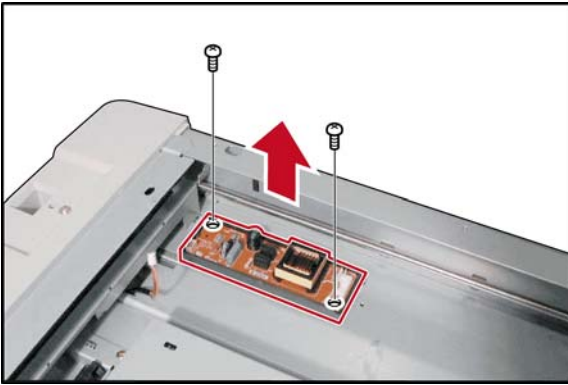

- (17) Remove 2 **Screws** (19).
 (18) Remove the **Inverter PC Board** (268).

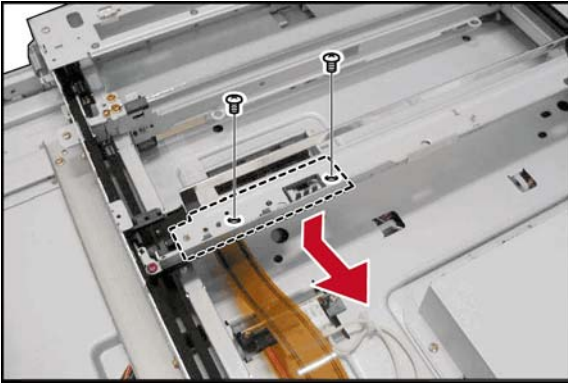

- (19) Remove 2 **Red Screws** (D24).
 (20) Remove the **FPC Cable Holder A** (215) Assembly.

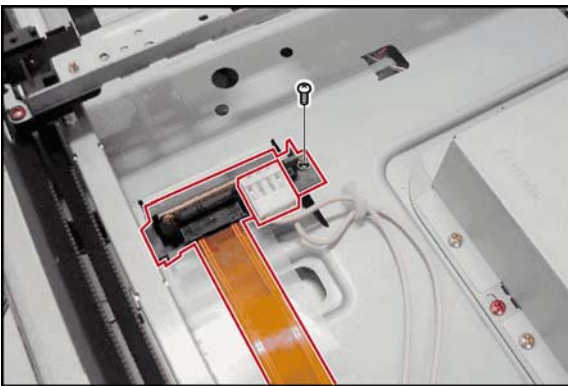

- (21) Holding by the center, slowly move the **Lamp Base Assembly** towards the left of the Scanner Base Frame.
 (22) Disconnect the **Harness** on the LFB PC Board (CN181).
 (23) Remove 1 **Screw** (19).
 (24) Remove the **FPC Cable Holder B** (216) Assembly.

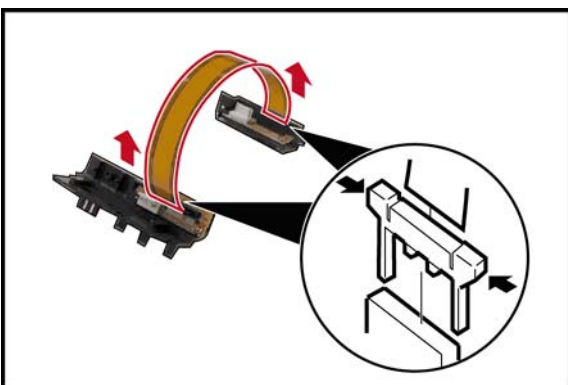

- (25) Remove 2 **Sliders** on the Connectors.
 (26) Remove the **FPC Cable** (260).

Note:

The Sliders must be reinstalled when reassembling.

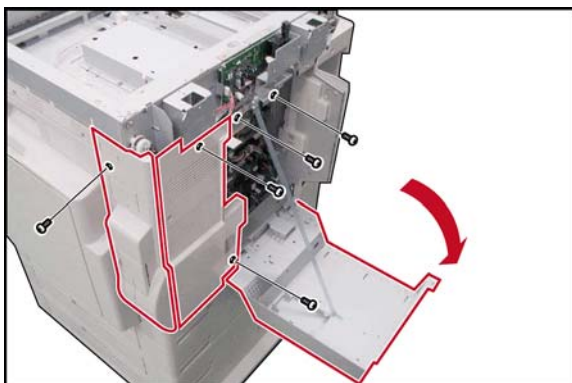

<Removing the Scanner Motor>

- (27) Remove 4 **Silver Screws** (S6).
- (28) Open the **Rear Cover**.
- (29) Remove 4 **Silver Screws** (S6).
- (30) Remove the **Rear Right Cover** (507) and the **Right Rear Cover** (518).

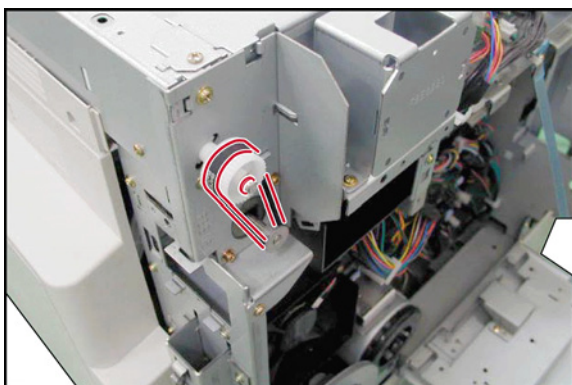

- (31) Remove the **E-Ring** (5Y).
- (32) Remove the **Synchro Belt** (208).

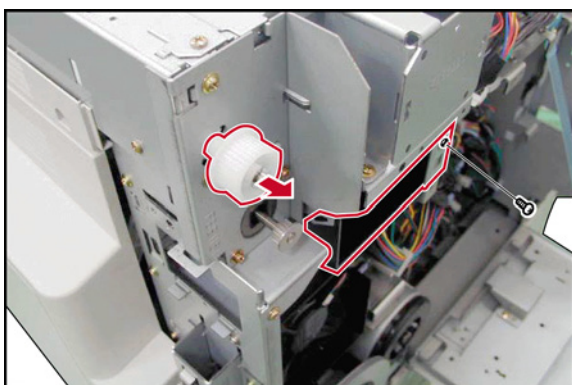

- (33) Remove the **MXL34 Pulley** (217).
- (34) Remove 1 **Screw** (6P).
- (35) Remove the **Fan** (459).

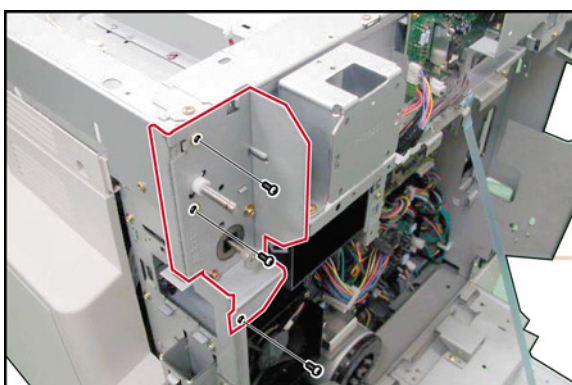

- (36) Disconnect the **Harness** on the Scanning Motor.
- (37) Remove 3 **Screws** (19).
- (38) Remove the **Motor Bracket** (249) Assembly.

Note:

When reinstalling the Motor Bracket, tighten the upper screw first.

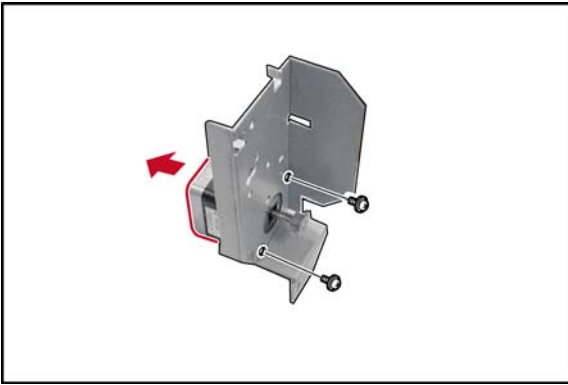

- (39) Remove 2 **Screws** (36).
 (40) Remove the **Scanning Motor** (201).

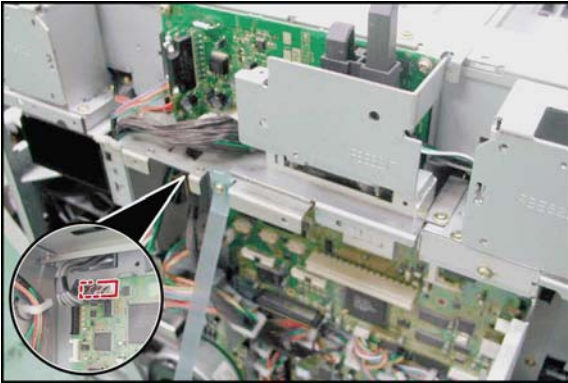

- (41) Disconnect the **Harness** on the SC PC Board (CN106).
 (42) Release 2 **Latch Clips** and remove the **Ferrite Core**.

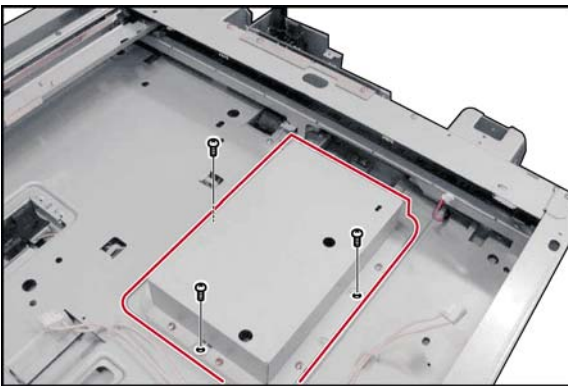

- (43) Remove 3 **Red Screws** (D24).
 (44) Remove the **CCD Assembly** (207).

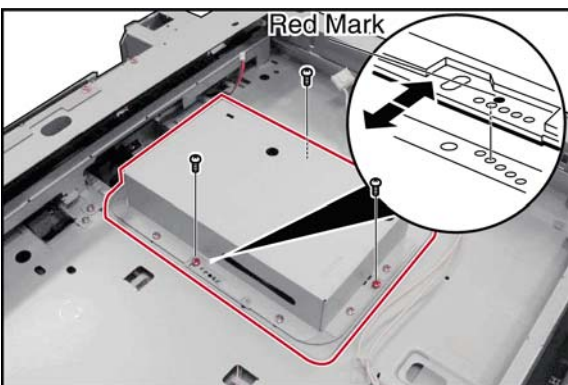

Note:

When reinstalling the CCD Assembly, align the hole with the Red Mark on the CCD Assembly with the hole on the Scanner Base Frame as illustrated and secure it with 3 Red Screws.

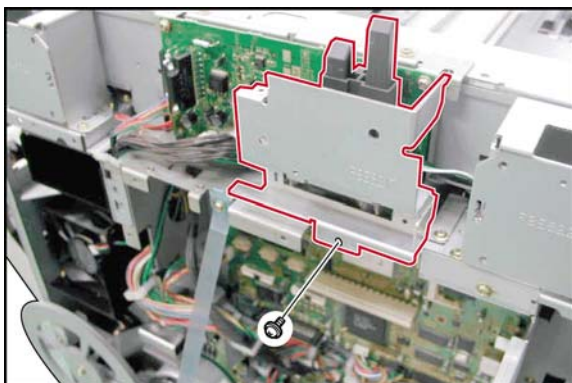

- (45) Remove 1 **Screw** (6P).
 (46) Remove the **CN Bracket** (511) Assembly.

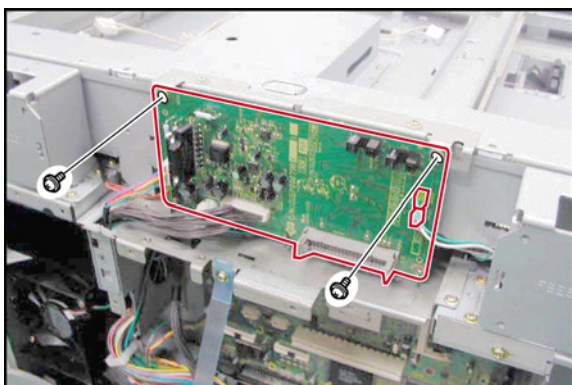

- (47) Remove 2 **Screws** (19).
 (48) Remove the **SDR PC Board** (1903).

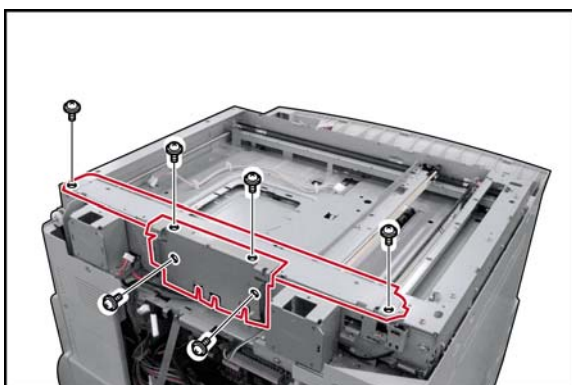

- (49) Remove 6 **Screws** (19).
 (50) Remove the **F/R Scanner Frame** (240).

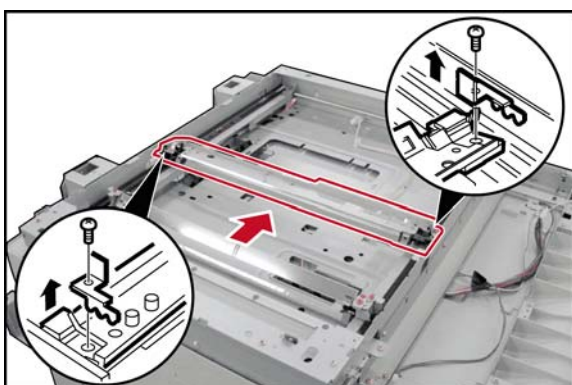

- (51) Remove 2 **Red Screws** (D24).
 (52) Remove the **Rear Lamp Belt Lock** (228).
 (53) Remove the **Front Lamp Belt Lock** (227).
 (54) Remove the **Lamp Base Bracket** (224) Assembly.

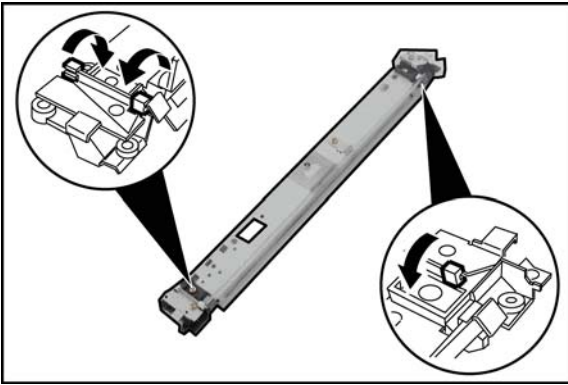

(55) Remove the 3 **Sliders** (211).

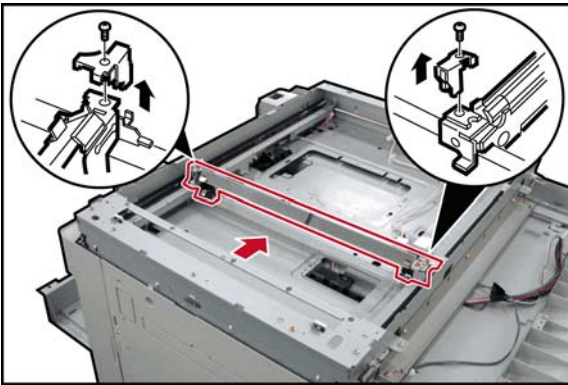

(56) Remove 2 **Screws** (18).

(57) Remove the **Rear Mirror Belt Lock** (238).

(58) Remove the **Front Mirror Belt Lock** (236).

(59) Remove the **Mirror 2 Bracket** (233) Assembly.

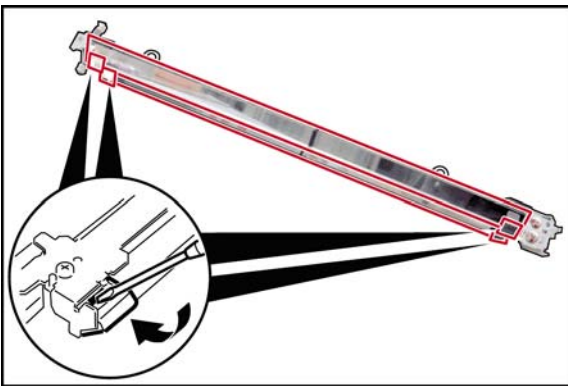

(60) Remove the 4 **Mirror 2 Plate Springs** (206).

(61) Remove the two **Mirror 2** (265).

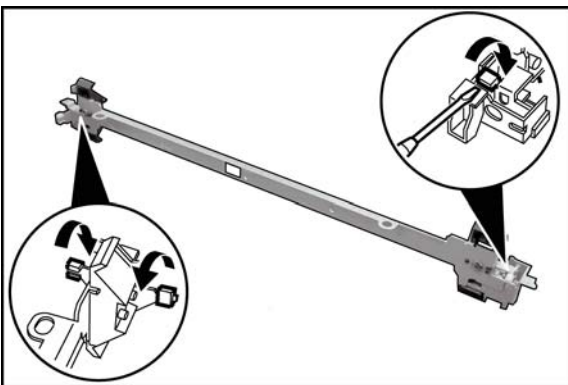

(62) Remove the 3 **Sliders** (211).

<Reinstalling the Lamp Base Assembly and the Mirror 2 Bracket Assembly>

- (1) Remove 2 **Screws** (19).
- (2) Remove the **Right Scanner Frame** (242).

Note:

When reinstalling the Right Scanner Frame, tighten the 2 **Screws** after reinstalling both sides of the F/R Scanner Frame.

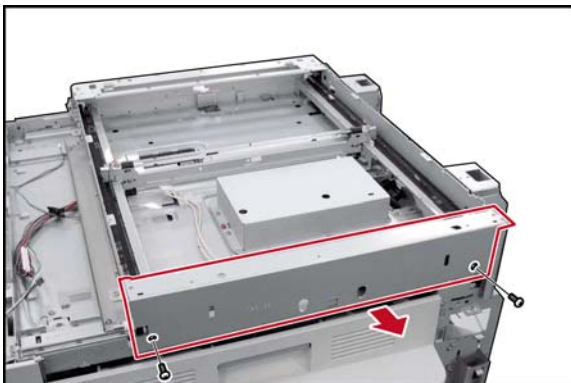

- (3) Install the **Mirror 2 Bracket** (233) Assembly.
- (4) Reinstall the 2 **Inner Timing Belts** (202).

Note:

The Bracket must be adjusted by moving it towards the center until it stops against the notches in the frame.

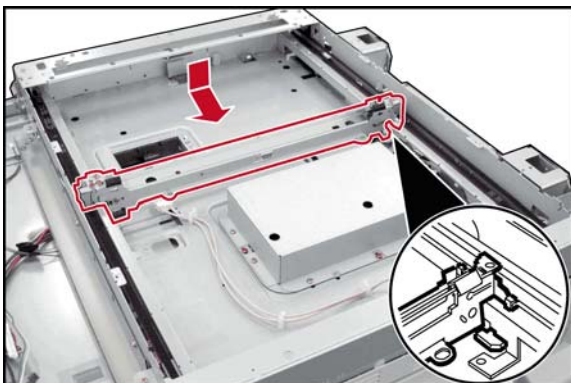

- (5) While holding each side of the Bracket against the notch, secure the **Rear Mirror Belt Lock** (238) and the **Front Mirror Belt Lock** (236) with 2 **Screws** (18).

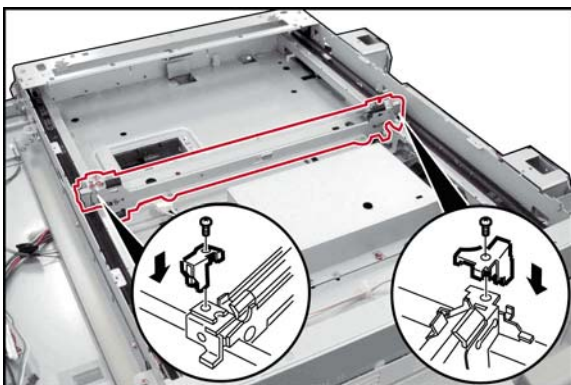

- (6) Install the **Lamp Base Bracket** (224) Assembly.

Note:

The Bracket must be adjusted by moving it towards the right edge until it stops against the notches in the frame. Make sure that the Mirror 2 Bracket Assembly is positioned in the notches in the center of the frame.

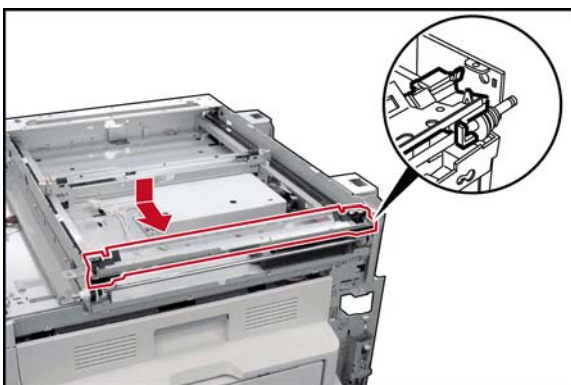

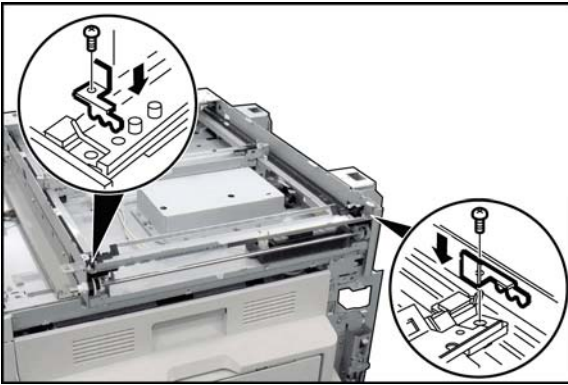

- (7) While holding each side of the Bracket against the notch, secure the **Rear Lamp Belt Lock (228)** and the **Front Lamp Belt Lock (227)** with **2 Red Screws (D24)**.

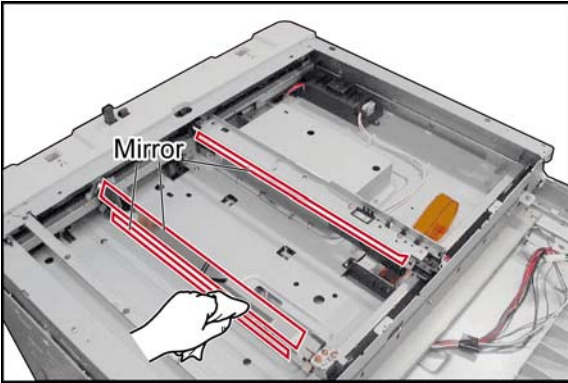

- (8) Clean the **Mirror 1 (264)**, the **Mirror 2 (265)**, and the **Multi Beam Sensor**.

Note:

1. Do not touch the surface of the Sensors with your hands.
2. Clean any dirt or fingerprints with a Dry Cotton Swab.
3. Do not use Isopropyl Alcohol / any Alcohol.

2.2.4. Process Unit

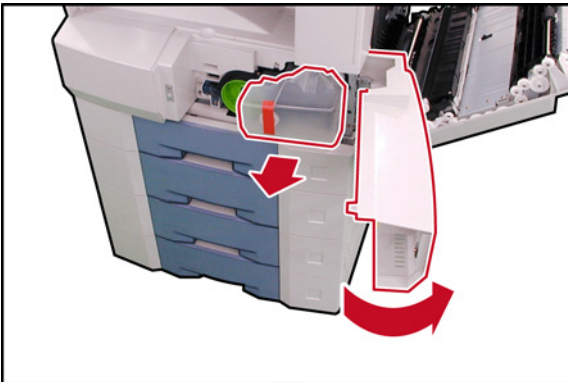

- (1) Open the **Right Cover (1201)**.
- (2) Open the **Front Cover (528)**.
- (3) Remove the **Toner Waste Container (618)**.



- (4) Remove the **Toner Bottle (617)**.
- (5) Remove 1 **Screw (19)**.
- (6) Remove the **Connector Cover (Clear Blue) (538)**.

Caution:

When reconnect the Harness, make sure the connector position and its keys. Insert it gently, and do not force the connector if it is facing the wrong way.

Caution:

When reinstalling the Connector Cover, make sure the Harness is not nipped by the Cover.

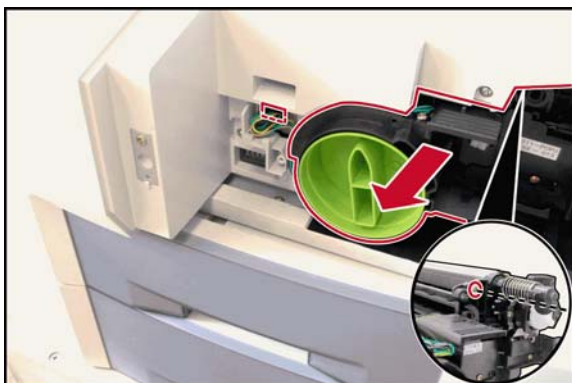

- (7) Disconnect the **Harness**.
- (8) Loosen the **Process Unit Screw** (743).
- (9) Slide the **Process Unit** out.

Caution:

To prevent damage to the Process Unit, ensure the Right Cover is still open before pulling the Process Unit out.

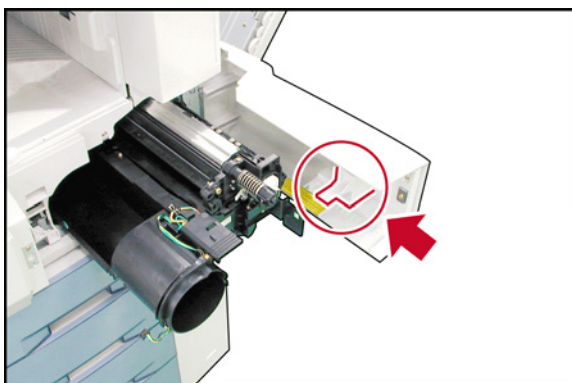
**Caution:**

Exercise caution not to scratch the surface of the **OPC Drum** (Green), and not to touch it with bare hands.

Caution:

The OPC Drum is sensitive to light. To prevent optical exposure problems, do not expose the OPC Drum to direct sunlight or bright light (even if it is a 1000-Lux fluorescent lamp).

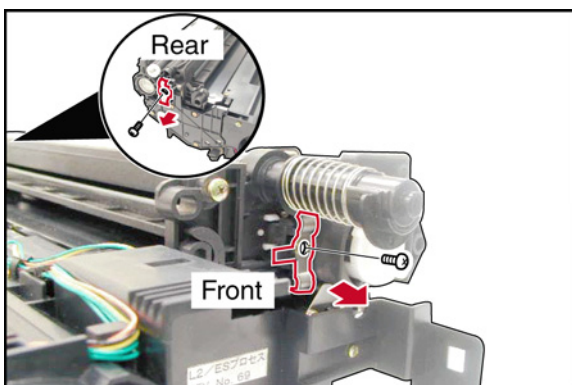

- (10) Remove 1 **Screw** (1Y).
- (11) Remove the **Front Lock Plate Assembly** (751) (longer plastic tab).
- (12) Remove 1 **Screw** (1Y).
- (13) Remove the **Rear Lock Plate Assembly** (752) (shorter plastic tab).

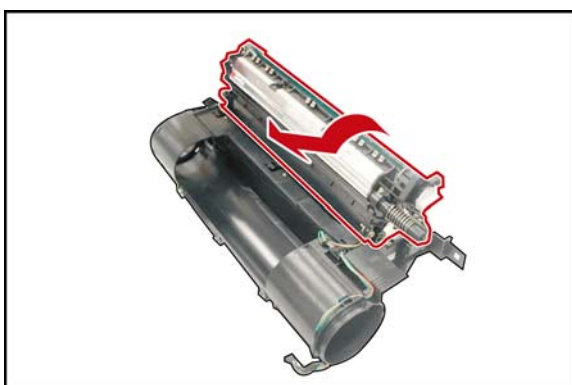

- (14) Turn the **OPC Drum Assembly** in the direction of the arrow and remove.

Caution:

Exercise caution not to scratch the surface of the **OPC Drum** (Green), and not to touch it with bare hands.

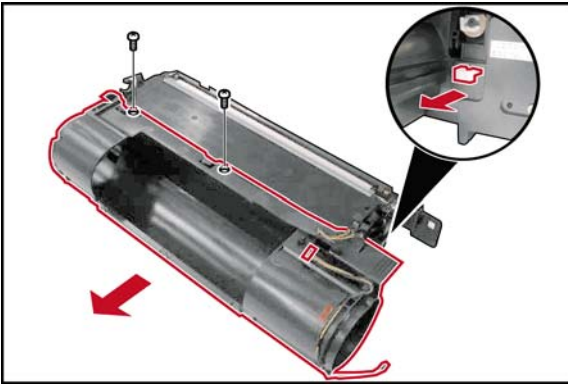

(15) Remove the **Harness** from clamp, disconnect the **Connector**.

(16) Remove 2 **Screws** (51) and 1 **Snap Ring** (G6).

(17) Remove the **Hopper Unit**.

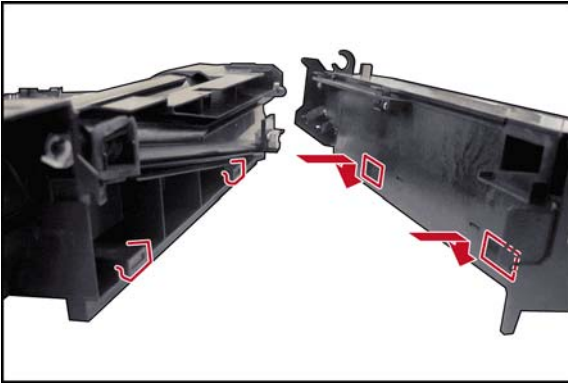

Note:

When reinstalling the Hopper Unit, insert the hooks into the recessed holes on the Developer Unit as illustrated.



(18) Release 3 **Latch Hooks** and remove the **Developer Cover** (825).



<Removing the Old Developer and Toner>

(19) Stand the Developer Unit as illustrated over a suitable container and dump the used Developer and Toner by rotating the Gear.

(20) Clean the **Developer Unit** with a dry soft cloth.

(21) Reinstall the **Hopper Unit**.

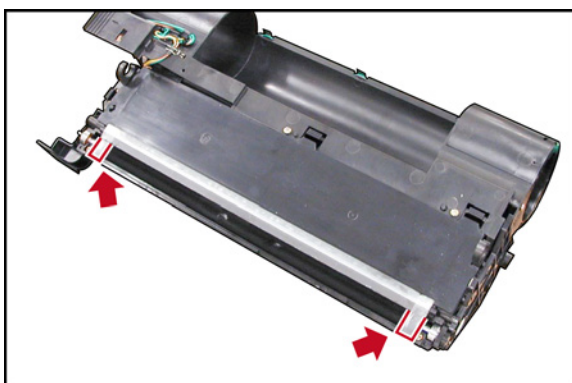

- (22) Shake the **Developer Bottle** thoroughly (approx. 30 seconds).
- (23) Pour the appropriate developer evenly into the developer unit. Make sure to empty the bottle.
- (24) Close the **Developer Cover**.

**Note:**

When reinstalling the Developer Cover, ensure that 2 Magnet Roller Sheets are outside as illustrated.

**<Removing the Old OPC Drum>**

- (25) Remove the **OPC Drum Shaft Holder** Assembly.
- (26) Lift the **OPC Drum**, holding the right side where the OPC Drum Shaft Holder Assembly was installed.

Note:

Do not touch the surface of the OPC Drum with bare hands when removing or reinstalling it. Grease from fingerprints will affect copy quality. When installing a new OPC Drum, clean the Bias Charge Roller with a soft dry cloth.

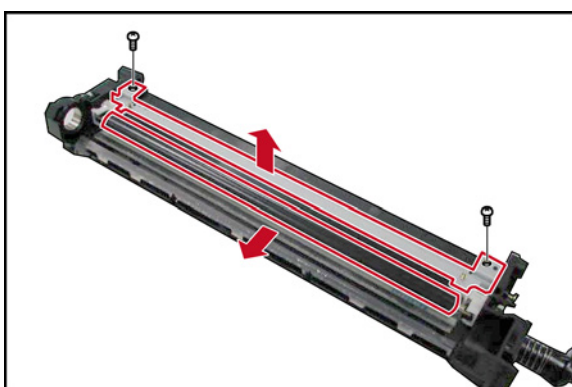

- (27) Remove the **Bias Charge Roller** (725).
- (28) Remove 2 **Screws** (20).

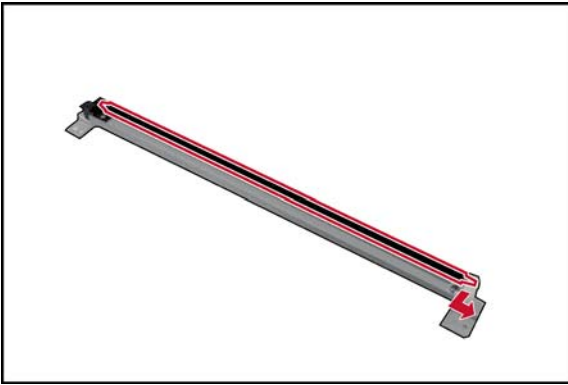

(29) Remove the **Cleaning Roller** (706).

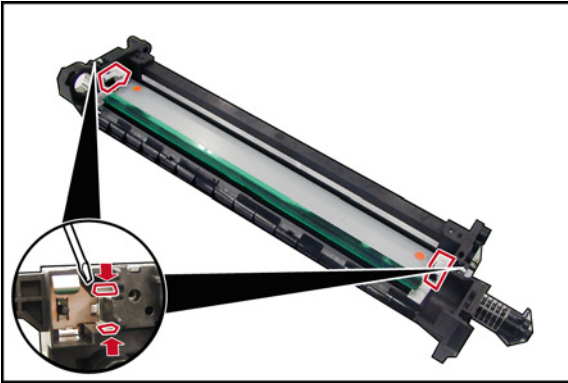

(30) Remove 2 **Bias Charge Roller Holder** (728) Assemblies.

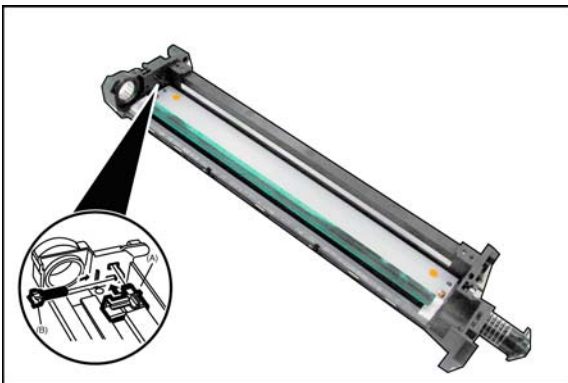

Note:

When reinstalling the Bias Charge Roller Holder Assembly on the rear side, install the Bias Charge Roller Holder (728) first and then the Bias Charge Roller Bushing (726) with the Bushing Coil Spring (727) as illustrated.



(31) Remove 2 **Screws** (23).

(32) Remove the **Cleaning Blade** (704).

(33) Remove the **Splash Prevention Sheet** (710).

2.2.5. Fuser Unit

CAUTION:

To prevent from getting burned, do not install, remove, clean or make adjustments when the Fuser Unit is hot.

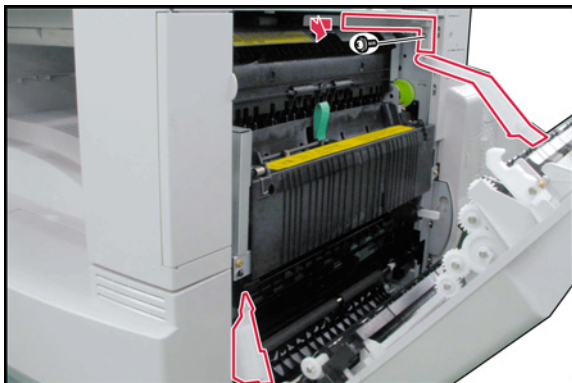

- (1) Open the **Right Cover** (1201).
- (2) Remove 1 **Screw** (6P).
- (3) Remove the **Harness Cover** (1525).
- (4) Unlock the **Angled Rear Arm** (1218) and the **Front Arm** (1217).

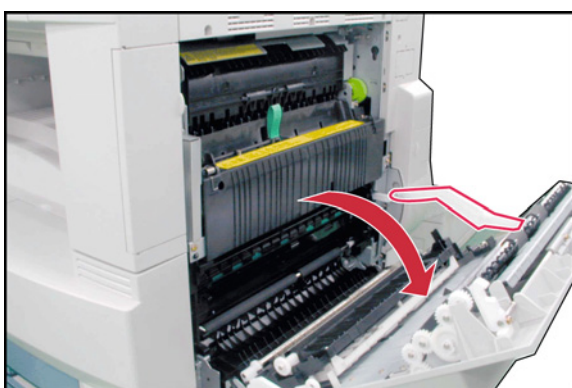

- (5) Open the **Right Cover** and hook the **Angled Rear Arm** into the lower Hook Hole.

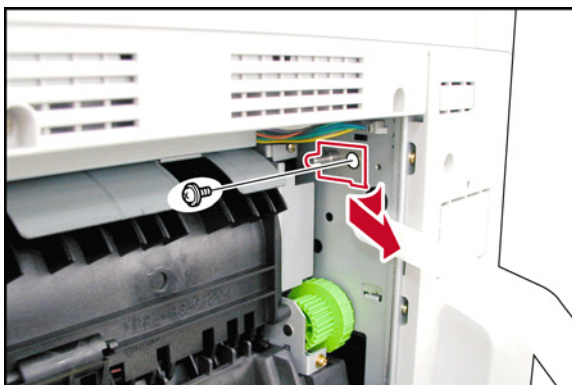

- (6) Remove 1 **Screw** (6P).
- (7) Remove the **Support Plate** (476).

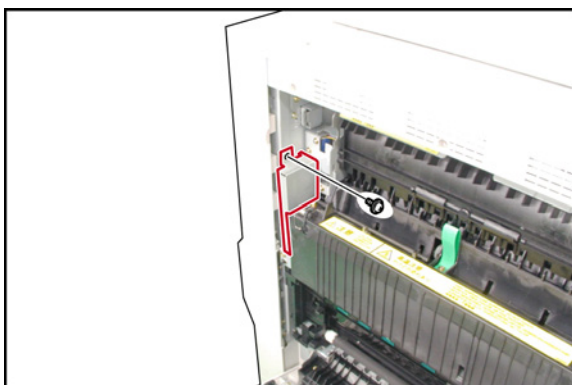

- (8) Remove 1 **Screw** (6P).
- (9) Remove the **Strap Cover** (1022).

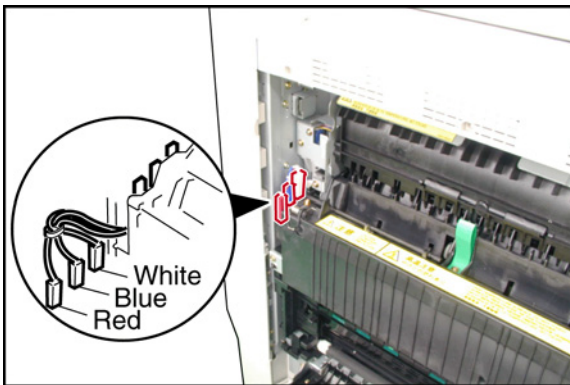

(10) Disconnect the 3 **Harnesses** on the Terminals of Fuser Unit.

Note:

When reinstalling, make sure that the 3 Harnesses are connected correctly as illustrated.

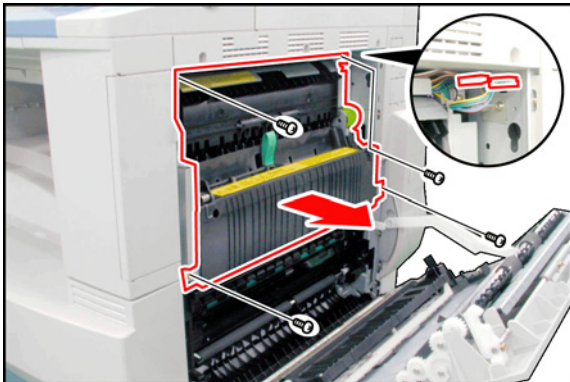

(11) Disconnect 2 **Harnesses**.

(12) Remove 4 **Screws** (4N).

(13) Remove the **Fuser Unit**.

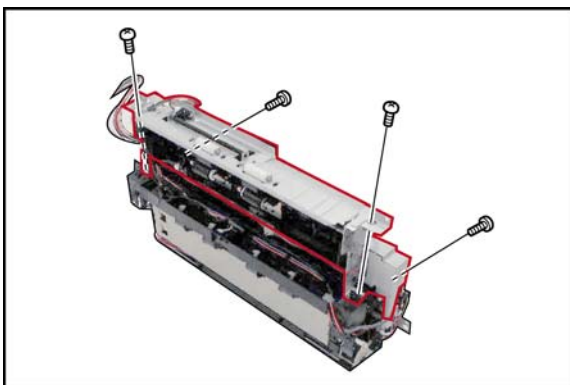

(14) Remove 4 **Screws** (6P).

(15) Remove the **Dual-Path Exit Guide**.

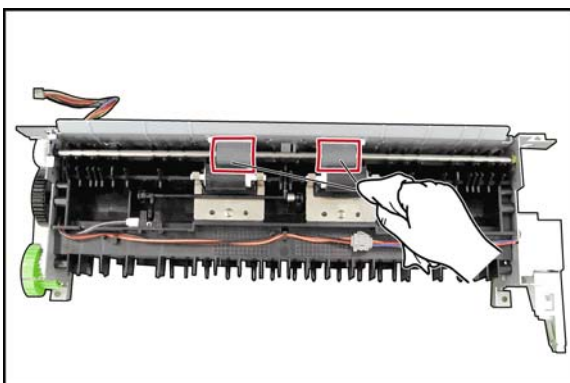

(16) Clean the **Feed Roller** (1510) with a soft cloth, saturated with isopropyl alcohol.

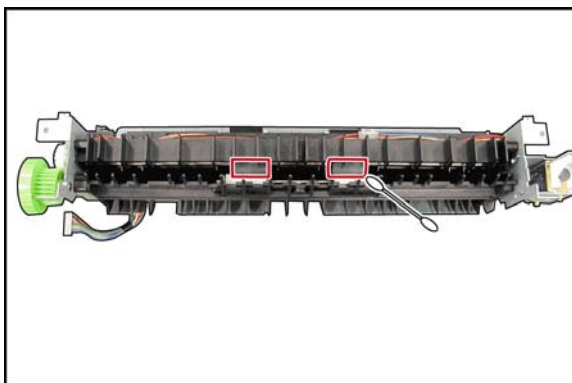

(17) Clean the **Feed Roller** (1510) with a soft cloth, saturated with isopropyl alcohol.

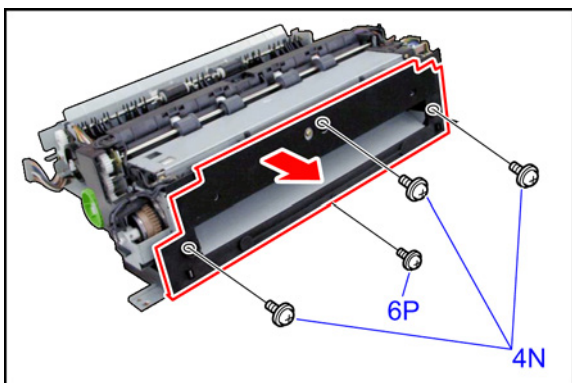

(18) Remove 3 **Screws** (4N).
 (19) Remove 1 **Screw** (6P).
 (20) Remove the **Lower Fuser Cover** (1003).

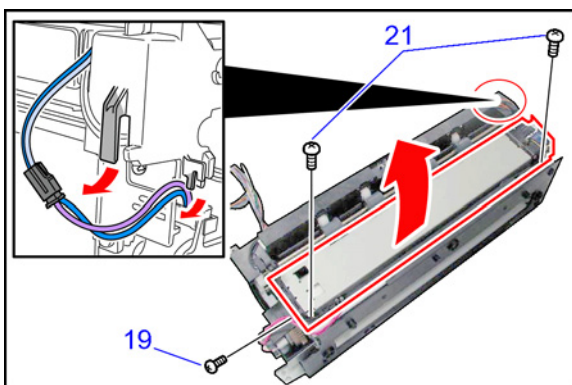

<Removing the Web Cleaning Roller>

(21) Remove 2 **Screws** (21) and 1 **Screw** (19).
 (22) Disconnect the **Harness**.
 (23) Remove the **Cleaning Web Roller Unit**.

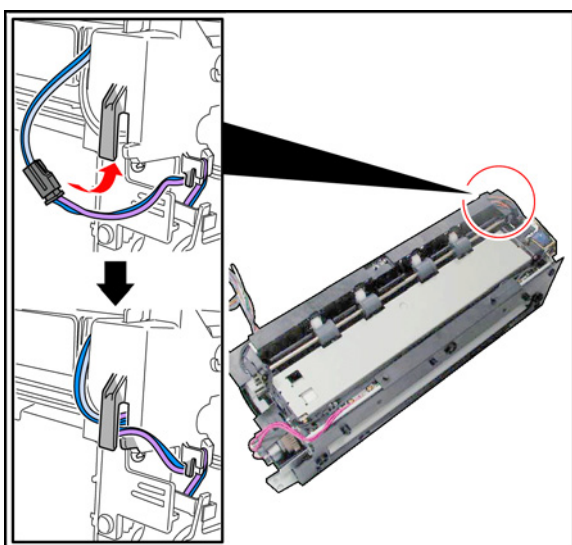

Caution:

When reinstall the Cleaning Web Roller Unit the extra Harness put into the Fuser cover as illustrated.

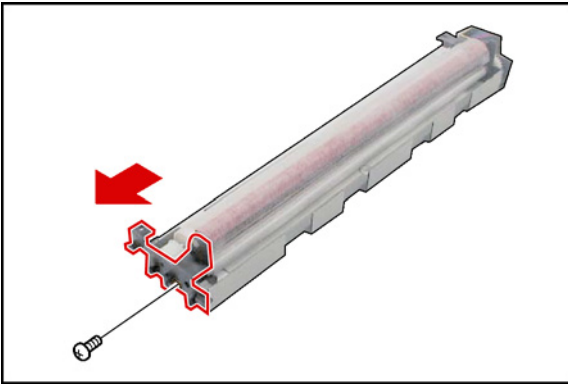

- (24) Remove 1 **Screw** (21).
- (25) Remove the **Rear Web Bracket** (1071).
- (26) Remove the **Cleaning Web Roller** (1083) and **Web Pressure Roller** (1080).

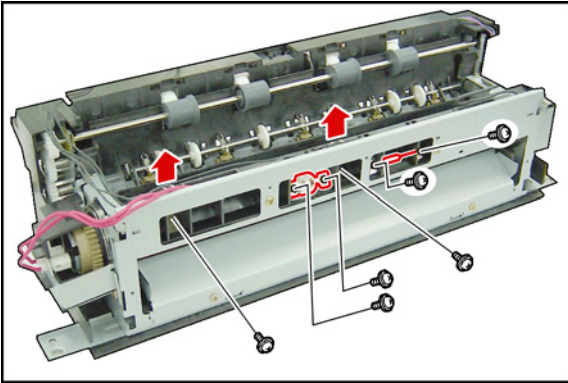

- (27) Remove 2 **Screws** (36).
- (28) Remove the **Thermostat** (1038).
- (29) Remove 2 **Screws** (36).
- (30) Remove the **Thermal Fuse** (1040).
- (31) Remove 2 **Screws** (1Y).
- (32) Remove the **Thermistor Assembly** (1041).

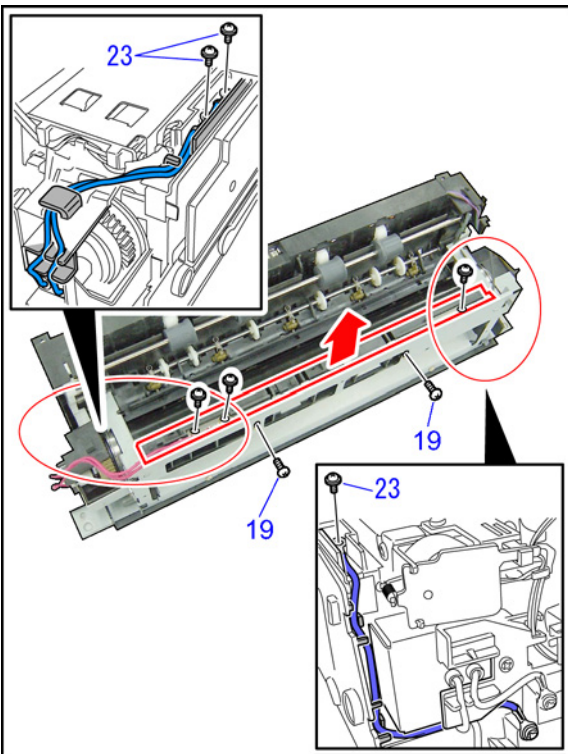

- (33) Remove 3 **Screws** (23).
- (34) Remove 2 **Screws** (19).
- (35) Remove the **Harness Guide** (1004).

Caution:

When reinstalling the Web unit, the Harnesses do not nip as illustrated.

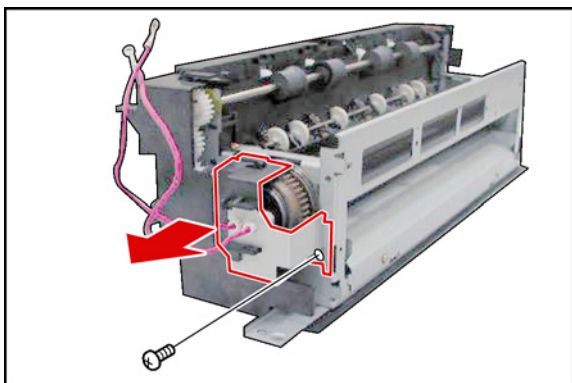

- (36) Remove 1 **Screw** (21).
 (37) Remove the **Rear Lamp Holder** (1021).

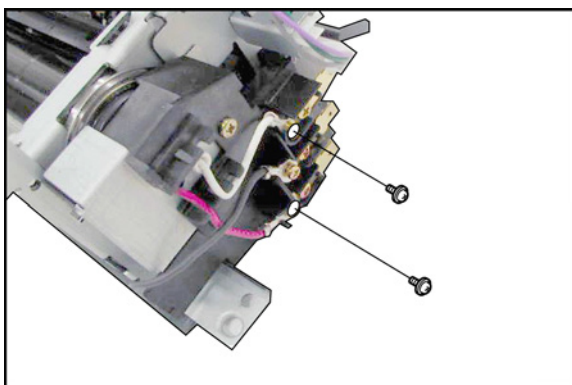

- (38) Remove 2 **Screws** (16).

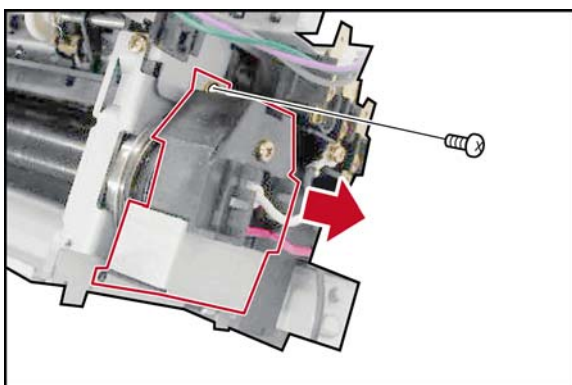

- (39) Remove 1 **Screw** (21).
 (40) Remove the **Front Lamp Holder** (1018).

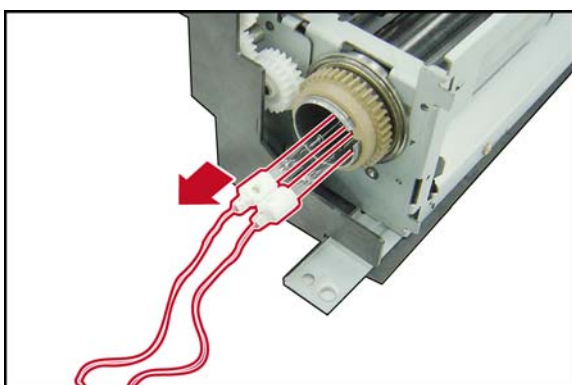

- (41) Remove 2 **Fuser Lamps** (1043 and 1044).

Note:

Make sure to check the wattage of each Fuser Lamp when replacing.

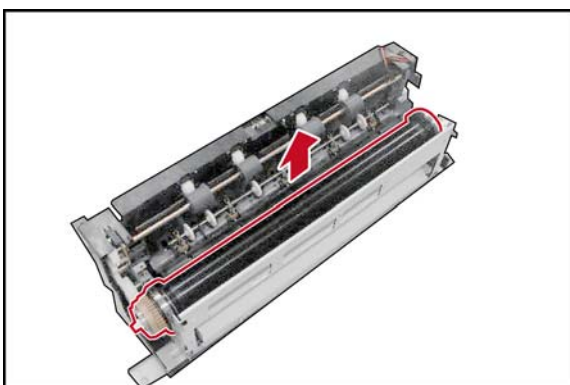
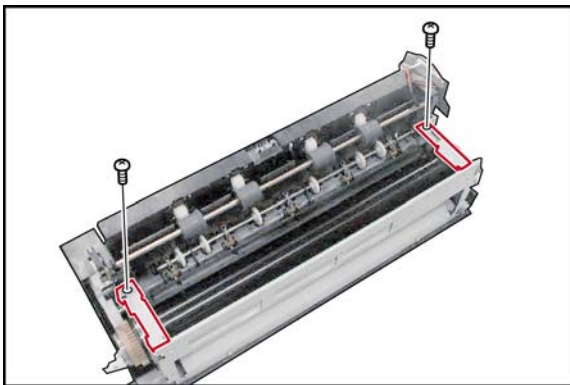
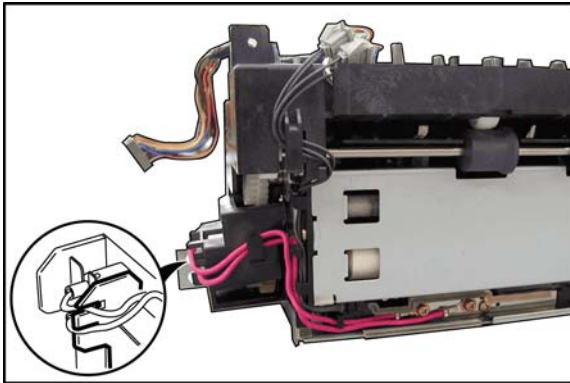
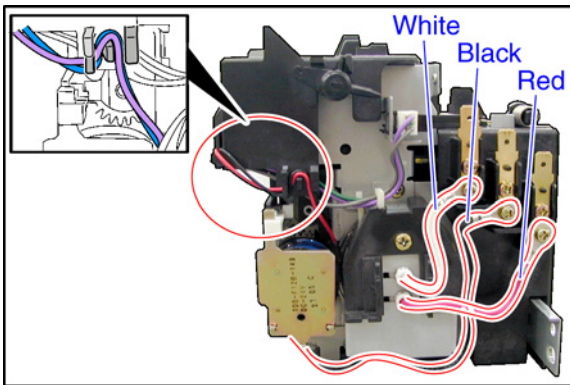

<Fuser Lamps Handling Precautions>

Note:

1. When reinstalling, route the Harnesses along the hooks as illustrated.
2. Be sure to install the longer Harness to the Gear side and the shorter Harness to the other side.
3. Make sure that the 600W Fuser Lamp (White Harness) is plugged into the upper left slot and the 450W Fuser Lamp (Red Harness) is plugged into the lower right slot.
4. Route the Harnesses (White, Black and Red) along the 3 hooks as illustrated.
5. Do not touch the glass portion of the Fuser Lamp with bare hands. Grease from the fingerprints will shorten its life cycle, use a soft cloth, saturated with isopropyl alcohol to clean fingerprints.
6. Use care when handling the Fuser Lamps to avoid breakage.

(42) Remove 2 **Screws** (21).

(43) Remove the **Front** and **Rear Roller Holders** (1056 and 1057).

(44) Remove the **Fuser Roller** (1026) Assembly.

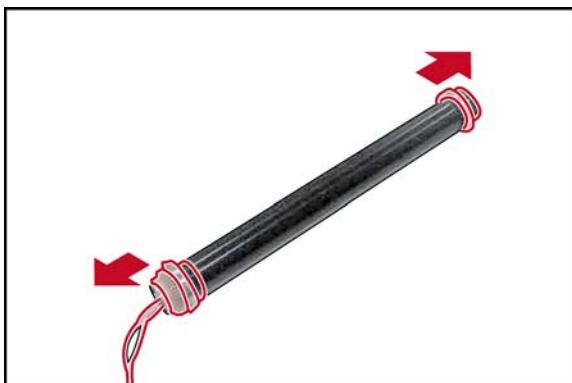

- (45) Remove the 2 **C-Rings** (1078).
- (46) Remove the **E40 Heat Roller Gear** (1014).
- (47) Remove the **Plate Spacer** (1023).
- (48) Remove the 2 **Insulation Bushings** (1006).
- (49) Remove the 2 **Bearings** (1046).

Note:

1. The Plate Spacer is installed only to the non-Gear side.
2. Do not scratch the surface of the Fuser Roller when removing or reinstalling it.

<Cleaning Insulation Bushings>

Clean the Insulation Bushings with a soft cloth, saturated with isopropyl alcohol.

<Cleaning Fuser Roller>

Clean the surface of the Fuser Roller with a soft cloth, saturated with isopropyl alcohol.

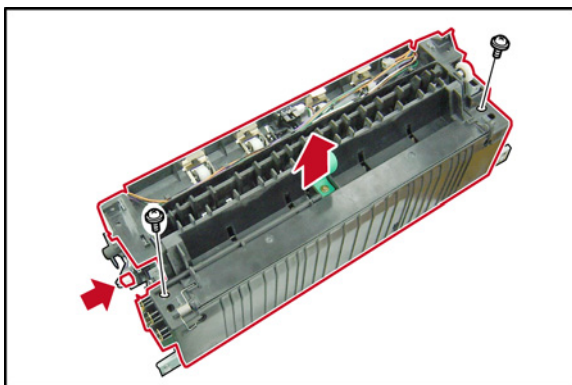

- (50) Disconnect the **Harness**.
- (51) Remove 2 **Screws** (23).
- (52) Remove the **Upper Fuser Cover** (1002).

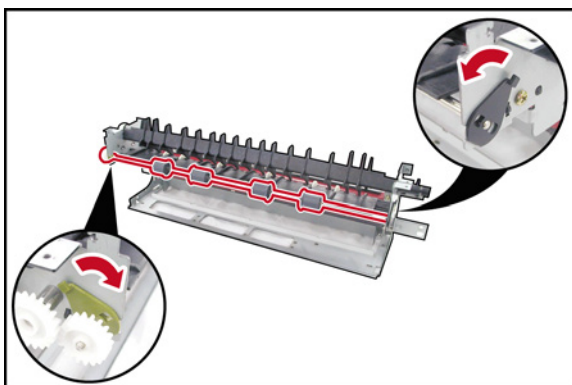

- (53) Remove the **Exit Roller** (1028).

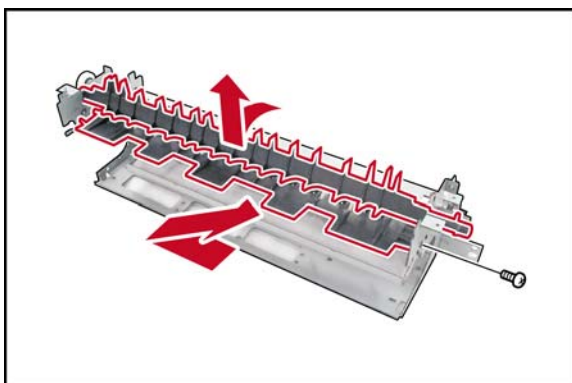

- (54) Remove the **Turn Guide** (1007).
- (55) Remove 1 **Screw** (19).
- (56) Remove the **Upper Guide** (1001).

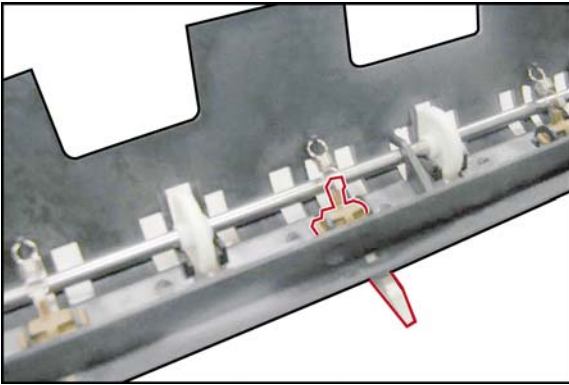

(57) Remove 5 **Upper Fingers** (1067).

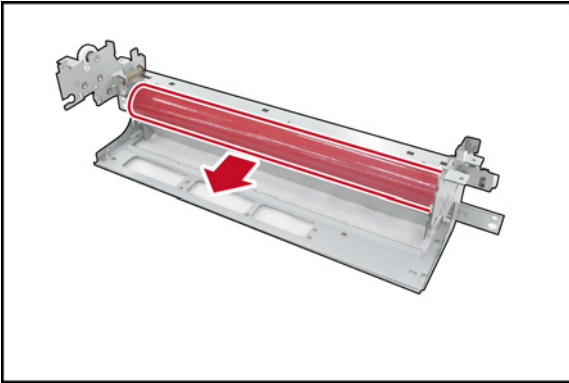

(58) Remove the **Pressure Roller** (1027).

Caution:

When disassembling, exercise care not to damage the Pressure Roller (1027).

<Cleaning Pressure Roller>

Clean the surface of the Pressure Roller with a soft cloth, saturated with isopropyl alcohol.

2.2.6. Drive Unit



(1) Remove 4 **Silver Screws** (S6).

(2) Open the **Rear Cover** (302).

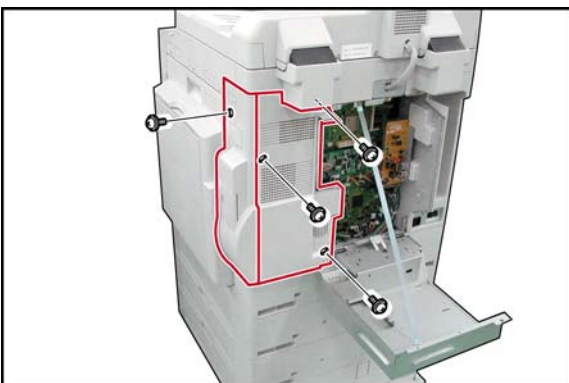

(3) Remove 4 **Silver Screws** (S6).

(4) Remove the **Rear Right Cover** (507) and the **Right Rear Cover** (518).

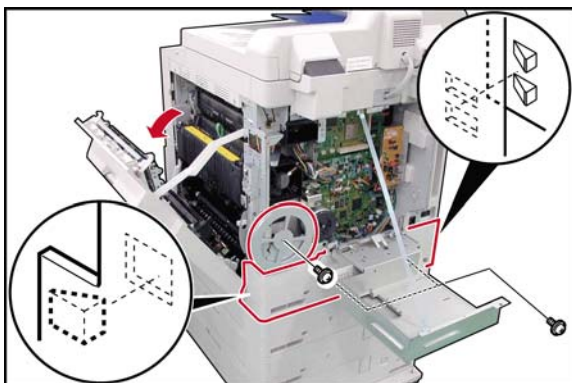

- (5) Remove 2 **Silver Screws** (B1).
- (6) Remove the **Lower Rear Cover** (506).
- (7) Remove 1 **Screw** (24).
- (8) Remove 5 **Fly Wheels** (922).

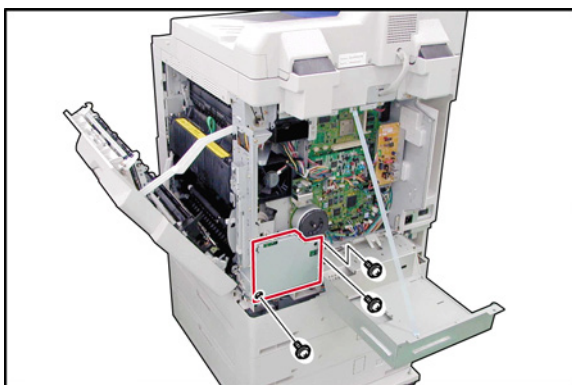

- (9) Remove the **Process Unit**. (Refer to 2.2.4.)
- (10) Remove 3 **Screws** (21).
- (11) Remove the **HVPS Unit**.

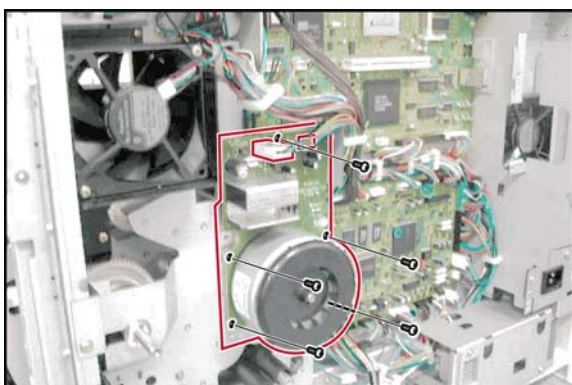

- (12) Disconnect the **MT Harness** (1926) on the Main Motor (CN1 and CN2).
- (13) Remove 5 **Screws** (4N).
- (14) Remove the **Main Motor** (907).

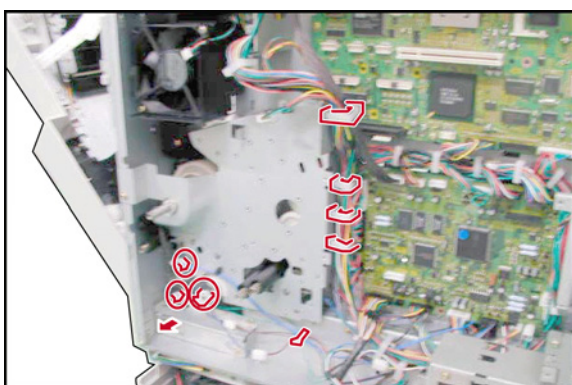

- (15) Disconnect the **Connector** on each of the 3 Clutches.
- (16) Remove 3 **Snap Rings** (S9).
- (17) Remove 3 **Clutches** (969, 1105 x 2).
- (18) Release The **Harnesses** from 4 Harness Clamps.

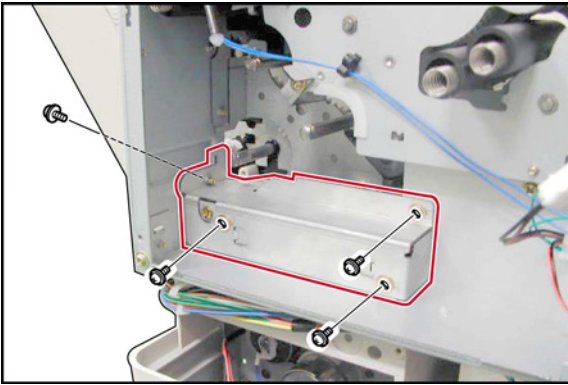

- (19) Remove 4 **Screws** (6P).
 (20) Remove the **RD Cover** (411).

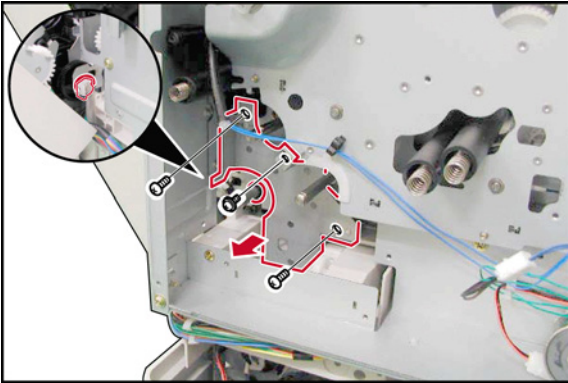

- (21) Remove 1 **Screw** (6P) and 2 **Screws** (19).
 (22) Remove the **1st Tray Drive Bracket** (939).

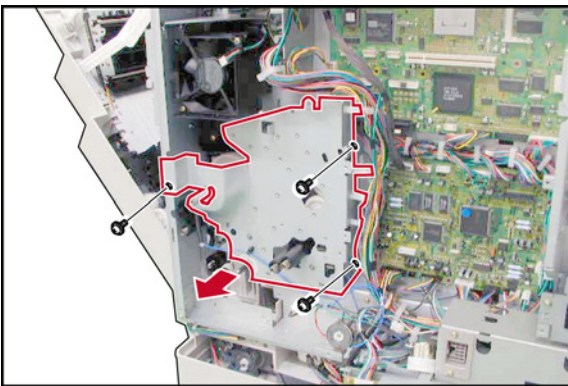

- (23) Remove 3 **Screws** (19).
 (24) Remove the **Motor Bracket** (908).

2.2.7. Right Cover

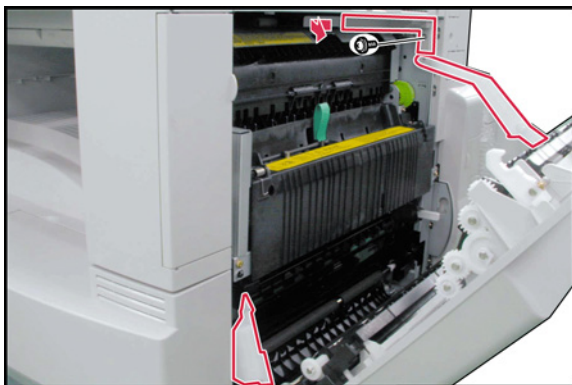

- (1) Open the **Right Cover** (1201).
- (2) Remove 1 **Screw** (6P).
- (3) Remove the **Harness Cover** (1525).
- (4) Unlock the **Angled Rear Arm** (1218) and the **Front Arm** (1217).

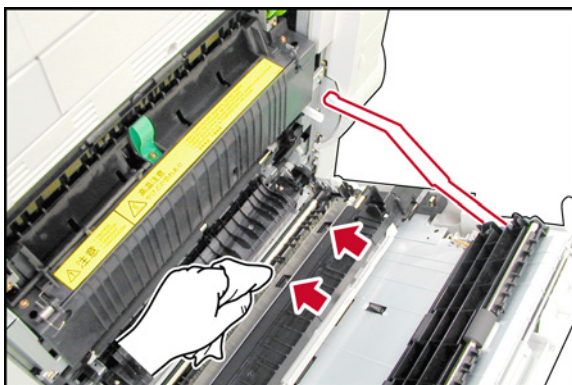

- (5) Hook the **Angled Rear Arm** (1218) into the lower hook hole.

<Cleaning the CDS PC Board>

Clean the Sensor on the CDS PC Board with a dry soft cloth.

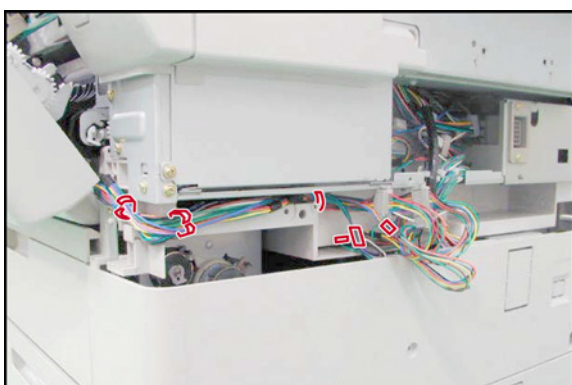

- (6) Remove the **Lower Rear Cover** (506).
(Refer to 2.2.6.)
- (7) Disconnect 3 **Connectors**.
- (8) Release the **Harnesses** from 3 Harness Clamps.

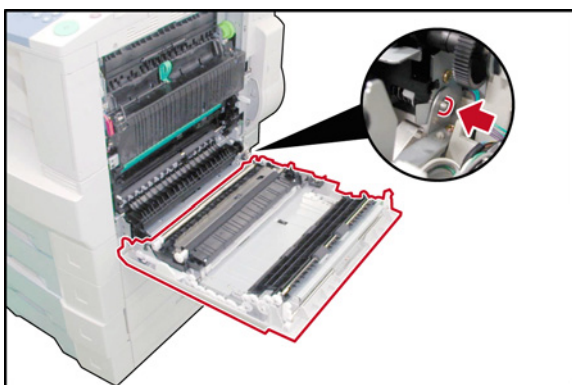

- (9) Unlock the **Angled Rear Arm** (1218).
- (10) Push the **Fulcrum Pin** (1215) and then remove the **Right Cover** (1201).

Note:

Please remove the Right Cover completely to prevent damage that could cause duplex skewing and jamming.

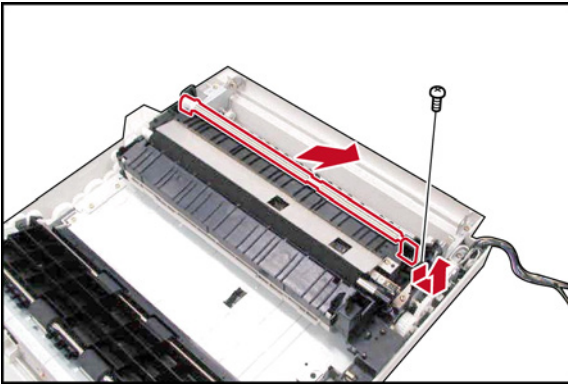

- (11) Remove 1 **Screw** (19).
- (12) Remove the **Registration Pinch Roller** (1222).

<Cleaning Registration Pinch Roller>

Clean the surface of the Registration Pinch Roller with a soft cloth, saturated with isopropyl alcohol.

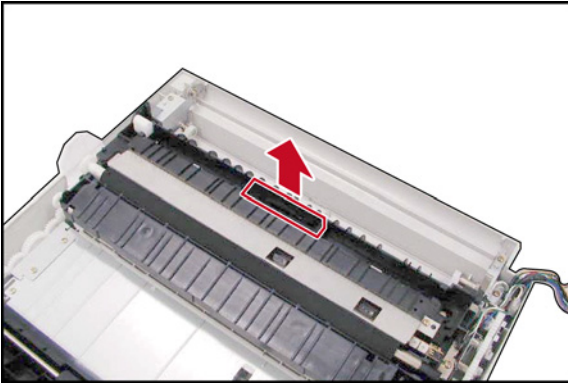

- (13) Remove the **Roller Cleaner** (1229).

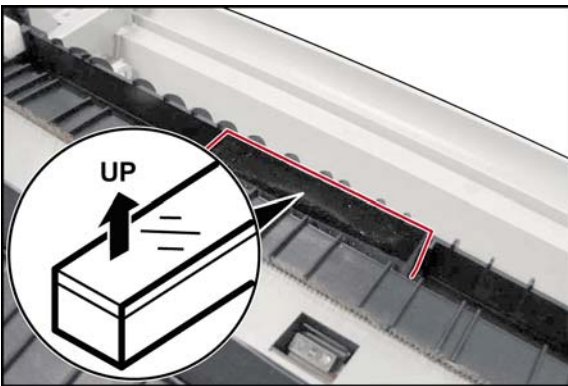

Note:

When installing the Roller Cleaner, make sure that turn a felt of black side upwards as illustrated.

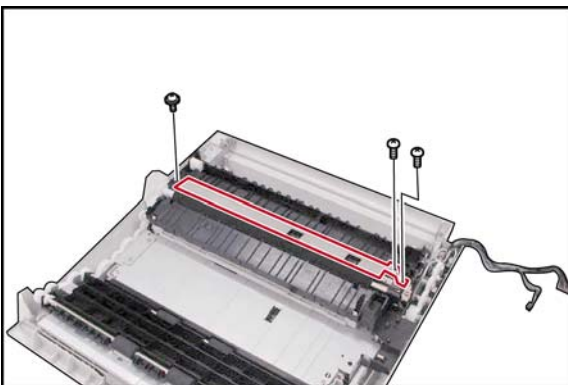

- (14) Remove 3 **Screws** (C8).
- (15) Remove the **BTR Guide** (1223).

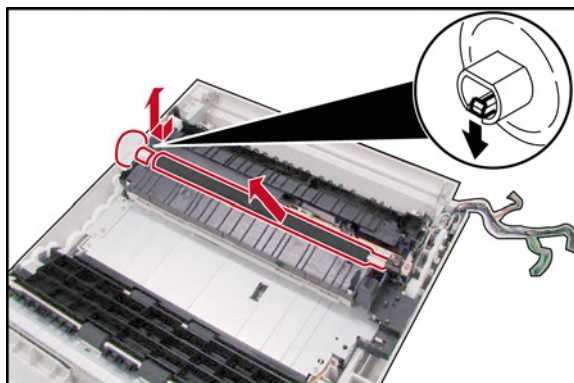

- (16) Remove the **BTR Gear** (1234).
- (17) Remove the **Bias Transfer Roller** (1221).

<Cleaning Bias Transfer Roller>

Clean the surface of the Bias Transfer Roller only with a soft dry cloth.

Caution:

When reinstalling the Right Cover, make sure the Harness is not nipped by the Cover.

2.2.8. Sheet Bypass

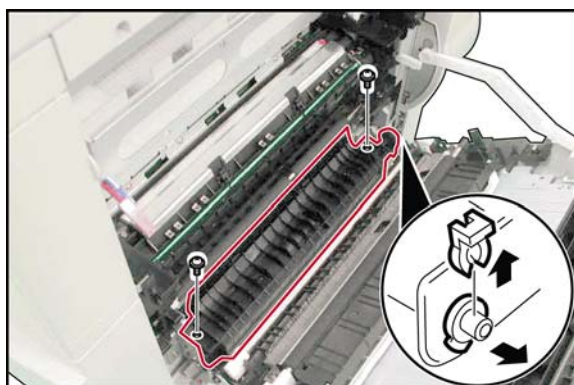

- (1) Remove 1 **Screw** (19).
- (2) Remove 1 **Screw** (1Y).
- (3) Remove the **Snap Ring** (S9).
- (4) Remove the **P6L5 Conductive Bushing** (972).
- (5) Remove the **Dual-Path Guide** (1203).

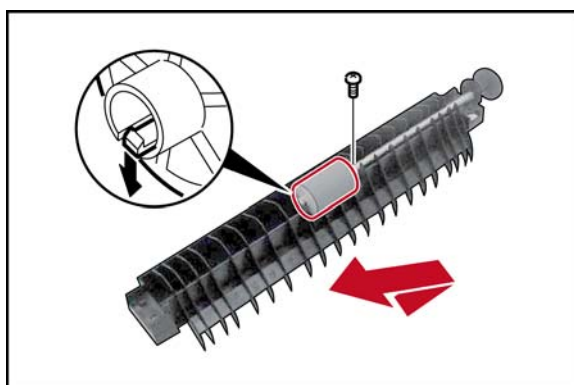

- (6) Remove 1 **Screw** (19).
- (7) Remove the **Feed Roller** (1244).

<Cleaning Feed Roller>

Clean the surface of the Feed Roller with a soft cloth, saturated with isopropyl alcohol.

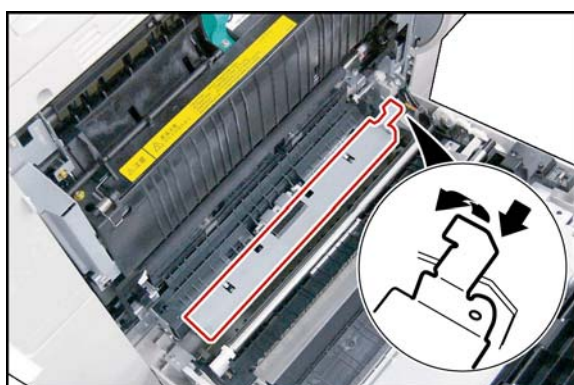

- (8) Remove the **Pressure Plate** (1295).

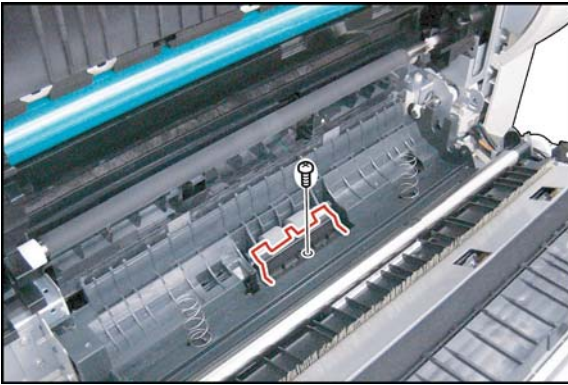

- (9) Remove 1 **Screw** (X6).
- (10) Remove the **Reverse Roller Guide** (1294).

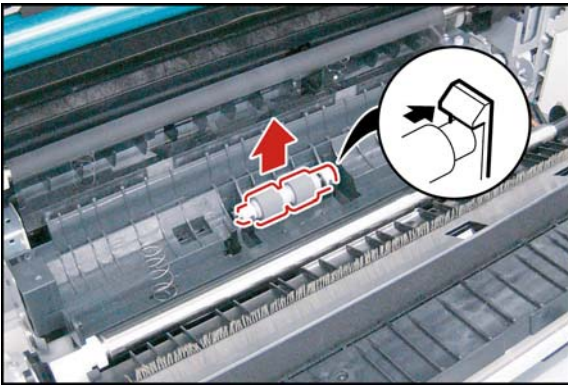

- (11) Remove the **Reverse Roller** (1291) Assembly.

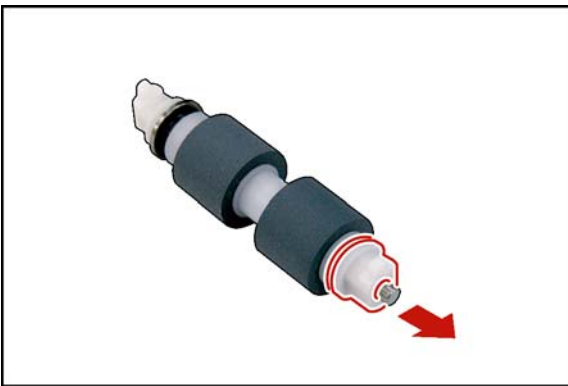

- (12) Remove the **Bushing** (1286).
- (13) Remove the **Washer** (1288).

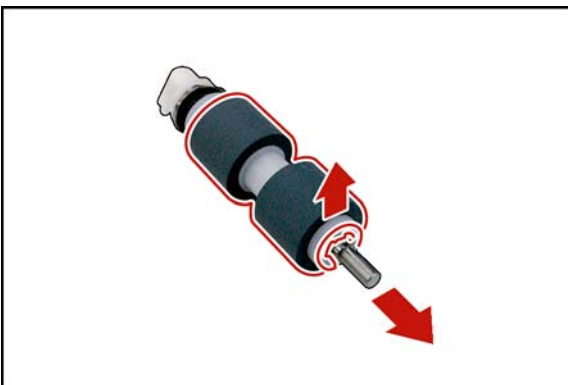

- (14) Remove the **E-Ring** (J7).
- (15) Remove the **Reverse Roller** (1291).

<Cleaning Reverse Roller>

Clean the surface of the Separation Roller with a soft cloth, saturated with isopropyl alcohol.

2.2.9. Paper Feed Module

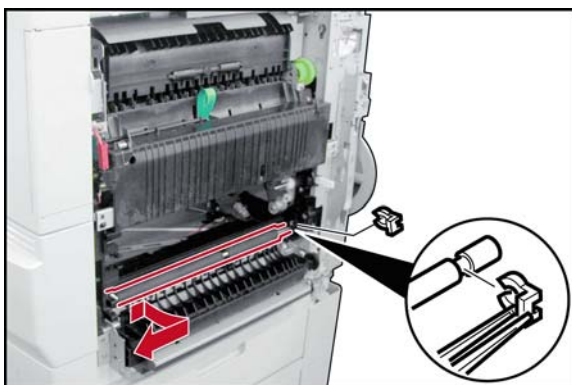

- (1) Remove the **Process Unit**. (Refer to 2.2.4.)
- (2) Remove the **Clutch** (1105). (Refer to 2.2.6.)
- (3) Remove the **Snap Ring** (S9).
- (4) Remove the **Registration Roller** (1121).

<Cleaning Registration Roller>

Clean the surface of the Registration Roller with a soft cloth, saturated with isopropyl alcohol.

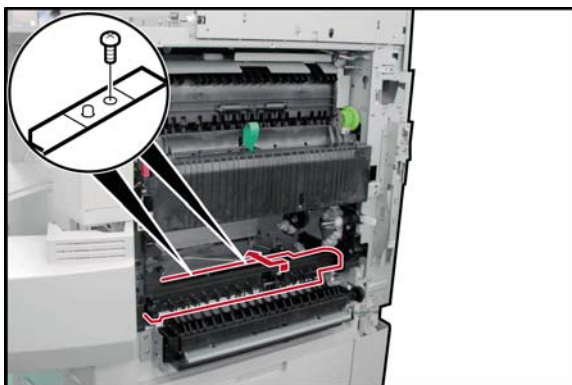

- (5) Remove 2 **Screws** (19).
- (6) Remove the **Process Unit Guide** (1104).

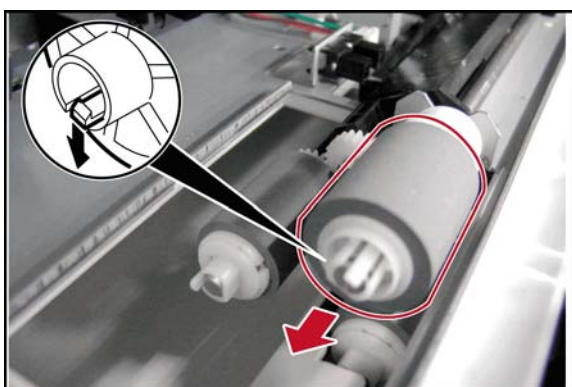

- (7) Slide the **1st Paper Tray** out.
- (8) Remove the **Paper Feed Roller** (1144).

<Cleaning Paper Feed Roller>

Clean the surface of the Paper Feed Roller with a soft cloth, saturated with isopropyl alcohol.

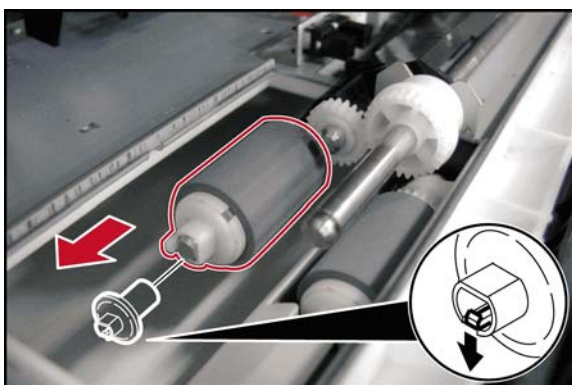

- (9) Remove the **Reverse Clutch** (1132).
- (10) Remove the **C25 Gear Roller** (1145).

<Cleaning C25 Gear Roller>

Clean the surface of the C25 Gear Roller with a soft cloth, saturated with isopropyl alcohol.

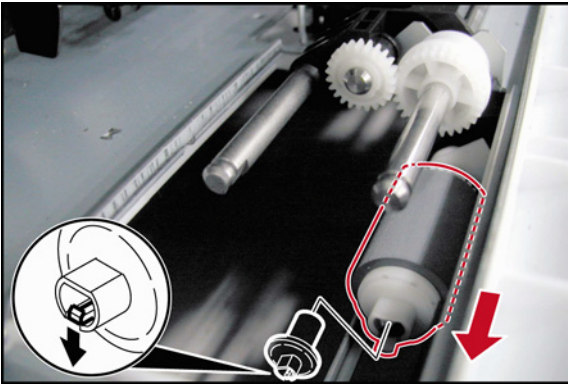

(11) Remove the **Reverse Clutch** (1132) and **Spring D** (1178).

(12) Remove the **C25 Gear Roller** (1145).

<Cleaning C25 Gear Roller>

Clean the surface of the C25 Gear Roller with a soft cloth, saturated with water.

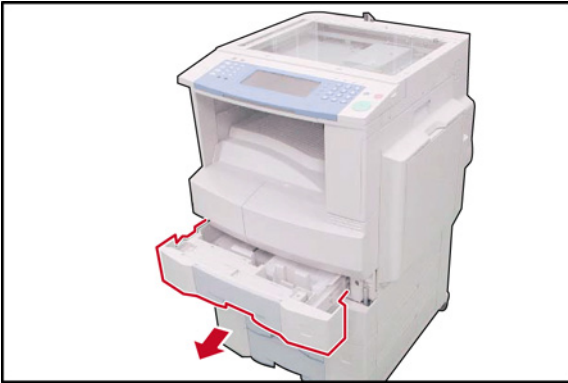

(13) Slide the **2nd Paper Tray** out.

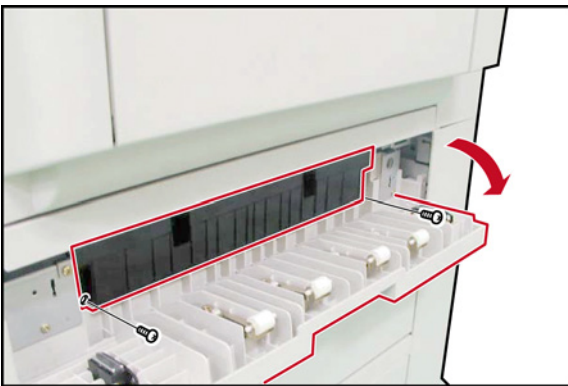

(14) Open the **Jam Access Cover** (2307).

(15) Remove 2 **Screws** (19).

(16) Remove the **Paper Guide** (1127).

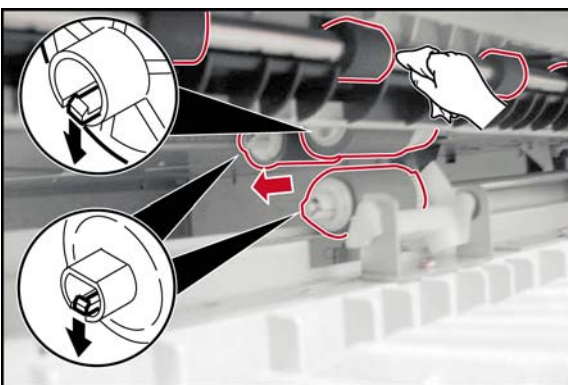

(17) Remove the **Paper Feed Roller** (1144).

(18) Remove 2 **Reverse Clutches** (1132).

(19) Remove the **Spring D** (1178).

(20) Remove 2 **C25 Gear Rollers** (1145).

<Cleaning the Intermediate Roller and 2 C25 Gear Rollers>

Clean the Intermediate Roller and 2 C25 Gear Rollers with a soft cloth, saturated with water.

2.2.10. LSU Unit

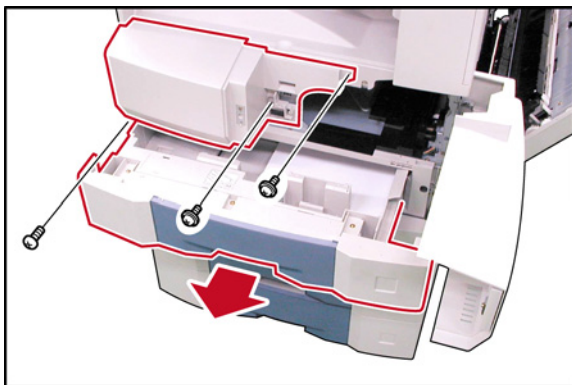

- (1) Remove the **Process Unit**. (Refer to 2.2.4.)
- (2) Slide the **1st Paper Tray** out.
- (3) Remove 1 **Screw** (19) and 2 **Screws** (6P).
- (4) Remove the **Front Left Cover** (534).



- (5) Remove the **Blind Cover** (530).
- (6) Remove 2 **Screws** (S6).
- (7) Remove the **S Inner Cover** (524).

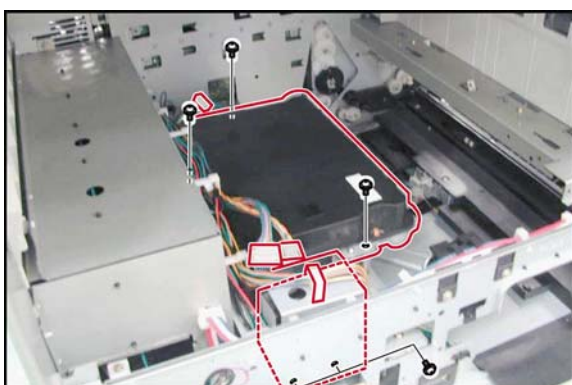

- (8) Disconnect 3 **Harnesses**.
- (9) Remove 3 **Screws** (23).
- (10) Remove the **LSU** (420).
- (11) Remove 2 **Screws** (6P).
- (12) Remove the **LSU Fan** (315) Assembly.

2.2.11. Paper Transport Unit

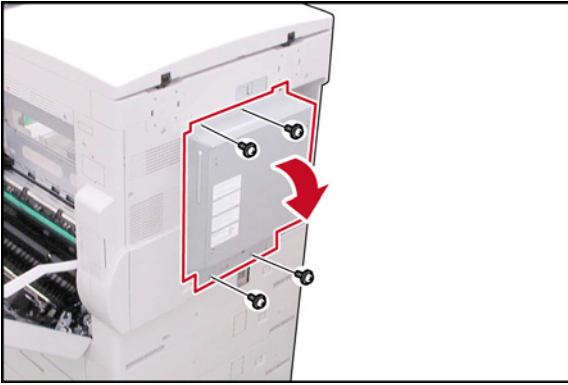

- (1) Open the **Right Cover** (1201).
- (2) Remove the **Fuser Unit**. (Refer to 2.2.5.)
- (3) Remove 4 **Silver Screws** (S6).
- (4) Open the **Rear Cover** (302).

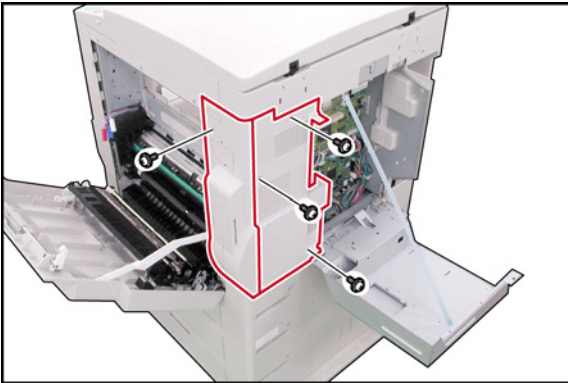

- (5) Remove 4 **Silver Screws** (S6).
- (6) Remove the **Rear Right Cover** (507), and the **Right Rear Cover** (518).

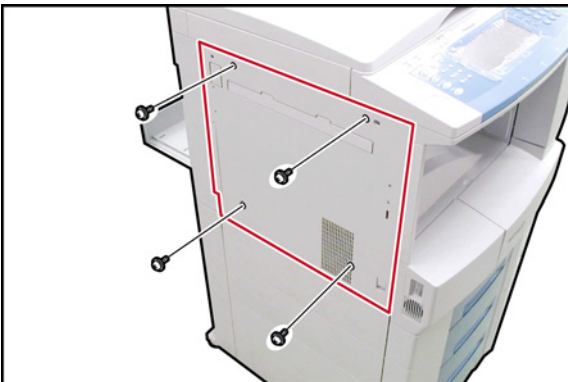

- (7) Remove 2 **Shoulder Silver Screws** (L8: Upper), and 2 **Silver Screws** (S6: Lower).
- (8) Remove the **Left Cover** (535).

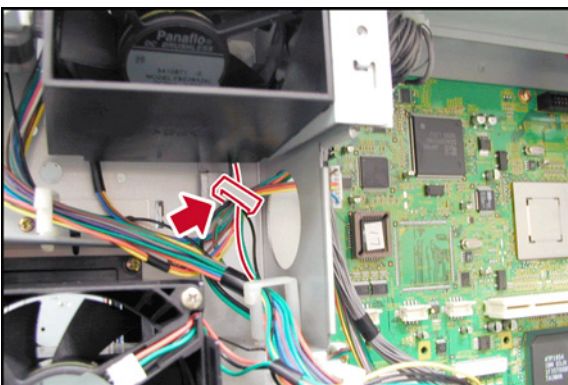

- (9) Remove the **FM Harnesses** from the Harness Clamp.

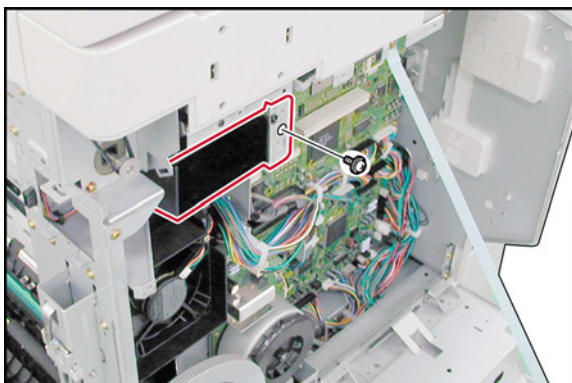

- (10) Remove 1 **Screw** (6P).
- (11) Remove the **Fan Assembly**.

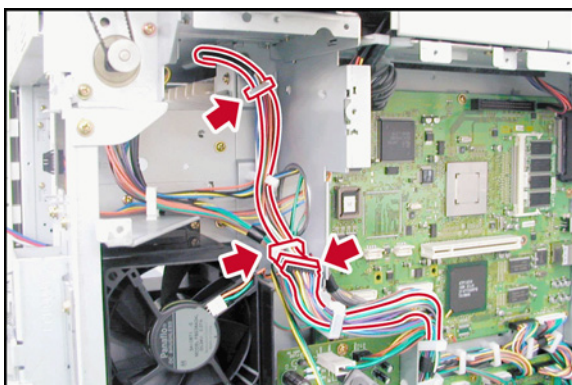

- (12) Remove the **EXFC Harnesses 2** from the 2 Harness Clamps.
- (13) Disconnect the **EXFC Harnesses** from the **EXFC Harnesses 2**.

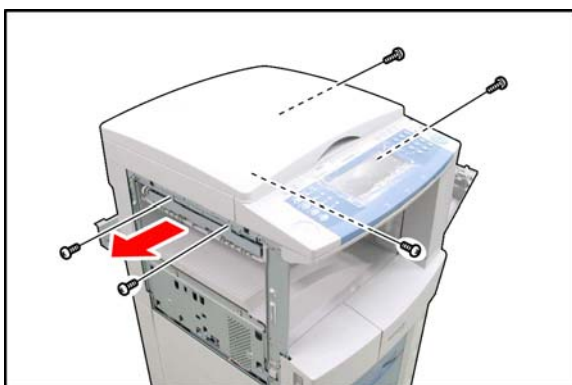

- (14) Remove 5 **Screws**.
- (15) Remove the **Paper Transport Unit**.

<Cleaning the Pinch Roller>

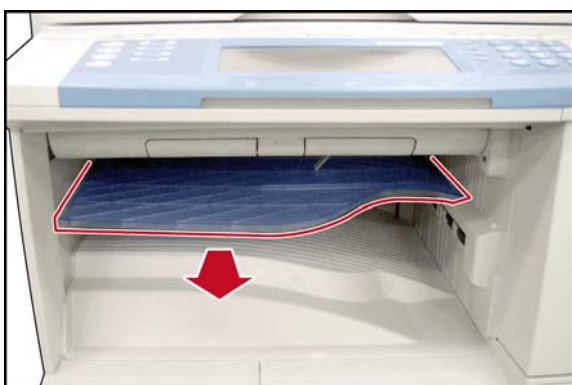

- (1) Remove the **Inner Tray** (1522).

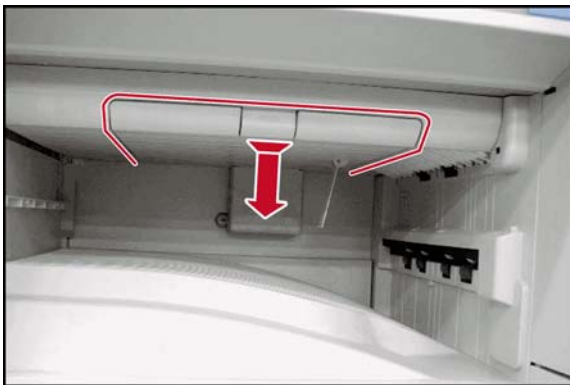

(2) Push to open the **Paper Transport Jam Cover** (1302).

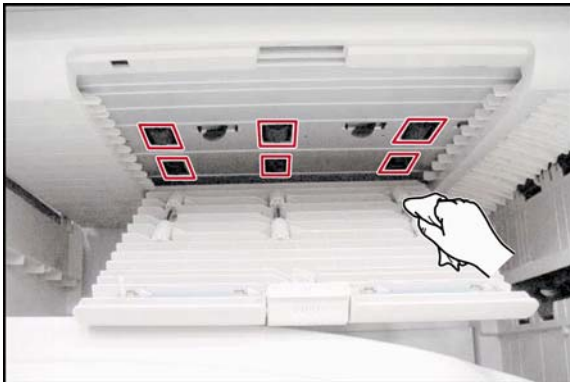

(3) Clean 6 **Pinch Rollers** (1518) with a soft cloth saturated with water.

2.2.12. PC Board

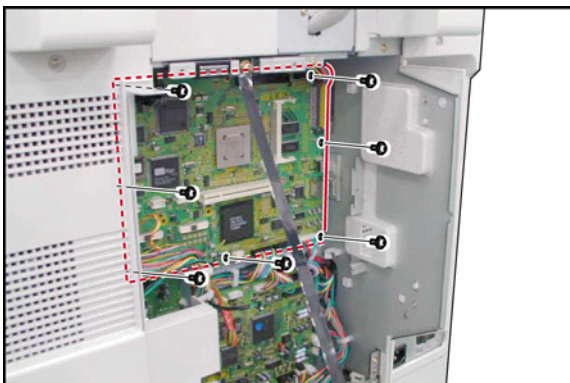

(1) Remove 7 **Screws** (6P).
 (2) Disconnect all the **Harnesses** on the SC PC Board.
 (3) Remove the **SC PC Board** (1901).

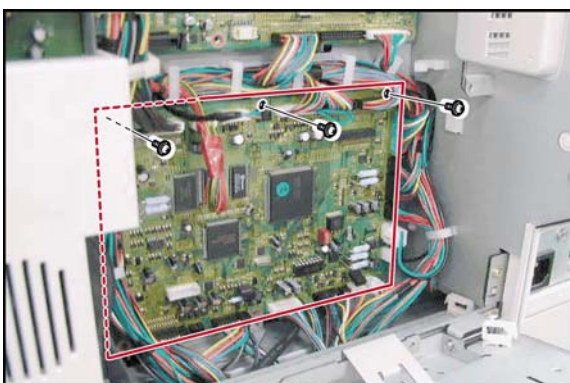

(4) Remove 3 **Screws** (6P).
 (5) Disconnect all the **Harnesses** on the SPC PC Board.
 (6) Remove the **SPC PC Board** (1902).



(7) Remove 2 **Shoulder Silver Screws** (L8: Upper) and 2 **Silver Screws** (S6: Lower).



(8) Remove 2 **Screws** (6P).
(9) Open the **LVPS Cover** (301).

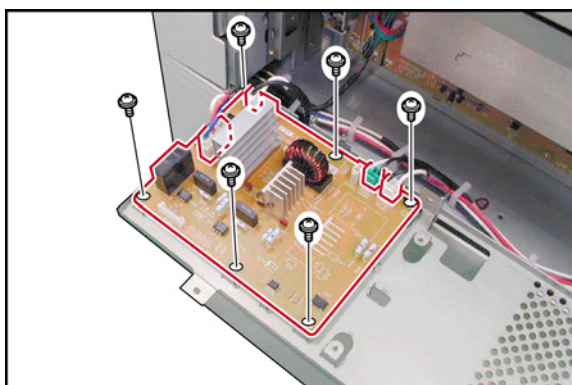

(10) Remove 6 **Screws** (6P).
(11) Disconnect all the **Harnesses** on the ACD PC Board.
(12) Remove the **ACD PC Board** (1904).

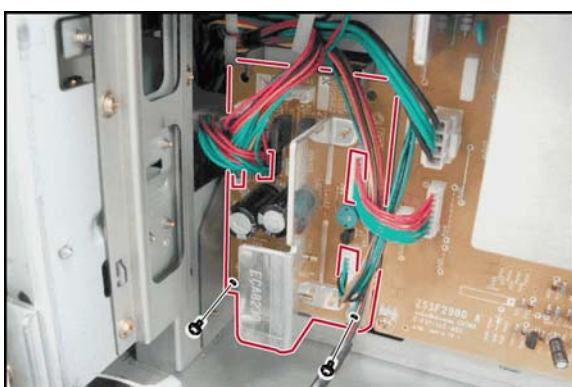

(13) Remove 2 **Screws** (6P).
(14) Disconnect all the **Harnesses** on the DC PC Board.
(15) Remove the **DC PC Board** (1905).

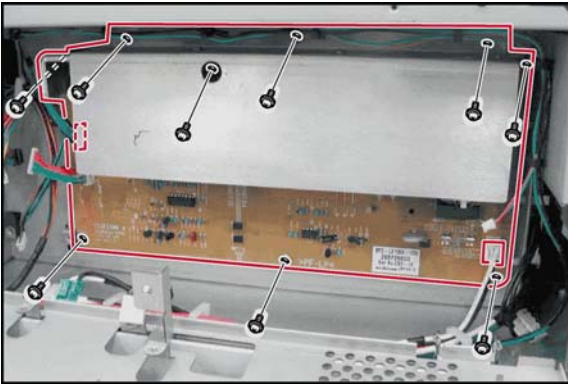









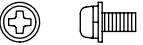



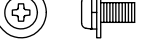
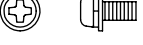



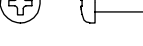





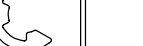



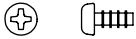

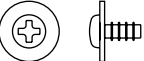

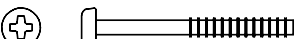
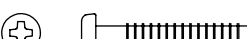
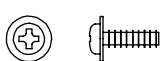
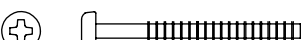

(16) Remove 9 **Screws** (6P).

(17) Remove all the **Harnesses** on the LVPS

(18) Remove the **LVPS** (1910).

2.3. Screw Identification Template

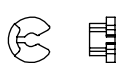
Ref. No.	Part No.	Figure	Remark
16	XYN3+J8FJ		Screw
18	XYN3+J6FJ		Screw
19	XTB3+8JFJ		Screw
20	XTB3+8FFJ		Screw
21	XTB3+6FFJ		Screw
23	XYN3+F8FJ		Screw
24	XYN4+F8FJ		Screw
36	XYN3+F6FJ		Screw
51	XTB3+10FFJ		Screw
62	XTB3+6JFJ		Screw
64	XWG3FJ		Washer
743	DZPA000094		Screw
1033	DZPA000095		Shoulder Screw
1052	XWG55E12FY		Washer
1Y	XTB3+10JFJ		Screw
4N	XSN3+W8FJ		Screw
5M	XYN3+F4FJ		Screw
5Z	XUC6FJ		E-Ring
6P	XTW3+6LFJ		Screw

Ref. No.	Part No.	Figure	Remark
7B	XTB26+6JFJ		Screw
B1	DZPB000007		Silver Screw
B4	XTB3+8JFI		Black Screw
C2	DZPB000020		Screw
C8	XTW3+8SFJ		Screw
D24	XTB3+8JFJ-R		Red Screw
D25	XTB3+8JFJ-B		Blue Screw
E5	XTB3+32JFJ		Screw
E6	XTB3+24JFJ		Screw
E8	XTW3+10SFJ		Screw
F4	DZPA000063		Screw
F6	DZPK000021		Washer
F7	XSN4+W10FN		Silver Screw
F9	XYC3+FG10FJ		Screw
F10	XTB3+8GFJ		Screw
G6	FFPFJ0039B		Snap Ring
H4	XTB26+8JFJ		Screw
H6	FFPFJ0033B		Snap Ring
H7	FFPFJ0041B		Snap Ring
J6	XUC3VM		E-Ring

Ref. No.	Part No.	Figure	Remark
J7	XUC4VM		E-Ring
J8	XUC7VM		E-Ring
L7	XUC2VM		E-Ring
L8	DZPB000031		Shoulder Screw
L9	XTB3+4FFJ		Screw
M2	DZPA000064		Thumb Screw
N3	XTB4+10FFJ		Screw
P1	XTB3+6FFJ-RP		Screw
P2	XTB3+12JFJ		Screw
P5	XTN3+8GFN		Screw
P7	FFPFA0152		Screw
S6	DZPA000086		Screw
S8	XTB3+12FFJ		Screw
S9	DZJM000171		Snap Ring
T2	DZPA000087		Screw
T4	XYN3+F5FJ		Screw
T5	XTN3+6FFJR		Red Screw
V4	XTW3+10LFN		Silver Screw

3 Maintenance, Adjustments and Check Points

3.1. Preventive Maintenance

Preventive maintenance is performed at specific intervals and consists of machine cleaning and parts replacement. It is essential to perform these service activities properly and at the specified intervals for customer satisfaction. The purpose of this service is to maintain machine performance and image quality.

- You should prepare the necessary PM kits, replacement parts, and tools for cleaning beforehand.
- After completing the preventive maintenance service, you should discard the used parts and packaging, in accordance with local regulations and clean the surrounding area.
- Before servicing the equipment disconnect the power cord from the wall outlet.
- Before using solvents such as IPA (Isopropyl alcohol), put on rubber gloves and eye protection.

1. Timing

- Perform the preventive maintenance service in accordance with the chart of preventive maintenance areas listed in the service manual.

2. Cleaning of Rollers

- Rollers should be cleaned with water and cloth.
- Use of IPA (Isopropyl alcohol) should be used sparingly.

3. Precautions for Disassembly, and Adjustment

Caution:

Turn the Main Power Switch on the Back, and the Power Switch on the Left Side of the machine to the OFF position, and then unplug the AC Power Cord before disassembling the machine.

- After taking the unit apart, do not attempt to operate the machine.
- When operating the machine with covers removed, be careful to avoid clothing being caught by moving components.
- While electricity is applied, the connectors of any PC Board must not be connected or disconnected.
- Use of a vacuum cleaner for the cleaning of the TDC sensor could cause electrostatic damage, therefore, use a blower brush or cotton swab for the cleaning of these parts. Before vacuuming the developer unit remove the TDC sensor.
- When handling the drum, the precautions listed in section 3.4. should be followed.
- Make sure to use the correct screw sizes.
- Use toothed lock washers for the installation of ground wires to ensure electrical continuity.
- To re-assemble, reverse the sequence of disassembly, unless otherwise specified.
- Blown fuses should only be replaced with fuses of the same specified rating.

4. Precautions for Handling Lasers

The laser optical system employed by this photocopier is completely sealed by a protective housing and an external cover. Therefore, the laser beam will not stray or leak during photocopier operation. However, when servicing the photocopier, take the following precautions:

1. Do not insert into the path of the laser, any screwdrivers or other tools that have high reflectance properties.
2. Before servicing the photocopier, take off any watches, rings, or other metallic objects that you may be wearing. (This is to avoid the danger of the laser entering the eye by reflecting off the metallic objects being worn.)

Since the laser beam cannot be seen with the naked eye, please follow the above precautions for maximum safety.

5. Precautions for Maintenance, and Disposal (Data Security)

1. The Service Mode Password is essential to maintaining the security of the machine. Service technicians must change the factory default password using the Service Mode **“F7-09: Service Mode Password”**, record the new password and store it in a safe place out of the reach of others. (Refer to the Service Manual Section 5.1.6.)

2. The Service Mode is used by service technicians to perform maintenance and/or repairs, as well as to maintaining security of the machine. Service technicians must not leave the machine in the Service Mode after servicing the unit.
3. Service technicians are required to keep the Flash Memory including the Firmware in a confidential and safe place. Make certain to remove the Flash Memory from the machine, if it was used for updating the Firmware, etc.
4. Before servicing the unit, back up the machine's data to prevent losing the settings.
 - a. Back up the settings data onto an Flash Memory using the Service Mode **“F9-11: Parameter Backup”**.
 - b. Back up the settings data onto a PC via a Network using **“Network Configuration Editor”**.
 - c. Print out the Service Parameters.
5. Service Technicians are required to keep the Flash Memory including the machine and the customer's information confidential and in a safe place.
6. When disposing/transferring this machine, delete all of the customer's information. Delete the Hard Disk Drive data by initializing the Hard Disk Drive as follows:
 - a. Press **“Function”** ->**“GENERAL SETTINGS”** -> **“09 Key Operator Mode”** -> **“29 Hard Disk Initialize”** -> **“Deletion”** -> **“High”**.
 - b. Delete the data in the F-ROM using the Service Mode **“F9-06-03: Shipment Set”**.
7. To secure the customer's information, make sure the Fax number/E-mail address is set correctly in the Check & Call feature.
8. Service Manuals, and Installation Instructions are essential to maintaining the security of the machine. Service technicians are required to keep the customer's information confidential and in a safe place.
9. When the SC PCB is replaced the MAC address will be different, make sure that the new MAC address is recognized on the Network.
10. When setting the Remote Registration function, there is a slight possibility of an unauthorized third party attempt to access your machine's settings using an E-mail function through the Firewall. When using this function, we recommend configuring your network environment with a switching hub, and encryption to prevent your device from being wiretapped.
11. When moving the machine for repair, etc. there is a remote possibility that the stored data can be vulnerable to unauthorized access, or get corrupted. Convey this to the customer and obtain their permission to Back up the data onto an Flash Memory or a PC, and then delete it from the machine.
12. While servicing the machine, it is imperative that the customer's data is maintained in strictest confidentiality to prevent security breach.
13. Delete the customer's data from the replaced/replacement machine or Hard Disc Drive to maintain security of the machine.
14. After repairs are completed, restore the customer's back up data and reset the passwords.
15. Delete the customer's data from the Flash Memory or from the PC to maintain security of the machine.

3.2. Required Tools

No.	Tools	No.	Tools
1	Soft Cloth	7	Pliers
2	Isopropyl Alcohol	8	Cotton Swab
3	Phillips Screwdriver (#2)	9	Brush
4	Stubby Phillips Screwdriver (#2)	10	KS-660 - Conductive Grease (Available from Shin-Etsu Silicones of America, Inc. URL: http://www.shinetsusilicones.com)
5	Slotted Screwdriver (3/32 in)	11	Molykote EM-50L Grease (Available from Dow Corning, URL: http://www.dowcorning.com)
6	Tweezer		

3.2.1. Preventive Maintenance Method

No.	Part Description	Important Action	Comments
1	Memory Data	Check	<ol style="list-style-type: none"> 1. Print the RAM DATA for reference and as a pre-caution. 2. After completing the task(s), print and compare the RAM DATA with the previously printed one.
2	Auto Document Feeder (ADF)	Check & Clean	<ol style="list-style-type: none"> 1. Clean all Rollers and Separation Rubber with a soft cloth saturated with water. <p>Note: For stubborn toner accumulation, wipe with a soft cloth saturated with Isopropyl Alcohol first, then follow up with a soft cloth saturated with water.</p>
3	Scanner Unit	Check & Clean	<ol style="list-style-type: none"> 1. Clean the Scanning Glass or White Seal Guide with Isopropyl Alcohol when required.
4	Document Size Sensor	Check & Clean	<ol style="list-style-type: none"> 1. Do not touch the surface of the Sensors with your hands. 2. Clean any dirt or fingerprints with a Dry Cotton Swab. <p>Note: Do not use Isopropyl Alcohol / any Alcohol.</p>
5	Transmitter Unit	Check & Clean	<ol style="list-style-type: none"> 1. Remove any foreign obstacles. 2. Clean the Rollers with Isopropyl Alcohol when required.
6	Mirrors	Check & Clean	<ol style="list-style-type: none"> 1. Do not touch the surface of the Mirrors with your hands. 2. Clean any dirt or fingerprints with a Dry Cotton Swab. <p>Note: Do not use Isopropyl Alcohol / any Alcohol.</p>
7	Inspection Items	Check	<ol style="list-style-type: none"> 1. Check the Harnesses. 2. Check the Connectors. 3. Check the Screws. If required, replace consumable parts.
8	Gears, Rollers Shafts	Check & Grease	<ol style="list-style-type: none"> 1. Check and grease the required Gears and Shafts.
9	Timing Belts	Check & Clean	<ol style="list-style-type: none"> 1. Check the belts for looseness or abrasion. 2. Adjust the Idle Pulley.

3.3. Preventive Maintenance Points

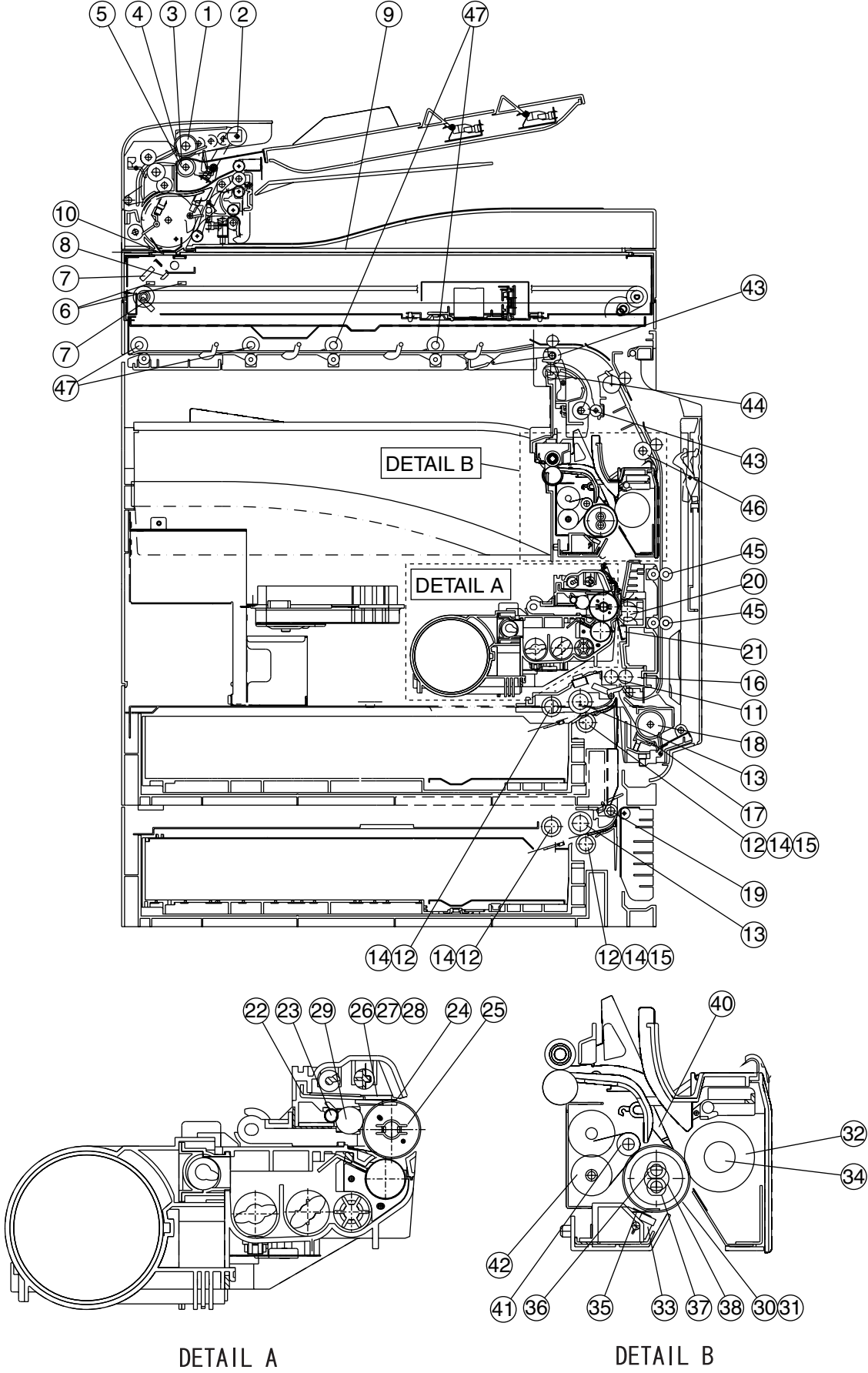

3.4. Preventive Maintenance Check List

No.	Mechanical Parts	Ref. No.	Cleaning		Replacement/Adjustment		Ref. Counter	
			Cycle (Sheet)	Method	Cycle (Sheet)	Procedure		
i-ADF/ADF Unit								
1	ADF Roller	1728	60K	Water ¹	120K	Refer to 2.2.1.	F7-02-03	
2	Pre Feed Roller	1731	60K	Water ¹	120K			
3	Separation Roller	1740	60K	Water ¹	120K			
4	Torque Limiter Bushing	1741	60K	Alcohol	120K			
5	Torque Limiter Spring	1742	60K	Alcohol	120K			
Scanner Unit								
6	Slider	211	-	-	600K	Refer to 2.2.3.	F7-02-02	
7	Mirror 1	264	60K	-	-			
8	Mirror 2	265	60K	-	-			
9	Glass L Assembly	557	60K	-	-			
10	Glass S	559	60K	-	-			
Paper Feed Module								
11	Registration Roller	1121	60K	Water ¹	480K	Refer to 2.2.9.	F7-03-01/-02/-03/-04	
12	Reverse Clutch	1132	-	-	120K			
13	Paper Feed Roller	1144	60K	Water ¹	120K			
14	C25 Gear Roller	1145	60K	Water ¹	120K			
15	Reverse Clutch Assembly	1146	-	-	120K			
16	Roller Cleaner	1229	60K	Dry soft cloth	240K		F7-02-01	
17	Separator Pad	1242	-	-	60K		F7-03-00	
	Reverse Roller	1291	60K	Water ¹	120K			
18	Feed Roller	1244	60K	Water ¹	120K		F7-02-01	
19	Intermediate Roller	2306	60K	Water ¹	-			
Bias Transfer Unit								
20	Bias Transfer Roller (BTR)	1221	60K	Dry soft cloth	120K	Refer to 2.2.7.	F7-02-01	
21	CDS PC Board	1986	60K	Dry soft cloth	-			
Process Unit								
-	Developer	-	-	-	120K	Refer to 2.2.4.	F7-02-09	
22	Cleaning Blade	704	-	-	120K		F7-01-06	
23	Cleaning Roller	706	-	-	120K			
24	Splash Prevention Sheet	710	-	-	120K			
25	OPC Drum	716	-	-	60K			F7-02-05
26	Front Cleaning Felt	717	-	-	120K			F7-02-06
27	Rear Cleaning Felt	718	-	-	120K			
28	Cleaning Sponge	720	-	-	120K			
29	Bias Charge Roller	725	60K	Dry soft cloth	120K			
Fuser Unit								
30	Fuser Roller Gear	1014	-	-	480K	Refer to 2.2.5.	F7-02-00	
31	Fuser Roller	1026	60K	Water ¹	240K			
32	Pressure Roller	1027	60K	Water ¹	480K			

No.	Mechanical Parts	Ref. No.	Cleaning		Replacement/Adjustment		Ref. Counter
			Cycle (Sheet)	Method	Cycle (Sheet)	Procedure	
33	Thermostat	1038	60K	Dry soft cloth	-	Refer to 2.2.5.	F7-02-00
34	Bearing	1039	-	-	240K		
35	Thermistor Assembly	1041	60K	Dry soft cloth	480K		
36	Fuser Lamp (450W)	1043	-	-	240K		
37	Fuser Lamp (600W)	1044	-	-	240K		
38	Fuser Roller Bearing	1046	-	-	240K		
39	(Available for Japan Only)	-	-	-	-		
40	Upper Finger	1067	60K	Alcohol	480K		
41	Web Pressure Roller	1080	-	-	480K		
42	Cleaning Web Roller	1083	-	-	120K		
Dual-Path Exit Guide							
43	Feed Roller	1510	60K	Water ¹	-	Refer to 2.2.5.	F7-02-01
44	Idle Roller	1511	60K	Water ¹	-		
Automatic Duplex Unit							
45	Drive Roller	1409	60K	Water ¹	-	Refer to 2.2.7.	F7-03-06
46	Drive Roller 2	1410	60K	Water ¹	-		
Paper Transportation							
47	Drive Roller	1314	60K	Water ¹	-	Refer to 2.2.11.	F7-02-01

Note:

- Clean all Rollers and Separation Rubber with a soft cloth saturated with water.
For stubborn toner accumulation, wipe with a soft cloth saturated with Isopropyl Alcohol first, then follow up with a soft cloth saturated with water.
- The Maintenance Cycle is based on the Counter Information for each individual module.
To verify the counter information, print the Total Counter List using the Service Mode: F7 - Electronic counter - 00 (List print).
- Cleaning, Replacement and Adjustment Cycle (Sheet) are based on using Panasonic's recommended standard paper and supplies. These cycles may vary with the kind of paper used and/or ambient conditions.
- The value is determined under the following test conditions. Four continuous prints per job using 6% image coverage of LT/A4 size.

3.5. Resetting the P/M (Preventive Maintenance) Counter

When the machine reaches the preset P/M Cycle, it will show “**Call for P/M**” or “**Replace The Toner Waste Container**” on the LCD Display. The PM Counter can be reset by following the procedures below.

3.5.1. “Call for P/M” (Default: 120K)

1. Perform the P/M (Preventive Maintenance). Refer to Section 3.3 and 3.4.
2. Press the “**FUNCTION**”, “**ORIGINAL SIZE (LEDGER/A3)**”, and the “**3**” keys simultaneously.
3. Input the password, and select the “**OK**” button to enter the Service Mode (default password is **00000000**).
4. Enter the Copy Service Mode F5-70 (PM cycle) and change to the desired value.
5. Press the “**FUNCTION**” and the “**C (CLEAR)**” keys simultaneously to exit the Service Mode.

3.5.2. “Call for P/M Fuser Web” (Default: 120K)

1. Perform the P/M (Preventive Maintenance). Refer to Section 3.3 and 3.4.
2. Press the “**FUNCTION**”, “**ORIGINAL SIZE (LEDGER/A3)**”, and the “**3**” keys simultaneously.
3. Input the password, and select the “**OK**” button to enter the Service Mode (default password is **00000000**).
4. Enter the Copy Service Mode F5-73 (Fuser Web PM Cycle) and change to the desired value.
5. Press the “**FUNCTION**” and the “**C (CLEAR)**” keys simultaneously to exit the Service Mode.

3.5.3. “Call for P/M ADF” (Default: Not Set)

1. Perform the P/M (Preventive Maintenance). Refer to Section 3.3 and 3.4.
2. Press the “**FUNCTION**”, “**ORIGINAL SIZE (LEDGER/A3)**”, and the “**3**” keys simultaneously.
3. Input the password, and select the “**OK**” button to enter the Service Mode (default password is **00000000**).
4. Enter the Copy Service Mode F5-87 (ADF PM Cycle) and change to the desired value.
5. Press the “**FUNCTION**” and the “**C (CLEAR)**” keys simultaneously to exit the Service Mode.

3.5.4. U14 “Replace The Toner Waste Container”



- A. Blinking Maintenance and Toner Waste Container Indicators
Upon detecting that the Toner Waste Container is full, the machine will complete the current job, and stop operating.
A blinking Maintenance and Toner Waste Container Indicators will appear on the display.
To continue using the machine temporarily while waiting for the Service Technician, press any key (up to 100 additional copies can be made).
- B. Steady Maintenance and Toner Waste Container Indicators
Upon reaching the 100 copies, the machine stops and will not allow further operation until the Toner Waste Container is replaced.
Replace the Toner Waste Container. Refer to Section 2.2.4..

3.6. Lubrication Point List

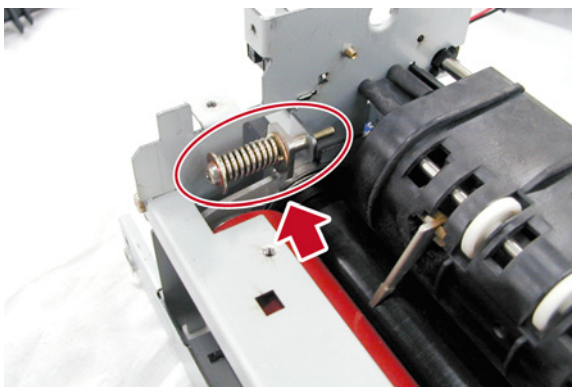
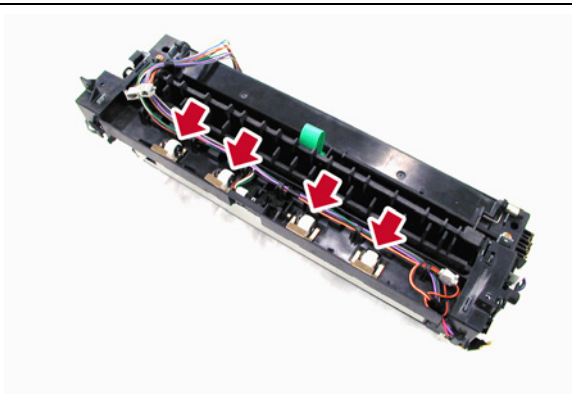
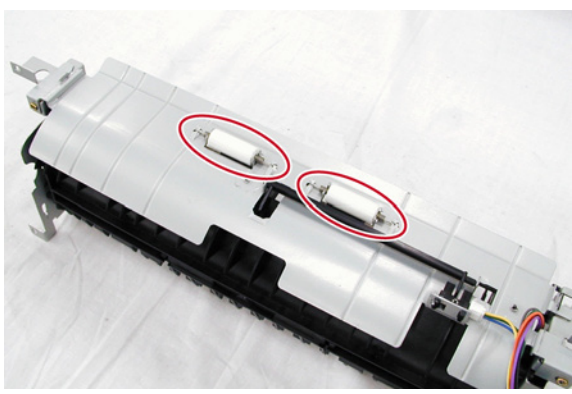
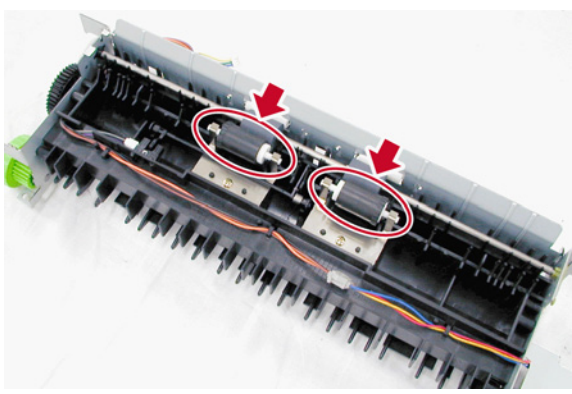
This information is used for routine Preventive Maintenance (PM) calls to ensure the highest degree of reliability. Inspect the following areas and lubricate as required. The inspection interval is usually 120K copies or more, however the interval may be reduced due to environmental conditions.

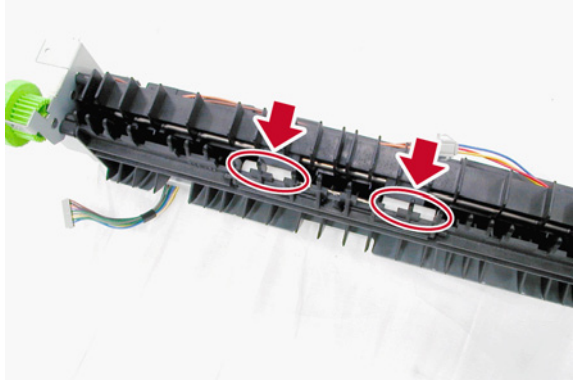
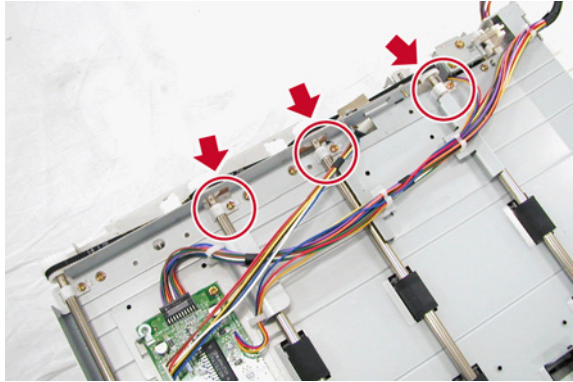
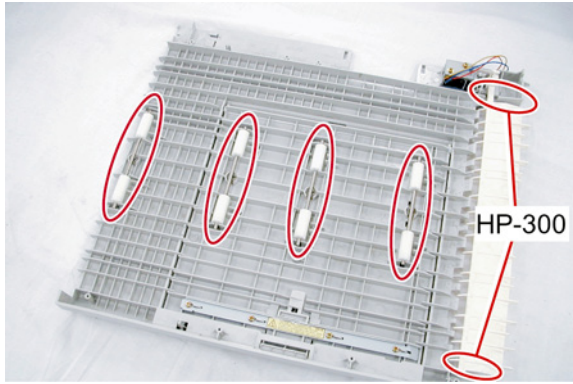
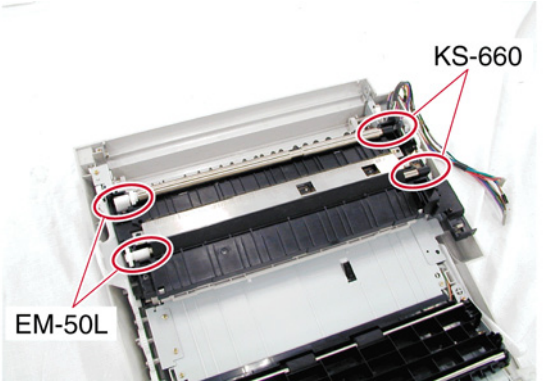
Mechanical Parts	Ref. No.	Grease	Lubrication Point
Fuser Unit			
Pressure Spring	1029	EM-50L	
Shoulder Screw	1033		
Idle Roller	1049	EM-50L	
Pinch Shaft	1068		
Dual-Path Exit Guide			
Top Duplex Guide	1406	EM-50L	
Pinch Spring	1411		
Pinch Roller	1518		
Idle Roller Plate Spring	1509	EM-50L	
Idle Roller	1511		

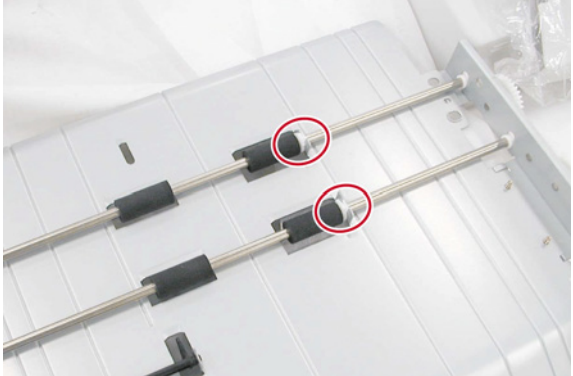
Mechanical Parts	Ref. No.	Grease	Lubrication Point
Roller Shaft	1313	EM-50L	
Pinch Roller	1518		
Paper Transportation			
Drive Roller	1314	EM-50L	
P6L8 Bushing	1322		
Roller Shaft	1313	EM-50L	
Pinch Roller	1518	HP-300	
Automatic Duplex Unit			
Bias Transfer Roller (BTR)	1221	EM-50L KS-660	
Registration Pinch Roller	1222		
Front Bushing	1231		
Rear Bushing	1233		

Mechanical Parts	Ref. No.	Grease	Lubrication Point
Roller Shaft	1313	EM-50L	
Pinch Roller	1518		
Drive Roller	1409	EM-50L	
P6L5 Bushing	1150		
Pinch Spring	1411	EM-50L	
Pinch Roller	1518		

3.7. Updating the Firmware

The Quickest and Most Easiest Method of Updating the Firmware is to use the Network Firmware Update Tool using Ethernet LAN Port and a Crossover Cable.

The Network Firmware Update Tool version must be 3.20 or higher.

3.7.1. Firmware Configuration

A. Hardware Configuration

This machine is controlled by three (3) CPUs which are located on the System Control (SC) PC Board, the Scanner Printer Control (SPC) PC Board and the Panel Control (PNL) PC Board.

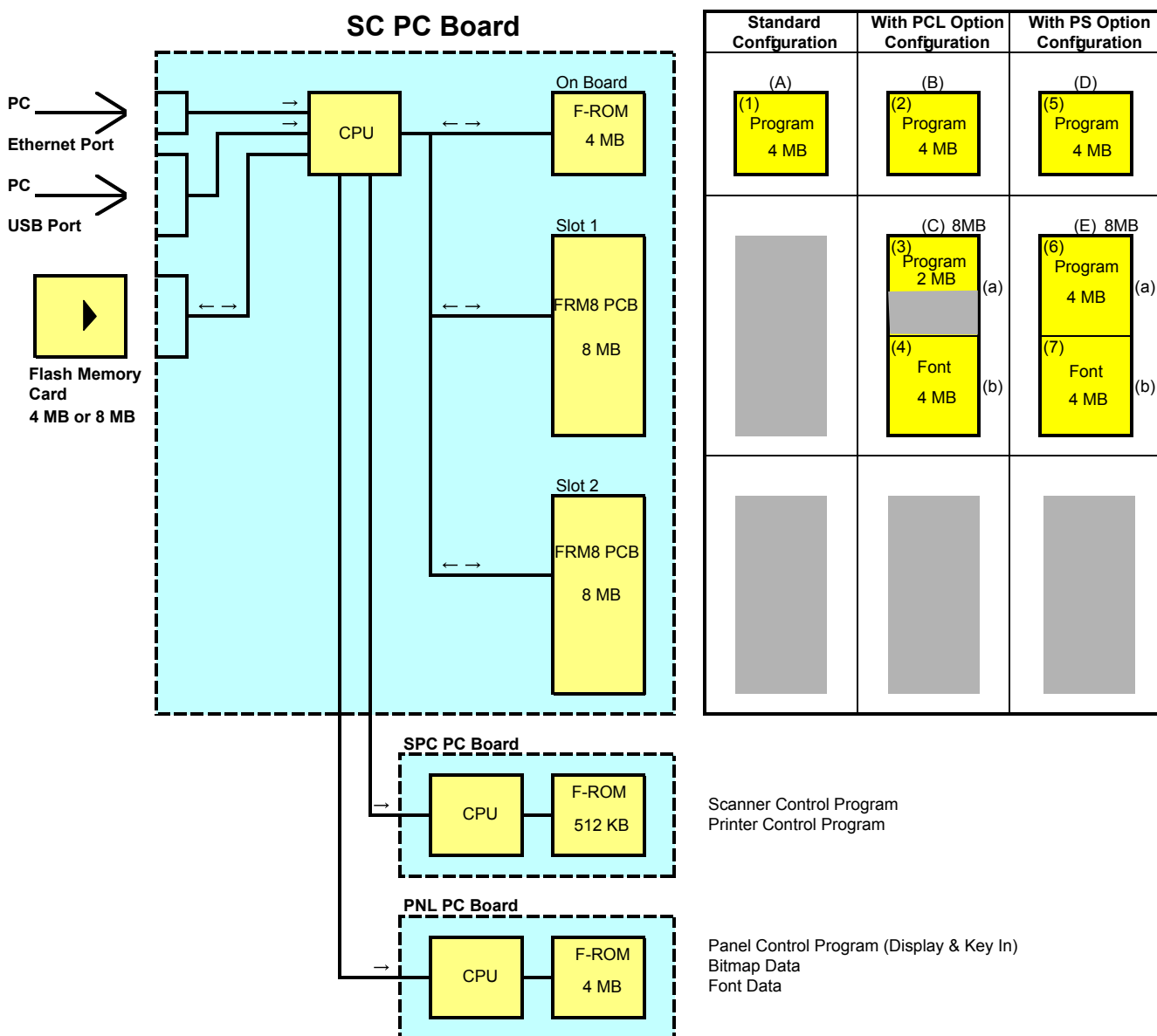

B. SC PC Board Firmware

The 4 MB Program Memory (F-ROM) is integrated on the SC PCB. Two (2) Optional Expansion 8 MB Program Memory (FRM8 PCB) can be installed into SLOT 1 and SLOT 2.

The Firmware to be written into the 4 MB onboard, the 8 MB of SLOT 1 / SLOT 2 depends upon the configuration of the Standard, PCL or PS Options.

(1) Standard

The Standard Program (1) is only written into the 4 MB onboard, which is assigned as ROM Code (A).

(2) For PCL Option

The PCL Control Program (2) must be written into the 4 MB onboard, which is assigned as ROM Code (B). The PCL Control Program (3) and PCL Font data (4) are written into the 8 MB in the SLOT 1. The Firmware (3) and (4) are assigned as ROM Code (C).

When using 8 MB Flash Memory Card, the 8 MB Program (C) can be written onto one card.

When using 4 MB Flash Memory Card, the 8 MB program (C) must be divided onto 2 cards, one 4 MB card for the PCL Control Program (3) and one 4 MB card for the PCL Font data (4).

(3) For PS Option

The PS Control Program must be written into the 4 MB onboard, which is assigned as ROM Code (D). The PS Control Program (6) and (7) are written into the 8 MB in the SLOT 1.

Both Firmwares (6) and (7) are assigned as ROM Code (E).

When using 4 MB Flash Memory Card, the 8 MB program (E) must be divided onto 2 cards, one 4 MB card for the PS Control Program (6) and one 4 MB card for the PS Control Program (7).

C. SPC PC Board Firmware

The 512 KB Program Memory (F-ROM) is integrated on the SPC PCB. The Programs for Scanner Control and Printer Control are saved on the Board. The Firmware is transferred as Serial Data from the SC PCB.

D. Panel (PNL) PC Board Firmware

The 4 MB Program Memory (F-ROM) is integrated on the PNL PCB. The Programs for Key Scan, Display Control, Energy Save Control, Bitmap Data and Font Data are saved on this Board. The Firmware is transferred as Serial Data from the SC PCB.

E. Firmware Updating Ports

Three (3) types of Ports are available for updating the firmware.

(1) Ethernet LAN Port (The Quickest and Most Easiest Method)

The machine's Firmware can be updated from a PC via Local Area Network (LAN). Refer to the Firmware Update Operation Instructions, Service Notes (8.1.) for additional details.

(2) USB Port (Alternate)

The machine's Firmware can be updated from a PC via USB Port. The Master Firmware Card can also be created from a PC using the USB Port. Refer to the Firmware Update Operation Instructions, Service Notes (8.1.) for additional details.

(3) Flash Memory Card (Alternate)

The machine's Firmware can be updated using the Master Firmware Card. The Master Firmware Card can be created by copying the Firmware from an existing machine's SC PCB using a 4 MB or 8 MB Flash Memory Card.

To update the SC, SPC and PNL PCB, 3 Flash Memory Cards are required for the Standard configuration or 5 Flash Memory Cards for the PCL or PS/PCL configuration.

3.7.2. Updating through a LAN Port (The Quickest and Most Easiest Method)

The firmware code can be easily updated when the main unit is connected to a LAN.

The Network Firmware Update Tool can also be used by connecting to the machine using a **crossover cable**, if the unit is not connected to a LAN.

1) Install the Network Firmware Update Tool to your PC

The Tool can be downloaded from your sales company's Web site, or the PCC Service Web site. Please refer to the Operating Instructions of the Tool for details.

Operating Instructions:

\\xFirmware\Tools\NwFirmup\NwFirmup OI.pdf (Refer to the [Network Firmware Update Tool OI](#) on the CD)

Setup:

\\xFirmware\Tools\NwFirmup\Setup\Setup.exe

2) Preparing the Firmware Code

Double click the appropriate Destination Shortcut Batch File, and copy the Firmware Code File on the

CD-ROM to the Firmware Data Folder in your PC, or access the Service Web site to download the latest Firmware Code. When performing the self-extraction wizard for preparing the Firmware Code File, make sure and agree with the license agreement, then input the password “**1Panasonic!**”. The Archive will be extracted automatically into the designated folder.

Example :

From : Destination Shortcut Batch File: D:(CD-ROM Drive) \ xFirmware \ USA.bat
 Firmware Code File : DP-8032_8025_xx_xxxxxx.exe
To : Firmware Data Folder : C:\ Panasonic \ Panasonic-FUP \ Data

Note:

For the Data Security Kit, Please refer to the Section 3.7.3., "Updating through USB Port (Alternate method)".

3) Preparing the Main Unit for the Firmware Upgrade

Print the F5/F6 Parameters List (Copier Service Mode F9-03-00).
 Make sure the unit's F7-01:Application password is the same as the tool's password.
 Make sure the unit is in an idle state (e.g. not making copies, not printing, etc.).

4) Upgrading the Main Unit's Firmware Code

Start the Network Firmware Update Tool and select the following **Firmware Code Folders** in the **C:\Panasonic\Panasonic-FUP\Data** folder, and then follow the display instructions to upgrade the Main Unit's Firmware Codes.

Parent Firmware File Folder	Sub Firmware File Folder
\ DP-8032_8025_xx_xxxxxx	\ Pnl \ L80_PNLAX\xxxxxx_xx
	\ Sc_Std \ SFD-L80Ax\xxxxxx_xx
	\ Sc_Pcl \ SFD-L80Bx\xxxxxx_xx
	\ Sc_Ps \ SFD-L80Dx\xxxxxx_xx
	\ Spc \ L80_SPCAAVxxxxxx

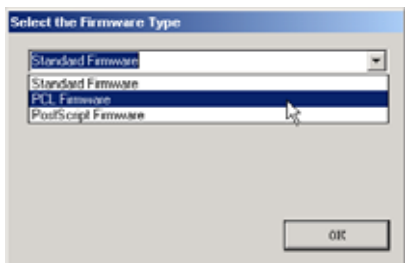

When you select the Parent Folder, as illustrated the Firmware Type window appears. Proper Sub File Folders are selected automatically by selecting the Firmware Type. The transferring order is set up automatically.

Note:

1. Manual mode must be used, when updating the designated version of the firmware or changing the type of the firmware.
 Please refer to the Section 2.2, "Setting up the Network Firmware Update Tool, File Selection Tab" of the Operating Instructions.
2. While updating the firmware code, the display may become garbled, however, it will return to normal upon completion of the firmware update.
3. If the firmware update fails and the unit does not boot up, the Network Firmware Update Tool will not be able to transfer the firmware code. If this occurs, please refer to the next section "Updating through the USB Port" and use the Local Firmware Update Tool to recover the unit.
4. The suffix "_xx" for the Folder Name or File Name may not exist depending on the destination location.

5) After the Firmware Update is completed, enter the F5 & F6 Parameters according to the lists printed in step 3).

3.7.3. Updating through USB Port (Alternate method)

If the device is not connected to the LAN, upgrade the firmware code using the USB Port.

1) Install the Local Firmware Update Tool to your PC

The Tool can be downloaded from your sales company's Web site, or the PCC Service Web site. Please refer to the Operating Instructions of the Tool for details.

Operating Instructions:

\xFirmware\Tools\Firmup\FIRMUP_OI.pdf (Refer to the [Local Firmware Update Tool OI](#) on the CD)

Setup:

\xFirmware\Tools\Firmup\Setup\Setup.exe

2) Preparing the Firmware Code

Double click the appropriate Destination Shortcut Batch File, and copy the Firmware Code File on the CD-ROM to the Firmware Data Folder in your PC, or access the Service Web site to download the latest Firmware Code. When performing the self-extraction wizard for preparing the Firmware Code File, make sure and agree with the license agreement, then input the password "1Panasonic!". The Archive will be extracted automatically into the designated folder.

Example:

From : Destination Shortcut Batch File: D:(CD-ROM Drive) \ xFirmware \ USA.bat
 Firmware Code File : DP-8032_8025_xx_XXXXXX.exe
To : Firmware Data Folder : C:\ Panasonic \ Panasonic-FUP \ Data

3) Preparing the Main Unit for the Firmware Upgrade

Important: DO NOT connect the USB Cable yet.

Print the F5/F6 Parameters List (Copier Service Mode F9-03-00).

Enter into Unit Maintenance Mode F9-07-01 to enable the unit to accept the programming code from the USB Port. If the unit does not boot up, follow the procedure below:

- Turn the power OFF (use the power switch on the back of the machine, not the side of the machine.).
- Turn the power ON while holding the **[ENERGY SAVER]** key.
- When the unit's front panel green lamp turns On, release the **[ENERGY SAVER]** key, it is now ready to accept the firmware code from the USB Port.

Now connect the USB Cable between the Unit and PC.

4) Upgrading the Main Unit's Firmware Code

Start the Network Firmware Update Tool, and select the following **Parent Firmware File Folder** in the **C:\Panasonic\Panasonic-FUP\Data** folder. The Firmware Type window appears, and proper Firmware Files are selected automatically by selecting the Firmware Type. Then follow the display instructions to upgrade the Main Unit's Firmware Codes.

Parent Firmware File Folder	Sub Firmware File Folder
\ DP-8032_8025_xx_XXXXXX	\ Sc_Std \ SFD-L80AxVXXXXX_xx
	\ Sc_Pcl \ SFD-L80BxVXXXXX_xx
	\ Sc_Ps \ SFD-L80DxVXXXXX_xx
	\ Spc \ L80_SPCAAVXXXX
	\ Pnl \ L80_PNLAXVXXXXX_xx

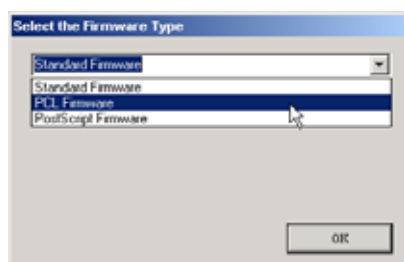

When you select the Parent Folder, as illustrated the Firmware Type window appears. Proper Firmware Files are selected automatically by selecting the Firmware Type.

The transferring order is set up automatically.

Note:

1. While updating the firmware code, the display may become garbled, however, it will return to normal upon completion of the firmware update.
 2. Please refer to the Firmware Update Tool OI for additional details.
 3. The suffix "_xx" for the Folder Name or File Name may not exist depending on the destination location.
- 5) After the Firmware Update is completed, enter the F5 & F6 Parameters according to the lists printed in step 3).

3.7.4. Updating the Firmware using the Master Firmware Card (Alternate method)

1. Before starting, print the F5/F6 Parameters List (Copy Service Mode F9-03-00).
2. Turn the Power Switch on the left side and the Main Power Switch on the back of the machine to the OFF position. (Refer to 3.7.7.)
3. Install the appropriate Master Firmware Card into the machine.
4. Turn the Main Power Switch on the back and the Power Switch on the left side of the machine to the ON position.
5. Press the "**FUNCTION**", "**ORIGINAL SIZE (LEDGER/A3)**", and the "**3**" keys simultaneously.
6. Input the password, and select the "**OK**" button to enter the Service Mode (default password is **00000000**).

Note:

If the Data Security Kit is installed, Enter the password, and select "OK" button (default password is **00000000**).

7. Perform the Copy Service Mode F9-07-00 (Update From Master Card).
8. The firmware is copied into the machine.
9. After the update is completed, the machine reboots itself and returns to standby.
10. Turn the Power Switch on the left side and the Main Power Switch on the back of the machine to the OFF position. (Refer to 3.7.7.)
11. Remove the Master Firmware Card from the machine.
12. Turn the Main Power Switch on the back and the Power Switch on the left side of the machine to the ON position.
13. Reprogram the F5 & F6 Parameters according to the lists printed in Step 1. above if the settings are other than factory default.

Note:

After the update is completed, the machine reboots itself and returns to standby mode.

Repeat the above steps if there are additional firmware code files to be updated.

Confirm that the update was successfully completed by checking the Firmware Version with F9 Parameters F9-02-xx.

Caution:

If the unit does not boot up properly in step 8, refer to 3.7.8. (Firmware Emergency Recovery)

3.7.5. Creating a Master Firmware Card**A. Utilizing the Firmware Update Kit****1) Install the Local Firmware Update Tool to your PC**

The Tool can be downloaded from your sales company's Web site, or the PCC Service Web site. Please refer to the Operating Instructions of the Tool for details.

Operating Instructions:

\xFirmware\Tools\Firmup\FIRMUP OI.pdf (Refer to the [Local Firmware Update Tool OI](#) on the CD)

Setup:

\xFirmware\Tools\Firmup\Setup\Setup.exe

2) Preparing the Firmware Code

Double click the appropriate Destination Shortcut Batch File, and copy the Firmware Code File on the CD-ROM to the Firmware Data Folder in your PC, or access the Service Web site to download the latest Firmware Code. When performing the self-extraction wizard for preparing the Firmware Code File, make sure and agree with the license agreement, then input the password “**1Panasonic!**”. The Archive will be extracted automatically into the designated folder.

Example:

From : Destination Shortcut Batch File: D:(CD-ROM Drive) \ xFirmware \ USA.bat
 Firmware Code File : DP-8032_8025_xx_xxxxxx.exe
To : Firmware Data Folder : C:\ Panasonic \ Panasonic-FUP \ Data

3) Preparing the Main Unit for the Programming Master Firmware Card

Important: DO NOT connect the USB Cable yet.

1. Turn the Power Switch on the left side and the Main Power Switch on the back of the machine to the OFF position. (Refer to 3.7.7.)
2. Insert the Flash Memory Card (4 MB or 8 MB) into the machine.
3. Turn the Main Power Switch on the back and the Power Switch on the left side of the machine to the ON position.
4. Press the “**FUNCTION**”, “**ORIGINAL SIZE (LEDGER/A3)**”, and the “**3**” keys simultaneously.
5. Input the password, and select the “**OK**” button to enter the Service Mode (default password is **00000000**).
6. Perform the Update Program Card Mode F9-09 (Update Program Card).

The unit is now ready to accept the firmware code from the USB Port.

Now connect the USB Cable between the Unit and PC. (Refer to the [Local Firmware Update Tool OI](#) on the CD)

Repeat the above steps if there are additional master firmware cards to be programmed.

B. Copying the Firmware from an Existing Machine using a Flash Memory Card (4 MB or 8 MB)

1. Turn the Power Switch on the left side and the Main Power Switch on the back of the machine to the OFF position. (Refer to 3.7.7.)
2. Install a Flash Memory Card (4 MB or 8 MB) into the machine.
3. Turn the Main Power Switch on the back and the Power Switch on the left side of the machine to the ON position.
4. Press the “**FUNCTION**”, “**ORIGINAL SIZE (LEDGER/A3)**”, and the “**3**” keys simultaneously.
5. Input the password, and select the “**OK**” button to enter the Service Mode (default password is **00000000**).
6. Perform the Copy Service Mode F9-08 (Program Backup).
7. The firmware is copied into the Flash Memory Card.
8. After the backup is completed, press the “**STOP**” key first, then press the “**FUNCTION**”, and “**C (CLEAR)**” keys simultaneously to exit the Service Mode.
9. Turn the Power Switch on the left side and the Main Power Switch on the back of the machine to the OFF position. (Refer to 3.7.7.)
10. Remove the Master Firmware Card that you just created from the machine.
11. Turn the Main Power Switch on the back and the Power Switch on the left side of the machine to the ON position.
12. Use this Master Firmware Card to update the firmware on other machines.

3.7.6. Erasing the Master Firmware Card

1. Turn the Power Switch on the left side and the Main Power Switch on the back of the machine to the OFF position. (Refer to 3.7.7.)
2. Install the Master Firmware Card into the machine.
3. Turn the Main Power Switch on the back and the Power Switch on the left side of the machine to the ON position.

4. Press the “**FUNCTION**”, “**ORIGINAL SIZE (LEDGER/A3)**”, and the “**3**” keys simultaneously.
5. Input the password, and select the “**OK**” button to enter the Service Mode (default password is **00000000**).
6. Perform the Service Mode F9-09 (Update Program Card).
7. After the Flash Memory Card is erased, machine prompts “**Update Program Card?**”. Press “**NO**”.
8. Press the “**STOP**” key first, then press the “**FUNCTION**”, and “**C (CLEAR)**” keys simultaneously to exit the Service Mode.
9. Turn the Power Switch on the left side and the Main Power Switch on the back of the machine to the OFF position. (Refer to 3.7.7.)
10. Remove the blank Flash Memory Card from the machine.
11. Repeat from Step 2 above if you are erasing another Master Firmware Card.

3.7.7. Notice after installing the HDD option

After the Hard Disc Drive Unit is installed, to prevent a Disc Scan Function from being performed (similar to Windows OS when the power is abruptly interrupted), it is important to follow the step sequence below when turning OFF the Power Switches on the machine.

1. Turn the Power Switch on the left side of the machine to the OFF position first.
2. Wait approximately 10 seconds while the machine writes the closing status onto the Hard Disc Drive Unit.
3. Turn the Main Power Switch on the back of the machine to the OFF position.

3.7.8. Firmware Emergency Recovery

The easiest method to recover the firmware in an Emergency Recovery routine is to either use the Local Firmware Update Tool software by selecting the Independent File method, or using the Master Firmware Flash Card method (3 Flash Cards required).

Whichever method you select, it is easier to restore the machine's firmware to the Standard (AAV) Type first as it only requires 3 files to bring the machine to initial working condition. (Install the files in this order: SC, SPC and PNL).

After recovering, if optional PCL or PS/PCL firmware is required, use the Network Firmware Update Tool or the Local Firmware Update Tool to update the firmware to the required level.

If the unit does not boot up properly, follow the steps below:

1. Turn the power Off (use the power switch on the back of the unit, not the side of the unit).
 - Before proceeding to the next step, you must prepare either the Local Firmware Update Tool or create the Master Firmware Flash Cards (read the appropriate sections first).
 - If using the Master Firmware Card, insert the Master Firmware Flash Cards in the unit.
2. Turn the power On while holding the **[ENERGY SAVER]** key.
3. When the green lamp on the front panel turns On, release the **[ENERGY SAVER]** key.
 - If using the Master Firmware Card, the unit will start updating the Firmware code files automatically.

The unit is now ready to accept the firmware code from the USB Port or Master Firmware Card. Repeat the above steps if there are additional firmware code files to be updated.

3.7.9. Firmware Version

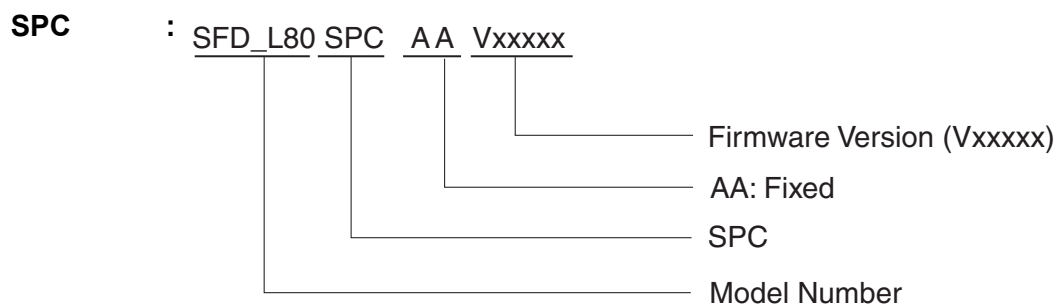
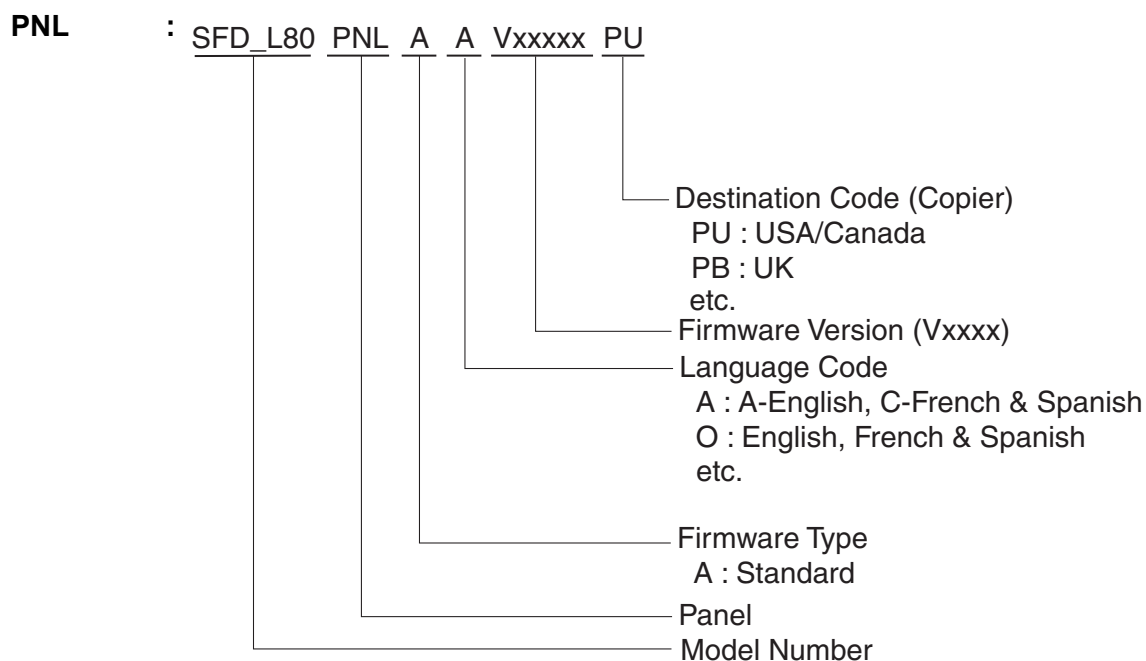
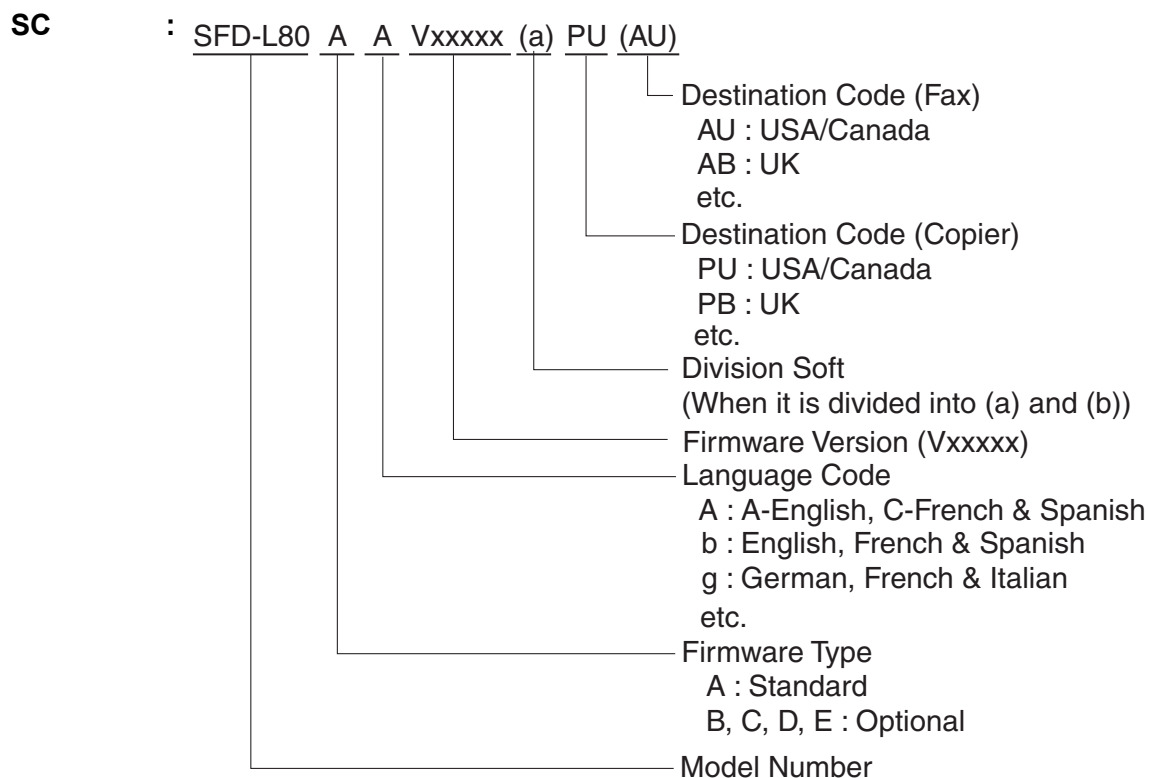

3.8. Adjusting the Printer Registration, LSU Image Side to Side

When installing the Paper Tray option, the following LSU Image Side to Side adjustment must be performed.

The Printer registration is adjusted at the factory.

If copy image is abnormal, specially in the Rotation Copy mode, adjust it by the following procedure.

3.8.1. Printer Registration

1. Insert Ledger or A3 size paper into the 1st tray and change the tray setting to the appropriate paper size. Empty or pull out all the remaining trays (including the bypass tray) to disable them.
2. Press the **"FUNCTION"**, **"ORIGINAL SIZE (LEDGER/A3)"**, and the **"3"** keys simultaneously.
3. Input the password, and select the **"OK"** button to enter the Service Mode (default password is **00000000**).
4. Perform the Service Mode F1-03 (Print Test Pattern 1).
5. Check the gap of the print pattern from the paper edge, refer to the Figure below.
6. Perform the Service Mode F6-04 (Printer Registration) to adjust the gap to be 5 mm.
7. If the gap is less than 5 mm, input a (-) value. If more than 5 mm, input a (+) value.
8. Press the **"STOP"** key first, then press the **"FUNCTION"**, and **"C (CLEAR)"** keys simultaneously to exit the Service Mode.

<Figure>

Two lines are printed on the top (Lead edge).
For Ledger or A3, place as Portrait.
For Letter or A4, place as Landscape.

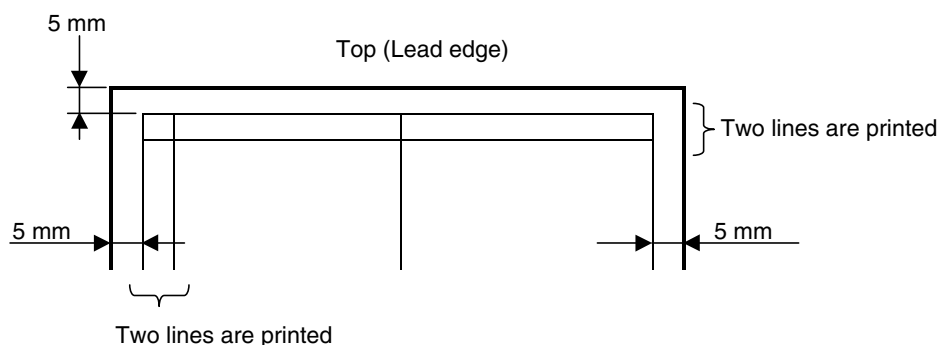

3.8.2. LSU Image Side to Side Adjustment for the Tray

1. Insert paper into the 1st tray and change the tray setting to the appropriate paper size. Empty or pull out all the remaining trays (including the bypass tray) to disable them.
2. Press the **"FUNCTION"**, **"ORIGINAL SIZE (LEDGER/A3)"**, and the **"3"** keys simultaneously.
3. Input the password, and select the **"OK"** button to enter the Service Mode (default password is **00000000**).
4. Perform the Service Mode F1-03 (Print Test Pattern 1).
5. Check the gap of the print pattern from the paper edge. (Refer to the <Figure>)
6. Perform the Service Mode F6-10 to F6-14, to adjust the gap to be 5 mm.
7. If the gap is less than 5 mm, input a (+) value. If more than 5 mm, input a (-) value.
8. Proceed the above steps for other Tray.
9. Press the **"STOP"** key first, then press the **"FUNCTION"**, and **"C (CLEAR)"** keys simultaneously to exit the Service Mode.

3.8.3. LSU Image Side to Side Adjustment for the ADU

1. Insert paper into the 1st tray and change the tray setting to the appropriate paper size. Empty or pull out all the remaining trays (including the bypass tray) to disable them.
2. Press the **"FUNCTION"**, **"ORIGINAL SIZE (LEDGER/A3)"**, and the **"3"** keys simultaneously.

3. Input the password, and select the **“OK”** button to enter the Service Mode (default password is **0000000**).
4. Perform the Service Mode F1-06 (Print Test Pattern 4).
5. Check the gap of the print pattern from the paper edge. (Refer to the “3.8.2. <Figure>”)
6. Perform the Service Mode F6-16 (ADU Side Adjust), to adjust the gap to be 5 mm.
7. If the gap is less than 5 mm, input a (+) value. If more than 5 mm, input a (-) value.
8. Press the **“STOP”** key first, then press the **“FUNCTION”**, and **“C (CLEAR)”** keys simultaneously to exit the Service Mode.

3.8.4. 100% Read Adjustment

1. Place the Original Document on the Platen Scanner.
2. Insert Ledger or A3 size paper into the 1st tray and change the tray setting to the appropriate paper size. Empty or pull out all the remaining trays (including the bypass tray) to disable them.
3. Press the **“FUNCTION”**, **“ORIGINAL SIZE (LEDGER/A3)”**, and the **“3”** keys simultaneously.
4. Input the password, and select the **“OK”** button to enter the Service Mode (default password is **0000000**).
5. Perform the Service Mode F2 (Single Copy Test).
6. Check the Image size of the Copy and the Original as Portrait.
7. Perform the Service Mode F6-00 (Adj 100% Side-Side Read), to adjust the Side to Side to be the same.
8. If the image is smaller than the Original, input a (+) value. If bigger than the Original, input a (-) value.
9. Perform the Service Mode F6-01 (Adj 100% Lead-Tail Read), to adjust the Top to End to be the same.
10. If the image is smaller than the Original, input a (+) value. If bigger than the Original, input a (-) value.
11. Press the **“STOP”** key first, then press the **“FUNCTION”**, and **“C (CLEAR)”** keys simultaneously to exit the Service Mode.

Note:

This is the size adjustment and do not worry about the positioning.

3.8.5. Original Registration & CCD Read Adjustments

1. Place the Original Document on the Platen Scanner.
2. Insert Ledger or A3 size paper into the 1st tray and change the tray setting to the appropriate paper size. Empty or pull out all the remaining trays (including the bypass tray) to disable them.
3. Press the **“FUNCTION”**, **“ORIGINAL SIZE (LEDGER/A3)”**, and the **“3”** keys simultaneously.
4. Input the password, and select the **“OK”** button to enter the Service Mode (default password is **0000000**).
5. Perform the Service Mode F2 (Single Copy Test).
6. Check the Image size of the Copy and the Original as Portrait.
7. Perform the Service Mode F6-03 (Original Registration), to adjust the Original Registration.
8. If the gap is smaller than the Original, input a (-) value. If bigger than the Original, input a (+) value.
9. Perform the Service Mode F6-53 (P Mode Image Density), to adjust the CCD Read for the side position.
10. If the gap is smaller than the Original, input a (+) value. If bigger than the Original, input a (-) value.
11. Press the **“STOP”** key first, then press the **“FUNCTION”**, and **“C (CLEAR)”** keys simultaneously to exit the Service Mode.

3.8.6. ADF 100% Image 1-Sided Adjustment

1. Place the Original Document on the ADF.
2. Insert Ledger or A3 size paper into the 1st tray and change the tray setting to the appropriate paper size. Empty or pull out all the remaining trays (including the bypass tray) to disable them.
3. Press the **“FUNCTION”**, **“ORIGINAL SIZE (LEDGER/A3)”**, and the **“3”** keys simultaneously.
4. Input the password, and select the **“OK”** button to enter the Service Mode (default password is **0000000**).

5. Perform the Service Mode F2 (Single Copy Test).
6. Check the Image size of the Copy and the Original as Portrait.
7. Perform the Service Mode F6-93 (ADF 100% Image 1-Sided), to adjust the Side to Side to be the same.
8. If the image is smaller than the Original, input a (+) value. If bigger than the Original, input a (-) value.
9. Press the **“STOP”** key first, then press the **“FUNCTION”**, and **“C (CLEAR)”** keys simultaneously to exit the Service Mode.

Note:

This is the size adjustment and do not worry about the positioning.

3.8.7. ADF Original Read Edge & ADF Main Scan Adjustments

1. Place the Original Document on the ADF.
2. Insert Ledger or A3 size paper into the 1st tray and change the tray setting to the appropriate paper size. Empty or pull out all the remaining trays (including the bypass tray) to disable them.
3. Press the **“FUNCTION”**, **“ORIGINAL SIZE (LEDGER/A3)”**, and the **“3”** keys simultaneously.
4. Input the password, and select the **“OK”** button to enter the Service Mode (default password is **00000000**).
5. Perform the Service Mode F2 (Single Copy Test).
6. Check the Image size of the Copy and the Original as Portrait.
7. Perform the Service Mode F6-91 (Original Read Edge ADF), to adjust the ADF Original Read Edge.
8. If the gap is less than the Original, input a (+) value. If bigger than the Original, input a (-) value.
9. Perform the Service Mode F6-90 (ADF Read Main Scan Pos.), to adjust the ADF Main Scan for Side position.
10. If the gap is less than the Original, input a (+) value. If bigger than the Original, input a (-) value.
11. Press the **“STOP”** key first, then press the **“FUNCTION”**, and **“C (CLEAR)”** keys simultaneously to exit the Service Mode.

3.9. Calibrating the LCD

1. Turn the Main Power Switch on the Back of the machine to the OFF (O) position (Wait approximately 10 seconds).
2. Leave the Power Switch on the Left Side of the machine in the ON (I) position.
3. Ensure that the F-ROM Card with Firmware Update is not installed in the machine. If the Card is installed in the machine, remove it.
4. Press and hold the **“ENERGY SAVER”** and **“FUNCTION”** keys down simultaneously, then turn the Main Power Switch on the Back of the machine to the ON (I) position and continue holding the keys for approximately 30 seconds until the Display becomes stable.
The LCD Display starts blinking and shows a “+” on the upper left edge of the display.

Note:

If you do not hold the **“ENERGY SAVER”** and **“FUNCTION”** keys down long enough, the Display may go OFF.

5. Press the **“+”** on the upper left edge of the display, press the **“+”** on the lower right edge and press the **“+”** on the center of the display. Then the display goes to stand-by.

Caution:

Prevent any damage to the LCD Display by not pressing with Sharp Edged Objects such as a Ball Point Pen, etc.

6. Reboot the machine by cycling the power. Turn the Main Power Switch on the Back of the machine to the OFF (O) then ON (I) position.

3.10. Glossary of Electrical Abbreviations

Signal Name	Function
+12V	+12 VDC Power Supply
+24V	+24 VDC Power Supply
+24VD1	+24 VDC Power Supply
+24VD2	+24 VDC Power Supply
+24VHL	+24 VDC Power Supply
+24VFB	+24 VDC Power Supply
+24VFL	+20/+24 VDC Power Supply
+24VFP	+24 VDC Power Supply
+24VM	+24 VDC Power Supply
+24VOPC	+24 VDC Power Supply
+24VOPF	+24 VDC Power Supply
+3.3V	+3.3 VDC Power Supply
+5V	+5 VDC Power Supply
+5VD	+5 VDC Power Supply
+5VP	+5 VDC Power Supply
24ELS	Scanner 24V Sensor Error Signal
ACL	AC Power Supply
ACLRLB	AC Power Supply
ACN	AC Power Supply
ACNRLB	AC Power Supply
ACSW	Fuser Relay
AGND	Ground
BD_A	Beam Detect A
BMCNT	Toner Bottle Motor Control Signal
BTHP	Toner Bottle Position Sensor Signal
BZCLK	Buzzer Signal
BZOFF	Buzzer OFF
CDSN1	Density Sensor 1 Signal
CDSN2	Density Sensor 2 Signal
CDSSOL	Density Sensor Solenoid
CR0	Charge Control AC Clock
CR1	Charge Control DC ON/OFF PWM
CR1	Charge Control AC Current
CSSRXD	CSS Reception Data
CSSTXD	CSS Transmission Data
DAA1	ADF Motor Current Control Signal
DADATA	D/A Converter Serial Data
DACLK	D/A Converter Serial Clock
DALTH	D/A Converter Serial Latch
DR0	Development Control AC ON/OFF PWM
DR1	Development Control DC ON/OFF PWM
DUPCLH1	ADU Clutch Control Signal
ELPCNT	Discharge Lamp
FLNG	Inverter Control Signal
GACLK+	Gate Array Clock +
GACLK-	Gate Array Clock -
GND	Ground

Signal Name	Function
GOPSW1	Developer Missing Detection
HSYNC	Horizontal Synchronous Signal
HUMSN	Temp Humidity Sensor Signal
IICSCSCL	IIC Transmission Clock
IICSDA	IIC Transmission Signal
IOUTA	Motor Control Signal
IOUTB	Motor Control Signal
IPRXD	Finisher IPC Reception
IPTXD	Finisher IPC Transmission
KCDET	Key Counter Option Detection
L+5V	Laser Circuit +5 VDC Power Supply
L1 (R)	Line Signal
L2 (T)	Line Signal
LD	Motor Lock Detection Signal
LD2WAY	Photo Sensor DC Drive Voltage
LDBT	Photo Sensor DC Drive Voltage
LDCST	Photo Sensor DC Drive Voltage
LDCST2	Photo Sensor DC Drive Voltage
LDCST3	Photo Sensor DC Drive Voltage
LDCST4	Photo Sensor DC Drive Voltage
LDDOR	Photo Sensor DC Drive Voltage
LDDUP1	Photo Sensor DC Drive Voltage
LDDUP2	Photo Sensor DC Drive Voltage
LDDUP3	Photo Sensor DC Drive Voltage
LDDUP4	Photo Sensor DC Drive Voltage
LDEN	Laser Control
LDESEN	Photo Sensor DC Drive Voltage
LDEX1	Photo Sensor DC Drive Voltage
LDEX2	Photo Sensor DC Drive Voltage
LDEX3	Photo Sensor DC Drive Voltage
LDEX4	Photo Sensor DC Drive Voltage
LDFPCHK2	Photo Sensor DC Drive Voltage
LDFPCHK3	Photo Sensor DC Drive Voltage
LDFPCHK4	Photo Sensor DC Drive Voltage
LDHTJ	Photo Sensor DC Drive Voltage
LDI+	Laser Diode Control +
LDI-	Laser Diode Control -
LDJAM2	Photo Sensor DC Drive Voltage
LDJAM3	Photo Sensor DC Drive Voltage
LDJAM4	Photo Sensor DC Drive Voltage
LDMF4	Photo Sensor DC Drive Voltage
LDMFP	Photo Sensor DC Drive Voltage
LDMFR	Photo Sensor DC Drive Voltage
LDPHK2	Photo Sensor DC Drive Voltage
LDPHK3	Photo Sensor DC Drive Voltage
LDPHK4	Photo Sensor DC Drive Voltage
LDPS	Photo Sensor DC Drive Voltage
LDRSEN	Photo Sensor DC Drive Voltage
LDTF	Photo Sensor DC Drive Voltage

Signal Name	Function
LDUPL	Photo Sensor DC Drive Voltage
LDUPL2	Photo Sensor DC Drive Voltage
LDUPL3	Photo Sensor DC Drive Voltage
LDUPL4	Photo Sensor DC Drive Voltage
LDWTD	Photo Sensor DC Drive Voltage
LEDA	Select Sensor Signal
LEDC	Select Sensor Signal
LEDX	Select Sensor Signal
LEDY	Select Sensor Signal
LEDZ	Select Sensor Signal
LPOW1	Low Power Control 1
LPOW2	Low Power Control 2
MCLK+	Master Clock +
MCLK-	Master Clock -
MGND	Ground
N.C.	Not Used
n2WAYKEP1	Paper Stopper Solenoid Signal
n2WAYKEP2	Paper Stopper Solenoid Signal
n2WAYSEN	Inner Upper Tray Paper Exit Signal
nA3SEN	Sheet Bypass Paper Size Detection Signal
nAA3S	Original Width Detection Signal
nAADL1	Original Length Detection Signal
nAADL2	Original Length Detection Signal
nAAPNT	Original Detection Signal
nAB1SN	Read Point Detection Signal
nAB2SN	Duplex Eject Detection Signal
nAB4S	Original Width Detection Signal
nACLOCKAD1	ADF Motor Control Clock Signal
nADF3	3rd Paper Tray Feed Roller Drive Signal
nADF4	4th Paper Tray Feed Roller Drive Signal
nAEJC	Original Eject Detection Signal
nAKEEP1	Reversing 1 Guide Solenoid Control Signal
nAKEEP2	Reversing 1 Guide Solenoid Control Signal
nAOAC	ADF Cover Open Detection Signal
nAPACHG	Duplex 2 Guide Solenoid Control Signal
nAPICR	Release Lever Plate Solenoid Control Signal
nAREV	ADF Exit Cover Open Detection Signal
nASTAMP	Stamp Control Signal
nASTROAD1	ADF Motor Control Strobe Signal
nATT	Attention Signal
nB4SEN	Sheet Bypass Paper Detection Signal
nCASET	Paper Tray Detection Signal (1st Feeder)
nCCLH1	Feed 2 Roller Clutch Control Signal
nCCLH2	ADF Roller Clutch Control Signal
nCCLH3	Inverting Roller Clutch Control Signal
nCLPIN	AFE Sample Hold Clamp Signal
nCOUNT	Counter Drive Signal
nCST2	2nd Paper Tray Detection Signal
nCST3	3rd Paper Tray Detection Signal

Signal Name	Function
nCST4	4th Paper Tray Detection Signal
nCSTOP	2nd Paper Feed Module Detection Signal
nCSTOP4	4th Paper Feed Module Detection Signal
nCTON	Ring Detection Signal
nDADFON	ADF Option Detection Signal
nDOOR	Paper Transport Unit Open Detection Signal
nDUACK	Duplex Print Acknowledge Signal
nDUPSEN1	Duplex Sensor 1 Signal
nDUPSEN2	Duplex Unit Paper Detection Signal
nDUPSEN3	Duplex Unit Paper Detection Signal
nDUPSEN4	Duplex Unit Paper Detection Signal
nDUREQ	Duplex Print Request
nESEN	Inner Exit Tray Paper Detection Signal
nEXDF1	Paper Transport Unit Paper Detection Signal
nEXDF2	Paper Transport Unit Paper Detection Signal
nEXDF3	Paper Transport Unit Paper Detection Signal
nEXDF4	Paper Transport Unit Paper Detection Signal
nFDPCHK2	2nd Paper Tray Paper Registration Detection Signal
nFDPCHK3	3rd Paper Tray Paper Registration Detection Signal
nFDPCHK4	4th Paper Tray Paper Registration Detection Signal
nFNRDT	Fan Ready Signal
nFNRDTB	Scanner Fan Ready Signal
nFNRDTL	LSU Fan Ready Signal
nFNRDTP	LVPS Fan Ready Signal
nGARST	CCD PCB Reset Signal
nHDF	Multi Feeder Feed Roller Drive Signal
nHKOF	External Phone Off-Hook Detection Signal
nHTJAM	Fuser Unit Jam Sensor Signal
nIMMP0a	Motor Drive Signal
nIMMP0b	Motor Drive Signal
nJAMDOR2	2nd Paper Tray Jam Access Cover Open Detection Signal
nJAMDOR3	3rd Paper Tray Jam Access Cover Open Detection Signal
nJAMDOR4	4th Paper Tray Jam Access Cover Open Detection Signal
nKCNT	Key Counter Option
nKEEP1	Paper Stopper Solenoid Signal
nKEEP2	Paper Stopper Solenoid Signal
nLIFT1	1st Paper Tray Lift Motor Signal
nLIFTM2	2nd Paper Tray Lift Motor Drive Signal
nLIFTM3	3rd Paper Tray Lift Motor Drive Signal
nLIFTM4	4th Paper Tray Lift Motor Drive Signal
nLPOW1	Not Used
nLPOW2	Not Used
nMFPCCK	Sheet Bypass Paper Detection Signal
nMFRCHK	Sheet Bypass Pressure Plate Detection Signal
nMFSEN4	Sheet Bypass Paper Length Detection Signal
nMMCK	Main Motor Clock
nMMON	Main Motor Rotation Control Signal
nMMP0a	Motor Drive Signal
nMMP0b	Motor Drive Signal

Signal Name	Function
nMMRDY	Main Motor Ready Signal
nMRCLH3	3rd Paper Tray Intermediate Roller Clutch Drive Signal
nMRCLH4	4th Paper Tray Intermediate Roller Clutch Drive Signal
nOE	Output Enable (Image Data)
nOP2WAY	2Way Unit Detection Signal
nOP3ENB	Option Feed FIFO Enable
nOP3FCK	Option Feed FIFO Clock
nOP3FDIN	Option Feed FIFO Input
nOP3FLD	Option Feed FIFO Load
nOP3FLT	Option Feed FIFO Latch
nOP3FOT	Option Feed FIFO Output
nOP3RST	Option Feed FIFO Reset
nOPDUP	Duplex Unit Detection Signal
nOPTRP	Transport Unit Installed Detection Signal
nORI	Home Position Detection Signal
nPACK	Printer ACK Signal
nPCHK1	1st Paper Tray Paper Detection Signal
nPCHK2	2nd Paper Tray Paper Detection Signal
nPCHK3	3rd Paper Tray Paper Detection Signal
nPCHK4	4th Paper Tray Paper Detection Signal
nPMON	Polygon Motor Rotation Signal
nPMRDY	Polygon Motor Ready Signal
nPNLRST	Panel Reset Signal
nRRCLH	Registration Roller Drive Signal
nPRDY	Printer Ready Signal
nPRGDWN	F-ROM Rewrite
nRSEN	Registration Sensor Signal
nPVSYNC	Print Registration
nS/H	Sample Hold Signal
nSACK	Scan ACK Signal
nSEN1	AFE Serial Data Output Enable Signal
nSENTIM	Scanner LSYNC Signal
nSREQ	Scanner Request Signal
nSSR1	Heater Control Signal
nSSR2	Heater Control Signal
nSSR3	Not Used
nSYNC	Horizontal Synchronous Signal
nTNSCLH	Toner Clutch Control
nTRPJAM	Transport Unit Open Detection Signal
nTRPSEN1	Transport Unit Sensor Signal
nTRPSEN2	Transport Unit Sensor Signal
nTRPSEN3	Transport Unit Sensor Signal
nTRPSEN4	Transport Unit Sensor Signal
nVRDY	VSYNC Reset Signal
nVREQ	Print ACK Request Signal
nWAKE	FAX Wake Up Signal
OPCCNT	OPC Drum Clutch Control Signal
OUTA	Motor Control Signal
OUTB	Motor Control Signal

Signal Name	Function
P/S	Motor Start/Stop
pADF2	2nd Paper Tray Feed Roller Drive Signal
pBLKCLP	AFE Black Level Clamp Switch Signal
pCMLD	Line Switching Relay Drive Signal
PFCLCNT	Paper Feed Clutch Drive Signal
pFLON	Inverter Ground
pLIFT2	2nd Paper Tray Lift Motor Signal
pLIFT4	4th Paper Tray Lift Motor Signal
PMCK	Polygon Motor Clock
pMMP0a	Motor Drive Signal
pMMP0b	Motor Drive Signal
pMRCLH2	2nd Paper Tray Intermediate Roller Clutch Drive Signal
PNLDO1	Panel F-ROM Rewrite Serial Data
PNLSCK1	PNL1 Serial Clock
POWCNTV	Laser Power Control Signal
pPRXD	Reception Data Signal
pPTXD	Transmission Data Signal
pSPCRST	SPC Reset Signal
pSPKOT	Line Dial Tone Signal
pTRPKP1	Transport Unit Solenoid Signal
pTRPKP2	Transport Unit Solenoid Signal
pTRPMDA	Transport Unit Motor Signal
pTRPMDB	Transport Unit Motor Signal
pTRPMNA	Transport Unit Motor Signal
pTRPMNB	Transport Unit Motor Signal
pUPLIMIT1	1st Paper Tray Paper Level Signal
pUPLIMIT2	2nd Paper Tray Paper Level Signal
pUPLIMIT3	3rd Paper Tray Paper Level Signal
pUPLIMIT4	4th Paper Tray Paper Level Signal
pVREF1	Transport Unit Motor Current Setup Signal
pVREF2	Transport Unit Motor Current Setup Signal
pZCIN	Heater Control Signal
RETRACE	Laser Control
SCLK+	AFE Serial Data Clock +
SCLK-	AFE Serial Data Clock -
SDI	AFE Serial Data Signal
SLPKY	Sleep Key
SPCRXD	SPC Reception Data Signal
SPCTXD	SPC Transmission Data Signal
SPOW	Scanner 24V Control Signal
STRVP	Control Signal
TDREF	Toner Density Reference Sensor
TDSN	Toner Density Sensor Signal
TED	Toner Detect Sensor Signal
TEMPSN	Temp Humidity Sensor Signal
TFSN	Toner Waste Sensor Signal
TG	TG Signal for Product Line
THERMA1	Fuser Thermistor A1
THERMA2	Fuser Thermistor A2

Signal Name	Function
THERMB1	Fuser Thermistor B1
THERMB2	Fuser Thermistor B2
TR0	Transfer Control Transfer Output
TR1	Transfer Control Cleaning Output
TxCLKOUT+	Image Data Transmission Clock +
TxCLKOUT-	Image Data Transmission Clock -
TxOUT0+	Image Data Out 0 +
TxOUT0-	Image Data Out 0 -
TxOUT1+	Image Data Out 1 +
TxOUT1-	Image Data Out 1 -
VCDS	Density Sensor ON
VCNT	Inverter Control Signal
VINA	Sensor Input Signal
VINX	Sensor Input Signal
VOUTA	Sensor Control Signal
VOUTB	Sensor Control Signal
VOUTX	Sensor Control Signal
VTED	Toner Detect Sensor ON
WEBSOL	Web Solenoid Control Signal
WTBSN	Toner Waste Container Detection Sensor Signal
X1	Touch Panel Matrix Signal
X2	Touch Panel Matrix Signal
Y1	Touch Panel Matrix Signal
Y2	Touch Panel Matrix Signal

4 Troubleshooting

4.1. Initial Troubleshooting Flowchart

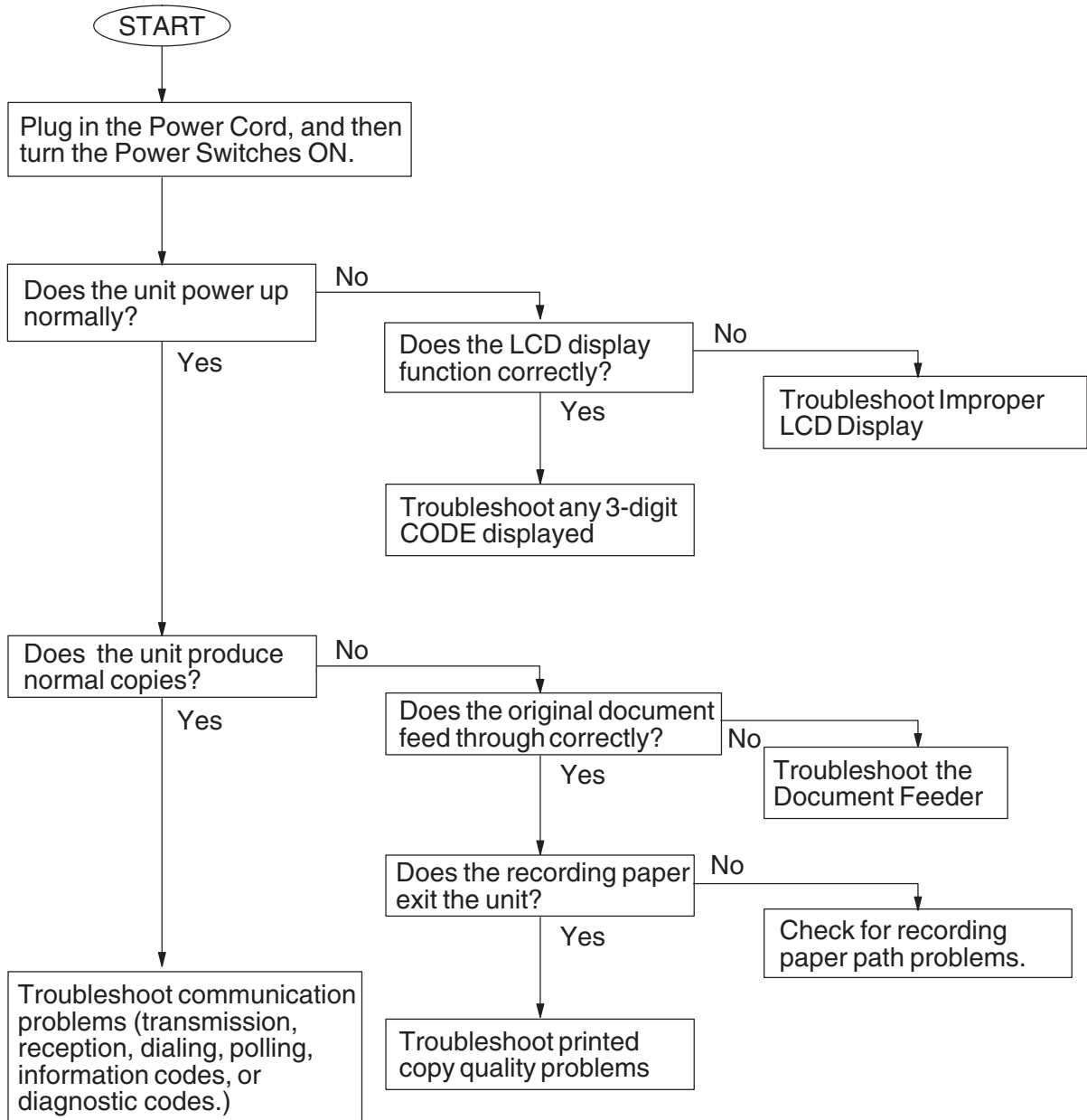

4.2. Improper LCD Display

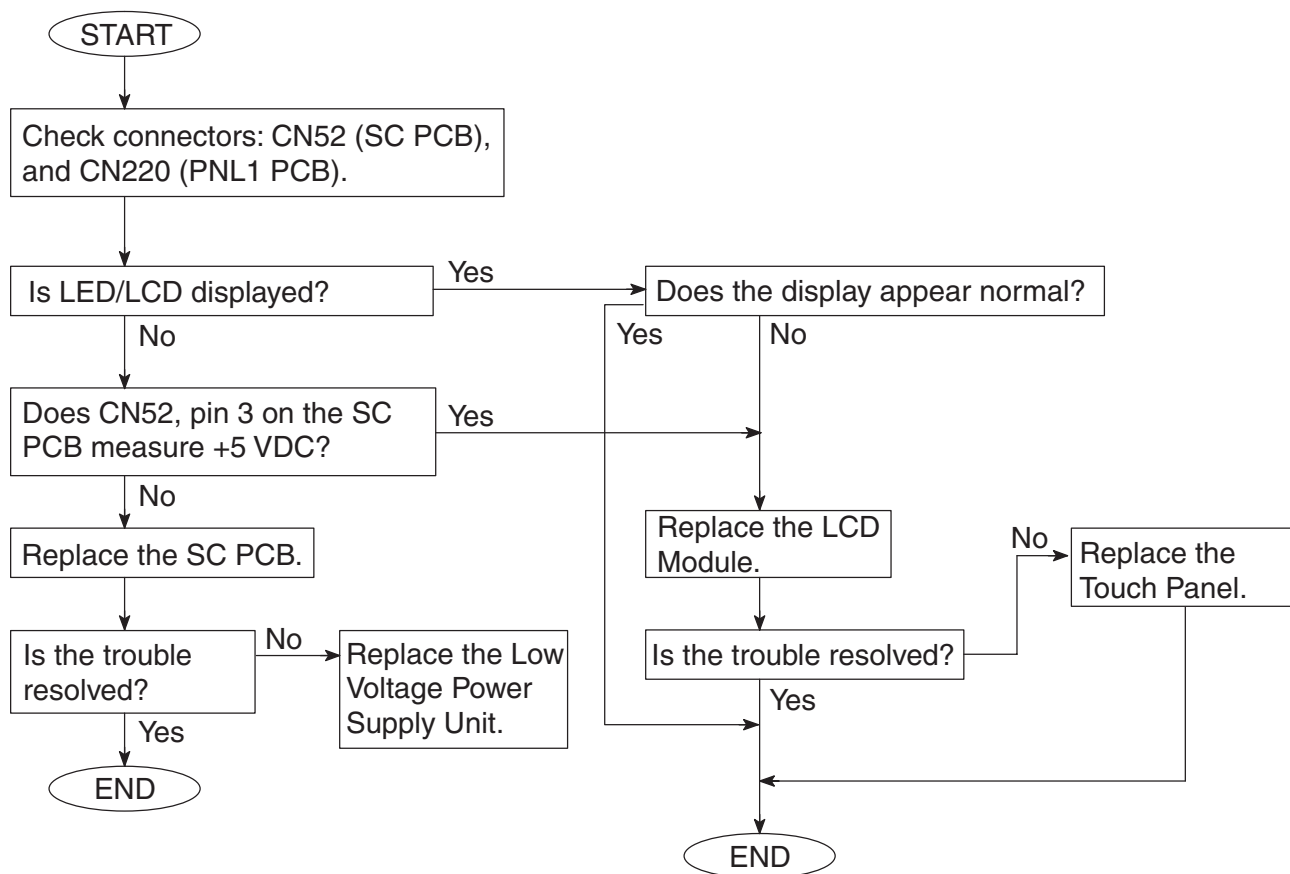

4.3. Printed Copy Quality Problems

4.3.1. Black Copy

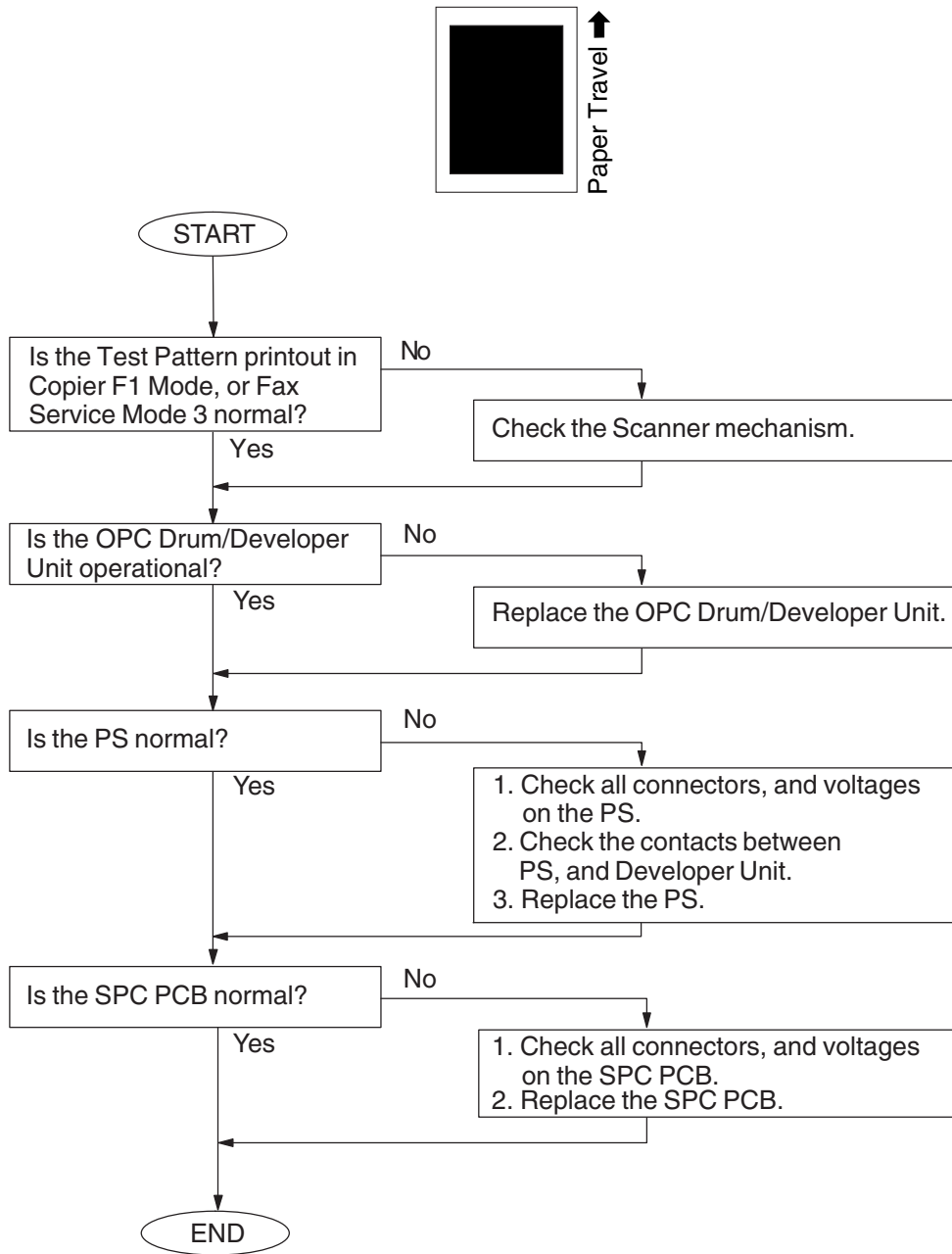

4.3.2. Blank Copy

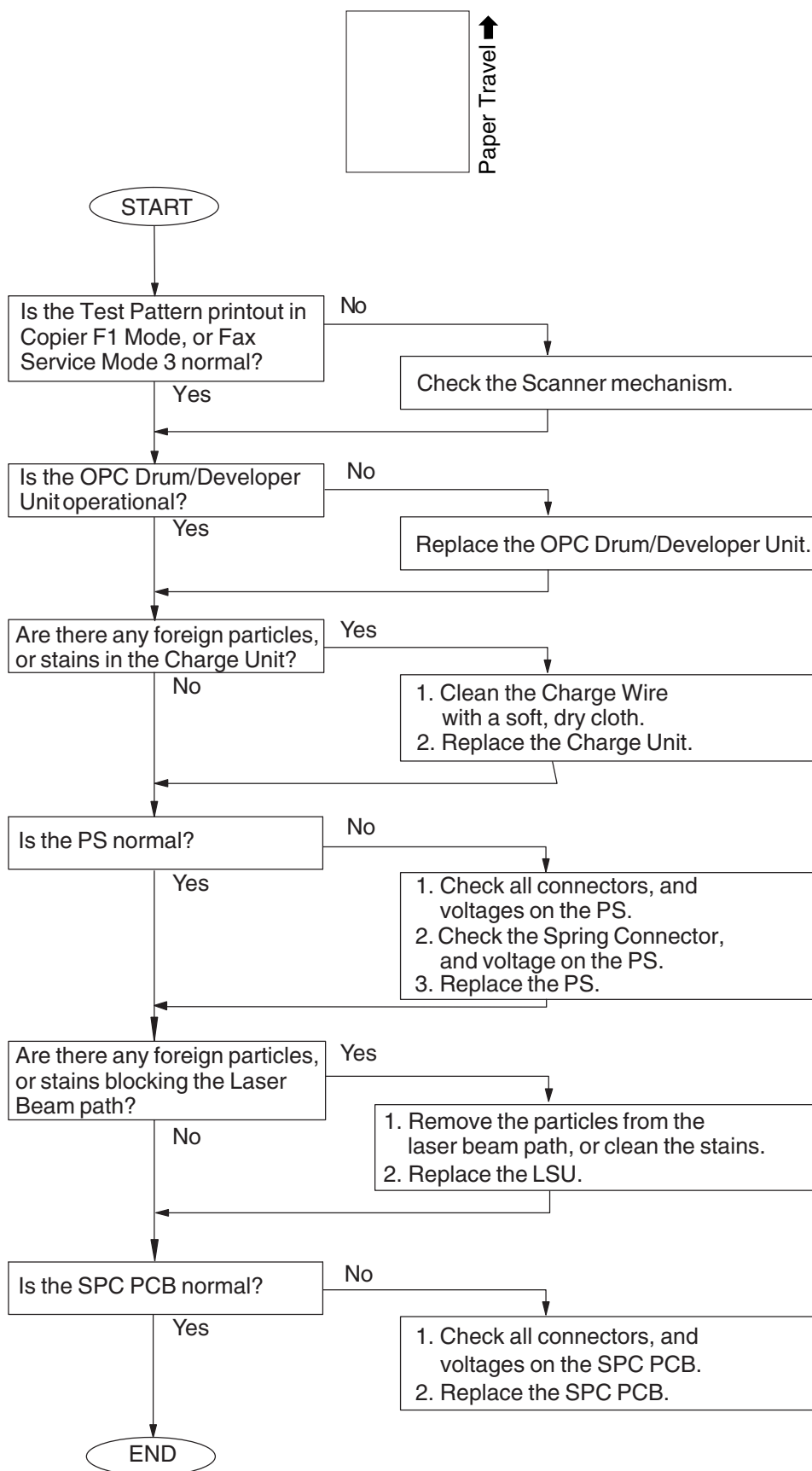

4.3.3. Vertical White Lines

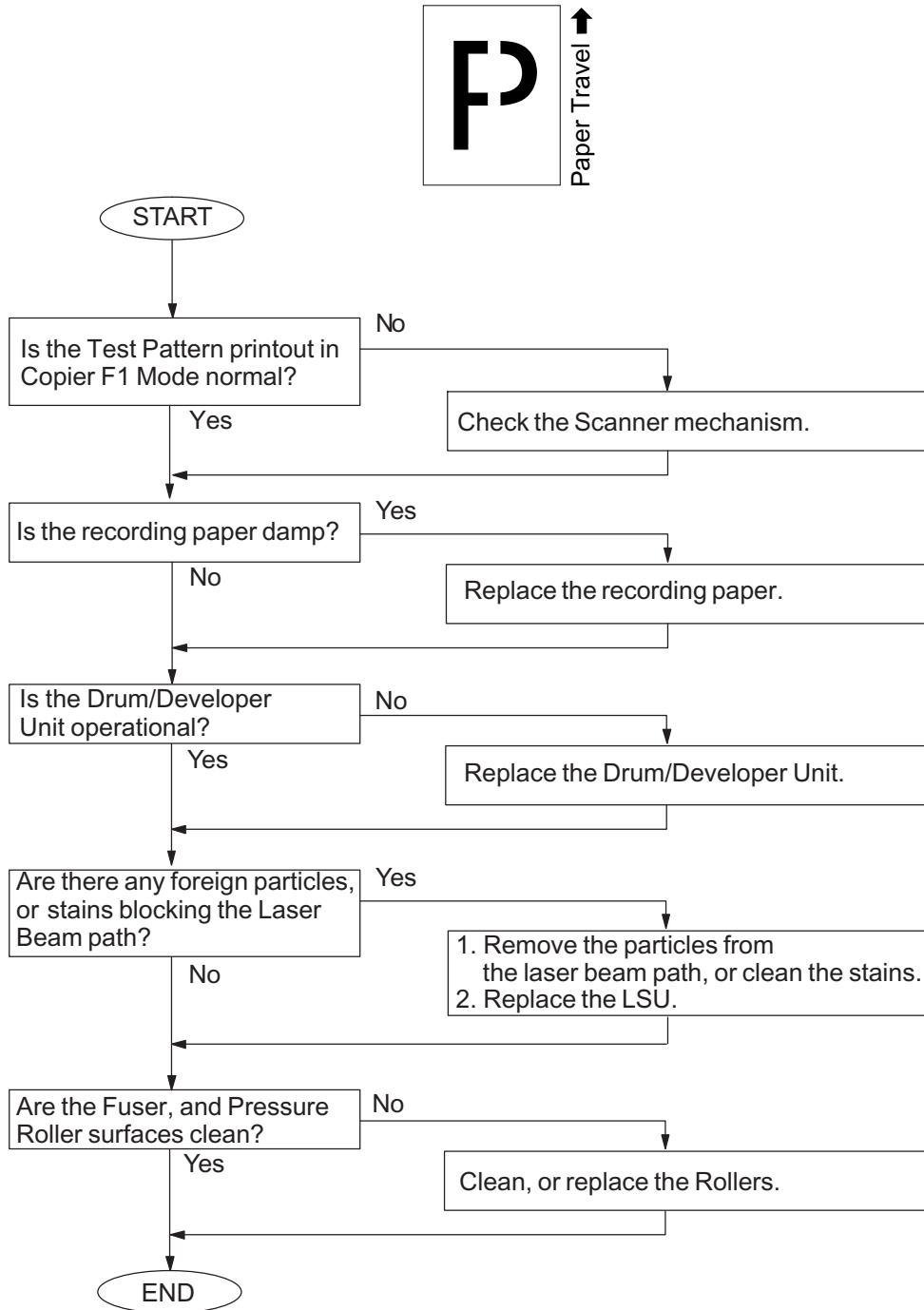

4.3.4. Ghost Images

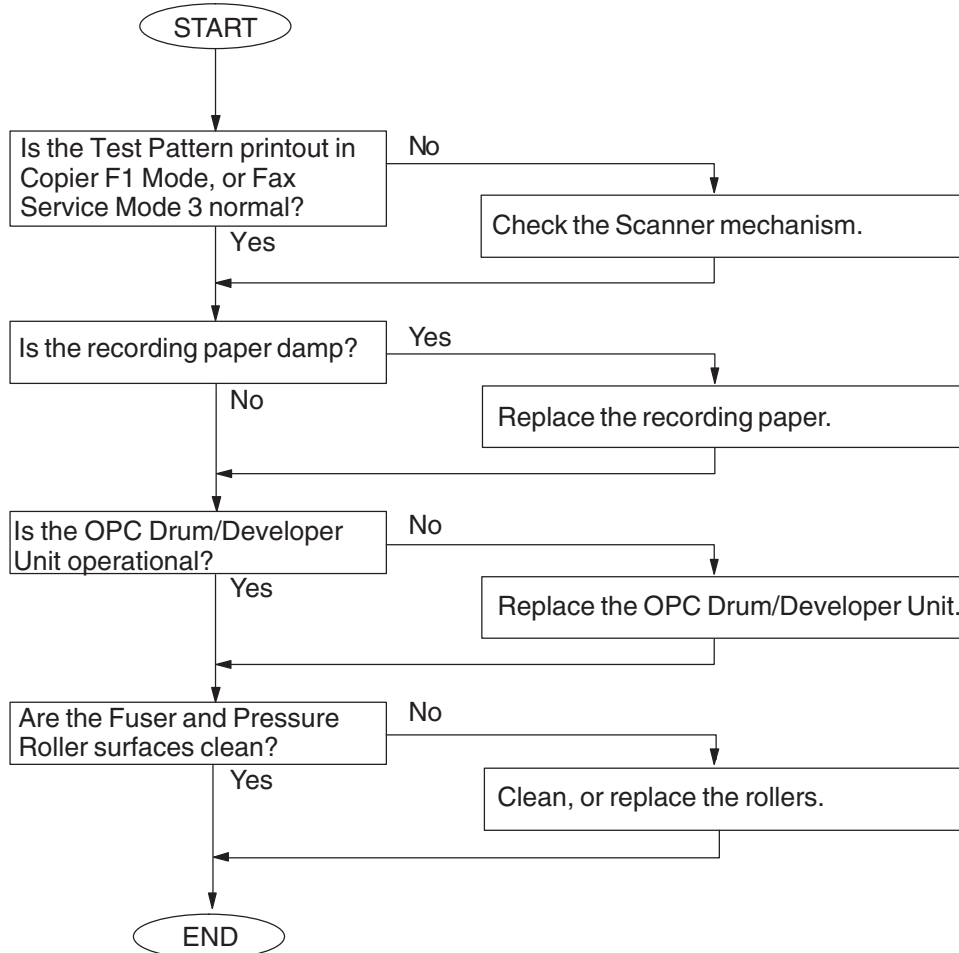
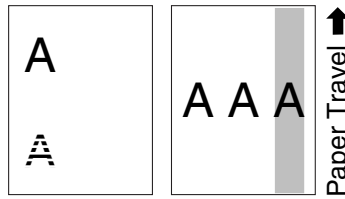

4.3.5. Vertical Dark Lines

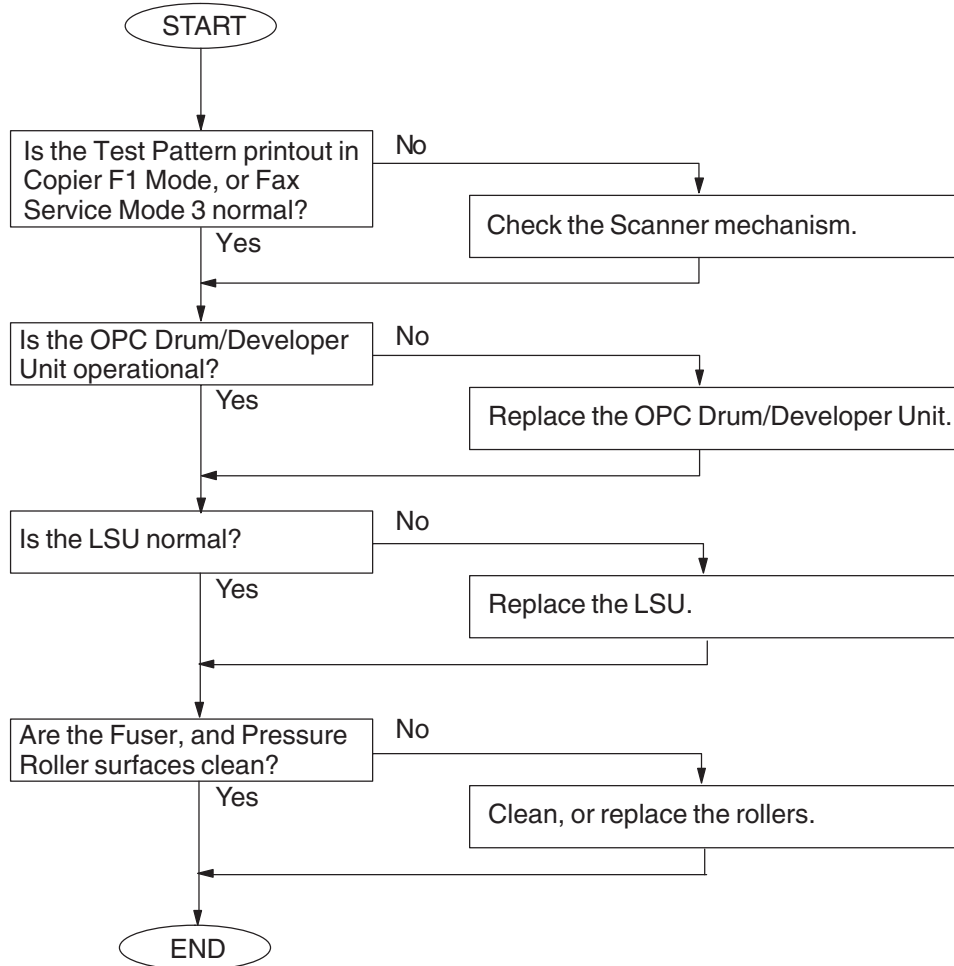
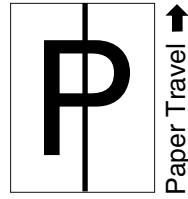

4.3.6. Horizontal Dark Lines

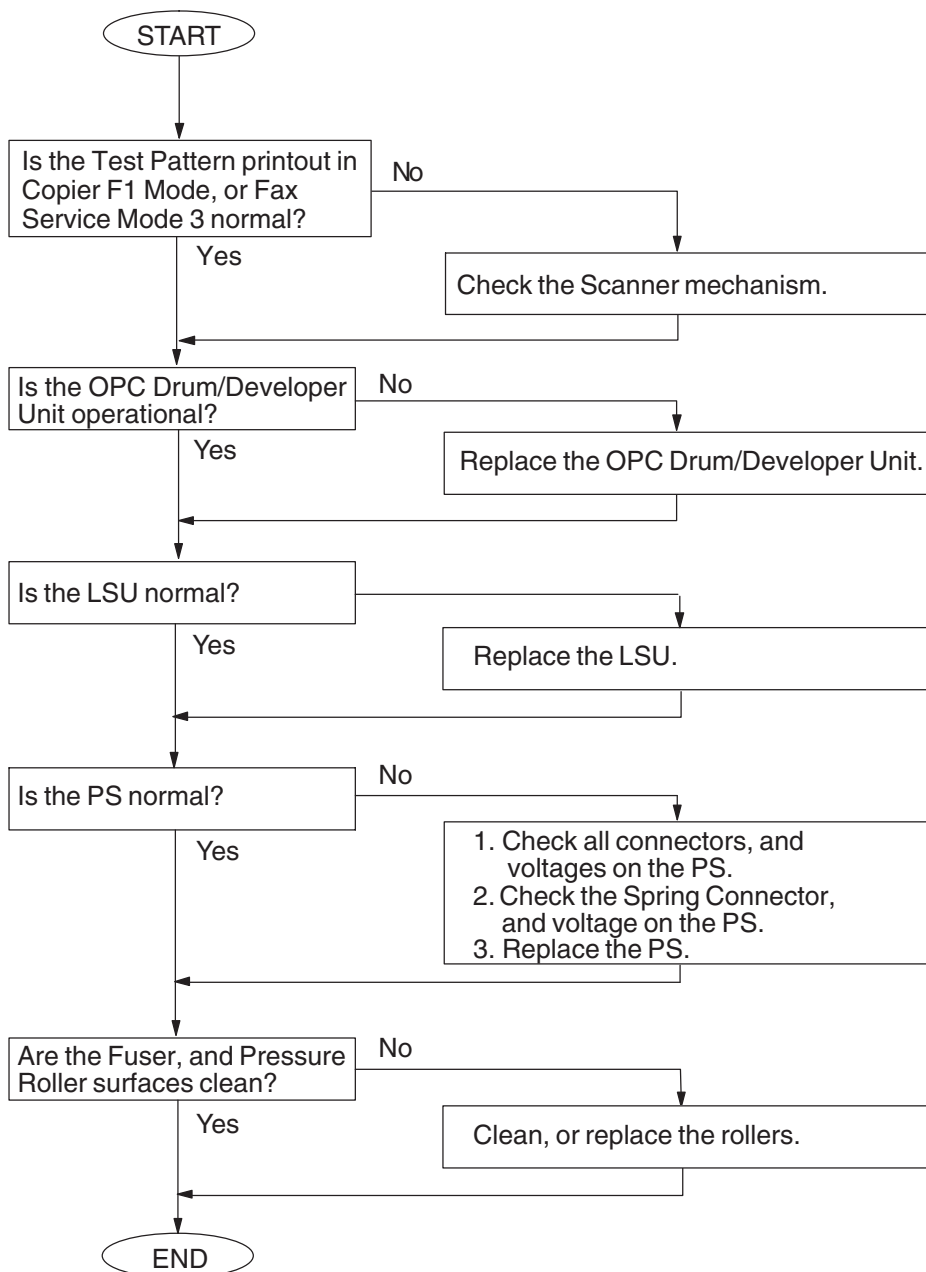
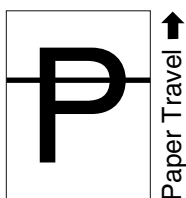

4.3.7. Dark Background

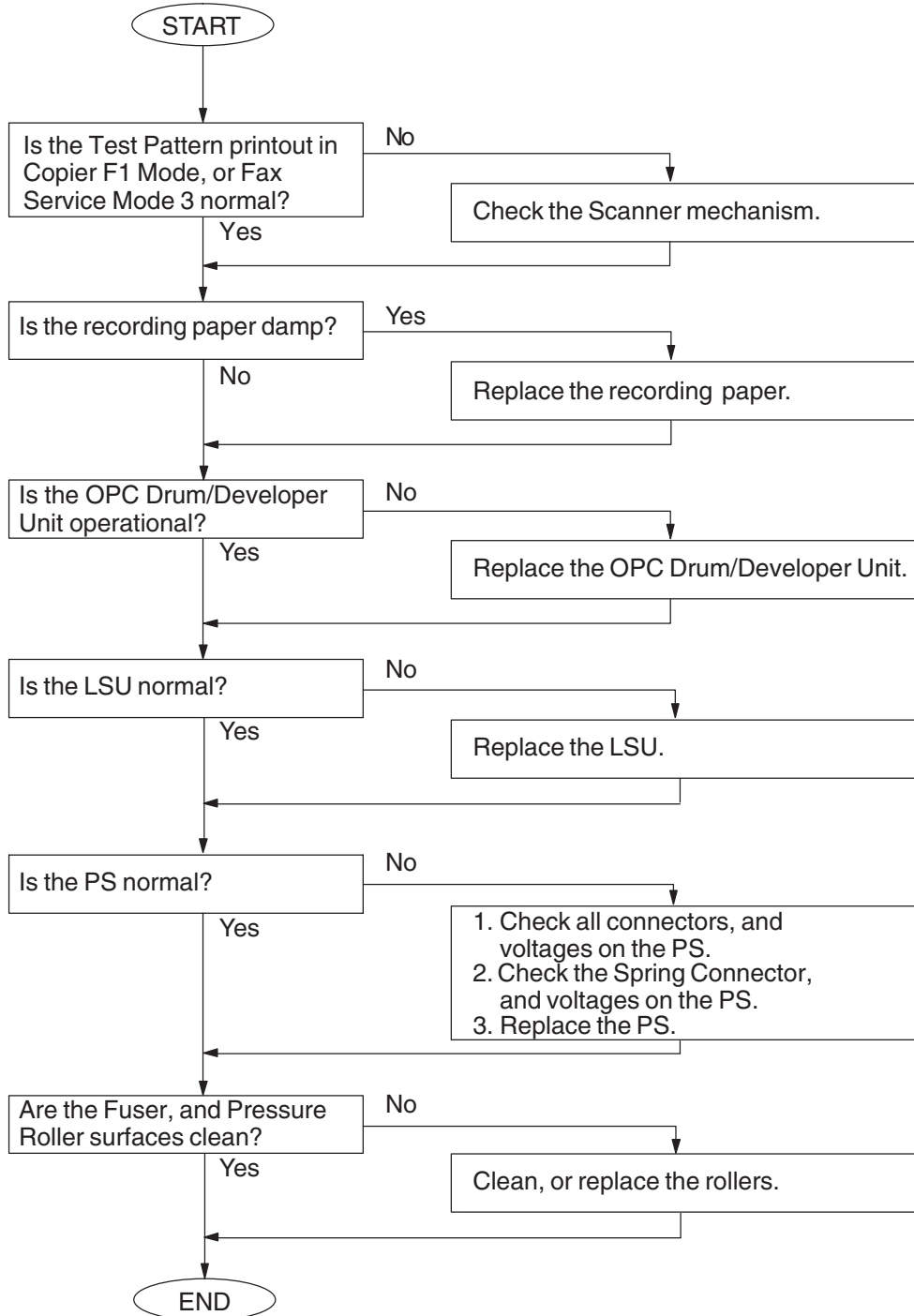
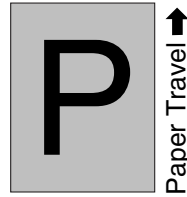

4.3.8. Light Print

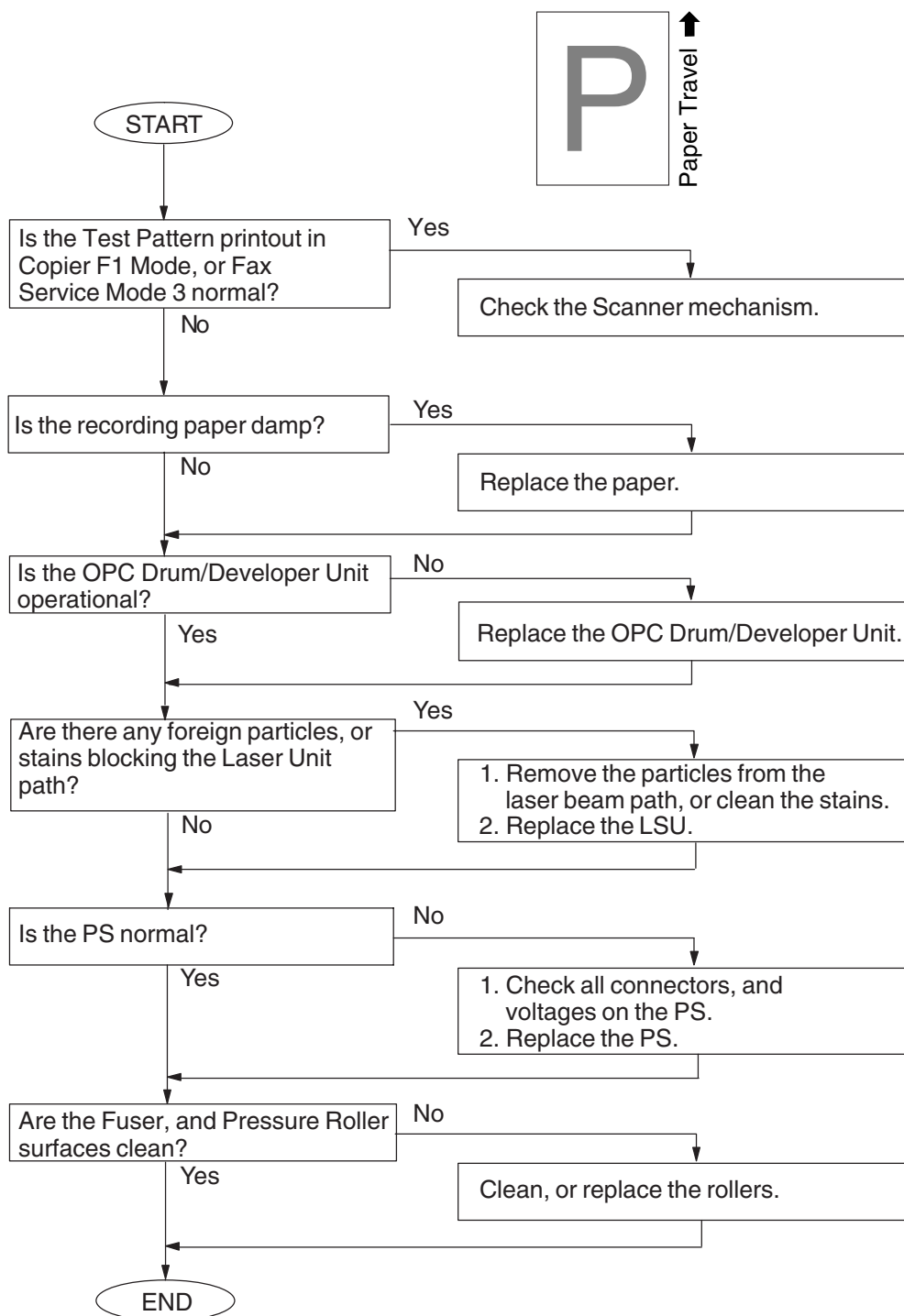

4.3.9. Horizontal White Lines

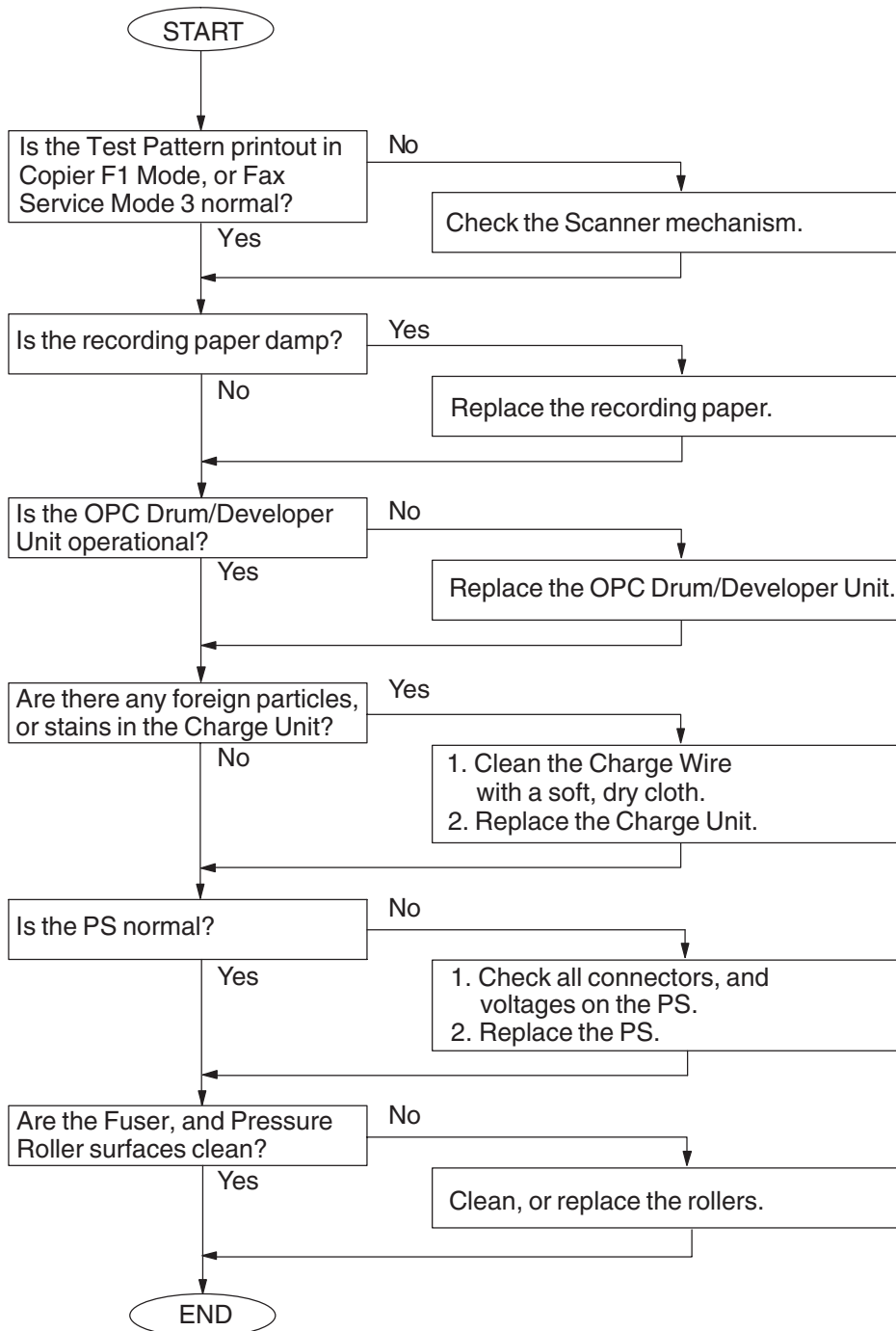
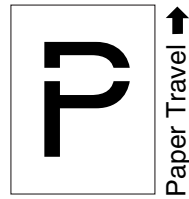

4.3.10. Improper Fusing (Printed image does not bond to the paper)

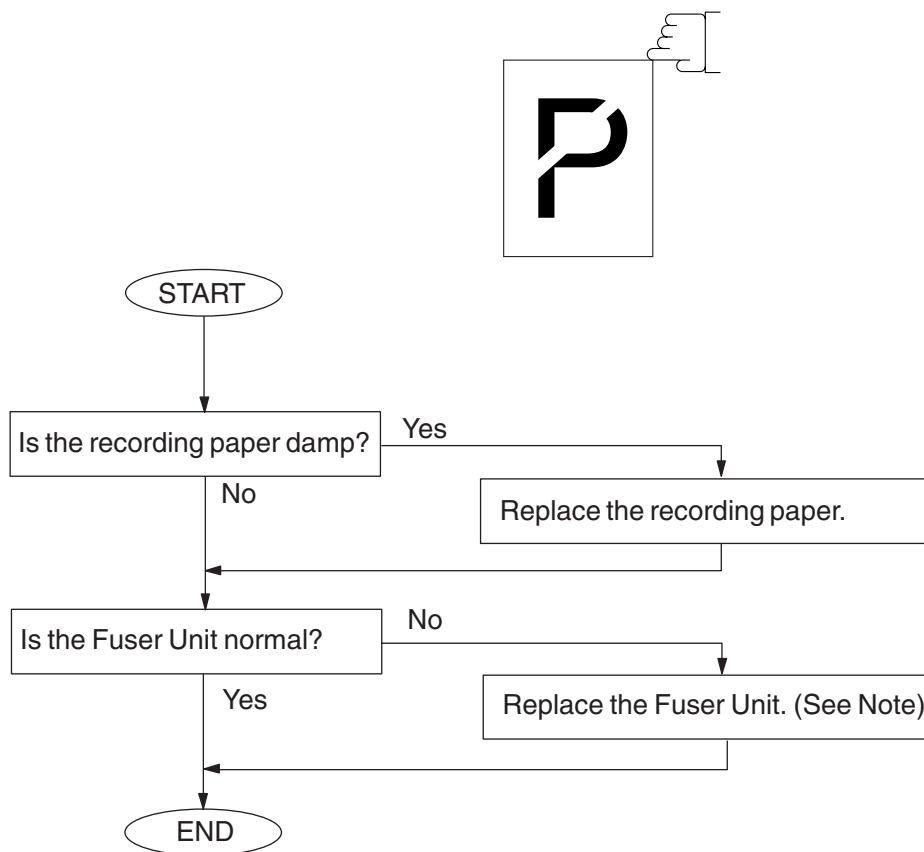
**Note:**

Replace the entire Fuser Unit when the Thermostat and/or the Thermistor fail (open-circuit).

4.3.11. Voids in Solid Areas

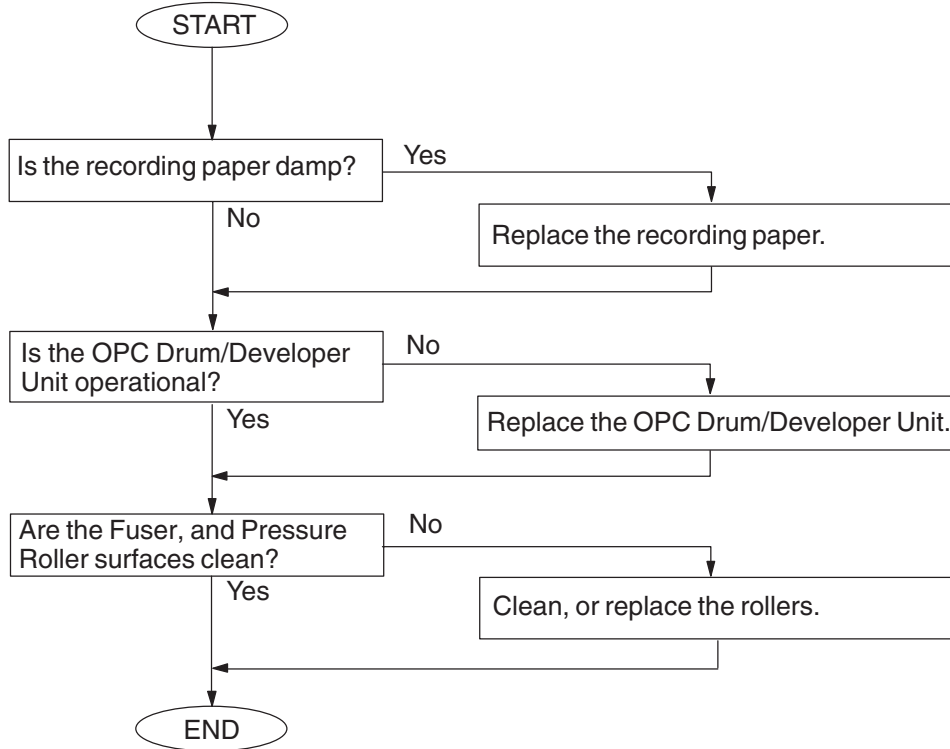
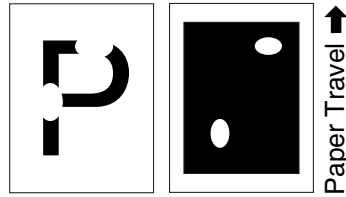

4.3.12. Black Dots

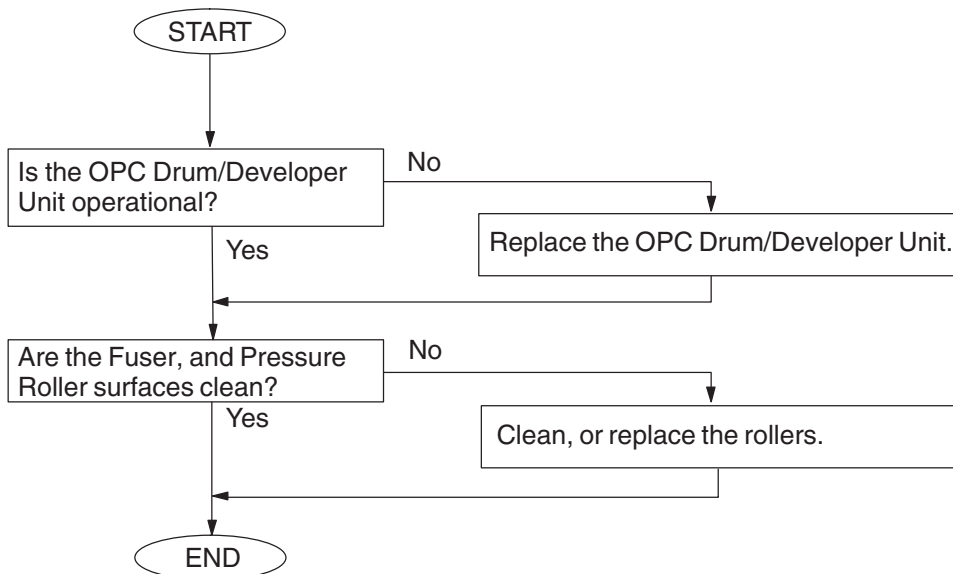
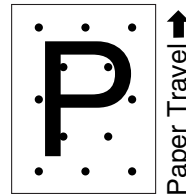

4.3.13. Recording Paper Creases

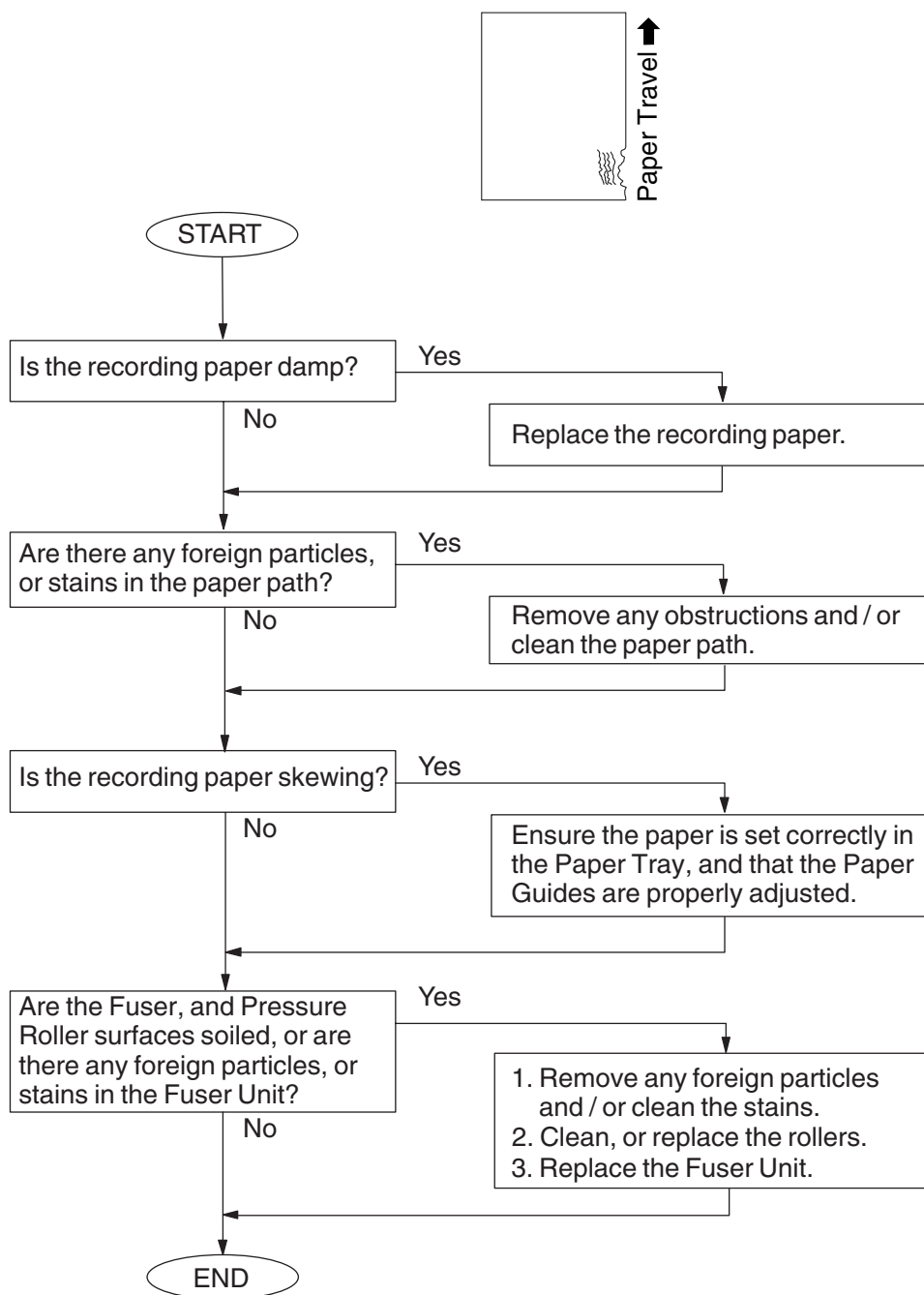

4.3.14. Poor Printed Copy Quality

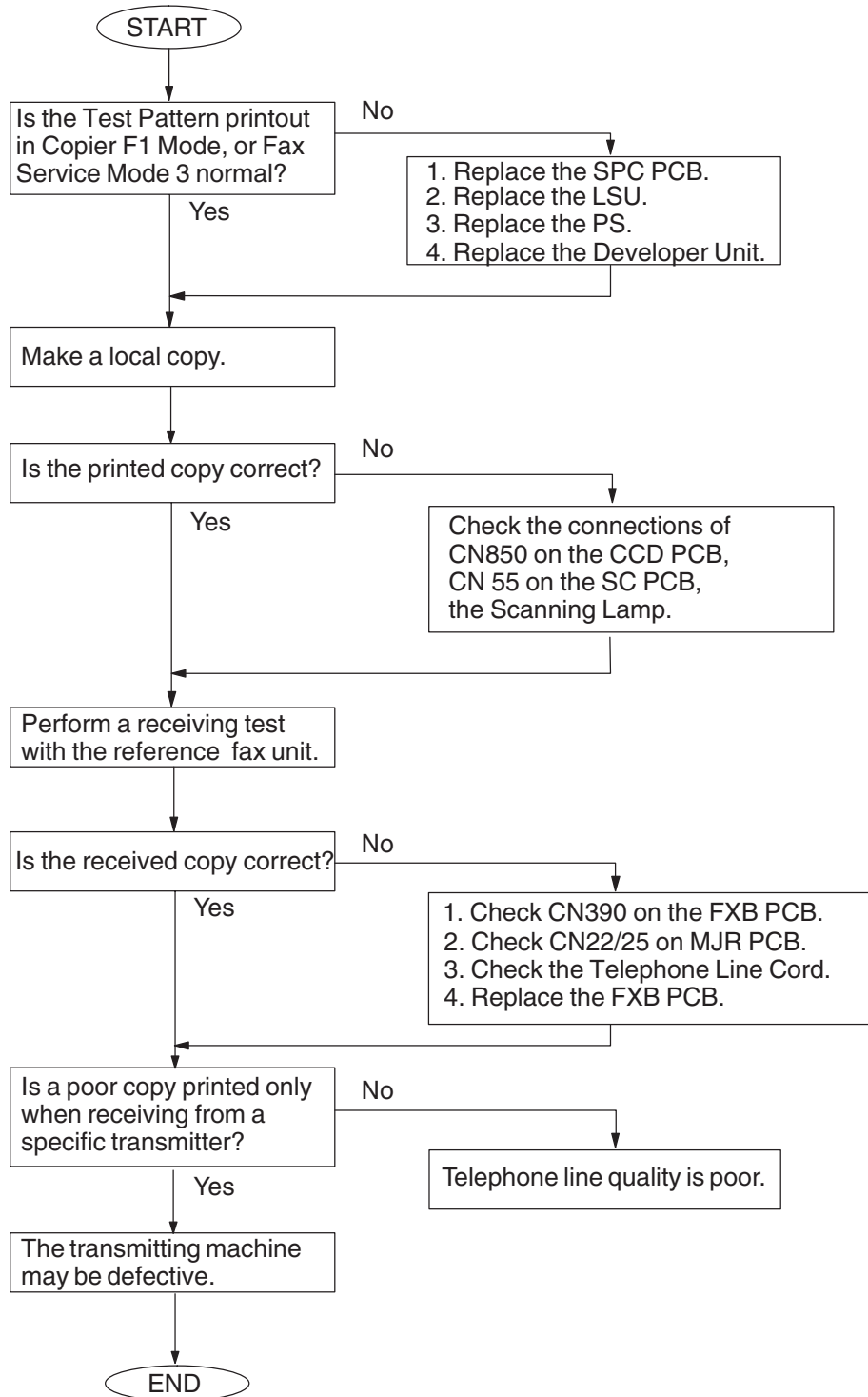

4.3.15. Document Skewing

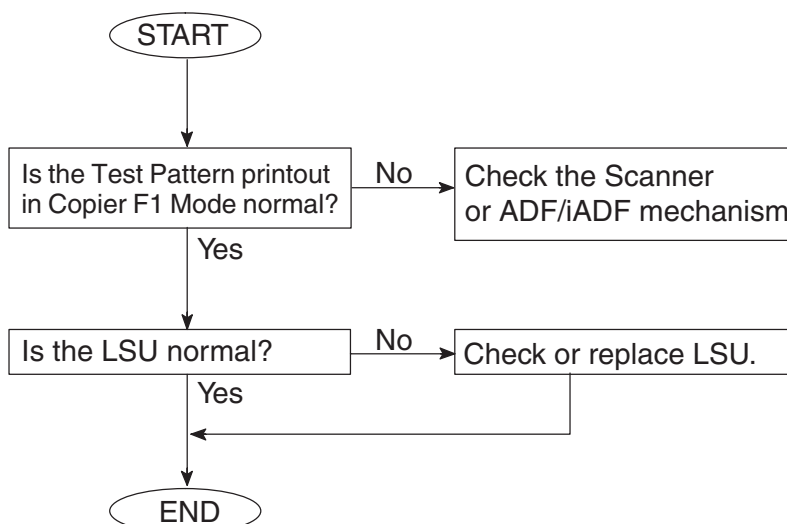
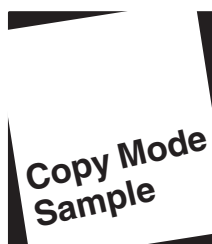

4.3.15.1. LSU Skew Adjustment

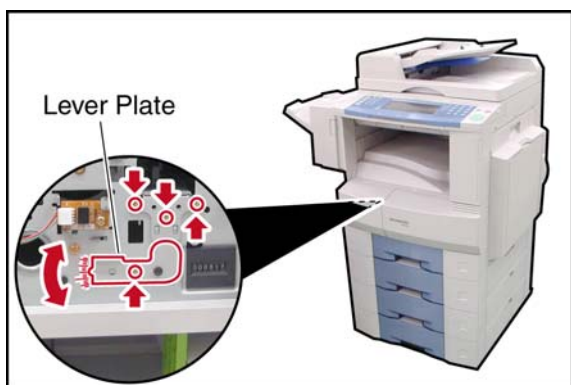

- (1) Open the Front Cover and the Right Cover.
- (2) Slide the Process Unit out. (Refer to 2.2.4.)

Caution:

Exercise caution not to scratch the surface of the **OPC Drum** (Green), and not to touch it with bare hands.

- (3) Remove the Front Left Cover. (Refer to 2.2.10.)
- (4) Loosen 4 Red Screws.

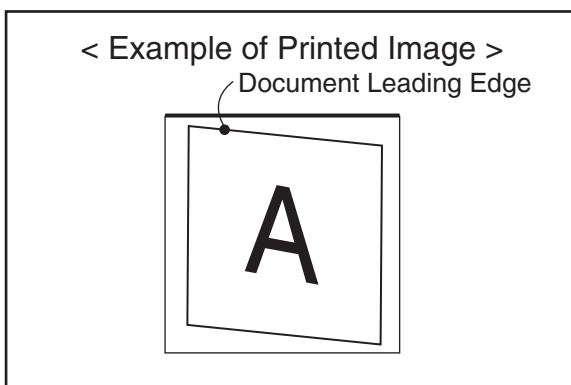

Adjust the Lever Plate downwards and recheck the Document Skewing. Readjust as needed.

One scale adjusts the skewed image by approximately 0.01 mm.

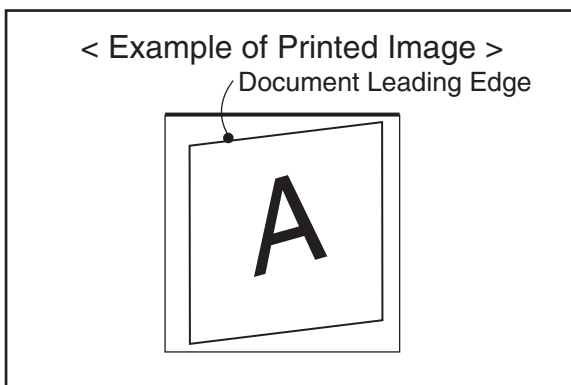

Adjust the Lever Plate upwards and recheck the Document Skewing. Readjust as needed.

4.3.16. Abnormal Printing

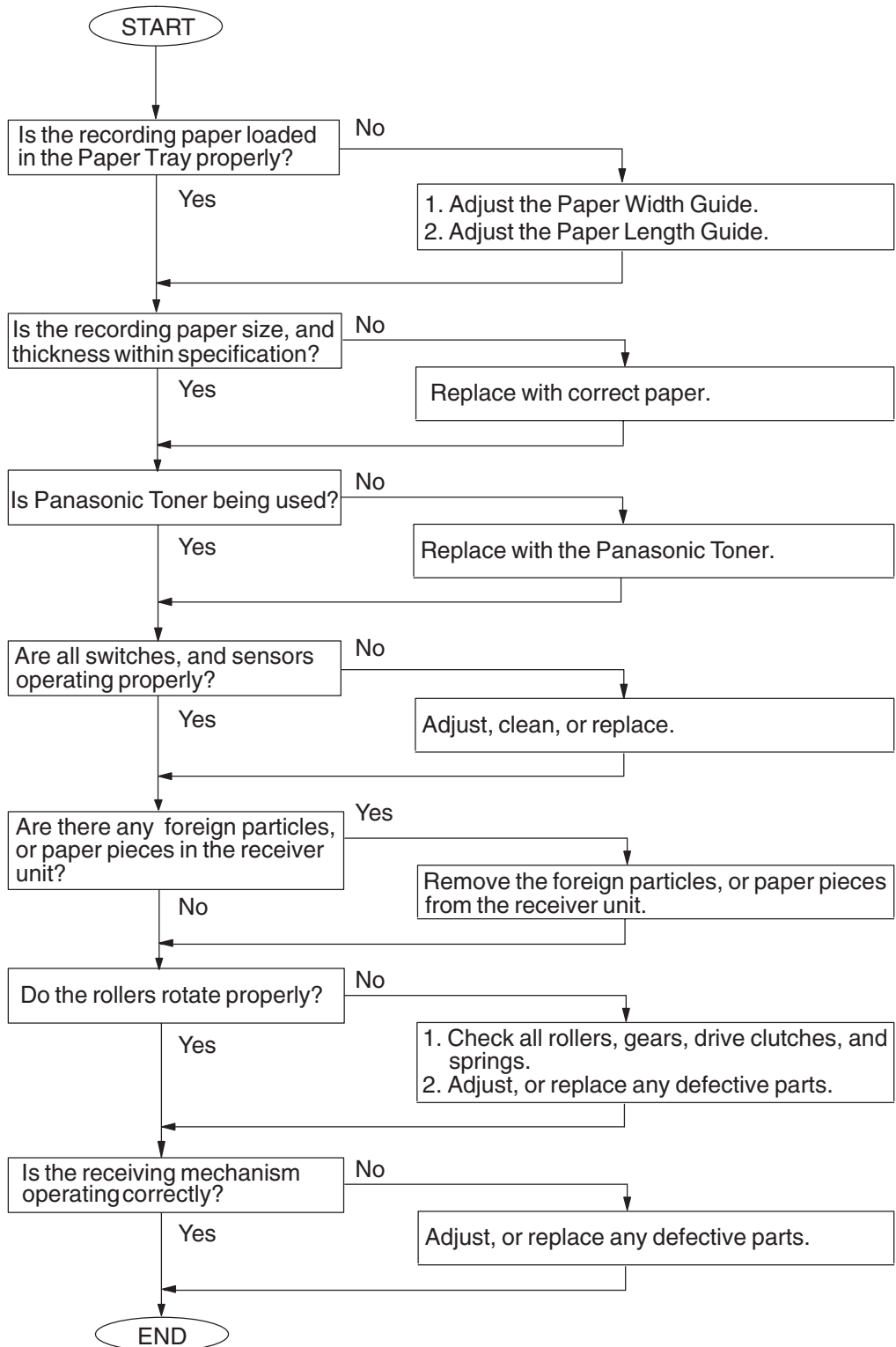

4.3.17. Scanned Copy Quality Problems

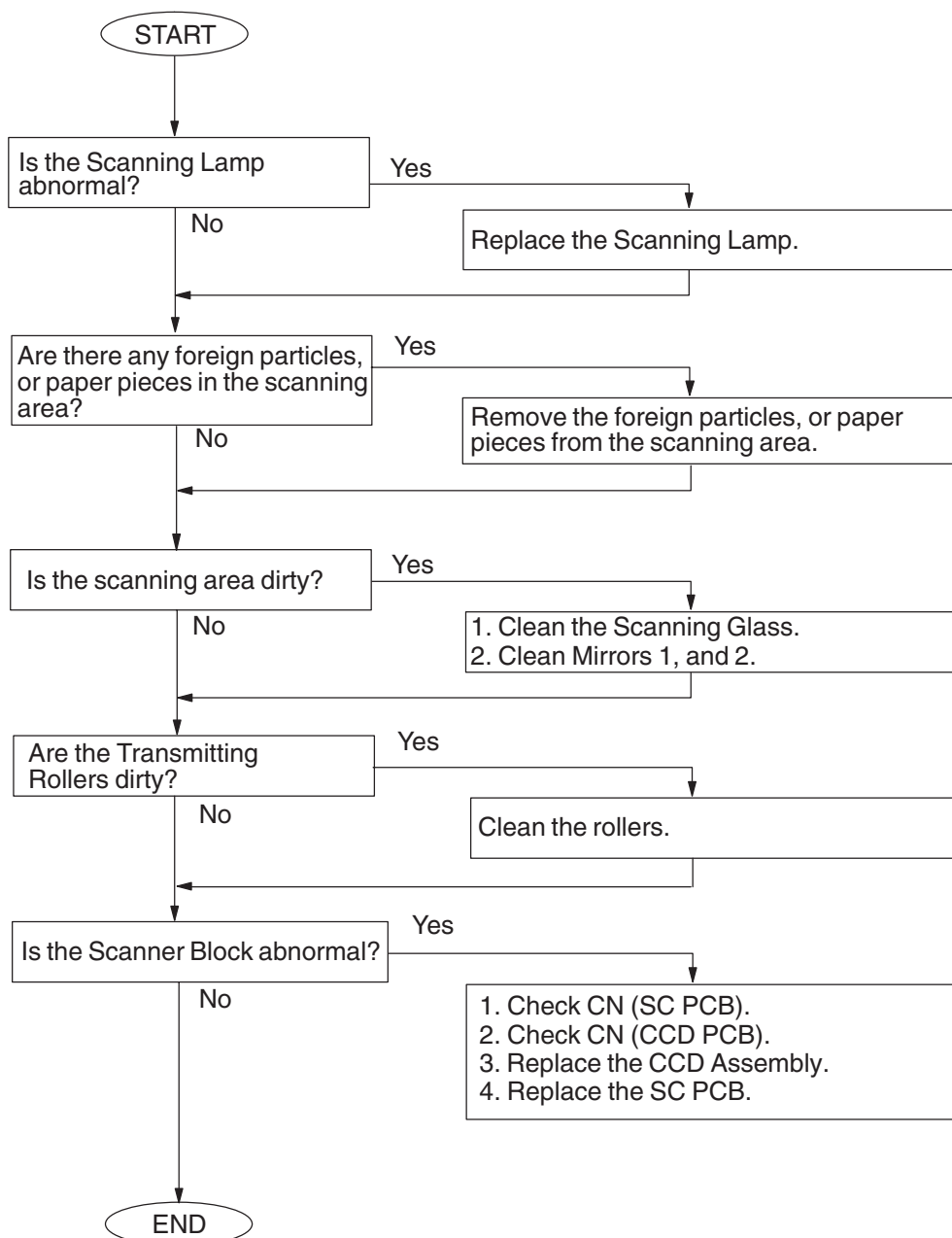

4.3.18. Print Skew Adjustment for Platen Glass Scanning

Follow the procedures below to adjust for the skewing when scanning original(s) from the Platen Glass.

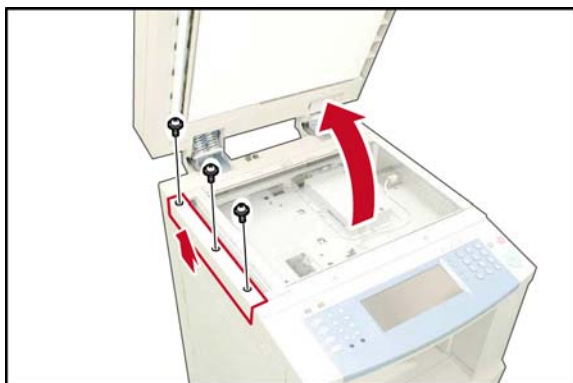

- (1) Make sure that the Scanner Unit is in the Standby Mode.
- (2) Remove 3 Screws and the Left Platen Cover.

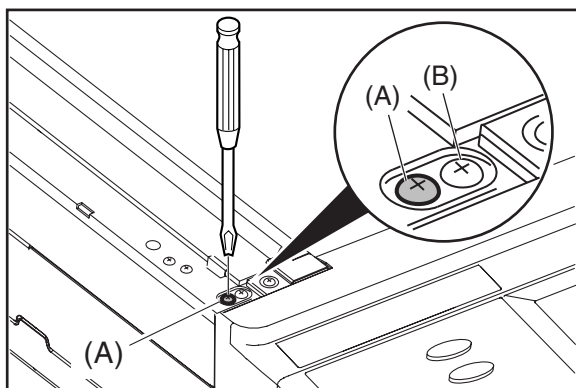

- (3) Loosen the Left Screw (A).

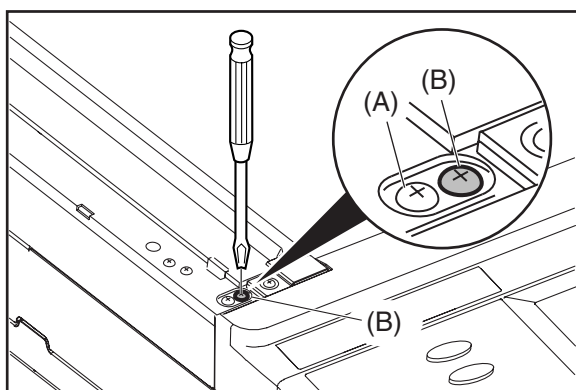

- (4) Adjust the Right Screw (B) to correct for the skew of the leading edge of the document.

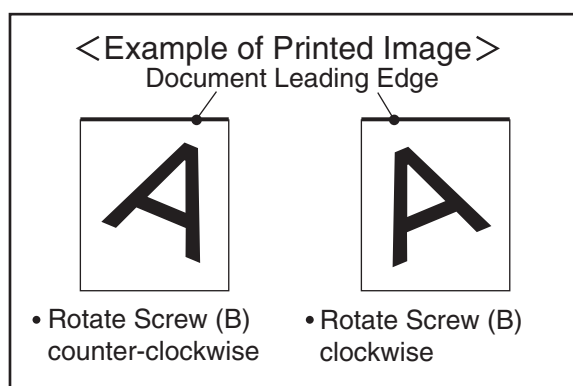

<Direction of Rotation and Skew Adjustment Amount>

- Counter-clockwise → When the printed image is skewed to the right side.
- Clockwise → When the printed image is skewed to the left side.
- Rotation and amount of movement → One rotation of the screw, adjusts the skewed image by approximately 1 mm.

Note:

Do not rotate 2-3 turns at once to avoid other problems.

- (5) Make a copy to confirm the correction.
- (6) Perform the Service Mode F6-03 to adjust the Top field, if necessary.
- (7) Tighten Screw (A) and reinstall the Left Platen Cover.

4.4. Document Feeder (ADF)

4.4.1. No Document Feed

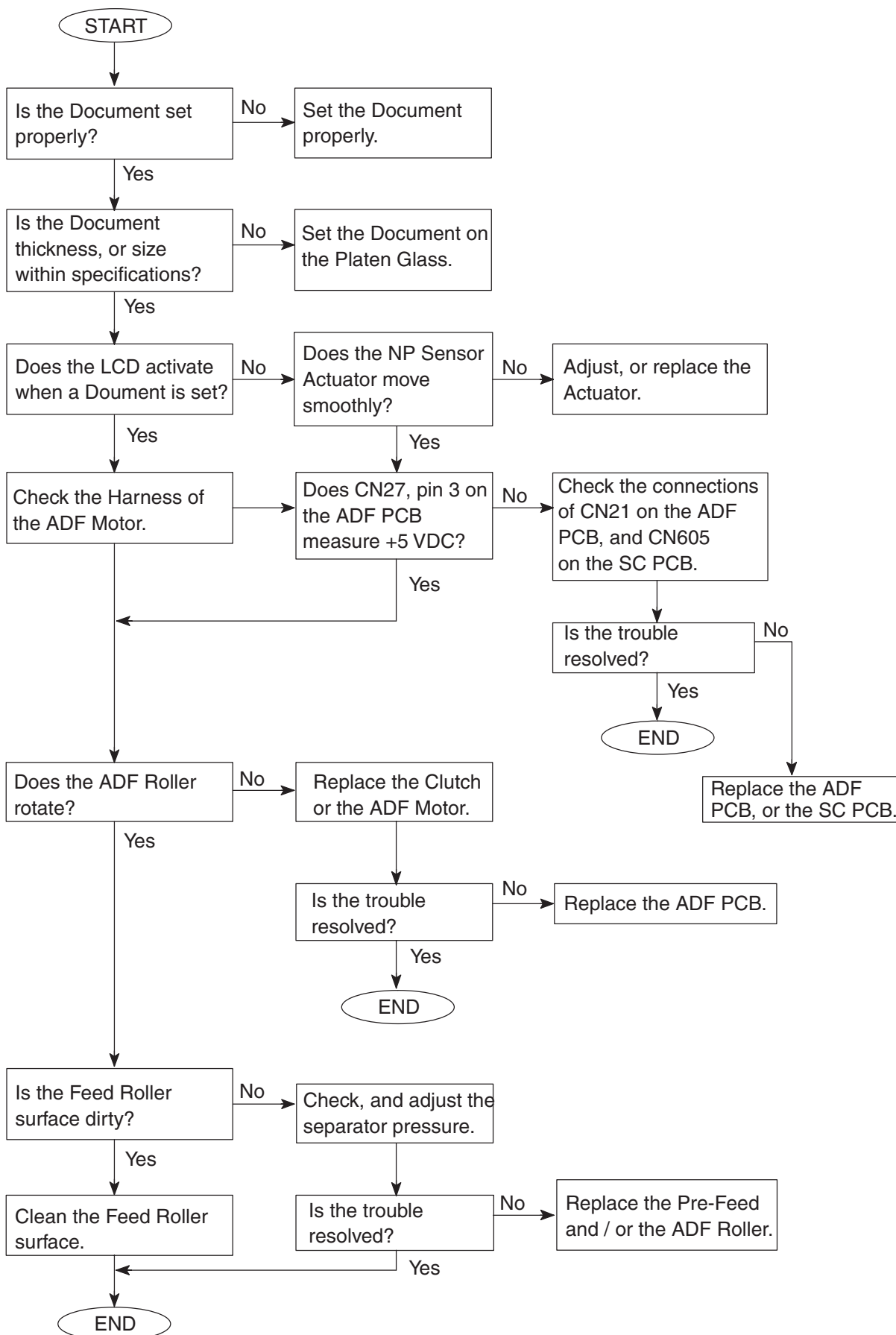

4.4.2. Document Jam

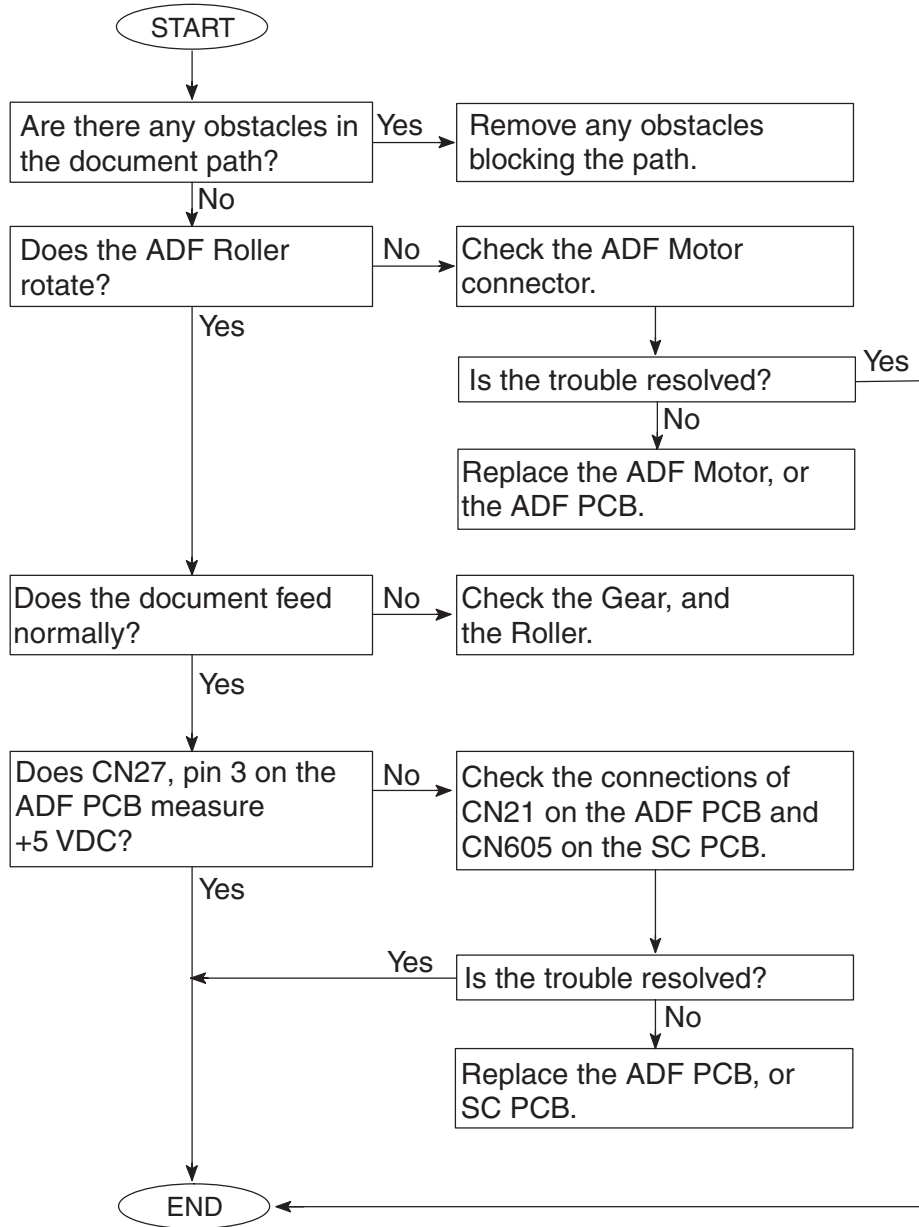

4.4.3. Document Skew

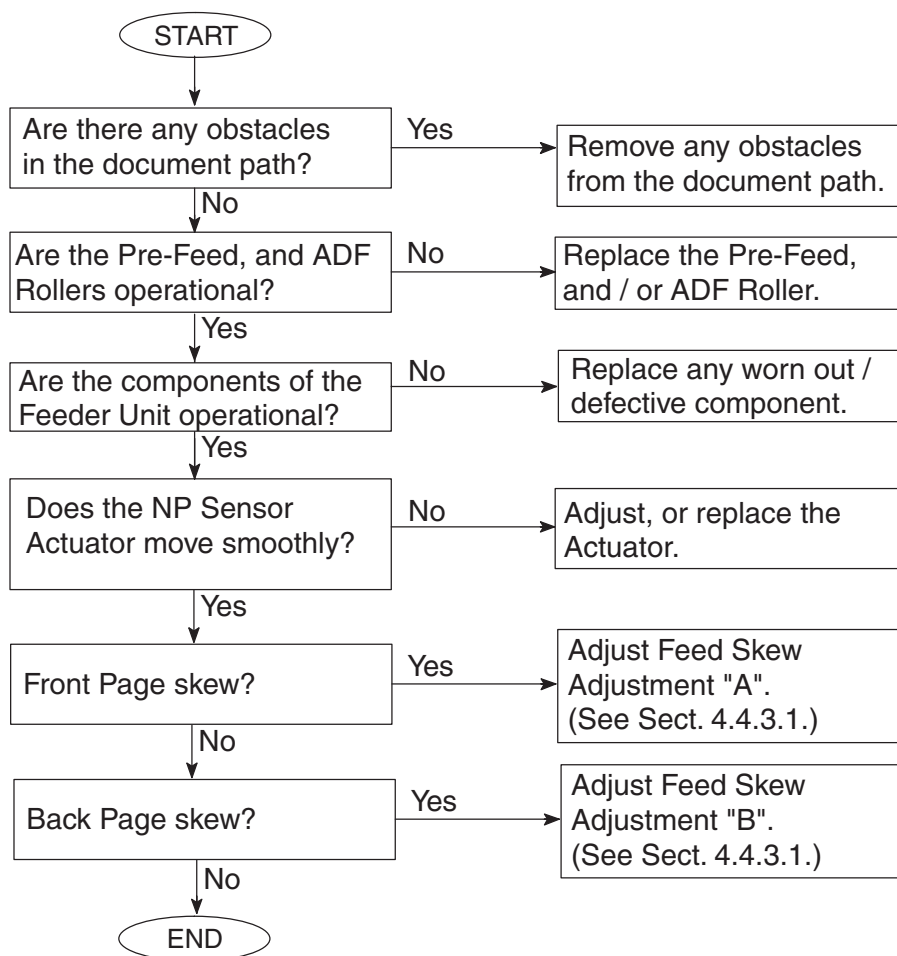

4.4.3.1. ADF / i-ADF Feed Skew Adjustment

Pinch Roller (1838)
(Feed Skew Adjustment "A")

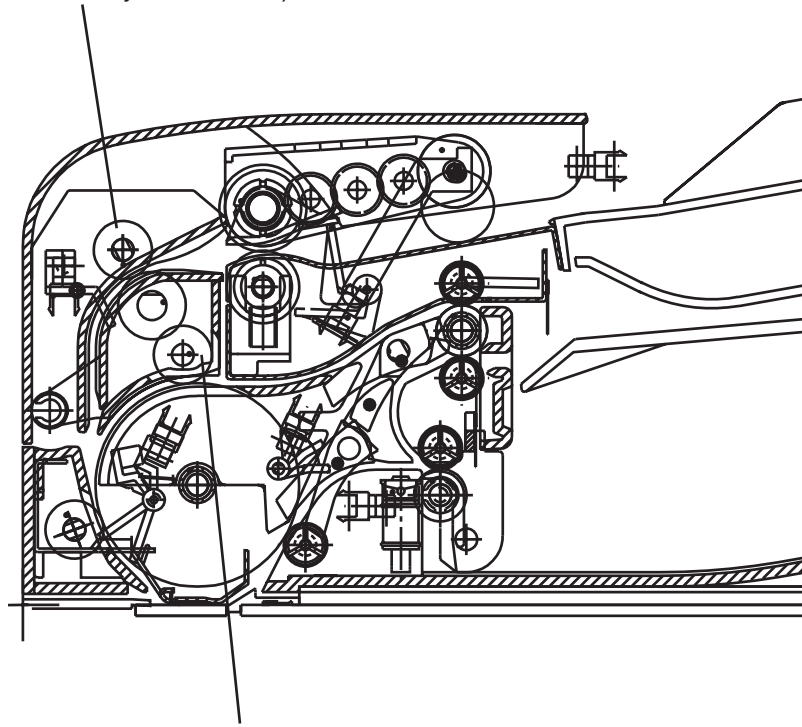

Pinch Roller (1838)
(Reverse Registration, or Feed Skew Adjustment "B")

1. Front Page Skew Adjustment

Using a lined original (about 20 lb (80 g/m²) weight paper), make a copy from the ADF / i-ADF to check for feeding alignment.

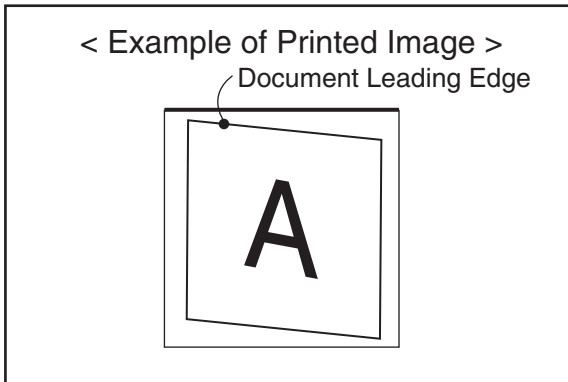

Adjust the Feed Skew Adjustment "A" downwards and recheck the feeding alignment. Readjust as needed.

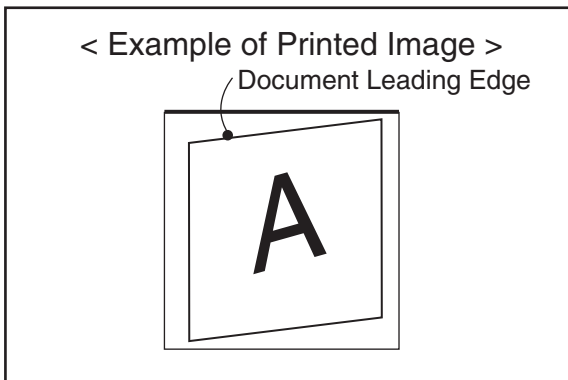

Adjust the Feed Skew Adjustment "A" upwards and recheck the feeding alignment. Readjust as needed.

2. Back Page Skew Adjustment (i-ADF Only)

Using a lined original (about 20 lb (80 g/m²) weight paper), make a copy from the i-ADF to check for feeding alignment.

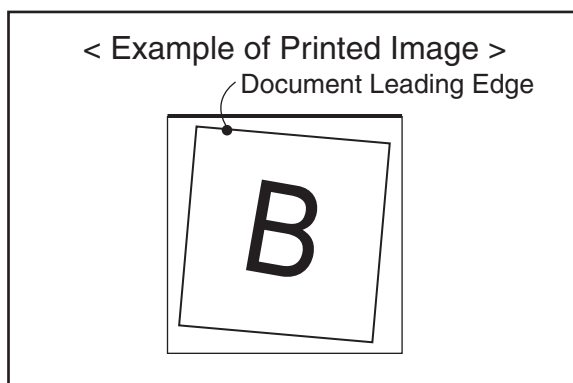

Adjust the Feed Skew Adjustment "B" downwards and recheck the feeding alignment. Readjust as needed.

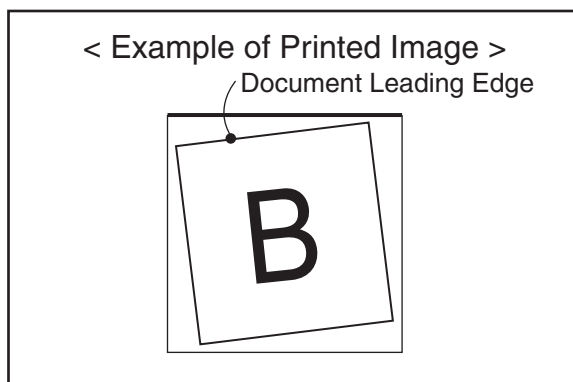

Adjust the Feed Skew Adjustment "B" upwards and recheck the feeding alignment. Readjust as needed.

4.4.4. ADF / i-ADF Free Stop Adjustment

Follow the procedure below to adjust the Free Stop function, if necessary.

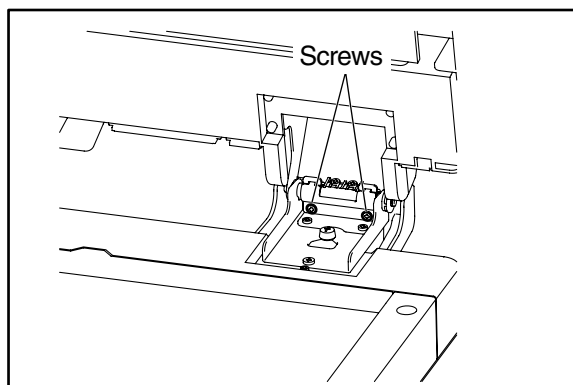

Fasten 2 Adjusting Screws on the Right Hinge.
The Adjustment should be performed by 1/4 turn while checking the Free Stop.
Make sure that the rotation values of both Adjusting Screws are the same.

4.5. Troubleshooting the LAN Interface

4.5.1. Checking Network Configuration

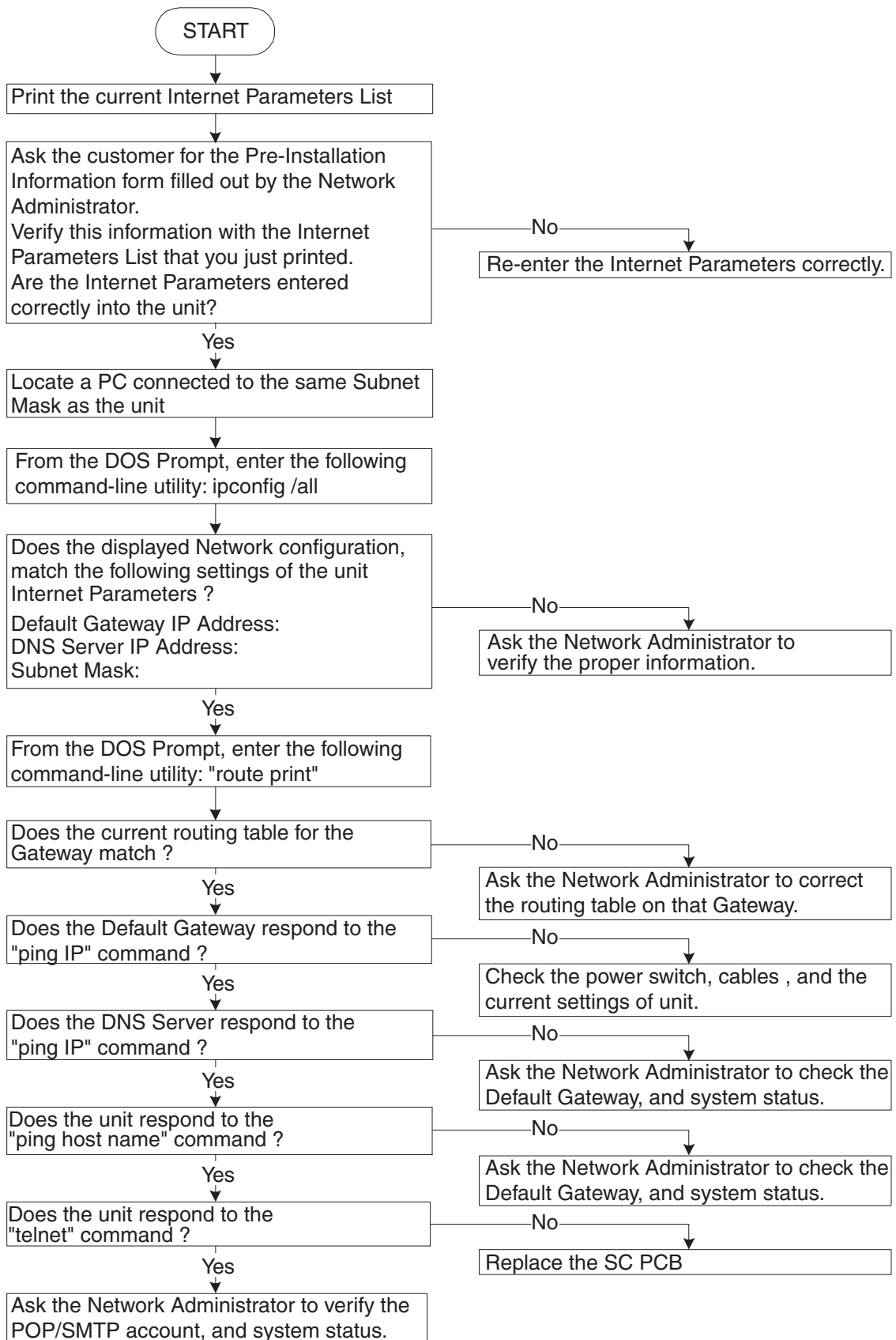

4.5.2. Testing the TCP/IP Network

It is beyond the scope of this Service Manual to cover Networking in detail, there are many excellent manuals on this subject, but we hope the information in this section will aid with your troubleshooting efforts. In most cases, the Network Administrator will be able to provide you with needed information or assistance. When encountering Network problems during an onsite service call or during the installation stage, try to isolate the steps that are not being completed so that you can quickly locate the components that don't work. It is best to organize your troubleshooting efforts by understanding what should be happening, then you can trace the path and see where the problem is occurring.

In our case, we use TCP/IP for transportation of data from one system to another, which involves a whole series of events occurring throughout a number of different layers.

As with all networking, TCP/IP works better when its plugged in, therefore, start your troubleshooting by checking the Physical Connectivity first, the cable(s).

In our examples, we'll use several simple tools readily available in the DOS command-line utility for troubleshooting. There are many other utilities available for checking more detailed information, some are Free of charge, others are available for a nominal fee.

1. System Diagram Model

Ask the customer to provide you with the Pre-Installation Information form, that was filled out by the Network Administrator.

A description or system diagram for the unit, including its physical address, email server and DNS server is required.

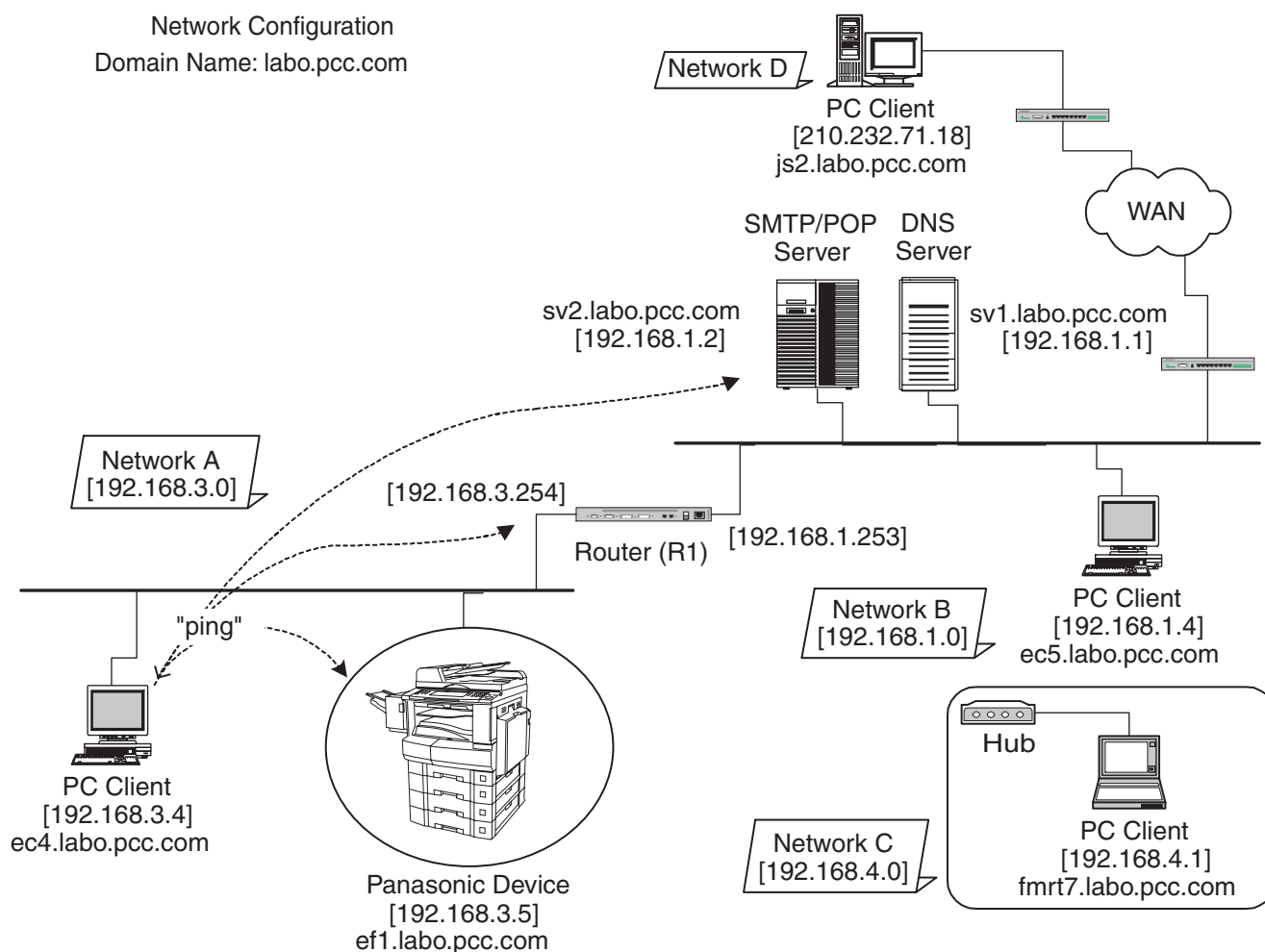

2. Checking Current Configuration

Print the current unit Internet Parameters configuration.

Locate a PC connected to the same Subnet Mask as the unit, then from the DOS Prompt, type the following command-line utility: "**ipconfig /all**" for Windows 98/Me/2000/NT/XP.

Verify that the displayed Network configuration on the PC, matches the following Internet Parameter

settings of the unit:

Default Gateway IP Address:

DNS Server IP Address:

Subnet Mask: (whether it is valid)

For Windows 98 / Me / 2000 / NT / XP

The following example shows the output after you type "ipconfig /all" at a command prompt:

```
C:\>ipconfig /all
Windows NT IP Configuration

    Host Name . . . . . : ec4.labo.pcc.com
    DNS Servers . . . . . : 192.168.1.1
    Node Type . . . . . : Hybrid
    NetBIOS Scope ID . . . . . :
    IP Routing Enabled. . . . . : No
    WINS Proxy Enabled . . . . . : No
    NetBIOS Resolution Uses DNS . . . : No

    Ethernet adapter IBMFE1 . . . . . :
    Description . . . . . : IBM 100/10 EtherJet PCI Adapter

    Physical Address . . . . . : 00-04-AC-EE-9C-E8
    DHCP Enabled . . . . . : No
    IP Address . . . . . : 192.168.3.4
    Subnet Mask . . . . . : 255.255.255.0
    Default Gateway . . . . . : 192.168.3.254
    Primary WINS Server . . . . . : 192.168.3.18
```

From the above examples, you know the Network configuration for the specified Subnet Mask is as follows: IP Address: 192.168.3.4; Subnet Mask: 255.255.255.0; Default Gateway (Default Router IP Address): 192.168.3.254; DNS Server: 192.168.1.1 and the Domain Name: labo.pcc.com (obtained from the Host Name).

3. Using "PING" to Test Physical Connectivity

The Packet Internet Groper (PING) is a command-line tool included with every Microsoft TCP/IP client (any DOS or Windows client with the TCP/IP protocol installed). PING is a simple utility that is used to send a test packet to a specified IP Address or Hostname, then, if everything is working properly, the packet is echoed back (returned).

Sample command-line PINGing and parameters are shown below. There are several available options that can be specified with the PING command. However, for our examples, we will use two options (-n and -w) which are commonly used when the response from the destination location is too long.

- n *count* : The number of echo requests that the command should send. The default is four.
- w *timeout* : Specifies the period PING will wait for the reply before deciding that the host is not responding.

PINGing the Unit

```
C:\WINDOWS>ping ef1.labo.pcc.com
Pinging ef1.labo.pcc.com [192.168.3.5] with 32 bytes of data:
Reply from 192.168.3.5: bytes=32 time=5ms TTL=253
Reply from 192.168.3.5: bytes=32 time=4ms TTL=253
Reply from 192.168.3.5: bytes=32 time=4ms TTL=253
Reply from 192.168.3.5: bytes=32 time=4ms TTL=253
```

PINGing the Default Gateway (Default Router IP Address)

```
C:\WINDOWS>ping 192.168.3.254
Pinging 192.168.3.254 with 32 bytes of data:
Reply from 192.168.3.254: bytes=32 time=5ms TTL=253
Reply from 192.168.3.254: bytes=32 time=4ms TTL=253
Reply from 192.168.3.254: bytes=32 time=4ms TTL=253
Reply from 192.168.3.254: bytes=32 time=4ms TTL=253
```

PINGing the SMTP/POP Server

```
C:\WINDOWS>ping sv2.labo.pcc.com
Pinging sv2.labo.pcc.com [192.168.1.2] with 32 bytes of data:
Reply from 192.168.1.2: bytes=32 time=5ms TTL=253
Reply from 192.168.1.2: bytes=32 time=5ms TTL=253
Reply from 192.168.1.2: bytes=32 time=5ms TTL=253
Reply from 192.168.1.2: bytes=32 time=5ms TTL=253
```

If for some reason, the physical connection is missing, the echo reply will not be received from the destination and the following output is displayed:

```
C:\WINDOWS>ping fmrt7.labo.pcc.com
Pinging fmrt7.labo.pcc.com [192.168.4.1] with 32 bytes of data:
Request timed out.
Request timed out.
Request timed out.
Request timed out.

Ping statistics for 192.168.4.1:
    Packets: Sent = 4, Received = 0, Lost = 4 (100% loss),
    Approximate round trip times in milli-seconds:
        Minimum = 0ms, Maximum = 0ms, Average = 0ms
```

If the physical destination is far and it's connected by WAN (Wide Area Network), the PING option command default value must be changed to compensate for the expected delayed response.

e.g.

- n 10 : The number of echo requests that the command should send.
- w 2000 : Specifies the period PING will wait for the reply before deciding that the host is not responding.

```
C:\WINDOWS>ping js2.labo.pcc.com -n 10 -w 2000
Pinging js2.labo.pcc.com [210.232.71.18] with 32 bytes of data:
Reply from 210.232.71.18: bytes=32 time=633ms TTL=252
Reply from 210.232.71.18: bytes=32 time=645ms TTL=252
Reply from 210.232.71.18: bytes=32 time=810ms TTL=252
Reply from 210.232.71.18: bytes=32 time=455ms TTL=252
Reply from 210.232.71.18: bytes=32 time=645ms TTL=252
Reply from 210.232.71.18: bytes=32 time=633ms TTL=252
Reply from 210.232.71.18: bytes=32 time=677ms TTL=252
Reply from 210.232.71.18: bytes=32 time=703ms TTL=252
Reply from 210.232.71.18: bytes=32 time=633ms TTL=252
Reply from 210.232.71.18: bytes=32 time=633ms TTL=252
```

4. Tracing a Packet Route

Another useful command-line utility is TRACERT, which is used to verify the route a packet takes to reach its destination. The result shows each router crossed and how long it took to get through each particular router to reach the specified destination.

The time it takes to get through a particular router is calculated three times and displayed for each

router hop along with the IP Address of each router crossed. If a FQDN (Fully Qualified Domain Name) is available, it will be displayed as well.

This utility is useful for two diagnostic purposes:

- a. To detect whether a particular router is malfunctioning along a known path. For example, if you know that packets on a network always go through London to get from New York to Berlin, but the communication is failing. A TRACERT to the Berlin address shows all the hops up to the point where the router in London should respond. If it does not respond, the time values are shown with an asterisk (*), indicating the packet timed out.
- b. To determine whether a router is slow and needs to be upgraded or additional routers should be installed on the network. You can determine this by simply comparing the time it takes for a packet to get through a particular router. If its return time is significantly higher than the other routers, it should be upgraded.

To use this utility, from the DOS command-line, type: `tracert <IP Address or Hostname>`

Tracing the Route to SMTP/POP Server

```
C:\WINDOWS>tracert sv2.labo.pcc.com
Tracing route to sv2.labo.pcc.com [192.168.1.2]
over a maximum of 30 hops:
  1  4 ms  2 ms  2 ms  192.168.3.254
  2  4 ms  5 ms  5 ms  sv2.labo.pcc.com [192.168.1.2]
Trace complete.
```

5. Managing Network Route Tables

In the simplest case a router connects two network segments. In this model, the system used to join the two segments needs to know only about these segments.

The routing table for router R1 in this case is simple; the following table shows its key routes:

Network Address	Netmask	Gateway	Interface
192.168.3.0	255.255.255.0	192.168.3.254	192.168.3.254
192.168.1.0	255.255.255.0	192.168.1.253	192.168.1.253

When the Unit at 192.168.3.5 attempts to communicate with the Unit at 192.168.1.x, IP performs the ANDing process to find two things: The local network ID is 192.168.3.0, and the destination network ID is not. This means, that the destination host is not on the local network.

IP, is responsible to find a route to the remote network, and therefore, it consults the routing table. Here, the local host normally determines that the next step in the route is the Default Gateway, and sends the packet to router R1.

The router R1, receives the packet. After determining that the packet is for another host and not the router itself, it checks the routing table. It finds the route to 192.168.1.0 and sends the packet through the interface to the Unit at 192.168.1.x, which receives the packet. This is a simple route that took only a single hop.

When another network is added as the number of hosts grows, it gets complicated, and the systems on the most distant networks cannot communicate. When the router receives a packet in this case, it cannot find a route to the remote network. It then discards the packet and a message indicating "destination host unreachable" is sent to the originator.

Here, is where the ROUTE command-line utility is useful when dealing with more than two networks, and is used by Administrators to statically manage a route table by adding, deleting, changing and clearing the route table. It has a number of options that are used to manipulate the routing tables,

some are shown below:

- MASK

If this switch is present, the next parameter is interpreted as the netmask parameter.

- Netmask

If included, specifies a sub-net mask value to be associated with this route entry. If not specified, it defaults to 255.255.255.255.

- Gateway

Specifies the gateway.

- METRIC

Specifies the metric / cost for the destination.

All symbolic names used for the destination are looked up in the network database file NETWORKS.

The symbolic names for the gateway are looked up the host name database file HOSTS.

When the packet does not reach the specified destination even when the physical connection is properly made, check the registered persistent routes on the same subnet as the Unit by typing "route print" in the DOS command-line. The output display is shown below:

```
C:\WINDOWS>route print
Active Routes:

```

Network Address	Netmask	Gateway Address	Interface	Metric
0.0.0.0	0.0.0.0	192.168.3.254	192.168.3.2	1
127.0.0.0	255.0.0.0	127.0.0.1	127.0.0.1	1
192.168.3.0	255.255.255.0	192.168.3.2	192.168.3.2	1
192.168.3.2	255.255.255.255	127.0.0.1	127.0.0.1	1
192.168.3.255	255.255.255.255	192.168.3.2	192.168.3.2	1
224.0.0.0	224.0.0.0	192.168.3.2	192.168.3.2	1
255.255.255.255	255.255.255.255	192.168.3.2	192.168.3.2	1

6. Host Name Query on DNS Server

Windows NT 4.0 also has a tool that enables you to test DNS to verify that it is working properly. This utility is not available on Windows 98/Me.

From the DOS command-line, type "NSLOOKUP" to display the following output:

```
C:\>nslookup
Default Server: sv1.labo.pcc.com
Address: 192.168.1.1
```

NS(Name Server) Record in Domain

From the DOS command-line, type "Is -t NS <Domain Name>" to display the following output:

```
> Is -t NS labo.pcc.com.
[sv1.labo.pcc.com.]
labo.pcc.com.      NS   server = sv1.labo.pcc.com
```

MX(Mail Exchange) Record in Domain

From the DOS command-line, type "Is -t MX <Domain Name>" to display the following output:

```
> Is -t MX labo.pcc.com
[sv1.labo.pcc.com]
labo.pcc.com.      MX   10  sv2.labo.pcc.com
```

A (Address) Record in Domain

From the DOS command-line, type "Is -t A <Domain Name>" to display the following output:

```

> ls -t A labo.pcc.com
[sv1.labo.pcc.com]
labo.pcc.com.      NS  server = sv1.labo.pcc.com
sv1                A   192.168.1.1
sv2                A   192.168.1.2
ec5                A   192.168.1.4
ec4                A   192.168.3.4
ef1                A   192.168.3.5

```

(To leave from this menu, type "exit" on the command-line.)

7. Testing Unit Using the TELNET Command

TELNET is a terminal emulation protocol. TELNET enables PCs and workstations to function as dumb terminals in sessions with hosts on internet works.

From Windows 98/Me/2000/NT/XP, use the TELNET to test the communication of TCP/IP and SMTP Protocol manually to the Unit. This method eliminates the SMTP Server.

For better understanding, type "telnet" in the DOS Command-line to bring up the Telnet screen. Then, click on the Terminal menu and on Preferences, check the "Local Echo" and "Block Cursor" radio dials and click on the OK button.

Click on the Connect menu, then click on Remote System.

Enter "25" in the "Port:" field and click on Connect button.

For example,

```

C:\WINDOWS>telnet

telnet to ef1.labo.pcc.com[192.168.3.5]
220 ef1.labo.pcc.com DP18xx V.xx
helo
250 Hello
mail from:test
250 Sender OK
rcpt to:fax@labo.pcc.com
250 Receipient OK
data
354 Email, end with "CRLF . CR LF"

[Press the Enter Key]
Panasonic Internet Fax
test
test
[Press the Enter Key]
[Press the Enter Key]
[Press the Enter Key]
250 OK, Mail accept

quit
221 Closing transaction channel

```

4.6. Error Codes (For Copier)

The self-diagnostic functions detect troubles in the important components of the copier. When any trouble occurs, the copier stops.

4.6.1. User Error Codes (U Code)

Note:

Uxx and a message will appear on the Panel Display.

User Error Codes (U Code) Table		
Code	Item	Possible Cause(s)
U0	Key Counter	<ol style="list-style-type: none"> 1. Key Counter is not installed. 2. Key Counter Harness disconnected.
U1	Close Front Cover	<ol style="list-style-type: none"> 1. Front Cover open. 2. Front Cover Sensor disconnected. 3. Front Cover Sensor defective 4. LVPS connector disconnected. 5. LVPS defective. 6. SPC PCB connector disconnected. 7. SPC PCB defective.
U4	Close Finisher	<ol style="list-style-type: none"> 1. Finisher open. 2. Paper in the output bin. 3. Stapler empty. 4. LVPS connector disconnected. 5. LVPS defective. 6. SPC PCB connector disconnected. 7. SPC PCB defective.
U6	Close Right Cover	<ol style="list-style-type: none"> 1. Right Cover open. 2. Right Cover Sensor disconnected. 3. Right Cover Sensor defective. 4. LVPS connector disconnected. 5. LVPS defective. 6. SPC PCB connector disconnected. 7. SPC PCB defective.
U7	Close Feed Cover	<ol style="list-style-type: none"> 1. Feed Cover open. 2. Feeder Unit incorrectly installed. 3. Feeder Unit connector disconnected. 4. Feeder Unit Sensor disconnected. 5. Feeder Unit Sensor defective. 6. LVPS connector disconnected. 7. LVPS defective. 8. CST2/CST3 PCB connector disconnected. 9. CST2/CST3 PCB defective.
U8	Close Paper Transport Unit	<ol style="list-style-type: none"> 1. Paper Transport Unit open. 2. Paper Transport Unit Sensor disconnected. 3. LVPS connector disconnected. 4. LVPS defective. 5. SPC PCB connector disconnected. 6. SPC PCB defective.
U11	Remove Paper in Finisher	<ol style="list-style-type: none"> 1. Paper in the Finisher. 2. Finisher Paper Exit Sensor defective.
U12	Close Finisher Staple Cover / Upper Cover	<ol style="list-style-type: none"> 1. Finisher Staple Cover open. 2. Finisher Staple Cover Sensor disconnected. 3. Finisher Staple Cover Sensor defective.

User Error Codes (U Code) Table		
Code	Item	Possible Cause(s)
U13	Add Toner	<ol style="list-style-type: none"> 1. Toner Bottle incorrectly installed. 2. Low Toner. 3. Toner Sensor disconnected. 4. Toner Sensor defective. 5. SPC PCB connector disconnected. 6. SPC PCB defective.
U14	Replace Toner Waste Container	<ol style="list-style-type: none"> 1. Toner Waste Container full. (See Sect. 3.5.4.)
U15	No Toner Waste Container	<ol style="list-style-type: none"> 1. Toner Waste Container not installed. 2. Toner Waste Container Sensor disconnected. 3. Toner Waste Container Sensor defective.
U16	No Developer Unit	<ol style="list-style-type: none"> 1. Developer Unit not installed.
U18	Total Copy Limit Over	<ol style="list-style-type: none"> 1. Department Copy Counter full.
U20	Close ADF Cover	<ol style="list-style-type: none"> 1. ADF Cover open. 2. ADF not installed correctly. 3. ADF Cover Sensor disconnected. 4. ADF Cover Sensor defective. 5. LVPS connector disconnected. 6. LVPS defective.
U21	Close ADF	<ol style="list-style-type: none"> 1. ADF and ADF Cover open. 2. ADF Sensor disconnected. 3. ADF Sensor defective.
U22	Close ADF Exit Cover	<ol style="list-style-type: none"> 1. ADF Exit Cover open. 2. ADF not installed correctly. 3. ADF Exit Cover Sensor disconnected. 4. ADF Exit Cover Sensor defective. 5. LVPS connector disconnected. 6. LVPS defective.
U25	Shake Toner Bottle	<ol style="list-style-type: none"> 1. Toner blocked in the Toner Bottle.
U90	Replace Battery	<ol style="list-style-type: none"> 1. Internal battery requires replacement.

4.6.2. Jam Error Codes (J Code)

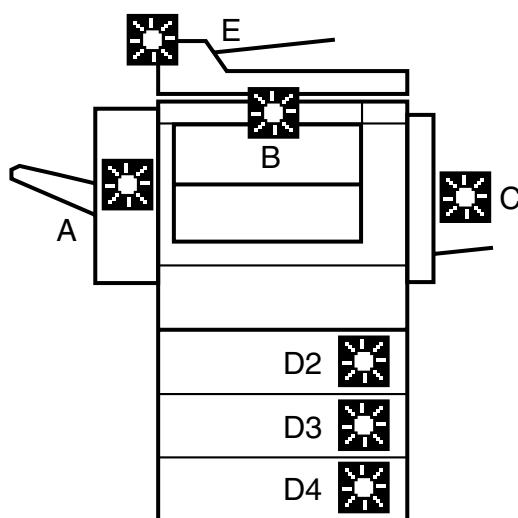

Section	Jam Location
A	Finisher
B	Paper Transport Area
C	Paper entry area
D2	2nd Paper Feed Unit
D3	3rd Paper Feed Unit
D4	4th Paper Feed Unit
E	ADF/i-ADF

• J Code Log View Mode

The 5 most recent J Codes can be displayed on the Panel Display by pressing "Function" and "3" keys in Standby mode.

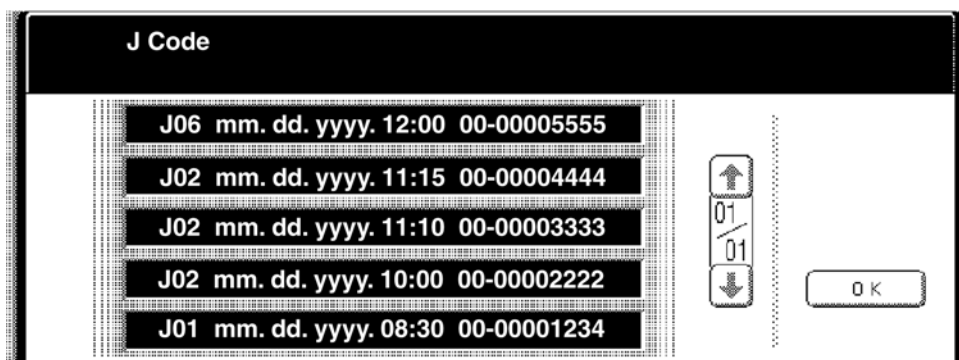

Note:

If the machine is jammed, follow the procedure below.

1. Turn the Power Switch on the Left Side and the Main Power Switch on the Back of the machine to the OFF position. (If Hard Disk Drive Unit is installed, refer to 3.7.7.)
2. Remove the Jammed paper.
3. Turn the Main Power Switch on the Back and the Power Switch on the Left Side of the machine to the ON position.
4. Press the "Function" and "3" keys.

• Jam Sensor Location of Printer

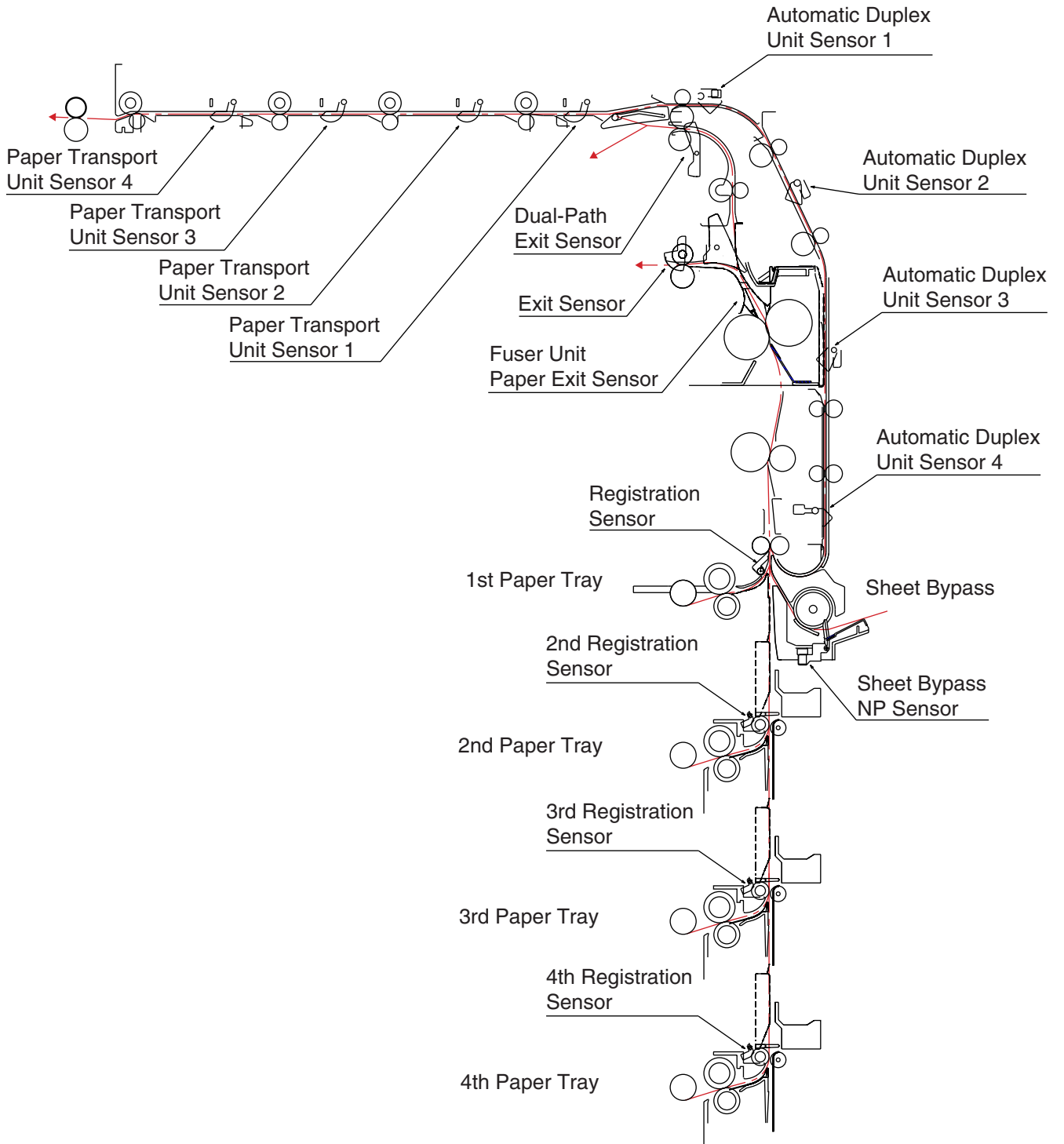

• Jam Sensor Location of Finisher

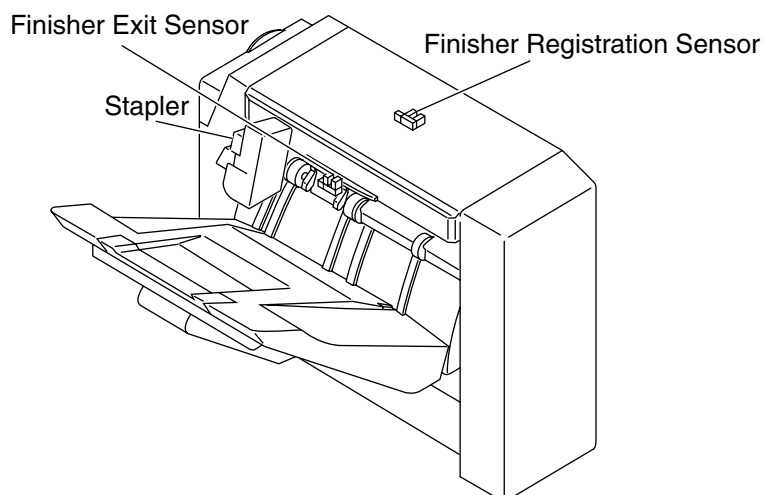

• Jam Sensor Location of i-ADF

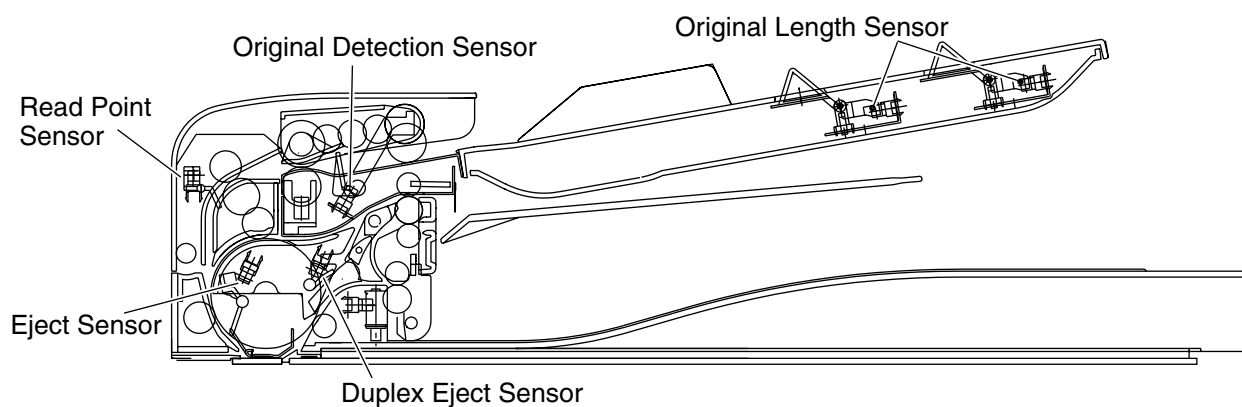

• Jam Sensor Location of ADF

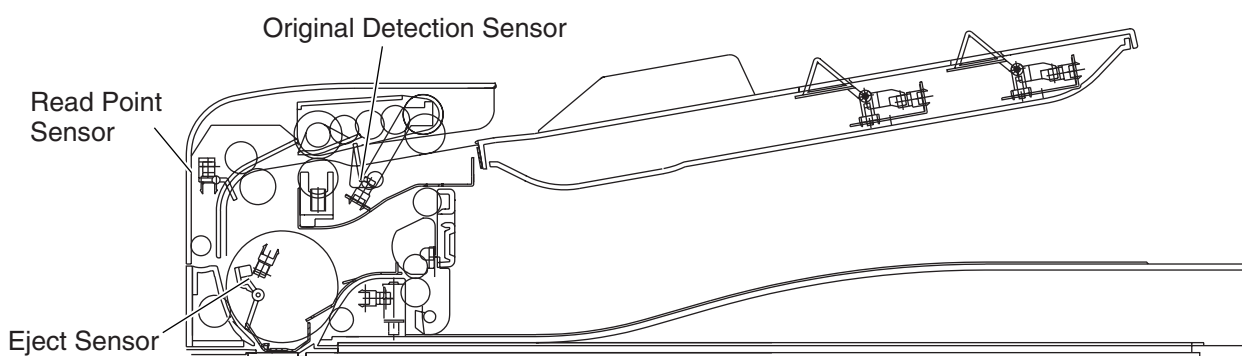

Jam Error Codes (J Code) Table

Code	Contents	Section
J00	The Registration Sensor does not detect paper within a predetermined time after the paper starts feeding. (Sheet Bypass)	C
J01	The Registration Sensor does not detect paper within a predetermined time after the Paper Feed Roller starts rotating. (1st Feeder Unit)	C
J02	The 2nd Registration Sensor does not detect paper within a predetermined time after the Paper Feed Roller starts rotating. (2nd Feeder Unit)	D2
J03	The 3rd Registration Sensor does not detect paper within a predetermined time after the Paper Feed Roller starts rotating. (3rd Feeder Unit)	D3
J04	The 4th Registration Sensor does not detect paper within a predetermined time after the Paper Feed Roller starts rotating. (4th Feeder Unit)	D4

Jam Error Codes (J Code) Table		
Code	Contents	Section
J07	The Registration Sensor does not detect paper within a predetermined time after the paper starts feeding from 2nd Feeder Unit. (2/3/4 Feeder Unit)	C, D2
J08	The Registration Sensor did not detect paper within a predetermined time after the Paper Feed Roller started rotating on the 3rd Feeder Unit. (3/4 Feeder Unit)	D3
J09	The Registration Sensor did not detect paper within a predetermined time after the Paper Feed Roller started rotating on the 4th Feeder Unit. (4th Feeder Unit)	D4
J12	The 2nd Registration Sensor does not go off within a predetermined time after the Paper Path Sensor is activated.	C, D2
J13	The 3rd Registration Sensor does not go off within a predetermined time after the Paper Path Sensor is activated.	D3
J14	The 4th Registration Sensor does not go off within a predetermined time after the Paper Path Sensor is activated.	D4
J19	The Registration Sensor does not detect within a predetermined time after the Automatic Duplex Unit Sensor 4 is activated.	C
J22	The 2nd Registration Sensor detect paper at the time of the initials.	C, D2
J23	The 3rd Registration Sensor detect paper at the time of the initials.	D2, D3
J24	The 4th Registration Sensor detect paper at the time of the initials.	D3, D4
J30	The Registration Sensor does not go off within a predetermined time after the Sensor is activated. (Sheet Bypass)	C
J31	The Registration Sensor does not go off within a predetermined time after the Sensor is activated. (Except Sheet Bypass)	C
J32	The Registration Sensor does not go off within a predetermined time after the Sensor is activated. (i-ADF)	C
J33	The Registration Sensor detects paper during non-printing mode.	C
J40	The Fuser Unit Paper Exit Sensor does not detect paper within a predetermined time after the Registration Sensor is activated.	C
J41	The Fuser Unit Paper Exit Sensor does not go off within a predetermined time after the Sensor is activated.	C
J42	The Fuser Unit Paper Exit Sensor detects paper during non-printing mode.	C
J43	The Exit Sensor does not detect paper within a predetermined time after the Fuser Unit Paper Exit Sensor is activated.	C
J44	The Paper Exit Sensor keeps detecting paper after a predetermined time.	C
J45	The Paper Exit Sensor keeps detecting paper after a predetermined time, during non-printing mode.	C
J46	The Dual-Path Exit Sensor does not go off within a predetermined time after the Sensor is activated.	C
J47	The Dual-Path Exit Sensor keeps detecting paper after a predetermined time, during non-printing mode.	C
J48	The Dual-Path Exit Sensor does not detect paper within a predetermined time after the Fuser Unit Paper Exit Sensor is activated.	C
J51	The Paper Transport Unit Sensor 2 does not detect paper within a predetermined time after eject paper Sensor of dual-path exit guide unit is activated.	B, C
J53	The Paper Transport Unit Sensor 4 does not detect paper within a predetermined time after eject paper Sensor of dual-path exit guide unit is activated.	B, C
J56	The Paper Transport Unit Sensor 2 does not go off within a predetermined time.	B, C
J58	The Paper Transport Unit Sensor 4 does not go off within a predetermined time.	B, C
J59	The Paper Transport Unit Sensor detects paper during non-printing mode.	B
J60	The Finisher Registration Sensor is not detects paper within a predetermined time after the Paper Transport Unit Sensor is activated.	A
J61	The stapler is not activated correctly.	A

Jam Error Codes (J Code) Table		
Code	Contents	Section
J62	The Finisher Registration Sensor does not go off within a predetermined time after the Sensor is activated.	A
J63	The Finisher Registration Sensor detects paper at the time of the initials.	A
J64	The Finisher Exit Sensor does not detect paper within a predetermined time after the Fuser Registration Sensor is activated.	A
J65	The Finisher Exit Sensor keeps detecting paper after a predetermined time.	A
J66	The Finisher Exit Sensor keeps detecting paper at the time of the initials.	A
J80	The Automatic Duplex Unit Sensor 1 does not detect paper within a predetermined time.	B
J82	The Automatic Duplex Unit Sensor 4 does not detect paper within a predetermined time after Automatic Duplex Unit Sensor 1 is activated.	C
J83	The Automatic Duplex Unit Sensor 1 does not go off within a predetermined time after the Sensor is activated.	C
J85	The Automatic Duplex Unit Sensor 4 does not go off within a predetermined time after the Sensor is activated.	C
J87	The Automatic Duplex Unit Sensor 1 detects paper during non-printing mode.	C
J88	The Automatic Duplex Unit Sensor 2, 3 or 4 detects paper during non-printing mode.	C
J97	After passing the Registration Sensor (Roller), the Paper does not clear the sensor within a predetermined time period.	C
J98	The VRDY Signal is not ON after a predetermined time has lapsed.	C
J99	No VSYNC Signal within a predetermined time after VRDY Signal is activated.	C

<J70~79, 92, 93 and 94 Codes>

Jam Error Codes (J Code) Table		
Code	Contents	Section
J70	Read Point Sensor does not detect paper within a predetermined time in the ADF. (Information Code 030 is printed on the Transaction Journal instead.)	E
J71	Read Point Sensor keeps detections paper after a predetermined time in the ADF. Original was longer than 78.7 in (2m). (Information Code 031 or 032 is printed on the Transaction Journal instead.)	
J72	Eject Sensor does not detect paper within a predetermined time after the Read Point Sensor is activated.	
J73	1. Eject Sensor keeps detecting paper after a predetermined time. 2. Eject Sensor keeps detecting paper after the Read Point Sensor is deactivated.	
J76	The Duplex Eject Sensor does not detect paper during 2-Sided Scanning.	
J78	The Duplex Eject Sensor keeps detecting paper during 2-Sided Scanning.	
J79	Read Point Sensor keeps detecting paper in the ADF.	
J92	The Original was pulled out when feeding an original.	
J93	The Original remained in the ADF.	
J94	Abnormal Timing (Paper Jam): 1. The Original was too small. 2. Duplex Eject Sensor detects Original during paper ejecting.	
	The ADF does not go off after the predetermined time.	

4.6.3. Mechanical Error Codes (E Code)

E1: Optical Unit Error		
Code	Function	Possible Cause(s)
E1- 01	Abnormal Platen Glass Scanning	<ol style="list-style-type: none"> 1. Home Position Sensor connector disconnected. 2. Home Position Sensor defective. 3. Scanner Motor connector disconnected. 4. Scanner Motor defective. 5. Scanning Mechanism defective. 6. SDR PCB connector disconnected. 7. SDR PCB defective. 8. SPC PCB connector disconnected. 9. SPC PCB defective. 10. LVPS defective.
E1- 20	Laser Unit Horizontal Synchronization	<ol style="list-style-type: none"> 1. LSU connector disconnected. 2. LSU defective. 3. SPC PCB connector disconnected. 4. SPC PCB defective.
E1- 22	Polygon Motor Synchronization	<ol style="list-style-type: none"> 1. Polygon Motor connector disconnected. 2. SPC PCB connector disconnected. 3. LSU connector disconnected. 4. Polygon Motor defective. 5. LVPS defective. 6. SPC PCB defective.
E1- 31	Scanning Lamp (Does not turn On)	<ol style="list-style-type: none"> 1. INV PCB connector disconnected. 2. INV PCB defective. 3. Scanning Lamp defective. 4. LFB PCB connector disconnected. 5. SDR PCB connector disconnected. 6. SDR PCB defective. 7. SPC PCB connector disconnected. 8. LVPS defective.
E1- 34	Scanning Lamp Harness	<ol style="list-style-type: none"> 1. INV PCB connector disconnected. 2. LFB PCB connector disconnected. 3. Scanning Lamp connector disconnected.
E1- 40	Book Fan Motor Rotation	<ol style="list-style-type: none"> 1. Book Fan connector disconnected. 2. Book Fan defective. 3. SPC PCB connector disconnected. 4. SPC PCB defective. 5. LVPS defective.
E1- 45	LSU Fan Motor Rotation	<ol style="list-style-type: none"> 1. LSU Fan connector disconnected. 2. LSU Fan defective. 3. SPC PCB connector disconnected. 4. SPC PCB defective. 5. LVPS defective.
E1-50	Size Sensor Adjustment	<ol style="list-style-type: none"> 1. Size Sensor defective. 2. Size Sensor connector disconnected. 3. SPC PCB connector disconnected. 4. SPC PCB defective. 5. ADF/Platen Cover open and Recording Paper not set on the Scanning Glass.

E2: Lift DC Motor Error		
Code	Function	Possible Cause(s)
E2- 01	Lift Motor Rotation (1st Paper Tray)	<ol style="list-style-type: none"> 1. Level Sensor connector disconnected. 2. Level Sensor defective. 3. Lift Mechanism defective. 4. Lift Motor connector disconnected. 5. Lift Motor defective. 6. SPC PCB connector disconnected. 7. SPC PCB defective. 8. LVPS defective.
E2- 02	Lift Motor Rotation (2nd Paper Tray)	<ol style="list-style-type: none"> 1. Level Sensor connector disconnected. 2. Level Sensor defective. 3. Lift Mechanism defective. 4. Lift Motor connector disconnected. 5. Lift Motor defective. 6. SPC PCB connector disconnected. 7. SPC PCB defective. 8. CST2 PCB connector disconnected. 9. CST2 PCB defective. 10. LVPS defective.
E2- 03 E2- 04	Lift Motor Rotation (3rd Paper Tray) Lift Motor Rotation (4th Paper Tray)	<ol style="list-style-type: none"> 1. Level Sensor connector disconnected. 2. Level Sensor defective. 3. Lift Mechanism defective. 4. Lift Motor connector disconnected. 5. Lift Motor defective. 6. SPC PCB connector disconnected. 7. SPC PCB defective. 8. CST2 PCB connector disconnected. 9. CST2 PCB defective. 10. CST3 PCB connector disconnected. 11. CST3 PCB defective. 12. LVPS defective.
E2- 08	Sheet Bypass Initialization	<ol style="list-style-type: none"> 1. Sensor connector disconnected. 2. Sensor defective. 3. SPC PCB connector disconnected. 4. SPC PCB defective. 5. LVPS defective.
E2- 10	System Console Drive Motor Rotation	<ol style="list-style-type: none"> 1. Drive Mechanism defective. 2. Drive Motor connector disconnected. 3. Drive Motor defective. 4. CST2 PCB connector disconnected. 5. CST3 PCB connector disconnected. 6. CST3 PCB defective. 7. LVPS connector disconnected. 8. LVPS defective. 9. SPC PCB connector disconnected. 10. SPC PCB defective.

E3: Development System Error		
Code	Function	Possible Cause(s)
E3- 01	Toner Bottle Motor Rotation	<ol style="list-style-type: none"> 1. Toner Bottle Motor connector disconnected. 2. Toner Bottle Motor defective. 3. Toner Bottle Motor Drive Mechanism defective. 4. Toner Bottle installed incorrectly. 5. SPC PCB connector disconnected. 6. SPC PCB defective. 7. Toner Bottle Home Position Sensor connector disconnected. 8. Toner Bottle Home Position Sensor defective.
E3- 03	Toner Density Sensor Gain	<ol style="list-style-type: none"> 1. Sensor connector disconnected. 2. Sensor defective. 3. SPC PCB connector disconnected. 4. SPC PCB defective.
E3- 20	Main Motor Rotation	<ol style="list-style-type: none"> 1. Drive Mechanism defective. 2. Main Motor connector disconnected. 3. Main Motor defective. 4. SPC PCB connector disconnected. 5. SPC PCB defective. 6. LVPS defective.
E3- 40	Copy Density Sensor Output Adjustment	<ol style="list-style-type: none"> 1. CDS PCB connector disconnected. 2. CDS PCB defective. 3. SPC PCB connector disconnected. 4. SPC PCB defective.

E4: Fuser Unit Error		
Code	Function	Possible Cause(s)
E4- 01	Fuser Warm-up Temperature	<ol style="list-style-type: none"> 1. Fuser Thermistor dirty. 2. Thermistor position incorrect. 3. Thermistor defective. 4. Thermistor connector disconnected. 5. Fuser Lamp connector disconnected. 6. Fuser Lamp defective. 7. Fuser Thermostat defective. 8. Thermal Fuse defective. 9. ACD PCB connector disconnected. 10. ACD PCB defective. 11. NFL PCB connector disconnected. 12. NFL PCB defective. 13. SPC PCB connector disconnected. 14. SPC PCB defective. 15. Fuser temperature low. (Adjust F6-31)
E4- 02	Fuser Paper Jam	<ol style="list-style-type: none"> 1. Paper Jam in Fuser Unit. 2. Paper Exit Sensor 1 or 2 disconnected. 3. Paper Exit Sensor 1 or 2 defective. 4. SPC PCB connector disconnected. 5. SPC PCB defective.
E4- 10	Fuser Fan Motor Rotation	<ol style="list-style-type: none"> 1. Fuser Fan connector disconnected. 2. Fuser Fan defective. 3. SPC PCB connector disconnected. 4. SPC PCB defective. 5. LVPS defective.

E5: System Error		
Code	Function	Possible Cause(s)
E5- 05	Vp (+24V, Scanner)	<ol style="list-style-type: none"> 1. SDR PCB connector disconnected. 2. SDR PCB defective. 3. SPC PCB connector disconnected. 4. SPC PCB defective. 5. LVPS defective.
E5- 11	Printer Engine Communication Abnormal	<ol style="list-style-type: none"> 1. SPC PCB connector disconnected. 2. SPC PCB defective. 3. SC PCB connector disconnected. 4. SC PCB defective.
E5- 12	Scanner Engine Communication Abnormal	
E5- 17	Scanner Synchronization	
E5- 19	Scanner Line Synchronization	
E5- 22	Finisher communication	<ol style="list-style-type: none"> 1. SPC PCB connector is disconnected (CN724). 2. SPC PCB is defective. 3. IPC PCB is disconnected. 4. IPC PCB is defective. 5. Finisher Interface Cable is disconnected. 6. OP LVPS connector is disconnected (CN64, 65, 66). 7. OP LVPS is defective. 8. DC PCB connector is disconnected (CN144). 9. Finisher is defective.
E5- 42	Total Counter Connection	<ol style="list-style-type: none"> 1. Total Counter connector disconnected. 2. Total Counter defective. 3. SPC PCB connector disconnected. 4. SPC PCB defective.
E5- 60	Power Supply Cooling Fan Motor Rotation	<ol style="list-style-type: none"> 1. Cooling Fan connector disconnected. 2. Cooling Fan defective. 3. SPC PCB connector disconnected. 4. SPC PCB defective. 5. LVPS defective.

E7: Optional Unit Error (DA-FS300)		
Code	Function	Possible Cause(s)
E7- 22	Finisher Damper Motor	<ol style="list-style-type: none"> 1. Motor Connector disconnected. 2. Motor defective. 3. Home Position Sensor Connector disconnected. 4. Home Position Sensor defective. 5. Gear defective.
E7- 23	Finisher Staple Motor	<ol style="list-style-type: none"> 1. Motor Connector disconnected. 2. Motor defective. 3. Home Position Sensor Connector disconnected. 4. Home Position Sensor defective. 5. Micro Switch Harness disconnected. 6. Micro Switch defective. 7. Solenoid Harness disconnected. 8. Solenoid defective. 9. Gear defective. 10. Motor wedged with a jammed Staple.

E7: Optional Unit Error (DA-FS300)		
Code	Function	Possible Cause(s)
E7- 27	Finisher Tray Shift Motor	<ol style="list-style-type: none"> 1. Motor Connector disconnected. 2. Motor defective. 3. Paper Height Sensor Connector disconnected. 4. Paper Height Sensor defective. 5. Gear defective.
E7- 59	Finisher Upper Limit	<ol style="list-style-type: none"> 1. Paper Upper Limit Sensor Connector disconnected. 2. Paper Upper Limit Sensor defective. 3. Paper Hold Sensor Connector disconnected. 4. Paper Hold Sensor defective.
E7- 90	Hardware Key Abnormal	<ol style="list-style-type: none"> 1. Incorrect Hardware Key installed. 2. Hardware Key defective.
E7- 91	Data Security Kit Abnormal	Hardware Key for Data Security Kit is not installed.

Note:

These error codes will appear only when the optional accessories are installed. Refer to the appropriate Optional Unit Service Manual.

E13: Out of Toner		
Code	Function	Possible Cause(s)
E13	No Toner Detection	<ol style="list-style-type: none"> 1. Out of Toner. 2. Toner Bottle not installed. 3. Toner Bottle not installed correctly. 4. Toner Sensor disconnected. 5. Toner Sensor defective. 6. SPC PCB connector disconnected. 7. SPC PCB defective.

Technician Warning:

The following message will be displayed in the event that the required Additional Sort Memory to operate the HDD is not installed.

LCD Message	Possible Cause(s)
HDD Option Requires Additional Sort Memory Minimum 16 MB	<ol style="list-style-type: none"> 1. Additional Sort memory is not installed. <ul style="list-style-type: none"> • DA-SM16 (16 MB) • DA-SM64 (64 MB) • DA-SM28 (128 MB) 2. Make sure the SDRM PC Board was installed properly.

4.7. Information Codes Table (For Facsimile)

Fax Information Codes				
Code	Mode	Phase	Description of Problem	Possible Cause(s)
012	RCV	C, D	The length of the received document is over 2 m.	
030	XMT	B	Read Point Sensor does not activate within 4 seconds after the document starts feeding.	Document not set properly. Defective Read Point Sensor.
031	XMT COPY	C	Transmitting document was longer than 2,000 mm (or 78.7 in). (Super Fine: 1,000 mm (or 39.4 in), 600 dpi: 430 mm (or 16.2 in))	Document may be jammed. Defective Read Point Sensor.
061	-	A	ADF Door is open.	Cover not firmly closed. Connectors not firmly connected.
200	RCV	C	Decoding process is not completed at the end of phase C.	Defective FXB PCB.
212	XMT RCV	A-E	Interface error occurred between the CPU and modem.	Modem defective. (FXB PCB) Software problem occurred. (SC PCB)
301	XMT RCV		System fault.	Software problem occurred. (SC PCB)
331	XMT	C	8-minutes timer error. (Germany only)	
400	XMT	B	T1 timer (35±5 sec) elapsed without detecting 300 bps signal.	Wrong number dialed and the START button is pushed. Telephone line disconnected while dialing. FXB PCB (Modem) or MJR PCB defective. Receiver defective. (It may only be transmitting CED)
401	XMT	B	DCN was returned from receiver while transmitter is waiting for CFR or FTT.	Your machine's ID Number not programmed. Possible incompatibility or incorrect Password (Password Reception, Selective Receive). Mailbox full.
402	XMT	B	DCN was returned from receiver while transmitter is waiting for NSF/DIS.	Receiver working in non-CCITT mode only. (Possible incompatibility)
403	RCV (Polling)	B	Transmitter had no polling function.	"POLLED=ON" (polling XMT ready) not set at the transmitter. Document to be transmitted not placed at the transmitter.
404	XMT	B	Transmitter sent NSS (or DCS) followed by TCF three times, but the receiver did not respond. (CFR or FTT is usually returned)	Receiver defective. (Modem, MJR PCB, etc.) FXB PCB or MJR PCB defective. Receiver disconnects line during first NSS (or DCS) transmitted.
405	XMT	B	Transmitter received FTT after it transmitted TCF at 2400 bps. Received RTN after communicating at 2400 bps.	Line quality poor. (TCF is damaged due to line noise) Receiver defective. (Modem, MJR PCB, etc.) FXB PCB or MJR PCB defective.

Fax Information Codes				
Code	Mode	Phase	Description of Problem	Possible Cause(s)
406	RCV (Password Comm.)	B	XMT-Password mismatched. RCV-Password mismatched. Selective RCV incomplete.	XMT, RCV password does not match. Last 4 digits of TSI does not match with the last 4 digits of Auto Dial telephone number.
407	XMT	D	Transmitter received no response after it transmitted post message, such as EOP, MPS, EOM, etc...or received DCN.	Receiver defective. (No paper, paper jamming, etc.) Receiver ceased receiving because of excessive errors. (Line quality poor) FXB PCB (Modem) or MJR PCB defective.
408	XMT	D	Transmitter received RTN after it transmitted EOP, MPS, or EOM.	Receiver receives data with errors. (Line quality poor) Receiver defective. (Modem, MJR PCB, etc.) FXB PCB or MJR PCB defective.
409	XMT	D	Transmitter receives PIN after it transmitted a post message, such as EOP, MPS, EOM, etc.	Receiver receives data with error due to poor line quality, and receiving operator requests voice contact. Receiver defective. (Modem, MJR PCB, etc.) FXB PCB or MJR PCB defective.
410	RCV	D	Received DCN while waiting for post command. (EOP, MPS, EOM, etc.)	Interface or line faulty. Transmitter defective.
411	RCV (Polling)	B	Received DCN after transmitting NSC.	Transmitter not ready for polling communication. Password does not match between transmitter and receiver.
412	G3 RX	B, D	No response within 12 seconds in NSS/DCS/MPS wait state. (After transmitting FTT)	Transmitter defective. FXB PCB defective.
414	RCV (Polling)	B	No response received after transmitting 3rd NSC.	Password does not match between transmitter and receiver. Transmitter defective. (No original, document jam, etc.)
415	XMT (Polling)	B	Remote side attempted to receive message from your machine in polling communication.	Inform the remote side that your machine does not have the polling transmission feature.
416	RCV	D	Receiver did not detect post command, such as EOP, MPS, EOM, etc.	Transmitter defective. Line quality poor. (RTC signal distorted due to line noise) FXB PCB or MJR PCB defective.
417	RCV	C	Receiver returned RTN in response to post message.	Line quality poor. (There are excessive errors in received data) FXB PCB or MJR PCB defective.
418	RCV	C	Receiver transmitted PIN in response to PRI-Q from transmitter. (Transmitting operator requests voice contact)	Line quality poor. (There are excessive errors in received data) FXB PCB or MJR PCB defective.
420	RCV	B	T1 timer (35 sec.) elapsed without detecting 300 bps signal.	Wrong number dialed. (Non-facsimile communication) Transmitter defective. FXB PCB or MJR PCB defective.

Fax Information Codes				
Code	Mode	Phase	Description of Problem	Possible Cause(s)
421	RCV	B	Busy Tone is detected after sending NSF Signal.	Remote station disconnected the line. Wrong number dialed.
422	XMT	B	Content of NSF (or DIS) or NSC (or DTC) was invalid.	Incompatible content
427	G3 RCV	B	DCN received to NSF/CSI/DIS transmitted.	Interface is incompatible.
433	XMT RCV	B, D	T.30 Protocol abnormal.	Defective remote station.
434	XMT or RCV	B	CD (response from Modem) did not turn OFF within 180 sec. after receiver detected FLAG signal.	Remote unit defective. FXB PCB or MJR PCB defective.
436	G3 RX	C	DCN received after transmitting FTT.	Transmitter defective or incompatible. Line quality poor.
438	RCV	B	Refusal ID (Junk Fax ID) received in Phase B.	Transmitter ID is registered as a Junk Fax. JUNK is printed as the Information Code on the Comm. Journal.
456	RCV	B	Received relay transfer request or confidential document to distribute to an end receiving station or all confidential mailboxes are used.	
457	RELAY XMT CONF. XMT/ POLL	B	Remote unit does not have Relayed XMT or Confidential Comm. capability.	
459	RCV	C	Failed training in Phase C.	Line quality poor. (Training signal distorted due to line noise) FXB PCB or MJR PCB defective.
490	RCV	C	Sum of error lines exceeded the limit (Function Parameter No. 70) of 64 lines.	Line quality poor. FXB PCB or MJR PCB defective.
494	RCV	C	Interval between two EOLs was more than 10 sec. when receiver received message data.	Transmitter defective. Line quality poor. (EOL damaged due to line noise) FXB PCB or MJR PCB defective.
495	XMT RCV	C	During reception, CD turned OFF or continued ON for long time. During communication, lost loop - current.	Line disconnected. Transmitter defective. FXB PCB or MJR PCB defective.
496	XMT	C	CS of modem is not able to turn ON.	FXB PCB defective.
501	XMT/ RCV(V.34)	B	Incompatible Modem on the Remote unit.	
502	XMT/ RCV(V.34)	B, C, D	During reception, CD turned OFF or continued ON for long time. During communication, lost loop - current.	Line disconnected. Transmitter defective. FXB PCB or MJR PCB defective.
503	XMT/ RCV(V.34)	B, C, D	CS of modem is not able to turn ON during training.	FXB PCB defective. Line disconnected.
504	RCV/V.34 (Polling)	B	Polling is rejected from the remote station.	No polling original set.
505	XMT/V.34 (Polling)	B	Polling XMT is rejected.	No polling original set.

Fax Information Codes				
Code	Mode	Phase	Description of Problem	Possible Cause(s)
540	XMT ECM	B	No response after transmitting 3rd CTC or DCN received.	Incompatible interface.
541	XMT ECM	D	No response after transmitting 3rd EOR or received DCN.	Faulty line. MJR PCB abnormal.
542	XMT ECM	D	No response to the 3rd RR transmitted or received DCN.	Remote unit abnormal.
543	XMT ECM	D	T5 timer (60 sec.) elapsed without MCF.	Remote unit abnormal.
544	XMT ECM	D	Stopped Transmission after EOR Transmission.	Faulty line. MJR PCB abnormal.
550	RCV ECM	C	Timer between frames in phase C has elapsed.	Defective remote station.
554	RCV ECM	D	Transmitted ERR after receiving EOR.	Faulty line.
555	RCV ECM	D	Transmitted PIN after receiving EOR.	Faulty line and Operator Call requested by RX side.
570	RCV	B	Password or machine code did not match during remote diagnostic communication.	
571	XMT	B	Remote unit did not have the remote diagnostic function.	
580	XMT	B	Sub-address transmission to a unit that has their DIS bit 49 (NSF bit 155) OFF.	Sub-address transmission to a unit that has no Sub-address function.
581	XMT	B	Sub-address Password transmission to a unit that has their DIS bit 50 (NSF bit 156) OFF.	Sub-address transmission to a unit that has no Sub-address function.
582	XMT	B	Sub-address SEP (for Polling) transmission to a unit that has their DIS bit 47 (NSF bit 130) OFF.	Sub-address transmission to a unit that has no Sub-address function.
601	XMT		ADF Door was opened during ADF transmission.	
623	XMT	A	No original was in the ADF. (Built-in dialer engaged)	Operator removed the original from the ADF after dialing was completed. Original was not set properly in the ADF.
630	XMT or RCV (Polling)	B	Redial count over.	No dial tone detected. Sensor dial tone is not detected. (Country dependent) Busy tone is detected. (Country dependent) T1 timer (35±5 sec) elapsed without a signal from the receiver.
631	XMT	A	"STOP" key was pressed during Auto Dialing.	
634	XMT	PSTN	Redial count over with no response or busy tone was not detected. Note: U.S.A. and Canadian models will redial only once if a busy tone is not detected.	

Fax Information Codes				
Code	Mode	Phase	Description of Problem	Possible Cause(s)
638	XMT	PSTN LAN	Power turned Off with applicable data in memory or during communication.	Power switched off. Power failure occurred.
700	XMT RCV	PSTN LAN	Communication terminated by Operator pressing the "STOP" key.	
712	XMT	LAN	Unknown email address replied from the Mail Server.	Mail Server received an incorrect email address. (Dependent on Server's Mail application)
714	XMT RCV	LAN	LAN Interface error. Cannot logon to the LAN.	The 10Base-T/100Base-TX cable not connected. An unexpected LAN problem occurred.
715	XMT	LAN	TCP/IP connection timed out.	Incorrect IP Address set. Verify the IP Address, Default Router IP Address, SMTP Server IP Address.
716	XMT	LAN	Cannot logon to the LAN.	Incorrect SMTP Server IP Address set. No email application activated on the Mail Server.
717	XMT	LAN	Incomplete SMTP Protocol transmission.	Mail Server's hard disk may be full. Mail Server defective.
718	XMT	LAN	Page Memory Overflow occurred while receiving printing data. The paper size selected within your application to print is larger than the paper size loaded in the paper tray(s).	Check the document size and resolution. Ask originator to re-send in a supported size and resolution.
719	RCV	LAN	Received data via LAN is in a format that is not supported.	Ask the originator to re-send with a supported file attachment: * In a TIFF-F format. * Image data conforming to A4/Letter size.
720	POP	LAN	Unable to connect to the POP Server.	Incorrect POP Server address set. POP Server is down.
721	POP	LAN	Unable to login to the POP Server.	Incorrect User Name or Password set.
722	RCV	LAN	Failed to obtain the Network Parameters (such as: IP Address, Subnet Mask, Default Gateway IP Address, etc.) from the DHCP server.	DHCP not available. (Contact the Network Administrator.)
725	XMT POP	LAN	DNS Server connection timed out.	Incorrect DNS Server address set. DNS Server is down.
726	XMT POP	LAN	Received an error response from the DNS Server.	Incorrect POP Server address set. Incorrect SMTP Server address set.
727	XMT	LAN	Received an Error or No Response from the Remote Internet Fax. (SMTP Direct XMT)	Remote Internet Fax Errors: Busy or Job Number Overflow for Relay XMT. (Retry is possible)
728	XMT	LAN		Remote Internet Fax Errors: Memory Overflow or No Power. (Retry is not possible)
729	XMT	LAN	Failed to authenticate (SMTP AUTHENTICATION) when connecting with the SMTP server.	SMTP AUTHENTICATION, User Name and/or Password are incorrect. (Contact the Network Administrator.)

Fax Information Codes				
Code	Mode	Phase	Description of Problem	Possible Cause(s)
730	RCV	LAN	Unable to program the Internet parameters or the autodialer via Email from a PC.	Verify that the Fax Parameter #158 is set to Valid.
731	RCV	LAN	Dialer full while Relayed Transmission Request was received.	Dial buffer for manual number dialing (70 stations) is being used.
741	XMT, Polling	PSTN	Unable to dial	Deleted the registered station name before dialing with Timer Controlled Communications, etc.
742	XMT	LAN	Unable to dial to Key Operator (Job Tracking, NYSE)	Incorrect setting or wrong number set.
800	Relay Comm.	PSTN	The machine was requested to relay a document but has no Relay Hub capability.	
814	Conf. XMT Conf. Polling Relay Comm.	PSTN	The remote station does not have Relay XMT nor Confidential Communication capability.	
815	Conf. RCV	PSTN	Mailbox full.	
816	Conf. Polled	PSTN	The received Polling Password did not match.	
825	Conf. RCV Conf. Polled	PSTN	Parameter settings of the remote station are not properly set.	
850	Relay Comm.	-	Relay Communication is rejected.	The dept. code of the Fax Driver/ Panafax Desktop is mismatched with the registered code in the machine.
870	MEM XMT Multi-Copy	PSTN LAN	Memory overflow occurred while storing documents into memory.	
879	Memory RCV	PSTN	Memory overflow occurred during substitute memory reception.	Memory overflow on the Fax side.
		LAN	Memory overflow. Mail Server sent a reset command while downloading the data to the machine.	Memory overflow on the Fax side. Mail server aborted the download (Busy with other higher priority jobs).
880	-	-	File Access Error.	
884	-	-	File Access Error.	
961	RCV	LAN	Memory file access error.	SC PCB defective.
962	XMT	PSTN	Memory file access error.	SC PCB defective.
		LAN	Memory file access error.	SC PCB defective.

4.8. Diagnostic Codes (For Facsimile)

The 13-digit Diagnostic Code is provided for the service engineer to analyze how the communication was performed. The code is recorded on the Journal.

Journal Example

```

***** -JOURNAL- ***** DATE MMM-dd-yyyy ***** TIME 09:39*****
NO. COMM. PAGES FILE DURATION X/R IDENTIFICATION DATE TIME DIAGNOSTIC
01 OK 001 129 00:00'42 XMT 123 456 789 MMM-dd 01:55 C8649003C0000
                                     1st digit 13th digit
-----
- PANASONIC MACHINE
***** - PANASONIC MACHINE- ***** -12345678901234567890- *****
    
```

1st Digit: Manufacturer Code

-: Not used/defined

Fax Diagnostic Codes				
Data	Definition			
	Manufacturer Code			
0	-			
1	Casio			
2	Canon			
3	Sanyo			
4	Sharp			
5	Tamura			
6	Toshiba			
7	NEC			
8	Oki			
9	Hitachi			
A	Xerox			
B	Fujitsu			
C	Matsushita			
D	Mitsubishi			
E	Murata			
F	Ricoh			

2nd Digit

-: Not used/defined

Fax Diagnostic Codes				
Data	Definition			
	ID (TSI, CSI, CIG)	RTN	DCN	STOP Button
0	-	-	-	-
1	Received	-	-	-
2	-	Received	-	-
3	Received	Received	-	-
4	-	-	Received	-
5	Received	-	Received	-
6	-	Received	Received	-
7	Received	Received	Received	-
8	-	-	-	Pressed
9	Received	-	-	Pressed
A	-	Received	-	Pressed
B	Received	Received	-	Pressed
C	-	-	Received	Pressed
D	Received	-	Received	Pressed
E	-	Received	Received	Pressed
F	Received	Received	Received	Pressed

3rd Digit

-: Not used/defined

Fax Diagnostic Codes				
Data	Definition			
	Resolution (dpi)	Paper Width		
0	-	A4		
1	S-Fine	A4		
2	400 x 400	A4		
3	300 x 300	A4		
4	-	B4		
5	S-Fine	B4		
6	400 x 400	B4		
7	300 x 300	B4		
8	600 x 600	A4		
9	600 x 600	B4		
A	-	-		
B	600 x 600	A3		
C	-	A3		
D	S-Fine	A3		
E	400 x 400	A3		
F	300 x 300	A3		

4th Digit

-: Not used/defined

Fax Diagnostic Codes				
Data	Definition			
	Scanning Rate	Resolution		
0	20 ms/line	Std		
1	5 ms/line	Std		
2	10 ms/line	Std		
3	-	Std		
4	40 ms/line	Std		
5	-	Std		
6	-	Std		
7	0 ms/line	Std		
8	20 ms/line	Fine		
9	5 ms/line	Fine		
A	10 ms/line	Fine		
B	-	Fine		
C	40 ms/line	Fine		
D	-	Fine		
E	-	Fine		
F	0 ms/line	Fine		

5th Digit

-: Not used/defined

Fax Diagnostic Codes				
Data	Definition			
	Deferred Comm.	Dialing/RCV	Memory/ Non-Memory	
0	-	Manual Communication	Non-Memory	
1	Used	Manual Communication	Non-Memory	
2	-	Auto Dialing	Non-Memory	
3	Used	Auto Dialing	Non-Memory	
4	-	Auto RCV	Non-Memory	
5	Used	Auto RCV	Non-Memory	
6	-	Remote RCV	Non-Memory	
7	Used	Remote RCV	Non-Memory	
8	-	Manual Communication	Memory	
9	Used	Manual Communication	Memory	
A	-	Auto Dialing	Memory	
B	Used	Auto Dialing	Memory	
C	-	Auto RCV	Memory	
D	Used	Auto RCV	Memory	
E	-	Remote RCV	Memory	
F	Used	Remote RCV	Memory	

6th Digit

-: Not used/defined

Fax Diagnostic Codes				
Data	Definition			
	Polling	XMT/RCV	Selective Comm.	Password Comm.
0	-	RCV	Off	Off
1	Yes	RCV	Off	Off
2	-	XMT	Off	Off
3	Yes	XMT	Off	Off
4	-	RCV	On	Off
5	Yes	RCV	On	Off
6	-	XMT	On	Off
7	Yes	XMT	On	Off
8	-	RCV	Off	On
9	Yes	RCV	Off	On
A	-	XMT	Off	On
B	Yes	XMT	Off	On
C	-	RCV	On	On
D	Yes	RCV	On	On
E	-	XMT	On	On
F	Yes	XMT	On	On

7th Digit

-: Not used/defined

Fax Diagnostic Codes				
Data	Definition			
	Sub-Address Comm.	Confidential Comm.	Relayed Comm.	Turnaround Polling
0	-	-	-	-
1	Yes	-	-	-
2	-	Yes	-	-
3	Yes	Yes	-	-
4	-	-	Yes	-
5	Yes	-	Yes	-
6	-	Yes	Yes	-
7	Yes	Yes	Yes	-
8	-	-	-	Yes
9	Yes	-	-	Yes
A	-	Yes	-	Yes
B	Yes	Yes	-	Yes
C	-	-	Yes	Yes
D	Yes	-	Yes	Yes
E	-	Yes	Yes	Yes
F	Yes	Yes	Yes	Yes

8th Digit

-: Not used/defined

Fax Diagnostic Codes				
Data	Definition			
	Advanced Comm.	Cover Sheet XMT		
0	-	-		
1	Report XMT	-		
2	Check & Call	-		
3	-	-		
4	Memory Transfer	-		
5	-	-		
6	-	-		
7	-	-		
8	-	Yes		
9	Report XMT	Yes		
A	Check & Call	Yes		
B	-	Yes		
C	Memory Transfer	Yes		
D	-	Yes		
E	-	Yes		
F	-	Yes		

9th Digit

-: Not used/defined

Fax Diagnostic Codes				
Data	Definition			
	Short Protocol	Standard/ Non-Standard		
0	-	Standard		
1	-	Standard		
2	-	Standard		
3	-	Standard		
4	-	Standard		
5	-	Standard		
6	-	Standard		
7	-	Standard		
8	-	Non-Standard		
9	B	Non-Standard		
A	-	Non-Standard		
B	D	Non-Standard		
C	-	Non-Standard		
D	B	Non-Standard		
E	-	Non-Standard		
F	D	Non-Standard		

10th Digit

-: Not used/defined

Fax Diagnostic Codes				
Data	Definition			
	Coding	ECM		
0	MH	-		
1	MR	-		
2	MMR	-		
3	JBIG	-		
4	-	-		
5	-	-		
6	-	-		
7	-	-		
8	MH	Yes		
9	MR	Yes		
A	MMR	Yes		
B	JBIG	Yes		
C	-	Yes		
D	-	Yes		
E	-	Yes		
F	-	Yes		

11th Digit

-: Not used/defined

Fax Diagnostic Codes				
Data	Definition			
	Symbol Rate (V.34)	V.34		
0	-	-		
1	-	-		
2	-	-		
3	-	-		
4	-	-		
5	-	-		
6	-	-		
7	-	-		
8	2400 sr	Yes		
9	-	Yes		
A	2800 sr	Yes		
B	3000 sr	Yes		
C	3200 sr	Yes		
D	3429 sr	Yes		
E	-	Yes		
F	-	Yes		

12th Digit

-: Not used/defined

Fax Diagnostic Codes				
Data	Definition			
	Modem Speed	Modem Speed (V.34)		
0	2400 bps	-		
1	4800 bps	2400 bps		
2	7200 bps	4800 bps		
3	9600 bps	7200 bps		
4	TC 7200 bps	9600 bps		
5	TC 9600 bps	12000 bps		
6	12000 bps	14400 bps		
7	14400 bps	16800 bps		
8	-	19200 bps		
9	-	21600 bps		
A	-	24000 bps		
B	-	26400 bps		
C	-	28800 bps		
D	-	31200 bps		
E	-	33600 bps		
F	-	-		

13th Digit

-: Not used/defined

Fax Diagnostic Codes				
Data	Definition			
	Symbol Rate (V.34)	V.34		
0	-	-		
1	-	-		
2	-	-		
3	-	-		
4	-	-		
5	-	-		
6	-	-		
7				
8				
9				
A				
B				
C				
D				
E				
F				

4.9. Troubleshooting (For Printer)

4.9.1. Checking the Basics

This section explains how to solve problems including error messages, or unexpected printing results.

If the Printing System is not printing or working as expected, and if you are not sure what to do, start your troubleshooting by checking the basics below:

- Ensure that the Ethernet LAN (10Base-T / 100Base-TX) Cable is connected properly
- Ensure that the Internet Parameters are correct
- Ensure that the Unit is turned On
- Ensure that the Paper is set properly in the Unit
- No error message is displayed on the Unit
- Try printing a test page from the printer driver properties dialog box

4.9.2. Document Does Not Print Properly

Problem	Possible Solution(s)
Character is not printing in the correct positions, or the characters near the edges of the page are missing.	<ul style="list-style-type: none"> • heck, and specify the paper size and orientation settings in the printer driver to coincide with the application. • Check if the specified paper is loaded in the Panasonic Device. • Increase the Page Margins in the application. The Panasonic Device requires minimum margins of . inches (5 mm) on all sides.
The font type is incorrect	<ul style="list-style-type: none"> • Check if the selected font is installed in the PC. • Check if the selected font is being replaced with a proper printer font in the Font Substitution Table of the Printer Driver Properties dialog box. • Select “Always use True Type fonts” from the Font tab of the Printer Driver Properties dialog box.
The character is not smooth.	<ul style="list-style-type: none"> • Select an outline font instead of a bit map font.
Fine line print cannot be obtained.	<ul style="list-style-type: none"> • Select 600 dpi resolution.
Poor photograph print quality.	<ul style="list-style-type: none"> • Select 600 dpi resolution.
Different character, or symbol from the document is printed.	<ul style="list-style-type: none"> • Check if the Panasonic Printing System (PCL) printer driver is selected.
The printer does not print anything, or prints irregular images from the middle of the 1 st page.	<ul style="list-style-type: none"> • Insufficient Printer Page Memory in the Panasonic Device, install an Expansion D-RAM Card, or change the resolution to 300 dpi in the Quality tab of the Printer Driver Properties dialog box.
Printing is exceedingly slow.	<ul style="list-style-type: none"> • Select the Spool settings “Start printing after first page is spooled” from the Details tab of the Printer Driver Properties dialog box. • Select 300 dpi resolution.

4.9.3. Error Message Appears on the PC

Error Message	Possible Solution(s)
Network Print DLL Error.	<ul style="list-style-type: none"> • Check if the Panasonic Device is turned “On”, and the 10Base-T/ 100Base-TX cable is properly connected. • Printer Properties may be incorrectly configured. (i.e. Printer Port)
Network Port is Busy.	<ul style="list-style-type: none"> • The Panasonic Device may be processing a different print job, please wait, and try again later. • The Panasonic Device is either Transmitting, or Receiving an email.
Cannot print because an error is found in the current printer setting.	<ul style="list-style-type: none"> • Verify, and specify the paper size, or orientation to coincide with the application, and the printer driver settings.

4.9.4. Error Message Appears on the Unit

Error Message	
Cannot complete print job; Image memory overflow	<ul style="list-style-type: none"> • There may not be enough Sort Memory available in the Panasonic Device to complete the print job. Either install an optional Sort Memory, or change the resolution to 300 dpi in the Printer Driver Properties dialog box.
Cannot complete print job; Confirm print condition	<ul style="list-style-type: none"> • The print settings may not be matched for the system. Change the printing settings in the Printer Driver Properties dialog box. Ex: Multi-sized printing.
Cannot print; System error	<ul style="list-style-type: none"> • Change the resolution to 300 dpi in the Printer Driver properties dialog box.

4.9.5. System Error (CD Drive Related Error During Installation)

Problem	Possible Solution(s)
Cannot read the drive.	<ul style="list-style-type: none"> • Insert the CD into the drive, and click "Retry".

5 Service Modes

5.1. Service Modes (For Copier)

These Service Modes are provided to assist the technician in checking for abnormalities in the copier and a means of making adjustments to the Input/Output of major components.

Caution:

The factory default parameters are preset (country dependent) for optimum performance and in compliance with the local telecommunication regulations/standards, and do not need to be changed. Changing some of these parameters may cause the unit to be no longer compliant or become inoperable.

5.1.1. Service Mode Procedure

1. To select the Service Mode

Press the “FUNCTION”, “ORIGINAL SIZE (LEDGER/A3)”, and the “3” keys simultaneously.

Input the password, and select the “OK” button to enter the Service Mode (default password is 00000000).

2. To exit the Service Mode

The Service Mode is reset when the “FUNCTION” and “C (CLEAR)” keys are pressed simultaneously.

5.1.2. Copier Service Mode Functions

Service Modes (For Copier)				
Service Mode	Item			Function
F1	Self Test	00	CCD Test	This test is used for checking the CCD.
		01	LCD/LED Test	This test is used for checking the LCD and LEDs.
		02	Page Memory Test	This test is used for checking the Page Memory.
		03	Print Test Pattern 1	Prints the pattern for setting the Paper position alignment.
		04	Print Test Pattern 2	Prints the Slant pattern for setting the Paper position alignment.
		05	Print Test Pattern 3	Prints the Grid pattern for setting the Paper position alignment.
		06	Print Test Pattern 4	Prints the pattern for setting the Duplex Paper position alignment.
F2	Single Copy Test			One sheet is copied when the Start key is pressed.
F3	Continuous Copy Test			Multi copies are made when the Start key is pressed.
F4	Input / Output Status Test			The functioning of Input / Output items (selected item numbers) is checked.
F5	Function Parameters			Various function settings (selected by code numbers) can be changed.
F6	Adjust Parameters			Various function settings (selected by code numbers) can be adjusted.
F7	Electronic Counters			Electronic Counters for Maintenance
F8	Service Adjustment			Perform pseudo-operation of an item (selected by code numbers)
F9	Unit Maintenance			Fax Function Parameters

F5 / F6 Information List (Sample)

*****-F5/F6 INFORMATION LIST-***** DATE MMM-dd-yyyy *** TIME12:01 *** P.01

F5-00	Country version	USA/CAN	F5-50	Auto contrast adjust.	Yes
F5-01	Frequency desired	60Hz	F5-51	Dept. Counter (COPY)	No
F5-02		F5-52	Dept. Counter (FAX)	No
F5-03	LSU startup speed	Full	F5-53	2-sided auto shift	No
F5-04	LSU off timer	15 Sec.	F5-54	Margin reduction	No
F5-05		F5-55	Margin value default	10mm
F5-06		F5-56	Edge value default	5mm
F5-07	Language default	English	F5-57	Book value default	20mm
F5-08	Batch Printing Mode	On	F5-58	U14 Clear	Any Keys
F5-09	Fuser lamp control	Off	F5-59	Ope.add toner alarm	Stop
F5-10		F5-60	Auto Tray selection	Yes
F5-11	Drum Life Warning	Off	F5-61	
F5-12	Printer fan extension	5 min	F5-62	Overflow Detection	No
F5-13		F5-63	U13 clear	Any keys
F5-14	Paper size tray1(cop.)	LETTER	F5-64	Dept. Counter (SCANNER)	Yes
F5-15	Paper size tray2(cop.)	LEDGER	F5-65	Dept. Counter (PRINTER)	Yes
F5-16	Paper size tray3(sys1)	LEDGER	F5-66	Interleaving default	Blank
F5-17	Paper size tray4(sys2)	LEDGER	F5-67	Page insertion default	Blank
F5-18		F5-68	Cover mode default	F,Blank
F5-19		F5-69	Reduce N in 1 space	No
F5-20	ADF	Auto	F5-70	PM cycle	120k
F5-21	Finisher	Auto	F5-71	
F5-22	System console	Auto	F5-72	Disable at web PM	Stop

*****-F5/F6 INFORMATION LIST-***** DATE MMM-dd-yyyy *** TIME12:01 *** P.02

F6-00	Adj 100% Side-Side Read	0	F6-50	T/P Mode Image Density	0
F6-01	Adj 100% Lead-Tail Read	0	F6-51	P Mode Image Density	0
F6-02	100% Selection	0	F6-52	
F6-03	Original Registration	0	F6-53	CCD Read Position Adj	0
F6-04	Printer Registration	0	F6-54	T Mode Contrast	0
F6-05	Main Motor Speed	0	F6-55	T/P Mode Contrast	0
F6-06	Polygon Motor Speed	0	F6-56	P Mode Contrast	0
F6-07	Registration Void	6	F6-57	Charge Roller Frequency	0
F6-08	Trail Edge Read Timing	0	F6-58	Charge Roller Current	0
F6-09	Trail Edge Print Timing	-6	F6-59	Trail Edge Trans Trays	3
F6-10	Side Adjust (Bypass)	0	F6-60	
F6-11	Side Adjust (Tray 1)	0	F6-61	
F6-12	Side Adjust (Tray 2)	0	F6-62	TDC Gain Voltage Adjust	0
F6-13	Side Adjust (Tray 3)	0	F6-63	Lead Edge Read Timing	0
F6-14	Side Adjust (Tray 4)	0	F6-64	Side Edge Read Adjust	0
F6-15		F6-65	Black Density Reference	0
F6-16	Side Adjust (ADU)	0	F6-66	Black Density Output	0
F6-17	Charge Roller Voltage	0	F6-67	ADF Image Density	0
F6-18	Standard Laser Power	0	F6-68	Paper Loop (Tray 3)	0
F6-19	Std Bias DC Voltage	0	F6-69	Stamp Position Adjust	0
F6-20	Print Contrast Adjust	0	F6-70	
F6-21	TDC Gain Voltage	0	F6-71	
F6-22		F6-72	

Machine Setup Information List (Sample)

*****-MACHINE SETUP INFORMATION-***** DATE MMM-dd-yyyy *** TIME12:01 *** P.01

1.MACHINE INFORMATION

MACHINE NAME : DP-XXXX
 MAC ADDRESS : 08002312137E

2.FIRMWARE VERSION

SC : AAV0000xPU
 SC BOOT : M13
 PNL : AAV0000xPU
 SPC : 30cpm V0000x
 FINISHER : Ver 6D01
 FAX MODEM :
 PDL FONT1 :
 SC2 :

3.MEMORY CAPACITY

PAGE MEMORY : 32 MB
 SORT MEMORY : 16 MB
 FAX MEMRY : 3 MB

4.OPTION

DOCUMENT FEEDER (iADF) : iADF
 2nd PAPER FEED MODULE : Yes
 3rd PAPER FEED MODULE : Yes
 4th PAPER FEED MODULE : Yes
 PAPER TRANSPORT UNIT : Yes
 DUPLEX UNIT (ADU) : Yes
 DUAL-PATH EXIT GUIDE : Yes
 FINISHER : FS300
 FAX BOARD : Yes
 NETWORK SCANNER : No
 PCL PRINTER : No
 PS PRINTER : No
 EMAIL : Yes
 HDD : No

5.ERROR LOG

TOTAL PRINT COUNT : 2082

NO.	DATE & TIME	ERROR CODE	ERROR COUNT	NO.	DATE & TIME	ERROR CODE	ERROR COUNT
01	MMM-dd-yyyy 11:11	J27	XX-00000008				
02	MMM-dd-yyyy 11:31	J41	XX-00000140				
			(See Remarks)				

-PANASONIC -

***** ***** - ***** - 0001- *****

Remarks:

XX-00000140

Page Count

00 : Printer Error
 02 : Scanner Error

F7 Total Counter List (Sample)

*****-F7 TOTAL COUNTER LIST-***** DATE MMM-dd-yyyy *** TIME12:01 *** P.01

F7-01 Key Operator ID Code : 0000

F7-02 Maintenance Count

Total Count : 295
PM Count : 295
Scanner PM Count : 61
ADF Count : 26
OPC Drum Count : 295
Process Unit Count : 295
ADF PM Count : 50
Fuser Web Count : 295
Developer Count : 295
Avg Print/Drum Rise Up : 5
Total OPC Rotation Time : 1
Avg Min/Drum Rise Up : 0

F7-03 Paper Feed Count

Sheet Bypass Count : 147
1st Paper Tray Count : 90
2nd Paper Tray Count : 15
3rd Paper Tray Count : 5
4th Paper Tray Count : 3
2-Sided Count : 28
A4/LETTER Count : 284
A4-R/LETTER-R Count : 73
A3/LEDGER Count : 19
B4/LEGAL Count : 3

F7-04 Scanner Count

ADF Count : 26
ADF Read Count : 26
Scanner Count : 61
Scanner Read Count : 18

5.1.3. F4 Mode: Input/Output Status Test

Set the machine to service mode and press “4” key on the Keypad.



Press the “START” key.



Enter the number to activate the test then press “START” key.



Press “STOP” key to cancel the test.



When the “C (CLEAR)” key is touched, the selected code input will not be accepted.



Press “FUNCTION” and “C (CLEAR)” keys simultaneously to exit the service mode.

1. Input Check

F4 Mode (Input Check)											
No.	Function	Condition	Message Display							Remarks (Ref.No.)	
			7	6	5	4	3	2	1		0
000	Power Supply Fan Signal	Normal.			0						(322)
001	LSU Fan Signal	Normal.							0		(315)
002	Toner Remaining Sensor Signal	Toner is detected.		0							(615)
003	Paper Feed Module Detection Sensor (2nd Paper Feed Module)	Unit is connected.	0								---
	Paper Tray Detection Sensor (2nd Paper Tray)	Paper Tray is not connected.	0								(1045) Fig.23 F6
	Paper Tray Detection Sensor (1st Paper Tray)	Paper Tray is not connected.			0						(1045) Fig.11 B5
	Key / Card Counter Detection Sensor	Counter is not detected.				1					---
	NP Sensor (Sheet Bypass)	Paper is not detected.					1				(1045) Fig.12-1 E8
	Paper Length Sensor (Sheet Bypass)	Sensor is activated.						0			(1045) Fig.12-1 J2
	Size Sensor 2 (Sheet Bypass, Inside)	Sensor is activated.							1		(1981)
	Size Sensor 1 (Sheet Bypass, Outside)	Sensor is activated.								1	(1981)

F4 Mode (Input Check)

No.	Function	Condition	Message Display							Remarks (Ref.No.)	
			7	6	5	4	3	2	1		0
004	Fuser Unit Paper Exit Sensor	Paper is detected.	0								(1045) Fig.10 G4
	Dual-Path Exit Guide Unit Detection Sensor	Unit is connected.	0								---
	ADU Detection Sensor	Unit is connected.		0							---
	JAM Access Cover Open Detection Sensor (2nd Paper Feed Module)	Cover is open.			0						(1045) Fig.23 I2
	Upper Limit Sensor (2nd Paper Tray)	Upper Limit is detected.					1				(1045) Fig.23 F2
	Upper Limit Sensor (1st Paper Tray)	Upper Limit is detected.						1			(1045) Fig.11 G5
	NP Sensor (2nd Paper Tray)	Paper is not detected.							0		(1045) Fig.23 F2
	NP Sensor (1st Paper Tray)	Paper is not detected.								0	(1045) Fig.11 G5
005	Total Counter Detection Sensor	Counter is not detected.	1								(331)
	Polygon Motor Lock Signal	Normal.		0							---
	Main Motor Lock Signal	Normal.			0						(907)
	Fuser Fan Lock Signal	Normal.					0				(459)
	Toner Waste Container Detection Sensor	Toner Waste Container is detected.						0			(1982)
	Toner Waste Container Full Detection Sensor	Toner Waste Container is full.							1		(1982)
006	Toner Bottle Motor Rotation Detection Sensor	Lock								0	---
	Dual-Path Exit Guide Unit Exit Sensor	Paper is detected.		0							(1045) Fig.15 G4
	Paper Transport Unit Sensor 1	Paper is detected.			0						(1045) Fig.13 H3
	ADU Sensor 1	Paper is detected.				0					(1045) Fig.15 I1
	Inner Lower Exit Sensor	Paper is detected.						0			(1045) Fig.10 G1
	Registration Sensor (2nd Paper Tray)	Paper is detected.							0		(1045) Fig.23 J2
007	Registration Sensor	Paper is detected.								0	(1045) Fig.11 I3
	Paper Transport Unit Detection Sensor	Unit is connected.	0								---
	Paper Transport Unit Door Sensor	Door is open.		0							(1045) Fig.13 F4
	Paper Transport Unit Sensor 4	Paper is detected.			0						(1045) Fig.13 H3
	Paper Transport Unit Sensor 3	Paper is detected.				0					(1045) Fig.13 H3
	Paper Transport Unit Sensor 2	Paper is detected.					0				(1045) Fig.13 H3
	ADU Sensor 4	Paper is detected.						0			(1045) Fig.14 B7
	ADU Sensor 3	Paper is detected.							0		(1045) Fig.14 I2
ADU Sensor 2	Paper is detected.								0	(1045) Fig.14 E2	

F4 Mode (Input Check)											
No.	Function	Condition	Message Display								Remarks (Ref.No.)
			7	6	5	4	3	2	1	0	
008	Bottom Sensor (Sheet Bypass)	Home position is detected.						1			(1045) Fig.12 D7
	Front / Right Cover Open Sensor 2	See Remarks.							*		Front / Right Cover is closed. Signal 1 = 0 Signal 2 = 0 Right Cover is open. Signal 1 = 1 Signal 2 = 1 (461)
	Front / Right Cover Open Sensor 1	See Remarks.							*		
	Developer Unit Detecting Sensor	Unit is connected.									1
009	JAM Access Cover Open Detection Sensor (4th Paper Feed Module)	Cover is open.	0								(1045) Fig.23 I1
	Paper Tray Detection Sensor (4th Paper Tray)	Paper Tray is not connected.	0								(1045) Fig.23 E6
	Upper Limit Sensor (4th Paper Tray)	Upper Limit is detected.			1						(1045) Fig.23 F2
	Paper Feed Module Detection Sensor (4th Paper Feed Module)	Unit is connected.				0					---
	Feed Motor Lock Signal (3rd Paper Tray)	Normal.					0				(2402)
	Paper Feed Module Detection Sensor 2 (3rd Paper Feed Module)	See Remarks.							*		Unit is connected. Signal 1 = 1 Signal 2 = 0
	Paper Feed Module Detection Sensor 1 (3rd Paper Feed Module)	See Remarks.								*	A different signal pattern, indicates that the unit is not connected, or CST 3 PCB is defective.
010	Registration Sensor (3rd Paper Tray)	Paper is detected.	0								(1045) Fig.24 J2
	JAM Access Cover Open Detection Sensor (3rd Paper Tray)	Cover is open.		0							(1045) Fig.24 I1
	Paper Tray Detection Sensor (3rd Paper Tray)	Paper Tray is connected.				1					(1045) Fig.24 E6
	Upper Limit Sensor (3rd Paper Tray)	Upper Limit is detected.					1				(1045) Fig.24 F2
	NP Sensor (3rd Paper Tray)	Paper is not detected.							0		(1045) Fig.24 F2
	Registration Sensor (4th Paper Tray)	Paper is detected.								0	(1045) Fig.23 J2
	NP Sensor (4th Paper Tray)	Paper is not detected.								0	(1045) Fig.23 F2
011	Book Fan Lock Signal	Normal.					0				(459)
012	Not Used										

F4 Mode (Input Check)

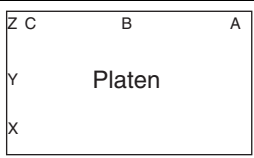
No.	Function	Condition	Message Display								Remarks (Ref.No.)			
			7	6	5	4	3	2	1	0				
013	Paper Entrance Sensor	Paper is detected.	1										1-Bin Finisher (FS300). No. 013-014 (2525) Fig.28 H1	
	Paper Exit Sensor	Paper is detected.	1										(2525) Fig.29 H6	
	Home Position Sensor	Home position is detected.			1								(2525) Fig.29 I6	
	Paper Level Sensor	Paper Hold Lever is outside.				0	0							(2525) Fig.26 D3
		Paper level is base line.				0	1							
		Paper Hold Sensor	Paper Hold Lever is inside.				1	0						
			Paper level is upper limit.				1	1						
	Paper Upper Limit Sensor	Paper Upper Limit is detected.							1				(2525) Fig.25 E4	
	Paper Tray Full Sensor	Paper Full is detected.								1			(2525) Fig.25 F3	
Front Stapler Home Position Sensor	Home position is detected.									1				
014	Stapler Cartridge Sensor	Stapler Cartridge is detected.	1										---	
	Staple Sensor	Staple is empty.	0											
	Stapler Unit Sensor	Stapler Unit is detected.			1								(2941)	
	Stapler Cover Switch	Cover is open.				0							(3018)	
	Top Cover Sensor	Cover is open.					0						(2525) Fig.30 C3	
	Joint Detect Sensor	Finisher Unit is not detected.						0					(2525) Fig.30 G4	
015-019	Not Used													
020	Size Sensor C	Original detected on the C position.									1		 <p>Front Side</p>	
	Size Sensor B	Original detected on the B position.									1			
	Size Sensor A	Original detected on the A position.							1					
	Size Sensor Z	Original detected on the Z position.					1							
	Size Sensor Y	Original detected on the Y position.				1								
	Size Sensor X	Original detected on the X position.			1									

F4 Mode (Input Check)											
No.	Function	Condition	Message Display								Remarks (Ref.No.)
			7	6	5	4	3	2	1	0	
021	Home Position Sensor	Home position is detected.								1	(270)
	ADF/Platen Cover Open Sensor	ADF/Platen Cover is open.							1		(1903)
	ADF/Platen Cover Angle Sensor	ADF/Platen Cover is open more than 30° angle.						1			
	Fuser Lamp Disconnect Detection Sensor	No Lighting					1				
	+24V Line Error Detecting Signal	+24V Line is ON.				1					---
022-029	Not Used										
030	ADF B1 Sensor	Original is detected.								1	(1045) Fig.18/33 C6
	ADF B2 Sensor	Original is detected.							1		(1045) Fig.17 C7 Fig.32 G4
	ADF Paper Exit Detection Sensor	Original is detected.						1			(1045) Fig.17 C8
	ADF Inverting Cover Open Detection Sensor	Cover is open.					1				(1045) Fig.17 G2 Fig.32 D3
	ADF Cover Open Detection Sensor	Cover is open.				1					(1045) Fig.16/33 E1
	ADF Detection Sensor 1	See Remarks.			*						iADF Signal 1 = 1 Signal 2 = 1 ADF Signal 1 = 1 Signal 2 = 0 A different signal pattern, indicates that the unit is not connected.
	ADF Detection Sensor 2	See Remarks.		*							
031	ADF Original Sensor	Original is detected.								1	(1045) Fig.17/32 G2
	ADF Original Width Sensor	Original is detected.							1		(1981)
	ADF Original Width Sensor	Original is detected.					1				
	ADF Original Length Sensor 2	Original is detected.				1					(1045) Fig.16/31 K2
	ADF Original Length Sensor 1	Original is detected.			1						
032-039	Not Used										

2. Output Check

Press the “START” key to start and press the “STOP” key to reset.

F4 Mode (Output Check)			
No.	Item	Function	Remark (Ref.No.)
040	Total Counter	When SPC PCB CN715-8 signal level changes to 0V from +24V, count up the Total Counter.	---

F4 Mode (Output Check)

No.	Item	Function	Remark (Ref.No.)
041	Key Counter / Card Counter	When SPC PCB CN726-2 signal level changes to 0V from +24V, count up the Key Counter. When SPC PCB CN726-6 signal level changes to 0V from +5V, count up the Card Counter.	---
042-049	Not Used		
050	Main Motor	When SPC PCB CN723-2 signal level changes to 0V from +5V, the Main Motor activates.	
051	Toner Bottle Motor Rotation In Forward Direction	When SPC PCB CN720-16 signal level changes to 0V from +24V, the Motor rotates in the forward direction.	---
052	Toner Supply Clutch	When SPC PCB CN720-18 signal level changes to 0V from +24V, the Clutch activates.	1 minute
053	LSU Fan / Power Supply Fan / Book Fan	When SPC PCB CN704-10 is 24V, LSU Fan rotation is high-speed. When SPC PCB CN704-9 is 24V, Power Supply Fan rotation is high-speed. When SPC PCB CN709-16 is 24V, Book Fan rotation is high-speed.	LSC (315) Power Supply (322) Book (459)
054	Density Sensor Solenoid	When SPC PCB CN714-6 signal level changes to 0V from +24V, the Solenoid activates.	2 seconds (1276)
055	Not Used		
056	Fuser Fan	When SPC PCB CN709-13 is 24V, Fuser Fan rotates.	(459)
057	Not Used		
058	Fuser Web Solenoid	When SPC PCB CN721-12 signal level changes to 0V from +24V, the Solenoid activates.	250 ms (1079)
059-060	Not Used		
061	Registration Clutch	When SPC PCB CN715-2 signal level changes to 0V from +24V, clutch operates.	1 minute (1105)
062	Not Used		
063	Paper Feed Roller Clutch (1st Paper Tray)	When SPC PCB CN715-4 signal level changes to 0V from +24V, clutch operates.	1 minute (1105)
064	Lift Motor (1st Paper Tray)	When SPC PCB CN706-2 signal level changes to 0V from +24V, motor rotates in the ascending direction.	(1168)
065	OPC Clutch	When SPC PCB CN728-2 signal level changes to 0V from +24V, clutch operates.	1 minute (950)
066-069	Not Used		
070	Paper Feed Roller Clutch (2nd Paper Tray)	When CST2 PCB CN773-2 signal level changes to 0V from +24V, clutch operates.	1 minute (1105)
071	Lift Motor (2nd Paper Tray)	When CST2 PCB CN774-2 signal level changes to 0V from +24V, motor rotates in the ascending direction.	(1168)
072	Intermediate Roller Clutch (2nd Paper Tray)	When CST2 PCB CN773-4 signal level changes to 0V from +24V, clutch operates.	1 minute (957)

F4 Mode (Output Check)			
No.	Item	Function	Remark (Ref.No.)
073-074	Not Used		
075	Paper Feed Motor (3rd Paper Tray)	When CST3 PCB CN805-4 signal level changes to 0V from +5V, activate the Motor.	(2402)
076	Paper Feed Roller Clutch (3rd Paper Tray)	When CST3 PCB CN806-2 signal level changes to 0V from +24V, clutch operates.	1 minute (1105)
077	Lift Motor (3rd Paper Tray)	When CST3 PCB CN804-2 signal level changes to 0V from +24V, motor rotates in the ascending direction.	(1168)
078	Intermediate Roller Clutch (3rd Paper Tray)	When CST3 PCB CN806-4 signal level changes to 0V from +24V, clutch operates.	1 minute (957)
079	Not Used		
080	Paper Feed Roller Clutch (4th Paper Tray)	When CST2 PCB CN773-2 signal level changes to 0V from +24V, clutch operates.	1 minute (1105)
081	Lift Motor (4th Paper Tray)	When CST2 PCB CN774-2 signal level changes to 0V from +24V, motor rotates in the ascending direction.	(1168)
082	Intermediate Roller Clutch (4th Paper Tray)	When CST2 PCB CN773-4 signal level changes to 0V from +24V, clutch operates.	1 minute (975)
083-084	Not Used		
085	Paper Feed Roller Clutch (Sheet Bypass)	When SPC PCB CN715-6 signal level changes to 0V from +24V, clutch operates.	1 minute (975)
086	Not Used		
087	ADU Intermediate Roller Clutch	When SPC PCB CN711-2 signal level changes to 0V from +24V, the Clutch operates.	1 minute (975)
088-099	Not Used		
100	Inner Upper Paper Exit Solenoid	When SPC PCB CN719-3 signal level changes to 0V from +24V, the clutch turns OFF.	(1516)
101	Inner Lower Paper Exit Solenoid	When SPC PCB CN719-1 signal level changes to 0V from +24V, the clutch turns.	(1516)
102	Paper Transport Unit Motor (Exit to Outer Tray)	Paper transport unit motor rotates in the forward direction.	(1320)
103	Paper Transport Unit Motor (Exit to ADU)	Paper transport unit motor rotates in the reverse direction.	(1320)
104	Paper Guide Solenoid ON	When EXFD PCB CN792-1 signal level changes to 0V from +24V, clutch turns ON for Straight Paper Exit.	(1127)
105	Paper Guide Solenoid OFF	When EXFD PCB CN792-3 signal level changes to 0V from +24V, clutch turns OFF for Inverting Paper Exit.	(1127)
106-109	Not Used		

F4 Mode (Output Check)

No.	Item	Function	Remark (Ref.No.)
110	Paper Feed Motor	Feed Motor rotates.	1Bin Finisher (FS300) No. 110-116 (3014)
111	Paper Alignment Motor	Paper Alignment Motor drives the Alignment Plate.	(2931)
112	Paper Tray Lift Motor	Paper Tray Lift Motor drives the Paper Tray up and down.	(2511)
113	Stapler Motor	Stapler Motor rotates 2 sec. cycle.	---
114	Paddle Solenoid	Solenoid turns ON/OFF 500 msec. cycle.	(2728)
115	Large Gear Solenoid	Solenoid turns ON/OFF 500 msec. cycle.	(2610)
116	Paper Hold Lever Solenoid	Solenoid turns ON/OFF 1 sec. cycle.	(2613)
117-119	Not Used		
120	Lamp	When SDR PCB CN656-1 signal level changes to 0V from +5V, Lamp operates.	(204)
121-159	Not Used		
160	ADF Motor Rotating (35% speed rotating)	ADF motor rotates at 35% speed.	(1801)
161	ADF Motor Rotating (100% speed rotating)	ADF motor rotates at 100% speed.	(1801)
162	ADF Motor Rotating (400% speed rotating)	ADF motor rotates at 400% speed.	(1801)
163	ADF Motor Reverse Rotating (35% speed rotating)	ADF motor rotates in reverse at 35% speed.	(1801)
164	ADF Motor Reverse Rotating (100% speed rotating)	ADF motor rotates in reverse at 100% speed.	(1801)
165	ADF Motor Reverse Rotating (400% speed rotating)	ADF motor rotates in reverse at 400% speed.	(1801)
166	ADF Paper Feed Roller Clutch 1	When ADF PCB CN22-10 signal level changes to 0V from +24V, clutch operates for 3 seconds.	(1788)
167	ADF Paper Feed Roller Clutch 2	When ADF PCB CN22-8 signal level changes to 0V from +24V, clutch operates for 3 seconds.	(1787)
168	ADF Paper Feed Roller Clutch 3	When ADF PCB CN24-2 signal level changes to 0V from +24V, clutch operates for 3 seconds.	(969)
169	ADF Paper Exit Solenoid	When ADF PCB CN26-2 signal level changes to 0V from +24V, Solenoid operates for 3 second.	(1762)
170-171	Not Used		
172	ADF Solenoid	When ADF PCB CN26-5 signal level changes to 0V from +24V, Solenoid operates for 1 second.	(1770)
173	ADF Inverting Solenoid	When ADF PCB CN26-3 signal level changes to 0V from +24V, Solenoid operates for 1 second.	(1770)
174	ADF Pinch Roller Solenoid	When ADF PCB CN26-7 signal level changes to 0V from +24V, Solenoid operates for 1 second.	(1762)
175	ADF Stamp Solenoid	When ADF PCB CN25-2 signal level changes to 0V from +24V, Solenoid operates for 1 second.	(1635)

5.1.4. F5 Mode: Function Parameters (For Copier)

Set the machine to Service Mode and press “5” key on the Keypad.



Press the “START” key.



Select the desired code number on the Touch Panel display.



If you wish to select another code number, scroll the menu with the arrow buttons.



Select the desired function on the Touch Panel display and touch the “OK” button.



When the “C (CLEAR)” key is touched, the selected code input will not be accepted.



Press “FUNCTION” and “C (CLEAR)” keys simultaneously to exit the service mode.



Reboot the machine after setting the parameter(s) to activate the setting(s).

F5 Mode			
No.	Item	Function	Default Setting
00	Country Version	0 : Japan 1 : USA/CAN 2 : Europe 3 : Other	Country Dependent
01	Frequency Desired	0 : Auto 1 : 50 Hz 2 : 60Hz	2 (for USA / Canada) 1 (for Europe)
02	Not Used		
03	LSU Startup Speed	0 : Low 1 : Full	1
04	LSU Off Timer	1 : 5 sec. 2 : 10 sec. 3 : 15 sec. 4 : 20 sec. 6 : 30 sec. 8 : 40 sec. 10 : 50 sec. 12 : 60 sec.	3
05	Not Used		
06	Job Tracking Server	0 : No 1 : Yes	0

F5 Mode			
No.	Item	Function	Default Setting
07	Language Default	English French C.French German Swedish Italian Dutch Portugal Spanish Norway Danish Finnish Turkish English Polish Hungary Japanese Czech Russian Greek Chinese Taiwan Korean	English
08	Batch Printing Mode	0 : Off 1 : On	1
09	Fuser Lamp Control	0 : Off 1 : Auto	0 (for USA / Canada) 1 (for Europe)
10	Not Used		
11	Drum Life Warning	0 : Off 1 : On	0
12	Printer Fan Extension	5 : 5 min 2 : 2 min 0 : Non	5
13	Paper Out Red Indicator	0 : Off 1 : On	1
14	Paper Size Tray 1	0 : None 1 : A3 2 : B4 3 : A4 4 : A4-R 5 : B5 6 : B5-R 7 : A5 8 : A5-R 9 : 8 x 13 10 : 8.5 x 13 11 : LEDGER 12 : LEGAL 13 : LETTER 14 : LETTER-R 15 : INVOICE	11 (for USA / Canada) 1 (for Europe)
15	Paper Size Tray 2	Same as F5-14	
16	Paper Size Tray 3	Same as F5-14	

F5 Mode			
No.	Item	Function	Default Setting
17	Paper Size Tray 4	Same as F5-14	
18-19	Not Used		
20	ADF	0 : No 1 : Auto	1
21	Finisher	0 : No 1 : Auto	1
22	System Console	0 : No 1 : Auto	1
23	Paper Transport Unit	0 : No 1 : Auto	1
24	Not Used		
25	Digital QUANTUM	0 : Off 1 : On	1
26	2-Sided Unit	0 : No 1 : Auto	1
27-29	Not Used		
30	Dual-Path Guide Unit	0 : No 1 : Auto	1
31	ADF Duplex Scanning	0 : No 1 : Auto	1
32	Job Build And SADF Mode	0 : No 1 : Yes	1
33	Not Used		
34	Multi Size Feed Default	0 : Off 1 : On	0
35	Output Tray (Inner 2)	0 : No 1 : Yes	0
36	Display DD key	0 : No 1 : Yes	1 (for USA / Canada) 0 (for Europe)
37	Output Tray (Outer)	0 : No 1 : Yes	0
38	2-Sided Mode Default	0 : No 1 : 1 to 2 2 : 2 to 2 3 : B to 2	0
39	Not Used		
40	Double Count	0 : No 1 : LDR 2 : LDR, LGL 3 : A3 4 : A3, B4	1 (for USA / Canada) 3 (for Europe)
41	Count Up Timing	0 : At feed 1 : At exit	1
42	KEY/DEPT Counter	0 : No 1 : Key Cntr 2 : DEPT. 3 : Card	0
43	Key Counter Timing	0 : At feed 1 : At exit	0
44	Insert Paper Count	0 : No 1 : Yes	0

F5 Mode			
No.	Item	Function	Default Setting
45	Dept Code Reentry Again	0 : No 1 : Yes	1
46-47	Not Used		
48	TH Sensor (DEV)	0 : No 1 : Mid 2 : Large	1
49	Not Used		
50	Auto Contrast Adjust	0 : No 1 : Yes	1
51	Dept. Counter (COPY)	0 : No 1 : Yes	1
52	Dept. Counter (FAX)	0 : No 1 : Yes	0
53	2-Sided Auto Shift	0 : No 1 : Auto sft	0
54	Margin Reduction	0 : No 1 : Yes	0
55	Margin Value Default	0 : 5 mm 1 : 10 mm 2 : 15 mm 3 : 20 mm	1
56	Edge Value Default	0 : 5 mm 1 : 10 mm 2 : 15 mm 3 : 20 mm	0
57	Book Value Default	0 : 15 mm 1 : 20 mm 2 : 25 mm 3 : 30 mm	1
58	U14 Clear	0 : Continue 1 : Any Keys	1
59	Oper. Add Toner Alarm	0 : Stop 1 : Continue	0
60	Auto Tray Selection	0 : No 1 : Yes	1
61	Not Used		
62	Overflow Detection	0 : No 1 : Yes	0
63	U13 Clear	0 : Any keys 1 : Func + 1	0
64	Dept. Counter (SCANNER)	0 : No 1 : Yes	1
65	Dept. Counter (PRINTER)	0 : No 1 : Yes	1
66	Interleaving Default	0 : Blank 1 : Copy	0
67	Page Insertion Default	0 : Blank 1 : Copy	0

F5 Mode			
No.	Item	Function	Default Setting
68	Cover Mode Default	0 : F, Blank 1 : F, Copy 2 : FB, Blank 3 : FB, Copy	0
69	Reduce N in 1 Space	0 : No 1 : Yes	0
70	PM Cycle	0 : No 1 : 1.5 K 2 : 2.5 K 3 : 5 K 4 : 10 K 5 : 15 K 6 : 20 K 7 : 30 K 8 : 40 K 9 : 60 K 10 : 80 K 11 : 90 K 12 : 120 K 13 : 150 K 14 : 200 K 15 : 240 K	12
71	Not Used		
72	Disable At Web PM	0 : Continue 1 : Stop	1
73	PM Cycle (Fuser Web)	0 : 120 K 1 : 240 K	0
74	Fuser Web Advance	0 : Short 1 : Standard 2 : Long	1
75-77	Not Used		
78	A4/LTR Size Select	0 : No 1 : Yes	0
79	Not Used		
80	Paper Size Priority	1 : A3 2 : B4 3 : A4 4 : A4-R 5 : B5 6 : B5-R 7 : A5 8 : A5-R 9 : 8 x 13 10 : 8.5 x 13 11 : LEDGER 12 : LEGAL 13 : LETTER 14 : LETTER-R 15 : INVOICE	13 (for USA / Canada) 3 (for Europe)
81	B4/FLS Size Selection	0 : B4 1 : 8 x 13 2 : 8.5 x 13	0

F5 Mode			
No.	Item	Function	Default Setting
82	Manual Skyshot Mode	0 : Off 1 : M1, On 2 : M2, On 3 : M1, M2, On	0
83	Digital Skyshot Mode	0 : No 1 : Normal 2 : Quality	1
84	Paper Tray Priority	0 : S > C > B 1 : C > S > B	1
85	Side Void Setting (ADF)	0 : None 1 : Yes	0
86	PM Cycle (Optics)	0 : No 1 : 40 K 2 : 60 K 3 : 120 K 4 : 240 K 5 : 360 K 6 : 480 K 7 : 600 K	0
87	PM Cycle (ADF)	0 : No 1 : 40 K 2 : 60 K 3 : 120 K 4 : 240 K 5 : 360 K 6 : 480 K 7 : 600 K	0
88	USB Port Function	0 : Off 1 : Once 2 : On	0
89	LAN Speed/Duplex	0 : Auto 1 : 10 Half 2 : 10 Full 3 : 100 Half 4 : 100 Full	0
90	TCH Panel Beep Sound	0 : Off 1 : Soft 2 : Loud	1
91	M1, Size	Set the default size for Manual Skyshot Mode, M1 and M2.	70 x 160
92	M2, Size		95 x 220
93-94	Not Used		
95	Paper Size (FA) (Factory use only)	0 : Japan 1 : USA/CAN 2 : Europe 3 : Other	1 (for USA / Canada) 2 (for Europe)
96	Bypass Detection (Factory use only)	0 : Japan 1 : USA/CAN 2 : Europe 3 : Other	1 (for USA / Canada) 2 (for Europe)
97	Bp tray B4/FLS/LGL (FA) (Factory use only)	0 : B4 1 : 8 x 13 2 : 8.5 x 13 3 : LEGAL	3 (for USA / Canada) 0 (for Europe)

5.1.5. F6 Mode: Adjust Parameters (For Copier)

Set the machine to Service Mode and press “6” key on the Keypad.



Press the “START” key.



Select the desired code number on the Touch Panel display.



If you wish to select another code number, scroll the menu with the arrow buttons.



Select the desired function on the Touch Panel display and touch the “OK” button.



When the “C (CLEAR)” key is touched, the selected code input will not be accepted.



Press “FUNCTION” and “C (CLEAR)” keys simultaneously to exit the service mode.



Reboot the machine after setting the parameter(s) to activate the setting(s).

F6 Mode			
No.	Item	Remarks	Setting Range
00	Adj 100% Side-Side Read	Adjustment of ratio for vertical position when scan is made.	-9 ~ +9 0.1 %
01	Adj 100% Lead-Tail Read	Adjustment of ratio for parallel position when scan is made.	-9 ~ +9 0.1 %
02	100% Selection	Adjustment from 99.1% to 100.9%	-9 ~ +9 0.1 %
03	Original Registration	Adjustment of platen original registration detection timing.	-30 ~ +30 0.2 mm
04	Printer Registration	Delay time is adjusted from registration roller clutch ON.	-50 ~ +50 0.5 mm
05	Main Motor Speed	Adjustment of Main Motor speed.	-10 ~ +10 0.1 %
06	Polygon Motor Speed	Adjustment Polygon Motor speed.	-5 ~ +5 0.1 %
07	Registration Void	Registration void should be adjusted.	0 ~ +99 0.5 mm
08	Trail Edge Read Timing	Adjustment of trail edge void.	-9 ~ 0 0.5 mm
09	Trail Edge Print Timing	Adjustment of trail edge void.	-9 ~ +15 0.5 mm
10	Side Adjust (Bypass)	Adjustment of LSU side-side (Sheet Bypass).	-8 ~ +7 0.5 mm
11	Side Adjust (Tray 1)	Adjustment of LSU side-side (1st Tray).	-8 ~ +7 0.5 mm
12	Side Adjust (Tray 2)	Adjustment of LSU side-side (2nd Tray).	-8 ~ +7 0.5 mm
13	Side Adjust (Tray 3)	Adjustment of LSU side-side (3rd Tray).	-8 ~ +7 0.5mm
14	Side Adjust (Tray 4)	Adjustment of LSU side-side (4th Tray)	-8 ~ +7 0.5 mm
15	Not Used		
16	Side Adjust (ADU)	Adjustment of LSU side-side (ADU).	-8 ~ +7 0.5 mm

F6 Mode			
No.	Item	Remarks	Setting Range
17	Charge Roller Voltage	Charge voltage compensation adjustment.	-76 ~ +76 2.60 V
18	Standard Laser Power	Laser power compensation adjustment.	-29 ~ +25
19	Std Bias DC Voltage	Adjustment of bias standard voltage.	-76 ~ 76 2.60 V
20	Not Used		
21	TDC Gain Voltage	Adjustment of toner density sensor gain voltage.	-86 ~ +40 0.033 V
22-24	Not Used		
25	Bias Duty Ratio (Factory use only)	Bias duty ratio adjustment	-5 ~ +5 0.80 %
26	TDC Judgment Level	Adjustment of toner supply starting judgement voltage level.	-26 ~ +26 19.5 mV
27	Bias Frequency (Factory use only)	AC Bias frequency adjustment	-5 ~ +3
28	QUANTUM White Density	Adjustment of standard white density level.	-99 ~ +99
29	QUANTUM Black Density	Adjustment of standard black density level.	-99 ~ +99
30	Light Halftone Adj.	Halftone duty ratio adjustment	-127 ~ +127
31	Fuser Temperature	Adjustment of fuser temperature.	-15 ~ +15 0.833 °C
32	Fuser Edge Temperature	Temperature compensation for edges	-15 ~ +15 0.833 °C
33	TDC Max. Read Only	Set by Digital QUANTUM (QUARC) control	-99 ~ +99 (Read only)
34	TDC Min. Read Only	Set by Digital QUANTUM (QUARC) control	-99 ~ +99 (Read only)
35	TDC Avg. Read Only	Set by Digital QUANTUM (QUARC) control	-99 ~ +99 (Read only)
36	Paper Loop (Tray 1)	Individual Fine Adjustment for Tray 1	-99 ~ +99 0.176 mm
37	Not Used		
38	ID Standard Voltage	Adjustment of judgement standard voltage.	-35 ~ +35
39	LSU Unit PWM Adjust	Adjustment of PWM value of LSU.	-32 ~ +32
40	Transfer Current Side 1	Adjustment of Transfer Current.	-16 ~ +15 0.6 μA
41	Paper Loop (Bypass)	Individual Fine Adjustment for Sheet Bypass	-99 ~ +99
42	Paper Loop (Tray 2)	Individual Fine Adjustment for Tray 2	-99 ~ +99 0.176 mm
43	Paper Loop (2-Sided)	Adjustment for the length of the loop formed before the copier timing roller.	-99 ~ +99 0.176 mm
44	FAX Laser Duty Adj	Printer Density Adjustment for FAX. (-) : Darker. (+) : Lighter.	-99 ~ +99
45	Not Used		
46	PRINTER Laser Duty Adj	Printer Density Adjustment for Printer. (-) : Darker. (+) : Lighter.	-99 ~ +99
47	Transfer Current Side 2	Adjustment of Transfer Current.	-16 ~ +15 0.6 μA

F6 Mode			
No.	Item	Remarks	Setting Range
48	Not Used		
49	T Mode Image Density	Image density adjustment for Text mode. (-) : Darker. (+) : Lighter.	-99 ~ +99
50	T/P Mode Image Density	Image density adjustment for Text/ Photo mode. (-) : Darker. (+) : Lighter.	-99 ~ +99
51	P Mode Image Density	Image density adjustment for Photo mode. (-) : Darker. (+) : Lighter.	-99 ~ +99
52	Not Used		
53	CCD Read Position Adj	Adjustment of CCD read position.	-42 ~ +44 0.2 mm
54	T Mode Contrast	Adjustment of Contrast for Text Mode.	-128 ~ +127
55	T/P Mode Contrast	Adjustment of Contrast for Text/Photo Mode.	-128 ~ +127
56	P Mode Contrast	Adjustment of Contrast for Photo Mode.	-128 ~ +127
57	Charge Roller Frequency	Adjustment of Charge Roller Frequency.	-56 ~ +25
58	Charge Roller Current	Adjustment of Charge Roller Current.	-58 ~ 0 5 μ A
59	Trail Edge Trans Trays	Trail Edge Transfer Image High Voltage Timing Adjustment for Trays 1-4 feeding.	-30 ~ +30 0.5 mm
60	Trail Edge Trans Bypass	Trail Edge Transfer Image High Voltage Timing Adjustment for Bypass Tray feeding.	-30 ~ +30 0.5 mm
61	Trail Edge Trans 2Sided	Trail Edge Transfer Image High Voltage Timing Adjustment for the 2nd side of 2-Sided printing.	-30 ~ +30 0.5 mm
62	TDC Gain Voltage Adjust	Adjustment of Toner Density sensor gain voltage.	-10 ~ +10 0.033V
63	Lead Edge Read Timing	Adjustment of Lead Edge Read Point.	0 ~ +9 0.5 mm
64	Side Edge Read Adjust	Adjustment of Side Edge Read Point.	0 ~ +9 0.5 mm
65	Black Density Reference	Reference voltage for Black Density sensor.	-127 ~ +127
66	Black Density Output	Compensate value for Black Density sensor output.	-127 ~ +127
67	ADF Image Density	Compensation of ADF image density.	-99 ~ +99
68	Paper Loop (Tray 3)	Individual Fine Adjustment for Tray 3	-99 ~ +99 0.176 mm
69	Stamp Position Adjust	Adjustment of verification stamp position.	-50 ~ +50 0.3 mm
70	Not Used		
71	ADF Main Scan Pos. 2S	Adjustment of ADF horizontal image read start position for 2-sided.	-99 ~ +99 0.05 mm
72	Orig. Lead Edge ADF 2S	Adjustment of original detection timing for 2-sided.	-99 ~ +99 0.3 mm
73	Orig. Trail Edge ADF 2S	Adjustment of trail edge detection timing for 2-sided.	-127 ~ +127 0.3 mm
74-77	Not Used		
78	Paper Loop (Tray 4)	Individual Fine Adjustment for Tray 4	-99 ~ +99 0.176 mm
79	MTF Adjust	Adjustment of Scanning Sharpness by digital image processing for Text /Photo Copy Mode.	-2 ~ +2

F6 Mode			
No.	Item	Remarks	Setting Range
80	QUANTUM Photo Mode Read	Value of QUANTUM Gamma Table for Photo Mode.	+1 ~ +5 (Read Only)
81	QUANTUM Halftone Read	Value of QUANTUM Laser duty of Check pattern.	+127 ~ +255 (Read Only)
82	QUANTUM Black Read	Value of QUANTUM Laser duty of Black pattern.	+127 ~ +255 (Read Only)
83	Temperature Sensor Value	Value of Temperature sensor.	0 ~ 255 (Read Only)
84	Humidity Sensor Value	Value of Humidity sensor.	0 ~ 255 (Read Only)
85	Not Used		
86	ADF Reverse Stop Posi.	Adjustment of ADF reverse stop position.	-99 ~ +99 0.3 mm
87	ADF Exhaust Stop Posi.	Adjustment of ADF exit stop position	-99 ~ +99 0.3 mm
88-89	Not Used		
90	ADF Read Main Scan Pos.	Adjustment of ADF horizontal image read start position.	-99 ~ +99 0.05 mm
91	Original Read Edge ADF	Adjustment of original detection timing.	-99 ~ +99 0.3 mm
92	Original Trail Edge ADF	Adjustment of trail edge detection timing.	-127 ~ 127 0.3 mm
93	ADF 100% Image 1-Sided	Adjustment of magnification for 1-sided.	-9 ~ +9 0.1 %
94	ADF 100% Image 2-Sided	Adjustment of magnification for 2-sided.	-9 ~ +9 0.1 %
95	Manual Photo Adj.	Adjustment of Gamma Table Value for Photo Mode (QUANTUM OFF)	+1 ~ +5
96	Manual Halftone Adj.	Adjustment of Laser duty of Check pattern for Text and Text/Photo Mode. (QUANTUM OFF)	+127 ~ +255
97	Manual Black Adj.	Adjustment of Laser duty of Black pattern for Text and Text/Photo Mode. (QUANTUM OFF)	+127 ~ +255
98	Not Used		
99	F5/F6 Initialization	Initialize F5/F6 parameter settings.	

5.1.6. F7 Mode: Electronic Counter

Set the machine to Service Mode and press “7” key on the Keypad.



Press the “**START**” key.



Select the desired code number on the Touch Panel display.



If you wish to select another code number, scroll the menu with the arrow buttons.



Select the desired function on the Touch Panel display and touch the “**OK**” button.



When the “**C (CLEAR)**” key is touched, the selected code input will not be accepted.



Press “**FUNCTION**” and “**C (CLEAR)**” keys simultaneously to exit the service mode.

F7 Mode						
Service Mode	Item				Remarks	
F7	Electronic Counters	00	List Print			
		01	Application password			Password for Version up, Job queue operation to print job and some PC application work.
		02	Maintenance Count	00	Total Count	Total count for all copies / prints.
				01	PM Count	Preventive Maintenance count.
				02	Scanner PM Count	PM count for scanner readings.
				03	ADF Count	Total count of originals fed through the ADF.
				04	Not Used	
				05	OPC Drum Count	PM count of recording paper fed through the OPC Drum.
				06	Process Unit Count	PM count of recording paper fed through the Process Unit.
				07	ADF PM Count	PM count of originals fed through the ADF.
				08	Fuser Web Count	PM Count for Fuser Web.
				09	Developer Count	PM Count for Developer.
				10	Not Used	
				11	Avg Print/Drum Rise Up	Average Print Count for OPC Drum.
				12	Total OPC Rotation Time	Rotation Time for OPC Drum.
		13	Avg Min / Drum Rise Up	Average Rotation Time for OPC Drum.		
		03	Paper Feed Count	00	Sheet Bypass Count	Total count of paper fed from the sheet bypass.
				01	1st Paper Tray Count	Total count of paper fed from the 1st paper tray.
				02	2nd Paper Tray Count	Total count of paper fed from the 2nd paper tray.
				03	3rd Paper Tray Count	Total count of paper fed from the 3rd paper tray.

F7 Mode							
Service Mode	Item				Remarks		
F7	Electronic Counters	03	Paper Feed Count	04	4th Paper Tray Count	Total count of paper fed from the 4th paper tray.	
				05	Not Used		
				06	2-sided Count	Total count of 2-sided Print.	
				07	A4 / LETTER Count	Total count of A4 / Letter Print.	
				08	A4R / LETTER R Count	Total count of A4-R / Letter-R Print.	
				09	A3 / LEDGER Count	Total count of A3 / Ledger Print.	
				10	B4 / LEGAL Count	Total count of B4 / Legal Print.	
		04	Scanner Count	00	ADF Count	Total count of originals fed through the ADF.	
				01	ADF Read Count	Total count of originals scanned through the ADF.	
				02	Scanner Count	Total count of scanning operations.	
				03	Scanner Read Count	Total count of scanner readings.	
		05	Copy Count	00	Copy Print Count	Total count of copies printed.	
				01	Copy Scan Count	Total count of copies scanned.	
		06	PC Count	00	PC Print Count	Total count printed from PC.	
				01	PC Scan Count	Total count scanned to PC.	
		07	Fax Count	00	Fax Transmit Count	Total count of Fax transmitted.	
				01	Fax Receive Count	Total count of Fax received.	
				02	Fax Print Count	Total count of Fax printed.	
		08	All Counter Clear				All counters are cleared.
		09	Service Mode Password (If the Data Security Kit is installed)				Password for Service Mode.

5.1.7. F8 Mode: Service Adjustment

Set the machine to Service Mode and press “8” key on the Keypad.



Press the “START” key.



Select the desired code number on the Touch Panel display.



If you wish to select another code number, scroll the menu with the arrow buttons.



Select the desired function on the Touch Panel display and touch the “OK” button.



When the “C (CLEAR)” key is touched, the selected code input will not be accepted.



Press “FUNCTION” and “C (CLEAR)” keys simultaneously to exit the service mode.

F8 Mode		
No.	Item	Remarks
00	Exp. Lamp replacement	When replacing the exposure lamp. Procedure: a) Press the Start key to move the exposure lamp to the position (approx. 250 mm from the optics home position) where it can be replaced. b) To return the optical system to the home position, press the CLEAR key.*
01-05	Not Used	
06	Error Log Print/View	a) Each time the arrow key is pressed, the machine errors or paper jam codes stored in memory are displayed, beginning with the oldest code. Note: Only the 30 most recent codes are displayed.
07	Error Log Clear	a) Press the Reset key. A Message "Error code can be cleared with the Start key" is displayed on the LCD.* b) Press the Start key.
08	(Factory use only)	Lock operation for Scanner Unit.
09	Toner Density adjustment	Adjustment operation of Toner Density.
10	Drum Charge adjustment	Adjustment operation of Drum Charge.
11	Not Used	
12	Org.size Sensor Adj.	Adjust the slice level for the original size detection sensors automatically. Execute this mode by closing the platen cover.
13	(Factory use only)	Adjustment operation of Black Density sensor.
14	Black Density gain	Adjustment operation of Black Density sensor gain.
15	QUANTUM Pattern	Print out the QUANTUM Test Pattern.
16-17	Not Used	
18	LSU PWM Pattern	Print out the Test Pattern. Proceed when the LSU is replaced.
19	Move Mirror To Lock	a) Press the Start key to move the mirror unit to the locked position for transporting the copier. b) When the mirror unit is locked, the machine will not accept any numerical key input. Note: The locking operation is automatically reset when the Power switch is turned ON again.

F8 Mode		
No.	Item	Remarks
20	TDC Check Operation	Adjustment of TDC sensor.
21-46	Not Used	
47	ADF Continuous Test	Press START key to begin.
48	Platen Continuous Test	Press START key to begin.
49-54	Not Used	

5.1.8. F9 Mode: Unit Maintenance

Set the machine to Service Mode and press “9” key on the Keypad.



Press the “START” key.



Select the desired code number on the Touch Panel display.



If you wish to select another code number, scroll the menu with the arrow buttons.



Select the desired function on the Touch Panel display and touch the “OK” button.



When the “C (CLEAR)” key is touched, the selected code input will not be accepted.



Press “FUNCTION” and “C (CLEAR)” keys simultaneously to exit the service mode.

F9 Mode							
Service Mode	Item				Remarks		
F9	Unit Maintenance	00	Fax Service Mode				
		01	Service Alert Tel #			Displays the contact number when a machine malfunction occurs.	
		02	Firmware Version	00	SC		Displays the firmware version for SC.
				01	SC Boot		Displays the firmware version for SC Boot.
				02	PNL		Displays the firmware version for PNL.
				03	SPC		Displays the firmware version for SPC.
				04	Finisher		Displays the firmware version for finisher.
				05	FAX Modem		Displays the firmware version for FAX option 1.
				06	Not Used		
				07	SC2		Displays the firmware version for Slot 1.
				08	Not Used		
				-			
				11			
				12	Data Security Kit		Displays the firmware version for Data Security Kit.
		03	Print Device Info.	00	F5/F6 Parameters		Prints the memory contents of the F5 and F6 modes.
				01	Machine Information		Prints the machine setup information list.
				02	System Address Info.		Prints the system memory setting.
				03	RAM Address Information		Prints the RAM data dump list.
		04	RAM Edit Mode	00	Relative Address		Setting of Relative address.
				01	Real Address		Setting of Real address.
05	Serial Number						

F9 Mode						
Service Mode	Item				Remarks	
F9	Unit Maintenance	06	RAM Initialize	00	Parameter Initialize	Resets the Fax and Function parameters to default values. Note: Turn the Power Switch to the OFF and back to the ON position to enable the parameter settings.
				01	All Job Clear	Clears all Jobs stored in Flash Memory.
				02	Not Used	
				03	Shipment Set	Clears All Jobs, All Preset Data, Parameter Initialize & Resets the Counters (Fax).
				04	LBP Fuser Reset	Clears the LBP fuser error.
				05	Dept. Counter Clear	
		07	Firmware Update	00	Update from F-ROM Master Card	Updates the firmware in the machine with the Master Firmware Card.
				01	Update from USB	Updates the firmware in the machine with the USB.
		08	Program Backup (Refer to Sect. 3.7.)	00	Main	Onboard F-ROM 4MB
				01	Option 1 all	Slot 1 FRM8 PCB 8MB
				02	Option 1 a	Slot 1 FRM8 PCB 4MB (a)
				03	Option 1 b	Slot 1 FRM8 PCB 4MB (b)
				04	Option 2 all	Slot 2 FRM8 PCB 8MB
				05	Option 2 a	Slot 2 FRM8 PCB 4MB (a)
				06	Option 2 b	Slot 2 FRM8 PCB 4MB (b)
		09	Update Program Card			Creates a Master Firmware Card using the Local Firmware Update Tool. A 4MB or 8MB Flash Memory Card will be required depending upon the model.
		10	Program Copy	00	From card to slot 1	Configuration for Program copy.
				01	From card to slot 2	
				02	From slot 1 to card	
				03	From slot 1 to slot 2	
				04	From slot 2 to card	
				05	From slot 2 to slot 1	
		11	Parameter Backup			Backup the Parameter.
		12	Parameter Restore			Restore the Parameter.
		13	Page Memory Size			Displays the page memory size (MB).
		14	Sort Memory Size			Displays the sort memory size (MB).

5.2. Service Modes (For Facsimile)

Caution:

The factory default parameters are preset (country dependent) for optimum performance and in compliance with the local telecommunication regulations/standards, and do not need to be changed. Changing some of these parameters may cause the unit to be no longer compliant or become inoperable.

5.2.1. Fax Service Mode Procedure

1. To select the Service Mode

Press the “**FUNCTION**”, “**ORIGINAL SIZE (LEDGER/A3)**”, and the “**3**” keys simultaneously.

Input the password, and select the “**OK**” button to enter the Service Mode (default password is **0000000**).

Press “**9**” and “**START**” keys to enter F9 Mode: Unit Maintenance.

Select “**00 FAX Service Mode**” on the Touch Panel display to enter Facsimile Service Mode.

2. To exit the Service Mode

The Service Mode is reset when the “**FUNCTION**” and “**C (CLEAR)**” keys are pressed simultaneously.

5.2.2. FAX Service Mode Table

The following service modes are provided to assist you in setting operational functions of the unit and determining the condition of the unit.

No.	Service Mode	Description
00	Not Used	
01	Function Parameter Setting	Allows changes to the function parameters (the home position, etc.).
02	RAM Edit Mode	Factory use only.
03	Print Parameter List / Report	Prints the Function Parameter List, Page Memory Test, Printer Report, All Document File, Protocol Trace and Toner Order Form.
04	Modem Tests	Generates various binary, tonal and DTMF signals, by the modem.
05	Not Used	
06	RAM Initialize	Initialize RAM and restore the default value of the function parameters. Note: Turn the Power Switch to the OFF and back to the ON position to enable the parameter settings.
07	Not Used	
08	Check & Call	Allows input of information for Service Alert Report, Maintenance Alert Report and Toner Order Form.
09	System Maintenance	Used for Firmware Update, Firmware Backup, Parameter Restore, Parameter Backup, Transferring Firmware from the PC to the Flash Card and Sending a Received File during a fatal printer error.

5.2.3. Fax Service Mode 1 (Function Parameter Setting)

Use the following procedure to change the function parameters.

Select the **“01 Function Param. Setting”** on the Touch Panel display.



Select the desired code number on the Touch Panel display.



If you wish to select another code number, scroll the menu with the arrow buttons.



Select the desired function on the Touch Panel display and touch the **“OK”** button.



Touch the **“OK”** button 3 times.



Press **“FUNCTION”** and **“C (CLEAR)”** keys simultaneously to exit the service mode.

Function Parameter Table

No.	Parameter	Selections	Function
000	Monitor/Tel Dial	1 = Monitor 2 = Tel/Dial	Selects whether the machine starts to TX automatically during On-Hook dialing. Monitor : Start to TX after pressing START TEL/DIAL : Start to TX automatically
001	Alarm Status	1 = Off 2 = Timer 3 = Constant	Selects the No Paper or No Toner alarm status. OFF : Alarm is disabled. Timer : Alarm will shut off after 6 seconds. Constant : Alarm will not stop until “STOP” is pressed or the error is cleared/ corrected.
002	Stop Comm. JRNL	1 = Off 2 = On	Selects whether the machine prompts to print the COMM. Journal when the printout condition is set to INC and STOP is pressed during communication.
003	Continuous Poll	1 = Off 2 = Stn (Tx only) 3 = Hub (Rx only)	Selects whether the Continuous Polling feature is enabled. Stn : Place the document(s) on the ADF or Platen, then press the assigned Program Key to store or add the documents into a polled file. (See Note 1) Hub : When the polling command is initiated, the machine will continuously poll originals from the remote stations until it is interrupted by pressing “STOP” .
004	Numeric ID Set	1 = Off (will not accept) 2 = On (accepts)	Selects whether the machine accepts and allows to set or change the Numeric ID.

Function Parameter Table			
No.	Parameter	Selections	Function
005	Destination Code	000 : Austria 001 : U.K. 002 : Canada 003 : Denmark 004 : Taiwan 005 : Finland 006 : Germany 007 : Netherlands 008 : Italy 009 : Spanish 010 : Hong Kong 011 : Australia 012 : Switzerland 013 : Norway 015 : Portuguese 016 : Ireland 017 : Belgium 018 : Sweden 019 : Turkey 020 : U.S.A. 021 : France 022 : New Zealand 025 : Japan 029 : Poland 030 : Czech 031 : Russia 032 : Greece 033 : Hungary 034 : Indonesia 035 : South Korea 038 : Malaysia 039 : China 045 : Thailand 048 : South Africa 049 : Singapore 050 : Universal 051 : East Euro	Sets the Destination Code after installing the Fax Communication Board (DA-FG300). Note: It is not necessary to set the parameter for the following suffix (Destinations). The Fax Firmware is automatically loaded with the Host Firmware. PB : UK PF : France PG : Switzerland PK : China PM : Germany PT : Taiwan PU : USA
006	ID Display	1 = Number (Numeric ID) 2 = Chara (Character ID)	Selects the priority of displaying the ID.
007	JRNL Column	1 = Station 2 = RCV'D ID	Selects the contents of the ID to display on the Journal.
008	Monitor	1 = Off 2 = On	Selects whether the Monitor is ON/OFF for monitoring fax signals. (FOR SERVICE USE ONLY)
009	DC Loop	1 = Off (Normal) 2 = On (Off Hook)	Selects a false Off Hook state for back to back communication test.
010	TX Level	00 = 0 dBm ~ 15 = -15 dBm	Selects the TX signal output level, 0 to -15 dBm in 1 dBm steps. (Refer to Chapter 4.3.)
011	RX Level	1 = -43 dBm 2 = -38 dBm 3 = -33 dBm 4 = -48 dBm	Selects the receiving sensitivity of -33/-38/-43/-48 dBm.

Function Parameter Table			
No.	Parameter	Selections	Function
012	DTMF Level	00 = 0 dBm ~ 15 = -15 dBm	Selects the DTMF output level, 0 to -15 dBm in 1 dBm steps.
013	G3 RX EQL	1 = 0dB 2 = 4dB 3 = 8dB 4 = 12dB	Selects the cable equalizer for G3 reception mode, 0dB, 4dB, 8dB or 12dB.
014	G3 TX EQL	1 = 0dB 2 = 4dB 3 = 8dB 4 = 12dB	Selects the cable equalizer for G3 transmission mode, 0dB, 4dB, 8dB or 12dB.
015 ~ 016	Not Used		
017	TX Start	1 = 2400 bps 2 = 4800 bps 3 = 7200 bps 4 = 9600 bps 5 = TC7200 6 = TC9600 7 = 12000 bps 8 = 14400 bps	Selects the transmission modem start speed, 14400/12000/TC9600/TC7200/9600/7200/4800/2400 bps. Note: This parameter is applicable only when communicating with regular G3 machines. When communicating with Super G3 (V.34) machines, use Parameter No. 32.
018	RX Start	1 = 2400 bps 2 = 4800 bps 3 = 7200 bps 4 = 9600 bps 5 = TC7200 6 = TC9600 7 = 12000 bps 8 = 14400 bps	Selects the reception modem start speed, 14400/12000/TC9600/TC7200/9600/7200/4800/2400 bps. Note: This parameter is applicable only when communicating with regular G3 machines. When communicating with Super G3 (V.34) machines, use Parameter No. 33.
019	ITU-T V.34	1 = Off 2 = On 3 = Select	Selects whether the ITU-T V.34 is Off, On or Select. Select: Select whether the ITU-T V.34 is Off or On, when entering Phone Book Dialing Numbers or Manual Number Dialing.
020	ITU-T ECM	1 = Off (Invalid) 2 = On (Valid)	Select the ECM mode. Note: When communicating with V.34, the ECM mode becomes effective automatically regardless of this parameter setting.
021	EP Tone	1 = Off (without EP Tone) 2 = On (with EP Tone)	Selects whether to add the echo protect tone on V.29 mode. (Used when Echo Suppression is disabled.) On : Add Off : Do not add
022	Signal Interval	1 = 100 ms 2 = 200 ms 3 = 500 ms	Selects the time interval between the receiving signal and the transmitting signal.
023	TCF Check	1 = Normal (Short) 2 = Long	Selects the TCF check interval Long/Short
024	CED Frequency	1 = 1080 Hz (non ITU-T) 2 = 2100 Hz	Selects the CED frequency 2100/1080 Hz

Function Parameter Table			
No.	Parameter	Selections	Function
025	COMM. Start-Up	1 = First 2 = Second	Selects the communication start-up condition (XMT and Polling). (Used when Echo Suppression is disabled.)
026	Non-Standard	1 = Off (Invalid) 2 = On (Valid)	Selects own mode (Panafax mode).
027	Short Protocol B	1 = Off (Invalid) 2 = On (Valid)	Selects the short protocol mode.
028	Short Protocol D	1 = Off (Invalid) 2 = On (Valid)	Selects the short protocol mode. When activated, it allows the machine to automatically store the modem speed for each Auto Dial Number.
029	Remote Diagnostics	1 = Off (will not accept) 2 = On (accepts)	Selects whether the machine accepts Remote Diagnostics from the service station.
030	CED & 300 bps	1 = 75 ms 2 = 1 sec	Selects the pause interval between the CED and the 300 bps signal. (Used when Echo Suppression is disabled.)
031	RTC = EOL x 12	1 = Off (EOLx6) 2 = On (EOLx12)	Selects the RTC signal, EOLx6 or EOLx12.
032	V34 TX Start	2400-33600bps	Selects the transmission modem start speed for V.34 communication, 33600-2400 bps.
033	V34 RX Start	2400-33600bps	Selects the receiving modem start speed for V.34 communication, 33600-2400 bps.
034	V34 TX SR	2400-3429sr	Selects the transmission symbol rate for V.34, 3429/3200/3000/2800/2400 sr. Press "V" or "Λ" to select the symbol rate.
035	V34 RX SR	2400-3429sr	Selects receiving symbol rate for V.34, 3429/3200/3000/2800/2400 sr. Press "V" or "Λ" to select the symbol rate.
036	Not Used		
037	Protocol Display	1 = Off (not displayed) 2 = On (displayed)	Selects whether to display the modem speed during communication. (Press the Job Status Key to display)
038	Not Used		
039	Flash Time	5 = 50 ms ~ 100 = 1000 ms	Selects the pause interval before activating the Flash key.
040	Flash Time (PSTN)	5 = 50 ms ~ 100 = 1000 ms	Selects the pause interval before activating the Flash key. (For Germany, Austria and Czech)
041	Pause Time	1 = 1 sec. ~ 10 = 10 sec.	Selects the pause interval from 1 sec. ~ 10 sec. for dialing through a switchboard or for international calls.
042	Not Used		
043	Redial Interval	0 = no waiting ~ 15 = 15 minutes	Selects the redial interval from 0 to 15 minutes in 1 minute steps.
044	Redial Count	0 = no redial ~ 15 = 15 times 0 ~ 9 (For Australia Only)	Selects the redial count from 0 to 15 times in 1 step intervals. Note: In order to comply with the requirements TBR21 in the EC countries, do not select 15 times.

Function Parameter Table			
No.	Parameter	Selections	Function
045	Ring Detect Count	1 = 1 ring ~ 9 = 9 rings	Selects the ring detection count from 1 to 9 rings in 1 ring step intervals.
046	On-Hook Time	0 = 0 sec. ~ 90 = 90 sec.	Selects the on-hook time between sequential communication calls in 1 second step intervals.
047	Response Wait Interval	1 = 1 sec. ~ 90 = 90 sec. 20 ~ 150 sec. (For France Only)	Selects the waiting interval for the response after completing the dialing.
048 ~ 049	Not Used		
050	Ring Detect Mode	1 = Normal 2 = Rough	Selects the quality of ringer detection. Use if the line signal is out of regulation, set to " Rough " so that the unit may detect the ringing signals.
051	Not Used		
052	Pulse Rate	1 = 10 pps 2 = 20 pps	Selects the dial pulse rate 10/20 pps.
053 ~ 054	Not Used		
055	Busy Tone Check	1 = Off 2 = On	Selects whether to detect the Busy Tone.
056	Dial Tone Check	1 = Off 2 = On	Selects whether to detect Dial Tone before dialing the telephone number.
057	DC Loop Check (Except for USA and Canada)	1 = Off 2 = On	Selects whether the unit checks the DC Loop during communication.
058	Comm. JRNL + Image	1 = Off (without image) 2 = On (with image)	Selects whether the machine prints the COMM. Journal with image.
059	Confidential RCV Report	1 = Off (does not print out) 2 = On (prints out)	Selects whether the machine prints the Confidential RCV Report.
060	Version	Indicates the Host software version.	
061	TX/RX/PRT/CPY	1 = Fax Transmit Count 2 = Fax Receive Count 3 = Total Count 4 = Copy Print Count	Displays the transmitted, received, total printed and copied document count.
062	Print Counter	1 = Off 2 = On	Selects whether to print in the Fax Parameter List, the counter information that is displayed in the Function Parameter No. 61.
063 ~ 067	Not Used		

Function Parameter Table			
No.	Parameter	Selections	Function
068	NYSE Fax Forward (USA and Canada Only)	1 = Off 2 = On	Selects whether the machine will forward the incoming and outgoing faxes to a specified station. Note: Once this parameter is activated, Fax Forwarding via Fax Parameter 054 is automatically disabled, an Access Code of "0000" is automatically assigned and Fax Parameter 038 has a new setting added called "NYSE".
069	NYSE Local Print (USA and Canada Only)	1 = Inc 2 = On (Always)	Selects the printing condition for the incoming faxes after FAX Forwarding. INC. : Prints only if FAX Forwarding fails. ON : Always prints.
070	Line Error	1 = 128 lines 2 = 256 lines 3 = 512 lines 4 = 1024 lines 5 = 2048 lines 6 = Off (will not disconnect line)	1. Selects the line disconnect condition during reception. If the number of line errors exceed this setting, the unit will disconnect the line. 2. Selects the transmit condition of RTP/PIP or RTN/PIN. (Available if No.73 Error Detect is set to "LINES") (See Note 1)
071	Total Error	1 = 5% 2 = 10% 3 = 15% 4 = 20%	Selects the transmit condition of RTP/PIP or RTN/PIN. (Available if No.73 Error Detect is set to "RATE".) (See Note 2)
072	Continuous Error	1 = Off (unlimited) 2 = 3 lines/STD 3 = 6 lines/STD 4 = 12 lines/STD	Selects the continuous total error criteria of Off/3/6 or 12 lines in Standard mode. If continuous total error exceeds this setting, the unit will transmit RTN/PIN. (Available if No.73 Error Detect is set to "RATE".)
073	Error Detect	1 = Lines 2 = Rate	Selects the error detect condition Lines/Rate.
074	RTN Receive	1 = Disconnect 2 = Continue	Selects whether to disconnect the phone line or continue when "RTN" is received.
075	Coding	1 = MH (MH only) 2 = MR (MH or MR) 3 = MMR (MH, MR or MMR) 4 = JBIG	Selects the coding scheme.
076	Batch TX (USA and Canada Only)	1 = Off 2 = On	Selects whether the batch transmission is available.
077	RX JAM Length	1 = Off (unlimited) 2 = 2 m	Selects the maximum length of a received document that can be printed.
078 ~ 079	Not Used		
080	Original Lead Edge ADF	-99 ~ +99	Adjusts the distance between the scanning sensor ON position and the scanning start position.
081	Original Tail Edge ADF	-127 ~ +127	Adjusts the distance between the scanning sensor OFF position and the scanning end position.

Function Parameter Table			
No.	Parameter	Selections	Function
082	JAM Length	1 = 1 m 2 = 2 m	Selects the maximum length of the original that can be scanned.
083	Not Used		
084	Line As No Paper	1 = Ring (ring) 2 = Busy (keep line busy)	Selects whether to ring or send a busy tone to the remote station when the recording paper runs out or the unit cannot receive because of any trouble.
085	Not Used		
086	Reduction Fine	1 = Off 2 = On	Selects whether the resolution is preset to Fine, when sending with reduction B4→A4.
087	Darker Level	0 (Lightest) ~ 15 (Darkest)	Selects the contrast level.
088	Normal Level	0 (Lightest) ~ 15 (Darkest)	Selects the contrast level.
089	Lighter Level	0 (Lightest) ~ 15 (Darkest)	Selects the contrast level.
090 ~ 091	Not Used		
092	Smoothing	1 = Off 2 = On	Selects whether the smoothing function is available.
093 ~ 101	Not Used		
102	Original Registration	-30 ~ +30	Adjustment of original registration detection timing.
103	Trail Edge Read Timing	-9 ~ 0	Adjustment of trail edge void.
104 ~ 109	Not Used		
110	MAC Address		Indicates the MAC Address.
111	Not Used		
112	Insert EMAIL TXT	1 = Off 2 = On	Selects whether the Text Template (email message) is programmable and added on all email sent in the message body above the top line of text. (Up to 40 characters Programmed in the User Parameters.) Note: After enabling this feature, aside from entering the text in the User Parameters, it also has to be activated in each Auto Dial Number before it will take effect. It does not work for Direct Dialed Numbers.
113 ~ 114	Not Used		

Function Parameter Table			
No.	Parameter	Selections	Function
115	Time Zone	1 = Scroll 2 = Direct	Selects the setting method for Time Zone. Scroll : Allows using "Scroll Keys" to scroll through the Time Zone Table. Direct : Allows you to input the Time Zone directly, (*) key to be used as a switch between +/- .
116	Overwrite Warning	1 = Yes 2 = No	Selects whether the Overwrite Warning is included on the Internet FAX Result Receipt when programming the Auto Dialer via email.
117 ~ 121	Not Used		
122	LDAP	1 = Off 2 = On	When LDAP is used, specialize characters may be displayed as different characters.
123 ~ 174	Not Used		
175	FAX/EMAIL Default	0 = Address Book 1 = Mode Set	Selects the FAX/EMAIL Default.
176 ~ 199	Not Used		

Note 1: Continuous Polling (Station Mode)

This feature allows you to store or add documents into a polled file in memory.

To enable the Continuous Polling feature set Function Parameter No. 003 to "2:Station".

The last Program Key will be assigned with the "Store 4 Poll" Key name automatically and cannot be changed.

To prepare the document(s) to be polled, simply place the document(s) on the ADF or Platen and then press the Program Key to store or add the document(s) into a polled file.

(Note: If a regular polled file is stored in memory, the Program Key for Continuous Polling will not be accepted.)

Note 2: Function Parameter No. 070 (Line Error)-Transmit condition of RTP/PIP or RTN/PIN

Signal	Setting					
	128	256	512	1024	2048	Off
MCF/PIP	0-31	0-63	0-127	0-255	0-511	Always
RTP/PIP	32-63	64-127	128-255	256-511	512-1023	-
RTN/PIN	64-127	128-255	256-511	512-1023	1024-2047	-

Note 3: Function Parameter No. 071 (Total Error)-Transmit condition of RTP/PIP or RTN/PIN

Signal	Setting			
	5%	10%	15%	20%
MCF/PIP	0-2	0-4	0-7	0-9
RTP/PIP	3-4	5-9	8-14	10-19
RTN/PIN	5-	10-	15-	20-

Note 4: The default setting of parameters depends on the country's specifications or regulations. Print the Function Parameter List to confirm the default settings.

5.2.4. Fax Service Mode 3 (Printout of Lists, Reports and Test Results)

From this Service Mode you can print the Function Parameter List, Page Memory Test, Printer Report, All Document File, Protocol Trace and the Toner Order Form.

5.2.4.1. Function Parameter List

A list of all Function Parameters can be printed by the following procedure.

Select the **“03 Print Param. List/Report”** on the Touch Panel display.



Select the **“01 Function Parameter List”** on the Touch Panel display.



Touch the **“OK”** button 3 times.



Press **“FUNCTION”** and **“C (CLEAR)”** keys simultaneously to exit the service mode.

Function Parameter List (Sample)

```

***** -FUNCTION PARAMETER- ***** DATE MMM-dd-yyyy ***** TIME 12:07 ***P.01

000 Monitor/Tel Dial      Monitor      050 Ring Detect Mode      Normal
001 Alarm Status         Timer        051 -----
002 Stop Comm. JRNL      On           052 Pulse Rate            10pps
003 Continuous Polling   Off          053 -----
004 Numeric ID Set       On           054 -----
005 Destination Code     999         055 Busy Tone Check      On
006 ID Display           Chara       056 -----
007 JRNL Column          Station     057 -----
008 Monitor              Off         058 Comm. JRNL + Image    On
009 DC Loop              Off         059 Confidential RCV Report On

010 TX Level              -11dBm     060 Version               AAV10300PU
011 RX Level              -43dBm     061 TX/RX/PRT/CPY 000080/000168/000003/000000
012 DTMF Level           -5dBm     062 Print Counter         Off
013 G3 RX EQL            0dB        063 -----
014 G3 TX EQL            0dB        064 -----
015 -----              065 -----
016 -----              066 -----
017 TX Start              14400bps   067 -----
018 RX Start              14400bps   068 NYSE Fax Forward      Off
019 ITU-T V.34            On          069 NYSE Local Print      Inc

020 ITU-T ECM             On          070 Line Error             128
021 EP Tone              Off         071 Total Error           10
022 Signal Interval      500ms     072 Continuous Error     Off
023 TCF Check            Normal     073 Error Detect           Rate
024 CED Frequency        2100Hz    074 RTN Receive          Discn
025 Comm. Start-Up       First     075 Coding                JBIG
026 Non-Standard         On          076 Batch TX              On
027 Short Protocol B     On          077 RX JAM Length         2 m
028 Short Protocol D     On          078 -----
029 Remote Diagnostics   On          079 -----

030 CED & 300bps         75ms      080 Original Lead Edge ADF 0
031 RTC = EOL x 12      Off        081 Original Tail Edge ADF 0
032 V34 TX Start         33600bps  082 JAM Length             2 m
033 V34 RX Start         33600bps  083 -----
034 V34 TX SR            3429sr    084 Line As No-Paper      Ring
035 V34 RX SR            3429sr    085 -----
036 -----              086 Reduction Fine       On
037 Protocol Display     Off         087 Darker Level           2
038 -----              088 Normal Level          8
039 Flash Time           500ms     089 Lighter Level         14

040 -----              090 -----
041 Pause Time           3sec      091 -----
042 -----              092 Smoothing              On
043 Redial Interval      3min      093 -----
044 Redial Count         5          094 -----
045 Ring Detect Count    2          095 -----
046 On-Hook Time         5sec      096 -----
047 Response Wait Interval 55sec     097 -----
048 -----              098 -----
049 -----              099 -----

```

- PANASONIC -

***** - ***** -12345678901234567890- *****

Function Parameter List (Sample)

```

***** -FUNCTION PARAMETER- ***** DATE MMM-dd-yyyy ***** TIME 12:07 ***P.02

100 ----- 150 -----
101 ----- 151 -----
102 Original Registration 0 152 -----
103 Trail Edge Read Timing 0 153 -----
104 ----- 154 -----
105 ----- 155 -----
106 ----- 156 -----
107 ----- 157 -----
108 ----- 158 -----
109 ----- 159 -----

110 MAC Address 080023000177 160 -----
111 ----- 161 -----
112 Insert EMAIL TXT Off 162 -----
113 ----- 163 -----
114 ----- 164 -----
115 Time Zone Scroll 165 -----
116 Overwrite Warning Yes 166 -----
117 ----- 167 -----
118 ----- 168 -----
119 ----- 169 -----

120 ----- 170 -----
121 ----- 171 -----
122 LDAP On 172 -----
123 ----- 173 -----
124 ----- 174 -----
125 ----- 175 FAX/EMAIL Default ADR.Book
126 ----- 176 -----
127 ----- 177 -----
128 ----- 178 -----
129 ----- 179 -----

130 ----- 180 -----
131 ----- 181 -----
132 ----- 182 -----
133 ----- 183 -----
134 ----- 184 -----
135 ----- 185 -----
136 ----- 186 -----
137 ----- 187 -----
138 ----- 188 -----
139 ----- 189 -----

140 ----- 190 -----
141 ----- 191 -----
142 ----- 192 -----
143 ----- 193 -----
144 ----- 194 -----
145 ----- 195 -----
146 ----- 196 -----
147 ----- 197 -----
148 ----- 198 -----
149 ----- 199 -----

-PANASONIC -

***** - ***** -12345678901234567890- *****
    
```

Note:

1. The contents of the Function Parameter List may vary depending on the country's regulations.
2. “*” mark will be shown on the left side of number when setting was changed from default.

5.2.4.2. Page Memory Test

A test pattern prints out for checking the page memory (IC120 and IC121 on the SC PCB) and printer mechanism using the following procedure.

Select the **“03 Print Param. List/Report”** on the Touch Panel display.



Select the **“03 Page Memory Test”** on the Touch Panel display.



Touch the **“OK”** button 3 times.



Press **“FUNCTION”** and **“C (CLEAR)”** keys simultaneously to exit the service mode.

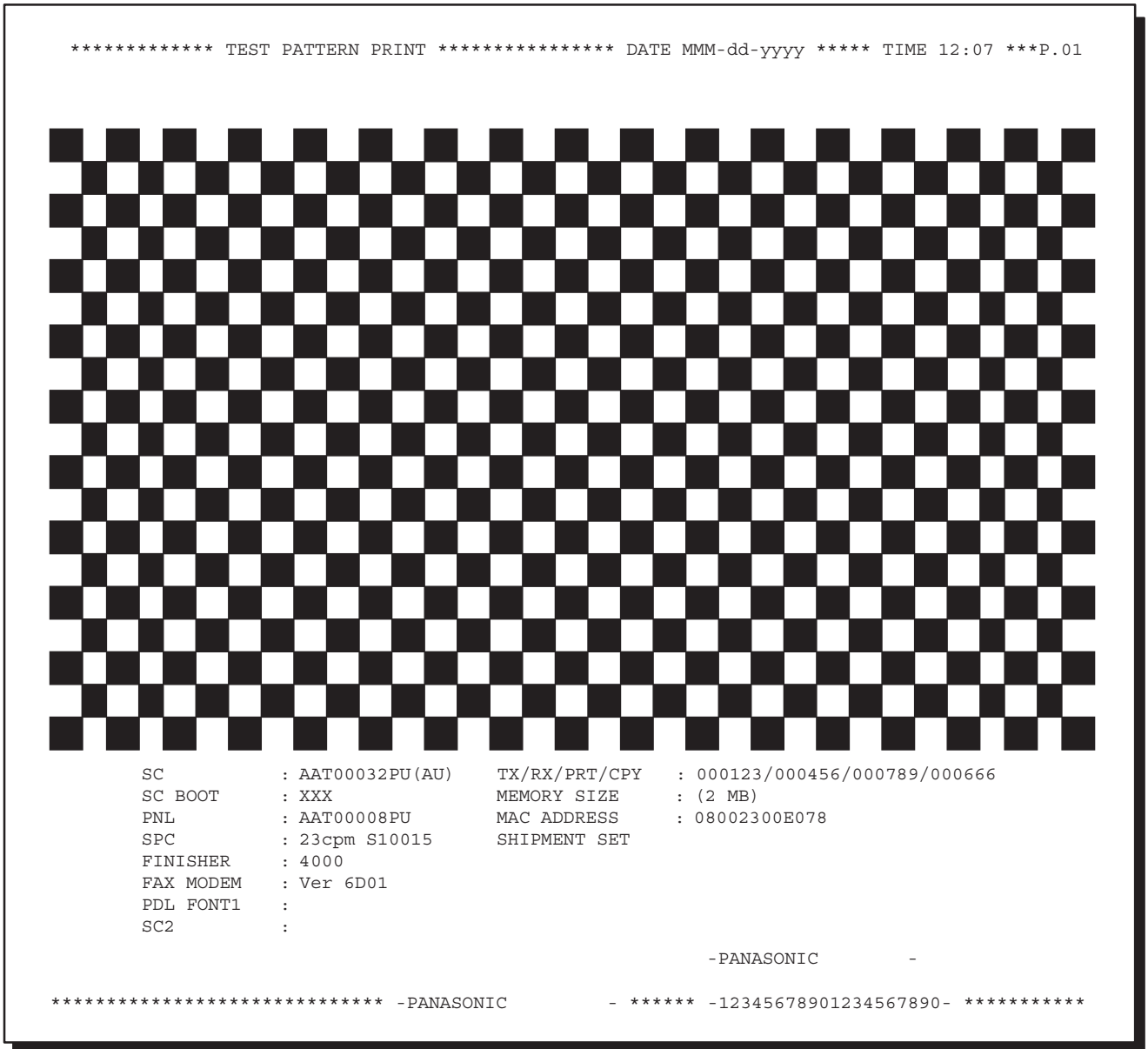

5.2.4.3. Printer Report

All printer errors are logged on the Printer Report which can be printed by the following procedure.

Select the **“03 Print Param. List/Report”** on the Touch Panel display.



Select the **“04 Printer Report”** on the Touch Panel display.



Touch the **“OK”** button 3 times.



Press **“FUNCTION”** and **“C (CLEAR)”** keys simultaneously to exit the service mode.

```

*****-PRINTER REPORT-***** DATE MMM-dd-yyyy ***** TIME 19:02*****

      LAST PRINT ERROR      : MMM-dd-yyyy 15:38 J00      00-00000016
      CUSTOMER ID           : 1234567890123456

      FIRMWARE VERSION
      SC                     : DAAV12900AU
      PNL                    : AAV20100
      SPC                    : 30cpm V20100

      TRANSMIT COUNTER       : 000475
      RECEIVE COUNTER        : 000398
      COPY COUNTER           : 000083
      PRINT COUNTER          : 000016

      NO.DATE & TIME        ERROR CODE RRROR COUNT | NO.DATE & TIME        ERROR CODE RRROR COUNT
      -----
      01.MMM-dd-yyyy 15:38 J00      00-00000016 |
      02.MMM-dd-yyyy 10:48 J02      00-00000016 |
      -----

                                     -PANASONIC -
*****-PANAFAX -*****-12345678901234567890-*****

```

5.2.4.4. All Document Files

Print the document files from the Flash Memory.

Select the **“03 Print Param. List/Report”** on the Touch Panel display.



Select the **“05 All Document Files”** on the Touch Panel display.



Touch the **“OK”** button 3 times.



Press **“FUNCTION”** and **“C (CLEAR)”** keys simultaneously to exit the service mode.

5.2.4.5. Protocol Trace

Print a Protocol Trace Report for the previous communication.

Select the **“03 Print Param. List/Report”** on the Touch Panel display.



Select the **“06 Protocol Trace”** on the Touch Panel display.



Touch the **“OK”** button 3 times.



Press **“FUNCTION”** and **“C (CLEAR)”** keys simultaneously to exit the service mode.

```

***** PROTOCOL LOG. REPORT ***** DATE MMM-dd-yyyy ***** TIME 16:56 *****

STATUS      : OK
MODE        : ECM-TX (STANDARD)
SPEED       : 9600bps 0MS/L
REMOTE CAPA. : DIS 00 CE B9 C4 80 12
LOCAL CAPA. : TSI 2B 20 20 20 38 37 2B 2B 2B 2B
              39 38 36 36 35 34 37 38 38 30
              DCS 00 C6 F8 44

COMMAND LOG.
REMOTE      : NSF   CSI   DIS           CFR
LOCAL      :
-----
REMOTE     : MCF
LOCAL     :   DCN

                                     -PANASONIC -
*****-PANASONIC -*****-12345678901234567890-*****

```

5.2.5. Fax Service Mode 4 (Modem Test)

5.2.5.1. Binary Signal

This Service Mode is used to check the binary signal output. Signals can be output to the line using the following procedure.

Select the **“04 MODEM Tests”** on the Touch Panel display.



Select the **“01 Binary Signal”** on the Touch Panel display.



Select the desired parameter on the Touch Panel display and touch the **“CLOSE”**.



Touch the **“OK”** button 3 times.



Press **“FUNCTION”** and **“C (CLEAR)”** keys simultaneously to exit the service mode.

Binary Signal Table

Number	Signals
1	V21 300bps
2	V27ter 2400bps
3	V27ter 4800bps
4	V29 7200bps
5	V29 9600bps
6	V17 TC7200bps
7	V17 TC9600bps
8	V17 12000bps
9	V17 14400bps

5.2.5.2. Tonal Signal

This Service Mode is used to check the tonal signal output. Signals can be output to the line using the following procedure.

Select the **“04 MODEM Tests”** on the Touch Panel display.



Select the **“02 Tonal Signal”** on the Touch Panel display.



Select the desired parameter on the Touch Panel display and touch the **“CLOSE”**.



Touch the **“OK”** button 3 times.



Press **“FUNCTION”** and **“C (CLEAR)”** keys simultaneously to exit the service mode.

Tonal Signal Table

Number	Signals
1	462 Hz
2	1080 Hz
3	1100 Hz
4	1300 Hz
5	1650 Hz
6	1850 Hz
7	2100 Hz

5.2.5.3. DTMF Signal

This Service Mode is used to check the DTMF (Dual Tone Multi Frequency) signal output. The DTMF signal can be generated using the following procedure.

- DTMF Single Tone

- Select the **“04 MODEM Tests”** on the Touch Panel display.
- ↓
- Select the **“03 DTM Single Tone”** on the Touch Panel display.
- ↓
- Select the desired parameter on the Touch Panel display and press the **“START”** key.
- ↓
- Press the **“STOP”** key and touch the **“CLOSE”**.
- ↓
- Touch the **“OK”** button 3 times.
- ↓
- Press **“FUNCTION”** and **“C (CLEAR)”** keys simultaneously to exit the service mode.

- DTMF Dual Tone

- Select the **“04 MODEM Tests”** on the Touch Panel display.
- ↓
- Select the **“04 DTMF Dual Tone”** on the Touch Panel display.
- ↓
- Select the desired parameter on the Touch Panel display.
- ↓
- Press the **“STOP”** key and touch the **“CLOSE”**.
- ↓
- Touch the **“OK”** button 3 times.
- ↓
- Press **“FUNCTION”** and **“C (CLEAR)”** keys simultaneously to exit the service mode.

DTMF Single Tone Table

Number	DTMF Signal Tones
1	697 Hz
2	770 Hz
3	852 Hz
4	941 Hz
5	1209 Hz
6	1336 Hz
7	1477 Hz
8	1633 Hz

DTMF Dual Tone Table

Number	DTMF Dual Tones
0	941 Hz + 1336 Hz
1	697 Hz + 1209 Hz
2	697 Hz + 1336 Hz
3	697 Hz + 1477 Hz
4	770 Hz + 1209 Hz
5	770 Hz + 1336 Hz
6	770 Hz + 1477 Hz
7	852 Hz + 1209 Hz
8	852 Hz + 1336 Hz
9	852 Hz + 1477 Hz
*	941 Hz + 1209 Hz
#	941 Hz + 1477 Hz

5.2.5.4. Binary Signal (V.34)

This Service Mode is used to check the binary signal output. Signals can be output to the line using the following procedure. (V.34)

Select the **“04 MODEM Tests”** on the Touch Panel display.



Select the **“05 V34 MODEM”** on the Touch Panel display.



Select the desired parameter on the Touch Panel display and touch the **“CLOSE”**.



Touch the **“OK”** button 3 times.



Press **“FUNCTION”** and **“C (CLEAR)”** keys simultaneously to exit the service mode.

Binary Signal Table

Number	Signals	Number	Signals	Number	Signals
01	V34 2400 sr 2400 bps	22	V34 3000 sr 9600 bps	43	V34 3429 sr 4800 bps
02	V34 2400 sr 4800 bps	23	V34 3000 sr 12000 bps	44	V34 3429 sr 7200 bps
03	V34 2400 sr 7200 bps	24	V34 3000 sr 14400 bps	45	V34 3429 sr 9600 bps
04	V34 2400 sr 9600 bps	25	V34 3000 sr 16800 bps	46	V34 3429 sr 12000 bps
05	V34 2400 sr 12000 bps	26	V34 3000 sr 19200 bps	47	V34 3000 sr 19200 bps
06	V34 2400 sr 14400 bps	27	V34 3000 sr 21600 bps	48	V34 3429 sr 16800 bps
07	V34 2400 sr 16800 bps	28	V34 3000 sr 24000 bps	49	V34 3429 sr 19200 bps
08	V34 2400 sr 19200 bps	29	V34 3000 sr 26400 bps	50	V34 3429 sr 21600 bps
09	V34 2400 sr 21600 bps	30	V34 3000 sr 28800 bps	51	V34 3429 sr 24000 bps
10	V34 2800 sr 4800 bps	31	V34 3200 sr 4800 bps	52	V34 3429 sr 26400 bps
11	V34 2800 sr 7200 bps	32	V34 3200 sr 7200 bps	53	V34 3429 sr 28800 bps
12	V34 2800 sr 9600 bps	33	V34 3200 sr 9600 bps	54	V34 3429 sr 31200 bps
13	V34 2800 sr 12000 bps	34	V34 3200 sr 12000 bps	55	V34 3429 sr 33600 bps
14	V34 2800 sr 14400 bps	35	V34 3200 sr 14400 bps	56	ANSam
15	V34 2800 sr 16800 bps	36	V34 3200 sr 16800 bps	57	CM
16	V34 2800 sr 19200 bps	37	V34 3200 sr 19200 bps	58	JM
17	V34 2800 sr 21600 bps	38	V34 3200 sr 21600 bps	59	INFO0c & TONEB
18	V34 2800 sr 24000 bps	39	V34 3200 sr 24000 bps	60	INFO0c & TONEA
19	V34 2800 sr 26400 bps	40	V34 3200 sr 26400 bps	61	PPh & AC & ALT
20	V34 3000 sr 4800 bps	41	V34 3200 sr 28800 bps		
21	V34 3000 sr 7200 bps	42	V34 3200 sr 31200 bps		

5.2.6. Fax Service Mode 6 (RAM Initialization)

Initializes RAM and restores the Function Parameters to their default values.

Note:

This operation should be performed when the unit is first installed.

Select the “**06 RAM initialize**” on the Touch Panel display.



Select the desired code number on the Touch Panel display.



Touch the “**YES**” key to initialize RAM.



Touch the “**OK**” button 3 times.



Press “**FUNCTION**” and “**C (CLEAR)**” keys simultaneously to exit the service mode.

RAM Initialization Table

No.	Initialize Mode	Description
01	Parameter Initialize	Restores the Fax and Function Parameters to default values. Note: Turn the Power Switch to the OFF and back to the ON position to enable the parameter settings.
02	Journal Clear	Clears the Journal contents.
03	Auto Dial Clear	Clears the One-touch, ABBR Numbers and Phone Books.
04	Program Dial Clear	Clears the Program keys.
05	LOGO/ID/PSWD Clear	Clears the Logo, ID, Polling Password.
06	LBP Error Log Clear	Clears the Printer Error Log.
07	Shipment Set	Deletes all setting information, except parameter number 80 and 81, then set default values.
08	Flash Memory Clear	Deletes all information in the Flash Memory.
09	All Job Clear	Clears all Jobs stored in Flash Memory.

5.2.7. FAX Service Mode 8 (Check & Call)

5.2.7.1. Overview

This feature enables the Authorized Servicing Dealers to manage and improve the machine maintenance to their customers by alerting them of equipment problems. It also can be used as a Supply Sales Tool by alerting the Dealer that the unit is running Low on Toner. The function overview is as follows:

1. The machine's printer error information is stored in the Printer Report.
2. The printer report can be manually printed when required.
3. When printer errors occurs, the unit can automatically transmit the Service Alert Report to the pre-registered telephone number or email address.
4. When the unit detects Low Toner or PM counter reached the maintenance timing, it can automatically transmit the Maintenance Alert Report to the pre-registered telephone number or email address.

Select the **"08 Check & Call"** on the Touch Panel display.



Select the desired code number on the Touch Panel display.

(i.e. 01 Service Alert Fax #, input the telephone No. or for an email address, press the **"FAX/EMAIL"** Mode key and input the email address.)



Touch the **"OK"** button.



Touch the **"OK"** button 3 times.



Press **"FUNCTION"** and **"C (CLEAR)"** keys simultaneously to exit the service mode.

5.2.7.2. Printer Reports

• Conditions under which a report can be printed or transmitted

1. Manual print

The Printer Report can be printed by Service Mode 3. (See Sect. 5.2.4.3.)

2. Automatic transmission/printout

a. Service Alert Report

When the unit detects an Emergency Printer Error, the unit will immediately transmit the Service Alert Report to the pre-registered telephone number or email address. However, the unit will not transmit the Service Alert Report if it finds the same error within the same date in the error log.

b. Maintenance Alert Report

When the unit detects Low Toner, the unit can automatically transmit the Maintenance Alert Report to the pre-registered telephone number or email address. Refer to the Error Code Table.

Note:

To activate the transmission of the Maintenance Alert Report, register both numbers "01 Service Alert Fax #" & "02 Maint Alert Fax #".

c. Call Counter Report

When the printer counter reaches the pre-set number, the unit can automatically transmit the Call Counter Report to the pre-registered telephone number or email address.

Note:

The Service and Maintenance Alert Reports are managed in the same manner as the normal memory transmission (Retry, Incomplete, File List, Display while it is transmitting, Journal).

Error Code	Log	Tx Report	Remarks
Ex-xx	O	S	Refer to the Mechanical Error Code (E Code) Table. (Sect. 4.6.3.)
E13	O		Out of Toner.
Jxx	O		Refer to the Jam Error Code (J Code) Table. (Sect. 4.6.2.) (J93 is not Logged.)
Uxx			Refer to the User Error Code (U Code) Table. (Sect. 4.6.1.)
U13	O	M	Low Toner.

Note:

TX (Transmission) Report: S = Service Alert Report, M = Maintenance Alert Report

5.2.7.3. SERVICE ALERT REPORT FORMAT

```

***** DATE MMM-dd-yyyy ***** TIME 03:47 *****
> SERVICE ALERT REPORT <
*****
LAST PRINT ERROR : MMM-dd-yyyy 20:07 E04-01 00-00000013

(5) SERIAL NUMBER : 01234567890
(1) CUSTOMER ID : ABC COMPANY
(2) FIRMWARE VERSION
    SC : BAV12600PU
    PNL : AAV10200PU
    SPC : 30cpm V11600
(3) COUNTER INFORMATION:
          CURRENT PM CYCLE
F7-02 Total Count : 13 240000 2-Sided Count : 0
    PM COUNT : 13 (-----) A4/LETTER Count : 3
    Scanner PM Count : 9 (-----) A4-R/LETTER-R Count : 10
    ADF Count : 1 (-----)
    OPC Drum Count : 13 (-----)
    Process Unit Count : 13 (-----)
    ADF PM Count : 1
          Developer Count : 13
          Corona Cleaning Count : 13
          Avg. Print/Drum Rise Up : 1.00
          Total OPC Rotation Time : 0.03
          Avg. Sec/Drum Rise Up : 0.01
          F7-04 ADF Count : 1
          ADF Read Count : 1
          Scanner Count : 9
          Scanner Read Count : 9
          F7-05 Copy Print Count : 3
          Copy Scan Count : 4
          F7-03 Sheet Bypass Count : 0
          1st Paper Tray Count : 3
          2nd Paper Tray Count : 10
          F7-06 PC Print Count : 0
          PC Scan Count : 6
          F7-07 FAX Transmit Count : 0
          FAX Receive Count : 0
          FAX Print Count : 0
(4) PRINT ERROR:
NO. DATE & TIME ERROR CODE ERROR COUNT | NO. DATE & TIME ERROR CODE ERROR COUNT
-----|-----
01 MMM-dd-yyyy 20:07 E04-01 00-00000013 |
02 MMM-dd-yyyy 20:04 E04-01 00-00000013 |
-----|-----
          -LOGO PANASONIC -
***** -CHARACTER ID - ***** -31415926535897932384-*****

```

Explanation of Contents

- (1) Customer ID
- (2) Firmware Version
- (3) Counter Information
- (4) Print Error
- (5) Serial Number

Last 30 records (Latest on top)

5.2.7.4. MAINTENANCE ALERT REPORT FORMAT

```

***** DATE MMM-dd-yyyy ***** TIME 12:00 *****

*****
> MAINTENANCE ALERT REPORT <
*****

LAST PRINT ERROR : MACHINE IS RUNNING OUT OF TONER (1)

SERIAL NUMBER    : 01234567890 (5)

CUSTOMER ID      : ABC COMPANY (2)

FIRMWARE VERSION (3)
  SC              : BAV12600PU
  PNL             : AAV10200PU
  SPC             : 30cpm V11600

TRANSMIT COUNTER : 000244 (4)
RECEIVE COUNTER  : 000082
COPY COUNTER     : 000000
PRINT COUNTER    : 000000

-LOGO PANASONIC -

***** -CHARACTER ID - ***** -31415926535897932384-*****

```

Explanation of Contents

- | | |
|--|--|
| (1) Low Toner Message (Fixed) | “MACHINE IS RUNNING OUT OF TONER” |
| (2) Customer ID | Up to 16 characters (User Identification Code) |
| (3) Firmware Version | |
| (4) Transmission / Reception / Copy / Print Counters | |
| (5) Serial Number | |

5.2.7.5. Toner Order Form

```

*****
>  TONER BOTTLE ORDER FORM  <
*****

```

**** The toner supply in your machine is running low **** (1)
To order a replacement Bottle from your Authorized Dealer

Panasonic Corp. (2)

by Phone: 1 201 111 5555 (3)
by Fax: 1 201 111 4444 (4)

Thank you for your order.

Customer Name and Address
=====

Ship to: _____ Bill to: _____

Attention: _____ Attention: _____
Phone No.: _____ Phone No.: _____

Customer ID: ABC COMPANY (5) P.O. No.(if required): _____
Toner Bottle No.: (6) Serial No.: _____

Quantity Required:

_____ / / _____
Print your name and title Signature & Date

Explanation of Contents

- | | |
|-------------------------------|---|
| (1) Low Toner Message (Fixed) | “The toner supply in your machine is running low” |
| (2) Dealer Name | Up to 25 digits |
| (3) Toner Order Tel # | Up to 36 digits |
| (4) Toner Order Fax # | Up to 36 digits |
| (5) Customer ID | Up to 16 characters (User Identification Code) |
| (6) Toner Bottle No. | DQ-TU15E-PU |

5.2.7.6. CALL COUNTER REPORT

```

***** DATE MMM-dd-yyyy ***** TIME 03:47 *****

> SCHEDULED REPORT - CALL COUNTER HAS REACHED PRE-SET VALUE <
*****
LAST PRINT ERROR : MMM-dd-yyyy 20:07 E04-01 00-00000013

(5) SERIAL NUMBER : 01234567890
(1) CUSTOMER ID : ABC COMPANY
(2) FIRMWARE VERSION
    SC : BAV12600PU
    PNL : AAV10200PU
    SPC : 30cpm V11600

(3) COUNTER INFORMATION:
          CURRENT PM CYCLE
PM COUNT : 13 (-----) A4/LETTER Count : 3
Scanner PM Count : 9 (-----) A4-R/LETTER-R Count : 10
ADF Count : 1 (-----) A3/LEDGER Count : 0
OPC Drum Count : 13 (-----) B4/LEGAL Count : 0
Process Unit Count : 13 (-----)
ADF PM Count : 1 F7-04 ADF Count : 1
Fuser Web Count : 240986 ADF Read Count : 1
Developer Count : 13 Scanner Count : 9
Corona Cleaning Count : 13 Scanner Read Count : 9
Avg. Print/Drum Rise Up : 1.00
Total OPC Rotation Time : 0.03 F7-05 Copy Print Count : 3
Avg. Sec/Drum Rise Up : 0.01 Copy Scan Count : 4

F7-03 Sheet Bypass Count : 0 F7-06 PC Print Count : 0
1st Paper Tray Count : 3 PC Scan Count : 6
2nd Paper Tray Count : 10
3rd Paper Tray Count : 0 F7-07 FAX Transmit Count : 0
4th Paper Tray Count : 0 FAX Receive Count : 0
FAX Print Count : 0

(4) Call Counter Pre-Set Value : 14000

PRINT ERROR:
NO. DATE & TIME ERROR CODE ERROR COUNT | NO. DATE & TIME ERROR CODE ERROR COUNT
-----|-----
01 MMM-dd-yyyy 20:07 E04-01 00-00000013 |
02 MMM-dd-yyyy 20:04 E04-01 00-00000013 |

-----|-----

-LOGO PANASONIC -
***** -CHARACTER ID - ***** -31415926535897932384-*****
    
```

Explanation of Contents

- (1) Customer ID
- (2) Firmware Version
- (3) Counter Information
- (4) Call Counter Pre-Set Value
- (5) Serial Number

5.2.8. Service Mode 9 (System Maintenance)

5.2.8.1. Overview

This Service Mode is used to maintain the machine. Use the following procedure for System Maintenance.

Select the **“09 System Maintenance”** on the Touch Panel display.



Select the **“01 Send RCV'D File”**. The display changes to the Fax Mode.



Select the desired Fax number.



Press **“START”** to send the Fax.

After the transmission, the machine returns to the Stand-by Mode.

Note:

If the File is NOT in the machine, it is not functioned.

Touch the "OK" button 3 times.



Press **“FUNCTION”** and **“C (CLEAR)”** keys simultaneously to exit the service mode.

System Maintenance Table

No.	Maintenance Mode	Description
01	Send RCV'D File	Transfers documents from memory to another fax machine during a fatal printer error.

6 System Description

6.1. Printing Process

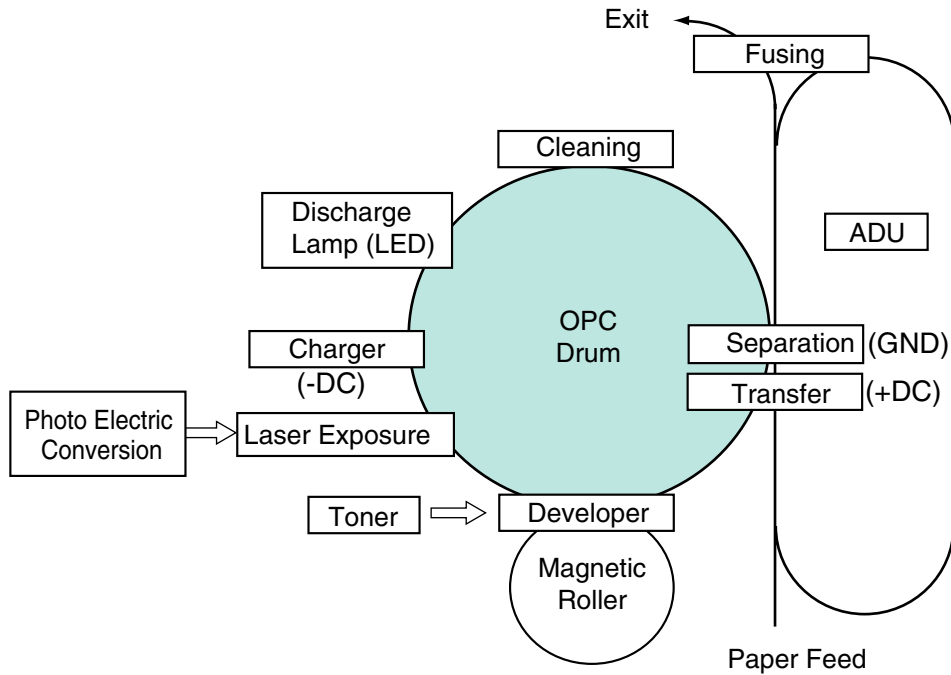

<p>Primary Charge:</p> <p>Drum Surface Approximately -750V DC</p>	<p>Image Exposure:</p>	<p>Developing:</p> <p>Latent Charge Image Image Toner Magnetic Roller Bias: -550 V Doctor Blade Gap = 0.6~0.7 mm</p>
<p>Transfer / Separation</p> <p>Latent Image Paper Discharge Plate Bias Transfer Roller Transfer Charge (+DC)</p>	<p>Fusing:</p> <p>Fuser Lamp Heat Roller Pressure Roller Paper</p>	<p>Cleaning:</p> <p>Cleaning Blade OPC Drum</p>
<p>Discharge Lamp:</p> <p>Discharge Lamp (LED) OPC Drum</p>		

6.2. Precaution with Consumables

(1) Photoreceptor (OPC) Drum

- Exercise caution not to scratch the surface of the OPC Drum (Green), and not to touch it with bare hands.
- Be careful not to smear the surface with saliva, water, oil, etc.
- Do not store in places where the temperature is high.
- Do not store it in strong light (such as direct sunlight or on the window).
- Do not expose it to chemical gas or vapor.
- Do not store the drum unit with the photoreceptor drum installed without covering it with clean paper.

(2) Toner / Developer

- 1) Do not mix different types of toner and developer.
 - The machines are designed to use exclusive toner and developer for specific models. Be careful not to use toner and developer from other models.
- 2) Do not mix foreign materials.

Be careful not to contaminate toner and developer with foreign materials. If you spill toner or developer on a table or floor when adding toner or developer in the developer unit, discard what was spilled. Such supplies may damage the drum as well as cause other image problems.
- 3) Do not place into other containers.

Toner and developer must not be placed into other containers, as some containers may change the characteristics of the supplies. Vinyl chloride potentially changes the characteristics of supplies due to migrating plasticizers.
- 4) Precautions during storage and transportation
 - Toner and developer additives are sensitive to temperature and humidity (high temperature or humidity in particular).
 - Store toner and developer in a dark and cool location (lower than 95 °F/35 °C) and out of direct sunlight.
 - Be careful not to expose toner and developer to rain or direct sunlight during transportation. When delivered by truck the temperature inside must not exceed 104 °F/40 °C. (Under the sun in summer, the inside temperature can typically be 140 °F/60 °C or higher in a closed vehicle compartment.)
 - In cold climate, store in a low humidity environment condition. Do not store supplies near heaters.
- 5) Safety and hygiene

Due to its properties, Toner can be easily wind blown.
Toner on skin does not cause any health risk. However inhalation is undesirable even if the powder is simply dust. Therefore, be careful not to inhale toner.

 - Handle the toner carefully when changing cartridges. Developer should also be handled carefully when poured into the developer unit.
If you inhale toner by mistake, rinse your mouth out with water.
Toner on the skin should be washed off with soapy water.
 - Toner stuck on clothing must be removed while in a dry state with a vacuum cleaner, brush or by beating, then by washing with soapy water.
Wiping off with benzine, alcohol, or thinner is not recommended as it may partially melt the components of toner resulting in a stain and spot.
 - Toner spills must be removed with a vacuum cleaner, and then wiped with a cloth which has been dampened with a neutral detergent.
 - If exposed to flames toner and developer will burn. Keep these supplies away from open flames.
 - Any used consumable (photoreceptor, developer and toner) should be recycled.
 - Wear rubber gloves, eye protection etc. before handling any solvents such as IPA.

6.3. New Image Stabilizing Technology

To improve the copy quality, a new Toner Density Controller (QUANTUM II System) is developed. The most important aim was to stabilize the Toner Density under various office environments. Up to now, the control method was controlled by Laser Power and Grid Voltage. The new method is controlled by Laser Pulse Duty with the Black and Gray Patterns for the Text and Text/Photo modes, and the Check Pattern for Photo mode. As a result, it optimizes the solid black density, keeps the line width consistent, and improves the halftone stability in photo mode. The following illustrations show the New System.

1. Outline

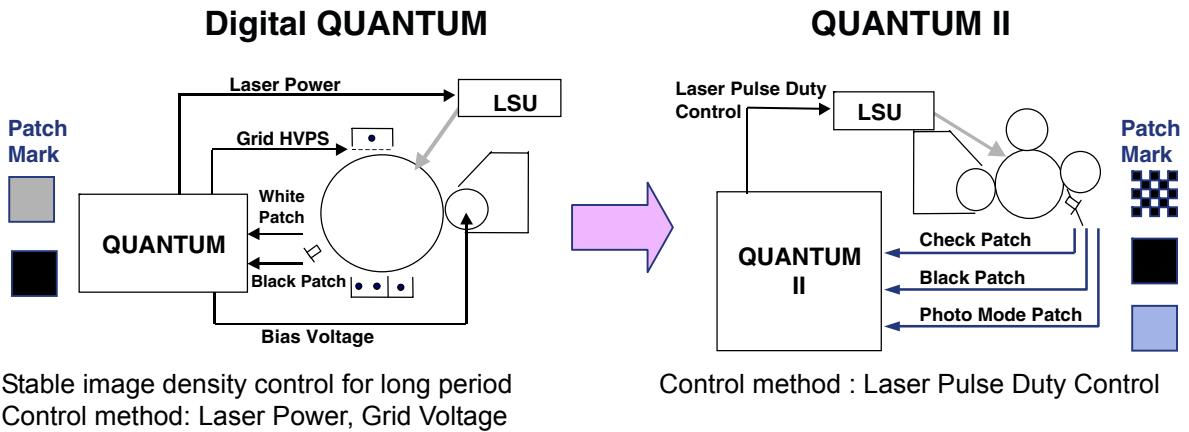

<p>Digital QUANTUM</p> <p>Black and white density is controlled to be stable by Laser Power and Grid Voltage for long periods.</p> <p>Difficult to control black solid density and line width of the image at the same time.</p>	<p>QUANTUM II</p> <p>Optimizes solid back density and keeps line width consistent by Laser Pulse Duty Control.</p> <p>Improves halftone stability in Photo Mode using Photo Mode Patch.</p>
---	--

2. Control System



Timer / Counter

QUANTUM Control Execute Timing:

1. After F8-09 (Toner Density Adj) and after F8-14 (Black Density Sensor Adjustment).
2. If QUANTUM Execute Flag* is enabled, when the Power Switch is ON or during Standby Mode.

*: QUANTUM Execute Flag is enabled after 8 hours have past since the previous QUANTUM control.

3. After 200 sheets print in condition No.2, and after every 1,000 sheets are printed.
4. Manual start by General Function Mode > Manual Copy Quality Adjustmentetc.

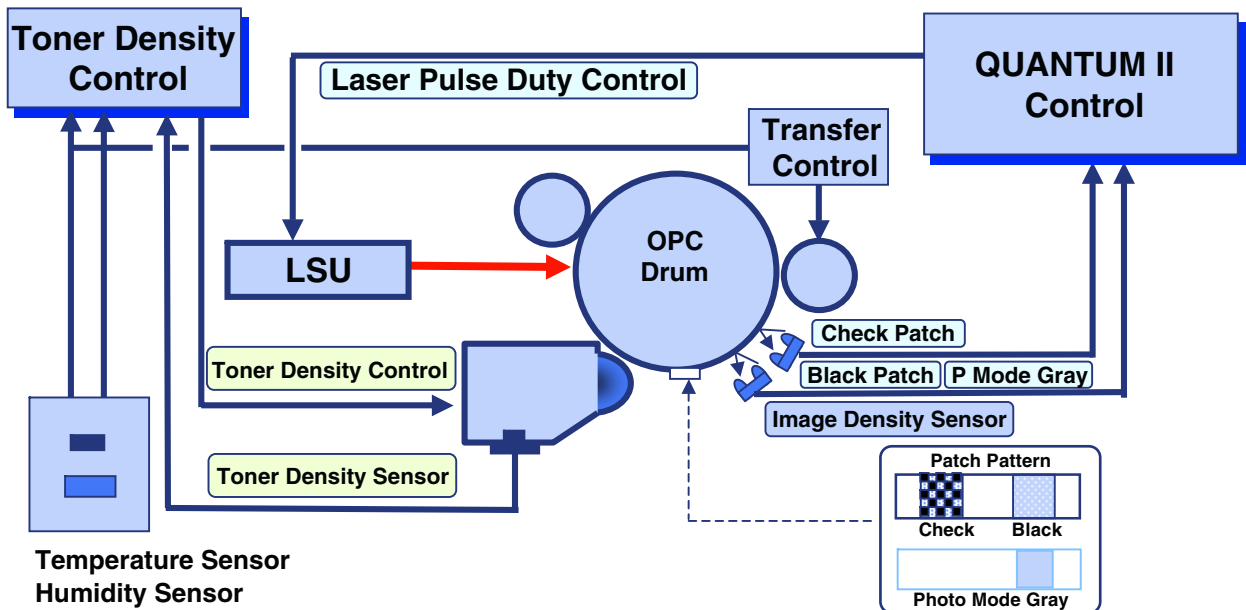

3. Control Method

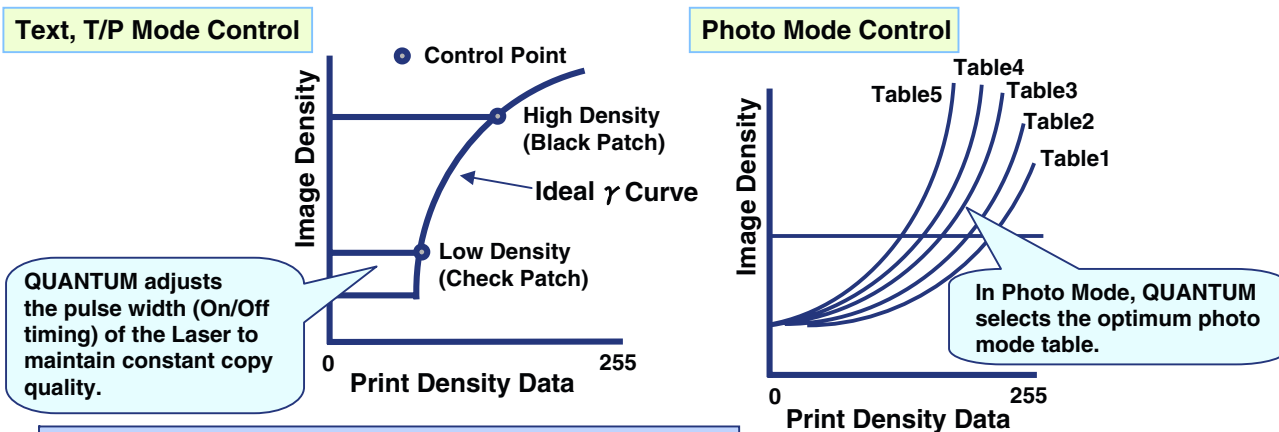

Print Image Edge Control

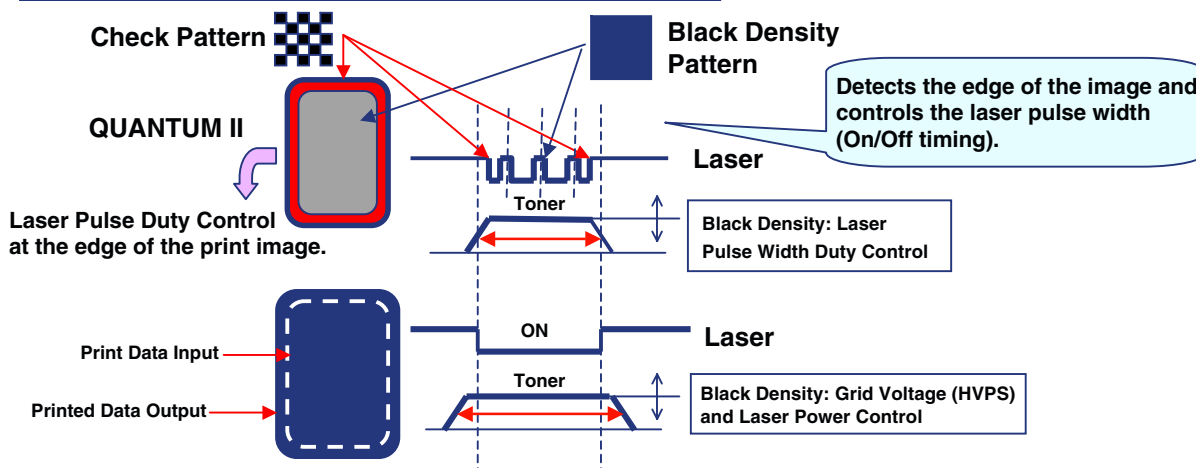

4. QUANTUM Adjustment

Compensation Values after DP-8032 / 8025 Adjustment

F5-25 QUANTUM ON
F6-80: QUANTUM Photo Mode Read
F6-81: QUANTUM Halftone Read (Laser Duty of Checkered Pattern)
F6-82: QUANTUM Black Read (Laser Duty of Black Pattern)

F5-25 QUANTUM OFF
F6-95: Manual Photo Adjustment (1-5)*1
F6-96: Manual Halftone Adjustment (Laser Duty of Checkered Pattern) (127-255)*2
F6-97: Manual Black Adjustment (Laser Duty of Black Pattern) (127-255)*2

*1: Select Photo Mode γ : Gamma Table Number
 *2: Laser Pulse Width Duty from 50% (127) to 100% (255)

Reference for DP-8060 / 8045 / 8035

F5-25 QUANTUM ON
F6-80: QUANTUM Exposure Voltage
F6-81: QUANTUM Bias DC Voltage
F6-82: QUANTUM Charge Voltage

5. Installing / Replacing Developer

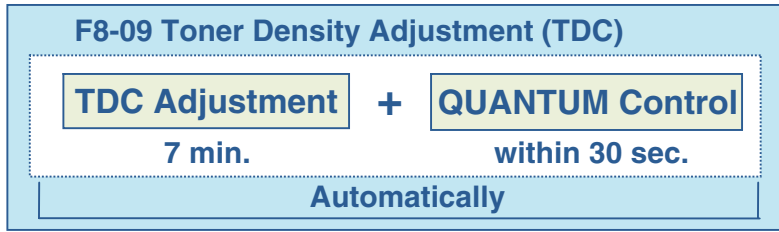

After F8-09 => F6-21: TDC Gain Voltage (0.1% / Step)
 F6-26: TDC Judgement Level

6. Installing / Replacing OPC Drum & Sensor Replacement

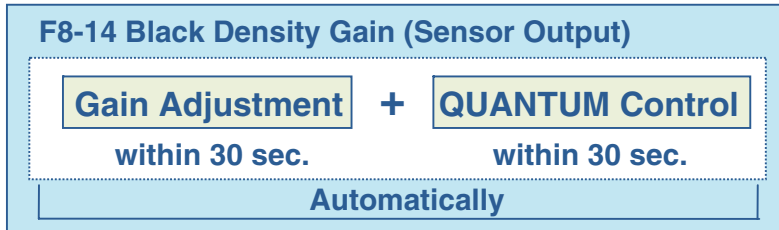

After F8-14 => F6-65: Black Density Reference (Voltage)
 F6-66: Black Density Output (Quantum Compensation = 0)

7. Service Parameters for Copy Image Compensation

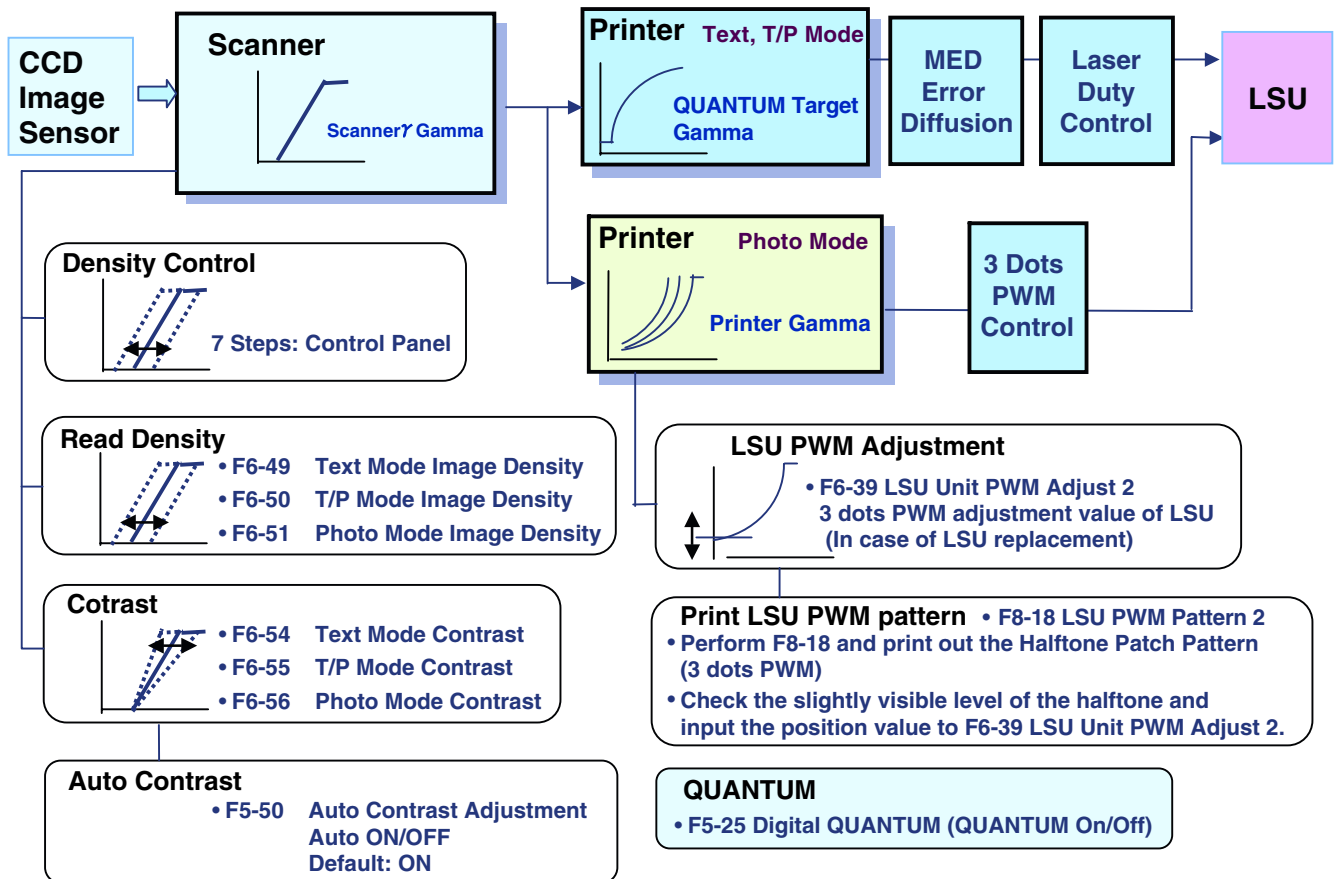

6.4. Mechanical Operation

6.4.1. Scanning Mechanism (Flatbed)

1. Scanning Mechanism

The Scanning Mechanism consisting of Lens, CCD PCB Assy (207), Mirrors, Xenon Lamp (204), Lamp Base Bracket (224) and Mirror 2 Bracket (233), is used to scan originals.

- The Mirror 1 (264) and Mirrors 2 (265) reflect image information, in the form of light, through the Lens.
- The Lens focuses the image information and passes it to the CCD.
- The CCD, mounted on the CCD PC Board, converts the image information into an electrical signal.
- The Inner and Outer Timing Belts (202 & 203) driven by the Stepping Motor (201), move the Scanner Assembly.

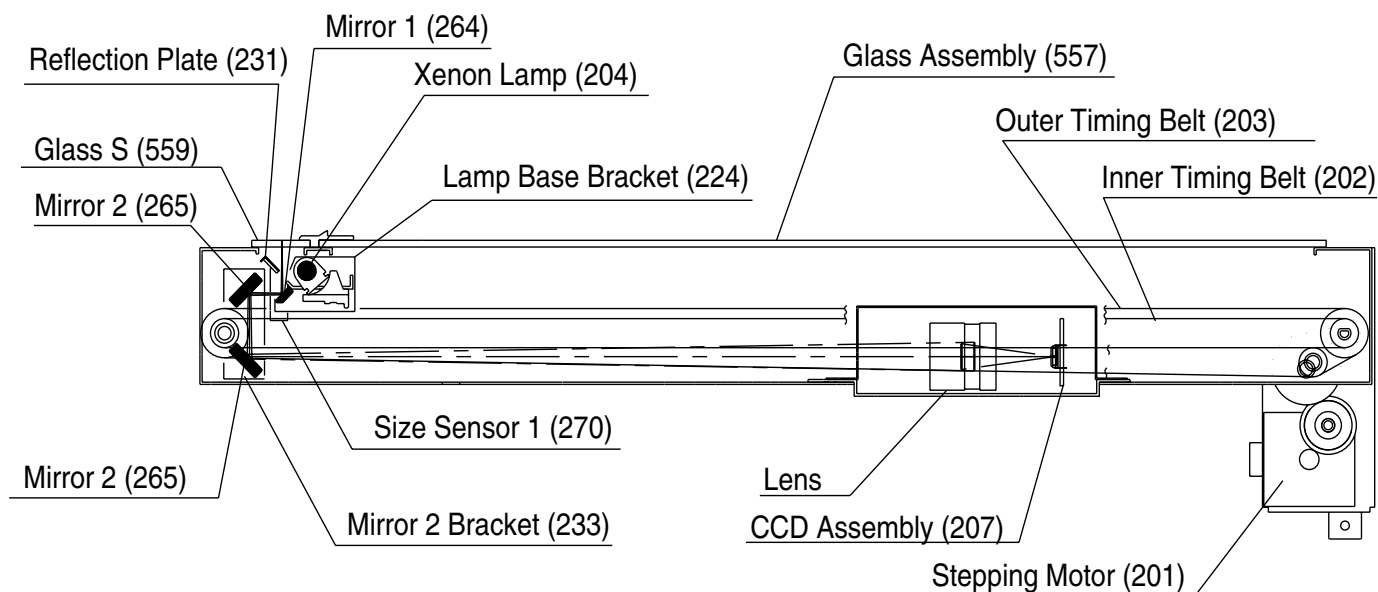

2. Transmit Mechanism

- When ADF is used, originals are scanned on the Glass S (559). The Glass Assembly (557) is used when scanning on the Platen.
- The Scanning point is established by the Size Sensor 1 (270).
- Document size is automatically set by the Original Size Sensor (1045) or manually set when the Platen is used.
- The Transmit Mechanism starts feeding and scanning originals based on the above Document Size Setting.
- When scanning is completed, the Stepping Motor (201) stops rotating and the Lamp Base and Mirror 2 Brackets (224 & 233) return to the standby position.

During scanning, the Lamp Base Bracket (224) and Mirror 2 Bracket (233) move in the direction of the Black arrow and while returning to standby position, it moves in the direction of the White arrow as shown in the illustration below. The location of these two brackets are established by the Size Sensor 1 (270) and the scanning length is established by the setting on the Touch Panel. The following illustrates the Drive system.

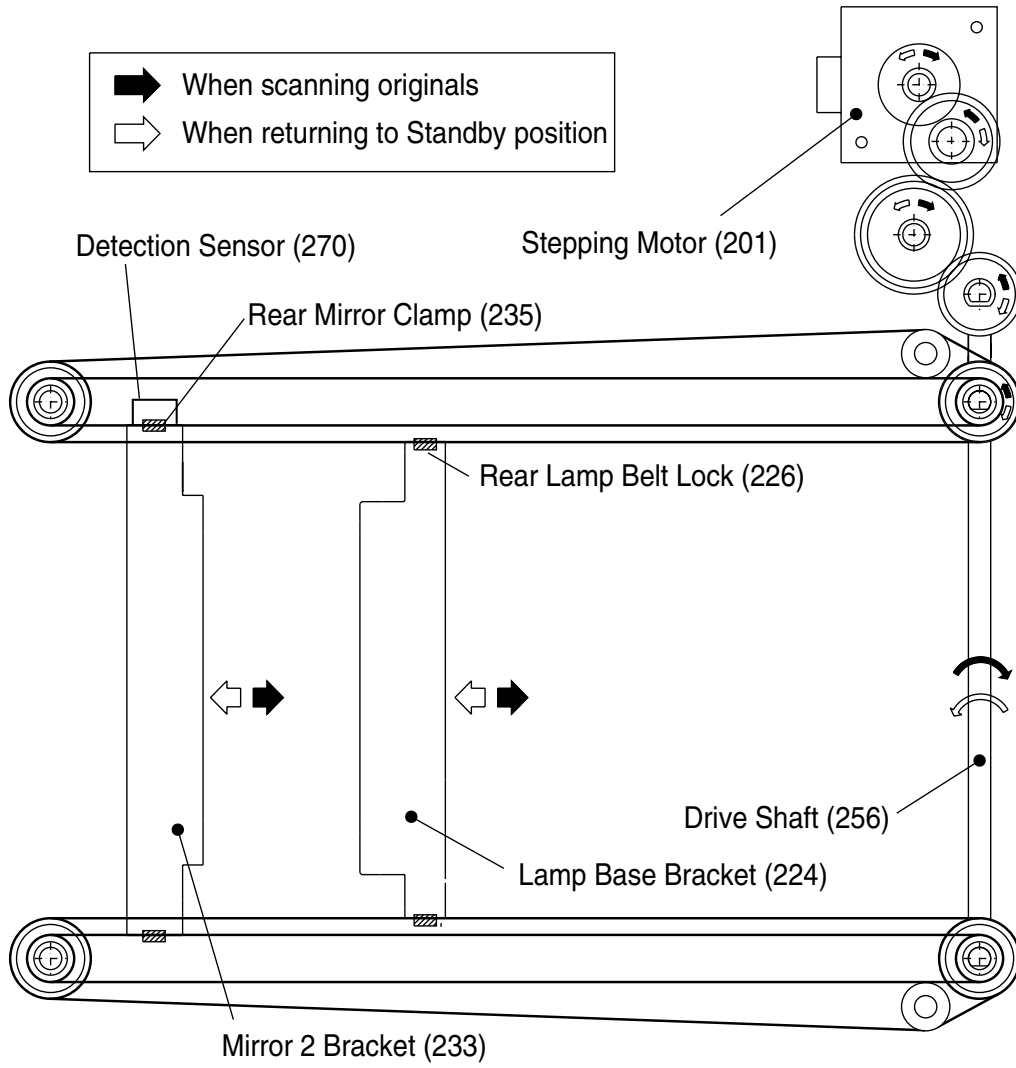

6.5. Automatic Document Feeder

The ADF (Automatic Document Feeder) automatically feeds paper into the unit, one original at a time. Its main features are:

1. Place originals Face-Up
2. Correct Order Stacking (Collation Mode)
3. Paper Feed Mechanism with Pre-Feed Roller
4. Oversized Feed 2 Roller for stable scanning

The following is the ADF/i-ADF Mechanical operation description.

6.5.1. Automatic Document Feeder

Automatic Document Feeder

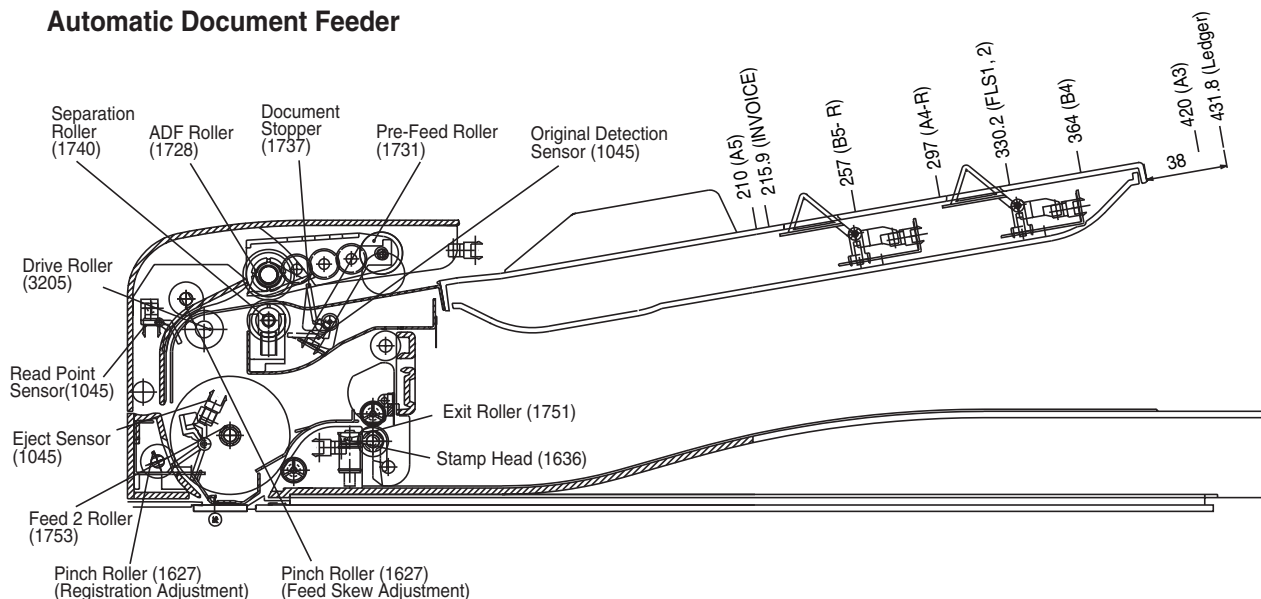

1. Initialization

The ADF begins its operation with the Eject phase in order to feed and eject any documents stuck inside the ADF. The Clutch (1788) starts rotating and lowering the Original Stopper (1737) and the Pre-Feed Roller (1731), after a few seconds the Clutch reverses the rotation direction raising the Document Stopper to its standby position.

2. Original Setting and Size Sensors

Place the original(s) face up on the ADF until the leading edge stops against the Document Stopper. Adjust the Original Guides (1605 & 1606) to center the original on the ADF. The Document Stopper prevents originals from skewing and multiple feeding. The Original Detection Sensor (1045) detects the presence of documents on the ADF when the original(s) actuate Actuator 1 (1836) on the ADF Cover (1831). The two Sensors mounted on the SNS PC Board (19116) which is installed in the ADF Input Tray (1604) are actuated by the Original Guides, their position determines the original's width and the Original Length Sensor1 (1045) and Length Sensor2 (1045) detect the length of the original.

3. Feeding and Separation

When the Start button is pressed, the Clutch (1260) starts to rotate and lowers the Document Stopper, causing the Pre-Feed Roller (1731) to apply a downwards pressure against the originals. After a few seconds, the Clutch (1260) reverses the direction of rotation and the Pre-Feed Roller is raised upwards along with the Document Stopper. The upper original is fed to the ADF Roller (1728), and the Separation Roller (1740) with Torque Limiter prevents multiple feeding.

4. Transmission and Ejection

The original is fed into the Drive Roller (3205) and when the original actuates the Read Point Sensor (1045), the ADF Roller stops rotating. The Eject Sensor (1045) detects the scanning position and the Feed 2 Roller (1753) transports the original while scanning. The Stamp Head (1636) stamps an [X]

mark on the front of the original after the document is successfully transmitted or stored. It consists of the Stamp Head (1636) and Stamp Solenoid (1635). The Exit Roller (1751) feeds and ejects the original out of the ADF. If there are additional originals on the ADF, the next one is fed into the feeder.

5. Final Operation

After ejecting the last original on the ADF, the Clutch reverses the direction of rotation raising the Document Stopper to its standby position.

6.5.2. Inverting Automatic Document Feeder

The i-ADF automatically inverts two-sided original(s) for faxing or copying of the second side. This feature enables machines with a duplexer mounted to perform duplex copying.

An i-ADF (Inverting Automatic Document Feeder) functions in a similar manner as the ADF (Automatic Document Feeder), with the main exception being the document eject path after scanning. The following is the description of the main differences.

Inverting Automatic Document Feeder

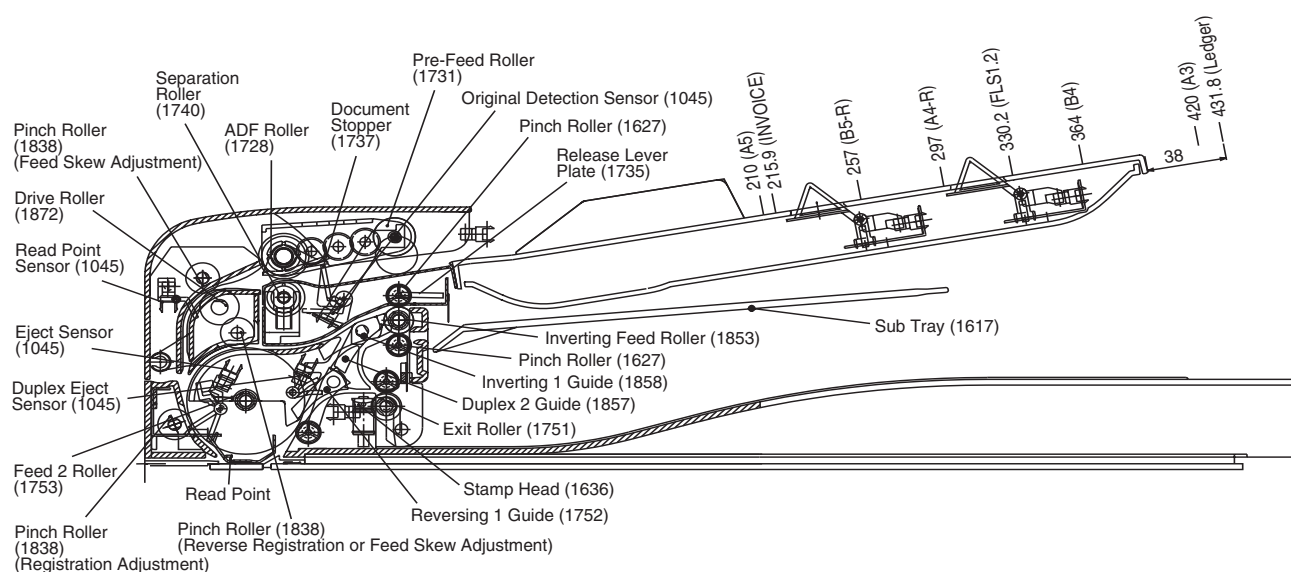

1. Switching from the ADF mode to the i-ADF mode

After passing through the Read Point Sensor (1045), the path of the original is switched over by the Duplex 2 Guide (1857), to the Exit Roller (1751) or to the Inverting Feed Roller (1853). For single-side scanning, the Duplex 2 Guide is rotated clockwise by the Solenoid (1770) guiding the original to the Exit Roller. For double-side scanning, the Duplex 2 Guide is rotated counter-clockwise by the Solenoid (1770) guiding the original to the Inverting Feed Roller (1853). The Duplex 2 Guide moves only once, in the direction according to whether a single or double-side scanning is selected (Copier or Fax) before the Start button is pressed.

It will remain in this position until a different operation is performed (i.e. if the last operation was 2-sided scanning, a single-side scanning is performed).

2. Scanning the Front and the Back Side of an Original

The scanning of the Front and Back side of a 2-sided original is accomplished by means of the Duplex 2 Guide (1857) and Inverting 1 Guide (1858).

After the Front side of the original is scanned, the original is transported through the Duplex 2 Guide, through the Inverting 1 Guide (1858) that was rotated counter-clockwise by the Solenoid (1762) and is carried beyond the Inverting Feed Roller (1853) and upper Pinch Rollers (1838) into the Sub Tray (1617).

The original is carried for a specified period of time after the trailing edge of the original triggers the Duplex Eject Sensor (1045) and stops within 10 to 20 mm from exiting the rollers.

Then, the Inverting 1 Guide is rotated clockwise by the Solenoid and the reverse rotation of the ADF Motor (1801) pulls the original back around the Feed 2 Roller (1753) and proceeds to scan the Back

side of the original.

After the Back side is scanned, the original is transported through the Duplex 2 Guide, through the Inverting 1 Guide and is carried beyond the Inverting Feed Roller and lower Pinch Rollers (1838) this time, into the Sub Tray, again stopping 10 to 20 mm from exiting the rollers.

3. Eject by Reverse Rotation

For the originals to stack properly, the above process repeats one more time. The Inverting 1 Guide is rotated clockwise by the Solenoid and the reverse rotation of the ADF Motor pulls the original back around the Feed 2 Roller, however, this time the original is routed to the Exit Roller (1751) and exits into the ADF Base (1633).

4. Sub Tray

The Inverting ADF system includes a Sub Tray (1617), which supports the originals during the ejection mode of the double-side scanning operation.

The Release Lever Plate (1735) grasps the originals and prevents them from being ejected into the Sub Tray.

6.6. Receive Mechanism

6.6.1. Paper Feed Modules

1. Paper Feed Module (1st/2nd/3rd/4th)

< NP Sensor Operation >

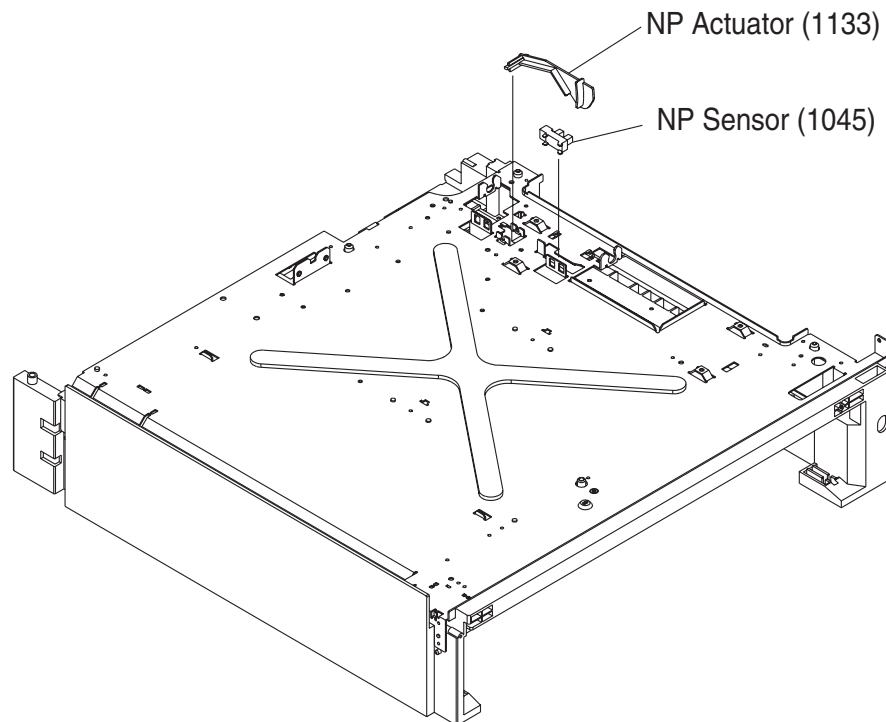

- a. The NP Actuators (1133) attached to the Paper Feed Blocks No.1, 2, 3 and 4 determine if there is paper in the paper tray.
- b. The paper in the paper tray lifts up the NP Actuator, allowing the light from the LED to actuate the NP Sensor (1045).

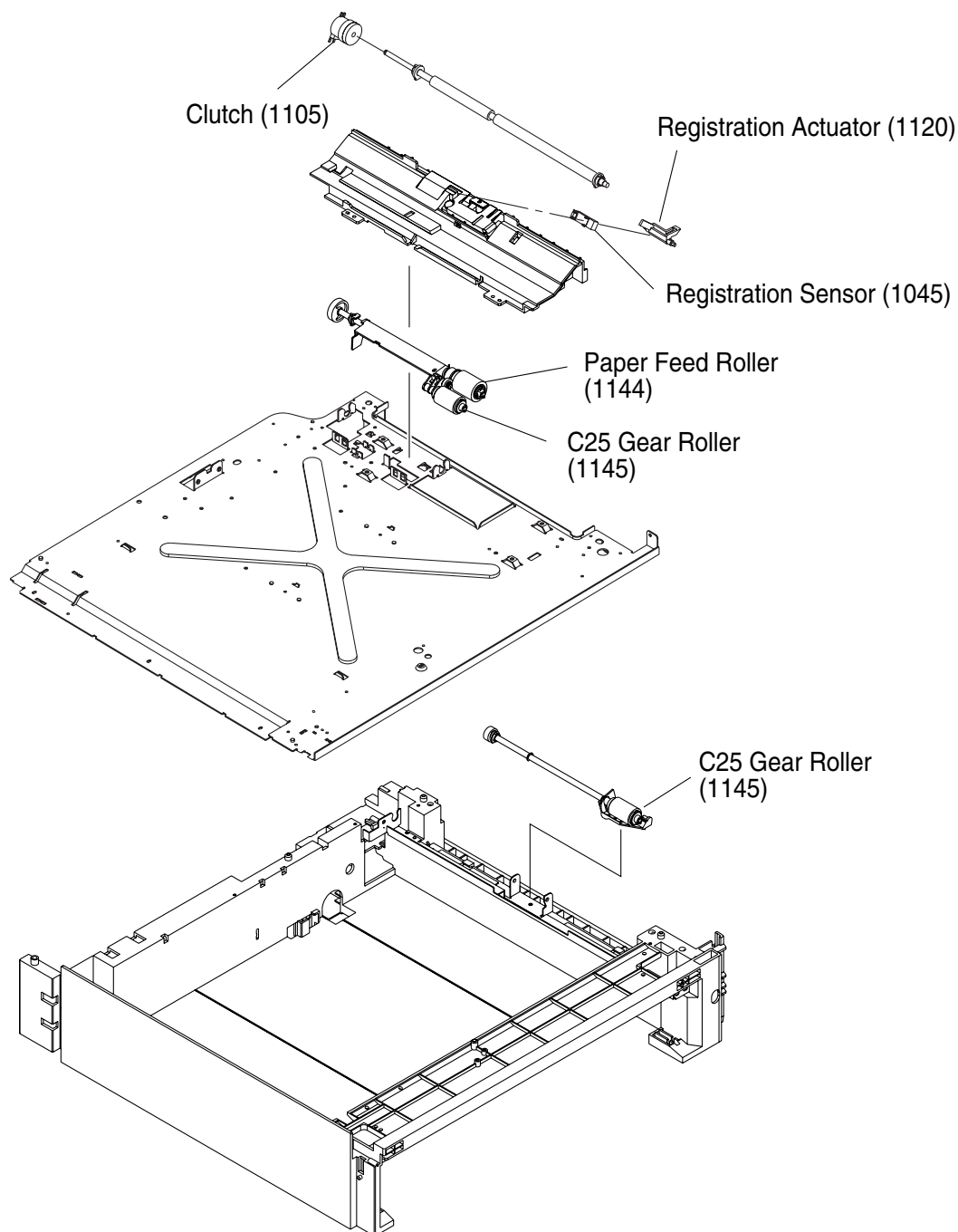
< Paper Feed Module Operation >

- When the printing operation begins, the Main Motor (907) starts driving the Gears.
- The Clutch (1105) is energized for a specified period of time and turns ON. This activates the Paper Feed Roller (1144). The paper is separated into individual sheets by the C25 Gear Roller (1145) and is transported.
- The paper is transported to the Registration Roller (1121), activating the Registration Sensor (1045). After a specified period of time, the Clutch (1105) is turned ON and the Registration Roller (1121) and the Registration Pinch Roller start rotating. The paper is transported to the OPC drum area.
- The paper passes through the Read Point Sensor (1045) and after a specified period of time, the Clutch (1105) is turned OFF. The Registration Roller and the Registration Pinch Roller stop rotating.

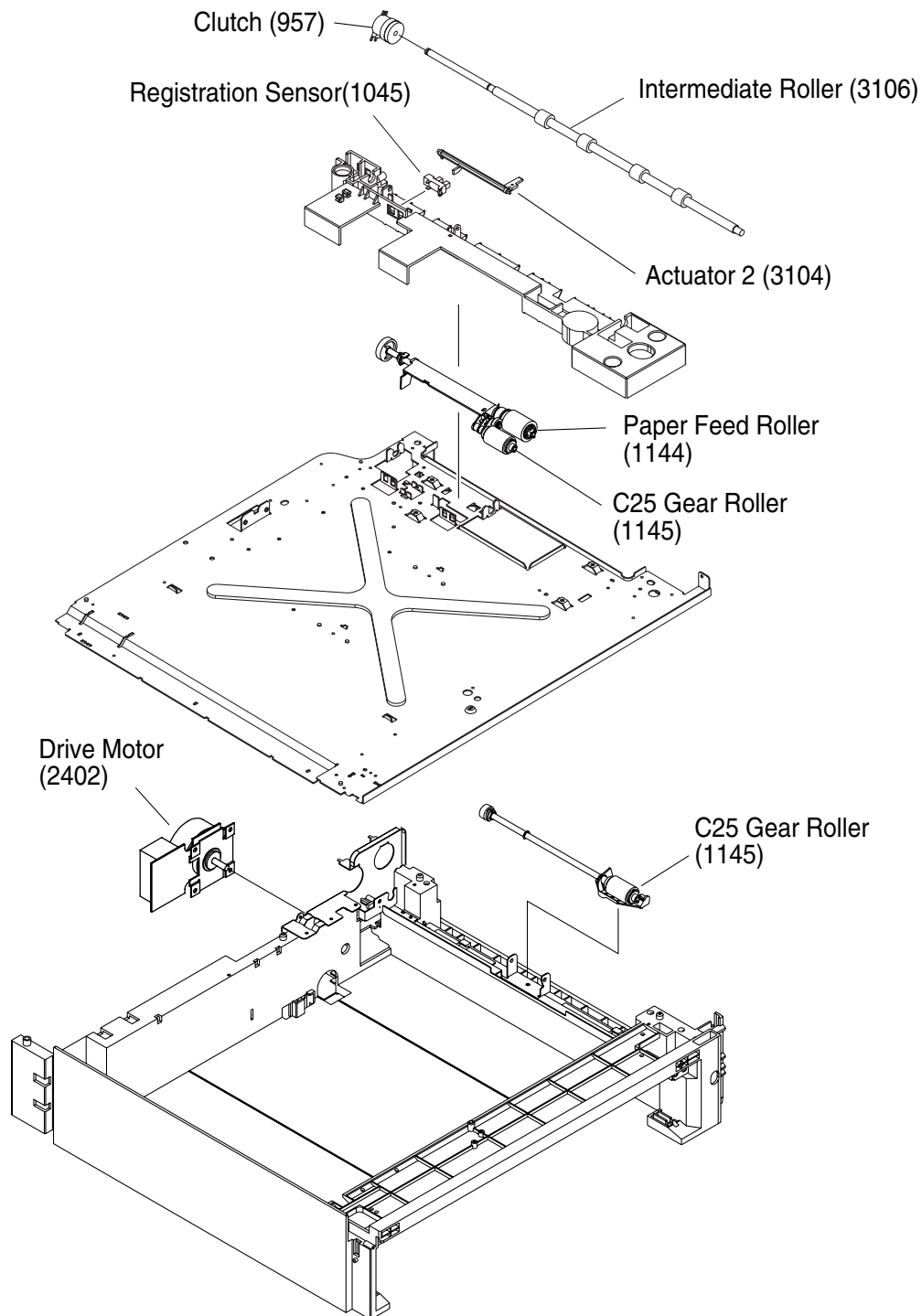
< Paper Feed Module (Optional) Operation >

- When the printing operation begins, the Main Motor (907) and the Drive Motor (2402) start driving the Gears.
- The Clutch (1105) is energized for a specified period of time and turns ON. This activates the Paper Feed Roller (1144). The paper is separated into individual sheets by the C25 Gear Roller (1145) and transported by the Intermediate Roller (2306).
- The paper is transported to the Registration Roller (1121), activating the Registration Sensor (1045). After a specified period of time, the Clutch (1105) is turned ON and the Registration Roller (1121) starts rotating. The paper is transported to the OPC drum area.
- The paper passes through the Read Point Sensor (1045) and after a specified period of time, the Clutch (1105) is turned OFF. The Registration Roller and the Registration Pinch Roller stop rotating.

< Paper Feed Module Lift up Mechanism >

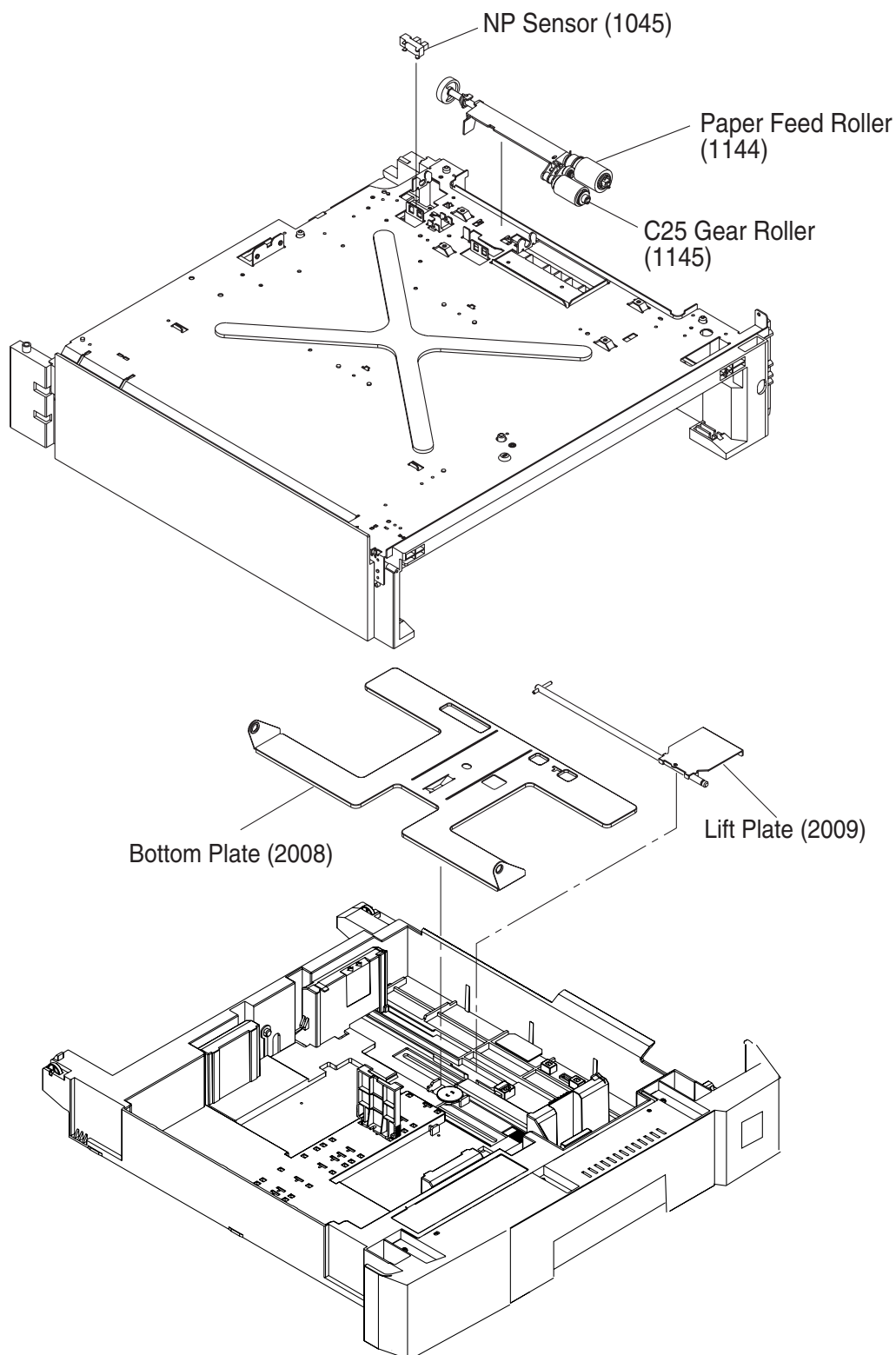

- a. When inserting the Paper Tray into the machine, the NP Sensor (1045) activates. At the same time, the Lift Plate (2009) is combined with the coupling which drives the Lift Plate of the machine. The Lift Plate rotates, lifting the Bottom Plate (2008) and the Recording Paper.
- b. Once the Bottom Plate and the Recording Paper are raised, the NP Sensor (1045) is turned ON. The Lift DC Motor (1152) stops rotating, maintaining the recording paper at the certain level.

< Paper Feed Module Recording Paper Size Setting >

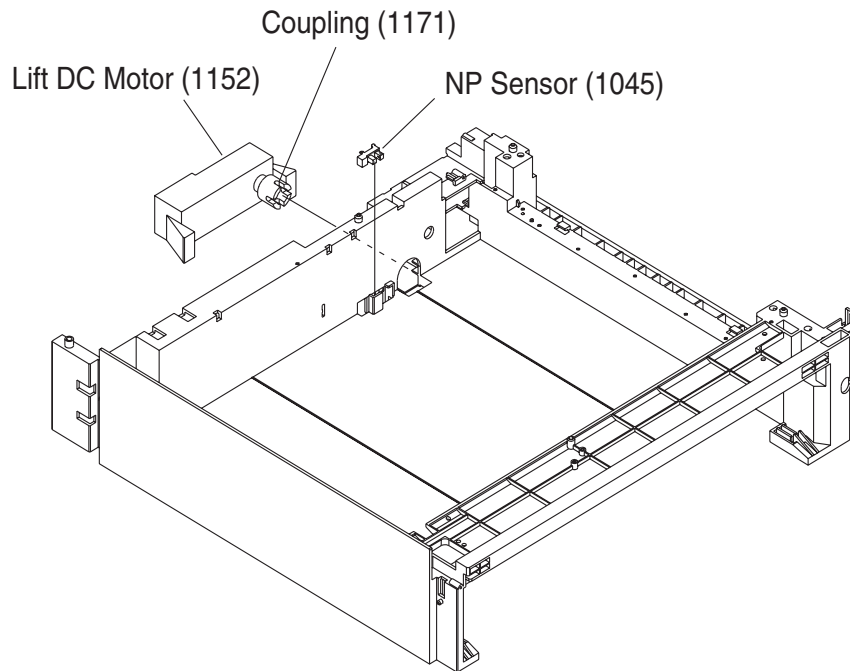

- a. The Recording Paper size in the Paper Feed Module is set on the Touch Panel.

2. Sheet Bypass

< NP Sensor Operation >

- a. The NP Actuator attached to the Paper Feed Unit determines if there is paper in the paper tray.
 b. The paper in the paper tray lowers the NP Actuator and the NP Sensor (1045) actuates.

< Sheet Bypass Operation >

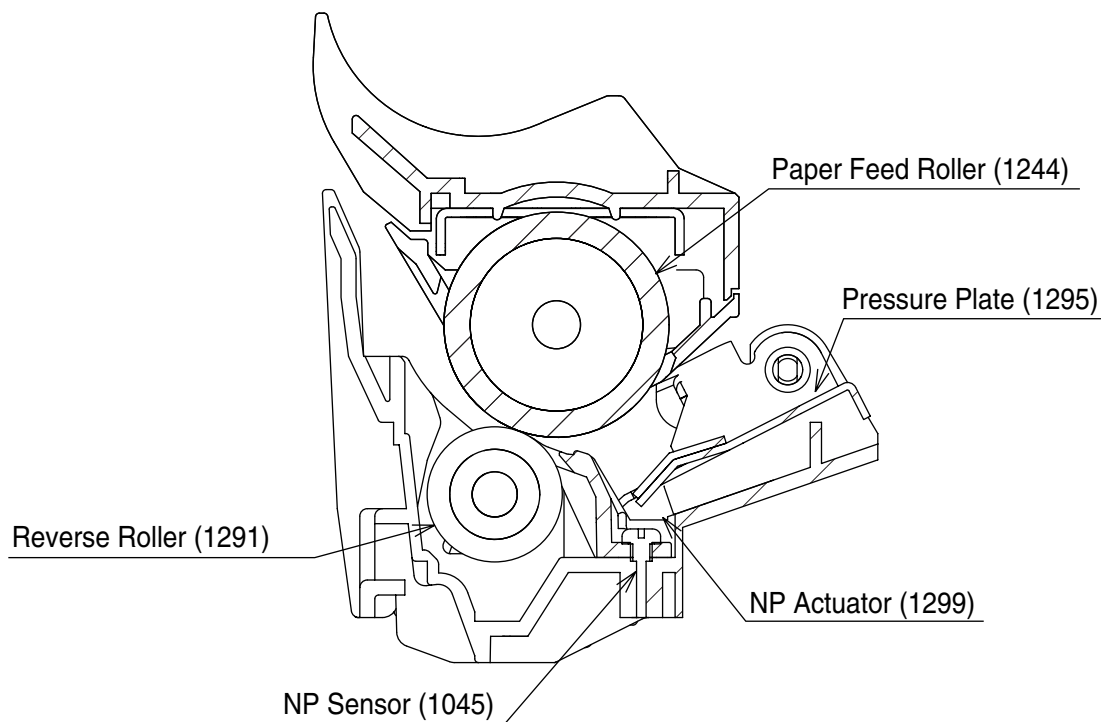

- a. When the printing operation begins, the PRINT (Print Request Signal) turns On and the Main Motor (907) starts driving the Gears.
 b. The Clutch (1105) is energized for a specified period of time and turns ON. This activates the Feed Roller (1244). The paper is raised by the Pressure Plate (1295) and is transported to the Reverse Roller (1291). The paper is separated into individual sheets by the Reverse Roller (1291).

- c. The paper is transported to the Registration Roller (1121), activating the Registration Sensor (1045).
- d. After a specified period of time, the Clutch (1105) is turned ON and the Registration Roller (1121) and the Registration Pinch Roller start rotating. The paper is transported to the OPC Drum area. After lowering the Pressure Plate (1295) during the specified period of time, the Clutch is turned OFF and the Feed Roller (1244) stops rotating.
- e. After the trailing edge of the paper passes the Registration Sensor (1045) and after a specified period of time, the Clutch (1105) is turned OFF. The Registration Roller and the Registration Pinch Roller stop rotating.

6.6.2. Laser Unit

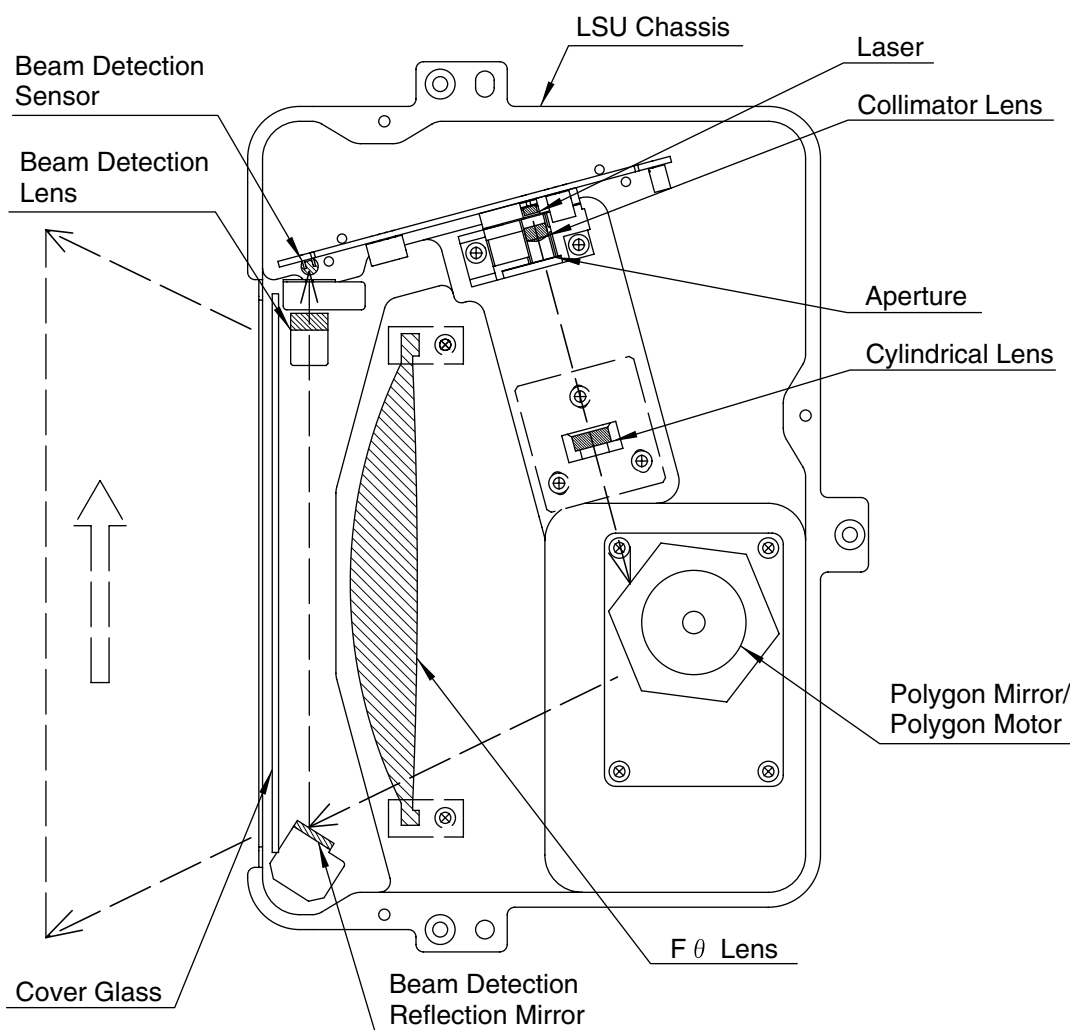

1. Laser

This Laser uses the semiconductor laser. The beam power on the drum surface is approximately 0.4 mW.

2. Collimator Lens and Cylindrical Lens

These lenses converge and focus the laser beam, converting it to parallel light.

3. Aperture

This controls the size of the laser beam.

4. Polygon Mirror and Polygon Motor

The polygon scanner consists of a 6-sided mirror, directly driven by a DC motor, revolving at 42,000 rpm. The laser beam is reflected against these mirrors and swept over the recorded width in the scanning direction.

5. Beam Detection (BD) Lens and Beam Detection (BD) Sensor

The BD Lens receives the reflected light from the Polygon Mirror and redirects it into the BD Sensor, which converts the laser beam into electrical signals and sets the start timing for the scanning line.

6. F- θ Lens

This amorphous plastic, molded lens is designed to provide parallel laser light across the surface of the drum, providing a constant scanning speed.

7. Cover Glass

This prevents a particle of dust invading into the LSU.

6.6.3. Fuser Operation

The paper passes through the Fuser Roller (1026) and is subjected to heat and pressure in the Fuser Unit. Pressure between the Fuser Roller (1026) and Pressure Roller (1027) fuses or bonds the toner into the paper.

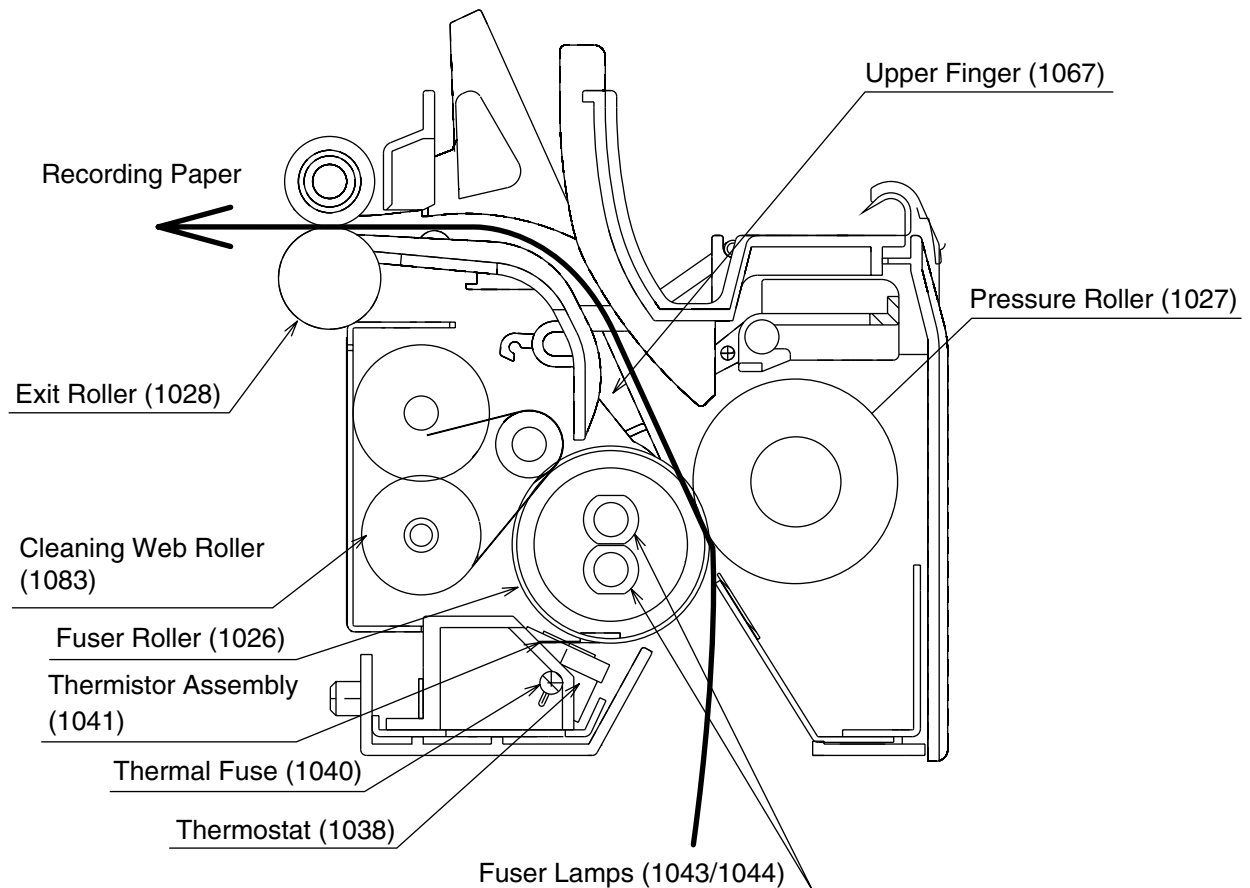

Fuser Roller (1026)

A Teflon coated roller supplies heat for bonding the toner to the paper. The temperature of the surface is kept constant at approximately 190°C ($\pm 10^\circ\text{C}$) (or 374°F).

Fuser Lamps (1043, 1044)

Located in the Fuser Roller (1026) are 2 Fuser Lamps (1043, 1044) that serve as the heat source for the Fuser Roller (1026).

Thermistor Assembly 1 & 2 (1041, 1042)

A heat sensitive resistor, in contact with the Fuser Roller (1026), monitors the surface temperature and keeps the temperature at the specified level by controlling the Fuser Lamps (1043, 1044).

Thermostat (1038) and Thermal Fuse (1040)

The Thermostat (1038) and the Thermal Fuse (1040) are installed in the Fuser Roller (1026), providing an extra overheat protection.

Printer Motor (901)

The Main Motor (907) provides the driving force to the Fuser Roller (1026) through the Fuser Roller Gears.

Pressure Roller (1027)

This converted PFA tube Silicon Rubber Roller applies pressure to the Fuser Roller, assisting in bonding the toner to the paper.

Cleaning Web Roller (1083)

The Cleaning Web Roller (1083) is installed in the Fuser Unit, which keeps cleaning the surface of the Fuser Roller (1026).

When the Fuser Unit does not reach the specified temperature within a certain period of time, an Error code is shown on the display, stopping the operation.

When the Thermistor Assembly (1041, 1042) is disconnected or the surface temperature of the Fuser Roller (1026) is out of limit, an Error code is shown on the display, stopping the operation.

7 Installation

7.1. Precautions During Set Up

Before you begin the installation, read these entire instructions. You must locate an appropriate site (firm, and leveled surface) for the installation. Reading this section assists you with the decision making process.

Machine performance, and the copy quality is subject to, and dependent on environmental conditions. To maintain good performance, quality, and safe operation, observe the following precautions:

1. For safe operation, and to avoid trouble, do not install the system under the following conditions:

- High temperature, high humidity, low temperature, or low humidity.

Ambient conditions	Temperature	: 50 - 86 °F (10 - 30 °C)
	Relative humidity	: 30 - 80 %
- Sudden changes in temperature, or humidity
- Exposed to direct sunlight
- Dusty environment
- Poorly ventilated location
- Exposed to chemical gases (such as ammonia gas)
- Exposed to strong vibration
- Exposed to direct air current (ex: Air conditioner vent)

2. The weight of the machine (options not included) is as follows:

DP-8032 / 8025: 181 lb (82 kg) with the i-ADF pre-installed

Place the machine on a level, and sturdy surface that can withstand the weight of the machine. If tilted, the machine may tip-over, and cause injuries.

3. The maximum power consumption is 1.5 kW. Depending on the product destination, the wall outlet must be rated for 120 VAC, or 220-240 VAC accordingly. It must also be protected for at least 15 amps for 120 VAC, or 10 amps for 220-240 VAC. If you are in doubt about a power source, ensure that a qualified electrician checks the outlet. Do not connect any other devices to the wall outlet designated for this machine. (Do not use an extension cord)
4. Make sure the outlet is properly grounded. (Do not ground to gas, or water pipe)
5. The machine should be installed in a well-ventilated area to minimize the ozone density in the air.
6. This machine has ventilation openings on the side, and rear, which must remain unobstructed for safe operation. The machine should be located at least 3.9 inches (100 mm) from the wall. Obstructing the ventilation openings could present a fire hazard.
 Using the space requirements shown on the following page, ensures that the machine has the ventilation it requires, and that you have the space needed for replacing the supplies.
7. There is a remote possibility of electrocution when installing the Fax option during a Lightning Storm. As a precaution, plug the AC Power Cord first, before connecting the Telephone Line Cable.

Space Requirements for Copier, and Options

Main Unit

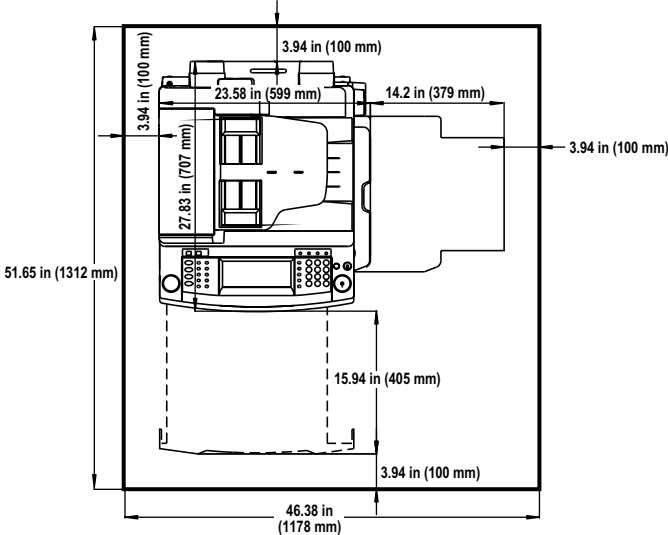

Main Unit + Outer Exit Tray

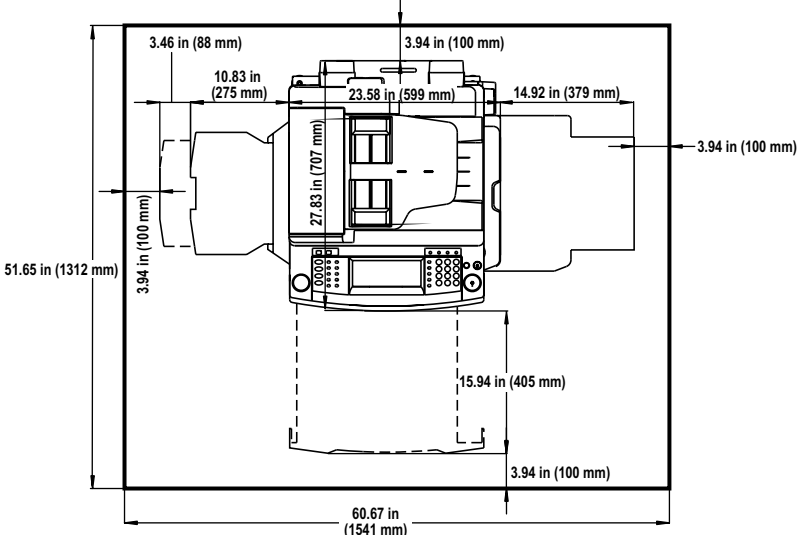

Main Unit + Finisher

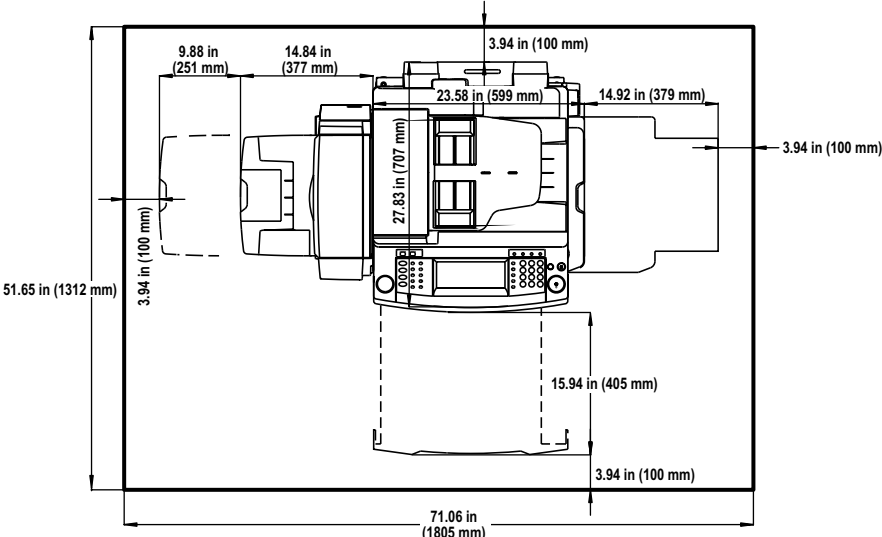

7.2. Unpacking

Visually check the condition and contents of the box for completeness, or for any shipping damage before starting with the installation.

Remove all Tapes, and the packing materials used to secure the Units during shipment.

After unpacking the product, dispose of the power plug cap and packing materials appropriately.

Caution:

The machine weights approximately 181 lb (82 kg) with the i-ADF pre-installed. To prevent injuries, use the appropriate number of personnel, and the proper equipment to lift, or move the machine.

Contents List

No.	Qty.	Description	Remarks
1	1	Main Unit	
2	1	Process Unit	
3	1	Operating Instructions CD, Quick Guide for Copy & Network Scan (Printed materials)	Printed materials only for Specified Destinations (See Note 1)
4	1	Panasonic Document Management System CD	Includes Operating Instructions
5	---	AC Power Cord	Depends on the Destinations
6	1	Tray Label	
7	1	Stamp Assembly	Specified Destinations only
8	1	License Agreement	
9	1	Caution Sheet	
10	1	Warranty Card	Specified Destinations only
11	1	WEEE Sheet (See Note 3)	Specified Destinations only
12	1	Installation Instructions	This document

Note:

1. Refer to the Parts List in the Parts Manual, the part number(s) may differ depending on the Destination.
2. Supplies (Developer, and Toner Bottle) are not included, and are sold separately.
3. Information on Disposal for Users of Waste Electrical & Electronic Equipment.

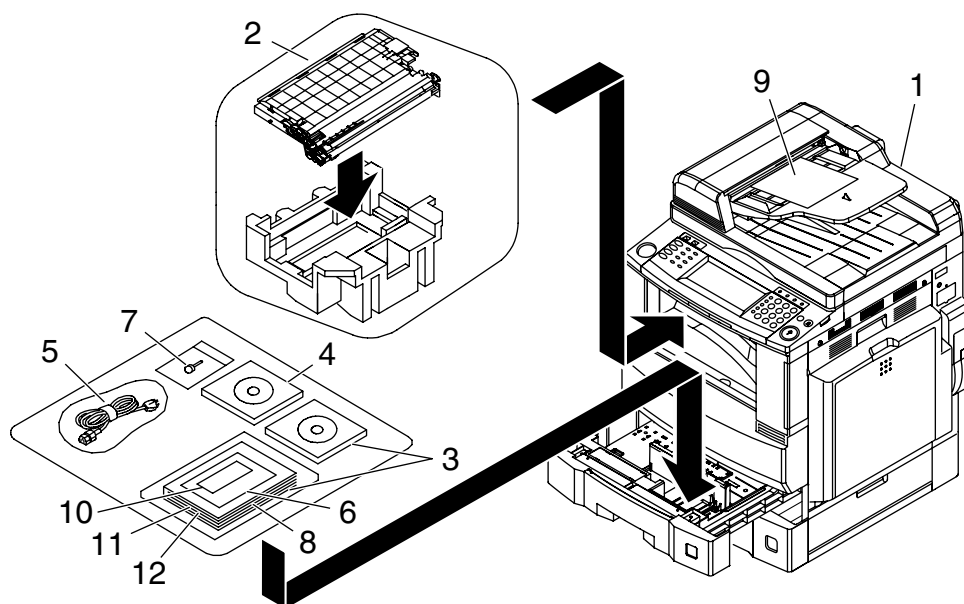

7.3. Installation Procedure

Caution:

1. Refer to each individual Installation Instructions when installing Stands, or other Options.
2. The following machine illustrations/LCD/Firmware, depict a Sample Unit with the USA/Canadian standard configuration, in details may differ depending on the Destinations etc.
3. The scanner is held in place by a Shipping Blue Screw to prevent damage during transit, and the Pressure Roller is also locked in the opened position to avoid the possibility of damaging the Pressure Roller.

Do Not turn the Power Switches ON before unlocking the Scanner / Pressure Roller (see steps (6) ~ (19)).

7.3.1. Installation Procedure

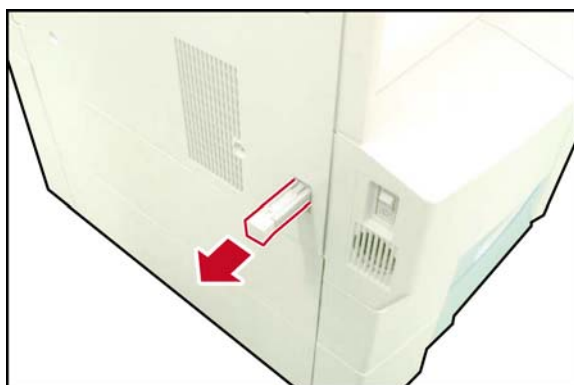

(1) Pull out the **Left Front Handle** to lock it in place.

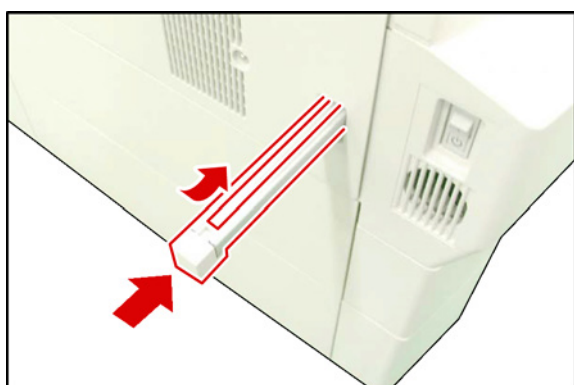

Note:

To release the Handle, pushing the Release Latch toward the machine, and push the Handle into the machine.

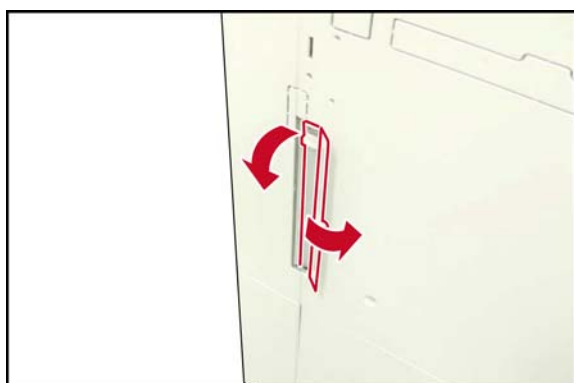

(2) Open the **Left Rear Handle Cover**, and swing the **Handle** downwards to lock it in place.

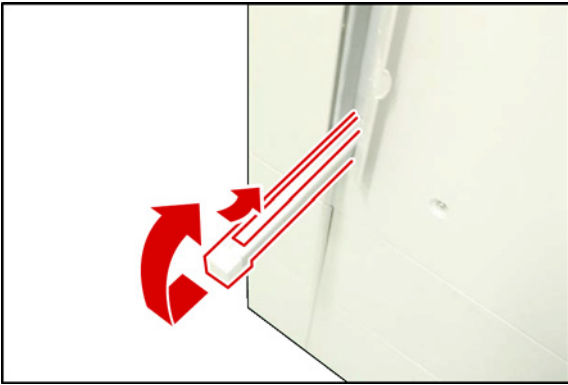
**Note:**

To release the Handle, pushing the Release Latch toward the machine, pull out then lift up the Handle into the machine.

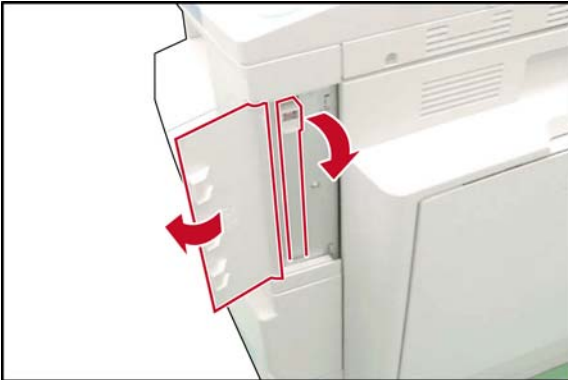

- (3) Open the **Right Front Handle Cover**, and swing the **Handle** downwards to lock it in place.

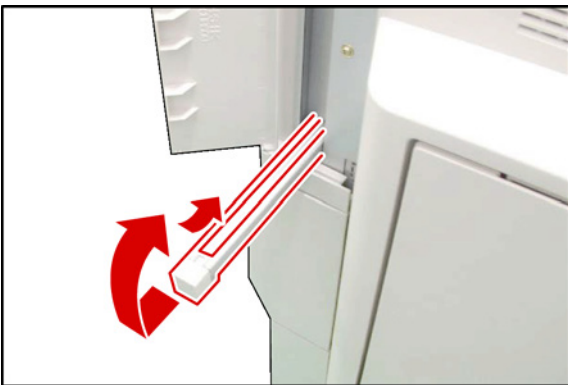
**Note:**

To release the Handle, pushing the Release Latch toward the machine, pull out then lift up the Handle into the machine.

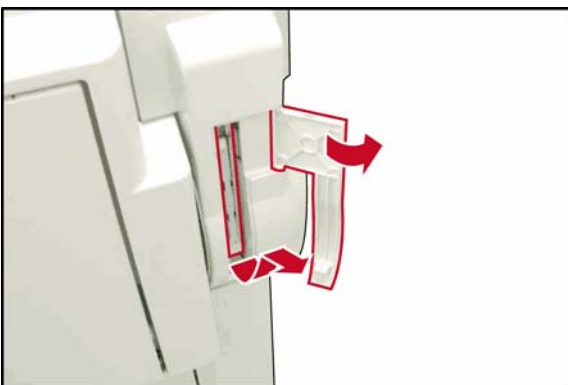

- (4) Open the **Right Rear Handle Cover**, lift up, and pull out the **Handle** to lock it in place.

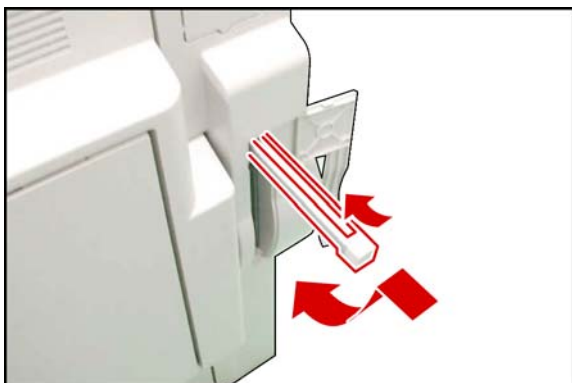
**Note:**

To release the Handle, pushing the Release Latch toward the machine, push down the Handle into the machine.



- (5) Lift, and place the machine on a suitable Stand / Paper Tray, aligning with front, and side covers.

Deluxe Stand:(DA1D320 / DA1D310/DA1D230)
USA only

Paper Tray: (DA-DS305 / DS306)

Caution:

The machine weights approximately 181 lb (82 kg) with the i-ADF pre-installed. To prevent injuries, use the appropriate number of personnel, and the proper equipment to lift, or move the machine.

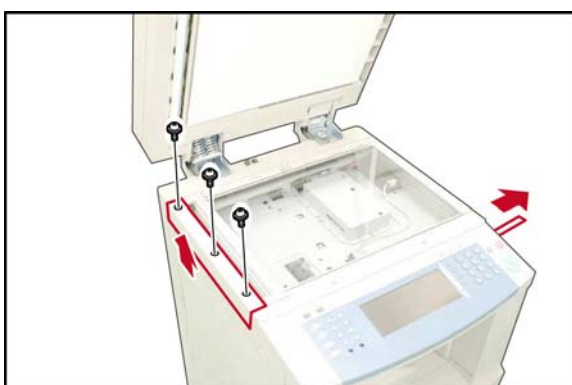
**<Unlocking the Protective Tape>**

- (6) Open the **ADF**.
(7) Remove the **Protective Tape** from the Battery.

<Unlocking the Scanner>

- (8) Remove 3 **Screws**.
(9) Remove the **Left Platen Cover**.

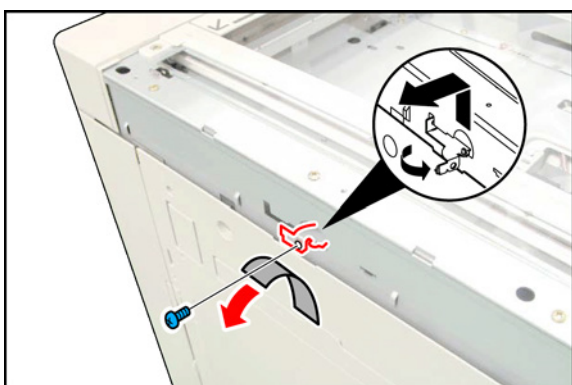

- (10) Remove the **Tape**.
(11) Remove 1 **Blue Screw**.
(12) Remove the **Shipping Metal Bracket** by rotating counterclockwise to unlock the Scanner.

Caution:

If the Shipping Material (Metal Bracket and Blue Screw) is not removed as instructed, the machine may get damaged when the Power Switches are turned ON.

Note:

Store the Shipping Material (Metal Bracket and Blue Screw) into the machine as shown in the following steps for future use.

- (13) Reinstall the **Left Platen Cover** and 3 **Screws**.
(14) Close the **ADF**.

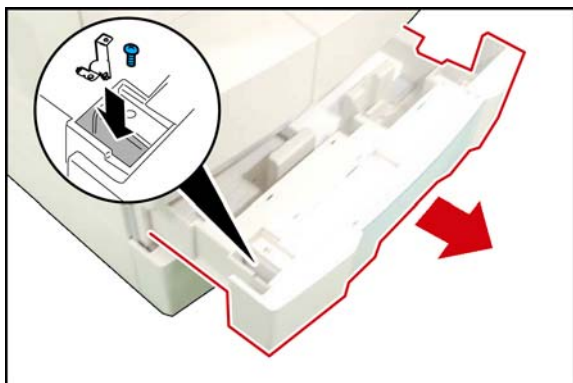

- (15) Open the **1st Paper Tray**.
- (16) Store the **Shipping Metal Bracket**, and the **Blue Screw** into the space provided in the 1st Paper Tray.
- (17) Close the **1st Paper Tray**.

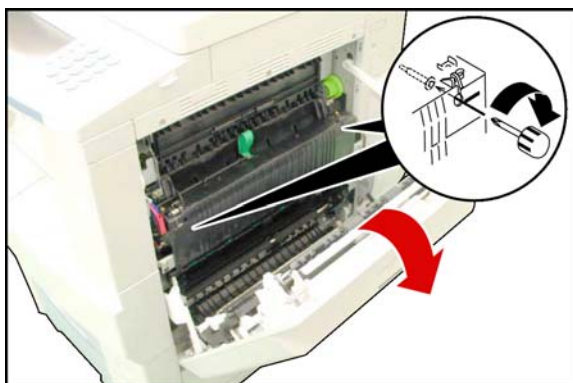

<Unlocking the Pressure Roller>

- (18) Open the **Right Cover**.
- (19) To unlock the **Pressure Roller**, using a Stubby Phillips Screwdriver, tighten 2 Screws recessed in the holes located on the Upper Fuser Cover.

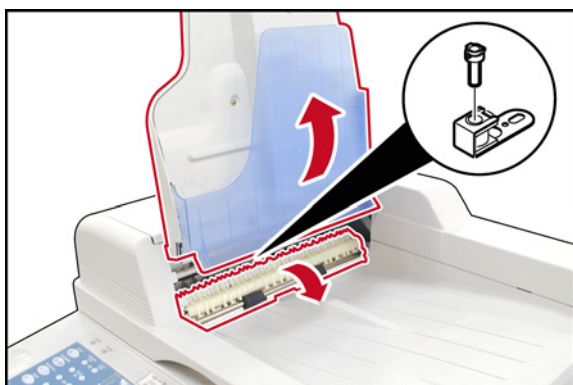

<Installing the Stamp Assembly for Specified Destinations only>

- (20) Lift the **Original Tray Assembly**.
- (21) Lower the **Inverting Guide 2 Assembly**.
- (22) Install the **Stamp Assembly**.
- (23) Return the **Inverting Guide 2 Assembly** and the **Original Tray Assembly** to former position.

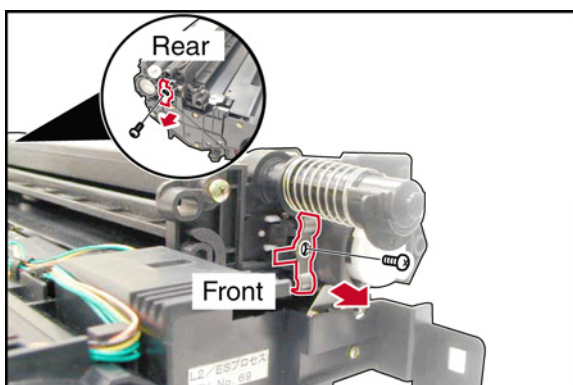

<Preparing the Process Unit>

- (24) Remove 1 **Screw (Front)**.
- (25) Remove the **Front Fixing Metal Bracket** (longer plastic tab).
- (26) Remove 1 **Screw (Rear)**.
- (27) Remove the **Rear Fixing Metal Bracket** (shorter plastic tab).

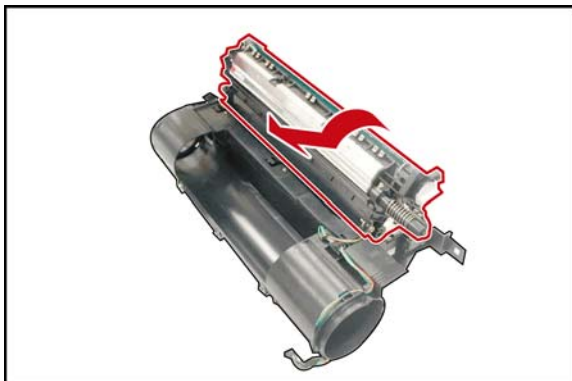

- (28) Carefully remove the packing tape and protective sheet from the OPC Drum Assembly.
- (29) Turn the **OPC Drum Assembly** in the direction of the arrow, and remove.

Caution:

Exercise caution not to scratch the surface of the **OPC Drum** (Green), and not to touch it with bare hands.

Caution:

The OPC Drum is sensitive to light. To prevent optical exposure problems, do not expose the OPC Drum to direct sunlight or bright light (even if it is a 1000-Lux fluorescent lamp).



- (30) Release 3 **Latch Hooks**, and remove the **Developer Cover**.

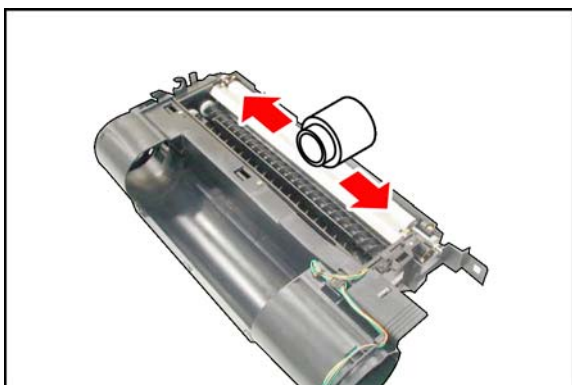

- (31) Shake the **Developer Bottle** thoroughly (approx. 30 seconds).
- (32) Pour the appropriate developer evenly into the developer unit. Make sure to empty the bottle.
- (33) Close the **Developer Cover**.
- (34) Reinstall the **OPC Drum Assembly**.
- (35) Reinstall 2 **Fixing Metal Brackets**, and 2 **Screws**.

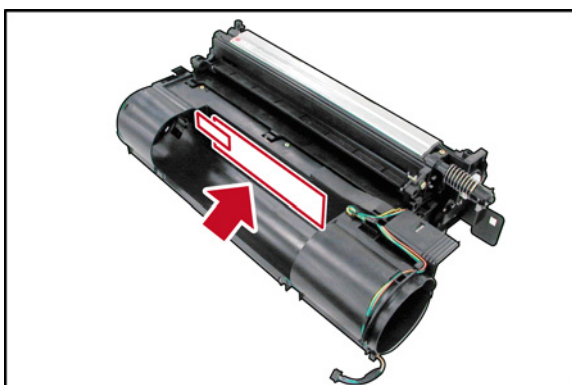

- (36) Remove the **Tape**, and the **Instruction Paper**.

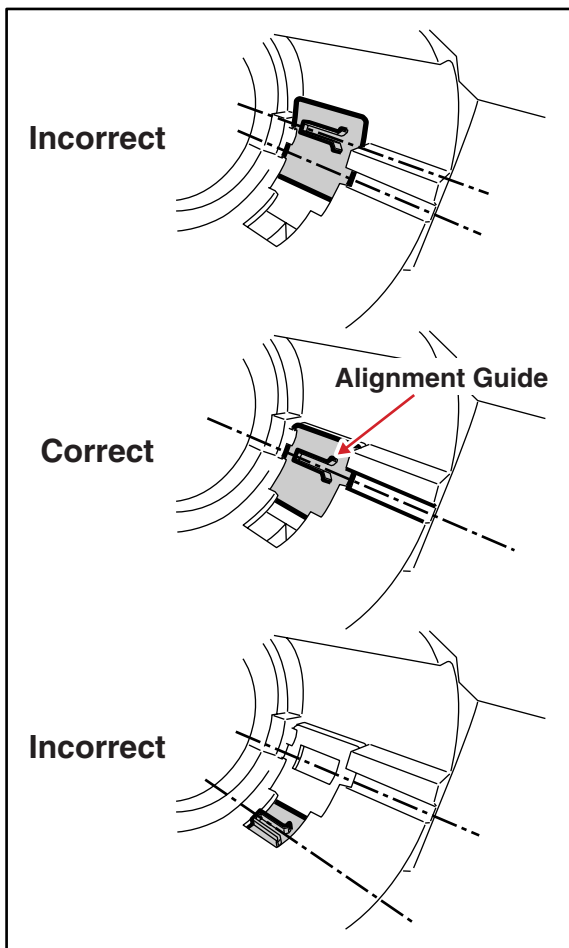
**Note:**

Before installing the Process Unit into the Machine, ensure that the Shutter's alignment guide is positioned as illustrated.



(37) Open the **Front Cover** wide.

(38) Remove 1 **Screw**.

(39) Remove the **Connector Cover** (Clear Blue).

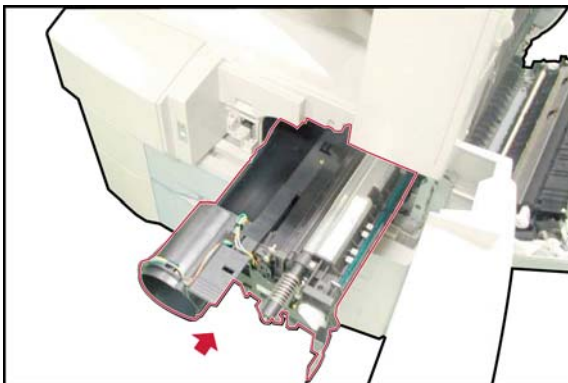

(40) Install the **Process Unit**.

Caution:

To prevent damage to the Process Unit, ensure the Right Cover is still open before inserting the Process Unit into the machine.

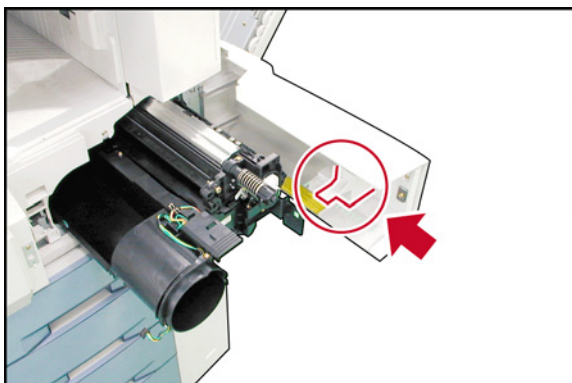
**Caution:**

Exercise caution not to scratch the surface of the **OPC Drum** (Green), and not to touch it with bare hands.

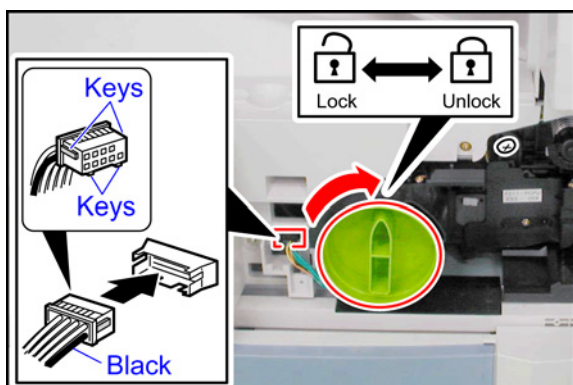

- (41) Fasten the Process Unit with 1 **Screw**.
- (42) Connect the Harness, and reinstall the **Connector Cover** and 1 **Screw**.

Caution:

When reconnect the Harness, make sure the connector position and its keys. Insert it gently, and do not force the connector if it is facing the wrong way.

Caution:

When reinstalling the Connector Cover, make sure the Harness is not pinched by the Cover.

- (43) Shake the **Toner Bottle** 10 to 15 times to loosen the contents.
- (44) Remove the **Tape**, however, do not open the Shutter or Toner will spill.
- (45) Insert the Toner Bottle into the Hopper Unit. Align the Toner Bottle Key with the Key Alignment Channel of the hopper unit. Insert the Bottle as far as it will go, and turn the Toner Bottle clockwise until it locks in place. (Bottle's Green Knob is lined up with the "Locked" symbol on the Process Unit label)
- (46) Install the **Toner Waste Container**.
- (47) Close the **Front Cover** and the **Right Cover**.
- (48) Load paper into all of the trays.
- (49) Plug the **AC Power Cord**.
- (50) If required, connect the **LAN / USB Cable** (not included).
- (51) Turn the Main Power Switch on the Back, and the Power Switch on the Left Side of the machine to the ON position.

**Note:**

Perform the following adjustments after the machine has warmed up, and displays:

Ready To Copy
Set Originals

7.4. Adjustment

7.4.1. Toner Density Control (TDC) Adjustment

1. Press the “**FUNCTION**”, “**ORIGINAL SIZE (LEDGER/A3)**”, and the “**3**” keys simultaneously.
2. Input the Password, and select the “**OK**” button to enter the Service Mode (default password is **00000000**).
3. Press the “**8**” key, and press the “**START**” key to enter the F8 Service Mode (Service Adjustment).
4. Select the “**↓**” button, and select “**09 Toner Density Adj**”.
5. Press the “**START**” key to begin the automatic TDC sensor gain adjustment.

Note:

Do not touch any keys, or turn the Power Switch OFF until the adjustment cycle stops (approximately 8 minutes). Refer to the Sequence Chart below.

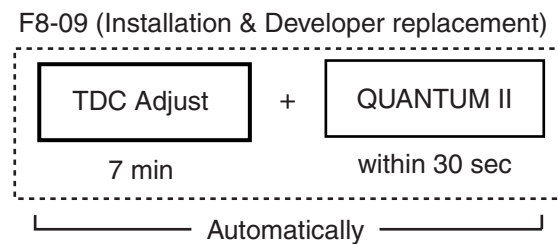

7.4.2. Black Density Sensor Output Gain Adjustment

1. Select the “**↓**” button, and select “**14 Black Density Gain**”.
2. Press the “**START**” key for automatic Black Density Sensor Output Gain adjustment.

Note:

Do not touch any keys, or turn the Power Switch OFF until the adjustment cycle stops (approximately 1 minutes). Refer to the Sequence Chart below.

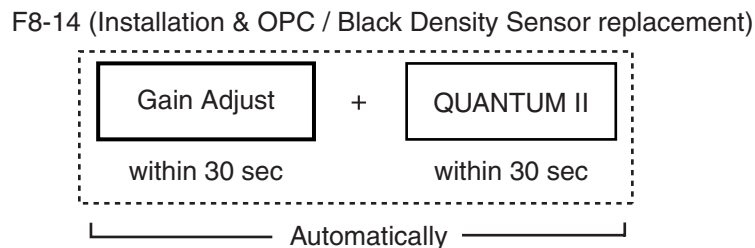

3. Press the “**STOP**” key.
4. Press the “**6**” key, and press the “**START**” key to enter the F6 Mode (Adjust Parameters).
5. Write the contents of F6-21, 26, and 65 on the memory sheet (included inside the 1st Paper Tray).

F6-21 : TDC Gain Voltage
 F6-26 : TDC Judgement Level
 F6-65 : Black Density Reference

6. Press the “**STOP**” key.
7. Press the “**FUNCTION**”, and the “**C (CLEAR)**” keys simultaneously to exit the Service Mode.

7.4.3. Set the Date, Time, and Language

1. Press the “**FUNCTION**” key.
2. Select “**GENERAL SETTINGS**”.
3. Select “**↓**” button, and select “**09 Key Operator Mode**”.
4. Enter the 8 character Code (default is **00000000**), and the “**OK**” button.
5. Select the “**OK**” button.

6. Select “**15 Language Default**”.
7. Select the desired Language, and select the “**OK**” button.
8. Select “**↓**” button, and select “**20 Date Time Setting**”.
9. Select the “**CHANGE**” button to input the new Date, and Time. (e.g. mm/dd/yyyy hh:mm) [24-hour format].
10. After setting the new information, and select the “**OK**” button.
11. Press the “**RESET**” key to exit the Function Mode.

7.4.4. Exposure (Standard Adjustment)

Caution:

Before making any adjustments, confirm that the following contents (F6-17, 18, and 19) are set to “**0**”.
DO NOT adjust these settings in the field.

F6-17 : Charge Roller Voltage compensation

F6-18 : Standard Laser Power compensation

F6-19 : Std Bias DC Voltage compensation

1. Press the “**FUNCTION**”, “**ORIGINAL SIZE (LEDGER/A3)**”, and the “**3**” keys simultaneously.
2. Input the Password, and select the “**OK**” button to enter the Service Mode (default password is **00000000**).
3. Press the “**2**” key, and press the “**START**” key to enter the F2 Service Mode (Single Copy Test).
4. Set the exposure to the center position.
Set the type of Original to TEXT / PHOTO Mode.
5. Make a copy of Test Chart 53/54 with gray scale (P/N FQ-SJ1011), and verify the density as shown below. If it is within specification, skip to step 14.
 - a. Gray scale “**A**” should not be visible.
 - b. Gray scale “**2**” should be clearly visible.

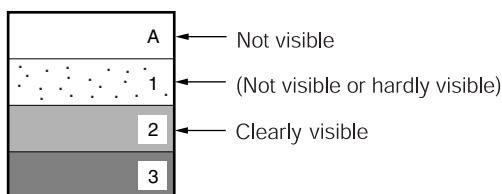

6. Press the “**RESET**” key to exit to the initial screen of the F2 Service Mode.
7. Press the “**6**” key, and press the “**START**” key to enter the F6 Service Mode (Adjust Parameters).
8. Select the “**↓**” button, and select “**50 T/P Mode Image Density**”.
9. Select the “**INPUT**” button.
10. Enter the new 2-digit value.

Note:

The “**RESET**” key is used to enter the “**-**” content.

(+) : Lighter side

(-) : Darker side

11. Select the “**OK**” button twice.
12. Press the “**2**” key, and press the “**START**” key to enter the F2 Service Mode (Single Copy Test).
13. Make a copy to confirm the adjustment.

Note:

Repeat step 4. to step 13. until proper density is attained.

F6-49 : T Mode Image Density (Text)

F6-51 : P Mode Image Density (Photo)

14. Press the “**STOP**” key.
15. Press the “**FUNCTION**”, and the “**C (CLEAR)**” keys simultaneously to exit the Service Mode.

7.4.5. Internet Fax Function Confirmation

It is not necessary to set the parameter for the following suffix (Destinations). The Internet Fax Firmware is automatically loaded with the Host Firmware.

PB : UK PG : Germany PM : Netherlands PK : China PT : Taiwan PU/PUG : USA

Note:

For other destinations below, set **“00 FAX Service Mode : 01 Function Param. Setting : #005 Destination Code”** by following the steps below.

000 : Austria	001 : UK	002 : Canada	003 : Denmark
004 : Taiwan	005 : Finland	006 : Germany	007 : Netherlands
008 : Italy	009 : Spain	010 : Hong Kong	011 : Australia
012 : Switzerland	013 : Norway	015 : Portugal	016 : Ireland
017 : Belgium	018 : Sweden	019 : Turkey	020 : USA
021 : France	022 : New Zealand	025 : Japan	029 : Poland
030 : Czech	031 : Russia	032 : Greece	033 : Hungary
034 : Indonesia	035 : South Korea	038 : Malaysia	039 : China
045 : Thailand	048 : South Africa	049 : Singapore	050 : Universal
051 : East Euro			

1. Press the **“FUNCTION”**, **“ORIGINAL SIZE (LEDGER/A3)”**, and the **“3”** keys simultaneously.
2. Input the Password, and select the **“OK”** button to enter the Service Mode (default password is **00000000**).
3. Press the **“9”** key, and press the **“START”** key to enter the F9 Service Mode (Unit Maintenance).
4. Select **“00 FAX Service Mode”**.
5. Select **“01 Function Param. Setting”**.
6. Select the **“↓”** button, and select **“005 Destination Code”**.
7. Select the **“CHANGE”** button.
8. Input the new Destination Code, and Select the **“OK”** button twice.
9. Select the **“↓”** button, and select **“06 RAM Initialize”**.
10. Select **“01 Parameter Initialize”**, and select the **“YES”** button.
11. Press the **“STOP”** key.
12. Press the **“FUNCTION”** and the **“C (CLEAR)”** keys simultaneously to exit the Service Mode.
13. Turn the Power Switch on the Left side of the machine to the **OFF**, and back to the **ON** position to enable the parameter settings.

Note:

If the desired Language is not showed on the LCD Display, proceed the steps 7.4.3. : 1. ~ 7. & 11. again.

7.4.6. User Authentication, and/or Via Fax Server Function Confirmation (Specified Destinations only)

If your customer requires User Authentication, and/or Via Fax Server Function, setup the feature(s) by referring to the Operating Instructions (For User Authentication) for the PU/PUG (USA/Canada, etc.).

Note:

For the other destinations below, set **“00 FAX Service Mode : 01 Function Param. Setting : #005 Destination Code”** by following steps.

000 : Austria	001 : UK	006 : Germany	009 : Spain
011 : Australia	021 : France	022 : New Zealand	

1. Press the **“FUNCTION”**, **“ORIGINAL SIZE (LEDGER/A3)”**, and the **“3”** keys simultaneously.
2. Input the Password, and select the **“OK”** button to enter the Service Mode (default password is **00000000**).
3. Press the **“9”** key, and press the **“START”** key to enter the F9 Service Mode (Unit Maintenance).

4. Select **"00 FAX Service Mode"**.
5. Select **"01 Function Param. Setting"**.
6. Select the **"↓"** button, and select **"005 Destination Code"**.
7. Select the **"CHANGE"** button.
8. Input the new Destination Code, and select the **"OK"** button twice.
9. Press the **"STOP"** key.
10. Press the **"FUNCTION"**, and **"C (CLEAR)"** keys simultaneously to exit the Service Mode.
11. Turn the Power Switch on the Left side of the machine to the **OFF**, and back to the **ON** position to enable the parameter settings.

8 Options and Supplies

8.1. Service Notes “Firmware Update” for PCL or PS Option Installation

To use **PCL (DA-PC302)** or **PS (DA-MC302)** option individually or in combination with other options, changing to **Type B** or **Type D** SC firmware is required. The required firmware is on the CD included with the options.

Note:

The 8 MB Expansion Board (DA-EM600) must be installed for the printer controllers. The only time a DA-EM600 is needed is if you are installing the PostScript (PS) or PCL option. There will never be a need for 2 of these, even if there are other options, such as Fax, added.

Before proceeding, it is important to determine the Final Configuration of your machine in order to correctly identify the required firmware from the table below. Carefully read and follow the Installation Instructions for the appropriate option.

The firmware for SC, SPC and PNL must be updated in this sequence as a set. Please update the firmware with the latest version as a set by referring to the following table.

Firmware Version Table

	Standard Firmware (SC = Type A)	PCL Firmware (SC = Type B)	PostScript Firmware (SC = Type D)
SC	SFD-L80AxVxxxxx_xx	SFD-L80BxVxxxxx_xx	SFD-L80DxVxxxxx_xx
PNL	L80_PNLxVxxxxx_xx	←	←
SPC	L80_SPCAAVxxxxx	←	←
Slot 1 FROM PCB	Not Required	Required	Required

Main Unit Firmware Code Updating Instructions

1. Updating through a LAN Port (The Quickest and Most Easiest Method)

The firmware code can be easily updated when the main unit is connected to a LAN.

The Network Firmware Update Tool can also be used by connecting to the machine using a **crossover cable**, if the unit is not connected to a LAN.

1) Install the Network Firmware Update Tool to your PC

The Tool can be downloaded from your sales company's Web site, or the PCC Service Web site. Please refer to the Operating Instructions of the Tool for details.

2) Preparing the Firmware Code

Double click the appropriate Destination Shortcut Batch File, and copy the Firmware Code File on the CD-ROM to the Firmware Data Folder in your PC, or access the Service Web site to download the latest Firmware Code. When performing the self-extraction wizard for preparing the Firmware Code File, make sure and agree with the license agreement, then input the password “**1Panasonic!**”. The Archive will be extracted automatically into the designated folder.

Example:

From : Destination Shortcut Batch File: D:(CD-ROM Drive) \ xFirmware \ USA.bat
 Firmware Code File : DP-8032_8025_xx_xxxxxx.exe
To : Firmware Data Folder : C:\ Panasonic \ Panasonic-FUP \ Data

3) Preparing the Main Unit for the Firmware Upgrade

Make sure the unit's F7-01:Application password is the same as the tool's password. Make sure the unit is in an idle state (e.g. not making copies, not printing, etc.).

4) Upgrading the Main Unit's Firmware Code

Start the Network Firmware Update Tool and select the following **Firmware Code Folders** in the **C:\Panasonic\Panasonic-FUP\Data** folder, and then follow the display instructions to upgrade the Main Unit's Firmware Codes.

Parent Firmware File Folder	Sub Firmware File Folder
\ DP-8032_8025_xx_xxxxxx	\ Pnl \ L80_PNLAxVxxxxx_xx
	\ Sc_Std \ SFD-L80AxVxxxxx_xx
	\ Sc_Pcl \ SFD-L80BxVxxxxx_xx
	\ Sc_Ps \ SFD-L80DxVxxxxx_xx
	\ Spc \ L80_SPCAAVxxxxx

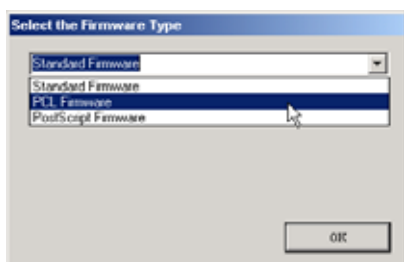

When you select the Parent Folder, as illustrated the Firmware Type window appears. Proper Sub File Folders are selected automatically by selecting the Firmware Type.

The transferring order is set up automatically.

Note:

1. Manual mode must be used, when updating the designated version of the firmware or changing the type of the firmware.
Please refer to the Section 2.2, “**Setting up the Network Firmware Update Tool, File Selection Tab**” of the Operating Instructions.
2. While updating the firmware code, the display may become garbled, however, it will return to normal upon completion of the firmware update.
3. If the firmware update fails, and the unit does not boot up, the Network Firmware Update Tool will not be able to transfer the firmware code. If this occurs, please refer to the next section “**Updating through the USB Port**” and use the Local Firmware Update Tool to recover the unit.
4. The suffix “_xx” for the Folder Name or File Name may not exist depending on the destination location.

2. Updating through the USB Port (Alternate Method)

If the device is not connected to the LAN, upgrade the firmware code using the USB Port.

1) Install the Local Firmware Update Tool to your PC

The Tool can be downloaded from your sales company's Web site, or the PCC Service Web site. Please refer to the Operating Instructions of the Tool for details.

2) Preparing the Firmware Code

Double click the appropriate Destination Shortcut Batch File, and copy the Firmware Code File on the CD-ROM to the Firmware Data Folder in your PC, or access the Service Web site to download the latest Firmware Code. When performing the self-extraction wizard for preparing the Firmware Code File, make sure and agree with the license agreement, then input the password “**1Panasonic!**”. The Archive will be extracted automatically into the designated folder.

Example:

From : Destination Shortcut Batch File: D:(CD-ROM Drive) \ xFirmware \ USA.bat
 Firmware Code File : DP-8032_8025_xx_xxxxx.exe
To : Firmware Data Folder : C:\Panasonic \ Panasonic-FUP \ Data

3) Preparing the Main Unit for the Firmware Upgrade

Important: DO NOT connect the USB Cable yet.

Enter into Unit Maintenance Mode F9-07-01 to enable the unit to accept the programming code from the USB Port.

If the unit does not boot up, follow the procedure below:

- Turn the power OFF (use the power switch on the back of the machine, not the side of the machine.).
- Turn the power ON while holding the **[ENERGY SAVER]** key.
- When the unit's front panel green lamp turns On, release the **[ENERGY SAVER]** key, it is now ready to accept the firmware code from the USB Port.

Now connect the USB Cable between the Unit and PC.

4) Upgrading the Main Unit's Firmware Code

Start the Network Firmware Update Tool, and select the following **Parent Firmware File Folder** in the **C:\Panasonic\Panasonic-FUP\Data** folder. The Firmware Type window appears, and proper Firmware Files are selected automatically by selecting the Firmware Type. Then follow the display instructions to upgrade the Main Unit's Firmware Codes.

Parent Firmware File Folder	Sub Firmware File Folder	Firmware File
\ DP-8032_8025_xx_XXXXXX	\ Sc_Std \ SFD-L80AxVxxxxx_xx	SFD-L80AxVxxxxx_xx.BIN
	\ Sc_Pcl \ SFD-L80BxVxxxxx_xx	SFD-L80BxVxxxxx_xx.BIN SFD-L80CxVxxxxxa_xx.BIN SFD-L80CxVxxxxxb.BIN
	\ Sc_Ps \ SFD-L80DxVxxxxx_xx	SFD-L80DxVxxxxx_xx.BIN SFD-L80ExVxxxxxa_xx.BIN SFD-L80ExVxxxxxb.BIN
	\ Spc \ L80_SPCAAVxxxxx	L80-SPCAxVxxxxx.BIN
	\ Pnl \ L80_PNLAxVxxxxx_xx	L80-PNLAxVxxxxx_xx.BIN

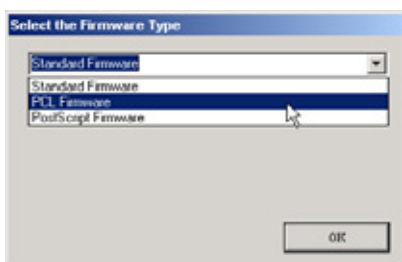

When you select the Parent Folder, as illustrated the Firmware Type window appears. Proper Firmware Files are selected automatically by selecting the Firmware Type. The transferring order is set up automatically.

Note:

- While updating the firmware code, the display may become garbled, however, it will return to normal upon completion of the firmware update.
- Please refer to the service manual for additional details.
- The suffix “**_xx**” for the Folder Name or File Name may not exist depending on the destination location.

8.2. Installing the Printer Controller Module for PCL6 (DA-PC302)

8.2.1. Contents

Visually check the condition and contents of the box for completeness, or for any shipping damage before starting the installation.

Remove all tapes, and the packing materials used to secure the units during shipment.

After unpacking, dispose the packing materials appropriately.

No.	Qty.	Description	Remarks
1	1	Hardware Key	PCL KEY
2	1	Software CD	Includes Operating Instructions
3	2	Locking Spacer	For Europe Only
4	1	FRM8 PCB ASSY	For Europe Only
5	1	Installation Instructions	DA-EM600 : For Europe Only
6	1	Installation Instructions	This document

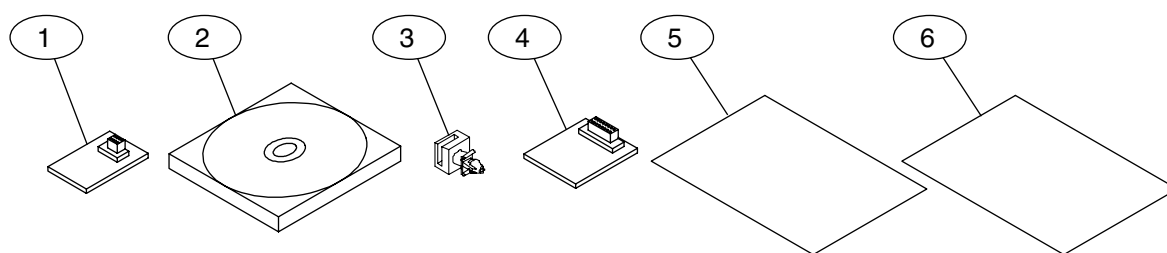

Note:

Refer to the Parts Manual for Part Number(s), Packing, and Accessories detail.

8.2.2. Installation

CAUTION!

Turn the Power Switch on the Left Side, and the Main Power Switch on the Back of the machine to the OFF position, and then unplug the AC Power Cord before beginning installation.

Caution:

Before installing this option, make sure the Program Expansion Board (DA-EM600) is installed into Slot 1 on the SC PC Board (CN62) first. Refer to the Installation Instructions of the Program Expansion Board (DA-EM600).

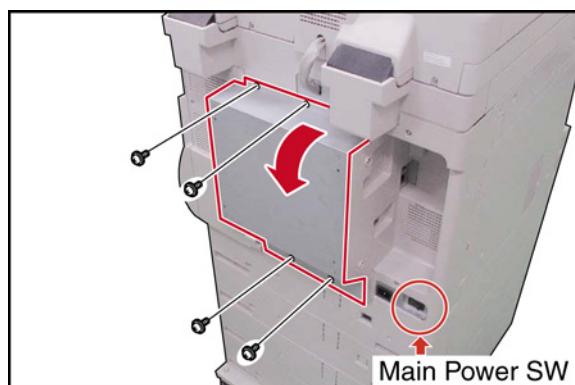

(1) Remove 4 **Silver Screws**.

(2) Open the **Rear Cover**.

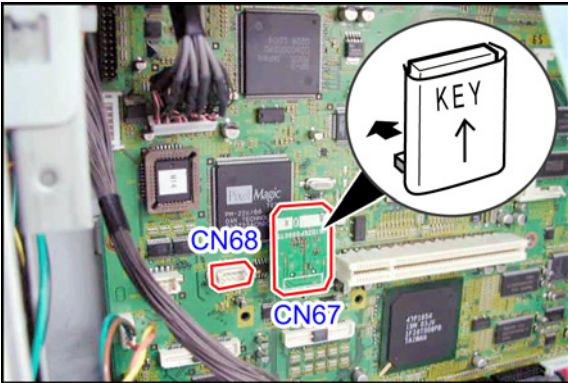
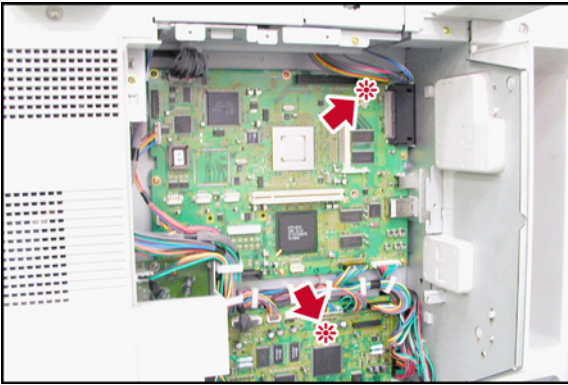

Caution:

If the LEDs on the SC and SPC PC Boards are lit (ON), the Power to the machine is still ON. Please read “8.2.2. Installation : CAUTION!” once again.

- (3) Install the **Hardware Key** into one of the two available connectors (CN67, CN68) on the SC PC Board.

Note:

The connectors are keyed, to prevent damage to the SC PC Board, install the Hardware Key as illustrated. Do not force the Hardware Key into the connector if facing the wrong way.

- (4) Proceed with the installation of other options. If finished, reinstall all **Harnesses** and **Covers**.
- (5) Plug the **AC Power Cord**, and turn the **Main Power Switch** on the Back and the **Power Switch** on the Left Side of the machine to the ON position.
- (6) Reconnect the **Telephone Line / LAN Cable** if disconnected.
- (7) Update the firmware of the unit to the PCL Option firmware. Refer to the attached “Service Notes”.
- (8) Install the PCL6 Software into the PC with the Operating Instructions by following the prompts of the Installation Wizard.

8.3. Installing the Printer Controller Module for PS/PCL6 (DA-MC302)

8.3.1. Contents

Visually check the condition and contents of the box for completeness, or for any shipping damage before starting the installation.

Remove all tapes, and the packing materials used to secure the units during shipment.

After unpacking, dispose the packing materials appropriately.

No.	Qty.	Description	Remarks
1	1	Hardware Key	PS KEY
2	1	Software CD	Includes Operating Instructions
3	1	Adobe PostScript 3 Label	
4	2	Locking Spacer	For Europe Only
5	1	FRM8 PCB ASSY	For Europe Only
6	1	Installation Instructions	DA-EM600 : For Europe Only
7	1	Installation Instructions	This document

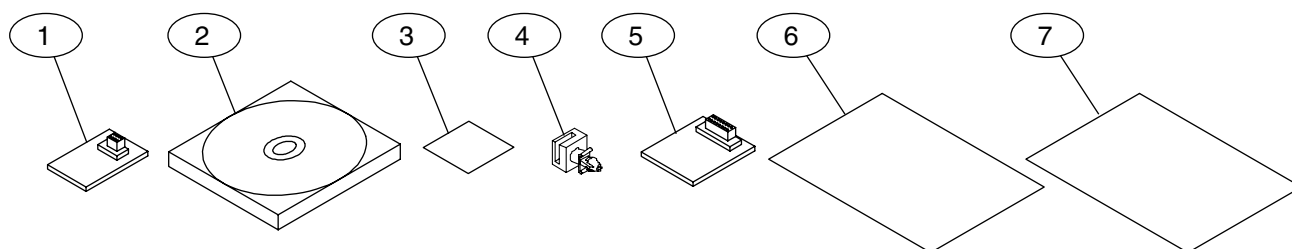

Note:

Refer to the Parts Manual for Part Number(s), Packing, and Accessories detail.

8.3.2. Installation

CAUTION!

Turn the Power Switch on the Left Side, and the Main Power Switch on the Back of the machine to the OFF position, and then unplug the AC Power Cord before beginning installation.

Caution:

Before installing this option, make sure the Program Expansion Board (DA-EM600) is installed into Slot 1 on the SC PC Board (CN62) first. Refer to the Installation Instructions of the Program Expansion Board (DA-EM600).

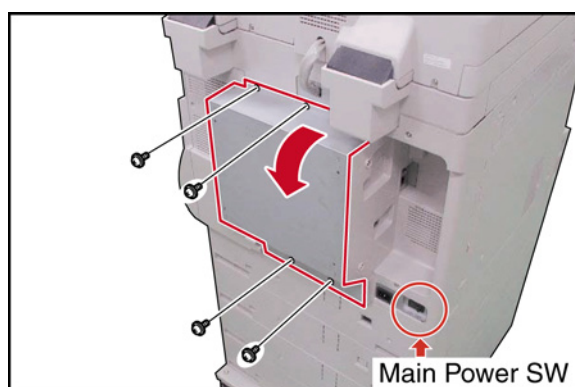

- (1) Remove 4 **Silver Screws**.
- (2) Open the **Rear Cover**.

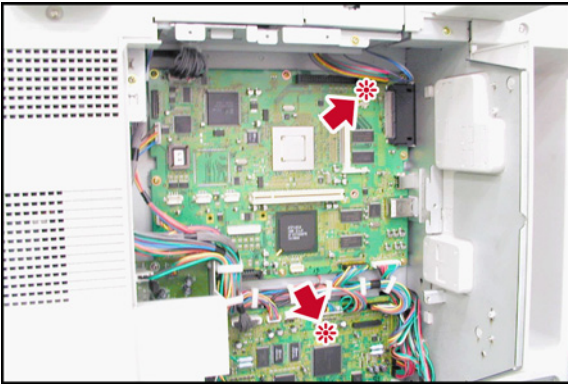
**Caution:**

If the LEDs on the SC and SPC PC Boards are lit (ON), the Power to the machine is still ON. Please read “8.3.2. Installation : CAUTION!” once again.

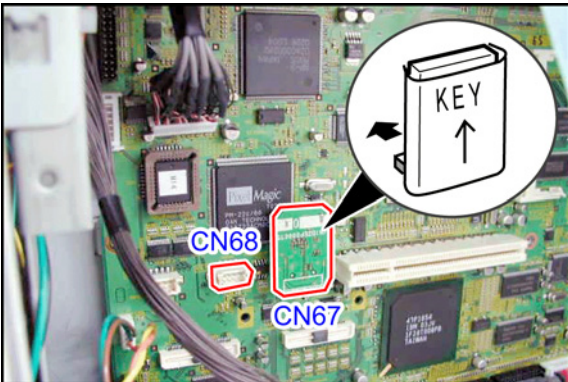

- (3) Install the **Hardware Key** into one of the two available connectors (CN67, CN68) on the SC PC Board.

Note:

The connectors are keyed, to prevent damage to the SC PC Board, install the Hardware Key as illustrated. Do not force the Hardware Key into the connector if facing the wrong way.

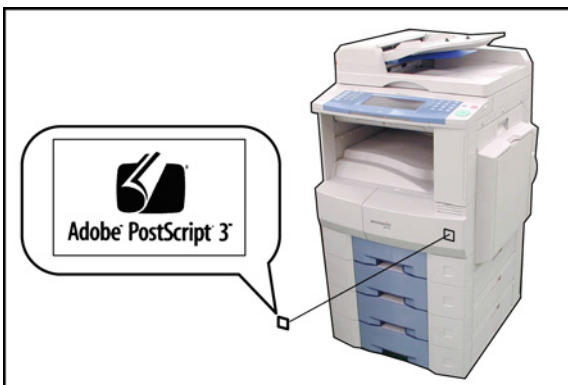

- (4) Proceed with the installation of other options. If finished, reinstall all **Harnesses** and **Covers**.
- (5) Plug the **AC Power Cord**, and turn the **Main Power Switch** on the Back and the **Power Switch** on the Left Side of the machine to the ON position.
- (6) Reconnect the **Telephone Line / LAN Cable** if disconnected.
- (7) Update the firmware of the unit to the PS/PCL Option firmware. Refer to the attached “Service Notes”.
- (8) Install the PS/PCL6 Software into the PC with the Operating Instructions by following the prompts of the Installation Wizard.
- (9) Attach the Adobe PostScript 3 Label to the Front Cover as illustrated.



8.4. Installing the Fax Communication Board (DA-FG300)

8.4.1. Contents

Visually check the condition and contents of the box for completeness, or for any shipping damage before starting with the installation.

Remove all Tapes, and the packing materials used to secure the Units during shipment.

After unpacking the product, dispose of the packing materials appropriately.

No.	Qty.	Description	Remarks
1	1	FXB PC Board Assembly	
2	1	MJR PC Board Assembly	
3	1	MJR Harness	
4	1	LIN Harness	
5	1	Speaker	
6	1	Telephone Line Cable	
7	1	Type Approval Label	
8	1	Line Label	
9	5	Screw (M3 x 6)	 
10	1	Quick Guide	
11	1	Operating Instructions CD	
12	1	Installation Instructions	This document

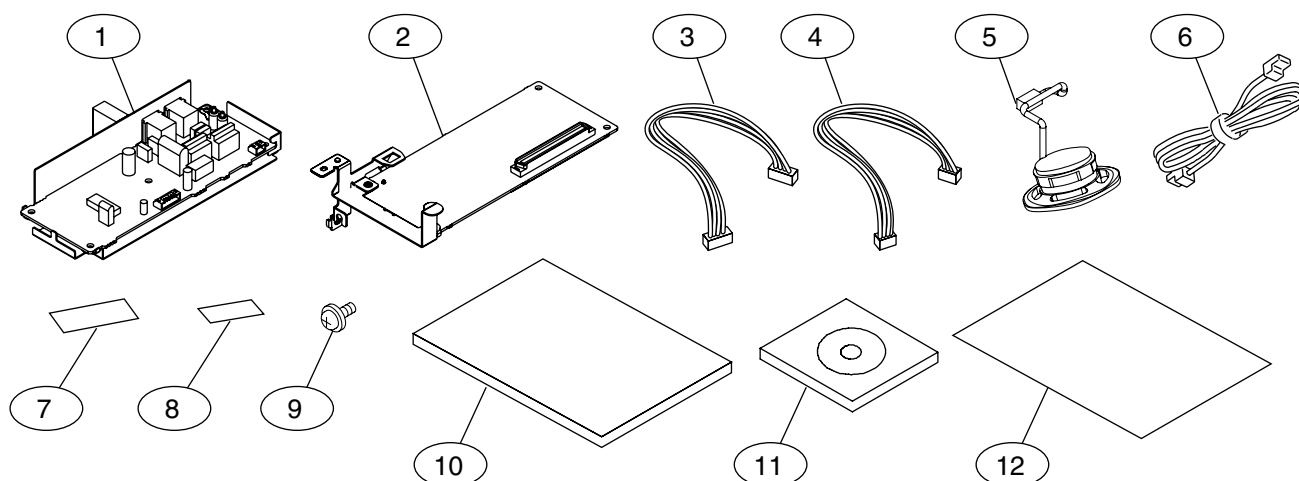

Note:

Refer to the Parts Manual for Part Number(s), Packing, and Accessories in details.

8.4.2. Installation

Caution:

The DP-8032 series has been described as an example of the representative.

Refer to each service manual for other models.

CAUTION!

Turn the Power Switch on the Left Side, and the Main Power Switch on the Back of the machine to the OFF position, and then unplug the AC Power Cord before beginning installation.

Caution:

If also installing the Program Expansion Board (DA-EM600), it must be installed first.

Refer to the Installation Instruction of the Program Expansion Board (DA-EM600).

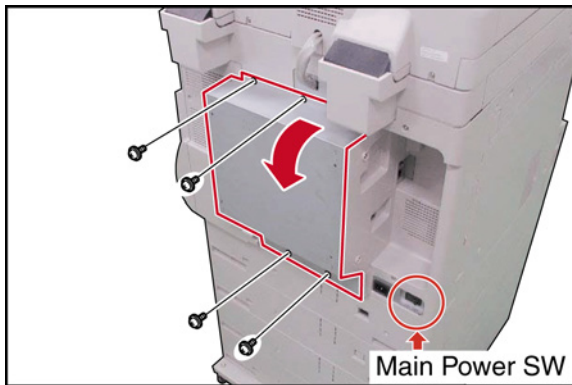

- (1) Remove 4 **Silver Screws**.
- (2) Open the **Rear Cover**.

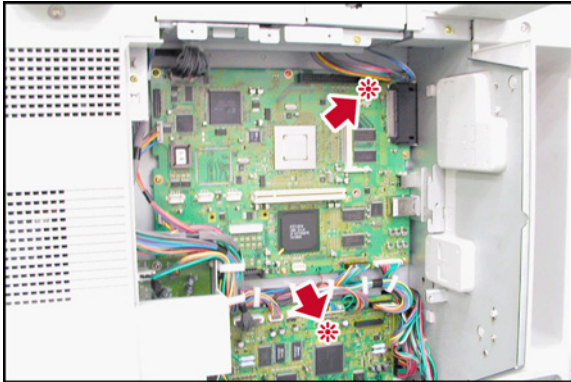

Caution:

If the LEDs on the SC and SPC PC Boards are lit (ON), the Power to the machine is still ON. Please read “8.4.2. Installation : **CAUTION!**” once again.

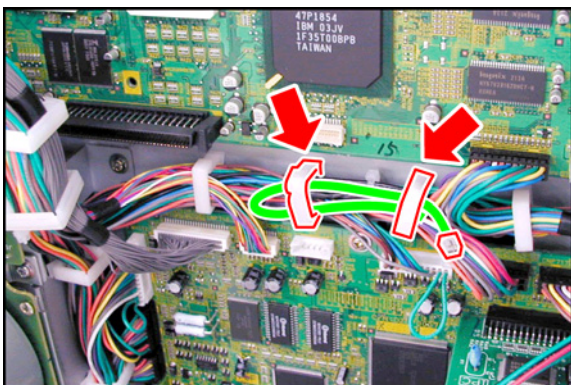

- (3) Release the **Pre-installed 2 wire Harness** from 2 Harness Clamps.

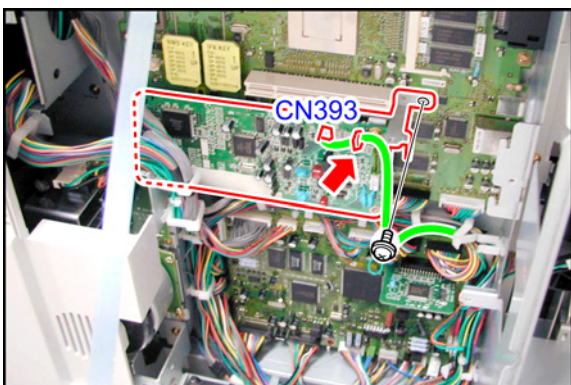

- (4) Plug the **FXB PC Board Assembly** into the SC PC Board with on Board Connector.
- (5) Secure the **FXB PC Board Assembly** with 1 **Screw**.
- (6) Connect the **Pre-installed 2 wire Harness** to the FXB PC Board (CN393).
- (7) Secure the **Pre-installed 2 wire Harness** with Harness Clamp on the FXB PC Board.

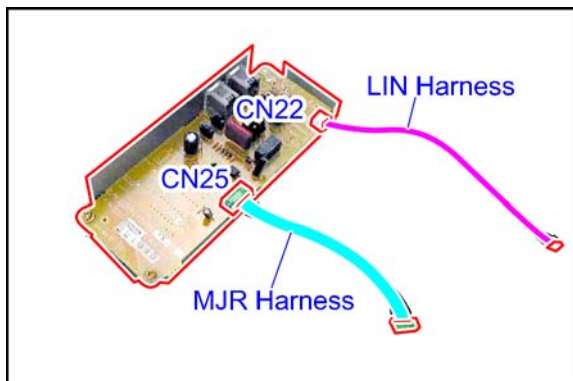

- (8) Connect one end of the **MJR Harness** and **LIN Harness** to the MJR PC Board Assembly (CN22 and CN25).

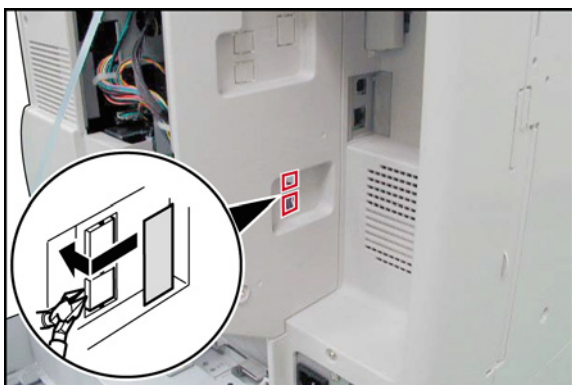

- (9) Remove the **Lower Protective Tab** on the Left Rear Cover for the LINE connection.
If installing an External Telephone, remove the upper protective tab as well.
- (10) Attach the **Line Label** to the Left Rear Cover as illustrated.

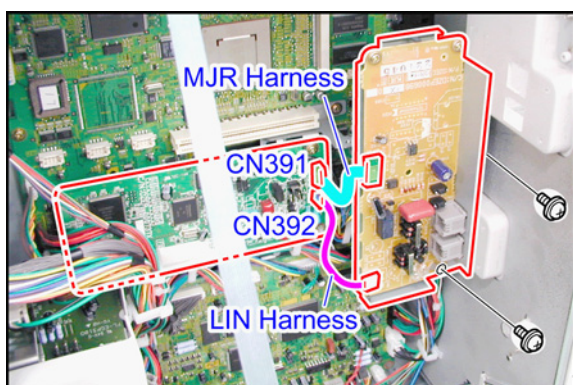

- (11) Install the **MJR PC Board Assembly** from the rear of the machine by inserting the hooks into the slots on the frame.
- (12) Secure the **MJR PC Board Assembly** with 2 **Screws**.
- (13) Connect the **MJR PCB Harnesses** to the FXB PC Board (CN391 and CN392).

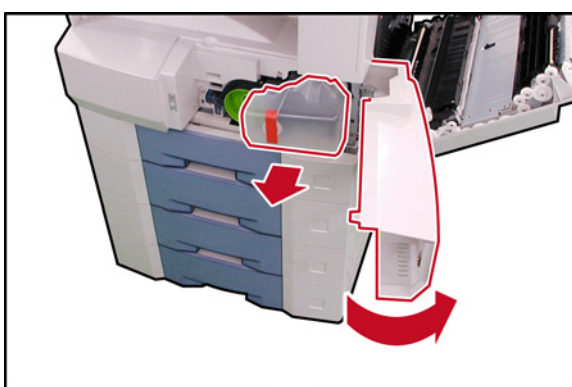

- (14) Open the **Right Cover** and **Front Cover**.
- (15) Remove the **Toner Waste Container**.



- (16) Remove 1 **Screw**.
 (17) Remove the **Connector Cover** (Clear Blue).



- (18) Disconnect the **Harness**.
 (19) Loosen 1 **Screw**.
 (20) Slide the **Process Unit** out.

Caution:

To prevent damage to the Process Unit, ensure the Right Cover is still open before pulling the Process Unit out.

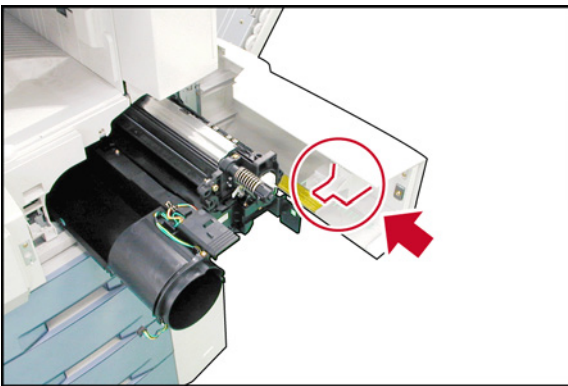

Caution:

Exercise caution not to scratch the surface of the **OPC Drum** (Green), and not to touch it with bare hands.

Caution:

The OPC Drum is sensitive to light. To prevent optical exposure problems, do not expose the OPC Drum to direct sunlight or bright light (even if it is a 1000-Lux fluorescent lamp).

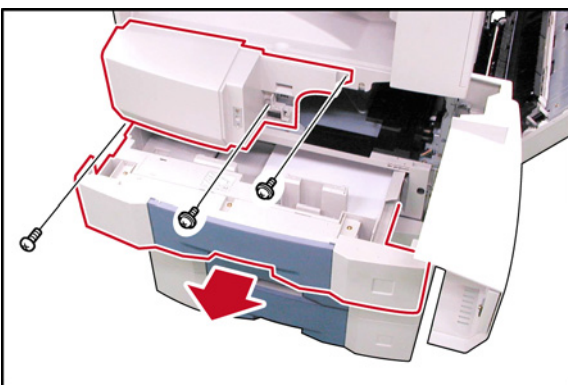

- (21) Slide the **1st Paper Tray** out.
 (22) Remove 3 **Screws**.
 (23) Remove the **Front Left Cover**.

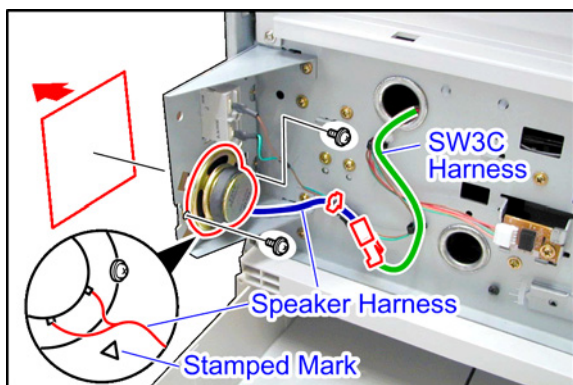

- (24) Remove the **Blind Label**.
- (25) Install the **Speaker** as illustrated.
- (26) Secure the **Speaker** with 2 **Screws**.
- (27) Connect the **Speaker Harness** to the **SW3C Harness**.
- (28) Insert the **Speaker Harness** into the Harness Clamp.
- (29) Reinstall the **Front Left Cover**, the Process Unit and Toner Waste Container.

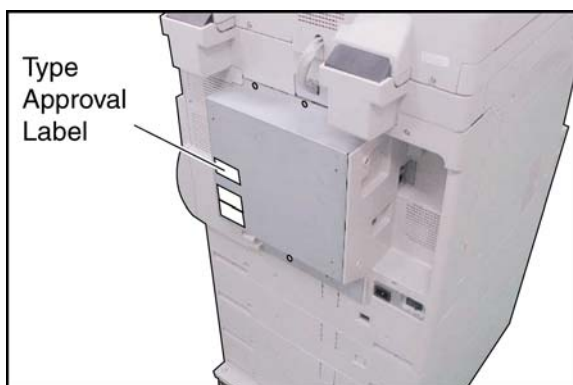

- (30) Attach the **Type Approval Label** (specified destination) to the Lower Rear Cover as illustrated.

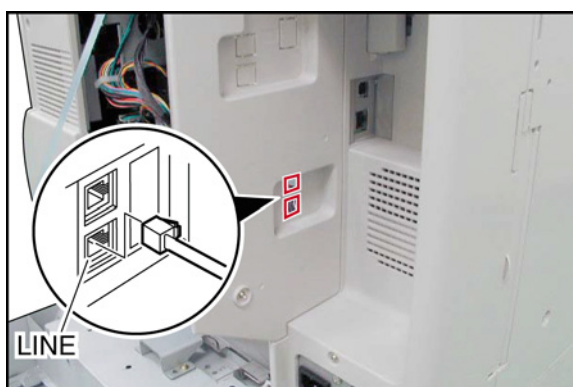

- (31) Proceed with the installation of other options. If finished, reinstall all **Harnesses** and **Covers**.
- (32) Connect one end of the **Telephone Line Cable** to the LINE Jack on the left side of the machine, and the other end to the RJ-11C Jack on the wall.
- (33) Plug the **AC Power Cord**, and turn the Main Power Switch on the Back and the Power Switch on the Left Side of the machine to the ON position.
- (34) Reconnect the **LAN Cable** if disconnected.

(35) It is not necessary to set the parameter for the following suffix (Destinations). The Fax Firmware is automatically loaded with the Host Firmware.

PB : UK PG : Germany PM : Netherlands PK : China PT : Taiwan PU/PUG : USA

Note:

For other destinations, set the “**00 FAX Service Mode : 01 Function Param. Setting : #005 Destination Code**”.

000 : Austria	001 : UK	002 : Canada	003 : Denmark
004 : Taiwan	005 : Finland	006 : Germany	007 : Netherlands
008 : Italy	009 : Spain	010 : Hong Kong	011 : Australia
012 : Switzerland	013 : Norway	015 : Portugal	016 : Ireland
017 : Belgium	018 : Sweden	019 : Turkey	020 : USA
021 : France	022 : New Zealand	025 : Japan	029 : Poland
030 : Czech	031 : Russia	032 : Greece	033 : Hungary
034 : Indonesia	035 : South Korea	038 : Malaysia	039 : China
045 : Thailand	048 : South Africa	049 : Singapore	050 : Universal
051 : East Euro			

- (36) Execute Parameter Initialize by following the steps below.
- a) Press the **“FUNCTION”**, **“ORIGINAL SIZE (LEDGER/A3)”** and **“3”** keys simultaneously.
 - b) Input the password, and select the **“OK”** button to enter the Service Mode (default password is **00000000**).
 - c) Press the **“9”** key, and press the **“START”** key to enter the F9 Service Mode (Unit Maintenance).
 - d) Select **“00 FAX Service Mode”**.
 - e) Select **“01 Function Param. Setting”**.
 - f) Select **“005 Destination Code”**.
 - g) Select the **“CHANGE”** button.
 - h) Input the new Destination Code, and Select the **“OK”** button twice.
 - i) Select **“06 RAM Initialize”**.
 - j) Select **“01 Parameter Initialize”**, and select **“Yes”** button.
 - k) After the initialization completion beep, and press the **“STOP”** key.
 - l) Press the **“FUNCTION”** and **“C (CLEAR)”** keys simultaneously to exit the Service Mode.
 - m) Reboot the machine after setting the parameter(s) to activate the setting(s). (Turn the Power Switch on the Left Side of the machine to the **OFF** then back to the **ON** position.)
- (37) Verify the position of the  stamp on the document. If it is not within the desired location at the bottom of the document, you can adjust its position by following the steps below.
- a) Press the **“FUNCTION”**, **“ORIGINAL SIZE (LEDGER/A3)”** and **“3”** keys simultaneously.
 - b) Input the password, and select the **“OK”** button to enter the Service Mode (default password is **00000000**).
 - c) Press the **“6”** key, and press the **“START”** key to enter the F6 Service Mode (Adjust Parameters).
 - d) Select **“69 Stamp Position Adjust”**.
 - e) Select the **“INPUT”** button, and enter a number (-50 to 50).

Note:

A positive number moves the  stamp position closer to the trail edge of the document, conversely, a negative number moves it in the opposite direction.
To change the current sign to either +/-, press the **“RESET”** key.
(Default setting = 0; 0.3 mm/step)

- f) Select the **“OK”** button twice.
- g) Press the **“FUNCTION”** and **“C (CLEAR)”** keys simultaneously to exit the Service Mode.

Perform the following steps if the Optional Hard Disk Drive Unit (DA-HD31) is also installed

<Changing from 200 to 1,000 Station Address Book>

An additional 800 stations (1,000 total) are available when the optional Hard Disk Drive (DA-HD31) is installed. If you wish to use the 1,000 Fax Address Book, please follow the steps below to change the address book setting of the machine.

Caution:

- The registered address book data will be deleted when the address book setting is changed. If your machine already has registered stations in the Fax Address Book, please make a backup first before changing the address book setting.
- Before changing the Fax Address Book setting, printout the Address Book information or copy the Data using the Address Book Editor in the Panasonic Document Management System software. After executing the setting change, re-enter the printed Address Book information or copy and paste the Data from the 200 to the 1,000 station Address Book file. (See the Operating Instructions for Document Management System and Printer)

Changing the Fax Address Book Setting

Execute the Auto Dial Clear and activate the 1,000 station Address Book by following the steps below.

- a) Press the **“FUNCTION”**, **“ORIGINAL SIZE (LEDGER/A3)”** and **“3”** keys simultaneously.
- b) Input the password, and select the **“OK”** button to enter the Service Mode (default password is **00000000**).
- c) Press the **“9”** key, and press the **“START”** key to enter the F9 Service Mode (Unit Maintenance).
- d) Select **“00 FAX Service Mode”**.
- e) Select **“06 RAM Initialize”**.
- f) Select **“03 Auto Dial Clear”**, and select the **“Yes”** button for **“Initialize?”**.
Select the **“Yes”** button for **“Address Book 1,000 stations?”**. Wait approximately 1 minute while unit displays **“In Progress”**, then the unit will return to stand-by.

<Using Network Address Book Editor to Transfer the Address Book Data>

The registered data in the 200 Station Address Book can be easily copied and transferred (copy and paste) to the 1,000 Station Address Book by using the Network Address Book Editor (NAE).

Note:

1. The size and configuration of the transferred data, varies according to the 200 or 1,000 Fax Address Book.
When installing the Panasonic Document Management System, 2 Address Book Editor modules are installed for the DP-8032/8025.
 - The **“DP-8032/8025”** is used for the standard 200 Fax Address Book.
 - The **“DP-8032/8025 (Fax1000)”** is used for the 1,000 Fax Address Book.
2. The model module of the Address Book Editor (NAE) can be confirmed by the following method.
 - a) Click on START\Programs\Panasonic\Panasonic Document Management System and select Device Explorer.
 - b) The Device Explorer screen is displayed, select your desired device.
 - c) Click on Device in the menu bar, and select Open Network Address book Editor in the drop down menu.
 - d) The Network Address Book Editor screen displays; If the Network Address book Editor Dialogue Box appears, click **“Update”** to access the web site and download the latest model module and then install it.

Using the Network Address Book Editor to Copy and Paste the Address Book Data

1. An appropriate Address Book Editor module is automatically selected depending on which style of Fax Address Book is activated on the DP-8032/8025. Retrieve the 200 Station, Fax Address Book data from the unit as follows:
 - a) Click on START\Programs\Panasonic\Panasonic Document Management System and select Device Explorer.
 - b) The Device Explorer screen is displayed, select your desired device.
 - c) Click on Device and select Open Network Address book Editor in the drop down menu.
 - d) In the menu bar, click on Tools and in the drop down menu on Address Book Editor.
 - e) The Network Address Book Editor "**DP-8032/8025**" screen appears, under the Address Book Editor directory, click on Fax Address Book.
 - f) When the 200 station Fax Address Book file is displayed, save the data file by clicking on File\Save As... and type the file name of your choice (i.e. 200 Station).
 - g) Then click the OK button.
2. Change the Address Book of the unit from 200 to 1,000 Stations, using the Service Mode described previous page.
3. Retrieve the 1,000 Fax Address Book (empty) data again from the unit using the same method as above. When the Address Book Editor appears this time, it will show "**DP-8032/8025 (Fax1000)**". Save the data file as above, except change to another name (i.e. 1,000 Station).
4. Open the 200 Fax data file of step 1. and the 1,000 Fax data file of step 3.. Copy the 200 Fax data and paste it into the 1,000 Fax data file, add additional desired names to the file, then save it again. (Refer to Help.)
5. Transfer the edited 1,000 Fax data file to the unit, by clicking on Transfer and Write in the menu bar. Close the Network Address Book Editor application after the transfer is successfully completed.



8.5. Installing the Hard Disk Drive Unit (DA-HD31)

8.5.1. Contents

Visually check the condition and contents of the box for completeness, or for any shipping damage before starting the installation.

Remove all tapes, and the packing materials used to secure the units during shipment.

After unpacking, dispose the packing materials appropriately.

No.	Qty.	Description	Remarks
1	1	Hard Disk Drive (HDD)	
2	1	HDD Bracket	
3	1	DC12 Harness	3 Connectors
4	1	HDD2 Harness	Flat Cable
5	1	HD Harness	Power Supply Cable
6	1	DC PCB	
7	4	Harness Clamp (Small)	
8	2	Harness Clamp (Metal)	
9	10	Screw (6-32 x 3/8)	
10	4	Screw (M3 x 6)	
11	2	Screw (M3 x 8)	
12	1	Ground Harness	
13	1	Installation Instructions	This document

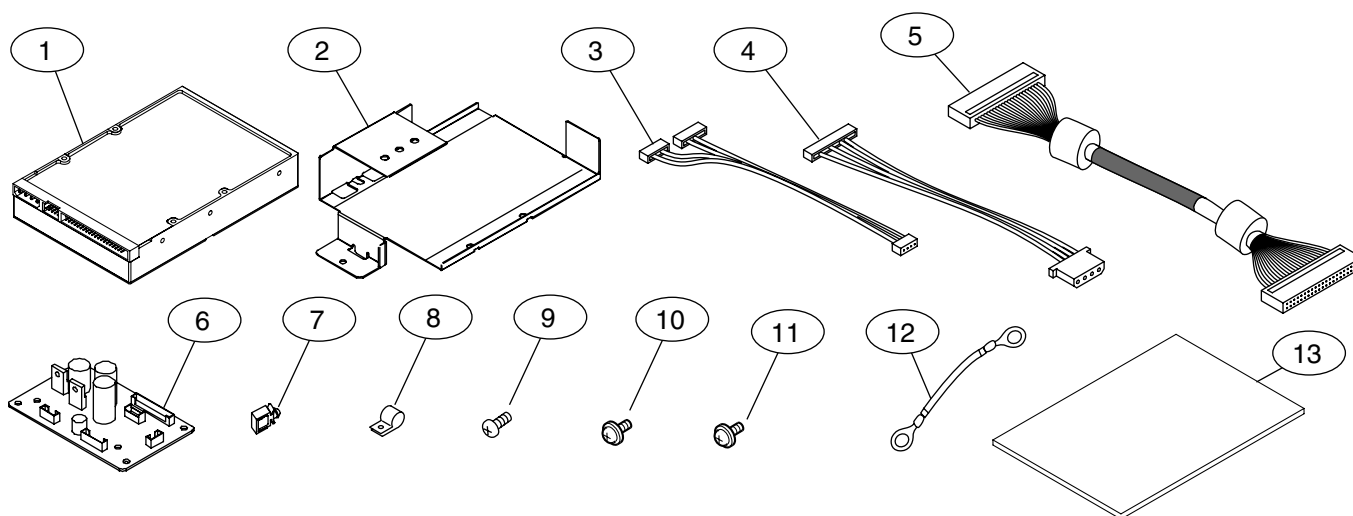

Note:

Refer to the Parts Manual for Part Number(s), Packing, and Accessories detail.

8.5.2. Installation

CAUTION!

Turn the **Power Switch** on the **Left Side**, and the **Main Power Switch** on the **Back** of the machine to the **OFF** position, and then unplug the **AC Power Cord** before beginning installation.

Caution:

Before installing the **Hard Disk Drive Unit**, make sure the optional **Sorting Image Memory** is installed in the memory socket on the **SC PC Board (CN65)** first. **At least an additional 16 MB (DA-SM16B) of Sorting Image Memory is required.**

Refer to the **Installation Instruction** of the **Sorting Image Memory (DA-SM16B/64B/28B)**.

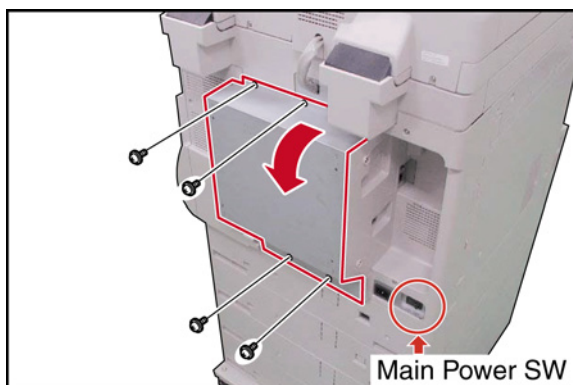

- (1) Remove 4 **Silver Screws**.
- (2) Open the **Rear Cover**.

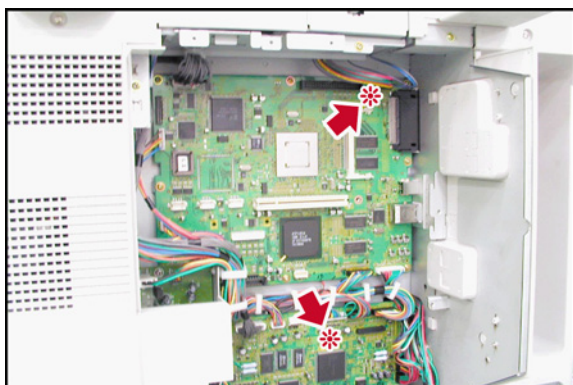

Caution:

If the LEDs on the **SC** and **SPC PC Boards** are lit (**ON**), the **Power** to the machine is still **ON**. Please read "**8.5.2. Installation : CAUTION!**" once again.

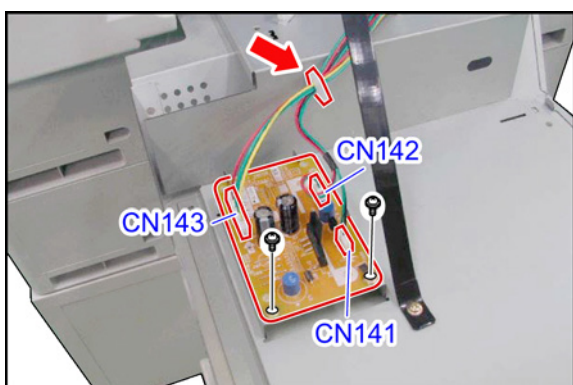

- (3) Install the **DC PC Board** onto the **Rear Cover** as illustrated.
- (4) Secure the **DC PC Board** with 2 **Screws (M3 x 6)**.
- (5) Install 1 **Harness Clamp (Small)** to the **Rear Cover**.
- (6) Connect the **HDD2 Harness (CN143)** and **DC12 Harness (CN141 & CN142)**.
- (7) Secure the **DC12 Harness** and **HDD2 Harness** with the **Harness Clamp (Small)**.

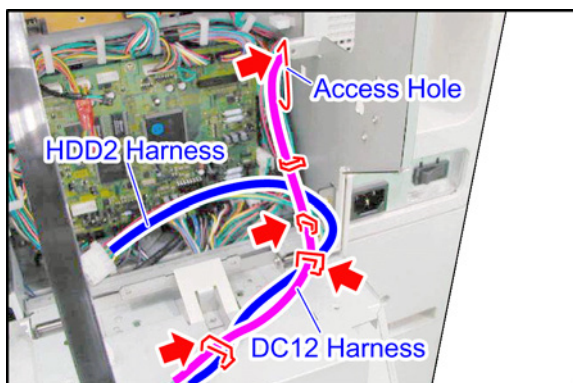

- (8) Install 3 **Harness Clamps (Small)** to the **Rear Cover**.
- (9) Secure the **HDD2 Harness** with the 2 Harness Clamps.
- (10) Secure the **DC12 Harness** with the 4 Harness Clamps.
- (11) Route the **DC12 Harness** through the access hole in the side frame.



- (12) Remove 2 **Shoulder Silver Screws** (Upper) and 2 **Silver Screws** (Lower).
- (13) Remove the **Left Cover**.

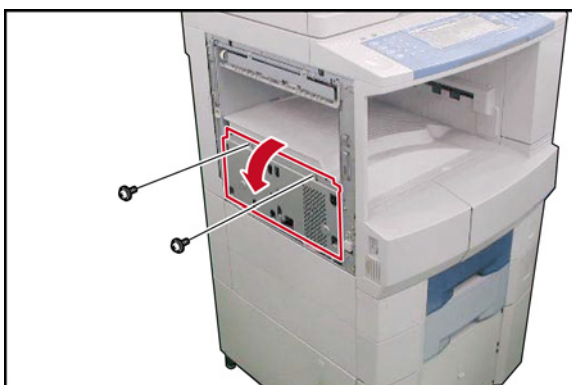

- (14) Remove 2 **Screws**.
- (15) Open the **LVPS Cover**.

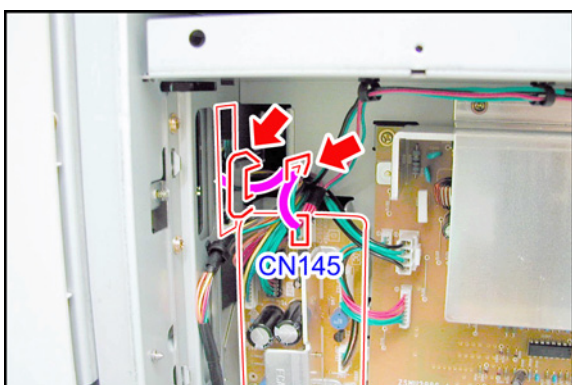

- (16) Connect the **DC12 Harness** on the DC PC Board (CN145).
- (17) Secure the **DC12 Harness** with the 2 Harness Clamps.

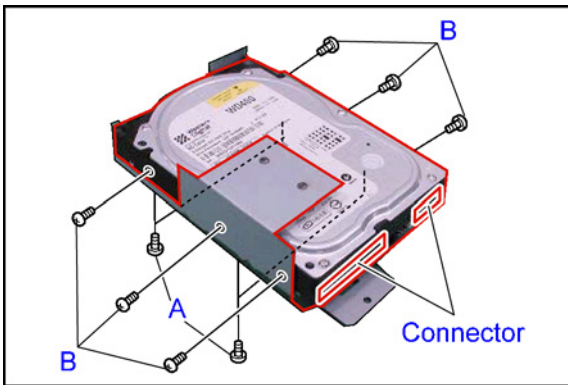

- (18) Install the **HDD** into the HDD Bracket.
- (19) Secure the **HDD Bracket** with 4 **Screws (A)** from bottom (6-32 x 3/8).
- (20) Secure the **HDD Bracket** with 6 **Screws (B)** from side (6-32 x 3/8).

Caution:

Exercise care to prevent the HDD from Shock, and Vibration damage.

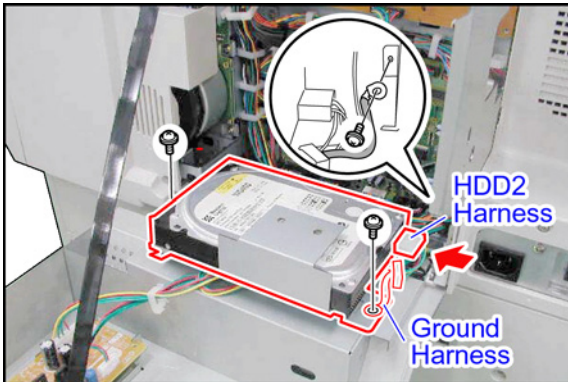

- (21) Connect the **HDD2 Harness** to the HDD.
- (22) Remove 1 **Screw** from the machine.
- (23) Secure the **Ground Harness** with 1 **Screw** removed in step (22).
- (24) Install the HDD Assembly onto the Rear Cover.
- (25) Secure the **HDD Assembly** and the **Ground Harness** with 2 **Screws (M3 x 6)**.

Caution:

Exercise caution not to pinch the wires under the HDD Assembly.

Caution:

Exercise care to prevent the HDD from Shock, and Vibration damage.

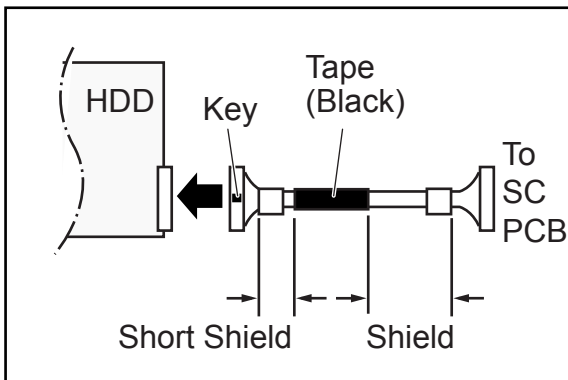

Caution:

Connect the Connector on the short shield side of the HD Harness to the HDD as illustrated.

Caution:

Make sure that the HD Harness is connected to the HDD correctly as illustrated.

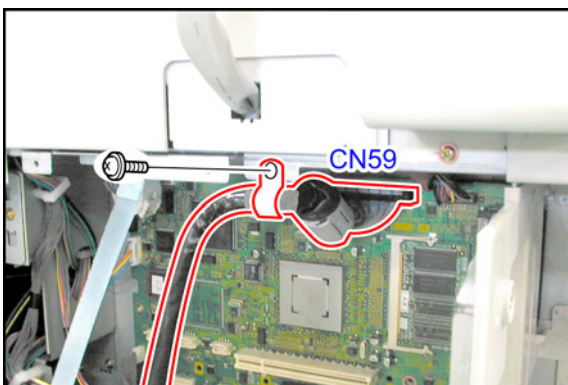

- (26) Remove 1 **Screw** from the machine.
- (27) Connect one end of the **HD Harness** to CN59 on the SC PC Board.
- (28) Secure the **HD Harness** with the **Harness Clamp (Metal)** and 1 **Screw (M3 x 8)**.

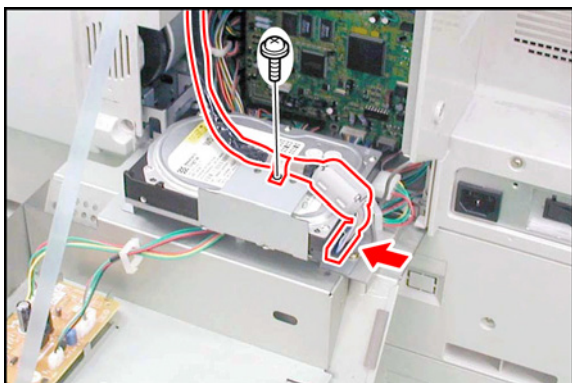

- (29) Connect the other end of the **HD Harness** to the HDD.
- (30) Secure the **HD Harness** with the **Harness Clamp (Metal)** and 1 **Screw (M3 x 8)**.

Caution:

Make sure to secure the Shield position of the HD Harness with the Harness Clamp (Metal).

- (31) Proceed with the installation of other options. If finished, reinstall all **Harnesses** and **Covers**.
- (32) Plug the **AC Power Cord**, and turn the Main Power Switch on the Back and the Power Switch on the Left Side of the machine to the ON position.
- (33) Reconnect the **Telephone Line / LAN Cable** if disconnected.

CAUTION! :

<Step sequence of turning OFF the Power Switch>

After the Hard Disk Drive Unit is installed, to prevent a Scan Disk Function from being performed (similar to when the power is abruptly interrupted to the PC), it is important to follow the step sequence below when turning OFF the Power Switches on the machine.

1. Turn the Power Switch on the Left Side of the machine to the OFF position first.
2. Wait approximately 10 seconds while the machine writes the closing status onto the Hard Disk Drive Unit.
3. Turn the Main Power Switch on the Back of the machine to the OFF position.
(This interrupts all the power to the machine)
4. Unplug the AC Power Cord.

<Perform the following steps if the Optional Fax Communication Board (DA-FG300) is also installed>

<Changing from 200 to 1,000 Station Address Book>

An additional 800 stations (1,000 total) are available when the optional Hard Disk Drive (DA-HD31) is installed. If you wish to use the 1,000 Fax Address Book, please follow the steps below to change the address book setting of the machine.

Caution:

- The registered address book data will be deleted when the address book setting is changed. If your machine already has registered stations in the Fax Address Book, please make a backup first before changing the address book setting.
- Before changing the Fax Address Book setting, printout the Address Book information or copy the Data using the Address Book Editor in the Panasonic Document Management System software. After executing the setting change, re-enter the printed Address Book information or copy and paste the Data from the 200 to the 1,000 station Address Book file. (See the Operating Instructions for Document Management System)

Changing the Fax Address Book Setting

Execute the Auto Dial Clear and activate the 1,000 station Address Book by following the steps below.

- a) Press the “**FUNCTION**”, “**ORIGINAL SIZE (LEDGER/A3)**” and “**3**” keys simultaneously.
- b) Input the password, and select the “**OK**” button to enter the Service Mode (default password is **0000000**).

- c) Press the “9” key, and press the “START” key to enter the F9 Mode (Unit Maintenance).
- d) Select “00 FAX Service Mode”.
- e) Select the “↓” button, and select “06 RAM Initialize”.
- f) Select “03 Auto Dial Clear”, and select the “Yes” button for “Initialize?”.
Select the “Yes” button for “Address Book 1,000 stations?”. Wait approximately 1 minute while unit displays “In Progress”, then the unit will return to stand-by.

<Using Network Address Book Editor to Transfer the Address Book Data>

The registered data in the 200 Station Address Book can be easily copied and transferred (copy and paste) to the 1,000 Station Address Book by using the Network Address Book Editor (NAE).

Note:

1. The size and configuration of the transferred data, varies according to the 200 or 1,000 Fax Address Book. When installing the Panasonic Document Management System, 2 Address Book Editor modules are installed for the DP-8032 / 8025.
 - The “DP-8032 / 8025” is used for the standard 200 Fax Address Book.
 - The “DP-8032 / 8025 (Fax1000)” is used for the 1,000 Fax Address Book.
2. The model module of the Address Book Editor (NAE) can be confirmed by the following method.
 - a) Click on START\Programs\Panasonic\Panasonic Document Management System and select Device Explorer.
 - b) The Device Explorer screen is displayed, select your desired device.
 - c) Click on Device in the menu bar, and select Open Network Address book Editor in the drop down menu.
 - d) The Network Address Book Editor screen displays; If the Network Address book Editor Dialogue Box appears, click “Update” to access the web site and download the latest model module and then install it.

Using the Network Address Book Editor to Copy and Paste the Address Book Data

1. An appropriate Address Book Editor module is automatically selected depending on which style of Fax Address Book is activated on the DP-8032 / 8025.
Retrieve the 200 Station, Fax Address Book data from the unit as follows:
 - a) Click on START\Programs\Panasonic\Panasonic Document Management System and select Device Explorer.
 - b) The Device Explorer screen is displayed, select your desired device.
 - c) Click on Device and select Open Network Address book Editor in the drop down menu.
 - d) In the menu bar, click on Tools and in the drop down menu on Address Book Editor.
 - e) The Network Address Book Editor “DP-8032 / 8025” screen appears, under the Address Book Editor directory, click on Fax Address Book.
 - f) When the 200 Station Fax Address Book file is displayed, save the data file by clicking on File\Save As... and type the file name of your choice (i.e. 200 Station).
 - g) Then click the “OK” button.
2. Change the Address Book of the unit from 200 to 1,000 Stations, using the Service Mode described previous page.
3. Retrieve the 1,000 Fax Address Book (empty) data again from the unit using the same method as above. When the Address Book Editor appears this time, it will show “DP-8032 / 8025 (Fax1000)”. Save the data file as above, except change to another name (i.e. 1,000 Station).
4. Open the 200 Fax data file of step 1. and the 1,000 Fax data file of step 3.. Copy the 200 Fax data and paste it into the 1,000 Fax data file, add additional desired names to the file, then save it again. (Refer to Help.)
5. Transfer the edited 1,000 Fax data file to the unit, by clicking on Transfer and Write in the menu bar. Close the Network Address Book Editor application after the transfer is successfully completed.

8.6. Installing the Accounting Software (DA-WA10)

8.6.1. Contents

Visually check the condition and contents of the box for completeness, or for any shipping damage before starting with the installation.

Remove all Tapes, and the packing materials used to secure the Units during shipment.

After unpacking the product, dispose of the packing materials appropriately.

No.	Qty.	Description	Remarks
1	1	Accounting Software CD	Includes Operating Instructions
2	1	Installation Instructions	This document

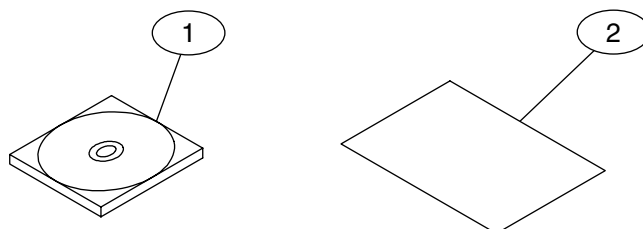

Note:

Refer to the Parts Manual for Part Number(s), Packing, and Accessories in details.

8.6.2. Installation

1. Before installing this option, make sure the Hard Disk Drive Unit (DA-HD31) is installed into the machine first. Refer to the Installation Instructions for the Hard Disk Drive Unit (DA-HD31).
2. Install the Accounting Software into the PC with the Operating Instructions by following the prompts of the Installation Wizard.
3. Set the Key/Dept. Counter function by following the steps below.
 - 1) Press the “**FUNCTION**”, “**ORIGINAL SIZE (LEDGER/A3)**”, and the “**3**” keys simultaneously.
 - 2) Input the password, and select the “**OK**” button to enter the Service Mode (default password is **00000000**).
 - 3) Press the “**5**” key, and press the “**START**” key to enter the F5 Service Mode. (Function Parameters).
 - 4) Select “**42 KEY/DEPT Counter**”.
 - 5) Select “**DEPT.**”, and the “**OK**” button to activate the Key/Dept. Counter function.
 - 6) Select the “**STOP**” key.
 - 7) Press the “**Function**”, and the “**C (CLEAR)**” keys simultaneously to exit the Service Mode.
4. Set the Key/Dept. Code, please refer to the Operating Instructions (For Copy & Network Scan Functions) to Function setting.

8.7. Installing the Expansion F-ROM Board (DA-EM600)

8.7.1. Contents

Visually check the condition and contents of the box for completeness, or for any shipping damage before starting with the installation.

Remove all Tapes, and the packing materials used to secure the Units during shipment.

After unpacking the product, dispose of the packing materials appropriately.

No.	Qty.	Description	Remarks
1	1	Expansion F-ROM Board	
2	2	PC Board Support	
3	1	Installation Instructions	This document

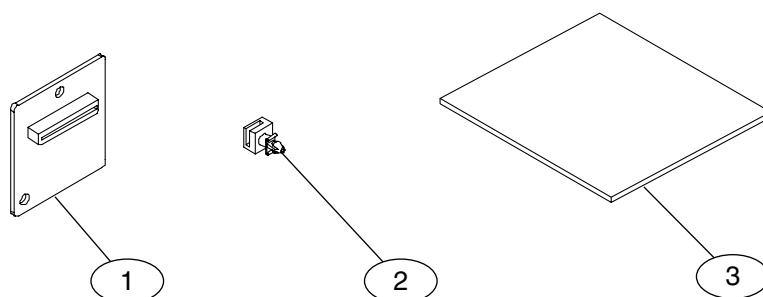

Note:

Refer to the Parts Manual for Part Number(s), Packing, and Accessories in details.

8.7.2. Installation

CAUTION!

Turn the Power Switch on the Left Side, and the Main Power Switch on the Back of the machine to the OFF position, and then unplug the AC Power Cord before beginning installation.

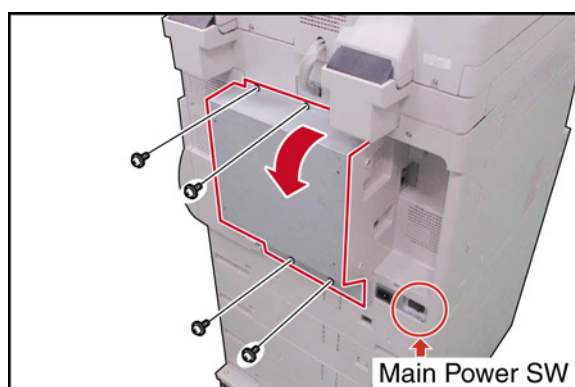

(1) Remove 4 **Silver Screws**.

(2) Open the **Rear Cover**.

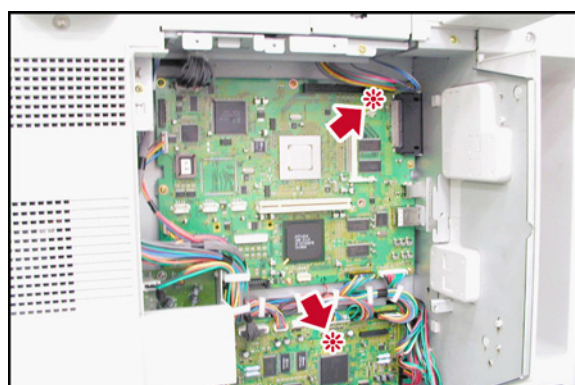

Caution:

If the LEDs on the SC and SPC PC Boards are lit (ON), the Power to the machine is still ON. Please read "8.7.2. Installation : CAUTION!" once again.

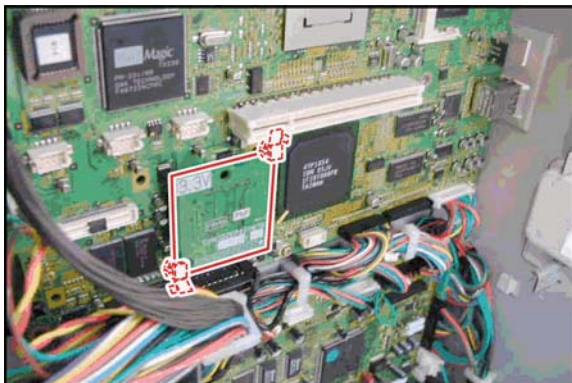

- (3) Remove the **Black Pin Protector** from Slot 1 (CN62), if it was pre-installed.
- (4) Install 2 **PC Board Supporters** for the Slot 1 on the SC PC Board.
- (5) Install the **Program Expansion Board** into **Slot 1 (CN62)** on the SC PC Board, and secure with the Supporters.

Note:

The Program Extension F-ROM Board must always be installed into Slot 1 (CN62) for the PCL or PCL/PS Printer Option to function.

- (6) Proceed with the installation of other options. If finished, close and secure the Rear Cover, and reinstall remaining Covers.
- (7) Plug the **AC Power Cord**, and turn the Main Power Switch on the Back, and the Power Switch on the Left Side of the machine to the ON position.
- (8) Reconnect the **Telephone Line / LAN Cable** if disconnected.

8.8. Installing the Sorting Image Memory 16 / 64 / 128 MB (DA-SM16B / 64B / 28B)

8.8.1. Contents

Visually check the condition and contents of the box for completeness, or for any shipping damage before starting with the installation.

Remove all Tapes, and the packing materials used to secure the Units during shipment.

After unpacking the product, dispose of the packing materials appropriately.

No.	Qty.	Description	Remarks
1	1	SDRM PC Board	16 MB
			64 MB
			128 MB
2	1	Installation Instructions	This document

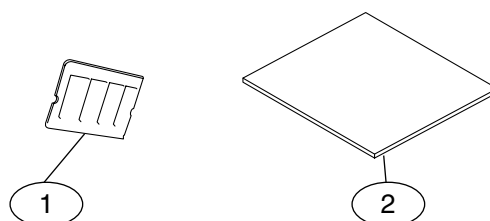

Note:

Refer to the Service Manual in detail.

8.8.2. Installation

CAUTION!

Turn the Power Switch on the Left Side, and the Main Power Switch on the Back of the machine to the OFF position, and then unplug the AC Power Cord before beginning installation.

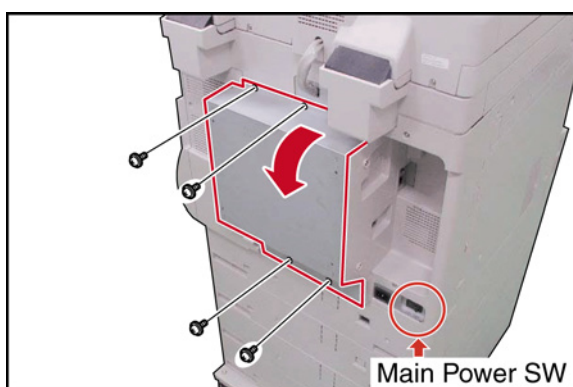

- (1) Remove 4 **Screws**.
- (2) Open the **Rear Cover**.

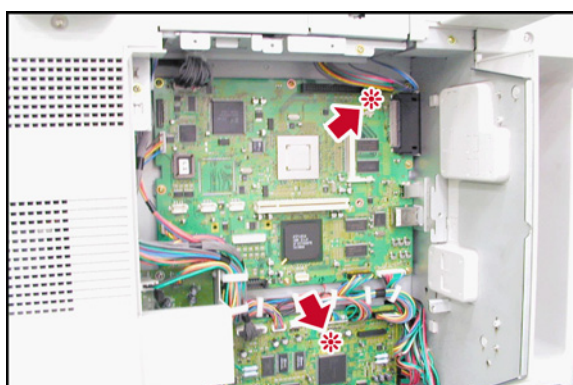

Caution:

If the LEDs on the SC and SPC PC Boards are lit (ON), the Power to the machine is still ON. Please read "8.8.2. Installation : CAUTION!" once again.

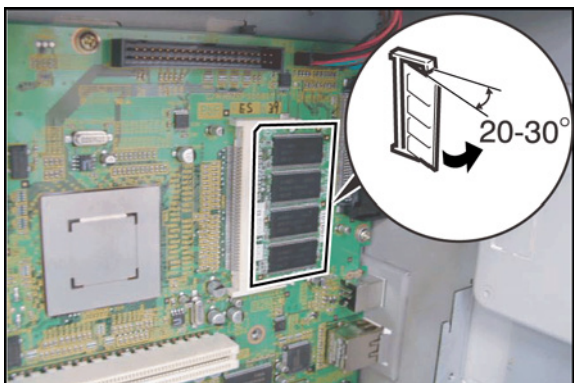

(3) Insert the **SDRM PC Board** into the Socket on the SC PC Board as illustrated.

Caution:

Make sure to insert the SDRM PC Board at a 20 - 30° angle into the memory socket, and then lock it down.

- (4) Proceed with the installation of other options. If finished, close and secure the Rear Cover, and reinstall remaining Covers.
- (5) Plug the **AC Power Cord**, and turn the Main Power Switch on the Back, and the Power Switch on the Left Side of the machine to the ON position.
- (6) Reconnect the **Telephone Line / LAN Cable** if it was disconnected.

8.9. Installing the Expansion Flash Memory Card 4/8 MB (UE-410047/410048)

8.9.1. Contents

Qty.	Description	Remarks
1	Image Memory	4 MB
		8 MB

Note:

1. The part number may differ depending on the Destination.
2. Refer to the Parts List in the Parts Manual.

8.9.2. Installation

CAUTION!

Turn the Power Switch on the Left Side, and the Main Power Switch on the Back of the machine to the OFF position, and then unplug the AC Power Cord before beginning installation.

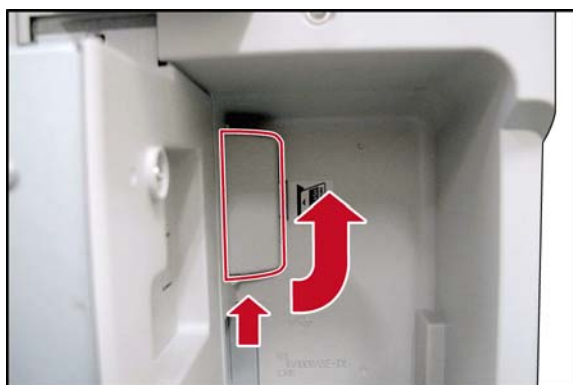
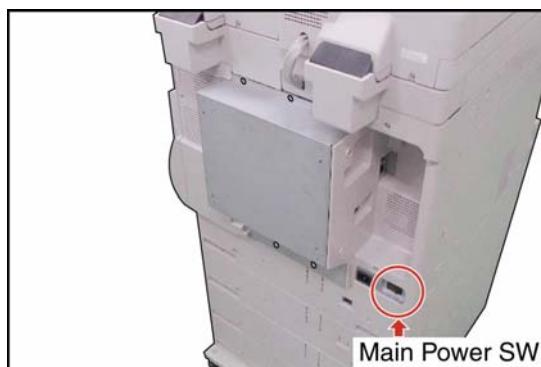

(1) Remove the Flash Memory Cover.



(2) Gently insert the Expansion Flash Memory Card as illustrated.

Caution:

Forcing the card into the slot may cause damage to the card or machine.



(3) Reinstall the Cover.

(4) Plug the AC Power Cord into the wall outlet and turn the Main Power Switch on the Back and the Power Switch on the Left Side of the machine to the ON position.



8.10. Installing the 3rd Paper Tray (DA-DS305) / 4th Paper Tray (DA-DS306) and the Stand for 4-Paper Tray Configuration (DA-DA230-PA)

8.10.1. Contents

<DA-DS305> 3rd Paper Tray

Qty.	Description	Remarks
1	3rd Paper Tray Unit	
4	Bracket	
1	Size Label	
8	Screw	 
1	Installation Instructions	This document



<DA-DS306> 4th Paper Tray

Qty.	Description	Remarks
1	4th Paper Tray Unit	
4	Bracket	
1	Size Label	
8	Screw	 
1	Installation Instructions	This document

<DA-DA230-PA> Stand for 4-Paper Tray Configuration

Note:

This option is available only for specified destinations.

Qty.	Description	Remarks
1	Caster	
2	Joint C Plate	
1	Joint F Plate	
1	Joint G Plate	
4	Screw	 
1	Installation Instructions	This document

Note:

1. The part number may differ depending on the Destination.
2. Refer to the Parts List in the Parts Manual.

8.10.2. Installing the 3rd and 4th Paper Trays

CAUTION!

Turn the **Power Switch** on the **Left Side**, and the **Main Power Switch** on the **Back** of the machine to the **OFF** position, and then unplug the **AC Power Cord** before beginning installation.

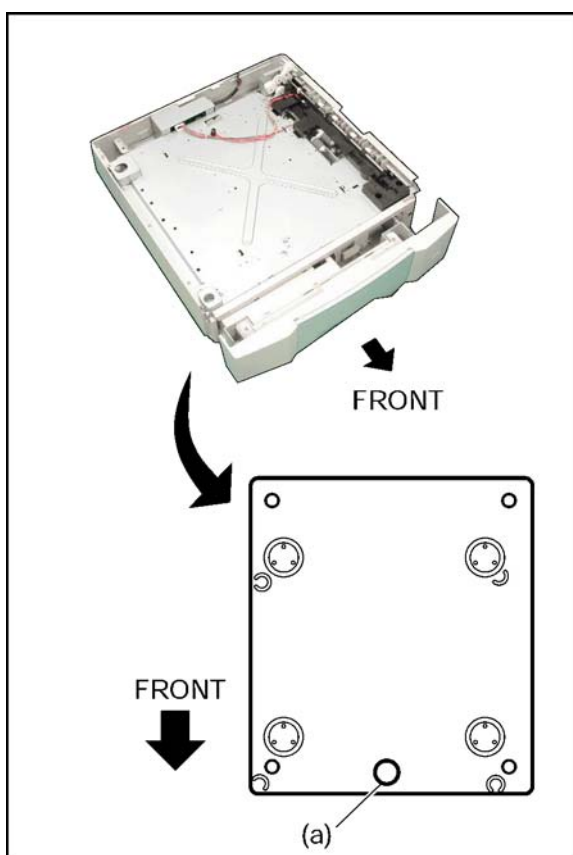

- (1) Slide the **4th Paper Tray** out of the unit.
- (2) Place the **4th Paper Tray Unit** on top of the Caster.

Note:

The side with the silver seal, indicated with an (a) in the illustration, is the **Front** side.

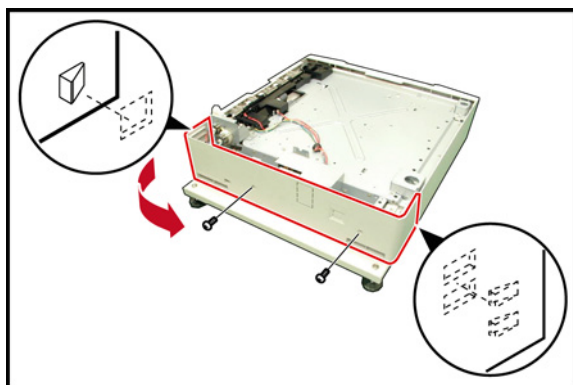

- (3) Remove 2 **Silver Screws**.
- (4) Remove the **Lower Rear Cover**.

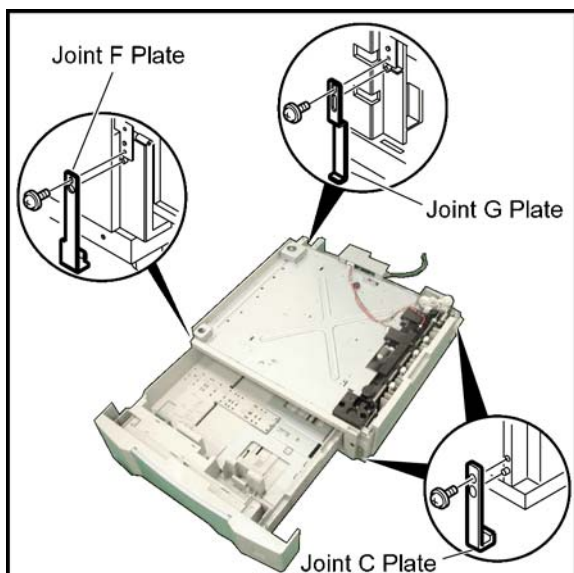

- (5) Join the **Caster** and the **4th Paper Tray Unit** with the Joint C Plates (FR/RR), Joint F Plate (FL) and Joint G Plate (RL).
- (6) Secure the **Joint C Plates, Joint F Plate and Joint G Plate** with 4 Screws.

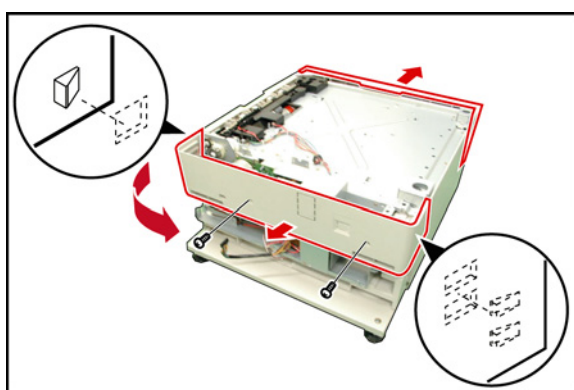

- (7) Place the **3rd Paper Tray Unit** on the 4th Paper Tray Unit.
- (8) Remove 2 **Silver Screws**.
- (9) Remove the **Lower Rear Cover**.
- (10) Slide the **3rd Paper Tray** out of the unit.

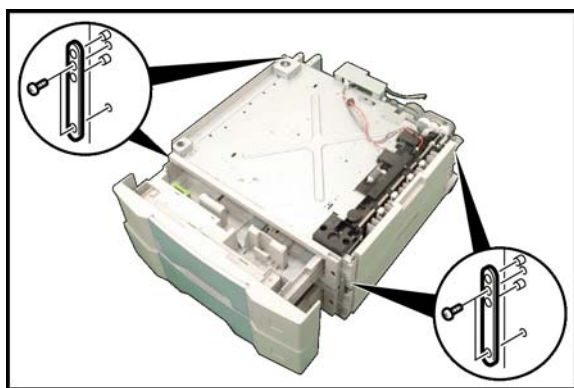

- (11) Install the 4 **Brackets**.
- (12) Secure the 4 **Brackets** with 8 Screws.

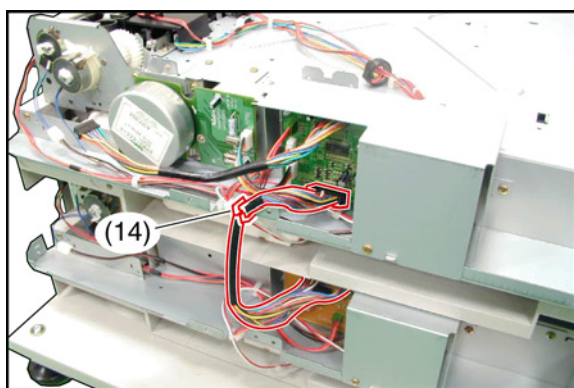

- (13) Connect the **Harness** of the 4th Paper Tray Unit to CN808 on the CST3 PC Board of the 3rd Paper Tray Unit.

Note:

Ensure the White Mark on the connector is facing Upward, inserting the connector upside down, may damage the machine's SPC or CST PC board.

- (14) Place the **Harness** into the clamp.



- (15) Place the **machine** on top of the 3rd Paper Tray Unit as illustrated.

Caution:

The machine weights approximately 181 lb (82 kg) with the i-ADF pre-installed. To prevent injuries, use the appropriate number of personnel and the proper equipment to lift or move the machine.

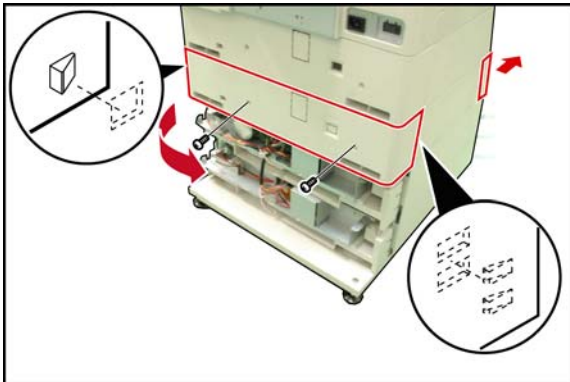

- (16) Remove 2 **Silver Screws**.
 (17) Remove the **Lower Rear Cover**.
 (18) Slide the **2nd Paper Tray** out of the unit.
 (19) Install the 4 **Brackets**, see Step (11).
 (20) Secure the 4 **Brackets** with 8 Screws.

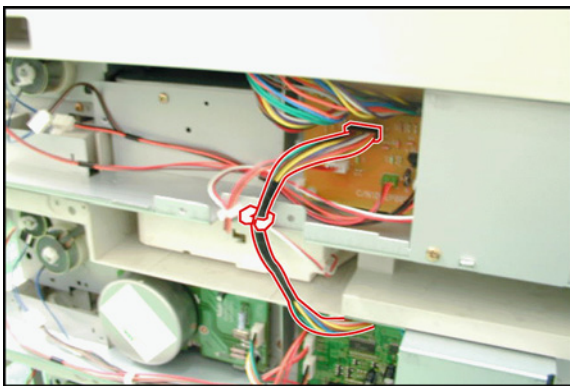

- (21) Connect the **Harness** of the 3rd Paper Tray Unit to CN772 on the CST2 PC Board of the 2nd Paper Tray Unit.

Note:

Ensure not to insert the connector upside down, as it may damage the machine's SPC or CST PC board.



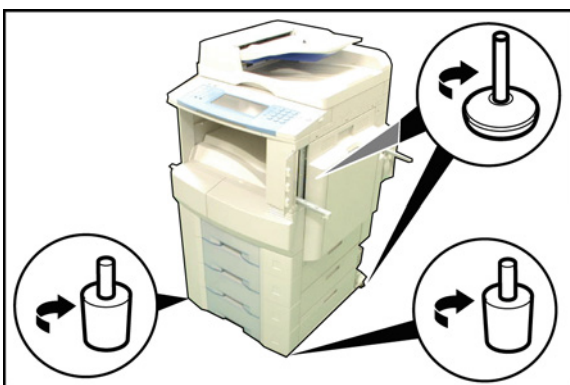

- (22) Place the **Harness** into the clamp.
 (23) Reinstall the **Lower Rear Covers** and the **Paper Trays**.

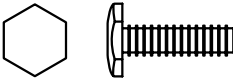

- (24) Level the **machine** with the 4 Adjusters as illustrated.
 (25) Attach the **Size Label(s)** onto the 3rd/4th Paper Tray(s).

8.11. Installing the Deluxe Stand (DA-DA310 / DA320) for USA Only

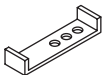
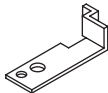
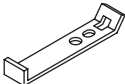
8.11.1. Contents

Qty.	Description	Remarks
1	Deluxe Stand (DA-DA310 = High)	2-Paper Trays Configuration
	Deluxe Stand (DA-DA320 = Low)	3-Paper Trays Configuration
4	Leveler	
1	Joint Bracket A (Right Front)	
1	Joint Bracket B (Right Rear)	Shorter piece 
1	Joint Bracket D (Left Front)	
1	Joint Bracket E (Left Rear)	Longer piece 
4	Screw	
1	Installation Instruction	This document

8.11.2. Installation

CAUTION!

Turn the Power Switch on the Left Side, and the Main Power Switch on the Back of the machine to the OFF position, and then unplug the AC Power Cord before beginning installation.

Note:

The following illustrations depict the Installation of Deluxe Stand (DA-DA310).

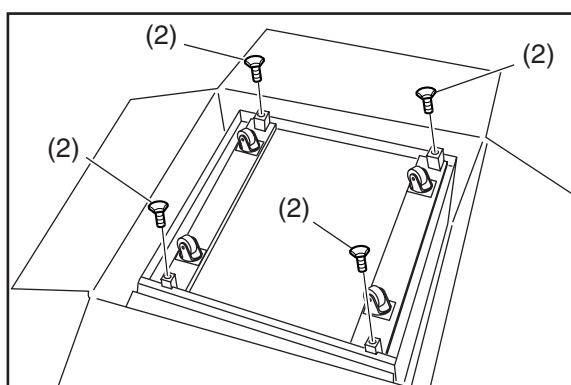

- (1) Open the top of the carton
- (2) Install 4 **Levelers** into each corner leg.
- (3) Turn the **Stand** right side up while its still in the carton and then lift and remove the **carton**.



- (4) Place the **machine** on top of the Deluxe Stand as illustrated.

Caution:

The machine weights approximately 181 lb (82 kg) with the i-ADF pre-installed. To prevent injuries, use the appropriate number of personnel and the proper equipment to lift or move the machine.

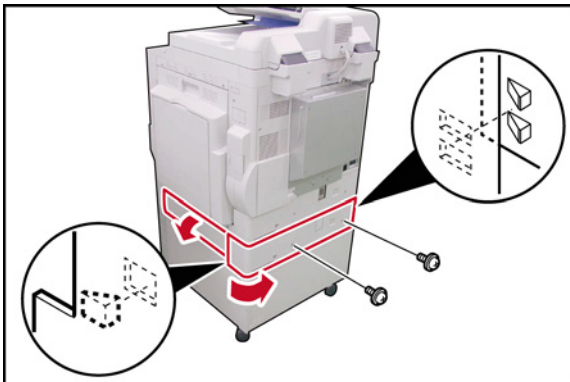

- (5) Remove 2 **Silver Screws**.
 (6) Open the **Jam Access Cover**.
 (7) Remove the **Lower Rear Cover**.

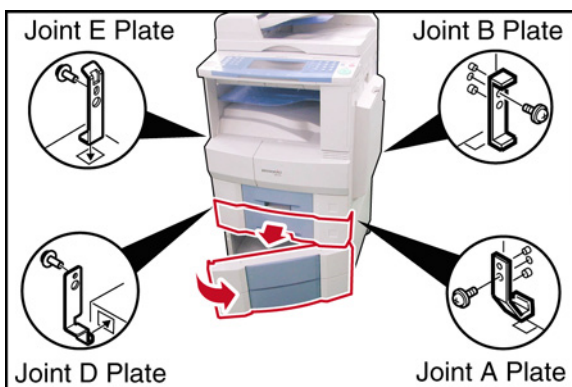

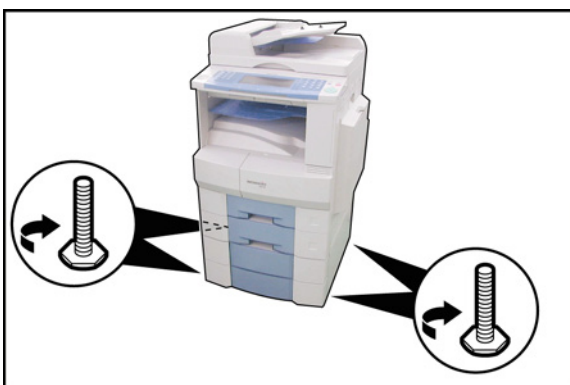

- (8) Open the **Front Cover** of the Deluxe Stand.
 (9) Open the **2nd Paper Tray**.
 (10) Connect the **machine** to the Deluxe Stand with 4 Joint Brackets.
 (11) Secure each **Joint Bracket** with 4 Screws.
 (12) Close the 2nd Paper Tray and the Front Cover of the Deluxe Stand.
 (13) Reinstall the Lower Rear Cover.



- (14) Place the machine at a desired location and lower the leveler on each corner to stabilize the machine.
 (15) Plug the AC Power Cord into the wall outlet and turn the Main Power Switch on the Back and the Power Switch on the Left Side of the machine to the ON position.

8.12. Installing the Stand (DA-DA310-PA / DA320-PA)

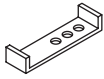
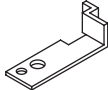
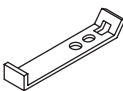
8.12.1. Contents

Qty.	Description	Remarks
1	Stand (DA-DA310-PA = High)	2-Paper Trays Configuration
	Stand (DA-DA320-PA = Low)	3-Paper Trays Configuration
1	Joint Bracket A (Right Front)	
1	Joint Bracket B (Right Rear)	Shorter piece 
1	Joint Bracket D (Left Front)	
1	Joint Bracket E (Left Rear)	Longer piece 
4	Screw	
1	Installation Instruction	This document

8.12.2. Installation

CAUTION!

Turn the Power Switch on the Left Side, and the Main Power Switch on the Back of the machine to the OFF position, and then unplug the AC Power Cord before beginning installation.

Note:

The following illustrations depict the Installation of Stand (DA-DA310).



(1) Place the **machine** on top of the Stand as illustrated.

Caution:

The machine weights approximately 181 lb (82 kg) with the i-ADF pre-installed. To prevent injuries, use the appropriate number of personnel and the proper equipment to lift or move the machine.

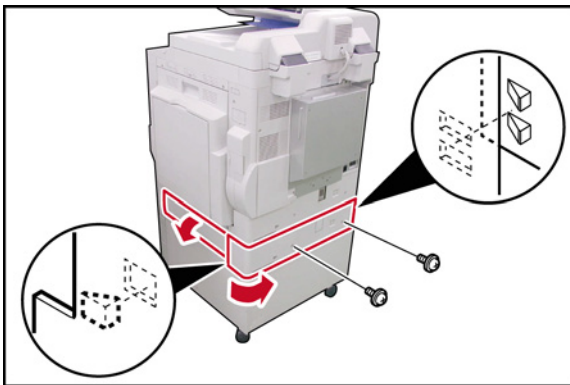

- (2) Remove 2 **Silver Screws**.
- (3) Open the **Jam Access Cover**.
- (4) Remove the **Lower Rear Cover**.

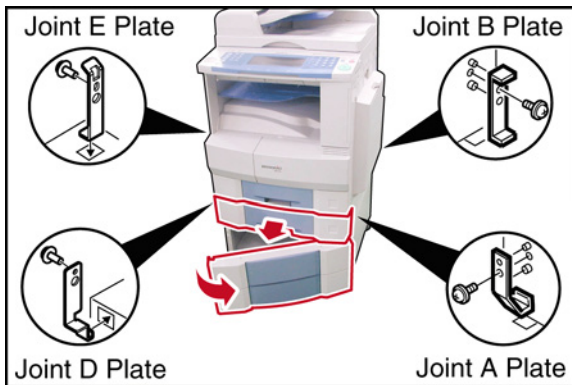

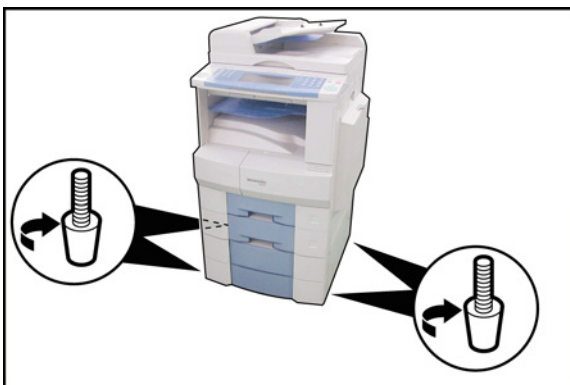

- (5) Open the **Front Cover** of the Stand.
- (6) Open the **2nd Paper Tray**.
- (7) Connect the **machine** to the Stand with 4 Joint Brackets.
- (8) Secure each **Joint Bracket** with 4 Screws.
- (9) Close the 2nd Paper Tray and the Front Cover of the Stand.
- (10) Reinstall the Lower Rear Cover.



- (11) Place the machine at a desired location and lower the leveler on each corner to stabilize the machine.
- (12) Plug the AC Power Cord into the wall outlet and turn the Main Power Switch on the Back and the Power Switch on the Left Side of the machine to the ON position.

8.13. Installing the Stand (DA-DA311-PA / DA321-PA)

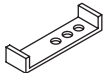
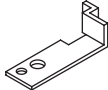
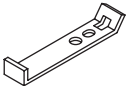
8.13.1. Contents

Qty.	Description	Remarks
1	Stand (DA-DA311-PA = High)	2-Paper Trays Configuration
	Stand (DA-DA321-PA = Low)	3-Paper Trays Configuration
1	Joint Bracket A (Right Front)	
1	Joint Bracket B (Right Rear)	Shorter piece 
1	Joint Bracket D (Left Front)	
1	Joint Bracket E (Left Rear)	Longer piece 
4	Screw	
1	Installation Instruction	This document

Note:

1. The part number may differ depending on the Destination.
2. Refer to the Parts List in the Parts Manual.

8.13.2. Installation

CAUTION!

Turn the Power Switch on the Left Side, and the Main Power Switch on the Back of the machine to the OFF position, and then unplug the AC Power Cord before beginning installation.

Note:

The following illustrations depict the Installation of Stand (DA-DA311).



- (1) Place the **machine** on top of the Stand as illustrated.

Caution:

The machine weights approximately 181 lb (82 kg) with the i-ADF pre-installed. To prevent injuries, use the appropriate number of personnel and the proper equipment to lift or move the machine.

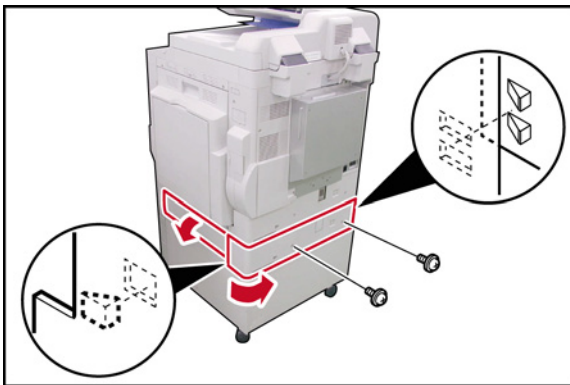

- (2) Remove 2 **Silver Screws**.
- (3) Open the **Jam Access Cover**.
- (4) Remove the **Lower Rear Cover**.

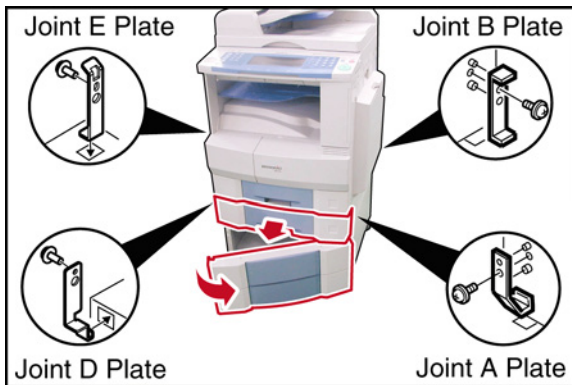

- (5) Open the **Front Cover** of the Stand.
- (6) Open the **2nd Paper Tray**.
- (7) Connect the **machine** to the Stand with 4 Joint Brackets.
- (8) Secure each **Joint Bracket** with 4 Screws.
- (9) Close the 2nd Paper Tray and the Front Cover of the Stand.
- (10) Reinstall the Lower Rear Cover.

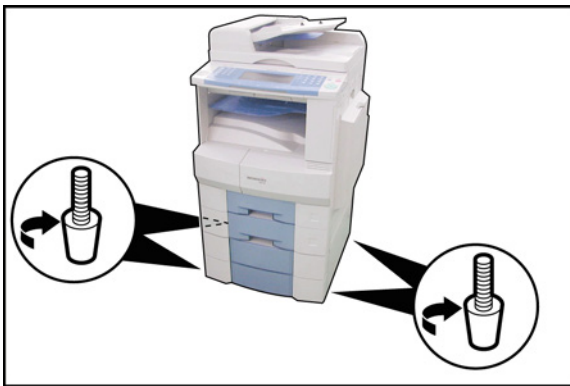

- (11) Place the machine at a desired location and lower the leveler on each corner to stabilize the machine.
- (12) Plug the AC Power Cord into the wall outlet and turn the Main Power Switch on the Back and the Power Switch on the Left Side of the machine to the ON position.

8.14. Installing the 1-Bin Finisher (DA-FS300)

8.14.1. Contents

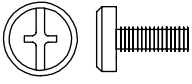
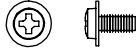
Qty.	Description	Remarks
1	1-Bin Finisher	
1	Finisher Tray Assembly	
1	Base Bracket	
1	Front Slide Guide Bracket	
1	Rear Slide Guide Bracket	
1	IPC PC Board	
1	Optional LVPS	For USA and Canada For EU and Other Destinations
1	FNS Harness	
1	LVS2 Harness	
2	Snap Ring	
4	Thumb Screw (Silver)	
7	Screw	
1	Installation Instructions	This document

Note:

1. The part number may differ depending on the Destination.
2. Refer to the Parts List in the Parts Manual.
3. Before you begin the installation of your 1 Bin Finisher (DA-FS300), read these entire instructions.

8.14.2. Installation

CAUTION!

Turn the Power Switch on the Left Side, and the Main Power Switch on the Back of the machine to the OFF position, and then unplug the AC Power Cord before beginning installation.

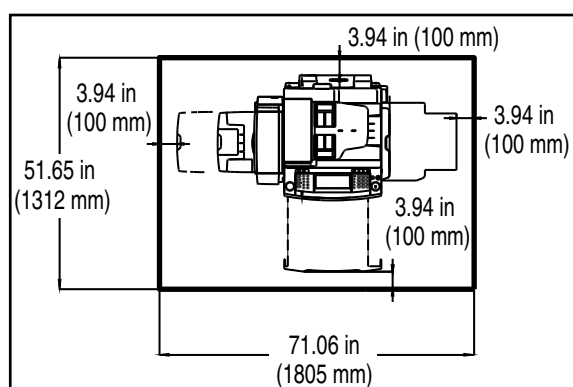

Note:

Make sure that there will be adequate space for working area (i.e., removal of paper).

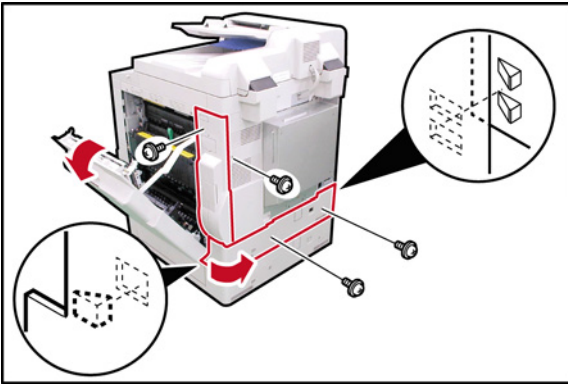

- (1) Open the **Right Cover**.
- (2) Remove 2 **Silver Screws**.
- (3) Remove the **Right Rear Cover**.
- (4) Remove 2 **Silver Screws**.
- (5) Remove the **Lower Rear Cover**.

Caution:

The OPC Drum is sensitive to light. To prevent optical exposure problems, do not expose the OPC Drum to direct sunlight or bright light (even if it is a 1000-Lux fluorescent lamp).

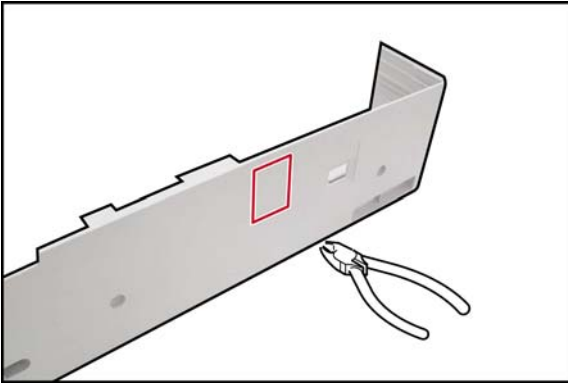

- (6) Cut off the **Protective Tab** on the Rear Cover.

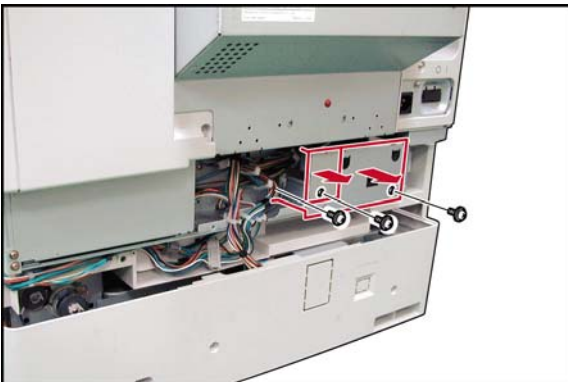

- (7) Remove 1 **Screw**.
- (8) Remove the **Access Plate**.
- (9) Remove 2 **Screws**.
- (10) Remove the **HP Cover**.

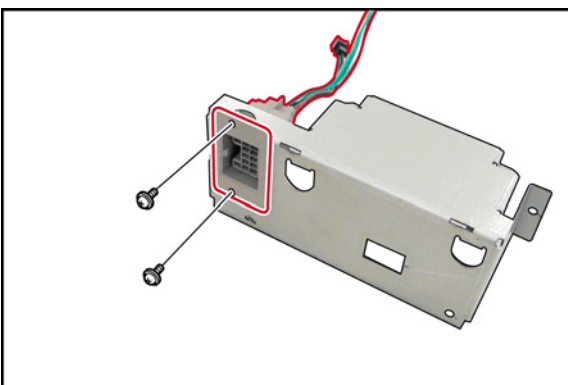

- (11) Install the **Connector** of the FNS Harness to the HP Cover.
- (12) Secure the **Connector** with 2 Screws (XTW3+6LFC).

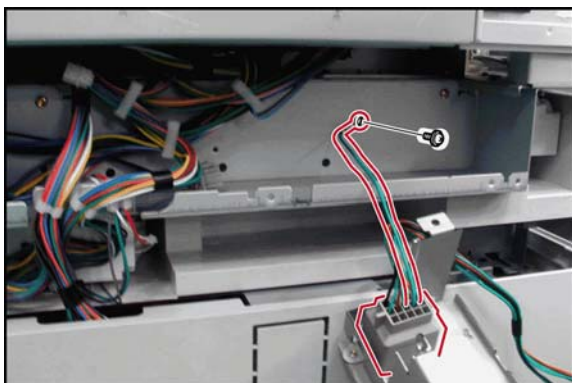

- (13) Secure the **Ground Harness** with 1 Screw (XTW3+6LFC).

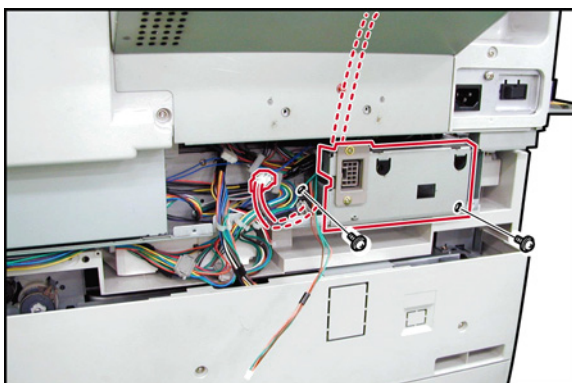

- (14) Reinstall the **HP Cover**.
 (15) Secure the **HP Cover** with 2 Screws.
 (16) Connect one **Harness** to Intermediate Connector.
 (17) Route the **FNS Harness** through the upper hole to the main PC Board area.

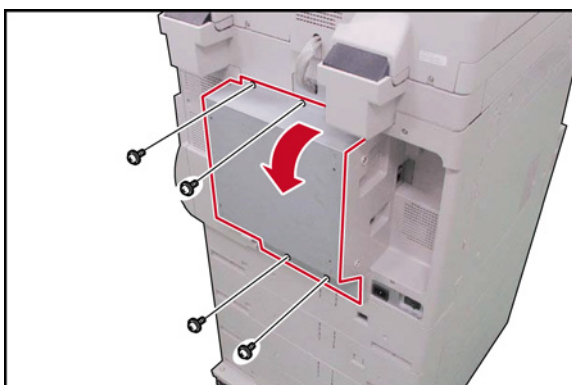

- (18) Remove 4 **Silver Screws**.
 (19) Open the **Rear Cover**.

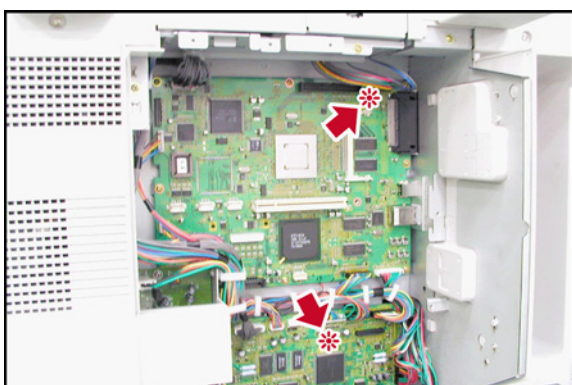

Caution:

If the LEDs on the SC and SPC PC Boards are lit (ON), the Power to the machine is still ON. Please read "**8.14.2. Installation : CAUTION!**" once again.

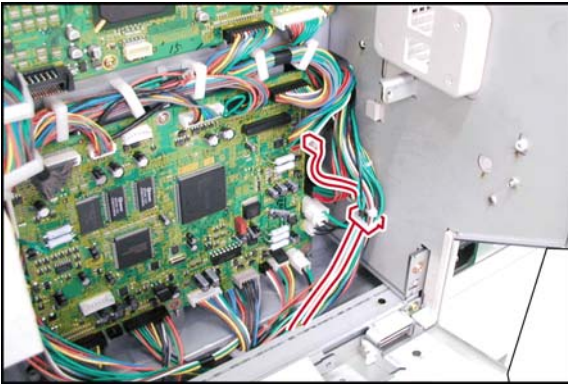

- (20) Pull the **FNS Harness** from the bottom hole and secure with the Harness Clamp.
- (21) Connect the **Harness** to CN724 on the SPC PC Board.

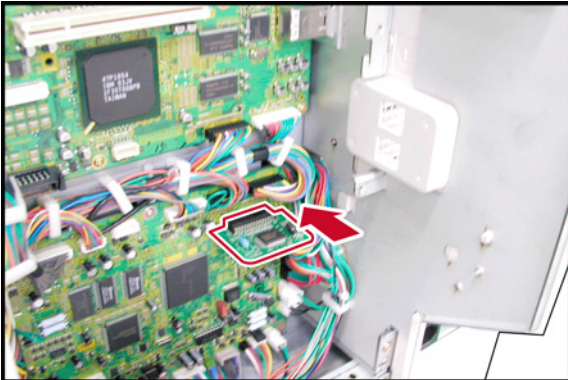

- (22) Install the Finisher **IPC PC Board** to CN725 on the SPC PC Board.



- (23) Remove 2 **Shoulder Silver Screws** (Upper) and 2 **Silver Screws** (Lower).
- (24) Remove the **Left Cover**.

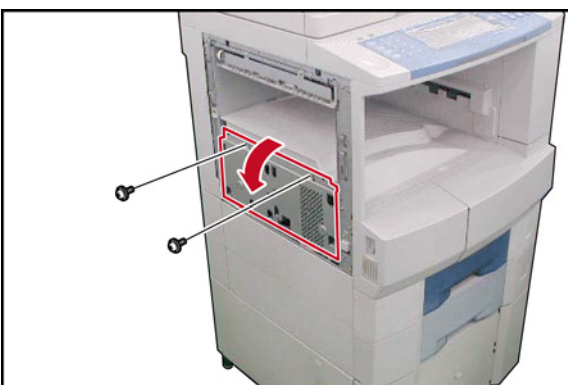

- (25) Remove 2 **Screws**.
- (26) Open the **LVPS Cover**.

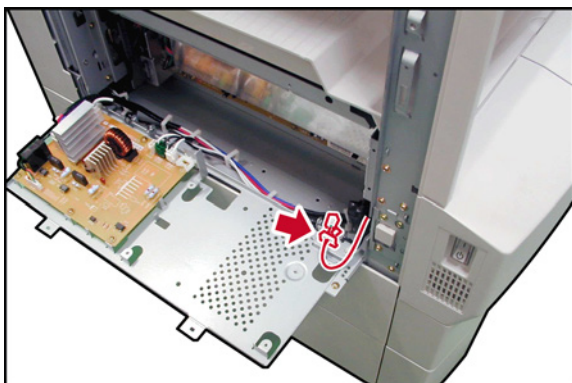

(27) Release the pre-installed **Harness** from the Harness Clamp.

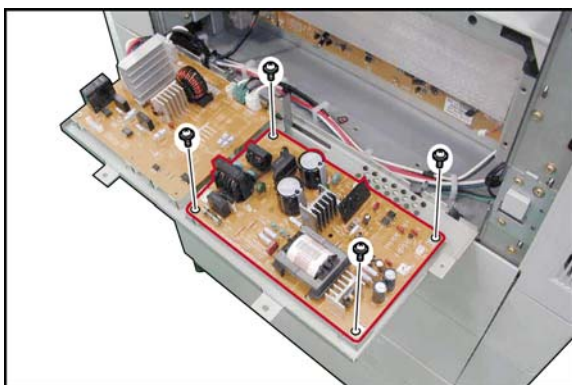

(28) Install the **Optional LVPS**.

(29) Secure the **Optional LVPS** with 4 Screws (XTW3+6LFC).

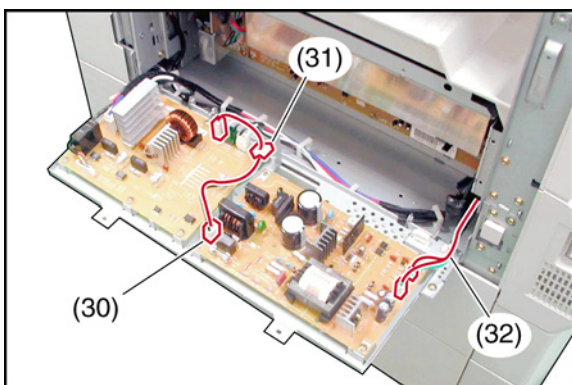

(30) Connect the **LVS2 Harness** to CN64 on the Optional LVPS and to CN102 on ACD PC Board.

(31) Secure the **LVS2 Harness** with the Harness Clamp.

(32) Connect the pre-installed **Harness** to CN65 and CN66 on the Optional LVPS.

(33) Close the **LVPS Cover**.

(34) Reinstall the **Left Cover**.

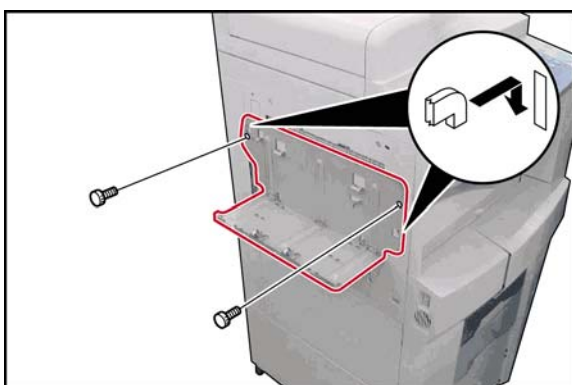

(35) Hook the **Base Bracket** and secure with 2 Silver Thumb Screws (PF4124P023).

Note:

- a. Ensure that the Mylar Sheet on the Base Bracket does not get damaged.
- b. It is easier to align the screw holes, if you insert the Front Screw first.

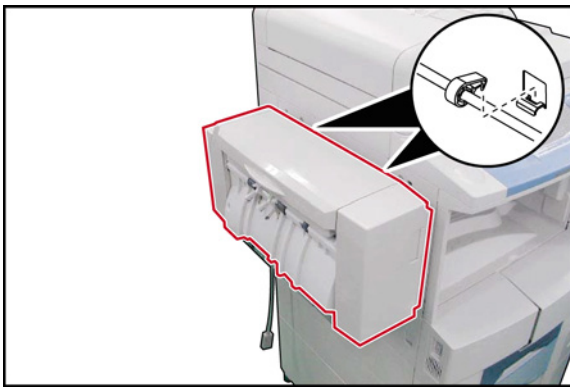

(36) Place the **Finisher** on the Base Bracket.

Note:

Make sure that 2 **Lock Levers** Hook into the Guide Bracket properly.

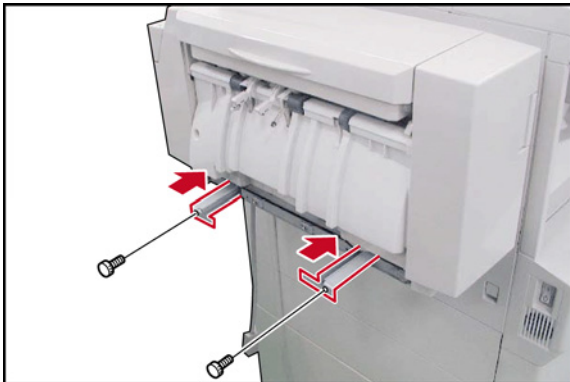

(37) Install 2 **Slide Guide Brackets**.

(38) Secure 2 **Slide Guide Brackets** with 2 Silver Thumb Screws (PF4124P023).

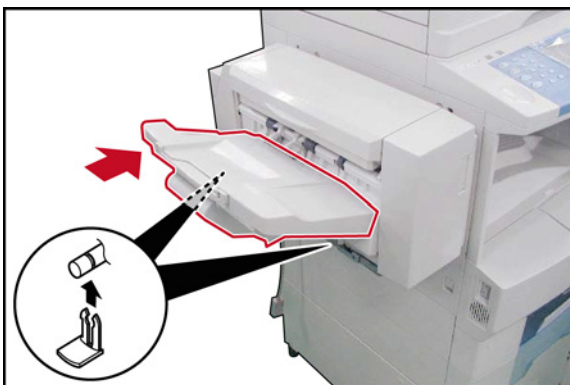

(39) Install the **Finisher Tray Assembly**.

(40) Secure the **Finisher Tray Assembly** with 2 Snap Rings.

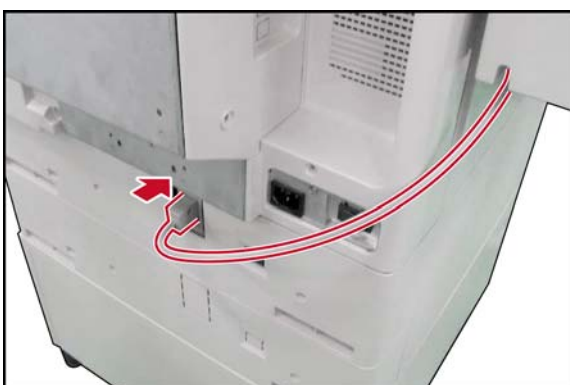

(41) Close the Rear Cover and reinstall all Covers.

(42) Connect the Finisher to the Host Machine with the Interface Cable.

(43) Plug the AC Power Cord into the wall outlet and turn the Main Power Switch on the Back and the Power Switch on the Left Side of the machine to the ON position.

8.15. Installing the Exit Tray [Inner] (DA-XN201)

8.15.1. Contents

Visually check the condition and contents of the box for completeness, or for any shipping damage before starting with the installation.

Remove all Tapes, and the packing materials used to secure the Units during shipment.

After unpacking the product, dispose of the packing materials appropriately.

No.	Qty.	Description	Remarks
1	1	Inner Tray	
2	1	Paper Holder Base	This will not be needed
3	1	Paper Holder	
4	1	Installation Instructions	This document

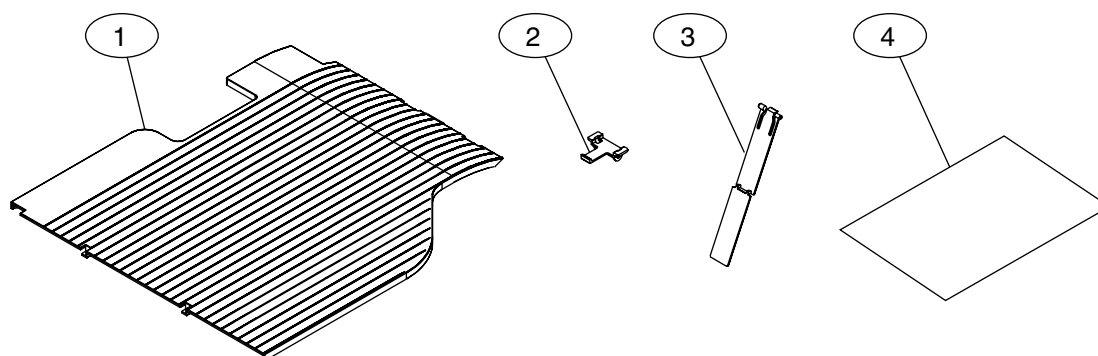

Note:

Refer to the Parts Manual for Part Number(s), Packing, and Accessories in details.

8.15.2. Installation

Caution:

The DP-8032 series has been described as an example of the representative.
Refer to each service manual for other models.

CAUTION!

Turn the Power Switch on the Left Side and the Main Power Switch on the Back of the machine to the OFF position, and then unplug the AC Power Cord before beginning installation.

<<Before Installing this Option. Perform this step first to avoid overlooking it later>>

Set the Service Parameter to activate the Tray by following the steps below.

1. Press the **"FUNCTION"**, **"ORIGINAL SIZE (LEDGER/A3)"**, and the **"3"** keys simultaneously.
2. Input the password, and select the **"OK"** button to enter the Service Mode (default password is **00000000**).
3. Press the **"5"** key, and press the **"START"** key to enter the F5 Service Mode.
4. Select **"35 Output Tray (Inner 2)"**.
5. Select the **"Yes"** button.
6. Select the **"OK"** button twice.
7. Press the **"FUNCTION"**, and the **"C (Clear)"** keys simultaneously to exit the Service Mode.
8. Reboot the machine after setting the parameter(s) to activate the setting(s). (Turn the Power Switch on the Left Side of the machine to the OFF then back to the ON position.)

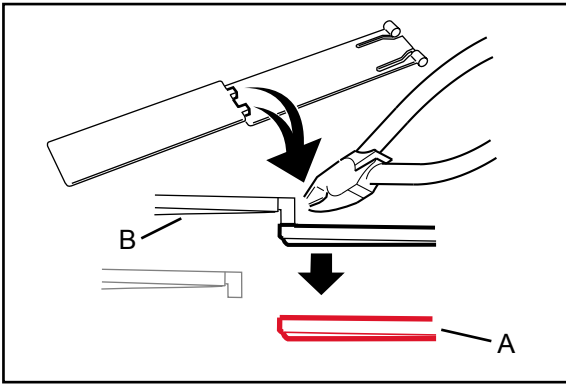

- (1) Cut off the **Paper Holder** at the joint into two parts with a nipper as illustrated.

Note:

- A. Cut the ends neatly.
B. Dispose of the bottom part of the Paper Holder.

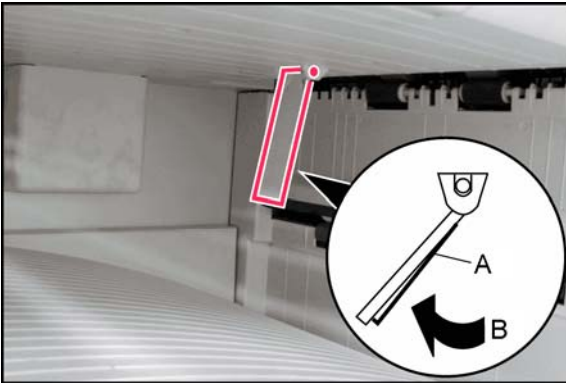

- (2) Install the **Paper Holder** to the Paper Holder Base which is already installed on the center of the Jam Cover.

Note:

- A. Make sure that the rib side of the Paper Holder is facing the exit cover.
B. When installing, swing the bottom part of the Paper Holder to the left as illustrated.

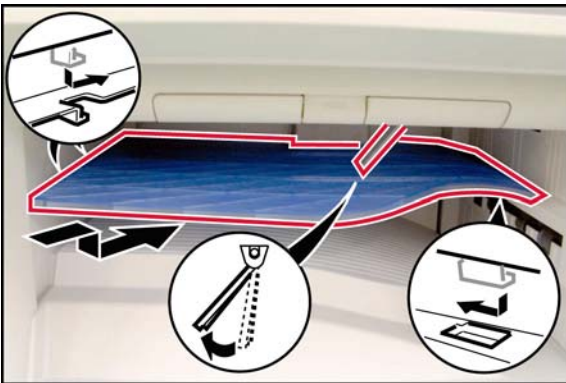

- (3) Swing the **Paper Holder** to the left.
(4) Install the **Inner Tray** in the direction of the arrow holding up the Paper Holder.
(5) Plug the **AC Power Cord**, and turn the **Main Power Switch** on the Back and the **Power Switch** on the Left Side of the machine to the ON position.
(6) Reconnect the **Telephone Line / LAN Cable** if disconnected.



8.16. Installing the Exit Tray [Outer] (DA-XT200)

8.16.1. Contents

Visually check the condition and contents of the box for completeness, or for any shipping damage before starting with the installation.

Remove all Tapes, and the packing materials used to secure the Units during shipment.

After unpacking the product, dispose of the packing materials appropriately.

No.	Qty.	Description	Remarks
1	1	Outer Cover Assembly	
2	1	Exit Tray Assembly	
3	4	Screw (M3 x 10)	 
4	1	Installation Instructions	This document

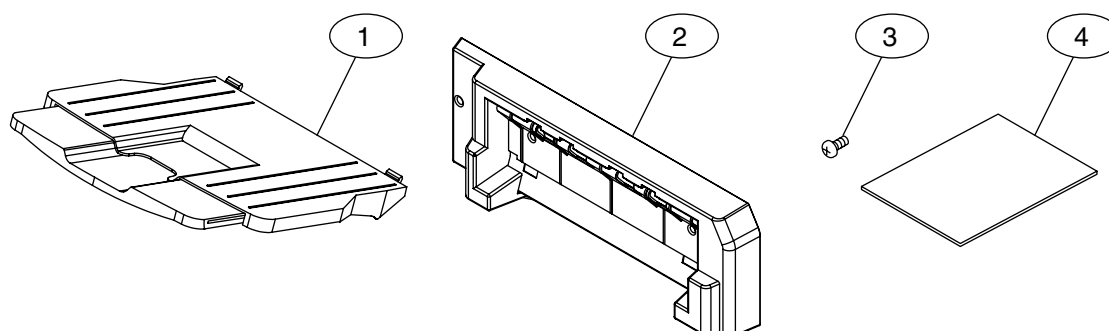

Note:

Refer to the Parts Manual for Part Number(s), Packing, and Accessories in details.

8.16.2. Installation

Caution:

The DP-8032 series has been described as an example of the representative.

Refer to each service manual for other models.

CAUTION!

Turn the Power Switch on the Left Side and the Main Power Switch on the Back of the machine to the OFF position, and then unplug the AC Power Cord before beginning installation.

<<Before Installing this Option. Perform this step first to avoid overlooking it later>>

Set the Service Parameter to activate the Tray by following the steps below.

1. Press the “**FUNCTION**”, “**ORIGINAL SIZE (LEDGER/A3)**”, and the “**3**” keys simultaneously.
2. Input the password, and select the “**OK**” button to enter the Service Mode (default password is **0000000**).
3. Press the “**5**” key, and press the “**START**” key to enter the F5 Service Mode.
4. Select “**37 Output Tray (Outer)**”.
5. Select the “**Yes**” button.
6. Select the “**OK**” button twice.
7. Press the “**FUNCTION**”, and the “**C (Clear)**” keys simultaneously to exit the Service Mode.
8. Reboot the machine after setting the parameter(s) to activate the setting(s). (Turn the Power Switch on the Left Side of the machine to the OFF then back to the ON position.)

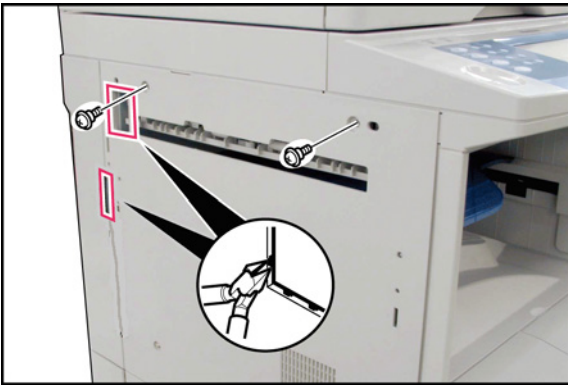

- (1) Cut off the **protective tabs** on the **Left Side Cover** and the **Left Rear Cover** (Upper Tab Only).
- (2) Remove 2 **Shoulder Silver Screws** from the upper side of the Left Side Cover.

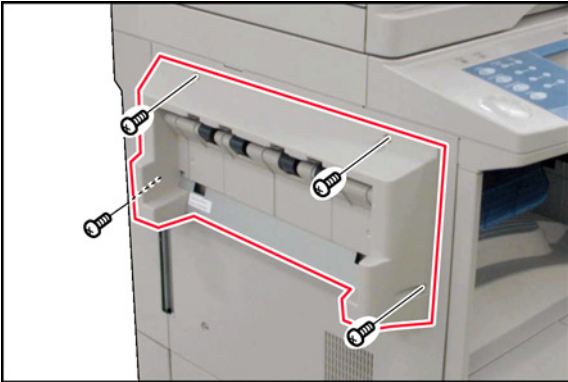

- (3) Install the **Outer Cover Assembly**, and secure the 4 **Screws** (M3 x 10).

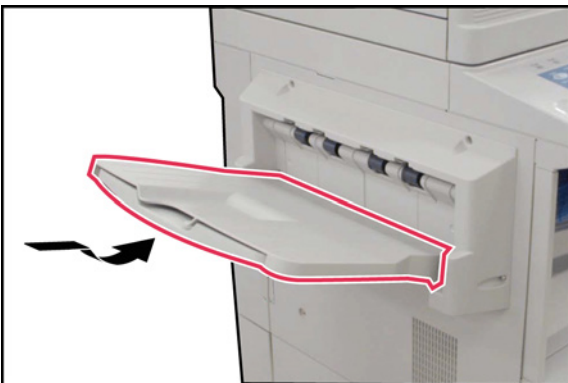

- (4) Install the **Exit Tray Assembly** onto the Outer Cover Assembly.
- (5) Plug the **AC Power Cord**, and turn the **Main Power Switch** on the Back and the **Power Switch** on the Left Side of the machine to the ON position.
- (6) Reconnect the **Telephone Line / LAN Cable** if disconnected.



8.17. Installing the Automatic Document Feeder (DA-AS201) and the Inverting Automatic Document Feeder (DA-AR251) < For EU and Other Destinations >

8.17.1. Contents

Visually check the condition and contents of the box for completeness, or for any shipping damage before starting with the installation.

Remove all Tapes, and the packing materials used to secure the Units during shipment.

After unpacking the product, dispose of the packing materials appropriately.

No.	Qty.	Description	Remarks
1	1	Inverting Automatic Document Feeder (i-ADF) / Automatic Document Feeder (ADF)	
2	1	Scanning Pad	
3	2	Hinge Stopper	
4	2	Hinge Cover	
5	2	Hinge Cover 2	
6	2	ADF Mounting Bracket	
7	2	Thumb Screw	
8	1	Stamp Unit	
9	2	Screw (Middle)	
10	5 (6)	Screw (Short)	 6 Screws : EU and Other Destinations
11	8	Screw (Long)	
12	1	Installation Instructions	This document

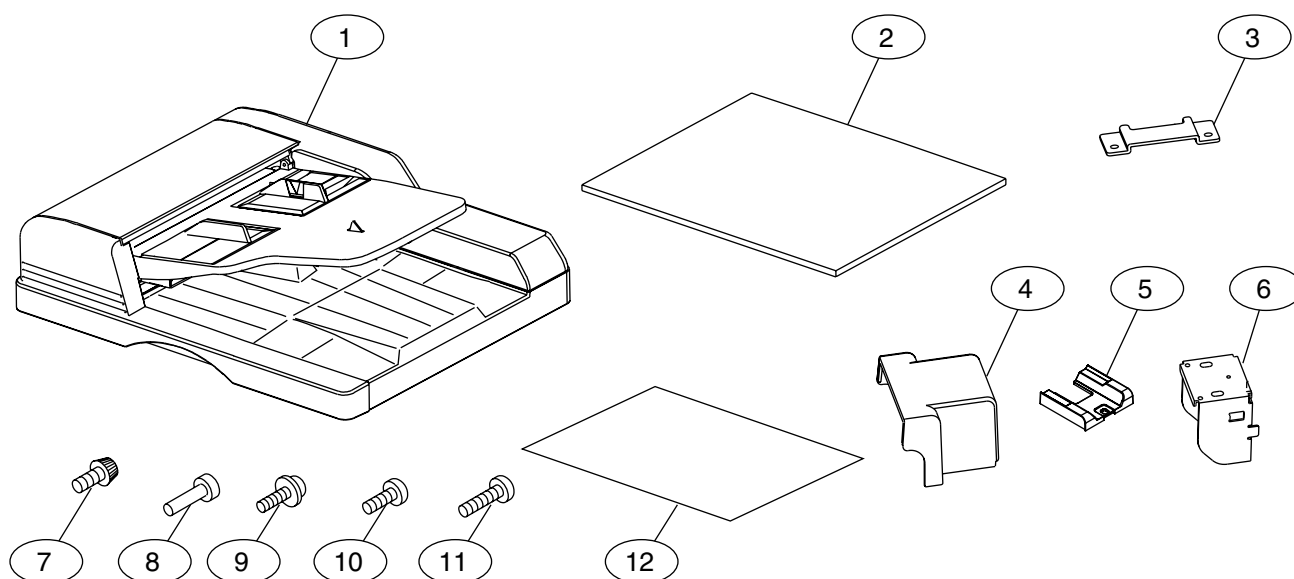

Note:

Refer to the Parts Manual for Part Number(s), Packing, and Accessories in details.

8.17.2. Installation

Caution:

The DP-8032 series has been described as an example of the representative.
Refer to each service manual for other models.

CAUTION!

Turn the Power Switch on the Left Side and the Main Power Switch on the Back of the machine to the OFF position, and then unplug the AC Power Cord before beginning installation.

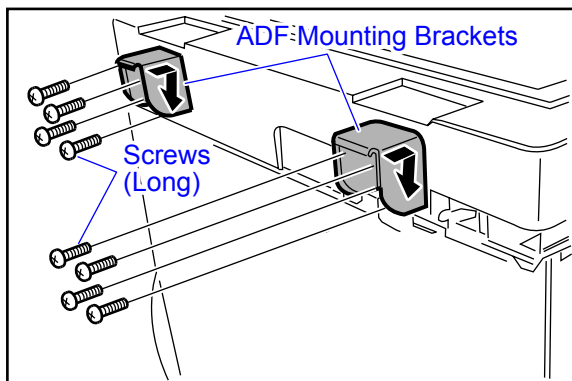

- (1) Install the 2 **ADF Mounting Brackets**, and push down as illustrated.
- (2) Secure the 2 **ADF Mounting Brackets** with 8 **Screws (Long)**.

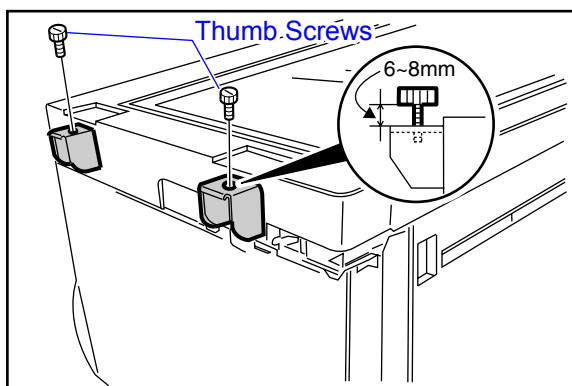

- (3) Install 2 **Thumb Screws**, one on each **ADF Mounting Bracket**.

Note:

When installing the 2 Thumb Screws, do NOT tighten the Screws. Keep about 6-8mm space as illustrated.

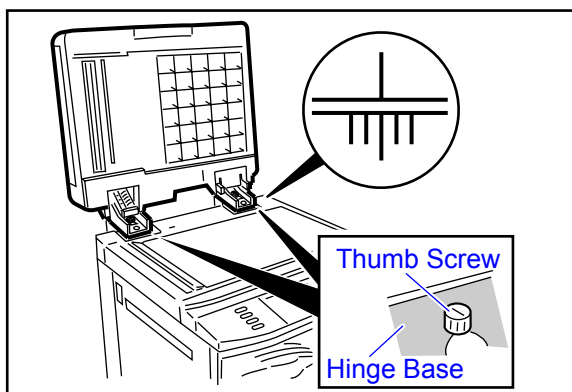

- (4) Install the **i-ADF / ADF** on top of the ADF Mounting Brackets.

Note:

1. Set the i-ADF / ADF in the direction of the arrow.
2. Align the hallmark on the right side of the Hinge Base and the ADF Mounting Bracket as illustrated.

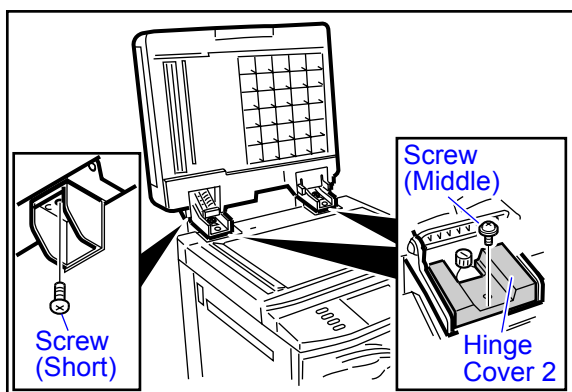

- (5) Install 2 **Hinge Cover 2**.
- (6) Secure the **i-ADF / ADF** with 2 **Screws (Middle)**.
- (7) Tighten the 2 **Thumb Screws**.
- (8) Install 1 **Screw (Short)** on the back of the left ADF Mounting Bracket from the bottom.

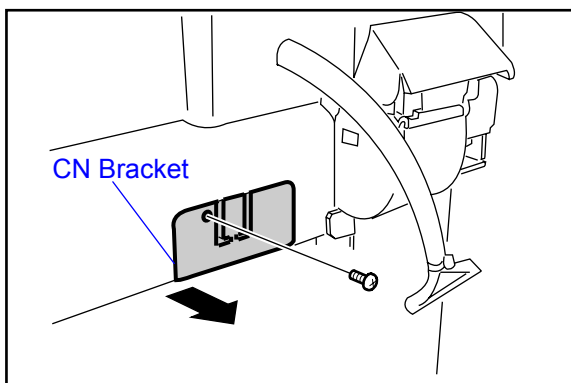

- (9) Remove 1 **Screw**.
 (10) Remove the **CN Bracket**.

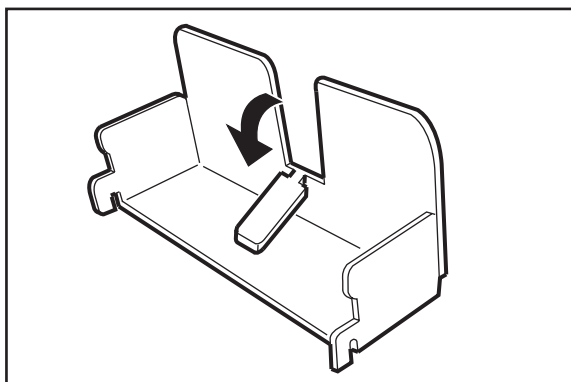

- (11) Bend the protective Tab on the **CN Bracket** more than 90° as illustrated.

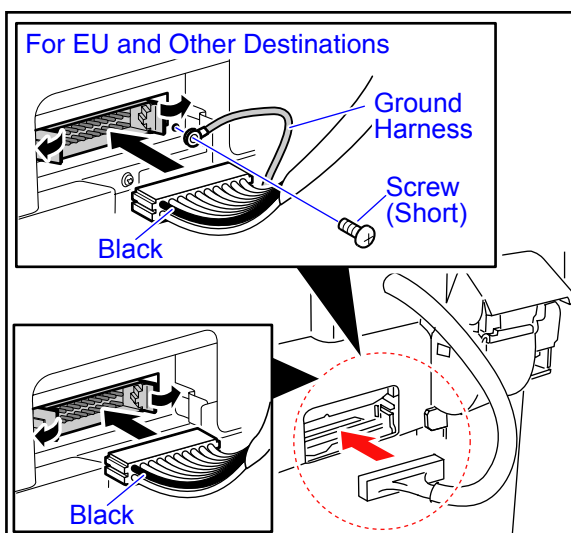

- (12) Connect the Connector of the **i-ADF / ADF**.

Note:

When reconnect the Harness, make sure the connector position and its keys. Insert it gently, and do not force the connector if it is facing the wrong way.

< For EU and Other Destinations >

After connecting the Connector of the **i-ADF / ADF**, secure the **Ground Harness** with 1 **Screw (Short)** as illustrated.

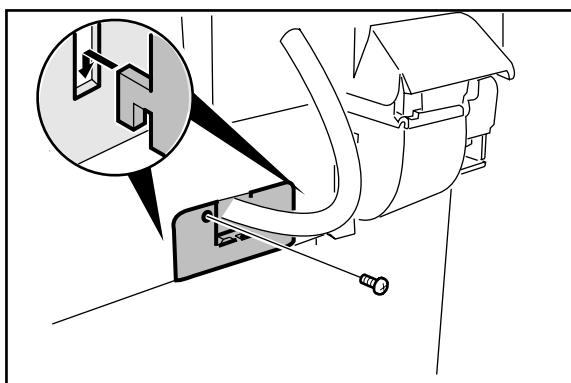

- (13) Reinstall the **CN Bracket**.
 (14) Secure the **CN Bracket** with 1 **Screw**.

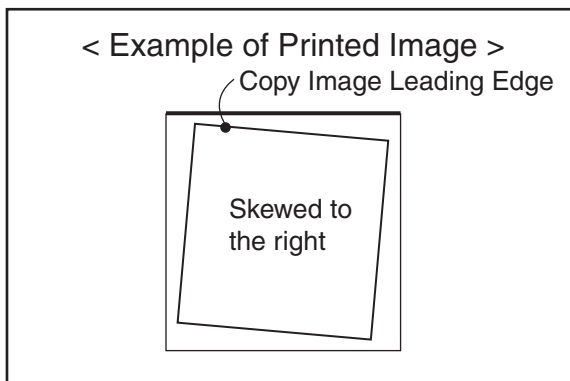

- (15) Using a lined original (about 20lb (80 g/m²) weight paper), make a copy from the **i-ADF / ADF** to check for feeding alignment.

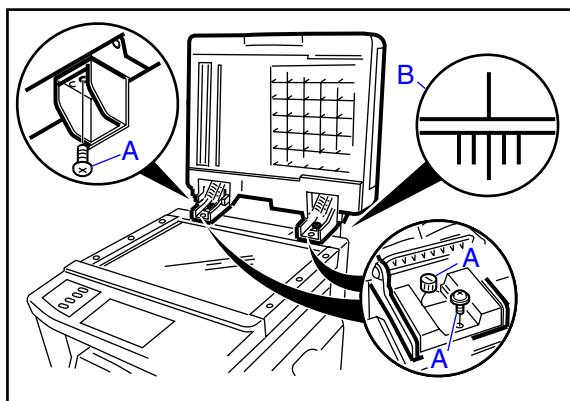

- (16) Check the printed copy. If the printed image is skewed either to the Right or Left, adjust the **i-ADF / ADF** position following the procedure below:

- A. Loosen the 5 **Screws** securing the **i-ADF / ADF**.
 B. Using the Hallmark on the Right **Hinge Base** and the **ADF Mounting Bracket** as a guide, shift the **i-ADF / ADF** position following the procedure below:

- When the printed image is skewed to the right, shift the **i-ADF / ADF** toward the front of the machine slightly.
- When the printed image is skewed to the left, shift the **i-ADF / ADF** toward the rear of the machine slightly.

- C. Tighten the 5 **Screws** loosened in step A..
 D. Repeat step (15) to recheck the feeding alignment and readjust the **i-ADF / ADF** position as needed.

- (17) Check for spacing between the **i-ADF / ADF** and the **Scanning Glass Guide** as illustrated.

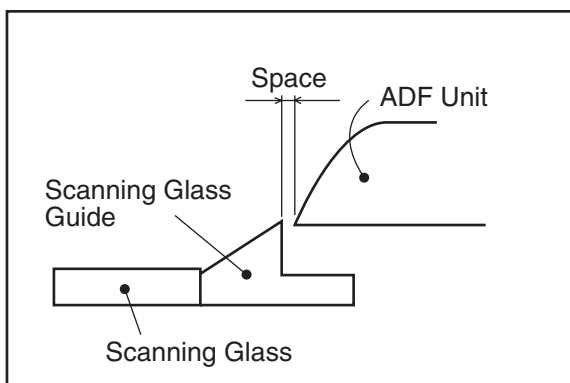

- (18) If there is no spacing, adjust the **Platen Glass** position following the procedure below:

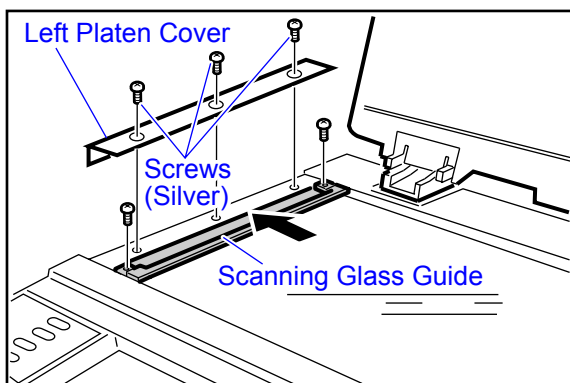

- A. Open the **ADF Unit**.
 B. Remove 3 **Screws (Silver)**.
 C. Remove the **Left Platen Cover**.
 D. Loosen 2 **Screws**.
 E. Shift the **Scanning Glass Guide** to the left and tighten the 2 **Screws**.
 F. Reinstall the **Left Platen Cover** and secure it with 3 **Screws (Silver)**.

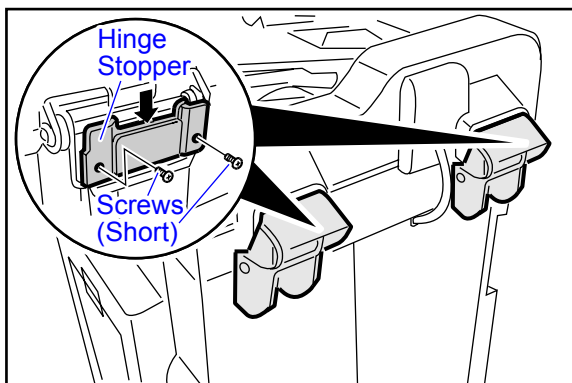

- (19) Install the 2 **Hinge Stoppers**.
 (20) Secure the 2 **Hinge Stoppers** with 4 **Screws (Short)**.

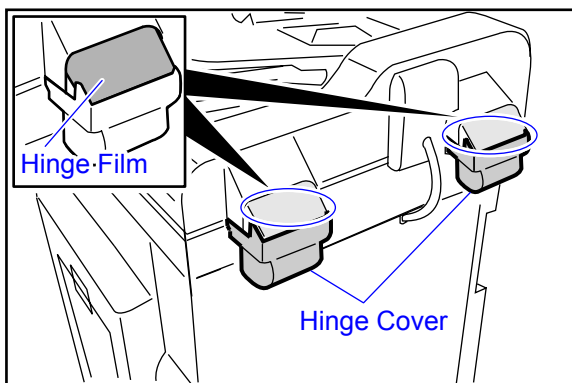

- (21) Install the 2 **Hinge Covers**.

Note:

When installing the Hinge Covers, make sure that each Hinge Film is put inside of each Hinge Cover.

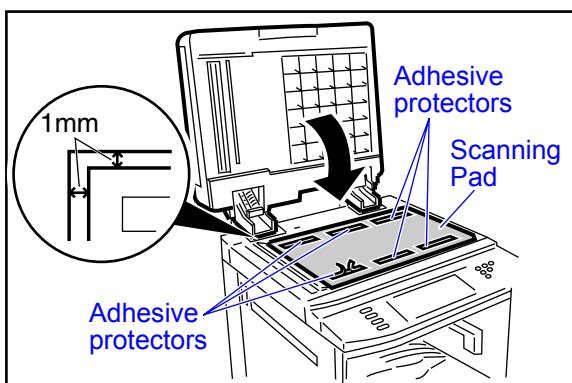

- (22) Peel off the 6 **Adhesive protectors** from the Scanning Pad.
 (23) Place the **Scanning Pad** on the glass aligning on the upper left corner, keeping 1mm space as illustrated.
 (24) Close the **i-ADF / ADF**.

Note:



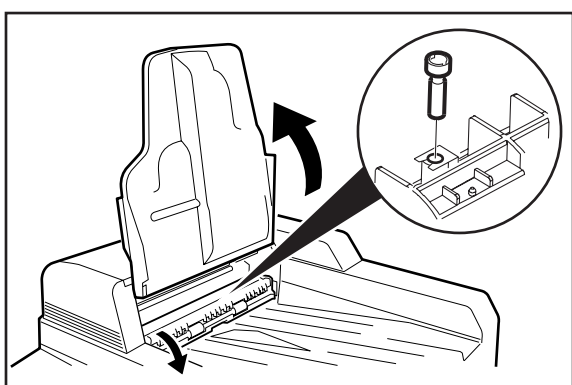



Reopen the i-ADF / ADF and push the Scanning Pad gently to paste it properly.

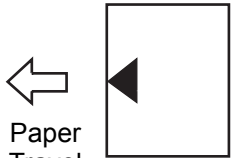

- (25) Lift the **Original Tray Assembly**.
 (26) Lower the **Inverting Guide 2 Assembly**.
 (27) Install the **Stamp Assembly**.
 (28) The **Inverting Guide 2 Assembly** and the **Original Tray Assembly** are returned to former position.
 (29) Proceed with the installation of other options. If finished, reinstall all **Harnesses** and **Covers**.
 (30) Plug the **AC Power Cord**, and turn the **Main Power Switch** on the Back and the **Power Switch** on the Left Side of the machine to the ON position.
 (31) Reconnect the **Telephone Line / LAN Cable** if disconnected.

<Adjust the Scanning Position>

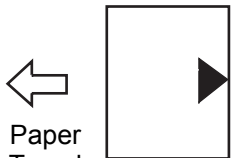
(32) Perform Service Mode F6 (No.71, 72, 73, 90, 91, 92, 93 and 94) to adjust the ADF Scanning Position.

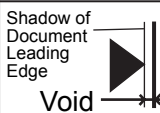
	Document	Printed Image	Adjustment	Adjustment Amount	Remarks
No. 90 / 71 1-Side / 2-Side ADF Detection Timing (ADF Image Read Start Position Adjustment)	 Paper Travel		+	0.05mm / 1 Point	Rebooting is not necessary to enable the Parameter Setting. 71, 72, 73, 94 are valid for i-ADF only.
			-	0.05mm / 1 Point	
No. 91 / 72 1-Side / 2-Side ADF Original Leading Edge Registration (Original Lead Edge Detection Timing Adjustment)	 Paper Travel		-	0.3mm / 1 Point	
			+	0.3mm / 1 Point	
No. 92 / 73 1-Side / 2-Side ADF Original Trailing Edge Registration (Original Trail Edge Detection Timing Adjustment)	 Paper Travel		+	0.3mm / 1 Point	
			-	0.3mm / 1 Point	
No. 93 / 94 1-Side / 2-Side Magnification Ratio (Top Feed) (Ratio Adjustment when the scan is made)	Reduced		+	0.1% / 1 Point	
	Enlarged		-	0.1% / 1 Point	

< When Adjusting the ADF Unit >

Adjust the ADF Unit to scan the lined part (inside of the margin 1.5 - 2.5mm) on the document as shown on the right.

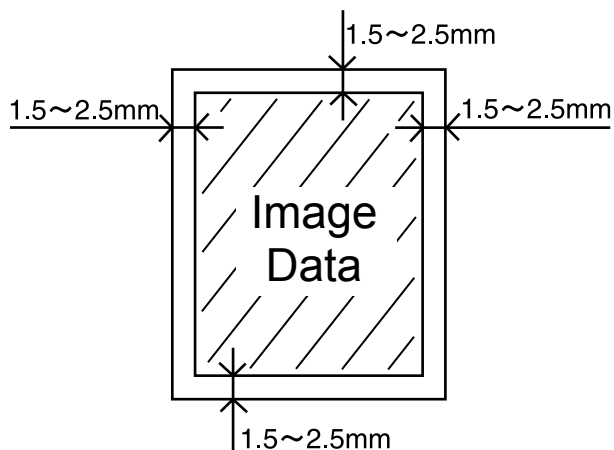

8.18. Installing the Platen Cover (DA-UC200) < For EU and Other Destinations >

8.18.1. Contents

Qty.	Description	Remarks
1	Platen Cover	
1	Scanning Pad	
2	Platen Hinge	
4	Screw	
1	Installation Instructions	This document

8.18.2. Installation

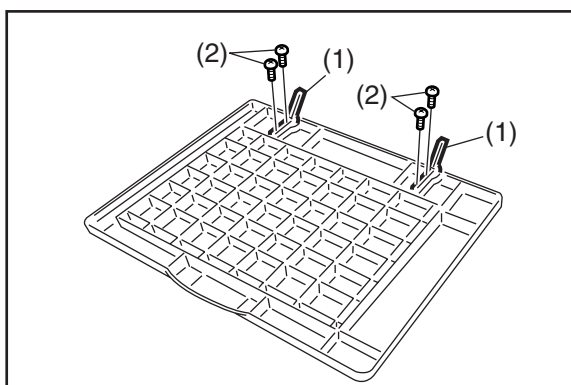

- (1) Install the 2 Platen Hinges.
- (2) Secure the Platen Hinges with 2 Screws each.

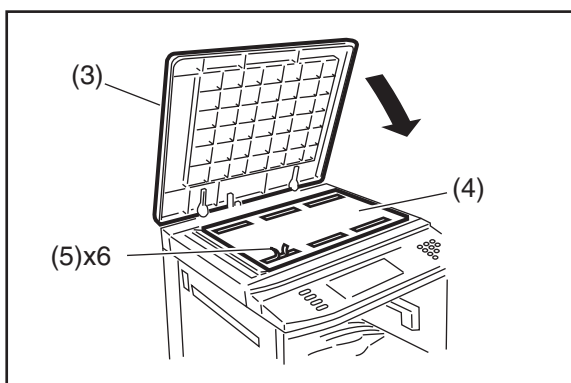

- (3) Install the Platen Cover.
- (4) Place the Scanning Pad on the glass aligning on the upper left corner.
- (5) Peel off the 6 adhesive protectors from the Scanning Pad.
- (6) Close the Platen Cover.

Note:

Reopen the Platen Cover and push the Scanning Pad gently to paste it properly.

8.19. Installing the Key Counter Harness Kit (DA-KH200)

8.19.1. Contents

Visually check the condition and contents of the box for completeness, or for any shipping damage before starting with the installation.

Remove all Tapes, and the packing materials used to secure the Units during shipment.

After unpacking the product, dispose of the packing materials appropriately.

Note:

The Key Counter is sold separately.

No.	Qty.	Description	Remarks
1	1	KEY Harness	Longer
2	1	KC Harness	Shorter
3	1	KC Bracket	
4	1	Key Counter Cover	
5	2	Screw (M3 x 35)	
6	1	Installation Instructions	This document

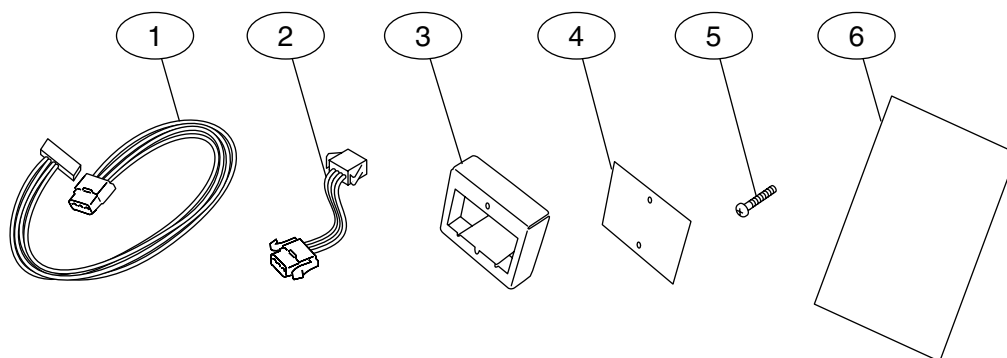

Note:

Refer to the Parts Manual for Part Number(s), Packing, and Accessories in details.

8.19.2. Installation

Caution:

The DP-8032 series has been described as an example of the representative.

Refer to each service manual for other models.

CAUTION!

Turn the Power Switch on the Left Side and the Main Power Switch on the Back of the machine to the OFF position, and then unplug the AC Power Cord before beginning installation.

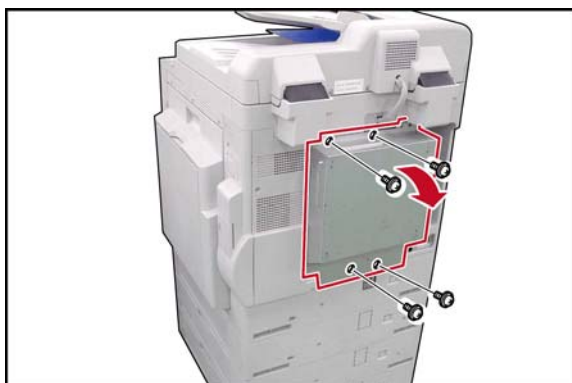

(1) Remove 4 **Screws**.

(2) Open the **Rear Cover**.

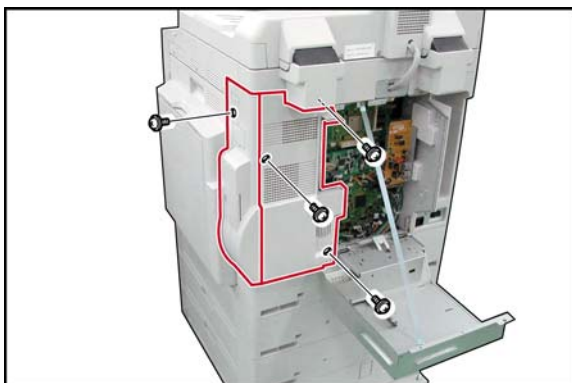

- (3) Remove 4 **Screws**.
- (4) Remove the **Right Rear Cover** and the **Rear Right Cover**.

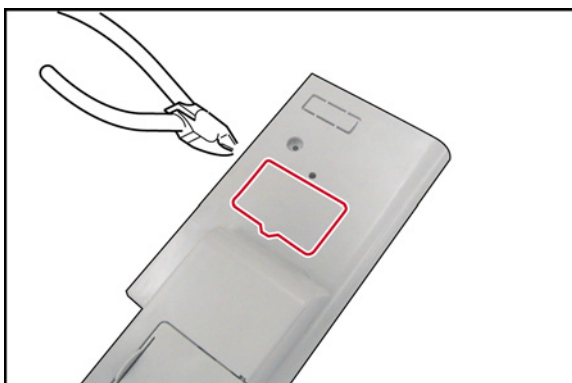

- (5) Cut the **Protective Tab** on the Right Rear Cover.

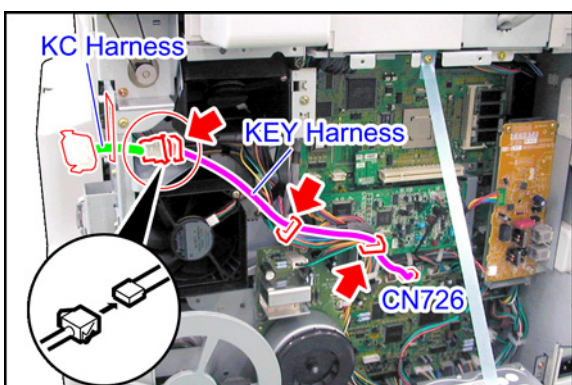

- (6) Connect the **KEY Harness** into the **KC Harness**.
- (7) Connect the **KEY Harness** to CN726 on the SPC PC Board.
- (8) Insert the **KC Harness** through the Access hole of the RR Frame.
- (9) Secure the **KEY Harness** with 3 Harness Clamps.
- (10) Reinstall the **Right Rear Cover** and the **Rear Right Cover**, and close the **Rear Cover**.

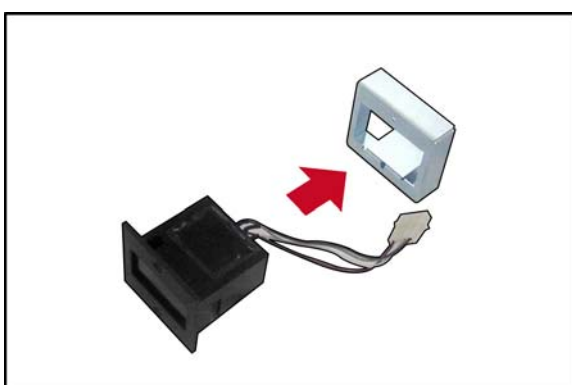

- (11) Route the **Key Counter Socket Harness** through the KC Bracket.

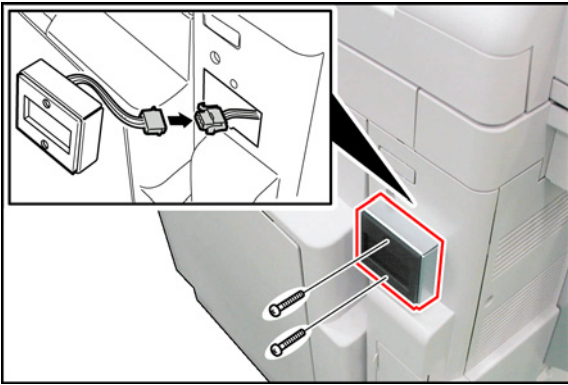

- (12) Connect the **Key Counter Socket Harness** into the KC Harness.
- (13) Install the **Key Counter Socket**.
- (14) Secure the **Key Counter Socket** with 2 **Screws** (M3 x 35).

Note:

If you are not installing the Key Counter at this time, cover the opening with the Key Counter Cover and secure it with 2 Screws.

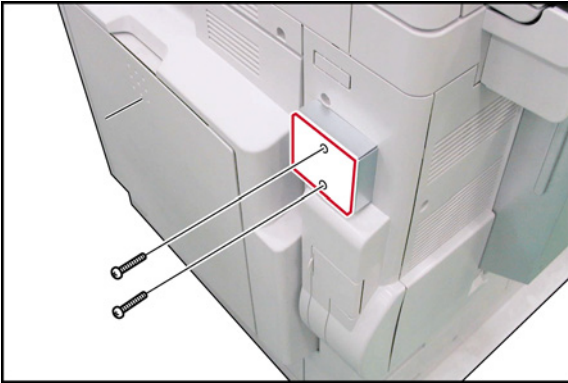



- (15) Plug the **AC Power Cord**, and turn the **Main Power Switch** on the Back and the **Power Switch** on the Left Side of the machine to the ON position.
- (16) Reconnect the **Telephone Line / LAN Cable** if disconnected.

8.20. Installing the Dehumidifier Heater Kit (DZTQ000048R)

8.20.1. Contents

DZTQ000048R

No.	Qty.	Description	Remarks
1	1	PC Board, RLB	
2	1	Switch, Power	
3	1	Heater Sheet, Heater	Assembled
4	1	Heater	
5	1	Thermistor	
6	1	Bracket, Heater	
7	1	Bracket 2, Heater	
8	1	Bracket, Dehumidifier	
9	1	Bracket, EMI	
10	1	Harness, RLB	
11	2	Harness 3, PTC-AC	
12	1	Harness, HT1	
13	1	Harness, HT3	
14	1	Harness, HT4	
15	1	Sheet, Protection	
16	1	Label, Heater	
17	1	Label, Power	
18	3	Screw	
19	1	Screw	
20	5	Screw	
21	3	Clamp, Harness	
22	1	Clamp, Harness	
-	1	Installation Instructions	This document

Note:

1. The part number may differ depending on the Destination.
2. Refer to the Parts List in the Parts Manual.

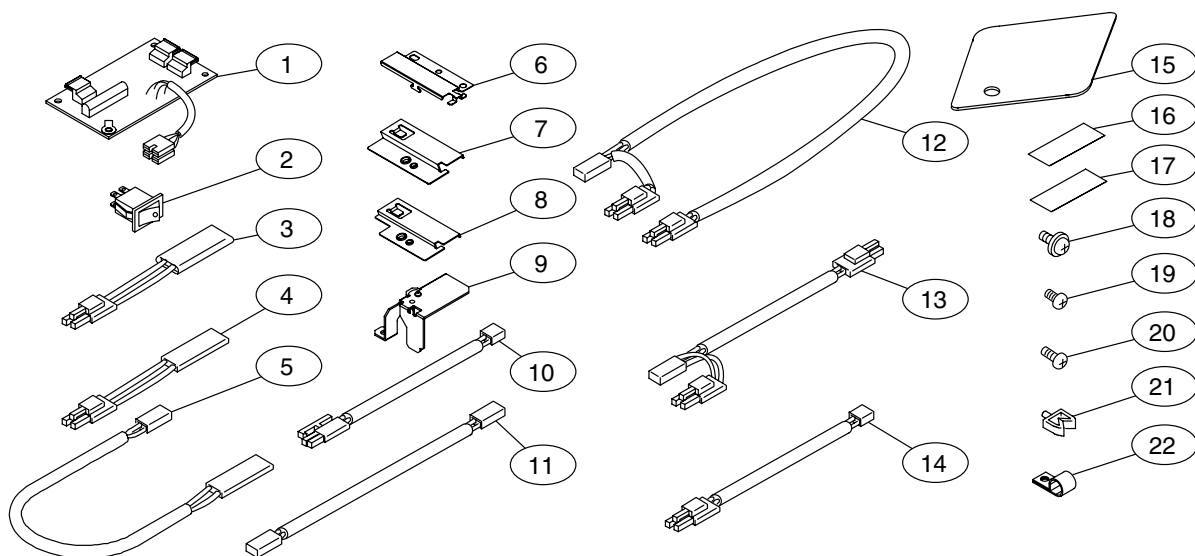

8.20.2. Installation

CAUTION!

Turn the Power Switch on the Left Side and the Main Power Switch on the Back of the machine to the OFF position, and then unplug the AC Power Cord before beginning installation.



- (1) Remove the Glass Assembly.
(Refer to 2.2.3. of the Service Manual)
- (2) Remove 7 **Screws**.
- (3) Remove the **CCD Cover**.

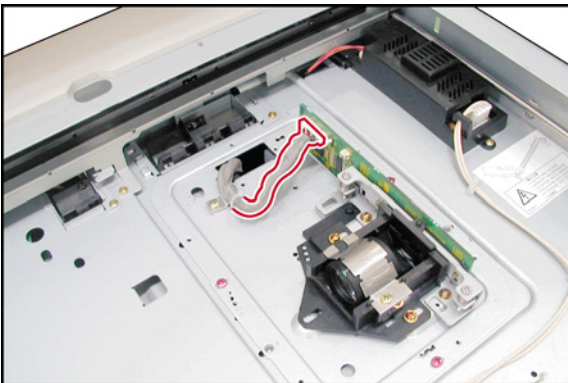

- (4) Disconnect the **CCD Harness**.

Note: (For Euro Destination only)

The EMI Bracket is already installed, remove it first.

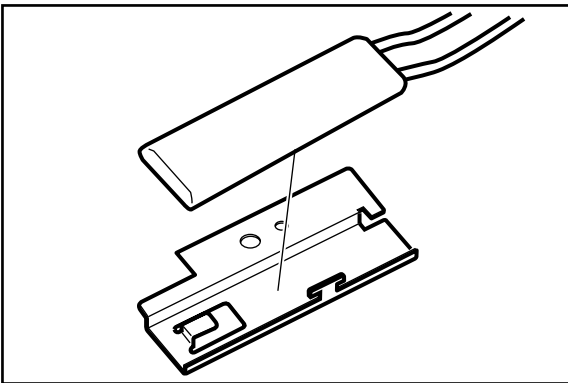

- (5) Mount the **Heater** (with Heat Sheet) onto the Dehumidifier Bracket.

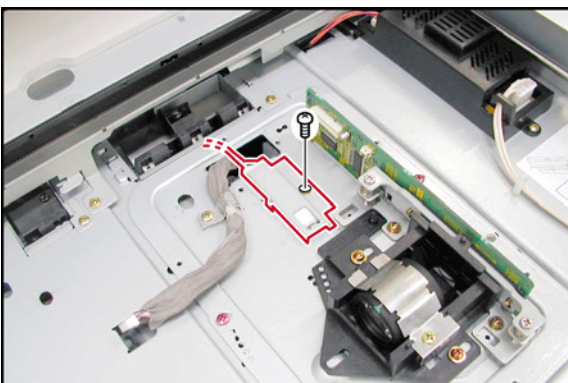

- (6) Install the **Heater** Assembly.
- (7) Secure the **Heater** Assembly with 1 Screw (XTB3+6J).
- (8) Route the **Harness** of the Heater Assembly to the lower section of the frame through the access hole as illustrated.

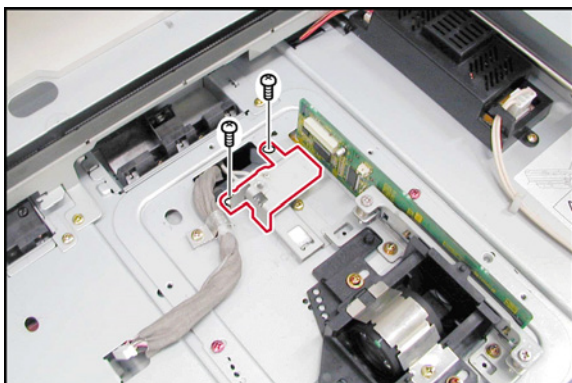

- (9) Install the **EMI Bracket**.
- (10) Secure the **EMI Bracket** with 2 Screws (XTB3+6J).

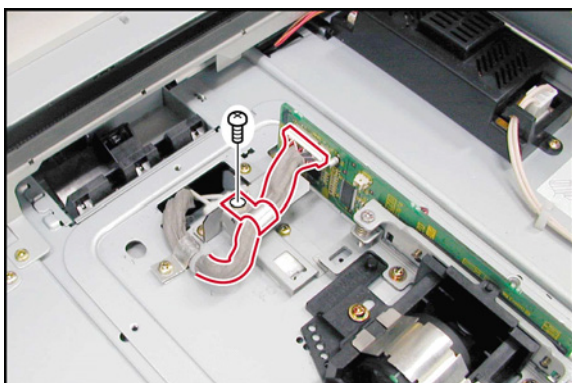

- (11) Connect the **CCD Harness** to the CCD PC Board.
- (12) Insert the **CCD Harness** into the Harness Clamp.
- (13) Secure the **Harness Clamp** with 1 Screw (XTB3+6J).

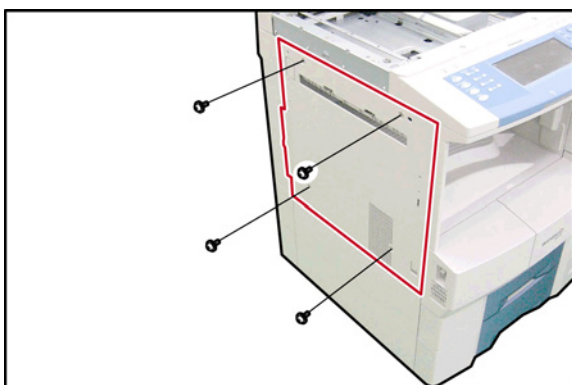

- (14) Remove 2 **Shoulder Silver Screws** (Upper) and 2 **Silver Screws** (Lower).
- (15) Remove the **Left Cover**.

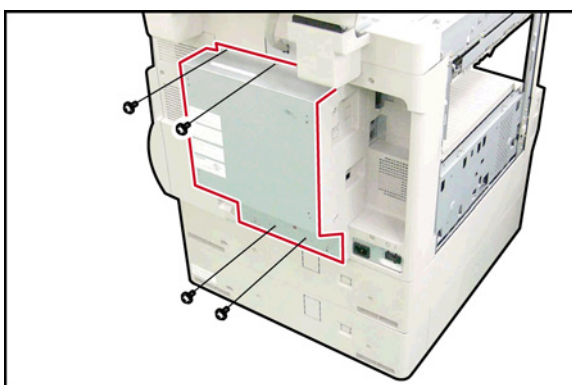

- (16) Remove 4 **Screws**.
- (17) Open the **Rear Cover**.

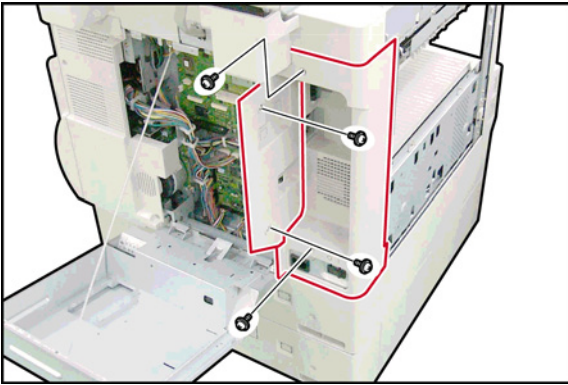

- (18) Remove 2 **Silver Screws**.
- (19) Remove the **Rear Blind Cover**.
- (20) Remove 2 **Silver Screws**.
- (21) Remove the **Rear Left Cover**.

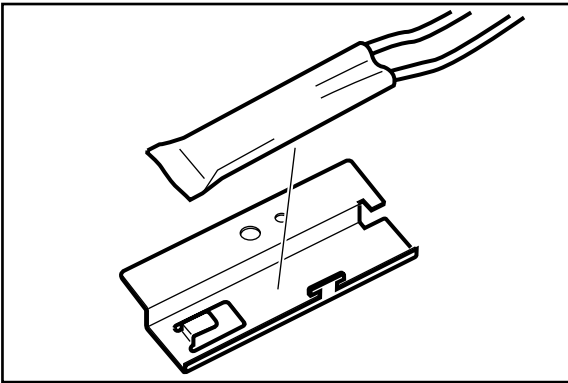

- (22) Mount the **Thermistor** onto the Heater Bracket 2.

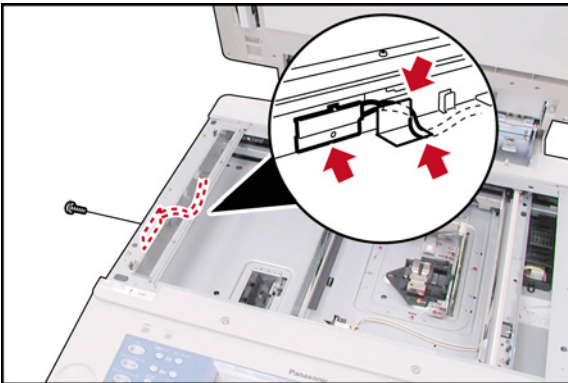

- (23) Route the **Harness** of the Thermistor to lower section of the frame through the access hole as illustrated.
- (24) Install the **Thermistor**.
- (25) Secure the **Thermistor** with 1 Screw (XTB3+6J).

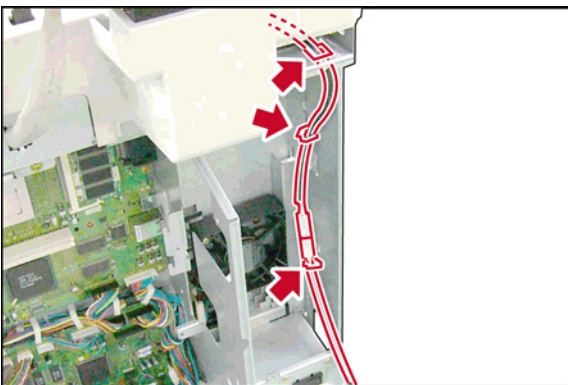

- (26) Route the **Harness** of the Thermistor to lower section of the frame through the access hole as illustrated.
- (27) Connect the **Thermistor** to the HT1 Harness.
- (28) Install 2 **Harness Clamps**.
- (29) Insert the **Thermistor** and **HT1 Harness** into 2 Harness Clamps.

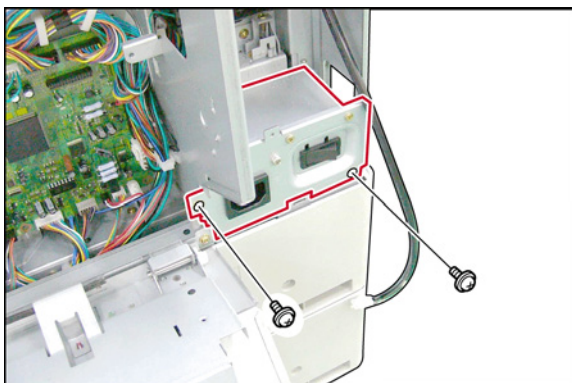

- (30) Remove 2 **Screws**.
- (31) Remove the **NFL PC Board**.

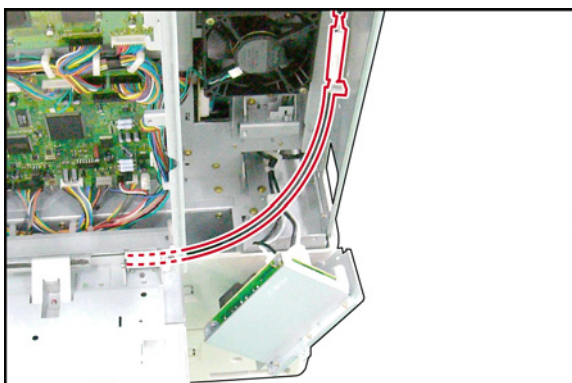

- (32) Route the **HT1 Harness** to the lower section of the frame as illustrated.

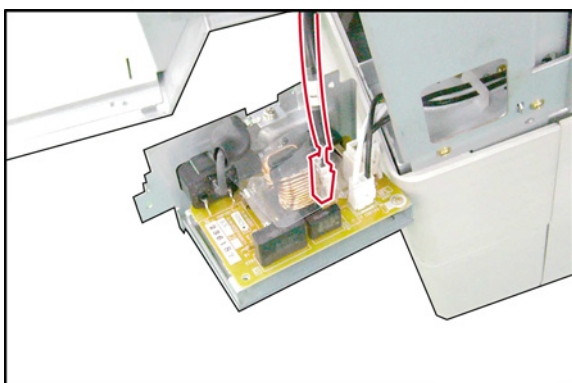

- (33) Connect the **RLB Harness** to the NFL PC Board (CN134).
- (34) Reinstall the **NFL PC Board**.

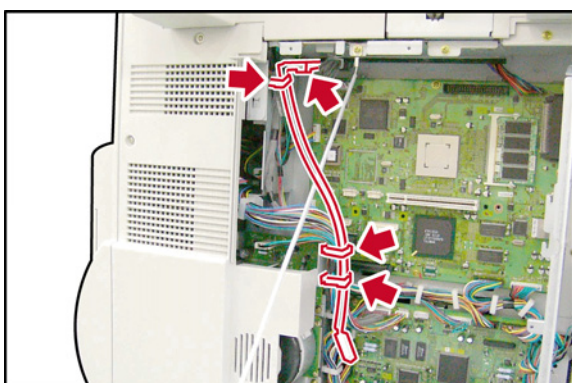

- (35) Connect the **PTC-AC Harness 3** to the Heater.
- (36) Insert the **PTC-AC Harness 3** to 3 Harness Clamps.

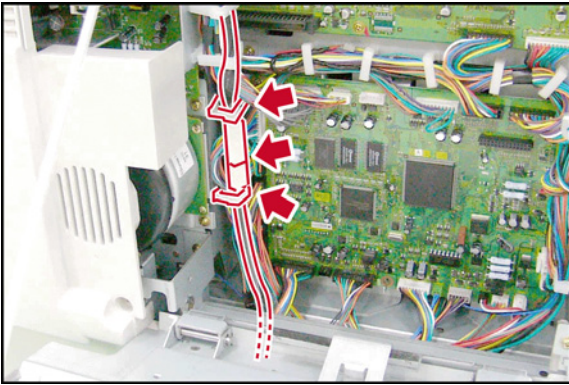

- (37) Connect the **PTC-AC Harness 3** to the HT3 Harness.
- (38) Insert the **HT3 Harness** and **PTC-AC Harness 3** to 2 Harness Clamps.
- (39) Route the **HT3 Harness** to the lower section of the frame as illustrated.

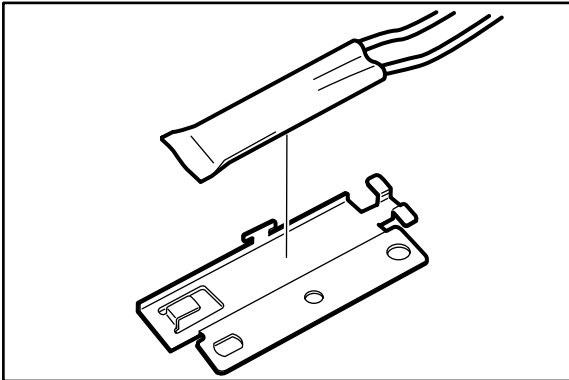

- (40) Mount the **Heater** onto the Heater Bracket.

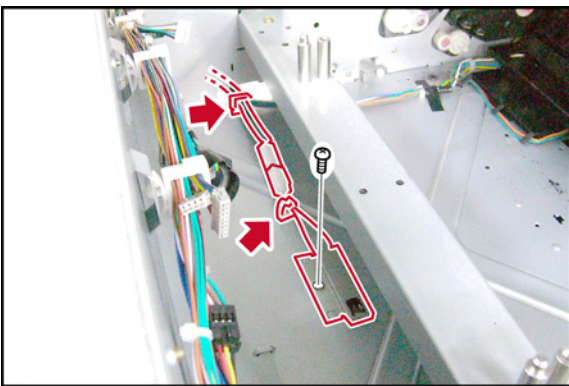

- (41) Remove the LSU Unit.
(Refer to 2.2.10. of the Service Manual)
- (42) Connect the **Heater** Assembly to the PTC-AC Harness 3.
- (43) Install the **Heater** Assembly.
- (44) Secure the **Heater** Assembly with 1 Screw (XTB3+4FFJ).
- (45) Install the **Harness Clamp**.
- (46) Insert the **PTC-AC Harness 3** to 2 Harness Clamps.
- (47) Route the **PTC-AC Harness 3** to the rear section of the frame through the access hole as illustrated.

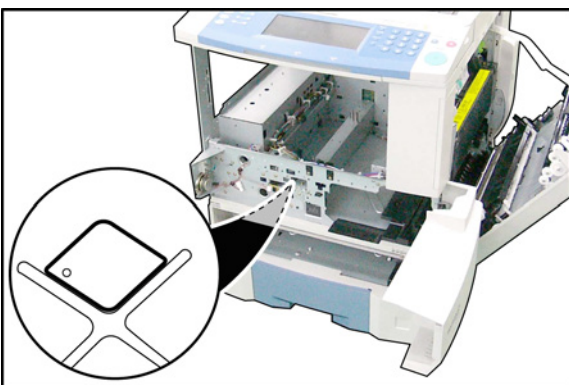

- (48) Slide the 1st Paper Tray out.
- (49) Install the **Protection Sheet**.

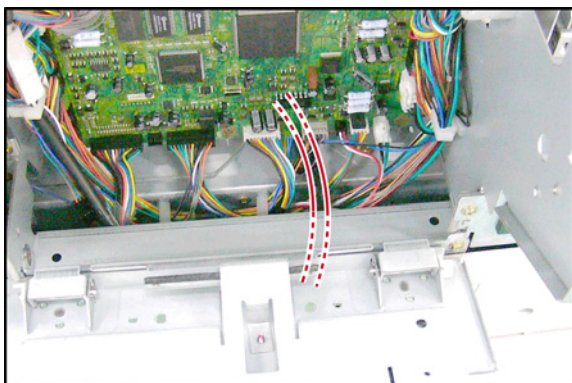

- (50) Route the **PTC-AC Harness 3** to the lower section of the frame as illustrated.
- (51) Close the **Rear Cover**.

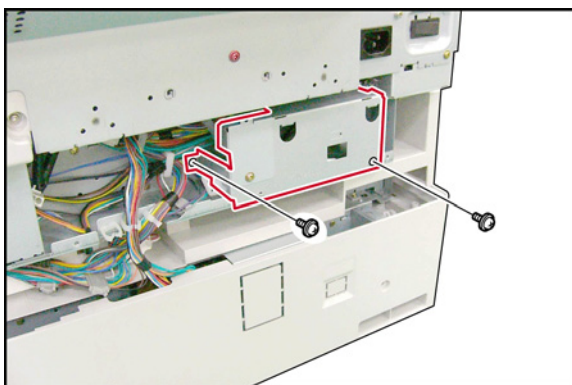

- (52) Remove the Lower Rear Cover.
(Refer to 2.2.6. of the Service Manual)
- (53) Remove 2 **Screws**.
- (54) Remove the **HP Cover**.

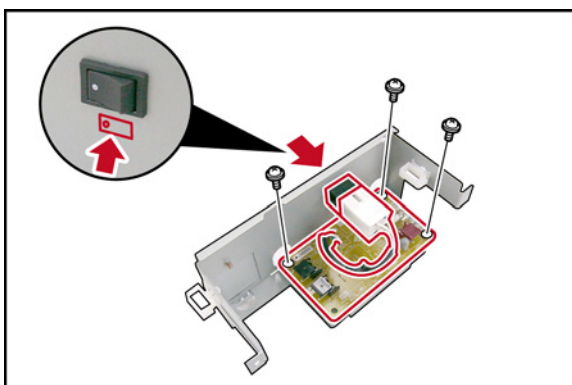

- (55) Install the **RLB PC Board** onto the HP Cover.
- (56) Secure the **RLB PC Board** with 3 Screws (XTW3+6LFC).
- (57) Install the **Power Switch** onto the HP Cover.

Note:

Ensure that the direction of the Power Switch is correct as illustrated.

- (58) Connect the **Harness** of RLB PC Board to the Power Switch.

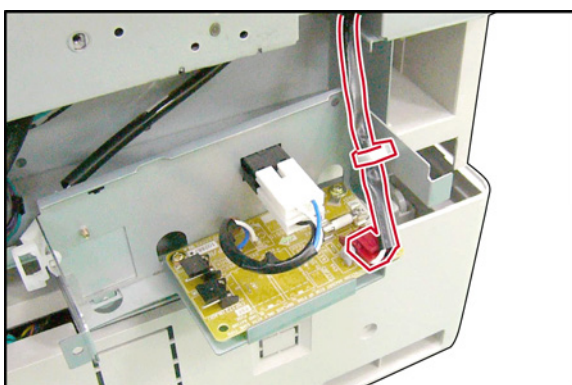

- (59) Connect the **RLB Harness** to the RLB PC Board (CN171).
- (60) Insert the **RLB Harness** to the Harness Clamp.

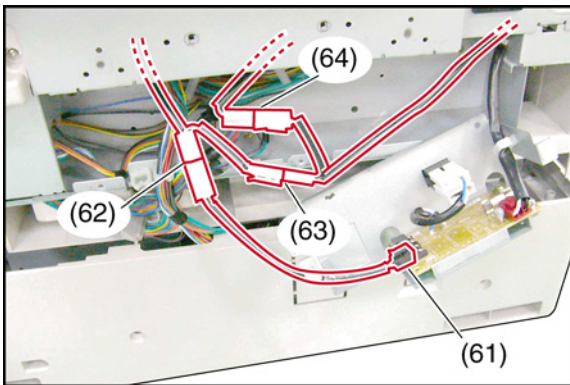

- (61) Connect the **HT4 Harness** to the RLB PC Board (CN172).
- (62) Connect the **HT3 Harness** to the HT4 Harness.
- (63) Connect the **HT1 Harness** to the HT3 Harness.
- (64) Connect the **PTC-AC Harness 3** to the HT1 Harness.
- (65) Reinstall the **HP Cover**.

Note:

When reinstalling, ensure that the Harnesses do not get damaged.

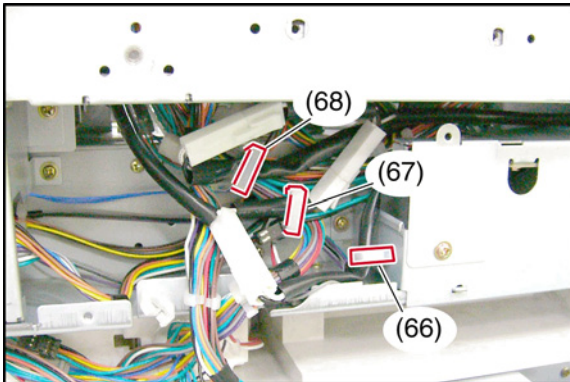

- (66) Insert the **HT4 Harness** to the Harness Clamp.
- (67) Insert the **HT1 Harness** to the Harness Clamp.
- (68) Insert the **PTC-AC Harness 3** to the Harness Clamp.

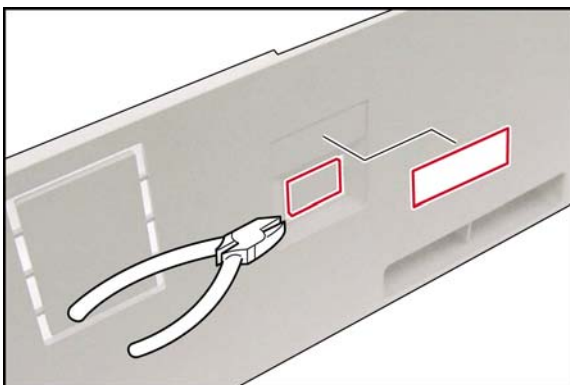

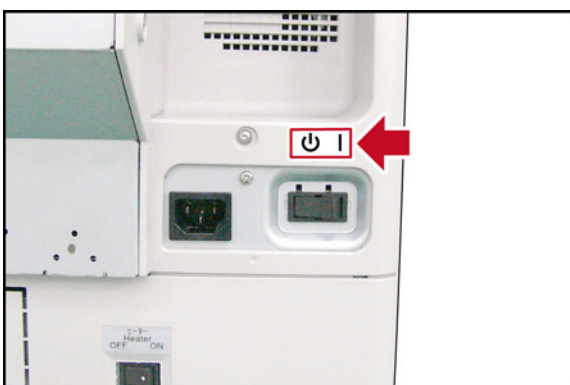

- (69) Cut off the **Protective Tab** on Lower Rear Cover.
- (70) Attach the **Heater Label**.
- (71) Reinstall all Covers.



- (72) Attach the **Power Label**.

8.21. Installing the Dehumidifier Heater Kit (DZTQ000049R)

8.21.1. Contents

No.	Qty.	Description	Remarks
1	1	Heater	
2	1	Bracket, Heater	
3	1	Harness, HT-CST	
4	1	Harness, HT2	
5	1	Harness, HT5	
6	1	Harness, HT6	
7	1	Sheet, Protection	
8	1	Screw	 
9	3	Clamp, Harness	
-	1	Installation Instructions	This document

Note:

1. The part number may differ depending on the Destination.
2. Refer to the Parts List in the Parts Manual.

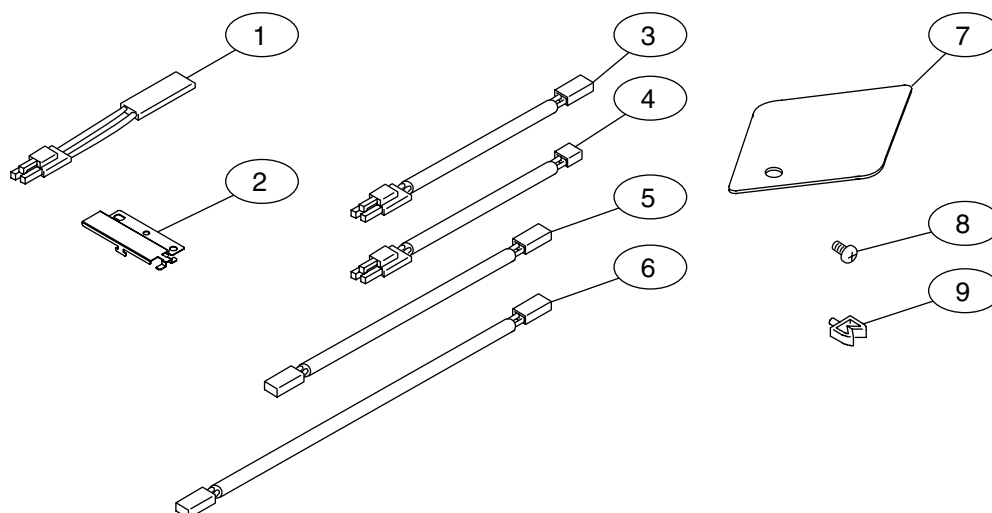

8.21.2. Installation

Before installing the Dehumidifier Heater Kit (DZTQ000049R), make sure the Dehumidifier Heater Kit (DZTQ000048R) is installed in the unit first.

CAUTION!

Turn the Power Switch on the Left Side and the Main Power Switch on the Back of the machine to the OFF position, and then unplug the AC Power Cord before beginning installation.

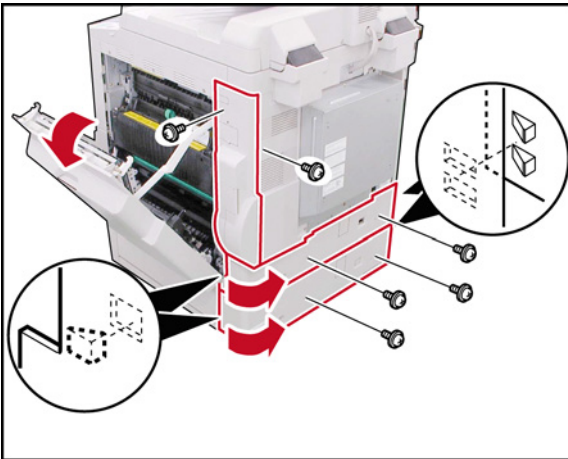

<For 2-Paper Tray Configuration>

- (1) Open the **Right Cover**.
- (2) Remove 2 **Silver Screws**.
- (3) Remove the **Right Rear Cover**.
- (4) Remove 4 **Silver Screws**.
- (5) Remove 2 **Lower Rear Covers**.

Caution:

The OPC Drum is sensitive to light. To prevent optical exposure problems, do not expose the OPC Drum to direct sunlight or bright light (even if it is a 1000-Lux fluorescent lamp).

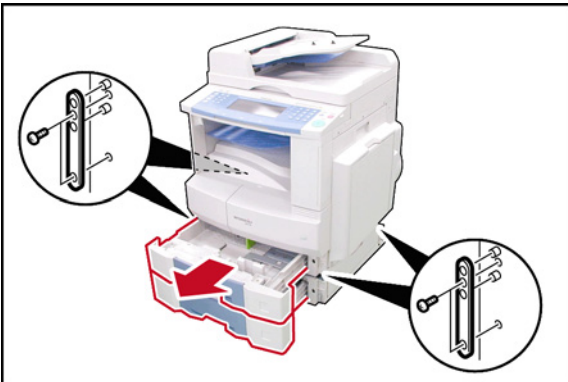

- (6) Slide the **1st and 2nd Paper Trays** out.
- (7) Remove 8 **Screws**.
- (8) Remove 4 **Brackets**.

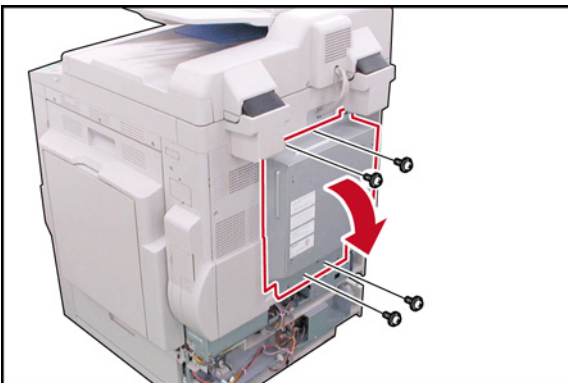

- (9) Remove 4 **Silver Screws**.
- (10) Open the **Rear Cover**.

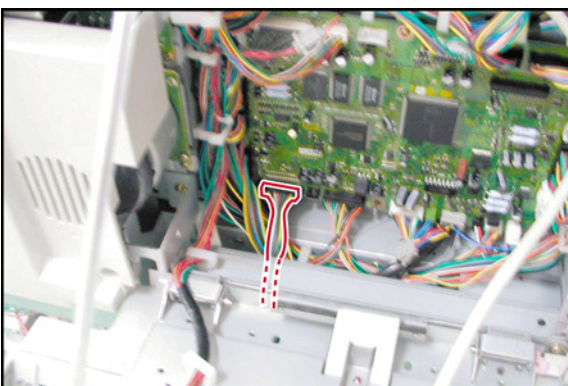

- (11) Disconnect the **CST2 Harness** from SPC PC Board (CN707).
- (12) Close the **Rear Cover**.

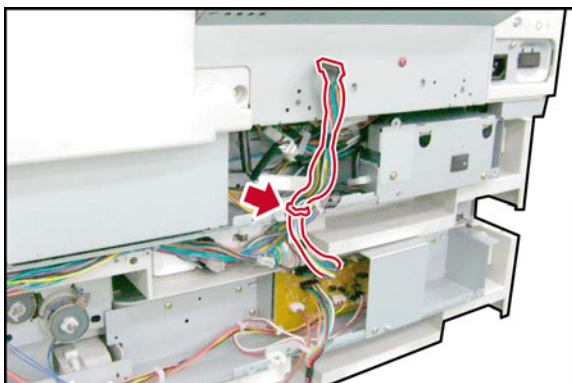

(13) Release the **CST2 Harness** from the Harness Clamp.



(14) Separate the **2nd Paper Feed Module** from the machine.

Caution:

The machine weights approximately 181 lb (82 kg) with the i-ADF pre-installed. To prevent injuries, use the appropriate number of personnel and the proper equipment to lift or move the machine.

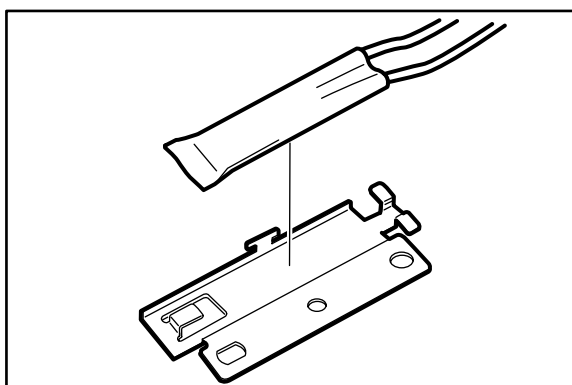

(15) Mount the **Heater** onto the Heater Bracket.

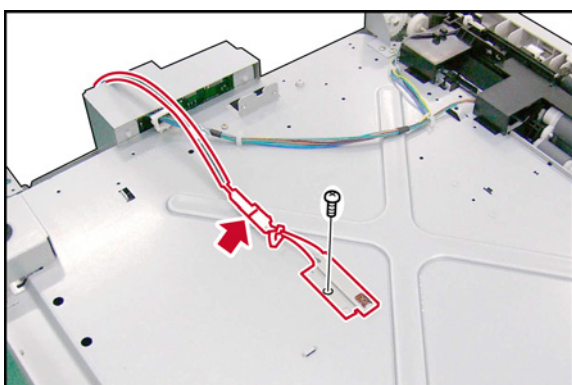

(16) Install the **Heater Assembly**.

(17) Secure the **Heater Assembly** with 1 Screw.

(18) Connect the **Heater Assembly** to the HT5 Harness.

(19) Install the **Harness Clamp**.

(20) Insert the **HT5 Harness** to the Harness Clamp.

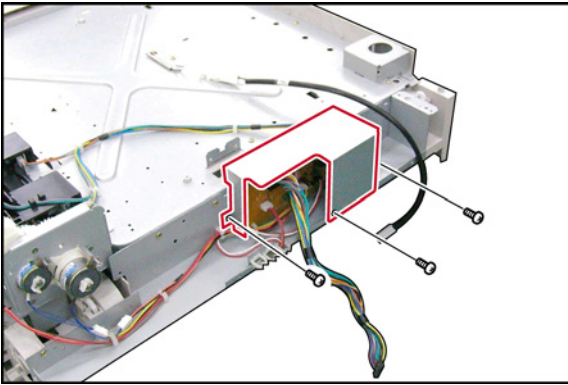

- (21) Remove 3 **Screws**.
- (22) Remove the **Protection Plate**.

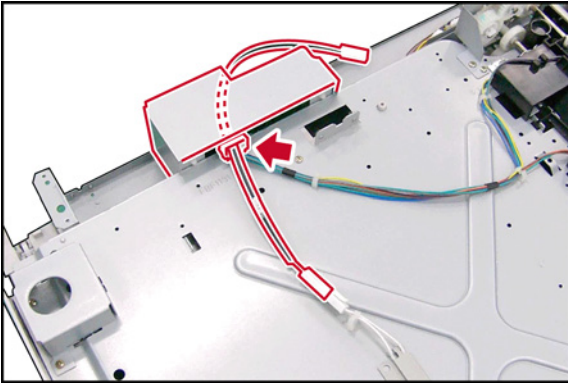

- (23) Route the **HT5 Harness** and secure to the Harness Clamp.
- (24) Reinstall the **Protection Plate**.

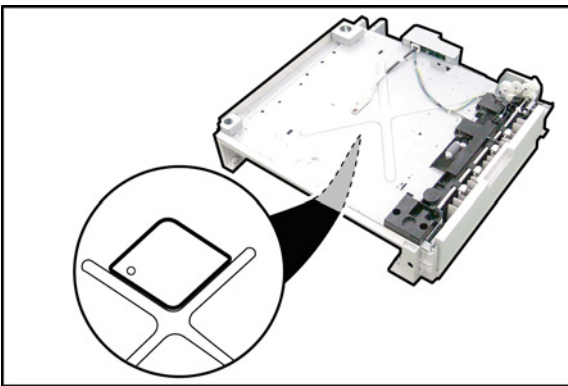

- (25) Pull the **2nd Paper Tray** out.
- (26) Install the **Protection Sheet**.



- (27) Place the **machine** on top of the 2nd Paper Feed Module.

Caution:

The machine weights approximately 181 lb (82 kg) with the i-ADF pre-installed. To prevent injuries, use the appropriate number of personnel and the proper equipment to lift or move the machine.

- (28) Reinstall 4 Brackets.

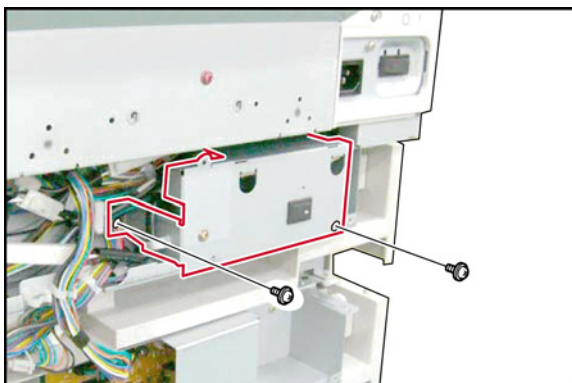

- (29) Remove 2 **Screws**.
- (30) Remove the **HP Cover**.

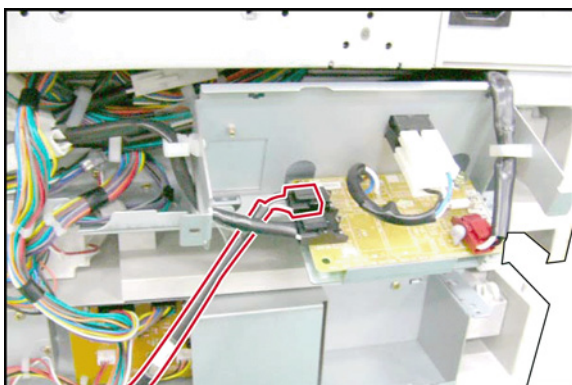

- (31) Connect the **HT2 Harness** to the RLB PC Board (CN174).
- (32) Reinstall the **HP Cover**.

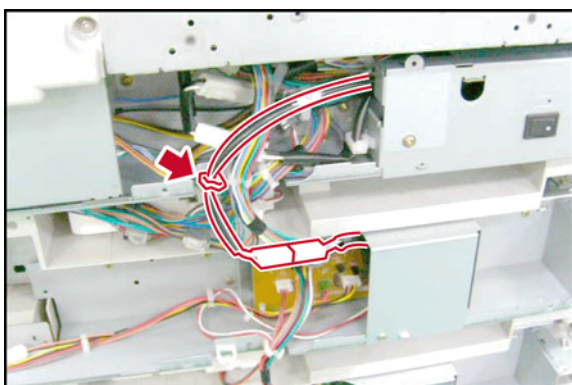

- (33) Connect the **HT5 Harness** to the HT2 Harness.
- (34) Insert the **HT5 Harness** to the Harness Clamp.
- (35) Connect the CST2 Harness to SPC PC Board (CN707).
- (36) Reinstall the all Covers.

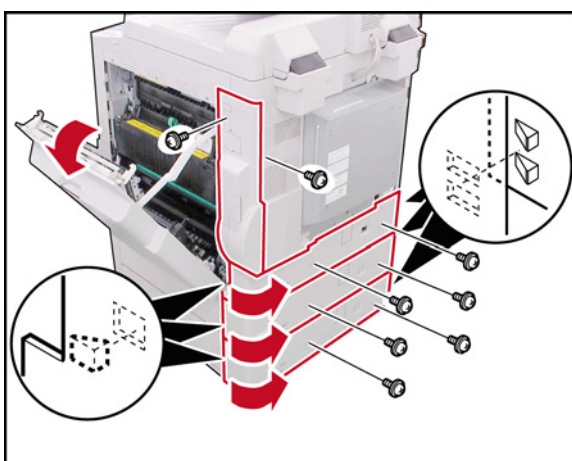

<For 3-Paper Tray Configuration>

- (1) Open the **Right Cover**.
- (2) Remove 2 **Silver Screws**.
- (3) Remove the **Right Rear Cover**.
- (4) Remove 6 **Silver Screws**.
- (5) Remove 3 **Lower Rear Covers**.

Caution:

The OPC Drum is sensitive to light. To prevent optical exposure problems, do not expose the OPC Drum to direct sunlight or bright light (even if it is a 1000-Lux fluorescent lamp).

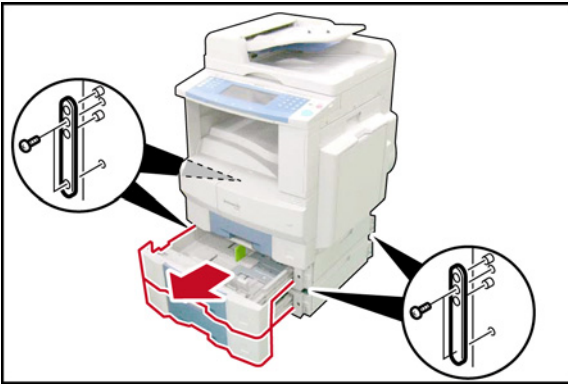

- (6) Slide the **2nd** and **3rd Paper Trays** out.
- (7) Remove 8 **Screws**.
- (8) Remove 4 **Brackets**.

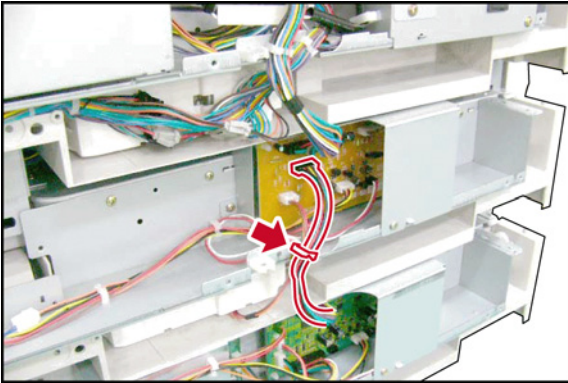

- (9) Disconnect the **CST3 Harness** from CST2 PC Board (CN772).
- (10) Release the **CST3 Harness** from the Harness Clamp.



- (11) Separate the **3rd Paper Feed Module** from the machine.

Caution:

The machine weights approximately 181 lb (82 kg) with the i-ADF pre-installed. To prevent injuries, use the appropriate number of personnel and the proper equipment to lift or move the machine.

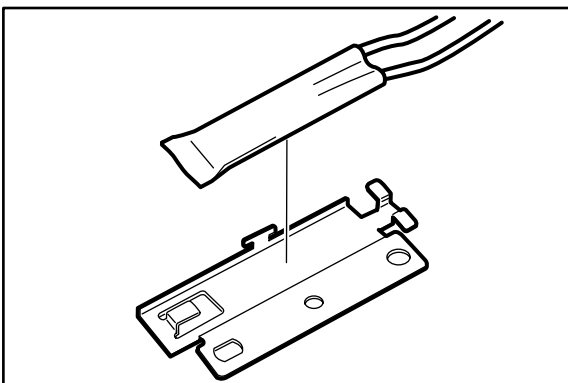

- (12) Mount the **Heater** onto the Heater Bracket.

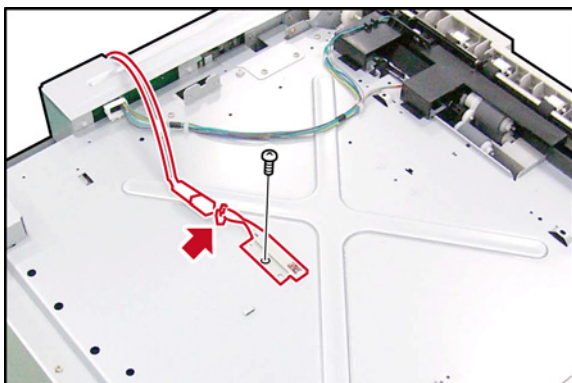

- (13) Install the **Heater Assembly**.
- (14) Secure the **Heater Assembly** with 1 Screw.
- (15) Connect the **Heater Assembly** to the HT5 Harness.
- (16) Install the **Harness Clamp**.
- (17) Insert the **HT5 Harness** to the Harness Clamp.

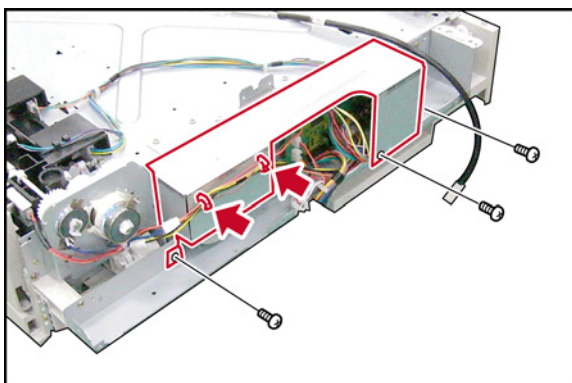

- (18) Release the **Harnesses** from 2 Harness Clamps.
- (19) Remove 3 **Screws**.
- (20) Remove the **Protection Plate**.

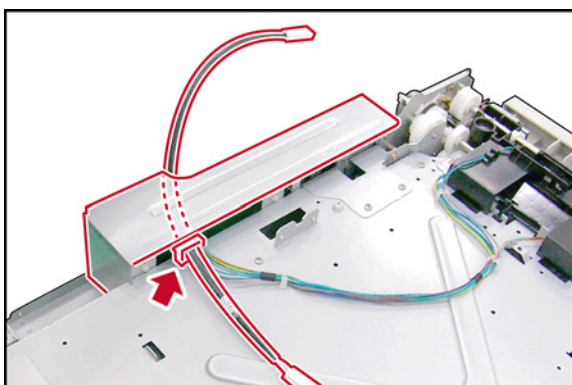

- (21) Route the **HT5 Harness** and secure to the Harness Clamp.
- (22) Reinstall the **Protection Plate**.

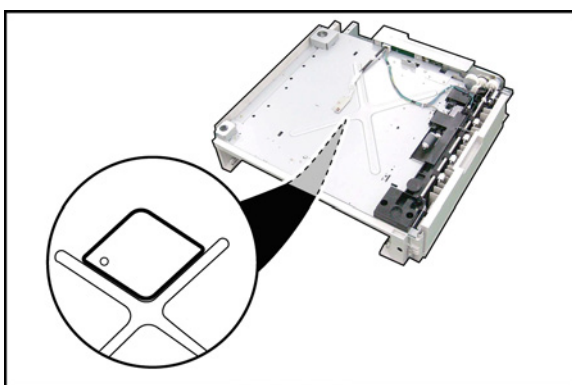

- (23) Pull the **3rd Paper Tray** out.
- (24) Install the **Protection Sheet**.



(25) Place the **machine** on top of the 3rd Paper Feed Module.

Caution:

The machine weights approximately 181 lb (82 kg) with the i-ADF pre-installed. To prevent injuries, use the appropriate number of personnel and the proper equipment to lift or move the machine.

(26) Reinstall 4 Brackets.

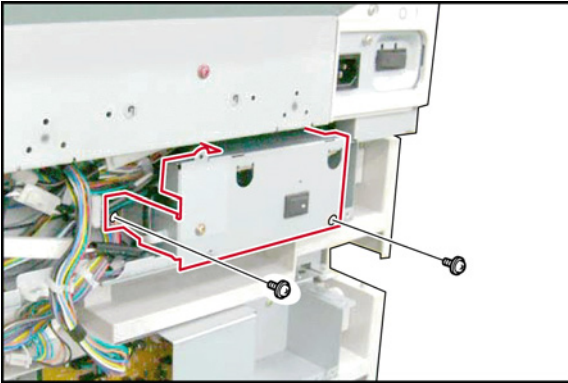

(27) Remove 2 **Screws**.

(28) Remove the **HP Cover**.

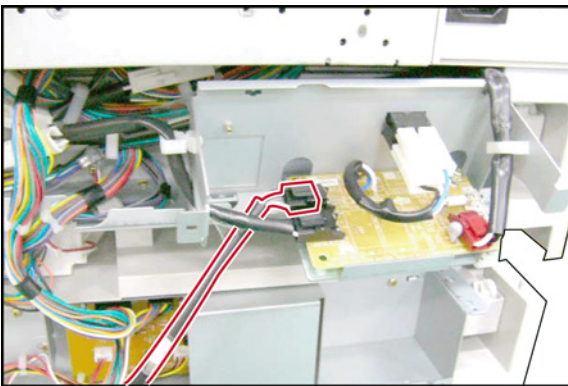

(29) Connect the **HT2 Harness** to the RLB PC Board (CN174).

(30) Reinstall the **HP Cover**.

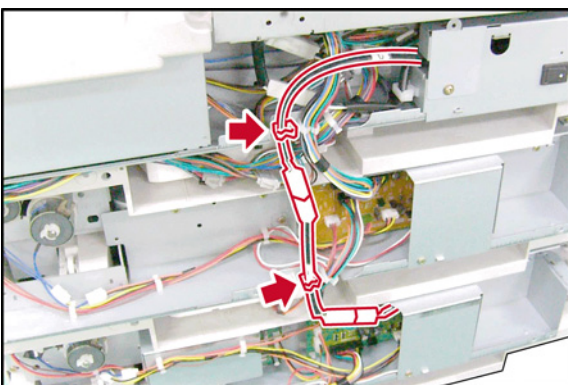

(31) Connect the **HT5 Harness** to the HT-CST Harness.

(32) Connect the **HT-CST Harness** to the HT2 Harness.

(33) Install the **Harness Clamp**.

(34) Insert the **Harnesses** to 2 Harness Clamps.

(35) Connect the CST3 Harness to CST2 PC Board (CN772).

(36) Reinstall all Covers.

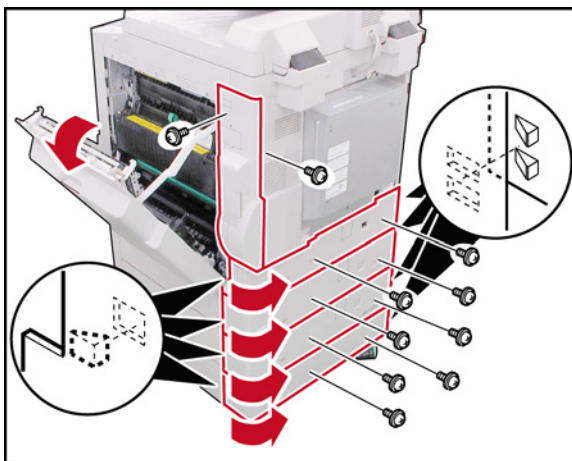

<For 4-Paper Tray Configuration>

- (1) Open the **Right Cover**.
- (2) Remove 2 **Silver Screws**.
- (3) Remove the **Right Rear Cover**.
- (4) Remove 8 **Silver Screws**.
- (5) Remove the 4 **Lower Rear Covers**.

Caution:

The OPC Drum is sensitive to light. To prevent optical exposure problems, do not expose the OPC Drum to direct sunlight or bright light (even if it is a 1000-Lux fluorescent lamp).

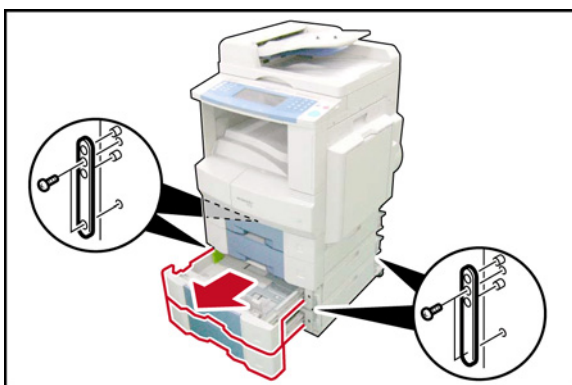

- (6) Slide the **3rd and 4th Paper Trays** out.
- (7) Remove 8 **Screws**.
- (8) Remove 4 **Brackets**.

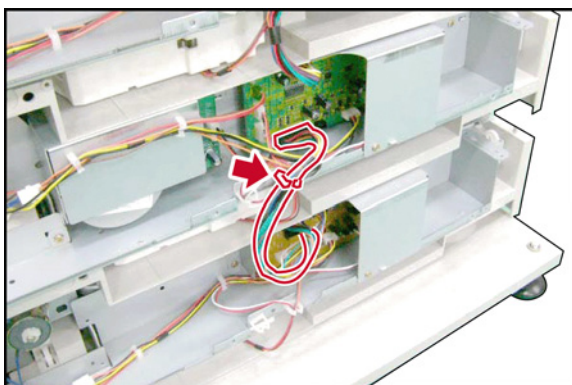

- (9) Disconnect the **CST2 Harness** from CST3 Harness (CN808).
- (10) Release the **CST2 Harness** from the Harness Clamp.



- (11) Separate the **4th Paper Feed Module** from the machine.

Caution:

The machine weights approximately 181 lb (82 kg) with the i-ADF pre-installed. To prevent injuries, use the appropriate number of personnel and the proper equipment to lift or move the machine.

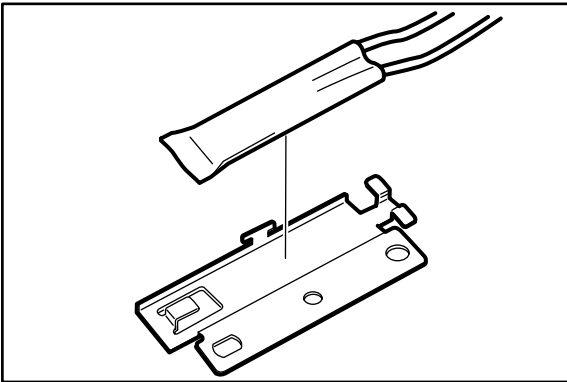

(12) Mount the **Heater** onto the Heater Bracket.

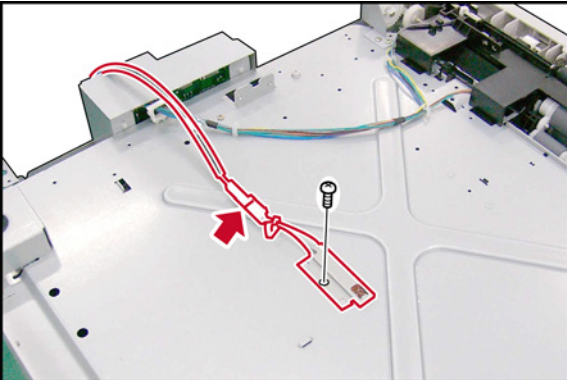

(13) Install the **Heater** Assembly.

(14) Secure the **Heater** Assembly with 1 Screw.

(15) Connect the **Heater** Assembly to the HT6 Harness.

(16) Install the **Harness Clamp**.

(17) Insert the **HT6 Harness** into the Harness Clamp.

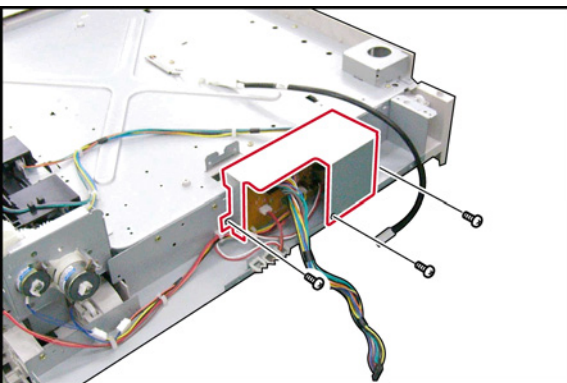

(18) Remove 3 **Screws**.

(19) Remove the **Protection Plate**.

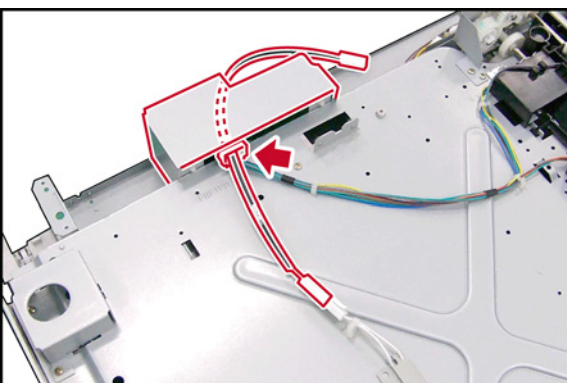

(20) Route the **HT6 Harness** and secure it into the Harness Clamp.

(21) Reinstall the **Protection Plate**.

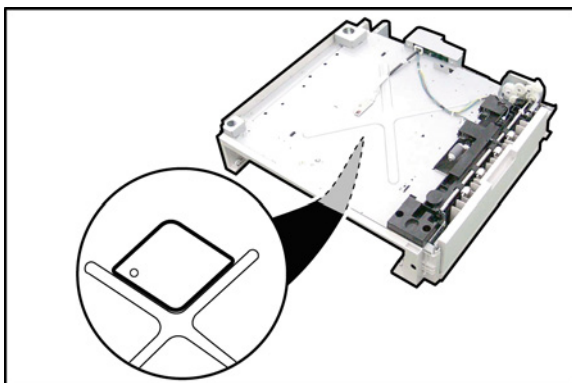

- (22) Pull the **4th Paper Tray** out.
 (23) Install the **Protection Sheet**.



- (24) Place the **machine** on top of the 4th Paper Feed Module.

Caution:

The machine weights approximately 181 lb (82 kg) with the i-ADF pre-installed. To prevent injuries, use the appropriate number of personnel and the proper equipment to lift or move the machine.

- (25) Reinstall 4 Brackets.

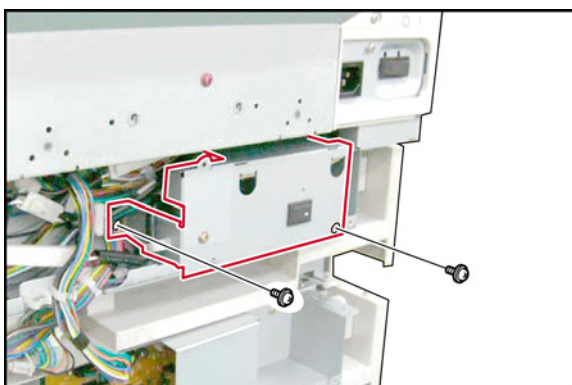

- (26) Remove 2 **Screws**.
 (27) Remove the **HP Cover**.

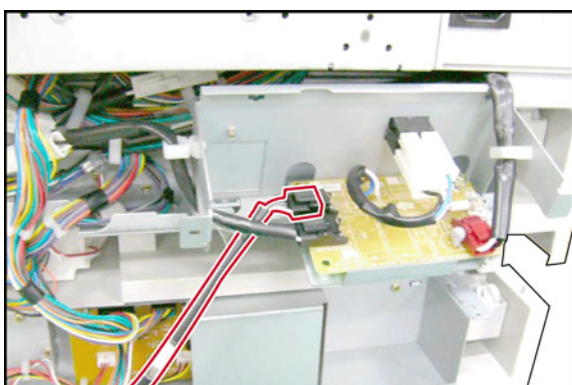

- (28) Connect the **HT2 Harness** to the RLB PC Board (CN174).
 (29) Reinstall the **HP Cover**.

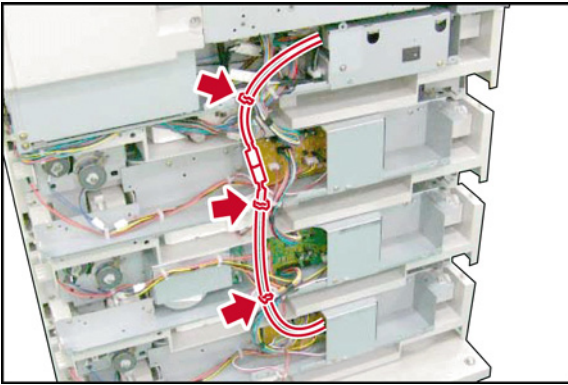

- (30) Connect the **HT6 Harness** to the HT2 Harness.
- (31) Install 2 **Harness Clamps**.
- (32) Insert the **HT6 Harness** into 3 Harness Clamps.
- (33) Connect the CST2 Harness to CST3 PC Board (CN808).
- (34) Reinstall all Covers.

8.22. Replacing the OPC Drum

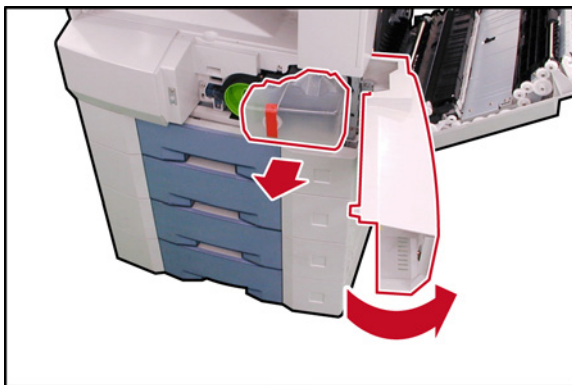

- (1) Open the **Right Cover**.
- (2) Open the **Front Cover**.
- (3) Remove the **Toner Waste Container**.



- (4) Remove 1 **Screw**.
- (5) Remove the **Connector Cover** (Clear Blue).

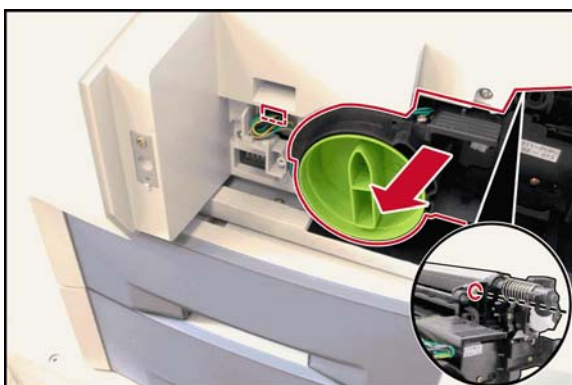

- (6) Disconnect the **Harness**.
- (7) Loosen 1 **Screw**.
- (8) Slide the **Process Unit** out.

Caution:

To prevent damage to the Process Unit, ensure the Right Cover is still open before pulling the Process Unit out.

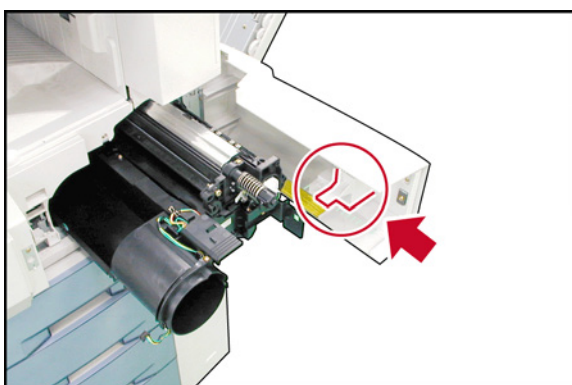

Caution:

Exercise caution not to scratch the surface of the **OPC Drum** (Green), and not to touch it with bare hands.

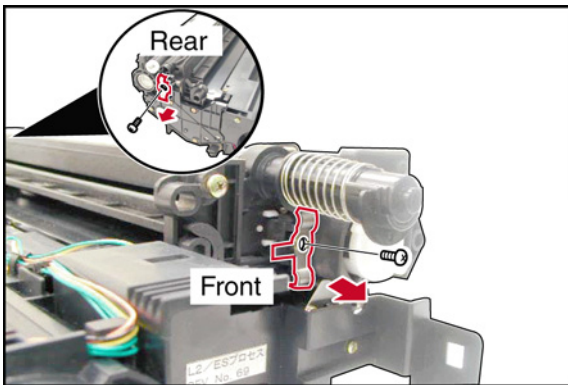

- (9) Remove 1 **Screw**.
- (10) Remove the **Front Fixing Metal Bracket** (longer plastic tab).
- (11) Remove 1 **Screw**.
- (12) Remove the **Rear Fixing Metal Bracket** (shorter plastic tab).

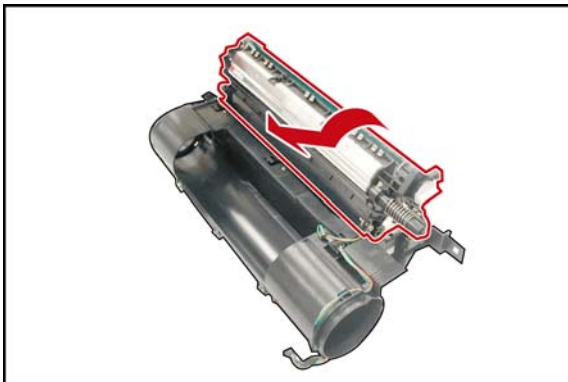

- (13) Turn the **OPC Drum Assembly** in the direction of the arrow and remove.

Caution:

Exercise caution not to scratch the surface of the **OPC Drum** (Green), and not to touch it with bare hands.



- (14) Remove the **OPC Drum Shaft Holder Assembly**.
- (15) Remove the **Front DSD Arm**.
- (16) Lift the **OPC Drum**, holding the right side where the OPC Drum Shaft Holder Assembly was installed.

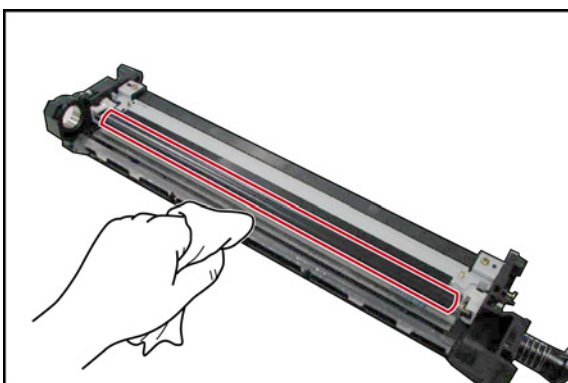

- (17) Clean the Bias Charge Roller with a soft dry cloth that came with the new OPC Drum.

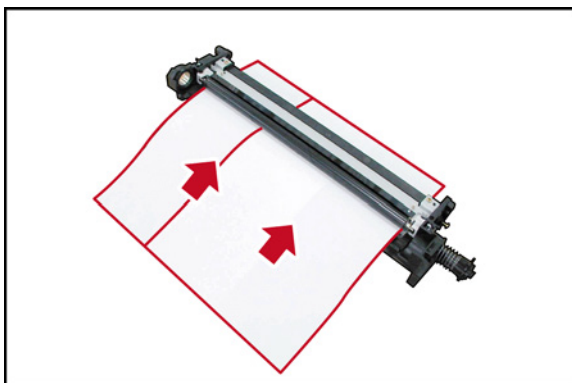

- (18) Insert 2 **LTR (A4) size papers (brand new)** under the Bias Charge Roller passing through the Discharge Light slit as illustrated.

Note:

The width of the paper should cover the entire width of the Bias Charge Roller.

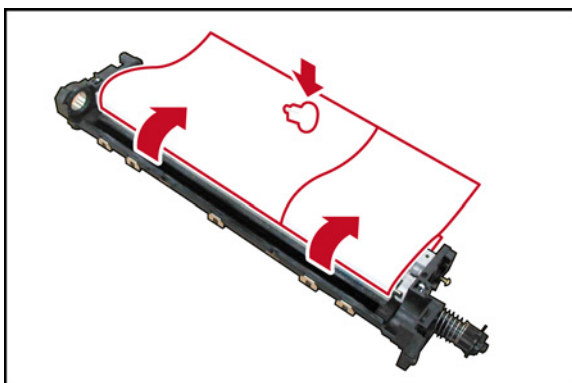

- (19) Lift both sides of the papers and cover the Bias Charge Roller, then place the **OPC Drum Shaft Holder** on top of the papers to act as a weight.

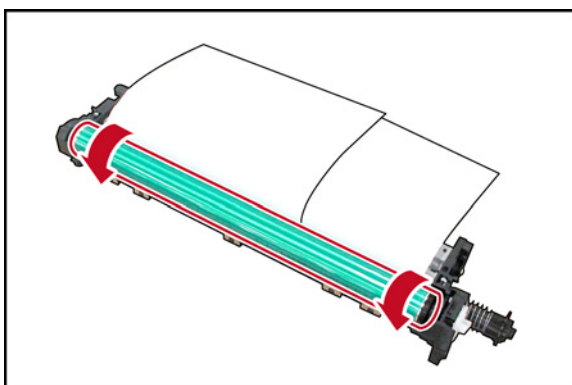

- (20) Ensure that the OPC Drum is fully coated with the Drum Starting Powder. Apply additional Drum Starting Powder onto the surface of the OPC Drum if required.

Note:

Do not touch the surface of the OPC Drum with bare hands when removing or reinstalling it. Grease from fingerprints will affect copy quality.

Caution:

The OPC Drum is sensitive to light. To prevent optical exposure problems, do not expose the OPC Drum to direct sunlight or bright light (even if it is a 1000-Lux fluorescent lamp).

- (21) Install the new **OPC Drum** onto the OPC Drum Shaft Holder.
- (22) Spin the OPC Drum in the arrow direction, turning by the edge (approximately 1 inch) with your fingers to collect the powder onto the cleaning blade and clean the OPC drum surface. Spin the drum until both papers are released from the Bias Charge Roller.

Caution:

If it does not spin smoothly, the Cleaning Blade or Gear(s) may be damaged. Inspect and repair before proceeding.

- (23) Insert the OPC Drum Assembly into the Process Unit.
- (24) Reinstall the Process Unit and the Toner Waste Container.
- (25) Perform the Copy Service Mode F8-14 (Black Density Gain) to clear the OPC Drum Counter.

8.23. Replacing the Laser Unit (LSU)

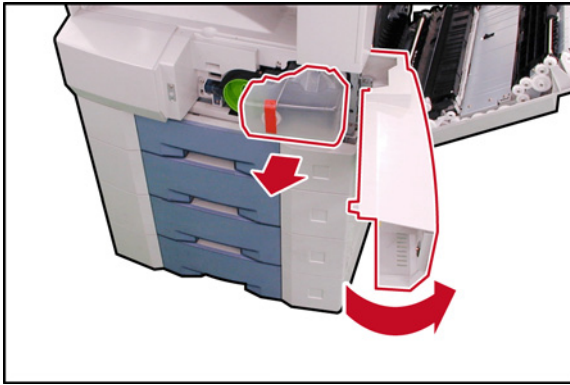

- (1) Open the **Right Cover**.
- (2) Open the **Front Cover**.
- (3) Remove the **Toner Waste Container**.



- (4) Remove 1 **Screw**.
- (5) Remove the **Connector Cover** (Clear Blue).

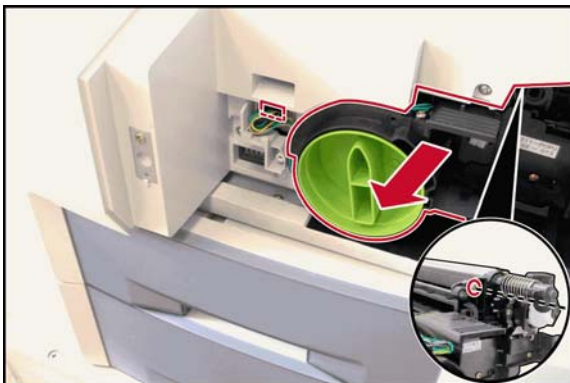

- (6) Disconnect the **Harness**.
- (7) Loosen 1 **Screw**.
- (8) Slide the **Process Unit** out.

Caution:

To prevent damage to the Process Unit, ensure the Right Cover is still open before pulling the Process Unit out.

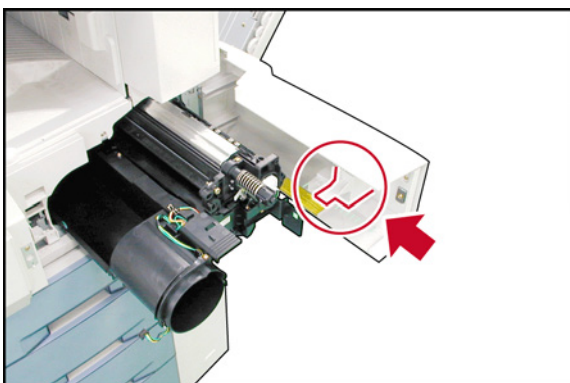

Caution:

Exercise caution not to scratch the surface of the **OPC Drum** (Green), and not to touch it with bare hands.

Caution:

The OPC Drum is sensitive to light. To prevent optical exposure problems, do not expose the OPC Drum to direct sunlight or bright light (even if it is a 1000-Lux fluorescent lamp).

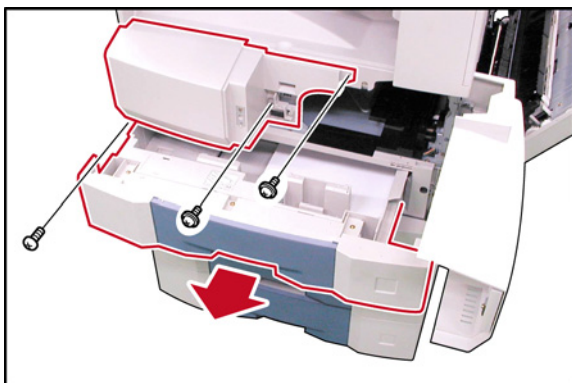

- (9) Slide the **1st Paper Tray** out.
- (10) Remove 3 **Screws**.
- (11) Remove the **Front Left Cover**.



- (12) Remove the **Blind Cover**.
- (13) Remove 2 **Screws**.
- (14) Remove the **S Inner Cover**.

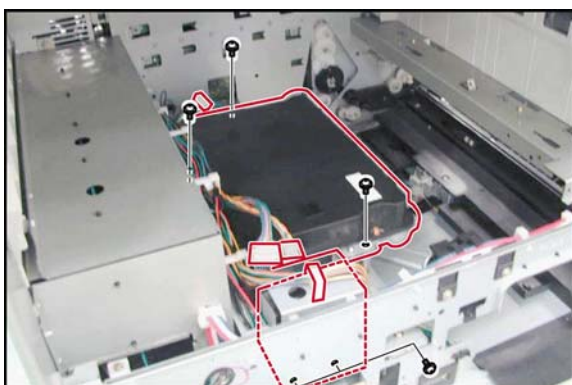

- (15) Disconnect 3 **Harnesses**.
- (16) Remove 3 **Screws**.
- (17) Remove the **LSU Unit**.
- (18) Install the **New LSU Unit**.

8.23.1. Laser Power (PWM Circuit) Adjustment

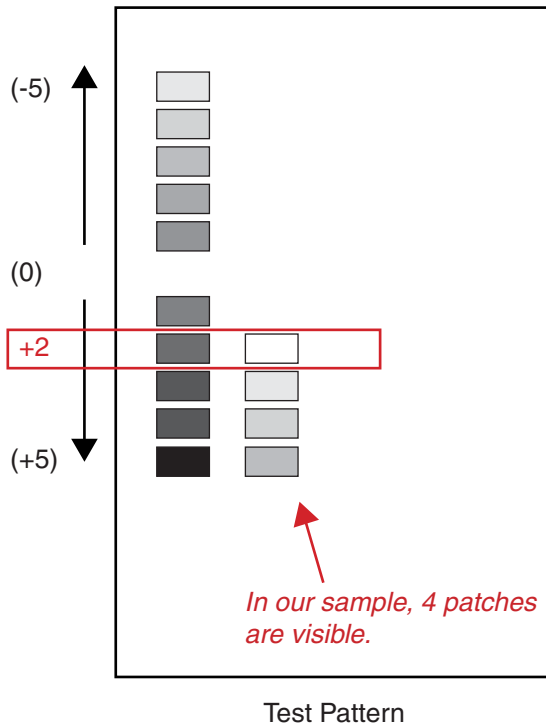

- (1) Ensure that Ledger / A3 Size Paper is loaded in one of the Trays, and pull the other Trays out.
- (2) Press the **"FUNCTION"**, **"ORIGINAL SIZE (LEDGER/A3)"**, and the **"3"** keys simultaneously.
- (3) Input the password, and select the **"OK"** button to enter the Service Mode (default password is **00000000**).
- (4) Press the **"8"** and **"START"** keys to enter the F8 Mode (Service Adjustment).
- (5) Press **"18 LSU PWM Pattern"** to print the Test Pattern.
- (6) Observe the position of the uppermost visible gray patch.

Sample:

4 gray patches are visible in the illustration, the value of the uppermost patch position is **"+2"** in our example.

- (7) Press the **"OK"**.
- (8) Press the **"6"** and **"START"** keys to enter the F6 Mode (Adjust Parameters)
- (9) Press **"39 LSU Unit PWM Adjust"**.
- (10) Press **"INPUT"** and enter the value of the gray patch, as established in Step (6).
- (11) Press **"OK"** button 2 times.
- (12) Press the **"FUNCTION"** and **"C (CLEAR)"** keys simultaneously to exit the Service Mode.

8.23.2. LSU Skew Adjustment

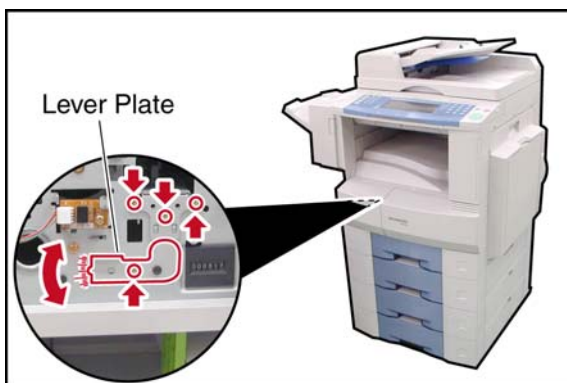

- (1) Remove the Front Left Cover. (Refer to "Replacing the LSU", steps (1) ~ (15))
- (2) Loosen 4 Red Screws.

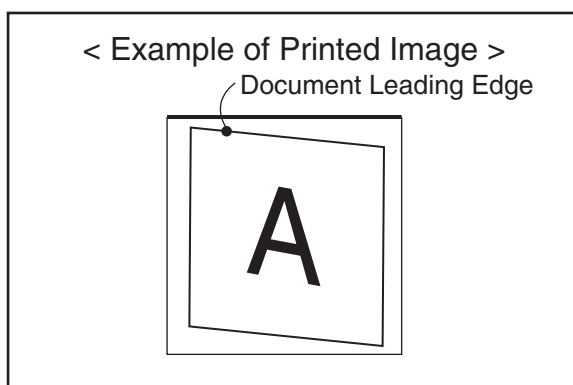

Adjust the Lever Plate downwards and recheck the Document Skewing. Readjust as needed.

One scale adjusts the skewed image by approximately 0.01 mm.

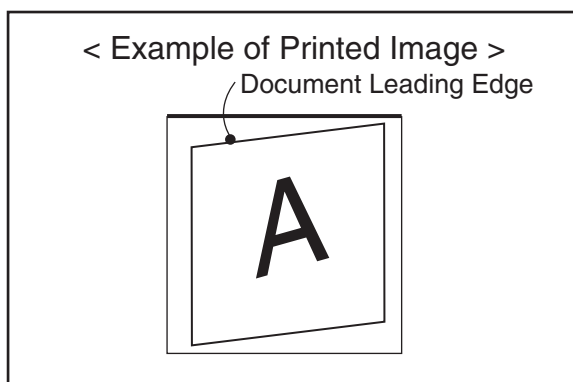

Adjust the Lever Plate upwards and recheck the Document Skewing. Readjust as needed.

9 Network Information

9.1. Programming or Retrieving Parameters via Email

9.1.1. General Description

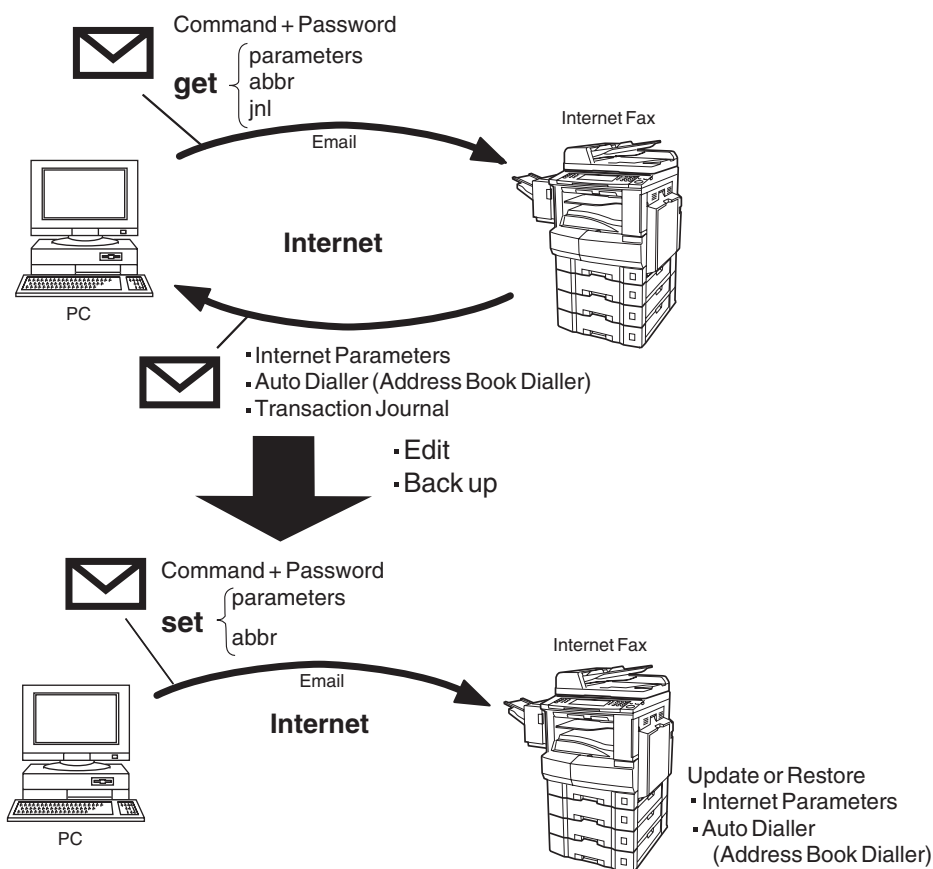

9.1.2. Using Email to Program or Retrieve Parameters

This feature is a powerful tool, which provides a convenient, and easy way of retrieving, or programming Internet Parameters, Address Book Dialling Numbers, Program keys, and Journal retrieval from your PC by sending a text email message to your machine.

Using your email application's "Subject:" line as a command-input field, you can request your machine to perform the following commands:

	"Subject:" Line Command	Function
1	#set parameters(password)#	Programs the Internet Parameters
2	#get parameters(password)#	Retrieves the Internet Parameters
3	#set abbr(password)#	Programs the Auto Dialler
4	#get abbr(password)#	Retrieves the Auto Dialler Data
3	#get jnl(password)#	Retrieves the current Journal data

Where:

- "set" is used to program the data
- "get" is used to retrieve the data
- "parameters" represents Internet Parameters
- "abbr" represents Auto Dialler
- "jnl" represents Journal
- "password" is the Remote Password programmed in your machine's User Parameters (i.e. 1234567890). Must be enclosed within the parenthesis "()".
- The command must be enclosed within the hash (#) signs.

9.1.3. Using a PC to Input the Internet Parameters Remotely

This feature provides a convenient, and an easy way to input the Internet Parameters right from your PC by sending a text email message to your machine.

The following parameters can be input remotely via a PC. The other parameters must be entered from the machine in the User Parameters. (See Operating Instructions for Facsimile and Internet Fax/Email Functions.)

- Sender Selection (up to 24 User Names, see Operating Instructions for Facsimile and Internet Fax/Email Functions.)
- Default Domain
- Selectable Domains (up to 10 additional Domain Names)
- Remote Password
- Manager's Email Address
- Relay XMT Password
- Relay Domain (up to 10 Domain Names authorized for Relay XMT Request)
- LDAP Server Name (Available for some countries only.)
- LDAP Login Name (Available for some countries only.)
- LDAP Password (Available for some countries only.)
- LDAP Search Base (Available for some countries only.)
- Community Name (up to 2 Community Names)
- Device Name
- Device Location

Your machine interprets the command that you enter in the "Subject" line of your email message, and performs one of the following functions, it Retrieves, or Stores data into the Internet Parameters (User Parameters).

The two types of commands that can be entered in the "Subject" line of your email:

- 1) To Store data, type : **#set parameters(password)#** : where the "password" is the Remote Password programmed in your machine's User Parameters (i.e. 1234567890). You can enter the Internet Parameters shown above with this command the first time. However, if these fields already contain data, do not use this command as the existing information will be deleted, and overwritten. Use the Retrieve command below instead, refer to the next pages.
- 2) To Retrieve data, type : **#get parameters(password)#**

Note:

To activate this feature, change the Fax Parameter No. 158 (PC Remote Update) to "Valid".
(See Operating Instructions for Facsimile and Internet Fax/Email Functions.)

9.1.4. To Retrieve Each Parameters

To retrieve the existing parameters, send a plain text email to the your machine's email address with the following command in the "Subject" line:

- **#get parameters(password)#** : To retrieve the Internet Parameters
 - **#get abbr(password)#** : To retrieve the Auto Dialler (Address Book Dialler)
 - **#get jnl(password)#** : To retrieve the Journal (Transaction Journal)
- : where the "password" is the Remote Password programmed in your machine's User Parameters (i.e. 1234567890). For security, always input a Remote Password in the User Parameters. If it was not programmed, signify with "()" (i.e. #get parameters()).
Make sure that the Cc..., Bcc... lines, and the body of the email message is Blank.

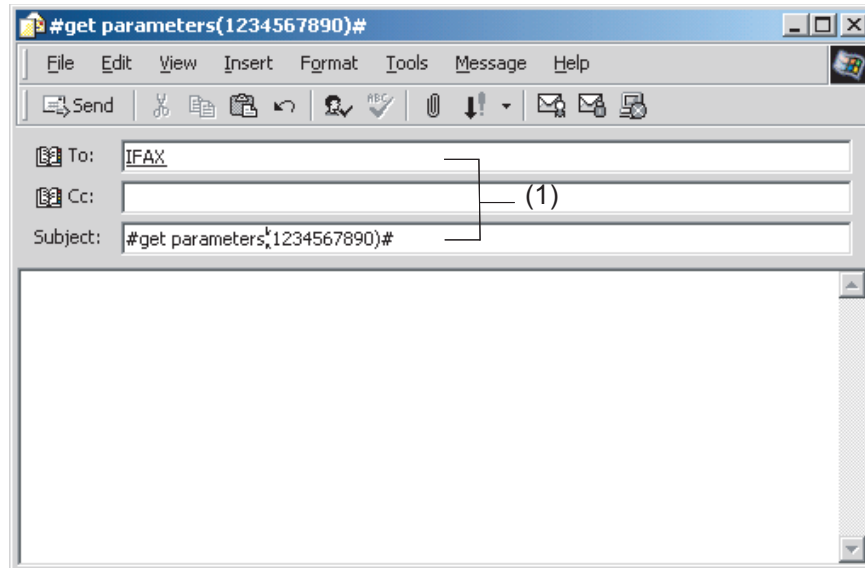
[Ex: Internet Parameters]

- (1) To : Your machine's email address.
- From : This field is normally not visible when creating new email message(s). It is your default email address (email application), for retrieving the Internet Parameters, and for error message notification. (Can be programmed with the configuration tool of your email program.)
- Subject : To Retrieve data, type: #get parameters(password)#
#get abbr(password)#
#get jnl(password)#

Using Email to Retrieve the Journal

The Journal will be send back to the originating station's email address.

After receiving the journal, use a fixed width font (i.e. Courier), in order to align the received journal's contents on the PC.

A separate email message is sent by your machine, an "Internet Fax Return Receipt" to the Manager's email address programmed in the User Parameters, informing of the Journal transfer.

9.1.5. To Edit the Retrieved or Backup Internet Parameters/Auto Dialler File

After receiving your machine's email with the Internet Parameters, and/or Auto Dialler (Address Book Dialler), store the email file as text (.txt) on your PC for backup purposes.

To change, or update the Internet Parameters, and/or Auto Dialler (Address Book Dialler), follow the steps below:

1. Create a New Email Message, fill out the "To", and "From" Address line, and the Subject line information for section (1) below:

- To : Your machine's email address.
- From : This field is normally not visible when creating new email message(s). It is your default email address (email application), for retrieving each Parameters, and for error message notification.
- Subject : To Store data, type: #set parameters(password)#
#set abbr(password)#

2. Open the backup, Internet Parameters, and/or Auto Dialler (Address Book Dialler) text file. Copy the body text, and paste it on the body of the newly created email message.
3. Delete any headers that may be present in the body of the email, as unsupported data will be rejected. The information following the "#" sign is ignored by your machine.
4. Edit a parameter, and/or add additional parameters.

- When finished, use the "File/Save as..." command, and save the updated file with ".txt" extension as a backup.
- Send the email message to your machine to update the Internet Parameters, and/or Auto Dialler (Address Book Dialler).

Your Machine's Internet Parameters Email Sample

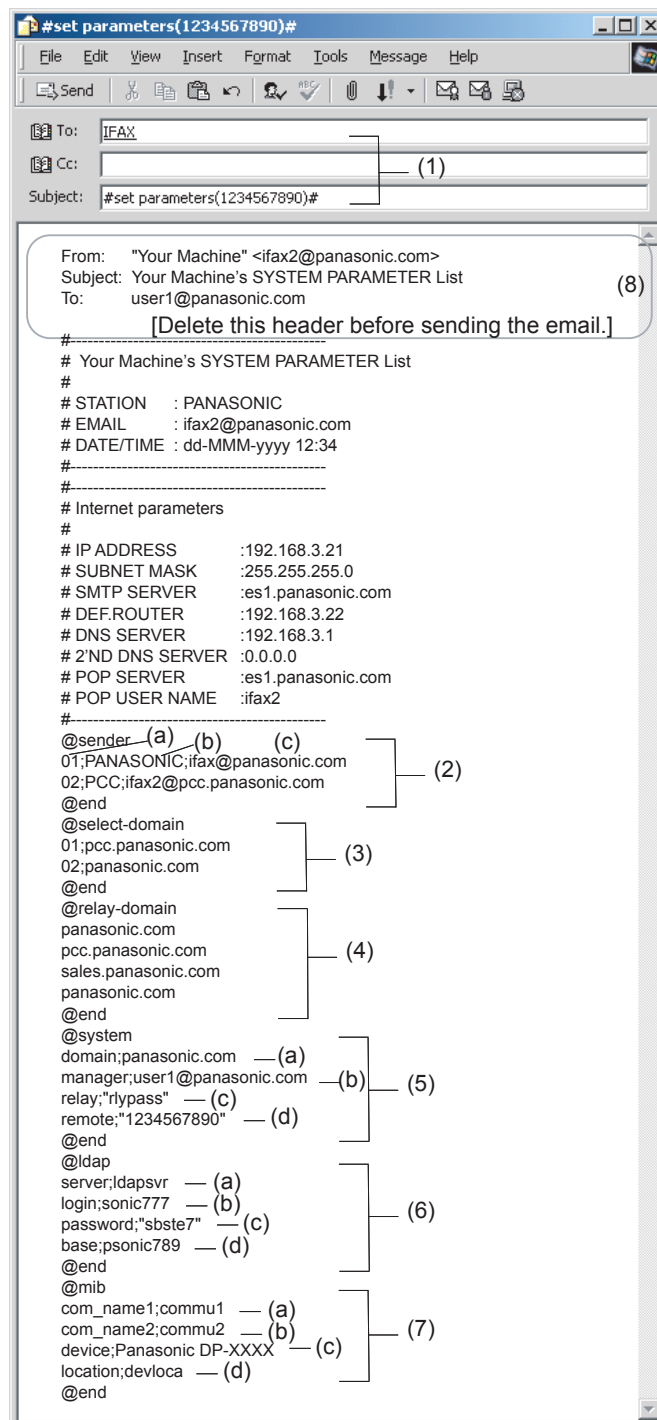

- (1) To : Your machine's email address.
- From : This field is normally not visible when creating new email message(s). It is your default email address (email application), for retrieving the Internet Parameters, and for error message notification. (Can be programmed with the configuration tool of your email program.)
- Subject : To Store data, type: #set parameters(password)#

- (2) @sender to @end : Defines the Sender information to be set in section (2) between @sender to @end block. Edit, Delete, or Register up to 24 User Names, and their Email Addresses for the Sender Selection feature.
(See Operating Instructions for Facsimile and Internet Fax/Email Functions.)
Separate each data field with a semicolon (;). (If the remaining fields are to remain blank, insert a semicolon (;) for each blank field)
The data string for each Sender Selection should be defined within a single line.
The syntax is: <Sender Selection Number>;<User Name>;<Email Address>
(a) 01 to 24: Indicates the Sender Selection Numbers
(b) User Name (25-characters maximum)
(c) Email Address (60-characters maximum)
- (3) @select-domain to @end : Defines the Selectable Domains to be set in section (3) between @select-domain to @end block. Register up to 10 alternate Domain Names that can be selected during manual email addressing. (30-characters maximum)
The syntax is: <Number>;<Domain>
- (4) @relay-domain to @end : Defines the Domain Names to be set in section (4) between @relay-domain to @end block. Register up to 10 Domain Names that have been authorized to access your Internet Fax for Relayed XMT Request. (30-characters maximum)
- (5) @system to @end : Defines the Internet Parameters to be set in section (5) between @system to @end block. Register the following Internet Parameters.
(a) Default Domain (50-characters maximum).
The syntax is:domain;<Default domain name>
(b) Manager.s Email Address (60-characters maximum).
The syntax is:manager;<Manager.s Email Address>
(c) Relay XMT Password (10-characters maximum).
The syntax is:relay;"<Relay XMT Password>". Quotation marks " " enclosing the password, is required, as shown in the example above.
(d) Remote Password (10-characters maximum).
The syntax is:remote;"<Remote Password>". Quotation marks " " enclosing the password, is required, as shown in the example above.
(Notice that for the above example, we have changed the Manager's Email Address, Relay XMT Password, and the Remote Password)
- (6) @ldap to @end : Defines the LDAP Parameters to be set in section (6) between @ldap to @end block. Register the following Internet Parameters.
(a) LDAP Server Name (60-characters maximum).
The syntax is:server;<LDAP Server Name>
(b) LDAP Login Name (60-characters maximum).
The syntax is:login;<LDAP Login Name>
(c) LDAP Password (30-characters maximum).
The syntax is:password;"<LDAP Password>". Quotation marks " " enclosing the password, is required, as shown in the example above.
(d) LDAP Search Base (40-characters maximum).
The syntax is:base;<LDAP Search Base>
- (7) @mib to @end : Defines the MIB to be set in section (7) between @mib to @end block. Register the following Internet Parameters.
(a) Community Name(1) (32-characters maximum).
The syntax is:com_name1;<Community Name(1)>

- (b) Community Name(2) (32-characters maximum).
The syntax is:com_name2;<Community Name(2)>
- (c) Device Name (32-characters maximum).
The syntax is:device;<Device Name>
- (d) Device Location (32-characters maximum).
The syntax is:location;<Device Location>

(8) This header must be deleted before the email is sent to your machine for reprogramming of Internet Parameters. The information following the "#" sign is ignored by your machine, therefore, you can leave it as is, or delete it if you wish.

Your Machine's Address Book (Auto Dialler) Email Sample

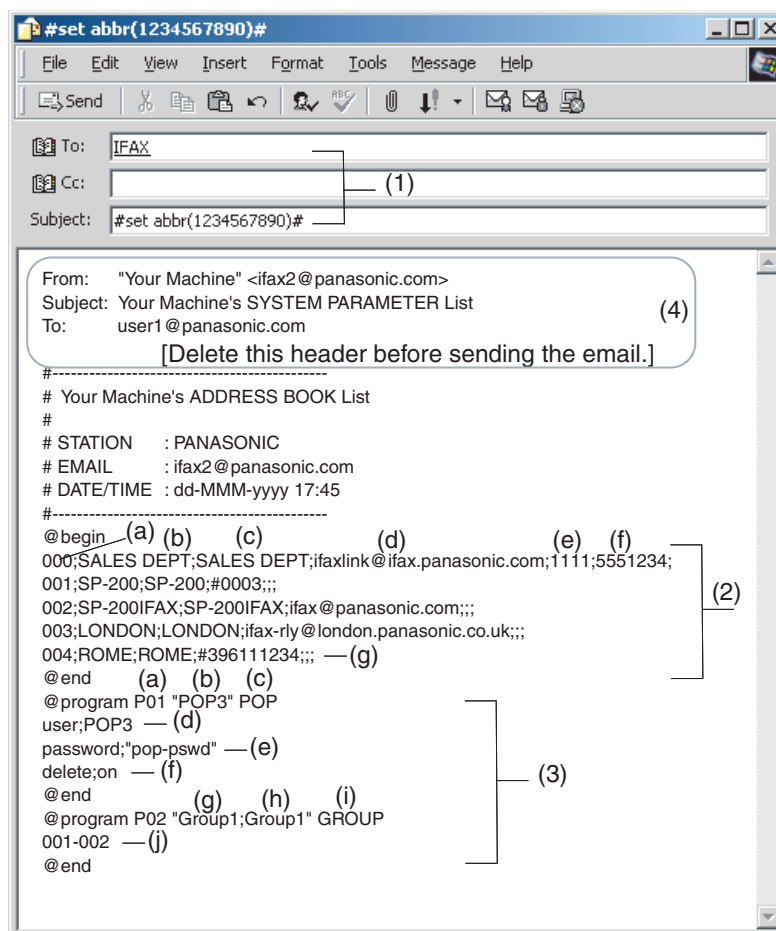

- (1) To : Your machine's email address.
- From : This field is normally not visible when creating new email message(s). It is your default email address (email application), for retrieving the Auto Dialler (Address Book Dialling) data, and for error message notification. (Can be programmed with the configuration tool of your email program.)
- Subject : To Store data, type: #set abbr(password)#
- (2) @begin to @end : Defines the Auto Dialler (Address Book Dialling) to be set in section (2) between @begin to @end block.
Edit, Delete, or Register the information. Separate each data field with a semicolon (;). (If the remaining fields are to remain blank, insert a semicolon (;) for each blank field)
The data string for each station should be defined within a single line.
The syntax is: <Entry-number>;<Station-name>;<Key-name>;<Station-address>;<Routing-subaddress>;<Routing-id-number>
(a) Entry-number: Address Book entries 000 to 199 (200 stations)

maximum)

- (b) Station-name: Name of the station being programmed (15 alpha-numeric characters maximum)
- (c) Key-name: Name of the key being programmed (15 alpha-numeric characters maximum)
- (d) Station-address: email address, or telephone number of the station being programmed
- (e) Routing-subaddress: sub-address to be used for routing (20-digit maximum)
- (f) Routing-id-number: TSI to be used for routing (20-digit maximum)
- (g) The End Receiving Station.s telephone number is entered after the hash sign (#).

- (3) @program to @end : Defines the Program Keys stored as a Group Key, or POP Access Key to be set in section (3) between @program to @end block. Edit, Delete, or Register the information.
- (a) Program Key: P01 - P12
 - (b) Key-name: Name of the Program key being programmed (15 alpha-numeric characters maximum)
 - (c) POP: The syntax used to set the Program Key as a POP Access Key.
 - (d) POP User-name: Name of the POP user account (40 alpha-numeric characters maximum)
 - (e) POP Password: POP Password (30 alpha-numeric characters maximum)
 - (f) Set whether the emails on the POP Server are deleted after retrieving the emails.
 - (g) Station-name as a Group Key: Name of the station being programmed (15 alpha-numeric characters maximum)
 - (h) Key-name: Group key name (15 alpha-numeric characters maximum)
 - (i) GROUP: The syntax used to set the Program Key as a Group Key
 - (j) ntry-number: Address Book entries 000 to 199 (200 stations maximum)

- (4) This header must be deleted before the email is sent to your machine for reprogramming of Auto Dialler (Address Book Dialling).
The information following the "#" sign is ignored by your machine, therefore, you can leave it as is, or delete it if you wish.

Note:

1. If a POP user account is programmed into the P1 to P12 program keys, the data programmed for this key cannot be deleted, even when the delete command is specified.
2. The email address, and the telephone number cannot be programmed via email when:
 - Address Book (Auto Dialler) Number has been used for communication reservation.
 - Received documents are stored in the image data memory of the machine.
 - While the machine is communicating, or printing.
3. When the email address, and telephone number are programmed via email, a program result email is sent back.
4. Some email applications automatically insert a line feed in the middle of a line when the number of characters in a line exceed a specific number. Turn "Off" the automatic line feed, or define the number of characters per line to prevent a line feed, or the data will be ignored.

9.1.6. Deleting the Entire Auto Dialler

If you wish to delete the entire Auto Dialler data in your machine, type the following command in the body of the email message:

@command
delete
@end

This command can also be inserted before the @begin to @end block, to erase the entire Auto Dialler data first, then reprogram it with new data.

This method will also prevent the "Overwrite Warning Message" that is sent back from your machine, when the current Auto Dialler station is overwritten.

To erase the entire Auto Dialler data, type the following command in the "Subject" line of your email:

#set abbr(password)# : where the "password" is the Remote Password programmed in your machine's User Parameters.

Retrieve, and backup the existing data onto your PC first by following the procedures for Retrieving, and Editing on the previous pages.

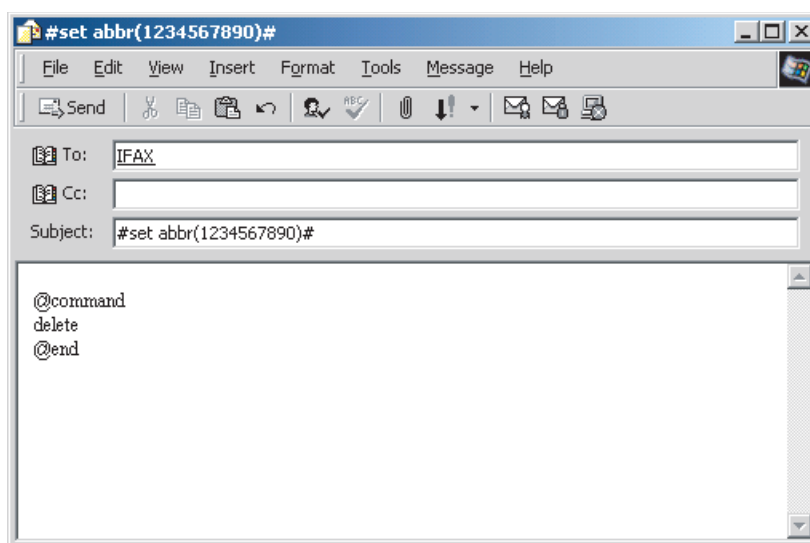

10 Schematic Diagram

10.1. General Circuit Diagram

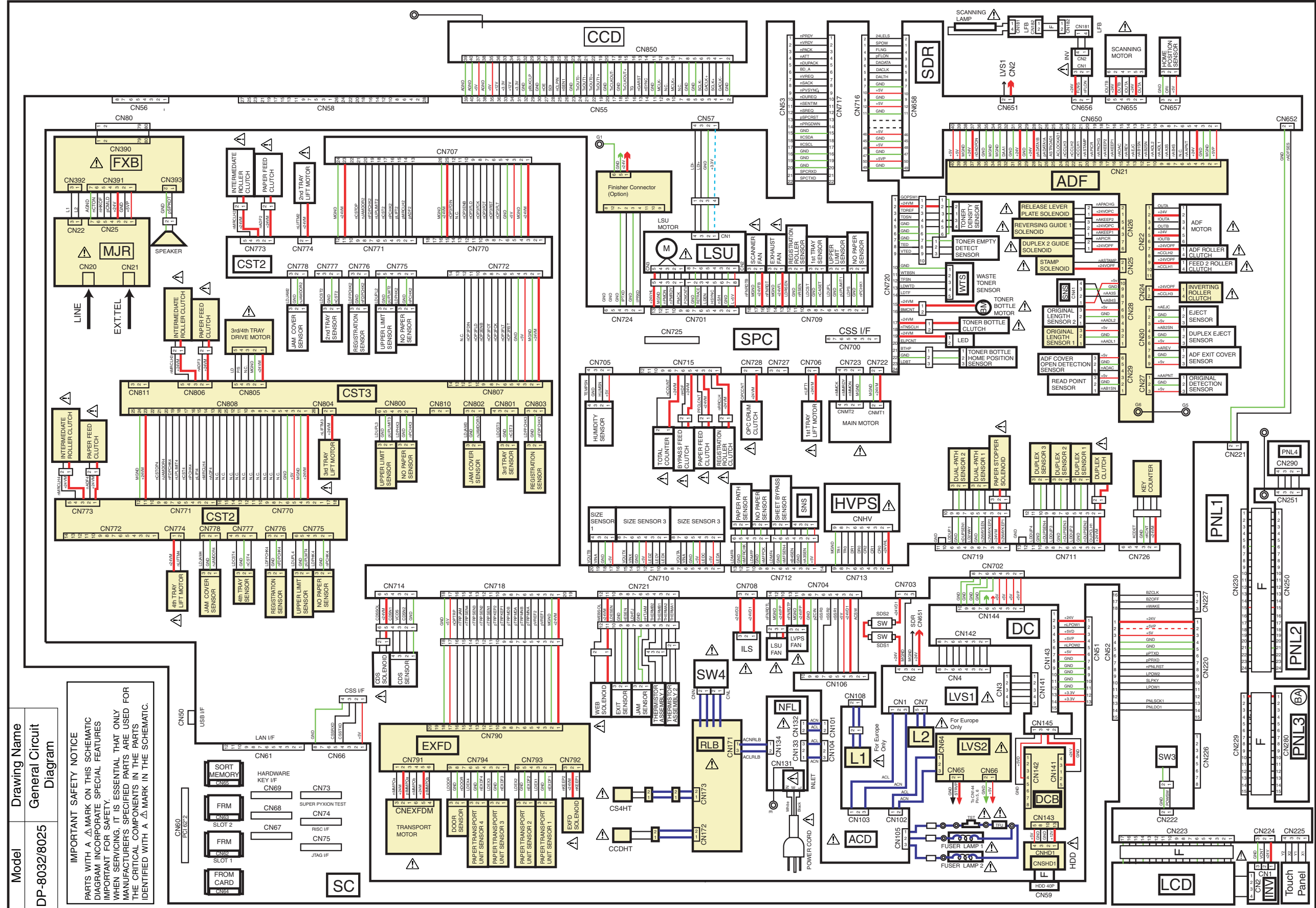

10.2. Finisher Circuit Diagram

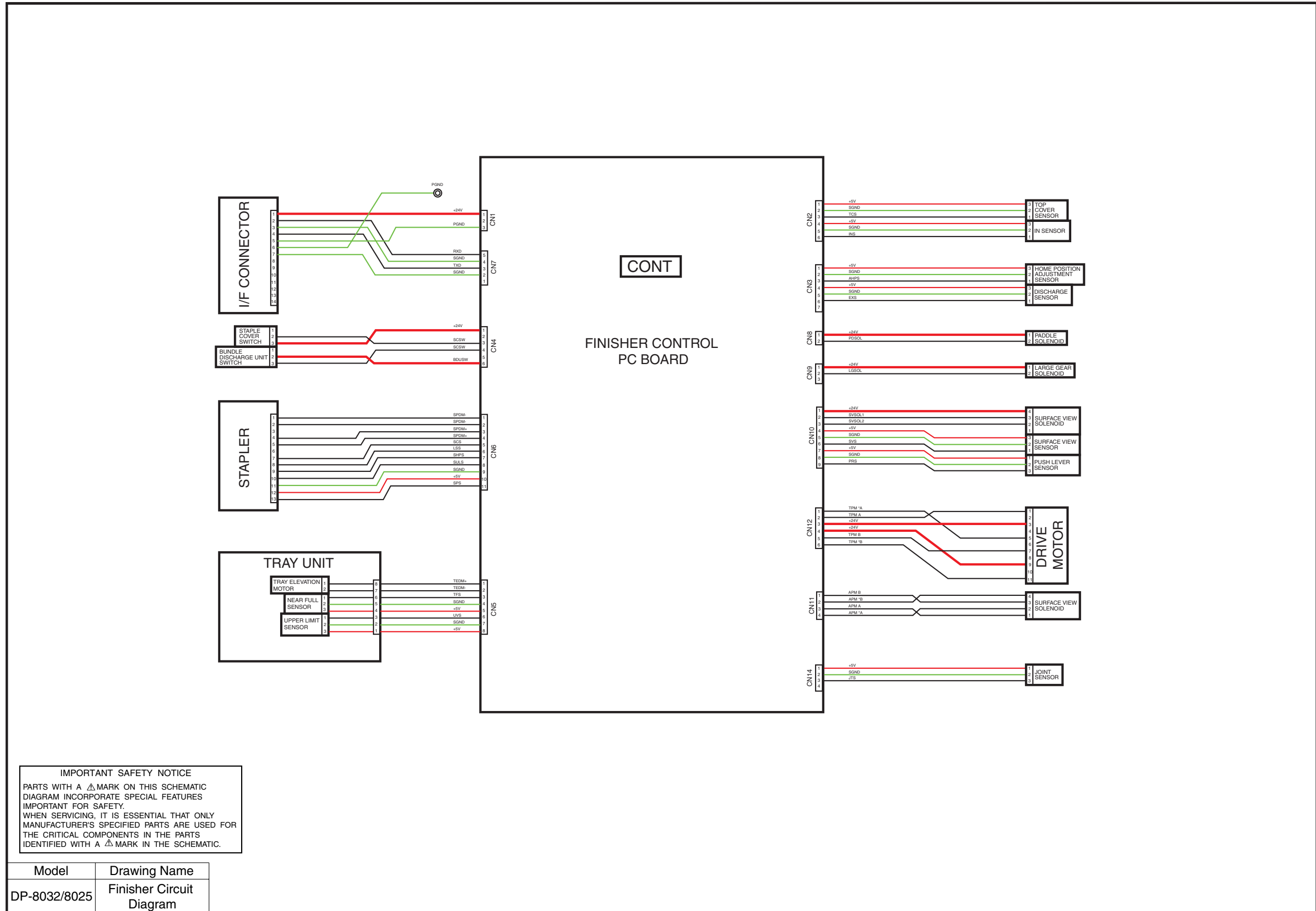

11 Finisher Option (DA-FS300)

11.1. General Description

11.1.1. Features

1. Compact and light weight

2. Sorting and stapling by shift-sort

Sheet Stacking, matching, offset stacking, and stapling are performed on a Halfway-processing Tray.

3. Stack Tray loading

The Stack Tray is capable of holding approximately 500 small-sized sheets, or 250 large-sized sheets.

11.1.2. Specifications

Item	Description	Remarks
Stacking	1 location Delivery Tray (descending type; 1 tray) Face-down	
Feed Reference	Center reference	
Stacking Paper Size	A3, A4, A4-R, A5, B4, B5, B5-R, LDR, LGL, LTR, LTR-R, FLS	
Paper Weight	17 - 24 lb (64 - 90 g/m ²)	
Mode	Non-Sort stack / Sort stack / Staple stack	
Stack Height	Non-Sort Small-size : 500 sheets : A4, A4-R, A5, B5, B5-R, LTR, LTR-R Large-size : 250 sheets : A3, B4, LDR, LGL, FLS Shift-Sort Small-size : 500 sheets : A4, A4-R, B5, B5-R, LTR, LTR-R Large-size : 250 sheets : A3, B4, LDR, LGL, FLS Staple Small-size : 10- 30 sheets; 45-16 sets / 2-9 sheets; 70-50 sets : A4, A4-R, B5, B5-R, LTR, LTR-R Large-size : 10- 20 sheets; 25-12 sets / 2-9 sheets; 70-28 sets : A3, B4, LDR, LGL, FLS	Note 1, 2
Paper Detection	No	
Control Panel	No	
Display	No	
Size (W x D x H)	7.17 x 19.61 x 10.12 in (182 x 498 x 257 mm)	Excluding the installation kit
Weight	Approx. 22 lb (10 kg)	
Power Supply	24 VDC from Host machine	
Maximum Power Consumption	Less than 48 W	
Stapling	Rotary cam type	
Stapling Position	Rear 1-Point stapling Refer to the illustration as follows.	
Stapling Thickness	Small-size : 30 sheets : A4, A4-R, B5, B5-R, LTR, LTR-R Large-size : 20 sheets : A4, A4-R, B5, B5-R, LTR, LTR-R	
Staple Supply	Cartridge of Staples (3,000/Cartridge)	
Replacement Staples	FQ-SS32	
Staple Detection	Yes	
Stapling Size	A3, A4, A4-R, B4, B5, LDR, LGL, LTR, LTR-R, FLS	
Manual Stapling	None	

Note 1 :

The number of sheets is computed based on 80 g/m² paper.

Note 2 :

Alignment is not guaranteed if the stack consists of sheets of different sizes or Staple/Shift-Sort modes.

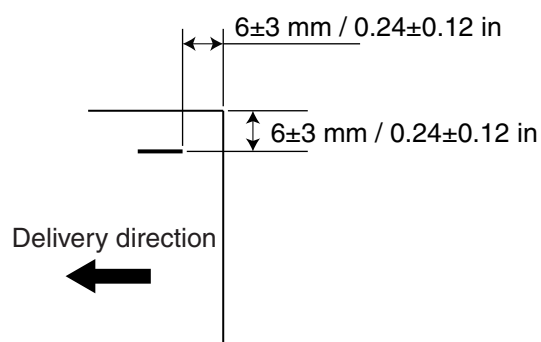
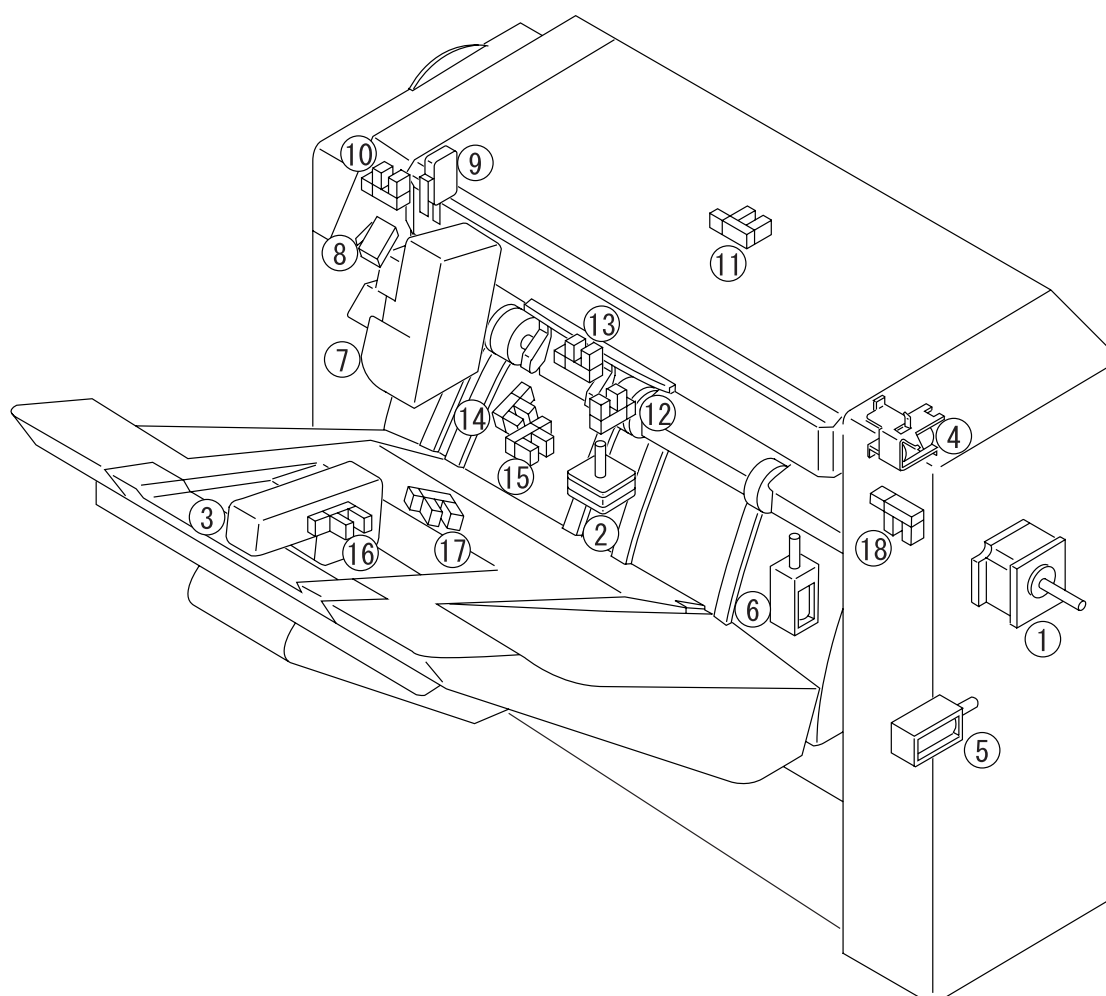
Stapling Position:**11.1.3. Electrical Components**

Name	Notation	Description
Motor	1	Feed Motor
	2	Alignment Motor
	3	Stack Tray Elevation Motor

Name	Notation	Description
Solenoid	4	Paddle Solenoid
	5	Large Gear Solenoid
	6	Paper Detection Solenoid
Stapler Unit	7	Stapler Unit
Micro Switch	8	Staple Safety detection
	9	Stapler Cover detection
Photo-interrupters	10	Upper Cover Open detection
	11	Inlet Paper detection
	12	Aligning Home Position Plate detection
	13	Paper Exit detection
	14	Stack Tray Paper Height detection
	15	Paper Hold Lever detection
	16	Stack Tray Upper Limit detection
	17	Paper Full detection
	18	Finisher Detachment detection

11.1.4. Routine Maintenance by the User

No.	Item	Timing
1	Staple Cartridge (Replacement)	When prompted (indicator on Host machine's Control Panel)

11.2. Maintenance and Inspection

11.2.1. Periodic Part Replacement

The unit does not have components that require periodical replacement.

11.2.2. Consumables and Durables

Some components may require replacement due to wear, deterioration or damage. Replace them as required.

11.2.2.1. Finisher Unit

No.	Part Name	Part No.	Q'ty	Expected Life	Remarks
1	Stapler	GH03-7811	1	200,000 operations	A single cartridge contains 3,000 staples.

11.2.2.2. Scheduled Maintenance

Item	Interval	Description	Remarks
Feeding Assembly Roller	Shortest cleaning interval of the Host machine	Cleaning	Wipe with clean cloth moistened in water.
Feeding Assembly Member			
Paper Path Guide			
Transmission Type Sensor			Wipe with a dry cloth.

11.2.3. Disassembly and Assembly

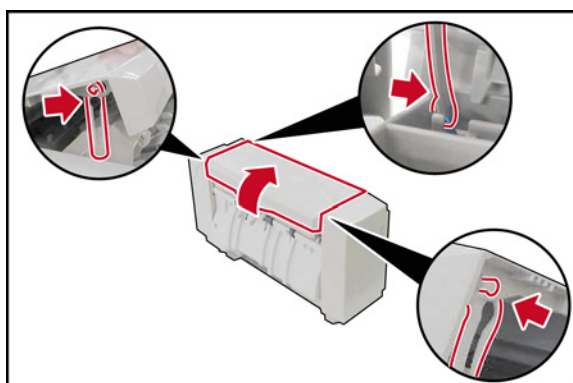

<Removing Finisher Cover Assembly>

- (1) Open and hold the **Finisher Cover** (2608).
- (2) Release the **Front and Rear Arms** (2609 and 2610).
- (3) Release the Rear Latch and remove the **Finisher Cover** (2608).

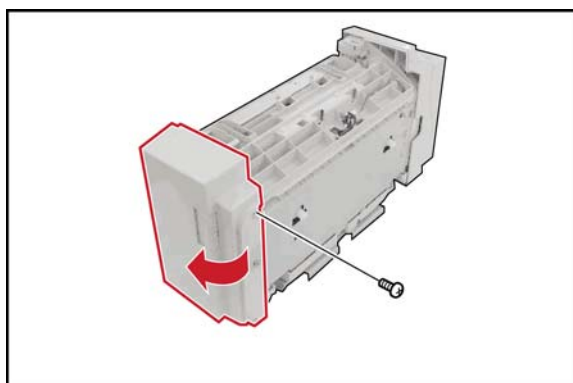

- (4) Remove 1 **Screw** (2633).
- (5) Remove the **Front Cover Assembly** (2601).

Note:

When reinstalling the Cover, make sure 1 Latch Hook is in the hole and the **Release Lever** works correctly.

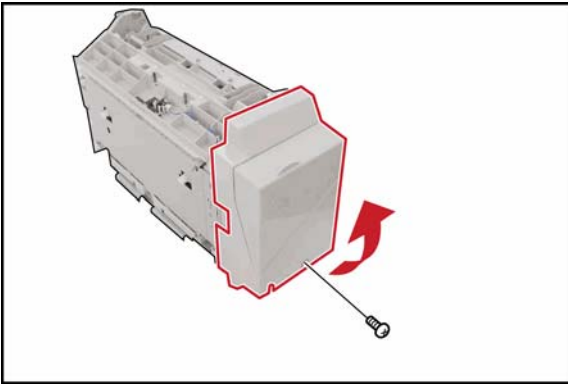

- (6) Remove 1 **Screw** (2521).
 (7) Remove the **Rear Cover Assembly** (2605).

Note:

When reinstalling the Cover, make sure 2 Latch Hooks are in the holes.

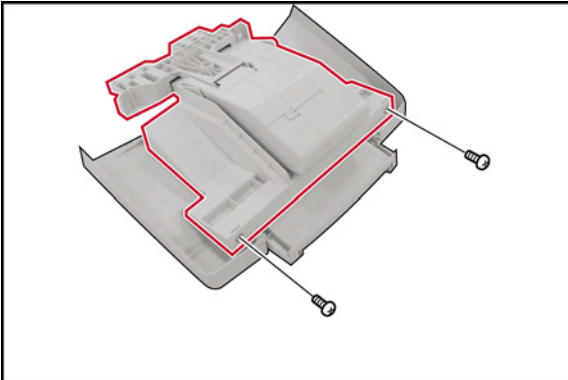

<Removing Finisher Tray Cover Assembly>

- (8) Remove 2 **Screws** (2521).
 (9) Remove the **Tray Assembly** (2515).

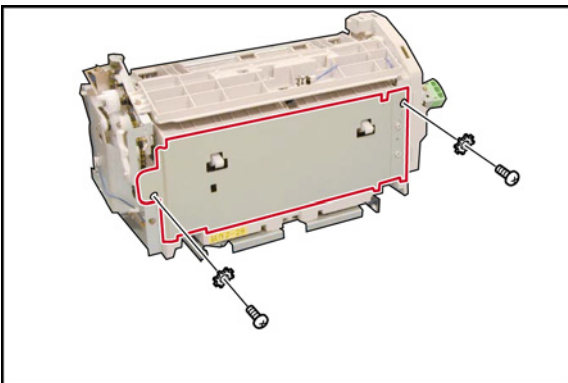

<Removing Finisher Controller PC Board>

- (10) Remove 2 **Screws** (2632) and 2 **Washers** (2634).
 (11) Remove the **Right Cover** (2604).

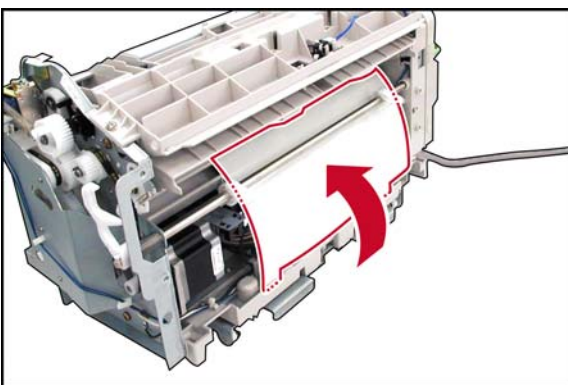

- (12) Lift the **PCB Cover Mylar** (2635) up.

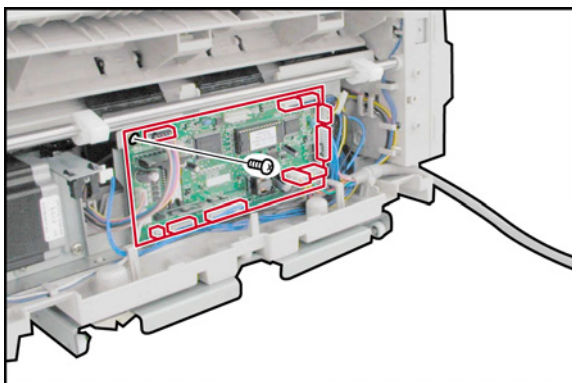

- (13) Disconnect all the **Harnesses** on the CONT PC Board.
- (14) Remove 1 **Screw** (2633).
- (15) Remove the **CONT PC Board** (3028).

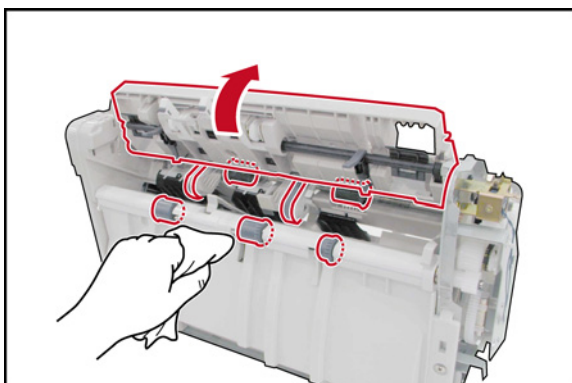

<Removing Rollers>

- (16) Lift up the **Guide Base** (2801) Assembly.
- (17) Clean the **Exit Roller** (2937).

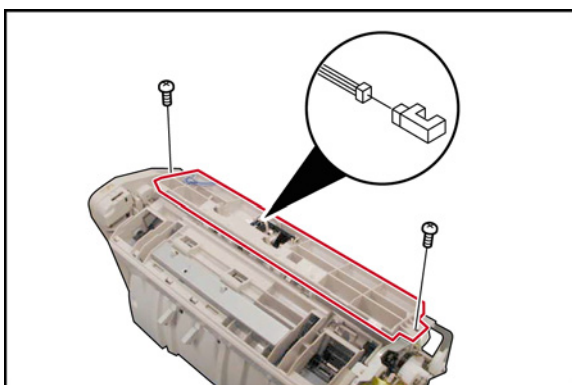

- (18) Disconnect the **Harness**.
- (19) Remove 1 **Screw** (2521) and 1 **Screw** (2631).
- (20) Remove the **Guide Base** (2832) Assembly.

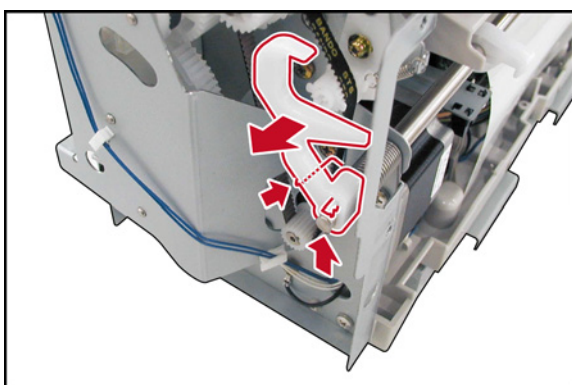

- (21) Release the **Tension Spring** (3024) and Latch, and then remove the **Lock Arm** (3025).

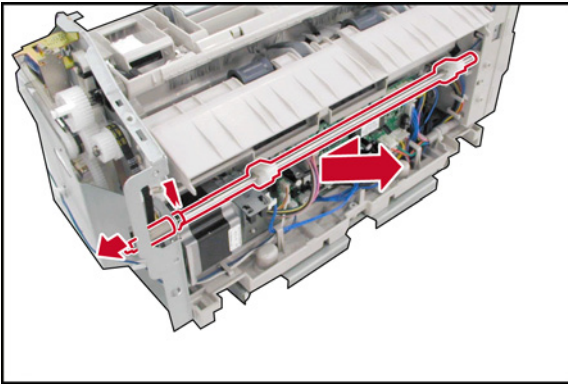

- (22) Remove the **Tension Spring** (3024).
- (23) Remove 1 **Snap Ring** (3023).
- (24) Remove the **Lock Lever Shaft** (3020) Assembly as illustrated.

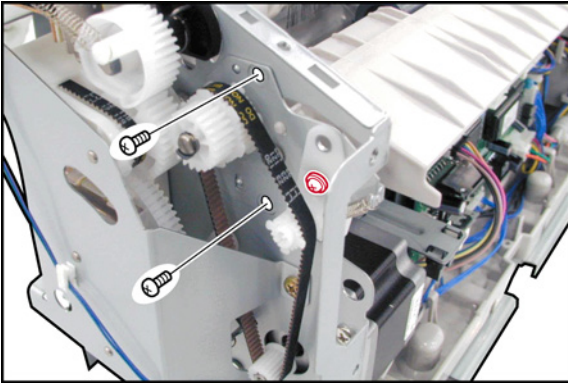

- (25) Loosen 1 **Screw** (2706).
- (26) Remove 2 **Screws** (2632).

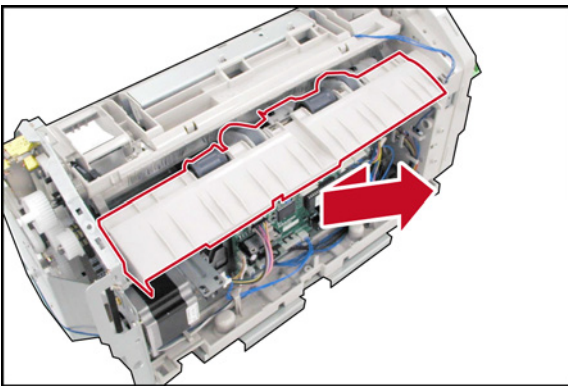

- (27) Remove the **Upper Guide Assembly** as illustrated.

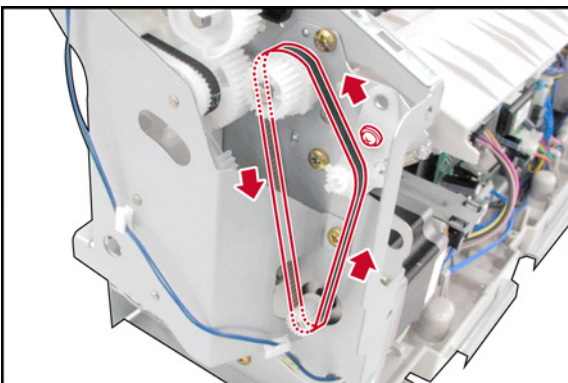

Note:

When reinstalling, rotate the Timing Belt counter-clockwise and then fasten 1 Screw.

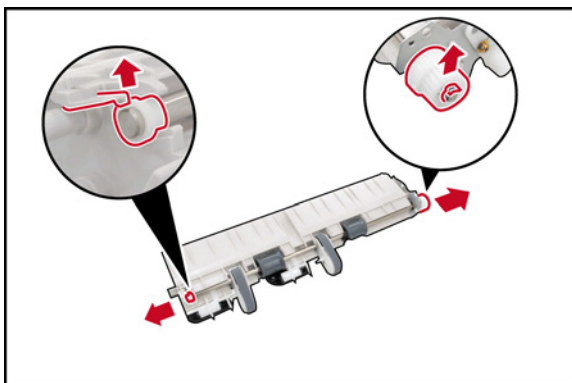

- (28) Remove 1 **Snap Ring** (2734).
 (29) Remove the **Feed Roller Gear** (2702).
 (30) Remove the **Bushing** (2919).

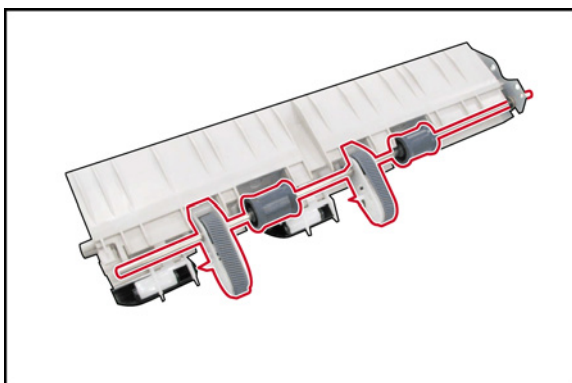

- (31) Remove the **Feed Roller Assembly** (2911).

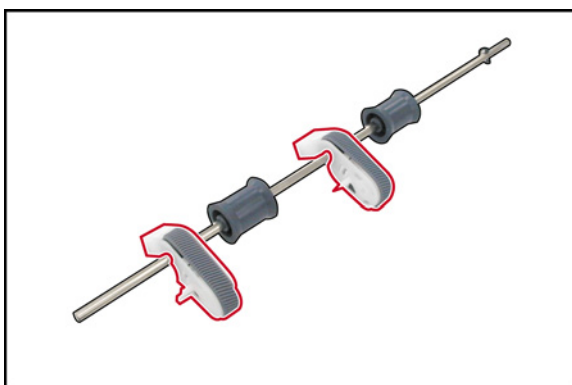

- (32) Remove the **Feed Arm Assembly** (2913).

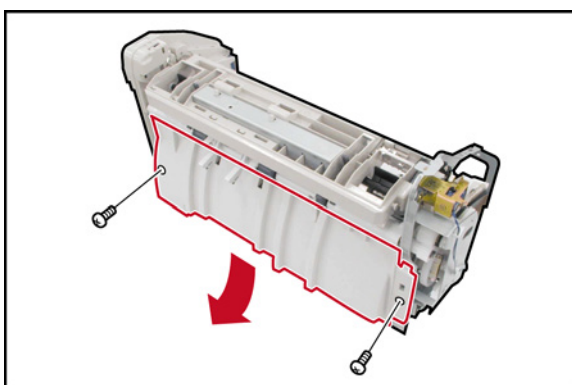

- (33) Remove 1 **Screw** (2521) and 1 **Screw** (2633).
 (34) Remove the **Tray Guide Assembly** (2611).

(35) Disconnect 3 **Harnesses** (2629).

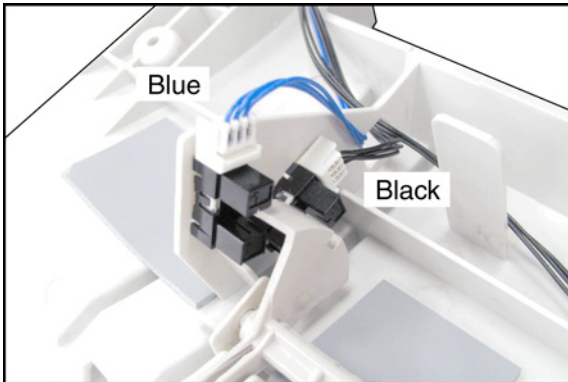
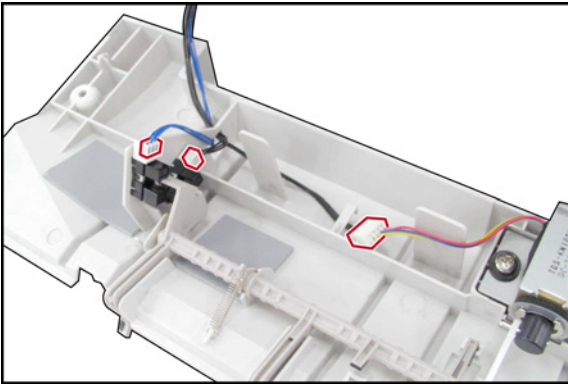

Note:

When reinstalling, ensure that the Harnesses are connected correctly as illustrated.

(36) Remove 1 **Snap Ring** (2734).

(37) Remove the **Exit Roller Gear** (2701).

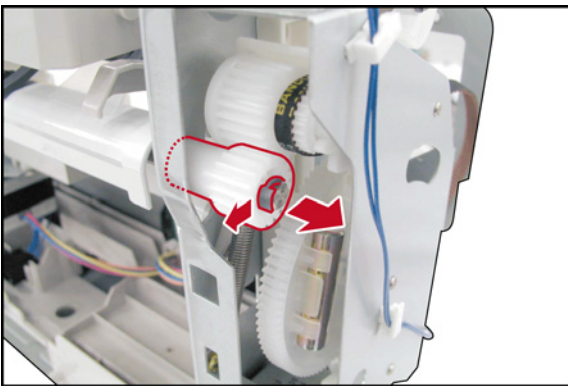

(38) Remove the **Bushing** (2919).

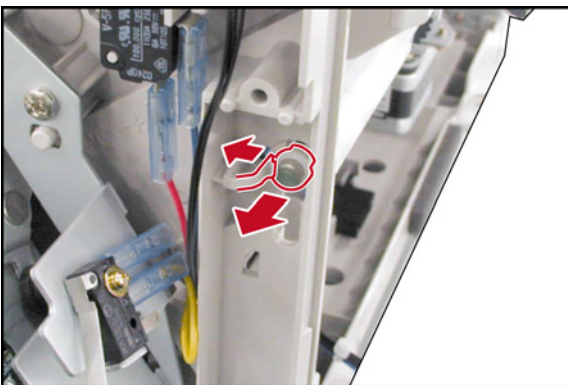

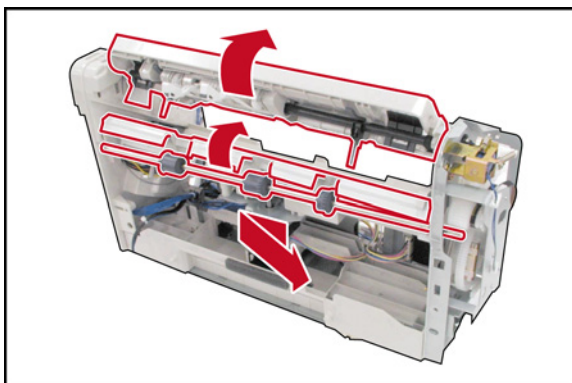

- (39) Lift up the **Guide Base (2801) Assembly**.
- (40) Lift up the **Paper Guide (2921)**.
- (41) Remove the **Exit Roller Assembly (2936)** as illustrated.

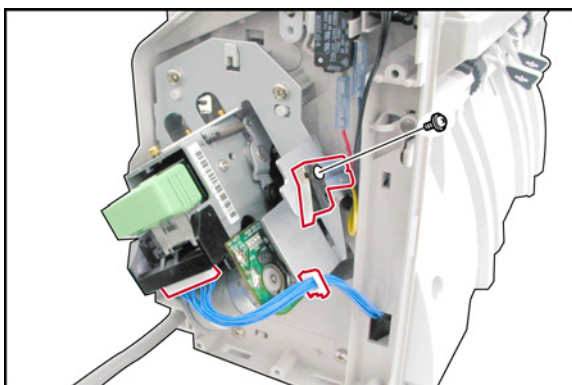

<Removing the Staple Unit>

- (42) Remove 1 **Screw (2943)**.
- (43) Remove the **Staple Safety Switch (2941)**.
- (44) Release the **Harness (2629)** from the Harness Clamp.
- (45) Disconnect the **Harness (2629)**.

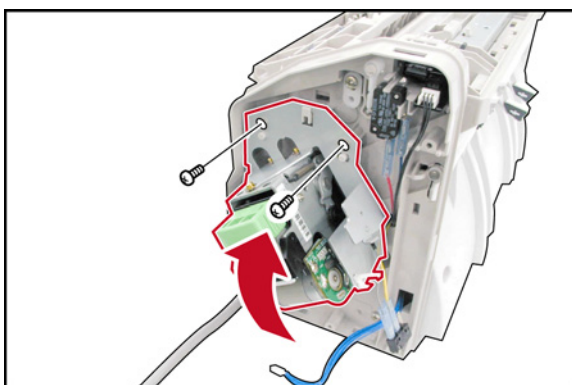

- (46) Remove 2 **Screws (2521)**.
- (47) Remove the **Staple Unit (2938) Assembly**.

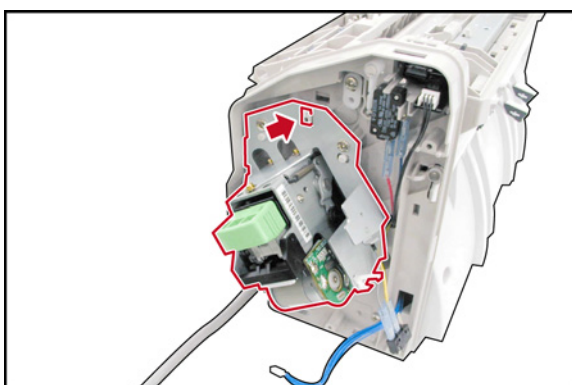

Note:

When reinstalling, ensure that Staple Unit Assembly is installed (hooked) correctly as illustrated.

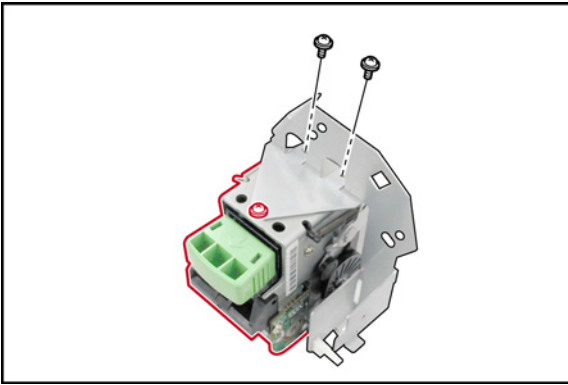

- (48) Remove 2 **Screws** (2736).
- (49) Loosen 1 **Screw**.
- (50) Remove the **Staple Unit** (2938).

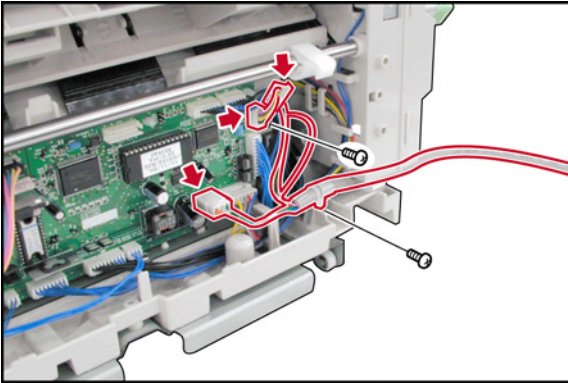

<Removing the Finisher Interface Cable>

- (51) Remove 2 **Screws** (2633).
- (52) Release the **Harness** from the Harness Clamps.
- (53) Disconnect 2 **Harnesses** and remove the Finisher Interface Cable.

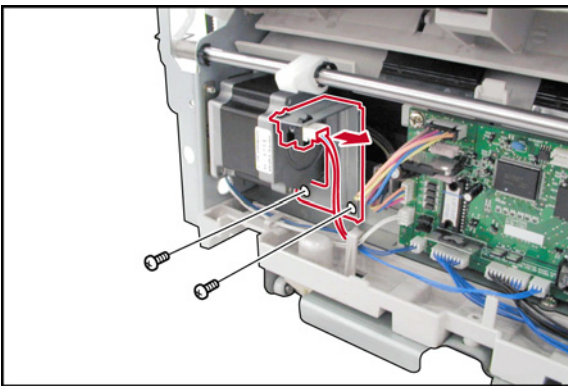

<Removing the Motors>

- (54) Disconnect the **Harness**.
- (55) Remove 2 **Screws** (3030).
- (56) Remove the **Sensor Hold Bracket** (3008).

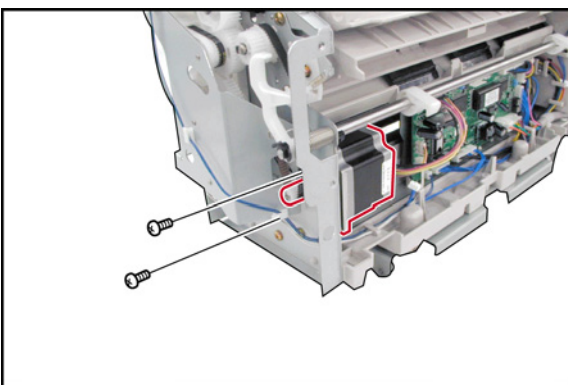

- (57) Remove 2 **Screws** (2633).
- (58) Remove the **Drive Motor** (3014).

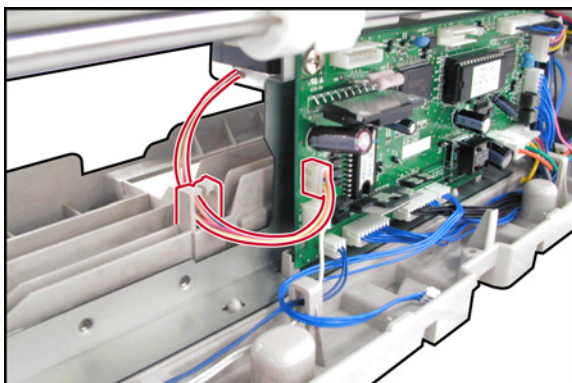

- (59) Disconnect the **Harness**.
 (60) Release the **Harness** from the Clamp.

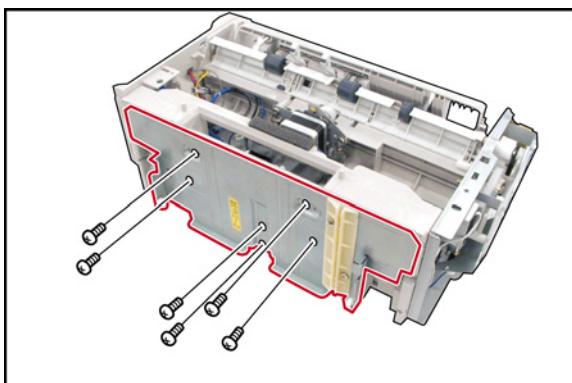

- (61) Remove 4 **Screws** (2632).
 (62) Remove 2 **Screws** (2521).
 (63) Remove the **Slide Base Bracket** (3003).

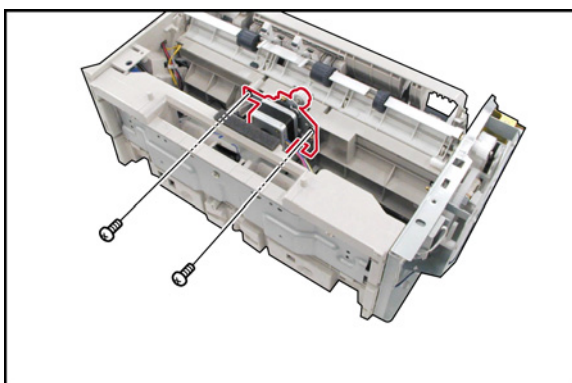

- (64) Remove 2 **Screws** (2521).
 (65) Remove the **Set Motor** (2931) Assembly.

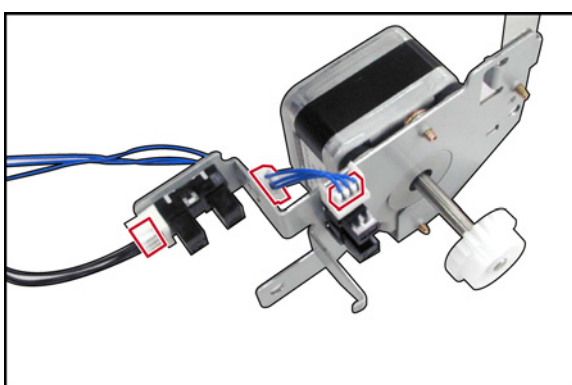

- (66) Disconnect 2 **Harnesses**.
 (67) Release the **Harness** from the Clamp.

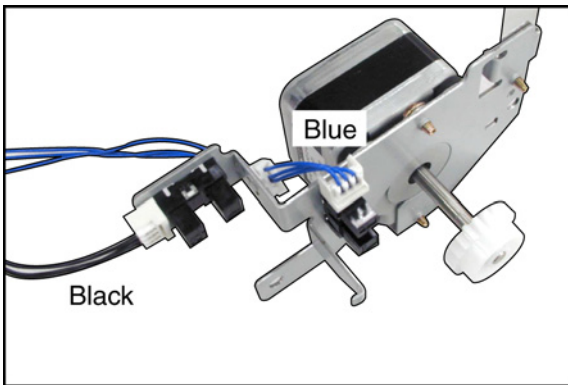
**Note:**

When reinstalling, ensure that the Harnesses are connected correctly as illustrated.

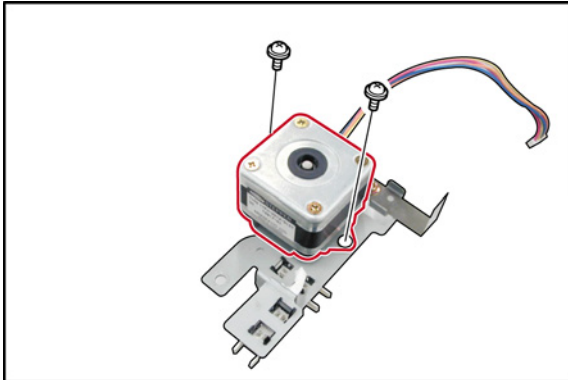

(68) Remove 2 **Screws** (2942).

(69) Remove the **Set Motor** (2931).

11.3. Operation and System Description

11.3.1. Outline of Operation

DA-DS330 and Host Machine exchange signals through serial communication and carry out the following 3 operation modes.

- **Normal Exit**

Discharge the paper into the Stack Tray.

- **Staple Exit**

Jog sheets of paper one at a time at the interstage stack, then staple when they reach the specified number, and discharge into the Stack Tray.

- **Shift Exit**

Jog sheets of paper one at a time at the interstage stack, carry out shift operation, and discharge into the Stack Tray.

11.3.2. Stapling Mechanism

Stapling Mechanism 1.

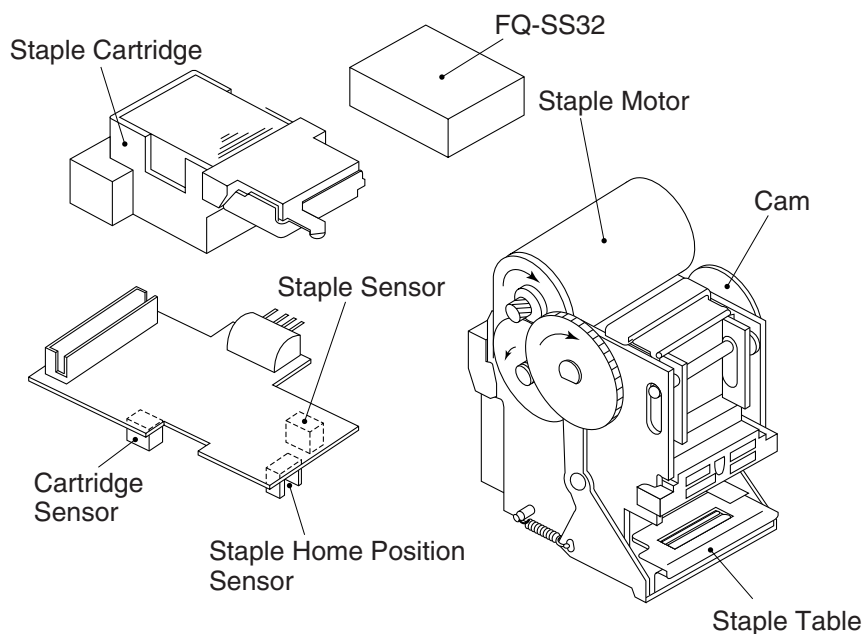

- The stapler's motor rotation drives the stapler by the rotating cam via gear.
- The link is in contact with the cam. When the cam revolves, the link moves around its supporting point.

Stapling Mechanism 2.

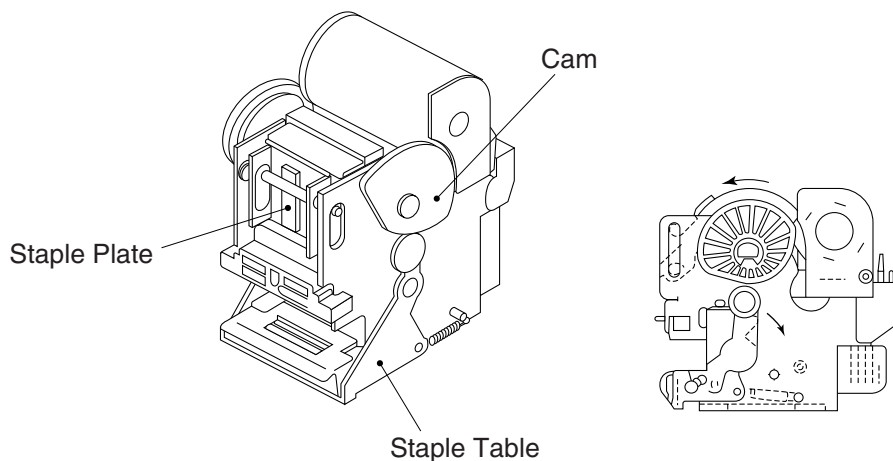

11.3.3. Electrical Parts (Motor and Solenoid Functions)

11.3.3.1. Feed Motor Control

1. Feed Motor, which moves Paper Feed, Paddle Drive, Stack Delivery Unit Elevation, is 1-2 phase exciting type, 2 phase stepping motor. Its control circuit is shown below.
2. Each signal pulse output from P20, P21, P22, P23 of IC2 in Control PCB (PBA-CONT) excites and rotates the coil in each phase. The Motor drive current is controlled by the duty cycle from P24 of IC2.
3. Motor stops when the output signals from P20, P21, P22, P23 of IC2 are changed to H and the power supply to the motor coils are cut off.

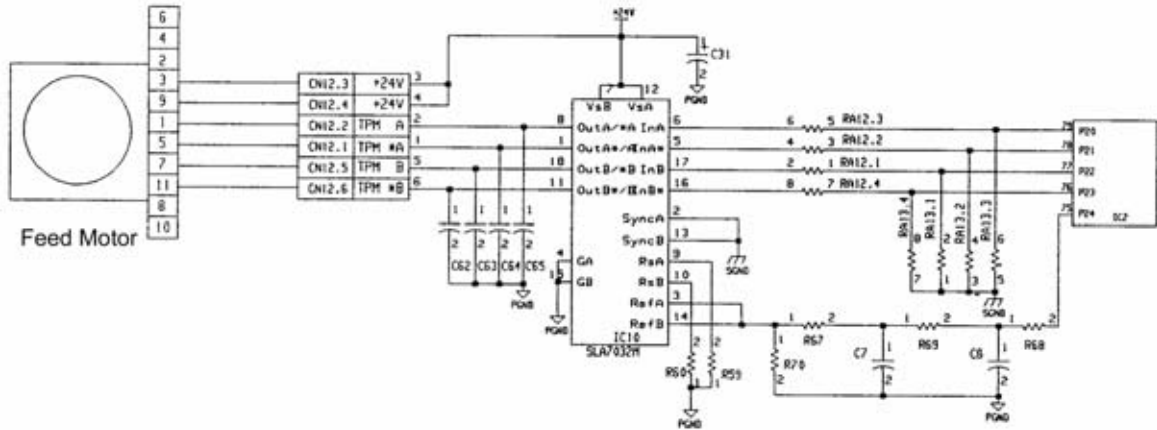

11.3.3.2. Alignment Motor Control

1. The Alignment Motor, which jogs papers in the stack and carries out offset operation in Paper Exit Unit, is a W1-2 phase exciting type, 2-phase stepping pulse motor. Its control is shown below.
2. Each signal pulse output from P10, P11, P12, P13 of IC2 in Control PCB (PBA-CONT) excites and rotates the coil in each phase. And it combines with this output and is IC2. The electromagnetic excitation is changed by the output of P14 and P15, and it controls the W1-2 phase exciting drive.
3. Motor stops when the output signals from P10, P11, P12, P13 of IC2 are changed to H and the power supply to the motor coils are cut off.

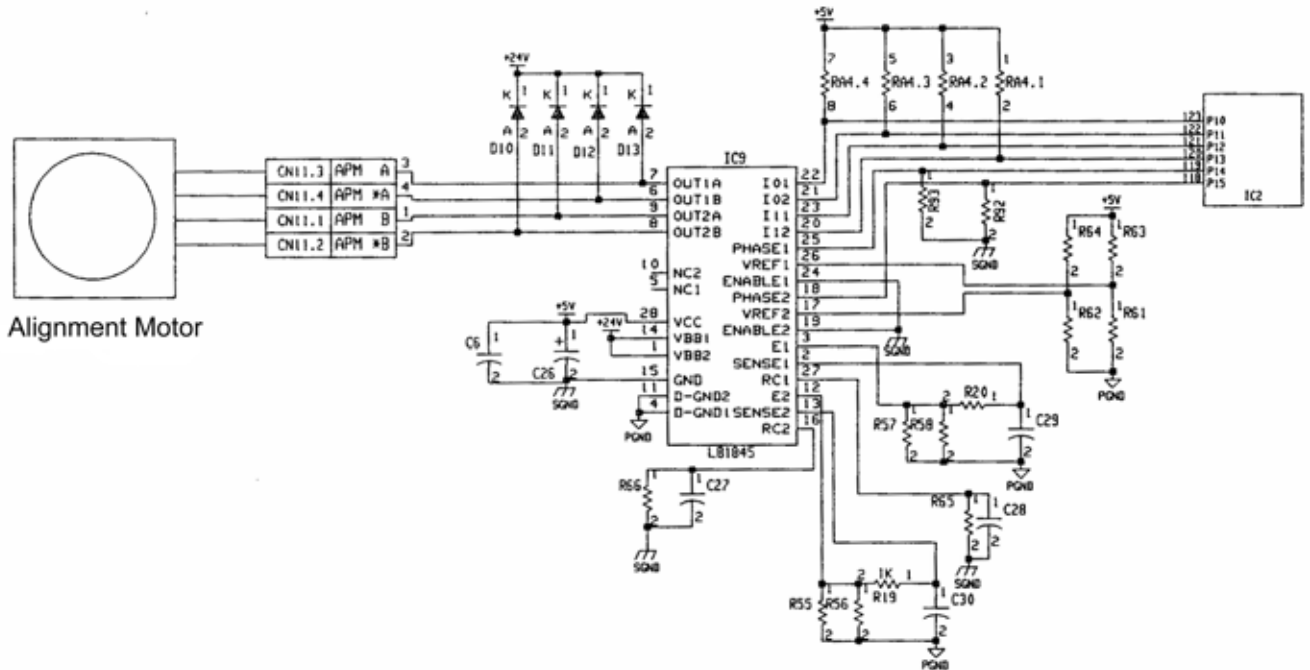

11.3.3.3. Elevation Motor Control

1. Elevation Motor, which moves Stack Tray up and down, is a +24V DC brush motor. The control circuit is shown below.
2. It is controlled by the combination of signals from P52 and P53 of IC2 in P.C.B. (PBA-CONT). Stack Tray is elevated when H is output from P52 and P53 respectively, and Stack Tray is descended when H and L are output from P52 and P53 respectively.
3. Motor stops and brakes when L and H are output from P52 and P53.

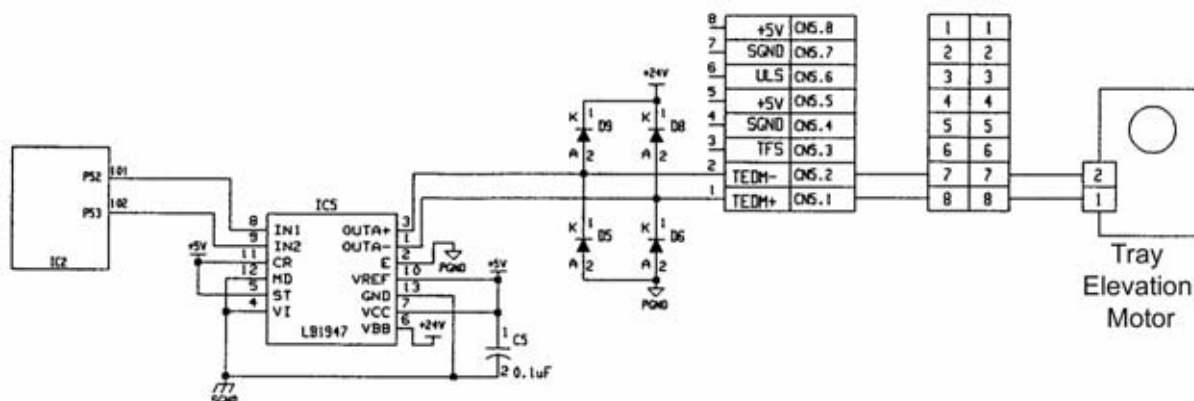

11.3.3.4. Staple Motor Control

1. Staple Motor, which carries out stapling, is a +24V DC brush motor. Its control circuit is shown below.
2. It is controlled by the combination of signals from PF1, PF0 and P50 of IC2 in P.C.B. (PBA-CONT). Stapling is done when L, L and H are output from PF1, PF0 and P50 respectively. Staple is at home position when H, L and L are output from PF1, PF0 and P50 respectively.
3. Staple Motor stops and brakes when L, H and L are output from PF1, PF0 and P50 for forward and reverse rotations.

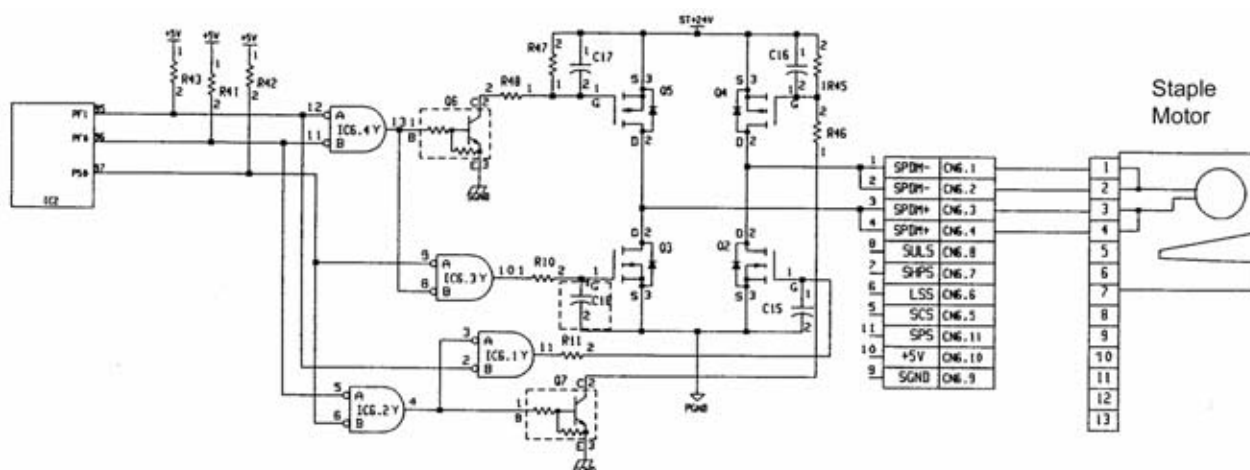

11.3.3.5. Large Gear Solenoid Control

1. An up-and-down motion of the Delivery Unit is performed by changing the drive of feed motor, which is controlled by the Large Gear Solenoid. If the Large Gear Solenoid is turned on during rotation of the feed motor, the Delivery Unit will move up and will be opened widely. When the Large Gear Solenoid is turned off, the Delivery Unit will move down and will be closed. The Solenoid is driven by +24V DC. Its control circuit is shown below.
2. It is controlled by the signal from P27 of IC2 in P.C.B. (PBA-CONT). When the P27 is H, the Large Gear Solenoid is turned on.

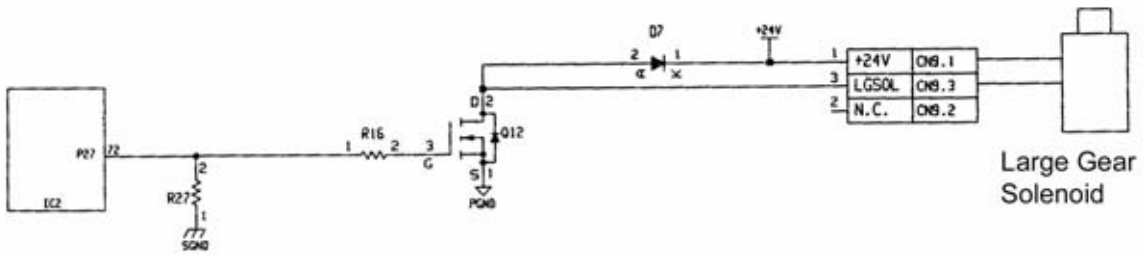

11.3.3.6. Paddle Solenoid Control

1. Paddle Solenoid switches the drive of the feed motor to the Paddle, which is a Flapper typed Solenoid and is operated by +24V DC. The control circuit is shown below.
2. Solenoid is turned ON and drives the Paddle when the signal H is transmitted from PG0 of IC2 in P.C.B. (PBA-CONT).

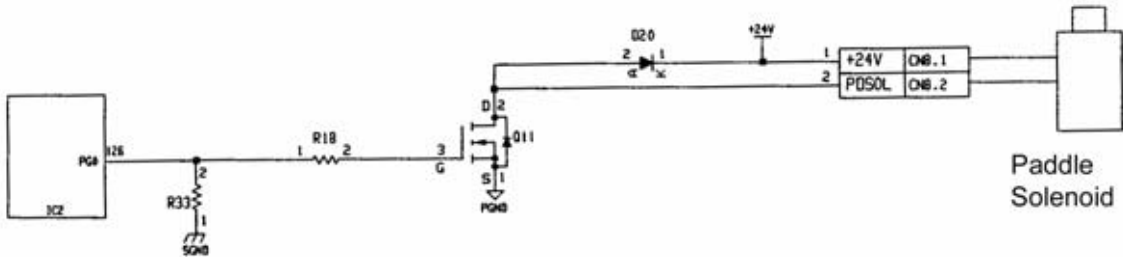

11.3.3.7. Paper Detection Solenoid Control

1. A +24V DC plunger solenoid along with a paper detection lever is used for detecting the height of the paper delivered to the Stack Tray. Its control circuit is shown below.
2. It is controlled by the signal from P26 of IC2 in P.C.B. (PBA-CONT). When the P26 is H, the Solenoid is turned on to pull the paper detection lever inside. When the P25 is H, the Solenoid is turned off to push the paper detection lever outside.

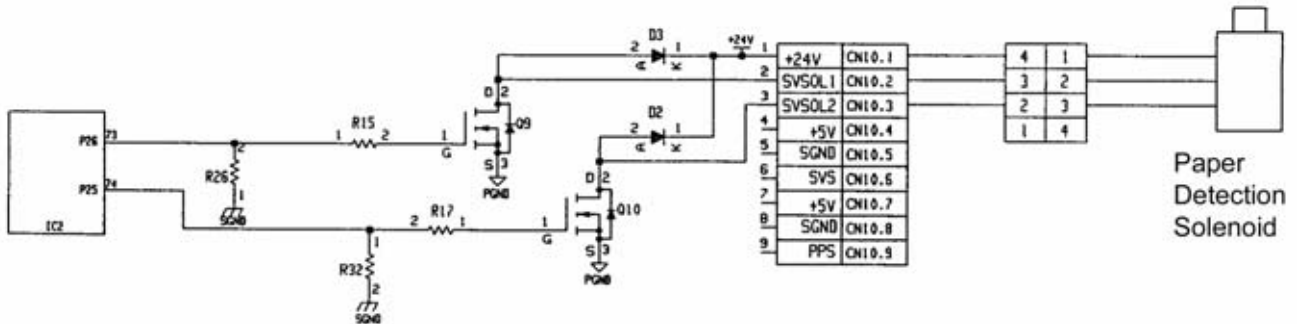

Software

Operating Instructions

Network Firmware Update Tool
for Service Technicians

Version 3

Table of Contents

1. General	3
1.1 Supported Operating Systems	3
1.2 Supported Panasonic Fax/MFP Models.....	3
2. Installation	4
2.1 Installing the Network Firmware Update Tool	4
2.2 Setting up the Network Firmware Update Tool	4
2.3 Uninstalling the Network Firmware Update Tool.....	5
3. Preparing the Firmware Update	6
3.1 Preparing the Unit to Accept the Firmware Code.....	6
3.1.1 For DX-600 / DX-800 (v1.31 or higher) only	6
3.1.2 For other models	6
3.2 Preparing the Firmware Code	6
4. Using the Network Firmware Update Tool	7

1st Edition : 2002 March 20
2nd Edition : 2002 August 1
3rd Edition : 2002 December 5
4th Edition : 2003 April 10
5th Edition : 2003 April 22
6th Edition : 2003 December 18
7th Edition : 2004 April 7
8th Edition : 2004 August 3
9th Edition : 2004 August 20
10th Edition : 2004 October 22
11th Edition : 2005 March 18
12th Edition : 2006 March 27
13th Edition : 2006 May 8
14th Edition : 2006 June 26
15th Edition : 2007 September 17

Microsoft and Windows are registered trademarks of Microsoft Corporation in the United States and/or other countries.

Windows 2000, Windows XP, Windows Server 2003, Windows Vista are trademarks and trade names of Microsoft Corporation in the United States and/or other countries.

Copyright © 1999 - 2007 Panasonic Communications Co., Ltd.

All rights reserved. Unauthorized copying and distribution is a violation of law.

The contents of these Operating Instructions are subject to change without notice.

1. General

The Network Firmware Update Tool allows a PC or laptop connected via LAN (TCP/IP) to a Panasonic Fax/MFP to quickly program the Firmware Code directly to the memory of the device.

1.1 Supported Operating Systems

This application software operation has been confirmed under the following Operating Systems

- Windows® 2000
- Windows® XP
- Windows Server® 2003
- Windows Vista®

1.2 Supported Panasonic Fax/MFP Models

- Please refer to the service manual of each model

2. Installation

2.1 Installing the Network Firmware Update Tool

1. Start Microsoft Windows.
Log on to the computer/network from an account with Administrator privileges.
2. Locate and Run the **Setup (.exe)** program for **Network Firmware Update Utility** in the software setup disk or folder.
3. Follow the instructions on your screen to install the program.
4. A confirmation message is displayed when the installation is completed. When prompted to do so, allow the program to restart your PC.

2.2 Setting up the Network Firmware Update Tool

1. Click the **Start** button on the Taskbar, point to **(All) Programs ▶ Panasonic ▶ Panasonic (Network) Firmware Update**, then select **Network Firmware Update Configuration**.

2. The **Configuration** dialog box appears.

General Tab

Note: Please only change the settings if necessary.

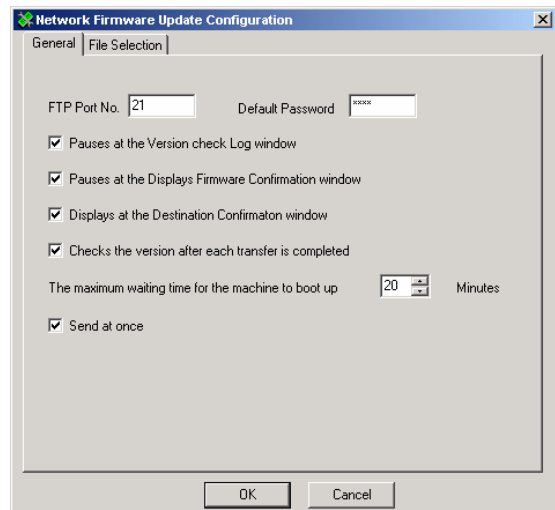

File Selection Tab

Auto-Select Update Mode

When you select this mode, the tool acquires the type of firmware and version from the device(s) of the specified address, and updates the device to the latest version from the "Local Firmware Folder".

However, this mode cannot change the type of firmware, so you must use the manual mode when changing from the standard firmware to the option firmware.

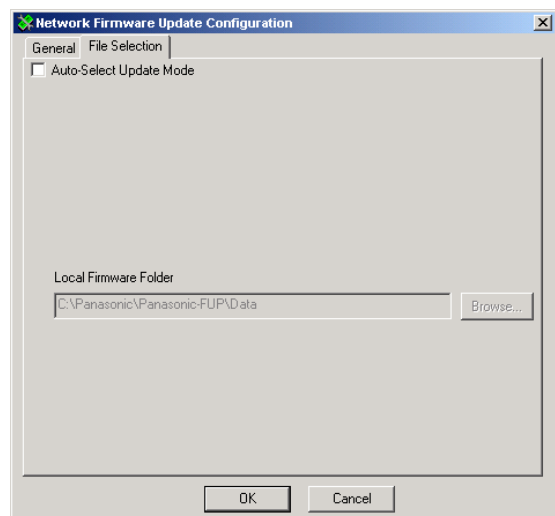

3. Click [OK] to finish the setup.

2.3 Uninstalling the Network Firmware Update Tool

The **Network Firmware Update Tool** can be uninstalled by using the included uninstall program.

Note: Do not delete the installed program folder from Windows Explorer directly as it may cause registry setting problems.

- 1.** Start Microsoft Windows.
Log on to the computer/network from an account with Administrator privileges.
- 2.** Click the **Start** button on the Taskbar, point to **(All) Programs ▶ Panasonic ▶ Panasonic Firmware Update**, then select **Uninstall Network Firmware Update Tool**.
- 3.** Follow the instructions on your screen to uninstall (Remove) the program.
- 4.** A confirmation message is displayed when the uninstall is completed.

3. Preparing the Firmware Update

3.1 Preparing the Unit to Accept the Firmware Code

3.1.1 For DX-600 / DX-800 (v1.31 or higher) only

1. If the device password was changed (Remote Password) from the default value (blank = 0000), it is not possible to program the firmware code. In this case, enter the password in advance to the Default Password in the Configuration dialog box, or enter the password at each communication.
2. Make sure the device is not in use (i.e. copying or printing) when performing a firmware update.
Note: It is recommended to update the firmware at night due to lower activity of the device.
3. Ensure the device is not in Service Mode and that the PC can ping it successfully before proceeding.

3.1.2 For other models

1. If the device password (**Service Mode F7-01** = Key Operator ID Code, or Operation Password) was changed from the default value (0000 or 000), it is not possible to program the firmware code. In this case, enter the password in advance to the Default Password in the Configuration dialog box, or enter the password at each communication.

For the 3-digit Key Operator Password devices, only the first three digits "000" of the default value are singled out of the 4-digit "0000" value.

2. Make sure the device is not in use (i.e. copying or printing) when performing a firmware update.
Note: It is recommended to update the firmware at night due to lower activity of the device.
3. Ensure the device is not in Service Mode and that the PC can ping it successfully before proceeding.

3.2 Preparing the Firmware Code

Copy the firmware Code file(s) to the following folder.

C:\Panasonic\Panasonic-FUP\Data

Note: An Archive File (i.e. DP-2310_PU_030327.exe) extracts the Firmware Code Files automatically into the designated folder without needing to paste the file into the folder manually. In this case the file may be downloaded to the desktop or to any other easily accessible location on the hard disk drive.

4. Using the Network Firmware Update Tool

1. Please close all applications that are currently running.

Note: When using the Network Firmware Update Tool you must be logged on with Administrator privileges.

2. From the Windows Desktop, double-click on the **Network Firmware Update** shortcut icon to start the Network Firmware Update Tool.

Note: If a shortcut was not created to the Windows Desktop, click the **Start** button on the Taskbar, point to **(All) Programs ▶ Panasonic ▶ Panasonic Firmware Update**, then select **Network Firmware Update Tool**.

Click [**Next>**].

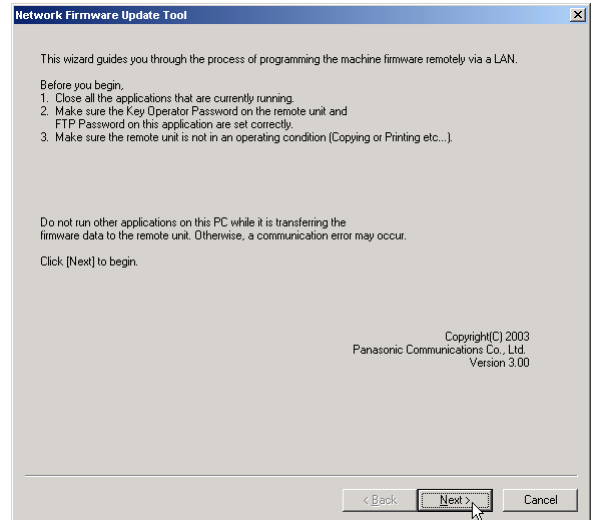

Note:

- 1) Make sure the device password (**Service Mode F7-01 = Key Operator ID Code or Operation Password**) on the device and the password on this application are set correctly.

Caution:

- 1) Make sure the device is not in use (i.e. Copying or Printing).
- 2) Do not run other applications on this PC while it is transferring the firmware data to the device, otherwise a communication error may occur.
- 3) If using a laptop for the update it is recommended the laptop be connected to a power outlet to prevent battery drain and/or automatic standby mode, which may cause the update to fail.
- 4) Do not operate nor reset the power of the device while it is updating the firmware code, otherwise the firmware update will fail and the device may not boot up again.
- 5) If the Network Firmware Update fails and the unit does not reboot automatically for more than 20 minutes, you may need to recover the firmware update again via a Parallel/USB port using the Local Firmware Update Tool, or with the FROM card.

3. Click [**Device Address List**] button.

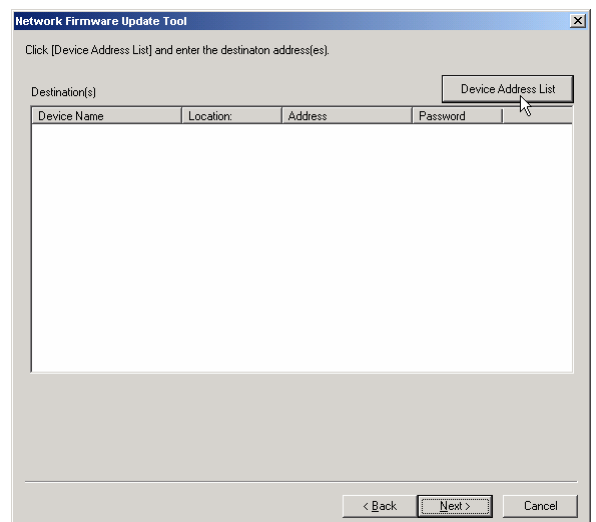

Network Firmware Update Tool (LAN)

4. Enter the device location on the network by using either **Manual Input** or **Device Address List** methods.

Manual Input Tab

Device Name: Type the name of the device you are updating (i.e. DP-3010)

IP Address: Type the IP Address of the device you are updating (this information can generally be located through the Key Operator or Service Modes)

Password: Enter the device password

Note: If the default password is used on the device there is no need to enter it in this box

When complete select the [>>] button to add the destination to the list.

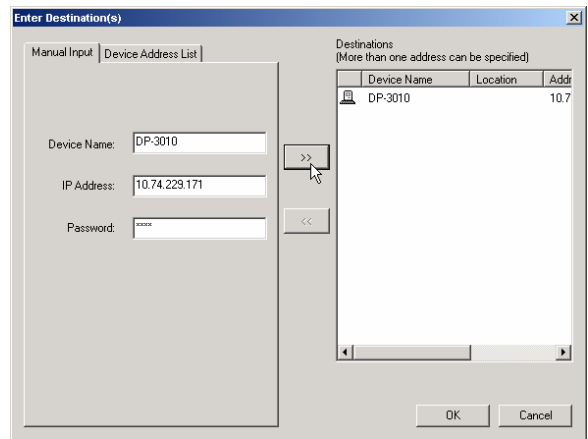

Device Address List Tab

Locate and select the device you would like to update on the Device Address List.

Select the [>>] button to add the destination to the list.

Note: Multiple destinations can be added to update more than one device.

Click [OK].

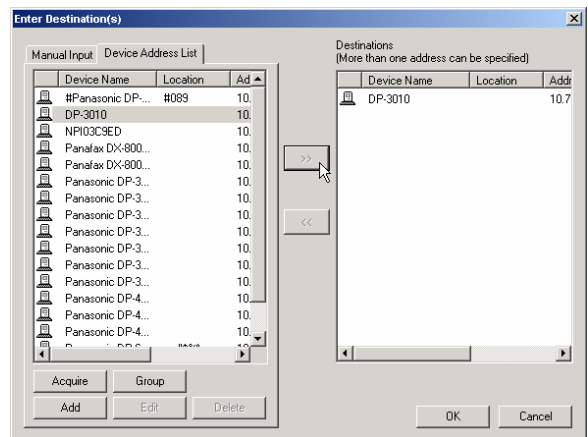

5. Confirm the device information and destination(s).

Click [Next>].

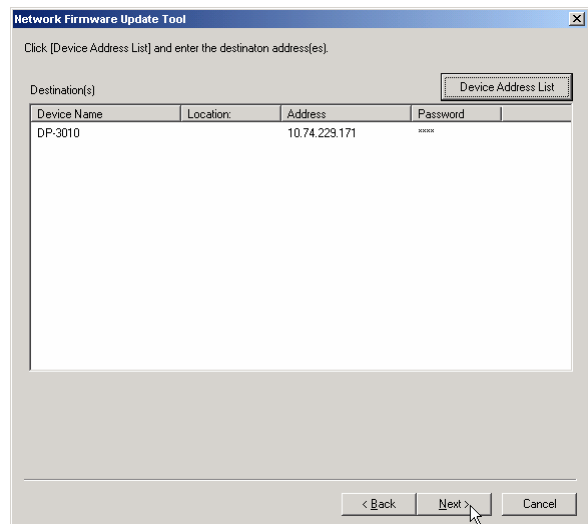

6. Specify the Firmware Code File using one of the following methods:

6.1 Select a Parent File Folder (Complete Set)

If the archive file is already extracted into the local **Panasonic-FUP\Data** folder, you can select the Parent File Folder directly from here. It is packaged as a set when the update of multiple firmware code files is necessary.

or

6.2 Select Independent File Folders

If the archive file is already extracted into the local **Panasonic-FUP\Data** folder, you can select independent file folders from here to upload firmware for separate modules in the device.

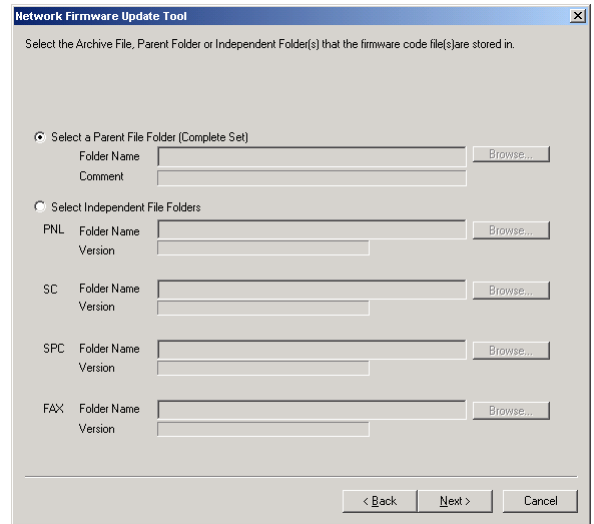

Note: Files are chosen automatically in the automatic mode, so the screen of step 6 is not shown.

6.1a Select a Parent File Folder (Complete Set)

Select **"Select a Parent File Folder (Complete Set)"**, and click **[Browse...]**.

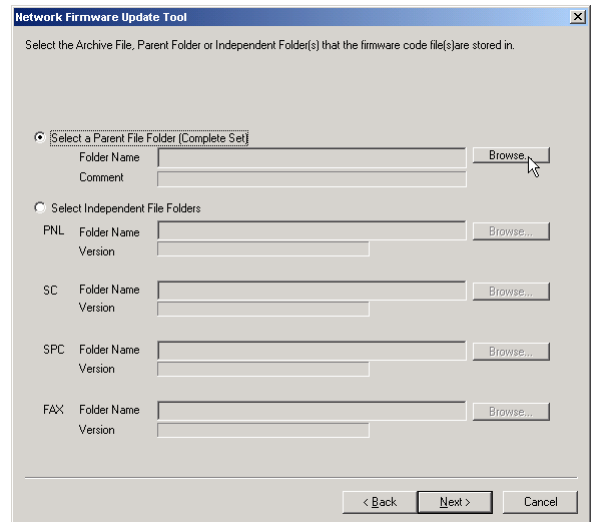

6.1b Select the name of Parent File Folder (For Example: DP-2310_3010_PU_030228), and Click **[OK]**.

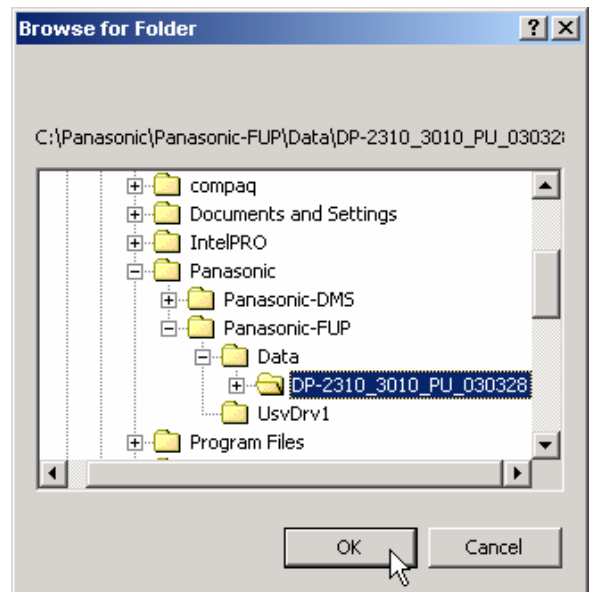

Network Firmware Update Tool (LAN)

- 6.1c Select the Firmware Type based on the options installed in the machine, and click [OK].

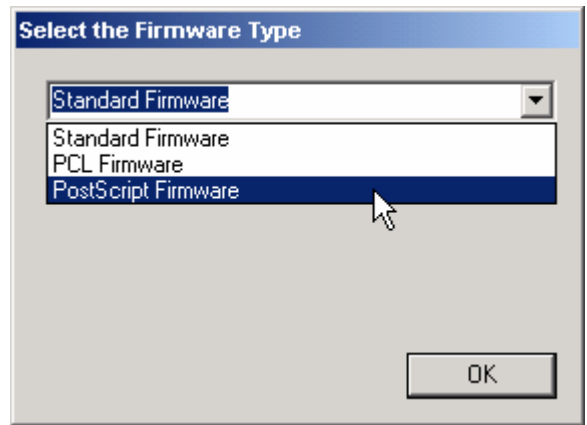

- 6.1d Firmware Code File selection is completed. Click [Next>].

Continue to Section 7.

6.2a Select Independent File Folders

Select "Select Independent File Folders" and click [Browse...].

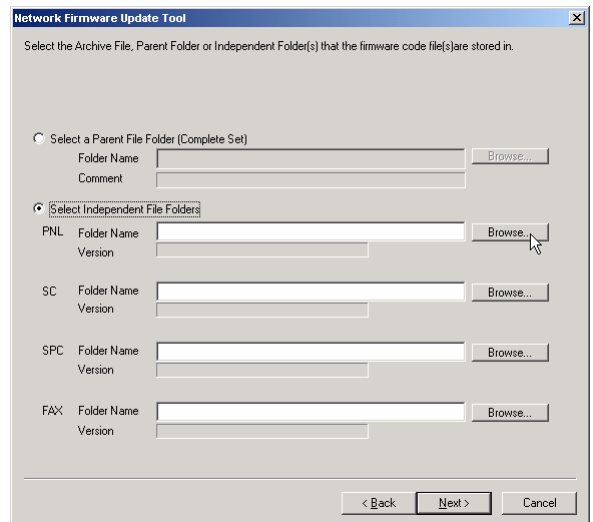
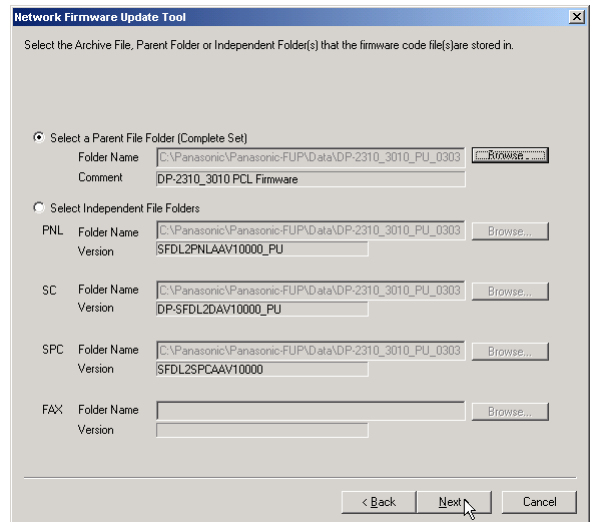

- 6.2b** Select the Firmware Code File Folder for PNL (For Example: SFDL2PNLAAV10000_PU.BIN) and click [OK].

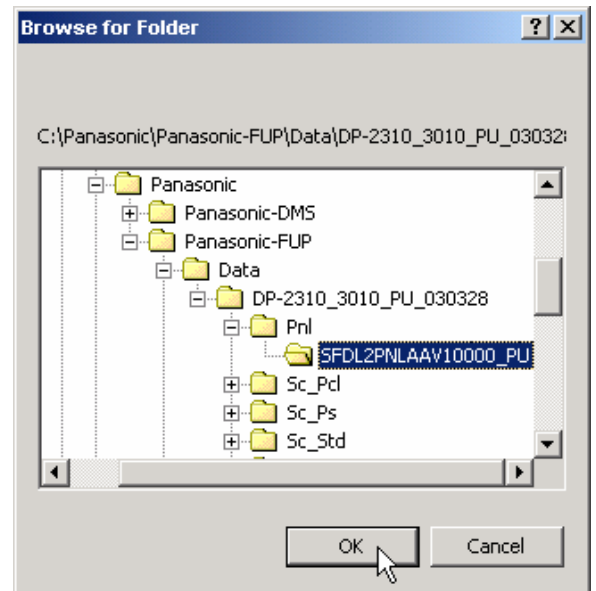

- 6.2c** Repeat steps for other Firmware Code File Folders if applicable, and click [OK].

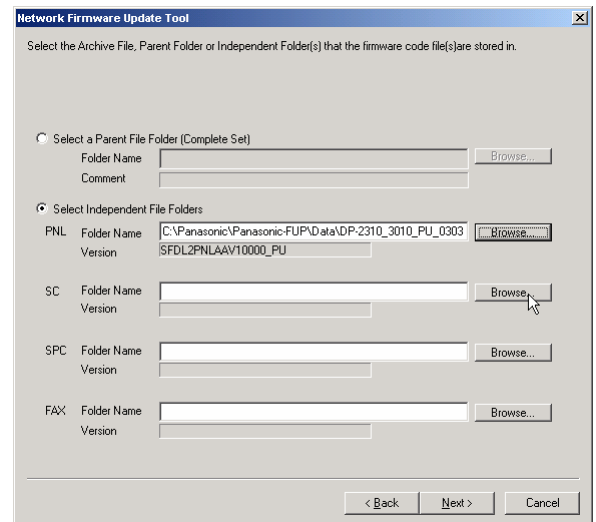

- 6.2d** Firmware Code File selection is completed. Click [Next>].

Continue Below.

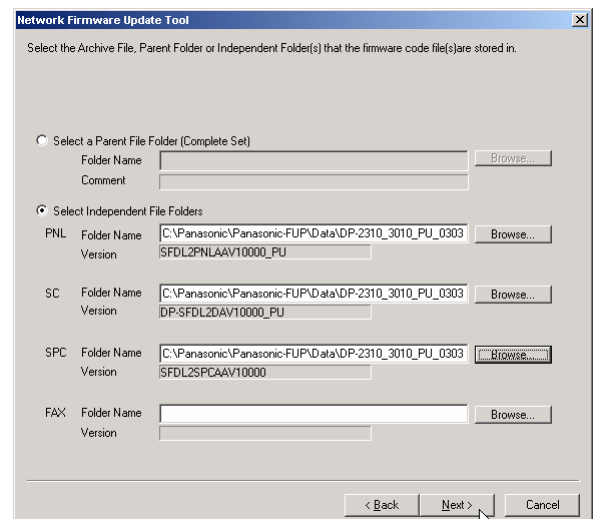

Network Firmware Update Tool (LAN)

- The version check for the specified devices starts automatically.
If 0 destinations fail the version check go to the next step.

Click [**Next>**].

Note: If a timeout error occurs, please confirm that the device is not currently in Service Mode and also that the Device's IP address pings successfully. You may need to go back and change some of the settings within the tool before proceeding with the update.

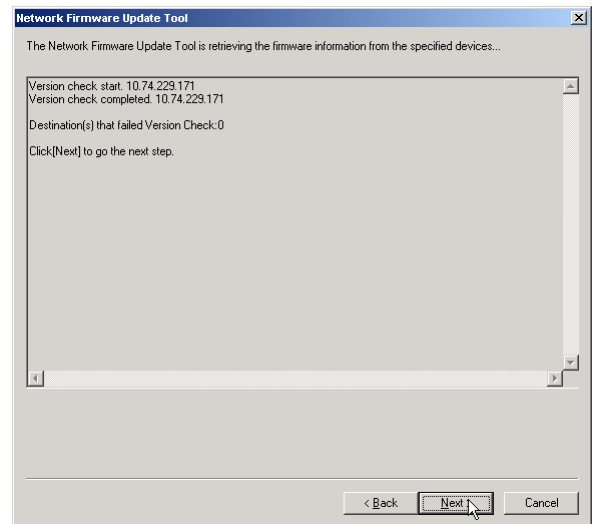

- Verify that the information you want to update is correct before proceeding.

Then click [**Next>**].

Note: If "Send at once" is checked, all firmware will be sent at once, and then erase, write and reboot are performed for the entire package. If "Send at once" is unchecked, each firmware (SC, PNL, SPC, etc.) is transmitted separately, and each time the unit erases, writes and reboots in the normal mode for each independent update.

This "Send at once", function cannot be used if the model is DP-6010 / 4510 / 3510, firmware type is PCL or PS, and the unit SC version is V1.xxxx.

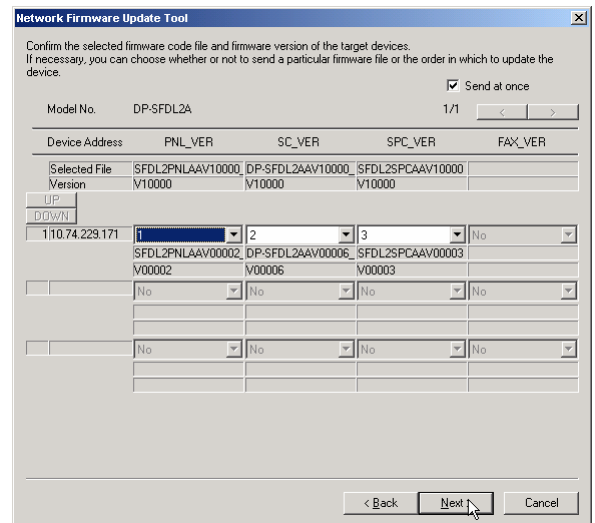

- Confirm the destination device(s) again.
Set timer communication if necessary, otherwise leave unchecked.

Then click [**Next>**].

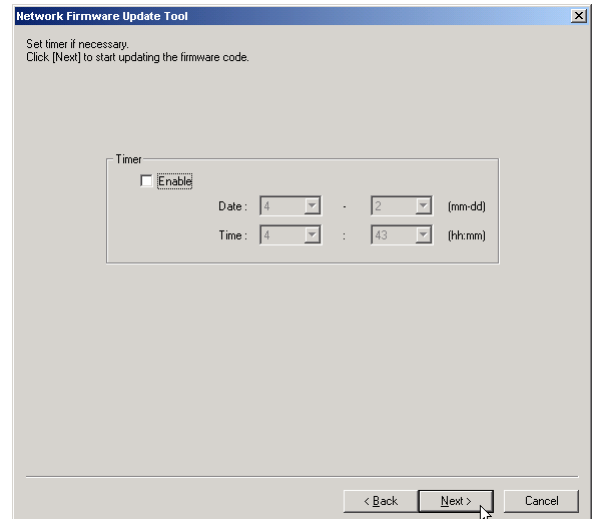

10. Data is then transferred to the Spooler, and the update is started.

The Spooler screen appears automatically showing the progress of the data transfer.

The spooler will take time to open depending on the number of addresses to update.

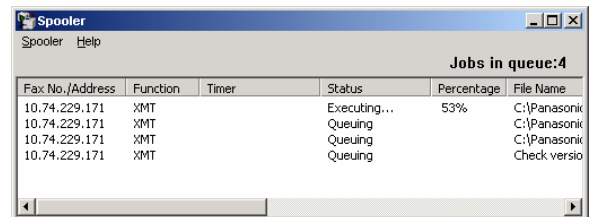
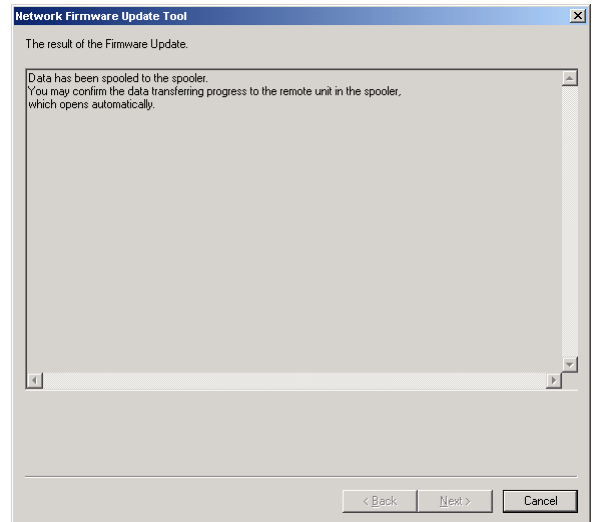

11. When the transfers are completed, all jobs in the spooler disappear, and the communication log is displayed.

After the firmware code is successfully programmed to the Firmware Flash Memory in the device, the device will shut down and reboot automatically.

Click **[Finish]**.

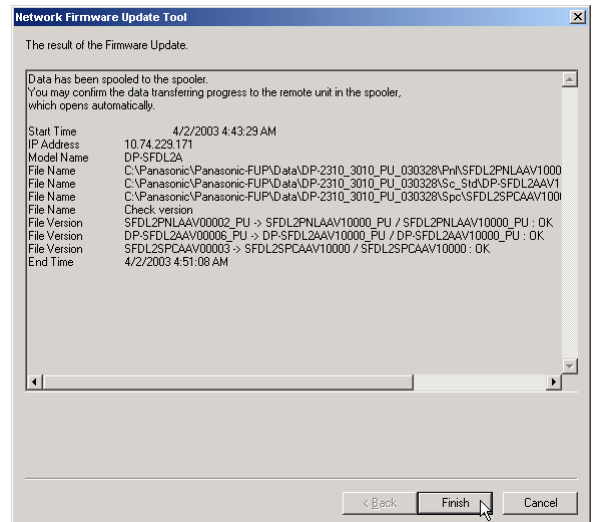

12. A Firmware Deletion confirmation screen will appear.

Click **[Yes]** to delete the firmware code files that you used for the update, or click **[No]** to keep the firmware code files in your PC for future use.

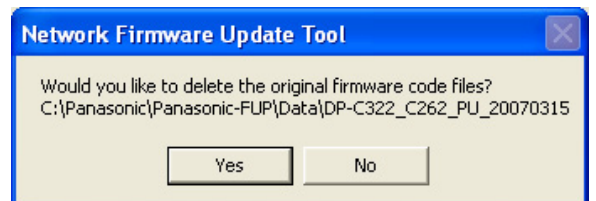

Network Firmware Update Tool (LAN)

13. Confirm the message in the text box and click **[OK]** to close the tool.

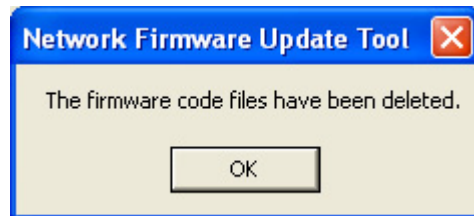

or

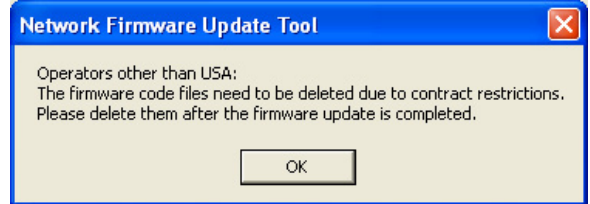

Software

Operating Instructions

Local Firmware Update Tool
for Service Technicians

Version 3

Table of Contents

1. General	3
1.1 Supported Operating Systems	3
1.2 Supported Panasonic Fax/MFP Models.....	3
2. Installation	4
2.1 Installing the Hardware Port on the Panasonic Fax/MFP Machine.....	4
2.2 Installing the Local Firmware Update Tool.....	4
2.3 Installing USB Firmware Update Driver (For the USB Port Model Only)	5
2.4 Uninstalling the Local Firmware Update Tool	6
3. Preparing the Firmware Update	7
3.1 Preparing the Unit to Accept the Firmware Code.....	7
3.2 Preparing the Firmware Code	7
4. Using the Local Firmware Update Tool	8

1st Edition : 1999 February 10
2nd Edition : 1999 September 30
3rd Edition : 2000 September 8
4th Edition : 2000 November 28
5th Edition : 2001 June 20
6th Edition : 2001 September 7
7th Edition : 2003 April 10
8th Edition : 2003 April 22
9th Edition : 2003 December 18
10th Edition : 2004 January 19
11th Edition : 2004 February 10
12th Edition : 2004 April 20
13th Edition : 2004 August 3
14th Edition : 2004 August 20
15th Edition : 2004 October 22
16th Edition : 2005 March 18
17th Edition : 2006 June 26
18th Edition : 2007 October 5

Microsoft, Windows, Windows Server and Windows Vista are either registered trademarks or trademarks of Microsoft Corporation in the United States and/or other countries.

Copyright © 1999 - 2007 Panasonic Communications Co., Ltd.

All rights reserved. Unauthorized copying and distribution is a violation of law.

The contents of this Operating Instructions are subject to change without notice.

1. General

The Local Firmware Update Tool (Parallel/USB) enables a PC to program the Firmware Code directly to the memory of the Panasonic Fax/MFP machine. The installation and operation are very similar to the installation of a USB or Parallel printer interface.

1.1 Supported Operating Systems

This application software operation has been confirmed under the following Operating Systems

- Windows® 2000
- Windows® XP
- Windows Server® 2003
- Windows Vista®

Note: 64bit version is not supported.

1.2 Supported Panasonic Fax/MFP Models

Please refer to the service manual of each model to determine compatibility.

2. Installation

2.1 Installing the Hardware Port on the Panasonic Fax/MFP Machine

- 1 Depending on the model, either a Parallel Port or a USB Port is required in the machine. If the machine is not already equipped with one of these ports please install an optional Parallel Port/USB Port Assembly into the supporting Panasonic Fax/MFP models by following the appropriate option installation instructions for that model.
- 2 Prepare the Parallel cable or USB cable for connecting the Panasonic Fax/MFP and your PC.
Important: For the USB port models, do not connect the USB cable yet.

2.2 Installing the Local Firmware Update Tool

- 1 Start Microsoft Windows.
Log on to the computer from an account with Administrator privileges.
Important: For the USB port models, do not connect the USB cable yet.
- 2 Locate and Run the **Setup(.exe)** program in the **Firmup** folder contained in the software setup disk or folder.
- 3 Follow the instructions on your screen to install the program.
Note:
The "**Digital Signature Not Found**" or "**Software Installation**" window will be displayed during the installation and indicate "Unknown software package" or "not passed Windows Logo testing", please click [YES] or [Continue Anyway] button to continue the installation.
- 4 A confirmation message is displayed when the installation is completed. When prompted to do so, allow the program to restart your PC.

2.3 Installing USB Firmware Update Driver (For the USB Port Model Only)

- 1 After installation of the Local Firmware Update Tool, if you need to install the USB Firmware Update Driver, please first set the unit to "**Update from USB/* IN PROGRESS ***" in the **Service Mode**, and then connect the USB Cable. The required Driver will then be installed automatically.

Note:

For instructions of how to enter the Service Mode, refer to your device's Service Manual.

- 2 Searching...



Installing driver...

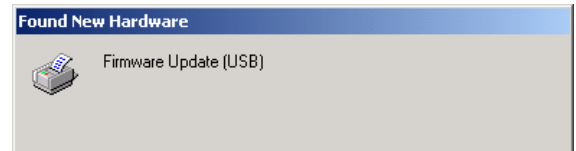

- 3 When the install screen disappears, the installation of the Firmware Update (USB) Driver is completed.

Note:

1. The installation screens will vary depending on the Operating System.
2. The "**Digital Signature Not Found**" or "**Software Installation**" window will be displayed during the installation and indicate "Unknown software package" or "not passed Windows Logo testing", please click **[YES]** or **[Continue Anyway]** button to continue the installation.
3. If you are asked for the **inf** file location, please specify the following folder.
C:\Panasonic\Panasonic-FUP\UsbDrv1
4. If you are asked for the **inf** file selection, please chose the larger version of the file.
5. After the USB Firmware Update Driver is installed, and if you are not updating the machine's firmware at this time, turn the Power Switch OFF and ON again to return your machine to the Standby mode.

2.4 Uninstalling the Local Firmware Update Tool

The Local **Firmware Update Tool** can be uninstalled by using it's Uninstall program.

Note: Do not delete the installed program folder from Windows Explorer directly, due to possible registry setting problems.

- 1.** Start Microsoft Windows.
Log on to the computer/network from an account with Administrator privileges.
- 2.** Click the **Start** button on the Taskbar, point to **(All) Programs ► Panasonic ► Firmware Update** then select **Uninstall Local Firmware Update Tool**.
- 3.** Follow the instructions on your screen to uninstall (Remove) the program.
- 4.** The completion message is displayed when the uninstall is completed.

Note:

The Firmware Update drivers are not deleted by the Uninstaller. If you wish to delete the Firmware Update drivers, please carry out in the following procedure.

- 1) On the **Printers and Faxes** selection of the **Control Panel**, choose the Firmware Update driver and select "Delete" from the right click menu to delete the driver.
- 2) Choose "**Server Properties**" from a right-click menu without choosing any drivers, and remove the "Firmware Update" driver on the **Driver** tab.
- 3) If you want to install the USB Firmware Update driver again, please carry it out after deleting a USB port by running **FupUninst.exe** which can be found in the **Cleanup_UsbPort** folder of the software setup disk or folder.

3. Preparing the Firmware Update

3.1 Preparing the Unit to Accept the Firmware Code

Please refer to the Service Manual for instructions to set the unit to Firmware Update Mode (Service Mode).

3.2 Preparing the Firmware Code

Copy the firmware Code file(s) to the following folder:

C:\Panasonic\Panasonic-FUP\Data

Note: An Archive File (i.e. DP-2310_PU_030327.exe) extracts the Firmware Code Files automatically into the designated folder without needing to paste the file into the folder manually. In this case the file may be downloaded to the desktop or to any other easily accessible location on the hard disk drive.

4. Using the Local Firmware Update Tool

- 1 Set the machine to the Firmware Update Mode and then connect the unit and PC with a Parallel cable or USB cable depending on machine option.

Note: For the USB Port Models, the Plug & Play of the Printer mode is activated when the USB cable is connected without the unit set in the USB Firmware Update Mode. If this happens, please click the [Cancel] button for the Plug and Play Driver installation.

- 2 Please close all applications that are currently running. Also ensure that the **Status Monitor** and/or **Port Controller** are **closed**. If they are running, right click on the icons in the system tray and select Exit/End.

Note: For Windows 2000/XP Administrator privileges are required.

- 3 From the Windows Desktop, double-click on the **Local Firmware Update Tool** shortcut icon to start the Panasonic Firmware Programming Wizard.

Note: If a shortcut was not created to the Windows Desktop at the time of installation, click the **Start** button on the Taskbar, point to **(All) Programs ► Panasonic ► Panasonic Firmware Update**, then select **Local Firmware Update Tool**.

Click **[Next>]**.

- 4 Select the Firmware Update Driver USB or Parallel depending on how the machine is connected to the PC.

Click **[Next>]**.

Note: The "Firmware Update Driver (USB)" is only displayed if you installed it with the unit as Plug and Play.

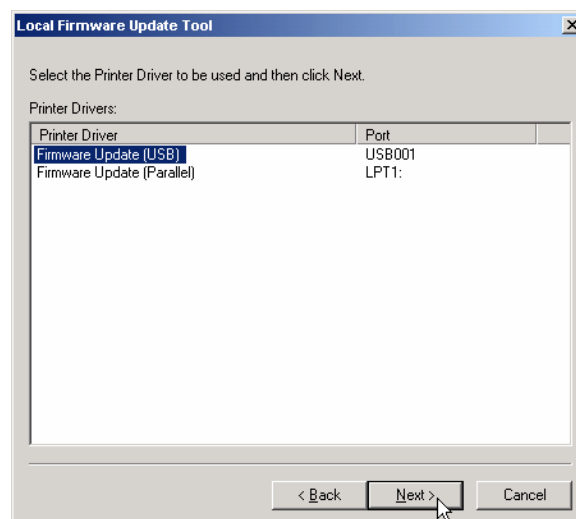
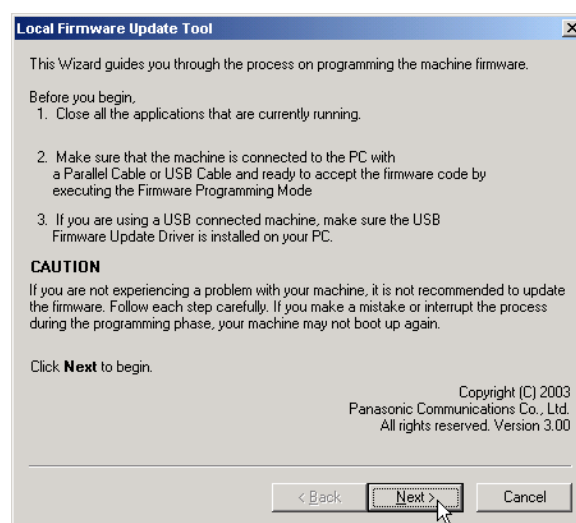

5 Specify the Firmware Code File by the following methods.

Select a Parent File Folder (Complete Set)

--> **Step 5.1**

If the archive file is already extracted into the local **\Data** folder, you can select the Parent File Folder directly here.

It is chosen as a set when the update of multiple firmware code files is necessary.

or

Select an Independent File

--> **Step 5.2**

If the archive file is already extracted into the local **\Data** folder, you can select an independent file here.

When updating multiple firmware files, you must repeat the file selection operation.

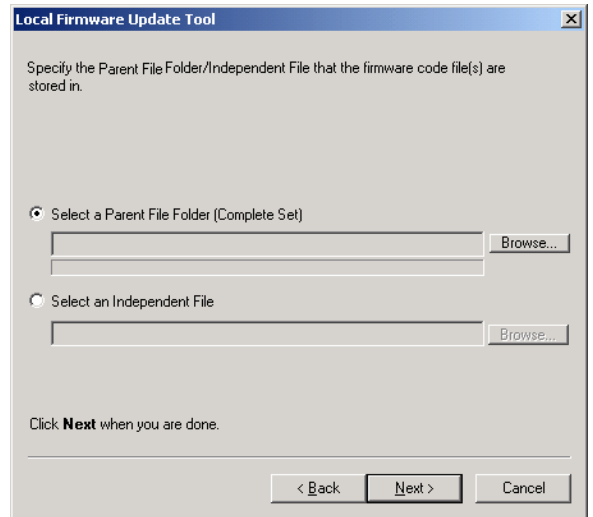

5.1 Select a Parent File Folder (Complete Set)

5.1a Select "Select a Parent File Folder (Complete Set)" and click [**Browse...**] button.

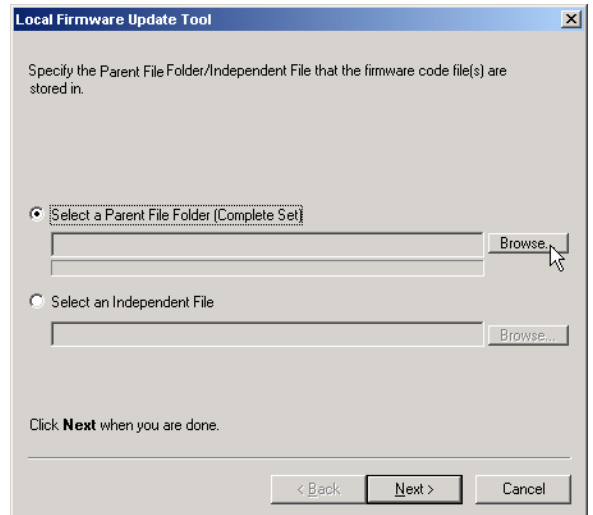

5.1b Select the Parent File Folder (For Example: DP-2310_3010_PU_030327) and Click [**OK**].

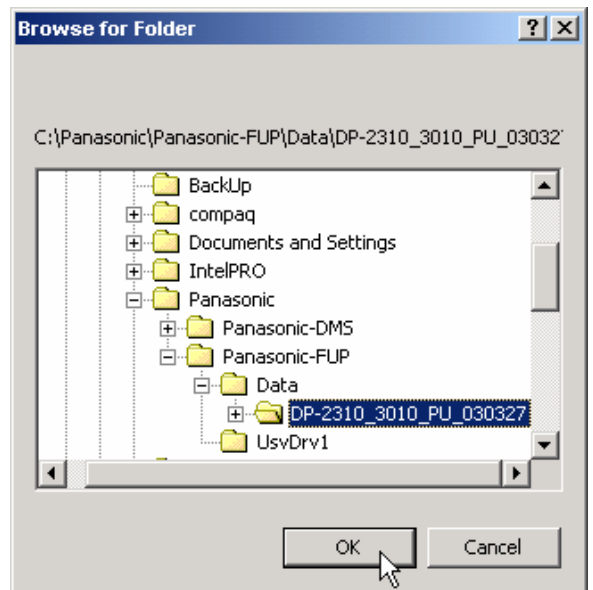

Local Firmware Update Tool (Parallel /USB Port)

5.1c Select the Firmware Type and click [OK].

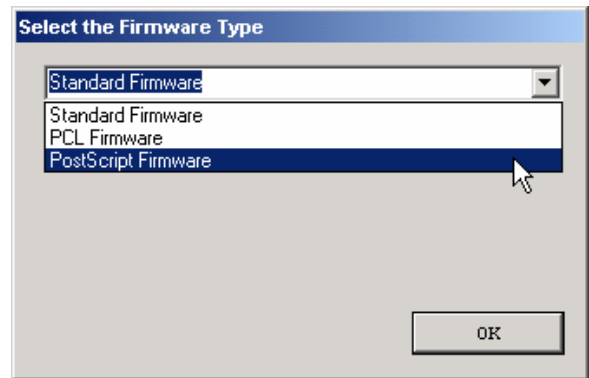

5.1d Firmware Code File selection is completed.
Click [Next >]

Please proceed to Step 6.

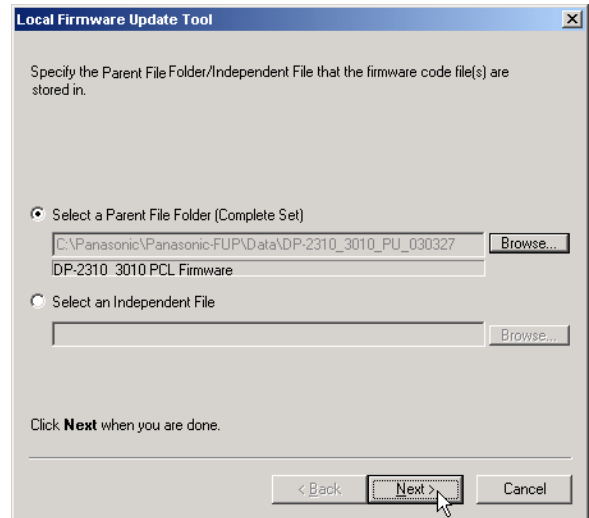

5.2 Select an Independent File

5.2a Select "Select an Independent File" and click [Browse...] button.

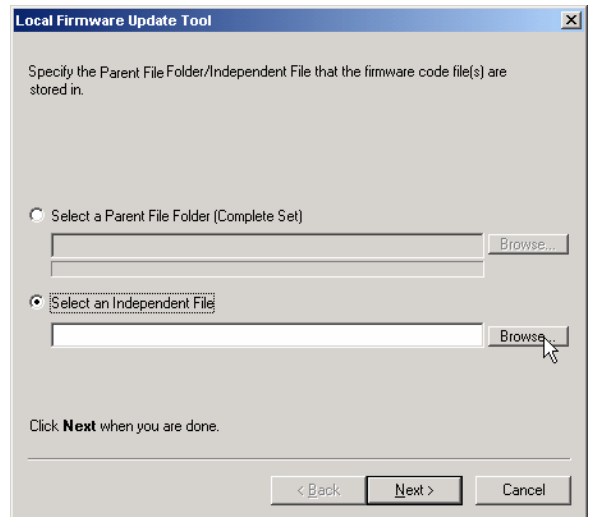

5.2b Select the Firmware Code File (For example SFDL2PNLAAV10000_PU.BIN) and click [Open].

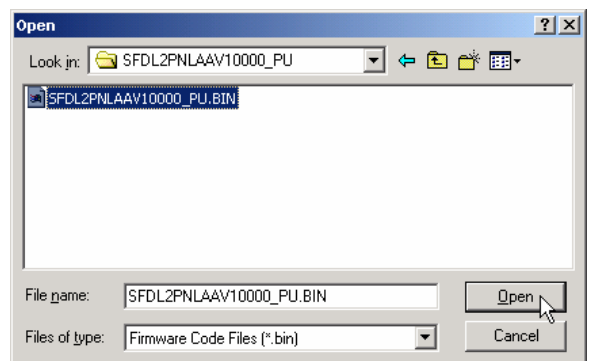

5.2c Firmware Code File selection is completed. Click [Next>].

Continue below.

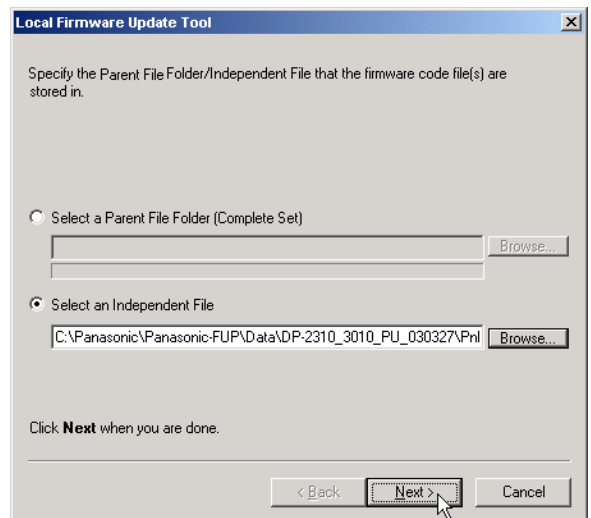

Local Firmware Update Tool (Parallel /USB Port)

- 6** The selected Firmware Code File(s) are indicated. Uncheck the box if you do not need to transfer a file.

On the unit side:

Set the unit to the Firmware Update Mode.

Before proceeding ensure that a USB cable or a Parallel cable are connected from the unit to the PC.

Click [**Next>**]

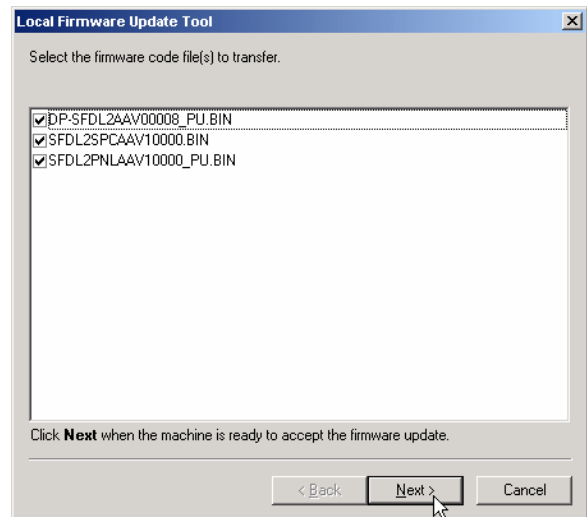

- 7** The Firmware Code File starts transferring.

When there is more than one file to be updated, the operation will be the following:

For **USB connected** unit:

they are transferred in turn automatically if the unit is ready to receive the next firmware code file.

Note: If you are updating the DP-2310/3010, the sending of sequential multiple files to the unit isn't done automatically. The "Waiting..." display on the PC will not advance to "Executing..." until you set the unit back to USB Firmware Update on the machine to start receiving the next file. See **Unit information of the Firmware Update Mode** on the next page.

For **Parallel connected** unit:

the confirmation screen is displayed when the current firmware code file transfer is finished and there are remaining firmware code files. Click [**OK**] when the machine is ready to receive the next file.

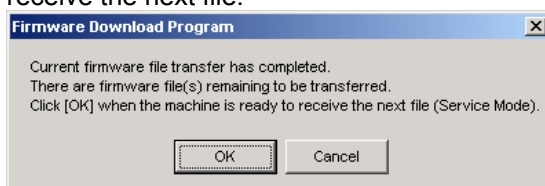
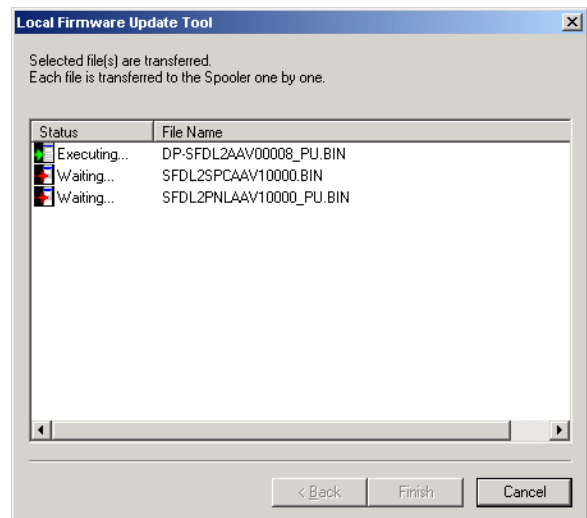

Unit information of the Firmware Update Mode:

For **USB Connected Unit (DP-2310/3010 only)**:

Every time the machine finishes receiving a firmware code file **the unit deletes and rewrites the firmware code and will return to Service Mode again. Set the unit back to USB Firmware Update after the machine returns to Service Mode and continue the firmware update.**

When the last firmware code file (PNL) is received, the unit will re-boot automatically and return to standby. The unit doesn't re-boot automatically when you select an independent file and the PNL firmware wasn't transferred. Cycle the power Off-On and reset the unit if the firmware code file transfer is finished and the unit has returned to the Service Mode.

For **USB Connected Unit (Other models)**:

Every time the machine finishes receiving a firmware code file, **the unit deletes and rewrites the firmware code and will return to USB Firmware Update and continue the firmware update automatically.**

When the last firmware code file (**AutoBoot**) is received the unit will re-boot automatically and return to standby. The unit doesn't boot automatically when you select an independent file. (The display returns to "Update in Progress") Cycle the power Off-On to reset the unit if the firmware code file transfer is finished and the display shows Completed.

For **Parallel Connected Unit**:

Every time the machine finishes receiving a firmware code file the unit deletes, rewrites the firmware code and then re-boots. Set the unit back to Parallel Firmware Update in Service Mode after boot up to continue the firmware update.

- 8 When the transfers of all the firmware files are finished, click [**Finish**] to close the tool.

Note: For USB Connected Unit only.

When the unit returns to standby, Plug and Play of the printer will popup. Click [**Cancel**] to close the Printer Plug and Play window.

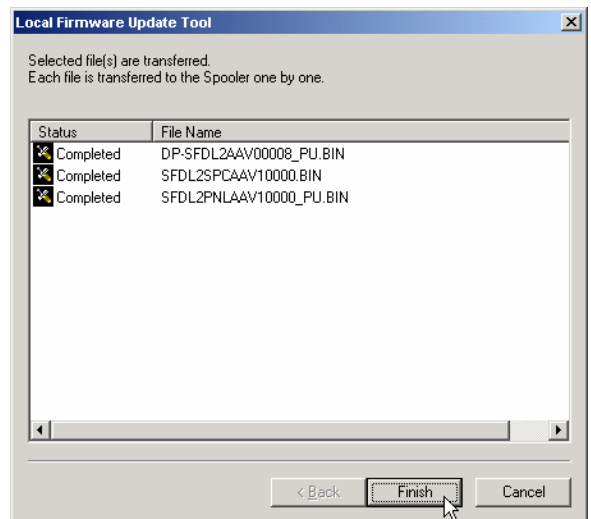

- 9 A Firmware Deletion confirmation screen will appear.

Click [**Yes**] to delete the firmware code files that you used for the update, or click [**No**] to keep the firmware code files in your PC for future use.

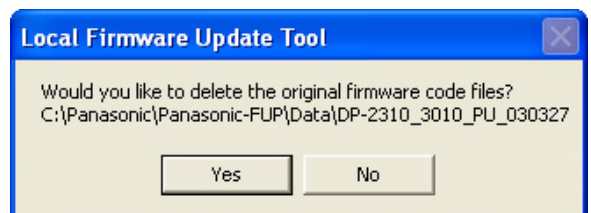

- 10** Confirm the message in the text box and click [OK] to close the tool.

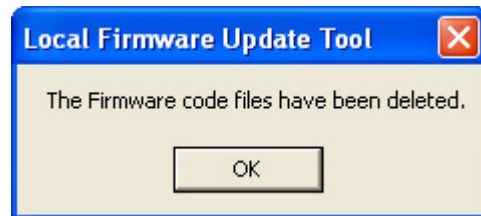

OR

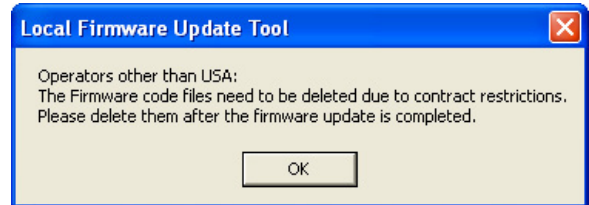

Precautions in replacing the Size Sensor and the SC PCB

- When replacing the Document Detect Sensor (269、275) and the SC PCB (1901) , follow the procedures below to adjust the Document Detect Sensor.
- Before adjusting the Document Detect Sensor
 - A. When the ADF/iADF Unit or the Platen Cover is installed
 1. Open the ADF/iADF Unit or the Platen Cover.
 2. Clean the white part of the Scanning Pad and the Scanning Glass with a soft cloth, soaked with isopropyl alcohol.
 3. Close the ADF/iADF Unit or the Platen Cover.
 - B. When the ADF/iADF Unit or the Platen Cover is not installed
 1. Clean the Scanning Glass with a soft cloth, soaked with isopropyl alcohol.
 2. Place A3/LEDGER recording paper or 2 A4/LETTER recording papers or 4 A5/INVOICE recording papers on the Scanning Glass aligning on the upper left corner.

Note: Use the unused white recording paper.

- How to set the recording paper -

(a) When setting A3/LEDGER recording paper

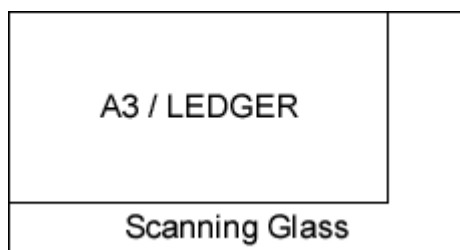

(b) When setting 2 A4/LETTER recording papers

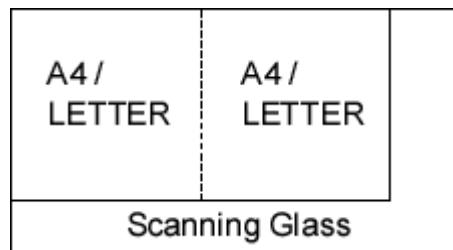

(c) When setting 4 A5/INVOICE recording papers

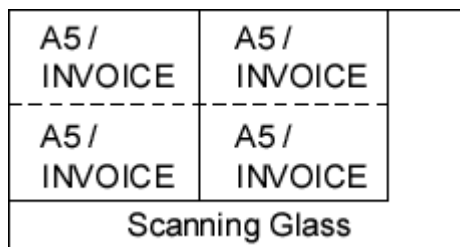

- Procedures for adjusting the Document Detect Sensor.
 1. Press the **"FUNCTION"**, **"ORIGINAL SIZE (LEDGER/A3)"**, and the **"3"** keys simultaneously.
 2. Input the Password, and select the **"OK"** button to enter the Service Mode (default password is **00000000**).
 3. In "Self Test ", press Key "8" on the keypad.
 4. Press "START".
 5. Select No.12 "Org. Size Sensor Adj."
 6. Press "START".
 7. The Xenon Lamp automatically turns ON, activating the Platen Mechanical Parts.
After a specified time, the Xenon Lamp turns OFF, inactivating the Platen Mechanical Parts and the display returns to "F8" "Service Adjustment" mode.

