

# PLASTIC-FORM

presentation



# Table of contents

## **Introduction**

## **Organizational structure**

## **Employees**

## **List of machines**

## **Latest and new investments**

## **Statistical informations**

## **Main profile**

- Total tooling management
- Making of new injection and blow moulding tools
- Repairing modifying and maintaining of injection and blow moulding tools
- Making special pieces
- Making special machines

## **Main profile details**

## **Technology overview**

### **Engineering / designing**

- Reverse Engineering & 3D scanning

### **Supply**

- Raw materials, mouldbase, semi-finished materials and hot runner systems

### **Conventional machining**

- Horizontal boring
- Vertical boring
- Turning
- Grinding

### **CNC machining**

- CNC milling
- EDM

### **Assembly process**

- Manual works
- Polishing
- Spotting press

### **Laser welding**

### **Quality control and management**

### **Transportation**

### **External services**

- Surface treatment, finishing, texturing
- Tool trials, short shot production

### **References**

### **Contact**

Plastic-Form Ltd's main activities are the making, repairing, modifying and maintaining of injection and blow moulding tools.

Plastic-Form Ltd was founded in 2001 with the objective of meeting the injection- and blow-moulding tool demand of Hungarian companies involved in the production of packaging, household and technical plastic products.

The founder is Mr. Janos Burai. He has over 30 years experience in mould making, and is now the manufacturing director.

The founder's son Mr. Zsolt Burai is a mechanical engineer, and is currently the company's managing director.

Apart from meeting domestic demand, our company soon became a partner of many famous, well-known automotive suppliers.

The basis of our activities, over and above our machinery and equipment, is provided by the highly qualified and experienced team of professionals who have been involved in mould tool manufacture for many years.

Our company, as a supplier of plastic injection and blow moulding products provides a full spectrum of services, from the designing of moulds, through their manufacturing right up to their servicing, as well as consultation.

# Introduction

**PLASTIC-FORM**

**Mouldmaker Ltd**

**Our new site since May of 2007 - Hungary, 4002 Debrecen, Jegvirag 16.**



# Introduction

**PLASTIC-FORM**

**Mouldmaker Ltd**

**Building extension in 2012** - Hungary, 4002 Debrecen, Jegvirag 16.

Total area of toolshop: 1500 m<sup>2</sup>



# Organizational structure

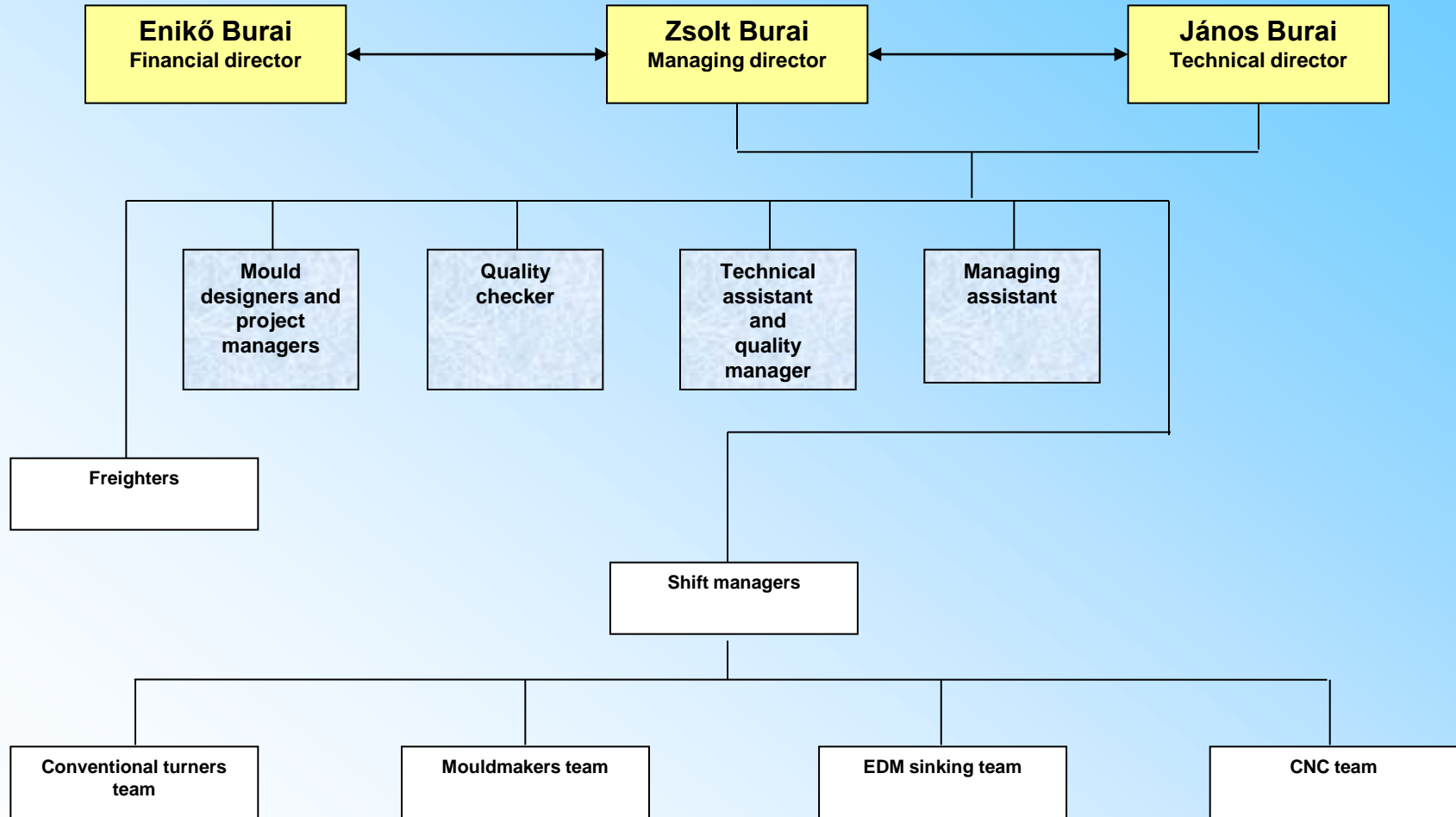

# Employees

## Number of employees

<b>Management</b>									
			Managing director			1			
			Technical director			1			
			Financial director			1			
<b>Management assistants</b>									
			Project management			2			
			Technical assistant			2			
			Computer system administrator			1			
<b>Designing</b>									
			Mould designing			8			
<b>Manufacturing</b>									
			Toolshop leader			2			
			CNC milling			16			
			Conventional milling			1			
			EDM			2			
			Mouldmaking			13			
			Grinding			3			
			Turning			3			
			CMM			2			
			Freighting			3			
			Storage			1			
			Plant service			3			
<b>Total</b>						<b>65</b>			

# List of machines

## Conventional machines

Machine	Type	Year	Quantity	Capacity	Bearing capacity	Other
bandsaw	SGMB 400 / II	1984	1	550 x 550 x 100		
bandsaw	BOMAR STG 230 G	2001	1	Ø 200 x 2000		
turning machine	E3N-750	1980	1	Ø 100 x 600		
turning machine	SUI 40		1	Ø 500 x 1500		
turning machine	USA 250	1988	1	Ø 500 x 1500		
turning machine	SUI 100		1	Ø 1100 x 2000		
milling machine	FND 32 T	1982	1	300 x 300 x 200		
horizontal milling machine	TOS VARNSDORF W75	1985	1	800 x 800 x 600		
surface grinder	BM 612	2007	1			
surface grinder	SPC 20 b	1981	1	200 x 500 x 100		
surface grinder	SPC 20 C	1987	1			
surface grinder	ELB		1			
universal grinder	KU-250-04	1990	1	Ø 250 x 700		
standing drill	2K52-1		1	300 x 300 x 300		
standing drill	CSEPEL RF-20		1	400 x 500 x 300		
standing drill	CSEPEL RF-20		1	400 x 500 x 300		
Small hole drilling EDM	SODICK	1991	1	600 x 600 x 300		



# List of machines

## CNC machines

Machine	Type	Year	Quantity	Capacity	Bearing capacity	Other
CNC turning machine	Masturn 550 i	2013	1			
CNC milling center	KONDIA A6	2006	1	400 x 800 x 400		
CNC milling center	MCV MAS 750	2001	1	500 x 1000 x 500		
CNC milling center	KONDIA HM 1060	2003	1	1100 x 600 x 500		
CNC milling center	FS-0	2005	1	700 x 1300 x 600		
CNC milling center	FS-2	2009	1	2000 x 1200 x 1500		
CNC milling center	Deckel Maho DMU 35 M	2001	1	400 x 300 x 300		
CNC milling center	Deckel Maho DMU 50 M	2001	1	500 x 500 x 400		
CNC milling center	MAS MCV 1000 Sprint	2012	1			
CNC milling center	MAS MCV 1210 ZPS	2013	1			
CNC milling center	TVB E-JET 550	2013	1			
EDM	ONA DATIC D-360-F	2001	1	600 x 400 x 400		
EDM	ONA NX-3	2008	1	500 x 300 x 300		
EDM	ONA NX-6	2008	1	1100 x 700 x 500		
Wire EDM	Fanuc Robocut $\alpha$ -1c	1998	1	600 x 600 x 300		
Wire EDM	Fanuc Robocut $\alpha$ -iE	2010	1	1000 x 800 x 300		

# List of machines

## Other

<b>Machine</b>	<b>Type</b>	<b>Year</b>	<b>Quantity</b>	<b>Capacity</b>	<b>Bearing capacity</b>	<b>Other</b>
3D scanner	ATOS	2011	1	1500 x 1130		
CMM	Coord	2003	1	500 x 700 x 300		
Spotting press	MIL 163	2008	1	1600 x 1000 x 1400	20 tons	Pressure: 150 tons
Laser welding machine	Alfa Laser ALM 200	2006	1			
Heat treating furnace		2005	3	300 x 300 x 400	25 kg	
Crane	Konecranes HK-1356	2007	1		20 tons	
Crane	Konecranes HK 1355	2007	1		5 tons	
Crane	Konecranes HK 1539		1		5 tons	
Crane	Konecranes HK-2079	2012	1		5 tons	
Forklift	Mitsubishi FG-30		1		3 tons	
Forklift	EP	2010	1		7 tons	

# Statistical informations

## Division of manufacturing

- Production: 75%
- Reparation: 25%

## Division of injection and blow moulding tools production

- Injection moulding tools: 65 %
- Blow moulding tools: 25 %
- Others: 10 %

## Revenue division

- Export: 14%
- Domestic: 86%

## Export revenue

- Production: 97%
- Reparation: 3%

## Domestic revenue

- Production 74%
- Reparation 26%

# Main profile

- 1. Total tooling management**
- 2. Making of new injection and blow moulding tools**
- 3. Repairing modifying and maintaining of injection and blow moulding tools**
- 4. Making special pieces**
- 5. Making special machines**

**These activities are the main profiles of our company.**

# Main profile details

## 1. Total tooling management

We offer our partners a complete service in the mouldmaking.

- Product development
- 3D product and mould designing
- CAD/CAM system for the product designing, mould designing
- Mould making
- Mould testing, tryout
- Plastic product moulding, sample making, if it is required.

# Main profile details

## 2. Making of new injection and blow moulding tools

Plastic-Form Mouldmaker Ltd designs and manufactures heavy-duty and long lifetime injection and blow moulding tools for difficult geometric 3D plastic parts in high quality level.

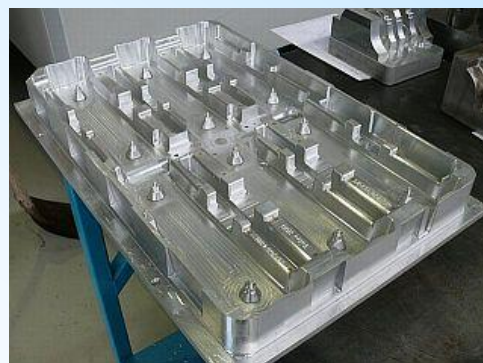
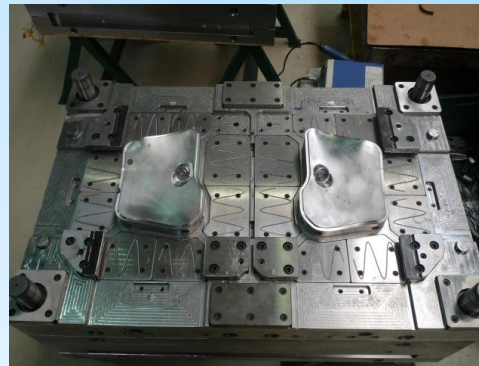
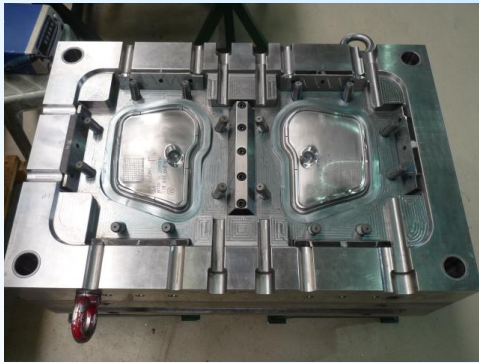

# Main profile details

## 3. Repairing, modifying and maintaining of injection and blow moulding tools

- Damaged moulds are repaired with high precision and used the best materials.
- Engineering change/management to existing moulds based on the supply of new/revised CAD data.
- Tool maintenance can be supported on an ongoing regular plan based on supplier requirements.



# Main profile details

## 4. Making of special pieces

Some of our partners require special pieces, what we make by individual drawings. These pieces are not accessories of moulds.





# Main profile details

## 5. Making of special machines

For example cutting machines, holders, cooling fixtures and jigs.

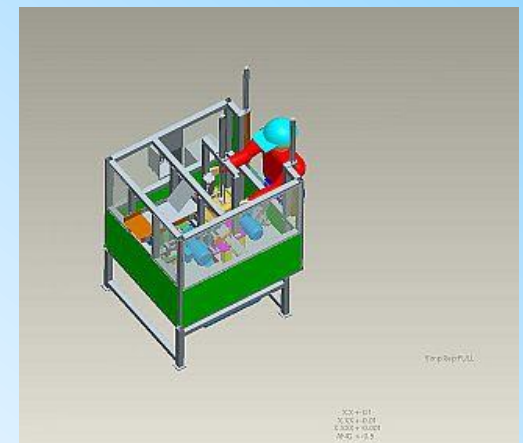
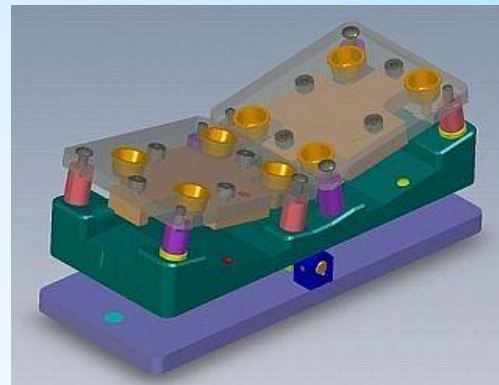
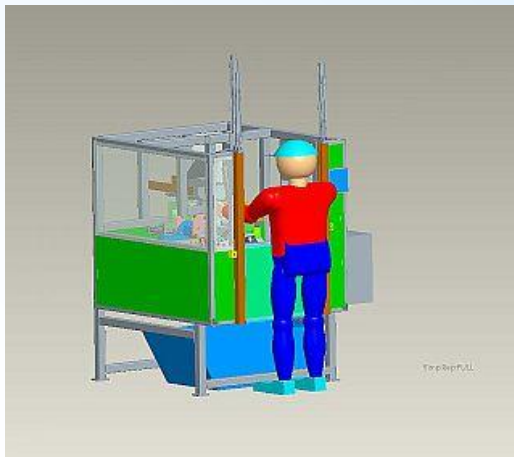
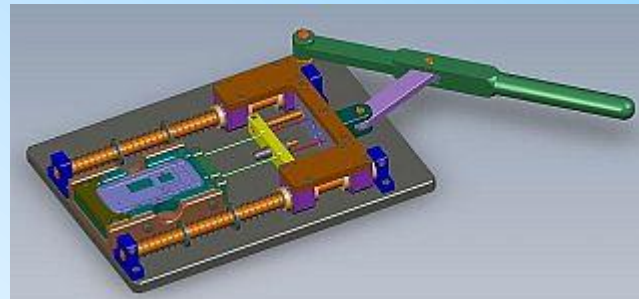

# Engineering and designing

**PLASTIC-FORM**

**Mouldmaker Ltd**

Engineering at Plastic-Form Ltd is based on CAD files or unique technical specifications provided by the Customer.

Qualified, experienced professionals generate the optimum design using integrated CAD systems.

Planning of mould construction and milling programs are made by **Creo (PRO-ENGINEER)** and **UNIGRAPHICS** software.

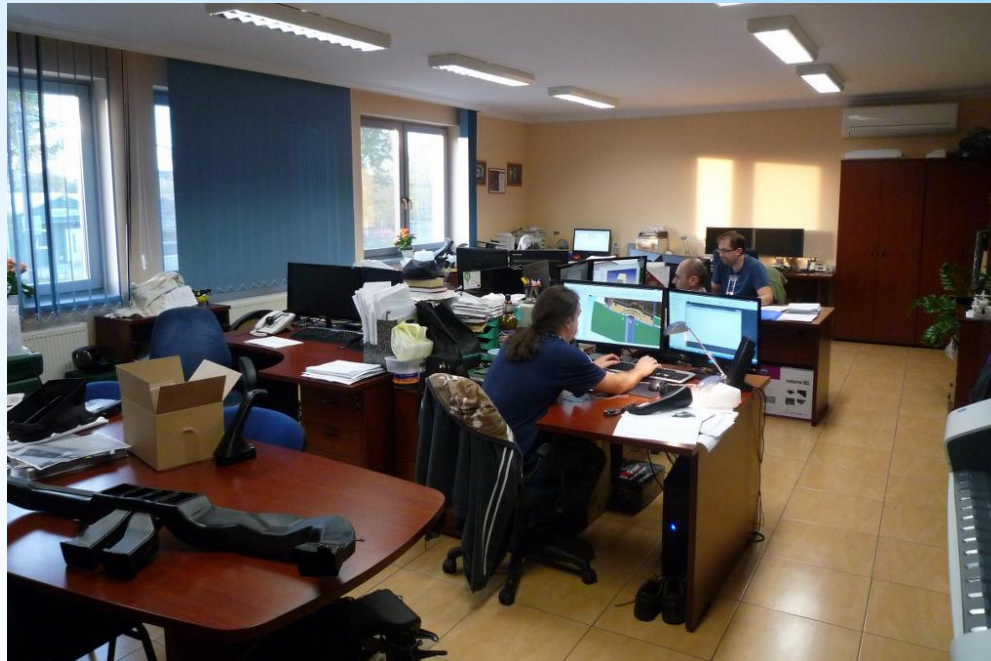

# Engineering and designing

## Moldflow analysis

Moldex3D helps us simulate versatile injection molding processes to optimize product designs, increase manufacturability.

Moldex3D software provides the technology to decrease the number of trials and errors, which contribute to the waste of time, energy and money during the mold-making process. Moldex3D help users to simulate and validate their part and mold designs before actual production.

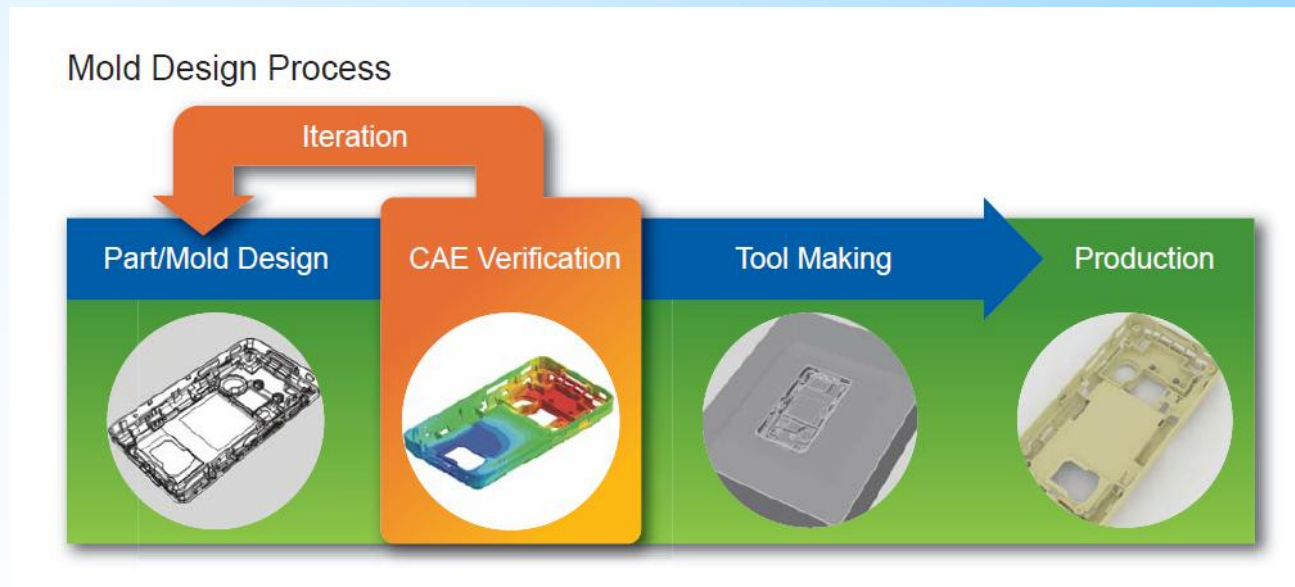

# 3D scanning & Reverse Engineering

**PLASTIC-FORM**

Mouldmaker Ltd

## ATOS II 3D scanner

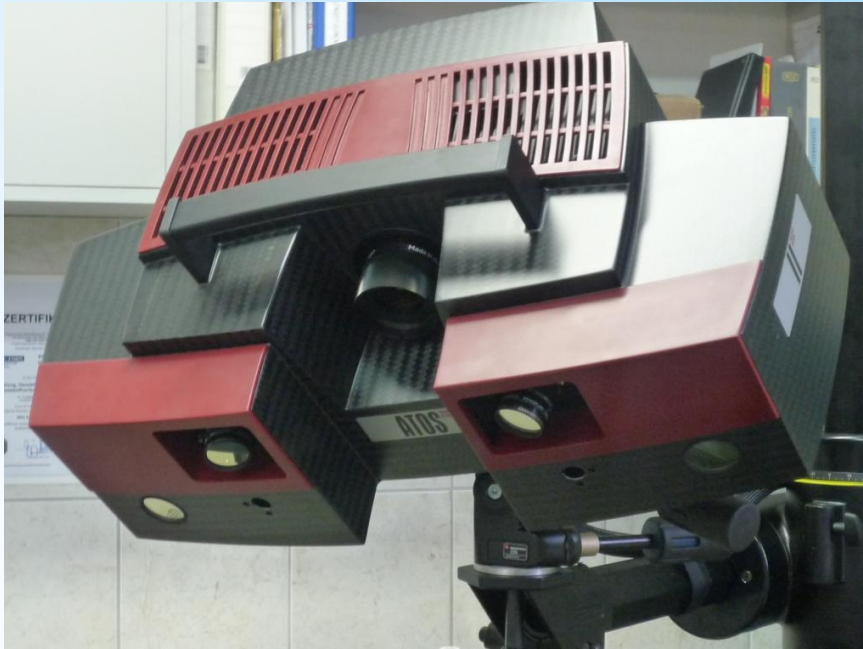

# 3D scanning & Reverse Engineering

## What is GOM ATOS II

GOM ATOS II is an industrial, high resolution, optical 3D scanner with Blue Light Technology. The ATOS II delivers three-dimensional measurement data for industrial components (metal parts, tools and dies, prototypes, injection molded and casted parts). Accuracy is 0,01 mm.

Instead of measuring single points, full part geometry is captured in a dense point cloud or polygon mesh describing the object's surface.

The ATOS 3D scanner is an accurate and cost-effective solution in a number of different application areas including:

- Quality Control, Quality Analysis
- Inspection
- Reverse Engineering
- Rapid Prototyping
- Rapid Milling
- Digital Mock-Up

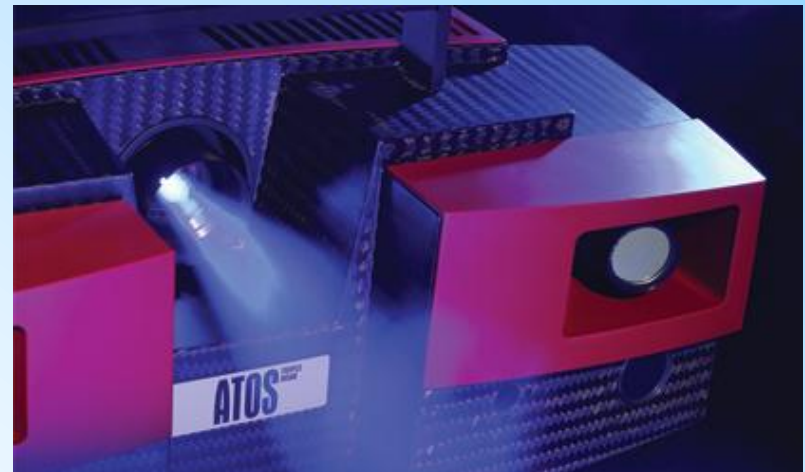

# 3D scanning & Reverse Engineering

## Measurement and inspection software

The powerful, process safe, traceable **ATOS Professional** included **GOM Inspect Professional** software controls the sensor head, processes the 3D point cloud and can edit and completely post-process the data. Through a simple graphical user interface, the ATOS Professional and GOM Inspect Professional software supports today's tasks in quality control, manufacturing processes and reverse engineering.

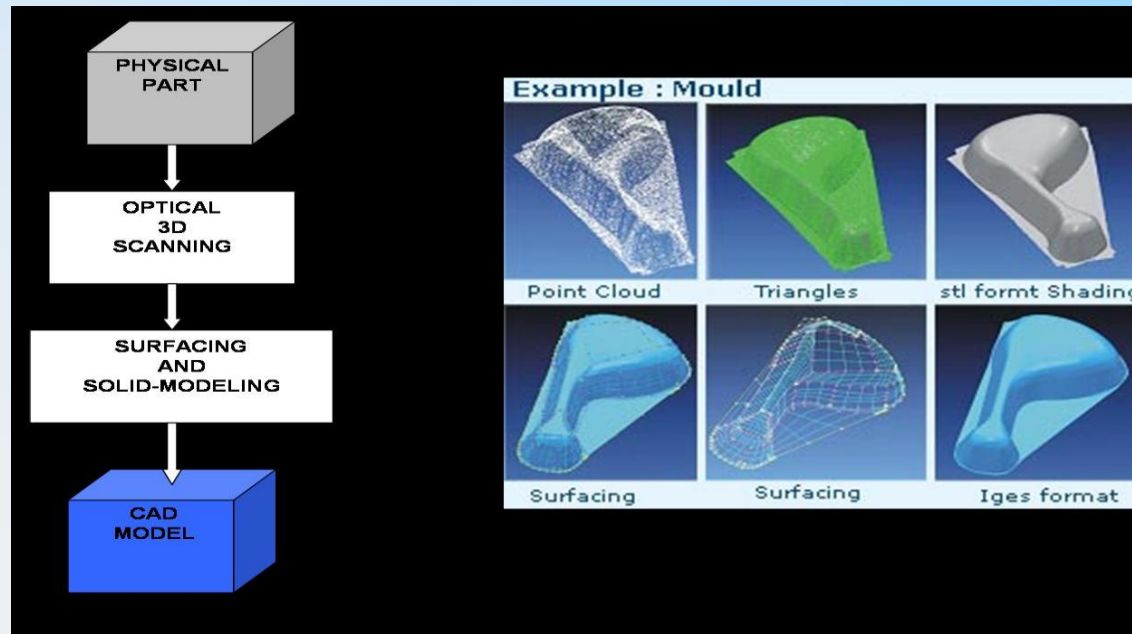

# 3D scanning & Reverse Engineering

## 3D scanning, 3D digitizing

With the high-end optical 3D Scanner we offer three dimensional, precise and accurate shape digitizing.

The GOM ATOS system is able to scan almost any kind of engineered parts.

The object can be any material including glass. Shiny objects will be temporary covered by a very thin white powder, to obtain better scan quality. It is possible to scan huge object piecewise with help of reference points.

Based on reference points (circular point markers), the software automatically transforms the individual measurements into a common, global coordinate system.

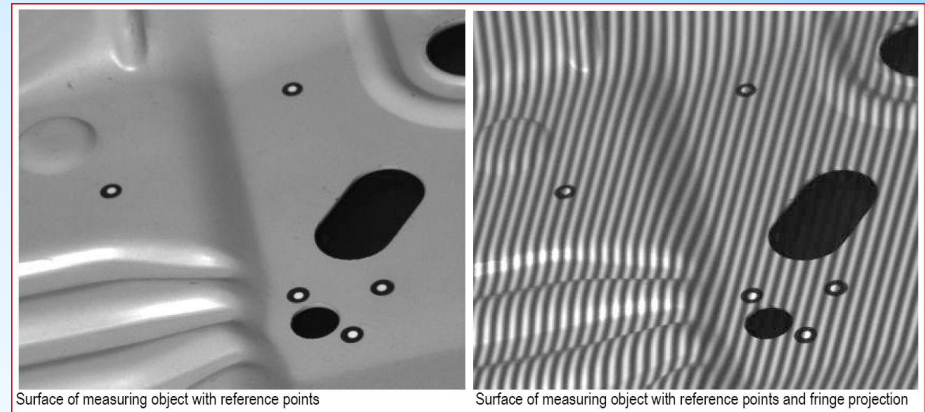
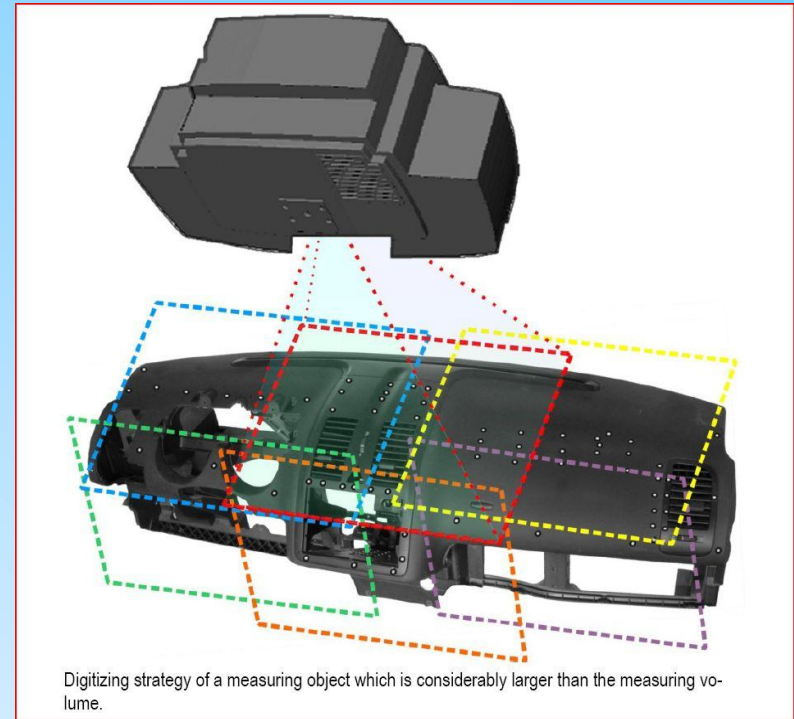

# 3D scanning & Reverse Engineering

## 3D scanning, 3D digitizing process

1. Positioning of sensor and blue light

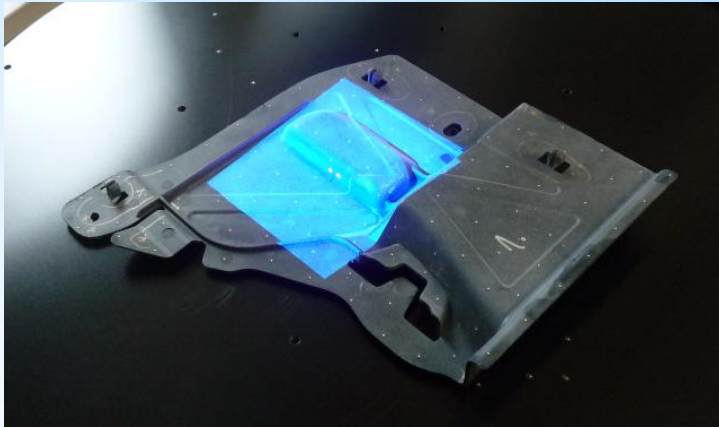

2. Scanning

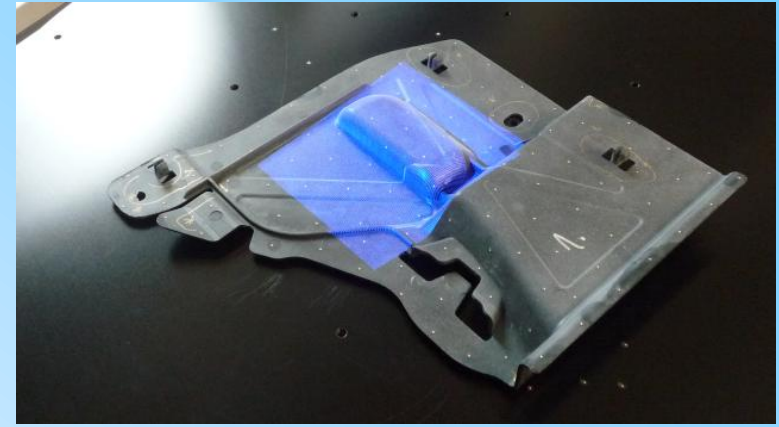

3. 3D model ready to measure and reverse engineering

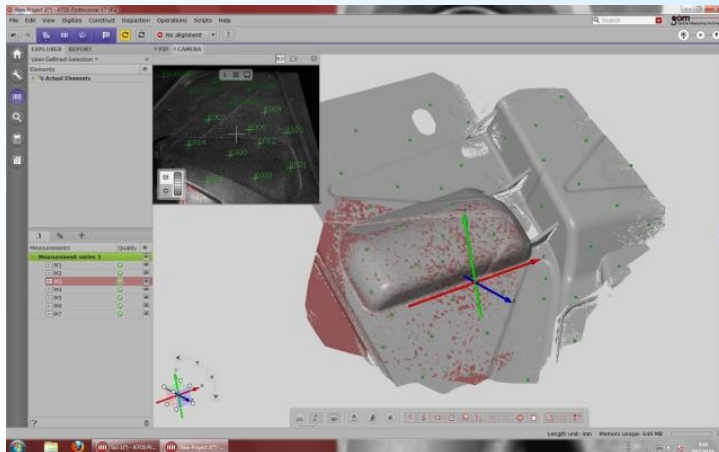

## Result

All measurements are automatically transformed into a common object coordinate system. The complete 3D data set can then be exported using standard file formats for an easy post-processing.



# 3D scanning & Reverse Engineering

## 3D scanning, 3D digitizing process

The result of the scanning is a high resolution, dense point-cloud, or triangulated mesh surface (.stl file). Optionally, surface or solid CAD model is available. The 3D digital data can be used for visualizing, archiving, part copying, finite element analysis, redesigning or for manufacturing quality check purposes.

The speciality is to scan and reverse engineer broken or rubbed injection moulding tools, or to measure and inspect complex, free-form shaped plastic or metal parts.

**Reference projects:** scan, reproduce broken or worn tools, digitizing for reverse engineering.

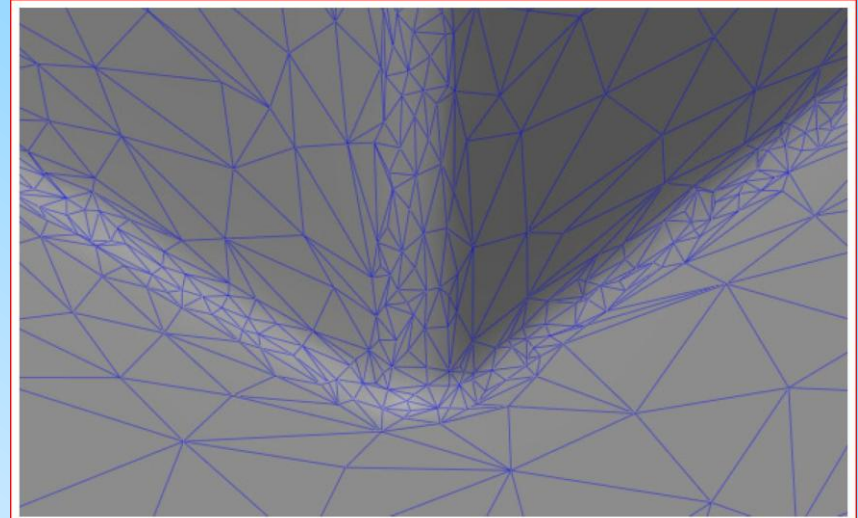

Polygonized surface of the measurement object with the polygons displayed

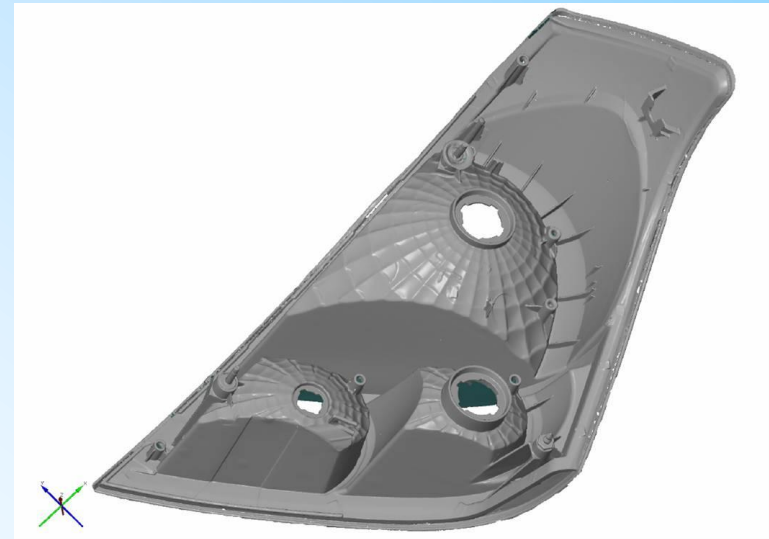

# 3D scanning & Reverse Engineering

## Reverse Engineering, Reverse Modeling

The 3D data acquired by the GOM ATOS 3D Scanner can be post-processed for CAD/CAM purposes. The reverse engineered model is representing the physical object as a 3D CAD data with all surface and geometrical error. Due the process, the model can be redesigned with any kind of shape modification.

It is possible to export the model in common standard formats, like .iges, .step or in special cases in feature and history based parametrical native formats, like SolidWorks .sldprt, Pro/E .prt, Siemens-UGS NX .prt file. In most cases the .iges file is perfect for importing and editing in any CAD/CAM system.

# 3D scanning & Reverse Engineering

## Operating principle and system configurations

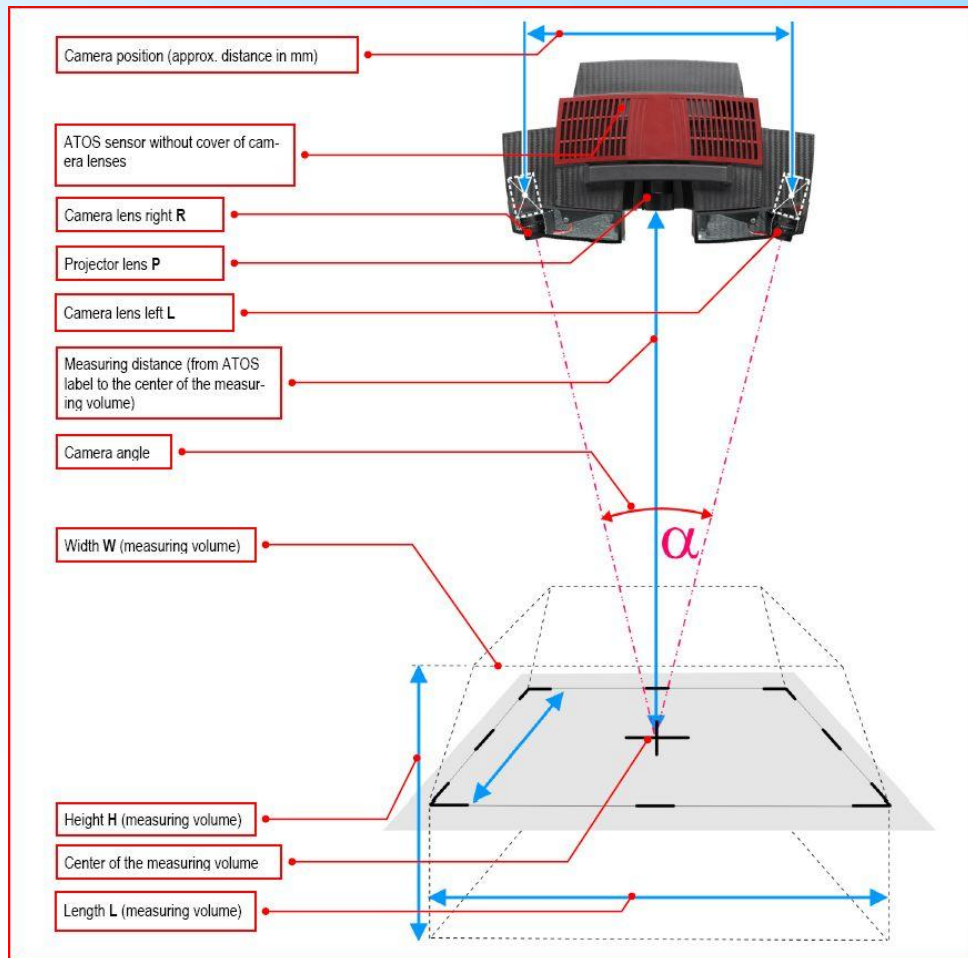

### System Configurations

### ATOS II Triple Scan

Camera Pixels	2 x 5 000 000
Measuring Area (mm <sup>2</sup> )	[38 x 29] – [1500 x 1130]
Point Spacing (mm)	0.02 - 0.62
Measured Points	5 million
Blue Light Technology	Yes
Triple Scan	Yes
High End PC	Yes
Notebook operation for extra mobility	Yes
Variable Workstation	Yes
Sensor Controller	Internal
Positioning Pointers	Yes

# Supply

## Suppliers

### 1. RAW MATERIALS

#### 1.1. Steel

- Böhler
- Akrostal
- Tyssenkrupp Ferroglobus

#### 1.2. Aluminium

- Amari

### Raw material quality and hardness

#### Raw material of cavity plates and inserts

##### Steel

- 1.2311 and 1.2312 = 32 HRc
- 1.2343, 1.2344, 1.2767, 1.2842, and Moldmax = 50 HRc
- Toolox 33 & Toolox 44

##### Aluminium

- Certal 380 HB

Selecting of these materials depend on

- plastic raw material and the
- lifetime of plastic part.

# Supply

## Suppliers

### 2. STANDARD ELEMENTS

- Meusburger
- Hasco
- DME
- Misumi

### 3. HOT RUNNER SYSTEMS

- Hasco
- Thermoplay
- Synventive
- Yudo
- Mold-Masters
- DME
- Incoe

Some working mould includes hot runner systems which were developed and made by Plastic-Form Ltd.

## Suppliers

### **4. ELECTRONIC ELEMENTS**

- Weidmüller
- Harting

### **5. PNEUMATIC ELEMENTS**

- Bosch-Rexroth
- Hafner
- Camozzi

### **6. HYDRAULIC ELEMENTS**

- Bosch-Rexroth
- Vega
- Roemheld
- Intertraco
- C-Matic

**Most elements are available in Hungary.**

# Machining

## Conventional machining

- **Horizontal boring**

The horizontal boring machine is used to machine holes and plane surfaces primarily on larger work pieces.

Applications:

Raw material preparation and drilling of water cooling channels.



# Machining

## Conventional machining

- **Vertical boring**

Applications:

Drilling of water cooling channels and other necessary holes.





# Machining

## Conventional machining

- **Turning**

Turners are working on conventional lathes and produce many kind of workpieces.



# Machining

## Conventional machining

- **Grinding**

Processing of fitting, guiding, shaping surfaces and heat-treated machine tools requires a high degree of accuracy. These accessories are made by universal grinding machine and surface grinding machines.



# Machining

## CNC machining

- CNC turning



# Machining

## CNC machining

- **CNC milling**

Milling technology has a significant role in machining tool parts and making spark erosion electrodes. For efficient machining of parts, CNC-controlled milling centres are available.

### CNC-1

#### Kondia A-6



### CNC-2

#### Kondia HM-1060



### CNC-3

#### MAS 750



# Machining

## CNC machining

- CNC milling

CNC-4

CME FS 0



CNC-5

Deckel Maho DMU 50



CNC-6

Deckel Maho DMU 35



# Machining

## CNC machining

- CNC milling

CNC-7  
CME FS 2



CNC-8  
MAS MCV 1000 Sprint



CNC-9  
MAS MCV 1210 ZPS



# Machining

## CNC machining

- **CNC milling of EDM electrodes from graphite only**

CNC-10

TVB E-JET 550

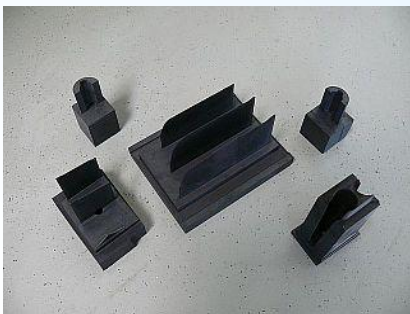

# Machining

## CNC machining

- **EDM (Electrical Discharge Machining )**

EDM is a machining method primarily used for hard metals or those that would be impossible to machine with traditional techniques. One critical limitation, however, is that EDM only works with materials that are electrically conductive.

EDM or Electrical Discharge Machining, is especially well-suited for cutting intricate contours or delicate cavities that would be difficult to produce with a grinder, and end mill or other cutting tools.



# Machining

## Making of electrodes

We are able to make electrodes for the EDM (Electrical Discharge Machining) technology. The electrodes can be made of copper or graphite.

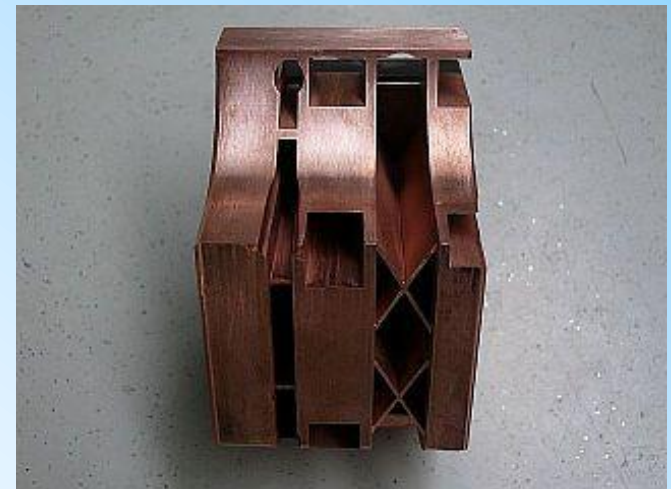

# Machining

## CNC machining

- **EDM**

Using of EDM, a graphite or copper electrode is machined into the desired shape and fed into the workpiece. This type of EDM is usually performed submerged in an oil based dielectric.

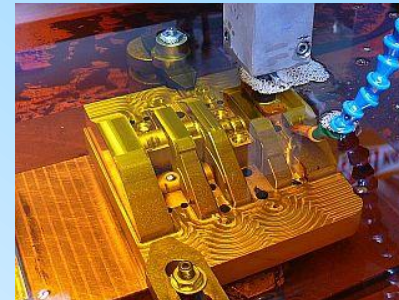
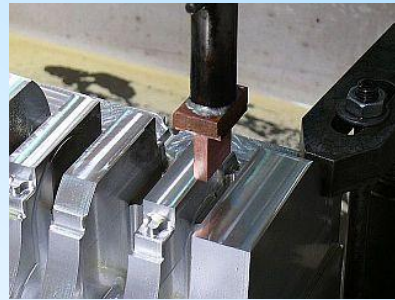

ONA Datic D-360-F



ONA NX3



ONA NX6



# Machining

## CNC machining

- **Wire EDM**

In wire EDM a very thin wire serves as the electrode. Special brass wires are typically used. The wire is slowly fed through the material and the electrical discharges actually cut the workpiece.

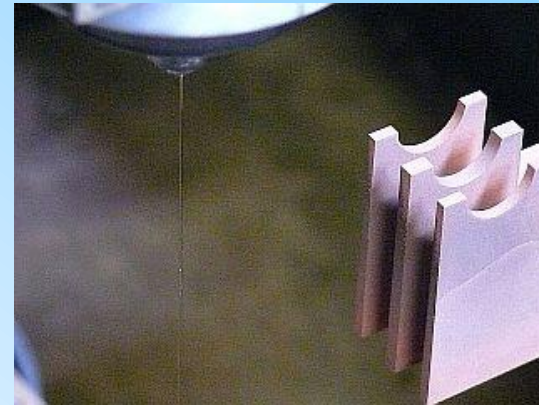

Fanuc Robocut  
α-1c



Fanuc Robocut  
α-iE

# Assembly

## Assembly process

- **Manual works**

Assembly of the work pieces by tool assembly specialists.

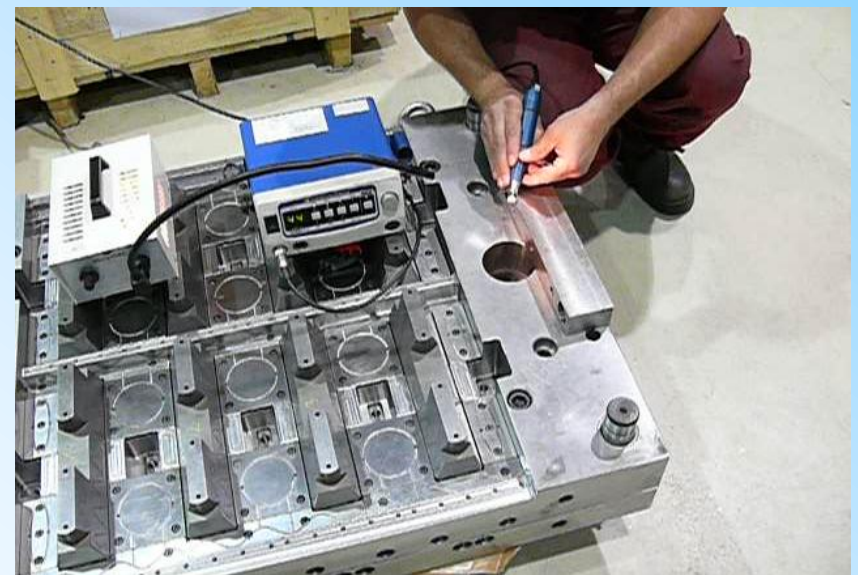
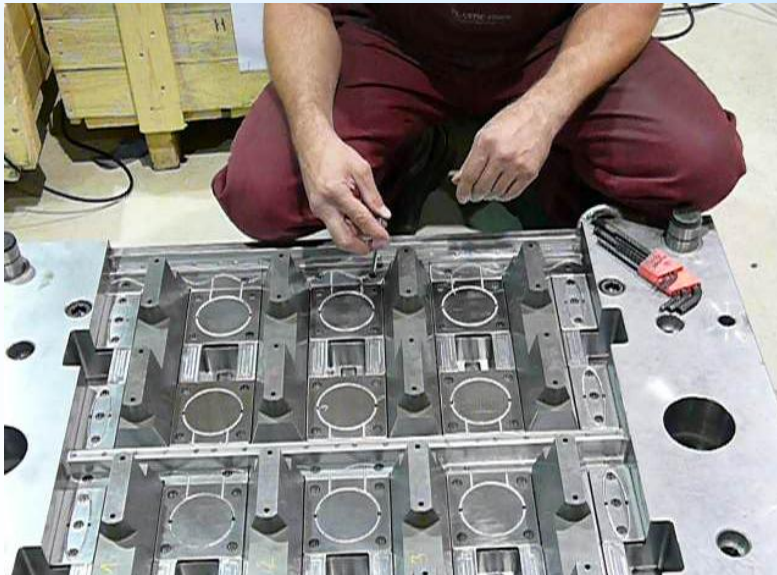

# Assembly

## Assembly process

- Polishing



# Assembly

## Assembly process

- **Spotting**

Our spotting press is convenient to check many moulds which are under production, maintaining or repairing.



### **Table size:**

X = 1600 mm

Y = 1000 mm

Maximum distance between tables:

Z = 1400 mm (depend on the mould opening size)

### **Bearing capacity of table:**

20 tons

### **Maximum press:**

150 tons

# Assembly

## Assembly process

- **Spotting**



# Laser welding

The main feature of laser welding is the price of repairing that is much lower than the price of a new tool. We use a mobile equipment, so it is appropriate to repair heavy weight, big-sized tools or places where difficult to access.

Laser welding can be used in the following area:

- filling, adding joint at worn edges,
- repairing hot channels, nozzles, tips,
- repairing at micro-size,
- changing or repairing damaged, worn tools
- repairing polished surfaces



Alpha Laser ALM 200



# Quality

## Quality management system

Plastic-Form Ltd knowingly developing and controlling the quality, that gives for partners.

In proof of this continual control we received ISO 9001:2000 quality management system.

Plastic-Form Ltd has got EN ISO 9001:2000 quality management system certification in march of 2004.



**PLASTIC-FORM**

**Mouldmaker Ltd**



# Quality

## Quality management system development

Plastic-Form Ltd has a new project management system called Norma-x.

This is a new, integrated, special production management software, that helps to collect, and provides to the managers many information about the following:

- procession and actual status of works
- fulfillments of purchase orders
- tracking of deadlines
- efficiency of the professionals and machines
- efficiency of accounts, prices, costs
- working hours of machines
- working hours in case of finished and actual works
- account of finished works
- RFQ's, contracts, CAD/CAM data and many information about a project

# Quality

## Quality assurance

Quality assurance is supported by a Coordinate Measuring Machine (CMM) and a 3D scanner which are available in a separated room in our plant. We can measure all surface in 3D. Results of measuring will be presented in inspection reports.

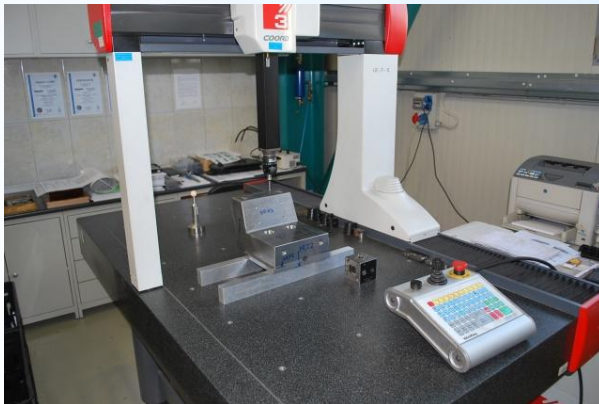
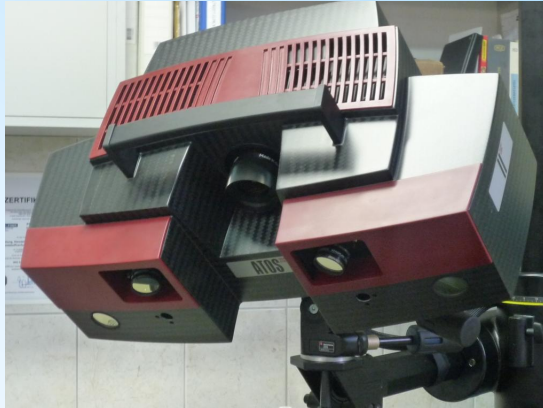

# Transportation

**PLASTIC-FORM**

**Mouldmaker Ltd**

**Plastic-Form Ltd has the ability of transporting up to 24 tons.**



# Transportation

**PLASTIC-FORM**

**Mouldmaker Ltd**

**Plastic-Form Ltd has the ability of transporting up to 24 tons.**



# External services

## Surface treatment, finishing, texturing

We can offer many kind of textured surfaces, so the result is a nice and resistant surface on the plastic product.

Texturing procedure will be realized with the help of our Hungarian and foreign suppliers.

- Mold-Tech Standex Bohemia s.r.o.
- Graphotex Kft



# External services

## Tool trials, short shot production

Tool trials and small volume manufacturing are available at local companies, so we can provide the first plastic samples to the customer.

New, repaired or modified tools can be delivered with some plastic parts, if it is required.

Injection machines are available close to Plastic-Form up to 650 tons.

# References

## **Plastic-Form Ltd has excellent references in mouldmaking.**

- **Automotive industries**

Automotive industry products are characterized by sophisticated shapes, large freely-designed and difficult surfaces. Plastic-Form Ltd are making high quality moulds for suppliers of many famous automotive industries to build injection-moulded, blow-moulded and surface-structured products in passenger cabins and engine cabins of cars.

- **Engineering plastics**

This is where enhanced accuracy and a long lifetime are essential requirements. Complex surfaces and parts geometries along with technical engineering polymers can be supported.

- **Packaging technology**

Plastic-Form Ltd has extensive experience in the area of producing tools for thin-wall containers and lids, where short cycle times and long lifetime are general requirements.

- **Household products**

This is where aesthetic and ergonomic requirements have an increased importance.

Plastic-Form Ltd can satisfy any demand in creating complicated and divided shapes.

Plastic-Form Ltd has extensive experience in making of moulds for decorative and structured surfaces even of large sizes.



# References in automotive industry

## Our partners in

- **Automotive industry:**
  - MAGYAR SUZUKI CORPORATION
  - ARRK-HUNGARY LTD – TISZA-AUTOMOTIVE LTD
  - ARRK-PDG
  - KALOPLASZTIK LTD
  - GM-AUTOVAZ
  - RAK ANTENNA LTD
  - INTERPLUS LTD
  - CADENCE
  - WEGU
  - PEMÜ LTD
  - KARSAI PLAST LTD
  - VIDEOTON MŰANYAG LTD
  - KUNPLAST KARSAI LTD
  - THERMOPLASTIK s.r.o.
  - AJKAI ELEKTRONIKAI LTD
  - BOSCH

# References in automotive industry

These companies and their suppliers ordered from us many new mould, mould modification and reparation for their plastic parts:



# References in automotive industry

## New moulds for Suzuki

### ➤ Ignis – 16 moulds



# References in automotive industry

## New moulds for Suzuki

### ➤ Swift – 29 moulds



# References in automotive industry

## New moulds for Suzuki

### ➤ SX 4 – 26 moulds



# References in automotive industry

## New moulds for Suzuki

### ➤ Splash – 19 moulds



## Mould modifications for the NWA project

- Kaloplasztik
- ARRK-Hungary Ltd
- RAK Antenna Ltd
- Dekorsy Ltd
- Wegu

*More than 70 mould modifications.*



# References in automotive industry

## New moulds for Suzuki

### ➤ Splash – 19 moulds



Box Comp, Luggage Floor for Suzuki Splash

# References in automotive industry

## New moulds for Suzuki

### ➤ Swift III – 42 moulds

14 pcs of tools are making visible parts in the passenger cabin, and other Japanese tool modification, reparation.





# References in automotive industry

## New moulds for Suzuki

### ➤ **SX4 S-CROSS – 50 moulds**



# References in automotive industry

**PLASTIC-FORM**

Mouldmaker Ltd

## New moulds for Opel Zafira



# References in automotive industry

**PLASTIC-FORM**

Mouldmaker Ltd

## New moulds for Opel Insignia



# References in automotive industry

**PLASTIC-FORM**

**Mouldmaker Ltd**

## New moulds for Bentley Mulsanne



# References in automotive industry

## New moulds for Bentley Mulsanne

### Projects:

#### - HVAC Ducts (14 blowing moulds)

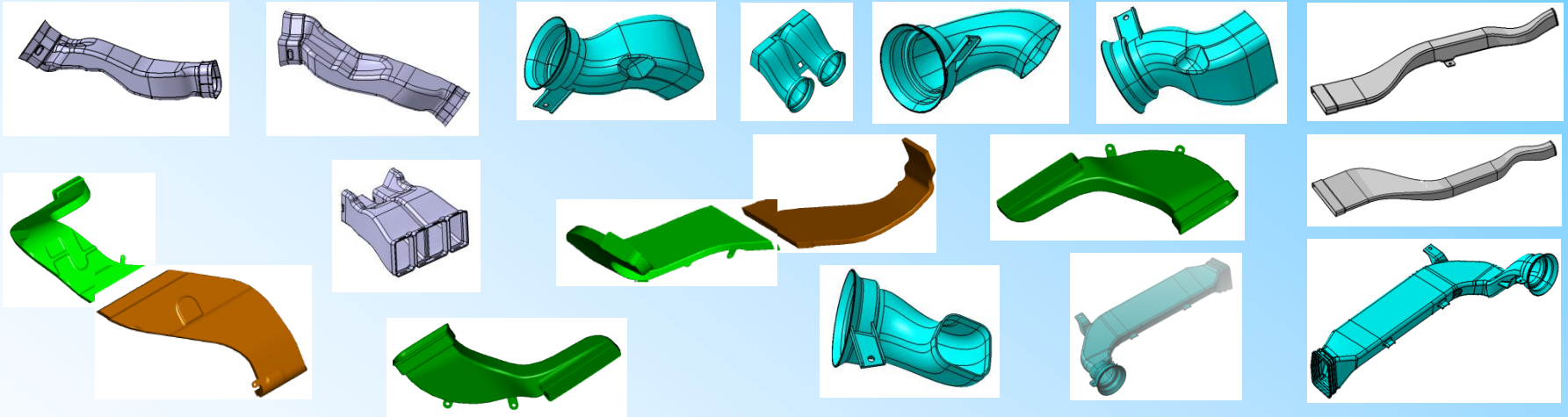

#### - Brake Cooling Ducts (3 injection moulds)

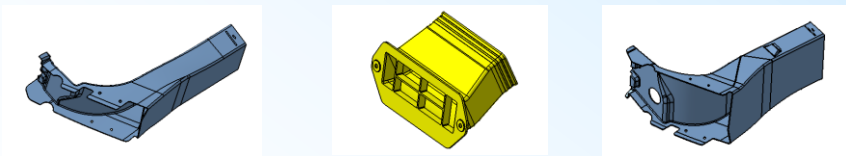

#### - Cold air pick up lower & upper RH / LH (2 injection moulds)

# References in automotive industry

**PLASTIC-FORM**

**Mouldmaker Ltd**

## New moulds for Bentley Continental GT



# References in automotive industry

**PLASTIC-FORM**

Mouldmaker Ltd

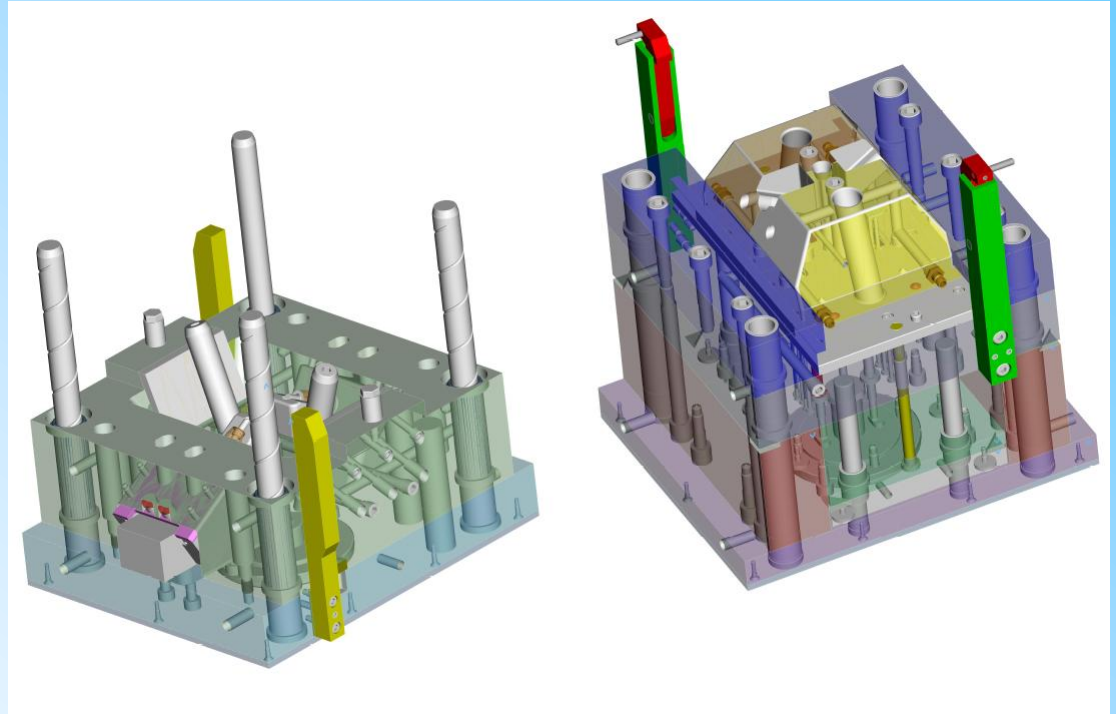

Night vision camera washer for Interplus Ltd

# References in automotive industry

**PLASTIC-FORM**

Mouldmaker Ltd

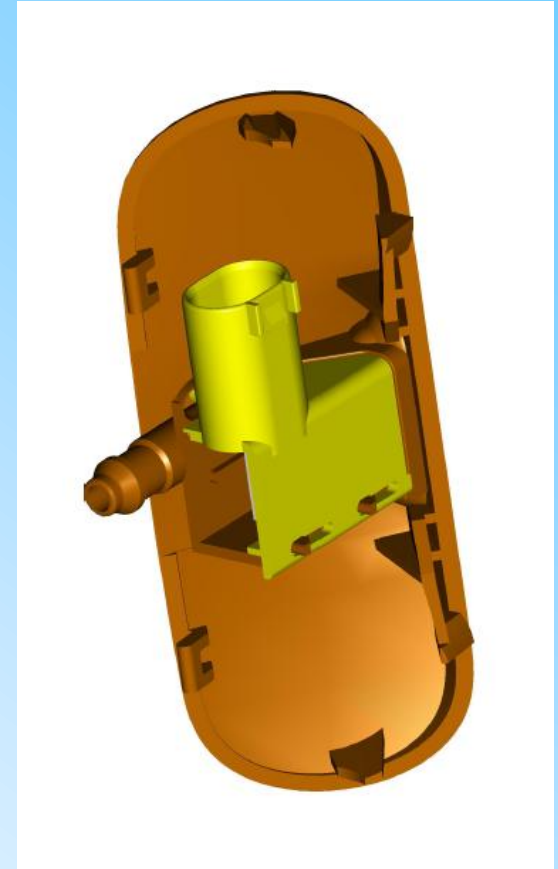
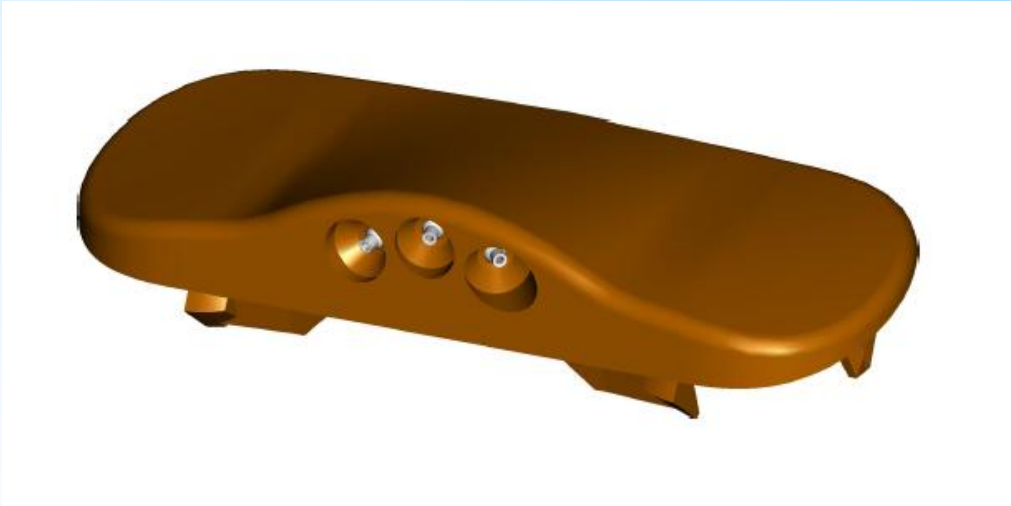

Audi Heated Nozzle for Interplus Ltd



# References in engineering plastics

## Our partners in

- **Engineering plastics:**
  - TER-KI-SZO LTD
  - KAUPERT KUNSTTOFFTECHNIK
  - NILFISK-ADVANCE
  - WEIDMÜLLER
  - FLEXTRONICS (LEGO TOOLS)
  - ELECTROLUX
  - POLIPACK LTD
  - STAR-PLUS LTD
  - METAMORF LTD

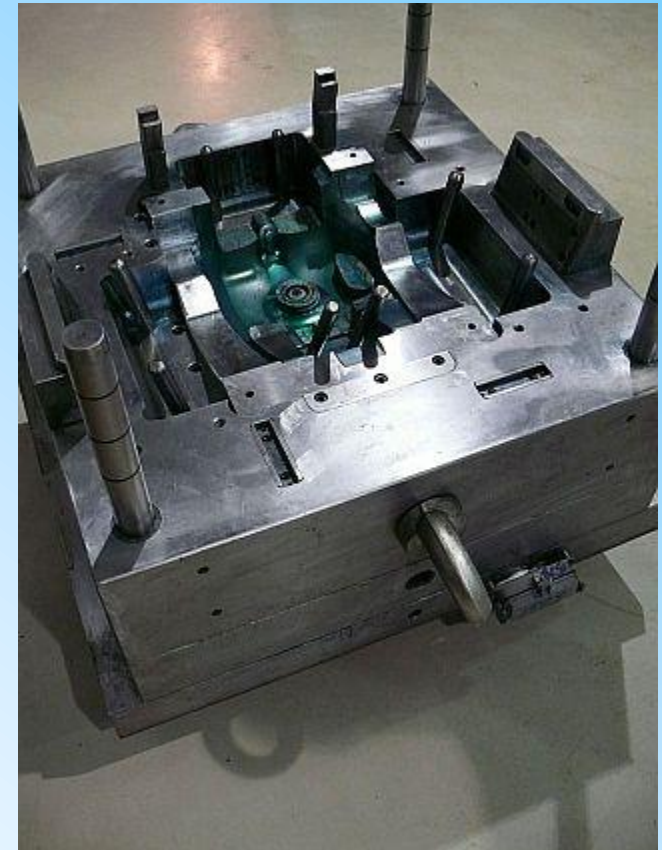
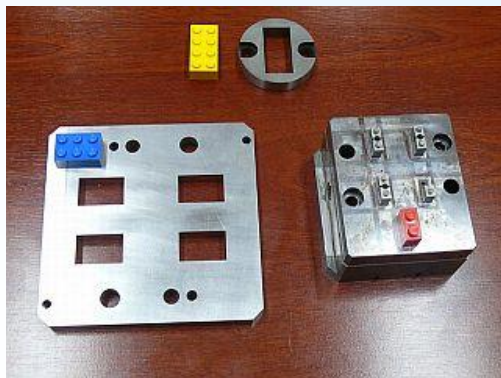

# References in engineering plastics

**PLASTIC-FORM**

Mouldmaker Ltd

## High pressure cleaning machine

Product development with Nilfisk-Alto in the Neptune 2 project.



Nilfisk – E-box



# References in engineering plastics

## Vacuum cleaner

Product development and making of new injection moulding tools in Nilfisk-Advance's GAS15 project.



# References in engineering plastics

## Case of drilling machine

Product development and making of new injection moulding tool for the drill BOSCH PSR 10.8 Li.



# References in engineering plastics

## Two components plastic parts

Producing of one plastic part by two steps, using of two injection moulding tools.

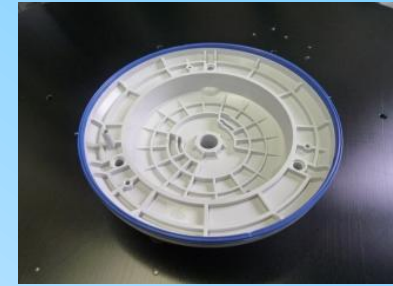
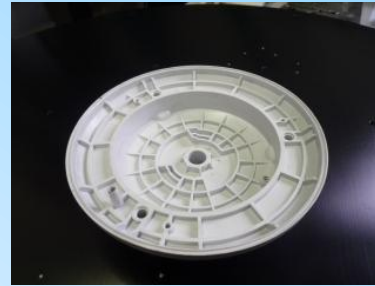

# References in packaging technology

## Our partners in

- **Packaging technology:**
  - PANNONPLAST GROUP
  - UNILEVER HUNGARY LTD
  - MALMARKS INTERNATIONAL AB



# References in packaging technology

Blow moulding tools for petrol-cans.  
Customer: Malmarks International Ab



# References in household products

## Our partners in

- **Household products:**

- IL-PE LTD
- STAR-PLUS LTD
- POLIPACK LTD
- CURVER





# Other references

## Zenith seat and backrest



## Other references

# Repairing, modifying and maintaining of injection and blowing moulds



## Other references

# Repairing, modifying and maintaining of injection and blowing moulds



Burr removing from lining moulds on the full circuit

at Karsai Plast Ltd



## Plastic-Form Kft.

Please accept this  
as a token of our  
appreciation  
for your excellent support  
of the Activate Program!

Kérjük, fogadja elismerésünket  
az Activate Programban nyújtott  
kiemelkedő támogatásáért!

László Ujvári - Project Manager

Rick Hopkins - Senior Program Manager

András Kurucz - Managing Director, Protekon Kft.

Adam Bezman - Senior Product Manager

Daniel Repplinger - Manager,  
Program Management

Kenneth Laughlin - Director,  
Program Management

Robert Goetsch - Global Sourcing Manager

Zoltán Fábrián - CPO Program Manager

# Geographical position

**PLASTIC-FORM**

**Mouldmaker Ltd**

GPS: N 47° 30' 28.93" & E 21° 40' 4.02"

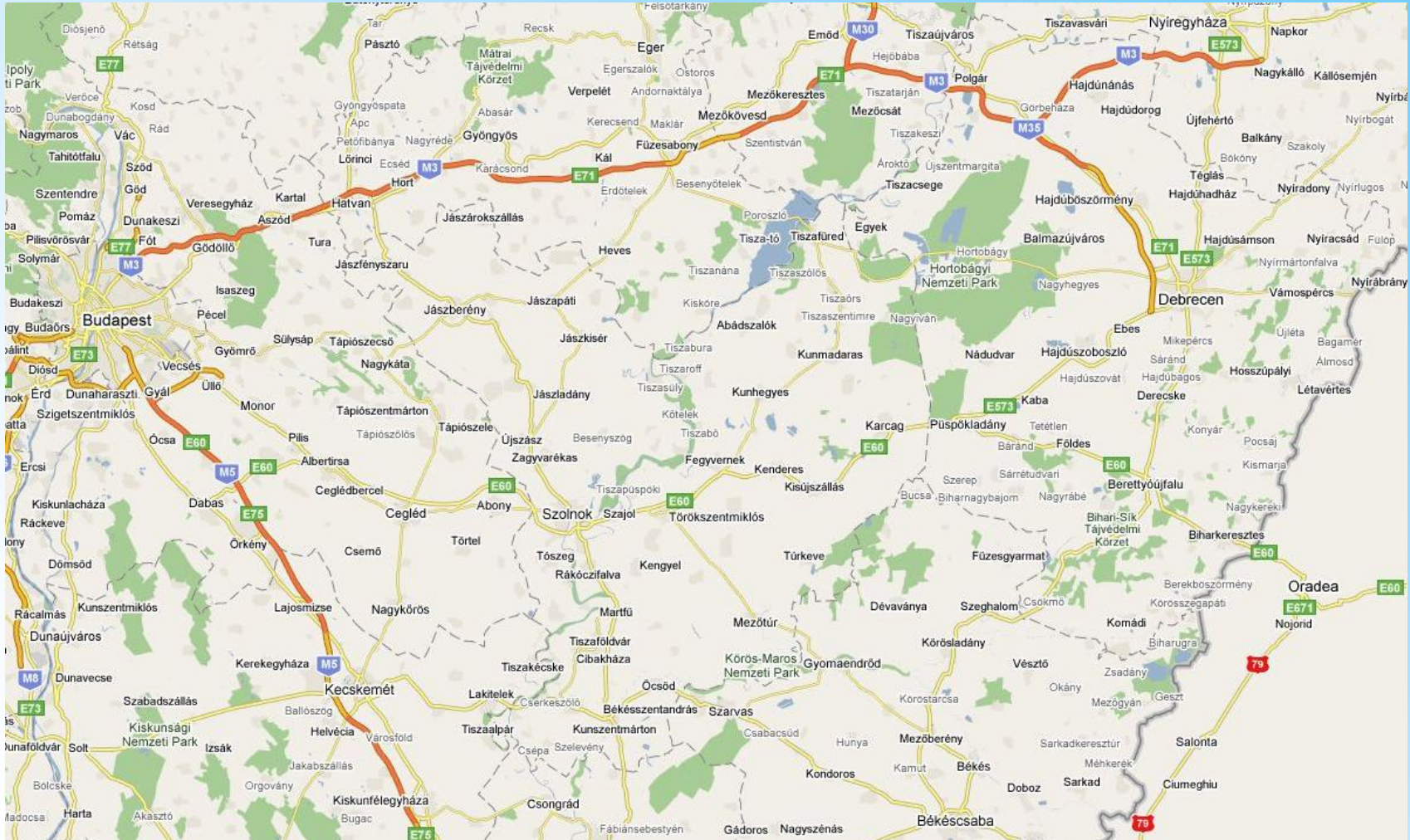

# Geographical position

GPS: N 47° 30' 28.93" & E 21° 40' 4.02"



# Geographical position

GPS: N 47° 30' 28.93" & E 21° 40' 4.02"



# Contact

**PLASTIC-FORM**

**Mouldmaker Ltd**

## **Plastic-Form Ltd**

Hungary, 4002 Debrecen, Jegvirag 16.

### **Zsolt Burai**

#### **Managing director**

Telephone: +36-52 / 446-284  
Mobile: +36-30 / 382-1268  
Fax: +36-52 / 535-013  
E-Mail: [buraizsolt@plasticform.hu](mailto:buraizsolt@plasticform.hu)

### **Janos Burai**

#### **Manufacturing director**

Telephone: +36-52 / 446-284  
Mobile: +36-30 / 965-1011  
Fax: +36-52 / 535-013  
E-Mail: [buraijanos@plasticform.hu](mailto:buraijanos@plasticform.hu)

### **Enikő Burai**

#### **Financial director**

Telephone: +36-52 / 446-284  
Mobile: +36-30 / 683-2091  
Fax: +36-52 / 535-013  
E-Mail: [buraieniko@plasticform.hu](mailto:buraieniko@plasticform.hu)



# Contact

**PLASTIC-FORM**

**Mouldmaker Ltd**

## **Plastic-Form Ltd**

Hungary, 4002 Debrecen, Jegvirag 16.

### **Janos Jobbagy**

**Technical assistant, quality manager**

Telephone: +36-52 / 446-284

Mobile: +36-30 / 636-9414

Fax: +36-52 / 535-013

E-Mail: [jobbagyjanos@plasticform.hu](mailto:jobbagyjanos@plasticform.hu)

### **Rudolf Jonas**

**CAD/CAM engineer**

Telephone: +36-52 / 446-284

Mobile: +36-30 / 496-1930

Fax: +36-52 / 535-013

E-Mail: [jonasrudolf@plasticform.hu](mailto:jonasrudolf@plasticform.hu)

### **Peter Nyirkos**

**Technical assistant**

Telephone: +36-52 / 446-284

Mobile: +36-30 / 604-1610

Fax: +36-52 / 535-013

E-Mail: [nyirkospeter@plasticform.hu](mailto:nyirkospeter@plasticform.hu)

**THANK YOU  
FOR YOUR ATTENTION!**