

# **OWNER'S GUIDE**



**JENSEN MARINE CORPORATION**  
235 Fischer Street • Costa Mesa, California • (714) 540-3440

## **IMPORTANT PLEASE READ**

## OWNER'S GUIDE - CAL-34

Welcome into the fast-growing owner's group of Jensen Fiberglass Yachts! Your CAL-34 has been carefully engineered and built to require a minimum of maintenance and a maximum of sailing pleasure. To insure this, the following is a description of the operational checks and tasks normally dealt with by the owner to maintain his CAL-34.

Let's become acquainted with these various operations by preparing a CAL-34 for a day's sail and discussing the maintenance routine which you should follow. It is good practice to close the Fuel Shut-off Valve and all Sea Cocks, except two, when leaving your boat, especially for extended periods of time. The "coming on board" and the opening of these fittings starts our "Sailing Check-off List."

### I. TANKAGE

A 25 gallon regular gas tank is located under the cockpit sole fill cap and vents aft in the port winch island. The Fuel Shut-off Valve is on the tank's forward starboard side and is reached via an access port in the starboard quarter berth. When the handle is parallel to the fuel line it is OPEN, at right angles, it is CLOSED. When not operating the engine, this valve should remain CLOSED. A partially filled gas tank can cause water condensation, a major cause of sticky valves. To avoid this, we recommend keeping the tank full and the carburetor bowl clean.

A 21 gallon fresh water tank is under the forward double berth. The tank fill, a bronze plug with a  $\frac{1}{2}$  inch square recess, is on the aft end and the vent is in the forepeak.

### II. SEA COCKS

All thru-hull fittings, except the optional speed indicator, are equipped with gate valves. To OPEN, turn counter-clockwise, to CLOSE, turn clockwise. Following is the location and function of these valves, starting with the two which remain OPEN at all times.

#### A. COCKPIT SCUPPERS, port and starboard

These two  $1\frac{1}{4}$ " valves are on either side of the engine and must remain open at all times to keep the cockpit dry. Both valves can be reached by removing the main companionway ladder. Once a month, close and re-open these valves to keep them in working order. At this time, check the packing glands on ALL gate valves to avoid water seepage.

## B. ENGINE COOLING WATER INTAKE

Located under the cabin sole at the foot of the main companionway ladder, this  $\frac{1}{2}$ " valve must be open when the engine is running. Water in the bilge? Our fiberglass hull is water tight but the ice box drains into the bilge! Also there could be some seepage from the thru-hull fittings and there should be a little from the propeller shaft packing gland. The optional Hand Bilge Pump is in the battery compartment under the aft settee seat.

## C. GALLEY SINK AND LAVATORY DRAINS

There are  $\frac{3}{4}$ " valves below both sinks. These valves should be kept closed while sailing as excessive heel could fill the sinks and splash water into the interior. If you have equipped your CAL-34 with an optional Depth Indicator Box, it is located below the head sink.

## D. MARINE TOILET WATER INTAKE AND DISCHARGE

The  $\frac{1}{2}$ " Water Intake Valve is located in the forward starboard hanging locker while the  $1\frac{1}{4}$ " Discharge Valve is directly behind the bowl. They may be kept open while sailing with no ill effects assuming the internal "Joker" valve is not held open by refuse.

## III. ENGINE

Operation procedures are well covered in the enclosed manual. Several important points should be re-emphasized.

- A. Turn the Main Battery Switch, located to port of the main companionway ladder, to the position you have designated as the engine battery. When the engine is IDLING, you may switch from one battery to another for charging. NEVER pass through the "OFF" position when the engine is running or the Alternator Diodes will be burned out. If both batteries are of equal charge, keep selector switch in "ALL" position. This position is also used to start the engine when both batteries are low. When not operating the engine, use one battery for ship's gear, thus saving the second battery for starting the engine.
- B. Run the Blower five minutes prior to starting the engine. Switch is on the main instrument panel in the starboard cockpit seat locker while the blower discharges out thru the port transom deck vent.
- C. Remove the Main Companionway Ladder. Check:
  1. Keep the Engine Oil Level between the #1 and #2 marks on the Bayonet Oil Gauge. Oil should be changed every forty to fifty operating hours with three to four quarts of SAE #30 "H.D." detergent oil. Havoline is



recommended by the manufacturer. After 1966, the built-in hand sump pump was replaced by a separate hand sump pump.

2. Periodically add oil to the Distributor Cup and tighten the Water Pump Grease Cap.
  3. The Carburetor Fuel Bowl may have to be filled using the hand primer on the fuel pump.
  4. Oil in the V-Drive Box should be changed after the first fifty hours and every 500 hours thereafter. Clean the magnetic drain plug at this time. Less than a one pound can of "Lubriplate APG-80" or the equivalent will fill the box. Note the dip stick on the port side and the rubber hoses leading in and out. The main engine sea water circulating system cools the V-Drive prior to its entering the engine.
  5. Propeller Shaft Packing Gland is directly under the transmission and should be damp. Tighten the nuts snug enough to eliminate any excessive water drips.
- D. Place Shift Lever into the large diameter ring of the Morse Control Head on the starboard cockpit seat riser. Start engine with lever in Vertical or NEUTRAL position. Lever FORWARD is FORWARD, AFT is REVERSE.
- E. Place Throttle Lever into the Notched Control Head and advance about 45° to start engine. Note that the throttle may be adjusted without the lever by grasping the notched control head and turning to the desired setting. Additional information on the Morse Control Unit has been included for your convenience.
- F. Water and fuel lines OPEN?
- G. Pull out Ignition Switch and Choke. Press Starter Button. When engine starts:
1. Gradually push in Choke.
  2. Adjust throttle to idling speed.
  3. Check Oil Pressure: 30 to 35 pounds on a cold engine.
  4. Cooling System is operating only if water is coming out of Exhaust Outlet in transom.
  5. If oil pressure is low, STOP the engine and check oil level.
  6. If water does not begin to flow out the transom outlet within 3 or 4 minutes, STOP the engine and check water intake valve.

7. Turn off Blower.

H. Run engine at Idle when shifting into forward or reverse. If equipped with a Martec Prop, (Right Hand, 16" x 13 x 1") please follow the instructions in the Appendix. At half throttle the CAL-34 will power around 6.5 knots using about one gallon of fuel per hour. In smooth water, higher speeds can be obtained with higher RPM's but fuel consumption will increase accordingly.

I. To Shut Down engine:

1. Push IN Ignition Switch.
2. Close Fuel Shut-off Valve and Cooling Water Intake Gate Valve.
3. Mark and align Propeller Shaft for Sailing Position and shift into FORWARD to lock. With a standard two blade solid or feathering prop, the blades should be vertical. With a folding prop, the blades should be horizontal.

#### IV. GALLEY

The Water System and Sink Drain have been covered earlier. Mention was also made that the 50 pound Ice Box drains into the bilge. A 2 or 3 burner Pressure Alcohol Stove is the normal optional installation so we have included operating instructions in the Appendix. A few additional points on stove operation are important.

The optional 2 gallon pressure tank is located behind the galley sink. When filling this tank, please observe the following BEFORE removing the stopper:

1. All burners are OFF.
2. Main Alcohol Shut-off Valve on top of pressure tank is CLOSED.
3. Tank pressure is ZERO: Remove Stopper.
4. Fill the tank three-quarters full to allow for air pressure.
5. Replace stopper and screw down tight.
6. Experience has shown that 5 pounds of tank pressure is more than adequate and imposes less strain on the fittings than the recommended 10 pounds.

#### V. HEAD

Operating instructions for the Marine Toilet are inclosed

but additional information and replacement parts can be obtained from the manufacturer.

Don't forget the earlier Gate Valve instructions!

## VI. ELECTRICAL SYSTEM

A 12 volt battery, with Master Switch and 15 amp fuses stores power for the electrical system. The Battery Compartment is under the aft settee seat. Factory installed batteries are an automotive type whose water level and charge must be checked. Since the engine is equipped with a 30 amp alternator, the Master Switch gets special attention and is covered under Step "A" of the engine section.

- A. All Exterior Light Switches are in the starboard cockpit seat locker instrument panel. The Fuse Panel is behind the Master Switch. All Cabin lights are individually switched but have their fuses here. Dim light indicate low batteries: Keep batteries well charged to avoid being "in the dark!"
- B. Double outlets for the optional 110 volt Shore Power are in the galley and head. The Breaker Switches are on the engine compartment bulkhead. The optional Speed Indicator thru-hull is under the center cabin sole inspection plate.

With the engine running, your CAL-34 is ready to get underway. We should pause for a moment and look about the deck and thus become acquainted with the sailing gear.

## VII. SPARS, RIGGING AND HARDWARE

It is impossible to fully guarantee the mast of your CAL-34 under our current warranty program. Rigging as well as tuning becomes all important when setting up the mast because of the light weight section we use. A knowledgeable person should oversee the rigging and tuning so as to eliminate the possibility of an eccentric load which might occur with an improperly loaded shroud. Special attention should be given to the initial stretch of the uppers and a further gradual stretch of the wire over the first few hard races.

### A. MAST TUNE

The mast should be set straight athwart-ships in the boat and have a slight rake aft. A straight mast can best be obtained by turnbuckle adjustment while sailing to windward in a 5 to 10 mph breeze. The head of the mast should NOT "hook" to windward. If not straight, it would be more desirable to have the head "fall-off" slightly to leeward. This should give the mast a smooth, even curve from head to deck. Sighting along the back of the mast on each tack, from deck level, will give a comparison and indicate the necessary adjustments.

For normal cruising conditions, we recommend a "loose" rig. Thus a dock side starting point would have the headstay, backstay and uppers just firm, with the lowers fairly loose. Now the backstay may be made slightly tighter to "hook" the top of the mast aft. One should be able to stand facing the mast, reach out and pull on any shroud and see the mast move in that direction. Try to get tension on both shrouds equal with about  $\frac{1}{2}$ " to 2" of play on the uppers and 2" to 3" on the lowers. The forward lowers might be slightly tighter than the after lowers.

When racing, the backstay may be tightened up to compensate for the additional forward loading applied by the genoa. At the conclusion of the race it is best to "slack-off" the amount you "took-up" on the backstay turnbuckle. This avoids setting up unnecessary strains on the hull and rig. Under NO circumstances should any of the rigging be set up "bar-tight."

A description of all standing and running rigging, if replacement is necessary, can be found in the Appendix. Following are some maintenance tips which should be of value.

#### B. SPARS

The finish of natural aluminum is protected against corrosion by a thin, transparent film of aluminum oxide. Dust, dirt, smoke, salt and traffic fumes will adhere to this film, making the surface dull and unsightly. Coating the new surfaces with a good paste wax like Vista or Simonize, will help protect the aluminum oxide from foreign matter. If the surface has become tarnished, any high grade cleaner - wax - polish (Collinite #34 or #38 for example) will restore the original sheen. Heavier pitting can be removed by wet-sanding with #600 paper prior to polishing and waxing. You need not worry about sanding, cleaning or polishing destroying the aluminum oxide film as it reforms or "heals" immediately.

Painted spars may require a touch-up in areas of chafe. Use the same or compatible paints for this job. Epoxy is applied at the factory. "Rust-Oleum", in spray cans, is an excellent touch-up paint.

If spars are black anodized, hose down portions subject to salt water spray after each sail.

The spreaders are of spruce and have been well varnished. Because of sail chafe and weather, they should be sanded and re-varnished every six months and the tips re-taped.

#### C. RIGGING

Clean rigging means clean sails. A quick trip aloft



with damp rags rakes care of this problem. While aloft, check the entire rig for loose screws, nuts, bolts, cotter pins and chafe which may have resulted from hard sailing. Periodic inspection of the rig from aloft is your best insurance against rigging and spar failure. Keeping halyards tied away from the mast stops the annoying dockside clanking and saves the mast finish.

Salt water will gradually stiffen dacron line. Hosing with fresh water or soaking in warm soapy water will make the line soft and flexible again. Keep coiled and stowed in a dry spot below.

#### D. HARDWARE

Many materials are used, all of which clean well with fresh water and a chamois. Winches must be kept clean and well oiled (Lubriplate is excellent unless the manufacturer recommends otherwise) as do all turnbuckles, track slides, sheaves and shackles. The chrome and stainless steel brighten up with the chamois while a good automotive chrome cleaner or mild kitchen abrasive like Comet takes care of the tarnished spots.

Keep all gear lubricated and in good working condition. Remember, the less an item is used, a turnbuckle, for example, the more apt it is to freeze-up.

#### VIII. SAILS

The mainsail, with battens removed and out haul slacked, is properly furled on the boom, under a cover. Headsails have been stripped of sheets and battens, properly folded and are bagged below ready to be brought on deck. The dacron and nylon sails do get wet and become caked with salt. When they do, hose them off with fresh water and dry thoroughly by hoisting them at the dock on a still, warm day.

Take care of your sails with periodic checks, especially spinnakers, for small tears and chafe. Hoisting and lowering sails, except spinnakers, while head-to-wind is good practice and easier on the sails.

#### IX. FIBERGLASS SURFACES

Periodic application of Tide and fresh, warm water with deck brush and sponge followed by a good hosing and chamois will do the cleaning job. If the gloss dulls or fades, wax the smooth surfaces with Vista or Meguiar's Mirror Glaze paste wax. Surfaces that have started to oxidize can be brought back with Meguiar's Fiberglass Boat Cleaner or DuPont White #7 Polishing Compound. Wax the hull with a power buffer and paste wax once a year. The non-skin surfaces can be brought back to life with a lather of Tide or Mr. Clean. Be sure to follow up with lots of fresh water to avoid streaks on the topsides.



Avoid any metal filings on the fiberglass surfaces as they will leave rust spots. These spots can be removed with oxcolic acid or Teak-Brite but first test a small area against bleaching out the surface color.

Consult the enclosed booklet for touch-up work and minor scars or breaks.

#### X. WOOD SURFACES

Aside from the spreaders, only the tiller will require a gloss varnish and should be re-varnished along with the spreaders. The rest of the exterior is teak which is weather resistant due to its natural oils. Teak does fade to a dull gray, which, if objectionable, can be scrubbed clean with "Teak-Brite." Teak's natural color and texture can be preserved by applications of Weldwood's "Woodlife" or similar sealers. Teak, when well varnished, produces the ultimate in a yacht wood finish but requires constant loving care!

All below deck mahogany surfaces are finished with a satin varnish. Treat all the materials used below deck as a home interior. Air is a wonderful cleaner: bring the vacuum cleaner aboard and always keep the boat well ventilated, especially the bilge and lockers.

Jensen Marine's interest in both customer and product continues long after you have commissioned your CAL-34. Within the limits of our specifications, the company's Parts Department is ready to serve your nearest dealer quickly and efficiently. All replacement parts or accessories are delivered through your dealer. He must have detailed information from you to be certain we send the parts requested.

Additional sailing and maintenance tips can be found in various boating publications. Yachting's Annual Maintenance Issue is an excellent starting point.

This brings us to the end of our "Sailing Check-List" and leaves only the securing of your CAL-34. If we ran the list in reverse, adding only one item, your CAL-34 will be ready for the next sail. This one important item is a GOOD HOSING. Nothing keeps a boat better than fresh water and the chamois. Use plenty of pressure, especially in the cockpit scuppers, non-skid areas and metal surfaces. Turn to with sponge and chamois and you will be rewarded with a sharp, sparkling yacht that is only matched by its comparable performance.

Good Luck and Happy Sailing

JENSEN MARINE



**CALIFORNIA MARINE PRODUCTS inc.**

P. O. BOX 1743 • (714) 646-1823 • NEWPORT BEACH - CALIF 92663

# **HILLERANGE**

## **INSTRUCTIONS FOR CARE AND OPERATION**

The alcohol burners in this range are designed to give trouble-free operation during years of use. Follow the simple operational suggestions and you will be assured of full satisfaction.

### **FUEL**

Gum-free alcohol should be used. To check, pour a little in a clean saucer, ignite it, and if a gummy residue remains, do not use in the stove. Personally I prefer a good clean denatured alcohol, some of which are virtually odorless.

### **OPERATION**

1. Priming the HILLERANGE is quickly and easily accomplished. It is necessary to preheat the burner and generator tube that runs over the center of the burner which gasifies the liquid alcohol.

2. First, pump up the tank pressure to approximately 10 pounds. Then turn valve knob counter-clockwise about ½ turn and count three slowly, which allows alcohol to flow into the pan under the burner. **CLOSE THE VALVE.** Wait a moment or two for the fuel to soak into priming wick. Then light. The priming flame should not be more than three or four inches above the burner. **IF IT IS HIGHER, YOU ARE PRIMING TOO MUCH!**

3. When the fuel in the priming pan is nearly burned out or blue flame around the burner shows the generator is heated, open the valve slowly, thus lighting the burner.

The full blue cooking flame will appear when the prime is entirely burned out.

4. Perfect control of your cooking flame is obtained by opening or closing the control valve. Unless fuel tank is nearly empty, very little additional pumping is required to maintain the air pressure. If more heat is desired, simply increase the tank pressure.

5. When through cooking, shut the control valve, **BUT NOT TOO TIGHT.** It usually takes a few seconds after closing the valve for the flame to die down. **DO NOT ATTEMPT TO FORCE THE BURNER CLOSED.** Force will injure the burner seat and may render the entire stove useless until new parts are installed. Release the pressure in the fuel tank by loosening the filler cap. Then loosen the burner control valve slightly so it will not seize or stick when the burner cools. **WHEN THROUGH COOKING, WE AGAIN EMPHASIZE; RELEASE THE AIR PRESSURE IN THE FUEL TANK AND SEE THAT ALL BURNER CONTROLS ARE CLOSED!**

### **MAINTENANCE**

Your HILLERANGE requires no attention other than normal cleaning. A poor or improper flame will usually indicate a dirty burner or clogged generator. In the event the trouble is in the generator, it is best to secure the services of a mechanic familiar with alcohol burners.

- Continued -

## LEAKAGE

The threaded joints in the HILLERANGE are all set up with an excellent heat resistant joint compound, and leaks at these points are extremely rare. The stuffing box on the valve stem is filled with a time tested packing. If leakage occurs at this point and flame appears at the stuffing nut, a 1/2" open end wrench will quickly tighten the nut, moving the wrench clockwise. If it persists a drop of light oil on the valve stem will lubricate the stem, and once the nut is tightened, no more trouble should occur.

**REMEMBER:** Water extinguishes burning alcohol. Your priming flame should not be more than three or four inches above the burner. **IF IT IS HIGHER YOU ARE**

**PRIMING TOO MUCH.** Releasing the air pressure on the tank always cuts off all fuel flow through piping and burners.

## CLEANING FUEL TANKS

When moisture accumulates in the fuel tank or in the cans kept as storage — the entire mixture should be thrown out. Water or moisture will tend to increase the accumulation of rust, dirt and foreign substances in the tank. These particles, carried to the burner will bake hard in the generator until the passages become completely clogged and the burner and generator must be replaced. It is suggested in cleaning the tank that it be removed from the boat, and dumped, making sure all scale, etc. is removed before replacing.

**IN CASE OF FIRE ABOUT BURNERS OR IN OVEN,  
DASH WATER ON FLAMES —  
THIS IS ALWAYS EFFECTIVE ON AN ALCOHOL FIRE.**

## ALCOHOL BURNER REPAIR PARTS

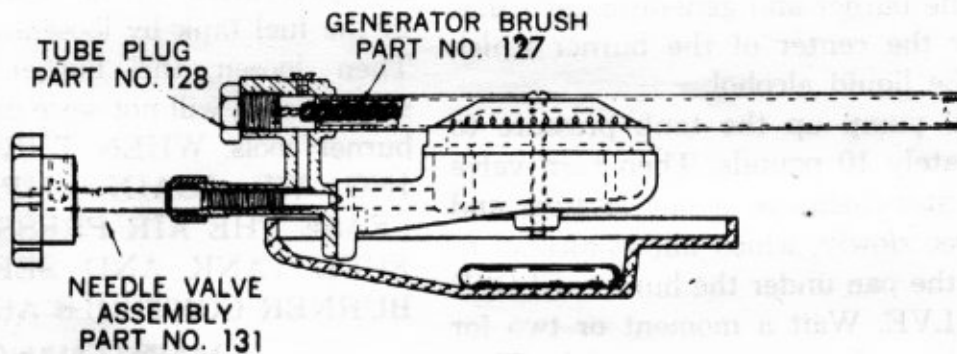

*Order By  
Part No.*

*Description*

124	Burner complete, as illustrated .....	\$19.00
128	Generator Tube Plug .....	.75
127	Generator Brush .....	1.50
125	Generator Tube, with end castings (does not include Part No. 128) .....	9.50
129	Burner Casting only .....	3.50
130	Priming Pan .....	3.00
131	Needle Valve Assembly .....	3.50



CAL-34  
WIRING DIAGRAM

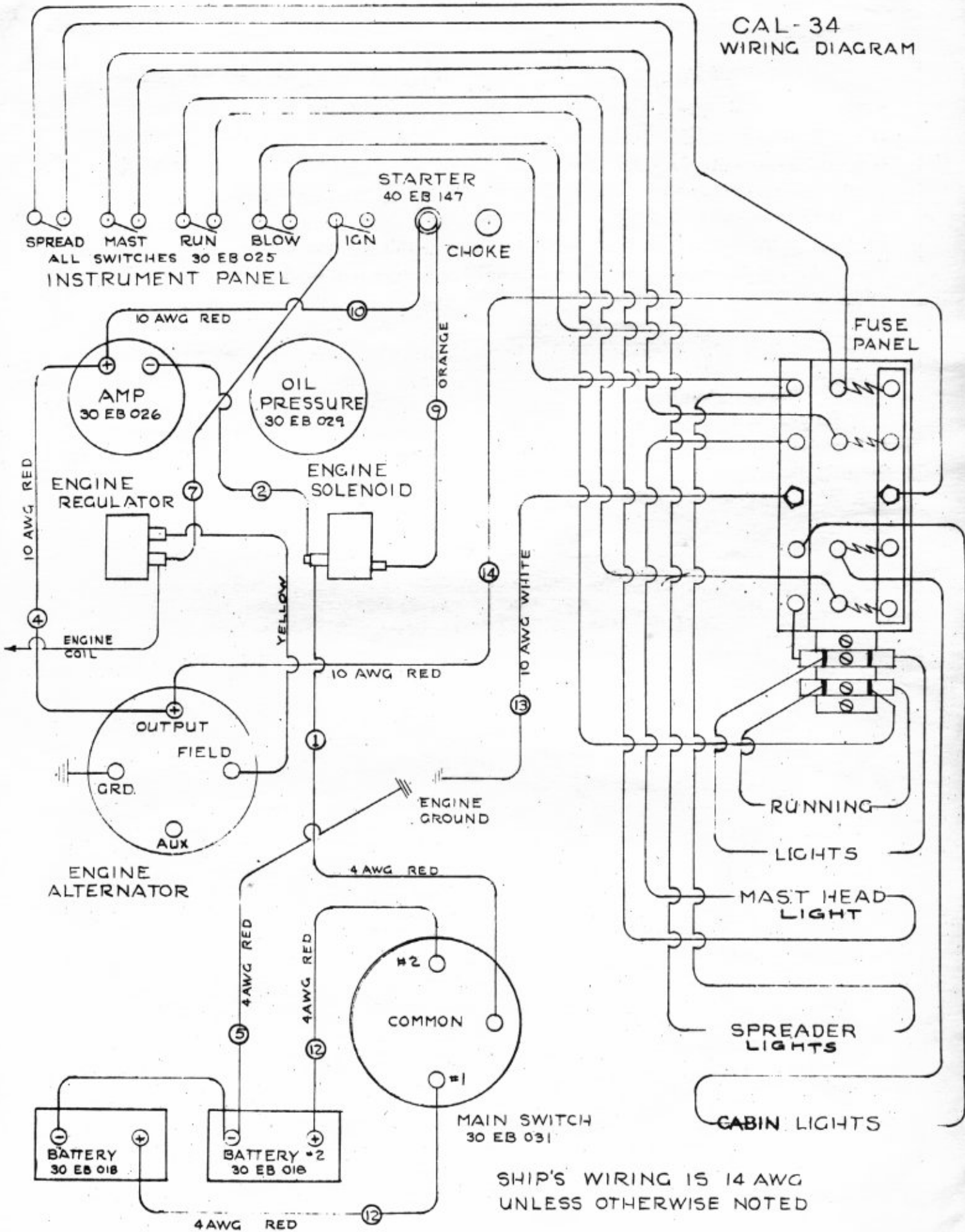

CAL-34

STANDING RIGGING

- 1 - Headstay - 9/32" 1x19 s/s x 39'10 $\frac{1}{4}$ ", Marine Eye & Fork with  $\frac{1}{2}$ " Pin
- 1 - Backstay - 7/32" 1x19 s/s x 42'0 $\frac{1}{4}$ ", Marine Eye & 3/8" Thd. Shank
- 1 - Boom Lift - 1/8" 7x19 s/s x 4'0", Nico Sleeve & Snap Hook @ 8'7"
- OR OPTIONAL
- Adj. Backstay - 7/32" 1x19 s/s x 41'8 5/8", Marine Eye top & 3/8" Sherman-Johnson Thd. Shank with handle bottom
- Boom Lift - 1/8" 7x19 s/s 4'0", Nico Sleeve & Snap Hook @ 8'4"
- 2 - Uppers - 7/32" 1x19 s/s x 37'11 $\frac{1}{2}$ ", Fork & 3/8" Thd. Shank
- 4 - Loweres - 3/16" 1x19 s/s x 18'8 $\frac{1}{2}$ ", Fork & 3/8" Thd. Shank
- 2 - Life Lines - 3/16" 1x19 s/s Plastic Coat x 29'6", Fork with Pelican Hook &  $\frac{1}{4}$ " Thd. Shank

NOTE:

- 1) All dimensions are center eye to eye or end of Thd. Shank.
- 2) On Insulated Backstays, keep insulators as far apart as possible and the lower insulator above the Boom Lift Nico Sleeve.

RUNNING RIGGING

- 1 - Main Halyard - All Wire - 1/8" 7x19 s/s x 73' Wire Rope
- 1 - Main Halyard - Standard - 1/8" 7x19 s/s x 36'10" Wire Rope
- 1 - Jib Halyard - " - 3/16" 7x19 s/s x 39'1" " "
- 2 - Halyard Tails - " - 3/8" x 40' Dacron Yacht Braid
- 1 - Main Sheet - " - 3/8" x 84' " " "
- 2 - Jib Sheets - " - 7/16" x 45' " " "
- 1 - Down Haul - " - 5/16" x 6' " " "
- 1 - Out Haul - " - 1/8" x 5' " " "

SPINNAKER GEAR

- 1 - Spinnaker Halyard - 3/8" x 82' Dacron Yacht Braid
- 2 - Spinnaker Sheets - 7/16" x 46' " " "
- 1 - Topping Lift - 5/16" x 63' " " "
- 1 - Fore Guy - 5/16" x 43' " " "

REEFING GEAR ON BOOM

- 1 - Clew Pennant - 3/8" x 30' Dacron Yacht Braid
- 1 - Tack Pennant - 5/16" x 17' " " "



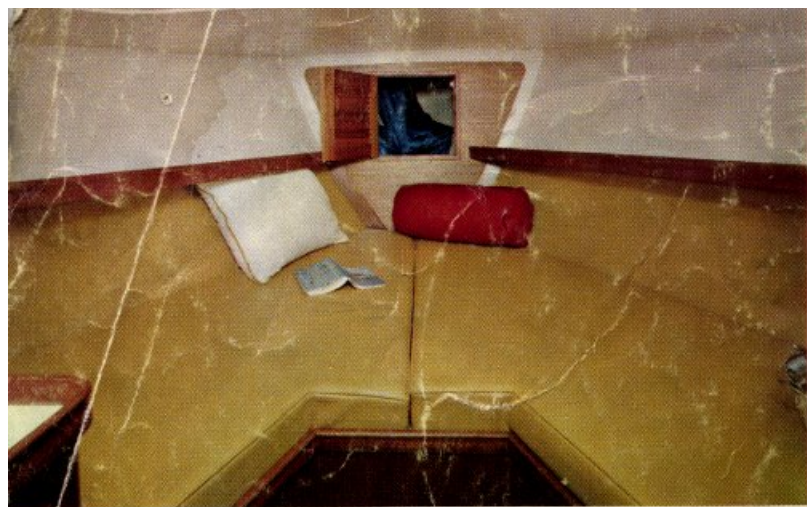

## CAL 34, BRIGHT TWO CABIN INTERIOR:

The bright two cabin interior of the Cal 34 is light and airy with 8 windows and warm natural mahogany finish throughout. Forward cabin has a double berth, a spacious hanging locker and a built-in dresser. The head is privately separated from either cabin by two mahogany doors and contains a mirrored dressing table and a generous hanging locker.

## CAL 34 — SPECIFICATIONS:

**STANDARD EQUIPMENT** *Hull:* One-piece reinforced fiberglass lamination. *Deck, trunk cabin, and cockpit:* Integrally molded fiberglass lamination with additional deck stiffening. Colors (20 to choose from) and non-skid surfacing are molded in; all exterior trim is natural teak. *Ballast:* Cast lead, 3,750 lbs. *Rigging:* Aluminum mast and boom. All standing rigging, including turnbuckles, fittings and cleats is stainless steel or bronze. Swaged fittings and Everdur chain plates. *Running rigging:* Dacron and stainless. *Winches:* Genoa halyard winch, and two #3 genoa winches. *Racing hardware:* Nine feet of stainless genoa track with 2 cars and 2 snatch blocks. Stainless mainsheet traveler track with stops, stainless spinnaker pole track on mast. 4 mooring cleats are mounted. *Ventilation and ports:* Four fixed aluminum framed windows plus four opening ports. *Water tank:* 26 gallon capacity, stainless steel. *Fuel tank:* 25 gallons, with shutoff valve. *Power:* Universal Atomic Four driving through a Walters V-Drive with 2:1 reduction; 7 knots nominal speed, with complete controls and instruments.

**ELECTRICAL EQUIPMENT:** 12 volt battery with 40 amp alternator; fused instrument panel; lighting in forward compartment, head, galley, dinette in addition to exterior running lights. *Berths:* Six vinyl covered foam berths. *Galley:* Stainless steel sink formica counter and 50 lb. icebox; four storage drawers and a front-opening cupboard. *Dinette:* Seats 6 to 8 comfortably, and converts into a double berth.

The large galley is located on the starboard side of the main cabin with a formica top, a 50 lb. ice box, a stainless steel sink with water pump and a room for a gimbaled three burner stove. There are two quarter berths for the extra tall crewmen, and plenty of stowage space for sails and other gear.

**OPTIONAL EQUIPMENT:** A wide variety of optional equipment is available for the 34, including pulpits, additional winches, life lines, spinnaker gear, cockpit cushions, electronic navigation and radio equipment, and gimbaled 3-burner stove with oven.

### DIMENSIONS

L.O.A. ....	33'3"	Ballast .....	3,750 lbs.
L.W.L. ....	26'	Displacement .....	9,500 lbs.
Beam .....	10'	Sail Area .....	515 Sq. Ft.
Draft .....	5'		

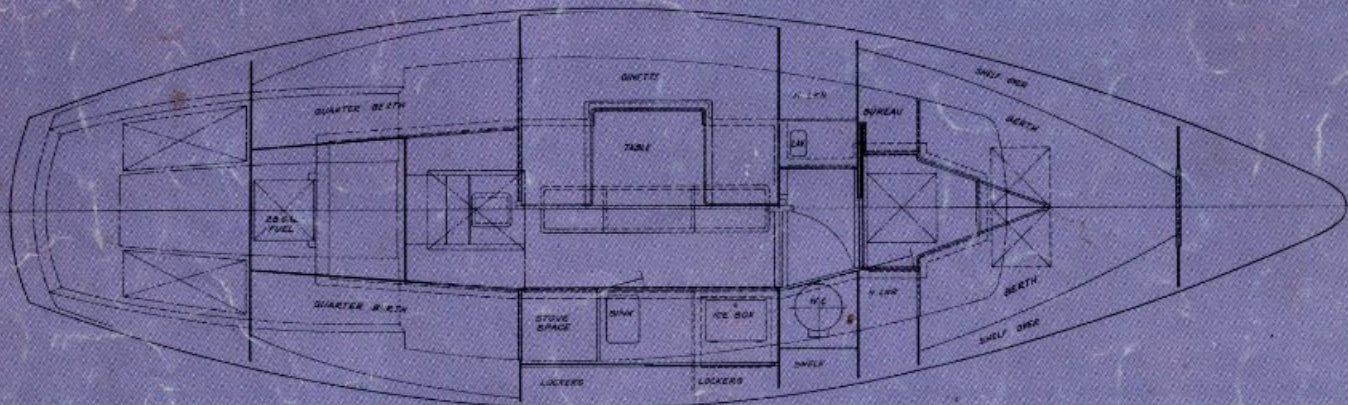

# JENSEN marine

A DIVISION OF BANGOR PUNTA CORPORATION

235 FISCHER STREET, COSTA MESA, CALIF., 92627

"BANGOR PUNTA'S WIDE WORLD OF BOATING" DUO/JENSEN/LUHR/S/O'DAY/SEAGOING/ULRICHSEN

20/21/22/23/24/25/26/27/28/29/30/31/32/33/34/35/36/37/38/39/40/41/42/43/44/45/46



# The new Cal-34

designed by C. Wm. Lapworth



DICK HUSSONG  
2353 SHELTER ISLAND DR.  
SAN DIEGO, CALIF. 92106

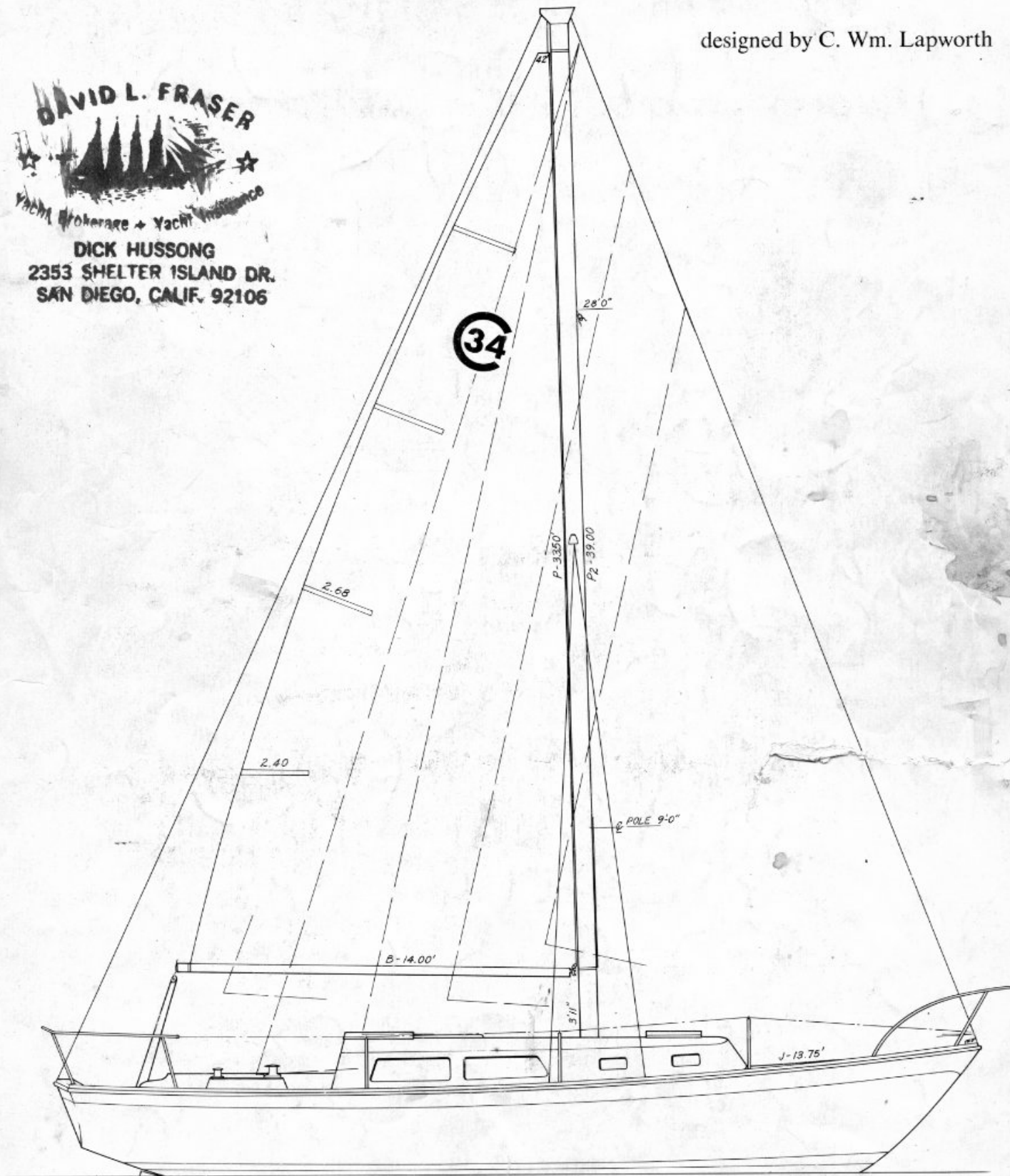

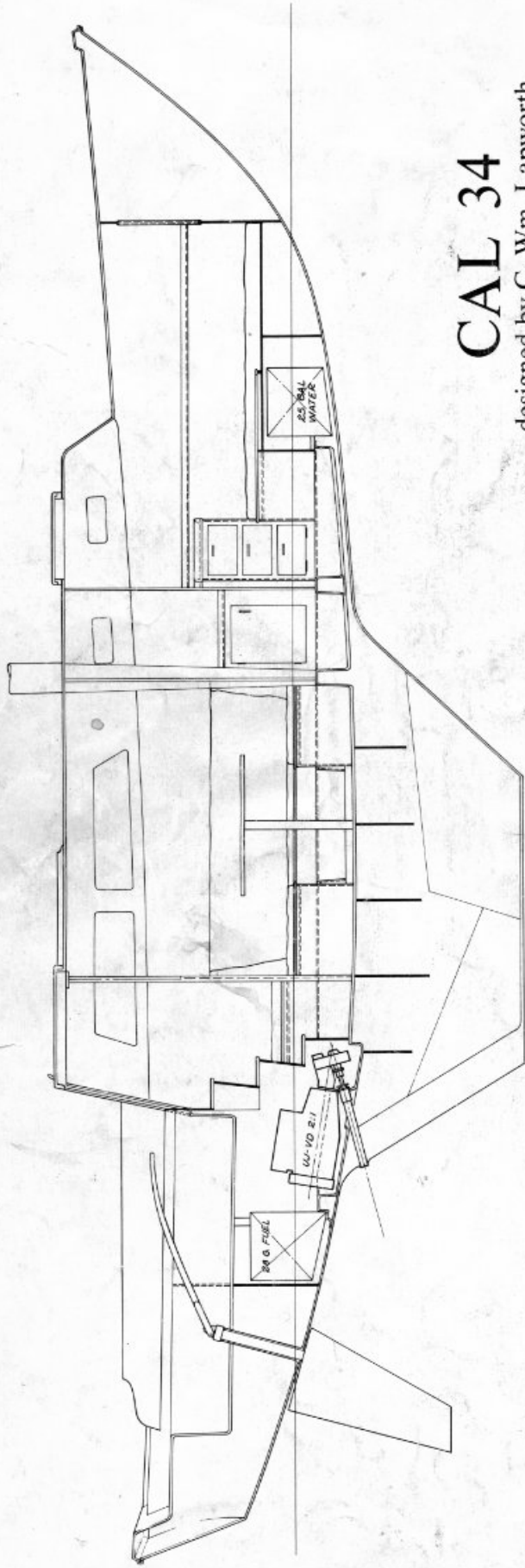

# CAL 34

designed by C. Wm. Lapworth

## DIMENSIONS

L.O.A. .... 33'3"  
 L.W.L. .... 26'0"  
 Beam .... 10'0"  
 Draft .... 5'0"  
 S.A. Area 515 sq. ft.  
 Displ. .... 9500 lbs.  
 Ballast .... 3750 lbs.

**JENSEN MARINE CORPORATION**  
 235 Fischer Street • Costa Mesa, California • (714) 540-3440

