



## Turning Shipping into a Competitive Advantage



**“Directly from within your SAP Landscape  
with ProShip Autobahn”**

**SAP**® Certified  
Integration with SAP Applications

Best Way Technologies, LLC  
29 N. Wacker Dr., Suite 700  
Chicago, IL. 60606  
(866) 944-2378

[www.bestwaytech.com](http://www.bestwaytech.com)

Best Way Technologies, LLC is a subsidiary of SPSI

Systems & Programming Solutions Inc.  
530 N. 108th Place, Suite 100  
Wauwatosa, WI 53226  
(800) 353-7774

[www.spsinet.com](http://www.spsinet.com)

TABLE OF CONTENTS

<b>Critical Success Factors</b>	<b>1</b>
Defining Objectives	1
The Best Way To Ship	2
ProShip's Benefits	3
<b>What ProShip Provides</b>	<b>4</b>
ProShip's Features/Functions	5
ProShip Enterprise Queuing System	6
Summing It Up	6
ProShip vs. the Competition	7
<b>Using Autobahn ProShip Software</b>	<b>9</b>
Ease of Use in SAP	9
Dashboards	10
Updates	10
Installation/ProCyclopedia	10
ProShip Office	12
ProShip Velocity	13
ProShip Labeler	13
ProShip Scheduler & Tracking	13
A Versatile and Effective Business Tool	14
<b>Appendix: Technical Considerations</b>	<b>15</b>
Carrier Certified Interfaces	15
Hardware Recommendations	16
ProShip Suite Diagram	18
<b>Contact Us</b>	<b>19</b>

## Critical Success Factors

Whether you are a SAP user in a busy business office, a large mail processing and production center, or a warehouse fulfilling high-volume package shipments, the timely and efficient handling of all your packages and outbound documents is one of your best – and most often overlooked – opportunities for gaining a competitive advantage. Put another way, if done right, you can turn your shipping department from a cost center into a profit center directly from within SAP.



With efficiency gains and customer satisfaction on the line, shipping is much more than just a financial issue. Operations managers, systems managers, sales managers, even website managers and call center managers have a stake in making sure that shipping actually adds value to your business.

But with multiple carriers, dozens of levels of service, constantly changing rates, and “gotcha” rules and restrictions, cost-efficient package shipping is fraught with many challenges, especially if your outbound parcels vary significantly in size and weight, and include anything hazardous, fragile, or perishable.

---

## Defining Objectives

The objectives in streamlining the shipping process are easy to summarize:

- Achieve the lowest possible freight costs on all shipments
- Reduce or eliminate any and all related charges
- Easily produce shipping labels and manifests in carrier-specified formats
- Increase operational efficiencies for high shipping volumes
- Improve on-time deliveries without increasing costs
- Exceed customer expectations for receipt of shipment
- Integrate perfectly with SAP ECC 4.6 or higher, electronic scales, label printers and other applications to leverage investments in existing technology
- Provide methods to charge back costs to originating departments
- Support for carrier invoice reconciliation
- Ease of use in a warehouse environment, including touch-screen interfaces when practical
- Provide accurate, usable reporting of all shipping costs and activities

Achieving those objectives is another matter, particularly if your shipments include international destinations requiring the use of multiple brokers and complex third-party duties and taxes.



## The Best Way to Ship

There is simply no way to achieve a competitive advantage in shipping today without using an integrated solution that can provide not only sophisticated “rate shopping” among a wide variety of carriers and services (including LTL and other freight haulers), but can also serve as a fully integrated, “turnkey” asset in your data management arsenal. Like any other profit-seeking function, cost management in the shipping world is a numbers-driven activity.



One of the leading solution providers able to achieve all of these objectives is Best Way Technologies ([www.bestwaytech.com](http://www.bestwaytech.com)), whose ProShip® Suite for managing multi-carrier parcel and LTL shipping is designed to optimize virtually any shipping environment including SAP Certified ProShip Autobahn. ProShip Autobahn allows you to utilize all of the benefits of ProShip directly from within your SAP environment. Best Way Technologies, part of the SPSI family of companies ([www.spsinet.com](http://www.spsinet.com)), operates five strategically located offices: Milwaukee, WI; Chicago; Minneapolis; Madison, WI and Cedar Rapids, IA.

With no limit to scalability, ProShip can handle over one million transactions an hour on a single system server, while supporting the most complex shipping methods, procedures, and business rules. It maintains all of the data associated with shipment history, interfaces to carriers for live package status and delivery updates, and can be configured to let your customers view their own orders and shipment information.

A multi-carrier parcel-shipping software suite, ProShip is a fully integratable, carrier-certified solution that can prepare your packages for nearly any parcel carrier, truck, rail or freight forwarder. Easily installed and customized, ProShip’s “Unified Shipping” capabilities can extend the rate shopping and accountability benefits of sophisticated multi-carrier shipping to your entire company, including advanced desktop shipping for office and warehouse employees.

The system’s multiple security and authentication capabilities protect sensitive data and assist with Sarbanes-Oxley and HIPAA compliance requirements. Shipping hazardous or dangerous materials? ProShip supports printing of your 49CFR and IATA declarations.

ProShip is a scalable enterprise solution, not a basic “PC” type of system. Yet ProShip’s modular architecture means you can install, pay for, and maintain only those

parts of the solution that you actually need, which saves both time and money.

SAP users can access all of the benefits of ProShip directly from SAP with our SAP Certified ProShip Autobahn shipping solution. In addition, our ProShip Velocity- [thick-client interface](#), ProShip Office- [Web Browser](#), SDK connection or XML application are some of the others ways you can access ProShip.

## ProShip Autobahn's Benefits

Before looking in greater detail at the more technical aspects of the system, let's summarize ProShip Autobahn's primary benefits, which compare favorably to the list of objectives above. Achieve all the benefits below from within your SAP Landscape:

- Seamlessly Integrated and Certified with the SAP ECC 4.6 or higher
- Fast manifesting at over a million packages an hour
- Certified by all major carriers
- Covers all carriers and service levels
- Carrier-compliant rate and manifesting engines
- Create new carriers quickly, as needed
- Best-in-class Service and Support
- Scalable, from a single work station to multiple warehouses
- Modular, enterprise architecture on multiple, fully integrated servers
- Accountable, with advanced reporting and visibility (instant access to tracking information for Customer Service personnel or direct to customers)
- International rates and manifests
- Unified rate-shopping throughout the company
- Run multiple instances and services simultaneously without ever having to bring the system down for maintenance
- The last shipping system you will ever need (constantly upgraded, never obsolete)

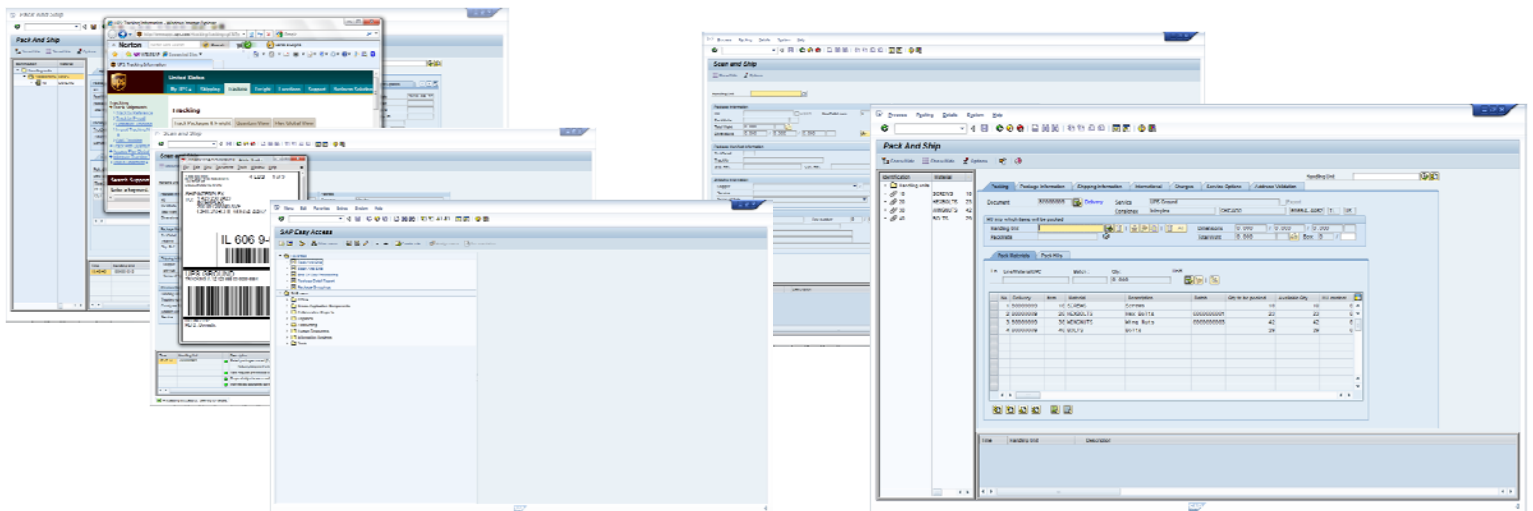

# What ProShip Provides

ProShip Unified Shipping Software consists of six modules:

- SAP Certified ProShip Autobahn
- ProShip Server
- ProShip Velocity
- ProShip Office
- ProShip Software Development Kit (SDK)
- ProShip Scheduling and Tracking

ProShip Server is the “heart” of the ProShip Suite (see diagram below). SAP Computer workstations company-wide can access ProShip's functionality and data from ProShip server via your existing corporate network with ProShip Autobahn.

With ProShip Autobahn, directly from SAP you have real-time monitoring of package status, tracking numbers, productivity reports, delivery status or other reporting features using any Internet browser with no special program installations required. A full-page version of the ProShip Suite Diagram below can be found on page 20.

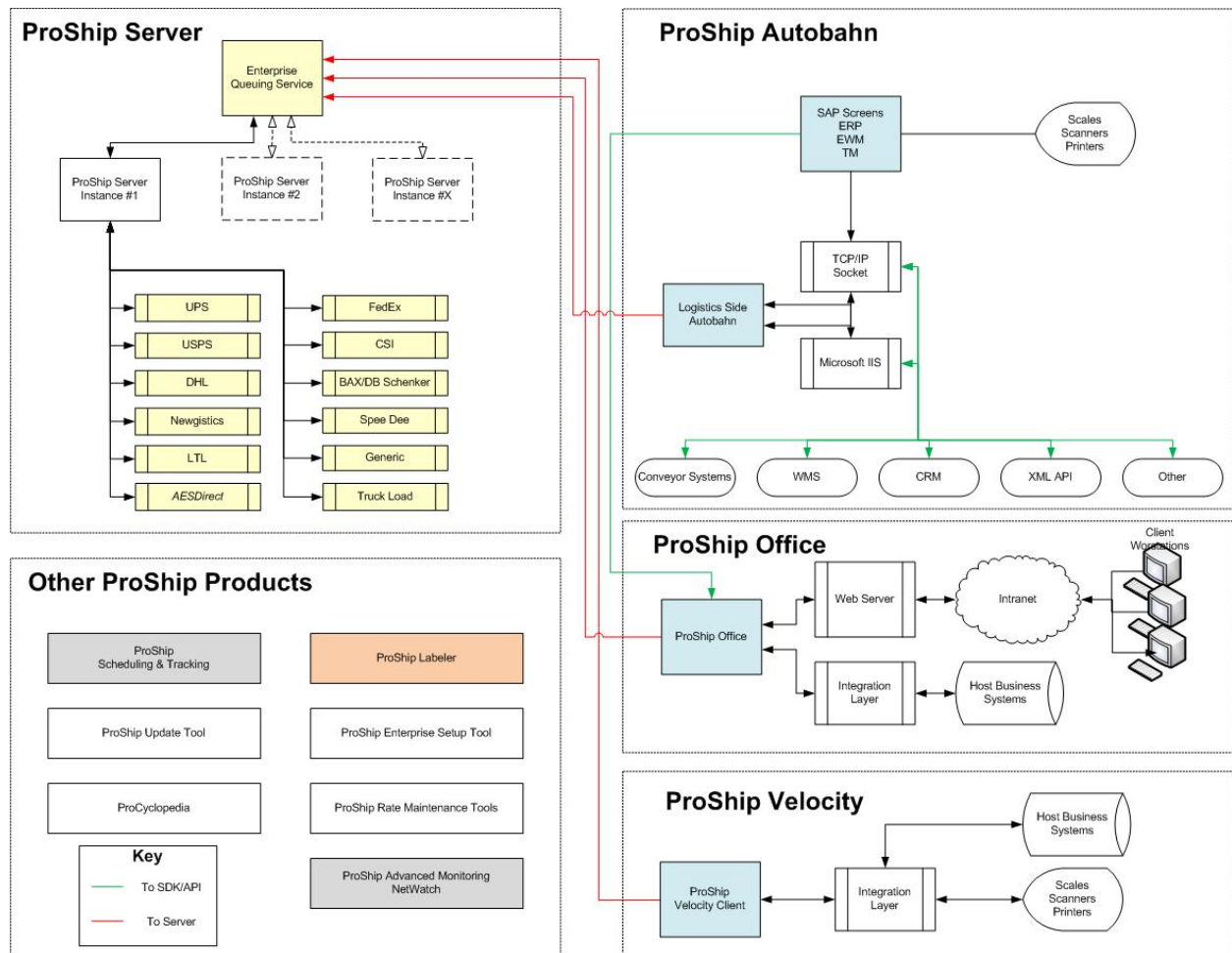



## ProShip Suite Features and Functions

**Ease of Use:** utilize all of ProShip's features and benefits directly from within your SAP environment, ProShip reduces your workforce investment in handling and managing all your company's shipments, whether in the warehouse, the office, or your production or service departments.

**High-volume Shipping:** handles multiple warehouses at the same time at exceptional speed while accommodating the most complex business rules.

**Most Carrier-compliant:** complies with carrier rules and requirements for labeling and manifest reporting. Produces customized shipping labels with dynamic return addresses and logos. Works with all four major carriers globally and most local and regional carriers; new carriers can be added quickly and easily.

**Best in Class Support:** We can provide up to 24/7 support and monitoring.

**Manage Complex Business Rules:** the system can implement your most complex business rules for optimizing carrier and service selection in managing any type of shipment, regardless of contents, size, destination or regulatory restrictions.

**Scalable Solution:** a multi-tier system in which multiple computer workstations access ProShip's shipping functionality and management data from a central server, with a modular approach for choice in components. This choice allows for scalability from a single workstation to an enterprise-wide solution.

**Multi-Carrier Package Rating:** rate shopping between major carriers for all their service levels and special service options. Shipping rate comparisons use published rates from carriers, *updated daily*, or your own negotiated rates with a carrier. Rates are calculated using each package's specifications (weight, dimensions, etc.).

**Dynamic Origin Rating:** rate shopping for shipments from one specific location to another, at a system price that is less than one-tenth what you pay for the ability to do this on other solutions (if you can find it at all).

**Document Production:** ProShip can produce all your requirement shipment documents, from packing slips and compliance labels to special reports and customer-required forms (including all bar coded formats).

**Multi-Piece Shipping:** processes multiple packages in a single shipment with different shipping parameters.

**Manifest Management:** end-of-day procedures that can be performed from any workstation, including closing out, printing carrier manifests, and transmitting manifest reports.

**Weight/Packing Verification:** retrieves individual item weights and, along with carton information, confirms each box leaving your dock for accuracy in packing.

**Inline Dimensioning:** built-in device drivers allow you to connect to virtually any laser or sonic dimensioning utility to automatically calculate box dimensions for air shipments, realizing potentially significant savings on dimensional rating chargebacks.

**RFID Option:** lets you employ RFID technology for applications that support them.

**High Visibility:** provides easy and immediate access to all tracking data regarding each shipment – when it was sent, where it is now, when it will be delivered.

**International Shipping:** allows printing of customs-related international documents such as Certificate of Origin, Commercial Invoice, and Shipper Export Declaration.

**AESDirect Filing:** As AESDirect Certified EDI Upload Software, ProShip is capable of electronically filing a Shipper Export Declaration (SED), obtaining an ITN number for your shipment, and creating carrier-compliant labels that eliminate carrier SED charges directly from within SAP.

## ProShip Enterprise Queuing System

ProShip Enterprise Queuing Service (EQS), part of the ProShip Server, handles incoming requests and dispatches them to a series of independent instances of the server components. Besides allowing for multiple concurrent processes on multi-core and hyperthreaded processors, it also gives the ability to test and apply updates on a running system with no downtime to shipping operations.

### *Summing ProShip Up...*



In short, **SAP Certified ProShip Autobahn Shipping Software** provides you with a full complement of essential cost-management advantages from within SAP:

**Overhead Reduction:** built for speed (capable of handling up to one million packages per hour), ProShip reduces workforce requirements, automating the tracking process, streamlining document production, and eliminating costly errors (and error tracking and correction).

**Reduced Shipping Charges:** assigning all shipments to the least-cost or most effective mode, carrier and service level, using the lowest published rates or your own negotiated rates (which benefit from ProShip's comprehensive tracking history), accurate package dimension and weight calculations, and error-free processing. What's more, ProShip covers more carriers and services than any other multi-carrier shipping solution (see chart below).



## ProShip verses the Competition (Can they do this?)

Feature	<b>ProShip</b> ®	Other(1)	Other(2)	Other(3)
<b>Carrier Compliance (Big Four)</b>	✓			
<b>All UPS Domestic and International Services Included as well as featured Services such as:</b>				
UPS Worldease, With Paperless Invoicing	✓			
Basic	✓			
Paperless Invoicing	✓			
Flexible Parcel Insurance	✓			
Dry Ice	✓			
Hazmat 49 CFR / IATA	✓			
Ground Freight Services	✓			
All Return Services	✓			
CWT Consolidation	✓			
Quantum View Notify	✓			
Proactive Response	✓			
Mail Innovations	✓			
<b>Authorized Integration to UPS Online Tools:</b>				
Street Level Address Validation with RDI	✓			
Time in Transit (Domestic & International)	✓			
<b>All FedEx Domestic and International Services Included as well as featured Services such as:</b>				
FedEx Smartpost	✓			
FedEx IPD (International Priority DirectDistribution)	✓			
FedEx International Broker Select	✓			
Dry Ice	✓			
All Return Services	✓			
FedEx Freight	✓			
Multi-weight Consolidation	✓			
Hazmat 49 CFR / IATA	✓			
FedEx Home Delivery	✓			
Street Level Address Validation with RDI	✓			

## ProShip versus the Competition (Can they do this? *con't*)

Feature	ProShip®	Other(1)	Other(2)	Other(3)
<b>All Retail USPS Domestic and International Services as well as Commercial Services such as:</b>				
Standard Mail	✓			
Manifest Mailing MAC Certified	✓			
Express Mail Manifesting	✓			
Certified Delivery / Signature Conformation Services	✓			
2976A Customs Paperwork	✓			
Endicia Online Postage	✓			
Commercial Plus Pricing	✓			
<b>All DHL Domestic and International Services Included as well as featured Services such as:</b>				
Global Mail	✓			
International Document	✓			
Worldwide Package Express	✓			
Domestic Express	✓			
<b>Technology "Must Haves"</b>				
Updates with zero down time	✓			
High Volume Shipping - 1M Transactions per hour	✓			
Database Agnostic	✓			
<b>Unified Shipping Including:</b>				
Browser Interface	✓			
Rich Client	✓			
SDK - XML API	✓			
Business Rules Engine	✓			
Online Documentation (Realtime Wiki)	✓			
Open Architecture - User Maintainable	✓			
<b>Your Last Parcel Manifest System</b>	✓			

# ProShip Autobahn Software

## Ease of Use

The SAP Certified ProShip Autobahn shipping system is a seamless integration with the SAP ECC 4.7 or higher and adds significant functionality to the overall solution. The ProShip Autobahn solution is a comprehensive, powerful and easy to use solution that simplifies all aspects of packing and shipping. It seamlessly integrates SAP and the industry leading ProShip rating engines. Now the un-matched ProShip transaction speed, the most certified carrier services and best-in-class service and support is available directly from within your SAP landscape.

For over 10 years, SAP customers have been using all of the benefits of the ProShip Suite via our ProShip Velocity “Rich” Client, ProShip Office and ProShip SDK. Those same ProShip benefits and features are available within your SAP landscape. ProShip Autobahn shipping solution is fully developed to SAP “Best Practices” in the native SAP program language (ABAP) and provides an easy to manage, centralized view of all packing and shipping processes.

The ProShip Autobahn shipping solution is the last shipping system that you will ever need to purchase. As your organization grows with SAP, the ProShip Autobahn shipping solution will grow with you and continue as the industry leader in transaction speed, carrier compliance certifications and best-in-class support.

ProShip Autobahn “Pack and Ship”

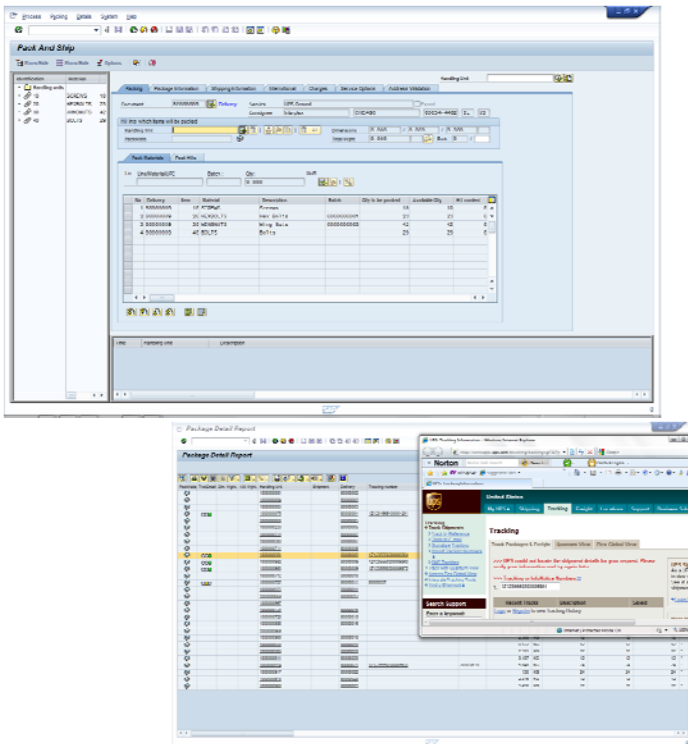

ProShip Autobahn “Package Reporting w/ Tracking”

ProShip Autobahn “Scan and Ship”

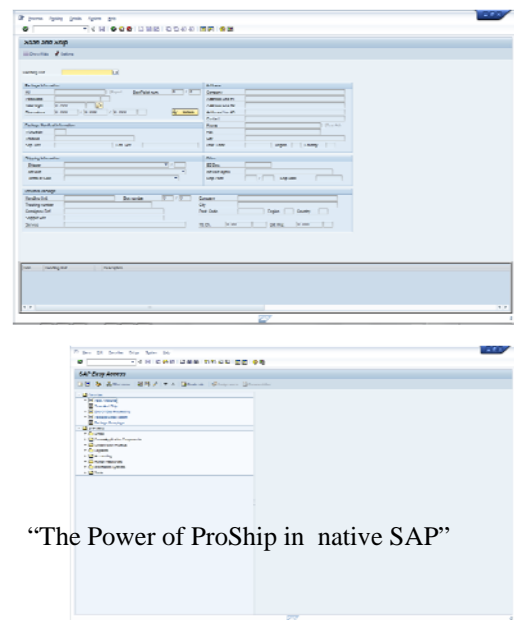

“The Power of ProShip in native SAP”

**SAP**® Certified  
Integration with SAP Applications

## Dashboards

ProShip Office provides a wide variety of “dashboard” reporting interfaces which can be set up by Best Way Technologies or by the user, with security access set by the user or work group log-on ID and available at both the record and field level.

Most system reports can be set up in a “dashboard” for ease of use and graphic representation of all of your shipping activity. Users can drag-and-drop dashboard components on-the-fly to completely customize their individual view of the data, with formatting options defined by field type.



Dashboards

## Updates

Updates are also provided on a regular and continuous basis using the ProShip Update Tool. Changes are made as often as necessary, and downloadable by the user when convenient (unlike the “traditional” approach, which is to send changes to users in the mail twice a year). All changes are extremely well documented, automatic, and backward compatible – and completely version safe. At anytime, any user can revert changes back within minutes.

The updating tool was very beneficial, for example, when Hurricane Katrina blacked out many service zip codes for the carriers. The updating tool immediately had all available updates for non-deliverable addresses for all Best Way customers.

When UPS offered paperless invoicing, Best Way Technologies offered it the very same day, rather than waiting for it to be requested by users, and then taking months to develop it.

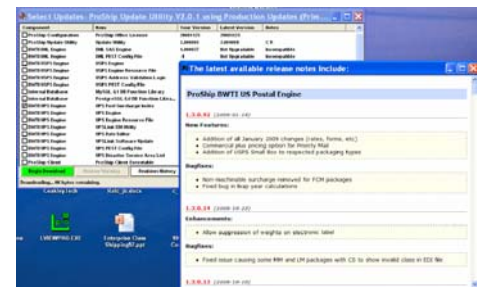

Updates

Carrier rate updates can be implemented without shutting any part of your system down.

## Installation and the “ProCyclopedia”

The ProShip Quick Install Guide, available online, is part of the comprehensive “ProCyclopedia,” which provides detailed step-by-step instructions for implementing and using ProShip Server and all of the other ProShip modules. We have reproduced the Table of Contents for ProShip Server installation below as an example of what’s available:

In addition to detailed instructions, the online documentation also includes step-by-step

illustrations such as this one for carrying out the implementation process and for using the ProShip Suite of solutions. Plus, nearly every user event in ProShip allows for interception and customized handling of a client's unique business rules with a rich variety of user interface tools and components, such as forms, dialog boxes, barcode scanner intercepts, and so on. You can also configure all display elements to suit your own needs and requirements.

Scripts can be configured for each system function, with specified user actions and display results.

The screenshot shows the 'Main Page' of ProCyclopedia. At the top, there are navigation tabs for 'article', 'discussion', 'edit', 'history', and 'watch'. A user profile for 'Choffman' is visible with links for 'my talk', 'my preferences', 'my watchlist', and 'my contributions'. The main heading is 'Main Page' with a sub-heading 'Welcome to ProCyclopedia'. Below this, a paragraph describes ProCyclopedia as a one-stop source for ProShip Unified Shipping Suite technical information, developed by Best Way Technologies Inc. A list of ProShip Suite components is provided, including ProShip Server, Velocity, Office, Labeler, ILS, Scheduled n Track, and Mobile. Other sections include 'carriers and engines' (listing UPS, FedEx, DHL, USPS, ABSDirect) and 'other navigation' (listing current events, main page, sales tools, hardware, ProShip University, and remote training). A table of contents is displayed on the right side of the page, listing 7 main sections and their sub-sections, such as '1 Download install files' and '2 ProShip Prerequisites'.

**Main Page**

Welcome to ProCyclopedia

ProCyclopedia is a one-stop source for all ProShip Unified Shipping Suite technical information. The ProShip Suite is developed, maintained and marketed by Best Way Technologies Inc.

- ProShip Server
- ProShip Velocity
- ProShip Office
- ProShip Labeler
- ProShip ILS
- Hardware documentation for shipping and data collection
- Carriers and Engines data files and documentation.
- Logistics Dictionary

In addition, authorized users can access the ProShip Training libraries for qualification standards and study materials.

To view any other pages in ProCyclopedia you must Login. If you do not have a login please contact @ Best Way Technologies

**proship suite**

- ProShip Server
- ProShip Velocity
- ProShip Office
- ProShip Labeler
- ProShip ILS
- ProShip Scheduled n Track
- ProShip Mobile

**carriers and engines**

- UPS
- FedEx/EG
- DHL
- USPS
- ABSDirect
- View All

**other navigation**

- Current events
- Main Page
- Sales Tools
- Hardware
- ProShip University
- Remote Training

**other**

- Download install files
  - Downloading the Install Installer
- ProShip Prerequisites
  - Internal Database
    - BestWay Provided Packages
  - If you are Installing ProShip Office or ILS Web Based Transactions
  - The .NET Framework
  - Script Editor
- ProShip Program File Installation
- Engine Installation (As Required)
  - DHL
  - Fedex
    - Prerequisites
    - FXRS Installation and Configuration
  - UPS
  - USPS
  - LTL
- Start Client in Local mode to test Engines
- Starting Client(s) in EGS mode
- Scripts and Client Configuration
  - Set up Client settings
  - Adding custom scripting
  - Set up Closeout
  - Set up Printing
  - Set up Attached Hardware
    - Set up Scale Input
    - Set up Scanner input



## ProShip Office

ProShip Office is tracking and reporting software that can be implemented as a stand-alone product, integrated into existing client systems, or set up as a part of the ProShip suite of products.

ProShip Office interfaces with all carriers' tracking websites. Like all Best Way solutions, it is easy to use, automating manual functions and with results displayed on existing systems or via a web browser.

ProShip Office can be integrated to allow multi-location users to ship from a company's intranet site or allow non-logistics personnel to enter all the required shipping information and then generate a "license plate" that allows qualified shipping personnel to review and perform the final shipping process on a letter or package.

Best-way shipping, shipment tracking, multi-piece shipping, manifest management, carrier-compliant labeling, AESDirect Filing, and the ProShip Enterprise Queuing System are all available with ProShip Office.

Like all ProShip products, ProShip Office lets you configure reports with user-definable fields, in user-specified formats, using your own business rules.

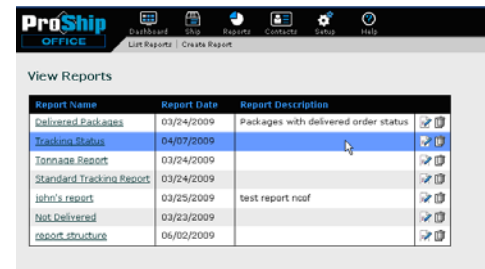

View Reports

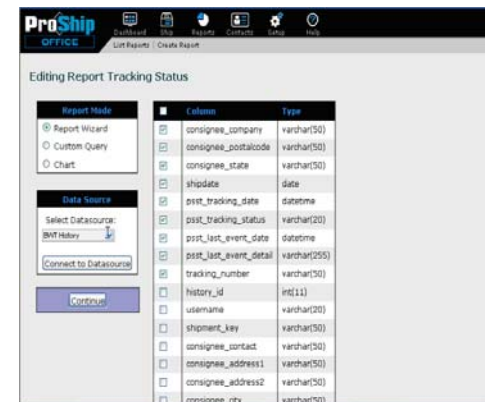

Report Tracking Status

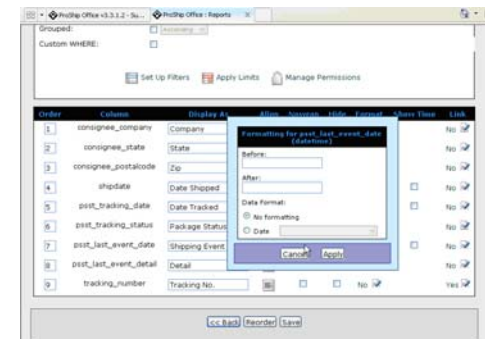

Tracking & Reporting

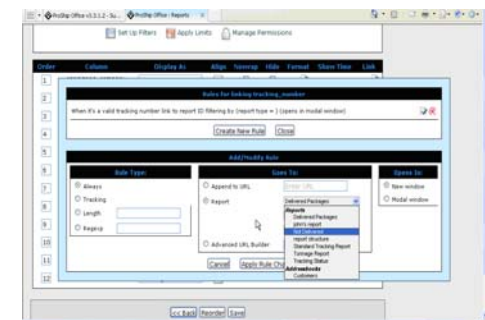

Report Configuration



## ProShip Velocity

ProShip Velocity is a multi-carrier shipping system that seamlessly integrates shipping processes and information between your ERP system and carrier vendors. The system is totally customizable for each user, and it's modular architecture permits extensive configuration by the user without requiring modified versions of the software.

It offers the same functionality and speed as other ProShip modules: best-way shipping, shipment tracking, multi-piece shipping, manifest management, carrier-compliant labeling, AESDirect Filing, and the ProShip Enterprise Queuing System.



## ProShip Labeler

ProShip Labeler is used to modify or create pick slips, packing slips, combination tickets (pick/pack slips with a shipping label for case picks), and shipping labels, which are UCC-compliant and can include customer data such as Purchase Order number, as well as customized bar codes.



## ProShip Scheduling and Tracking (PSST)

PSST was built with the ProShip Common Infrastructure (CPI) which allows it to:

- Communicate with EQS
- Share code with other CPI components like ILS
- Allow for work flow based integration via Visual Basic.NET
- Data is stored in the working database and can also, via integration, be sent to:
  - Additional databases
  - Web services
  - Email address(es)

ProShip Office can leverage the built-in database or a custom database to create reports for shipments that have been:

- Delivered
- In transit
- Returned an error
- Past commitment time

These reports allow you to be proactive rather than reactive in your customer relationships.

## A Versatile and Effective Business Tool

The fastest multi-carrier Enterprise Shipping Solution available, ProShip Software has been engineered for speed in handling shipping transactions. For instance, ProShip Server engines were developed in C to support high transaction volumes; other ProShip modules were developed in .NET. One of the company's largest customers handle over 150,000 shipments a day on a single server.

Speed, accuracy, user-configurability, ease-of-use, dashboard-style reporting, immediate access to all shipment information, and the most comprehensive database of carrier rates and services make the ProShip Unified Software Suite the most accomplished business tool in the shipping business.

**All of this can be utilized directly within your SAP landscape with ProShip Autobahn.**

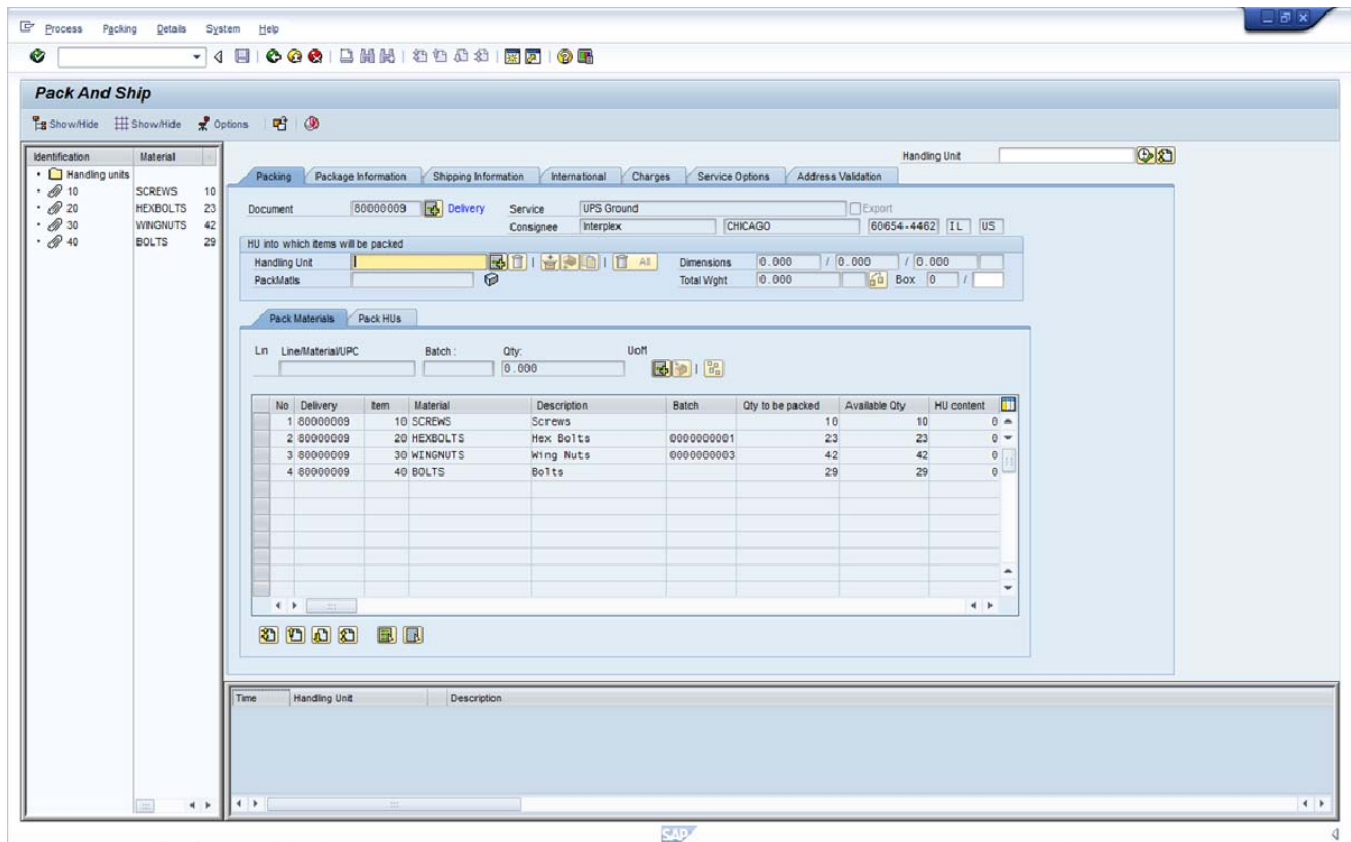

# Appendix: Technical Considerations

## Carrier Certified Interfaces

ProShip supports the following carriers:

- UPS Express and Ground
- UPS Mail Innovations
- UPS Freight
- FedEx Express
- FedEx Ground
- FedEx Smartpost
- USPS (IBI postage, manifested mail, and postage applied)
- DHL Express Worldwide
- DHL Globalmail
- Purolator
- Purolator Freight
- Canpar
- Candian Post
- DB Schenker
- Consolidators
- Newgistics
- On-Trac
- Spee-Dee
- Eastern Connection
- Evans Transportation
- Lone Star
- LTL and TL Carriers (ABF, Central Conway, Roadway, Watkins, Yellow, etc.)
- Ocean Freight brokers (Catapult Intl et al)
- Various regional and superregional carriers

## Hardware Recommendations

### Physical Server Recommendations

The following server specification will support 50k shipments per day with no issues:

- Intel Xeon Quad Core 2.5 Ghz
- 2- 4 Gigabytes Ram
- 1 Gigabyte Physical Disk space
- Windows 2005 - 2008 server

Customers exceeding 50k shipments per day should contact BWTI Support for specific recommendations.

Fault tolerant storage systems such as raid 5 or any other industry standard mirroring methodologies are both recommended and fully supported in all installations.

### Client Hardware Recommendations

#### Rich Client

Pentium-III 1GHZ (or equiv. AMD) processor

Windows XP pro

1GB of free HD space

512MB RAM

RS-232 (serial) connected scanner (HHP scanners recommended)

RS-232 (serial) connected scale (NCI scales recommended)

Parallel port connected ZPL-2 203DPI Thermal Printer

PCL5 compatible laser printer

#### Web Client

Pentium-III 1GHZ (or equiv. AMD) processor

Windows XP pro

512MB RAM

PCL5 compatible laser printer

IE, Firefox browser supported

PDF viewing application

## **Peripheral Hardware Support**

### Compliant Label Printing 203DPI

- Zebra thermal printers (ZPL)
- Eltron Thermal printers (EPL)
- DataMax thermal printers (DPL)
- PDF and PNG outputs supported

### Additional document printing

- Any supported windows printer
- PDF outputs as well

### Scales

- MCI
- Mettler Toledo
- Detecto
- Fairbanks
- Trancell
- Salter Breknel
- *and many more...*

### Scanners

- Wasp
- Symbol
- Sick
- and any other industry standard serial scanner

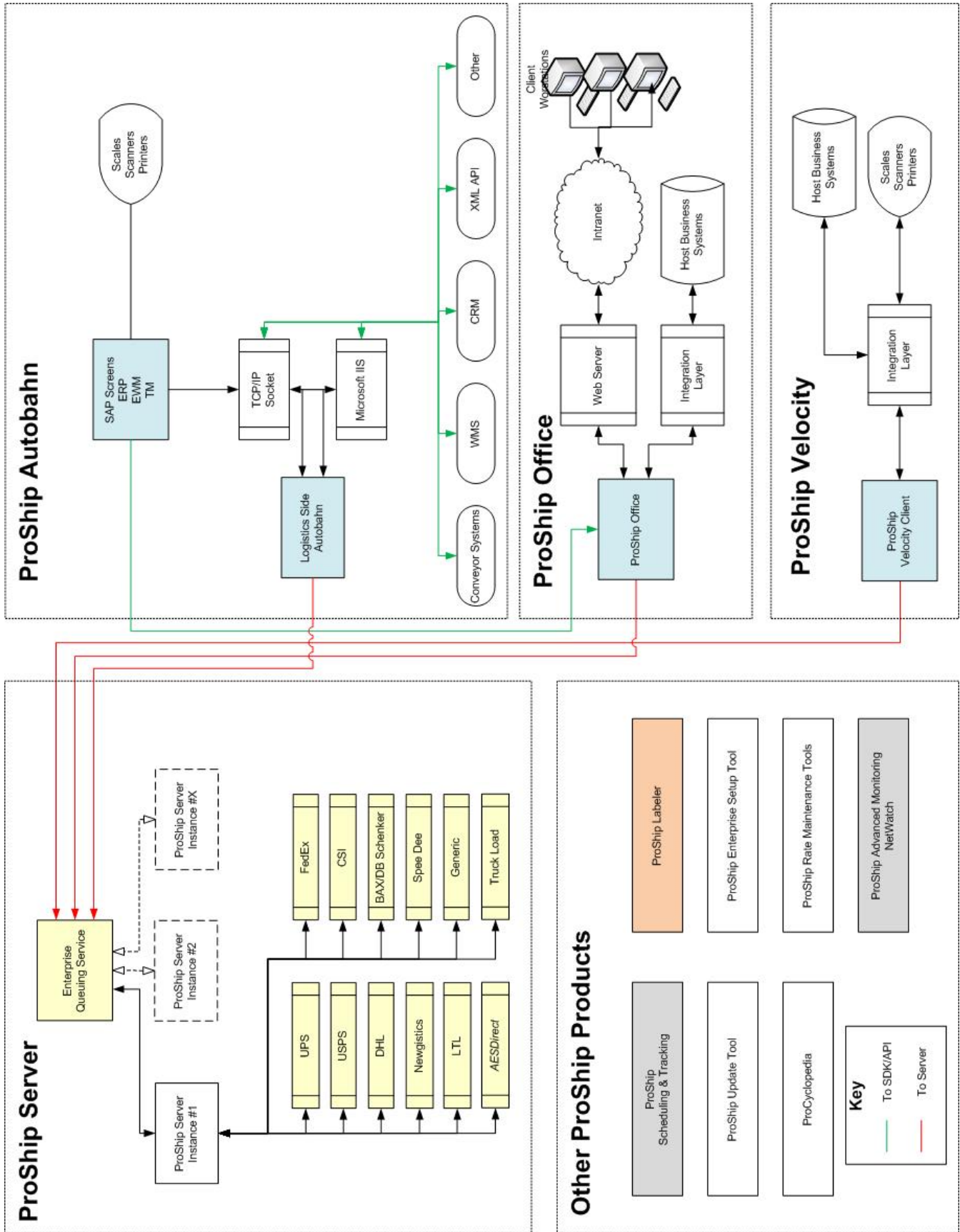

ProShip Suite Diagram





**Best Way Technologies, LLC**

29 N. Wacker Dr., Suite 700

Chicago, IL. 60606

(866) 944-2378

[www.bestwaytech.com](http://www.bestwaytech.com)

Best Way Technologies, LLC is a subsidiary of SPSI

**Systems & Programming Solutions Inc.**

530 N. 108th Place, Suite 100

Wauwatosa, WI 53226

(800) 353-7774

[www.spsinet.com](http://www.spsinet.com)

