



**CARBON ZAPP**  
INNOVATION DRIVEN

# Welcome to an Innovation Driven World



**CARBON ZAPP**  
INNOVATION DRIVEN

**Main Offices & Production Plant**  
364 Varis-Koropiou Ave. Koropi  
194 00 Athens, Greece

**Headquarters**  
A.I.S.S. GmbH  
68165 Mannheim, Germany

**email** [contact@carbonzapp.com](mailto:contact@carbonzapp.com)  
**tel** +30 210 9856110  
**fax** +30 210 9928655

[carbonzapp.com](http://carbonzapp.com)

Product Catalog 

---

 CZ 2016

## Welcome to an Innovation Driven World



Carbon Zapp is dedicated in manufacturing Automotive Injection Service Solutions, providing a worldwide sales network, investing constantly in R&D and offering efficient support. With today's exponential increase in the automotive industry, Carbon Zapp offers solutions for a healthier, less polluted environment, specializing in designing and manufacturing Diesel and Gasoline Injector Service Benches, that have become a standard for major OE's and general workshops.

---

*We always strive for excellence and innovation.*

---

As a global supplier to diverse users, with broad knowledge in the automotive industry and through teamwork and skillful personnel, Carbon Zapp is able to support your corporate vision and fulfill your market's needs.

Let's make together the first step towards future and success!

**Nikolaos Pantazis**  
General Director

**Dimitrios Pantazis**  
Manufacturing Director

## Contents

Carbon Zapp Company Profile CZ 03

## Diesel Injection Systems CZ 06

CRDi Solutions CZ 08

Heavy Duty Solutions: EUI/EUP & HEUI Systems CZ 12

Diesel Specialists Solutions CZ 20

Injector Repair Solutions CZ 26

## Gasoline Injection Systems CZ 30

Direct Injection Solutions CZ 32

Fuel Injection Solutions CZ 36

## Engine Service Solutions CZ 42

Service Equipment CZ 44

Fuel Injection Handheld Tools CZ 46



### Our Company

Carbon Zapp was founded in 1989 by Bill Pantazis. As a leading manufacturer of Automotive Injection Service Equipment and Tools, Carbon Zapp has its production plant in Athens, Greece and a constantly growing global network in every continent. Recently, the company expanded in Germany by establishing its global headquarters and business administration.

Through a wide range of innovative products, including injector test benches for Diesel and Gasoline injection systems, Engine service equipment and tools, Carbon Zapp offers high quality equipment and customer service to automotive dealers, workshops and educational institutions, as well as for specialized developers, remanufacturers and most major automotive OE's. Carbon Zapp uses over 35% of its profits to update existing products with newer technological advancements and aims to provide simpler methods and tools for a safer environment.

### Our Mission

Carbon Zapp aims to provide user friendly, compact and time saving solutions to a wide range of operators, focusing in the automotive injection systems.

*"We have earned our position to the global market because of our commitment to quality products and well known customer service. If we fail to provide satisfaction to our customers, we forfeit our right to their business. Carbon Zapp's Management and staff loyalty to this business makes it a win-win situation"*

**Bill Pantazis,**  
Founder of Carbon Zapp



“Innovation is the key to continuous growth and competitive advantage.”

**Innovation Driven Company**

“Innovation” is the key to continuous growth and competitive advantage. Carbon Zapp “Drives” its research team to keep a high ambition level and work on their research, development and technical skills.

On an annual basis, the company invests more than 35% of its profits on research and development for upgrading existing and implementing new products. Carbon Zapp has fostered an extensive group of intellectual property and talented personnel throughout the years. Strategic agreements and world-class component suppliers have contributed in developing advanced technologies and products.

**Our Customers**

- |                              |                       |
|------------------------------|-----------------------|
| Diesel Service Centers       | Parts Remanufacturers |
| Auto Workshops / Dealerships | Automotive OE's       |
| Automotive Aftermarket OEM's | Developers            |



**Support**

At Carbon Zapp, customer satisfaction is a major priority. The staff offers the best service to increase customer trust, earn their loyalty and built their respect. The key to this success is to acknowledge the customers' needs and listen to them.

**Global Sales Network**

With a logistics center in Athens, Greece, Carbon Zapp can effectively export its products globally in all 5 continents and over 65 countries. The products are trusted internationally for their world class quality. Carbon Zapp takes pride in consistently delivering premium products and reliable customer services.







# DIESEL INJECTION SYSTEMS

Innovative, compact  
and professional solutions  
for every workshop  
to test & service Diesel  
Injection Systems

1

**CRDi Solutions**  
CRU.4R, CRU.2R, DS1R,  
DS2R-A, DSF-4R

2

**Heavy Duty Solutions**  
UIPr-S, UIPr-A  
HUIr-S, HUIr-A

3

**Specialists Solutions**  
MTBr, TCCMr

4

**Injector Repair Solutions**  
CRRS, Tools/Extractors

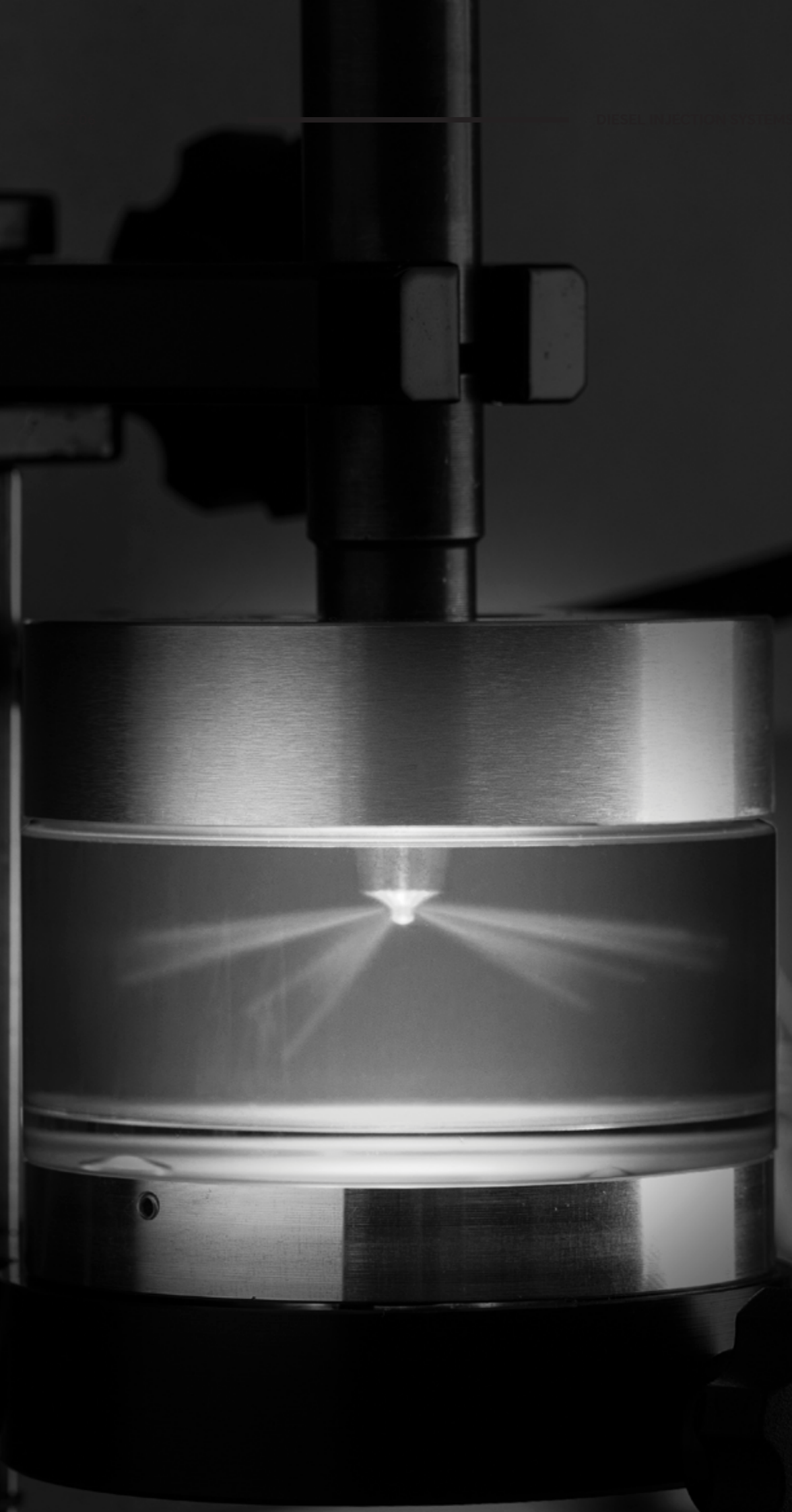

## 1 CRDi Solutions

Common Rail Revolutionary testing solutions for BOSCH, DELPHI, DENSO and CONTI/VDO

Heavy Duty and Light Duty applications

All types Piezo, Solenoid & Dual-Solenoid actuators.



### CRU.4R

Test Bench for 4 CRDi's  
Up to 2500Bar HP with 6.5 bar air supply  
Injector Coding C2i/C3i, IMA/ISA and others\*\*  
Dynamic Electronic Mass Measurement (BK)  
Acc: 0.2%FS, repeatability: 0.05%  
Under 25min testing phase  
**Fully Automatic Operation**  
Diesel Specialist level of Diagnosis  
10" Touchscreen HMI  
Capable of EUI/EUP and HEUI  
Testing with optional Attachment units



### CRU.2R

Test Bench for 1 CRDi  
Up to 2500Bar HP with 6.5 bar air supply  
Injector Coding C2i/C3i, IMA/ISA and others\*\*  
Dynamic Electronic Mass Measurement (BK)  
Acc: 0.2%FS, repeatability: 0.05%  
Under 8min testing phase  
**Fully Automatic Operation**  
Diesel Specialist level of Diagnosis  
Flushing / Cleaning capability\*  
10" Touchscreen HMI  
Capable of EUI/EUP and HEUI  
Testing with optional Attachment units



### DS2R-A

Test Bench for 1 CRDi  
Up to 2000Bar HP @ 6Bar LP  
Analog Volumetric Measurement (VT)  
Resolution: 0.5ml, Acc:  $\pm 1\text{ml}/65\text{ml}$   
**Manual Operation**  
Workshop level of Diagnosis  
Flushing / Cleaning capability\*  
16 min testing phase  
8" Touchscreen HMI  
Capable of EUI/EUP and HEUI  
Testing with optional Attachment units



### DSF.4R

Flushing / Servicing bench for 4 Diesel Injectors  
Up to 2000Bar HP with 6 bar air supply  
**Semi-Automatic Operation**  
Diesel Specialist and Workshop level  
R2LC and CFL Testing only  
8" Touchscreen HMI



NEW  
2016

### DS1R

Test Bench for 1 CRDi  
Up to 2000Bar HP with 6 bar air supply  
Electronic Static Mass Measurement (DFAP)  
Resolution: 0.1mm<sup>3</sup>, Acc: 0.6%FS  
**Manual or Automatic Operation**  
Workshop level of Diagnosis  
10-15 min testing phase  
8" Touchscreen HMI



## Tests Performed

### R2LC

Electrical actuator test for  $k\Omega/\mu F$ ,  $\Omega/\mu H$

### CFL

Check For Leaks test (injector internal or external)

### NLT

Nozzle Leakage Test

### LKT

Static Back Leak Test

### aNOP

Automatic Nozzle Opening Pressure test

### iVM (FL, PL, EM, LL, PI)

Injector Volume Measuring test  
(full-load, part-load, emissions, low-load,  
pre/post-injection tests and more...)

### iVM-DFI

Injector Volume Measuring test (multiple  
test-points slope per Pressure)

### RSP

Injector nozzle Response-time test

### SPR

Dynamic Spray test performed in all testing  
conditions

## Features

### iPSC

Illuminated Pressurized spray chamber

View of injection pattern up to 2500Bar

Visually diagnose NOP, incorrect spraying, leaky / seized  
injectors

### RSP

Sensor adaptable to all nozzles

Precise measurement of nozzle reaction time

Easily diagnose a slow acting injector, a retarded injection  
event, poor engine performance and emissions issues.

### AZO Software

Advanced Android based HMI/PC

Wi-Fi printing, sharing, syncing, software/hardware  
& database updating, via USB or WiFi

Real-time Oscilloscope and CSV data export

TeamViewer Support and more...

### Reports

Easy fail-track color report for each injector.

Single-page Quick report or Multi-page  
Analytic reporting

### Specifications

All Makes OE Manufacturer  
& User Database

Developer and OE customizing

Piezo & Solenoid programmable  
actuation profiles

(HV: 0-300 Volts / 0-35A)

Injector & PCB protection circuit  
(StG, StB, SC, OC, IC)

Multiple Injections capability

User friendly, ergonomic, dynamic  
& robust design

Spill-free hose quick connectors

aMACC – Automatic chemical  
treatment and flushing of the injector  
before testing\*

Complementary set of CRi adapters,  
fittings and connectors for all makes  
& types

\* Available Optionals \*\* Future Updates

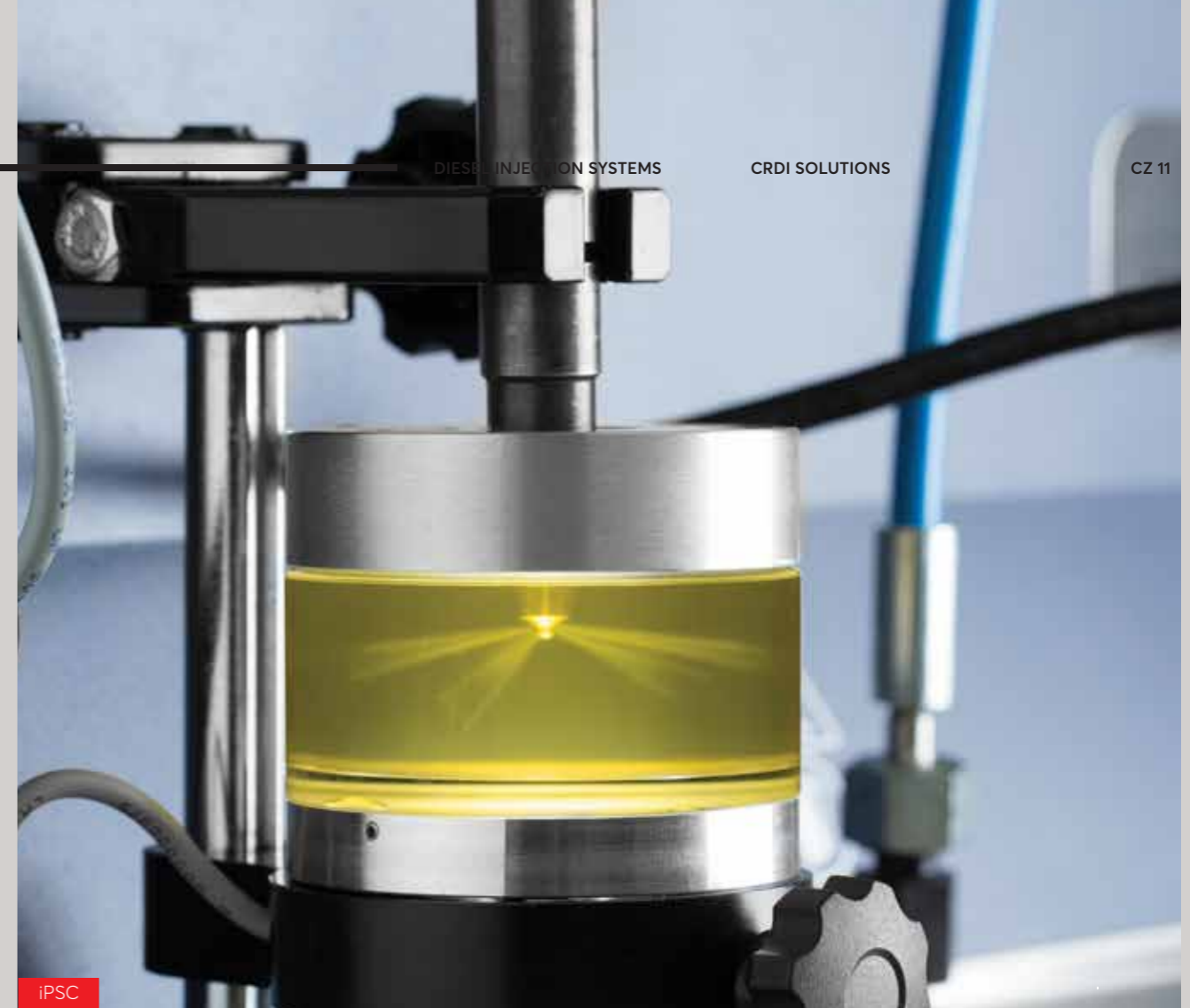

iPSC



iPSC



RSP



AZO SOFTWARE

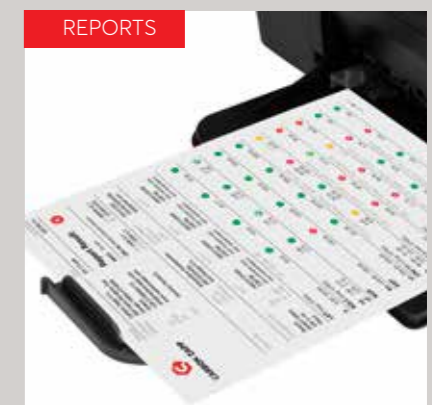

REPORTS

## 2 Heavy Duty Solutions EUI/EUP & HEUI Systems

Standalone pneumatically actuated units for servicing all Makes & Types of Unit Injection Systems is made easy not only for Diesel Specialists, but also for every workshop.

### Hydraulic Unit Injection Systems Applications

Caterpillar 3126, 7.3L,

Caterpillar C7/C9,

Navistar/ Ford Powerstroke 6.0L, 7.6L, 9.3L

Isuzu Trooper

### HUIR-A

Test & Service Attachment bench for 1 HEUI Diesel Injector up to 300Bar  
Semi-Automatic Operation  
Under 15min testing phase  
Advanced Workshop and Expert level



attaches to  
**CRU.4R**  
**CRU.2R**  
**DS2R**

### HUIR-S

Standalone Test Bench for 1 HEUI Diesel Injector up to 300Bar Solenoid & Dual-Solenoid actuators

Electronic Static Mass Measurement (DFAP)  
Resolution: 0.1mm3,  
Acc: 0.6%FS

Workshop and Diesel Specialist level of Diagnosis

**Semi-Automatic Operation**

10min testing phase

8" Touchscreen HMI



**BK** Dynamic Electronic Mass Measurement

**VT** Analog Volumetric Measurement

**DFAP** Electronic Static Mass Measurement

### UIPR-A

Test & Service Attachment bench for 1 EUI/EUP Diesel Injector  
Semi-Automatic Operation  
Under 15min testing phase  
Advanced Workshop and Expert level



attaches to  
**CRU.4R**  
**CRU.2R**  
**DS2R**

### Heavy Duty, Industrial, Marine and Passenger Car UIS Applications

Delphi E3/E1, Delphi DAF (Smart Pump/Injector), Scania/Cummins HPI,

Volvo (Bosch & Delphi), John Deere, Scania /Yanmar, Iveco, VW PDE

All CAT's, Cummins Celect, Detroit Diesel, Cummins,

MB Actros, MB Atego, Mack, DAF, and more...

### UIPR-S

Standalone Test Bench for 1 EUI/EUP Diesel Injector  
Piezo, Solenoid & Dual-Solenoid actuators

Electronic Static Mass Measurement (DFAP)  
Resolution: 0.1mm3,  
Acc: 0.6%FS

Workshop and Diesel Specialist level of Diagnosis

**Semi-Automatic Operation**

10min testing phase

8" Touchscreen HMI



\* Available Optionals \*\* Future Updates



### Tests Performed

**R2LC**

Electrical actuator test for  $k\Omega/\mu F$ ,  $\Omega/\mu H$

**CFL**

Check For Leaks test (injector internal or external)

**RSP**

Injector nozzle Response-time test

**iVM (FL, PL, EM, LL, PI)**

Injector Volume Measuring test (min 15-steps)  
(full-load, part-load, emissions, low-load,  
pre/post-injection tests and more...)

**BIP [UIPR]**

Injector Control Valve Response time test

**SPR**

Dynamic Spray test performed in all testing  
conditions

\* Available Optionals \*\* Future Updates

HEUI TESTING

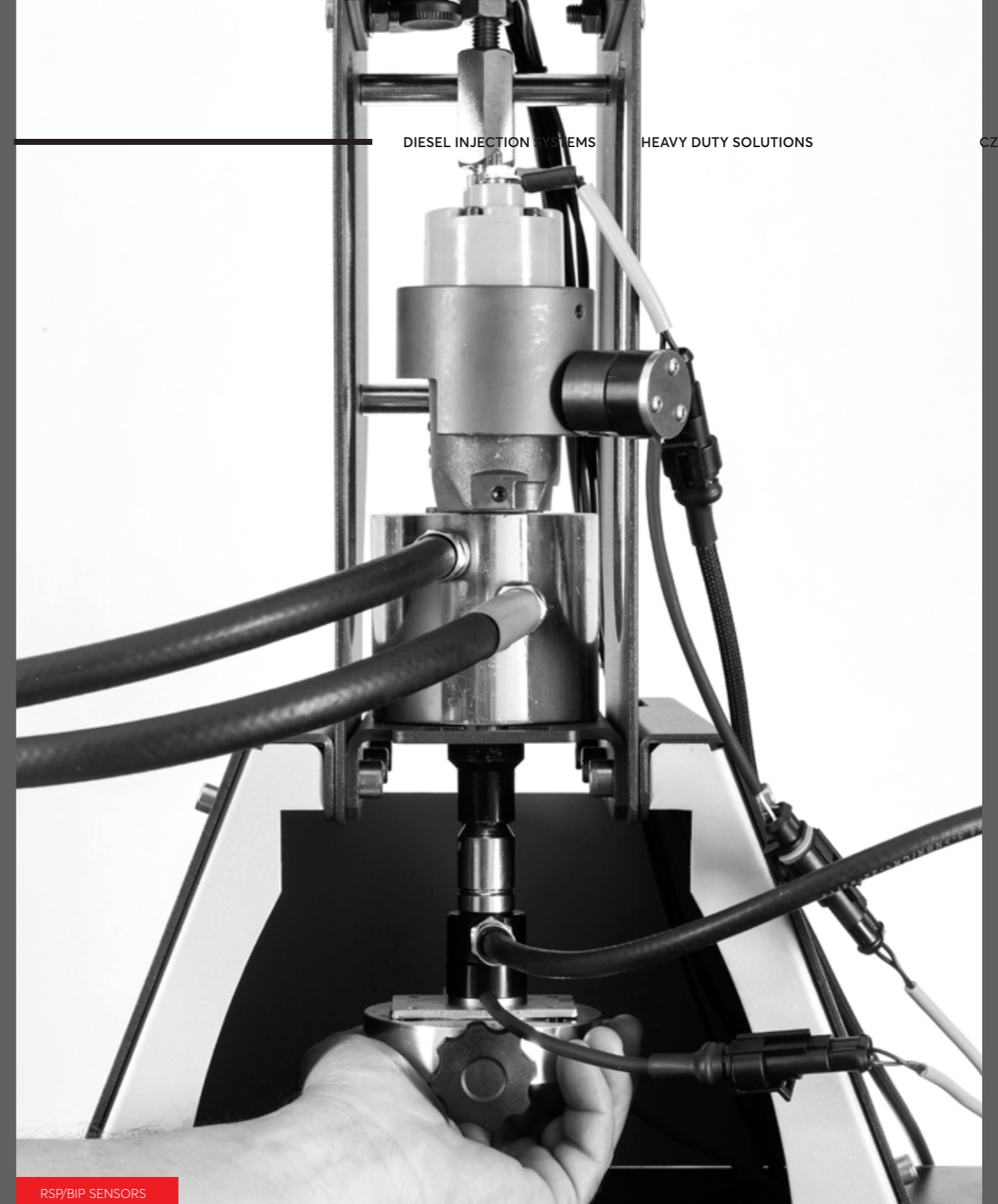

RSP/BIP SENSORS



### Specifications

All Makes CZ & User Database  
 Developer and OE customizing  
 Pneumatic operated unit  
 (Test Bench NOT required)  
 Fast mounting and dismounting  
 of Unit injector/pump  
 Hydraulic system control & indication  
 (30-300 Bar / 40-4350 psi) [HUIR]  
 Low supply automatic  
 pressure control (10Bar)  
 Piezo & Solenoid programmable  
 actuation profiles  
 (HV: 0-300 Volts / 0-35A)  
 Injector & PCB protection circuit  
 (StG, StB, SC, OC, IC)  
 Multiple Injections capability  
 User friendly, ergonomic,  
 dynamic & robust design  
 Spill-free hose quick connectors  
 aMACC – Automatic chemical  
 treatment and flushing of the injector  
 before testing\*

## Features

### iPSC

Illuminated Pressurized spray chamber  
 View of injection pattern up to 2500Bar  
 Visually diagnose NOP, incorrect spraying, leaky  
 /seized injectors

### Easy

Adjustable Cam stroke 4-20mm with the use of variable  
 wheel [UIPR]

### RSP/BIP

RSP Sensor adaptable to all Nozzles  
 BIP Sensor adaptable to most Control Valves [UIPR]  
 Precise measurement of C.V. & Nozzle actuation  
 delay from signal  
 Easily diagnose a slow acting injector, a retarded injection  
 event, poor engine performance and emissions issues.

### AZO Software

Advanced Android based HMI/PC  
 Wi-Fi printing, sharing, syncing, software/hardware  
 & database updating, via USB or WiFi  
 Real-time Oscilloscope and CSV data export  
 TeamViewer Support and more...

### Reports

Easy fail-track color report for each injector.  
 Single-page Quick report or Multi-page  
 Analytic reporting

\* Available Optionals \*\* Future Updates



**Extras optional**

**adapters kit**

**1 CRDi Solutions**

A complete range of CRIN adapters kits for Heavy Duty applications are available\*



**2 Heavy Duty Solutions  
EUI/EUP Systems**

A complete range of UI/UP adapter kits, rods, wiring harnesses and more are available\*



**HEUI Systems**

A complete range of HEUI adapter kits, wiring harnesses and more are available\*



**Ultrasonic Devices**

Ultrasonic Baths are available at sizes up to 120L featuring:  
42KHz frequency  
Sweep technology\*  
Degas function\*,  
Controlled Heater and more...



**Oils & Fluids**

1. Diesel Injector Calibration Oil (ISO4113)
2. Ultrasonic Solvent (Concentrated)  
4L | 20L | 208L
3. Diesel Injector Flushing Detergent  
2L | 25L

**Portable stand**

Compact, lightweight, robust with accessories cabinet



\* Available Optionals \*\* Future Updates



### 3 Diesel Specialists Solutions

Service all Diesel Injection Systems in the industry, utilizing test points from the largest OE database in the market. Upgrade existing Test Benches or Experience Carbon Zapp's Innovative Solution.

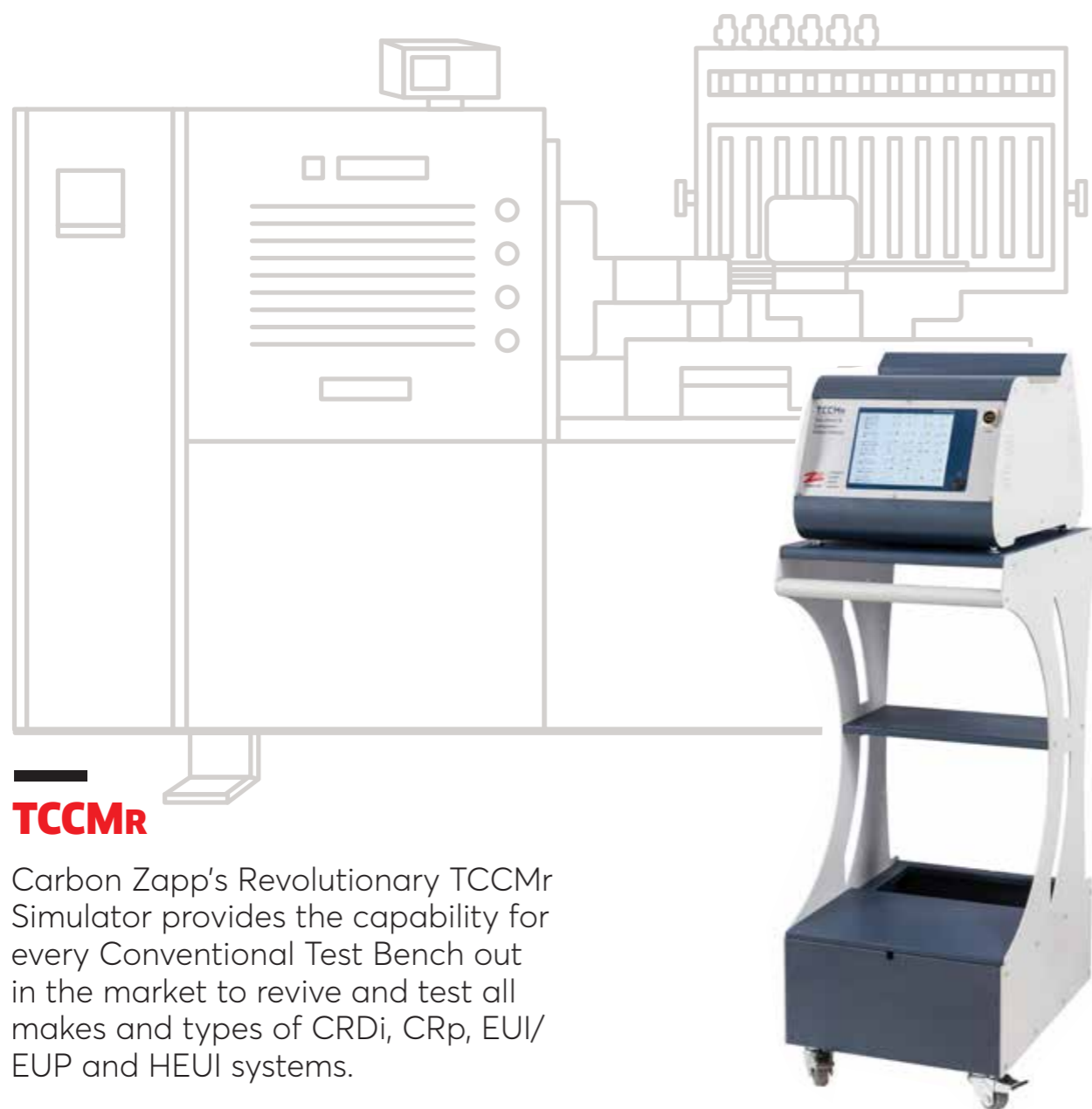

#### TCCMr

Carbon Zapp's Revolutionary TCCMr Simulator provides the capability for every Conventional Test Bench out in the market to revive and test all makes and types of CRDi, CRp, EUI/ EUP and HEUI systems.

#### MTBR

The Only Compact Diesel Specialist Solution for all Diesel Injection Systems available in the Automotive, Commercial, Industrial and Marine market today...

Can test all Makes and Types of CRDi, CRp, EUI/ EUP and HEUI systems.

- Up to 2500Bar HP
- Electronic and safe Protective Hood Opening
- Injector Coding C2i/C3i, IMA/ISA and others\*\*
- Dynamic Electronic Mass (BK) Measurement (CRDi, HEUI, EUI/EUP)  
Acc: 0.2%FS, repeatability: 0.05%
- Static Electronic Mass (DFAP) Measurement (CRp)  
Resolution: 1mm<sup>3</sup>, Acc: 0.6%FS
- Fully Automatic and fast testing phase
- Diesel Specialist level of Diagnosis
- Internal cooling system (No water connection needed)
- Instantaneous Emergency Stop function
- 15" Touchscreen HMI

**NEW  
2016**



\* Available Optionals \*\* Future Updates

## Tests Performed

### R2LC

Electrical actuator test for  $k\Omega/\mu F, \Omega/\mu H$

### CFL

Check For Leaks test (injector internal or external)

### NLT

Nozzle Leakage Test

### LKT

Static Back Leak Test

### aNOP

Automatic Nozzle Opening Pressure test

### iVM (FL, PL, EM, LL, PI)

Injector Volume Measuring test (full-load, part-load, emissions, low-load, pre/post-injection tests and more...)

### iVM-DFi

Injector Volume Measuring test (multiple test-points slope, per Pressure)

### RSP

Injector nozzle Response-time test

### BIP [UIS systems]

Injector Control Valve Response time test

### SPR

Dynamic Spray Test performed in all testing conditions

### Additionally

High pressure Control Valve operation (DRV, IMV, PCV, etc...)

High Pressure Sensor reaction

High Pressure relief safety valve operation

CR Pump flow limiter valve operation (ZME, IMV, SCV, VCV, etc...)

## Features

### iPSC

Illuminated Pressurized spray chamber

View of injection pattern up to 2500Bar

Visually diagnose NOP, incorrect spraying, leaky / seized injectors

### RSP (CRDi & EUI/EUP & HEUI KIT)

RSP Sensor adaptable to all Nozzles

BIP Sensor adaptable to most Control Valves [EUI/EUP]

Precise measurement of C.V. & Nozzle reaction time

Easily diagnose a slow acting injector, a retarded injection event, poor engine performance and emissions issues.

### AZO Software

Advanced Android based HMI/PC

Wi-Fi printing, sharing, syncing, software/hardware

& database updating, via USB or WiFi

Real-time Oscilloscope and CSV data export

TeamViewer Support and more...

### Reports

Easy fail-track color report for each injector.

Single-page Quick report or Multi-Page Analytic reporting

### Specifications

All Makes OE, CZ & User Database

Developer and OE customizing

Piezo & Solenoid programmable actuation profiles

(HV: 0-300 Volts / 0-35A)

Injector & PCB protection circuit

(StG, StB, SC, OC, IC)

Multiple Injections capability

Fast mounting and dismounting of Unit injector/pump

Hydraulic system control & indication (30-300 Bar / 40-4350 psi)

Low supply automatic pressure control (10Bar)

User friendly, ergonomic, dynamic & robust design

Spill-free hose quick connectors

Complimentary startup kit of CRp / CRi adapters, fittings and connectors for all makes & types

## MTBR

### Compact Standalone Diesel Test Bench



#### Technical data

Input frequency	50/60 Hz
Number of phases	3 P/PE
Speed range	0 – 4,000 rpm
Powerful Motor with thermal protection	15HP
Maximum operating ambient temperature	50°C
Base to axis center height	125 mm
High Pressure system Max Pressure	2500 Bar
Supply pump pressure	10 – 800 kPa
Test oil tank	35 L
Waste Oil tank	10 L
Dimensions (W x D x H)	750 x 700 x 1610 mm
Weight	300 kg

NEW  
2016

## Application



CRDi / HEUI



CRp



CamBox

Clamping brackets\* for all Types and Makes CP pumps  
A complete range of CRiN adapters\* for Heavy Duty applications

## TCCMr

### Test Bench and Component Control Module

Controls all Types and Makes of Injectors & Pumps

Includes OEM database and test plans

Works with every Conventional Test Bench in the Market

Electronic Measurement upgrade for Conventional Test Bench\*

Connects to any Cambox\* (Proximity Triggered) and CRDi Simulator Kit\*

Connects to Carbon Zapp's HUIr-A solution for HEUI systems

Compact, Lightweight and Portable unit



## Extras optional



CRDi & CRp Function Kits are available for all Makes and Types



A Universal Cambox that fits most Conventional Test Benches in the market (h:125mm).Adapters for all Makes and Types of UIS systems are available



HUIr-A Unit. The fast, easy and precise solution to test HEUI's

## Tests Performed

### R2LC

Electrical actuator test for  $k\Omega/\mu F$ ,  $\Omega/\mu H$

### CFL

Check For Leaks test (injector internal or external)

### NLT

Nozzle Leakage Test

### LKT

Static Back Leak Test

### aNOP

Automatic Nozzle Opening Pressure test

### iVM (FL, PL, EM, LL, PI)

Injector Volume Measuring test (full-load, part-load, emissions, low-load, pre/post-injection tests and more...)

### iVM-DFi

Injector Volume Measuring test (multiple test-points slope per Pressure)

### RSP

Injector nozzle Response-time test

### BIP [UIS systems]

Injector Control Valve Response time test

### SPR

Dynamic Spray Test performed in all testing conditions

### Additionally

High pressure Control Valve operation (DRV, IMV, PCV, etc...)

High Pressure Sensor reaction

High Pressure relief safety valve operation

CR Pump flow limiter valve operation (ZME, IMV, SCV, VCV, etc...)



### Specifications

All Makes OE, CZ & User Database

Developer and OE customizing

Piezo & Solenoid programmable actuation profiles

(HV: 0-300 Volts / 0-35A)

Injector & PCB protection circuit (StG, StB, SC, OC, IC)

Multiple Injections capability

User friendly, ergonomic, dynamic & robust design

## Features

### AZO Software

Advanced Android based HMI/PC

Wi-Fi printing, sharing, syncing, software/hardware & database updating, via USB or WiFi Real-time Oscilloscope and CSV data export

### Reports

Easy fail-track color report for each injector.

Single-page Quick report or Multi-page Analytic reporting

## Electronic Measurement Upgrades\*

### 1. Dynamic Electronic Mass Measurement Kit (BK)

Injector Coding Capability\*

Acc: 0.2%FS, repeatability: 0.05%

Applications: CRDi, EUI/EUP, HEUI

### 2. Electronic Static Mass Measurement Kit (DFAP)

Resolution: 0.1mm<sup>3</sup>, Acc: 0.6%FS

Applications: CRp



\* Available Optionals \*\* Future Updates



## 4 Injector Repair Solutions

Repair Diesel injectors to achieve higher torque, lower emissions, fuel economy, quiet and efficient fuel injection performance, easy and affordable.



### Systems

VDO  
BOSCH  
DENSO  
DELPHI

### CRRS

- Standalone HMI & PC (15" touchscreen)
- Electronic (Activation & COM) Module Kit (with cables)
- Calibration Base for Accurate measurements
- Injector Mounting/Dismounting position
- Injector Measurement position (with micro adjustment wheel)
- Accurate electronic micrometer comparator Mitutoyo
- Electronic Torque Wrench



Note:  
Injector Calibration Spare Parts  
are available for Bosch, Denso, Delphi  
& VDO Common Rail injectors

### Features

Latest OE specifications  
Under 15' repair  
6-step flow:

1. Ultrasonic Cleaning of all dismantled parts
2. Solenoid & Injector Nozzle Replacement
3. HP Control Valve Repair
4. Calibration (1µm Accuracy):
  - a. residual air gap
  - b. nozzle needle lift
  - c. nozzle spring strength
  - d. armature (valve) lift
  - e. valve spring strength
  - f. extra lift
5. Replacement of the HP sealing washer
6. Final Inspection on Carbon Zapp Diesel Test Bench

## Injector Repair Tools

Tools and Kits for Repairing Diesel Injectors



SRA-061CR



SRA-370



SRA-400



SRA-491

SRA-500  
SRA-501SRA0313-CELL1  
SRA0313-CR

DiT-062



GV3-352CR



SRA0501-CR32



SRA-129CR



SRA0134-00



SRA-440



SRA0127-00

### DiT-062

Diesel injector manual hand pump tester  
0-600bars

### SRA-370

Universal Injector Seat (engine cylinder head)  
cleaning for BOSCH, DELPHI, DENSO, CONTI/VDO

### SRA-400

Lapping tool kit for CR Injector Control Valve  
Spherical seat (Is used to recondition the conic seat  
of the closing valve (CR return valve) positioned under the  
CR injector solenoids)

### SRA-500

CRDi Solenoid wrench Dismounting Wrench for  
solenoid HEX. 29mm

### SRA-503

Illuminated lens with X10 magnification, led operated

### GV3-352CR

Advanced universal tool to dismount & mount all type of  
nozzle holders [CRDi] of all DI makes

### SRA-129CR

Universal Adjustable Clamp Plate for vice to hold injectors  
upright and service.  
Applicable to all type of injectors

### SRA-061CR

Universal Complete Tool kit to disassemble and repair  
Common Rail Injectors [Bosch and others]

### SRA-491

Nozzle holder cap wrench for DELPHI injectors  
models: FORD Mondeo – Transit, and others..

### SRA-440

Tools Kit to extract and replace the fiber ring on the  
control spool valve of the BOSCH CR injectors  
(components: Puller, Inserter, Positioning device)

### SRA-501

CRDi Solenoid wrench Dismounting Wrench for  
solenoid HEX. 30mm

### SRA0127-00

Dismounting plate for UI/UP: 28,2 mm - 32,50 mm - 39,50 mm

### SRA0134-00

Swivel vice for dismounting plate

### SRA0313-CELL1

Load Cell for pick-up Force (with digital indicator)

### SRA0313-CR

Advanced Universal Tool to dismount and mount all types  
of Diesel Injection Systems [CRDi,  
EUI, EUP, PLD and PDE]

### SRA0501-CR32

Open wrench diam. 32mm

## Injector Extractors

Diesel injector extractors for professional mechanics



GV3-0260



GV3-0320



GV3-8400



GV3-8500



GV3-7903



GV3-0640



GV3-0760



GV3-4400



GV3-6601



GV3-2200



GV3-6900



GV3-2700

### GV3-0260

Universal complete set suitable for removing Bosch &  
Delphi CRDi models: MERCEDES, VOLVO, FORD,  
RENAULT, KIA, Trucks and General injectors

### GV3-8400

Universal kit for All Makes injector removal, with two  
distinct procedures:  
i) the pliers with holding arms  
ii) or the use of the articulated joint adapter and the pivot

### GV3-7903

DELPHI EMBR (Piezo & Solenoid) Extractor extension with  
adapter M18X1,5-M12. Slide hammer is Not supplied. models:  
Mercedes OM651, DFI 1.5 DELPHI (EURO 5), and others..

### GV3-0760

Copper Seal-Ring Extractor. Can remove seized copper  
sealing rings without damaging the cylinder head.  
Equipped with a slide hammer for ease of operation.

### GV3-6601

Universal complete set suitable for removing All Makes  
CRDi's. Specific for disassembling very locked injectors in  
restricted positions [mechanical operation] (GV3-2200  
Cylinder Not Supplied)

### GV3-6900

Complete set for removing all types DENSO injectors.  
Equipped with hammer.  
models: TOYOTA, NISSAN, MAZDA,  
OPEL/VAUXHALL, LEXUS and others.

### GV3-0320

Extractor specific for MERCEDES injectors including socket  
for dismounting the electrical connection CDI models:  
MERCEDES Sprinter – Vito – Viano – Vario, etc..

### GV3-8500

Universal kit for CRDi removal.  
Allows working safely and efficiently on removed engine  
using a slide hammer.  
Systems: BOSCH, CONTI/VDO, DELPHI

### GV3-0640

DELPHI Injectors extractor [EJBR, EJDR]  
models: SSANGYONG,  
MERCEDES, MAZDA, KIA and others..

### GV3-4400

Copper Seal-Ring Extractor for Trucks. Can remove seized  
copper sealing rings without damaging the cylinder head.  
Equipped with a slide hammer for ease of operation.

### GV3-2200

Mechanical-Hydraulic cylinder:  
12tons-stroke 8mm. Compact size allows its application  
directly on the vehicle, therefore it is not necessary  
to remove the engine. [Works with GV3-6601]

### GV3-2700

Universal injector seat cleaner and milling kit. Kit to be  
used for removing the combustion residues that remain in  
the Injectors' Seat without any damages.

\* Available Optionals \*\* Future Updates



# Gasoline Injection Systems

The only professional solutions for OE's, Remanufacturers and workshops to test & service Gasoline Injection Systems

5

**Direct Injection Solutions**  
GDU.4R, GDU.2R,  
GD1R

6

**Fuel Injection Solutions**  
GS8, GS4, GS2

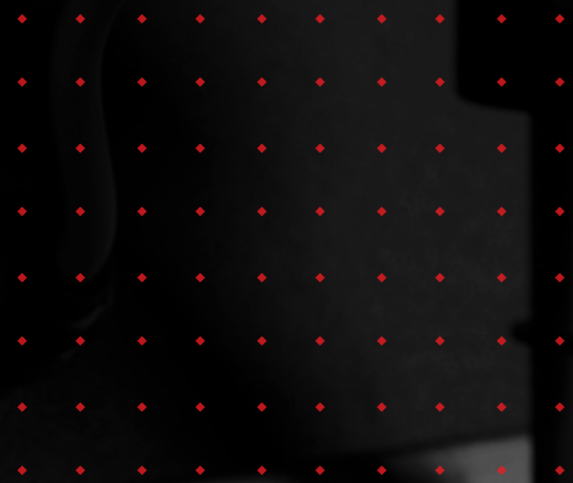

injector  
sh sensor

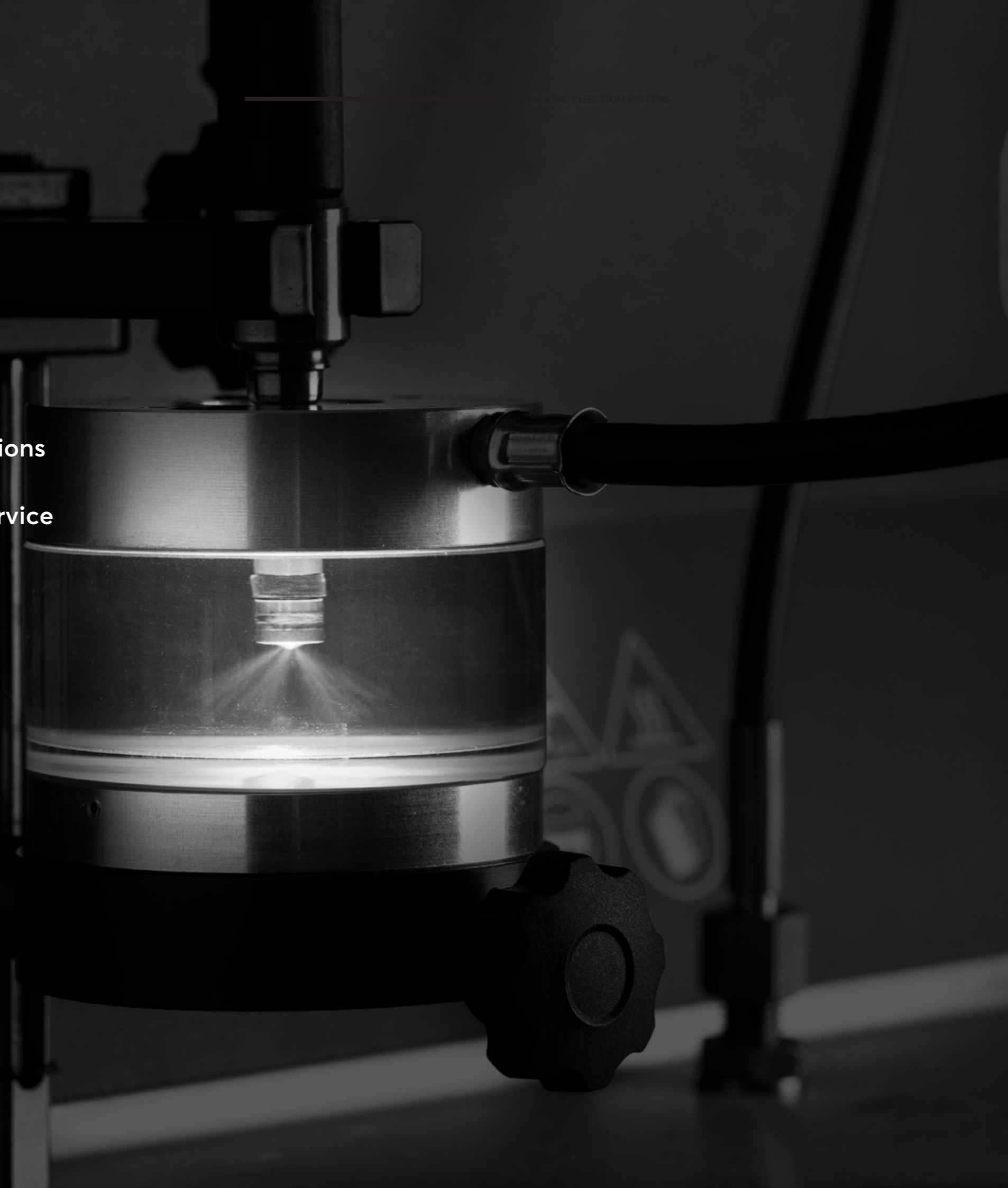



## 5 Direct Injection Solutions

Gasoline direct injection requires high pressure testing to truly diagnose operation faults. Carbon Zapp once again provides the only complete testing solution in the market today, with the Revolutionary GDU.4r, GDU.2r and GD1r Test benches.



### GDU.4r

Test bench for 4 Direct Injectors  
Up to 850Bar\* HP with 6.5 bar air supply  
Test bench for 4 Conventional MPFi or 4 Racing application Injectors 0-10Bar  
Gasoline Expert level of Diagnosis  
Dynamic Electronic Mass Measurement (BK) Acc: 0.2%FS, repeatability: 0.05%  
Under 15min testing phase  
**Fully Automatic Operation**  
Flushing / Cleaning capability\*  
10" Touchscreen HMI  
Ultrasonic cleaning function



### GDU.2r

Test bench for 1 Direct Injector  
Up to 850Bar\* HP with 6.5 bar air supply  
Test bench for 1 Conventional MPFi or 1 Racing application Injector 0-10Bar  
Gasoline Expert level of Diagnosis  
Dynamic Electronic Mass Measurement (BK) Acc: 0.2%FS, repeatability: 0.05%  
Under 5min testing phase  
**Fully Automatic Operation**  
Flushing / Cleaning capability\*  
10" Touchscreen HMI  
Ultrasonic cleaning function

**NEW  
2016**



### GD1r

Test bench for 1 Direct Injector  
Up to 300Bar HP with 6.5 bar air supply  
Test bench for 1 Conventional MPFi or 1 Racing application Injector 0-10Bar\*\*  
Electronic Static Mass Measurement (DFAP)  
Resolution: 0.1mm<sup>3</sup>, Acc: 0.6%FS  
**Manual or Automatic Operation**  
Workshop & Expert level of Diagnosis  
7-8 min testing phase  
8" Touchscreen HMI  
Ultrasonic cleaning function

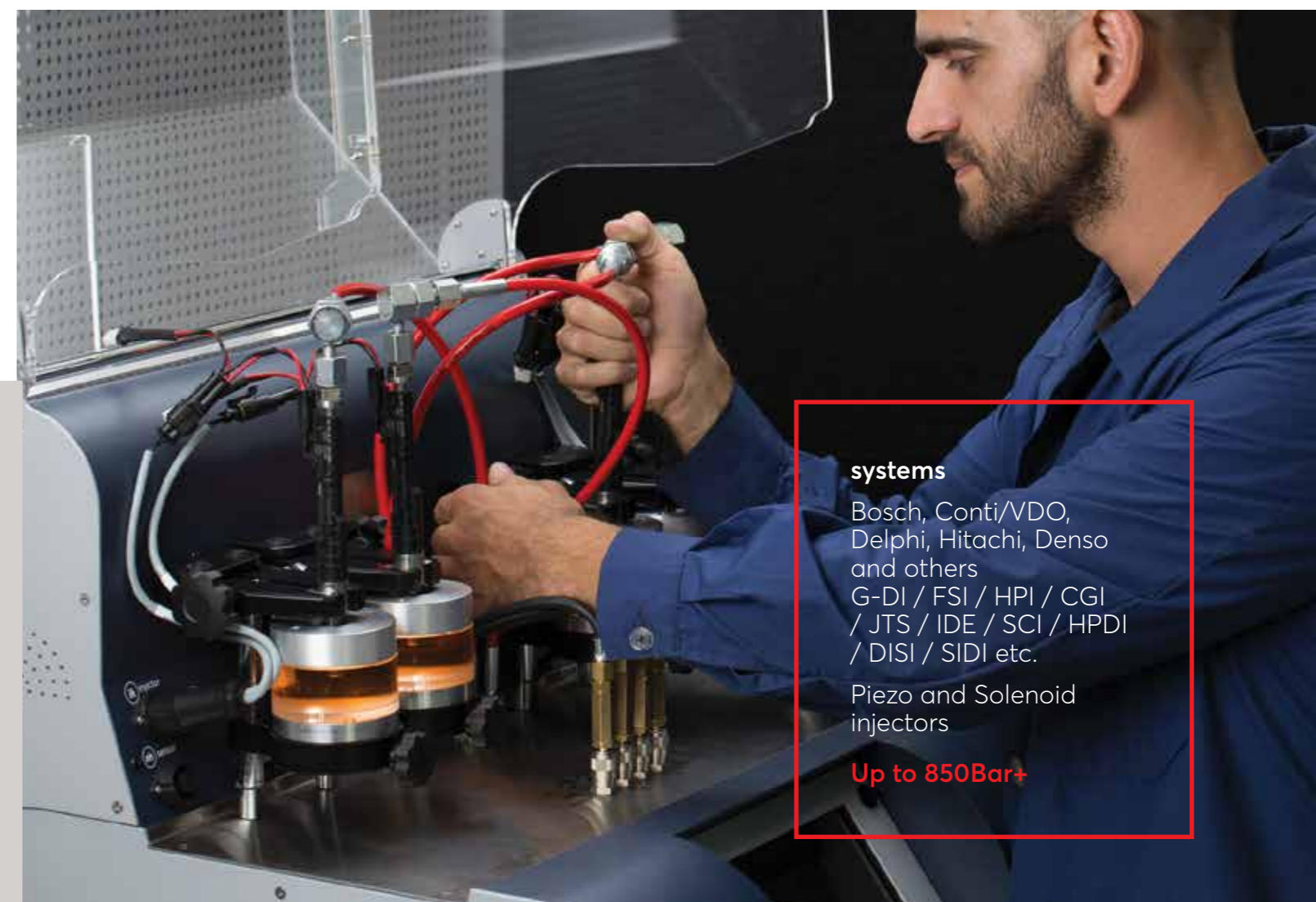

### systems

Bosch, Conti/VDO,  
Delphi, Hitachi, Denso  
and others  
G-DI / FSI / HPI / CGI  
/ JTS / IDE / SCI / HPDI  
/ DISI / SIDI etc.

Piezo and Solenoid  
injectors

**Up to 850Bar+**

## Tests Performed

- R2LC**  
Electrical test for  $k\Omega/\mu F$ ,  $\Omega/\mu H$
- CFL**  
Check For Leaks test (injector internal or external)
- NLT**  
Nozzle Leakage Test @High Pressure
- iVM (FL, PL, EM, LL, PI)**  
Injector Volume Measuring test  
(full-load, part-load, emissions, low-load, pre/post-injection tests and more...)
- RSP**  
Injector nozzle Response-time test
- SPR**  
Dynamic Spray test performed in all testing conditions

## Features

- iPSC**  
Illuminated Pressurized spray chamber  
View of injection pattern up to 1000Bar  
Visually diagnose NOP, incorrect spraying, leaky / seized injectors
- RSP**  
Sensor adaptable to all nozzles  
Precise measurement of nozzle reaction time  
Easily diagnose a slow acting injector, a retarded injection event, poor engine performance and emissions issues.

### Specifications

All Makes OE, CZ & User Database

Developer and OE customizing

Piezo & Solenoid programmable actuation profiles

(HV: 0-300 Volts / 0-35A)

Injector & PCB protection circuit  
StG, StB, SC, OC, IC)

Multiple Injections capability

User friendly, ergonomic, dynamic & robust design

Spill-free hose quick connectors

aMACC – Automatic chemical treatment and flushing of the injector before testing\*

Complementary set of GDi adapters, fittings and connectors for all makes & types

### AZO Software

Advanced Android based HMI/PC  
Wi-Fi printing, sharing, syncing, software/hardware & database updating, via USB or WiFi  
Real-time Oscilloscope and CSV data export  
TeamViewer Support and more...

### Reports

Easy fail-track color report for each injector.  
Single-page Quick report or Multi-page Analytic reporting

\* Available Optionals \*\* Future Updates

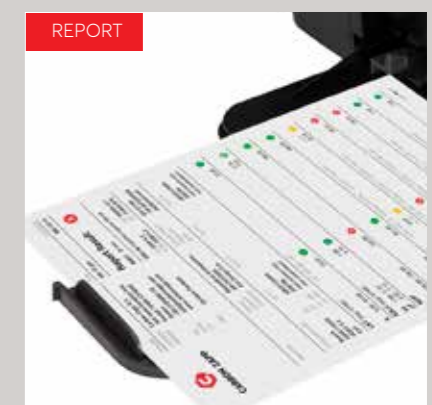



## 6 Fuel Injection Solutions

The efficient, cost-effective and proven workshop solution to bench test and service every gasoline fuel injector.

### GS8 GS4 & GS2

#### Systems Tested

Solenoid Direct Injectors (G-Di, FSI...)

Multi-Port Fuel Injectors (MPFI / SPFI)

Racing Application Injectors\*

Central-Port Fuel Injectors (CSFI / CPFJ)

Throttle Body Injectors (TBI / CFI)

Continuous Injection Injectors (K-Jetronic),

Marines Application Injectors (E-TEC / FICHT)

Motorcycle Application Injectors (Racing\*)

LPG & Alternative fuels Injectors



### GS8

Bench for Testing & Ultrasonic Cleaning up to 8 Fuel Injectors  
Fully Automatic Function  
Electronic Pressure Control 0-10Bar  
Racing Injectors Capable\*  
Dynamic & Static iVM  
Auto-iRF function  
Injector Leak Test function  
User-Friendly Design  
Language Localization



### GS4

Bench for Testing & Ultrasonic Cleaning up to 4 Fuel Injectors  
Fully Automatic Function  
Electronic Pressure Control 0-10Bar  
Racing Injectors Capable\*  
Dynamic & Static iVM  
Auto-iRF function  
Injector Leak Test function  
User-Friendly Design  
Language Localization

### GS2

Bench for Testing & Ultrasonic Cleaning up to 4 Fuel Injectors  
Manual Function  
Electronic Pressure Control 0-10Bar  
Dynamic & Static iVM  
Manual-iRF function  
Injector Leak Test function





## Features

### iVM: Injection Volume Metering

Precise graduated led illuminated tubes are used for efficient diagnosis of uneven flow rates and weak or defective nozzle springs. Automatic drainage after each test. resolution 1ml, accuracy  $\pm 1\text{ml}/130\text{ml}$

### iSPC

Illuminated Spray Pattern Chamber used for visual diagnosis of correct injection

### Ultrasonic Cleaning

Baths Available at sizes up to 120L\* featuring:

42KHz frequency

Sweep technology\*

Degas function\*,

Controlled Heater and more...

### iRF

Injector Reverse Flush Device used to remove all dirt remained inside injector body after cleaning with the use of Ultrasonics

### eRSO

Electrical Resistance, Short Circuit & Open Circuit Test

### 0-10 Bar

Testing Capability of All Types of Injectors up to 10Bars Maximum.

GD Units are available for High Pressure Direct Injectors up to 850Bars

## Service & Repair

Increased exhaust emissions

Reduced engine performance (Power, Torque)

Increased fuel consumption

Poor drive-ability situations

Direct injection systems failure

(Leaks, Pressure drop)

Rough idle and periodic stall of the engine

Conditions that lead to long-term catalytic converter damage

Extended engine start-up

MIL - check engine light-up



iVM / iSPC

ULTRASONIC BATH



iRF



DISPLAY SCREEN

## Extras optional

### adapters kit

#### 5 Direct Injection Solutions

A complete range of adapters\* for All Makes and Types GD-I and Top-Feed Conventional Injectors are available



#### 6 Fuel Injection Solutions

##### Standard Kit [GSx-10 units]

Fuel Rail & Adapters for all Makes and Types of Top-Feed and G-DI Injectors

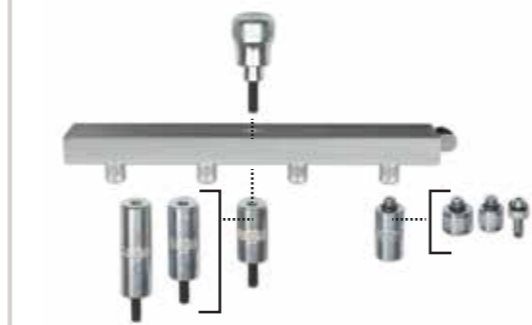

##### TBI Kit \* [GSx-10 units]

Fuel Rail & Adapters for all Makes and Types of Throttle Body and Side-Feed Injectors



##### Exclusive Kit [GSx-20/30 units]

Complete set of Fuel Rail & Adapters, designed for Easy and Fast adaptation to all Makes and Types of Top-Feed, G-Di and Side-Feed Injectors

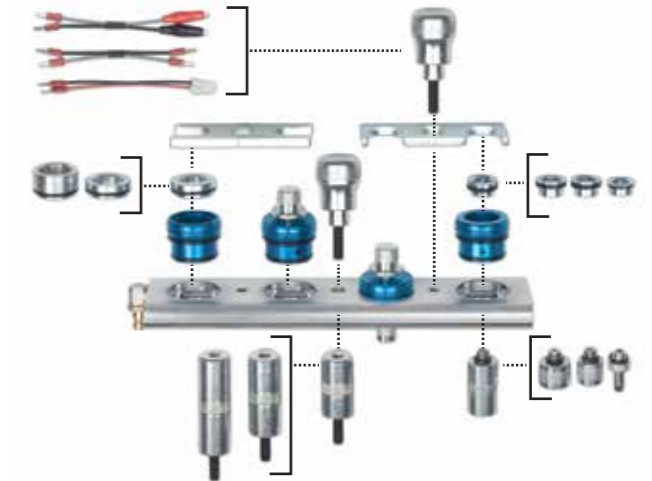

### MARINE

##### E-TEC Kit \*

Complete Rail Kit specially designed for adaptation to E-TEC / FICHT Injectors



### Ultrasonic Devices

Ultrasonic Baths are available at sizes up to 120L featuring:  
42KHz frequency  
Sweep technology\*  
Degas function\*,  
Controlled Heater and more...



### Portable stand

Compact, lightweight, robust with accessories cabinet



### Tools

**SRC-505**  
Gasoline injector screen filter extractor tool



**GV3-4100**  
Injector puller kit suitable for gasoline direct injection engines (VAG-FSI and others)



### Oils & Fluids

1. Gasoline Injector Calibration Oil (Exxsol D40)  
4L | 20L | 208L
2. Ultrasonic Solvent (Concentrated)  
4L | 20L | 208L
3. Gasoline Injector Flushing Detergent  
2L | 25L





# Engine Service Solutions

7

Service Equipment

8

Fuel Injection Handheld Tools

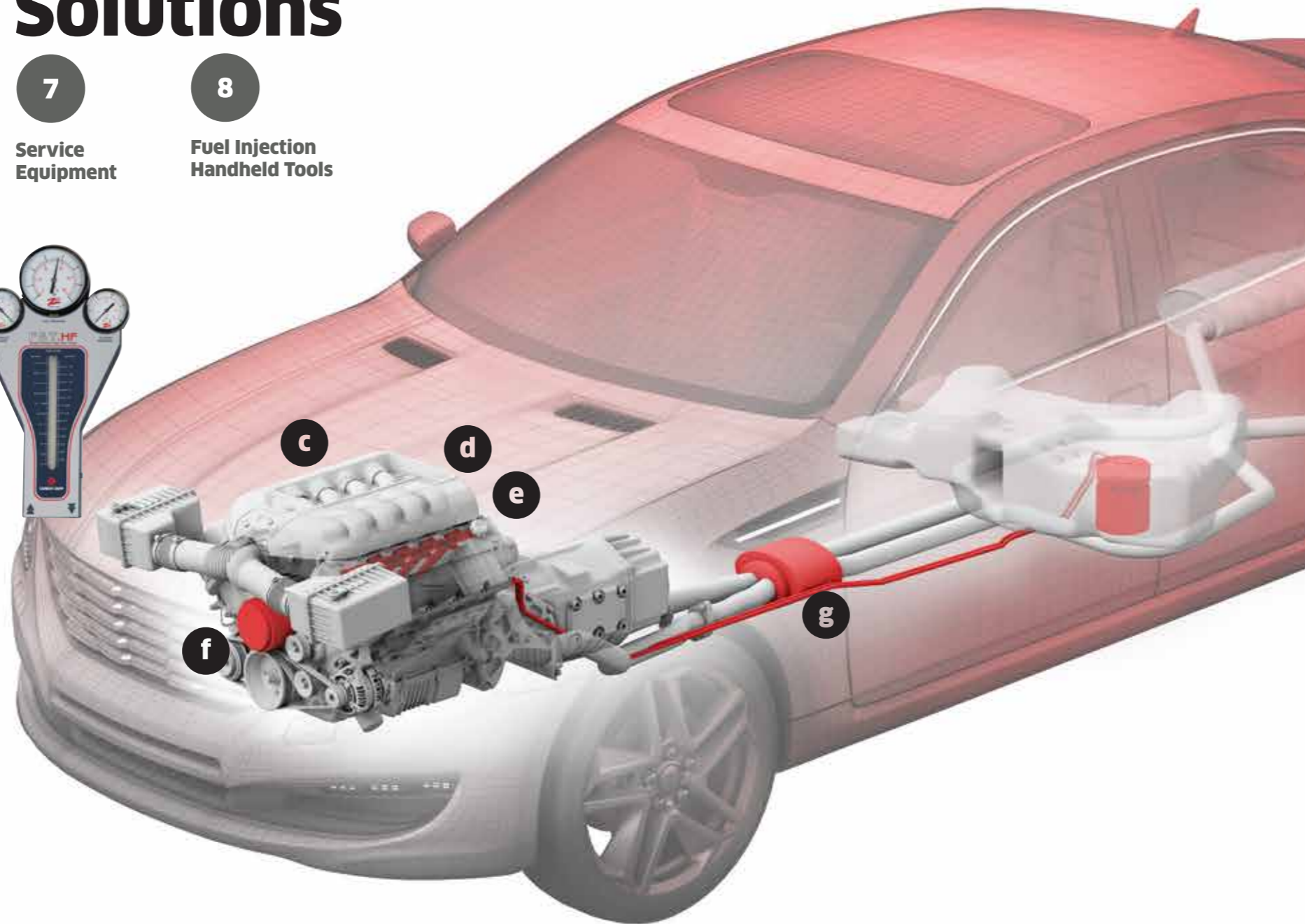

**a** **ES.3**  
Engine & Exhaust  
De-Carbonizing  
Solution

**b** **FST**  
Fuel System Tester

**c** **CRMK**  
CRDi Return Kit

**d** **CRMK**  
CR Pump Tester

**e** **HP-G2500HP / G250**  
High Pressure Gauges

**f** **IMC.01**  
Intake Manifold Cleaning Kit

**g** **DPF.01**  
Diesel Particulate Filter Cleaning Kit

Modern engine servicing,  
calls for time-saving, easy-to-use  
and cost-effective solutions.



## 7 Service Equipment

### Diesel & Gasoline Engine Treatment Unit

#### Benefits

- Exhaust emissions reduction more than 70%
- De-Carbonization of the combustion chamber
- De-Carbonizing of Intake Manifold and throttle body
- De-carbonization of the catalytic converter & DPF
- Maximum restoration of engine's performance
- Reduction of fuel consumption
- Common-Rail system cleaning
- High Pressure pump conditioning
- Optimum fuel combustion gain
- Blocked valves and piston rings release
- Improved idle-speed stability
- Fading of engine knocking
- Prevention of long term expensive repairs

User-Friendly, On-Display guide with language localization

#### Systems

- Common-Rail and Conventional Diesels
- Gasoline Direct Injection (G-Di, FSI, HPI, CGI etc.)
- Conventional Fuel Injection (MPFI / TBI / CIS)
- LPG and Alternative fuels
- Carburated Engines

Automatic Pressure adjustment

Use of External Tank

Dual-Tank system

Adaptability to all makes and models

Portable, Lightweight and Robust unit

**ES.3**



#### Detergent



The environmental friendly ENGINE TECH Detergent activates the inert carbon molecules, resins, dust varnish and gums that accumulate inside the engine components, and burns them with the combustion process.

#### Adapters

Exclusive fuel system adapters kit available for all types of engine configurations\*



#### DPF.01

Diesel Particulate Filter Cleaning Adapter Kit. Use of Non-Combustible environmental friendly detergent to efficiently clean Particulate Matter, Carbon Soot, Ash, Organic materials and Sulfates. Application programmable duty-cycle software integrated



#### IMC.01

Intake Manifold Cleaning Adapter Kit and Non-Combustible environmental friendly detergent. Application programmable duty-cycle software integrated



\* Available Optionals \*\* Future Updates

## 8 Fuel Injection Handheld Tools

### FST / FST-HF

Diesel & Gasoline Fuel System Tester



#### DIAGNOSIS

- Incorrect fuel pressure
- Incorrect system fuel flow
- Plugged fuel filter
- Faulty fuel pump
- Plugged fuel pump inlet strainer
- Faulty fuel pump check valve
- Leaky fuel injectors
- Incorrect operation of the fuel pressure regulator
- Fuel foaming and/or contamination
- Restrictions in supply/ return fuel lines
- Intake manifold vacuum fluctuation
- Exhaust back-pressure for testing DPF & Catalytic Converter
- Turbo-boost pressure operation
- Adaptability for all Makes, Models and Types

#### FEATURES

- Compact, Portable and Robust tool for use in the workshop
- High flow capability for Racing and Performance applications [FST-HF]
- Easy readable analog gauges: Fuel Pressure, Manifold Vacuum, Exhaust Back-Pressure
- Durable and clear analog flow tube
- Spill-free quick connectors
- Easy hook for mounting on engine hood



### HP-G2500

Common-Rail Gauge

#### FEATURES

- New Common Rail Injection Systems
- Up to 2500Bar
- Compact & Portable
- Dynamic & Static tests
- Adaptable to all CRDi Systems



### HP-G250

High Pressure Gauge

#### FEATURES

- Conventional Diesel Systems
- G-Di Gasoline Fuel Systems
- Up to 250Bar
- Compact & Portable
- Dynamic & Static tests
- Adaptable to all DI & G-Di Systems\*



### CRPT-110

Digital Common Rail Pressure Tester

#### DIAGNOSIS

- CRDi system operating pressure
- CRDi system leaking

#### FEATURES

- Easy Operation / Robust design
- Adaptability to All Makes sensors
- Operation Range 0-2000 Bar
- Measurement resolution of 1 bar
- Indication for defective pressure sensor
- Fault detection indicated by a red warning LED
- Automatic shut-off after 1 minute
- Power supply by 9 V battery (standalone unit)



### CRMK-110

Common Rail Injector's Backflow Kit for All Injector Makes

#### DIAGNOSIS

- CRDi Excessive Back-Leak

#### FEATURES

- Test kit for checking the return flow volumes from Common-Rail Injectors
- Plexiglass robust container with graduated scales for easy comparison
- Metal chain hook to hold tester in upright position of the engine hood
- Set of backleak connectors for BOSCH, CONTI/ VDO, DELPHI and DENSO injectors

### PIMK-010

Piezo CRDi Backflow Pressure Tester

#### DIAGNOSIS

- Piezo CRDi return pressure
- Piezo injector proper operation

#### FEATURES

- Transparent Plexiglass tester to permit view of any air pockets which may be present in the fuel
- Interchangeable vacuum gauge on the test unit for further testing capabilities
- Adaptability for most injectors in the market
- Pressure relief valve for safe removing from engine
- Adaptable to BOSCH (15 Bar gauge) and CONTI/ VDO, DELPHI & DENSO (+3 Bar gauge)

\* Available Optionals \*\* Future Updates

