

---

**The role of swash in the ecology of Ecuadorian sandy beach macrofauna,  
with special reference to the surfing gastropod *Olivella semistriata***

---

De rol van swash in de ecologie van macrofauna op Ecuadoriaanse zandstranden,  
met speciale aandacht voor de surfende gastropode *Olivella semistriata*



Thomas Vanagt

Promotor: Prof. Dr. Magda Vincx

Co-promotor: Dr. Steven Degraer

Academic year 2006 – 2007

Thesis submitted in partial fulfillment of the requirements  
for the degree of Doctor in Science (Biology)

### **Members of the reading committee**

Prof. Dr. Magda Vincx, promotor (UGent, Belgium)

Dr. Steven Degraer, co-promotor (UGent, Belgium)

Prof. Dr. Mariano Lastra (University of Vigo, Spain)

Prof. Dr. Jean-Pierre Maelfait (UGent, Belgium)

### **Members of the examination committee**

Prof. Dr. Wim Vyverman, Chairman (UGent, Belgium)

Prof. Dr. Magda Vincx, promotor (UGent, Belgium)

Dr. Steven Degraer, co-promotor (UGent, Belgium)

Prof. Dr. Mariano Lastra (University of Vigo, Spain)

Prof. Dr. Jean-Pierre Maelfait (UGent, Belgium)

Dr. Dries Bonte (UGent, Belgium)

Prof. Dr. Maria Pilar Cornejo (ESPOL, Ecuador)

Dr. Nancy Fockedey (VLIZ, Belgium)

Prof. Dr. Ann Vanreusel (UGent, Belgium)

‘Treat the Earth well:  
it was not given to you by your parents,  
it was loaned to you by your children.  
We do not inherit the Earth from our ancestors,  
we borrow it from our children’

*Native-American saying*





	<b>Dankwoord</b>	
	<b>Samenvatting</b>	I
	<b>Summary</b>	VII
	<b>Resumen</b>	XII
<b>PART I</b>	<b>INTRODUCTION AND AIMS</b>	1
<b>1.1</b>	<b>Introduction</b>	3
1.1.1	Sandy beaches	3
1.1.2	Macrofauna	12
1.1.3	Survival strategies of macrofauna on sandy beaches	20
1.1.4	The sandy beach gastropod <i>Olivella semistriata</i>	25
1.1.5	Framework of this thesis	27
<b>1.2</b>	<b>Aims and thesis outline</b>	28
<b>PART II</b>	<b>MACROFAUNA ON ECUADORIAN SANDY BEACHES: THE ROLE OF SWASH AND MORPHODYNAMICS</b>	31
<b>Chapter 1</b>	<b>Changes in macrofaunal assemblage structure along a morphodynamic sandy beach gradient in the eastern tropical Pacific</b>	33
	Abstract	34
2.1.1	Introduction	35
2.1.2	Materials and Methods	37
2.1.3	Results	43
2.1.4	Discussion	63
2.1.5	Conclusions	72
<b>Chapter 2</b>	<b>Swash zonation patterns of two surfers on exposed tropical sandy beaches</b>	73
	Abstract	74
2.2.1	Introduction	75
2.2.2	Materials and Methods	77
2.2.3	Results	82
2.2.4	Discussion	88
2.2.5	Conclusions	94
<b>Chapter 3</b>	<b>Size distribution of the surfing gastropod <i>Olivella semistriata</i> along a cross-shore gradient in an Ecuadorian sandy beach</b>	95
	Abstract	96
2.3.1	Introduction	97
2.3.2	Material and Methods	98
2.3.3	Results	101
2.3.4	Discussion	108
2.3.5	Conclusions	112

<b>PART III</b>	<b>SOME ASPECTS OF THE BIOLOGY OF THE GASTROPOD <i>OLIVELLA SEMISTRIATA</i></b>	113
<b>Chapter 4</b>	<b>Is the burrowing performance of a sandy beach surfing gastropod limiting for its macroscale distribution?</b>	115
	Abstract	116
3.4.1	Introduction	117
3.4.2	Material and Methods	118
3.4.3	Results	121
3.4.4	Discussion	129
3.4.5	Conclusions	133
<b>Chapter 5</b>	<b>Can sandy beach molluscs show an endogenous controlled circatidal migration behaviour? Hints from a swash rig experiment</b>	135
	Abstract	136
3.5.1	Introduction	137
3.5.2	Material and Methods	139
3.5.3	Results	144
3.5.4	Discussion	146
3.5.5	Conclusions	149
<b>Chapter 6</b>	<b>Surfing on sandy beaches: an efficient strategy to flourish in a highly dynamic environment?</b>	151
	Abstract	152
3.6.1	Introduction	153
3.6.2	Material and Methods	155
3.6.3	Results	148
3.6.4	Theoretical models	168
3.6.5	Discussion	173
3.6.5	Conclusions	180
	Appendix 1	181
	Appendix 2	182
<b>PART IV</b>	<b>GENERAL DISCUSSION</b>	185
<b>4.1</b>	<b>Sandy beaches in Ecuador</b>	187
<b>4.2</b>	<b>Distribution of macrofauna in Ecuador</b>	189
4.2.1	Temporal effects	190
4.2.2	Sandy beach macrofauna and ENSO	191
4.2.3	Spatial distribution	192
4.2.4	Explaining the spatial patterns	195
<b>4.3</b>	<b>Biology of <i>Olivella semistriata</i></b>	199
4.3.1	Distribution of the species	199
4.3.2	Feeding habits	203
4.3.3	Surfing behaviour	204
<b>4.4</b>	<b>Open questions</b>	207
4.4.1	Studying macrofauna on exposed beaches	207
4.4.2	Macrofauna and ENSO	207
4.4.3	<i>Olivella semistriata</i>	207

<b>PART V</b>	<b>ADDENDA</b>	<b>209</b>
<b>Addendum 1</b>	<b>Macrofaunal community structure and zonation of an Ecuadorian sandy beach (bay of Valdivia)</b>	<b>211</b>
	<b>Critical note</b>	<b>228</b>
<b>Addendum 2</b>	<b>Spatial and temporal patterns in the sandy beach surf zone benthos of the tropical East Pacific.</b>	<b>231</b>
<b>Addendum 3</b>	<b>ENSO and sandy beach macrobenthos of the tropical East Pacific: some speculations</b>	<b>255</b>
	<b>Reference List</b>	<b>267</b>



## Dankwoord

Dit doctoraat is het resultaat van vier jaar wetenschappelijk onderzoek aan de Sectie Mariene Biologie van de Universiteit Gent, in samenwerking met de polytechnische universiteit van Guayaquil (ESPOL) in Ecuador. Het schrijven van een doctoraat, maar vooral het voorafgaande onderzoek, is een proces dat niet alleen de inzet van de doctorandus vergt, maar evenzeer de hulp, steun en motivatie van een hele reeks mensen, die ik bij deze dan ook graag in de bloemetjes wil zetten.

Allereerst wil ik mijn promotor, Prof. Dr. Magda Vincx, bedanken om mij de kans te geven dit project te starten. Hoewel het een weg was met vele obstakels, is ze mij altijd blijven steunen. Haar rol in het effenen van de paden in Ecuador was zonder meer cruciaal, en ik heb mij er regelmatig over verbaasd hoe de naam *La doctora Vincx* deuren kon openen die anders zeker gesloten zouden blijven. De dagelijkse begeleiding lag in goeie handen van Dr. Steven Degraer, mijn co-promotor. Van het begin tot het einde van mijn doctoraat kon ik altijd rekenen op zijn wetenschappelijke creativiteit en zijn kracht om mensen te motiveren. Daarnaast speelde hij ook de soms ondankbare rol van ‘advocaat van de duivel’ bij het doornemen van mijn schrijfsels. Tenslotte wil ik Steven ook bedanken voor de twee korte trips die we samen in Ecuador gemaakt hebben, en die cruciaal gebleken zijn in de onderzoekslijn die ik uiteindelijk gevolgd heb.

When in Ecuador, I could always count on the full support of the Oceanography and Marine Sciences department of ESPOL and the aquaculture institute CENAIM in San Pedro. In ESPOL, I was always welcome in the lab of Dr. Maria Pilar de Cornejo. Dr. Jorge Calderon, Dr. Sam Stern, Ing. Andrés Pedrazzoli and Dr. Stanislaus Sonnenholzner guaranteed me total freedom in my work at CENAIM, even if many last-minute changes had to be arranged. I know it always seemed weird to the people of CENAIM that someone could do scientific research with nothing but a spade, a bucket and a frame, but I hope this PhD proves it can. Of course, I also want to thank my Ecuadorian colleagues, Sonia, Luis, Veronica, Alba and Mare, for the happy times in Ecuador, and their help in translating my abstracts, summaries and talks into Spanish! Special thanks go to Galo, without whom I would never have survived the many road trips and sampling campaigns.

Uiteraard bepaalt de omgeving waarin je werkt voor een groot stuk de werkvreugde. Ik wil dan ook heel graag mijn collega's en ex-collega's van de Sectie Mariene Biologie bedanken voor een creëren van een gemoedelijke maar wetenschappelijk stimulerende sfeer. Ik denk dat ik bij zowat elke collega wel eens (of soms vele malen) ben langsgeweest met één of andere vraag. In het bijzonder zou ik graag Maarten, Marleen en Nancy vermelden voor hun hulp bij allerhande problemen die ik op mijn weg ben tegengekomen. De – voor mij althans – ingewikkelde wiskundige modellen van hoofdstuk zes werden opgebouwd door Bea. Mijn bureaugenoten, Jan, Veronique en Veronique wil ik bedanken voor de vele leuke babbels tussen het werk door.

Ook mijn collega-strandjutters, Tom en Jeroen, verdienen een plaatsje in dit dankwoord, voor de vaak levendige discussies over beach indices en staalnameprotocols. De soms lange dagen werden een stuk lichter gemaakt door de aangename lunchpauzes met de resto-gangers. Voor allerhande praktische beslommeringen kon ik altijd terecht bij Isolde, Annick en Guy. Voor de verwerking van de sedimentstalen en hulp bij het bepalen van omgevingsvariabelen kon ik dan weer rekenen op Danielle, Bart en Dirk. Jurgen en Yves zorgden ervoor dat ik de swashomgeving kon nabootsen in het laboratorium door de swash rig te ontwerpen en te bouwen.

Veel van het zware staalnamewerk en het uitsorteren van de stalen is gebeurd door mijn thesisstudenten, Eveline, Pieter, An, Lien en Leen, waarvoor mijn oprechte dank. Jullie verblijven in Ecuador zorgden voor een aangename afwisseling, en ik hou er heel mooie herinneringen aan over!

Bij de verwerking van de soms moeilijk interpreteerbare gegevens heb ik veel hulp gehad aan de bezoeken bij Frederik Hendrickx en Stijn Vansteelandt alsook aan de mailconversaties met Andrew Short en Dave Schoeman. De juryleden van mijn doctoraat hebben dankzij hun opmerkingen en suggesties geleid tot een beter eindproduct.

In het dagelijks leven hebben een hele reeks mensen, elk op hun manier, een steentje bijgedragen tot dit werk, vaak zonder het te beseffen. Daarom, merci 'foute vrienden', 'fotovrienden', 'biologievrienden', 'schaatsvrienden', familie en schoonfamilie. In Ecuador, I had great nights out, and lots of diverting chats with mis amigos/-as Ecuatorianos/-as.

Mijn eerste stappen in de wondere wereld van de biologie heb ik gezet samen met mijn moeder en Oom Willem. De ervaringen die ik tijdens onze vele uitstapjes in binnen- en buitenland heb opgedaan, koester ik voor de rest van mijn leven. Mam, het is dankzij jouw steun en inzet dat ik heb kunnen en mogen doen wat ik graag doe. Vrijheid en zelfstandigheid zijn misschien wel de mooiste dingen die je in een opvoeding kan meekrijgen.

Katrien en Pieter, jullie wonen misschien ver weg (de aandelen van Belgacom nemen niet voor niets een hoge vlucht), maar dat neemt niet weg dat jullie altijd hard jullie best gedaan hebben om jullie kleine broertje op het juiste pad te houden. Of dat gelukt is, laat ik in het midden...

Je geliefde bedanken zonder melig te klinken, is enkel weggelegd voor Grote Schrijvers, en dat ben ik jammergenoeg niet. So be it. Evie, bedankt voor de afgelopen acht fantastische jaren samen, ik hoop dat er nog veel zo mogen volgen. Je bent niet alleen mijn partner en levensgezellin, maar ook mijn beste vriendin, mijn ideale reismakker en mijn beste motivator. Dat dit doctoraat tot een goed einde is gebracht, heb ik voor een groot stuk aan jouw steun en hulp te danken. En je had natuurlijk al het goeie voorbeeld gegeven. Ook in de volgende uitdaging ben je mij voorgegaan: ik kijk ernaar uit om samen verder te bouwen aan jouw - en binnenkort ons - Liverpools avontuur.

**Dit doctoraat werd gefinancierd met een doctoraatsbeurs van het Fonds voor Wetenschappelijk Onderzoek Vlaanderen (FWO). Bijkomende reisbeursen werden bekomen via het FWO, het Leopold III fonds en de Universiteit Gent.**





## Samenvatting

Gedurende de periode van dit doctoraat werden verschillende aspecten van de biologie van macrofauna op Ecuatoriaanse zandstranden onderzocht, met als doel een beter beeld te krijgen van het functioneren van de zandstrandfauna in het tropische deel van de oostelijke Stille Oceaan. Deze regio was tot voor dit doctoraat zo goed als een onbeschreven blad op het gebied van zandstrandonderzoek, ondanks het grote belang van zandstranden in het locale ecosysteem en voor de locale economie. Net zoals in andere regio's vormen de Ecuatoriaanse zandstranden het centrum van het kusttoerisme. Daarnaast worden ze ook een rol toebedeeld in de levenscyclus van de garnaal *Litopenaeus vannamei*, de belangrijkste aquacultuursoort van Ecuador en het op één na belangrijkste exportproduct van het land.

In drie pilootstudies, weergegeven in de addenda, werden een aantal basiskennmerken van de Ecuatoriaanse zandstrandfauna onderzocht. Bovendien leverden deze pilootstudies waardevolle feedback betreffende de staalnamestrategie die zou gebruikt worden voor de daaropvolgende studies. **Addendum 1** bevat de beschrijving van de zonatie van macrofauna in de baai van Valdivia. In deze baai is onder andere het intermediaire strand van San Pedro gelegen, dat als modelstrand werd gekozen voor alle verdere onderzoeken. De studie uit Addendum 1 gaf ons een mooi beeld van de diversiteit en densiteit aan macrofauna uit verschillende zones van het intertidaal. De belangrijkste soort bleek de slak *Olivella semistriata* te zijn. Deze kleine slak (ongeveer 1 cm schelpenlengte) werd in zeer grote aantallen teruggevonden in de swashzone, de zone waar de golven op en af het strand lopen. Deze studie leerde ons echter ook dat de staalnamestrategie, die gebaseerd was op voorgaande onderzoeken langs de Belgische kust, niet geschikt was voor de sterk geëxposeerde Ecuatoriaanse stranden. Deze aanpak werd dan ook gecorrigeerd voor de verdere onderzoeken.

**Addendum 2** behandelt de ruimtelijke en temporele variatie van de laagstrandmacrofauna, in combinatie met het hyper- en epibenthos van de surfzone. Negen stranden werden op vier verschillende tijdstippen doorheen het jaar bemonsterd. Uit deze studie bleek dat macrofauna vooral verschilt tussen verschillende types stranden, terwijl hyperbenthos vooral temporeel sterke variatie vertoont; epibenthos vertoonde geen duidelijke patronen, mogelijks omwille van de extreem lage dichtheden. De waargenomen temporele patronen voor de macrofauna waren daarenboven verschillend tussen de verschillende strandtypes. Dit maakt het veralgemenen van patronen erg moeilijk.

In **Addendum 3** werden een aantal hypothesen voorgesteld betreffende de invloed van het ENSO klimaatfenomeen op de Ecuadoriaanse zandstrandfauna. Tijdens de koude La Niña fase werd een veel lagere dichtheid aan weekdieren en schaaldieren waargenomen. De eerste hypothese stelt dat deze lage waarden veroorzaakt werden door de zeer sterke El Niño, die aan de La Niña voorafging en waarvan jammer genoeg geen biologische gegevens beschikbaar waren. De tweede hypothese, daarentegen, verklaart het waargenomen patroon als een rechtstreeks gevolg van La Niña, waarbij de fauna van een tropisch milieu - zoals de Ecuadoriaanse kust - sterk beïnvloed wordt door lage temperaturen.

Met de informatie uit de studies weergegeven in de addenda, werd een ontwerp gemaakt voor de verdere onderzoeken van dit doctoraat. De idee was om eerst een gedetailleerd beeld te krijgen van de ruimtelijke verspreiding van de zandstrandmacrofauna over een continuüm van strand types - van vlakke tot zeer steile stranden, maar ook van de ruimtelijke verspreiding binnen één strand (Hoofdstuk 1). Daarna zouden zoveel mogelijk facetten van de ecologie van de dominante slak *Olivella semistriata* bestudeerd worden (Hoofdstukken 2 t.e.m. 6). In de eerste drie hoofdstukken, samengebracht in Deel II, wordt de invloed van swash en andere strandkarakteristieken op de ruimtelijke verspreiding van macrofauna in het algemeen, en van *O. semistriata* in het bijzonder, behandeld. De laatste drie hoofdstukken (Deel III) belichten meer specifiek de biologie – voeden, migreren en ingraven - van *O. semistriata*.

Net zoals op andere zandstranden in de wereld, vonden wij ook in Ecuador een duidelijke stijging van soortenrijkdom, en in mindere mate van dichtheid (ind/m<sup>2</sup>) en biomassa (g AFDW), van steile naar vlakke stranden (**Hoofdstuk 1**). Daarnaast konden op de steile stranden slechts drie zones over het intertidaal onderscheiden worden, terwijl intermediaire en vlakke stranden vier zones herbergden. Er werd ook een verschuiving waargenomen in soortensamenstelling: de steile stranden werden gedomineerd door schaaldieren en interstitiële borstelwormen en vielen op door de afwezigheid van weekdieren. Op de intermediaire en vlakke stranden werd een veel rijkere fauna gevonden, met naast schaaldieren en borstelwormen, ook veel weekdieren (zowel tweekleppigen als slakken) en stekelhuidigen. Deze patronen werden ook weerspiegeld in de samenstelling van voedingstypes op de verschillende stranden. Waar detritivoren algemeen waren op vlakke stranden maar afwezig op steile stranden, werd het

omgekeerde vastgesteld voor interstitiële voeders. Filtervoeders waren het meest abundant op alle strandtypes, gevolgd door carnivoren.

Verschillende omgevingsvariabelen werden gemeten, teneinde de onderliggende oorzaken van de waargenomen verspreidingspatronen te kunnen verklaren. We concludeerden dat zowel strandhelling, korrelgrootte van het sediment als de swasheigenschappen (meer bepaald de frequentie waarmee de swash boven de waterverzadigingslijn komt, en de tijd dat de swash op haar maximale positie stilstaat) een belangrijke rol spelen in het structureren van de zandstrandmacrofauna. Daarnaast werd ook gesuggereerd dat de permeabiliteit van het sediment mogelijks een cruciale rol speelt.

In Hoofdstuk 1 werd zonatie over de volledige intergetijdenzone beschouwd. Verschillende soorten leven echter zo goed als uitsluitend in de swashzone, en verplaatsen zich ook in en met de swash gedurende de getijdencycli. Daardoor verandert hun intergetijdenpositie. We wilden daarom nagaan in hoeverre ook hun positie binnen de swashzone verandert. Daartoe werd een nieuwe manier van staalname ontwikkeld (**Hoofdstuk 2**), waarbij de verschillende staalnamestations afgeschermd werden door middel van houten boxen. Hierdoor werd vermeden dat de dieren migreerden tussen het nemen van stalen.

In Hoofdstuk 2 werd deze staalnamestrategie toegepast op twee verschillende stranden tijdens afgaand tij. De doelsoorten waren de surfers *Olivella semistriata* en *Emerita rathbunae* (een molkrab). Uit dit onderzoek bleek dat beide soorten een gelijkaardig zonatiepatroon vertoonden binnen de swashzone, en dat dit patroon quasi onveranderd bleef bij hoog, midden of laag water, en dit op beide stranden. Het patroon zelf was unimodaal, met de hoogste densiteit bovenaan in de swash. Deze piek lag hoger in de swash voor *O. semistriata* dan voor *E. rathbunae*. Het waargenomen swashzonatiepatroon werd verklaard door volgende hypothese: de swash zonatie is een weerspiegeling van de voedingscondities binnen de swashzone. Beide soorten filteren de *backwash* en de tijd die daarvoor beschikbaar is, verandert binnen de swashzone. Volgens onze hypothese volgt die backwash-filtertijd eveneens een unimodale curve binnen de swashzone. De verschillen in piekdensiteit tussen de twee soorten werd verklaard door de capaciteit van *E. rathbunae* om om te gaan met hevige swashcondities.

Hoe lager in de swashzone, hoe heviger de swash. Deze soort werd ook teruggevonden op steilere stranden, met hevige swashcondities.

In **Hoofdstuk 3** werd de swashzonatie van *Olivella semistriata* meer in detail bestudeerd: er werden meer stations op het droge deel van de intergetijdenzone (het stuk van de intergetijdenzone dat niet overspoeld wordt tijdens laag water) bemonsterd en ook het opgaand tij werd gevolgd. De resultaten kwamen grotendeels overeen met wat in Hoofdstuk 2 was aangetoond. Ook tijdens opkomend tij werd dezelfde, typische, unimodale verspreidingscurve teruggevonden. Wel viel op dat de densiteiten sterk daalden naar laag water toe: heel wat dieren, vooral de exemplaren kleiner dan 4 mm, bleven achter op het droge strand. Er was dus een lengtezonatie met gemiddeld kleinere individuen bij hoog water en grotere bij laag water. Dezelfde lengtezonatie werd ook binnen de swashzone aangetroffen: kleine slakken leven hoger in de swash dan grote slakken.

Tenslotte werden de gegevens gebruikt om de populatiegrootte van *Olivella semistriata* te bepalen. De schattingen liepen vrij sterk uiteen, waarschijnlijk omwille van de sterke patchiness in de verspreiding, met waardes van 19,000 tot 96,000 individuen per meter strandlengte (ind/m). Voor biomassa lagen de waardes tussen 40 en 190 gram as-vrij drooggewicht per meter strandlengte (g AFDW). Vooral de abundantiewaarden zijn opvallend. Met bijna 100,000 ind/m behoort *O. semistriata* tot de meest abundante zandstrandsoorten ter wereld, en is het hoogstwaarschijnlijk de meest abundante slak van zandstranden.

In Deel III werd dieper ingegaan op een aantal aspecten van de biologie van *Olivella semistriata*, met speciale aandacht voor het surfgedrag. Tijdens surfen maakt een zandstranddier gebruik van de swashbeweging om te migreren over de breedte van het strand. Zoals beschreven in vorige delen, beweegt een groot deel van de populatie van *O. semistriata* op een uniforme wijze doorheen de getijdencyclus over het intertidaal. Dit doen ze door massaal te surfen op inkomende (tijdens vloed) of wegtrekkende (tijdens eb) swashgolven.

Een belangrijke eigenschap voor het overleven als surfende soort, is het snel kunnen ingraven in het sediment. Dit is nodig om te verhinderen opnieuw weggespoeld te worden door de volgende golf. In **Hoofdstuk 4** werd het graafgedrag van *Olivella semistriata* bestudeerd in functie van sediment, grootte, verspreiding en in vergelijking met andere surfers. *O. semistriata* blijkt een snelle graver te zijn: adulte exemplaren

hebben minder dan 10 seconden nodig om zich in te graven (in veldcondities). Er was een duidelijke correlatie tussen schelplengte en graafsnelheid, waarbij kleine exemplaren duidelijk sneller groeven. Ingraaftijd was beduidend langer in zeer fijn of juist grof zand (onder laboratoriumcondities). De graafcapaciteit van *O. semistriata* blijkt vergelijkbaar te zijn met die van andere surfende weekdieren, maar is een heel stuk minder dan van surfende molkrabben. Deze laatste zijn dan ook de enige surfers die voorkomen op steile stranden. Er werd vooropgesteld dat de graafcapaciteit van *O. semistriata* limiterend is voor zijn verspreiding op steile stranden, omdat ze zich niet snel genoeg kunnen ingraven tijdens het korte swashinterval, en omwille van de korte tijd dat de swash op haar maximale positie stilstaat op dit type stranden.

Omdat *Olivella semistriata* zeer moeilijk te bestuderen is in laboratoriumcondities, zoals in aquaria of stroomgoten, werd een toestel ontwikkeld om swashgolven na te bootsen in het laboratorium: een swashgoot (**Hoofdstuk 5**). Met dit toestel kunnen swashgolven van verschillende grootte en verschillende swashperiode losgelaten worden op een artificieel strand. De hellingsgraad van het strand, alsook de sedimentsamenstelling, kunnen naar wens veranderd worden. Op deze manier is er onafhankelijke controle over de belangrijkste fysische parameters. In een eerste experiment werd aangetoond dat *O. semistriata* mogelijks over een ingebouwde klok beschikt die toelaat het onderscheid te maken tussen opgaand en afgaand tij. Op deze manier weten de dieren dus in welke richting ze moeten migreren. Het is de eerste maal dat een dergelijke endogene klok vastgesteld werd voor een zandstrandweekdier.

In **Hoofdstuk 6**, tenslotte, werd gekeken hoe de dynamiek van de swash de voedingsefficiëntie en de tijdsbesteding van *Olivella semistriata* bepaalt. Zoals voorspeld in Hoofdstuk 2, blijkt de totale voedingstijd alsook de voedingsefficiëntie een unimodale curve te vertonen binnen de swashzone, met ideale omstandigheden in het bovenste deel van de swash. Het patroon kwam zeer goed overeen met de swashzonatie zoals gevonden in Hoofdstuk 2 en 3. Het lijkt er dus sterk op dat de zonatie van *O. semistriata* niet fysisch gestuurd is, zoals algemeen aangenomen wordt voor zandstrandfauna, maar eerder biologisch. Dit werpt een nieuw licht op zandstrandecologie.

Tenslotte werd een model gemaakt waarbij gekeken werd in welke mate de voedingstijd van *Olivella semistriata* kan toenemen door te surfen in vergelijking met een fictieve soort die niet zou surfen. Uit het model bleek dat, hoewel surfen maar 1-3% van het totale tijdsbudget inneemt, het de voedingstijd verhoogt met 529%. Surfen is dus

duidelijk een bijzonder interessante strategie op geëxposeerde stranden met een waarneembaar getijdenregime. Dit wordt uiteraard weerspiegeld door de dominantie van *Olivella semistriata* op Ecuatoriaanse zandstranden.

## Summary

During this thesis, we investigated different aspects of the ecology of macrofauna on Ecuadorian sandy beaches. The ultimate goal was to improve our knowledge about the functioning of sandy beach macrofauna in the tropical part of the East Pacific Ocean. Prior to the start of this project this region had not seen any major research on sandy beach ecology, despite the great importance of beaches in both the local marine ecosystem and the local economy. As in other regions, the Ecuadorian sandy beaches attract most of the coastal tourism. Additionally, sandy beaches are thought to play a vital role in the life cycle of the shrimp *Litopenaeus vannamei*, Ecuador's most important aquaculture species and the country's second most important export product.

In three pilot studies, reported in the addenda, some basic features of Ecuadorian sandy beach fauna were investigated. Moreover, these pilot studies provided useful feedback concerning the sampling strategy that should be applied for further investigations. **Addendum 1** lists a description of the zonation of macrofauna in the bay of Valdivia. One of the beaches in this bay, the intermediate beach of San Pedro, was used as model beach throughout this thesis. Addendum 1 provides an interesting overview of the macrofaunal diversity and density distribution in different intertidal zones. The gastropod *Olivella semistriata* proved to be the most dominant and conspicuous species. This small snail (shell length around 1 cm) was found in incredibly large numbers in the swash zone, the zone with wave run-up and run-off. This study also learned us, however, that the sampling strategy, which was based on previous research along the Belgian coast, is not suitable for the very exposed Ecuadorian beaches. Hence, a different approach was used in further studies.

In **Addendum 2**, the spatial and temporal variability of the macrofauna from the sublittoral fringe was studied, in combination with the surf zone hyper- and epibenthos. Therefore, nine different beaches were sampled at four occasions during one year. The macrofaunal assemblage was clearly different between different beach types, whereas hyperbenthos varied primarily on a temporal scale. Moreover, the temporal variation in endobenthos was not uniform over the different beach types, making generalizations very difficult.

In **Addendum 3**, several hypotheses about the impact of the climate phenomenon El Niño Southern Oscillation (ENSO) on Ecuadorian sandy beach macrofauna are discussed. During the cold La Niña phase we noted a much lower density in molluscs and crustaceans compared to the normal situation. The first hypothesis states that these low numbers were caused by the very strong preceding El Niño. Unfortunately, no data preceding, or during, this El Niño are available. The alternative hypothesis, however, explains the observed patterns as a direct cause of the La Niña itself, in which the fauna of a tropical ecosystem – like the Ecuadorian coast – is severely affected by low temperatures.

The information retrieved from the pilot studies was used as an outline for this thesis. The idea was to start by constructing a detailed image of the spatial distribution of sandy beach macrofauna over a continuum of beach types – from flat, dissipative to steep reflective beaches, as well as looking at distribution patterns within one beach (Chapter 1). Subsequently, a comprehensive study of the ecology of the dominant gastropod *Olivella semistriata* was performed (Chapters 2 to 6). The first three chapters, bundled in Part II, deal with the impact of swash and other morphodynamic beach factors on the distribution of macrofauna in general and *O. semistriata* in specific. The last three chapters (Part III) report some aspects of the biology of *O. semistriata*: feeding, migrating and burrowing.

In accordance with many other papers from various locations, macrofaunal diversity, and to a lesser extent abundance (ind/m) and biomass (AFDW), increased from reflective to dissipative beaches (**Chapter 1**). Moreover, only three macrofaunal zones could be identified over the intertidal on reflective beaches, whereas intermediate and dissipative beaches harboured four different zones. There was also a shift in species composition: reflective beaches were dominated by crustaceans and interstitial polychaetes; molluscs were completely absent from reflective beaches. Intermediate and especially dissipative beaches held a much richer fauna, with crustaceans, polychaetes, as well as molluscs (both bivalves and gastropods) and echinoderms. The patterns were confirmed by the composition of feeding types on the different beaches. While detritivores were common on dissipative beaches and absent from reflective beaches, the opposite was true for interstitial dwellers. Filter feeding was the most frequent feeding type on any beach, followed by carnivores.



Several environmental parameters were measured to identify the underlying factors causing the observed patterns in macrofaunal distribution. We concluded that not only beach slope and sediment grain size, but also swash characteristics (more specifically the number of effluent line crossings and swash standstill time) play a crucial role in structuring sandy beach macrofauna. Finally, we also added sediment permeability to the list of influential beach factors.

Chapter 1 considered zonation over the full intertidal. Several species, however, are limited in their actual distribution to the swash zone, and move with the swash during the tidal cycle. Consequently, their intertidal position changes constantly. We wanted to investigate if their position within the swash zone also changed with the tide. Therefore, a new sampling strategy had to be developed (**Chapter 2**), in which the different sampling stations were covered from wave action by means of wooden boxes. This prevented migration from the animals while collecting samples of the swash transect.

This sampling strategy was implemented on two different beaches, during falling tide, in Chapter 2. The investigated species were two surfers: *Olivella semistriata* and *Emerita rathbunae* (a mole crab). Both species showed a remarkably similar swash zonation pattern, independent of the tidal state or beach. The patterns themselves were symmetrical to negatively-skewed unimodal, with highest densities in the upper half of the swash zone. This peak density was found lower in the swash for *E. rathbunae* than for *O. semistriata*. We hypothesized that the swash zonation is a reflection of the feeding conditions within the swash zone. Both species filter the backwash; backwash feeding time logically changes with position in the swash, and according to our hypothesis backwash feeding time likewise follows a unimodal pattern within the swash zone. We could explain the difference in peak density by the ability of *E. rathbunae* to deal with harsh swash conditions: the lower in the swash zone, the more hostile the swash conditions are. This was confirmed by the distribution of both species as found in Chapter 1: *E. rathbunae* was very abundant on reflective beaches with harsh swash conditions.

In **Chapter 3**, the swash zonation of *Olivella semistriata* was studied in more detail: more stations were sampled on the drying intertidal (i.e. the part of the intertidal that is not flooded by the low tide swash) and also upcoming tide was monitored. The results were generally very similar to what was demonstrated in Chapter 2. During upcoming tide, a comparable unimodal distribution curve was found. The densities,

however, dropped dramatically towards the low beach: many snails, especially specimens shorter than 4 mm, stayed behind on the drying intertidal. Hence, there was a zonation in shell length with on average smaller individuals on the high beach and larger ones on the low beach. A similar length zonation was seen within the swash zone: small snails lived higher in the swash than large snails.

Finally, the detailed data allowed us to estimate the population size of *Olivella semistriata*. The estimates varied considerably, probably due to the patchy alongshore distribution of the species, with values ranging from 19,000 to 96,000 individuals per meter beach length (ind/m). Biomass values were measured between 40 and 190 gram ash-free dry weight per meter beach length (g AFDW/m). The high abundance of *O. semistriata*, with values up to almost 100,000 ind/m, is very remarkable, making it one of the most abundant sandy beach species, and probably the most abundant gastropod ever found on a sandy beach.

In Part III, we focused on several aspects of the biology of *Olivella semistriata*, with an emphasis on its exceptional surfing behaviour. Surfing sandy beach fauna use swash movement to migrate over the beach face. As we have seen, the population of *O. semistriata* moves uniformly over the intertidal throughout the tidal cycle. This is a result of surfing *en masse* on incoming (during flood) or outgoing (during ebb) swash waves. One of the crucial characteristics required for successful surfing, is the ability to rapidly burrow in the sediment. This is necessary to not being swept away by the next wave. The burrowing behaviour of *Olivella semistriata* was studied in **Chapter 4** in relation to sediment, shell length, distribution and in relation to other surfing species. *O. semistriata* proved to be a very accomplished burrower: adult specimens can complete burial in less than 10 seconds (in the field). There was a clear positive relation between shell length and burial time. Burial time was markedly longer in very fine and coarse to very coarse sand (under laboratory conditions). Burrowing of *O. semistriata* was comparable to other surfing molluscs, yet one order of magnitude slower than burrowing of surfing mole crabs. These are indeed the only surfers found on reflective beaches with harsh swash conditions. It thus seems that the burrowing capacity of *O. semistriata* is limiting its expansion towards reflective beaches. Their burrowing is not fast enough to secure foothold on beaches with short swash intervals and short swash standstill time.

Because *Olivella semistriata* is very difficult to study in laboratory conditions, be it in aquaria or flumes, we designed a device that allowed us to reproduce swash waves in

the laboratory: the swash rig (**Chapter 5**). With this device, swash waves of different amplitude and at different intervals can be created on an artificial beach. Upon request, beach slope and sediment composition of the artificial beach can be changed. This way, we have independent control over the most important beach factors. In a first experiment, we demonstrated *O. semistriata* possibly possesses an endogenous clock. This clock tells the animals the difference between upcoming and falling tide, ensuring migration in the correct direction, even without exogenous directional cues. This is the first report of such endogenous clock in a sandy beach mollusc.

Finally, in **Chapter 6**, we investigated how swash dynamics control the feeding behaviour and time budget of *Olivella semistriata*. As was predicted in Chapter 2, total feeding time and feeding efficiency indeed followed a unimodal curve within the swash zone, with optimal conditions in the upper part of the swash zone. The patterns were remarkably similar to the swash distribution of the species found in Chapter 2 and 3. Hence, it seems that the actual zonation of *Olivella semistriata* is not physically driven, as is widely accepted amongst sandy beach ecologists, yet rather biologically driven. This adds an interesting new perspective to sandy beach ecology.

Ultimately, a model was constructed to calculate the advantage in feeding time by surfing of *Olivella semistriata* compared to a fictive non-surfing species. Although surfing only takes 1-3 % out of the time budget of *O. semistriata*, it increases the feeding time by 529%. Surfing is thus clearly a very interesting survival strategy on tidal, exposed beaches, as is demonstrated by the dominance of *O. semistriata* on Ecuadorian beaches.

## Resumen

Durante esta tesis, nosotros investigamos diferentes aspectos de la vida de la macrofauna en las playas arenosas ecuatorianas. El objetivo final fue mejorar el conocimiento acerca del funcionamiento de la macrofauna de playas arenosas en un sitio tropical del Océano Pacífico Este. Antes de esta tesis, esta región no ha sido mayormente investigada sobre la ecología de playas arenosas, a pesar de la gran importancia de las playas en ambos aspectos, tanto en el ecosistema marino como en la economía local. Como en otras regiones, las playas arenosas ecuatorianas juegan un rol vital en el ciclo de vida de los camarones *Litopenaeus vannamei*, siendo la especie acuícola más importante del país y el segundo producto de exportación.

En los tres estudios piloto, reportados en las addendas, algunas características básicas de la fauna de las playas arenosas ecuatorianas fueron investigadas. Después, estos estudios proporcionaron una información útil concerniente a la estrategia de muestreo que podría ser aplicada para futuras investigaciones. El **Addendum 1** enlista una descripción de la zonación de la macrofauna en la Bahía de Valdivia. Una de estas playas ubicada en la Bahía de Valdivia, es la playa intermedia de San Pedro, la cual fue usada como playa modelo a través de esta tesis. El Addendum 1 proporciona una interesante revisión general de la densidad y diversidad de la macrofauna en diferentes zonas intermareales. El gasterópodo *Olivella semistriata* resultó ser la especie más dominante y conspicua. Este pequeño caracol (longitud de concha alrededor de 1 cm) fue encontrada en increíblemente largos números en la zona de *swash*, la zona con movimiento de flujo y reflujos. De este estudio además aprendemos, sin embargo, que la estrategia de muestreo, la cual fue basada en previas investigaciones a lo largo de la costa de Bélgica, no es conveniente para las playas Ecuatorianas muy expuestas. Por lo tanto, una aproximación diferente fue usada en estudios posteriores.

En el **Addendum 2**, la variabilidad espacial y temporal de la macrofauna desde la franja sublitoral fue estudiada, conjuntamente con la zona de rompiente del hiperbentos y epibentos. Por lo tanto, nueve playas diferentes fueron muestreadas en 4 ocasiones durante un año. La comunidad de la macrofauna era claramente diferente entre diversos tipos de playa, mientras que el hiperbentos varió sobre todo en una escala temporal. Por otra parte, la variación temporal del endobentos no era uniforme sobre los diversos tipos de playa, haciendo generalizaciones muy difíciles.

En el **Addendum 3**, varias hipótesis sobre el impacto del fenómeno climático de El Niño Oscilación Sur (ENOS) en la macrofauna de las playas arenosas ecuatorianas se discute. Durante la fase fría de Niña nosotros observamos una densidad mucho más baja en los moluscos y los crustáceos comparados con una situación normal. La primera hipótesis indica que estos bajos números fueron causados por el precedente muy fuerte El Niño. Desafortunadamente, no hay datos disponibles de antes o durante este EL Niño. La hipótesis alternativa, sin embargo, explica que los patrones observados son una causa directa de La Niña, en la cual la fauna de un ecosistema tropical - como la costa ecuatoriana - es severamente afectada por bajas temperaturas.

Con la información obtenida de los estudios piloto, un plan para esta tesis fue definida. La idea era comenzar construyendo una imagen detallada de la distribución espacial de la macrofauna de la playa arenosa sobre una serie continua de tipos de playa - desde plana, disipativas hasta playas inclinadas reflexivas - así que la dispersión espacial dentro de una sola playa (capítulo 1). Posteriormente, un estudio comprensivo de la ecología del gasterópodo dominante *Olivella semistriata* sería realizado (capítulos 2 a 6). Los primeros tres capítulos, agrupados en la Parte II, explican el impacto de la zona de *swash* y otros factores morfodinámicos de la playa en la distribución de la macrofauna en general y de *O. semistriata* en particular. Los tres últimos capítulos (Parte III) reportan algunos aspectos de la biología de *O. semistriata*: alimentación, migración y excavación.

De acuerdo con muchos otros artículos de varios sitios, la diversidad de la macrofauna, y en un grado inferior la densidad ( $\text{ind}/\text{m}^2$ ) y la biomasa (AFDW), de las playas ecuatorianas, incrementan desde playas reflexivas a playas disipativas (**Capítulo 1**). Por otra parte, solamente tres zonas de la macrofauna se podrían identificar sobre la zona intermareal en las playas reflexivas, donde las playas intermedias y disipativas abrigaron cuatro diversas zonas. Había también un cambio en la composición de las especies: las playas reflexivas fueron dominadas por los crustáceos y los poliquetos intersticiales; los moluscos estaban totalmente ausentes en las playas reflexivas. Las playas intermedias y especialmente las playas disipativas tuvieron una fauna mucho más rica, con los crustáceos, poliquetos, así como los moluscos (ambos bivalvos y gasterópodos) y los equinodermos. Los patrones fueron confirmados por la composición de tipos de alimentación en las diversas playas. Donde los detritívoros fueron comunes en las playas disipativas, siendo ausentes en las playas reflexivas, lo opuesto fue para los habitantes intersticiales. Los filtradores fueron los más frecuentes en cualquier tipo de playa, seguido por los carnívoros.

Varios parámetros ambientales fueron medidos para identificar los factores subyacentes responsables de los patrones observados en la distribución macrofaunal. Concluimos que además de la declinación de la payas, tamaño del grano del sedimento, pero también las características del **swash** (más específicamente el número que el swash cruza la línea de efluente y tiempo chapoteante de la parada) juegan un papel crucial en la estructuración de la macrofauna de la playa arenosa. Finalmente, también agregamos permeabilidad del sedimento a la lista de los factores que influyen en la playa.

El capítulo 1 consideró la zonación intermareal. Sin embargo, varias especies, se limitan en su distribución real a la zona de *swash*, y se mueven con el *swash* durante el ciclo de marea. Consecuentemente, sus cambios constantes en la posición intermareal, con todo nosotros investigamos también si su posición dentro de la zona de *swash* cambió con la marea. Por lo tanto una nueva estrategia de muestreo tuvo que ser desarrollada (**Capítulo 2**), en el cual las diversas estaciones del muestreo fueron cubiertas de la acción de la onda por medio de las cajas de madera. Esto previno la migración de los animales mientras que recogía muestras del transecto de *swash*.

Esta estrategia de muestreo fue puesta en ejecución en dos playas diferentes, durante bajamar, en el capítulo 2. Las especies investigadas fueron dos surfistas: *Olivella semistriata* y *Emerita rathbunae* (cangrejo topo o michugo). Ambas especies muestran un muy remarcable y similar patrón de zonación de *swash*, independiente del estado de marea o la playa. Los patrones en sí eran simétricos a unimodal negativamente sesgada, con las densidades más altas en la mitad superior de la zona de *swash*. Este pico de densidad fue encontrado en la parte más baja de la zona de *swash* para *E. rathbunae* que para *O. semistriata*. Nuestra hipótesis es que la zonación de *swash* es una consecuencia de las condiciones de alimentación dentro de la zona. Ambas especies filtran el *backwash*; el tiempo de alimentación del *backwash* cambia lógicamente con la posición en el *swash*, y de acuerdo a nuestra hipótesis el tiempo de alimentación sigue además un patrón unimodal dentro de la zona de *swash*. Podríamos explicar la diferencia en densidad máxima por la capacidad de *E. rathbunae* al reparto en condiciones difíciles en la zona de *swash*: mientras mas cerca de la zona de *swash*, más hostiles las condiciones. Esto fue confirmada por la distribución de ambas especies según los resultados en el capítulo 1: *E. rathbunae* fue muy abundante en las playas reflexivas con condiciones difíciles en la zona de *swash*.

En el **Capítulo 3**, la zonación de *swash* de *Olivella semistriata* fue estudiada más detalladamente: más estaciones fueron muestreadas en la zona intermareal de sequía (es decir la parte intermareal que no es inundada por el *swash* bajo de la marea) y también la marea próxima fue monitoreada. Los resultados eran generalmente muy similares a los encontrados en el capítulo 2. Durante marea próxima, también una curva de distribución unimodal comparable fue encontrada. Las densidades, sin embargo, cayeron dramáticamente hacia la parte baja de la playa: muchos caracoles, especialmente especímenes más pequeños a 4 milímetros, permanecían detrás en la sequedad intermareal. Por lo tanto, hubo una zonación en la longitud de la concha con un promedio de los individuos más pequeños en la parte alta de la playa y los más grandes en la parte baja de la playa. Una zonación similar de la longitud fue considerada dentro de la zona de *swash*: los caracoles pequeños vivieron más arriba en el *swash* que los caracoles grandes.

Finalmente, los datos detallados permitieron que estimáramos el tamaño de la población de *Olivella semistriata*. Las estimaciones variaron considerablemente, probablemente debido a la desigual distribución de las especies, con valores que van desde 19000 a 96000 individuos por metro de longitud de playa (ind/m). Los valores de la biomasa fueron medidos entre 40 y 190 gramos de peso seco libre de ceniza por metro de longitud de playa (g AFDW/m). Especialmente la alta abundancia es remarcable, y con valores hasta casi 100000 ind/m, *O. semistriata* es una de las especies más abundantes de la playa arenosa, y probablemente el gasterópodo más abundante encontrado siempre en una playa arenosa.

En la Parte III, nos enfocamos en varios aspectos de la biología de *Olivella semistriata*. Especialmente el comportamiento que practica surf es extraordinario. La fauna de la playa arenosa que practica surf utiliza el movimiento de *swash* para emigrar sobre la cara de la playa. Como es escrito en las partes anteriores, la población de *O. semistriata* se mueve uniformemente sobre la zona intermareal a través del ciclo de marea. Éste es un resultado de surfear la masa sobre la entrante (durante la inundación) o (durante reflujo) el movimiento de *swash*.

Una de las características cruciales requeridas para practicar surf, es la capacidad de esconderse rápidamente en el sedimento. Esto es necesario para no ser arrastrado lejos por la siguiente ola. El comportamiento de madriguera de *Olivella*

*semistriata* fue estudiado en el **Capítulo 4** en lo referente al sedimento, longitud de la concha, distribución y en lo referente a la otra especie que practicaba surf. *O. semistriata* demostró ser un excelente excavador: los especímenes adultos pueden enterrarse en menos de 10 segundos (en el campo). Había una clara relación positiva entre la longitud de la concha y el tiempo de enterrase. El tiempo de enterrase era más largo en arena muy fina y gruesa a arena muy gruesa (bajo condiciones del laboratorio). La excavación de *O. semistriata* era comparable a otros moluscos que practicaban surf, con todo a una magnitud más lenta que la excavación de los cangrejos topo que practicaban surf. Éstas son de hecho los únicos organismos que practica surf encontradas en las playas reflexivas con condiciones difíciles de *swash*. Tal parece que la capacidad de enterrarse de *O. semistriata* está limitando su extensión hacia las playas reflexivas. Su capacidad de excavar no es suficientemente rápida para asegurar el equilibrio en las playas con intervalos cortos de *swash* y tiempo corto de la parada.

Porque *Olivella semistriata* es muy difícil de estudiar en condiciones de laboratorio, sea en los acuarios o los rig *swash*, diseñamos un dispositivo que permitió que reprodujéramos ondas de *swash* en el laboratorio: el aparejo de *swash* (**Capítulo 5**). Con este dispositivo, ondas de diversa amplitud y en diversos intervalos se pueden crear en una playa artificial. Por requerimiento, la cuesta de la playa y la composición del sedimento de la playa artificial pueden ser cambiadas. De esta manera, tenemos control independiente sobre los factores más importantes de la playa. En un primer experimento, demostramos que *O. semistriata* posiblemente posee un reloj endógeno. Este reloj dice a animales la diferencia entre la pleamar y bajamar, asegurando la migración en la dirección correcta, incluso sin señales direccionales exógenas. Éste es el primer informe de tal reloj endógeno en un molusco de playa arenosa.

Finalmente, en el **Capítulo 6**, vimos cómo las dinámicas de *swash* controlan el comportamiento y tiempo de alimentación de *Olivella semistriata*. Como fue predicho en el capítulo 2, el tiempo de alimentación total y la eficacia de alimentación siguieron de hecho una curva unimodal dentro de la zona de *swash*, con condiciones óptimas en la parte superior de la zona de *swash*. Los patrones eran notablemente similares a la distribución de *swash* de las especies encontradas en el capítulo 2 y 3. Por lo tanto, parece que la zonación real de *Olivella semistriata* no es físicamente conducida, como es ampliamente aceptada entre ecologistas de playas arenosas, con todo biológicamente si



es conducida. A esto se agrega una nueva perspectiva interesante a la ecología de la playa arenosa.

En última instancia, un modelo fue construido para calcular el aumento en tiempo de alimentación por surfing de *Olivella semistriata* comparado con una especie que no practicaba surf. Aunque el practicar surf toma solamente 1-3 % del tiempo de *O. semistriata*, aumenta el tiempo de alimentación en el 529%. El practicar surf es así claramente una estrategia muy interesante de la supervivencia al régimen de mareas en playas expuestas, como es demostrado por la dominancia de *O. semistriata* sobre las playas ecuatorianas.



---

**- PART I -**

**INTRODUCTION AND AIMS**

---

‘Science and art have that in common that everyday things  
seem to them new and attractive.’

*Friedrich Nietzsche*



## 1.1 Introduction

### 1.1.1 Sandy beaches

#### 1.1.1.1 What is a sandy beach?

**a sandy beach is:**

*“a wave-deposited accumulation of sand lying between modal wave base (i.e. the maximum depth at which a wave can transport sediment towards the shoreward) and upper swash limit”*

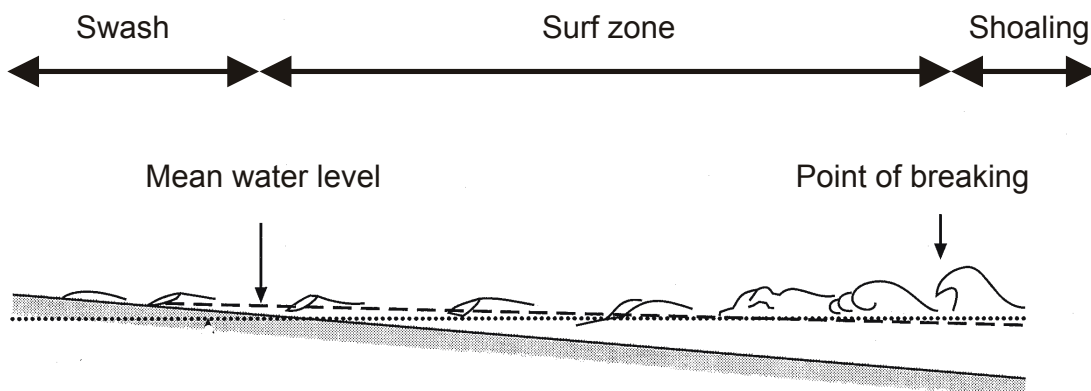
(Short 1999)

As stated in Short’s definition, three requirements have to be met to have a sandy beach: **sand**, **waves (i.e. moving water)** and **shoreline**. It is the sand that is transported by waves to the shore that forms the sandy beach.

Sand, and by extension **sediment**, can be classified according to its origin and its grain size. Sediment on beaches can be quartz (terrestrial origin) or carbonate (marine origin) sand, and in some occasions shell fragments, volcanic sand or rocks from different origin in form of pebbles. Sediment grain size is generally defined according to the scale of Wentworth (Buchanan, 1984) in phi units, with  $\phi = -\log_2(\text{diameter})$  and ranges from less than 63  $\mu\text{m}$  to more than 1 mm. Everything between 63  $\mu\text{m}$  and 2 mm ( $0 < \phi < 4$ ) is defined as **sand**. Beaches with finer sediment (i.e. mud) are called **mudflats**, beaches with coarser sediment (i.e. pebbles) are called **pebbled beaches**.

A **wave** is, in general, a wind-driven transport of energy through water. No material is transported by waves; water circulation is a twisting ellipse. Waves remain stable as long as the wave height is less than 1/7 of the wave length. Wave action penetrates the water column to a depth of approximately half of the wave length. Close to the **shore**, water depth will decrease to a point where the base of the wave will touch the sea floor. From here on, the wave will not only transport energy but also material. This is the modal wave base from Short’s definition and thus the lower edge of the beach. The waves will start compacting, the wave length will decrease and the ratio wave height /

wave length increases. This is called *shoaling* (Fig. 1.1). Now the lower part of the wave will slow down because of drag created by the sediment and the wave becomes depth-dependent. This results in a different wave speed at the upper and lower part of the wave. Together with the wave height / wave length ratio surpassing the stability point of  $1/7$ , this causes the collapse of the wave, called *breaking* (Fig. 1.1). Different kinds of breaking waves exist, although in nature they present a continuum. The most common breaker types are *spilling* and *plunging* breakers (Fig. 1.2). If the energy of the broken wave is still sufficiently concentrated, the wave will continue its shoreward movement in a surfing way, sometimes creating *secondary spilling breakers* or *bores* (Fig. 1.1). The zone with surfing waves is the *surf zone*. The last phase of the wave action is where the water runs up and down the beach face, called the **swash** (Fig. 1.1). Breaking can occur in the swash as well, in form of *collapsing* and *surgings* waves (Fig. 1.2). The highest point reached by the highest wave at spring high tide is the upper limit of the beach, according to the beach definition stated higher.



**Fig. 1.1** - Changes of a wave entering a beach (modified from Short, 1999).

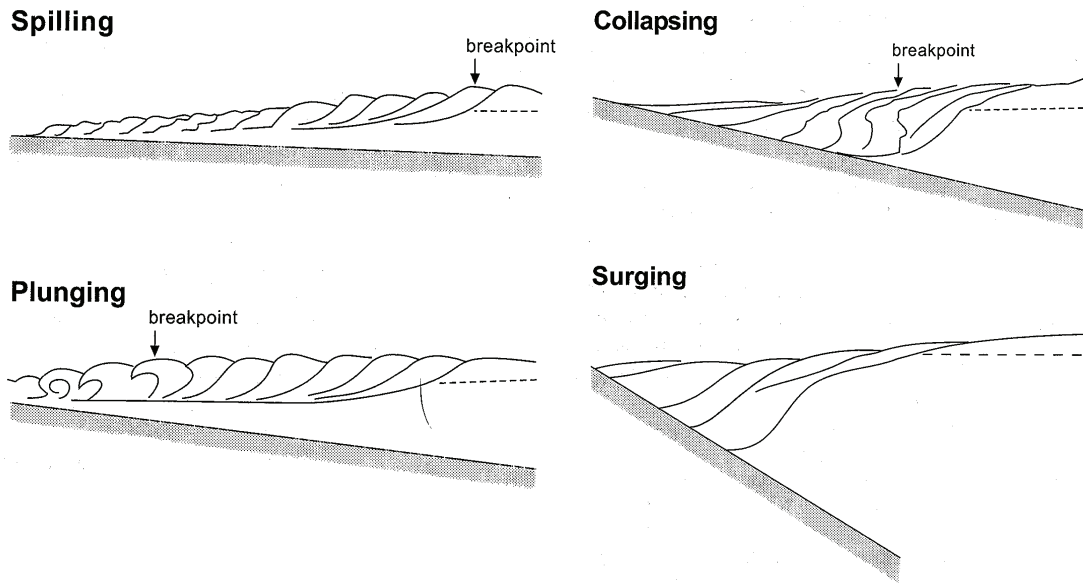


Fig. 1.2 - Types of breakers (modified from Short, 1999).

Within this general scheme, many variations are possible, creating a wide range of beach types. Variations can be due to sediment type, sediment grain size, wave action, exposure, tidal range and shore morphology. Many of these factors are interdependent. Sediment grain size, for instance, depends on the wave action, which in its turn depends on exposure and shore morphology. Most beach type classifications are based on three parameters: sediment grain size, wave action and tidal range. The most widely accepted classification using these parameters (Fig. 1.3) was introduced by Masselink and Short (1993). On the horizontal axis, **Dean's parameter  $\Omega$**  (with  $\Omega = H_b / W_s * T$ ), a function of sediment ( $W_s$ ), breaker height ( $H_b$ ) and breaker period ( $T$ ), divides the beaches into three types: reflective ( $\Omega < 2$ ), intermediate ( $2 < \Omega < 6$ ) and dissipative ( $\Omega > 6$ ). The **relative tidal range** ( $RTR = MSR / H_b$ ) on the vertical axis is calculated from the mean spring tidal range ( $MSR$ ) and the breaker height and increases with increasing tidal influence on the beach.

**Reflective beaches** are characterized by steep slopes and coarse sediment. The waves break on the beach face itself, eliminating a surf zone. The swash zone is narrow, with high swash velocity. On the high beach, cusps<sup>1</sup> are often present. **Dissipative beaches**, in contrast, have waves breaking far out at sea, and a wide surf zone, where much of the wave energy is dissipated. This results in very flat beaches with fine to very fine sands. An **intermediate beach** is anything in between.

<sup>1</sup> Cusps are longshore undulations on the high beach, caused by edge waves. Edge waves are longshore waves within the surf zone

The schemes of Masselinck and Short (1993) and Short (1996) both use wave information to some extent. Although wave regime is probably the most important agent in sandy beach formation, it is difficult to measure in the field. It can also be questioned to what extent the wave regime at a given day is representative for the waves that formed the beach as it is on that day. Both Dean's parameter and relative tidal range, for instance, are predictive, rather than descriptive tools (Short, 1999). Therefore, biologists have developed beach classification parameters, which do not require wave measurements and which are descriptive. Two of these are discussed by McLachlan and Dorvlo (2005): the **beach index (BI)** and **beach deposit index (BDI)**. Both use intertidal beach slope and sediment data, two parameters that can easily be measured in the field. The former index also includes tidal range, which facilitates comparison between beaches on a large spatial scale. The BDI is only suitable for studies on a smaller spatial scale, with no or minor differences in tidal range between the studied sites.

Beaches are not only classified according to their 'beach type' in terms of morphodynamics, but also according to **exposure**. This is particularly important for ecological studies. A very comprehensive classification scheme was proposed by McLachlan (1980). Four categories, from very sheltered to very exposed, are defined with a rating system based on wave, biological and morphodynamic characteristics (Fig. 1.4). An overview of beach classification is given in Table 1.1.

**Table 1.1** - Overview of the three different families of beach types.

	<b>Beach type</b>		
	<b>Dissipative</b>	<b>Intermediate</b>	<b>Reflective</b>
<b>Dean's parameter (<math>\Omega</math>)</b>	<2	2-5	>5
<b>Wave energy</b>	High	Intermediate	Low
<b>Breaker type</b>	Spilling	Spilling/plunging	Plunging
<b>Morphology</b>	Flat	Intermediate slope	Steep
	Multiple bars No cusps	Variable bars Cusps	No bars Cusps
<b>Surf zone</b>	Wide	Narrow	No surf
<b>Sediment</b>	Fine sand	Fine – Intermediate	Coarse sand
<b>Filtered volume</b>	Small	Intermediate	Large
<b>Intertidal zone</b>	Wide	Intermediate	Narrow
<b>Swash zone</b>	Wide	Intermediate	Narrow



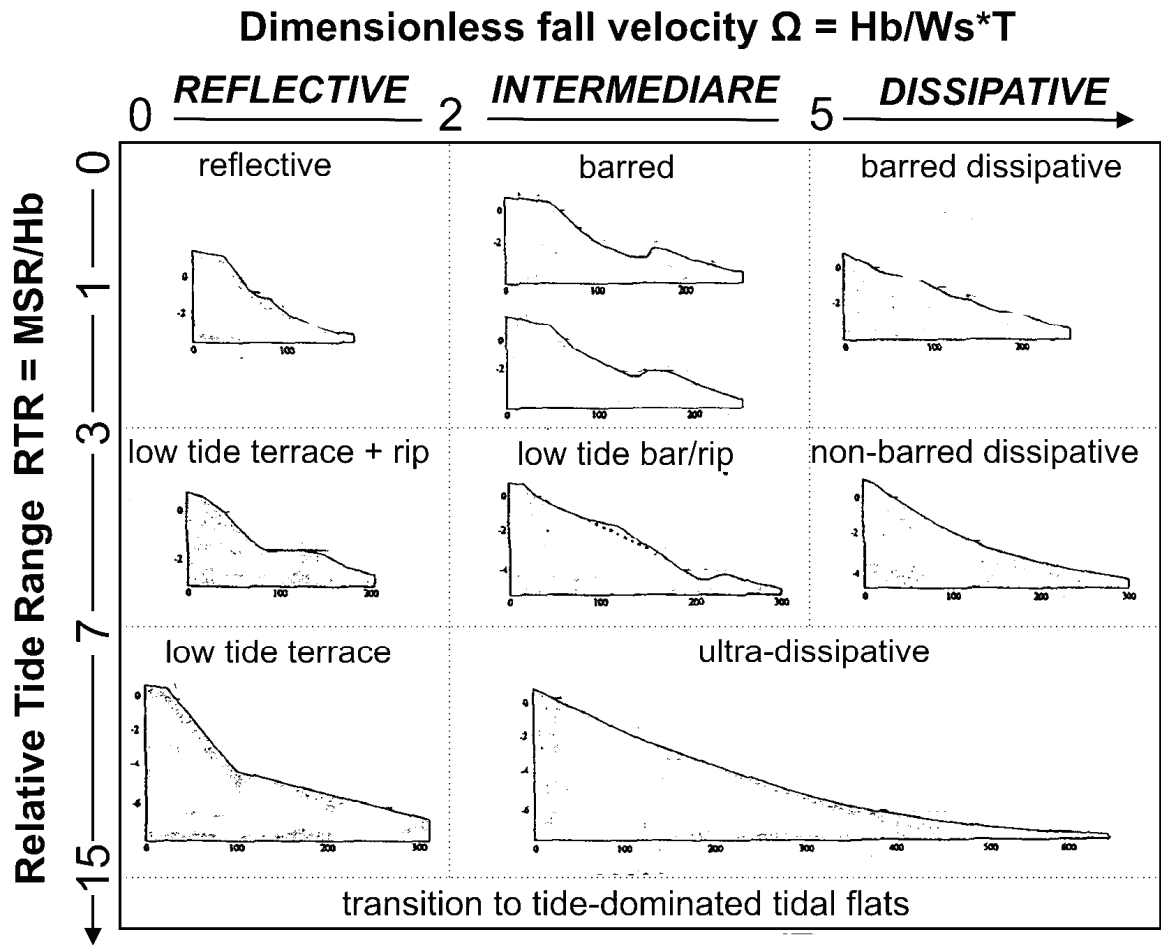


Fig. 1.3 - Beach classification scheme from Masselink and Short (1993).

Parameter	Rating	Score				
Wave action	Practically absent	0				
	Variable, slight to moderate, wave height seldom exceeds 0.5m	1				
	Continuous, moderate, wave height seldom exceeds 1m	2				
	Continuous, heavy, wave height mostly exceeds 1m	3				
	Continuous, extreme, wave height never less than 1.5m	4				
Surf zone width (only if wave action score > 1)	Very wide, waves first break on bars	0				
	Moderate, waves usually break 50-150m from shore	1				
	Narrow, large waves break on beach	2				
% very fine sands (62-125µm)	> 5%	0				
	1-5%	1				
	< 1%	2				
Median particle diameter (µm)	Slope of intertidal zone					
		<1/10	1/10-1/15	1/15-1/25	1/25-1/50	>1/50
	>710 (>0.5φ)	5	6	7	8	9
	500-710 (1.0-0.5φ)	4	5	6	7	8
	350-450 (1.5-1φ)	3	4	5	6	7
	250-350 (2.0-1.5φ)	2	3	4	5	6
	180-250 (2.5-2φ)	1	2	3	4	5
180 (>2.5φ)	0	0	1	2	3	
Depth of reduced layers (cm)	0-10					0
	10-25					1
	25-50					2
	50-80					3
	>80					4
Stable burrowers	present					0
	absent					1
	Maximum score					20
	Minimum score					0

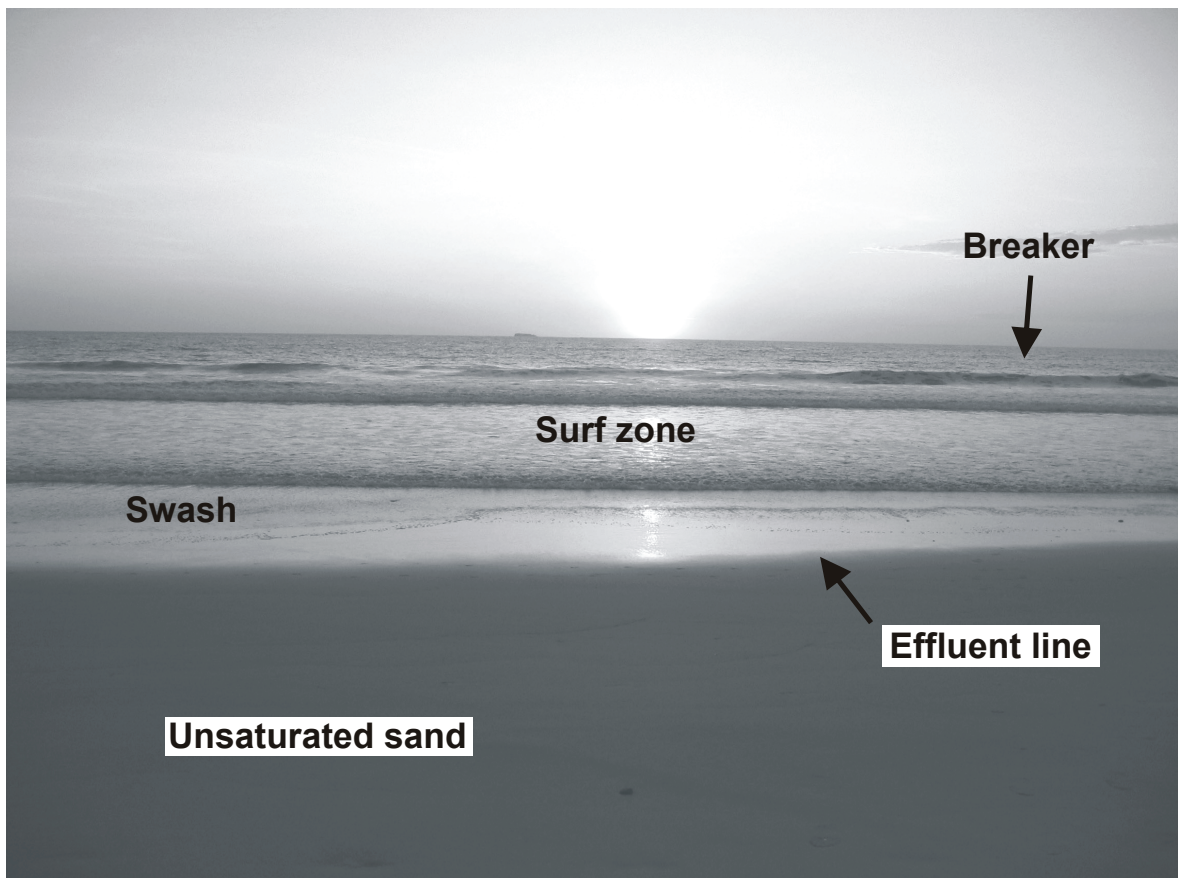
Score	Beach type	Description
1-5	Very sheltered	Virtually no wave action, shallow reduced layers, abundant macrofaunal burrows
6-10	Sheltered	Little wave action, reduced layers present, usually some macrofaunal burrows
11-15	Exposed	Moderate to heavy wave action, reduced layers deep if present, usually no macrofaunal burrows
16-20	Very exposed	Heavy wave action, no reduced layers, macrofauna only of tough motile fauna

Fig. 1.4 - Exposure rating scheme, modified from McLachlan (1980).

### 1.1.1.2 Sediment and swash

The two most important physical characteristics of sandy beaches concerning macrofauna are sediment and swash conditions (see 1.1.2.3-1.1.2.5).

Sediment texture is not only the immediate surface of interference with the animals; it also determines porosity (i.e. the volume of space between the sand grains), permeability (i.e. the rate of drainage of water through the sand), penetrability (i.e. the force needed to penetrate the sand) and thixotrophy (i.e. the resistance of the sand by its fluidity) of the sand bed, and as such the filtration rate of the swash water and the water content of the beach. In general, coarser sands can filter much more but hold much less water. This results in a higher permeability but lower porosity of the sand. The water saturation level on beaches with coarse sand is thus much lower. Therefore the interstitial water table will surface lower on the beach. This surfacing of the interstitial water table, or the transition between unsaturated and saturated surface sand, is called the **effluent line** (EL) and is easily seen as a 'glassy layer' (see Picture 1.1). The relation between sediment grain size and penetrability and thixotrophy is more complex and depends on several other factors as well.

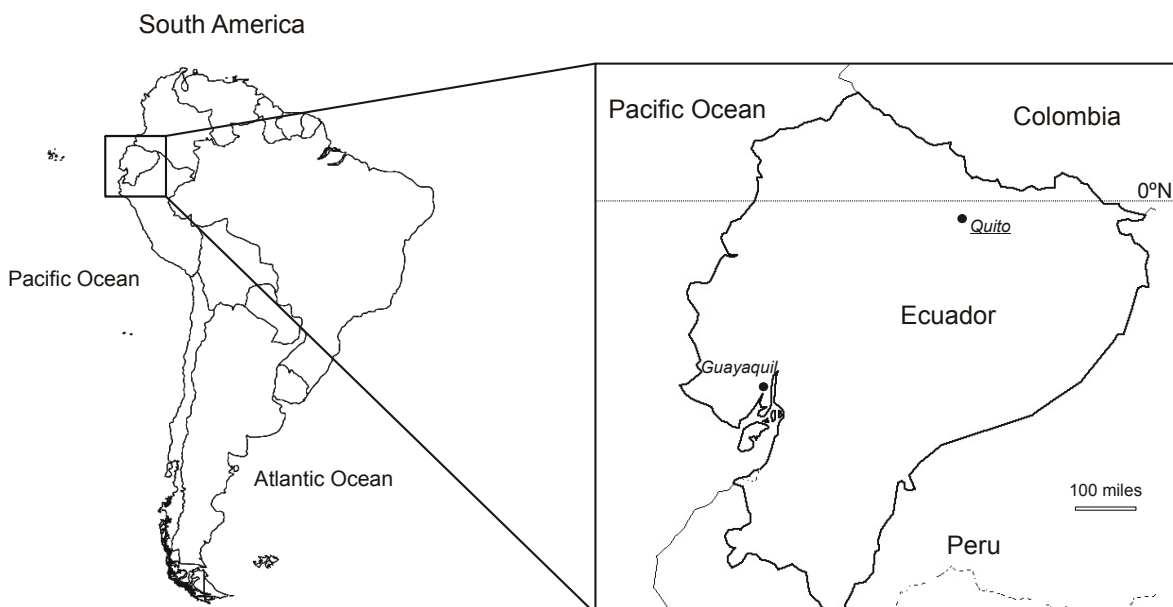


**Picture 1.1** - The beach of San Pedro at sunset. The different zones on the beach are indicated, as well as the effluent line

Swash, the run-up and run-off of water on the beach face, is the transferring agent of wave energy and water to the beach. As such, the swash characteristics are crucial in the formation of beaches. The ecologically important features of the swash are the swash period, swash interval, swash velocity and the number of effluent line crossings (McArdle and McLachlan, 1991, 1992). Swash period is the time between two swash waves, and is dependent on wave conditions and beach slope (Short, 1999). Swash interval is the period between two emersion phases at a certain position in the swash. The higher in the swash zone, the longer the swash interval. Swash velocity can be the average or maximum velocity of the wave run-up and/or backwash. In general, these swash factors are less favourable or 'harsher' on reflective beaches, with shorter swash periods and intervals, higher swash velocities and more effluent line crossings, especially at low tide (McArdle and McLachlan, 1991, 1992; Short, 1999).

### 1.1.1.3 Ecuador and its sandy beaches

Ecuador is one of the smallest countries in South America and lies centred around the equator, at the west side of the continent. The country is stretched in a north-south axis, facing the Pacific Ocean with a fairly long coastline of over 1000 km (Fig. 1.5). Of great (marine) ecological importance is Ecuador's offshore archipelago of the Galápagos. This, however, is a complete different ecosystem and is of no further interest for this thesis. The only real interruption to the oceanic coastline of mainland Ecuador is the very wide mouth of the river Guayas, in the South of the country. About 60% of intertidal habitat consists of sandy beaches; the other 40% are shared between rocky shore and the gradually disappearing mangroves where rivers mouth.



**Fig. 1.5** - Map of South American continent (left) and of Ecuador (right) with indication of the capital Quito and the largest city, Guayaquil. Dotted line is the equator.

Unfortunately, no extensive survey of the Ecuadorian sandy beaches exists. Boothroyd and co-workers (1994) gave an overview of the complete Ecuadorian coastline, with reference to shore type (sandy, muddy or rocky). In case of sandy shores, however, no mention is made of sediment type, intertidal distance, intertidal slope or any other parameter that could be useful for identifying the beach type. What is presented here is thus a combination of the information from Boothroyd *et al.* (1994), personal comments and own observations.

The tidal regime in Ecuador is mesotidal (Davies, 1964), with a maximum spring tidal range of about 2.5 m in the South, gradually increasing to slightly over 4 m in the North (data retrieved from tide tables, published by INOCAR). Most beaches are of the reflective to intermediate type, with an intertidal width of 10 to roughly 400 m; to our knowledge, no true dissipative beaches exist in Ecuador. Sediment is generally of quartz origin and ranges in size from fine sands on the flatter beaches to very coarse sands on the steep reflective beaches. We have not seen pebbled beaches, but they might exist in small bays. Except for the beaches in the Guayas river mouth and beaches that are sheltered by bays, islands, peninsulas or man-made structures, beaches are of the exposed to very exposed type. Varying with exposure, average breaker height can be anything from almost zero up to 4 m.

#### *1.1.1.4 El Niño – Southern Oscillation (ENSO)*

El Niño – Southern Oscillation (ENSO) is a climate phenomenon with an unpredictable periodicity of 3 – 7 years, and consists of an oceanic (El Niño / La Niña) and an atmospheric (Southern Oscillation) component. An ENSO event is initiated by a change in the normal trade wind conditions in the central Pacific, the cause of which still being unknown. In case of an El Niño, the usual westbound trade winds now blow eastward. This triggers a set of oceanic and atmospheric changes. The mass of warm water that is formed in the Western Pacific is moved towards South America. Hence, the thermocline becomes flatter and the upwelling of cold and nutrient rich water along the South American West coast reduces. Together with the warm water mass, an atmospheric rain front moves to South America. The effects for the central part of the South American West coast include an increase in sea and air temperature by several degrees Celsius, a raise of the sea level and a large number of tropical rainstorms.

An El Niño, which normally takes place between December and June, is sometimes followed by an inverse La Niña event, which is characterized by stronger

westbound trade winds, steeper thermocline and lower temperatures in central South America, with severe droughts.

With its position around the equator at the West coast of South America, Ecuador is one of the countries most severely impacted by ENSO events. The two foremost important El Niño events of the last few decades were the so-called 'super-Niño's' of 1982-1983 and 1997-1998, both of which were followed by a very strong La Niña.

## **1.1.2 Macrofauna**

### *1.1.2.1 What is macrofauna?*

Definitions of macrofauna or macrobenthos vary according to different authors. Mees and Jones (1997) defined macrobenthos as all marine fauna that is dependent of the sediment and is retained on a sieve with 1 mm mesh-size. Further subdivision is then made in endobenthos, animals living in the sediment, epibenthos, animals living on the sediment, and hyperbenthos, animals living in the water column just above the sea floor. These categories do not display sharp boundaries: some species, for instance, live partially hyperbenthic, partially endobenthic. In general, this subdivision is based on the sampling device. The size definition of 1 mm is sometimes extended to all animals that are retained on a 0.5 mm mesh-sized sieve (e.g. Brazeiro and Defeo, 1996; James and Fairweather, 1996; Defeo and Martinez, 2003).

Other authors use the term macrofauna for what Mees and Jones (1997) defined as endobenthos, thus animals that live buried in the sediment and are sampled by means of a frame or core (see McLachlan and Brown, 2006). This definition will be used throughout this thesis.

### *1.1.2.2 Macrofauna on sandy beaches*

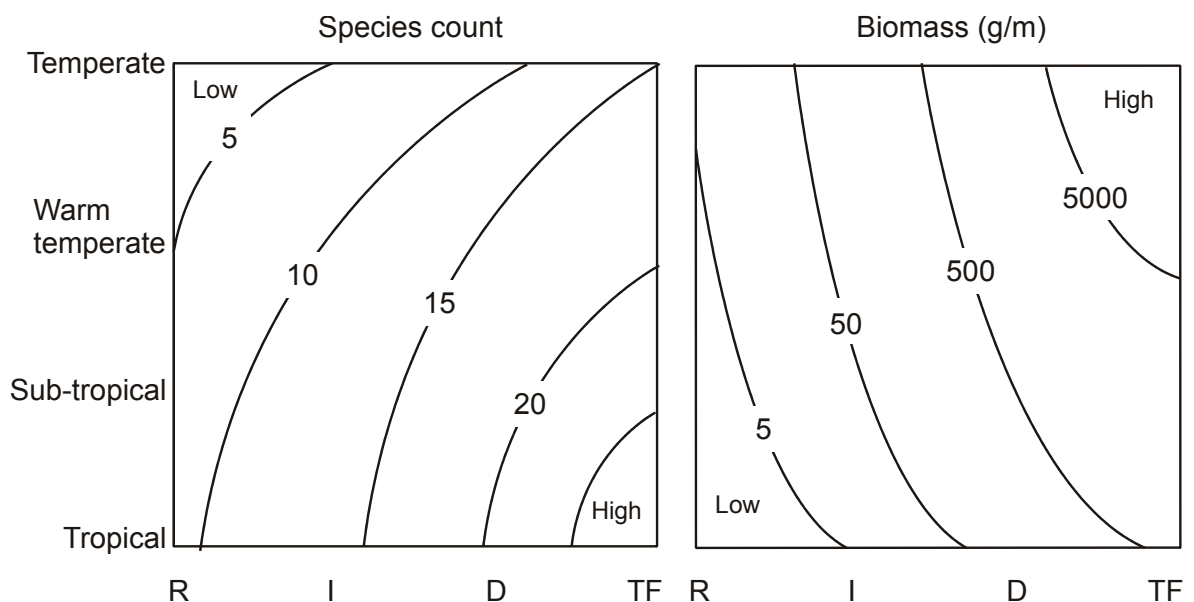
Sandy beach macrofauna as defined above consists mainly of animals belonging to three taxa: Crustacea, Annelida (mainly Polychaeta) and Mollusca (Bivalvia and Gastropoda). On the lower beach, Echinodermata may be present. An extensive overview of sandy beach fauna up to genus level is given by Brown and McLachlan (1990).

Species composition and distribution of sandy beach macrofauna change at different spatial scales: there are differences in latitude and differences between beaches (macroscale, see 1.1.2.3), within one beach alongshore and cross-shore (mesoscale, see 1.1.2.4) and very locally (microscale, see 1.1.2.5). Whereas the processes at the macro- and mesoscale are physically driven on exposed beaches (Defeo and McLachlan, 2005),

biological interactions such as predation, competition and adult-larvae relations start to play a role on the microscale (McLachlan and Brown, 2006). Due to these processes at different scales, there is a huge variety in macrofaunal species richness, abundance and biomass between sandy beaches. An exposed sandy beach can harbour anything from only a few air-breathing supralittoral species to 30 different true marine species. McLachlan and Brown (2006) listed possible numbers for abundance going from less than one animal per meter-wide transect to nearly 1 million macrofauna organisms per meter transect, with 100 to 10,000 being 'more typical'. Biomass (dry weight) numbers range from less than 1 g/m to nearly 10,000 g/m, with 'typical' values between 10 and 1,000 g/m.

### 1.1.2.3 Processes on the macroscale

It has long been thought that beaches in temperate regions are richer than tropical beaches, contradicting the general trend in terrestrial ecology (Dexter, 1992). Yet, Soares (2003) showed that in the tropics the species pool is clearly larger than in temperate regions. However, in temperate regions beaches are more often of the dissipative beach type, explaining why the average temperate beach is richer than the average tropical beach (McLachlan and Dorvlo, 2005). The lower inshore productivity in the tropics explains the lower abundance and biomass values on tropical sandy beaches compared to temperate beaches (Fig. 1.6; McLachlan and Dorvlo, 2005).

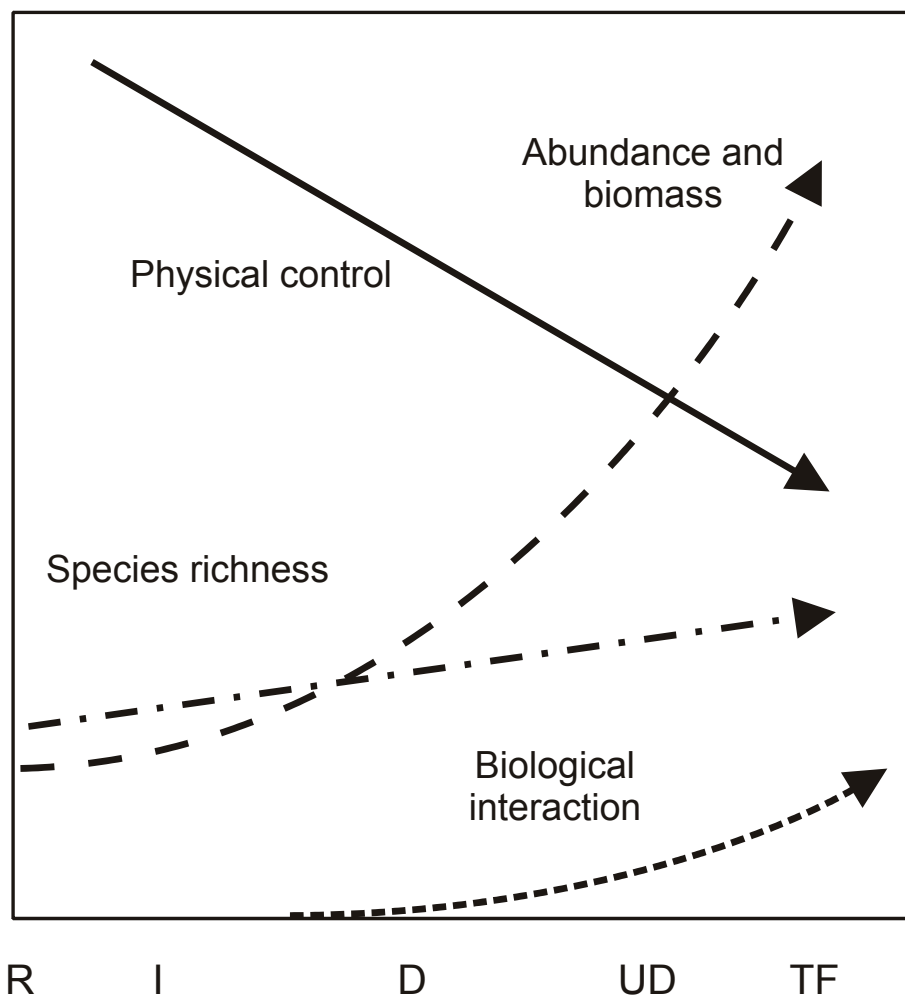


**Fig. 1.6** - Model of the latitudinal variation in species richness and biomass as a function of beach type (after Defeo and McLachlan, 2005). R = reflective, I = Intermediate, D = Dissipative and TF = Tidal Flat.



Within one geographical region the general pattern in sandy beach macrofauna is a decrease in species richness, abundance and biomass when moving from the dissipative to the reflective beach state (reviewed by McLachlan and Dorvlo, 2005). This pattern, which is found at any latitude, is now considered one of the paradigms in sandy beach ecology (McLachlan and Brown, 2006).

Beaches can be described by a set of physical parameters (see 1.1.1.1), most of which could be potential structuring factors for sandy beach macrofauna, but unfortunately these factors are also intercorrelated. This makes it very difficult to take the step from pattern detection to revealing causal links. Species richness, for instance, increases with decreasing sediment grain size, with decreasing slope, with increasing tide range, with increasing intertidal width and with decreasing swash harshness (i.e. swash period, velocity and effluent line crossings; McLachlan and Dorvlo, 2005). The correlations between abundance and biomass with the above listed environmental factors are similar, though more subjected to noise in the data (McLachlan and Dorvlo, 2005). An overview of the patterns at the macroscale is given in Fig. 1.7.



**Fig. 1.7** - Overview of the macroscale patterns (after Defeo and McLachlan, 2005). R = reflective, I = Intermediate, D = Dissipative, UD = Ultra Dissipative and TF = Tidal Flat.



Beaches are considered physically controlled environments because they lack biogenic structure and are extremely dynamic over space and time. In physically controlled environments, the autecological hypothesis (Noy-Meir, 1979; McLachlan et al., 1993) can be applied, stating that the communities are structured by the independent response of individual species to the physical environment. Thus, the ecology of the community is the sum of the autecologies of all species present. Since every species can possibly react differently to different factors, the patterns for sandy beach communities are even harder to explain.

Sandy beach macrofauna interacts with three different suites of physical factors: (1) the sand in which they burrow, (2) the (swash) water movement over the sand, and (3) the intertidal gradient of exposure to air. All three factors are strongly correlated to beach state (see higher), but act at a different level. Sediment characteristics, generally expressed as grain size, influence the burrowing and anchoring of species, as well as the amount of water that is filtered through the sand bed. The swash water movement, which is wave- and tide-driven (Short, 1999), supplies food to the beach, creates shelter from predators and provides migratory and dispersive possibilities for adult and juvenile animals (Gibson, 2003). The exposure gradient is the most likely cause of cross-shore zonation and will be discussed in the next paragraph (1.1.2.4).

Where the macroscale patterns are widely seen and accepted as a paradigm, the underlying factors controlling the macroscale patterns remain unclear and have been one of the most debated topics in sandy beach ecology over the last decade. Several hypotheses have been proposed, some of these concerning one physical factor, others multifactorial. Amongst the single factors, (sand) grain size and beach slope, were the first to be identified as possible causes for changes in macrofaunal biodiversity and abundance (McLachlan et al., 1981; McLachlan 1990). In the early 1990s, McArdle and McLachlan (1991, 1992) showed a clear coupling between beach type and swash conditions, which resulted in the 'Swash Exclusion Hypothesis' (McLachlan et al., 1993). This hypothesis states that the decrease in species richness, abundance and biomass from dissipative to reflective beaches is caused by increasing harshness of the swash. At population level this was translated into the 'Habitat Harshness Hypothesis' (HHH, Defeo et al., 200; Defeo and Martinez, 2003) which predicts that on reflective beaches the harsh environment forces macrofauna to divert more energy towards maintenance, leaving less for reproduction and causing higher mortality – thus making it more difficult individuals to spawn. Brazeiro (2001) found that not only swash and sediment characteristics but also the accretion-erosion dynamics on beaches could influence sandy beach macrofauna. He

argued that those three factors act together and as such postulated the 'Multicausal Environmental Severity Hypothesis' (Brazeiro, 2001).

All existing ideas were reviewed by McLachlan and Dorvlo (2005) and synthesized in the Hypothesis of Macroscale Physical Control. Two levels of factors controlling the macroscale patterns are identified: (1) primary control is by (a) tide range, which defines the dimensions of the intertidal environment and the number of niches/zones (see further) that can be accommodated, and (b) latitude, which influences the size of the species pool. (2) Secondary control is by (a) swash climate, (b) sediment grain size and (c) beach/sediment stability. Hence, the primary factors determine the maximum number of species that could occur under ideal conditions in a particular region; the secondary factors limit the actual species count through exclusion of less well-adapted species under harsher, more reflective conditions.

#### *1.1.2.4 Mesoscale patterns: alongshore and cross-shore (i.e. zonation)*

Like the macroscale, the meso- or intra-beach scale is primarily physically structured, while biological interactions start to come into play. If we neglect the vertical dimension – most species live very close to the sediment surface, the beach habitat can be treated as a two-dimensional plane, the two dimensions being alongshore and cross-shore.

The alongshore distribution of macrofauna on a beach is one of the least studied topics in sandy beach research, and only limited information is available. Beach length is thought to play an important role once the beach is shorter than two kilometres (Brazeiro, 1999a), with a decrease in species richness with decreasing beach length. Other factors that can influence the alongshore distribution of macrofaunal species include the presence of rocky shores, estuarine input, human impact (McLachlan and Brown, 2006). Within one beach, exposure can also vary, for instance on a curved beach or where one side of the beach is sheltered by a peninsula or an island. In general macrofaunal populations are most developed in the middle of a beach, with a unimodal bell-shaped distribution towards both sides.

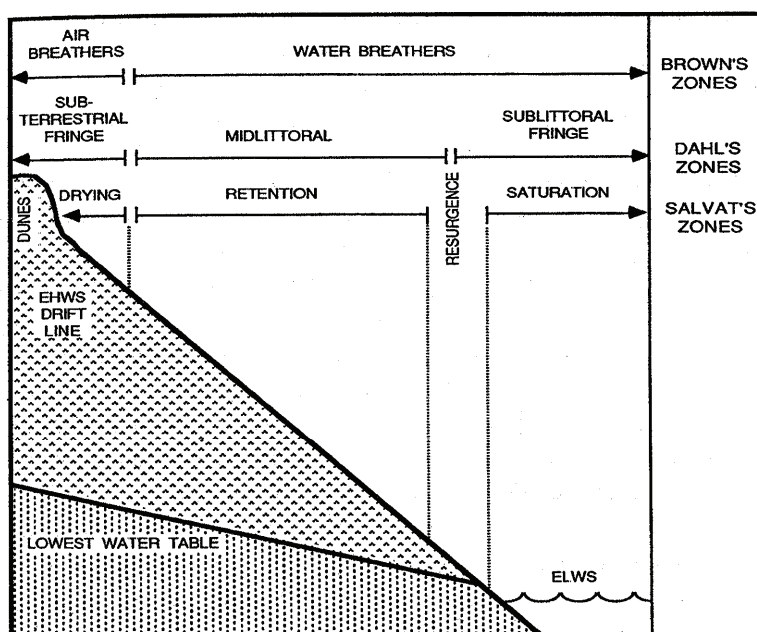
At a finer scale, the presence of a cusp system can impact the beach fauna. Cusp swash circulation can passively sort the smaller and less mobile animals into the cusp bays, whereas the more mobile and robust species inhabit the cusp horns (James, 1999; Defeo and McLachlan, 2006). Other small-scale alongshore variability is often regarded as patchiness, and can be caused by passive sorting by the swash, by local variations in

sediment texture, food availability or biological interactions (James and Fairweather, 1996).

Cross-shore variability can be divided into general macrofaunal patterns and zonation, i.e. the sum of the response of each species to cross-shore gradients. The general cross-shore pattern is an increase in species number towards the subtidal area (McLachlan and Jaramillo, 1995; Degraer et al., 2003; McLachlan and Brown, 2006).

Several cross-shore environmental gradients exist on sandy beaches. The most important stratified factors on sandy beaches are physical wave action, water temperature and salinity, precipitation, insulation, sediment and sand saturation. Food availability is generally also zoned. On tidal beaches, most of these factors change with the tide, blurring the gradients. On non-tidal beaches, boundaries are much sharper than on tidal beaches.

Many studies have been published on the zonation of sandy beach macrofauna (reviewed by McLachlan and Jaramillo, 1995) and several zonation schemes have been proposed (Fig. 1.8). The four most commonly cited ideas are: (1) there is no clear zonation on sandy beaches (McLachlan and Brown, 2006), (2) there are two zones: one consists of air-breathers above the drift line and the other is populated by water-breathers or true marine species (Brown's scheme, in McLachlan, 1983b); (3) there are three zones based on crustacean distribution (Dahl's scheme, Dahl, 1952) and (4) there are four, physically delimited zones, based on sand moisture content across the shore (Salvat's scheme, 1964, 1967).



**Fig. 1.8** - Overview of the three most common zonation schemes for sandy beach macrofauna (after McLachlan and Brown, 2006). ELWS = Extreme Low Water Spring Tide; EHWS = Extreme High Water Spring Tide.

Most authors have recognized three or four zones on exposed sandy beaches (see reviews by McLachlan and Jaramillo, 1995 and Defeo and McLachlan, 2005), supporting either Dahl's or Salvat's scheme. The zones of both schemes, however, are almost identical, with Dahl's sublittoral fringe divided in the resurgence and saturation zone in Salvat's scheme (Fig. 1.8). The subterrestrial fringe (biologically defined) or drying zone (physically defined) is the highest beach zone and is characterized by air-breathers such as talitrid amphipods, oniscid isopods and ocypodid crabs. This zone is present on all undisturbed beaches, even under the most reflective conditions. The mid-littoral or retention zone, positioned below the drift line but above the low tide effluent line, is inhabited by the true intertidal marine species such as cirrolanid isopods, haustoriid amphipods, spionid polychaetes and some mollusc species. Only on very reflective beaches this zone disappears. The sublittoral fringe or saturation zone is basically an upward extension of the surf zone up to the low tide effluent line. Typical taxa are hippid crabs, mysids, donacid bivalves, nephtyid and glycerid polychaetes and subtidal or surf zone species such as echinoderms. Since a surf zone is absent on reflective beaches, the sublittoral fringe is absent or non-distinguishable under reflective conditions. On highly dissipative beaches with a meso- or macrotidal regime, however, this zone can be very extensive and is sometimes seen as two distinct zones: the low intertidal and the sublittoral zone.

It should be noted that zonation on sandy beaches is an extremely variable phenomenon, on both the short and the long term (Brazeiro and Defeo, 1996). Moreover, zones are not defined by sharp boundaries, making the identification of zonation patterns difficult and often not statistically supportable (Brazeiro, 1999b). Since many macrofaunal species from exposed sandy beaches exhibit circatidal migrations, with the population often compacted at high tide, the consensus amongst sandy beach ecologists is to consider zonation at the time of low tide, when the intertidal is at its widest.

#### *1.1.2.5 Processes on the microscale*

The microscale is defined as the 'quadrat scale', which comprises mainly the interactions between individual organisms and micro-gradients in the environment. In this thesis, the swash zone is also treated as a microscale dimension. The microscale environmental gradients are diverse, causing local patchiness (James and Fairweather, 1996), but while the macro- and mesoscale are basically physically structured, biological interactions are the key factors on the microscale. Still, keystone species are not known

from sandy beaches, and most biological interactions seem to be restricted to competition between two species in simple predator-prey relationships.

In contrast to rocky shores, sandy beaches are a three dimensional habitat, making competition for space less likely to occur (McLachlan and Brown, 2006). This is for instance illustrated by the absence of true sessile species and macrophytes on sandy beaches. Most records of competition on sandy shores come from dissipative or sheltered beaches, or from the supralittoral, semi-terrestrial zone. These habitats can be considered less dynamic, making room for competition. One form of competition is between two similar species, as was demonstrated by Defeo et al. (1997) for the cirrolanid isopods *Excirrolana armata* and *E. braziliensis*, or between two totally different taxa, inhabiting the same zone and using the same food source. This was demonstrated for the swash filter feeders *Donax hanleyanus* and *Emerita braziliensis* (Cardoso and Veloso, 2003) and *Mesodesma donacium* and *E. analoga* (Dugan et al., 2004). Still, it remains very difficult to prove competition on sandy beaches and a lot remains to be done in this field of research (McLachlan and Brown, 2006).

Most of the energy that is consumed in sandy beaches is exogenous through swash (Romer and McLachlan, 1986) or wrack input (Colombini and Chelazzi, 2003; Dugan et al., 2003), making predation amongst macrofaunal species less important. The number of carnivorous species is very limited, and some carnivores, especially the smaller polychaetes, feed on the interstitial meiofauna (McLachlan, 1990). Scavengers, however, are very common on beaches, and in times of food shortage, they might hunt for intertidal macrofauna. Well-known examples are the ocypodid crabs, glycerid and nereid polychaetes and some larger gastropod species.

The most important predatory pressure on sandy beaches is thus exogenous as well: birds or insects from land and fish or large crustaceans from the sea. Little is known, however, on the impact of these predatory forces on the population size or distribution.

### 1.1.3 Survival strategies of macrofauna on sandy beaches

Sandy beaches are a hostile, physically controlled environment, and conditions can vary considerably over very short time periods. Hence, animals inhabiting sandy beaches should be highly adapted to this dynamic environment. Several morphological and behavioural solutions have evolved to cope with the conditions on sandy beaches. The three most important activities in sandy beach life are feeding, migrating and reproducing. Reproduction was not studied in this thesis, and will not be discussed further. Besides, we concentrate on the true intertidal marine species; even though the supralittoral community is highly adapted to the beach conditions above the drift line, these air-breathing species could be considered terrestrial forms with adaptations to occasional marine input.

#### 1.1.3.1 Feeding habits

The two most common feeding guilds amongst sandy beach macrofauna are scavengers and suspension feeders, generally by filtering swash or interstitial water (Ricciardi and Bourget, 1999). Scavengers can be found anywhere on a beach, from the sublittoral fringe to the foredunes. These species are very opportunistic and have acquired several morphological and behavioural adaptations to locate and consume carrion efficiently. Because their food source is highly erratic in occurrence, scavengers have developed a number of feeding methods. Most scavengers, for instance, can turn into predatory carnivores when easy prey is available or in times of food shortage.

In terms of biomass, filter feeders make up the chief part of the sandy beach macrofauna, especially where bulky molluscs of the genera *Donax* or *Mesodesma* are present. Although food particles in suspension are of lower nutritional value than carrion, this food source is always readily available in large quantities (McLachlan and Brown, 2006). The suspended organic matter is most commonly brought in by the swash, making direct filtering of the swash uprush or – predominantly - backwash the most straightforward way to access this food source. On tidal beaches, where the swash shifts over the beach face with the tide, maximizing feeding opportunities is achieved by following the swash zone. This is commonly seen in well-known filter-feeders such as mole crabs of the genus *Emerita* and whelks of the genus *Donax*, which maintain position in the swash by surfing (see further).

### 1.1.3.2 Locomotion

The extremely dynamic nature of nutrition on sandy beaches in terms of availability (for scavengers) and location (for both scavengers and filter-feeders), highlights the advantage of high mobility of macrofauna. Maintaining position, in cross-shore and vertical direction, and regaining position are crucial for optimizing feeding time. In addition, locomotion is also used to escape from predators. Generally, this predator escape response consists of deep burrowing during low tide, although some forms have swimming or crawling escape responses.

The locomotory or migratory adaptations itself originate from the combination of three environmental challenges: the instability of the substratum, the swash action and tide. The one locomotory form all sandy beach macrofauna share is burrowing. Other well-known gaits are swimming, crawling, running and surfing. For this thesis, we concentrate on burrowing and surfing.

#### Burrowing

There exist a number of burrowing mechanisms, the two most important being the *digging-cycle burrowing* of soft-bodied animals and the *excavating technique* of hard-shelled crustaceans. For soft-bodied animals such as polychaetes and molluscs, the first important phase is the liquefying of the sediment (Trueman and Ansell, 1969; Brown *et al.*, 1989). Increasing the thixotrophy of the sediment (i.e. liquefying the sediment), by probing with the head (polychaetes) or foot (molluscs), facilitates penetration into the sediment. Burrowing is then achieved by a series of alternating contractions and dilatations, called digging cycles and resulting in a 'stepping motion'. Within the soft-bodied species, the main differences in burrowing are seen in the probing of the sediment, which is very obvious in bivalves but almost absent in gastropods, and the angle at which they burrow. Polychaetes and bivalves tend to burrow vertically, whereas most gastropods burrow at an angle of less than 20 degrees, reducing the required forces (Brown *et al.*, 1989).

Because of the rigid exoskeleton, crustaceans cannot use alternating body extension and contraction for burrowing. They use their extremities instead, and apparently to great success. Crustaceans are by far the fastest burrowers on sandy beaches, and in contrast to soft-bodied animals, they can also burrow in unsaturated sand, giving them a huge advantage on the upper parts of the beach (McLachlan and Brown, 2006). A third common way of burrowing, which is found in almost all faunal groups, is 'sinking' into the sediment. This is achieved by liquefying or removing the sediment underneath the body, for instance through rapidly moving of extremities.



There are a number of reasons why sandy beach animals burrow into the sediment. Some forms live permanently in burrows or use burrows as a refuge; others burrow in completion of a migrational movement. One important aspect of burrowing is maintaining vertical position. Every incoming swash wave is a possible cause of sediment accretion or erosion, changing the position of a buried animal relative to the sediment surface. The initial position can be regained by burrowing up or down the sand bed.

Depending on the location (macro- and mesoscale) and the burrowing application, the speed and efficiency of burrowing can change significantly. Because of the relative stability of the habitat and the more favourable swash conditions, species inhabiting sheltered beaches are mostly slower burrowers (Trueman and Ansell, 1969). Not only do they have more time in between two waves to bury themselves, they also have to apply burrowing much more infrequent, and some species never leave their burrow. Very mobile species from exposed beaches, in contrast, have little time to complete burial between two waves, especially when they live low on the beach or low in the swash zone, and burrowing needs to be extremely fast. Stanley (1970) proposed an index to compare the burrowing capacity of different species by dividing the cube root of the wet mass by the burrowing time, resulting in the Burrowing Rate Index (BRI):

$$BRI = \frac{\sqrt[3]{\text{Wet mass (g)}}}{\text{Burrowing time (s)}} \times 100$$

Values below 2 indicate slow burrowers, very fast burrowers have values above 6, with fast burrowers between 2 and 6. Most species from exposed sandy beaches show fast to very fast burrowing, with BRI-values above 3 (McLachlan and Brown, 2006). Burrowing speed itself is generally size-dependent, with smaller animals burrowing faster than large specimens (e.g. Alexander *et al.*, 1993; Nel *et al.*, 2001). The burrowing capacity of a species is also sediment dependent. Under similar conditions of sediment permeability, burrowing is fastest in fine sands, and BRI decreases with increasing sediment grain size. Some species, such as *Hippa*, can burrow very fast in a wide range of sediments, and are considered sediment generalists (Lastra *et al.*, 2002).

### Surfing

Surfing or 'swash riding', a behaviour in which the swash is used to migrate over the beach face, has been a very successful strategy for animals inhabiting exposed sandy beaches. Surfing is found in a range of molluscs and crustaceans. Well-known examples are the beach clams of the genus *Donax* (Ellers 1995a), beach whelks of the genus *Bullia* (Trueman and Brown, 1976; Brown, 2001) and mole crabs of the genera *Emerita* (Cubit,



1969), *Hippa* (Lastra *et al.*, 2002) and *Lepidopa* (Dugan *et al.*, 2000). Filter feeders such as *Donax* and most of the mole crabs use surfing to maintain optimal feeding conditions in the swash (McLachlan and Brown, 2006); *Bullia* rides swash waves in pursuit of its prey (Brown, 2001). Several characteristics are necessary for surfing: (1) active emergence from the sediment; (2) mainly passive, though partially controlled, riding of the swash – wave uprush when migrating upshore and backwash when migrating downshore; and (3) fast burrowing.

The active emergence from the sediment is a reaction of the animals upon a certain stimulus, a change in environmental conditions. A whole range of triggers for surfing have been proposed in the past, such as changes in sediment thixotropy, mechanical pressure, light, temperature, hydration, wave sounds, swash current or any combination of these factors (Cubit, 1969; Morgan, 1984; Forward, 1986; Ellers, 1995b; McLachlan and Brown, 2006). Ellers (1995b) demonstrated that *Donax variabilis* responds to the sound made by big waves when moving upshore. Upon ‘hearing’ the collapse of a large breaker they emerge from the sediment, even before the bore has become a potent swash wave. The migration trigger in *Emerita analoga* was explained by changes in sediment thixotropy throughout the swash zone (Cubit, 1969), thereby rejecting earlier claims that *Emerita* reacts to changes in hydrostatic pressure (Enright, 1962). Changes in hydrostatic pressure do play a role, though, in the surfing of the amphipod *Synchelidium micropleon* (Enright, 1961; Forward, 1986).

The surfing itself can be active/passive swimming and floating, such as in *Emerita* (Cubit, 1969), or a passive ‘sailing’. This is seen in *Bullia*, which uses the rigid and concave extensions of the foot as an underwater sail, increasing the drag surface (Brown, 2001). *Donax variabilis* is transported in an efficient way thanks to the shell form and animal density (Ellers, 1995c).

It has to be noted that surfing is not necessarily an energy-efficient way of locomotion. Brown (1982) demonstrated that surfing in *Bullia* is as costly per unit of time as burrowing, and far more costly than crawling. However, it is relatively cheap in terms of distance covered and it is a very rapid way of locomotion, probably more important to tidally migrating animals than saving energy (McLachlan and Brown, 2006).

### 1.1.3.3 *Endogenous rhythms and clocks*

Although sandy beaches are a highly dynamical environment, several changes occur with a certain cyclicity, the most obvious of which are the tidal, day-night and semi-lunar cycles. Instead of reacting solely to exogenous clues, endogenous rhythmicity can

help a species to adjust its behaviour to these cycles. Two degrees in endogenous behavioural control exist. The simplest form is an *endogenous clock*, which tells the animals the state of the cycle. This means the animals can distinguish between upcoming and falling tide, resulting in a different response to the same non-directional clue. The most common, yet most complex, form is an *endogenous rhythm* in behaviour. This indicates that the animals have a different kind or degree of behaviour depending on the tidal state.

There are numerous examples of such endogenous rhythms, mainly from crustaceans. Well-studied examples are the isopods *Eurydice* and *Excirolana*, which show increased swimming activity at the time of high tide, even when kept in constant, clueless conditions in the laboratory (e.g. Enright, 1972; Naylor and Rejeki, 1996). Typical for endogenous rhythms is that they persist for several cycles in laboratory conditions. Day-night and lunar cycles in endogenous behaviour are characteristic for the supralittoral fauna (Jaramillo *et al.*, 2000b; Nardi *et al.*, 2003).

#### 1.1.3.4 Orientation

It is crucial for sandy beach fauna to orient itself relative to the beach/sea interface, e.g. to regain position on the beach. While supralittoral crustaceans are by far the most accomplished and best-studied in terms of orientation (e.g. Pardi and Papi, 1952; Pardi and Scapini, 1983; Brown and Odendaal, 1994; Scapini *et al.*, 1995), also intertidal species have been shown to have orientation mechanisms. Whereas non-directional stimuli act as triggers for migration (see 1.1.3.2), directional stimuli, such as light or water current, are orientation cues. This has been shown for the amphipod *Synchelidium*, which used phototaxis to orientate on the beach (Forward, 1986).

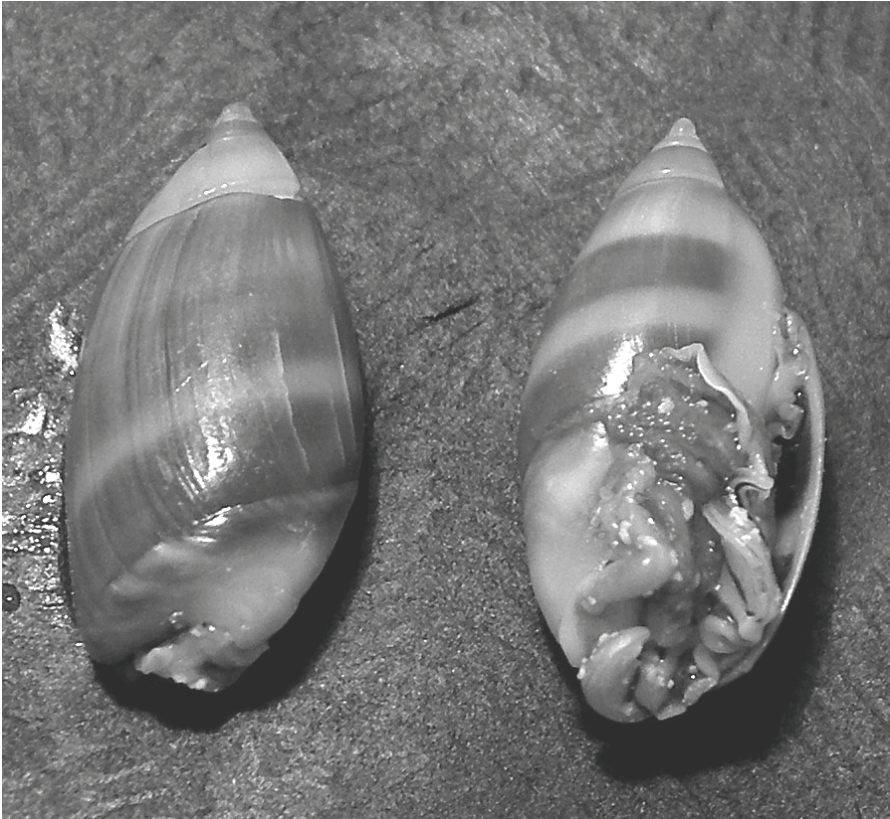
#### 1.1.4 The sandy beach gastropod *Olivella semistriata*

A major part of this thesis is devoted to the sandy beach gastropod *Olivella semistriata*. Prior to this thesis, very little was known about this species, and several aspects of its distribution and behaviour are discussed in the following chapters.

*Olivella semistriata* is part of the family of Olividae (Latreille, 1825), which consists of two major genera: *Olivella* (Swainson, 1831) and *Oliva* (Bruguière, 1789). Both species-rich genera share a lot of characteristics, and are predominantly distinguished based on the shell length, with *Olivella* being much smaller. Olivid shells are easily recognized by the cylindrical shape of the shell, the long aperture that is open at both sides, the low spire and the glassy, smooth and shiny shell surface. *Olivella semistriata* can be identified by the presence of a weak operculum, its size (adult shell length 1-1.5 cm), the colouring of the shell (Picture 1.2) and the size of the aperture, which is less than half the diameter of the shell (Olsson, 1956). This is in contrast with its sister-species, *Olivella columellaris*, which has a wide aperture.

Most of the Olividae are found in soft bottom, coastal environments, such as sandy beaches and the shallow subtidal, where they live as predators, suspension feeders or scavengers (Olsson, 1956; Tursch and Greifeneder, 2001). Most species are found in the tropics. *Olivella semistriata* is a typical sandy beach species, and its distribution ranges from the north of Peru to central Mexico, along the Pacific coasts of Central and South-America. They are filter feeders, and show surfing behaviour (see earlier) to maintain position on the shore. Known predators are larger Olivids (Olsson, 1956).

To our knowledge, no information exists on the basic biology of the species. There are a few reports, however, on the biology of an other *Olivella* species: *Olivella biplicata* (Edwards, 1968 and 1969). Sexes in this species are separate, though no clear sexual dimorphism exists, and mating occurs year-round. They have a bottom-swimming larval stage. After reaching around half the adult shell length after the first year, juveniles grow at a rate of 1 mm per year, and they can live as long as 15 years.



**Picture. 1.2 - *Olivella semistriata***

### **1.1.5 Framework of this thesis**

The collaboration between Ghent University and the Escuela Superior Politécnica del Litoral (Ecuador) started in 1999 within the framework of a VLIR-IUC programme. One of the scientific projects within this programme is devoted to a sustainable management of the coastal zone of Ecuador (project 4, director: Dr. M.P. Cornejo de Grunauer). Within this project, I had the opportunity to take part in the investigation of sandy beach benthos along the Ecuadorian coast (cf. addenda of this thesis). Based on that information, I started this Ph.D. research, mainly focusing on the specific aspects of the dynamics of Ecuadorian beaches and its impact on the infauna. The main part of the work was performed in CENAIM (Centro Nacional de Acuicultura e Investigaciones Marinas), where I got full logistic support for this work.

The author was financially supported by a Ph.D. grant of the Fund for Scientific Research (FWO). Additional travel grants were acquired from the Fund for Scientific Research (FWO), the Leopold III foundation and of the Ghent University.

## 1.2 Aims and thesis outline

At the start of this thesis, no quantitative studies had been published on the macrofauna of Ecuadorian sandy beaches. Even more, general studies on mesotidal tropical beaches were scarce. A baseline study was thus required before starting off with the study of Ecuadorian sandy beach macrofauna. Since these baseline descriptions are not the core subject of this thesis, the three papers describing spatial and temporal patterns in Ecuadorian sandy beach macrofauna are listed in the addenda.

**Addendum 1** served as the baseline study for zonation on a typical intermediate sandy beach from Ecuador. This paper was published in *The Belgian Journal of Zoology* in 2004. **Addendum 2** deals with both temporal and spatial variability of one macrofaunal community (the supralittoral fringe community) in combination with hyper- and epibenthos. The question asked in this paper was if the three macrobenthic communities from Ecuadorian beaches are primarily structured on a spatial or a temporal scale. Addendum 2 has been submitted to *Journal of Coastal Research*. In **Addendum 3** the temporal variability of the macrofauna at higher taxonomical level is seen in light of the ENSO-phenomenon. The goal of this paper was to identify the role of a very strong La Niña on the macrofauna of a typical intermediate beach from Ecuador. The results were published in *Advances in Geosciences* in 2006.

The baseline studies revealed that the sandy beaches of the exposed Ecuadorian coast function in a different way than the sheltered Belgian beaches. Hence, for the first part of this thesis, we decided to focus on the structuring factors of Ecuadorian sandy beach fauna, in particular the swash conditions.

### Part 2: Macrofauna on Ecuadorian sandy beaches: the role of swash and morphodynamics

**Chapter 1** deals with the impact of morphodynamics on several characteristics of sandy beach fauna: species richness, abundance, biomass, zonation and trophical structure. This study is unlike other papers on this topic, as the swash was included as an environmental variable.

**Chapter 2 and 3** transfer the concept of zonation to the microscale: the swash zone. In Chapter 2 a new approach to sample swash zonation is described, and this strategy was tested on two surfing species from Ecuador: *Emerita rathbunae* and *Olivella semistriata*. This chapter is submitted to *Marine Biology*. Chapter 3 is a more detailed

study of the swash zonation of *Olivella semistriata*. Biomass and abundance estimation is also discussed in this paper, which has been submitted to *Estuarine and Coastal Shelf Science*.

### Part 3: Some aspects of the biology of the gastropod *Olivella semistriata*

Given the dominance of *Olivella semistriata* on Ecuadorian sandy beaches, and the interesting surfing behaviour of this species, Part 3 concentrates on several aspects of the behaviour of *O. semistriata*. In **Chapter 4** the burrowing capacity of *O. semistriata* is studied under different sediment conditions. The results are compared to other surfing species from sandy beaches. This paper is submitted to *Journal of Experimental Marine Biology and Ecology*. **Chapter 5** describes a new tool to study sandy beach macrofauna in the laboratory, which allows the inclusion of swash action as a controllable parameter. This is demonstrated by an experiment in which a possible endogenous clock in *O. semistriata* is checked. This chapter is submitted to *Marine Ecology*. Finally, **Chapter 6** investigates the relationship between feeding and swash dynamics. The field data are combined with theoretical assumptions to construct models about the feeding rate of *O. semistriata*, and about the efficiency of surfing as a migration strategy.

### Part 4: General discussion

In the general discussion, all results of the six chapters and the three addenda are integrated and discussed. Some general concepts in sandy beach ecology are confirmed, while others are put into question, and new ideas are proposed based on the collected results and observations. This discussion also aims to establish a general hypothesis to synthesize all acquired knowledge of the surfing of *Olivella semistriata*.





---

**- PART II -**

**MACROFAUNA ON ECUADORIAN SANDY  
BEACHES: THE ROLE OF SWASH AND  
MORPHODYNAMICS.**

---

‘The important thing in science is not so much to obtain new facts as to discover new ways of thinking about them.’

*Sir William Bragg*



# CHAPTER 1

## CHANGES IN MACROFAUNAL ASSEMBLAGE STRUCTURE ALONG A MORPHODYNAMIC SANDY BEACH GRADIENT IN THE EASTERN TROPICAL PACIFIC.

---

Vanagt T., Steenhuyse L., Vincx M., Degraer S.

Paper in preparation

Keywords: macrofauna, surfing, sandy beaches, morphodynamics, zonation, swash.

## Abstract

The macrofauna of seven beaches along the coast of Ecuador, in the tropical part of the Eastern Pacific, was sampled along transects. The beaches covered the entire range of beach types that occur in this part of the continent. The aim of the study was to identify the relation between morphodynamic state of beaches and several biological characteristics of the macrofauna: biodiversity, density, abundance, biomass, zonation and trophic structure.

The Ecuadorian beaches were characterized by a very diverse macrofaunal community; a total of 47 species were identified. This confirms the recent idea of a larger species pool existing in the tropics than in temperate regions. There was a very clear drop in species count when moving from the flat, dissipative beaches to the steep, reflective beaches. This was partly due to the absence of molluscs from the reflective beaches. Biomass and abundance (ind/m) likewise decreased towards reflective beach states, but not density (ind/m<sup>2</sup>), because reflective beaches harboured dense populations of interstitial polychaetes. Changes in biodiversity and, to a lesser extent, biomass could be linked to four environmental factors: sediment grain size, beach slope, number of effluent line crossings and swash width.

The zonation patterns confirmed the current state of knowledge on the topic, with four distinct zones on dissipative and intermediate beaches and only three zones on reflective beaches. This seems to be caused by the relatively wide swash zone compared to the intertidal width, combined with the absence of a surf zone on reflective beaches. The major distinction between the two groups of beaches was based on the presence of a rich middle and lower beach species association on the dissipative / intermediate beaches and the abundant interstitial community on the reflective beaches; the upper beach association was very similar on all beaches.

Six different feeding types were distinguished. Trophic diversity was markedly higher in the dissipative situation. Filter feeders were dominant on all beaches, followed by scavengers and carnivores. Deposit feeders peaked on the dissipative beaches; the reflective beaches were characterized by a high density of interstitial dwellers.

In conclusion, the dissipative and intermediate beaches were very similar in species composition, density, abundance and trophic structure. The reflective beaches were clearly different in all these aspects. It seems that there is a gradual change from dissipative to intermediate beaches yet an abrupt change from intermediate to reflective beaches.

### 2.1.1 Introduction

Exposed sandy beaches can be considered as very harsh ecosystems, where macrofaunal populations are mainly structured by the physical environment (Defeo and McLachlan, 2005). Conditions change with beach type, from a benign situation on flat, high energy, dissipative beaches to very harsh conditions on steep, reflective beaches (Short, 1999; McLachlan and Dorvlo, 2005), coinciding with a decrease in macrofaunal species richness, abundance and biomass from the dissipative to the reflective end of the beach spectrum. This has now widely been accepted as one of the paradigms in sandy beach ecology (McLachlan and Dorvlo, 2005; McLachlan and Brown, 2006). Many authors have described this pattern, though primarily in temperate regions (e.g. Australia: Hacking, 1997; Belgium: Degraer *et al.*, 2003; South-Africa: Soares, 2003; Uruguay: Defeo *et al.*, 1992; Chile: Jaramillo and McLachlan, 1993 and Brazeiro, 1999a; Brazil: Soares, 2003).

While the patterns are very clear and only few exceptions have been found, the underlying explanatory mechanisms remain highly debatable. Several hypotheses have been proposed, some of these concerning one physical factor, others multifactorial. Amongst the single factors, sand grain size and beach slope were the first to be identified as possible causes for changes in macrofaunal biodiversity and abundance (McLachlan *et al.*, 1981; McLachlan 1990). In the early 1990s McArdle and McLachlan (1991, 1992) showed a clear coupling between beach type and swash conditions, which resulted in the Swash Exclusion Hypothesis (McLachlan *et al.*, 1993). This hypothesis states that the decrease in species richness, abundance and biomass from dissipative to reflective beaches is caused by increasing harshness of the swash. At population level this was translated into the Habitat Harshness Hypothesis (HHH, Defeo *et al.*, 2001 and 2003), which predicts that on reflective beaches the harsh environment forces macrofauna to divert more energy towards maintenance, leaving less for reproduction and causing higher mortality – thus making it more difficult for populations to establish.

Brazeiro (2001) found that not only swash and sediment characteristics could influence sandy beach macrofauna, but also the accretion-erosion dynamics on beaches. He argued that those three factors act together and, as such, postulated the Multicausal Environmental Severity Hypothesis (Brazeiro, 2001). On the macroscale also indirect effects, such as the length of the beach and the tide range, could limit the occurrence of certain species (Brazeiro, 1999; Defeo and McLachlan, 2005). Finally, latitudinal effect should be taken into account: Soares (2003), for instance, demonstrated that the species pool is larger in the tropics than at temperate latitudes.

The Ecuadorian coast, with its wide variety in beaches over a relatively short distance, offers a great opportunity to test all those hypotheses in conditions which have not been investigated before: mesotidal tropical sandy beaches. For this study seven exposed beaches with contrasting morphodynamics were chosen. According to the paradigm described above, macrofaunal diversity, density, abundance and biomass are expected to decrease from dissipative to reflective beaches. This should go along with changes in swash and sediment conditions.

Although predictions have been made, the impact of morphodynamics on the zonation of the macrofauna, and especially on the trophic structure, has received much less attention than the impact on biodiversity, abundance and biomass. Jaramillo *et al.* (1993) could identify more zones on dissipative beaches than on reflective beaches, yet this study was done in a region with a microtidal regime (Chile). Similar results were found by Borzone *et al.* (1996), Brazeiro and Defeo (1996) and Nel (2001), again in microtidal conditions. With increasing tide range the intertidal widens and, as such, offers more space for macrofauna to be zoned over. One of the questions addressed in this paper is if zonation is altered by morphodynamics under mesotidal conditions.

Studies dealing with trophic links on sandy beaches are, unfortunately, almost always performed in a single beach type (reviewed in McLachlan and Brown, 2006). McLachlan and Brown (2006) noted a change in trophic groups from predominantly filter feeders on dissipative beaches to scavengers and carnivores on reflective beaches. Deposit feeders increase with finer sediments and flatter slopes (Ricciardi and Bourget, 1999) and under more sheltered conditions (McLachlan and Brown, 2006). The last aim of this study is to identify the changes in trophic structure groups over a range of beach types.

Thus, this paper seeks to identify and explain the impact of morphodynamics under tropical, mesotidal conditions on 1) sandy beach macrofaunal diversity, density, abundance and biomass, on 2) the zonation of the sandy beach macrofauna and on 3) the trophic structure of the macrofauna.

## 2.1.2 Material and Methods

### 2.1.2.1 Study sites and period

Seven beaches along the southwestern coastline of Ecuador (between  $0^{\circ}31'18$  and  $2^{\circ}09'07$  S and  $80^{\circ}26'34$  and  $80^{\circ}47'29$  W) were sampled for macrofauna (Fig. 2.1.1). All beaches are exposed to the Pacific Ocean and have a maximal tidal range of 2.6-3.0 m (mesotidal regime: Davies, 1964). Sampling took place between July 18<sup>th</sup> (Ballenita) and July 23<sup>rd</sup> (Portéte) 2004. During the dry season (May through November), the oceanographic features of the Ecuadorian coast are mainly under influence of the Humboldt Current, coming from the South.



**Fig. 2.1.1** – Map of Ecuador with indication of the sampled beaches (for coordinates, see text).

### 2.1.2.2 Sampling strategy

Per beach one transect perpendicular to the shoreline was sampled. Transects were divided in nine (Ballenita) to 16 (San Clemente) sampling levels, equally spaced over the intertidal. The number of levels that were sampled depended on the intertidal width of the beach; only nine levels were sampled in Ballenita because of logistic reasons. Two to four of the sampling levels were placed in the active low tide swash zone. Three replicate samples, 2 m apart, were collected per sampling level, except for Ballenita, where only two replicates were taken because of the extremely coarse sand. The samples were collected by excavating a metal frame with a surface area of 0.1026 m<sup>2</sup> to a depth of 15 cm. To prevent migration of the animals during sampling of the levels in the swash zone, stations were isolated by simultaneously placing a wooden box (plywood, 100x50x50 cm lxxw) over each sampling spot (for a detailed description of this technique, see Chapter 2). The samples were sieved over a 1 mm mesh-sized sieve; the retained organisms were stored in an 8% formaldehyde-seawater solution.



**Picture 2.1.1** – Sampling on the reflective beach of Ballenita.



At each station, one sediment sample was collected for grain size analysis, using a core with diameter of 3.6 cm, to a depth of 15 cm. Beach profiles were measured using a leveller, taking measurements every 2 meter. Wave height and wave period were estimated by monitoring 11 consecutive breaking waves. At high tide (low tide in San Pablo) the swash was recorded on videotape during 5 – 10 min, with plastic poles placed at 1 and 2 m intervals on the beach as reference. From the videotapes, swash time, swash width and swash period were identified (McArdle and McLachlan, 1991). Both at high (HT) and low tide (LT) the number of effluent line crossings in a 10 min period of time (EL-crossings) was counted.

### **2.1.2.3 Laboratory treatment**

Samples were sorted for macrofauna and all specimens were identified to the lowest taxonomical level possible. The sediment grain size distribution between 2 and 850  $\mu\text{m}$  was determined with a laser COULTER LS and classified according to the Wentworth scale (Buchanan, 1984). Weight percentage of the coarser sediment ( $>850 \mu\text{m}$ ) was measured by sieving and weighing dried sediment fractions. To calculate the median grain size over the full sediment spectrum, a conversion of weight percentage to volume percentage of the coarse sand ( $>850 \mu\text{m}$ ) was performed.

Biomass (Ash-Free Dry Weight or AFDW) estimates for all molluscs, polychaetes and larger crustaceans (Anomura) were obtained by loss of mass on ignition ( $450^{\circ}\text{C}$  for 4 h) of oven-dried samples ( $70^{\circ}\text{C}$  for 48 h). For smaller crustaceans, assigned biomass values were calculated from determining the AFDW of a large number of specimens, using the same protocol as described above.

### **2.1.2.4 Statistical analyses**

Beach profiles were constructed based on the measurements and the tide predictions for the nearby ports of La Libertad (Ballenita, Olon, Portéte, San Pedro and San Pablo), Manta (San Clemente) and Bahía de Cáraces (Briceño). Lowest swash point at low tide was assumed to be the low water level (Short, 1999) and is referred to as 0 m of elevation. Highest point of the intertidal was the lower swash limit at high tide. Intertidal width and beach slope were calculated from this highest point and the zero point. Swash characteristics (swash time, swash period and swash width) were retrieved from the videotapes. Swash velocity was calculated from swash time and swash width (McArdle and McLachlan, 1991).

Beach characterisation was done using two beach indices: 'beach index' (BI) and 'beach deposit index' (BDI) (McLachlan and Dorvlo, 2005). These indices were calculated as:

$$BI = \log\left(\frac{Sand \cdot Tide}{Slope}\right)$$

$$BDI = \left(\frac{1}{\tan B}\right)\left(\frac{a}{Mz}\right)$$

where *Tide* is the maximum spring tide range (meters), *Slope* or  $\tan B$  is the beach slope, *a* is 1.03125 (mm), *Mz* is the mean sand particle size (mm) and *Sand* is the mean sand particle size in phi units +1. BI has dimension  $\log \phi \cdot m$ , BDI is dimensionless. Both indices increase from reflective to dissipative conditions.

Because of logistic reasons, not the same sampling effort could be achieved on all beaches. Hence, to analyse differences in macrofauna between beaches, we opted for measures that compensate for sampling effort. For biodiversity, these measures were Dominance (D), Evenness (E), estimated number of species (first-order jackknife estimation) and expected number of species. To assess the concentration of specimens, density (ind/m<sup>2</sup>), abundance (ind/m), and biomass (g AFDW/m and g AFDW/m<sup>2</sup>) were used.

For estimation of the species richness, the first-order jackknife algorithm (*Jack1*) was applied (with 999 random permutations). This has been demonstrated to be the most suitable estimator for sandy beach macrofaunal biodiversity sampled along transects (Brose and Martinez, 2004; Schoeman, pers. comm.), and is computed as:

$$Jack1 = S_{obs} + Q_1 \cdot \left(\frac{m-1}{m}\right)$$

with  $S_{obs}$  the observed number of species over the total sampling pool,  $Q_1$  the number of singletons (species that occur in only one sample) and  $m$  the number of samples. A good property of the jack1 estimator is that a variance can be calculated (Heltshe and Forrester, 1983):

$$Var(Jack1) = \left(\frac{m-1}{m}\right) \cdot \left(\sum_{j=0}^{S_{obs}} j^2 \cdot f_j - \frac{Q_1^2}{m}\right)$$

with  $f_j$  the number of quadrates containing  $j$  singletons. The jack1 data were also used to construct a species-area curve.

The species diversity was also assessed as Expected number of Species (Hurlbert, 1971). ES(n)-values were used to construct rarefaction curves. The lowest number of specimens (325, Portéte) was used for maximum value of n.

Other biodiversity indices that were calculated are Dominance (D) and Evenness (E) (Magurran, 2004):

$$D = \sum p^2$$

$$E = \frac{\sum (p \cdot \ln(p))}{\ln(N_o)}$$

with  $p$  the relative density of a species in a sample and  $N_o$  the number of species in that sample. Dominance was also used in a cumulative dominance plot

To express the concentration of specimens, the data are listed in two measures: density and abundance. Density shows the occurrence of a species on a given surface and is given in individuals per square meter ( $\text{ind}/\text{m}^2$ ). Abundance estimation was done using the IST (individuals per strip transect;  $\text{ind}/\text{m}$ ) technique (Defeo, 1996). IST is calculated by multiplying the average sample density ( $\text{ind}/\text{m}^2$ ) by the intertidal width in which the animals occur. The obtained value gives an estimate of the total population size present over the entire intertidal width (cross-shore) when considering one meter of beach length (alongshore). Biomass estimation was done using BST (biomass per strip transect:  $\text{g AFDW}/\text{m}$ ; Defeo, 1996).

For all encountered taxa, their feeding type was checked in literature. Where no information was available, feeding type of other members of the same genus was chosen. The categories that were used are *scavengers*, *filter feeders*, *carnivores*, *deposit feeders*, *interstitial dwellers* and *non-feeders*. Non-feeders were zoea-larvae, a larval stage in which no feeding occurs; interstitial dwellers is not a feeding type *an sich*, yet it stands apart from the traditional foraging that occurs in sandy beach macrofauna. The Index of trophic diversity was calculated as (Heip *et al.*, 1985):

$$\text{trophic diversity} = \sum p^2$$

with  $p$  the relative density of each trophic group per beach. The trophic diversity decreases with increasing value of the index; minimal diversity is reached at a value of 1.

Correlation between environmental parameters and beach indices (*BDI*, *BI*, *median grain size*, *slope*, *intertidal width*, *swash velocity*, *swash period*, *HT* and *LT effluent line crossings* and *swash width*) were done through Spearman's rank correlation (Underwood, 1981).

Biological parameters (*diversity indices, species count, density, IST, biomass and BST*) were expressed as a function of beach indices (*BDI and BI*) and environmental parameters (*median grain size, slope, intertidal width, swash velocity and swash width*) with a first order General Linear Mixed Model (GLMM). The biological parameters were pooled per transect for each beach, and *transect nested in beach* was used as random factor in the models (McCullagh and Nelder, 1989).

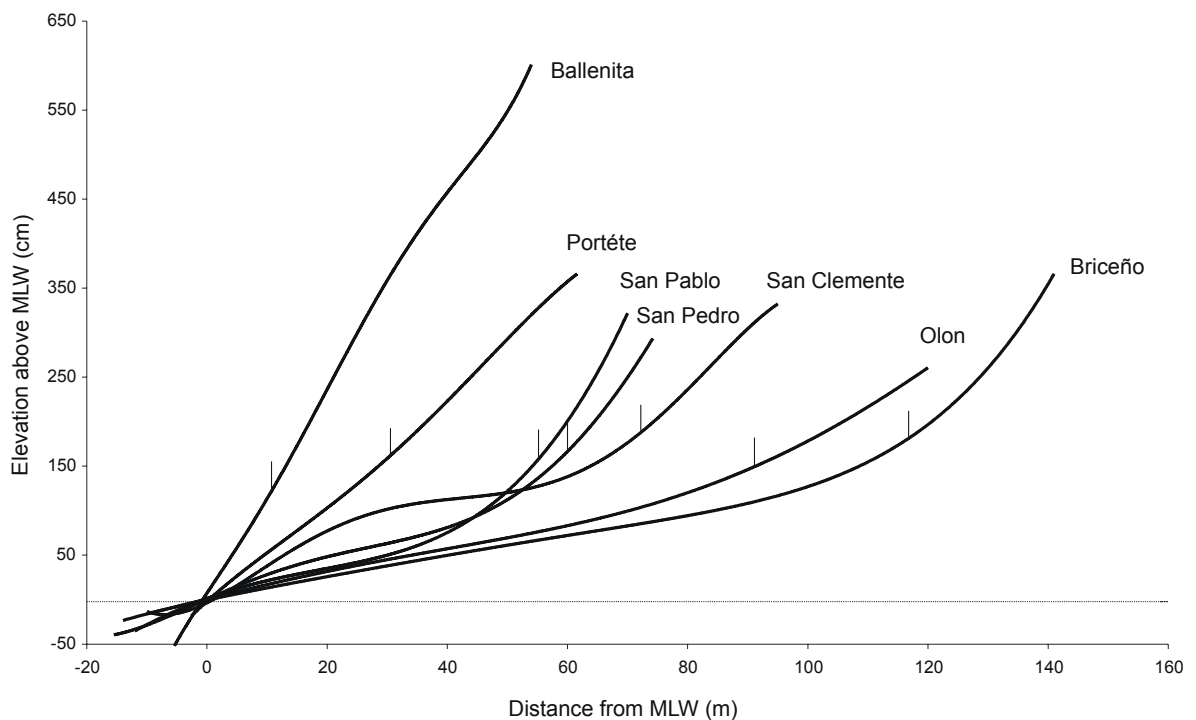
Multivariate analyses were calculated with Primer 5.2 software package (Clark and Gorley, 2001). All analyses were performed on a reduced dataset, including only the species that contributed to at least 3% of a sample. Similarity matrices were generated by calculating Bray-curtis dissimilarities (biological data) or Normalized Euclidean distances (environmental data) on the fourth-root transformed data (Clark and Gorley, 2001). These matrices were then used for cluster analyses (by group averaging) and non-metric multidimensional scaling (MDS) for biological (between beach types and within beaches) or environmental data (between beach types). *Beach type* was chosen *a priori* to categorize the seven beaches in three different groups. The stress-factor on the MDS-plots indicates the correctness of the high-dimensional relationship between the points, and values below 0.20 are considered acceptable. Differences in macrofauna between beach types were tested with a nested two-way analysis of similarity (ANOSIM; *beach nested in beach type*). To identify the characterizing species causing differences in dissimilarities between beach types or zones (within one beach), the similarity-percentages procedure (SIMPER) was applied. Likewise, differences in feeding type composition between beaches were tested with the SIMPER procedure.

The 15 most common species were selected to identify species assemblages over all beaches. A Bray-curtis dissimilarity matrix (with all samples) was constructed, and MDS- and cluster-analysis (by group averaging) was performed (Clark and Gorley, 2001). Zoeae-larvae were deleted because they were too far apart from the other species.

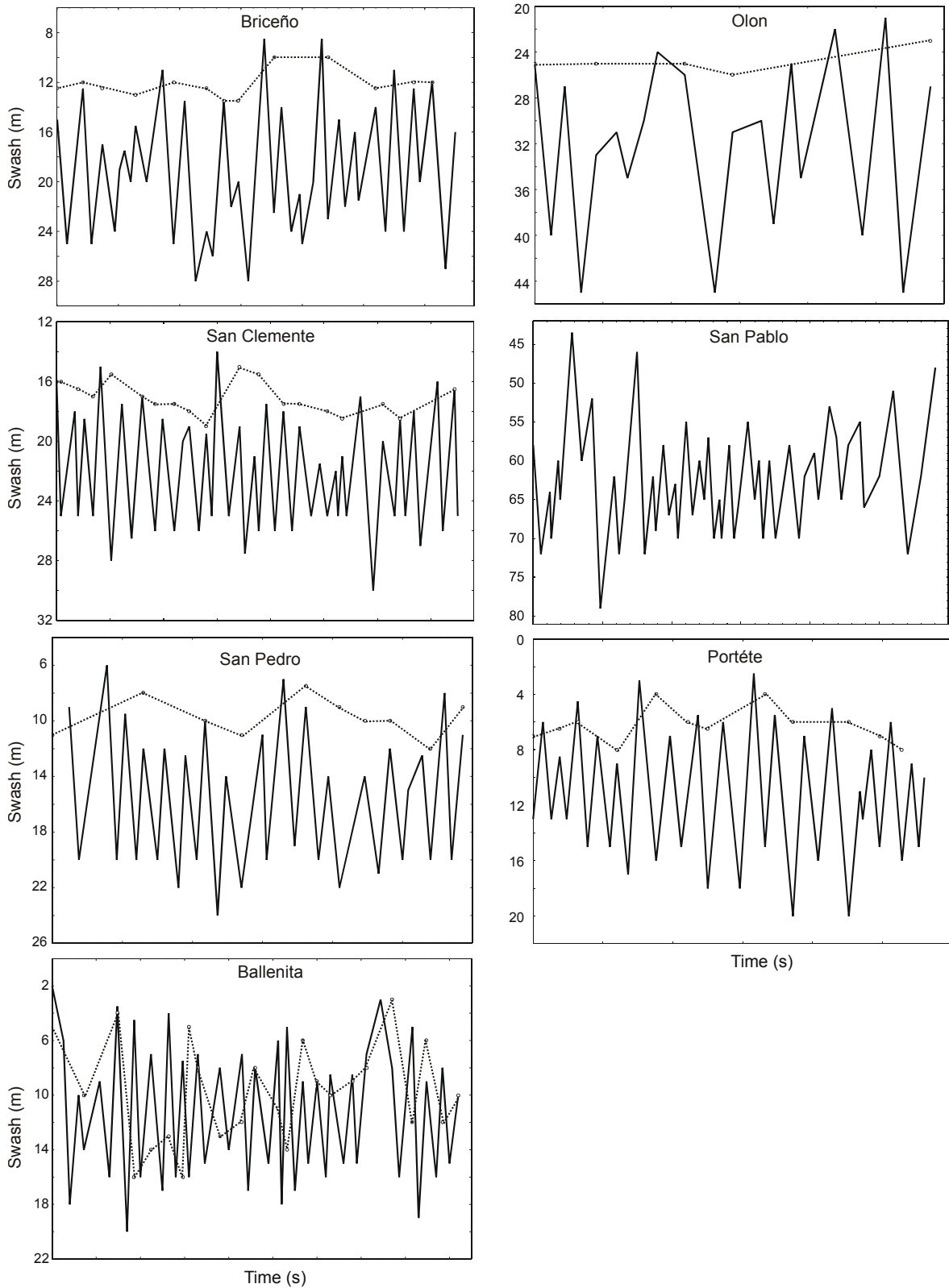
## 2.1.3 Results

### 2.1.3.1 Physical environment

The seven beaches were chosen to cover the wide range of beach types present along the Ecuadorian coast. The steepest beach was Ballenita, with a slope of 1/7, whereas with a slope of 1/63 Briceño was the flattest beach (Table 2.1.1; Fig. 2.1.2). Only in Ballenita and Portéte the low tide swash crossed the low tide effluent line, resp. 25 and 15 times per 10 min. Ballenita also showed the shortest intertidal width and swash width, coarsest sediment and highest breaker wave height. Because of the extremely short intertidal width in Ballenita, the low tides swash covered 95% of the intertidal; this ratio was much lower on other beaches (Table 2.1.1). The most dissipative conditions were found in Briceño and Olon. San Clemente, San Pablo and San Pedro had similar intermediate conditions. Beach indices (BI and BDI) confirmed the trend from the reflective beaches of Ballenita and Portéte to the dissipative beaches of Briceño and Olon (Table 2.1.1). The high tide swash profile of the beaches is shown in Fig. 2.1.3. The position of the effluent line was very erratic in Ballenita, and the waves not only crossed the effluent line very often but also by a large margin. This was also the case in Portéte, be it to a lesser extent. In the other beaches, especially in Briceño en Olon, the effluent line stayed very constant, and, if the waves did cross the effluent line, this was only by less than five meters.



**Fig. 2.1.2** - Profiles of the seven beaches, with indication of the high tide position (vertical lines). X-axis is the distance from the Mean Low Water (MLW) position, Y-axis the elevation above the MLW level.



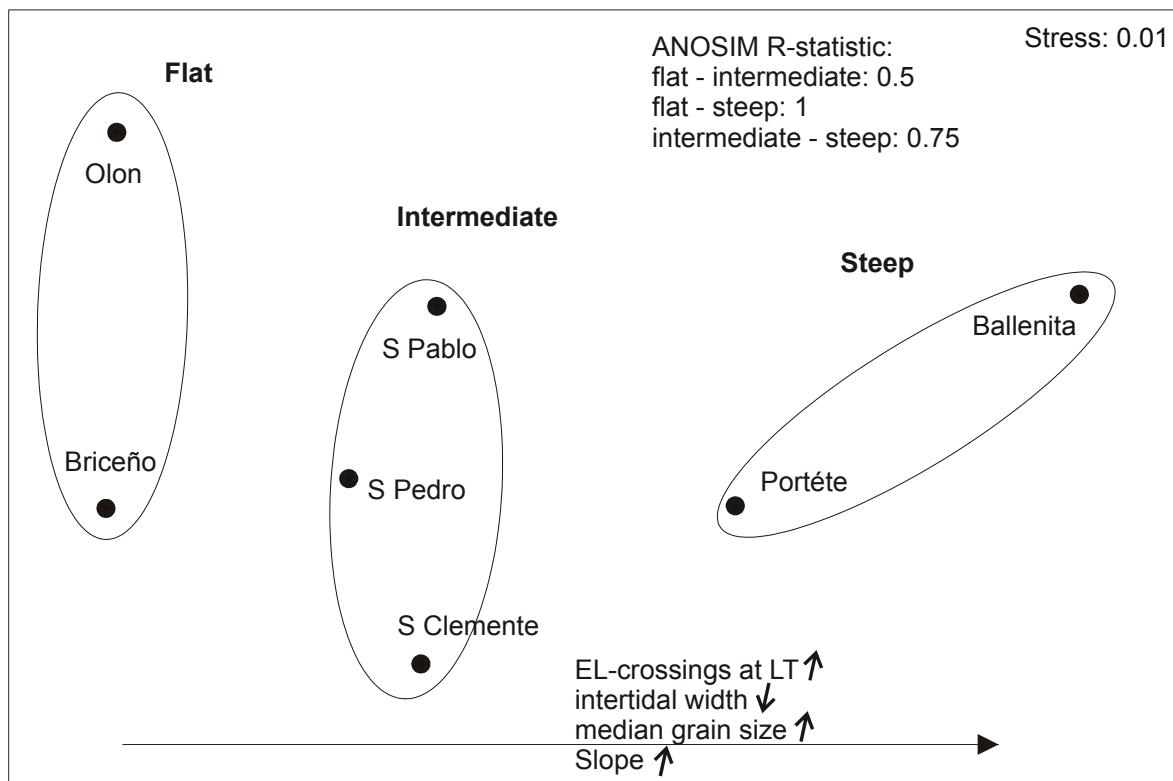
**Fig. 2.1.3** - Swash profiles for the seven beaches. Open dots and dotted line indicate the positions of the effluent line. Position of the swash waves (Y-axis) is relative to a fixed point on the high beach. All series were measured at high tide, except for San Pablo.

**Table 2.1.1** - Environmental parameters per beach. Average values  $\pm$  SE.

	<b>Briceño</b>	<b>Olon</b>	<b>San Clemente</b>	<b>San Pablo</b>	<b>San Pedro</b>	<b>Portéte</b>	<b>Ballenita</b>
<b>Low tide EL-crossings (#/10 min)</b>	0	0	0	0	0	15	25
<b>High tide EL-crossings (#/10 min)</b>	11	12	13	23	10	/	25
<b>Breaker height (m)</b>	0.78 $\pm$ 0.06	0.54 $\pm$ 0.05	0.39 $\pm$ 0.04	0.78 $\pm$ 0.06	0.68 $\pm$ 0.05	0.45 $\pm$ 0.03	1.78 $\pm$ 0.33
<b>Breaker period (s)</b>	20	17	14	16	14	13	19
<b>BDI</b>	329	393	154	162	185	56	15
<b>BI</b>	2.73	2.78	2.45	2.49	2.52	2.11	1.62
<b>Slope</b>	1/63	1/59	1/38	1/36	1/34	1/19	1/7
<b>Median Grainsize (<math>\mu</math>m)</b>	194.3 $\pm$ 5.0	190.5 $\pm$ 9.9	248.1 $\pm$ 2.42	229.4 $\pm$ 6.0	206.6 $\pm$ 3.4	444.0 $\pm$ 18.6	536.4 $\pm$ 17.7
<b>Intertidal width (m)</b>	118.0	91.0	73.0	55.5	59.5	30.5	11.0
<b>Low tide swash width (m)</b>	47.0	29.5	17.0	16.4	18.0	17.0	10.4
<b>Swash velocity (m/s)</b>	1.19 $\pm$ 0.11	0.94 $\pm$ 0.17	1.06 $\pm$ 0.11	1.13 $\pm$ 0.11	1.24 $\pm$ 0.13	1.09 $\pm$ 0.08	1.06 $\pm$ 0.12
<b>Swash period (s)</b>	16.26 $\pm$ 0.93	22.55 $\pm$ 3.20	15.46 $\pm$ 0.86	19.44 $\pm$ 1.71	16.63 $\pm$ 1.36	15.67 $\pm$ 1.00	18.91 $\pm$ 0.87
<b>Swash width / Intertidal width</b>	0.40	0.32	0.23	0.30	0.30	0.56	0.95

Multivariate analyses (MDS and cluster analyses, cluster not shown), based on environmental parameters, divided the seven beaches into three different groups (Fig. 2.1.4): two flat beaches (Briceño and Olon), characterized by fine sands, flat slope and long intertidal width; two steep beaches (Ballenita and Portéte) with EL-crossings at low tide, steep slopes, coarse sands and short intertidal width; and three intermediate beaches (San Clemente, San Pablo and San Pedro) with intermediate characteristics. This subdivision was confirmed by the multivariate ANOSIM test (Fig. 2.1.4).

Not surprisingly, slope, median grain size, intertidal width and swash width were highly intercorrelated and correlated with the two beach indices, BDI and BI (Table 2.1.2). This was also the case with effluent line-crossings at low tide, yet not with effluent line-crossings at high tide. Swash velocity and swash period were not correlated with other environmental parameters, or with the beach indices.



**Fig. 2.1.4** - MDS-plot of the seven beaches (each point represents the pooled data per beach) based on the environmental variables, with indication of the statistical significance of the group division (ANOSIM-test). The environmental variables that were used for the analyses were: EL-crossings at high tide (HT) and low tide (LT), intertidal width, slope, median grain size, breaker height, breaker period, swash width, swash velocity and swash period.



**Table 2.1.2** – Spearman’s rank correlation values (r- and p-value) for the environmental parameters and beach indices. NS= non-significant at 0.05-level.

	High tide EL-crossings	BDI / BI	Slope	Median grain size	Intertidal width	Low tide swash width	Swash velocity	Swash period	Swash width / Intertidal width
<b>Low tide EL-crossings</b>	NS	-0.802 (0.0301)	0.802 (0.0301)	0.802 (0.0301)	-0.802 (0.0301)	NS	NS	NS	-0.802 (0.0301)
<b>High tide EL-crossings</b>	--	NS	NS	NS	NS	-0.829 (0.0416)	NS	NS	NS
<b>BDI / BI</b>		---	-0.857 (0.0137)	-1.000 (<0.0001)	0.857 (0.0137)	0.847 (0.0162)	NS	NS	NS
<b>Slope</b>			---	0.857 (0.0137)	-1.000 (<0.0001)	-0.883 (.0085)	NS	NS	NS
<b>Median Grainsize</b>				---	0.857 (0.0137)	0.857 (0.0137)	NS	NS	NS
<b>Intertidal width</b>					---	0.883 (.0085)	NS	NS	NS
<b>Low tide swash width</b>						---	NS	NS	NS
<b>Swash velocity</b>							---	NS	NS
<b>Swash period</b>								---	NS

**Table 2.1.3** - Species list, with indication of the occurrence on the different beaches (x for more than one individual; o for one individual).

		Br	OI	S Cl	S Pa	S Pe	Po	Ba
ISOPODA (C)	<i>Exciorolana brasiliensis</i> (RICHARDSON, 1912)	X	X	X	X	X	X	X
	<i>Exosphaeroma</i> sp. (STEBBING, 1900)	X	X		X	O	X	
AMPHIPODA (C)	<i>Haustorius</i> sp. (MÜLLER, 1775)	X	X	X	X	X	O	
	Pinnotheridae sp. (DE HAAN, 1833)	X	O					
	Amphipoda sp.1				O			
	Amphipoda sp.2						X	
	Platyischnopidae sp. (BARNARD, 1979)	X	X	X	X	X	O	
	Caprellidae sp. (LEACH, 1814)							O
ANOMURA (C)	<i>Emerita rathbunae</i> (SCHMIDT, 1935)	X	X	X	X	X	X	X
	<i>Lepidopa deamae</i> (BENEDICT, 1903)	X	X	X	X	X		
MYSIDA (C)	Mysini sp.	O						
	<i>Bowmaniella</i> cfr. <i>Braziliensis</i> (BACESCU, 1968)	X	X	O	X	X		
DECAPODA (C)	zoeae-larva							X
BIVALVIA (M)	<i>Donax asper</i> (HANLEY, 1845)				O			
	<i>Donax dentifer</i> (HANLEY, 1843)	X	X	X		O		
	<i>Donax assimilis</i> (HANLEY, 1845)			X				
	<i>Donax ecuadorianus</i> (OLSSON, 1961)	O	X	X		O		
	<i>Donax obesulus</i> (REEVE, 1854)	X		X	O	O		
	<i>Donax spat</i> (LINNAEUS, 1758)	X	X	X	X	X		
	<i>Crassinela ecuadoriana</i> (ORBIGNY, 1842)	O	X			O		
	<i>Strigilla chroma</i> (SALISBURY, 1934)	X	X	X		X		
	<i>Tivela byronensis</i> (GRAY, 1838)	X	X	X	X			
GASTROPODA (M)	<i>Sinum cymba</i> (MENKE, 1828)					O		
	<i>Mazatlaniana fulgurata</i> (PHILIPPI, 1846)		X	O	X	X		
	<i>Oliva undatella</i> (LAMARCK, 1811)	X	X	X	X	X		
	<i>Olivella semistriata</i> (GRAY, 1839)	X	X	X	X	X		
POLYCHAETA (A)	<i>Hemipodus armata</i> (HARTMAN, 1950)	X	X	X	X	X	X	X
	<i>Lumbrineris inflata</i> (MOORE, 1911)	X	X	X	X	X	O	
	<i>Magelona pacifica</i> (MORNO, 1933)	X	X	X	X			
	<i>Malacoceros indicus</i> (FAUVEL, 1928)					O		
	<i>Marphysa</i> sp. (QUATREFAGES, 1865)	O			O			
	<i>Nephtys</i> sp.1 (CUVIER, 1817)	X	X	X	X	X	O	
	<i>Nephtys</i> sp.2 (CUVIER, 1817)	X		X	X	X	O	
	<i>Pisione indica</i> (GRUBE, 1857)						X	X
	<i>Pisionella indica</i> (AIYAR & ALIKUNHI, 1941)	O		X	X		X	X
	<i>Saccocirrus sonomacus</i> (MARTIN, 1977)		O	O			X	X
	<i>Scolecopsis agilis</i> (BLAINVILLE, 1828)		O		X	X	O	
	<i>Scoloplos armiger</i> (MÜLLER, 1776)	X	X	O	X	X		
	<i>Sthenelais helenae</i> (KINBERG, 1855)	O	O		X			
NEMERTEA	Nemertea sp.1	X	X	X	X		O	
	Nemertea sp.2	X	O					
	Nemertea sp.3	O						
	Nemertea sp.4							O
ECHINODERMATA	Ophiuroidea sp.1	O	O	X	X			
	Ophiuroidea sp.2				X			
	<i>Encope grandis</i> (AGASSIZ, 1841)	X	X			X		
	<i>Mellita longifissa</i> (MICHELIN, 1858)	O	X			X		

### 2.1.3.2 Biodiversity vs. morphodynamics

A total of 47 macrofauna species were identified (Table 2.1.3; note that seven species were only found once), belonging to six higher taxonomical groups: crustaceans (13 species), polychaetes (13 species), bivalves (9 species), gastropods (4 species), nemerteans (4 species) and echinoderms (4 species). The lowest number of species was found in Ballenita (9 out of 47, or 19% of the total species pool; Table 2.1.4), the highest species richness in Briceño (33 out of 47, or 69% of the species pool). Although an equal number of crustacean and polychaete species were found in total, for all beaches polychaetes were the richest taxon, followed by crustaceans. Where the flat and intermediate beaches were rich in molluscs, no gastropods nor bivalves were found on the steep beaches of Ballenita and Portéte (Table 2.1.4). Echinoderms were also absent from the steep beaches.

A list of characterizing species per beach based on multivariate SIMPER analyses is given in Table 2.1.4. The cirrolanid isopod *Excirrolana braziliensis*, the mole crab *Emerita rathbunae* and the polychaete *Hemipodus armiger* were the only three species that were present on all seven beaches. On the steep beaches of Ballenita and Portéte the interstitial polychaetes *Pisionella indica*, *Pisione indica* and *Saccocirrus sonomacus* were characteristic. The intermediate and flat beaches shared the most characterizing taxa, such as the polychaetes *Lumbrineris inflata*, *Nephtys* sp.1, the amphipod *Haustorius* sp. but especially the gastropod *Olivella semistriata*.

Species richness estimation by using the jackknife 1 extrapolation yielded values between 12 species for Ballenita up to 43 species for Briceño (Table 2.1.4), yet no asymptotic values were obtained for Briceño, Portéte and San Pedro (Fig. 2.1.5). The trends, however, were confirmed by the expected number of species (ES) analysis (Fig. 2.1.6; Table 2.1.4). Dominance (D) was highest on the steep beaches (Table 2.1.4; Fig. 2.1.7), although Evenness (E) was surprisingly highest in Portéte as well.

The relationship between biodiversity data and the environmental characteristics is summarized in Table 2.1.5 and Fig. 2.1.8 and Fig. 2.1.9. There is a very clear increase in species richness with increasing value of the beach indices BDI (Fig. 2.1.8 and 2.1.9b) and BI (not shown), as well as with decreasing beach slope (not shown), increasing intertidal width (Table 2.1.5), and, to a lesser extent, with decreasing sediment grain size and decreasing number of effluent line-crossings (not shown). This also holds true when considering the different taxonomical groups separately as a function of BDI, except for number of polychaetes. Dominance (D) likewise showed a very clear decrease with

increasing BDI (Fig. 2.1.9a). This was not the case, however, for Evenness (E). Overall, species diversity was best explained by BDI, followed by BI and intertidal width.

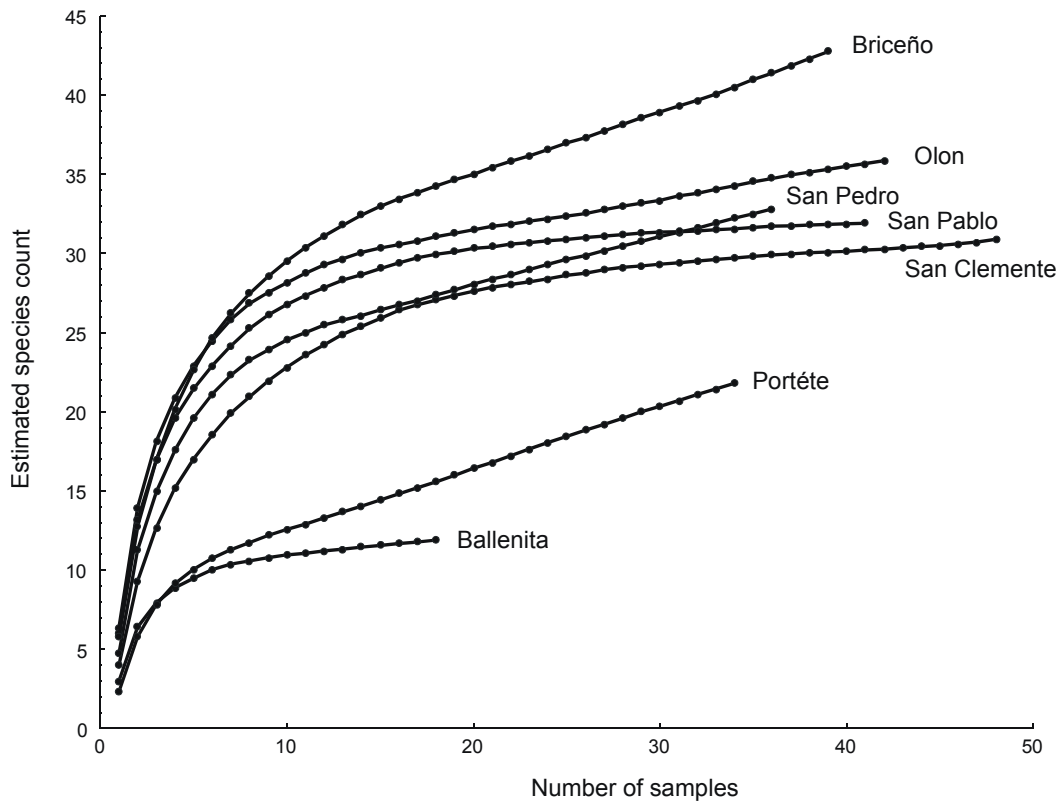


Fig. 2.1.5 – Species-area curve of the estimated species number (jackknife 1 estimator) per beach.

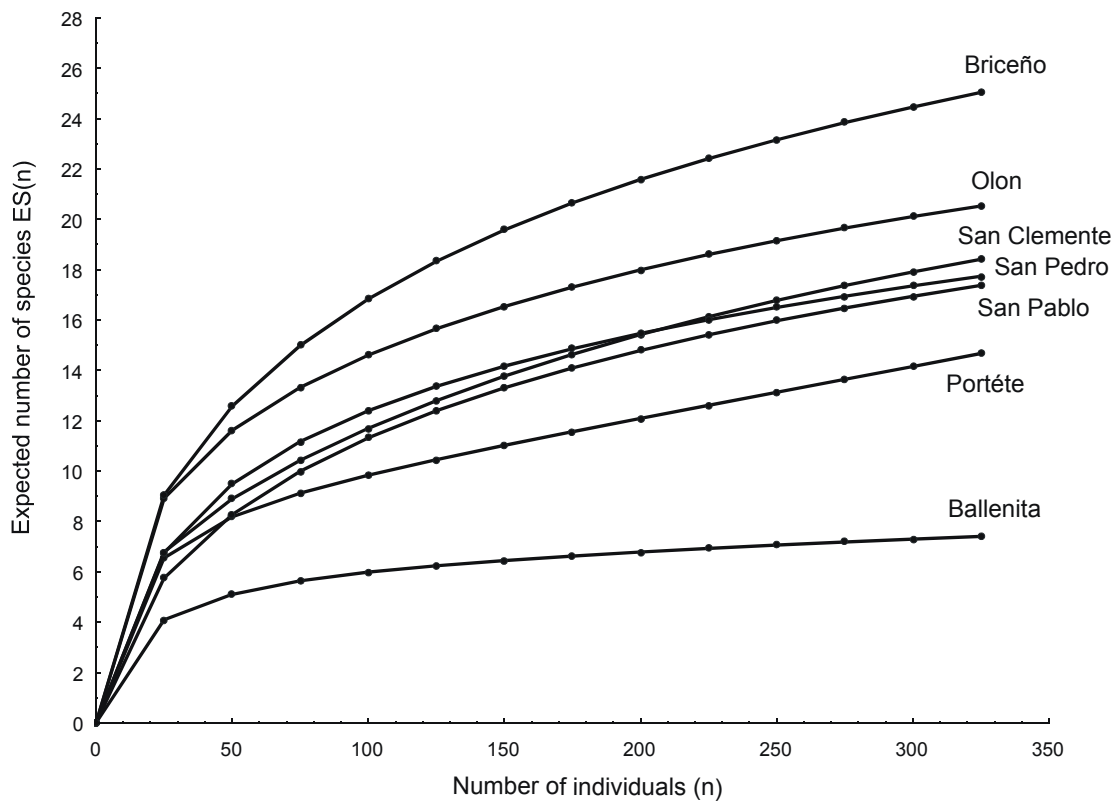
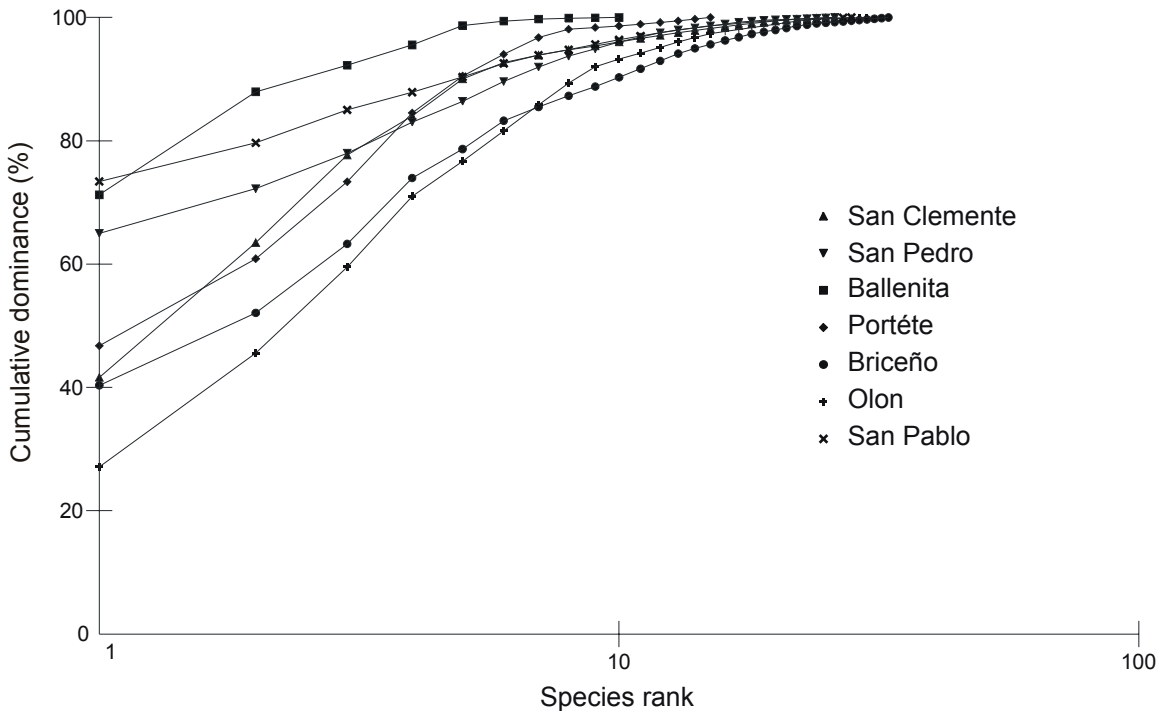


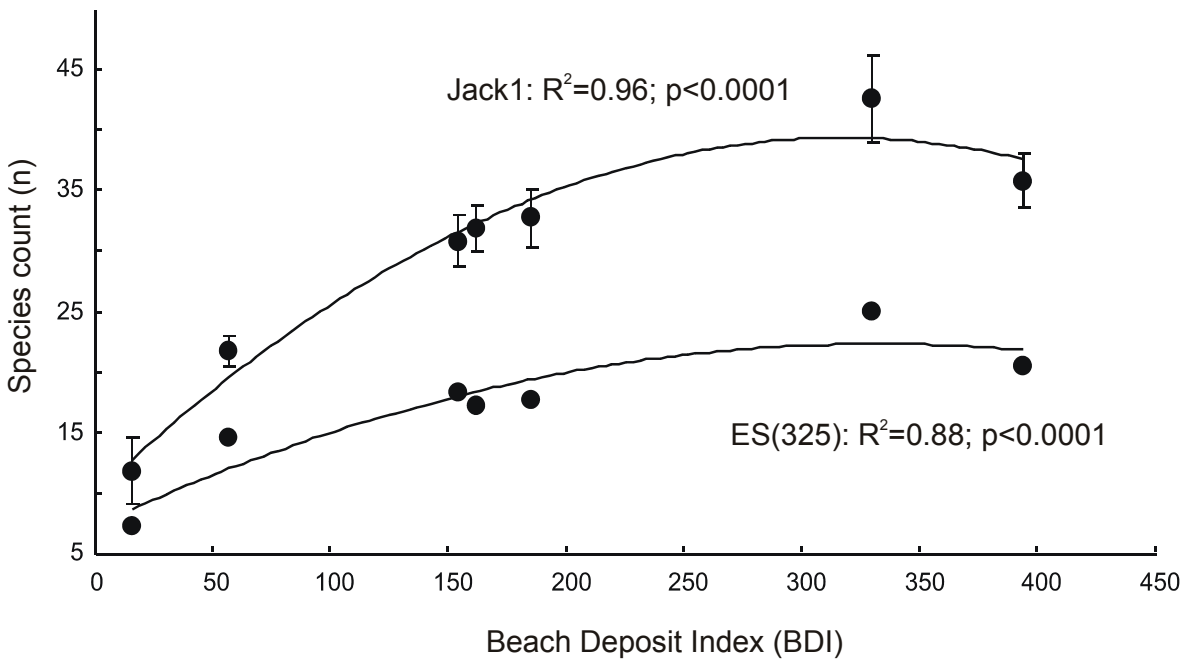
Fig. 2.1.6 – Rarefaction curves of the expected number of species for the pooled data per beach.

**Table 2.1.4** - Biodiversity data for the seven beaches and characterizing species based on SIMPER analysis.

	Briceño	Olon	San Clemente	San Pablo	San Pedro	Portete	Ballenita
<b>Number of species</b>							
Crustacea	9	8	6	8	7	6	4
Bivalvia	7	6	7	3	6	0	0
Gastropoda	2	3	3	3	4	0	0
Polychaeta	9	8	8	10	7	8	4
Echinodermata	3	3	1	2	2	0	0
<b>Total number of species (No)</b>	33	30	26	27	26	15	9
<b>% of the total species pool</b>							
<b>Jack1 ± SD</b>	42.7 ± 13.1	35.9 ± 5.0	30.9 ± 4.4	31.9 ± 3.5	32.8 ± 5.5	21.8 ± 7.4	11.9 ± 1.7
<b>ES(325)</b>	25.0	20.5	18.4	17.4	17.7	14.7	7.4
<b>Evenness ± SE (E)</b>	0.75 ± 0.03	0.74 ± 0.05	0.69 ± 0.03	0.58 ± 0.04	0.53 ± 0.04	0.77 ± 0.03	0.53 ± 0.07
<b>Dominance ± SE (D)</b>	0.39 ± 0.04	0.38 ± 0.04	0.58 ± 0.03	0.58 ± 0.04	0.58 ± 0.04	0.65 ± 0.05	0.64 ± 0.07
<b>Characterizing species</b>	<i>Lumbrineris sp.</i> <i>Nephtys sp.1</i> <i>Olivella semistriata</i> <i>Strigilla chroma</i>	<i>Nephtys sp.1</i> <i>Lumbrineris sp.</i> <i>Exosphaeroma sp.</i> <i>Strigilla chroma</i> <i>Haustrorius sp.</i>	<i>Haustrorius sp.</i> <i>Donax spat</i> <i>Olivella semistriata</i> <i>E. brazilensis</i> <i>Nephtys sp.1</i>	<i>Olivella semistriata</i> <i>Nephtys sp.1</i> <i>Nephtys sp.2</i> <i>Tivela byronensis</i> <i>Emerita rathbunae</i>	<i>Olivella semistriata</i> <i>Nephtys sp.1</i> <i>Haustrorius sp.</i> <i>Lumbrineris sp.</i>	<i>Pisone indica</i> <i>Pistonella indica</i> <i>Emerita rathbunae</i> <i>Hemipodus armiger</i> <i>E. brazilensis</i>	<i>Pisoneilla indica</i> <i>Pisone indica</i> <i>Excirrolana brazilensis</i> <i>Hemipodus armiger</i>



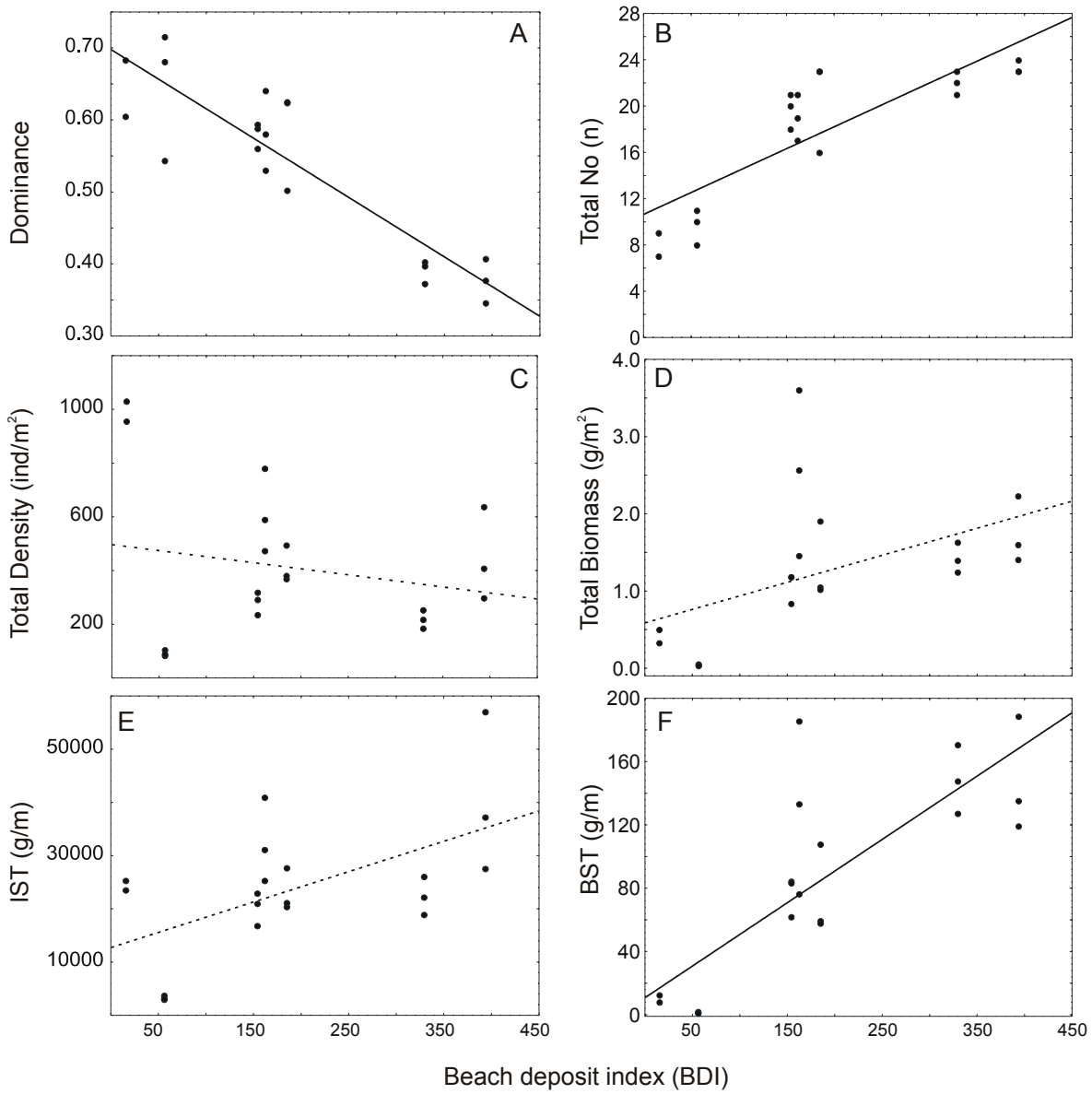
**Fig. 2.1.7** - Cumulative dominance plot per beach. X-axis is the rank of species (log-scale).



**Fig. 2.1.8** – Species richness estimators – jack1 and ES(325) - as a function of the Beach Deposit Index (BDI). Lines represent second order linear regressions.

**Table 2.1.5** – Biological parameters as a function of the Beach deposit index (BDI) and intertidal width. Estimate (Es), t-value and p-value of first order mixed models (with transects nested in beach as random factor); *DF* of intercept = 13. Italic/grey numbers indicate non-significant regression. Bold values indicate a more significant regression with intertidal width than with BDI. Regressions coloured in grey are shown in Fig 2.1.9.

		<i>DF</i>	BDI			Intertidal width		
			Es	t-value	p-value	Es	t-value	p-value
<b>Biodiversity</b>	Dominance	5	-0.001	-8.44	0.0004	-0.002	-3.93	0.0111
	Eveness	5	0.001	1.23	0.2721	0.002	1.43	0.2116
<b>Species count</b>	Total	5	0.060	5.49	0.0027	<b>0.192</b>	<b>5.78</b>	<b>0.0022</b>
	Crustacea	5	0.011	5.45	0.0028	0.040	4.43	0.0068
	Bivalvia	5	0.021	3.34	0.0207	<b>0.066</b>	<b>4.95</b>	<b>0.0043</b>
	Gastropoda	5	0.010	2.84	0.0362	0.029	2.38	0.0629
	Polychaeta	5	0.008	1.76	0.1380	0.026	1.78	0.1348
<b>Density (ind/m<sup>2</sup>)</b>	Total	5	-0.497	-0.93	0.3952	-3.264	-1.82	0.1286
	Crustacea	5	-1.153	-1.87	0.1211	-2.784	-2.13	0.0861
	Bivalvia	5	0.226	1.69	0.1522	0.914	1.78	0.1348
	Gastropoda	5	1.090	1.89	0.1169	3.192	1.68	0.1546
	Polychaeta	5	-0.855	-2.36	0.0651	<b>-13.039</b>	<b>-3.45</b>	<b>0.0183</b>
<b>Biomass (g/m<sup>2</sup>)</b>	Total	5	0.644	2.27	0.0722	1.902	1.98	0.104
	Crustacea	5	-0.019	-1.01	0.3568	-0.085	-1.17	0.2955
	Bivalvia	5	0.139	1.95	0.1085	<b>0.574</b>	<b>3.17</b>	<b>0.0247</b>
	Gastropoda	5	0.579	1.93	0.1121	1.744	1.75	0.1398
	Polychaeta	5	-0.031	-0.89	0.4143	-0.067	-0.81	0.4528
<b>IST (ind/m)</b>	Total	5	57.554	2.19	0.0802	61.532	0.40	0.7061
	Crustacea	5	-6.169	-0.34	0.7446	5.407	0.09	0.9287
	Bivalvia	5	20.667	2.03	0.0979	77.805	1.84	0.1250
	Gastropoda	5	64.789	2.25	0.0742	190.600	2.00	0.1013
	Polychaeta	5	-110.71	-2.34	0.067	<b>-289.09</b>	<b>-3.12</b>	<b>0.0263</b>
<b>BST (g/m)</b>	Total	5	51.378	4.31	0.0076	168.030	3.86	0.0119
	Crustacea	5	0.991	0.88	0.4209	4.038	0.93	0.3954
	Bivalvia	5	0.124	2.16	0.0831	<b>0.517</b>	<b>3.39</b>	<b>0.0195</b>
	Gastropoda	5	0.351	2.56	0.0508	1.091	2.31	0.0687
	Polychaeta	5	2.740	2.22	0.0768	8.33	2.00	0.1021



**Fig. 2.1.9** – Biological parameters in function of the Beach deposit index (BDI). Each point represents the pooled data of one transect. For regression details, see Table 2.1.5; dotted lines are non-significant regressions. A) Dominance; B) Total number of species; C) Total density; D) Total biomass; E) Total abundance (expressed in IST); F) Total biomass expressed in BST



### 2.1.3.3 Density, abundance and biomass vs. morphodynamics

Although the beach of Ballenita had the lowest number of species, it harboured the highest densities of macrofauna, due to the presence of high numbers of crustaceans but especially polychaetes (Table 2.1.6). By far the lowest densities were found in Portéte. Crustaceans were dominant in Olon, polychaetes dominated the steep beaches of Ballenita and Portéte and gastropods were the dominant taxon in Briceño, San Clemente, San Pablo and San Pedro. Echinoderm densities were always very low (less than 16 ind/m<sup>2</sup>).

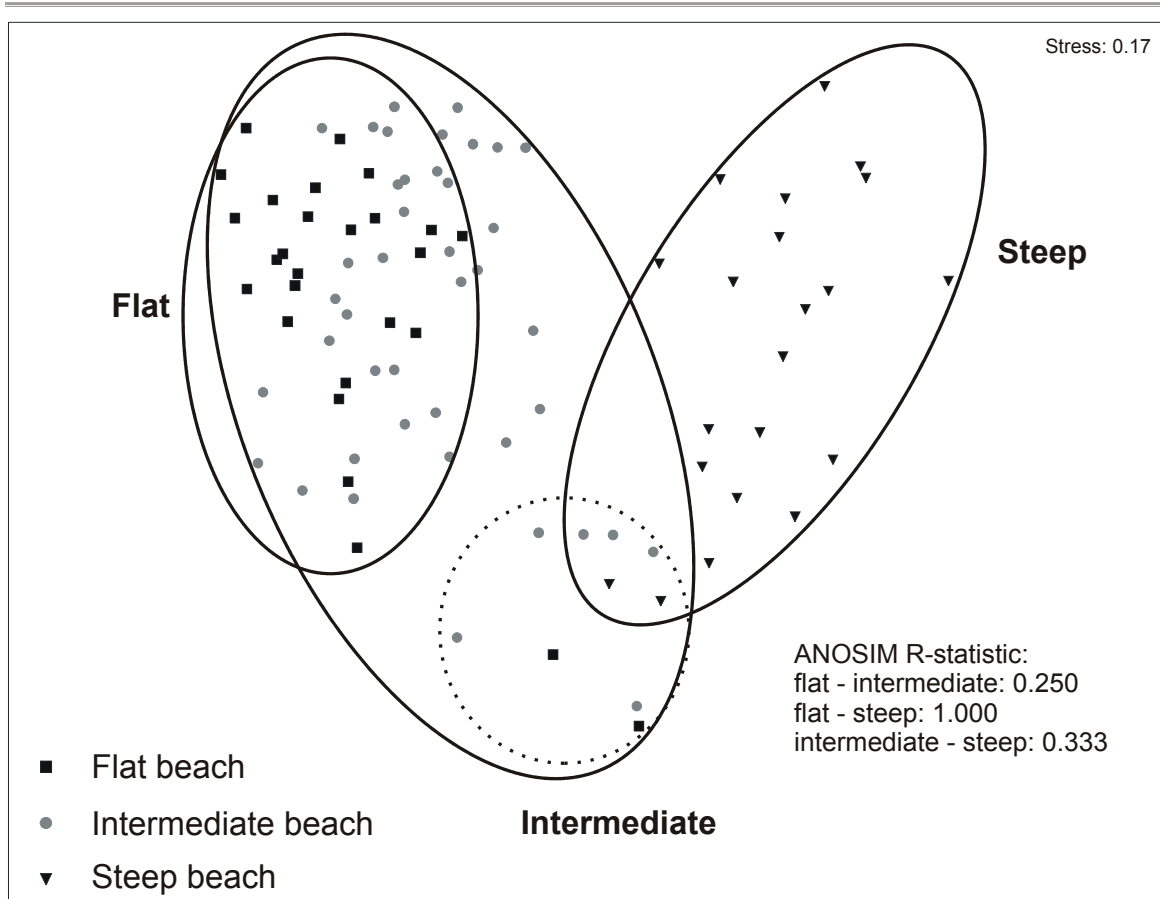
Olon harboured by far the highest total abundance, followed by San Pablo (Table 2.1.6). In Portéte the macrofaunal abundance was almost one order in magnitude lower than on any of the other beaches. With 27,569 ind/m gastropods in San Pablo were by far the most abundant taxon, although a high gastropod abundance was also found in San Pedro. Abundance of crustaceans was much higher in Olon than on any other beach; the same could be said about the polychaete abundance in Ballenita.

Biomass numbers ranged from 0.04 to 2.54 g AFDW/m<sup>2</sup> or 1.5 to 166.7 g AFDW/m (Table 2.1.6). Where highest average densities were found in Ballenita, its average biomass numbers were much lower compared to the other beaches, except Portéte. The high densities of polychaetes in Ballenita were mainly composed of very small interstitial forms, which resulted in extremely low average polychaete biomass numbers (0.14 g AFDW/m<sup>2</sup>). Only gastropods (in Olon, San Pablo and San Pedro) reached a biomass exceeding 1 g AFDW/m<sup>2</sup>.

Whereas biodiversity measures showed very clear linear correlations with the environmental parameters, this was – apart from a few exceptions – not so much the case for density nor biomass data (Table 2.1.5). Beach deposit index (BDI) and intertidal width were still the best predictors, but significant results were only found for total BST (Fig. 2.1.9f), BST and biomass of bivalves, BST of gastropods (all increasing with increasing BDI or intertidal width) and for polychaete density and abundance (decreasing with increasing BDI or intertidal width). Total biomass (g/m<sup>2</sup>) and abundance (ind/m) increased with increasing BDI, but the trend was not significant (Figs. 2.1.9d and e). With total density (ind/ m<sup>2</sup>), there were no trends at all.

**Table 2.1.6** - Density, abundance and biomass (AFDW) data for the seven beaches. Average values  $\pm$  SE.

	Briceño	Olon	San Clemente	San Pedro	Porté	Ballenita
<b>Density /</b>						
<b>Abundance</b>						
Total	219 $\pm$ 53 ind./m <sup>2</sup>	448 $\pm$ 184 42683 $\pm$ 17525 ind./m	420 $\pm$ 281 21430 $\pm$ 6720 ind./m <sup>2</sup>	614 $\pm$ 147 36842 $\pm$ 8836 25 $\pm$ 6.00	92 $\pm$ 25 3323 $\pm$ 884 25 $\pm$ 6.00	994 $\pm$ 420 25053 $\pm$ 10582 229 $\pm$ 89
Crustacea	3570 $\pm$ 1028 29 $\pm$ 7 ind./m <sup>2</sup>	21563 $\pm$ 6691 119 $\pm$ 77 ind./m	4518 $\pm$ 925 88 $\pm$ 30 6731 $\pm$ 2296 ind./m <sup>2</sup>	3314 $\pm$ 1357 43 $\pm$ 13 2618 $\pm$ 763 283 $\pm$ 65 16369 $\pm$ 3774 absent	8898 $\pm$ 216 absent	5758 $\pm$ 2237 absent
Bivalvia	3235 $\pm$ 745 95 $\pm$ 30 ind./m <sup>2</sup>	11301 $\pm$ 7374 58 $\pm$ 31 ind./m	6731 $\pm$ 2296 120 $\pm$ 43 9129 $\pm$ 3281 13 $\pm$ 2 975 $\pm$ 178 1.0 $\pm$ 0.5 77 $\pm$ 40 absent	2618 $\pm$ 763 459 $\pm$ 105 27569 $\pm$ 6301 37 $\pm$ 4 2113 $\pm$ 245 16 $\pm$ 5 908 $\pm$ 280 absent	absent	absent
Gastropoda	10626 $\pm$ 3403 58 $\pm$ 6 ind./m <sup>2</sup>	5485 $\pm$ 2918 41 $\pm$ 4 ind./m	9129 $\pm$ 3281 13 $\pm$ 2 975 $\pm$ 178 1.0 $\pm$ 0.5 77 $\pm$ 40 absent	27569 $\pm$ 6301 52 $\pm$ 6 3147 $\pm$ 359 3 $\pm$ 1 195 $\pm$ 55 absent	absent	764 $\pm$ 330 19253 $\pm$ 8315 absent
Polychaeta	6526 $\pm$ 654 4 $\pm$ 1 ind./m <sup>2</sup>	3892 $\pm$ 427 4 $\pm$ 1 ind./m	975 $\pm$ 178 1.0 $\pm$ 0.5 77 $\pm$ 40 absent	3147 $\pm$ 359 3 $\pm$ 1 195 $\pm$ 55 absent	absent	absent
Echinodermata	446 $\pm$ 118 ind./m	442 $\pm$ 115 ind./m	77 $\pm$ 40 absent	195 $\pm$ 55 absent	absent	absent
<b>Biomass</b>						
Total	1.42 $\pm$ 0.45 158.8 $\pm$ 50.0 g/m <sup>2</sup> g/m	1.75 $\pm$ 0.74 166.7 $\pm$ 70.7 g/m <sup>2</sup> g/m	1.07 $\pm$ 0.40 81.4 $\pm$ 30.4 g/m <sup>2</sup> g/m	2.54 $\pm$ 0.95 152.7 $\pm$ 57.0 0.08 $\pm$ 0.03 4.8 $\pm$ 1.6 0.00 $\pm$ 0.00 0.2 $\pm$ 0.1 0.01 $\pm$ 0.01 0.8 $\pm$ 0.7 absent	0.04 $\pm$ 0.01 1.5 $\pm$ 0.4 0.02 $\pm$ 0.00 0.6 $\pm$ 0.2 absent	0.41 $\pm$ 0.18 10.5 $\pm$ 4.5 0.28 $\pm$ 0.12 7.0 $\pm$ 3.1 absent
Crustacea	5.6 $\pm$ 1.9 0.58 $\pm$ 0.23 65.0 $\pm$ 25.3 g/m <sup>2</sup> g/m	8.6 $\pm$ 2.8 0.44 $\pm$ 0.17 41.5 $\pm$ 16.6 g/m <sup>2</sup> g/m	10.9 $\pm$ 8.7 0.44 $\pm$ 0.16 33.7 $\pm$ 12.2 g/m <sup>2</sup> g/m	3.6 $\pm$ 1.2 0.01 $\pm$ 0.01 0.8 $\pm$ 0.7 absent	absent	absent
Bivalvia	0.61 $\pm$ 0.17 67.7 $\pm$ 19.2 g/m <sup>2</sup> g/m	1.10 $\pm$ 0.52 105.0 $\pm$ 49.5 g/m <sup>2</sup> g/m	0.45 $\pm$ 0.12 34.6 $\pm$ 9.0 g/m <sup>2</sup> g/m	1.16 $\pm$ 0.36 67.2 $\pm$ 20.6 0.09 $\pm$ 0.02 5.0 $\pm$ 0.9 absent	absent	absent
Gastropoda	0.18 $\pm$ 0.03 20.5 $\pm$ 3.6 g/m <sup>2</sup> g/m	0.12 $\pm$ 0.02 11.6 $\pm$ 1.7 g/m <sup>2</sup> g/m	0.03 $\pm$ 0.01 2.2 $\pm$ 0.5 g/m <sup>2</sup> g/m	0.13 $\pm$ 0.02 7.8 $\pm$ 1.3 0.03 $\pm$ 0.01 0.9 $\pm$ 0.3 absent	0.03 $\pm$ 0.01 0.9 $\pm$ 0.3 absent	0.14 $\pm$ 0.06 3.5 $\pm$ 1.4
Polychaeta						



**Fig. 2.1.10** - MDS-plot of the seven beaches (each point representing one sampling level) based on the density data, with indication of the statistical significance of the group division (two-way nested ANOSIM-test). Global R-statistic for the ANOSIM-test was 0.275. The dotted circle highlights the high beach stations of all beaches

The seven beaches were divided into three groups based on multivariate analyses of the environmental data. This could only partly be repeated when considering the density data of the macrofauna (MDS in Fig. 2.1.10; cluster analysis not shown). The two steep beaches were clearly separated from the other beaches; while the two flat beaches clustered together, this cluster was found entirely within the cluster of intermediate beaches. This was confirmed by the multivariate ANOSIM test, which was highly significant for the steep beaches vs. the other beaches but had a low R-value (0.250) for flat vs. intermediate beaches. Note that the stations positioned high on the beach (level 1 and 2) grouped together (Fig. 2.1.10), clearly caused by the dominance of one species, *Excirolana braziliensis*, in this zone on all seven beaches (see also further).

SIMPER analysis using the three different beach types as grouping variable showed that the steep beaches were mainly characterized by the interstitial polychaetes *Pisionella indicans* and *Pisione indicans* and the absence of *Olivella semistriata*.

Differences between the intermediate and flat beaches were not found in presence/absence of dominant species yet in their densities: the intermediate beaches had high numbers of *Olivella semistriata* compared to the high numbers of *Excirolana braziliensis*, *Haustorius* sp., *Nephtys* sp.1 and *Donax*-species on the flat beaches.

#### 2.1.3.4 Zonation and community analyses

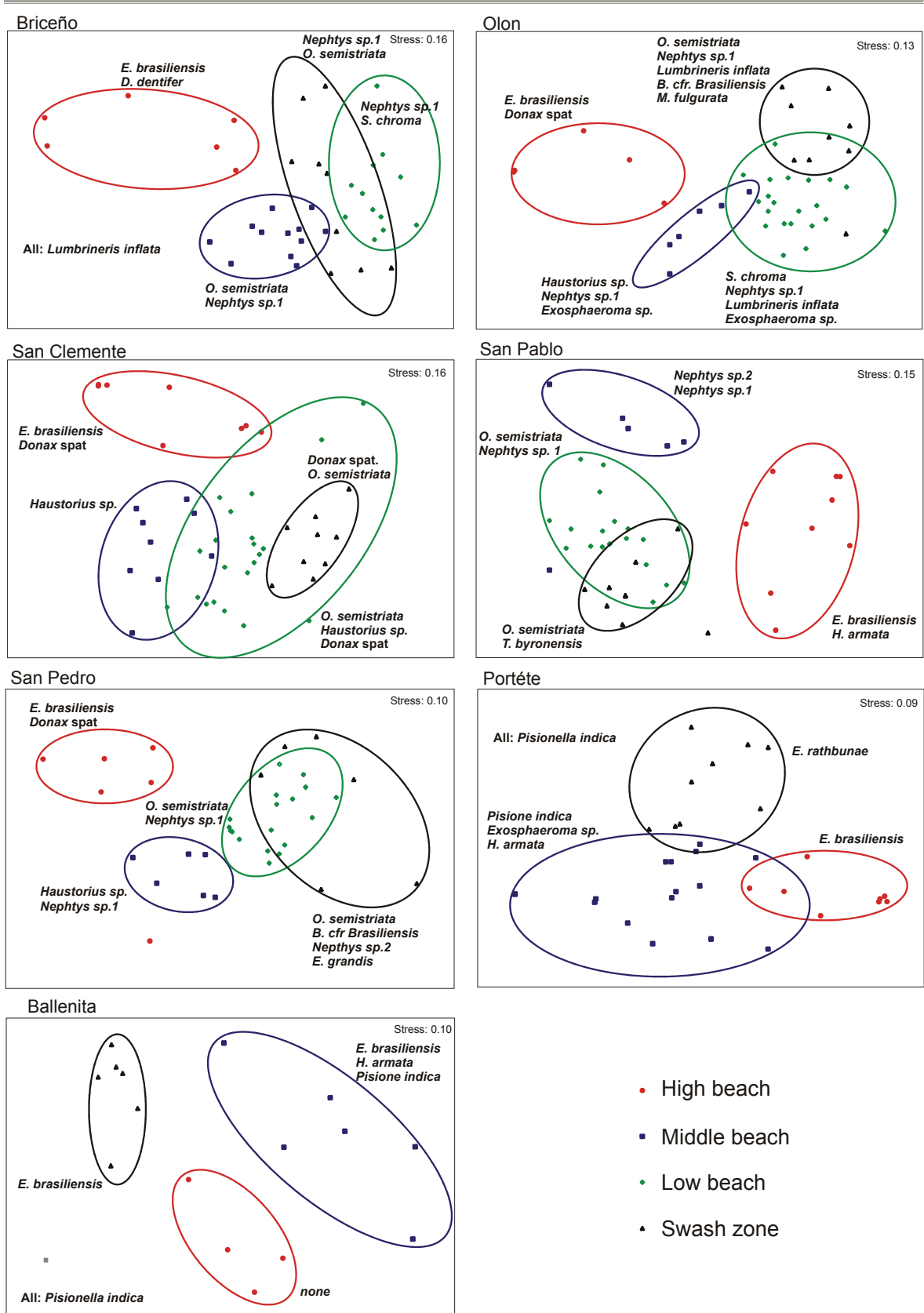
Cluster analyses and MDS-plotting was used to define zonation of the macrofauna per beach. The samples collected in the swash zone were defined as a separate zone *a priori* (see Chapters 2 and 3). The MDS-graphs per beach, with grouping based on the cluster analyses, are shown in Fig. 2.1.11.

On the two steep beaches, Ballenita and Portéte, only two zones could be distinguished: an upper beach zone characterized by *Excirolana braziliensis* and a lower beach zone with interstitial polychaetes, *Hemipodus armata* and *Exosphaeroma* sp. The swash zone confirmed its status as a separate zone with high numbers of *Emerita rathbunae*. The dominant interstitial polychaete *Pisionella indica* was present over the entire intertidal.

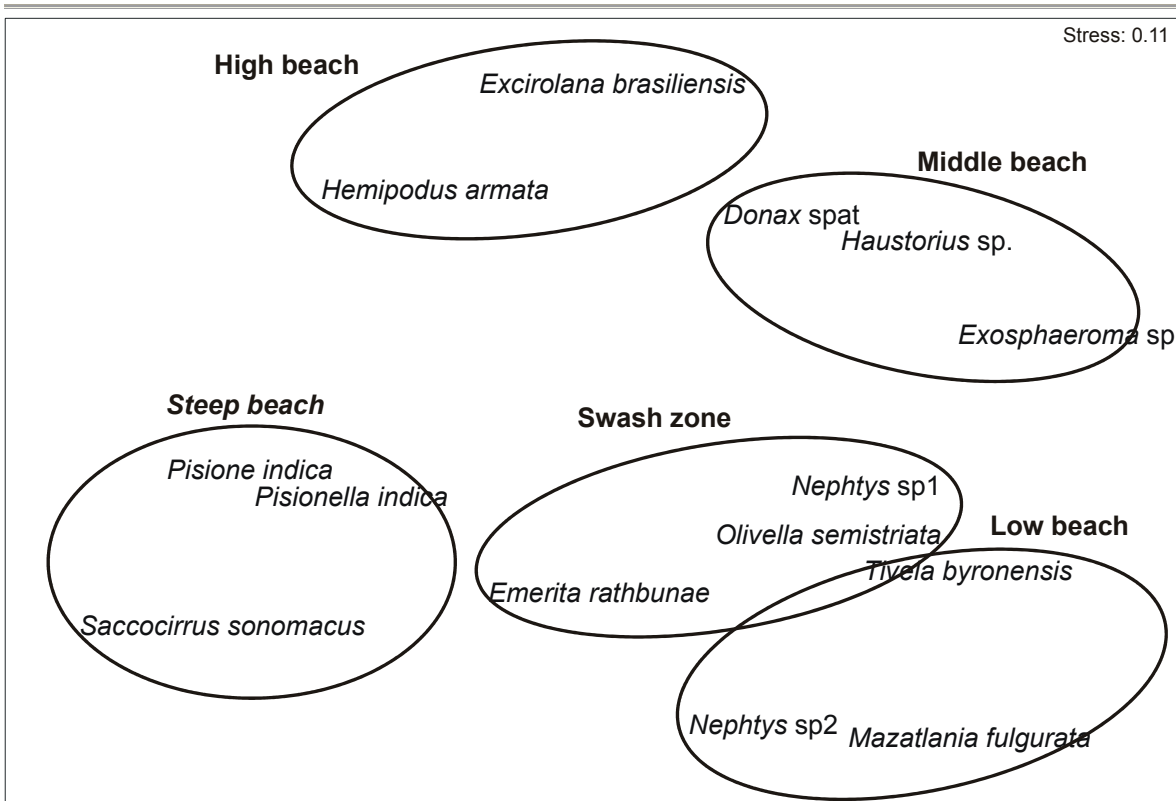
On all other beaches three zones were identified: an upper beach, middle beach and lower beach zone. The upper beach zone typically consisted of *Excirolana braziliensis* and *Donax*. The middle beach zone was dominated by *Haustorius* sp. and nephtyids. The lower beach zone was richest in species, but without any typical taxa.

The swash zone, inhabited by *Olivella semistriata*, could be found very close to or within the lower beach species association (Fig. 2.1.11).

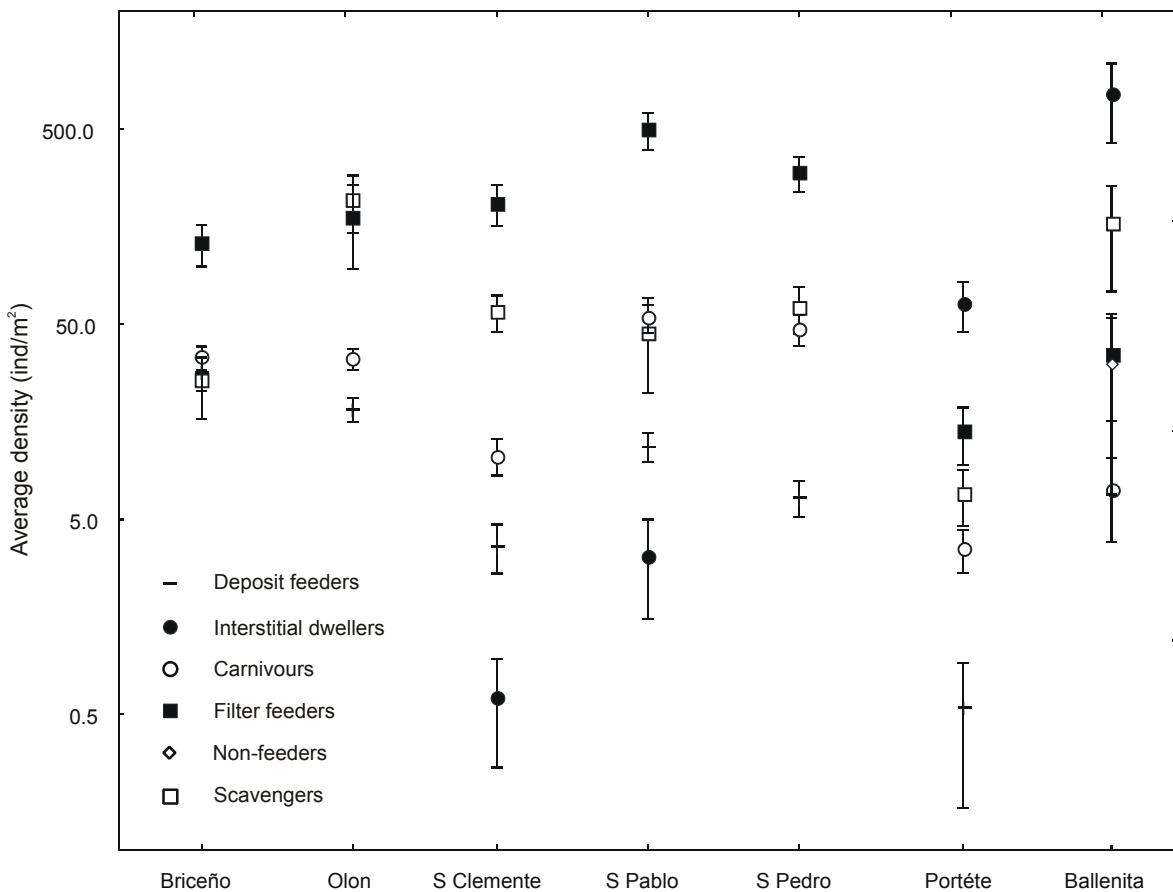
Over all beaches, five different species associations were identified: an upper beach association, a middle beach association, a lower beach association, a swash zone association and a *steep beach* association (Fig. 2.1.12). This division was confirmed by a cluster analysis.



**Fig. 2.1.11** - MDS-plot per beach with indication of the different zones (each point representing one sample) based on the density data. Division of zones is done *a posteriori* based on the MDS-plots and cluster analysis; *swash zone* is defined *a priori*. Indicator species based on the multivariate SIMPER analysis. Colour codes as indicated on the figure.



**Fig. 2.1.12** - MDS-plot of the five different macrofaunal communities found over all beaches. This division was confirmed by cluster analysis.

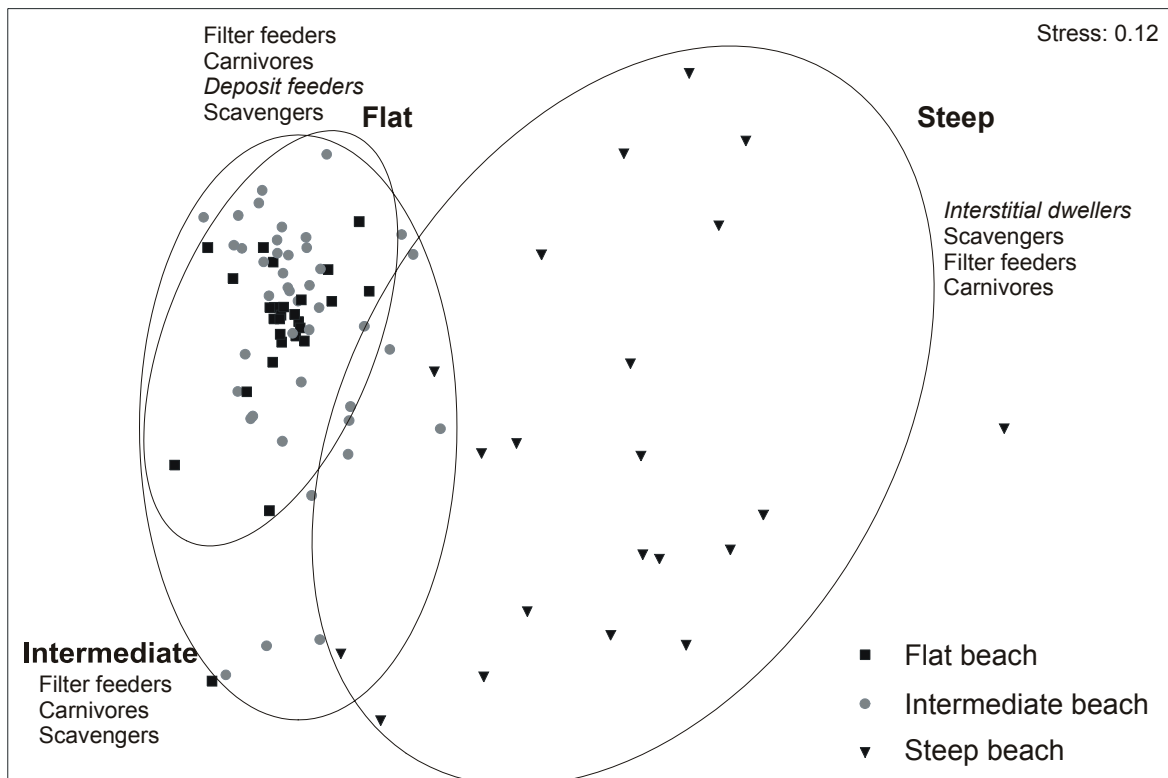


**Fig. 2.1.13** - Average density  $\pm$  SE (log-scale) of the different trophic types at the seven beaches.

### 2.1.3.5 Feeding types vs. morphodynamics

All encountered species were ascribed to one of the following feeding types: scavengers, filter feeders, carnivores, deposit feeders, interstitial dwellers and non-feeders. The most diverse group were the filter feeders. There were only three interstitial dwellers and one non-feeding taxon. Deposit feeders were absent from the beach of Ballenita (Table 2.1.7); scavengers but especially interstitial dwellers were dominant on this beach (Fig. 2.1.13). Interstitial dwelling was also the most dominant feeding type in Portéte. All other beaches were dominated by filter feeders, both in number of species and in densities (Table 2.1.7). Olon also had high numbers of scavengers (Fig. 2.1.13). Carnivores and deposit feeders were not found in high densities on any of the beaches.

Just as with the density data, the beaches grouped into two different clusters in the multivariate analyses: steep vs. intermediate and flat (MDS Fig. 2.1.14; cluster analysis not shown). Feeding type occurrence was not significantly different between the flat and intermediate beaches (Fig. 2.1.14). The steep beaches were characterized by interstitial dwellers and scavengers. Flat beaches harboured more deposit feeders than intermediate beaches, although both beach types were dominated by filter feeders and carnivores. On average flat beaches showed a higher tropical diversity (0.40-0.41) than intermediate or steep beaches (0.56 - 0.68).



**Fig. 2.1.14** - MDS-plot of the seven beaches (each point representing the pooled data for one sampling level) based on the trophic groups. Division in three groups was confirmed by cluster analysis, with *flat* found entirely in the *intermediate* cluster. Indicator feeding types are listed, based on the multivariate SIMPER analysis; italic feeding types are unique for one beach type.

**Table 2.1.7** - Number of species and density (ind/m<sup>2</sup> ± SE) per feeding type of the seven beaches.

	Briceño	Olon	San Clemente	San Pablo	San Pedro	Portéte	Ballenita
<b>Number of species</b>							
Scavenger	4	4	2	4	4	4	4
Filter feeder	11	10	10	6	10	1	2
Carnivour	5	5	6	6	6	4	1
Deposit feeder	4	5	4	5	3	2	0
Interstitial dweller	1	1	2	1	0	3	3
Non-feeder	0	0	0	0	0	0	1
<b>Average density</b>							
Scavenger	26 ± 9	218 ± 71	58 ± 12	45 ± 23	61 ± 16	7 ± 2	164 ± 91
Filter feeder	130 ± 31	177 ± 82	209 ± 50	498 ± 106	299 ± 60	14 ± 5	35 ± 19
Carnivour	34 ± 5	33 ± 4	11 ± 2	54 ± 9	47 ± 8	4 ± 1	7 ± 3
Deposit feeder	28 ± 6	18 ± 3	4 ± 1	12 ± 2	6.5 ± 1.3	0.5 ± 0.4	absent
Interstitial dweller	0.2 ± 0.2	0.2 ± 0.2	0.6 ± 0.3	3 ± 2	absent	64 ± 18	757 ± 331
Non-feeder	absent	absent	absent	absent	absent	absent	31 ± 25
<b>Index of tropical diversity</b>	0.41	0.40	0.59	0.68	0.56	0.55	0.61



## 2.1.4 Discussion

### 2.1.4.1 Physical environment

Given the tidal range present along the Ecuadorian coast (mean spring range around 2.5 m), the beaches that were investigated for this study represent the full spectrum of possible beach types. A mesotidal regime indeed prevents the formation of extremely reflective or ultra-dissipative beaches (Masselinck and Short, 1993). The Beach Index (BI) values were positioned around the average value that was found by McLachlan and Dorvlo (2005) for a large number of beaches worldwide (this study: 1.62 – 2.78; McLachlan and Dorvlo (2005): 0.77 – 3.20 with a mean of 2.15). Neglecting the factor tide (Beach Deposit Index, BDI), we came very close to covering the full spectrum described by McLachlan and Dorvlo (2005): 15 – 393 for this study compared to their 6 – 454.

It was very difficult to find reflective beaches in the conditions present along the Ecuadorian coast. Ecuador's coastal waters are characterized by a significant swell, fed by a constant input of large waves from the Pacific Ocean. This favours the formation of relatively flat, high energy beaches, especially combined with a meso- or macrotidal regime (Short, 1999). Consequently the two steep beaches we sampled are not textbook reflective beaches. Portéte is a very small pocket beach (beach length of about 200 m), yet fully exposed. Ballenita is a very steep, coarse sanded beach, but is known for its extremely high breakers and the absence of a surf zone (this study and Cornejo, pers. comm.), uncharacteristic to reflective beaches (Short, 1999). A last particularity of Ecuadorian beaches is the very long breaker period (13 – 20 s in this study). For open oceanic beaches this usually is in the range of 7 - 13 s (McArdle and McLachlan, 1992; McLachlan *et al.*, 1993).

### 2.1.4.2 Macrofauna on Ecuadorian beaches

This is only the second paper describing the macrofauna of exposed beaches in Ecuador, the other being from one single beach (Addendum 1). Moreover, information on the sandy beach macrofauna of the tropical coast of the Eastern Pacific in South-America is almost non-existing, and none of the studies from the region consider the beach morphodynamics (Dexter, 1974; Riascos and Rallon, 2001; Addendum 1).

Considering the fact that we did not sample above the drift line and as such neglected the supralittoral fauna, which by some authors is regarded as beach fauna (McLachlan and Brown, 2006), the number of macrofaunal species we encountered was

very high (47 species over 7 beaches). Degraer *et al.* (2003), for instance, found 35 species (also excluding the supralittoral fauna) on eight beaches along the Belgian coast. These were all very flat, dissipative beaches, which should normally support a very rich fauna (Defeo and McLachlan, 2005; McLachlan and Brown, 2006). Along the same coastline of the present study, but much more to the south in Chile, Jaramillo and McLachlan (1993) could only find 18 macrofaunal species, including species from above the drift line, although they extensively sampled ten beaches with contrasting morphodynamics.

The only equally high, or even higher, number of species found in beach surveys are all from tropical regions. Soares (2003) found 53 species on beaches in Madagascar and 42 in tropical part of Brazil, but he sampled more beaches (11 resp. 10). The highest recorded species richness comes from North-East Australia where Hacking (1997) identified 61 species from 15 sandy beaches. The results from Ecuador clearly justify Soares' hypothesis that tropical regions have a larger species pool than temperate regions (Soares, 2003), thereby contradicting Dexter (1992), who claimed that the number of species found per beach decreases with decreasing latitude.

Most investigated beaches were dominated by polychaetes in terms of number of species, closely followed by crustaceans and molluscs. Crustaceans dominated in San Pedro; molluscs were the most diverse taxon in San Clemente, but were absent from Ballenita and Portéte. Crustaceans are generally dominating the species diversity on South-American beaches (McLachlan and Jaramillo, 1995; Soares, 2003), especially on exposed shores (Dexter, 1992). Polychaetes, in contrast, seem to prefer sheltered beaches, with mollusc diversity being highest on intermediate beaches (Dexter, 1992). These trends are thus not supported by our findings. Although the Ecuadorian beaches are highly exposed and tend more towards the reflective end of the beach spectrum, more polychaete than crustacean or mollusc species were found per beach, even though the total number of species encountered over all seven beaches was as high for polychaetes as for crustaceans and molluscs.

Not only the species richness on the Ecuadorian beaches was very high, but also the abundance and, to a lesser extent, biomass values were rather high (3,323 – 42,683 ind/m and 1.5 – 166.7 g/m). McLachlan and Brown (2006) regard values between 100 and 10,000 ind/m and 10 and 1,000 g/m as typical. However, the values mentioned by McLachlan and Brown (2006) are Dry Weight, whereas we used Ash-Free Dry Weight (Crisp, 1984), so for better comparison their values should be reduced by a factor 4 to 10

(depending on the proportion of molluscs). Much higher values, however, can be obtained. In Chile, for instance, Jaramillo and McLachlan (1993) found abundance values up to 100,000 ind/m with a biomass of nearly 5,000 g DW/m. Interestingly, in Chapter 3 we recorded abundance values for the gastropod *Olivella semistriata* on the beach of San Pedro (from this study) of nearly 100,000 ind/m. We argued that, because of the very specific zonation in the swash of this species, standard transect sampling of the full intertidal could cause an under- or overestimation of the population size (Chapter 2 and 3). It might well be that the two or three swash stations we used in the present study are not sufficient to locate the peak density of *Olivella semistriata* in the swash, with an underestimation of the population size as a consequence.

Where polychaetes, on average, dominated in terms of species diversity, this was only the case in Ballenita for abundance and in Portéte for biomass. Most beaches were dominated, both in abundance and biomass, by gastropods. This was almost solely because of the very high numbers of the surfing gastropod *Olivella semistriata*. Molluscs dominating the biomass on beaches is a well-documented phenomenon (Soares, 2003; McLachlan and Brown, 2006), although this is nearly always because of bivalves (McLachlan *et al.*, 1996; Defeo, 2003).

Where *Olivella semistriata* is by far the most dominant species on the intermediate and flat beaches, the steep beaches were dominated by the interstitial polychaete *Pisionella indicans*. Note that this species, and other interstitial polychaetes of considerable size (*Saccocirrus sonomacus* and *Pisione indicans* from this study), is sometimes regarded as part of the meiofauna (McLachlan and Brown, 2006). The division of macro- and meiofauna, however, is arbitrary and the fact that we recorded high numbers of these polychaetes despite sieving over a 1 mm mesh-size, where even 0.5 mm is also used for macrofauna (e.g. Brazeiro and Defeo, 1996; James and Fairweather, 1996; Defeo and Martinez, 2003) justifies the inclusion of the interstitial polychaetes in our macrofauna dataset.

Other typical species were the cirrolanid isopod *Excirolana braziliensis*, omnipresent throughout the whole of South-America (McLachlan and Jaramillo, 1995), the mole crab *Emerita rathbunae*, which replaces the well-known *E. analoga* in the tropical part of the Eastern Pacific, and the amphipod *Haustorius* sp. The presence of several beach clams of the genera *Donax* and *Tivela* seems to be ubiquitous (McLachlan and Brown, 2006). *Nephtys* and *Lumbrineris* were the most widespread polychaete genera in our study.

### 2.1.4.3 Macrofauna and beach morphodynamics

There was a very clear linear increase in biodiversity moving from the steep, reflective beaches to the flat, dissipative beaches. This pattern is very well-documented from sites all over the world, independent of latitude or tidal range (e.g. Defeo *et al.*, 1992; Jaramillo and McLachlan, 1993; Hacking, 1997; Brazeiro, 1999; Degraer *et al.*, 2003; Soares, 2003). Together with biodiversity, also abundance and biomass tend to increase when moving towards the dissipative end of the beach spectrum (Defeo and McLachlan, 2005; McLachlan and Dorvlo, 2005). We found a decrease in density (ind/m<sup>2</sup>) and no clear pattern for abundance (ind/m). However, if the interstitial polychaetes are left out of the dataset (see higher), the trend of increasing abundance from steep to flat beaches becomes visible. For biomass, values were lower in Portéte than in Ballenita, although the latter is a more reflective beach. However, both beaches supported a much lower biomass than the other five beaches.

The increase in biodiversity, abundance and biomass was mainly because molluscs were absent from the two steep, reflective beaches. Crustacean density, abundance nor biomass, on the other hand, showed a relation with beach type; polychaete (including interstitial forms) density and abundance decreased where biomass increased from reflective to dissipative beach states (non-significant trends; see Table 2.1.5).

For all taxa, density and biomass numbers were lowest in Portéte, although Ballenita is a more reflective beach and has fewer species. Portéte, however, is a very short pocket beach. Brazeiro (1999) showed that to support sustainable populations beaches should be at least 2 km in length, below which species richness could drop significantly. In the case of Portéte, it seems that the length of the beach was not so much limiting for the number of species that could settle on the beach. It is clear, however, that no large populations had developed on this short beach.

Looking at the species composition, the two steep beaches noticeably harbour a unique, but poor community, with species that were not found on the other beaches. Between the flat and intermediate beaches, on the other hand, there is a gradual shift in species composition and the species group is fairly similar. The beach of Portéte harboured the typical interstitial steep beach community, as well as some of the intermediate/flat beach polychaetes and crustaceans and could as such be considered as a transitional state. This might explain the relatively high species count, despite the very short beach length. It would be interesting to see if there exists a beach state at which

also molluscs could survive, without losing the interstitial community. This could theoretically lead to an unusually high biodiversity under rather reflective conditions.

#### **2.1.4.4 Zonation and beach morphodynamics**

One of the paradigms in sandy beach ecology is that zonation of populations is physically controlled, with the exception of sheltered, dissipative beaches where biological interactions can occur (McLachlan and Brown, 2006). With increasing tide range and flattening of the slope the number of zones that could be identified, grows (Defeo and McLachlan, 2005). On dissipative and intermediate beaches three or four zones are generally present (reviewed in McLachlan and Jaramillo, 1995): a supralittoral zone, a littoral zone and one or two sublittoral zones. On reflective beaches the sublittoral zone, which is an upward extension of the surf zone, is normally absent (McLachlan and Brown, 2006).

Since we did not sample above the drift line the supralittoral zone is not included in this study. Starting from the drift line we could identify three different zones (upper, middle and lower beach) on all but the two reflective beaches, where only two distinct zones were present. The swash zone, although physically distinguished from the low intertidal, did not show up as a clear different zone on the dissipative and intermediate beaches, yet it did differ considerably from the middle beach zone on the steep beaches.

Thus, if we assume that a supralittoral community with its distinct zone is present on all exposed beaches (McLachlan and Jaramillo, 1995; in this study ocypodid crabs were observed on all beaches), on the exposed mesotidal beaches of Ecuador three (reflective beaches) or four (intermediate and dissipative) zones are present. Moreover, it seems that, at least on reflective beaches, the swash zone harbours a separate community. In Chapters 2 and 3 we advocated to treat – and sample – the swash fauna as a separate community. The subdivision of the lower beach or sublittoral zone into two different zones is normally only possible on dissipative beaches (McLachlan and Brown, 2006). Most studies, however, have been performed in microtidal conditions. A small intertidal range indeed leaves little room for several distinct zones. In Ecuador the mesotidal regime seems to allow for a clearer zonation in the lower intertidal. Similar results were also found on macrotidal beaches (Degraer *et al.*, 2003).

On steep, reflective beaches the low tide swash zone covers more than half of the intertidal width (56 and 95% in this study). So, even at low tide, more than half of the intertidal part of the beach is still secured of regular swash input. This leaves only a limited area to be zoned; this is probably one of the reasons why there is a reduced number of

macrofaunal zones on reflective beaches. Additionally, there is no surf zone on reflective beaches (Short, 1999) and as such, no sublittoral beach community exists (McLachlan and Brown, 2006).

It has to be noted that identifying zonation is a tricky and often subjective science (Brazeiro and Defeo, 1996; Brazeiro, 2001; McLachlan and Brown, 2006). Especially on microtidal beaches zonation can change considerably over time (Brazeiro and Defeo, 1996), although this is also the case on macrotidal beaches in temperate regions where seasonality plays a very important role (McLachlan and Jaramillo, 1995; Degraer *et al.*, 1999). Group division, based on multivariate tests such as correspondence analysis, cluster analysis and multi-dimensional scaling, is not tested for significance and should be treated with caution (Brazeiro, 2001). Therefore, our findings concerning zonation should be considered as indicative.

#### **2.1.4.5 Macrofauna and beach morphodynamics: underlying factors?**

While the patterns of macrofaunal distribution on the macroscale (*sensu* Defeo and McLachlan, 2005) may be clear, the underlying causal links are not. Several physical factors such as beach slope, sediment grain size and swash characteristics have been considered as principal functioning forces in the distribution of macrofauna on sandy beaches (McLachlan *et al.*, 1981; McLachlan *et al.*, 1993; Brazeiro, 2001; Defeo *et al.*, 2001; Nel *et al.*, 2001). The state-of-the-art in beach ecology seems to support Brazeiro's Multicausal Environmental Severity Hypothesis (2001) of sediment grain size, swash characteristics and accretion-erosion dynamics acting together as driving forces in the distribution of sandy beach macrofauna, and more specifically in limiting the occurrence of species towards reflective beaches due to increasing environmental severity with coarse sands, heavy swash action and a fast-changing beach profile.

Since we did not monitor the beaches over time we could not check the influence of accretion-erosion dynamics on the macrofauna in Ecuador. It was very clear, however, that the reduction in species richness coincided with an increase in sand grain size. There was a very strong linear, negative correlation between grain size and all species richness variables (total and per taxon). These results were not repeated for density of biomass, because values were lowest for Portéte although the sand was finer on this beach than in Ballenita.

Interestingly, the results for the swash parameters differed considerably from earlier reports in the literature. We could not find a correlation between slope and swash velocity or swash period, where McArdle and McLachlan (1992) and Brazeiro (2001) did. On the other hand swash width and number of effluent line crossings did follow the same pattern as described by McArdle and McLachlan (1991, 1992). Not surprisingly we could thus only demonstrate a clear relationship between species richness and swash width and effluent line crossings but not with swash velocity or period. McArdle and McLachlan (1991) predicted that an increase in number of effluent line crossings and swash velocity as well as a decrease in swash period and swash width would correspond with a drop in species richness. This was later confirmed by Brazeiro (2001) for number of effluent line crossings, swash velocity and swash period, and is now confirmed by our results for swash width.

Beach slope is one of the best predictors of species richness and the number of species seems to decrease consistently with steepening of the beach slope (e.g. McLachlan, 1990; Defeo *et al.*, 1992; Brazeiro, 2001; Nel, 2001; Bayed, 2003; McLachlan and Dorvlo, 2005). Its direct impact on structuring or limiting macrofauna, however, is generally questioned, since changes in slope concur with changes in sediment grain size, the latter being acknowledged as the forcing factor (Defeo *et al.*, 1992; Borzone *et al.*, 1996; Rodil and Lastra, 2004). The beach of Portéte offered a unique opportunity to distinguish between slope and grain size, since the upper two or three centimetres of the sand bed consisted of very fine sand (median grain size of 283  $\mu\text{m}$ ), the sort of sand expected on a relatively flat beach, yet on a beach with a steep slope (1/19). Underneath the fine top sediment layer was very coarse sand, so with an average grain size of 444  $\mu\text{m}$  the overall sand was coarse. Several mollusc species (*Olivella semistriata*, *Mazatlaniana fulgurata*, *Strigilla chroma* and some of the *Donax* species) that only burrow superficially and as such would stay in the upper layer of fine sand were present on the intermediate beaches but not in Portéte. Hence, since grain size cannot be the limiting factor in this case, another factor must act as restrictive for the presence of these species. Two possibilities are beach slope and swash action. Swash parameters, however, were very similar to those of the intermediate beaches (especially San Clemente). It thus seems that beach slope itself prevented the molluscs from settling on the steep beach of Portéte.

Field studies can, of course, not prove any causal links between factors and patterns. To do that, field or laboratory experiments are needed. The different factors that



are thought to structure the macrofauna should be investigated one at a time. This has proven to be very difficult (Chapter 5), and therefore field campaigns have been and will continue to be a valuable tool to describe patterns and identify possible causal links.

#### **2.1.4.6 Trophic structure and beach morphodynamics**

The trophic structure of a community is a good measure for the complexity of the habitat, with a more diverse community expected in stable conditions (MacArthur, 1955; Watt, 1964). In sandy beach terms this means that dissipative beaches should host a fauna with a higher tropical diversity. This is exactly what we found on the beaches in Ecuador. The trophic diversity was clearly higher on the two dissipative beaches; there was no difference, however, between the intermediate and reflective beaches.

The configuration of the trophic structure depends on the food web of the ecosystem. Since primary production is very limited on exposed sandy beaches, the fauna inhabiting the beach largely depends on external input of nutrients at the base of the food web (McLachlan and Brown, 2006). Filter feeding of material that is in suspension is logically the dominant feeding type on beaches (Steele, 1976; Ansell *et al.*, 1978; Ricciardi and Bourget, 1999; McLachlan and Brown, 2006), as was the case in our study. Other ways of addressing the exogenous food supply is through deposit feeding and (herbivorous) scavenging. Sandy beach carnivores predate on both beach macroinfauna and hyperbenthos (McLachlan, 1990). Finally we also included 'non-feeding' as a feeding type for the zoeae larvae present in large numbers in Ballenita and 'interstitial dwellers' for the interstitial polychaetes since these could be considered as part of a interstitial food web, which is basically independent from the macrofaunal food web (McLachlan and Brown, 2006). The reason why interstitial species flourish on reflective beaches is to be found in the large amount of water that is filtered through coarse sands (Short, 1999), providing much more organic matter to the interstitial space than on intermediate and reflective beaches.

Deposit feeders were absent from the steep beaches and reached their highest numbers on the flat beaches of Briceño and Olon. Deposit feeding is indeed only possible under more stable conditions (McLachlan and Brown, 2006) and Ricciardi and Bourget (1999) demonstrated a significant decrease in deposit feeder biomass with steepening of the beach slope. There were no clear trends for scavengers or carnivores, which is in



contrast to what Bayed found for mesotidal exposed beaches in Morocco (2003): an increase in carnivore diversity and density with decreasing importance of filter feeders.

Note that we did not find any wrack on the beaches. Wrack can play an important role in the sandy beach faunal composition (Dugan *et al.*, 2003) and can be the most important source of carbon for the sandy beach food web (Hayes, 1974; Robertson and Hansen, 1981; Griffiths *et al.*, 1983; Dugan *et al.*, 2003). Beaches subjected to large wrack inputs can harbour a dominant population of scavengers in the supra- and midlittoral (Colombini and Chelazzi, 2003).

## 2.1.5 Conclusions

- 1) During this study the full spectrum of beach types along the Ecuadorian coast was sampled for macrofauna. Ecuador offers a unique environment with a mesotidal regime and tropical coastal waters.
- 2) With 47 species collected on 7 sites the Ecuadorian beaches prove to be very rich in species.
- 3) Biodiversity decreased from dissipative to reflective beaches; similar trends were found for biomass and abundance but not for density.
- 4) Changes in biodiversity could be linked to four environmental factors: sediment grain size, beach slope, number of effluent line crossings and swash width.
- 5) On the reflective beaches three different zones were identified; the intermediate and dissipative beaches had one more zone: the lower beach or sublittoral zone.
- 6) The two dissipative beaches had a highest diversity in trophic groups, indicating a more stable environment. Filter feeders were dominant on all beaches; deposit feeders only reached significant densities on the dissipative beaches. The reflective beaches were characterized by a unique interstitial fauna.
- 7) Overall, the dissipative and intermediate beaches seem very similar in species composition, density, abundance and trophic structure. The reflective beaches were clearly different in all these aspects. It seems that there is a gradual change from dissipative to intermediate beaches yet an abrupt change from intermediate to reflective beaches.

## CHAPTER 2

# SWASH ZONATION PATTERNS OF TWO SURFERS ON EXPOSED TROPICAL SANDY BEACHES.

---

Vanagt T., Dewinter P., Steenhuyse L., Vincx M., Degraer S.

Submitted to *Marine Biology*

Keywords: *Olivella*, *Emerita*, surfing, sandy beaches, competition, zonation, swash.

## Abstract

Macrofaunal species that show surfing behaviour on tidal sandy beaches use the swash to migrate up and down the beach. When studying the zonation of these surfers, some complications arise which do not occur for sessile organisms or organisms that remain burrowed for some time during the tidal cycle. In this paper, a new approach for sampling mobile swash fauna is proposed. The described method deals with two problems innate to investigating swash zonation of surfing species: setting a reference point independent of the tidal state and taking all the samples of a transect without having migration in due course. The upper swash limit, defined as the highest swash wave during 10 minutes of observation, was chosen as reference point. By placing wooden boxes at every sampling spot prior to sampling, migration while taking the samples was prevented. This allowed us to sample transects in the swash zone, producing swash zonation data for two surfing species on Ecuadorian sandy beaches: the gastropod *Olivella semistriata* and the mole crab *Emerita rathbunae*.

Both species showed a symmetric to negatively skewed unimodal swash distribution curve, independent of the tidal state or sampling location. Peak densities were typically found around 15-60 % of the upper swash limit, with *O. semistriata* living higher and *E. rathbunae* living lower in the swash. It is hypothesized that this zonation is a result of a gradient in feeding time, with optimal feeding conditions around the middle of the swash zone. The different position of peak densities is thought to be caused by differences in morphology and behaviour. The mole crab is a much faster swimmer and burrower than the snail, and its feeding structures seem more robust. This idea is supported by distribution data for both species from beaches with different morphodynamics: where *O. semistriata* is restricted to relatively flat beaches with fine sediment and gentle swash conditions, *E. rathbunae* is mostly present on reflective beaches with coarse sediment and vigorous swash action.

## 2.2.1 Introduction

Zonation is a very important feature in intertidal communities within both hard (Kaiser *et al.*, 2005) and soft substrates (McLachlan and Jaramillo, 1995). Sandy beach zonation has been fairly well studied over a range of beach types and at almost all latitudes. General patterns were reviewed by McLachlan and Jaramillo (1995). Zonation is caused by gradients in environmental and biological factors. Whereas rocky shore zonation is mainly defined biologically (Lewis, 1964), sandy beach zonation is generally thought to be structured by environmental factors (McLachlan and Jaramillo, 1995; Defeo and McLachlan, 2005 and many others), although recent work by Defeo *et al.* (1997) and Dugan *et al.* (2004) suggest that competition cannot be discarded as a structuring force in sandy beach zonation. Knowledge on the zonation pattern of a species is crucial for the understanding of its functioning within the ecosystem, and allows for estimating temporal and spatial variability in population sizes.

Variation in sandy beach zonation of species and communities can be found at different scales, both spatially and temporally (Defeo and McLachlan, 2005). Zonation dynamics can occur on a circatidal, daily, circalunar or seasonal base, as well as because of unpredictable events such as storms or climate cycles (Brazeiro and Defeo, 1996; Gimenez and Yannicelli, 1997; Defeo and Rueda, 2002; Defeo and McLachlan, 2005). On a spatial scale, differences exist at different latitudes, in between beaches, alongshore, cross-shore, within cross-shore zones and at microspatial scale (Dexter, 1992; James and Fairweather, 1996; Jones *et al.*, 1998; Defeo and Rueda, 2002; Defeo and McLachlan, 2005; McLachlan and Dorvlo, 2005). Brazeiro and Defeo (1996) showed that on microtidal beaches temporal processes are of predominant importance. These beaches are generally wind-driven, making them vulnerable to erratic changes in morphodynamics (Short, 1999; Brazeiro, 2001). Studying zonation under these conditions requires a proper temporal scale (Brazeiro and Defeo, 1996), especially where there is a clear seasonality.

With increasing tidal range, tide replaces wind as major driving force in the morphodynamics of sandy beaches (Masselink, 1993; Short, 1999). The intertidal width and thus the room for cross-shore spatial differences in zonation likewise increases with tidal range. James and Fairweather (1996) demonstrated that zonation has to be studied on a detailed spatial scale, with a sufficient number of levels per cross-shore zone. One of these zones, the swash zone, plays a crucial part in the functioning of macrofaunal communities on exposed sandy beaches (McLachlan and Brown, 2006). According to McLachlan and Brown (2006) exposed sandy beaches are dominated by a mobile swash fauna and McLachlan *et al.* (1993) hypothesized that swash condition is the major force

limiting the distribution of macrofauna towards reflective beaches (SEH or Swash Exclusion Hypothesis).

Surfing species, such as the beach whelk *Bullia* (Trueman and Brown 1976), clams of the genus *Donax* (Ansell and Trevallion, 1969; Ellers, 1995a), and mole crabs (*Emerita*: Cubitt, 1969; *Lepidopa* and *Blepharipoda*: Dugan *et al.*, 2000; Hippa: Lastra *et al.*, 2002), use the swash to migrate over the beach face with the tide (McLachlan and Brown, 2006). Although they can be found over the entire intertidal during the tidal cycle, their actual distribution is restricted to the swash zone, which, on tidal beaches, is narrower than the intertidal. It is thus unlikely that the actual zonation pattern, the 'swash zonation', will be revealed by the sampling strategies generally applied on sandy beaches, i.e. sampling the complete intertidal at low tide, from above the drift line to the lower swash limits (McLachlan and Brown, 2006). Moreover, swash zonation can vary on a circatidal scale. The reference frame to assess swash zonation over the tidal cycle should thus not be the drift line, yet a point relative to the swash. Jones and colleagues (1998) described the 'median-wave technique' to sample tidally migrating amphipods of the genus *Exoediceros*. Transects are stationed around a swash reference point, resulting in a distribution dataset of swash zonation independent of the tidal state.

A second complicating factor in sampling swash zonation is to obtain, per swash transect, a true snapshot sampling. Surfers use swash waves to migrate over the beach face. While they tend to ride the bigger waves (Ellers, 1995a; Chapter 6) migration can occur in even the smallest waves (Chapter 6). With standard frame or core sampling, it is thus impossible to prevent migration from happening while sampling a transect in the swash. For this study, we tried to develop a sampling strategy that, on the one hand, contained a swash reference point corrected for differences caused by the tidal state or the wave conditions, and on the other hand allowed us to sample a swash transect without migration happening while sampling, i.e. a true snapshot.

On exposed sandy beaches in Ecuador, the snail *Olivella semistriata* and the mole crab *Emerita rathbunae* are dominant surfing species (Chapter 1). Both species inhabit the swash zone and use the backwash for filter feeding (Olsson, 1956; Caine, 1975), apparently occupying an overlapping ecological niche. In this paper, we discuss how these species are distributed at three different spatial scales (*sensu* Defeo and McLachlan, 2005): (1) between beaches with different morphodynamics (macroscale), (2) cross-shore (mesoscale) and (3) in the swash zone (microscale). The hypothesis is that, despite their similar feeding and migrating ecology, *O. semistriata* and *E. rathbunae*

handle swash conditions in a different way, and as such avoid interspecific competition. We expect these differences to be reflected in their distribution and swash zonation pattern.

## **2.2.2 Material and Methods**

### **2.2.2.1 Study sites and period**

Two beaches in the Guayas province of South-western Ecuador were investigated: the beaches of San Pedro de Manglaralto (1°57'11"S and 80°43'28"W) and Playas (2°39'28"S and 80°22'53"W). These are exposed sandy beaches with a maximal tidal range of 2.6 – 3.0 m. Sampling took place on August 21<sup>st</sup> (Playas) and August 22<sup>nd</sup> (San Pedro) of 2003.

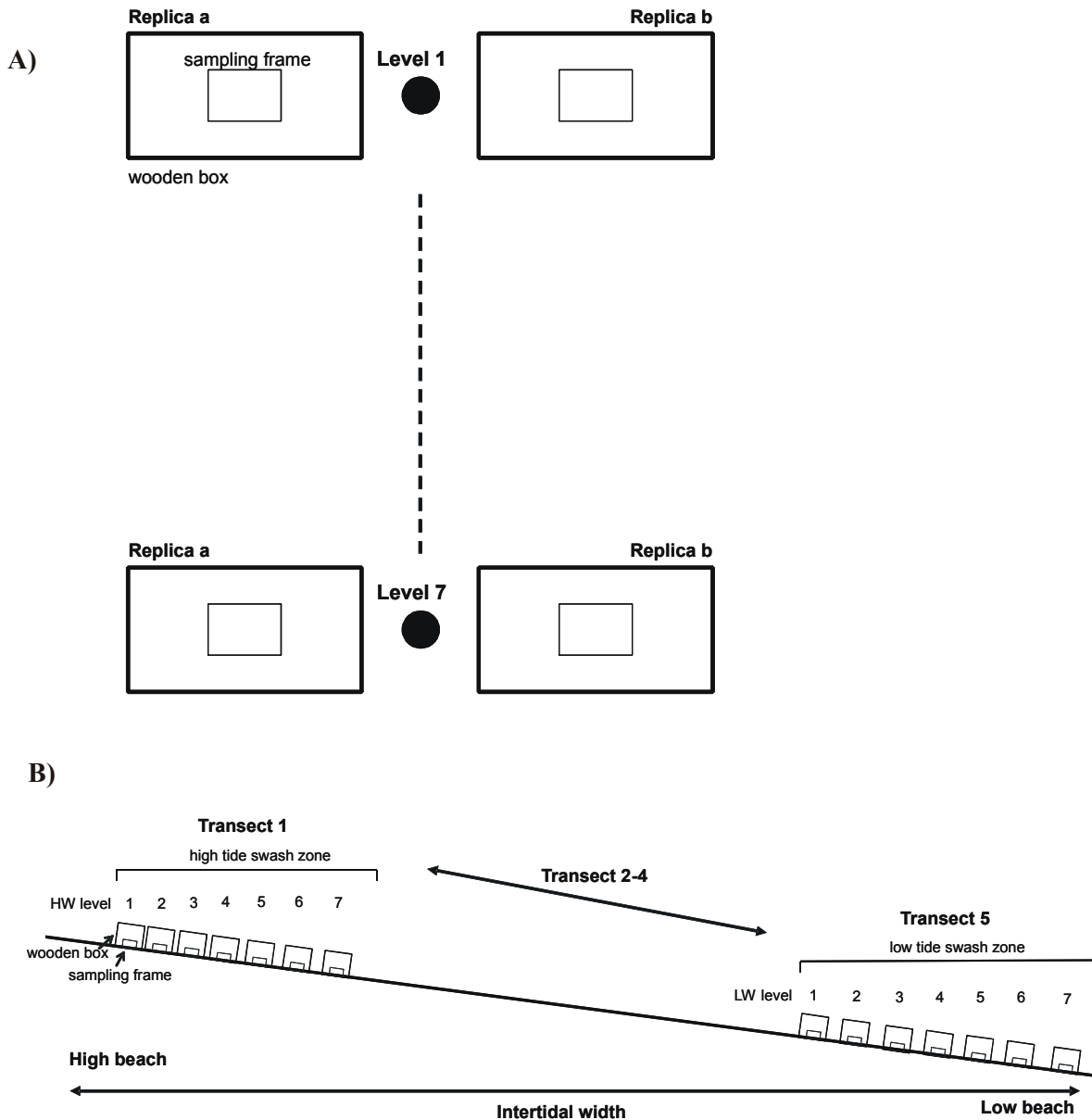
### **2.2.2.2 Sampling strategy**

Per beach five transects were sampled (Fig. 2.2.1). Two transects at high tide (HW1 and HW2), one transect two hours after high tide (MW1), one three hours after high tide (MW2) and one transect at low tide (LW). Each transect consisted of 5-7 levels in the swash zone and one level 1-2 m above the upper swash limit. The levels in the swash were placed at 1 to 3 m intervals between the upper and lower part of the swash. Before setting out the positions of the levels, the swash was monitored during 10 minutes to find the upper and lower limit. At low tide an extra three levels between the upper swash limit at low tide and the high tide level, on the air-exposed part of the intertidal, were sampled.

At each level, two replicate samples were taken by excavating a metal frame with a surface area of 0.1026m<sup>2</sup> to a depth of 15 cm. To prevent migration of the animals during sampling of one transect, levels were isolated by simultaneously placing a wooden box (plywood, 100 x 50 x 50 cm l x h x w) over each sampling spot (Fig. 2.2.1a and b; Picture 2.2.1 and 2.2.2). We had a total of eight boxes, which were put into place after a swash wave fully retreated, beginning with the lowest four levels (4 x 2 boxes for the replicates; see Picture 2.2.1). Firstly, the two replicates of the lowest level were sampled. Then the boxes of this level were moved to lowest level that was not yet protected by boxes. The second lowest level was then the next to be sampled. This procedure was repeated till all samples were taken. More details about the use of these wooden boxes can be found in the discussion section. The samples were sieved alive over a 1 mm

mesh-sized sieve; the retained organisms were stored in an 8 % formaldehyde-seawater solution.

At each level, one sediment sample was collected for grain size analysis, using a core with diameter of 3.6 cm, to a depth of 15 cm. Beach profile was assessed using a leveller, taking measurements every 2 meter. Wave height and period was estimated by monitoring 11 consecutive breaking waves.



**Fig. 2.2.1** - Sampling design, with use of wooden boxes (see text for details). A) View from above of one swash transect with indication of the first and last level and the 2 replicates per level. B) Cross-sectional view of a beach with the first and last swash transect (7 levels per transect). HW = High Water; LW = Low Water.





**Picture 2.2.1** – Sampling protocol (beach of Playas). Wooden boxes are in place to hold the upcoming swash. In total, 8 boxes were used (only 4 shown) so 2x4 levels could be secured at the start of a sampling run (see text).



**Picture 2.2.2** – Sampling protocol. Wooden box with sampling frame.

### 2.2.2.3 Laboratory treatment

Samples were sorted for macrofauna and all specimens of *Olivella semistriata* and *Emerita rathbunae* were identified and counted. The sediment grain size distribution between 2 and 850 µm was determined with a laser COULTER LS and classified according to the Wentworth scale (Buchanan, 1984). Coarser sediment (>850 µm) was not present in a sufficient amount to be quantified.

### 2.2.2.4 Statistical analyses

Beach profiles were calculated from the relative height differences, together with tide predictions for the nearby port of La Libertad (San Pedro) or for Data de Posorja (Playas). Lowest swash point at low tide was assumed to be the low water level (Short, 1999) and is referred to as 0 m of elevation. The highest point of the intertidal was the lowest swash level at high tide. Intertidal distance and beach slope were calculated from this highest point and the 0-point.

Beach characterisation was done using two beach indices: 'Beach Index' (BI) and 'Beach Deposit Index' (BDI) (McLachlan and Dorvlo, 2005). These indices were calculated as:

$$BI = \log\left(\frac{Sand \cdot Tide}{Slope}\right)$$

$$BDI = \left(\frac{1}{\tan B}\right)\left(\frac{a}{Mz}\right)$$

where *Tide* is the maximum spring tide range (meters), *Slope* or  $\tan B$  is the beach slope, *a* is 1.03125 (mm), *Mz* is the mean sand particle size (mm) and *Sand* is the mean sand particle size in phi units +1. BI has dimension  $\log \phi \cdot m$ , BDI is dimensionless. Both indices increase from reflective to dissipative conditions.

Population size (i.e. abundance) estimation was done using the IST (individuals per strip transect; ind/m) technique (Defeo, 1996). IST is calculated by multiplying the average sample density (ind/m<sup>2</sup>) by the intertidal width in which the animals occur. The obtained value gives an estimate of the total population size present over the entire intertidal width (cross-shore) when considering one meter of beach length (along-shore).

Since the swash zone widens towards the low tide level on beaches with a concave slope, such as the investigated beaches in this study, using a relative scale for the swash position allows for a better comparison between transects. Relative swash position was calculated from the measured swash position. The zero value indicates the upper swash limit. Negative values represent the level positioned 1-2 m above the upper swash limit. Densities are also expressed in relative numbers in order to facilitate comparison of the density distribution between transects (see Fig. 2.2.3, 2.2.4, 2.2.5 and 2.2.7). Relative densities are in reference to total densities of one transect.

Regression fitting of the swash zonation per transect was done using second order generalized linear models (GLM) with Poisson distribution, log-link function and correction for overdispersion (McCullagh and Nelder, 1989). Dependent variable was the *absolute density*, the *relative swash position* was used as explanatory variable. The Proc Genmod syntax was applied with SAS 9.1.3 software. To identify the average zonation pattern per beach and per species, *transect* was added as random factor.

To compare the swash zonation between beaches (per species), a generalized linear mixed model (GLMM) was computed. *Absolute density* was the dependent variable, *relative swash position* (second order) and *beach* were the independent variables. *Transect* nested in *beach* (*transect(beach)*) was the random factor. The computations were performed with the proc GLIMMIX statement in SAS 9.1.3 (with Poisson distribution and log-link function). Differences in cross-shore zonation of the two species were tested with a GLMM, with *absolute densities* as dependent variables, *cross-shore position*, *species*, *beach* and *species\*beach* as independent variables and *transect(beach)* as random factor. For comparison of the densities of the two species between the two beaches, a non-parametric Mann Whitney-U test was used, after rejecting the assumptions for parametric tests. Statistical analyses were performed using Statistica 6.0 software package (StatSoft, 1996).

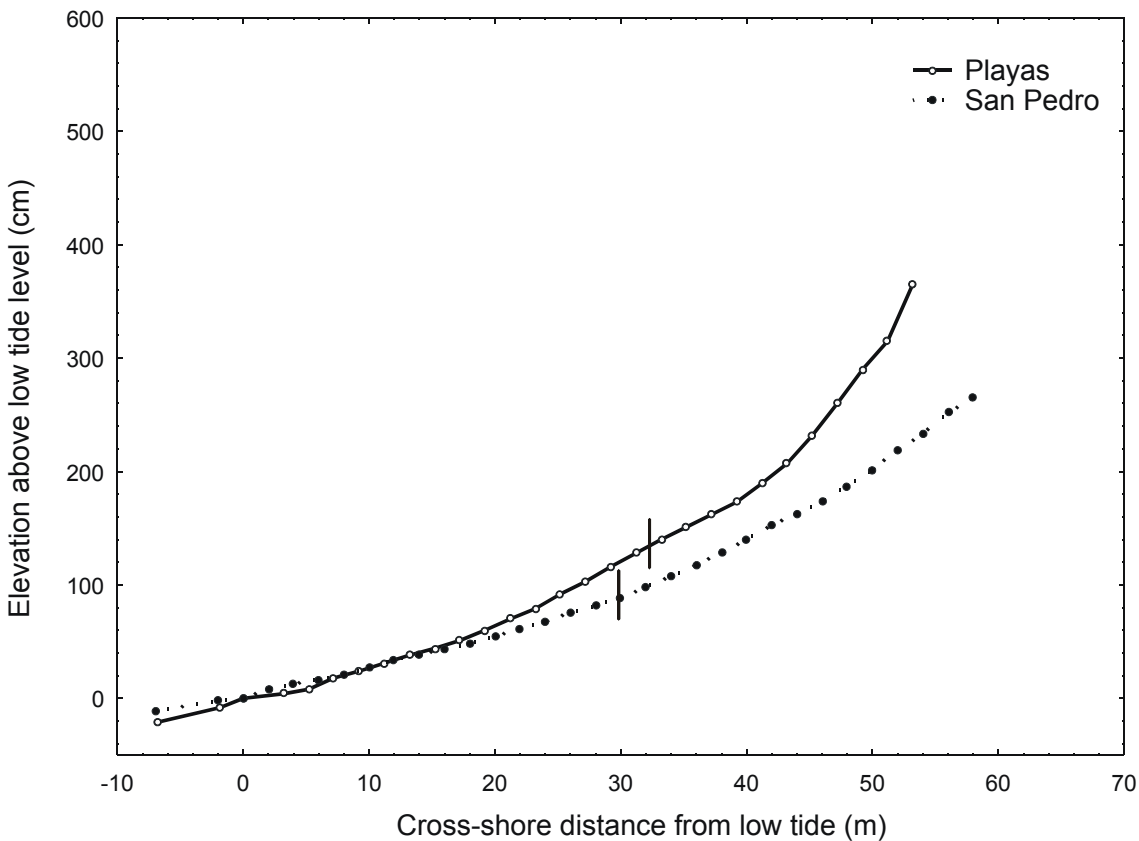
#### **2.2.2.5 Macroscale distribution of the two species**

The density distribution (ind/m<sup>2</sup>) and abundance (ind/m) of *Emerita rathbunae* and *Olivella semistriata* was investigated on seven sandy beaches with contrasting morphodynamics along the Pacific coast of Ecuador. Details about the sampling can be found in Chapter 1. The abundance of both species was expressed in terms of the Beach Index (BI, see Chapter 1) by second order linear regression.

## 2.2.3 Results

### 2.2.3.1 Physical environment

Both the beach at Playas and the beach at San Pedro are exposed sandy beaches with a similar tidal regime. The beach profiles are plotted in Fig. 2.2.2. Playas is the most reflective of the two beaches, with a steeper slope, coarser sediment and lower BI and BDI (Table 2.2.1).



**Fig. 2.2.2** - Beach profiles of Playas and San Pedro. X-axis is intertidal distance from the low tide level; Y-axis indicates elevation above low tide level. Vertical bars mark the high tide level.

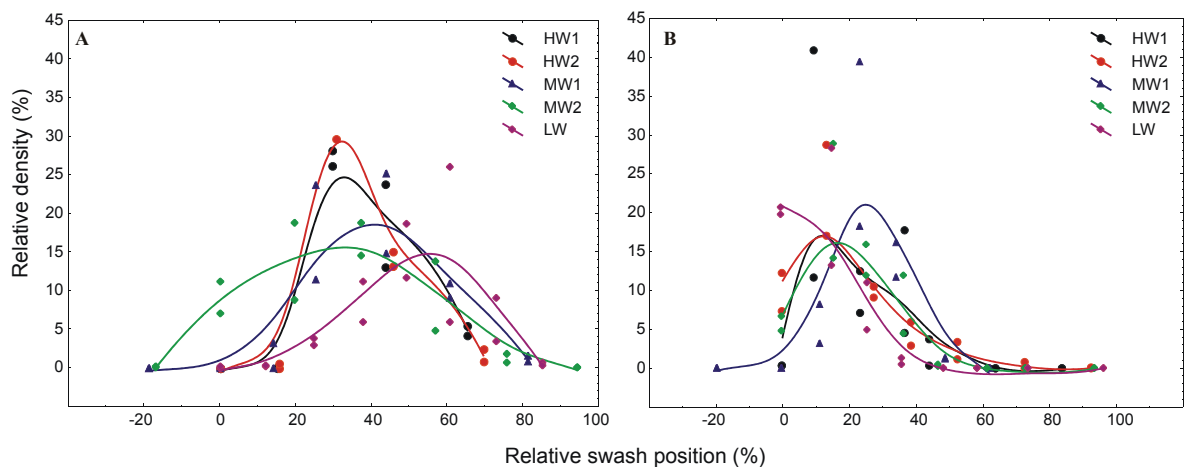
**Table 2.2.1** - Environmental parameters for both investigated beaches. Tidal range is the maximum spring tidal range for the sampling month; wave height and wave period are the average of 11 consecutive waves at low tide; BI is Beach index; BDI is Beach deposit index.

	<b>Intertidal distance</b>	<b>Slope</b>	<b>Median grainsize</b>	<b>Tidal range</b>	<b>Wave height</b>	<b>Wave period</b>	<b>BI</b>	<b>BDI</b>
<b>Playas</b>	31.2 m	1/24	275.3 $\mu\text{m}$	2.69 m	1.0 m	14.5 s	2.27	89.90
<b>San Pedro</b>	30.0 m	1/34	222.4 $\mu\text{m}$	2.74 m	0.8 m	16.5 s	2.47	156.30

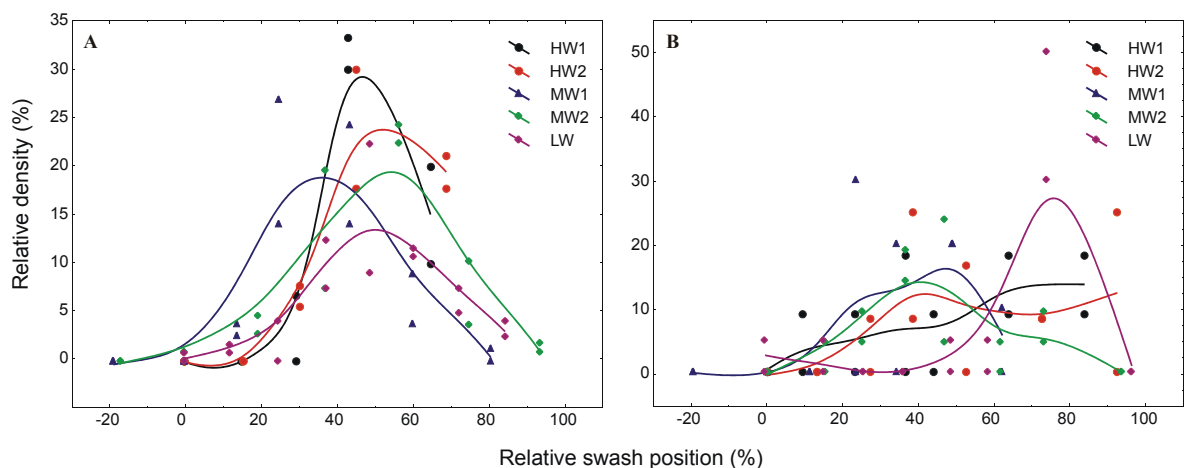


### 2.2.3.2 Swash zonation of *Olivella semistriata* and *Emerita rathbunae*

Swash zonation per sampled transect is presented in Fig. 2.2.3 for *O. semistriata* and in Fig. 2.2.4 for *E. rathbunae*. Both species show a remarkably similar distribution pattern, independent of the beach or tidal state. Densities rise from zero at or just above the upper limit of the swash zone to peak around the middle of the swash (between 8 and 52% of the upper limit for *O. semistriata* and between 38 and 83% for *E. rathbunae*) and drop back to zero towards the surf zone. Except for the low tide transect in San Pedro for *Olivella semistriata*, the distribution curve has a symmetric to negatively skewed unimodal shape. Except for *E. rathbunae* in San Pedro, most second order regressions are significant, with  $\alpha$ -values around 0, positive  $\beta$ -values and negative  $\gamma$ -values (Table 2.2.2), confirming the unimodal shape of the distribution curves. All but two  $\alpha$ -parameters of the total regressions are significant. However,  $\alpha$  does not change the shape of the curve, only the height of the peak.



**Fig. 2.2.3** - Relative densities per swash transect of *Olivella semistriata* plotted against the relative swash position. Fitting by distance weighted least square estimates. A) Playas; B) San Pedro.



**Fig. 2.2.4** - Relative densities per swash transect of *Emerita rathbunae* plotted against the relative swash position. Fitting by distance weighted least square estimates. A) Playas; B) San Pedro.

**Table 2.2.2** - Generalized linear model for density data from Playas and San Pedro. Model structure:  $y = e^{\alpha + \beta \cdot x + \gamma \cdot x^2}$  with y as the swash density and x as the relative swash position. Max (%) is the relative position at which the densities peak.

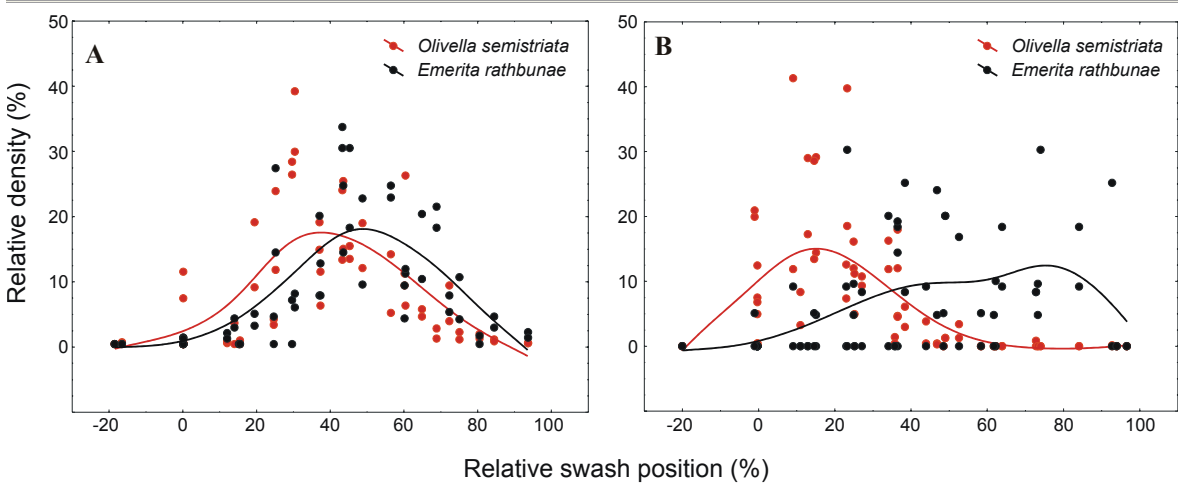
SAN PEDRO								
Transect	$\alpha \pm SE$	$X^2$ (p-level)	$\beta \pm SE$	$X^2$ (p-level)	$\gamma \pm SE$	$X^2$ (p-level)	N Max (%)	
<i>Olivella</i>	HW1	4.95 ± 0.67	54.35 (p<0.0001)	13.77 ± 7.05	3.83 (p=0.0500)	-35.55 ± 16.19	4.82 (p=0.0281)	14 19
	HW2	8.17 ± 2.37	1174.16 (p<0.0001)	3.82 ± 2.37	2.60 (NS)	-14.46 ± 5.09	8.09 (p=0.0045)	14 13
	MW1	3.22 ± 0.78	17.19 (p<0.0001)	36.81 ± 6.19	35.40 (p<0.0001)	-71.32 ± 12.08	34.88 (p<0.0001)	14 26
	MW2	6.62 ± 0.28	540.47 (p<0.0001)	13.43 ± 2.68	25.06 (p<0.0001)	-36.81 ± 6.25	34.65 (p<0.0001)	16 18
	LW	6.80 ± 0.12	3046.89 (p<0.0001)	6.27 ± 2.03	9.54 (p=0.0020)	-40.47 ± 7.64	28.04 (p<0.0001)	16 8
<b>Total</b>	<b>6.85 ± 0.26</b>	<b>708.87 (p&lt;0.0001)</b>	<b>8.78 ± 2.46</b>	<b>12.73 (p=0.0004)</b>	<b>-24.75 ± 5.56</b>	<b>19.82 (p&lt;0.0001)</b>	<b>74</b>	<b>18</b>
<i>Emerita</i>	HW1	0.50 ± 1.08	0.22 (NS)	5.28 ± 4.66	1.28 (NS)	-3.18 ± 4.54	0.49 (NS)	14 83
	HW2	-0.40 ± 1.68	0.06 (NS)	9.42 ± 6.24	2.28 (NS)	-6.92 ± 5.35	1.68 (NS)	14 68
	MW1	-1.86 ± 2.31	0.65 (NS)	23.51 ± 12.17	3.73 (NS)	-28.58 ± 15.18	3.55 (NS)	14 41
	MW1	-0.33 ± 1.23	0.07 (NS)	16.71 ± 5.68	8.65 (p=0.0033)	-18.68 ± 6.25	8.93 (p=0.0028)	16 45
	LW	-1.67 ± 3.21	0.27 (NS)	13.47 ± 10.27	1.72 (NS)	-9.03 ± 7.84	1.33 (NS)	16 75
<b>Total</b>	<b>0.15 ± 0.66</b>	<b>0.05 (NS)</b>	<b>8.90 ± 2.58</b>	<b>11.86 (p=0.0006)</b>	<b>-7.13 ± 2.38</b>	<b>8.95 (p=0.0028)</b>	<b>74</b>	<b>62</b>
PLAYAS								
Transect	$\alpha \pm SE$	$X^2$ (p-level)	$\beta \pm SE$	$X^2$ (p-level)	$\gamma \pm SE$	$X^2$ (p-level)	N Max (%)	
<i>Olivella</i>	HW1	2.51 ± 1.62	2.41 (NS)	28.38 ± 8.22	11.93 (p=0.0006)	-35.41 ± 10.24	11.95 (p=0.0005)	10 40
	HW2	1.37 ± 2.39	0.33 (NS)	37.63 ± 14.01	7.21 (p=0.0072)	-51.62 ± 19.96	6.69 (p=0.0097)	10 36
	MW1	3.94 ± 0.77	26.26 (p<0.0001)	19.82 ± 4.00	24.61 (p<0.0001)	-23.89 ± 4.92	23.59 (p<0.0001)	14 41
	MW2	6.36 ± 0.25	630.53 (p<0.0001)	7.25 ± 1.49	23.69 (p<0.0001)	-12.03 ± 2.22	29.39 (p<0.0001)	14 30
	LW	0.07 ± 1.35	0.00 (NS)	26.08 ± 5.29	24.34 (p<0.0001)	-25.11 ± 5.03	24.84 (p<0.0001)	16 52
<b>Total</b>	<b>4.47 ± 0.50</b>	<b>79.50 (p&lt;0.0001)</b>	<b>16.41 ± 2.63</b>	<b>38.96 (p&lt;0.0001)</b>	<b>-20.87 ± 3.29</b>	<b>40.20 (p&lt;0.0001)</b>	<b>64</b>	<b>39</b>
<i>Emerita</i>	HW1	-9.95 ± 3.18	9.75 (p=0.0018)	58.21 ± 12.84	20.53 (p<0.0001)	-57.17 ± 12.45	21.08 (p<0.0001)	10 51
	HW2	-3.07 ± 1.32	5.39 (p=0.0202)	31.66 ± 5.29	35.81 (p<0.0001)	-28.68 ± 5.02	32.61 (p<0.0001)	10 55
	MW1	1.24 ± 0.72	2.94 (NS)	21.06 ± 4.13	25.99 (p<0.0001)	-27.75 ± 5.51	25.35 (p<0.0001)	14 38
	MW2	1.27 ± 0.67	3.63 (NS)	16.11 ± 2.67	36.36 (p<0.0001)	-15.74 ± 2.56	37.71 (p<0.0001)	14 51
	LW	0.64 ± 0.87	0.55 (NS)	16.87 ± 3.49	23.32 (p<0.0001)	-16.05 ± 3.37	22.70 (p<0.0001)	16 53
<b>Total</b>	<b>0.78 ± 0.54</b>	<b>2.05 (NS)</b>	<b>16.89 ± 2.31</b>	<b>53.39 (p&lt;0.0001)</b>	<b>-16.54 ± 2.34</b>	<b>49.81 (p&lt;0.0001)</b>	<b>64</b>	<b>51</b>

### 2.2.3.3 Comparison between swash and cross-shore zonation of *Olivella semistriata* and *Emerita rathbunae*

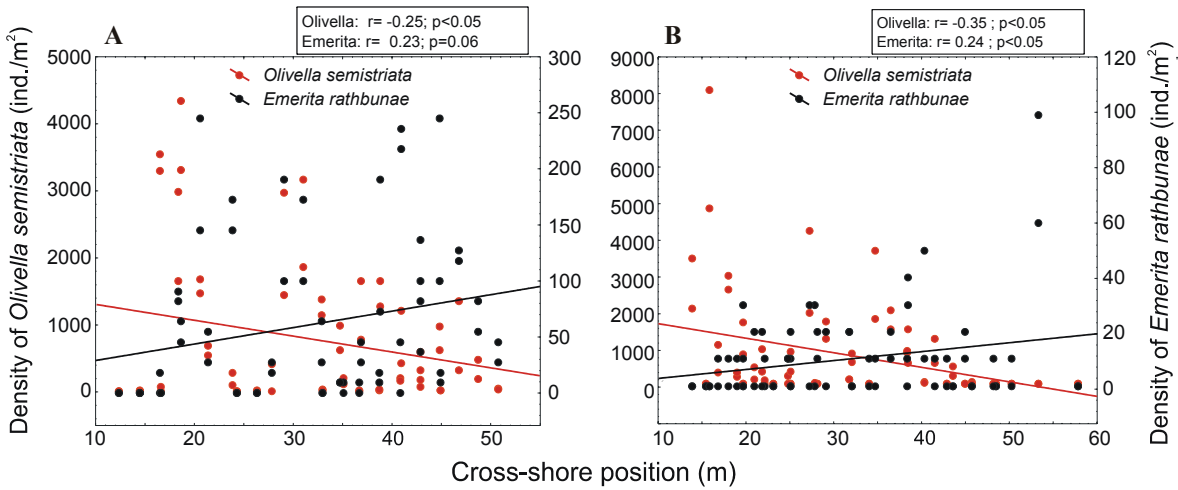
The distribution pattern in the swash of both investigated species was compared for Playas and San Pedro. Fig. 2.2.5a and b shows the average swash zonation curve, in relative numbers, for *O. semistriata* and *E. rathbunae*. Although the shape of the curves is very similar, the peak density of *O. semistriata* occurs higher in the swash than the peak density of *E. rathbunae* for all but one transect (Table 2.2.2).

The cross-shore zonation (presented as the sum of all swash transects over the entire intertidal) is completely the opposite for *O. semistriata* and *E. rathbunae* (Fig. 2.2.6a and b; GLMM:  $DF=263$ ,  $F\text{-value}=55.35$ ;  $p<0.0001$ ). Where *O. semistriata* reaches its highest densities high in the intertidal and significantly drops towards the low intertidal, the densities of *E. rathbunae* gradually increase when moving down-shore; cross-shore pattern was not different between beaches (GLMM:  $DF=8$ ;  $F\text{-value}=0.15$ ;  $p=0.7098$ ).

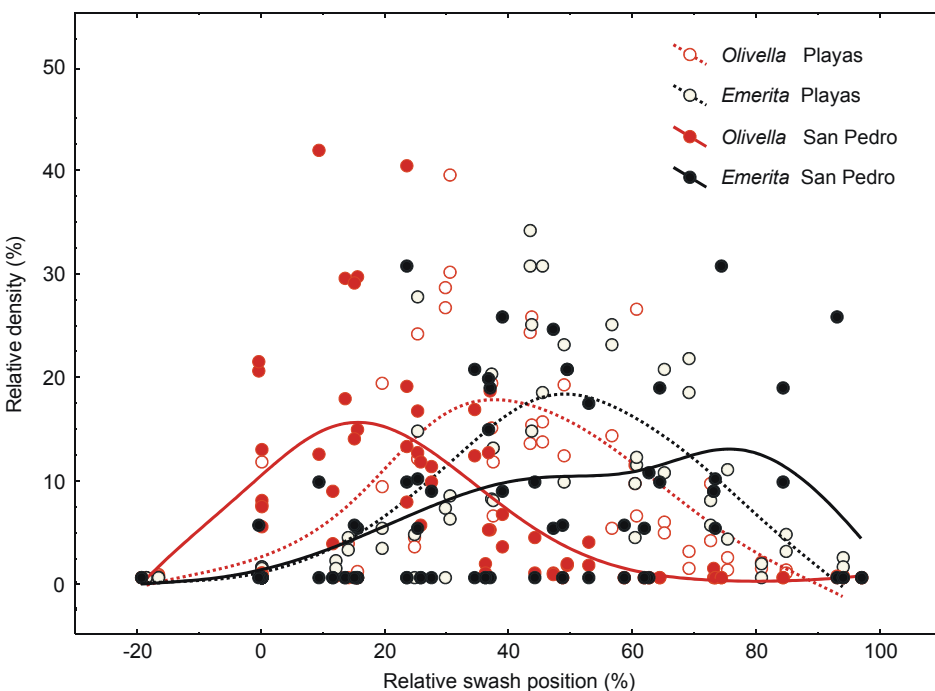
Only very few specimens were found in the three extra samples collected on the air-exposed intertidal at low tide: 0.4 % of the *Emerita rathbunae*-population and 0.0 % of the *Olivella semistriata*-population in Playas, and 0.0 % for *E. rathbunae* and 22.1 % for *O. semistriata* in San Pedro.



**Fig. 2.2.5** - Relative densities of both *Olivella semistriata* (red) and *Emerita rathbunae* (black), pooled per beach and plotted against the relative swash position. Fitting by distance weighted least square estimates. A) Playas; B) San Pedro.



**Fig. 2.2.6** - Cross-shore distribution (absolute densities) of *Olivella semistriata* (red) and *Emerita rathbunae* (black). Position (X-axis) from high beach to low beach. Fitted line is a simple linear regression. A) Playas ; B) San Pedro.



**Fig. 2.2.7** - Relative swash zonation for both species, pooled per beach. Fitting by distance weighted least square estimates.

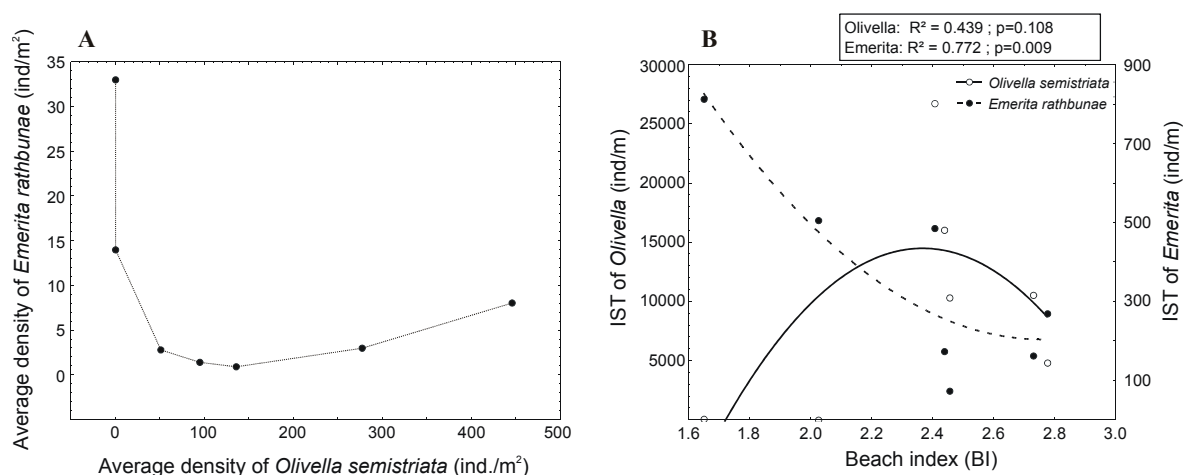


### 2.2.3.4 Comparison between the two study sites

If the average of all swash zonation curves is plotted (Fig. 2.2.7), it can be seen that the peak density of *Olivella semistriata* in San Pedro is positioned higher in the swash than in Playas (15 versus 35 %), whereas the peak for *Emerita rathbunae* is situated more towards the surf in San Pedro (75 versus 45 %). Relative peak densities are also lower for both species in San Pedro. Average density ( $\pm$ SE) of *O. semistriata* does not differ between the two beaches ( $849 \pm 76$  ind/m<sup>2</sup> for Playas compared to  $777 \pm 16$  ind/m<sup>2</sup> for San Pedro; GLMM:  $DF=8$ , F-value=0.77,  $p=0.4049$ ). For *E. rathbunae*, the average density at Playas ( $65 \pm 9$  ind/m<sup>2</sup>) is more than six times higher than at San Pedro ( $10 \pm 2$  ind/m<sup>2</sup>; GLMM:  $DF=8$ , F-value=62.32,  $p<0.0001$ ).

### 2.2.3.5 Occurrence of the two species on seven beaches with different morphodynamics

Seven beaches with different morphodynamics, from highly reflective to almost dissipative, along the Ecuadorian coast were sampled during another campaign. In Fig. 2.2.8a, the average densities of *E. rathbunae* and *O. semistriata* are plotted against each other. Where *O. semistriata* is absent, *E. rathbunae* reaches its highest average densities. Abundance (expressed as ind/m) of *E. rathbunae* drops significantly with increasing BI, although the trend weakens around BI of 2.4 (Fig. 2.2.8b). The opposite is found for *O. semistriata*: at low values of BI, the species is not present. Largest populations are found around a BI of 2.4, but they drop again towards the more dissipative beaches (Fig. 2.2.8b).



**Fig. 2.2.8** - A) Average density per sample for *Olivella semistriata* (X-axis) and *Emerita rathbunae* (Y-axis) on 7 beaches with different morphodynamics. B) Abundance (IST, in ind/m) of *Olivella semistriata* (Y<sub>1</sub>-axis, circles) and *Emerita rathbunae* (Y<sub>2</sub>-axis, filled dots) compared to the Beach Index (BI) of 7 beaches. Lines represent second order linear regressions.

## 2.2.4 Discussion

### 2.2.4.1 Sampling mobile swash fauna

Species showing surfing behaviour on tidal sandy beaches use the swash to migrate up and down the beach (McLachlan and Brown, 2006). When studying the zonation of these surfers, some complications arise which are not encountered for organisms with limited mobility. For those non-surfing species, sampling a transect over the intertidal at low tide should be sufficient (McLachlan and Brown, 2006; Jaramillo *et al.*, 1993). Surfers, however, are more likely to be zoned within the swash, and their high mobility, inherent to their lifestyle, implies some sampling strategy difficulties.

Brown and McLachlan (1990) discussed the problem of sampling highly mobile fauna on exposed sandy beaches and proposed integration of samples over the beach width (IST: individuals per strip transect, as defined by Defeo, 1996) as a tool for comparing whole populations, including mobile fauna, between tidal states, seasons or beaches. This, however, does not solve the problem of how to correctly sample very mobile animals, such as surfers, over a swash transect. When sampling along transects migration of a part of the population to or away from the next sampling point is very likely, leading to an over- or underestimation of the population size.

This methodological trap was acknowledged by Jones *et al.* (1998), stating: '*faunal mobility (...) can pose problems in estimation distribution and abundance. For example, it may cause a single population to be sampled in more than one locality or not sampled at all depending on the spatio-temporal pattern of sampling*'. Their solution comprised the identification of the 'median wave level of the swash' (the median of 10 consecutive swash waves), after which the sampling levels were positioned around this reference point. This way, zonation can be assessed independently of the tidal state or wave regime. Whether this method provides a satisfactory solution to the problem of migration in between the taking of two samples depends on the migration rate of the sampled species and the environmental conditions. It might be appropriate for the species studied by Jones *et al.* (1998), amphipods from the genus *Exoediceros* on sheltered beaches, but it is definitely not suitable for investigating *Olivella semistriata* and *Emerita rathbunae*, the two most important surfers on exposed Ecuadorian sandy beaches. For both species, migration can occur with every wave (Chapter 6). The average wave period is between 14 and 16 seconds, which is much less than the time needed to take one sample. It is therefore impossible to sample a full transect in the swash while excluding the possibility of migration, unless all samples are taken simultaneously. This would require as many people as the number of samples one wants to take. And even then,

working with a frame as sampling device (as in this study and numerous others where low densities are expected; see also McLachlan and Brown, 2006) in the lower swash zone would remain impossible, since the frame has to be fully excavated before it is submerged by a next swash wave.

Hence, there was a need for a new sampling strategy, dealing with both methodological shortcomings discussed above: (1) to have a reference point allowing for comparison independent of the tidal state or wave regime at the time of sampling, and (2) to prevent migration while sampling a transect in the swash. For the first issue, we used a modified version of the idea proposed by Jones *et al.* (1998): instead of monitoring 10 consecutive waves, which proved to be insufficient to deal with the very high variability in swash waves on the investigated beaches, the swash was monitored during ten minutes (i.e. about 40 waves). The most shoreward position reached by a swash wave during this period was used as a reference point for sampling.

To solve the second problem, migration while sampling, we designed wooden boxes (as a protective support for the sampling frames) which were positioned at the different levels, prior to sampling (Fig. 2.2.1). Immediately after placing the boxes, the sampling frames were placed within the boxes and excavated, starting with the lowest swash level. Hence, because of the protective boxes, waves that entered the swash zone while sampling could not reach the sediment of the sampling spots, preventing animals from migrating. Due to the high current speed and impact of waves entering the swash zone at some locations (especially during high tide), sampling in the lowest part of the swash zone was not always possible; the boxes were swept away.

The combination of the swash reference point and the wooden boxes allowed us to sample true snapshot swash transects at different times during the tidal cycle, suitable to analyse possible changes in swash zonation on a circatidal scale.

#### **2.2.4.2 Swash zonation of two surfers on Ecuadorian sandy beaches**

The swash zonation pattern of surfing species *Olivella semistriata* and *Emerita rathbunae* showed a very distinct unimodal curve, with the majority of the population positioned around the middle of the distribution range. This unimodal pattern was found at almost all transects, proving to be independent of the tidal state or sampling location. Similar unimodal distribution curves were found for other sandy beach species, such as the beach clam, *Mesodesma mactroides* (Defeo *et al.*, 1986) and the cirrolanid isopod, *Excirrolana armata* (Defeo and Rueda, 2002).

A unimodal distribution is present where a species is confronted with a gradient from a central source (Whittaker, 1967; Begon *et al.*, 1996). The gradient most likely to cause the unimodal distribution of filter feeding surfers is the backwash feeding time. Since both species use the backwash for filter feeding (with modified antennae for *Emerita*: Caine, 1975; Ruppert and Barnes, 1994; modified tentacles for *Olivella*: own field observations), backwash time in relation to swash interval probably influences their choice of position. Close to the upper swash limit, swash interval is very long and backwash time very short, resulting in few and short feeding opportunities. Moving lower in the swash, swash interval will gradually decrease and backwash time will increase. At a certain point, incoming swash waves will overrun the backwash of the previous wave, reducing feeding time. Hence, we could hypothesize that feeding opportunity follows a unimodal curve over the swash zone, enhancing a similar distribution pattern for mobile sandy beach filter feeders. Although swash width varies with tide (because of the concave beach slope), we could assume that the relative feeding opportunity pattern remains constant, explaining the similar distribution curve of both surfing species at different tidal states.

In Playas, 0% of the *Olivella*-population and 0.4% of the *Emerita*-population was found on the part of the intertidal that was not covered by the swash at low tide. In San Pedro, these numbers were 22.1% (of which all but one individual at the same level) for *Olivella* and 0% for *Emerita*. This suggests that both species are very efficient surfers, and the numbers are comparable to what McLachlan *et al.* (1979) found for *Bullia digitalis*, although an earlier study reported only 12% of this species' population to be surfing down the beach (Brown, 1971). Brown *et al.* (1989) ascribe this high variability in surfing success to factors such as the nutritional state of the animals, food availability, beach slope and wave action.

#### **2.2.4.3 Comparison of zonation patterns in *Olivella semistriata* and *Emerita rathbunae***

As discussed above, the swash zonation curve of both species is roughly the same, yet peak densities on both beaches occur higher in the swash for *Olivella semistriata* than for *Emerita rathbunae*. On a cross-shore scale, highest numbers of the snail are found around high tide, whereas for the mole crab densities increase towards the subtidal. In San Pedro, the more dissipative beach, peak densities of the two species are further apart than in Playas. Because of the low densities of *E. rathbunae* in San Pedro, this observation should be treated with caution.

A possible explanation for the differences in peak density distribution and different cross-shore zonation patterns could be that these species, where occurring on one beach, try to avoid competition for a common source: backwash feeding opportunities. Using the hypothesis stated earlier, this would imply that *O. semistriata* and *E. rathbunae* use the shared source in a different way, resulting in a shifted unimodal distribution curve of the feeding time and thus densities in the swash zone. The mole crab, living lower in the swash, should therefore be adapted to the stronger swash conditions of the lower swash zone (Short, 1999): faster backwash current speeds to feed upon and less time between waves to burrow after surfing.

The burrowing rate of *Emerita* species was found to be amongst the fastest ever recorded for any sandy beach species (Ansell and Trueman, 1973; Dugan *et al.*, 2000; Lastra *et al.*, 2004): adult crabs of *Emerita analoga* have shown to burrow in less than 4 s and small animals as fast as 0.3 s. No data exist for *E. rathbunae*, but all species of the genus are very similar, so we can assume that *E. rathbunae* is a very fast burrower as well. From field observations and laboratory experiments, we know that the burial time of *O. semistriata* is much slower, ranging from 4 to 15 s (Chapter 4). In general, molluscs have a much lower burrowing rate than crustaceans (McLachlan and Brown, 2006; Chapter 4). These observations support our hypothesis that *E. rathbunae* is adapted to live under harsher swash conditions, such as low in the swash, than *O. semistriata*.

Further evidence comes from the swimming ability of both species. *Emerita* is known to be a very good swimmer and surfing is - at least partially - an active movement (Cubit, 1969). The surfing of *Olivella semistriata* is merely a passive floating in the swash, only enhanced and possibly controlled by extending the wing-like flaps of the metapodium (Olsson, 1956; Chapter 6). The mole crab will therefore have a better control over its surfing in the lower and harsher swash zone, a mandatory capacity for keeping position with the changing tide.

Although no empirical data exist, we also noted that the feeding habit and apparatus of *Emerita* seems more suitable for filter feeding at higher backwash speeds. For instance, *Emerita* burries itself seaward (Caine, 1975), with the feeding structures (second antennae) following the current. *Olivella semistriata* buries shoreward (own field observations), so the feeding structures (mucous net hanging between the tentacles) have to be directed against the backwash current.

It should be noted that the data presented here were sampled on two days during the same season. Zonation, however, is known to vary in time (Brazeiro and Defeo, 1996; Gimenez and Yannicelli, 1997) and Dugan *et al.* (2004) showed that the relative

distribution of two species (the beach clam *Mesodesma donacium* and the mole crab *Emerita analoga*) can also be highly variable. Contrary to our findings, they also described a circatidal shift in relative zonation of the two investigated species. Where we worked with two true swash species, *Mesodesma donacium* does not show consistent tidal migrations, which probably explains why the relative position of *M. donacium* and *E. analoga* changes with the tide (see Fig. 2.2.5 in Dugan *et al.*, 2004).

#### 2.2.4.4 Distribution on the macroscale

The hypothesis that *Emerita rathbunae* is better adapted to the harsher conditions of the lower swash zone than *Olivella semistriata* could be further extended to the spatial distribution of both species on the macroscale. To test this, seven beaches along the Ecuadorian coast from a range of morphodynamic states were sampled for macrofauna. Both *E. rathbunae* and *O. semistriata* were dominant species, the former occurring on all beaches, the latter on all but two beaches.

It is very clear that where the snail is absent, the mole crab reaches its highest average densities. Remarkable is that the beach with the highest densities of *O. semistriata* also has reasonable densities of *E. rathbunae*, suggesting both species are not avoiding each other entirely. Population size of *E. rathbunae* drops significantly with increasing BI, although the trend weakens around BI of 2.4. The opposite is found for *O. semistriata*: at low values of BI, the species is not present. Largest populations are found around a BI of 2.4, but densities drop again towards the more dissipative beaches.

Obviously, the mole crab is able to colonize reflective beaches, but is present throughout the whole morphodynamic range. As previous research has shown, *Emerita*-species are sediment generalists (Dugan *et al.*, 2000; Jaramillo *et al.*, 2000a) and dominate in reflective conditions (Dugan and Hubbard, 1996). *Olivella semistriata* is completely absent from beaches with coarse sediment and steep slopes. Where *Emerita* can survive on beaches with very harsh swash conditions, *Olivella* is clearly incapable of coping with very reflective conditions. This is in accordance with the predictions from the swash exclusion hypothesis (McLachlan *et al.*, 1993) which says that many macrofaunal taxa, especially molluscs (McLachlan *et al.*, 1995), are excluded for reflective beaches because of the harsh swash conditions.

It is interesting to note that populations of especially *O. semistriata* decrease once conditions are too dissipative. This is probably due to the large beach and swash width at those beaches: i.e. when the ratio 'feeding / migrating to maintain position' becomes too

small, surfing behaviour seems to be a less successful strategy. In some cases, swash conditions at dissipative beaches might also be too gentle to be used for surfing (Cubit, 1969).

#### **2.2.4.5 Swash exclusion**

As discussed in the previous section our findings on the macroscale are supported by the predictions of the swash exclusion hypothesis (McLachlan *et al.*, 1993). Where the swash exclusion hypothesis was intended to describe the distribution patterns of species along the range of beach types, swash exclusion can also be extended to a smaller spatial scale (i.e. the microscale): within the swash zone swash conditions become harsher from the upper to the lower swash limit. The observation that the mole crab *Emerita rathbunae*, dominating on reflective beaches under harsh swash conditions, lives lower in the swash under more benign conditions than *Olivella semistriata*, supports the idea of swash conditions as a limiting factor in the distribution of species, both on a large and small spatial scales. As such, this is an interesting addition to the original concept of swash exclusion.

#### **2.2.4.6 Implications for interpreting zonation data**

In this study, we have demonstrated the existence of a clear zonation pattern of surfing species on a very small cross-shore scale, i.e. the swash zone. Almost the entire population can be concentrated in the 10 to 15 m of the swash zone at any time of the tidal cycle (e.g. Playas). It is obvious that, when one wants to study populations of surfers, the swash zone should be sampled carefully and extensively. However, when a beach is sampled for all macrofauna, as is the case in many studies, the presence of surfers should be checked. If present, at least two, but preferably more, swash levels should be sampled.

Since the distribution pattern of the investigated species follows a unimodal pattern within the swash, high densities are only present in a very narrow band. Thus, when too few swash levels are sampled, it is very likely that no levels are sampled in this narrow densely populated zone, resulting in an underestimation of the population size. On the other hand, when the receding tide is followed as a sampling strategy (Addendum 1; Degraer *et al.*, 1999, 2003), the same population of surfers could be sampled several times, overrating the population size. Both obstacles should be considered when interpreting existing data on sandy beach macrofaunal zonation.



### 2.2.5 Conclusions

- 1) By monitoring the swash limits for 10 minutes, a reference point relative to the swash and independent of the beach or tidal state can be obtained. This is necessary to sample swash zonation.
- 2) Placing the sampling device within protective boxes allows for sampling a true snapshot.
- 3) *Olivella semistriata* and *Emerita rathbunae*, the most common surfers from Ecuadorian sandy beaches, show a very similar swash zonation patterns. This patterns has a unimodal shape and remains almost unvaried throughout the tidal cycle.
- 4) Peak density of *O. semistriata* is found higher in the swash than peak density of *E. rathbunae*. It seems that the latter species is better adapted to harsh swash conditions than the former species.
- 5) This is confirmed by the macroscale distribution: *E. rathbunae* is very abundant on reflective beaches, where *O. semistriata* is completely absent.



## CHAPTER 3

### SIZE DISTRIBUTION OF THE SURFING GASTROPOD

### *OLIVELLA SEMISTRIATA* ALONG A CROSS-SHORE

### GRADIENT IN AN ECUADORIAN SANDY BEACH

---

Vanagt T., Vincx M., Degraer S.

Submitted to *Estuarine Coastal Shelf Sciences*

Keywords: *Olivella semistriata*, surfing, swash riding, zonation, Ecuador, sandy beach.

## Abstract

The gastropod *Olivella semistriata* is by far the most dominant taxon on mesotidal, intermediate sandy beaches in Ecuador. Its surfing behaviour, in which the snails follow the swash with the tide, makes it very difficult to determine the distribution pattern of this species. In this paper, transect sampling of the swash at different stages in the tidal cycles and at both upcoming and falling tide was used to obtain swash and cross-shore zonation patterns of *O. semistriata*. The swash zonation showed a uniform unimodal curve, independent of the tidal state and of ebb sampling or flood sampling. Maximum densities were typically found in the upper half of the swash zone. Although the swash zonation pattern did not change towards the low intertidal, densities dropped dramatically. A large part of the population, mainly small individuals, remained stranded on the dry intertidal. Hence, there was a clear increase in shell length towards the subtidal, with only animals larger than 4 mm on the low beach. The same trend of increasing length was also found within the swash: the closer to the surf, the larger the snails.

Along with density data, biomass distribution was calculated. This allowed for population size estimation in terms of both abundance and biomass. Therefore, two measures were compared: IST (individuals per strip transect) and IPE (integration population size estimation). Although no significant differences were found, IPE is proposed as the more precise approach. With abundance values of up to 96257 ind./m beach length, *Olivella semistriata* seems to be an extremely abundant species for sandy beaches.

### 2.3.1 Introduction

Surfing or swash-riding is a behaviour in which animals use the swash to migrate over the beach face. Several molluscs, such as beach clams of the genus *Donax* (Eilers 1995a) and whelks of the genus *Bullia* (Trueman and Brown, 1976; Brown, 2001), as well as crustaceans, mainly mole crabs of the genera *Emerita* (Cubit, 1969), *Hippa* (Lastra *et al.*, 2002) and *Lepidopa* (Dugan *et al.*, 2000), have developed adaptations to surfing. Filter feeders (e.g. *Donax*, mole crabs) use surfing to find optimal feeding conditions in the swash; *Bullia* rides swash waves in pursuit of its prey (Brown, 2001). They all share several characteristics: (1) they actively emerge from the sediment; (2) they ride the swash - uprush when migrating upshore and backwash when migrating downshore - in a mainly passive though (partially) controlled way; and (3) they are fast burrowers.

*Olivella semistriata* is a dominant surfing species on exposed Ecuadorian sandy beaches (Chapter 1, Addendum 1): they actively crawl out of the sediment, float with the swash, using their extended metapodium to control the movement (Olsson, 1956; Chapter 6), and actively burrow after surfing. The backwash is filtered by use of a mucus net between the extended tentacles. Extensive field observations have shown that *O. semistriata* surfs in a similar way as other filter feeders such as *Donax* (Eilers, 1995a) and *Emerita* (Cubit, 1969; Caine, 1975), but to date detailed information about its behaviour and distribution are lacking.

Where present, the species is very prominent on the beach, densely packed in a narrow band at the upper swash zone. However, the surfing behaviour of *Olivella semistriata*, with the population shifting cross-shore with the tide, makes it very difficult to identify its zonation pattern as well as to estimate its population size. A strategy to sample the swash zonation of surfing species was described in Chapter 2. Instead of working with transects mapped out over the entire intertidal, for studying surfers a swash zone transect is used. To ensure no migration takes places while sampling one transect, wooden boxes are placed at each level prior to sampling (see also Material & Methods and discussion of Chapter 2).

Where the previous study in Chapter 2 focused on how to sample swash zonation, with the surfers *Olivella semistriata* and *Emerita rathbunae* as examples, the present study aims to identify in detail the zonation patterns of *O. semistriata* in the swash zone and over the full intertidal width (cross-shore) during both rising and falling tide. If assumed that swash zonation is caused by feeding conditions (Chapter 2), we expect to find a similar swash zonation pattern at any time of the tidal cycle. Also zonation by size, well described for rocky intertidal shores (Vermeij, 1972), was investigated. The

hypothesis was that smaller specimens live higher in the swash, where swash conditions are physically less stressful.

In general macrofauna on sandy beaches are rather inconspicuous. *Olivella semistriata*, however, is very noticeable in its behaviour, and the very dense band of snails in the swash tends to label the species as dominant. The detailed swash zonation, in combination with the length data, allowed us to estimate the population size in both numbers and biomass, and thus validate the prediction that *O. semistriata* is a very abundant and dominant species for sandy beaches.

## **2.3.2 Material and Methods**

### **2.3.2.1 Study site and period**

The study site was the sandy beach of San Pedro de Manglaralto, Ecuador (1°59'S and 80°45'W). This beach is dominated by *Olivella semistriata* (Chapter 1; Addendum 1) and can be considered representative for reflective to intermediate, exposed beaches in Ecuador (Chapter 1). The tidal regime is semi-diurnal, mesotidal (Davies, 1964), and ranges between 1.0 and 2.6 m. Modal breaker height varies from 0.1 to 2.0 m (average = 0.49 m), with a wave period of about 14 s. In Addendum 1 we found  $\Omega$ -values around 1.5 for this beach, with a RTR of 5.3, classifying the beach as a low tide terrace and rip, reflective to intermediate beach (Masselink and Short, 1993; Short 1996). The beach is, using the scale of McLachlan (1980), 'exposed'.

### **2.3.2.2 Sampling strategy**

Two samplings took place: one during ebb and one during flood tide. The sampling with falling tide (further referred to as 'ebb sampling') took place on August 23<sup>rd</sup> of 2003, with upcoming tide ('flood sampling') on August 27<sup>th</sup> of 2003. Given the time needed to sample half a tidal cycle (around 7 hours) and the short daytime in Ecuador (11 hours), ebb and flood sampling could not be done on the same day. Per sampling, 3x2 transects over time were sampled: two at high tide (HW1 and HW2), two at mid tide (MW1 and MW2) and two at low tide (LW1 and LW2; one at low tide on August 23<sup>rd</sup>: LW). Each transect consisted of 5-8 sampling levels in the swash and one level 1-2 m above the upper swash limit. The levels in the swash were placed at 1 to 3 m intervals between the upper and lower part of the swash. At low tide, 4 (August 23<sup>rd</sup>) and 10 (August 27<sup>th</sup>) extra levels were sampled between the upper swash limit at low tide and the high tide mark, on

the drying part of the intertidal. Before setting out the position of the levels, the swash was monitored during 10 minutes to find the upper and lower swash limit (Chapter 2).

At each level, three replicate samples were taken by forcing a plastic core with 10 cm diameter (sampling surface area: 0.0079 m<sup>2</sup>) to a depth of 15 cm. Preliminary trials proved this to be an adequate sampling technique for *Olivella semistriata* (Vanagt, unpublished data). To prevent migration of *O. semistriata* during sampling of a transect, levels were sheltered by placing a wooden box (plywood, 100 x 50 x 50 cm l x h x w) at each level. For more details about the use of these wooden boxes and the sampling procedure, see Chapter 2. The samples were sieved alive over a 1 mm mesh-sized sieve; the retained organisms were stored in an 8 % formaldehyde-seawater solution.

One sediment sample was collected at each level for grain size analysis, using a core with diameter of 3.6 cm, to a depth of 5 cm. Beach profile was assessed using a leveller, taking measurements every 2 meter.

### 2.3.2.3 Laboratory treatment

*Olivella semistriata* specimens were counted. A minimum of 50 specimens per sample were measured to the nearest 0.05 mm shell length (SL = base of mouth to apex) using callipers.

The sediment grain size distribution between 2 and 850 µm was determined with a laser COULTER LS (volume percentage of sediment grain size classes) and classified according to the Wentworth scale (Buchanan, 1984).

### 2.3.2.4 Biomass / Length regression

Length scale between 2 mm and 13.5 mm was divided in 0.5 mm intervals. Per interval, the biomass of 2 – 18 specimens (depending on availability; n = 209) was measured. Animals were dried at 110 °C for 18 hours, weighed (DW), burned at 550 °C for 2 hours and weighed again for shell dry weight (SDW). Ash-free dry weight (AFDW) was calculated as DW – SDW.

Polynomial regression (4<sup>th</sup> order) of the data resulted in the following equation (p<0.0001; r<sup>2</sup>=0.9970):

$$\text{AFDW (mg)} = 1.2238 - 8.8625 \cdot \text{SL (mm)} + 26.8964 \cdot \text{SL}^2 - 25.1324 \cdot \text{SL}^3 + 13.8039 \cdot \text{SL}^4$$

### 2.3.2.5 Statistical analyses

Beach profiles were calculated from the relative height differences between levels, together with tide predictions for the nearby port of La Libertad. Lowest swash point at low tide was assumed to be the low water level (Short, 1999) and is referred to as 0 m of elevation. Highest point of the intertidal was the lowest swash level at high tide. Intertidal distance and beach slope were calculated from this highest point and the 0-point.

Since the swash zone widens towards the low tide level on beaches with a concave slope, such as the investigated beach, using a relative scale for the swash position allows for a better comparison between transects. Relative swash position was calculated from the measured swash position. The zero value indicates the upper swash limit. Negative values represent the level positioned 1-2 m above the upper swash limit. Densities are also expressed in relative numbers in order to facilitate comparison of the density distribution between transects. Relative densities are in reference to total densities of one transect.

Regression fitting of the swash zonation was done using second order generalized linear models (GLM) with Poisson distribution, log-link function and correction for overdispersion (McCullagh and Nelder, 1989). Dependent variable was the *absolute density* of *Olivella semistriata*, with *relative swash position* as explanatory variable. The Proc Genmod syntax was applied with SAS 9.1.3 software.

Two methods to estimate the total population size (i.e. abundance in ind/m) were used and compared. The first method is the calculation of densities per running meter based on the average density and the transect width (IST: individuals per strip transect; Defeo 1996). The second method, introduced in this paper, uses integration of the separate pieces of the distribution curves (IPE: integrated population estimate). Calculations were made for the high water transects and for the sum of the air-exposed intertidal and low water transects.

Differences in shell length between the dry beach samples and the swash samples were tested with a Generalized Linear Mixed Model (GLMM), with *shell length* as dependent variable in function of *cross-shore position* and *dry beach/swash* as predictors and *transect* as random factor (McCullagh and Nelder, 1989). Pairwise comparison between IST and IPE-estimation and between the high tide vs. 'dry beach + LW' was done with the t-test for dependent samples (Zar, 1999). The relation between shell length and swash position or cross-shore position was tested with first-order linear regression. For non-linear fitting, distance weighted least square estimates were used (Statsoft, 1996).

## 2.3.3 Results

### 2.3.3.1 Beach characterisation

The sediments consisted of well-sorted fine to very fine sands, with an average median grain size of 217  $\mu\text{m}$  (191 – 254  $\mu\text{m}$ ). There was no zonation in sediment particle size. Intertidal distance was 32 m on the 23<sup>rd</sup> of August (ebb sampling) with a tidal range of 1.0 m, and 60 m on the 27<sup>th</sup> of August (flood sampling) with a tidal range of 1.7 m. The beach slope was 1/32 during ebb sampling, 1/35 during flood sampling (Fig 2.3.8).

### 2.3.3.2 Densities: zonation in the swash

As shown in Fig. 2.3.1a (ebb sampling) and 2.3.1b (flood sampling), there is a remarkable similarity in distribution pattern amongst the different transects. Except for two transects during ebb sampling (LW and MW1) the shape of the distribution pattern is consistently a symmetric to slightly negatively skewed unimodal curve, with densities peaking between 18 and 45% of the swash position (Table 2.3.1; except for flood sampling MW2, which peaks at 9%, and the non-significant LW curve). Around 30% of the sampled animals are found at the peak (with a highest average density of over 25,000 ind./m<sup>2</sup> at high tide during the ebb sampling). GLM parameters are very similar for all transects, with positive  $\alpha$  and  $\beta$  and negative  $\gamma$  (all significant), with ebb LW as the only exception (Table 2.3.1). These values confirm the unimodal shape of the density curves.

### 2.3.3.3 Densities: cross-shore change in zonation

Figures 2.3.2a (ebb sampling) and 2.3.2b (flood sampling) clearly demonstrate that only part of the population migrates downshore (see dotted lines). Especially during the ebb sampling, densities dramatically drop after high tide, with even lower densities at low tide. The high numbers that are not migrating downshore, are mainly found again just below the high tide position (dry beach transects in Fig. 2.3.2a and 2.3.2b). Note the big difference in peak density between transects sampled at similar tidal position ('a' versus 'b' transects).

**Table 2.3.1** - Generalized linear model for density and biomass data. Model structure:  $y = e^{\alpha + \beta \cdot x + \gamma \cdot x^2}$  with y as the (absolute) swash density or biomass and x as the relative swash position. \* indicates where a third order model was more appropriate. Max (%) is the relative swash position at which the density or biomass was maximal.

Transect	$\alpha \pm SE$	$X^2$ (p-level)	$\beta \pm SE$	$X^2$ (p-level)	$\gamma \pm SE$	$X^2$ (p-level)	N	Max (%)
<b>DENSITY</b>								
<b>Ebb</b>								
HW1	7.57 ± 0.34	504.49 (p<0.0001)	13.81 ± 2.93	22.21 (p<0.0001)	-31.04 ± 6.26	24.63 (p<0.0001)	27	22
HW2	5.00 ± 0.65	59.48 (p<0.0001)	30.14 ± 4.01	56.57 (p<0.0001)	-46.08 ± 6.03	58.49 (p<0.0001)	30	33
MW1	7.11 ± 0.25	809.13 (p<0.0001)	7.08 ± 2.44	8.44 (p=0.0037)	-20.13 ± 4.81	17.54 (p<0.0001)	24	18
MW2	4.13 ± 0.69	35.75 (p<0.0001)	10.72 ± 3.49	9.46 (p=0.0021)	-11.97 ± 4.05	8.74 (p=0.0031)	24	45
Lw *	6.17 ± 0.27	527.98 (p<0.0001)	-7.40 ± 3.29	5.03 (p=0.0249)	5.50 ± 5.71	0.93 (NS)	19	-20 *
<b>Total</b>	<b>6.38 ± 0.42</b>	<b>230.14 (p&lt;0.0001)</b>	<b>16.92 ± 3.08</b>	<b>30.16 (p=0.0002)</b>	<b>-30.29 ± 5.37</b>	<b>31.77 (p&lt;0.0001)</b>	<b>124</b>	<b>28</b>
<b>Flood</b>								
HW1	6.20 ± 0.54	131.67 (p<0.0001)	18.17 ± 4.63	15.37 (p<0.0001)	-36.94 ± 9.36	15.56 (p<0.0001)	21	25
HW2	7.86 ± 0.49	255.01 (p<0.0001)	7.64 ± 3.75	4.15 (p=0.0417)	-15.87 ± 6.46	6.03 (p=0.0141)	21	24
MW1	3.88 ± 0.81	23.23 (p<0.0001)	25.74 ± 5.94	18.80 (p<0.0001)	-46.39 ± 10.43	19.77 (p<0.0001)	24	28
MW2	7.93 ± 0.20	1594.48 (p<0.0001)	17.89 ± 3.85	21.62 (p<0.0001)	-95.29 ± 16.98	31.51 (p<0.0001)	18	9
LW1	5.31 ± 0.39	188.17 (p<0.0001)	16.55 ± 3.13	28.01 (p<0.0001)	-32.45 ± 5.89	30.35 (p<0.0001)	21	26
LW2	4.72 ± 0.49	94.04 (p<0.0001)	18.94 ± 4.62	16.83 (p<0.0001)	-44.07 ± 10.41	17.93 (p<0.0001)	21	21
<b>Total</b>	<b>7.02 ± 0.26</b>	<b>735.34 (p&lt;0.0001)</b>	<b>8.13 ± 2.27</b>	<b>12.86 (p=0.0003)</b>	<b>-18.59 ± 4.42</b>	<b>17.66 (p&lt;0.0001)</b>	<b>124</b>	<b>22</b>
<b>BIOMASS</b>								
<b>Ebb</b>								
HW1	10.93 ± 0.43	632.45 (p<0.0001)	13.80 ± 3.79	13.25 (p=0.0003)	-31.12 ± 8.11	14.72 (p=0.0001)	27	22
HW2	8.17 ± 0.72	129.02 (p<0.0001)	30.07 ± 4.18	51.76 (p<0.0001)	-43.28 ± 5.90	53.87 (p<0.0001)	30	35
MW1	11.37 ± 0.23	2439.38 (p<0.0001)	7.18 ± 2.38	9.09 (p=0.0026)	-21.55 ± 4.90	19.38 (p<0.0001)	24	17
MW2	6.55 ± 0.87	56.79 (p<0.0001)	16.23 ± 3.97	16.75 (p<0.0001)	-16.80 ± 4.27	15.52 (p<0.0001)	24	48
Lw *	10.20 ± 0.32	1040.51 (p<0.0001)	-5.69 ± 4.67	1.48 (NS)	-0.24 ± 9.77	0.00 (NS)	19	-20 *
<b>Total</b>	<b>10.16 ± 0.38</b>	<b>728.73 (p&lt;0.0001)</b>	<b>14.10 ± 2.67</b>	<b>27.83 (p=0.0025)</b>	<b>-24.72 ± 4.51</b>	<b>29.99 (p&lt;0.0001)</b>	<b>124</b>	<b>29</b>
<b>Flood</b>								
HW1	9.04 ± 0.64	200.32 (p<0.0001)	21.32 ± 4.73	20.30 (p<0.0001)	-37.55 ± 8.42	19.91 (p<0.0001)	21	29
HW2	11.09 ± 0.55	404.24 (p<0.0001)	7.06 ± 3.82	3.41 (NS)	-12.04 ± 5.99	4.04 (p=0.0444)	21	29
MW1	2.09 ± 2.61	0.64 (NS)	61.18 ± 17.84	11.75 (p=0.0006)	-99.72 ± 29.01	11.81 (p=0.0006)	24	31
MW2	11.06 ± 0.27	1690.28 (p<0.0001)	25.82 ± 4.63	31.06 (p<0.0001)	-113.09 ± 18.67	36.68 (p<0.0001)	18	11
LW1	9.41 ± 0.43	488.85 (p<0.0001)	16.33 ± 3.34	23.86 (p<0.0001)	-30.98 ± 6.12	25.65 (p<0.0001)	21	26
LW2	8.50 ± 0.60	200.20 (p<0.0001)	17.37 ± 5.38	10.41 (p=0.0013)	-38.08 ± 11.41	11.15 (p=0.0008)	21	23
<b>Total</b>	<b>10.40 ± 0.28</b>	<b>1430.12 (p&lt;0.0001)</b>	<b>8.90 ± 2.21</b>	<b>16.14 (p&lt;0.0001)</b>	<b>-17.60 ± 4.01</b>	<b>19.29 (p&lt;0.0001)</b>	<b>124</b>	<b>25</b>



#### 2.3.3.4 Length distribution: zonation in the swash and cross-shore zonation

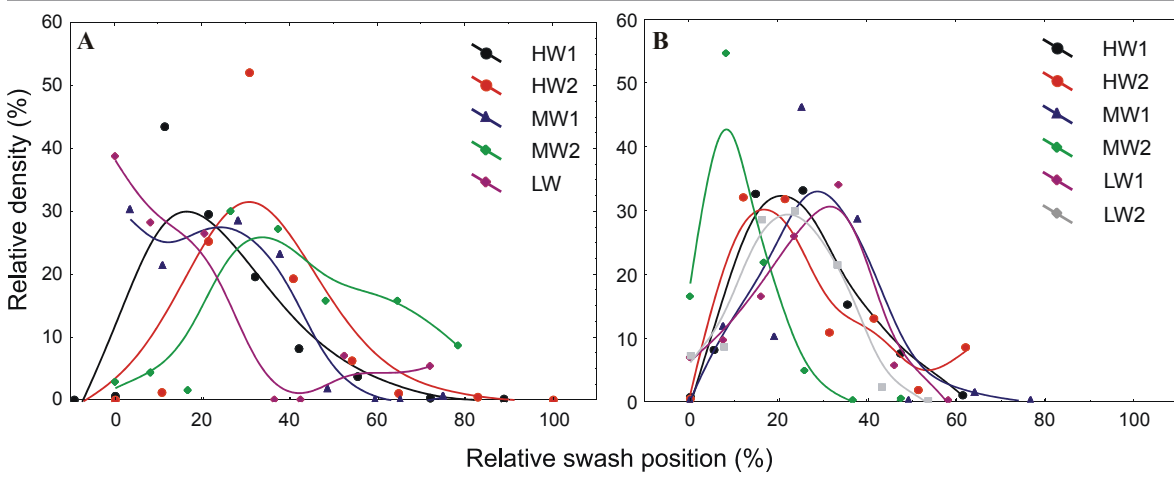
Only two ebb sampling (HW2 and MW2) transects showed a significant relationship between shell length and distance: both indicated an increase in length from high to low swash (Fig. 2.3.3a). However, during flood sampling, there was a significant increase in length from high to low swash for all six transects (Fig. 2.3.3b). Furthermore, moving downshore seems to correspond to an increase in shell length. Indeed, Fig. 2.3.4a (ebb sampling) and 2.3.4b (flood sampling) show a significant increase of average shell from the high to the low intertidal. This increase is clearly caused by the reduction in number of small individuals, with no change in maximum shell length (Fig. 2.3.4a and b). It can easily be seen that no shells smaller than 4 mm are found at low tide (Fig. 2.3.3b).

Comparing the average shell length within the swash zone and on the air-exposed intertidal, both cases show a significant increase towards the low tide level (Fig. 2.3.5a and b). The average shell length is significantly lower on the air-exposed intertidal than in the swash (Flood sampling: 5.9 mm vs. 4.7 mm; GLMM:  $DF=117$ ,  $F=5.24$ ,  $p=0.0239$ ; Ebb sampling: 5.7 mm vs. 4.6 mm; GLMM:  $DF=99$ ,  $F=13.34$ ,  $p=0.0004$ ).

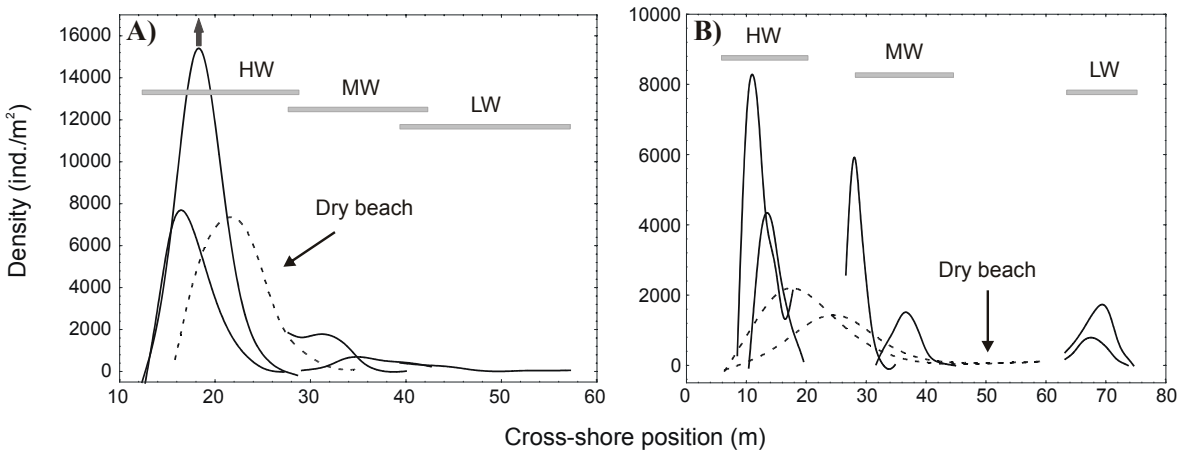
#### 2.3.3.5 Biomass: zonation in the swash and cross-shore zonation

Swash zonation of *Olivella semistriata* in terms of densities has a very distinct pattern. There is, however, a clear zonation in size as well. Since biomass data are calculated from shell length, a different zonation pattern is expected for biomass than for densities. However, very similar trends were found for biomass as for densities: a symmetric to negatively skewed unimodal shaped curve with peak biomass between 10 and 35% of the swash position (Fig. 2.3.6a for ebb sampling and 2.3.6b for flood sampling). The highest recorded average biomass at one level was 492 g AFDW/m<sup>2</sup> (high tide during ebb sampling). With the exception of ebb LW, model parameters are very similar to those for density data (Table 2.3.1), with positive  $\alpha$  and  $\beta$  and negative  $\gamma$  (all but two significant), confirming the unimodal shaped curve. Also the position of the maxima is very similar.

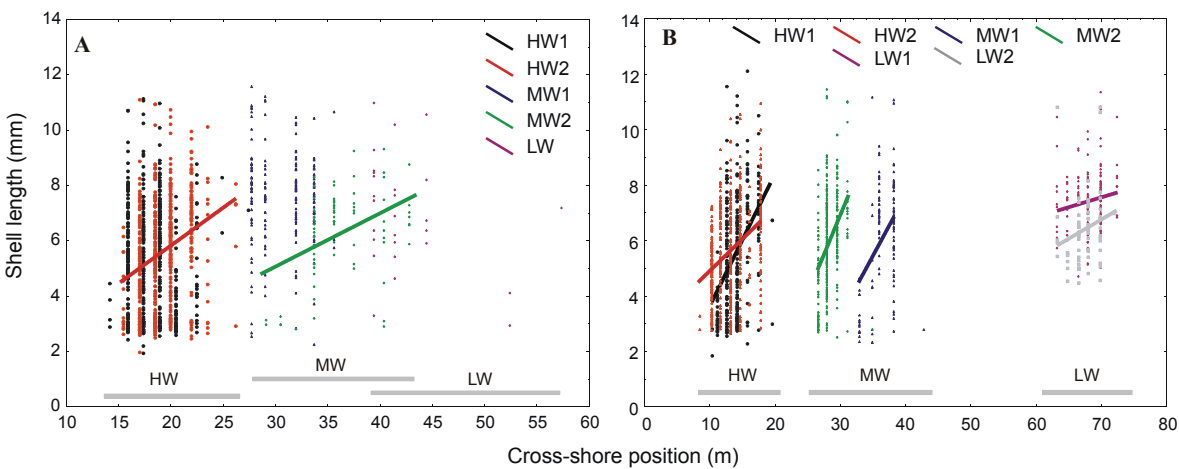
Cross-shore zonation in terms of biomass is very similar to cross-shore density zonation (not shown).



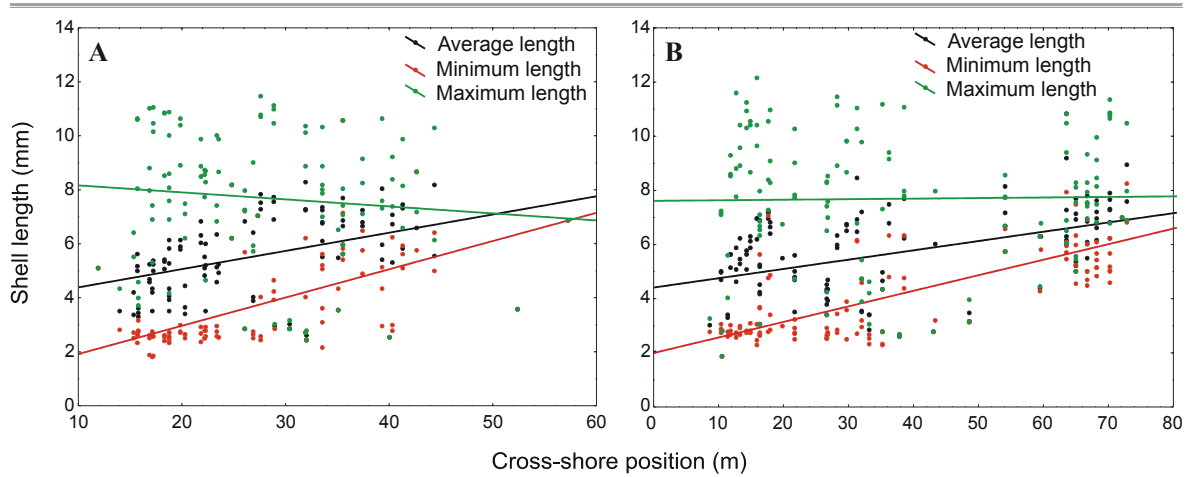
**Fig 2.3.1** - Relative densities per swash transect (for abbreviations, see text) of *Olivella semistriata* plotted against relative swash position. Fitting by distance weighted least square estimates. A) Ebb; B) Flood.



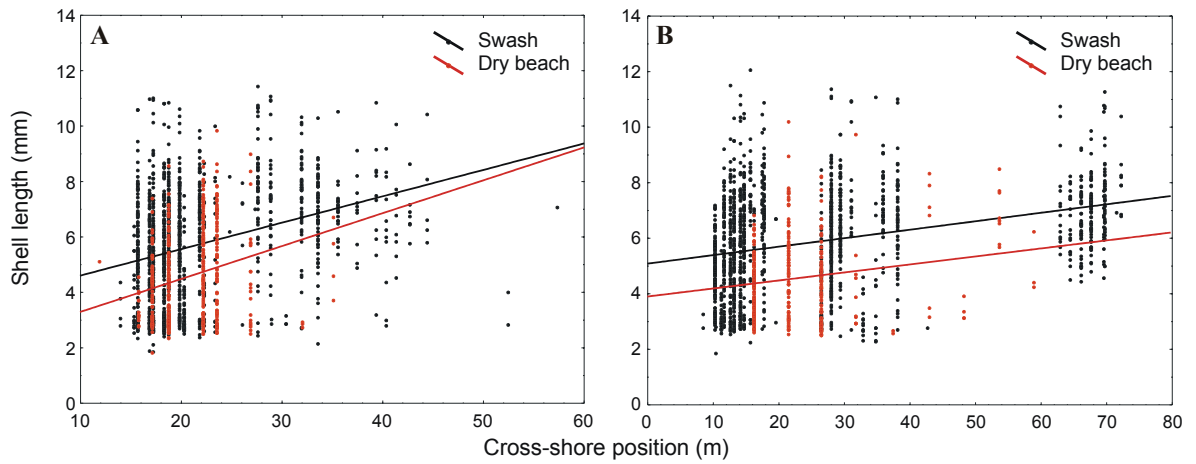
**Fig 2.3.2** - Cross-shore distribution of absolute densities of *Olivella semistriata*. Each line represents the pooled data of on transect. The dotted lines are the samples taken on the drying intertidal ('dry beach'). X-axis is the distance from a reference point on the high beach. Fitting by distance weighted least square estimates. A) Ebb, bold arrow indicates 3 values between 23,000 and 28,000 ind./m<sup>2</sup>; B) Flood.



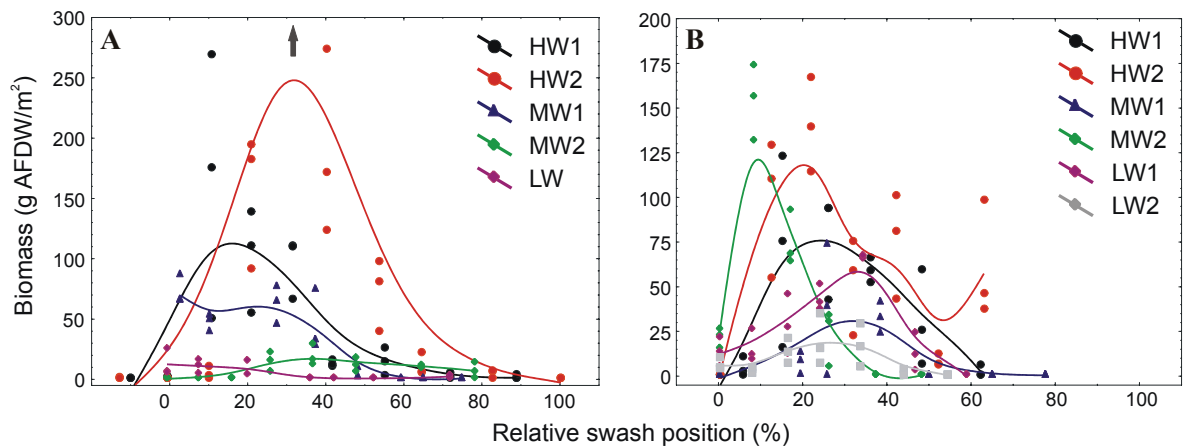
**Fig 2.3.3** - Shell length per transect of *Olivella semistriata* plotted against intertidal (i.e. cross-shore) distance from reference point on the high beach. Solid lines indicate a significant linear regression. A) Ebb: shell length for HW2 and MW2 is positively correlated with distance; B) Flood: positive correlation between shell length and distance for all transects.



**Fig 2.3.4** - Minimum, maximum and average shell length plotted against intertidal distance from reference point on the high beach. Lines indicate simple linear regression. A) Ebb, minimum length:  $p < 0.05$  with  $r = 0.49$ ; maximum length: NS; average length:  $p < 0.05$  with  $r = 0.31$ . B) Flood, minimum length:  $p < 0.05$  with  $r = 0.73$ ; maximum length: NS; average length:  $p < 0.05$  with  $r = 0.46$ .



**Fig 2.3.5** - Shell length plotted against intertidal distance from reference point on the high beach. Dark line is the linear regression for the swash transects, grey line the linear regression for the dry beach samples. A) Ebb, swash length:  $p < 0.05$  with  $r = 0.32$ ; dry beach length:  $p < 0.05$  with  $r = 0.23$ . B) Flood, swash length:  $p < 0.05$  with  $r = 0.31$ ; dry beach length:  $p < 0.05$  with  $r = 0.17$ .



**Fig 2.3.6** - Biomass per swash transect plotted against the relative swash position. Fitting by distance weighted least square estimates. A) Ebb, arrow indicates three values between 350 and 500 g/m<sup>2</sup>; B) Flood.

### 2.3.3.6 Ebb sampling versus Flood sampling

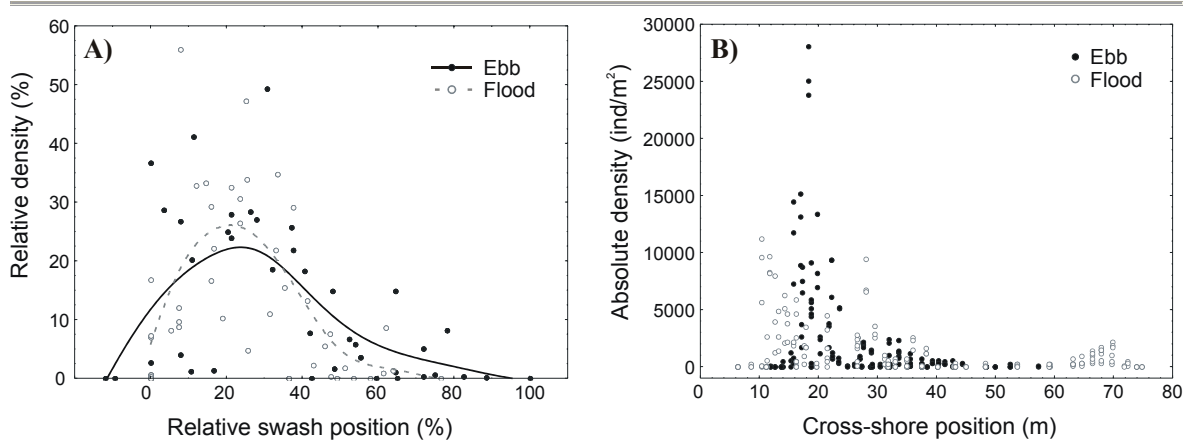
Although differences exist in both densities and zonation, the average pattern is very similar for both sampling series (Figs. 2.3.1 - 2.3.6). The within-swash zonation of the ebb sampling series seems to be spread over a wider relative position (Fig. 2.3.7a), but the pattern is almost identical. The cross-shore zonation, however, does show some differences (Fig. 2.3.7b): during flood sampling, the six sampling transects are much more distinct and the intertidal width is larger (intertidal range of 1.7 m compared to 1.0 m at ebb sampling), with a wider distribution as a consequence.

### 2.3.3.7 Population estimation

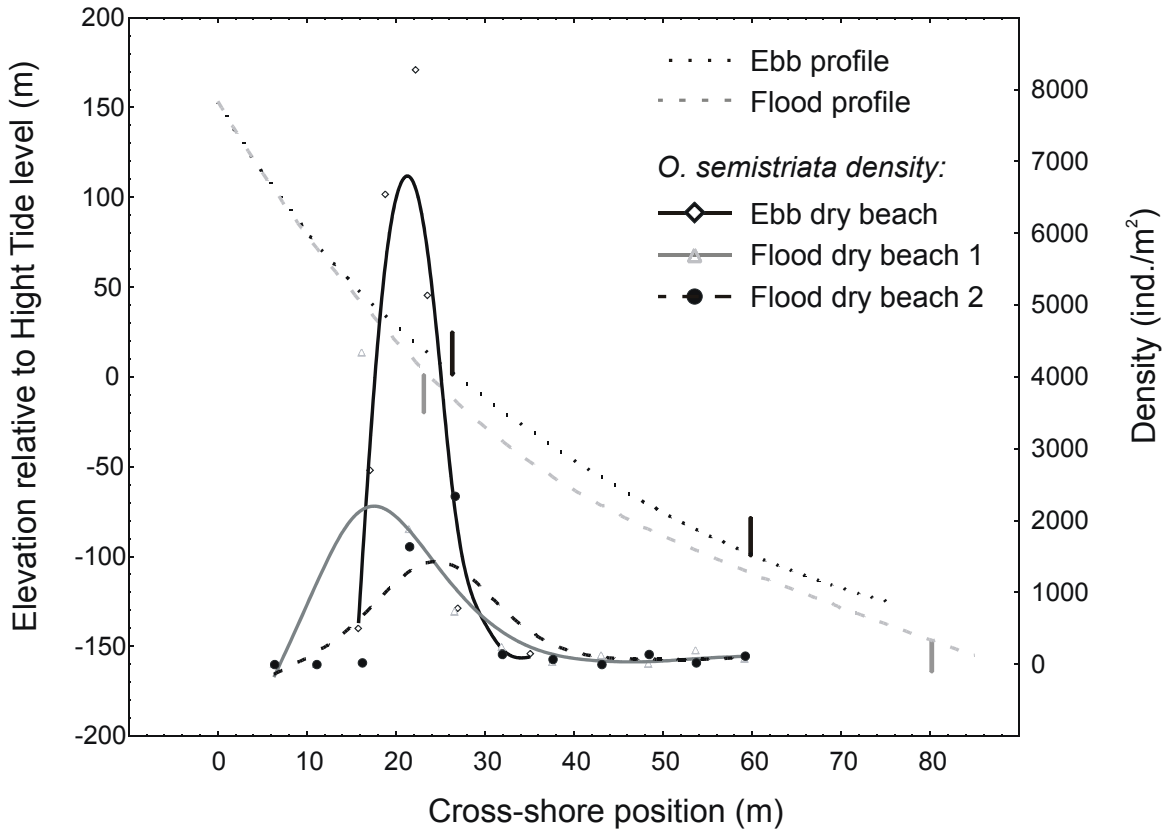
Population estimates in abundance range between 19,077 and 96,257 individuals per meter of beach length; biomass estimates go from 82.22 to 185.17 gram AFDW per meter of beach length (Table 2.3.2). Though not significant, differences exist between using IST or IPE. The same holds true when using the high water series or the combination of the air-exposed intertidal and low water series for population estimation: the differences are not significant.

**Table 2.3.2** - Population estimation over the total beach width for abundance (ind/m) and biomass (g/m) during ebb and flood. IST = individuals per strip transect; IPE = integration population estimation. p-values from t-test for dependent samples.

		EBB			FLOOD				HW vs. 'Dry beach' + LW	IST vs. IPE
		HW1	HW2	'Dry beach' + LW	HW1	HW2	'Dry beach a' + LW1	'Dry beach b' + LW2		
<b>Abundance</b>	<b>IST</b>	48802	96257	77322	19077	39414	55157	29842	p=0.47	p=0.53
	<b>IPE</b>	48196	88830	66634	22227	43182	55840	31329		
<b>Biomass</b>	<b>IST</b>	83.51	185.17	111.31	42.16	73.53	123.32	63.44	p=0.99	p=0.25
	<b>IPE</b>	82.22	173.21	99.17	50.67	78.08	98.26	62.26		



**Fig 2.3.7** - A) Average relative densities for ebb (black dots) and flood (grey circles) plotted against the relative swash position. Fitting by distance weighted least square estimates. B) Cross-shore distribution of average absolute densities for ebb and flood. X-axis is the distance from a reference point on the high beach. Fitting by distance weighted least square estimates.



**Fig 2.3.8** - Beach profile combined with dry beach density data for ebb and flood. Vertical bars indicate high and low water point. Curves are least square estimates of the density of *Olivella semistriata* at the air-exposed (dry beach) levels.

## 2.3.4 Discussion

### 2.3.4.1 Swash zonation of *Olivella semistriata*

The zonation of *Olivella semistriata* within the swash shows a very distinct pattern with a symmetric to slightly skewed unimodal curve, as was described in Chapter 2. This indicates that there is one very narrow zone within the swash, always at 10% to 30% of the upper swash limit, where both densities and biomass are peaking. Given the fact that the distribution pattern is very similar at high, middle and low tide, the population of *O. semistriata* shifts over the beach in a uniform way. If we assume that survival conditions are, on average, optimal where the highest numbers of animals are found (Begon *et al.*, 1996), we can conclude that the upper part of the swash remains, regardless of the tide, the species' optimal zone. We hypothesized this is due to the total feeding time, which must be highest in the upper part of the swash zone and follows a unimodal distribution curve within the swash (Chapter 2).

### 2.3.4.2 Cross-shore zonation of *Olivella semistriata*

Although the within-swash zonation is very constant over the intertidal, there is a dramatic drop in densities between high and middle tide, with a further drop towards low tide. We found that minimum and average shell length increases towards the low intertidal, while the maximum shell length remains constant. This indicates that mainly small individuals stay behind on the high beach (Fig. 2.3.4). Because surfing is a very complicated behaviour that requires several skills such as timing and judging distance and direction, we hypothesize that the younger – smaller – individuals are not as successful in surfing as the adults and that quantity of good surfing movements, required to move up and down the beach, increases with experience. The very small individuals (<4 mm, with transparent shell) do not migrate beyond the mid tidal level at all. An experience factor in behavioural plasticity of sandy beach fauna, especially on exposed sandy beaches, was already suggested by Brown (1996).

The fact that a large number of snails, also some bigger ones (see Fig. 2.3.5), do not migrate down-shore, raises the question whether migrating all the way down the beach is energetically beneficial or necessary. Brown (1982) measured the energy cost of migration for the surfing gastropod *Bullia digitalis* and concluded that migrating is far more energy consuming than staying in one place. Several swash species, such as *Excrolana braziliensis* and *Eurydice pulchra*, remain burrowed on the high beach at middle and low

tide (*Excirolana*: Yannicelli *et al.*, 2001; *Eurydice*: Alheit and Naylor, 1976), suggesting that feeding for a short period of time and then waiting for a long period of time is more interesting than having to adjust their position all the time to ensure good feeding conditions. Moreover, it is not unlikely that the individuals of *Olivella semistriata* that remain stranded on the high beach, but below the low tide effluent line - no burrowing is possible above the effluent line, can obtain food in a different way than filter feeding the backwash. It is commonly seen that stranded snails crawl about in a haphazardous way, just below the sediment surface (personal observations). This could be a foraging behaviour in which they graze on diatoms that are attached to the sand particles, using their radula. On the other hand, they could be in search of the swash zone, though a more directional movement would then be expected. It might well be, however, that they are clueless for orientation without a water current. Staying behind does seem to increase the predation risk – the animals are very easily seen when crawling about, questioning the foraging hypothesis.

#### **2.3.4.3 Length zonation**

As mentioned above, *Olivella semistriata* is zoned according to length, with smaller individuals higher on the beach and higher in the swash. Length zonation is a well-known phenomenon amongst intertidal species. This can be a response to an environmental or a biological gradient (Vermeij, 1972). Swash zonation by size is known for species of the genus *Emerita*. As for *O. semistriata*, smaller animals of *Emerita* live higher in the swash and higher on the beach (Efford, 1965 and references herein; Forward *et al.*, 2005). *Olivella biplicata*, however, was found to be zoned in the opposite way: smaller animals were found closer to the surf zone (Edwards, 1969), possibly because larger animals can better withstand desiccation. Since *O. semistriata* surfs down the beach, desiccation is not an important factor for the species. Length zonation for intertidal gastropods from rocky shores was reviewed by Vermeij (1972). He clearly found two patterns, with increasing length upshore for animals from the littoral fringe and increasing length downshore for animals from the lower intertidal. He ascribed these patterns to a different response to gradients in the intensity and nature of postlarval prereproductive mortality on the shore. Although the length zonation of *O. semistriata* logically falls in the group of gastropods living in the low intertidal, the explanation that for these animals biotic interactions and predation is more intense at low levels, does not seem to fit. It is rather the more severe physical conditions lower in the swash that will cause length zonation. This seems to hold true for several surfing species, such as *O. semistriata* and *Emerita*. This could possibly be explained by a physically driven force:

sand particles settle according to water currents with an increase in particle size from calm to harsh conditions. Since the migration of *O. semistriata* is mainly a passive floating in the swash, the same rules as for sand particles apply: the lower in the swash, the higher the water currents, the bigger the specimens.

#### 2.3.4.4 Population estimation

Because of its very high densities in the swash zone, *Olivella semistriata* is by far the most conspicuous animal on intermediate Ecuadorian beaches. The zone in which they occur at one time, however, is limited to a few meters. To know just how abundant the species is, several ways of estimating the population size were applied. The final goal of these calculations was to have the population size over the full intertidal per meter beach length (i.e. abundance), a measure that allows for straightforward comparison with other species and locations. Population was estimated in both numbers and biomass (ash-free dry weight).

Defeo (1996) proposed IST (individuals per strip transect), with  $IST (ind/m) = \text{average sample density } (ind/m^2) * \text{distribution width of the species (cross-shore)}$ , as a good proxy for population estimation (for biomass, it is also named BST: biomass per strip transect). This method is based on the assumption that a population is zoned in a perfect bell-shaped way, since the average number (density or biomass) per level is multiplied by the beach width in which the animals occur. Additionally, we estimated abundance by integrating the zonation curve. Each straight line between two levels in the zonation curve was integrated over the distance between the two levels. The sum of all these integrals gives the population. It was expected that this IPE (integrated population size estimation) would render a more precise population size estimate than IST, especially for non-symmetrical distribution curves. Although differences exist (Table 2.3.2), pairwise comparison did not show a significant result for IST versus IPE. Still, we tend to prefer IPE as a general population size estimation tool. It is almost as straightforward to compute as IST, but is logically more precise.

If assumed that the total population of *Olivella semistriata* migrates with the tide and remains zoned in the swash, sampling a swash transect should yield a good population proxy, independent of the current tidal state. However, as we have discussed above, it is clear that a major part of the population does not migrate beyond the high



beach. Since distribution curves within the high tide transect start at zero and end with zero, we can still conclude that the total population is present in the swash at high tide. Consequently, transect sampling within the swash at high tide should thus render a good estimate of the population size.

At low tide only part of the population is found in the active swash. The rest of the animals remain stranded on the air-exposed intertidal. The sum of the snails found in the low tide swash and on the air-exposed intertidal at the time of low tide, should also give a good estimate of the population size.

Both calculations, high tide and low tide swash and air-exposed intertidal, were compared (Table 2.3.2). No significant difference could be found, although numbers did vary substantially. The variation between the parallel transects, however, was also very large, suggesting strong alongshore patchiness in the distribution of *Olivella semistriata*. At flood sampling, for instance, IPE for the HW1 transect was 22,227 ind/m beach length, compared to 43,182 ind/m beach length for the adjacent HW2 transect. Similar differences were found during ebb sampling. It is very likely that this alongshore patchiness is caused by small-scale morpho- and consequently hydrodynamic effects, since migration of *O. semistriata* is mainly a passive floating in the swash. It seems that sampling several parallel transects is necessary to get a good abundance estimate of the species (James and Fairweather, 1996). Whether this is done at high tide or at low tide, does not play such an important role. Since the sampling effort at high tide is much lower, this will generally be the preferred approach. Note that especially the distribution of the left-behind specimens on the air-exposed intertidal is extremely patchy: almost all individuals were found in a very narrow cross-shore zone (Fig. 2.3.8). It is thus crucial to sample enough levels if these animals are not to be missed.

#### **2.3.4.5 Population size of *Olivella semistriata***

For correct comparison of the abundance in numbers and biomass of *Olivella semistriata* with other species, a value in terms of meter per beach length (see above) is needed. Unfortunately, only few studies mention abundance or biomass in this scale. Nevertheless, it is clear that *O. semistriata* is a very abundant species for a sandy beach, both in population size and in biomass. The maximum recorded abundance of almost 100,000 ind/m (ebb sampling HW2) is higher than any other population size number found in literature, even for total sandy beach macrobenthic communities. The maximum biomass (185.17 g AFDW/m) is also rather high for a single species on an intermediate beach. Brazeiro and Defeo (1996) found a total average abundance of 72,890 ind/m and

biomass of 2,081 g Dry Weight/m on an exposed, microtidal dissipative beach in Uruguay, with *Excirolana armata* as the most densely distributed species (59,831 ind/m) and *Mesodesma mactroides* as the most dominant species in terms of biomass (1,657 g DW/m), but the latter is a very large and heavy species, and known for its high productivity (McLachlan *et al.*, 1996). The highest macrobenthic abundance found on Chilean beaches by McLachlan *et al.* (1993) was 66,783 ind/m on an intermediate beach ( $\Omega = 4.1$ ). The highest macrobenthic biomass they found was 3,087 g DW/m ( $\Omega = 5.4$ ). High biomasses (up to 3,504 g DW/m) were found for *Emerita analoga* in California, United States, but in abundances less than 15,000 ind/m (Dugan and Hubbard, 1996). However, no mention is made whether the biomass values are dry weight or ash-free dry weight (the latter being used for *Olivella semistriata*). All high values retrieved from literature were from beaches with a Dean's parameter much higher (i.e. more dissipative) than from the beach investigated in this study ( $\Omega < 2$ ). Abundance and biomass tends to increase with increasing  $\Omega$  (McLachlan and Dorvlo, 2005). This makes the extremely high population size found for *Olivella semistriata* even more spectacular.

### 2.3.5 Conclusions

- 1) The zonation of *Olivella semistriata* within the swash showed a uniform unimodal curve, independent of the tidal state.
- 2) No major differences existed between ebb or flood sampling.
- 3) Maximum densities were typically found close to the higher swash limit.
- 4) A large part of the population, mainly small individuals, remained stranded on the air-exposed intertidal, which might be due to a lack of surfing experience.
- 5) Shell length increased towards the subtidal, with only animals larger than 4 mm on the lower part of the beach.
- 6) The same trend of increasing length was also found within the swash: the lower in the swash zone, the larger the snails.
- 7) Abundance estimates ranged from 19,000 to 97,000 ind/m; biomass estimates were found between 42 and 185 g AFDW/m.
- 8) With densities of up to 96,257 ind/m, *Olivella semistriata* is considered to be an extremely abundant species for sandy beach standards.

---

**- PART III -**

**SOME ASPECTS OF THE BIOLOGY OF THE  
GASTROPOD *OLIVELLA SEMISTRIATA*.**

---

‘I love fools experiments. I am always making them.’

*Charles Darwin*



## CHAPTER 4

# IS THE BURROWING PERFORMANCE OF A SANDY BEACH SURFING GASTROPOD LIMITING FOR ITS MACROSCALE DISTRIBUTION ?

---

Vanagt T., Vincx M., Degraer S.

Submitted to *The Journal of Experimental Marine Biology and Ecology*

Keywords: *Olivella semistriata*, surfing, swash riding, burial time, Ecuador, sandy beach, Burrowing Rate Index.

## Abstract

The burrowing capacity of the gastropod *Olivella semistriata*, an extremely abundant surfer on exposed sandy beaches in the tropical East Pacific, was investigated in terms of shell length and sediment grain size. For all investigated sand classes there was a significant increase in burial time with size. Burrowing was fastest in sand with grain size between 150 and 355  $\mu\text{m}$ , as well as in native sediment (median grain size: 209  $\mu\text{m}$ ) and in field conditions (median grain size: 223  $\mu\text{m}$ ). Values of the Burrowing Rate Index (BRI) were found between 3 and 7, valuing the burrowing capacity of *O. semistriata* as fast to very fast.

Data from previous qualitative and quantitative sampling campaigns were used to identify the distribution of *Olivella semistriata* in terms of sediment grain size and swash conditions. Swash period was shorter than burial time, excluding this as a limiting factor. Swash standstill time (the time between uprush and backwash), however, was just long enough on the beaches where *O. semistriata* was present to allow for securing anchorage. On reflective beaches the swash standstill time is as short as one or two seconds, denying *O. semistriata* the time to burry itself before being swept away by the backwash. As such, swash standstill time is advocated as a valuable part of the swash exclusion hypothesis.

A survey of the available literature on the burrowing of surfers shows that mole crabs are by far the fastest burrowers, and the only surfers that burrow sufficiently fast to withstand the extremely short swash standstill time on reflective beaches. Burrowing ability of surfing gastropods is found in the same range as surfing bivalves, both being insufficient to cope with coarse sediment on steep beaches.

Finally, we suggest that not burial time nor BRI, yet the *minimal burial time* – the time needed to anchor securely in a certain sand at a given swash velocity – should be used to judge the limitations of burial in terms of sediment and swash conditions.

### 3.4.1 Introduction

*Olivella semistriata* is a surfing gastropod that lives on exposed sandy beaches along the Ecuadorian Pacific coast. With densities up to almost 100,000 individuals per meter strip transect (Chapter 3) it is one of, if not the most abundant sandy beach gastropod species worldwide. Large aggregates migrate cross-shore at the upper boundary of the swash, traveling distances of up to 100 meter per tidal cycle. The surfing behaviour consists of three different movements. Upon inundation of a surfable wave, the animals crawl actively out of the sediment (1). Timing of this movement is crucial to maintain or regain position on the beach (Ellers, 1995a,b), and can be initiated by wave sounds (Ellers, 1995b), changes in light conditions, thixotrophy or hydrostatic pressure (Brown and McLachlan, 1990) and is often regulated by an endogenous clock (Warman *et al.*, 1993; Ellers, 1995b). The exact trigger for migration of *Olivella semistriata* is not known, although in Chapter 5 we showed the presence of an endogenous circatidal clock and hinted on mechanical agitation of the sediment as the initiator of a surfing movement. After the animals emerge from the sediment they passively ride the swash wave (2). In *O. semistriata* this seems to be controlled by using the extended metapodium as an underwater sail (Olsson, 1956; personal observations), as was also described for *Bullia digitalis* (Brown *et al.*, 1989). Distance traveled per surfing movement is optimally around 3.75 m (Chapter 6). The surfing ends by anchoring to the sediment through rapid burrowing (3).

Fast burrowing has repeatedly been reported as a crucial characteristic for survival on exposed sandy beaches (e.g. Brown *et al.*, 1989; Brown and McLachlan, 1990; Nel *et al.*, 2001; Lastra *et al.*, 2002). The limits of a species' burrowing capacity is often considered to restrict the distribution, mainly towards the reflective end of the beach spectrum, where rapid burrowing is necessary to withstand the harsh swash conditions (Brown *et al.*, 1989; McLachlan *et al.*, 1995; Nel *et al.*, 2001; de la Huz *et al.*, 2002). Many species, especially bivalves and gastropods, are incapable of fast burrowing in the coarse sediment that is found on reflective beaches. Nel *et al.* (2001) showed a clear increase in burial time of two intertidal *Donax*-species from fine to coarse sand. Similar results were obtained by Alexander *et al.* (1993) for a wide range of bivalves.

Although burial time is undoubtedly very important for the mobile fauna of exposed beaches, it remains debatable whether the burrowing performance in certain sediment types has a direct influence on the distribution of species or not. While Nel *et al.* (2001) ascribed the absence of *Donax* on reflective beaches to the slow burrowing of the taxa in coarse sediment, McLachlan (1990) hypothesized that the total swash climate -

including grain size – regulates the presence of species on different beach types. Subsequently, McArdle and McLachlan (1991, 1992) proposed the ‘swash exclusion hypothesis’, which states that swash climate is the key factor controlling macrofaunal sandy beach communities. The swash climate on fine-grained dissipative beaches was described to be more suited for macrofauna, and only few species could cope with the harsh swash conditions on reflective beaches (McLachlan *et al.*, 1993).

The goals we set for this paper were to identify the burrowing capacity of *Olivella semistriata* over a range of sediment types, to test if this is reflected by or possibly influences the distribution of the species in terms of swash and sediment and to compare the burrowing performance of *O. semistriata* to other sandy beach surfers.

## **3.4.2 Material and Methods**

### **3.4.2.1 Study site and period for burial time**

For field measurements and collection of *Olivella semistriata*, the sandy beach of San Pedro de Manglaralto, Ecuador (1°59’S and 80°45’W) was chosen. The macrofaunal zonation of this beach is described in Addendum 1. Swash zonation of *Olivella semistriata* from this location is discussed in Chapter 2 and 3, as are the beach characteristics (intermediate beach with fine, well sorted sediment and a gentle slope which steepens at the high tide cusps).

### **3.4.2.2 Field data collection**

For the field measurements, one specimen at a time was followed during a surfing movement. Burial time was assessed by means of a hand stopwatch, and was clocked from the start of the burrowing (after the surfing movement) till the apex of the shell disappeared under the sediment. After the burrowing, the animal was collected and shell length was measured with callipers to the nearest 0.05 mm. Animals that were helped in their burrowing by sediment movement were excluded from the dataset, as were animals that turned around 180° while burrowing. 26 measures were retained for further analyses.

The swash was monitored at several occasions, during upcoming and falling tide. Data were collected by filming the swash with a 50 Hz video camera during 10 to 15 minutes. Plastic reference poles were placed in the swash at two meter intervals. *Swash standstill time* was the period at maximum swash run-up when no cross-shore swash current was visible on videotape.



### 3.4.2.3 Laboratory data collection

Seven different sets of sediment were prepared: six according to grain size class and one with sediment from the collection site. To obtain sediment with a wide variety of grain sizes, sand was collected from several beaches, dried for 24 hours at 70°C and sieved through a series of sieves. The six size classes that were obtained were very fine (<150 µm), fine (150-250 µm), medium 1 (250-355 µm), medium 2 (355-500 µm), coarse (500-1000 µm) and very coarse (>1000 µm) sand, according to the Wentworth scale (Buchanan, 1984). Transparent plastic 1 litre bottles were filled with 5 cm of sand and 2 cm of sea water.

Animals were collected from the beach by sieving the upper sediment layer of the swash zone through a 1 mm mesh-sized sieve. The collected specimens were then transported to the laboratory (average transport time of 5 min), where they were placed in plastic trays (30x20x4 cm) filled with 1 cm of sediment and 1 cm of sea water. To measure burial time, one specimen was placed per bottle filled with selected sand, and given the time to burrow. Sediment was then agitated to stimulate emergence, as happens in the swash zone, and burial time was measured in a similar way as in the field. This procedure was repeated twice for each specimen (three times with the mixed sediment). A total of 20 specimens per sand class and 39 for the mixed sediment were measured. Again, burrowing movements involving a 180° turn and vertical burrowing movements (compared to the normal burrowing angle of 25°) were neglected. Subsequent specimens were chosen to obtain data from the full shell length range of the species; individual specimens were only used once.

Water temperature was kept constant at  $24 \pm 1$  °C, which was equal to the swash water temperature in the field.

### 3.4.2.4 Sediment characterisation

A sediment sample was taken at the site of field data collection. A subsample was also taken from the sediment that was used for the mixed sand laboratory experiment. Both samples were analysed with a laser COULTER LS. Median grain size for the field sample was 223 µm and 209 µm for the sand used in the laboratory.

### 3.4.2.5 Distribution of *Olivella semistriata*

The distribution and population size of *O. semistriata* was investigated quantitatively on seven sandy beaches with different morphodynamics along the Pacific coast of Ecuador. Details about the sampling can be found in Chapter 1. Additional unpublished data from pilot studies were used to complete the picture. Since sampling was not always done in a similar way, these data were only treated for qualitative investigation. Quantitative data are expressed in density (ind/m<sup>2</sup>) and in abundance as individuals per meter strip transect (IST; ind/m), which is a good measure of the total populations size independent of the beach type (Defeo, 1996). To describe the beach type, the Beach index (BI) was used (McLachlan and Dorvlo, 2005). Values increase from reflective to dissipative beaches.

### 3.4.2.6 Statistical analyses

For field measurements and per sand class (laboratory experiment) a first order linear regression with burial time as dependent variable and shell length as explanatory variable was performed. Differences in slope between the regression lines was checked with a mixed model (proc mixed statement in SAS 9.1) with interaction term shell length\*sand class. Where the slope was not significantly different, a Tukey post-hoc test was calculated to find differences in intercept.

Biomass data were retrieved from the shell length data, using the following equation:

$$\text{Wet weight} = 10^{-0.61076 + 2.7873 * \log(\text{Shell Length})}$$

(see Chapter 3 for the description of this regression).

This was used to calculate the burrowing rate index (BRI), defined as the cube root of the wet weight (g), divided by the burial time (s) and multiplied by 100 (Stanley, 1970):

$$\text{BRI} = [ \text{Wet mass (g)}^{0.33} / \text{Burrowing time (s)} ] \times 100$$

The burrowing rate can, therefore, be defined as the mass (g) per second. Values below 2 indicate slow burrowers, between 2 and 5 fast burrowers and above 6 very fast burrowers (Stanley, 1970). BRI was expressed in terms of shell length with a first-order linear regression.

McArdle and McLachlan (1992) found that swash period, beach type (expressed as Dean's parameter) and sediment grain size were highly correlated on exposed sandy

beaches. From the data they list, a second-order linear regression of *swash period* as a function of *sediment grain size* was calculated. Likewise, from the present study, the *swash standstill time* was expressed as a function of *sediment grain size* (for the data, see Table 3.4.4) with a second order linear regression. Both regression lines were superimposed on Fig. 3.4.2. This graph shows the burial time of *Olivella semistriata* in the different sand classes, but divided into three shell length groups (<6mm; 6-9mm and >9mm; chosen to divide the data in three equal groups). To plot the regression, the median value of every sand class was used as sediment grain size value (x-value in the second order regressions).

### 3.4.3 Results

#### 3.4.3.1 Burial time in relation to size and sand characteristics

For all laboratory experiments as well as for the field data, there was a significant ( $p < 0.0001$ ) increase in burial time with increasing shell length (Fig. 3.4.1; Table 3.4.1), indicating that larger animals take more time to achieve complete burial. The rate of increase in burial time with size was similar in all but the coarsest sand, which showed a much steeper slope of burial time as a function of size (Tukey's post hoc test for comparison of slopes – not shown). Burial time ranged from 2.4 s to just under 24 s (Fig. 3.4.2). Burrowing was fastest in the fine and medium 1 sand (between 150 and 355  $\mu$ m); in the very coarse sediment burial time was markedly longer than in the other sands (14.26 s compared to between 6.84 and 11.05 s). For the remaining sand, three significantly different groups existed (Table 3.4.2): fine and medium 1 sand (average burial time of 6.84 s); very fine (8.66 s) and medium 2 sand (8.98 s) and coarse sand (11.05 s). The mixed sand and field data lied between the fine / medium 1 and very fine / medium 2 group.

A generalized linear model of the relation between swash period and sediment grain size was calculated based on data from McArdle and McLachlan (1992). The burrowing of *O. semistriata* takes longer than the average swash period where coarse or very coarse sediment occurs (Fig. 3.4.2). For the medium 2 sand, the larger animals burrow, on average, slower than the time between two swash waves.

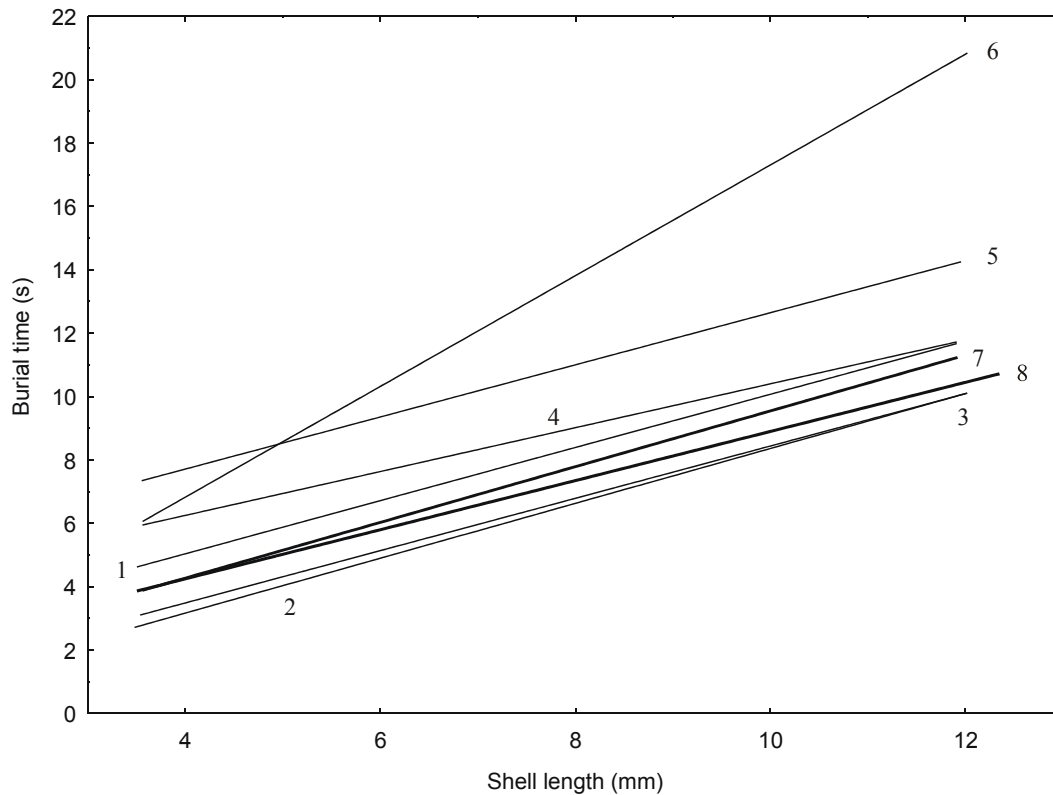
The burrowing rate index (BRI) ranged from 2.13 to 10.13. There was no correlation between shell length and BRI (Fig. 3.4.3), except for the medium 2 and coarse sand, where BRI significantly increased with size ( $p=0.001$  and  $p=0.008$  respectively). BRI was highest, and thus burrowing fastest, in fine and medium 1 sand. Lowest BRI was found in the very coarse sediment. Burrowing was fast for all sands and very fast for the fine, medium 1 and mixed sand, as well as for the field data (Fig. 3.4.3).

**Table 3.4.1** - Linear regressions of burial time ( $t$ ) in terms of shell length ( $L$ ) for the six different sand classes, mixed sand and field measurements

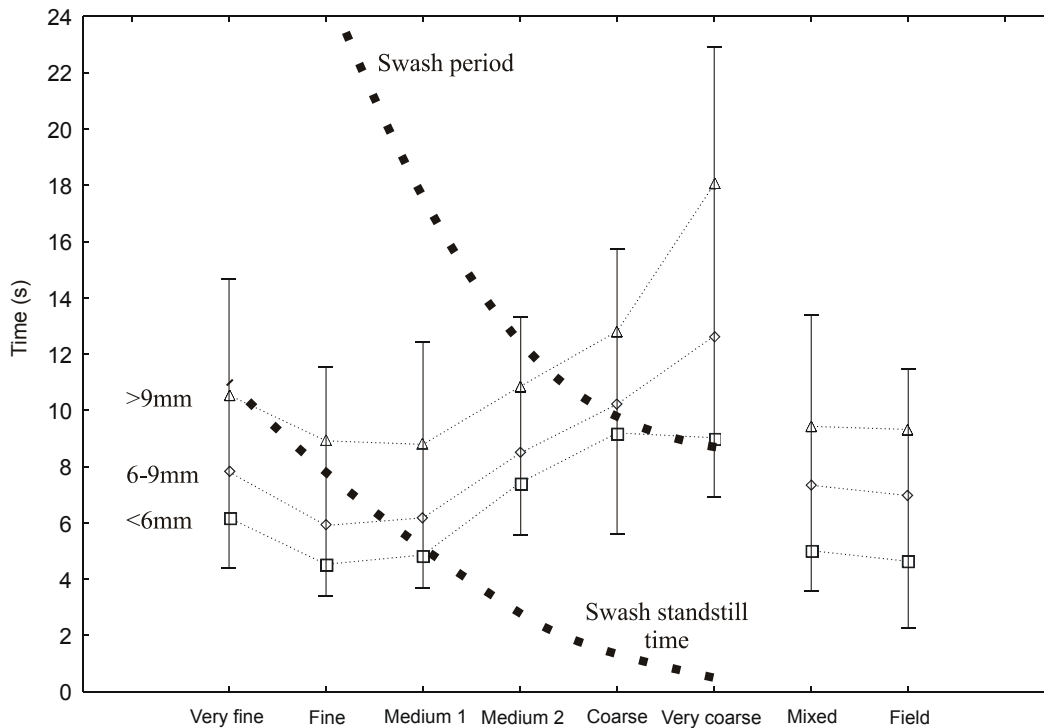
Sediment class	Sand ( $\mu\text{m}$ )	Burial time (s) vs. shell length (mm)	Adj. $R^2$	n	F-value	p-value
1	Very fine (<150)	$t = 1.69 + 0.84L$	0.52	40	43.37	$p < 0.0001$
2	Fine (150-250)	$t = -0.29 + 0.87L$	0.67	40	81.37	$p < 0.0001$
3	Medium 1 (250-355)	$t = 0.19 + 0.83L$	0.75	40	118.19	$p < 0.0001$
4	Medium 2 (355-500)	$t = 3.48 + 0.69L$	0.52	40	42.83	$p < 0.0001$
5	Coarse (500-1000)	$t = 4.43 + 0.82L$	0.50	40	39.95	$p < 0.0001$
6	Very coarse (>1000)	$t = -0.16 + 1.75L$	0.66	40	77.85	$p < 0.0001$
7	mixed (209)	$t = 0.76 + 0.88L$	0.37	107	62.01	$p < 0.0001$
8	field (223)	$t = 1.15 + 0.77L$	0.62	26	41.97	$p < 0.0001$

**Table 3.4.2** - Significance level (p-value) of the Tukey's post hoc comparison indicating differences in intercept of burial times (BT) vs. shell length regressions (see table 3.4.1) of *O. semistriata* individuals between different sands. Slope was not different, except for very coarse sand

Sediment class	Sand type	Mean Length (mm)	Mean BT (s)	Fine	Medium 1	Medium 2	Coarse	Mixed	Field	Very coarse
1	Very fine	8.32	8.66	<0.0001	<0.0001	0.55 (NS)	<0.0001	0.42 (NS)	0.10 (NS)	Different slope
2	Fine	8.24	6.84		<0.0001	<0.0001	<0.0001	<0.0001	0.56 (NS)	Different slope
3	Medium 1	8.06	6.84			<0.0001	<0.0001	0.0074	0.80 (NS)	Different slope
4	Medium 2	7.95	8.98				<0.0001	0.0009	0.0004	Different slope
5	Coarse	8.07	11.05					<0.0001	<0.0001	Different slope
7	Mixed	8.62	8.34						0.79 (NS)	Different slope
8	Field	8.22	7.52							Different slope
6	Very coarse	8.26	14.26							Different slope



**Fig. 3.4.1** – Regressions of burial time as a function of shell length of *O. semistriata* in a series of well-sorted sands. For regression equations see Table 3.4.1.



**Fig. 3.4.2** - Changes in burial time (Y-axis) with changing sand class (X-axis) for three *O. semistriata* shell length classes. Values are means per size class, with indication of the minimum and maximum range for all animals per sand type. The regression line for swash period (Y-axis) as a function of sediment grain size is based on data from McArdle and McLachlan (1992). The regression for swash standstill time (Y-axis) as a function of sediment grain size is based on data from this paper. Both regression lines are shown as bold dotted lines.

### 3.4.3.2 Burrowing of *Olivella semistriata* compared to other sandy beach surfers

From the many records in literature on burrowing behaviour of sandy beach macrofauna, those were selected that describe the relation between size and burial time for surfing species (Fig 3.4.4; Table 3.4.3). Twenty-one series of 14 species (two gastropods, four hippid crabs and eight bivalves) were added to the data from this paper. All experiments were done in approximately the same sand size class (around 300  $\mu\text{m}$ , see Table 3.4.3). Most species live in temperate regions, but inhabit a wide range of beach types, from dissipative to reflective. For all species there is a positive relation between size and burial time. Hippid crabs are the fastest burrowers (Fig. 3.4.4). Their burial time lies far below the average swash period on reflective beaches. Except for two slow-burrowing bivalve species (*Tivela stultorum* and *Atactodea striata*) all gastropod and bivalve species seem to have similar burial times or at least comparable relations between burial time and shell length. For all species burrowing is fast (BRI > 2) to very fast (BRI > 6). Highest BRI values for molluscs were found in surfing *Donax*-species. BRI of the mole crabs is in a completely different league, with values up to 140.

### 3.4.3.3 Distribution of *Olivella semistriata* in relation to sediment

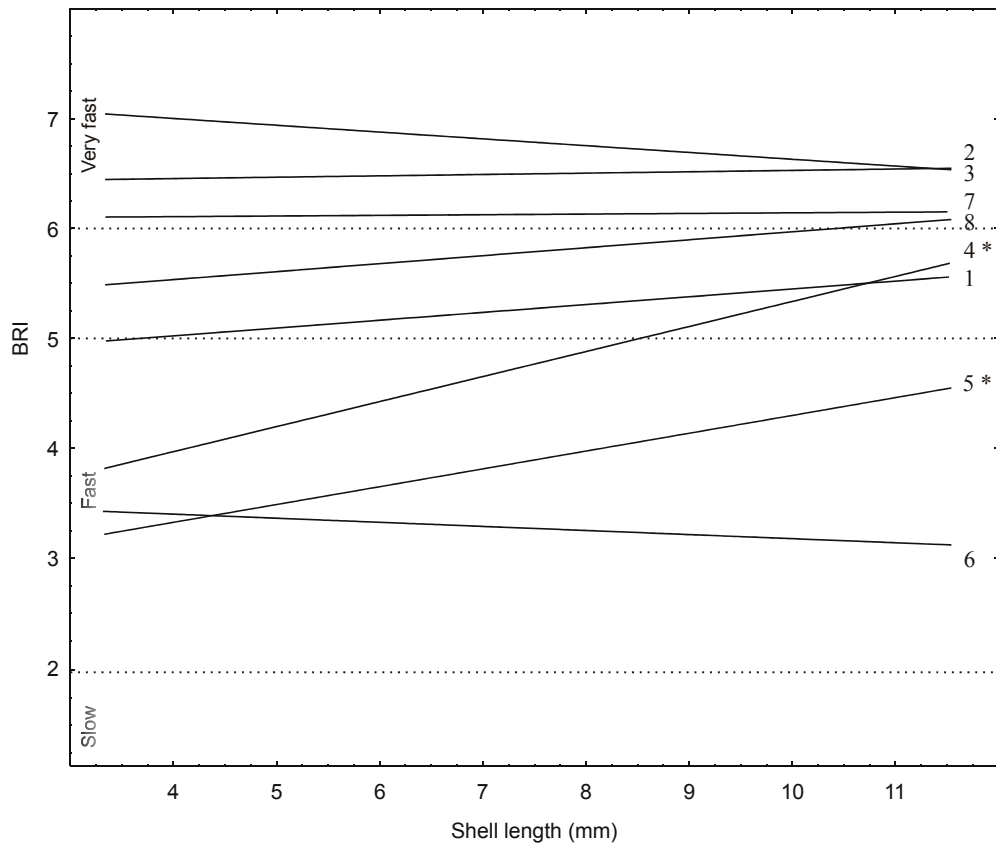
The seven beaches that were sampled quantitatively have different morphodynamics, from highly reflective to almost dissipative, and from very coarse to very fine sand (Table 3.4.4). *Olivella semistriata* was found on six of the seven beaches, although the presence of two juveniles on the reflective beach of Ballenita can be regarded as erratic. The population density and abundance increased with increasing sediment grain size to peak at 31,189 ind/m or 520 ind/m<sup>2</sup> on the beach of San Pablo (median grain size 229  $\mu\text{m}$ ) and drop to zero from sediment with median grain size of 300  $\mu\text{m}$  on (Fig. 3.4.5). This was more or less the inverse pattern of the burial time, which dropped after the finest sediment class, and raised again from 355  $\mu\text{m}$  on (Fig. 3.4.5).

The six additional beaches that were sampled qualitatively confirm these trends, with the exception of Pedernales (Table 3.4.4). On this beach, no *Olivella semistriata* was recorded, although beach slope and sediment grain size seem to be well within the tolerance range of the species. The bay of Ayangue (Ayangue 1) hosted an extremely large population of *Olivella semistriata* at the south side, whereas the species was absent at the north end of the bay (not shown; distance between sampling transects: 250 m).

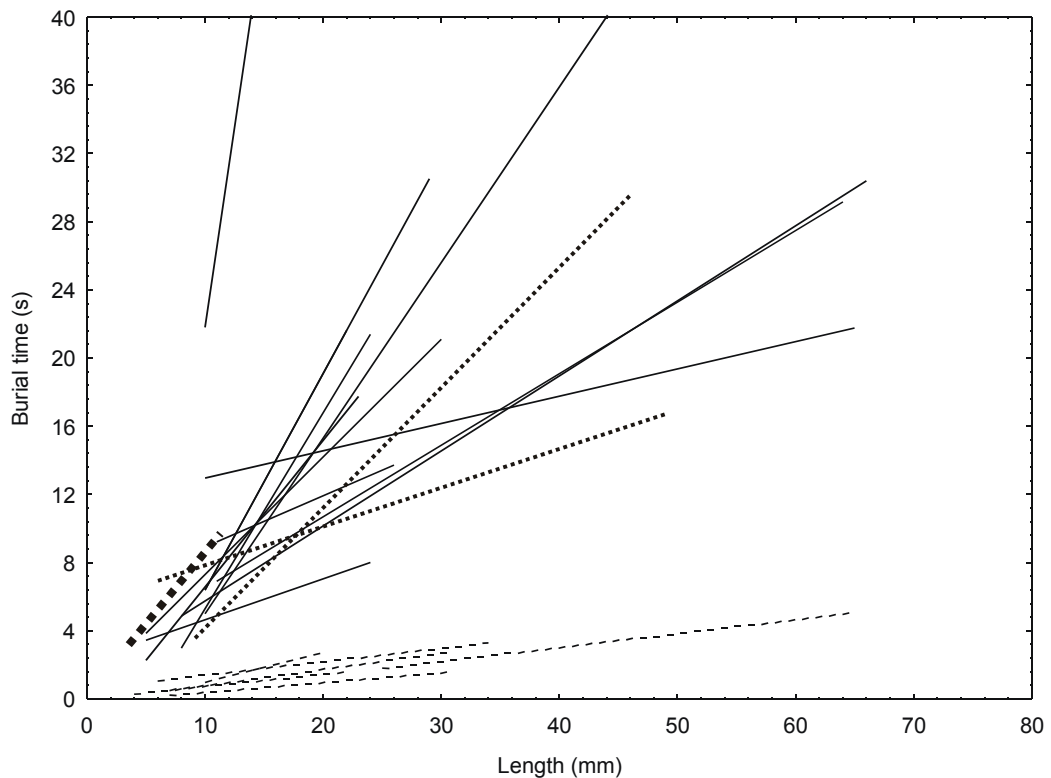
**Table 3.4.3** - Regression lines of length vs. burial time for different sandy beach surfers, retrieved from literature. Type G = gastropod; B = bivalve and C = crustacean. \* Surfing status unclear. ‡ data from Trueman and Brown, 1989. † calculated from regressions for the largest specimens.

Type	Genus	Species	Paper	Size range (mm)	Sediment class ( $\mu\text{m}$ )	BRI	Location	Climate	Beach type	Remarks
G	<i>Bullia</i>	<i>digitalis</i>	McLachlan & Young, 1982	9-46	$\pm 300$	4.6‡	South Africa	warm – temperate	intermediate	at 20°C
G	<i>Bullia</i>	<i>rhodostoma</i>	McLachlan & Young, 1982	6-49	$\pm 300$	4.6‡	South Africa	warm – temperate	intermediate	at 20°C
B	<i>Donax</i>	<i>serra</i>	McLachlan & Young, 1982	11-64	$\pm 300$	-	South Africa	warm – temperate	intermediate	at 20°C
B	<i>Donax</i>	<i>sordidus</i>	McLachlan & Young, 1982	10-29	$\pm 300$	-	South Africa	warm – temperate	intermediate	at 20°C
B	<i>Donax</i>	<i>serra</i>	Nel et al, 2001	10-65	250-355	$\pm 10$	South Africa	warm – temperate	intermediate	
B	<i>Donax</i>	<i>sordidus</i>	Nel et al, 2001	11-26	250-355	$\pm 11$	South Africa	warm – temperate	intermediate	
C	<i>Emerita</i>	<i>analoga</i>	Lastra et al, 2004	7-31	250-500	-	Chile	cold – temperate	high intermediate	
C	<i>Emerita</i>	<i>analoga</i>	Lastra et al, 2004	7-31	250-500	-	Chile	cold – temperate	reflective	
C	<i>Hippa</i>	<i>pacifica</i>	Lastra et al, 2002	4-22	250-500	-	Hawaii, USA	tropical	very reflective	
G	<i>Olivella</i>	<i>semistriata</i>	this paper	3.5-11.5	250-355	6.5	Ecuador	tropical	intermediate - reflective	
B	<i>Donax</i>	<i>faba</i>	McLachlan et al, 1995	? - 24	?	7	Western Australia	cold – temperate	reflective	
B	<i>Donacilla</i>	<i>angusta</i>	McLachlan et al, 1995	? - 23	?	6	Western Australia	cold – temperate	reflective	
B	<i>Donax</i>	<i>serra</i>	McLachlan et al, 1995	? - 66	?	11	South Africa	warm – temperate	dissipative - intermediate	*
B	<i>Donax</i>	<i>sordidus</i>	McLachlan et al, 1995	? - 22	?	6	South Africa	warm – temperate	intermediate	
B	<i>Mesodesma</i>	<i>macroides</i>	McLachlan et al, 1995	? - 76	?	4	Uruguay	warm – temperate	dissipative	*
B	<i>Donax</i>	<i>hanleyanus</i>	McLachlan et al, 1995	? - 24	?	15	Uruguay	warm – temperate	dissipative	*
B	<i>Tivela</i>	<i>stultorum</i>	McLachlan et al, 1995	? - 113	?	6	California, USA	temperate	dissipative	*
B	<i>Atactodea</i>	<i>striata</i>	McLachlan et al, 1995	? - 36	?	2	Queensland, Australia	warm – temperate	reflective	*
B	<i>Paphies</i>	<i>subtriangulata</i>	McLachlan et al, 1995	? - 30	?	-	New Zealand	warm – temperate	dissipative	*
C	<i>Emerita</i>	<i>analoga</i>	Dugan et al, 2000	6 - 34	"medium"	40†	California, USA	temperate	dissipative - intermediate	
C	<i>Lepidopa</i>	<i>californica</i>	Dugan et al, 2000	10 - 20	"medium"	140†	California, USA	temperate	dissipative - intermediate	
C	<i>Blepharipoda</i>	<i>occidentalis</i>	Dugan et al, 2000	25 - 65	"medium"	83†	California, USA	temperate	Dissipative - intermediate	

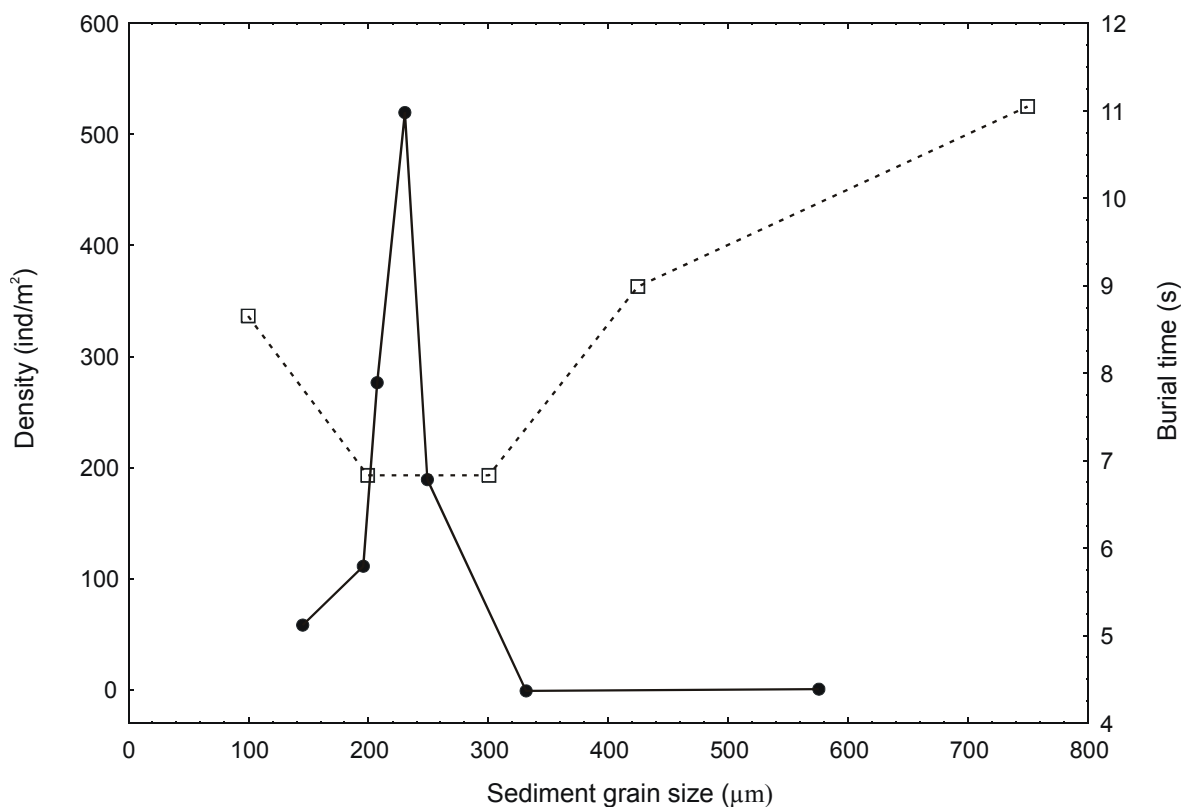




**Fig. 3.4.3** - Regression lines for Burrowing Rate Index (BRI) as a function of shell length. Numbers of lines refer to Table 3.4.1; \* indicates a significant regression, other regression are not significant. Dotted lines mark the margins between slow, fast and very fast burrowers.



**Fig. 3.4.4** – Burial time as a function of length of several surfing species, retrieved from literature and own research. Solid lines indicate bivalves, dotted lines gastropods and striped line indicate crustaceans. The bold dotted line is *O. semistriata*. Y-axis is cut off at 40 seconds. For regression equations, see Table 3.4.3.



**Fig. 3.4.5** – Average density (ind/m<sup>2</sup>) of *Olivella semistriata* (Y<sub>1</sub>-axis; solid line) and burial time of *O. semistriata* (Y<sub>2</sub>-axis; dotted line) versus sediment grain size (X-axis). Sediment grain size for the density data is the average median grain size per beach (see Table 3.4.4); for the burial time it is the median value of each sediment grain size class.

**Table 3.4.4** - Distribution of *Olivella semistriata* along the Ecuadorian Pacific coast. \* indicates erratic values (see text).

	Beach	BI	Median grain size (µm)	Slope	Swash standstill time (s)	Average density (ind/m <sup>2</sup> )	IST (ind/m)	Remarks
Quantitative	Ballenita	1.56	575	1/7	1.0	1.66 *	40.76 *	Very reflective beach
	Briceno	2.74	194	1/63	7.8	111.64	12459.33	Wide beach
	Olon	2.80	144	1/59	7.3	59.29	5650.50	Wide beach, some tourism
	Portete	2.12	331	1/19	2.1	Absent	Absent	Steep pocket beach
	San Clemente	2.48	248	1/38	/	190.06	14482.46	Very touristy beach
	San Pablo	2.46	229	1/34	5.6	519.82	31189.08	Very exposed
	San Pedro	2.50	207	1/36	6.1	277.08	16015.32	Artisan beach fisheries
Qualitative	Ayangue 1	2.48	165	1/32	-	Very abundant		Artisan fisheries and tourism; sheltered bay
	Ayangue 2	1.71	604	1/11	-	No <i>Olivella</i>		Steep pocket beach
	Crucita	2.33	261	1/29	-	Abundant		Touristy beach
	Pedernales	2.41	218	1/27	-	No <i>Olivella</i>		Pristine, undisturbed
	Playas	2.27	275	1/24	-	Abundant		Very touristy; in Guayas River mouth
	Punta Prieta	2.16	243	1/19	-	Scarce		Undisturbed, steep upper beach

### 3.4.4 Discussion

#### 3.4.4.1 Burrowing performance of *Olivella semistriata*

Burrowing abilities of the surfing gastropod *Olivella semistriata* were clearly affected by the sediment grain size, yet remained fast (<20 s) even in the coarsest sand we tested. Burrowing was fastest in fine to median sands as well as in the mixed sand and in field conditions. For all tested sediments burial time significantly increased with shell length. Similar results are reported in numerous studies for *Donax* (McLachlan *et al.*, 1995; Nel *et al.*, 2001; de la Huz *et al.*, 2002) and mole crabs (Dugan *et al.*, 2000; Lastra *et al.*, 2004). Values of the burrowing rate index (BRI) ranged between three and seven and did not vary with size, suggesting that burrowing is fast to very fast from an early age on and does not improve with age. This was also found in *Donax sordidus*, while BRI increased with shell length in *D. serra* (Nel *et al.*, 2001). The authors ascribed this to the large size of *D. serra*.

The only other known information on the burrowing of *Olivella semistriata* showed BRI values that were much lower than in this study (Dudley and Vermeij, 1989). They found a BRI of  $0.57 \pm 0.11$  or  $0.95 \pm 0.18$  when expressed in seconds (minutes were used by Dudley and Vermeij, 1989), whereas we found values of 3 to 7. So, even though their experiments were done in coarse sediments, there remains a big difference. This could be due to the temperature at which the experiments were conducted (24°C in this study; not mentioned by Dudley and Vermeij, 1989). McLachlan and Young (1982) demonstrated a clear negative impact of low temperature on the burial time of molluscs. Another difference between the two studies is that we worked with freshly caught animals, where Dudley and Vermeij (1989) kept the animals in the laboratory up to two days, which might have caused starvation and consequently a lower burrowing performance.

The burrowing performance of a mollusc is a function of shell form and structure, density of the animal, burrowing behaviour and sediment characteristics (grain size, thixotrophy and sorting). The relatively good burrowing performance of *Olivella semistriata* could be thanks to the smooth shell, strong foot muscle and large aperture (Vermeij and Zipser, 1986; Dudley and Vermeij, 1989).

Whereas bivalves are infaunal by origin and thus burrowing molluscs *par excellence*, gastropods are primarily adapted to rocky shores (Brown *et al.*, 1989). This might suggest that intertidal sandy beach bivalves are better burrowers than their gastropod counterparts. As far as burial time is concerned, this is contradicted by the results in Fig. 3.4.4: all three surfing gastropod species have burial times that are very similar to or even lower than the surfing bivalves. Taking biomass into account (BRI, see

Table 3.4.3) bivalves indeed seem to have the edge, although their burrowing mode (vertical and deep) is much more energetically costly than the oblique and superficial burrowing of gastropods (Brown *et al.*, 1989).

#### **3.4.4.2 Burial time and distribution of *Olivella semistriata***

Although the distribution pattern of *Olivella semistriata* along the beach type spectrum follows the inverse curve as the burial time (Fig. 3.4.4), it is very difficult to identify a cause-and-effect relation. The species is absent from beaches with median grain size above 300  $\mu\text{m}$ . This is more or less the sediment class present on beaches where the swash period starts to enter the burial time interval (Fig. 3.4.2: medium 2 sand). Swash period, however, is derived from the lower swash boundary (McArdle and McLachlan, 1992), whereas *O. semistriata* occupies the upper swash zone (Chapter 2 and 3). More important to the species is thus the swash interval at the position where they actually sit. Even on very reflective beaches the swash interval at the upper swash boundary is longer than the burial time of *Olivella semistriata*. Towards the dissipative end burial time likewise increases, while swash period and swash interval are much longer than on the intermediate beaches (McArdle and McLachlan, 1991 and 1992) where *O. semistriata* is very abundant. It thus seems unlikely that the low numbers or even absence of *Olivella semistriata* at both reflective and dissipative beaches is limited by their burial time.

#### **3.4.4.3 Burrowing performance of surfers**

It is clear from Fig. 3.4.4 that all investigated sandy beach surfers are fast to very fast burrowers. This is indeed a crucial requirement to survive on the exposed sandy beaches where surfers flourish (e.g. Brown *et al.*, 1989; Brown and McLachlan, 1990; Nel *et al.*, 2001; Lastra *et al.*, 2002). After riding a swash wave the animals have to be anchored to the sediment as soon as possible to prevent from being swept away by the next swash wave. This inspired Nel *et al.* (2001) and de la Huz *et al.* (2002) to name the swash period as a limiting factor for survival on sandy beaches. During downward migration the time they have to secure their position is indeed dependent on the swash period or swash interval. Swash interval decreases with increasing slope and from dissipative to reflective beaches, but increases shoreward within the swash zone (Short, 1999). During upward migration, however, the animals have to burrow themselves in the short period of swash standstill, in order to not be carried down the beach again by the same wave. Ellers (1995c), for instance, observed that *Donax variabilis* gains foothold

during or just after swash standstill, when the backwash starts to gain speed. Swash wave standstill is logically much shorter than swash interval. We thus hypothesize that not swash period or swash interval but swash wave standstill time combined with backwash velocity most probably is a limiting factor for the distribution of sandy beach surfers. Swash wave standstill generally decreases and backwash velocity increases towards the reflective beach spectrum (Short, 1999) and is, as such, a valuable part of the swash exclusion hypothesis (McLachlan *et al.*, 1993).

When the swash standstill time (of the upper swash limit) is plotted on the burial time/sediment class graph (Fig. 3.4.2), we can now see that, except for very fine and fine sands, burrowing is not fast enough to be completed while the swash wave is fully extended. If we assume that *Olivella semistriata* can still burrow at low currents, the time they have to burrow could be lengthened (both before and after swash standstill) by a few seconds, bringing medium 1 sand (<350  $\mu\text{m}$ ) into the choice of sediment they could live on. Coarser sands in combination with steeper beaches are well outside the tolerance range of the species. So, the burrowing capacity of *O. semistriata* indeed is probably a limiting factor for the distribution towards the reflective end of the beach spectrum.

However, burrowing performance does not explain the low number we found on flat beaches with fine sands. Cubit (1969) hypothesized that surfers require a certain swash action, not reached on dissipative beaches, to be able to surf. This is possibly because a minimum swash velocity is necessary to orientate in the swash (Eilers, 1995c). In Chapter 6 we added that intertidal distance is becoming so long on dissipative beaches that surfing is not an energy efficient strategy anymore.

#### **3.4.4.4 Measuring burrowing performance: some complexities**

It has to be noted that burial time itself might not be a good measure for the capability to cope with certain swash conditions. Burial time is generally considered as the time between start of the burrowing movement till the animal is completely covered by sand, and is generally measured in stagnant water (McLachlan and Young, 1982; McLachlan *et al.*, 1995; Dugan *et al.* 2000 and many others). Gaining foothold in the substratum, however, can be secured before the animal is completely covered, especially in bivalves and gastropods, substantially reducing what could be called the *minimal burial time*. Trueman (1971), for instance, found that *Donax* had to be buried at least 2/3 to be anchored securely. This is ecologically more relevant than burial time itself. Note that the *minimal burial time* is dependent on the swash velocity and hence the beach morphodynamics. Additionally, we have observed in the field that burrowing can be speed

up by several second due to sediment transportation in the swash (data not shown). Unfortunately, it is very difficult to investigate the direct influence of wave standstill and sediment transportation on the burrowing or more important the anchoring of swash fauna. Detailed information could be obtained by combining field measurements and experiments in a swash rig (Chapter 5) or a flume tank. To our knowledge, the only attempt to measure burrowing capacity in running water conditions was done by Yannicelli *et al.* (2002) on two *Excirolana* species. They did not find an influence of current. Unfortunately the highest water velocity they used (0.3 m/s) is 10 times lower than the highest swash velocity we measured in the field.

Just as burial time is maybe ecologically not as relevant as previously argued, the same could be said about the Burrowing Rate Index (see also Brown and Trueman, 1994). The BRI was intended to compare different species by calculating the burial time per unit of mass (Stanley, 1970). High values indicate fast burrowers. Large species, however, can be categorized as very fast burrowers because of their weight, although their burial time is very high. And in perspective of withstanding swash conditions, it is the burial time – or minimal burial time as advocated earlier – that is crucial. A large bivalve, for instance, can have a BRI value of 6, just as a lighter and smaller species, yet its burial time will be two or three times higher. This could exactly make the difference between securing position before the next wave comes in or not. Still, the absolute mass of an animal does influence its capacity to cope with certain wave conditions: lighter animals will be carried away at lower swash velocity than heavier species. So weight is important in the ecological relevance of burrowing. Since the *minimal burial time* should be measured in running water, it will automatically inflict the impact of weight.

Another complicating factor in the burrowing of surfers is orientation. Surfers that filter the backwash have to be orientated correctly to do so. *Emerita*-species, for instance, burry themselves seaward (Caine, 1975), whereas *Olivella semistriata* is oriented with the shell mouth shoreward (own observations) and *Donax* burries vertically, anterior end first (Brown *et al.*, 1989; Ellers, 1995c). The correct orientation can be obtained while surfing, just before burrowing or during burrowing. *Donax variabilis* generally burrows in the backwash, even when moving upshore, and is – due to the shell shape - passively orientated with the anterior end shoreward, ready to burrow (Ellers, 1995c). It is thus unlikely that orientation will lengthen the burial time. The same is true for *Emerita*, which turns around before starting to burrow (own observations). *Olivella semistriata*, in contrast, turns around while burrowing during downward migration. We have noted in the field that this can elongate the burial time by several seconds. They only start to turn, however,

after they are buried for about 2/3, so we can assume that this has no effect on the *minimal burial time*.

### 3.4.5 Conclusions

- 1) Burial time of *Olivella semistriata* is dependent on sediment grain size and shell length, and lengthens with increasing grain size and shell length.
- 2) BRI values were found between 3 and 7, indicating that burrowing is fast to very fast.
- 3) Apart from a few exceptions all macrobenthic surfers show fast to very fast burrowing, with by far the best performances for the mole crabs.
- 4) Bivalves and gastropods have comparable burrowing capacities.
- 5) Burial time was not found shorter than the swash period, even under very reflective conditions.
- 6) We hypothesize that not swash period but swash standstill time at maximum run-up is a limiting factor for *Olivella semistriata* and other mollusc surfers.
- 7) Swash standstill time on reflective beaches was found to be much shorter (< 4 s) than burial time, and is thus in agreement with the swash exclusion hypothesis. We can conclude that the burrowing capacity of surfing molluscs is indeed very likely limiting for their macroscale distribution.





## CHAPTER 5

# CAN SANDY BEACH MOLLUSCS SHOW AN ENDOGENOUSLY CONTROLLED CIRCATIDAL MIGRATING BEHAVIOUR? HINTS FROM A SWASH RIG EXPERIMENT.

---

Vanagt T., Vincx M., Degraer S.

Submitted to *Marine Ecology*

Keywords: sandy beach, swash, swash rig, macrofauna, *Olivella*, endogenous rhythm, tidal clock.

## Abstract

Many macrofaunal species inhabiting exposed sandy beaches are dependent on the swash for their nutrition and for migration and are highly adapted to the harsh physical conditions of the swash. The most important physical factors that determine the distribution and behaviour of swash related fauna, next to the swash itself, are sediment grain size and beach slope. Crucial swash parameters are swash period and swash velocity. Studying the influence of these factors on the animals in the field is often very difficult and it is almost impossible to identify which factor causes what effect.

Crucial knowledge about the direct role of the swash itself is lacking. Therefore a device that generates swash waves on an artificial beach under laboratory conditions was designed: the swash rig. In the swash rig, full and independent control on sediment grain size, beach slope, swash velocity and swash period is present. This will allow us to do a variety of experiments on the influence of each of these factors, independently or combined, on swash fauna.

In one such experiment, *Olivella semistriata* - a dominant surfing gastropod on Ecuadorian sandy beaches – was placed in the swash rig during rising and falling tide and subjected – under constant conditions - to an equal wave regime. During falling tide, and in absence of any tidal cue, almost all specimens moved downshore, as they would in the field; hardly any specimens moved upshore. During upcoming tide, however, there was noticeable upward migration in the swash rig, and half of the runs showed a net upward migration.. Contrary to the common understanding that the behaviour of sandy beach molluscs is entirely environmentally driven, this experiment hints to the presence of an endogenous circatidal clock which is used to direct the tidal migration of the species.

### 3.5.1 Introduction

Exposed sandy beaches are one of the world's most hostile environments because of the high degree of disturbance. It is mainly the combination of heavy wave action with an unstable substratum that makes life so hard on a sandy beach. The most important adaptations required to survive under these conditions are rapid and powerful burrowing and a high degree of mobility (Brown and McLachlan, 1990). It is also essential that the animals can maintain or regain their position on the shore. Only very few taxa have developed these skills. It is mainly crustaceans, together with some mollusc species, that have been successful on exposed sandy beaches (Brown and McLachlan, 1990; Dexter, 1992; McLachlan and Jaramillo, 1995). Many of these species are 'swash riders' or 'surfers', who use the swash to migrate over the beach (Naylor and Rejeki, 1996). They have also developed several strategies to feed in the swash zone, such as filtering the backwash. Living in the swash zone provides the fauna with an almost unlimited and easily accessible food supply (Brown and McLachlan, 1990). Moreover, the time of exposure to predation is very short. Marine predators such as large crustaceans and surf-zone fish, as well as terrestrial predators such as birds, do not have enough time to find their prey because of the swash (Dugan *et al.*, 2004).

Swash dependent fauna is found on a range of beach types, from intermediate to highly reflective beaches, from beaches with very fine to very coarse sediment. Some species can inhabit a variety of beach types, such as the mole crabs of the genus *Emerita* (Jaramillo *et al.*, 2000a) and *Hippa* (Lastra *et al.*, 2002), whereas other species are limited in their distribution to a specific beach type (Brown *et al.*, 1989). Several interdependent physical factors, e.g., sediment grain size, breaker height and intertidal beach slope may limit the distribution of macrofauna on exposed sandy beaches (reviewed in Brown and McLachlan, 1990). Yet, more recent studies (McLachlan *et al.*, 1993, 1995) suggest that also the swash climate itself, and especially the number of effluent line crossing, plays a crucial part in the distribution of mobile macrofauna on exposed beaches. This theory, known as the 'swash exclusion hypothesis', states that the decrease in number of species and decrease in densities from dissipative to reflective beaches is caused by an increase in swash harshness towards the reflective end of the beach spectrum (McLachlan *et al.*, 1993).

Studying swash fauna *in situ* cannot reveal all information about the mechanisms behind the behaviour and distribution of these animals. To understand the underlying mechanisms, it is crucial to have independent control over the different physical parameters, which explains the need for laboratory experiments. So far experimental work

on swash fauna has always been performed in aquaria (Ellers, 1995a; McLachlan and Young, 1982; Naylor and Rejeki, 1996) or flumes (Warman *et al.*, 1993; Ellers, 1995b; Yannicelli *et al.*, 2002). Although valuable results were obtained, these studies pass by the crucial factor for swash fauna: the presence of swash waves, as was for instance acknowledged by Ellers (1995b). If one wants to investigate the influence of physical factors on the distribution, migration and feeding behaviour of swash fauna, a 'swash simulating device' with independent control of swash period, swash velocity, beach slope and sediment grain size is needed. Based on a design used by Dr. O'Donoghue and colleagues from the University of Aberdeen, Scotland, we built a 'swash rig'. In this paper, we illustrate the functioning and application of this swash rig by means of an experiment on *Olivella semistriata*.

Exposed sandy beaches along the Pacific coast of Ecuador are dominated by the snail *Olivella semistriata* (Chapter 1, Addendum 1). These molluscs live in the upper part of the swash zone, where they filter the backwash (Chapter 6). They maintain their position by surfing. Previous tests showed that in absence of swash waves, experiments of the surfing behaviour of the species were bound to fail. We hypothesized that this could be solved by using the swash rig.

In a first test of the effectiveness of the swash rig, the presence of an endogenous circatidal clock in the migration behaviour of *Olivella semistriata* was investigated. It has been demonstrated for several crustacean swash species that the tidal rhythm in activity is directed by an endogenous clock. Due to this internal clock, the tidal behaviour often remains present in the laboratory for several tidal cycles, even in the absence of a tidal cue. Alheit & Naylor (1976) showed that *Eurydice pulchra*, kept in aquaria without tidal regime, mainly swims at times of high tide, and this behaviour persisted for more than 5 tidal cycles. Similar responses have been described for *Excirolana* and other crustaceans (Enright, 1972; Yannicelli *et al.*, 2001).

Evidence for an internal circatidal clock in sandy beach molluscs, however, is missing. The regulation of the observed tidal migrations have been ascribed to the changing physical conditions during ebb and flow (Ansell, 1983; Brown *et al.*, 1989). For *Donax variabilis* the specific trigger that initiates migration is the sound of incoming waves (Ellers, 1995b), for other *Donax* species it is probably the change in liquefaction of the substratum (Trueman, 1971). Ellers (1995b) noted that the regulation of these environmental-driven triggers, however, could be by an endogenous clock. The swash rig hands us a unique tool to investigate the response of a surfing mollusc to swash under controlled laboratory conditions.

## 3.5.2 Material and Methods

### 3.5.2.1 Description of the swash rig

The concept of generating swash waves by using a gate system was derived from a model used by Dr. O'Donoghue and colleagues from the University of Aberdeen, Scotland (<http://www.eng.abdn.ac.uk/envhrg/facilities/swashrig.hti>). The original design consists of a swash rig with a built-in wave generating device. We made several modifications to that model, which was originally designed to generate just one swash wave per experiment.

#### 3.5.2.1.1 Wave generating device (Fig. 3.5.1)

The wave generating device is a wooden box (18mm water resistant plywood) with two gates, dividing the box in two parts (Fig. 3.5.1). Measures are 80x100x50cm (w $\times$ l $\times$ h), with the inner gate at 20cm from the front and the outer gate at the front of the box. The part behind the inner gate is the reservoir, where the water input (2x 40 l/min) is located. This reservoir is perforated by several holes at different heights. By adding or removing taps in this holes, the maximum water level can be controlled without changing the water input. The front part contains the water that will be released to create a swash wave. By lifting the inner gate, the front part is being filled by water coming from the reservoir (Fig. 3.5.2a). After closing the inner gate, the outer gate can be opened. Lifting this gate at high speed will create a surfing wave (Fig. 3.5.2b). Immediately after releasing the water, the front gate can be closed, and the process can start again (Fig. 3.5.2c). This device can easily be manipulated by one person.

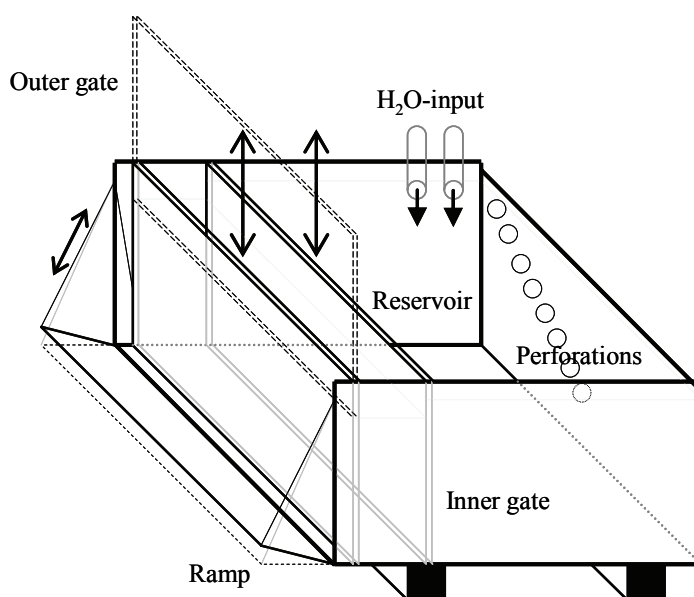
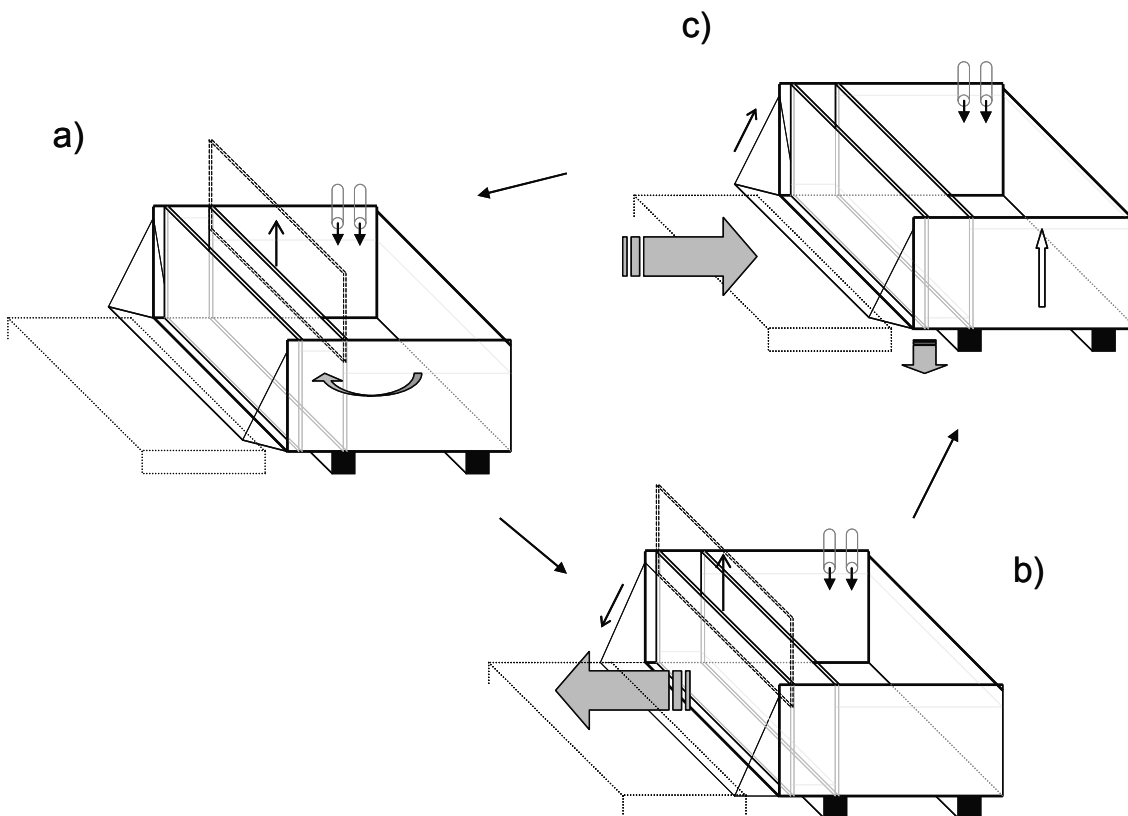


Fig. 3.5.1 - Wave generating device.

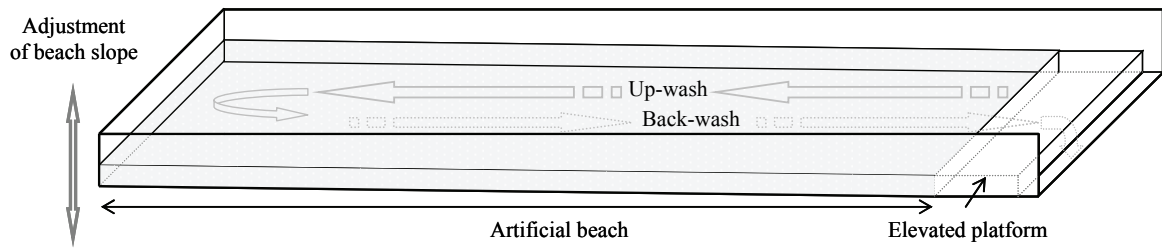
To have the water from the backwash removed from the swash rig, there should be a gap between the swash rig and the wave generating device. The incoming wave, however, should enter the swash rig without finding obstacles such as a gap. To achieve this, we attached a ramp to the front of the wave generating device. This ramp is operated by the front gate, in such a way that the ramp is opened with the front gate closed, and closed by opening the front gate (Fig. 3.5.2b). When opened, the outlet of the swash rig is opened so that the backwash can run away. When closed, the ramp serves as a 'bridge' for the incoming swash wave.



**Fig. 3.5.2** - Working of the wave generating device. a) lifting of the inner gate; b) closing inner gate and lifting outer gate, creation of swash wave; c) closing of outer gate, filling of reservoir.

### 3.5.2.1.2 Artificial beach in the swash rig (Fig. 3.5.3)

The rig containing the beach is made of polyester around a plywood body. Dimensions are 80x450x30cm (w<sub>x</sub>l<sub>x</sub>h). This rig is not attached to the wave generating device, which allows for changing the beach slope. The first 50cm of the tank has a 10cm elevated platform in polyester, on which the incoming swash wave lands (Fig. 3.5.3). This platform also holds the sediment in place. The beach itself is thus 4m long and 80cm wide, with a sediment depth of 10cm.



**Fig. 3.5.3** - Artificial sandy beach. Arrows indicate swash movement.

#### 3.5.2.1.3 Limitations of the experimental setup

For our experiments with *Olivella semistriata*, the dimensions of the swash rig are satisfactory. The distance the animal travels on the beach is generally less than four meters (Chapter 6), so a beach length of four meter was sufficient for the goals we set.

The maximum amount of water that could be released at one time, 80 l, was just sufficient to create a swash wave till the upper part of the artificial beach at a beach slope of 1/10, which is much steeper than the steepest beach where we recorded *Olivella semistriata* in Ecuador (1/19; Chapter 4), and steeper than the slope we used for the endogenous clock experiment (see further). With a double input of 40 l/min, a maximal wave could be generated every minute, which is more frequent than the average interval between two waves entering the swash zone where *Olivella semistriata* lives (75 seconds).

According to the animals one wants to study, the dimensions of the swash rig could easily be changed. We doubt it would be very useful to narrow the beach, but beach length could be adjusted to the needs of the particular research. The maximum swash volume and thus swash speed can be controlled by changing the position of the inner gate and the position of the holes in the reservoir. A higher frequency of swash waves could be achieved by increasing the water input and/or increasing the volume of the reservoir.

#### 3.5.2.1.4 Problems

The only real problem we encountered was erosion. Because of the turbulence created by the entering swash wave, sediment is eroded from the lower part of the beach and deposited higher on the beach. Hence, after a number of waves, an even slope will turn into an S-shaped profile. As a result of this, there will always be some water at the

base of the beach after the wave recedes. This reduces the swash velocity of the next incoming swash wave. The formation of this small water volume takes place after the first swash wave, however, so we think it should not influence the results as long as the very first wave is not included in the experiment. In order to reduce the erosion, which is probably due to the abrupt change in consistency from the elevated platform to the sediment, we placed a rigid plastic net with 1 mm mesh-size over the first 30 cm of the beach. This reduced the erosion process substantially.

The change in beach morphology did not interfere with the kind of experiments that were done so far, but it might become a problem when tackling other aspects of surfing.

### **3.5.2.2 *Olivella semistriata* endogenous rhythm experiment**

#### *3.5.2.2.1 Study site and period*

The experiments were conducted in the Centro de Investigacion Acuicultura y (CENAIM) in San Pedro, Ecuador. Animals were collected from the beach in front of the institute. The macrofaunal zonation of this beach is described in Addendum 1. Swash zonation of *O. semistriata* from this location is discussed in Chapter 2 and 3. The experiments took place between June 6<sup>th</sup> and July 23<sup>rd</sup> of 2005, on 10 different days, during daylight hours. A total of 27 experimental runs were performed.

#### *3.5.2.2.2 Swash rig setup*

The sediment was brought from the intertidal of the same beach as the studied population; sediment was refreshed every two days. Sediment analysis was done using a laser COULTER LS. The slope of the artificial beach was similar to the slope of the San Pedro beach (1/30). Sea water was pumped from the surf zone of the same beach, and had the same temperature as in natural conditions.

#### *3.5.2.2.3 Collecting and treating animals*

Live animals were collected 3 h before and after low tide, using a net with 1 mm mesh-size. Only animals larger than 5 mm were used, since smaller specimens do not show the same migrating behaviour as the larger ones (Chapter 3). The animals were immediately brought to the laboratory (average travelling time of 5') and placed in the artificial beach. About 1000 individuals were placed in a patch of 30x30 cm. Burrowing



was stimulated by creating a gentle water stream, until all animals were fully burrowed. Before the start of the experiment, two gentle swash waves were created to wash out specimens that were not adjusted to the new conditions.

Another 1000 individuals were kept in trays of 30x20x4 cm, filled with 1 cm of sediment and 1 cm of sea water. These individuals were used in the swash rig 6 h after collection. After the experiment, all the animals were collected and placed back in their natural habitat.

#### 3.5.2.2.4 Wave regime

The swash was monitored in the field where densities of *O. semistriata* were very high (easily visible as a dense band). The average recorded wave interval was used in the swash rig. The wave distance and velocity was kept constant over all the experimental runs. Swash waves were filmed using a 50 Hz video camera. Per experimental run, five waves were released. The migrating animals were collected using a net with 1mm mesh-size just above and below the patch. To minimize the influence of the nets on the swash wave, the upper net was only applied during the water up-rush, the lower net during the backwash. After the experiment, the artificial beach was cleared from any remaining specimens by sieving the upper 5 cm of the substratum over a 1 mm sieve.

#### 3.5.2.2.5 Data analyses

Swash velocity was calculated from the time the up-wash and backwash need to cover a fixed distance.

Total number of upward and downward migrating animals was pooled per experimental run, and a ratio of up- and downward migration was calculated as followed:

$$ratio = \frac{\text{number of downward migration} + 1}{\text{number of upward migration} + 1}$$

If ratio >1 there is a net downward migration. Differences in migration ratio between treatments was tested with a Generalized Linear Mixed Model (GLMM), with *tide*, *postponement* (i.e. tide + 6 hours) and *tide\*postponement* interaction as fixed effects. Therefore, the proc GLIMMIX syntax was used in SAS 9.1.3 software (with binomial distribution and logit-link function)(McCullagh and Nelder, 1989).

### 3.5.3 Results

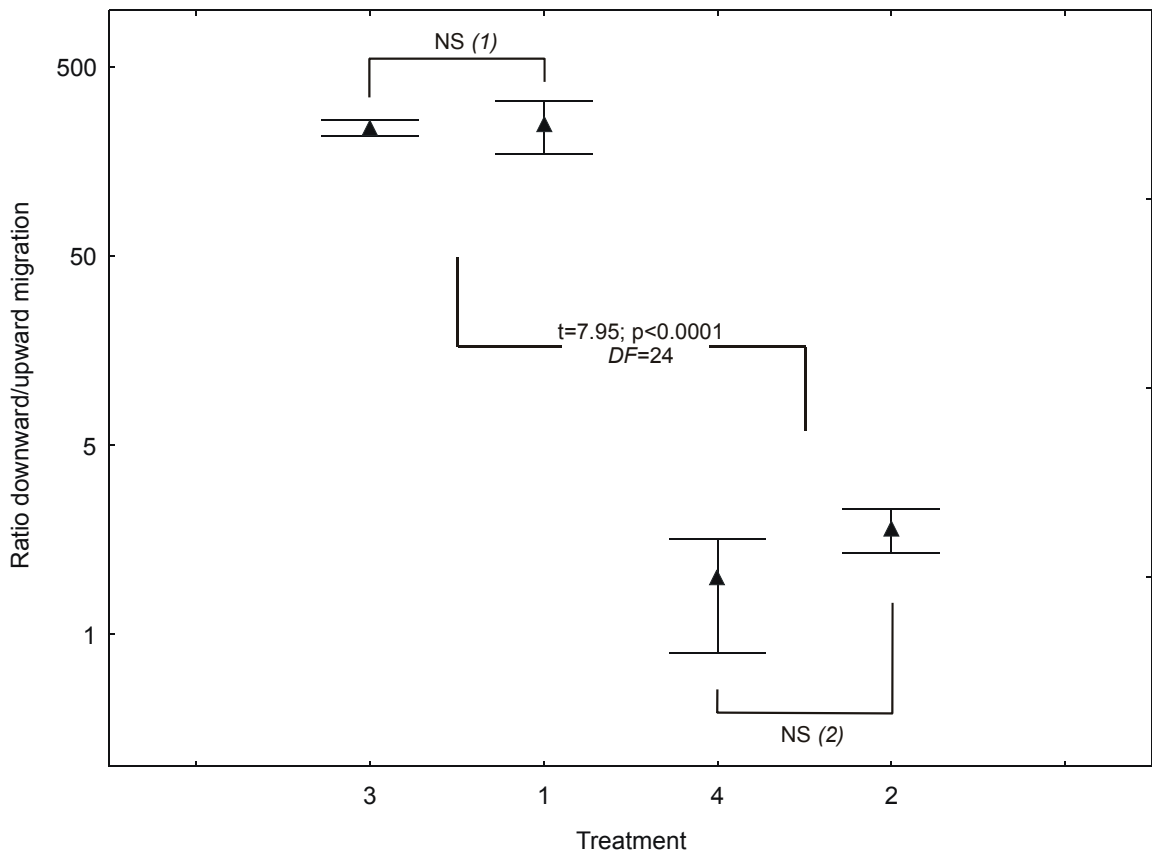
Average swash period at the place where *Olivella semistriata* was present in high densities, was 75 seconds. This swash interval was applied in the swash rig. The sediment that was used in the swash rig consisted mainly of fine to medium sands (125-500  $\mu\text{m}$ ). The median grain size was 212  $\mu\text{m}$ . Swash velocity on the beach ranged from 0.21 to 3.00 m/s (average  $1.22 \pm 0.47$  m/s); in the swash rig we set the swash velocity slightly higher at 2.0 m/s, to stimulate migration.

From the total of 27 experimental runs, 15 were done during falling tide (treatment 1+3) and 12 during upcoming tide (treatment 2+4). Ten runs were done with animals that had been kept in tanks for six hours. Six of these were with animals that were collected during upcoming tide and placed in the swash rig during falling tide (treatment 3); four runs were performed during upcoming tide with specimens that had been collected six hours prior, during falling tide (treatment 4).

None of the runs during falling tide (treatment 1+3) had a net upward migration, the maximum number of individuals migrating upward was 6 (Table 3.5.1). Three out of eight and three out of four of the runs during upcoming tide (treatment 2 and 4 respectively) had a net upward migration, with at least 11 and on average 46 individuals migrating upward (Table 3.5.1; Fig. 3.5.4). The ratio ranged from 0.07 to 3.36 for upcoming tide (treatments 2 and 4) and 41 to 301 for falling tide (treatments 1 and 3). No differences were found between the runs that were tested at the same tidal state, i.e. treatment 1 and 3 and treatment 2 and 4 did not differ statistically. The total number of migrating individuals was much lower during upcoming tide (a maximum of 207) compared to falling tide (a maximum of 822).

**Table 3.5.1** - Number of downward/upward migrating individuals, with the ratio between brackets. Ratio values < 1 indicate a net upward migration.

treatment 1	treatment 2	treatment 3	treatment 4
411/6 (59)	22/40 (0.56)	819/3 (205)	77/28 (2.69)
192/2 (64)	20/62 (0.33)	237/0 (238)	4/71 (0.07)
163/3 (41)	47/17 (2.67)	740/3 (185)	34/64 (0.54)
601/1 (301)	110/32 (3.36)	161/1 (81)	82/125 (0.66)
441/1 (221)	117/36 (3.19)	595/2 (199)	
183/0 (184)	14/11 (1.25)	223/1 (112)	
182/1 (92)	15/48 (0.33)		
284/0 (285)	48/18 (2.58)		
665/2 (222)			



**Fig. 3.5.3** - Average  $\pm$  SE of the downward/upward migration ratio (log-scale) of the four different treatments. Differences between treatments were tested with a GLMM: NS (1):  $t=-0.27$ ;  $p=0.7916$ ;  $DF=23$ . NS (2):  $t=1.95$ ;  $p=0.0629$ ;  $DF=23$ .

### 3.5.4 Discussion

When we started investigating the swash behaviour of the sandy beach snail *Olivella semistriata*, a dominant species on exposed Ecuadorian beaches (Chapter 1; Addendum 1), we were soon confronted with the limitations of using aquaria and flow tanks for experimental work. In the absence of waves, the animals did not behave accordingly to field observations. We thus needed an experimental setup that would enable us to create swash waves in a controlled environment. The swash rig as described in this paper proved to serve the task.

#### 3.5.4.1 Research possibilities

The possibilities a swash rig provides for experimental work are very promising. First of all, the question which of the major physical parameters of sandy beaches has a determining influence on the distribution and the behaviour of sandy beach macrofauna can be addressed. Some authors suggest that it is the sediment size that limits species towards reflective beaches (Nel *et al.*, 2001; de la Huz *et al.*, 2002), whereas others think this is due to the beach slope or the wave action (reviewed in Brown & McLachlan, 1990). McLachlan *et al.* (1993) hypothesized that it is the swash climate itself that makes it impossible for some species to survive on reflective beaches. In the swash rig, each of the physical parameters can be changed in a controlled way, keeping the others constant.

Other possibilities include investigation of endogenous rhythms (see further) or endogenous sense of orientation. The latter could be studied by changing the position of the artificial beach relative to the position of the natural beach. Also more complicated studies on a longer term, for instance to detect circa-tidal, circa-diurnal or circa-lunar cycles lie within the possibilities of a swash rig. This, however, would imply the need for an automatization of the wave generating device.

#### 3.5.4.2 Endogenous rhythm experiment with *Olivella semistriata*

During falling tide, and in absence of any tidal cue, almost all specimens moved downshore, as they would in the field; hardly any specimens moved upshore. During upcoming tide, however, there was noticeable upward migration in the swash rig, and half of the runs showed a net upward migration. We could demonstrate that this rhythm remains present for at least half a tidal cycle: animals that were collected during upcoming tide (mid-tide) and kept under constant laboratory conditions migrated downward six hours later (during falling tide) and vice versa. Since the conditions in the swash rig were

identical during all runs, these results can be best explained by an endogenous circatidal clock.

Two degrees in endogenous circatidal behavioural control exist. The simplest form is an endogenous clock which tells the animals the state of the tide. As a result, the response of species to migration cues ('triggers') such as changes in thixotrophy, light intensity or direction or hydrostatic pressure is different during upcoming and falling tide (Warman *et al.*, 1993; Naylor and Rejeki, 1996). The most common, yet most complex, form is an endogenous rhythm in behaviour: animals show a different degree of activity depending on the tidal state and depending on directional or non-directional cues.

Both types of endogenous behavioural control help intertidal fauna to maintain or regain their position on the beach and are thus important in structuring intertidal zonation (Yannicelli *et al.*, 2001; Thurman, 2004; Forward *et al.*, 2005). Endogenous rhythms have been found in several sandy beach taxa, though mainly crustaceans. When placed in aquaria under constant conditions, cirrolanid isopods of the genus *Excirrolana* and isopods of the genus *Eurydice*, all inhabiting the upper part of the beach, retain their natural activity rhythm: swimming around high tide and remaining burrowed for the rest of the tidal cycle (*E. braziliensis*: Yannicelli *et al.*, 2001; *Eurydice pulchra*: Alheit and Naylor, 1976; Naylor and Rejeki, 1996). Similar results were found for downshore migrants, such as *Talitrus saltator*, and upshore migrants, such as *Crangon crangon* and *Carcinus maenas* (reviewed by Naylor and Rejeki, 1996). Other examples of sandy beach crustaceans showing endogenous tidal behaviour are the amphipod *Bathyporeia pilosa* (Preece, 1971) and the mole crab *Emerita talpoida* (Forward *et al.*, 2005). Along with a circatidal rhythm, these species often possess a circadian and a circalunar rhythm (Alheit and Naylor, 1976; Naylor and Rejeki, 1996; Thurman, 2004). The endogenous response can persist under laboratory conditions for several tidal cycles, and even up to several weeks (Enright, 1972; Forward *et al.*, 2005). Enright (1972) suggested that a long-lasting endogenous response is necessary for species inhabiting a zone on the beach which might only be flooded around spring high tide. For the surfer *O. semistriata*, which migrates over the full intertidal width (Chapter 2, 3) stranding will probably never last longer than half a tidal cycle, so the endogenous response of six hours as demonstrated in this paper seems sufficient. Note that we did not test whether the endogenous response lasts for longer than six hours.

Endogenous circatidal rhythms in tidal migrants are often expressed as changes in response to exogenous non-directional or directional cues, helping the animals to

maintain position on the beach. In other species like the surfing mole crab *Emerita analoga*, however, there is no endogenous rhythm in response to environmental cues and the migratory process is solely regulated by changes in the thixotrophy of the sediment (Cubit, 1969), although this was earlier contradicted by Enright (1963) and Efford (1965). The surfing clam *Donax variabilis* seems to show an endogenous tidal response to sediment agitation, but this response is symmetrical and consequently does not tell the difference between upcoming and falling tide (Eilers, 1995b). Brown *et al.* (1989) stated that nor the surfing clam *Donax serra*, nor the surfing whelk *Bullia digitalis* possess an endogenous clock. Thus, it seems that species that actively swim (amphipods, isopods) need endogenous rhythms for cross-shore migration, whereas in surfers that float with the waves (mole crabs, clams) this is regulated by the interaction between waves and sediment, with a less clear role for circatidal rhythms. *Olivella semistriata*, however, is a surfer but nonetheless shows an endogenous circatidal migration behaviour, which discriminates between upcoming and falling tide.

An endogenous circatidal response to directional cues seems to be a necessary characteristic for the surfing gastropod *Olivella semistriata*. It does not, however, suffice for successful tidal migration since it does not solve the problem of timing of the individual migration movements. The 'trigger' for tidal migration excursions could be changes in temperature, salinity, hydrostatic pressure, inundation, sediment thixotrophy or mechanical agitation (Brown and McLachlan, 1990). For *Donax variabilis*, for example, it is the sound of large incoming waves that gives the animals the cue when to jump out of the sediment and ride a wave (Eilers, 1995b). At this stage, we do not know what the exact trigger is for *O. semistriata* to use a specific wave for surfing. From field observations we know that the species is very sensitive to mechanical agitation of the sediment (they emerge from the sediment upon mechanical pressure), suggesting that sediment thixotrophy could be triggering migration; further investigation, however, is needed to evaluate this. Detection of the swash direction, crucial for cross-shore migration, could be through the siphon, which sticks out of the sediment when they are burrowed. This is in contrast to migrating crustaceans, where current detection is thought to be through phototaxis (Alheit and Naylor, 1976; Forward, 1986; Warman *et al.*, 1993).

With the kind of experiment performed during this study, it is difficult to judge the efficiency of the endogenous clock. During some runs, the number of migrating specimens was quite low. Laboratory experiments concerning endogenous circatidal rhythms may indeed sometimes exhibit contradicting results, with only part of the investigated specimens showing tidal behaviour (Warman *et al.*, 1993; Eilers, 1995b; Palmer, 1995).

This does not explain why downward migration was much more efficient in the swash rig than upward migration. A possible explanation is that the transportation to the laboratory of the animals resets the tidal clock, since it could be considered as being stranded above the high tide level. A longer period without environmental cues, such as waves, has indeed been shown to reset tidal clocks (Warman *et al.*, 1993; Palmer, 1995).

### 3.5.5 Conclusions

- 1) The swash rig as described here is the first experimental tool that allows scientists to investigate swash-related organisms in the presence of possibly their most influencing environmental factor: the swash.
- 2) We demonstrated that the surfing of the sandy beach gastropod *Olivella semistriata* could be controlled by a circatidal endogenous clock.
- 3) The endogenous clock is manifested as a directional control over non-directional triggers for migration, which enables the animals to distinguish between upcoming and falling tide.
- 4) The presence of an endogenous circatidal migration behaviour is crucial in explaining the surfing pattern of this species.





## CHAPTER 6

### **SURFING ON SANDY BEACHES: AN EFFICIENT STRATEGY TO FLOURISH IN A HIGHLY DYNAMIC ENVIRONMENT?**

---

Vanagt T., Merckx, B., Vincx M., Degraer S.

Paper in preparation

Keywords: surfing, swash, *Olivella*, sandy beaches, feeding, time budget.

## Abstract

The gastropod *Olivella semistriata* is a dominant surfer on exposed, intermediate beaches in the tropical part of the East-Pacific. The impact of the swash dynamics on the feeding behaviour of the species was studied in order to improve the understanding of the swash zonation pattern of *O. semistriata*, and its general success on beaches.

The feeding activity of dense patch of *Olivella semistriata* was monitored for 5 to 15 min, while simultaneously noting the swash dynamics. *Feeding time* and *feeding rate* (both expressed per wave) were a function of three swash parameters: *swash distance* (i.e. swash run-up above the monitored patch), *swash time* (immersion time of the patch by a swash wave) and *swash interval* (time between two consecutive swash waves). The longer the swash time, the longer species could feed upon the backwash. Large waves were generally less favourable for feeding: the possibility of the next swash wave interrupting the backwash was very high.

With the combination of the swash parameters (distance, time and interval), the feeding parameters could be modelled in terms of the swash position (i.e. the position relative to the swash boundaries). Both feeding time and feeding rate were found to follow a skewed unimodal curve within the swash zone, with highest feeding time and feeding rate in the upper half of the swash zone. Maximal feeding rate was modelled to be 32.25%. The feeding curves over the swash zone show remarkable similarities with the swash zonation of *Olivella semistriata*, suggesting that the zonation of the species is a result of the feeding opportunities.

A migration model was built to calculate the total feeding time of *Olivella semistriata* per 6 hours as a function of distance travelled per surfing movement. The highest feeding time was found at 17 surfing movements per 6 hours, or 3.5 m per movement (on a beach of 60 m wide).

Finally, using the migration model, a time budget for *Olivella semistriata* was calculated. With the optimal surfing distance of 3.5 m, just over 1% of the time has to be spent surfing (0.16% for emerging from the sediment, 0.47% for surfing itself and 0.73% for burrowing). This allows the species to feed during 30.26% of the time. Under the same conditions, a hypothetical non-migratory species would only be able to feed during 5.72% of the time. Thus, spending no more than 1% of the time or around 5% extra energy by surfing increases the feeding time by 529%, clearly demonstrating the benefits of this behaviour.

### 3.6.1 Introduction

Surfing or 'swash riding', a behaviour in which the swash is used to migrate over the beach face, has been a very successful strategy for animals inhabiting exposed sandy beaches. Surfing is found in a range of molluscs and crustaceans. Well-known examples are the beach clams of the genus *Donax* (Ellers 1995a), beach whelks of the genus *Bullia* (Trueman and Brown, 1976; Brown, 2001) and mole crabs of the genera *Emerita* (Cubit, 1969), *Hippa* (Lastra *et al.*, 2002) and *Lepidopa* (Dugan *et al.*, 2000). Filter feeders, such as *Donax* and most of the mole crabs, use surfing to maintain optimal feeding conditions in the swash (McLachlan and Brown, 2006); *Bullia* rides swash waves in pursuit of its prey (Brown, 2001). They all share several characteristics which are necessary for surfing: (1) active emergence from the sediment; (2) mainly passive though partially controlled riding of the swash – wave uprush when migrating upshore and backwash when migrating downshore; and (3) fast burrowing.

Another example of surfing behaviour is found in the olivid gastropod *Olivella semistriata*, a dominant species on exposed sandy beaches of the intermediate type along the East-Pacific coast of Ecuador (Chapter 1; Addendum 1). Its surfing consists of actively crawling out of the sediment, floating with the swash, using its extended metapodium to control the movement (Olsson, 1956; personal observations), and actively burrowing after surfing. A mucus net between the extended tentacles is used to filter the backwash. No empiric information exists about the surfing itself, although field observations suggest *O. semistriata* surfs in a similar way as other swash riders such as *Donax* (Ellers, 1995), *Bullia* (Brown *et al.*, 1989) and *Emerita* (Cubit, 1969; Caine, 1975).

Surfing has been investigated in numerous macrofaunal species (Ansell and Trueman, 1973; Brown, 1982, 2001; Brown *et al.*, 1989; Cubit, 1969; Dugan *et al.*, 2000; Ellers, 1995a,b,c; Forward, 1986; Lastra *et al.*, 2002, 2004; this thesis). Some studies concentrated on the intertidal dynamics of the surfer's population (Lastra *et al.*, 2004; Dugan *et al.*, 2000; Chapter 2, 3) whereas others focused on the behavioural aspects of surfing (Lastra *et al.*, 2002; Ellers, 1995a,b,c; Brown, 2001; Forward, 1986). Only few attempts, however, have been made to determine the ecological relevance of surfing. Brown (1982) and Ansell and Trueman (1973) calculated the costs in terms of energy expenditure and time allocation that come with surfing in molluscs of the genera *Bullia* and *Donax* and in an *Emerita* mole crab. They found that surfing only adds an extra 3 to 10% to the daily energy cost. Hence, surfing is an energetically very cheap way of locomotion in terms of distance covered, compared with for instance crawling or burrowing.

While the extra costs of surfing have been studied and seem to be rather limited, no attempt has been made to identify the actual benefits of surfing. It is widely accepted that surfing is an interesting predator-avoidance strategy and that it increased the feeding opportunities (Ansell and Trueman, 1973; Dugan *et al.*, 2004; McLachlan and Brown, 2006). This, however, has never actually been demonstrated.

In this paper, feeding of *Olivella semistriata* was analysed in terms of prevailing swash conditions. In Chapters 2 and 3, we demonstrated that the swash zonation pattern of *O. semistriata* shows a very distinct unimodal shape, which remains nearly constant over the complete tidal cycle. We hypothesized that this specific unimodal swash zonation of *Olivella semistriata* might be a reflection of the changing feeding opportunities over the swash zone. Theoretically, backwash feeding time follows a unimodal pattern within the swash, with very low values at the upper swash limit (hardly any waves are coming that high), gradually increasing towards the lower swash and decreasing again where the interval between swash waves becomes too small to allow feeding. Additionally, a short field sampling of feeding activity at different degrees of beach slope was used to show the impact of beach slope on the feeding behaviour of *O. semistriata*.

Based on the field measurements, two theoretical models were constructed to describe: (1) the feeding rate in terms of swash zonation, and (2) the balance between feeding and migration. This last model is used to calculate a time budget of *Olivella semistriata* and to identify the possible advantage of surfing in terms of feeding opportunities.

This paper thus aims to identify the influence of the swash conditions on the feeding behaviour of the surfing gastropod *Olivella semistriata*, to analyse how the swash controls the time management of the species and to see if the surfing behaviour of *O. semistriata* could explain its success on Ecuadorian sandy beaches.

## 3.6.2 Material and Methods

### 3.6.2.1 Study site and period

The surveys were conducted on the sandy beach of San Pedro de Manglaralto, Ecuador. This is an intermediate, exposed beach, with fine sands. The macrofaunal zonation of this beach is described in Chapter 1. Swash zonation of *O. semistriata* from this location is discussed in Chapter 2 and 3. Surveys took place in June and July of 2005. The high tide feeding sampling was done on the 2<sup>nd</sup> of July 2004.

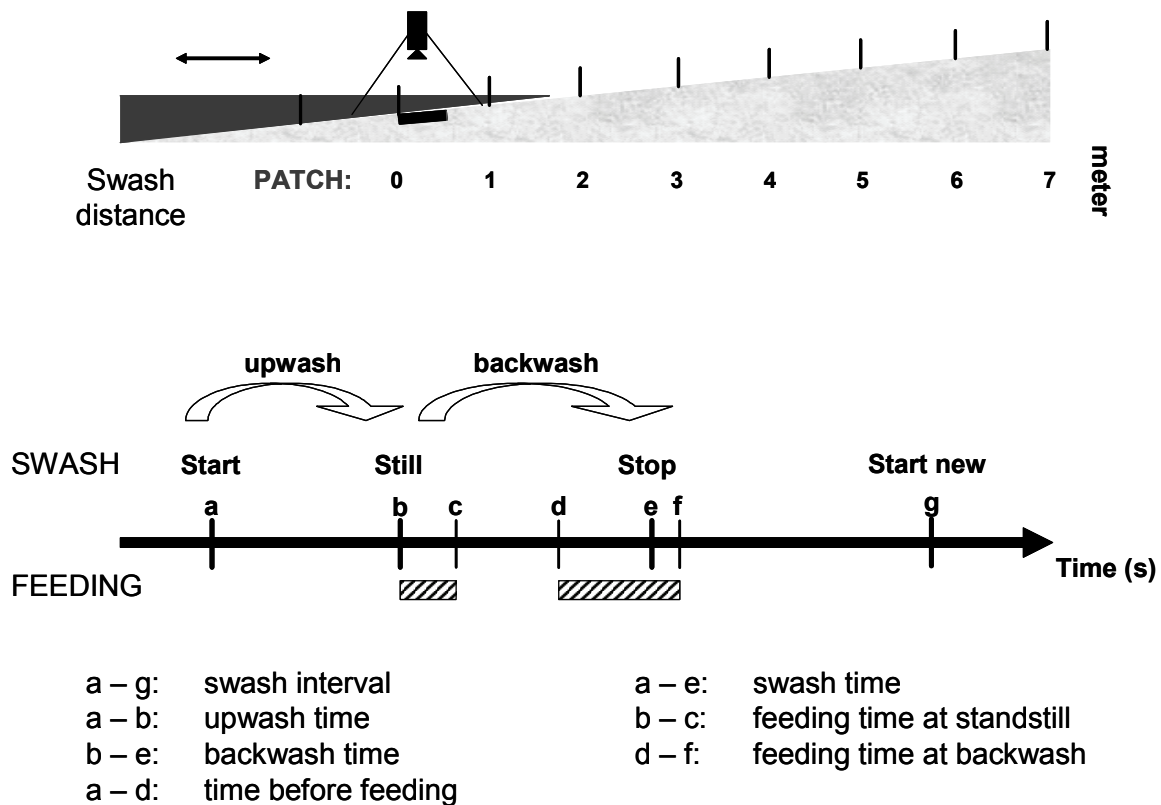
### 3.6.2.2 Feeding survey (Fig. 3.6.1)

Feeding activity of *Olivella semistriata* in relation to swash climate was monitored by filming a patch of animals in the field using a Sony DV (50Hz) video camera. The start and ending of a feeding bout could be identified on the video images. At the same time, swash data were recorded. Plastic poles placed at 1 m intervals were used as reference frame for monitoring the swash position. Each survey lasted for 10 to 20 minutes. In total, six surveys were filmed during falling tide, four during upcoming tide.

The videotapes were analysed frame by frame and the following activities were timed: start of the flooding of the patch; swash standstill; end of patch flooding; start of feeding; end of feeding. Wave position of every swash wave was also recorded. Where possible, the number of feeding cycles and migration in the patch was noted. From these data, a set of parameters was calculated:

- total time: time between start and end of one survey
- swash distance: swash run-up above the monitored patch; a big wave causes a long swash distance and vice versa
- swash interval (a-g): time between two waves that fully cross the patch
- swash time (a-e): time from the start of flooding till the end of the backwash
- % flooded: ratio of swash time and swash interval
- feeding time at standstill and during backwash: see Fig. 3.6.1
- feeding time: sum of feeding time at standstill and feeding time during backwash
- interrupted swash: when a new incoming wave interrupts the backwash of the previous wave (i.e. when g falls before f, see Fig. 3.6.1)

- time before feeding (a-d): time between the start of the flooding and the start of feeding during backwash
- feeding rate: ratio of the feeding time and the swash interval of one swash wave
- total feeding time: total feeding during one survey
- total feeding rate: ratio of total feeding time and total time of one survey



**Fig. 3.6.1** - Setup of the feeding survey and schematic overview of the parameters retrieved from the videotapes. Start (a) indicates the start of the flooding of the patch by a swash wave; Still (b) is when there is no visual cross-shore swash movement over the patch. Stop (e) is when the swash wave has completely retreated from the monitored patch.

### 3.6.2.3 High tide feeding sampling

To test the influence of beach slope on the feeding behaviour of *Olivella semistriata*, two short perpendicular transects were sampled in the high tide swash zone of the San Pedro beach. One transect was situated on the steep slope of a cusp, the other transect was placed on a very flat part of the upper beach (the truck entrance to the beach). The two sites were just 22 m apart (along-shore) and were subjected to the same

wave regime. After a swash wave, feeding activity was recorded by taking two digital pictures (4 megapixel) of a 30 x 30 cm quadrant. Subsequently two replicate core samples (10 cm diameter, to 15 cm depth) were collected - from the photographed spot - to assess the density of *Olivella semistriata*. This was repeated at five different spots for both transects.

Relative beach slope was measured for both transects using a leveller. Breaker height and period were assessed by monitoring 10 consecutive waves. At each transect the position of 10 consecutive swash waves was noted.

The number of feeding specimens was counted from the pictures, and was calculated to individuals per square meter. Densities from the samples were also expressed as ind/m<sup>2</sup>.

#### **3.6.2.4 Statistical analyses**

Differences in swash and feeding parameters between the surveys sampled during *upcoming* or *falling tide*, and on the *low* or *high beach* were tested with a mixed effects model (*survey* as random effect). Univariate correlation between swash and feeding parameters was executed with Pearson's correlation test. Feeding parameters (time before feeding, feeding time and feeding rate) were expressed as a function of swash parameters (distance, time and interval) by first or second order linear regression.

For regression analyses of the feeding survey data with several fixed and random factors, Generalized Linear Mixed Models (GLMM) were calculated (McCullagh and Nelder, 1989) using the proc MIXED statement in SAS 9.1 (SAS Institute Inc, 2004). The fixed effects were *time* (per survey, starting at 0 for the first wave of each survey), *swash time*, *swash interval*, *swash distance* and all possible interactions. *Survey* and the interaction *survey\*time* were the random factors. Non-significant parameters were eliminated by a backward procedure. The model for feeding time (s) was performed on log-transformed data, the model for feeding rate (%) on arcsin-transformed data (Underwood, 1981).

To detect differences in environmental (swash velocity) and biological (density, feeding and the ratio between density and feeding) variables between the two transects of the feeding sampling, a Student t-test or a non-parametric Mann-Whitney U test was used. The assumption of homogeneity of variances was tested with Levene's test (Underwood, 1981).

### 3.6.3 Results

#### 3.6.3.1 Feeding survey

Ten surveys were videotaped and analyzed, four during upcoming tide, six during falling tide (Table 3.6.1). All but two surveys were placed on the low beach (i.e. under the low tide effluent line). Average swash distance (relative to the monitored patch) ranged between 1.3 and 11.4 m; high swash distance indicates a patch low in the swash. Most surveys had around 50% of the swash waves interrupted; two surveys had no interrupted swash waves, two surveys had more than 85% interrupted swash waves. The average feeding rate per wave, i.e. feeding time during one wave against swash interval, was found between 38 and 70%, resulting in a total feeding rate (total feeding time against total time of the survey) of 14 to 40%. Feeding was observed at swash velocities below  $0.53 \pm 0.03$  m/s.

Swash time and swash interval were higher during falling tide than during upcoming tide (Table 3.6.2); swash distance was not significantly different. Feeding time at backwash was much shorter during upcoming tide, resulting in a lower overall feeding time. Feeding rate, however, did not differ significantly. Swash time was significantly lower on the high beach than on the low beach, as were feeding time at backwash and total feeding time. There was no significant difference between feeding rate on the high or low beach.

There was a very strong correlation between the following five parameters: swash distance, swash time, swash interval, time before feeding and feeding time (Table 3.6.3). Only swash distance and swash time were not correlated. The only negative correlations were between swash distance and feeding time and swash distance and swash interval.



**Table 3.6.1** - Overview of the feeding survey data.

<b>Total feeding rate (%)</b>	32	39	40	14	29	20	29	44	17	34
<b>Average feeding rate (%)</b>	60	58	61	55	38	46	70	50	67	35
<b>Total feeding time (s)</b>	221	187	308	65	98	75	240	197	44	272
<b>Average feeding time (s)</b>	20	17	15	7	6	12	13	22	15	7
<b>Average time before feeding (s)</b>	14	13	10	6	9	18	24	16	9	32
<b>Average swash time (s)</b>	37	29	25	13	15	27	35	44	22	20
<b>Average swash interval (s)</b>	69	43	39	52	20	63	47	50	86	21
<b>Average swash distance (m)</b>	3.9	3.2	3.3	1.3	3.2	3.1	6.1	5.6	2.0	11.4
<b>Total time (s)</b>	693	478	773	470	340	379	840	448	259	806
<b>% flooded</b>	54	68	66	25	75	43	41	89	25	97
<b>% interrupted</b>	50	45	65	0	29	50	44	89	0	95
<b>N (waves)</b>	10	11	20	9	17	6	18	9	3	39
<b>Location</b>	Low beach	Low beach	Low beach	High beach	High beach	Low beach	Low beach	Low beach	Low beach	Low beach
<b>Tide</b>	down	down	up	up	up	down	down	down	down	up
<b>Survey number</b>	1	2	3	4	5	6	7	8	9	10

**Table 3.6.2** - Mixed effects models for differences of swash and feeding parameters between surveys (as random factor) monitored at upcoming or falling tide and on the low or high beach. F- and p-values are listed. For the actual data, see Table 3.6.1.

	Upcoming vs. falling tide			Low vs. high beach	
	DF	F-value	p-value	F-value	p-value
Swash time (s)	132	14.39	0.0002	7.11	0.0086
Swash distance (s)	131	0.21	0.6470	1.26	0.2635
Swash interval (s)	132	8.00	0.0054	0.88	0.3505
Feeding time at standstill (s)	44	2.34	0.1330	no values for high beach	
Feeding time at backwash (s)	87	7.32	0.0082	12.56	0.0006
Feeding time (s)	132	8.04	0.0053	4.50	0.0357
Feeding rate (%)	132	0.12	0.9052	1.27	0.2624

**Table 3.6.3** – Pearson's correlation matrix of the main parameters of the feeding survey. Non-significant correlations are given in italic.

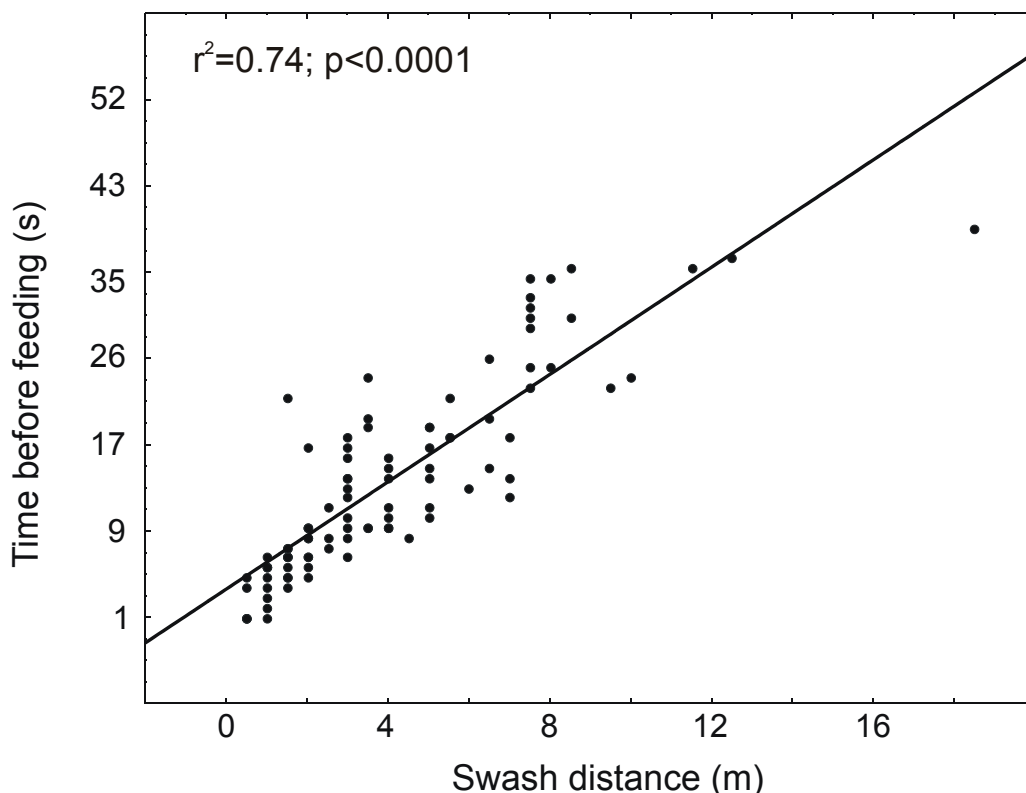
Parameter	N	Range	Average ± S.D.	Swash time	Swash interval	Time before feeding	Feeding time
Swash distance (m)	141	0.5 – 21.5	6.3 ± 5.1	<i>0.111</i> <i>p=0.1882</i>	-0.200 p=0.0173	0.861 p<0.0001	-0.210 p=0.0127
Swash time (s)	142	2 - 84	25 ± 15	---	0.593 p<0.0001	0.720 p<0.0001	0.801 p<0.0001
Swash interval (s)	142	2 - 183	39 ± 34		---	0.205 p=0.0471	0.653 p<0.0001
Time before feeding (s)	94	0 - 39	14 ± 10			---	0.381 p=0.0002
Feeding time (s)	142	0 - 62	12 ± 11				---

There was a particularly significant linear relation between swash distance and time before feeding (Fig. 3.6.2). For feeding time, swash distance (Fig. 3.6.3a), swash interval (Fig. 3.6.3b) and swash time (Fig. 3.6.3c) were significant predictors: the longer the swash time, the longer the feeding time. With both swash distance and swash interval, the relation was parabolic; feeding time peaked at a swash distance of 3 m and a swash interval of 100 s.

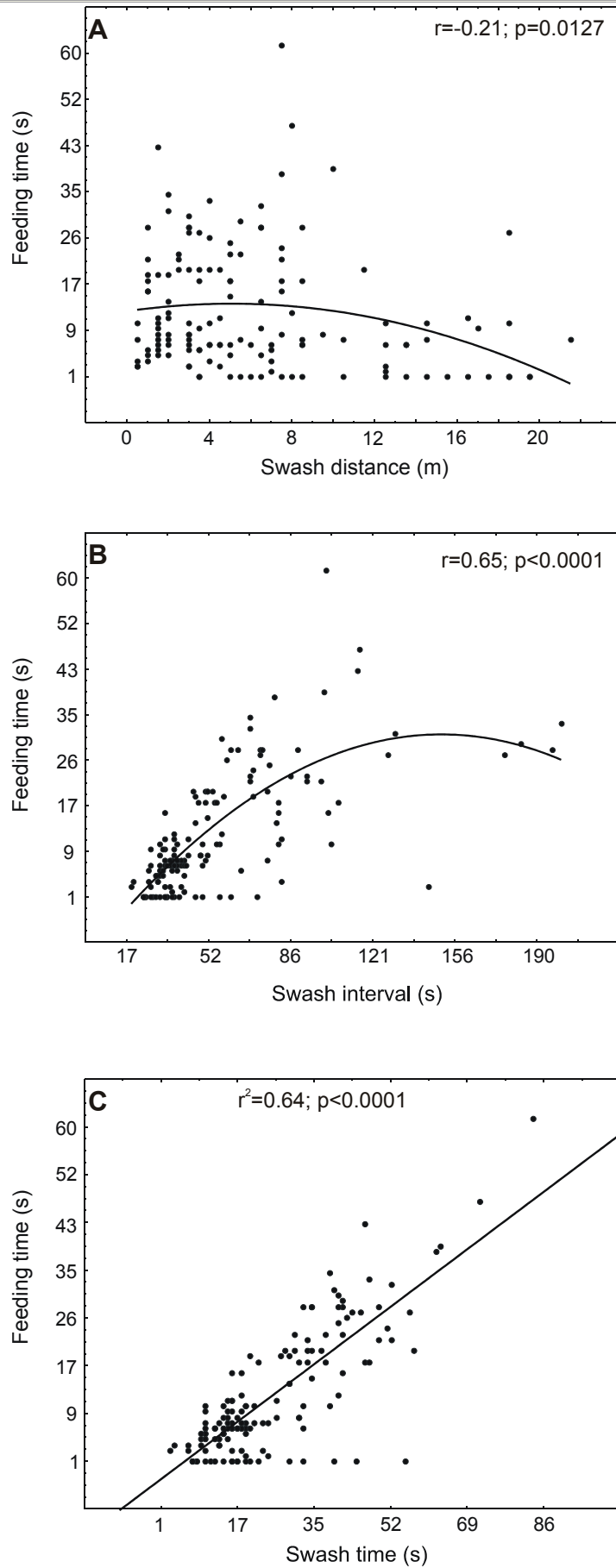
Three examples of surveys are shown in Fig. 3.6.4: one survey was placed low in the swash and as such had 95% of the swash waves interrupted (Fig. 3.6.4a), resulting in very few feeding opportunities during the backwash but with a fair amount of feeding during swash standstill. The second survey was positioned on the high beach, around the effluent line (Fig. 3.6.4b). No swash waves were interrupted here, swash distance was

much shorter and there was no feeding at swash standstill. Fig. 3.6.4c shows a survey from the middle of the low beach swash zone, with a clear balance between feeding at swash standstill and feeding during the backwash.

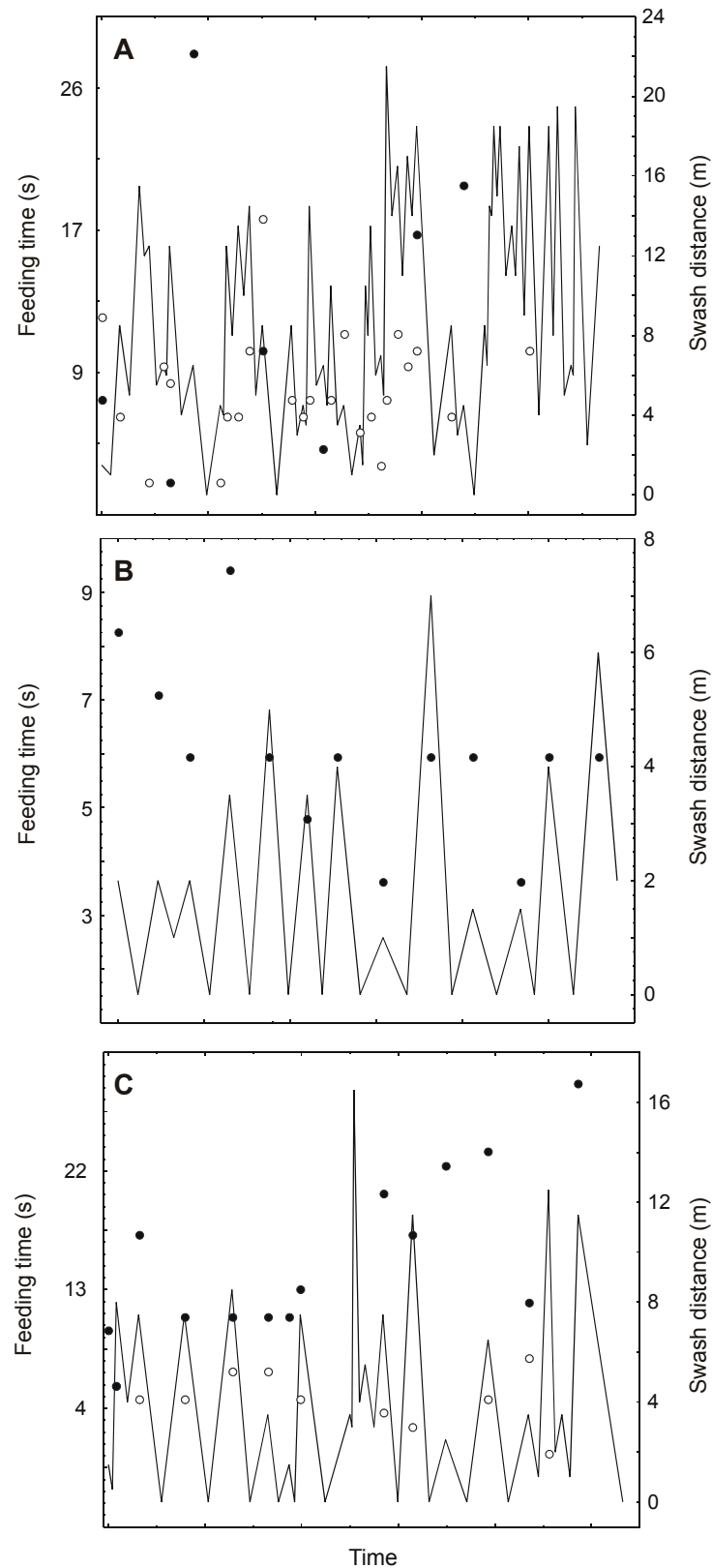
Generalised linear mixed models with feeding time or feeding rate as dependent variables and swash distance, swash interval and swash time as predictors gave highly significant results (Table 3.6.4). Swash interval was not retained as a predictor for feeding time (Table 3.6.4). Feeding time always increased with increasing swash time, but the increase was steeper at short swash distances (Fig. 3.6.5). The feeding that existed with very short but big waves (<20 s and >20 m) was restricted to feeding at standstill (see also Fig. 3.6.4a). The feeding rate was high where waves were small but swash intervals were short or where waves were big and intervals long (Fig. 3.6.6a); the feeding rate was very low to even zero when big waves followed each other rapidly or when small waves were far apart in time (Fig. 3.6.6a). Feeding rate was highest when the swash time was close to the swash interval (Fig. 3.6.6b).



**Fig. 3.6.2** - Time before feeding (y-axis) as a function of swash distance (x-axis). Line represents linear regression, with  $r^2$  and p-value



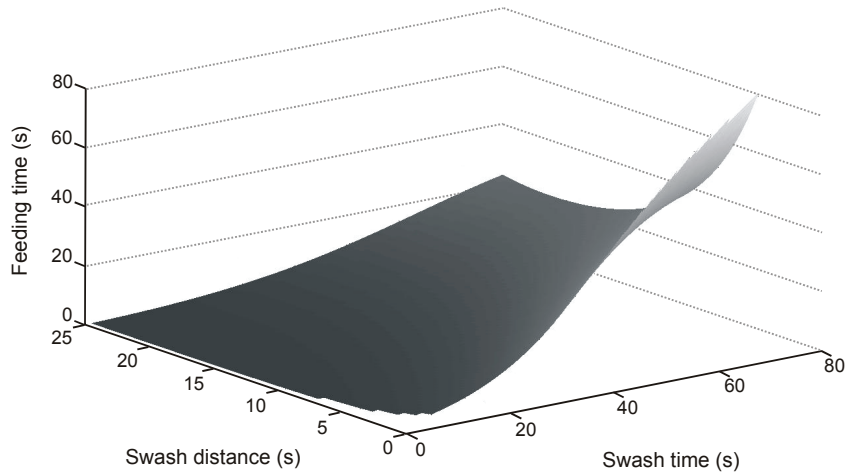
**Fig. 3.6.3** – Scatter plots of feeding time (y-axis) as a function of A) swash distance (with second order linear regression), B) swash interval (with second order linear regression) and C) swash time (with first order linear regression).



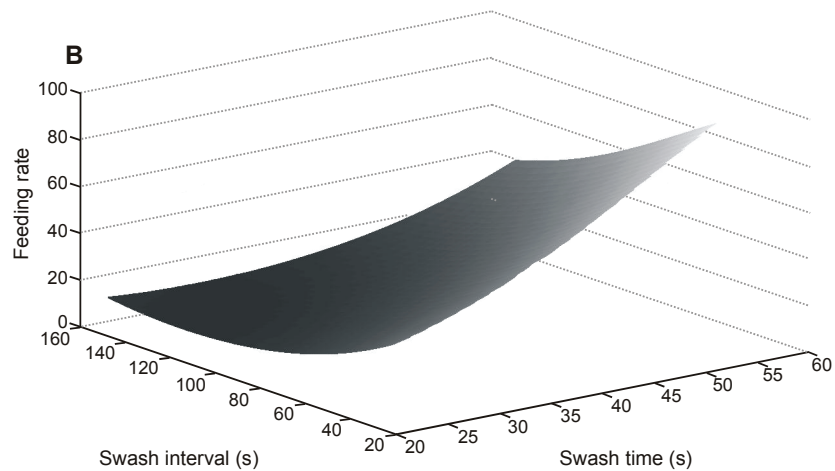
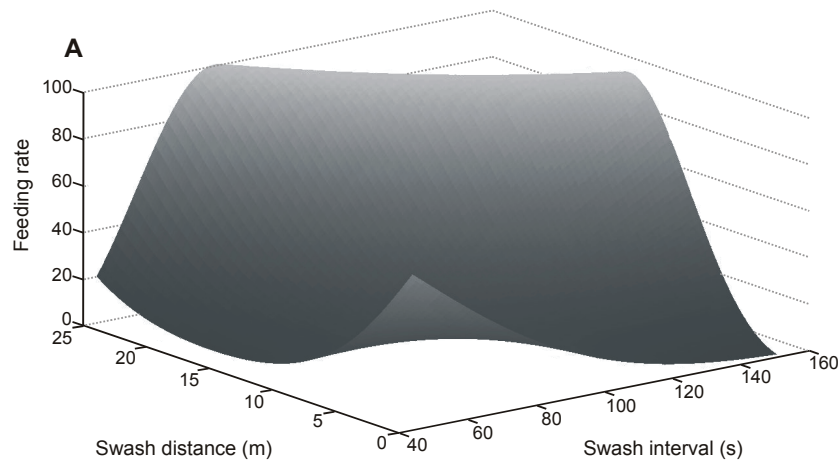
**Fig. 3.6.4** – Three examples of the feeding surveys. Closed dots represent the feeding time during backwash and open dots feeding time at swash standstill (feeding time on  $Y_1$ -axis). Solid lines illustrate the swash dynamics (swash distance on  $Y_2$ -axis; 0-value indicates the monitored patch). A) Survey (number 10) low in the low beach swash with many interrupted waves (solid line not reaching 0-level). B) Survey (number 5) on the high beach (around the Effluent Line). C) Survey (number 7) in the middle of the low beach swash with 44% interrupted waves.

**Table 3.6.4** - GLM Models for feeding time (log-transformed data) and feeding rate (arcsin-transformed data)

Parameter	Feeding time (s)					Feeding rate				
	DF	Estimate	Standard error	t-value	p-value	DF	Estimate	Standard error	t-value	p-value
<b>Intercept</b>	9	1.1787	0.2485	4.74	0.0011	9	1.0490	0.1000	10.48	<0.0001
<b>Fixed effects</b>										
<i>Time (s)</i>	122			-0.70	0.4853	122			-0.62	0.5392
<i>Swash time (s)</i>	127	0.0877	0.0141	6.24	<0.0001	123			0.62	0.5364
<i>Swash interval (s)</i>	123			1.38	0.1711	124	-0.0125	0.0031	-4.00	0.0001
<i>Swash distance (m)</i>	127	-0.2137	0.0467	-4.57	<0.0001	124	-0.1296	0.0223	-5.81	<0.0001
<i>Swash time * Swash time</i>	127	-0.00045	0.00020	-2.28	0.0245	124	0.00031	0.00007	4.57	<0.0001
<i>Swash distance *</i>										
<i>Swash distance</i>	127	0.0050	0.0023	2.19	0.0300	124	0.0029	0.0009	3.32	0.0012
<i>Swash interval *</i>	124			-0.85	0.3954	124	0.00003	0.00002	2.08	0.0391
<i>Swash interval</i>										
<i>Swash interval</i>	120			0.15	0.8829	124	0.0025	0.0007	3.68	0.0003
<i>Swash distance</i>										
<i>Swash interval * Swash time</i>	121				0.8516	121			0.18	0.8580
<i>Swash time * Swash distance</i>	126			-0.93	0.3560	120			0.18	0.8571
<i>Swash time * Swash interval *</i>										
<i>Swash distance</i>	125			1.49	0.1383	124	-0.00004	0.00001	-3.16	0.0020
<b>Random effects</b>										
<i>Survey</i>		0.0743	0.0591				0.0101	0.0075		
<i>Survey * Time</i>		/	/				/	/		



**Fig. 3.6.5** – 3D chart based on the GLM Model for feeding time. Feeding time is shown as a function of swash distance and swash time.



**Fig. 3.6.6** - 3D chart based on the GLM Model for feeding rate. Feeding rate is shown as a function of A) swash distance and swash interval (at the modal value of swash time: 25s); B) swash interval and swash time (at the modal value of swash distance: 3m)

### 3.6.3.3 High tide feeding sampling

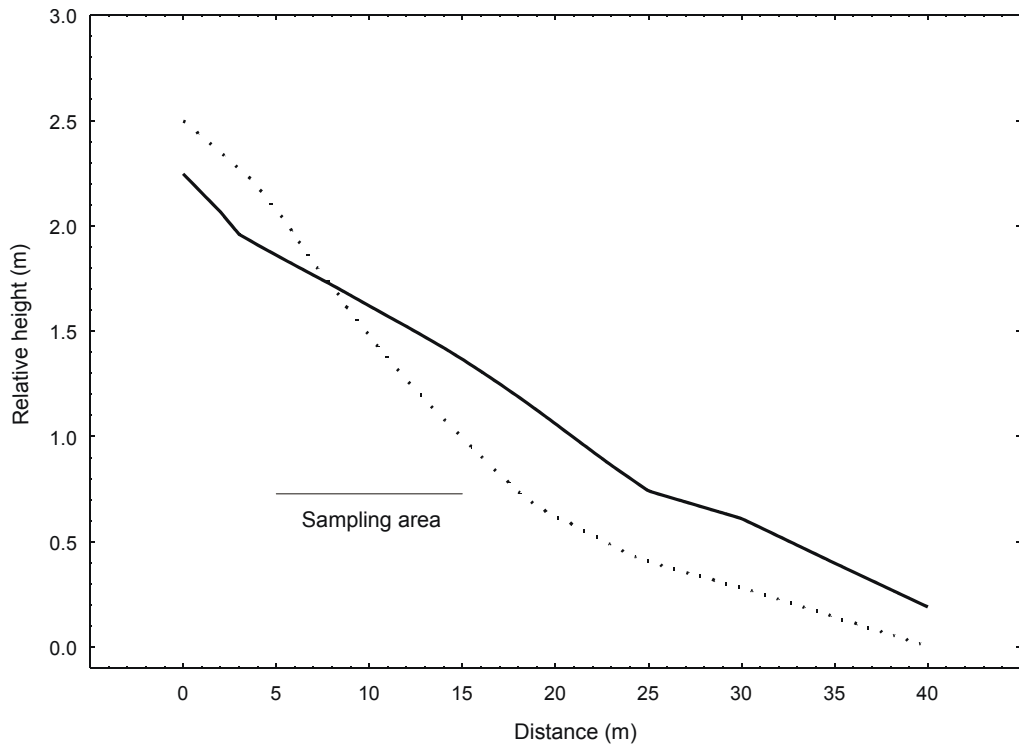
The slope of the flat transect was obviously flatter than of the steep transect; this was especially in the part where the samples were taken (sampling area) (Fig. 3.6.7; Table 3.6.5). Both uprush and backwash speeds were lower on the flat transect, though this was only significant ( $p < 0.05$ ) for the backwash speed (Table 3.6.5). Sediment grain size was comparable between the two transects; penetrability of the sediment was not measured, however, it was very clear that on the steep slope, most of the backwash ran back through the sediment, whereas on the flat slope the backwash was much more significant.

Although densities were higher on the steep transect, no feeding activity could be observed (Fig. 3.6.8). Yet, all stations on the flat transect had apparent feeding activity, with 22 to 522 ind/m<sup>2</sup> feeding on the backwash. The ratio feeding/density was thus obviously much higher for the flat transect.

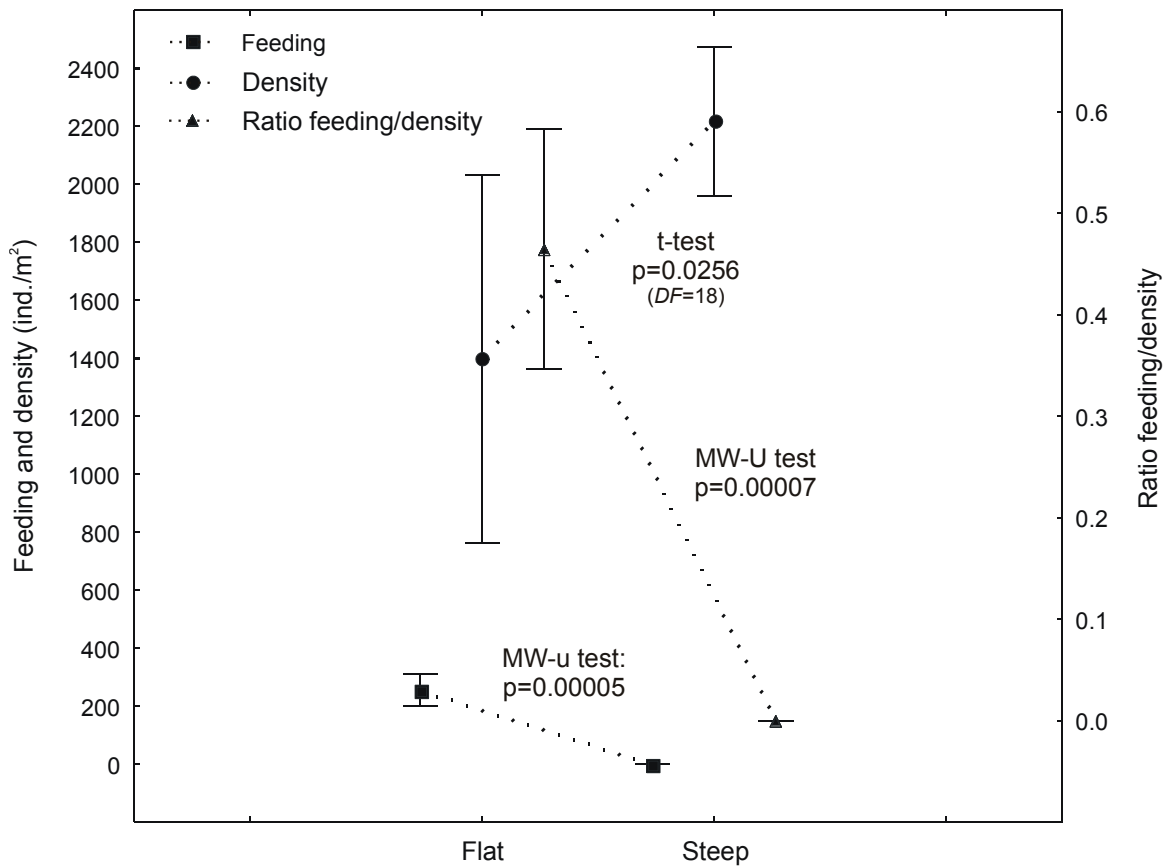
**Table 3.6.5** - Environmental data of high tide feeding sampling. NS indicates non-significant t-test :  $DF=18$ ,  $t=1.95$  with  $p=0.067$ ; \*\* significant t-test:  $DF=18$ ,  $t=3.23$  with  $p=0.005$

	Breaker height (m)	Breaker period (s)	Distance (m)	Elevation drop (m)	Slope	Sampling area (m)	Elevation drop sampling area (m)	Slope sampling area	Uprush speed (m/s)	Backwash speed (m/s)	Sediment grain size ( $\mu\text{m}$ )
<b>Steep</b>	0.78	14.4	40	2.50	1/16	5 – 15	0.96	<b>1/9</b>	1.95 (NS)	<b>1.31 **</b>	241
<b>Flat</b>			40	2.06	1/19	6 – 15	0.47	<b>1/21</b>	1.44 (NS)	<b>0.95 **</b>	228





**Fig. 3.6.7** - Profile of the two sampled transects. The solid line is the flat transect, the dotted line the steep transect. The part of the transect that was sampled is indicated as 'sampling area'. The 0-point on the X-axis is a fixed reference point on the high beach.



**Fig. 3.6.8** - Differences in feeding ( $Y_1$ -axis), density ( $Y_1$ -axis) and ratio feeding/density ( $Y_2$ -axis) between the steep and flat transect, with indication of the p-values.

### 3.6.4 Theoretical models

#### 3.6.4.1 Feeding (zonation) models

With the information from the feeding survey we modelled the theoretical feeding time (FT) and feeding rate (F) according to position in the swash (S). This is the position relative to the upper and/or lower swash boundary at a given time, with S=0 being the lower swash limit. To do so, the following assumptions had to be made (1) the upper and lower limit of the swash zone stay constant for a certain period of time, and (2) the width of the swash zone is 20 m (see also Chapter 1), so  $0 \leq S \leq 20$ .

With the data from the feeding survey (see higher) the feeding time (FT) and feeding rate (F) were modelled in function of the swash distance (D), swash interval (I) and swash time (T) with the following GLM Models (Table 3.6.4):

$$FT = e^{(1.1787+0.088 \cdot T - 0.214 \cdot D - 0.00045 \cdot T^2 + 0.0050 \cdot D^2)} \quad (\text{eq. 1})$$

$$F = \left[ \sin \left( \begin{array}{l} 1.0490 - 0.0125 \cdot I - 0.1296 \cdot D + 0.0025 \cdot I \cdot D + \\ 0.0029 \cdot D^2 + 0.0003 \cdot T^2 + 0.00003 \cdot I^2 - 0.00003 \cdot T \cdot I \cdot D \end{array} \right) \right]^2 \quad (\text{eq. 2})$$

Each of the predictors (D, I and T) had to be expressed in terms of position in the swash (S):

- to calculate the swash distance (D) in function of the position in the swash (S), an algorithm was created based on the average swash distance (and its distribution) from a range of field measurements. From the average swash distance and its distribution a hypothetical set of 20 consecutive waves was generated. For each of these waves the swash distance was then determined in function of S, going from 0 to 20 (Appendix 1). This iteration was repeated 1000 times and resulted in the following equation:

$$D = -0.0004 \cdot S^3 + 0.0404 \cdot S^2 - 1.289 \cdot S + 13.173 \quad (\text{eq. 3})$$

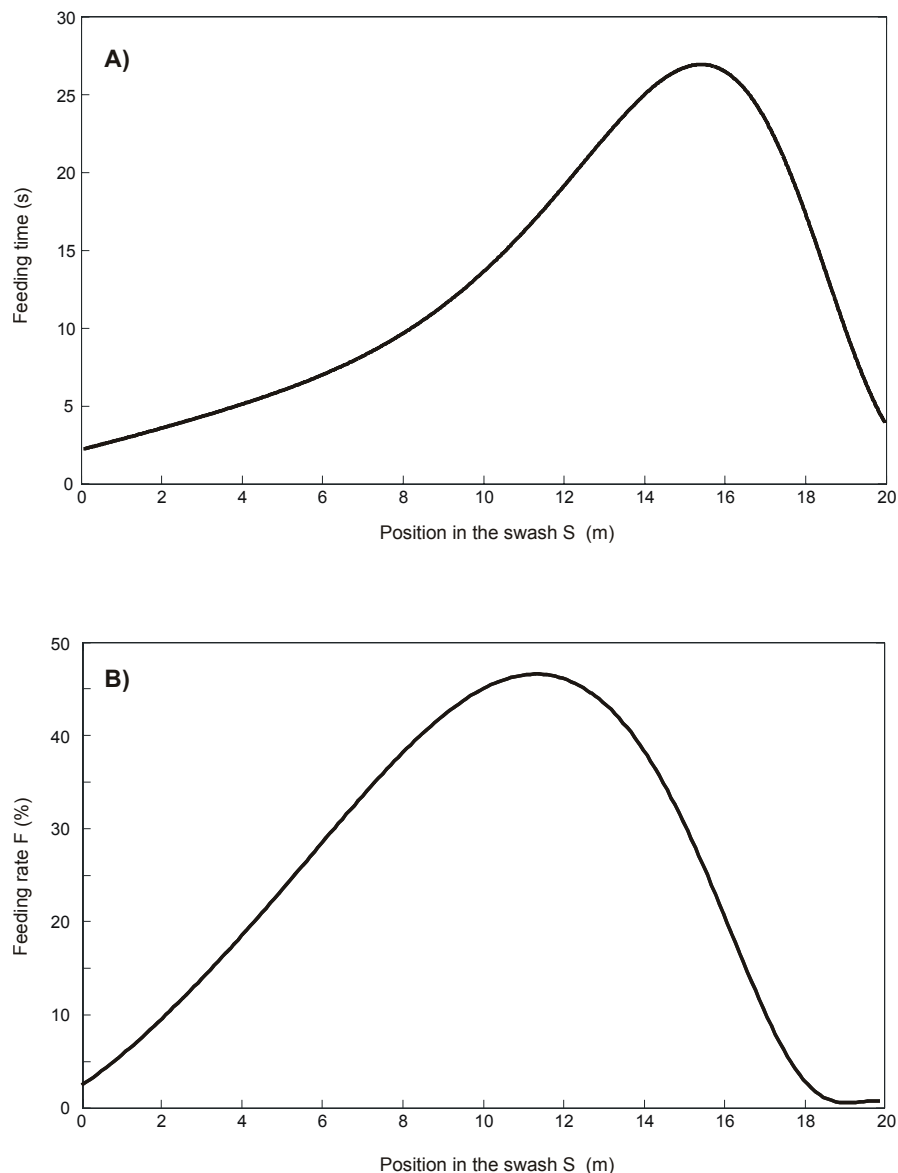
- the distribution of the swash interval (I) in function of swash distance (S) was calculated from field data: the swash period, i.e. the swash interval at S=0, was 17 s. The maximum swash interval (at S=20) was 200 s. This gave the following equation:

$$I = 0.0345 \cdot S^3 + 0.4055 \cdot S^2 + 3.4289 \cdot S + 14.925 \quad (\text{eq. 4})$$

- swash time (T) could be predicted by swash interval (I) and swash distance (D) through a GLM Model (fixed effects: I, D, I<sup>2</sup>, D<sup>2</sup> and I\*D; random effect: surveys; DF=127, p<0.0001 for all parameters) and could thus be described as:

$$T = 7.088 + 0.4333 \cdot I + 0.04895 \cdot I \cdot D - 0.0394 \cdot D^2 - 0.0025 \cdot I^2 \quad (\text{eq. 5})$$

The variables I, T and D from eq. 1 and 2 can now be replaced by eq. 3, eq.4 and eq. 5. These are the models of feeding time (FT) and feeding rate (F) in function of position in the swash (S). The resulting graphs for a swash zone of 20 m width are given in Fig. 3.6.9. Longest feeding time is obtained at a swash position of 15.38 m (i.e. at 23.1% from the upper swash limit; for comparison with zonation data from Chapter 3, which are listed relative to the upper swash limit); the feeding rate peaks, with a value of 32.25 %, at a swash position of 11.42 m (i.e. at 42.9% from the upper swash limit). The curve of both models can be described as a skewed unimodal curve.



**Fig. 3.6.9** - Graph of the feeding model with A) predicted feeding time and B) predicted feeding rate (F) in terms of position in the swash (S). S=0 is the lower swash limit, S=20 is the upper swash limit.

### 3.6.4.2 Migration model

The feeding rate model is a fixed model and does not include the shift of the swash zone over the beach with the tide. Consequently, this model does not take account of the migration of the animals. To include the loss of feeding time due to migration (i.e. emerging from the sediment, surfing and burrowing) the fixed feeding rate model was extended to a dynamic migration model over time. This migration model covers the total feeding time, based on the feeding rate model, during half a tidal cycle (6h).

The set of assumptions was expanded with the following:

- the beach profile is uniform and so are the environmental and feeding conditions over the intertidal width
- the intertidal zone ( $W$ ) is 60 m wide (see also Chapter 1)
- the swash zone shifts over the beach in a uniform way (this is not the case in reality: the tide moves slower around low and high tide)
- per surfing movement one wave is lost for feeding (based on extensive field observations); one wave takes 53 s ( $WT$ , for the optimal feeding point  $S=11.42$  in eq. 4)
- the animals try to stay as close as possible to the optimal feeding point; as such their migration keeps them in a symmetrical way around the optimal feeding point, i.e. 32.25% of the upper swash limit. For example: a specimen that migrated 2 m per surfing movement will stay till one meter away from the optimal feeding point and subsequently move to a spot one meter beyond the optimal feeding point.

The purpose of the model is to describe the total time a specimen can feed during 6 hours (TFT) in terms of the distance covered per surfing movement (DS). The hypothesis is that with increasing distance covered per surfing movement, the total time lost through surfing decreases, yet the period of the oscillation around the optimal feeding point becomes larger, resulting in a lower average feeding rate. There must be an optimal surfing distance (DS) at which the resulting total feeding time is maximal.

The breakdown of the model can be found in Appendix 2. To obtain the total feeding time over a period of 6 hours (i.e. 21,600 s) a polynomial estimation (ES; power 10) of eq. 2 (feeding rate model) is integrated over a certain swash position interval. The value of this interval is dependent on the distance travelled during one surfing event (DS), with the optimal feeding position (11.42 m) lying in the middle of the interval. The number

of surfing movements (N) can be described by eq. 6, which is then used to calculate the total time spent for surfing during 6 h (TS; eq. 7):

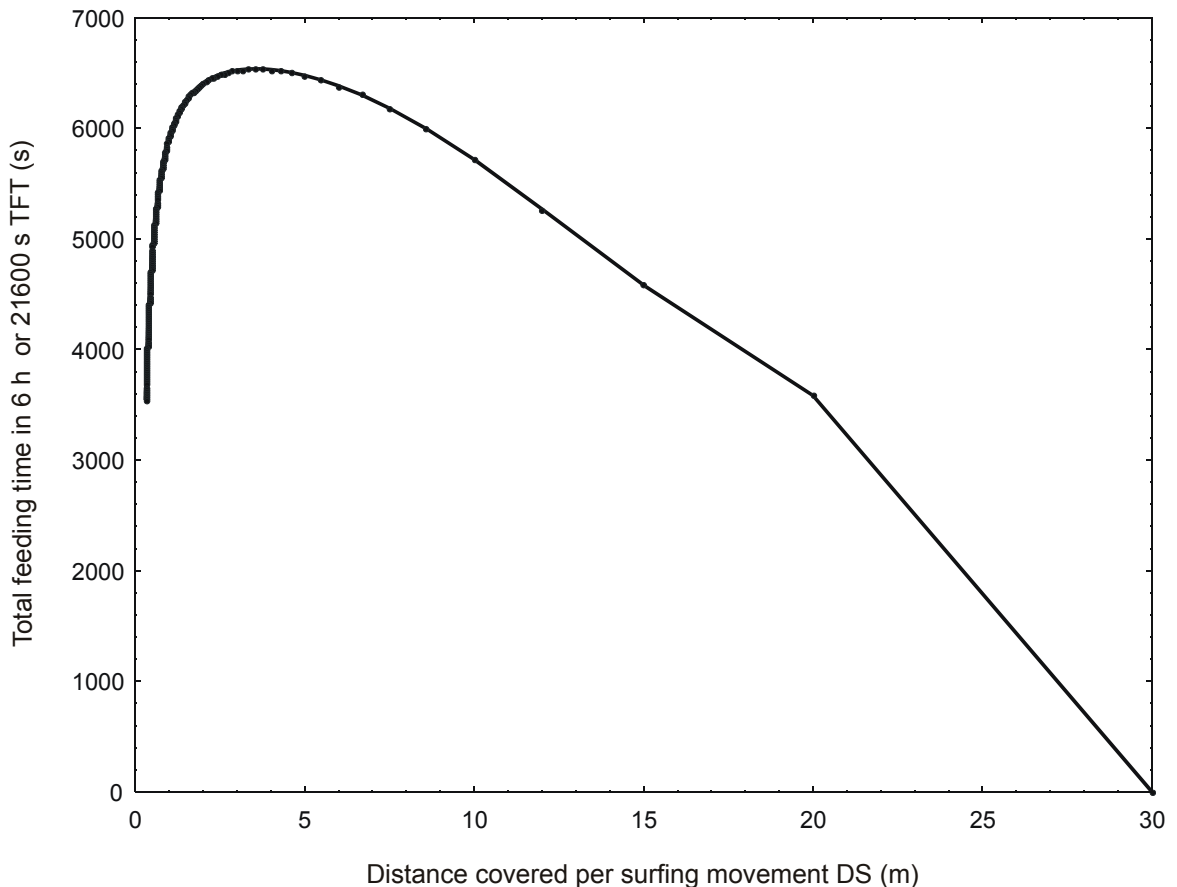
$$N = \frac{W}{DS} \quad (\text{eq. 6})$$

$$TS = N \cdot WT \quad (\text{eq. 7})$$

The total feeding time (TFT) can now be expressed as:

$$TFT(s) = (21600 - TS) \cdot \int_{11.4 - \frac{S}{2}}^{11.4 + \frac{S}{2}} ES(F) \quad (\text{eq. 8})$$

The solution of eq. 8 with varying distance per surfing movement (DS) is shown in Fig. 3.6.10. The highest total feeding time (TFT) of 6,538 s per 6 hours (i.e. 30.26% of the time) is obtained with a surfing distance (DS) of 3.5 m or 17 surfing movements (N) per 6 hours. TFT rapidly declines with decreasing DS and half the maximal TFT (i.e. 3250 s) is obtained at a surfing distance (DS) of 0.27 m. The drop in total feeding time (TFT) is more gentle with longer surfing distances (DS) and half the maximal TFT is now obtained at surfing distances (DS) of 21 m.



**Fig. 3.6.10** - Graph of the migration model with total feeding time during 6 hours (TFT) predicted in terms of distance covered per surfing movement (DS).

### 3.6.4.3 Time budget

The migration model allows us to construct a time budget distribution for *Olivella semistriata*. The three main activities of the species are (1) surfing, (2) feeding and (3) remaining buried without apparent activity. Surfing can be divided into three different actions: (1.1) emerging from the sediment, (1.2) surfing itself and (1.3) burrowing. For each of these activities the time allocation per 6 hours can be calculated:

- (1) Surfing: the total number of surfing movements per 6 hours (N) is optimally 17.
  - 1.1: emerging from the sediment takes around 2 s (assumption based on laboratory measurements)
 

→ **34.0 s** or **0.16%**
  - 1.2: if we assume that surfing speed is half the swash velocity (1.24 m/s; Chapter 1), and take 3.5 m as surfing distance, the time spent for surfing itself is 5.95 s
 

→ **101.2 s** or **0.47%**
  - 1.3: the average burrowing time for an adult specimen in field conditions is 9.3 s (Chapter 4). Note that this value is higher during falling tide, since animals have to turn 180° during burrowing to be ready to feed upon the next wave (Chapter 4)
 

→ **158.1 s** or **0.73%**

Surfing → **293.3 s** or **1.36%**

- (2) feeding: as calculated from the migration model, the maximal feeding time is:
 

→ **6,538 s** or **30.26%**
- (3) time buried: the total time animals are waiting to exert one of the active behaviours is thus:
 

→ 21,600 s – 293.3 s – 6,538 s = **14,768.7 s** or **68.84%**

In theory remarkably little time (1.36%) has to be spent to keep up with the moving tide. Even if the distance travelled per surfing movement is significantly reduced (e.g. 1 m; calculations not shown), still only a mere 3.3% of the total time has to be allocated to surfing.

If *Olivella semistriata* was a sessile species, unable to surf, instead of staying close to the optimal feeding point of the feeding rate model, they would gradually be found at every possible swash position with the changing tide. The average feeding rate would then be 17.17% (integration of  $ES(F)$  over the entire swash width, i.e. 0 – 20 m), and the time they would actually be in the swash zone per 6 hours would be 2 hours or 7,200 s (swash zone 1/3 of the intertidal width). This means that the total feeding time in absence of surfing would be 1,236 s or 5.72% of the time. Thus, by surfing 1 – 3% of the time, feeding time can be increased from 5.72% to 30.26%, or an increase of 529%.

### 3.6.5 Discussion

Surfing or swash-riding is a very complex behaviour for animals living in a dynamic environment such as exposed sandy beaches. It requires detecting certain exogenous cues, analysing them in order to choose the appropriate set of circumstances to take action and respond rapidly yet in a controlled manner. Species that have mastered these difficulties are thought to benefit from a number of assets: they are exposed to the active swash – a zone with excellent feeding conditions for filter feeders and scavengers - throughout most of the tidal cycle and, they maintain position in a zone which provides shelter from both avian and piscine predation (Dugan *et al.*, 2004).

The exogenous factors to which the animals have to respond are ample and include, amongst others, the swash conditions, food supply, biological interactions, insulation, hydration, desiccation and sediment thixotrophy. For animals living in the swash zone, most of these factors are directed by the swash conditions: food, for instance, is brought in by the swash and the swash determines the balance between inundation (hydration) and air exposure (insulation) and therefore affects the changes in sediment thixotrophy. Hence, we could hypothesize that in order to be successful as a surfer, a species must be able to detect and handle the prevailing swash conditions. This idea was tested for the feeding dynamics of the gastropod *Olivella semistriata*, a thriving surfing species from sandy beaches in the tropical East-Pacific (Chapter 1). Feeding was monitored as a function of the following swash parameters: swash distance, swash interval and swash time.

### 3.6.5.1 Filter feeding and swash conditions

In Chapter 2 we hypothesized that feeding conditions for a swash filter feeder, such as feeding time and feeding rate, follow a unimodal curve within the swash zone. Low in the swash, close to the surf zone, the interval between two swash waves is short, and the swash velocity is very high. Before the backwash velocity has dropped sufficiently to allow for filter feeding, there is a great possibility that the next swash wave will already have entered the swash zone. Feeding conditions are therefore very limited. Moving higher in the swash, the swash interval increases and the swash velocity gradually decreases, adding up to an increase in the feeding opportunities. At a certain point in the swash zone, the swash interval will become so long and the backwash time will become so short that feeding conditions will decrease again. Ultimately at the upper swash limit feeding will be close to zero once more.

*Olivella semistriata* offers a unique opportunity to study the influence of swash on the feeding behaviour of a surfer. It is present in very high number in the upper swash zone (Chapter 2 and 3) and feeding activity can very easily be seen in the field and on video images. Unfortunately, it is very difficult to directly measure feeding in terms of position in the swash itself. This would require intensive and simultaneous observation of a set of levels within the swash, combined with monitoring of the swash. An alternative method is to use the indirect approach of observing one patch at a time, thereby omitting direct information of swash position. However, three swash parameters – swash distance, swash time and swash interval - could be quantified, which ultimately allowed us to model the position in the swash.

The univariate results of the feeding survey (Table 3.6.3; Figs. 3.6.2 and 3.6.3) are very straightforward to interpret. The longer the swash distance (i.e. the further a swash wave crosses the patch of snails), the shorter the swash interval, the longer before *Olivella semistriata* can start feeding on the backwash and consequently the shorter the feeding time. Feeding time, however, increases with increasing swash time and swash interval. With a big wave, it is thus very likely that a new wave will enter the patch before the backwash speed has dropped sufficiently (below  $\pm 0.5$  m/s) for the animals to start feeding; as such, feeding in big waves is predominantly during the few seconds of maximal wave extension that the swash stands still.

In a multivariate approach (GLM Model) it becomes more difficult to understand what happens exactly. The impact of swash time on feeding time is still easily explained (Fig. 3.6.5): the longer the swash takes the longer the animals can feed, especially in



smaller waves (short swash distance). The feeding rate regression, however, gave a much more complex result (Fig. 3.6.6). Feeding rate at short swash intervals is high with small waves, very low with average waves and again higher with big waves, probably because feeding at swash standstill is only noticeable with big waves. At long swash intervals the feeding rate rapidly decreases with decreasing swash distance: even if the wave itself is used very efficiently for feeding, the total feeding time on a small wave will be very low compared to the swash interval. Feeding is only very efficient where swash time is relatively long and equals the swash interval.

Ultimately, the pieces of the puzzle fall into place by modelling the position in the swash as a function of the measured swash parameters (distance, time and interval). For both feeding time and feeding rate a pattern very similar to the hypothesized unimodal curve (Chapter 2) is obtained (Fig. 3.6.9). The curves are not symmetrical, though, yet rather skewed. Most favourable conditions are clearly found in the upper half of the swash, where there is an optimal balance between swash interval, time and distance.

The high tide feeding sampling showed the impact of slope on the distribution of the species through its feeding opportunities. A steep slope results in a higher swash velocity as well as in a faster drainage of the backwash through the sediment (Short, 1999; McLachlan and Brown, 2006). The combination of these two factors hamper the presence of a slow backwash - a laminar stream of water, which is exactly what *Olivella semistriata* feeds upon. The maximum swash velocity at which they can start feeding was found around 0.5 m/s. It is unlikely such low swash velocities are reached on a steep part of the beach – or on a steep beach for that matter. So, even though the animals were present in high numbers on the steep part of the high tide intertidal, and had thus surfed to this place, no feeding activity was observed. Only 20 m further on the beach, at the same elevation level, animals were feeding in high numbers where the slope was much more gentle.

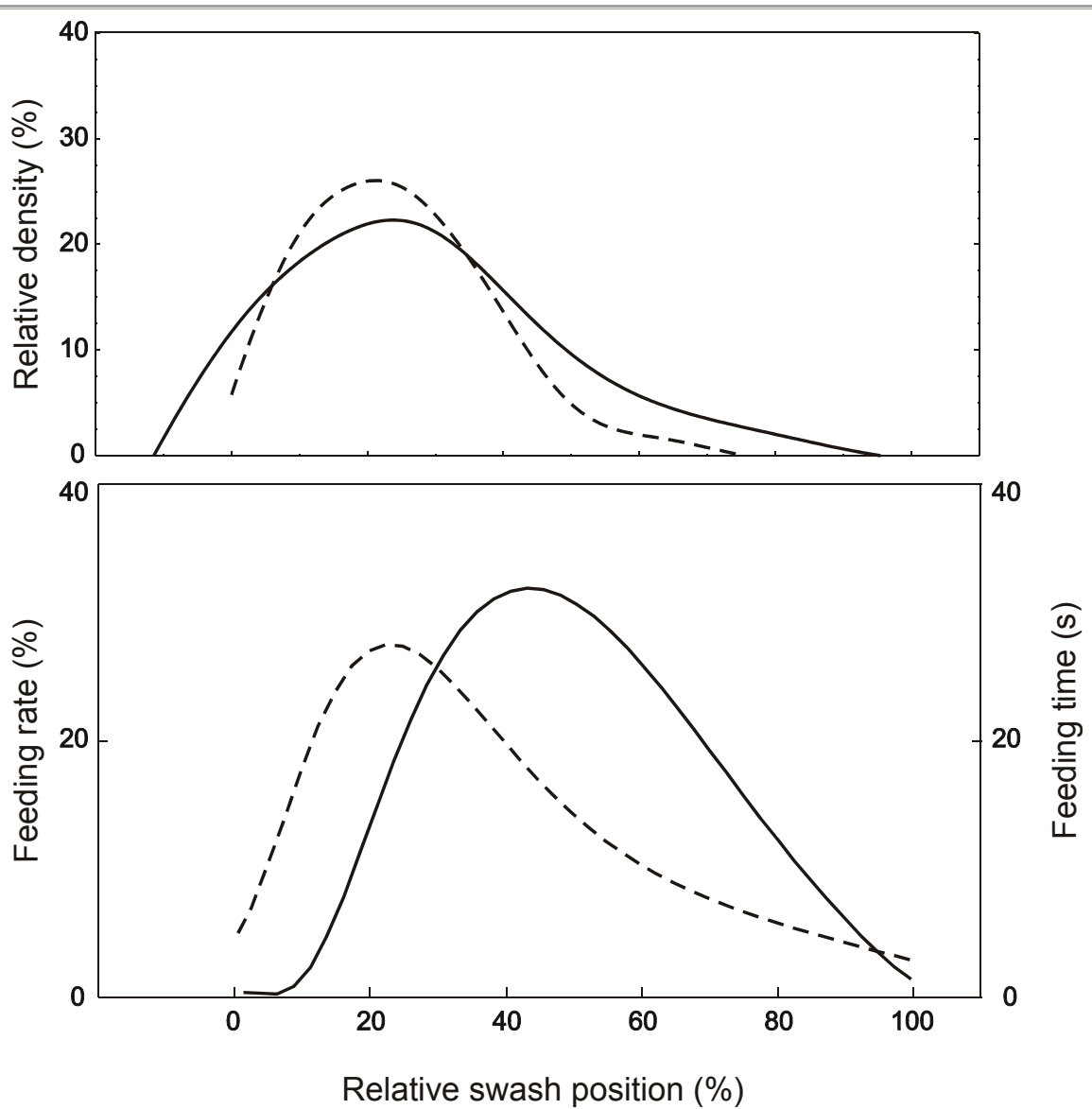
### **3.6.5.2 Feeding conditions and swash zonation**

In a highly dynamic environment, the zonation of a species is caused by its response to one or several environmental and/or biological gradients (autecology hypothesis; Noy-Meir, 1979). Highest densities can be expected where conditions are optimal, with a decrease at either side of this optimum, resulting in a unimodal distribution. The zonation of *Olivella semistriata* was found to be confined to the swash zone and showed to be uniformly of a unimodal (symmetric to negatively skewed) shape,

independent of the tidal state – high, middle or low tide during falling or upcoming tide (Chapter 3) - or location (Chapter 2). Highest densities were typically found in the upper half of the swash zone. The two general swash models based on relative densities and relative swash position, for upcoming and falling tide, from Chapter 3 were combined with the results of the feeding models, also expressed in relative numbers, from this paper (Fig. 3.6.11). The similarities between the zonation data on the one hand and the feeding predictions on the other hand are striking. The shape of the curves is almost identical and the peaks are relatively close to each other.

Although we cannot provide direct evidence, our findings strongly suggest that the zonation of *Olivella semistriata* in the swash zone is a result of the feeding conditions at different positions within the swash and that they actively aggregate in the most suitable areas. As such, this brings the science of sandy beach zonation, which has been stuck at a very descriptive level (McLachlan and Jaramillo, 1995; McLachlan and Brown, 2006), to a point where causal links can be sought. Explaining zonation of species or communities will require a shift from studies of population dynamics and the likes, to behavioural response studies, such as this paper, or experimental studies (e.g. Dugan *et al.*, 2004).

Our findings also question the paradigm in sandy beach ecology that intertidal zonation on sandy beaches is environmentally driven (Defeo and McLachlan, 2005; McLachlan and Brown, 2006). Although feeding conditions are a result of swash dynamics, an environmental factor, the reason why the species shows its typical unimodal zonation in the swash is very likely to be exactly because of the feeding conditions and not the swash dynamics. Where the paradigm of environmentally driven zonation on sandy beaches has already been extended to competition and predation under certain circumstances (Cardoso and Veloso, 2003; Defeo *et al.*, 1997; Dugan *et al.*, 2004), it seems that food availability has to be added as well. Note that swash dynamics do play a crucial role in the formation of the swash zonation pattern of *O. semistriata* through its surfing behaviour. Thus, we could say that the reason for the swash zonation of *Olivella semistriata* is biological (feeding conditions) but the zonation pattern appears because of the environmental conditions (swash action).



**Fig. 3.6.11** - Above (modified from Chapter 3): relative densities in the swash zone during falling (solid line) and upcoming tide (dotted line). Fitting by distance weighted least square estimates.

Below: feeding time model (dotted line) and feeding rate model (solid line) on a relative swash position scale. 0-value on the X-axis indicates the upper swash limit; 100% indicates the lower swash limit.

### 3.6.5.3 Activity budget and the benefits of surfing

It has been widely demonstrated that surfing is a very successful strategy on exposed beaches, especially of the intermediate type (e.g. Brown, 2001; McLachlan and Brown, 2006; Chapter 1). This has been credited to the advantages of maintaining position in the swash zone: good shelter from predators and continuous feeding opportunities (Ansell, 1983; Dugan *et al.*, 2004; McLachlan and Brown, 2006). There could be a number of ways to demonstrate these benefits of surfing, however, studying feeding behaviour and biological interaction on beaches, and especially in the swash zone, is very challenging (Peterson, 1991; McLachlan, 1998; Dugan *et al.*, 2004). So far, only a limited number of papers about the costs and benefits of surfing have been published. One of the approaches has been to investigate the energetics of surfing. The energy cost of surfing itself is surprisingly high, especially for *Bullia* (Brown, 1982) but also for *Donax* and *Emerita* (Ansell and Trueman, 1973), although it is relatively cheap in terms of distance covered (Brown, 1982). Surfing also requires emerging from the sediment and reburial after floating, both energy-consuming activities as well (Brown, 1982). Combining these energetics with an activity budget of the species can give an idea of how costly surfing is in terms of energy expenditure. Brown (1982) calculated that, where surfing takes up 6.4% of the time budget of *Bullia digitalis*, it requires almost 10% of the daily energy consumption. For *Donax incarnatus* and *Emerita hothuisi* surfing was less costly, with around 3% of the daily energy consumption (Ansell and Trueman, 1973). In this study, however, no account was given for emerging from the sediment and surfing itself, so the actual figure will be higher. Note that neither study mentions time or energy allocation to feeding.

There is no reason to believe that the energy cost of surfing should be much different for *Olivella semistriata*, compared to *Bullia* or *Donax*, given the similarities in their surfing behaviour and dynamics. Moreover, the theoretical calculations of the activity budget of *Olivella semistriata* render numbers that are in the same magnitude as the observation made for *Bullia* (Brown, 1982). For both species emerging and burrowing takes less than 1% of the daily time budget, and surfing itself requires 0.5% (*O. semistriata*) to 5% (*B. digitalis*). This higher number for surfing in *Bullia* is probably due to the feeding nature of this species, consisting of actively pursuing prey. Reaching a food item normally requires several surfing movements (Brown, 2001).

In this study, we have not looked at the costs yet at the possible benefits in terms of feeding rate and feeding time. It seems that, where surfing adds about 3-10% to the daily energy cost, it increases the daily feeding time by 529% compared to a species that would live sedentary and filter feed the backwash in a similar fashion as *Olivella*

*semistriata*. Even if we change the numbers and increase the total time spent surfing, for instance because several short excursions are needed for fine-tuning the position in the swash, the figures remain undisputable: moving on average 1 m per surfing excursion reduces the maximal total feeding time with 9.3%, which is still 480% higher than when not moving at all. The benefit is further reduced because more surfing movements require a higher energy expenditure, but this does not stand against the very large increase in feeding time. Moreover, filter feeders that do not migrate cross-shore still have to migrate vertically in order to keep their position relative to the sediment surface, which changes continuously through erosion and accretion (Ansell and Trueman, 1973).

Our calculations do not include feeding success nor measurements of the energy uptake through filter feeding and the energy cost of filter feeding, but it seems very clear that for a species that acquires its nutrition through filtering the backwash on intermediate sandy beaches, surfing is a very interesting strategy, probably explaining the dominance of such species under these conditions (Brown, 2001; McLachlan and Brown, 2006; Chapter 1).

### 3.6.6 Conclusions

- 1) Feeding time and rate are a function of three swash parameters: swash distance, time and interval.
- 2) Highest feeding time and rate are reached in the upper half of the swash zone, with a modelled maximum feeding rate of 32.25 %.
- 3) The curve displayed by both feeding time and feeding rate within the swash zone is very similar to the zonation of the species within the swash.
- 4) During one tidal cycle, feeding time was modelled to be highest with an average surfing distance of 3.5 m per movement (on a 60 m wide beach) and resulted in a total feeding rate of 30.27% during the tidal cycle.
- 5) Surfing increases the feeding opportunities with 529% compared to a non-migratory species with similar feeding habits.
- 6) Surfing is a very interesting strategy for filter feeders inhabiting exposed, intermediate beaches, probably explaining their dominance under these conditions

**Appendix 1: Swash distance (D) in function of position in the swash (S)**

Swash distance (m)	Position in the swash S (m)																				
	0	1	2	3	4	5	6	7	8	9	10	11	12	13	14	15	16	17	18	19	20
6	6	5	4	3	2	1	0	0	0	0	0	0	0	0	0	0	0	0	0	0	0
20	20	19	18	17	16	15	14	13	12	11	10	9	8	7	6	5	4	3	2	1	0
5	5	4	3	2	1	0	0	0	0	0	0	0	0	0	0	0	0	0	0	0	0
9	9	8	7	6	5	4	3	2	1	0	0	0	0	0	0	0	0	0	0	0	0
15	15	14	13	12	11	10	9	8	7	6	5	4	3	2	1	0	0	0	0	0	0
17	17	16	15	14	13	12	11	10	9	8	7	6	5	4	3	2	1	0	0	0	0
14	14	13	12	11	10	9	8	7	6	5	4	3	2	1	0	0	0	0	0	0	0
18	18	17	16	15	14	13	12	11	10	9	8	7	6	5	4	3	2	1	0	0	0
11	11	10	9	8	7	6	5	4	3	2	1	0	0	0	0	0	0	0	0	0	0
4	4	3	2	1	0	0	0	0	0	0	0	0	0	0	0	0	0	0	0	0	0
17	17	16	15	14	13	12	11	10	9	8	7	6	5	4	3	2	1	0	0	0	0
2	2	1	0	0	0	0	0	0	0	0	0	0	0	0	0	0	0	0	0	0	0
16	16	15	14	13	12	11	10	9	8	7	6	5	4	3	2	1	0	0	0	0	0
16	16	15	14	13	12	11	10	9	8	7	6	5	4	3	2	1	0	0	0	0	0
19	19	18	17	16	15	14	13	12	11	10	9	8	7	6	5	4	3	2	1	0	0
19	19	18	17	16	15	14	13	12	11	10	9	8	7	6	5	4	3	2	1	0	0
3	3	2	1	0	0	0	0	0	0	0	0	0	0	0	0	0	0	0	0	0	0
7	7	6	5	4	3	2	1	0	0	0	0	0	0	0	0	0	0	0	0	0	0
12	12	11	10	9	8	7	6	5	4	3	2	1	0	0	0	0	0	0	0	0	0
11	11	10	9	8	7	6	5	4	3	2	1	0	0	0	0	0	0	0	0	0	0
<b>D</b>	<b>12.05</b>	<b>11.05</b>	<b>10.05</b>	<b>9.10</b>	<b>8.20</b>	<b>7.35</b>	<b>6.55</b>	<b>5.80</b>	<b>5.10</b>	<b>4.40</b>	<b>3.75</b>	<b>3.10</b>	<b>2.55</b>	<b>2.05</b>	<b>1.55</b>	<b>1.10</b>	<b>0.70</b>	<b>0.40</b>	<b>0.20</b>	<b>0.05</b>	<b>0.00</b>

Average value of D at each swash position S (m)

**Appendix 2: Breakdown of the migration model (matlab code)**

```

S=0.01:0.01:20 (range of swash position);
I= 0.0345*S.^3 - 0.4055*S.^2 + 3.4289*S + 14.925 (I in function of S);
D= -0.0004*S.^3 + 0.0404*S.^2 - 1.289*S + 13.173 (D in function of S);
T= 7.0878 + 0.4333*I + 0.04895*I.*D -0.00246*I.*I - 0.03944*D.*D (T in function of I and D);
F= 1.0490- 0.01247 * I - 0.1296*D + 0.002489*I.*D + 0.002906*D.*D + 0.00031*T.*T + 0.00003*I.*I
- 0.00004* T.*I.*D (F in function of I, D and T);
F=sin(F);
F=F.*F (F in function of I, D and T);

```

```

[A,B]=size(F);
Max=0;
Min=1;
for j=1:B
    if F(j)>Max
        Max=F(j);
        Smax=j*0.01;
    end
    if F(j)<Min
        Min=F(j);
        Smin=j*0.01;
    end
end
plot(S,F) (Feeding rate model plot);

```

**Polynomial fit of feeding rate model:**

```

Npoly=10;
p=polyfit(S,F,Npoly);
SP=0.01:0.01:20;
LP=0;
for i=1:(Npoly+1)
    LP=p(i)*SP.^(Npoly+1-i)+LP;
end

for b=1:B
    if F(b)>1
        F(b)=NaN;
    end
end
end

```



```
plot(S,F,S,LP);
```

```
res=LP-F;
```

```
MaxErr=max(abs(res));
```

```
for i=1:(Npoly+1)
```

```
    Pint(i)=p(i)/(Npoly+2-i);
```

```
end
```

### Migration model:

```
N=200 (maximum number of migration movements N);
```

```
MinSpringen=ceil(60/19.2);
```

```
Efficientie=zeros(N,1);
```

```
for n=MinSpringen:1:N
```

```
    Tgraven = 53 (time lost per surfing movement);
```

```
    Vgolf = 60/(3600*6);
```

```
    TEten=(3600*6)/n-Tgraven (time left for feeding);
```

```
    Smax=11.42; (optimal position in the swash)
```

```
    VoedingsInterval=Vgolf*TEten;
```

```
    IntervalOndergrens=Smax-VoedingsInterval/2;
```

```
    IntervalBovengrens=Smax+VoedingsInterval/2;
```

```
    LPintB=0;
```

```
    LPintO=0;
```

```
    for i=1:(Npoly+1)
```

```
        LPintB=Pint(i)*IntervalBovengrens.^(Npoly+2-i)+LPintB;
```

```
        LPintO=Pint(i)*IntervalOndergrens.^(Npoly+2-i)+LPintO;
```

```
    end
```

```
    Oppervlakte = LPintB-LPintO;
```

```
    Efficientie(n)=Oppervlakte/(IntervalBovengrens-IntervalOndergrens);
```

```
    Voedingstijd(n)= Efficientie(n)*TEten (feeding per surfing movement);
```

```
    TFT(n)= Efficientie(n)*TEten*n (Total feeding time in 6 hours);
```

```
end
```

```
plot(TFT);
```



---

**- PART IV -**

**GENERAL DISCUSSION**

---

‘I could not help concluding this man had the most  
supreme pleasure while he was driven so fast and so  
smoothly by the sea.’

*Captain James Cook on ‘surfing’*



## 4.1 Sandy beaches in Ecuador

During the four years of this study, we have visited a wide range of beaches along a major part of Ecuador's Pacific coastline, except for the southern province of Machala and the province of Esmeraldas, in the north (Fig. 4.1). Some of these beaches were sampled for macrofauna quantitatively, others only qualitatively; some beaches were just visually inspected. This enables us to make a description of the occurrence of several types of beaches along the coast, partly based on measurement, partly based on observations. Literature is unfortunately almost non-existing, except for one published report on coastal morphology (Boothroyd, 1994) and three undergraduate theses (all dealing with beaches that were sampled during this thesis).

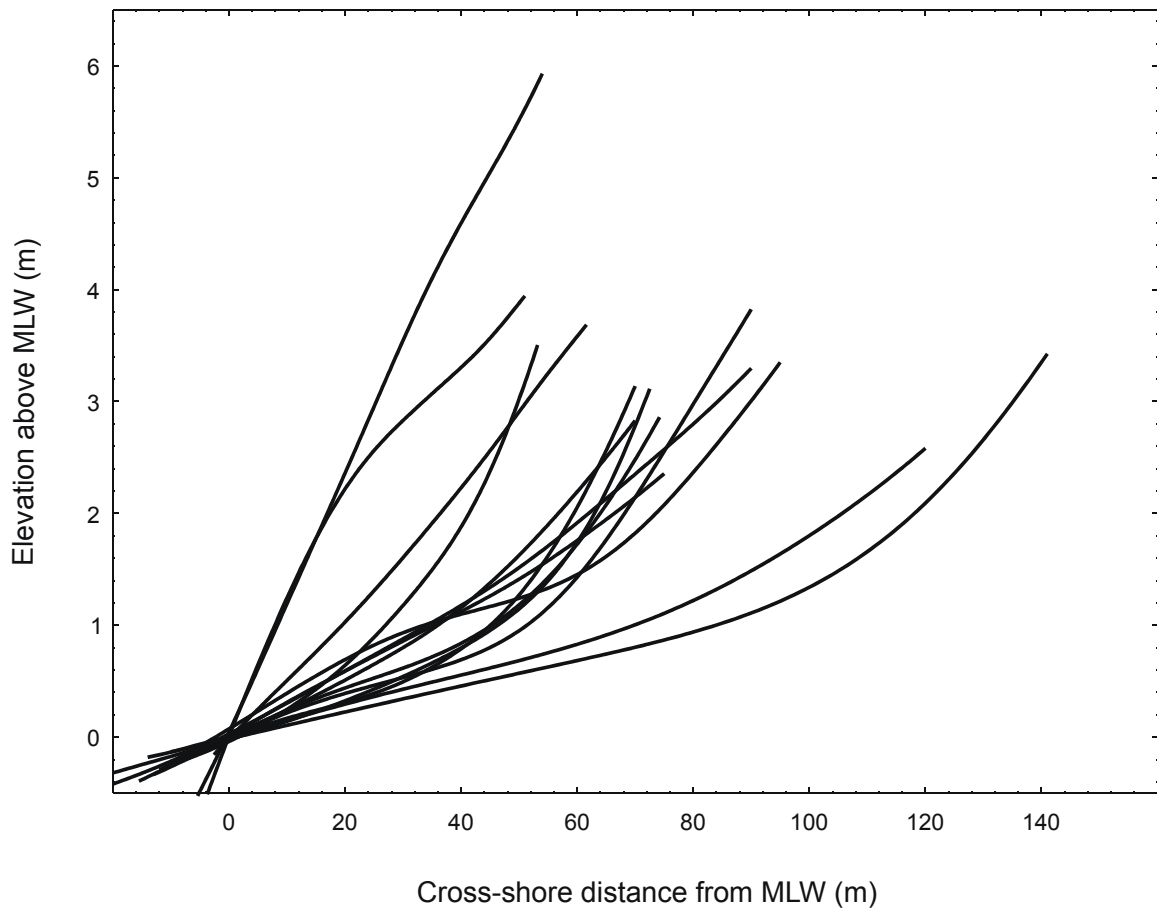


**Fig. 4.1** - Map of Ecuador, with indication of the northernmost (Pedernales) and southernmost (Playas) beach visited during this thesis.

A vast majority of the Ecuadorian beaches is highly exposed (McLachlan, 1980) to the Pacific Ocean. Only in small bays, such as the beach of Ayangue (Chapter 1 and 4), or when protected by man-made structures (beach of Salinas), islands or peninsulas, beaches are of the sheltered type. As a result, most beaches are subjected to heavy wave action, especially in the rainy season (January – April). Average breaker heights have been reported to be around 0.3 – 0.7 m, although breakers up to 4 m are not unusual (own data, INOCAR data and undergraduate theses). Wave periods are relatively long (5 – 15 s), but especially the long breaker periods (12 to 18 s, see Chapter 1) are striking and seem to be much longer than along other exposed coast.

The tidal regime of 2.5 – 4 m (spring tide range) can be categorized as mesotidal (Davies, 1964), and positions the Ecuadorian beaches near the transition point between wind-driven and tide-driven (Masselink, 1993). Therefore, and because of the peculiar wave regime, the range of beach types does not seem to fit into the classification schemes that are widely used (Masselink and Short, 1993; Short, 1996). In Chapter 1, for instance, we have described seven Ecuadorian beaches with contrasting morphodynamics. The range of values for the two beach indices that do not include wave parameters, BI and BDI, covered most of what was found by Dorvlo and McLachlan (2005) for 161 beaches worldwide. However, using the Masselink and Short scheme (1993), the beaches we studied would all be grouped in the upper left corner of their classification scheme (see Fig. 2.1.3).

In terms of beach type, Ecuadorian beaches can predominantly be classified as intermediate, with average slopes of  $1/20$  –  $1/40$ , an intertidal width of 50-70 m (Fig. 4.2) and fine to very fine, well-sorted sediment (200 – 250  $\mu\text{m}$ ). Under certain circumstances reflective to very reflective beaches can occur as well. Remarkably, these are generally situated at locations with strong wave action (Ballenita, Chapter 1), or in small pocket beaches (Ayangue 2, Chapter 4 and Portéte, Chapter 1). These beaches are characterized by a steep slope ( $<1/20$ ), absence of a true surf zone, very narrow intertidal zone ( $<30$  m) and medium to coarse sands (350 – 750  $\mu\text{m}$ ). The number of very reflective beaches, however, seems to be rather low. Dissipative beaches are found north of Bahía de Cáraces (Briceño, Chapter 1), where the tidal range becomes larger. The intertidal zone can easily exceed 100 m on these beaches, with an equally wide surf zone. Median sediment grain size is well below 200  $\mu\text{m}$  and the slope is flatter than  $1/50$ .



**Fig. 4.2** - Overview of beach profiles from beaches studied during this thesis (MLW = Mean Low water)

## 4.2 Distribution of macrofauna in Ecuador

When starting to work in a region where little to no research has been done, it is important to construct a baseline study that can be used as reference for further investigations. Before initiating this thesis, only qualitative or anecdotal information on the macrofauna of Ecuador was available (e.g. Olsson, 1956; Cruz, 1992). The first work of this thesis should thus be seen as a framework on some basic characteristics of Ecuadorian sandy beach macrofauna, such as species composition and richness, spatial distribution, temporal distribution and zonation, and the results are therefore listed as addenda. Unfortunately these papers contain some major flaws in sampling, study design and analyses (see critical note of Addendum 1) and the information should therefore be treated with caution. Paragraphs 4.2.1 and 4.2.2 list the trustworthy conclusions from Addenda 1, 2 and 3, in combination with the information from Chapter 1.

#### 4.2.1 Temporal effects

Except for the limited (on the mesoscale) study of Addendum 2 and the short Chapter on ENSO (Addendum 3), the emphasis of this thesis was put on spatial effects or very short-term effects. There is growing evidence, however, that – at least on microtidal beaches or in temperate regions – the temporal scale is very important in sandy beach ecology and should therefore not be discarded (Brazeiro and Defeo, 1996; Degraer *et al.*, 1999; Dugan *et al.*, 2004). The lack of replication in time of several of the ecological studies (Chapter 1, 2, 3 and Addendum 1) is one of the, if not the most important limitation of this thesis.

The temporal aspect of Addendum 3 was analysed in terms of ENSO, and will be discussed in detail in the next paragraph (4.2.2). One of the main conclusions of Addendum 2 was that, for macrofauna, spatial patterns on the macroscale are clearly more important than the temporal variation. Moreover, we could not detect equal temporal patterns at different locations. It seems that different beach types show different temporal variation.

Although the results from Addendum 2 suggest that macrofauna is primarily structured in a spatial way, the information is far too limited to contradict Brazeiro and Defeo (1996) and state that the temporal scale is less important on mesotidal, tropical beaches. The results from various chapters of this thesis makes us confident, however, that tackling the appropriate spatial scale - at macro-, meso- and microscale- is at least as important as using an adequate temporal scale.

The circatidal variation in swash zonation of *Olivella semistriata*, as discussed in Chapter 3, is also a temporal pattern, albeit very short-term. While the zonation pattern remained almost unchanged, the densities dropped significantly towards the low tide swash zone (see Chapter 2, 3). This has major implications for population estimation of swash species: sampling a swash zone transect at high tide will render a completely different result than sampling at low tide. For *O. semistriata*, the complete population is compacted in the high tide swash zone. Hence, sampling the high tide swash zone is sufficient to estimate the population size (Chapter 3). When the low tide swash is sampled, it is important to sample an adequate amount of additional levels on the drying intertidal in order to obtain a good idea of the number of animals that do not migrate all the way down the beach. This is clearly illustrated by the differences we found between the cross-shore zonation at low tide from *O. semistriata* between Chapter 2 and 3: in Chapter 2 only three levels were sampled on the drying intertidal, representing 0 to 22% of the



---

population, and we concluded that *Olivella semistriata* is a very efficient surfer. In Chapter 3, however, ten levels were sampled on the drying intertidal, which represented 71 to 78% of the population. There are two possible explanations for this huge difference: (1) surfing success is very variable or (2) animals that do not surf down the beach are left behind in dense patches and are easily missed when under-sampling the drying intertidal. According to Brown *et al.* (1989), a high variability in surfing success could be ascribed to changes in factors such as the nutritional state of the animals, food availability and wave action (supporting the first hypothesis). The second hypothesis is supported by the results of Chapter 3 (see Fig. 2.3.2 and 2.3.8), but both hypotheses are not mutually exclusive.

#### 4.2.2 Sandy beach macrofauna and ENSO

During this thesis, no anomalies caused by ENSO were recorded at the Ecuadorian coast, despite a weak El Niño-event over the central Pacific Ocean in 2003-2003 (Lagerloef *et al.*, 2003). The only macrofaunal data we could use to investigate a possible impact of ENSO was a sampling campaign from 2000-2001, at the end of a strong La Niña. We compared these data with an equivalent sampling campaign under normal conditions in 2002-2003 (Addendum 3). Additional data from Addendum 2 (from 1999, at the peak of the La Niña) were used to complete the picture.

The results of this study were quite remarkable, with differences in total density of 300% between the La Niña and the normal phase, with even lower densities during 1999. These differences were mainly caused by the very low densities of the dominant gastropod *Olivella semistriata*, which was almost absent during the La Niña. Yet, also crustacean and bivalve densities increased after the 1999-2001 La Niña. The opposite trend was observed for Polychaetes and Echinoderms.

Our findings are exactly the opposite of what happened in Peru during the severe El Niño of 1982-1983 (Arntz, 1986; Tarazona and Paredes, 1992), where a dramatic drop in densities was found, with some species even being completely wiped out.

Two hypotheses were proposed to explain the observed patterns. The first hypothesis ascribes the low densities during the 1999-2001 period to the severity of the preceding 1997-1998 El Niño, in analogy with the observations from the 1982-1983 El Niño from Peru. Snails like *Olivella semistriata* are slow-growing species (Tursch and

Greifeneder, 2001) and it is very likely that in 2001 the population had not yet recovered from a massive decline caused by the El Niño.

However, this hypothesis is contradicted by data from the 1997-1998 El Niño from Colombia (Riascos, 2002), where no drastic impact on the macrofauna was seen. The Ecuadorian coastal system is, just as the Colombian, a tropical warm-water system, whereas the cold Humboldt Current year-round dominates the Peruvian coast. The alternative hypothesis states that not an El Niño but a La Niña itself has a negative impact on the macrofauna of a tropical ecosystem. However, more information is needed to confirm this hypothesis. It could possibly work for any ecosystem, though, so maybe the analysis of existing datasets on plankton, for instance, could provide further evidence, or oppose the hypothesis.

### **4.2.3 Spatial distribution**

Spatial patterns are detectable at different scales: macroscale or between beaches, mesoscale or within one beach, and microscale (Defeo and McLachlan, 2005; McLachlan and Brown, 2006). Within the mesoscale, variation exists alongshore and cross-shore, better known as zonation. All scales were tackled; the alongshore information, however, is very limited; microscale patterns (swash zonation) were studied at the species-level for two important surfers, *Emerita rathbunae* (Chapter 2) and *Olivella semistriata* (Chapter 2, 3 and 6).

#### *4.2.3.1 Patterns at the macroscale*

One of the best-documented features of sandy beach ecology is the decrease in species richness, abundance and biomass from dissipative to reflective beach states (for recent reviews, see Defeo and McLachlan, 2005; Dorvlo and McLachlan, 2005 and McLachlan and Brown, 2006). This was confirmed by the study in Chapter 1. The additional spatial information from Addendum 2 is very limited – only the supralittoral fringe was sampled – but also here patterns did match the expected, with a decrease in species richness from dissipative to reflective beaches.

McLachlan and Dorvlo (2005) noted that abundance and biomass follow a similar trend, be it less clear. This is also what we found in Ecuador. The most reflective beach we sampled, Ballenita (Chapter 1), harboured a more abundant fauna with higher biomass than the less reflective – and species richer – beach of Portéte. It seems that the

explanation for the observed trends should not only be sought after in underlying physical factors (see 4.2.4) but also in the species composition itself, especially for biomass.

Species richness was studied in three papers: Chapter 1, Addendum 1 and 3. In Chapter 1, 47 species were found on seven different beaches. In Addendum 1, the number of species was 31 on a single beach (over six transects); 51 species were recorded in Addendum 2, from nine beaches and on four dates, yet only from the sublittoral fringe. These are all very high species counts, especially considering the fact we never sampled the supralittoral community nor did we encounter very dissipative beaches. Macrofaunal biodiversity on sandy beaches, even under macrotidal dissipative conditions, is generally much lower, and higher species counts are only reported from studies comprising much more beaches (e.g. Dexter, 1983: 84 beaches in Australia, 78 species; Dexter, 1988, 1990: 60 beaches in Europe, 50 species; Hacking, 1997: 15 beaches in Australia, 61 species). Hence, our results support the idea of Soares (2003) that, despite the dominance of reflective and intermediate beaches, the tropics support a larger species pool than temperate regions.

#### 4.2.3.2 *Patterns at the mesoscale (including zonation)*

The general cross-shore pattern observed in Chapter 1 and Addendum 1 confirms the current knowledge in sandy beach ecology: species richness increases towards the low beach (e.g. McLachlan and Jaramillo, 1995; Degraer *et al.*, 2003; McLachlan and Brown, 2006).

Intertidal zonation is a well-studied phenomenon (see 1.1.2.4 for more details). On dissipative and intermediate beaches three or four zones are generally present (reviewed in McLachlan and Jaramillo, 1995): a supralittoral zone, a littoral zone and one or two sublittoral zones. On reflective beaches the sublittoral zone, which is an upward extension of the surf zone, is normally absent (McLachlan and Brown, 2006).

We studied the macrofaunal zonation in Chapter 1. Since we did not sample above the drift line, the supralittoral zone was not included in this paper. Starting from the drift line three different zones (upper, middle and lower beach) were present on all but the two reflective beaches, where only two distinct zones could be identified. The swash zone, although physically distinguished from the low intertidal, did not show up as a clear

biological zone on the dissipative and intermediate beaches, yet it did differ considerably from the other zones on the steep beaches.

Hence, assuming that a supralittoral community with its distinct zone is present on all exposed beaches (McLachlan and Jaramillo, 1995), on the exposed mesotidal beaches of Ecuador three (reflective beaches) or four (intermediate and dissipative) zones are present. Moreover, it seems that, at least on reflective beaches, the swash zone harbours a separate community, and in Chapter 2 and 3 we advocated that the swash fauna should be treated – and sampled – as a separate community.

On steep, reflective beaches the low tide swash zone covers more than half of the intertidal width. So, even at low tide, more than half of the intertidal part of the beach is still regularly submersed by the incoming swash. The physical conditions are thus less zoned; this is probably one of the reasons why there are a reduced number of macrofaunal zones on reflective beaches.

The subdivision of the lower beach or sublittoral zone into two different zones is normally only possible on dissipative beaches (McLachlan and Jaramillo, 1995; McLachlan and Brown, 2006). Most studies, however, have been performed under microtidal conditions. A small intertidal range leaves little room for several distinct zones. In Ecuador, on the other hand, the mesotidal regime seems to allow a clearer zonation in the low intertidal. Similar results were also found on macrotidal beaches (McLachlan and Jaramillo, 1995; Degraer *et al.*, 2003).

#### 4.2.3.3 *Patterns at the microscale*

The true microscale (*sensu* Defeo and McLachlan, 2005) was not studied in this thesis. However, two chapters (2 and 3) were dedicated to the zonation within the swash zone, a spatial scale falling in between meso- and microscale.

Two different surfers, the mole crab *Emerita rathbunae* and the snail *Olivella semistriata*, were studied at two sites (Chapter 2). Both species showed a symmetric to negatively skewed parabolic swash distribution curve, independent of the tidal state or sampling location (for more details about *O. semistriata*, see 4.3.1). Peak densities were typically found around 15-60 % of the swash zone, with *O. semistriata* living higher and *E. rathbunae* living lower in the swash. We hypothesized that this zonation is a result of a gradient in feeding time, with optimal feeding conditions around the middle of the swash zone. This was later demonstrated for *O. semistriata* in Chapter 6 (see 4.3.1.2). The different position of peak densities between the two species could be caused by

differences in morphology and behaviour, possibly selected because of competition. The mole crab is a much faster swimmer and burrower than the snail, and its feeding structures seem more robust. They seem better adapted to live in the more hostile low swash zone. This idea is supported by distribution data for both species from beaches with different morphodynamics: where *O. semistriata* is restricted to relatively flat beaches with fine sediment and gentle swash conditions, *E. rathbunae* is mostly present on reflective beaches with coarse sediment and vigorous swash action (see also Chapter 1).

#### **4.2.4 Explaining the spatial patterns**

##### *4.2.4.1 Influence of different beach-related factors*

As stated in paragraph 4.2.3.1, abundance, biomass, but especially species richness decreases when moving from dissipative to reflective beaches. Most sandy beach ecologists agree that the underlying driving forces are of a physical nature (see 1.2.3). The most important physical factors that are considered to influence the distribution of macrofauna are tide range, sediment grain size, exposure, swash action, and accretion-erosion dynamics (Brazeiro, 2001; Soares, 2003; McLachlan and Dorvlo, 2005). All these factors are linked to the morphodynamics of beaches (Short, 1999; Soares, 2003). Several of these beach parameters have been studied during this thesis in terms of species distribution and species exclusion (Chapter 1, 2, 4 and 6).

Sediment grain size was negatively correlated with macrofaunal species richness, abundance and biomass. There are a number of reasons to assume this is a causal link. First of all, many species find it difficult or are even unable to burrow in coarse sands (McLachlan *et al.*, 1995; Nel *et al.*, 1999, 2001, de la Huz *et al.*, 2002; Chapter 4), thereby seriously hampering their survival chances: a long burial time increases the predation risk and the probability to be swept away by the next incoming swash. Secondly, coarse sand provides a less stable anchoring substrate, increasing the chance to be washed out of the sediment. Finally, sediment grain size indirectly impacts the fauna through its influence on swash and sand bed permeability (see further). Note that interstitial space is larger with coarse sediment, thereby creating opportunities for an interstitial macrofaunal community to flourish (Chapter 1).

The second set of beach characteristics we could link to the spatial patterns were the swash conditions and swash dynamics. The structuring impact of swash is very complex. On the microscale we have demonstrated how species can be zoned within the swash through swash dynamics (see 4.2.3.2 and 4.2.3.3). However, swash conditions also play on the level of species exclusion (McLachlan *et al.*, 1993; Chapter 1, 2, 4 and 6). In general, swash becomes harsher on reflective beaches (McArdle and McLachlan 1991, 1992). This is seen through a number of swash parameters, all with potential impact on the fauna: swash period, swash interval, swash width, uprush and backwash velocity, effluent line crossings and position and swash standstill time. We could only demonstrate a clear link between beach state on the one hand and swash width, effluent line crossings and swash standstill time on the other hand (Chapter 1 and 4), but other authors have described similar relationships with swash period, swash interval and uprush and backwash velocity (McArdle and McLachlan, 1991, 1992; McLachlan *et al.*, 1993; Brazeiro, 2001; Soares, 2003).

Each of these swash parameters could cause the exclusion of a species. *Swash period* (time between two swash waves at the transition surf/swash), and by extension *swash interval* (time between two immersions at a given position in the swash), determines the time species have to secure foothold in the sand, the time species can move about in the swash (surfing or swimming) and the time species can feed on or in the swash. High *uprush* and/or *backwash velocity* might inhibit feeding, for instance for filter feeders (Chapter 6). Controlling migration at high swash velocities is also possibly problematic.

With increasing *number of effluent line crossings*, the probability of being stranded on unsaturated sand becomes larger. Many species cannot burrow in unsaturated sand (McLachlan and Brown, 2006). A stranded individual is thus an easy prey for terrestrial or avian predators, or is prone to desiccation. On reflective beaches the effluent line retreats with the swash to the low beach, so even at low tide the swash crosses the effluent line regularly, in contrast to the situation on intermediate and dissipative beaches (Chapter 1; *effluent line position*). Moreover, on reflective beaches the effluent line is crossed by a much larger distance than on other beaches. This adds to the limiting of species expansion towards reflective beach states.

Finally, in Chapter 4 we added *swash standstill time* to the existing list of influencing swash parameters. We defined swash standstill time, as the time the swash does not move when at its maximum run-up position. This is almost 10 seconds on dissipative beaches, yet only 1 or 2 seconds on reflective beaches (Chapter 4). For

animals that burrow again after moving about in the swash, it is crucial to secure foothold before being carried back by the swash, especially when their movement is directional. A swash standstill time of less than 2 seconds is only long enough to secure foothold for the very fast burrowing mole crabs that live in the swash zone (Chapter 4).

Although beach slope itself cannot be of direct influence (McLachlan and Defeo, 2005), it is clear that it does play an important underlying role in structuring the intertidal fauna (Soares, 2003). In Chapter 6, for instance, we demonstrated that feeding of *Olivella semistriata* was not possible at high tide where the beach steepened, while under the same sediment and wave conditions feeding was observed on an adjacent, flatter part of the beach. Obviously, the swash conditions were different on the steep section, with a higher backwash velocity and a shorter swash standstill time. A similar observation was made in Portéte (Chapter 1): although several swash parameters were identical to those measured on flatter beaches, and despite a top-layer with fine sand, no molluscs were present on this beach, and the total macrofaunal abundance and biomass were extremely low. There must be another physical parameter that limits the presence or expansion of certain species on steep beaches.

We hypothesize that sediment permeability is the missing link. Unfortunately, permeability is difficult to measure, and to our knowledge no studies linking permeability to macrofauna exist. Soares (2003), however, noted that sediment permeability could replace sediment grain size as a descriptor of beach state, thereby stressing the importance of permeability as a physical parameter. On beaches with high sediment permeability, a significant part of the swash uprush will run back through the sand, instead of over the sand. Backwash is thus largely reduced (Soares, 2003), as well as swash standstill time (Chapter 4). Moreover, the position of the effluent line shifts much faster. Hence, filter feeders that are dependent on backwash water to collect food are unable to do so when sediment permeability is too high. This is probably what happened on the steep part of the high beach during the high tide feeding sampling from Chapter 6. Similarly, the coarse underlying sediment and steep slope of Portéte resulted in a high permeability, short swash standstill time and limited backwash action on this beach, explaining the absence of molluscs.

In conclusion, we support the idea of multicausality (Brazeiro, 2001) in the underlying forcing factors for the macro- and mesoscale patterns. Beach slope, sediment grain size and permeability and swash characteristics and swash dynamics (this thesis), in combination with tide range (McLachlan and Dorvlo, 2005) and beach accretion/erosion dynamics (Brazeiro, 2001), can all directly or indirectly impact each other and macrofaunal species distribution and expansion.

#### *4.2.4.2 Investigating causal links: field and experimental work*

It remains almost impossible to test the influence of each single physical factor on the beach fauna by field samplings, and evidence is always circumstantial. Experiments are needed to provide real proof. So far, however, experimental work in the field or in the laboratory has yielded very limited success. This is partly due to the lack of independent control over the different physical parameters, but also because swash action – possibly the single most important environmental factor for macrofauna - has never been applied under laboratory conditions. The experimental setup we designed and discussed in Chapter 5 is the first device that allows studying the influence of swash action on sandy beach fauna. Moreover, beach slope and sediment grain size can be changed upon request. Unfortunately, the lack of an automation of the setup seriously limits the kind of experiments that can be done (see Chapter 5). The one experiment we could run, however, provided very interesting and promising results. The few existing shortcomings in the design of the swash rig could easily be improved. We are confident that using a swash rig to its full capacity would open a whole new range of research possibilities in sandy beach ecology.



### 4.3 Biology of *Olivella semistriata*

As was obvious from the general ecological studies listed in the addenda, the gastropod *Olivella semistriata* occupies a very special place in the ecosystem of intermediate, exposed beaches in Ecuador. This species is not only by far the most dominant species in terms of density, abundance and biomass, it is also the most conspicuous of all Ecuadorian macrofaunal species. Its surfing behaviour offers a unique opportunity to study adaptations to the harsh and difficult environmental conditions of sandy beaches in general and the swash zone in particular. During this thesis we have tackled as many aspects of the biology of *O. semistriata* as possible: the distribution at different scales and the reasons behind it; the feeding dynamics and several components of the locomotory behaviour such as burrowing and surfing. A number of features that were not studied but would definitely be very interesting are listed in paragraph 4.4.3.

#### 4.3.1 Distribution of the species

##### 4.3.1.1 Macroscale

The distribution of *Olivella semistriata* on the macroscale was investigated in Chapter 1 and Chapter 4. It is clear that the species prefers the intermediate beaches, where its abundance can peak at around 100,000 ind/m, an astonishingly high number, especially given the fact that its cross-shore distribution is very limited (see further). Biomass numbers top 185 g/m ash-free dry weight. Records of similar high abundance numbers are very rare in the literature. McLachlan and Brown (2006) list an extreme value of up to 1,000,000 ind/m on ultra-dissipative beaches for all macrofauna, yet without reference to an actual case; more typical numbers for all macrofauna range from 100 to 10,000 ind/m, well below the highest abundance we found for a single species.

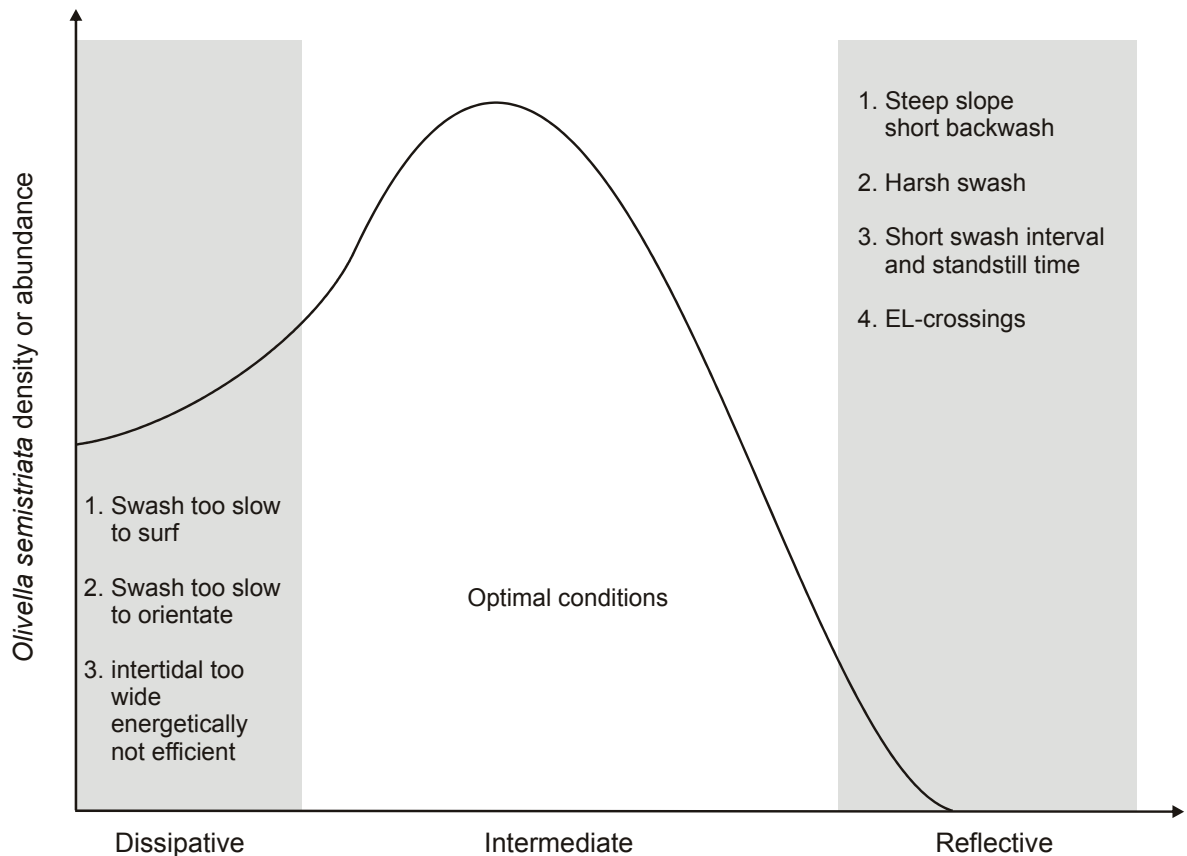
*Olivella semistriata* was completely absent from steep, reflective beaches, such as Ballenita, Portéte (Chapter 1) and Ayangué 2 (Chapter 4). This is due to a number of reasons. Firstly, because of the steep slope, feeding becomes difficult, as demonstrated in the high tide feeding sampling (Chapter 6): before the swash velocity has dropped below 0.5 m/s (maximum swash velocity at which *O. semistriata* can filter the backwash, see Chapter 6), the swash will have disappeared in the voluminous and porous interstitial space formed between the coarse sand. Secondly, swash conditions are too harsh for both surfing and feeding. Above a certain swash velocity it becomes impossible for *O. semistriata* to control the surfing. Thirdly, swash interval and swash standstill time are

markedly shorter on the reflective beaches, giving the animals very little time to secure foothold before being carried again by the swash. Moreover, the coarse sands on reflective beaches increase the burial time of *Olivella semistriata* and it is very likely that securing foothold in coarse sand is more difficult than on fine sand, or even impossible. Finally, the number of effluent line crossings on reflective beaches is very high, even at low tide. This increases the probability of being swept above the effluent line - where burrowing is impossible - dramatically. The last three hypotheses are in accordance with the predictions from the swash exclusion hypothesis (McLachlan *et al.*, 1993), which says that many macrofaunal taxa, especially molluscs (McLachlan *et al.*, 1995), are excluded for reflective beaches because of the harsh swash conditions.

Towards the dissipative end of the beach spectrum abundance but especially densities of *Olivella semistriata* declined significantly (Table 3.4.4). There are several factors that could cause this decrease. Cubitt (1969) hypothesized that surfers require a certain swash action, not reached on dissipative beaches, to be able to surf. This is possibly because a minimum swash velocity is necessary to orientate in the swash (Ellers, 1995c). We added that intertidal distance is becoming so long on dissipative beaches that surfing is not an energy efficient strategy anymore (Chapter 2). To test this hypothesis, we recalculated the migration model of Chapter 6, but with an intertidal width of 120 m instead of 60 m. In order to optimize feeding - at a value of 5% lower than on the intermediate beach - the number of migration movements has to increase by 56% with an average surfing distance of 4.8 m. This clearly shows that surfing is energetically less favourable on a dissipative beach than on an intermediate beach.

Note that while the swash conditions did not differ very much between beach types in terms of average swash velocity and swash period (Chapter 1), these parameters do vary substantially when the upper half of the swash zone, the part relevant to *Olivella semistriata*, is considered. This is because the swash zone is much wider on intermediate, but especially on dissipative, beaches. When the average swash velocity is equal for a 10 m and a 20 m wide swash zone, this means that in the upper half of the swash zone the velocity will be higher in the smaller swash. The same can be said for swash interval (being the derivative of swash period relevant for *O. semistriata*).

An overview of the macroscale distribution mechanisms is given in Fig. 4.3.



**Fig. 4.3** - Macroscale distribution of *Olivella semistriata*: a synthesis.

#### 4.3.1.2 Meso- and microscale (cross-shore, alongshore and swash)

Since *Olivella semistriata* is entirely dependent on the swash for its survival, it was expected that the functional zone is confined to the swash itself (Chapter 2 and 3). The density and biomass zonation within the swash zone show a consistent parabolic pattern, with highest numbers in the upper part of the swash. This zonation remained almost identical, independent of location (two beaches), falling or upcoming tide, or position on the beach (high, middle and low beach).

The numbers, however, did change over the tidal cycle. While shifting downshore with the tide, a lot of animals were left behind on the drying part of the intertidal, especially on the high beach. As such, the cross-shore zonation at low tide is not restricted to the swash zone: the population is stretched out over the full intertidal.

The animals we found on the drying intertidal were mainly small individuals; in the low tide swash zone no specimens smaller than 4 mm shell length were found. There is thus a cross-shore length zonation - at the time of low tide - from small individuals high

on the shore to large individuals near the surf. The same length zonation exists within the swash zone: the average shell length increases from the upper to the lower swash zone.

We hypothesize that this length zonation is a result of the swash conditions, which are more hostile lower in the swash: swash velocity is higher and swash interval shorter. It is not unlikely, though, that the zonation itself is initiated because of a passive length segregation. Small individuals have less chance to settle lower in the swash and are thus automatically carried higher up.

The fact that the entire population is compacted in the high tide swash zone means that estimating the population size is fairly straightforward: only the high tide swash zone should be sampled. Sampling a mobile species in the swash, however, is not easy. Not only does one need a reference point other than the generally used drift line, but one also has to make sure no migration takes place while sampling at the different sampling levels. A solution to these two issues is provided in Chapter 2, where the use of wooden boxes is described to prevent migration while sampling. The upper and lower swash limits, determined by monitoring the swash for 10 minutes, are used as reference points.

We did not investigate alongshore variation as a separate topic, but it is clear from the parallel transects sampled for Chapter 3 that even over a very short alongshore distance, differences can be vast. This is especially the case when there are high tide cusps, present on many of the intermediate, exposed beaches. Almost no animals can be found on the crests of the cusps. Another example of alongshore variation is discussed in paragraph 4.3.1.3 (San Pedro beach and impact of artisan fisheries).

#### 4.3.1.3 *Other factors influencing the distribution*

A last point that should be addressed is the human impact on the distribution of *Olivella semistriata*. The most important human activities on Ecuadorian sandy beaches are tourism and artisan fisheries. Tourism is very localized, both spatially and temporally. From this thesis, Playas (Chapter 2) and Ayangué (Chapter 4) are by far the touristiest beaches. Almost any village on the coast has a major fishermen's community. The disturbance they cause is by bringing their small fishing boats on and off the beach, for which they use large and heavy wooden trunks.

Without having to sample, the presence of *Olivella semistriata* can easily be checked because of its prominent position in the swash. This way, we could observe that

there is a clear influence of human activity on the population of *O. semistriata*. For instance, on the beach of San Pedro the species is extremely abundant, except right in front of the village, where numerous boats are brought to and from the sea per day. The same observation was done at various other locations.

The impact of tourism is clearly illustrated in the small bay of Ayangue. At the south end of this bay, there is no human activity, and *Olivella semistriata* is very abundant. The north end of this beach is a very popular tourist spot. As soon as one gets to the place where the tourists wander, *O. semistriata* almost instantly disappears. The difference in density between the south and north end of this bay is 21 vs. 1070 ind/m<sup>2</sup> (unpublished research). The village of Ayangue stretches out over the whole bay, thereby minimizing the possibility that wastewater discharge is the influencing factor.

The reason for the sensitivity of *Olivella semistriata* to human activities is probably associated with its surfing behaviour. The timing and regulation of surfing is crucial to maintain position in the swash; constant disturbance of the swash zone is very likely to confuse the species, and in the end this will lead to lower population sizes, or even to the complete disappearance of *O. semistriata*, such as in the extremely touristy beach of Salinas. Similar ideas were also proposed by Dugan for *Emerita* (personal communication).

#### 4.3.2 Feeding habits

*Olivella semistriata* filters the backwash by placing its tentacles in the water current. Catch surface is enlarged through a mucous net that is hung between the tentacles. This net is only used during the first capture of a backwash wave. The same wave is then filtered several times more with just the tentacles, until the swash current is almost zero.

*Olivella semistriata* can feed at two moments during a swash wave: at swash wave standstill and in the backwash. Wave standstill in the zone where *O. semistriata* lives is only sufficiently long for feeding with very large swash waves, and the feeding time is very limited (usually less than 10 s). Filtering the backwash starts at swash velocities below 0.5 m/s. Depending on the backwash time, feeding can be from a few seconds to as long one minute (Chapter 6).

The feeding dynamics are dependent on the swash conditions and the position of the animal within the swash zone. The parameters that determine the feeding time and

efficiency are swash time, swash interval and swash distance. The longer the swash time, the longer animals can feed. Swash time, however, decreases with decreasing swash interval, especially with large swash distances, where the next wave will interrupt the backwash of the previous wave, thereby limiting or inhibiting feeding on the backwash. In general, feeding time and efficiency follow a negatively skewed parabolic curve within the swash, with optimal conditions in the upper half of the swash zone. The pattern is almost identical to the swash zonation pattern of *Olivella semistriata* (see Fig. 3.6.11). This observation leads to an interesting paradox: the distribution of food availability seems to control the swash zonation of *O. semistriata*, so we could say the zonation is biologically driven. This contradicts the paradigm that zonation on sandy beaches is environmentally driven (McLachlan and Jaramillo, 1995; Defeo and McLachlan, 2005). However, the reason why the food availability follows a parabolic curve is due to the swash dynamics, an environmental parameter.

#### **4.3.3 Surfing behaviour**

The surfing behaviour of *Olivella semistriata* is probably the species' most remarkable characteristic. Surfing is used to maintain position (and zonation, see higher) in the swash with the changing tide. There are two major advantages to surfing: firstly the swash zone is as good a protection from predators as it gets on a sandy beach; predation time for both avian and piscian predation is very limited (Dugan *et al.*, 2004). The second benefit of surfing is that it maximizes the feeding opportunities (McLachlan and Brown, 2006). In *O. semistriata*, the populations surfs over the beach in a simultaneous way, making its surfing a migratory behaviour. This is not always the case (Ellers, 1995a). *Bullia*, for instance, surfs in order to catch prey (Brown, 2001), so its surfing is not migratory.

Surfing is a combined active/passive way of locomotion (Ellers, 1995a; McLachlan and Brown, 2006), and consists of three different movements: emerging from the sediment, surfing itself and burrowing. All three components require their own regulatory mechanisms. Emerging is an active process in all surfing species (Cubit, 1969; Ellers, 1995a,b; Brown, 2001 and this thesis). Surfing itself is, in general, a passive floating in the swash for molluscs (Ellers, 1995a,b; Brown, 2001 and this thesis); surfing crustaceans tend to swim actively (Cubit, 1969). For upshore migration, animals ride the swash uprush. Surfing the backwash brings the animals down the beach. After riding the wave the animals burrow again in the sediment.

#### 4.3.3.1 *Emerging from the sediment*

Emerging from the sediment can be addressed from two sides: the functional morphology and the timing, which in itself consists of a trigger part, a dynamics part and a regulatory mechanism. Only the last two factors were investigated in depth.

Emerging from the sand is the reverse movement of burrowing (Brown *et al.*, 1989) and was estimated to take around 2 s. The exact moment at which an animal decides to jump out of the sediment is crucial for its surfing success. Emerging from the sediment occurs in response to a certain change in the environmental conditions, a certain trigger. There are several changes in the environment that could potentially make the animals emerge from the sediment, and although we only did some very short and small-scale experiments (unpublished results), we hypothesize that *Olivella semistriata* can detect the swash current, with a possible additional effect of sediment thixotrophy.

*Olivella semistriata* especially reacts to big waves, both for up- and downward migration (unpublished results). The biggest waves are less favourable, probably because surfing would be difficult to control. When no appropriate large wave is available, the animals tend to surf even upon the smallest waves, if necessary (field observations). Small waves are equally used on days with extremely calm conditions, when there are simply no big waves, or to adjust the position in the swash, i.e. the fine-tuning of the swash position.

The overall regulation of all these mechanisms seems to be an endogenous circatidal clock, which tells the animals whether the tide is rising or falling. The presence of such a tidal clock, so far never found in sandy beach molluscs, was demonstrated by a swash rig experiment (Chapter 5). To verify the presence of the endogenous circatidal clock, animals were subjected to identical conditions during upcoming and falling tide. Migration turned out to be fairly similar to what happens in the field, even if the animals had been kept in constant laboratory conditions for 6 hours.

#### 4.3.3.2 *Surfing itself*

The way *Olivella semistriata* surfs seems to be very similar to *Bullia digitalis*, a well-studied species from exposed beaches in Southern Africa. The main difference is that *Bullia* surfs at an angle to the swash current while *Olivella* goes in the same direction as the swash. Apart from that, they both use their extended metapodium as a concave underwater sail to increase drag surface (Brown, 1961; Brown *et al.*, 1989), which is

normally kept rigid by contraction of the dorsoventral pedal muscles (Brown *et al.*, 1989). Flapping these thin extensions of the foot generates a forward propulsion, which is used in very small waves, and could be considered swimming. *O. semistriata* travels at about half the velocity of the wave they surf upon.

An additional advantage of using an underwater sail is that the animals are passively oriented in the correct direction. Orientation in surfing bivalves, such as *Donax*, is caused by the shell shape (Eilers, 1995c). Gastropods that do not have an underwater sail tumble around in the swash, leading to a much less efficient migration. This is, for instance, seen in *Mazatlanina fulgurata*, a gastropod that lives in the low tide swash on Ecuadorian beaches (personal observations).

#### 4.3.3.3 *Burrowing*

The ability to burrow rapidly is one of the most crucial characteristics to survive on exposed sandy beaches (McLachlan and Brown, 2006). For surfers, burrowing superficially is sufficient and, as such, helps to reduce burial time. Typical burial time of *Olivella semistriata* in native sediment or in the field was around 8 s for a 10 mm specimen. Burial time increased with increasing shell length. Under laboratory conditions burrowing was fastest in fine sand with grain size between 150 and 350  $\mu\text{m}$ . In finer or coarser sand burrowing was significantly slower, especially in very coarse sands ( $> 1000 \mu\text{m}$ ). The burrowing rate index (BRI), which expresses the burial time to the volume of the animal (Stanley, 1970), showed values higher than 5 for all but the three coarsest sand groups ( $> 350 \mu\text{m}$ ), indicating a very fast burrowing mode.

Compared to other sandy beach surfers, *Olivella semistriata* has a similar burrowing capacity as other gastropods and bivalves. The burrowing rate index of mole crabs is more than a magnitude higher than of molluscs. Where mole crabs flourish on reflective beaches, characterized by heavy swash action, short swash periods and a very short swash standstill time, molluscs are absent under these conditions (Chapter 1). It seems that the burrowing capacity plays an important role in this. Our results indicate that swash standstill time in combination with sediment grain size are the main limiting factors, in that slower burrowers such as molluscs do not get enough time to secure foothold in coarse sand.



---

## 4.4 Open questions

### 4.4.1 Studying macrofauna on exposed beaches

The most prominent question that comes out of the work on macrofauna reported in this thesis, is what happens at different temporal scales. It would be most interesting to repeat the study from Chapter 1 on a regular base, although the sampling load would be very high. Ideally, at least one beach of each type should be sampled bi-weekly. Additionally, it could be more appropriate to monitor the swash both at high and low tide. Finally, gathering information about the sediment permeability and porosity could shed a new light on macrofauna and beach morphodynamics.

A second point of interest is the alongshore variation, and patchiness of macrofauna. This has only been given attention in very few studies, despite the importance in for instance population estimation. This was clearly illustrated by the substantial difference in population estimates retrieved from adjacent transects in Chapter 3.

Finally, we strongly believe in the potential of the swash rig (Chapter 5) to unravel questions about causality between beach factors and macrofaunal patterns.

### 4.4.2 Macrofauna and ENSO

Studying the impact of a long-term change on macrofauna is logistically very difficult, especially with an irregular and unpredictable phenomenon as ENSO. A field monitoring campaign over many years, with a reasonable resolution (monthly or every two months), should be combined with mesocosmos experiments on indicator species. However, therefore detailed information about the natural temporal variation is needed. Additionally, keeping macrofauna in laboratory conditions might prove very difficult (see Chapter 5 for *Olivella semistriata*).

### 4.4.3 *Olivella semistriata*

Although we did manage to answer numerous core questions about the biology of *Olivella semistriata*, quite a few questions remain. The most important one is the population dynamics of the species. We know that Olividae are slow-growing and long-living species (Tursch and Greifeneder, 2001), but we have no information about the generation time, recruitment and age distribution of the species. A better understanding of the population dynamics would also help to further identify the possible quality of *O.*

*semistriata* as an indicator species for natural and human impact studies. We propose that a high tide swash zonation sampling on a bi-weekly base would be the ideal way to study the population dynamics.

One of the most striking findings of this thesis was the possible presence of an endogenous clock in *Olivella semistriata*. This has never been demonstrated for any intertidal sandy beach mollusc. However, much more study is needed to fully understand the functioning of this clock, and it would be highly interesting to see whether this endogenous clock is combined with an endogenous circatidal rhythm in behaviour, such as found in *Donax* (Ellers, 1995b) and many crustaceans (Enright, 1963; Gibson, 2003; Forward *et al.*, 2005). One way to do this is by further experiments in the swash rig. One could, for instance, compare the migration of dead and live animals at different times of the tidal cycle.

Another aspect that has not seen enough attention is the actual trigger for migration. In a set of short experiments, we found swash current to be the most likeable candidate, but these experiments were too limited to provide firm proof for the hypothesis on the one hand and to exclude different triggers on the other hand.

---

**- PART V -**

**ADDENDA**

---



## **ADDENDUM 1**

# **MACROFAUNAL COMMUNITY STRUCTURE AND ZONATION OF AN ECUADORIAN SANDY BEACH (BAY OF VALDIVIA).**

---

Aerts, K., Vanagt, T., Degraer, S., Guartatanga, S., Wittoeck, J., Fockedey, N., Cornejo-Rodriguez, M.P., Calderon, J. and Vincx, M.

Published in *The Belgian Journal of Zoology* (2004) 134 (1): 15-22

Keywords: macrobenthos, sandy beach, Ecuador.

## Abstract

The sandy beach macrofauna of the Bay of Valdivia (Ecuador) was sampled in August-September 1999 along six replicate transects between the high and low water line. The sediment consisted of well-sorted, fine to medium sand. Taking into account the dimensionless fall velocity ( $\Omega$ ) and the relative tidal range, the beach was characterized as an exposed, low tide terrace - rip beach. The distribution of the macrofauna was mainly determined by the elevation on the beach. Thirty-one taxa were found throughout the study, varying between 10 and 22 taxa per transect. Molluscs were the most dominant taxon (overall average: 285 ind/m<sup>2</sup>, max.: 2,135 ind/m<sup>2</sup>), followed by crustaceans. The gastropod *Olivella semistriata* (overall average: 243 ind/m<sup>2</sup>, max. 2,131 ind/m<sup>2</sup>) was the most abundant species. The crustaceans were the most diverse taxon (10 spp.); *Haustorius* sp., *Excirolana braziliensis* and *Emerita rathbunae* were the most abundant species. Densities of polychaetes were low in comparison with the previous two taxa mentioned (overall average: 13 ind/m<sup>2</sup>). The total average density over the entire bay was 370 ind/m<sup>2</sup>. Three zones of macrofaunal distribution along the tidal gradient could be distinguished: an upper beach, a middle beach and a lower beach assemblage. The upper beach assemblage consisted mainly of *Excirolana braziliensis* and ghost crabs. The middle beach assemblage had highest macrofaunal densities and was dominated by *Olivella semistriata* and *Haustorius* sp. The most diverse assemblage was found on the low beach, with representatives of different taxa, but with lower densities. These results are in conformity with other studies along the Pacific coast of South America and fit into the zonation scheme of Dahl (1952). Given that many other studies from South America were done at temperate latitudes, we conclude that, although differences in species composition were found, the general pattern of macrobenthos zonation on sandy beaches is similar in tropical regions.

## A1.1 Introduction

Macrofaunal zonation on sandy beaches is a distinctive and well-described phenomenon of intertidal zones (McLachlan and Jaramillo, 1995). The existence of species zonation on exposed sandy beaches is thought to be mainly caused by species specific responses to swash climate and sedimentology, with a less critical role of biological interactions (McLachlan, 1983a; McLachlan *et al.*, 1993; McLachlan and Jaramillo, 1995).

Different generalizing zonation schemes for sandy beach macrofauna were proposed (Davenport, 1903; Mortensen, 1921; Schulz, 1937) with the schemes of Dahl (1952) and Salvat (1964 and 1967) as the most commonly used. Dahl (1952) suggested a distinction between three zones, defined in terms of a typical crustacean fauna inhabiting each zone, while Salvat proposed a four zone system based on physical conditions.

In all of the studies describing intertidal zonation within different South American Atlantic and Pacific regions, three zones were recognized (McLachlan and Jaramillo, 1995 and references herein), supporting Dahl's scheme. Several studies (Clarke and Peña, 1988; Defeo *et al.*, 1992; Dexter, 1974, McLachlan and Jaramillo, 1995) showed that crustaceans are the most diverse taxon on South American sandy beaches. The upper parts of tropical and subtropical beaches are characterized by ocypodid crabs, while hippid crabs, bivalves and amphipods dominate the lower beach. Cirolanid isopods (*Excirolana* spp.) are abundant on the midshore, together with opheliid and spionid polychaetes; the bivalves *Mesodesma* spp. and *Donax* spp. are other characteristic organisms. To our knowledge, no information is available about sandy beach macrofauna in Ecuador. Nearest studies to Ecuador of sandy beach macrofauna were conducted to the south in Peru (8° S) by Bocanegra *et al.* (1985) and to the north in Colombia (1° 48' N) by Riascos and Rallón (2001), locations with different environmental conditions. Because the Ecuadorian coastal waters are divided by two opposite currents, the warm El Niño-current coming from the north, and the cold Humboldt-current coming from the south, and because of the tropical location of Ecuador, a different macrobenthic community structure might be expected.

In this study the intertidal zonation and assemblage structure of the macrofauna of the Bay of Valdivia (Ecuador; 1-2° S) was investigated. This bay was chosen because of the importance of the beach for harvesting shrimp larvae, which are used in one of Ecuador's largest economy.

This paper presents the distribution patterns of the macrofauna in order to set up a larger project on the influence of ENSO on macrobenthic communities of sandy beaches in Ecuador.

## **A1.2 Material and Methods**

### **A1.2.1 Study site**

The study area is located in the Bay of Valdivia, Ecuador ( $1^{\circ}54'00''$  -  $1^{\circ}58'20''$  S and  $80^{\circ}46'00''$  -  $80^{\circ}45'30''$  W), approximately 50 km west of Guayaquil (Fig. A1.1). This 10 km long bay consists of 8 km of exposed sandy beaches with rock formations on either side.

The beaches have a semi-diurnal, mesotidal regime (Davies, 1964) with a tidal range of 2.5 - 3 m (average: 2.6 m). The modal breaker height ( $H_b$ ) is 0.49 m. The modal wave period ( $T$ ) is 14 s (unpublished pers. comm. S. Guartatanga).

The Ecuadorian coastal climate is characterised by two seasons: a dry-cool season (May-December) and a wet-warm season (January-April) and is influenced by currents in the Pacific Ocean. From July until October the area is subjected to the relatively cold ( $<22$  °C) Humboldt Current, heading North, while during the months January until April the warm ( $>25$  °C) El Niño current, heading South, dominates.

Additional to the normal seasonality, with a periodicity of three to seven years, the climatologic and oceanographic phenomenon ENSO dramatically alters the conditions in the Ecuadorian coast, with higher temperatures and precipitation levels during El Niño and lower temperatures during the subsequent La Niña.

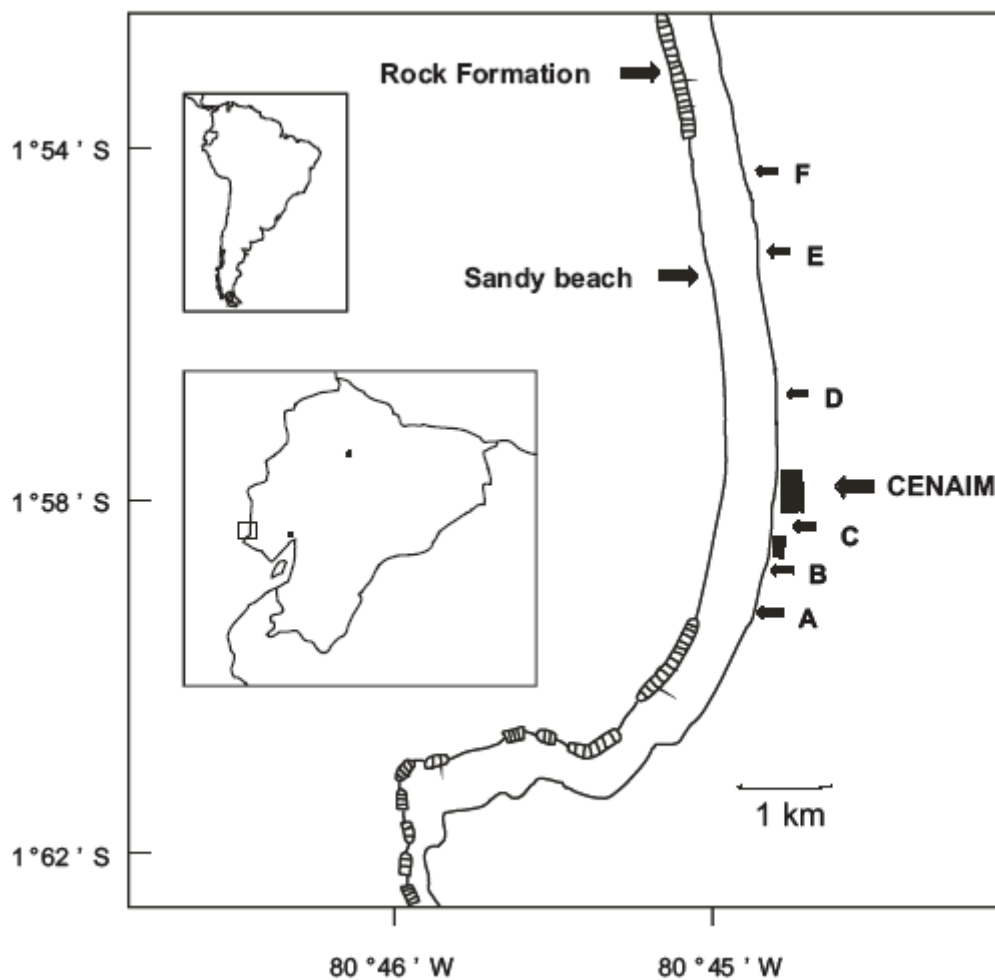
### **A1.2.2 Sampling and laboratory work**

Sampling took place between 31 August and 5 September 1999. To cover habitat variability over the bay, six transects, distributed over the whole bay and perpendicular to the waterline, were sampled (Fig. A1.1: A-F). Each transect was sampled at six stations: five stations were situated in the intertidal zone, while a sixth one was located on the dry beach. Sampling of the intertidal zone always started at high tide, following the receding water down the beach. To distribute the stations evenly across the intertidal gradient, the transect was sampled in the swash zone every 90 minutes (Fig. A1.2). At each station three replicate samples were collected by excavating a metal frame (sampling surface



area:  $0.1026 \text{ m}^2$ ) to a depth of 15 cm. The samples were sieved alive over a 1 mm mesh-sized sieve. The organisms retained were stored in 8 % formaldehyde-seawater solution.

At each station, one sediment sample was collected for grain size analysis using a core with diameter 3.6 cm. In addition, the relative elevations of the different stations were measured using an altimeter. Distances between all sample sites were measured.



**Fig. A1.1** - Geographical situation of the six sample transects (A-F) from the Bay of Valdivia, Ecuador (modified from Boothroyd *et al.*, 1994).

### **A1.2.3 Laboratory treatment**

Macrobenthic organisms were counted and identified to species level, where possible.

The sediment grain size distribution between 2 and 850  $\mu\text{m}$  was determined with a laser COULTER LS and classified according to the Wentworth scale (Buchanan, 1984). The median grain size of the sand was largely biased by the mixture with shell fragments present in all samples, while the modal grain size remained unaffected. Hence, the modal grain size was preferred over median grain size as a good representation of the sediment's main characteristic.

### **A1.2.4 Mathematical analyses**

Combining the relative elevation of the lowest station of each transect with the data from the tide table for La Libertad (INOCAR) allowed to estimate their absolute elevation (relative to the mean low water level at spring tide, MLWS), from which the absolute elevation of all higher stations was calculated and beach profiles were obtained. By means of these beach profiles, the mean slope between low and high water of every transect was calculated. In this study, beach width is defined as the distance between the low water line and the lowest edge of the terrestrial vegetation.

The morphodynamic state of each transect was assessed by calculating the dimensionless fall velocity ( $\Omega = H_b / w_s T$ ) (Dean, 1973) and the relative tide range (RTR =  $\text{MSR}/H_b$ ) (Masselink and Short, 1993). Sediment fall velocity ( $w_s$ ) was obtained from sediment particle size after Gibbs *et al.* (1971). Mean spring tidal range (MSR) was obtained from the tide table (INOCAR).

For each sample the species richness ( $N_0$ ) (Hill, 1973) and diversity (Shannon-Wiener diversity index,  $H'$ ) were determined (Shannon and Weaver, 1949). Community analysis was done by means of Cluster-analysis (Clifford and Stephenson, 1975), Canonical Correspondence Analysis (CCA) (Ter Braak, 1988) and Indicator Species Analysis (Dufrêne and Legendre, 1997). Correlations between environmental variables were analysed by means of the non-parametric Spearman rank correlation coefficient (Conover, 1971).

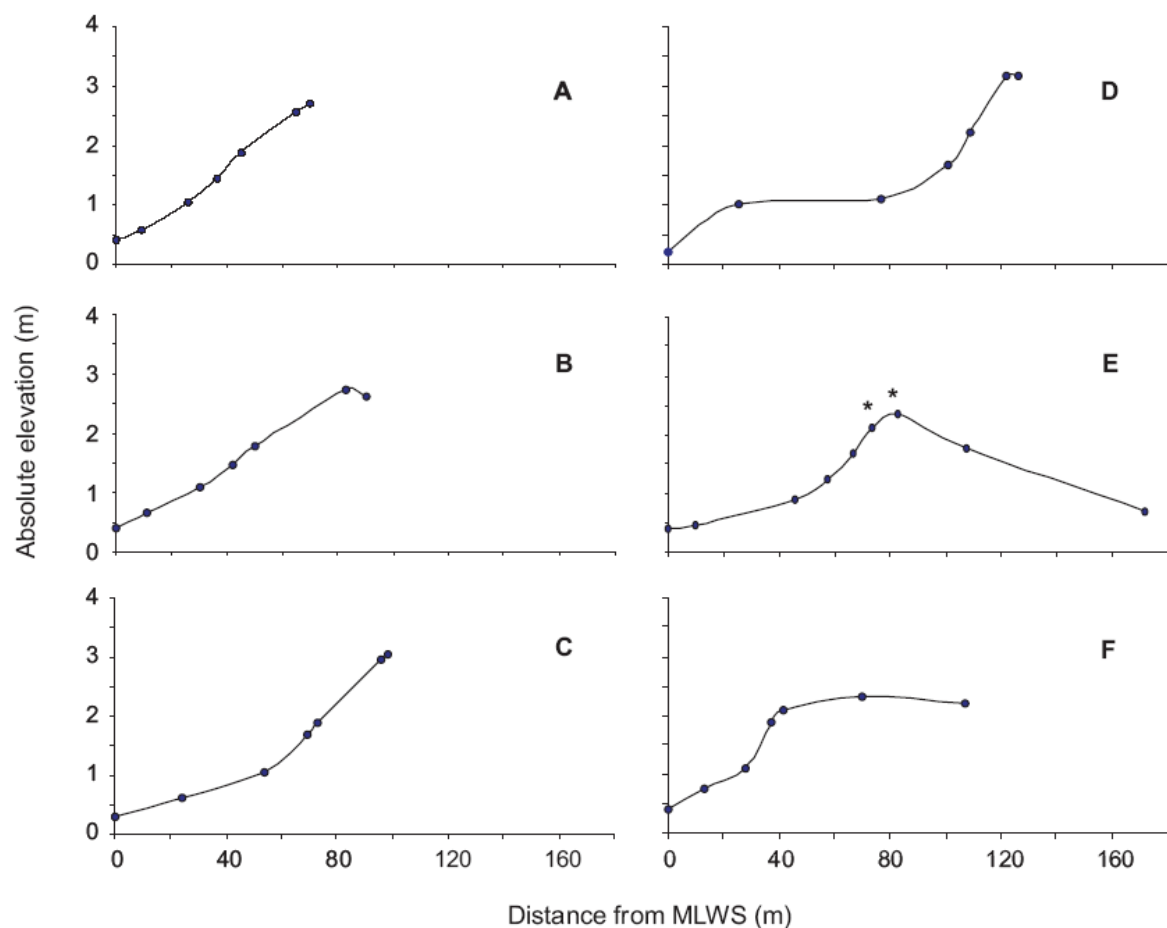
To visualize zonation patterns of density and the number of species ( $N_0$ ), polynomial functions were fit to the data according to the distance-weighted least squares smoothing procedure, using STATISTICA 5.1 (StatSoft, 1996).

## A1.3 Results

### A1.3.1 Environment

The beach width ranged from 70 and 172 m, while the width of the intertidal zone ranged from 42 to 109 m. The beach slope varied between 1:25 and 1:54.  $\Omega$  was found between 1.172 and 1.541; RTR had a value of 5.306.

Although all transects were situated on the same beach, some variation in beach profile was observed (Fig. A1.2). Furthermore, an alternation of ridges and runnels was present at transect F, while all other transects showed a quite featureless beach profile. Transects C and D showed a break in their slope. The upper part of transect C was steeper than the lower part (1:14 versus 1:39). The middle part of transect D had a gentle slope compared to the lower and upper part.



**Fig. A1.2** - Beach profiles at the six transects (\*: additional measure points; the most right point is the vegetation line).

Fine to medium sands (125-500  $\mu\text{m}$ ) dominated the sediment. The stations modal grain size ranged between 171  $\mu\text{m}$  and 262  $\mu\text{m}$ , except for the lowest stations of the two northern-most transects (modal grain size: 325  $\mu\text{m}$ ). The fraction of silt and clay (< 63  $\mu\text{m}$ ) was low (0-3.2 %) and was negatively correlated with the elevation ( $r=-0.707$ ;  $p<0.0001$ ) as was the fraction of coarse sand (>500  $\mu\text{m}$ ) ( $r=-0.428$ ;  $p<0.0001$ ).

### A1.3.2 Macrofauna

A total of 31 macrofaunal taxa (10 taxa of crustaceans, 8 of molluscs, 8 of polychaetes and 5 others) were collected (Table A1.1: species list), ranging from 10 to 22 taxa per transect and varying between 0 and 10 taxa per station.  $H'$  diversity index ranged from 0 to 2.87. Overall average macrobenthic density was 370 ind/ $\text{m}^2$ . Molluscs dominated the fauna (average: 285 ind/ $\text{m}^2$ , max. 2,135 ind/ $\text{m}^2$ ), followed by crustaceans (average: 66 ind/ $\text{m}^2$ , max. 413 ind/ $\text{m}^2$ ). The gastropod *Olivella semistriata* was the most dominant species of the whole beach (average: 243 ind/ $\text{m}^2$ , max.: 2131 ind/ $\text{m}^2$ ). Other abundant species were the gastropods *Mazatlania hesperia*, *Mazatlania* sp., the polychaetes *Nephtys* sp., *Hemipodus* sp. and *Lumbrineris* sp., the haustoriid amphipod *Haustorius* sp., the cirrolanid isopod *Excirolana braziliensis*, the anomuran crabs *Emerita rathbunae* and *Lepidopa deamae* and spat of bivalves.

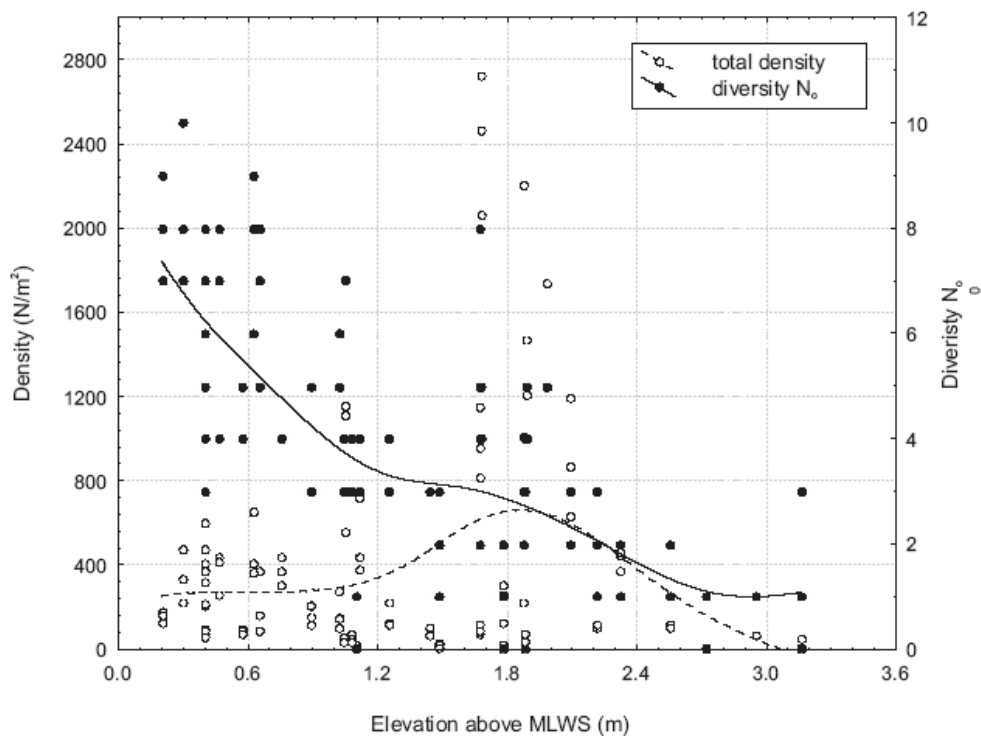
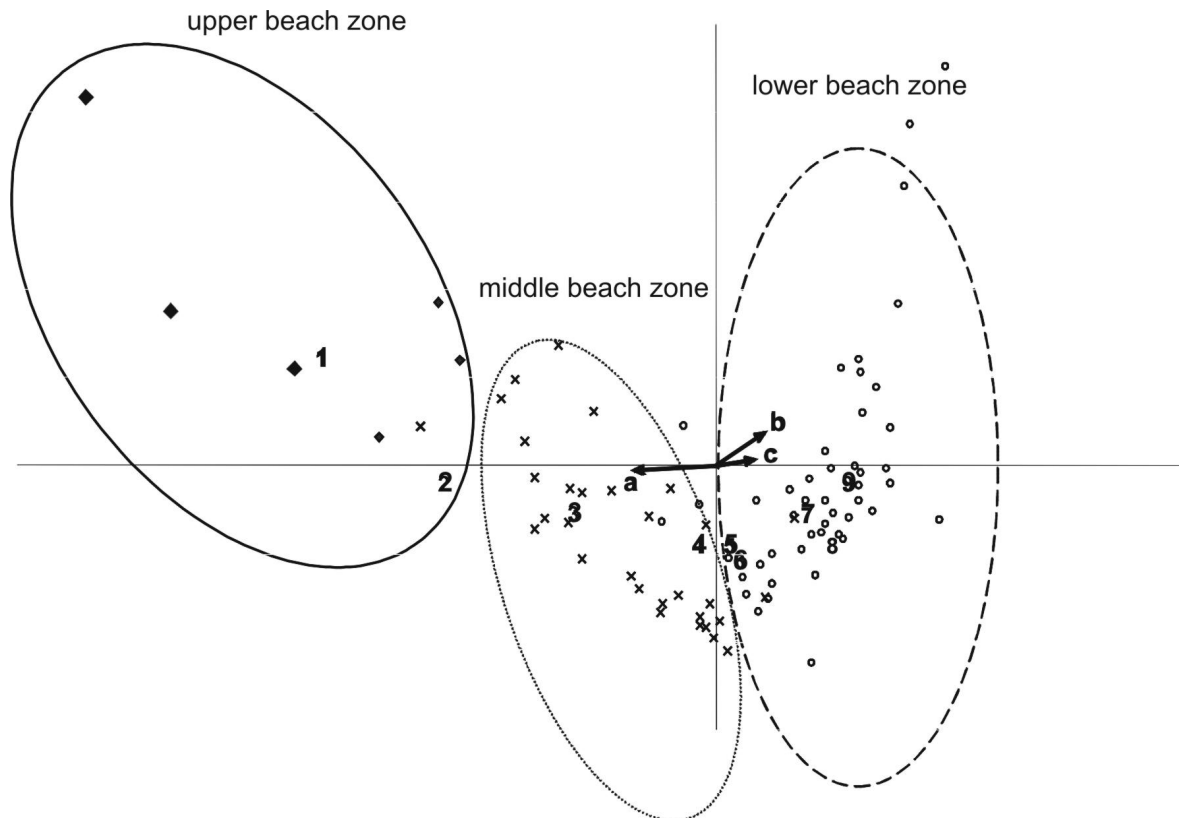


Fig. A1.3 - Total density and  $N_0$  diversity set against elevation.

Along the whole beach, highest species richness ( $N_0$ ) was situated at the lower beach (Fig. A1.3): species richness generally decreased towards the upper beach. Highest densities (up to 2,400 ind/m<sup>2</sup>) were found between 1.6 and 2.2 m above MLWS. The stations on the dry zone of the beach (> 2.4 m) had the lowest densities (maximum: 100 ind/m<sup>2</sup>). Below 1.6 m, densities remained more or less equal (generally: 80 – 600 ind/m<sup>2</sup>): no obvious density increase towards MLWS was observed.

Multivariate techniques, CCA, Cluster analysis and species indicator analysis consistently distinguished between three station groups (Fig. A1.4). Station elevation was the most determining variable as far as upper and middle beach zones are concerned, % mud and % very fine sand (< 125  $\mu$ m) distinguished the lower beach fauna. The most important indicator species were *Excirolana braziliensis*, *Olivella semistriata*, *Haustorius* sp., *Bivalvia* spat and *Nemertea* sp.



**Fig. A1.4** - CCA-output with the three distinguished zones; group division is based on the outcome of all three applied multivariate techniques (eigenvalue axis 1: 0.500; axis 2: 0.183); a: elevation, b: % silt and clay (< 63  $\mu$ m), c: % very fine sand (63 – 125  $\mu$ m); 1: Insecta sp., 2: *Excirolana braziliensis*, 3: *Haustorius* sp., 4: *Olivella semistriata*, 5: *Nephtys* sp., 6: *Emerita rathbunae*, 7: *Nemertea* sp., 8: *Mazatlania* sp., 9: *M. hesperia*; ○: lower beach (47 stations), x: middle beach (33 stations), ◆: upper beach (19 stations).

**Table A1.1** - Species list (\* not sampled and not counted in analyses).

		<b>Family</b>	<b>Species</b>	
Annelida	Polychaeta	Maldanidae	Maldanidae sp.	
		Lumbrineridae	<i>Lumbrineris</i> sp. (BLAINVILLE, 1828)	
		Magelonidae	<i>Magelona</i> cf. <i>mirabilis</i> (JOHNSTON, 1865)	
		Pisionidae	<i>Pisione</i> sp. (GRUBE, 1857)	
		Glyceridae	<i>Hemipodus</i> sp. (QUATREFAGES, 1865)	
		Nephtyidae	<i>Nephtys</i> sp. (CUVIER, 1817)	
		Spionidae	<i>Scolelepis</i> sp. 1 (BLAINVILLE, 1828) <i>Scolelepis</i> sp. 2 (BLAINVILLE, 1828)	
Crustacea	Decapoda	Albuneidae	<i>Lepidopa daemae</i> (BENEDICT, 1903)	
		Hippidae	<i>Emerita rathbunae</i> (SCHMIDT, 1935)	
		Paguridae	<i>Pagurus</i> sp. (FABRICIUS, 1775)	
		Ocypodidae *	<i>Ocypode occidentalis</i> (STIMPSON, 1860)	
		Portunidae	<i>Arenaesus mexicanus</i> (GERSTAECKER, 1856)	
	Amphipoda	Haustoriidae	<i>Haustorius</i> sp. (MÜLLER, 1775) <i>Bathyporeia</i> sp. (LINDSTRÖM, 1855)	
		Isopoda	Cirolanidae	<i>Excirrolana braziliensis</i> (RICHARDSON, 1912)
	Mysidacea	Sphaeromatidae	<i>Paracerceis</i> sp. (HANSEN, 1905)	
		Mysidae		<i>Bowmaniella</i> sp. (BACESCU, 1968)
				<i>Metamysidopsis</i> sp. (TATTERSALL, 1951)
Echinodermata	Echinoidea	Mellitidae	<i>Mellita longifissa</i> (MICHELIN, 1858)	
	Stelleroidae		Ophiurae sp.	
Mollusca	Bivalvia	Donacidae	<i>Donax mancorensis</i> (OLSEN, 1961) <i>Donax</i> sp. (LINNAEUS, 1758)	
		Tellinidae	<i>Strigilla chroma</i> (SALISBURY, 1934)	
		Gastropoda	Collumbellidae	<i>Mazatlania hesperia</i> (PILSBRY & LOWE, 1932) <i>Mazatlania</i> sp. (DALL, 1900)
		Olividae	<i>Olivella semistriata</i> (GRAY, 1839)	
		Terebridae	<i>Hastula luctuosa</i> (HINDS, 1844)	
		Vitrinellidae	<i>Anticlimax willetti</i> (HERTLEIN & STRONG, 1951)	
Hexapoda	Insecta		Insecta sp.	
Nemertea			Nemertea sp.	

**Table A1.2** - Characteristics of the three distinguished zones.

		Lower beach zone	Middle beach zone	Upper beach zone
Elevation (m above MLWS)		0.3-1.3	1.0-2.1	1.8-3.2
Sediment	% silt and clay (<63µm)	1.3	0.4	0.1
	% very fine sand (63-125µm)	8.1	3.9	3.1
	% fine sand (125-250µm)	48.5	50.5	57.0
	% medium sand (250-500µm)	31.3	37.9	37.0
	% coarse sand (500-800µm)	9.0	6.3	2.0
Average N <sub>0</sub>		5.38	3.47	1.42
Number of species	All taxa	27	15	7
	Mollusca	8	3	2
	Polychaeta	7	4	1
	Crustacea	9	7	3
Average density (ind/m <sup>2</sup> )	All taxa	268	662	154
	Mollusca	221.0	577.0	2.6
	Polychaeta	18.8	11.2	0.5
	Crustacea	14.5	111.0	148.0
Percentage of all taxa within zone (%)	Mollusca	82.5	82.5	1.7
	Polychaeta	7.0	1.6	0.3
	Crustacea	5.4	15.9	96.0
Dominant taxa (>2%)		<i>O. semistriata</i>		
		Bivalvia spat		
		<i>M. hesperia</i>	<i>O. semistriata</i>	<i>E. braziliensis</i>
		<i>Mazatlanian</i> sp.	<i>Haustorius</i> sp.	Insecta sp.
		<i>E. rathbunae</i>		
		<i>Nephtys</i> sp.		
	Nemertea sp.			

The first group of 47 replicates was found between 0.3 to 1.3 m above MLWS, the lower beach zone (Fig. A1.4 and Table A1.2). The fine sand fraction (49 %) dominated the sediment. A relatively high percentage of mud (average: 1 %) and coarse sand (average: 9 %) was present. A total of 27 taxa was found, evenly divided over the molluscs, polychaetes and crustaceans (Fig. A1.5). Macrofaunal density (average: 268 ind/m<sup>2</sup>) was dominated by molluscs (83 %), mainly *Olivella semistriata* (48 %). Other abundant macrofauna comprised spat of bivalves (28 %), *Mazatlanian* sp. (4 %), *Emerita rathbunae* (3 %), nemerteans (3%), *Nephtys* sp. (2 %), and *Mazatlanian hesperia* (2 %).

The second group (33 replicates) was situated between 1.0 and 2.1 m above MLWS, the middle beach zone. Sediment was mainly composed of fine sand (50.5 %), with 0.4 % of mud and 6.0 % of coarse sand on average. Fifteen taxa, of which seven were crustaceans, were present. This zone was characterized by a high density (average: 662 ind/m<sup>2</sup>). Molluscs, especially the gastropod *Olivella semistriata* (82 %), dominated the

macrofauna (Fig. A1.5). The amphipod *Haustorius* sp. was the second most abundant species (13 %).

The third group (19 replicates) was found between 1.8 and 3.2 m above MLWS (upper beach zone), including the upper intertidal and supralittoral zone (high tide mark at 2.4 m above MLWS). Sediment was dominated by fine sand (average: 57.0 %) with low mud and coarse sand contents (average: 0.1 and 2.0 %, respectively). Seven taxa were found, with an average macrofaunal density of 154 ind/m<sup>2</sup>. This zone was dominated by crustaceans (96 %), mainly *Excirolana braziliensis* (Fig. A1.5). Next to crustaceans, several insect species were present. *Excirolana braziliensis* was found both on the dry beach and at the highest intertidal station. The insects were only present on the dry beach, together with high numbers of ocypodid crabs.

The mole crabs *Emerita rathbunae* and *Lepidopa deamae* were found across the entire intertidal gradient.



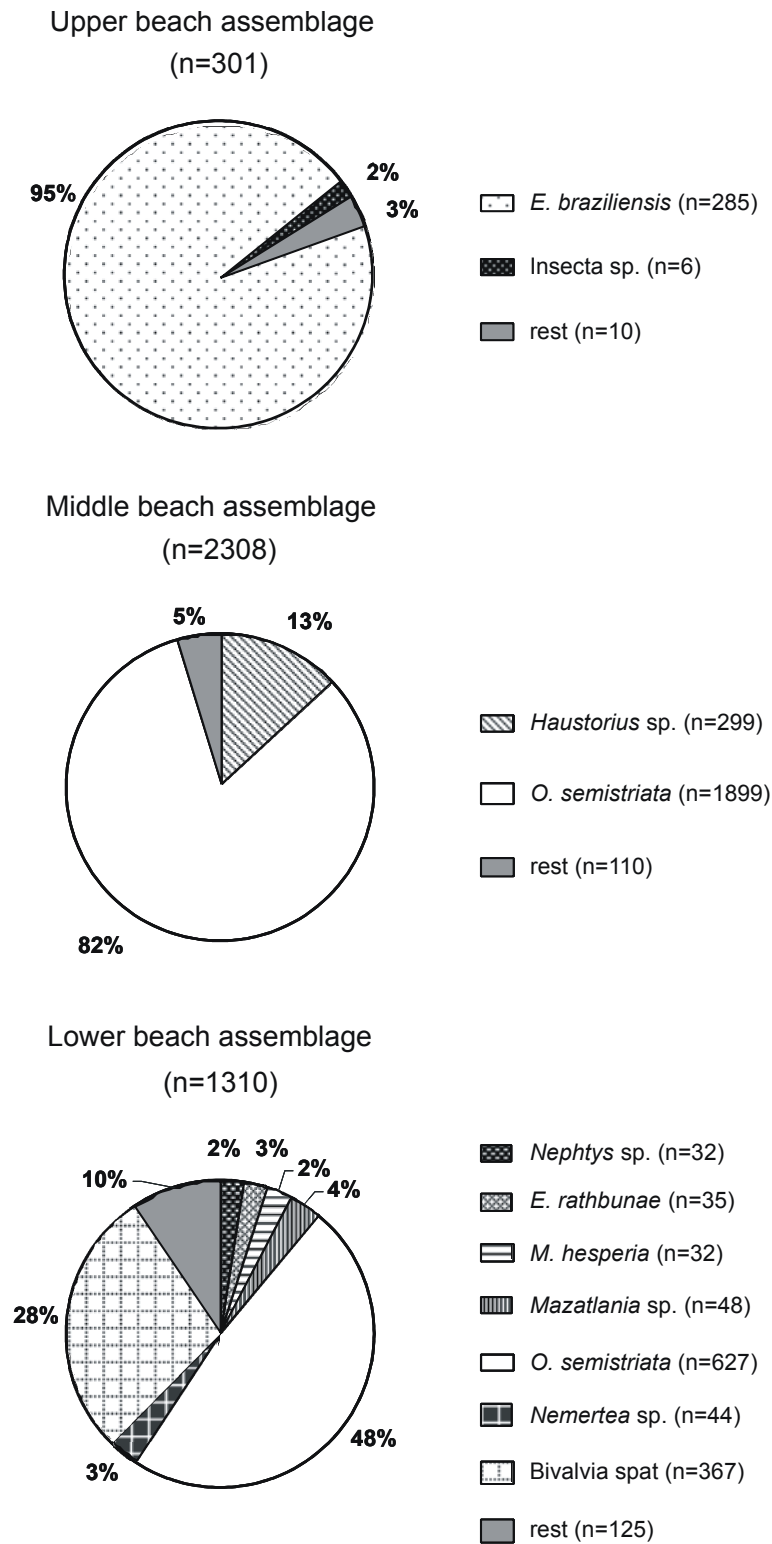


Fig. A1.5 - Taxon distribution for the three distinguished assemblages.

## A1.4 Discussion

This study was initiated as a pilot study for macrofauna research on Ecuadorian sandy beaches. Because only one beach was sampled, generalization of the results to all Ecuadorian beaches cannot be made. Further, since the beach was only sampled at one date, no inference about seasonal trends can be made. It has to be emphasized that the macrobenthic community structure and zonation pattern, which are obtained by data collected in a short period of time, are not necessarily representing the distribution during the rest of the year (Haynes and Quinn, 1995; Brazeiro and Defeo, 1996). In this study, the macrofaunal zonation during the dry, cool season is documented.

Sampling took place during a very strong La Niña phase of the ENSO cycle, and the preceding year was one of the strongest El Niño years ever recorded (Chavez *et al.*, 2002). There is some evidence that ENSO, and more specifically a strong El Niño, has a substantial influence on macrobenthic communities of sandy beaches (Tarazona *et al.*, 1988; Tarazona and Paredes, 1992). It is thus very likely that the situation encountered in this study was altered by the abnormal climatologic conditions of the two preceding years. Regardless of these shortcomings, if interpreted with caution, the present study provides a first overview on the community structure and zonation of Ecuadorian sandy beach macrofauna.

### A1.4.1 Environment

According to the morphodynamic classification scheme of Masselink and Short (1993), all investigated transects can be classified as low tide terrace - rip beaches ( $\Omega$ : 0-2; RTR: 3-7). Although differences between the different transects exist, the six transects were regarded as replicates of the same beach, rather than transects along six different beaches. Therefore, the zonation patterns might be less clear, but can be considered as representative for the whole bay (Degraer *et al.*, 1999). The differences in beach profile for the six sampled transects of the same beach (Fig. A1.2) show that it could be dangerous to only sample one transect when investigating the macrofauna of a sandy beach.

#### A1.4.2 Macrofauna: General

Molluscs, crustaceans and polychaetes were reported to be the three most abundant macrofaunal taxa on sandy beaches worldwide (Souriea, 1957; Pichon, 1967; Dexter, 1969; McLachlan, 1983b). Crustaceans tend to dominate exposed beaches, polychaetes sheltered beaches, while molluscs reach maximum densities in intermediate situations (Dexter, 1983). The investigated beach had a high richness of crustaceans (10 taxa) but was, in terms of density, dominated by molluscs. Especially the gastropod *Olivella semistriata* proved to be very abundant in this study (66 % of the overall macrofauna). So far, this genus was only found in low numbers on sandy beaches in Peru (Suarez Calvanapon, 1981), Columbia (Riascos and Rallón, 2001) and the Pacific coast of Mexico (Cupul -Magana and Téllez-Duarte, 1997). The high numbers found might be an overestimation of the actual density of this species, since this gastropod is thought to appear in high density patches (Riascos and Rallón, 2001). Still, preliminary research on other sandy beaches in Ecuador supports the statement of *O. semistriata* being a very dominant species (Vanagt, unpublished). It thus seems that this species is more abundant towards the Equator.

The bivalve *Donax* sp. only appeared in low numbers in Valdivia Bay, but has been reported to be very abundant at other sandy beaches from the same geographical area (Dexter, 1974; Perez Nieto, 1980; Riascos, 2002). There might be a negative correlation between *Donax* and *Olivella semistriata*-populations. Another possibility is that *Donax* was negatively influenced or *O. semistriata* positively influenced by the strong El Niño one year before sampling or by the strong La Niña during the sampling campaign. This hypothesis is supported by the fact that another common bivalve of South American Pacific beaches, *Mesodesma* spp., was absent on the Ecuadorian beach. Tarazona and Paredes (1992) reported that in Peru *Mesodesma donacium* might disappear almost entirely after a strong El Niño.

This study shows, in agreement with different other studies (e.g. Clarke and Peña, 1988; Defeo *et al.*, 1992; Dexter, 1974, McLachlan and Jaramillo, 1995), that crustaceans are the most diverse taxon on South American beaches along the Pacific coast. Cirolanid isopods, especially *Excirolana braziliensis*, were abundant in Valdivia Bay. This species is widely spread along the coasts of Central and South America, but shows a high spatial variability in density, attributed to variable beach temperatures (Zuñiga *et al.*, 1985). Next to *E. braziliensis*, *Haustorius* sp. (average: 27 ind/m<sup>2</sup>) and *Emerita rathbunae* (average: 6 ind/m<sup>2</sup>) were abundant crustaceans as well. These latter two crustaceans groups were also found on many other South American beaches (e.g. Peru: Suarez Calvanapon, 1981; Chile: Jaramillo *et al.*, 1993 and Uruguay: Giménez and Yannicelli, 1997). Ghost crabs

(*Ocypode occidentalis*) appeared in high numbers above the drift line on the investigated beaches, as was the case in Valdivia Bay. They were not sampled because of the applied sampling technique.

Polychaete species of the genera *Hemipodus*, *Lumbrineris* and *Nephtys*, which were the most abundant polychaete taxa in this study, have been reported from Peru (Suarez Calvanapon, 1981), Chile (Clarke and Peña, 1988) and Columbia (Dexter, 1974). Spionid polychaetes were only found in very small numbers. Opheliid polychaetes (e.g. *Euzonus furciferus*), which were found on several other South American beaches (Clarke and Peña, 1988; Gianuca, 1983; Escofet *et al.*, 1979) were not registered in the present study.

In general, taxon composition in Valdivia Bay was similar to other South American sandy beaches. Some differences, mainly in molluscs, were found, possibly due to the location near the Equator with its tropical conditions.

#### **A1.4.3 Macrofauna: Zonation**

In the Bay of Valdivia, three beach zones were distinguished: upper, middle and lower zone. The presence of three zones was already demonstrated for several sandy beaches around the world (McLachlan and Jaramillo, 1995 and references herein).

Generally, the upper beach zone of South American sandy beaches is dominated by a low number of species. Cirolanid isopods (e.g. *Excirolana braziliensis*) are often encountered (Dexter, 1974; Bocanegra *et al.*, 1985), together with large numbers of air-breathing ghost crabs (*Ocypode occidentalis*). This is typical for the transition zone between the marine and the terrestrial environment (Jaramillo, 1987).

Compared with the upper beach zone, a higher diversity of very abundant macrofaunal species is found at the middle beach. Again, crustaceans tend to be characteristic for this zone along many South American beaches (McLachlan and Jaramillo, 1995). In the present study, however, the most abundant species within the middle beach zone is the gastropod *Olivella semistriata*. Although polychaetes are rarely abundantly present in the middle beach zone of South American beaches, some species might be (e.g. opheliids, spionids and nephtyids) (McLachlan and Jaramillo, 1995). In Valdivia Bay, few polychaetes were found in the middle beach zone.

The lower beach zone of all exposed South American beaches is characterized by a large number of abundant species (McLachlan and Jaramillo, 1995), as is the case in the intermediate beach in our study. The lower beach zone is often regarded as an

intertidal extension of the subtidal habitat. The higher diversity of the lower beach zone could be a reflection of the high subtidal diversity (Degraer *et al.*, 1999). Also, the short period of exposure to the air allows more species to inhabit the lower beach zone.

It has to be emphasized that no sharp boundaries between the different zones were found, partly because of the morphodynamic differences between the replicate transects. Moreover, zonation on sandy beaches has to be seen as an artificial division of a continuum, with an overlap between adjoining zones (Degraer *et al.*, 1999).

In general, the zonation pattern of the macrobenthic assemblages on the investigated tropical beach was similar to other beaches at different latitudes in South America and the rest of world.

## **Acknowledgements**

This study was made possible by ESPOL (Escuela Superior Politécnica del Littoral) in Guayaquil, Ecuador. Financial support for co-author T.V. comes from the Fund for scientific research – Flanders (FWO). The following people are acknowledged for their assistance in the field and in the laboratory: Bart Bulckaen, Micheline De Mey, Daniëlle Schram, Dirk Van Gansbeke and Guy Desmet. Valuable comments on this manuscript were made by Mariano Lastra.

## A1.5 Critical note

The paper from Addendum 1 was published in 2004 and is reproduced here in its original form. Data collection of this chapter was done in 1999, three years before the start of this thesis. During the last two years of this PhD, however, we have come to several conclusions that question the outcome of some of the aspects of Chapter 1. These points of auto-criticism are listed in this critical note.

First of all, the sampling design used in Addendum 1 was not appropriate for the given circumstances and the goals of the study. Sampling the intertidal with the falling tide, with the sampling stations positioned in the upper swash zone, is a strategy that is commonly used on sheltered beaches along the Belgian coast (Elliott *et al.*, 1997; Degreear *et al.*, 1999, 2003). When the sandy beach research was transferred to the exposed sandy beaches of Ecuador's Pacific coast, the same strategy was applied. In contrast to sheltered beaches, exposed sandy beaches harbour a very mobile fauna, which often migrates up and down the intertidal with the swash (McLachlan and Brown, 2006; Chapter 1, 2 and 3). Positioning the sampling stations in the swash zone at different times during the tidal cycle will thus lead to an overestimation of the population size of swash migratory species (Chapter 2). This was demonstrated for *Olivella semistriata* by Mercx (2005): sampling with the falling tide renders a population size which is much larger than sampling the intertidal at the time of low tide. Thus, although all studies from the bay of Valdivia (Chapter 1, 2 and 3) agree that *O. semistriata* is the most abundant species from this beach, the numbers in Addendum 1 should be treated with care.

Secondly, the main goal set for Addendum 1, identifying zonation on an Ecuadorian sandy beach, is not correctly achieved by sampling with the falling tide. McLachlan and Brown (2006) explicitly state that sandy beach zonation should be assessed at low tide. Although Mercx (2005) demonstrated that the zonation results of sampling with the falling tide or sampling at the time of low tide do not differ significantly, the overestimation of mobile fauna could blur zonation patterns. Moreover, in Chapter 1 and 2 we argue that mobile swash fauna should be treated as a different zone. As such, the middle beach zone from Addendum 1, dominated by the surfer *Olivella semistriata*, is false. Still, the patterns are very alike those of found in Chapter 1, where a more appropriate sampling design was used.

Thirdly, the upper beach zone was not treated correctly in Addendum 1. We did not sample above the drift line, thereby neglecting the supralittoral fauna. Although this should not be problematic *an sich* (Chapter 1, Degraer *et al.*, 2003), the supralittoral community does form one of the three or four separate zones recognized on sandy beaches (McLachlan and Jaramillo, 1995; McLachlan and Brown, 2006). In Addendum 1 the qualitatively sampled ocypodid crab *Ocypode occidentalis*, one of the typical members of the supralittoral community, was placed in the upper beach zone, together with *Excirolana braziliensis*. These two species, however, inhabit a different zone, the former being an air-breather and the latter a true marine species (McLachlan and Brown, 2006). The upper beach zone remains valid, but *Ocypode occidentalis* should be moved to an additional – not sampled - supralittoral zone. The number of zones present in the bay of Valdivia is thus not three but four, as was also found in Chapter 1.

Finally, some of the taxa have been identified differently since the publication of Addendum 1. *Mazatlanina* sp. and *M. hesperia* are one and the same species, namely *M. fulgurata*. *Paracerceis* sp. has been identified as *Exosphaeroma* sp. The *Pisione*-species is *P. indica* and *Donax mancorensis* was re-identified as *D. obesulus*.

The remaining value of this paper lies in its baseline description of the macrofaunal species composition and distribution on a typical intermediate Ecuadorian sandy beach.





## **ADDENDUM 2**

### **SPATIAL AND TEMPORAL PATTERNS IN THE SANDY BEACH SURF ZONE BENTHOS OF THE TROPICAL EAST PACIFIC.**

---

Vanagt T., Fockedey N., Vandepitte L., Cornejo-Rodriguez M.-P., Calderón J., Vincx M.  
and Degraer S.

Submitted to *Journal of Coastal Research*

Keywords: epibenthos, hyperbenthos, endobenthos, macro-invertebrates, sandy beach,  
surf zone, Ecuador, Pacific.

## Abstract

Despite the importance of benthos in the sandy shore ecosystem, studies comprising the different macrobenthic groups of sandy beaches are almost non-existent. In this paper, the sublittoral fringe of nine sandy beaches along the tropical East Pacific coast of Ecuador was sampled for epi-, hyper- and endobenthos on four occasions (August 1999 - May 2000). Spatial and temporal patterns within and in between these three macrobenthic groups were investigated.

The endobenthos showed the highest average densities (754 ind/m<sup>2</sup>), whereas the hyperbenthos had the highest average species richness (15 higher taxonomic groups or 43 morphospecies). Lowest total densities were found in epibenthos (0.04 ind/m<sup>2</sup>).

Within the endo- and hyperbenthos, five beach groups could be observed, which were different for hyper- and endobenthos. Endobenthic assemblages were primarily distinguished based on differences in beach related physical factors such as beach morphology and sedimentology. For the hyperbenthos, the opposite was true: they were mainly structured by temporal factors; local abiotic beach parameters were not as influential as for the endobenthos. Within the epibenthos, there was an unexplained trend of higher densities and species richness towards beaches with antropogenic impact. The use of density data did not allow us to find clear structural links between the three benthic groups.

We conclude that when studying surf zone systems, for example within the framework of environmental impact studies, one should bear in mind that (1) different benthic groups can show different spatial and temporal patterns, (2) temporal patterns are not geographically homogeneous within one region and (3) the structuring function of environmental variables differs considerably between the macrobenthic subgroups.

## A2.1 Introduction

Sandy beaches harbour a benthic fauna of great ecological importance. Beaches have a significant function within the marine ecosystem, in which they can serve as a nursery ground for fish larvae, a refuge area and a feeding ground for a wide range of organisms (Brown & McLachlan, 1990; Beyst, 2001; Beyst *et al.*, 2001b). The sandy beach macrobenthos, defined as fauna larger than 1 mm, can be divided into endo-, epi- and hyperbenthos, based on their position relative to the water/sediment interface (Mees & Jones, 1997). For this paper, we used their definitions of *endobenthos* as the animals living buried in the sediment, *epibenthos* as the animals living on the surface of the sediment and *hyperbenthos* as the animals living in the water layer close to the sea bed.

The distribution of benthic organisms differs in terms of space (i.e. location), time and anthropogenic disturbance. Which is the dominant factor depends on each taxon's habitat preference and tolerance to changing conditions. Hyperbenthos and epibenthos by definition spend more time in the water column. This makes them more dependent on beach hydrodynamics and less on the beach sedimentology and slope than endobenthic species. Hence, temporal variation is expected to be higher in hyper- and epibenthos (Hamerlynck & Mees, 1991) compared to endobenthos, of which the distribution is known to be highly related to beach characteristics (Defeo and McLachlan, 2005). The impact of human activities on sandy beach macrobenthos is much less documented and so far no unambiguous patterns have been reported (Defeo and de Alava, 1995; Jaramillo *et al.*, 1996; Lercari & Defeo, 2003).

Probably the most important human activity in the surf zone of Ecuadorian sandy beaches was the artisan fishery by 'larveros' of the peneaid shrimp postlarvae of *Litopenaeus vannamei* (belonging to the hyperbenthos). Despite the economical and ecological importance of the surf zone system in Ecuador, little research has been done on the macrobenthos of Ecuadorian sandy beaches, and tropical sandy beaches in general. The zonation pattern of the endobenthos on one Ecuadorian beach (Valdivia Bay) was described in Addendum 1, but no temporal nor spatial patterns were examined. Cornejo *et al.* (1993) investigated the (inter)annual variation of fish larvae in the surf zone and, more recently, Domínguez *et al.* (2004) analyzed the spatial and tidal patterns of the hyperbenthic community at the same beach. To our knowledge, no data are available on surf zone epibenthos from Ecuadorian sandy beaches.

Despite their shared dependency on the beach bottom, different macrobenthic groups are rarely studied together. Most studies focus on one component, be it hyper-, epi- or endobenthos. This study provides valuable knowledge in simultaneously describing

the species composition of tropical sandy beach hyper-, epi- and endobenthos from the sublittoral fringe. Moreover, spatial and temporal variation within and in between the three macrobenthic groups were analyzed along the Ecuadorian coast on nine sandy beaches with different morphodynamics and anthropogenic pressure.

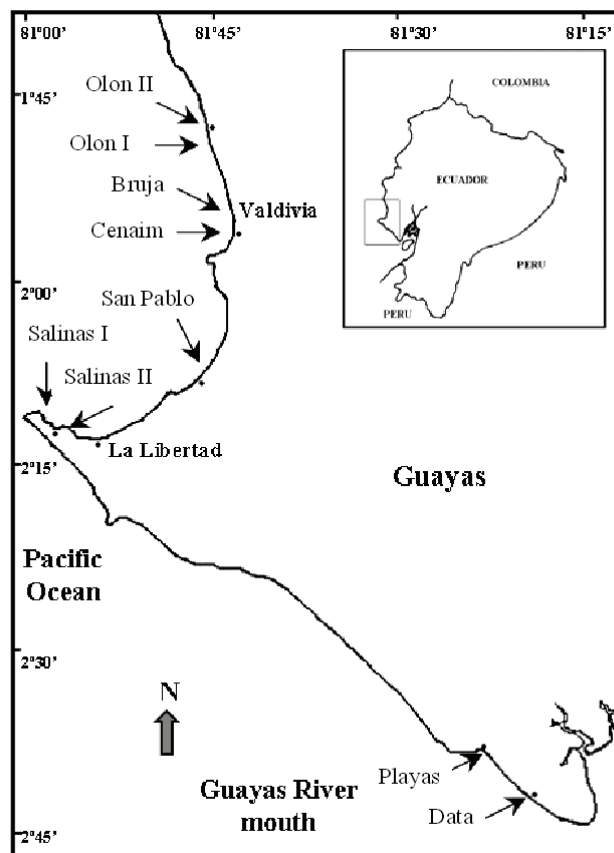
## A2.2 Material and Methods

### A2.2.1 Study area

Nine sandy beaches along the coast of the Santa Elena Peninsula (between 1°45'S – 81°00'W and 2°45'S – 81°15'W), situated in the Guayas Province of Ecuador (Fig. A2.1).

The sampling points of Data (DA) and Playas (PL) are situated in the Gulf of Guayaquil and are under influence of the estuarine plume of the Guayas River (Boothroyd *et al.*, 1994). The beach of Data de Villamil (DA) was extensively used by artisan shrimp larvae fishermen. To the north-west lies the beach of General Villamil, locally named Playas (PL). It is a small tourist resort during the summer (December – February). Salinas is situated at the westernmost

point of the Santa Elena Peninsula and has two beaches: Salinas I (S1) and Salinas II (S2). Salinas I has a smooth slope, a benign surf zone and fine sands, whereas Salinas II is steep with very coarse sediments. Both beaches are situated in a small, sheltered bay. They are extensively used by tourists and the municipality dumps its waste water directly into the bay. The beach of San Pablo (SP) is an exposed, relatively steep and small beach that is situated about 20 km north of Salinas. San Pablo itself is a small fishing community. The exposed beach of Cenaim (CE) is situated at the fishing village of San Pedro, in the southern part of the 8 km wide Valdivia Bay. The southern part of the bay



**Fig. A2.1** - Geographical location of the nine sampling sites along the Ecuadorian coast.

was also exploited by 'larveros' until 2002. The beach of Bruja (BR) is located in the same bay, but 7 km more to the north. The beach of Olon is 8.5 km long, with a gentle slope. The first sampling point, Olon I (O1) lies 1 km from the cliff of Punta Montañita, while Olon II (O2) is situated at the mouth of a lagoon. All beaches have a semi-diurnal, mesotidal regime (Davies, 1964) with a mean tidal spring range of 2.5 to 3 m (average: 2.6 m).

The Ecuadorian coastal climate is characterized by two clearly distinguished seasons: a dry-cool season (May-November) and a wet-warm season (December-April). The climate is influenced by two major currents in the Pacific: the cold Humboldt Current (from July till October), heading north; and the warmer El Niño current (from January till April), heading south. Additionally, the climatologic and oceanographic phenomenon ENSO (El Niño Southern Oscillation) can, with a periodicity of three to seven years, alter the conditions drastically along the Ecuadorian coast, with higher temperatures and precipitation during the El Niño phase and lower temperatures and precipitation during the subsequent La Niña phase.

### **A2.2.2 Sampling and laboratory treatment**

The nine beaches were sampled on four occasions: 18–26 August 1999 (Aug), 16-25 November 1999 (Nov), 21-24 February 2000 (Feb) and 16-22 May 2000 (May). These sampling dates include the dry (Aug) and wet (Feb) season, as well as the transition periods (Nov and May). The samples of the three benthic groups were taken from the same intertidal zone. To accomplish this, the hyper- and epibenthic samples were taken within a period of two hours before or after low tide, while the endobenthos was sampled at low tide.

Endobenthic samples were taken in the upper swash zone at low tide. At each location, five replicate samples were collected by excavating a metal frame (sampling surface area: 0.1026 m<sup>2</sup>) to a depth of 15 cm. The samples were sieved over a 1 mm mesh-sized sieve and the retained organisms were fixed and preserved in a neutral 8 % formaldehyde solution. In the laboratory, the sieved samples were elutriated ten times to collect the benthic organisms. The remaining material was examined to collect the larger or heavy specimens. Endobenthic organisms were identified to the lowest taxonomic level possible. Species that do not belong to the endobenthos or that are not sampled efficiently with the used sampling technique, were excluded from further analyses (Porifera, Callianasidae and *Metamysidopsis* sp.).

Hyperbenthic samples were taken with a hyperbenthic trawl, which consisted of a heavy metal frame (0.7 x 0.5 m) on two sledges. The attached fishing net had a mesh-size

of 1x1 mm. The trawl was pulled by two persons over a distance of 400 meters (200 m back and forth in one haul) parallel to the coastline at a water depth of approximately 1 meter. The collected fauna was preserved in a 8 % neutral formaldehyde solution. Hyperbenthic animals were identified to the finest level possible (for identification keys, see Domínguez *et al.*, 2004). When an organism could not be identified to species level with certainty, it was defined as a specific morphospecies if there existed a clear (external) morphological contrast between different individuals of the same genus, family or a higher taxonomic level (as in Domínguez *et al.*, 2004). Adult crabs and fish were not further considered as they are not sampled efficiently by the hyperbenthic trawl. All beaches except San Pablo (logistic reasons) were sampled.

Epibenthic samples were taken with a 2-meter beam trawl. The attached fishing net (5 x 5 cm meshed) was three meter long, and was provided with a tickler-chain in the ground rope. Trawling distance was equal to that used for hyperbenthos: 200 m back and forth. The catch was preserved in an 8 % formaldehyde solution. In the laboratory, all organisms were counted and identified to the lowest taxonomic level possible.

### **A2.2.3 Environmental variables**

Surf zone water salinity and temperature were measured *in situ* using a hand refractometer and a mercury thermometer. Water samples were taken for the determination of Chlorophyll *a* (chl<sub>a</sub>), suspended particulate matter (SPM) and particulate organic matter (POM). The water samples were transported to the laboratory in dark, cooled conditions, where they were passed through Whatman GF/C filters: plain ones were used for pigment analyses, whereas dried (65°C for two hours) and pre-weighed filters were used for the seston analyses. The obtained filters were immediately frozen for further analysis. For the Chlorophyll *a* determination, filters were subjected to extraction of pigments with acetone (90 %) and a spectrophotometric determination was done using the method described by Parsons *et al.* (1984). The other filters were dried at 105°C for 24 hours and SPM values were then obtained by weight difference. The same filters were subsequently ashed at 550°C for two hours to obtain the POM value.

One sediment sample was collected from the low water line at each station, using a core of 3.6 cm diameter (15 cm depth). The sediment grain size distribution between 2 and 850 µm was measured with a laser Coulter LS and classified according to the Wentworth scale (Buchanan, 1984). Relative gravel weight (>1000 µm) was additionally determined by sieving.

At each sampling location, the beach profile was measured by means of an altimeter (measurements at 10 m intervals starting from the vegetation line). Intertidal width was defined as the distance between the low water line and the lowest edge of the terrestrial vegetation. Wave height ( $H_b$ ) and wave period (T) were measured by visually estimating the height of the breaker waves during one minute for three times ( $H_b$ ) and the time interval between five successive breaker waves (T). The local littoral current velocity was measured as the time needed for an underwater drifter to move 50 m parallel to the coast in a water depth of about 1 m.

#### **A2.2.4 Statistical analysis**

Hyperbenthic and epibenthic densities were extrapolated to individuals per 100 m<sup>2</sup> (for comparison with other studies) and individuals per m<sup>2</sup> (for comparison with the endobenthos), whereas endobenthic densities were extrapolated to individuals per m<sup>2</sup>. Density values of the hyper- and epibenthos have to be considered as minimum estimates since the catch efficiency of the sledge and beam trawl is unknown (Mees & Hamerlynck, 1992; Beyst *et al.*, 2001b), although for comparison between locations this is of lesser importance.

The morphodynamic state of the beaches was assessed by calculating the dimensionless fall velocity ( $\Omega = H_b/w_s T$ ) and the relative tidal range ( $RTR = MSR/H_b$ ), where  $H_b$  is the modal breaker height in meter, T is the modal wave period in s, MSR is the mean spring range in m, and  $w_s$  is the sediment fall velocity in m/s (Masselink & Short, 1993). The sediment fall velocity was calculated from the sediment median grain size of the low tide sample (Gibbs *et al.*, 1971).

Temporal and spatial patterns were examined with Correspondence Analysis (CA) (Ter Braak, 1986) and cluster analysis using group average sorting and Bray-Curtis similarities (Bray & Curtis, 1957). A fourth root transformation was performed on the density data of endo- and hyperbenthos prior to the analyses. For the epibenthos, not only the environmental variables were plotted on the CA graph, but also endo- and hyperbenthic densities. This was done by calculating the total densities of the most important taxonomic groups (Polychaeta, Crustacea, Bivalvia, Gastropoda and Cephalopoda) per sampling campaign and per benthic group. These densities were then treated as environmental variables and could be plotted on the CA, together with the true environmental variables. Correlations between environmental variables were analysed with a Spearman Rank correlation test (Conover, 1971). If variables were significantly correlated ( $p < 0.05$ ), only one of them was retained for further analysis. A Kruskal-Wallis

test (Siegel, 1956) was performed on the selected variables to detect significant differences between the environmental conditions from the beaches and the defined communities.

For the analyses of the hyperbenthos, a taxonomic level higher than morphospecies was selected (Table A2.5). There exists some protest to use a low taxonomic resolution in an ecological approach, especially in poorly know environments (Terlizzi *et al.*, 2003). In this research, however, we were primarily interested in the general spatial and seasonal variability. Due to the high diversity of phyla within the hyperbenthos, the taxonomic level chosen was not the same for all groups, but this made little difference to the outcome of the multivariate analyses.

Diversity was calculated and expressed as  $N_0$  (Hill, 1973). For hyperbenthos, both higher taxonomic level and morphospecies level were used. Diversity was used as dependent variable in linear regression analysis with beach parameters as independent factors.



## A2.3 Results

### A2.3.1 Environment

Averaged over the 9 beaches, temperature and Chla concentrations of the surf zone showed a highly significant seasonal response with highest values in the wet and hot season (Table A2.1). SPM concentration, current and slope showed highly significant differences ( $p < 0.03$ ) between beaches. Generally, salinity was lowest (on average 31 and 31.8 psu) and temperature highest (on average 26.8 and 27.1 °C) in DA and PL. Chla values averaged between 1.9 (S1) and 11.8 mg/m<sup>3</sup> (DA). Gravel percentage was markedly higher at S2 than at other beaches: 55% compared to 0.5%, respectively (Table A2.2). In S1 and S2, there was no perceptible current, while the strongest currents were measured in DA and PL (0.51 and 0.44 m/s respectively). S2 was found to be the most steep beach (1:10); O2 had the gentlest slope (1:63). Median grain size varied between 156 to 323 µm (average: 228 µm) with the lowest values recorded at the beaches of O1 and O2 (Table A2.2).

The relative tidal range (RTR) varied from 2.27 to 11.35, whereas the dimensionless fall velocity ( $\Omega$ ) differed between 0.92 and 4.63 (Table A2.2). According to the morphodynamic classification scheme of Masselink & Short (1993), PL, SP, CE and BR were reflective beaches with low tide terrace and rips, S1 and S2 were reflective low tide terrace without rips, O1 and O2 were intermediate, barred beaches and finally DA was classified as an intermediate, low tide bar/rip beach. S1 and S2 were sheltered beaches, while the other beaches were exposed. In S2, there is an underestimation of the median grain size because of the high percentage of gravel in the sediment samples (Table A2.2). Since  $w_s$  (sediment fall velocity) is calculated from the median grain size, this value cannot be correct and will have an influence on the determination of the morphodynamic beach state.

**Table A2.1** - Temporal variability of the main environmental parameters; means  $\pm$  SE. Sal: salinity (psu); Chla: Chlorophyll *a* content (mg/m<sup>3</sup>); SPM: suspended particulate matter (mg/l); Median: median grain size (µm); slope (m).

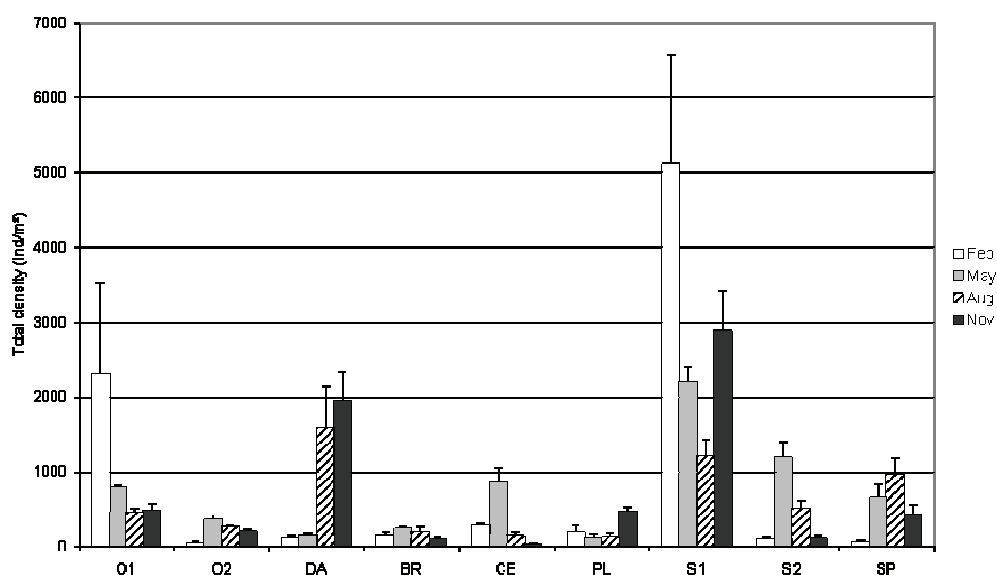
	Aug	Nov	Feb	May	
<b>Sal</b>	33.0 $\pm$ 0.7	34.6 $\pm$ 0.3	33.9 $\pm$ 0.9	34.5 $\pm$ 0.8	n.s.
<b>Temp</b>	23.3 $\pm$ 0.3	26.0 $\pm$ 0.2	27.2 $\pm$ 0.6	25.9 $\pm$ 0.7	$p < 0.05$
<b>Chla</b>	2.9 $\pm$ 1.2	1.6 $\pm$ 0.3	10.4 $\pm$ 2.6	3.5 $\pm$ 1.1	$p < 0.05$
<b>SPM</b>	171.3 $\pm$ 61.7	119.3 $\pm$ 32.8	353.0 $\pm$ 92.1	258.3 $\pm$ 779.1	n.s.
<b>Median</b>	228.1 $\pm$ 22.8	221.5 $\pm$ 15.0	221.2 $\pm$ 16.9	239.1 $\pm$ 30.3	n.s.
<b>Slope</b>	28.3 $\pm$ 7.2	35.1 $\pm$ 8.3	44.0 $\pm$ 12.2	34.8 $\pm$ 7.8	n.s.

**Table A2.2** - Main characteristics of the studied sandy beaches with means  $\pm$  SE. Sal: salinity (psu); Chla: chlorophyll a content ( $\text{mg}/\text{m}^3$ ); SPM: suspended particulate matter ( $\text{mg}/\text{l}$ ); Gravel%: gravel percentage (weight%); Median: median grain size ( $\mu\text{m}$ ); Current (m/s); slope (m);  $\Omega$ : dimensionless fall velocity (dimensionless); RTR: relative tidal range (dimensionless). \* = underestimation; \*\* = overestimation (see text)

	Sal	Chla	SPM	Gravel%	Median	Current	Slope	$\Omega$	RTR
DA	31.0 $\pm$ 2.7	11.8 $\pm$ 7.8	357.3 $\pm$ 196.1	0.0 $\pm$ 0.0	221.5 $\pm$ 21.1	0.51 $\pm$ 0.23	1:32	2.48	3.82
PL	31.8 $\pm$ 3.1	6.6 $\pm$ 5.0	382.7 $\pm$ 123.6	0.7 $\pm$ 0.9	290.1 $\pm$ 91.2	0.44 $\pm$ 0.16	1:18	1.16	3.82
S1	34.8 $\pm$ 0.9	1.9 $\pm$ 1.3	20.2 $\pm$ 10.2	0.0 $\pm$ 0.0	194.2 $\pm$ 8.8	0.00 $\pm$ 0.00	1:32	1.09	11.35
S2	34.8 $\pm$ 0.5	2.3 $\pm$ 1.2	127.4 $\pm$ 182.7	55.2 $\pm$ 16.9	243.5 $\pm$ 29.8 *	0.00 $\pm$ 0.00	1:10	0.92 **	9.08 *
SP	34.3 $\pm$ 0.5	3.0 $\pm$ 3.3	320.5 $\pm$ 406.1	1.2 $\pm$ 2.3	225.4 $\pm$ 15.0	0.27 $\pm$ 0.20	1:20	1.44	4.54
CE	35.0 $\pm$ 0.8	2.6 $\pm$ 1.0	399.1 $\pm$ 175.1	0.0 $\pm$ 0.0	225.0 $\pm$ 25.9	0.27 $\pm$ 0.20	1:30	1.40	4.63
BR	35.0 $\pm$ 0.8	2.2 $\pm$ 1.6	178.7 $\pm$ 104.9	1.0 $\pm$ 1.2	322.9 $\pm$ 30.8	0.39 $\pm$ 0.34	1:33	0.85	4.63
O1	35.0 $\pm$ 1.2	4.6 $\pm$ 7.5	122.8 $\pm$ 91.8	0.7 $\pm$ 1.4	169.0 $\pm$ 5.8	0.14 $\pm$ 0.18	1:51	4.59	2.27
O2	34.5 $\pm$ 1.3	6.2 $\pm$ 8.8	90.8 $\pm$ 10.1	0.4 $\pm$ 0.9	156.1 $\pm$ 6.7	0.19 $\pm$ 0.26	1:63	4.63	2.52

### A2.3.2 Endobenthos

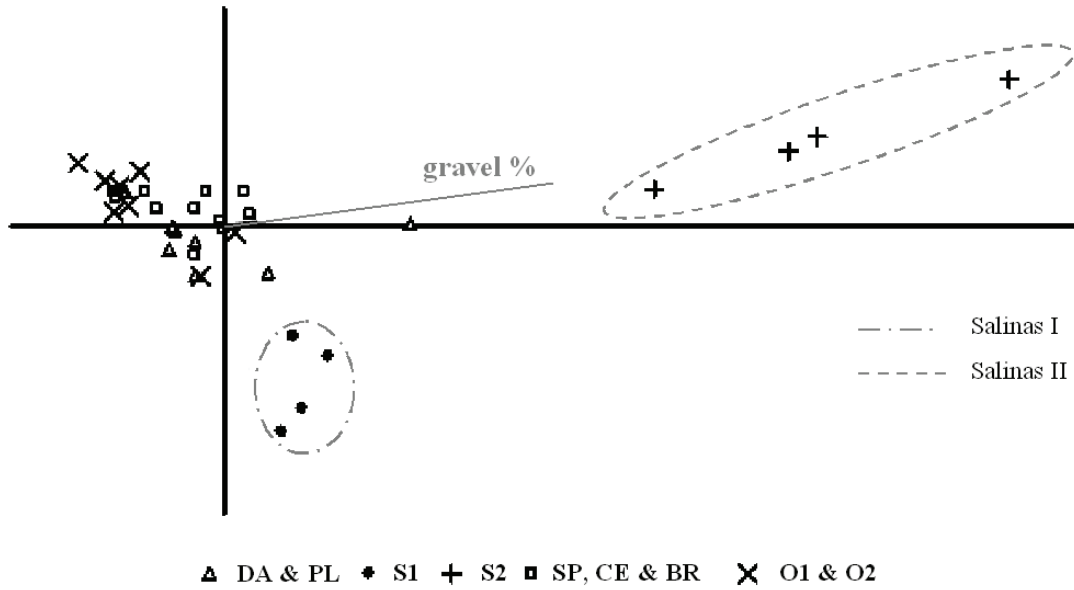
A total of 51 endofaunal taxa were recorded, belonging to Polychaeta (19 taxa), Mollusca (14 taxa), Crustacea (11 taxa), Echinodermata (3 taxa), Nemertea (1 taxon) and Turbellaria (1 taxon) (Table A2.3). Characteristic taxa varied from beach to beach and changed with sampling period. Number of taxa per sampling period ranged from 4 (S2-Nov and S2-Feb) to 25 (O2-May), with an average of 10 taxa per beach per sampling campaign (Table A2.4). There was a significant negative relation between number of taxa and slope ( $r^2 = 0.65$ ;  $N_0 = 14.9 - 115.1 \cdot \text{slope}$ ;  $p < 0.05$ ). Total densities per sampling period varied considerably (Fig. A2.2): the lowest density observed was in CE-Nov (39  $\text{ind}/\text{m}^2$ ), the highest density was 5,113  $\text{ind}/\text{m}^2$  in S1-Feb. On average, there were  $745 \pm 520 \text{ ind}/\text{m}^2$  per sampling campaign over all 9 beaches.



**Fig. A2.2** - Total endobenthic densities (average + SE) per sampling campaign; x-axis: beach; y-axis: total density ( $\text{ind}/\text{m}^2$ ).

**Table A2.3** - Endobenthos species list. Presence/Absence from the different communities is shown in the last 5 columns. Community: 1 = DA and PL ; 2 = S1 ; 3 = S2 ; 4 = SP, CE and BR ; 5 = O1 and O2

	Family	Species	Community					
			1	2	3	4	5	
Annelida	Polychaeta	Polychaeta sp.	*		*		*	
		Sigalionidae	<i>Sthenelais helenae</i> (Kinberg, 1855)				*	*
			<i>Thalenessa</i> sp. (Baird, 1868)					*
		Pisionidae	<i>Pisione indicans</i> (Grube, 1857)			*	*	
			<i>Pisionella indicans</i> (Aiyar & Alikunhi, 1943)	*	*	*	*	
		Phyllodocidae	<i>Phyllodoce</i> sp. (Lamarck, 1818)					*
		Nephtyidae	<i>Nephtys</i> sp.1 (Cuvier, 1817)	*			*	*
		Glyceridae	<i>Hemipodus armata</i> (Hartman, 1950)	*			*	*
		Onuphidae	<i>Onuphis</i> sp. (Audouin & Milne Edwards, 1833)	*				*
		Lumbrineridae	<i>Lumbrineris inflata</i> (Moore, 1911)	*		*	*	*
		Orbiniidae	<i>Scoloplos armiger</i> (O.F. Müller, 1776)				*	*
		Spionidae	<i>Scolelepis agilis</i> (Blainville, 1828)	*	*		*	*
			<i>Spiophanes</i> sp. (Grube, 1860)				*	*
		Magelonidae	<i>Magelona pacifica</i> (Morno, 1933)				*	*
		Flabelligeridae	<i>Pherusa papillata</i> (Johnson, 1901)	*				
		Opheliidae	<i>Euzonus</i> sp. (Grube, 1866)					*
		Maldanidae	Maldanidae sp. (Malmgren, 1867)				*	
	<i>Nicomache</i> sp. (Malmgren, 1865)				*			
	Ampharetidae sp. (Malmgren, 1867)					*		
Crustacea	Ostracoda	Ostracoda sp. (Latreille, 1802)	*				*	
	Decapoda	Hippidae	<i>Emerita rathbunae</i> (Schmidt, 1935)	*	*	*	*	*
			<i>Emerita</i> sp. (Scopoli, 1777)	*	*	*	*	*
		Albunidae	<i>Lepidopa deamae</i> (Benedict, 1903)			*	*	*
		Pinnotheridae	<i>Pinnaxodes</i> sp. (Heller, 1865)	*	*	*	*	*
	Mysidacea	Mysidae	<i>Bowmaniella</i> cfr. <i>Braziliensis</i> (Bacescu, 1968)	*			*	
	Isopoda	Sphaeromatidae	Dynameninae sp. Bowman, 1981	*	*			*
		Cirolanidae	<i>Excirologa</i> sp. (Richardson, 1912)			*		
	Amphipoda		Gammaridea sp. (Latreille, 1802)		*		*	
		Haustoriidae	Haustoriidae sp. (Stebbing, 1906)	*	*		*	*
	Platyischnopidae	Platyischnopidae sp. (Barnard & Drummond, 1979)				*	*	
Echinodermata	Stelleroidea	Ophiuroidea sp. (Gray, 1840)	*			*	*	
	Echinoidea	Mellitidae	<i>Encope grandis</i> (L. Agassiz, 1841)				*	*
		<i>Mellita longifissa</i> (Michelin, 1858)				*	*	
Mollusca	Bivalvia	Spat	*	*		*	*	
		Mytilidae	<i>Brachidontes semilaevis</i> (Menke, 1849)	*				
		Donacidae	<i>Donax ecuadorianus</i> (Olsson, 1961)	*	*		*	
			<i>Donax obesulus</i> (Reeve, 1854)				*	
			<i>Donax</i> sp. (Linnaeus, 1758)	*	*		*	
		Tellinidae	<i>Strigilla chroma</i> (Salisbury, 1934)				*	*
			<i>Tellina</i> sp. (Linnaeus, 1758)				*	
		Veneridae	<i>Tivela byronensis</i> (Grey, 1838)	*			*	*
	Gastropoda		Spat					*
		Columbellidae	<i>Mazatlanian fulgurata</i> (Philippi, 1846)				*	*
		Oliviae	<i>Oliva undatella</i> (Lamarck, 1811)				*	
			<i>Olivella semistriata</i> (Gray, 1839)	*	*		*	*
		Naticidae	<i>Sinum cymba</i> (Menke, 1828)				*	*
		Terebridae	<i>Terebra</i> sp.1 (Bruguière, 1789)					*
		<i>Terebra</i> sp.2 (Bruguière, 1789)					*	
	Vitrinellidae	Vitrinellidae sp. (Bush, 1897)					*	
Nemertea		Nemertea sp.	*	*	*	*	*	
Platyhelminthes	Turbellaria	Turbellaria sp.			*		*	

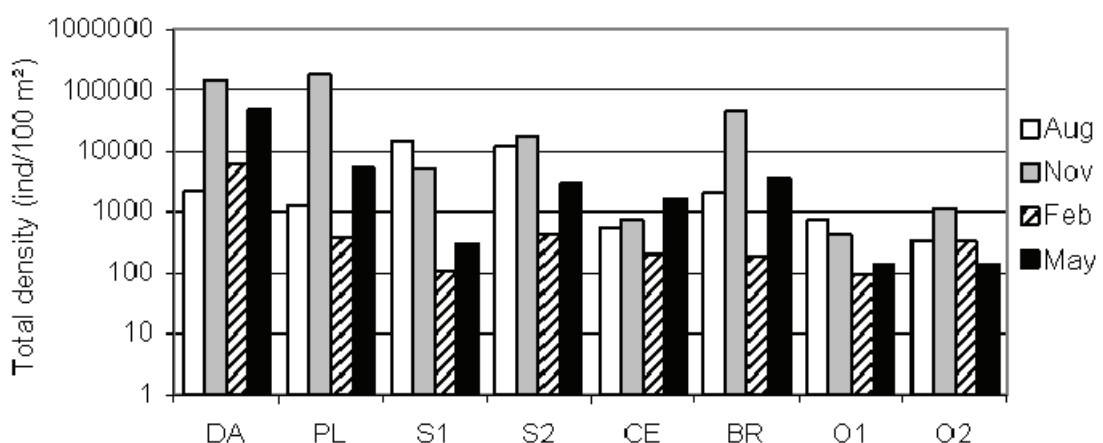


**Fig. A2.3** - CA-plot of the endobenthos with indication of the different communities. Gravel content (%) superimposed on the graph; eigenvalue axis 1 = 0.542; eigenvalue axis 2 = 0.463.

**Table A2.4** -  $N_0$  diversity per sampling campaign for the macrobenthos. Hyperbenthos: genera ~ morphospecies; -: not sampled.

	Endobenthos				Hyperbenthos				Epibenthos			
	Aug	Nov	Feb	May	Aug	Nov	Feb	May	Aug	Nov	Feb	may
<b>DA</b>	10	6	15	11	12 ~ 30	5 ~ 15	19 ~ 80	15 ~ 38	8	3	11	5
<b>PL</b>	8	6	7	6	13 ~ 24	5 ~ 9	15 ~ 54	14 ~ 34	6	4	7	6
<b>S1</b>	10	6	5	10	20 ~ 91	11 ~ 22	14 ~ 46	20 ~ 48	7	7	7	10
<b>S2</b>	5	4	4	5	23 ~ 87	12 ~ 27	12 ~ 52	21 ~ 73	4	8	6	6
<b>SP</b>	8	15	8	11	-	-	-	-	3	5	5	3
<b>CE</b>	6	6	9	16	16 ~ 44	10 ~ 24	16 ~ 47	13 ~ 30	6	2	7	3
<b>BR</b>	7	7	14	15	14 ~ 36	7 ~ 13	17 ~ 37	14 ~ 32	3	5	5	4
<b>O1</b>	14	13	14	20	21 ~ 72	17 ~ 38	13 ~ 36	19 ~ 54	2	3	3	3
<b>O2</b>	10	13	8	25	19 ~ 60	15 ~ 46	12 ~ 27	18 ~ 42	-	3	5	2

Based on beach characteristics and species composition, five endobenthic assemblages were distinguished: (1) DA and PL, (2) S1, (3) S2, (4) SP, CE and BR and (5) O1 and O2. Within these communities, different temporal patterns could be identified. In a CA, the sheltered beaches of S1 and S2 were clearly separated from the others (Fig. A2.3). S1 is characterized by the highest total density of Crustacea observed (on average 2 793 ind/m<sup>2</sup> or 95 %), with Haustoriidae, Dynameninae and *Emerita rathbunae* as most abundant taxa, while S2 was a very coarse-grained beach dominated by *Pisone indicans* (Nov: 89 %, Feb: 69 %, May: 33 %) and/or *Pisionella indicans* (Aug: 48 %, May: 43 %). The beaches of DA and PL were separated from the other beaches based on their high chla values and low salinity (Table A2.2). Here, *Olivella semistriata* is the dominant species in Aug and Nov, but is not present in May. Highest densities of Bivalvia spat occurred at the beaches of O1 and O2 (respectively 127 and 43 ind/m<sup>2</sup>), both defined as intermediate, barred beaches with gentle slope. Total densities at O1 were significantly higher than those at O2 ( $p < 0.05$ ). Highest species richness ( $N_0$ ) is observed at O1 and O2 ( $8.6 \pm 3.2$  and  $6.8 \pm 3.2$  respectively). The exposed beaches of SP, CE and BR did not have aberrant values concerning total densities or species richness. All three beaches were dominated by *Olivella semistriata*. In SP and CE, this species represented more than 50 % of the total density and dominated every sampling period. In BR however, Bivalvia spat were dominant in Nov and Feb.

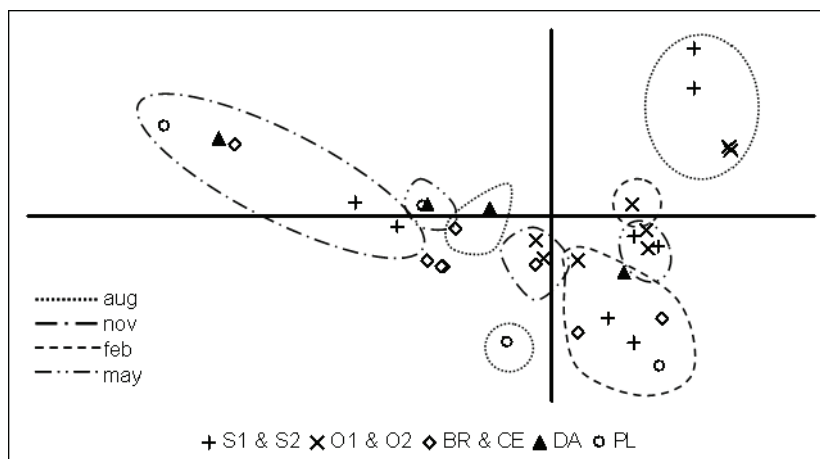


**Fig. A2.4** - Total hyperbenthic densities per sampling campaign; x-axis: beach; y-axis: total density (log ind/m<sup>2</sup>).

### A2.3.3 Hyperbenthos

In total 32 higher taxa and 401 morphospecies were recorded (Table A2.5). The number of higher taxa ('groups') per sampling campaign ranged from 5 (DA-Nov and PL-Nov) to 23 (S2-Aug), with an average of 15 groups per sample. Number of morphospecies, on the other hand, ranged from 9 (PL-Nov) to 91 (S1-Aug), with an average of 43 (Table A2.4). There were no trends between number of species and beach parameters. The average total density of hyperbenthic fauna over all beaches per sampling period was 15,773 ind/100 m<sup>2</sup>, ranging from 59 (O1-Feb) to 184,228 ind/100 m<sup>2</sup> (PL-Nov) (Fig. A2.4). Mysidacea were the dominant taxon in 18 of the 35 samples.

Multivariate analyses resulted in grouping of the beaches into the five following station groups: (1) S1 and S2, (2) O1 and O2, (3) BR and CE, (4) DA and (5) PL. When all samples were considered, there was a very strong seasonal response, meaning that samples of the same months grouped together (Fig. A2.5). In the case of DA and PL (single beach assemblages), Nov and Feb were clearly separated from the other months and average number of groups per beach was very similar (13 and 12 groups respectively), yet there was no sufficient evidence to classify both beaches in one community. DA was characterised by the highest chla values recorded ( $11.8 \pm 7.8$  mg/m<sup>3</sup>) and showed the highest average density of all beaches (50,523 ind/100 m<sup>2</sup>). Mysidacea were the overall dominant group. In Feb, dominance was taken over by Calanoida. On average, PL had relatively high SPM values ( $382.74 \pm 123.59$  mg/l) and was characterised by the lowest average species richness of 12 groups or 30 morphospecies. Highest Mysidacea density was also recorded at PL-Nov, where 184,205 ind/100 m<sup>2</sup> were found, representing 99.99 % of the total density. The strong dominance of mysids in Nov coincided with the lowest species richness in that month.

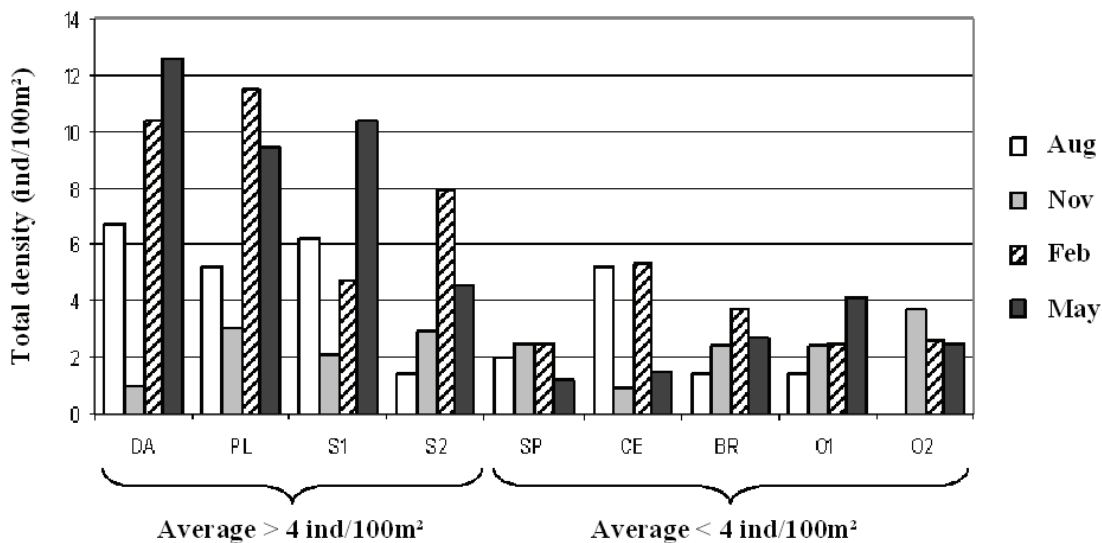


**Fig. A2.5** - CA-plot of the hyperbenthos with indication of the different communities and the seasonality; eigenvalue axis 1 = 0.242; eigenvalue axis 2 = 0.162

**Table A2.5** - Hyperbenthos taxonomic list with indication of the final level used in further analyses and the number of morphospecies per higher selected taxon Presence/Absence from the different communities is shown in the last 5 columns. Community: : 1 = S1 and S2 ; 2 = O1 and O2 ; 3 = BR and CE ; 4 = DA ; 5 = PL

	'Groups'	Final level used	Number of morphospecies	Community				
				1	2	3	4	5
Cnidaria	Scyphozoa	Class	35	*	*	*	*	*
	Siphonophora	Class	10	*	*	*	*	*
Ctenophora		Phylum	2	*	*	*	*	*
Annelida	Polychaeta	Class	24	*	*	*	*	*
Mollusca	Bivalvia	Class	10	*	*	*	*	*
	Gastropoda	Class	15	*	*	*	*	*
	Cephalopoda	Class	2	*	*	*	*	*
Crustacea	Cladocera	Order	1	*	*	*	*	*
	Ostracoda	Class	1	*	*	*	*	*
	Cirripedia	Subclass	1	*	*	*	*	*
	Copepoda	Order	10	*	*	*	*	*
		Order	28	*	*	*	*	*
		Order	8	*	*	*	*	*
		Order	17	*	*	*	*	*
		Infraorder	16	*	*	*	*	*
		Infraorder	5	*	*	*	*	*
		Infraorder	1	*	*	*	*	*
		Infraorder	30	*	*	*	*	*
		Infraorder	52	*	*	*	*	*
		Order	2	*	*	*	*	*
		Order	7	*	*	*	*	*
		Order	7	*	*	*	*	*
		Order	7	*	*	*	*	*
		Order	22	*	*	*	*	*
		Order	9	*	*	*	*	*
		Order	7	*	*	*	*	*
		Class	4	*	*	*	*	*
		Phylum	7	*	*	*	*	*
		Phylum	7	*	*	*	*	*
		Class	6	*	*	*	*	*
		Class	1	*	*	*	*	*
		Class-egg	14	*	*	*	*	*
		Class-larv/juv	40	*	*	*	*	*
Chaetognatha								
Echinodermata								
Chordata								
	Thaliacea							
	Larvacea							
	Pesces							
	Egg							
	Larvae - juveniles							
<b>TOTAL</b>			<b>401</b>				<b>32</b>	

Contrary to the endobenthos, S1 and S2 were now placed in one community. They had no perceptible current, hereby distinguishing them from the other beaches. Both beaches were also characterised by the highest average species richness (respectively  $52 \pm 29$  and  $60 \pm 26$  morphospecies). The intermediate beaches of O1 and O2 are both characterised by very low average total densities (360 - 480 ind/100 m<sup>2</sup>), comparable values for environmental variables (Table A2.2) and they showed a parallel seasonal trend regarding species richness ( $N_0$ ) (Table A2.4). Species composition was very similar but the dominant taxa differed between the beaches: O1 was dominated by Chaetognatha (Aug), Mysidacea (Nov-May) and Calanoida (Feb), whereas O2 was dominated by Calanoida (Aug), Mysidacea (Nov), Pisces eggs (Feb) and Bivalvia (May). CE and BR are very similar beaches concerning their species composition, dominance, total densities (Fig. A2.5) and environmental variables (Table A2.2). All months, except Feb, are dominated by Mysidacea. In Feb, CE is dominated by Pisces eggs (21 %), whereas BR is dominated by Ctenophora (67 %). Here, Feb is also characterised by the highest species richness (Table A2.4).



**Fig. A2.6** - Total epibenthic densities (ind/100 m<sup>2</sup>) per sampling campaign with indication of the two groups distinguished on total average density.



#### A2.3.4 Epibenthos

A total of 26 species, belonging to 17 families, were recorded (Table A2.6). No samples were taken in O2 in Aug. Total densities were very low compared to endo- and hyperbenthos and ranged from 1 to 13 ind/100 m<sup>2</sup> with an average of 4 ind/100 m<sup>2</sup>. Minimum total density for all beaches was observed in Aug or Nov, except for O2 where it occurred in May. Average number of species per beach ( $N_0$ ) varied from 2.5 (O2) to 7.8 (S1). No trends between number of species and beach parameters could be detected. Based on total average densities ( $p < 0.05$ ) and  $N_0$  ( $p < 0.05$ ), the beaches could be divided into two groups: (1) DA, PL, S1 and S2 where the total average density was  $> 4$  ind. per 100 m<sup>2</sup> and an average  $N_0$  of more than 5.5 and (2) SP, CE, BR, O1 and O2, which had a total average density less than 3.5 ind per 100 m<sup>2</sup> and an average  $N_0 < 4.8$  (Fig. A2.6 and Table A2.4). The most abundant species was the brachyuran *Arenaeus mexicanus*, which was present in 33 of the 35 sampled stations, with an average of 1.35 ind/100 m<sup>2</sup> per campaign. Over the year, *A. mexicanus* was the only species present on every beach, whereas the other species only appeared at maximum six out of nine beaches (*Arius* sp., *Pomadasyus* sp., *Polydactylus approximans* and *Citharichthys* sp.) or less.

Multivariate analyses showed no clear spatial nor temporal patterns within the epibenthos. With environmental variables plotted on a CA, only SPM and salinity seemed to structure the distribution of the samples. However, if the total densities of the most abundant higher taxonomic levels of endo- and hyperbenthos (Polychaeta, Crustacea, Bivalvia, Gastropoda, Cephalopoda) were introduced as environmental variables, 'Bivalvia' and 'Gastropoda' of the endobenthos also had a structuring influence on the epibenthic sample distribution. Three species were associated with the variable 'Bivalvia', of which only one was a carnivore (*Arenaeus mexicanus*). The other two species were a filter feeder (*Atherinella nocturna*) and a herbivore (*Mellita longifissa*). The main species associated with 'Gastropoda' were *Anchoa* sp. (filter feeder), *Callinectes toxotes* (carnivore) and Sciaenidae sp. (carnivore).

#### A2.3.5 All macrobenthos

When combining the three benthic groups, a total of 109 taxa were recorded. Number of observed taxa ranged from 11 (SP-Aug) to 44 (O2-May), with an average of 28 taxa per beach. Epibenthic taxa were characterised by the lowest densities, endobenthic taxa had the highest densities. On average, all beaches were dominated by an endobenthic taxon, except for PL where a mysid shrimp was the dominant taxon. Average

total density of all the macrobentic groups was 885 ind/m<sup>2</sup>, ranging from 46 (O2-Feb) to 5,114 ind/m<sup>2</sup> (S1-Feb). O1 and O2 had the highest average species richness (resp. 36.5 and 33 taxa), whereas DA and S1 had the highest average abundances (resp. 1,409 and 2,896 ind/m<sup>2</sup>).

**Table A2.6** - Epibenthos species list. Presence/Absence from the different communities is shown in the last 2 columns. Community : 1 = S, S2, PL and DA ; 2 = O1, O2, BR, SP and CE

		Species	Community	
			1	2
Crustacea	Brachyura	<i>Callinectes toxotes</i> (Ordway, 1863)	*	*
		<i>Arenaeus mexicanus</i> (Gerstaecker, 1856)	*	*
Stelleroidea		<i>Stelleroidea</i> sp. (Lamarck, 1816)	*	
Echinoidea	Mellitidae	<i>Mellita longifissa</i> (Michelin, 1858)	*	*
		<i>Encope grandis</i> (L.Agassiz, 1841)	*	*
Rajiformes	Urolophidae	<i>Urolophus</i> sp. (Müller & Henle, 1837)	*	
	Gymnuridae	<i>Gymnura marmorata</i> (Cooper, 1864)	*	
Clupeiformes	Engraulidae	<i>Anchoa</i> sp. (Jordan & Evermann, 1927)	*	*
Siluriformes	Ariidae	<i>Arius</i> sp. (Valenciennes, 1840)	*	*
	Synodontidae	<i>Synodus lacertinus</i> (Gillbert, 1890)	*	
Atheriniformes	Atherinidae	<i>Atherinella nocturna</i> (Myers & Wade, 1942)	*	*
Perciformes	Carangidae	<i>Trachinotus paitensis</i> (Cuvier, 1832)	*	*
		<i>Caranx</i> sp. (Lacepède, 1801)	*	
		<i>Selene brevoortii</i> (Gill, 1863)	*	
	Gerreidae	<i>Gerres cinereus</i> (Walbaum, 1792)	*	
	Haemulidae	<i>Pomadasys</i> sp. (Lacepède, 1801)	*	*
	Polynemidae	<i>Polydactylus approximans</i> (Lay & Bennett, 1839)	*	*
	Sciaenidae	<i>Menticirrhus nasus</i> (Günther, 1868)	*	*
		<i>Stellifer lanceolatus</i> (Holbrook, 1855)	*	*
		<i>Umbrina xanti</i> (Gill, 1862)	*	*
		Sciaenidae sp.		
Pleuronectiformes	Paralichthyidae	<i>Citharichthys</i> sp. (Bleeker, 1862)	*	*
		<i>Hippoglossina macrops</i> (Steindachner, 1876)	*	
	Cynoglossidae	<i>Symphurus melanurus</i> (Clark, 1936)	*	
Tetraodontiformes	Tetraodontidae	<i>Sphoeroides lobatus</i> (Steindachner, 1870)	*	

---

## A2.4 Discussion

### A2.4.1 Environmental variables

Variability of the measured environmental factors was much higher on a spatial than on a temporal scale. Only for temperature and Chlorophyll *a* there was a significant change over the seasons, both peaking in the wet and hot season (Feb).

As expected, the two beaches (DA and PL) in the mouth of the Guayas-river differ from the oceanic beaches in terms of temperature and salinity. They were also subjected to the strongest shore currents, associated with very high values for both SPM and Chlorophyll *a*. In contrast to the other beaches, the two Salinas stations (S1 and S2) were situated in a sheltered bay, with very little exposition, as shown by the absence of a shore current and the low values for SPM. The S2 station is, with a slope of 1:10 and a gravel content of 55.2%, by far the most reflective of the investigated beaches. Though only a couple of hundred meters apart, the morphodynamics of the S1 beach are very different. This beach has a much gentler slope and very fine sediment.

For the remaining five, all very exposed beaches, SP, CE and BR have very similar characteristics. Their RTR-value is almost equal (4.54, 4.63 and 4.63), they have the same beach profile with slopes from 1:20 to 1:33. The two Olon stations (O1 and O2) are much flatter (slope 1:51 and 1:63) with low SPM-values and very fine sediment.

Based on the environmental data, we expected to find a clearly different fauna for the stations in the river mouth, the beaches from the sheltered bay and the exposed beaches. Within the last group, the two stations in Olon (O1 and O2) were expected to differ from the other three beaches (CE, BR and SP).

### A2.4.2 Endobenthos

Endobenthic communities on sandy beaches are mainly structured by abiotic factors, rather than biological factors (Defeo and McLachlan, 2005). Beach morphology plays an important role: dissipative and intermediate beaches have higher diversity than reflective beaches (McLachlan, 1983a; McLachlan and Dorvlo, 2005). This was also observed in our study: O1 and O2 are both intermediate beaches and have the gentlest slope. They were characterized by the highest average species richness. DA is also an intermediate beach, but had a lower species richness, which could be explained by the fresh water influence of the river Guayas.

According to McLachlan and Dorvlo (2005) also density should be highest at dissipative and intermediate beaches, which was not the case in our study. This might be due to the fact we only sampled the littoral fringe, where in most studies on sandy beach endobenthos the entire intertidal zone is studied.

The overall dominance of Pisionidae at S2 was related to the high gravel content at this beach. As Pisionidae are active burrowers that live in the interstitial cavities of the sand bottom, a coarse grained beach is an ideal environment for this taxon. The low species richness at S2 might be related to the high gravel content and the steep slope (1:10). McLachlan *et al.* (1981) obtained significant negative correlations between endofauna species numbers and abundance and both grain size and beach slope, suggesting that steep slope and coarse sands limit the fauna.

In comparison to the other beaches, CE, BR and SP did not show any peculiar values concerning the environmental variables. The evenness and the overall dominance of *Olivella semistriata* were responsible for the grouping of these three beaches. Dominance of *O. semistriata* (48 %) was also found in Addendum 1 within the lower beach assemblage of the CE and BR beach.

In the multivariate analyses, the endobenthic samples were first separated on spatial characteristics and then, within these spatial groups, temporal patterns could be distinguished. However, these temporal patterns differed between the spatially distinguished communities. It is important to keep this in mind when studying the influence of climate changes on the endobenthos along a coastline.

#### **A2.4.3 Hyperbenthos**

Hyperbenthic communities were strongly dominated by seasonal fluctuations, an aspect also found by Hamerlynck & Mees (1991), who ascribed this to the sequential appearance, high abundance and disappearance of different species of the temporary hyperbenthos or merohyperbenthos (e.g., larval stages of endobenthic animals, larval and post-larval decapods).

As described in numerous studies, Mysidacea are the most common hyperbenthic taxon (e.g. Mauchline, 1980; Hamerlynck & Mees, 1991; Lock *et al.*, 1999; Beyst *et al.*, 2001a, Domínguez *et al.*, 2004). Mysidacea often show a seasonal maximum in their occurrence (e.g. Mauchline, 1971 and references herein). Some of the fluctuations in densities can be correlated with periods of active breeding when the population increases

in size, while others are probably caused by predation (Mauchline, 1971). Mysids are also known to actively migrate to areas of high primary production (Wooldridge, 1989).

DA and PL were characterized by relatively high total densities, as expected because of the lower salinity values. Both beaches showed high concentrations of Chlorophyll *a*, which can point to the presence of primary producers (in this study: observation of microphytobenthos mats in DA; Fockedey, pers. obs.), probably explaining the extremely high densities of Mysidacea at those beaches (48 711 and 47 415 ind./100 m<sup>2</sup> respectively). The higher densities at these beaches might also be supported by higher food availability coming from the river Guayas, which can be deduced from the relatively high SPM (Table A2.2) and POM values (not shown) for these beaches. Munilla *et al.* (1998) also reported higher densities at Mediterranean beaches near rivers than at beaches without riverine influence.

Based on species composition, diversity and seasonality, S1 and S2 formed one group in the hyperbenthos, instead of two in the endobenthos. This indicates that abiotic factors related to beach morphology - gravel content, median grain size and slope significantly differed between these two beaches - are of lesser importance in structuring the hyperbenthos compared to the endobenthos.

We do not have an explanation for the low total densities of hyperbenthos at O1 and O2. Nevertheless, both beaches have a relatively high species richness, which could be related to the fact that both beaches have benign surf zone conditions as typically found on intermediate beaches (Brown & McLachlan, 1990).

#### **A2.4.5 Epibenthos**

Contrary to the endo- and hyperbenthos, no temporal nor spatial patterns could be found in the epibenthos. This is in contrast with previous research dealing with epibenthos (e.g. Ross *et al.*, 1987; Gibson *et al.*, 1993; Beyst *et al.*, 2001b). Only two environmental variables (SPM and salinity) seemed to structure the epibenthos, but not to an extent that temporal or spatial patterns could be distinguished. It is, however, possible that other, not measured or hidden correlated variables controlled or at least influenced the measured densities (Clark *et al.*, 1996).

When a seasonal pattern is detected within the surf zone epibenthos, temperature appears to be one of the major variables influencing the seasonality. But, most of these results come from research in more temperate areas (e.g. North Sea: Beyst *et al.*, 2001b; west coast of Scotland, Atlantic Ocean: Gibson *et al.*, 1993; USA, Atlantic Ocean: Lazzari

*et al.*, 1999), where seasonal responses are observed because of the larger temperature difference between summer and winter. In the tropics, there the modest seasonality in sea water temperature is probably too small to cause a clear seasonal variation in epibenthos. Moreover, a number of factors, such as shoaling behaviour in function of tidal dynamics (Ross *et al.*, 1987; Gibson *et al.*, 1993) and variations in catch efficiency of the net (e.g. Pierce *et al.*, 1990), might have obscured possible seasonal trends.

Although no clear temporal nor spatial patterns were visible, the beaches were be divided into two groups, based on species richness ( $N_0$ ) and densities. Highest densities and species richness were observed at S1, S2, DA and PL, all beaches with strong anthropogenic influences in terms of tourism. Beach recreation can cause high turbidity in the surf zone. Indeed, SPM values, an indirect measure for turbidity, were generally high for these beaches. Research on surf zone fish assemblages in the Gulf of Mexico (Ross *et al.*, 1987) has indicated that fish abundance was lowest during periods of clear water. Clark *et al.* (1996) found similar results in False Bay (South Africa). Research in estuarine systems has indicated that a higher turbidity gives a reduction in light intensity which prevents prey species to visually locate possible predators such as piscivorous fish (Clark *et al.*, 1996). The higher diversities and densities at the S1 and S2 beaches might be explained by the high habitat diversity within the bay: a lot of man made structures such as jetties and a harbour are present and the bay is surrounded by rocks.

#### **A2.4.6 All Macrobenthos**

In this study, we have only considered densities, species composition and richness and a limited number of environmental variables as factors for temporal or spatial patterns. These factors seem to be sufficient when considering the endo- and hyperbenthos separately, but for epibenthos and total macrobenthos, other factors such as the degree of disturbance of the beach by tourism or pollution should perhaps be taken into consideration. The complexity of combining different benthic groups, however, will always make pattern detection very difficult.

In an alternative approach, we plotted the densities of endo- and hyperbenthic groups as additional explanatory variables on a CA with epibenthos as dependent variable. Hyperbenthos, widely known as prey for epibenthos (McLachlan and Brown, 2006), did not explain any of the observed variation. This is probably due to the high mobility of hyperbenthos compared to both epi- and endobenthos. Gastropods and bivalves of the endobenthos, on the other hand, appeared to be structuring the epibenthos. This could only partially be linked to prey preference of epibenthic key

species. It still does give an indication that combining density data of different trophic levels can add information to food web research with techniques such as stomach analyses and stable isotopes.

## **A2.5 Conclusions**

1. Hyperbenthos was by far the most diverse group on Ecuadorian beaches; endobenthos reached highest densities. Epibenthos densities were extremely low.
2. Endobenthos communities were first structured on a spatial scale, with subsequent temporal patterns; the important physical factors were beach slope and sediment grain size
3. Temporal variation in endobenthos was not the same in the different beach groups
4. Hyperbenthos showed a clear seasonality, and the spatial grouping was primarily based on environmental factors such as water current, chlorophyll *a*, SPM and POM.
5. No temporal or spatial patterns were detected for epibenthos. It seemed, however, that touristy beaches harbour denser epibenthos populations
6. The three macrobenthic groups seemed to vary independent of each other. Only indirect hints for structuring links between different benthic groups could be found.





## **ADDENDUM 3**

# **ENSO AND SANDY BEACH MACROBENTHOS OF THE TROPICAL EAST PACIFIC: SOME SPECULATIONS**

---

Vanagt T., Beekman E., Vincx M. and Degraer S.

Published in *Advances in Geosciences* (2006) 6: 57-61

Keywords: ENSO, macrofauna, tropical East Pacific

## Abstract

The influence of the ENSO cycle on marine fauna and flora has only recently been given the attention it deserves. The very strong 1997-1998 El Niño and its obvious effects on marine biota was a key point in ENSO research, but unfortunately few quantitative data about the 1997-1998 El Niño itself are available.

To gather information about the effect of ENSO on the macrobenthos, we performed a bi-weekly transect monitoring on an Ecuadorian sandy beach in 2000-2001, during the strong La Niña following the 1997-1998 El Niño, and in the normal period of 2002-2004.

In this paper, intertidal macrofaunal densities at higher taxonomic level are used to compare a La Niña phase with the 'normal' situation. The few existing documents about El Niño and sandy beach macrobenthos, and scattered data from previous and current research, were used to complete the picture.

Total macrobenthos densities were 300% lower during the La Niña phase compared with equal months in the normal phase. Especially Crustacea and Mollusca showed a marked increase in densities towards the normal situation (94% and 341% respectively). Polychaeta and Echinodermata, however, showed higher densities during the La Niña phase (22% and 73% respectively).

Two possible explanations are proposed. (1) Low densities during the La Niña could be due to the very strong preceding El Niño, suggesting the populations were still recovering. This hypothesis is supported by previous work done in the south of Peru. This is, however, a cold water system, compared to the Ecuadorian warm water system. (2) The second hypothesis states that a La Niña will have a very severe impact on the intertidal macrofauna of a warm water system like the Ecuadorian coast.

---

### A3.1 Introduction

Although the ENSO cycle has a very obvious influence on life in and around the sea, its impact on marine, especially benthic, biota has not yet seen the attention it deserves. The very severe 1997-1998 El Niño was a key point in the research of impacts of the ENSO cycle on the biological environment. Information from before 1998 is rather scarce and scattered. Unfortunately, the 1997-1998 El Niño itself is also poorly documented, especially for sandy beaches. The work presented here was initiated with future El Niño events in mind. After all, it is very important to have data of long-term monitoring if one wants to observe anomalies caused by climate phenomena. For this paper, two eight-month periods are discussed. The first period coincides with the very strong and long lasting La Niña of 1999-2001, the second period can be considered normal.

Most of the studies on the impact of ENSO on marine benthos were done in subtidal areas and in subtropical or temperate regions. Only few papers concerning sandy beach fauna are available. The 1982-1983 and 1997-1998 'super-El Niños' seemed to have had a dramatic impact on the sandy beach fauna of Peruvian sandy beaches (Arntz, 1986; Arntz *et al.*, 1987; Tarazona and Paredes, 1992; Arntz, personal comment), causing a decrease of up to 99.99% of the densities and a southward movement of 7° latitude of some species, but with a positive effect on other species (Arntz, 1986). In contrast, Riascos (2002) could not find major changes in sandy beach macrobenthos densities on the Colombian coast during the 1997-1998 El Niño. Species richness dropped slightly during the end of 1997 but already recovered in January 1998, at a time SST anomalies were at their highest.

In contrast to the Peruvian system described by Tarazona and Paredes (1992), which is year-round dominated by the cold Humboldt Current, the Colombian beaches are part of an intrinsic warm-water system. Ecuador lies in between both, with warm water during the rainy season and relatively cold water during the rest of the year. Still, in general, the Ecuadorian coast can be considered as a tropical environment. On top of that, Ecuador is, because of its position right on the equator, one of the countries in the tropical East Pacific that will be most severely struck by an El Niño or La Niña event.

In this paper we describe some results from the last La Niña period compared to a normal situation for Ecuador. We also give some speculations on how the Ecuadorian warm water system might react differently to ENSO events than the Peruvian cold water system.

## **A3.2. Material and Methods**

From June 2000 through July 2001 and December 2002 through January 2004, the sandy beach of San Pedro de Manglaralto (1°54'00"S and 80°46'00"W) was sampled on a bi-weekly basis, with a sampling technique as described by Aerts *et al.* (2004). Only the 1-mm fraction was preserved and identified. Measured environmental variables were precipitation, cloudiness, surf water and air temperature, sediment characteristics, wave height and period and surf water salinity. The beach profile was assessed using a leveler. For this paper, only the months December – July of the two periods are discussed, named phase 1 and phase 2, respectively. For beach characteristics, we refer to Aerts *et al.* (2004).

Additional data from 1999-2000 were used. The same beach was sampled once in August and November 1999 and February and June 2000, but only at low tide. These data are referred to as phase 0.

Climatologic and oceanographic data were retrieved from the Oceanographic Centre of El Pelado (Fundación CENAIM-ESPOL). This station is situated approximately 1km offshore from the sampled beach.

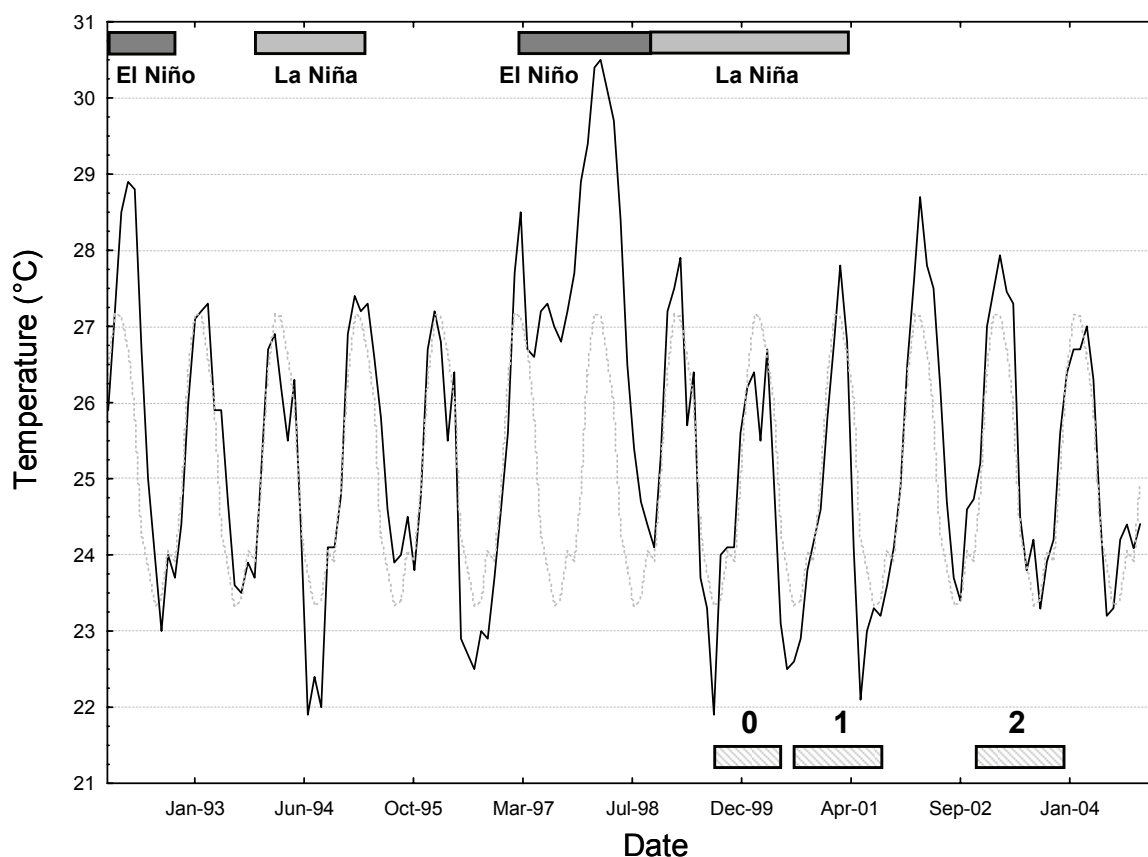
Macrobenthos data were calculated to densities and expressed as ind/m<sup>2</sup>. In this paper, only total densities and densities at higher taxonomic level (Polychaeta, Echinodermata, Crustacea, Bivalvia and Gastropoda) are discussed. Non-parametric Kruskal-Wallis and Mann-Whitney U and Spearman's rank correlation tests were performed using Statistica 6.0 (Statsoft, 1996).

## **A3.3. Results**

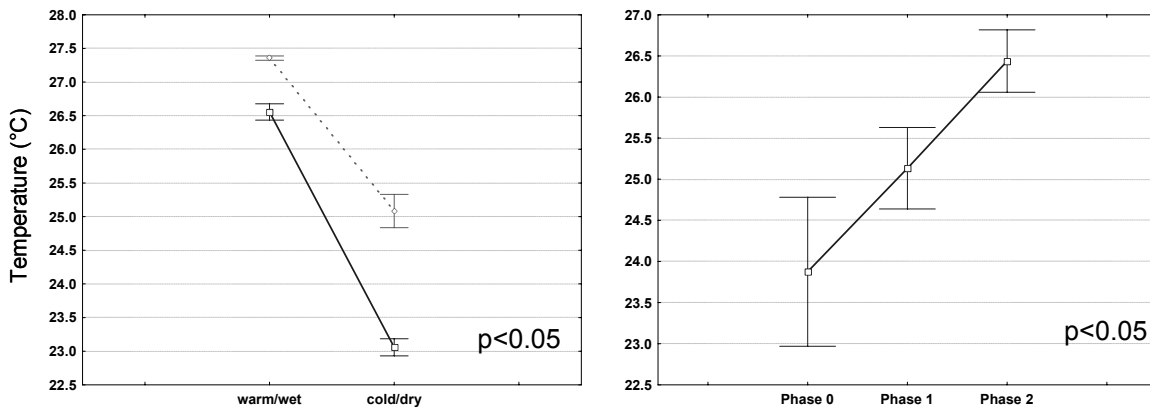
### **A3.3.1 Environment**

SST values from the last 13 years for EL Pelado are plotted in Fig. A3.1. The three phases are marked, as are the last ENSO events, based on both SST data and thermocline depth data for El Pelado. SST during sampling ranged from 21.9 to 27.9°C, with an average of 25.6°C. Average SST for the three phases was 23.8, 25.1 and 26.4°C, respectively (Kruskal-Wallis test:  $p < 0.05$ ). Correlation of the SST values for El Pelado with Niño3.4 anomalies showed an  $r$ -value of 0.24 ( $p < 0.05$ ).

SST data for the seasons of the two phases are plotted in Fig. A3.2. The warm and wet season persisted from December through April, and the cold and dry season continued from May through November. Mean SST for the warm/wet season over the two phases was 26.8 °C, and 24.1°C for the cold/dry season (Mann-Whitney U test:  $p < 0.05$ ). Mean SST for the warm/wet season for the first phase was 26.5°C and 27.1°C for the second phase (Mann-Whitney U test:  $p < 0.05$ ). For the cold/dry season values were 23.1°C and 25.1°C respectively (Mann-Whitney U test:  $p < 0.05$ ).



**Fig. A3.1** - SST values from the last 13 years for the EL Pelado station (full line: actual values; dotted line: long-term average). El Niño and La Niña events are marked at the top of the graph; the three phases are marked at the bottom of the graph.



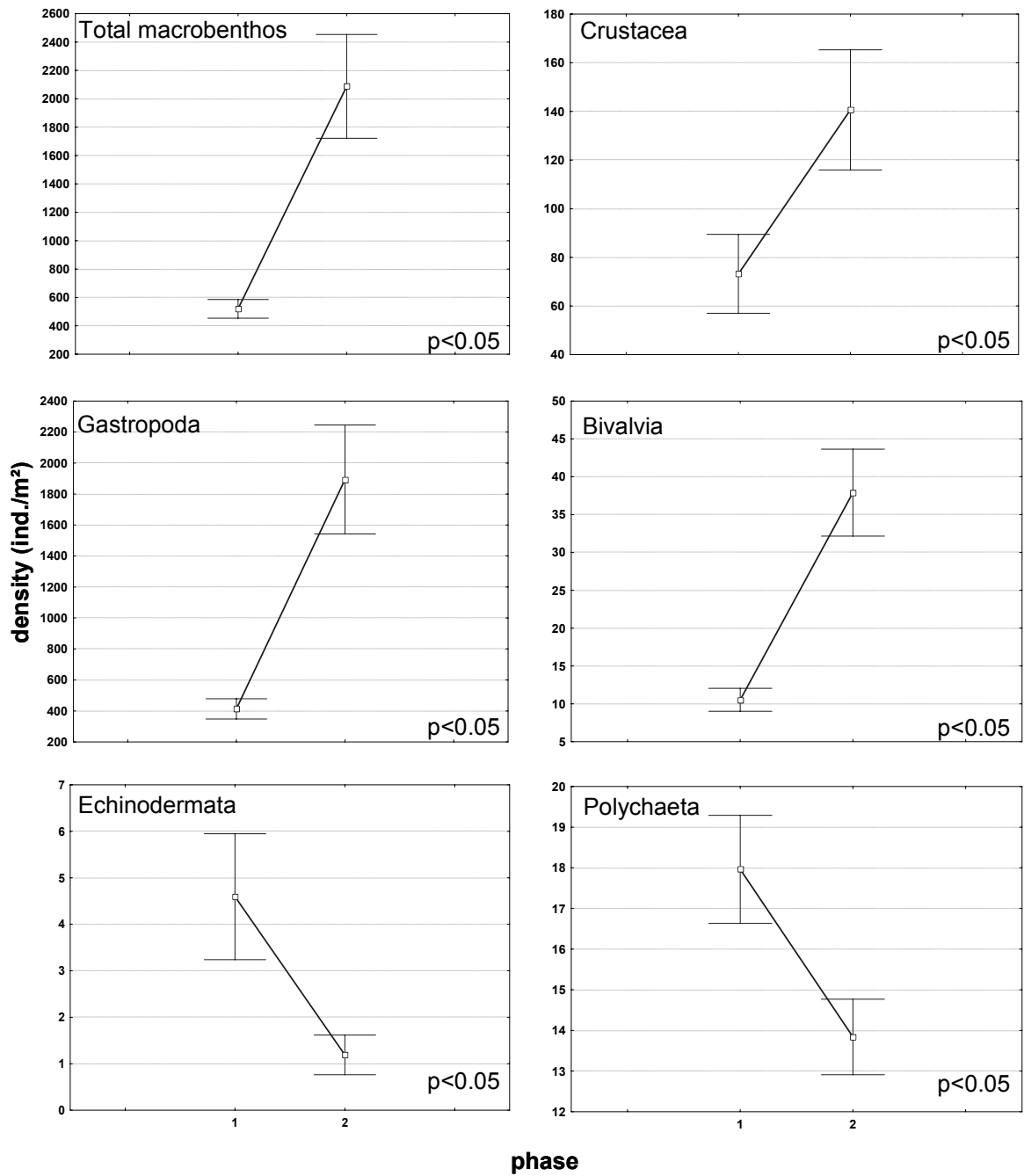
**Fig. A3.2** - Left: SST values from El Pelado for phase 1 (solid line: La Niña) and phase 2 (dotted line: Normal). Right: SST values from El Pelado for the three phases. Average values  $\pm$  SE.

### A3.3.2 Macrobenthos

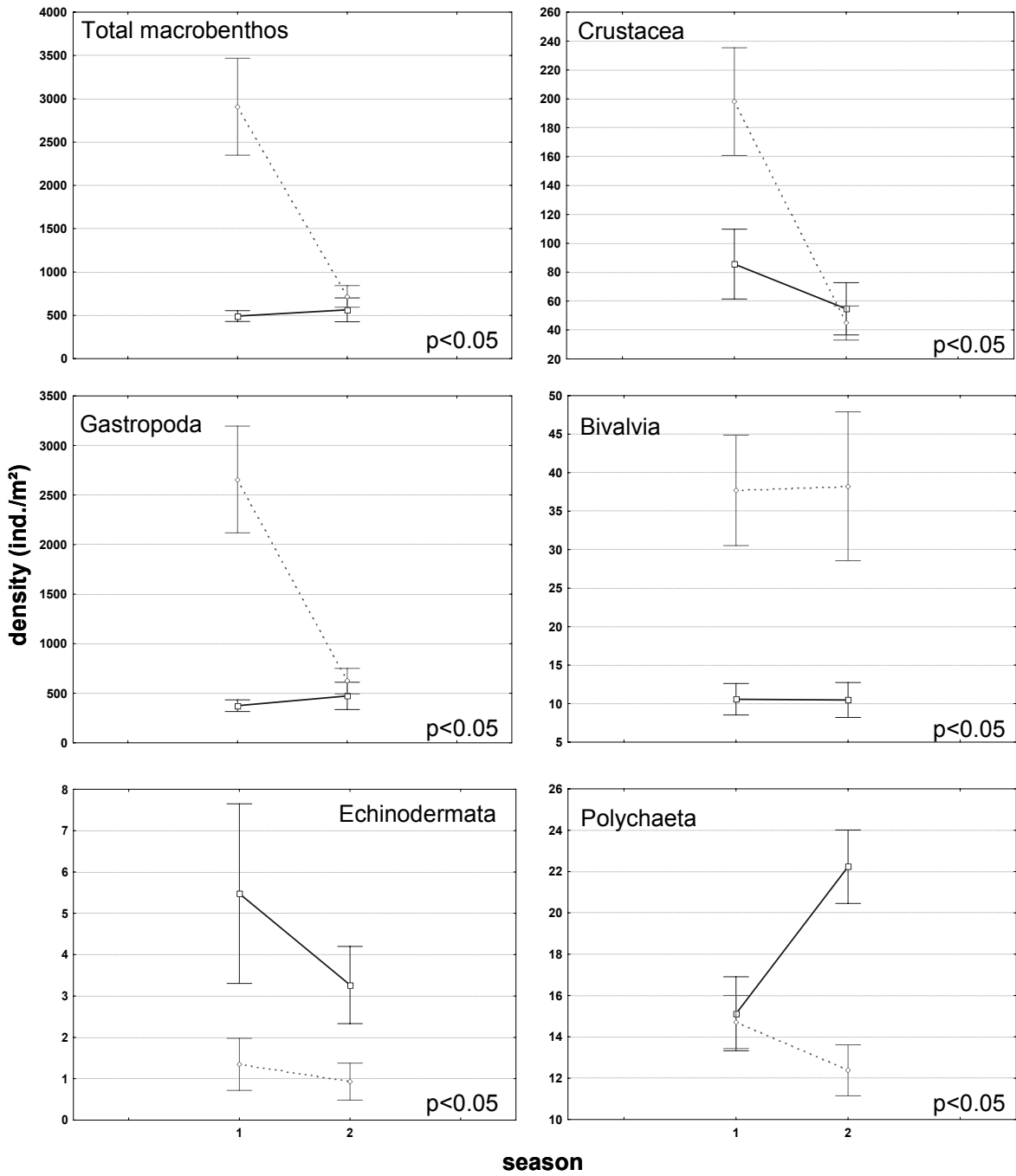
A total of 48 macrobenthic species were found during both periods, 13 of which in large numbers ( $> 2.5$  ind/ $m^2$  averaged over all samples). Most dominant groups were crustaceans (17 species), bivalves (11 species), polychaetes (10 species), gastropods (7 species) and echinoderms (4 species).

Comparison of the average densities for total macrobenthos and for the higher taxonomical groups between the two phases is shown in Fig. A3.3. From phase 1 to phase 2, average total densities increased with 300%, mainly due to the increase in Mollusca (+358%). Crustacea (+92%) and Bivalvia (+260%) also increased significantly (Mann-Whitney U test:  $p < 0.05$ ). Significant (Mann-Whitney U test:  $p < 0.05$ ) decreases were found for Polychaeta (-23%) and Echinodermata (-74%).

In Fig. A3.4 the differences in seasonality between the two phases are stated. It is easily seen that the differences mentioned before are mainly due to differences in the warm/wet season. Only for Polychaeta is the difference noticeable in the cold/dry season. For Bivalvia both seasons show equal differences.



**Fig. A3.3** - Density values for total macrobenthos and higher taxonomic groups for phase 1 and 2. Average values  $\pm$  SE.



**Fig. A3.4** - Seasonal density values for total macrobenthos and higher taxonomic groups for phase 1 (solid line: La Niña) and phase 2 (dotted line: Normal). 1: warm/wet season; 2: cold/dry season. Average values  $\pm$  SE.

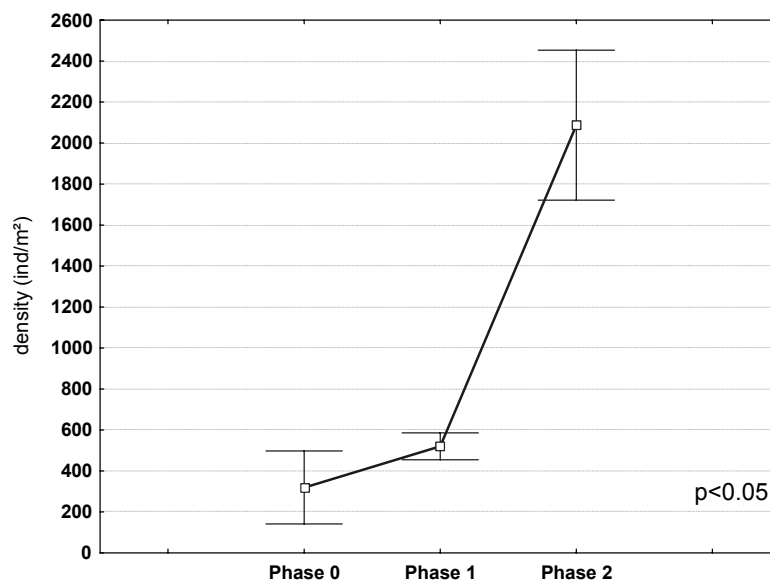


### A3.4. Discussion

As for the entire east coast of South America, Ecuador was very severely struck by the 1997-1998 El Niño. This El Niño was followed by an almost as severe La Niña, which persisted until the end of 2001 for the Ecuadorian coast, and was only sporadically interrupted by normal periods. For the El Pelado station, this can especially be seen in the thermocline depth, which was very shallow during this whole La Niña period.

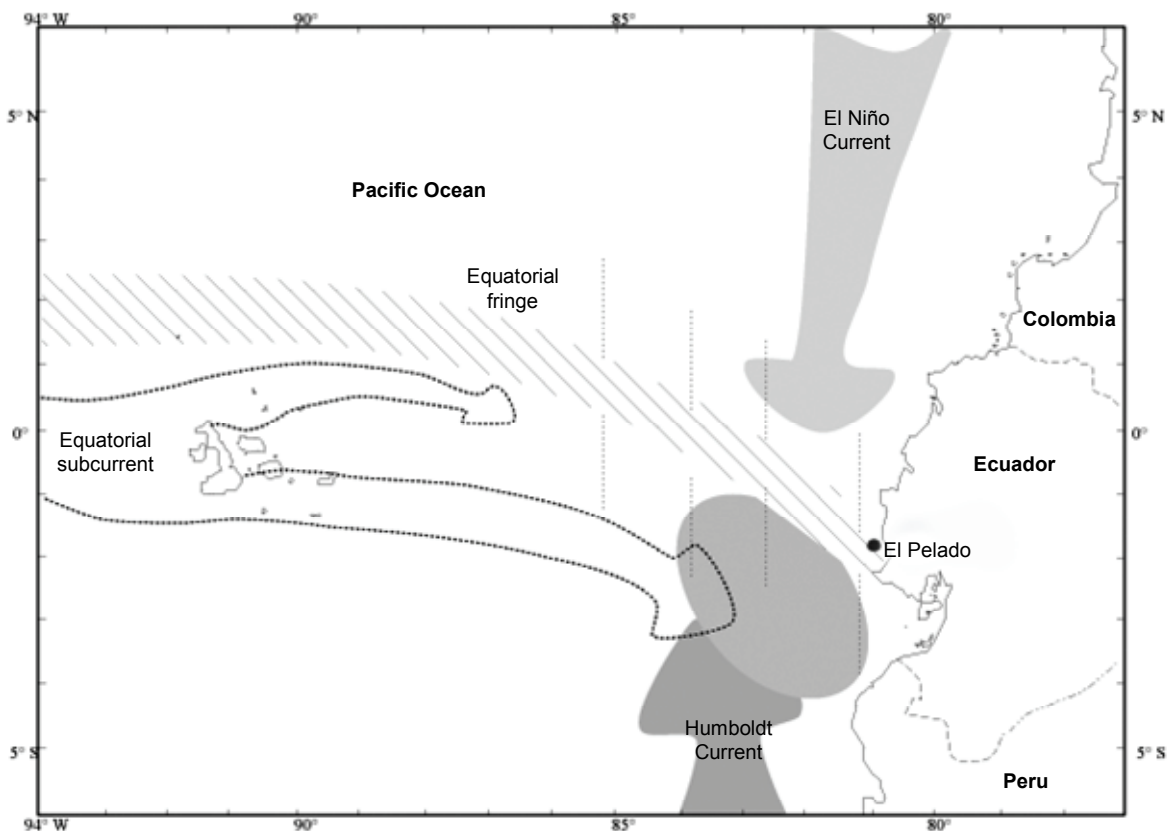
Although SST for the two phases are significantly different, especially for the warm/wet season, one could argue that this difference does not justify categorizing the first phase as a La Niña. However, if we look at the SST for the months preceding the first phase, we see markedly lower temperatures compared to the SST for the months preceding the second phase. This makes us confident that for the macrobenthos, the first phase can be regarded as a La Niña period, opposed to the normal second phase.

There was a very strong increase in macrobenthos densities from the first to the second phase, except for the Polychaeta and the Echinodermata, which make up a lesser part of the total sandy beach macrobenthos. Total macrobenthos densities during the peak of the La Niña (phase 0) were even lower than those from phase 1 (Fig. A3.5). From field observations and ongoing research, we know that the densities found during the second phase are comparable to current densities, suggesting they are to be considered as 'normal'. This leaves us to explain the very low densities during the end of the La Niña phase.



**Fig. A3.5** - Density values of the low water station for total macrobenthos and higher taxonomic groups for phase 0, 1 and 2. Average values  $\pm$  SE.

The most obvious explanation would be to hold the very low densities during La Niña against the preceding 'super-El Niño'. Indeed, several papers describe a dramatic decrease in densities of certain sandy beach macrofauna during very strong El Niños (Arntz, 1986; Tarazona and Paredes, 1992), and it could be assumed that populations were still recovering during the first sampling period. However, these data were retrieved from studies in central and south Peru, where a strong influence of an El Niño on the cold water system is to be expected. Riascos (2002) could not find such a dramatic influence of the 1997-1998 El Niño on the sandy beach fauna of Colombia, a warm water system.



**Fig. A3.6** - Map of the central Ecuadorian coast with dominant currents.

Unlike the Peruvian upwelling-system beaches (Arntz *et al.*, 1987), the investigated beach is not a low species richness/high dominance system. With a total of 48 species over both campaigns, this Ecuadorian beach can be compared with many European beaches, considered to be highly diverse (Dexter, 1992; Degraer *et al.*, 2003). With an average intertidal density of 1,329 ind/m<sup>2</sup> this beach could well prove to be a very productive beach, although no biomass data are available to check this statement. This difference between Ecuador and Peru might be related to the currents and upwelling off their coasts: Peru is year-round dominated by the cold Humboldt Current and has very

strong upwelling of nutrient rich, cold water, whereas Ecuador has the interaction between the cold Humboldt and the warm El Niño Current (Fig. A3.6), leading to the typical seasonality in both temperature and upwelling. Thus, the Peruvian beaches are basically part of a cold water system; the Ecuadorian beaches are part of a warm water system. This can be verified by looking at the species composition. Indeed, Peru shares many species with Chile; Ecuador has many species that can be found in Panama and Colombia (Aerts *et al.*, 2005, Dexter, 1974; Riascos, 2002, Jaramillo and Gonzales, 1991; Tarazona *et al.*, 1986).

The alternative hypothesis we are proposing is that a La Niña, much more than an El Niño, will cause a dramatic effect on the sandy beach benthos of a warm water system such as is present in Ecuador. Unfortunately, we have little data to support this hypothesis from this study nor from other sandy beach benthos studies. We, therefore, suggest to carefully analyze all the existing data for benthic organisms from the warm water system and compare the influence of an El Niño and a La Niña. Furthermore, going into species level could prove very valuable for testing this hypothesis: does a La Niña typically cause the disappearance of warm water species while cold water species flourish, and vice versa?

## **Acknowledgements**

The first author is financially supported by the FWO Flanders. We would like to thank all the people who contributed in the field and laboratory work for this study: Nancy Fockedeey, Jan Wittoeck, Sonnia Guartatanga, Luis Dominguez, Veronica Ruiz, Dirk Van Gansbeke and Danielle Schram and numerous students from ESPOL. Lab facilities and logistics in Ecuador were provided by ESPOL in Guayaquil in person of Maria Pilar de Cornejo and by CENAIM in San Pedro by Jorge Calderon. Finally we would like to thank Johnny Chavarria for his help with the climatological data.



---

**- REFERENCE LIST -**

---



- 
- Aerts, K., Vanagt, T., Degraer, S., Guartatanga, S., Wittoeck, J., Fockedey, N., Cornejo-Rodriguez, M.P., Calderon, J. and Vincx, M. (2004) Macrofaunal Community Structure and Zonation of an Ecuadorian Sandy Beach (Bay of Valdivia). *Belg. J. Zool* 134: 15-22.
- Alexander R. Stanton R. and Dodd J. (1993) Influence of sediment grain size on the burrowing of bivalves: correlation with distribution and stratigraphic persistence of selected neogene clams. *Palaios* 8: 289-303.
- Alheit J. and Naylor E. (1976) Behavioural basis of intertidal zonation in *Eurydice pulchra* Leach. *J. Exp. Mar. Biol. Ecol.* 23: 135-144.
- Ansell A. (1983) The biology of the genus *Donax*. In 'Sandy Beaches as Ecosystems'. Eds. McLachlan A. and Erasmus T. Junk, The Hague. pp 607-635.
- Ansell A. and Trevallion A. (1969) Behavioural adaptations of intertidal mollusks from a tropical beach. *J. Exp. Mar. Biol. Ecol.* 4: 9-35.
- Ansell A. and Trueman E. (1973) The energy cost of migration of the bivalve *Donax* on tropical sandy beaches. *Mar. Behav. Physiol.* 2: 21-32.
- Ansell A. McLusky D., Stirling A. and Trevallion A. (1978) Production and energy flow in the macrobenthos of two sandy beaches in South West India. *Proc. Roy. Soc. Edinb.* 76B: 269-296.
- Arntz W. (1986) The two faces of El Niño 1982-83. *Meeresforschung* 1: 1-46.
- Bayed A. (2003) Influence of morphodynamic and hydroclimatic factors on the macrofauna of Moroccan sandy beaches. *Est. Coast. Shelf Sci.* 58S: 71-82
- Begon M., Townsend C. and Harper J. (1996) *Ecology – individuals, populations and communities*. 3th edition. Blackwell Science.
- Beyst B. (2001) Epi- and hyperbenthic communities of Belgian sandy beaches. PhD. Thesis, University of Ghent.

- Beyst B., Buysse D., Dewicke A. and Mees J. (2001a) Surf zone hyperbenthos of Belgian sandy beaches: seasonal patterns. *Est. Coast. Shelf Sci.* 53: 877-895.
- Beyst B., Hostens K. and Mees J. (2001b). Factors influencing fish and macrocrustacean communities in the surf zone of sandy beaches in Belgium: temporal variation. *J. Sea Res.* 46: 281-294.
- Bocanegra C., Carbajal W., Oliva J. and Ancieta H. (1985). Estructura de la comunidad de macroinvertebrados bentónicas en las playas arenosas de Trujillo. *Anuario I Congreso Nacional de Biología Pesquera (Trujillo, Perú)*: 213-218.
- Boothroyd J., Ayon H., Robadue D.D., Vasconez J. and Noboa R. (1994) Características de la línea costera del Ecuador y recomendaciones para su manejo. Shoreline characteristics and management recommendations for the coast of Ecuador. Technical Report 2076.
- Borzzone C., Souza J. and Soares A. (1996). Morphodynamic influence on the structure of inter- and subtidal macrofaunal communities of subtropical sandy beaches. *Rev. Chil. Hist. Nat.* 69: 565-577.
- Bray J. and Curtis J. (1957) An ordination of the upland forest communities of southern Wisconsin. *Ecological Monographs*, 27: 325-349.
- Brazeiro A. (1999a) Community patterns in sandy beaches of Chile: richness, compositionm distribution and abundance of species. *Rev. Chil. Hist. Nat.* 72: 93-105.
- Brazeiro A. (1999b) Detection of non-random zonation patterns in sandy beach intertidal communities. *J. Coast. Res.* 15: 121-127
- Brazeiro A. (2001) The relationship between species richness and morphodynamics in sandy beaches: Which are the underlying factors? *Mar. Ecol. Prog. Ser.* 224:35-44.



- 
- Brazeiro A. and Defeo O. (1996) Macroinfauna zonation in microtidal sandy beaches: is it possible to identify patterns in such variable environments? *Est. Coast. Shelf Sci.* 42: 523-536.
- Brose U. and Martinez D. (2004) Estimating the richness of species with variable mobility. *Oikos*. 105: 292-300
- Brown A. (1961) Physiological-ecological studies on two sandy-beach Gastropoda from South Africa: *Bullia digitalis* (Meuschen) and *Bullia laevissima* (Gmelin). *Zeit. Morph. Okol. Tiere.* 49: 629-657.
- Brown A. (1971) The ecology of the sandy beaches of the Cape Peninsula, South Africa. Part 2: the mode of life of *Bullia* (Gastropoda). *Trans. Royal. Soc. S. Afr.* 39: 281-333.
- Brown A. (1982) Towards an activity budget for the sandy-beach whelk *Bullia digitalis* (Dillwym). *Malacologia.* 22: 681-683.
- Brown A. (1996) Behavioural plasticity as a key factor in the survival and evolution of macrofauna on exposed sandy beaches. *Rev. Chil. Hist. Nat.* 69: 469-474.
- Brown A. (2001) Surfing in the sandy-beach whelk *Bullia digitalis* (Dillwyn). *Afr. Zool.* 36 (2): 121-127.
- Brown A. and McLachlan A. (1990) *Ecology of Sandy Shores*. Elsevier, Amsterdam.
- Brown A. and Odendaal F. (1994) The biology of the oniscid Isopoda of the genus *Tylos*. *Adv. Mar. Biol.* 30: 89-153.
- Brown A. and Trueman E. (1994) The burrowing rate index. *J. Mollusc. Stud.* 60: 354-355.
- Brown A., Stenton-Dozey J. and Trueman E. (1989) Sandy-beach Bivalves and Gastropods: a comparison between *Donax serra* and *Bullia digitalis*. *Adv. in Mar. Biol.* 25:179-247.
- Buchanan J. (1984) Sediment analysis. In: Holme & McIntyre (eds), *Methods for the study*

- of marine benthos. Oxford and Edinburg Blackwell Scientific Publications: 41-65.
- Caine E. (1975) Feeding and masticatory structures of selected *Anomura*. J. Exp. Mar. Biol. Ecol. 18: 277-301.
- Cardoso R. and Veloso V. (2003) Population dynamics and secondary production of the wedge clam *Donax hanleyanus* (Bivalvia: Donacidae) on a high-energy, subtropical beach of Brazil. Mar. Biol. 142: 153-162.
- Chavez F., Pennington J., Castro C., Ryan J., Michisaki R., Schlining B., Walz P., Buck K., McFadyen A. and Collins C. (2002) Biological and chemical consequences of the 1997-1998 El Niño in central California waters. Prog. Oceanogr. 54: 205-232.
- Clark B., Bennett B. and Lambert S. (1996) Temporal variations in the surf zone fish assemblages from False Bay, South Africa. Mar. Ecol. Prog. Ser. 131: 35-47.
- Clark K. and Gorley R. (2001) PRIMER v5: User Manual/Tutorial. Plymouth Marine Laboratory, Plymouth, England.
- Clarke M. and Peña R. (1988) Zonación de la macroinfauna en una playa de arena del norte de Chile. Estud. Oceanol. 7: 17-31.
- Clifford H. and Stephenson W. (1975) An introduction to numerical classification. New-York: Academic Press.
- Colombini I. and Chelazzi L. (2003) Influence of allochthonous input on sandy beach communities. Oceanogr. Mar. Biol. Ann. Rev. 14: 115-159.
- Conover W. (1971) Practical nonparametric statistics. John Wiley & Sons, New York.
- Cornejo-Rodriguez M., Blacio E., Guartatanga R., Schwarz L., Bonilla-Coello M. and A. Milstein A. (1993) Variación anual de larvas y postlarvas de peces en una zona de rompiente de playa arenosa (Guayas-Ecuador). Acuic. Trop. 1: 17-21.
- Crisp D. (1984) Energy flow measurementents. In Holme N. and McIntyre A. (Eds.) Methods for the study of marine benthos. Oxford: Blackwell. 284-372.

- 
- Cruz M. (1992) Estado actual del recurso malacológico (Bivalvos y Gastropodos) de la zona infralitoral del golfo de Guayaquil. *Ac. Oceanogr. Pacífico*. 7: 41-68.
- Cubit J. (1969) Behaviour and physical factors causing migration and aggregation of the sand crab *Emerita analoga* (Stimpson). *Ecol.* 50:118-123.
- Cupul-Magana L. and Téllez-Duarte M. (1997) Space-Time variations in macrobenthic fauna of a sandy beach, related to changes in the macrobenthos of the sandy beach profile and sediment grain size, at El Pelicano Beach, Baja California. *Cienc. Mar.* 23 (4): 419-434.
- Dahl E. (1952). Some aspects of the ecology and zonation of the fauna on sandy beaches. *Oikos* 4: 1-27.
- Davenport C. (1903) The animal ecology of the Cold Spring Sandspit, with remarks on the theory of adaptation. University of Chicago Decennial Publication Series, 1 (10): 157-176.
- Davies J. (1964) A morphogenic approach to world shorelines. *Z. Geomorphol.* 8: 127-142.
- Dean R. (1973) Heuristic models of sand transport in the surf zone. *Proceedings of Conference on Engineering Dynamics in the Surf Zone*: 208-214.
- Defeo O. (1996) Experimental management of an exploited sandy beach bivalve population. *Rev. Chil. Hist. Nat.* 69: 605-614.
- Defeo O. (2003) Marine invertebrate fisheries in sandy beaches: an overview. *J. Coast. Res.* 35: 56-65.
- Defeo O. and de Alava A. (1995) Effects of human activities on long-term trends in sandy beach populations: the wedge clam *Donax hanleyanus* in Uruguay. *Mar. Ecol. Prog. Ser.* 123: 73-82.

- Defeo O. and Rueda M. (2002) Spatial structure, sampling design and abundance estimates in sandy beach macroinfauna: some warnings and new perspectives. *Mar. Biol.* 140: 1215-1225.
- Defeo O. and Martinez G. (2003) The habitat harshness hypothesis revisited: life history of the isopod *Excirolona braziliensis* in sandy beaches with contrasting morphodynamics. *J. Mar. Biol. Ass. U.K.* 83: 331-340.
- Defeo O. and McLachlan A. (2005) Patterns, processes and regulatory mechanisms in sandy beach macrofauna: A multi-scale analysis. *Mar. Ecol. Prog. Ser.* 295: 1-20.
- Defeo O., Layerle C. and Masello A. (1986) Spatial and temporal structure of the yellow clam *Mesodesma mactroides* (Deshayes, 1854) in Uruguay. *Med. Amb.* 8: 48-57.
- Defeo O., Jaramillo E. and Lyonnet A. (1992) Community structure and intertidal zonation of the macroinfauna on the atlantic coast of Uruguay. *J. Coast. Res.* 8 (4): 830-839.
- Defeo O., Brazeiro A., de Alava A. and Riestra G. (1997) Is sandy beach macrofauna only physically controlled? Role of substrate and competition in isopods. *Est. Coast. Shelf Sci.* 45: 453-462.
- Defeo O., Gomez J. and Lercari D. (2001) Testing the swash exclusion hypothesis in sandy beach populations: the mole crab *Emerita brasiliensis* in Uruguay. *Mar. Ecol. Prog. Ser.* 212: 159-170.
- Defeo O. Lercari D. and Gomez J. (2003) The role of morphodynamics in structuring sandy beach populations and communities: what should be expected? *J. Coast. Res.* 35S: 352-362.
- Degraer S., Mouton I., De Neve L. and Vincx M. (1999) Community structure and intertidal zonation of the macrobenthos on a macrotidal, ultra-dissipative sandy beach: summer-winter comparison. *Estuaries.* 22 (3B): 742-752.

- Degraer S., Volckaert S. and Vincx M. (2003) Macrobenthic zonation patterns along a morphodynamical continuum of macrotidal, low tide bar/rip and ultra-dissipative sandy beach. *Est. Coast. Shelf Sci.* 56:459-468.
- de la Huz R., Lastra M. and Lopez J. (2002) The influence of sediment grain size on burrowing, growth and metabolism of *Donax trunculus* L. (Bivalvia: Donacidae). *J. Sea Res.* 47:85-95.
- Dexter D. (1969) Structure of an intertidal sandy beach community in North Carolina. *Chesapeake Sci.* 10: 93-98.
- Dexter D. (1974) Sandy beach fauna of the Pacific and Atlantic coasts of Costa Rica and Colombia. *Rev. Biol. Trop.* 22: 51-66.
- Dexter D. (1983) Community structure of intertidal sandy beaches in New South Wales, Australia. In: McLachlan & Erasmus (eds), *Sandy Beaches as Ecosystems*, The Hague: Junk: 461-473.
- Dexter D. (1992) Sandy beach community structure: the role of exposure and latitude. *J. Biog.* 19: 59-66.
- Domínguez L., Fockedey N., De Mey M., Beyst B., Cornejo M., Calderon J. and Vincx M. (2004) Spatial patterns of the surf zone hyperbenthic fauna of Valdivia Bay (Ecuador). *Hydrobiologia.* 529 (1): 205-224.
- Dufrêne M. and Legendre P. (1997) Species assemblages and indicator species: the need for a flexible asymmetrical approach. *Ecol. Monogr.* 67: 345-366.
- Dugan J. and Hubbard D. (1996) Local variations in populations of sand crab *Emerita analoga* on sandy beaches in southern California. *Rev. Chil. Hist. Nat.* 69: 579-588.
- Dugan J., Hubbard D., Martin D., Engle J., Richards D., Davis G., Lafferty K. and Ambrose R. (2000a) Macrofauna communities of exposed sandy beaches on the southern California mainland and Channel Islands. *Proc. V<sup>th</sup> California Islands Symposium.* 339-346.

- Dugan J., Hubbard D. and Lastra M. (2000b) Burrowing abilities and swash behavior of three crabs, *Emerita analoga* Stimpson, *Blepharipoda occidentalis* Randall, and *Lepidopa californica* Efford (Anomura, Hippidae), of exposed sandy beaches. *J. Exp. Mar. Biol. Ecol.* 255: 229-245.
- Dugan J., Hubbard D., McCrary M. and Pierson M. (2003) The response of macrofauna communities and shorebirds to macrophyte wrack subsidies on exposed sandy beaches of southern California. *Est. Coast. Shelf Sci.* 58S: 25-40.
- Dugan J., Jaramillo E. and Hubbard D. (2004) Competitive interactions in macrofaunal animals of exposed sandy beaches. *Oecologia.* 139: 630-640.
- Edwards D. (1968) Reproduction in *Olivella biplicata*. *Veliger* 10: 297-304.
- Edwards D. (1969) Zonation by size as an adaptation for intertidal life in *Olivella biplicata*. *Amer. Zool.* 9:399-417.
- Efford I. (1965) Aggregation in the sand crab, *Emerita analoga* (Stimpson). *J. Anim. Ecol.* 34 (1): 63-75.
- Efford I. (1966) Feeding in the sand crab *Emerita analoga* (Stimpson) (Decapoda, Anomura). *Crustaceana.* 10: 166-182.
- Ellers O. (1995a) Behavioral control of swash-riding in the clam *Donax variabilis*. *Biol. Bull.* 189: 120-127.
- Ellers O. (1995b) Discrimination among wave-generated sound by a swash-riding clam. *Biol. Bull.* 189: 128-137.
- Ellers O. (1995c) Form and motion of *Donax variabilis* in flow. *Biol. Bull.* 189: 138-147.
- Enright J. (1961) Pressure sensitivity of an Amphipod. *Science.* 133: 758-760.
- Enright J. (1962) Responses of an amphipod to pressure changes. *Comp. Biochem. Physiol.* 7: 131-145.

- Enright J. (1963) The tidal activity rhythm of a sandbeach amphipod. *J. Mar. Biol. Ass. UK* 46: 276-313.
- Enright J. (1972) The virtuoso isopod. *J. Comp. Physiol.* 77: 141-162.
- Escofet A., Gianuca N., Maytia S. and Scarabino V. (1979). Playas arenosas del Atlántico sudoccidental entre los 29 y 43 LS.: consideraciones generales y esquema biocenológico. UNESCO Seminar, Montevideo, Uruguay: 245-58.
- Forward R. (1986) Behavioral responses of a sand-beach amphipod to light and pressure. *J. Exp. Mar. Biol. Ecol.* 102: 55-74.
- Forward R., Diaz H. and Cohen J. (2005) The tidal rhythm in activity of the mole crab *Emerita talpoida*. *J. Mar. Biol. Ass. U.K.* 85: 895-901.
- Gianuca N. (1983). A preliminary account of the ecology of sandy beaches in southern Brazil. In: McLachlan & Erasmus (eds), *Sandy Beaches as Ecosystems*, The Hague: Junk: 413-419.
- Gibbs R., Mathews M. and Link D. (1971) The relationship between size and settling velocity. *J. Sed. Petrol.* 41: 7-18.
- Gibson R. (2003) Go with thhe flow: tidal migration in marine animals. *Hydrobiol.* 503: 153-161.
- Gibson R., Ansell A. and Robb L. (1993) Seasonal and annual variations in abundance and species composition of fish and macrocrustacean communities on a Scottish sandy beach. *Mar. Ecol. Prog. Ser.* 98: 89-105.
- Giménez L. and Yannicelli B. (1997) Variability of zonation patterns in temperate microtidal Uruguayan beaches with different morphodynamic types. *Mar. Ecol. Prog. Ser.* 160: 197-207.
- Griffiths C. Stenton-Dozey J. and Koop K. (1983) Kelp wrack and energy flow through a sandy beach. In: McLachlan & Erasmus (eds), *Sandy Beaches as Ecosystems*, The Hague: Junk: 547-556.

- Hacking N. (1997) Sandy beach macrofauna of eastern Australia: a geographical comparison. Ph.D. thesis. University of New England. Australia.
- Hamerlynck O. and Mees J. (1991) Temporal and spatial structure in the hyperbenthic community of a shallow coastal area and its relation to environmental variables. *Oceanologica Acta* 11: 205-212.
- Hayes W. (1974) Sand beach energetics: importance of the isopod *Tylos punctatus*. *Ecology*. 55: 838-847.
- Haynes D. and Quinn G. (1995) Temporal and spatial variability in community structure of a sandy intertidal beach, Cape Paterson, Victoria, Australia. *Mar. Freshwater Res.* 46: 931-942.
- Heip C., Vincx M. and Vranken G. (1985) The ecology of marine nematodes. *Oceanogr. Mar. Biol. Ann. Rev.* 23: 399-489.
- Heltsh J. and Forrester N. (1983) Estimating species richness using the jackknife procedure. *Biometrics*. 39: 1-11.
- Hill M. (1973) Diversity and evenness: a unifying notation and its consequences. *Ecol.* 54: 427-432.
- INOCAR (2003) Tabla de mareas. Guayaquil, Ecuador.
- INOCAR (2004) Tabla de mareas. Guayaquil, Ecuador.
- INOCAR (2005) Tabla de mareas. Guayaquil, Ecuador.
- INOCAR (2006) Tabla de mareas. Guayaquil, Ecuador.
- James R. and Fairweather P. (1996) Spatial variation of intertidal macrofauna on a sandy ocean beach in Australia. *Est. Coast. Shelf Sci.* 43: 81-107.
- Jaramillo E. (1987) Sandy beach macroinfauna from the Chilean coast: zonation patterns and zoogeography. *Vie et Milieu*. 37: 165-174.



- Jaramillo E. and Gonzales M. (1991) Community structure of the macrofauna along a dissipative-reflective range of beach category in southern Chile. *Studies on Neotrop. Fauna and Env.* 26: 193-212.
- Jaramillo E. and McLachlan A. (1993) Community and population responses of the macroinfauna to physical factors over a range of exposed sandy beaches in south-central Chile. *Est. Coast. Shelf Sci.* 37: 615-624.
- Jaramillo E., McLachlan A. and Coetzee P. (1993) Intertidal zonation patterns of macroinfauna over a range of exposed sandy beaches in south-central Chile. *Mar. Ecol. Prog. Ser.* 101: 105-118.
- Jaramillo E., Contreras H. and Quijon P. (1996) Macroinfauna and human disturbance in a sandy beach of south-central Chile. *Rev. Chil. Hist. Nat.* 69: 655-663.
- Jaramillo E., Dugan J. and Contreras H. (2000a) Abundance, tidal movement, population structure and burrowing rate of *Emerita analoga* (Anomura, Hippidae) at a dissipative and a reflective sandy beach in South-central Chile. *Mar. Ecol.* 21 (2): 113-127.
- Jaramillo E., Avellanal M., Gonzalez M. and Kennedy F. (2000b) Locomotor activity of *Phallerisidia maculata* Kulzer (Coleoptera, Tenebrionidae) on Chilean sandy beaches. *Rev. Chil. Hist. Nat.* 73: 67-77.
- Jones A., Murray A. and Marsh R. (1998) A method for sampling sandy beach amphipods that tidally migrate. *Mar. Freshwater Res.* 49: 863-865.
- Kaiser M., Attrill M., Jennings S., et al. (2005) *Marine Ecology – Processes, systems, and impacts.* Oxford University Press.
- Lagerloef G., Lukas R., Bonjean F., Gunn J., Mitchum G., Bourassa M. and Busalacchi A. (2003) El Niño Tropical Pacific Ocean surface current and temperature evolution in 2002 and outlook for early 2003. *Geophys. Res. Lett.* 30:1514

- Lastra M., Dugan J. and Hubbard D. (2002) Burrowing and swash behavior of the pacific mole crab *Hippa pacifica* (Anomura, Hippidae) in tropical sandy beaches. *J. Crust. Biol.* 22 (1): 53-58.
- Lastra M., Jaramillo E., Lopez J., Contreras H., Duarte C. and Rodriguez G. (2004) Population abundances, tidal movement, burrowing ability and oxygen uptake of *Emerita analoga* (Stimpson) (Crustacea, Anomura) on a sandy beach of South-central Chile. *Mar. Ecol.* 25 (1) 71-89.
- Lazzari M., Sherman S., Brown C., King J., Joule B., Chenoweth S. and Langton R. (1999) Seasonal and annual variations in abundance and species composition of two near shore fish communities in Maine. *Estuaries* 22: 636-647.
- Lercari D. and Defeo O. (2003) Variation of a sandy beach macrobenthic community along a human-induced environmental gradient. *Est. Coast. Shelf Sci.* 58: 17-24.
- Lewis J. (1964) *The ecology of rocky shores*. English University Press, London.
- Lock K., Beyst B. and Mees J. (1999) Circatidal patterns in the tidal plankton of a sandy beach in Zeebrugge (Belgium). *Belg. J. Zool.* 169: 339-352.
- MacArthur R. (1955) Fluctuations of animal populations and a measure of community stability. *Ecology.* 36: 533-536.
- Magurran A. (2004) *Measuring biological diversity*. Blackwell Publishing. New York.
- Masselink G. (1993) Simulating the effects of tides on beach morphodynamics. *J. Coast. Res.* 15: 180-197.
- Masselink G. and Short A. (1993) The effect of tide range on beach morphodynamics and morphology: a conceptual beach model. *J. Coastal. Res.* 9 (3): 785-800.
- Mauchline J. (1971) Seasonal occurrence of mysids (Crustacea) and evidence of social behaviour. *J. Mar. Biol. Ass. U.K.* 51: 809-825.

- 
- Mauchline J. (1980) The larvae and reproduction. In: Blaxter, J.H.S., Russel, S.F. & Yonge, M. (eds). The biology of mysids and euphausiids. Adv. Mar. Biol. 1839-1865.
- McArdle S. and McLachlan A. (1991) Dynamics of the swash zone and effluent line on sandy beaches. Mar. Ecol. Prog. Ser. 76: 91-99.
- McArdle S. and McLachlan S. (1992) Sandy beach ecology: swash features relevant to the macrofauna. J. Coast. Res. 8: 398-407.
- McCullagh P. and Nelder J. (1989) Generalized linear models, second edition. Chapman and Hall, London.
- McLachlan A. (1980) The definition of sandy beaches in relation to exposure: a simple rating system. S. Afr. J. Sci. 76: 137-138.
- McLachlan A. (1983a) Sandy Beach Ecology - a review. In: McLachlan & Erasmus (eds), Sandy Beaches as Ecosystems, The Hague: Junk: 321-380.
- McLachlan A. (1983b) The ecology of sandy beaches in the Eastern Cape, South Africa. In: McLachlan & Erasmus (eds), Sandy Beaches as Ecosystems, The Hague: Junk: 539-546.
- McLachlan A. (1990) Dissipative beaches and macrofauna communities on exposed intertidal sands. J. Coast. Res. 6: 57-71.
- McLachlan A. (1998) Interactions between two species of *Donax* on a high energy beach: an experimental approach. J. Mollusc. Stud. 64: 492-495.
- McLachlan A. and Young N. (1982) Effects of low temperature on burrowing rates of four sandy beach molluscs. J. Exp. Mar. Biol. Ecol. 65: 275-284.
- McLachlan A. and Jaramillo E. (1995) Zonation on sandy beaches. Oceanogr. Mar. Biol. 33: 305-335.

- McLachlan A. and Dorvlo A. (2005) Global patterns in sandy beach macrobenthic communities. *J. Coast. Res.* 21 (4): 674-687.
- McLachlan A. and Brown A. (2006) *The ecology of sandy shores*. Second edition. Elsevier, Amsterdam.
- McLachlan A., Wooldridge T. and Van der Horst G. (1979) Tidal movements of the macrofauna on an exposed sandy beach in South Africa. *J. Zool.* 188: 433-442.
- McLachlan A., Wooldridge T. and Dye A. (1981) The ecology of sandy beaches in Southern Africa. *S. Afr. J. Zool.* 16: 219-231.
- McLachlan A., Jaramillo E., Donn T. and Wessels F. (1993) Sandy beach macrofauna communities and their control by the physical environment: A geographical comparison. *J. Coast. Res.* 15: 27-38.
- McLachlan A., Jaramillo E., Defeo O., Dugan J., de Ruyck A. and Coetzee P. (1995) Adaptations of bivalves to different beach types. *J. Exp. Mar. Biol. Ecol.* 187: 147-160.
- McLachlan A., Dugan J., Defeo O., Ansell A., Hubbard D., Jaramillo E. and Penchaszadeh P. (1996) Beach clam fisheries. *Oceanogr. Mar. Biol. Ann. Rev.* 34: 163-232.
- Mees J. and Hamerlynck O. (1992) Spatial community structure of the winter hyperbenthos of the Schelde Estuary, The Netherlands and the adjacent coastal waters. *Neth. J. Sea Res.* 29: 357-370.
- Mees J. and Jones M. (1997) The hyperbenthos. *Oceanogr. Mar. Biol. Ann. Rev.* 35: 221-255.
- Mercx A. (2005) *Vergelijkende studie van twee technieken voor het bemonsteren van macrofauna op zandstranden*. Ghent University, M.Sc. thesis.
- Morgan E. (1984) The pressure-responses of marine invertebrates: a psychophysical perspective. *Zool. J. Linn. Soc.* 80: 209-230.

- Mortensen T. (1921) Biologisk Studier over Sanstrandfaunen, saerlig ved de danske Kyster. Videnskabelige Meddelelser Dansk Naturhistorisk Forening, 74: 23-56.
- Munilla T., Corrales M. and San Vicente C. (1998) Suprabenthic assemblages from Catalan beaches: zoological groups. Orsis 13: 67-78.
- Nardi M., Morgan E. and Scapini F. (2003) Seasonal variation in the free-running period in two *Talitrus saltator* populations from Italian beaches differing in morphodynamics and human uses. Est. Coast. Shelf Sci. 58S: 199-206.
- Naylor E. and Rejeki S. (1996) Tidal migrations and rhythmic behaviour of sandbeach Crustacea. Rev. Chil. Hist. Nat. 69: 475-484.
- Nel R. (2001) Physical and biological factors structuring sandy beach macrofauna communities. Ph.D. thesis. University of Cape Town. South Africa.
- Nel R., McLachlan A. and Winter D. (1999) The effect of sand particle size on the burrowing ability of the beach mysid *Gastrosaccus psammodytes* Tattersall. Est. Coast. Shelf Sci. 48: 599-604.
- Nel R., McLachlan A. and Winter D. (2001) The effect of grain size on the burrowing of two *Donax* species. J. Exp. Mar. Biol. Ecol. 265: 219-238.
- Noy-Meir I. (1979) Structure and function of desert ecosystems. Israel J. Bot. 28; 1-19.
- Odendaal F., Turchin P., Hoy G., Wickens P., Wells J. and Schoeder G. (1992) *Bullia digitalis* (Gastropoda) actively pursues moving prey while swash riding. J. Zool. 228: 103-113.
- Olsson A. (1956) Studies on the genus *Olivella*. Proc. Acad. Nat. Sci. Philadelphia 108: 155-225.
- Palmer J. (1995) The biological rhythms and clocks of intertidal animals. Oxford University Press, Oxford.

- Pardi L. and Papi F. (1952) Die sonne als Kompass bei *Talitrus saltator* (Montagu)(Amphipodam Talitridae). Maturwiss. 39: 262-263.
- Pardi L. and Scapini F. (1983) Inheritance of solar direction finding in sandhoppers; mass-crossing experiments. J. Comp. Physiol. 151: 435-440.
- Parsons T., Maita Y. and Lalli C. (1984) A manual of chemical and biological methods for seawater analysis. Pergamon Press. Oxford.
- Paul D. (1981) Homologies between body movements and muscular contractions in the locomotion of two decapods of different families. J. Exp. Biol. 94: 159-168.
- Peterson C. (1991) Intertidal zonation of marine invertebrates in sand and mud. Am. Sci. 79: 236-249.
- Perez Nieto H. (1980) Estudio ambiental marino costero de Golfo Triste y marco de referencia para evaluar efectos de operaciones petroleras. Tomo II. Informe técnico. Universidad Simón Bolívar (INTECMAR), Maravan y Caracas, Venezuela.
- Pichon M. (1967) Contribution to the study of populations of tropical sandy beaches in the vicinity of Tulear, Madagascar. Recl Trav Sta Mar Endoume Suppl, 7: 57-100.
- Pierce C., Rasmussen J. and Leggett W. (1990) Sampling littoral fish with a seine: corrections for variable catch efficiency. Can. J. Fish. Aq. Sci. 47: 1004-1010.
- Preece G. (1971) The swimming rhythm of *Bathyporeia pilosa* (Crustacea: Amphipoda). J. Mar. Biol. Ass. UK 51: 777-791.
- Riascos J. and N. Rallon (2001) Patrones de distribución espacial del macrobenthos de playa arenosa en el Pacífico Colombiano. Actual. Biol. 23 (74): 15-20.
- Riascos J. (2002) Changes in the macrobenthos of a sandy beach during „El Niño“ 1997-98 in the Malaga Bay, Colombian Pacific. Cienc. Mar., 28 (1): 13-25.

- 
- Ricciardi A. and Bourget E. (1999) Global patterns of macroinvertebrate biomass in marine intertidal communities. *Mar. Ecol. Prog. Ser.* 185: 21-35.
- Robertson A. and Hansen J. (1981) Decomposing seaweed: a nuisance or a vital link in coastal food chains? CSIRO Mar. Lab. Res. Rep., Perth, Australia: 75-83.
- Rodil I. and Lastra M. (2004) Environmental factors affecting benthic macrofauna along a gradient of intermediate sandy beaches in northern Spain. *Est. Coast. Shelf Sci.* 61: 37-44.
- Romar G. and McLachlan A. (1986) Mullet grazing on surf diatom accumulations. *J. Fish Biol.* 28: 93-104.
- Ross S., McMichael R. and Ruple D. (1987) Seasonal and diel variation in the standing crop of fishes and macroinvertebrates from a Gulf of Mexico surf zone. *Est. Coast. Shelf Sci.* 25: 391-412.
- Ruppert E. and Barnes R. (1994) *Invertebrate zoology*. 6th edition. Saunders College Publishing.
- Salvat B. (1964) Les conditions hydrodynamiques interstitielles des sédiments meubles intertidaux et la répartition verticale de la faune endogène. *C. R. Hebd. Seances Acad. Sci.* 259: 1576-1579.
- Salvat B. (1967) La macrofaune carinologique endogène des sédiments meubles intertidaux (tanadaïces, isopodes et amphipodes) : éthologie, binomie et cycle biologique. *Mém. Mus. Nat. Hist. Nat., Paris, Série A* 45: 1-275.
- SAS Institute Inc. (2004) SAS OnlineDoc® 9.1.3. Cary, NC: SAS Institute Inc., Cary, NC, USA.
- Scapini F., Lagar M. and Mexxetti M. (1993) The use of slope and visual information in sandhoppers: innateness and plasticity. *Mar. Biol.* 115: 545-553.
- Scapini F., Buiatti M., De Matthaeis E. and Mattoccia M. (1995) Orientation behaviour and heterozygosity of sand hopper populations in relation to stability of beach

environments. *J. Evol. Biol.* 8: 43-52.

Scapini F., Fallaci M. and Mezzetti M. (1996) Orientation and migration in sandhoppers. *Rev. Chil. Hist. Nat.* 69: 553-563.

Schulz E. (1937) Das Farbstreifen-Sandwatt und seine Fauna, eine Ökologisch biozonotische Untersuchungen an der Nordsee. *Kieler Meeresforsch* 1: 359-378.

Shannon, C. & W. Weaver (1949). *The mathematical theory of communication*. University of Illinois Press, Urbana.

Short A. (1996) The role of wave height, period, slope, tide range and embaymentisation in beach classifications: a review. *Rev. Chil. Hist. Nat.* 69: 589-604.

Short A. (1999) *Handbook of beach and shoreface morphodynamics*. J. Wiley & Sons.

Siegel S. (1956) *Non-parametric statistics for the behavioural sciences*. McGraw Hill, New York.

Souriea R. (1957) Etude écologique des plages de la côte Sénégalaise aux environs de Dakar. *Ann. Ec. Sup. Sci. Dakar* 3: 1-110.

Soares A. (2003) *Sandy beach morphodynamics and macrobenthic communities in temperate subtropical and tropical regions: a macroecological approach*. Ph.D. thesis. University of Port Elizabeth. South Africa.

StatSoft, Inc. (1996) *Statistica for WINDOWS (Computer program manual)*. Tulsa, OK, USA.

Steele J. (1976) Comparative studies of beaches. *Phil. Trans. Roy. Soc. Edinb.* 274B : 401-415

Stanley S. (1970) Relation of shell form to life habits of the Bivalvia (Mollusca). *Geological Society of American Mem* 125, Baltimore, Maryland.

Suarez Calvanapon H. (1981) Análisis preliminar de la estructura de la comunidad de macroinvertebrados bentónicos en el litoral arenoso de la provincia de Chiclayo-



- departamento de Lambayeque (Abril-Diciembre de 1978). *Universidad* 3 (1): 11-23.
- Tarazona J. and Paredes C. (1992) Impacto de los eventos El Niño sobre las comunidades bentónicas de playa arenosa durante 1976-1986. In: Ortlieb & Marcharé (eds), *Paleo ENSO Records, International Symposium, Lima, Perú*: 299-303.
- Tarazona, J., Paredes C, and Igrada M. (1986). Estructura del macrobenthos en las playas arenosas de la zona de Lima, Perú. *Rev. Cienc. Univ. Nac. Mayor San Marcos (Lima, Perú)*. 74: 103-116.
- Tarazona, J., Salzwedel H. and Arntz W. (1988). Positive effects of 'El Niño' on macrozoobenthos inhabiting hypoxic areas of the Peruvian upwelling system. *Oecol*, 76: 184-190.
- Tarazona J., Arntz W., Canahuire E., Ayala Z. and Robles A. (1985). Modificaciones producidas durante 'El Niño' en la infauna bentónico de áreas someras del ecosistema de afloramiento peruano. In: Arntz, Landa & Tarazona (eds), *El fenómeno El Niño y su impacto en la fauna marina, Boletín del Instituto del Mar del Perú, Callao, Special issue*: 55-63.
- Ter Braak C. (1988) CANOCO-FORTRAN program for canonical community ordination by (partial) (detrended) (canonical) correspondance analysis, principal components analyses and redundancy analysis (Version 2.1). Wageningen: Agricultural Mat. Group.
- Ter Braak C. (1986) Canonical correspondence analysis: a new eigenvector technique for multivariate direct gradient analysis. *Ecology* 67: 1167-1179.
- Terlizzi A., Bevilacqua S., Fraschetti S. and Boero F. (2003) Taxonomic sufficiency and the increasing insufficiency of taxonomic expertise. *Mar. Poll. Bull.* 46: 556-561.
- Thurman C. (2004) Unravelling the ecological significance of endogenous rhythms in intertidal crabs. *Biol. Rhythm. Res.* 35: 43-67.

- Trueman E. (1971) The control of burrowing and the migratory behaviour of *Donax denticulatus* (Bivalvia: Tellinacea). *J. Zool.* 165: 453-467.
- Trueman E. and Ansell A. (1969) The mechanism of burrowing into soft substrates by marine animals. *Oceanogr. Mar. Biol. Ann. Rev.* 7: 315-366.
- Trueman E. and Brown A. (1976) Locomotion, pedal retraction and extension, and the hydraulic systems of *Bullia* (Gastropoda: Nassariidae). *J. Zool.* 178: 365-384.
- Trueman E. and Brown A. (1987) Locomotory function of the pedal musculature of the nassariid whelk, *Bullia*. *J. Mollusc. Stud.* 53: 287-288.
- Trueman E. and Brown A. (1992) The burrowing habit of marine gastropods. *Adv. Mar. Biol.* 28: 389-431.
- Tursch B. and Greifeneder (2001) *Oliva* shells: the genus *Oliva* and the species problem. Ancona l'Informatore Piceno, Italy.
- Underwood A. (1981) Techniques of analysis of variance in experimental marine biology and ecology. *Oceanogr. Mar. Biol. Ann. Rev.* 19: 513-605.
- Vanagt T., Beekman E., Vincx M. and Degraer S. (2006) ENSO and sandy beach macrobenthos of the tropical East Pacific: some speculations. *Adv. Geosc.* 6: 57-61.
- Vermeij G. (1972) Intraspecific shore-level size gradients in intertidal molluscs. *Ecology* 53: 693-700.
- Warman D., Reid D. and Naylor E. (1993) Circatidal variability in the behavioural responses of a sandbeach isopod *Eurydice pulchra* (Leach) to orientational cues. *J. Exp. Mar. Biol. Ecol.* 168: 59-70.
- Watt K. (1964) Comment on fluctuations of animal populations and measures of community stability. *Can. Entomol.* 96: 1434-1442.
- Whittaker R. (1967) Gradient analysis of vegetation. *Biol. Rev.* 5: 207-264.

- Wooldridge T.H. (1989) The spatial and temporal distribution of mysid shrimps and phytoplankton accumulations in high energy surfzone. *Vie Milieu* 38: 127-133.
- Yannicelli B., Palacios R. and Gimenez L. (2001) Activity rhythms of two cirolanid isopods from an exposed microtidal sandy beach in Uruguay. *Mar. Biol.* 138: 187-197.
- Yannicelli B., Palacios R. and Gimenez L. (2002) Swimming ability and burrowing time of two cirolanid isopods from different levels of exposed sandy beaches. *J. Exp. Mar. Biol. Ecol.* 273: 73-88,
- Zar J. (1999) *Biostatistical analysis*. Upper Saddle River, New Jersey.
- Zuñiga O., Peña R. and Clarke M. (1985) *Excirolana braziliensis* Richardson, 1912 (Isopoda: Cirolanidae) Life history and production. *Estud. Oceanol.* 4: 9-19.

