

On the utility of female genitalia in the systematics of Curculionidae: examples from Entimini and Hylobiina (Coleoptera: Curculionidae)

FABIO GAIGER⁽¹⁾ & SERGIO ANTONIO VANIN⁽²⁾

⁽¹⁾Museu de Zoologia, Universidade de São Paulo, Caixa Postal 42594, 04299-970 São Paulo, SP, Brazil

⁽²⁾Departamento de Zoologia, Instituto de Biociências, Universidade de São Paulo, Caixa Postal 11461, 05422-970 São Paulo, SP, Brazil

Abstract. The utility of the female genitalia and associated sclerites (tergite and sternite VIII) in the systematics of the Curculionidae is discussed. Examples from the tribe Entimini (Entiminae) and subtribe Hylobiina (Molytinae: Hylobiini) are given. The female characters prove to be informative for establishing the phylogenetic relationships among genera of Entimini. They are essential in determining species groups within the genus *Arniticus* Pascoe, Hylobiina.

Résumé. Sur l'utilité des organes génitaux femelles en systématique de Curculionidae. Exemples d'Entimini et de Hylobiina (Coleoptera : Curculionidae). L'utilité des organes génitaux femelles et des sclerites associés (tergite et sternite VIII) en systématique du Curculionidae est discutée. Des exemples de la tribu Entimini (Entiminae) et de la sous-tribu Hylobiina (Molytinae : Hylobiini) sont donnés. Les caractères femelles s'avèrent informatifs pour établir les rapports phylogénétiques parmi des genres d'Entimini. Ils sont essentiels pour déterminer les groupes d'espèces dans le genre *Arniticus* Pascoe, Hylobiina.

Keywords: Curculionidae, Entiminae, female genitalia, Hylobiina, morphology, systematics.

The female genitalia and their associated sclerites as described by Howden (1995) have long been neglected in the taxonomy of Curculionidae and some other Coleoptera. A great proportion of morphological studies on Coleoptera systematics have ignored the female genital apparatus; not only for descriptions of species, but also in revisions or cladistic analyses. Nonetheless, the female genitalia are proving to be an important source of characters, from description of taxa (species or genera) to cladistic analysis (e.g. Vanin 1986; Anderson 1989; Lanteri & Morrone 1991; O'Brien & Askewold 1992; Howden 1993, 1996; Lyal 1993; Morrone 1993, 1996; Morimoto & Kojima 1994; Lanteri & Diaz 1994; Kuschel 1995; Kojima & Morimoto 1996, 1998; Marvaldi & Morrone 2000; Marvaldi *et al.* 2002; Franz & O'Brien 2001a, 2001b; Franz 2003, 2004; Marvaldi 2005). Herein we offer examples from our work on the systematics of the tribe Entimini (Vanin & Gaiger 2005) and the tribe Hylobiini, subtribe Hylobiina (Gaiger 2003), in which the characters of the female genitalia and associated sclerites show significant impact on the final results. We hope this work will not only draw attention to their importance but also encourage coleopterologists to examine these structures in future works.

Material & Methods

The species and genera studied are from two different subfamilies and tribes of Curculionidae: the Entimini (*sensu* Alonso-Zarazaga & Lyal 1999; Vanin & Gaiger 2005) and the Neotropical genera of Hylobiina (Gaiger 2003). Species of all Entimini genera except *Trachyus* Kuschel and *Cyriophthalmus* Faust and species of all the Neotropical genera of Hylobiina, except for of *Haplogenus* Kuschel, *Plethes* Pascoe, *Syphorbus* Pascoe and *Iphipus* Schoenherr were analyzed. The examined material pertains to the following institutions; the names of the respective curators are listed in parentheses. Abbreviations are available from the Bishop Museum, Hawaii, USA (<http://hbs.bishopmuseum.org/codens/codens-inst.html>): **AMNH**: American Museum of Natural History, New York (L.H. Herman); **CPDC**: Centro de Pesquisas do Cacau, Itabuna (J. Valverde); **DZUP**: Departamento de Zoologia, Universidade Federal do Paraná, Curitiba (G.H. Rosado-Neto); **IBSP**: Instituto Biológico, São Paulo (S. Ide); **INPA**: Instituto Nacional de Pesquisa da Amazônia, Manaus (C. Magalhães); **MIZA**: Museo del Instituto de Zoología Agrícola, Maracay (J. Clavijo); **MLUH**: Martin Luther Universität, Halle (K. Schneider); **MNHN**: Muséum National d'Histoire Naturelle, Paris (H. Perrin); **MNNC**: Museo Nacional de Historia Natural, Santiago (M. Elgueta); **MNRJ**: Museu Nacional, Rio de Janeiro (M.A. Monné); **MPEG**: Museu Paraense Emílio Goeldi, Belém (A.Y. Harada); **MZSP**: Museu de Zoologia, Universidade de São Paulo, São Paulo (S.A. Vanin); **NHRS**: Naturhistoriska Riksmuseet, Stockholm (B. Viklund); **OXUM**: University Museum of Natural History, Oxford (G.C. McGavin); **SMTD**: Staatliches Museum für Tierkunde, Dresden (R. Krause); **USNM**: National Museum of Natural History, Washington D.C. (D. Furth).

E-mail: fgaiger@usp.br, savanin@ib.usp.br

Accepté le 26 juin 2007

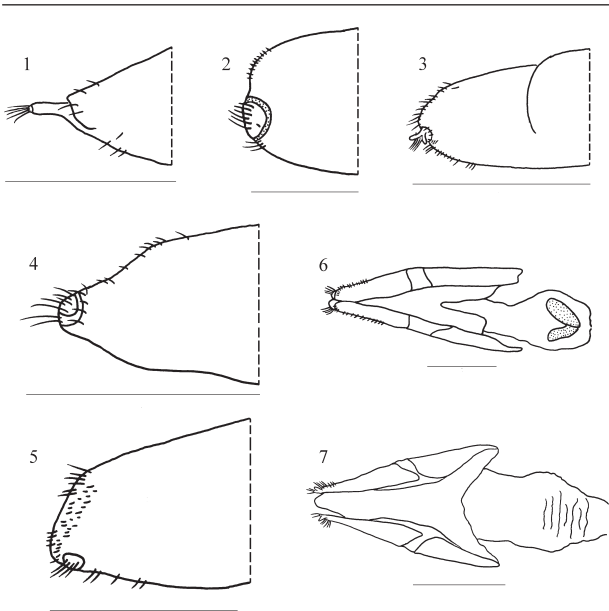

Figures 1-7
Character states of the female genitalia from the Entimini study. Style of gonocoxites, lateral view. 1, long (*Rhigus tribuloides* (Pallas)); 2, reduced (*Entimus imperialis* (Linnaeus)); 3, dentiform (*Polyteles guerini* Fähræus); 4, apical (*Cydianerus araneiformis* (Dalman)); 5, pre-apical (*Nasocomptus obyberaba*). Bursa copulatrix, dorsal view. 6, sclerites present (*Entimus imperialis*); 7, sclerites absent (*Phaedropus togatus* Boheman). Scale = 1 mm.

Dissection of the female genitalia

The dry specimens were first boiled in soap water until the tissues were sufficiently soft to perform the dissections, which followed immediately in water under a Wild M5 stereomicroscope. The whole abdomen was then removed and dissected; the ventrites were isolated from the tergites, along

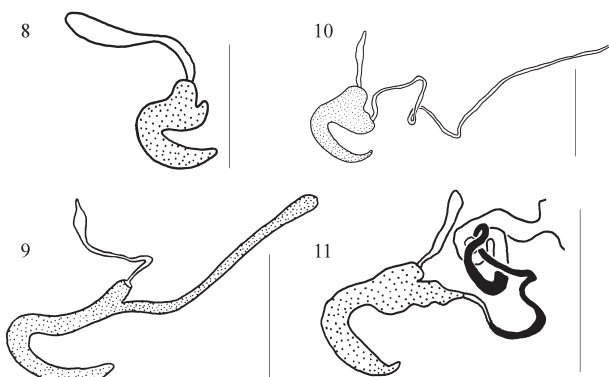

Figures 8-11
Character states of the female genitalia from the Entimini study. Length of spermatheca *collum*. 8, short (*Entimus imperialis*); 9, very long (*Polyteles guerini*). Sclerotization of the proximal portion of spermathecal duct. 10, absent (*Cydianerus araneiformis*); 11, present (*Nasocomptus obyberaba*). Scale = 1 mm.

with the internal structures. The ventrites were then dried in air and glued to a card, which was pinned with the specimen. The tergites and internal structures were boiled in 10% KOH for a few minutes, until the female genitalia and associated sclerites could be separated. These structures were then placed in 70% ethanol. For the observations, they were relocated in a properly identified micro-container, and immersed in a 1:10 solution of glycerin and 70% ethanol.

The spermathecae of the species of Hylobiina were detached from the remaining parts of the genitalia and observed under a Leitz SM LUX microscope, due to their small size. After the examination, the abdominal tergites were glued to the same cardboard as the ventrites. The spermathecae of the Entimini species were not separated; they were therefore examined jointly with the female genitalia and associated sclerites. All structures were kept in a microvial with glycerin, and pinned with the specimen.

Results and discussion

Review of characters from the female genitalia

Aslam (1961) and Morimoto (1962) were pioneering in using characters of the female genitalia of Curculionioidea to make phylogenetic inferences. The first author employed mainly characters from the soft parts, for example number of ovarioles, presence of bursa copulatrix, presence of vaginal pouches, shape of vagina, shape of spermathecal gland and length of spermathecal duct. Aslam (1961) also indicated the importance of the structure and shape of the spermatheca and its component parts, as well as the entry of the spermathecal duct, as useful characters at subfamily, tribal, generic and specific level. Morimoto (1962) used mostly traits of the coxites, from which we could mention: coxite present or absent, divided in distal and proximal region or not divided, styli of coxites present or absent and toothed plate at apex of coxite present or absent. Other characters described by Morimoto (1962), not related to the coxites, are the presence of apodeme of sternite VIII and the number of ovarioles per ovary. Calder (1990) study on the soft parts of the male and female reproductive systems of Curculionioidea, presented two new characters, in addition to observations of three features, already described by Aslam (1961) and Morimoto (1962), in additional weevils. Characters originally described are: presence of spermathecal gland and proximity of spermathecal duct to spermathecal gland. Many characters originally described by Aslam (1961), Morimoto (1962) and Calder (1990) were later used in cladistic studies of the Superfamily (Kuschel, 1995; Marvaldi & Morrone, 2000; Marvaldi *et al.*, 2002) and for isolated families of Curculionioidea, for example Platypodidae (Kuschel *et al.*, 2000) and Belidae (Marvaldi, 2005).

Thompson (1992) provided a detailed and clearly illustrated morphological study of the abdomen, mandibular processes, tibiae and male genitalia, as well as a key for the families and subfamilies of Curculionoidea including characters from the female genitalia. This article gave an important stimulus on the classification of Curculionoidea, as can be seen by the increase of articles on this issue published subsequently (e.g. Kuschel 1995; Marvaldi 2005; Marvaldi & Morrone 2000; Marvaldi *et al.* 2002). Howden (1995) published a review of the structures related to oviposition in the Superfamily that elucidated the terminology and presented many new features later used in formal cladistic analyses, some of which were already described by Morimoto (1962): apodeme of sternite VIII present or absent, margin of tergite VIII dentate or smooth, tergite IX sclerotized at least at the margins or membranous, coxites present or absent, coxites subdivided or not, styli of coxites present or absent, and toothed plate at apex of coxite present or absent.

The first proper cladistic analysis of Curculionoidea was realized by Kuschel (1995), in which 10 out of 138 characters were interpreted from the female genitalia, including the spermatheca. Most of the characters of the coxites and styli described above were plotted in Kuschel's matrix together with the following: distal coxites apex sclerotization, spermathecal shape and pigmentation, spermathecal duct insertion on bursa, and spermathecal duct and gland proximity on spermathecal capsule.

Most of those characters on female genitalia were used and re-coded in subsequent phylogenetic studies of Curculionoidea (Marvaldi 1997; Marvaldi & Morrone 2000; Marvaldi *et al.* 2002). Further cladistic analyses, at lower levels, like those of the families Platypodidae (Kuschel *et al.* 2000) and Belidae (Marvaldi 2005), introduced new attributes of less inclusive distribution. For example, proximal coxites pigmentation and spermathecal duct inserted

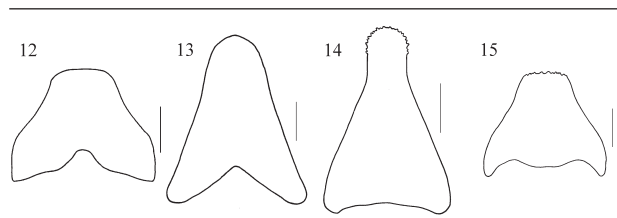

Figures 12–15

Character states of the female genitalia from the *Arniticus* study. Shape of tergite VIII. 12, trapezoidal (*A. hylobioides* (Boheman)); 13, sub-triangular (*A. arrogans* (Pascoe)); 14, constricted (*A. pardus* (Germt)). Apex of tergite VIII. 15, slightly dentate (*A. granellus* (Boheman)); 13, smooth; 14, dentate. Scale = 0.5 mm.

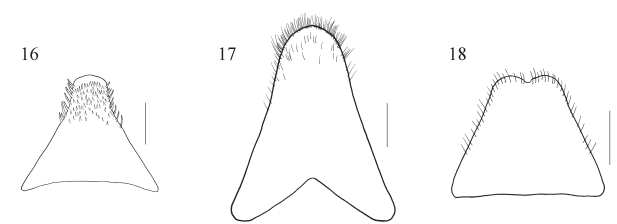

Figures 16–18

Character states of the female genitalia from the *Arniticus* study. Setae of tergite VIII. 16, curled (*A. rusticanus* (Boheman)); 17, not curled (*A. arrogans*). Distribution of tergite VIII apex setae. 17, adjacent; 18, not adjacent (*A. latipennis* (Pascoe)). Apex of tergite VIII. 17, not invaginated; 18, invaginated. Scale = 0.5 mm.

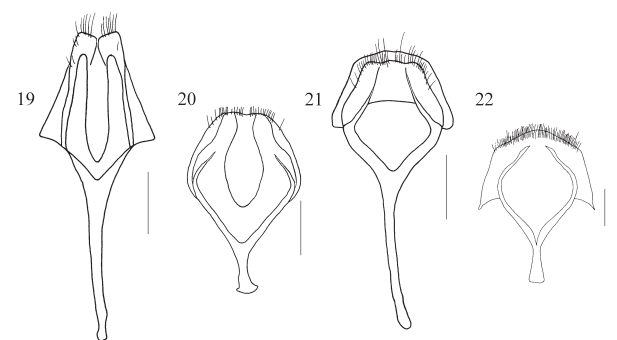

Figures 19–22

Character states of the female genitalia from the *Arniticus* study. Length relation between projection and lobe of sternite VIII. 19, similar in length (*A. pardus*); 20, shorter (*A. sp. nov.*); 21, longer (*A. lituratus* (Boheman)). Shape of lobe of sternite VIII. 19, narrow; 20, as wide as long; 22, wide (*A. hylobioides*). Distribution setae on sternite VIII. 22, continuous; 19, patchy. Scale = 0.5 mm.

Figures 23–30

Character states of the female genitalia from the *Arniticus* study. Relation of length between *collum* and *cornu* of spermatheca. 23, similar in length (*A. costalis* (Boheman)); 24, shorter (*A. cestatus* (Boheman)); 25, longer (*A. arrogans*). Spermatheca: shape of *ramus*. 26, thick (*A. cingulatus* Champion); 27, neither thick nor slender (*A. hylobioides*); 28, slender (*A. pardus*). Spermatheca: projection of *collum*. 27, absent; 28, present. Spermatheca: lobes of *cornu*. 23, absent; 24, present. Spermatheca: projection of *cornu*. 26, present; 23, absent. Spermatheca: shape of *cornu*. 29, globose (*A. perturbatus* (Boheman)); 30, elongated (*A. neglectus* (Faust)); 28, cylindrical. Scale = 0.1 mm.

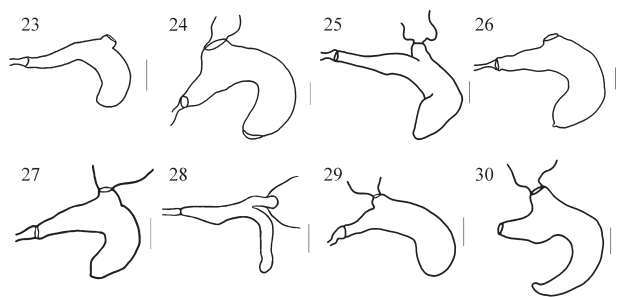

on bursa or on a common oviduct (Marvaldi 2005), spermathecal shape at apex, spermathecal duct length, spermathecal gland presence, and spermathecal gland sclerotization (Kuschel *et al.* 2000).

Other studies at the level of subfamilies, tribes and genera of Curculionoidea, employing cladistic analysis or not, also make use of attributes from the female genitalia and associated sclerites (*e.g.* Anderson 1989; O'Brien & Askevold 1992; Morrone 1993, 1996; Askevold *et al.* 1994; Lanteri & Diaz 1994; Morimoto & Kojima 1994; O'Brien *et al.* 1994, 1995; Kojima & Morimoto 1996, 1998; Kojima 1997; Morimoto & Miyakawa 1996; Normark & Lanteri 1998; Franz & O'Brien 2001a, 2001b; Franz 2003, 2004; Sousa *et al.* 2004). As expected, these characters are of more limited universality and some of them are similar to the ones used in the *Arniticus* and Entimini studies, as in all of the following: apodeme and lobe of sternite VIII length relation (Anderson 1989; Lyal 1993; Morrone 1996; Franz 2004), sternite VIII arms form (O'Brien

& Askevold 1992; Askevold *et al.* 1994; O'Brien *et al.* 1994, 1995; Franz & O'Brien 2001b; Franz 2003, 2004), sternite VIII apodeme (O'Brien & Askevold 1992; Morrone 1993; Askevold *et al.* 1994; O'Brien *et al.* 1994, 1995; Kojima & Morimoto 1998), apical setae of sternite VIII (Morrone 1993; O'Brien *et al.* 1995), apex of tergite VIII shape (Lyal 1993; O'Brien *et al.* 1994, 1995; Sousa *et al.* 2004), styli of coxites present or absent (Morrone 1993; Morimoto & Kojima 1994), apical region of sternite VIII (Franz 2003), spermathecal gland lobe length (O'Brien & Askevold 1992; O'Brien *et al.* 1994; Morrone 1996; Kojima & Morimoto 1998), gland lobe location on spermathecal body (O'Brien & Askevold 1992; Kojima & Morimoto 1996; Morimoto & Miyakawa 1996; Kojima 1997; Franz 2003), spermathecal duct and gland lobe proximity on spermatheca (Franz & O'Brien 2001b), spermathecal apex shape (Lanteri & Diaz 1994; Normark & Lanteri 1998; Franz & O'Brien 2001a; Franz 2004), spermathecal duct insertion (Lyal

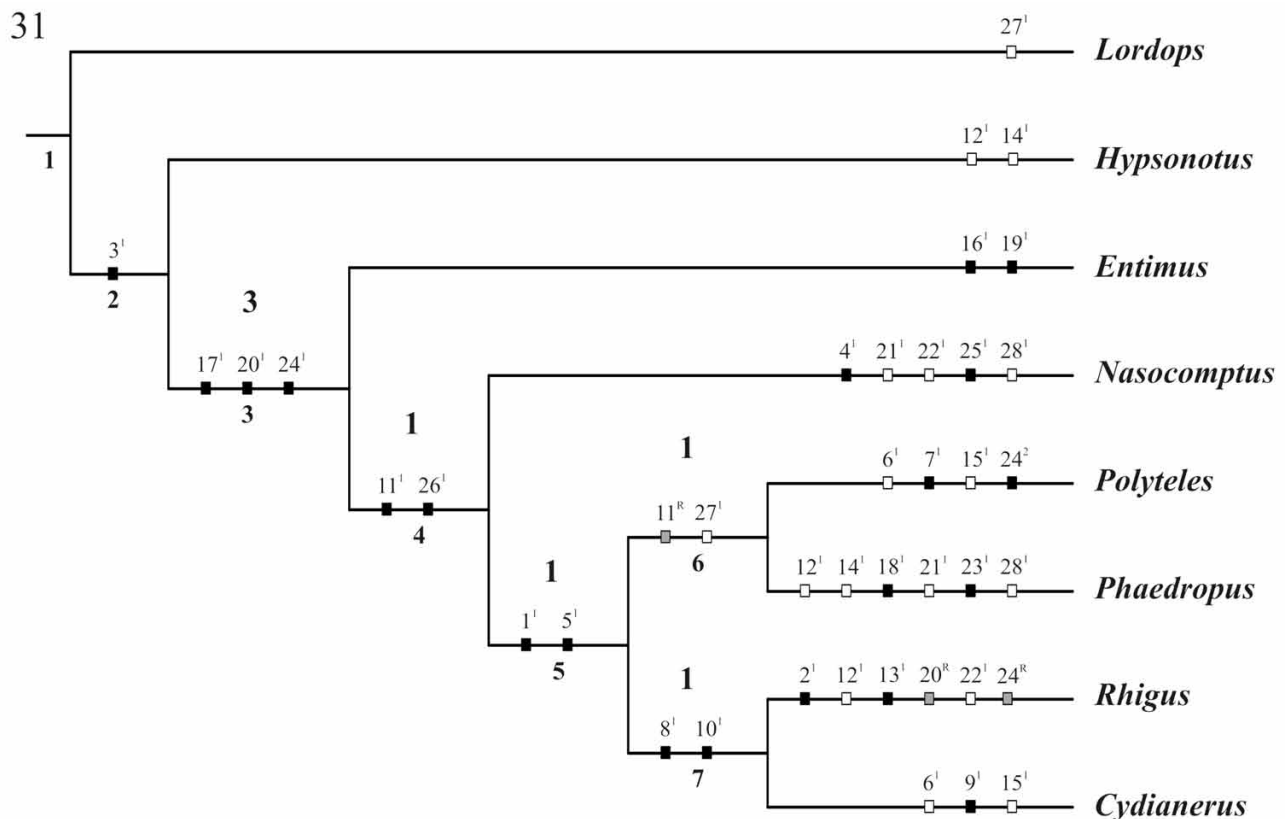

Figure 31

The single most parsimonious tree found for the cladistic relationships among the Neotropical genera of Entimini (except *Trachius*) (L=41; C.I.=70; R.I.=55), female characters included. Character states are plotted on the branches; numbers above branches indicate Bremer support and below branches correspond to node numbering. The color of the squares shows the character conditions: black = nonhomoplasic, white = convergent, and grey = reversions.

1993), and spermathecal duct sclerotization and length (Lanteri & Diaz 1994; Howden 1996; Normark & Lanteri 1998; Sousa *et al.* 2004). It can be said from the above account that characters from the female genitalia and associated sclerites are being employed in Curculionoidea systematics, nevertheless, far from being an ordinary practice.

List of characters and character states from the female genitalia

Total number of characters used in the analyses is 27 and 81 for the Entimini and *Arniticus* study, respectively (see Gaiger 2003 and Vanin & Gaiger 2005 for complete list of characters). The data matrix for the *Arniticus* study is provided (Table 1). The characters of the female genitalia are in bold and the order follows that presented below, between parentheses is the character number in the original matrix.

Entimini

1. Styli of coxites: (0) long (Fig. 1); (1) reduced (Fig. 2); (2) dentiform (Fig. 3). C.I.=66; R.I.=50. Non-additive.
2. Styli of coxites: position; (0) apical (Fig. 4); (1) pre-apical, ventral (Fig. 5). Autapomorphy of *Nasocomptus obyberaba*.
3. Bursa copulatrix: sclerites; (0) present (Fig. 6); (1) absent (Fig. 7). C.I.=100; R.I.=100.
4. Spermatheca: duct lobe length; (0) short (Fig. 8); (1) very long (Fig. 9). C.I.=50; R.I.=50.
5. Spermathecal duct: sclerotization of the proximal portion; (0) absent (Fig. 10); (1) present (Fig. 11). C.I.=50; R.I.=0.

Hylobiini, *Arniticus*

1. (44) Tergite VIII: shape; (0) trapezoidal (Fig. 12); (1) sub-triangular (Fig. 13); (2) constricted (Fig. 14). C.I.=16; R.I.=54. Non-additive.
2. (45) Tergite VIII: apex; (0) slightly dentate (Fig. 15); (1) smooth (Fig. 13); (2) dentate (Fig. 14). C.I.=10; R.I.=46. Non-additive.
3. (46) Tergite VIII: shape of apex setae; (0) curled (Fig. 16); (1) not curled (Fig. 17). C.I.=33; R.I.=66.
4. (47) Tergite VIII: distribution of apex setae; (0) adjacent (Fig. 17); (1) not adjacent (Fig. 18). C.I.=9; R.I.=44.
4. (48) Tergite VIII: invagination of apex; (0) absent (Fig. 17); (1) present (Fig. 18). C.I.=25; R.I.=57.
5. (49) Sternite VIII: relation of length between projection and lobe; (0) between 1.0 and 1.2 times (Fig. 19); (1) a maximum of 0.8 times longer (Fig. 20); (2) a minimum of 1.7 times longer (Fig. 21). C.I.=15; R.I.=35. Non-additive.
6. (50) Sternite VIII: shape of lobe; (0) narrow, length at least 1.4 times its width (Fig. 19); (1) as wide as long, length between 0.8 and 1.1 times its width (Fig. 20); (2) wide, length less than 0.5 times its width (Fig. 22). C.I.=20; R.I.=27. Additive.
7. (51) Sternite VIII: distribution of setae; (0) continuous (0) (Fig. 22); (1) patchy (Fig. 19). C.I.=6; R.I.=50.
8. (52) Spermatheca: relation of length between duct lobe and spermatheca; (0) similar, duct lobe length between 0.9 and 1.1 times spermatheca length (0) (Fig. 23); (1) shorter, duct lobe length not greater than 0.6 times spermatheca length (Fig. 24); (2) longer, duct lobe length at least 1.4 times spermatheca length (Fig. 25). C.I.=10; R.I.=39. Non-additive.
9. (53) Spermatheca: shape of gland lobe; (0) thick, length not greater than 0.5 times its width (Fig. 26); (1) neither thick nor slender, length between 0.9 and 1.3 times its width (Fig. 27); (2) slender, length at least 2.0 times its width (Fig. 28). C.I.=12; R.I.=56. Additive.
10. (54) Spermatheca: projection of duct lobe; (0) absent (Fig. 27); (1) present (Fig. 28). C.I.=7; R.I.=56.
11. (55) Spermathecal lobes; (0) absent (Fig. 23); (1) present (Fig. 24). C.I.=33; R.I.=0.

32a

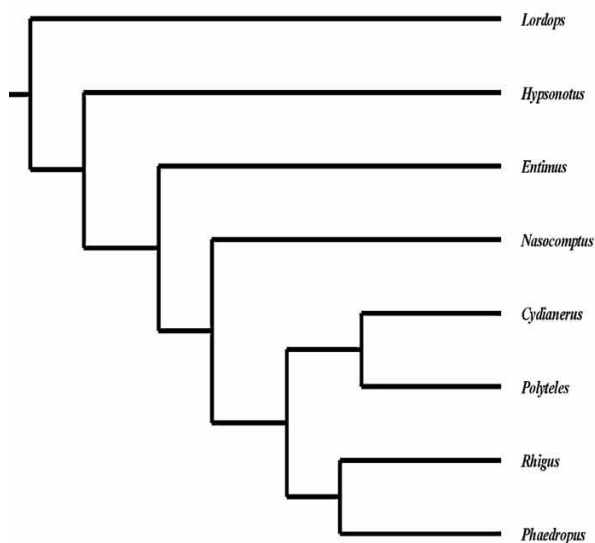

32b

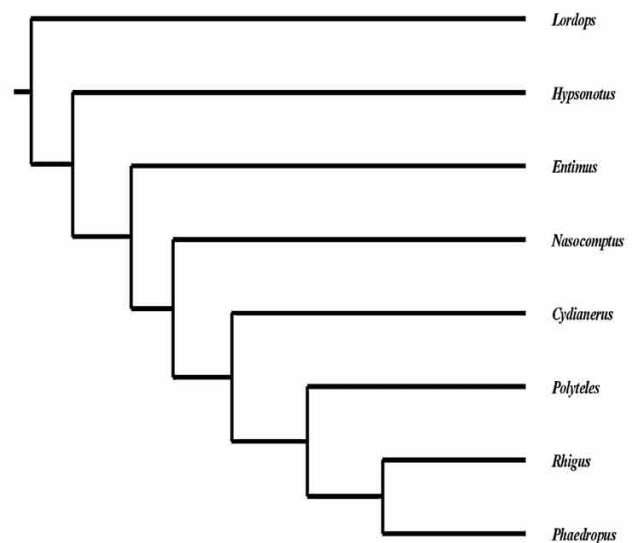

Figures 32a and b

The two most parsimonious trees found for the cladistic relationships among the Neotropical genera of Entimini (except *Trachius*) (L=32; C.I.=71; R.I.=55), female characters excluded.

12. (56) Spermathecal projection; (0) present (Fig. 26); (1) absent (Fig. 23). C.I.=5; R.I.=42.
 13. (57) Shape of spermatheca; (0) globose (Fig. 29); (1) elongated (Fig. 30); (2) cylindrical (Fig. 30). C.I.=28; R.I.=50. Non-additive.

The coded female genital characters were important for the description and identification of species, and also informative for the cladistic analysis. Many characters gathered from the female genitalia resulted phylogenetically informative at both the generic (Entimini) and the specific level (*Armiticus*).

Entimini

Rhigus Schoenherr, a genus of Entimini, was revised recently (Gaiger 2001), although the female genitalia were not studied. Nonetheless, further studies towards a cladistic analysis of the genera of Entimini revealed that the female genitalia are quite conservative at the generic level (Vanin & Gaiger 2005). Among

genera, however, there was considerable variability in the spermatheca, its duct, the coxites, and in the bursa copulatrix (Figs. 1–11). The descriptions and illustrations of the five cladistic characters are provided above. They played a major role in determining the topology of the cladogram (Fig. 31), as seen in comparison with the consensus (Fig. 32c) of the two trees (Figs. 32a and 32b) obtained after the female characters were removed. These characters support nodes 3, 4 and 6 (as numbered in Fig. 31). Therefore, the female genitalia provided important evidence for establishing the phylogenetic relationships among the genera of Entimini, especially if we consider that traits of the female genitalia amount for only 18% of total characters but sustain 43% of the cladogram branches.

32c

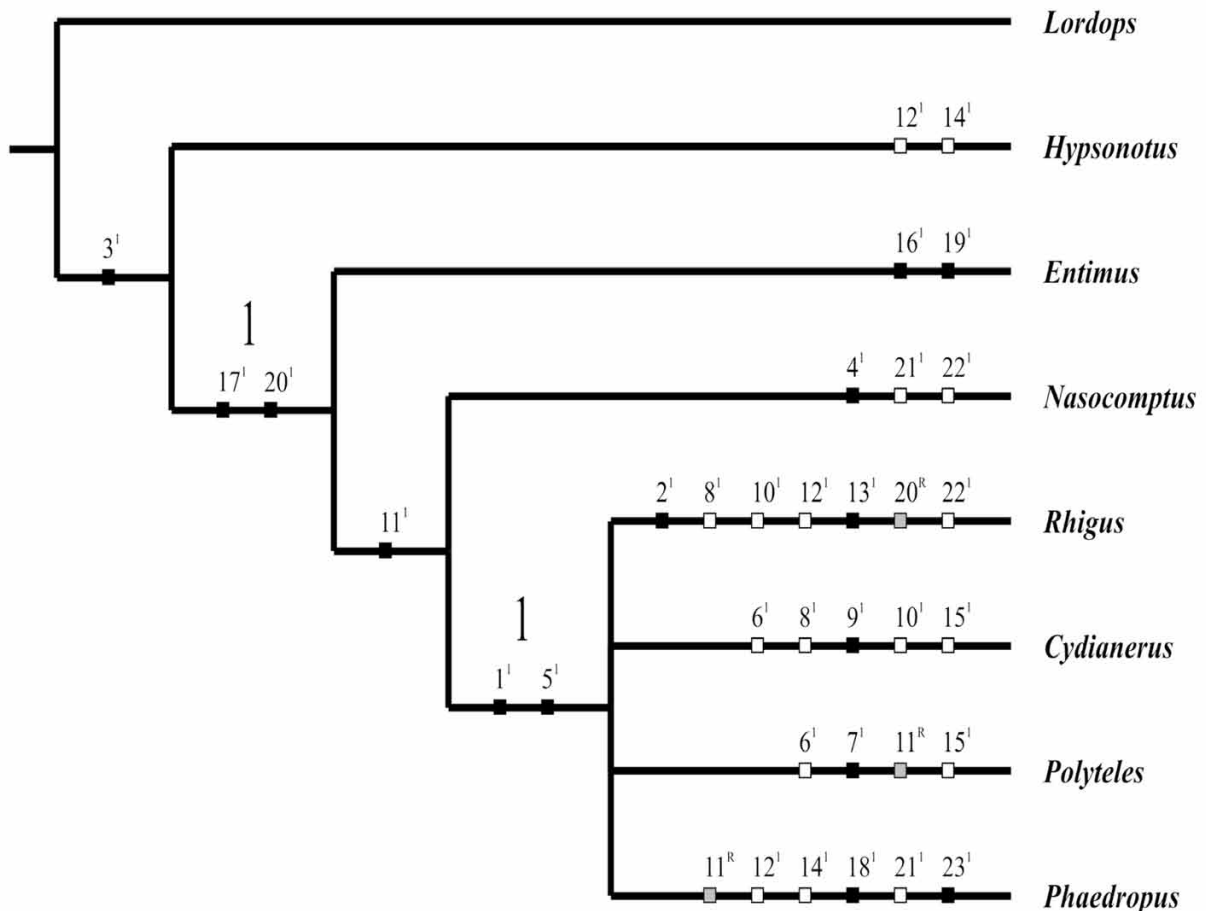
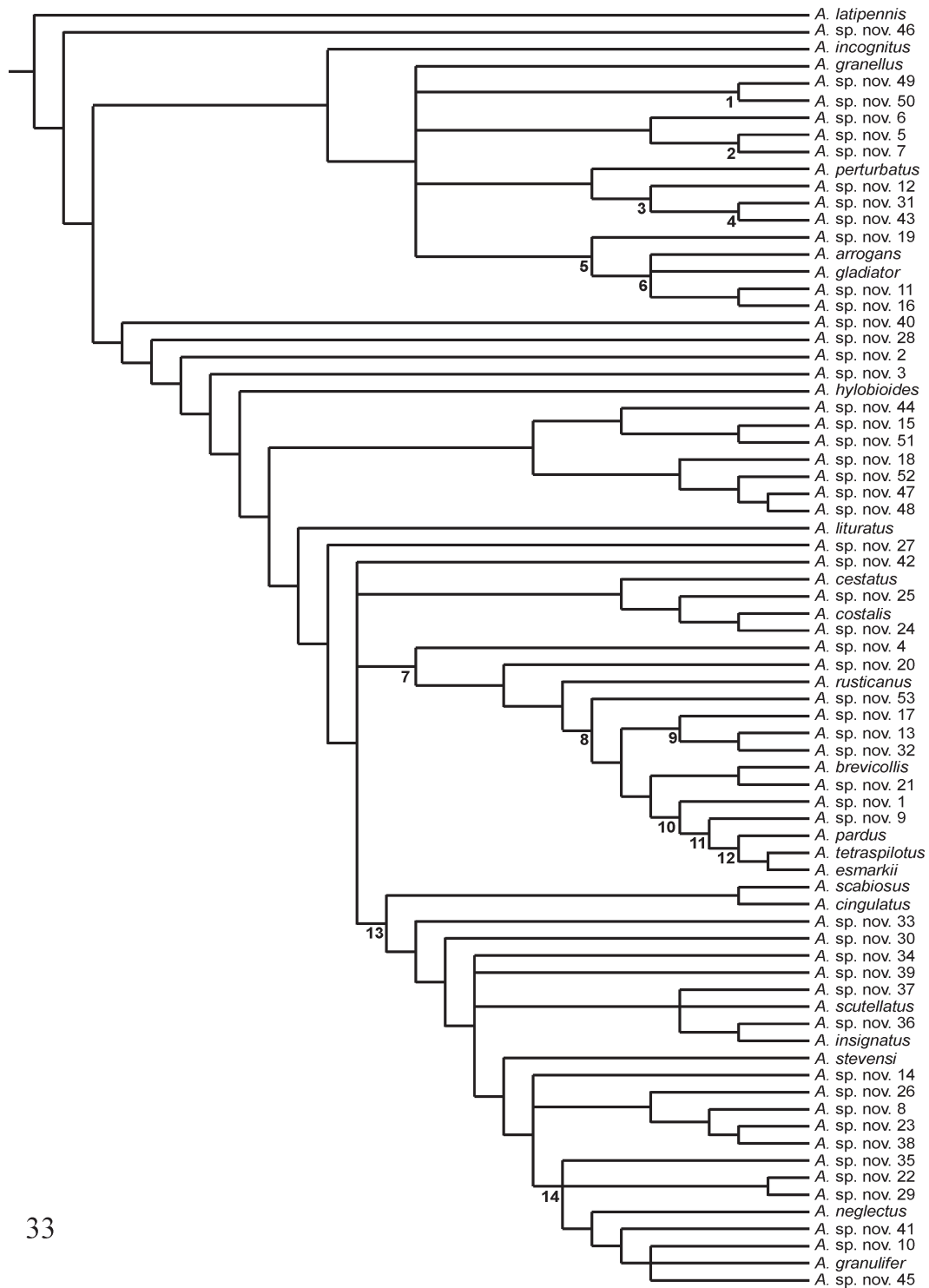

Figure 32c

Consensus tree of the two most parsimonious trees above (L=35; C.I.=65; R.I.=40); character states are plotted on the branches; numbers above branches indicate Bremer support. Color of squares shows character condition black = nonhomoplastic, white = convergent, and grey = reversions.



33

Figure 33
 Strict consensus cladogram (L=871; C.I.=13; R.I.=45) of the 128 trees obtained (L=854; C.I.=13; R.I.=46) in the *Armiticus* analysis. Nodes are numbered as mentioned in text.

Arniticus Pascoe 1881

The revision and cladistic analysis of the genus *Arniticus* (Fig. 33) was carried out as part of the first author's dissertation (Gaiger, 2003). A total of 75 of the 77 recognized species of the genus were available for study. The female genital and associated sclerite characters stem from the following structures (the number of characters from each structure is written in parentheses): tergite VIII (5), sternite VIII (3), and spermatheca (6). The descriptions and illustrations of each of the 14 characters are provided above.

The effect of the female characters on the cladogram topology was less significant than in the Entimini. Nevertheless, these characters supported many species groups. The group of node 10 (as numbered in Fig. 33) is one where the female apparatus' signal is important, with five supporting characters. Other groups sustained by this kind of characters are those of nodes 1–14. Only one character, the lobes of the spermatheca, did not support any clade. Overall, characters from the female genitalia were essential in establishing species groups within *Arniticus*. This can be illustrated by the fact that while summing just 17.5% of total matrix characters female genitalia characters support 22.5% of total cladogram branches.

Conclusions

Studies at the generic (Entimini) and at the specific level (*Arniticus*) illustrated the importance of the female genitalia and associated sclerites for providing diagnostic and phylogenetic characters. These characters critically affected the respective cladogram topologies. They were also valuable for the description and identification of taxa.

We do not intend to state that traits of the female genitalia are more significant than any other character system. We simply expect that coleopterologists no longer neglect these structures, but on the contrary acknowledge their importance in systematics.

We agree with Howden (1995) when she states that "...female reproductive system conveys much information of systematic value, but function should always be considered when interpreting morphology." (p. 98). Nevertheless, the inspection of female genitalia should become a standard procedure in studies of Curculionoidea, as is already the case with the aedeagus, even though male and female genitalia may not always contribute useful characters.

Acknowledgments. Thanks are due to the anonymous referees for critics and suggestions that improved the paper, and to "Fundação de Amparo à Pesquisa do Estado de São Paulo" (FAPESP) for providing the grants Proc.1999/01445-7, Proc. 2003/06542-8 and Proc. 2003/06501-0.

References

- Alonso-Zarazaga M. A., Lyal C. H. C. 1999. A world catalogue of Families and Genera of Curculionoidea (Insecta: Coleoptera) (Excepting Scolytidae and Platypodidae). Barcelona, Spain: Entomopraxis, 315 p.
- Anderson R. A. 1989. Revision of the Subfamily Rhynchaeninae in North America (Coleoptera, Curculionidae). *Transactions of the American Entomological Society* **115**: 207-312.
- Askevold I. S., O'Brien C. W., Morimoto K. 1994. Systematics and evolution of weevils of the genus *Bagous* Germar (Coleoptera: Curculionidae), III. Phylogenetic analysis of the species known from Japan. *Esakia* **34**: 75-129.
- Aslam N. A. 1961. An assessment of some internal characters in the higher classification of the Curculionidae s.l. (Coleoptera). *Transactions of the Royal Entomological Society of London* **113**: 417-480.
- Calder A. A. 1990. Gross morphology of the soft parts of the male and female reproductive systems of Curculionoidea (Coleoptera). *Journal of Natural History* **24**: 453-505.
- Franz N. M. 2003. Systematics of *Cyclanthura* gen. n., a new genus of Derelomini (Coleoptera: Curculionidae). *Insect Systematics and Evolution* **34**: 153-198.
- Franz N. M. 2004. Analysing the history of the derelomine flower weevil–*Carludovica* association (Coleoptera: Curculionidae; Cyclanthaceae). *Biological Journal of the Linnean Society* **34**: 153-198.
- Franz N. M., O'Brien C. W. 2001a. Revision and phylogeny of *Perelleschus* (Coleoptera: Curculionidae) with notes on its association with *Carludovica* (Cyclanthaceae). *Transactions of the American Entomological Society* **127**: 255-287.
- Franz N. M., O'Brien C. W. 2001b. *Ganglionus* a new genus of Derelomini (Coleoptera: Curculionidae) associated with *Carludovica* (Cyclanthaceae). *Annals of the Entomological Society of America* **94**: 835-850.
- Gaiger F. 2001. Systematic Revision and cladistic analysis of the Genus *Rhigus* Schoenherr, 1823 (Coleoptera, Curculionidae). *Revista Brasileira de Entomologia* **45**: 43-85.
- Gaiger F. 2003. *Revisão sistemática e análise cladística do Gênero Arniticus Pascoe, 1881*. PhD thesis, University of São Paulo, Brazil, 338 p.
- Howden A. T. 1993. Revision of the Mesoamerican species of *Airosimus* Howden (Coleoptera: Curculionidae). *The Coleopterists Bulletin* **47**: 249-267.
- Howden A. T. 1995. Structures related to oviposition in Curculionoidea. *Memoirs of the Entomological Society of Washington* **14**: 53-100.
- Howden A. T. 1996. Neotropical *Pandeleiteius* (Coleoptera: Curculionidae) with irregular elytral striae. *The Canadian Entomologist* **128**: 877-955.
- Kojima H. 1997. New Oriental weevils of the Tribes Rhamphini and Ochyromerini (Coleoptera, Curculionidae). *Esakia* **37**: 121-134.
- Kojima H., Morimoto K. 1996. Systematics of the flea weevils of the tribe Rhamphini (Coleoptera, Curculionidae) from East Asia II. Phylogenetic analysis and higher classification. *Esakia* **36**: 97-134.
- Kojima H., Morimoto K. 1998. Two new species of the genus *Ochyromera* (Coleoptera, Curculionidae) from Japan. *Esakia* **38**: 113-122.
- Kuschel G. 1995. A phylogenetic classification of Curculionoidea to families and subfamilies. *Memoirs of the Entomological Society of Washington* **14**: 5-33.
- Kuschel G., Leschen R. A. B., Zimmerman E. C. 2000. Platypodidae under scrutiny. *Invertebrate Taxonomy* **14**: 771-805.
- Lanteri A. A., Diaz N. B. 1994. Systematic study and cladistic analysis of the genus *Aramigus* Horn (Coleoptera: Curculionidae). *Transactions of the American Entomological Society* **120**: 113-144.
- Lanteri A. A., Morrone J. J. 1991. Cladistic analysis of *Priocyphus* Hustache and related genera (Coleoptera: Curculionidae). *Proceedings of the Entomological Society of Washington* **93**: 278-287.
- Lyal C. H. C. 1993. *Cryptorhynchinae* (Insecta: Coleoptera: Curculionidae). Fauna of New Zealand. Number 29. Manaaki Whenua Press, New Zealand, 307 p.

- Marvaldi A. E. 1997.** Higher level phylogeny of Curculionidae (Coleoptera: Curculionoidea) based mainly on larval characters, with special reference to broad-nosed weevils. *Cladistics* **13**: 285-312.
- Marvaldi A. E. 2005.** Larval morphology and biology of oxycorynine weevils and the higher phylogeny of Belidae (Coleoptera, Curculionoidea). *Zoologica Scripta* **34**: 37-48.
- Marvaldi A. E., Morrone J. J. 2000.** Phylogenetic systematics of weevils (Coleoptera: Curculionoidea): a reappraisal based on larval and adult morphology. *Insect Systematics and Evolution* **31**: 43-58.
- Marvaldi A. E., Sequeira A. S., O'Brien C. W., Farrell B. D. 2002.** Molecular and morphological phylogenetics of weevils (Coleoptera, Curculionoidea): Do niche shifts accompany diversification. *Systematic Biology* **51**: 761-785.
- Morimoto K. 1962.** Comparative morphology and phylogeny of the Superfamily Curculionoidea of Japan (Comparative morphology, phylogeny and systematics of the Superfamily Curculionoidea of Japan. I). *Journal of the Faculty of Agriculture Kyushu University* **11**: 331-373.
- Morimoto K., Kojima H. 1994.** On the systematic position of the genus *Euphyllobiomorphus* an adelognathous weevil with cylindrical rostrum (Coleoptera: Curculionidae). *Esakia* **34**: 131-146.
- Morimoto K., Miyakawa S. 1996.** Systematics of the flea weevils of the tribe Ramphini (Coleoptera, Curculionidae) from East Asia I. Descriptions of new taxa and distribution data of some species. *Esakia* **36**: 61-96.
- Morrone J. J. 1993.** Cladistic and biogeography analyses of the weevil genus *Listroderes* Schoenherr (Coleoptera: Curculionidae). *Cladistics* **9**: 397-411.
- Morrone J. J. 1996.** The South American weevil genus *Rhyephenes* (Coleoptera: Curculionidae: Cryptorhynchinae). *Journal of the New York Entomological Society* **104**: 1-20.
- Normark B. B., Lanteri A. A. 1998.** Incongruence between morphological and mitochondrial-DNA characters suggests hybrid origin of parthenogenetic weevil lineages (Genus *Aramigus*). *Systematic Biology* **47**: 475-494.
- O'Brien C. W., Askevold I. S. 1992.** Systematics and evolution of weevils of the genus *Bagous* Germar (Coleoptera: Curculionidae): I. Species of Australia. *Transactions of the American Entomological Society* **118**: 331-452.
- O'Brien C. W., Askevold I. S., Morimoto K. 1994.** Systematics and evolution of weevils of the genus *Bagous* Germar (Coleoptera: Curculionidae): II. Taxonomic treatment of the species of Japan. *Esakia* **34**: 1-73.
- O'Brien C. W., Askevold I. S., Morimoto K. 1995.** Systematics and evolution of weevils of the genus *Bagous* Germar (Coleoptera: Curculionidae): IV. Three new species from Japan. *Esakia* **35**: 1-15.
- Sousa W. O., Santos G. B., Rosado-Neto G. H. 2004.** Morphological aspects of *Pseudopiazurus obesus* (Boheman) and considerations about the synonymy with *Pseudopiazurus papayanus* (Marshall) (Coleoptera: Curculionidae). *Acta Biologica Paranaense* **33**: 167-179.
- Thompson R. T. 1988.** Revision of the weevil genus *Leptostethus* Waterhouse, 1853 (Coleoptera: Curculionidae: Entiminae). *Cimbebasia* **7**: 1-80.
- Thompson R. T. 1992.** Observations on the morphology and classification of weevils (Coleoptera, Curculionoidea) with a key to major groups. *Journal of natural History* **26**: 835-891.
- Vanin S. A. 1986.** Systematics, cladistic analysis, and geographical distribution of the tribe Erodiscini (Coleoptera, Curculionidae, Otidoccephalinae). *Revista Brasileira de Entomologia* **30**: 427-674.
- Vanin S. A., Gaiger F. 2005.** A cladistic analysis of the genera of the tribe Entimini (Coleoptera, Curculionidae), with description of a new genus and species from the Amazonian Region. *Zootaxa* **1053**, 1-21.