



PHONES

(044) 360-7-130
(050) 336-0-130
(063) 788-0-130
(067) 233-0-130
(068) 282-0-130

130
COM.UA

Internet store of
autogoods



ICQ
294-0-130
597-0-130

SKYPE
km-130

CAR RECEIVERS — Receivers • Media receivers and stations • Native receivers • CD/DVD changers • FM-modulators/USB adapters • Flash memory • Facia plates and adapters • Antennas • Accessories |
CAR AUDIO — Car audio speakers • Amplifiers • Subwoofers • Processors • Crossovers • Headphones • Accessories | TRIP COMPUTERS — Universal computers • Model computers • Accessories |
GPS NAVIGATORS — Portable GPS • Built-in GPS • GPS modules • GPS trackers • Antennas for GPS navigators • Accessories | VIDEO — DVR • TV sets and monitors • Car TV tuners • Cameras • Videomodules
• Transcoders • Car TV antennas • Accessories | SECURITY SYSTEMS — Car alarms • Bike alarms • Mechanical blockers • Immobilizers • Sensors • Accessories | OPTIC AND LIGHT — Xenon • Bixenon • Lamps
• LED • Stroboscopes • Optic and Headlights • Washers • Light, rain sensors • Accessories | PARKTRONICS AND MIRRORS — Rear parktronic • Front parktronic • Combined parktronic • Rear-view mirrors
• Accessories | HEATING AND COOLING — Seat heaters • Mirrors heaters • Screen-wipers heaters • Engine heaters • Auto-refrigerators • Air conditioning units • Accessories | TUNING — Vibro-isolation
• Noise-isolation • Tint films • Accessories | ACCESSORIES — Radar-detectors • Handsfree, Bluetooth • Windowlifters • Compressors • Beeps, loudspeakers • Measuring instruments • Cleaners • Carsits
• Miscellaneous | MOUNTING — Installation kits • Upholstery • Grilles • Tubes • Cable and wire • Tools • Miscellaneous | POWER — Batteries • Converters • Start-charging equipment • Capacitors
• Accessories | MARINE AUDIO AND ELECTRONICS — Marine receivers • Marine audio speakers • Marine subwoofers • Marine amplifiers • Accessories | CAR CARE PRODUCTS — Additives • Washer fluid •
Care accessories • Car polish • Flavors • Adhesives and sealants | LIQUID AND OIL — Motor oil • Transmission oil • Brake fluid • Antifreeze • Technical lubricant



In store "130" you can find and buy almost all necessary goods for your auto in Kyiv and other cities, delivery by ground and postal services. Our experienced consultants will provide you with exhaustive information and help you to chose the very particular thing. We are waiting for you at the address

<http://130.com.ua>



litebox

**Power Amplifier
Instruction Manual**

To ensure maximum performance and safety,
please follow this manual. Please retain the
manual for future reference after installation

Models:

**LITEBOX BASS 1 -V1
LITEBOX STEREO 2 -V1
LITEBOX STEREO 4 -V1**

www.vibeaudio.co.uk

OWNERS MANUAL

Congratulations on purchasing your VIBE amplifier, please read this manual in order to fully understand how to get the best results from your amplifier and ensure that all advice on how to look after the amplifier is followed.

Thank you for buying VIBE, we hope you enjoy listening to your product as much as we enjoyed creating it.

VIBE R&D Division



This equipment is designed for Supercars, modified and tuned vehicles and is ideal for marine applications. A specially treated circuit board and lightweight aluminium construction prevent rust and corrosion. Minimal weight, maximum performance

Attention

An aftermarket audio amplifier will place an additional load on the vehicles charging system, most modern vehicles have sufficient capacity in the charging system as not all the electrical components of the vehicle will be switched on at once. Check the fuse rating of the amplifier and use this as the peak current requirement, generally the continuous current draw will be a third of the peak current, in other words an amplifier fused at 30 amps will have a continuous current draw of 10 amps when playing music, however it may peak at 30 amps on occasions. Please check with the manufacturer as to whether your vehicle can cope with the additional load of your amplifier, in some instances it may be necessary to upgrade the alternator and battery or risk damage to the vehicles electrical system.

Mounting Guidelines

Your VIBE amplifier is designed with a swift installation routine in mind. Please mount the amplifier in a dry location on a solid surface. NEVER mount the amplifier upside down, this will cause the amplifier to over heat and will eventually damage the amplifier. Before fixing the amplifier in place please ensure that there is sufficient air flow around the exterior of the casing, at least two inches is sufficient.

Connections

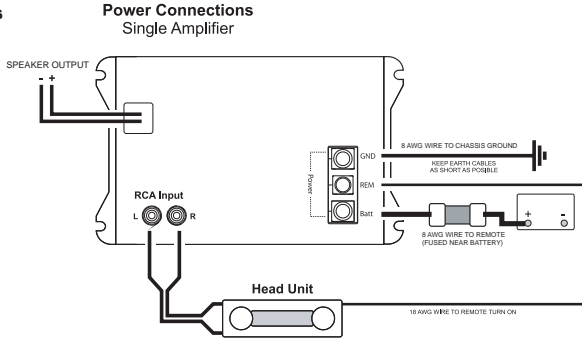

IMPORTANT NOTE:
Only strap identical models of amplifier.

Power Cable

- At least 8 gauge cable 8 gauge cable should be used for the power connection to the amplifier.
- The power cable should be taken directly from the battery. Rubber grommets should be used when passing through any bulkheads to prevent the cable from becoming chaffed or cut.
- It is vital that a fuse / circuit breaker (of at least equal value to the one fitted on the amplifier) is placed inline with the power cable and is no further than eighteen inches away from the battery.
- Please ensure that the fuse is not fitted until the entire installation procedure is complete.
- The two tables below are to help you decide on what cable is correct for you. The first enables you to select the size of cable depending on the length required. The second will help you convert the cable size from American Wire Gauge to Metric and Imperial if you need to.

Current demand	Length of Run							
	0 – 4 Ft	4 – 7 Ft	7 – 10 Ft	10 – 13 Ft	13 – 16 Ft	16 – 19 Ft	19 – 22 Ft	22 – 28 Ft
0–20 amps	14	12	12	10	10	8	8	8
20–35 amps	12	10	8	8	6	6	6	4
35–50 amps	10	8	8	6	4	4	4	4
50–65 amps	8	8	6	4	4	4	4	2
65–85 amps	6	6	4	4	2	2	2	0
85–105 amps	6	6	4	2	2	2	2	0
105–125 amps	4	4	4	2	0	0	0	0
125–150 amps	2	2	2	0	0	0	0	0

AWG Number	Inch	mm	mm ²
0	0.325	8.25	53.5
1	0.289	7.35	42.4
2	0.258	6.54	33.6
3	0.229	5.83	26.7
4	0.204	5.19	21.1
5	0.182	4.62	16.8
6	0.162	4.11	13.3
7	0.144	3.66	10.5
8	0.128	3.26	8.36
9	0.114	2.91	6.63
10	0.102	2.59	5.26

Ground Cable

- At least 8 gauge should be used for the ground connection to the amplifier.
- The amplifier ground should be connected directly to the chassis of the vehicle, to bare metal.
- The cable length should be kept to an absolute minimum.
- It is not recommended that you connect the ground cable to the vehicles seatbelts anchor point.

Remote Turn On

- A minimum of 18 gauge cable should be used for this connection.
- The cable should be run with exactly the same care and attention as the power cable and taken back to the source (headunit) and joined to the remote cable provided.
- If the source (headunit) does not have a remote turn on cable then a 12v supply should be used. This will require a switch to be fitted inline to enable the amplifier to be turned on and off. Remember that if this switch is left on you will flatten the car battery.

RCA Cables

- Depending on the model number of your amplifier and the number of speakers you wish to power you will have to run either one or two RCA cables from the source to the amplifier.
- Please take extra care when running these cables from the source to the amplifier. Ensure that they are placed away from all items that can generate any interference, wiring harnesses etc.
- It is recommended that the RCA cables should be run on opposite sides of the car to the previously installed power cables if possible, to avoid the cable picking up interference.

Auto Sense

- The LiteBox amplifiers feature a Patent pending auto sense circuit.
- This circuit allows the Litebox amplifier to switch on without a remote turn on wire when connected to the speaker outputs of a factory headunit .
- The LiteBox auto sense circuit senses the power IC used in most headunits as opposed to sensing signal, providing much more consistent operation and also eliminating annoying turn on thumps and flat batteries associated with inferior signal sensing circuitry.
- When the auto sense circuit is used the remote terminal of the amplifier becomes a switched +12 volt output that can be used to turn on other components in the audio system such as equalizers, crossovers and other amplifiers without the auto sense function

Auto Sense Procedure

- Connect the supplied RCA to speaker level to the speaker output of the headunit
- Set the INPUT LEVEL switch to HI
- Set the AUTO SENSE switch to ON

Auto sense : controls and connections

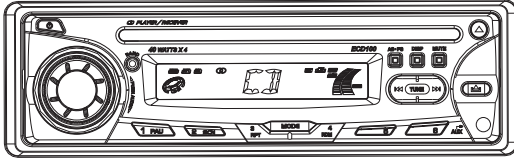

Connect the supplied RCA to speaker level to the speaker output of the headunit

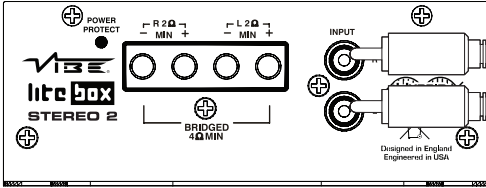

Red wire = Positive
Blue wire = Negative

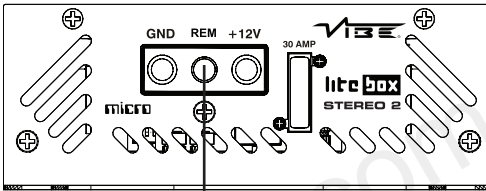

+12 VOLT switched output

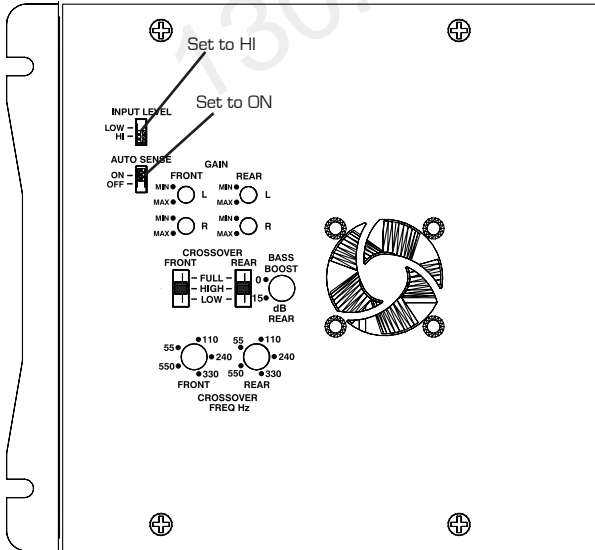

Terminals and controls : LiteBox Bass 1

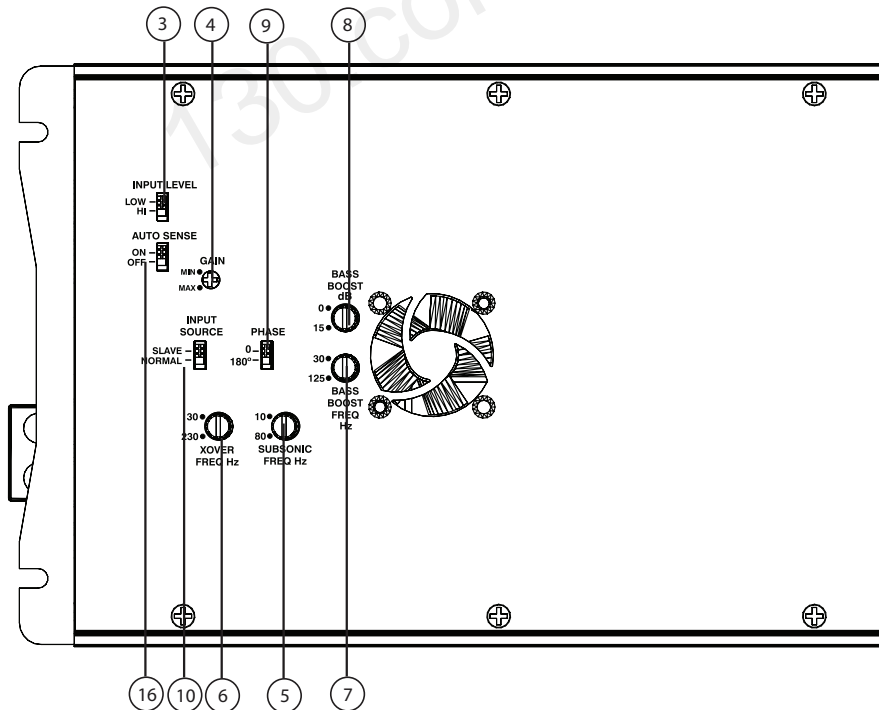
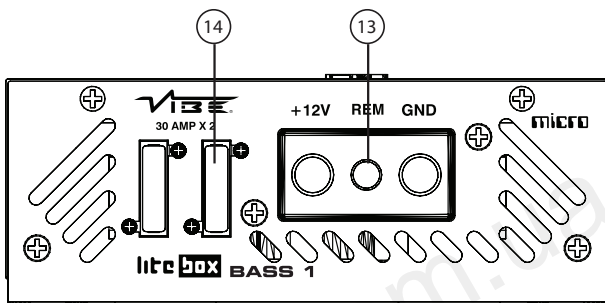
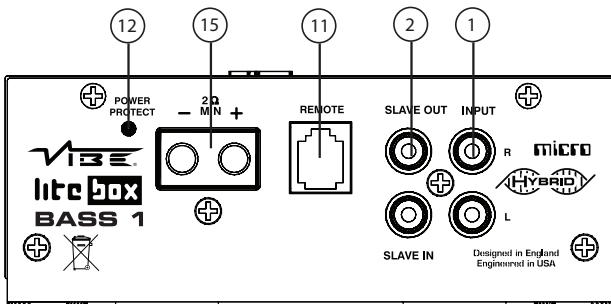

1. Audio input

For connection to the source [headunit] For low level input (this is your RCA output from the source) connect using RCA leads to the low level output of the source.

For high level input connect the supplied speaker wire to RCA adaptors to the speaker output of the source (see page 5 for diagram)

Left high level input (white RCA plug)

positive - red wire
Negative - blue wire

Right high level input (red RCA plug)

Positive - red wire
Negative - blue wire

2. Slave input / output

RCA input and output connections used for amplifier strapping

3. High level / low level input select switch

This switch is used to select either high level (speaker wire) input or low level (RCA) input

4. Gain control

Used to match the input signal of the source to the amplifier. See the setup section for more details.

5. Subsonic filter control

This control allows the subsonic filter frequency to be set, the filter is adjustable from 10Hz to 80 Hz

6. Crossover frequency control

This control is used to set the crossover point for the amplifier.
The frequency ranges on the low pass filter are from 30 Hz to 230 Hz,

7. Bass boost frequency control

This control sets the frequency that will be boosted by the bass boost control, the frequency ranges from 30Hz to 125Hz

8. Bass boost control

This control provides up to an extra +15 dB of bass boost at the chosen frequency. Use this boost to increase bass output from the amplifier.

9. Phase switch

This allows the phase of the amplifier to be set to 0 or 180 degrees, one setting will make the bass from the subwoofer sound more in time with the front speakers.

10. Source switch

This switch is set according to amplifier application, in normal operation it should be set to NORMAL and if the amplifier is acting as a slave in a strapped configuration it should be set to SLAVE IN.

11. Gain remote input jack

Use to plug in the remote supplied bass level controller

12. Indicator LED

When the amplifier is operating correctly the LED will illuminate constant green

When the amplifier is in protection mode the LED will flash to indicate protection condition - see table for fault code diagnosis.

Thermal	●	●	●	●	●	●	●	●	●
Power On Reset	●	●	●	○	○	●	○	●	○
Overvolt	●	●	○	○	●	○	●	○	●
Short	●	●	○	○	●	○	●	○	○
Repeated Shorts	●	●	○	○	●	○	●	○	●
Turn on Delay	●	○	●	○	●	○	●	○	●

13. Power connections

See Connections section for details on correct connections.

14. Fuses

Please ensure the following fuse rating is used when replacing fuses: 30 amp x 2

15. Speaker terminal output

For connection to the speakers. See Application section for wiring examples.

15. Auto Sense select switch

This switch is used to turn the auto sense circuit on or off (see page 5 for more details)

Set Up Section

To correctly set the gain control of the amplifier to match that of the source (headunit) use the following setup routine:

Turn the gain control to minimum on the amplifier.

Ensure the bass boost is set to 0 dB.

On the headunit set all crossovers (if applicable) to flat and both bass and treble to zero.

Turn up the source (headunit) to approx 3/4 volume.

Very slowly turn up the gain on the amplifier until distortion can be heard in any of the speakers or until the volume reaches an uncomfortable listening level when this is reached turn down the gain control slightly.

The gain control is now set.

The setting of the crossover will depend on what kind of speaker you are installing.

For a subwoofer it is recommended that the crossover is set to Low Pass and the frequency is set to match that of the speakers specifications, or your preferred frequency - this is usually about 60 - 120

Note:

By using the crossovers correctly you will not only lengthen the life of your speakers but you will also get better performance from them. To optimise your setup seek the advice of a professional installation engineer or visit your local VIBE audio dealer.

Amp strapping

The VIBE LiteBox Bass 1 amplifier is capable of being strapped together to deliver the combined output of both amplifiers into a single channel.

NOTE: only identical amplifiers may be strapped together.

Strapping procedure

- Connect the RCA input from the source unit to the left and right RCA input of the master amplifier.
- Connect a mono RCA lead between the SLAVE OUT output of the master amplifier and the SLAVE IN input
- Set the source switch of the master amplifier to normal
- Set the source switch of the slave amplifier to slave in
- Set the phase switch of the master amplifier to 0 degrees
- Set the phase switch of the slave amplifier to 180 degrees
- Connect speaker cable between the negative speaker output of the master amp and the negative speaker output of the slave amplifier. The cable must be of the same gauge you will be using to connect the amplifiers to the subwoofer
- The master positive speaker output is to be connected to the subwoofer positive terminal
- The slave positive speaker output is to be connected to the subwoofer negative terminal

LiteBox Bass 1 applications

Diagram for one VIBE LiteAir Subwoofer connected to two strapped amplifiers

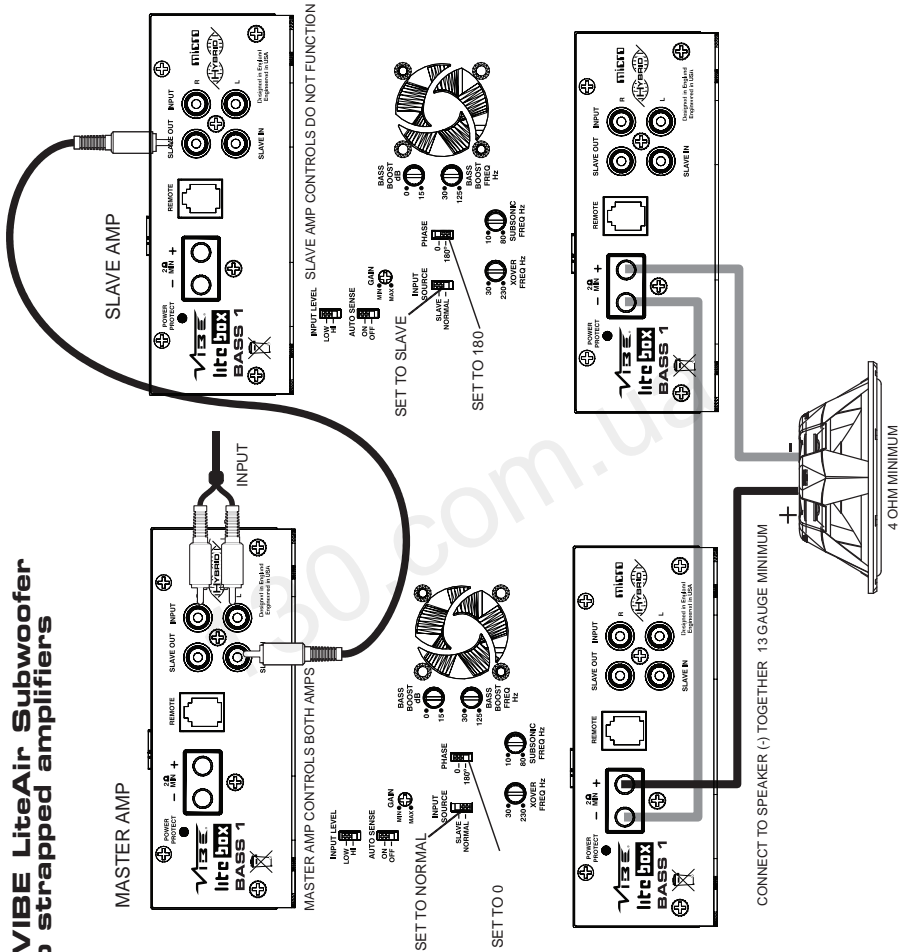

Diagram for four VIBE LiteAir Subwoofers connected to one master and three slave amplifiers

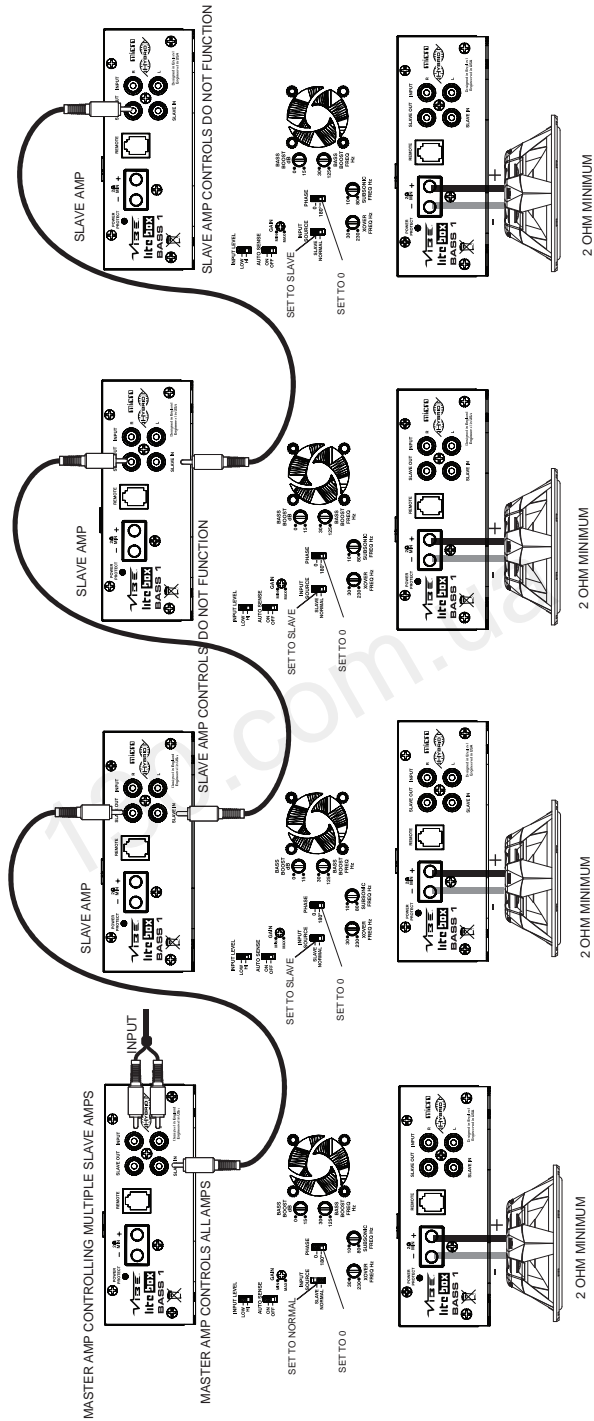
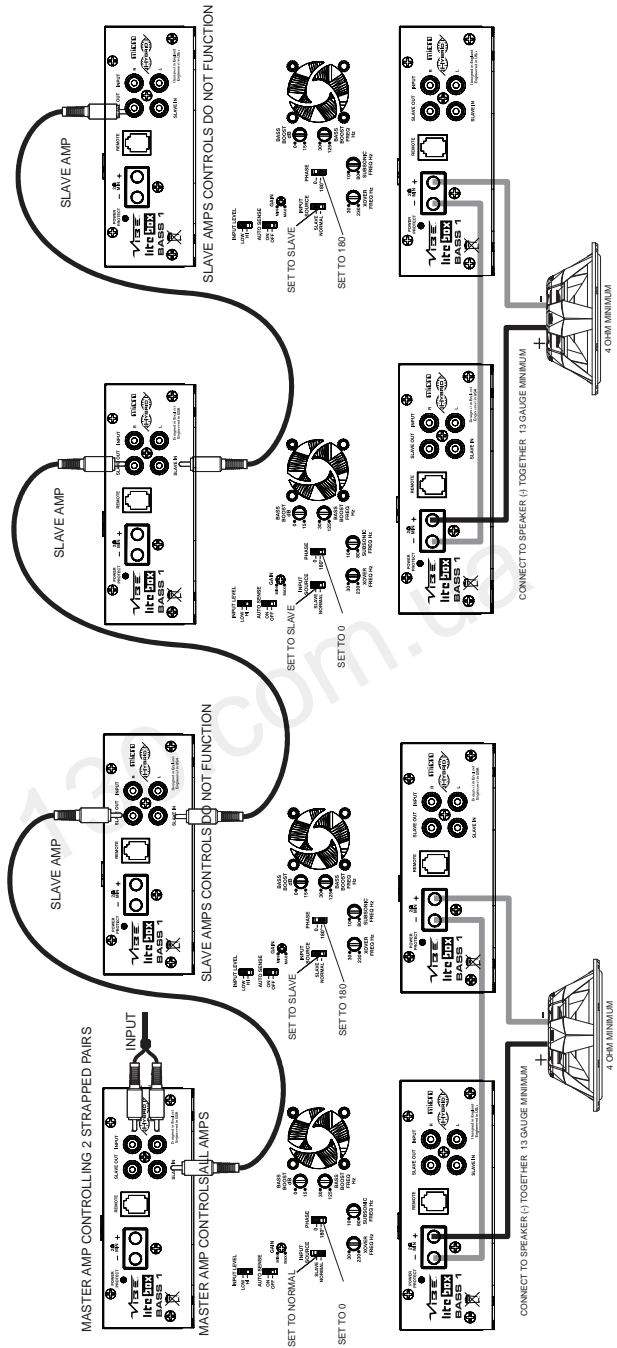
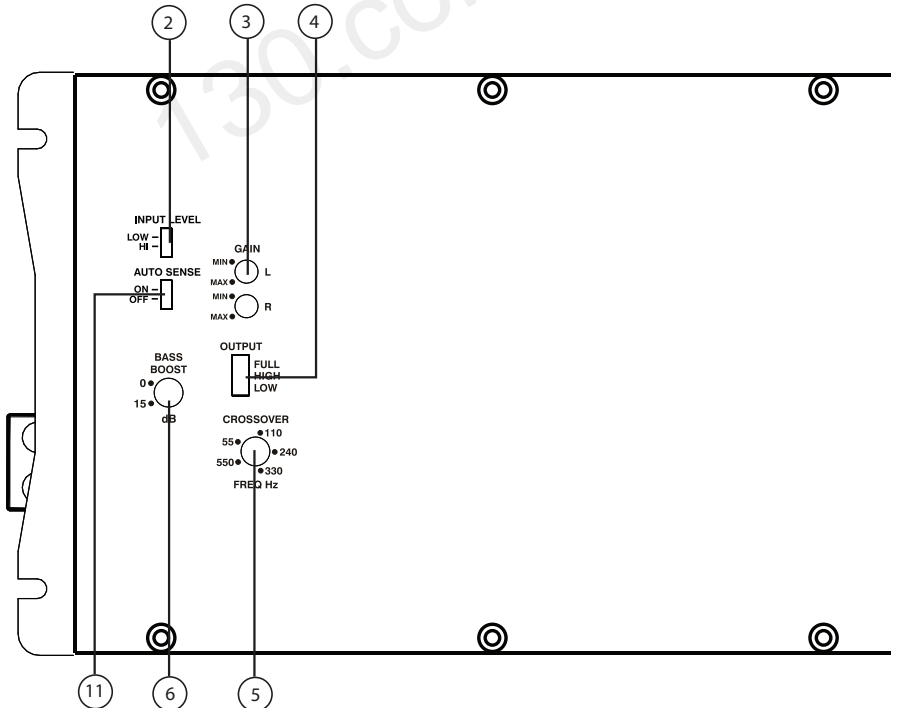
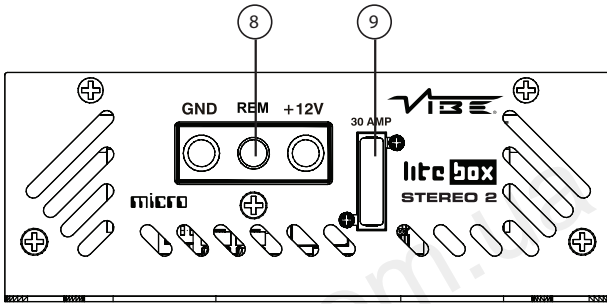
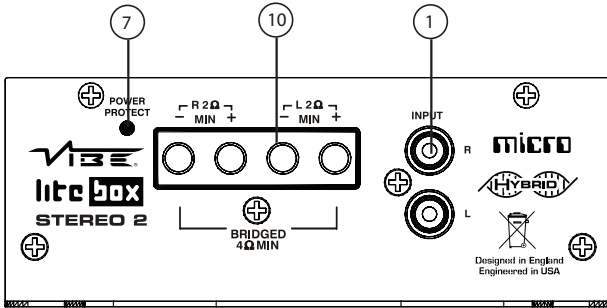

Diagram for two VIBE LiteAir Subwoofers connected to one master and three slave amplifiers configured as two strapped pairs



Terminals and controls : LiteBox Stereo 2



1. Audio input

For connection to the source [headunit] For low level input (this is your RCA output from the source) connect using RCA leads to the low level output of the source.

For high level input connect the supplied speaker wire to RCA adaptors to the speaker output of the source (see page 5 for diagram)

Left high level input (white RCA plug)

positive - red wire
Negative - blue wire

Right high level input (red RCA plug)

Positive - red wire
Negative - blue wire

2. High level / low level input select switch

This switch is used to select either high level (speaker wire) input or low level (RCA) input

3. Gain control

Used to match the input signal of the source to the amplifier. See the setup section for more details.

4. Crossover mode switch

The switch is used to select between low pass filter LP, high pass filter HP or no filter at all OFF.

5. Crossover frequency control

This control is used to set the crossover point for the amplifier. The frequency ranges on the low pass filter are from 55 Hz to 550 Hz, The frequency ranges on the high pass filter are from 55 Hz to 550Hz.

6. Bass boost control

This control provides up to an extra +15 dB of bass boost at 45 Hz. Use this boost to increase bass output from the amplifier.

7. Indicator LED

When the amplifier is operating correctly the LED will show as blue.

When the amplifier is in protection mode the LED will flash to indicate protection mode.

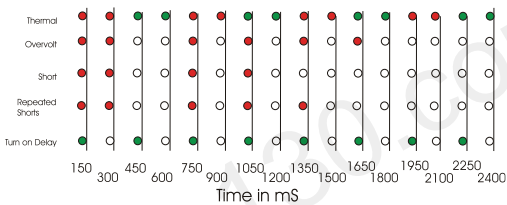

8. Power connections

See Connections section for details on correct installation.

9. Fuses

Please ensure the following fuse rating is used when replacing fuses: 30 amp x 1

10. Speaker terminal output

For connection to the speakers. See Application section for wiring examples.

11. Auto Sense select switch

This switch is used to turn the auto sense circuit on or off (see page 5 for more details)

LiteBox Stereo 2 applications

Diagram for a LiteBox stereo 2 connected to a single LiteAir 12 wired for 4 ohms

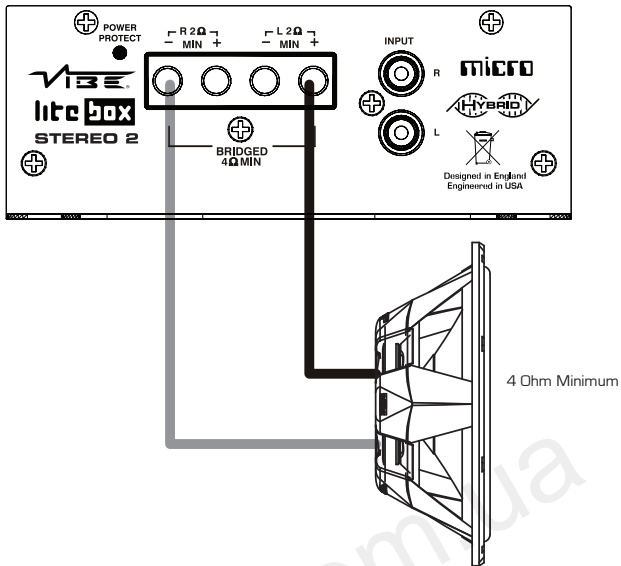
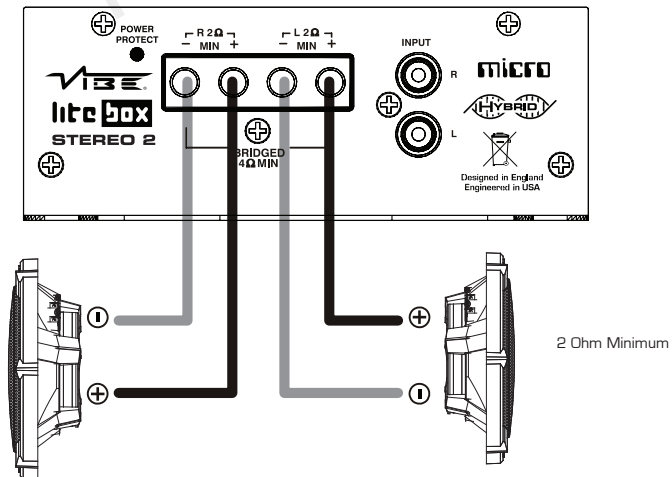

Diagram for a LiteBox Stereo 2 running a pair of LiteAir 5 component speakers



Set Up Section

To correctly set the gain control of the amplifier to match that of the source (headunit) use the following setup routine:

Turn the gain control to minimum on the amplifier.

Ensure the bass boost is set to 0 dB.

On the headunit set all crossovers (if applicable) to flat and both bass and treble to zero.

Turn up the source (headunit) to approx 3/4 volume.

Very slowly turn up the gain on the amplifier until distortion can be heard in any of the speakers or until the volume reaches an uncomfortable listening level when this is reached turn down the gain control slightly.

The gain control is now set.

The setting of the crossover will depend on what kind of speaker you are installing.

For a subwoofer it is recommended that the crossover is set to Low pass and the frequency is set to match that of the speakers specifications, or your preferred frequency - this is usually about 60 - 120 Hz

For a pair of full range speakers it is recommended that the crossover is set to Flat. The two frequency controls will then have no effect on the amplifiers output and the speaker will receive a full range signal. However, using the high pass crossovers will allow more control of your speakers. By removing the bass (low frequencies) the speakers can perform at higher volumes with less distortion.

Note: The smaller the speaker, the less bass it can handle. Adjust the crossover to get the most and best sound from your speakers. The easiest way to do this is by limiting the amount of bass you feed them.

For a pair of speakers with a passive crossover it is recommended that the crossover is set to High Pass and the frequency is set to match that of the speakers specifications. - This is usually about 40 - 120Hz

Note:

By using the crossovers correctly you will not only lengthen the life of your speakers but you will also get better performance from them. To optimise your setup seek the advice of a professional installation engineer or visit your local VIBE audio dealer.

Terminals and controls : LiteBox Stereo 4

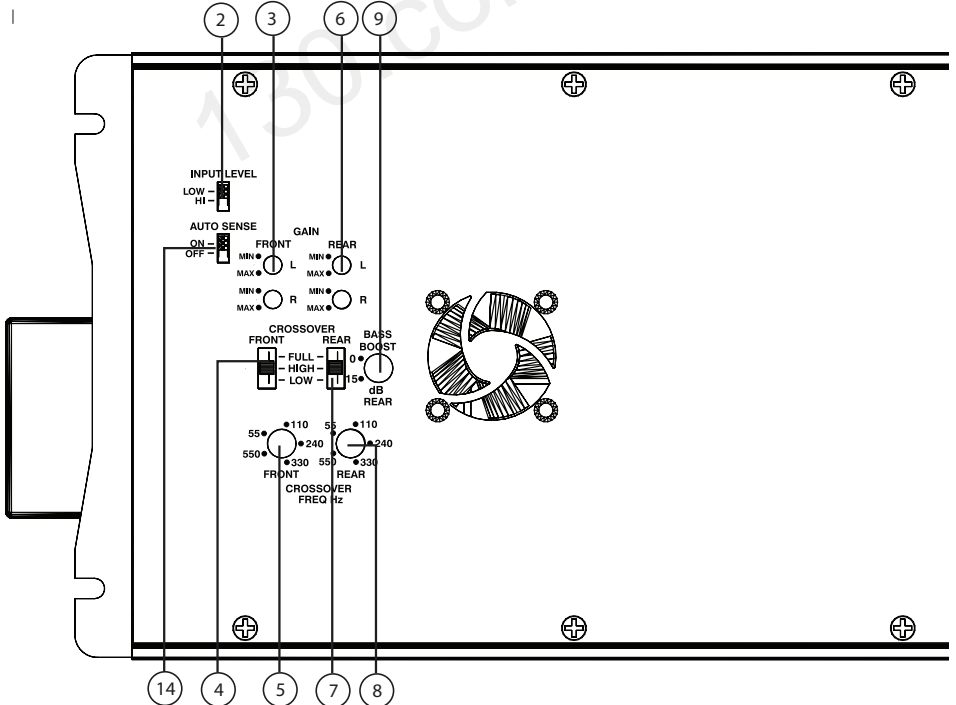
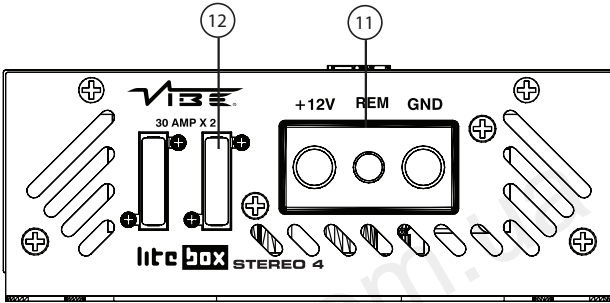
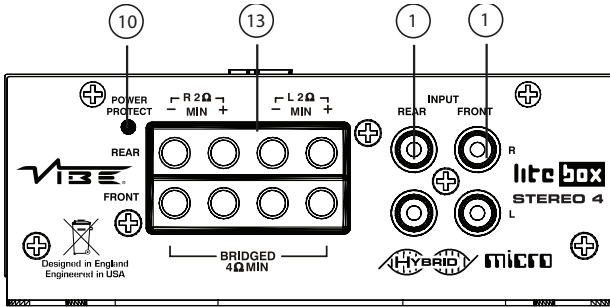

1. Audio input

For connection to the source (headunit) For low level input (this is your RCA output from the source) connect using RCA leads to the low level output of the source.
For high level input connect the supplied speaker wire to RCA adaptors to the speaker output of the source (see page 5 for diagram)

Left high level input (white RCA plug)

positive - red wire
Negative - blue wire

Right high level input (red RCA plug)

Positive - red wire
Negative - blue wire

2. High level / low level input select switch

This switch is used to select either high level (speaker wire) input or low level (RCA) input

3. Front gain control

Used to match the input signal of the source to the amplifier. See the setup section for more details.

4. Front crossover mode switch

The switch is used to select between low pass filter LP, high pass filter HP or no filter at all OFF.

5. Front crossover frequency control

This control is used to set the crossover point for the amplifier. The frequency ranges on the low pass filter are from 55 Hz to 550 Hz, The frequency ranges on the high pass filter are from 55 Hz to 5.5 KHz.

6. Rear gain control

Used to match the input signal of the source (headunit), to the amplifier. See the setup section for more details.

7. Rear crossover mode switch

The switch is used to select between low pass filter LP, high pass filter HP or no filter at all OFF.

8. Rear crossover frequency control

This control is used to set the crossover point for the amplifier.
The frequency ranges on the low pass filter are from 55 Hz to 550 Hz, The frequency ranges on the high pass filter are from 55 Hz to 5.5 KHz.

9. Bass boost control

This control provides up to an extra +15 dB of bass boost at 45 Hz. Use this boost to increase bass output from the amplifier.

10. Indicator LED

When the amplifier is operating correctly the LED will show as blue.
When the amplifier is in protection mode the LED will flash to indicate protection mode.

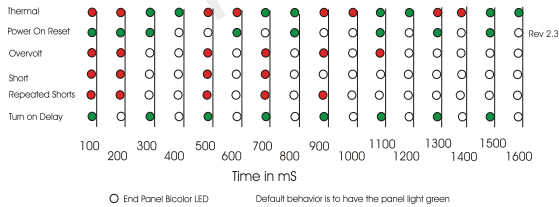

11. Power connections

See Connections section for details on correct installation.

12. Fuses

Please ensure the following fuse rating is used when replacing fuses: 30 amp x 2

13. Speaker terminal output

For connection to the speakers. See Application section for wiring examples.

11. Auto Sense select switch

This switch is used to turn the auto sense circuit on or off (see page 5 for more details)

LiteBox Stereo 4 applications

Diagram for a LiteBox Stereo 4 running three channel connected to a pair of LiteAir 5 component speakers and a single LiteAir 12 wired for 4 ohms

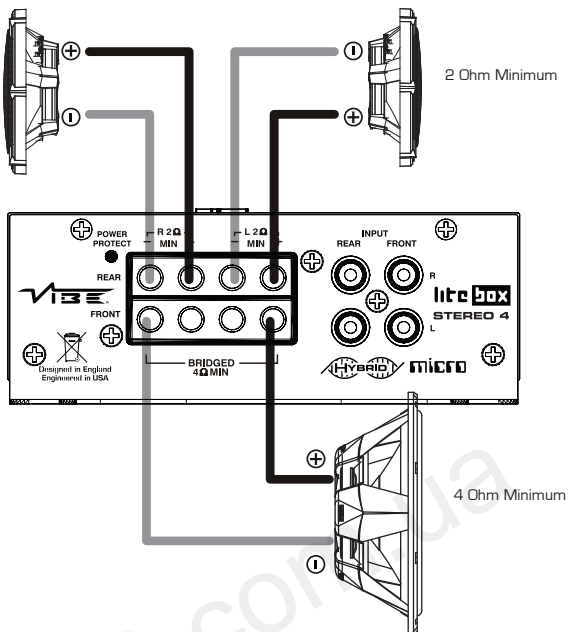
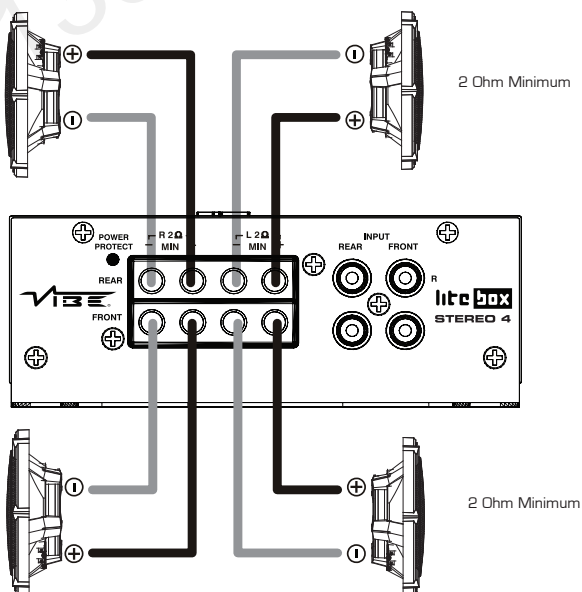

Diagram for a SpaceBox Stereo 4 running for channel connected to two pairs of Space 5 component speakers



Set Up Section

To correctly set the gain control of the amplifier to match that of the source [headunit] use the following setup routine:

Turn the gain control to minimum on the amplifier.

Ensure the bass boost is set to 0 dB.

On the headunit set all crossovers (if applicable) to flat and both bass and treble to zero.

Turn up the source [headunit] to approx 3/4 volume.

Very slowly turn up the gain on the amplifier until distortion can be heard in any of the speakers or until the volume reaches an uncomfortable listening level when this is reached turn down the gain control slightly.

The gain control is now set.

The setting of the crossover will depend on what kind of speaker you are installing.

For a subwoofer it is recommended that the crossover is set to Low pass and the frequency is set to match that of the speakers specifications, or your preferred frequency - this is usually about 60 - 120 Hz

For a pair of full range speakers it is recommended that the crossover is set to Flat. The two frequency controls will then have no effect on the amplifiers output and the speaker will receive a full range signal. However, using the high pass crossovers will allow more control of your speakers. By removing the bass (low frequencies) the speakers can perform at higher volumes with less distortion.

Note: The smaller the speaker, the less bass it can handle. Adjust the crossover to get the most and best sound from your speakers. The easiest way to do this is by limiting the amount of bass you feed them.

For a pair of speakers with a passive crossover it is recommended that the crossover is set to High Pass and the frequency is set to match that of the speakers specifications. - This is usually about 40 - 120Hz

Note:

By using the crossovers correctly you will not only lengthen the life of your speakers but you will also get better performance from them. To optimise your setup seek the advice of a professional installation engineer or visit your local VIBE audio dealer.

Specification	Bass 1	Stereo 2	Stereo 4
RMS Power @ 13.8v DC			
Power @ 4 Ohms stereo	n/a	2 x 90 watts RMS	4 x 90 watts RMS
Power @ 2 Ohms stereo	n/a	2 x 125 watts RMS	4 x 125 watts RMS
Power @ 4 Ohms mono	300 watts RMS	1 x 250 watts RMS	2 x 250 watts RMS
Power @ 2 Ohms mono	500 watts RMS	n/a	n/a
Max power	1000 watts	500 watts	1000 watts
Strapped power @ 8 Ohms mono	600 watts RMS	n/a	n/a
Strapped power @ 4 Ohms mono	1000 watts RMS	n/a	n/a
Minimum speaker impedance	2 Ohms	2 Ohms stereo	2 Ohms stereo
		4 Ohms mono	4 Ohms mono
THD Distortion	0.01%	0.01%	0.01%
IMD Distortion	0.01%	0.01%	0.01%
Frequency Response	20Hz - 230 Hz	1Hz - 69 Khz	1Hz - 69 Khz
Input Sensitivity	0.3V - 7V	0.3V - 7V	0.3V - 7V
Input Impedence	10 K ohms	47.5K ohms	47.5K ohms
Signal to Noise Ratio	82dB	111 dB	109 dB
Channel Separation	N/A	61 dB	74 dB
Remote GAIN control	0.3mV - 7V	N/A	N/A
Crossover Network			
Low pass filter	30 Hz – 230 Hz	55 Hz – 550 Hz	55 Hz – 550 Hz
High pass filter	n/a	55 Hz – 550 Hz	55 Hz – 550 Hz
Bass boost	0 dB - +15 dB	0 dB - +15 dB	0 dB - +15 dB
Subsonic filter	10 Hz – 80 Hz	N/A	N/A
Fuse rating	30A x 2	30A x 1	30A x 2
Size height x width x depth	50 x 295 x 135 (mm)	50 x 210 x 135 (mm)	50 x 295 x 135 (mm)

Troubleshooting

- Before removing the amplifier, refer to the list below and follow the suggested procedures.
- Always test the speakers and confirm that they are wired correctly first.
- If in any doubt please seek advice from your local authorized VIBE dealer.

Amplifier Will Not Power Up

- ✓ Check for good ground connections. Ensure Ground cable is connected directly to bare metal and not a painted surface.
- ✓ Using a multimeter check that remote terminal has at least 7V DC.
- ✓ Using a multimeter check that there is battery voltage of at least 10.5v DC on the positive terminal.
- ✓ Check all fuses.
- ✓ Check that the protection light is not illuminated. If it is lit, shut off the amplifier by turning off for thirty seconds and then turning it back on.

Protection LED Illuminates When Amplifier Is Powered Up

- ✓ Check for shorts on all speakers wires. (IE no speaker wires should be joined together and no speaker wires should be touching the cars chassis)
- The amplifier is designed to shut down automatically when the units temperature goes above 80 degrees. If the amplifier feels very hot then this may be the reason for the amplifier not starting.
- Remove the speaker wires and reset the amplifier. If the Protection LED still comes on then the amplifier is faulty. This damage may have been caused by either failure to follow these setup guidelines or abuse.

Amplifier Gets Very Hot

- ✓ Check the minimum speaker impedance for the amplifier is correct.
- ✓ Check for shorts on all speakers wires. (ie no speaker wires should be joined together and no speaker wires should be touching the cars chassis)
- ✓ Check that there is good airflow around the amplifier. In some applications an external fan may be required.

Blown Fuse(s)

- ✓ Check both positive supply and ground for shorts.
- ✓ Check that the positive wire is connected to the positive terminal on the amplifier.
- ✓ Check that the negative wire is connected to the ground terminal on the amplifier.
- ✓ Ensure that the correct rated fuse is fitted:

LiteBox Bass1 amplifier uses 2 x 30 amp fuse
LiteBox Stereo 2 amplifier uses 1 x 30 amp fuse
LiteBox Stereo 4 amplifier uses 2 x 30 amp fuse

Distorted Sound

- ✓ Check the gain control is not set at too high. If the speakers sound distorted turn down the gain until the sound is clear.
- ✓ Check that all crossover frequencies are correct. See Setup section for more details.
- ✓ Check for shorts on all speaker wires.
- ✓ Check all speakers are wired correctly. With the correct polarity being observed on each connection.



In order to protect your purchase and aid your warranty please fill in the following form and keep it safe for your future reference.
For online registration please visit:
www.vibeaudio.co.uk/warranty

Model Number:

Serial Number:

Purchased From:

Date of Purchase:

KEEP IT SAFE
Staple your
receipt here:

Limited Warranty

All VIBE products carry a full twelve months warranty, valid from the date of the original receipt / proof of purchase. In order to validate this warranty, the warranty card should be returned to VIBE within seven days of the original purchase date. The original receipt and packaging should also be retained for this twelve month period.

If at any stage during the warranty period you have a problem with the product then it should be returned to the point of purchase, with proof of purchase in its original packaging, complete with no items missing.

If the store is unable to fix the product it may have to be returned to VIBE this process takes around 7 working days.
A full description of VIBE's warranty information can be found on our website:

www.vibeaudio.co.uk/warranty

A written version can also be obtained from VIBE warranty Dept PO BOX 11000 B75 7WG

Technical enquires call 09067031420

calls cost 50p per minute call costs correct at date of publication (01/11/09) Hours of business 9.00am - 5.30pm all calls are recorded for training purposes MIDBASS Distribution PO Box 11000 B75 7WG

Copyright

All content included in this manual such as text, graphics, logos, icons, images and data, are the property of VIBE Technologies Limited (herein referred to as "VIBE", "us" or "we") and its affiliate or their content and technology providers, and are protected by United Kingdom and International copyright laws. All rights reserved.2008

All stylised representations of product names, or the abbreviations of product names, as logos are all trademarks of VIBE. Graphics and logos are trademarks or trade dress of VIBE Technologies Ltd or its subsidiaries.

VIBE's trademarks and trade dress may not be used in connection with any product or service that is not VIBE's, in any manner that is likely to cause confusion among customers or in any manner that disparages or discredits VIBE. All other trademarks not owned by VIBE or its subsidiaries that appear in this manual are the property of their respective owners, who may or may not be affiliated with, connected to, or sponsored by VIBE or its subsidiaries.

TO THE FULLEST EXTENT PERMITTED AT LAW, VIBE IS PROVIDING THIS MANUAL AND ITS CONTENT ON AN "AS IS" BASIS AND MAKES NO (AND EXPRESSLY DISCLAIMS ALL) REPRESENTATIONS OR WARRANTIES OF ANY KIND, EXPRESS OR IMPLIED, WITH RESPECT TO THIS MANUAL OR THE INFORMATION, CONTENT, MATERIALS OR PRODUCTS INCLUDED IN THIS MANUAL INCLUDING, WITHOUT LIMITATION, WARRANTIES OF MERCHANTABILITY AND FITNESS FOR A PARTICULAR PURPOSE.

IN ADDITION, VIBE DOES NOT REPRESENT OR WARRANT THAT THE INFORMATION CONTAINED IN THIS MANUAL IS COMPLETE OR CURRENT, AND THAT ALL SPECIFICATIONS AND INFORMATION CONTAINED WITHIN THIS MANUAL ARE SUBJECT TO CHANGE WITHOUT NOTICE.

VIBE RECOMMEND CAUTION WHEN LISTENING TO MUSIC REPRODUCED THROUGH VIBE EQUIPMENT. VIBE EQUIPMENT IS CAPABLE OF PRODUCING SOUND AND SOUND PRESSURE LEVELS THAT CAN PERMANENTLY DAMAGE HEARING OF YOU AND THAT OF OTHERS. FOR SAFE AND ENJOYABLE LISTENING, THE SOUND SHOULD BE CLEAR WITHOUT DISTORTION AT A COMFORTABLE VOLUME.

BY USING ANY VIBE EQUIPMENT, YOU AGREE TO TAKE FULL RESPONSIBILITY FOR YOUR OWN SAFETY AND THE SAFETY OF OTHERS WHEN LISTENING TO MUSIC AT HIGH VOLUMES THROUGH EQUIPMENT YOU HAVE PURCHASED. USE OF ANY VIBE EQUIPMENT CONSTITUTES AGREEMENT TO THIS DISCLAIMER.

Except as specifically stated in this manual, to the fullest extent permitted at law, neither VIBE nor any of its affiliates, directors, employees or other representatives will be liable for damages arising out of or in connection with the use of this manual or the information, content, materials or products included.
This is a comprehensive limitation of liability that applies to all damages of any kind, including (without limitation) compensatory, direct, indirect or consequential damages, loss of data, income or profit, loss of or damage to property and claims of third parties. For the avoidance of doubt, VIBE does not limit its liability for death or personal injury to the extent only that it arises as a result of negligence of VIBE, its affiliates, directors, employees or other representatives.

Anti VIBE®

Sound Deadening Material

LESS RATTLE, MORE BASS

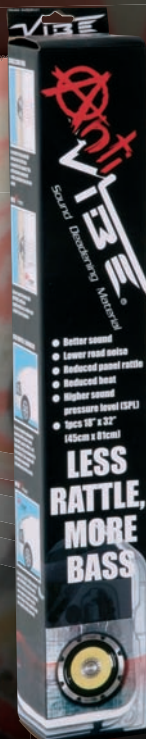

- Better sound
- Lower road noise
- Reduced panel rattle
- Reduced heat
- Higher sound pressure level (SPL)



AVAILABLE AT ALL VIBE DEALERS
OR VISIT
www.vibeaudio.co.uk



Autogood products Internet store "130"

FLATBASS™ 13 SPK Bass speaker cable

There are many powerful bass amplifiers on today's market – the ever increasing power is putting huge strains on speaker wire – VIBE present a new breed of speaker cable specially developed for BASS applications – the VIBE FLATBASS speaker cable offers SolidCore™ that can handle and sustain considerably more power than conventional speaker cable.

Model: FlatBass 13 SPK – 13 gauge SolidCore™ flat BASS speaker cable

VIBE 140 amp circuit breaker

Big systems require big protection – The VIBE circuit breaker is rated at a massive 140 amps and offers critical protection to your system – if the system over powers or short circuits the breaker will cut in and save your equipment. No need to replace expensive fuses, systems resist via a simple switch – also offers safe and instant system shutdown.

Model: CB140 – 140 amp circuit breaker

FLAT Y 2M / FLAT Y 2F RCA Y leads

Our professional quality full range OFC Y-interconnect guarantees a pure and strong signal. With a flat design and ferrite loaded gold plated plugs interference is greatly reduced. The FLAT-Y Interconnect is available in 1 male – 2 female FLAT Y 2F and 2 male – 1 female FLAT Y 2M configurations.

Model: FLAT Y 2F – 1 pair RCA Y lead 1male to 2 female
Model: FLAT Y 2m – 1 pair RCA Y lead 2male to 1female

VIBE BC10 level controller

The VIBE BC10 gain level controller is a perfect addition to any subwoofer system, the BC10 allows the level of the amplifier to be controlled from the driver's seat giving the user easy adjustment of gain level. Particularly useful for adjusting the gain level for amplifiers controlling subwoofers. The BC10 controller is RCA input and output making it compatible with any system allowing gain level adjustment of any amplifier it is connected to. It can also be used with full range amplifiers.

Model: BC10 – RCA Gain level control

Slick level remote

A new addition to the Slick range of amplifiers is the Slick level control which allows level adjustment of the amplifier from the front of the car – Simply plug the supplied cable into the Slick remote level port on the end panel of the amplifier and remote gain control is yours, it is that easy.

Model: SLR1 – optional remote for use with all Slick amplifiers

VIBE PortPlug™

The VIBE PortPlug™ allows easy tuning of the VIBE CBF bass enclosures. The PortPlug™ is used to tightly seal the VIBE Turbo™ in the enclosure to either create a sealed enclosure for better transient response or in the case of a multi ported enclosure re-tune the enclosure using only 1 PortPlug™

Model: PP25 – PortPlug™ for 2.5" TurboPort™
Model: PP30 – PortPlug™ for 3" TurboPort™

VIBE official Merchandise

MFS – VIBE polo shirt with embroidered VIBE logo on front and rear
MTS – VIBE T-shirt with small VIBE printed logo on front
MCD – VIBE CD, containing exclusive VIBE bass tracks as featured on the Bass Tunnel and VIBE Dredd.
MCC – VIBE CD case, metallic silver CD case with VIBE logo.
VFL – VIBE fleece with embroidered logo on the front and large on back.
VTD – VIBE tax disc holder, stylish silver tax disc holder featuring VIBE logo.

VIBE SD4/5 subwoofer defender grill

The new VIBE subwoofer defender not only provides protection for your sub but also adds style with its metallic badge and black rubberised steel construction allow it to integrate perfectly with the VIBE EVO enclosures

Model: SD4 – sub grill fits both 10" and 12" subwoofers
Model: SD5 – sub grill fits 15" subwoofers

VIBE GB41 banana plug

The VIBE GB41 banana plugs are the easy and convenient way to quickly remove your bass enclosure without having to constantly re-thread your speaker cable into the box terminal, simply attach the speaker cable to the VIBE GB41 banana plug and you have a reliable quick release solution. Designed for optimum use with the TP-2 and GP-4 terminal, our professional gold plated 4mm banana plugs are polarity marked and feature rubber shrouds.

Model: GB41 – Gold Banana plug

VIBE DB6 non fused distribution block

The VIBE DB6 non fused distribution block is a professional non fused distribution block which gives easy connection for up to 5 amplifiers. The VIBE DB6 has 2 x 4AWG input and 4 x BAWG outputs which can be used for power distribution or ground distribution giving a common grounding point for all system components eliminating the risk of ground loop interference.

Model: DB6 non fused distribution block

VIBE FD4 fused distribution block

The VIBE FD4 fused distribution block is a professional AGU fused distribution block which gives easy connection for up to 4 amplifiers. The VIBE FD4 has 1 x 4AWG input and 4 x BAWG outputs each individually fused up to a maximum of 80 amps (AGU fuses available separately)

Model: FD4 – 4 way AGU fused distribution block, 1 x 4 gauge input 4 x 8 gauge outputs

VIBE CT0 / CT4 compression fit ring terminal

The VIBE CT range of gold plated ring terminals are professional compression fit designed for maximum conductivity when connecting power cable to the vehicle battery. The VIBE RT compression fit terminals are the best way to connect heavy gauge power cable to the vehicles battery.

Model: CT0 – 0 gauge compression fit ring terminal
Model: CT4 – 4 gauge compression fit ring terminal

VIBE RT4 / RT8 crimp on ring terminal

The professional range of VIBE RT gold plated ring terminals for connecting power cable to the vehicle battery. Packed in pairs and include red and black rubber over-boots with an easy crimp design.

Model: RT8 – 1 pair of 8 gauge crimp on ring terminals with PVC overboots
Model: RT4 – 1 pair of 4 gauge crimp on ring terminals with PVC overboots

VIBE AGU30, AGU60, AGU80 fuses

The VIBE AGU fuse series are the perfect companion to the VIBE FD4 fused distribution block and the Active and stereo system wiring kits.

Model: AGU30 – 1 pair 30 amp AGU fuses to fit all AGU fuse holders
Model: AGU60 – 1 pair 60 amp AGU fuses to fit all AGU fuse holders
Model: AGU80 – 1 pair 80 AGU fuses to fit all AGU fuse holders

All Accessories are available direct, for next day delivery call 0870 765 8423 or visit www.vibeshop.co.uk (UK ONLY)

For more product info see www.vibeaudio.co.uk

Autogood products Internet store "130"



The CriticalLink™ range of FLAT series cabling from VIBE

The VIBE CriticalLink range of cabling has been developed to achieve the critical link between source (headunit), amplifier and speakers – VIBE audio equipment is high quality, using anything less than the VIBE CriticalLink™ range of cables will severely compromise your equipment and will not allow it to perform to its maximum potential.

NOTE: Your audio equipment will only ever be as good as the cables you use to connect it. The link between your audio equipment is critical for a bigger clearer sound.

VIBE cabling and interconnects can enhance your system power and sound quality by more than 20% over other brand cable.

All Accessories are available direct, for next day delivery call 0870 765 8423 or visit www.vibeshop.co.uk (UK ONLY)
For more product info see www.vibeaudio.co.uk



BASS SYSTEM KIT

The VIBE 3000watt BASS KIT is specifically designed to gain maximum output from high power Bass systems. Featuring the best BASS specific cables from the VIBE CriticalLink™ Range.

Contents of this Kit:
 FLATLINES™ 6AWG PWR Power and Ground cable
 FLATBASS™ RCA SolidCore™ Interconnect
 FLATBASS™ 13 SPK Bass speaker cable
 FLATLINES™ remote 18
 VIBE 140 amp circuit breaker

All cable is terminated with crimped terminal rings in place and accessory fitting kit

COMPATIBILITY

This kit is compatible with the majority of amplifiers on the market – VIBE recommends this kit for all VIBE BASS monoblock amplifiers new, current and old models.

Model: Bass Kit – Bass specific amplifier wiring kit



STEREO SYSTEM KIT

The VIBE 1500watt STEREO KIT is specifically designed to gain maximum output from high power full range systems. Combining the best full range cables from the VIBE CriticalLink™ range.

Contents of this Kit:
 FLATLINES™ 6AWG PWR Power and Ground cable
 VIBE FLATSTEREO™ RCA - OFC high definition full range interconnect
 FLATSTEREO™ remote 18
 FLATSTEREO™ speaker cable
 AGU Fuse Holder

All cable is terminated with crimped terminal rings in place and accessory fitting kit

COMPATIBILITY

This kit is compatible with the majority of amplifiers on the market – VIBE recommends this kit for all VIBE full range STEREO amplifiers new, current and old models. FLATLINES™ B PWR Power

Model: Stereo Kit – full range stereo amplifier wiring kit



ACTIVE SYSTEM KIT

The VIBE 1500watt ACTIVE BASS KIT is specifically designed to gain maximum output from high power Active Bass systems (Bass Boxes). Featuring BASS specific components from the VIBE CriticalLink™ range.

Contents of this Kit:
 FLATLINES™ 6AWG PWR Power and Ground cable
 FLATBASS™ RCA SolidCore™ Interconnect
 FLATLINES™ remote 18
 AGU Fuse Holder
 FastPlug™

COMPATIBILITY

This kit is compatible with the majority of amplifiers on the market – VIBE recommends this kit for all VIBE active bass enclosures new, current and old models.

Model: Active Kit – Bass specific active enclosure wiring kit



PC15
1.5 farad power capacitor

The VIBE 1.5 farad power capacitor is a must for any high performance audio system. VIBE's 1.5 farad power capacitor bridges the gap between the vehicles battery and the amplifiers ensuring rapid smooth current flow resulting in louder tighter bass and clean crisp midrange and treble. The built in digital voltage display constantly and accurately displays the systems DC voltage. An all new VIBE power distribution block is built into the top of the capacitor to allow easy wiring into the system and also will allow 3 amplifiers to be wired directly to the capacitor for maximum current flow to the amplifiers.

Model: PC15



The DeltaBox line driver is the ideal solution for those looking to install multiple amplifiers from a single RCA preout. Most people use RCA "Y" splitters for this task unaware of the signal degradation caused. The DeltaBox not only divides the signal but also isolates and boosts the signal to a maximum of 3 volts independently for each of the 3 output channels giving much cleaner sound and excellent signal to noise ratio. For SPL competition the DeltaBox is an essential tool as each of the outputs can be split 4 times giving control of 12 amplifiers from a single gain enabling precise adjustment of the system without having to reset every amplifier individually. Additionally if your headunit has a weak preout or you wish to run multiple amps but only have one output the DeltaBox™ is your ideal solution. Model: DELTABOX



The VIBE FastPlug™ (pat. pending) is a product long overdue. Designed and developed by VIBE Engineers the plug offers safe, fast removal of your active bass enclosure (bass box) or amplifier. You may wish to remove your system for security reasons, or for the full use of your boot space, whatever the reason the VIBE FastPlug makes it easy and safe.

The plug is a heavy duty connector that connects positive, negative and remote wires. It is made up of 2 parts – one end to connect to your equipment and the other to your power source – made from high quality ABS plastic the device is tough and hard wearing. Model: FASTPLUG



FLATLINES™ Power and Ground Cable

VIBE FlatLines™ power cable has been developed to maximise voltage transfer from battery to amplifier - The cable has 2 main lines running side by side which are made up of fine copper strands - This design makes the cable flat allowing us to make very slim heavy duty power cable which is highly flexible easing installation.

Available in system kits, by the roll or by the metre

Model: FLATLINES B PWR - 8gauge red power cable Model: FLATLINES B GND - 8gauge black power cable
 Model: FLATLINES 4 PWR - 4gauge red power cable Model: FLATLINES 4 PWR - 4gauge red power cable
 Model: FLATLINES 0 PWR - 0gauge red power cable Model: FLATLINES 0 GND - 0gauge black power cable



FLATSTEREO™ High Definition full range Interconnect

The VIBE FLATSTEREO RCA is an OFC high definition full range interconnect - delivering the fullest signal possible from source to amplifier - the cable make up has been developed to run flat with left and right cables running parallel both with individual screening but sharing an outer FLAT jacket easing installations.

Available in:

Model: FlatStereo RCA 1m - 1 metre full range interconnect
 Model: FlatStereo RCA 5m - 5 metre full range interconnect



FLATBASS™ - SolidCore™ Bass interconnect

The VIBE FLATBASS™ interconnect has been specifically developed for use in BASS SYSTEMS - the cable make up has a unique super-FLAT™ design easing installation - its trick ingredient is oversized SolidCore™ OFC signal wires - allowing a heavier voltage to be passed down the cable. This is the central wire that carries the main signal from source to amplifier.

Available in:

Model: FlatBass RCA 1m - 1 metre BASS interconnect
 Model: FlatBass RCA 5m - 5 metre BASS interconnect

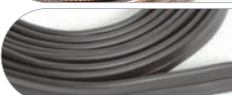

FLATFLEX™ High Definition speaker cable

The delivery of power and signal to the speaker is the final CriticalLink™ in any audio system - VIBES FlatFlex OFC high definition speaker cable is produced from super-fine OFC copper strands collectively picking up all the detail in your music - the multi strands are aligned in a row making the cable super-FLAT™ which can be run invisibly under carpets.

Available in:

Model: FlatFlex 16 SPK - 16 gauge High definition flat flexible speaker cable
 Model: FlatFlex 12 SPK - 12 gauge High definition flat flexible speaker cable