



## Alfa Laval ALDEC G3 decanter centrifuge

Maximum performance, minimum environmental impact



### Applications

Alfa Laval ALDEC G3 decanter centrifuges are the latest generation of this type of equipment, designed to set a significantly higher standard for both process performance and environment impact. They are used for thickening and dewatering sludge from municipal and industrial water and waste treatment plants.

The ALDEC G3 decanter centrifuge is ideal for use in thickening and dewatering operations intended to make a significant contribution to a sustainable environment. The innovative design delivers peak performance at all times, while also reducing total power consumption by as much as up to 40%. This significant improvement results in big reductions in CO2 emissions.

The advanced technology built into the ALDEC G3 design helps ensure easy installation and reliable operation, as well as significant energy savings.

### Benefits

The ALDEC G3 decanter centrifuge design provides operating benefits that include

- Exceptional dewatering performance: this cuts down on transport and disposal costs
- Higher capacity within a small footprint: the compact, modular design saves space
- Best performance combined with lowest energy consumption: lower operating and maintenance costs

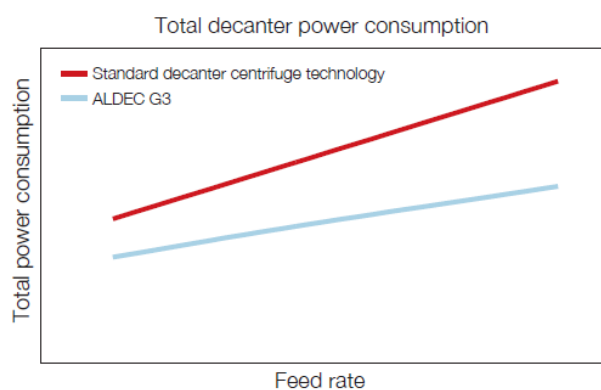

Fig 1. Power consumption vs. feed rate

## Features

- Power plates/tubes and slimline conveyor design
- Critical components made of wear-resistant material
- Fully open feed zone for improved separation
- 360° solids discharge to avoid blocking
- Baffle disc provides higher capacity and drier cake solids
- Steep or shallow cone configuration for effective separation of any type of slurry
- Selection of conveyor designs available for use with different types of slurry
- Different forms of wear protection for conveyor flights, to suit any processing requirements
- Complete, fully enclosed cleaning-in-place (CIP)

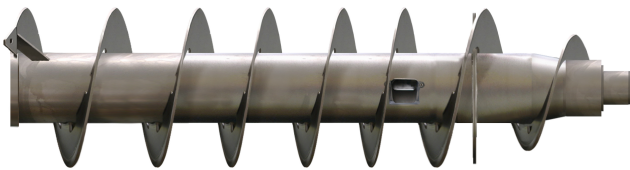

Fig 2. Slimline conveyor

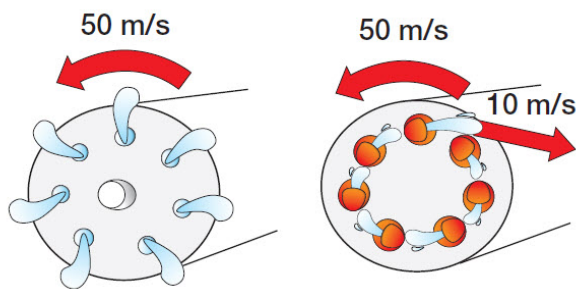
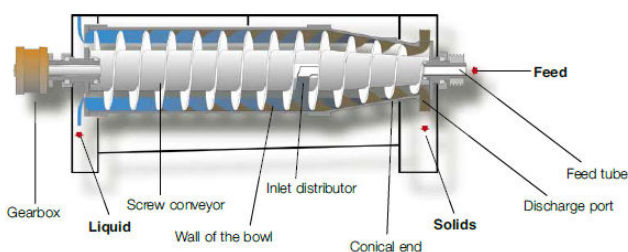

Fig 3. How power plates/tubes work

## Working principle

Separation takes place in a horizontal cylindrical bowl equipped with a screw conveyor (see drawing). The feed enters the bowl through a stationary inlet tube and is accelerated smoothly by an inlet distributor. The centrifugal force that results from the rotation then causes sedimentation of the solids on the wall of the bowl.



The conveyor rotates in the same direction as the bowl, but slightly slower, thus moving the solids towards the conical end of the bowl. The cake leaves the bowl through the solids discharge openings into the casing. Separation takes place throughout the entire length of the cylindrical part of the bowl, and the clarified liquid leaves the bowl by flowing over power tubes into the casing.

## Process optimization

ALDEC G3 decanter centrifuges can be adjusted to suit specific requirements by varying

- Bowl speed to obtain the G-force required for most efficient separation
- Conveying speed for the most efficient balance between liquid clarity and solids dryness
- Pond depth in the bowl for the most efficient balance between liquid clarity and solids dryness

## Design

The rotating part of ALDEC G3 decanter centrifuges is mounted on a compact, in-line frame, with main bearings at both ends.

Vibration dampers are placed under the frame. The rotating part is enclosed in a casing with a stainless steel cover and a bottom section with integrated outlets for both solids and the liquid being removed.

## Drive system

In all ALDEC decanter centrifuges, the bowl is driven by an electric motor and a V-belt transmission drive. Power is transferred to the conveyor via a Direct Drive gearbox.

Operation can either be pre-set to a suitable set of parameters, or the difference between the speeds of the bowl and the conveyor can be controlled automatically, with no need for changing belts or pulleys.

## Materials

The bowl, conveyor, inlet tube, outlets, cover and other parts in direct contact with process media are all made of stainless steel.

The discharge ports, conveyor flights and feed zone are protected with materials that are highly resistant to erosion. Different types of additional optional wear protection can be added, including conveyor flights protection with flame-sprayed hard surfacing, and/or sintered tungsten carbide tiles. For the larger sizes, a full tungsten carbide covered feed zone is available as an option for exceptional wear protection.

The frame is made of mild steel with an epoxy enamel finish.

## PLUS – world-class control system

Every ALDEC G3 decanter is equipped with a PLUS control package as standard, pre-installed and tested in conjunction with each particular unit. The combination of PLUS controls with the ALDEC G3 ensures the best possible performance, keeping costs for installation, commissioning, operation and maintenance to a minimum.

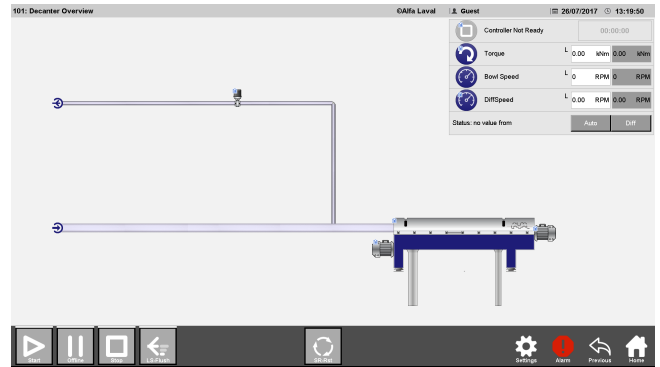

## Technical specifications

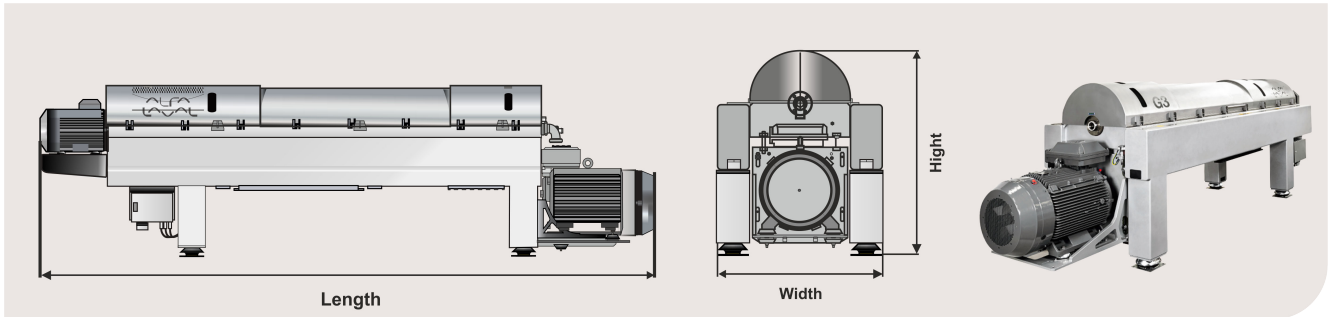

Designation	Length mm (inches)	Width mm (inches)	Height mm (inches)	Max. weight kg (lbs) drive	Typical main size kW (HP)	Typical back drive size kW (HP)	Back drive control VFD
ALDEC G3-75	4959 mm (195 inches)	1060 mm (42 inches)	1441 mm (57 inches)	3200 kg (7050 lbs)	11-55 kW (15-75 HP)	7.5/15 kW (10/20 HP)	VFD
ALDEC G3-95	5682 mm (224 inches)	1150 mm (46 inches)	1601 mm (63 inches)	4500 kg (9900 lbs)	18.5-90 kW (25-125 HP)	11/22kW (15/30 HP)	VFD
ALDEC G3-105	5861 mm (231 inches)	1300 mm (51 inches)	1696 mm (67 inches)	5000 kg (11023 lbs)	30-132 kW (40-150 HP)	15/30 kW (20/40 HP)	VFD
ALDEC G3-115	6502 mm (256 inches)	1450 mm (57 inches)	1791 mm (71 inches)	6500 kg (14300 lbs)	37-160 kW (50-200 HP)	15/30 kW (20/40 HP)	VFD
ALDEC G3-125	6901 mm (272 inches)	1510 mm (60 inches)	1852 mm (73 inches)	8600 kg (18959 lbs)	55-250 kW (75-350 HP)	22/37 kW (30/50 HP)	VFD
ALDEC G3-165	8672 mm (342 inches)	2050 mm (81 inches)	2248 mm (89 inches)	19000 kg (42000 lbs)	132-355 kW (150-400 HP)	37/55 kW (50/75 HP)	VFD

Different materials are available to meet different requirements.



This document and its contents is owned by Alfa Laval Corporate AB and protected by laws governing intellectual property and thereto related rights. It is the responsibility of the user of this document to comply with all applicable intellectual property laws. Without limiting any rights related to this document, no part of this document may be copied, reproduced or transmitted in any form or by any means (electronic, mechanical, photocopying, recording, or otherwise), or for any purpose, without the expressed permission or authorized by Alfa Laval Corporate AB. Alfa Laval Corporate AB will enforce its rights related to this document to the fullest extent of the law, including the seeking of criminal prosecution.

200000399-1-EN-GB

© Alfa Laval Corporate AB

---

**How to contact Alfa Laval**

Up-to-date Alfa Laval contact details for all countries are always available on our website at [www.alfalaval.com](http://www.alfalaval.com)