

**SIEMENS**



# SIPART

Electropneumatic positioners  
SIPART PS2 with PROFIBUS PA (6DR55..)

Operating Instructions

Edition

02/2016

Answers for industry.



# SIEMENS

## SIPART

### Electropneumatic positioner SIPART PS2 with PROFIBUS PA

#### Operating Instructions

6DR55..

02/2016  
A5E00127926-AB

<u>Introduction</u>	<b>1</b>
<u>Safety information</u>	<b>2</b>
<u>Description</u>	<b>3</b>
<u>Installing/mounting</u>	<b>4</b>
<u>Connect</u>	<b>5</b>
<u>Operation</u>	<b>6</b>
<u>Commissioning</u>	<b>7</b>
<u>Functional safety</u>	<b>8</b>
<u>Parameter assignment</u>	<b>9</b>
<u>Functions/operations using PROFIBUS PA</u>	<b>10</b>
<u>Alarm, fault and system messages</u>	<b>11</b>
<u>Service and maintenance</u>	<b>12</b>
<u>Technical data</u>	<b>13</b>
<u>Dimension drawings</u>	<b>14</b>
<u>Spare parts / accessories / scope of delivery</u>	<b>15</b>
<u>Appendix</u>	<b>A</b>
<u>Abbreviations</u>	<b>B</b>

## Legal information

### Warning notice system

This manual contains notices you have to observe in order to ensure your personal safety, as well as to prevent damage to property. The notices referring to your personal safety are highlighted in the manual by a safety alert symbol, notices referring only to property damage have no safety alert symbol. These notices shown below are graded according to the degree of danger.

<b>⚠ DANGER</b>
indicates that death or severe personal injury <b>will</b> result if proper precautions are not taken.

<b>⚠ WARNING</b>
indicates that death or severe personal injury <b>may</b> result if proper precautions are not taken.

<b>⚠ CAUTION</b>
indicates that minor personal injury can result if proper precautions are not taken.

<b>NOTICE</b>
indicates that property damage can result if proper precautions are not taken.

If more than one degree of danger is present, the warning notice representing the highest degree of danger will be used. A notice warning of injury to persons with a safety alert symbol may also include a warning relating to property damage.

### Qualified Personnel

The product/system described in this documentation may be operated only by **personnel qualified** for the specific task in accordance with the relevant documentation, in particular its warning notices and safety instructions. Qualified personnel are those who, based on their training and experience, are capable of identifying risks and avoiding potential hazards when working with these products/systems.

### Proper use of Siemens products

Note the following:

<b>⚠ WARNING</b>
Siemens products may only be used for the applications described in the catalog and in the relevant technical documentation. If products and components from other manufacturers are used, these must be recommended or approved by Siemens. Proper transport, storage, installation, assembly, commissioning, operation and maintenance are required to ensure that the products operate safely and without any problems. The permissible ambient conditions must be complied with. The information in the relevant documentation must be observed.

### Trademarks

All names identified by ® are registered trademarks of Siemens AG. The remaining trademarks in this publication may be trademarks whose use by third parties for their own purposes could violate the rights of the owner.

### Disclaimer of Liability

We have reviewed the contents of this publication to ensure consistency with the hardware and software described. Since variance cannot be precluded entirely, we cannot guarantee full consistency. However, the information in this publication is reviewed regularly and any necessary corrections are included in subsequent editions.

# Table of contents

<b>1</b>	<b>Introduction.....</b>	<b>13</b>
1.1	Purpose of this documentation.....	13
1.2	History.....	13
1.3	Purpose.....	14
1.4	Checking the consignment.....	14
1.5	Transportation and storage.....	15
1.6	Product information.....	15
1.7	Notes on warranty.....	15
<b>2</b>	<b>Safety information.....</b>	<b>17</b>
2.1	Precondition for use.....	17
2.2	Warning symbols on the device.....	17
2.3	Laws and directives.....	17
2.4	Conformity with European directives.....	17
2.5	Improper device modifications.....	18
2.6	Requirements for special applications.....	18
2.7	Use in hazardous areas.....	19
<b>3</b>	<b>Description.....</b>	<b>21</b>
3.1	Function.....	21
3.2	Structure.....	21
3.2.1	Design overview.....	21
3.2.2	Nameplate layout.....	24
3.2.3	Explanation of Ex information.....	25
3.3	Device components.....	26
3.3.1	Overview of device components.....	26
3.3.2	Overview of device components (Ex).....	27
3.3.3	Basic electronics.....	28
3.4	Functional principle.....	28
3.4.1	PROFIBUS system configuration.....	30
3.4.2	SIMATIC PDM.....	31
3.5	PROFIBUS PA.....	31
3.5.1	Overview.....	31
3.5.2	Transmission technology.....	31
3.5.3	Bus topology.....	32
3.5.4	Properties.....	33
3.5.5	Profile.....	33
3.5.6	Connection.....	33

3.5.7	Number of connectable devices.....	35
3.5.8	Assigning the device addresses.....	35
<b>4</b>	<b>Installing/mounting.....</b>	<b>37</b>
4.1	Basic safety instructions.....	37
4.1.1	Proper mounting.....	40
4.2	Mounting the linear actuator.....	40
4.3	Mounting the part-turn actuator.....	45
4.4	Using the positioner in a humid environment.....	50
4.5	Position controllers subjected to fast acceleration or strong vibration.....	51
4.5.1	Introduction locking the setting.....	51
4.5.2	Procedure locking the setting.....	52
4.6	External position detection.....	53
4.7	Installing the optional modules.....	54
4.7.1	General information about the installation of option modules.....	54
4.7.1.1	Unsuitable device for the hazardous area.....	54
4.7.1.2	Installing optional modules in the standard and intrinsically safe version.....	54
4.7.1.3	Installing the optional modules in the "flameproof enclosure" version.....	58
4.7.2	Position feedback module.....	62
4.7.3	Alarm module.....	63
4.7.4	Slit initiator alarm module.....	64
4.7.5	Mechanical limit switch module.....	67
4.7.6	Internal NCS module 6DR4004-5L/-5LE.....	70
4.7.7	EMC filter module.....	73
4.7.8	Accessories.....	76
<b>5</b>	<b>Connect.....</b>	<b>77</b>
5.1	Basic safety instructions.....	77
5.1.1	Improvement of interference immunity.....	80
5.1.2	Interference immunity.....	81
5.1.3	Safety shutdown.....	81
5.2	Electrical wiring.....	82
5.2.1	Bus cable.....	82
5.2.2	Wiring diagram for basic electronics.....	85
5.2.3	Wiring NCS sensor to EMC filter module.....	86
5.2.4	Connecting the external position detection system to the EMC filter module.....	87
5.2.5	Option modules.....	90
5.2.5.1	Alarm modules 6DR4004-6A and -8A.....	90
5.2.5.2	Position feedback modules 6DR4004-6J and -8J.....	91
5.2.5.3	SIA modules 6DR4004-6G and -8G.....	91
5.2.5.4	Mechanical limit switch modules 6DR4004-6K and -8K.....	92
5.2.6	Option device version M12 connector.....	93
5.2.6.1	M12 connector in the basic device.....	94
5.2.6.2	M12 connector for connection of the outputs of the alarm module 6DR4004-6A / -8A (-Z D55).....	94
5.2.6.3	M12 connector for connecting the outputs of the position feedback module 6DR4004-6J / 8J (-Z D53).....	95
5.2.6.4	M12 connector for connecting the external position detection system (-Z D54).....	95
5.2.6.5	M12 connector for connecting the outputs of the SIA module 6DR4004-6G /-8G (-Z D56).....	95

5.3	Pneumatic connection.....	96
5.3.1	Pneumatic connection for 6DR55.0/1/2/3.....	96
5.3.2	Integrated pneumatic connection.....	96
5.3.3	Pneumatic connection for 6DR55.5-0E.....	97
5.3.4	Reaction to failure of auxiliary powers.....	98
5.3.5	Pneumatic connection.....	101
5.4	Restrictors.....	102
<b>6</b>	<b>Operation.....</b>	<b>103</b>
6.1	Operating elements.....	103
6.1.1	Display.....	103
6.1.2	Buttons.....	104
6.1.3	Firmware version .....	105
6.2	Operating modes.....	106
6.2.1	Overview of operating modes.....	106
6.2.2	Changing the operating mode.....	107
6.2.3	Overview of configuration.....	108
6.2.4	Description of operating modes.....	108
6.2.5	Optimization of controller data.....	110
<b>7</b>	<b>Commissioning.....</b>	<b>113</b>
7.1	Basic safety instructions.....	113
7.2	Overview.....	115
7.3	Sequence of automatic initialization.....	116
7.4	Purge air switching.....	122
7.5	Commissioning linear actuators.....	123
7.5.1	Preparing linear actuators for commissioning.....	123
7.5.2	Automatic initialization of linear actuators.....	124
7.5.3	Manual initialization of linear actuators.....	127
7.6	Commissioning part-turn actuators.....	130
7.6.1	Preparing part-turn actuators for commissioning.....	130
7.6.2	Automatic initialization of part-turn actuators.....	131
7.6.3	Manual initialization of part-turn actuators.....	133
7.7	Device replacement.....	136
<b>8</b>	<b>Functional safety.....</b>	<b>139</b>
8.1	Range of applications for functional safety.....	139
8.2	Safety function.....	139
8.3	Safety Integrity Level (SIL).....	140
8.4	Settings.....	142
8.5	Safety characteristics.....	143
8.6	Maintenance/check.....	143
<b>9</b>	<b>Parameter assignment.....</b>	<b>145</b>
9.1	Introduction to parameter assignment section.....	145

9.2	Tabular overview of the parameters.....	146
9.2.1	Overview of initialization parameters 1 to 5.....	146
9.2.2	Overview of application parameters 6 to 55.....	147
9.2.3	Overview of advanced diagnostics parameters A to P.....	150
9.3	Description of parameters.....	154
9.3.1	Initialization parameters 1 to 5.....	154
9.3.1.1	'1.YFCT' Type of actuator.....	154
9.3.1.2	'2.YAGL' Rated angle of rotation of feedback.....	155
9.3.1.3	'3.YWAY' Range of stroke.....	156
9.3.1.4	'4.INITA' Initialization (automatically).....	156
9.3.1.5	'5.INITM' Initialization (manual).....	157
9.3.2	Application parameters 6 to 55.....	157
9.3.2.1	'6.SDIR' Setpoint direction.....	157
9.3.2.2	'7.TSUP' Setpoint ramp UP / '8.TSDO' Setpoint ramp DOWN.....	158
9.3.2.3	'9.SFCT' Setpoint function.....	158
9.3.2.4	'10.SL0' ... '30.SL20' Setpoint turning point.....	159
9.3.2.5	'31.DEBA' Deadband of controller.....	160
9.3.2.6	'32.YA' Manipulated variable limiting Start / '33.YE' Manipulated variable limiting End.....	160
9.3.2.7	'34.YNRM' Manipulated variable standardization.....	160
9.3.2.8	'35.YDIR' Direction of action of manipulated variable for display and position feedback.....	162
9.3.2.9	'36.YCLS' Tight closing with manipulated variable.....	162
9.3.2.10	'37.YCDO' Lower value for tight closing / '38.YCUP' Upper value for tight closing.....	163
9.3.2.11	'39.BIN1' / '40.BIN2' Function of binary inputs.....	163
9.3.2.12	'41.AFCT' Alarm function.....	164
9.3.2.13	'42.A1' / '43.A2' Alarm response threshold.....	166
9.3.2.14	'44.\FCT' Function fault message.....	166
9.3.2.15	'45.\TIM' Monitoring time for setting of fault messages.....	167
9.3.2.16	'46.\LIM' Response threshold for fault message.....	167
9.3.2.17	'47.\STRK' Limit monitoring for the number of total strokes.....	168
9.3.2.18	'48.PRST' Preset.....	168
9.3.2.19	'49.PNEUM' Fail in place.....	169
9.3.2.20	'50.XDIAG' Activation of extended diagnostics.....	170
9.3.2.21	'51.FSTY' Safety position.....	171
9.3.2.22	'52.FSTI' Monitoring time to set the safety position.....	172
9.3.2.23	'53.FSVL' Safety setpoint.....	172
9.3.2.24	'54.STNR' Station number.....	172
9.3.2.25	'55.IDENT' Device operating mode (ID No.).....	173
9.3.3	Extended diagnostics parameters A to P.....	173
9.3.3.1	Partial stroke test 'A.\PST'.....	173
9.3.3.2	Monitoring of dynamic control valve behavior 'b.\DEVI'.....	179
9.3.3.3	Monitoring pneumatic leakage 'C.\LEAK'.....	181
9.3.3.4	Monitoring the stiction (slipstick) 'd.\STIC'.....	183
9.3.3.5	Monitoring the deadband 'E.\DEBA'.....	185
9.3.3.6	Monitoring the lower endstop 'F.\ZERO'.....	186
9.3.3.7	Monitoring the upper endstop 'G.\OPEN'.....	187
9.3.3.8	Monitoring the low limit temperature 'H.\TMIN'.....	189
9.3.3.9	Monitoring the high limit temperature 'J.\TMAX'.....	190
9.3.3.10	Monitoring the number of total strokes 'L.\STRK'.....	192
9.3.3.11	Monitoring the number of changes in direction 'O.\DCHG'.....	193
9.3.3.12	Monitoring the position average value 'P.\PAVG'.....	195



<b>10</b>	<b>Functions/operations using PROFIBUS PA.....</b>	<b>199</b>
10.1	System integration.....	199
10.2	Acyclic data transfer.....	199
10.2.1	Acyclic data transfer using SIMATIC PDM.....	199
10.2.2	'Device' menu.....	200
10.2.2.1	Load to device.....	200
10.2.2.2	Load into PG/PC.....	200
10.2.2.3	Assign address and TAG.....	200
10.2.2.4	Value comparison.....	200
10.2.2.5	Object properties.....	201
10.2.2.6	Calibration report.....	202
10.2.2.7	Change log.....	203
10.2.2.8	Wizard.....	204
10.2.2.9	Partial stroke test (PST).....	205
10.2.2.10	PST trace characteristic.....	205
10.2.2.11	Offline leakage test.....	206
10.2.2.12	Maintenance and diagnostics.....	206
10.2.2.13	Initialization parameters.....	207
10.2.2.14	Initialization.....	207
10.2.2.15	Operation.....	208
10.2.2.16	Simulation.....	210
10.2.2.17	Date and time in the device.....	211
10.2.2.18	Write protection.....	211
10.2.2.19	Reset parameters in PDM.....	211
10.2.2.20	Reset parameters on the device.....	212
10.2.2.21	Reset the field device.....	212
10.2.3	'View' menu.....	213
10.2.3.1	Process variables / diagnostics cockpit.....	213
10.2.3.2	Starting the lifelist.....	214
10.2.4	'Diagnostics' menu.....	214
10.2.4.1	Updating diagnostics.....	214
10.2.4.2	Device diagnostics.....	216
10.2.4.3	Maintenance information.....	217
10.2.4.4	Trend characteristic.....	218
10.2.4.5	Histograms.....	218
10.2.4.6	Alarm logbook.....	218
10.2.4.7	Characteristic curve.....	219
10.3	Cyclic data transfer.....	219
10.3.1	Configuration.....	219
10.3.2	Useful data through PROFIBUS.....	222
10.3.2.1	Possible combinations of the useful data.....	223
10.3.2.2	Diagnostics.....	227
10.3.3	Adjustable status (condensed status).....	228
10.3.3.1	Diagnostics messages in case of deactivated condensed status.....	232
10.3.3.2	Diagnostics messages in case of activated condensed status.....	234
10.3.3.3	Definition of the status.....	236
10.3.3.4	Sub-status for deactivated condensed status.....	236
10.3.3.5	Sub-status for activated condensed status.....	237
10.3.3.6	List of diagnostics events with status and diagnostics message for deactivated condensed status.....	237

10.3.3.7	List of diagnostics events with status and diagnostics message for activated condensed status.....	240
<b>11</b>	<b>Alarm, fault and system messages.....</b>	<b>245</b>
11.1	Output of system messages in the display.....	245
11.1.1	System messages during operation.....	245
11.1.2	System messages before initialization.....	246
11.1.3	System messages during initialization.....	247
11.1.4	System messages when exiting the Configuration mode.....	249
11.1.5	System messages during operation.....	250
11.2	Diagnostics.....	252
11.2.1	Display of diagnostics values.....	252
11.2.2	Saving the diagnostics values.....	253
11.2.3	Overview of diagnostics values.....	253
11.2.4	Meaning of the diagnostic values.....	255
11.2.4.1	Diagnostic value '1.STRKS - Number of total strokes'.....	255
11.2.4.2	Diagnostic value '2.CHDIR - Number of changes in direction'.....	255
11.2.4.3	Diagnostic value '3.\CNT - Number of fault messages'.....	255
11.2.4.4	Diagnostic value '4.A1CNT - Number of alarms 1' / '5.A2CNT - Number of alarms 2'.....	255
11.2.4.5	Diagnostic value '6.HOURS - Number of operating hours'.....	256
11.2.4.6	Diagnostic value '7.HOURR - Resettable operating hours counter'.....	256
11.2.4.7	Diagnostic value '8.WAY - Determined travel'.....	256
11.2.4.8	Diagnostic value '9.TUP - Travel time UP' / '10.TDOWN - Travel time DOWN'.....	256
11.2.4.9	Diagnostic value '11.LEAK - Leakage test'.....	257
11.2.4.10	Diagnostic value '12.PST - Monitoring of partial stroke test'.....	258
11.2.4.11	Diagnostic value '13.PRPST' - Time since last partial stroke test'.....	259
11.2.4.12	Diagnostic value '14.NXPST - Time until next partial stroke test'.....	259
11.2.4.13	Diagnostic value '15.DEVI - General control valve fault'.....	259
11.2.4.14	Diagnostic value '16.ONLK - Pneumatic leakage'.....	259
11.2.4.15	Diagnostic value '17.STIC - Stiction (slipstick)'.....	260
11.2.4.16	Diagnostic value '18.ZERO - Lower endstop'.....	260
11.2.4.17	Diagnostic value '19.OPEN - Upper endstop'.....	260
11.2.4.18	Diagnostic value '20.PAVG - Average value of position'.....	261
11.2.4.19	Diagnostic value '21.P0 - Potentiometer value of lower endstop (0%)' / '22.P100 - Potentiometer value of upper endstop (100%)'.....	261
11.2.4.20	Diagnostic value '23.IMPUP - Impulse length UP' / '24.IMPDN - Impulse length DOWN'.....	263
11.2.4.21	Diagnostic value '25.PAOTP - Pulse interval'.....	263
11.2.4.22	Diagnostic value '26.DBUP - Deadband UP' / '27.DBDN - Deadband DOWN'.....	263
11.2.4.23	Diagnostic value '28.SSUP - Slow step zone UP' / '29.SSDN - Slow step zone DOWN'.....	263
11.2.4.24	Diagnostic value '30.TEMP - Current temperature'.....	264
11.2.4.25	Diagnostic value '31.TMIN - Minimum temperature' / '32.TMAX - Maximum temperature'.....	264
11.2.4.26	Diagnostic value '33.T1' ... '41.T9' - Number of operating hours in the temperature range 1 to 9.....	264
11.2.4.27	Diagnostic value '42.VENT1' / '43.VENT2'.....	264
11.2.4.28	Diagnostic value '44.VEN1R' / '45.VEN2R'.....	265
11.2.4.29	Diagnostic value '46.STORE - Save maintenance data'.....	266
11.2.4.30	Diagnostic value '47.PRUP - Prediction UP' / '48.PRDN - Prediction DOWN'.....	266
11.2.4.31	Diagnostic value '49.WT00' ... '56.WT95' - Number of operating hours in the travel range WT00 to WT95.....	266
11.3	Online diagnostics.....	267
11.3.1	Overview of online diagnostics.....	267

11.3.2	Overview of error codes.....	268
11.3.3	XDIAG parameter .....	269
11.3.4	Meaning of error codes.....	270
11.3.4.1	1 Remaining control deviation.....	270
11.3.4.2	2 Device not in "Automatic" mode.....	270
11.3.4.3	3 Binary input BIN1 or BIN2 active.....	270
11.3.4.4	4 Monitoring the number of total strokes.....	270
11.3.4.5	5 Monitoring the number of changes in direction.....	271
11.3.4.6	6 Monitoring the lower endstop / 7 Monitoring the upper endstop.....	271
11.3.4.7	8 Monitoring deadband.....	271
11.3.4.8	9 Partial stroke test.....	271
11.3.4.9	10 Monitoring of dynamic control valve behavior.....	272
11.3.4.10	11 Monitoring the pneumatic leakage.....	272
11.3.4.11	12 Monitoring of stiction (slipstick).....	272
11.3.4.12	13 Monitoring the lower limit temperature.....	272
11.3.4.13	14 Monitoring the upper limit temperature.....	272
11.3.4.14	15 Monitoring the position average value.....	272
11.3.4.15	16 Monitoring the plausibility of values for the partial stroke test.....	272
11.4	Fault correction.....	273
11.4.1	Fault identification.....	273
11.4.2	Remedial measures table 1.....	273
11.4.3	Remedial measures table 2.....	274
11.4.4	Remedial measures table 3.....	275
11.4.5	Corrective measures Table 4.....	275
11.4.6	Remedial measures table 5.....	276
<b>12</b>	<b>Service and maintenance.....</b>	<b>277</b>
12.1	Basic safety instructions.....	277
12.2	Cleaning of the screens.....	278
12.2.1	Positioners with Makrolon enclosure 6DR5..0, aluminum enclosure 6DR5..3, and flameproof aluminum enclosure 6DR5..5.....	278
12.2.2	Positioners with stainless steel enclosure 6DR5..2, flameproof stainless steel enclosure 6DR5..6, and narrow aluminum enclosure 6DR5..1.....	279
12.3	Replacing the basic electronics with the "Fail in Place" function.....	280
12.4	Repair/Upgrading.....	280
12.5	Return procedure.....	281
12.6	Disposal.....	281
<b>13</b>	<b>Technical data.....</b>	<b>283</b>
13.1	Rated conditions.....	283
13.2	Pneumatic data.....	284
13.3	Construction.....	284
13.4	Controller.....	286
13.5	Certificates, approvals, explosion protection.....	287
13.6	Electrical specifications.....	288
13.7	Technical data for natural gas as actuator medium.....	290

13.8	Option modules.....	291
13.8.1	Alarm module.....	291
13.8.2	Position feedback module.....	292
13.8.3	SIA module.....	293
13.8.4	Mechanical limit switch module.....	294
13.8.5	EMC filter module.....	295
13.8.6	NCS 6DR4004-.N.20 and 6DR4004-.N.30.....	296
13.8.7	Internal NCS modules 6DR4004-5L and 6DR4004-5LE.....	297
13.8.8	External position sensing system.....	297
13.8.8.1	Rated conditions for external position detection system.....	297
13.8.8.2	Construction for external position detection system.....	298
13.8.8.3	Certificates, approvals, explosion protection for external position detection system.....	298
<b>14</b>	<b>Dimension drawings.....</b>	<b>301</b>
14.1	Positioner in non-flameproof enclosure.....	301
14.2	Terminal strip for positioners with Makrolon enclosure 6DR5..0 and aluminum enclosure 6DR5..3.....	302
14.3	Positioner with flameproof enclosure.....	303
<b>15</b>	<b>Spare parts / accessories / scope of delivery.....</b>	<b>305</b>
15.1	Order data.....	305
15.2	Overview.....	305
15.3	Spare parts.....	306
15.4	Scope of delivery of external position detection system.....	307
15.5	Scope of delivery of mechanical limit switch module.....	308
15.6	Scope of delivery EMC filter module .....	308
15.7	Accessories.....	309
<b>A</b>	<b>Appendix.....</b>	<b>311</b>
A.1	Operation with boosters.....	311
A.2	Certificates.....	312
A.3	Technical support.....	312
<b>B</b>	<b>Abbreviations.....</b>	<b>313</b>
B.1	Abbreviations for positioners.....	313
B.2	Abbreviations for functional safety.....	314
	<b>Glossary.....</b>	<b>317</b>
	<b>Index.....</b>	<b>325</b>

# Introduction

## 1.1 Purpose of this documentation

These instructions contain all information required to commission and use the device. Read the instructions carefully prior to installation and commissioning. In order to use the device correctly, first review its principle of operation.

The instructions are aimed at persons mechanically installing the device, connecting it electronically, configuring the parameters and commissioning it, as well as service and maintenance engineers.

## 1.2 History

This history establishes the correlation between the current documentation and the valid firmware of the device.

The documentation of this edition applies to the following firmware:

Edition	Firmware code
02/2016	FW 6.00.00 or higher

The **most important** changes in the documentation as compared to the respective previous edition are given in the following table.

Edition	Note
02/2016	<ol style="list-style-type: none"> <li>1. Section Installing/mounting (Page 37) &gt; Simpler commissioning of part-turn actuators using coupling wheel with two pins.</li> <li>2. New parameters and values in section Parameter assignment (Page 145): <ul style="list-style-type: none"> <li>– 1.YFCT - Actuator &gt; Initialization of actuators with inverted direction of action is now possible. Linear actuator &gt; Mounting with carrier pin on actuator stem using 'FWAY/-FWAY' parameter value is now possible.</li> <li>– 48.PRST - Preset &gt; Resetting of individual parameter groups is now possible.</li> <li>– 49.PNEUM &gt; Fail in place function can now be activated with appropriate pneumatic system.</li> </ul> </li> <li>3. New functions for the diagnostics parameters &gt; section Partial stroke test 'A.\PST' (Page 173): <ul style="list-style-type: none"> <li>– A5.RPMD and A6.RPRT &gt; Partial stroke test is now possible in ramp mode.</li> <li>– A7.FLBH &gt; Response following failed PST can now be defined.</li> </ul> </li> <li>4. New functions for the diagnostics values in section Diagnostics (Page 252): <ul style="list-style-type: none"> <li>– 7.HOURR &gt; Resettable operating hours counter added.</li> <li>– 11.LEAK &gt; Offline leakage test added.</li> <li>– 21.P0 and 22.P100 &gt; Modification of upper and lower endstops now possible without initialization.</li> <li>– 25.PAOTP &gt; Adjustable pulse pause added.</li> </ul> </li> </ol>

### 1.3 Purpose

The electropneumatic positioner is used for the continuous control of process valves with pneumatic drives in the following industries.

- Chemicals
- Oil and gas
- Energy production
- Food and beverages
- Pulp and paper
- Water/waste water
- Pharmaceutical industry
- Offshore plants

Operate the device according to the specifications in section "Technical data (Page 283)".

For additional information, refer to the operating instructions for the device.

### 1.4 Checking the consignment

1. Check the packaging and the delivered items for visible damage.
2. Report any claims for damages immediately to the shipping company.
3. Retain damaged parts for clarification.
4. Check the scope of delivery by comparing your order to the shipping documents for correctness and completeness.

 <b>WARNING</b>
<b>Using a damaged or incomplete device</b> Danger of explosion in hazardous areas. <ul style="list-style-type: none"><li>• Do not use damaged or incomplete devices.</li></ul>

## 1.5 Transportation and storage

To guarantee sufficient protection during transport and storage, observe the following:

- Keep the original packaging for subsequent transportation.
- Devices/replacement parts should be returned in their original packaging.
- If the original packaging is no longer available, ensure that all shipments are properly packaged to provide sufficient protection during transport. Siemens cannot assume liability for any costs associated with transportation damages.

 <b>CAUTION</b>
<b>Insufficient protection during storage</b>
The packaging only provides limited protection against moisture and infiltration.
<ul style="list-style-type: none"><li>• Provide additional packaging as necessary.</li></ul>

Special conditions for storage and transportation of the device are listed in Technical data (Page 283).

## 1.6 Product information

The programming manual is an integral part of the CD, which is either supplied or can be ordered. The programming manual is also available on the Siemens homepage.

On the CD, you will also find the catalog extract with the ordering data, the Software Device Install for SIMATIC PDM for additional installation, and the required software.

### See also

SIPART PS2 product information (<http://www.siemens.com/sipartps2>)

Process instrumentation catalog (<http://www.siemens.com/processinstrumentation/catalogs>)

## 1.7 Notes on warranty

The contents of this manual shall not become part of or modify any prior or existing agreement, commitment or legal relationship. The sales contract contains all obligations on the part of Siemens as well as the complete and solely applicable warranty conditions. Any statements regarding device versions described in the manual do not create new warranties or modify the existing warranty.

The content reflects the technical status at the time of publishing. Siemens reserves the right to make technical changes in the course of further development.





## Safety information

### 2.1 Precondition for use

This device left the factory in good working condition. In order to maintain this status and to ensure safe operation of the device, observe these instructions and all the specifications relevant to safety.

Observe the information and symbols on the device. Do not remove any information or symbols from the device. Always keep the information and symbols in a completely legible state.

### 2.2 Warning symbols on the device

Symbol	Meaning
	Consult operating instructions

### 2.3 Laws and directives

Observe the test certification, provisions and laws applicable in your country during connection, assembly and operation. These include, for example:

- National Electrical Code (NEC - NFPA 70) (USA)
- Canadian Electrical Code (CEC) (Canada)

Further provisions for hazardous area applications are for example:

- IEC 60079-14 (international)
- EN 60079-14 (EC)

### 2.4 Conformity with European directives

The CE marking on the device shows conformity with the regulations of the following European guidelines:

2.6 Requirements for special applications

Electromagnetic Compatibility EMC 2004/108/EC	Directive of the European Parliament and of the Council on the approximation of the laws of the Member States relating to electromagnetic compatibility and repealing Directive 89/336/EEC.
Atmosphère explosible ATEX 94/9/EC	Directive of the European Parliament and the Council on the approximation of the laws of the Member States concerning equipment and protective systems intended for use in potentially explosive atmospheres.
LVD 2006/95/EC	Directive of the European Parliament and of the Council of the harmonisation of the laws of Member States relating to electrical equipment designed for use within certain voltage limits.

The applied standards can be found in the EC conformity declaration of the device.

See also

Certificates (<http://www.siemens.com/processinstrumentation/certificates>)

## 2.5 Improper device modifications

 <b>WARNING</b>
<b>Improper device modifications</b> Danger to personnel, system and environment can result from modifications to the device, particularly in hazardous areas. <ul style="list-style-type: none"><li>• Only carry out modifications that are described in the instructions for the device. Failure to observe this requirement cancels the manufacturer's warranty and the product approvals.</li></ul>

## 2.6 Requirements for special applications

Due to the large number of possible applications, each detail of the described device versions for each possible scenario during commissioning, operation, maintenance or operation in systems cannot be considered in the instructions. If you need additional information not covered by these instructions, contact your local Siemens office or company representative.

**Note**

**Operation under special ambient conditions**

We highly recommend that you contact your Siemens representative or our application department before you operate the device under special ambient conditions as can be encountered in nuclear power plants or when the device is used for research and development purposes.

## 2.7 Use in hazardous areas

### Qualified personnel for hazardous area applications

Persons who install, connect, commission, operate, and service the device in a hazardous area must have the following specific qualifications:

- They are authorized, trained or instructed in operating and maintaining devices and systems according to the safety regulations for electrical circuits, high pressures, aggressive, and hazardous media.
- They are authorized, trained, or instructed in carrying out work on electrical circuits for hazardous systems.
- They are trained or instructed in maintenance and use of appropriate safety equipment according to the pertinent safety regulations.

 <b>WARNING</b>
<b>Unsuitable device for the hazardous area</b>
Danger of explosion.
<ul style="list-style-type: none"><li>• Only use equipment that is approved for use in the intended hazardous area and labelled accordingly.</li></ul>

 <b>WARNING</b>
<b>Loss of safety of device with type of protection "Intrinsic safety Ex i"</b>
If the device has already been operated in non-intrinsically safe circuits or the electrical specifications have not been observed, the safety of the device is no longer ensured for use in hazardous areas. There is a danger of explosion.
<ul style="list-style-type: none"><li>• Connect the device with type of protection "Intrinsic safety" solely to an intrinsically safe circuit.</li><li>• Observe the specifications for the electrical data on the certificate and/or in Chapter "Technical data".</li></ul>



## Description

### 3.1 Function

- The electropneumatic positioner and an actuator form a control system. The current position of the actuator is recorded by a servo potentiometer and the actual value  $x$  is fed back. The setpoint and the actual value are also shown simultaneously on the display.
- The control system provides the setpoint  $w$  digitally to the positioner over the bus.
- The positioner works as a predictive five-point positioner, through whose output value  $\pm\Delta y$  the integrated valves can be controlled by pulse length modulation.
- These input signals change pressure in the actuator chamber(s) and displace the actuator until the control deviation becomes zero.
- Using the three buttons and the display with the enclosure cover removed, operation (manual mode) and configuration (structuring, initialization, and parameter assignment) can be performed.
- By default, the basic unit has a binary input (BIN). This binary input can be individually configured and used, for example, to block the control levels.
- It has a friction clutch and a switchable gear so that the positioner can be used with different mechanical part-turn and linear actuators.
- In the case of positioners with the "Fail in Place" function, the current position of the actuator is held if the electric and/or pneumatic auxiliary power fails. Does not function in conjunction with SIL.
- Parameter "51.FSTY" must be set to "FSSP" in the case of the "Fail in Place" function if the current position is to be held when switching on again following failure of the electric auxiliary power.

### 3.2 Structure

#### 3.2.1 Design overview

The following sections describe the mechanical and electrical structure, components, and principle functionality of the positioner.

The positioner and the PROFIBUS PA communication interface function as components in a digital process automation system. It functions as a slave and communicates with the master through the PROFIBUS PA fieldbus. Apart from communication, the fieldbus also supplies electrical auxiliary power to the positioner.

3.2 Structure

The positioner is used to move and control pneumatic actuators. The positioner works electropneumatically, using compressed air as auxiliary power. The positioner is used to control valves, for example, with:

- Linear actuator
- Part-turn actuator VDI/VDE 3845

Various add-on extensions are available for linear actuators:

- IEC 60534-6-1 (NAMUR)
- Integrated mounting ARCA, except with flameproof versions
- Integrated addition to SAMSON in non-flameproof aluminum enclosure



- ① Pressure gauge block, single-acting
- ② Valve
- ③ Yoke / actuator yoke
- ④ Single-acting positioner in non-flameproof aluminum enclosure
- ⑤ Actuator

Figure 3-1 Positioner attached to a single-acting linear actuator

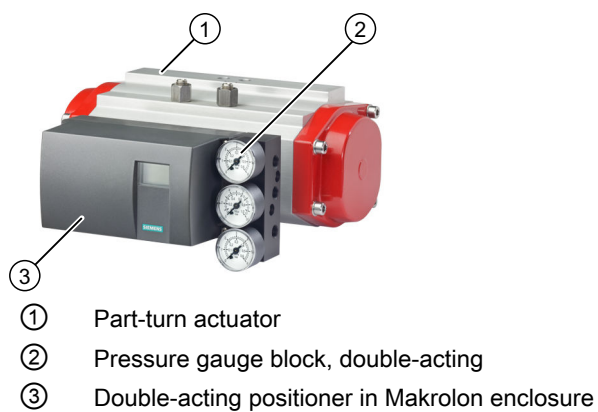

Figure 3-2 Positioner attached to double-acting part-turn actuator

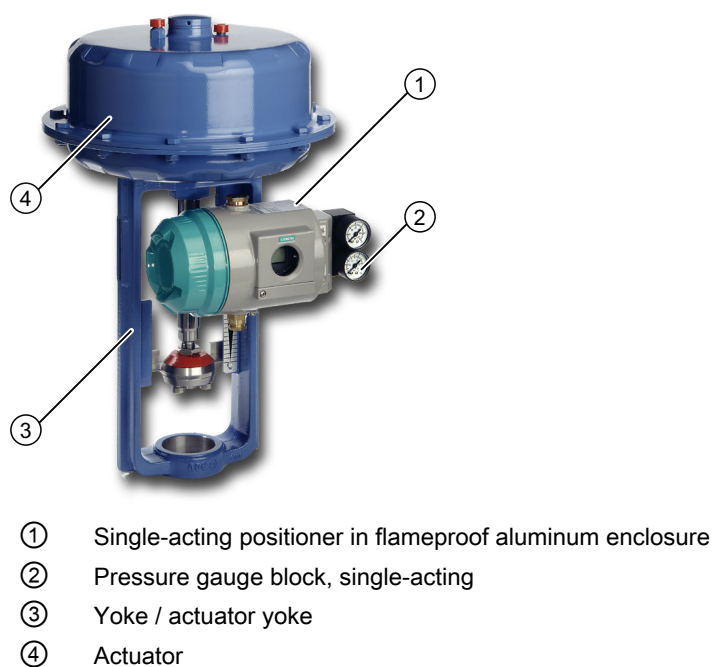
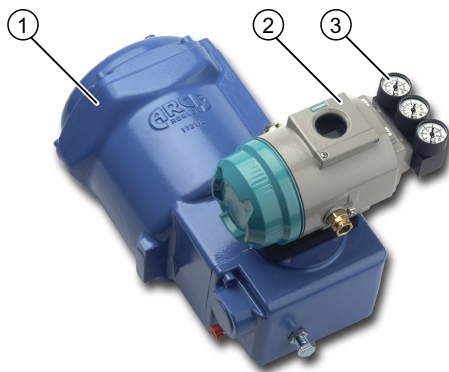

Figure 3-3 Positioner in flameproof aluminum enclosure attached to linear actuator



- ① Part-turn actuator
- ② Double-acting positioner in flameproof aluminum enclosure
- ③ Pressure gauge block, double-acting

Figure 3-4 Positioner in flameproof aluminum enclosure attached to part-turn actuator

### 3.2.2 Nameplate layout

#### Layout of the nameplate

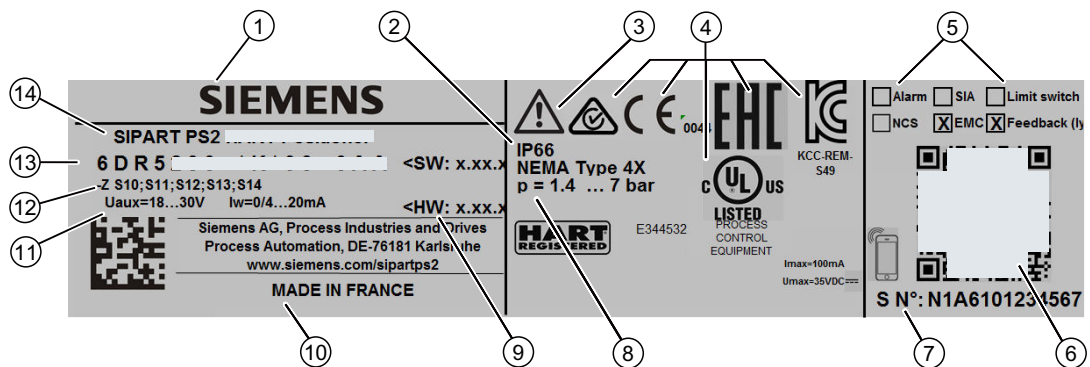

- ① Manufacturer
- ② Protection class
- ③ Consult operating instructions
- ④ Conformity with country-specific directives
- ⑤ Built-in option module
- ⑥ QR code to the mobile website with device-specific information on the product
- ⑦ Serial number
- ⑧ Auxiliary power (supply air PZ)
- ⑨ Software/hardware version
- ⑩ Place of manufacture
- ⑪ Auxiliary power
- ⑫ Ordering supplement (Order code)
- ⑬ Article number
- ⑭ Product name

Figure 3-5 Nameplate layout, example



### Layout of Ex nameplate

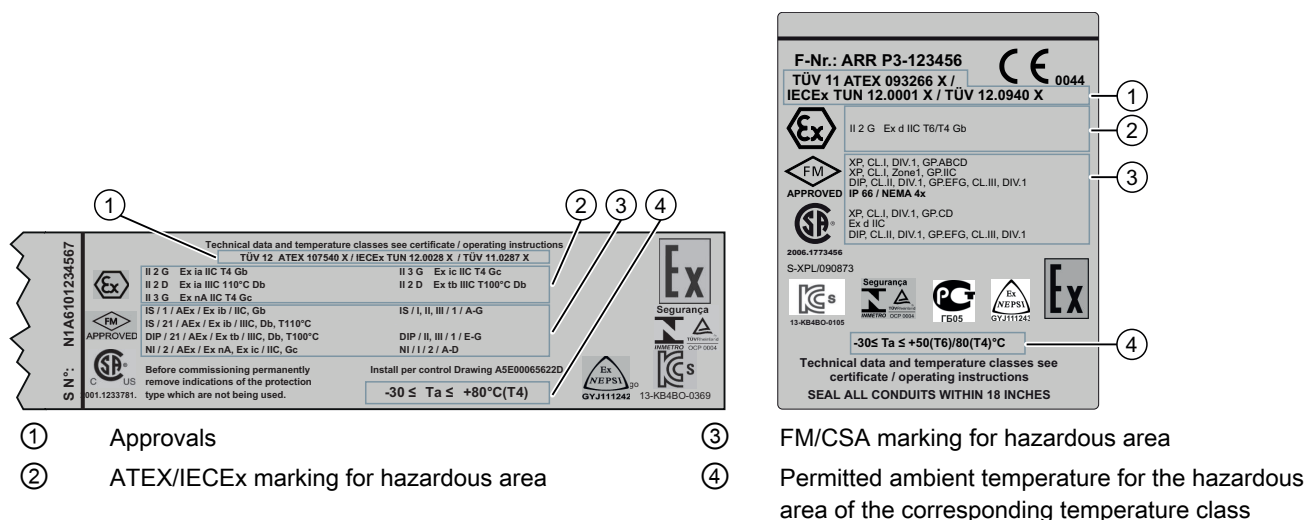

Figure 3-6 Ex nameplate layout, example

## 3.2.3 Explanation of Ex information

### Explanation of Ex information

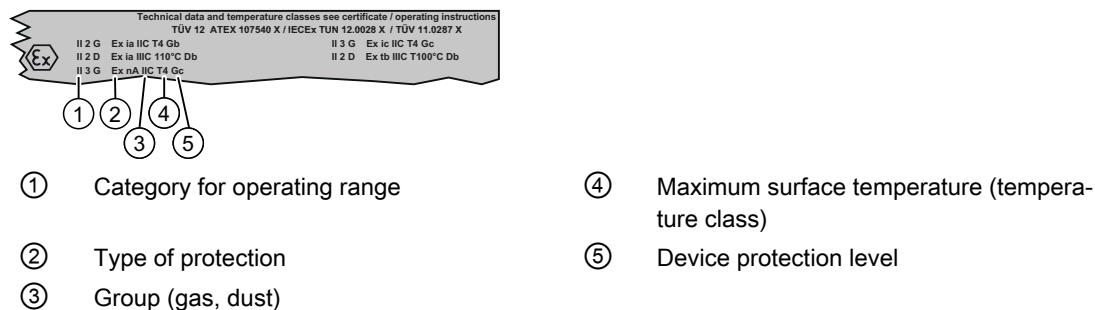
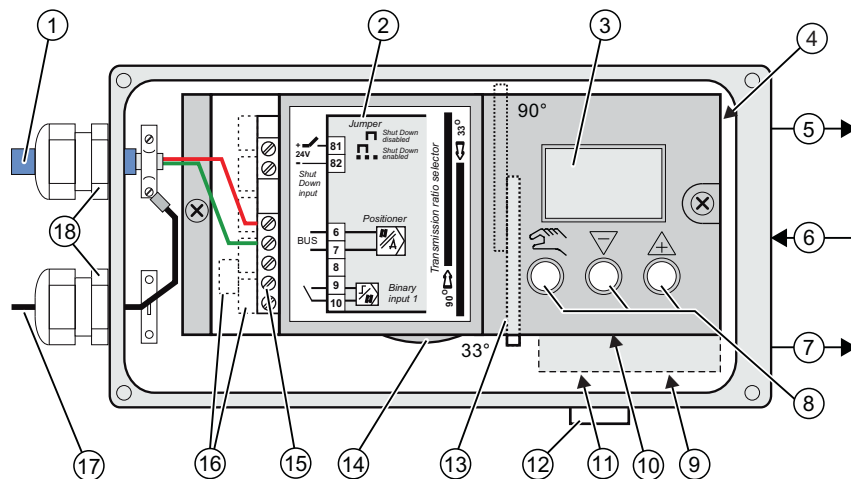

Figure 3-7 Explanation of Ex information

### 3.3 Device components

#### 3.3.1 Overview of device components



- |   |  |
|---|--|
| ① Bus cable                                 | ⑩ Restrictor Y1 for single-acting actuators          |
| ② Wiring diagram on module cover            | ⑪ Restrictor Y1 for double-acting actuators          |
| ③ Display                                   | ⑫ Exhaust air outlet with a sound absorber           |
| ④ Purging air selector                      | ⑬ Transmission ratio selector                        |
| ⑤ Output: Actuating pressure Y1             | ⑭ Friction clutch adjustment wheel                   |
| ⑥ Input: Supply air                         | ⑮ Basic electronics                                  |
| ⑦ Output: Actuating pressure Y2             | ⑯ Connecting terminals of option modules             |
| ⑧ Buttons                                   | ⑰ Shield connection (only with a Makrolon enclosure) |
| ⑨ Restrictor Y2 for double-acting actuators | ⑱ Cable gland  |

Figure 3-8 View of the positioner (cover open; Makrolon enclosure)

## 3.3.2 Overview of device components (Ex)

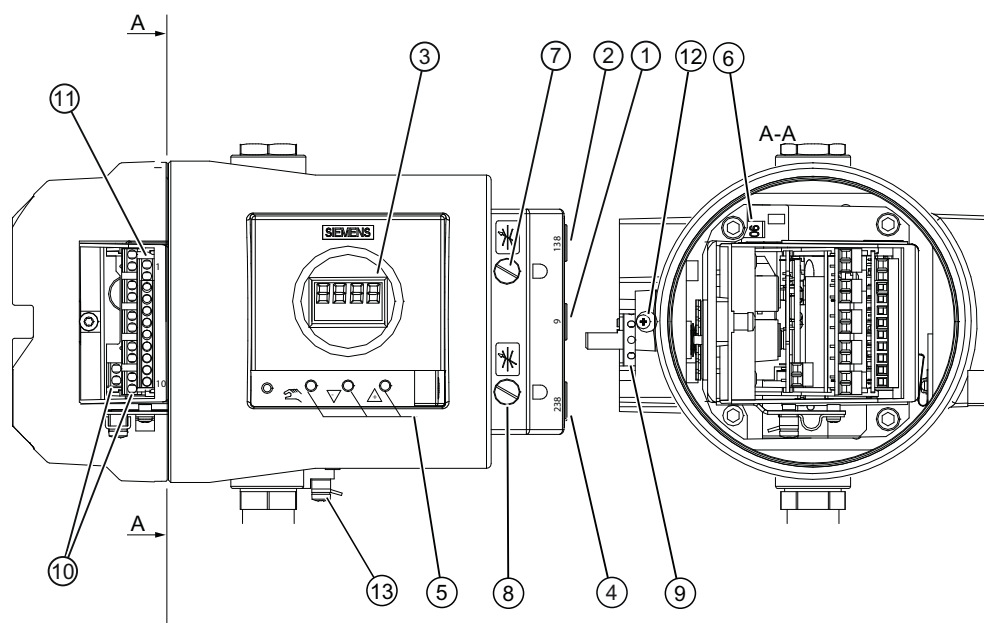

- |   |   |   |   |
|---|---|---|---|
| ① | Input: Supply air PZ                        | ⑧ | Restrictor Y2 <sup>1)</sup>               |
| ② | Output: Actuating pressure Y1               | ⑨ | Friction clutch adjustment wheel          |
| ③ | Display                                     | ⑩ | Connecting terminals of option modules    |
| ④ | Output: Actuating pressure Y2 <sup>1)</sup> | ⑪ | Connecting terminals of basic electronics |
| ⑤ | Buttons                                     | ⑫ | Safety catch                              |
| ⑥ | Transmission ratio selector <sup>2)</sup>   | ⑬ | Ground terminal                           |
| ⑦ | Restrictor Y1                               |   |   |

<sup>1)</sup> for double-acting actuators

<sup>2)</sup> only possible when positioner is open

Figure 3-9 View of positioner in flameproof enclosure, cover opened

### 3.3.3 Basic electronics

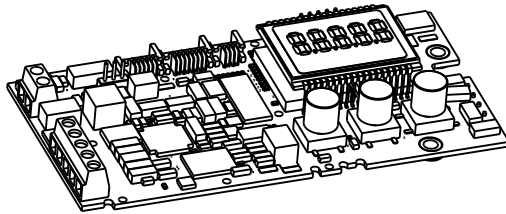

Figure 3-10 Basic electronics, schematic representation

The basic electronics contains:

- CPU
- Memory
- Analog-to-digital converter
- Display
- Buttons
- Terminal strips to connect the option module to the basic electronics

## 3.4 Functional principle

### Control loop

The electropneumatic positioner forms a control loop with the pneumatic actuator:

- The actual value  $x$  represents the position of the actuator spindle for linear actuators or the position of the actuator shaft for part-turn actuators.
- The higher-level control loop provides the setpoint  $w$ .

The stroke or rotary movement of the actuator is transferred to a potentiometer using suitable attachments, positioner shaft and a backlash-free, switchable gear drive, and then to the analog input of the microcontroller.

The current position can also be forwarded to the positioner using an external sensor. A **Non-Contacting Position Sensor (NCS)** is used to record the stroke or rotary angle directly on the actuator.

The microcontroller:

- Corrects the angle error of the shaft pick-up if necessary.
- Compares the potentiometer voltage as actual value  $x$  with setpoint  $w$ .
- Calculates the manipulated variable increments  $\pm\Delta y$ .

The piezo-controlled inlet or exhaust air valve is opened depending on the magnitude and direction of the control deviation ( $x-w$ ). The actuator volume integrates the controller increment for the actuating pressure  $y$  which is proportional to the drive rod or the drive shaft. This controller increment change the actuating pressure until the control deviation becomes zero.

Pneumatic actuators are available in single and double-acting versions. In a single-acting version, only one pressure chamber is ventilated and depressurized. The pressure developed works against a spring. In a double-acting version, two pressure chambers work against each other. Ventilating the volume of one chamber simultaneously depressurizes the volume of the other.

## Control algorithm

The control algorithm is an adaptive, predictive five-point controller.

In case of large control deviations, the valves are controlled using permanent contact. This takes place in the so-called fast step zone.

In case of medium control deviations, valves are controlled using pulse-length modulated pulses. This takes place in the so-called slow step zone.

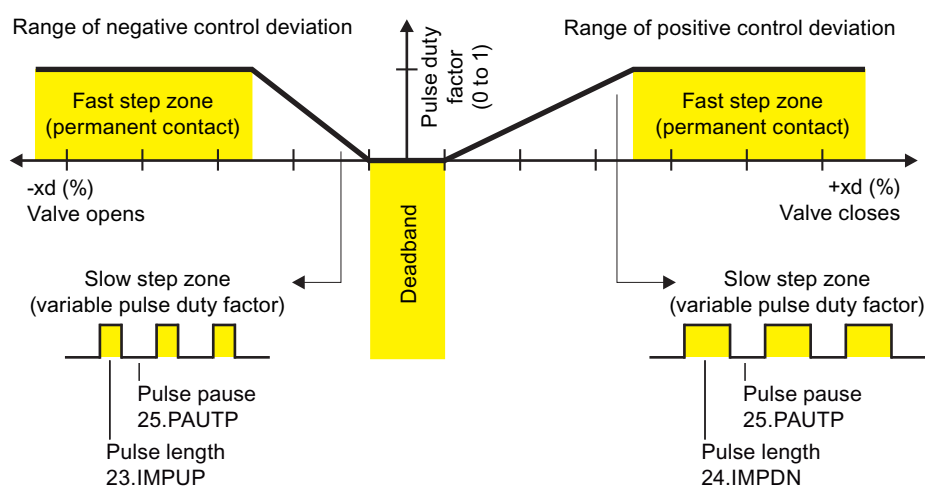

Figure 3-11 Functional principle of five-point controller

Small control deviations do not send control pulses in the zone. This takes place in the so-called adaptive deadband. The deadband adaptation and the continuous adaptation of minimum pulse lengths in "Automatic" mode ensure the best possible control accuracy with the smallest number of operating cycles. The start parameters are determined during the initialization phase and stored in the non-volatile memory. The most important start parameters are:

- The real actuator travel with end positions
- Travel times
- The deadband size

The number of fault messages, changes in direction, and the number of total strokes are continuously determined during operation and saved every 15 minutes. You can read and document these parameters using communication programs such as SIMATIC PDM and AMS. By comparing the old values with the current ones, you can draw conclusions about the wear and tear of the valve. You can use the diagnostics function for this.

### 3.4.1 PROFIBUS system configuration

#### Overview

The positioner can be used in a number of system configurations.

Use with the SIMATIC PCS 7 Automation System is described below.

#### System communication

The Operator Station of the SIMATIC PCS 7 process control system allows easy and safe control of the process by the operating personnel using OS Multi-Clients.

The Maintenance Station assists the maintenance engineer in guaranteeing high plant availability, securing this long-term using optimization measures, and implementing the maintenance measures using a minimum of personnel, materials, energy, costs etc.

The field devices are integrated over PROFIBUS PA with:

- PA Link to the gateway between PROFIBUS PA and PROFIBUS DP
- Control system, e.g. SIMATIC PCS 7 Automation System, which communicates over PROFIBUS
- Engineering Station, SIMATIC PDM (Process Device Manager) which communicates over Industrial Ethernet

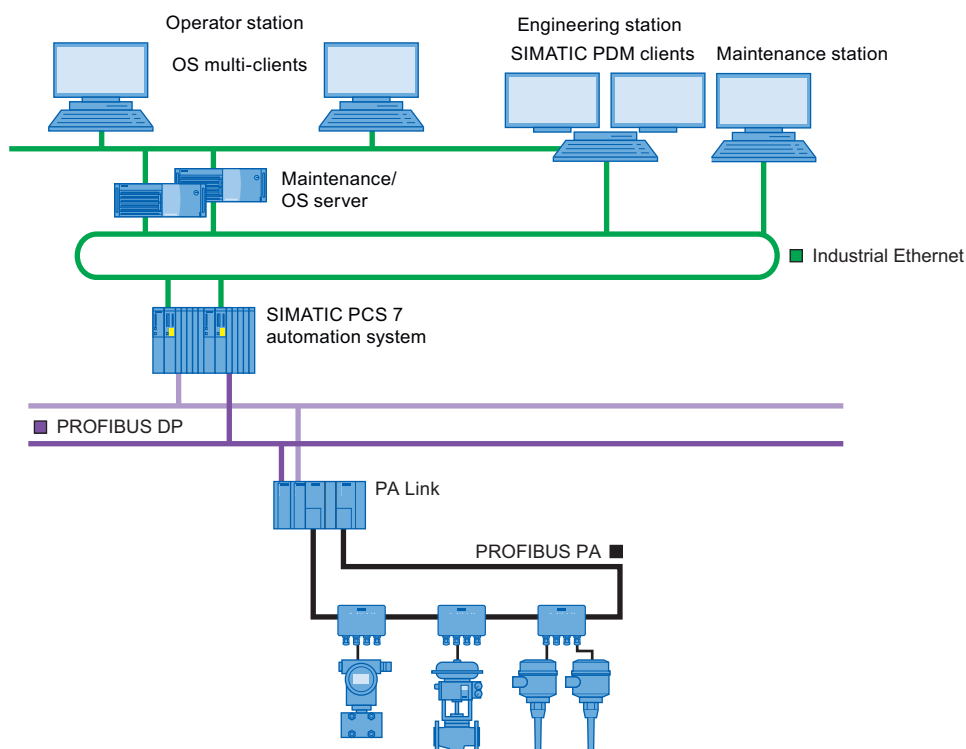

Figure 3-12 Typical system configuration

### 3.4.2 SIMATIC PDM

SIMATIC PDM is a software package for configuring, parameter assignment, commissioning, diagnostics and maintenance of this device and other process devices.

SIMATIC PDM offers simple monitoring of process values, alarms, and device status information.

SIMATIC PDM allows the process device data to be:

- displayed
- set
- modified
- saved
- diagnosed
- checked for plausibility
- managed
- simulated

Additional information on SIMATIC PDM can be found at SIMATIC PDM instructions and manuals (<https://support.industry.siemens.com/cs/products?dtp=Manual&pnid=16983&lc=en-VW>).

## 3.5 PROFIBUS PA

### 3.5.1 Overview

The Process Fieldbus (PROFIBUS) is an open communications system for automation technology and is specified in the international standard IEC 61158.

PROFIBUS Process Automation (PROFIBUS PA) is a variant of PROFIBUS Decentral Peripherals (PROFIBUS DP), which is widely used in process technology.

### 3.5.2 Transmission technology

PROFIBUS PA uses a special transmission technology, enabling it to fulfill the requirements of process automation and process technology. This transmission technology is defined in the international standard IEC 61158-2. The low transmission rate reduces the power loss in comparison to PROFIBUS DP, enabling an intrinsically safe technology for use in hazardous zones with explosive atmospheres. The PROFIBUS PA and PROFIBUS DP protocols are identical.

### 3.5.3 Bus topology

The bus topology is mainly able to be selected as desired. Therefore, line, star and tree structures, and mixed forms are possible. All types of field devices such as transmitters, actors, analysis devices, etc. can be connected to the PROFIBUS PA.

Advantages include:

- Savings on installation costs
- More extensive diagnostics, leading to increased availability of installation sections
- Automatic management of installation documentation
- Installation optimization on the fly during operation

In an automation system, there are generally multiple PROFIBUS PA lines connected to fast PROFIBUS DP via coupler units. This is also connected to the process control system.

Both bus systems use the same protocol layer. This makes PROFIBUS PA a "communications-compatible" extension of the PROFIBUS DP into the field.

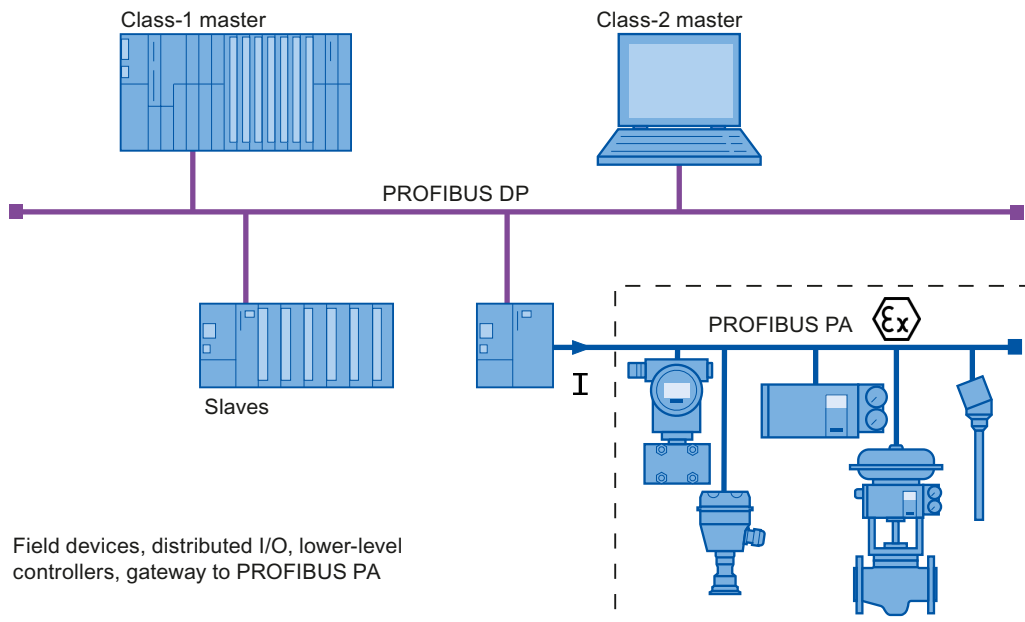

Figure 3-13 Functional principle of the PROFIBUS automation system

The figure shows a section of a typical PROFIBUS automation system. The control system consists of two masters with distributed tasks.

The class-1 master recognizes the control and regulation tasks. The class-2 master enables the operating and monitoring functions. Between the class-1 master and the field devices there is a periodic exchange of measurement and settings data. The status information from the field devices is transmitted parallel to this data, and evaluated in the class-1 master. Assignment of parameters for the field devices or the reading of additional device information is not performed during periodic operation.

Besides periodic operation, one or more class-2 masters can access the field devices asynchronously. Using this type of communication, additional information can be retrieved from the devices or settings sent to them.



### 3.5.4 Properties

PROFIBUS PA allows bidirectional communication between a bus master and field devices. At the same time, the shielded two-strand wiring provides auxiliary power to the two-wire field devices.

### 3.5.5 Profile

As an extension to the EN 50170 standard, the PROFIBUS user organization (PNO) defined the functionality of the individual field device types in a so-called profile description. This profile determines minimum functional requirements and optional extensions. The device-internal "Device Management" provides the configuration tool of the control system with all necessary basic information to find profile parameters. One parameter assignment tool serves all profile-conforming devices, regardless of type or manufacturer.

Depending on the size of the installation (and therefore the number of field devices) and the time behavior required, you implement the system with one or more PROFIBUS PA strands. One PROFIBUS PA strand consists of the components shown in the following figure.

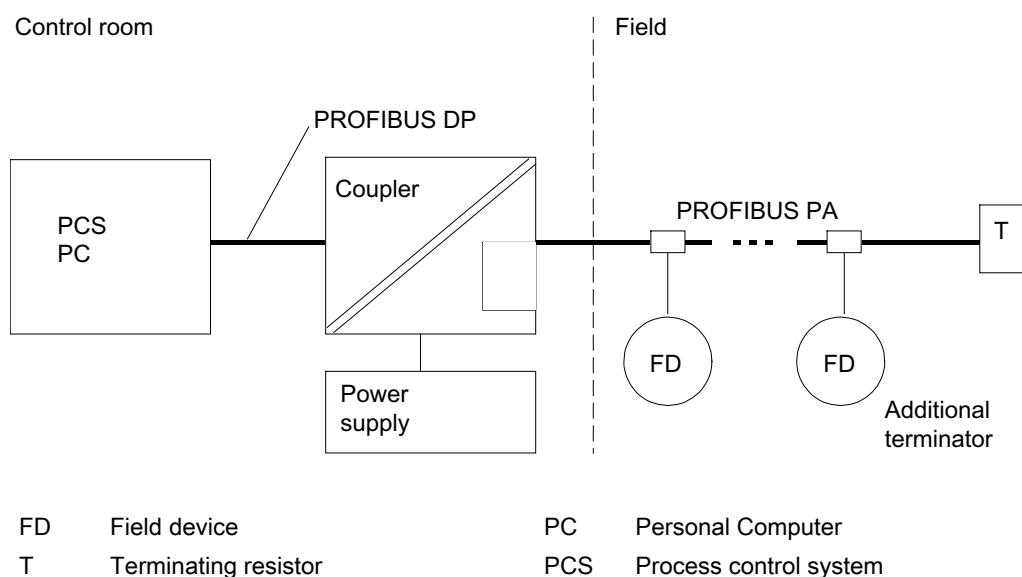

Figure 3-14 PROFIBUS PA strand

### Reference

PNO PROFIBUS-PA interest group

### 3.5.6 Connection

Control is performed by the central process control system (PCS) or by a PC for lower-performance requirements.

### 3.5 PROFIBUS PA

In general, the following functions are combined into one coupling assembly:

- DP/PA signal transfer
- Bus power
- Bus termination

Depending on the number of the PROFIBUS PA field devices to be operated in the automation system and the time behavior required, a DP/PA coupler or a DP/PA link is used. For standard requirements, you use a DP/PA coupler; for higher requirements, a more powerful DP/PA link.

For reasons related to transmission technology, the bus is also equipped on the far end with a terminating resistance T. When using the recommended bus cable, the theoretical maximum cable length is 1900 meters. The theoretical maximum cable length is the sum of all cable segments. During planning, also take into account the voltage drop over the wires powering the field devices.

However, the power requirements of the individual nodes and the voltage drop on the cable must also be calculated during projection. The individual field devices (FD) can be connected at nearly any point in the bus system.

DP/PA couplers or DP/PA links are supplied using a safety extra-low voltage (SELV) power supply. This power supply must have sufficient reserves to bridge over temporary power failures.

The maximum number of devices which can be connected to one bus strand depends on their power consumption and the conditions of use. When operated in the safe zone, the couplers or links supply the bus with up to 400 mA.

When operated in explosive atmospheres, intrinsic safety is only guaranteed if all devices, components, etc. connected to the bus (e.g. bus terminator) fulfill the following requirements:

- They are certified as intrinsically safe equipment.
- They fulfill the requirements of the FISCO model (Fieldbus Intrinsic Safety Concept).

Power supply devices in particular (bus couplers) must be certified as so-called FISCO power supplies. Observe the safety-relevant maximum values and other specifications of the EG type test certificate.

Connect power supplies (bus couplers) which are not explosion protected and certified to intermediate EX-certified zener barriers. Observe the specifications of the EG type test certificate.

 **WARNING**

For power supply to intrinsically safe PROFIBUS, use only power supplies, DP/PA couplers, or DP/PA links certified as compliant with the FISCO model.

Switch through zener barriers if using non-EX-protected power supplies. See the requirements of the EG type test certificate.

### 3.5.7 Number of connectable devices

The number of devices which can be connected to a bus strand can be calculated from the sum of the maximum power consumption of the devices and the power available. By default, assume 10 mA per device. For safety reasons, plan for a power reserve. Otherwise you run the risk of a defective device overloading the bus with an increased power consumption. This can interrupt the power supply and communication with the functioning nodes. The amount of power reserved is based on the nominal power increase given by the manufacturer in case of failure.

### 3.5.8 Assigning the device addresses

So that the connected process devices can be distinguished from one another, each device has its own address.

Be sure that the device addresses are set before operating two or more field devices on the bus. Each address may only be given once to make sure they are unique.

Principally, the address range is from 1 to 125. The address 126 is set for the delivery state. Normally, masters in PROFIBUS systems receive lower addresses. Therefore, we recommend starting at 30 when assigning addresses to the positioners. Either use the keys on the positioner or the SIMATIC PDM software via the bus to set the addresses. In the last case, a new positioner is always connected to the bus and the new address is set via the software. The next positioner is then connected to the bus and processed the same way.

We recommend writing the set address on the field device with a wipe resistant pen.

#### See also

Process instrumentation catalog (<http://www.siemens.com/processinstrumentation/catalogs>)

*Description*

---

*3.5 PROFIBUS PA*

## Installing/mounting

### 4.1 Basic safety instructions

 <b>WARNING</b>
<b>Unsuitable device for the hazardous area</b>
Danger of explosion.
<ul style="list-style-type: none"><li>• Only use equipment that is approved for use in the intended hazardous area and labelled accordingly.</li></ul>

 <b>WARNING</b>
<b>High operating force with pneumatic actuators</b>
Risk of injury when working on control valves due to the high operating force of the pneumatic actuator.
<ul style="list-style-type: none"><li>• Please observe the corresponding safety instructions for the pneumatic actuator in use.</li></ul>

 <b>WARNING</b>
<b>Lever for position detection</b>
Danger of crushing and shearing with mounting kits which use a lever for position detection. During commissioning and ongoing operation, severing or squeezing of limbs could occur as a result of the lever. Risk of injury when working on control valves due to the high operating force of the pneumatic actuator.
<ul style="list-style-type: none"><li>• Do not reach into the range of motion of the lever following mounting of the positioner and mounting kit.</li></ul>

 <b>WARNING</b>
<b>Impermissible accessories and spare parts</b>
Danger of explosion in areas subject to explosion hazard.
<ul style="list-style-type: none"><li>• Only use original accessories or original spare parts.</li><li>• Observe all relevant installation and safety instructions described in the instructions for the device or enclosed with the accessory or spare part.</li></ul>

 <b>WARNING</b>
<b>It is possible to damage the cover gasket</b>
If the cover gasket is not positioned correctly in the groove of the base plate, it could be damaged when the cover is mounted and screwed tight.
<ul style="list-style-type: none"><li>• Therefore make sure that the gasket is seated correctly.</li></ul>

 <b>WARNING</b>
<b>Open cable inlet or incorrect cable gland</b>
Danger of explosion in hazardous areas.
<ul style="list-style-type: none"><li>• Close the cable inlets for the electrical connections. Only use cable glands or plugs which are approved for the relevant type of protection.</li></ul>

 <b>WARNING</b>
<b>Exceeded maximum ambient or process media temperature</b>
Danger of explosion in hazardous areas.
Device damage.
<ul style="list-style-type: none"><li>• Make sure that the maximum permissible ambient and process media temperatures of the device are not exceeded. Refer to the information in Chapter "Technical data (Page 283)".</li></ul>

 <b>CAUTION</b>
<b>Unsuitable compressed air</b>
Device damage. As a general rule, the positioner must only be operated with dry and clean compressed air.
<ul style="list-style-type: none"><li>• Use the customary water separators and filters. An additional dryer is required in extreme cases.</li><li>• Use dryers, especially if you operate the positioner at low ambient temperatures.</li></ul>

 **CAUTION**

**Please note the following before working on the control valve and when attaching the positioner**

Danger of injury.

- Prior to working on the control valve, you must move the control valve into a completely pressureless state. Proceed as follows:
  - Depressurize the actuator chambers.
  - Switch off the supply air PZ.
  - Lock the valve in its position.
- Make sure that the valve has reached the pressureless state.
- If you interrupt the pneumatic auxiliary power to the positioner, the pressureless position may only be reached after a certain waiting time.
- When mounting, observe the following sequence imperatively to avoid injuries or mechanical damage to the positioner/mounting kit:
  - Mount the positioner mechanically.
  - Connect the electrical auxiliary power supply.
  - Connect the pneumatic auxiliary power supply.
  - Commission the positioner.

 **WARNING**

**Mechanical impact energy**

In order to ensure the degree of protection of the housing (IP66), protect the housing versions of the positioners listed here from mechanical impact energy:

- 6DR5..3; not greater than 2 Joule
- 6DR5..0; not greater than 1 Joule
- 6DR5..1 with inspection window; not greater than 1 Joule

**NOTICE**

**Torque with NPT screwed gland**

Device damage. The maximum torque of the cable gland must not be exceeded.

- To avoid damage to the device, the NPT adapter must be held in place while the NPT gland is screwed into the NPT adapter. Refer to the section "Technical specifications > Construction (Page 284)" for the torque value.

### 4.1.1 Proper mounting

<b>NOTICE</b>
<b>Incorrect mounting</b> The device can be damaged, destroyed, or its functionality impaired through improper mounting. <ul style="list-style-type: none"><li>• Before installing ensure there is no visible damage to the device.</li><li>• Make sure that process connectors are clean, and suitable gaskets and glands are used.</li><li>• Mount the device using suitable tools. Refer to the information in Technical data (Page 283) for installation torque requirements.</li></ul>

 <b>CAUTION</b>
<b>Loss of degree of protection</b> Damage to device if the enclosure is open or not properly closed. The degree of protection specified on the nameplate or in Chapter "Technical data (Page 283)" is no longer guaranteed. <ul style="list-style-type: none"><li>• Make sure that the device is securely closed.</li></ul>

## 4.2 Mounting the linear actuator

### Requirements

There are linear actuators for standard mounting in accordance with IEC 60534 and for integrated mounting. Use the reduced mounting kit 6DR4004-8VK for actuators with integrated mounting. Integrated mounting is not possible with flameproof stainless steel enclosure (6DR5..6).

This section describes how to connect the positioner to the actuator using the mounting kit 6DR4004-8V. You require different installation parts of this mounting kit depending on the selected actuator type. All installation parts listed in the following table are included in the product package of the mounting kit 6DR4004-8V. The mounting kit is suitable for a stroke of 3 to 35 mm. In the event of a larger range of stroke, you require the accessory "Lever for



strokes greater than 35 to 130 mm", article number 6DR4004-8L, in addition to the mounting set 6DR4004-8V. Keep the suitable installation parts ready:

Actuator type	Required installation components	
Yoke with fin	<ul style="list-style-type: none"> <li>Hexagon bolt ⑧</li> <li>Washer ⑪</li> <li>Spring lock washer ⑩</li> </ul>	
Yoke with plane surface	<ul style="list-style-type: none"> <li>Four hexagon bolts ⑧</li> <li>Washer ⑪</li> <li>Spring lock washer ⑩</li> </ul>	
Yoke with columns	<ul style="list-style-type: none"> <li>Two U-bolts ⑦</li> <li>Four hexagon nuts ⑫</li> <li>Washer ⑪</li> <li>Spring lock washer ⑩</li> </ul>	

## Procedure

"Linear actuator IEC 60534 (3 to 35 mm)" mounting kit 6DR4004-8V and 6DR4004-8L			
Sr. no. ʹ	Quantity	Name	Note
①	1	NAMUR mounting bracket IEC 60534	Standardized connection point for mount with fin, column or plane surface
②	1	Pick-up bracket	Guides the pulley with the carrier pin and rotates the lever arm.
③	2	Clamping piece	Installs the pick-up bracket on the actuator spindle

4.2 Mounting the linear actuator

"Linear actuator IEC 60534 (3 to 35 mm)" mounting kit 6DR4004-8V and 6DR4004-8L			
Sr. no. <sup>*)</sup>	Quantity	Name	Note
④	1	Carrier pin	Installation with pulley ⑤ on lever ⑥
⑤	1	Pulley	Installation with carrier pin ④ on lever ⑥
⑥	1	Lever	For the range of stroke from 3 mm to 35 mm The lever 6DR4004-8L is additionally required for ranges of stroke > 35 mm to 130 mm (not included in the scope of delivery).
⑦	2	U-bolts	Only for actuators with columns
⑧	4	Hexagon bolt	M8x20 DIN 933-A2
⑨	2	Hexagon bolt	M8x16 DIN 933-A2, torque see the section "Technical specifications > Construction (Page 284)"
⑩	6	Spring lock washer	A8 - DIN 127-A2
⑪	6	Washer	B8.4 - DIN 125-A2
⑫	2	Washer	B6.4 - DIN 125-A2
⑬	1	Spring	VD-115E 0.70 x 11.3 x 32.7 x 3.5
⑭	1	Spring lock washer	A6 - DIN 137A-A2
⑮	1	Lock washer	3.2 - DIN 6799-A2
⑯	3	Spring lock washer	A6 - DIN 127-A2
⑰	3	Socket cap screw	M6x25 DIN 7984-A2
⑱	1	Hexagon nut	M6 - DIN 934-A4
⑲	1	Square nut	M6 - DIN 557-A4
⑳	4	Hexagon nut	M8 - DIN 934-A4

<sup>\*)</sup> The serial numbers refer to the images of the description of the installation steps below.

1. Install the clamping pieces ③ on the actuator spindle. Use spring lock washers ⑯ and socket cap screws ⑰ for this purpose.
2. Slide the pick-up bracket ② into the milled recesses of the clamping pieces ③.

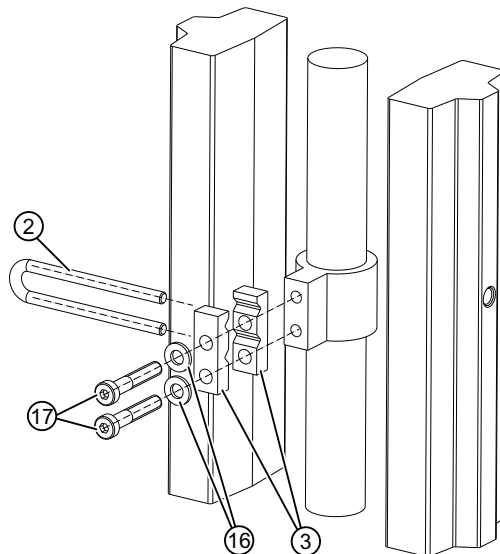

Figure 4-1 Pick-up bracket

3. Set the necessary length.

4. Tighten the screws ⑰ so that you can still shift the pick-up bracket ②.
5. Fix the pre-installed carrier pin ④ to the lever ⑥. Use the flat washer ⑫, spring lock washer ⑭ and hexagon nut ⑱ for this purpose.

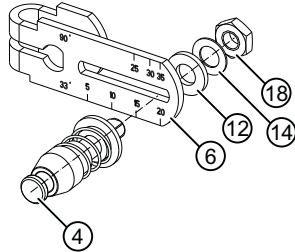

Figure 4-2 Lever with carrier pin

6. Set the stroke value. Use the stroke value specified on the nameplate of the actuator for this purpose. If none of the values on the lever scale matches the stroke value of the actuator, select the next higher value on the scale. Position the pin center ④ on the corresponding value of the scale. If you need the value of actuator travel after initialization in mm: ensure that the configured stroke value matches the value of the "3.YWAY" parameter.
7. Install the following components on the lever ⑥: Socket cap screw ⑰, spring lock washer ⑭, flat washer ⑫, square nut ⑱.

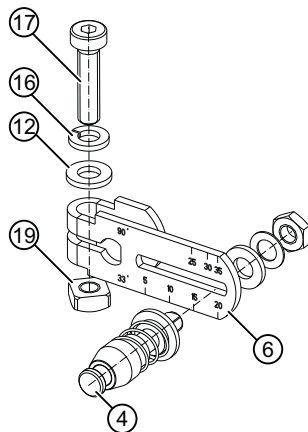

Figure 4-3 Components on the lever

8. Push the pre-installed lever ⑥ up to the endstop on the positioner shaft. Fasten the lever ⑥ with socket cap screw ⑰.

4.2 Mounting the linear actuator

9. Install the mounting bracket ① at the rear side of the positioner. Use 2 hexagon bolts ⑨, 2 spring lock washers ⑩ and 2 flat washers ⑪ for this purpose.

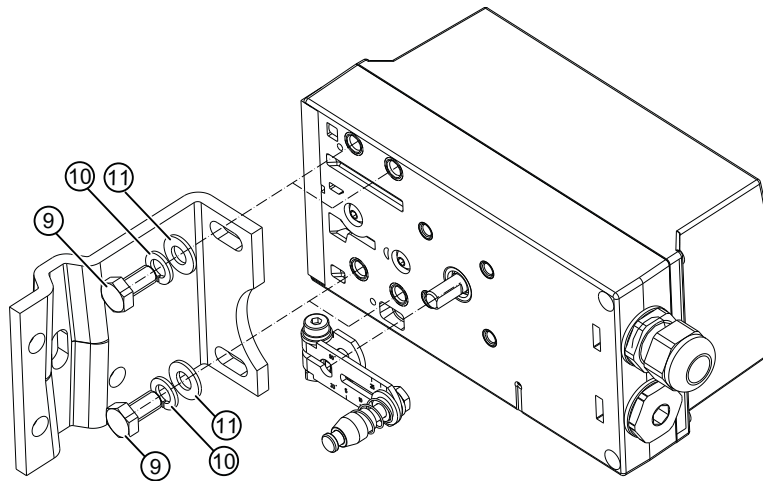

Figure 4-4 Installation with mounting bracket

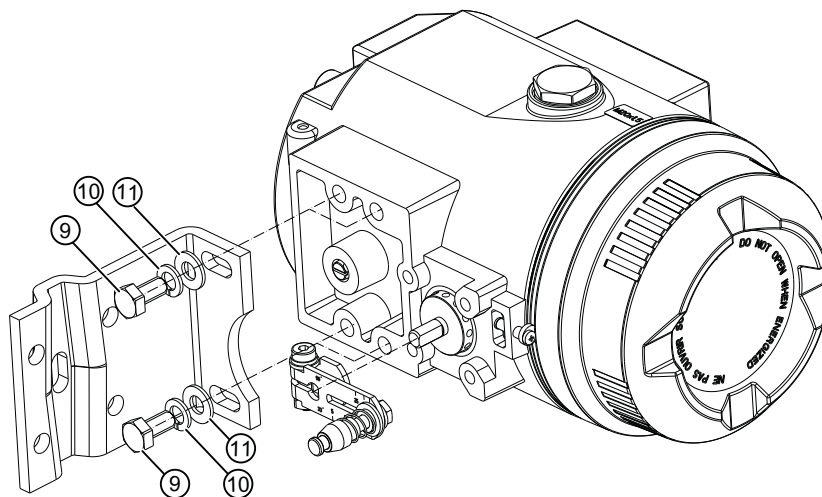

Figure 4-5 Installation with mounting bracket, flameproof enclosure

10. Select the row of holes. The selection of the row of holes depends on the yoke width of the actuator. Select the row of holes in such a way that the carrier pin ④ meshes with the pick-up bracket ② near the spindle. Ensure that the pick-up bracket ② does not touch the clamping pieces ③.
11. Keep the positioner and the fastening bracket on the actuator. Ensure that the carrier pin ④ is guided inside the pick-up bracket ②.

12. Tighten the pick-up bracket ②.
13. Fasten the positioner on the yoke. Use the installation parts suitable for the corresponding actuator.

**Note****Height adjustment of the positioner**

When you fasten the positioner on the yoke, the following applies to its height adjustment:

1. Set the height of the positioner in such a way that the horizontal lever position is near the center of the stroke.
2. Orient yourself by the lever scale of the actuator.
3. If symmetrical mounting is not possible, you must always ensure that the horizontal lever position is maintained within the range of stroke.

## 4.3 Mounting the part-turn actuator

### Requirements

You require an actuator-specific VDI/VDE 3845 mount to install the positioner on a part-turn actuator. Because of the high weight of the version in the flameproof stainless steel enclosure 6DR5..6, you should select a particularly stable mount.

### Procedure

"Part-turn actuator" mounting kit 6DR4004–8D			
Sr. no. *)	Quantity	Name	Note
①	1	Coupling wheel	Installation on positioner shaft
②	1	Carrier	Installation on stump of actuator shaft
③	1	Multiple plate	Display of the position, consisting of scale ⑤ and pointer mark ⑥
④	8	Scale	Different divisions
⑤	2	Pointer mark	Reference arrow for scale
⑥		Mount	Actuator-specific, VDI/VDE 3845
⑦	4	Hexagon bolt	M6x12 DIN 933, torque see the section "Technical specifications > Construction (Page 284)"
⑧	4	Lock washer	S6
⑨	1	Socket cap screw	M6x16 DIN 84
⑩	1	Washer	6.4 DIN 125
⑪	1	Hexagon socket-head screw	For coupling wheel
	1	Machinist's wrench	For hexagon socket-head screw ⑪

\*) The serial numbers refer to the images of the description of the installation steps below.

4.3 Mounting the part-turn actuator

1. Rest the actuator-specific VDI/VDE 3845 mount ⑥ on the rear side of the positioner. Tighten the mount using the hexagon bolts ⑦ and lock washers ⑧.
2. Stick the pointer mark ⑤ on the mount. Position the pointer mark ⑤ at the center of the centering hole.

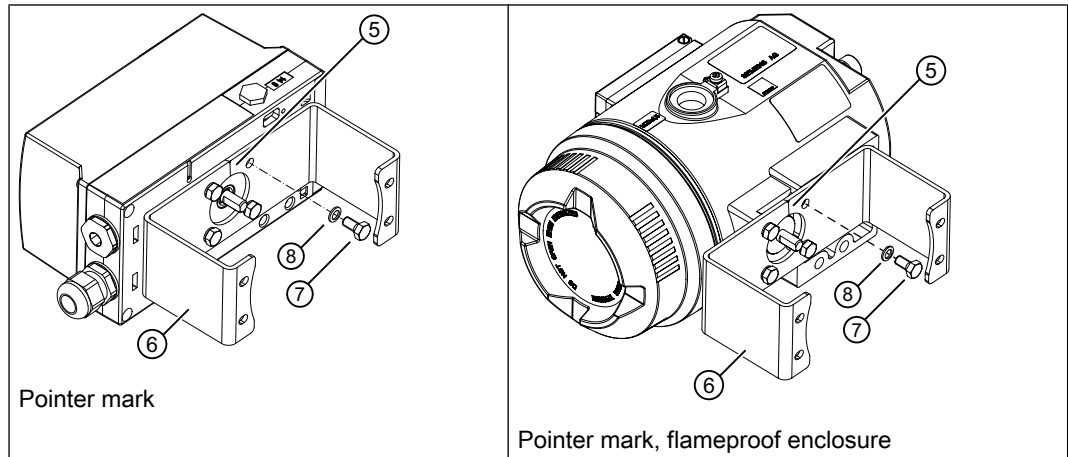

3. Push the coupling wheel ① or the stainless steel coupling up to the endstop on the positioner shaft. Then retract the coupling wheel or the stainless steel coupling by approximately 1 mm. Tighten the hexagon socket-head screw ⑪ using the machinist's wrench provided. Maximum tightening torque = 1 Nm. If you are using the stainless steel coupling, omit the next step.

**Note**

**Coupling wheel**

Instead of the plastic coupling wheel ①, it is possible to use a stainless steel coupling (article number TGX: 16300-1556).

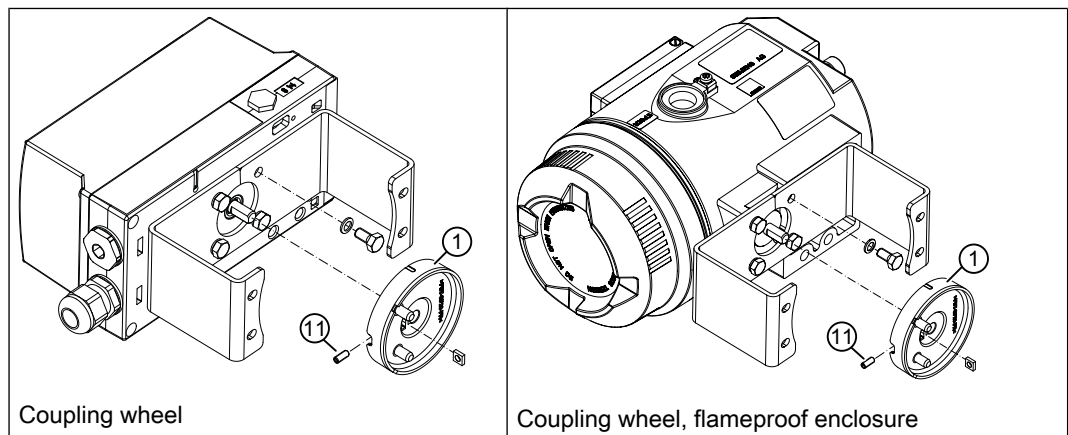

4. Place the carrier ② on the stump of the actuator shaft. Tighten the carrier ② using the socket cap screw ⑨ and the washer ⑩.

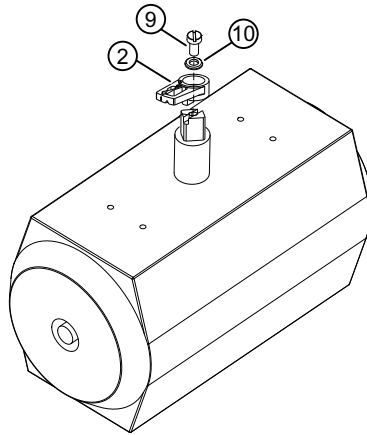

Carrier

4.3 Mounting the part-turn actuator

- 5. Place the positioner and the mount on the actuator carefully. One of the two pins of the coupling wheel ① must fit in the carrier ② when you do this. You need not adjust the friction clutch if you use the pins ⑫ as described below. This greatly simplifies commissioning. Each of the two pins ⑫ has a recess, see the following figures.

For actuators which **close in the clockwise direction**, use the pin on which the recess has a V shape (B).

For actuators which **open in the clockwise direction**, use the pin on which the recess has a rectangular shape (A).

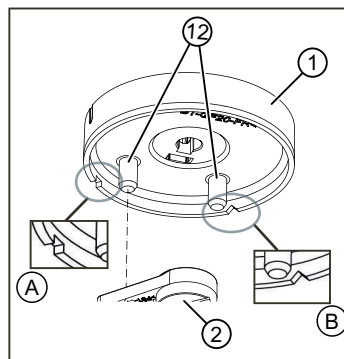
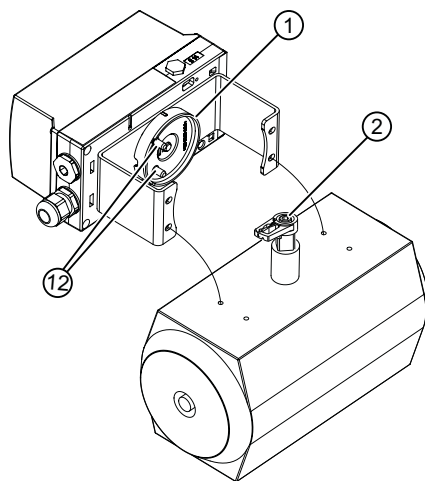

Orientation of mount

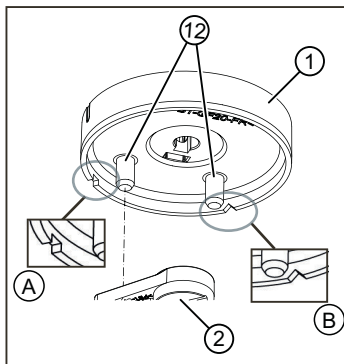
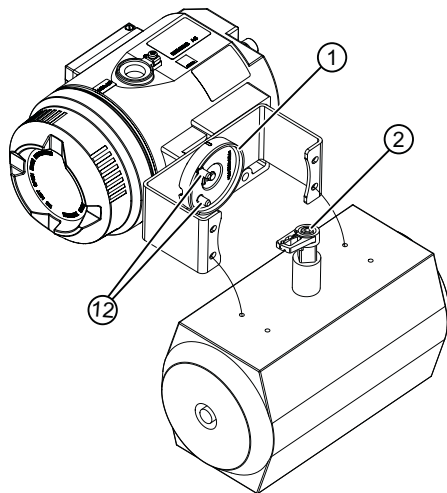

Orientation of mount, flameproof enclosure

- 6. When using the stainless steel coupling (article number TGX: 16300-1556): Place the positioner and the mount on the actuator carefully. Place the stainless steel coupling on the stump of the actuator's positioner shaft.
- 7. Align the positioner/mount at the center of the actuator.
- 8. Tighten the positioner/mount unit.
- 9. Initialize the positioner.



10. After commissioning, drive the positioner to the end position.

11. Stick the scale ④ with the direction of rotation or the swivel range on the coupling wheel ①. The stickers with scale are self-adhesive.

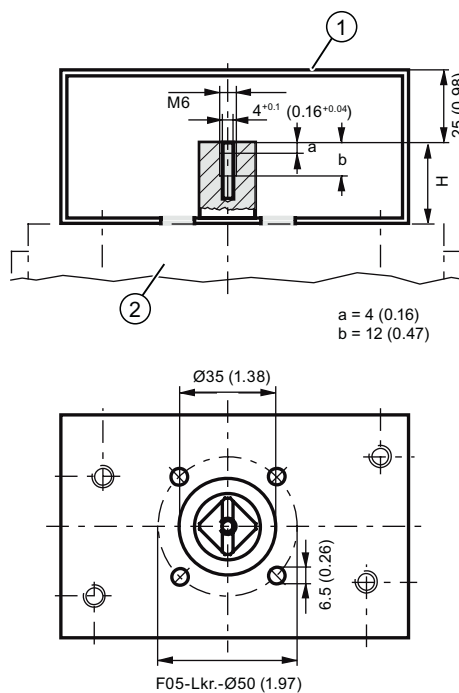
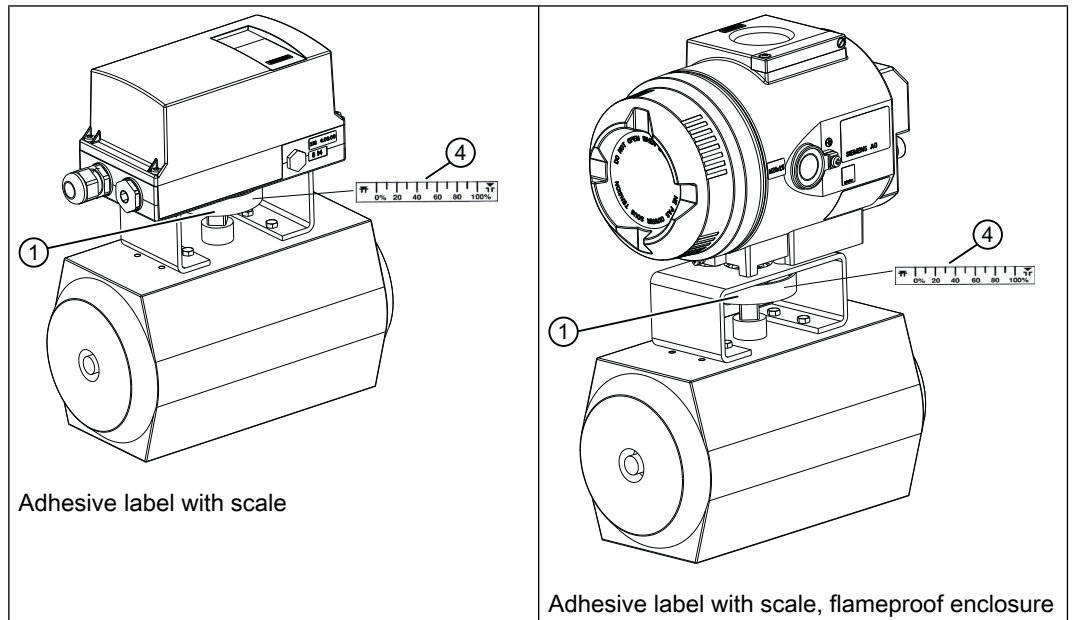

H = height of shaft butt

- ① Fixing level of positioner on mount
- ② Part-turn actuator

Figure 4-6 Dimensions of mount in accordance with VDI/VDE 3845 (depends on actuator)

See also

Preparing part-turn actuators for commissioning (Page 130)

## 4.4 Using the positioner in a humid environment

### Introduction

The positioner enclosure provides IP66 protection with an intended installation position. It can therefore be operated in a moist or wet environment in the mounting positions shown below. Do not use other mounting positions since it would then be possible for liquids, fluff, fibers or dusts to enter the device via the exhaust openings.

### Favorable and unfavorable mounting positions

Avoid the unfavorable mounting positions:

- To prevent fluids seeping through during normal operation of the device, e.g. through exhaust air openings.
- Otherwise the display becomes poorly legible.

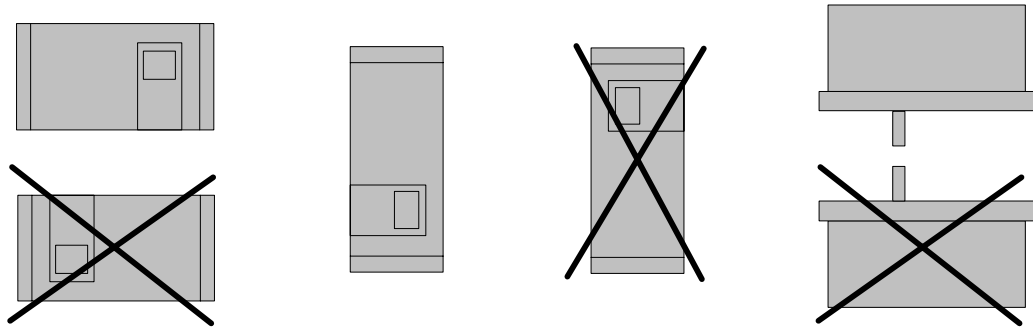

Figure 4-7 Favorable and unfavorable mounting positions

### Additional measures to prevent liquids from seeping through

Take additional measures to prevent liquids from seeping through if the conditions force you to operate the positioner in an unfavorable mounting position.

Additional measures required to prevent liquids from seeping through depend on the selected mounting position. You may also require:

- Gland with sealing ring, e.g. FESTO: CK - 1 / 4-PK-6
- Approximately 20 to 30 cm plastic hose, e.g. FESTO: PUN - 8 x 1.25 SW
- Cable tie; the number and the length depend on the local conditions.

## Procedure

1. Install the casing such that rain water or condensate running along the pipes can be drained before the terminal strip of the positioner.
2. Check the seals of electrical connections for perfect fitting.
3. Check the seal in the enclosure cover for damage and contaminations. Clean and/or replace if required.
4. Install the positioner such that the sintered bronze attenuator at the bottom side of the enclosure points downwards in the vertical mounting position. If this is not possible, replace the attenuator with a suitable gland with a plastic hose.

## Procedure for installing the plastic hose on the gland

1. Unscrew the sintered bronze attenuator from the exhaust air opening at the bottom side of the enclosure.
2. Screw in the aforementioned gland into the exhaust air opening.
3. Install the aforementioned plastic hose into the gland and check whether it fits firmly.
4. Fasten the plastic hose with a cable tie onto the control valve such that the opening points downwards.
5. Ensure that the plastic hose does not have any kinks and the exhaust air flows out without any hindrance.

## 4.5 Position controllers subjected to fast acceleration or strong vibration

### 4.5.1 Introduction locking the setting

The electropneumatic positioner has an gear latch for the friction clutch and for the transmission ratio selector.

Strong acceleration forces act on control valves that are subjected to heavy mechanical loads, e.g. breakaway valves, strongly shaking or vibrating valves, as well as in case of "vapor shocks". These forces may be much higher than the specified data. This may cause the friction clutch to move in extreme cases.

The positioner is equipped with an gear latch for the friction clutch to counter these extreme cases. The setting of the transmission ratio selector can also be locked.

The locking procedure is illustrated and described below.

---

#### Note

#### Use of external NCS sensor / internal NCS module

If you use the accessory part "NCS sensor for contactless position measurement" or a built-in internal NCS module, the locking and fixing measures described in this section are **not** necessary.

---

### 4.5.2 Procedure locking the setting

#### Overview diagram

**NOTICE**

**Wrong registration of the rotary or part-turn movement**

A different setting of the transmission ratio selector and the gear latch results in a hysteresis in position registration. The hysteresis in position registration can result in unstable control behavior of the higher level control loop.

- Make sure the transmission ratio selector ⑤ and the gear latch ① are set to the same value, either to 33° or to 90°.

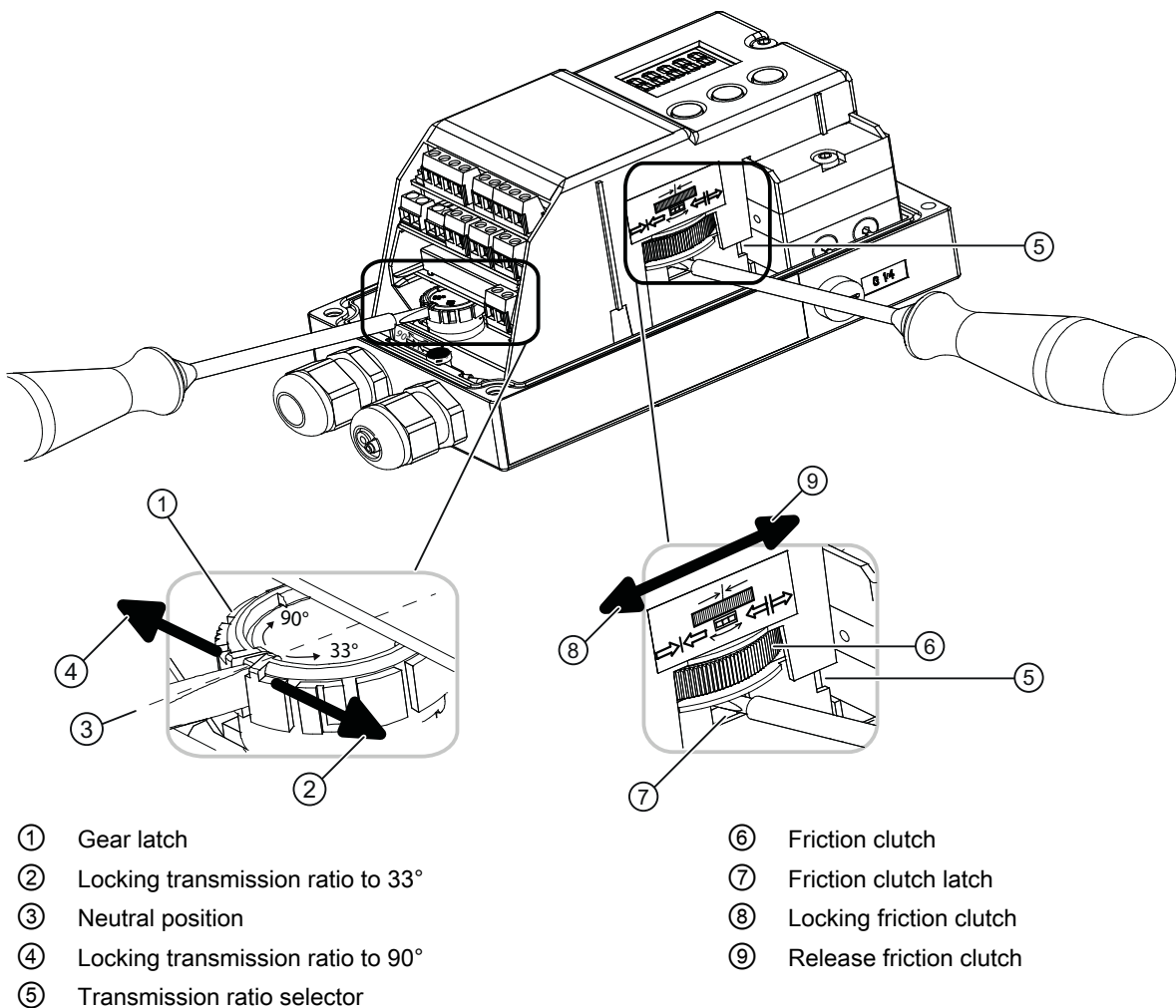

Figure 4-8 Locking friction clutch and transmission ratio

## Requirements

- The positioner is mounted.
- You know whether the transmission ratio is to be set to 33° or 90°.
- The positioner has been commissioned successfully, i.e. initialization was completed with "FINISH".

## Procedure

### NOTICE

#### The following is applicable for the "flameproof enclosure" version:

- A friction clutch is provided on the outside of the positioner shaft. Change the work area using this friction clutch, legend number ⑨ in "Overview of device components (Ex) (Page 27)".
- Do not open the flameproof enclosure of the positioner in explosion-prone atmospheres.

Fix the setting acquired by initialization as follows:

1. Make sure the gear latch ① is in neutral position ③. The neutral position is between 33° and 90°.
2. Make sure the transmission ratio selector ⑤ is in the correct position.
3. Fix the transmission ratio with the gear latch ①. Turn the gear latch ① with a standard approx. 4 mm wide screwdriver until the gear latch ① locks. Turning right locks the transmission ratio to 33° ②. Turning left locks the transmission ratio to 90° ④. The transmission ratio is locked.

### Note

#### Changing the setting of the transmission ratio selector

The setting of the transmission ratio selector ⑤ can only be changed effectively if the gear latch ① is in the neutral position ③.

4. To fix the friction clutch ⑥, insert a standard approx. 4 mm wide screwdriver in the friction clutch gear latch ⑦ (does not apply to device version "Flameproof enclosure").
5. Use the screwdriver to turn the friction clutch gear latch ⑦ anticlockwise until it engages. The friction clutch ⑥ is fixed (does not apply to device version "Flameproof enclosure").

## 4.6 External position detection

### WARNING

#### External position detection system

Versions with flameproof enclosures may not be operated with an external position detection system.

4.7 Installing the optional modules

The aforementioned measures are not adequate in some applications. For example, continuous and strong vibrations, high or too low ambient temperatures and nuclear radiation.

The position detection system and the controller unit are mounted separately for these applications. A universal component is available for this purpose. It is suitable for part-turn and linear actuators. You will require the following:

- An external position detection system with the article number C73451-A430-D78 comprising a positioner enclosure with integrated friction clutch, built-in potentiometer as well as various blanking plugs and seals.
- Or an NCS sensor for contact-free position detection 6DR4004-6N.../8N...
- A positioner
- An EMC filter module with the article number C73451-A430-D23 is provided in a set along with cable clamps and M20 cable glands.

The EMC filter module is used for the controller unit whenever an external position detection system is used instead of the internal position sensor. An external position detection system is, for example, a potentiometer with a 10 kΩ resistance or an NCS sensor.

## 4.7 Installing the optional modules

### 4.7.1 General information about the installation of option modules

#### 4.7.1.1 Unsuitable device for the hazardous area

 <b>WARNING</b>
<b>Unsuitable device for the hazardous area</b>
Danger of explosion.
<ul style="list-style-type: none"><li>• Only use equipment that is approved for use in the intended hazardous area and labelled accordingly.</li></ul>

#### 4.7.1.2 Installing optional modules in the standard and intrinsically safe version

##### Introduction

The following option modules are available for the positioner in the standard and intrinsically safe version:

- Position feedback module
- Alarm module
- SIA module

- Mechanical limit switch module
- Internal NCS module
- EMC filter module

Overview screen

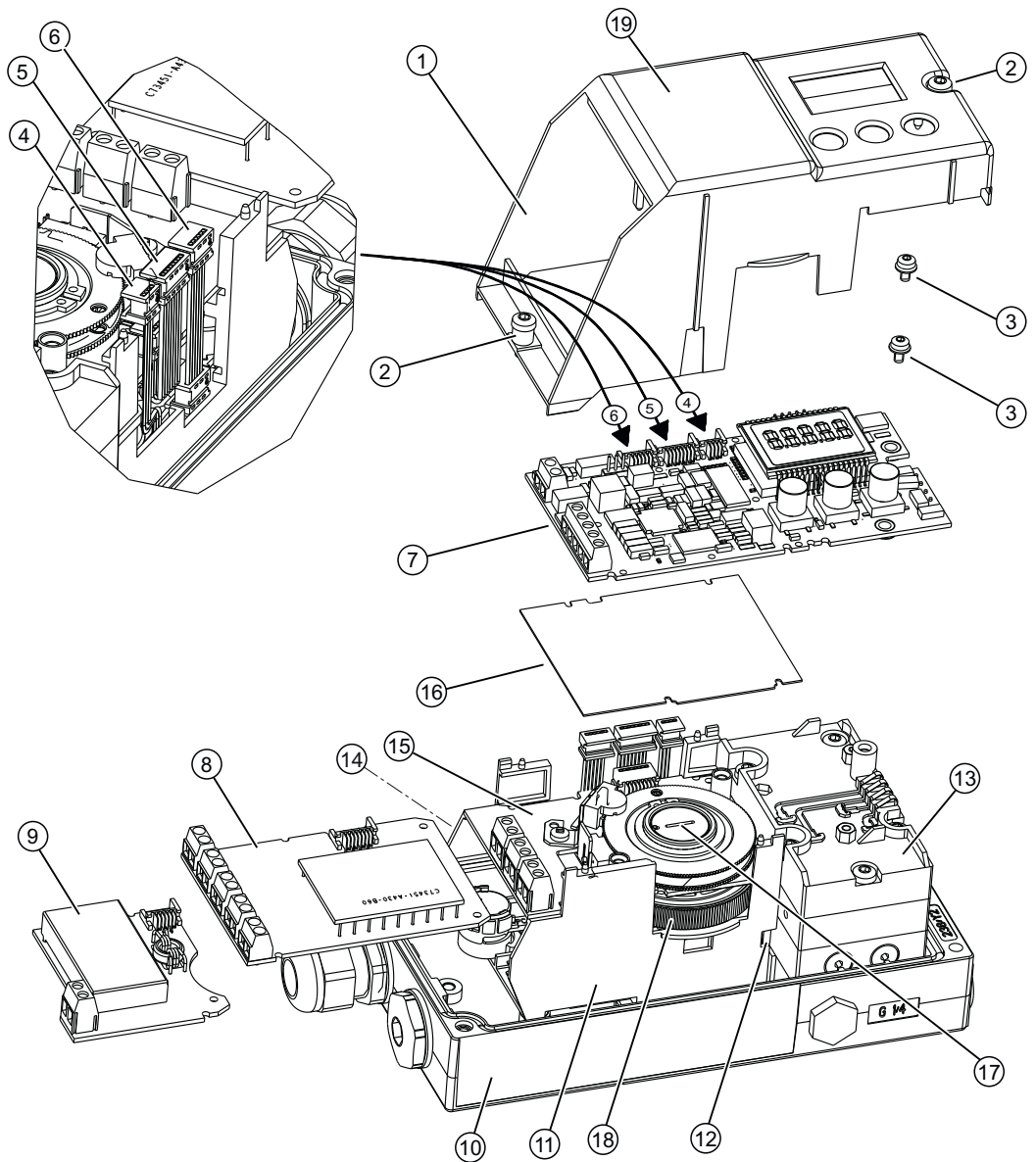

- |   |  |
|---|--|
| ① Module cover  | ⑪ Adapter  |
| ② Fixing screws module cover  | ⑫ Transmission ratio selector                      |
| ③ Fixing screws basic electronics   | ⑬ Pneumatic block                                  |
| ④ Ribbon cable/connector for fitted potentiometer or external position detection system | ⑭ Warning label on the side opposite the nameplate |
| ⑤ Ribbon cable/connector for alarm module, SIA module or mechanical limit switch module | ⑮ SIA module or mechanical limit switch module     |
| ⑥ Ribbon cable/connector for position feedback module                                   | ⑯ Insulating cover, yellow                         |
| ⑦ Basic electronics   | ⑰ Special screw                                    |
| ⑧ Alarm module  | ⑱ Friction clutch adjustment wheel                 |



- ⑨ Position feedback module  
⑩ Nameplate
- ⑲ Wiring diagram on module cover

Figure 4-9 Installing the optional modules in the standard and intrinsically safe version

### **General procedure for optional modules in the standard and intrinsically safe version**

1. Open the positioner. Unscrew the four fixing screws of the enclosure cover.
2. Disconnect the power supply lines or de-energize them.
3. Remove the module cover ①. To do this, unscrew the two fixing screws ②.
4. Install the optional modules as described in the corresponding sections for the individual optional modules.
5. Now start with the assembly. Install the module cover ①. To this end, turn the fixing screws ② counter clockwise until they noticeably engage in the thread pitch. The module cover protects and locks the optional modules mechanically.

---

#### **Note**

##### **Untimely wear**

The module cover is fastened using self-tapping screws, one screw for the base plate and one screw for the valve.

- Proceed as described here in order to avoid premature wear of the base plate and valve.

---

Carefully tighten both fixing screws ② in a clockwise direction.

6. Continue to assemble the positioner by executing steps 3 to 1 in reverse order.

### 4.7.1.3 Installing the optional modules in the "flameproof enclosure" version

#### Introduction

The following option modules are available for the positioner in the flameproof enclosure:

- Position feedback module
- Alarm module
- Internal NCS module
- EMC filter module

 <b>DANGER</b>
<b>Risk of explosion</b>
You must fulfill the following conditions before supplying auxiliary power to the positioner in potentially hazardous areas:
<ul style="list-style-type: none"><li>• The installed electronic unit has been approved.</li><li>• The enclosure of the positioner is closed.</li><li>• The duct openings for electronic connections must be closed. Only use the Ex d certified cable entries or sealing plugs.</li><li>• You must install an ignition trap if you use a "conduit piping system". The maximum distance between the ignition trap and the positioner enclosure is 46 cm or 18".</li></ul>

Overview screen

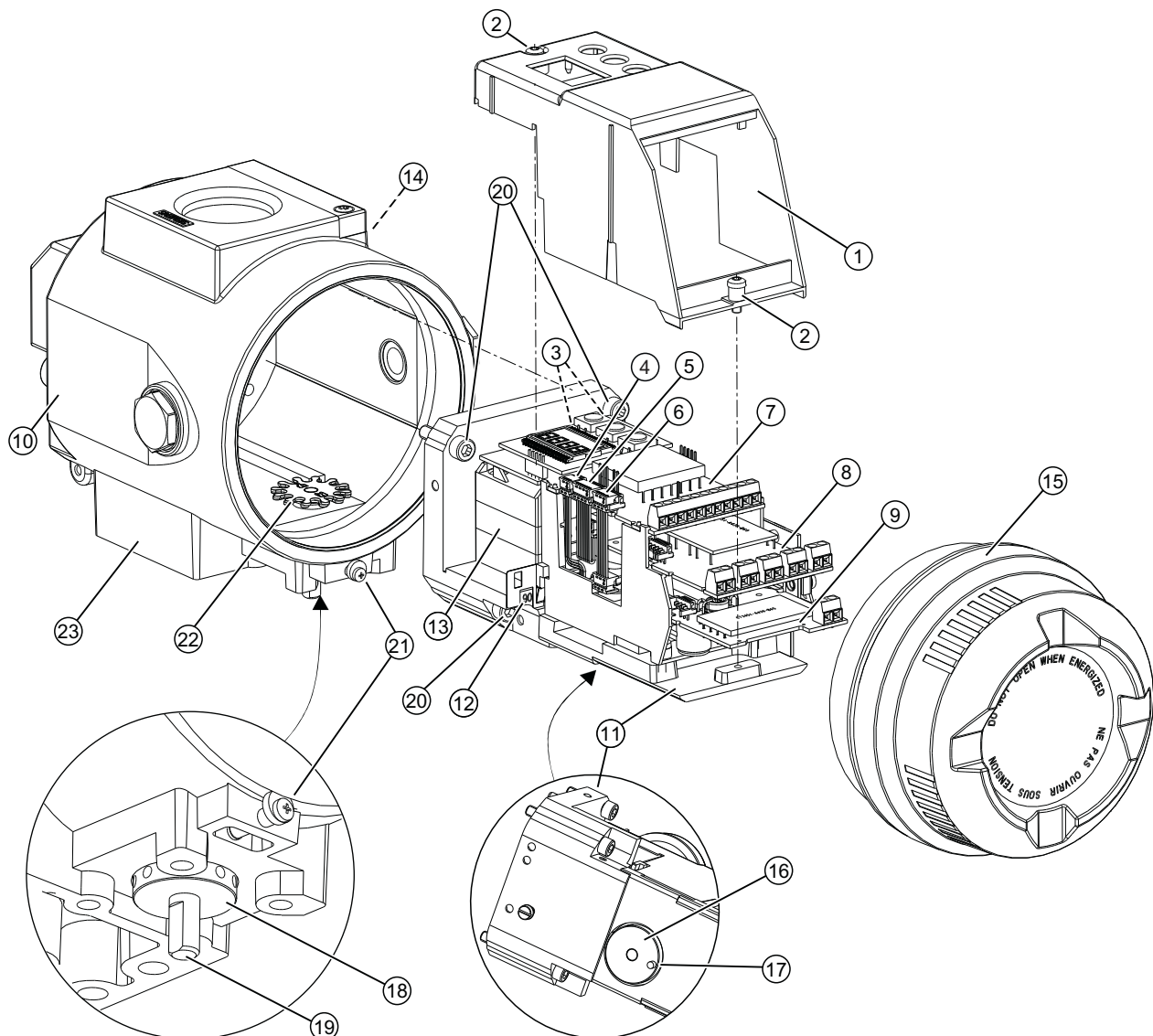

- |   |   |   |  |
|---|---|---|--|
| ① | Module cover  | ⑬ | Pneumatic block                                  |
| ② | Fixing screws module cover  | ⑭ | Warning label on the side opposite the nameplate |
| ③ | Fixing screws basic electronics   | ⑮ | Screw cap  |
| ④ | Ribbon cable/connector for fitted potentiometer or external position detection system | ⑯ | Feedback lever bracket with pin                  |
| ⑤ | Ribbon cable/connector for alarm module, SIA module or mechanical limit switch module | ⑰ | Pin (feedback lever bracket)                     |
| ⑥ | Ribbon cable/connector for position feedback module                                   | ⑱ | Adjustment wheel for external friction clutch    |
| ⑦ | Basic electronics   | ⑲ | Feedback shaft                                   |
| ⑧ | Alarm module  | ⑳ | Fixing screws adapter                            |
| ⑨ | Position feedback module  | ㉑ | Safety catch                                     |
| ⑩ | Nameplate   | ㉒ | Ring gear  |

4.7 Installing the optional modules

- ⑪ Adapter
- ⑫ Transmission ratio selector
- ⑳ Enclosure

Figure 4-10 Installing the optional modules in the "flameproof enclosure" version

**General procedure for optional modules in the "flameproof enclosure" version**

1. Disconnect the power supply lines or de-energize them.
2. Open the safety catch ⑳.
3. Unscrew the screw cap ⑮.
4. Completely dismount the positioner from the actuator.
5. The positioner comes with a ring gear ㉒ and a pin (feedback lever bracket) ⑰ which interlock and ensure backlash-free position feedback. To ensure backlash-free position feedback make sure you remove the adapter ⑪ carefully. To this end, turn the feedback shaft ⑱ on the positioner until the pin (feedback lever bracket) ⑯ below the adapter ⑪ shows in the direction of removal. You determine the position of the pin by looking into the enclosure below the adapter. Now, the pin can be easily removed from the ring gear ㉒.

**Note**

**Damage to the ring gear**

The ring gear consists of two washers fastened staggered to each other. This offset ensures that path detection is backlash-free.

- Do not change this offset mechanically.

6. Unlatch the four fixing screws ㉑.
7. Completely remove the adapter ⑪ from the enclosure ㉓.

<b>NOTICE</b>
<b>Displaced O-rings</b>
There are several O-rings between adapter ⑪ and enclosure ㉓. These O-rings may come off during removal.
• Carefully remove the adapter. Make sure the O-rings do not get lost during removal.

8. Remove the module cover ①. Unlatch both screws ② using a screwdriver.
9. Install the optional modules as described in the corresponding sections for the individual optional modules.
10. Now start with the assembly. Install the module cover ①. To this end, turn the screws ② counter clockwise until they noticeably engage in the thread pitch. The module cover protects and locks the optional modules mechanically.

**Note**

**Untimely wear**

The module cover is fastened using a **self-tapping** screw for the valve.

- Proceed as described here in order to avoid premature wear of the valve.

Carefully tighten both fixing screws ② in a clockwise direction.

11. Continue to assemble the positioner by executing steps 7 to 5 in reverse order. Check whether the position of the O-rings is correct. Make sure no loose items in the enclosure interfere with the assembly.
12. Now check carefully whether the feedback shaft ⑨ can be smoothly turned by 360°. If you feel resistance, do **not** continue to turn but turn the feedback shaft ⑨ back again to the point of removal, making sure to remember the previously performed steps.
13. Once you have completed all previous steps successfully, continue by performing steps 4 to 1 in reverse order.

## 4.7.2 Position feedback module

### Function

- The optional position feedback module indicates the current position as a two-wire signal with the travel range  $I_y = 4$  to 20 mA. The position feedback module is electrically isolated from the basic device.
- The current position is indicated only after successful initialization.
- Operational faults are signaled by a fault current of 3.6 mA.

### Device features

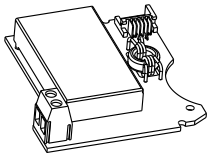

Figure 4-11 Position feedback module

The position feedback module is:

- Single channel
- Potentially separated from the basic device.

### Requirements

You are familiar with the general procedure described in the section "General information about the installation of option modules (Page 54)".

### Procedure

1. Slide the position feedback module up to the endstop in the lower bay of the rack.
2. Connect the module to the basic electronics. For this purpose, use the 6-pin flat ribbon cable provided.

### 4.7.3 Alarm module

#### Function

The alarm module triggers fault messages and alarms via three binary outputs. The message function is based on the change in the signal status:

- If the signal status is "HIGH", there is no alarm message and the binary inputs are conductive.
- If the signal status is "LOW", the module reports an alarm by shutting down binary outputs using a high-resistance.
- Operational faults are signaled at a high-resistance output. Set the following parameters to activate and configure the output of alarms and fault messages:
  - "AFCT" - Alarm function
  - "A1" - Response threshold, alarm 1
  - "A2" - Response threshold, alarm 2
  - "FCT" - Function for fault message output
  - "TIM" - Monitoring time
  - "LIM" - Response threshold

Apart from binary outputs, the alarm module has a binary input BIN2. Depending on the selected parameters, it is used to block the actuator or to move it to its end position. Configure the suitable settings on parameter "BIN2".

#### Device features

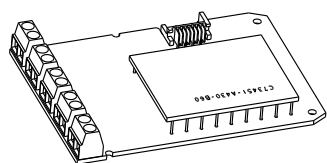

Figure 4-12 Alarm module

#### 4.7 Installing the optional modules

The alarm module has the following features:

- Available in two versions.
  - Explosion-proof version for connecting to a switching amplifier in conformity with EN 60947-5-6.
  - Non-explosion-proof version for connecting to power sources having a maximum of 35 V.
- Three binary outputs. Binary inputs are potentially separated from the basic configuration and from each other.
- The binary input BIN2 has two inputs. Both inputs are implemented as logical OR combination.
  - Input 1 at terminals 11/12: Is electrically isolated, and is triggered by an active signal.
  - Input 2 at terminals 21/22: Is not electrically isolated, and is triggered by a passive NO contact.

#### Procedure for installing the alarm module

1. You have performed the steps described in the section General information about the installation of option modules (Page 54).
2. Slide the alarm module into the rack below the basic electronics . Ensure that you slide it up to the endstop.
3. Connect the module to the basic electronics. For this purpose, use the 8-pin flat ribbon cable provided.
4. Proceed with the corresponding steps in the section General information about the installation of option modules (Page 54).

#### 4.7.4 Slit initiator alarm module

##### Function

If the standard controller requires electrically independent limit value messages, the slotted initiator alarm module with slotted initiators is used instead of the alarm module.

- A binary output is used to display a collective fault message. Compare with the function of the alarm module. The floating binary output is implemented as an automatic fault indicating semiconductor output.
- The other two binary outputs are used to signal the two limits L1 and L2 which can be adjusted mechanically using slotted initiators. Both these binary outputs are electrically independent from the remaining electronic unit.



## Device features

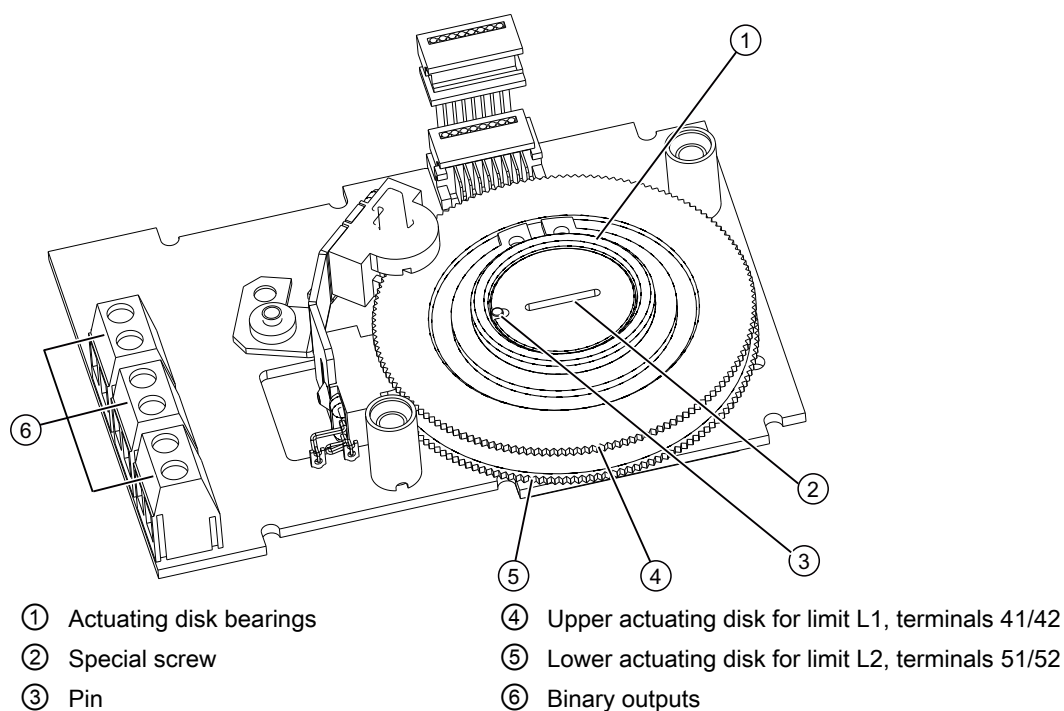

Figure 4-13 SIA module

The slotted initiator alarm module, SIA module for short, consists of three binary outputs ⑥.

### Procedure for installing the slot initiator alarm module

1. You have performed the steps described in the section General information about the installation of option modules (Page 54).
2. Disconnect all electrical connections of the basic electronics.
3. Loosen the two fixing screws of the basic electronics.
4. Remove the basic electronics.
5. Insert the SIA module from the top up to the upper printed circuit board guide of the rack.
6. Slide the SIA module in the printed circuit board of the rack approximately 3 mm to the right.
7. Screw in the special screw ② through the SIA module into the positioner shaft. Tighten the special screw ② with a **torque of 2 Nm**.

#### Note

##### Pin in the actuating disk bearing

A pin ③ is pressed in the actuating disk bearing ①.

1. Align pin ③ before placing the adjustment screw ② into the actuating disk bearing ①.
2. Rotate the actuating disk bearing ① and the special screw ② simultaneously so that the pin ③ is inserted into the special screw ②.

#### 4.7 Installing the optional modules

8. Set the limits L1 and L2 as described in the section "Slit initiator alarm module (Page 64)".
9. An insulating cover (yellow) is required over the module. This insulating cover is supplied with the module. Place the insulating cover on one side under the basic electronics seat of the rack. The recesses of the insulating cover must fit in the corresponding webs of the rack.
10. Place the basic electronics onto the four holders.
11. Fix the basic electronics using both the fixing screws.
12. Reestablish all electrical connections between the basic electronics and the option modules. Connect the basic electronics and the option modules to the ribbon cables provided. Connect the basic electronics and the potentiometer to the potentiometer cable.
13. Using both the screws, fasten the module cover provided. Do **not** use the standard module cover.
14. Select the labels that are already present on the standard version of the module cover from the label set provided. Affix the selected labels on the installed module cover as per the standard version.
15. Proceed with the corresponding steps in the section General information about the installation of option modules (Page 54).

#### See also

Installing optional modules in the standard and intrinsically safe version (Page 54)

#### Procedure: Determining the switch status of the slotted initiators

You will require a suitable display device to determine the switch status. For example, use the initiator tester type 2 / Ex from Pepperl + Fuchs.

1. Connect the display device to the following terminals of the SIA module:
  - 41 and 42
  - 51 and 52
2. Read the switch status of slotted initiators.

#### Procedure: Setting the L1 and L2 limits

The consecutive numbers in the following text refer to the above image in this section. Proceed as follows to set the limits:

1. Move the actuator to the first desired mechanical position.
2. Adjust the upper actuating disk ④ manually until the output signal at terminals 41 and 42 changes. Set a high-low or a low-high switchover as follows:
  - Rotate the actuating disc ④ beyond the switching point until you reach the next switching point.

3. Move the actuator to the second desired mechanical position.
4. Adjust the lower actuating disk ⑤ manually until the output signal at terminals 51 and 52 changes. Set a high-low or a low-high switchover as follows:
  - Rotate the actuating disc ⑤ beyond the switching point until you reach the next switching point.

**Note****Adjusting the actuating disk**

The actuating disks ④ and ⑤ are relatively difficult to move. This design prevents their unintentional movement during operation. You can achieve an easier and finer adjustment by reducing stiction temporarily.

- Move the actuator to and fro while simultaneously holding the actuating disks ④ and ⑤.

### 4.7.5 Mechanical limit switch module

**Requirement**

You are familiar with the procedure described in the section "Installing optional modules in the standard and intrinsically safe version (Page 54)".

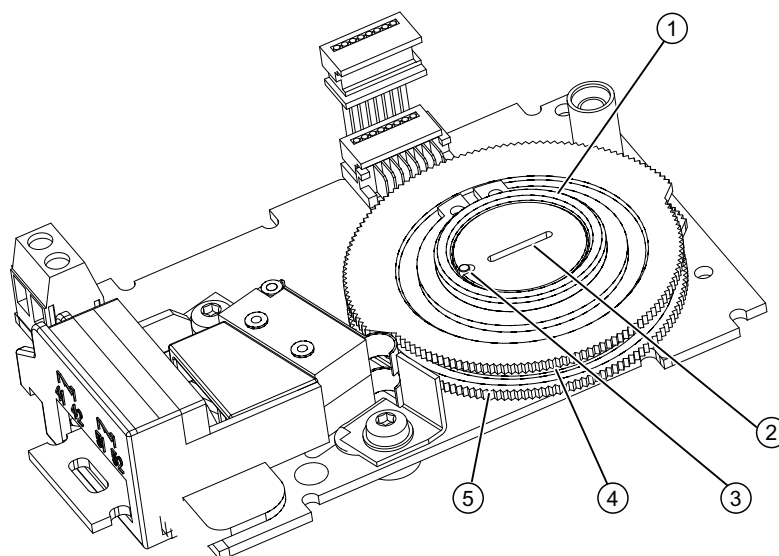
**Procedure for installing the mechanical limit switch module**

① Actuating disk bearings

② Special screw

③ Pin

④ Upper actuating disk for limit L1, terminals 41/42

⑤ Lower actuating disk for limit L2, terminals 51/52

Figure 4-14 Mechanical limit switch module

4.7 Installing the optional modules

1. Disconnect all electrical connections of the basic electronics.
  2. Loosen the two fixing screws of the basic electronics.
  3. Remove the basic electronics.
  4. Insert the mechanical limit switch module from the top up to the upper printed circuit board guide of the module rack.
  5. Slide the mechanical limit switch module in the printed circuit board of the module rack approximately 3 mm towards right.
  6. Screw in the special screw ② through the mechanical limit switch module into the positioner shaft. Tighten the special screw ② with a **torque of 2 Nm**.
- 

**Note**

**Pin in the actuating disk bearing**

A pin ③ is pressed in the actuating disk bearing ①.

1. Align pin ③ before placing the adjustment screw ② into the actuating disk bearing ①.
  2. Rotate the actuating disk bearing ① and the special screw ② simultaneously so that the pin ③ is inserted into the special screw ②.
- 

7. Set the limits L1 and L2 as described below.
  8. An insulating cover is provided over the mechanical limit switch module. Place the insulating cover on one side under the basic electronics seat on the walls of the rack. The recesses of the insulating cover must fit in the corresponding webs of the container wall.
  9. Place the insulating cover on the mechanical limit switch module by bending the walls of the rack carefully.
  10. Place the basic electronics onto the four holders.
  11. Fix the basic electronics using both the fixing screws.
  12. Reestablish all electrical connections between the basic electronics and the option modules. Connect the basic electronics and the option modules to the ribbon cables provided. Connect the basic electronics and the potentiometer to the potentiometer cable.
  13. Using both the screws, fasten the module cover provided. Do not use the standard module cover.
  14. Select the labels that are already present on the standard version of the module cover from the label set provided. Affix the selected labels on the installed module cover as per the standard version.
  15. Establish all electrical connections.
- 

**Note**

**Protective conductor connector**

A protective conductor connector is not required for safety reasons and therefore is not provided.

---

**Procedure: Setting the limits L1 and L2**

1. Move the actuator to the first desired mechanical position.
2. Adjust the upper actuating disk ④ manually until the output signal at terminals 41 and 42 changes. Set a high-low or a low-high switchover as follows:
  - Rotate the actuating disc beyond the switching point until you reach the next switching point.
3. Move the actuator to the second desired mechanical position.
4. Adjust the lower actuating disk ⑤ manually until the output signal at terminals 51 and 52 changes. Set a high-low or a low-high switchover as follows:
  - Rotate the actuating disc beyond the switching point until you reach the next switching point.

---

**Note****Adjusting the actuating disk**

The actuating disks ④ and ⑤ are relatively difficult to move. This design prevents their unintentional movement during operation. You can achieve an easier and finer adjustment by reducing stiction temporarily.

- Move the actuator to and fro while simultaneously holding the actuating disks ④ and ⑤.
- 

**See also**

Mechanical limit switch module (Page 67)

### 4.7.6 Internal NCS module 6DR4004-5L/-5LE

#### Function

Wear-free, contact-free position detection

#### Device features

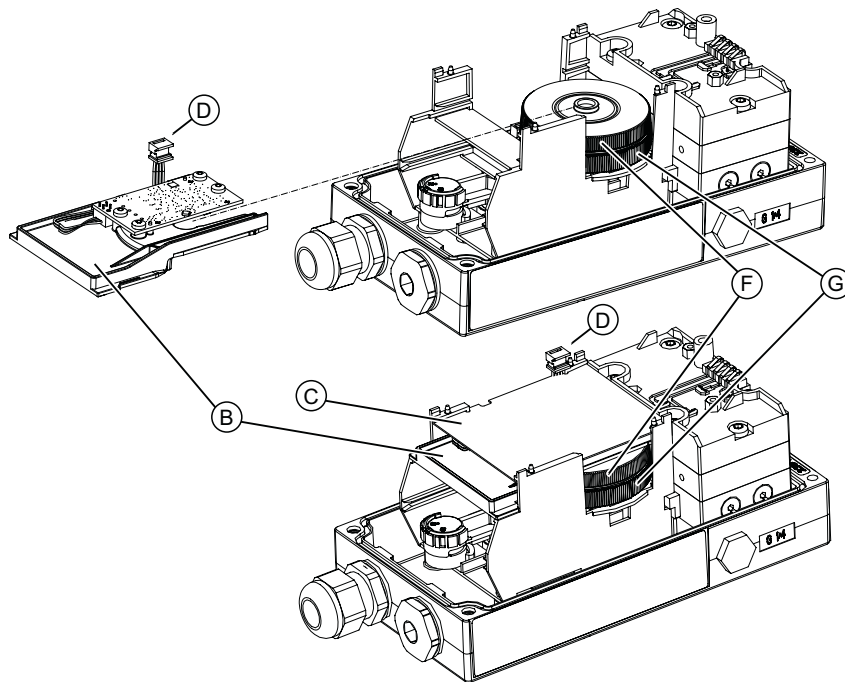

- (B) Internal NCS module 6DR4004-5L.
- (C) Insulating cover, yellow
- (D) Ribbon cable of the internal NCS module
- (F) Adjustment wheel for the magnet clamp
- (G) Adjustment wheel for the friction clutch (without function)

Figure 4-15 Installing the internal NCS module

#### Requirement

- The slot required for the internal NCS module in the rack is free. The following option modules use the same slot in the rack:
  - Alarm module
  - SIA module
  - Mechanical limit switch module
  - Internal NCS module
- The positioner is mounted, or is to be mounted, directly on the valve using the positioner shaft.

### Procedure for installing the internal NCS module

1. You have performed the steps described in the section General information about the installation of option modules (Page 54).  
The legend numbers refer to the indicated section. The legend letters refer to the figures in this section.
2. Unplug the ribbon cable connector (4) to the installed potentiometer from the basic electronics (7).
3. Remove the basic electronics (7) from the positioner. To do this, remove the two screws that fasten the basic electronics to the pneumatic block (13).
4. Insert the connector of the ribbon cable (A) into the slot as shown below.  
Note: There is no space for the ribbon cable (A) in earlier versions of the positioner. Here you fasten the ribbon cable to the container using a cable tie.

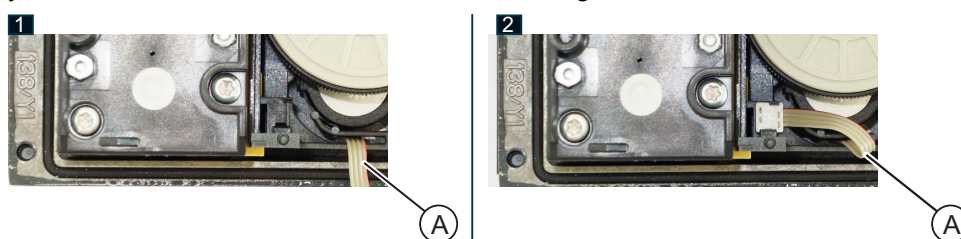

5. Screw the special screw (E) into the shaft of the positioner. Tighten the special screw (E) with a torque of 2 Nm.

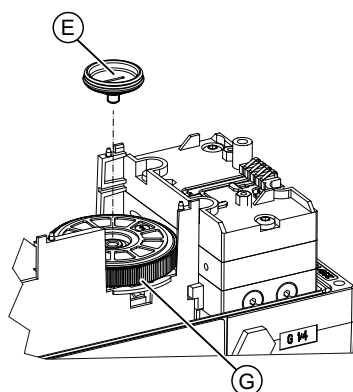

6. Press the adjustment wheel of the magnet clamp (F) firmly onto the special screw (E) of the friction clutch until you clearly hear it click into place.

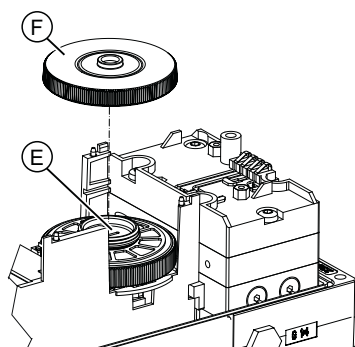

*4.7 Installing the optional modules*

7. Position the ribbon cable of the internal NCS module (D) upwards, as shown in the figure, before you slide the internal NCS module into the rack.
8. Slide the internal NCS module (B) under the basic electronics into the rack until you hear it click into place.
9. An insulating cover is required over the internal NCS module. This insulating cover is supplied with the internal NCS module. Place the insulating cover (C) on one side under the basic electronics seat of the rack.
10. Now position the insulating cover by pressing one end against the seat of the rack and slowly lowering the other end.
11. Firmly press the other end until the insulating cover is underneath the contact surface of the basic electronics. The recesses of the insulating cover must fit in the corresponding webs of the rack.
12. Install the basic electronics back into the positioner.
13. Insert the ribbon cable connector of the internal NCS (D) module onto the positioner basic electronics.  
Note for installed position feedback module: Reestablish all electrical connections between the basic electronics and the position feedback module.
14. Using both the screws, fasten the module cover provided. Do **not** use the standard module cover of the positioner. The provided module cover has a larger recess to accommodate the adjustment wheel of the magnet clamp (F).
15. Make sure that the ribbon cable is not trapped.
16. Select the labels that already exist on the standard version of the module cover from the label set provided. Affix the selected labels on the installed module cover as per the standard version.
17. Proceed with the corresponding steps in the section General information about the installation of option modules (Page 54).



### 4.7.7 EMC filter module

#### Function

You will require the EMC filter module if you use an external position sensor on the positioner, e.g. a potentiometer or a non-contacting sensor. The EMC filter module forms the interface between external position sensors and the basic electronics of the positioner. This module protects the positioner from electromagnetic effects.

#### Device features

- EMC protection
- Connection to basic electronics
- Connecting terminals for an external potentiometer

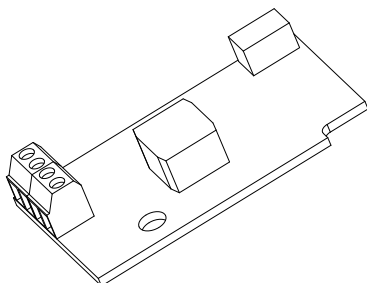

Figure 4-16 EMC filter module

#### Requirement

- You have an EMC filter module, article number C73451-A430-D23.
- The module cover is removed.
- Any already installed optional module has been removed.

A description of how to remove the module cover and install the optional modules is provided in the section "General information about the installation of option modules (Page 54)"

**Procedure for installing the EMC filter module**

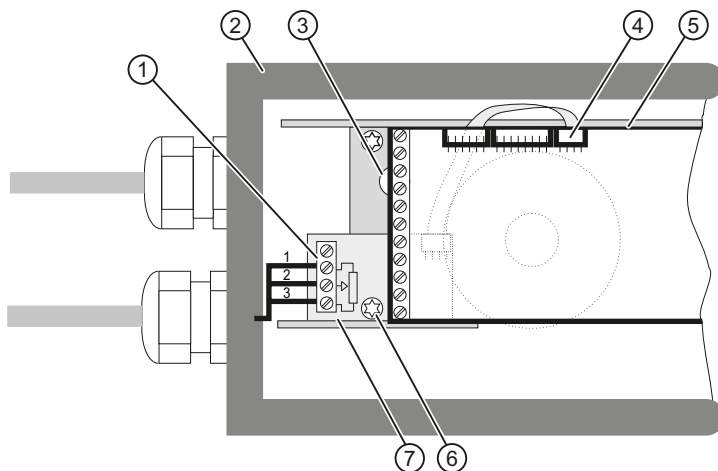

- |  |                                     |
|--|-------------------------------------|
| ① EMC filter module terminals  | ⑤ Basic electronics                 |
| ② Positioner   | ⑥ Screw                             |
| ③ Yellow wheel for locking the position detection  | ⑦ EMC filter module C73451-A430-D23 |
| ④ Ribbon cable connector of fitted potentiometer, or ribbon cable connector of EMC filter module |                                     |

Figure 4-17 Installation EMC filter module

1. You have performed the steps described in the section "General information about the installation of option modules (Page 54)".
2. Unplug the ribbon cable connector ④ to the fitted potentiometer from the basic electronics ⑤.
3. Remove the basic electronics ⑤ from the positioner. To this end, remove the two screws that fix the basic electronics to the pneumatic block.
4. Loosen the screw ⑥ in the connection area of the positioner.
5. Insert the connector of the ribbon cable (A) into the slot as shown below.  
Note: There is no space for the ribbon cable (A) in earlier versions of the positioner. Here you fasten the ribbon cable with the supplied cable tie at the container.

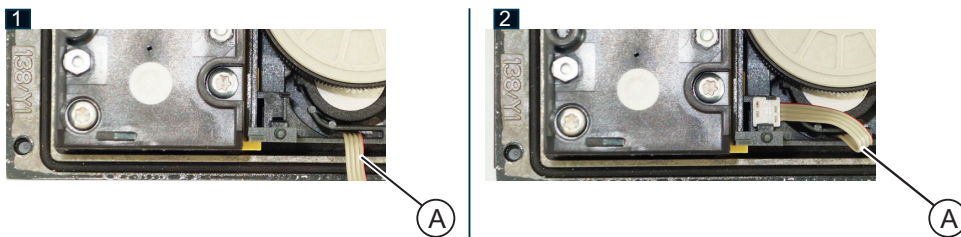

6. Secure the EMC filter module using the screw ⑥ loosened in the fourth step.
7. Fit the basic electronics ⑤ back into the positioner.
8. Insert the ribbon cable connector ④ of the EMC filter module onto the positioner basic electronics.

9. Fasten the module cover. Make sure that the ribbon cable is not trapped.
10. Proceed with the corresponding steps in the section "General information about the installation of option modules (Page 54)".

**See also**

Scope of delivery EMC filter module (Page 308)

Scope of delivery of external position detection system (Page 307)

### 4.7.8 Accessories

#### Pressure gauge block

Pressure gauge blocks that are available as accessories are illustrated below. The gauges display measured values for the actuating pressure and supply air. The image to the left shows the pressure gauge block for single-acting actuators. The image to the right shows the pressure gauge block for double-acting actuators.

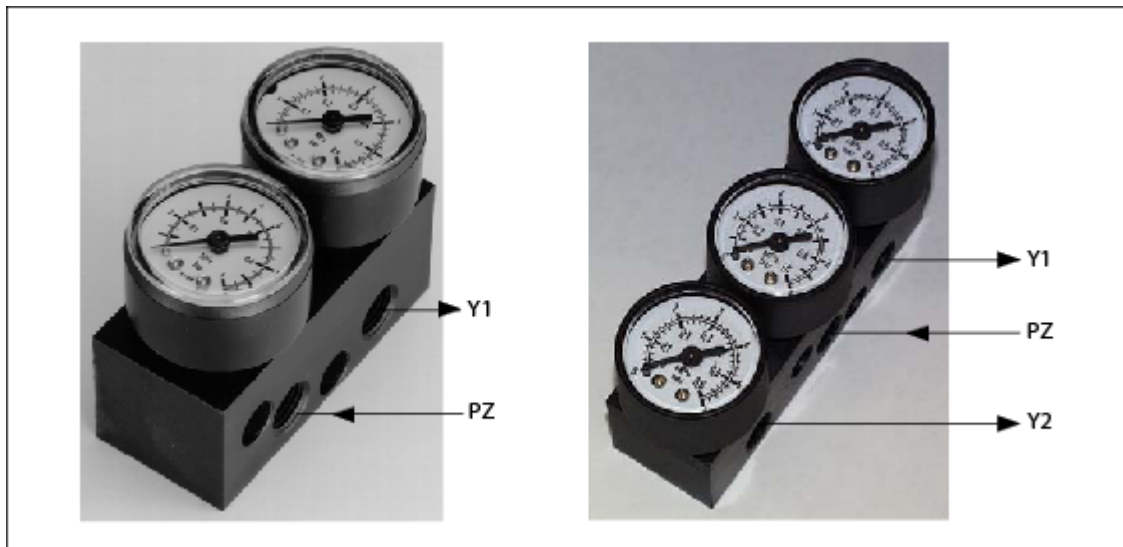



- Y1     Actuating pressure
- P<sub>z</sub>    Supply air
- Y2     Actuating pressure

#### Fixing the pressure gauge block

The pressure gauge block is fixed onto the lateral pneumatic connection of the positioner using the screws provided. Use the provided O-rings as sealing elements.

## 5.1 Basic safety instructions

 <b>WARNING</b>
<b>Improper power supply</b> Danger of explosion in hazardous areas as result of incorrect power supply, e.g. using direct current instead of alternating current. <ul style="list-style-type: none"><li>• Connect the device in accordance with the specified power supply and signal circuits. The relevant specifications can be found in the certificates, in Chapter "Technical data (Page 283)" or on the nameplate.</li></ul>

 <b>WARNING</b>
<b>With intrinsically device version (Ex i)</b> Risk of explosion in hazardous areas. For intrinsically safe device versions only the certified circuits may be connected as auxiliary power supply, control and signal circuits. <ul style="list-style-type: none"><li>• Make sure that the power source of the used circuits is marked as intrinsically safe.</li></ul>

 <b>WARNING</b>
<b>Unsafe extra-low voltage</b> Danger of explosion in hazardous areas due to voltage flashover. <ul style="list-style-type: none"><li>• Connect the device to an extra-low voltage with safe isolation (SELV).</li></ul>

 <b>WARNING</b>
<b>Connecting device in energized state</b> Danger of explosion in hazardous areas. <ul style="list-style-type: none"><li>• Connect devices in hazardous areas only in a de-energized state.</li></ul> <b>Exceptions:</b> <ul style="list-style-type: none"><li>• Circuits of limited energy may also be connected in the energized state in hazardous areas.</li><li>• Exceptions for type of protection "Non-sparking nA" (Zone 2) are regulated in the relevant certificate</li></ul>

 <b>WARNING</b>
<b>Lack of equipotential bonding</b> Danger of explosion through compensating currents or ignition currents through lack of equipotential bonding. <ul style="list-style-type: none"><li>• Ensure that the device is potentially equalized.</li></ul> <b>Exception:</b> It may be permissible to omit connection of the equipotential bonding for devices with type of protection "Intrinsic safety Ex i".

 <b>WARNING</b>
<b>Unprotected cable ends</b> Danger of explosion through unprotected cable ends in hazardous areas. <ul style="list-style-type: none"><li>• Protect unused cable ends in accordance with IEC/EN 60079-14.</li></ul>

 <b>WARNING</b>
<b>Improper laying of shielded cables</b> Danger of explosion through compensating currents between hazardous area and the non-hazardous area. <ul style="list-style-type: none"><li>• Only ground shielded cables that run into the hazardous area at one end.</li><li>• If grounding is required at both ends, use an equipotential bonding conductor.</li></ul>

 <b>WARNING</b>
<b>Unsuitable cables and/or cable glands</b> Danger of explosion in hazardous areas. <ul style="list-style-type: none"><li>• Only use suitable cables and cable glands complying with the requirements specified in Chapter "Technical data".</li><li>• Tighten the cable glands in accordance with the torques specified in Chapter "Technical data".</li><li>• When replacing cable glands use only cable glands of the same type.</li><li>• After installation check that the cables are seated firmly.</li></ul>

**⚠ WARNING****Incorrect selection of type of protection**

Danger of explosion in areas subject to explosion hazard.

This device is approved for several types of protection.

1. Decide in favor of one type of protection.
2. Connect the device in accordance with the selected type of protection.
3. In order to avoid incorrect use at a later point, make the types of protection that are not used permanently unrecognizable on the nameplate.

**NOTICE****Condensation in the device**

Damage to device through formation of condensation if the temperature difference between transportation or storage and the mounting location exceeds 20 °C (36 °F).

- Before taking the device into operation let the device adapt for several hours in the new environment.

**NOTICE****Ambient temperature too high**

Damage to cable sheath.

- At an ambient temperature  $\geq 60$  °C (140 °F), use heat-resistant cables suitable for an ambient temperature at least 20 °C (36 °F) higher.

**NOTICE****Standard cable gland/torque**

Device damage.

- Owing the reasons pertaining to tightness (IP enclosure rating) and the required tensile strength, only use the cables having a diameter  $\geq 8$  mm for standard M20x1.5 cable gland, or use a suitable seal insert in case of smaller diameters.
- In the NPT version, the positioner is delivered with a coupling. When inserting a counter piece in the coupling, ensure that the maximum permissible torque of 10 Nm is not exceeded.

 <b>CAUTION</b>
<b>Maximum AC/DC switching voltage with UL approval E344532</b>
The mechanical limit switch module 6DR4004-6K is approved for use for positioners with UL approval. The maximum supply voltage in this case is 30 V AC/DC.
The mechanical limit switch module 6DR4004-8K is not approved for use for positioners with UL approval.
If this information is ignored, the UL approval for the mechanical limit switch module for the positioner becomes invalid.

## Two-wire mode

<b>NOTICE</b>
<b>Connection of voltage source to current input</b>
Device damage if a voltage source is connected to the current input $I_w$ (terminals 6 and 7).
<ul style="list-style-type: none"><li>• Never connect the current input <math>I_w</math> to a voltage source, otherwise the positioner may be destroyed.</li><li>• Always use a voltage source with a maximum output current of <math>I = 20</math> mA.</li></ul>

### 5.1.1 Improvement of interference immunity

---

#### Note

##### Improvement of interference immunity

- Lay signal cables separate from cables with voltages > 60 V.
  - Use cables with twisted wires.
  - Avoid getting too close to large electrical process cells.
  - Use shielded cables to guarantee the full specification.
  - Take account of the conditions for communication specified in the technical data.
- 

## Electromagnetic compatibility

The Macrolon enclosure is metalized from inside to increase the electromagnetic compatibility (EMC) with respect to high-frequency radiation. The shield is connected to the threaded bush shown in the following picture such that it is electrically conductive.

Note that this protection is effective only if you connect at least one of these bushes to the earthed control valves through electrically conductive (bare) attachments.



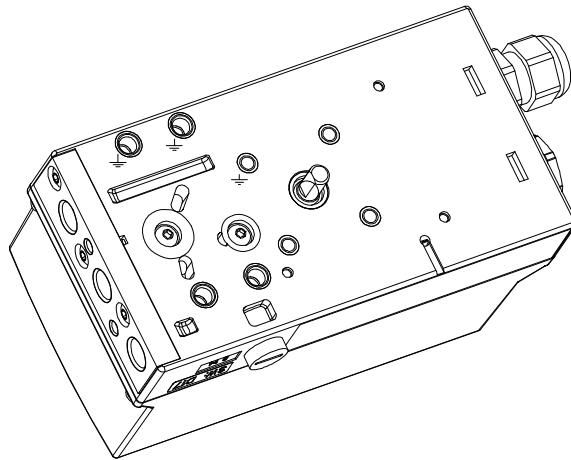

⊞ Shield

Figure 5-1 Base plate

### 5.1.2 Interference immunity

If the bus shield is fully effective, the interference immunity and the interference emission conform to the specifications. The following measures ensure that the bus shield is fully effective:

- The shields have been connected to the metallic connections of the positioner.
- The shields have been laid up to the terminal boxes, the distributor and the transceiver.

---

#### Note

##### Dissipation of glitch impulses/equipotential bonding

In order to dissipate glitch impulses, the positioner must be connected to an equipotential bonding cable (earth potential) using a low resistance. The positioner in the Makrolon enclosure is therefore equipped with an additional cable. Connect this cable to the shield of the bus cable and the equipotential bonding cable using a cable clamp.

Devices in the stainless steel or aluminum enclosure have a corresponding terminal on the outer side of the enclosure. This terminal must also be connected to the equipotential bonding cable.

For applications in hazardous areas, ensure an adequately suitable equipotential bonding between the hazardous and non-hazardous areas.

---

### 5.1.3 Safety shutdown

The positioner is equipped with an additional input (terminal 81 [+] and terminal 82 [-]) to approach the safety position. After activating this function, this input must be continuously supplied with +24 V in order to retain the normal control function.

If the 24-V signal is interrupted, the safety position is set as described in chapter "Pneumatic connection (Page 101)".

Communication with the master is still possible. The "Jumper" on the basic electronics is used to activate this function. It can be accessed after removing the module cover, and must be switched from the right position (delivery state) to the left position.

## 5.2 Electrical wiring

### 5.2.1 Bus cable

The following image will help you in preparing the bus cable for the connection:

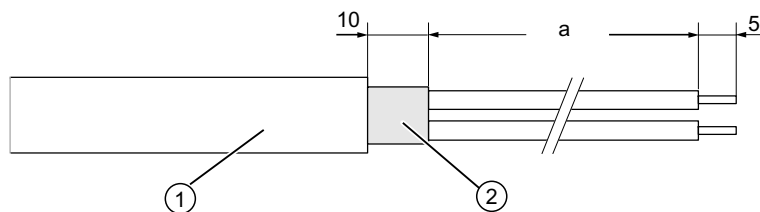

- a     80 mm: Normal version of device  
      120 mm: Version with flameproof enclosure (6DR5..5)
- ①     Bus cables to be used:  
      SIMATIC NET, PB FC Process Cable, bus cable for IEC 61158-2
- ②     Cable shield

Figure 5-2 Preparation of bus cable

#### Devices without flameproof enclosure are:

- Normal version of devices
- Intrinsically safe versions
- Versions for zones 2 and 22

### Procedure for device versions without flameproof enclosure

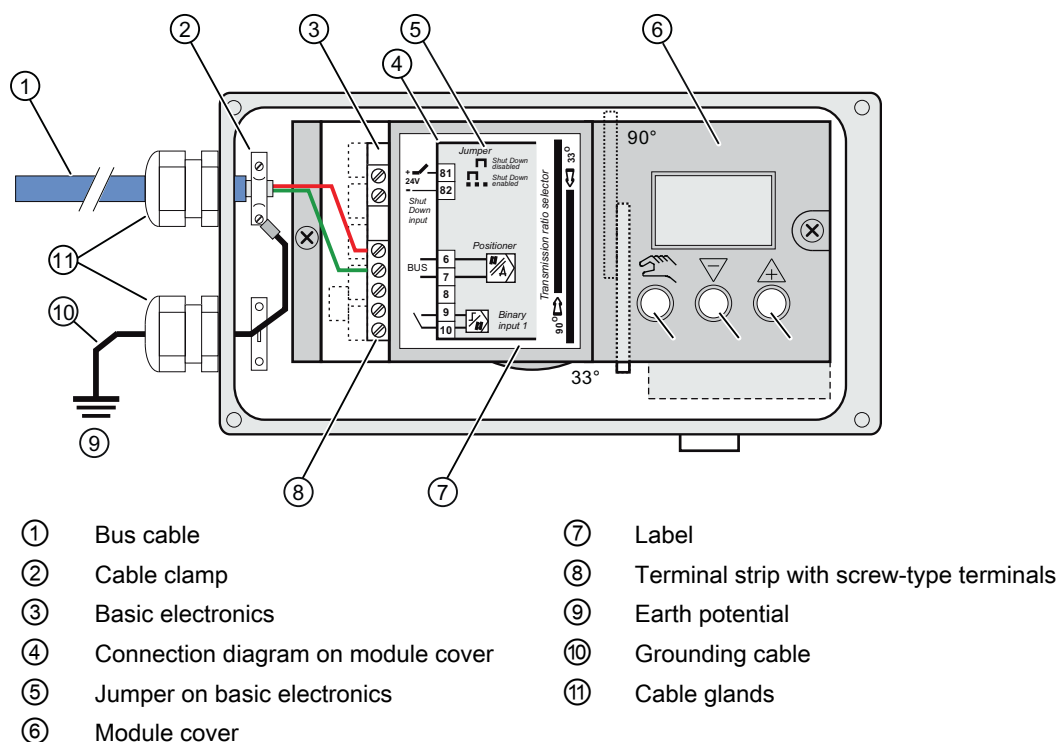

Figure 5-3 Connection of bus cable and grounding cable for device version with Makrolon enclosure

1. Strip the bus cable ①.
2. Open the enclosure of the positioner by unlatching the four cover screws.
3. Insert the prepared bus cable (described in Bus cable (Page 82)) through the cable inlet.
4. Fasten the shield using the clamp ② and the two screws on the enclosure.
5. Tighten the cable inlet.
6. Connect the red and the green wires to terminals 6 and 7 of the basic electronics as shown in the following picture. The polarity does not play any role here.

#### Note

#### Bus cable and grounding cable for device version with stainless steel/aluminum enclosure

In the case of the stainless steel or aluminum enclosure, use the grounding terminal provided on the outside of the device.

### Procedure for device versions with flameproof enclosure "Ex d"

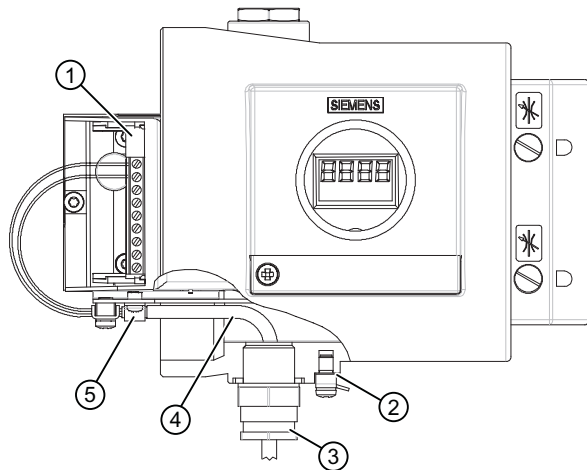

- ① Basic electronics bus cable
- ② Grounding terminal
- ③ Ex d certified cable inlet
- ④ Bus cable
- ⑤ Cable clamp/shield

Figure 5-4 Connection of bus cable for versions with flameproof enclosure

1. Strip the bus cable.
2. Open the safety catch and unscrew the screw cap to open the positioner.
3. Insert the prepared bus cable ④ (described in Bus cable (Page 82)) through the Ex d-certified cable inlet ③. Follow the corresponding guidelines if you are using a conduit piping system.
4. Fasten the shield on the adapter using the clamp ⑤ and the two screws.
5. Tighten the Ex d-certified cable inlet ③.
6. Connect the red and the green wires to terminals 6 and 7 of the basic electronics as shown in the following picture. The polarity does not play any role here.

If a bus connection is not present, connect a separate power source with the following values to terminals 6/7:

- With intrinsically-safe devices: intrinsically-safe isolating power supply with 24 V DC
- With non-intrinsically-safe devices: 15 to 30 V DC

Then match the positioner to the respective actuator by configuring and initializing it. Finally set the bus address.

### 5.2.2 Wiring diagram for basic electronics

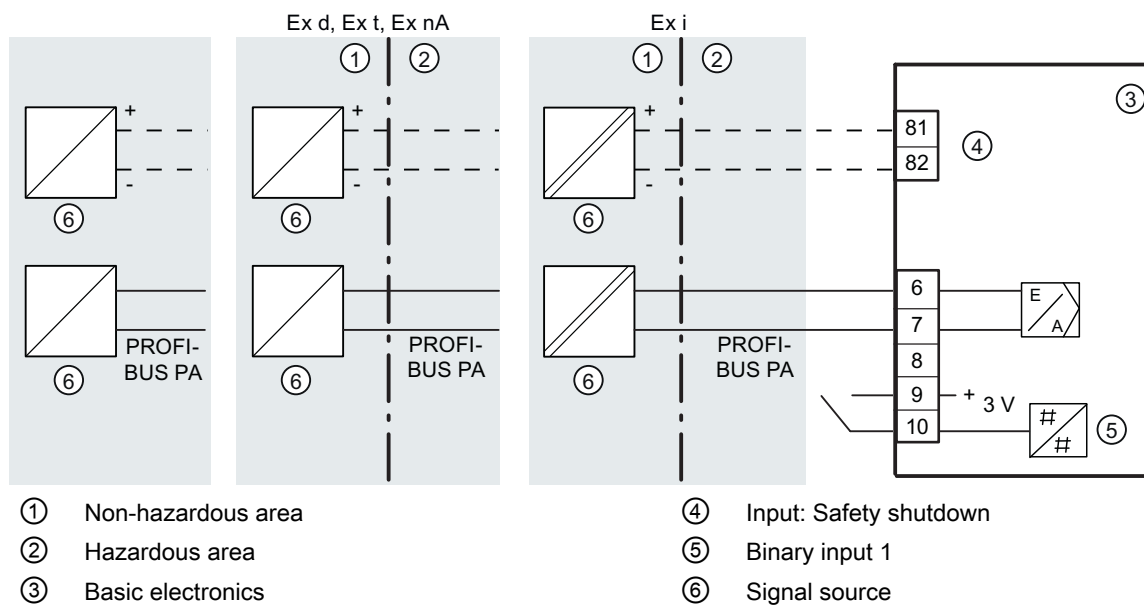

Figure 5-5 Device version with PROFIBUS PA

### 5.2.3 Wiring NCS sensor to EMC filter module

#### Requirement

You need the EMC filter module, article number C73451-A430-D23, for the electrical connection of the accessory part "NCS sensor for contactless position measurement" to the positioner. The positioner supplies auxiliary power to the NCS sensor via the EMC filter module.

#### Wiring diagram

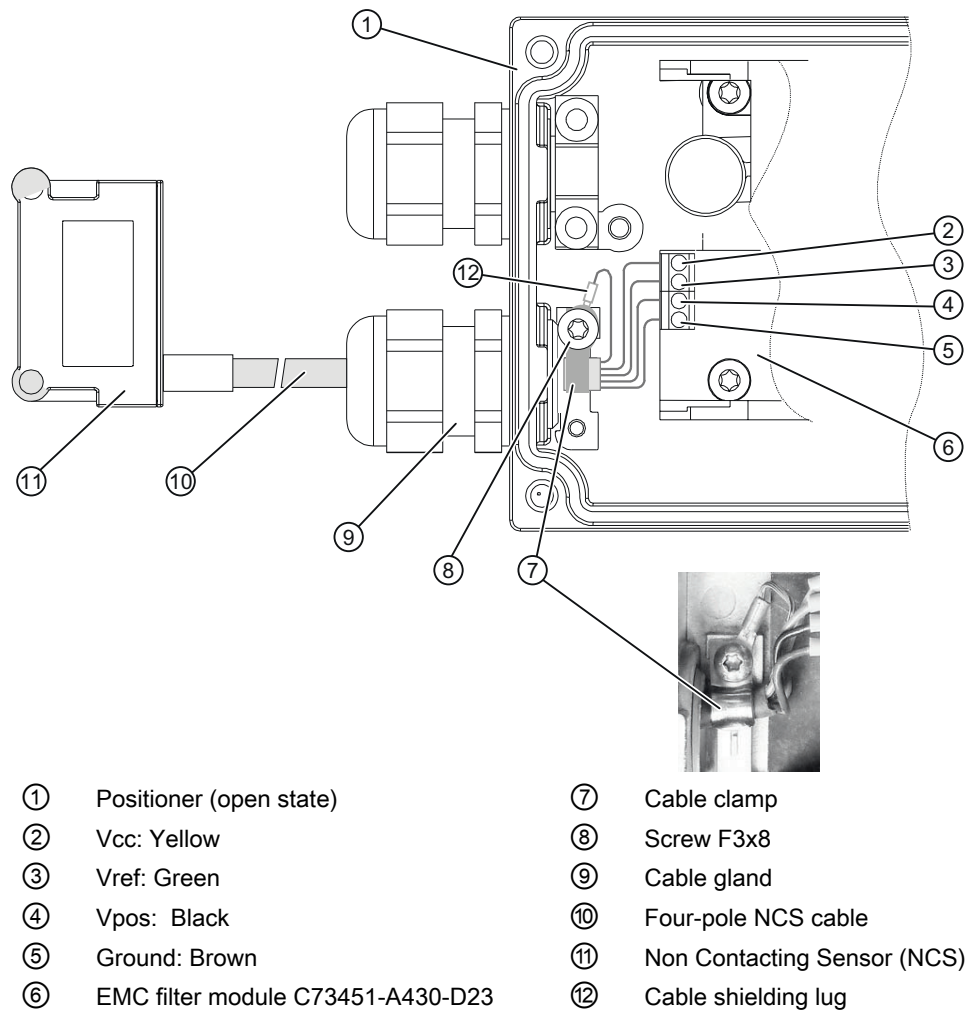

Figure 5-6 Example of connecting the NCS to the EMC filter module

## Procedure

The NCS sensor is equipped with a shielded four-pole cable. Wire this cable to the positioner as follows:

1. Feed the four-pole NCS cable ⑩ through the union nut and the cable gland. Note: The type of cable gland depends on the positioner version.
2. Tighten the cable gland ⑨.
3. Terminate the four-pole NCS cable ⑩ in the positioner in accordance with the wiring diagram.
4. Place the cable clamp ⑦ onto the outer insulation of the four-pole NCS cable ⑩.
5. Use the screw ③ to bond the cable shielding lug ⑫ and the cable clamp ⑦ to the ground terminal of the positioner.
6. Grounding:  
The rear steel panel of the NCS sensor is inevitably bonded to the ground potential of the system when mounting on the console. This ground connection is only functional if there is a low-impedance connection to ground potential of the system. Ensure this state by measuring the ground resistance. If necessary, ensure proper grounding by means of an additional cable from the NCS sensor to ground potential.

### 5.2.4 Connecting the external position detection system to the EMC filter module

#### Requirement

You need the EMC filter module with article number C73451-A430-D23 for the electrical connection of an external position detection system, article number C73451-A430-D78, to the positioner.

Wiring diagram

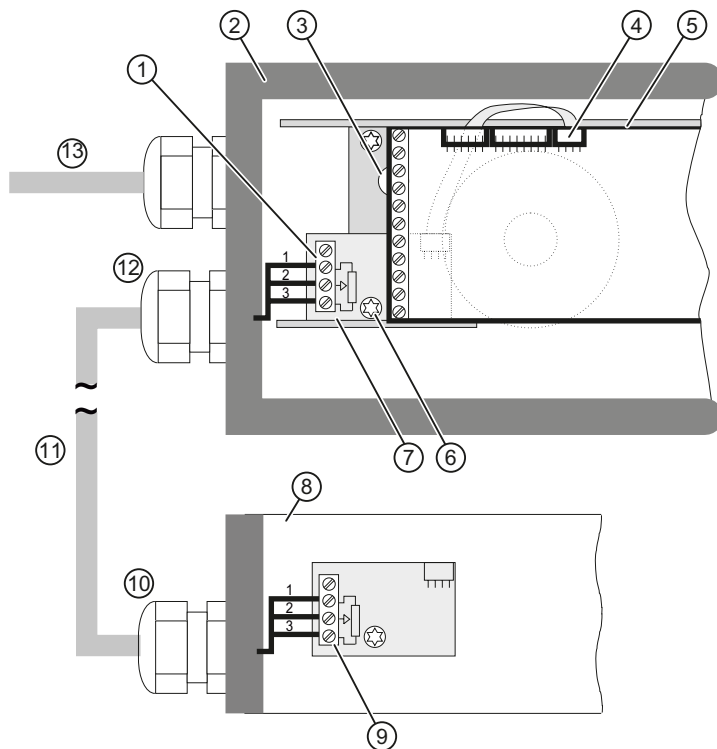

- |  |  |
|--|--|
| ① EMC filter module terminals  | ⑧ External position detection system C73451-A430-D78 |
| ② Positioner with integral EMC filter module C73451-A430-D23                                     | ⑨ External position detection system terminals       |
| ③ Yellow wheel for locking the position detection  | ⑩ External position detection system cable gland     |
| ④ Ribbon cable connector of fitted potentiometer, or ribbon cable connector of EMC filter module | ⑪ Cable  |
| ⑤ Basic electronics  | ⑫ EMC filter module cable gland                      |
| ⑥ Screw  | ⑬ Input signal for positioner                        |
| ⑦ EMC filter module C73451-A430-D23  |  |

Figure 5-7 Connection to positioner

Preparing the positioner

1. You have performed the steps described in the section "General information about the installation of option modules (Page 54)".
2. Unplug the ribbon cable connector ④ to the fitted potentiometer from the basic electronics ⑤.
3. Remove the basic electronics ⑤ from the positioner. To this end, remove the two screws that fix the basic electronics to the pneumatic block.
4. Loosen screw ⑥ in the connection area of the positioner.



5. Insert the connector of the ribbon cable (A) into the slot as shown below.  
 Note: There is no space for the ribbon cable (A) in earlier versions of the positioner. Here you fasten the ribbon cable with the supplied cable tie at the container.

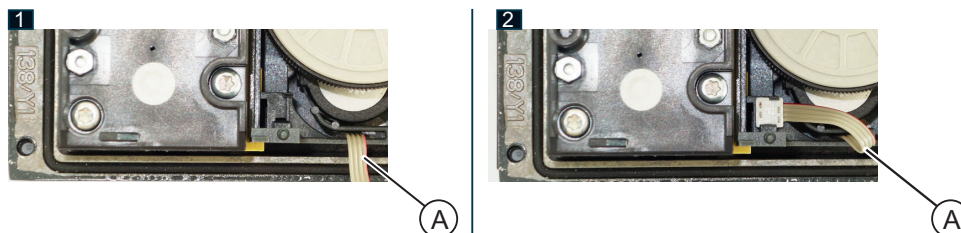

6. Secure the EMC filter module using the screw ⑥ loosened in the third step.  
 7. Fit the basic electronics ⑤ back into the positioner.  
 8. Insert the ribbon cable connector ④ of the EMC filter module onto the positioner basic electronics.  
 9. In **non-hazardous** environment:
- Stick the supplied nameplate over the nameplate on the external position detection system ⑧.
  - Replace the blue cable gland ⑩ by the supplied gray cable gland.

Refer to section "Scope of delivery of external position detection system (Page 307)", items "Nameplate for device version **without** explosion protection" and "Gray cable gland".

### Procedure for connecting an external position detection system

1. Connect the three terminals of the external position detection system ⑨ to the three terminals of the EMC filter module ① using a cable as shown in the wiring diagram.
2. Tighten the cable glands ⑩ and ⑫.

### 5.2.5 Option modules

#### 5.2.5.1 Alarm modules 6DR4004-6A and -8A

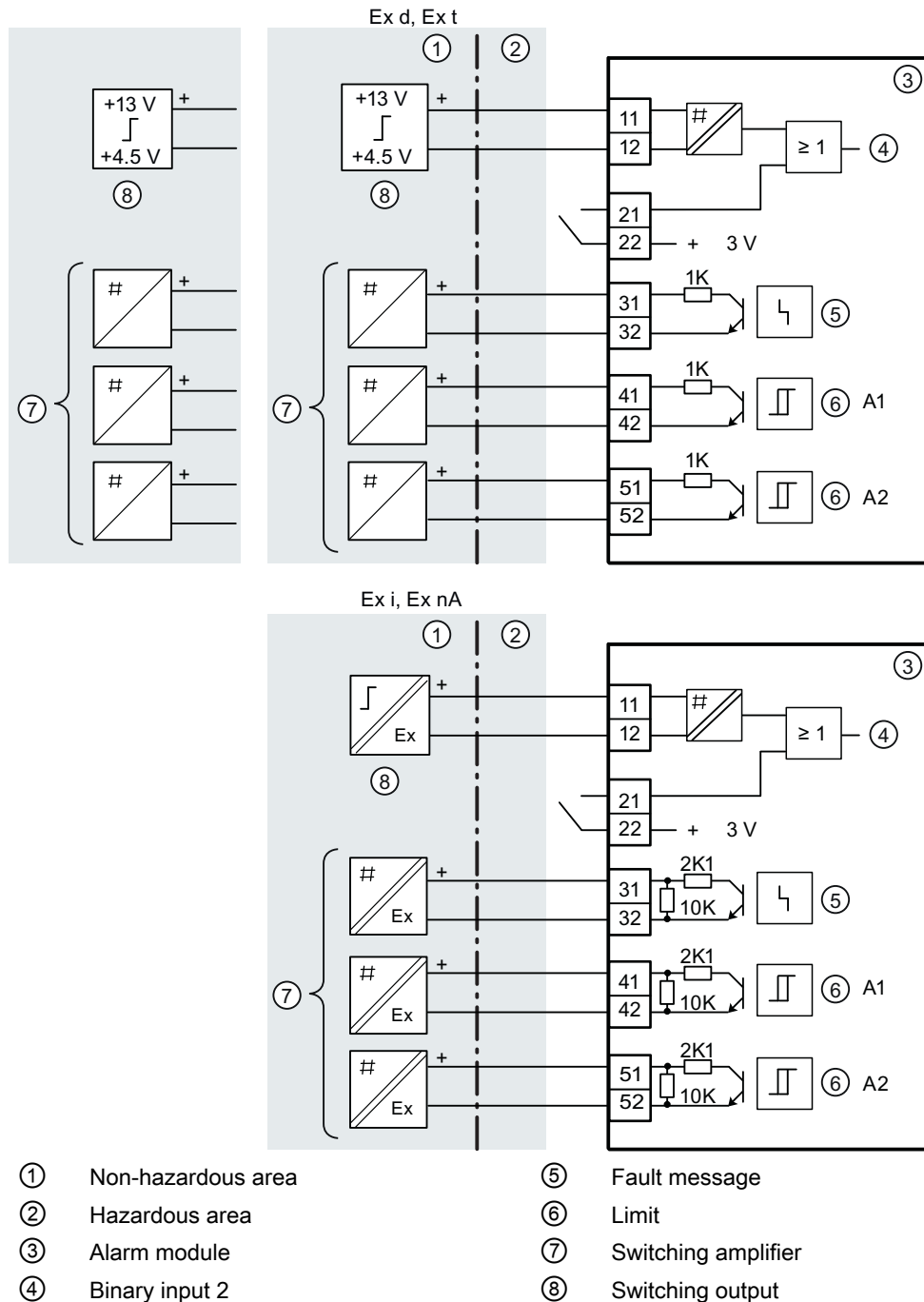

Figure 5-8 Alarm module

### 5.2.5.2 Position feedback modules 6DR4004-6J and -8J

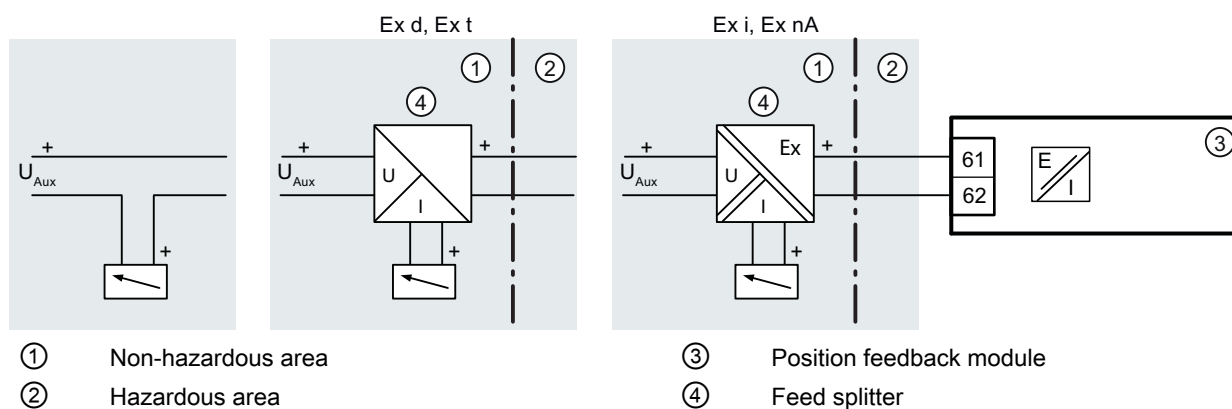

Figure 5-9 Position feedback module

### 5.2.5.3 SIA modules 6DR4004-6G and -8G

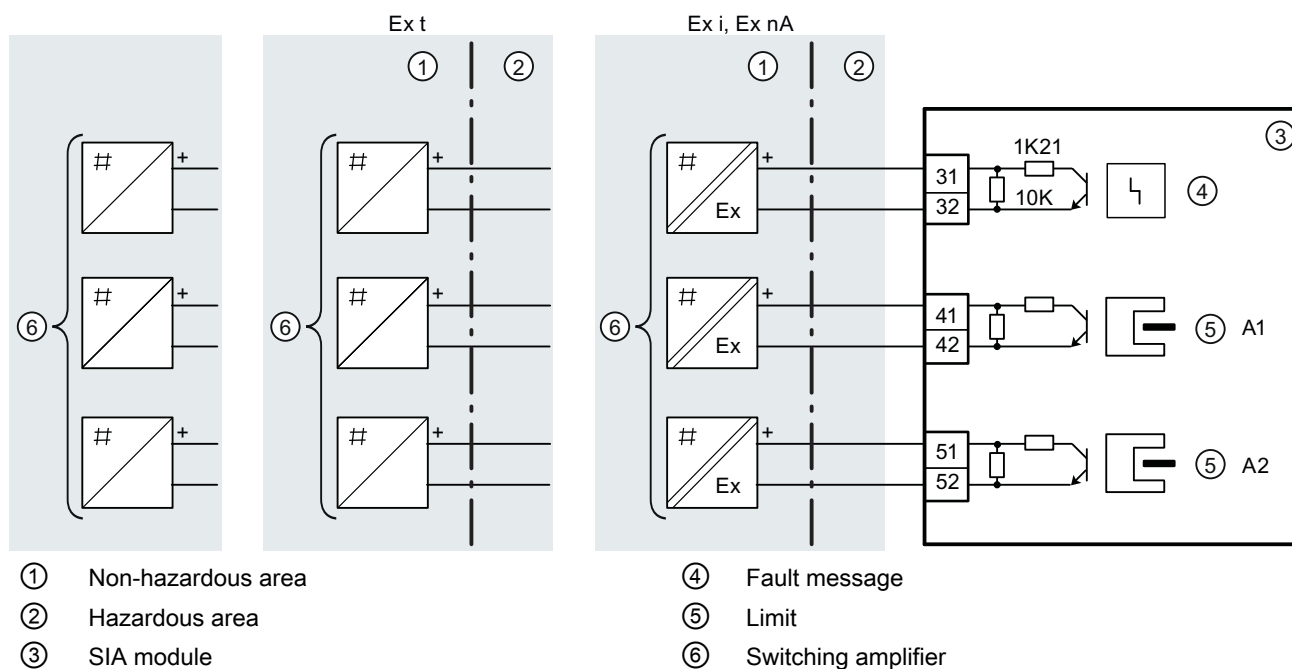

Figure 5-10 SIA module

5.2.5.4 Mechanical limit switch modules 6DR4004-6K and -8K

**⚠ DANGER**

**Supply with hazardous voltage**

When you supply the non-intrinsically safe version of the module with hazardous voltage, you must read the following safety rules before starting work on the device:

1. Isolate the device from power. Use a circuit breaker positioned near the device to do this.
2. Make sure that the device cannot be switched back on inadvertently.
3. Make sure the device is truly isolated from power.

**⚠ CAUTION**

**Maximum AC/DC switching voltage with UL approval E344532**

The mechanical limit switch module 6DR4004-6K is approved for use for positioners with UL approval. The maximum supply voltage in this case is 30 V AC/DC.

The mechanical limit switch module 6DR4004-8K is not approved for use for positioners with UL approval.

If this information is ignored, the UL approval for the mechanical limit switch module for the positioner becomes invalid.

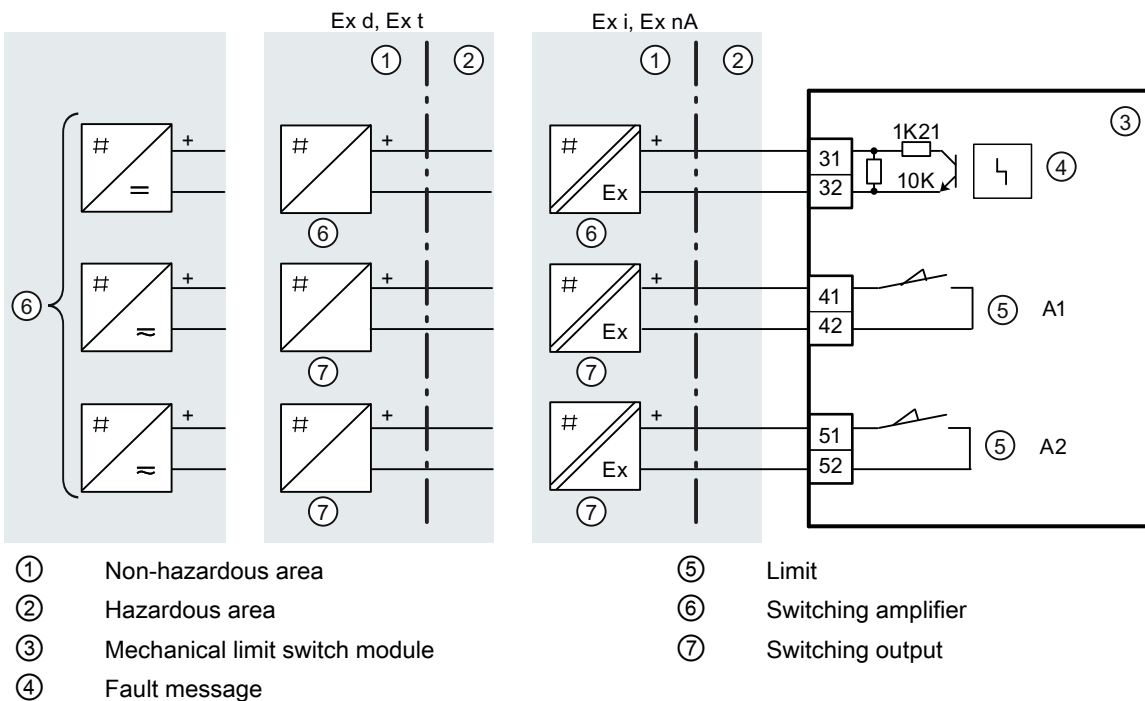

Figure 5-11 Mechanical limit switch module

## Procedure

1. Loosen the screw ① on the transparent cover ②.
2. Pull the transparent cover ② up to the front end stop.
3. Tighten every cable in the corresponding terminal.
4. Slide the transparent cover ② up to the end stop of the basic electronics.
5. Tighten the screw ① of the transparent cover ②.
6. Connect the cables of each switch to the lug of the printed circuit board in pairs. Use the provided cable ties ③ for this purpose.

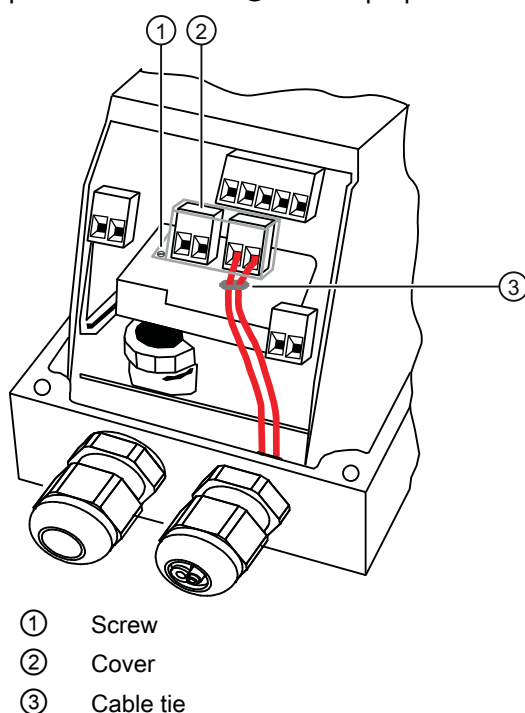

Figure 5-12 Connecting the cables

### 5.2.6 Option device version M12 connector

This section describes which terminal of the devices and option modules listed below is connected with the respective pole of the M12 connector.

#### Note

#### Technical specifications

Observe the specifications for the electrical data in the certificate and/or in section "Technical data (Page 283)".

**View of the mating side pole pattern**

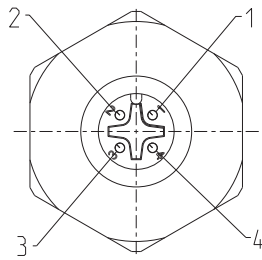

Pole designation	Wire color of M12 connector
1	Brown
4	Black
3	Blue
2	White

**5.2.6.1 M12 connector in the basic device**

You have a positioner 6DR55..-0.R.. or 6DR55..-0.S. In this case the M12 connector is connected to the bus circuit of the basic electronics.

Table 5-1 Assignment diagram

Bus circuit terminal	Pole designation
7	1 - Brown
Shield support of housing	4 - Black
6	3 - Blue

**5.2.6.2 M12 connector for connection of the outputs of the alarm module 6DR4004-6A / -8A (-Z D55)**

You have a positioner with order suffix -Z order code D55. This version of the positioner is connected via an M12 connector to the current output of the position feedback module.

Table 5-2 Assignment diagram

Alarm output terminal	Pole designation
41 (+)	1 - Brown
52 (-)	4 - Black
42 (-)	3 - Blue
51 (+)	2 - White

### 5.2.6.3 M12 connector for connecting the outputs of the position feedback module 6DR4004-6J / 8J (-Z D53)

You have a positioner with order suffix -Z order code D53. In this version of the positioner, an M12 connector is used to electrically connect the current output of the position feedback module.

Table 5-3 Assignment diagram

Current output terminal	Pole designation
61 (+)	1 - Brown
Shield support of housing	4 - Black
62 (-)	3 - Blue

### 5.2.6.4 M12 connector for connecting the external position detection system (-Z D54)

You have a positioner with order suffix -Z order code D54. In this version of the positioner the M12 connector connects the external position detection system with the built-in EMC filter module (C73451-A430-D23).

Table 5-4 Assignment diagram

Terminal	Pole designation
POT (X1/2)	3 - Blue
VCC (X1/4)	1 - Brown
GND (X1/1)	4 - Black
VREF (X1/3)	2 - White

### 5.2.6.5 M12 connector for connecting the outputs of the SIA module 6DR4004-6G /-8G (-Z D56)

You have a positioner with order suffix -Z order code D56. In this version of the positioner, an M12 connector is used to electrically connect the outputs of the SIA module.

Table 5-5 Assignment diagram

Alarm output terminal	Pole designation
41 (+)	1 - Brown
52 (-)	4 - Black
42 (-)	3 - Blue
51 (+)	2 - White

## 5.3 Pneumatic connection

### 5.3.1 Pneumatic connection for 6DR55.0/1/2/3

#### Structure

The pneumatic connections are provided on the right side of the positioner.

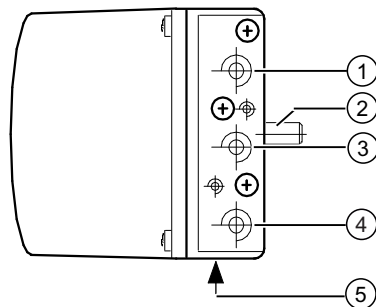

- ① Actuating pressure Y1 for single and double-acting actuators
- ② Positioner shaft
- ③ Supply air PZ
- ④ Actuating pressure Y2 for double-acting actuators
- ⑤ Exhaust air outlet with a sound absorber

Figure 5-13 Pneumatic connection on the standard controller

### 5.3.2 Integrated pneumatic connection

#### Structure

The following pneumatic connections are provided at the rear side of the basic device for the integrated attachment for single-acting linear actuators:

- Actuating pressure Y1
- Exhaust air outlet

These connections are sealed with screws when the device is delivered.

The exhaust air outlet is corrosion-resistant for the blanketing of the pick-up room and the spring chamber with dry instrument air.



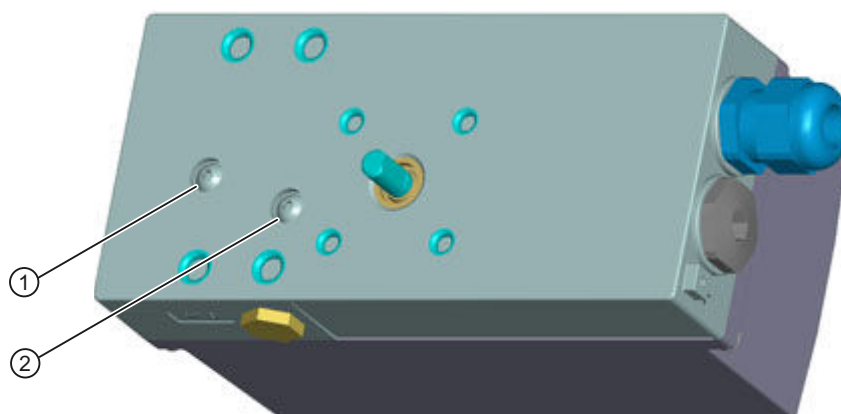

- ① Actuating pressure Y1
- ② Exhaust air outlet

Figure 5-14 Integrated pneumatic connection

### 5.3.3 Pneumatic connection for 6DR55.5-0E...

#### Structure

The pneumatic connections are provided on the right side of the positioner.

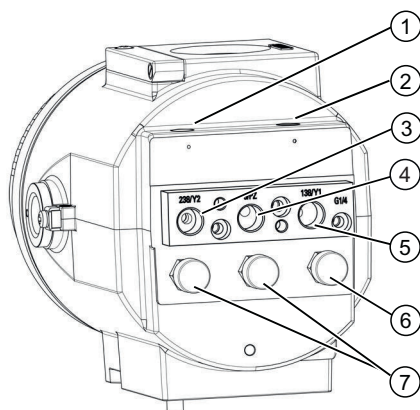

- ① Restrictor Y2 \*)
- ② Restrictor Y1
- ③ Actuating pressure Y2 \*)
- ④ Supply air PZ
- ⑤ Actuating pressure Y1
- ⑥ Exhaust air outlet
- ⑦ Enclosure ventilation (2x)

\*) for double-acting actuators

Figure 5-15 Pneumatic connection in the flameproof enclosure

### 5.3.4 Reaction to failure of auxiliary powers

#### Overview

The following overview diagram shows the pneumatic connection versions for different actuator types, regulating action and safety position after an auxiliary power supply failure.

 <b>CAUTION</b>
<b>Before working on the control valve</b>
Note that before working on the control valve, you must first move it to the safety position. Make sure that the control valve has reached the safety position. If you only interrupt the pneumatic auxiliary power supply to the positioner, the safety position may in some cases only be attained after a certain delay period.







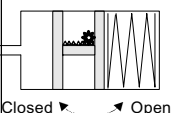

Actuating pressure Connection	Actuator type	Safety position after auxiliary power failure		
		Electric	Pneumatic	
Y1		Closed 	Closed 	<p>With part-turn actuators the counterclockwise direction of rotation - viewed on the actuating shaft of the valve - is defined as "Open".</p>  <p>Closed → Open</p>
Y1		Open 	Open 	
Y2		Open 	Last position (before auxiliary power failure)	
Y1		Closed 		
Y1		Closed	Closed	 <p>Open → Closed</p>
Y1		Open	Open	
Y2		Open	Last position (before auxiliary power failure)	
Y1		Closed		

Figure 5-16 Regulating action of pneumatic connection

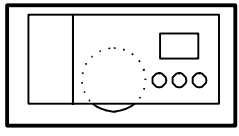
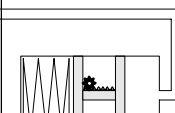
Overview of positioning effect for fail in place version

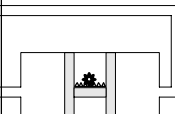
Actuating pressure Connection	Actuator type	Position following failure of auxiliary energy		
		Electrical	Pneumatic	
Y1		Hold in position	Hold in position	<p>With part-turn actuators, the direction of rotation opposite to the clockwise direction – when viewed onto the actuating shaft of the valve – is usually defined as "Open".</p> 
Y1		Hold in position	Hold in position	
Y2 Y1		Hold in position	Hold in position	
Y1 Y2		Hold in position	Hold in position	
Y1		Hold in position	Hold in position	
Y1		Hold in position	Hold in position	
Y2 Y1		Hold in position	Hold in position	
Y1 Y2		Hold in position	Hold in position	

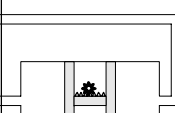
Figure 5-17 Pneumatic connections for positioning effect with fail in place version

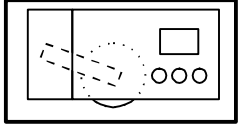
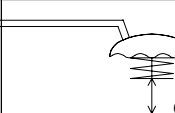
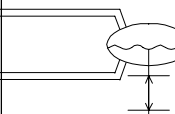
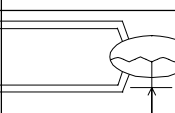
### 5.3.5 Pneumatic connection

**⚠ WARNING****Pneumatic auxiliary power**

Owing to safety reasons, the pneumatic auxiliary power supply must be fed after installation only if the positioner is switched to the "P-manual mode" when an electrical signal is available, refer to the as-delivered condition.

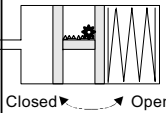
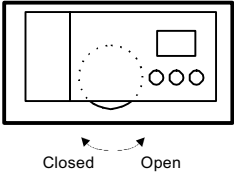
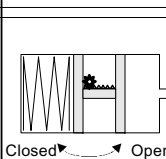
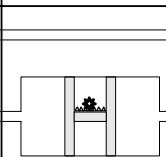
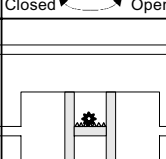
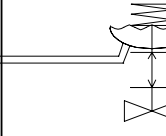
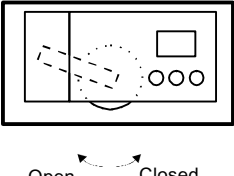
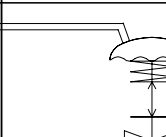
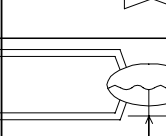
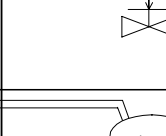
**Note****Specifications regarding air quality**

Observe the specifications regarding the air quality, see section "Technical specifications > Pneumatic data (Page 284)".

- If required, connect the pressure gauge block for supply air and actuating pressure.
- Connection via female thread G $\frac{1}{4}$  or  $\frac{1}{4}$ " NPT:
  - Y1: actuating pressure 1 for single and double-acting actuators
  - Y2: actuating pressure 2 for double-acting actuators
  - Exhaust air outlet with a sound absorber. Remove the sound absorber if required.
- For double-acting actuators, connect actuating pressure Y1 or Y2 depending on the desired safety setting.
- Safety position in case of electrical auxiliary power supply failure:
  - Positioner with single-acting pneumatic system: Y1 depressurized
  - Positioner with double-acting pneumatic system: Y1 pressurized (maximum actuating pressure), Y2 depressurized
  - Positioner with Fail in Place pneumatic system: Hold Y1 and Y2 (current actuating pressure)

**Note****Leakage**

Besides continuous air consumption, a leakage can cause the positioner to try to compensate the position deviation. This will result in premature wear in the entire control device.

- After installing the pneumatic connections, check the tightness of the entire control valve.

**See also**

Reaction to failure of auxiliary powers (Page 98)

Changing the operating mode (Page 107)

## 5.4 Restrictors

- Reduce the air output to achieve travel times of  $T > 1.5$  s for small actuators. Use restrictors Y1 ① and Y2 ② for this purpose.
- When turned clockwise, they reduce the air output and finally shut it off.
- In order to set the restrictors, we recommend closing them and then opening slowly.
- In case of double-acting valves, ensure that both restrictors have approximately the same setting.

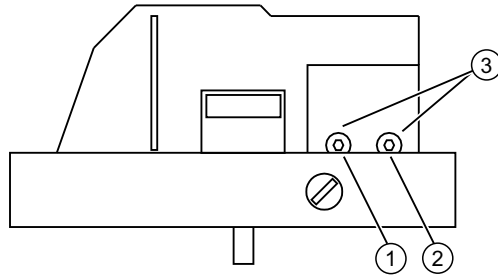

- ① Restrictor Y1
- ② Restrictor Y2, only in the version for double-acting actuators
- ③ Hexagon socket-head screw 2.5 mm

Figure 5-18 Restrictors

### See also

Pneumatic connection for 6DR55.5-0E... (Page 97)

Sequence of automatic initialization (Page 116)

## Operation

### 6.1 Operating elements

#### 6.1.1 Display

##### Introduction

###### Note

###### Repetition rate display

When operated in temperature ranges below  $-10^{\circ}\text{C}$ , the liquid crystal display of the positioner becomes sluggish and the repetition rate display reduces considerably.

The display has two lines. These two lines are segmented differently. Each element in the upper line has 7 segments, whereas that in the lower line has 14 segments. Contents of the display depend on the selected mode.

##### Display options as per the mode

An overview of mode-specific display options is given below.

Operating mode	Representation in the display	Pos.	Legend
P manual mode		①	Potentiometer setting [%]
		②	Blinking indicator for the non-initialized status.
Initialization mode		①	Potentiometer setting [%]
		②	Display of the current status of initialization or a fault message.
		③	Indicator for ongoing initialization or a fault message.
Configuring		①	Parameter value
		②	Parameter name
		③	Parameter number

6.1 Operating elements

Operating mode	Representation in the display	Pos.	Legend
Manual mode (MAN)		①	Position [%]
		②	Setpoint [%]
		③	Fault message
Automatic (AUT)		①	Position [%]
		②	Setpoint [%]
		③	Fault message
Diagnostics		①	Diagnostics value
		②	Diagnostics name
		③	Diagnostics number

See also

System messages before initialization (Page 246)

Changing the operating mode (Page 107)

6.1.2 Buttons

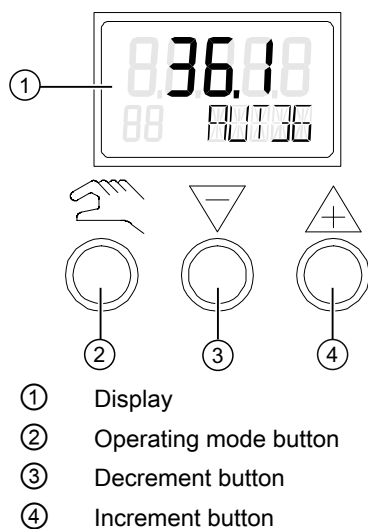

Figure 6-1 Display and buttons of the positioner



- You can use three buttons to operate the positioner.
- The function of the buttons depends on the mode selected.
- In a positioner with a flameproof enclosure, the buttons are protected with a cover. The button cover can be opened after unlatching the locking screw.

---

**Note****Key cover**

In positioners with flameproof enclosures, the button cover prevents liquids from seeping through. The IP66/NEMA 4x degree of protection is not ensured when the enclosure or the button cover is open.

---

You have to remove the enclosure cover to operate the buttons of the basic device or the "intrinsically safe" version.



---

**Note****Degree of protection**



The IP66/NEMA 4x degree of protection is not ensured as long as the positioner is open.

---

**Function of buttons:**

- The  button is used to select the modes and to forward the parameters.
  - The  button is used to select parameter values in "Configuration" mode. You can use this button to move the actuator in "Manual" mode.
  - The  button is also used to select parameter values in "Configuration" mode. You can use this button to move the actuator in "Manual" mode.
- 

**Note****Order**

Parameters are activated in the reverse order when the  and  buttons are pressed simultaneously.

---

**See also**

Display (Page 103)

**6.1.3 Firmware version**

The current firmware version is displayed when you exit the configuration menu.

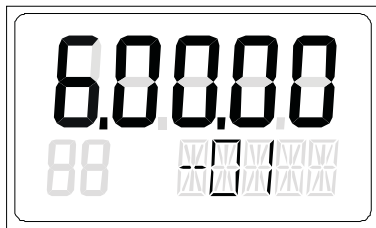

Figure 6-2 Firmware version, e.g. version 6.00.00

## 6.2 Operating modes

### 6.2.1 Overview of operating modes

You have five operating modes at your disposal to operate the positioner:

1. P-manual mode (as-delivered condition)
2. Configuration and initialization mode
3. Manual mode (MAN)
4. Automatic (AUT)
5. Diagnostics

## 6.2.2 Changing the operating mode

The following picture illustrates the available operating modes and switching between the operating modes.

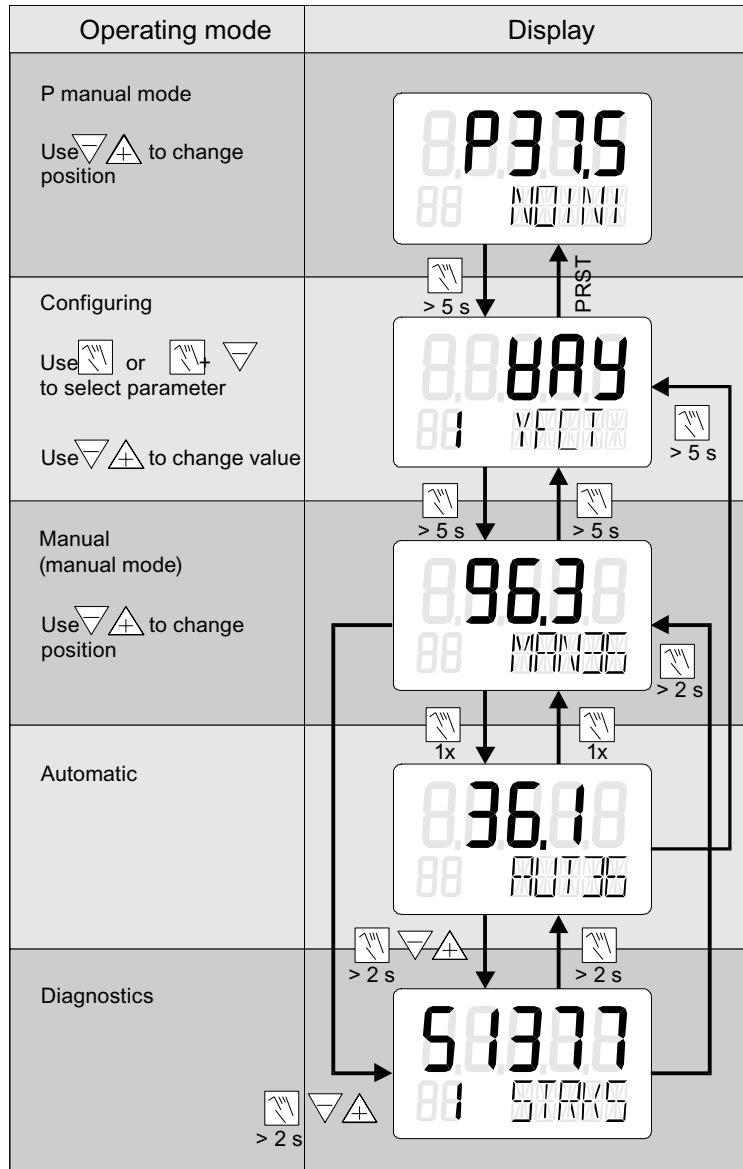

Figure 6-3 Switching between the operating modes

### See also

Display (Page 103)

### 6.2.3 Overview of configuration

The following picture illustrates the handling of operating modes such as "Configuration" and "Initialization mode":

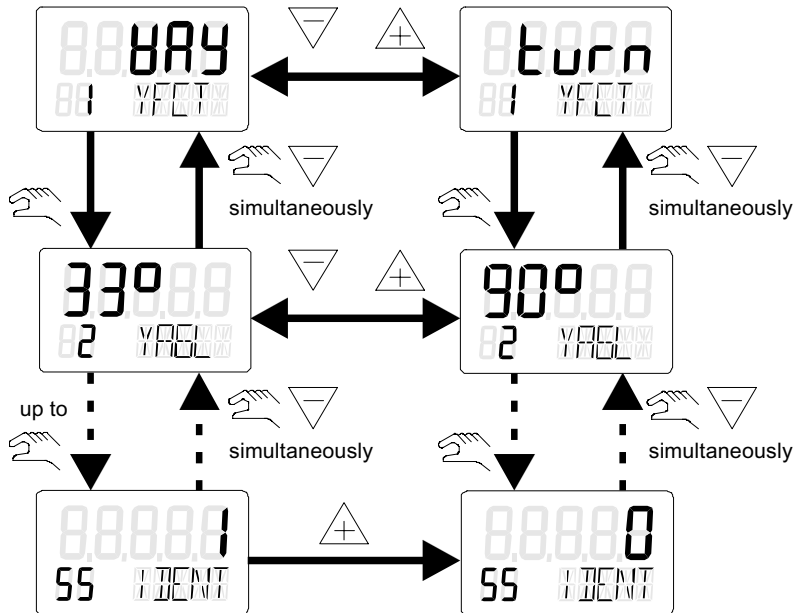

Figure 6-4 Overview of the "Configuration" operating mode

### 6.2.4 Description of operating modes

#### P manual mode

**Note**

**Delivery state**

The "P manual mode" is preset for the positioner in the delivery state.

The display of the positioner shows the current potentiometer position in the upper line. "NOINI" blinks in the second line of the display.

Move to the actuator with the  $\nabla$  or  $\triangle$  buttons.

Switch to "Configuration" mode to adapt the actuator to the positioner.

Alarms or position feedbacks can be triggered after initializing the positioner completely.

#### Configuration and initialization

To get to the "Configuration" mode, press the  button for at least 5 seconds.

You can use the "Configuration" mode to adjust the positioner individually as per your actuator and start commissioning or initialization.

The positioner reports the "Configuration" mode with a configurable fault message. A position feedback or display of limits A1 and A2 is not possible.

---

**Note****Failure of electrical auxiliary power**

If electrical auxiliary power supply fails when configuring, the positioner responds as follows when the power supply is reestablished:

- The positioner switches to the first parameter.
- Settings of the values already configured are retained.

In order to save the changed parameter values, exit the "Configuration" mode or switch to another parameter. When "Configuration" mode is restarted, the output in the display switches to the last activated parameter.

---

## Manual mode (MAN)

In this mode, you move the actuator with  $\nabla$  or  $\triangle$ . The setting selected here is retained irrespective of the setpoint current and leakages, if any.

---

**Note****Accelerating the actuator movement**

Proceed as follows if you wish to accelerate the actuator movement:

1. Keep one of the two direction buttons pressed.
  2. Press the remaining direction button simultaneously.
- 

**Note****Failure of power supply**

When the power supply is reestablished after a failure, the positioner switches to the "Automatic" mode.

---

## Automatic (AUT)

Automatic is the standard mode. In this mode, the positioner compares the setpoint position with the actual position. The positioner moves the actuator until the control deviation reaches the configurable deadband. An error message is displayed if the deadband cannot be reached.

## Diagnostics

Proceed as follows to call the "Diagnostics" mode from the "Automatic" or "Manual" modes:

Press the three buttons of the positioner at the same time for at least 2 seconds.

Current operating data can be called and displayed in this mode, e.g.:

- Number of total strokes
- Number of changes in direction
- Number of fault messages

---

**Note**

**Setting the mode**

The "Automatic" and "Manual" modes remain set when switching to the "Diagnostics" mode. The positioner responds as per the configured mode:

- The predefined setpoint is used as the control variable in "Automatic" mode.
  - The last reached position is retained in "Manual" mode.
- 

**See also**

Overview (Page 115)

Overview of advanced diagnostics parameters A to P (Page 150)

Overview of diagnostics values (Page 253)

## 6.2.5 Optimization of controller data

---

**Note**

**Initializing**

Initialize the positioner automatically before changing the parameter settings as per your specific requirements.

---

The positioner determines the data for control quality automatically during the initialization process.



The data determined is optimized for a short transient time in the case of minor overshoots.

The adjustment can be accelerated or the attenuation can be intensified by optimizing the data.

The following special cases are suitable for targeted data optimization:

- Small actuators with travel times < 1 s.
- Operation with boosters, described in section "Operation with boosters (Page 311)"

**Procedure**

1. Switch to "Diagnostics" mode.
2. Select the diagnostics parameters.
3. Press the three buttons of the positioner at the same time for at least 2 seconds.
4. Activate the setting function. Press the  or  button for at least 5 seconds.

The modified diagnostics values are effective immediately. The effects on the controller results can then be tested.

In order to optimize the controller data, change the values of the diagnostics parameters listed below.

### Diagnostics parameters '23.IMPUP' Impulse length UP / '24.IMPDN' Impulse length DOWN

You can use these diagnostics parameters to determine the smallest impulse lengths for each actuating direction. The actuator is then moved with these lengths. The optimum value depends in particular on the volume of the actuator. Small values lead to small controller increments and frequent activation of the actuator. Large values are advantageous for large actuator volumes.

---

#### Note

##### Controller increments

- There is no movement if the values are too small.
  - Large controller increments also lead to large movements with small actuators.
- 

### Diagnostics parameters '28.SSUP' Slow step zone UP / '29.SSDN' Slow step zone DOWN

The slow step zone is the area of mean control deviation. For more information on the slow step zone, refer to the section "Functional principle (Page 28)".

Select small values to achieve high speeds of shifting even with small control deviations. Select large values to reduce overshoots particularly in case of large changes in the setpoint.

<b>NOTICE</b>
<b>Overshoots or too low speeds of shifting</b>
Too small values can result in overshoots.
<ul style="list-style-type: none"><li>• Enter a higher value.</li></ul>
Too large values result in too slow speeds of shifting near the adjusted status.
<ul style="list-style-type: none"><li>• Enter a smaller value.</li></ul>

### Diagnostics parameters '47.PRUP' Prediction UP / '48.PRDN' Prediction DOWN

These diagnostics parameters act as attenuation factors and are used to set the control dynamics. Changes in the diagnostics values have the following results:

- Small values result in quick adjustments with overshoots.
- Large values result in slow adjustments without overshoots.

---

#### Note

##### Reference variable

It is advantageous to use a fixed reference variable to optimize the control data. Therefore, change the deadband of the controller in the '34.DEBA' parameter from "Auto" to a fixed value.

---





## 7.1 Basic safety instructions

 <b>WARNING</b>
<b>Improper commissioning in hazardous areas</b> Device failure or danger of explosion in hazardous areas. <ul style="list-style-type: none"><li>• Do not commission the device until it has been mounted completely and connected in accordance with the information in Chapter "Technical data (Page 283)".</li><li>• Before commissioning take the effect on other devices in the system into account.</li></ul>

 <b>WARNING</b>
<b>Loss of explosion protection</b> Danger of explosion in hazardous areas if the device is open or not properly closed. <ul style="list-style-type: none"><li>• Close the device as described in Chapter "Installing/mounting (Page 37)".</li></ul>

 <b>WARNING</b>
<b>Opening device in energized state</b> Danger of explosion in areas subject to explosion hazard. <ul style="list-style-type: none"><li>• Only open the device in a de-energized state.</li><li>• Check prior to commissioning that the cover, cover locks, and cable inlets are assembled in accordance with the directives.</li></ul> <b>Exception:</b> Devices having the type of protection "Intrinsic safety Ex i" may also be opened in energized state in hazardous areas.

 <b>WARNING</b>
<b>Water in compressed air line</b>
Device damage and possibly loss of type of protection. The factory setting for the purging air selector is "IN". In the "IN" position, water from the compressed air line may enter the device from the pneumatics during initial commissioning.
<ul style="list-style-type: none"><li>• Before commissioning, make sure that no water is present in the compressed air line.</li></ul>
If you cannot be sure that there is no water in the compressed air line:
<ul style="list-style-type: none"><li>• Set the purging air selector to "OUT". In this way, you prevent water from the compressed air line from penetrating the device.</li><li>• Only set the purging air selector to "IN" again when all water has been discharged from the compressed air line.</li></ul>

 <b>CAUTION</b>
<b>Loss of degree of protection</b>
Damage to device if the enclosure is open or not properly closed. The degree of protection specified on the nameplate or in Chapter "Technical data (Page 283)" is no longer guaranteed.
<ul style="list-style-type: none"><li>• Make sure that the device is securely closed.</li></ul>

 <b>WARNING</b>
<b>Commissioning and operation with pending error</b>
If an error message appears, correct operation in the process is no longer guaranteed.
<ul style="list-style-type: none"><li>• Check the gravity of the error.</li><li>• Correct the error.</li><li>• If the error still exists:<ul style="list-style-type: none"><li>– Take the device out of operation.</li><li>– Prevent renewed commissioning.</li></ul></li></ul>

When operating the positioner with natural gas, you must follow and adhere to the following safety notes:

<p><b>⚠ WARNING</b></p> <p><b>Operation with natural gas</b></p> <ol style="list-style-type: none"><li>1. Only positioners and option modules which are connected to power supplies with type of protection "Intrinsic safety, protection level [ia]" may be operated with natural gas.</li><li>2. Do not operate the positioner with natural gas in closed spaces.</li><li>3. Natural gas is continuously blown off in the servo-drive depending on the model. Special care must therefore be taken during maintenance activities near the positioner. Always ensure that the immediate surroundings of the positioner are adequately ventilated. The maximum values for ventilation are listed in section "Technical data for natural gas as actuator medium (Page 290)".</li><li>4. The mechanical limit switch module must not be used when operating the positioner with natural gas.</li><li>5. Depressurize the devices operated with natural gas adequately during maintenance activities. Open the cover in an explosion-free atmosphere and depressurize the device for at least two minutes.</li></ol>
---

---

**Note****Quality of natural gas**

Only use natural gas which is clean, dry and free from additives.

---

## 7.2 Overview

---

**Note**

- During the initialization process, the operating pressure must be at least one bar more than that required to close or open the valve. However, the operating pressure should not be greater than the maximum permissible operating pressure for the actuator.
- 

### General information about commissioning

1. After installing the positioner on a pneumatic actuator, you must supply electric and pneumatic auxiliary power to it.
2. The positioner is in the "P manual mode" before initialization. At the same time, "NOINI" blinks in the lower line of the display.

3. Position feedback: You can adjust the range of position detection using the friction clutch if necessary.
4. Adjust the positioner as per the respective actuator with the help of the initialization process and by setting the parameters. If required, use the "PRST" parameter to cancel the adjustment of the positioner on the actuator. The positioner is again in the "P manual mode" after this process.

### Types of initialization

You can initialize the positioner as follows:

- Automatic initialization:  
during automatic initialization, the positioner determines the following one after the other:
  - The direction of action
  - The actuator travel and angle of rotation
  - The travel time of the actuator

The positioner also adjusts the control parameters as per the dynamic response of the actuator.

- Manual initialization:  
the actuator travel and the angle of rotation of the actuator are set manually. The remaining parameters are automatically determined. This function is useful for valves which are lined, for example, with PTFE.
- Copying the initialization data when replacing a positioner:  
the initialization data of a positioner can be read and copied into another positioner. A defective device can thus be replaced without interrupting an ongoing process through initialization.

You have to define a few parameters for the positioner before initialization. Owing to the preset values, you cannot adjust further parameters for initialization.

You can use a suitably configured and activated binary input to protect the configured settings against accidental adjustment.

### See also

Overview of operating modes (Page 106)

## 7.3 Sequence of automatic initialization

### Overview

The automatic initialization takes place in the following phases:

Automatic initialization phase	Description
Start	-
RUN1	Establishing the direction of action.

Automatic initialization phase	Description
RUN2	Checking the actuator travel and trimming the lower and upper endstops.
RUN3	Establishing and displaying the travel time (leakage test)
RUN4	Minimization of controller increments
RUN5	Optimization of the transient response
End	-

The following structured charts describe the sequence of initialization. The "Up/Down" names indicate the direction of action of actuators.

#### Linear actuator

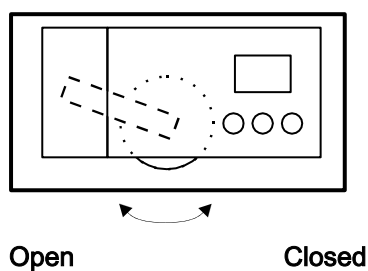

#### Part-turn actuator

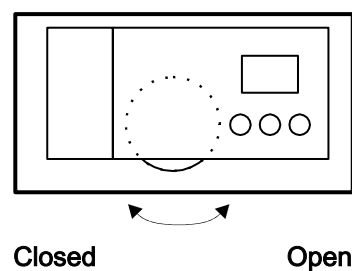

Sequence of RUN1

This structured chart describes the process to establish the direction of action.

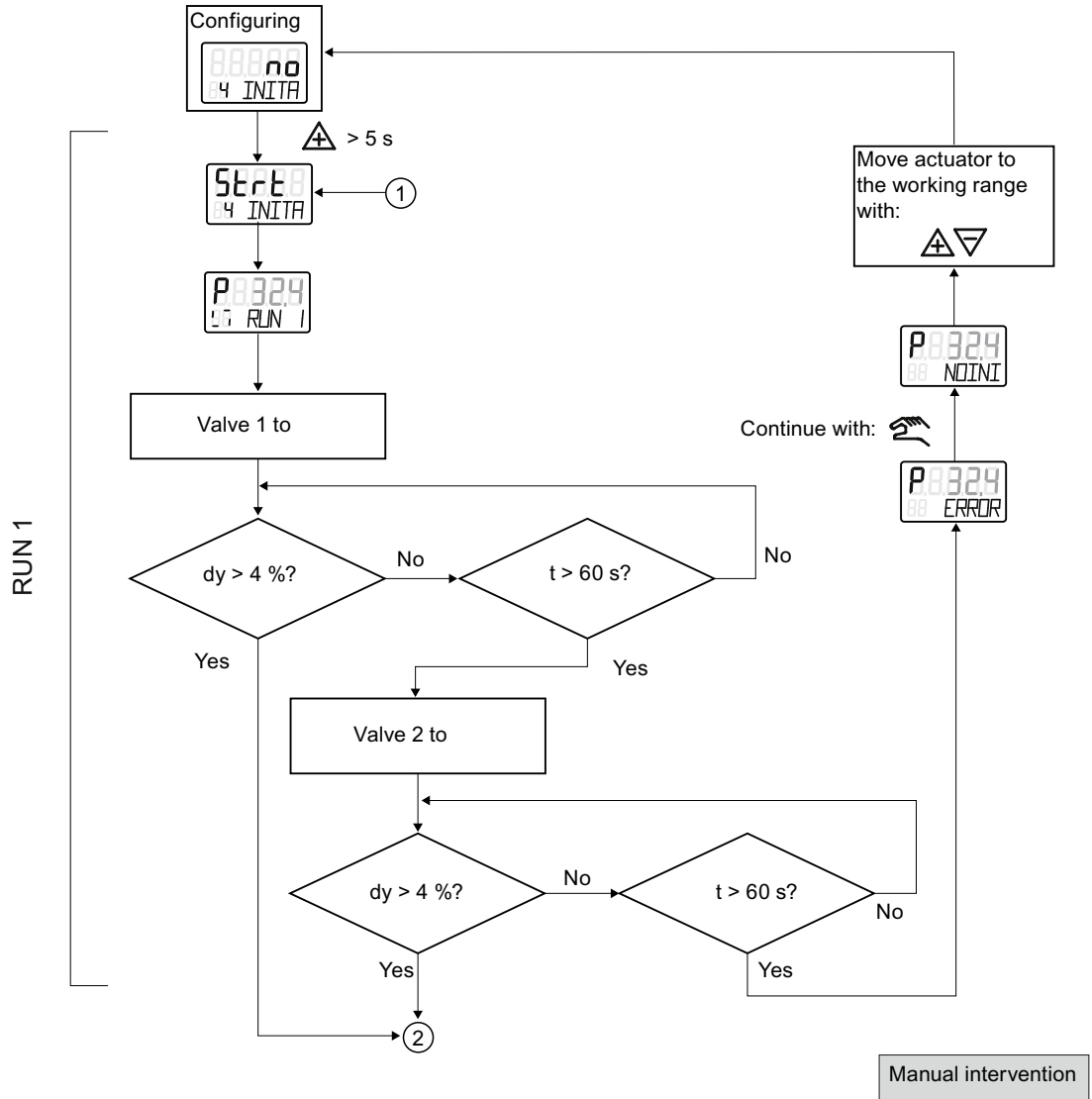

Sequence of RUN2 for part-turn actuators

This structured chart describes the sequence for checking the actuator travel. It also contains information about the sequence for trimming the lower and upper endstops.

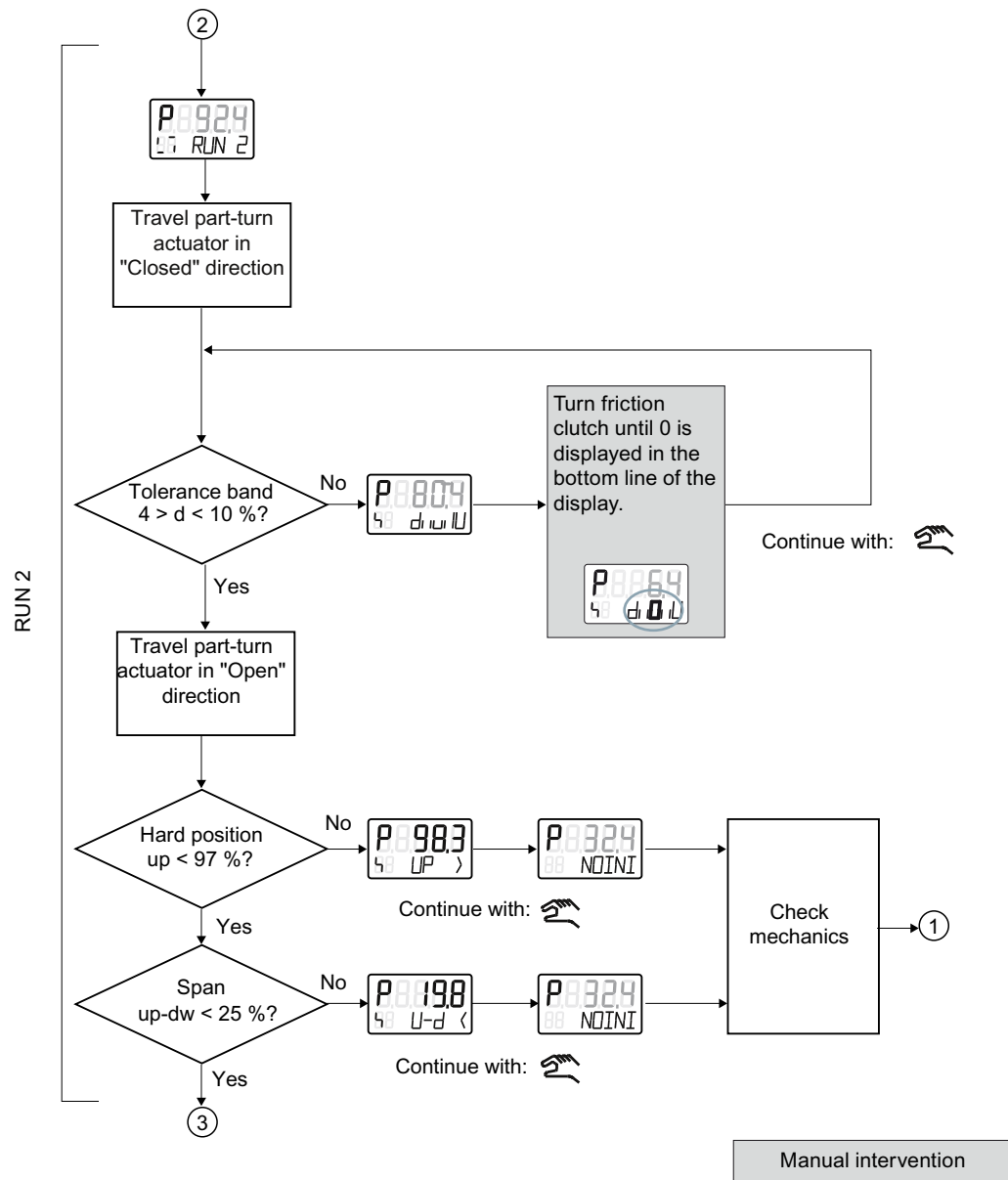

### Sequence of RUN2 for linear actuators

This structured chart describes the process to determine the actuator travel checks. It also contains information about the sequence for trimming the lower and upper endstops.

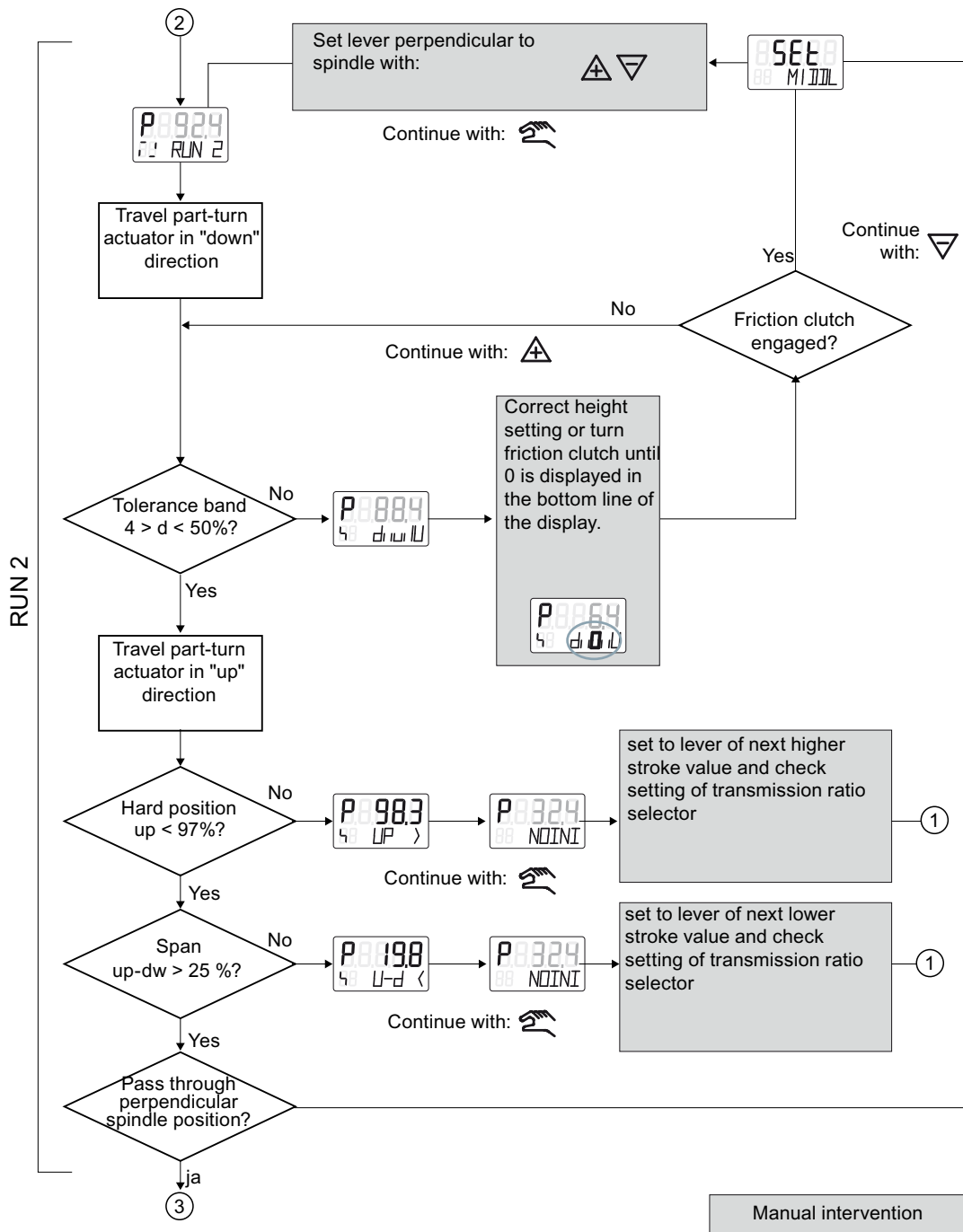

Sequence of RUN3 to RUN5

This structured chart describes:



- Establishing and displaying the travel time/leakage in RUN3
- Minimization of controller increments in RUN4
- Optimization of the transient response in RUN5

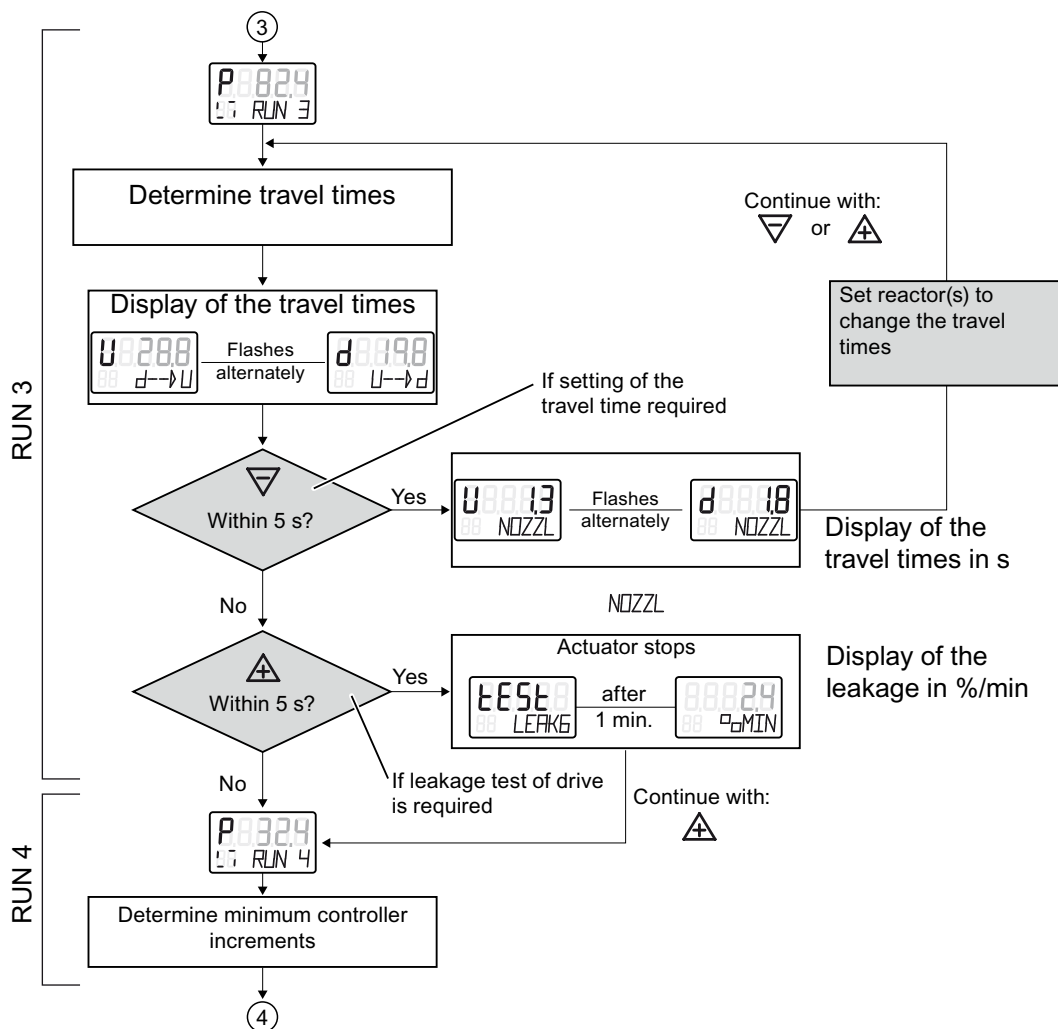

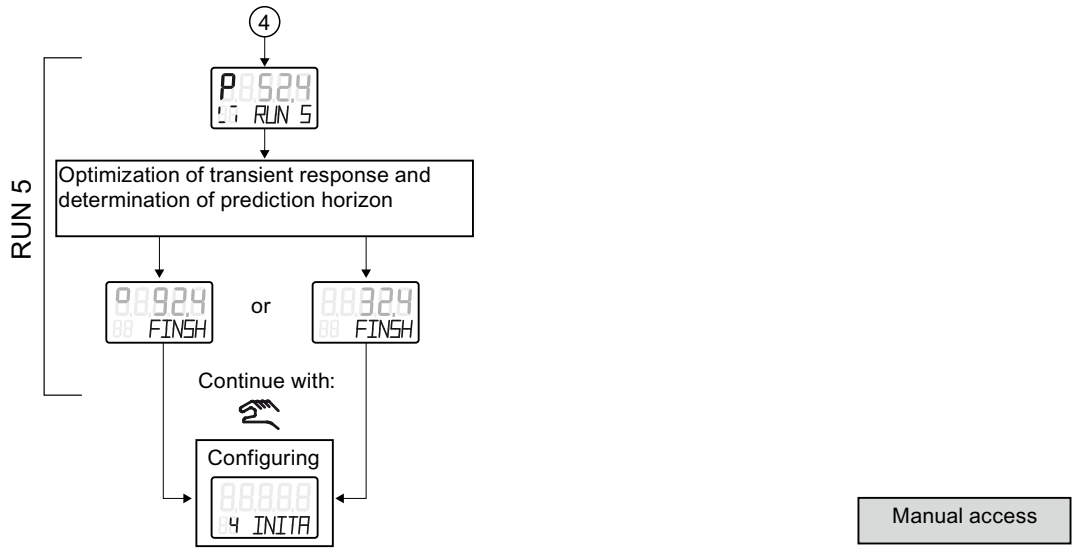

## 7.4 Purge air switching

When the enclosure is open, the purge air switch above the pneumatic terminal strip on the pneumatic block can be accessed.

- In the IN position, the enclosure is flushed from inside with a small volume of clean and dry instrument air.
- In the OUT position, the purge air is directly directed towards outside.

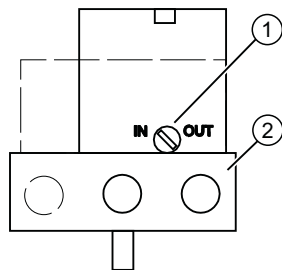

- ① Purging air selector
- ② Pneumatic connections Y1, PZ and Y2

Figure 7-1 Purge air switch on the pneumatic block; view of the positioner on the pneumatic connection side when the cover is open

The factory setting is the "IN" position.

## 7.5 Commissioning linear actuators

### 7.5.1 Preparing linear actuators for commissioning

#### Requirement

You have already installed the positioner using the suitable mounting kit.

#### Setting the transmission ratio selector

##### Note

##### Commissioning

The setting of the transmission ratio selector is extremely important to commission the positioner.

Stroke [mm]	Position of the transmission ratio selector
5 ... 20	33°
25 ... 35	90°
40 ... 130	90°

#### Connecting the positioner

1. Connect a suitable current or voltage source. The positioner is now in the "P manual mode". The current potentiometer voltage (P) in percent is shown in the upper line of the display, e.g.: "P37.5", and "NOINI" flashes in the bottom line:



2. Connect the actuator and the positioner to the pneumatic lines.
3. Supply the pneumatic auxiliary power to the positioner.

### Setting the actuator

1. Check whether the mechanical unit can be moved freely in the entire travel range. Move the actuator to the respective end position for this purpose using the  $\triangle$  or  $\nabla$  button.

---

#### Note

##### End position

By simultaneously pressing the  $\triangle$  and  $\nabla$  buttons, you reach the end position faster.

---

2. Now move the actuator to the horizontal position of the lever.
3. A value between "P48.0" and "P52.0" is shown on the display.
4. If a value beyond this value range is shown on the display, you must move the friction clutch. Move the friction clutch until a value between "P48.0" and "P52.0" is achieved. The closer this value is to "P50.0", the more accurately the positioner determines the stroke travel.

---

#### Note

##### Device versions with flameproof enclosure

The inner friction clutch is fixed. Therefore, only move the outer friction clutch. This also applies when using an internal NCS module.

##### The following applies to device versions without flameproof enclosure with internal NCS module 6DR4004-5L.:

The inner friction clutch has no function. This means you should only adjust the adjustment wheel of the magnet clamp, see section "Internal NCS module 6DR4004-5L/-5LE (Page 70)". Requirement: The '1.YFCT' Type of actuator (Page 154) parameter is set.

---

### See also

- Device components (Page 26)
- Installing the optional modules (Page 54)
- External position detection (Page 53)
- Mounting the linear actuator (Page 40)

## 7.5.2 Automatic initialization of linear actuators

### Requirements

The following conditions must be fulfilled before activating the automatic initialization:

1. The actuator spindle can be moved completely.
2. The actuator spindle is at a central position after moving.

## Initializing the linear actuator automatically

### Note

#### Interrupting initialization

An ongoing initialization can be interrupted at any time. To do this, press . The settings configured until then are retained.



All parameters are reset to factory settings only if you have explicitly activated the preset settings in the "PRST" parameter.

1. Switch to the "Configuration" mode. To do this, press the  button for at least 5 seconds. The display shows the following:

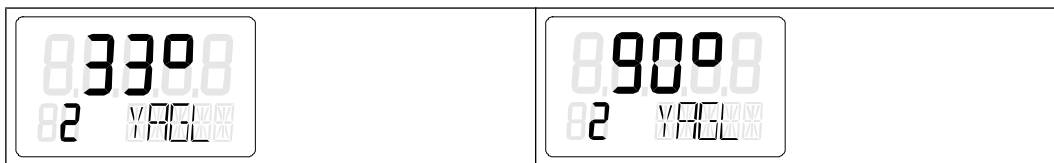

2. Call the "2.YAGL" parameter. To do this, briefly press the  button. The following is shown on the display depending on the setting:



3. Check whether the value displayed in the "2.YAGL" parameter matches the setting of the transmission ratio selector. If required, change the setting of the transmission ratio selector to 33° or 90°.
4. Set the "3.YWAY" parameter to determine the total stroke in mm. The setting of parameter 3 is optional. The display shows the determined total stroke only at the end of the initialization phase.
  - Briefly press the  button if you do not require any information about the total stroke in mm. You are then directed to parameter 4.
  - Call the "3.YWAY" parameter. To do this, briefly press the  button. The display shows the following:



### Note

#### Set the "3.YWAY" parameter

Proceed as follows to set parameter 3:

1. On the scale of the lever, read the value marked by the carrier pin.
2. Set the parameter with the buttons or to the read value.

- 5. Call the "4.INITA" parameter. To do this, briefly press the  button. The display shows the following:



- 6. Start the initialization process. To do this, press the  button for at least 5 seconds until the display shows the following:

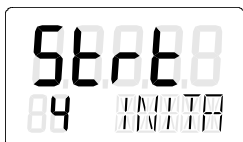

The positioner runs through five initialization steps during the automatic initialization process. Displays for the initialization steps from "RUN 1" to "RUN 5" are shown in the lower line on the display. The initialization process depends on the actuator used, and takes up to 15 minutes.

- 7. The following display indicates that the automatic initialization is complete:



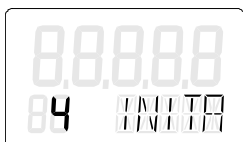

### Aborting the automatic initialization process

- 1. Press the  button. The display shows the following:



The positioner is in the "Configuration" mode.

- 2. Exit the "Configuration" mode. To do this, press the  button for at least 5 seconds. The software status is displayed. After releasing the  button, the positioner is in "P manual mode". The positioner is not initialized.

### See also

Sequence of automatic initialization (Page 116)

### 7.5.3 Manual initialization of linear actuators

You can use this function to initialize the positioner without needing to move the actuator to the lower and upper endstops. The lower and upper endstops of the actuator travel are set manually. When the control parameters are optimized, the further initialization process runs automatically.

#### Requirements

The following requirements must be fulfilled before activating manual initialization:

1. The positioner has been prepared for using on linear actuators.
2. The actuator spindle can be moved completely.
3. The displayed potentiometer position is within the permissible range between "P5.0" and "P95.0".

#### Initializing the linear actuator automatically



1. Switch to the "Configuration" mode. To do this, press the  button for at least 5 seconds until the display shows the following:

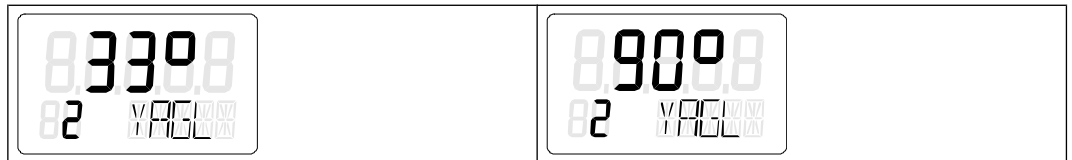

2. Call the "2.YAGL" parameter. To do this, briefly press the  button. The following is shown on the display depending on the setting:



3. Check whether the value displayed of the "2.YAGL" parameter matches with the setting of the transmission ratio selector. If required, change the setting of the transmission ratio selector to 33° or 90°.



4. Set the "3.YWAY" parameter to determine the total stroke in mm. The setting of the "3.YWAY" parameter is optional. The display shows the determined total stroke only at the end of the initialization phase.
  - Briefly press the  button if you do not require any information about the total stroke in mm. You are then directed to parameter 4.
  - Call the "3.YWAY" parameter. To do this, briefly press the  button. The display shows the following:



**Note**

**Set the "3.YWAY" parameter**

To set the "3.YWAY" parameter proceed as follows:

1. On the scale of the lever, read the value marked by the carrier pin.
2. Set the parameter to the read value with the  or  button.

5. Call the "5.INITM" parameter. To do this, press the  button twice. The display shows the following:





6. Start the initialization process. To do this, press the  button for at least 5 seconds until the display shows the following:



The current potentiometer position is output on the display after 5 seconds. Examples of the displayed potentiometer positions are given below:



7. Determine the lower endstop of the actuator spindle.
8. Move the actuator to the desired position using the  or  button.









9. Press the  button. The current position of the actuator is applied. The display shows the following:



---

**Note**
**Fault message "RANGE"**



The selected end position is beyond the permissible measuring range if the "RANGE" message is output on the display. Correct the settings as follows:

1. Move the friction clutch until the display shows "OK".
  2. Press the  button.
  3. Move the actuator to another position using the  or  button.
  4. Abort the manual initialization process by pressing the  button.
  5. Then return to "P manual mode" mode.
  6. Correct the actuator travel and the position detection.
- 
10. Determine the upper endstop of the actuator spindle. Move the actuator to the desired position using the  or  button.
11. Press the  button. The current position of the actuator is applied.

---

**Note**
**Fault message "Set Middl"**

The lever arm is not in the horizontal position if the "Set Middl" message is output on the display. To correct the fault, set the reference point of the sine correction. Proceed as follows:

1. Move the lever arm to the horizontal position using the  or  button.
  2. Press the  button.
- 
12. The initialization process is automatically resumed. Initialization steps "RUN1" to "RUN5" are output in the bottom line of the display. The following is displayed when the initialization has been completed successfully:







---

**Note**
**Total stroke**

If the "3.YWAY" parameter has been set, the display shows the total stroke in mm.

---

### Aborting the manual initialization process

1. Press the  button. The display shows the "5.INITM" parameter. The positioner is in the "Configuration" mode.
2. Exit the "Configuration" mode. To do this, press the  button for at least 5 seconds. The software status is displayed. After releasing the  button, the positioner is in "P manual mode". The positioner is not initialized.

## 7.6 Commissioning part-turn actuators

### 7.6.1 Preparing part-turn actuators for commissioning

---

#### Note

#### Setting of the adjustment angle

The usual adjustment angle for part-turn actuators is 90°.

- Set the transmission ratio selector in the positioner to 90°.
- 

### Requirements

The following conditions must be fulfilled before activating the initialization:

1. You have installed the positioner for the part-turn actuators using the suitable mounting kit.
2. You have connected the actuator and the positioner to the pneumatic lines.
3. Pneumatic auxiliary power is supplied to the positioner.
4. The positioner has been connected to a suitable current or voltage source.

## Setting the actuator

1. The positioner is in the "P manual mode". The current potentiometer voltage P in percent is shown on the upper line in the display. "NOINI" blinks in the lower line of the display. Examples of corresponding displays are given below:



2. Check whether the mechanical unit can be moved freely in the entire travel range. Move the drive to the respective end position for this purpose using the  $\triangle$  or  $\nabla$  button.

---

### Note

#### End position

By simultaneously pressing the  $\triangle$  and  $\nabla$  buttons, you reach the end position faster.

---

3. After checking, move the actuator to a central position. This accelerates the initialization process.

## See also

External position detection (Page 53)

## 7.6.2 Automatic initialization of part-turn actuators

### Requirements

The following conditions must be fulfilled before activating the automatic initialization:

1. The travel range of the actuator can be passed through completely.
2. The actuator shaft is at a central position.

### Initializing the part-turn actuator automatically

---

#### Note

##### Interrupting initialization

An ongoing initialization can be interrupted at any time. To do this, press  $\square$ . The settings configured until then are retained.

All parameters are reset to factory settings only if you have explicitly activated the preset settings in the "PRST" parameter.

---

7.6 Commissioning part-turn actuators

1. Switch to the "Configuration" mode. To do this, press the  button for at least 5 seconds until the display shows the following:



2. Use the  button to change from linear actuator to part-turn actuator until the display shows the following:



3. Call the "2.YAGL" parameter. To do this, briefly press the  button. This parameter has already been set to 90° automatically. The display shows the following:



4. Call the "4.INITA" parameter. To do this, briefly press the  button. The display shows the following:



5. Start the initialization process. To do this, press the  button for at least 5 seconds until the display shows the following:



The positioner runs through five initialization steps during the automatic initialization process. Displays for the initialization steps from "RUN1" to "RUN5" are shown in the lower line on the display. The initialization process depends on the actuator used, and takes up to 15 minutes.

6. The following display indicates that the automatic initialization is complete. The total angle of rotation of the actuator is shown on the upper line on the display:



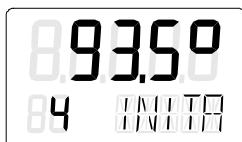

### Aborting the automatic initialization process

1. Press the  button. The display shows the following:



The positioner is in the "Configuration" mode.

2. Exit the "Configuration" mode. To do this, press the  button for at least 5 seconds. The software status is displayed. After releasing the  button, the positioner is in "P manual mode". The part-turn actuator is not initialized.

### See also

Sequence of automatic initialization (Page 116)

## 7.6.3 Manual initialization of part-turn actuators

You can use this function to initialize the positioner without needing to move the actuator to the lower and upper endstops. The lower and upper endstops of the actuator travel are set manually. When the control parameters are optimized, the further initialization process runs automatically.

### Requirements

The following requirements must be fulfilled before activating manual initialization:

1. The positioner has been prepared for using on part-turn actuators.
2. The actuator can be moved completely.
3. The displayed potentiometer position is within the permissible range between "P5.0" and "P95.0".

---

#### Note

##### Setting of the adjustment angle

The usual adjustment angle for part-turn actuators is 90°. Accordingly set the transmission ratio selector in the positioner to 90°.

---

### Initializing the positioner manually

1. Switch to the "Configuration" mode. To do this, press the  button for at least 5 seconds until the display shows the following:



2. Set the "YFCT" parameter to "turn". To do this, press . The display shows the following:



3. Call the second parameter "YAGL". To do this, press . The display shows the following:



4. Call the "INITM" parameter. To do this, press the  button twice. The display shows the following:





5. Start the initialization process. Press the  button for at least 5 seconds until the display shows the following:



6. The current potentiometer position is output on the display after 5 seconds:



7. Determine the lower endstop of the actuator.
8. Move the actuator to the desired position using the  or  button.

9. Press the  button. The current position of the actuator is applied. The display shows the following:











---

#### Note

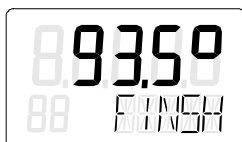

##### Fault message "RANGE"

The selected end position is beyond the permissible measuring range if the "RANGE" message is output on the display. Correct the settings as follows:

1. Move the friction clutch until the display shows "OK".
  2. Press the  button.
  3. Move the actuator to another position using the  or  button.
  4. Abort the manual initialization process by pressing the  button.
  5. Then return to "P manual mode".
  6. Correct the actuator travel and the position detection.
- 
10. Determine the upper endstop of the actuator. Move the actuator to the desired position using the  or  button.
11. Press the  button. The current position of the actuator is applied.
12. The initialization process is automatically resumed. Initialization steps "RUN1" to "RUN5" are output in the bottom line of the display. The following display indicates that the initialization has been completed successfully:



### Aborting the manual initialization process

1. Press the  button. The display shows the "INITM" parameter. The positioner is in the "Configuration" mode.
2. Exit the "Configuration" mode. To do this, press the  button for at least 5 seconds.
3. The software status is displayed.
4. After releasing the  button, the positioner is in "P manual mode". "P manual mode" means that the positioner has not been initialized.

## 7.7 Device replacement

### Introduction

---

#### Note

##### Initialization

The positioner can be replaced without having to interrupt ongoing processes. However, copying and pasting of the initialization parameters only allows an approximate adjustment of the positioner to your actuator. Following initialization, the positioner initially works with the manually defined parameters.

- For this reason, an automatic or manual initialization should be carried out as soon as possible.
- 

#### Note

##### Deferred initialization

Initialize the new positioner as soon as possible. The following properties can be ensured only after initializing:

- Optimum adjustment of the positioner as per the mechanical and dynamic properties of the actuator.
  - Non-deviating position of end stops
  - Correctness of the maintenance data
- 

There are two ways of replacing a positioner when the equipment is in operation, without having to interrupt the process. The two options depend on whether your positioner has communication.

### First possibility - with communication

1. Read the initialization parameters from the previous positioner. Use the parameter assignment tools suitable for this purpose.
2. Read the initialization parameters from Point 1 into the new positioner.
3. Fix the actuator at its current position mechanically or pneumatically. Use the locking function of your mounting kit, if available.
4. Determine the actual position value. To do this, read the actual position value from the display of the previous positioner. Note down the read value.
5. Dismount the previous positioner from the actuator.
6. Attach the lever arm of the previous positioner to the new positioner.
7. Mount the new positioner on the actuator.
8. Set the transmission ratio selector of the new positioner to the same position as that of the previous positioner.
9. If the displayed actual position value differs from the noted value, correct the deviation by moving the friction clutch.



10. The new positioner is ready for operation when the displayed and noted values match.
11. Release the fixing of the actuator.

### Second possibility - without communication

1. Fix the actuator at its current position mechanically or pneumatically. Use the locking function of your mounting kit, if available.
2. Determine the actual position value. To do this, read the actual position value on the display of the previous positioner. Note down the read value.

---

#### Note

##### Electronics defect

If the positioner's electronics is defective, measure the actual position value with a ruler or protractor at the actuator or valve. Convert the read value into %. Note down the converted value.

---

3. Dismount the previous positioner from the actuator.
4. Attach the lever arm of the previous positioner to the new positioner.
5. To prevent interference with the ongoing process, initialize the new positioner on an actuator with a similar stroke or swivel range. Attach the new positioner to this actuator. Initialize the new positioner.
6. Then dismount the new, initialized positioner from this actuator.
7. Mount the new, initialized positioner on the fixed actuator.
8. If the displayed actual position value differs from the noted value, correct the deviation by moving the friction clutch.
9. Use the buttons on the positioner to enter the parameters which deviate from the factory setting, such as type of actuator or tight closing.
10. Change to the measured value view using the  button, see section "Description of operating modes (Page 108)".
11. Release the fixing of the actuator.



# Functional safety

## 8.1 Range of applications for functional safety

The positioner is suitable for use on valves that satisfy the special requirements in terms of functional safety up to SIL 2 in accordance with IEC 61508 or IEC 61511. The 6DR5.1.-0....-....- Z C20 versions are available for this.

These are single-acting positioners for mounting on pneumatic actuators with spring return.

The positioner automatically depressurizes the valve actuator on demand or in case of faults, which thus switches the valve to the specified safety position.

This positioner meets the following requirement:

- Functional safety up to SIL 2 in accordance with IEC 61508 or IEC 61511 for safe venting

### See also

Functional safety in process instrumentation (<http://www.siemens.com/SIL>)

## 8.2 Safety function

### Safety function on positioner

Depressurizing of the connected actuator is the safety function for the positioner. The built-in spring brings the valve to the required safety position. Depending on the direction of action of this spring, the valve is completely opened or closed.

This safety function can be triggered by:

- The signal at the input for the safety shutdown (terminals 81 and 82) is  $< 4.5$  V.  
This function is also referred to as "safety shutdown" in the device documentation.
- Failure of the auxiliary power supply via the bus connection.

The safety function is not affected by other device functions, particularly the microcontroller, software and communication interface. With respect to this safety function, the positioner must therefore be considered as a type A subsystem in accordance with EN 61508-2.

8.3 Safety Integrity Level (SIL)

Situations in which it is not possible to depressurize the actuator on demand or in the case of a fault represent a dangerous failure.

<p><b>⚠ WARNING</b></p> <p><b>Disregarding conditions for fulfilling the safety function</b></p> <p>Disregarding conditions can result in a malfunction of the process system or application, for example, process pressure too high, maximum level exceeded.</p> <p>The mandatory settings and conditions are listed in sections Settings (Page 142) and Safety characteristics (Page 143).</p> <ul style="list-style-type: none"><li>• These conditions must be met in order to fulfill the safety function.</li></ul>
--

The pneumatic block of the positioner pressurizes and depressurizes the actuator. The pneumatic block contains two pilot valves. The characteristic service life of the pneumatic block depends on the load. On average it is approx. 200 million switching cycles for each of the two pilot valves with symmetrical load. The number of control procedures for the switching cycles is called in the local display or via the communication function. For more details, see Diagnostic value '42.VENT1' / '43.VENT2' (Page 264).

**Safety-instrumented system in single-channel operation (SIL 2)**

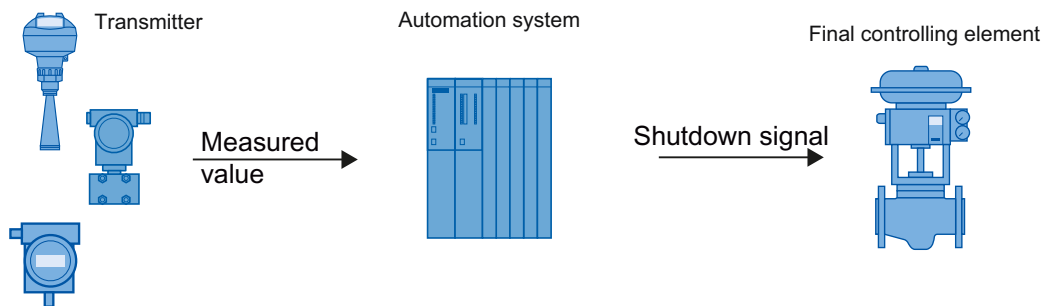

Figure 8-1 Safety-instrumented system in single-channel operation

The combination of transmitter, automation system and final controlling element forms a safety-instrumented system that performs a safety function.

The transmitter generates a process-related measured value that is transferred to the automation system. The automation system monitors this measured value. If the measured value exceeds the range of the high or low limit, the automation system generates a shutdown signal for the connected final controlling element, which switches the associated valve to the specified safety position.

**8.3 Safety Integrity Level (SIL)**

The international standard IEC 61508 defines four discrete Safety Integrity Levels (SIL) from SIL 1 to SIL 4. Every level corresponds to a probability range for the failure of a safety function.

**Description**

The following table shows the dependency of the SIL on the "average probability of dangerous failures of a safety function of the entire safety-instrumented system" (PFD<sub>AVG</sub>). The table deals with "Low demand mode", i.e. the safety function is required a maximum of once per year on average.

Table 8-1 Safety Integrity Level

SIL	Interval
4	$10^{-5} \leq \text{PFD}_{\text{AVG}} < 10^{-4}$
3	$10^{-4} \leq \text{PFD}_{\text{AVG}} < 10^{-3}$
2	$10^{-3} \leq \text{PFD}_{\text{AVG}} < 10^{-2}$
1	$10^{-2} \leq \text{PFD}_{\text{AVG}} < 10^{-1}$

The "average probability of dangerous failures of the entire safety-instrumented system" (PFD<sub>AVG</sub>) is normally split between the following three components:

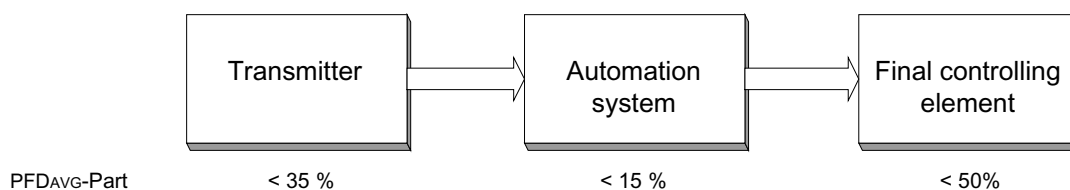



Figure 8-2 PFD distribution

The following table shows the achievable Safety Integrity Level (SIL) for the entire safety-instrumented system for type A devices depending on the safe failure fraction (SFF) and the hardware fault tolerance (HFT).

- Type A devices include analog transmitters and shut-off valves **without** complex components, e.g. microprocessors (see also IEC 61508, Section 2).
- The specific values for your device are listed in the manufacturer's declaration (SIL Declaration of Conformity, Functional Safety according to IEC 61508 and IEC 61511): Certificates (<http://www.siemens.com/processinstrumentation/certificates>).

SFF	HFT for type A devices		
	0	1	2
< 60%	SIL 1	SIL 2	SIL 3
60 to 90 %	SIL 2	SIL 3	SIL 4
90 to 99 %	SIL 3	SIL 4	SIL 4
> 99%	SIL 3	SIL 4	SIL 4

## 8.4 Settings

 <b>WARNING</b>
<b>Safety function: Positioning "Jumper" on the basic electronics</b>
The safety function is not activated in the delivered state; the "Jumper" is in the "Normal" position. "Normal" means: Without safety function, no depressurizing of the connected actuator. To activate the safety function, proceed as follows:
<ul style="list-style-type: none"><li>• Insert the "Jumper" in the left position facing the terminals. This corresponds to the position "Shut Down enabled" on the wiring diagram present on the module cover, see "Figure 3-8 View of the positioner (cover open; Makrolon enclosure) (Page 26)".</li></ul>
Or
<ul style="list-style-type: none"><li>• Remove the "Jumper" from the basic electronics.</li></ul>

Special parameter settings are not necessary.

### Protection against configuration changes

You should attach the housing cover so that the device is protected against unwanted and unauthorized changes/operation.

### Checking the safety function

#### Prerequisite for checking the safety function

- Positioner is in operation.
- The actuator belonging to the positioner is **not** in the safety position.

#### Procedure

1. In order to test the safety shutdown, apply a LOW level, i.e. a voltage of maximum 4.5 V, to the input for the safety shutdown.
2. Verify that the valve returns to the safety position.
3. In order to test the response of the actuator, apply a HIGH level, i.e. a voltage >13 V, to the input for the safety shutdown.
4. Set the setpoint to 50% using a local operation (manual operation) or bus communication.
5. Reduce the inlet pressure (PZ) to a third of the maximum supply pressure.
6. Verify that the valve returns to the safety position.
7. Check the filters in the pneumatic connections for contamination and clean them if necessary.

### See also

Overview of device components (Page 26)

Safety function (Page 139)

## 8.5 Safety characteristics

The safety characteristics necessary for use of the system are listed in the SIL declaration of conformity. These values apply under the following conditions:

- The positioner is only used in applications with low demand rate for the "Low demand mode".
- "Jumper" on the basic electronic system was plugged into the left position facing the terminals at position "Shut Down enabled" or removed completely.
- The positioner is blocked against unwanted and unauthorized changes/operation.
- The shut-off signal for the positioner is generated at the input for the safety shutdown (terminals 81 and 82) by a safe system which meets at least SIL 2. The LOW level has a maximum of 4.5 V at the input terminals.
- The connected actuator must be single-acting and return the valve to the safe end position by spring force in the following scenario:
  - At a chamber pressure (Y1 connection) up to a third of the maximum available intake pressure ( $P_z$  connection)
- The air outlet does not contain any additional cross-sectional contractions leading to an increased dynamic pressure. In particular, a silencer is only allowed if icing or other contamination is ruled out.
- The restrictor in the Y1 circuit may not be completely closed during operation.
- The auxiliary pneumatic power is free of oil, water and dirt in line with: DIN/ISO 8573-1, maximum class 2
- The average temperature viewed over a long period is 40 °C.
- Fault rates are calculated on the basis of a mean time to repair (MTTR) of 8 hours.
- In case of a fault, the pneumatic outlet of the positioner is depressurized. A spring in the pneumatic actuator must move the valve to the pre-defined, safe end position.
- A dangerous failure of the positioner is when the pressure outlet is not depressurized, or the safety position is not reached, with a LOW level of maximum 4.5 V at the input for the safety shutdown.

### See also

Settings (Page 142)

## 8.6 Maintenance/check

### Interval

We recommend that the functioning of the positioner is checked at regular intervals of one year.

### **Checking the safety function**

Check the safety function as detailed in chapter "Settings (Page 142)"

### **Checking safety**

Verify the safety function of the entire safety circuit on a regular basis in accordance with IEC 61508/61511. The test intervals are determined in the course of calculations for each safety circuit of a system ( $PFD_{AVG}$ ).



# Parameter assignment

## 9.1 Introduction to parameter assignment section

A positioner is responsible for controlling a valve and for monitoring the status of a valve. The parameters described in this section are used to optimally adapt the positioner to the valve and its application.

The parameters are divided into initialization parameters, application parameters, and the extended diagnostics parameters.

- Initialization parameters 1 to 5 (Page 154): Describes die parameters which are relevant for initial commissioning of the positioner on the valve. For example, you can start the automatic initialization here.
- Application parameters 6 to 55 (Page 157): Describes die parameters with which the positioner is adapted to the valve application, for example tight closing at the end stops.
- Extended diagnostics parameters A to P (Page 173): Describes the diagnostics functions which are provided by the positioner. These include monitoring of leakages as well as the partial stroke test. Following activation of these functions, the positioner continuously monitors the status of the valve. If you enter thresholds in the parameters of the diagnostics functions, the positioner actively signals high or low violation of these thresholds. The current monitoring state for these thresholds is displayed as a diagnostic value. For additional details on diagnostics and diagnostic values, refer to the section Diagnostics (Page 252).

The following configuration schematic shows the principle of operation of the parameters. This is followed by a tabular overview of the parameters. Finally, the individual parameters and their functionality are described.

Furthermore, the positioners with HART, PA and FF communication interface in combination with a host system, e.g. SIMATIC PDM or HART communicator etc., offer the following advantages:

- Offline tests such as full stroke test, step response test, multi-step response test and valve performance test.
- Diagnostics cockpit which provides an overview of the state of positioner and valve.
- Logbook with time stamp for documentation of all events such as the violation of thresholds.
- Wizards which provide prompting through the relevant parameters during commissioning, the partial stroke test as well as the offline test.

## 9.2 Tabular overview of the parameters

### 9.2.1 Overview of initialization parameters 1 to 5

#### Introduction

Parameters 1 to 5 are the same for all versions of the positioner. These parameters are used to adjust the positioner to the actuator. Normally, setting these parameters is sufficient to be able to operate the positioner on an actuator.

If you want to get to know all details of the positioner, gradually try out the effects of the remaining parameters by systematic testing.

---

#### Note

Factory-set parameter values are printed in bold in the following table.

---

#### Overview

Parameter	Function	Parameter values		Unit
1.YFCT	Type of actuator	Normal	Inverted	
	Part-turn actuator	turn	-turn	
	Linear actuator	<b>WAY</b>	-WAY	
	Linear actuator - carrier pin on actuator spindle	FWAY	-FWAY	
	Linear actuator - external linear potentiometer	LWAY	-LWAY	
	Part-turn actuator with NCS	ncSt	-ncSt	
	Linear actuator with NCS	ncSL	-ncSL	
	Linear actuator with NCS and lever	ncSLL	-ncLL	
2.YAGL	Rated angle of rotation of positioner shaft <sup>1)</sup>			Degrees
	<b>33°</b>			
	90°			
3.YWAY <sup>2)</sup>	Range of stroke (optional setting) <sup>3)</sup>			mm
	<b>OFF</b>			
	5   10   15   20 (Short lever 33°, range of stroke 5 to 20 mm)			
	25   30   35 (Short lever 90°, range of stroke 25 to 35 mm)			
40   50   60   70   90   110   130 (Long lever 90°, range of stroke 40 to 130 mm)				
4.INITA	Initialization (automatic)	<b>NOINI</b>   no / ###.#   Strt		
5.INITM	Initialization (manual)	<b>NOINI</b>   no / ###.#   Strt		

1)	Set the transmission ratio selector accordingly.
2)	Parameter only appears with "WAY", "-WAY", "ncSLL", and "-ncLL"
3)	If used, the value on the actuator must correspond to the set range of stroke on the lever arm. Carrier must be set to the value of the actuator travel or, if this value is not scaled, to the next larger scale value.

**See also**

Commissioning (Page 113)

**9.2.2 Overview of application parameters 6 to 55****Introduction**

These parameters are used to configure the following additional functions of the positioner:

- Setpoint preparation
- Actual value preparation
- Binary signal processing
- Tight closing function
- Limit detection

**Note**

Factory-set parameter values are printed in bold in the following table.

**Overview**

Parameter	Function	Parameter values	Unit
6.SDIR	Setpoint direction		
	Rising	<b>riSE</b>	
	Falling	<b>FALL</b>	
7.TSUP	Setpoint ramp up	Auto / <b>0</b> ... 400	s
8.TSDO	Setpoint ramp down	<b>0</b> ... 400	s

Parameter assignment

9.2 Tabular overview of the parameters

Parameter	Function		Parameter values	Unit
9.SFCT	Setpoint function			
		Linear	<b>Lin</b>	
		Equal percentage	1 : 25	1 - 25
			1 : 33	1 - 33
			1 : 50	1 - 50
		Inverse equal percentage	25 : 1	n1 - 25
			33 : 1	n1 - 33
	50 : 1		n1 - 50	
	Freely adjustable		FrEE	
10.SL0 ... 30.SL20 <sup>1)</sup>	Setpoint turning points with free characteristic			
10.SL0	At	0 %	0 ... 100.0	%
11.SL1 ....		5 % ...		
29.SL19		95 %		
30.SL20		100 %		
31.DEBA	Deadband of closed-loop controller		<b>Auto</b> / 0.1 ... 10.0	%
32.YA	Start of the manipulated variable limit		<b>0.0</b> ... 100.0	%
33.YE	End of the manipulated variable limit		0.0 ... <b>100.0</b>	%
34.YNRM	Standardization of manipulated variable			
		To mechanical travel	<b>MPOS</b>	
		On flow	FLoW	
35.YDIR	Direction of action of manipulated variable for display and position feedback			
		Rising	<b>riSE</b>	
		Falling	FALL	
36.YCLS	Tight closing manipulated variables			
		None	<b>no</b>	
		Up only	uP	
		Down only	do	
		Up and down	uP do	
37.YCDO	Low value for tight closing		<b>0.0</b> ... 100.0	%
38.YCUP	Upper value for tight closing		0.0 ... <b>100.0</b>	%
39.BIN1 <sup>2)</sup>	Binary input 1 function		<b>Normally open contact</b>	<b>Normally closed contact</b>
		None	<b>OFF</b>	
		Message only	on	-on
		Block configuration	bloc1	
		Block configuring and manual operation	bloc2	
		Move valve to position YE	uP	-uP
		Move valve to position YA	doWn	-doWn
		Block movement	StoP	-StoP
		Partial stroke test	PST	-PST

Parameter	Function	Parameter values		Unit	
		Normally open contact	Normally closed contact		
40.BIN2 <sup>2)</sup>	Binary input 2 function				
		None	OFF		
		Message only	on	-on	
		Move valve to position YE	uP	-uP	
		Move valve to position YA	doWn	-doWn	
		Block movement	StoP	-StoP	
	Partial-Stroke-Test	PST	-PST		
41.AFCT <sup>3)</sup>	Alarm function	Normal	Inverted		
		none	OFF		
		A1 = Min, A2 = Max	$\overline{A1} \overline{A2}$	$\overline{A1} A2$	
		A1 = Min, A2 = Min	$\overline{A1} \overline{A2}$	$\overline{A1} A2$	
		A1 = Max, A2 = Max	$A1 A2$	$\overline{A1} \overline{A2}$	
42.A1	Trigger threshold, alarm 1	0.0 ... 10.0 ... 100		%	
43.A2	Trigger threshold, alarm 2	0.0 ... 90.0 ... 100		%	
44. <sup>4)</sup> FCT <sup>3)</sup>	Fault message function	Normal	Inverted		
		Fault	$\overline{F}$	$F$	
		Fault + not automatic <sup>4)</sup>	$\overline{F} \overline{A}$	$\overline{F} A$	
		Fault + not automatic + BIN <sup>4)</sup>	$\overline{F} \overline{A} \overline{B}$	$\overline{F} \overline{A} B$	
45. <sup>4)</sup> TIM	Monitoring period for setting the fault message "Control deviation"	Auto / 0 ... 100		s	
46. <sup>4)</sup> LIM	Response threshold of the fault message 'Control deviation'	Auto / 0 ... 100		%	
47. <sup>4)</sup> STRK	Limit monitoring for the number of total strokes	0 ... 1.00E9			
48.PRST	Preset				
		Reset all parameters which can be reset by Init, PArA and diAg .	ALL		
		Reset initialization parameters 1.YFCT to 5.INITM.	Init		
		Reset parameters 6.SDIR to 47. <sup>4)</sup> STRK and 51.FSTY to 53.FSVL.	PArA		
		Reset parameters A to P of the extended diagnostics function as well as parameter 50.XDIAG.	diag		
49.PNEUM	Fail in Place				
		Standard pneumatic block	Std		
		Fail in place pneumatic block	FIP		
50.XDIAG	Activation of extended diagnostics				
		Off	OFF		
		Single stage message	On1		
		Two stage message	On2		
		Three stage message	On3		

9.2 Tabular overview of the parameters

Parameter	Function	Parameter values	Unit
51.FSTY	Safety setting		
		Parameterized safety setpoint	FSVL
		Last setpoint	FSSP
		Open vent valve	<b>FSAC</b>
52.FSTI	Monitoring period for setting the safety setting	<b>0 ... 100</b>	s
53.FSVL	Safety setpoint	<b>0.0 ... 100.0</b>	%
54.STNR	Station number	<b>0 ... 126</b>	
55.IDENT	Device operating mode (ID No.)		
		Vendor-independent profile ID number	9710
		Device-specific ID number for full functionality	8079
		Automatic adaptation by the control system	<b>AdAPT</b>

- 1) Setpoint turning points only appear when '9.SFCT = FrEE' is selected.
- 2) "Normally closed" means: Operation when a switch is open or Low level  
 "Normally open" means: Action on switch closed or High level
- 3) "Normal" means: High level, no fault message  
 "Inverted" means: Low level, no fault message
- 4) "+" means: Logical OR combination

9.2.3 Overview of advanced diagnostics parameters A to P

Introduction

These parameters are used to set the extended diagnostics functions of the positioner.

**Note**

**Factory setting**

Factory-set parameter values are printed in bold in the following table.

**Note**

**Display**

Parameters A to P and their sub-parameters are only displayed when the extended diagnostics has been activated in parameter "'50.XDIAG' Activation of extended diagnostics (Page 170)" with setting "On1", "On2" or "On3".

## Overview parameter A

Parameter	Function	Parameter values	Unit
A.½PST	Partial stroke test with the following parameters:		
A1.STPOS	Start position	0.0 ... <b>100.0</b>	%
A2.STTOL	Start tolerance	0.1 ... <b>2.0</b> ... 10.0	%
A3.STRKH	Stroke height	0.1 ... <b>10.0</b> ... 100.0	%
A4.STRKD	Stroke direction	uP / do / uP do	
A5.RPMD	Ramp mode	<b>OFF</b> / On	
A6.RPRT	Ramp rate	0.1 ... <b>1.0</b> ... 100.0	%/s
A7.FLBH	Behavior after failed PST	<b>Auto</b> / HOLD / AirIn / AirOu	
A8.INTRV	Test interval	<b>OFF</b> / 1 ... 365	Days
A9.PSTIN	Reference stroke time for partial stroke test	<b>NOINI</b> / (C)### / FdInI / rEAL	s
AA.FACT1	Factor 1	0.1 ... <b>1.5</b> ... 100.0	
Ab.FACT2	Factor 2	0.1 ... <b>3.0</b> ... 100.0	
AC.FACT3	Factor 3	0.1 ... <b>5.0</b> ... 100.0	

## Overview parameter b

Parameter	Function	Parameter values	Unit
b.½DEVI	Monitoring of dynamic control valve behavior with the following parameters:		
b1.TIM	Time constant	<b>Auto</b> / 1 ... 400	s
b2.LIMIT	Limit	0.1 ... <b>1.0</b> ... 100.0	%
b3.FACT1	Factor 1	0.1 ... <b>5.0</b> ... 100.0	
b4.FACT2	Factor 2	0.1 ... <b>10.0</b> ... 100.0	
b5.FACT3	Factor 3	0.1 ... <b>15.0</b> ... 100.0	

## Overview parameter C

Parameter	Function	Parameter values	Unit
C.½LEAK	Monitoring of pneumatic leakage with the following parameters:		
C1.LIMIT	Limit	0.1 ... <b>30.0</b> ... 100.0	%
C2.FACT1	Factor 1	0.1 ... <b>1.0</b> ... 100.0	
C3.FACT2	Factor 2	0.1 ... <b>1.5</b> ... 100.0	
C4.FACT3	Factor 3	0.1 ... <b>2.0</b> ... 100.0	

9.2 Tabular overview of the parameters

Overview parameter d

Parameter	Function	Parameter values	Unit
d.↳STIC	Monitoring of stiction (slipstick) with the following parameters:		
d1.LIMIT	Limit	0.1 ... <b>1.0</b> ... 100.0	%
d2.FACT1	Factor 1	0.1 ... <b>2.0</b> ... 100.0	
d3.FACT2	Factor 2	0.1 ... <b>5.0</b> ... 100.0	
d4.FACT3	Factor 3	0.1 ... <b>10.0</b> ... 100.0	

Overview parameter E

Parameter	Function	Parameter values	Unit
E.↳DEBA	Monitoring of deadband with the following parameters:		
E1.LEVL3	Threshold	0.1 ... <b>2.0</b> ... 2.9	%

Overview parameter F

Parameter	Function	Parameter values	Unit
F.↳ZERO	Monitoring of lower endstop with the following parameters:		
F1.LEVL1	Threshold 1	0.1 ... <b>1.0</b> ... 10.0	%
F2.LEVL2	Threshold 2	0.1 ... <b>2.0</b> ... 10.0	
F3.LEVL3	Threshold 3	0.1 ... <b>4.0</b> ... 10.0	

Overview parameter G

Parameter	Function	Parameter values	Unit
G.↳OPEN	Monitoring of upper endstop with the following parameters:		
G1.LEVL1	Threshold 1	0.1 ... <b>1.0</b> ... 10.0	%
G2.LEVL2	Threshold 2	0.1 ... <b>2.0</b> ... 10.0	
G3.LEVL3	Threshold 3	0.1 ... <b>4.0</b> ... 10.0	

Overview parameter H

Parameter	Function	Parameter values	Unit
H.↳TMIN	Monitoring of lower limit temperature with the following parameters:		
H1.TUNIT	Temperature unit	°C      °F	°C/°F
H2.LEVL1	Threshold 1	-40 ... <b>-25</b> ... 90      -40 ... 194	
H3.LEVL2	Threshold 2	-40 ... <b>-30</b> ... 90      -40 ... 194	
H4.LEVL3	Threshold 3	<b>-40</b> ... 90      -40 ... 194	



## Overview parameter J

Parameter	Function	Parameter values		Unit
J.½TMAX	Monitoring of upper limit temperature with the following parameters:			
J1.TUNIT	Temperature unit	°C	°F	°C/°F
J2.LEVL1	Threshold 1	-40 ... <b>75</b> ... 90	-40 ... 194	
J3.LEVL2	Threshold 2	-40 ... <b>80</b> ... 90	-40 ... 194	
J4.LEVL3	Threshold 3	-40 ... <b>90</b>	-40 ... 194	

## Overview parameter L

Parameter	Function	Parameter values		Unit
L.½STRK	Monitoring of number of total strokes with the following parameters:			
L1.LIMIT	Limit for number of total strokes	1 ... <b>1E6</b> ... 1E8		
L2.FACT1	Factor 1	0.1 ... <b>1.0</b> ... 40.0		
L3.FACT2	Factor 2	0.1 ... <b>2.0</b> ... 40.0		
L4.FACT3	Factor 3	0.1 ... <b>5.0</b> ... 40.0		

## Overview parameter O

Parameter	Function	Parameter values		Unit
O.½DCHG	Monitoring the number of changes in direction with the following parameters:			
O1.LIMIT	Limit for number of changes in direction	1 ... <b>1E6</b> ... 1E8		
O2.FACT1	Factor 1	0.1 ... <b>1.0</b> ... 40.0		
O3.FACT2	Factor 2	0.1 ... <b>2.0</b> ... 40.0		
O4.FACT3	Factor 3	0.1 ... <b>5.0</b> ... 40.0		

## Overview parameter P

Parameter	Function	Parameter values		Unit
P.½PAVG	Monitoring the position average value with the following parameters:			
P1.TBASE	Time basis of average value generation	<b>0.5h</b> / 8h / 5d / 60d / 2.5y		
P2.STATE	Status of monitoring of position average value	<b>IdLE</b> / rEF / ###.# / Strt		
P3.LEVL1	Threshold 1	0.1 ... <b>2.0</b> ... 100.0		%
P4.LEVL2	Threshold 2	0.1 ... <b>5.0</b> ... 100.0		%
P5.LEVL3	Threshold 3	0.1 ... <b>10.0</b> ... 100.0		%

## 9.3 Description of parameters

### 9.3.1 Initialization parameters 1 to 5

#### 9.3.1.1 '1.YFCT' Type of actuator

Requirement:	Type of actuator as well as mounting type and direction of action are known.																
Possible settings:	<table><tr><td>Actuator with normal direction of action</td><td>Actuator with inverted direction of action</td></tr><tr><td>• turn</td><td>• -turn</td></tr><tr><td>• WAY</td><td>• -WAY</td></tr><tr><td>• FWAY</td><td>• -FWAY</td></tr><tr><td>• LWAY</td><td>• -LWAY</td></tr><tr><td>• ncSt</td><td>• -ncSt</td></tr><tr><td>• ncSL</td><td>• -ncSL</td></tr><tr><td>• ncSLL</td><td>• -ncLL</td></tr></table>	Actuator with normal direction of action	Actuator with inverted direction of action	• turn	• -turn	• WAY	• -WAY	• FWAY	• -FWAY	• LWAY	• -LWAY	• ncSt	• -ncSt	• ncSL	• -ncSL	• ncSLL	• -ncLL
Actuator with normal direction of action	Actuator with inverted direction of action																
• turn	• -turn																
• WAY	• -WAY																
• FWAY	• -FWAY																
• LWAY	• -LWAY																
• ncSt	• -ncSt																
• ncSL	• -ncSL																
• ncSLL	• -ncLL																
Purpose:	<p>Use this parameter to adjust the positioner to the respective actuator.</p> <ul style="list-style-type: none"><li>• turn/-turn: Use this setting for a part-turn actuator with a directly mounted positioner.</li><li>• WAY/-WAY: Use this setting for a linear actuator with a carrier pin mounted on the lever.</li><li>• FWAY/-FWAY: Use this setting for a linear actuator with a carrier pin mounted on the actuator spindle.</li><li>• LWAY/-LWAY: Use this setting for an external linear potentiometer on a linear actuator.</li><li>• ncSt/-ncSt: Use this setting for an NCS sensor (6DR4004-.N.10 and -.N.40) on a part-time actuator.</li><li>• ncSL/-ncSL: Use this setting for an NCS sensor (6DR4004-.N.20) on a linear actuator for strokes &lt; 14 mm (0.55 inch).</li><li>• ncSLL/-ncLL: Use this setting for an NCS sensor (6DR4004-.N.30) on a linear actuator for strokes &gt; 14 mm (0.55 inch) and for an internal NCS module. No limitations apply to the internal NCS module.</li></ul> <p>In the case of actuators with inverted direction of action, use the settings with the minus sign, e.g. -turn.</p>																
Description:	<p><b>Meaning of actuator with normal direction of action:</b></p> <ul style="list-style-type: none"><li>• Part-turn actuator closes when the drive shaft, positioner shaft or magnet of the NCS sensor rotates in the <b>clockwise</b> direction.</li><li>• Linear actuator closes when the actuator spindle rotates downwards and the positioner shaft or magnet of the NCS sensor rotates in the <b>anti-clockwise</b> direction.</li></ul>																

**Meaning for actuator with inverted direction of action:**

- Part-turn actuator closes when the drive shaft, positioner shaft or magnet of the NCS sensor rotates in the anti-clockwise direction.
- Linear actuator closes when the actuator spindle rotates downwards and the positioner shaft or magnet of the NCS sensor rotates in the clockwise direction.

**Additional information:**

- The '3.YWAY' Range of stroke (Page 156) parameter is displayed only for 'WAY', '-WAY', 'ncSLL' or '-ncLL'.
- turn/-turn: The '2.YAGL' Rated angle of rotation of feedback (Page 155) parameter is automatically set to 90° and cannot be changed.
- WAY/-WAY: The positioner compensates the non-linearity caused due to the transformation of the linear movement of the linear actuator into the rotary movement of the positioner shaft. For this purpose, the positioner is set in the factory in such a way that it displays a value between 'P49.0' and 'P51.0' when the lever on the positioner shaft is perpendicular to the linear actuator spindle.

Factory setting: WAY

### 9.3.1.2 '2.YAGL' Rated angle of rotation of feedback

**Requirement:** Transmission ratio selector and the value set in the '2.YAGL' parameter match. Only then does the value shown on the display match the actual position.

**Possible settings:**

- 33°
- 90°

**Purpose:** Use this parameter for a linear actuator. For a linear actuator, set an angle of 33° or 90° depending on the range of stroke. The current setting of the actuator is then measured more accurately. The following is applicable:

- 33°: Strokes ≤ 20 mm
- 90°: Strokes 25 ... 35 mm
- 90°: Strokes > 40 ... 130 mm

Use the mounting kit:

- 6DR4004-8V for strokes up to 35 mm
- 6DR4004-8L for strokes greater than 35 up to 130 mm

'2.YAGL' can only be adjusted if '1.YFCT' is set to 'WAY'/'-WAY' or 'FWAY'/'-FWAY'.

With all other settings of '1.YFCT', an angle of 90° is automatically set for '2.YAGL'.

Factory setting: 33°

**See also**

Sequence of automatic initialization (Page 116)



**9.3.1.3 '3.YWAY' Range of stroke**

- Requirement:
- Positioner is mounted.
  - Carrier pin is mounted on the lever in accordance with the actuator's range of stroke as described in section Mounting the linear actuator (Page 40), Figure 4-2 Lever with carrier pin (Page 43).
- Possible settings:
- OFF
  - 5.0 | 10.0 | 15.0 | 20.0 | 25.0 | 30.0 | 35.0 | 40.0 | 50.0 | 60.0 | 70.0 | 90.0 | 110.0 | 130.0
- Purpose:
- Use this parameter to display the determined stroke value in mm when initialization of a linear actuator has been completed.
- If you select the 'OFF' setting, the real stroke is not displayed after initialization.
- From the possible settings shown above, select the value which corresponds to the range of stroke of your actuator in mm.
- If the range of stroke of the actuator does not correspond to a possible setting, use the next higher value. Use the value specified on the nameplate of the actuator for this purpose.
- '3.YWAY' is only displayed if '1.YFCT' is set to 'WAY'/'-WAY' or 'ncSLL'/'-ncLL'.
- Factory setting: OFF

**9.3.1.4 '4.INITA' Initialization (automatically)**

- Possible settings:
- NOINI
  - no / ###.#
  - Strt
- Purpose:
- Use this parameter to start the automatic initialization process.
1. Select the "Strt" setting.
  2. Then press the  button for at least 5 seconds.
- The sequence of the initialization process from "RUN1" to "RUN5" is output in the bottom line of the display.
- Factory setting: NOINI

### 9.3.1.5 '5.INITM' Initialization (manual)

Possible settings:	<ul style="list-style-type: none"><li>• NOINI</li><li>• no / ###.#</li><li>• Strt</li></ul>
Purpose:	Use this parameter to start the manual initialization process. <ol style="list-style-type: none"><li>1. Select the "Strt" setting.</li><li>2. Then press the  button for at least 5 seconds.</li></ol>
Description:	If the positioner has already been initialized and if the "4.INITA" and "5.INITM" values are set, it is possible to reset the positioner to the non-initialized status. To do this, press the  button for at least 5 seconds.
Factory setting:	NOINI

## 9.3.2 Application parameters 6 to 55

### 9.3.2.1 '6.SDIR' Setpoint direction

Possible settings:	<ul style="list-style-type: none"><li>• riSE</li><li>• FALL</li></ul>
Purpose:	This parameter is used to set the setpoint direction. The setpoint direction is used to reverse the direction of action of the setpoint. <ul style="list-style-type: none"><li>• Rising (riSE): A higher value at the setpoint input results in opening of the valve.</li><li>• Falling (FALL): A higher value at the setpoint input results in closing of the valve.</li></ul> The setpoint direction is primarily used for the split-range mode and for single-acting actuators with the safety setting 'uP'.
Factory setting:	riSE



### 9.3.2.4 '10.SL0' ... '30.SL20' Setpoint turning point

Adjustment range: 0.0 ... 100.0  
 Purpose: These parameters are used to assign a flow coefficient in units of 5% to each setpoint turning point. The setpoint turning points form a polyline with 20 linear segments which models the valve characteristic; see figure below.  
 Factory setting: 0, 5 ... 95, 100

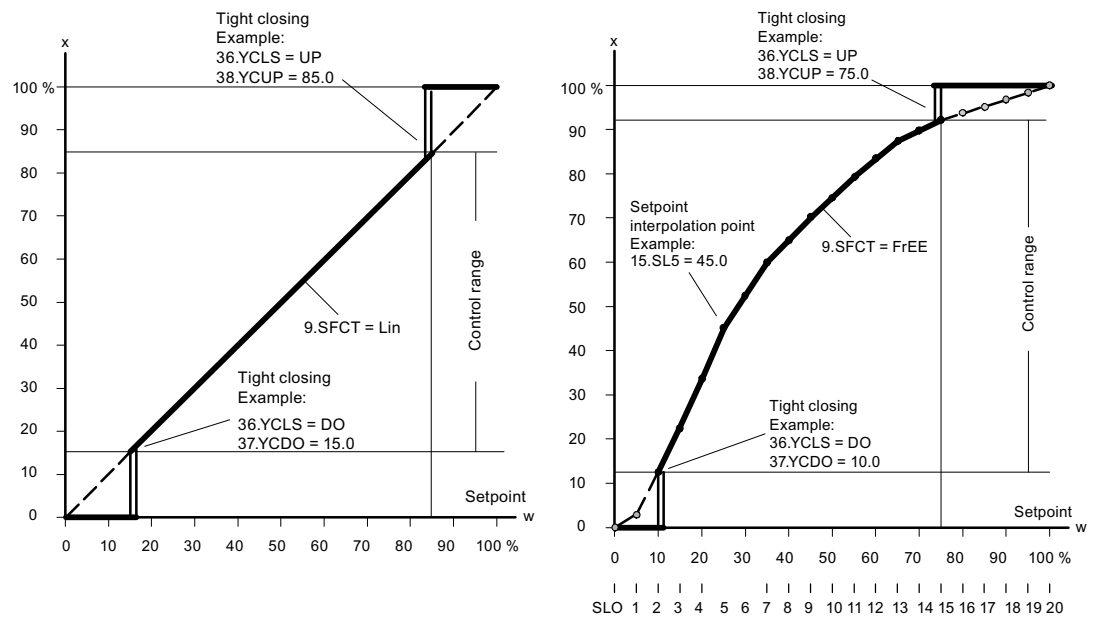

Setpoint characteristic curves, standardization of manipulated variables, and tight closing function

Input of the setpoint turning points is only possible if the "'9.SFCT' Setpoint function (Page 158)" parameter is set to "FrEE". You can only enter one monotone rising characteristic curve and two consecutive interpolation points must differ by at least 0.2%.





The FLoW scale is the standardization from 0 to 100% in the range between the 'YA' and 'YE' parameters. Over this range, the setpoint  $w$  is also always 0 to 100%. This results in a more or less flow-proportional display and position feedback 'IY'. The flow-proportional display and position feedback 'IY' also result when using valve characteristics.

In order to calculate the control deviation, the setpoint in the display is also shown in the corresponding scale.

The following uses the example of an 80-mm linear actuator to illustrate the dependence of the stroke on the scaling as well as on the 'YA' and 'YE' parameters; see the following figure.

Factory setting:

MPOS

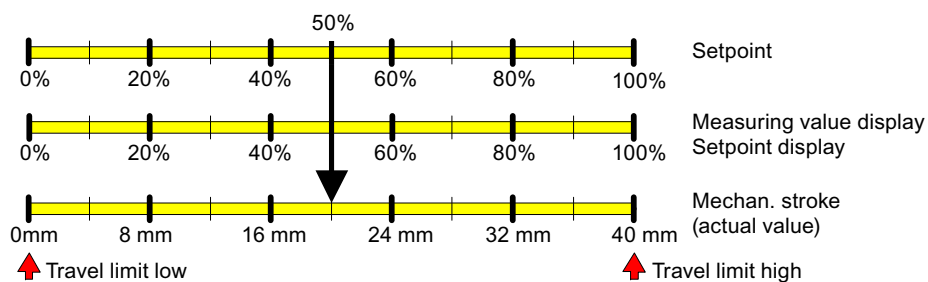

Figure 9-1 YNRM = MPOS or YNRM = FLoW; default: YA = 0 % and YE = 100 %

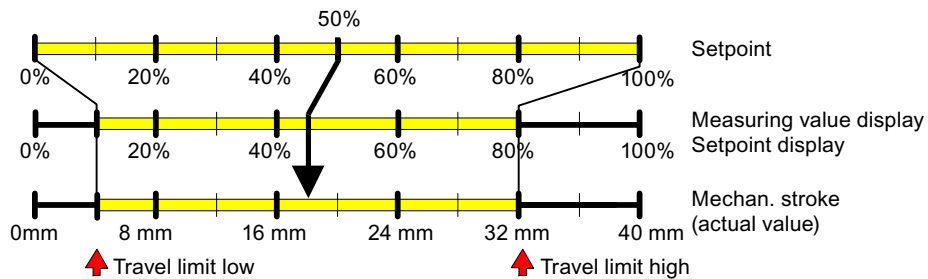

Figure 9-2 Example: YNRM = MPOS with YA = 10 % and YE = 80 %

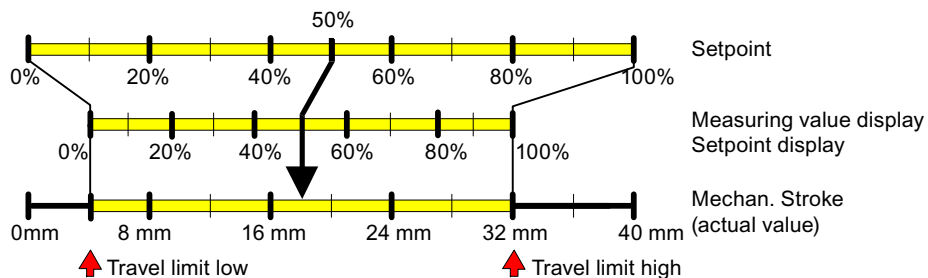

Figure 9-3 Example: YNRM = FLoW with YA = 10 % and YE = 80 %

**See also**

'36.YCLS' Tight closing with manipulated variable (Page 162)

**9.3.2.8 '35.YDIR' Direction of action of manipulated variable for display and position feedback**

Possible settings:

- riSE
- FALL

Purpose: This parameter is used to set the direction of action of the display and the position feedback  $I_V$ . The direction can be rising or falling.

Factory setting: riSE

**9.3.2.9 '36.YCLS' Tight closing with manipulated variable**

Possible settings:

- no
- uP
- do
- uP do

Purpose: This parameter is used to move the valve into its seat with the maximum force of the actuator (permanent contact of the piezo valves). The tight closing function is activated on one side or for both end positions. Parameter "36.YCLS" becomes effective when the effective setpoint is at or below parameter "37.YCDO" or at or above parameter "38.YCUP".

Factory setting: no

See the figure in the description of the "'34.YNRM' Manipulated variable standardization (Page 160)" parameter and the figure in the description of the "'10.SL0' ... '30.SL20' Setpoint turning point (Page 159)" parameter.

---

**Note**

**Activated tight closing function**

If the tight closing function is activated, then for parameter "46.  $I_{LIM}$ " the monitoring of control deviation is turned off in the appropriate overflow direction. Parameter "YCDO: < 0 %" and parameter "YCUP: > 100 %" are applicable in such a case. This functionality is especially advantageous for valves with soft seats. For a long-term monitoring of the end stop positions, we recommend activating the parameters "F.  $I_{ZERO}$ " and "G.  $I_{OPEN}$ ".

---

### 9.3.2.10 '37.YCDO' Lower value for tight closing / '38.YCUP' Upper value for tight closing

Adjustment range:	0.0 ... 100.0	
Purpose:	These parameters are used to set the values for "Lower value for tight closing " (YCDO) and "Upper value for tight closing" (YCUP) in %.	
Factory setting:	When "YCDO": 0.0	When "YCUP": 100.0

#### Note

The value in the parameter "YCDO" is always smaller than that in "YCUP". The tight closing function has a fixed hysteresis of 1%. The parameters "YCDO" and "YCUP" are relative to the mechanical stops. The parameters "YCDO" and "YCUP" are independent of the value set in the "'6.SDIR' Setpoint direction (Page 157)" parameter.

### 9.3.2.11 '39.BIN1' / '40.BIN2' Function of binary inputs

Setting option	<ul style="list-style-type: none"> <li>Binary input 1</li> </ul>																		
	<table> <thead> <tr> <th>Normally open</th> <th>Normally closed</th> </tr> </thead> <tbody> <tr><td>OFF</td><td>OFF</td></tr> <tr><td>on</td><td>-on</td></tr> <tr><td>bloc1</td><td>-uP</td></tr> <tr><td>bloc2</td><td>-doWn</td></tr> <tr><td>uP</td><td>-StoP</td></tr> <tr><td>doWn</td><td>-PST</td></tr> <tr><td>StoP</td><td></td></tr> <tr><td>PST</td><td></td></tr> </tbody> </table>	Normally open	Normally closed	OFF	OFF	on	-on	bloc1	-uP	bloc2	-doWn	uP	-StoP	doWn	-PST	StoP		PST	
Normally open	Normally closed																		
OFF	OFF																		
on	-on																		
bloc1	-uP																		
bloc2	-doWn																		
uP	-StoP																		
doWn	-PST																		
StoP																			
PST																			
	<ul style="list-style-type: none"> <li>Binary input 2</li> </ul>																		
	<table> <thead> <tr> <th>Normally open</th> <th>Normally closed</th> </tr> </thead> <tbody> <tr><td>OFF</td><td>OFF</td></tr> <tr><td>on</td><td>-on</td></tr> <tr><td>uP</td><td>-uP</td></tr> <tr><td>doWn</td><td>-doWn</td></tr> <tr><td>StoP</td><td>-StoP</td></tr> <tr><td>PST</td><td>-PST</td></tr> </tbody> </table>	Normally open	Normally closed	OFF	OFF	on	-on	uP	-uP	doWn	-doWn	StoP	-StoP	PST	-PST				
Normally open	Normally closed																		
OFF	OFF																		
on	-on																		
uP	-uP																		
doWn	-doWn																		
StoP	-StoP																		
PST	-PST																		

Purpose: These parameters determine the function of the binary inputs. The possible functions are described below. The direction of action can be adapted to a normally closed or normally open mode.

- BIN1 or BIN2 = On or -On  
Binary messages from peripherals, e.g. from pressure or temperature switches, are read over the communication interface or fed through a logical OR combination with other messages to trigger the error message output.

- BIN1 = bLoc1  
Use this parameter value to interlock the "Configuration" mode against adjustment. The lock is performed e.g. with a jumper between terminals 9 and 10.
- BIN1 = bLoc2  
If binary input 1 has been activated, the "Manual" as well as "Configuration" modes are blocked.
- BIN1 or BIN2 =  
contact uP or doWn closes, or  
contact -uP or -doWn opens  
If the binary input is activated, the actuator uses the value defined by the "'32.YA' Manipulated variable limiting Start / '33.YE' Manipulated variable limiting End (Page 160)" parameter for controlling in "Automatic" mode.
- BIN1 or BIN2 contact closes = StoP or -StoP contact opens  
In "Automatic" mode, the piezo valves are blocked when the binary input is activated. The actuator remains at the last position. Leakage measurements can be performed in this way without using the initialization function.
- BIN1 or BIN2 = PSt or -PSt  
Using binary inputs 1 or 2, a partial-stroke test can be triggered by actuation of your choice of a normally closed or normally open switch.
- BIN1 or BIN2 = OFF  
No function  
Special function of binary input 1: If binary input 1 is activated in "P-manual mode" by means of a jumper between terminals 9 and 10, the firmware version will be displayed when the mode button is pressed.

If one of the above functions is activated simultaneously with the "BIN1" and "BIN2" parameters, then: "Blocking" takes priority over "uP". "uP" takes priority over "doWn". "doWn" takes priority over "PST".

Factory setting: OFF

### 9.3.2.12 '41.AFCT' Alarm function

Possible settings: See representation below

Purpose: This parameter can be used to determine the value at which going above or below a given offset or angle will result in a message. The triggering of alarms (limits) is relative to the MPOS scale. Alarms are signaled through the alarm module. In addition, alarms can also be read via the communication interface.

The direction of action of the binary outputs can be adjusted from "High active" to "Low active" for the next system.

Factory setting: OFF

Direction of action and hysteresis			
Limit	Alarm module		
	A1	A2	
	<b>Examples</b>		
	A1 = 48	AFCT = MIN / MAX	
	A2 = 52		
	Way = 45	<b>Active</b>	
	Way = 50		
	Way = 55		<b>Active</b>
A1 = 48	AFCT = -MIN / -MAX		
A2 = 52			
Way = 45		<b>Active</b>	
Way = 50	Active	Active	
Way = 55	<b>Active</b>		
A1 = 52	AFCT = MIN / MAX		
A2 = 48			
Way = 45	<b>Active</b>		
Way = 50	Active	Active	
Way = 55		<b>Active</b>	
A1 = 52	AFCT = -MIN / -MAX		
A2 = 48			
Way = 45		<b>Active</b>	
Way = 50			
Way = 55	<b>Active</b>		

**Note**

If the extended diagnostic is activated using parameter "'50.XDIAG' Activation of extended diagnostics (Page 170)" with setting "On3", then the alarms are not output through the alarm module. Alarm A1 is output with setting "On2". However, notification via the communication interface is possible at any time.



### 9.3.2.15 '45.\TIM' Monitoring time for setting of fault messages

Possible settings:	<ul style="list-style-type: none"><li>• Auto</li><li>• 0 ... 100</li></ul>
Purpose:	The '4TIM' parameter is used to set the time in seconds within which the positioner must have reached the regulated condition. The corresponding response threshold is specified in the '4LIM' parameter. When the configured time is exceeded, the fault message output is set.
Factory setting:	Auto

---

#### Note

##### Activated tight closing function

If the tight closing function is activated, then for the '4LIM' parameter the monitoring of control deviation is turned off in the appropriate overflow direction. Then 'YCDO: < 0 %' and 'YCUP: > 100 %'. This functionality is especially advantageous for valves with soft seats. For long-term monitoring of the endstop positions, we recommend activating the parameters Monitoring the lower endstop 'F.\ZERO' (Page 186) and Monitoring the upper endstop 'G.\OPEN' (Page 187).

---

### 9.3.2.16 '46.\LIM' Response threshold for fault message

Possible settings:	<ul style="list-style-type: none"><li>• Auto</li><li>• 0 ... 100</li></ul>
Purpose:	This parameter is used to set a value for the permissible size of the control deviation to trigger a fault message. The value is given in percent.  If the '4TIM' and '4LIM' parameters are set to 'Auto', then the fault message is set if the slow step zone is not reached within a certain period of time. Within 5 to 95% of the actuator travel, this time is twice the initialization travel time, and ten times the initialization travel time outside of 10 to 90%.
Factory setting:	Auto

---

#### Note

##### Activated tight closing function

If the tight closing function is activated, then for the '4LIM' parameter the monitoring of control deviation is turned off in the appropriate overflow direction. Then 'YCDO: < 0 %' and 'YCUP: > 100 %'. This functionality is especially advantageous for valves with soft seats. For long-term monitoring of the endstop positions, we recommend activating the parameters Monitoring the lower endstop 'F.\ZERO' (Page 186) and Monitoring the upper endstop 'G.\OPEN' (Page 187).

---

### 9.3.2.17 '47.\STRK' Limit monitoring for the number of total strokes

Possible settings:	0 ... 1.00E9
Purpose:	Use this parameter to set a limit for the number of total strokes. This parameter corresponds to the profile parameter 'TOTAL_VALVE_TRAVEL_LIMIT' and was applied for compatibility reasons.
Description:	If the configured limit is exceeded, the 'CB_TOT_VALVE_TRAV' bit is set in the profile parameter 'CHECK_BACK'. This function enables preventive maintenance of the control valve.
Factory setting:	1E9

#### See also

Monitoring the number of total strokes 'L.\STRK' (Page 192)

'50.XDIAG' Activation of extended diagnostics (Page 170)

Diagnostic value '1.STRKS - Number of total strokes' (Page 255)

### 9.3.2.18 '48.PRST' Preset

Possible settings:	<ul style="list-style-type: none"><li>• ALL</li><li>• Init</li><li>• PArA</li><li>• diAg</li></ul>
Purpose:	Use this parameter to restore the factory settings for most parameters. The following parameter groups are available: <ul style="list-style-type: none"><li>• ALL: Reset all parameters together which can be reset by 'Init', 'PArA' and 'diAg'.</li><li>• Init: Reset initialization parameters '1.YFCT' to '5.INITM'.</li><li>• PArA: Reset parameters '6.SDIR' to '47.\STRK' and '51.FSTY' Safety position (Page 171) to '53.FSVL' Safety setpoint (Page 172).</li><li>• diAg: Reset parameters A to P of the extended diagnostics function as well as parameter '50.XDIAG'.</li></ul>

An overview of the parameters and factory settings can be found in section Tabular overview of the parameters (Page 146).

In order to select one of the parameter groups listed above, repeatedly press the ▽ button until the desired setting is output in the display. Start the function by keeping the ▲ button pressed until 'oCAY' is output in the display. The values of the parameter group are now the factory settings.



Description:	<p>If you wish to use a previously initialized positioner on a different control valve, set the parameters to the factory settings prior to a new initialization. To do this, use the 'ALL' or 'Init' setting.</p> <p>Restore the factory settings if you have changed several parameters at once without being able to predict their effect and the undesired reactions which may occur as a result. To do this, use the 'ALL' setting.</p>
Factory setting:	ALL

### 9.3.2.19 '49.PNEUM' Fail in place

Requirement:	You have a positioner with the "Fail in Place" function, article number with order suffix -Z F01.
Possible settings:	<ul style="list-style-type: none"> <li>• Std</li> <li>• FIP</li> </ul>
Purpose:	<p>You only require this parameter for servicing if the basic electronics has been replaced.</p> <p>If you order a positioner for Fail in Place applications, it is then equipped with a special pneumatic block. The "PNEUM" parameter is preset to "FIP".</p> <p>When you replace the basic electronics, you have to set the pneumatic type:</p> <ol style="list-style-type: none"> <li>1. Set the "49.PNEUM" parameter from "Std" to "FIP".</li> <li>2. Set the "'51.FSTY' Safety position (Page 171)" parameter to "FSSP" so that the positioner retains the current position even following switching on again.</li> </ol>

### 9.3.2.20 '50.XDIAG' Activation of extended diagnostics

Use this parameter to activate the extended diagnostics and simultaneously the online diagnostics. At the factory, extended diagnostics are deactivated. 'XDIAG' parameter is set to 'OFF'. To activate extended diagnostics, there are three modes available:

- On1: Extended diagnostics is activated. Threshold 3 messages will be output via the error message output. Single stage message (maintenance required).
- On2: Extended diagnostics is activated. Threshold 2 messages will be activated via alarm output 2. Threshold 3 messages will also be output via the error message output. Two stage message (maintenance demand).
- On3: Extended diagnostics is activated. Threshold 1 messages will be activated via alarm output 1. Threshold 2 messages will be activated via alarm output 2. Threshold 3 messages will also be output via the error message output. Three stage message (maintenance alarm).

---

#### Note

##### Activation of extended diagnostics

Please note that the parameters of extended diagnostics from 'A.\PST' to 'P.\PAVG' will only be shown in the display following selection of one of the modes 'On1' to 'On3'.

In the factory settings, the 'A.\PST' to 'P.\PAVG' parameters are deactivated by default. 'XDIAG' parameter is set to 'OFF'. The corresponding parameters are only displayed after you have activated the appropriate menu item with 'On'.

---

#### Note

##### Cancellation of messages

If a threshold is exceeded or fallen below, the positioner outputs a message in the form of an error code and a column in the display. The message is cancelled if, for example:

- The counter is reset.
- The threshold is set to a new value.
- The device is re-initialized at the upper and lower endstops.
- Monitoring is deactivated.

---

With extended diagnostics, the threshold of the message is displayed using columns ① in addition to the error code. These columns ① are shown on the display as follows:

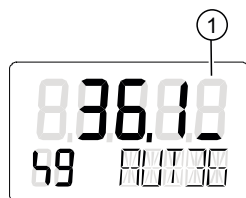

Figure 9-4 Display of a threshold 1 message (maintenance required)

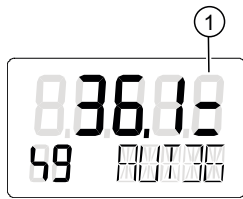

Figure 9-5 Display of a threshold 2 message (maintenance demand)

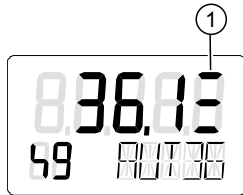

Figure 9-6 Display of a threshold 3 message (maintenance alarm)

The factory setting is 'OFF'.

## See also

Partial stroke test 'A.\\PST' (Page 173)

Monitoring the position average value 'P.\\PAVG' (Page 195)

Overview of error codes (Page 268)

### 9.3.2.21 '51.FSTY' Safety position

Possible settings:	<ul style="list-style-type: none"><li>• FSVL</li><li>• FSSP</li><li>• FSAC</li></ul>
Purpose:	Use this parameter to move the actuator to a defined safety position when communication fails.
Description:	Three settings are available: <ul style="list-style-type: none"><li>• FSVL: the actuator is controlled using the configured safety setpoint. This value also becomes effective following failure of the auxiliary power supply.</li><li>• FSSP: the actuator is controlled using the last effective setpoint.</li><li>• FSAC: the positioner responds in the same way as when the auxiliary power supply fails, see section "Reaction to failure of auxiliary powers (Page 98)".</li></ul>

9.3 Description of parameters

Fail in Place	The following must be observed when using the "Fail in Place" function: The "51.FSTY" parameter must be set to "FSSP" so that the positioner retains the current position even following switching on again.
Factory setting:	FSAC

**9.3.2.22 '52.FSTI' Monitoring time to set the safety position**

Possible settings:	0 ... 100
Purpose:	If communication fails, the positioner switches to the safety position after the set value expires. This parameter is used to set the value in seconds.
Factory setting:	0

**9.3.2.23 '53.FSVL' Safety setpoint**

Possible settings:	0.00 ... 100
Purpose:	Default value of the safety position.
Description:	Note that the safety setpoint of 0% set here always refers to the mechanical position in which the actuator is depressurized. The mechanical position is especially important if you have set the '6.SDIR' Setpoint direction (Page 157) parameter to 'FALL' and expect 100% mechanical position at 0% setpoint default. The 'FALL' setting corresponds a declining characteristic curve of the setpoint.
Factory setting:	0.0

**9.3.2.24 '54.STNR' Station number**

Possible settings:	0 ... 126
Purpose:	A separate station number must be set on each device in order to address the devices on the bus separately.
Factory setting:	126

### 9.3.2.25 '55.IDENT' Device operating mode (ID No.)

Possible settings:	<ul style="list-style-type: none"><li>• 9710</li><li>• 8079</li><li>• AdAPT</li></ul>
Purpose:	<p>The positioner identifies two device operating modes with respect to the response to the DP master of class 1:</p> <ul style="list-style-type: none"><li>• [9710] Vendor-independent profile ID number. Can be replaced by positioners of other manufacturers complying with PROFIBUS PA profile 3.0.</li><li>• [8079] Device-specific ID number for full functionality. Complete functional range of the positioner (condition at delivery).</li><li>• AdAPT Automatic adaptation by the control system.</li></ul>
Description:	<p>A specific GSD file is allocated to every device operating mode. If the configuration of your PROFIBUS PA path does not match the set device operating mode, the device cannot accept the cyclic data exchange. The station number and the device operating mode cannot be modified during ongoing communication with a master of class 1. You can recognize successful establishment of connection to a cyclic master in that the positioner responds to the setpoint of the master. Communication with an acyclic master is indicated by a flashing decimal point in the top line of the positioner's display.</p>
Factory setting:	1

#### See also

Cyclic data transfer (Page 219)

## 9.3.3 Extended diagnostics parameters A to P

### 9.3.3.1 Partial stroke test 'A.\\PST'

#### A.\\PST - Partial Stroke Test

Requirement:	The '50.XDIAG' Activation of extended diagnostics (Page 170) parameter is set to 'On1', 'On2' or 'On3'.
Possible settings:	<ul style="list-style-type: none"><li>• OFF</li><li>• On</li></ul>

9.3 Description of parameters

**Purpose:** Use this parameter to activate and deactivate the partial stroke test. To activate monitoring, set the parameter to 'On'. Sub-parameters are displayed.

Trigger the partial stroke test using:

- Buttons on the device
- A binary input
- Communication
- A cyclic test interval

The current status of the partial stroke test displayed in Diagnostic value '12.PST - Monitoring of partial stroke test' (Page 258).

Diagnostic value '13.PRPST' - Time since last partial stroke test' (Page 259) and Diagnostic value '14.NXPST - Time until next partial stroke test' (Page 259) provide further information on the partial stroke test.

**Factory setting:** OFF

**A1.STPOS - Start position**

**Adjustment range:** 0.0 ... 100.0

**Purpose:** Use this sub-parameter to define the start position of the partial stroke test in percent. Set the start position in a range from '0.0' to '100.0'. The triggering of alarms (limits) is relative to the MPOS scale. The actuator moves during the partial stroke test from the start position to the target position. The target position is determined from the interaction between start position (A1.STPOS), stroke height (A3.STRKH) and stroke direction (A4.STRKD).

**Factory setting:** 100.0

**A2.STTOL - Start tolerance**

**Adjustment range:** 0.1 ... 10.0

**Purpose:** Use this sub-parameter to define the start tolerance of the partial stroke test in percent. Set the start tolerance relative to the start position in a range from '0.1' to '10.0'.

**Example:** You have set '50.0' as a start position and '2.0' as a start tolerance. In this case, a partial stroke test is initiated during operation only between a position of 48 and 52%.

**Factory setting:** 2.0

### A3.STRKH - Stroke height

Adjustment range:	0.1 ... 100.0
Purpose:	Use this sub-parameter to define the stroke height of the partial stroke test in percent. Set the stroke height in a range from '0.1' to '100.0'.
Factory setting:	10.0

### A4.STRKD - Stroke direction

Possible settings:	<ul style="list-style-type: none"><li>• uP</li><li>• do</li><li>• uP do</li></ul>
Purpose:	Use this sub-parameter to set the stroke direction of the partial stroke test. <b>uP:</b> Actuator only moves upward <ul style="list-style-type: none"><li>• The actuator moves from its start position to the upper target position.</li><li>• After reaching the upper target position, the actuator moves back to the start position.</li></ul>
Formula (uP):	Upper target position = Start position (A1.STPOS) ± Start tolerance (A2.STTOL) + Stroke height (A3.STRKH) <b>do:</b> Actuator only moves downward <ul style="list-style-type: none"><li>• The actuator moves from its start position to the lower target position.</li><li>• After reaching the lower target position, the actuator moves back to the start position.</li></ul>
Formula (do):	Lower target position = Start position (A1.STPOS) ± Start tolerance (A2.STTOL) + Stroke height (A3.STRKH) <b>uP do:</b> Actuator moves up and down <ul style="list-style-type: none"><li>• The actuator first moves from its start position to the upper target position.</li><li>• It then moves from the upper target position to the lower target position.</li><li>• After reaching the lower target position, the actuator moves back to the start position.</li></ul>
Formula (uP do)	Target position = Start position (A1.STPOS) ± Start tolerance (A2.STTOL) + Stroke height (A3.STRKH)
Factory setting:	do

### A5.RPMD - Ramp mode

- Setting options:
- OFF
  - On
- Purpose:
- Enable or disable ramp mode.
- OFF: The partial stroke test is executed in an uncontrolled manner.
  - On: The partial stroke test is executed in a controlled manner. Control is at the ramp rate set in the 'A6.RPRT' parameter.
- Use ramp mode to shorten or extend the time of the partial stroke test. Extend the partial stroke test to give the higher-level control loop a chance to react to the partial stroke test.
- Factory setting: OFF

### A6.RPRT - Ramp rate

- Adjustment range: 0.1 ... 100.0
- Purpose:
- Change the ramp rate to shorten or extend the duration of the partial stroke test. The ramp rate refers to the total stroke of the control valve and is set in % stroke per second (%/s). Smaller values extend the duration, larger values shorten the duration of the partial stroke test. Example: Setting '10.0' means that the partial stroke test is run with 10% stroke per second.
- Factory setting: 1.0

### A7.FLBH - Behavior after failed PST

- Setting options:
- Auto
  - HOLd
  - AirIn
  - AirOu
- Purpose:
- Specify how the positioner is to respond if a partial stroke test fails. Note: A partial stroke test fails if the limit threshold set in 'Factor 3 (AC.FACT3)' is exceeded.
- Auto: Switch to 'Automatic' mode. 'AUT' is displayed on the device.
  - HOLd: Hold current position.
  - AirIn: Pressurize actuator with supply air PZ.
  - AirOu: Depressurize actuator.
- Factory setting: Auto



## A8.INTRV - Test interval

Adjustment range:	OFF, 1 ... 365
Purpose:	Use this sub-parameter to enter the interval time for the cyclic partial stroke test in days. Set the test interval in a range from 1 to 365.
Factory setting:	OFF

## A9.PSTIN - Reference stroke time for partial stroke test

Indication on the display:	<ul style="list-style-type: none"><li>• NOINI</li><li>• (C)##.#</li><li>• FdInI</li><li>• rEAL</li></ul>
Purpose:	Status for reference stroke time in seconds
Description:	<p>Use this sub-parameter to measure the reference stroke time for the partial stroke test.</p> <p>The reference stroke time corresponds to the controlled movement from the start position to the target position.</p> <p>If the positioner has already been initialized, the calculated average travel time of the control valve is displayed as a reference value.</p> <ul style="list-style-type: none"><li>• NOINI: Positioner has not yet been initialized.</li><li>• (C)##.#: An average travel time of 1.2 seconds, for example, is shown in the display as 'C 1.2', where 'C' stands for 'calculated'. The average travel time can be used as a reference stroke time. However, it merely represents a rough guideline value.</li><li>• FdInI: 'FdInI' is displayed if the start position cannot be approached or the stroke target cannot be reached. 'FdInI' stands for 'failed PST initialization'.</li><li>• rEAL: Set the sub-parameters 'A1.STPOS' to 'A5.RPMD' according to your requirements. Then start measuring the reference stroke time by pressing the  button for at least 5 seconds. The display shows 'rEAL' during these 5 seconds. The device then moves to the configured start position automatically and executes the desired stroke. The current position in percent is continuously shown on the display. 'inPST' for 'initialize partial stroke test' appears in the lower line of the display.</li></ul>
Factory setting:	NOINI

### AA.FACT1 - Factor 1

Adjustment range:	0.1 ... 100.0
Purpose:	Use this sub-parameter to set the factor for formation of threshold 1. Set the factor in a range from '0.1' to '100.0'. The threshold is the product of the reference stroke time and 'AA.FACT1'. Determining the reference stroke time is described under 'A9.PSTIN'. The threshold 1 message is displayed when threshold 1 is exceeded. The process to activate and display this message is described in the 'XDIAG' parameter.
Factory setting:	1.5

### Ab.FACT2 - Factor 2

Adjustment range:	0.1 ... 100.0
Purpose:	Use this sub-parameter to set the factor for formation of threshold 2. Set the factor in a range from '0.1' to '100.0'. The threshold is the product of the reference stroke time and 'Ab.FACT2'. Determining the reference stroke time is described under 'A9.PSTIN'. The threshold 2 message is displayed when threshold 2 is exceeded. The process to activate and display this message is described in the 'XDIAG' parameter.
Factory setting:	3.0

### AC.FACT3 - Factor 3

Adjustment range:	0.1 ... 100.0
Purpose:	Use this sub-parameter to set the factor for formation of threshold 3. Set the factor in a range from '0.1' to '100.0'. The threshold is the product of the reference stroke time and 'AC.FACT3'. The process to determine the reference stroke time is described under 'A9.PSTIN'. The threshold 3 message is displayed when threshold 3 is exceeded. The process to activate and display this message is described in the 'XDIAG' parameter. The positioner responds in accordance with the option set in the sub-parameter 'A7.FLBH - Behavior after failed PST'.
Factory setting:	5.0

### 9.3.3.2 Monitoring of dynamic control valve behavior 'b.\DEVl'

#### b.\DEVl - Monitoring of dynamic control valve behavior

Requirement:	The '50.XDIAG' Activation of extended diagnostics (Page 170) parameter is set to 'On1', 'On2' or 'On3'.
Possible settings:	<ul style="list-style-type: none"><li>• OFF</li><li>• On</li></ul>
Purpose:	<p>This parameter allows you to monitor the dynamic control valve behavior. The actual position course is compared with the expected position course for this purpose. This comparison helps in drawing a conclusion about the correct operational response of the control valve. Monitoring is performed in three steps. To activate monitoring, set the parameter to 'On'. Sub-parameters are displayed. Appropriately set the sub-parameters.</p> <p>The current value is displayed in Diagnostic value '15.DEVI - General control valve fault' (Page 259). The positioner triggers a message if the current value exceeds one of the three thresholds.</p>
Factory setting:	OFF

#### b1.TIM - Time constant of low-pass filter

Possible settings:	<ul style="list-style-type: none"><li>• Auto</li><li>• 1 ... 400</li></ul>
Purpose:	<p>Use this sub-parameter to define the attenuation effect of the low-pass filter. The unit is seconds. The time constant 'b1.TIM' is calculated from the travel times 'uP' and 'doWn' determined during the initialization. This time constant becomes effective when the 'b1.TIM' parameter is set to 'Auto'.</p> <p>If the time constant is inadequate, the setting of 'b1.TIM' can be changed manually. Set the time constant in a range from '1' to '400'. In this case:</p> <ul style="list-style-type: none"><li>• Setting '1' indicates a very weak attenuation.</li><li>• Setting '400' indicates a strong attenuation.</li></ul> <p>The currently determined deviation is displayed in Diagnostic value '15.DEVI - General control valve fault' (Page 259). The positioner triggers a message if the current value exceeds one of the three parameterizable thresholds.</p>
Factory setting:	Auto

### b2.LIMIT - Limit for dynamic control valve behavior

Adjustment range:	0.1 ... 100.0
Purpose:	Use this sub-parameter to set a base limit in percent. The base limit defines the magnitude of the permissible deviation from the expected position course. The limit serves as a reference variable for the fault message factors. Set the base limit in a range from '0.1' to '100.0'.
Factory setting:	1.0

### b3.FACT1 - Factor 1

Adjustment range:	0.1 ... 100.0
Purpose:	Use this sub-parameter to set the factor for formation of threshold 1. Set the factor in a range from '0.1' to '100.0'. The threshold is the product of 'b2.LIMIT' and 'b3.FACT1'. The threshold 1 message is displayed when threshold 1 is exceeded. This message is only output if threshold 2 or 3 is not exceeded at the same time. The process to activate and display this message is described in the 'XDIAG' parameter.
Factory setting:	5.0

### b4.FACT2 - Factor 2

Adjustment range:	0.1 ... 100.0
Purpose:	Use this sub-parameter to set the factor for formation of threshold 1. Set the factor in a range from '0.1' to '100.0'. The threshold is the product of 'b2.LIMIT' and 'b4.FACT2'. The threshold 2 message is displayed when threshold 2 is exceeded. This message is only output if threshold 3 is not exceeded at the same time. The process to activate and display this message is described in the 'XDIAG' parameter.
Factory setting:	10.0

### b5.FACT3 - Factor 3

Adjustment range:	0.1 ... 100.0
Purpose:	Use this sub-parameter to set the factor for formation of threshold 1. Set the factor in a range from '0.1' to '100.0'. The threshold is the product of 'b2.LIMIT' and 'b5.FACT3'. The threshold 3 message is displayed when threshold 3 is exceeded. The process to activate and display this message is described in the 'XDIAG' parameter.
Factory setting:	15.0

### 9.3.3.3 Monitoring pneumatic leakage 'C.\\LEAK'

#### C.\\LEAK - Monitoring pneumatic leakage

---

**Note****Accuracy of results**

Please note that this monitoring only delivers results in the case of single-acting, spring-loaded actuators and a setpoint from 5 to 95%.

---

**Note****Activated tight closing function**

Please note that this monitoring only delivers results in the case of an activated tight closing function and a setpoint with the following values:

Lower value for tight closing (YCDO) +5 % up to upper value for tight closing (YCUP) -5 %

---

Requirement:	The '50.XDIAG' Activation of extended diagnostics (Page 170) parameter is set to 'On1', 'On2' or 'On3'.
Possible settings:	<ul style="list-style-type: none"><li>• OFF</li><li>• On</li></ul>
Purpose:	Use this parameter to detect leakages in the actuator or in the pipe installation. Monitoring is performed in three steps. To activate monitoring, set the parameter to 'On'. Sub-parameters are displayed. Appropriately set the sub-parameters.  The current value is displayed in Diagnostic value '16.ONLK - Pneumatic leakage' (Page 259). The positioner triggers a message if the current value exceeds one of the three thresholds.
Factory setting:	OFF

#### C1.LIMIT - Limit for leakage indicator

Adjustment range:	0.1 ... 100.0
Purpose:	Use this sub-parameter to set the limit of the leakage indicator in percent. Set the limit in a range from '0.1' to '100.0'. If no leakage exists, monitoring of the pneumatic leakage is automatically calibrated in such a way during the initialization (see section Commissioning (Page 113)) that the leakage indicator remains below the value 30. If a value above 30 is displayed, this means that a leakage exists. '30.0' is therefore an advisable setting for the parameter. After a certain time this limit can be varied slightly depending on the application.

To optimize the sensitivity of the monitoring of the pneumatic leakage to your specific application, follow these steps:

1. After initializing the positioner automatically, use a calibration device to initiate a ramp movement.
2. Conditions for the ramp movement:
  - The ramp covers the normal operating range of the valve.
  - The steepness of the ramp matches the dynamic requirements of the corresponding application.
  - The characteristic of the ramp corresponds to the characteristic of the setpoint that actually occurs.
3. During the ramp movement, the Diagnostic value '16.ONLK - Pneumatic leakage' (Page 259) provides information about the actual values. Define the limit of the leakage indicator accordingly.

The positioner triggers a message if the current value exceeds one of the three thresholds. How to set the three thresholds is described below.

Factory setting: 30.0

### C2.FACT1 - Factor 1

Adjustment range: 0.1 ... 100.0

Purpose: Use this sub-parameter to set the factor for formation of threshold 1. Set the factor in a range from '0.1' to '100.0'. The threshold is the product of 'C1.LIMIT' and 'C2.FACT1'.

The threshold 1 message is displayed when threshold 1 is exceeded. The process to activate and display this message is described in the 'XDIAG' parameter.

Factory setting: 1.0

### C3.FACT2 - Factor 2

Adjustment range: 0.1 ... 100.0

Purpose: Use this sub-parameter to set the factor for formation of threshold 2. Set the factor in a range from '0.1' to '100.0'. The threshold is the product of 'C1.LIMIT' and 'C3.FACT2'.

The threshold 2 message is displayed when threshold 2 is exceeded. The process to activate and display this message is described in the 'XDIAG' parameter.

Factory setting: 1.5

**C4.FACT3 - Factor 3**

Adjustment range:	0.1 ... 100.0
Purpose:	Use this sub-parameter to set the factor for formation of threshold 3. Set the factor in a range from '0.1' to '100.0'. The threshold is the product of 'C1.LIMIT' and 'C4.FACT3'. The threshold 3 message is displayed when threshold 3 is exceeded. The process to activate and display this message is described in the 'XDIAG' parameter.
Factory setting:	2.0

**9.3.3.4 Monitoring the stiction (slipstick) 'd.\STIC'****d.\STIC - Monitoring the stiction (slipstick)**

Requirement:	The '50.XDIAG' Activation of extended diagnostics (Page 170) parameter is set to 'On1', 'On2' or 'On3'.
Possible settings:	<ul style="list-style-type: none"> <li>• OFF</li> <li>• On</li> </ul>
Purpose:	Use this parameter to continuously monitor the current stiction (slipstick) of the control valve. If the parameter is activated, the positioner detects the slipstick that may occur. Sudden changes in the valve position, so-called slip jumps, indicate excessive stiction. Where slip jumps are detected, the filtered step height is stored as a slipstick value. If slip jumps no longer exist, the stiction (slipstick) is reduced slowly. Monitoring is performed in three steps. To activate monitoring, set the parameter to 'On'. Sub-parameters are displayed. Appropriately set the sub-parameters. The current value is displayed in Diagnostic value '17.STIC - Stiction (slipstick)' (Page 260). The positioner triggers a message if the current value exceeds one of the thresholds.
Factory setting:	OFF

---

**Note****Incorrect interpretation in case of travel times below one second**

If the travel times are less than one second, the positioner does not accurately differentiate between a normal movement of the actuator and a sudden change. Therefore, increase the travel time if required.

---

### d1.LIMIT - limit for slipstick detection

Adjustment range:	0.1 ... 100.0
Purpose:	Use this sub-parameter to set the base limit for slipstick detection in percent. Set the base limit in a range from '0.1' to '100.0'.
Factory setting:	1.0

### d2.FACT1 - Factor 1

Adjustment range:	0.1 ... 100.0
Purpose:	Use this sub-parameter to set the factor for formation of threshold 1. Set the factor in a range from '0.1' to '100.0'. The threshold is the product of the values entered for 'd1.LIMIT' and 'd2.FACT1'. The threshold 1 message is displayed when threshold 1 is exceeded. The process to activate and display this message is described in the 'XDIAG' parameter.
Factory setting:	2.0

### d3.FACT2 - Factor 2

Adjustment range:	0.1 ... 100.0
Purpose:	Use this sub-parameter to set the factor for formation of threshold 2. Set the factor in a range from '0.1' to '100.0'. The threshold is the product of the values entered for 'd1.LIMIT' and 'd3.FACT2'. The threshold 2 message is displayed when threshold 2 is exceeded. The process to activate and display this message is described in the 'XDIAG' parameter.
Factory setting:	5.0

### d4.FACT3 - Factor 3

Adjustment range:	0.1 ... 100.0
Purpose:	Use this sub-parameter to set the factor for formation of threshold 3. Set the factor in a range from '0.1' to '100.0'. The threshold is the product of the values entered for 'd1.LIMIT' and 'd4.FACT3'. The threshold 3 message is displayed when threshold 3 is exceeded. The process to activate and display this message is described in the 'XDIAG' parameter.
Factory setting:	10.0

### See also

Diagnostic value '15.DEVI - General control valve fault' (Page 259)



### 9.3.3.5 Monitoring the deadband 'E.\DEBA'

#### E.\DEBA - Monitoring the deadband

Requirement:	The '50.XDIAG' Activation of extended diagnostics (Page 170) parameter is set to 'On1', 'On2' or 'On3'. The '31.DEBA' Deadband of controller (Page 160) parameter is set to 'Auto'.
Possible settings:	<ul style="list-style-type: none"><li>• OFF</li><li>• On</li></ul>
Purpose:	Use this parameter to continuously monitor the automatic adaptation of the deadband. Monitoring is performed in three steps. To activate monitoring, set the parameter to 'On'. The sub-parameter is displayed. Appropriately set the sub-parameter. The current value is displayed in Diagnostic value '26.DBUP - Deadband UP' / '27.DBDN - Deadband DOWN' (Page 263). The positioner triggers a message if the current value exceeds the threshold.
Factory setting:	OFF

#### E1.LEVL3 - Deadband threshold

Adjustment range:	0.1 ... 2.9
Purpose:	Use this sub-parameter to set the threshold to the deadband in percent. Set the threshold in a range from '0.1' to '2.9'. The threshold 3 fault message is displayed when the current deadband exceeds the threshold during the test. The procedure to activate and display this error message is described in the 'XDIAG' parameter.
Factory setting:	2.0

---

#### Note

##### Fault message display

The three-stage alarm display has not been implemented for monitoring of the deadband. The positioner triggers only threshold 3 fault messages depending on the setting.

---

### 9.3.3.6 Monitoring the lower endstop "F.\ZERO"

#### F.\ZERO - Monitoring the lower endstop

---

**Note**

**Fault detection**

Monitoring the lower endstop not only responds to faults in the valve. If the limit thresholds of the lower endstop are exceeded due to misalignment of the position feedback, the misalignment also triggers a diagnostics message.

---

Requirement:	The '50.XDIAG' Activation of extended diagnostics (Page 170) parameter is set to 'On1', 'On2' or 'On3'. The '36.YCLS' Tight closing with manipulated variable (Page 162) parameter is set to 'do' or 'uP do'.
Possible settings:	<ul style="list-style-type: none"><li>• OFF</li><li>• On</li></ul>
Purpose:	Use this parameter to activate continuous monitoring of the lower endstop. The monitoring is executed whenever the valve is in the 'Lower tight closing' position. It checks whether the lower endstop has changed compared to its value during initialization. Monitoring is performed in three steps. Set the following sub-parameters appropriately. To activate monitoring, set the parameter to 'On'. Sub-parameters are displayed. The current value is displayed in Diagnostic value '18.ZERO - Lower endstop' (Page 260). The positioner triggers a message if the current value undershoots one of the three thresholds.
Factory setting:	OFF

#### F1.LEVL1 - threshold 1

Adjustment range:	0.1 ... 10.0
Purpose:	Use this sub-parameter to set threshold 1 for the lower endstop in percent. Set the threshold in a range from '0.1' to '10.0'. The positioner triggers a message if the difference between the lower endstop and the initialization value undershoots threshold 1. The process to activate and display this message is described in the 'XDIAG' parameter.
Factory setting:	1.0

## F2.LEVL2 - threshold 2

Adjustment range:	0.1 ... 10.0
Purpose:	Use this sub-parameter to set threshold 2 for the lower endstop in percent. Set the threshold in a range from '0.1' to '10.0'. The positioner triggers a message if the difference between the lower endstop and the initialization value undershoots threshold 2. The process to activate and display this message is described in the 'XDIAG' parameter.
Factory setting:	2.0

## F3.LEVL3 - threshold 3

Adjustment range:	0.1 ... 10.0
Purpose:	Use this sub-parameter to set threshold 3 for the lower endstop in percent. Set the threshold in a range from '0.1' to '10.0'. The positioner triggers a message if the difference between the lower endstop and the initialization value undershoots threshold 3. The process to activate and display this message is described in the 'XDIAG' parameter.
Factory setting:	4.0

### 9.3.3.7 Monitoring the upper endstop 'G.\\OPEN'

#### G.\\OPEN - Monitoring the upper endstop

---

##### Note

##### Fault detection

Monitoring the upper endstop not only responds to faults in the valve. If the limit thresholds of the upper endstop are exceeded due to misalignment of the position feedback, the misalignment also triggers a message.

---

Requirement:	The '50.XDIAG' Activation of extended diagnostics (Page 170) parameter is set to 'On1', 'On2' or 'On3'. The '36.YCLS' Tight closing with manipulated variable (Page 162) parameter is set to 'uP' or 'uP do'.
Possible settings:	<ul style="list-style-type: none"><li>• OFF</li><li>• On</li></ul>

**Purpose:** Use this parameter to activate continuous monitoring of the upper endstop. The monitoring is executed whenever the valve is in the 'Upper tight closing' position. It checks whether the upper endstop has changed compared to its value during initialization. Monitoring is performed in three steps. Set the following sub-parameters appropriately. To activate monitoring, set the parameter to 'On'. Sub-parameters are displayed.  
The value is displayed in Diagnostic value '19.OPEN - Upper endstop' (Page 260). The positioner triggers a message if the current value exceeds one of the three thresholds.

**Factory setting:** OFF

### G1.LEVL1 - threshold 1

**Adjustment range:** 0.1 ... 10.0

**Purpose:** Use this sub-parameter to set threshold 1 for the upper endstop in percent. Set the threshold in a range from '0.1' to '10.0'.  
The positioner triggers a message if the difference between the upper endstop and the initialization value overshoots threshold 1. The process to activate and display this message is described in the 'XDIAG' parameter.

**Factory setting:** 1.0

### G2.LEVL2 - threshold 2

**Adjustment range:** 0.1 ... 10.0

**Purpose:** Use this sub-parameter to set threshold 2 for the upper endstop in percent. Set the threshold in a range from '0.1' to '10.0'.  
The positioner triggers a message if the difference between the upper endstop and the initialization value overshoots threshold 2. The process to activate and display this message is described in the 'XDIAG' parameter.

**Factory setting:** 2.0

### G3.LEVL3 - threshold 3

**Adjustment range:** 0.1 ... 10.0

**Purpose:** Use this sub-parameter to set threshold 3 for the upper endstop in percent. Set the threshold in a range from '0.1' to '10.0'.  
The positioner triggers a message if the difference between the upper endstop and the initialization value overshoots threshold 3. The process to activate and display this message is described in the 'XDIAG' parameter.

**Factory setting:** 4.0

### 9.3.3.8 Monitoring the low limit temperature 'H.\TMIN'

#### H.\TMIN - Monitoring the low limit temperature

Requirement:	The '50.XDIAG' Activation of extended diagnostics (Page 170) parameter is set to 'On1', 'On2' or 'On3'.
Possible settings:	<ul style="list-style-type: none"><li>• OFF</li><li>• On</li></ul>
Purpose:	<p>The current temperature inside the enclosure of the field device is recorded by a sensor on the basic electronics. Use this parameter to activate continuous monitoring of the low limit temperature inside the enclosure. Monitoring is performed in three steps. To activate monitoring, set the parameter to 'On'. Sub-parameters are displayed. Appropriately set the sub-parameters.</p> <p>The value is displayed in Diagnostic value '31.TMIN - Minimum temperature' / '32.TMAX - Maximum temperature' (Page 264). The positioner triggers a message if the current value undershoots one of the three thresholds.</p>
Factory setting:	OFF

#### H1.TUNIT - temperature unit

Possible settings:	°C °F
Purpose:	Use this sub-parameter to set the temperature unit '°C' or '°F'. The selected temperature unit is then also applicable for all other temperature-based parameters.
Factory setting:	°C

#### H2.LEVL1 - threshold 1

Adjustment range:	-40.0C ... 90.0C -40.0F ... 194.0F
Purpose:	<p>Use this sub-parameter to set the temperature for threshold 1.</p> <p>The positioner triggers a message if the current temperature inside the enclosure undershoots threshold 1. The process to activate and display this message is described in the 'XDIAG' parameter.</p>
Factory setting:	-25.0C

### H3.LEVL2 - threshold 2

Adjustment range:	-40.0C ... 90.0C -40.0F ... 194.0F
Purpose:	Use this sub-parameter to set the temperature for threshold 2. The positioner triggers a message if the current temperature inside the enclosure undershoots threshold 2. The process to activate and display this message is described in the 'XDIAG' parameter.
Factory setting:	-30.0C

### H4.LEVL3 - threshold 3

Adjustment range:	-40.0C ... 90.0C -40.0F ... 194.0F
Purpose:	Use this sub-parameter to set the temperature for threshold 3. The positioner triggers a message if the current temperature inside the enclosure undershoots threshold 3. The process to activate and display this message is described in the 'XDIAG' parameter.
Factory setting:	-40.0C

#### 9.3.3.9 Monitoring the high limit temperature 'J.\TMAX'

##### J.\TMAX - Monitoring the upper limit temperature

Requirement:	The '50.XDIAG' Activation of extended diagnostics (Page 170) parameter is set to 'On1', 'On2' or 'On3'.
Possible settings:	<ul style="list-style-type: none"><li>• OFF</li><li>• On</li></ul>
Purpose:	The current temperature inside the enclosure of the field device is recorded by a sensor on the basic electronics. Use this parameter to activate continuous monitoring of the high limit temperature inside the enclosure. Monitoring is performed in three steps. To activate monitoring, set the parameter to 'On'. Sub-parameters are displayed. Appropriately set the sub-parameters. The value is displayed in Diagnostic value '31.TMIN - Minimum temperature' / '32.TMAX - Maximum temperature' (Page 264). The positioner triggers a message if the current value exceeds one of the three thresholds.
Factory setting:	OFF

### **J1.TUNIT - temperature unit**

Possible settings:	°C °F
Purpose:	Use this sub-parameter to set the temperature unit '°C' or '°F'. The selected temperature unit is then also applicable for all other temperature-based parameters.
Factory setting:	°C

### **J2.LEVL1 - threshold 1**

Adjustment range:	-40.0C ... 90.0C -40.0F ... 194.0F
Purpose:	Use this sub-parameter to set the temperature for threshold 1. The positioner triggers a message if the current temperature inside the enclosure overshoots threshold 1. The process to activate and display this message is described in the 'XDIAG' parameter.
Factory setting:	75.0C

### **J3.LEVL2 - threshold 2**

Adjustment range:	-40.0C ... 90.0C -40.0F ... 194.0F
Purpose:	Use this sub-parameter to set the temperature for threshold 2. The positioner triggers a message if the current temperature inside the enclosure overshoots threshold 2. The process to activate and display this message is described in the 'XDIAG' parameter.
Factory setting:	80.0C

### **J4.LEVL3 - threshold 3**

Adjustment range:	-40.0C ... 90.0C -40.0F ... 194.0F
Purpose:	Use this sub-parameter to set the temperature for threshold 3. The positioner triggers a message if the current temperature inside the enclosure undershoots threshold 3. The process to activate and display this message is described in the 'XDIAG' parameter.
Factory setting:	90.0C

### 9.3.3.10 Monitoring the number of total strokes 'L.\STRK'

#### L.\STRK - Monitoring the number of total strokes

Requirement:	The '50.XDIAG' Activation of extended diagnostics (Page 170) parameter is set to 'On1', 'On2' or 'On3'.
Possible settings:	<ul style="list-style-type: none"><li>• OFF</li><li>• On</li></ul>
Purpose:	Use this parameter to continuously monitor the total strokes covered by the actuator. A total stroke corresponds to the path from the lower endstop of the actuator to the upper endstop and back again, in other words twice the travel. During operation, partial strokes of the actuator are added together into total strokes. Monitoring is performed in three steps. To activate monitoring, set the parameter to 'On'. Sub-parameters are displayed. Appropriately set the sub-parameters. The current value is displayed in Diagnostic value '1.STRKS - Number of total strokes' (Page 255). The positioner triggers a message if the current value exceeds one of the three thresholds. This message is only output if threshold 2 or 3 is not exceeded at the same time.
Factory setting:	OFF

#### L1.LIMIT - Limit for number of total strokes

Adjustment range:	1 ... 1.00E8
Purpose:	Use this sub-parameter to set the base limit for the number of total strokes. Set the base limit in a range from '1' to '1.00E8'.
Factory setting:	1.00E6

#### L2.FACT1 - Factor 1

Adjustment range:	0.1 ... 40.0
Purpose:	Use this sub-parameter to set the factor for formation of threshold 1. Set the factor in a range from '0.1' to '40.0'. The threshold is the product of 'L1.LIMIT' and 'L2.FACT1'. The threshold 1 message is displayed when threshold 1 is exceeded. The process to activate and display this message is described in the 'XDIAG' parameter.
Factory setting:	1.0



**L3.FACT2 - Factor 2**

Adjustment range:	0.1 ... 40.0
Purpose:	Use this sub-parameter to set the factor for formation of threshold 1. Set the factor in a range from '0.1' to '40.0'. The threshold is the product of 'L1.LIMIT' and 'L3.FACT2'. The threshold 1 message is displayed when threshold 1 is exceeded. The process to activate and display this message is described in the 'XDIAG' parameter.
Factory setting:	2.0

**L4.FACT3 - Factor 3**

Adjustment range:	0.1 ... 40.0
Purpose:	Use this sub-parameter to set the factor for formation of threshold 1. Set the factor in a range from '0.1' to '40.0'. The threshold is the product of 'L1.LIMIT' and 'L4.FACT3'. The threshold 1 message is displayed when threshold 1 is exceeded. The process to activate and display this message is described in the 'XDIAG' parameter.
Factory setting:	5.0

**9.3.3.11 Monitoring the number of changes in direction 'O.\DCHG'****O.\DCHG - Monitoring the number of changes in direction**

Requirement:	The '50.XDIAG' Activation of extended diagnostics (Page 170) parameter is set to 'On1', 'On2' or 'On3'.
Possible settings:	<ul style="list-style-type: none"> <li>• OFF</li> <li>• On</li> </ul>
Purpose:	Use this parameter to continuously monitor the number of changes in direction of the actuator beyond the deadband. Monitoring is performed in three steps. Set the following sub-parameters appropriately. To activate monitoring, set the parameter to 'On'. Sub-parameters are displayed. The current value is displayed in Diagnostic value '2.CHDIR - Number of changes in direction' (Page 255). The positioner triggers a message if the current value exceeds one of the three thresholds.
Factory setting:	OFF

### O1.LIMIT - Limit for number of changes in direction

Adjustment range: 1 ... 1.00E8  
Purpose: Use this sub-parameter to set the base limit for the changes of direction of the actuator. Set the base limit in a range from '1' to '1.00E8'.  
Factory setting: 1.00E6

### O2.FACT1 - Factor 1

Adjustment range: 0.1 ... 40.0  
Purpose: Use this sub-parameter to set the factor for formation of threshold 1. Set the factor in a range from '0.1' to '40.0'. The threshold is the product of 'O1.LIMIT' and 'O2.FACT1'.  
The threshold 1 message is displayed when threshold 1 is exceeded. The process to activate and display this message is described in the 'XDIAG' parameter.  
Factory setting: 1.0

### O3.FACT2 - Factor 2

Adjustment range: 0.1 ... 40.0  
Purpose: Use this sub-parameter to set the factor for formation of threshold 1. Set the factor in a range from '0.1' to '40.0'. The threshold is the product of 'O1.LIMIT' and 'O3.FACT2'.  
The threshold 1 message is displayed when threshold 1 is exceeded. The process to activate and display this message is described in the 'XDIAG' parameter.  
Factory setting: 2.0

### O4.FACT3 - Factor 3

Adjustment range: 0.1 ... 40.0  
Purpose: Use this sub-parameter to set the factor for formation of threshold 1. Set the factor in a range from '0.1' to '40.0'. The threshold is the product of 'O1.LIMIT' and 'O4.FACT3'.  
The threshold 1 message is displayed when threshold 1 is exceeded. The process to activate and display this message is described in the 'XDIAG' parameter.  
Factory setting: 5.0

### 9.3.3.12 Monitoring the position average value 'P.\PAVG'

#### P.\PAVG - Monitoring the position average value

Requirement:	The '50.XDIAG' Activation of extended diagnostics (Page 170) parameter is set to 'On1', 'On2' or 'On3'.
Possible settings:	<ul style="list-style-type: none"><li>• OFF</li><li>• On</li></ul>
Purpose:	<p>Use this parameter to activate the test to calculate and monitor the average value of position. During the test, the average values of position and reference are always compared at the end of a time interval.</p> <p>The current value is displayed in Diagnostic value '20.PAVG - Average value of position' (Page 261). The positioner triggers a message if the current average value of position undershoots one of the three thresholds.</p>
Factory setting:	OFF

#### P1.TBASE - Time basis of average value generation

Possible settings:	0.5h / 8h / 5d / 60d / 2.5y
Purpose:	<p>Use this sub-parameter to set the time interval to calculate the average value of position. The following values are available to define the time intervals:</p> <ul style="list-style-type: none"><li>• 30 minutes</li><li>• 8 hours</li><li>• 5 days</li><li>• 60 days</li><li>• 2.5 years</li></ul> <p>After starting the calculation for average value of reference and expiry of the time interval, a position average over the interval period is determined and compared with the average value of reference. The test is then restarted.</p>
Factory setting:	0.5h

### P2.STATE - Status of monitoring position average value

Possible settings:	IdLE / rEF / ###.# / Strt
Purpose:	Use this sub-parameter to start the calculation for average value of position. If an average value of reference has never been determined, the parameter value is 'IdLE'. Then start the calculation by pressing the  button for 5 seconds. The value in the display changes from 'IdLE' to 'rEF'. The average value of reference is calculated. When the time interval expires, the calculated average value of reference is shown on the display.
Factory setting:	IdLE

---

#### Note

#### Current average value of position

The respective current average value of position is displayed in the Diagnostic value '20.PAVG - Average value of position' (Page 261). If no average value of position has been calculated, 'COMP' is displayed as the diagnostic value.

---

### P3.LEVL1 - threshold 1

Possible settings:	0.1 ... 100.0
Purpose:	Use this sub-parameter to set threshold 1 for the maximum deviation of the current average value of position from the average value of reference. The value is given in percent. Set the threshold in a range from '0.1' to '100.0'. The positioner triggers a message if the difference between the average value of position and the average value of reference exceeds threshold 1. The procedure to activate and display this message is described in the 'XDIAG' parameter.
Factory setting:	2.0

### P4.LEVL2 - threshold 2

Possible settings:	0.1 ... 100.0
Purpose:	Use this sub-parameter to set threshold 2 for the maximum deviation of the current average value of position from the average value of reference. The value is given in percent. Set the threshold in a range from '0.1' to '100.0'. The positioner triggers an error message if the difference between the average value of position and the average value of reference exceeds threshold 2. The process to activate and display this message is described in the 'XDIAG' parameter. The factory setting is '5.0'.
Factory setting:	5.0

### P5.LEVL3 - threshold 3

Possible settings:	0.1 ... 100.0
Purpose:	<p>Use this sub-parameter to set threshold 3 for the maximum deviation of the current average value of position from the average value of reference. The value is given in percent. Set the threshold in a range from '0.1' to '100.0'.</p> <p>The positioner triggers a message if the difference between the average value of position and the average value of reference exceeds threshold 3. The procedure to activate and display this message is described in the 'XDIAG' parameter.</p>
Factory setting:	10.0



## Functions/operations using PROFIBUS PA

### 10.1 System integration

A control system (master) uses acyclic and cyclic data transfer to operate and monitor the positioner. You must set an address of the positioner in advance so that it can communicate with the master as a slave.

The PROFIBUS address is set to 126 in the as-delivered condition. You set the PROFIBUS address on the device or use a configuration tool like SIMATIC PDM to set the address through the bus.

### 10.2 Acyclic data transfer

#### 10.2.1 Acyclic data transfer using SIMATIC PDM

##### SIMATIC PDM

The acyclic data transfer is mainly used to transfer parameters during commissioning and maintenance, for batch processes or to display other measured variables that do not participate in the cyclic transmission of useful data.

The data is transferred between a class 2 master and a field device using the so-called C2 connections. The device supports up to four C2 connections, so the multiple class 2 masters can access the same positioner simultaneously.

SIMATIC PDM is preferably used for the acyclic data transfer. It is a software package for project planning, parameterization, commissioning, diagnostics and maintenance of the positioner and other field devices.

SIMATIC PDM enables access to process values, alarms, status and diagnostics information of the device. You can use SIMATIC PDM to execute the following functions for field devices:

- Display
- Set
- Change
- Compare
- Check for plausibility
- Manage and simulate

##### Procedure for acyclic data transfer:

We recommend the following general procedure:

## 10.2 Acyclic data transfer

1. First read the current settings from the device using the "Load to PG/PC" menu item.
2. Check the current settings.
3. Make any necessary settings.
4. Load the parameter settings into the device using the "Download to device" menu item.
5. Save the settings in the SIMATIC PDM as well.

The menu bar of SIMATIC PDM contains the "File", "Device", "View", "Diagnostics" and "Help" menus. The "Device" and "View" menus, which also contain other sub-menus, are described below in detail.

### 10.2.2 'Device' menu

#### 10.2.2.1 Load to device

Use this sub-menu to load the parameters from the offline display of SIMATIC PDM into the device. Call up the function using the following button:



Figure 10-1 Load to device

#### 10.2.2.2 Load into PG/PC

Use this sub-menu to read the parameters from the device. These parameters are then displayed in SIMATIC PDM. Call up the function using the following button:



Figure 10-2 Load to PG/PC

#### 10.2.2.3 Assign address and TAG

Use this sub-menu to assign a new address and TAG. Note that this is only possible if the slave is not yet integrated into the cyclic service.

#### 10.2.2.4 Value comparison

Use this dialog box to start the comparison of device parameters. The parameter values of a device which are always saved in the project form the basis for the comparison of values.



The parameter values of a device which are saved in the project can be compared with the following data types.

- Offline data: The parameter values of a device which are saved in the project.
- Online data: Parameter values currently saved in the device.

### 10.2.2.5 Object properties

#### "General" tab

In this "General" tab you can find information on the PDM object and enter optional additional information.

In the "General" tab you can find:

- Object name
- Description
- Message
- Properties

#### "Device" tab

In this "Device" tab you display the device data.

The contents of the fields cannot be changed. The contents are derived from the Device Description assigned to the object if these have been entered in it.

Certain entries are displayed as keys and not as plain text.

In the "Device" tab you can find:

- Device type
- Manufacturer
- Order No.
- Catalog path
- Device DDL
- EDD version
- Device version

#### "Diagnostics" tab

In this "Diagnostics" tab you can display information for device communication. The symbol which is displayed on the device is formed in accordance with this information.

## 10.2 Acyclic data transfer

In the "Diagnostics" tab you can find:

- Communication
- Last test
- Message text

### "Communication" tab

In this "Communication" tab you can display the address of a device. If the device has been configured in the process device network view, you can change the address.

In the "Communication" tab you can find:

- Redundancy

### "Document manager" tab

In this "Document manager" tab, you can assign documents to a PDM object.

## 10.2.2.6 Calibration report

The "Calibration report" section contains information on the following topics:

### "Test environment" tab

In this "Test environment" tab you can find:

- Data on the field device
- Data on the operator and test date of the calibration report
- Operator remarks concerning the test
- Comment field
- Settings for scheduling

### "Diagnostics" tab

In this "Diagnostics" tab you can find:

- Information on display of the communication connection status
- Information on display of the device status
- Date of the last change
- Messages of the last test

### "Measuring range settings" tab

In this "Measuring range settings" tab you can find:

- Channel-specific Information (configurable: maximum 8 channels)
- Channel selection
- Configurable settings per channel:
  - Measuring circuit unit
  - Measuring range
  - Output unit
  - Permissible deviation in output range (setpoint/actual value)
  - Comment fields

### "Appendices" tab

Configure files which are to be linked to the report.

In the "Appendices" tab you can find:

- Possible file types:
  - pdf
  - doc; docx
  - xls; xlsx
  - txt
  - jpg

### "Comments" tab

Additional comments for various types of comment

In the "Comments" tab you can find:

- Wiring errors
- Unsuitable measuring point
- Device error
- Error comment

#### 10.2.2.7 Change log

The change log is used to record the actions carried out on system objects using SIMATIC PDM.

## 10.2 Acyclic data transfer

### Properties:

- The change log is part of the associated SIMATIC project.
- The change log is a circular log (first in - first out). Some fields in the change log are created automatically. The information is entered in the language which is pre-selected in the SIMATIC project.

### Requirements for using the "Change log" function:

You require the license key for "SIMATIC PDM Extended" in order to use the "Change log" function.

### Entries in the change log:

Actions are shown in the dialog window "SIMATIC PDM change log" which have been executed in the project or also on individual objects (devices). The displayed actions depend on the object displayed in SIMATIC PDM.

You can restrict the displayed information by setting the filter. The drop-down list "Action" of the filter shows the actions which can be displayed.

## 10.2.2.8 Wizard

This menu item is only available if the extended diagnostics has been previously activated in the parameter list. In this menu you can display and execute the various diagnostics options: The following diagnostics options can be activated and parameterized:

### 'Quick Start' wizard

Use the 'Wizard - Quick Start' button to start up the device.

### 'Partial Stroke Test' wizard

Use the 'Wizard - Partial Stroke Test' button to set a diagnostics function which moves and monitors the stroke over a certain distance.

### 'Full Stroke Test' wizard

Use the 'Wizard - Full Stroke Test' button to set a diagnostics function which moves and monitors the stroke over the complete distance.

### 'Step Response Test' wizard

Use the 'Wizard - Step Response Test' button to set a diagnostics function which moves and monitors the stroke over an intentional distance.

### 'Multi-Step Response Test' wizard

Use the 'Wizard - Multi-Step Response Test' button to set a diagnostics function which repeatedly moves and monitors the stroke over an intentional distance.

### 'Valve Performance Test' wizard

Use the 'Wizard - Valve Performance Test' button to set a diagnostics function which determines the characteristic values of the valve in accordance with IEC 61298-2.

#### 10.2.2.9 Partial stroke test (PST)

##### Availability

This menu item is only available if previously activated in the parameter list using the 'Extended diagnostics' menu. You can then activate and parameterize the partial stroke test.

##### Functions

Use the 'Partial stroke test' button to access the functions of the partial stroke test:

- Execute the partial stroke test.
- Cancel the partial stroke test.
- Deactivate diagnostics

Changes become effective as soon as the Transfer button is pressed.

#### 10.2.2.10 PST trace characteristic

##### Availability

This menu item is only available if the extended diagnostics has been previously activated in the parameter list. Use this menu item to call the following sub-menus:

- Read trace
- Export as \*.csv file
- Import a .csv file

##### Read trace

When executing a partial stroke test, the temporal course of the actual value is scanned in the background and saved in the RAM of the positioner with a maximum of 1000 data points. Use this menu item to read in the saved data in SIMATIC PDM. The end of the reading process is displayed in the SIMATIC PDM status bar.

##### Export as \*.csv file

Use this menu item to save the currently read in temporal course of the partial stroke test in the SIMATIC PDM as a csv file.

### 10.2.2.11 Offline leakage test

#### Application

Use this menu item to open an online dialog in which you can recognize following execution whether a leakage is present in the actuator or in the piping.

You will also obtain information about the statuses in the diagnostic field 'Leakage test status':

- Not executed (only '-' is shown in the positioner display)
- Running
- Stopped
- Complete

If you execute the test using the 'Start offline leakage test' button in the online dialog, the leakage is measured at the position at which the positioner is currently present. The measured leakage [%/min] is subsequently saved in the '11.LEAK' parameter.

A distinction must be made here between the extended diagnostics 'Monitoring pneumatic leakage C.\LEAK' and the 'Offline leakage test'. Monitoring is not activated by the 'Offline leakage test'. A single offline test is executed to check for leakages and save the measured leakage value [%/min] in the '11.LEAK' parameter.

### 10.2.2.12 Maintenance and diagnostics

#### Application

The sub-menu "Maintenance and diagnostics" is only available if the extended diagnostics has been activated. You can then activate and parameterize the following extended diagnostics parameters:

- Monitoring the dynamic control valve behavior "b.\DEVI'
- Monitoring the pneumatic leakage 'C.\_LEAK'
- Monitoring the stiction (slipstick) "d.\STIC'
- Monitoring the deadband "E.\DEBA'
- Monitoring the lower endstop "F.\ZERO'
- Monitoring the upper endstop 'G.\OPEN'
- Monitoring the lower limit temperature "H.\TMIN'
- Monitoring the high limit temperature 'J.\TMAX'
- Monitoring the number of total strokes "L.\STRK'
- Monitoring the number of changes in direction "O.\DCHG'
- Monitoring the position average value 'P.\PAVG'

Changes become effective as soon as the Transfer button is pressed.

### 10.2.2.13 Initialization parameters

#### Use

Not only you can display the initialization parameters in this menu, but also change them specifically. Allow only specialists to change the initialization parameters.

You also need this function if you need to replace the electronic unit. However you cannot initialize at the moment.

### 10.2.2.14 Initialization

#### Application

With SIMATIC PDM, you also have the option to initialize the positioner for the first time.

#### First initialization

 <b>WARNING</b>
<b>Start initialization</b>
You are not located on-site at the positioner. In order to prevent personal injuries and material damage, take in-house precautionary measures before starting the initialization process.

---

#### Note

Also ensure that you always start the initialization process from the acyclic master even if the positioner is in automatic mode and contains setpoints of a cyclic master.

If required, you can interrupt the ongoing initialization by pressing the "Stop initialization" button. You can also press the operating mode button or disconnect the power supply to interrupt the initialization process on the device.

Proceed as follows to initialize the positioner using SIMATIC PDM for the first time:

1. Go to the "Device" menu and then to the "Initialization" sub-menu. A window containing an overview of the initialization status then opens.
2. Press the "Start initialization" button. A warning is then displayed. Follow this warning without fail to prevent personal injuries and damage to the system.
3. Acknowledge the warning.

The initialization process starts once you acknowledge the warning. You can monitor the progress in the "Status (initialization)" field in the open window of the initialization menu. As soon as the initialization is completed successfully, the positioner continues working in the operating mode from which the initialization process was started. If a fault message appears, an on-site correction is required.

### 10.2.2.15 Operation

Open the 'Device > Operation' menu. An online dialog is opened with two tabs. Go to the 'Operation' tab.

#### Target mode

The following target modes (operating modes of function blocks) are possible:

- Automatic (AUT)
- Manual (MAN)
- Out of service (O/S)

Note that the target modes refer to the operating modes of function blocks of the PROFIBUS PA block model, and should not be confused with the "Automatic" and "Manual" operating modes of the positioner.

The above target modes are effective when the positioner is in automatic mode (AUT). If the positioner is in manual mode (MAN), they are only effective after an on-site switchover to automatic mode (AUT).

These target modes are saved in the positioner in the power failure-safe manner.

#### Automatic mode

As long as the positioner is not integrated into the cyclic service as a slave, SIMATIC PDM can be used to send a setpoint to it in a cyclic manner.

Make the following settings:

1. Go to the "Operating mode" tab.
2. Set the target mode to "Automatic".
3. Enter a value between 0 and 100% for the desired setpoint, quality as "Good" and the status as "OK".
4. Transfer these settings to the positioner.

The positioner is controlled using the desired setpoint until a cyclic master starts communication with a slave or you switch over the positioner to the "Manual" mode on-site.

---

#### Note

Note that the positioner responds with the "Poor" quality and the "Constant value" status after sending the data.

If you exit this target mode and no other master sends a setpoint to the positioner, it is controlled using the configured fail-safe value after the set monitoring time expires.

---

#### Manual mode

You can use SIMATIC PDM to send a setpoint to the positioner even when cyclic communication is active. To do this, you need only set priority over the cyclic master beforehand.



Make the following settings:

1. Go to the "Operating mode" tab.
2. Set the target mode to "Manual".
3. Enter a value between 0 and 100% as a starting value, "Good" as the quality and "OK" as the status.
4. Transfer these settings to the positioner.

The positioner is now controlled using the desired starting value and reports this manual mode through "MM" on the display.

Note that the starting value entered in the manual mode is directly written in the starting block of the positioner without scaling.

You can switch the positioner to the manual mode on-site and move the actuator using buttons. The setpoint is tracked as per the current actual value. The manual mode and the current position are retained after switching back to the automatic mode.

After a power failure, the positioner is controlled in the manual mode depending on the direction of action of the actuator using the value set in the "YA" or "YE" parameters.

---

**Note**

You must set the target mode to "Automatic" to reactivate the setpoints of the cyclic master.

---

## Out of service (O/S)

You can use SIMATIC PDM to put the positioner out of service irrespective of the cyclic communication.

 <b>CAUTION</b>
--

<b>Depressurize</b>
---------------------

In order to prevent physical injuries and material damage, you must ensure that the actuator is depressurized when it is put out of service.
--

Make the following settings:

1. Go to the "Operating mode" tab.
2. Set the target mode to "Out of service (O/S)".
3. Transfer these settings to the positioner.

The successful transmission is reported by "OS--" on the display of the positioner.

You can switch the positioner to the manual mode on-site and move the actuator using buttons in this target mode also. "MAN--" is then shown on the display.

## 10.2 Acyclic data transfer

The "Out of service (O/S)" mode is retained after switching back to the automatic mode. The actuator remains depressurized after a power failure.

---

### Note

You must set the target mode to "Automatic" to reactivate the setpoints of the cyclic master.

---

## 10.2.2.16 Simulation

### Register

Use this sub-menu to access the "Simulation" online menu that is split into the following four tabs:

- Simulation of actual value
- Simulation of device status
- Simulation of device diagnostics

### Simulation of actual value

You can activate the actual value simulation in this tab and also define the actual value to be simulated and its quality and status. The following feedback values are available:

- Setpoint
- Actual value
- Setpoint deviation
- Checkback

Changes become effective as soon as the Transfer button is pressed.

### Simulation of device status

You can activate simulation of the device status in this tab and then select the diagnostics messages to be simulated. This concerns the content of the "DIAGNOSTICS physical block parameter" that generates different diagnostics messages depending on whether the condensed status has been activated or deactivated. Changes become effective as soon as the Transfer button is pressed.

### Simulation of device diagnostics

In this tab you enable simulation of device diagnostics.

You can then select the desired diagnostics events in the simulation of device diagnostics, and use device diagnostics and message text to obtain the feedback indicating that the corresponding event has been triggered in the device. Changes become effective as soon as the Transfer button is pressed.

### 10.2.2.17 Date and time in the device

#### Application

Use this menu item to open an online dialog in which you can set the date and time in the device.

### 10.2.2.18 Write protection

#### Application

Following completion of commissioning, you can set the write protection to prevent undesired changes by an acyclic master.

However, you can change the parameters of the positioner on-site as before.

#### Enabling write protection

1. Call the "Write protection" sub-menu.
2. Set 'Write protection' in the sub-menu to 'On'.

If you still try to write, the PDM displays the 'Connection terminated' message.

---

#### Note

##### Write protection

1. If 'On' is displayed for 'Hardware write protection' in the online dialog 'Write protection', the application parameter '39.BIN1' / '40.BIN2' Function of binary inputs (Page 163) 'bLoc1' or 'bLoc2' has been set on the positioner. Writing via SIMATIC PDM is thus also blocked. The write protection directly activated in the positioner can only be canceled again directly on the positioner.
  2. In SIMATIC PDM, the write protection can only be changed via the online dialog 'Write protection' in the 'Device' menu. You cannot change the write protection via the tree topology in the parameter table 'Security'.
- 

### 10.2.2.19 Reset parameters in PDM

#### Application

Use this menu item to open a dialog box to reset all SIMATIC PDM parameters to their factory settings (default values).

SIMATIC PDM parameters are reset when you press the 'OK' button. You can then transfer the parameters to the SIMATIC PDM memory using 'File->Save'.

Select 'Device->Load to device' to transfer the reset parameters to the positioner as well.

### 10.2.2.20 Reset parameters on the device

#### Application

Use this menu item to open an online dialog to reset the parameters in the positioner to their factory settings (default values).

The following parameters can be selected for resetting:

- Initialization parameters
- Device parameters (except 49.PNEUM, 54.STNR and 55.IDENT)
- Parameters of extended diagnostics
- Offline test parameters

The parameters are reset when you press the 'OK' button.

Select 'Device->Load to PG/PC' to transfer the reset parameters of the positioner to SIMATIC PDM as well.

### 10.2.2.21 Reset the field device

#### Resetting to delivery state

If the positioner has been maladjusted such that it can no longer perform its control task, you can use the 'Reset' function to restore the delivery state. This function resets all parameters to their factory settings except for the PROFIBUS address.

Resetting is displayed in the online dialog by the diagnostics message 'Device status' as "Restart (cold startup) carried out". You must then reset all parameters and execute an initialization process.

#### Warm restart

With the warm restart you initiate a complete restart of the positioner. This interrupts and then reestablishes communication.

This restart is displayed in the online dialog by the diagnostics message 'Device status' as "New startup (warm startup) carried out". If no measured values are available, the automation or control system reads in the "Uncertain, initial value, constant value" status.

#### Resetting the address (STRN) to 126

If no device in your system has the preset address 126, you can add your positioner to the PROFIBUS path during ongoing operation of the automation or control system. You must subsequently change the address of the newly connected device to a different value.

If you remove a positioner from the PROFIBUS path, you must reset its address to 126 using this function 'Resetting the address (STRN) to 126' so that you can re-integrate a positioner in this or another system depending on the requirement.

The address cannot be reset if a cyclic master is already communicating with the positioner.

## 10.2.3 'View' menu

### 10.2.3.1 Process variables / diagnostics cockpit

#### "Cockpit overview" tab

This "Cockpit overview" tab contains:

- Bar graph displays of actual value and setpoint [stroke/%]
- Bar graph of absolute control deviation [control deviation/%]
- Bar graph of current temperature '30.TEMP' [temperature/°C]
- Information on the TAG, description, message and setpoint function '9.SFCT'

#### "Trend view (setpoint/actual value)" tab

This "Trend view (setpoint/actual value)" tab displays the setpoint/actual value as a bar and as a trend.

Furthermore, menu items exist with which you can call the following sub-menus:

- Export as \*.csv file
- Import a .csv file
- Connect axes
- Print

#### "Status" tab

In the "Status" tab you can find:

- Information about checkback, binary input 1 and binary input 2
- Information about limit status

There is an additional 'Detailed status' button in which you can obtain detailed device diagnostics 1 and device diagnostics 2.

#### "More cockpit options" tab

You can find additional buttons in the "More cockpit options" tab:

- Min/Max temperature
- Trend charts 'Temperature' and 'Control deviation'
- Setpoint function
- Diagnostics system status
- Maintenance counter

### 10.2.3.2 Starting the lifelist

#### Application

In this menu it is possible to identify active field devices without configuring. Use 'Lifelist' to carry out a scan on one of the following PDM objects:

- PROFIBUS DP network
- PROFIBUS PA network
- HART modem network
- Foundation Fieldbus network

### 10.2.4 'Diagnostics' menu

#### 10.2.4.1 Updating diagnostics













Use this sub-menu to update the diagnostics information in SIMATIC PDM that is visualized using symbols. The symbols are shown before the device name. Call up the function using the following button:





Figure 10-3 Updating diagnostics

The following table shows the symbols and the associated diagnostics information.

Meaning	Symbols
<b>Deactivated</b> No device description (EDD) from the device catalog has yet been assigned to the field device / Field device cannot be accessed.	
<b>Not validated</b> A device description from the device catalog has been assigned to the field device.	
<b>Communication disrupted</b> Communication error; communication has been interrupted or no communication could take place with the device at the configured address. The device cannot provide detailed diagnostics information.	
<b>Assignment error</b> The field device is incompatible with the configured field device or the device has been configured incorrectly. The device cannot provide detailed diagnostics information.	
<b>Maintenance alarm</b> Maintenance is required immediately as there is a device fault.	

Meaning	Symbols
<p><b>Maintenance demand</b></p> <p>Maintenance is required to prevent a possible device fault from occurring. Additional diagnostics information is available.</p>	
<p><b>Maintenance required</b></p> <p>Maintenance must be scheduled. No functional restriction has been diagnosed for the field device, service is requested. Additional diagnostics information is available.</p>	
<p><b>Manual mode</b></p> <p>There is a communication connection with the field device. The device is in manual mode.</p>	
<p><b>Simulation mode</b></p> <p>There is a communication connection with the field device. The device is in manual mode. For example, the device is in manual mode "Out of service".</p>	
<p><b>Out of service</b></p> <p>There is a communication connection with the field device. The device is in manual mode. For example, the device is in manual mode "Out of service".</p>	
<p><b>Configuration error</b></p> <p>Field device fault due to a parameter or configuration error in the hardware components. A maintenance alarm is triggered automatically.</p>	
<p><b>Configuration warning</b></p> <p>Field device warning due to invalid parameters for which substitute values are used. A maintenance request is triggered automatically.</p>	
<p><b>Configuration changed</b></p> <p>The parameters set for the device do not match the parameter data saved in the project. Communication with the device is possible to carry out a value comparison or to change parameter settings.</p>	
<p><b>Unknown diagnostics status</b></p> <p>Unknown field device status due to invalid parameters for which substitute values are used. A maintenance request is triggered automatically.</p>	
<p><b>Process value alarm</b></p> <p>At least one process value has exceeded or fallen below a hardware interrupt limit whose parameters were assigned in the device. Communication with the device is possible.</p>	
<p><b>Process value warning</b></p> <p>At least one process value has exceeded or fallen below a process warning limit whose parameters were assigned in the device. Communication with the device is possible.</p>	
<p><b>Process value tolerance</b></p> <p>At least one process value has exceeded or fallen below a process tolerance limit whose parameters were assigned in the device. Communication with the device is possible.</p>	
<p><b>No messages</b></p> <p>No functional restrictions or diagnostics information known.</p>	

Meaning	Symbols
<p><b>No diagnostics check</b> No functional restrictions known. The field device does not support additional diagnostics information.</p>	
<p><b>Test mode (background color of diagnostics icon)</b> The device is in local test mode. All the displayed information or diagnostics may be simulated. The information transferred to the automation systems (process values and status) may also be simulated.</p>	

### 10.2.4.2 Device diagnostics

#### "Diagnostics" tab

In this "Diagnostics" tab you can find:

- Communication
- Device status
- Last test
- Message text

#### "Messages" tab

In this "Messages" tab you can find:

- Device status
- Checkback
- Limit status (group signal of all three-stage diagnostics events, detailed diagnostics events can be found under the "Device diagnostics" tab)
- Binary input 1
- Binary input 2

#### "Device diagnostics" tab

In this "Device diagnostics" tab you can find:

- Device diagnostics 1
- Device diagnostics 2
- Quality
- Status



### 10.2.4.3 Maintenance information

#### "Current" tab

In this "Current" tab you can find information about the values of the positioner which were determined during the last initialization. The following values are displayed:

- Manipulated variable zero point / upper endstop
- Travel time UP / DOWN
- Impulse length UP / DOWN
- Deadband UP / DOWN
- Slow step zone UP / DOWN
- Determined actuator travel
- Leakage

The 'Save maintenance information (last maintenance)' button requests you to enter a maintenance date. The current values are saved in the positioners and in the "Last maintenance" tab. The values can be used as reference values in the "Last maintenance" tab for comparison purposes during subsequent reinitialization of the positioner.

Use the 'Reset maintenance information' button to reset the maintenance date to '01.01.2000'. This date informs the positioner that no maintenance has been carried out yet.

#### "Last maintenance" tab

In this "Last maintenance" tab, you can find the values which have been saved from the "Current" tab. These values include a save date.

#### "Maintenance counter" tab

In this "Maintenance counter" tab, you can find an overview of the number of:

- 100% strokes
- Changes of direction
- Fault messages
- Alarms
- Operating hours
- Switching cycles

Press the 'Reset maintenance counter' button to access a selection menu to reset all maintenance counters at one go or individually.

#### "Temperature" tab

This "Temperature" tab displays the minimum, current and maximum temperatures [Temperature/°C] as a bar graph and as a trend.

#### 10.2.4.4 Trend characteristic

##### Application

The temporal course of the corresponding measured variable over the selected interval is shown in a trend characteristic. The trend characteristic provides an overview of the previous development of the measured value and can be used as the basis to estimate the future course.

If sufficient measured values are available, trends over the last 30 minutes, eight hours, five days, two months and 30 months can be processed.

You can use the menu item "Trend charts" to display trends of the following sub-menus:

- Actual value
- Control deviation
- Leakage
- Stiction (slipstick)
- Zero point
- Upper endstop
- Temperature
- Deadband

#### 10.2.4.5 Histograms

##### Application

A class division over the entire measuring range of a variable is included in a histogram. The time spent by the measured variable within different classes is also displayed.

You can use the position histogram to assess whether a control valve has been designed practically and whether it was essentially in the expected operating point during its use so far.

You can use the menu item "Histograms" to display histograms of the following sub-menus:

- Position
- Control deviation
- Temperature

#### 10.2.4.6 Alarm logbook

##### Application

You can use the menu item "Alarm logbook" to display information about the time stamp, operating hours, interrupts and status.

### 10.2.4.7 Characteristic curve

#### Characteristic curve

The characteristic curves of devices are displayed here if it has been set to "free (user-defined)".

If tight closing is active, the tight closing limits are also displayed irrespective of the setting of the characteristic curve.

## 10.3 Cyclic data transfer

The cyclic data transfer is used to transfer the useful data relevant for the process automation between the class 1 master (control or automation system) and the positioner.

### 10.3.1 Configuration

#### Configuring with the GSD

Information about input and output ranges as well as the consistency of the cyclically transferred data is defined in the GSD file that is used by the device to check the configuration telegram and to declare it as valid if required.

The useful data to be transferred in the cyclic operation is determined during the projecting planning. The data volume to be transferred can thus be optimized. The GSD files of all common devices are already stored in the Siemens control systems. GSD files can be imported later. You can download the GSD files from:

[www.siemens.de/sipartps2](http://www.siemens.de/sipartps2)

Under "More Info", click on "→ Downloads".

#### Configuring the useful data

The useful data made available to the control system or the controller through PROFIBUS depends on the selected desired configuration.

---

#### Note

##### Configuration tool

In case of STEP 7, the configuration tool used is HW config.

---

10.3 Cyclic data transfer

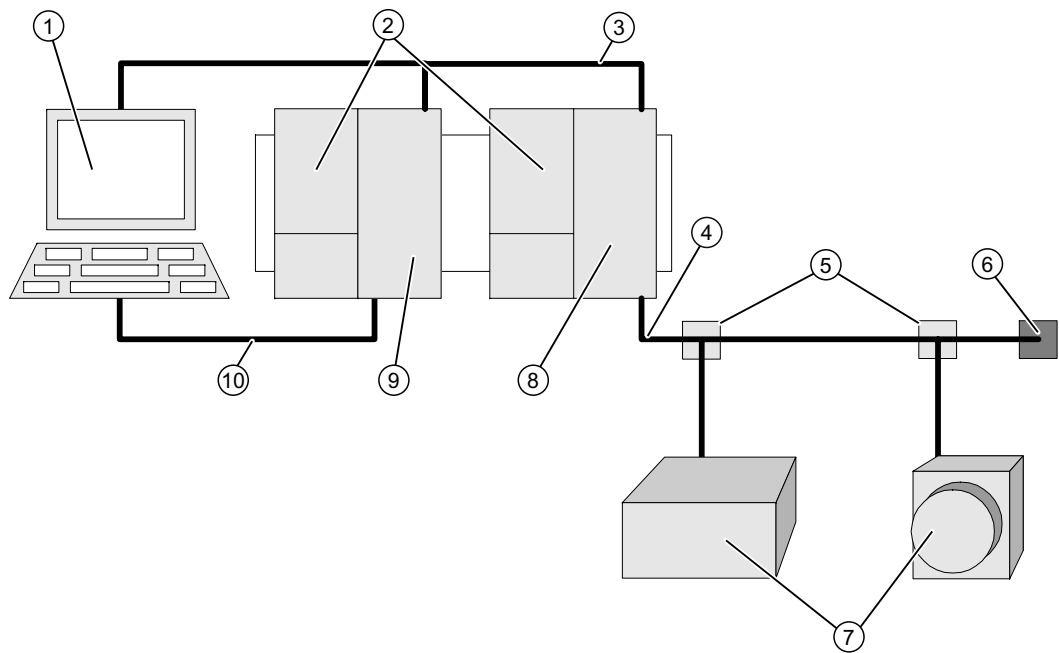

Figure 10-4 Example of a small PROFIBUS DP/PA system

- |                             |   |
|-----------------------------|---|
| ① PC or PG (master class 2) | ⑦ PA devices  |
| ② Power supply              | ⑧ DP/PA coupler/link                                    |
| ③ PROFIBUS DP               | ⑨ CPU SIMATIC S7 (master class 1)                       |
| ④ PROFIBUS PA               | ⑩ MPI cable (required for commissioning and monitoring) |
| ⑤ Splitter                  |   |
| ⑥ Bus terminator            |   |

A small STEP 7 program that establishes cyclic exchange with the positioner using PROFIBUS PA (positioner) is given below.

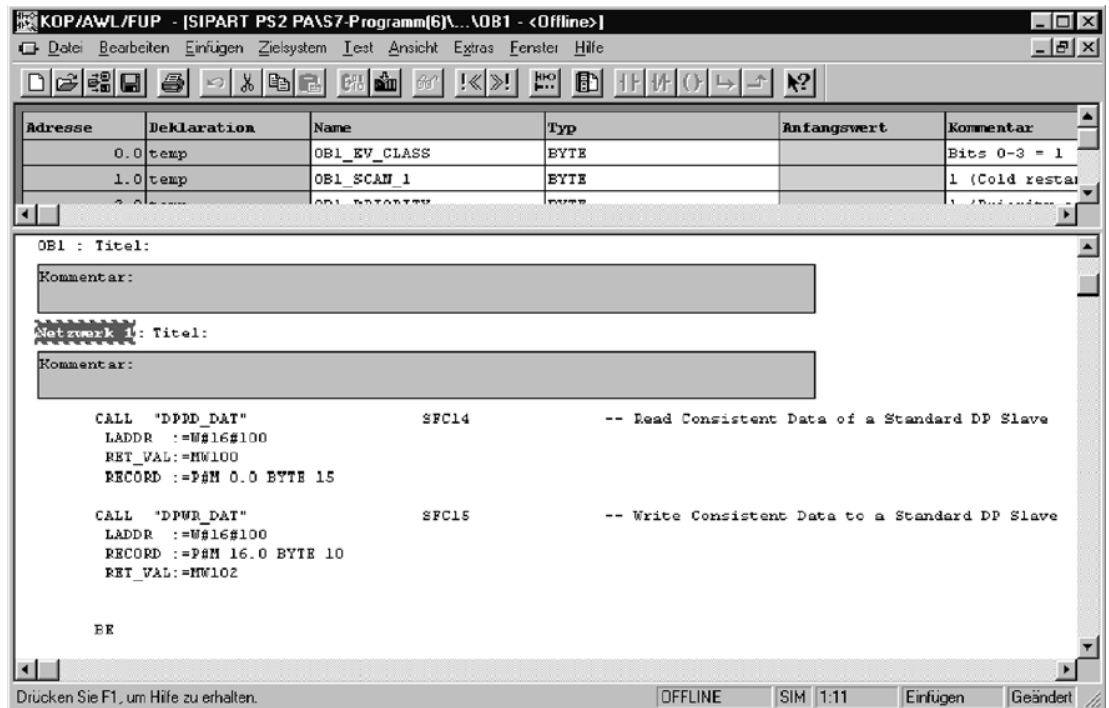

Figure 10-5 STEP 7 sample program

In this example, all data in the input and output directions supported by the device are transferred. The selected peripheral starting address is 256 (W#16#100).

**Note**

Only the older SIMATIC CPUs require the SFC14 and SFC16 modules for consistent reading and writing.

Legend of the sample program			
Byte	Function	Composition	Number of bytes
Byte 15	Input data	READBACK	5
		RCAS_OUT	5
		CHECKBACK	3
		POS_D	2
Byte 10	Output data	SP	5
		RCAS_IN	5

### 10.3.2 Useful data through PROFIBUS

#### Cyclic useful data

The positioner can exchange a combination of the following cyclic useful data through PROFIBUS:

Name		Abbreviation	Direction from the positioner's point of view	Length in byte	Comprising:
German	English				
Setpoint	Setpoint	SP	Input	5	Value/Status
Readback	Readback	RB	Output	5	Value/Status
Position discrete	Position discrete	POS_D	Output	2	Value/Status
Checkback	Checkback	CB	Output	3	Value
Remote Cascade Input	Remote Cascade Input	RCAS_IN	Input	5	Value/Status
Remote Cascade Output	Remote Cascade Output	RCAS_OUT	Output	5	Value/Status

#### Setpoint

The setpoint is divided into a floating point value (4 bytes) and the corresponding status (1 byte, see further below).

#### Actual value

The actual value indicates the valve position. The actual value is divided into a floating point value (4 bytes) and the corresponding status (1 byte).

#### Position discrete

The discrete valve position is displayed as a value (1 byte) having the following meaning:

0 = not initialized

1 = valve closed

2 = valve open

3 = valve in the intermediate position: Even this value has a status (1 byte).

#### Checkback

The checkback is displayed in 3 bytes in a bit-coded format:

	Bit	Meaning of "1"	Remarks
0	0	Device in the fail safe position	The position is determined by the "49.FSTY" parameter.
	1	Request for on-site operation	Reports that a button has been pressed.
	2	The device is operated on-site.	The device is parameterized on-site, e.g. using the "1.YFCT" parameter or is not initialized.

	Bit	Meaning of "1"	Remarks
	3	Emergency operation active	The device is in the manual mode. Representation on the display: MAN or P
	4	Deviation of the movement direction	Not required for the positioner.
	5	End stop reached (valve completely open)	Not required for the positioner.
	6	End stop reached (valve completely closed)	Not required for the positioner.
	7	Run time overshoot	The device could not be adjusted. Monitoring time and threshold in the "44.TIM" and "45.LIM" parameters exceeded, e.g. due to the lack of compressed air
1	0	The valve is opened.	The "Ventilate actuator" command issued
	1	The valve is closed.	The "Depressurize actuator" command issued
	2	Parameters were changed.	Set temporarily after switching back from the "Configuration" mode if one or more parameters were changed.
	3	Simulation mode	The simulation mode was released. Master class 2 can overwrite the current actual value, e.g., to test the response of limits in the control system.
	4	Not occupied in profile 3.	-
	5	Fault in the closed-loop control.	Not required for the positioner.
	6	Closed-loop control inactive	Not required for the positioner.
	7	Self-monitoring active	Not required for the positioner.
2	0	Path integral exceeded	Set if the set limit for the path integral has exceeded
	1	Additional input active	Binary 1 was activated.
	2	Additional input active	Binary 2 was activated.

### Remote cascade input

The remote cascade input is used as a setpoint in the remote cascade mode (actual mode = remote cascade). The remote cascade input comprises the floating point value (4 bytes) and the status (1 byte).

### Remote cascade output

This output delivers the current setpoint in the AUTO and Remote cascade modes. The status is specially used for the transfer from AUTO to Remote cascade.

In combination with the input variable parameter (primary value scale), not only you can define the setpoints as a percentage of the valve position, but also in terms of physical variables such as cubic meter per day or liter per minute. Even the actual values are adjusted as per this scale.

#### 10.3.2.1 Possible combinations of the useful data

##### Useful data and position in the address room

You can select a combination of values for the communication of cyclic useful data between the master and the positioner:

**SP**

Setpoint:

Output (master view)		
Starting address	0	SP - floating point number
	1	
	2	
	3	
	4	SP - status

**RCAS\_OUT, RCAS\_IN**

Remote cascade output, remote cascade input:

Input (master view)		
Starting address	0	RCAS_OUT - floating point number
	1	
	2	
	3	
	4	RCAS_OUT - status

Output (master view)		
Starting address	0	RCAS_IN - floating point number
	1	
	2	
	3	
	4	RCAS_IN - status

**READBACK, POS\_D, SP**

Actual value, discrete position, setpoint:

Input (master view)		
Starting address	0	READBACK - floating point number
	1	
	2	
	3	
	4	READBACK - status
	5	POS_D
	6	POS_D - status



Output (master view)		
Starting address	0	SP - floating point number
	1	
	2	
	3	
	4	SP - status

### Checkback, SP

Checkback, setpoint:

Input (master view)		
Starting address	0	CHECKBACK
	1	
	2	

Output (master view)		
Starting address	0	SP - floating point number
	1	
	2	
	3	
	4	SP - status

### READBACK, CHECKBACK, POS\_D, SP

Actual value, discrete position, checkback, setpoint:

Input (master view)		
Starting address	0	READBACK - floating point number
	1	
	2	
	3	
	4	READBACK - status
	5	POS_D
	6	POS_D - status
	7	CHECKBACK
	8	
9		

Output (master view)		
Starting address	0	SP - floating point number
	1	
	2	
	3	
	4	SP - status

**RCAS\_OUT, CHECKBACK, RCAS\_IN**

Remote cascade output, checkback, remote cascade input:

Input (master view)		
Starting address	0	READBACK - floating point number
	1	
	2	
	3	
	4	READBACK - status
	5	POS_D
	6	POS_D - status

Output (master view)		
Starting address	0	RCAS_IN - floating point number
	1	
	2	
	3	
	4	RCAS_IN - status

**READBACK, RCAS\_OUT, POS\_D, CHECKBACK, SP, RCAS\_IN**

Actual value, remote cascade output, discrete position, checkback, setpoint, remote cascade input:

Input (master view)		
Starting address	0	READBACK - floating point number
	1	
	2	
	3	
	4	READBACK - status
	5	RCAS_OUT - floating point number
	6	
	7	
	8	
	9	RCAS_OUT - status
	10	POS_D
	11	POS_D - status
	12	CHECKBACK
	13	
	14	

Output (master view)		
Starting address	0	SP - floating point number
	1	
	2	
	3	
	4	SP - status
	5	RCAS_IN - floating point number
	6	
	7	
	8	
	9	RCAS_IN - status

**10.3.2.2 Diagnostics**

**Function**

The positioner can report active information about its device status. These diagnoses are important information that can be used by an automation system to initiate remedial measures.

Standard mechanisms of PROFIBUS-DP are used to transfer the diagnostics information and report it actively to the class 1 master. PROFIBUS-DP has a protocol to transfer the information that has higher priority than the useful data to the class 1 master.

10.3 Cyclic data transfer

The contents of the "Device status" parameter from the physical block are reported along with the information whether a status change (event received/event sent) has occurred.

**Diagnostics as per PROFIBUS DP (DDLMSlave\_Diag)**

The positioner delivers the diagnostics data in the following format:

Input (master view)			
Starting address	0	Station_status_1	
	1	Station_status_2	
	2	Station_status_3	Standard DP - diagnostics
	3	Diag_Master_Add	
	4	Ident_Number	
	5	Ident_Number	
	6	Header	
	7	Status_Type	Status coding as per DP/V1
	8	Slot_Number	
	9	Specifier	
	10	Diagnostics (0)	Diagnostics object of the physical block
	11	Diagnostics (1)	
	12	Diagnostics (2)	
	13	Diagnostics (3)	

**Specifier**

The following specifiers are available:

- 1: Incoming event
- 2: Outgoing event

**10.3.3 Adjustable status (condensed status)**

Diagnostics messages are generated in the DIAGNOSTICS physical block parameter depending on the diagnostics events in the device. At the same time, the statuses of three PowerTags (FEEDBACK\_VALUE, READBACK and POS\_D) that are sent to the master by the SIPART PS2 PA positioner are affected.

In the device, there is now an option to use diagnostics messages and predefined status messages that are permanently associated with the triggering diagnostics events. The condensed status must be deactivated for this purpose.

If the condensed status is activated, the diagnostics messages in a specific frame can be allocated to a smaller number of collective diagnostics messages and selectable status messages. This "routing" of diagnostics events is shown in the following picture.

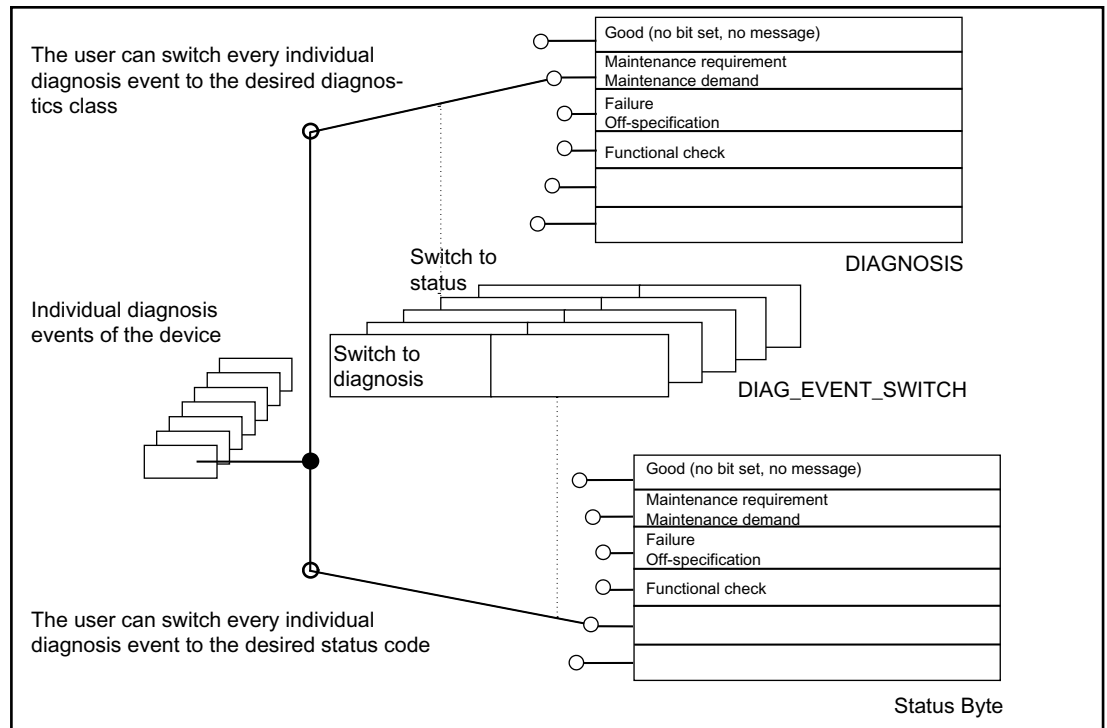

Figure 10-6 Routing of a diagnostics event

**Note**

Please note that the condensed status cannot be changed using the SIMATIC PDM when the device is in a cyclic operation with a master class 1.

10.3 Cyclic data transfer

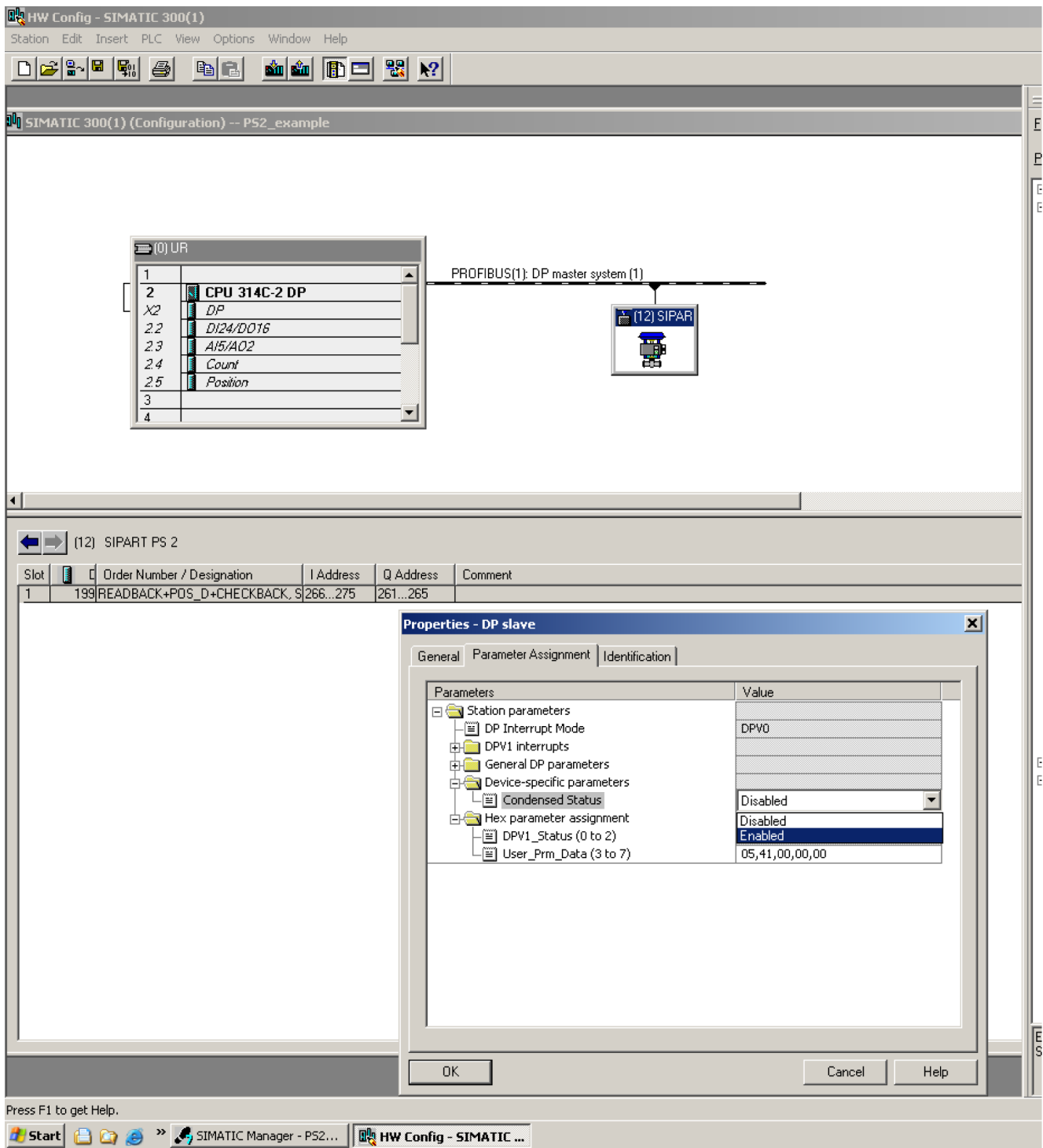

Figure 10-7 Activating the condensed status for the device parameterization - with an example of HW configuration with SIMATIC S7

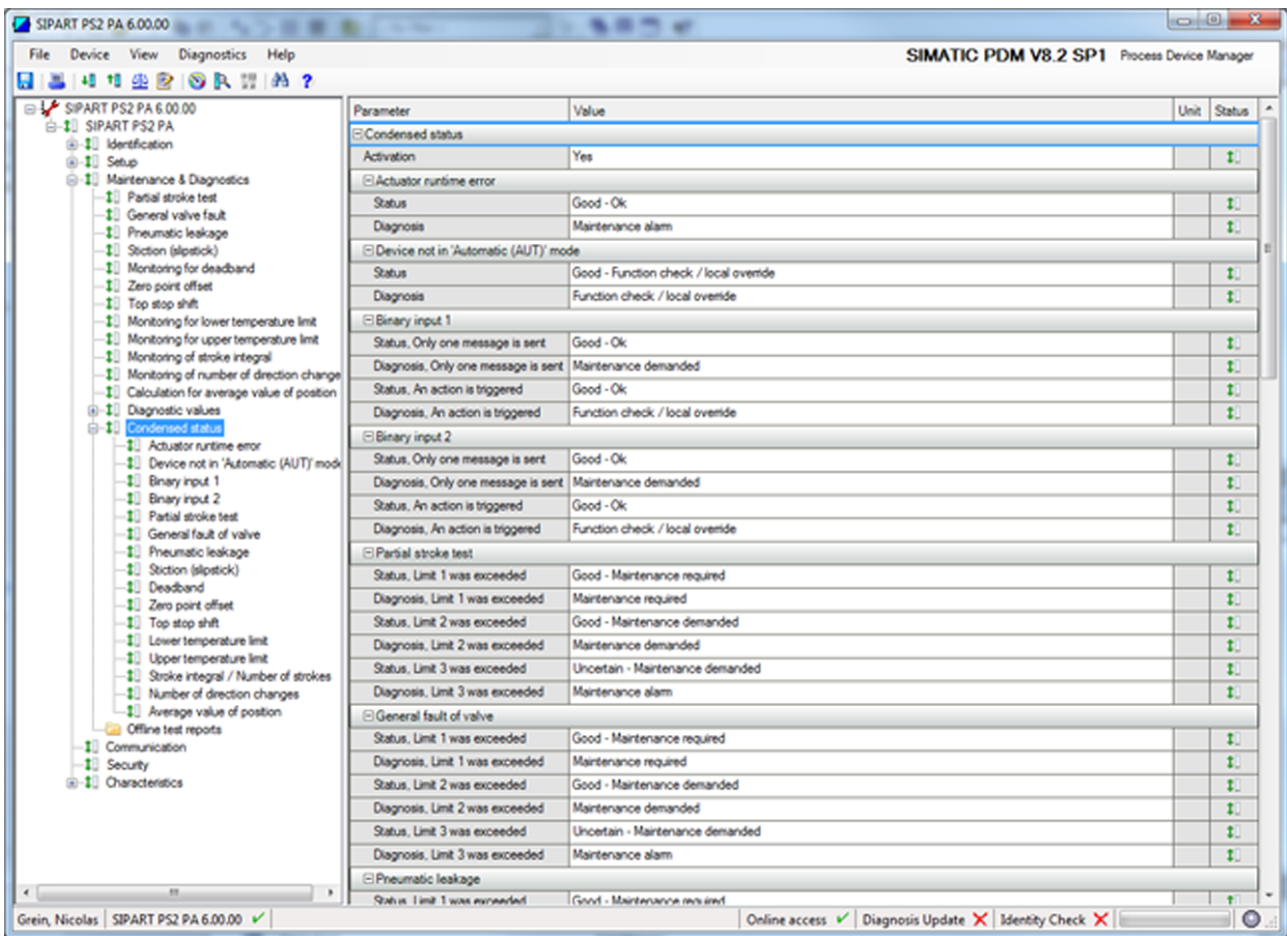

Figure 10-8 Activating the condensed status for the device parameterization - with an example of SIMATIC PDM

**10.3.3.1 Diagnostics messages in case of deactivated condensed status**

The diagnostics messages of the DIAGNOSTICS physical block parameter in case of the deactivated condensed status are shown in the following table:

Byte	Bit	Name and meaning	Cause	Measure
0	0 ... 2	Not used	-	-
	3	DIA_TEMP_ELECTR Electronic unit temperature too high	The temperature measured at the device electronic unit has exceeded one or more set thresholds.	Check why the temperature is beyond the specified range.
	4	DIA_MEM_CHKSUM Memory error	During operation, the memory is constantly checked for the checksum and write/read errors. This message is generated in case of an error.	Replace the electronic unit.
	5	Not used	-	-
	6	DIA_NOT_INIT Device not initialized	The initialization process required for the device functioning has not yet been carried out successfully.	Carry out the device initialization process.
	7	DIA_INIT_ERR Error in initialization	Values obtained during the initialization process cannot be used.	Carry out the device initialization process again. Check the relevant parameter settings.



Byte	Bit	Name and meaning	Cause	Measure
1	0	DIA_ZERO_ERR Lower end stop beyond the tolerance	The lower end stop is beyond the set tolerance.	Check the valve. Flow restrictors and/or the seat ring are probably worn out.
	1	DIA_SUPPLY Error in the compressed air supply	A run time overshoot was detected. In all probability, the energy (compressed air) is not available.	Establish the compressed air supply and check the feed lines.
	2	Not used	-	-
	3	DIA_WARMSTART Warm restart executed (goes to "0" after 10 s)	Power was fed to the device.	Check the cabling and the supply unit.
			SIMATIC PDM was used to trigger a warm restart.	
			The internal watchdog has responded.	
	4	DIA_COLDSTART Restart executed (goes to "0" after 10 s)	The device was reset to factory settings.	-
	5	DIA_MAINTENANCE Maintenance required	To determine the cause, check in DIAGNOSTICS_EXTENSION and DIAGNOSTICS_EXTENSION_2 which diagnostics event has triggered the message.	Depends on the triggering diagnostics event.
6	DIA_CHARACTER Characteristic curve invalid	The parameterized characteristic curve does not have the required monotony, number of support points, or the x values are not arranged in 5% distances. The original characteristic curve is used further.	Modify the configuration data (change the GSD) such that it is consistent with the identification number set in the device.	
7	IDENT_NUMBER_VIOLATION Identification number changed	You have changed the PROFIBUS identification number parameter during the active cyclic operation. The device reports the identification number violation and displays a failure warning. In case of a warm restart, the device no longer participates in the cyclic transfer of useful data without changing the system configuration.	Modify the configuration data (change the GSD) such that it is consistent with the identification number set in the device.	
2	0 ... 7	Reserved	-	-
3	0 ... 6	Reserved	-	-
	7	EXTENSION_AVAILABLE Extension available	Further information about the triggering diagnostics event is available in DIAGNOSTICS_EXTENSION and DIAGNOSTICS_EXTENSION_2.	-

### 10.3.3.2 Diagnostics messages in case of activated condensed status

#### Thematic classification

Collective diagnosis messages of the DIAGNOSIS physical block parameter when the condensed status is activated are given below. The Group column contains a thematic classification of diagnostics messages. The same meaning is also used for status messages:

**Maintenance:**

M1	MAINTENANCE REQUIRED
M12	MAINTENANCE REQUIRED, MAINTENANCE DEMAND
M	MAINTENANCE REQUIRED, MAINTENANCE DEMAND, MAINTENANCE ALARM

**Process-dependent:**

P	PROCESS RELATED
---	-----------------

**Function check:**

F	FUNCTION CHECK
---	----------------

#### Collective diagnostics messages

Collective diagnostics messages in the case of the activated condensed status are shown in the following table:

Byte	Bit	Name and meaning	Cause	Measures	Group
0	0 ... 7	Reserved	-	-	-
1	0 ... 2	Reserved	-	-	-
	3	DIA_WARMSTART Warm restart executed (goes to "0" after 10 s)	To determine the cause, check in DIAGNOSIS_EXTENSION and DIAGNOSIS_EXTENSION_2 which diagnosis event has triggered the message.	Check the wiring and the supply voltage.	-
	4	DIA_COLDSTART Restart executed (goes to "0" after 10 s)	-	-	-
	5	DIA_MAINTENANCE Maintenance required	You have changed the PROFIBUS identification number parameter during the active cyclic operation. The device reports the identification number violation and displays a failure warning. In case of a restart, the device will no longer participate in cyclic user data exchange unless the system configuration is changed.	Depends on the triggering diagnostics event.	M1, M12, M
	6	Reserved	-	-	-
	7	IDENT_NUMBER_VIOLATION Identification number changed	To determine the cause, check in DIAGNOSIS_EXTENSION and DIAGNOSIS_EXTENSION_2 which diagnosis event has triggered the message.	Modify the configuration data (change the GSD) such that it is consistent with the identification number set in the device.	-
2	0	DIA_MAINTENANCE_ALARM Maintenance alarm	To determine the cause, check in DIAGNOSIS_EXTENSION and DIAGNOSIS_EXTENSION_2 which diagnosis event has triggered the message.	Depends on the triggering diagnostics event.	M
	1	DIA_MAINTENANCE_DEMANDED Maintenance demand	To determine the cause, check in DIAGNOSIS_EXTENSION and DIAGNOSIS_EXTENSION_2 which diagnosis event has triggered the message.	Depends on the triggering diagnostics event.	M12, M
	2	DIA_FUNCTION_CHECK Function check	The device is in on-site operation or the FEEDBACK_VALUE is simulated	-	F
	3	DIA_INV_PRO_COND Invalid process conditions	To determine the cause, check in DIAGNOSIS_EXTENSION and DIAGNOSIS_EXTENSION_2 which diagnosis event has triggered the message.	Depends on the triggering diagnostics event.	P
	4 ... 7	Reserved	-	-	-

10.3 Cyclic data transfer

Byte	Bit	Name and meaning	Cause	Measures	Group
3	0 ... 6	Reserved	-	-	-
	7	EXTENSION_AVAILABLE Extension available	Further information about the triggering diagnosis event is available in DIAGNOSIS_EXTENSION and DIAGNOSIS_EXTENSION_2.	-	-

10.3.3.3 Definition of the status

Status byte

The status is used to provide information about the quality of the input and output values. This information is classified into four stages. Quality stages such as "Bad", "Uncertain", "Good" and "Good (cascade)" are accompanied with further information. In this case, it deals with the sub-status and the limit bits. The status byte has the following structure:

Status byte structure							
7	6	5	4	3	2	1	0
Quality		Sub-status				Limit bits	

- Quality
  - 00 Bad
  - 01 Uncertain
  - 10 Good
  - 11 Good (cascade)
  
- Limit bits
  - 00 Good
  - 01 Lower limit reached
  - 10 Upper limit reached
  - 11 Value is constant.

The meaning of the sub-status depends on whether the condensed status is activated or not. The sub-status is therefore specified separately for both the cases.

10.3.3.4 Sub-status for deactivated condensed status

Bit								Name profile	German name
7	6	5	4	3	2	1	0		
0	0	0	0	0	0	x	x	Bad, non specific	Schlecht
0	0	0	0	0	1	x	x	Bad, configuration error	Schlecht, Konfigurationsfehler
0	0	0	0	1	0	x	x	Bad, not connected	Schlecht, keine Verbindung
0	0	0	0	1	1	x	x	Bad, device failure	Schlecht, Gerätefehler
0	0	0	1	0	0	x	x	Bad, sensor failure	Schlecht, Sensorfehler

Bit								Name profile	German name
7	6	5	4	3	2	1	0		
0	0	0	1	1	1	x	x	Bad, out of service	Schlecht, Außer Betrieb
0	1	0	0	0	0	x	x	Uncertain, non specific	Unsicher
0	1	0	1	0	0	x	x	Uncertain, sensor conversion not accurate	Unsicher, Wert ungenau
0	1	0	1	1	1	x	x	Uncertain, configuration error	Unsicher, Konfigurationsfehler
0	1	1	0	0	0	x	x	Uncertain, simulated value	Unsicher, Simulationswert
1	0	0	0	0	0	x	x	Good, ok	Gut, Ok
1	0	0	0	0	1	x	x	Good, update event	Gut, Aktiver Blockalarm
1	0	1	0	0	1	x	x	Good, maintenance required	Gut, Instandhaltungsbedarf
1	1	0	0	0	0	x	x	Good (Cascade), ok	Gut (Kaskade), Ok
1	1	0	0	0	1	x	x	Good (Cascade), initialisation acknowledged	Gut (Kaskade), Initialisierung bestätigt
1	1	0	0	1	0	x	x	Good (Cascade), initialisation request	Gut (Kaskade), Initialisierung angefordert
1	1	0	0	1	1	x	x	Good (Cascade), not invited	Gut (Kaskade), Nicht eingeladen
1	1	0	1	1	0	x	x	Good (Cascade), local override	Gut (Kaskade), Vor-Ort-Bedienung
1	1	1	0	0	0	x	x	Good (Cascade), initiate fail safe	Gut (Kaskade), Sicherheitsstellung anfahren

### 10.3.3.5 Sub-status for activated condensed status

Bits								Name		Group
7	6	5	4	3	2	1	0	Profile	German	
0	0	1	0	0	1	x	x	Bad, maintenance alarm	Schlecht, Instandhaltungsalarm	M
0	0	1	0	1	0	x	x	Bad, process related, no maintenance	Schlecht, Prozess-Störung, kein Wartungsbedarf	P
0	0	1	1	1	1	x	x	Bad, function check /local override; value not usable	Schlecht, Funktion überprüfen / Handbetrieb	F
0	1	1	0	1	0	x	x	Uncertain, maintenance demand	Uncertain, maintenance demand	M
0	1	1	1	1	0	x	x	Uncertain, process related, no maintenance	Unsicher, Prozess-Störung, kein Wartungsbedarf	P
1	0	0	0	0	0	x	x	Good, ok	Gut, Ok	-
1	0	1	0	0	1	x	x	Good, maintenance required	Gut, Instandhaltungsbedarf	M1, M12, M
1	0	1	0	1	0	x	x	Good, maintenance demand	Good, maintenance requirement	M12, M
1	0	1	1	1	1	x	x	Good, function check	Gut, Funktion überprüfen / Handbetrieb	F

### 10.3.3.6 List of diagnostics events with status and diagnostics message for deactivated condensed status

A list of diagnostics events with status and diagnostics message for deactivated condensed status is given in the following table. DIAGNOSTICS\_EXTENSION and DIAGNOSTICS\_EXTENSION\_2 are physical block parameters.

**DIAGNOSTICS\_EXTENSION physical block parameter**

Byte	Bit	No.	Diagnostics events	Hard-coded effect of a diagnostics event	
				Quality status code	DIAGNOSTICS bit
0	0	1	Run time error of the actuator	Bad, maintenance requirement	DIA_SUPPLY
	1	2	The device is not in the "Automatic mode"	Uncertain, simulation value	None
	2	3	Binary 1 is active (only message)	Good, maintenance required	DIA_MAINTENANCE
	3	4	Action triggered by binary input 1	Uncertain, simulation value	None
	4	5	Binary 2 is active (only message)	Good, maintenance required	DIA_MAINTENANCE
	5	6	Action triggered by binary input 2	Uncertain, simulation value	None
		7 ... 21	Reserved	-	-
2	5	22	Limit for alarm A1 exceeded	Good, maintenance required	DIA_MAINTENANCE
	6	23	Limit for alarm A2 exceeded	Good, maintenance required	DIA_MAINTENANCE
	7	24	Error in the device electronic unit	Bad, device error	DIA_MEM_CHKSUM
3	0	25	The device is not yet ready for operation (not initialized)	Bad, configuration error	DIA_NOT_INIT
	1	26	The device is not yet ready for operation (initialization error)	Bad, configuration error	DIA_INIT_ERR
	3	27	Reserved	-	-
	3	28	Reserved	-	-
	4	29	Device in the Manual mode (FB in the Manual mode)	Depends on the set status	None
	5	30	Device in the Simulation mode (FEEDBACK is simulated)	Depends on the simulated status	None
	6	31	Device in the TRACE mode	-	None
	7	32	Diagnostics simulation (diagnostics events are simulated)	Depends on the simulated diagnostics event	Depends on the simulated diagnostics event
	33 ... 48	Reserved	-	-	

**DIAGNOSTICS\_EXTENSION\_2 physical block parameter**

Byte	Bit	No.	Diagnostics events	Hard-coded effect of a diagnostics event	
				Quality status code	DIAGNOSTICS bit
0	0	49	General control valve fault (limit 1)	Good, maintenance required	DIA_MAINTENANCE
	1	50	General control valve fault (limit 2)	Good, maintenance required	DIA_MAINTENANCE
	2	51	General control valve fault (limit 3)	Good, maintenance required	DIA_MAINTENANCE
	3	52	Pneumatic leakage (limit 1)	Good, maintenance required	DIA_MAINTENANCE
	4	53	Pneumatic leakage (limit 2)	Good, maintenance required	DIA_MAINTENANCE
	5	54	Pneumatic leakage (limit 3)	Good, maintenance required	DIA_MAINTENANCE
	6	55	Static friction (limit 1)	Good, maintenance required	DIA_MAINTENANCE
	7	56	Static friction (limit 2)	Good, maintenance required	DIA_MAINTENANCE
1	0	57	Static friction (limit 3)	Good, maintenance required	DIA_MAINTENANCE
	1	58	Lower end stop monitoring (limit 1)	Good, maintenance required	DIA_ZERO_ERR
	2	59	Lower end stop monitoring (limit 2)	Good, maintenance required	DIA_ZERO_ERR
	3	60	Lower end stop monitoring (limit 3)	Good, maintenance required	DIA_ZERO_ERR
	4	61	Upper end stop monitoring (limit 1)	Good, maintenance required	DIA_ZERO_ERR
	5	62	Upper end stop monitoring (limit 2)	Good, maintenance required	DIA_MAINTENANCE
	6	63	Upper end stop monitoring (limit 3)	Good, maintenance required	DIA_MAINTENANCE
	7	64	Limit 1 for path integral (100% strokes) exceeded	Good, maintenance required	DIA_MAINTENANCE
2	0	65	Limit 2 for path integral (100% strokes) exceeded	Good, maintenance required	DIA_MAINTENANCE
	1	66	Limit 3 for path integral (100% strokes) exceeded	Good, maintenance required	DIA_MAINTENANCE
	2	67	Limit 1 for changes of direction exceeded	Good, maintenance required	DIA_MAINTENANCE
	3	68	Limit 2 for changes of direction exceeded	Good, maintenance required	DIA_MAINTENANCE
	4	69	Limit 3 for changes of direction exceeded	Good, maintenance required	DIA_MAINTENANCE
	5	70	Limit 1 for position average exceeded	Good, maintenance required	DIA_MAINTENANCE
	6	71	Limit 2 for position average exceeded	Good, maintenance required	DIA_MAINTENANCE
	7	72	Limit 3 for position average exceeded	Good, maintenance required	DIA_MAINTENANCE

10.3 Cyclic data transfer

Byte	Bit	No.	Diagnostics events	Hard-coded effect of a diagnostics event	
				Quality status code	DIAGNOSTICS bit
3	0	73	PST reference time exceeded (limit 1)	Good, maintenance required	DIA_MAINTENANCE
	1	74	PST reference time exceeded (limit 2)	Good, maintenance required	DIA_MAINTENANCE
	2	75	PST reference time exceeded (limit 3)	Good, maintenance required	DIA_MAINTENANCE
		76 ... 80	Reserved	-	-
4	0	81	Permissible device temperature exceeded (limit 1)	Good, maintenance required	DIA_TEMP_ELECTR
	1	82	Permissible device temperature exceeded (limit 2)	Good, maintenance required	DIA_TEMP_ELECTR
	2	83	Permissible device temperature exceeded (limit 3)	Good, maintenance required	DIA_TEMP_ELECTR
	3	84	Permissible device temperature undershot (limit 1)	Good, maintenance required	DIA_TEMP_ELECTR
	4	85	Permissible device temperature undershot (limit 2)	Good, maintenance required	DIA_TEMP_ELECTR
	5	86	Permissible device temperature undershot (limit 3)	Good, maintenance required	DIA_TEMP_ELECTR
	6	87	Limit for dead zone monitoring exceeded	Good, maintenance required	DIA_TEMP_ELECTR
		88 ... 96	Reserved	-	-

**10.3.3.7 List of diagnostics events with status and diagnostics message for activated condensed status**

A list of diagnostics events with status and diagnostics message for activated condensed status is given in the following table. DIAGNOSTICS\_EXTENSION and DIAGNOSTICS\_EXTENSION\_2 are physical block parameters.

Different status and diagnostics messages can be allocated to individual diagnostics events as per the following tables. The frame in which an allocation is possible is defined by the group in the selection column. The following principle is used: in case of three-stage diagnostics events of the MAINTENANCE group, the effect of the higher level events can be downgraded, but that of the lower level events cannot be upgraded.



**DIAGNOSTICS\_EXTENSION physical block parameter**

Byte	Bit	No.	Diagnostics events	Effect of the event <sup>1)</sup>		Group
				Quality status code	DIAGNOSTICS bit	
0	0	1	Run time error of the actuator	Good, Ok	DIA_MAINTENANCE_ALARM	M
	1	2	The device is not in the "Automatic mode"	Good, check function / manual mode	DIA_FUNCTION_CHECK	F
	2	3	Binary 1 is active (only message)	Good, Ok	DIA_MAINTENANCE_DEMANDED	M, F, P
	3	4	Action triggered by binary input 1	Good, Ok	DIA_FUNCTION_CHECK	M, F, P
	4	5	Binary 2 is active (only message)	Good, Ok	DIA_MAINTENANCE_DEMANDED	M, F, P
	5	6	Action triggered by binary input 2	Good, Ok	DIA_FUNCTION_CHECK	M, F, P
		7 ... 21	Reserved	-	-	-
2	5	22	Limit for alarm A1 exceeded	Good, maintenance requirement	DIA_MAINTENANCE	None, hard-coded
	6	23	Limit for alarm A2 exceeded	Good, maintenance requirement	DIA_MAINTENANCE	None, hard-coded
	7	24	Error in the device electronic unit	Bad, maintenance requirement	DIA_MAINTENANCE_ALARM	None, hard-coded
3	0	25	The device is not yet ready for operation (not initialized)	Bad, maintenance requirement	DIA_MAINTENANCE_ALARM	None, hard-coded
	1	26	The device is not yet ready for operation (initialization error)	Bad, maintenance requirement	DIA_MAINTENANCE_ALARM	None, hard-coded
	3	27	Reserved	-	-	-
	3	28	Reserved	-	-	-
	4	29	Device in the Manual mode (FB in the Manual mode)	-	DIA_FUNCTION_CHECK	None, hard-coded
	5	30	Device in the Simulation mode (FEEDBACK is simulated)	Depends on the simulated status	DIA_FUNCTION_CHECK	None, hard-coded
	6	31	Device in the TRACE mode	-	DIA_FUNCTION_CHECK	None, hard-coded
	7	32	Diagnostics simulation (diagnostics events are simulated)	Depends on the simulated diagnostics event	Depends on the simulated diagnostics event	-
		33 ... 48	Reserved	-	-	-

<sup>1)</sup> Effects of the event can be set using the DIAG\_EVENT\_SWITCH or DIAG\_EVENT\_SWITCH\_2 parameters (default settings in this case)

**DIAGNOSTICS\_EXTENSION\_2 physical block parameter**

Byte	Bit	No.	Diagnostics events	Effect of the event <sup>1)</sup>		Group
				Quality status code	DIAGNOSTICS bit	
0	0	49	General control valve fault (limit 1)	Good, maintenance requirement	DIA_MAINTENANCE	M1
	1	50	General control valve fault (limit 2)	Good, maintenance requirement	DIA_MAINTENANCE_DEMANDED	M12
	2	51	General control valve fault (limit 3)	Uncertain, maintenance demand	DIA_MAINTENANCE_ALARM	M
	3	52	Pneumatic leakage (limit 1)	Good, maintenance requirement	DIA_MAINTENANCE	M1
	4	53	Pneumatic leakage (limit 2)	Good, maintenance demand	DIA_MAINTENANCE_DEMANDED	M12
	5	54	Pneumatic leakage (limit 3)	Uncertain, maintenance demand	DIA_MAINTENANCE_ALARM	M
	6	55	Static friction (limit 1)	Good, maintenance requirement	DIA_MAINTENANCE	M1
	7	56	Static friction (limit 2)	Good, maintenance demand	DIA_MAINTENANCE_DEMANDED	M12
1	0	57	Static friction (limit 3)	Uncertain, maintenance demand	DIA_MAINTENANCE_ALARM	M
	1	58	Lower end stop monitoring (limit 1)	Good, maintenance requirement	DIA_MAINTENANCE	M1
	2	59	Lower end stop monitoring (limit 2)	Good, maintenance demand	DIA_MAINTENANCE_DEMANDED	M12
	3	60	Lower end stop monitoring (limit 3)	Uncertain, maintenance demand	DIA_MAINTENANCE_ALARM	M
	4	61	Upper end stop monitoring (limit 1)	Good, maintenance requirement	DIA_MAINTENANCE	M1
	5	62	Upper end stop monitoring (limit 2)	Good, maintenance demand	DIA_MAINTENANCE_DEMANDED	M12
	6	63	Upper end stop monitoring (limit 3)	Uncertain, maintenance demand	DIA_MAINTENANCE_ALARM	M
	7	64	Limit 1 for path integral (100% strokes) exceeded	Good, maintenance requirement	DIA_MAINTENANCE	M1

Byte	Bit	No.	Diagnostics events	Effect of the event <sup>1)</sup>		
				Quality status code	DIAGNOSTICS bit	Group
2	0	65	Limit 2 for path integral (100% strokes) exceeded	Good, maintenance demand	DIA_MAINTENANCE_DEMANDED	M12
	1	66	Limit 3 for path integral (100% strokes) exceeded	Uncertain, maintenance demand	DIA_MAINTENANCE_ALARM	M
	2	67	Limit 1 for changes in direction exceeded	Good, maintenance requirement	DIA_MAINTENANCE	M1
	3	68	Limit 2 for changes of direction exceeded	Good, maintenance demand	DIA_MAINTENANCE_DEMANDED	M12
	4	69	Limit 3 for changes of direction exceeded	Uncertain, maintenance demand	DIA_MAINTENANCE_ALARM	M
	5	70	Limit 1 for position average exceeded	Good, maintenance requirement	DIA_MAINTENANCE	M1, P
	6	71	Limit 2 for position average exceeded	Good, maintenance demand	DIA_MAINTENANCE_DEMANDED	M12, P
	7	72	Limit 3 for position average exceeded	Uncertain, maintenance demand	DIA_MAINTENANCE_ALARM	M, P
3	0	73	PST reference time exceeded (limit 1)	Good, maintenance requirement	DIA_MAINTENANCE	M1
	1	74	PST reference time exceeded (limit 2)	Good, maintenance demand	DIA_MAINTENANCE_DEMANDED	M12
	2	75	PST reference time exceeded (limit 3)	Uncertain, maintenance demand	DIA_MAINTENANCE_ALARM	M
		76 ... 80	Reserved	-	-	-

10.3 Cyclic data transfer

Byte	Bit	No.	Diagnostics events	Effect of the event <sup>1)</sup>		
				Quality status code	DIAGNOSTICS bit	Group
4	0	81	Permissible device temperature exceeded (limit 1)	Uncertain, process fault, no maintenance required	DIA_INV_PRO_COND	M1, P
	1	82	Permissible device temperature exceeded (limit 2)	Uncertain, process fault, no maintenance required	DIA_INV_PRO_COND	M12, P
	2	83	Permissible device temperature exceeded (limit 3)	Uncertain, process fault, no maintenance required	DIA_INV_PRO_COND	M, P
	3	84	Permissible device temperature undershot (limit 1)	Uncertain, process fault, no maintenance required	DIA_INV_PRO_COND	M1, P
	4	85	Permissible device temperature undershot (limit 2)	Uncertain, process fault, no maintenance required	DIA_INV_PRO_COND	M12, P
	5	86	Permissible device temperature undershot (limit 3)	Uncertain, process fault, no maintenance required	DIA_INV_PRO_COND	M, P
	6	87	Limit for dead zone monitoring exceeded	Uncertain, maintenance demand	DIA_MAINTENANCE_ALARM	M
		88 ... 96	Reserved	-	-	-

<sup>1)</sup> Effects of the event can be set using the DIAG\_EVENT\_SWITCH or DIAG\_EVENT\_SWITCH\_2 parameters (default settings in this case)

## Alarm, fault and system messages

### 11.1 Output of system messages in the display

#### 11.1.1 System messages during operation

Remarks about the tables:

nn Stands for variable numeric values

⌋ Error symbol

/ (slash): the texts on the left and right of the slash flash alternately

#### Messages during operation

Message	Line		Operating mode			Meaning/cause	Measure
	Up	Bot- tom	Automat- ic	Manual mode	P man- ual mode		
CPU START	X					Message after application of electrical auxiliary power.	<ul style="list-style-type: none"> <li>Wait.</li> </ul>
HW / ER- ROR		X				Fault in the hardware.	<ul style="list-style-type: none"> <li>Replace electronics.</li> </ul>
NOINI		X			X	Positioner is not initialized.	<ul style="list-style-type: none"> <li>Start initialization.</li> </ul>
nnn.n	X		X	X		Actual position [in %] for initialized positioner. Flashing decimal point shows communication with a class 2 master.	
AUTnn		X	X			Automatic mode (nn = setpoint)	
MANnn		X		X		Manual mode (nn = setpoint)	<ul style="list-style-type: none"> <li>Switch to automatic mode with mode button.</li> </ul>
oFL / 127.9	X		X	X		Display range exceeded. Possible causes: <ul style="list-style-type: none"> <li>Friction clutch or</li> <li>Transmission ratio selector was moved or</li> <li>Positioner was installed on a different actuator without being re-initialized.</li> </ul>	<ul style="list-style-type: none"> <li>Offset friction clutch so that, when the actuator moves, the actual value display stays between 0.0 and 100.0, or</li> <li>transmission ratio selector, or</li> <li>Perform factory settings (Preset) and initialization.</li> </ul>
EXSTP		X	X			Actuator was stopped by the binary input.	

11.1 Output of system messages in the display

Message	Line		Operating mode			Meaning/cause	Measure
	Up	Bot- tom	Automat- ic	Manual mode	P man- ual mode		
EX UP		X	X			Actuator is moved to the upper endstop by the binary input.	
EXDWN		X	X			Actuator is moved to the lower endstop by the binary input.	
EXPSt						The partial stroke test was activated, e.g. by the binary input.	
InPSt						Cyclic partial stroke test.	
FST		X	X			Full stroke test running.	
SRT		X	X			Step response test running.	
MSRT		X	X			Multi-step response test running.	
VPT		X	X			Valve performance test running.	
LEAKR		X	X			A leakage test started by communication is running.	

11.1.2 System messages before initialization

Remarks about the tables:

- nn        Stands for variable numeric values
- ↳        Error symbol
- /        (slash): the texts on the left and right of the slash flash alternately

Messages before initialization (first commissioning)

Message	Line		Meaning / cause	Measure
	Up	Down		
CPU Start	X	X	Message after application of electrical auxiliary power	<ul style="list-style-type: none"> <li>• Maintenance</li> </ul>
Pnnn.n	X		Potentiometer voltage of a non-initialized positioner (P-manual mode) (actual position value in % of the measuring range).	<ul style="list-style-type: none"> <li>• Check whether the complete travel can be covered using the ▲ and ▼ buttons and that "P---" is never displayed.</li> <li>• Execute the initialization process.</li> </ul>
P---	X		Measuring range was exceeded, the potentiometer is in the inactive zone, the transmission ratio selector or the effective lever arm are not adjusted as per the actuator travel.	<ul style="list-style-type: none"> <li>• Switch the transmission ratio selector to 90°, especially in the case of part-turn actuators.</li> <li>• Adjust the effective lever length of linear actuators as per the measuring range.</li> </ul>
NOINI		X	Positioner is not initialized.	<ul style="list-style-type: none"> <li>• Start initialization.</li> </ul>

**See also**







Display (Page 103)

**11.1.3 System messages during initialization**

Remarks about the tables:

- nn        Stands for variable numeric values  
 †        Error symbol  
 /        (slash): the texts on the left and right of the slash flash alternately

**Messages during initialization**



Message	Line		Meaning/cause	Measure
	Up	Down		
P---	X		Measuring range was exceeded, the potentiometer is in the inactive zone, the transmission ratio selectors or the effective lever arm are not adjusted as per the actuator travel	<ul style="list-style-type: none"> <li>Switch the transmission ratio selector to 90°, especially in the case of part-turn actuators.</li> <li>Adjust the effective lever length of linear actuators as per the measuring range.</li> </ul>
RUN1		X	Initialization was started, part 1 is active (the direction of action is determined)	<ul style="list-style-type: none"> <li>Wait.</li> </ul>
RUN2		X	Initialization part 2 is active (actuator travel check and determination of endstops)	<ul style="list-style-type: none"> <li>Wait.</li> </ul>
RUN3		X	Initialization part 3 is active (determination and display of travel times)	<ul style="list-style-type: none"> <li>Wait.</li> </ul>
RUN4		X	Initialization part 4 is active (determination of the minimum controller increment length)	<ul style="list-style-type: none"> <li>Wait.</li> </ul>
RUN5		X	Initialization part 5 is active (optimization of the transient response)	<ul style="list-style-type: none"> <li>Wait until "FINSH" is displayed. Initialization was completed successfully.</li> </ul>
YEND1		X	The first end position can be approached only in case of a manual initialization	<ol style="list-style-type: none"> <li>Approach first end position using  or  key.</li> <li>Acknowledge using  key.</li> </ol>
YEND2		X	The second end position can be approached only in case of a manual initialization	<ol style="list-style-type: none"> <li>Approach second end position using  or  key.</li> <li>Acknowledge using  key.</li> </ol>

Alarm, fault and system messages

11.1 Output of system messages in the display

Message	Line		Meaning/cause	Measure
	Up	Down		
RANGE		X	The end position or the measuring span is beyond the permissible measuring range only in case of a manual initialization	<ul style="list-style-type: none"> <li>Approach a different end position using  or  key and acknowledge using  key.</li> <li>Move the friction clutch until "ok" is displayed, and then acknowledge with the  key.</li> <li>Terminate the initialization process using the  key, switch to the P-manual mode, and correct the actuator travel and the position displacement sensor.</li> </ul>
ok		x	The permissible measuring range of end positions is achieved only in case of a manual initialization	<ul style="list-style-type: none"> <li>Acknowledge with the operating mode button; the remaining steps ("RUN1" to "FINSH") execute automatically.</li> </ul>
RUN1 / ERROR		X	Error in "RUN1", no movement e.g. due to the lack of compressed air	<p>Possible causes:</p> <ul style="list-style-type: none"> <li>Insufficient supply of compressed air.</li> <li>Restrictor(s) blocked.</li> <li>Actuator does not move freely.</li> </ul> <p>Measures:</p> <ol style="list-style-type: none"> <li>Eliminate possible causes.</li> <li>Restart initialization.</li> </ol>
↳d__U		X	Bar graph display of the zero point is outside the tolerance range	<ol style="list-style-type: none"> <li>Set between "P 4.0" and "P 9.9" ( &gt;0&lt; ) using friction clutch.</li> <li>Continue using  or  key.</li> </ol>
SEt	X		Friction clutch was moved; "P 50.0" not displayed when the lever is horizontal	<ol style="list-style-type: none"> <li>In the case of linear actuators, use the  or  key to bring the lever perpendicular to the spindle.</li> <li>Briefly acknowledge using  key (initialization is continued).</li> </ol>
MIDDL		X		
↳UP >		X	"UP" tolerance range was exceeded or the inactive zone of the potentiometer was covered.	<ol style="list-style-type: none"> <li>Increase the effective lever length of the linear actuators or switch the transmission ratio selector to 90°.</li> <li>Briefly acknowledge using  key.</li> <li>Restart initialization.</li> </ol>
↳90_95		X	Possible only in case of part-turn actuators: actuator travel is not in the range between 90 and 95%	<ol style="list-style-type: none"> <li>Use the  or  key to move it in the range between 90 and 95%.</li> <li>Briefly acknowledge using  key.</li> </ol>
↳U-d>		X	"Up-Down" measuring span was undershot	<ol style="list-style-type: none"> <li>Decrease the effective lever length of the linear actuators or switch the transmission ratio selector to 33°.</li> <li>Briefly acknowledge using  key.</li> <li>Restart initialization.</li> </ol>



Message	Line		Meaning/cause	Measure
	Up	Down		
U nn.n	X		Display of the "Up" travel time	<ul style="list-style-type: none"> <li>• Wait until initialization continues in RUN4.</li> <li>• To change the travel time, interrupt the initialization process using the ▽ key.</li> <li>• Activate the leakage test using the ▲ key.</li> </ul>
D->U		X		
D nn.n	X		Display of the "Down" travel time	<ul style="list-style-type: none"> <li>• Wait until initialization continues in RUN4.</li> <li>• To change the travel time, interrupt the initialization process using the ▽ key.</li> <li>• Activate the leakage test using the ▲ key.</li> </ul>
U->d		X		
NOZZL		X	Actuator stops (the initialization process was interrupted using the "-" button when the actuation speed display was active)	<ol style="list-style-type: none"> <li>1. The travel time can be changed by adjusting the restrictor(s).</li> <li>2. Redetermine the positioning speed using the ▽ key.</li> <li>3. Continue using ▲ key.</li> </ol>
TEST	X		Leakage test active (the "+" button was pressed when the actuation speed display was active)	<ul style="list-style-type: none"> <li>• Wait for one minute.</li> </ul>
LEAKG		X		
nn.n	X		Value and unit of the result after the leakage test	<ul style="list-style-type: none"> <li>• Rectify the leakage if the value is too large.</li> <li>• Continue using ▲ key.</li> </ul>
%/MIN		X		
nn.n	X		Initialization completed successfully with the display of actuator travel or the actuator angle	<ol style="list-style-type: none"> <li>1. Briefly acknowledge using  key.</li> <li>2. Leave configuration level by long pressing of  key.</li> </ol>
FINISH		X		

**See also**

System messages before initialization (Page 246)

**11.1.4 System messages when exiting the Configuration mode**

Remarks about the tables:

nn        Stands for variable numeric values

↳        Error symbol

/        (slash): the texts on the left and right of the slash flash alternately

Messages when exiting the configuration mode:

Message	Line		Operating mode			Meaning / cause	Measure
	Up	Bot- tom	Automatic	Manual mode	P manual mode		
n.nn.nn- nn	X	X				Software version	• Maintenance
Error SLnn	X	X				Monotony interruption of the free characteristic on the setpoint turning point n	• Correct the value

11.1.5 System messages during operation

Remarks about the tables:

- nn        Stands for variable numeric values
- ↳        Error symbol
- /        (slash): the texts on the left and right of the slash flash alternately

Messages during operation:

Message	Line		Operating mode			Meaning/cause	Measure
	Top	Bot- tom	Automat- ic	Manual	P-man- ual		
CPU START	X	X				Message after application of electrical auxiliary power.	• Wait.
HW / ER- ROR		X				Fault in the hardware.	• Replace electronics.
NOINI		X			X	Positioner is not initialized.	• Start initialization.
nnn.n	X		X	X		Actual position [in %] for initialized positioner. Flashing decimal point shows communication with a class 2 master.	
AUnn		X	X			Automatic mode (nn = setpoint)	
FS --		X	X			Failsafe (the vent valve is opened). Possible causes:	
						<ul style="list-style-type: none"> <li>• No communication connection to master.</li> <li>• Target mode is at "MA".</li> <li>• Master sends a wrong status.</li> </ul>	<ul style="list-style-type: none"> <li>• Correct the station address.</li> <li>• Set the target mode with class-2 master to "Automatic".</li> <li>• Send the "0x80" status (good).</li> </ul>

11.1 Output of system messages in the display

Message	Line		Operating mode			Meaning/cause	Measure
	Top	Bot- tom	Automat- ic	Manual	P-man- ual		
FS nn		X	X			Controlled using the configured failsafe position (Cause: see above).	See above
MM nn		X	X			Positioner is in "Manual" mode.	<ul style="list-style-type: none"> <li>Set the target mode with class-2 master to "Automatic".</li> <li>Send the "0x80" status (good).</li> </ul>
MAnn				X		Manual mode (nn = setpoint)	<ul style="list-style-type: none"> <li>Switch to automatic mode using operating mode button.</li> </ul>
LO nn		X	X			Positioner is in "Local override" mode.	<ul style="list-style-type: none"> <li>Set the target mode with class-2 master to "Automatic".</li> <li>Send the "0x80" status (good).</li> </ul>
OS --	X		X	X		Positioner is in "Out of service" mode.	<ul style="list-style-type: none"> <li>Set the target mode with class-2 master to "Automatic".</li> <li>Send the "0x80" status (good).</li> </ul>
oFL / 127.9						Display range exceeded. Possible causes: <ul style="list-style-type: none"> <li>Friction clutch or</li> <li>Transmission ratio selector moved or</li> <li>Positioner was installed on a different actuator without being reinitialized</li> </ul>	<ul style="list-style-type: none"> <li>Adjust friction clutch so that when the actuator moves, the actual value display stays between 0.0 and 100.0, or</li> <li>Adjust the transmission ratio selector or</li> <li>Perform factory settings (preset) and initialization</li> </ul>
EXSTP		X	X			Actuator was stopped by the binary input.	
EX UP		X	X			Actuator is moved to the upper endstop by the binary input.	
EXDWN		X	X			Actuator is moved to the lower endstop by the binary input.	
EXPSt						The partial stroke test was activated, e.g. by a binary input.	
InPSt						Cyclic partial stroke test.	
FST		X	X			Full stroke test running.	

Message	Line		Operating mode			Meaning/cause	Measure
	Top	Bot- tom	Automat- ic	Manual	P-man- ual		
SRT		X	X			Step response test running.	
MSRT		X	X			Multi-step response test running.	
VPT		X	X			Valve performance test running.	
LEAKR		X	X			A leakage test started by communication is running.	

## 11.2 Diagnostics

### 11.2.1 Display of diagnostics values



#### Structure of the diagnostics display

The display in "Diagnostics" mode has a structure similar to that in "Configuration" mode:



- The upper line shows the value of the diagnostics variable.
- The lower line shows the number and the abbreviation of the displayed variable.

Some diagnostics value can be greater than 99999. In such a case, the display switches over to the exponential view. Example: The value "1234567" is shown as "1.23E6".

#### General procedure

1. Press all three buttons at the same time for at least 2 seconds. You are now in the diagnostics display.
2. Use the  button to select the next diagnostics value.
3. Press the  button for at least 2 seconds in order to exit the diagnostics display.

#### How to show the diagnostics values in reverse order

Press the  and  buttons simultaneously.

#### How to set values to zero

Specific values can be set to zero by pressing the  button for at least 5 seconds. The diagnostics values which can be reset are listed in the table in section "Overview of diagnostics values (Page 253)".

## 11.2.2 Saving the diagnostics values

The diagnostic values are written into a non-volatile memory every 15 minutes so that, in the event of a power failure, only the diagnostic values of the previous 15 minutes are lost. The values in the resettable parameters can be set to zero.

To do this, press the  button for at least 5 seconds.

The diagnostic values which can be reset can be found in the table in section Overview of diagnostics values (Page 253).

## 11.2.3 Overview of diagnostics values

### Explanatory notes on the following table

- The "Representable diagnostics values" column shows the factory settings for the diagnostics parameters in bold type.
- The "Properties" column shows the properties of the diagnostics parameters:
  - ① Diagnostics value can be read and reset.
  - ② Diagnostics value can be read but **not** reset.
  - ③ Diagnostics value can be read but **not** reset. A function can be executed.
  - ④ Diagnostics value can be read, manually reset, and manually changed.

### Overview of diagnostics values

No.	Abbreviation	Meaning	Representable diagnostics values	Unit	Properties
1	STRKS	Number of total strokes	<b>0 ... 4.29E9</b>	-	①
2	CHDIR	Number of changes in direction	<b>0 ... 4.29E9</b>	-	①
3	hCNT	Number of fault messages	<b>0 ... 4.29E9</b>	-	①
4	A1CNT	Number of alarms 1	<b>0 ... 4.29E9</b>	-	①
5	A2CNT	Number of alarms 2	<b>0 ... 4.29E9</b>	-	①
6	HOURS	Number of operating hours	<b>0 ... 4.29E9</b>	Hours	②
7	HOURR	Resettable operating hours counter	<b>0 ... 4.29E9</b>		①
8	WAY	Determined actuator travel	<b>0 ... 130</b>	mm or °	②
9	TUP	Travel time UP	<b>0.0 / 0 ... 1000</b>	s	②
10	TDOWN	Travel time DOWN	<b>0.0 / 0 ... 1000</b>	s	②
11	LEAK	Leakage test	- / <b>0.0 ... 100.0</b>	%/minute	③
12	PST	Monitoring of the partial stroke test	<b>OFF / ###.#, Fdlnl, notSt, SdtSt, fdtSt, notoL, Strt, StoP</b>	s for ###.#	③
13	PRPST	Time since the last partial stroke test	<b>###, notSt, Sdst, fdtSt</b>	Days	②
14	NXPST	Time until the next partial stroke test	<b>OFF / ###</b>	Days	②

Alarm, fault and system messages

11.2 Diagnostics

No.	Abbreviation	Meaning	Representable diagnostics values	Unit	Properties
15	DEVI	Dynamic control valve behavior	OFF / 0.0 ... 100.0	%	②
16	ONLK	Pneumatic leakage	OFF / 0.0 ... 100.0	-	②
17	STIC	Stiction (slipstick)	OFF / 0.0 ... 100.0	%	②
18	ZERO	Lower endstop	OFF / 0.0 .. 100.0	%	②
19	OPEN	Upper endstop	OFF / 0.0 ... 100.0	%	②
20	PAVG	Average value of position	OFF, IdLE, rEF, COMP 0.0 ... 100.0	%	②
21	P0	Potentiometer value of lower endstop (0%)	0.0 ... 100.0	%	③
22	P100	Potentiometer value of upper endstop (100%)	0.0 ... 100.0	%	③
23	IMPUP	Impulse length up	6 ... 160	ms	④
24	IMPDN	Impulse length down	6 ... 160	ms	④
25	PAUTP	Pulse interval	2 ... 28 ... 320	ms	④
26	DBUP	Deadband up	0.1 ... 10.0	%	②
27	DBDN	Deadband down	0.1 ... 10.0	%	②
28	SSUP	Slow step zone up	0.1 ... 10.0 ... 100.0	%	④
29	SSDN	Slow step zone down	0.1 ... 10.0 ... 100.0	%	④
30	TEMP	Current temperature	-50 ... 100 -58 ... 212	°C °F	②
31	TMIN	Minimum temperature (min/max pointer)	-50 ... 100 -58 ... 212	°C °F	②
32	TMAX	Maximum temperature (min/max pointer)	-50 ... 100 -58 ... 212	°C °F	②
33	T1	Number of operating hours in temperature range 1	0 ... 4.29E9	Hours	②
34	T2	Number of operating hours in temperature range 2	0 ... 4.29E9	Hours	②
35	T3	Number of operating hours in temperature range 3	0 ... 4.29E9	Hours	②
36	T4	Number of operating hours in temperature range 4	0 ... 4.29E9	Hours	②
37	T5	Number of operating hours in temperature range 5	0 ... 4.29E9	Hours	②
38	T6	Number of operating hours in temperature range 6	0 ... 4.29E9	Hours	②
39	T7	Number of operating hours in temperature range 7	0 ... 4.29E9	Hours	②
40	T8	Number of operating hours in temperature range 8	0 ... 4.29E9	Hours	②
41	T9	Number of operating hours in temperature range 9	0 ... 4.29E9	Hours	②
42	VENT1	Number of switching cycles of pilot valve 1	0 ... 4.29E9	-	②
43	VENT2	Number of switching cycles of pilot valve 2	0 ... 4.29E9	-	②
44	VEN1R	Number of switching cycles of pilot valve 1, resettable	0 ... 4.29E9	-	①
45	VEN2R	Number of switching cycles of pilot valve 2, resettable	0 ... 4.29E9	-	①
46	STORE	Save the current values as 'last maintenance' (press  key for 5 seconds)	-	-	③
47	PRUP	Prediction up	1 ... 40	-	④
48	PRDN	Prediction down	1 ... 40	-	④
49	WT00	Number of operating hours in the travel range WT00	0 ... 4.29E9	Hours	①

No.	Abbreviation	Meaning	Representable diagnostics values	Unit	Properties
50	WT05	Number of operating hours in the travel range WT05	0 ... 4.29E9	Hours	①
51	WT10	Number of operating hours in the travel range WT10	0 ... 4.29E9	Hours	①
52	WT30	Number of operating hours in the travel range WT30	0 ... 4.29E9	Hours	①
53	WT50	Number of operating hours in the travel range WT50	0 ... 4.29E9	Hours	①
54	WT70	Number of operating hours in the travel range WT70	0 ... 4.29E9	Hours	①
55	WT90	Number of operating hours in the travel range WT90	0 ... 4.29E9	Hours	①
56	WT95	Number of operating hours in the travel range WT95	0 ... 4.29E9	Hours	①

## 11.2.4 Meaning of the diagnostic values

### 11.2.4.1 Diagnostic value '1.STRKS - Number of total strokes'

Display range: 0 ... 4.29E9

Purpose: In operation, the movements of the actuator are summed up and displayed in this diagnostics parameter as the number of strokes.  
Unit: 100% strokes, i.e. the path between 0 and 100% and back.

### 11.2.4.2 Diagnostic value '2.CHDIR - Number of changes in direction'

Display range: 0 ... 4.29E9

Purpose: Every change in direction of the actuator is noted in the controller and added to the number of changes in direction.

### 11.2.4.3 Diagnostic value '3.\CNT - Number of fault messages'

Display range: 0 ... 4.29E9

Purpose: Every fault is noted in the closed-loop controller with '3.\CNT' and added to the number of fault messages.

### 11.2.4.4 Diagnostic value '4.A1CNT - Number of alarms 1' / '5.A2CNT - Number of alarms 2'

Requirement: '4.AFCT' Alarm function (Page 164) parameter is activated.

Display range: 0 ... 4.29E9

Purpose: This value indicates how often the alarm has been triggered.

**11.2.4.5 Diagnostic value '6.HOURS - Number of operating hours'**

Display range: 0 ... 4.29E9  
Purpose: The runtime meter is incremented every hour as soon as electric auxiliary power is supplied to the positioner.

**11.2.4.6 Diagnostic value '7.HOURR - Resettable operating hours counter'**

Display range: 0 ... 4.29E9  
Purpose: The runtime meter is incremented every hour as soon as electric auxiliary power is supplied to the positioner. In contrast to Diagnostic value '6.HOURS - Number of operating hours' (Page 256), this value can be reset.  
Description: In order to minimize the control valve wear resulting from a poor control quality, it makes sense to optimize the positioner's parameters. You can recognize optimum parameter settings when the values of the Diagnostic value '44.VEN1R' / '45.VEN2R' (Page 265) are low. Low values mean that the switching frequency of the positioner pneumatics is also low. In order to carry out a comparison with various parameter settings, determine the number of switching cycles per hour. To do this, use the values of the Diagnostic value '44.VEN1R' / '45.VEN2R' (Page 265) and '7.HOURR'. These three parameters can be reset to enable simpler determination of the values.

**11.2.4.7 Diagnostic value '8.WAY - Determined travel'**

Requirement for linear actuator: The travel is set in the '3.YWAY' Range of stroke (Page 156) parameter.  
Display range: 0 ... 130  
Purpose: This value in mm or ° specifies the travel determined during the initialization.

**11.2.4.8 Diagnostic value '9.TUP - Travel time UP' / '10.TDOWN - Travel time DOWN'**



Display range: 0 ... 1000  
Purpose: This value indicates the current UP or DOWN travel time in seconds determined during the initialization.



### 11.2.4.9 Diagnostic value '11.LEAK - Leakage test'

Requirement	The positioner is initialized and in manual mode (MAN).
Display range:	<ul style="list-style-type: none"> <li>• -</li> <li>• 0.0 ... 100.0</li> </ul>
Purpose:	<p>You can use this diagnostics parameter to read the last test result or start an offline leakage test with which you can detect leakages in the actuator or in the pipe installation. Display is percent stroke per minute referred to the total stroke. A test result originates from one of the following options:</p> <ul style="list-style-type: none"> <li>• Function '11.LEAK' has already been carried out.</li> <li>• Leakage test was already carried out during initialization, see procedure of RUN3 in section Sequence of automatic initialization (Page 116).</li> <li>• 'Offline leakage test' function was already executed by a HOST system.</li> </ul> <p>"-" in the display can have the following causes:</p> <ul style="list-style-type: none"> <li>• A leakage test has not yet been carried out.</li> <li>• Resetting to the factory settings was carried out using the "48.PRST" Preset (Page 168) &gt; ALL' parameter.</li> <li>• Positioner is not initialized.</li> </ul> <p>How to start the test</p> <ol style="list-style-type: none"> <li>1. Move the actuator to the position at which you wish to start the test. <i>Recommendation:</i> Set value to approx. 50. The actuator is in the center position.</li> <li>2. In 'Diagnostics' mode, go to the '11.LEAK' diagnostic value as described in section Display of diagnostics values (Page 252).</li> <li>3. Start the function by pressing the  button for at least 5 seconds.</li> </ol>
Description:	<p>'Strt' is output in the display. The function is started after 5 seconds. 'tEST' and the current position of the actuator (actual value) are then displayed alternately for one minute.</p> <p>After one minute, the display shows the difference in the actuator position before and after the test. This means: the actuator position has changed by the displayed value in one minute.</p>

### 11.2.4.10 Diagnostic value '12.PST - Monitoring of partial stroke test'

Indication on the display:	<ul style="list-style-type: none"><li>• OFF</li><li>• C-ERR</li><li>• FdInI</li><li>• notSt</li><li>• ###.#</li><li>• SdtSt</li><li>• FdtSt</li></ul>
Purpose:	<p>This diagnostics parameter indicates the stroke time measured during the last partial stroke test.</p> <p>A partial stroke test can be initiated manually or a current partial stroke test can be interrupted by pressing the  button.</p>
Description of indications on the display:	<ul style="list-style-type: none"><li>• OFF: The partial stroke test function is deactivated.</li><li>• C-ERR: Configuration error. Partial stroke test cannot be started. Settings in the 'A1.STPOS starting position', 'A3.STRKH stroke height' and 'A4.STRKD direction of stroke' parameters are not plausible.</li><li>• FdInI - Failed PST Initialization: The reference stroke time measurement of the partial stroke test has failed.</li><li>• notSt - No Test: A manual partial stroke test has not yet been executed.</li><li>• ###.#: Corresponds to the measured stroke time in seconds. The last partial stroke test was successfully executed.</li><li>• SdtSt - Stopped Test: The last partial stroke test was interrupted.</li><li>• FdtSt - Failed Test: The last partial stroke test has failed.</li></ul>
Status messages:	<p>The following status messages appear when you hold the  button pressed:</p> <ul style="list-style-type: none"><li>• notoL - No Tolerance: The control valve is beyond the tolerance range to start the partial stroke test. A manual partial stroke test is not started.</li><li>• Strt - Start: A manual partial stroke test is started five seconds after pressing the button.</li><li>• StoP - Stop: The current partial stroke test is interrupted. 'WAIT' is output in the display.</li></ul>
Factory setting:	OFF

**11.2.4.11 Diagnostic value '13.PRPST' - Time since last partial stroke test'**

- Indication on the display: • ###  
 • notSt  
 • Sdtst  
 • FdtSt
- Purpose: This diagnostics parameter shows the elapsed time in days since the last partial stroke test.
- Status messages: • notSt - No Test: A manual partial stroke test has not yet been executed.  
 • SdtSt - Stopped Test: The last partial stroke test was interrupted.  
 • FdtSt - Failed Test: The last partial stroke test has failed.

**11.2.4.12 Diagnostic value '14.NXPST - Time until next partial stroke test'**

- Requirement: • The partial stroke test is activated in 'Configuration' mode.  
 • The test interval is set in the 'A8.INTRV' parameter.
- Indication on the display: • OFF  
 • ###
- Purpose: This diagnostics parameter shows the time in days until the next partial stroke test. If one of the above-mentioned conditions is not met, 'OFF' is shown on the display.

**11.2.4.13 Diagnostic value '15.DEVI - General control valve fault'**

- Requirement: '50.XDIAG' Activation of extended diagnostics (Page 170) parameter is activated.
- Display range: • OFF  
 • 0.0 ... 100.0
- Purpose: This value in percent provides information about the current dynamically determined deviation from the model response. If the underlying function is deactivated, 'OFF' is displayed.

**11.2.4.14 Diagnostic value '16.ONLK - Pneumatic leakage'**

- Requirement: Monitoring pneumatic leakage 'C.\LEAK' (Page 181) parameter is activated.
- Display range: • OFF  
 • 0 ... 100
- Purpose: This diagnostics parameter shows the current leakage indicator. If the leakage detection is deactivated, 'OFF' is displayed.

**11.2.4.15 Diagnostic value '17.STIC - Stiction (slipstick)'**

Requirement: Monitoring the stiction (slipstick) 'd.\STIC' (Page 183) parameter is activated.

Display range: 

- OFF
- 0.0 ... 100.0

Purpose: This diagnostics parameter shows the filtered value of the slip jumps in percent resulting from the stiction.

**11.2.4.16 Diagnostic value '18.ZERO - Lower endstop'**

Requirement: '50.XDIAG' Activation of extended diagnostics (Page 170) parameter is activated.  
'36.YCLS' Tight closing with manipulated variable (Page 162) parameter is set to 'do' or 'uP do'.

Display range: 

- OFF
- 0.0 ... 100.0

Purpose: Indication of how many percent the lower endstop has changed compared to its value during initialization. If the underlying function is deactivated, 'OFF' is displayed.

**11.2.4.17 Diagnostic value '19.OPEN - Upper endstop'**

Requirement: '50.XDIAG' Activation of extended diagnostics (Page 170) parameter is activated.  
'36.YCLS' Tight closing with manipulated variable (Page 162) parameter is set to 'uP' or 'uP do'.

Display range: 

- OFF
- 0.0 ... 100.0

Purpose: An indication of the current shift of the upper endstop compared to its initialization value. If the underlying function is deactivated, 'OFF' is displayed.

**11.2.4.18 Diagnostic value '20.PAVG - Average value of position'**

- Indication on the display:
- OFF
  - IdLE
  - rEF
  - COMP
- Purpose:
- This value shows the last calculated comparison average. Meaning of the displays:
- OFF: The underlying function is deactivated in the configuration menu.
  - IdLE : Inactive. The function has not been started yet.
  - rEF: The reference average is calculated. The function was started, and the reference interval is in progress at the moment.
  - COMP: The comparison average is calculated. The function was started, and the comparison interval is in progress at the moment.

**11.2.4.19 Diagnostic value '21.P0 - Potentiometer value of lower endstop (0%)' / '22.P100 - Potentiometer value of upper endstop (100%)'**

- Display range:
- NO
  - 0.0 ... 100.0
- 'NO': Changing the low or upper endstop is not possible in the current state of the control valve. Initialize the positioner again.
- Requirement 1 - read values
- Purpose 1
- Read values**
- You can use the P0 and P100 parameters to read the values for the lower endstop (0%) and the upper endstop (100%) of the position measurement as determined during the automatic initialization. The values of manually approached end positions are applicable for manual initialization.
- Requirement 2 - change values
- The positioner is initialized and in manual mode (MAN) or automatic mode (AUT).
  - The current position of the actuator is within the range -10 to +10% of the lower endstop (P0).
  - The current position of the actuator is within the range 90 to 110% of the upper endstop (P100).

Purpose 2:

**Change values**

You can use these two parameters to change the lower endstop (P0) and the upper endstop (P100).

Since initialization is not usually carried out under process conditions, the values for the lower endstop (P0) and the upper endstop (P100) may change when the process is started. These changes may result from temperature changes with the associated thermal expansion of the material. If the Monitoring the lower endstop 'F.\VZERO' (Page 186) and Monitoring the upper endstop 'G.\OPEN' (Page 187) parameters are active, the thresholds set in these two parameters can be exceeded as a result of thermal expansion. An error message is output in the display.

The process-dependent thermal expansion may represent the normal state in your application. You do not wish to receive an error message as a result of this thermal expansion. Therefore reset the 'P0' and/or 'P100' parameters after the process-dependent thermal expansion has had its complete effect on the control valve. The procedure is described in the following.

Description:

**Procedure for manual mode (MAN)**

1. Move the actuator to the desired position of the lower endstop (upper endstop) using the  $\Delta$  and  $\nabla$  keys.
2. Switch to diagnostics mode.
3. Go to diagnostic value 21.P0 (22.P100).
4. Apply the setting by pressing the  $\Delta$  button for at least 5 seconds. After 5 seconds, '0.0' (with 22.P100: '100.0') is displayed. Result: The lower endstop (upper endstop) now corresponds to the current position of the actuator.
5. Switch to manual mode (MAN). Result: Values for the upper endstop (lower endstop) have changed.

**Procedure for automatic mode (AUT)**

1. Check in the display whether the current position of the actuator is at the desired position of the lower endstop (upper endstop).
2. Switch to diagnostics mode.
3. Go to diagnostic value 21.P0 (22.P100).
4. Apply the setting by pressing the  $\Delta$  button for at least 5 seconds. After 5 seconds, '0.0' (with 22.P100: '100.0') is displayed. Result: The lower endstop (upper endstop) now corresponds to the current position of the actuator.
5. Switch to automatic mode (AUT).

**See also**

Changing the operating mode (Page 107)

- 11.2.4.20 Diagnostic value '23.IMPUP - Impulse length UP' / '24.IMPDN - Impulse length DOWN'**
- Display range: 6 ... 160
- Purpose: The smallest impulse lengths that can be used to move the actuator are determined during the initialization process. They are separately determined for the 'Up' and 'Down' directions and displayed here. Display in ms.  
In the case of special applications you can additionally set the smallest impulse lengths in these two parameters.
- Factory setting: 6
- 11.2.4.21 Diagnostic value '25.PAOTP - Pulse interval'**
- Display range: 2 ... 320
- Purpose: This value is not changed during an initialization process. Display in ms.  
For applications with high stiction (slipstick), adjusting this parameter improves the control quality.  
This parameter can be set for special applications.
- Factory setting: 28
- 11.2.4.22 Diagnostic value '26.DBUP - Deadband UP' / '27.DBDN - Deadband DOWN'**
- Display range: 0.1 ... 10.0
- Purpose 1: In this parameter, you can read the deadbands of the controller in the 'Up' and 'Down' directions. Display in percent. The values correspond either to the manually configured value of the '31.DEBA' Deadband of controller (Page 160) parameter or to the value automatically adapted by the device if 'DEBA' was set to 'Auto'.
- 11.2.4.23 Diagnostic value '28.SSUP - Slow step zone UP' / '29.SSDN - Slow step zone DOWN'**
- Display range: 0.1 ... 100.0
- Purpose: The slow step zone is the zone of the closed-loop controller in which control signals are issued in a pulsed manner. Display is in percent. The impulse length is thus proportional to the control deviation. If the control deviation is beyond the slow step zone, the valves are controlled using permanent contact.  
This parameter can be set for special applications.
- Factory setting: 10.0

**11.2.4.24 Diagnostic value '30.TEMP - Current temperature'**

Display range: °C: -50 ... 100  
 °F: -58 ... 212

Purpose: Current temperature in the positioner enclosure. The sensor is present on the basic electronics. In order to switch over the temperature display between °C and °F, press the  button.

**11.2.4.25 Diagnostic value '31.TMIN - Minimum temperature' / '32.TMAX - Maximum temperature'**

Display range: °C: -50 ... 100  
 °F: -58 ... 212

Purpose: The minimum and maximum temperatures within the enclosure are constantly determined and saved as with a slave pointer. This value can only be reset in the factory.

In order to switch over the temperature display between °C and °F, press the  button.

**11.2.4.26 Diagnostic value '33.T1' ... '41.T9' - Number of operating hours in the temperature range 1 to 9**

Display range: 0 ... 4.29E9

Purpose: Statistics about the duration of operation in different temperature ranges is maintained in the device. An average of the measured temperature is taken every hour and the counter assigned to the corresponding temperature range is incremented. This helps in drawing conclusions about the past operating conditions of the device and the entire control valve.

The temperature ranges are classified as follows:

	T1	T2	T3	T4	T5	T6	T7	T8	T9
Temperature range [°C]	-	≥ -30	≥ -15	≥ 0	≥ 15	≥ 30	≥ 45	≥ 60	≥ 75
	≤ -30	< -15	< 0	< 15	< 30	< 45	< 60	< 75	-

Operating hours in temperature ranges T1 to T2

**11.2.4.27 Diagnostic value '42.VENT1' / '43.VENT2'**

'42.VENT1' Number of switching cycles of pilot valve 1  
 '43.VENT2' Number of switching cycles of pilot valve 2

Display range: 0 ... 4.29E9



Purpose:	Control procedures of the pilot valves in the pneumatic block of the positioner are counted and displayed in this parameter.
Description:	<p>The pneumatic block of the positioner pressurizes and depressurizes the actuator. The pneumatic block contains two pilot valves. The characteristic service life of the pneumatic block depends on the load. This amounts on average to approx. 200 million switching cycles for each of the two pilot valves with symmetrical load. The number of control procedures for the switching cycles serves to assess the switching frequency of the pneumatic block.</p> <p>Counting procedure for single-acting actuators:</p> <ul style="list-style-type: none"> <li>• Pressurize =&gt; 42.VENT1</li> <li>• Depressurize =&gt; 43.VENT2</li> </ul> <p>Counting procedure for double-acting actuators:</p> <ul style="list-style-type: none"> <li>• Pressurize (Y2) / Depressurize (Y1) =&gt; 42.VENT1</li> <li>• Depressurize (Y1) / Pressurize (Y2) =&gt; 43.VENT2</li> </ul> <p>The value is written hourly into a nonvolatile memory.</p>

#### 11.2.4.28 Diagnostic value '44.VEN1R' / '45.VEN2R'

'44.VEN1R'	Number of switching cycles of pilot valve 1, resettable
'45.VEN2R'	Number of switching cycles of pilot valve 2, resettable
Display range:	0 ... 4.29E9
Purpose:	Control procedures of the pilot valves in the pneumatic block of the positioner are counted since the last time this parameter was reset, and displayed here.
Description:	Corresponds to the description for Diagnostic value '42.VENT1' / '43.VENT2' (Page 264) referred to the diagnostics parameters 'VEN1R' and 'VEN2R' described here.

**11.2.4.29 Diagnostic value '46.STORE - Save maintenance data'**

**Purpose:** The minimum and maximum temperatures within the enclosure are constantly determined and saved as with a slave pointer. This value can only be reset in the factory. In order to switch over the temperature display between °C and °F, press the  $\Delta$  key for at least 5 seconds in order to initiate a save function. The values of the diagnostics parameters Diagnostic value '8.WAY - Determined travel' (Page 256) to Diagnostic value '11.LEAK - Leakage test' (Page 257) and Diagnostic value '21.P0 - Potentiometer value of lower endstop (0%)' / '22.P100 - Potentiometer value of upper endstop (100%)' (Page 261) to Diagnostic value '28.SSUP - Slow step zone UP' / '29.SSDN - Slow step zone DOWN' (Page 263) are saved in the non-volatile memory as 'data of last maintenance'. This diagnostics data contains selected values whose changes can give information about mechanical wear and tear of the valve.

This function is normally operated through the PDM, menu command 'Diagnostics-> Save maintenance information'. The data of the last maintenance operation can be compared with the current data using SIMATIC PDM.

**11.2.4.30 Diagnostic value '47.PRUP - Prediction UP' / '48.PRDN - Prediction DOWN'**

**Display range:** 1 ... 40

**Purpose:** This value specifies the prediction of the controller for the up (PRUP) and down (PRDN) movements.

For more information, refer also to the section Optimization of controller data (Page 110).

**Factory setting:** 1

**11.2.4.31 Diagnostic value '49.WT00' ... '56.WT95' - Number of operating hours in the travel range WT00 to WT95**

**Display range:** 0 ... 4.29E9

**Purpose:** When the positioner is in "Automatic" mode, statistics are continuously maintained regarding the duration for which a valve or a flap is operated in a particular section of the travel range. The entire travel range is divided into 8 sections from 0 to 100 %. The positioner records the current position continuously and increments the runtime meter assigned to the corresponding travel range every hour. This helps in drawing conclusions about the past operating conditions and especially in assessing the control properties of the control loop and the entire control valve.

Travel range	WT00	WT05	WT10	WT30	WT50	WT70	WT90	WT95
Travel range section [%]	-	≥ 5	≥ 10	≥ 30	≥ 50	≥ 70	≥ 90	≥ 95
	< 5	< 10	< 30	< 50	< 70	< 90	< 95	-

Division of travel ranges

You can simultaneously set the eight operating hours counters to zero.

**TIP:** Since the travel ranges are provided at the end of the diagnostics parameters, press the  $\nabla$  key several times along with the  key. This will help you to access the desired diagnostics parameters faster.

## 11.3 Online diagnostics

### 11.3.1 Overview of online diagnostics

Online diagnostics means diagnostics during ongoing operation. A few important variables and parameters are continuously monitored during the operation of the positioner. In "Configuration" mode, you can configure this monitoring in such a way that the fault message output will be activated if, for instance, a limit is exceeded.

Information about what events can activate the fault message output can be found in the table in chapter "Overview of error codes (Page 268)".

This chapter contains information about the following situations in particular:

- Possible causes of the fault message.
- Events which activate the fault message output or alarm outputs.
- Setting of parameters needed for event monitoring.
- Canceling a fault message

When the fault message output is triggered in automatic or manual mode, the display shows which fault triggered the message. Both digits at bottom-left indicate the corresponding error code. If multiple triggers occur at the same time, they are displayed one after the other cyclically.

#### See also

Extended diagnostics parameters A to P (Page 173)

### 11.3.2 Overview of error codes

#### Overview of error codes that activate the fault message output

Error code	Three-stage	Event	Parameter setting	Error message disappears when	Possible causes
h1	No	Control deviation: Actual value response has exceeded values for TIM and LIM	Always active	... the actual value response falls below the value for LIM	Compressed air failure, actuator fault, valve fault (e.g. blockade).
h2	No	Device not in "Automatic" mode	** .hFCT <sup>1)</sup> =h nA or = h nAB	... the device is changed to "Automatic" mode.	The device has been configured or is in the manual mode
h3	No	Binary input BIN1 or BIN2 active	** .h FCT <sup>1)</sup> =h nAB and binary function BIN1 or BIN2 to "On"	... the binary input is no longer activated.	The contact connected to the binary input was active (e.g. packing gland monitoring, overpressure, temperature switch).
h4	Yes	Limit for number of total strokes exceeded	L .hSTRK≠OFF	... the stroke counter is reset or the thresholds are increased	The total path covered by the actuator exceeds one of the configured thresholds.
h5	Yes	Limit for number of changes in direction exceeded	O .hDCHG≠OFF	... the counter for changes of direction is reset or the thresholds are increased.	The number of changes of direction exceeds one of the configured thresholds.
h6	Yes	Lower endstop limit exceeded	F .hZERO≠OFF ** .YCLS = do or up do	... the deviation of the endstop disappears or the device is re-initialized.	Wear and tear of the valve seat, deposits or foreign bodies in the valve seat, mechanical misalignment, friction clutch moved.
h7	Yes	Upper endstop limit exceeded	G .hOPEN≠OFF ** .YCLS <sup>1)</sup> = do or up do	... the deviation of the endstop disappears or the device is re-initialized.	Wear and tear of the valve seat, deposits or foreign bodies in the valve seat, mechanical misalignment, friction clutch moved.
h8	No	Deadband limit exceeded	E .hDEBA≠OFF ** .DEBA <sup>1)</sup> = Auto	... the limit is undershot again	Increased packing gland friction, mechanical gap in the position feedback.
h9	Yes	Case 1: Reference stroke time for partial stroke test is exceeded.	A .hPST≠OFF	Case 1: ... a partial stroke test is successfully executed within the reference stroke time or the function is deactivated.	Case 1: Valve is stuck or rusted. Increased stiction.
		Case 2: Start position outside the start tolerance		Case 2: Move the actuator into the range of the PST start tolerance. Or increase the PST start tolerance until the actuator (PST start position) is within the PST start tolerance. Start the partial stroke test again.	Case 2: Valve is present in the safety position.

Error code	Three-stage	Event	Parameter setting	Error message disappears when	Possible causes
10	Yes	Deviation from expected dynamic control valve behavior	b. $\downarrow$ DEVI#OFF	... the position is again in a narrow corridor between the setpoint and the model, or the function is deactivated.	Actuator fault, valve fault, valve jams, increased stiction, decreased compressed air
11	Yes	Pneumatic leakage limit exceeded	C. $\downarrow$ LEAK#OFF	... the leakage drops below the configured thresholds, or the function is deactivated.	Pneumatic leakage
12	Yes	Stiction limit (slipstick) exceeded	d. $\downarrow$ STIC#OFF	... Slipjumps can no longer be detected, or the function is deactivated.	Increased stiction, valve no longer moves smoothly but in jerky motion.
13	Yes	Temperature undershot	H. $\downarrow$ TMIN#OFF	... the low temperature thresholds are no longer undershot.	Ambient temperature too low
14	Yes	Temperature overshoot	J. $\downarrow$ TMAX#OFF	... the high thresholds are no longer overshoot.	Ambient temperature too high
15	Yes	Position average deviates from the reference value	P. $\downarrow$ PAVG#OFF	... the average position value calculated after a comparison interval is again within the thresholds for the reference value, or the function is deactivated.	In the last comparison interval, the valve trajectory was changed so severely that a deviating average value of position was calculated.
16	No	Partial stroke test is to be carried out with non-plausible parameter values	A. $\downarrow$ PST#OFF	the parameter values entered in A1.STPOS, A3.STRKH and A4.STRKD are plausible.	Parameters for partial stroke test are non-plausible

<sup>1)</sup> Refer to the corresponding parameter descriptions for additional information about parameters

## See also

Overview of initialization parameters 1 to 5 (Page 146)

Overview of application parameters 6 to 55 (Page 147)

### 11.3.3 XDIAG parameter

You can use the advance diagnostics parameters to display fault messages in one, two or three stages. In addition to the fault message output, alarm outputs 1 and 2 are then used. For this purpose, set the "XDIAG" parameter as described in the following table:

Settings of XDIAG	Message due to
OFF	Advanced diagnostics not activated
On 1	Fault message output for threshold 3 fault messages (one-stage)

Settings of XDIAG	Message due to
On 2	Fault message output for threshold 3 fault messages and alarm output 2 for threshold 2 fault messages (two-stage)
On 3	Fault message output for threshold 3 fault messages and alarm output 2 for threshold 2 fault messages and alarm output 1 for threshold 1 fault messages (three-stage)

Possible settings of the "XDIAG" parameter

### 11.3.4 Meaning of error codes

#### 11.3.4.1 1 Remaining control deviation

The deviation between the setpoint and the actual value is continuously monitored in "Automatic" mode. The fault message for a remaining control deviation is activated depending on the setting of the application parameters "hTIM" - monitoring time for setting the fault messages - and "hLIM" - response threshold for the fault message. The fault message is cancelled as soon as the control deviation drops below the response threshold. This monitoring function is always active.

#### 11.3.4.2 2 Device not in "Automatic" mode

When the device is not in automatic mode, an error message is generated if the "hFCT" parameter (function of fault message output) is set correctly. A warning is then sent to the control system if the device was switched to manual or configuration mode on-site.

#### 11.3.4.3 3 Binary input BIN1 or BIN2 active

If the binary input is activated, an error message is generated when the "hFCT" parameter (function of fault message output) and the "BIN1" parameter (function of binary input 1) are set correctly. For example, it can be a switch to monitor the packing glands, a temperature switch or a limit switch (e.g. for pressure).

Binary input 2 (in the optional alarm module) can be configured in a similar manner.

#### 11.3.4.4 4 Monitoring the number of total strokes

The diagnostics value "1 STRKS" is constantly compared with the thresholds that are determined from the "L1.LIMIT" to "L4.FACT3" parameters. If the thresholds are exceeded, the fault message output or the alarm outputs respond depending on the mode of the extended diagnostics. These two functions can be deactivated using the parameter setting "OFF" for "L.hSTRK".

#### 11.3.4.5 5 Monitoring the number of changes in direction

The diagnostics value "2 CHDIR" is constantly compared with the thresholds that are determined from the "O1.LIMIT" to "O4.FACT3" parameters. If the thresholds are exceeded, the fault message output or the alarm outputs respond depending on the mode of the extended diagnostics. These two functions can be deactivated using the parameter setting "OFF" for "O. 4DCHG".

#### 11.3.4.6 6 Monitoring the lower endstop / 7 Monitoring the upper endstop

If the parameter "F. 4ZERO" is set to "ON", monitoring of the lower endstop is activated. This function can be used to detect the errors in the valve seat. An overshoot limit indicates the possibility of deposits or foreign bodies in the valve seat. An undershoot limit indicates probable wear and tear of the valve seat or flow restrictor. Even a mechanical misalignment of the position feedback can trigger this fault message.

Monitoring is always carried out whenever the valve is in the "down tight closing" position. The current position is compared with the position that was determined as the lower endstop at the time of initialization. The activation of "down tight closing" ("YCLS" parameter) is therefore the condition.

Example: A value of 3% is set. The position is normally adopted for "down tight closing". A fault is reported if a value  $> 3\%$  or  $< -3\%$  is determined instead.

The fault message remains activated until either a subsequent monitoring remains within the tolerance or a re-initialization process is executed. Even the deactivation of monitoring ("F. 4ZERO"=OFF) may trigger an error message.

This monitoring function does not deliver any utilizable results if the end stops were not determined automatically at the time of initialization, but the limits were set manually (manual initialization, "5.INITM").

Similar diagnostics is carried out for the upper endstop. The "G. 4OPEN" parameter is used to set the limit for this. The activation of "up tight closing" ("YCLS" parameter) is therefore the condition.

#### 11.3.4.7 8 Monitoring deadband

If the deadband increases disproportionately when adjusting it automatically ("DEBA"=Auto parameter), it indicates an error in the system (e.g. severely increased packing gland friction, play in the position displacement sensor, leakage). A limit can therefore be entered for this value ("E1.LEVL3", threshold for deadband monitoring). An error message output is activated when this value is exceeded.

#### 11.3.4.8 9 Partial stroke test

On the one hand, this fault message appears when a manual or cyclic partial stroke test is initiated and the test cannot be started since the valve is not within the starting tolerance. On the other hand, the fault message appears when one of the three thresholds of the partial stroke test that are determined from the 'A9.PSTIN' reference stroke time multiplied by factors 'AA.FACT1', 'Ab.FACT2' and 'AC.FACT3' is violated. The severity of the fault message is shown by the number of bars on the display. The severity of the fault message is simultaneously

displayed using the fault message output or alarm outputs depending on the mode of the advanced diagnostics.

**11.3.4.9 10 Monitoring of dynamic control valve behavior**

The monitoring of the operational behavior responds when the actual valve position shifts from a narrow corridor between the setpoint and the expected position course. In this case, the deviation between the expected and actual position course is filtered, displayed and compared with the configured thresholds that are determined from the "b2.LIMIT" limit multiplied by the factors "b3.FACT1" to "b5.FACT3".

**11.3.4.10 11 Monitoring the pneumatic leakage**

This fault message appears when the leakage indicator exceeds the configured thresholds. Keep in mind that the complete sensitivity of this function can be used only if a ramp movement was initiated after initialization to set the leakage indicator (see explanations for "C1.LIMIT").

**11.3.4.11 12 Monitoring of stiction (slipstick)**

If the stiction of the control valve increases during operation or if an increasing number of Slipjumps is detected, "d1.LIMIT" could be exceeded and result in this fault message.

**11.3.4.12 13 Monitoring the lower limit temperature**

This fault message appears when the lower limit temperature thresholds are undershot.

**11.3.4.13 14 Monitoring the upper limit temperature**

This fault message appears when the upper limit temperature thresholds are overshot.

**11.3.4.14 15 Monitoring the position average value**

This fault message appears when a position value calculated after the expiry of a comparison interval deviates from the reference value by more than the configured thresholds.

**11.3.4.15 16 Monitoring the plausibility of values for the partial stroke test**

This error message is triggered if, when starting a partial stroke test, the plausibility check of the "A1.STPOS", "A3.STRKH" and "A4.STRKD" parameters was not successful.



## 11.4 Fault correction

### 11.4.1 Fault identification

#### Diagnostics guide

Fault	Corrective measures, see table			
<b>In which mode does a fault occur?</b>				
• Initialization	1			
• Manual and automatic modes	2	3	4	5
<b>In which environment and under which boundary conditions does a fault occur?</b>				
• Wet environment (e.g. strong rain or constant condensation)	2			
• Vibrating (oscillating) control valves	2	5		
• Impact or shock loads (e.g. vapor shocks or breakaway valves)	5			
• Moist (wet) compressed air	2			
• Dirty (contaminated with solid particles) compressed air	2	3		
<b>When does a fault occur?</b>				
• Regularly (reproducible)	1	2	3	4
• Sporadically (not reproducible)	5			
• Mostly after a specific operation time	2	3	5	

### 11.4.2 Remedial measures table 1

Fault profile (symptoms)	Possible cause(s)	Corrective measures
<ul style="list-style-type: none"> <li>Positioner remains in "RUN 1".</li> </ul>	<ul style="list-style-type: none"> <li>Initialization started from the end position and</li> <li>The response time of a maximum of 1 minute was not observed.</li> <li>Supply air PZ not connected or pressure of supply air PZ too low.</li> </ul>	<ul style="list-style-type: none"> <li>A waiting time of up to 1 minute is essential.</li> <li>Do not start initialization from the end position.</li> <li>Ensure supply air PZ.</li> </ul>
<ul style="list-style-type: none"> <li>Positioner remains in "RUN 2".</li> </ul>	<ul style="list-style-type: none"> <li>Transmission ratio selector and parameter 2</li> <li>"YAGL" and the real stroke do not match.</li> <li>Incorrectly set stroke on the lever.</li> <li>Piezo valve does not activate.</li> </ul>	<ul style="list-style-type: none"> <li>Check settings: see leaflet: Fig. "Device view ⑦" as well as parameters 2 and 3</li> <li>Check the stroke setting on the lever. See Table 2.</li> </ul>

11.4 Fault correction

Fault profile (symptoms)	Possible cause(s)	Corrective measures
<ul style="list-style-type: none"> <li>Positioner remains in "RUN 3".</li> </ul>	<ul style="list-style-type: none"> <li>Actuator travel time is too high.</li> </ul>	<ul style="list-style-type: none"> <li>Open the restrictor completely and/or set the pressure PZ (1) to the highest permissible value.</li> <li>Use a booster if required.</li> </ul>
<ul style="list-style-type: none"> <li>Positioner remains "RUN 5", does not go up to "FINISH" (waiting time &gt; 5 min).</li> </ul>	<ul style="list-style-type: none"> <li>"Gap" (play) in the positioner - actuator - control valve system</li> </ul>	<ul style="list-style-type: none"> <li>Part-turn actuator: check for the firmness of the grub screw of the coupling wheel</li> <li>Linear actuator: check for the firmness of the lever on the positioning shaft.</li> <li>Correct any other play between the actuator and the control valve.</li> </ul>

Fault table 1

11.4.3 Remedial measures table 2



Fault profile (symptoms)	Possible cause(s)	Corrective measures
<ul style="list-style-type: none"> <li>"CPU testt" blinks on the display approximately every 2 seconds.</li> <li>Piezo valve does not activate.</li> </ul>	<ul style="list-style-type: none"> <li>Water in the pneumatic block (due to wet compressed air)</li> </ul>	<ul style="list-style-type: none"> <li>At an early stage, this fault can be rectified with a subsequent operating using dry air, if required, in a temperature cabinet at 50 to 70°C.</li> <li>Otherwise: Repair</li> </ul>
<ul style="list-style-type: none"> <li>In the manual and automatic modes, the actuator cannot be moved or can be moved only in one direction.</li> </ul>	<ul style="list-style-type: none"> <li>Moisture in the pneumatic block</li> </ul>	
<ul style="list-style-type: none"> <li>Piezo valve does not activate (a gentle click sound is not audible when the "+" or "-" buttons are pressed in the manual mode.)</li> </ul>	<ul style="list-style-type: none"> <li>The screw between the shrouding cover and the pneumatic block has not been tightened firmly or the cover got stuck.</li> </ul>	<ul style="list-style-type: none"> <li>Tighten the screw firmly; if required, rectify the deadlock.</li> </ul>
	<ul style="list-style-type: none"> <li>Dirt (swarf, particles) in the pneumatic block</li> </ul>	<ul style="list-style-type: none"> <li>Repair or a new device; clean and/or replace the built-in fine screens.</li> </ul>
	<ul style="list-style-type: none"> <li>Deposits on the contacts between the electronic printed circuit board and the pneumatic block may develop due to abrasion owing to continuous loads resulting from strong vibrations.</li> </ul>	<ul style="list-style-type: none"> <li>Clean all contact surfaces with spirit; if required, bend the pneumatic block contact springs.</li> </ul>

Fault table 2

See also

Repair/Upgrading (Page 280)

## 11.4.4 Remedial measures table 3

Fault profile (symptoms)	Possible cause	Corrective measures
<ul style="list-style-type: none"> <li>Actuator does not move.</li> </ul>	<ul style="list-style-type: none"> <li>Compressed air &lt; 1.4 bar</li> </ul>	<ul style="list-style-type: none"> <li>Set pressure of supply air PZ to &gt; 1.4 bar.</li> </ul>
<ul style="list-style-type: none"> <li>Piezo valve does not switch (however, a gentle clicking sound can be heard when the  or  button is pressed in "Manual" mode.)</li> </ul>	<ul style="list-style-type: none"> <li>Restrictor valve turned off (screw at the right end stop)</li> </ul>	<ul style="list-style-type: none"> <li>Open the restrictor screw by turning it anticlockwise, see leaflet, Fig. "Device view .</li> </ul>
	<ul style="list-style-type: none"> <li>Dirt in the pneumatic block</li> </ul>	<ul style="list-style-type: none"> <li>Repair or a new device; clean and/or replace the built-in fine screens.</li> </ul>
<ul style="list-style-type: none"> <li>A piezo valve is switched constantly in stationary automatic mode (constant setpoint) and in "Manual" mode.</li> </ul>	<ul style="list-style-type: none"> <li>Pneumatic leakage in the positioner - actuator system; start the leakage test in "RUN 3" (initialization).</li> </ul>	<ul style="list-style-type: none"> <li>Rectify leakage in the actuator and/or feed line.</li> <li>In case of an intact actuator and tight feed line: Repair or new device</li> </ul>
	<ul style="list-style-type: none"> <li>Dirt in the pneumatic block</li> </ul>	<ul style="list-style-type: none"> <li>See above</li> </ul>

Fault table 3

## See also

Repair/Upgrading (Page 280)

## 11.4.5 Corrective measures Table 4

Fault profile (symptoms)	Possible cause(s)	Corrective measures
<ul style="list-style-type: none"> <li>In stationary automatic mode (constant setpoint) and in "Manual" mode, both piezo valves continually switch alternately, and the actuator oscillates around an average value.</li> </ul>	<ul style="list-style-type: none"> <li>Stiction of the packing gland from the control valve or actuator too large</li> </ul>	<ul style="list-style-type: none"> <li>Reduce stiction or increase deadband of positioner (parameter "dEbA") until the oscillation stops.</li> </ul>
	<ul style="list-style-type: none"> <li>Looseness (play) in the positioner/ actuator/control valve system</li> </ul>	<ul style="list-style-type: none"> <li>Part-turn actuator: Check for firm seating of set screw on coupling wheel.</li> <li>Linear actuator: Check for firm seating of lever on positioner shaft.</li> <li>Correct any other play between the actuator and the control valve.</li> </ul>
	<ul style="list-style-type: none"> <li>Actuator too fast</li> </ul>	<ul style="list-style-type: none"> <li>Increase travel times using throttle screws.</li> <li>If a quick travel time is needed, increase the deadband (parameter "dEbA") until the oscillation stops.</li> </ul>
<ul style="list-style-type: none"> <li>Positioner doesn't move control valve to the stop (at 20 mA).</li> </ul>	<ul style="list-style-type: none"> <li>Supply pressure too low. Load on the feeding controller or system output is too low.</li> </ul>	<ul style="list-style-type: none"> <li>Increase supply pressure, insert ballast converter</li> <li>Select 3/4-wire mode</li> </ul>

Error table 4

11.4 Fault correction

See also

Cleaning of the screens (Page 278)

11.4.6 Remedial measures table 5

Fault profile (symptoms)	Possible cause(s)	Corrective measures
<ul style="list-style-type: none"> <li>Zero point displaces sporadically (&gt; 3%).</li> </ul>	<ul style="list-style-type: none"> <li>Impact or shock loads result in accelerations so high that the friction clutch moves, e.g. due to "vapor shocks" in vapor lines.</li> </ul>	<ul style="list-style-type: none"> <li>Rectify the causes for shock loads.</li> <li>Re-initialize the position controller.</li> </ul>
<ul style="list-style-type: none"> <li>The device function has completely failed: No representation on the display either.</li> </ul>	<ul style="list-style-type: none"> <li>Electrical auxiliary power supply is not adequate.</li> <li>In case of very high continuous loads due to vibrations (oscillations):</li> <li>Screws of the electrical connecting terminals may be loosened.</li> <li>Electrical connecting terminals and/or electronic components may be knocked out.</li> </ul>	<ul style="list-style-type: none"> <li>Check the electrical auxiliary power supply.</li> <li>Tighten the screws firmly and secure using sealing wax.</li> <li>Repair</li> <li>For prevention: Install the positioner on the damping pads.</li> </ul>

Fault table 5

See also

Repair/Upgrading (Page 280)

## Service and maintenance

### 12.1 Basic safety instructions

 <b>WARNING</b>
<b>Impermissible repair of the device</b> <ul style="list-style-type: none"><li>• Repair must be carried out by Siemens authorized personnel only.</li></ul>

 <b>WARNING</b>
<b>Impermissible accessories and spare parts</b> <p>Danger of explosion in areas subject to explosion hazard.</p> <ul style="list-style-type: none"><li>• Only use original accessories or original spare parts.</li><li>• Observe all relevant installation and safety instructions described in the instructions for the device or enclosed with the accessory or spare part.</li></ul>

 <b>WARNING</b>
<b>Improper connection after maintenance</b> <p>Danger of explosion in areas subject to explosion hazard.</p> <ul style="list-style-type: none"><li>• Connect the device correctly after maintenance.</li><li>• Close the device after maintenance work.</li></ul> <p>Refer to Chapter "Connect (Page 77)".</p>

<b>NOTICE</b>
<b>Penetration of moisture into the device</b> <p>Device damage.</p> <ul style="list-style-type: none"><li>• Make sure when carrying out cleaning and maintenance work that no moisture penetrates the inside of the device.</li></ul>

 <b>CAUTION</b>
<b>Releasing key lock</b> <p>Improper modification of parameters could influence process safety.</p> <ul style="list-style-type: none"><li>• Make sure that only authorized personnel may cancel the key locking of devices for safety-related applications.</li></ul>

 <b>WARNING</b>
<b>Electrostatic charge</b> Danger of explosion in hazardous areas if electrostatic charges develop, for example, when cleaning plastic surfaces with a dry cloth. <ul style="list-style-type: none"><li>• Prevent electrostatic charging in hazardous areas.</li></ul>

 <b>WARNING</b>
<b>Dust layers above 5 mm</b> Danger of explosion in hazardous areas. Device may overheat due to dust build up. <ul style="list-style-type: none"><li>• Remove dust layers in excess of 5 mm.</li></ul>

### Cleaning the enclosure

- Clean the outside of the enclosure with the inscriptions and the display window using a cloth moistened with water or a mild detergent.
- Do not use any aggressive cleansing agents or solvents, e.g. acetone. Plastic parts or the painted surface could be damaged. The inscriptions could become unreadable.

## 12.2 Cleaning of the screens

The positioner is maintenance-free to a large extent. Screens are installed in the pneumatic connections of the positioners to protect them from rough dirt particles. If there are dirt particles in the pneumatic auxiliary power supply, they damage the screens and hamper the function of the positioner. Clean the screens as described in the following two chapters.

### 12.2.1 Positioners with Makrolon enclosure 6DR5..0, aluminum enclosure 6DR5..3, and flameproof aluminum enclosure 6DR5..5

 <b>DANGER</b>
<b>Risk of explosion due to electrostatic charge</b> Electrostatic charges develop when cleaning the positioner in the Makrolon enclosure with a dry cloth, for example. It is imperative you avoid electrostatic charges in the hazardous environment.

### Procedure for removal and cleaning of the screens

1. Disconnect the pneumatic auxiliary power supply.
2. Remove the lines.
3. Unscrew the cover of the Makrolon enclosure 6DR5..0 or aluminum enclosure 6DR5..3.
4. Unscrew the three screws on the pneumatic terminal strip.
5. Remove the screens and O-rings behind the terminal strip.
6. Clean the screens, e.g. using compressed air.

### Procedure for installation of the screens

 **CAUTION**

**Damage to the Makrolon enclosure**

- The enclosure is damaged due to screwing in the self-tapping screws improperly.
- Ensure that the available thread pitches are used.
- Turn the screws anticlockwise until they engage noticeably in the thread pitch.
- Tighten the self-tapping screws only after they have engaged.

1. Insert the screens into the recesses of the enclosure.
2. Place the O-rings on the screens.
3. Insert the pneumatic terminal strip.
4. Tighten the three screws. Note: With the Makrolon enclosure, the screws are self-tapping.
5. Place the cover and tighten it.
6. Reconnect the pipelines and feed the pneumatic power supply.

## 12.2.2 Positioners with stainless steel enclosure 6DR5..2, flameproof stainless steel enclosure 6DR5..6, and narrow aluminum enclosure 6DR5..1

### Removal, cleaning and installation of the screens

1. Disconnect the pneumatic auxiliary power supply.
2. Remove the pipelines.
3. Remove the metal screen from the bores carefully.
4. Clean the metal screens, e.g. using compressed air.
5. Insert the screens.
6. Connect the pipelines again.
7. Feed the pneumatic auxiliary power supply.

## 12.3 Replacing the basic electronics with the "Fail in Place" function

### Requirements

You have a positioner with the "Fail in place" function, order suffix -Z F01.

### Replacing the basic electronics with the "Fail in Place" function

When replacing the basic electronics for positioning controllers with the function "Fail in Place", order suffix -Z F01, the parameters for the pneumatic type have to be set. The procedure is described here.

---

#### Note

##### Possible Movement of the Drive

While replacing the basic electronics, the drive can unintentionally vent itself.

- Observe the procedure described below.
- 

1. Switch off the supply air PZ.
2. Remove the enclosure cover of the positioner.
3. Replace the basic electronics as described in section "General information about the installation of option modules (Page 54)".
4. Set the '49.PNEUM' Fail in place (Page 169) parameter of "Std" to "FIP".
5. Set the '51.FSTY' Safety position (Page 171) parameter to "FSSP" so that the positioner retains the current position even following switching on again.
6. Install the enclosure cover.
7. Switch on the supply air PZ again.
8. Initialize the positioner as described in section "Commissioning (Page 113)".

## 12.4 Repair/Upgrading

Send defective devices to the repairs department, together with information on the malfunction and the cause of the malfunction. When ordering replacement devices, please provide the serial number of the original device. You can find the serial number on the nameplate.

### See also

Nameplate layout (Page 24)

Technical support (Page 312)



## 12.5 Return procedure

Enclose the bill of lading, return document and decontamination certificate in a clear plastic pouch and attach it firmly to the outside of the packaging.

### Required forms

- Delivery note
- Return document (<http://www.siemens.com/processinstrumentation/returngoodsnote>) with the following information:
  - Product (item description)
  - Number of returned devices/replacement parts
  - Reason for returning the item(s)
- Decontamination declaration (<http://www.siemens.com/sc/declarationofdecontamination>)  
With this declaration you warrant "that the device/replacement part has been carefully cleaned and is free of residues. The device/replacement part does not pose a hazard for humans and the environment."  
If the returned device/replacement part has come into contact with poisonous, corrosive, flammable or water-contaminating substances, you must thoroughly clean and decontaminate the device/replacement part before returning it in order to ensure that all hollow areas are free from hazardous substances. Check the item after it has been cleaned. Any devices/replacement parts returned without a decontamination declaration will be cleaned at your expense before further processing.

The forms can be found on the Internet as well as in the documentation which comes with the device.

## 12.6 Disposal

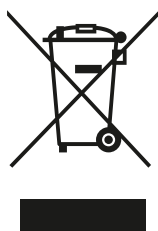

Devices identified by this symbol may not be disposed of in the municipal waste disposal services under observance of the Directive 2002/96/EC on waste electronic and electrical equipment (WEEE).

They can be returned to the supplier within the EC or to a locally approved disposal service. Observe the specific regulations valid in your country.



## Technical data

### 13.1 Rated conditions

Rated conditions	
Ambient conditions	For use indoors and outdoors.
Ambient temperature	In hazardous areas, observe the maximum permissible ambient temperature corresponding to the temperature class.
<ul style="list-style-type: none"> <li>Permissible ambient temperature for operation <sup>2)3)</sup></li> </ul>	-30 ... +80 °C (-22 ... +176 °F)
<ul style="list-style-type: none"> <li>Height</li> </ul>	2000 m above sea level. At altitudes greater than 2000 m above sea level, use a suitable power supply.
<ul style="list-style-type: none"> <li>Relative humidity</li> </ul>	0 ... 100%
Degree of pollution	2
Overvoltage category	II
Degree of protection <sup>1)</sup>	IP66 to IEC/EN 60529 / NEMA 4X
Mounting position	Any; in wet environment, pneumatic connections and outlet opening not upward
Vibration resistance	
<ul style="list-style-type: none"> <li>Harmonic oscillations (sine) according to EN 60068-2-6/10.2008</li> </ul>	3.5 mm (0.14"), 2 ... 27 Hz, 3 cycles/axle 98.1 m/s <sup>2</sup> (321.84 ft/s <sup>2</sup> ), 27 ... 300 Hz, 3 cycles/axle
<ul style="list-style-type: none"> <li>Bumping (half-sine) according to EN 60068-2-27/02.2010</li> </ul>	150 m/s <sup>2</sup> (492 ft/s <sup>2</sup> ), 6 ms, 1000 shocks/axle
<ul style="list-style-type: none"> <li>Noise (digitally controlled) according to EN 60068-2-64/04.2009</li> </ul>	10 ... 200 Hz; 1 (m/s <sup>2</sup> ) <sup>2</sup> /Hz (3.28 (ft/s <sup>2</sup> ) <sup>2</sup> /Hz) 200 ... 500 Hz; 0.3 (m/s <sup>2</sup> ) <sup>2</sup> /Hz (0.98 (ft/s <sup>2</sup> ) <sup>2</sup> /Hz) 4 hours/axle
<ul style="list-style-type: none"> <li>Recommended range of continuous operation of the entire control valve</li> </ul>	≤ 30 m/s <sup>2</sup> (98.4 ft/s <sup>2</sup> ) without resonance peak
Climate class	
<ul style="list-style-type: none"> <li>Storage</li> </ul>	1K5, but -40 ... +80°C (1K5, but -40 ... +176°F)
<ul style="list-style-type: none"> <li>Transport</li> </ul>	2K4, but -40 ... +80°C (2K4, but -40 ... +176°F)

<sup>1)</sup> Max. impact energy 1 Joule for enclosure with inspection window 6DR5..0 and 6DR5..1 or max. 2 Joule for 6DR5..3

<sup>2)</sup> At ≤ -10 °C (≤ 14 °F) the display refresh rate of the indicator is limited. When using position feedback module, only T4 is permissible.

<sup>3)</sup> The following applies to order suffix (order code) **-Z M40**: -40 ... +80 °C (-40 ... +176°F)

## 13.2 Pneumatic data

<b>Pneumatic data</b>	
Auxiliary power (air supply)	Compressed air, carbon dioxide (CO <sub>2</sub> ), nitrogen (N), noble gases or cleaned natural gas
• Pressure <sup>1)</sup>	1.4 ... 7 bar (20.3 to 101.5 psi)
Air quality to ISO 8573-1	
• Solid particulate size and density	Class 2
• Pressure dew point	Class 2 (min. 20 K (36°F) below ambient temperature)
• Oil content	Class 2
Unrestricted flow (DIN 1945)	
• Inlet air valve (ventilate actuator) <sup>2)</sup>	
2 bar (29 psi)	4.1 Nm <sup>3</sup> /h (18.1 USgpm)
4 bar (58 psi)	7.1 Nm <sup>3</sup> /h (31.3 USgpm)
6 bar (87 psi)	9.8 Nm <sup>3</sup> /h (43.1 USgpm)
• Exhaust valve (deerate actuator for all versions except fail in place) <sup>2)</sup>	
2 bar (29 psi)	8.2 Nm <sup>3</sup> /h (36.1 USgpm)
4 bar (58 psi)	13.7 Nm <sup>3</sup> /h (60.3 USgpm)
6 bar (87 psi)	19.2 Nm <sup>3</sup> /h (84.5 USgpm)
• Exhaust valve (deerate actuator for fail in place version)	
2 bar (29 psi)	4.3 Nm <sup>3</sup> /h (19.0 USgpm)
4 bar (58 psi)	7.3 Nm <sup>3</sup> /h (32.2 USgpm)
6 bar (87 psi)	9.8 Nm <sup>3</sup> /h (43.3 USgpm)
Valve leakage	< 6·10 <sup>-4</sup> Nm <sup>3</sup> /h (0.0026 USgpm)
Throttle ratio	Adjustable up to ∞: 1
Auxiliary power consumption in the controlled state	< 3.6·10 <sup>-2</sup> Nm <sup>3</sup> /h (0.158 USgpm)
Sound pressure level	L <sub>A,eq</sub> < 75 dB L <sub>A,max</sub> < 80 dB

<sup>1)</sup> The following applies to fail in place: 3 ... 7 bar (43.5 to 101.5 psi)

<sup>2)</sup> When using device versions Ex d (6DR5..5-... and 6DR5..6-...), values are reduced by approximately 20%.

## 13.3 Construction

<b>Construction</b>	
How does it work?	
• Range of stroke (linear actuator)	3 ... 130 mm (0.12 ... 5.12") (angle of rotation of the positioner shaft 16 ... 90°)
• Angle of rotation (part-turn actuator)	30 ... 100°
Mounting method	

<b>Construction</b>	
• On the linear actuator	Using mounting kit 6DR4004-8V and, where necessary, an additional lever arm 6DR4004-8L on actuators according to IEC 60534-6-1 (NAMUR) with a fin, columns, or a plane surface.
• On the part-turn actuator	Using mounting kit 6DR4004-8D on actuators with mounting plane according to VDI/VDE 3845 and IEC 60534-6-2: The required mount must be provided on the actuator-side.
<b>Weight, positioner without option modules or accessories</b>	
• 6DR5..0 Glass-fiber reinforced polycarbonate enclosure	Approximately 0.9 kg (1.98 lb)
• 6DR5..1 aluminum enclosure, narrow	Approx. 1.3 kg (2.86 lb)
• 6DR5..2 stainless steel enclosure	Approx. 3.9 kg (8.6 lb)
• 6DR5..3 aluminum enclosure	Approx. 1.6 kg (3.53 lb)
• 6DR5..5 aluminum enclosure, flameproof	Approx. 5.2 kg (11.46 lb)
• 6DR5..6 stainless steel enclosure, flameproof	Approx. 8.4 kg (18.5 lb)
<b>Material</b>	
• Enclosure	
6DR5..0 Makrolon	Glass-fiber reinforced polycarbonate (PC)
6DR5..1 aluminum, narrow	GD AlSi12
6DR5..2 stainless steel	Austenitic stainless steel 316 Cb, mat. No. 1.4581
6DR5..3 aluminum	GD AlSi12
6DR5..5 aluminum, flameproof	GK AlSi12
6DR5..6 stainless steel enclosure, flameproof	Austenitic stainless steel 316 L, mat. No. 1.4409 or 316 Ti, mat. No. 1.4571
• Pressure gauge block	Aluminum AlMgSi, anodized or stainless steel 316
<b>Versions</b>	
• In Makrolon enclosure 6DR5..0	Single-acting and double-acting
• In aluminum enclosure 6DR5..1	Single-acting
• In aluminum enclosures 6DR5..3 and 6DR5..5	Single-acting and double-acting
• In stainless steel enclosures 6DR5..2 and 6DR5..6	Single-acting and double-acting
<b>Torques</b>	
• Part-turn actuator fixing screws DIN 933 M6x12-A2	5 Nm (3.7 ft lb)
• Linear actuator fixing screws DIN 933 M8x16-A2	12 Nm (8.9 ft lb)
• Gland pneumatic G $\frac{1}{4}$	15 Nm (11.1 ft lb)
• Gland pneumatic $\frac{1}{4}$ " NPT	
Without sealant	12 Nm (8.9 ft lb)
With sealant	6 Nm (4.4 ft lb)
• Cable glands	
Screw-in torque for plastic gland in all enclosures	4 Nm (3 ft lb)
Screw-in torque for cable gland made of metal/stainless steel in Makrolon enclosure	6 Nm (4.4 ft lb)
Screw-in torque for metal/stainless steel glands in aluminum/stainless steel enclosure	6 Nm (4.4 ft lb)

## Technical data

### 13.4 Controller

Construction	
Screw-in torque for NPT adapter made of metal/stainless steel in Makrolon enclosure	8 Nm (5.9 ft lb)
Screw-in torque for NPT adapter made of metal/stainless steel in aluminum/stainless steel enclosure	15 Nm (11.1 ft lb)
Screw-in torque for NPT gland in the NPT adapter NOTE: To avoid damage to the device, the NPT adapter must be held in place while the NPT gland is screwed into the NPT adapter.	68 Nm (50 ft lb)
Tightening torque for union nut made of plastic	2.5 Nm (1.8 ft lb)
Tightening torque for union nut made of metal/stainless steel	4 Nm (3 ft lb)
Manometer	
• Degree of protection	
Manometer made of plastic	IP31
Manometer, steel	IP44
Manometer made of stainless steel 316	IP54
• Vibration resistance	
	In accordance with DIN EN 837-1
Connections, electrical	
• Screw terminals	
	2.5 mm <sup>2</sup> AWG30-14
• Cable gland	
	Without Ex protection as well as with Ex i: M20x1.5 or ½-14 NPT With explosion protection Ex d: Ex d certified M20x1.5, ½-14 NPT or M25x1.5
Connections, pneumatic	Female thread G¼ or ¼-18 NPT







## 13.4 Controller

Controller	
Control unit	
• Five-point controller	
	Adaptive
• Dead zone	
dEbA = auto	Adaptive
dEbA = 0.1 ... 10 %	Can be set as fixed value
Analog-to-digital converter	
• Scanning time	
	10 ms
• Resolution	
	≤ 0,05 %
• Transmission error	
	≤ 0,2 %
• Temperature influence	
	≤ 0.1 %/10 K (≤ 0.1 %/18 °F)

## 13.5 Certificates, approvals, explosion protection

Certificates and approvals	
Classification according to pressure equipment directive (PED 97/23/EC)	For fluid group 1 gases; fulfills requirements according to article 3, paragraph 3 (good engineering practice SEP)
CE conformity	The applicable directives and applied standards with their revision levels can be found in the EC declaration of conformity on the Internet.

### Explosion protection

Explosion protection	Ex markings	
Explosion protection in accordance with	ATEX/IECEX	FM/CSA
Flameproof enclosure encapsulation "d", "XP" 6DR5..5/6	 II 2 G Ex d IIC T6/T4 Gb	FM: XP, Class I, Division 1, GP.ABCD CSA: XP, Class I, Division 1, GP.CD FM/CSA: XP, Class I, Zone 1, AEx d, IIC, T6/T4
Intrinsic safety "i", "IS"		
• 6DR5..0/1/2/3	 II 2 G Ex ia IIC T6/T4 Gb	IS / I, II / 1 / A-D
	 II 3 G Ex ic IIC T6/T4 Gc	IS / 1 / AEx / Ex ib / IIC, Gb
• 6DR5..1/2/3	 II 2 D Ex ia IIIC T110°C Db	IS / III / 1 / E-G IS / 21 / AEx / Ex ib / IIIC, Db, T110°C
Non-sparking "nA", "NI"	 II 3 G Ex nA IIC T6/T4 Gc	NI / 1 / 2 / A-D NI / 2 / AEx / Ex nA, Ex ic / IIC, Gc
Dust, protection by means of enclosure "t", "DIP"	 II 2 D Ex tb IIIC T100°C Db	DIP / II, III / 1 / E-G DIP / 21 / AEx / Ex tb / IIIC, Db, T100°C
• 6DR5..1-.D/K...		
• 6DR5..2-.D/K...		
• 6DR5..3-.D/K...		
• 6DR5..6-.E...		

### Breakdown of the article numbers for assignment of the maximum permissible ambient temperature ranges

6DR5ayb-	0cdef-	g..h-	Z jji
a = 0, 2, 5, 6	c = E, G, D, F, K	g = 0, 2, 6, 7, 8	A20, A40, C20, D53, D54, D55, D56, F01, K**, L1A, M40, R**, S**, Y** * = any character
y = 1, 2	d = G, N, M, P, R, S	h = 0, 1, 2, 3, 4, 9	
b = 0, 1, 2, 3	e = 0, 1, 2, 3		
	f = 0, 1, 2, 3		

**Maximum permissible ambient temperature ranges with types of protection Ex ia, Ex ic and Ex nA**

Explosion protection in accordance with	ATEX/IECEX	FM/CSA
• 6DR5ayb-0cdef-g.Ah-Z ...	T4: $-30 \leq T_a \leq +80 \text{ °C}$ ( $-22 \leq T_a \leq +176 \text{ °F}$ ) T6: $-30 \leq T_a \leq +50 \text{ °C}$ ( $-22 \leq T_a \leq +122 \text{ °F}$ )	
• 6DR5ayb-0cdef-g.Ah-Z <b>M40</b>	T4: $-40 \leq T_a \leq +80 \text{ °C}$ ( $-40 \leq T_a \leq +176 \text{ °F}$ ) T6: $-40 \leq T_a \leq +50 \text{ °C}$ ( $-40 \leq T_a \leq +122 \text{ °F}$ )	
Position feedback module (already fitted or can be retrofitted)		
• Already fitted: 6DR5ayb-0cdef-g.Ah-Z ... with the data (f = 1 or 3)	T4: $-30 \leq T_a \leq +80 \text{ °C}$ ( $-22 \leq T_a \leq +176 \text{ °F}$ )	
• Can be retrofitted 6DR4004-6J		
• Already fitted and can be retrofitted: 6DR5ayb-0cdef-g.Ah-Z <b>M40</b> with the data (f = 1 or 3)	T4: $-40 \leq T_a \leq +80 \text{ °C}$ ( $-40 \leq T_a \leq +176 \text{ °F}$ )	
Option modules		
• Non contacting sensor (NCS) 6DR4004-6N..-0-...	T4: $-40 \leq T_a \leq +90 \text{ °C}$ ( $-40 \leq T_a \leq +194 \text{ °F}$ ) T6: $-40 \leq T_a \leq +70 \text{ °C}$ ( $-40 \leq T_a \leq +158 \text{ °F}$ )	T4: $-40 \leq T_a \leq +85 \text{ °C}$ ( $-40 \leq T_a \leq +185 \text{ °F}$ ) T6: $-40 \leq T_a \leq +70 \text{ °C}$ ( $-40 \leq T_a \leq +158 \text{ °F}$ )
• External position detection system C73451-A430-D78	T4: $-40 \leq T_a \leq +90 \text{ °C}$ ( $-40 \leq T_a \leq +194 \text{ °F}$ ) T6: $-40 \leq T_a \leq +60 \text{ °C}$ ( $-40 \leq T_a \leq +140 \text{ °F}$ )	T4: $-40 \leq T_a \leq +85 \text{ °C}$ ( $-40 \leq T_a \leq +185 \text{ °F}$ ) T6: $-40 \leq T_a \leq +60 \text{ °C}$ ( $-40 \leq T_a \leq +140 \text{ °F}$ )

**Maximum permissible ambient temperature ranges with type of protection Ex t**

Explosion protection in accordance with	ATEX/IECEX	FM/CSA
• 6DR5ayb-0cdef-g.Ah-Z ... with the data (c = D or K)		$-30 \leq T_a \leq +80 \text{ °C}$ ( $-22 \leq T_a \leq +176 \text{ °F}$ )
• 6DR5ayb-0cdef-g.Ah-Z <b>M40</b> with the data (c= D or K)		$-40 \leq T_a \leq +80 \text{ °C}$ ( $-40 \leq T_a \leq +176 \text{ °F}$ )

## 13.6 Electrical specifications

	Basic device without explosion protection	Basic device with explosion protection Ex d	Basic device with explosion protection Ex "ia"	Basic device with explosion protection Ex "ic", "nA", "t"
Auxiliary power supply bus circuit			Bus-powered	
Bus voltage	9 ... 32 V	9 ... 32 V	9 ... 24 V	9 ... 32 V
For connecting to circuits with the following peak values				



	Basic device without explosion protection	Basic device with explosion protection Ex d	Basic device with explosion protection Ex "ia"	Basic device with explosion protection Ex "ic", "nA", "t"
• Bus connector with FISCO supply unit	-	-	U <sub>i</sub> = 17.5 V I <sub>i</sub> = 380 mA P <sub>i</sub> = 5.32 W	"ic": U <sub>i</sub> = 17.5 V I <sub>i</sub> = 570 mA "nA"/"t": U <sub>n</sub> ≤ 32 V
• Bus connector with barrier			U <sub>i</sub> = 24 V I <sub>i</sub> = 250 mA P <sub>i</sub> = 1.2 W	"ic": U <sub>i</sub> = 32 V "nA"/"t": U <sub>n</sub> ≤ 32 V
Effective inner capacitance C <sub>i</sub>	-	-	Negligible	Negligible
Effective inner inductance L <sub>i</sub>	-	-	8 μH	"ic": 8 μH
Current consumption	11.5 mA ± 10 %			
Additional fault current	0 mA			
<b>Safety shutdown can be activated using "Jumper" (terminals 81 and 82)</b>	Electrically isolated from bus circuit and binary input			
• Input resistance	> 20 kΩ			
• Signal status "0" (shutdown active)	0 ... 4.5 V or unused			
• Signal status "1" (shutdown inactive)	13 ... 30 V			
• For connecting to power source with the following peak values	-	-	U <sub>i</sub> = 30 V I <sub>i</sub> = 100 mA P <sub>i</sub> = 1 W	"nA": U <sub>n</sub> ≤ 30 V I <sub>n</sub> ≤ 100 mA "ic": U <sub>i</sub> = 30 V I <sub>i</sub> = 100 mA
• Effective internal capacitance and inductance	-	-	Negligible	Negligible
<b>Binary input BE1 (terminals 9 and 10) electrically connected to the bus circuit</b>	Jumpered or connection to switch contact. Suitable only for floating contact; max. contact load < 5 μA with 3 V			
<b>Galvanic isolation</b>				
• For basic device without Ex protection and for basic device with Ex d	Galvanic isolation between the basic device and the input for safety shutdown and the outputs of option modules.			
• For basic device Ex "ia"	The basic device, the input for safety shutdown, and the outputs of option modules are individual intrinsically safe circuits.			

13.7 Technical data for natural gas as actuator medium

	Basic device without explosion protection	Basic device with explosion protection Ex d	Basic device with explosion protection Ex "ia"	Basic device with explosion protection Ex "ic", "nA", "t"
• For basic device Ex "ic", "nA", "t"	Galvanic isolation between the basic device and the input for safety shutdown and the outputs of option modules.			
Test voltage	DC 840 V, 1 s			

## 13.7 Technical data for natural gas as actuator medium

### Introduction

Note when using an actuator with natural gas that this can escape at the following points:

- At the exhaust air outlet with sound absorber.
- At the enclosure vent.
- At the control air outlet near the pneumatic connections.

#### Note

##### Exhaust air outlet with a sound absorber

The positioner is supplied as standard with a sound absorber. To provide an outlet for the exhaust air, replace the sound absorber by a G $\frac{1}{4}$  pipe coupling.

##### Enclosure ventilation and control air outlet

Enclosure ventilation and control air outlet cannot be collected and channeled off.

Please refer to the following table for the maximum ventilation values.

### Maximum values for escaping natural gas

Ventilation process	Operating mode	6DR5.1.-.E...	6DR5.2.-.E...
		Single-acting	Double-acting
		[Nl/min]	[Nl/min]
Ventilation of the enclosure volume. Purge air switch is at "IN":	Operation, typical	0.14	0.14
	Operation, max.	0.60	0.60
	Error case, max.	60.0	60.0
Ventilation via the control air outlet near the pneumatic connections:	Operation, typical	1.0	2.0
	Operation, max.	8.9	9.9
	Error case, max.	66.2	91.0

Ventilation process	Operating mode	6DR5.1.-.E...	6DR5.2.-.E...
		Single-acting	Double-acting
		[NI/min]	[NI/min]
Ventilation through the exhaust air outlet with a sound absorber	Operation, max.	358.2 <sup>1)</sup>	339 <sup>1)</sup>
	Error case, max.		
Volume	Max. [l]	1.26	1.23

1) Depending on the actuating pressure and volume of the actuator as well as the frequency of control. The maximum flow rate is 470 NI/min at a differential pressure of 7 bar.

**See also**

Basic safety instructions (Page 113)

Pneumatic connection for 6DR55.0/1/2/3 (Page 96)

## 13.8 Option modules

### 13.8.1 Alarm module

	Without explosion protection or suitable for use in the SIPART PS2 Ex d	With Ex protection Ex "ia"	With Ex protection Ex "ic", "nA", "t"
<b>Alarm module</b>	6DR4004-8A	6DR4004-6A	6DR4004-6A
3 binary output circuits			
<ul style="list-style-type: none"> <li>• Alarm output A1: Terminals 41 and 42</li> <li>• Alarm output A2: Terminals 51 and 52</li> <li>• Fault message output: Terminals 31 and 32</li> </ul>			
• Auxiliary voltage $U_H$	$\leq 35\text{ V}$	-	-
• Signal status			
High (not addressed)	Conductive, $R = 1\text{ k}\Omega$ , $+3/-1\%$ *)	$\geq 2.1\text{ mA}$	$\geq 2.1\text{ mA}$
Low *) (addressed)	Deactivated, $I_R < 60\text{ }\mu\text{A}$	$\leq 1.2\text{ mA}$	$\leq 1.2\text{ mA}$
*) The status is also Low if the basic device is faulty or without an auxiliary power.	*) When using in the flame-proof housing, the current consumption must be restricted to 10 mA per output.	Switching thresholds for supply as per EN 60947-5-6: $U_H = 8.2\text{ V}$ , $R_i = 1\text{ k}\Omega$	Switching thresholds for supply as per EN 60947-5-6: $U_H = 8.2\text{ V}$ , $R_i = 1\text{ k}\Omega$

## Technical data

### 13.8 Option modules

	Without explosion protection or suitable for use in the SIPART PS2 Ex d	With Ex protection Ex "ia"	With Ex protection Ex "ic", "nA", "t"
<ul style="list-style-type: none"> <li>For connecting to circuits with the following peak values</li> </ul>	-	$U_i = 15 \text{ VDC}$ $I_i = 25 \text{ mA}$ $P_i = 64 \text{ mW}$	"ic": $U_i = 15 \text{ VDC}$ $I_i = 25 \text{ mA}$ "nA"/"t": $U_n \leq 15 \text{ VDC}$
Effective internal capacitance	-	$C_i = 5.2 \text{ nF}$	$C_i = 5.2 \text{ nF}$
Effective internal inductance	-	$L_i = \text{negligibly small}$	$L_i = \text{negligibly small}$
1 binary input circuit			
<ul style="list-style-type: none"> <li>Binary input BI2: Terminals 11 and 12, terminals 21 and 22 (jumper)</li> <li>Galvanically connected with the basic device</li> </ul>			
Signal status 0		Floating contact, open	
Signal status 1		Floating contact, closed	
Contact load		3 V, 5 $\mu\text{A}$	
<ul style="list-style-type: none"> <li>Electrically isolated from the basic device</li> </ul>			
Signal status 0		$\leq 4.5 \text{ V}$ or open	
Signal status 1		$\geq 13 \text{ V}$	
Internal resistance		$\geq 25 \text{ k}\Omega$	
<ul style="list-style-type: none"> <li>Static destruction limit</li> </ul>	$\pm 35 \text{ V}$	-	-
<ul style="list-style-type: none"> <li>Connecting to circuits with the following peak values</li> </ul>	-	$U_i = \text{DC } 25.2 \text{ V}$	"ic": $U_i = \text{DC } 25.2 \text{ V}$ "nA"/"t": $U_n \leq \text{DC } 25.5 \text{ V}$
Effective internal capacitance	-	$C_i = \text{negligibly small}$	$C_i = \text{negligibly small}$
Effective internal inductance	-	$L_i = \text{negligibly small}$	$L_i = \text{negligibly small}$
Galvanic isolation	The three outputs, the BI2 input and the basic device are galvanically isolated from each other.		
Test voltage		DC 840 V, 1 s	

### 13.8.2 Position feedback module

	Without explosion protection or suitable for use in the SIPART PS2 Ex d	With Ex protection Ex ia (only in temperature class T4)	With Ex protection Ex "ic", "nA", "t"
<b>Position feedback module</b>	6DR4004-8J	6DR4004-6J	6DR4004-6J
Direct current output for position feedback			
1 current output, terminals 61 and 62			
		2-wire connection	

	Without explosion protection or suitable for use in the SIPART PS2 Ex d	With Ex protection Ex ia (only in temperature class T4)	With Ex protection Ex "ic", "nA", "t"
Rated signal range		4 ... 20 mA, short-circuit proof	
Dynamic range		3.6 ... 20.5 mA	
Auxiliary voltage $U_H$	+12 ... +35 V	+12 ... +30 V	+12 ... +30 V
External load $R_B$ [kΩ]		$\leq (U_H [V] - 12 V)/I$ [mA]	
Transmission error		$\leq 0.3 \%$	
Temperature influence		$\leq 0.1\%/10 \text{ K}$ ( $\leq 0.1\%/18 \text{ °F}$ )	
Resolution		$\leq 0.1 \%$	
Residual ripple		$\leq 1 \%$	
For connecting to circuits with the following peak values		$U_i = \text{DC } 30 \text{ V}$ $I_i = 100 \text{ mA}$ $P_i = 1 \text{ W}$	"ic": $U_i = \text{DC } 30 \text{ V}$ $I_i = 100 \text{ mA}$ "nA"/"t": $U_n \leq \text{DC } 30 \text{ V}$ $I_n \leq 100 \text{ mA}$ $P_n \leq 1 \text{ W}$
Effective internal capacitance	-	$C_i = 11 \text{ nF}$	$C_i = 11 \text{ nF}$
Effective internal inductance	-	$L_i = \text{negligibly small}$	$L_i = \text{negligibly small}$
Galvanic isolation		Safe galvanic isolation from alarm option and basic device	
Test voltage		DC 840 V, 1 s	

### 13.8.3 SIA module

	Without Ex protection	With Ex protection Ex "ia"	With Ex protection Ex "ic", "nA", "t"
<b>SIA module</b>	6DR4004-8G	6DR4004-6G	6DR4004-6G
Limit encoder with slotted initiators and fault message output			
2 slotted initiators			
<ul style="list-style-type: none"> <li>Binary output (limit transmitter) A1: Terminals 41 and 42</li> <li>Binary output (limit transmitter) A2: Terminals 51 and 52</li> </ul>			
<ul style="list-style-type: none"> <li>Connection</li> </ul>	2 wire technology in accordance with EN 60947-5-6 (NAMUR), for switching amplifiers connected on load side		
<ul style="list-style-type: none"> <li>Signal state High (not triggered)</li> </ul>		> 2.1 mA	
<ul style="list-style-type: none"> <li>Signal state Low (triggered)</li> </ul>		< 1.2 mA	
<ul style="list-style-type: none"> <li>2 slotted initiators</li> </ul>		Type SJ2-SN	
<ul style="list-style-type: none"> <li>Function</li> </ul>		NC contact (NC, normally closed)	

## Technical data

### 13.8 Option modules

	Without Ex protection	With Ex protection Ex "ia"	With Ex protection Ex "ic", "nA", "t"
<ul style="list-style-type: none"> <li>Connecting to circuits with the following peak values</li> </ul>	Nominal voltage 8 V; current consumption: $\geq 3$ mA (limit not activated), $\leq 1$ mA (limit activated)	$U_i = DC 15 V$ $I_i = 25 mA$ $P_i = 64 mW$	"ic": $U_i = DC 15 V$ $I_i = 25 mA$ "nA": $U_n \leq DC 15 V$ $P_n \leq 64 mW$
Effective internal capacitance	-	$C_i = 41 nF$	$C_i = 41 nF$
Effective internal inductance	-	$L_i = 100 \mu H$	$L_i = 100 \mu H$
1 fault message output			
<ul style="list-style-type: none"> <li>Binary output: Terminals 31 and 32</li> </ul>			
Connection	At switching amplifier in accordance with EN 60947-5-6: (NAMUR), $U_H = 8.2 V$ , $R_i = 1 k\Omega$ .		
Signal state High (not triggered)	$R = 1.1 k\Omega$	$> 2.1 mA$	$> 2.1 mA$
Signal state Low (triggered)	$R = 10 k\Omega$	$< 1.2 mA$	$< 1.2 mA$
Auxiliary power $U_H$	$U_H \leq DC 35 V$ $I \leq 20 mA$	-	-
Connecting to circuits with the following peak values	-	$U_i = DC 15 V$ $I_i = 25 mA$ $P_i = 64 mW$	"ic": $U_i = DC 15 V$ $I_i = 25 mA$ "nA": $U_n \leq DC 15 V$ $P_n \leq 64 mW$
Effective internal capacitance	-	$C_i = 5.2 nF$	$C_i = 5.2 nF$
Effective internal inductance	-	$L_i =$ negligibly small	$L_i =$ negligibly small
Galvanic isolation	The 3 outputs are galvanically isolated from the basic device.		
Test voltage	DC 840 V, 1 s		

### 13.8.4 Mechanical limit switch module

	Without Ex protection	With Ex protection Ex ia	With Ex protection Ex "ic", "t"
<b>Mechanical limit switch module</b>	6DR4004-8K	6DR4004-6K	6DR4004-6K
Limit encoder with mechanical switching contacts			
2 limit contacts			
<ul style="list-style-type: none"> <li>Binary output 1: Terminals 41 and 42</li> <li>Binary output 2: Terminals 51 and 52</li> </ul>			
Max. switching current AC/DC	4 A	-	-

	Without Ex protection	With Ex protection Ex ia	With Ex protection Ex "ic", "t"
<ul style="list-style-type: none"> <li>For connecting to circuits with the following peak values</li> </ul>	-	$U_i = 30\text{ V}$ $I_i = 100\text{ mA}$ $P_i = 750\text{ mW}$	"ic": $U_i = 30\text{ V}$ $I_i = 100\text{ mA}$ "t": $U_n = 30\text{ V}$ $I_n = 100\text{ mA}$
Effective internal capacitance	-	$C_i = \text{negligibly small}$	$C_i = \text{negligibly small}$
Effective internal inductance	-	$L_i = \text{negligibly small}$	$L_i = \text{negligibly small}$
<ul style="list-style-type: none"> <li>Max. switching voltage AC/DC</li> </ul>	250 V/24 V	DC 30 V	DC 30 V
1 fault message output			
<ul style="list-style-type: none"> <li>Binary output: Terminals 31 and 32</li> </ul>			
Connection	On switching amplifier according to EN 60947-5-6: (NAMUR), $U_H = 8.2\text{ V}$ , $R_i = 1\text{ k}\Omega$ .		
Signal state High (not triggered)	$R = 1.1\text{ k}\Omega$	$> 2.1\text{ mA}$	$> 2.1\text{ mA}$
Signal state Low (triggered)	$R = 10\text{ k}\Omega$	$< 1.2\text{ mA}$	$< 1.2\text{ mA}$
Auxiliary power	$U_H \leq \text{DC } 35\text{ V}$ $I \leq 20\text{ mA}$	-	-
<ul style="list-style-type: none"> <li>Connecting to circuits with the following peak values</li> </ul>	-	$U_i = 15\text{ V}$ $I_i = 25\text{ mA}$ $P_i = 64\text{ mW}$	"ic" : $U_i = 15\text{ V}$ $I_i = 25\text{ mA}$ "t": $U_n = 15\text{ V}$ $I_n = 25\text{ mA}$
Effective internal capacitance	-	$C_i = 5.2\text{ nF}$	$C_i = 5.2\text{ nF}$
Effective internal inductance	-	$L_i = \text{negligibly small}$	$L_i = \text{negligibly small}$
Galvanic isolation	The 3 outputs are galvanically isolated from the basic device		
Test voltage	DC 3150 V, 2 s		
Rated condition height	Max. 2 000 m mean sea level Use a suitable power supply at an altitude of more than 2 000 m above sea level.	-	-

### 13.8.5 EMC filter module

	Without Ex protection	With Ex protection Ex ia	With Ex protection Ex "ic", "nA", "t"
EMC filter module type C73451-A430-D23 is required for NCS sensor or an external potentiometer. External position sensor (potentiometer or NCS; option) with the following maximum values			
Resistance of the external potentiometer		10 kΩ	

## Technical data

### 13.8 Option modules

	Without Ex protection	With Ex protection Ex ia	With Ex protection Ex "ic", "nA", "t"
Maximum values when powered by the PROFIBUS basic device	-	U <sub>o</sub> = 5 V I <sub>o</sub> = 75 mA static I <sub>o</sub> = 160 mA short-term P <sub>o</sub> = 120 mW	U <sub>o</sub> = 5 V I <sub>o</sub> = 75 mA P <sub>o</sub> = 120 mW
Maximum values when powered by other basic devices	-	U <sub>o</sub> = 5 V I <sub>o</sub> = 100 mA P <sub>o</sub> = 33 mW C <sub>o</sub> = 1 µF L <sub>o</sub> = 1 mH	U <sub>o</sub> = 5 V I <sub>o</sub> = 75 mA P <sub>o</sub> = 120 mW C <sub>o</sub> = 1 µF L <sub>o</sub> = 1 mH
Galvanic isolation		Galvanically connected with the basic device	



### 13.8.6 NCS 6DR4004-.N.20 and 6DR4004-.N.30

Additional modules	Without Ex protection	With Ex protection Ex "ia"	With Ex protection Ex "ic", "nA"
Travel range			
• Linear actuator 6DR4004-.N.20		3 to 14 mm (0.12 to 0.55")	
• Linear actuator 6DR4004-.N.30	10 to 130 mm (0.39 to 5.12"); up to 200 mm (7.87") on request		
• Part-turn actuator		30 to 100°	
Linearity (after corrections made by positioner)		± 1 %	
Hysteresis		± 0.2 %	
Temperature influence (range: rotation angle 120° or stroke 14 mm)		≤ 0.1 %/10 K (≤ 0.1 %/18 °F) for -20 to +90 °C (-4 to +194 °F) ≤ 0.2%/10 K (≤ 0.2%/18 °F) for -40 to -20 °C (-40 to -4 °F)	
Climate class		According to IEC/EN 60721-3	
• Storage		1K5, but -40 to +90 °C (-40 to +194 °F)	
• Transport		2K4, but -40 to +90 °C (-40 to +194 °F)	
Vibration resistance			
• Harmonic oscillations (sine) according to IEC 60068-2-6		3.5 mm (0.14"), 2 to 27 Hz, 3 cycles/axis 98.1 m/s <sup>2</sup> (321.84 ft/s <sup>2</sup> ), 27 to 300 Hz, 3 cycles/axis	
• Bumping according to IEC 60068-2-29		300 m/s <sup>2</sup> (984 ft/s <sup>2</sup> ), 6 ms, 4000 shocks/axis	
Torque for cable gland nut made of	Plastic	Metal	Stainless steel
	2.5 Nm (1.8 ft lb)	4.2 Nm (3.1 ft lb)	4.2 Nm (3.1 ft lb)
Housing protection type	IP68 according to IEC/EN 60529; NEMA 4X / Encl. Type 4X		
For connecting to circuits with the following peak values	-	U <sub>i</sub> = 5 V I <sub>i</sub> = 160 mA P <sub>i</sub> = 120 mW	U <sub>i</sub> = 5 V
Effective internal capacitance	-	C <sub>i</sub> = 180 nF	C <sub>i</sub> = 180 nF
Effective internal inductance	-	L <sub>i</sub> = 922 µH	L <sub>i</sub> = 922 µH



**Certificates and approvals**

CE conformity	The applicable directives and applied standards with their revision levels can be found in the EC declaration of conformity on the Internet.
---------------	--

Explosion protection Types of protection	Ex markings	
	ATEX/IECEX	FM/CSA
• Intrinsic safety "ia"	Zone 1:  II 2 G Ex ia IIC T6/T4 Gb	IS, Class I, Divison 1, ABCD IS, Class I, Zone 1, AEx ib, IIC
• Intrinsic safety "ic"	Zone 2:  II 3 G Ex ic IIC T6/T4 Gc	-
• Non-sparking "nA"	Zone 2:  II 3 G Ex nA IIC T6/T4 Gc	NI, Class I, Divison 2, ABCD NI, Class I, Zone 2, AEx nA, IIC
<b>Perm. ambient temperature</b>	T4: -40 ... +90 °C (-40 ... +194 °F) T6: -40 ... +70 °C (-40 ... +158 °F)	T4: -40 ... +85 °C (-40 ... +185 °F) T6: -40 ... +70 °C (-40 ... +158 °F)

**13.8.7 Internal NCS modules 6DR4004-5L and 6DR4004-5LE**

Additional modules	Without Ex protection	With Ex protection Ex "ia"	With Ex protection Ex "ic", "nA", "t"
<b>Internal NCS module</b>	6DR4004-5L	6DR4004-5LE	6DR4004-5LE
Linearity (after corrections made by positioner)	± 1 %	± 1 %	± 1 %
Hysteresis	± 0.2 %	± 0.2 %	± 0.2 %

**13.8.8 External position sensing system**

**13.8.8.1 Rated conditions for external position detection system**

<b>Ambient temperature</b>	<b>In hazardous areas, observe the maximum permissible ambient temperature corresponding to the temperature class.</b>
• Perm. ambient temperature for operation	-40 ... +90 °C (-40 ... +194 °F)
Degree of protection <sup>1)</sup>	IP66 to IEC/EN 60529 / NEMA 4X
Climate class	According to IEC/EN 60721-3
• Storage	1K5, but -40 ... +90 °C (1K5, but -40 ... +194 °F)
• Transport	2K4, but -40 ... +90 °C (2K4, but -40 ... +194 °F)
• Operation	4K3, but -40 ... +90 °C (4K3, but -40 ... +194 °F)

<sup>1)</sup> ) Impact energy max. 1 joule.



### 13.8.8.2 Construction for external position detection system

Construction	
How does it work?	
• Range of stroke (linear actuator)	3 ... 130 mm (0.12 ... 5.12") (angle of rotation of the positioner shaft 16 to 90°)
• Angle of rotation (part-turn actuator)	30 ... 100°
Mounting method	
• On the linear actuator	Using mounting kit 6DR4004-8V and, where necessary, an additional lever arm 6DR4004-8L on actuators according to IEC 60534-6-1 (NAMUR) with a fin, columns, or a plane surface.
• On the part-turn actuator	Using mounting kit 6DR4004-8D on actuators with mounting plane according to VDI/VDE 3845 and IEC 60534-6-2: The required mount must be provided on the actuator-side.
Material	
• Enclosure	Makrolon® glass-fiber reinforced polycarbonate (PC)
Weight, basic device	Approximately 0.9 kg (1.98 lb)
Torque for cable gland nut made of plastic	2.5 Nm

### 13.8.8.3 Certificates, approvals, explosion protection for external position detection system

Electrical data	
For connecting to circuits with the following peak values	$U_i = 5 \text{ V}$ $I_i = 100 \text{ mA}$ $P_i = 160 \text{ mW}$ $C_i = \text{negligibly small}$ $L_i = \text{negligibly small}$

Certificates and approvals	
CE conformity	The applicable directives and applied standards with their revision levels can be found in the EC declaration of conformity on the Internet.

Explosion protection	Ex markings
Explosion protection in accordance with	ATEX
Intrinsic safety "ia"	Zone 1:  II 2 G Ex ia IIC T6/T4 Gb Zone 21:  II 2 D Ex ia IIIC T110°C Db
Intrinsic safety "ic"	Zone 2:  II 3 G Ex ic IIC T6/T4 Gc

Explosion protection	Ex markings
Non-sparking "nA"	Zone 2:  II 3 G Ex nA IIC T6/T4 Gc
Permissible ambient temperature	T4: -40 ... +90 °C (-40 ... +194 °F) T6: -40 ... +60 °C (-40 ... +140 °F)



## Dimension drawings

### 14.1 Positioner in non-flameproof enclosure

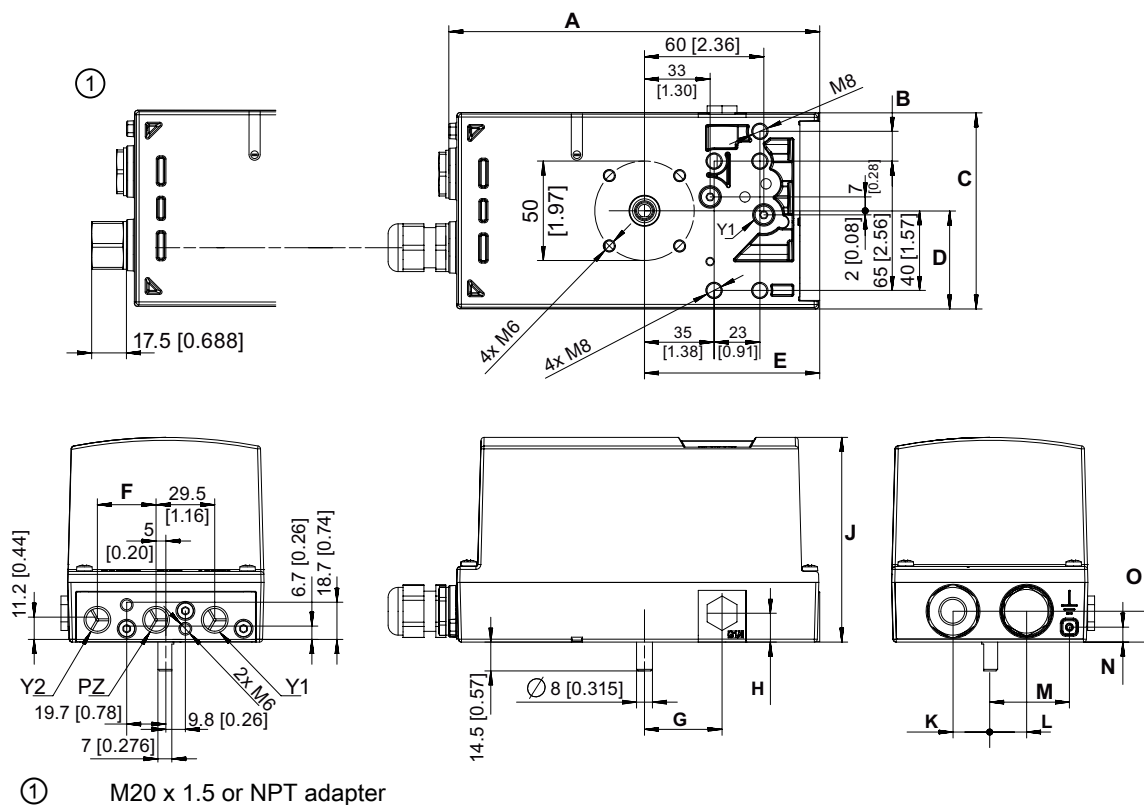
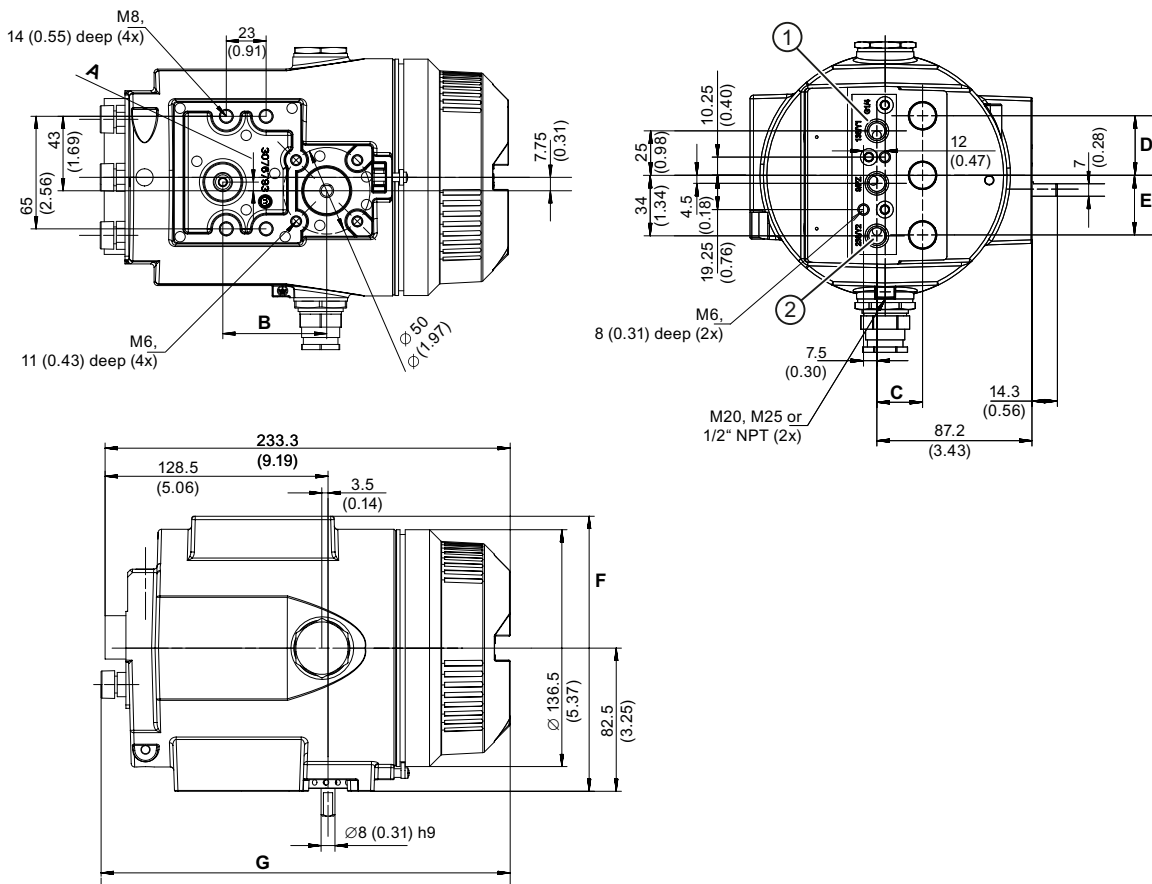

Figure 14-1 Dimension drawing, dimensions in mm (inch)

	6DR5..0		6DR5..1	6DR5..2	6DR5..3 / 6DR64..	
	G $\frac{1}{4}$	$\frac{1}{4}$ -NPT			G $\frac{1}{4}$	$\frac{1}{4}$ -NPT
A	184.5 [7.26]	186.5 [7.34]	185 [7.28]	186.5 [7.34]	186.5 [7.34]	188.5 [7.42]
B	-	-	-	15 [0.59]		
C	95 [3.74]		84 [3.31]	99 [3.90]	98.6 [3.88]	
D	48 [1.89]		34.5 [1.36]	49.5 [1.95]	48.6 [1.91]	
E	88.5 [3.48]		90.5 [3.56]	88.5 [3.48]	88.8 [3.50]	
F*)	29.5 [1.16]		-	29.5 [1.16]	29.5 [1.16]	
G	39 [1.54]		44 [1.73]	39 [1.54]	39 [1.54]	
H	14.5 [0.57]		16 [0.63]	16 [0.63]	14.5 [0.57]	
J	96.6 [3.80]		96.6 [3.80]	98.5 [3.88]	103 [4.06]	
K	18.5 [0.73]		22 [0.87]	18.5 [0.73]	18.5 [0.73]	
L	18.5 [0.73]		7 [0.23]	18.5 [0.73]	18.5 [0.73]	



### 14.3 Positioner with flameproof enclosure



- ① All air connections G $\frac{1}{4}$  or  $\frac{1}{4}$ " NPT
- ② Air connection Y2, only with double-acting version

Figure 14-3 Dimensions of positioner in flameproof enclosure

	6DR5..5	6DR5..6
A	5 [0.2]	-
B	60 [2.36]	-
C	25.7 [1.01]	21.7 [0.85]
D	33.5 [1.32]	25 [0.99]
E	33.5 [1.32]	-
F	158.5 [6.24]	160 [6.3]
G	235.3 [9.26]	227.6 [8.96]

Dimensions in mm [inch]

6DR5..5 Aluminum enclosure, flameproof; dimensions with pneumatic connection G $\frac{1}{4}$  or  $\frac{1}{4}$ " NPT

6DR5..6 Stainless steel enclosure, flameproof





## Spare parts / accessories / scope of delivery

### 15.1 Order data

In order to ensure that the ordering data you are using is not outdated, the latest ordering data is always available on the Internet:

Process instrumentation catalog (<http://www.siemens.com/processinstrumentation/catalogs>)

### 15.2 Overview

 <b>WARNING</b>
<b>Assembling the components</b>
When assembling components, ensure that only those positioners and option modules are combined with each other that are approved for the corresponding operating range.
These conditions particularly apply to safe operation of the positioner in hazardous areas. Observe the applicable certificates and approvals or the "Technical data (Page 283)".

#### Basic version

The positioner can be delivered for:

- Double-acting actuators
- Single-acting actuators

The positioner and its option modules are delivered as separate units and with different versions for the operation in:

- Hazardous environments and atmospheres
- Non-hazardous environments and atmospheres

#### Enclosure

The electronic unit with display, the position feedback, and the pneumatic block are integrated in the enclosure.

The enclosure is available in the following versions:

- Makrolon enclosure for single and double-acting actuators
- Aluminum enclosure for single-acting or double-acting actuators
- Stainless steel enclosure for single and double-acting actuators
- Flameproof enclosure for single and double-acting actuators

15.3 Spare parts

**Options**

The positioner can be equipped with different option modules. The following modules are normally available:

- Position feedback module: two-wire current output 4 to 20 mA for position feedback
- Alarm module: 3 binary outputs and 1 binary input
- SIA module: one binary output for fault messages, two binary outputs for limit monitors
- Mechanical limit switch module with two switches and one alarm output
- Internal NCS module 6DR4004-5L/-5LE

The SIA module and the mechanical limit switch module cannot be used in device versions with flameproof enclosure. For more limitations, please refer to section "Technical data (Page 283)".

**Accessories**

- Pressure gauge block: 2 or 3 pressure gauges for single and double-acting positioners
- Mounting flange (NAMUR) for safety pneumatic block
- Mounting kits for linear and part-turn actuators

For separate mounting of positioner and position sensor

- External position detection system
- NCS sensor for contactless position detection





**Note**

The version is identified using a special nameplate.

**15.3 Spare parts**

	Description	Order No.	For version
	Basic electronics, 2-wire, not Ex, without HART	A5E00082459	6DR50..-N
	Basic electronics 2-wire, Ex, without HART	A5E00082457	6DR50..-D/E/F/G/K
	Basic electronics, 2-wire, not Ex, with HART	A5E00082458	6DR51..-N
	Basic electronics, 2/3/4-wire, Ex, with HART	A5E00082456	6DR52..-D/E/F/G/K
	Basic electronics, 2/3/4-wire, not Ex, without HART	A5E00102018	6DR53..-N
	Basic electronics, PROFIBUS PA, not Ex	A5E00141523	6DR55..-N
	Basic electronics, PROFIBUS PA, Ex	A5E00141550	6DR55..-D/E/F/G/K
	Basic electronics, FOUNDATION Fieldbus, not Ex	A5E00215467	6DR56..-N
Basic electronics, FOUNDATION Fieldbus, Ex	A5E00215466	6DR56..-D/E/F/G/K	

## 15.4 Scope of delivery of external position detection system

	Description	Order No.	For version
	Pneumatic block, single-acting, with seal and screws	C73451-A430-D80	6DR5...
	Pneumatic block, double-acting, with seal and screws	C73451-A430-D81	6DR5...
	Valve manifold for Fail in Place, with seal, cover panel and screws	A5E34409029	-Z F01
	Potentiometer (complete)	C73451-A430-D84	6DR5...
	Magnet holder made of fiberglass reinforced polyester including magnet for non-contacting position detection for part-turn actuators	A5E00078030	6DR4004-.N.10
	Magnet holder made of anodized aluminum including magnet for non-contacting position detection for part-turn actuators	A5E00524070	6DR4004-.N.40
	Stainless steel sound absorber, 3 units	A5E32527711	6DR5..0; 6DR5..1; 6DR5..2; 6DR5..3
	Manometer 0 to 10 bar, metal, G1/8, 3 units	A5E32527731	6DR5...
	Manometer 0 to 10 bar, stainless steel, G1/8, 3 units	A5E32527735	6DR5...

**Note**

See Catalog FI 01 "Field devices for process automation" for additives and possible modules".

## 15.4 Scope of delivery of external position detection system

Scope of delivery of external position detection system C73451-A430-D78	
Quantity	Designation
1	DVD with the complete documentation for all variants and accessories
1	External position detection system
1	Gray cable gland
1	Sealing set 2x5 mm for cable gland
1	Plug for sealing set
1	Nameplate for device version <b>without</b> explosion protection

## 15.5 Scope of delivery of mechanical limit switch module

If the mechanical limit switch module was ordered for later installation, then the following components are included in the scope of delivery:

- One mechanical limit switch module with accessories
- DVD with product documentation
- One housing cover with enlarged aperture
- One insulating cover
- Two cable ties
- One set of signs; how these are to be attached depends on the version.

## 15.6 Scope of delivery EMC filter module

### Cable glands and adapters

The EMC filter module is supplied with various cable glands and adapters. The following diagram shows the different variants.

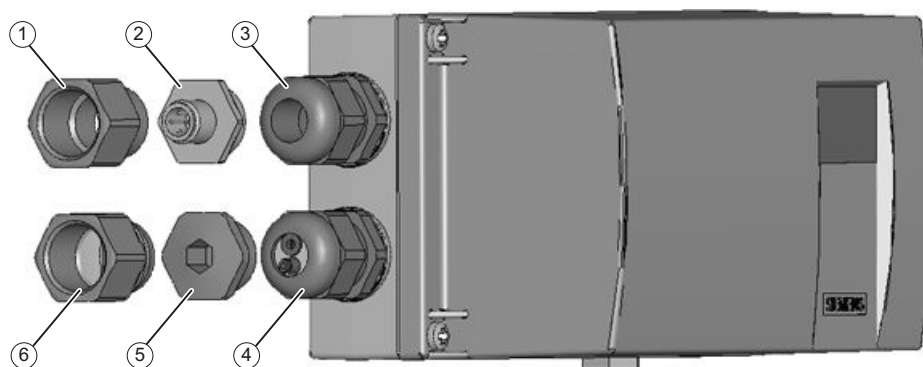

Connections ① to ③ for power supply

- ① Adapter M20 to ½-14 NPT for
  - 6DR5..0/1/2/3-0.N/P
- ② M12 connector for device version with PROFIBUS or FOUNDATION fieldbus communication
  - 6DR55..-0.R/S
  - 6DR56..-0.R/S
- ③ Cable gland for connection thread M20x1.5 for
  - 6DR5..0/1/2/3-0.G/M



Connections ④ to ⑥ for optional modules

- ④ Cable gland for connection thread M20x1.5 with seal insert
  - 6DR55..0-0.G/M/R/S
  - 6DR56..0-0.G/M/R/S
- ⑤ Dummy plug for device version without optional modules
  - 6DR5...-0..00
- ⑥ Adapter M20 to ½-14 NPT for
  - 6DR5..0/1/2/3-0.N/P

Figure 15-1 Positioner with the different cable glands and adapter

**Scope of delivery EMC filter module**

Legend numbers refer to the graphic

	Description
	EMC filter module C73451-A430-L8
	Sealing ring for ⑥
	Cable tie
⑥	Adapter M20 to 1/2-14 NPT
④	Cable gland for connection thread, gray
④	Cable gland for connection thread, blue
	Sealing set for ④
	Sealing set plug for ④
	Screw for plastic
	Oval head screw M3x6

**15.7 Accessories**

For accessories, refer to Catalog FI 01 "Field devices for process automation", for example:

- Option modules
- NCS sensor for contactless position detection
- Mounting kits
- Operating software



# Appendix

## A.1 Operation with boosters

### Introduction

In order to shorten the travel times, it is possible to use a booster between the positioner and actuator. The booster increases the air performance.

With single-acting positioners you require a booster which must be connected to the air output Y1. With double-acting positioners you require two boosters which must be connected to the air output Y1 and to Y2.

<b>NOTICE</b>
<b>Avoid pressure variations</b>
Ensure pressure variations do not occur in the supply air PZ on the positioner due to the booster.

<b>NOTICE</b>
<b>Note when selecting the boosters:</b>
<ul style="list-style-type: none"><li>• Only boosters may be used which do not have a continuous air consumption in the setpoint input.</li><li>• The boosters must not have a follow-up time.</li></ul>
A stable operating state will not be reached if these two points are not observed. All process components involved are subject to faster wear.



### Procedure

1. Reduce the air performance. To do this, use the restrictors on the positioner.
2. Set the deadband "DEBA" to the largest value permissible for your process.
3. Start the initialization process.
4. If necessary, adjust the travel times during the initialization process.

If the process value on the display does not remain stable or if a constant manipulated variable cannot be achieved for a constant setpoint, further optimization of the controller data is necessary. This is described in section "Optimization of controller data (Page 110)".

### See also

Sequence of automatic initialization (Page 116)

## A.2 Certificates

The certificates can be found on the DVD supplied and on the Internet at: Certificates (<http://www.siemens.com/processinstrumentation/certificates>)

## A.3 Technical support

### Technical Support

If this documentation does not provide complete answers to any technical questions you may have, contact Technical Support at:

- Support request (<http://www.siemens.com/automation/support-request>)
- More information about our Technical Support is available at Technical support (<http://www.siemens.com/automation/csi/service>)

### Internet Service & Support

In addition to our documentation, Siemens provides a comprehensive support solution at:

- Service&Support (<http://www.siemens.com/automation/service&support>) where you will find support news, support documents including EDDs and software, and also support from experts.

### Additional Support

If you have additional questions about the device, please contact your local Siemens representative.

Find your local contact partner at:

- Partner (<http://www.automation.siemens.com/partner>)

Documentation for various products and systems is available at:

- Instructions and manuals (<http://www.siemens.com/processinstrumentation/documentation>)

### See also

E-mail (<mailto:support.automation@siemens.com>)

SIPART PS2 product information (<http://www.siemens.com/sipartps2>)

Process instrumentation catalog (<http://www.siemens.com/processinstrumentation/catalogs>)



## Abbreviations

### B.1 Abbreviations for positioners

Abbreviation	Long form	Meaning
A/D	Analog-to-digital converter	-
AC	Alternating current	Alternating current
AMS	Asset Management Solutions	Communication software from Emerson Process comparable with the PDM
AUT	Automatic	Operating mode
ATEX	Atmosphère explosible	Product and operation directive of European Commission for explosion protection.
CENELEC	Comité Européen de Normalisation Electrotechnique	European committee for electrotechnical standardization
CPU	Central processing unit	Master processor
CSA	Canadian Standard Association	-
DC	Direct current	Direct current
DI	Digital Input	Digital input
DIN	Deutsche Industrie Norm	-
DO	Digital Output	Digital output
DTM	Device Type Manager	-
EDD	Electronic Device Description	-
Ex	Explosion protection	-
EMC	Electromagnetic compatibility	-
FDT	Field Device Tool	-
FF	FOUNDATION Fieldbus	Fieldbus of the Fieldbus Foundation
FM	Factory Mutual	American testing agency/insurance company
FW	Firmware	Device-specific software
GSD	Device master data	-
HART®	Highway Addressable Remote Transducer	Communication system for the development of industrial field busses.
IP	International Protection Ingress Protection	International protection types (long form as per DIN) Seepage protection (long form as used in US)
LC	Liquid crystal	Liquid crystal
MAN	Manual	Operating mode
NAMUR	Standards working group for measurement and control technology in the chemicals industry	Association of users in process conductor technology
µC	Microcontroller	One-Chip computer system
NCS	Non Contacting Sensor	Sensor for contactless position detection
NEMA	National Electrical Manufacturers Association	US standards institution National Electrical Manufacturers Association

## Abbreviations

### B.2 Abbreviations for functional safety

Abbreviation	Long form	Meaning
NPT	National Pipe Thread Taper	Pipe threading for self-sealing threads as per ANSI B.1.20.1
OPOS interface®	Open Positioner Interface	Standard interface for the connection between a positioner and a pneumatic linear or part-turn actuator
PA	Process Automation	Process automation
PDM	Process Device Manager	Siemens communication software / Engineering tool
PROFIBUS	Process Field Bus	Fieldbus
SIA	Slit initiator alarm module	-
VDE	Verband der Elektrotechnik, Elektronik und Informationstechnik e. V.	Industrial and professional association
VDI	Verein Deutscher Ingenieure e. V.	Technical/scientific association

## B.2 Abbreviations for functional safety

Abbreviation	Full term in English	Meaning
FIT	Failure in Time	Frequency of failure Number of faults within 10 <sup>9</sup> hours
HFT	Hardware Fault Tolerance	Hardware fault tolerance: Capability of a function unit to continue executing a required function in the presence of faults or deviations.
MooN	"M out of N" voting	Classification and description of the safety-instrumented system in terms of redundancy and the selection procedures used. A safety-instrumented system or part that consists of "N" independent channels. The channels are connected to each other in such a way that "M" channels are in each case sufficient for the device to perform the safety instrumented function. Example: Pressure measurement: 1oo2 architecture. A safety-instrumented system decides that a specified pressure limit has been exceeded if one out of two pressure sensors reaches this limit. In a 1oo1 architecture, there is only one pressure sensor.
MTBF	Mean Time Between Failures	Average period between two failures
MTTR	Mean Time To Restoration	Average period between the occurrence of a fault in a device or system and restoration of functionality
PFD	Probability of Dangerous Failure on Demand	Probability of dangerous failures of a safety function on demand
PFD <sub>AVG</sub>	Average Probability of Dangerous Failure on Demand	Average probability of dangerous failures of a safety function on demand
SFF	Safe Failure Fraction	Proportion of safe failures: Proportion of failures without the potential to bring the safety-instrumented system into a dangerous or non-permissible functional status.

Abbreviation	Full term in English	Meaning
SIL	Safety Integrity Level	The international standard IEC 61508 defines four discrete Safety Integrity Levels (SIL 1 to SIL 4). Each level corresponds to a range of probability for failure of a safety function. The higher the Safety Integrity Level of the safety-instrumented system, the lower the probability that it will not execute the required safety functions.
SIS	Safety Instrumented System	A safety-instrumented system (SIS) executes the safety functions that are required to achieve or maintain a safe status in a system. It consists of sensors, logic unit/control system and final controlling elements.



# Glossary

## Actuator

Converter that converts electric signals into mechanical or other non-electric variables.

## Actuator chamber

For pneumatic actuators which consist of two pressure chambers in double-acting versions and of a pressure chamber and a spring chamber in single-acting versions.

## Analog

A signal type which represents data using continuously varying, measurable and physical quantities, e.g. current or voltage. Opposite to digital. The range between 4 and 20 mA is often used to transfer analog signals.

## Analog-to-digital converter

An analog-to-digital converter is an interface between the analog environment and the digitally working computers. Only then can the computers be used for measurement and control tasks.

Analog-to-digital converters convert analog input signals to digital signals. Analog measurement data is thus converted into digital information. On the other hand, a digital-to-analog converter converts digital information into analog signals.

## Asset Management Solution (AMS)

Software package by Emerson Process. The AMS Device Manager, which is somewhat similar to the PDM, is the most significant part of the package.

## ATEX

ATEX is the abbreviation of the French term "Atmosphère explosible". ATEX stands for the two directives of the European Community in the field of explosion protection: the ATEX product directive 94/9/EC and the ATEX operation directive 1999/92/EC.

## Auxiliary voltage

Auxiliary voltage is an electric supply or reference voltage that is required by some electric circuits in addition to the standard supply. The auxiliary voltage can, for example, be specially stabilized, have a particular level or polarity and/or other properties which are important for the correct functioning of switch components. Auxiliary voltage is used, for example, with four-wire systems.

### **Chamber**

A largely or completely enclosed cavity in a machine or apparatus.

### **Conduit piping system**

A piping system for the American market, wherein the electric and pneumatic lines are protected by a casing.

### **Configuring**

See parameter assignment.

### **Control fitting**

A valve consisting of an actuator + control valve + positioner.

### **Cornerstone**

Management software for process instrumentation.

### **Decrement**

From the Latin word *decrementare*, decrease. Decrement is the defined amount of change when decreasing a variable gradually. IT term that refers to a step-by-step decrease in a numeric value. → Increment.

### **Degree of protection**

The degree of protection of a device indicates the extent of protection. The extent of protection includes the safety of persons against coming in contact with live or rotating parts, and the protection of electric resources against the penetration of water, foreign bodies and dust. The degrees of protection of electric machines are indicated by an abbreviation comprising two letters and two numbers (e.g. IP55). The degree of protection is coded using the IP code. The degrees of protection are standardized in DIN EN 60529.

### **Device category 1**

Category 1 devices must be procured such that they ensure an extremely high degree of safety. Devices in this category must ensure an extremely high degree of safety even for faults that occur rarely. Even if two faults occur in the device, it should not lead to ignition. Devices in this category are suitable for use in zone 0 or 20.

### **Device category 2**

Category 2 devices must be procured such that they ensure a high degree of safety. Devices in this category must ensure the required degree of safety in case of frequent faults or ones that can be normally expected, e.g. defects in the device, and avoid ignition sources. Devices in this category are suitable for use in zone 1 or 21.

**Device category 3**

Category 3 devices must be procured such that they ensure a normal degree of safety. Devices in this category must ensure the required degree of safety in case of frequent faults or ones that can be normally expected, e.g. defects in the device, and avoid ignition sources. Devices in this category are suitable for use in zone 2 or 22.

**Digital**

Representation of a variable in the form of characters or numbers. The functional course of an originally changeable analog variable is simulated in predefined stages. Predefined values are assigned to these stages. Opposite to "analog".

**EEPROM**

EEPROM (Electrically Erasable Programmable Read-Only Memory) is a non-volatile electronic memory chip. EEPROMs are often used when individual data bytes change over long time periods and need to be saved in a manner protected against power failure, e.g. configuration data or operating hours counters.

**Electromagnetic compatibility**

Definition as per the EMC law: EMC is the capability of a device to operate satisfactorily in an electromagnetic environment without itself emitting electromagnetic signals which interfere with other devices in that environment.

**Ex d**

"Flameproof enclosure" type of protection. When the potentially explosive mixtures enter the enclosure of a resource and an ignition source exists in the enclosure. The transfer of the explosion inside the enclosure to the surrounding space must be ruled out.

- d: flameproof enclosure

**Ex ia / Ex ib / Ex ic**

If potentially explosive mixtures enter the enclosure of a resource, it should not lead to ignition. Demarcation of energy and increased temperatures.

**Ex n**

Equipment containing energy-limiting, non-sparking contacts as well as circuits whose contacts are supplied with limited energy.

**Ex t**

Dust ignition protection with "t" enclosure. Dust ignition protection where the electric equipment has an enclosure providing protection against dust ingress and a measure for limiting the surface temperature.

## Factory Mutual

Industrial property insurer and certification agency in the USA. FM Global is one of the largest industrial insurers in the world who are specialized in the field of technically-supported property insurance. It offers services like product research, testing and certification.

## Failure that causes a dangerous situation

Failure with the potential to switch a safety-instrumented system to a hazardous or non-functioning safety status.

## Fieldbus

A fieldbus is an industrial communication system used to connect a number of field devices with a control device. Field devices include temperature transmitters, pressure transmitters, and positioners.

## Firmware

Firmware (FW) is software that is embedded on a chip in electronic devices – in contrast to software which is saved on hard disks, CD-ROMs or other media. These days, firmware is mostly stored in a flash memory or an EEPROM. Firmware is software in the hardware, and is thus an intermediate between software and hardware. Firmware is normally model-specific. This means that it does not function on other device models and is delivered by the manufacturing company. The corresponding devices cannot function without the firmware. The firmware mostly contains elementary functions to control the device, as well as input and output routines.

## Frequency shift keying

Frequency shift keying (FSK)

Frequency shift keying is a simple modulation format in which digital values 0 and 1 are represented by two different frequencies.

## GSD file

The file that describes the properties of a PROFIBUS DP slave or a PROFINET IO device.

The GSD file is a database file for PROFIBUS devices. The device manufacturer provides the corresponding GSD file containing the description of device properties. The information in the file can be read using Engineering Tools.

## Increment

From the Latin word incrementare, increase. Increment is the defined amount of change when increasing a variable gradually. IT term that refers to a step-by-step increase in a numeric value.→Decrement.



**Initialization**

Setting the most important basic parameters. Requirement for commissioning the positioner.

**IP code**

The abbreviation IP stands for International Protection as per DIN. In English-speaking countries, IP stands for Ingress Protection.

**Makrolon**

Glass-fiber reinforced polycarbonate (PC).

**Microcontroller**

Microcontrollers (also  $\mu$ Controller,  $\mu$ C, MCU) are single-chip computer systems in which almost all components such as master processor, program memory, working memory and input/output interfaces are included in a single chip.

**NAMUR**

Standardization association for measurement and control in chemical industries. NAMUR is an association of users of process control technology. The members are mainly companies from German-speaking countries. The association was formed in Leverkusen in 1949.

**NEMA**

National Electrical Manufacturers Association. NEMA is a standardization institute in the USA. NEMA was formed in 1926 with the merge of Associated Manufacturers of Electrical Supplies and the Electric Power Club.

**NEMA 4**

An enclosure standard of the National Electrical Manufacturers Association. NEMA 4-compliant devices are suitable for use in indoor and outdoor applications. Protection is provided against dust particles, rain as well as spray and splash water.

**NEMA 4x**

The same protection as NEMA 4. Additional protection of the enclosure from corrosion.

**Parameter assignment**

Individual parameter settings are specifically changed to adjust the positioner as per the actuator or other requirements. Parameter assignment is carried out after the complete commissioning of the positioner.

### **Piezoelectric effect**

Name of a physical phenomenon. Due to mechanical compression loads on a crystal, an electric potential develops on specific crystal surfaces. In a reverse case, applying an electric field to specific crystal surfaces leads to crystal deformation.

### **Potentially explosive atmosphere**

Mixture of air, combustible gases, fluff, fibers or dusts.

### **Pressure chamber**

The pneumatic actuators are available in single and double-acting versions. In a single-acting version, only one pressure chamber is pressurized and depressurized. The pressure developed works against a spring. In a double-acting version, two pressure chambers work against each other. Pressurizing the volume of one chamber simultaneously depressurizes the volume of the other.

### **Process Device Manager**

PDM is a Siemens software package for configuration, parameter assignment, commissioning and maintenance of network configurations and field devices. Part of SIMATIC STEP 7. Used for configuration and diagnostics.

### **PROFIBUS**

PROFIBUS stands for process fieldbus. PROFIBUS is a vendor-independent standard for networking field devices (e.g. PLCs, actuators, final control elements, and sensors). PROFIBUS is compatible with protocols such as DP (decentralized peripherals), FMS (fieldbus message specification) and PA (process automation).

### **Protection level**

- ia: Protection level. Electric equipment operating fault-free, and with existence of two countable errors.
- ib: Protection level. Electric equipment operating fault-free, and with existence of one countable error.
- ic: Protection level. Electrical equipment is not able to cause an ignition when operating fault-free.

### **Protocols**

Protocols contain information about data formats, time sequences and error handling when exchanging data between computers.

A protocol is a convention about establishing, monitoring and terminating a connection. Different protocols are required for a data connection. Protocols can be assigned to every layer of the reference model. Transport protocols are used for the lower four layers of the reference model and higher protocols are used for control, data provision and application.

**Safety function**

Defined function executed by a safety-instrumented system with the objective of attaining or maintaining a safe status of the system by taking a defined hazardous incident into account.

Example: limit pressure monitoring

**Safety-instrumented system**

A safety-instrumented system (SIS) executes safety functions that are required to attain or maintain the safe status in a system. It consists of sensors, logic unit/control system and final controlling elements.

Example: a safety-instrumented system consists of a pressure transmitter, a limit signal indicator and a servo valve.

**Sensor**

Converter that converts mechanical or other non-electric variables into electric signals.

**SIL**

The international standard IEC 61508 defines four discrete safety integrity levels (SIL) from SIL 1 to SIL 4. Every level indicates a probability range for the failure of the safety function. The higher the SIL of the safety-instrumented system, the higher the probability that the required safety function works. The achievable SIL is determined by the following safety-instrumented characteristics:

- Average probability of dangerous failures of a safety function on demand (PFD<sub>AVG</sub>)
- Hardware fault tolerance (HFT)
- Safe failure fraction (SFF)

**SIMATIC software**

Programs for process automation (e.g. PCS 7, WinCC, WinAC, PDM, STEP 7).

**Zone 0**

Area in which potentially explosive atmospheres build up often, regularly or over long durations during the normal operation of a device.

**Zone 1**

Area in which potentially explosive atmospheres build up occasionally during the normal operation of a device.

**Zone 2**

Area in which a potentially explosive atmosphere normally never builds up or builds up only for a short while during the normal operation of a device.

**Zone 20**

Zone 20 is an area in which a potentially explosive atmosphere in the form of a cloud of combustible dust in air is present continuously, over a long period, or frequently.

**Zone 21**

Zone 21 is an area in which a potentially explosive atmosphere in the form of a cloud of combustible dust in air can be occasionally produced during normal operation.

**Zone 22**

Zone 22 is an area in which a potentially explosive gaseous atmosphere in the form of a cloud of combustible dust in air never develops or develops only for a short while during normal operation.

# Index

## A

- Accessories, 306
- Actuating pressure, 26
- Adapter, 308
- Additional Support, 312
- Alarm module
  - Installation, 63
  - Position, 56, 59
- Amplifier, (See booster)
- Article number
  - on the nameplate, 24
- Attenuator, 290
- Auxiliary power supply
  - Failure, 98

## B

- Basic electronics, 306, (Motherboard)
  - Graphic, 28
  - Position, 56, 59
- Booster, 311
- Bus cable, 26
  - Connecting, 82

## C

- C73451-A430-D23, (See EMC filter module)
- C73451-A430-D78, (See position detection system)
- Cable gland, 308
- Carrier, 45, 147
- Carrier pin, 125, 128
- Certificates, 17, 312, (Certificates)
  - characteristics
    - Safety, 143
- Commissioning
  - Automatically, 125, 131
  - Cancel, 126, 133
  - Interrupting, 125
  - Manual, 127, 134
- Compressed air, 38
- Connecting
  - NCS sensor, 86
  - Position detection system, 87
  - SIA module, 91
- Connection
  - Pneumatic, 96, 122

- Control air outlet, 290
- Control system, 21, 140
- Correct usage, (See improper device modifications)
- Coupler, 34
- Customer Support Hotline, 312

## D

- Device operating mode
  - Parameter, 173
- Diagnostics, 252
  - During ongoing operation, 267
  - Extended, 150, 170
- Diagnostics guide, 273

## E

- EMC filter module
  - Installation, 74
  - Scope of delivery, 309
- Enclosure, 305
- Enclosure ventilation, 290
- Ex markings, 287, 297, 298, 299
- Exhaust air outlet, 26, 290, 291
- Extended diagnostics, 170
  - Parameter, 150

## F

- Factory setting
  - Resetting to ~, 125, 131
- Fault identification, 273
- Final controlling element, 140
- Firmware, 13
- FISCO, 34
- Five-point controller, 21, 29
- Flow rate, 291
- Friction clutch, 21, 26, 53
  - Position, 56

## G

- Gear
  - switchable, 21

- H**
- Hazardous area
  - Laws and directives, 17
- History, 13
- Hotline, 312
  
- I**
- Improper device modifications, 18
- Initialization, (Commissioning)
  - Automatically, 116
  - Interrupting, 131
- Installation
  - Alarm module, 63
  - Position feedback module, 62
  - SIA module, 65
- Internal NCS module
  - Commissioning, 124
  - Installation, 51, 70
  - Technical specifications, 297
- Internet, 312
- ly module, (See position feedback module)
  
- L**
- Leakage
  - Pneumatic, 151
- Leakage test
  - Offline, 257
- Limit monitoring for total strokes, 168
- Linear actuator
  - Automatic commissioning, 125
  - Automatic commissioning (flowchart), 117
  - Manual commissioning, 127
  - Pneumatic connection, integrated, 96
  - Single-acting, 22
- Link, 34
  
- M**
- Manometer
  - Mounting, 76
- Master
  - Class-1 master, 32
  - Class-2 master, 32
- Mechanical limit switch module, 115
  - Position, 56, 59
- Mode of operation, 28
  
- Module cover
  - Position, 56, 59
- Motherboard, (See basic electronics), (See basic electronics)
- Mount
  - Dimensions, 49
- Mounting kit
  - Linear actuator, 40
  
- N**
- Nameplate
  - Position, 57, 59
- Natural gas
  - Maximum values for ventilation, 290
  - Operation, 115
- NCS, 73
- NCS sensor
  - Connecting to EMC filter module, 86
  
- O**
- Offline leakage test, 257
- Online diagnostics, 267
- Operation
  - Natural gas, 115
- Option module
  - Terminal, 26
- Option modules, 306
  - Installation, 57
- Order code, 24
- Ordering supplement, 24
  
- P**
- Parameters 1 to 5
  - Overview, 146
- Parameters 6 to 53
  - Overview, 147
- Parameters A to P
  - Overview, 151
- Part-turn actuator
  - Automatic commissioning, 131
  - Automatic commissioning (flowchart), 117
  - Double-acting, 23
  - Manual commissioning, 134
  - Mounting, 45
- Pneumatic actuator, 29
- Pneumatic block, (See pneumatic block)
  - Position, 56, 59
- Purging air selector, 122

Pneumatic connections, 122  
Position detection system  
  External, 87  
Position feedback module, 91  
  Installation, 62  
  Position, 57, 59  
Positioner  
  Replacing, 136  
  With linear actuator, 22  
Potentiometer, 73  
  External, 87  
  Position, 56, 59  
Pressure gauge block, 22  
Printed circuit board, (See basic electronics)  
Product name, 24  
PROFIBUS, 31  
  Automation system, 32  
  Connection, 33  
  DP, 31  
  Eigenschaft, 33  
  PA, 31  
  Profile, 33  
  Strand, 33  
  Topology, 32  
Purge air switch, 290  
Purging air selector, 26, 122  
Pz, 143

## Q

Qualified personnel, 19

## R

Reading initialization parameters, 136  
Ribbon cable  
  Graphic, 56, 59

## S

Safety function, 139  
Safety position  
  Parameter, 172  
Safety shutdown, 139  
Scope of delivery, 14  
  EMC filter module, 309  
Screen  
  Cleaning of~, 278  
Screw terminal, 83  
SELV, 34  
Service, 312

servo valve  
  Integrated, 21  
Shield connection, 26  
SIA module  
  Connecting, 91  
  Installation, 65  
  Position, 56, 59  
SIL 2, 140  
Single-channel operation, 140  
Slot initiator, (See SIA module)  
Sound absorber, 26  
Special screw  
  Position, 56  
Station number  
  Parameter, 172  
Support, 312  
Symbols, (Refer to warning symbols)  
System integration  
  PDM, 13  
System pressure, (see Supply air)

## T

Terminal strip, 122  
  Without flameproof enclosure, 83  
Terminating resistor, 34  
Terminating resistor T, 33  
Test certificates, 17  
Tight closing, 139  
Transmission ratio selector, 26  
  Position, 56, 60  
Transmitter, 140  
Travel integral  
  Refer to limit monitoring for total strokes, 168

## W

Warning label  
  Position, 56, 59  
Warning symbols, 17  
Wiring diagram on module cover, 57

## Y

Y1, 143







## Get more information

[www.siemens.com/processautomation](http://www.siemens.com/processautomation)  
[www.siemens.com/positioners](http://www.siemens.com/positioners)

Siemens AG  
Process Industries and Drives  
Process Automation  
76181 Karlsruhe  
GERMANY

Subject to change without prior notice  
A5E00127926-AB  
© Siemens AG 2016



A5E00127926



A5E00127926

[www.siemens.com/automation](http://www.siemens.com/automation)