



CONNECTING IMPLEMENTS TO THE TRACTOR

HOSTA Task Sheet 5.1

Core

NATIONAL SAFE TRACTOR AND MACHINERY OPERATION PROGRAM

Introduction

“The owner says that I should be able to connect (hitch) the rake to the tractor and be in the nearby field within 5 minutes. It has been 10 minutes, and I still can’t seem to get the drawbar of the tractor lined up with the hitch on the rake.”

Can you steer in reverse? Can you use the clutch and brakes smoothly? If not, review the lessons on steering in reverse and moving and steering the tractor.

Do you understand where to hitch to the load to insure tractor stability? If not, review the lessons on tractor stability.

This task sheet provides an overview of safe and efficient hitching of implements to the tractor. See Task Sheet 5.2 or 5.3 for additional details.

Hitching and the Center of Gravity

In Task Sheet 4.12, *Tractor Stability*, you learned about the tractor’s center of gravity and stability baseline. Tractor hitches are designed so the downward and rearward force during a pull are below the center of gravity (see Figure 5.2.a.). To maintain tractor stability, the “angle of pull” should be kept as low as possible by hitching to the drawbar only.

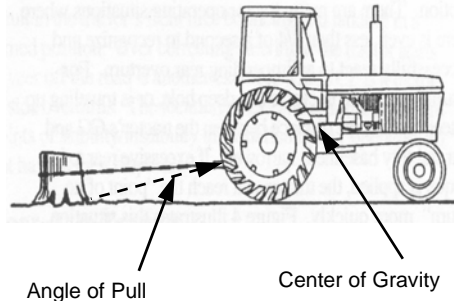

Figure 5.1.a. An example of safe hitching. The drawbar will lower if the front end lifts off the ground. This reduces the “angle of pull” and the risk of a rear overturn.

Pulling a load with the downward and rearward force above the tractor’s center of gravity will result in a rear overturn. You must hitch only to the drawbar to prevent the tractor from rearing up and turning over. Even small lawn and garden-size tractors can flip rearward if not properly hitched to a load.

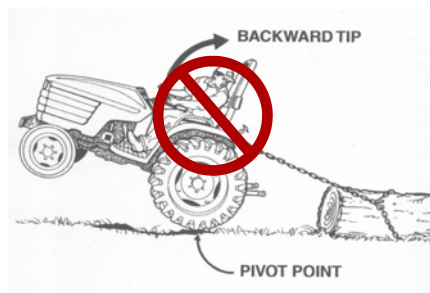

Figure 5.1.b. The log is fairly immovable. A chain hooked above the center of gravity of the tractor (e.g., top of 3-point hitch bracket), allows a rearward tip of the tractor. Improper hitching has overridden safe tractor engineering design. Many people have lost their lives as a result. *Safety Management for Landscapers, Grounds-Care Businesses, and Golf Courses*, John Deere Publishing, 2001. Illustrations reproduced by permission. All rights reserved.



Figure 5.1.c. The tractor drawbar is the only safe place to connect a load. Do not hitch higher than the drawbar so all pulling forces stay below the tractor’s center of gravity. For most operations, the drawbar should be placed midpoint between the rear tires to maximize pulling power. Hillside operations may require a drawbar adjustment to one side to balance the pulling forces.

Hitch to the drawbar only! Hitching anywhere else can result in rear turnover and death.

Learning Goals

- To safely connect an implement to the tractor’s drawbar
- To safely connect an implement to the tractor’s 3-point hitch

Related Task Sheets:

| | |
|---------------------------------------|------|
| Tractor Stability | 4.12 |
| Using the Tractor Safely | 4.13 |
| Operating the Tractor on Public Roads | 4.14 |
| Using Drawbar Implements | 5.2 |
| Using 3-Point Hitch Implements | 5.3 |

Figure 5.1.d. Tractor drawbars are designed at the correct height from the ground to keep the pull forces below the center of gravity. Only use the drawbar to tow a load. A swinging or floating drawbar permits adjustment of the center line of pull to be maintained even on a hillside.

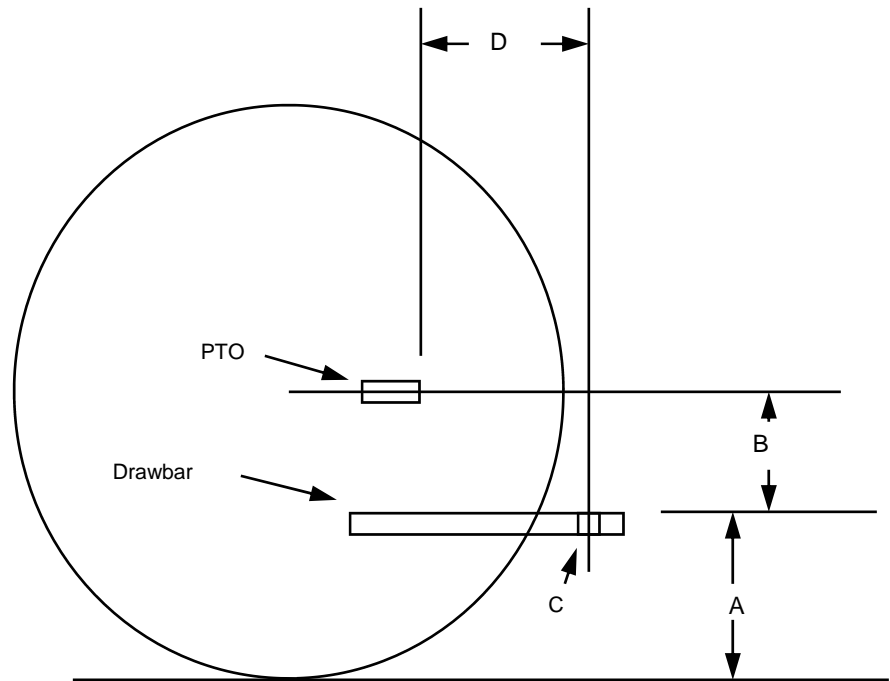

Figure 5.1.e. The tractor power take-off and drawbar position are designed with specific measurements for the size and horsepower rating of the tractor. The operator should not make changes to these design standards by changing the hitch point. Table 5.1.a lists the measurements and relationships at points A, B, C, and D above for each range of tractor size.

A bolt laying around the farm shop is not a substitute hitch pin! Hitch pins are designed for specific drawbar loads and power ratings and must fit the drawbar hole.

| Item | Drawbar Hitch Category | | | |
|-------------------------|------------------------|--------------|-------------|----------------|
| | I | II | III | IV |
| Tractor HP | 20-45 | 40-100 | 80-275 | 180-400 |
| Drawbar Height | | | | |
| above ground (A) | 15" +/-2" | 15" +/-2" | 19" +/-2" | 19" +/-2" |
| Drawbar to PTO (B) | 8"-12" | 8" - 12.5" | 8.5" -14" | 10" -14" |
| Hitch-Pin Hole Size(C)* | 1.1" | 1.3" | 1.7" | 2.1" |
| Nominal Hitch Pin Size* | 1.0" | 1.2" | 1.6" | 2.0" |
| Drawbar Dimensions | | | | |
| (Thickness x width) | 1-3/16"x2.0" | 1-9/16"x2.5" | 2"x 3-3/16" | 2-3/8"x 4-7/8" |
| Regular Size PTO | | | | |
| Stub Shaft to Drawbar | | | | |
| Hitch Hole (D) | 14-20" | 14-20" | 14-20" | 14-20" |

* The measurement has been rounded to the nearest 1/10 (0.1) inch. Hitch pins must fit the hitch-pin hole without excessive movement.

Table 5.1.a. Drawbar Sizing and Positioning Standards (ASAE S482)

The 3-Point Hitch

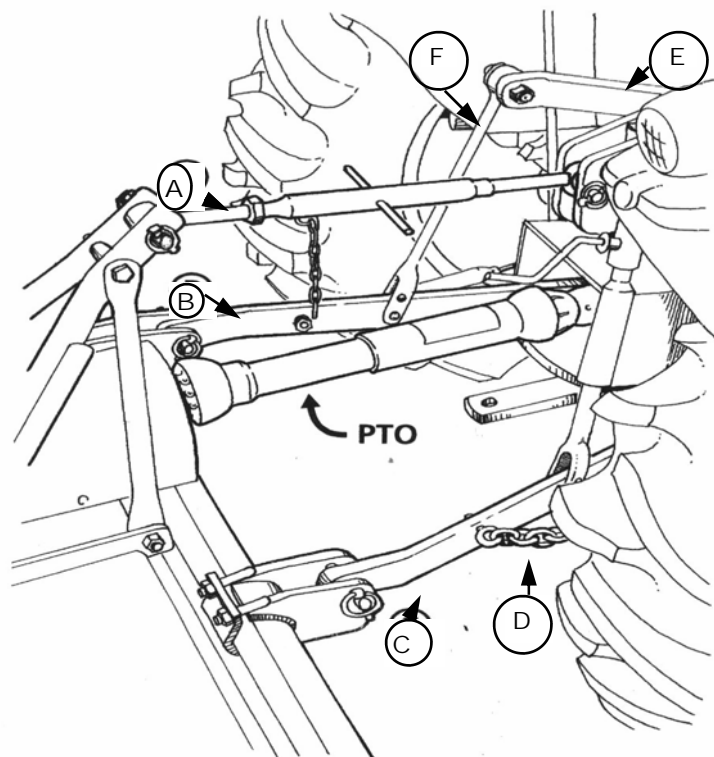

Figure 5.1.f. Parts of the 3-Point Hitch

- A. Upper Link B,C. Draft Arms D. Anti-sway bar or chain
- E. Lift Arm F. Lift Rod

Safety Management for Landscapers, Grounds-Care Businesses, and Golf Courses, John Deere Publishing, 2001. Illustrations reproduced by permission. All rights reserved.

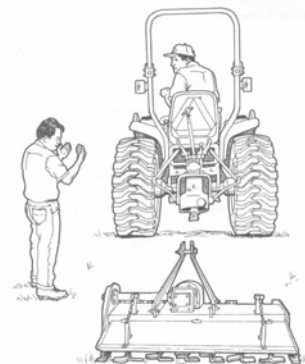

Figure 5.1.g. Never let another person stand between the tractor and the implement during hitching. Too fast of an approach or the operator's foot slipping from the clutch can lead to injury or fatality to the person standing nearby. *Safety Management for Landscapers, Grounds-Care Businesses, and Golf Courses, John Deere Publishing, 2001. Illustrations reproduced by permission. All rights reserved.*

Implement Hitching

Follow these steps for hitching to a drawbar: Also see Task Sheet 5.2.

1. Position the tractor to align the hole in the drawbar with the hole in the implement hitch. This is called spotting. You may need to practice this skill.
2. Stop the engine, put the tractor in park, and set the brakes.
3. Attach the implement using the proper-sized hitch pin and security clip.
4. Raise the implement jack stand and remove chock

blocks from the wheels.

5. Connect the PTO shaft, hydraulic hoses, and/or electrical connections as required. Refer to the appropriate task sheets on these subjects.

Follow these steps for hitching to a 3-point hitch attachment: Also see Task Sheet 5.3.

1. Move the stationary tractor drawbar forward for clearance.
2. Position the tractor so the pin holes of the draft arms are closely aligned with the implement hitch points.
3. Raise or lower the draft arms

to match the implement hitch points.

4. Stop the engine, securely park the tractor, set the brakes.
5. Attach each draft arm to the implement hitch point using the proper size hitch pin and security clip.
6. Remount and start the tractor to use the hydraulic system to raise the lift arms if needed.
7. Match the upper link of the 3-point hitch to the implement's upper hitch point. The upper link is adjustable by screw threads to make the final connection. The implement may not be level if the upper link has been adjusted too many times. If it is out of level, the machine may not work properly *If you cannot level the machine, ask for help.*
8. Securely attach the upper hitch pin with the proper size hitch pin and security clip.



Figure 5.1.h. Tractors equipped with quick-attach couplers have hooks which must be latched to lock the implement into place. If you have never used one of these quick-attach couplers, have a qualified operator demonstrate the correct procedure or find the information in the Owner's Manual.

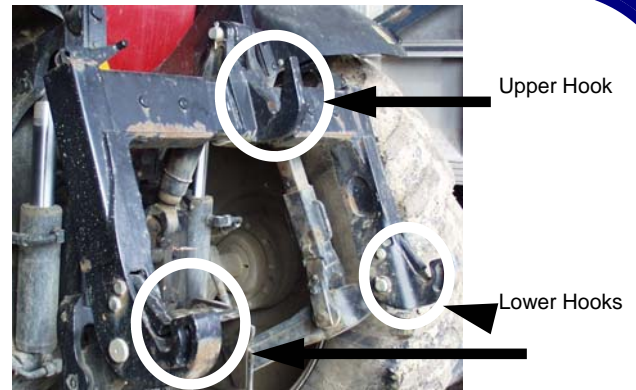

Figure 5.1.i. Heavy-duty quick-attach couplers are mounted onto the tractor's 3-point hitch and can safely handle large 3-point hitch implements without a person moving between the tractor and the implement. See the circled areas which show these hook and latch points. Refer to the Owner's Manual for additional instructions on their use.

Safety Activities

1. Practice backing a tractor with a drawbar to an implement to "spot" the hole in the drawbar to the hole in the implement tongue. You should be able to perform this skill with a minimum number of changes of direction to be a proficient tractor operator.
2. Practice backing a tractor with a 3-point hitch to an implement to adjust the pin hole in the draft arms to the lower hitch pins on the implement's 3-point hitch attachment. As you become more able to align these points, securely park the tractor. Attach the draft arm hitch pins, restart the tractor, adjust the draft arms to align, and connect the upper link point. You should be able to perform this skill with a minimum change of direction to be a proficient tractor operator.
3. On a tractor you can easily measure, take measurements and record the following:
 - a. distance from ground to drawbar _____ inches
 - b. dimensions of drawbar (width and thickness) _____ x _____ inches
 - c. hitch-pin hole opening in drawbar _____ inches
 - d. vertical distance from drawbar to center of PTO stub shaft _____ inches
 How do these measurements compare with the standards shown on Table 5.2a?
4. Using a battery-operated toy truck or tractor, devise a place to hitch a load at a point above the toy's axle. Make a sled from sheet metal or cardboard, and attempt to pull a load of small objects such as nuts, bolts, etc. What happens as the toy attempts to pull the load? Change the height and length of the angle of pull, and record the reaction of the toy truck or tractor to the changes made.

References

1. www.asae.org/Click on Technical Library/Find Standards on pull down menu/Type in Drawbars, Download PDF for S482, December 1998.
2. www.asae.org/Click on Technical Library/Find Standards on pull down menu/Type in Three-Point Free Link Attachment, Download PDF for S217, December 2001.
3. Safety Management for Landscapers, Grounds-Care Businesses, and Golf Courses, John Deere Publishing, 2001. Illustrations reproduced by permission. All rights reserved.

Contact Information

National Safe Tractor and Machinery Operation Program
 The Pennsylvania State University
 Agricultural and Biological Engineering Department
 246 Agricultural Engineering Building
 University Park, PA 16802
 Phone: 814-865-7685
 Fax: 814-863-1031
 Email: NSTMOP@psu.edu

Credits

Developed, written and edited by WC Harshman, AM Yoder, JW Hilton and D J Murphy, The Pennsylvania State University. Reviewed by TL Bean and D Jepsen, The Ohio State University and S Steel, National Safety Council. Version 4/2004

This material is based upon work supported by the Cooperative State Research, Education, and Extension Service, U.S. Department of Agriculture, under Agreement No. 2001-41521-01263. Any opinions, findings, conclusions, or recommendations expressed in this publication are those of the author(s) and do not necessarily reflect the view of the U.S. Department of Agriculture.



USING POWER TAKE-OFF (PTO) IMPLEMENTS

HOSTA Task Sheet 5.4.1

Core

NATIONAL SAFE TRACTOR AND MACHINERY OPERATOR PROGRAM

Introduction

The power take-off (PTO) shaft, or Implement Input Driveline (IID), is an efficient means of transferring mechanical power between farm tractors and implements. This power transfer system helped to revolutionize North American agriculture during the 1930s. The PTO is also one of the oldest and most persistent hazards associated with farm machinery. This task sheet discusses several aspects of PTO safety.

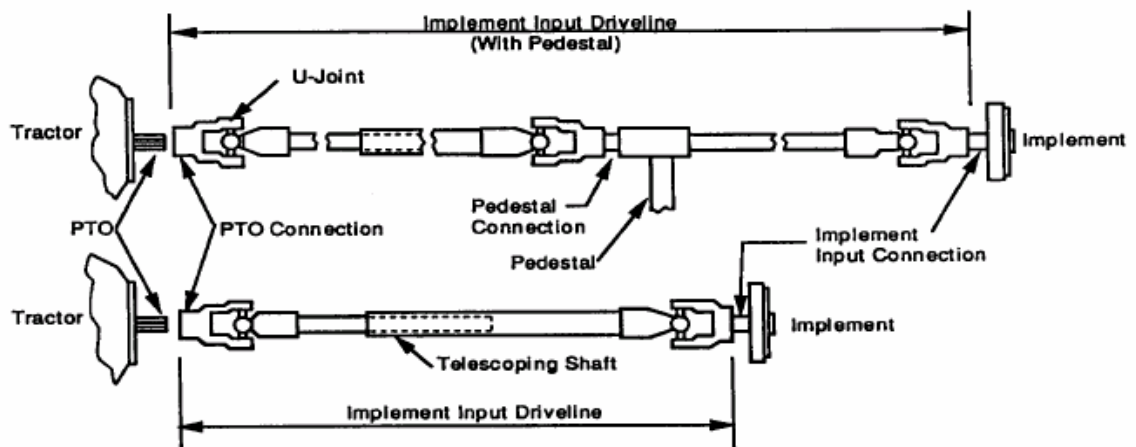

Figure 5.4.1.a. The major components of a PTO system.

PTO Components

Figure 5.4.1.a. is a diagram of the components of an implement PTO system. Two typical PTO system arrangements are shown. The top drawing is of a PTO system involving a pedestal connection, such as one found on many types of towed implements (hay balers, forage choppers, large rotary mowers, etc.). The lower drawing is of a PTO system where the implement's input driveline connects directly to the tractor PTO stub. Examples of this type of connection include three-point hitch-mounted equipment, such as post hole diggers, small rotary

mowers, fertilizer spreaders, and augers.

Connections from the tractor to the implement are made through the flexible universal joints. The "U-joints" are connected by a square rigid shaft which turns inside another shaft. The PTO shaft can telescope in and out for use in turns or over uneven terrain.

The combination of universal joints and turning shafts provides the remote power source to a farm implement. Without proper guarding, a serious threat to the operator's safety is created. Study this task sheet carefully.

Learning Goals

- To identify the components of a PTO system
- To identify the hazards involved with PTO use
- To develop safe habits when using a PTO

Related Task Sheets:

| | |
|------------------------|-----|
| Reaction Time | 2.3 |
| Mechanical Hazards | 3.1 |
| Making PTO Connections | 5.4 |

PTO Stub

- Transfers power from the tractor to the machine
- Rotates at 540 rpm (9 times/sec.) or at 1,000 rpm (16.6 times/sec.)

Master Shield

- Protects the operator from the PTO stub
- Is often damaged or removed and never replaced.



Figure 5.4.1.b. The major components of a PTO system found on the tractor.

The PTO is one of the oldest and most persistent hazards associated with farm machinery.

PTO Entanglement

This information is taken from the Purdue University source listed at the end of this fact sheet. This reference is the most comprehensive study of power take-off injury incidents to date. The data shown includes fatal and nonfatal injury incidents. Generally, PTO entanglements:

- involved the tractor or machinery operator 78 percent of the time
- occurred when shielding was absent or damaged in 70 percent of the cases
- were at the PTO coupling, either at the tractor or implement connection nearly 70 percent of the time
- involved a bare shaft, spring-loaded push pin, or through bolt component at the point of contact in nearly 63 percent of the cases
- occurred with stationary equipment, such as augers, elevators, post-hole diggers, and grain mixers in 50 percent of the cases
- involved semi-stationary equipment, such as self-unloading forage wagons and feed wagons in 28 percent of the cases
- happened mostly with incidents involving non-moving machinery, such as hay balers, manure spreaders, rotary mowers, etc., at the time of the incident (the PTO was left engaged).
- occurred 4% of the time when no equipment was attached to the tractor. This means the tractor PTO stub was the point of contact at the time of the entanglement.

PTO Guards

Implement Input Connection (IIC) Shield

- Protects the operator from the IIC, including the implement input stub and the connection to the IID

Safety Chain

- Keeps the integral journal shield from spinning
- Shows that the shield is not attached to the IID
- Should be replaced immediately if damaged or broken



Figure 5.4.1.c. The major guards of a PTO system.

Master Shield

- Protects the operator from the PTO stub and the connection of the IID to the PTO stub

Integral Journal Shield

- Completely encloses the IID
- May be made of plastic or metal
- Mounted on bearings to allow it to spin freely from the IID
- Always check before operation for free movement

PTO Safety Practices

There are several ways to reduce the risk of PTO injuries and fatalities. These safety practices offer protection from the most common types of PTO entanglements.

- Keep all components of PTO systems shielded and guarded.
- Regularly test driveline guards by spinning or rotating them to ensure they have not become stuck to the shaft.
- Disengage the PTO and shut off the tractor before dismounting to clean, repair, service, or adjust machinery.
- Walk around tractors and machinery rather than stepping over a rotating shaft.
- Always use the driveline

recommended for your machine. Never switch drivelines among different machines.

- Position the tractor's drawbar properly for each implement used. This will help prevent driveline stress and separation on uneven terrain and in tight turns. See Task Sheet 5.1.
- Reduce PTO shaft abuse by observing the following: avoid tight turns that pinch rotating shafts between the tractor and machine; keep excessive telescoping to a minimum; engage power to the shaft gradually; and avoid over tightening of slip clutches on PTO-driven machines.

If PTO guards are removed or damaged, they should be replaced immediately.



Figure 5.4.1.d. A bent shaft guard offers no protection from a spinning PTO shaft. Also notice the missing master shield and the inadequate guarding of the universal joint near the PTO pedestal.

PTO Safety Activities

1. Fill in the blanks in the following figure of the major components of a PTO system based on the information in this sheet.

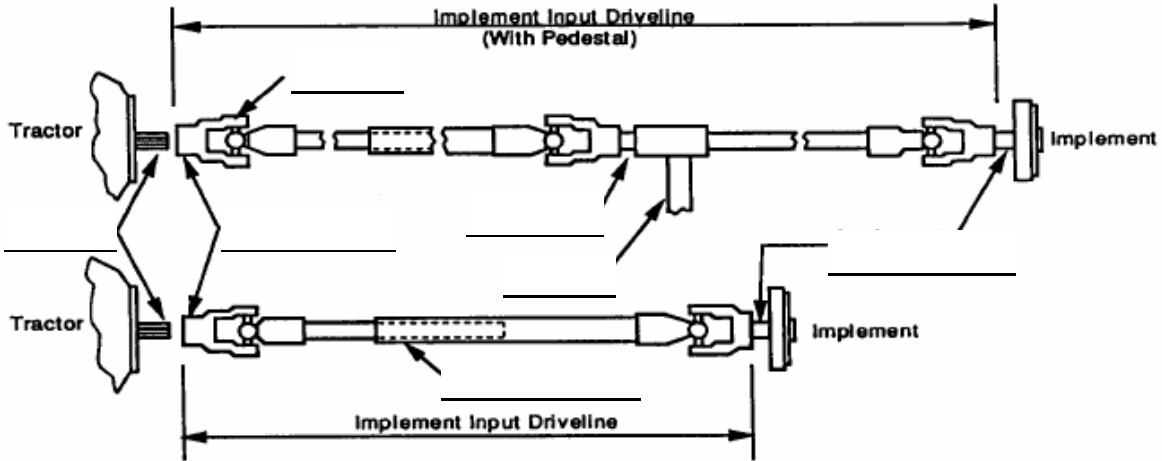

2. You are working with another tractor operator. He/she is sitting on the tractor seat and is able to reach the PTO control. If your shoelace is caught in the PTO shaft, how long does the shoelace need to be in order for the tractor operator to have enough time to shut off the PTO before your foot is pulled into the PTO shaft? The PTO shaft is spinning at 540 rpms, the shaft diameter is 3 inches (d), and the operator can react by shutting off the PTO in 3 seconds.

a. Find the circumference of the PTO shaft.

Circumference = $\pi d = 3.14 \times 3 \text{ inches} = \underline{\hspace{2cm}}$ inches

b. How many times does the PTO shaft rotating 540 revolutions per minute rotate in one second?

$\frac{540 \text{ revolutions}}{1 \text{ Min}} \times \frac{1 \text{ Min}}{60 \text{ sec}} = \frac{540 \text{ revolutions}}{60 \text{ sec}} = \underline{\hspace{2cm}}$ revolutions per second

c. How many times does the PTO shaft rotate in 3 seconds?

Answer b x 3 sec = $\underline{\hspace{2cm}}$ revolutions

d. How much shoelace will become wrapped up in the PTO in 3 seconds?

Answer a (in inches) x Answer c (in revolutions) = $\underline{\hspace{2cm}}$ inches of shoelace.

1. See Figure 5.4.a
 2a. 9.42 inches
 2b. 9 revolutions per second
 2c. 27 revolutions in 3 seconds
 2d. 254.34 inches or 21.20 feet

References

1. Campbell, W.P. 1987. *The Condition of Agricultural Driveline System Shielding and Its Impact in Injuries and Fatalities*. M.S. Thesis. Department of Agricultural Engineering, Purdue University, West Lafayette, IN.
2. Farm and Ranch Safety Management, John Deere Publishing, 1994.
3. Murphy, D.J. 1992 *Power Take-Off (PTO) Safety*, Fact Sheet E-33. The Pennsylvania State University. University Park, PA.
4. Safe Operation of Agricultural Equipment: Student Manual. 1988, Revised. Hobar Publications, St. Paul, MN.

Contact Information

National Safe Tractor and Machinery Operation Program
 The Pennsylvania State University
 Agricultural and Biological Engineering Department
 246 Agricultural Engineering Building
 University Park, PA 16802
 Phone: 814-865-7685
 Fax: 814-863-1031
 Email: NSTMOP@psu.edu

Credits

Developed, written and edited by WC Harshman, AM Yoder, JW Hilton and D J Murphy, The Pennsylvania State University. Reviewed by TL Bean and D Jepsen, The Ohio State University and S Steel, National Safety Council. Version 4/2004
 This material is based upon work supported by the Cooperative State Research, Education, and Extension Service, U.S. Department of Agriculture, under Agreement No. 2001-41521-01263. Any opinions, findings, conclusions, or recommendations expressed in this publication are those of the author(s) and do not necessarily reflect the view of the U.S. Department of Agriculture.