

2012 IBC Inspection of Fire-Resistance Rated Floors, Ceilings and Roofs

2012 IBC Inspection of Fire-resistance-Rated Floors, Ceilings and Roofs

Based on 2012 International Building Code



Accreditation



- The International Code Council has been accredited as an Authorized Provider by the International Association for Continuing Education and Training (IACET).
 - As a result of their Authorized Provider accreditation status, ICC is authorized to offer IACET CEUs for its programs that qualify under the ANSI/IACET Standard.
- You will obtain full CEUs for this course, if you actively participate in the training activities and stay for the entire session. Evidence of this will be the sign out sheet.



2012 IBC Inspection of Fire-Resistance Rated Floors, Ceilings and Roofs

2

Class Outline

- Introduction
 - Determining fire resistance
 - Test standards
 - Definitions
 - Alternate methods

(continues next slide)



2012 IBC Inspection of Fire-Resistance Rated Floors, Ceilings and Roofs

3

Class Outline (continued)

- Type of Rated Horizontal Assemblies
 - Floor, Roof, Floor/Ceiling or Roof/Ceiling
 - Differences between the various assembly types
 - Importance of ceiling membrane and affect on test temperatures
 - Protection of structural members
 - Marking and identification requirements (if applicable - for smoke barriers)



2012 IBC Inspection of Fire-Resistance Rated Floors, Ceilings and Roofs

4

2012 IBC Inspection of Fire-Resistance Rated Floors, Ceilings and Roofs

Class Outline (continued)

- Code Requirements
 - Difference between Sections 711 and 712
 - Conditions that require rated horizontal assemblies
 - Section 711 details
 - Section 712 details
 - Unprotected openings allowed in roof



2012 IBC Inspection of Fire-Resistance Rated Floors, Ceilings and Roofs

5

Class Outline (continued)

- Miscellaneous topics
 - Beam and girder substitution: modifying approved assemblies
 - Calculated wood assemblies
 - Eave overhangs and protection of soffits



2012 IBC Inspection of Fire-Resistance Rated Floors, Ceilings and Roofs

6

ASTM E 119 and UL 263 Test Standard

- The average test furnace temperatures used in the tests are:
 - 1,000°F at 5 minutes
 - 1,400°F at 15 minutes
 - 1,550°F at 30 minutes
 - 1,700°F at 60 minutes
 - 1,850°F at 120 minutes
 - 1,925°F at 180 minutes
 - 2,000°F at 240 minutes

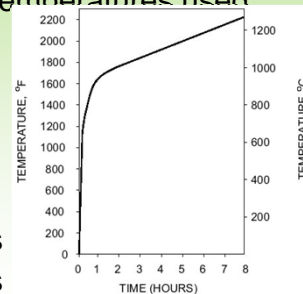

2012 IBC Inspection of Fire-Resistance Rated Floors, Ceilings and Roofs

7

Floor Assembly Fire Test

ASTM E 119 Fire Test for Floor Assemblies

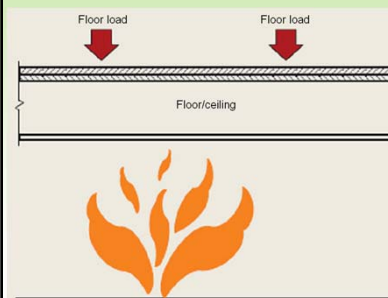

Assembly must:

- Sustain applied load.
- Have no passage of flame or gas hot enough to ignite cotton waste.
- Have average temperature rise on unexposed surface not more than 250°F (121°C) above initial temperature or more than 325°F (163°C) at any point.



2012 IBC Inspection of Fire-Resistance Rated Floors, Ceilings and Roofs

8

2012 IBC Inspection of Fire-Resistance Rated Floors, Ceilings and Roofs

Section 703.2 – Fire-Resistance Ratings

Where materials, systems or devices that have not been tested as part of a fire-resistance-rated assembly are incorporated into the building element, component or assembly, sufficient data shall be made available to the building official to show that the required fire-resistance rating is not reduced.

- Important to realize since adding insulation to some assemblies has been shown to reduce rating by 20%

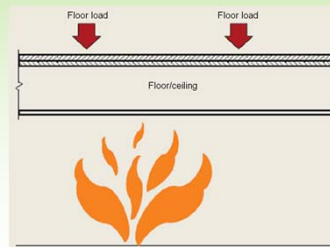

Section 703.3 – Alternative methods for determining fire resistance

- The application of any alternative methods to be based on fire exposure and acceptance criteria specified in ASTM E 119 or UL 263.



Section 703.3 – Alternative methods for determining fire resistance

- The required fire-resistance of a building element is permitted to be established by any of the following methods or procedures:
 - Designs documented in approved sources.
 - Prescriptive designs per Section 721.
 - Calculations in accordance with Section 722.
 - Engineering analysis based upon a comparison with elements tested in accordance with ASTM E 119 or UL 263.
 - Alternative methods in accordance with Section 104.11.



Table 721.1(3) – Prescriptive Fire-Resistance

TABLE 721.1(3)
MINIMUM PROTECTION FOR FLOOR AND ROOF SYSTEMS^{1,4}

| FLOOR OR ROOF CONSTRUCTION | ITEM NUMBER | CEILING CONSTRUCTION | THICKNESS OF FLOOR OR ROOF SLAB (inches) | | | | MINIMUM THICKNESS OF CEILING (inches) | | | | |
|---|-------------|---|--|--------|--------|--------|---------------------------------------|--------|--------|--------|-------|
| | | | 4 hour | 3 hour | 2 hour | 1 hour | 4 hour | 3 hour | 2 hour | 1 hour | |
| 1. Siliceous aggregate concrete | 1-1.1 | Slab (no ceiling required). Minimum cover over nonprestressed reinforcement shall not be less than 1/2" b. | 7.0 | 6.2 | 5.0 | 3.5 | — | — | — | — | — |
| 2. Carbonate aggregate concrete | 2-1.1 | | 6.6 | 5.7 | 4.6 | 3.2 | — | — | — | — | — |
| 3. Sand-lightweight concrete | 3-1.1 | | 5.4 | 4.6 | 3.8 | 2.7 | — | — | — | — | — |
| 4. Lightweight concrete | 4-1.1 | | 5.1 | 4.4 | 3.6 | 2.5 | — | — | — | — | — |
| 21. Wood joists, wood I-joists, floor trusses and flat or pitched roof trusses spaced a maximum 24" o.c. with 1/2" wood structural panels with exterior glue applied at right angles to top of joist or top chord of trusses with 8d nails. The wood structural panel thickness shall not be less than nominal 1/2" nor less than required by Chapter 23. | 21-1.1 | Base layer 1/2" Type X gypsum wallboard applied at right angles to joist or truss 24" o.c. with 1 1/4" Type S or Type W drywall screws 24" o.c. Face layer 1/2" Type X gypsum wallboard or veneer base applied at right angles to joist or truss through base layer with 1 1/4" Type S or Type W drywall screws 12" o.c. at joints and intermediate joist or truss. Face layer Type G drywall screws placed 2" back on either side of face layer end joints, 12" o.c. | — | — | — | Varies | — | — | — | — | 1 1/4 |

2012 IBC Inspection of Fire-Resistance Rated Floors, Ceilings and Roofs

Purpose of rated assemblies

FIRE RESISTANCE. That property of materials or their assemblies that prevents or retards the passage of excessive heat, hot gases or flames under conditions of use.

FIRE-RESISTANCE RATING. The period of time a building element, component or assembly maintains the ability to confine a fire, continues to perform a given structural function, or both, as determined by the tests, or the methods based on tests, prescribed in Section 703.



2012 IBC Inspection of Fire-Resistance Rated Floors, Ceilings and Roofs

13

Purpose of rated assemblies

FIRE PROTECTION RATING. The period of time that an opening protective will maintain the ability to confine a fire as determined by tests prescribed in Section 715. Ratings are stated in hours or minutes.



2012 IBC Inspection of Fire-Resistance Rated Floors, Ceilings and Roofs

14

Types of Horizontal Assemblies

Horizontal assemblies may be either:

- a floor or
- roof assembly

Some may rely on the ceiling as a part of a floor/ceiling or roof/ceiling assembly. The ceiling assembly is often an integral part of a fire-resistance-rated floor/ceiling or roof/ceiling assembly; therefore:

- the integrity of the ceiling assembly must be maintained in order to reduce the potential for premature failure of the floor or roof of a building.



2012 IBC Inspection of Fire-Resistance Rated Floors, Ceilings and Roofs

15

Horizontal Assembly with Ceiling

Where a ceiling membrane is a part of a rated assembly, the ability of the membrane to remain in place is important to the viability of the rating. Section 711.3.1 addresses upward force.

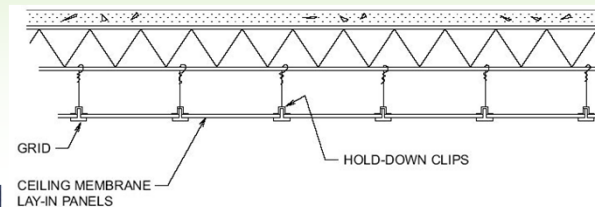

2012 IBC Inspection of Fire-Resistance Rated Floors, Ceilings and Roofs

16

2012 IBC Inspection of Fire-Resistance Rated Floors, Ceilings and Roofs

Horizontal Assembly Fire Test

As a part of the fire test, thermocouples are placed not only on the unexposed surface, but also on the steel structural elements in the assembly. Therefore the ceiling membrane is important as well as the steel member size.

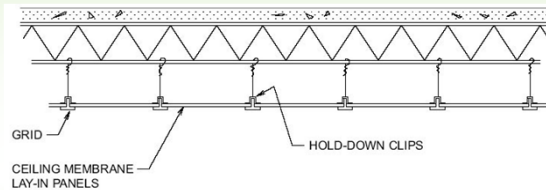

2012 IBC Inspection of Fire-Resistance Rated Floors, Ceilings and Roofs

17

Horizontal Assembly Fire Test

Temperature of steel:
[Standard contains additional criteria and limitations]

Within horizontal assembly (structural steel in floors, roofs or beams) general limits:

- 1,100°F average
- 1,300°F at any one point

Reinforcing and prestressing steel in concrete floors, roofs or beams:

- 800°F average
- 1,100°F at any one point

2012 IBC Inspection of Fire-Resistance Rated Floors, Ceilings and Roofs

18

Protection of Structural Members – Section 704

Individual encasement

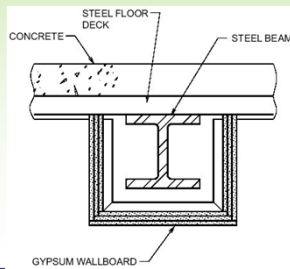

2012 IBC Inspection of Fire-Resistance Rated Floors, Ceilings and Roofs

19

Membrane

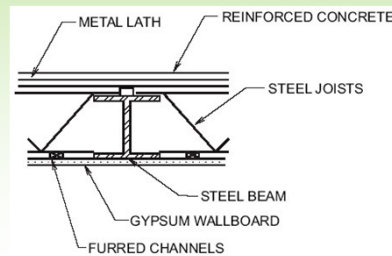

Protection of Structural Members – Section 704

Individual encasement required for primary structural frame (other than columns) where:

- Support more than two floors
- Support more than one floor and roof
- Support a load-bearing wall or non-load bearing wall more than two stories high

Combination – Individual encasement and membrane

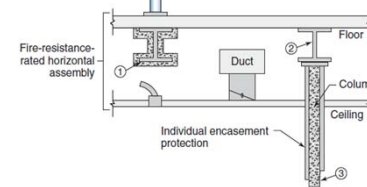

Code requirements:

1. Individual protection for structural members, other than columns, is required if supporting loads are from more than two floors or from more than one floor and roof.
2. Otherwise, protection may be by individual encasement, membrane or ceiling protection in accordance with Section 711 or combination of both.
3. Columns must be individually encased and protected for full height. (Section 704.2)

2012 IBC Inspection of Fire-Resistance Rated Floors, Ceilings and Roofs

20

2012 IBC Inspection of Fire-Resistance Rated Floors, Ceilings and Roofs

Alternative Materials, Design and Methods of Construction

104.11 Alternative materials, design and methods of construction and equipment. The provisions of this code are not intended to prevent the installation of any material or to prohibit any design or method of construction not specifically prescribed by this code, provided that any such alternative has been *approved*.

Alternates are:

- Approved
- Complies with intent of the code
- Equivalent to code in:
 - Quality, Strength, Effectiveness, Fire-resistance, Durability and Safety



Guidelines on Fire Ratings of Archaic Materials and Assemblies – IEBC Chapter Resource A

The *Guideline on Fire Ratings of Archaic Materials and Assemblies* focuses upon the fire-related performance of archaic construction. "Archaic" encompasses construction typical of an earlier time, generally prior to 1950. "Fire-related performance" includes fire resistance, flame spread, smoke production and degree of combustibility.



Harmathy's 10 Rules – See IEBC

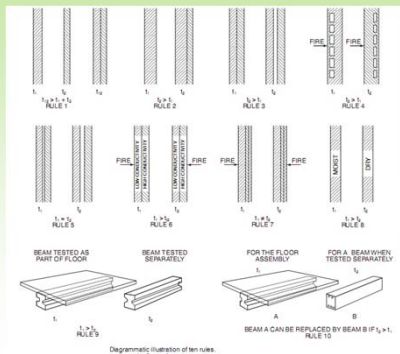

1. Reproduced from the May 1965 *Fire Technology* (Vol. 1, No. 2). Copyright National Fire Protection Association, Boston. Reproduced by permission.



Multiple Use Fire Assemblies

701.2 Multiple use fire assemblies. Fire assemblies that serve multiple purposes in a building shall comply with all of the requirements that are applicable for each of the individual fire assemblies.

If it serves multiple purposes, must comply with all requirements.

Example: Rated floor also serving as a smoke barrier. Must meet horizontal fire assembly provisions and smoke barrier penetration and joint requirements.



2012 IBC Inspection of Fire-Resistance Rated Floors, Ceilings and Roofs

Definitions

- Annular Space
- Building Element
- Ceiling Radiation Damper
- Combination Fire/Smoke Damper
- Draftstop
- F Rating
- Fire Barrier
- Fire Damper
- Fire Door Assembly
- Fire Partition
- Fire Protection Rating
- Fire Resistance
- Fire-resistance Rating
- Fire-resistant Joint System



2012 IBC Inspection of Fire-Resistance Rated Floors, Ceilings and Roofs

25

Definitions (continued)

- Fire Separation Distance
- Firewall
- Fire Window Assembly
- Fireblocking
- Horizontal Assembly
- Joint
- Member Penetration
- Shaft
- Shaft Enclosure
- Smoke Barrier
- Smoke Compartment
- T Rating
- Through Penetration
- Primary Structural Frame
- Secondary members



2012 IBC Inspection of Fire-Resistance Rated Floors, Ceilings and Roofs

26

Sections 711 and 712 Different Topics

- **Section 711**
Primarily is the construction requirements for horizontal assemblies
- **Section 712**
Primarily is addressing the openings and protection of them through the horizontal assembly



2012 IBC Inspection of Fire-Resistance Rated Floors, Ceilings and Roofs

27

Section 711

- Horizontal assemblies are required by various provisions of the code:
 - Type of construction requirements
 - Separated occupancies
 - Incidental accessory occupancy separation
 - Separation of fire areas
 - Horizontal exit alternative
 - Dwelling unit and sleeping unit separations
 - Horizontal separation allowances (Section 510)
 - Due to supporting rated walls



2012 IBC Inspection of Fire-Resistance Rated Floors, Ceilings and Roofs

28

2012 IBC Inspection of Fire-Resistance Rated Floors, Ceilings and Roofs

Table 601

**TABLE 601
FIRE-RESISTANCE RATING REQUIREMENTS FOR BUILDING ELEMENTS (HOURS)**

| BUILDING ELEMENT | TYPE I | | TYPE II | | TYPE III | | TYPE IV HT | TYPE V | |
|--|--------------------|------------------|------------------|----------------|------------------|---|---------------------|------------------|---|
| | A | B | A ^d | B | A ^d | B | | A ^d | B |
| Primary structural frame ^e (see Section 202) | 3 ^a | 2 ^a | 1 | 0 | 1 | 0 | HT | 1 | 0 |
| Bearing walls | | | | | | | | | |
| Exterior ^{f, g} | 3 | 2 | 1 | 0 | 2 | 2 | 2 | 1 | 0 |
| Interior | 3 ^a | 2 ^a | 1 | 0 | 1 | 0 | 1/HT | 1 | 0 |
| Nonbearing walls and partitions | See Table 602 | | | | | | | | |
| Exterior | See Table 602 | | | | | | | | |
| Interior ^e | 0 | 0 | 0 | 0 | 0 | 0 | See Section 602.4.6 | 0 | 0 |
| Floor construction and associated secondary members (see Section 202) | 2 | 2 | 1 | 0 | 1 | 0 | HT | 1 | 0 |
| Roof construction and associated secondary members (see Section 202) | 1 1/2 ^b | 1 ^{b,c} | 1 ^{b,c} | 0 ^c | 1 ^{b,c} | 0 | HT | 1 ^{b,c} | 0 |

2012 IBC Inspection of Fire-Resistance Rated Floors, Ceilings and Roofs

29

Section 711.3 – Fire-resistance rating

- Where the floor assembly separates mixed occupancies under the separated occupancy method, the assembly shall have a fire-resistance rating of not less than that required by Section 508.4 based on the occupancies being separate.

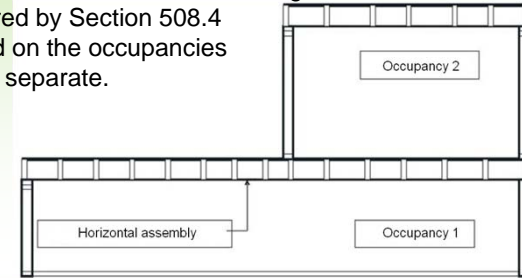

2012 IBC Inspection of Fire-Resistance Rated Floors, Ceilings and Roofs

30

Section 711.3 – Fire-resistance rating

- Where the floor assembly separates a single occupancy or multiple occupancies into different fire areas, the assembly shall have a fire-resistance rating of not less than that required by Section 707.3.10.

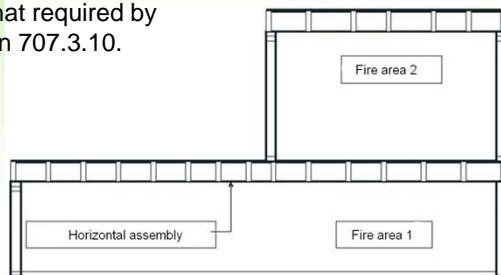

2012 IBC Inspection of Fire-Resistance Rated Floors, Ceilings and Roofs

31

Table 707.3.10

**TABLE 707.3.10
FIRE-RESISTANCE RATING REQUIREMENTS FOR FIRE BARRIER ASSEMBLIES OR HORIZONTAL ASSEMBLIES BETWEEN FIRE AREAS**

| OCCUPANCY GROUP | FIRE-RESISTANCE RATING (hours) |
|--------------------------------------|--------------------------------|
| H-1, H-2 | 4 |
| F-1, H-3, S-1 | 3 |
| A, B, E, F-2, H-4, H-5, I, M, R, S-2 | 2 |
| U | 1 |

2012 IBC Inspection of Fire-Resistance Rated Floors, Ceilings and Roofs

32

2012 IBC Inspection of Fire-Resistance Rated Floors, Ceilings and Roofs

Section 711.3 – Fire-resistance rating

- Floor assemblies separating dwelling units in the same building or sleeping units that same building shall be a minimum of 1-hour fire-resistance-rated construction.

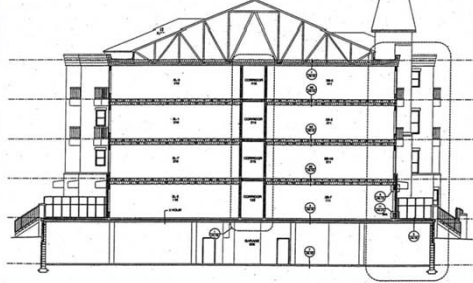

2012 IBC Inspection of Fire-Resistance Rated Floors, Ceilings and Roofs

33

Section 711.3 – Exception

- Dwelling and sleeping unit separations in buildings of Types IIB, IIIB and VB construction shall have fire-resistance ratings of not less than ½-hour in buildings equipped throughout with an automatic sprinkler system in accordance with Section 903.3.1.1

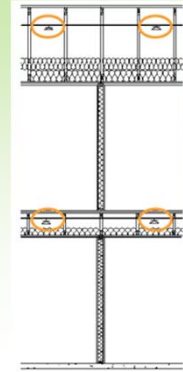

2012 IBC Inspection of Fire-Resistance Rated Floors, Ceilings and Roofs

34

Access Doors and Floor Fire Doors

- **Access doors – 711.3.2**
 - Permitted to be installed in ceiling of fire-resistance-rated floor/ceiling or roof/ceiling assembly
 - Tested to ASTM E 119 or UL 263 as horizontal assembly
 - Ensures thermal transmission through door does not affect assembly (different than typical “door” test – NFPA 252 or UL 10)
- **Floor Fire Door Assemblies – 711.8**
 - Installed in the floor
 - Tested to NFPA 288
 - Has fire-resistance rating instead of a fire-protection rating
 - Limits the temperature transmission to the unexposed side of the assembly (like floor itself)

2012 IBC Inspection of Fire-Resistance Rated Floors, Ceilings and Roofs

35

Section 711.3.3 – Unusable space

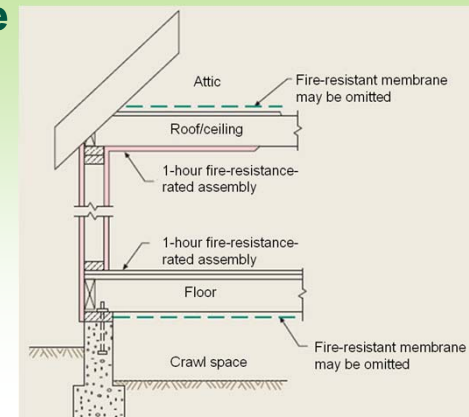

2012 IBC Inspection of Fire-Resistance Rated Floors, Ceilings and Roofs

36

2012 IBC Inspection of Fire-Resistance Rated Floors, Ceilings and Roofs

Section 711.4 – Continuity

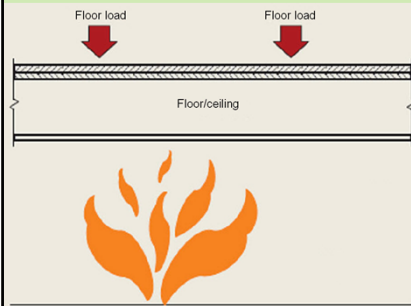

Continuous assembly without openings, penetrations or joints except as allowed by code

- Skylights and other roof penetrations allowed if:
 - Structural integrity is maintained
 - Not in roofs rated in accordance with 705.8.6



2012 IBC Inspection of Fire-Resistance Rated Floors, Ceilings and Roofs

37

Unprotected Skylights and Other Penetrations

Certain code provisions prohibit openings (protected or unprotected) in specific locations of horizontal assemblies. Examples:

- Adjacent to fire walls – Section 706.6 exceptions 2, 3 or 4
- Lower roof of stepped building – Section 706.6.1
- Plastic skylight near exterior wall requiring protected openings – Section 2610.7



2012 IBC Inspection of Fire-Resistance Rated Floors, Ceilings and Roofs

38

Section 706.6 – Exception 1

Roof Protection for Stepped Building

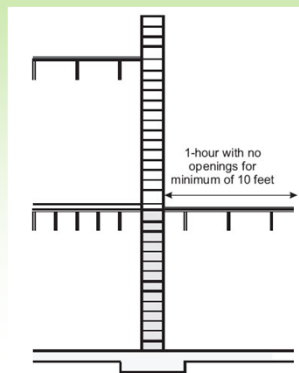

2012 IBC Inspection of Fire-Resistance Rated Floors, Ceilings and Roofs

39

Section 706.6 – Exception 2

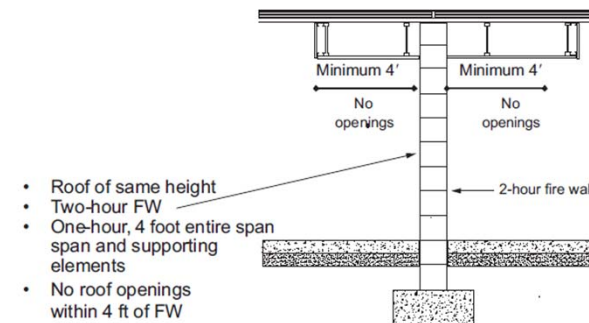

- Roof of same height
- Two-hour FW
- One-hour, 4 foot entire span span and supporting elements
- No roof openings within 4 ft of FW

For SI: 1 foot = 304.8 mm.



2012 IBC Inspection of Fire-Resistance Rated Floors, Ceilings and Roofs

40

2012 IBC Inspection of Fire-Resistance Rated Floors, Ceilings and Roofs

Section 706.6 – Exception 3

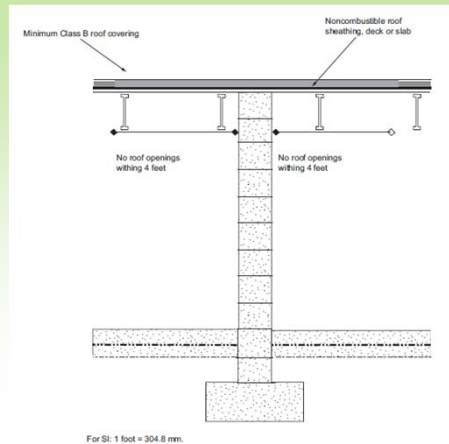

2012 IBC Inspection of Fire-Resistance Rated Floors, Ceilings and Roofs

41

Section 706.6 – Exception 4

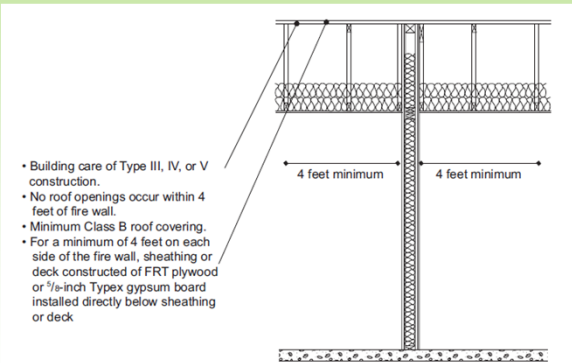

- Building core of Type III, IV, or V construction.
- No roof openings occur within 4 feet of fire wall.
- Minimum Class B roof covering.
- For a minimum of 4 feet on each side of the fire wall, sheathing or deck constructed of FRT plywood or 5/8-inch Typex gypsum board installed directly below sheathing or deck

For SI: 1 foot = 304.8 mm.

2012 IBC Inspection of Fire-Resistance Rated Floors, Ceilings and Roofs

42

Section 711.4 – Continuity

- Construction supporting a horizontal assembly shall be protected to afford the required fire-resistance rating of the horizontal assembly supported.

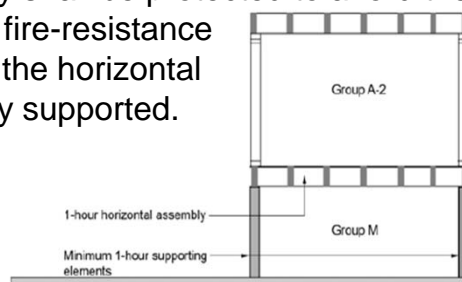

2012 IBC Inspection of Fire-Resistance Rated Floors, Ceilings and Roofs

43

Continuity – Support of Assembly

In Types II-B, III-B or V-B construction, the supporting construction is not required to be fire-resistance-rated at:

- Separations of incidental uses (Table 509) that don't exceed 1-hour
- Separation of dwelling or sleeping units (Section 420.3)
- Smoke barriers constructed per Section 709.

2012 IBC Inspection of Fire-Resistance Rated Floors, Ceilings and Roofs

44

2012 IBC Inspection of Fire-Resistance Rated Floors, Ceilings and Roofs

Different Types of Fire-Protection

- Penetrations – 711.5 (Section 714)
- Joint Systems – 711.6 (Section 715)
- Ducts and Air Transfer Openings – 711.7 (Section 717)
 - Dampers
- Floor fire door assemblies – 711.8



2012 IBC Inspection of Fire-Resistance Rated Floors, Ceilings and Roofs

45

Section 711.9 – Smoke barrier

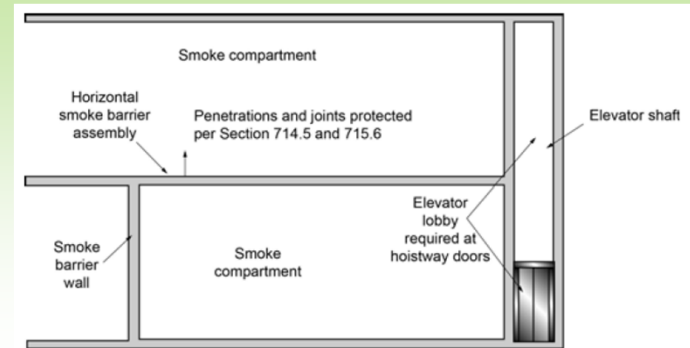

2012 IBC Inspection of Fire-Resistance Rated Floors, Ceilings and Roofs

46

Section 711.9 – Smoke Barrier

If horizontal assembly is required to resist movement of smoke by other sections:

- Penetrations and joints protected as required for smoke barriers (714.5 and 715.6)
- Protect elevator shaft doors with elevator lobby (regardless of number of stories)
- Protect openings with shaft enclosures (713)
- Unprotected vertical openings not allowed



2012 IBC Inspection of Fire-Resistance Rated Floors, Ceilings and Roofs

47

Vertical Openings
Protecting holes in horizontal assemblies

Section 712



2012 IBC Inspection of Fire-Resistance Rated Floors, Ceilings and Roofs

48

2012 IBC Inspection of Fire-Resistance Rated Floors, Ceilings and Roofs

Section 712.1.1 – Shaft enclosure

- Vertical openings are permitted when contained within a shaft enclosure that complies with the provisions of Section 713.

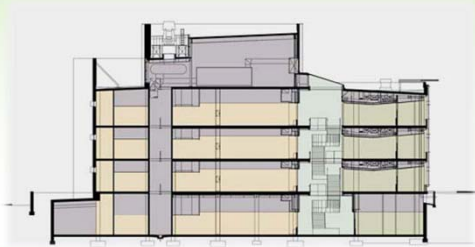

2012 IBC Inspection of Fire-Resistance Rated Floors, Ceilings and Roofs

49

Section 712.1.2 – Individual dwelling unit

- Vertical openings that occur totally within an individual dwelling unit, where connecting no more than four stories, are permitted.

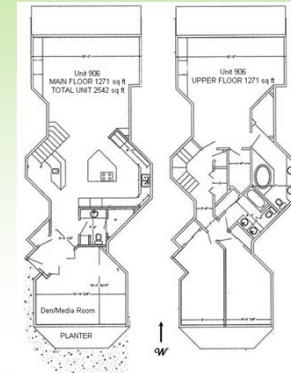

2012 IBC Inspection of Fire-Resistance Rated Floors, Ceilings and Roofs

50

Section 712.1.3 – Escalator openings

- Under prescribed conditions, escalator openings are permitted between stories where:
 - Building is sprinklered throughout.
 - Protected according to Section 712.1.3.1 or Section 712.1.3.2.



2012 IBC Inspection of Fire-Resistance Rated Floors, Ceilings and Roofs

51

Section 712.1.3.1 – Opening size

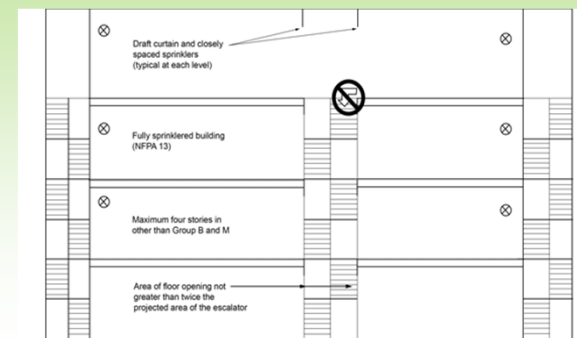

2012 IBC Inspection of Fire-Resistance Rated Floors, Ceilings and Roofs

52

2012 IBC Inspection of Fire-Resistance Rated Floors, Ceilings and Roofs

Escalator Opening Size – 712.1.3.1

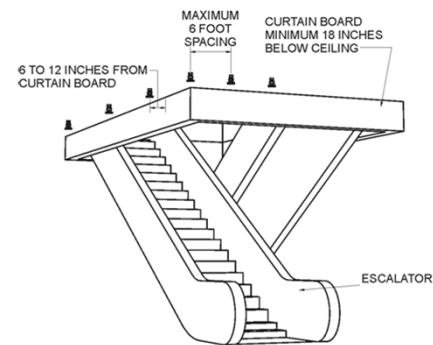

2012 IBC Inspection of Fire-Resistance Rated Floors, Ceilings and Roofs

53

Escalator Opening Size – 712.1.3.1

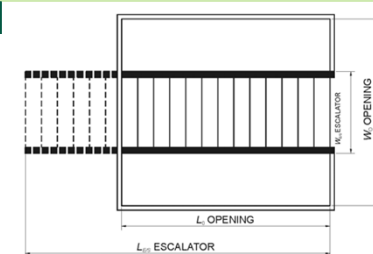

FLOOR OPENING CANNOT EXCEED TWICE THE HORIZONTAL PROJECTED AREA OF THE ESCALATOR

THEREFORE $L_2 \times W_6 \leq 2 \times L_1 \times W_1$

For SI: 1 inch = 25.4 mm, 1 foot = 304.8 mm.

2012 IBC Inspection of Fire-Resistance Rated Floors, Ceilings and Roofs

54

Section 712.1.3.2 – Automatic shutters

- Approved automatic shutters provided at every floor.
- Shutters to be of noncombustible construction with minimum 90-minute fire-resistance rating.
- Shutter closure to be smoke detector actuated.
- Shutter actuation to initiate escalator shutdown.
- Maximum shutter speed of 30 feet/minute.
- Shutter to have sensitive leading edge to arrest progress when in contact with obstacle, then continue upon release.

2012 IBC Inspection of Fire-Resistance Rated Floors, Ceilings and Roofs

55

Automatic shutters – 712.1.3.2

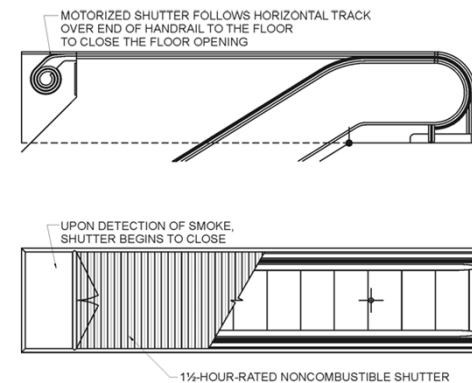

2012 IBC Inspection of Fire-Resistance Rated Floors, Ceilings and Roofs

56

2012 IBC Inspection of Fire-Resistance Rated Floors, Ceilings and Roofs

Section 712.1.4, 712.1.5 – Penetrations and ducts

- Penetrations by pipe, tube, conduit, wire, cable and vents protected in accordance with Section 714 are permitted.
- Penetrations by ducts protected in accordance with Section 717.6 are permitted. Grease ducts shall be protected in accordance with the *International Mechanical Code*[®] (IMC[®]).



2012 IBC Inspection of Fire-Resistance Rated Floors, Ceilings and Roofs

57

Section 712.1.4

Penetrations which create vertical openings in horizontal assemblies shall comply with Section 714. This includes:

- Horizontal assemblies
 - Fire-resistance-rated assemblies
 - Through penetrations
 - Membrane penetrations
 - Non fire-resistance-rated assemblies
- Smoke barriers



2012 IBC Inspection of Fire-Resistance Rated Floors, Ceilings and Roofs

58

Section 714.4 – Horizontal assemblies

- Penetrations of horizontal assemblies are regulated for:
 - Floors.
 - Floor/ceiling assemblies.
 - Ceiling membranes of roof/ceiling assemblies.
- Requirements are applicable to:
 - Fire-resistance-rated assemblies.
 - Nonfire-resistance-rated assemblies.



2012 IBC Inspection of Fire-Resistance Rated Floors, Ceilings and Roofs

59

Penetrations

- Floor

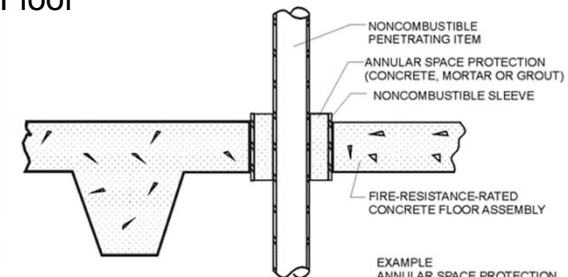

2012 IBC Inspection of Fire-Resistance Rated Floors, Ceilings and Roofs

60

2012 IBC Inspection of Fire-Resistance Rated Floors, Ceilings and Roofs

Penetrations

- Floor/Ceiling or Ceiling of Roof

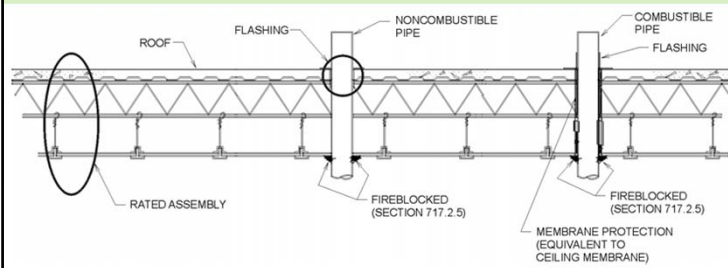

2012 IBC Inspection of Fire-Resistance Rated Floors, Ceilings and Roofs

61

Section 714 - Penetrations

Penetrations of fire-resistive assemblies can be protected by one of three basic methods:

- Tested as a part of the original fire-resistive assembly test
- Tested as a Penetration Firestop System – complying with ASTM E 714 or UL 1479
- Comply with one of the exceptions listed in Sections 714.4.1.1 or 714.4.1.2



2012 IBC Inspection of Fire-Resistance Rated Floors, Ceilings and Roofs

62

Penetration Firestop Systems

- Review and understand definitions!
- Tested and listed as a system. Must be installed and used for walls and penetrants as tested.
- Required to have an “F” and a “T” rating of not less than the fire-resistance rating of the floor. (Section 714.4.1.1.2)
- Required to have an “L” rating for penetrations in smoke barriers (Section 714.5)



2012 IBC Inspection of Fire-Resistance Rated Floors, Ceilings and Roofs

63

Special Inspection – Section 1705.16

Special inspection of penetration firestops, joint systems and perimeter barrier systems is required in:

- High-rise buildings
- Buildings in Risk Category III or IV in accordance with Section 1604.5



2012 IBC Inspection of Fire-Resistance Rated Floors, Ceilings and Roofs

64

2012 IBC Inspection of Fire-Resistance Rated Floors, Ceilings and Roofs

Risk Category – Table 1604.5

| RISK CATEGORY | NATURE OF OCCUPANCY |
|---------------|---|
| III | <p>Buildings and other structures that represent a substantial hazard to human life in the event of failure, including but not limited to:</p> <ul style="list-style-type: none"> • Buildings and other structures whose primary occupancy is public assembly with an occupant load greater than 300. • Buildings and other structures containing elementary school, secondary school or day care facilities with an occupant load greater than 250. • Buildings and other structures containing adult education facilities, such as colleges and universities, with an occupant load greater than 500. • Group I-2 occupancies with an occupant load of 50 or more resident care recipients but not having surgery or emergency treatment facilities. • Group I-3 occupancies. • Any other occupancy with an occupant load greater than 5,000⁶. • Power-generating stations, water treatment facilities for potable water, waste water treatment facilities and other public utility facilities not included in Risk Category IV. • Buildings and other structures not included in Risk Category IV containing quantities of toxic or explosive materials that: Exceed maximum allowable quantities per control area as given in Table 307.1(1) or 307.1(2) or per outdoor control area in accordance with the <i>International Fire Code</i>; and Are sufficient to pose a threat to the public if released⁶. |



Risk Category – Table 1604.5

| RISK CATEGORY | NATURE OF OCCUPANCY |
|---------------|--|
| IV | <p>Buildings and other structures designated as essential facilities, including but not limited to:</p> <ul style="list-style-type: none"> • Group I-2 occupancies having surgery or emergency treatment facilities. • Fire, rescue, ambulance and police stations and emergency vehicle garages. • Designated earthquake, hurricane or other emergency shelters. • Designated emergency preparedness, communications and operations centers and other facilities required for emergency response. • Power-generating stations and other public utility facilities required as emergency backup facilities for Risk Category IV structures. • Buildings and other structures containing quantities of highly toxic materials that: Exceed maximum allowable quantities per control area as given in Table 307.1(2) or per outdoor control area in accordance with the <i>International Fire Code</i>; and Are sufficient to pose a threat to the public if released⁶. • Aviation control towers, air traffic control centers and emergency aircraft hangars. • Buildings and other structures having critical national defense functions. • Water storage facilities and pump structures required to maintain water pressure for fire suppression. |



Section 714.4.1.1 – Through penetrations

- Unless protected by a shaft enclosure, through penetrations of fire-resistance-rated horizontal assemblies shall:
 - Be installed as tested in an approved fire-resistance-rated assembly; or
 - Protected by an approved penetration firestop system (ASTM E 814 or UL 1479).



Section 714.4.1.1 – Exception 1

- Through-penetration firestop systems are not required for through penetrations of a single fire-resistance-rated floor assembly for steel, ferrous or copper conduits, pipes, tubes or vents where:
 - Annular space protected with materials that prevent the passage of flame and hot gases in accordance with ASTM E 119 or UL 263.



2012 IBC Inspection of Fire-Resistance Rated Floors, Ceilings and Roofs

Section 714.4.1.1 – Exception 2

- Through-penetration firestop systems are not required for through penetrations of a single fire-resistance-rated concrete floor assembly for steel, ferrous or copper conduits, pipes, tubes or vents where:
 - Maximum size of penetrating item is 6 inches in diameter.
 - Annular space is protected with concrete, grout or mortar for the full thickness of the floor or the thickness required to maintain the fire-resistance rating.



2012 IBC Inspection of Fire-Resistance Rated Floors, Ceilings and Roofs

69

Section 714.4.1.2 – Membrane penetrations

- Penetrations of membranes that are a part of a fire-resistance-rated horizontal assembly shall comply with the requirements for through penetrations in such horizontal assemblies.



2012 IBC Inspection of Fire-Resistance Rated Floors, Ceilings and Roofs

70

Section 714.4.1.2 – Exception 1

- Annular space protection of membrane penetrations permitted in lieu of listed firestop system where:
 - Penetrating items are steel, ferrous or copper pipes, tubes or conduits.
 - Annular space is protected to prevent the free passage of flame and products of combustion.
 - Aggregate area of openings through membrane is limited to 100 square inches in any 100 square feet.



2012 IBC Inspection of Fire-Resistance Rated Floors, Ceilings and Roofs

71

Section 714.4.1.2 – Exception 2

- Ceiling membrane penetrations of steel electrical boxes may be made subject to the following conditions:
 - Horizontal assembly to be maximum 2 hours.
 - Boxes to be a maximum of 16 square inches.
 - Aggregate area of boxes is not to exceed 100 square inches per 100 square feet of wall area.
 - Annular space between box and ceiling membrane is not to exceed 1/8 inch.



2012 IBC Inspection of Fire-Resistance Rated Floors, Ceilings and Roofs

72

2012 IBC Inspection of Fire-Resistance Rated Floors, Ceilings and Roofs

Section 714.4.1.2 – Exception 3 and 4

- Ceiling membrane penetrations of listed electrical boxes of any material may be made subject to the following conditions:
 - Boxes have been tested for use in a fire-resistance-rated assembly.
 - Boxes are installed in accordance with their listing.
 - Annular space between the box and ceiling membrane is not to exceed 1/8 inch.



2012 IBC Inspection of Fire-Resistance Rated Floors, Ceilings and Roofs

73

Section 714.4.1.2 – Exception 5

- Ceiling membrane penetrations created by the penetration of a fire sprinkler need not be protected by an approved firestop system provided the annular space is covered by a metal escutcheon plate.
 - Applicable only where a sprinkler is installed at the point of the ceiling membrane penetration.



2012 IBC Inspection of Fire-Resistance Rated Floors, Ceilings and Roofs

74

Section 714.4.1.2 – Exception 5

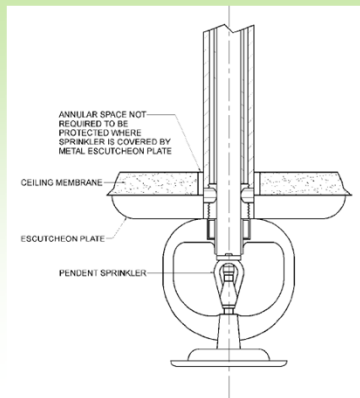

2012 IBC Inspection of Fire-Resistance Rated Floors, Ceilings and Roofs

75

Section 714.4.1.2 – Exception 6

- Penetrations of noncombustible items are permitted where cast into concrete building elements provided the items do not penetrate both the top and bottom surfaces of the element.



2012 IBC Inspection of Fire-Resistance Rated Floors, Ceilings and Roofs

76

2012 IBC Inspection of Fire-Resistance Rated Floors, Ceilings and Roofs

Section 714.4.1.2 – Exception 7

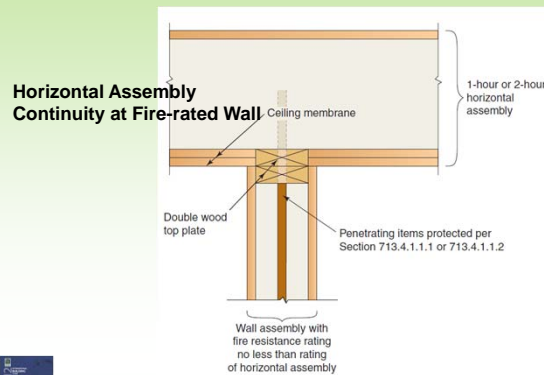

2012 IBC Inspection of Fire-Resistance Rated Floors, Ceilings and Roofs

77

Section 714.4.2 – Nonfire-resistance-rated assemblies

- Penetrations of nonfire-resistance-rated horizontal assemblies shall comply with:
 - Section 713, for shaft enclosures.
 - Section 714.4.2.1, for noncombustible penetrating items.
 - Section 714.4.2.2, for penetrations that connect a maximum of two stories.

2012 IBC Inspection of Fire-Resistance Rated Floors, Ceilings and Roofs

78

Section 714.4.2.1 – Noncombustible penetrating items

- Noncombustible penetrations of nonfire-resistance-rated horizontal assemblies need not meet the shaft enclosure provisions of Section 713 provided the:
 - Penetrating items do not connect more than five stories; and
 - Annular space is filled with an approved noncombustible material to resist the free passage of flame and the products of combustion.

2012 IBC Inspection of Fire-Resistance Rated Floors, Ceilings and Roofs

79

Section 714.4.2.2 – Penetrating items

- Combustible penetrations of nonfire-resistance-rated horizontal assemblies need not meet the shaft enclosure provisions of Section 713 provided the:
 - Penetrating items do not connect more than two stories; and
 - Annular space is filled with an approved noncombustible material to resist the free passage of flame and the products of combustion.

2012 IBC Inspection of Fire-Resistance Rated Floors, Ceilings and Roofs

80

2012 IBC Inspection of Fire-Resistance Rated Floors, Ceilings and Roofs

Section 714.5 – Penetrations in smoke barriers

- Penetrations in smoke barriers to be protected by a through-penetration firestop system installed and tested in accordance with UL 1479 for air leakage L rating of the system, measured at 0.30 inch (7.47 Pa) of water in both the ambient and elevated temperature tests, not to exceed:
 - 5.0 cubic feet per minute (cfm) per square foot per penetration; or
 - Cumulative leakage of 50 cfm for any 100 square feet of wall or floor area.



2012 IBC Inspection of Fire-Resistance Rated Floors, Ceilings and Roofs

81

Section 712.1.5 Ducts

Reference to Section 717.6.

- Fire dampers, smoke dampers and combination fire/smoke dampers protect openings created by duct penetrations and air transfer openings in those fire-resistance-rated assemblies required to be protected.
- Ceiling radiation dampers protect duct penetrations, which only penetrate the ceiling membrane of a fire-resistance-rated assembly.



2012 IBC Inspection of Fire-Resistance Rated Floors, Ceilings and Roofs

82

Section 717.1.1 – Ducts that penetrate fire-resistance-rated assemblies without dampers

- Ducts that penetrate horizontal assemblies and not required to be within a shaft and not required to have dampers shall comply with the provisions of Section 714.4 through 714.4.2.2 and are regulated as penetrations.
- The annular space around ducts penetrating nonrated floor assemblies shall comply with 717.6.3.



2012 IBC Inspection of Fire-Resistance Rated Floors, Ceilings and Roofs

83

Section 717.3 – Damper testing, ratings and actuation

- Dampers shall be listed, labeled and in compliance with the following standards:
 - Fire dampers: UL 555.
 - Smoke dampers: UL 555S.
 - Combination fire/smoke dampers to comply with both UL 555 and 555S.
 - A “Corridor damper” is a specific type of combination damper used in a tunnel type corridor.
 - Ceiling radiation dampers: UL 555C.



2012 IBC Inspection of Fire-Resistance Rated Floors, Ceilings and Roofs

84

2012 IBC Inspection of Fire-Resistance Rated Floors, Ceilings and Roofs

Section 717.3 – Damper testing, ratings and actuation

TABLE 717.3.2.1
FIRE DAMPER RATING

| TYPE OF PENETRATION | MINIMUM DAMPER RATING (hours) |
|--|-------------------------------|
| Less than 3-hour fire-resistance-rated assemblies | 1.5 |
| 3-hour or greater fire-resistance-rated assemblies | 3 |



2012 IBC Inspection of Fire-Resistance Rated Floors, Ceilings and Roofs

85

Section 717.4 – Access and identification

- Fire and smoke dampers are to be provided with an approved means of access:
 - Large enough to permit inspection and maintenance.
 - Access points identified on exterior by label indicating type of damper.
 - Access doors to be tight fitting and suitable for the duct construction.
- Ceiling radiation dampers not listed – but should still provide access. Generally OK through ceiling diffuser.



2012 IBC Inspection of Fire-Resistance Rated Floors, Ceilings and Roofs

86

Section 717.6 – Horizontal assemblies

- Penetrations by ducts and air transfer openings of a floor, floor/ceiling assembly or the ceiling membrane of a roof/ceiling assembly shall be protected by a shaft enclosure that complies with Section 713 or shall comply with Sections 717.6.1 through 717.6.3.



2012 IBC Inspection of Fire-Resistance Rated Floors, Ceilings and Roofs

87

Section 717.6.1 – Through penetrations

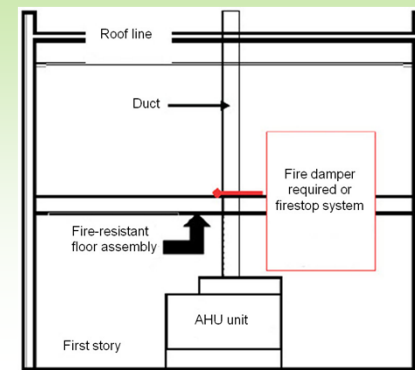

2012 IBC Inspection of Fire-Resistance Rated Floors, Ceilings and Roofs

88

2012 IBC Inspection of Fire-Resistance Rated Floors, Ceilings and Roofs

Section 717.6.1 – Exception

- A duct is permitted to penetrate three floors or less without a fire damper at each floor provided:
 - Duct within wall cavity;
 - Minimum 26 gage in thickness;
 - Duct opens to only one dwelling or sleeping unit, and duct is continuous from the unit to exterior;



2012 IBC Inspection of Fire-Resistance Rated Floors, Ceilings and Roofs

89

Section 717.6.1 – Exception (continued)

- A duct is permitted to penetrate three floors or less without a fire damper at each floor provided:
 - Maximum 4-inch diameter duct with maximum total area of 100 square inches per 100 square feet of floor area;
 - Annular space protected to prevent the passage of flame and hot gases; and
 - Grille openings located in floor/ceiling or roof/ceiling assembly shall be protected with ceiling damper.



2012 IBC Inspection of Fire-Resistance Rated Floors, Ceilings and Roofs

90

Section 717.6.2 – Membrane penetrations

- Ducts and air transfer openings constructed of approved materials that penetrate the ceiling of a fire-resistance-rated floor/ceiling assembly shall be protected with one of the following:
 - Shaft enclosure in accordance with Section 713.
 - Listed ceiling radiation damper installed at the ceiling line where a:
 - Duct penetrates the ceiling.
 - Diffuser with no duct attached penetrates the ceiling.



2012 IBC Inspection of Fire-Resistance Rated Floors, Ceilings and Roofs

91

Section 717.6.2.1 – Ceiling radiation dampers

Ceiling radiation dampers are not required where:

- Tests (see ASTM E 119 or UL 263) have shown that the dampers are not necessary to maintain the fire-resistance rating of the assembly; or
- Exhaust duct penetrations are:
 - Protected in accordance with Section 714.4.1.2 (penetrations).
 - Located within the cavity of the wall; and
 - Do not pass through another dwelling unit or tenant space.



2012 IBC Inspection of Fire-Resistance Rated Floors, Ceilings and Roofs

92

2012 IBC Inspection of Fire-Resistance Rated Floors, Ceilings and Roofs

Section 717.6.3 – Nonfire-resistance-rated floor assemblies

- Duct systems of approved materials that penetrate nonfire-resistance-rated floor assemblies shall be protected by any of the following methods:
 - Shaft enclosure in accordance with Section 7138.
 - Where duct only connects two stories, protection of annular space around penetrating duct with approved noncombustible material that resists the free passage of flame and products of combustion.
 - Where duct connects a maximum of three stories, protection of annular space around penetrating duct with approved noncombustible material that resists the free passage of flame and products of combustion; and a fire damper is installed at each floor line.



2012 IBC Inspection of Fire-Resistance Rated Floors, Ceilings and Roofs

93

Damper Inspection Issues

- Dampers must be installed in accordance with their listing. Get and review manufacturer's installation instructions.
- Verify access is provided per Section 717.4.
- Verify proper type of damper being used and is installed in the correct direction.
- Breakaway connections provided on ductwork.
- Proper gap and support brackets provided around damper. (See manufacturer's instructions)



2012 IBC Inspection of Fire-Resistance Rated Floors, Ceilings and Roofs

94

Section 712.1.6 – Atriums

- For other than Group H occupancies, the atrium provisions of Section 404 are permitted as a method of addressing vertical openings.



2012 IBC Inspection of Fire-Resistance Rated Floors, Ceilings and Roofs

95

Section 712.1.7 –Masonry chimney

- Approved masonry chimneys may penetrate floors and floor/ceiling assemblies where annular space protection is provided at each floor level in accordance with Section 718.2.5

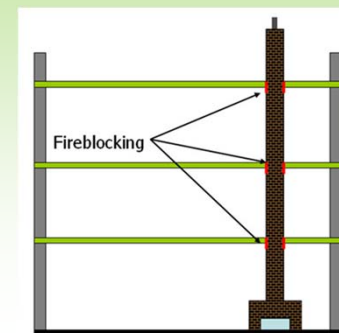

2012 IBC Inspection of Fire-Resistance Rated Floors, Ceilings and Roofs

96

2012 IBC Inspection of Fire-Resistance Rated Floors, Ceilings and Roofs

Section 712.1.8 – Two-story openings

- In other than Group I-2 and I-3 occupancies, a floor opening is permitted where all of the following conditions are met:
 - Does not connect more than two stories.
 - Is not concealed within construction of a wall or floor/ceiling assembly.
 - Is not open to a corridor in Group I and R occupancies.
 - Is not open to a corridor on nonsprinklered floors.
 - Is separated from other floor openings and air transfer openings by construction equal to shaft construction.
 - Is limited to the same smoke compartment, and same fire area, where applicable.



2012 IBC Inspection of Fire-Resistance Rated Floors, Ceilings and Roofs

97

Section 712.1.9 through 712.1.11 – Parking garages, mezzanine and joints

- Automobile ramps in open and enclosed parking garages constructed in accordance with Sections 406.5 and 406.6, respectively are permitted.
- Floor openings between a mezzanine and the floor below, are permitted.
- Joints protected by a fire-resistant joint system in accordance with Section 715 are permitted.



2012 IBC Inspection of Fire-Resistance Rated Floors, Ceilings and Roofs

98

Section 715.1 – General

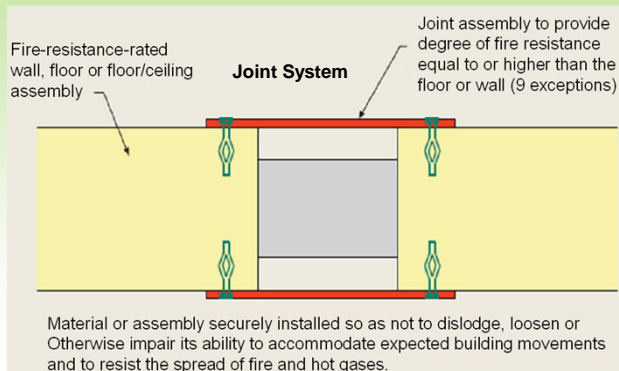

2012 IBC Inspection of Fire-Resistance Rated Floors, Ceilings and Roofs

99

Section 715.1 – Exceptions

Fire-resistant joint systems are not required in the following locations:

Floors:

- Within a single dwelling unit
- Where the joint is protected by a shaft enclosure
- Within atriums
- Within malls
- Within open parking garages
- Mezzanines

Other locations:

- Walls permitted to have unprotected openings
- Roofs where openings are permitted
- Maximum 5/8-inch (15.9 mm) wide control joints (tested in accordance with ASTM E 119 or UL 263)



2012 IBC Inspection of Fire-Resistance Rated Floors, Ceilings and Roofs

100

2012 IBC Inspection of Fire-Resistance Rated Floors, Ceilings and Roofs

Section 712.1.12 – Unenclosed stairs and ramps

- Floor openings are permitted where they contain unenclosed stairs and ramps and are permitted where in compliance with the applicable provisions of Sections 1009.2 and 1009.3.
- In other than Group I-2 and I-3 occupancies, exit access stairways that serve, or atmospherically communicate between, only two stories are not required to be enclosed.



2012 IBC Inspection of Fire-Resistance Rated Floors, Ceilings and Roofs

101

Section 712.1.13

Floor Fire Doors

- Requires fire-resistance rating
- Tested in accordance with NFPA 288

Essentially restores the floor back to being a complete fire-resistive assembly without an opening in it.



2012 IBC Inspection of Fire-Resistance Rated Floors, Ceilings and Roofs

102

Section 712.1.14 – Group I-3

Vertical openings within an I-3 when done in accordance with Section 408.6.

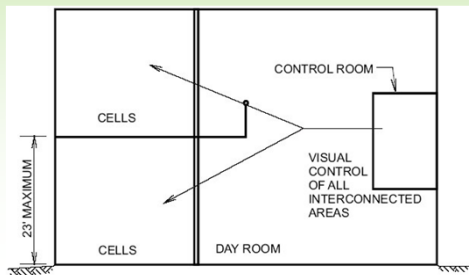

2012 IBC Inspection of Fire-Resistance Rated Floors, Ceilings and Roofs

103

Sections 712.1.15 and 712.1.16

Where contained within and serving only the parking garage, vertical openings are allowed for:

- Elevators
- Mechanical supply or exhaust ducts

Conceptually similar to 712.1.9 for the vehicle ramps. If they are allowed to be open, then why get excited about these other floor openings?



2012 IBC Inspection of Fire-Resistance Rated Floors, Ceilings and Roofs

104

2012 IBC Inspection of Fire-Resistance Rated Floors, Ceilings and Roofs

Miscellaneous Items



2012 IBC Inspection of Fire-Resistance Rated Floors, Ceilings and Roofs

105

Calculated Fire-Resistance

Calculated fire-resistance (Section 722) provides many options that may help with assemblies:

- Can calculate ratings for concrete, steel or wood assemblies
- Can substitute steel beam and girder sizes from tested assemblies (722.5.2.1.2)
- Can modify amount of sprayed fire-resistant material from approved assembly (722.5.2.2)



2012 IBC Inspection of Fire-Resistance Rated Floors, Ceilings and Roofs

106

Beam Substitution – Section 722.5.2.1.2

Can substitute member from tested assembly provided the replacement beam/girder has an equal or greater weight to heated perimeter.

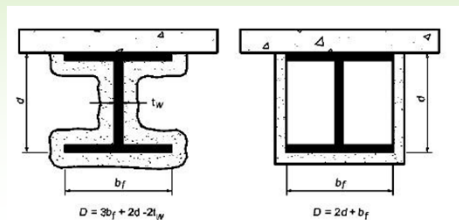

2012 IBC Inspection of Fire-Resistance Rated Floors, Ceilings and Roofs

107

Horizontal Assemblies

The horizontal fire test is a more severe test condition. An assembly that can pass as a wall, probably will not pass if installed in the horizontal condition:

- Watch out for tops and bottoms of shafts

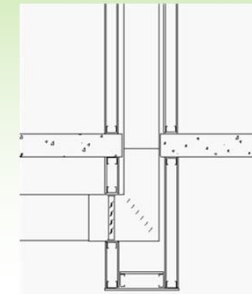

2012 IBC Inspection of Fire-Resistance Rated Floors, Ceilings and Roofs

108

2012 IBC Inspection of Fire-Resistance Rated Floors, Ceilings and Roofs

Section 713.12 – Enclosure at the top

- A shaft enclosure that does not extend to the underside of the roof sheathing, deck or slab of the building shall be enclosed at the top with construction of the same fire-resistance rating as the topmost floor penetrated by the shaft, but not less than the fire-resistance rating required for the shaft enclosure

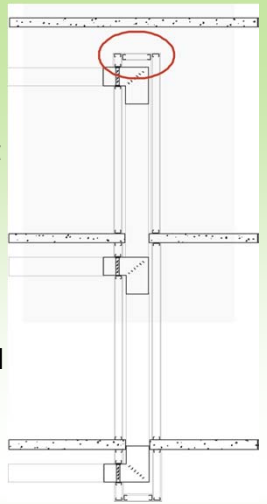

2012 IBC Inspection of Fire-Resistance Rated Floors, Ceilings and Roofs

109

Section 708.4 – Exception 3 Tunnel Corridor

Allows corridor ceiling to be constructed as required for wall.

Requires “corridor damper” if duct penetrates this horizontal assembly.

- A unique type of damper

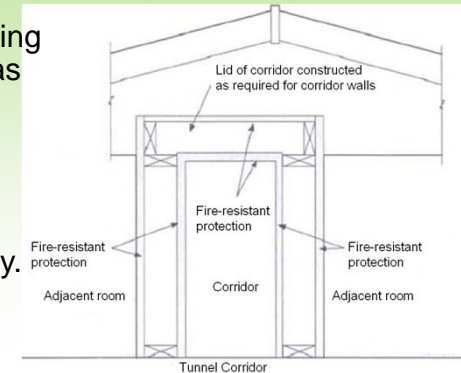

2012 IBC Inspection of Fire-Resistance Rated Floors, Ceilings and Roofs

110

How do you handle?

The protection of soffits or eave overhangs?

- Does it affect attic vents
- Is there a difference depending on if a truss is used versus rafters?



2012 IBC Inspection of Fire-Resistance Rated Floors, Ceilings and Roofs

111

Closing Comment

It is only through the proper construction and protection of openings or penetrations that a fire-resistance rated assembly can do what it is intended to do.

If one aspect is done incorrectly it can compromise the integrity of the assembly and lead to it not doing its intended job.

So verify construction, continuity and protection of openings of all fire-resistance-rated walls.



2012 IBC Inspection of Fire-Resistance Rated Floors, Ceilings and Roofs

112

2012 IBC Inspection of Fire-Resistance Rated Floors, Ceilings and Roofs

International Code Council is a Registered Provider with The American Institute of Architects Continuing Education Systems. Credit earned on completion of this program will be reported to CES Records for AIA members. Certificates of Completion for non-AIA members are available on request.

This program is registered with the AIA/CES for continuing professional education. As such, it does not include content that may be deemed or construed to be an approval or endorsement by the AIA of any material of construction or any method or manner of handling, using, distributing, or dealing in any material or product. Questions related to specific materials, methods, and services will be addressed at the conclusion of this presentation.



2012 IBC Inspection of Fire-Resistance Rated
Floors, Ceilings and Roofs

Copyright Materials

This presentation is protected by US and International Copyright laws. Reproduction, distribution, display and use of the presentation without written permission of the speaker is prohibited.

© International Code Council 2013



2012 IBC Inspection of Fire-Resistance Rated
Floors, Ceilings and Roofs

114

Thank you for participating

To schedule a seminar, contact:

The ICC Training & Education Department

1-888-ICC-SAFE (422-7233) Ext. 33818

or

E-mail: icctraining@iccsafe.org



2012 IBC Inspection of Fire-Resistance Rated Floors, Ceilings and Roofs

115