

UNIT-5

GSM System Operations (Traffic Cases)

Registration, call setup, and location updating

Call setup

Interrogation phase

For the interrogation phase The initial address message comes outside the GSM network.

Radio resource connection establishment

The MSC/VLR initiates the call setup process by sending a message to the appropriate BSC. The BSC sends a paging command message to the appropriate BTS, finally BTS sends a paging request to the appropriate MS.

Service request

The service request occurs as soon as the MS has tuned to the new channel assigned to it . The BTS sends back the MS an UA frame that contains the original paging response message.

The paging response message is forwarded to the BSC.

Authentication

Authentication request message is sent to the MS. The message containing 128bit RAND number, CKSN. The MS stores the CKSN and then calculates the value of signed response. The value of SREs is returned to the MSC/VLR as a authentication response message.

Ciphering mode setting

The MSC/VLR sends cipher mode command to the BSC. This message contains the value of Kc. This value is forwarded to the BTS. BTS stores this value

IMEI check

If the IMEI number is to be checked the MSC/VLR sends an identity request message to the MS. This is sent to the BSC. The value of IMEI sent by the mobile is checked against the equipment identity register database.

TMSI reallocation

If TMSI number is to be used it is sent to the MS from the MSC/VLR. The value of TMSI number is stored in the SIM card and TMSI reallocation complete message is sent to the MSC/VLR

Call initiation procedure

Connection management message is sent from the BTS to the MS. The MS will send a call confirmed message if it can handle the requested service.

Assignment of a traffic channel

Traffic channel assignment is initiated by the MSC. The MSC sends an assignment request message to the BSC. If the assignment is done, then the BSC calculates the MS output power level, selects an idle channel and sends an channel activation message to the BTS. At this point MS tunes to the new channel

Call confirmation, call accepted, and call release

The call confirmation procedure starts when the MS sends an alerting message to the MSC. When the alerting message is received the MSC/VLR sends the TUP address complete message to the calling subscriber who can now hear the ringing tone generated in the MSC.

Location updating

Normal location updating (idle mode)

The basic steps are radio resource connection establishment, service request, authentication, cipher mode setting and then radio resource connection release.

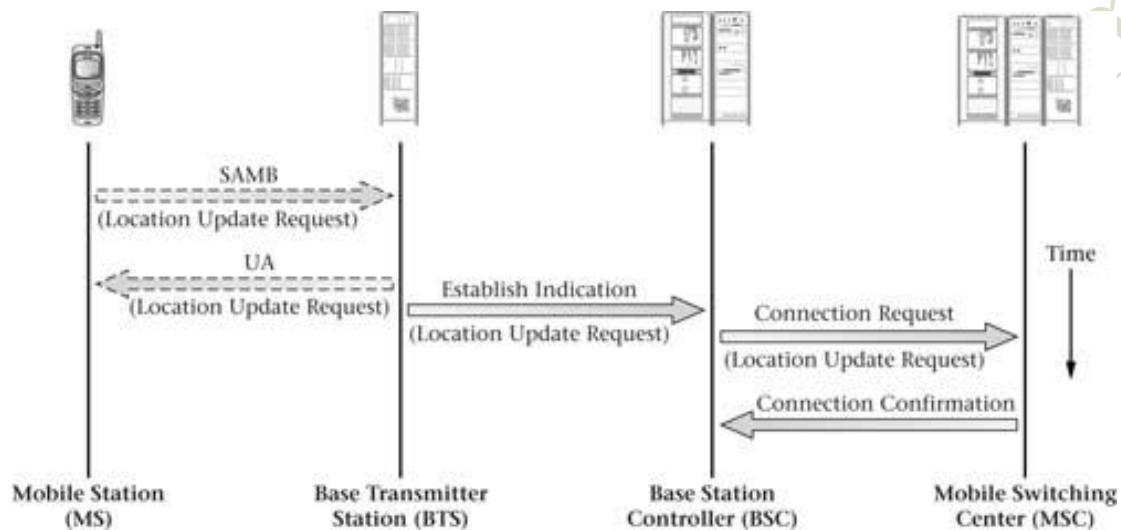

IMSI detach/attach location updating

When the MS is being turned off the mobile requests the SDCCH, the message sends the message to the network that is about to enter the detached state . The MS denotes the MS status in the VLR . The VLR will reject incoming calls for the MS sending a voice message back to the caller that the subscriber is currently unavailable.

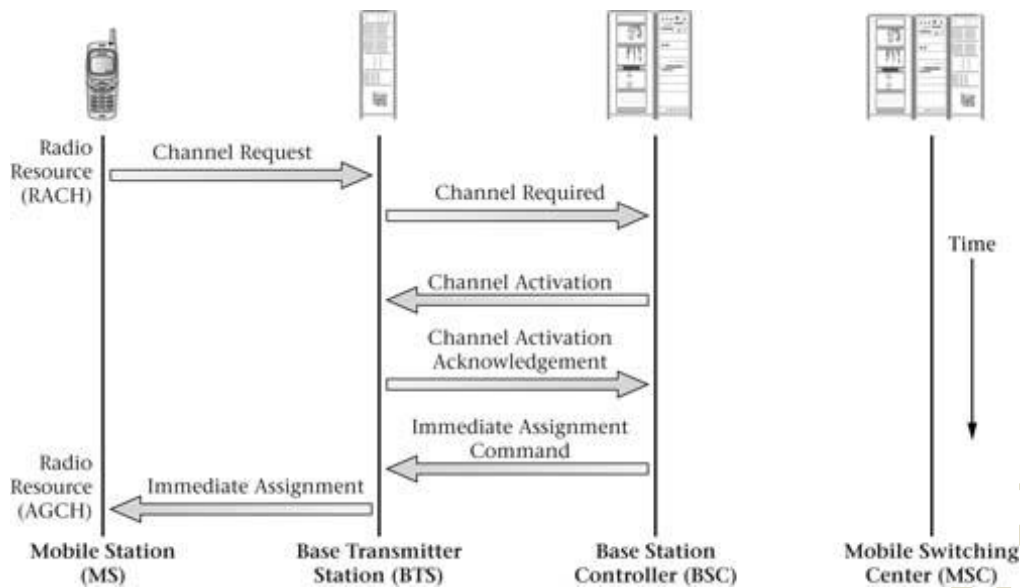

Periodic location updating

Periodic location updating is used to prevent unnecessary use of network resources such as the paging of a detached MS.

Call handoff

Intra-BSC handover

In this case the handover is occurring between the cells that are connected to the same BSC.

- (1) MS and BTS A perform RSS measurements.
- (2) Measurement report is sent to BSC.
- (3) TCH activation message is sent to BSC B.
- (4) New TCH information is sent to MS over old BTS (A).
- (5) Handover access burst is sent to new BTS (B).
- (6) Timing advance information is sent to MS.
- (7) Handover complete message is sent to BSC.
- (8) Channel deactivation order is sent to old BTS.

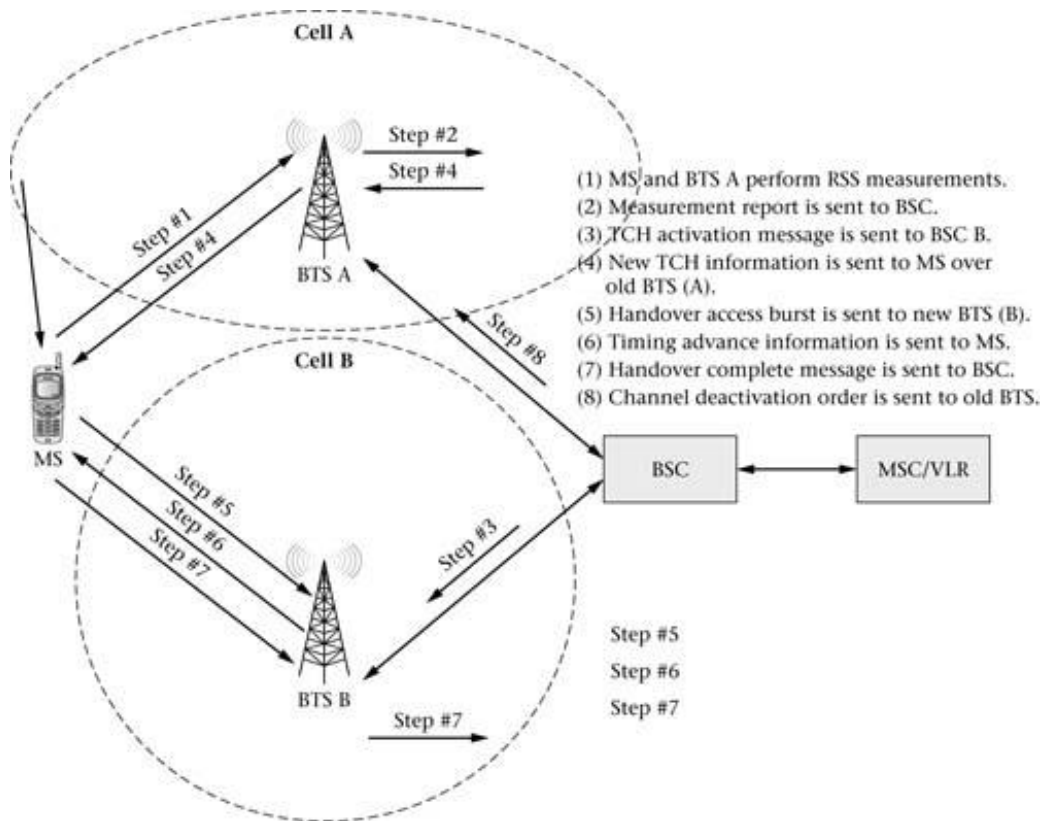

Inter-BSC handover

In this case the mobile has moved to a cell that is in different location area and therefore has different BSC.

The serving BSC decides that the call must be handed over to a new cell that belongs to different BSC.

- (1) Handover request is sent by serving BSC to MSC.
- (2) Handover request is sent by MSC to new BSC (B).
- (3) BSC B sends activation order to BTS 1B.
- (4) BSC B sends handover information to MSC.
- (5) MSC sends handover information to BSC A.
- (6) BSC A sends MS new TCH information.
- (7) MS sends handover access burst to new BTS (1B).
- (8) Timing advance information is sent to the MS.
- (9) BTS 1B sends handover detection message to BSC B.
- (10) MS sends handover complete message to BSC B.
- (11) BSC B sends handover complete message to the old BSC (A).
- (12) Old BSC (A) sends channel deactivation message to old BTS (1A).

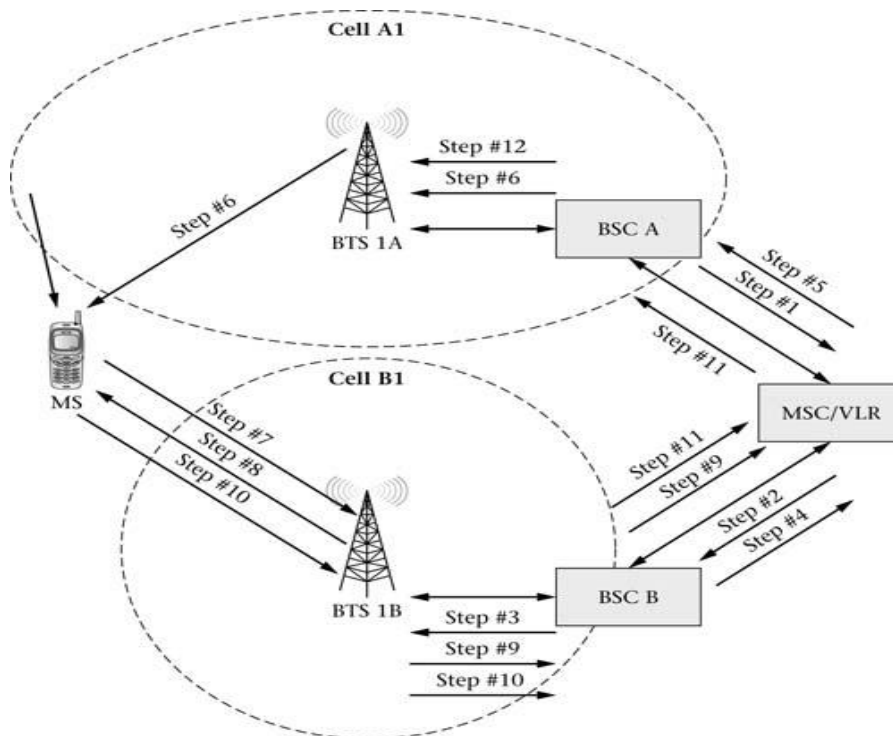

- (1) Handover request is sent by serving BSC to MSC.
- (2) Handover request is sent by MSC to new BSC (B).
- (3) BSC B sends activation order to BTS 1B.
- (4) BSC B sends handover information to MSC.
- (5) MSC sends handover information to BSC A.
- (6) BSC A sends MS new TCH information.
- (7) MS sends handover access burst to new BTS (1B).
- (8) Timing advance information is sent to the MS.
- (9) BTS 1B sends handover detection message to BSC B.
- (10) MS sends handover complete message to BSC B.
- (11) BSC B sends handover complete message to the old BSC (A).
- (12) Old BSC (A) sends channel deactivation message to old BTS (1A).

Inter-MSC handover

Another possible handover that can occur is when the BSC decides that a handover should occur and the new cell belongs to the new MSC.

- 1) Handover request is sent by serving BSC (A1) to MSC A.
- 2) MSC A requests assistance from MSC B.
- 3) MSC B provides MSC A with handover number and sends new BSC (B1) a handover request.
- 4) New BSC (B1) sends handover activation order to new BTS (1B1).
- 5) BSC sends handover information to new MSC.
- 6) Handover information is sent to old MSC.
- 7) A signaling/traffic link is set up between the two MSCs.

- (8) Handover message is sent to MS.
 - (9) MS sends handover access burst to new BTS.
 - (10) New BTS sends timing advance information to MS.
 - (11) Old MSC is sent handover detected message.
 - (12) MS sends handover complete message to new BSC.
- BSC sends handover complete message to the old BSC.
 Old BSC sends channel deactivation message to old BTS (1A1).

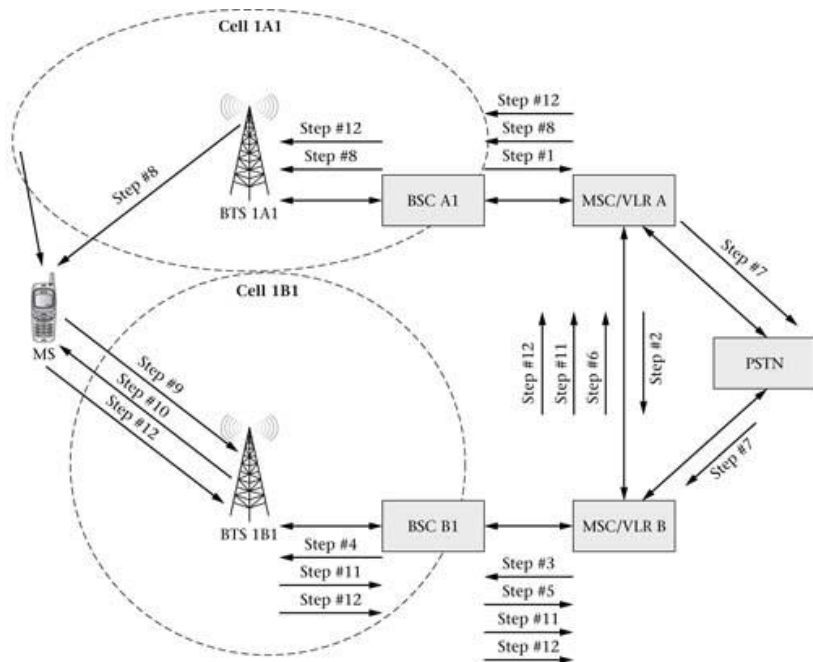

- (1) Handover request is sent by serving BSC (A1) to MSC A.
 - (2) MSC A requests assistance from MSC B.
 - (3) MSC B provides MSC A with handover number and sends new BSC (B1) a handover request.
 - (4) New BSC (B1) sends handover activation order to new BTS (1B1).
 - (5) BSC sends handover information to new MSC.
 - (6) Handover information is send to old MSC.
 - (7) A signaling/traffic link is set up between the two MSCs.
 - (8) Handover message is sent to MS.
 - (9) MS sends handover access burst to new BTS.
 - (10) New BTS sends timing advance information to MS.
 - (11) Old MSC is sent handover detected message.
 - (12) MS sends handover complete message to new BSC.
- BSC sends handover complete message to the old BSC.
 Old BSC sends channel deactivation message to old BTS (1A1).

GSM Infrastructure Communications (Um Interface)

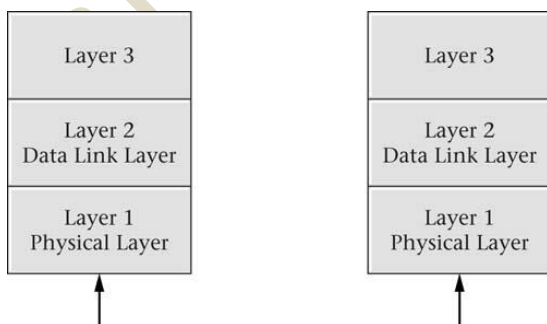

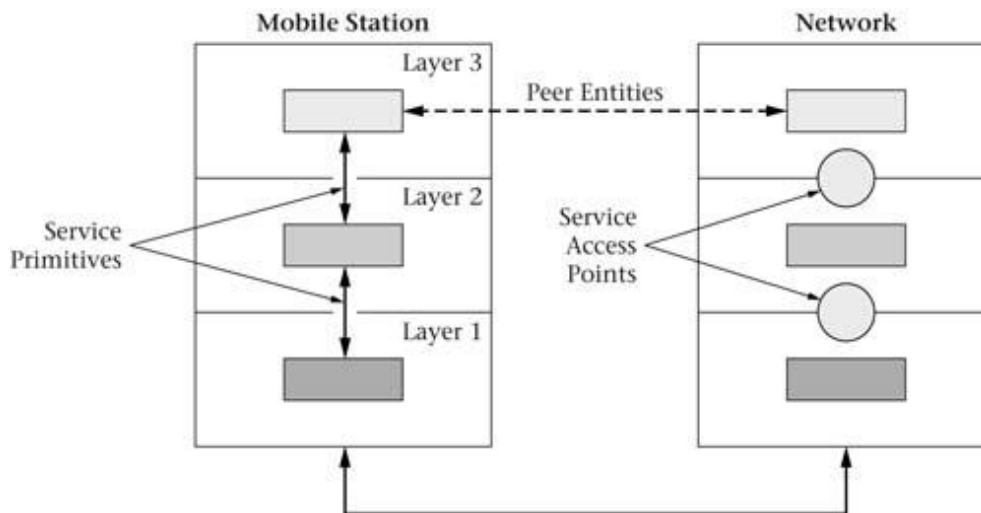

Layer 3: Networking layer operations

GSM network layer provides the mobile network signaling service for mobile subscribers.

The MNS includes

- Connection management

CM sublayer contains functions for call control, call related supplementary services, non call related supplementary services.

Call control- these procedures are used during call establishment . Provides service using MNCC-SAP

Short message service support- Short message service entities known as short message control use short message control protocol, (SM-CP)

Supplementary services – SS handles services that are not related to a specific call.

- Mobility management

MM sublayer performs 3 types of procedures that are related to mobility support, subscriber confidentiality , and service of the CM entity.

- Radio resource management

The primary function of the RR procedure is to establish , maintain and when no longer needed , release a dedicated connection between the MS and BTS.

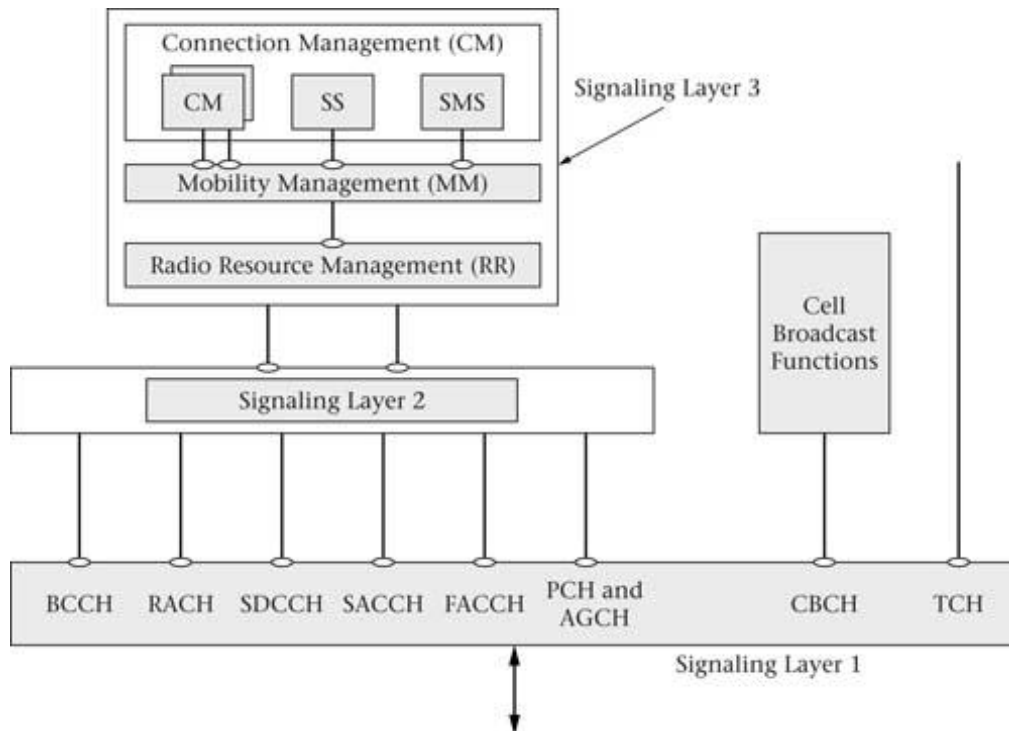

Layer 2: Data Link layer operations

LAPD operations- LAPD is used on the GSM interface between the BSC and the BTS.

Supports two types of operation

- Unacknowledged
- Acknowledged

Service access points – These are the gateways through which services are offered to the higher layers.

Data link layer procedure-

- Data link procedure
- Data link distribution procedure
- Random access procedure

Layer 1: Physical layer operations

Physical layer is the actual physical hardware , modulation schemes, channel coding .

Physical layer interfaces the data link layer

North American TDMA

NA- TDMA was developed as 2G cellular system. The first implementation did not support packet data transfer.

The 3G version has added additional air interface standard.

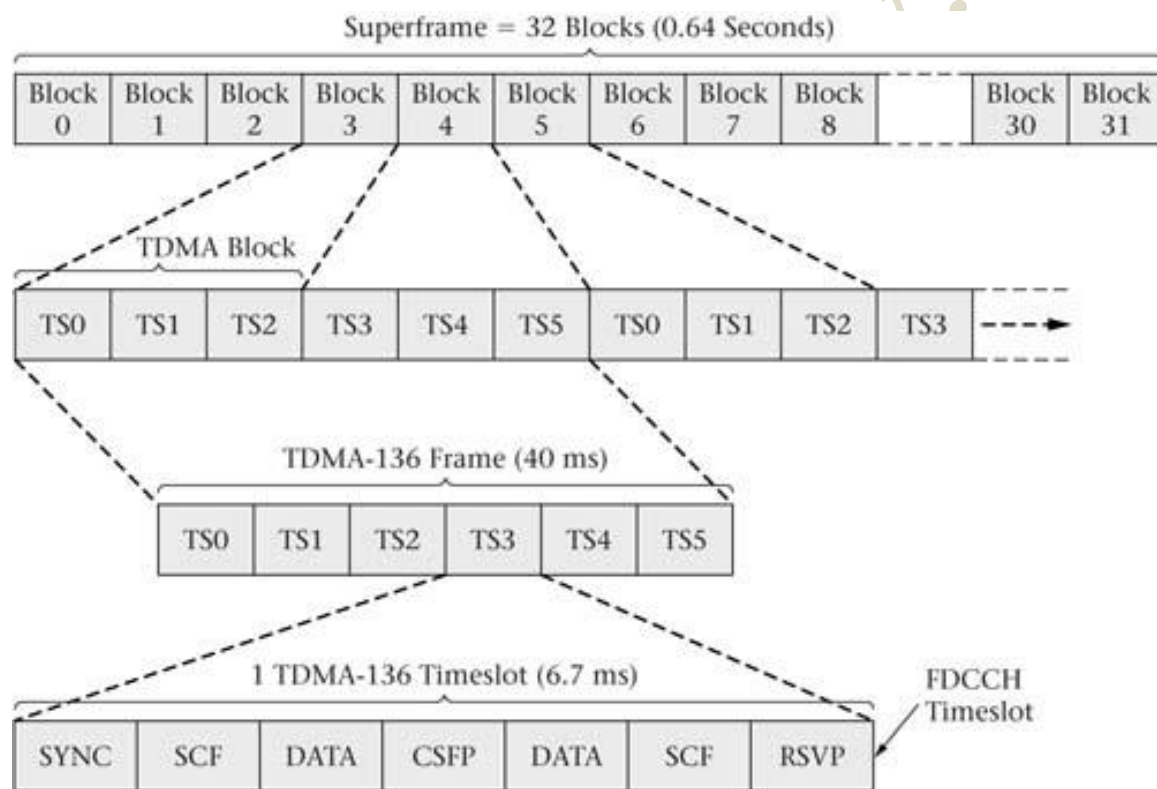

Data or Signaling Messages Undergo Channel Coding and Interleaving Before Being Transmitted.

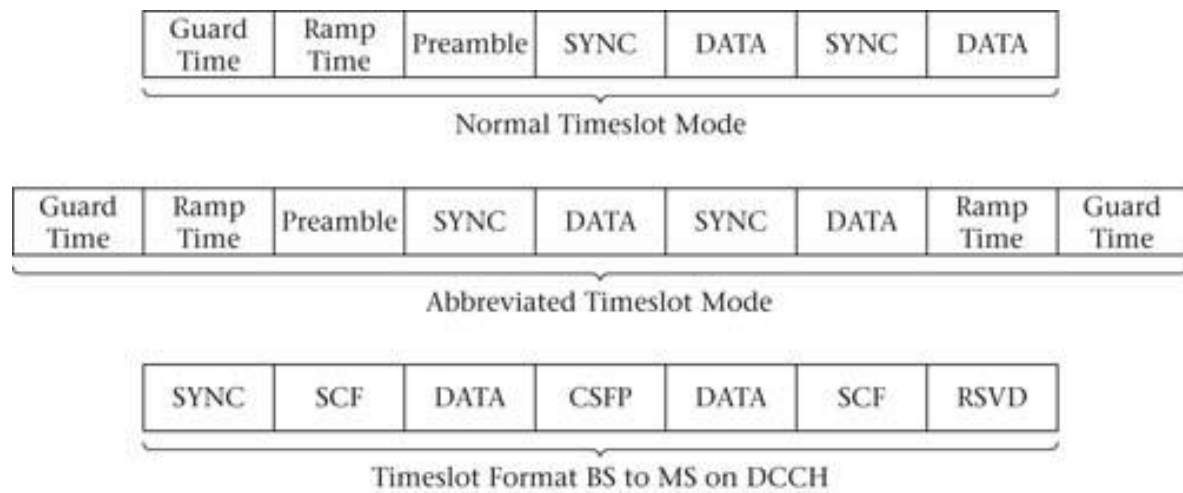

Answers to Problems and Questions

Chapter 5

Section 5.1

1. The TDMA frame uses 8 equal length repeating time slots (refer to Figure 5-3).

2. The spacing of GSM channels is 200 kHz hence the bandwidth of a GSM channel is taken to be approximately 0.2 MHz.

Section 5.2

3. The three major subsystems of a GSM wireless cellular network are the: network switching system, the base station system, and the mobile station.

4. The GSM SIM card is part of the GSM mobile station. It provides functionality to the GSM mobile station (i.e. once inserted into the GSM mobile, the mobile becomes functional).

5. The Um interface is the “air interface” between the mobile station and the base station.

6. There are two protocol stacks (referring to Figure 5-6) within the MSC node of a GSM system because one protocol stack deals with the MSC to BSC interface (A) while the other protocol stack deals with the interface between the MSC and the PSTN (signaling is done over the SS7 system).

Section 5.3

7. The sub-categories of GSM signaling and control channels are the: broadcast channels, common control, channels, and dedicated control channels.

8. The PCM system takes and samples a voice signal at a rate of 8000 times per second. Each sample is converted to an eight-bit code. This process yields 64 kbps. A vocoder performs the digital encoding of voice in a different manner. Depending upon the type of vocoder it takes 20 msec (approximately) segments of voice and encodes each segment into a much smaller number of digital bits (typically 8 kbps).

9. The GSM TDMA timeslot consists of a data burst that takes about 156.25 bit times to complete or approximately 0.577 ms. The contents of these data bursts can vary depending upon their purpose.

10. The GSM TDMA frame is the basic time unit of the system. There are several other time frames that also exist. A hyperframe consists of 2,715,648 TDMA frames. The hyperframe consists of 2,048 superframes. A Superframe consists of 1,326 TDMA frames. Multiframes are either 26 or 51 TDMA frames in length. Superframes consist of either 51 (26 frame) multiframes or 26 (51 frame) multiframes.

11. A typical normal GSM “burst” consists of 3 tail bits, 57 encrypted bits, a flag bit, 26 training sequence bits, another flag bit, another 57 encrypted bits, and 3 more tail bits.

12. The purpose of the GSM burst training sequence is to adjust the GSM receiver’s adaptive equalizer.

13. The purpose of the GSM synchronization burst is to provide system timing.

14. The function of the GSM access burst is to facilitate random access requests by the mobile and handover operations.

15. The significance of timeslot 0 on channel c_0 for a GSM system is that a special combination of logical channels must be transmitted on this frequency channel to provide the information for the mobile station to determine timeslot 0 and to synchronize with the frame structure of the cell.

16. The purpose of the GSM dedicated control channels is to provide channels to allow for call setup, handover, measurement, and short message service.

17. The GSM dedicated control channel is specifically tasked with facilitating the handover operation.

18. The GSM mobile station knows the paging group it belongs to since this information is supplied to it via messages from the base station.

19. The advantages of using a GSM half-rate channel are that GSM system capacity may be doubled.

20. The reason why there several types of GSM multiframes is to allow for optimization of GSM systems to serve different environments (i.e. urban and suburban locations) with different traffic patterns.

Section 5.4

21. The GSM MS Roaming Number is constructed according to the E.164 numbering plan from the ITU.

22. The TMSI number is used by the GSM network to protect the subscriber's privacy over the air interface.

Section 5.5

23. The "attached" condition for a GSM mobile is when the mobile has identified itself to the network and subsequently been authenticated by the network.

24. The "detached" condition for a GSM mobile is when the mobile is either out of range of a GSM system or has been shut off by the subscriber (or the battery has died).

25. The purpose of periodic location updating is to save system resources. This process can help to eliminate unnecessary network or system operations such as the paging of a detached mobile.

26. The basic difference between intra-BSC handover and inter-BSC handover is that two BSCs and the MSC are involved in an inter-BSC handover while the intra-BSC handover involves only two BTS connected to the same BSC.

27. The basic difference between an inter-BSC and an inter-MSR handover is that the first operation involves only one MSR while the second operation involves two MSRs.

Section 5.6

28. The basic functions located within the connection management sublayer are those of: call control, call-related supplementary services management, non-call-related supplementary service, and short message service.

29. The basic functions located within the mobility management sublayer are those of: location updating, authentication, TMSI reallocation, and MS identification through the IMSI or the IMEI, and service to the different entities within the CM sublayer.

30. The basic functions located within the radio resource sublayer are those of: providing services to the MM sub-layer and communicating directly with Layer 1 for the exchange of information related to measurement control and channel management.

31. The function of the various GSM system timers and counters is to provide a particular waiting time for acknowledgement messages and to keep track of how many times that a retransmission may take place.

32. A modified version of LAPD is necessary for the Um interface because there may be a need to segment messages that are sent over the air interface. This is not done with LAPD.

Section 5.7

33. The fundamental difference between GSM and NA-TDMA in the context of access technology is that GSM supports up to eight users via an 8 time-slot TDMA frame while NA-TDMA only supports three users over a 6 time-slot TDMA frame.

34. The required bandwidth requirements of AMPS, GSM, and NA-TDMA are dependent upon the access technology used. AMPS and NA-TDMA both use 30 kHz bandwidths for compatibility reasons (i.e. NA-TDMA may be overlaid on an AMPS system) while the GSM system uses 200 kHz channels.

35. The first operation performed by a NA-TDMA mobile upon powering up is to scan the DCCHs within a cell and select a suitable DCCH from which it can receive timeslot and frame synchronization information.