

MAY-JUNE 2014

# ARMY SUSTAINMENT

WWW.ARMY.MIL/ARMYSUSTAINMENT



*The Impact of  
**Enterprise  
Resource  
Planning**  
Systems on  
Army Sustainment*

Improving Tactical  
Cost Forecasting to  
Optimize Readiness

**GCSS-Army:**  
A Dynamic Readiness Tool  
for Mission Command

*Plus:*

**Sustainment for  
Army 2020**

# ON THE COVER

## FEATURES

- 10 Improving Tactical Cost Forecasting to Optimize Readiness**  
*What obstacles exist to forecasting tactical costs, and how can the Army optimize readiness in an environment of fiscal uncertainty? By Col. E. Deacon Maddox*
- 23 Global Combat Support System–Army: A Dynamic Readiness Tool for Mission Command**  
*Implementing GCSS–Army requires a completely new mindset for all involved in sustainment, beginning with leaders. Preparing to integrate GCSS–Army into sustainment operations requires specific training and planning to ensure success. By Capt. Mei-Ling Guarino*
- 26 Sustainment for the Army of 2020**  
*The Combined Arms Support Command proposed a new division–aligned force structure to provide sustainment capabilities from echelons above brigade using combat sustainment support battalions. By Col. Robert Hatcher, Jeffrey A. Martin, and Lt. Col. Karl F. Davie Burgdorf*

## FOCUS

- 2 The Impact of Enterprise Resource Planning Systems on Army Sustainment**  
*Enterprise resource planning systems improve equipment management, parts and supply ordering, and financial accountability while providing visibility of equipment in the supply pipeline. By Maj. Gen. Larry D. Wyche*

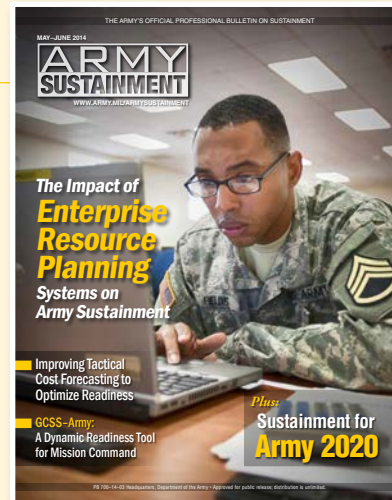

*Pfc. Kinney Fields takes a final exam using the Global Combat Support System (GCSS)–Army during advanced individual training at Fort Lee, Va., April 24, 2014. GCSS–Army training has been implemented in initial–entry training and professional military education to ensure units have a robust knowledge base before they receive the system. (Photo by Fred W. Baker III)*

“Global Combat Support System–Army will benefit the entire force.”

*Maj. Gen. Larry D. Wyche  
The Impact of Enterprise Resource Planning Systems on Army Sustainment, p. 2.*

## DEPARTMENTS

### COMMENTARY

- 5 Mission Command: The Starfish and the Spider**  
*Dr. Christopher R. Paparone and George L. Topic Jr.*
- 6 Train as We Fight: Using Sustainment Vehicles for Convoy Protection**  
*Lt. Col. William Kepley and Stephen Harper*

### FEATURES

- 15 Leveraging Information for a Competitive Advantage**  
*Col. Jeffrey C. Powell*
- 19 Separating Resource Management From Finance Operations**  
*Gina Smith*

## OPERATIONS

### 32 Establishing the Afghanistan Transportation Network

*Capt. Warren R. Crocker*

## TRAINING AND EDUCATION

### 34 Logistics Simulations for Battle Staff Training

*Kathryn Bailey and Calvin Pilgrim*

### 37 Sustainment Synchronization: Key to Supporting Operational Units

*Capt. David A. Wallace*

### 39 Supporting Task Force Lift

*Capt. Carlos M. Sanford, 1st Lt. Ryan C. Cloud, and  
1st Lt. Timothy D. Hryniewicz*

### 42 Forward Support Company Operations in Separate Units

*Capt. Thomas A. Knothe*

## TOOLS

### 44 Improving Materiel Fielding on the Korean Peninsula

*Maj. Timothy J. Barrett*

### 47 BUILDER: Condition-Based Maintenance for Facilities

*Nadia Abou-El-Scoud and Claude Matsui*

### 49 A Repair Versus Replace Maintenance Culture

*Chief Warrant Officer 4 Steven Dewey*

### 52 The Visibility of Integrated Tactical Logistics Project

*Grady M. Embrey*

## HISTORY

### 54 Getting There Was the Battle: Part II

*Dr. James P. Herson Jr.*



PB 700-14-03  
VOLUME 46, ISSUE 3  
May-June 2014

PHONE: (804) 765-4755 (DSN 539-4755)  
EMAIL: USARMY.LEE.TRADOC.MBX.LEEEASM@MAIL.MIL  
WEBSITE: WWW.ARMY.MIL/ARMYSUSTAINMENT

*Army Sustainment* (ISSN 2153-5973) is a bimonthly professional bulletin published by the Army Logistics University, 2401 Quarters Road, Fort Lee, Virginia 23801-1705. Periodicals postage is paid at Petersburg, VA 23804-9998, and at additional mailing offices.

**Mission:** *Army Sustainment* is the Department of the Army's official professional bulletin on sustainment. Its mission is to publish timely, authoritative information on Army and Defense sustainment plans, programs, policies, operations, procedures, and doctrine for the benefit of all sustainment personnel. Its purpose is to provide a forum for the exchange of information and expression of original, creative, innovative thought on sustainment functions.

**Disclaimer:** Articles express opinions of authors, not the Department of Defense or any of its agencies, and do not

change or supersede official Army publications. The masculine pronoun may refer to either gender.

**Reprints:** Articles may be reprinted with credit to *Army Sustainment* and the author(s), except when copyright is indicated.

**Distribution:** Units may obtain copies through the initial distribution system (DA Form 12 series). Private domestic subscriptions at \$30.00 per year and international subscriptions at \$42.00 per year are available by visiting <http://bookstore.gpo.gov> on the Web. Subscribers should submit address changes directly to *Army Sustainment* (see address below). *Army Sustainment* also is available at <http://www.army.mil/armysustainment>.

**Postmaster:** Send address changes to:  
EDITOR ARMY SUSTAINMENT/ALU/2401  
QUARTERS RD/FT LEE VA 23801-1705.

## BOARD OF DIRECTORS

### Chairman

**Maj. Gen. Larry D. Wyche**  
Commander  
Combined Arms Support Command

### Members

**Lt. Gen. Raymond V. Mason**  
Deputy Chief of Staff, G-4  
Department of the Army

**Lt. Gen. Michael E. Williamson**  
Principal Military Deputy  
to the Assistant Secretary of the Army  
Acquisition, Logistics, and Technology

**Lt. Gen. Patricia E. McQuiston**  
Deputy Commanding General  
Army Materiel Command

**Lt. Gen. Joseph E. Martz**  
Military Deputy for Budget and the  
Assistant Secretary of the Army  
Financial Management and Comptroller

**Lt. Gen. Patricia D. Horoho**  
The Army Surgeon General

### Ex Officio

**Brig. Gen. John E. O'Neil IV**  
The Quartermaster General

**Brig. Gen. John "Jack" Haley**  
Chief of Ordnance

**Brig. Gen. John P. Sullivan**  
Chief of Transportation

**Brig. Gen. Paul Chamberlain**  
Commander  
Army Soldier Support Institute

**Brig. Gen. Theodore "Ted" C. Harrison**  
Commanding General  
Army Expeditionary Contracting Command

**Maj. Gen. (Dr.) Joseph Carvalho Jr.**  
Commanding General  
Army Medical Research and Materiel Command

## ARMY LOGISTICS UNIVERSITY

**John E. Hall**  
President

**David J. Rohrer**  
Civilian Deputy

**Col. Robert A. Harney Jr.**  
Commandant/Military Deputy

## STAFF

**Fred W. Baker III**, Editor  
**Kari J. Chenault**, Associate Editor  
**April K. Morgan**, Assistant Editor  
**Julianne E. Cochran**, Assistant Editor  
**Adam Gramarossa**, Layout and Graphic Design  
**Louanne E. Birkner**, Administrative Assistant

This medium is approved for the official dissemination of material designed to keep individuals within the Army knowledgeable of current and emerging developments within their areas of expertise for the purpose of enhancing their professional development.

By Order of the Secretary of the Army:

**RAYMOND T. ODIERNO**  
General, United States Army  
Chief of Staff

Official:

**GERALD B. O'KEEFE**  
Administrative Assistant to the Secretary of the Army

1411208

# The Impact of Enterprise Resource Planning Systems on Army Sustainment

Enterprise resource planning systems improve equipment management, parts and supply ordering, and financial accountability while providing visibility of equipment in the supply pipeline.

■ By Maj. Gen. Larry D. Wyche



As we look past Army Sustainment 2020 to Force 2025 and beyond, the importance of advanced technologies, logistics systems, and improved business practices is becoming even more apparent.

The Army is faced with a reduced budget and force levels that make automation and technology vital. These reduced levels are expected to continue as the Army streamlines its operations and transforms from an Army at war to an Army of preparation.

Long used by the business community, enterprise resource planning (ERP) systems allow companies to store and manage data for every stage of business. This information is shared among all users of the system, facilitating near-real-time collaboration across all business areas.

The collaboration allows for greatly increased communication velocity and enhanced accuracy while ensuring situational awareness across operational, logistics, finance, and human resources areas of interest.

## ERP Systems

Over the past few years, the Army and Department of Defense have made great strides in updating their business processes and implementing ERPs with associated business process reengineering. The Logistics Modernization Program (LMP), fully deployed in 2010, replaced 35-year-old legacy systems with a single, fully integrated enterprise solution. LMP users include the following:

- The Army Materiel Command.
- The Communications-Electronics Command.

- The Aviation and Missile Command.
- The TACOM Life Cycle Management Command.
- The Joint Munitions and Lethality Life Cycle Management Command.
- Depots and ammunition plants.
- The Army Sustainment Command.
- National Maintenance Program users.
- The Defense Finance and Accounting Service.

LMP resides and is maintained at the national level, whereas the Global Combat Support System–Army (GCSS–Army) resides with and is maintained by tactical logisticians. The two systems are sister programs and can share data.

Similar to LMP, GCSS–Army is an ERP solution that combines several automated sustainment information systems into a single, integrated, web-based system. GCSS–Army will bring the same benefits to brigades, battalions, and companies that LMP brought to the national level.

The system will improve readiness and accountability and, for the first time, allow for full financial auditability. It can track spending according to the individual serial number on the equipment, the specific person doing the work, and the specific appropriation used.

## GCSS–Army Fielding

GCSS–Army Wave 1 fielding began in November 2012 and will continue throughout 2015. The fielding was separated into waves based on lessons learned from previous standard Army management information

“ Instead of ‘chasing data’ through multiple sources, GCSS–Army provides a single source for logistics readiness data. ”

system (STAMIS) and industry ERP implementations.

The wave process mitigates risk and allows for more rapid fielding, increased system familiarity, and an overall better system. By reducing the fielding complexity, a smaller amount of change occurs, allowing units to more easily integrate the system into their operations.

The wave method creates system familiarity while associated schoolhouse training builds the knowledgeable user base that GCSS-Army and ERPs require. The method also allows for lessons learned to be applied to future updates, improving the overall product the Army receives.

GCSS-Army fielding Wave 1 focuses on the supply support activity and supporting finance functions. GCSS-Army replaces the Standard Army Retail Supply System (SARSS) while maintaining full interoperability with legacy systems. By focusing on SARSS and finance in Wave 1, the GCSS-Army team can completely replace a single legacy STAMIS throughout the Army.

Units in the continental United States will receive the system later this year, starting with Fort Campbell, Ky., Fort Stewart, Ga., the West Virginia National Guard, and the Georgia National Guard.

Continuing throughout the rest of the world, the team will field to units in the Pacific (Hawaii and Korea) and move on to Europe, where Germany and Italy will receive the software for the first time.

By the end of 2014, 59 percent of GCSS-Army Wave 1 fielding will be complete. The fielding team will maintain this rapid pace until Wave 1 ends in the fourth quarter of fiscal year 2015.

The fielding process includes a 180-day organizational change management period to prepare units for the changeover to GCSS-Army. Every 30 days until the transition is complete, the unit and fielding team have key events that must occur for fielding to continue.

These activities include site prepa-

ration, advanced lead user training, prerequisite web-based training, lead user workshops, audience analysis, and data cleansing.

The organizational change management period provides units with ample time to prepare their people, processes, and data for the conversion from their legacy STAMISs to the improved processes and systems within GCSS-Army.

This is essential to the conversion since GCSS-Army has very strict input criteria for data entry and improved work processes that mimic industry best practices.

After-action reviews from fielded units have highlighted the importance of a thorough and detailed scrub of data before switching over to GCSS-Army. Valuable feedback is already helping to improve the system for future units.

The GCSS-Army programming team has addressed many issues that were brought up during various global updates, discovered during fielding and reported through the GCSS-Army help desk. Patches to the system occur on a routine basis, addressing bugs and improving functionality based on this important user input.

Wave 2 fielding will begin in fiscal year 2015 and run through the fourth quarter of fiscal year 2017. During Wave 2, GCSS-Army will replace legacy maintenance, unit supply, property book, and remaining finance and materiel management systems. These systems include the Property Book Unit Supply Enhanced and Standard Army Maintenance System-Enhanced (SAMS-E).

The first GCSS-Army Wave 2 working-level integrated product team meetings with major Army commands were held recently. Discussions included change management, data cleansing, site preparation, future fielding planning, and implementation concerns.

### **Training on GCSS-Army**

Training is a critical aspect of the implementation for complex systems such as ERPs. GCSS-Army training

has been implemented early in initial-entry training and professional military education to ensure units have a robust knowledge base before they receive the system.

The Army introduced institutional training for GCSS-Army in the first quarter of fiscal year 2013 to ensure users were prepared for the transition.

Both Warrant Officer Basic Course students and automated logistical specialists now receive GCSS-Army training. SARSS and SAMS-E will be removed from programs of instruction beginning no later than the third quarter of fiscal year 2014 and replaced with GCSS-Army training.

Since the Systems, Applications, and Products in Data Processing (SAP) enterprise application is the ERP software powering GCSS-Army, the team is working to build a base of SAP-certified logisticians.

The Army Logistics University has partnered with Virginia State University to offer SAP certification at Fort Lee, Va. Graduates of the course are providing valuable feedback on how the program can be improved to meet future learning needs.

### **Impacts of GCSS-Army**

GCSS-Army will benefit the entire force. Affecting materiel management, property accountability, unit supply functions, maintenance operations, and finance, GCSS-Army improves visibility and accountability for users throughout the logistics pipeline.

As a single web-based solution that replaces multiple STAMISs, GCSS-Army allows universal permission-based access through a web browser worldwide. The system standardizes and simplifies sustainment work processes and saves sustainment Soldiers' time.

With near-real-time access to transaction statuses, users can identify and solve problems almost as soon as they occur. The many tools the ERP provides allow for detailed fill-rate analysis and interactive adjustment capabilities that were not possible through previous solutions.

With Wave 2, maintenance records will be immensely improved, with all transactions recorded throughout an item's entire life cycle.

Records will no longer be subject to loss during lateral transfers between units or when items enter reset. Repair parts and supplies will be fully tracked; GCSS-Army allows for in-transit visibility of shipments as they occur.

GCSS-Army also provides valuable tools for commanders and sustainment planners across Army sustainment functions. It features unprecedented asset visibility and status information down to individual modified table of organization equipment subparagraphs.

These individual organizational assets can be attached and detached in any way commanders require. Concise reports provide commanders with the maintenance, supply, and

monetary details needed to make important decisions.

Feedback from units using GCSS-Army has been extraordinarily positive. Commanders, maintenance managers, and accountants rave about how the system improves logistics processes within their units. Maintenance supervisors appreciate the much greater visibility of transactional data, which saves time and improves readiness.

Instead of "chasing data" through multiple sources, GCSS-Army provides a single source for logistics readiness data. Coordination among sustainment functions is improved, with resource managers and logisticians working together to facilitate operations.

The Army is well into fielding its future tactical logistics system. GCSS-Army replaces many legacy STAMISs with one integrated web-

based solution.

The ERP system greatly improves equipment management, parts and supply orders, and financial auditability. It provides near-real-time visibility of equipment status in the supply pipeline, and simplifies reporting of readiness and budget information across the chain of command. GCSS-Army improves commanders' situational awareness, facilitating decisions using the latest information.

---

Maj. Gen. Larry D. Wyche is the commanding general of the Combined Arms Support Command and Sustainment Center of Excellence at Fort Lee, Va.

## Submitting an Article to *Army Sustainment*

**W**e are always looking for quality articles to share with the Army sustainment community. If you are interested in submitting an article to *Army Sustainment*, please follow these guidelines:

- Ensure your article is appropriate to the magazine's subjects, which include Army logistics, human resources, and financial management.
- Ensure that the article's information is technically accurate.
- Do not assume that those reading your article are Soldiers or that they have background knowledge of your subject; *Army Sustainment's* readership is broad.
- Write your article specifically for *Army Sustainment*. If you have

submitted your article to other publications, please let us know at the time of submission.

- Keep your writing simple and straightforward.
- Attribute all quotes to their correct sources.
- Identify all acronyms, technical terms, and publications.
- Review a past issue of the magazine; it will be your best guide as you develop your article.

### Submitting an Article

Submit your article by email to [usarmy.lee.tradoc.mbx.leeasm@mail.mil](mailto:usarmy.lee.tradoc.mbx.leeasm@mail.mil).

Submit the article as a simple Microsoft Word document—not in layout format. We will determine the layout for publication.

Send photos as .jpg or .tif files

at the highest resolution possible. Photos embedded in Word or PowerPoint cannot be used.

Include a description of each photo in your Word document.

Send photos and charts as separate documents.

For articles intended for the Operations department, obtain an official clearance for public release, unlimited distribution, from your public affairs and operational security offices before submitting your article. We will send you the forms necessary for these clearances.

If you have questions about these requirements, please contact us at [usarmy.lee.tradoc.mbx.leeasm@mail.mil](mailto:usarmy.lee.tradoc.mbx.leeasm@mail.mil) or (804) 765-4761 or DSN 539-4761.

# Mission Command: The Starfish and the Spider

■ By Dr. Christopher R. Paparone and George L. Topic Jr.

The concept of mission command has been a significant area of discussion and doctrinal development across the Department of Defense in recent years. It is, in fact, a central precept that guides the development of Joint Force 2020 and serves as the philosophical base for a range of initiatives, programs, and concepts both within the services and in joint organizations.

We agree that mission command represents a crucial aspect of future military operations, and we have written a number of pieces in support of the overarching concept. That said, we feel that it is appropriate to talk about some of the limitations and challenges of a blanket implementation, particularly in the context of the joint logistics enterprise.

Throughout history, various aspects of mission command and a number of variants of the concept have been developed and practiced—often with great success. At times mission command became a de facto operating principle in military operations because of disruptions to communications, changing political decisions, and sheer chance.

Two antecedents of mission command are the German Wehrmacht concept of “Auftragstaktik,” used effectively in World War II, and more recently, organization theory, specifically open systems frameworks and their derivative—network organizational design.

In *The Starfish and the Spider*, Ori Brafman and Rod A. Beckstrom offer a concise yet compelling argument that circumstances call sometimes for “starfish,” or network organizations, and sometimes for “spiders,” or more traditional hierarchical organizations.

With the Army’s 2012 release of Army Doctrine Publication 6–0, Mission Command, the mission command

warfighting function has officially replaced command and control (C2). As logisticians, we should applaud the cultural mindset shift required by that change. We know that decentralized logistics teams, particularly those supporting widely distributed operations, must operate under mission command, which is defined as “the exercise of authority and direction by the commander using mission orders to enable disciplined initiative within the commander’s intent to empower agile and adaptive leaders in the conduct of unified land operations.”

Our argument is that the Army perhaps went too far in its adaptation of mission command and should have expressed the concept along a continuum. One end of the continuum represents the ideal, tight, bureaucratic forms of C2 associated with spider organizations. The other represents the ideal organizational decentralization of mission command associated with starfish organizations.

Some organizational tasks have no room for error and the spider-style C2 is required. One example of such tasks is the financial accounting required for weapon system purchases in order to capture budgetary reports for Congress. Another is the supply chain management processes for nuclear ammunition distribution. For both, tight bureaucratic controls are generally considered a good thing.

Starfish, or mission command, organizational qualities make sense when logisticians are faced with novel and ever-morphing support situations. For example, when logisticians sought to open a northern supply route to Afghanistan, conforming to the red tape of the Defense Acquisition Regulation would have made it nearly impossible.

Logisticians in Afghanistan operate

along a continuum as they attempt to provide consistent logistics support for a mature theater of operations (primarily through traditional, tight C2) while improvising to adapt to changing conditions during complex retrograde operations (practicing more of the mission command philosophy).

Widely dispersed operational efforts in Africa and other places around the world are based on creative “disciplined initiative” approaches and are operated more on the mission command side of the continuum. Performance based logistics (PBL) in acquisition could be described as another example of emphasizing mission command to contractors, while the assured delivery of logistics at the right place and time and at an affordable price may call for more of a C2 approach to performance work statements.

We applaud the mission command concept but at the same time urge logistics training and education institutions and logistics senior leaders to be cautious in not thinking that the mission command (starfish) approach is always appropriate. Complex situations generally require that frame of mind. More stable and predictable situations may be handled with the more traditional C2 (spider) arrangement. Success is in knowing when to shift one way or another, depending on the circumstance.

---

Dr. Christopher R. Paparone is the dean of the College of Professional and Continuing Education at the Army Logistics University at Fort Lee, Va.

George L. Topic Jr. is a retired Army colonel and the vice director for the Center for Joint and Strategic Logistics at the National Defense University at Fort McNair, Washington, D.C.

# Train as We Fight: Using Sustainment Vehicles for Convoy Protection

Brigade support battalions should be using authorized equipment to protect their convoys in training to prepare for future deployments.

■ By Lt. Col. William Kepley and Stephen Harper

The Training and Doctrine Command (TRADOC) Capability Manager—Armored Brigade Combat Team (TCM—ABCT) at Fort Benning, Ga., observes ABCT training at combat training centers to ensure they are meeting doctrine, organizations, training, materiel, leadership and education, personnel, and facilities requirements. TCM—ABCT and the observer-controller/trainers at the National Training Center (NTC) at Fort Irwin, Ca., have noted some nondoctrinal use of vehicles that are not part of the brigade support battalion (BSB) modified table of organization and equipment (MTOE) during recent rotations.

Soldiers started using vehicles nondoctrinally during Operations Iraqi Freedom and Enduring Freedom, when they lived on forward operating bases and contingency operating bases, received their mission orders, and moved out to conduct their missions.

The mission set for the ABCT formation today centers on a decisive action mission set of offense or defense, stability operations, and defense support to civilian authorities. None of these operations can be successful unless the forward support companies deliver the daily logistics package resupply on time, every time.

Current practice has units using nondoctrinal security vehicles to protect logistics convoys and recovery operations at home station and during NTC rotations. Units man these security vehicles with Soldiers from resupply wheeled vehicles,

which means that fewer vehicles are hauling class I (subsistence), III (petroleum, oils, and lubricants), and V (ammunition).

When Soldiers man these security vehicles, they do not maintain their regularly assigned vehicles and maintenance skills deteriorate. Units also use unforecasted class IX (repair parts) funds to maintain these security vehicles.

## The Way Forward

We recommend units stop using vehicles that are not part of their MTOE and instead use what is assigned to accomplish the mission. Units need to use their own convoy vehicles to provide convoy protection.

The MTOE shows commanders the number of ring mounts and weapons within each section. It is up to the commander to match the ring mount and weapon to the proper wheeled platform. Commanders should ensure that authorized ring mounts are installed and used on their BSB vehicles and other wheeled-vehicle fleets. This will allow their convoys to protect themselves if attacked. This skill does not just happen in convoy operations.

Convoy security, convoy operations, and wheeled-vehicle crew gunnery need to be trained beginning at home station, rehearsed at the combat training centers, and then executed when units deploy.

## Convoy Security

The ABCT must train with and prepare to use the equipment it is authorized and has on hand. If an

ABCT is ordered to deploy, the odds are that it will deploy with its own equipment. Units will not likely draw and sign for a fleet of mine-resistant ambush-protected vehicles (MRAPs) if they are not authorized on the MTOE, and the BSBs are not manned to operate them. Some vehicles will not be manned because a crew is “double-slotted” in two vehicles—their own vehicle and the MRAP.

It is difficult enough for a crew to properly maintain one vehicle, let alone two or more. This extra maintenance requirement will force units to protect their heavy expanded-mobility tactical truck (HEMTT) and medium tactical vehicle (MTV) convoys on resupply and recovery missions—on their own without the assurance of an Abrams tank or Bradley fighting vehicle shepherding the wheeled vehicles. Before they deploy, units need to train with their own equipment to provide convoy security.

## Tactical Convoy Operations

In January 2009, the Army, Marine Corps, Navy, and Air Force published Field Manual (FM) 4–01.45, Multi-Service Tactics, Techniques, and Procedures for Tactical Convoy Operations. FM 4–01.45 is a pocket-sized publication that every convoy commander should have and use in planning his individual and collective training programs.

The FM covers the basics: troop leading procedures, general planning, route selection, and convoy organization. This manual needs to become a



basic issue item for every leader in an ABCT BSB.

The following are some tenets of convoy security covered in FM 4-01.45:

- Administrative moves do not exist in a combat zone.
- A tactical convoy has no passengers.
- Security must cover 360 degrees.
- Convoy battle drills and rehearsals must be conducted.

### Crew Gunnery Training NCO

In his article, “Master Driver Trainer (MDT) in Action,” published in the January–March 2013 *Division Transportation Officer & Mobility Officer Newsletter*, Command Sgt. Maj. Allen B. Offord Jr., the 11th Transportation Corps regimental command sergeant major, proposed a military occupational specialty (MOS) 88M30/40 transportation noncommissioned officer

(NCO) position. This NCO would advise commanders on developing and maintaining a driver’s training program and standardizing the program across the unit. This would be a position for only the best Transportation Corps NCOs.

An NCO from this subset would be ideal to manage convoy security or unstabilized gunnery live-fire training. This NCO also would be responsible for forecasting the class V (ammunition) requirements and coordinating the use of gunnery ranges for a convoy live-fire exercise.

The Army National Guard Warrior Training Center at Fort Benning, Ga., offers a course called the Senior Gunner Course. This course trains Soldiers to be subject matter experts in unstabilized systems. The course is open to Soldiers in the ranks of sergeant (promotable) to master sergeant in all MOSs.

After completing the 14-day

course, graduates will be able to assist commanders at all levels in planning, executing, and evaluating crew and collective unstabilized, direct-fire, platform gunneries. The instruction includes gunnery skills testing on the M249, M240B, M2, and MK19 crew-served weapons, their capabilities, ammunition, optics, training devices engagement process, live-fire exercise prerequisites, unstabilized crew evaluation range operations, and gunnery training management. Further details are available at <http://www.benning.army.mil/tenant/wtc/sgc.html>.

### Unstabilized Platform Crew Gunnery

Training Circular 4-11.46, Convoy Protection Platform Gunnery, provides doctrinal guidance for commanders and their staffs when planning and executing this training. The circular provides the tasks, conditions, and standards of unstabilized

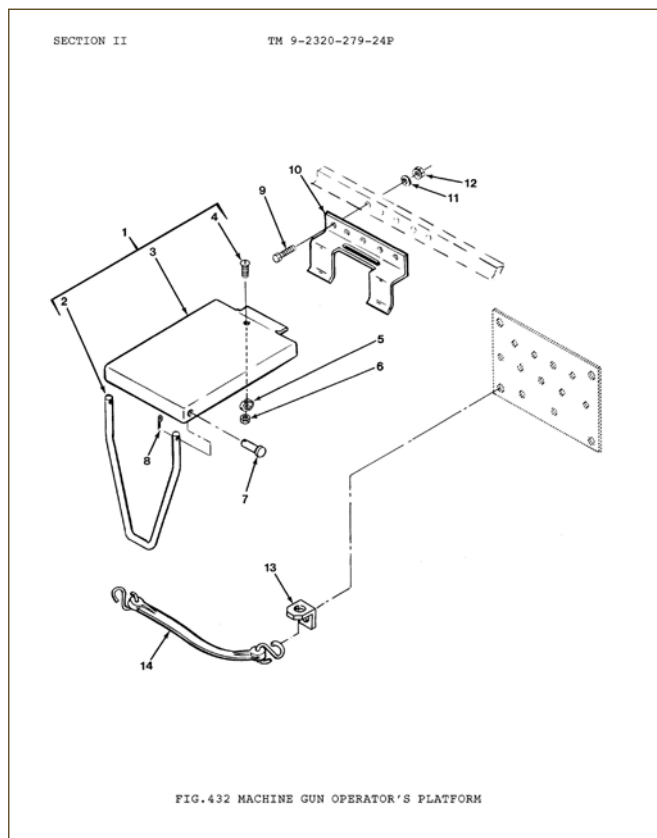
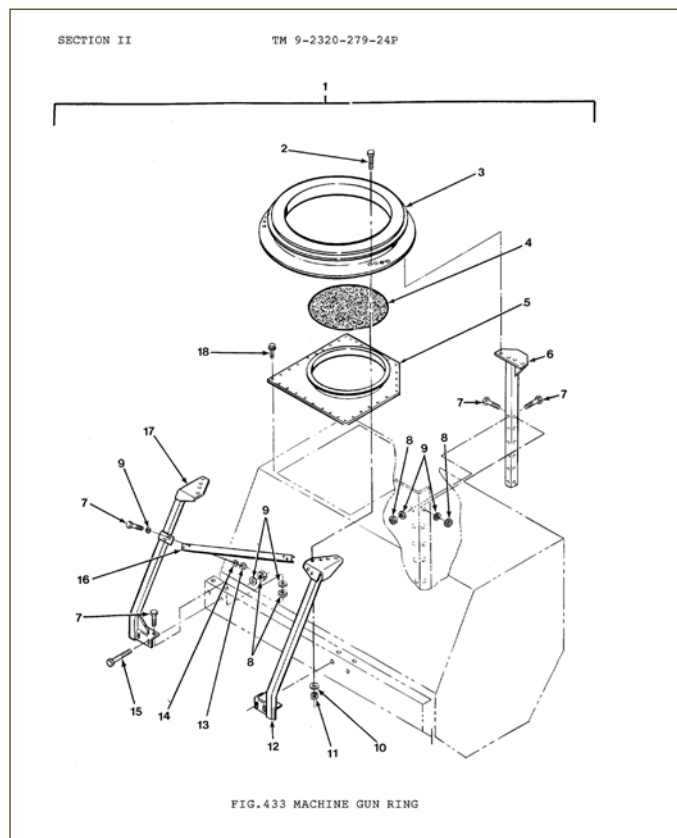

Drawings from Technical Manual 9-2320-279-24P-2 show the HEMTT installation kit, NSN 1005-01-519-2126 (left) and HEMTT machine gun operator’s platform, NSN 2510-01-155-5750 (right).

gunnery training, which includes training and certifying leaders, individual gunnery skills (such as familiarization and testing with a Soldier's crew-served weapon), and multiple live and virtual gunnery lanes. The suggested training culminates with the convoy live-fire exercise for multiple vehicle crews with their mounted crew-served weapons.

ABCT BSBs that can successfully train with their weapons mounted on their vehicles will become more comfortable in executing resupply operations without the "crutch" of additional security vehicles like MRAPs, which the ABCT is not yet authorized. The Army's ABCTs must get used to training to provide security with their own wheeled vehicles.

### Wheeled Vehicle Ring Mounts

The ABCT BSB is authorized at least 125 M66 .50-caliber machine gun ring mounts (line item number [LIN] M74364), and at least 125 MK93 40-millimeter machine gun mounts (LIN M12647). Maneuver line company headquarters elements within the ABCT are authorized one M66 or MK93 for the company MTV.

The M66 will mount to the MTV cab, and the MK93 attaches to the ring mount. The M66 and MK93 can be mounted directly to the roof of the A0, A1, and A1P2 versions of the MTV.

The M66 and MK93 can be mounted on the HEMTT A0 and A2 and the palletized load system (PLS) A0. Units must order the HEMTT installation kit, national stock number

(NSN) 1005-01-519-2126, and the machine gun operator's platform to stand on, NSN 2510-01-155-5750.

These mounts do not mount to the HEMTT A4 or PLS A1 variants, and there is currently no requirement or funding to develop M66 and MK93 kits for those models. Program Manager-Heavy Tactical Vehicles (PM-HTV) is working with the Department of the Army staff to secure that funding.

Installing the mounts will provide the best current protection for the vehicle crew and allow them to protect their own convoys throughout the battlefield. Units should also order and install gunner restraint systems. The gunner restraint system for the HEMTT and PLS is NSN 2540-01-582-5139; for the MTV, use NSN 2510-01-567-8727.

Since the ABCT has wheeled platforms that can mount a weapon system, TCM-ABCT recommends that units install the ring mount kits. Once the weapons are mounted, crew gunnery and convoy security can be trained and executed. The more units train with their vehicles, the easier it becomes to execute the missions to standard.

The wheeled vehicle draw fleet at NTC does not have ring mounts installed. NTC should be resourced for ring mounts—properly laterally transferred to the NTC property book—and the man-hours to maintain the vehicles with the mounts.

If the Army is serious about training as we fight and requiring deploying BCTs to use their own equipment,

it should resource their training. The rotational training of units will maximize their valuable training time working toward collective training tasks of convoy security and convoy fire distribution rather than the individual tasks of unstabilized gunnery and weapon employment.

Units may contact PM-HTV by telephone at (586) 282-8679 or Program Manager-Medium Tactical Vehicles (PM-MTV) at (586) 282-3905 with any questions regarding HTV or MTV products.

Great sources of additional information are the wheel platform -20 manual and the TCM-ABCT mil-Wiki on milSuite: <https://www.mil-suite.mil/book/groups/t>.

---

Lt. Col. William Kepley is the "other systems" chief (anything not an Abrams or a Bradley) for the TRADOC Capability Manager-Armored Brigade Combat Team (TCM-ABCT) formation at Fort Benning, Ga. He holds a bachelor's degree in mathematics from the University of Louisville. He is a graduate of the Armor Officer Basic and Advanced Courses, Intermediate Level Education, and the Airborne School.

Stephen Harper is the sustainment subject matter expert for the TCM-ABCT formation, Jacobs Advanced Systems Group. He holds a bachelor's degree in business from Upper Iowa University and is a member of the Order of St. George and the Order of Samuel Sharpe.

## Convoy Security Articles

*Army Logistician* and *Army Sustainment* have published several excellent articles on how to conduct convoy operations in Operations Iraqi Freedom, New Dawn, and Enduring Freedom. The following articles are highly recommended to increase your knowledge of convoy security operations.

"The Logistics Convoy: A Combat Operation," by Capt. Daniel T. Rossi, *Army Logistician*, January-February

2005. <http://www.almc.army.mil/alog/issues/JanFeb05/combat.html>

"Convoy, Not CLP: Defining a Logistics Core Competency," by Maj. Gen. James E. Chambers, *Army Logistician*, March-April 2009. <http://www.almc.army.mil/alog/issues/MarApr09/convoynotclp.html>

"Convoy Operations in Afghanistan," by Maj. Timothy S. Moon,

*Army Sustainment*, March-April 2012. [http://www.almc.army.mil/alog/issues/MarApril12/Convoy\\_Operations\\_Afghanistan.html](http://www.almc.army.mil/alog/issues/MarApril12/Convoy_Operations_Afghanistan.html)

"Training and Certification for Convoy Escort Teams," by Capt. Jeffrey B. Frembling, *Army Sustainment*, September-October 2012. [http://www.alu.army.mil/alog/issues/SepOct12/Training\\_Certification.html](http://www.alu.army.mil/alog/issues/SepOct12/Training_Certification.html)



# Let's Get Social!

It has been a little more than one year since *Army Sustainment* established a presence on Google+ and Twitter. It has also been a year and half since we established our first social media presence on Facebook. Today we are richly engaged with an audience of more than 195 on Google+ and 350 on Twitter, and we have more than 700 followers on Facebook.

Why is this important? It means that we are getting content to our readers whenever, wherever, and however they are connected to the Internet. It also means we are reaching new and potential sustainers who will be a part of the Army 2020 and providing them with information from leaders and units within the sustainment community. So, are you connecting with these Army sustainers and accessing the additional content *Army Sustainment* provides through its social media channels? You should be.

Have something to share? Send us an email with a link to your content to [usarmy.lee.tradoc.mbx.leeasm@mail.mil](mailto:usarmy.lee.tradoc.mbx.leeasm@mail.mil) with the subject line "Social." Or tag *Army Sustainment* in your photos and posts to keep us up to date on your unit's social content.

Like and share our pages to get extra reach for your unit's activities, and include us in all of your social media efforts to help us improve our effort to be the "go to" social source for sustainment content.

**Army Sustainment**  
581 likes · 41 talking about this · 1 was here

Government Organization · Book & Magazine Distribution  
The Army's Official Professional Bulletin on Sustainment  
<http://www.army.mil/armysustainment>

About Photos RSS/Blog Twitter Notes 5

**Post Details**

**Army Sustainment**  
Soldiers from the 2nd Brigade Combat Team "STRIKE", 101st Airborne Division (Air Assault) were the first wave of passengers to transit through Mihail Kogalniceanu Air Base, Romania, en route to a mission in Southwest Asia. Here, the air assault Soldiers prepare to check-in at the passenger holding area Feb. 2, newly constructed by the 21st Theater Sustainment Command. (Photo by Sgt. Michael A. Currin, 21st TSC Regional Support Element)  
Read more: <http://www.army.mil/article/119424>

23,424 People Reached

730 Likes, Comments & Shares

FROM YOUR PAGE AND POSTS		
36 Likes	0 Comments	54 Shares

FROM LIKES, COMMENTS & SHARES		
612 Likes	24 Comments	4 Shares

TOTAL		
648 Likes	24 Comments	58 Shares

2,207 Post Clicks

854 Photo Views	31 Link Clicks	1,322 Other Clicks
-----------------	----------------	--------------------

NEGATIVE FEEDBACK

0 Hide Post	0 Hide All Posts
0 Report as Spam	4 Unlike Page

about 2 weeks ago

Like Comment Share 36 Likes 54 Shares

23,424 people saw this post Boost Post

*During the first week of February 2014, Army Sustainment's top Facebook post reached over 23,000 people and engaged roughly 10 percent of that audience.*

## Connect Mobile!



Website



Google+



Facebook



Twitter



# Improving Tactical Cost Forecasting to Optimize Readiness

■ By Col. E. Deacon Maddox

Forecasting the cost of readiness at the tactical level is a critical skill that has implications at the operational and strategic levels. As the Army continues operating in an environment of fiscal uncertainty, tactical-level forecasting skills take on increased significance. Over the past three years, the Army has begun fielding enterprise tools to assist with resource management; however, more is needed at the tactical level.

This article examines the state of forecasting at the tactical level through the lens of one installation, Fort Bliss, Texas, as units there prepared for and executed operations under federal sequestration in 2013. I will attempt to address what impediments exist to accurate cost forecasting at the tactical level and how the Army can remove these obstacles in order to optimize readiness in an environment of fiscal uncertainty.



*Pfc. Michael Mazzarella, a cannon crew member with the 4th Battalion, 27th Field Artillery Regiment, 2nd Brigade, 1st Armored Division, awaits orders in an M109A6 Paladin during Network Integration Evaluation 14.1 at Fort Bliss, Texas, Oct. 24, 2013.*

## Background

On March 1, 2013, the U.S. government began operating under the Budget Control Act of 2011 (BCA). Commonly referred to as “sequestration,” the BCA mandated across-the-board spending cuts split evenly between defense and nondefense accounts.

Gen. Raymond T. Odierno, chief of staff of the Army, told the Senate

each FORSCOM installation. The purpose of the conference was for the FORSCOM commander to hear how each of his subordinate commanders planned to implement his EXORD guidance and to outline how the cuts to OMA would affect the Army’s combat forces stationed in the continental United States.

As the conference unfolded, it was

---

The enormity of the funds being cut during sequestration virtually ensures that savings will be realized by optimizing training resource forecasting. Aside from the direct savings, an effective forecasting program coupled with a force trained in basic resource management would improve trust throughout the Army.

---

Armed Services Committee on Feb. 12, 2013, that the Army’s share of the first round of sequestration was estimated to be \$12 billion, with nearly half of that coming from operations and maintenance Army (OMA) accounts.

Then Deputy Secretary of Defense Ashton B. Carter testified during the same hearing that, in accordance with the BCA, the Army was bound by law to make the cuts on a straight percentage basis across all nonexempt accounts, including OMA, once sequestration took effect.

On Feb. 21, 2013, Gen. David M. Rodriguez, the Forces Command commander, issued an order titled “U.S. Army Forces Command (FORSCOM) Optimizing Readiness to Ensure a Highly Capable Force Execution Order (EXORD).” In the EXORD, the FORSCOM commander outlined very specific instructions regarding how subordinate units should plan and execute training for the remainder of fiscal year 2013. The commander’s intent stated, “Success ahead requires a shift in mindset from ‘doing more with less,’ to ‘doing what matters with less.’”

Less than a week later, on Feb. 27, Gen. Rodriguez chaired a video teleconference involving leaders from

clear that this was a priority effort at each installation and that significant preparation had gone into analyzing available resources, prioritizing efforts, and making hard decisions regarding the readiness of the force. On its face, it seemed a simple thing to do: implement clear guidance on a specific task. The devil, as the phrase goes, was in the details.

At Fort Bliss, preparation included a comprehensive review of scheduled deployments, planned training exercises, and discretionary initiatives underway to address a host of issues ranging from improving Soldier quality of life to training area improvements.

As part of the preparation, representatives from each major subordinate command at Fort Bliss came to the senior commander’s headquarters in the week before the video teleconference to brief their training schedules, expenditures, and associated spending plans for the remainder of fiscal year 2013.

This series of meetings ultimately proved to be an effective way for all involved to understand requirements and priorities, reach compromises, and recommend prudent cuts. However, a lack of software tools coupled with inexperienced staff members presented significant impediments to efficiency.

## Estimating the Cost of Training

What the Fort Bliss sequester planning sessions repeatedly demonstrated was that most of the participants had little experience forecasting the costs of training. This lack of experience resulted in inaccurate forecasts of what units would need, and in almost all cases, unit representatives underestimated their costs because they had incomplete information.

For example, fuel—one of the bigger costs in readiness—was not discussed comprehensively in any single spending plan. Repair parts, another high readiness expense on an armor-heavy installation, were accounted for marginally. Although the unit representatives were keenly aware of the costs of external contracts needed for interpreters, role players, and field toilets, they generally had no understanding of how much it would cost to move a brigade and its equipment to a combat training center for a training exercise.

The senior commander’s staff tried to fill in the gaps by querying historical data in the Army’s financial and retail supply systems of record. The resulting reports summarized the units’ financial obligations in time and, because the data came from systems of record, reflected actual costs; however, these reports lacked the context of what events were occurring at the time of the obligations.

For follow-up meetings, unit representatives gathered and brought historical training information: calendars, schedules, and operation orders. The senior commander’s staff produced detailed logistics and finance reports, including document history from the Integrated Logistics Assistance Program (ILAP) and financial reports from the General Fund Enterprise Business System (GFEBS). The participants then manually reconciled the data sets to produce a more detailed history, which in turn produced spending plans that were more accurate.

## Estimating Maintenance Costs

On Feb. 13, 2013, Lt. Gen. Raymond V. Mason, Army Deputy Chief of Staff, G-4, published a memo-

randum to the Army called, “Waiver Guidance Based on Fiscal Uncertainty.” The memorandum allowed commanders to maintain equipment at a lesser level called, “fully mission capable plus safety.”

This memorandum stands as another example of how seemingly simple guidance from the strategic level resulted in inaccurate forecasts at the tactical level because of a lack of effective tools. As with FORSCOM’s “Optimizing Readiness” EXORD, the fully mission capable (FMC) waiver required significant manual reconciliation in order to understand the financial implications of the change.

The information required to analyze item priority designators (to determine whether a repair part would bring an item to FMC status) and essentiality codes (to determine if a repair part was required for the safe operation of the item) for the FMC waiver resides in the ILAP document history. After cancellations and rejections of requisitions have occurred, the actual amount of funds obligated within the Army’s retail supply system resides in GFEBS.

Any useful tool for building a model and scenarios for repair parts ordering must be developed internally, but the technical expertise required to build the databases and spreadsheets following the business rules of the retail supply and finance systems is rare. To the hypothetical and often insistent questions from the senior commander and his deputies about what kinds of savings would be realized by going to the lesser maintenance standard, only scientific guesses could be made without a reliable percentage of statistical error.

### Case Conclusions

Four major conclusions can be drawn from both cases. First, there is no automated way for commanders to tie expenses to discrete training events. Second, no available analytical tools allow a commander to place a historical event in the context of financial obligations in order to forecast the costs of similar events in the future.

Third, any reconciliation among

training management, resource management, and retail supply systems will require significant manual intervention by highly skilled individuals at multiple echelons. Finally, the stakes are high and margins are shrinking; accuracy matters. Getting to an 80 or 90 percent solution for expenditure planning is not sustainable in the current fiscal environment.

### Recommended Solutions

To remove the impediments and improve forecasting accuracy, the Army should provide resource management training and a cloud-based tool that allows personnel to select and task organize force elements from GFEBS. The Army should provide resource management training for officers and senior noncommissioned officers in the Captains Career Course, the Command and General Staff Officers’ Course, the Senior Leader Course, and the First Sergeant Academy.

Such training should focus on how to draft (and defend) a spending plan that supports training objectives within the higher commander’s budget and how to read GFEBS reports. At a minimum, graduates of these courses should be trained on how to request and analyze GFEBS expense reports outlining the following:

- Government travel, to include meals and incidental expenses, per diem, transportation, and rental vehicles.
- Strategic movement in a training capacity, to include troop and equipment movements by air, rail, and line haul.
- Contracts and military interdepartmental purchase requests, to include government purchase card expenses, service contracts, and equipment and facility leasing.
- Supplies requisitioned from the Army’s automated retail supply system, to include general supplies, packaged petroleum products, construction supplies and repair parts.
- Medical supplies requested through medical logistics channels and bulk fuel purchased from Defense Logistics Agency–Energy.

The Army should provide a cloud-based tool that allows personnel to select and task organize force elements from GFEBS and subsequently tag GFEBS documents with a named training event. This tool will essentially synchronize the unit’s Digital Training Management System records with GFEBS.

From these inputs, the tool must be capable of merging training events with expenditures to render event cost summaries. Moreover, the tool must be capable of using these summaries to model future events and produce spending plans at the company, battery, and troop levels. A convenient way to visualize this tool would be to imagine a form of Intuit Quicken or Mint for GFEBS.

The enormity of the funds being cut during sequestration virtually ensures that savings will be realized by optimizing training resource forecasting. Aside from the direct savings, an effective forecasting program coupled with a force trained in basic resource management would improve trust throughout the Army.

These solutions would allow tactical commanders to provide context to what is otherwise random data at the strategic level. The Army has long prided itself on its ability to succeed with a “90 percent solution.” In the age of sequestration and steep reductions in OMA funding, the Army will have to rethink this maxim.

---

Col. E. Deacon Maddox is an ordnance officer and a U.S. Army War College fellow attending the Massachusetts Institute of Technology Supply Chain Management program. He holds a bachelor’s degree from the Virginia Military Institute and a master of military arts and science degree from the Command and General Staff College. He is a graduate of the Ordnance Officer Basic Course and the Combined Logistics Officer Advanced Course.



*Soldiers from the 143rd Sustainment Command (Expeditionary) analyze logistics data during a command post exercise-sustainment at Fort Hood, Texas. (Photo by Sgt. John L. Carkeet IV)*





# Leveraging Information for a Competitive Advantage

The Army must implement a strategy for effectively analyzing its data and providing key decision-makers with the information needed to make well-informed decisions in a rapidly changing environment.

■ By Col. Jeffrey C. Powell

On Feb. 24, 2014, the secretary of defense unveiled the Department of Defense's (DOD's) fiscal year 2015 budget request. This document made one thing perfectly clear: the Army has officially entered an indefinite period of declining resources.

Given anticipated fiscal constraints, the Army must find a way to make the sustainment warfighting function more effective and efficient if it is to remain the world's dominant land power. Seeking constant improvement is vital since most of the Army's budget is spent recruiting, retaining, paying, and equipping our Soldiers and keeping them healthy.

Beginning with the adoption of linear programming during World War II, the value of data analytics to

military logistics has been significant. Integrated data from logistics, maintenance, and financial systems have the potential to help logisticians optimize supply chains. The data allows logisticians to identify the most cost effective ground, air, and shipping options and improve warehousing strategies and inventory levels at depots and unit locations.

## Lessons From the Private Sector

In the private sector, some of the world's most successful companies have used data analytics to shorten decision cycles, make decisions with the best available information, and improve the success rate of implemented decisions. We must apply lessons learned from industry-leading companies in the private sector, such

as the United Parcel Service (logistics), Bell Laboratories and Chase Manhattan Bank (financial services), the Oakland Athletics (personnel), and Wellpoint (health services), to gain insights into effectively analyzing data and leveraging the results to achieve a competitive advantage.

The following examples demonstrate how data analytics have been successfully applied by the public sector to improve sustainment operations.

**Logistics.** The United Parcel Service's On-Road Integrated Optimization and Navigation (ORION) system combines delivery, order, and current route information to provide drivers with point-to-point driving directions updated in real time based on current driving conditions.

ORION optimizes directions in order to reduce fuel consumption and wear and tear on vehicles. In 2013, ORION saved the United Parcel Service approximately 1.5 million gallons of gasoline while improving customer service.

**Financial services.** Financial management companies were among the first to successfully integrate data analytics into daily operations. Chase Manhattan Bank and other credit card companies have successfully used the buying, spending, and billing patterns of their customers to detect potential fraud.

Bell Laboratories used advanced analytics to pioneer the field of continuous auditing, which leverages information technology to identify processing errors and potential fraud in near-real time.

By successfully applying similar methods, the Army could speed the processing of routine transactions while focusing extremely limited auditing and internal control assets on those transactions most likely to prove either inaccurate or fraudulent.

Ensuring accurate financial data is critical because it is so often combined with other data to help predict spending patterns and demand, thus helping logisticians predict the demand for goods and services.

**Human resources.** Private sector companies on the cutting edge of human resources management are using data analysis to identify effective employee incentives and accurately predict the likelihood of a prospective employee to succeed. One particularly high-profile instance of human resources analytics in action is how Billy Bean, the general manager of the Oakland Athletics baseball team, used predictive analytics to make informed personnel decisions.

By taking a unique analytical approach to personnel decisions, Billy Bean was able to identify a player's true market worth to the team. He did this by using often overlooked statistics, such as the number of times a player walked and the average number of pitches per at bat. This analysis helped him identify which players were undervalued or overvalued.

Billy Bean's analytical approach to human resources management allowed the 2002 Oakland Athletics to compile one of the best regular season records in history with the second lowest payroll in Major League Baseball. Similar analytics techniques could have a profound impact on how the Army manages its human capital. By combining the information from various data sources, such information could help shape how and who the Army recruits.

Analytics could also help shape retention offers by identifying not only whether a Soldier is likely to succeed but also for which career field he is best suited. Being able to answer these questions could potentially save the Army millions of dollars annually in recruiting, retention, and training costs while ensuring it has the right people filling the right jobs.

**Health services.** While still in its infancy, the field of health services analytics is showing tremendous potential for lowering costs and improving patient outcomes. Wellpoint, one of the largest health benefits companies in the United States, and IBM have partnered for just this purpose.

Together they are using the Watson supercomputer to help doctors identify the most effective treatment options for their patients. By effectively leveraging advanced analytics techniques, Wellpoint and IBM are finding ways to avoid unnecessary tests, which will drive down costs and reduce repeat visits caused by misdiagnosed conditions.

Using the vast amount of data collected in the Army Medical Department's Medical Protection System, which tracks personnel immunization, medical readiness, and deployability data, it may be possible to develop predictive models to help physicians identify that a patient is likely to develop a health condition in the future.

With such a prediction, the physician could then institute a preventive course of treatment before a chronic condition manifests. If the Army could successfully integrate advanced data analytics to improve diagnosis accuracy and avert potential illness, it could greatly improve medical readiness and reduce healthcare costs.

If the Army is to emulate these successes from the private sector, it must incorporate data analytics into the operations process. Doing this requires an enterprisewide strategy for converting the vast amounts of data at the department's disposal into actionable information. The three following recommendations should result in the effective integration of data analytics into the operations process.

### **Chief Analytical Officer**

First, the Army should establish the position of chief analytical officer (CAO). Establishing a CAO is necessary because the sustainment warfighting function is fragmented. As documented in U.S. Code Title 10, separate assistant secretaries of the Army are charged with oversight of financial management and comptroller, manpower and reserve affairs, and acquisition, logistics, and technology.

This segregation of duties has led to the creation of stove-piped deci-



*Brig. Gen. Bryan W. Wampler, center, commanding general of the 143rd Sustainment Command, conducts a battle update assessment during a command post exercise—sustainment with observers Maj. Gen. Jimmie Jaye Wells, left, commanding general of the 75th Training Command, and Maj. Gen. Peter S. Lennon, commander of the 377th Theater Sustainment Command. (Photo by Spc. Aaron Ellerman)*

sion support systems for each individual Title 10 function but no comprehensive system to optimize the sustainment warfighting function as an enterprise. A CAO would have the responsibility for establishing an enterprisewide perspective.

The CAO would also be responsible for ensuring the data required by command analysts is accurate, integrated, and stored so that it is readily accessible and that data analysts are properly trained and organized to have the greatest operational impact.

#### **Access to Data**

Second, the Army must ensure that data analysts have reliable access to relevant, accurate data. The

ability to capture and store accurate data is simple in concept but exceedingly difficult in practice. This point is illustrated by the DOD's inability to produce auditable financial statements.

Fortunately, Congress mandated that the secretary of defense establish the Financial Improvement and Audit Readiness Plan. The plan serves as a road map for ensuring the DOD's financial statements are validated as ready for audit no later than Sept. 30, 2017.

Adhering to this mandate, the Army has spent more than \$10 billion in the development and implementation of four key enterprise resource planning (ERP) systems: the

Global Combat Support System—Army (GCSS—Army), the Logistics Modernization Program, the General Fund Enterprise Business System (GFEBS), and the Integrated Personnel and Pay Systems—Army.

The successful implementation of these ERP systems coupled with improved, standardized business processes should result in the Army's ability to produce auditable financial statements by the 2017 deadline. Producing auditable financial statements is significant since this will verify the validity of the Army's vast trove of financial, logistics, and human resources information.

Simply collecting data is not enough, however. Leaders within

the sustainment community must develop a plan for using this data to achieve a competitive advantage.

Creating a competitive advantage through the use of data analytics requires integrating and normalizing the data captured by the Army. The Army created the Army Enterprise Systems Integration Program (AESIP) to accomplish this task.

AESIP integrates data by linking business processes and data across existing information technology systems. Through AESIP, the Army compiles and maintains the Army enterprise materiel master, which provides a single authoritative source for materiel data supporting all Army (modernized and legacy) systems.

In order to incorporate data analytics into the sustainment warfighting function, the CAO must work with the key stakeholders, data analysts, and the AESIP project manager to ensure the data collected and archived by AESIP is relevant and readily accessible.

A recent analysis of the world's 400 largest companies illustrates the potential importance of data compiled by AESIP. This analysis indicates that companies that effectively analyze available data have a quicker decision cycle, are more likely to execute decisions as intended, and are twice as likely to perform in the top 25 percent of their industry as their peers who do not routinely employ data analytics.

### Recruiting and Training

Third, the Army must recruit, hire, and train technically competent analysts. Recruiting and hiring technically competent analysts is exceedingly difficult. For one thing, good analysts are hard to find.

Since the duties of data analysts require them to routinely use statistics, information modeling, and quantitative or qualitative analysis techniques to provide information for decision-making, they must have a thorough knowledge of both sustainment operations (logistics, personnel services, and health service support) and statistics.

Since very few sustainment professionals currently have both the mathematical skills and knowledge of sustainment operations needed to develop complex predictive models, an effective training or professional development strategy is imperative.

In order to improve the skill sets of current GFEBs and GCSS-Army users, the Army Logistics University and Army Financial Management School have partnered with Virginia State University and the University of South Carolina to provide logisticians and financial managers with an opportunity to be certified in Integrated Business Processes with SAP [Systems, Applications, and Products in Data Processing] ERP (also known as TERP10).

These programs are designed to provide students with an overall understanding and a working knowledge of the function, design, control, and use of ERP systems implemented by the federal government. They are an important initial step in providing sustainers with the skills necessary to apply data analytics. The Army should build on this by developing a comprehensive training and leader development strategy to maintain and enhance the skills of its analysts.

The skills, knowledge and attributes of professional analysts make them extremely rare and valuable assets. For this reason, careful consideration must be given to how they will be organized and distributed throughout the sustainment community.

To provide commanders with the best possible support, I recommend that analysts be managed in a semicentralized manner, with analytical centers of excellence located within the Office of the Surgeon General of the Army and the Offices of the Assistant Secretaries of the Army for Financial Management and Comptroller, Manpower and Reserve Affairs, and Acquisition, Logistics, and Technology. Affiliated subordinate analytical cells should be located at the Combined Arms Support Command and Sustainment Center of

Excellence, the Soldier Support Institute, and the Army Medical Department Center and School.

The analysts at the centers and schools would then serve as consultants to commanders as needed. This semicentralized construct would allow analysts to support senior leaders when making decisions concerning requirements generation, validation, and budget preparation, defense, and execution.

During the past decade, the Army has invested billions of dollars in developing and implementing information technology and ERP systems in order to streamline business processes and produce auditable financial statements.

If the department is to turn this investment into an enduring competitive advantage, it must implement a strategy for effectively analyzing the Army's vast treasure trove of data and providing key decision-makers with the information they need to make well-informed decisions in a rapidly changing environment.

The most effective way to do this is to establish a CAO to lead analytical efforts. The Army must collect relevant data and ensure that it is organized and stored so that it can be accessed when and where it is needed.

Lastly and most importantly, the Army must hire, train, and organize a professional cadre of analysts who will be charged with providing decision-makers with timely and relevant information. The Army will then have the ability to turn its vast amounts of raw data into information routinely used by leaders to make better decisions that can be executed effectively.

---

Col. Jeffrey C. Powell is the commandant of the Army Financial Management School and chief of the Finance Corps. He has a bachelor's degree in business administration from the University of Maine, an MBA from Syracuse University, and a master's degree in strategic studies from the Army War College.



*Spc. Nicoll C. Flores, a cashier with the 101st Financial Management Support Detachment, Massachusetts National Guard, fills out the exchange transaction record at Bagram Airfield, Afghanistan, to withdraw money as part of a transaction that allows a Soldier to exchange Afghan currency to U.S. dollars or vice versa. (Photo by Sgt. Sinthia Rosario)*

## Separating Resource Management From Finance Operations

■ By Gina Smith

Financial management (FM) has been a sustainment function for the past decade. Sustainment leaders must understand what financial managers bring to their formations. The purpose of this article is to describe the functions of FM, the organizations involved in FM, and the key players that execute

FM at the operational and tactical levels.

FM is defined in Field Manual 1-06, Financial Management Operations, published in April 2011, as “the sustainment of U.S. Army, joint, interagency, interdepartmental, and multinational operations through the execution of two mu-

tually supporting core functions, Resource Management (RM) and Finance Operations (FO).”

The term FM reflects the 2008 merger of the finance branch (basic branch code 44) and the comptroller career field (functional area 45) into the FM career field (branch code 36) as part of the FM redesign.

## FM Functions

Sustainment leaders must understand that there is a difference between RM and FO. In simple terms, RM manages the “checkbook”—deciding if the funds are available and appropriate given the requirement’s purpose, date required, and the amount of goods or services needed. With some exceptions, RM is a function typically performed at the G–8 (comptroller) level at echelons above brigade.

FO is “cash” management. It uses a negotiable instrument to pay for supplies and services obligated by the government. FO includes the calculation of vendor payments and support to operational contracting. This function is performed by the financial management support center (FMSC) located at the theater sustainment command (TSC) level and the financial management support unit (FMSU) and financial management support detachments (FMSDs) located within the sustainment brigade.

## FM Organizations and Key Players

As stated above, echelons-above-

brigade financial managers in the G–8 shops perform the RM function. Some separate brigades, including engineer brigades, military police brigades, and special operations forces brigades, groups, or regiments, also have FM officers who are resource managers. Recent force structure changes created a brigade combat team (BCT) S–8 as part of the third maneuver battalion initiative.

Fiscal year 2014 modified tables of organization and equipment (MTOEs) reflect this change with the addition of an FM captain and sergeant first class. If an S–8 position is not documented on the MTOE (for example, in battlefield surveillance brigades, combat aviation brigades, fires brigades, and maneuver enhancement brigades), the logistics officer in the S–4 is normally assigned the budget responsibilities for the brigade. In cases like this, the logistics officer manages available funds to spend as opposed to certifying that they are available.

**G–8 or S–8.** The G–8s and brigade S–8s are expected to manage resources by identifying the appropri-

ate sources of funding to meet the commander’s requirements and to certify that funds are available. If the commander does not have appropriate funding available, the G–8 or S–8 works those issues with higher headquarters to find the resources.

**The FMSC.** Financial managers in the FMSC, FMSU, and FMSD perform the FO function. Field Manual 1–06 describes the FMSC as a modular, tailorable, operational FM unit that is linked to the theater Army service component command G–8 but assigned to a TSC. The FMSC director, a colonel, is the senior adviser to the TSC commander for finance operations.

The FMSC provides the link to key national providers, including the Department of Treasury, the Defense Finance and Accounting Service, and the Assistant Secretary of the Army (Financial Management and Comptroller). It maintains visibility of all finance operations and placement of all operational and tactical FM units in theater, develops theater currency requirements, provides central funding support (to include U.S. currency, foreign currency, and U.S. Treasury checks), and negotiates with host nation banking facilities.

The FMSC enforces policies and guidelines established by national financial management providers and provides guidance to the theater financial management units in coordination with the Army service component command G–8.

As a directorate, the FMSC’s relationship with subordinate FMSUs and FMSDs is one of “technical coordination” since these tactical units are habitually assigned to sustainment brigades and under the mission command of the special troops battalion.

**The FMSU and FMSD.** The FMSU, commanded by a major, provides mission command of the unit headquarters and three to seven FMSDs. The FMSD, commanded by a captain, provides general support financial management on an



*Spc. Joan Bazan, a pay analyst with the 106th Financial Management Support Unit, issues casual pay to Sgt. Maj. Johnny Valdez at Mihail Kogalniceanu Air Base, Romania. (Photo by Sgt. Maj. Michael Pintagro)*



*Master Sgt. Yuen S. Lee, the internal control noncommissioned officer-in-charge with the 27th Financial Management Company, 371st Sustainment Brigade, reviews paperwork with Spc. Gustavo A. Ramirez, 249th Financial Management Detachment, at Camp Buehring, Kuwait. (Photo by Staff Sgt. Kimberly Hill)*

area basis to a brigade task force or equivalent-sized unit or as directed by the financial management support unit commander.

Doctrinally, one FMSD can support up to 6,000 Soldiers. It provides timely and accurate payment for contracting and commercial vendor services, conducts disbursing and funding support operations, and performs limited military pay support.

**The FM SPO.** As a result of FM redesign, the Army created an FM position within the support operations (SPO) section of the expeditionary sustainment command and the sustainment brigade. The FM SPO, which is led by a major at both levels, determines requirements and coordinates finance capabilities for the supported units of the command.

The FM SPO ensures the FO for the command are nested, synchro-

nized, and integrated with the command's operation plan. The FM SPO recommends priorities of support and maintains situational awareness of all finance support provided to organizations across the battlefield.

The FM SPO, in coordination with the FMSC, develops the FM staff estimate and concept of support. Performing his or her duties correctly, the FM SPO assists the FMSU commander with planning and enables the commander to focus on execution of finance operations.

Sustainment leaders must understand that both the RM and FO functions fall within a FM officer's scope of duties. RM is a G-8 staff officer function. Below the brigade level, RM, or rather budget management, is usually an additional duty.

The FMSU and FMSD perform FO within the sustainment brigade.

FM SPO sections currently exist in the expeditionary sustainment command and the sustainment brigade to assist in FO planning. In the absence of a command and control relationship, coordination is essential among the G-8, the FMSC, the FM SPO sections, the FMSUs, and the FMSDs in order to obtain and distribute financial resources to support the commander.

---

Gina Smith, a retired Army officer, is an assistant professor in the Department of Logistics and Resource Operations at the Army Command and General Staff College. She holds a master's degree in procurement and acquisition from Webster University and is a graduate of the Army Command and General Staff College.

*Spc. Arisleindy Valdez-Gomez, a supply specialist assigned to the 21st Theater Sustainment Command trains with the Global Combat Support System-Army at the 240th Quartermaster Company Supply Support Activity at Smith Barracks in Baumholder, Germany. (Photo by Staff Sgt. Alexander Burnett)*





# Global Combat Support System–Army: A Dynamic Readiness Tool for Mission Command

■ By Capt. Mei-Ling T. Guarino

As the Global Combat Support System–Army (GCSS–Army) continues to be implemented throughout the force, discussions and articles about its benefits and challenges are increasing across the sustainment community. The fielding of GCSS–Army is ongoing across Army Reserve, Army National Guard, and Active Army units.

The GCSS–Army Product Manager office has been developing the system with civilian enterprise resource planning (ERP) implementation guidelines in mind, using commercial off-the-shelf Systems, Applications, and Products in Data Processing (SAP) software. The fielding strategy and supporting programs have been developed so that they adapt to the military environment and mitigate many ERP implementation challenges. Leaders now must take their role in implementing the system as its fielding continues.

This article looks at the challenges of commercial versus military ERP implementation strategies and offers recommendations for leaders on

successfully implementing GCSS–Army. In addition, the article examines how to manage organizational change and enable leaders to employ GCSS–Army to apply mission command as they support operations.

## GCSS–Army as an ERP System

GCSS–Army will replace existing decentralized Army logistics information systems with an integrated web-based solution. This dynamic system has major impacts on processes and operations in all command groups, supply support activities, organizational and field maintenance activities, supply rooms, and resource management offices across the Active Army, Army National Guard, and Army Reserve. Major long-term benefits include near-real-time property visibility, integration of processes, transaction traceability and transparency, and enhanced stewardship.

GCSS–Army does more than replace the functionality of current systems; it also eliminates some unnecessary processes. New processes are introduced, which can lead to

substantial benefits across Army sustainment to improve Army readiness. None of these benefits can be realized if leaders fail to overcome implementation challenges.

## ERP Challenges and Lessons

The GCSS–Army Product Management Office developed Army-tailored organizational change management programs to enable GCSS–Army implementation. These programs include lessons learned, policy updates, and education programs, which provide sustainment leaders with measures to avoid common ERP business implementation shortfalls.

However, they do not decrease the complexities of implementing commercial ERP software in a noncommercial military environment. Educating sustainment leaders on the challenges that organizations face in adopting ERP will aid in mitigating the challenges of instituting this major change.

The *Harvard Business Review* article, “Putting the Enterprise into the Enterprise System,” by Thomas H.

Davenport, defines key guidelines for civilian ERP initiative success. Guidelines such as changing business practices to match ERP, putting the right people in place, and installing the system gradually were found to enable ERP adoption. Adapting those concepts to the military environment will further enable GCSS-

Army's success. Initial implementation efforts have resulted in exposing several application problems, negative perceptions of GCSS-Army are slowly growing. All of these negative responses are common even in successful ERP implementation initiatives.

To alleviate these challenges, GCSS-Army product managers

positive change. Commanders can overcome resistance to change by addressing organizational behavior challenges early while training system users.

GCSS-Army's training strategy contains six training components: early education, web-based training, the lead user program, new equipment training, over-the-shoulder support, and sustainment support (end user manuals and smart books). These training resources are provided to units being fielded GCSS-Army 120 days before the system is expected to start operating. The GCSS-Army Product Manager office also educates strategic and operational leaders through site visits and briefings.

---

Sustainment personnel should expect some degree of discomfort during the GCSS-Army implementation process. This is a normal reaction during an ERP implementation of this complexity.

---

Army's success.

Key challenges in Army sustainment for ERP adoption are organizational resistance to change, challenges in educating the force, developing and communicating a comprehensive implementation strategy, and understanding the changes in sustainment operations. Army sustainment leaders would benefit from learning how to overcome these challenges in order to improve Army sustainment capabilities.

**Resistance to change.** ERP systems have their own logic for processing transactions within an organization. This forces organizations to conduct business practices that match the ERP system logic. For a business to successfully implement ERP, it must agree to change its internal processes to match ERP functionality. This becomes a challenge when the organization uses internal processes to drive their competitive advantage.

In the commercial environment, adapting to an ERP system leads to overall resistance to change. The same hesitance is expected in Army sustainment activities. The change will be even more challenged by personnel who do not consider Army sustainment operations comparable to private sector businesses.

Some may argue that the Army does not fit similar commercial procedures because it is not driven by similar goals. Additionally, since ini-

evaluated SAP's ERP functionalities while working with programmers to develop GCSS-Army and ensure processes would fit Army sustainment purposes. Significant changes in terminology and processes are unavoidable when making the change to an ERP system.

The considerable process changes in GCSS-Army will make it difficult for experienced logistics information system users to accept the new system as beneficial in the near term. It may not be until after units have implemented GCSS-Army and built confidence and competency in the system that they fully realize the benefits.

For leaders, this means personally accepting and championing the change throughout the organization. Soldiers will be more accepting when leaders advocate change and support the project initiatives. When leaders set GCSS-Army training efforts as a priority, Soldiers become more aware of GCSS-Army as a significant effort. This is certainly happening at the highest Army levels, and it must continue to be driven down to leaders at all levels.

**Training strategy.** Civilian organizations that did not include an education strategy early in their ERP implementation experienced immense hardship and even failure. In addition to early education, managing trained personnel is essential to perpetuating

The Army Logistics University (ALU) and the Combined Arms Support Command have been gradually refining GCSS-Army institutional education for all logistics students. Wave 1 training has been implemented in advanced individual training at the Quartermaster and Ordnance Schools and in leader training at ALU. Wave 1 training includes the functions of finance and warehouse operations. Wave 2, which is currently under development, will include the functions of maintenance and property book management.

GCSS-Army leader familiarization training has been piloted in the Combined Logistics Captains Career Course, Quartermaster Basic Officer Leader Course, and Quartermaster Warrant Officer Basic and Advanced Courses since the beginning of fiscal year 2014. The purpose is to expose leaders to the system's functionality, impacts, and training resources. It also covers the roles leaders will play in implementing the system.

Students are required to complete web-based training modules and become familiar with training videos and resources on the GCSS-Army website. ALU has also partnered with Virginia State University to offer SAP certification to interested leaders and is integrating the program into logistics intern education.

Educated leaders can have a significant effect on their organizations when they are being fielded GCSS-Army. Lieutenants, captains, and battalion commanders are exposed to ERP fundamentals and implementation complexity, allowing them to be more prepared for challenges during fielding.

**Implementation.** Changing too much at once can put a business in an operational nosedive because of the massive shift in how information is processed. To avoid this, GCSS-Army's functionality is being released gradually. This strategy allows for early identification of organization or application issues.

The problems encountered in the first fielding allowed the fielding teams to identify SAP process logic faults and formulate short-term fixes to better prepare for future supply support activity conversions. Gradual fielding also gives fielding teams the opportunity to build competency in the Wave 1 implementation program and lessen extended failures and downtime.

To address the initial implementation problems, the GCSS-Army product managers established a help desk process to address functionality concerns. Trouble ticket submissions resulted in local fixes, corrections in programming, and updated policies issued through all Army activities (ALARACT) messages. As the fielding projects continue, improvements are applied to each subsequent implementation. As more lessons learned are generated and shared, units can be better prepared for the upcoming fielding.

As noted earlier, adopting ERP leads to changing business processes. For an organization to adapt to those changes, policies must change to match new logistics processes. The reason for using ALARACT messages is to track policy changes during implementation, which will result in updated sustainment doctrine.

Leaders contribute in this effort by staying informed of policy updates and enforcing them in their organi-

zations. All ERP ALARACT messages are posted on the GCSS-Army website.

**Sustainment benefits.** If the Army can overcome the above implementation challenges, it can realize the benefits of ERP. For the Army, one of those benefits would be enhanced mission command.

While users focus on how to process transactions, leaders need to focus on how to leverage GCSS-Army and improve the application of information for mission command purposes. In order to accomplish globally responsive sustainment goals and enhance mission command functions, leaders should anticipate implementation challenges by deliberately setting the pace for change to enable sustainment process improvements.

GCSS-Army provides data and reports for leaders to translate into useful information for mission command warfighting function tasks, such as the operations process, knowledge management, and information management. Leaders must learn how to process, integrate, and manage the information provided through GCSS-Army into relevant knowledge for planning operations and influencing unit activities.

A proposed "commander's dashboard" capability for GCSS-Army would enable leaders to assess future operational environment challenges through improved life cycle cost visibility, demand forecasting, and readiness visibility. If the Army can overcome the implementation challenges, the system has the potential to support the globally responsive sustainment goals of leveraging game-changing capabilities, preserving the readiness of the force, and being responsible stewards of the nation's financial resources.

### The Way Ahead

As the Army continues to field GCSS-Army, sustainment leaders must increase their awareness of ERP challenges and ways to mitigate them. Resources have been developed to support the sharing of les-

sons learned through the milSuite Sustainment Knowledge Network GCSS-Army site and the GCSS-Army website.

Key leaders must be identified as champions for positive change during implementation in order to advocate the necessary behavioral and process changes that will allow GCSS-Army to be a success. If issues surface, they should be due to system functionalities, not lack of support or effort.

Policies and institutional training are continually updated throughout the implementation process. In a culture driven by policies, having regulations that coincide with new process change is a method of driving change across a large organization. Updated doctrine and tailored institutional training can drive implementation success and potentially lead the logistics force to meet the globally responsive sustainment initiatives through more efficient application of data within mission command functions.

Sustainment personnel should expect some degree of discomfort during the GCSS-Army implementation process. This is a normal reaction during an ERP implementation of this complexity.

Using change management, education, lessons learned, and help desk programs may be arduous now, but it would be unrealistic to expect the new system to be a seamlessly adopted and perfect product from the beginning. Realizing benefits will come with time as users and leaders gain competency with the new processes and apply GCSS-Army's functionality to mission command functions.

---

Capt. Mei-Ling T. Guarino is a deputy course director for the Sustainment Pre-Command Course at the Army Logistics University at Fort Lee, Va. She holds a master's degree in business administration from the College of William and Mary and a green belt in Lean Six Sigma.



*Soldiers from A Company, 296th Brigade Support Battalion, 3-2 Stryker Brigade Combat Team, 7th Infantry Division, prepare to conduct fuel operations for their brigade's six battalions at the Yakima Training Center, Wash. (Photo by Staff Sgt. Chris McCullough)*

## Sustainment for the Army of 2020

The Combined Arms Support Command proposed a new division-aligned force structure to provide sustainment capabilities from echelons above brigade through combat sustainment support battalions.

■ By Col. Robert Hatcher, Jeffrey A. Martin, and Lt. Col. Karl F. Davie Burgdorf

Modern warfare is three dimensional, and Army forces conduct a fluid mix of simultaneous offensive, defensive, and stability operations and support to civil authorities.

In the past 12 years, the Army evolved while fighting two simultaneous conflicts and transitioning from the Army of Excellence force structure to a modular force.

Lessons learned from the conflicts allowed leaders and Soldiers to better

understand sustainment's role in future Army operations.

Recognizing future challenges, the chief of staff of the Army, Gen. Raymond T. Odierno, tasked senior leaders to identify force management gaps and some mitigating strategies for effectively developing the force within current constraints.

Leaders ultimately identified more than 200 potential force design updates for possible consideration in Total Army Analysis (TAA) 14-18.

### The Guidance

The 2012 Army Campaign Plan identified a major objective of creating "an Army 2020 force that is: affordable, agile, capable, networked, responsive and adaptive, able to address the complex future operating environment characterized by complex, hybrid threats and demanding missions." Using that guidance, Army leaders looked at how to create the force of Army 2020.

Leaders developed decision points

to address each area of potential change. Their solutions included multiple efforts, including the following:

- Redesigning the brigade combat teams (BCTs).
- Revising the sustainment concept of support.
- Designing a new Army Force Generation model.
- Maintaining an “operational reserve.”
- Creating regionally aligned forces.
- Integrating special operations and conventional forces.
- Improving echelons-above-brigade (EAB) mission command.
- Aligning brigades to divisions and corps.
- Implementing a tactical wheeled-vehicle strategy to reduce vehicles.
- Ensuring reversibility and expansibility.

In 2011, the Training and Doctrine Command (TRADOC) was tasked with developing solutions for several of the decision points in order to create a capable, agile, adaptive BCT-based force that meets force reduction targets while retaining the ability to prevent, shape, and win in 2020. This task included designing the future BCT and developing criteria and strategies to support the Army 2020 initiative.

In relation to sustainment, TRADOC was assigned Decision Point 15 (DP 15), the “sustainment design and support concept campaign of learning line of effort.” DP 15 specifically addresses the migration of sustainment capabilities out of the BCT to EAB. TRADOC assigned the Combined Arms Support Command (CASCOM) as the lead for DP 15.

CASCOM began extensive gap and seam analysis, course of action (COA) development, and field reviews. The gap analysis focused on the following:

- Emerging sustainment capability and capacity gaps as the Army of 2020 migrates selected BCT logistics capabilities into EAB units.

- Shortfalls created by the elimination of the maneuver enhancement brigade (MEB) brigade support battalion (BSB).
- Stryker brigade combat team (SBCT) mission command and capability gaps related to its lack of forward support companies (FSCs).

CASCOM’s COAs were to develop effective and efficient sustainment organizations to execute wartime missions and security cooperation activities and to develop options to improve command relationships in support of deployment, garrison operations, and training mission command.

Working with the TRADOC Analysis Center at Fort Lee (TRAC Lee), CASCOM analyzed the known and emerging gaps and offsets in tactical-level sustainment from the BCT to EAB. Adhering to the requirement to gain economies of scale—an essential element for force planning to operate effectively in a resource-constrained environment—CASCOM proposed redesigning units, creating a new type of transportation company, and adding sustainment capabilities to the SBCT.

### The Background

Proposed changes to future maneuver formations have profound effects on sustainment. Without changing sustainment in response to those maneuver formation changes, gaps created by previous decisions will adversely affect the maneuver force’s ability to fully execute its mission.

For example, armored brigade combat teams (ABCTs), SBCTs, and infantry brigade combat teams (IBCTs) reduced their organic sustainment capability in order to maintain lighter, more agile formations. This reduced fuel distribution and eliminated stationary fuel storage, water production, and troop transport capability in the IBCT. It also reduced distribution and days of supply in all of the BCTs.

Force development decisions made between 2001 and 2012 centered on

meeting a high operating tempo and forced the Army to rebalance itself. Those decisions caused BCT and sustainment designers to focus on modifying units to conduct forward operating base (FOB) operations and wide-area security. The simultaneous implementation of modularity played a large role in reshaping the force. As the warfighting formations are redesigned for Army 2020, sustainment unit design and employment must adapt with them.

Previous TAA decisions eliminated significant portions of the Active component sustainment force structure and shifted others to the Army Reserve and Army National Guard. By 2017, 78 percent of sustainment units will be in the Reserve component; more specifically, 89 percent of truck companies, 95 percent of petroleum, oils, and lubrications companies, and 95 percent of water companies will reside in the Reserve. Anticipated reductions of the Active component by 2020 may further increase the reliance on the Reserve component.

Previous decisions left substantial sustainment gaps. For example, TAA 14–18 eliminated the BSB from the MEB. The change eliminated direct sustainment support for the MEB’s subordinate units and moved that workload to EAB without additional resources or doctrinal guidance to cover the gap. Other gaps were fuel distribution shortfalls within division areas, organic mission command shortfalls in the SBCT, property accountability, and theater petroleum distribution and planning.

Changes to the BCT structure, including the addition of a third maneuver battalion, the transition of the special troops battalion to a brigade engineer battalion, and the addition of an engineer battalion in the SBCT, caused significant growth in the size of the BCTs.

To keep the BCTs deployable and averaging 4,500 Soldiers, and to keep the total Active component force limited to 490,000, the Army identified sustainment capabilities

that could be moved out of the BCT: water purification, bulk fuel distribution, bulk fuel storage, and troop movement capability in the IBCT. This decision placed a high demand on EAB sustainment organizations to provide these functions, but Army leaders determined that the shift maintained a prudent level of risk.

### The Analysis

CASCOM conducted its analysis with the goal of designing sustainment structure and capabilities to meet the needs of the Army of 2020 in an era of fiscal austerity. Constrained by a smaller Army end strength, force developers were instructed not to increase the size of EAB.

CASCOM first examined tactical-level sustainment gaps associated with supporting BCTs and other functional brigades, including the lack of adequate mission command in the SBCT, lack of a BSB in the MEB, lack of efficient and adequate support for the fires brigade, and lack of required petroleum distribution at the theater level.

Planners also examined the four major offsets created by the BCT redesign: water purification, bulk fuel distribution, bulk fuel storage, and troop movement.

As the analysis progressed, force developers realized the natural tension in achieving economies of scale in sustainment while producing a streamlined, effective concept of support—efficiency versus effectiveness. Organizations are designed to support average demand since the Army cannot afford to build for the extreme.

Several CASCOM-developed concepts were analyzed to ensure they go beyond simply plugging holes to temporarily fill gaps and seams. Instead, CASCOM took a holistic approach to improving sustainment for all units that depend on EAB support.

Planners also remained mindful of the flexibility, capability, and faults of modularity. Sustainment was modular before the Army officially transitioned from the Army of Excellence to modularity in 2007. When modularity

was adopted, in some cases sustainment became “hypermodular.” The added flexibility worked in principle but came at the price of mission command, economy of scale, and synergy.

With new concepts being offered, CASCOM brought in TRAC Lee to provide a balanced analytic assessment of the sustainment concept of support. TRAC Lee ran multiple sustainment concept models for each BCT formation to measure capabilities and identify the associated risks of each. The analysis criteria measured the ability of the sustainment structure to provide operational reach, prolonged endurance, and freedom of action.

Using the TRAC Lee analysis, CASCOM drafted a sustainment concept of support that acknowledges the Army’s migration of capabilities to EAB and creates a new division-aligned structure to provide these capabilities from EAB through combat sustainment support battalions (CSSBs). It proposed new company-level structures for quartermaster, transportation, and ordnance units assigned to the CSSB.

### COAs

Three COAs were developed to address the passback of capabilities from the BCT to EAB units while offering varying cost-to-risk options for fixing existing gaps. TRAC Lee submitted its validated COAs at a sustainment operational assessment in June 2012, where current and former brigade, BSB, and CSSB commanders and S-3s and division G-3s and G-4s assessed the COAs.

Leaders were briefed on the capabilities of sustainment units in 2017 (the year of the last Army structure memorandum), BCT changes for Army 2020, sustainment gaps and offsets created by Army 2020, and the three COAs offered as solutions. Then they were allowed to ask questions and vote on the best COA to present to the TRADOC commander for implementation.

Most leaders supported a COA that aligned CSSBs to divisions and corps (Active and Reserve), added

FSCs to SBCTs, and eliminated the fires brigade BSB. Voting members of the sustainment operational assessment also provided comments. Many leaders were concerned about placing so much demand on CSSBs, while others expressed doubts about reducing the organic sustainment capabilities of the fires brigade.

Planners used the information and comments to develop an alternative COA to address the most significant concerns. The derivative COA became the CASCOM recommended COA and was approved by the TRADOC commander, Gen. Robert Cone, on Aug. 24, 2012.

### The Concept of Support

When Gen. Cone approved the CASCOM-recommended COA, he agreed to significant changes in Army sustainment. Although significant, the changes are not wholesale changes to the way sustainment does business on the battlefield, especially from a sustainment customer perspective. The concept of support addresses how to most effectively and efficiently support the warfighter and increase agility while operating in a fiscally constrained environment.

The concept centers on habitually aligning selected logistics capabilities into three corps-aligned CSSBs and 10 division-aligned CSSBs. An additional eight division-aligned CSSBs are expected in the Army National Guard. In turn, these division and corps CSSBs have the added responsibility of providing general support to units within corps or division areas of responsibility.

Gaining synergy through area support is essential to balance the Army and maintain an effective force. Consolidating capabilities and being able to distribute them back to the force on a geographic basis leverages economy of force and flexibility and saves time, materiel, and resources.

For example, area support reduces security risks by consolidating movement; there are fewer vehicles and drivers providing sustainment, resulting in lower fuel and manpower

requirements, a smaller sustainment footprint, and an increased capacity in a theater-level supply pipeline. By making these organizational and support relationship changes, sustainment forces provide the same, and in some cases better, support to the maneuver force.

In addition to changes to the CSSB, the concept proposes a significant change to SBCT sustainment. Unlike other BCTs, SBCTs currently do not have FSCs. Without these critical units, the SBCT's BSB has been facing a mission command challenge. The 2020 concept of support adds FSCs to the SBCT, giving the maneuver battalions better support. It also gives the SBCT, IBCT, and ABCT the same sustainment structure, allowing for easier cross organization of a task force.

### **The CSSB in 2020**

CSSBs currently play a significant role in providing mission command for sustainment units that provide area support to units in an assigned area that is not contiguous with the division area. The key difference between the current CSSB and a CSSB in 2020 is that the newly designed CSSB comes fielded with a standard base capability of transportation, supply, and maintenance and provides the BCT with water purification, bulk fuel storage and distribution, and troop transport.

Each corps- and division-aligned CSSB is designed with the same capabilities to organically and simultaneously support EAB units. In the new design, both division- and corps-aligned CSSBs are modular and consist of a headquarters company, composite truck company (CTC), composite supply company (CSC), and support maintenance company (SMC) capable of providing flexible and responsive sustainment throughout the corps and division operating environments.

The CSSB gains its flexibility through sustainment mission command as a subordinate of the sustainment brigade. Sustainment units

assigned a mission in general support can weight the division or corps commander's main effort by shifting resources.

A CSSB can have mission command of up to seven companies, so it can be tailored with integrated capabilities to provide additional supply, ammunition, fuel, water, transportation, mortuary affairs, field services, aerial delivery, financial management, and human resources management. Without being reconfigured, it can support more units on an area support basis through supply point and unit distribution operations.

In keeping with TRADOC's decision to move some sustainment capabilities out of the BCTs, the sustainment concept moves capabilities to the CTCs and CSCs. The most direct change is moving water purification and stationary fuel storage capability to the division-aligned CSCs.

In addition, the concept moves personnel transport with integrated convoy protection platforms for dismounted infantry in the IBCT into the division CSSB CTC to better pool resources and offer more flexibility and agility. By centralizing capability to distribute these commodities and offering corps and division commanders more agility in directing the priority of supply, CSSBs maintain integrated, responsive, survivable, and less complicated support to maneuver forces.

By design, CSSBs provide general support capabilities, typically on an area basis. The new CSSB is doctrinally responsible for the capabilities passed back from the BCTs, but it also provides support to every unit within or passing through the assigned sustainment footprint.

The responsibilities within the CSSB and sustainment brigade include supply, maintenance, transportation, field services, health services, personnel services, and finance. Using general support, CSSBs simultaneously support BCTs and division or corps EAB units.

This provides agility and economy of force to meet sustainment re-

quirements of the battlefield without compromising the responsiveness or effectiveness of support. Capabilities now embedded into the CSSB make it a powerful combat multiplier for the supported BCTs. Even with this added capability, flexibility and modularity are still crucial to success.

### **Composite Truck Company**

Of all the changes within the CSSB, one of the most substantial is the creation of a CTC. During the past 12 years of conflict, one of the chief complaints from tactical-level commanders was the makeup of transportation units. Commanders said they needed "some of this and a little bit of that" when it came to truck companies, but they rarely needed the full capabilities of a specific type of truck unit.

Taking this into account, the CTC gives commanders what they asked for—some of this and some of that. The CTC comes in two types: light and heavy. Light CTCs consist of a company headquarters, a maintenance section, two palletized load system platoons, and two medium tactical vehicle platoons.

Heavy CTCs consist of a company headquarters, a maintenance section, two palletized load system platoons, one medium tactical vehicle platoon, and one heavy equipment transporter platoon. The CTC also has organic convoy protection platforms and maintenance.

### **Composite Supply Company**

In 2020, the CSC will have several major changes, including the addition of a petroleum and water platoon and the possible addition of ammunition transfer and holding point assets. These additions offer three major capabilities to the CSSB that give EAB units and BCTs higher levels of support while meeting the economies of scale required by BCT passbacks.

Having an ammunition transfer and holding point would help fill gaps in class V (ammunition) distribution to the MEB and provide versatility to EAB support. This could eliminate

the CSSB's often double-handling of class V—a redundancy recognized during gap analysis.

Additionally, the petroleum and water platoon specifically addresses the passbacks from the BCTs under Army 2020. This section's bulk fuel and water capabilities can be used by

the CSSB for EAB or BCT support or can be pushed directly into a BCT, if required.

### Support Maintenance Company

Although a few minor adjustments were made to the SMC for Army 2020, the most significant change was

a reduction in the number of standard requirements codes (SRCs) from 22 to one. Previously, planners had difficulty determining which SMC assets (SRCs) to bring to battle.

For example, during the conflicts in Iraq and Afghanistan, planners “ordered” an incomplete SMC because

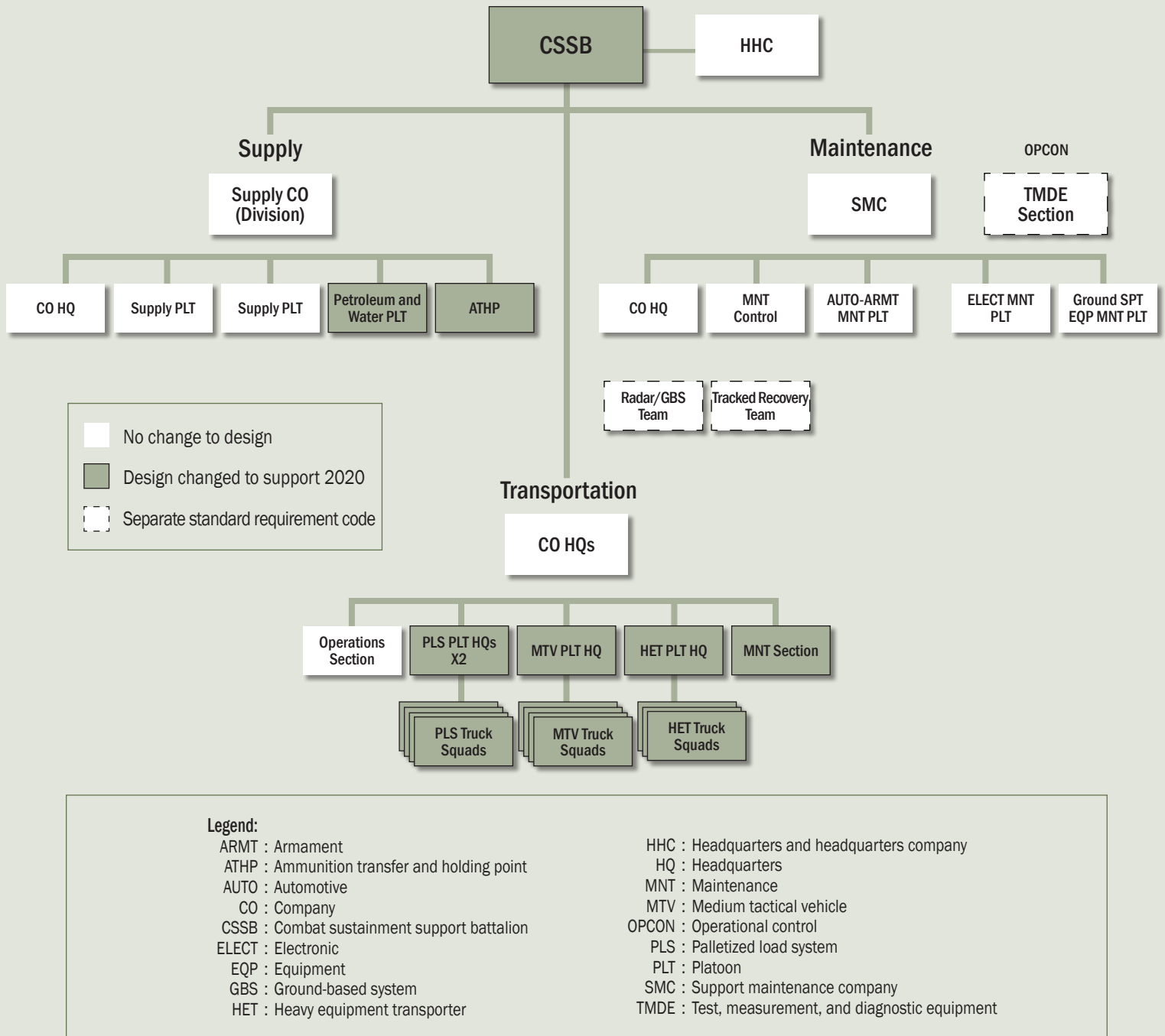

*This organization chart represents the new division- and corps-aligned combat sustainment support battalion that is being implemented across the Army.*



they did not realize that the SMC had multiple SRCs. By making the SMC a single SRC, planners can ensure the full capabilities of the SMC will be brought to the battlefield.

### FSCs in the SBCT

In several specific areas, the concept of support involves filling gaps and gaining efficiencies. One of the largest gaps was in the SBCT, where the subordinate battalions lacked FSCs and, thus, sufficient mission command and sustainment structure. This gap made sustainment more challenging and made it difficult to task organize BCTs.

Without the changes approved in DP 15, the SBCT's maintenance company was on the path to becoming the largest tactical company in the Army because of the elimination of contracted maintenance. Between 2001 and 2012, the company grew twofold. But during that time, mission command was never adjusted based on resourcing constraints. This left a captain to command almost 400 Soldiers operating throughout the SBCT area of operations—well more than the standard 200 for an Army tactical unit.

Without FSCs, the SBCT BSB was forced to create ad hoc, non-standard forward logistics elements (FLEs) constructed from pieces of the BSB without adequate mission command or equipment. Lieutenants or noncommissioned officers—often cooks or mechanics with little multifunctional sustainment experience—were expected to conduct FSC-like operations.

The result was a degraded capacity to provide support for freedom of action and operational reach without adjustments to mission command, maintenance control, and distribution.

Task organizing SBCTs was also a challenge. Without FSCs in the subordinate battalions, SBCTs had no sustainment mission command at the battalion level unless leaders created an ad hoc team to fill the role. This was challenging for task force planners and commanders who were

operating with an SBCT.

Adding FSCs into the SBCT formation fills the mission command gap and provides the personnel and equipment necessary to fill the maintenance roles that are currently provided by contracted mechanics and maintenance managers. It also gives the SBCT the same sustainment structure as the other BCTs, allowing for easier task organization.

### The Future

In September 2013, Army leaders made many decisions regarding Army 2020 through the Army analysis and decision-making process and published them in an Army structure memorandum. CASCOM's redesigns for the sustainment forces of Army 2020 use fiscal year 2017 as a baseline.

As a result, many of the changes made to unit tables of organization and equipment for 2020 will take two to four years to be implemented for the current forces. Consequently, changes from some previous unpublished decisions and the acceleration of new decisions appear uncoordinated or sporadic as they are implemented.

Sustainment must make adjustments at the same pace as BCTs to ensure that there are no gaps at home station or on the battlefield. TRADOC is making changes to doctrine to describe how the newly designed CSSB and other operational- and tactical-level sustainment units will complete their missions in Army 2020. Planners, force designers, and doctrine writers are working together to create updated doctrinal guidance that will allow for changes in training.

While the Army resizes, forces are likely to be restationed, creating challenges to sustain those organizations at home station. As stationing decisions are made, sustainment structure must be moved or built to meet garrison sustainment and training requirements. The Department of the Army will coordinate decisions for stationing with Forces Command and TRADOC to reduce friction and enable home station sustainment.

Although the 2020 concept of sup-

port is conducive to all components, Reserve forces have additional challenges, especially the Army National Guard. Since the Guard stretches across state lines with both Title 32 and Title 10 responsibilities, it must determine how to design its forces to meet its missions. Both the Reserve and Guard will convert to the new design.

Planning and designing formations and how they fight or support the fight are evolutionary processes. Since it is an evolutionary process, making changes to formations and doctrine must be methodical, comprehensive, and holistic.

Army processes, including the force design updates and total Army analyses, will continue to shape the force and require updates in relation to both strategy and doctrine. CASCOM integrates feedback from commanders in the field, operational deployments, training center rotations, modeling, and simulations to help determine the path forward as we now look to the Army of 2025.

---

Col. Robert Hatcher is the director of the Combined Arms Support Command (CASCOM) Force Development Directorate. He commanded the 64th Brigade Support Battalion, 3rd Brigade Combat Team, 4th Infantry Division, and has served in NATO, the Army Special Operations Command, and at the National Training Center in both light and heavy formations.

Jeffrey A. Martin is the deputy director of the CASCOM Force Development Directorate. He retired from the Army after 30 years of active duty service.

Lt. Col. Karl F. Davie Burgdorf is a Reserve officer on active duty serving in the CASCOM Force Development Directorate Multifunctional Division. He has a bachelor's degree in history from Wofford College and is a graduate of the Transportation Officer Basic and Advanced Courses and the Command and General Staff College Intermediate Level Education.



*A delivery truck parks along the Khyber Pass outside of Forward Operating Base Torkham, Afghanistan. The heavily decorated truck is known as a jingle truck because of the sound it makes when in movement. Fewer jingle trucks are being used to transport supplies in the Afghanistan Transportation Network because they often require reconfiguration in order to properly load the assets, requiring additional time and resources and causing costly delays. (Photo by Staff Sgt. Darian George)*

# Establishing the Afghanistan Transportation Network

Using local tribal elders as an integral part of the Afghanistan Transportation Network helps ensure its success.

■ By Capt. Warren R. Crocker

Developing partnerships with coalition forces, local communities, and influential business leaders to strengthen Iraq's trucking industry and reduce the number of coalition convoys was successful during Operations Iraqi Freedom and New Dawn. Using the Iraqi Transportation Network as a model, the 3rd Sustainment

Brigade has helped prove that the concept is the optimal transportation choice in Afghanistan, especially as the country transitions to self-sustainment.

The host nation-led trucking company, the Afghanistan Transportation Network (ATN), has become the go-to choice across Regional Commands South and Southwest

and National Support Element West. In December 2012, the 3rd Sustainment Brigade assumed responsibility for sustainment and retrograde operations in these three regions of Afghanistan.

With that came the responsibility for the day-to-day control of the ATN. After assuming these responsibilities, the brigade oversaw more

than 5,500 ATN missions covering more than 703,000 miles and accomplishing 99 percent of deliveries by the required delivery date. During these missions, approximately 40,000 U.S. Soldiers remained off the road and out of harm's way.

### **ATN Establishment**

The ATN concept began in October 2009 with the primary intent of moving various supplies throughout the Combined Joint Operations Area-Afghanistan and relieving coalition forces from convoy duties. The overarching goal was to establish a network to secure a long-haul supply distribution system throughout Afghanistan.

The brigade developed relationships with tribal elders and community leaders to form an Afghan-owned and -operated transportation system. These Afghan companies have created opportunities for increased economic expansion, entrepreneurship, and skills training for the people of Afghanistan.

The Army, with the assistance of the Marine Corps, established a means of vetting proposed elders and Afghan drivers to facilitate the transportation of cargo and assets among forward operating bases within Regional Commands South and Southwest and National Support Element West.

Using elder engagement teams that promote the program, the contractors who administer the ATN contract identify elders and community leaders who are interested in partnering with the U.S. government. Once the elders and community leaders are identified and vetted, they are either accepted or denied entry to the ATN program. The purpose of the vetting process is to ensure that individuals permitted to access FOBs in support of the ATN contract pose minimal risk to the U.S. government and its coalition partners.

### **Mission Success**

A transportation mission is considered a success when it arrives at

its destination by the date specified on the transportation movement release (TMR) with zero pilferage or damage to the cargo. By ensuring the success of each mission, the elders and drivers can maintain good business relationships with the U.S. government.

The elders, with assistance from the contractor, teach each driver about the importance of driver safety, the

ment the cargo is uploaded until it is downloaded. The 3rd Sustainment Brigade and its CSSBs are available 24/7 to meet the needs of the customers. Soldiers and customers rely on the brigade's ability to logistically and methodically mitigate any potential for error.

The impressive statistics of the ATN are easily quantified, and the

---

The brigade developed relationships with tribal elders and community leaders to form an Afghan-owned and -operated transportation system. These Afghan companies have created opportunities for increased economic expansion, entrepreneurship, and skills training for the people of Afghanistan.

---

need to remain vigilant, and the importance of continual communication between the elders and the U.S. government. To ensure safe passage, the elders use their community influence to collect information on the designated routes their trucks travel.

Should pilferage or damage occur, the contractor and elder are held financially responsible. Up to the time I left the theater, fewer than 10 occurrences of pilferage occurred, and in each case, the elder, through his network of connections and affiliations, recovered 100 percent of the missing items.

### **CSSB Support**

The day-to-day inner workings of the ATN is directly attributed to the combat sustainment support battalion's (CSSB's) multifunctional abilities. The CSSB receives all TMRs from customers, screens all information for accuracy, and then processes requests so contractors can allocate the appropriate assets to meet the customers' needs.

After a CSSB releases the TMRs to the contractor, the CSSB's job is far from complete. It must track the progress of the mission from the mo-

long-term benefits have far-reaching economic effects. The establishment of ATN routes can easily turn into enduring local distribution networks that connect communities and villages across the many provinces, promoting economic development.

The economic implications of a defined transportation network, when paired with established businesses and communities, will aid in a more robust import and export market promoting community and business development.

---

Capt. Warren R. "Randy" Crocker is attending the Combined Logistics Captains Career Course. He served in Afghanistan as a contracting support officer and as a contracting officer representative for the Afghanistan Transportation Network contract. He holds a bachelor's degree from Norfolk State University and is a graduate of the Transportation Basic Officer Leader Course.

*Army Sustainment Online*  
[www.army.mil/armysustainment](http://www.army.mil/armysustainment)



*Soldiers are evaluated on the Dismounted Soldier Training System during the 4th Sustainment Command (Expeditionary) Best Warrior Competition in San Antonio, Texas. (Photo by Robert Ramon)*

# Logistics Simulations for Battle Staff Training

The Battle Command Sustainment Support System allows sustainment Soldiers to gain experience in supporting the fight without going to the field to train.

■ By Kathryn Bailey and Calvin Pilgrim

*A fires brigade commander in Afghanistan prepares to execute an offensive maneuver. He requests an update on the status of the rocket resupply for the Army Tactical Missile System and the maintenance status of the Multiple Launch Rocket System (MLRS).*

*His supply sergeant queries the Battle Command Sustainment Support System (BCS3) for the last known location*

*of the convoy transporting the rockets and also opens a maintenance unit status report to see the progress of the MLRS repair.*

*Determining that the convoy left two hours ago and the MLRS is still in the shop but all parts are available for the repair, the sergeant then verifies that the estimated time of arrival of both the convoy and the MLRS is in six hours.*

*Finally, a personnel query confirms that two new Soldiers are scheduled to arrive one day ahead of schedule.*

**W**hile the above scenario was actually part of a simulated exercise, the up-to-date fire support and personnel data contributed to a successful attack, and the exercise underscored

the fact that logistics support training is just as critical to the mission as tactical training for combat operations.

### BCS3 Simulations

Simulations, such as those provided by BCS3, are used to train commanders and staffs without them having to deploy.

BCS3 provides real-time, map-based, logistics operational capabilities to commanders at all echelons and includes the logistics reporting tool (LRT) for sustainment status reports, supply and equipment in-transit visibility, and personnel asset visibility. It is one of the logistics tools used for mission command and provides sustainment information in the command post computing environment (CP CE).

The CP CE is one of several computing environments nested inside the Army's common operating environment. It aims to simplify systems architecture for mission command capability development at tactical echelons.

When the BCS3 Simulations and Stimulations (Sim-Stim) Team began to support simulations in the 1990s, it had to travel to each site to set up a server suite. But in 2011, the National Simulation Center at Fort Lee, Va., began hosting the BCS3 simulation team and the national data portal. The simulation team conducts many of the 12 major annual exercises at Fort Lee, but the team also supports exercises worldwide through the portal, saving the Army money.

Exercises are tailored to unit requests, generally last 10 days, and include participation from the Active and Reserve components. The BCS3 architecture allows an organization to execute myriad sustainment operations. In more complex situations, the BCS3 architecture can be expanded to accommodate a greater number of systems that are sometimes called BCS3 clients.

To ensure the most realistic experience for sustainment Soldiers, the

BCS3 Sim-Stim Team stimulates the scenarios by injecting data.

Injecting data is intended to test the responses of sustainment personnel. The types of simulations exercised are part of two logistics federations: the Multi-Resolution Federation (MRF) and the Entity Resolution Federation (ERF).

MRF uses Warfighter Simulation (WARSIM) for the combat model and Logistics Federation (LOGFED) for the logistics model. ERF interfaces with mission command systems through the Joint Conflict and Tactical Simulation as the combat model and Joint Deployment Logistics Model as the logistics model.

### Tailoring Simulations

The actual scenarios vary depending on the training requirements, so the BCS3 Sim-Stim team closely coordinates each exercise to ensure the exercise meets the command's expectations. For example, a command may need to prepare for an upcoming deployment, requiring its Soldiers to learn how to track class I (subsistence) items. The simulation then pushes out a supply status to the user's BCS3 terminal but withholds

class I updates.

The simulated environment begins when logistics data flows from the LOGFED server through a gateway to the LOGFED Sim-Stim client, which then feeds to the BCS3 main gateway. The gateway pushes that data down to the BCS3 clients.

In the Sim-Stim client, the unit task organization and tracked items list, a crucial listing of the commodities the commander deems necessary to complete the mission, are built and passed to the BCS3 national data portal and the BCS3 clients (the training audience) through the main gateway.

### Practicing Resupply Procedures

The output is unit basic load (UBL) data from WARSIM, which is provided by the Program Executive Office for Simulation, Training, and Instrumentation, and supply point data from LOGFED, which is packaged and distributed to all the BCS3 gateways and client systems in the exercise architecture.

The UBL data provides several classes of supply, from class I through class IX (repair parts). This data is sent in the form of a logistics status



*Spc. Noelle Foster and Sgt. 1st Class John Zapata work in the 35th Combat Aviation Brigade tactical operations center during a training exercise at the Army Aviation Warfighting Simulation Center at Fort Rucker, Ala. (Photo by Capt. Marvin J. Baker)*



*Soldiers from the 3rd Sustainment Command (Expeditionary) use simulations to train on forward operating base defense tactics at the Training Support Center at Fort Knox, Ky. (Photo by Sgt. 1st Class Gary Cooper)*

report message and is posted in the running estimate reports, combat power, and LRT sections of BCS3.

Using the data from WARSIM, a unit can use BCS3 to monitor the degradation of stocks. For instance, users can set the UBL to send out an alert if fuel supplies reach 75 percent. Or users can track ammunition resupply by setting an alert to sound after 100 rounds are shot. On the LOGFED side, the simulation teaches users how to track the convoys carrying the supplies.

Convoys are visible in the common operational picture in BCS3, and the in-transit visibility information sent from LOGFED can be published to the Battle Command Server so other Army battle command systems, such as Command Post of the Future and Command Web, can subscribe to them and see the convoys in their common operational picture.

Another popular capability is the logistics factor file, which allows the user to set logistics factors that affect their status in the areas of planning

consumption factors, days of supply, and status thresholds. This function allows unit leaders to weight the aforementioned factors to help determine their readiness status. Units also request BCS3's combat power capability for an all-inclusive analysis of their logistics readiness to perform their missions.

Training for Sim-Stim operations is available to units, and LRT is the most requested module. Users appreciate that they can use LRT to submit a report from the lowest level and then have the data automatically populate at each echelon based on the unit's task organization.

A new LRT enhancement includes equipment grouping, which allows a user to use a default grouping. An example of a default grouping is "combat, assault and tactical vehicles, and tracked," which contains major combat equipment, such as tanks, armored personnel carriers, and Bradley fighting vehicles.

The BCS3 simulations team con-

tinues to improve the system's interface, and as BCS3 is modernized and migrates into a web-enabled environment, the team is ensuring that the Sim-Stim environment will also transform to remain similar to the web-enabled environment.

---

Kathryn Bailey is a public communications advisor with Engineering, Solutions, and Products (ESP) and is assigned to Project Manager Mission Command at Aberdeen Proving Ground, Md. She holds a bachelor's degree in communications studies from the University of Maryland University College.

Calvin Pilgrim is the product director for Sustainment System Mission Command at Aberdeen Proving Ground, Md. He is a graduate of the United States Military Academy and holds a master's degree from the Florida Institute of Technology. He is a graduate of the Defense Language Institute Foreign Language Center and holds language certificates in German and Turkish.

# Sustainment Synchronization: Key to Supporting Operational Units

An observer-coach/trainer from the Joint Readiness Training Center explains some of the common areas that cause units to fall short in sustaining operational units.

■ By Capt. David A. Wallace

Synchronizing the sustainment of an operational unit is difficult since it encompasses so many different focus areas. Because of the complexity of this subject, sustainment must be looked at holistically and rationally. In order to understand unified action, units must build a common operational picture of what it takes to sustain unified land operations in an austere environment.

As a cavalry squadron forward support company (FSC) senior observer-coach/trainer at the Joint Readiness Training Center at Fort Polk, La., I have observed certain shortfalls in meeting the sustainment requirement. These shortfalls come from a limited understanding of the roles and responsibilities of the key players in sustainment operations, a lack of synchronization between the battalion sustainment cell and the brigade support battalion (BSB) support operations officer (SPO), and a failure to integrate the sustainment cell with current and future operations.

The attitude has been that sustainment is not important—until the supported unit depletes a critical class of supply during a mission. By that time, it is entirely too late to emphasize sustainment.

To better set conditions for success, units need to clearly define roles and responsibilities of the key sustainment players. Each sustainer must understand and perform specific roles and responsibilities in order to ensure the supported battalion is postured for mission success.

## Lack of Sustainment Synchronization

During past rotations, my team observed that one key to success for sustainment is often executed incorrectly: the logistics synchronization meeting. Most battalion combat train command posts (CTCPs) do not properly synchronize sustainment operations, current and future operations, and regularly scheduled logistics synchronization meetings.

They often fail to have the appropriate leaders and staff members attend the meetings. Often, organizations conduct logistics synchronization meetings without the battalion executive officer (XO) attending. The XO needs a clear understanding of the importance of the logistics synchronization meeting and what his responsibilities are in sustaining the organization. Without the appropriate leader chairing the meeting, emphasis on accurate and timely reporting is not enforced.

## Logistics Synchronization Meeting

The attendees for the logistics synchronization meeting should include the battalion XO, S-4, S-1, supported unit representatives, FSC key leaders, an S-3 representative, and an S-2 representative. The results of the meeting should be a logistics common operational picture and a logistics synchronization matrix. These items should be based on the battalion concept of support and synchronized with the operations plan.

During the meeting, logistics status numbers should be verified, unit representatives should gain a clear understanding of what resupply to

expect and when to expect it, and the FSC should learn exactly what resupply missions will be executed over the next 24 to 72 hours.

Output from the logistics synchronization meeting is meant to provide the battalion S-4 with accurate data to properly analyze the supported unit's logistics requirements. This synchronization allows the development of running estimates and historical data.

Additionally, current operations and future operations can connect with logistics requirements to ensure the battalion is receiving the correct supplies at the right time and at the right locations. However, based on combat training center observations, the battalion S-4 often ends up collecting and analyzing inaccurate data. This usually leads to the FSCs communicating directly with supported elements to consolidate requirements and develop a plan without synchronizing their actions with the battalion.

## Experience Is Key for the Battalion S-4

Another friction point that my team observed is some units' inability to adequately and accurately synchronize sustainment efforts because of the battalion S-4's lack of experience. The battalion S-4 billet in a maneuver battalion is often filled by an officer who has not attended a captains career course and has no experience or training in logistics.

In some cases, the battalion S-4 position is used as a temporary or transitional position for a pre- or post-company command maneu-

ver officer, often pending a permanent change of station to another duty assignment. This modified table of organization and equipment (MTOE) construct is unfair to an organization; it causes a lack of logistics continuity.

I recommend changing the battalion S-4 billet in the MTOE to a logistician position. This could minimize inaccurate reporting and facilitate proper forecasting for future logistics requirements.

Maneuver battalion S-4s and FSCs often do not effectively gather and communicate requirements to the

ing combat fatigue over the course of a deployment are often common.

Two efforts will significantly assist in improving these conditions. First, co-locating the CTCP and tactical operations center (TOC) will create, to some degree, a synergistic effect that significantly improves information sharing. It will enable cross-talk, situational awareness, and an overall understanding of operations. The improved communications resulting from co-locating the CTCP and TOC will also assist in clearly identifying requirements and the subsequent actions needed to respond to those requirements.

---

“You will not find it difficult to prove that battles, campaigns, and even wars have been won or lost primarily because of logistics.”

—*Gen. Dwight D. Eisenhower*

---

SPO and BCT S-4. This lack of accurate information gathering, when coupled with poor reporting, reduces productivity. As a result, units often execute unnecessary tactical convoy operations or emergency resupply from the brigade support area, rather than allowing the BSB to use its logistics systems.

Consequently, the FSCs experience an increased workload (delivering supplies forward) with a reduction in the efficiency of the operation. Furthermore, the fatigued Soldiers and their equipment are then exposed to increased, imprudent risks.

### **Co-locating the CTCP and TOC**

With the design of the BSB and FSCs tailored for a distribution-based system, except under specific types of operations (such as forcible entry operations) or geographic conditions, performing supply point operations adds unnecessary and increased requirements for the FSC. In a theater of operations like Iraq or Afghanistan, especially when geographic distances are significant, increased exposure to risk and hasten-

Second, the battalion S-4 and the FSC commander must capture requirements on a designated information system, such as the Battle Command Sustainment Support System, and describe the context for future requirements to the BSB SPO and BCT S-4. This way, the nature and timing of the resupply mission are clearly understood. The result will be a more efficient operation where the workload is properly distributed and the delivery of supplies and personnel are synchronized with battlefield operations.

### **Operations Center Integration**

Traditionally, the CTCP elements (S-1, S-4, and the medical officer) and the S-3 work in distinct, compartmentalized areas, which results in a mutual lack of situational awareness. As a result, operations suffer and typically force FSCs to be reactive rather than predictive when providing critical and synchronized logistics support to units.

Effective battalion operations require sustainment operations to work together with ongoing and future maneuver operations. A simple solu-

tion is to place an S-4 noncommissioned officer (NCO), an S-1 NCO, and a medical NCO in a hybrid administrative and logistics operations center cell in the TOC. This cell can then better understand current and future operations, evaluate the impact of logistics on the operation, and provide critical and timely feedback to the concept of operations.

Having an administrative and logistics operations center cell in the TOC improves efficiency in communicating with FSCs in order to synchronize logistics. It also ensures that the S-3 recognizes, plans for, monitors, and responds to ongoing logistics missions and calculates their effect on operations.

Sustaining the warfighter is a difficult task to synchronize. Units may find it necessary to assess how well they do a few things in terms of sustainment.

First, does the unit clearly define the roles and responsibilities for the key players in sustainment operations? Second, is there synchronization between the battalion S-4 and the FSC commander? Finally, is the reporting to the BCT S-4 and BSB SPO accurate?

This last question is probably the most critical piece to the sustainment puzzle. All these areas of sustainment operations will not be complete without being nested within a common operational picture on a continuous basis. Battalion operations require integration of sustainment operations with ongoing and future maneuver operations.

---

Capt. David A. Wallace is the task force sustainment cavalry squadron forward support company senior observer-coach/trainer at the Joint Readiness Training Center at Fort Polk, La. He holds a bachelor's degree in banking and finance from Fayetteville State University. He is a graduate of the Ordnance Basic Officer Leader Course and the Combined Logistics Captains Career Course.





*A Soldier executes rearming operations at a forward arming and refueling point at the Joint Readiness Training Center, Fort Polk, La. (Photo by 1st Lt. Timothy D. Hryniewicz.)*

## Supporting Task Force Lift

The forward support company of a general support aviation battalion deploying to the Joint Readiness Training Center found itself performing functions normally conducted by higher echelon units.

■ By Capt. Carlos M. Sanford, 1st Lt. Ryan C. Cloud, and 1st Lt. Timothy D. Hryniewicz

As logisticians, we first must match requirements with capabilities in order to define and extend the possible. Next, we must design creative contingencies that are easily integrated with the operations of those we support. Last, we must be innovative, agile, and adaptive to keep pace with the tactical operations conducted by our maneuver counterparts.

Typically, Joint Readiness Training Center (JRTC) rotations at Fort Polk, La., cater to the brigade combat team (BCT). In the case of E Company, the forward support com-

pany (FSC) for the 7th Battalion, 101st Aviation Regiment (7-101st General Support Aviation Battalion [GSAB]), 159th Combat Aviation Brigade, the rotation was unique. JRTC Rotation 13-10 catered to the 7-101st GSAB, a multifunctional aviation task force. A ground force did not deploy to JRTC, which meant that the FSC would have no reach-back support.

The intent was clear: E Company had to extend the maneuver battalion's operational reach by providing class I (subsistence), class IIIB (bulk petroleum, oils, and lubricants), and class

IX (repair parts). The task force commander's intent was to validate his capabilities in support of the ground force commander's requirements.

In the absence of higher echelon support, E Company had to fill the logistics requirements that are normally covered by the aviation support battalion (ASB) and, in many situations, a brigade support battalion (BSB) organic to a supported BCT. To set the conditions, the company assumed tasks of the ASB support operations section while executing deliberate command post operations that enabled the FSC commander to

intuitively implement mission command at all levels.

With that in mind, E Company implemented the fix-fuel-feed concept as one of the company commander's priorities to ensure a successful rotation. Additionally, FSC leaders briefed a sustainment plan and conducted a sustainment rehearsal with the task force commander and staff to ensure all the key players understood how logistics would be integrated during each phase of the operation.

The company commander's fix-fuel-feed priorities were as follows:

- **Fix:** Maintain the task force ground equipment at a 90-percent operational readiness rate.
- **Fuel:** Properly track fuel consumption to mitigate the possibility of aircraft being grounded. "Keep 'em flying."
- **Feed:** Execute a seamless field feeding plan that is synchronized with the task force flight schedule.

### Fix

E Company deployed to JRTC with three 92A (automated logistical specialist) Soldiers. Normally, the entire sustainment automation support management office from the BSB would deploy to help troubleshoot logistics information systems on the battlefield.

During the initial in-progress review for the JRTC rotation, it was noted that the FSC would have no reach-back support. This was an issue because the FSC was set to deploy to JRTC with only 69 Soldiers. The company requested that a sustainment automation support management office representative from the ASB be attached to the company for the rotation.

Within 24 hours of its arrival at the forward operating base, the company set up the very small aperture terminal. It began requisitioning parts from the supply support activity the following day. Establishing this critical information system enabled the maintenance control section to quickly input data for vehicles drawn



*A Soldier updates battle trackers at the E Company command post at the Joint Readiness Training Center at Fort Polk, La. (Photo by Spc. Michael Torres)*

from the pre-positioned stock yard.

Most aviation flight companies are not authorized executive officers, so the maintenance control sergeant, with the assistance of the FSC executive officer, managed the 026 report for the battalion to ensure parts were being ordered correctly through the Standard Army Maintenance System-Enhanced.

The FSC operations section created trackers and made updating them, at 0800 and 1700, daily battle rhythm events. This allowed any Soldier who entered the command post to know what equipment was not mission capable and what parts were on order to make it fully mission capable.

### Fuel

Logistics support is essential for continuous operations at JRTC. It must be delivered seamlessly by forecasting operational needs and coordinating with supplying units. Class IIIB was essential in these continuing operations, particularly to the aviation task force.

The distribution platoon deployed with six M978 heavy expanded-

mobility tactical trucks (HEMTTs), two advanced aviation forward area refueling systems, and other distribution equipment for the heavy use of fuel forecasted to support the rotation.

At JRTC, class IIIB was drawn directly from Cubic-ESG [exercise support group]—a contractor that typically works and communicates with the BSB support operations office—and transferred directly to the distribution platoon for refueling operations. In this method, known as throughput distribution, at least one echelon in the supply system is bypassed to minimize handling and speed delivery.

Although this may sound simple, it places additional duties on the receiving unit's distribution platoon. The FSC operations section must request fuel through the battalion S-4 and, in most cases, coordinate with Cubic-ESG because of the ever-changing environment.

The mission of the distribution platoon at JRTC was to ensure all aircraft were topped off with aviation fuel throughout the exercise in order to continue operations. However, the

implied task was to accurately forecast fuel needs because it was essential to have the right amount of fuel on hand without fail and to forecast a fuel drawdown so that there was no excess fuel at the end of the rotation.

To accurately determine fuel numbers, several factors need to be examined in relation to each other: total fuel storage capacity of the distribution platoon (such as HEMTT fuel tankers and fuel blivets), the number of aircraft being fueled throughout the rotation by type (including their fuel capacities and consumption rates), flight schedules and anticipated movement, and the possible times to receive fuel pushes from Cubic-ESG.

Until efforts to draw down begin, having a near-capacity supply of fuel going into nighttime operations is preferable. Proper forecasting allows units to continue operations until the end of the exercise and then distribute the remaining fuel by predetermined methods. The receiving unit's commander should regulate fuel resupply in order to approve its release for issue and avoid conflicting directives.

The modified table of organization and equipment did not authorize critical skill sets that the FSC needed when the aviation battalion was task-organized for JRTC. The mission the FSC received involved running two active forward arming and refueling points (FARPs) simultaneously and being ready to launch a jump FARP on order. This required 89B (ammunition specialist) and 15J (OH-58 armament/electrical/avionics systems repairer) Soldiers, who were requested from D Company and the ASB.

## Feed

The FSC's assumption of ASB roles led to its very deliberate training to complete the tasks. One example is the implementation of a concept of support and a synchronization matrix to assist with the planning effort for situational training exercises and force-on-force exercises. At the beginning of the situational training exercises, the FSC developed

the concept of support with the data of all classes of supply used by the troops over the first week of training.

The FSC used a throughput supply flow system because of its on-hand capabilities. Two large refrigerated containers were used to keep a three-day supply of unitized group rations—A on hand. Allocating class I rations was possible because of the direct relationship the FSC developed with the troop issue subsistence activity 100 days before arriving at JRTC.

Through a contract with Cubic-ESG, the FSC also had three bulk water supply points and four water buffaloes on hand to provide more than 3,000 gallons of water a day. The goal was for all 800 Soldiers to have two hot meals daily (plus a meal ready-to-eat, for lunch) and ensure uninterrupted field feeding at JRTC.

The JRTC rotation for E Company, 7-101st GSAB, posed a number of unusual challenges. It also provided an excellent opportunity for the FSC to learn from those challenges. The FSC staff identified the following lessons learned based on this JRTC rotation:

- Conduct precombat checks and inspections aggressively at the platoon level. Conduct daily synchronization meetings with the big 3 (commander, first sergeant, and executive officer).
- Reach out to the observer-coach/trainers at JRTC for trends, and communicate with them early and often before the rotation starts.
- Create trackers to facilitate a common operational picture and forecasting at the company level.
- Enable mission command by encouraging disciplined initiative.
- Look for opportunities to cross-train Soldiers to build depth and flexibility for the supported unit.
- Empower leaders to develop a relationship that builds trust and respect with the customer.
- Every mission should incorporate troop leading procedures.

- Ensure all filter separators are tested; fuel filter effectiveness tests should be done every 30 days according to regulation.

- Establish playbooks for FARP operations—silent FARP, jump FARP, and active FARP—and rehearse them before the combat training center rotation.

- Communication is key; no operation is successful without flat and continuous communication among adjacent commanders.

- Conduct teleconferences with Army Materiel Command personnel early and often to set the conditions for logistics support.

---

Capt. Carlos M. "Mike" Sanford is the company commander of E Company, 7th Battalion, 101st Aviation Regiment, 159th Combat Aviation Brigade. He holds a bachelor's degree in history from Methodist University and a master's degree in logistics management from the Florida Institute of Technology. He is a graduate of the Transportation Officer Basic Course and the Combined Logistics Captains Career Course. He also was a 2012 Institute for Defense and Business Strategic Studies Fellow.

1st Lt. Ryan C. Cloud is the executive officer of E Company, 7th Battalion, 101st Aviation Regiment, 159th Combat Aviation Brigade. He holds a bachelor's degree in health care administration from St. Joseph's College of Maine and a master's degree in public health with a certificate in disaster management from Benedictine University. He is a graduate of the Quartermaster Basic Officer Leader Course, the Unit Movement Officer Course, and the Sling Load Inspectors Course.

1st Lt. Timothy D. Hryniewicz is the distribution platoon leader of E Company, 7th Battalion, 101st Aviation Regiment, 159th Combat Aviation Brigade. He holds a bachelor's degree in criminology from Central Connecticut State University. He is a graduate of the Officer Candidate School and the Ordnance Basic Officer Leader Course.



*Spc. Michael Steen, part of the 4th Engineer Battalion's forward support company (FSC), demonstrates the capabilities of his welding trailer. The FSC provides shop maintenance support, such as welding and small-arms and generator repair, for all the companies in the battalion.*

## Forward Support Company Operations in Separate Units

Forward support company structures and operations vary depending on the supported unit.

■ By Capt. Thomas A. Knothe

The integration of forward support companies (FSCs) into maneuver battalions has resulted in a much greater combat role for logisticians. FSCs have enabled Soldiers in logistics military occupational specialties (MOSs) to work directly for maneuver, fire, and effects (MFE) battalions.

In a traditional armored brigade

combat team (BCT), four FSCs are assigned to the brigade support battalion (BSB) as D, E, F, and G companies. Each FSC is attached to and supports an MFE battalion within the BCT.

Falling into formation with and supporting the reconnaissance, surveillance, and target acquisition squadron is the D company. E and

F companies normally have identical modified tables of organization and equipment and support the combined arms battalions. G company supports the field artillery battalion.

The mission of these FSCs is to provide full-spectrum logistics support to their assigned maneuver battalions in order to sustain unified land combat operations. FSCs pro-

vide transportation, supply, maintenance, and food service support to enable their supported units to execute combat missions; thus, by definition, all FSCs are multifunctional.

### Separate Brigade and Battalion FSCs

FSCs assigned to separate engineer battalions outside of BCTs are still responsible for supporting their battalions, but these FSCs are different in one major way. FSCs subordinate to separate battalions and brigades are not organic to a BSB like their BCT counterparts are. These FSCs are assigned directly to and fall under the mission command of the engineer battalions they support.

Not having a BSB over an engineer FSC results in increased responsibilities for the FSC command team. The FSC executive officer (XO) serves as the support operations officer (SPO) for the supported battalion and coordinates support requirements with the other company XOs. The FSC commander is the senior logistics officer in the battalion, and the FSC first sergeant must be proficient not only in his MOS but also in all of the different logistics MOSs inside the FSC.

### Maintenance Operations

The task organization for an engineer FSC and an FSC within a BCT are very similar. Each is primarily made up of Soldiers from the same support MOSs, and the missions for the companies are fundamentally the same. The one major difference in their capabilities is the fact that an engineer FSC contains no maintenance support teams (MSTs).

An MST is normally a squad-sized element, led by a sergeant first class, that provides maintenance support for one supported company. A BCT FSC usually has four MSTs, one for each supported line company.

In an engineer battalion, an MST organic to the line company completes vehicle and track maintenance, while in a BCT, the MST is organic to the FSC and attached to the MFE company.

The engineer FSC often is assigned fewer Soldiers than the BCT FSC because it has fewer maintenance requirements. The engineer FSC supervises all maintenance control for the battalion and provides shop maintenance support, such as welding, small-arms, and generator repair, for all the companies in the battalion. However, it maintains only FSC and HHC equipment.

### Support Operations

Support operations inside and outside the BCT are coordinated for and executed much differently, although the operations are basically identical. Inside a BCT, the brigade SPO coordinates and tasks support companies with specific missions. A separate engineer battalion has no SPO to coordinate support operations. The requests for support come directly from line company Soldiers to the FSC.

The FSC commander, acting as a SPO, is ultimately responsible for everything that the company does or fails to do, which includes providing all sustainment the supported engineer battalion requires. Typically, an FSC (whether it belongs to a BCT or an engineer battalion) provides field feeding, vehicle and shop maintenance, fuel and water support, and distribution operations.

The main difference between the units is the manner in which the FSCs receive the support taskings. Inside a BCT, a request for support originates from a leader within a supported company to a member of the SPO section. The SPO section then validates the request and prioritizes it based on need and the availability of assets. After the SPO shop validates the request, the S-3 shop decides which support unit will receive the tasking and then publishes it in the daily fragmentary order.

In an engineer battalion, the requests for support are less formal. Most support requests come directly from the XOs and platoon leaders within the line company to the FSC XO. The FSC XO then reviews the requirements for any conflicts and ei-

ther supports the request or proposes a different timeline. If the requester is not happy with the FSC XO's proposal, then the battalion XO resolves the issue by establishing which operation has the highest priority.

The engineer battalion will occasionally publish a tasking within the fragmentary order requesting support from the FSC, but those are mostly for high-visibility support requirements involving multiple sections.

The FSC XO not only must run day-to-day operations for the FSC but also must serve as the point of contact for all support requests from the line companies. Most FSCs prefer that the requests for support go through either the XO or the commander so that the company headquarters section maintains visibility of the FSC platoons' assignments. Visibility within the FSC headquarters provides the commander with troops-to-task oversight, which prevents overburdening sections and ultimately mission failure.

Engineer battalion FSCs and BCT FSCs may have different capabilities, personnel numbers, support relationships, and higher headquarters, but their functions are essentially the same. Whether the FSC falls under a BCT, an engineer battalion, or something totally different, the FSC exists to provide full-spectrum logistics support to its supported unit.

---

Capt. Thomas A. Knothe is a phase I instructor at the Combined Logistics Captains Career Course at the Army Logistics University at Fort Lee, Va. He previously served as the commander of the Forward Support Company, 4th Engineer Battalion, 555th Engineer Brigade, at Fort Carson, Colo. He holds a bachelor's degree in economics from Auburn University and is a graduate of the Ordnance Officer Basic Course and the Combined Logistics Captains Career Course.



*Soldiers from the 210th Field Artillery Brigade, 2nd Infantry Division, participate in a divisionwide alert on Jan. 27, 2014, at Camp Casey, South Korea, to test and improve the unit's readiness to deter aggression toward the Republic of Korea. (Photo by Pfc. Song Gun-woo)*

## Improving Materiel Fielding on the Korean Peninsula

■ By Maj. Timothy J. Barrett

The 8th Army G-3/5 section formed a force integration working group (FIWG) in accordance with Department of the Army Pamphlet (DA PAM) 700-142, Instructions for Materiel Release, Fielding, and Transfer. The FIWG's goal was to eliminate the problems created by the high personnel turn over in Korea, including the accountability of newly fielded equipment.

A group of 8th Army G-3/5 force integrators, called the 8AG35FI, was responsible for running the FIWG. The group created an avenue through which other fielding-related con-

cerns could be addressed. This article describes how the FIWG was formed and how it can be modeled.

### Forming the FIWG

Concerns raised by the 2nd Infantry Division resulted in the formation of the FIWG. The 2nd Infantry Division requested improved fielding support and closure with the product managers (PMs)—who came from the continental United States to support the materiel fielding in Korea—before they left the 8th Army area of responsibility (AOR).

During a round table, the 2nd Infantry Division identified an existing

gap involving a PM's closeout. Hand receipts were being signed, but equipment was not listed on the property book or captured in a system of record before the PM's departure.

The 2nd Infantry Division also explained the stresses to its organization caused by tremendous turbulence, including a 65-percent annual personnel turnover rate and a 400-percent increase in equipment fieldings between fiscal years 2007 and 2013.

The division's goal was to establish a 24-month planning cycle and incorporate new equipment training into that cycle to reduce turbulence

during equipment issue and other fielding processes.

The division's leaders explained their desire to establish an enduring process to address their systemic issues. This process would include creating a materiel fielding execution checklist, which brigade and battalion commanders would use during the new materiel introductory briefing (NMIB).

The materiel fielding execution checklist would be designed to endure beyond personnel turnovers, especially for critical jobs, such as property book officers and supply sergeants.

The leaders also wanted to reduce equipment training problems and ensure that proper fielding authorizations were reflected on modified tables of organization and equipment. They wanted PMs to complete all modification work orders prior to the fielding date of execution and to post all fielding actions into the Property Book Unit Supply Enhanced system before departing Korea.

The 403rd Army Field Support Brigade (AFSB) commander noted that the brigade was prepared to support the establishment of a system of systems that would synchronize the procurement, fielding, and accounting of fieldings within the 8th Army AOR. This support would be executed following DA PAM 700-142, Chapter 4.

During a subsequent meeting with the 2nd Infantry Division deputy commanding general-support (DCG[S]), the 403rd AFSB commander detailed the recent key leader engagement with the principal military deputy to the assistant secretary of the Army (acquisition, logistics, and technology). During this meeting, they discussed the high personnel turnover and equipment accountability problems.

The 403rd AFSB also received buy-in to solidify PM and sustainment community relationships and pledged to assist PMs and the gaining command in getting the new equipment fielding (NEF) on a sys-

tem of record.

The 8AG35FI briefed the 2nd Infantry Division DCG(S) on the goals of the FIWG efforts: to define stakeholder roles and responsibilities, finalize a fielding process checklist for use across the Korean Peninsula, lead all future NEF rehearsal of concept drills, synchronize fieldings into the 2nd Infantry Division's 24-month calendar, and synchronize fieldings with the rotational forces in Korea.

### Defining Stakeholder Roles

Some units within the 8th Army AOR understood stakeholder roles and responsibilities in the fielding process, but others did not. The 8AG35FI addressed the lack of understanding using the FIWG.

Through the FIWG, the 8th Army explained that its roles and responsibilities include Korean theater of operations policy and redistribution authority, property book and database oversight, demand validation and unit distribution plans, and readiness authority.

The 403rd AFSB also explained its roles and responsibilities in the fielding process, which include supporting Army forces and combatant command operations in Korea and Japan, providing acquisition, logistics, and technology (ALT) program management support for equipment on hand, and supporting the strategic outcome to sustain forward stationed and rotational forces.

The 403rd's ALT section is the brigade's face to the fielding process. The section works closely with the 8AG35FI almost daily. The ALT section responsibilities include assisting in planning, synchronizing, and integrating all fieldings occurring in the 8th Army AOR.

The section also works very closely with the 2nd Infantry Division force modernization officer. The division's roles and responsibilities include retaining policy and redistribution authority, maintaining property book and database oversight, validating demands, and vetting unit distribution plans.

### Launching the FIWG

As soon as it began, the 8AG35FI-led FIWG offered solutions for the initial concerns identified by the 2nd Infantry Division and identified other shortfalls.

In preparation for the first meeting, the 403rd AFSB submitted a fielding and modernization flowchart to the 8AG35FI in accordance with DA Pam 700-142, Appendix D, Table 2. This chart described the various fielding and modernization activities from phase 1, preparation, through phase IV, feedback.

The first FIWG meeting included all 8th Army mission-supported units on the Korean Peninsula. The purpose of the meeting was to define key stakeholder responsibilities and provide a forum to discuss and resolve force integration issues, policies, and procedures during NEF.

Several key initial FIWG outputs followed the first meeting. Particularly, the stakeholder roles and responsibilities were defined for each mission-supported unit. (See figure 1.)

### Outputs

The 8AG35FI-led FIWG meetings resulted in a series of follow-on outputs. The group produced a revised NMIB and created a comprehensive materiel fielding execution checklist. The U.S. Army Materiel Support Center-Korea produced a pamphlet on its roles and responsibilities to the PMs. NMIB in-progress reviews and outbrief participation roles and responsibilities were also defined for each meeting.

The outbrief was identified as the most critical period between the fielding execution and PM departure. This period was the most common time for property not to be transferred to a system of record. The 8AG35FI stressed the critical importance of the PM, property book officer, and supply sergeant being involved in the outbrief.

The 8AG35FI used the FIWG to produce an 8th Army fielding point paper and pamphlet. It identified the intended audience to be stakeholders

not stationed on the Korean Peninsula. These publications clearly communicate for that audience the roles and responsibilities of all key players on the peninsula.

The FIWG’s next discussion in-

involved explaining and clarifying the differences between displaced equipment and retrograde according to DA PAM 700–142, Chapter 5.

The intent was to establish a system to keep the commander and subject

matter experts informed. This negated the effects of high personnel turnover, and it was supported through semiannual 8th Army G–4 logistics conferences, 19th Expeditionary Sustainment Command workshops, and 8th Army logistics bulletins.

Future FIWG discussions will focus on the 24-month fielding timeline in order to lock in the modified tables of organization and equipment for the 2nd Infantry Division and create a “system of systems integrator.”

This information will feed unit equipping and reuse conference working groups and the semiannual Army Equipping and Reuse Conference. The U.S. Army Medical Materiel Agency will be included in future discussions to smooth its fielding nuances.

The FIWG created an effective solution to capture NEF issues. DA PAM 700–142 provided the effective groundwork to establish a FIWG. The PMs were very supportive in conducting final closeout briefs to the 8AG35FI. After the FIWG’s establishment, the problem of property not being on a system of record before a PM’s departure immediately improved.

The FIWG allows all key mission-supported units to raise concerns and standardize solutions. It will continue to provide a channel for improving materiel fielding on the Korean Peninsula, influence other key players participating in the fielding process in places other than Korea, and influence both U.S. Army Pacific and Headquarters, Department of the Army. This FIWG is a best practice that can be modeled for use elsewhere.

Maj. Timothy J. Barrett is the executive officer for the 403rd Army Field Support Brigade at Camp Henry, Korea. He holds a master’s degree in supply chain management and logistics from the University of Kansas.

Stakeholder Roles and Responsibilities		
Headquarters, Department of the Army		Assistant Secretary of the Army (ALT)
<ul style="list-style-type: none"> <li>G–3/5/7 sets priorities and approves materiel requirements.</li> <li>G–4 assists in development of policy and validates funding.</li> <li>G–6 provides spectrum and interoperability guidance.</li> <li>G–8 directs integration and unit set fielding in accordance with Army command policy.</li> </ul>		<ul style="list-style-type: none"> <li>Establishes and develops type classification, materiel release, fielding, and transfer policies.</li> <li>Develops, acquires, provides NEF/NET, and life cycle sustainment until the system is stabilized and has met all of the transition criteria before being turned over to the LCMC.</li> </ul>
Lead Materiel Integrator	Gaining Command/Unit (Policy)	Sustainment Support (Execution)
<p><b>Army Materiel Command</b></p> <ul style="list-style-type: none"> <li>Research and development, procurement and production, distribution and maintenance, and disposal.</li> <li>Integration of ALT support.</li> </ul> <p><b>ASC DMC</b></p> <ul style="list-style-type: none"> <li>Develops UDPs.</li> <li>Facilitates vetting process.</li> <li>Issues distribution/redistribution orders in coordination with ASCC/HQDA directives.</li> <li>Acts as decision support tool proponent.</li> <li>Identifies Armywide shortfalls.</li> <li>Facilitates unit equipping and reuse conferences.</li> <li>Adjudicates issues with HQDA.</li> <li>Reports excess line item numbers to HQDA.</li> </ul>	<p><b>USARPAC (ASCC)</b></p> <ul style="list-style-type: none"> <li>Theater redistribution authority.</li> <li>Entry point for ASC lead materiel integrator UDPs.</li> <li>Property book/database oversight.</li> <li>Theater policy authority.</li> <li>Demand validation/vet UDPs.</li> <li>Readiness authority.</li> </ul> <p><b>8th Army (gaining command)</b></p> <ul style="list-style-type: none"> <li>Korean theater of operations policy/redistribution authority.</li> <li>Property book/database oversight.</li> <li>Demand validation/vet UDPs.</li> <li>Readiness authority.</li> </ul> <p><b>Mission Support Commands</b></p> <ul style="list-style-type: none"> <li>Mission support command policy/redistribution authority.</li> <li>Property book/database oversight.</li> <li>Demand validation/vet UDPs.</li> </ul>	<p><b>8th TSC and 19th ESC</b></p> <ul style="list-style-type: none"> <li>Senior Army theater sustainment headquarters.</li> <li>Provides distribution management support.</li> <li>Supervises equipment modernization.</li> <li>Executes sustainment plan.</li> </ul> <p><b>403rd AFSB</b></p> <ul style="list-style-type: none"> <li>Single point of contact for ALT.</li> <li>Product manager coordination link.</li> <li>OCONUS pre-positioned storage.</li> <li>Monitors execution.</li> <li>Logistics Assistance Program support.</li> <li>Feedback loop to product manager.</li> </ul>
<p>AFSB : Army field support brigade            ALT : Acquisition, logistics, and technology            ASC : Army Sustainment Command            ASCC : Army service component command            ESC : Expeditionary sustainment command            DMC : Distribution management center            HQDA : Headquarters, Department of the Army</p>		<p>LCMC : Life cycle management command            NEF : New equipment fielding            NET : New equipment training            OCONUS : Outside continental United States            TSC : Theater sustainment command            UDP : Unit distribution plan            USARPAC : U.S. Army Pacific</p>

Figure 1. This diagram defines the fielding roles and responsibilities of each player, from Army headquarters to the gaining command.



# BUILDER: Condition-Based Maintenance for Facilities

Condition-based maintenance can provide prognostic building “health” information for a facility manager to forecast maintenance and repairs.

■ By Nadia Abou-El-Seoud and Claude Matsui

The Army Corps of Engineers (USACE) is working diligently to standardize facilities and infrastructures to support civil and military operations and national security. To accomplish this goal, USACE has established advanced technologies to transform its traditional business practices into proactive, predicative solutions.

Delivering successful facilities and infrastructure to the Army worldwide is one of USACE’s primary military construction missions. USACE civilians do not simply design, construct, or renovate buildings; their work has evolved into shaping the sustainment and condition measurement of buildings throughout the Department of Defense (DOD).

Efficiency and cost effectiveness will require a systematic approach to computing facility management formulas for real property assessments, building age, and building components. This approach will ensure that facilities continue to meet their functional requirements and withstand changing dynamics in the years ahead.

Members of the Combat Readiness Support Team (CRST), subject matter experts who primarily focus on the condition-based maintenance (CBM) of ground combat vehicles and aviation systems, believe that CBM can also be used for facilities.

A team of engineers and program managers from the Army Engineering Research and Development Center’s Construction Engineering Research Laboratory in Champaign, Ill., created a comprehensive system

to assess a building’s performance, life expectancy, and necessary repairs, maintenance, and renovations. The tool and process called BUILDER is leading the way in CBM modeling for facilities and infrastructure.

## Using CBM for Facilities

CBM is a tool used for combat vehicles and combat aviation systems to optimize maintenance and repair operations. It is a predictive modeling tool used to reduce sustainment costs of materiel end-items. CBM continues to be a top DOD priority because it decreases component failure and support costs and increases unit readiness. The goal is to repair a system when it needs to be repaired versus repairing it after it fails. This capability allows warfighters to perform maintenance or parts replacement before systems fail.

Although CBM is intended to be an integral capability of new weapon systems, existing systems, and legacy systems, BUILDER is essentially a manual operation. It requires technical skills and experience to assess the condition of building components (roofs, walls, and floors) and distribution systems (air conditioning, electrical, and communications). An integrated set of performance metrics for facility and building condition is needed to predict when to reuse, repurpose, or renovate structures instead of building new ones.

## BUILDER

BUILDER has revolutionized the way USACE does business. The

CRST is coaching, synchronizing, and reinforcing the asset posture assessment that BUILDER can provide as a component of the Installation Status Report and Army Facilities Investment Strategy.

BUILDER was first adopted and used by the Marine Corps, Navy, Air Force, and Defense Logistics Agency. It has since been requested by the Army, Defense Health Agency, Defense Commissary Agency, National Nuclear Security Administration, and the DOD Education Activity, and the list continues to grow.

BUILDER provides project managers, project delivery teams, and facility operations personnel with the information needed to assess change impacts or develop standards to make renovation or repurposing decisions. A comprehensive analysis is conducted to define the condition of the facility using functionality and engineering performance to illustrate its operational life span and maintenance needs.

For each building managed by BUILDER, its “health” information provides the condition index used to predict its life expectancy. Building managers and engineers use this information to qualify and quantify work needed to sustain a structure. The Army intends to use this same information to determine budgetary requirements, conduct value assessments, and identify appropriate facility information for the Office of the Secretary of Defense.

BUILDER data collection provides the engineering details needed

to make facility investment decisions based on actual conditions. As such, it can serve as the blueprint for facility CBM.

Using the information entered by the facility assessors on portable tablets, BUILDER is filled with the required metrics and measurements of all components of a building. The information acts as the foundation for providing a facility's condition so that BUILDER can assess the key components, age, materials, and any additional property data selected by the building manager.

As BUILDER expands to become the system of record for the facility condition index and building condition index for the DOD, the question is what comes next.

### BUILDER to Provide CBM

BUILDER is a management tool with limited predictive modeling algorithms. In order to perform as a deci-

sion support and investment enabler, the CRST believes BUILDER must evolve into a prognostic tool with more robust predictive modeling capabilities.

Forecasting facility conditions and predicting repairs before failure occurs can save time, money, and manpower. Anticipating repairs also allows the supply chain to have materials or parts on hand before beginning repairs or renovations, thus reducing delays in returning to full operational capability.

Buildings cannot talk, so to make an inanimate infrastructure come to life, a predictive modeling system offers a shortcut to collecting and analyzing data. BUILDER uses robust predictive modeling or simulation instead of manual data collection, analysis, and documentation.

BUILDER can predict the effects of intensive or accelerated use, changing requirements and standards, and the introduction of advanced technologies. The predictive outcome also

determines functional relevance and estimated life span of a facility.

Funding is limited, and considering DOD's fiscal constraints, an efficient method to diagnose and treat facility inefficiencies is needed.

### The Way Ahead

USACE, using experts from CRST to serve as liaisons for the Army staff, the chief of Engineers, and USACE, has begun drafting ideas with other Department of the Army activities to plan for the uncertainty of future requirements, technology adoption, and stationing needs within a fiscally constrained environment. Their plans include using BUILDER to benefit the Army Facilities Strategy and ensure USACE has the capability to forecast and make sound facility investments.

The Army continues to be "building strong" by expanding what it knows and doing it better. The CRST has coordinated with the DOD and Army logistics communities to assess CBM for years. By adopting CBM lessons learned, performance-oriented methodologies, and modified algorithms, the facilities community can predict change, assess alternatives, and prioritize resources using building systems performance and current condition.



*Two engineers and an interior designer conduct an initial assessment on a building whose maintenance will be managed using BUILDER.*

Nadia Abou-El-Seoud is the strategic communications officer and project manager for ground systems for the Combat Readiness Support Team, U.S. Army Corps of Engineers, Fort Worth District, Texas. She holds a bachelor's degree from the University of Illinois at Urbana-Champaign.

Claude Matsui is the Army program coordinator for readiness and modernization support for the Office of the Chief of Engineers, Headquarters, Department of the Army. For the past 33 years, he has been an Army strategic plans and military construction subject matter expert on the application of facilities and infrastructure standards and criteria to meet joint and Army operational and readiness requirements.



*Pfc. Jeremiah Balete, Spc. Xavier Loretto, and Pfc. Gregory Bettencourt, 25th Brigade Support Battalion, 1st Stryker Brigade Combat Team, 25th Infantry Division, at Fort Wainwright, Alaska, repair full up power packs instead of replacing them, saving the unit more than \$200,000 on each pack repaired. (Photos by Maj. Karl Beier)*

## A Repair Versus Replace Maintenance Culture

The harsh budgetary environment led the 25th Brigade Support Battalion to change how it conducts maintenance, ultimately saving millions of dollars.

■ By Chief Warrant Officer 4 Steven Dewey

Following drastic budget cuts that occurred within the 1st Stryker Brigade Combat Team, 25th Infantry Division (1–25th SBCT), at the beginning of fiscal year 2013, the brigade analyzed maintenance trends and class IX (repair parts) expenses and identified that nearly \$4 million had been spent over a 90-day period. After wargaming

ways to train and keep readiness high while keeping costs low, a plan was approved by the brigade commander to bring field-level engine repair, tire assembly repair, and battery charging to the brigade level for resourcing and management oversight.

Within the first 90 days, savings in these three maintenance areas reached nearly \$3.5 million. This savings came

from in-depth troubleshooting of engine maintenance issues and from repairing major assemblies instead of replacing subassemblies.

### Field-Level Engine Repair

In order to save money in maintenance and repair, 1–25th SBCT developed and refined troubleshooting procedures and engaged in robust

training for –10-level maintainers. Focusing on “back to basics” maintenance practices allowed the brigade to save money in repair costs so that money could be allocated to training and other readiness resources.

Using a local dealer for parts provided cost savings for many major assembly repairs. For example, a \$20 seal from a local dealer fixed a \$230,000 full up power pack (FUPP). The unit also saved approximately \$900 buying a Caterpillar engine compressor from a local vendor at a cost of \$700; if ordered through the Army supply system, the compressor would have cost approximately \$1,600.

The Caterpillar 3126 FUPP powers many Stryker variants. The FUPP includes the engine and transmission and costs just over \$230,000, according to the January 2013 Federal Logistics Data (FEDLOG).

Over the past 10 years, it be-

came common practice to remove a faulty FUPP and send it to sustainment-level maintenance for repair. Given the extreme cost of this component, developing a process for local repair became a priority.

During the second quarter of fiscal year 2013, a total of 13 FUPPs were repaired by purchasing local, low-cost repair parts, such as temperature switches, main seals, gasket sets, transmission wire harnesses, transmission pans, and manifold replacements, from the local Caterpillar dealer. In all cases, the technical manual suggested replacing the FUPP as a means of repair. The total savings realized during the quarter by replacing parts was just under \$3 million dollars.

The engine component of the FUPP (NSN 2815-01-505-1476) alone costs \$25,152, and the stand-alone Stryker transmission cost

\$27,662. With the FUPP costing \$170,000 more than its raw materials, repairing should be a priority in financially difficult times.

Repair versus replacement of other equipment yielded significant savings, too. For example, several load handling system engines were repaired by replacing a \$200 head gasket rather than replacing the entire \$48,000 engine as suggested in the –20 manual. Recommendations to improve repair manuals to highlight repair versus replace have been submitted to the TACOM Life Cycle Management Command. These changes are essential to cutting repair costs.

#### Field-Level Tire Assembly Repair

Tire assembly repair has not been a common practice for maintainers over the past 5 years. The “Tire to Wheel Assembly Transition Policy



*Pvt. Shelby Lee, 25th Brigade Support Battalion, 1st Stryker Brigade Combat Team, 25th Infantry Division, makes authorized tire repairs, saving the unit hundreds of thousands of dollars.*

for Army Tactical Vehicles, DTG: 292043Z,” issued as a Department of the Army message in April 2010, said that tire assemblies would be ordered from one of the main tire rebuild facilities instead of being repaired locally. But repairing a \$2 valve core assembly is a cheaper and more practical course of action than replacing a \$5,000 tire assembly.

### Battery Recharging

Because of the extreme cold weather experienced in Alaska’s interior, the 1–25th SBCT’s batteries frequently fail. Prior to establishing battery recharging capabilities, the brigade replaced approximately \$400,000 worth of batteries in a 90-day period.

The brigade support battalion established a recharging station within the ground support equipment shop. Operations during the following 90 days yielded significant savings. Thanks to the recharging station, no vehicle batteries were requested through the supply support activity.

### The Need for Institutional Support

The SBCT still faces other issues that impede further savings: a gap in generational knowledge, outdated technical manuals that do not coincide with current operating procedures, and the excessive amount of time it takes to receive parts.

**The knowledge gap.** An institutional knowledge gap was partially caused by the transition from civilian contractors to trained Army mechanics conducting Stryker vehicle maintenance. There is also a generational knowledge gap in the skills of field-level maintainers.

Ten years ago, engine repair was a common practice. Now, the replacement of a load handling system engine’s head gasket is not taught as part of current programs of instruction (POIs) used in advanced individual training. New maintainers do not know how to replace an engine head gasket even though it is an authorized field-level repair. The institutional knowledge of this common

practice left the Army when senior mechanics and technicians departed, leaving the current generation of mechanics to relearn basic field-level engine repair.

Engine assembly repair is only one example of assembly repairs that were once common for Army maintainers to perform. Mechanics once

---

New maintainers do not know how to replace an engine head gasket even though it is an authorized field-level repair. The institutional knowledge of this common practice left the Army when senior mechanics and technicians departed, leaving the current generation of mechanics to relearn basic field-level engine repair.

---

repaired many other assemblies, including starters, generators, radiators, and tires.

Given the likelihood of ongoing fiscal constraints, it is imperative that the Training and Doctrine Command (TRADOC) reestablish these lost skills by updating its current POIs with subassembly repair versus major assembly replacement.

**Technical manuals.** Outdated technical manuals (TMs) provided to field-level maintainers also pose significant challenges.

Many TMs used today for troubleshooting Stryker vehicles are out of sync with the current operating tempo and lack the details to repair equipment, specifically class IX (repair parts) assemblies. One example is the aforementioned engine troubleshooting procedures (gasket replacement). Another is that the TMs for the Stryker FUPP call for assembly replacement rather than a simple repair by replacing a temperature sensor, speed sensor, or wire harness on the FUPP assembly.

A third example is the troubleshooting steps pertaining to remote weapon systems. In most cases, the TM will suggest a component replacement that does not resolve the maintenance issue. A fourth example is that the TMs for the Stryker

indicate assembly replacement over the most cost-effective solution. The current TMs recommend replacing a broken water separator kit, which costs \$4,598. A better solution would be to order individual repair parts for the kit. The total cost to rebuild the water separator kit is only \$243.

The Army will save a tremendous amount of money by updating TMs to recommend repair instead of replacement of major assemblies. TRADOC needs to update POIs to strengthen troubleshooting techniques that have been lost during the past decade-plus of combat operations. These two recommendations will assist the Department of Defense in reducing the overall operating cost while maintaining a high operational readiness rate, skillful maintainers, and a highly trained fighting force.

---

Chief Warrant Officer 4 Steven Dewey is the support operations maintenance senior warrant officer for 25th Brigade Support Battalion, 1st Stryker Brigade Combat Team, 25th Infantry Division, at Fort Wainwright, Alaska. He holds an associate degree in applied science and a bachelor’s degree in homeland security from Thomas Edison State University. He is a graduate of the Warrant Officer Candidate School, Warrant Officer Basic Course, and Warrant Officer Advanced Course.

*The author would like to thank Lt. Col. Michael Scarlett, Maj. Karl Beier, and Maj. Thomas Chandler for their contributions to this article.*

# The Visibility of Integrated Tactical Logistics Project

■ By Grady M. Embrey

*The year is 2025. An armored brigade combat team (ABCT) is conducting combat operations during the initial stage of a conflict against a modern, conventional-force adversary in a distant theater. The theater's infrastructure is austere, with virtually no available host-nation support, requiring U.S. forces to rely primarily on organic capabilities for all logistics functions.*

*The brigade is currently involved in an offensive mission that began just hours ago and is scheduled to last several days without any significant pauses. This requires logistics planners in the brigade S-4 shop and support operations office (SPO) to have near-real-time, accurate logistics information available at all times so they can ensure that uninterrupted support is provided to subordinate units in accordance with the brigade commander's intent.*

*They must provide uninterrupted support over internal brigade supply lines that could extend up to 60 miles in length while units constantly maneuver day and night in combat conditions.*

Imagine working on the SPO staff of a brigade combat team (BCT) where near-real-time information flows seamlessly to your computer terminal, precluding the need to request up-to-date logistics statuses for commodities and equipment under your purview. Imagine not having to call units for status reports or to make sense out of incomplete, hand scribed numbers jotted down hurriedly by fuelers and ammunition handlers at reissue and drop-off points.

And imagine not having to try to figure out where your logistics convoy vehicles are in the tactical battlespace. This is precisely the direction the Army is headed under the auspices of sense and respond logistics and network-enabled mission command.

Historically, accounting for bulk fuel at supply points and tracking fuel disbursed from tankers and trailers has been a manual process. Fuel supply point personnel use a stick and string to measure fuel quantities. Truck drivers hand write fuel delivery information, such as quantity delivered and location. The information is then passed to the battalion SPO for accounting purposes.

Often, sustainment planners who are responsible for tracking, ordering, and resupplying combat units in

the midst of battle never receive the information. If the information is received, it is often fragmented and difficult to read, and aggregating the information while planning the next resupply convoy is time-consuming.

To provide uninterrupted support, the brigade's senior logisticians must have the following key elements of information on a nearly continuous basis for mission planning purposes:

- Who (which unit) has priority of support during each phase of the mission?
- What (ammunition, fuel, maintenance support) is needed by whom?
- When do they need it?
- Where are they located in the battlespace, and where is the designated logistics rendezvous point?
- Do we (the brigade support battalion) have sufficient assets on hand, or will we need support from echelons above brigade?
- What are the current locations of all resupply convoys in the brigade's battlespace, and what cargo are they carrying?
- Did we deliver the essential support on time to the units that needed it?
- Can we see the current aggregated combat readiness status of the brigade's subordinate units in the

mission command information system (displayed as green, amber, or red) to confirm that the support provided satisfied the requirements of the supported units?

## Visibility of Integrated Tactical Logistics

The Logistics Innovation Agency (LIA), a field operating agency of the Army G-4, is currently working to enhance the speed and accuracy of bulk fuel reporting by automating it through an initiative called the Visibility of Integrated Tactical Logistics (VITaL) project. The intent is to use sensor technology to pass real-time data from supply points and vehicles transiting the tactical battlespace through the existing command and control systems (which are part of the Joint Battle Command-Platform [JBC-P]) to the Battle Command Sustainment Support System (BCS3), the Army's system of record for logistics mission command. BCS3 will be used as the commander's common operational picture, allowing the staff to receive automated, real-time updates.

VITaL is not a new system. It is merely a method of linking existing systems to streamline the data flow and enhance visibility of the commodities. The overarching goal of the VITaL project is to explore, develop, test, and demonstrate an initial set of integrated logistics mission com-

mand capabilities in 2014 and 2015. To accomplish this, the project will focus on the critical logistics functional areas of bulk fuel, ammunition, tactical-level in-transit visibility (ITV), and select combat platform readiness.

To further define the project scope, the VITaL team is focusing on scenarios that involve the ABCT and Stryker brigade combat team (SBCT) formations in the tactical space during high-operating tempo, high-intensity combat operations. The ABCT and SBCT have been selected because they are at the center of the Army's modular force structure and contain a large number of essential, logistics-intensive weapon systems.

### VITaL Capability Blocks

The project will be executed in four distinct increments called capability blocks: fuel, ITV, platform, and ammunition.

Block 1, VITaL–Fuel, consists of automatically transmitting bulk fuel data from gauges on collapsible fuel storage tanks to BCS3 using a data integration interface designed for the project. The VITaL project team successfully conducted a field demonstration of this capability block in March 2013.

Block 2, VITaL–ITV, will focus on generating, transmitting, and integrating data on the visibility of bulk fuel and ammunition being transported on BCT logistics vehicles over the last tactical mile. This will require the use of transport vehicle sensors that are linked to the on-board JBC–P system for transmission to and integration with BCS3.

Block 3, VITaL–Platform, will work to automatically generate and pass platform combat power mission command readiness data from sensors embedded in combat platforms to the JBC–P system and on to BCS3, where it can be reported in a unit-aggregated format for logistics mission planning.

Block 4, VITaL–Ammunition, will focus on automatically generating ammunition storage visibility data

through the ammunition management information system at the BCT ammunition holding and transfer point to BCS3.

### Project Management

Given the complex nature and multi-year duration of the VITaL project, LIA has implemented a project management structure that is flexible enough to accommodate the requirements of the diverse organizations that make up the project team while ensuring unity of effort. The project management process focuses on the outside agencies that make up the stakeholder team and their active participation, contribution of subject matter expertise, and shared interest in improving capabilities for Soldiers in the field.

Synchronizing team member short-term and long-term schedules, coordinating budget requests and spending plans, and modifying currently existing systems to bring an integrated set of products to a field ready state by the project's scheduled 2020 end date are the keys to success.

The main elements of the project management process include stakeholder partnership, laboratory-based development and integration testing, field demonstrations, and contributions by the project manager and combat developer.

**Partnerships among VITaL project stakeholders.** Since stakeholder team members have a variety of primary missions, the team must use a consensus-based management process. LIA is the project coordinator and facilitator in this effort, not a directive-issuing authority. Cooperation is the key to success.

**Laboratory-based development and integration.** The concept of a lab-based development effort enables an integration of this complexity. This lab-based process is cost effective, particularly when multiple facilities are engaged in a virtual laboratory environment. When possible and feasible, this development and testing strategy includes the use of standard Army software, hardware, communications networks, and standards.

**Field demonstrations.** When each VITaL capability block is successfully tested in a lab environment, the products developed are then subjected to field demonstrations for further user assessment and evaluation. The VITaL team successfully conducted its initial field demonstration (VITaL–Fuel, capability block 1) in March 2013 at Fort Lee, Va.

**Project manager (PM) and combat developer contributions.** To the maximum extent possible, the VITaL project leverages the work of the participating PMs and combat developers who are responsible for developing field-ready products. The final suite of VITaL capabilities will require its own PM to successfully conduct Army-wide fielding events and technology upgrades and then manage them throughout the life cycle process.

The VITaL project is not inventing new logistics information systems but weaving together key systems that already exist to produce near-real-time logistics mission command information for Soldiers at forward operating bases.

The completion of the VITaL project does not mean the end of the logistics information development process. Many more capability blocks outside the scope of the VITaL project will need to be developed, tested, and demonstrated in order for units to possess full integration across all of the functional areas and classes of supply that exist in the Army's logistics domain. However, so far, VITaL represents a series of first big steps in the right direction.

---

Grady M. Embrey is the project lead for the Visibility of Integrated Tactical Logistics program at the Logistics Innovation Agency. He holds a bachelor's degree in public administration from George Mason University and a master's degree in public administration from Shippensburg University. He is a graduate of the Army War College.



*Cavalry Soldiers from the 1st Armored Division drive an M1A2 Abrams tank over the Sava River. (Photo courtesy of the Joint Combat Camera Center)*

## Getting There Was the Battle: Part II

This second half of a historical assessment of the U.S. deployment in Operation Joint Endeavor, continued from the March–April 2014 issue, focuses on the Implementation Force deployment in Bosnia and the deleterious impact that the downsizing of logistics units had on force projection capabilities.

■ By Dr. James P. Herson Jr.

In early December 1995, U.S. Army Europe (USAREUR) area support groups were ordered to execute the rail movement of designated Task Force Eagle (TFE) and national support element forces into Hungary and Croatia from multiple railheads in Germany. The groups in turn tasked their base support battalions to execute the planned rail flow.

However, the battalions had difficulty pushing units out of Germany because of rapid changes in the task organization and composition of TFE and national support elements in Tazsar and Kaposvar, Hungary. Train orders and railcar configurations changed frequently because of USAREUR and European Command fragmentary orders.

Those orders modified Implementation Force (IFOR) and intermediate staging base (ISB) unit compositions, which were predicated on late breaking and often contradictory guidance from the Department of Defense (DOD) and NATO.

### Coordination Complications

Like many units in USAREUR,



the base support battalions were not promptly informed of the numerous and often conflicting deployment changes.

Their organizations had also suffered major personnel losses during the drawdown, and their knowledge of moving and deploying units was rusty. Despite the battalions' efforts to adjust to the dynamic changes dictated by echelons above them, the backlog of frustrated cargo trains and troop passengers grew.

USAREUR (through V Corps) planned to establish an ISB in Hungary to facilitate the further deployment of IFOR's TFE into the former Republic of Yugoslavia (FRY). Such a site would give both USAREUR Forward (FWD), which was a derivative of the V Corps headquarters with a few USAREUR staff members, and TFE an opportunity to better shape the subsequent move into the FRY.

Placing the ISB in Hungary was politically advantageous and would likely be viewed as a neutral choice by the warring factions to its south and east. Moreover, keeping the ISB outside the NATO area of responsibility in the FRY would enable USAREUR to avoid losing control of its forces to NATO prematurely.

It appeared that since the V Corps did not have a direct role in Operation Joint Endeavor, it opted to "command the deployment" as a means of participation, albeit at the periphery and unfortunately inexpertly.

USAREUR decided to keep the deployment categorized as an in-theater movement and ruled out the use of time-phased force deployment data and the Joint Operational Planning and Execution System for transportation deconfliction (after discovering that several headquarters had populated databases without cross-coordination). USAREUR instead chose to use Microsoft Excel to create a transportation synchronization matrix.

This decision unfortunately froze out participation by the U.S. Transportation Command, which had

expertise and assets that could have been of major assistance given the theater's paucity of organic transportation capabilities and general lack of logistics wherewithal.

Many USAREUR units experienced excessive turmoil connected with the deployment. This turbulence was sometimes caused by their own higher headquarters, largely because of the way deployment information flowed through commands and units and the impact of late breaking diplomatic inputs on the formal military planning process.

The impact of the Clinton administration's imposed compartmentalization on the way planning information and orders were passed was particularly difficult to offset.

At the tactical level, for example, a deploying battalion commander from the 1st Armored Division (TFE) recounted, "I often felt overcome by all the changing deployment requirements coming down from USAREUR, V Corps, and the 1st Armored Division [1AD]. It seemed like not a day passed in which a new idea failed to filter down, requiring the expenditure of more time and effort. . . . On any given day, I would receive telephone calls from all three levels of command (USAREUR, V Corps, and 1AD) regarding some deployment requirement."

It was evident that the U.S. and NATO military planning process for a peacemaking deployment instead of war was fractured, confused, and stymied by nonpublicized national concerns and post-Cold War inertia. Overall the V Corps did well in preparing for a possible deployment to the FRY; however, attempting to command the deployment by itself created many of the very problems it had sought to avoid.

### **Leaving Germany by Rail**

Transporting USAREUR units by rail from Germany to the FRY should have been smooth administrative movements, given the extensive and routine use of rail by units to get to gunnery and training areas.

However, the Operation Joint Endeavor rail deployment instead became a major international transit debacle.

French rail strikes, unforeseen impacts of German post-Cold War railroad privatization, a lack of deepwell cars for oversized equipment, unplanned commandeering of early train flow by V Corps, inflexible fiscal authorities, and other factors made moving the U.S. IFOR a major logistics hurdle.

A 3rd Corps Support Command (COSCOM) transportation staff officer shared, "Rail operations proved to be exceptionally difficult in the ISB due to changing unit priorities, increased flow of combat units and a compressed time line. . . . The backlog got so bad that around 16 December, with 10 cargo-laden trains waiting on Hungarian rail lines, that the U.S. Ambassador to Hungary gave the military an ultimatum: unload the trains more quickly or temporarily hold any further trains from leaving Germany."

### **The Transportation Battlefield**

Like the other portions of Bosnia, the U.S. sector lacked a modern transportation infrastructure. However, unlike the British and French IFOR sectors, the U.S. sector was bordered by the Sava River.

Because there were no standing bridges linking Bosnia to Croatia over the Sava River, most of TFE would have to conduct deliberate river crossing operations to meet the Dayton Accords' stringent boots-on-the-ground occupation requirement. Even after a successful bridging, difficult terrain, mines, and decayed infrastructure caused onward movement to be a challenge.

The conditions of Bosnian railroads were marginal. Since the beginning of the FRY civil wars, little railroad maintenance had been conducted in Bosnia or eastern Croatia. Washouts, sabotage, bridge destruction, and railbed degradation ruled out the primary use of railroads for heavy force insertion into the contested province.

When the Dayton Accords were signed on Dec. 14, 1995, almost no railroads were operating in Bosnia.

Shipping the U.S. IFOR from the port of Bremerhaven, Germany, had been carefully considered. However, the sail time from Germany to the Adriatic ports of Split or Ploce,

control Agency (TMCA) lacked sufficient staff, planners, and movement control personnel, all of whom are vital in planning, sequencing, and controlling large multimodal, cross-border echeloned unit movements.

The shortages seen at the theater level in transportation command

## The Great Train Robbery

As a force provider, V Corps likely recognized that its primary force provider mission would be complete after it got the 1st Armored Division and its attached elements onto the northern banks of the nearly frozen Sava River. In order to facilitate control of the deployment under the aegis of meeting Title 10 requirements, V Corps established a forward headquarters (USAREUR FWD) at Taszar Air Base to help meter the flow of follow-on forces and establish a forward operational headquarters presence.

As well intentioned as this mission command may have been, it initially caused more problems than it solved.

As the Combat Studies Institute found, "the decision [to establish the USAREUR FWD headquarters] was allegedly made for two reasons: to keep the U.S. Transportation Command out of the deployment process and thus speed up the movement of force and also to retain USAREUR control over the deployment of U.S. Army forces." Essentially, planners chose control rather than enhanced logistics capabilities.

Getting USAREUR logistics elements to the ISB and ready to receive soon-to-follow 1st Armored Division forces (in reality, they arrived almost concurrently) for reception, staging, onward movement, and integration (RSOI) required that the first series of trains from Germany be composed of adequate logistics forces and key enablers to establish RSOI capability in Hungary.

However, several hundred logisticians along with their hundreds of trucks, trailers, containers, and equipment entering German railheads for loading (having already been called forward for movement) were met with a big surprise.

Unknown to USAREUR's movement control community and base support battalions, the first several logistics trains bound for the ISB and Croatia were abruptly comman-

---

"Our plan is to go in fast. . . . We expect to have more than half of the force in and operating in Bosnia within three weeks [of signing the treaty], and the entire force there in six to eight weeks."

—*Secretary of Defense William J. Perry,*  
*December 7, 1995*

---

Croatia, would take nearly eight days (not counting loading and off-loading if a ship was available) under perfect conditions.

Once the ships were unloaded, truck drivers dealt with narrow hairpin turns and poorly maintained bridges of uncertain weight classifications while exiting the port.

Port availability was also an issue. Both ports were used to capacity by Great Britain and France and could not accommodate American requirements without significant delay. Given the compressed timetable of the Dayton Accords for U.S. boots-on-the-ground, USAREUR could not rely on moving forces by sealift; it would simply take too long.

Therefore, the most viable method of moving U.S. forces into Hungary or Croatia from Germany was by road and rail. M1070 heavy equipment transporters (HETs) and other Army ground transport systems then moved the forces forward into Bosnia.

Transporting TFE using USAREUR's diminished truck fleet from rail sites in Hungary or Croatia was the best method of getting the U.S. IFOR into Bosnia on time. Other transportation alternatives would take too long and miss the Dayton Accords' occupation deadline.

The 1st Theater Movement Con-

and control were also seen further down in the movement control chain.

The two remaining movement control battalions (MCBs) left in USAREUR had already been stretched extremely thin because of downsizing. The 27th MCB, part of the 3rd COSCOM, was deployed to the ISB and the FRY to control the flow of forces from Hungary into the NATO area of responsibility. The 1st TMCA's 39th MCB stayed in Germany to push trains, aircraft, and convoys forward to the Hungarian ISB or Croatia.

Movement control procedures broke down early in the deployment. As a V Corps observer noted, "In fact, the deployment was neither orderly nor deliberate, because Operation Joint Endeavor immediately went off the synchronization matrix."

A 3rd COSCOM battle captain explained, "Once the 27th Transportation Battalion, with their two understrength movement control teams, the 15th and 30th, deployed, the entire function of movement control support for all remaining forces in Germany was suddenly thrust upon the TMCA. This, coupled with the deployment and the TMCA's own personnel shortage, left a gaping void in movement control capabilities in theater."



*NATO and U.S. forces constructed a second bridge over the Sava River in the spring to accommodate rising civilian and military traffic. (Photo courtesy of the Joint Combat Camera Center)*

deered by the USAREUR crisis action team to move its own headquarters into Hungary.

This created a major problem and a ripple of schedule conflicts that became magnified further down in the rail plan. It caused hundreds of U.S. troops to be left in unheated railcars in Croatia for days.

Trains laden with vital U.S. equipment were lost to the system when aggravated European railroad officials had them pushed to inactive sidings to relieve pressure on their train systems. Thousands of other U.S. troops experienced significant delays in Germany, and the uncertainty of the mission timeline in-

creased the anxiety felt by the deploying troops' families.

### **Actions and Consequences**

Exacerbating the rail situation, the USAREUR commander's decision to insert a cavalry squadron into the rail flow had not been factored into the rail plan. Moving this combat force up in the queue pushed back the arrival of logistics units and other essential enablers.

One of many consequences of this decision was that the frontloaded cavalry unit was unable to offload itself in Croatia because the logistics units that were trained and equipped to unload them were left

back in Germany.

Delaying the deployment and establishment of important logistics capabilities (and their headquarters for command and planning) in the ISB, the hijacking of trains, and the resulting lack of materials-handling equipment for unloading and executing cargo operations at destination points further worsened international rail problems and contributed to the slowing tempo.

Pushing back the arrival of the 3rd COSCOM and 21st Theater Army Area Command (TAACOM) headquarters—both of which could furnish information on the deployment, establish the ISB, and syn-

chronize the flow of forces—made them incapable of responding to increasingly impatient requests by the already in place USAREUR FWD headquarters.

Thus, without full staffs and equipment, these now late arriving logistics organizations could not adequately process, refine, and control the deployment.

Further degrading the nascent logistics command's establishment

event over their radios; fearing that numerous Soldiers were drowned. Water rapidly reached 15 feet above ground level, washing away equipment and personal effects in the cataclysm. When dawn broke, however, every Soldier was miraculously found alive and without serious injury.”

Because the Sava River was now twice as wide, another float bridge was required to span it. A combination of U.S. Air Forces in Europe

ion could not provide the required two drivers per vehicle for any of its HETs because of its low authorized level of organization. This was an early symptom of the deleterious impact that the Army's tiered approach on manning and readiness had on actual named operations.

The unit drove approximately 60 percent of its 48 HETs on the first convoy to the ISB in mid-December 1995 and then flew its drivers back to drive the remaining HETs from Mannheim, Germany, to the ISB. The V Corps transportation battalion at best could provide an average of 1.3 operators for each vehicle in all its units.

Having sufficient HETs to move the heavy task force from the ISB along a 10-to-14-hour convoy route to the Sava bridge site and beyond required significantly more HETs and HET-qualified drivers than USAREUR had.

Consequently, HET management became one of the primary metrics used for deployment progress reporting.

Despite combining the HETs from the 1st Armored Division and 3rd Infantry Division with the V Corps HET assets (a total of 48 more HETs), a serious shortage of this key vehicle remained.

In desperation, USAREUR had 56 older model M911 HETs from the theater rebuild program sent to the ISB by rail. These systems were to be driven by contracted local Hungarian drivers supervised by Brown and Root contractors and military personnel in a provisional HET task force.

However, every M911 HET that came to the ISB was in a significantly not-mission-capable condition and could not be made operable quickly. Ultimately, the broken M911s remained stuck between aircraft revetments at Taszar Air Base until they could be moved by crane back onto railcars and returned in mid-1996.

Although establishing a provisional HET task force to move the

---

“To many European politicians, the press, and the public, the seemingly slow deployment—in particular of the American portion—of the NATO Implementation Force to Bosnia, comes as a disappointing surprise.”

—Bruce E. Arlinghaus and Geoff Hopwood,  
*European Security, Volume 5, Issue 1, 1996*

---

was an 11th hour decision by the USAREUR FWD commander on Christmas Eve 1995 to move the combined 21st TAACOM and 3rd COSCOM headquarters from a large three-story building into a series of wooden shacks across two base camps, thereby fracturing operations and planning.

### **Bridging the Sava**

Among the earliest USAREUR personnel to deploy were its engineers. Fortunately, most engineer units made it to the Sava bridge site close to schedule before rail flow modifications led to transportation chaos.

In late December 1995, as TFE engineers were constructing the bridge and readying float sections, a massive snow melt flooded the area. The Sava surged far over its banks during the night of Dec. 29, destroying much of the work already accomplished. Many feared that troops had been drowned in the icy darkness when the Sava surged with little warning.

The senior Operation Joint Endeavor historian noted, “USAREUR FWD monitored the disaster and listened to the unfolding and terrifying

(USAFE) aircraft, trains, and several oversized convoys from the ISB rapidly moved components of a second bridge from war stocks. Army heavy-lift helicopters flew pieces of the second bridge from Tuzla Air Base, where they had been hastily flown in by USAFE aircraft from Belgium and Germany.

With the bridge finally in place, elements of the 1st Armored Division's 1st Brigade Combat Team, led by Col. Gregory Fontenot, crossed into Bosnia on Dec. 31, 1995. Thirty days after the deployment began, approximately 23 percent of TFE had occupied the zone of separation sectors. Overall, the bridging operation took more than two weeks, almost twice as long as planned.

### **Convoys and Intermodal Chaos**

Given the rail problems and the need to get RSOI forces to the emerging ISB, USAREUR authorized some of its transportation units and other enablers to self-deploy by road to Hungary, a movement that took three days and covered more than 1,400 kilometers.

Notably, the heavy truck company in V Corps' transportation battal-

IFOR was explored, the amount of time and number of trained drivers, facilities, and HETs were insufficient to establish this enhanced HET capability.

Once TFE units arrived from Germany by rail to one of four small railheads in the vicinity of the ISB's 29th Area Support Group's "Dragonier City" in Taszar, they went through the RSOI process and were sequenced for onward movement. Convoys with up to 25 trucks per serial departed the Taszar staging runway from 0430 until 1100 hours with 30-minute intervals between serials.

Once in Croatia or Bosnia, however, many truck drivers were forced to abandon their loaded trailers and return to the ISB without a retrograde load. Customer units had either moved or refused to accept their cargo for a variety of reasons, most frequently because they could not get them unloaded.

Consequently, hundreds of loaded trailers and palletized loading system flatracks littered the roads on both sides of the Sava because of a lack of an in-theater cargo transfer company (CTC) capability.

Having a CTC is critical when supplies and equipment come into airports, seaports, or railheads and require reconfiguration for shipment. USAREUR had none, having "rightsized" that capability. As the lack of a cargo transfer unit became acute, USAREUR requested a CTC capability from the Forces Command in the continental United States. Subsequently, a CTC platoon from Fort Bragg, N.C., arrived in mid-January 1996.

A small platoon element remained at the ISB to help run an ad hoc freight forwarding area (eventually augmented with a Reserve component unit, the 146th Transportation Detachment [Air Terminal Movement Control Team]).

The rest of the CTC platoon was attached to the corps' palletized loading system truck company in Croatia to help establish a container

yard near the Sava bridge to hopefully break the logjam.

For more than 75 days, RSOI, fuel, and container convoys ran from the ISB to TFE, often over roads that were nearly impassable. Surprisingly, the accident rate was relatively low in spite of the harsh winter environment, mines, and daunting black road conditions.

V Corps and 21st TAACOM transportation units ran more than 3,775 convoys back and forth between Germany, the Hungarian ISB, and the FRY from mid-December 1995 until Feb. 27, 1996.

More than 507 buses, 1,358 passenger aircraft, and 409 trains with more than 7,400 railcars were used in moving the IFOR and national support element. In total, more than 24,000 troops were transported, some 12,000 pieces of equipment moved, and more than 200,000 short tons of supplies and equipment were shipped in less than 75 days.

Unfortunately, the previously hard-learned lessons seen in the premature deployment of combat units at the detriment of logistics enabling forces in earlier U.S. operations was again ignored, thereby ensuring the IFOR deployment would ultimately take longer.

Deprived of appropriate logistics capabilities, in particular sufficient truck fleets and transportation troops, planners made the choice to retain a heavier combat arms composition instead of a more balanced blend of units with sufficient logistics capabilities. That decision proved to be a significant contributor to USAREUR's Operation Joint Endeavor deployment woes.

It also created increased risk for the troops, a salient fact not widely acknowledged by the period's senior military or political leaders.

U.S. troops were told that they would be in Bosnia-Herzegovina for only a year to implement the Dayton Accords. However, the number of U.S. Soldiers in that country remained sizable for nearly a decade.

Ultimately, more than 100,000 U.S. troops served in Bosnia until they were relieved by European Union forces in 2004.

Despite the stovepiped, multi-echelon, and international planning that was constrained by limited information sharing, convoluted diplomatic and military decision-making at multiple levels, insufficient logistics forces, cuts on the RSOI troop cap to less than 50 percent of what was needed, harsh weather, and other factors, USAREUR met the Dayton Accords' deadline as a force provider, but it was much later than what had been publicly promised.

By the time of its departure almost a year later, the IFOR had fulfilled many of the military provisions of the Dayton Accords. The political and economic provisions of that agreement, however, lagged far behind, necessitating the deployment of a temporary "covering force." That force later morphed into the semi-permanent NATO Stabilization Force, which finally departed in 2004.

Perhaps summing up the Operation Joint Endeavor deployment best, the 1st Armored Division's deployment officer-in-charge shared his opinion in a later U.S. Army War College monograph.

He wrote, "I have seen numerous articles and speeches in which people have lauded the deployment to Bosnia as a great success. I would characterize it as more of a triumph of the human spirit over an insane system, one that only narrowly averted catastrophe."

---

Dr. James P. Herson Jr. is the command historian for the U.S. Special Operations Command at MacDill Air Force Base, Fla. He retired from the Army in 2009 following a brigade command. He spent half of his career in the infantry and the other half in logistics. He is a graduate of the Army War College, the Army School of Advanced Military Studies, and the Command and General Staff College.

# Army Sustainment Departments

Your submission should be geared toward one of *Army Sustainment's* departments, which are described in detail below. If you have an article that does not fit into one of our departments but you think it is appropriate for our audience, feel free to contact us.

**Commentary** articles contain opinions and informed criticisms. Commentaries are intended to promote independent thoughts and new ideas. Commentary articles typically are 800 to 1,600 words.

**Features** includes articles that offer broader perspectives on topics that affect a large portion of our readers. These can focus on current hot topics, or the future of the force. These articles can be referenced, but it is not required if the content is within the purview of the author. While these articles can be analytic in nature and can draw conclusions, they should not be opinion pieces. Features typically are 1,600 to 5,000 words.

**Spectrum** is a department of *Army*

*Sustainment* intended to present well-researched, referenced articles typical of a scholarly journal. Spectrum articles most often contain footnotes that include bibliographical information or tangential thoughts.

In cooperation with the Army Logistics University, *Army Sustainment* has implemented a double-blind peer review for all articles appearing in its Spectrum section. Peer review is an objective process at the heart of good scholarly publishing and is carried out by most reputable academic journals. Spectrum articles typically are 2,500 to 5,000 words.

**Operations** includes articles that describe units' recent deployments or operations. These articles should include lessons learned and offer suggestions for other units that will be taking on similar missions. These articles require an official clearance for open publication from the author's unit. Photo submissions are highly encouraged in this section. Please try to include five to 10 high-resolution

photos of varying subject matter. Operations articles typically are 1,200 to 2,400 words.

**Training and Education** is dedicated to sharing new ideas and lessons learned about how Army sustainers are being taught, both on the field and in the classroom. Training and Education articles typically are 600 to 1,100 words.

**Tools** articles contain information that other units can apply directly or modify to use in their current operations. These articles typically contain charts and graphs and include detailed information regarding unit formations, systems applications, and current regulations. Tools articles typically are 600 to 1,800 words.

**History** includes articles that discuss sustainment aspects of past wars, battles, and operations. History articles should include graphics such as maps, charts, old photographs, etc., that support the content of the article. History articles typically are 1,200 to 3,000 words.

## Check out *Army Sustainment* online!



Website



Facebook



Google+



Twitter

### Online

[www.army.mil/armysustainment](http://www.army.mil/armysustainment)

### Facebook

[www.facebook.com/ArmySustainment](http://www.facebook.com/ArmySustainment)

### Twitter

[www.twitter.com/ArmySustainment](http://www.twitter.com/ArmySustainment)

### Google+

<https://plus.google.com/104580352456205964995>



# Center for Army Lessons Learned

10 Meade Avenue, Building 50, Fort Leavenworth, KS 66027

COM: (913) 684-9533

DSN: 552-9533

## Check out our latest publications.

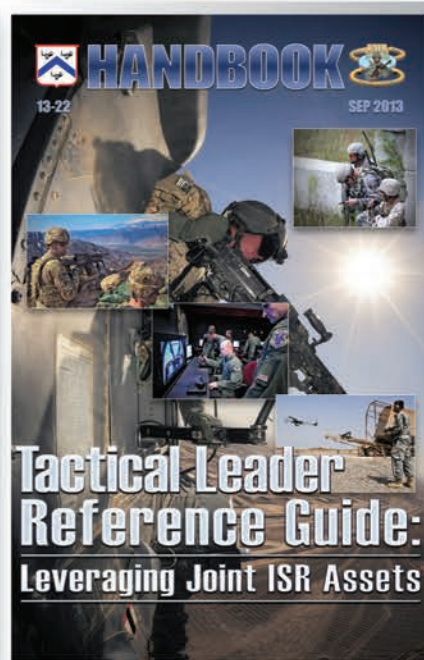
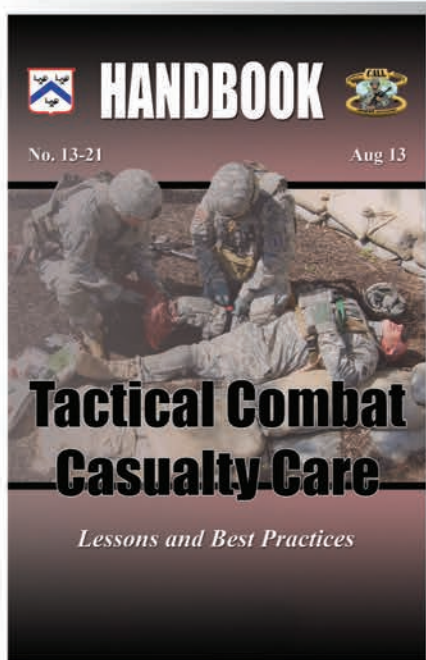

## Visit the CALL Website for more publications.

**Public Website:**  
<http://call.army.mil>

**Restricted Website  
(CAC access):**  
<https://call2.army.mil>

ISSN 2153-5973  
DEPARTMENT OF THE ARMY  
ARMY SUSTAINMENT  
US ARMY LOGISTICS UNIVERSITY  
2401 QUARTERS ROAD  
FORT LEE VIRGINIA 23801-1705

Official Business

PERIODICALS POSTAGE  
AND FEES PAID  
AT PETERSBURG VIRGINIA  
AND ADDITIONAL CITIES



### Sustainer Spotlight

*Quartermaster Corps Regimental Command Sgt. Maj. Spencer L. Gray (far left) sings "Dogface Soldier," the 3rd Infantry Division's official song, with members of the Fort Stewart, Ga., culinary arts team after they claimed the top trophy at the 39th Annual Military Culinary Arts Competitive Training Event during a March 14, 2014, awards ceremony at Fort Lee, Va. (Photo by T. Anthony Bell)*