

Explore the Raspberry Pi in 45 Electronics Projects

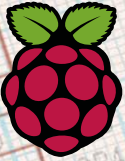

**3rd
Edition**
Fully updated for
Raspberry Pi 4

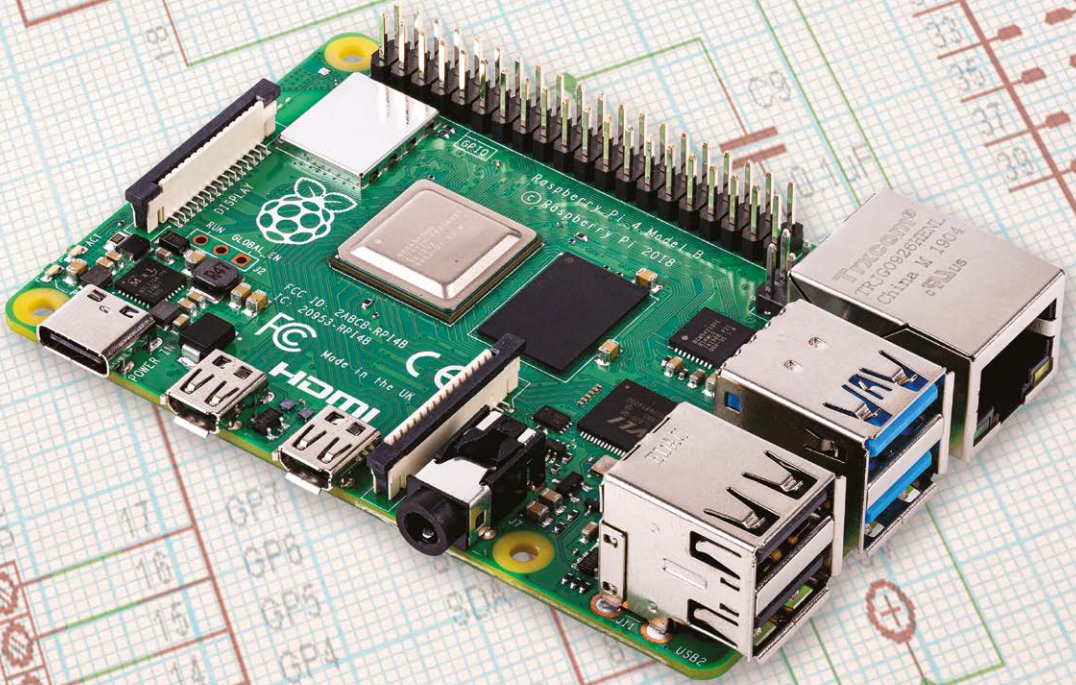

Bert van Dam



LEARN **DESIGN** **SHARE**

N • SHARE • LEARN • DESIGN • SHARE • LEARN • DESIGN • SHARE • LEARN • DESIGN • SHARE • LEARN • DESIGN • SHARE • LEARN • DE
SHARE • LEARN • DESIGN • SHARE • LEARN • DESIGN • SHARE • LEARN • DESIGN • SHARE • LEARN • DESIGN • SHARE • LEARN • DESIGN •
LEARN • DESIGN • SHARE • LEARN • DESIGN • SHARE • LEARN • DESIGN • SHARE • LEARN • DESIGN • SHARE • LEARN • DESIGN • SHARE
GN • SHARE • LEARN • DESIGN • SHARE • LEARN • DESIGN • SHARE • LEARN • DESIGN • SHARE • LEARN • DESIGN • SHARE • LEARN • D
SHARE • LEARN • DESIGN • SHARE • LEARN • DESIGN • SHARE • LEARN • DESIGN • SHARE • LEARN • DESIGN • SHARE • LEARN • DESIGN

Explore the Raspberry Pi in 45 Electronics Projects



Bert van Dam



elektor

LEARN > DESIGN > SHARE

● This is an Elektor Publication. Elektor is the media brand of
Elektor International Media B.V.
78 York Street, London W1H 1DP, UK
Phone: (+44) (0)20 7692 8344

● All rights reserved. No part of this book may be reproduced in any material form, including photocopying, or storing in any medium by electronic means and whether or not transiently or incidentally to some other use of this publication, without the written permission of the copyright holder except in accordance with the provisions of the Copyright Designs and Patents Act 1988 or under the terms of a licence issued by the Copyright Licensing Agency Ltd., 90 Tottenham Court Road, London, England W1P 9HE. Applications for the copyright holder's permission to reproduce any part of the publication should be addressed to the publishers.

● Declaration

The author and publisher have used their best efforts in ensuring the correctness of the information contained in this book. They do not assume, or hereby disclaim, any liability to any party for any loss or damage caused by errors or omissions in this book, whether such errors or omissions result from negligence, accident or any other cause..

● British Library Cataloguing in Publication Data

A catalogue record for this book is available from the British Library

● **ISBN 978-1-907920-82-0**

© Copyright 2020: Elektor International Media b.v.
Prepress Production: D-Vision, Julian van den Berg
3rd Edition. Fully updated for Raspberry Pi 4
First published in the United Kingdom 2020



Elektor is part of EIM, the world's leading source of essential technical information and electronics products for pro engineers, electronics designers, and the companies seeking to engage them. Each day, our international team develops and delivers high-quality content - via a variety of media channels (including magazines, video, digital media, and social media) in several languages - relating to electronics design and DIY electronics. www.elektormagazine.com

LEARN > DESIGN > SHARE

Introduction	9
Chapter 1 • Requirements	10
1.1 Raspberry Pi	10
1.2 SD Card	12
1.3 Keyboard	12
1.4 Mouse	13
1.5 Display	13
1.6 Internet Connection	15
1.7 Power Supply	16
1.8 Loudspeaker (Or Earphones)	16
1.9 Breadboard	16
1.10 Components	17
1.11 Software Oscilloscope	18
Chapter 2 • A Quick Tour Of The Raspberry Pi	21
2.1 The Nano Text Editor	21
2.2 Some Useful Commands	22
2.3 Raspberry Pi Desktop	25
2.3.1 Application Menu	26
2.3.2 Web Browser Menu	28
2.3.3 File Manager Menu	28
2.3.4 Terminal Menu	28
2.3.5 Bluetooth Icon	29
2.3.6 WiFi Icon	29
2.3.7 Volume Control	30
Chapter 3 • Installing The Software	31
3.1 Raspberry Pi	31
3.1.1 Keyboard	31
3.1.2 Larger SD Card	32
3.1.3 Changing The Memory Allocation (Memory Split)	32
3.1.4 Raspbian Buster Installation Steps On Raspberry Pi 4	32
3.1.5 Remote Access	35
3.1.6 Using Putty	36

3.1.7 Configuring the Putty	38
3.1.8 Using the Windows 10 SSH Client	38
3.1.9 Running Graphical Programs – Remote Access of the Desktop	40
3.1.10 WinSCP	46
3.1.11 Windows 10 SCP Client	48
3.2 Static IP Address	48
3.3 Windows PC (Optional)	50
3.3.1 Disk Imager	50
3.3.2 Python, wxPython and IdleX	51
Chapter 4 • Short Introductions To....	53
4.1 Debian Linux	53
4.2 Programming in Bash	59
4.3 Programming in Python	64
4.4 Programming in JavaScript	91
Chapter 5 • GPIO	95
5.1 Introduction	95
5.2 LED	97
5.3 Flashing LED	101
5.4 Alternating Flashing LED	103
5.5 Timer LED with Window	105
5.6 Switch	108
5.7 Time Switch	114
5.8 Toggling Switch	114
5.9 Switch State in a Window	115
5.10 A Button with Sound	118
5.11 Pin Communications	120
Chapter 6 • More Power	123
6.1 TD62783 8-Channel High Source Driver	123
6.1.1 Light (6 V, 65 mA)	124
6.1.2 Motor (5 V, 145 mA)	126
6.2 ULN2003 7 Open Darlington Arrays	127
6.2.1 Fan (12 V, 150mA) and Light (6 V, 65 mA)	128

6.3 IRF740 MOSFET	130
6.3.1 Motor (5 V, 550 mA)	130
Chapter 7 • PWM	134
7.1 PWM LED with Graph	136
7.2 Light with Gradually Increasing Brightness	139
7.3 Motor with Variable Speed	143
Chapter 8 • SPI	144
8.1 Introduction to SPI	144
8.2 MAX522 Digital to Analog (DAC)	147
8.3 DAC with Opamp	152
8.4 More than two SPI devices	157
8.5 MCP3008 Analog to Digital (ADC)	158
8.6 MCP3008 pseudo-differential measurement	164
Chapter 9 • I²C	166
9.1 Introduction to I ² C.	166
9.2 MCP23008 I/O extender	167
9.3 More power for the extender.	174
9.4 TC74 digital thermometer.	175
Chapter 10 • Serial.	182
10.1 Introduction to RS232	183
10.1.1 Serial loopback.	183
10.2 Serial connection between Raspberry Pi and Piccolino	186
10.2.1 Serial echo.	189
10.2.2 Serial Analog Measurement (ADC)	191
10.3 Bluetooth	198
Chapter 11 • Web Server (WiFi or Wired)	201
11.1 Introduction	201
11.2 HTML server	201
11.3 CGI	204
11.3.1 Hello User	204
11.3.2 Visitor counter in a file.	207
11.3.3 Passing variables from the browser to the server	209

11.3.4 GPIO	212
11.3.5 GPIO with JavaScript.	218
11.3.6 I ² C Fridge alarm with automatic web page	221
Chapter 12 • Client Server (WiFi or Wired)	226
12.1 Introduction	226
12.2 TCP multiplication	226
12.3 TCP LED control.	232
12.4 TCP DAC	233
12.5 TCP sawtooth and square wave generator.	235
12.6 TCP Voltmeter with 8 channels	243
12.7 UDP echo	248
12.8 UDP light meter.	251
Chapter 13 • Bluetooth Project	255
13.1 Android Bluetooth Apps	256
Chapter 14 • LEGO Board	260
14.1 Introduction	260
14.2 Design	261
14.3 Commands	267
14.4 The Useless Box	270
Appendix A	274
1 Adjustable power supply	274
2 GPIO header circuit	275
Appendix B	278
1 Contents of the download package	278
2 Parts list	281
Appendix C	283
Python 2.x vs Python 3.x	283
Index	284

Introduction

In this book, we concentrate on one of the more powerful aspects of the Raspberry Pi: the combination of programming and electronics. The Raspberry Pi costs just a handful of dollars, yet you get a complete computer, which you can easily connect to all kinds of electronics.

After a short introduction to the Raspberry Pi we install the required software. If you bought the SD card for this book you'll find that all the Raspberry Pi software you need is already installed on the card. All the software for the (optional) Windows PC is free and can be downloaded in a single, convenient package.

This is followed by a quick overview of Linux (the operating system), and we start programming in Bash, Python and JavaScript. We concentrate mostly on Python, but we keep it short for all of them. We look only at the most important details, and then get involved with the projects straight away.

There are over 45 exciting and fun projects in this book. It varies from flashing lights to a motor speed controller; from processing and creating analog signals to a CGI web server and client-server programs. You can use this book as a project book, building the projects and using them in practical applications. The clear explanations, circuit diagrams, and photos of the setup on a breadboard make building the projects an enjoyable experience. When you're not building the projects in sequence, you should read section 5.1 first, since it contains important safety instructions.

You can also use this book as a study guide. For each project an explanation is given why it was designed in a certain way. This teaches you a lot about the Raspberry Pi and the components used, enabling you to enhance the projects or even combine several projects.

The book is also very handy as a reference guide. You can easily find projects via the index, which can then be used as a starting point for your own projects. Even if you've built all the projects, it still deserves a place next to your Raspberry Pi for this reason.

I would like to take this opportunity to thank Bert Oudshoorn for his help with the final editing of the original Dutch version of the book, and for testing the projects.

Bert van Dam

Chapter 1 • Requirements

You will obviously need a Raspberry Pi, but that's not all. As a minimum, you will also need the following components:

- Power supply
- SD card with operating system
- Solderless breadboard
- Discrete components
- Software oscilloscope (optional)

More information on these components can be found later in this chapter. The other components needed depend on the way in which you intend to use the Raspberry Pi.

1. Normal operation. In other words, you'll sit "behind" the Raspberry Pi and use it like a PC. In this case you'll need:

- Keyboard
- Mouse
- Monitor
- USB hub (optional)
- Loudspeaker (optional)
- Internet connection (optional)

2. Headless operation. In other words, you control the Raspberry Pi remotely from a PC over an intranet. Both your PC and your Raspberry Pi have to be connected to your router and you have to install some specific software on your PC (as described in section 3.2). In this case you'll need:

- Internet connection

3. Both normal and headless operation. In this case you'll need:

- Everything listed in options 1 and 2.

Please read the rest of this chapter before you go out and buy anything, so you have a good idea of what's best to buy.

1.1 Raspberry Pi

You will obviously need a Raspberry Pi. Although you can use the SD Card and this book with all current models, our advice is simple: buy the most expensive model. It is not much more expensive than the other models while offering more speed and peripherals. For example, model 4B has WiFi built in and boasts a Bluetooth adapter. Plus it is fast enough to act as a modest Linux desktop PC. Table 1.1 and Table 1.2 show a comparison of different models.

Model	1A	2B	Zero	3B
Processor	ARM1176JZ-F	Cortex A7	ARM11	Cortex A53
Clock speed	700 MHz	900 MHz	1 GHz	1.2 GHz
# of Cores	1	4	1	4
USB	1 full	4 full	1 micro	4 full
Header	26	40	401	40
GPIO on header	8	17	17	17
SD slot	standard	micro	micro	micro
Memory	256 MB	1 GB	512 MB	1 GB
Ethernet	no ²	1 x 10/100	no	1 x 10/100
Power supply	500 mA	1000 mA	500 mA	1000 mA ³
PAL/NTSC4	RCA plug	3.5 mm jack	3.5 mm jack	3.5 mm jack
Onboard WiFi	no	no	no	yes
Onboard Bluetooth	no	no	no	yes
¹ header is not supplied; you have to buy it separately and mount it				
² a connection to the internet can only be established via a WiFi adapter (to be acquired separately) which connects to USB. Obviously such an adapter can also be used with other models.				
³ 2.5 A is recommended				
⁴ we advise to use the HDMI connection, providing a much better image quality (and embedded audio)				

Table 1.1 Comparison of different models (early models)

Model	Zero W	3B+	3A+	4
Processor	ARM1176JZF-S	Cortex A53	Cortex A53	Cortex A72
Clock speed	1 GHz	1.4 GHz	1.4 GHz	1.5 GHz
# of Cores	1	4	1	4
USB	1 full	4 full	1 full	4 full
Header	40	40	40	40
GPIO on header	17	17	17	17
SD slot	micro	micro	micro	micro
Memory	512 MB	1 GB	512 MB	1,2,4 GB
Ethernet	1 x 10/100	1 x 10/100	no	1 x 10/100
Power supply	180 mA	1130 mA	470 mA	2500 mA
PAL/NTSC4	RCA plug	3.5 mm jack	3.5 mm jack	3.5 mm jack
Onboard WiFi	yes	yes	yes	yes
Onboard Bluetooth	yes	yes	yes	yes

Table 1.2 Comparison of different models (later models)

The Raspberry Pi is usually supplied on its own, without any peripheral components.

1.2 SD Card

The Raspberry Pi doesn't use a hard drive, but uses an SD card instead. This card has to contain the operating system and have enough room to store your own files. You can buy an SD card along with this book that already has the full operating system installed. It also contains all of the software required with this book, such as drivers for controlling the GPIO pins, I²C, SPI, PWM, sound and serial communications. All of the source code from this book is also on the card, so you won't have to type any of it into the Raspberry Pi. It is a fast 16 GB card, which is suitable for all of the projects in this book.

We'll describe how to make a backup of this card in section 3.3.1. Once you have your backup, you can always revert to the original if something goes wrong.

Pro tip:

Backup the SD card **before** you use it!

1.3 Keyboard

You will need a keyboard with a USB connection. It is best not to use a wireless type to avoid potential problems with drivers. Once you have gained some experience with the Raspberry Pi you can always change over to a wireless keyboard if you prefer this. The use of a Bluetooth keyboard is optional (see Chapter 10), but you will still need a wired keyboard for the installation.

1.4 Mouse

You will need a mouse with a USB connection. It is best not to use a wireless type to avoid potential problems with drivers. Once you have gained some experience with the Raspberry Pi, you can always change over to a wireless mouse if you like.

1.5 Display

Option 1: HDMI

The standard monitor connection on the Raspberry Pi is for an HDMI monitor. The latest model Raspberry Pi 4 includes two micro size HDMI ports. If you already have such a monitor, this will be the easiest option to use. Apart from the monitor, you will also need an HDMI cable. If you are using a Raspberry Pi 4, you will also need an HDMI adapter to convert between standard size HDMI and micro HDMI. You should first turn on the monitor, then wait until the message "no HDMI signal" (or similar) appears, and only then turn on the Raspberry Pi. If you still need to buy an HDMI monitor, you should check beforehand if it is suitable for use with an Raspberry Pi. In most cases, it should be possible to use an LCD television with an HDMI connector as monitor. ¹

Option 2: Analog TV

It is also possible to use an analog TV as monitor. In that case, you will need a composite video cable (yellow plug). There is no composite connection for the sound, so you will need to connect separate loudspeakers for this. The disadvantage of an analog TV is that the resolution is fairly low, which means you won't get a very sharp picture. Another disadvantage is that large windows won't fit on the screen. In most cases, it is easy to reduce the size of the windows, but this is not always possible. For example, the windows for the Thonny (the Python editor) and the WiFi settings can't be resized. In practice you'll find an analog TV unsuitable if you're interested in programming. In context of the material provided in this book we advise against the use of an analog TV.

¹ Most HDMI monitors and TVs will work straight away, but you may have to change the settings in config.txt. Details for these settings can be found at: "http://elinux.org/RPi_config". When your display doesn't work, you won't be able to type anything in, since you can't see what you're doing. We therefore need to gain access to the Raspberry Pi in some other way, which will be via an intranet. Connect the Raspberry Pi to your router as described in section 1.6. Install the program Putty on your PC, as described in section 3.1.6. Now log in using Putty, and issue the command "sudo nano /boot/config.txt". You should now type in the required parameters that you found on the website we just mentioned. Save the file by holding down the Ctrl key and momentarily pressing "x". Then press "y", followed by the Enter key. The editor then stops. Type in "sudo reboot" to restart the Raspberry Pi. Make sure that your HDMI monitor is turned on and connected before you restart the Raspberry Pi.

Option 3: HDMI-VGA Converter



Figure 1.1 On the left is a Ligawo converter, on the right an Edimax WiFi adaptor.

If you still have an old VGA monitor, you could use this instead. However, you do need to obtain an HDMI to VGA converter (for Raspberry Pi 4 you need a micro HDMI connector). This has to be a proper converter with its own power supply. On the Internet you'll sometimes come across advice that suggests using a simple conversion cable without a power supply. Although it may work, the conversion chip in the cable then needs to get its power from the Raspberry Pi, which hasn't been considered by the designers. If you're lucky, you'll only blow up the protection diode (sometimes after a while). In that case, you have to desolder it and replace it with a new one. However, if you're unlucky you may cause some internal damage to the Raspberry Pi.

One possible converter you could use is the "HDMI zu VGA Converter Wandler digital zu analog - HDCP, 1080p, 1:1, DAC" (see Figure 1.1) made by Ligawo, which is available via Amazon.² You use a normal VGA cable to connect the VGA monitor to the converter, which is connected to the Raspberry Pi via an HDMI cable (and with its own power supply).³ You should always turn on the monitor and converter first, wait a while (say 5 seconds) and only then turn on the Raspberry Pi. If you turn on everything at the same time, you won't get a picture.⁴

2 Amazon tends to be one of the cheapest suppliers wherever you live. Make sure that you buy one with the correct AC line plug and voltage.

3 Note that you need a VGA cable where all 15 pins are connected. Some plugs have pin 9 missing (sometimes pins 11, 12 and 15 as well). Without all the pins present, you may find that you won't get a picture and/or sound.

4 This converter has been tested on the following VGA screens: Samsung SyncMaster E1920 (1280x1024, 19"), Samsung SyncMaster LS22B150 (1920x1080, 22"), Sima/Medion MD7315TB (1024x768, 15") and Philips 150 S4 (1024x768, 15"), which all had a perfect picture. You don't need to change any settings for these screens: they "just" work. However, this isn't a guarantee that your old VGA screen will also work without changing any settings.

When you use the converter for sound, you will get a better quality than from the audio socket on the RASPBERRY PI. However, you first need to turn this option on. Carry out the following instructions:

1. Open the Terminal (via the icon on the desktop).
2. Type in the following command:

```
sudo nano /boot/config.txt
```

3. Scroll down with the arrow key until you get to the following line:

```
#hdmi_drive=2
```

4. Change it so it looks as follows (i.e. take away the hash symbol):

```
hdmi_drive=2
```

5. Then press Ctrl-O (hold down the control key, press the letter O briefly, then let go of the control key) to save the file and accept using the Enter key.
6. Then press Ctrl-X to close nano. When nano has closed the LXterminal will still be open.
7. Now type in the following command:

```
sudo reboot
```

The Raspberry Pi will now reboot and will take the modified setting into account. We will cover audio in more depth in section 5.10, where you'll also be shown how to switch between HDMI and the socket on the Raspberry Pi. ⁵

1.6 Internet Connection

It is not necessary to connect the Raspberry Pi to the Internet. However, when you want to try out the web server and client-server projects it speaks for itself that you *will* need an Internet connection. You will obviously also need an Internet connection if you want to use the Raspberry Pi in a headless configuration. Note that in this context by 'Internet' we mean a connection to your router.

Option 1: using a cable

The easiest way is to use a network cable. Plug the network cable into the Raspberry Pi and router **before** you turn on the Raspberry Pi and the connection will be established automatically.

⁵ There are some VGA screens that can't produce sound from the HDMI-VGA converter. In that case, you have no choice but to use the socket on the Raspberry Pi.

Option 2: wireless (WiFi)

You can also make a wireless WiFi connection. Most Raspberry Pi models have integrated WiFi modules, but if you have a model with no WiFi module then you will need a USB WiFi adapter. The recommended adaptor is the Edimax EW-7811Un made by Edimax (see Figure 1.1). You should plug the WiFi adapter into a USB port of the Raspberry Pi **before** you turn it on.



Figure 1.2. The WiFi symbol is on the left.

Left-click the WiFi symbol in the top right of the screen (see Figure 1.2). You will see a list of available networks. Pick the preferred one by clicking it and enter your data. "Preshared Key" is the WiFi password.

When a connection is established you can see the assigned IP address by hovering the mouse over the WiFi symbol.

1.7 Power Supply

The power supply should deliver a precisely regulated 5 V DC. The minimum required current depends on the model, but a minimum of 1 A is recommended for the older models. With model 4 this jumps to 2.5 A. Raspberry Pi 4 official power supply is recommended which provides up to 3A. It is therefore not recommended or even possible to use a USB connection on your PC to supply the Raspberry Pi since it can supply only 500 mA. If nothing else is connected to the Raspberry Pi and it's "not too busy", you may find that earlier models may work for a while. However, you'll soon start to get sudden resets when the voltage drops (also known as brown-outs). It is even possible that you could damage the USB port on your PC if it isn't properly protected against overloads. A separate power supply is therefore the best solution.

1.8 Loudspeaker (Or Earphones)

You can connect earphones to the Raspberry Pi, or a small loudspeaker set that is also sold for use with a PC. In the latter case we recommend that you buy a type that comes with an external power supply, since it's not such a good idea to power loudspeakers via a USB connection on the Raspberry Pi. The Raspberry Pi doesn't really have much "spare" current left over. When you use an HDMI-VGA converter, it is best to connect the earphones or loudspeakers to this converter since it has a better sound quality. More detailed instructions can be found in section 1.5.

When you use an HDMI monitor you can use its built-in loudspeakers for the sound reproduction, so you won't need any extra loudspeakers or earphones.

1.9 Breadboard

For all projects we will be using a breadboard. This can be used to quickly build and dismantle a circuit without soldering. A breadboard consists of two or more strips with supply connections and a large central area. The holes in the central area are connected together

in each numbered column up to the gap in the middle. The supply strips are usually connected together horizontally, with a gap in the middle.

First of all, we have to prepare the breadboard for use. This means that we have to connect the four supply strips together. We also put a small 0.1 μF capacitor at each of the corners of the breadboard, which will prevent interference on the supply strips. A number of projects won't work (well) without these capacitors. You can see what the breadboard should look like in Figure 1.3.⁶

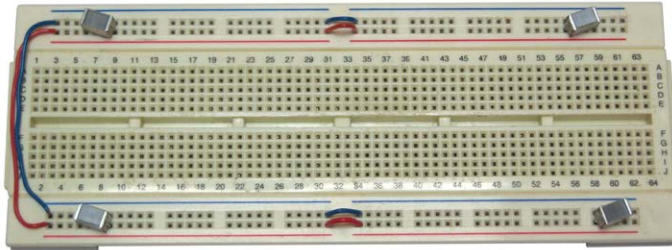

Figure 1.3. Breadboard with wire links and capacitors.

Whenever you use the breadboard, you should set it up like this, even if it isn't explicitly mentioned. Always remember this: you won't be the first to wonder why a circuit doesn't work, only to find out that part of it simply doesn't have power.

When you want to put a circuit to permanent use and decide to make a printed circuit board for it, you should remember to include sufficient decoupling capacitors. You should at least have a 100 nF capacitor across the supply next to each IC, as close as possible to the IC. Any other capacitors that are explicitly shown in the circuit must also be included, of course.

1.10 Components

Depending on what you want to build you will need some electronic components. You should ask for components that fit on a breadboard or stripboard. Some components will have pins that are too thick for a breadboard. Also, some chips such as SMD types cannot be mounted on a breadboard without special adapters. You should solder thinner leads to these pins. Don't force them into the breadboard as you could bend the internal contacts and cause permanent damage to the breadboard.

You will only need a small number of components for this book. You can buy a kit of parts from Elektor or you can use the parts list in the appendix as a shopping list. Note that the GPIO connector on the Raspberry Pi consists of a set of vertical pins, for which you need to use single way male-female cables. These are obviously included in the kit of parts.

⁶ The capacitors may look different, depending which type you have. They are marked as " μ1 " or " 104 ".

1.11 Software Oscilloscope

When you're experimenting with PWM, you'll find that an oscilloscope comes in very handy. It doesn't have to be an expensive piece of equipment though. A simple program that runs on your PC is more than sufficient for the projects in this book. The program doesn't even have to be installed on the PC and can be run from a memory stick.

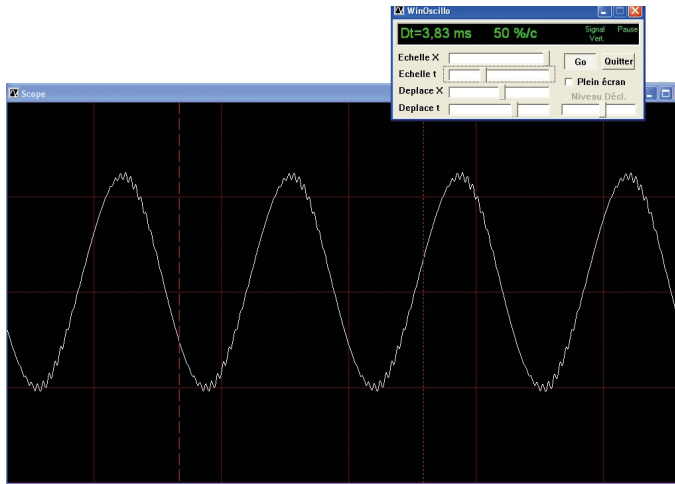

Figure 1.4. Software Oscilloscope WinOscillo.

There are several PC based oscilloscope software available free of charge on the Internet. Links to some popular ones are:

<http://www.zen22142.zen.co.uk/Prac/winscope.htm>

<https://windowsreport.com/oscilloscope-software-pc-laptop/>

<http://www.winoscillo.com>

The one used in this book is the WinOscillo. As shown in Figure 1.4, this is a software based oscilloscope that uses the sound card in your Windows PC to capture the signals, which has its limitations. You'll need to build a circuit similar to the one given in Figure 1.5 to go between the PC and your circuit, which protects the input of the sound card.

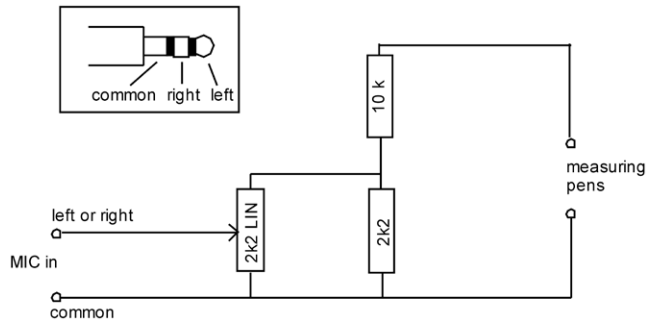

Figure 1.5. Interface for the mic or line input of the PC sound card.

The circuit in the figure above limits the signal level at the microphone or line input of the PC to less than 18% of the original input level. In this book we use 3.3 V, which is therefore reduced to 0.6 V., Make sure that the earth of the microphone plug really is connected to earth. Also, make sure that when you're using this interface, the earth is connected to the earth of your circuit and that you use the other wire for the measurement. To avoid mistakes it's best if you use a black wire for the earth and a red wire for the measurement. All the earths inside your PC (microphone, RS232, USB etc.) are connected together. If you connect the wires the wrong way round you'll create a short circuit, which could cost you a fuse, or worse.

You must obviously turn on the microphone in the Windows Sound Mixer and set it to maximum. Any noise suppression or similar options should be turned off.

WinOscillo can also record the signal to a file and make copies of the display so you can save them. You will come across these regularly in this book. Figure 1.6 shows a saved display from the oscilloscope.

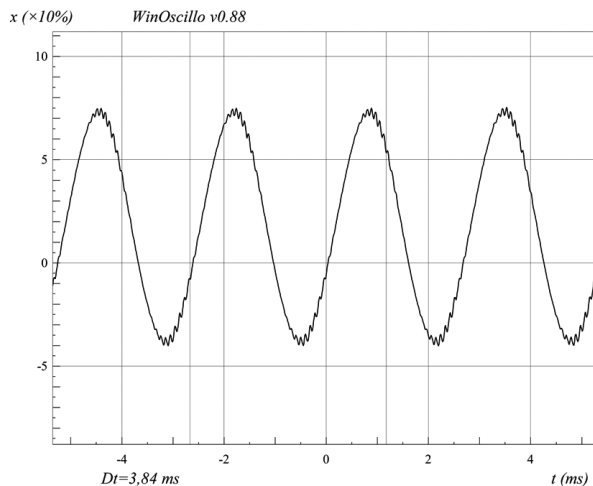

Figure 1.6. A saved display from WinOscillo, showing cursor lines and interval.

Unfortunately, the program can only be operated in French. Table 1.2 shows the translations for the commands used most often. In practice you'll find that you only need a few and those are easy to remember.

Command	Description
F2	Select oscilloscope...
F3	... or spectrum analyzer.
alt-enter	Full screen (the controls stay in the foreground).
Ctrl-S	Save the signal (as a short .wav, or as .csv for Excel).
Ctrl-L	Load a signal (first select pause, otherwise it takes very long!).
Ctrl-M	Save screen capture as .wmf.
Ctrl-V	Vertical cursor line.
Ctrl-H	Horizontal cursor line.
Ctrl-W	Switch between them (if both are on).
Ctrl-G	Tone generator (enter level with decimal comma).

Table 1.3. Using WinOscillo.

The text on the windows is also in French. Table 1.3 shows the translations for the most important terms.

Screen text	Translation
echelle	Scale.
deplace	Pan.
niveau decl.	Trigger level (if turned on).
Dt	Horizontal time.
%/c	Percentage of the maximum signal level per square.

Table 1.4. Overview of screen text.

The two cursor lines can be operated using the mouse. With the left mouse button you can move the dashed line and with the right mouse button you can move the dotted line. They jump to the mouse cursor, so you can first position the mouse cursor at the exact position you want and then click on the mouse button. The window shows which of the lines is currently active (Hor. or Vert.)

Since WinOscillo uses the sound card, the frequency range is fairly limited: from about 20 Hz to 20 kHz. But at this price you can't really complain (the program is free). It's part of the download package.

Chapter 2 • A Quick Tour Of The Raspberry Pi

When you turn on a Raspberry Pi with the SD card that can be ordered along with this book, you go straight to the Raspberry Pi command mode where you are prompted to enter the username and password. The default username and password are **pi** and **raspberry** respectively. The command mode is identified by the following prompt:

```
pi@raspberrypi:~ $
```

By default you are located at the home directory which is `/home/pi`. Your current directory is shown by entering the command `pwd`. There are many commands that can be entered in the command mode. Some of these commands are summarized in chapter 4. Interested readers can find detailed information on the Internet on all the valid commands.

Some commands that you may find interesting in addition to the ones given in Chapter 4 are given in the next section.

2.1 The Nano Text Editor

Nano is a small, fast editor that can only be controlled via the keyboard. To start this program type **nano** in the terminal, followed by the Enter key.

```

pi@raspberrypi: ~
File Edit Tabs Help
GNU nano 2.2.6 File: hello.c

#include <stdio.h>

int main() {
    printf("Hello World\n");
    return 0;
}

^G Get Help  ^O WriteOut  ^R Read File  ^Y Prev Page  ^K Cut Text  ^C Cur Pos
^X Exit      ^J Justify   ^W Where Is  ^V Next Page  ^U UnCut Text ^T To Spell
  
```

Figure 2.1. Nano, with a C program.

Its functions are accessed via the control key, in conjunction with certain other keys. Ctrl-O, for example, means that you have to hold down the control key, briefly press the O key, and then let go of the control key. The PgUp and PgDn keys (page up and page down) scroll the text up and down by one page when it's too large to fit on one page. You can't scroll with the mouse since the scrollbar on the right has been turned off. Some useful commands of nano are:

- Ctrl-O Save your work (press Enter to save with the given file name).
If need be, press Y to overwrite the file.
- Ctrl-X Exit the program.
- Ctrl-G Help screen (use Ctrl-X to close the help screen).
- Ctrl-K Cut a whole line.
- Ctrl-U Paste a whole line.

In this book we use Nano mainly for editing system files, although you can also use it to write programs. It's not very useful for Python since it does not provide automatic indentation, but it is perfectly adequate for C. The traditional "Hello World" could be written in C as follows:

1. Start LXterminal, and type in the following:

```
nano hello.c
```

2. Nano now starts with the (empty) hello.c program.

3. Type in this C program:

```
#include <stdio.h>

int main()
{
    printf("Hello World\n");
    return 0;
}
```

4. Save the program with Ctrl-O followed by Enter, and close Nano with Ctrl-X.

5. Compile the program with gcc :

```
gcc -o hello hello.c
```

6. Nothing appears to happen for a moment, but then the command prompt will return.

7. Type in ./hello to run the new program. The text "Hello World" will now appear on the screen.

2.2 Some Useful Commands

Now that we have created a text file in our default directory, we can have a look at some useful commands.

- Enter command `ls` to display the files in our default directory.

- Enter command `cat hello.c` to display the contents of file `hello.c`.
- Enter command `head -3 hello.c` to display the first 3 lines of file `hello.c`.
- Enter command `tail -4 hello.c` to display the last 4 lines of file `hello.c`.

```

pi@raspberrypi:~ $ ls
Desktop  Downloads  MagPi  Pictures  Templates
Documents hello.c    Music  Public   Videos
pi@raspberrypi:~ $ cat hello.c
#include <stdio.h>

int main()
{
    printf("Hello World\n");
    return 0;
}

pi@raspberrypi:~ $ head -3 hello.c
#include <stdio.h>

int main()
pi@raspberrypi:~ $ tail -4 hello.c
    printf("Hello World\n");
    return 0;
}

```

Figure 2.2 Some useful file commands

- Enter command `mkdir test` to create a directory under our default directory. Check with command `tree` that a new directory has been created under our default directory.
- Change the default directory to `test` by entering the command `cd test`. Enter command `pwd` to show the new default directory. Enter command `cd ~` to move back to the default login directory.

```

pi@raspberrypi:~ $ mkdir test
pi@raspberrypi:~ $ tree
.
├── Desktop
│   └── New
├── Documents
├── Downloads
├── hello.c
├── MagPi
│   └── MagPi83.pdf
├── Music
├── Pictures
├── Public
├── Templates
├── test
└── Videos

11 directories, 2 files
pi@raspberrypi:~ $ cd test
pi@raspberrypi:~/test $ pwd
/home/pi/test
pi@raspberrypi:~/test $ cd ~
pi@raspberrypi:~ $ █

```

Figure 2.3 Some useful directory commands

- Enter command `cp hello.c test/hello2.c` to copy file `hello.c` to directory `test` and change the filename to `hello2.c`. Enter command `tree` to show the directory structure.
- Enter command `rm test/hello.2` to delete file `hello.2` from directory `test`. Enter command `cd test` to move to directory `test` and enter `ls` to display the contents of this directory.

```
pi@raspberrypi:~ $ cp hello.c test/hello2.c
pi@raspberrypi:~ $ tree
.
├── Desktop
│   └── New
├── Documents
├── Downloads
├── hello.c
├── MagPi
│   └── MagPi83.pdf
├── Music
├── Pictures
├── Public
├── Templates
├── test
│   └── hello2.c
└── Videos

11 directories, 3 files
pi@raspberrypi:~ $ rm test/hello2.c
pi@raspberrypi:~ $ cd test
pi@raspberrypi:~/test $ ls
pi@raspberrypi:~/test $ █
```

Figure 2.4 Some useful file and directory commands

- Enter command `rmdir test` to delete directory `test`. Enter command `tree` to show the directory structure.
- Enter command `date` to display the current date and time.
- Enter command `cal` to display the current calendar.

```

pi@raspberrypi:~ $ rmdir test
pi@raspberrypi:~ $ tree
.
├── Desktop
│   └── New
├── Documents
├── Downloads
├── hello.c
├── MagPi
│   └── MagPi83.pdf
├── Music
├── Pictures
├── Public
├── Templates
└── Videos

10 directories, 2 files
pi@raspberrypi:~ $ date
Wed 18 Sep 18:44:22 BST 2019
pi@raspberrypi:~ $ cal
    September 2019
Su Mo Tu We Th Fr Sa
 1  2  3  4  5  6  7
 8  9 10 11 12 13 14
15 16 17 18 19 20 21
22 23 24 25 26 27 28
29 30

```

Figure 2.5 Some useful commands

2.3 Raspberry Pi Desktop

The desktop provides GUI based graphical interface to the user. If you have a monitor directly connected to your Raspberry Pi then you can move to the Desktop mode by entering command `startx`.

If you are connected to your Raspberry Pi over a WiFi link using your PC, then you can move to the Desktop mode using the **VNC** tool or **Xming** as described fully in chapter 4. This section assumes that you are already in Desktop mode. Figure 2.6 shows the top part of the Raspberry Pi desktop.



Figure 2.6 Top part of the Raspberry Pi desktop

At the top left hand side we have the Applications Menu. Next to it is the Web Browser, File Manager, and Terminal. At the top right hand side we have the VNC Sever icon, Bluetooth icon, WiFi icon, Volume control, and the current time. The Waste Basket is located on the desktop screen.

2.3.1 Application Menu

This menu has the options shown in Figure 2.9. The Programming options includes several programming tools such as Java, Mathematica, Mu, Node-Red, Scratch, Scratch2, Sonic Pi, Thonny, Wolfram and so on. In this book we will be using the Thonny in our Python programs.

Scratch

This program can be used to easily create some simple games. The program has been designed for use by children and as such makes use of a simple graphical programming language. Despite its simplicity, you can create surprisingly remarkable games with it. If you are a child, or if you have one, then this is certainly an interesting program with which to familiarize yourself. As an adult, you could still use this program to create some great animations. Figure 2.7 shows the Scratch screen.

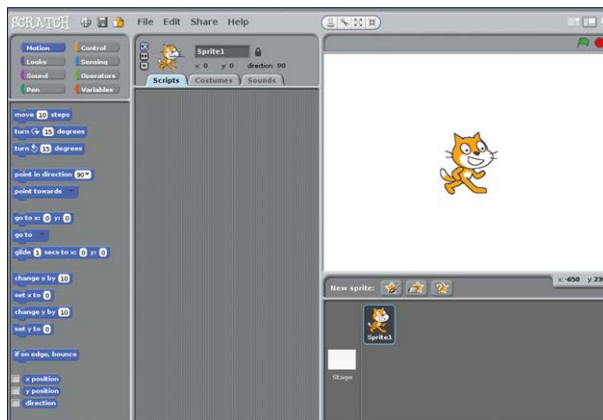

Figure 2.7 Scratch screen

The Education menu includes the SmartSim.

The Office menu includes a number of programs for office use, such as Libre Office Base (database), Libre Office Calc (spreadsheet), Libre Office Draw (drawing), Libre Office Writer (word processing), and so on. As an example clicking on Libre Office Writer starts the word processing package as shown in Figure 2.8.

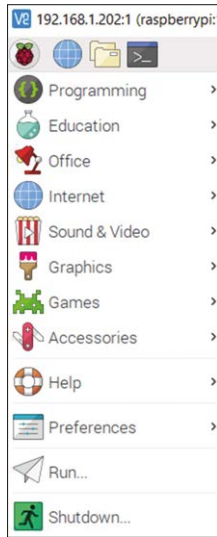

Figure 2.9 Application Menu options

2.3.2 Web Browser Menu

This menu includes the Chromium web browser

2.3.3 File Manager Menu

This menu includes various file management options found in standard Windows applications such as File, Edit, Sort, Go and Tools. You could consider this menu as a simpler version of Windows Explorer. You can browse graphically through the directories, open files and run programs. With the right-hand mouse button you can access the file's properties. From here you can modify the permission settings for files etc.

2.3.4 Terminal Menu

This menu enables commands to be entered to the Raspberry Pi as if we are in command mode. Figure 2.10 shows the screen when this option is selected.

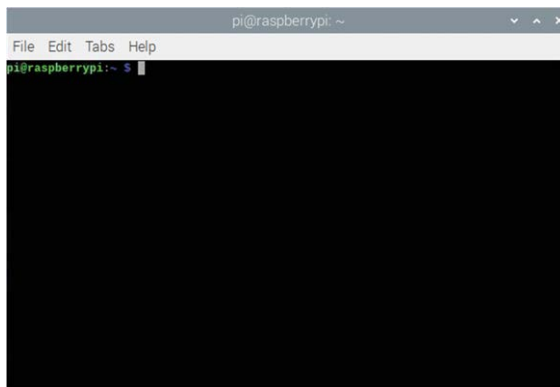

Figure 2.10 Terminal menu option

A useful command that is available while in this option is the `Scrot` which is described below.

Scrot

`scrot` is a program which is used to capture screen images. If you enter the following command in Terminal menu, you will capture the screen contents and store the result in `myscreen.bmp`:

```
scrot myscreen.bmp
```

The file will be stored in the directory from which you issued the command. You can also take a screen capture after five seconds:

```
scrot -d 5 myscreen.bmp
```

If you don't want to capture the whole screen, you can use the mouse to select only the part that interests you. First you enter the command, and then you use the mouse to select part of the screen. The screen capture will take place as soon as you let go of the mouse button:

```
scrot myscreen.bmp -s
```

You can close the Terminal menu with the `exit` command.

2.3.5 Bluetooth Icon

Clicking on this icon enables the Bluetooth settings to be configured. The options are shown in Figure 2.11.



Figure 2.11 Bluetooth options

2.3.6 WiFi Icon

Clicking on this icon enables the WiFi settings to be configured. The options are shown in Figure 2.12.

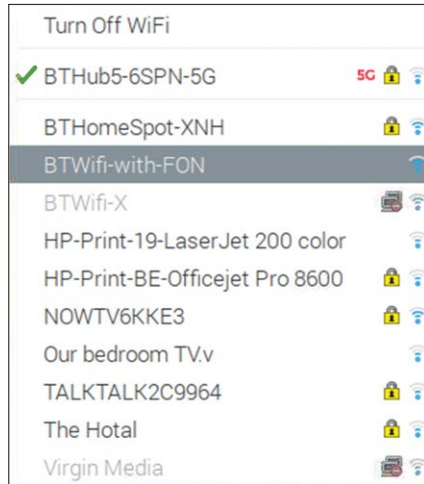

Figure 2.12 WiFi options

2.3.7 Volume Control

This is a slide control that enables the audio volume to be changed.