

THIS FILE (1989)

2

REPORT CONTROL SYMBOL DD-M(A)1592

AD-A211 866

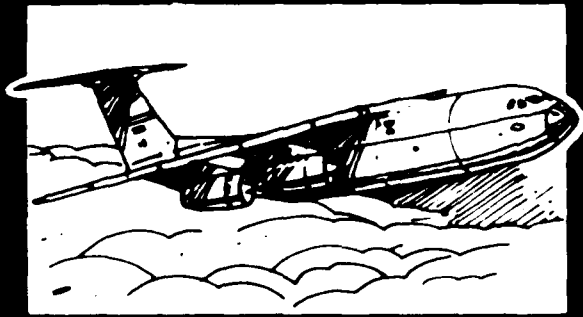
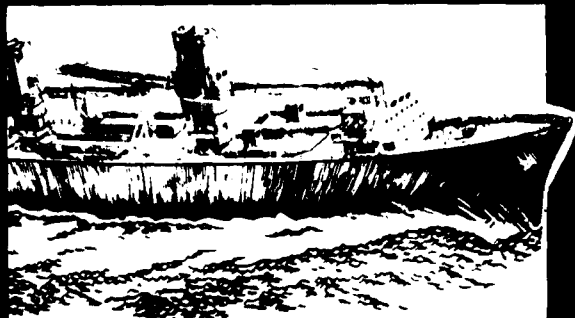
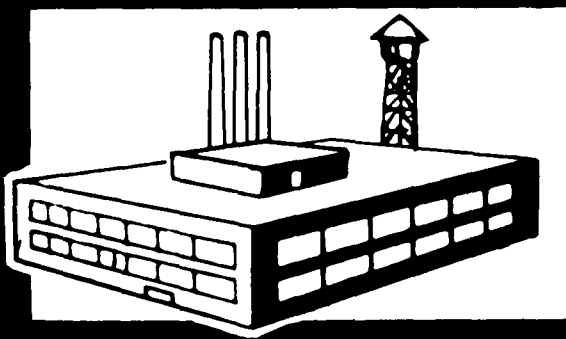

DTIC
ELECTE
JUL 19 1989
S D
(4) D

1989 Container System Hardware

STATUS REPORT,

Distribution is unlimited.

DISTRIBUTION STATEMENT A
Approved for public release
Distribution Unlimited

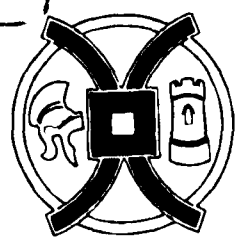

Intermodal Schematic

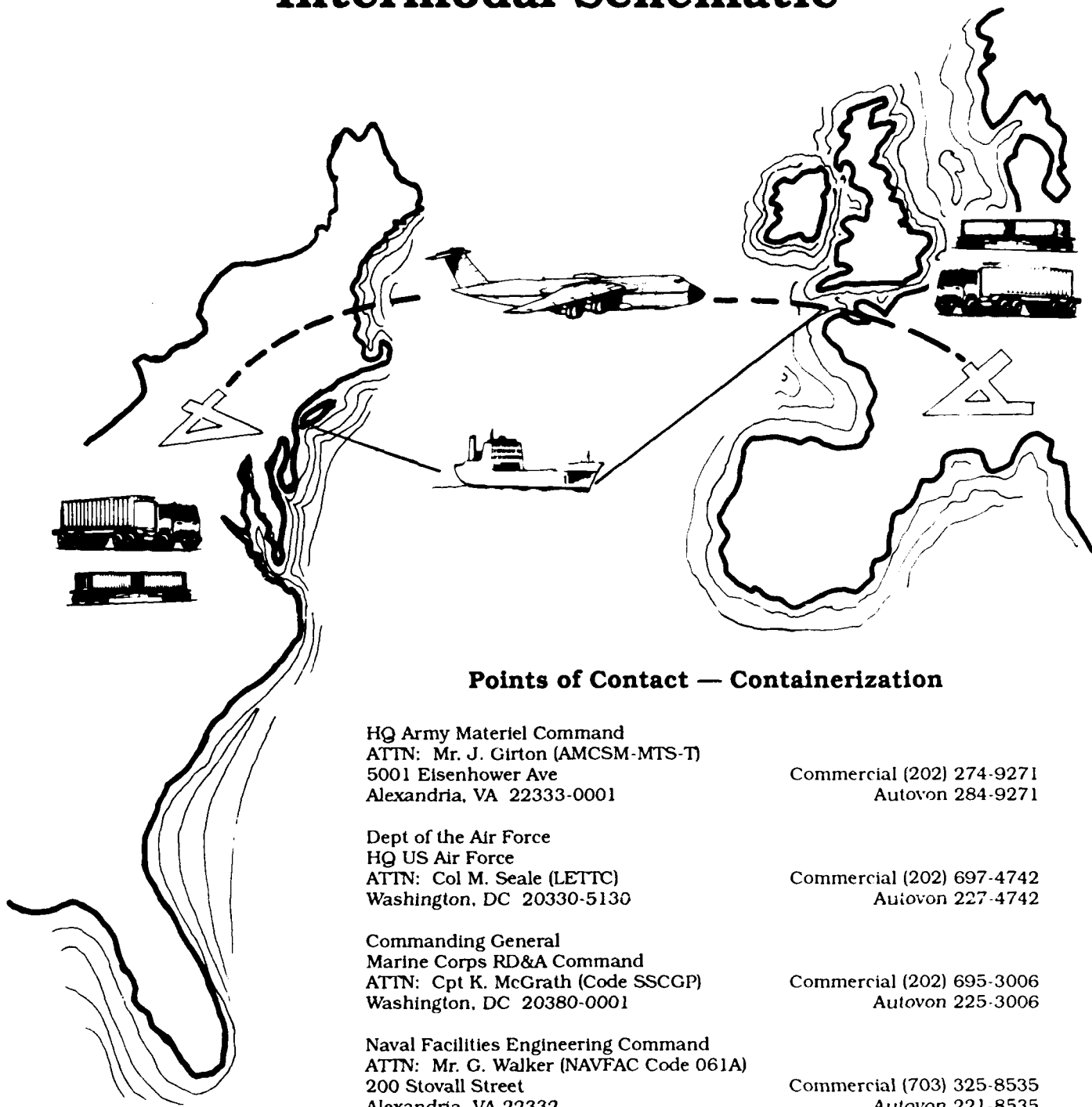

Points of Contact — Containerization

HQ Army Materiel Command
 ATTN: Mr. J. Girton (AMCSM-MTS-T)
 5001 Eisenhower Ave
 Alexandria, VA 22333-0001

Commercial (202) 274-9271
 Autovon 284-9271

Dept of the Air Force
 HQ US Air Force
 ATTN: Col M. Seale (LETC)
 Washington, DC 20330-5130

Commercial (202) 697-4742
 Autovon 227-4742

Commanding General
 Marine Corps RD&A Command
 ATTN: Cpt K. McGrath (Code SSCGP)
 Washington, DC 20380-0001

Commercial (202) 695-3006
 Autovon 225-3006

Naval Facilities Engineering Command
 ATTN: Mr. G. Walker (NAVFAC Code 061A)
 200 Stovall Street
 Alexandria, VA 22332

Commercial (703) 325-8535
 Autovon 221-8535

Naval Sea Systems Command
 ATTN: Mr. M. Fink (PMS-377K)
 Washington, DC 20362-5101

Commercial (202) 692-4834
 Autovon 222-4834

Naval Supply Systems Command
 ATTN: Mr. F. Crawmer (Code 051B)
 Washington, DC 20376-5000

Commercial (202) 746-3991
 Autovon 286-3991

Foreword

Today virtually all of the products and equipment shipped overseas as well as by rail are shipped using some form of shipping container. The Merchant Marine industry has made the transition from the breakbulk fleet of the past to the current containership fleet which has made the Department of Defense (DOD) examine the ways deployed forces are supported in contingency situations.

This publication was initiated in 1977 by the former office of the Project Manager, Army Container Oriented Distribution System to provide information to various Army activities which had an interest in the development and fielding of the Container Oriented Distribution System. Later, the Joint Intermodal Steering Group (formerly the Joint Container Steering Group) requested that the status of items, associated with containerization, of the Departments of the Navy and Air Force be included beginning with the January 1979 issue. In November 1981, publication responsibility was transferred to the former US Army Mobility Equipment Research and Development Command (presently Belvoir Research, Development, and Engineering Center) as a function of its development responsibilities in the Container Oriented Distribution System. Since the January 1982 issue, this publication has been published in accordance with the DOD Project Master Plan for a Container Oriented Distribution System (DOD Directive 4540.6) and all services have been included.

The Container System Hardware Status Report was published semi-annually before 1982 and has been published every year since 1982 though the 1987 and 1988 issues were not published.

The Technical Coordinator for this publication is Mr. Norman Fertman and the editor is Mr. William Brower both at Autovon 354-1143 or Commercial (703) 664-1143. Comments on this report may be submitted to:

Commander
US Army Belvoir RD&E Center
ATTN: STRBE-FMR
Fort Belvoir, VA 22060-5606

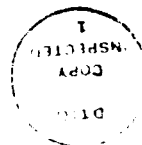

Comments on the individual services containerization programs should be submitted to the appropriate service point of contact listed inside the front cover. Comments on particular pieces of equipment should be submitted to the point of contact shown for that program.

Norman Fertman

NORMAN FERTMAN
Technical Coordinator
Logistics Equipment Directorate
Belvoir RD&E Center

1989 Container System Hardware

Contents

	Page
PART I. CONTAINER EQUIPMENT	1
MILVAN ← Ammunition Restraint	3
MILVAN → General Cargo	5
Refrigerated Container	7
20-Foot Flatrack, Project EASY ISO	9
Load and Roll Pallet (LRP)	11
40-Foot Heavy Duty Flatrack	13
Shipping Frame, 8 x 8 x 10 Foot	15
Shipping Frame, 4 x 6 ² / ₃ x 8 Foot	17
Quadruple Container (QUADCON)	19
Ammunition Containerization Evaluation	21
Palletized Loading System (PLS) Logistics	23
20-Foot ISO Side-Opening Container	25
ISO Tactical Shelter	27
PLS Container (COMPODS)	29
PART II. HANDLING EQUIPMENT	31
Palletized Loading System (PLS)	33
Spreader Bars, Intermodal Container Handling	35
Spreader Bars, Intermodal Container Handling, Lightweight Expandable	37
Mobile Loading Ramp	39
4,000-Pound Capacity Forklift Truck, Rough Terrain (RTFLT)	41
6,000-Pound Capacity Variable Reach Forklift Truck, Rough Terrain (6K VRRFTLT)	43
4,000-Pound Capacity Forklift Truck	45
50,000-Pound Capacity Container Handler, Rough Terrain (RTCH)	47
Rough Terrain Container Transporter (RTCT)	49
20/40-Foot Container Sideloader	51
Lightweight Amphibious Container Handler (LACH)	53
Rough Terrain Container Crane (RTCC)	55
140-Ton, Truck-Mounted, Container Handling Crane	57
250/300-Ton, Truck-Mounted, Container Handling Crane	59
Crane Rotator	61

	Page
PART III. TRANSPORTATION EQUIPMENT	63
Logistics Vehicle System.....	65
Chassis, Semitrailer: Coupleable, MILVAN Container Transporter	67
Truck Tractor, Linehaul, 6 x 4, M915.....	69
Truck Tractor, Linehaul, 6 x 4, M915A1.....	71
Truck Tractor, Yard Type, 4 x 2, M878A1	73
Semitrailer, Linehaul, Breakbulk/Container, M872 Series.....	75
Semitrailer, Tactical, Dual Purpose Breakbulk/ Container Transporter, 22 ¹ / ₂ -Ton, M871 Series	77
Railway Car, Flat (Heavy Duty), 140-Ton Capacity, DS	79
5-Ton Truck Bed with ISO-Configured Locking Devices.....	81
 PART IV. LOTS, HARBOR, AND CONTAINER OFFLOADING AND TRANSFER EQUIPMENT	 83
Lighter Air Cushion Vehicle, 30-Ton (LACV-30).....	85
Lighter, Amphibian, Heavy-Lift (LAMP-H).....	87
Logistics Support Vessel (LSV)	89
Landing Craft, Utility (LCU).....	91
Temporary Container Discharge Facility (TCDF).....	93
Fast Logistic Ship (T-AKR) Program.....	95
Auxiliary Crane Ship (T-ACS)	97
Containership Strikeup System (CSUS).....	99
Causeway Section, Powered (CSP).....	101
Cantilevered Elevated Causeway (CANTELCAS)	103
Roll-On/Roll-Off Discharge Platform (RO/RO DP)	105
Container Offloading and Transfer System (COTS) Cantilevered Lift Beam	107
Floating Causeway (FC).....	109
SEASHED System	111
Basic Merchant Ship Naval Augmentation Program (MSNAP) Module.....	113
Habitability and Utility Support System (HUSS).....	115
Modular Mobile Repair System (MMRS).....	117
Causeway Ferry (CF).....	119
High Sea State Container Transfer System (HISEACOTS).....	121
Pontoon Air Cushion Kit (PACK)	123

	Page
PART V. AERIAL PORT/TERMINAL EQUIPMENT	125
40,000-Pound 463L Aircraft Loader	127
25,000-Pound 463L Aircraft Loader	129
35-Ton Bridge Crane	131
Elevator Loader	133
463L/ISO Adapter System.....	135
Mobile Straddle Crane.....	137
22,000-Pound Capacity Forklift	139

Part I

Container Equipment

MILVAN—Ammunition Restraint

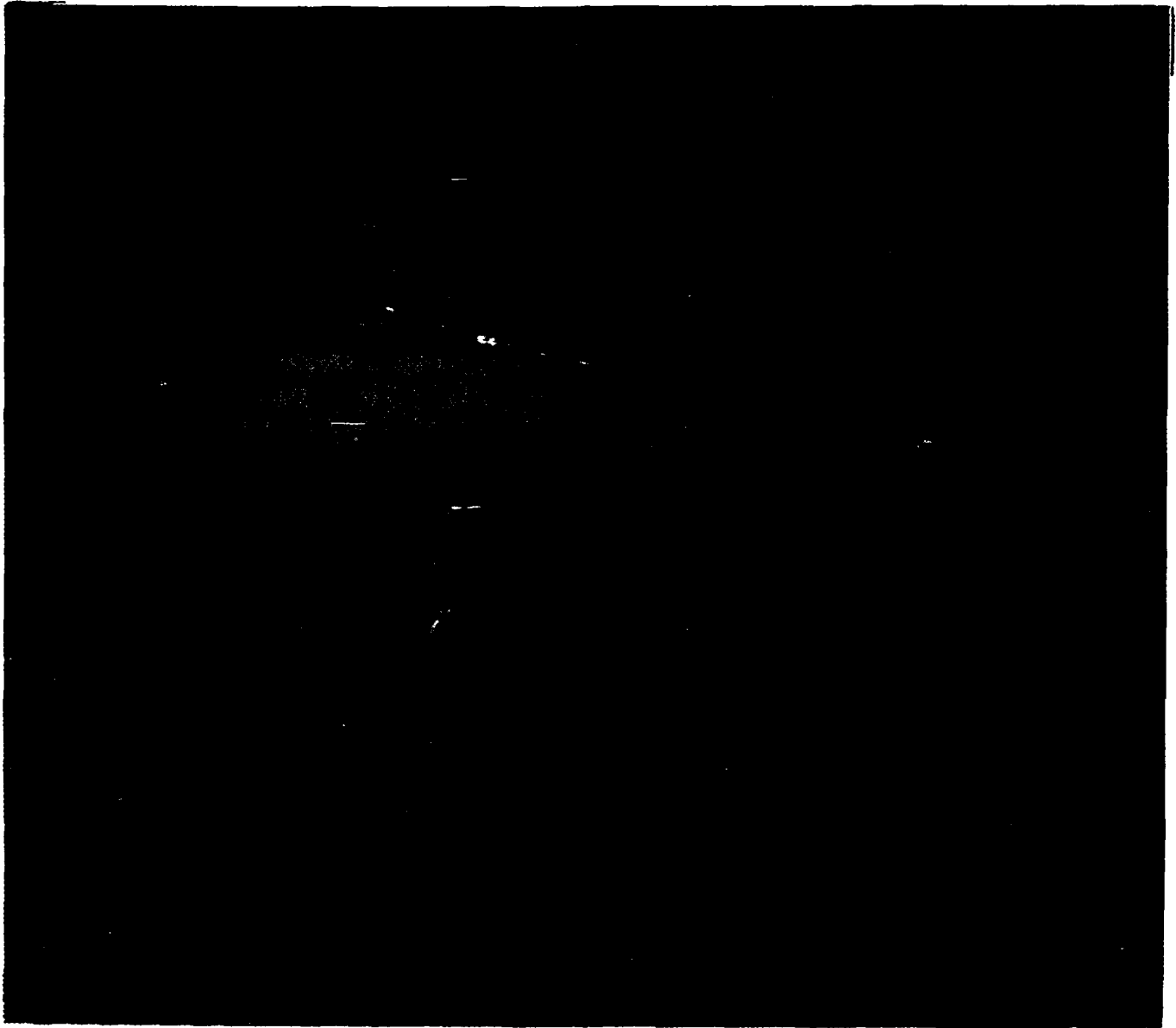

LENGTH: 20 FEET
WIDTH: 8 FEET
HEIGHT: 8 FEET
WEIGHT EMPTY: 5,785 POUNDS
GROSS WEIGHT (DESIGNED): 44,800 POUNDS

MILVAN - Ammunition Restraint

POINT OF CONTACT

P. Barickman
US Army Belvoir RD&E Center, STRBE-FMR
Fort Belvoir, VA 22060-5606
Autovon 354-4490/Commercial (703) 664-4490

ITEM DESCRIPTION

The MILVAN ammunition restraint container is essentially a standard ANSI/International Standards Organization (ISO) container equipped with restraint hardware capable of handling approximately 20 tons of ammunition. The restraint system consists of eight slotted steel rails permanently installed on each side wall and 25 adjustable crossbars that can be inserted in the slotted rails. Its use at full rated load has been approved by the US Coast Guard and the Association of American Railroads. The MILVAN container is 8 x 8 x 20-feet, though some 8 x 8.5 x 20-foot containers have been bought, and weighs 5,785 pounds including 1,300 pounds for the restraint system.

STATUS

The Army procured 4,500 MILVAN ammunition restraint containers and there are 4,268 in the present inventory. A total of 249 MILVANs, each 8 x 8.5 x 20-foot with composite flooring and corrosion resistant steel, were procured.

PROGRAM PLAN

The Army is scheduled to procure 725 units in FY90.

MILVAN—General Cargo



LENGTH: 20 FEET
WIDTH: 8 FEET
HEIGHT: 8 FEET
VOLUME INSIDE: 1,060 CUBIC FEET
WEIGHT EMPTY: 4,700 POUNDS
GROSS WEIGHT: 44,800 POUNDS

MILVAN - General Cargo

POINT OF CONTACT

P. Barickman
US Army Belvoir RD&E Center, STRBE-FMR
Fort Belvoir, VA 22060-5606
Autovon 354-4490/Commercial (703) 664-4490

ITEM DESCRIPTION

The MILVAN provides a capability of handling up to 20 tons of general cargo. It is used to transport and temporarily store military cargo. The MILVAN dimensions are 8 x 8 x 20-feet, weighs 4,770 pounds when empty, and has an internal volume of 1,060 cubic feet. The MILVAN is designed to ANSI/ISO standards and procured with a military performance specification. The container is of steel construction with hardwood flooring and the walls are lined with plywood.

STATUS

The Army procured 2,200 MILVAN general cargo containers and there are 2,141 in the present inventory. The International Convention for Safe Containers (CSC) was ratified by the United States 3 January 1978. The US Coast Guard, as the implementing agency, issued approval to the Army for the existing MILVAN fleet on 9 November 1978. With depot participation, the container inventory was refurbished and the CSC approval plate mounted beginning in 1978.

PROGRAM PLAN

The Army is scheduled to procure 250 units in FY90.

Refrigerated Container



LENGTH: 20 FEET
WIDTH: 8 FEET
HEIGHT: 8 FEET
WEIGHT: 8,000 POUNDS
DOOR OPENING HEIGHT: 82 INCHES
DOOR OPENING WIDTH: 89 INCHES

Refrigerated Container

POINT OF CONTACT

P. Barickman
US Army Belvoir RD&E Center, STRBE-FMR
Fort Belvoir, VA 22060-5606
Autovon 354-4490/Commercial (703) 664-4490

ITEM DESCRIPTION

The refrigerated container provides a capability to transport, temporarily store, and distribute temperature-sensitive cargo. The container, including the refrigeration unit, is nominally 8 x 8 x 20-foot and weighs approximately 8,000 pounds. The unit is powered by a military standard 10kW diesel engine generator set or by an external electrical power supply. The refrigerated container is a modified commercial design and procured to a military specification. It meets all ISO requirements for intermodal shipments.

STATUS

A total of 665 containers, including 24 for the US Navy, were purchased and delivered by 1980. Approximately 225 have been deployed to Europe where they are in constant use. The Navy procured an additional 49 units in FY85.

PROGRAM PLAN

There is no current plan to procure additional quantities.

20-Foot Flatrack, Project EASY ISO



20-Foot Flatrack, Project EASY ISO

POINT OF CONTACT

D. Swanick
Armament Division/YNP
Eglin AFB, FL 32542-5000
Autovon 872-4173/Commercial (904) 882-4173

ITEM DESCRIPTION

Evaluation of ISO flatrack containers for transport of munitions by DOD. Expect increased utility in loading and downloading, use of existing munitions handling equipment, and reduced cost for retrograde shipping.

STATUS

In March 1983, the Air Force Armament Division at Eglin AFB, FL, gained US Coast Guard (USCG) and Bureau of Explosives (BOE) approval for load plan drawings of 30mm ammunition loaded on a 20 x 8 x 5-foot, 8-inch flatrack. The loaded flatrack was successfully shipped to Korea in June 1983. This shipment confirmed the flatrack advantages of effective cube utilization and ease of unloading with conventional munitions handling equipment.

Also, in March 1983, HQ FACAF completed the static test loading of 11 different air munitions loads on a 20 x 8 x 8-foot flatrack. Drawings for these load configurations have been submitted to the US Army Defense Ammunition Center and School for preparation of load plans and USCG/BOE approval.

Transportability testing of the flatrack for use on Federal Republic of Germany railroads was completed in September 1985.

PROGRAM PLAN

The Air Force is pursuing the development of approved load plans for munitions movement using flatracks. Other applications are being investigated for the flatracks.

Load and Roll Pallet (LRP)

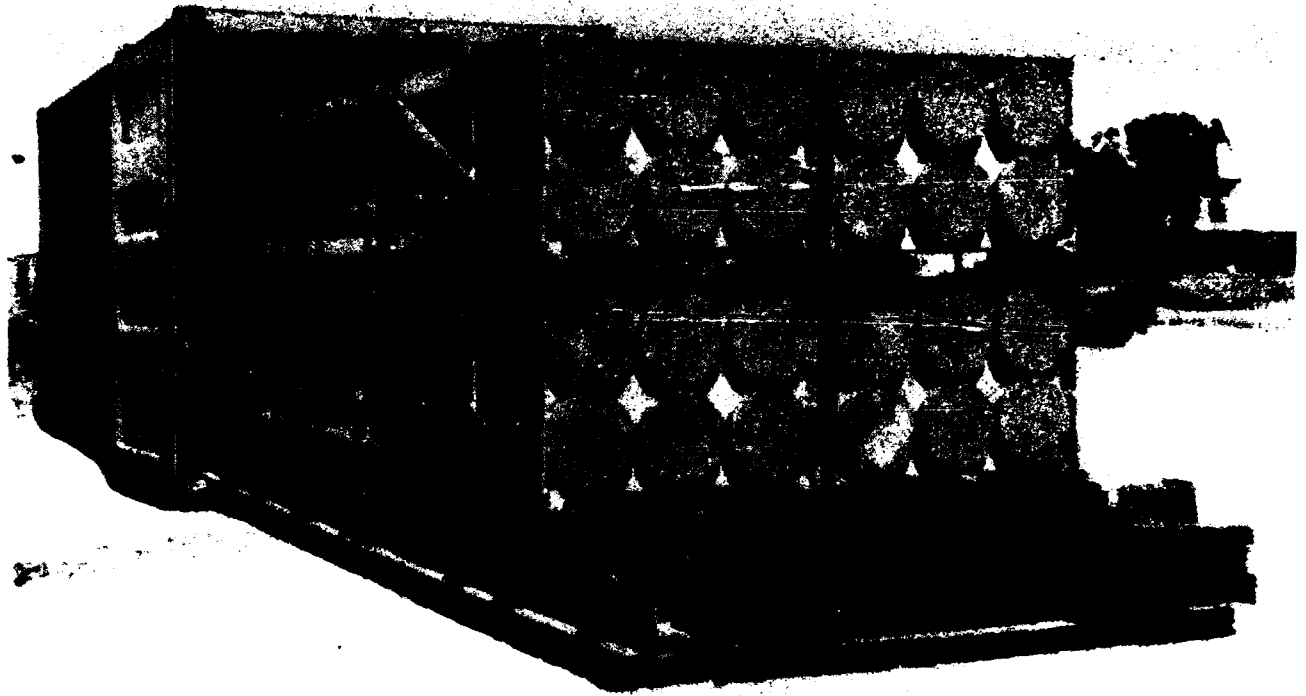

Load and Roll Pallet (LRP)

POINT OF CONTACT

D. Chesnulovitch
PM-AMMOLOG, AMCPM-AL
Picatinny Arsenal, NJ 07806-5000
Autovon 880-4737/Commercial (201) 724-4737

ITEM DESCRIPTION

The Load and Roll Pallet (LRP) fits inside of a standard 20-foot ANSI/ISO container. The LRP allows a complete load of four Multiple Launch Rocket System (MLRS) Pods (each weighing 5,078 pounds) to be rolled out of an end opening container so they can be easily unloaded from the side. Two 6,000-pound capacity forklifts or one 10,000-pound capacity or larger forklift lifts up one end of the fully loaded LRP just high enough to clear the floor of the container and can easily roll the entire load in or out of the containers. The LRP can also be extracted with the Heavy Expanded Mobility Tactical Truck (HEMTT), 5-ton wrecker, or a 5-ton truck with a winch. Unloading can be accomplished in the field in approximately one-fourth of the time required using the current method of dragging the MLRS Pods out of the container.

The LRP can also be used to unload a container on the back of a truck bed or trailer with the use of the Gear Leg System. The Gear Leg System is a stand which allows the LRP to be pulled out and supported so that the MLRS Pods can be accessed by forklift, wrecker, or directly transferred to a resupply vehicle such as the HEMTT.

STATUS

Testing of the concept was conducted during November 1987 at Miesau Army Depot and the results were favorable. Ten LRPs were bought and delivered to the US Army Defense Ammunition Center and School in 2QFY89.

PROGRAM PLAN

The purchased LRPs will be utilized on an initial pilot program basis to gather more data on the effectiveness of the LRP during actual use. Develop plans to conduct a more extensive pilot program of 250 LRPs.

40-Foot Heavy Duty Flatrack

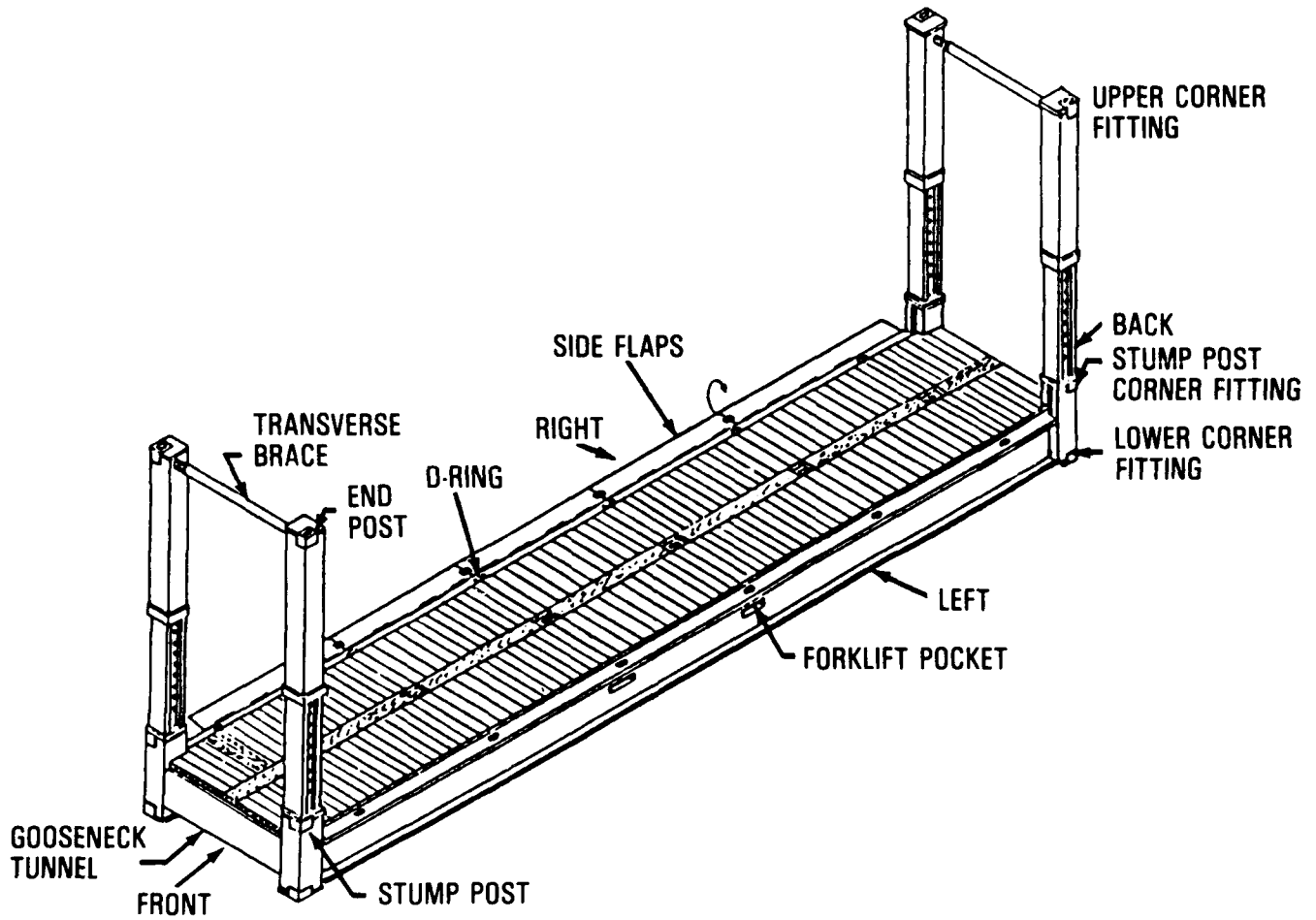

40-Foot Heavy Duty Flatrack

POINT OF CONTACT

M. Baig
Naval Sea Systems Command, PMS-377K2
Washington, DC 20362-5101
Autovon 222-7881/Commercial (202) 692-7881

ITEM DESCRIPTION

The 40-foot heavy duty flatrack was developed to provide a breakbulk capability to container ships for the carriage of tanks and other heavy and/or oversized cargo. The 40-foot heavy duty flatrack is a relatively uncomplicated structural steel frame, decked over and fitted with tiedown points. There are two types of flatracks, each having different weight handling capabilities. The first type of flatrack has a weight handling capability of 60 light-tons and has telescoping corner posts which are adjustable from 8.5 to 13 feet for various cargo heights. The second type of flatrack has a weight handling capacity of 72 light-tons and has corner posts 13 feet high. The corner posts on both types fold down to facilitate stacking and storage. The flatracks are to be inserted into the container cell empty and then loaded.

STATUS

The heavy duty flatrack was initially authorized in the FY83 budget for 223 units; the FY84 budget was for 135 units. The delivery of the 358 flatracks was completed during 2QFY86. Two contracts for the second type of flatrack were awarded during 2QFY88. Each contract was for 1,001 flatracks.

PROGRAM PLAN

Final delivery for the second type of flatrack is planned for 4QFY90.

Shipping Frame, 8 x 8 x 10 Foot

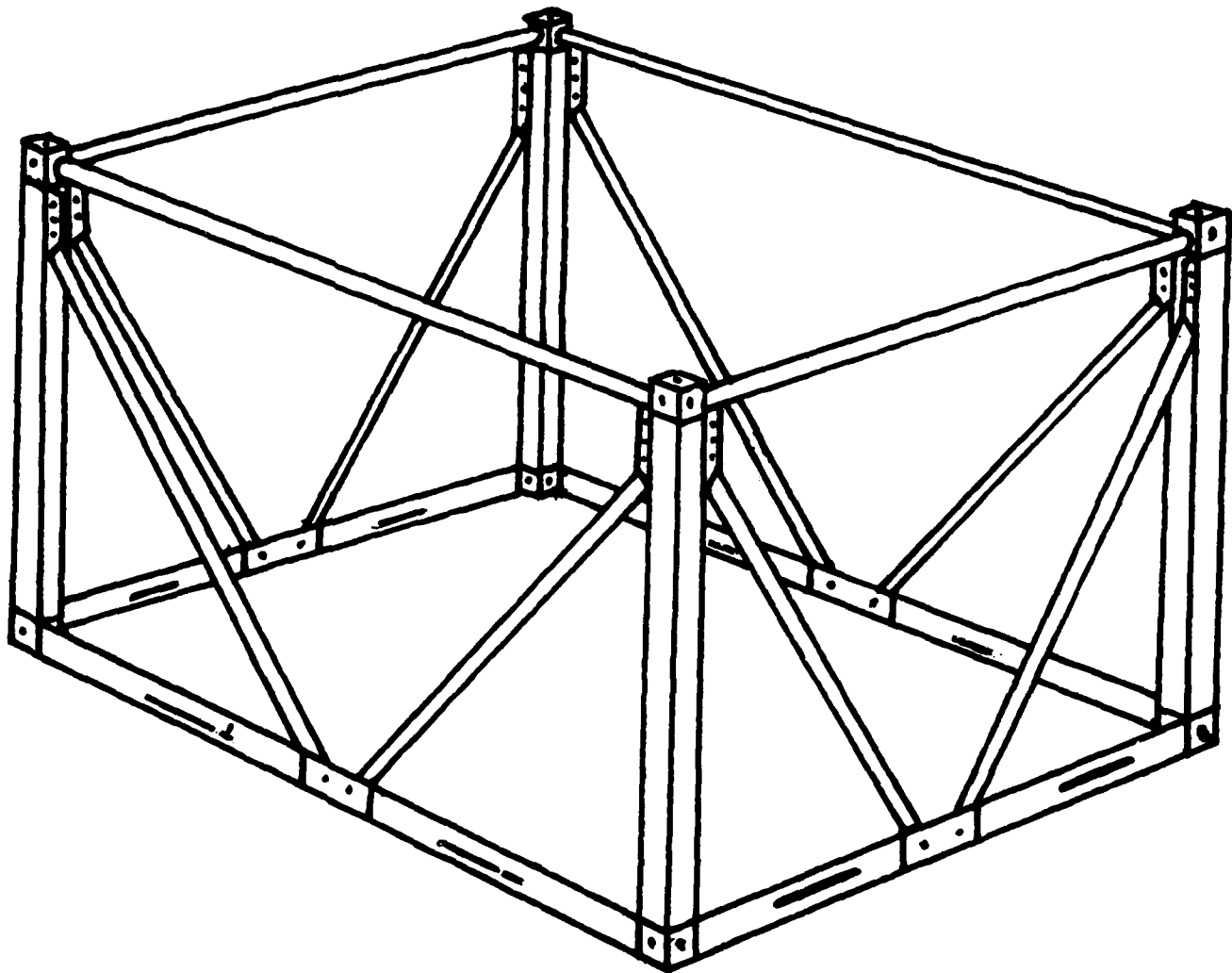

LENGTH: 10 FEET
WIDTH: 8 FEET
HEIGHT: 8 FEET
ARRAYED CONFIGURATION: 8 FEET x 8 FEET x 20 FEET

Shipping Frame, 8 x 8 x 10 Foot

POINT OF CONTACT

CAPT K. McGrath
CG, Marine Corps RD&A Command, Code SSCGP
Washington, DC 20380-0001
Autovon 225-3006/Commercial (202) 695-3006

ITEM DESCRIPTION

An open top cargo carrier of steel construction which features a four-way forklift handling capability and standard ISO corner fittings. An array of two frames forms an 8 x 8 x 20 foot configuration and fits the 20-foot cells of a containership. The frame is used to support the mounting and movement of the reverse osmosis water purification unit (ROWPU).

STATUS

Approved for service use was obtained in May 1981. An Army contract was awarded 30 September 1983 for the procurement of 496 frames which satisfied Marine Corps requirements.

PROGRAM PLAN

No further procurement is anticipated.

Shipping Frame, 4 x 6²/₃ x 8 Foot

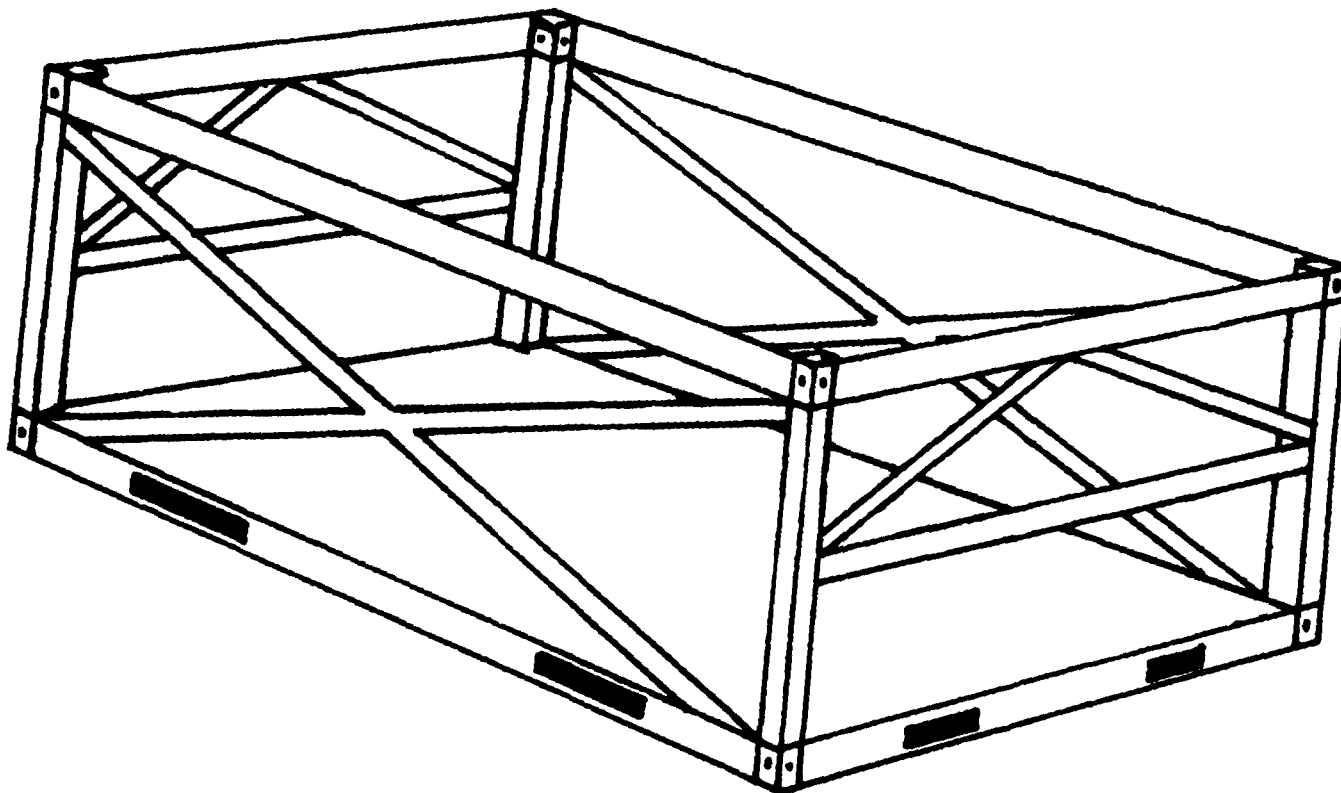

LENGTH: 6²/₃ FEET
WIDTH: 8 FEET
HEIGHT: 4 FEET
ARRAYED CONFIGURATION: 8 FEET x 8 FEET x 20 FEET

Shipping Frame, 4 x 6²/₃ x 8 Foot

POINT OF CONTACT

CAPT K. McGrath
CG, Marine Corps RD&A Command, Code SSCGP
Washington, DC 20380-0001
Autovon 225-3006/Commercial (202) 695-3006

ITEM DESCRIPTION

Reusable open top cargo carrier with four-way forklift handling capability with ISO standard corner fittings. Can be arrayed up to six, forming an 8 x 8 x 20 foot configuration to fit the cell of a containership. Capability objective is to provide an open container of intermediate size compatible with US Navy amphibious ships and the Merchant Fleet. The frame is used as an integral component of SIXCON fuel/water storage and pump modules though it could be used for general cargo and organizational property.

STATUS

A procurement contract for 402 shipping frames was conducted with all shipping frames being recently received.

PROGRAM PLAN

Field the 402 shipping frames received. No further procurement is anticipated.

Quadruple Container (QUADCON)

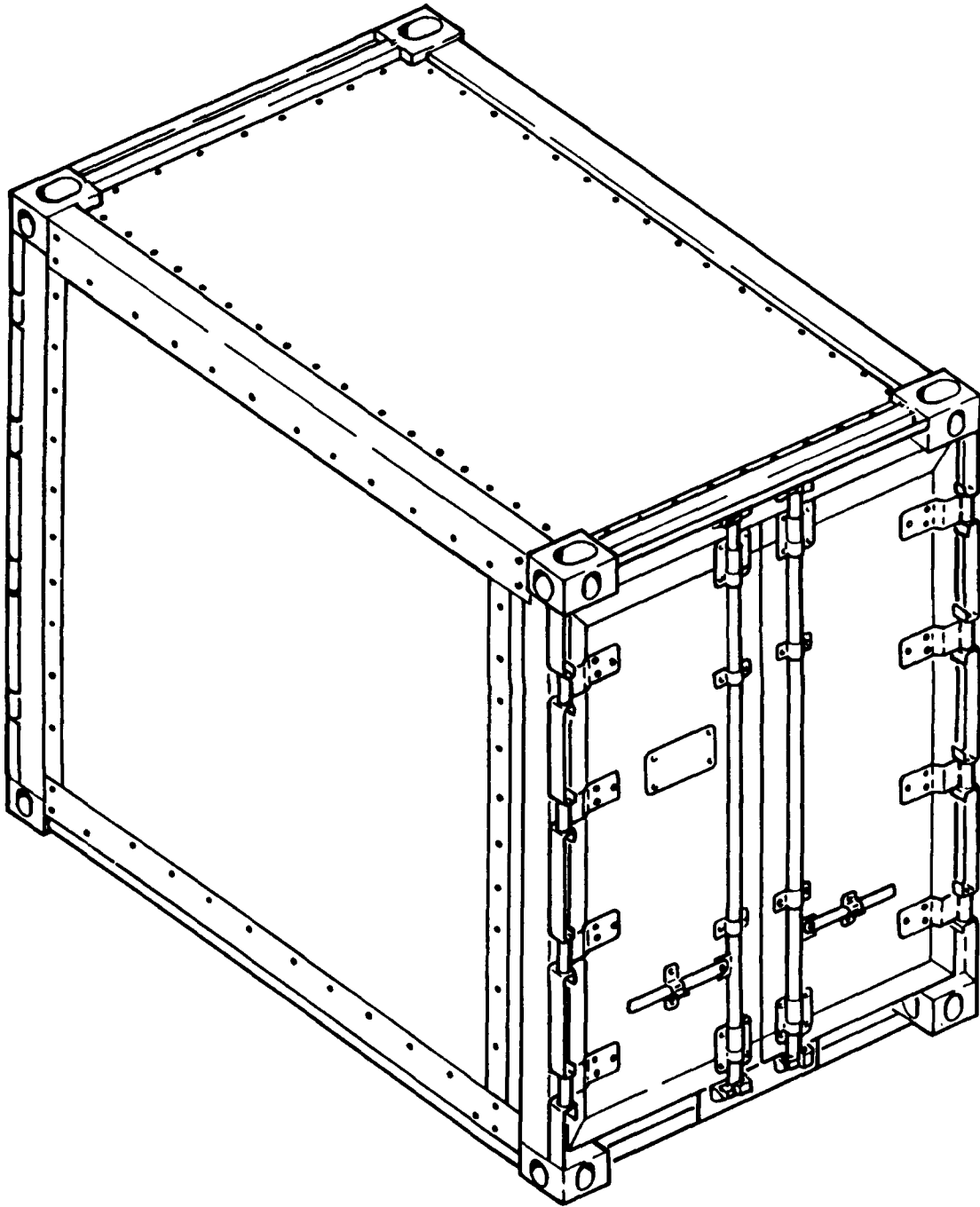

LENGTH: 96 INCHES
WIDTH: 57 $\frac{1}{2}$ INCHES
HEIGHT: 82 INCHES
CARGO CAPACITY: 8,000 POUNDS

Quadruple Container (QUADCON)

POINT OF CONTACT

CAPT K. McGrath
CG, Marine Corps RD&A Command, Code SSCGP
Washington, DC 20380-0001
Autovon 225-3006/Commercial (202) 695-3006

ITEM DESCRIPTION

The QUADCON is an 82 x 57.5 x 96 inch lockable, weatherproof, reusable, prefabricated container with a cargo capacity of 8,000 pounds. The QUADCON has a structural steel welded frame; top sides and door panels of plywood coated with a plastic laminate; and a floor of high-density plywood covered on both sides with sheet steel. It has ISO corner fittings for lifting and restraint, and for coupling QUADCONs into arrays up to four units, and a tineway base with four-way forklift entry. A four-array of QUADCONs is nearly equivalent in volume to one 8 x 8 x 20 foot commercial container and is compatible with the 20-foot cells of a containership.

STATUS

Field evaluation of 522 QUADCONs was completed in May 1987. A contract to manufacture the first generation of the QUADCON was awarded during 1QFY89. A second generation developmental contract will be sought during FY89 to prepare a procurement package for FY92 and beyond to implement recommended changes.

PROGRAM PLAN

The following quantities of QUADCONs are programmed for procurement during the years indicated:

FY89	150
FY90	1,145
FY91	1,137
FY92	1,530

Ammunition Containerization Evaluation

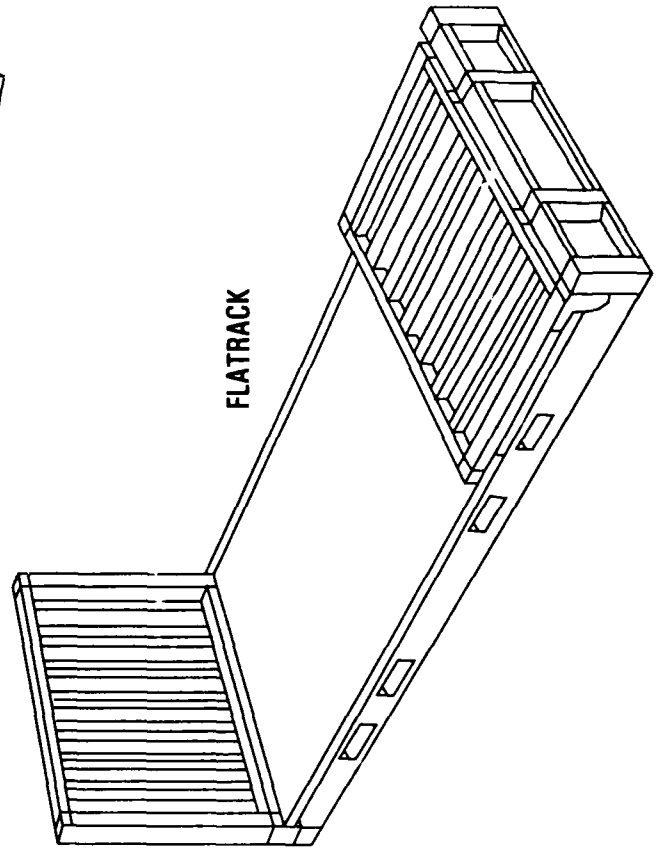
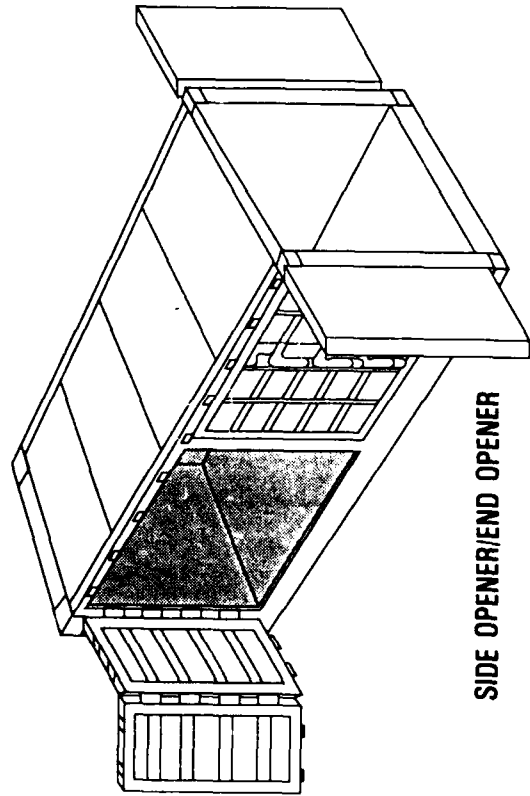
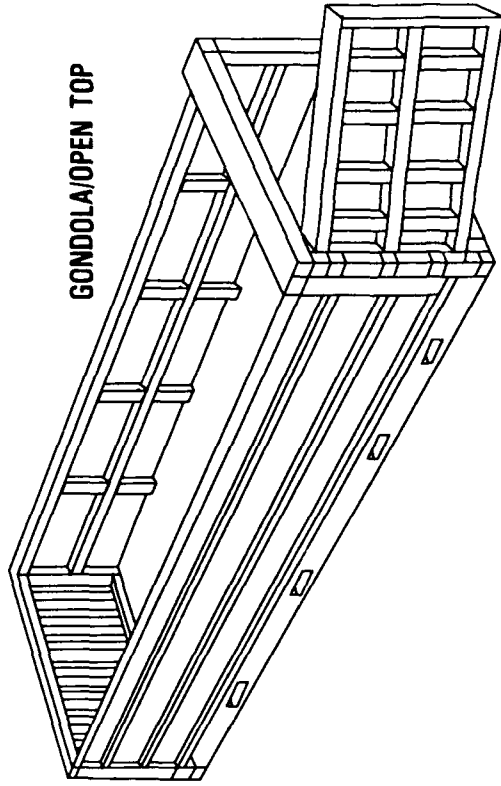
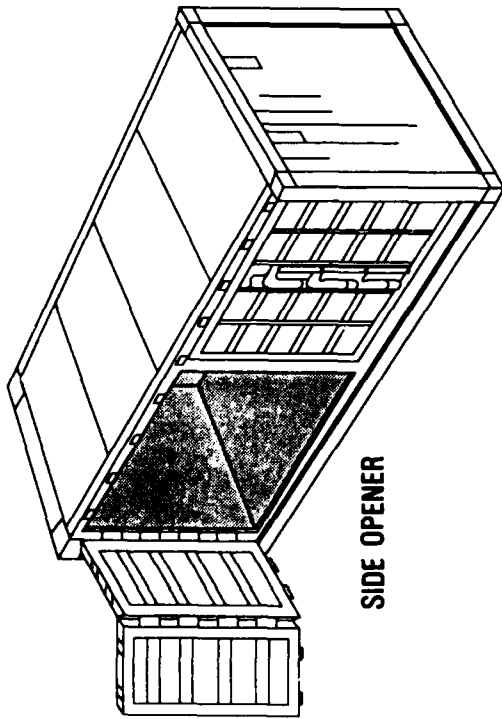

Ammunition Containerization Evaluation

POINT OF CONTACT

D. Chesnulovitch
PM-AMMOLOG, AMCPM-AL
Picatinny Arsenal, NJ 07806-5000
Autovon 880-4737/Commercial (201) 724-4737

ITEM DESCRIPTION

In conjunction with our TRADOC counterpart, the Munitions Systems Manager (MSM) and representatives from several organizations (USADACS, BRDEC, MTMC-TEA, OMMCS, HEL, JCCO), PM-AMMOLOG initiated a three-part container program to achieve the following objectives:

- Demonstrate the utility of special and standard ANSI/ISO containers in the AMMOLOG system as part of the present peacetime resupply operations.
- Quantify commercial container availability.
- Determine blocking and bracing alternatives.

STATUS

Container Demonstration: Completed in November 1987. Test results indicated all container types showed promise, especially the side opener. Tailoring the container munitions families is the key.

Commercial Container Survey: This survey, performed by the Department of Transportation, highlighted the need for common inspection criteria for all container users.

Blocking and Bracing Effort: Identified two high payoff solutions—the Load and Roll Pallet (LRP) and TYGARD (a tape system).

PROGRAM PLAN

PM-AMMOLOG will initiate program efforts as follows:

- Pilot program with AMCCOM, MICOM, and MTMC to utilize commercial containers as a supplement to the ammunition restraint MILVAN fleet.
- Blocking and bracing work to develop a matrix listing ammunition types, a container of choice, blocking and bracing procedure, and the benefits/savings to be realized.
- A Simple Container Handling Equipment (SCHE) program to look at NDI hardware that would augment a unit's ability to handle containers.
- Develop a joint service Strategic Transportation Initiative to address consolidated ammunition through past deficiencies for DOD.

Palletized Loading System (PLS) Logistics

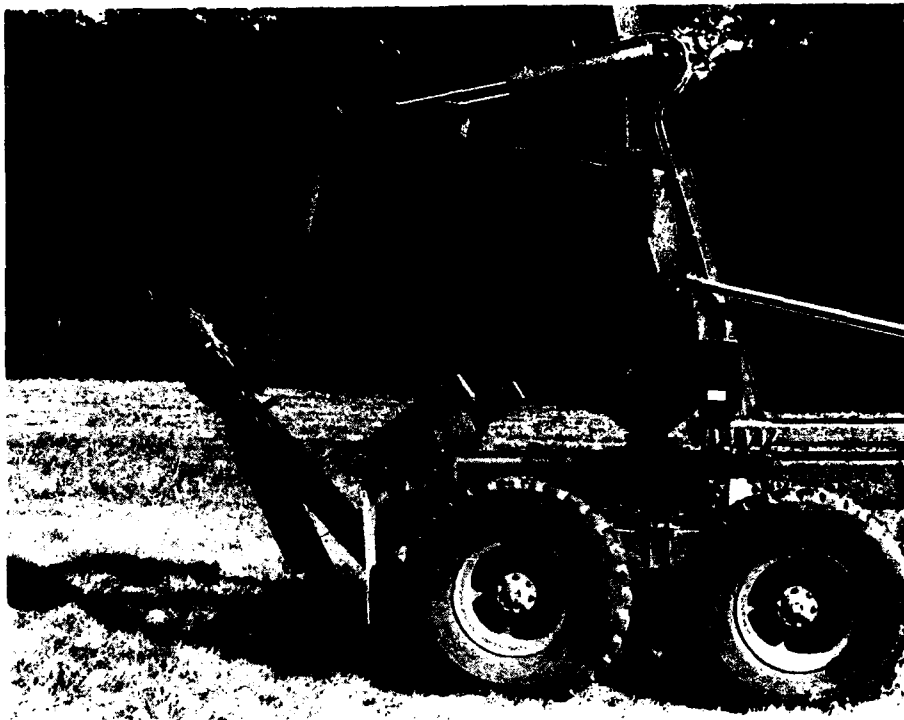

HOOKLIFT INTERFACE KIT (HIK)



AMMUNITION CONTAINER (AMCON)

Palletized Loading System (PLS) Logistics

POINT OF CONTACT

D. Chesnulovitch
PM-AMMOLOG, AMCPM-AL
Picatinny Arsenal, NJ 07806-5000
Autovon 880-4737/Commercial (201) 724-4737

ITEM DESCRIPTION

The present ammunition logistics system in the theater of operations must overcome material handling and transportation shortfalls associated with the delivery of Class V (ammunition) materials to combat units. Currently, two different methods are being examined to meet this need. The concept of PLS Logistics is to demonstrate a direct connectivity between PLS and strategic transportation assets.

The first concept, Hooklift Interface Kit (HIK), is a device that enables the PLS truck to lift, transport, and download any commercial 8 x 20 foot container directly. HIK is made up of two components: an X-frame that attaches to the hook on the load handling system, and a support frame mounted to the rear of the truck. Follow-on prototypes will give the PLS truck driver the flexibility to pick up an ISO container directly with the X-frame or drop the X-frame and pick up any NATO, A-framed flatrack.

The second concept, Ammunition Container (AMCON), is a commercial ISO container design, modified to interface directly with PLS. With this design, AMCONs can be loaded in CONUS and shipped all the way to the weapon system on the battlefield. Future versions of AMCON will be directly compatible with all USAF cargo aircraft as well as 25K and 40K USAF loaders.

STATUS

Two contracts were awarded during June and July 1989 for procurement of two HIKs and two AMCONs. Hardware was received during October 1988. A demonstration of the HIK and AMCON were completed during December 1988.

PROGRAM PLAN

Award Phase II contract for additional HIKs and AMCONs during 3QFY89. USADACS test and validate HIK and AMCON 1QFY90. Transition program to PLS Item Manager 4QFY90.

20-Foot ISO Side-Opening Container

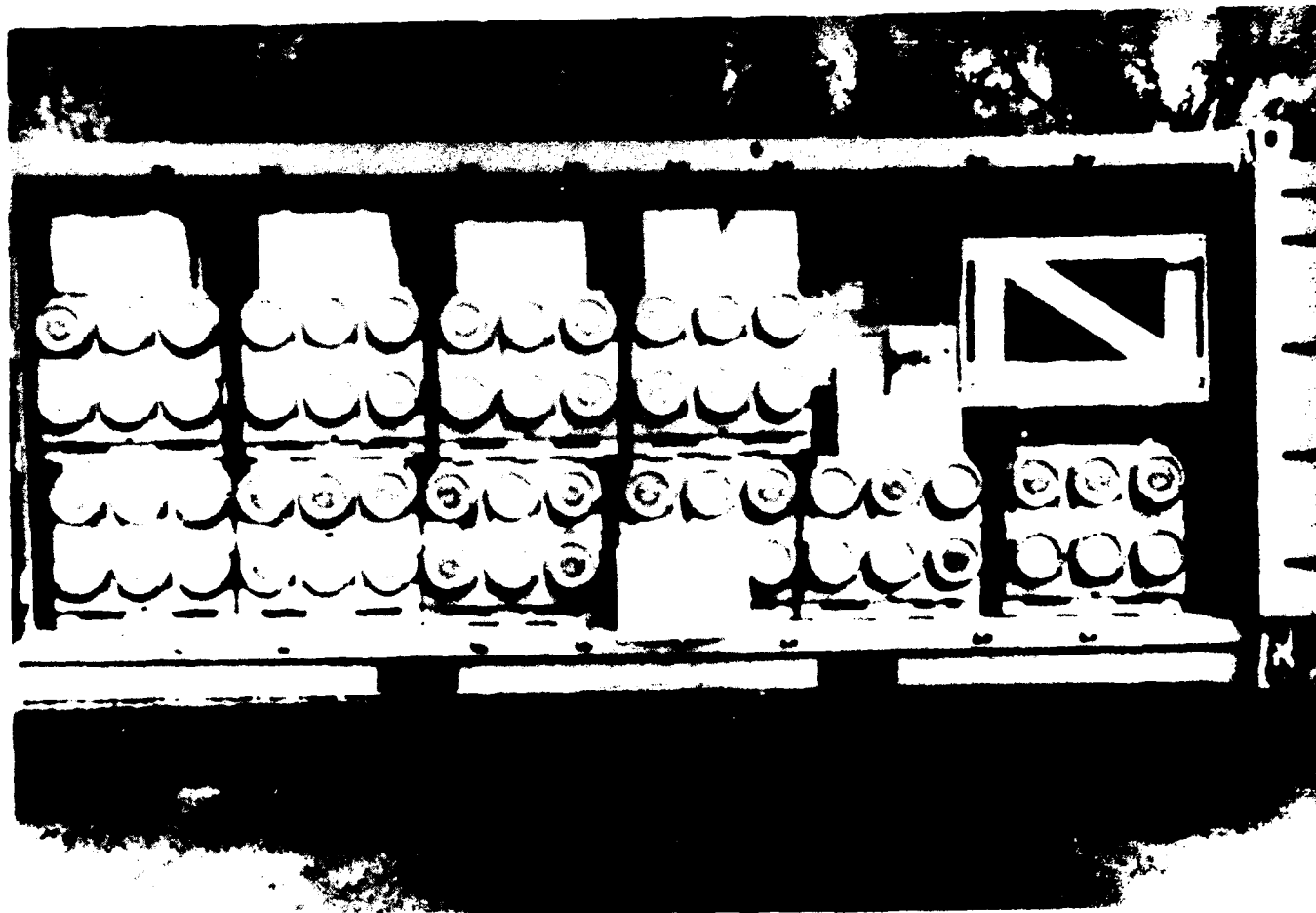

20-Foot ISO Side-Opening Container

POINTS OF CONTACT

J. Weeks

OO-ALC, DSTRM

Hill AFB, UT 84056-5999

Autovon 458-5771/Commercial (801) 777-5771

CMSGT Brooks

HQ USAF, LEYW

Washington, DC 20330

Autovon 227-5760/Commercial (202) 697-5760

ITEM DESCRIPTION

The Air Force is evaluating side-opening ISO containers for munitions storage and shipment. The side-opening container was selected for ease in munitions loading and unloading.

STATUS

HQ USAFE static test loaded side-opening containers with munitions. The initial test was designed to determine the storage capability of side-opening containers for munitions in a complete round configuration. The test also determined the number of fighter aircraft sorties that could be supported by the munitions placed in a single 20-foot container.

HQ USAFE released a request for proposal in FY86 to purchase 20-foot side-opening ISO containers. These containers were initially used as interim munitions storage facilities. As permanent fixed facilities become available, these containers will be used for munitions shipments, if approved.

The Armament Division (AD) leased 10 side-opening ISO containers of three designs:

- One side door, one end door
- Ventilated; full side access doors, one end door
- Side doors, both sides; one end door.

Three containers of each design were shipped to USAFE, PACAF, and MAC for operational testing and evaluation. Test results will be used to determine performance requirements for future Air Force container buys.

PROGRAM PLAN

The urgent need to improve munitions storage capability in USAFE necessitated procuring containers before AD testing is complete.

ISO Tactical Shelter

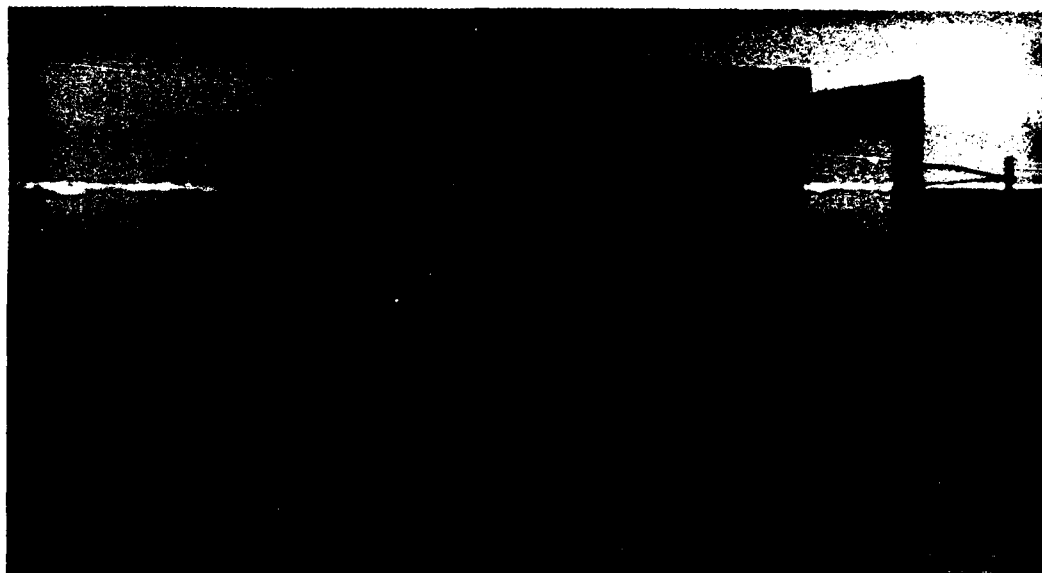

ISO Tactical Shelter

POINT OF CONTACT

A. Murphy
US Army Natick RD&E Center (STRNC-UST)
Natick, MA 01760-5017
Autovon 256-5246/Commercial (508) 651-5246

ITEM DESCRIPTION

An ISO Tactical Shelter is a presized, transportable structure designed for a functional requirement and provides a live-in, work-in or container capability. This structure can be either expandable or non-expandable and will conform to applicable ANSI/ISO container standards. All services are increasing their utilization of the shelter concept, and the impact of shelters on the transportation and materiel handling system will become more and more significant in coming years. A standard family of 20-foot rigid wall ISO shelters has been developed by the US Army Natick Research, Development and Engineering Center for DOD use. The shelter family includes three types:

- Non-Expandable Shelter, Tactical (11,100 pound payload)
- One-Side Expandable Shelter, Tactical (9,700 pound payload)
- Two-Side Expandable Shelter, Tactical (8,300 pound payload)

STATUS

ISO Tactical Shelters have completed development and a Technical Data Package is finalized. The First Production contract was awarded on 27 April 1984 for 762 shelters with an FY85 option for 200% more. Initial production deliveries began in December 1985. A total of 1,739 shelters will be delivered under this contract with delivery up through December 1988. The following quantities represent standard ISO shelters procured since 1978 for both the Army Formal Shelter Development Program and for specific new Navy, Air Force, and Army ISO sheltered systems:

	Approximate Quantity
ISO Tactical Shelter (Non-Expandable)	7
ISO Tactical Shelter (One-Side Expandable)	1,035
ISO Tactical Shelter (Two-Side Expandable)	697

In August 1988 a contract was awarded for 700 Army Standard Family ISO Tactical Shelters with a 100% option.

PROGRAM PLAN

Conduct contract and field ISO Tactical Shelters.

PLS Container (COMPODS)

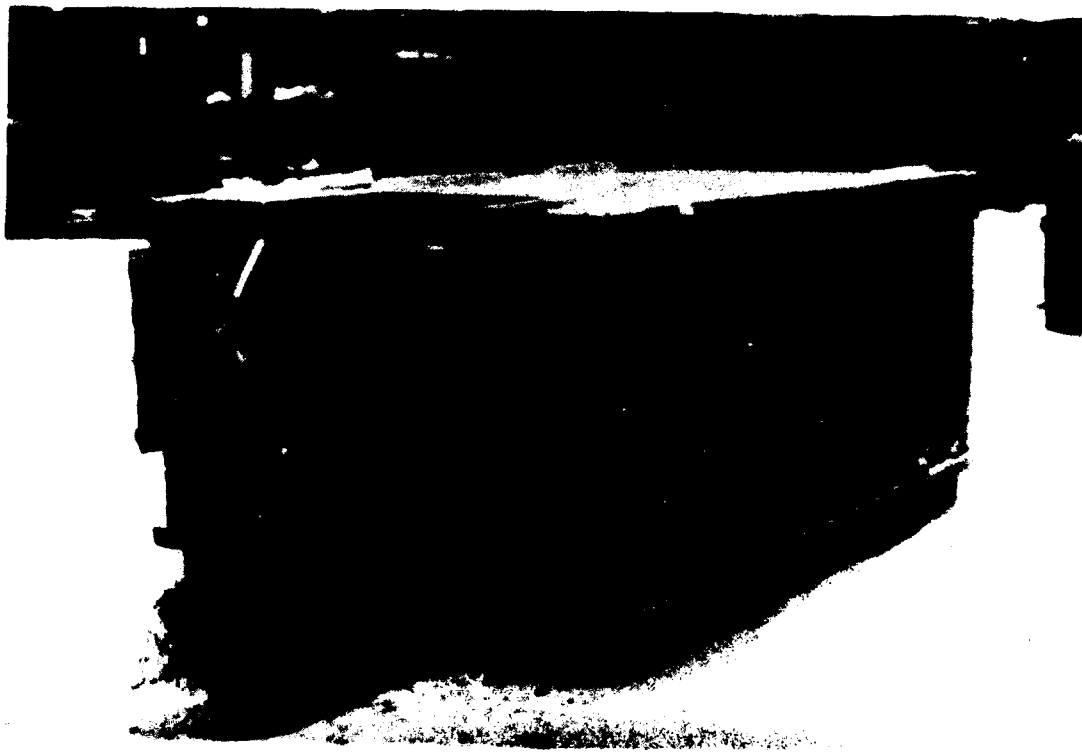
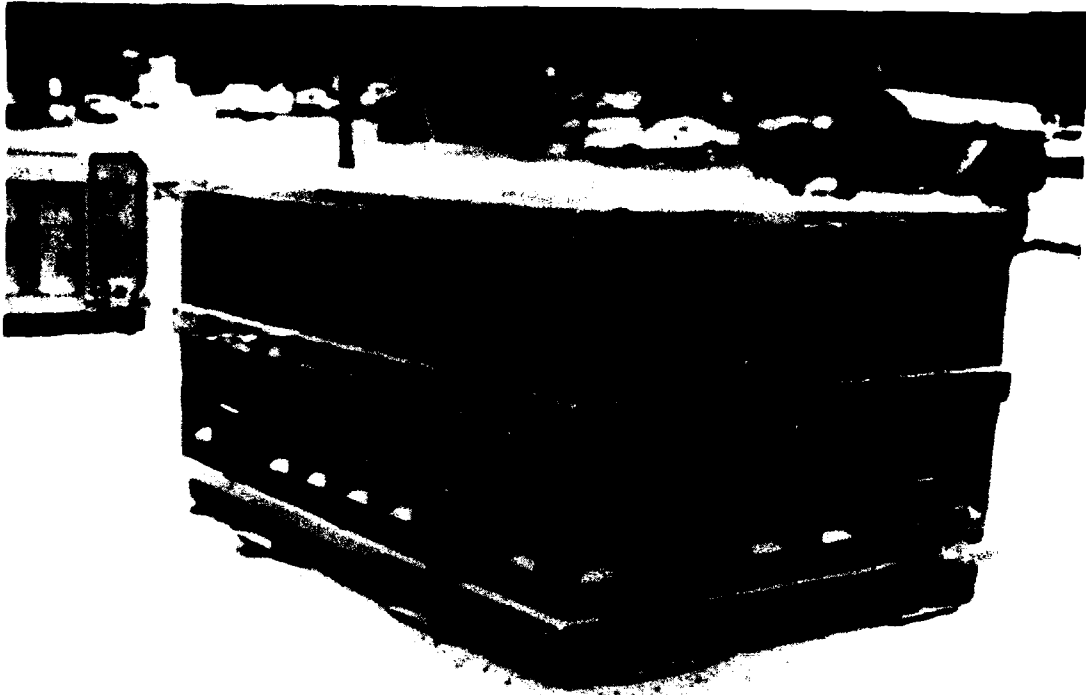

PLS Container (COMPODS)

POINT OF CONTACT

N. Fertman
US Army Belvoir RD&E Center, STRBE-FMR
Fort Belvoir, VA 22060-5606
Autovon 354-1143/Commercial (703) 664-1143

ITEM DESCRIPTION

Containers were adapted from commercial designs for use on the palletized loading system (PLS) flatracks. Basic design was a pallet and "butterdish" cover for the dry freight, and tank containers for water and fuels. The containers were equipped with four-way forklift pockets and lifting/tiedown fittings. They were 4 x 5 x 8 foot and sized so that eight units fit in a MILVAN or on an ISO flatrack. The units stack and nest. The tank units were equipped with a handpump for fluid transfer in the field.

STATUS

Units have been tested at the Army Development Employment Agency (ADEA) Fort Lewis, WA, and Belvoir RD&E Center. The units were returned to the contractor at the end of the test lease.

PROGRAM PLAN

None.

Part II

Handling Equipment

Palletized Loading System (PLS)

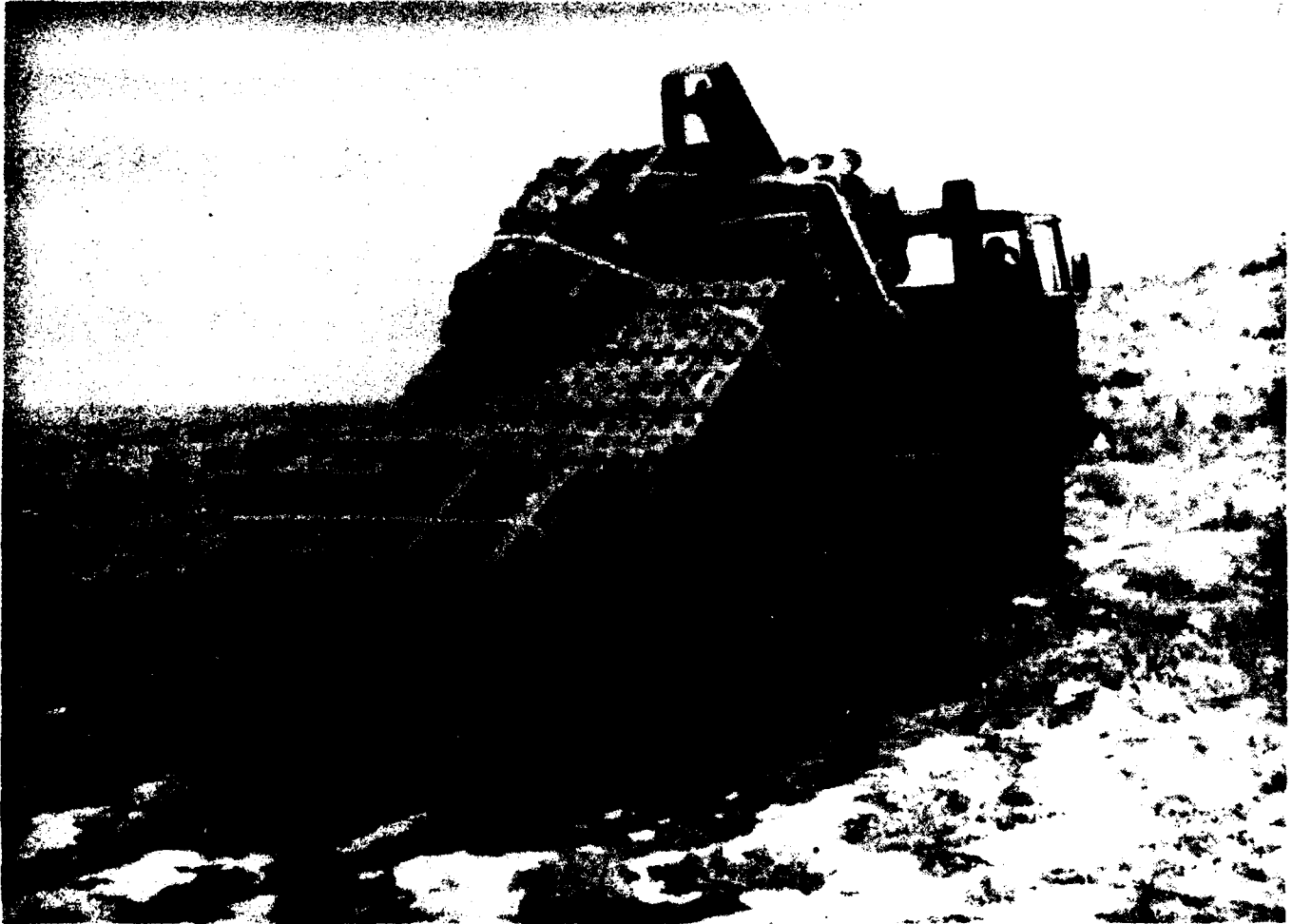

Palletized Loading System (PLS)

POINT OF CONTACT

COL W. Heggie
US Army Tank-Automotive Command, AMCPM-TVH
Warren, MI 48397-5000
Autovon 786-5800/Commercial (313) 574-5800

ITEM DESCRIPTION

The Palletized Loading System (PLS) consists of a standard mobility heavy truck chassis, an integral hydraulic load handling mechanism, a compatible trailer, and a number of flatracks. The system is capable of self-loading and self-unloading the flatracks from the ground onto the truck chassis using the integral load handling system. The vehicle-mounted load handling system also has the capability to load and unload flatracks onto the companion trailer. Both the truck and the companion trailer have a 16.5 ton payload capacity.

STATUS

Three heavy (15-ton payload) PLSs were evaluated for 2 years by ADEA and the 9th ID at Fort Lewis, WA. Three additional heavy and 15 medium (7.5-ton payload) PLSs were evaluated by ADEA between 2QFY85 and 2QFY86. Under a separate program, the Tank-Automotive Command (TACOM) leased 46 PLSs of 10- and 15-ton payloads for use in Force Development Test and Evaluation (FDTE) at Fort Hood, TX, during 1QFY87. The results showed the advantages of PLS in the distribution of ammunition.

PROGRAM PLAN

The solicitation for producing PLS prototypes was released and the prototype contract award made on 18 January 89. The production contract is planned for 3QFY90.

Spreader Bars, Intermodal Container Handling

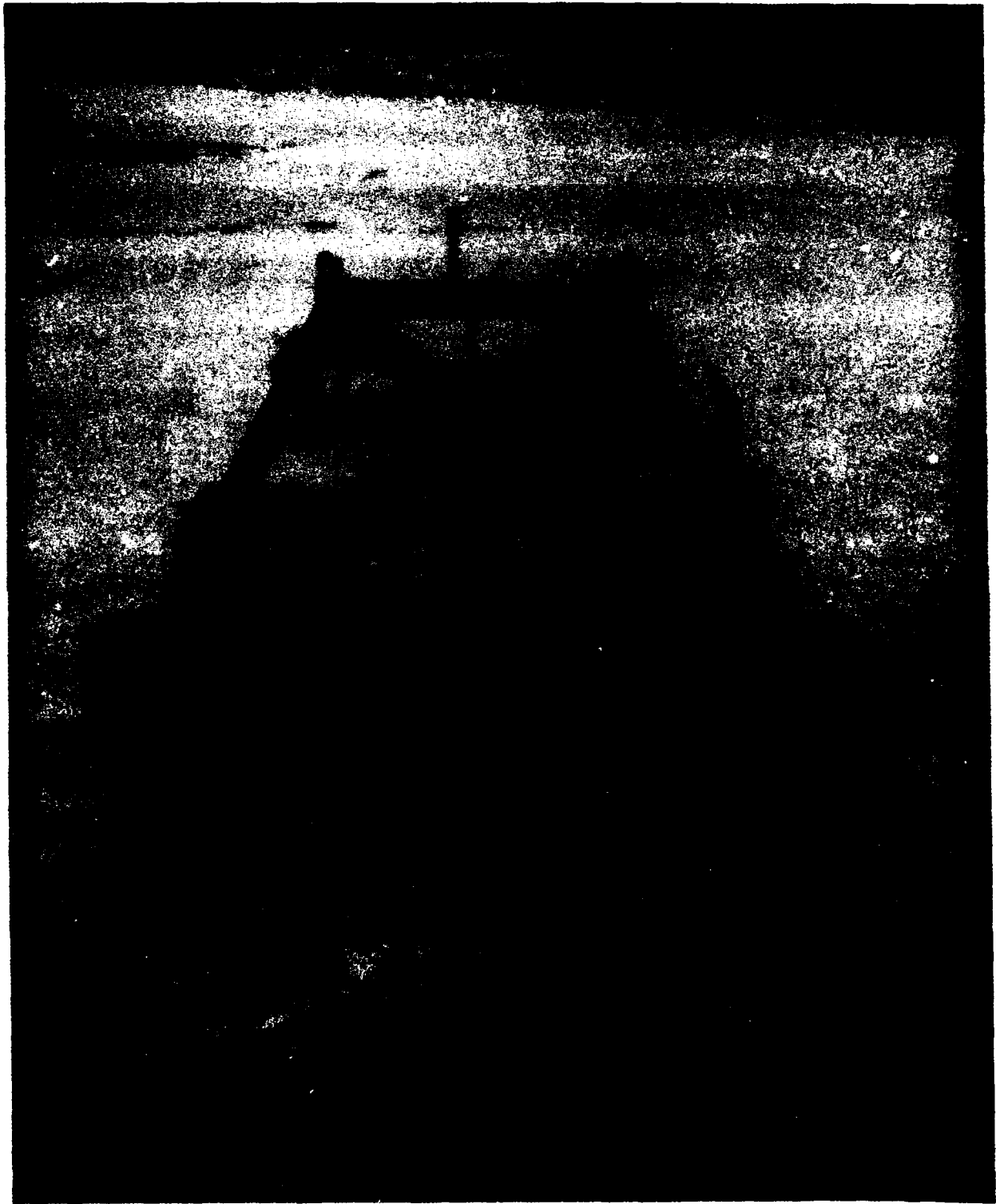

Spreader Bars, Intermodal Container Handling

POINT OF CONTACT

R. Riley
US Army Belvoir RD&E Center, STRBE-FMR
Fort Belvoir, VA 22060-5606
Autovon 354-4490/Commercial (703) 664-4490

ITEM DESCRIPTION

A manually operated locking frame, conforming to MIL-S-52713B(ME), used for lifting and handling ISO and intermodal containers.

STATUS

A contract was awarded in FY87 to Isometrics, Inc., for 476 20-foot spreaders and 154 40-foot spreaders. These spreaders were procured in support of the Rough Terrain Container Crane (RTCC), currently in production. First Article Testing of the spreaders was conducted in two phases: the first phase was successfully conducted at the manufacturers facilities, and the second phase was conducted in conjunction with the First Article Test for the RTCC.

PROGRAM PLAN

No additional procurement actions have been scheduled.

Spreader Bars, Intermodal Container Handling, Lightweight Expandable

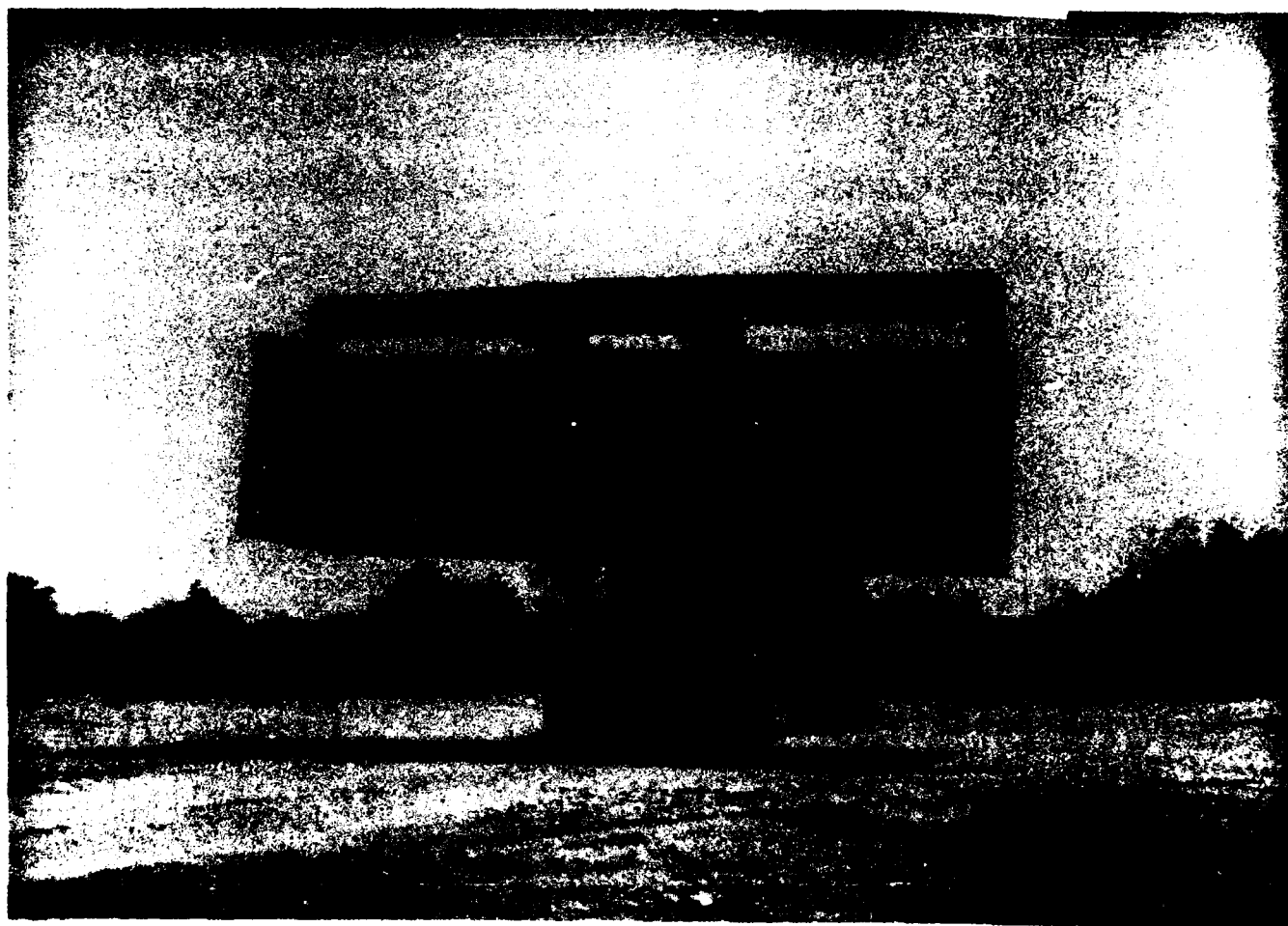

Spreader Bars, Intermodal Container Handling, Lightweight Expandable

POINT OF CONTACT

R. Riley
US Army Belvoir RD&E Center, STRBE-FMR
Fort Belvoir, VA 22060-5606
Autovon 354-4490/Commercial (703) 664-4490

ITEM DESCRIPTION

The lightweight expandable spreader bar is an electro/hydraulic activated spreader used with the Army's 50,000-pound capacity Rough Terrain Container Handler (RTCH) for lifting and handling ISO and intermodal containers. The spreader weighs under 10,000 pounds and is capable of expanding longitudinally to handle 20-, 35-, and 40-foot containers.

STATUS

Three lightweight expandable spreader bars were obtained on loan from various commercial manufacturers during FY84. Conceptual testing, conducted at Fort Belvoir, VA, was completed during FY85. Two lightweight expandable spreaders were procured during FY86 for additional testing. Concept Evaluation Program (CEP) tests were conducted at Fort Eustis, VA, during FY86. Results of the CEP tests were evaluated during FY87. The Transportation School recommended that additional CEP testing be conducted. The additional CEP testing was conducted at Fort Eustis, VA during 4QFY88.

PROGRAM PLAN

The additional CEP test reports will be published during 3QFY89. Results from this additional testing will be used to develop Organizational and Operational (O&O) Plan.

Mobile Loading Ramp

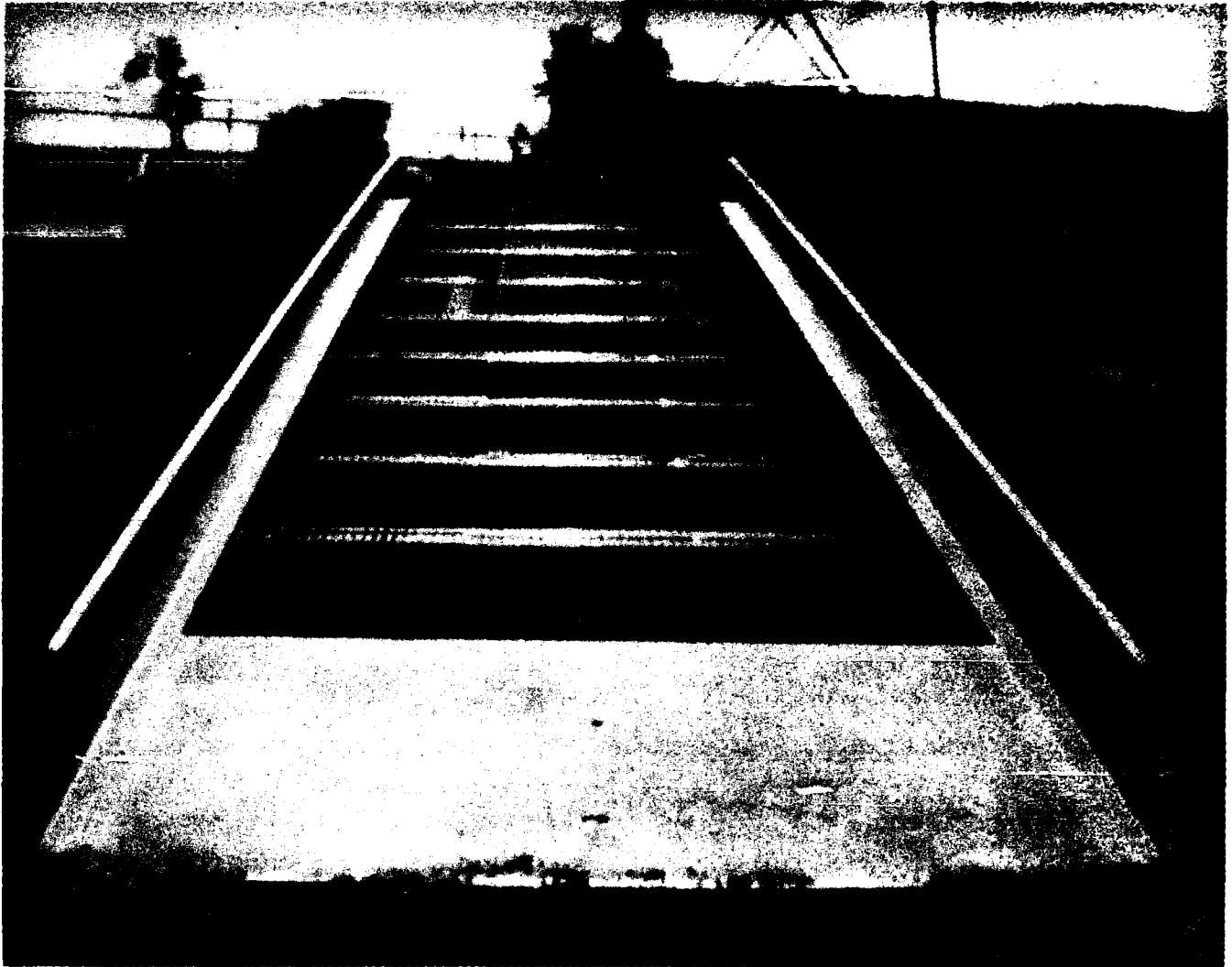

CAPACITY: 16,000 POUNDS
LENGTH: 36 FEET INCLUDING 6 FOOT LEVEL-OFF SECTION
WIDTH: 8 FEET APPROXIMATELY
HEIGHT: ADJUSTABLE FROM 46 INCHES TO 65 INCHES
WEIGHT: 6,000 POUNDS APPROXIMATELY

Mobile Loading Ramp

POINT OF CONTACT

N. Fertman
US Army Belvoir RD&E Center, STRBE-FMR
Fort Belvoir, VA 22060-5606
Autovon 354-1143/Commercial (703) 664-1143

ITEM DESCRIPTION

This item is used in conjunction with the 4,000-pound Rough Terrain Forklift Truck for stuffing and stripping the 8 foot wide family of containers when the container is on a semitrailer/chassis. The ramp is 96 inches wide; 36 foot long, including a 6-foot, level-off section; weighs approximately 6,000 pounds; and costs approximately \$6,500. The bed height is adjustable from 45 to 65 inches.

STATUS

A firm fixed price contract was awarded to Magline, Inc., for 83 commercial units. The preproduction testing was completed in March 1976. Final production delivery took place as scheduled for June 1976 through April 1977. A contract was negotiated with Magline, Inc., to increase the curb height to 12 inches on the 83 fielded ramps to overcome safety deficiencies. Delivery of the Magline ramps has been completed. A second multi-year contract was awarded in November 1977 to Brooks and Perkins, Inc., to provide an additional quantity of 346 ramps. Under the option in the Brooks and Perkins contact, additional quantities of 346 units were procured. A two-step multi-year procurement contract was awarded to Magline, Inc., in 4QFY81 for additional ramps. A total of 828 ramps were delivered.

PROGRAM PLAN

Next procurement is planned for FY90 and FY91.

4,000-Pound Capacity Forklift Truck, Rough Terrain (RTFLT)



CAPACITY: 4,000 POUNDS AT 24 INCHES LC
LENGTH WITH FORKS: 205 INCHES
WIDTH: 79 INCHES
HEIGHT WITH ROPS: 80 INCHES
WEIGHT: 10,000 POUNDS

4,000-Pound Capacity Forklift Truck, Rough Terrain (RTFLT)

POINT OF CONTACT

W. Brower
US Army Belvoir RD&E Center, STRBE-FMR
Fort Belvoir, VA 22060-5606
Autovon 354-1143/Commercial (703) 664-1143

ITEM DESCRIPTION

This item provides a capability of stuffing and stripping the 8 foot wide family of containers under field conditions. The vehicle is sized to effectively operate within the container including placing two pallet loads side by side within the container. The vehicle weighs approximately 10,000 pounds, is 79 inches wide, 80 inches high, and 165 inches long, excluding forks.

STATUS

A multi-year contract was awarded to J. I. Case Company during FY78. A total of 1,910 forklifts were delivered between August 1980 and July 1984. Initial fielding of 209 units was made to Korea and USAREUR. Additional fielding was made on call-up.

PROGRAM PLAN

Perform necessary actions as required to support the fielded forklifts. A solicitation for a production contract for 786 vehicles was issued 10 March 1989 with award scheduled for 4QFY89.

**6,000-Pound Capacity Variable Reach Forklift Truck,
Rough Terrain (6K VRRTFLT)**



6,000-Pound Capacity Variable Reach Forklift Truck, Rough Terrain (6K VRRTFLT)

POINTS OF CONTACT

D. Krawchuk

US Army Belvoir RD&E Center, STRBE-FMR
Fort Belvoir, VA 22060-5606

Autovon 354-1143/Commercial (703) 664-1143

MAJ J. Smith

Dep CG, Marine Corps RD&A Command, SSEA
Quantico, VA 22134-5080

Autovon 278-2022/Commercial (703) 640-2022

ITEM DESCRIPTION

This item provides a capability of loading and unloading the 8 x 8 x 20-foot MILVAN and ISO containers on the ground or mounted on the M871 Trailer under field conditions. The vehicle is designed to handle the Multiple Launch Rocket System (MLRS) pods loaded four to a container requiring a 6,000-pound capacity at a 15-foot reach, and also handle 4,000-pound Ammunition Pallets in containers requiring a reach of 23.5 feet. The vehicle weighs 27,200 pounds, has a width of 102 inches, height of 101 inches, and a length, excluding forks, of 253 inches. The vehicle is essentially a modified commercially available non-developmental item (NDI) and will replace the 6,000-pound Rough Terrain Forklift when fielded.

STATUS

The 6K VRRTFLT was Type Classified for Army use in November 1984. A production contract was awarded to TRAK International in January 1988.

The Marine Corps, under its Extendable Boom Forklift (EBFL) Program, awarded a production contract 30 September 1988 to Lull Corporation for a 10,000-pound capacity forklift.

PROGRAM PLAN

The US Army's expected FUE is 1QFY90. US Marine Corps' FUE is expected to be during FY90.

4,000-Pound Capacity Forklift Truck



CAPACITY: 4,000 POUNDS AT 24 INCH LC
LENGTH WITH FORKS: 145 INCHES
WIDTH: 45 INCHES
HEIGHT WITH ROPS: 81 INCHES

4,000-Pound Capacity Forklift Truck

POINTS OF CONTACT

R. Riley

US Army Belvoir RD&E Center, STRBE-FMR
Fort Belvoir, VA 22060-5606

Autovon 354-4490/Commercial (703) 664-4490

COL Drum

Warner Robins Air Logistics Center,
WRALC/MMVV

Robins AFB, GA 31098-5609

Autovon 468-2062/Commercial (912) 926-2062

ITEM DESCRIPTION

This unit provides Air Force bases and Army Depots the capability to load and unload ISO containers. It is a commercial type pneumatic tired forklift with a lift height of at least 144 inches. The forklift has a capacity of 4,000 pounds at a 24-inch Load Center.

STATUS

The Army has an inventory of approximately 1,700 gasoline engine powered units.

PROGRAM PLAN

In FY85, the Army awarded a 5-year contract to Hyster to procure approximately 1,056 clean-burn, diesel engine powered units.

The Air Force is planning a reprocurement contract in 4QFY89.

50,000-Pound Capacity Container Handler, Rough Terrain (RTCH)

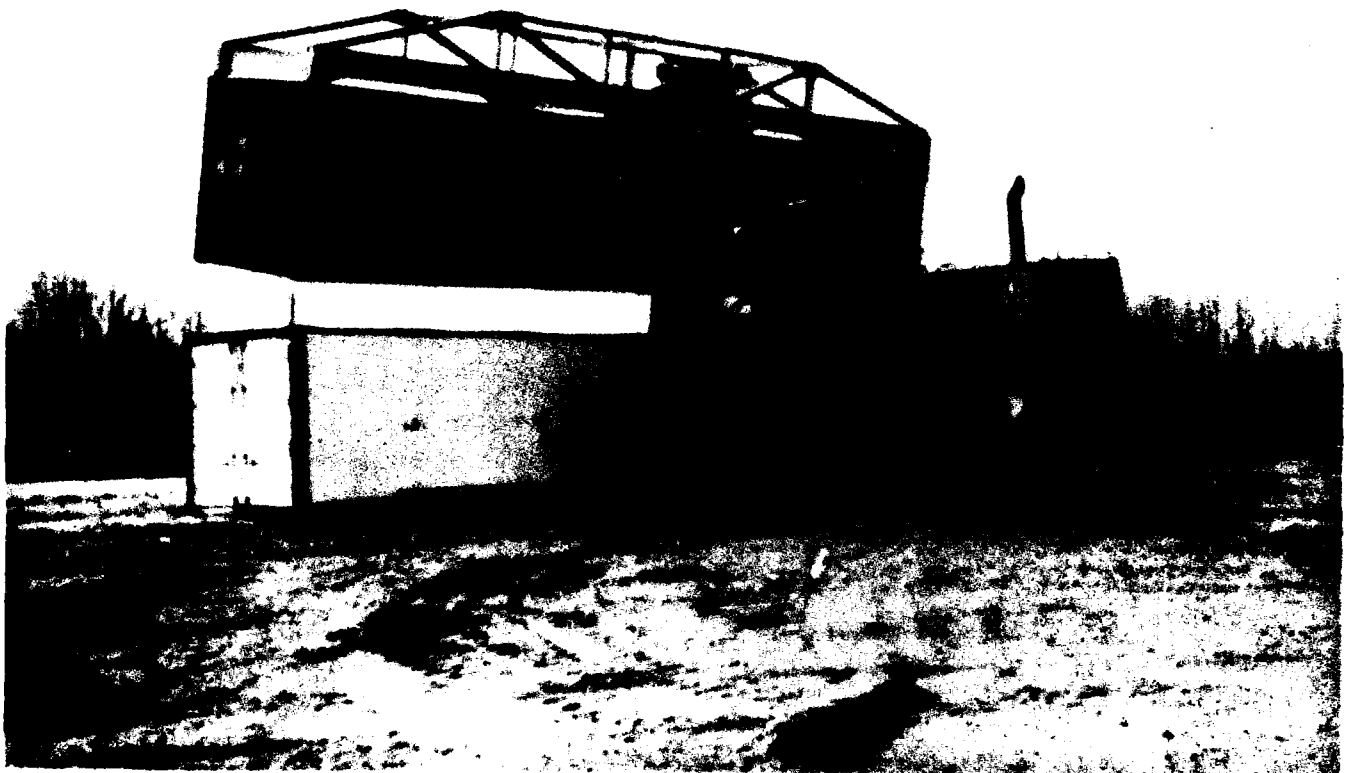

CAPACITY: 50,000 POUNDS AT 48 INCHES LC
LENGTH: 420 INCHES
WIDTH: 138 INCHES
HEIGHT: 167 INCHES
WEIGHT: 103,000 POUNDS (W/O SPREADER)

SPREADER BAR WEIGHTS

20 FEET: 3,800 POUNDS
35 FEET: 9,120 POUNDS
40 FEET: 9,927 POUNDS

50,000-Pound Container Handler, Rough Terrain (RTCH)

POINTS OF CONTACT

N. Fertman

US Army Belvoir RD&E Center, STRBE-FMR
Fort Belvoir, VA 22060-5606

Autovon 354-1143/Commercial (703) 664-1143

MAJ J. Smith

Dep CG, Marine Corps RD&A Command, SSEA
Quantico, VA 22134-5080

Autovon 278-2022/Commercial (703) 640-2022

COL Drum

Warner Robins Air Logistics Center, WRALC/MMVV
Robins AFB, GA 31098-5609

Autovon 468-2062/Commercial (912) 926-2062

ITEM DESCRIPTION

This item provides a capability of handling the 8 foot wide family of containers weighing up to 50,000 pounds and 20-, 35-, and 40-foot long. It is capable of operating as a rough terrain truck primarily in supply holding storage and marshalling areas by selected supply, ammunition, and transportation units. The RTCH is a modified commercial design and procured to a military specification. The vehicle weighs approximately 103,000 pounds, is 138 inches wide, 167 inches high, and 35 feet long.

STATUS

A multi-year contract was awarded to the Caterpillar Tractor Company for 344 units. The Air Force procured three of these trucks for use with CADS shipments, and the Marine Corps procured 21 trucks. Production and delivery of all units have been completed. The Marine Corps increased their quantity to a total of 68 trucks by awarding a contract for the additional RTCHs which were delivered in FY88. Ten trucks are aboard each Maritime Prepositioning Ship Squadron.

PROGRAM PLAN

Provide support for fielded units. The Marine Corps' truck deliveries to the FMF began in FY88 and are scheduled to be completed by FY89. The Air Force is scheduled to field four additional trucks in FY89 with six scheduled for FY90.

Rough Terrain Container Transporter (RTCT)

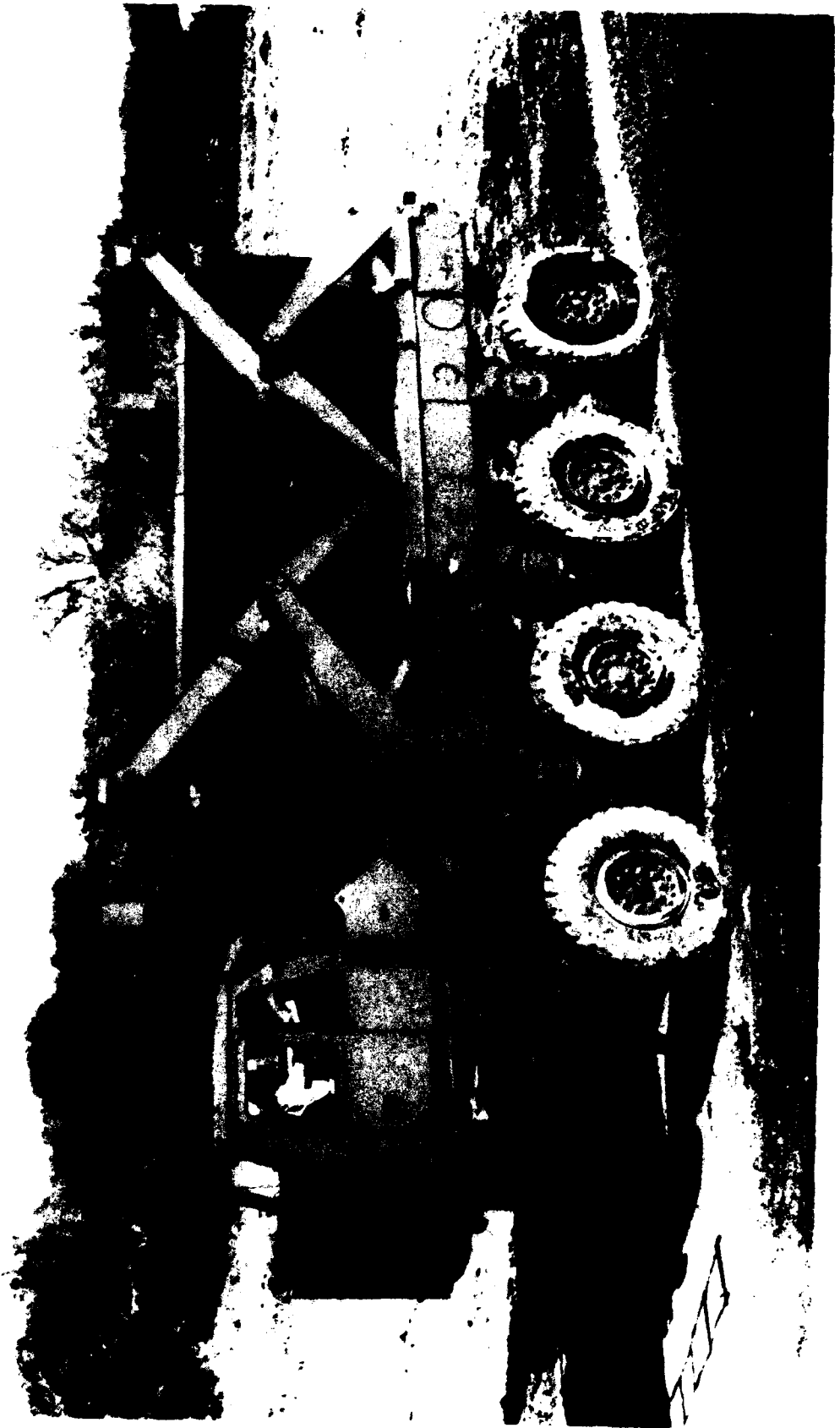

Rough Terrain Container Transporter (RTCT)

POINTS OF CONTACT

D. Dodge
US Army Belvoir RD&E Center, STRBE-FMR
Fort Belvoir, VA 22060-5606
Autovon 354-1143/Commercial (703) 664-1143

MAJ J. Smith
Dep CG, Marine Corps RD&A Command, SSEA
Quantico, VA 22134-5080
Autovon 278-2022/Commercial (703) 640-2022

ITEM DESCRIPTION

The RTCT will self-load, transport, ground, and stack 20-foot long ISO shelters and shipping containers weighing up to 50,000 pounds. It will be used by US Marine Corps units and US Army Transportation units to off-load ISO containers from beached landing craft and transport them through the surf and over land to marshalling areas in Logistics-Over-The-Shore (LOTS) operations. The RTCT will ground and stack the containers or place them on flatbed semi-trailers for transport over paved highways. The RTCT may also be used by medical units and maintenance units to deploy field hospitals and maintenance shelters in forward battle areas. The hydrostatic drive undercarriage will provide superb rough terrain mobility when transporting shelters and containers at speeds up to 30 mph. The RTCT will have a variable width ranging from 102 to 156 inches.

STATUS

The RTCT is currently completing the Proof of Principle (POP) phase of the research and development process. An Operational and Organizational (O&O) Plan has been approved. The POP prototype being tested has successfully proven the concept of handling 20-foot ISO Containers. Engineer Design Tests and Force Development Test and Evaluation were completed during FY87.

PROGRAM PLAN

Testing by the Marine Corps of the RTCT is being conducted at Port Hueneme, CA. The US Marine Corps is conducting a parallel effort entitled *Container Handler - All Purpose (CHAP)*. Under this program, the Marine Corps has evaluated a tracked version of a container handler. Advanced Development testing has been completed with the CHAP and Engineering Development testing is planned for FY89. Test data from both prototypes will be jointly evaluated by both the Army and Marine Corps throughout the research and development program. The RTCT will be fielded in FY95 as a replacement for the Lightweight Amphibious Container Handler (LACH). It will also supplement the Rough Terrain Container Handler (RTCH) and the Rough Terrain Container Crane (RTCC) in LOTS operations.

20/40-Foot Container Sideloader

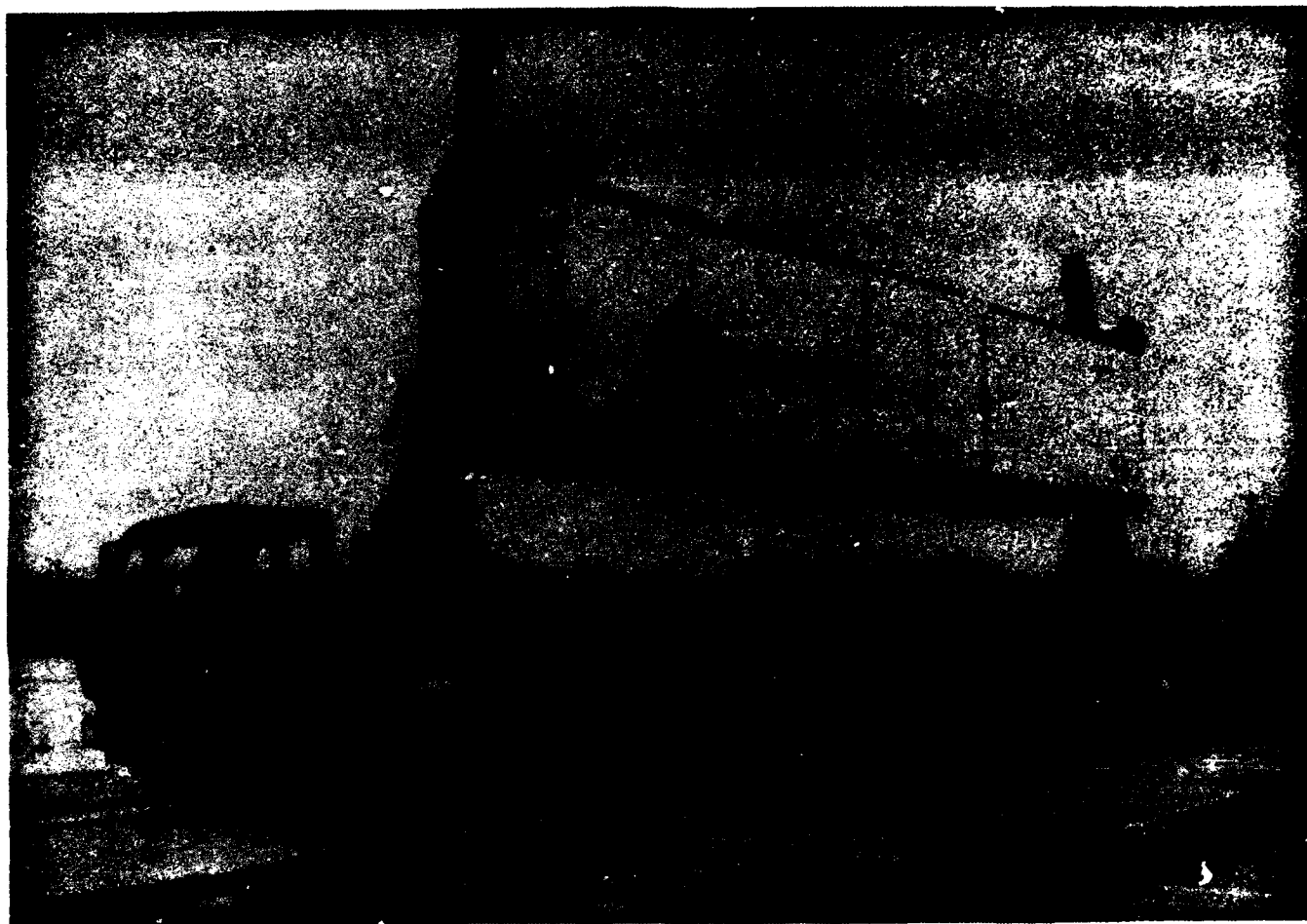

20/40 Foot Container Sideloader

POINTS OF CONTACT

W. Allenbacher
HQ US Air Force Europe, LGTT
Ramstein AB, GE, APO New York 09094
Autovon 480-6321/7468
Commercial 06371-47-6321/7468

N. Fertman
US Army Belvoir RD&E Center, STRBE-FMR
Fort Belvoir, VA 22060-5606
Autovon 354-1143/Commercial (703) 664-1143

ITEM DESCRIPTION

This diesel-powered container sideloader is capable of transferring or self-loading and transporting 20- through 40-foot ISO containers or tactical shelters. Maximum lifting capability is 66,150 pounds, with an additional 10 percent safety weight factor built-in. The unit has a telescopic spreader bar for 20-, 35-, and 40-foot containers, and will also operate/lift containers with slings. The sideloaders can transport containers within maximum road height limitations. They also have an air ride suspension making it viable to transport ISO containers carrying delicate equipment. The unit is self-deployable by road and possibly by C-5 military airlift. Estimated unit cost, with 26-ton tractor, is approximately \$200,000. The tractor is optional.

STATUS

Four Klaus handlers were procured for Miesau Army Ammo Depot in 1972 to meet an urgent requirement for container handling. A BeSima/Marmon handler and a Steadman handler were procured and evaluated by Belvoir RD&E Center in 1975-76. The Steadman handler was subsequently provided to ASP-1 Vilseck, Germany. In August 1978, four additional Klaus handlers with tractors were procured for Army use at ASP-1. In 1982, the Air Force successfully tested the use of a sideloader (on loan from the Army) during an Air Force CADS movement to Germany. USAFE purchased two sideloaders in early 1984 under the Productivity Investment Program. These sideloaders are presently assigned to Morbach Munitions Depot and were used successfully to support several CADS movements in both MILVANs and SEAVANs during 1984. The Program Objective Memorandum (POM) was approved for an additional 30 sideloaders for USAFE. These sideloaders will be used throughout Europe to support CADs and ISO container moves. USAFE received 27 40-foot sideloaders between FY86 and FY88. The Army in Germany has met its inventory objective of 18 units for 20-foot container (44,800-pound) capacity sideloaders.

PROGRAM PLAN

USAFE is planning a procurement of eight 20-foot sideloaders during FY90 or FY91. The Army has no active program for this item.

Lightweight Amphibious Container Handler (LACH)

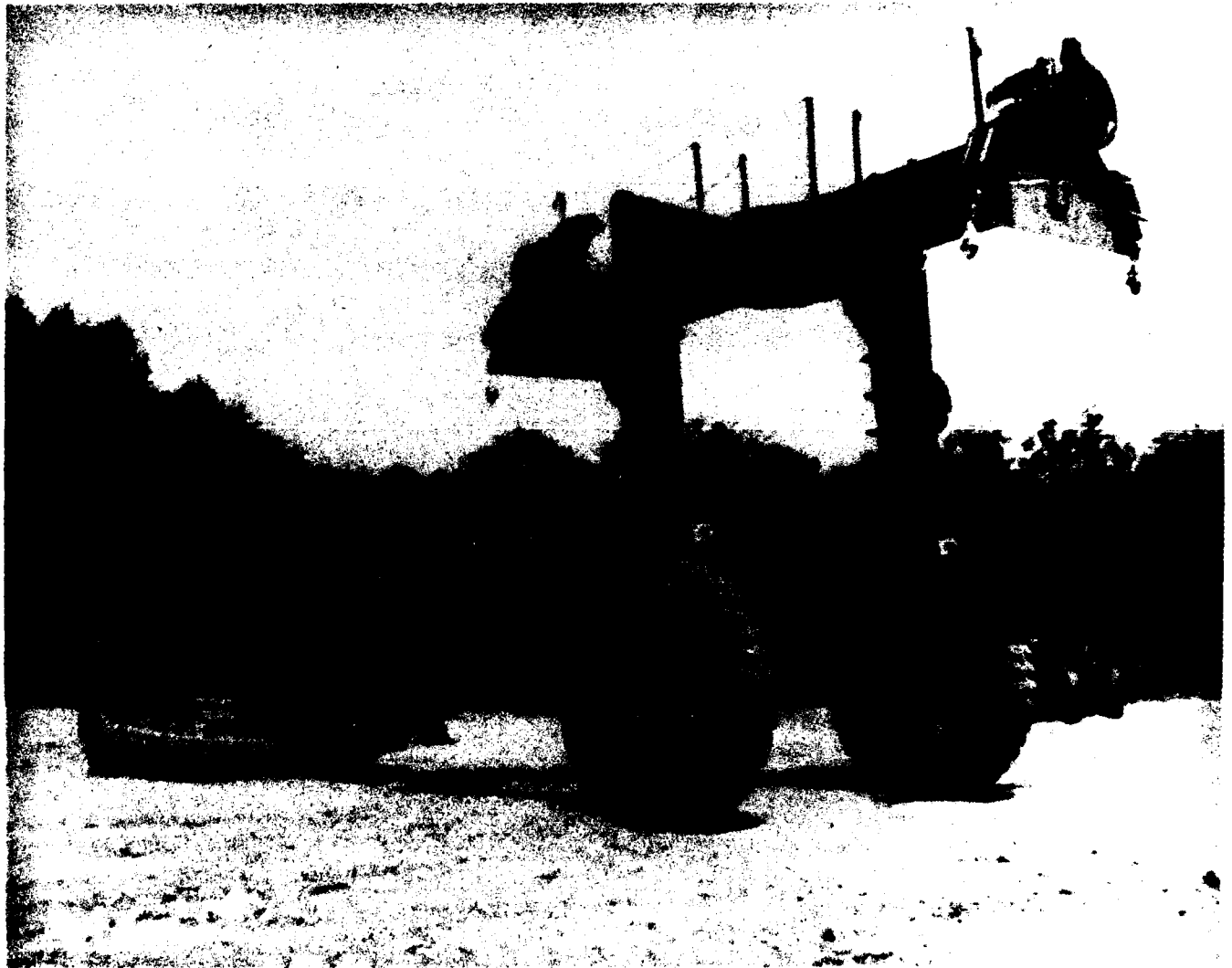

Lightweight Amphibious Container Handler (LACH)

POINT OF CONTACT

MAJ J. Smith
Dep CG, Marine Corps RD&A Command, SSEA
Quantico, VA 22134-5080
Autovon 278-2022/Commercial (703) 640-2022

ITEM DESCRIPTION

The LACH is a straddle-lift type, towed, two-wheel mounted, container handler. The LACH is capable of lifting and carrying containers, ramp entry into large landing craft, and loading and unloading containers onto/from cargo trailers during amphibious operations. The LACH, when propelled by its prime mover (medium size bulldozer), can be maneuvered in the surf zone in up to 5 feet of water with a 20-foot container weighing up to 50,000 pounds.

STATUS

FY81 funds were appropriated for the production procurement of 56 LACHs to complete the Marine Corps inventory objective. All LACHs have been delivered to MCLBs. Each Maritime Prepositioning Ship Squadron were equipped with four LACHs.

PROGRAM PLAN

No additional procurement actions are planned.

Rough Terrain Container Crane (RTCC)

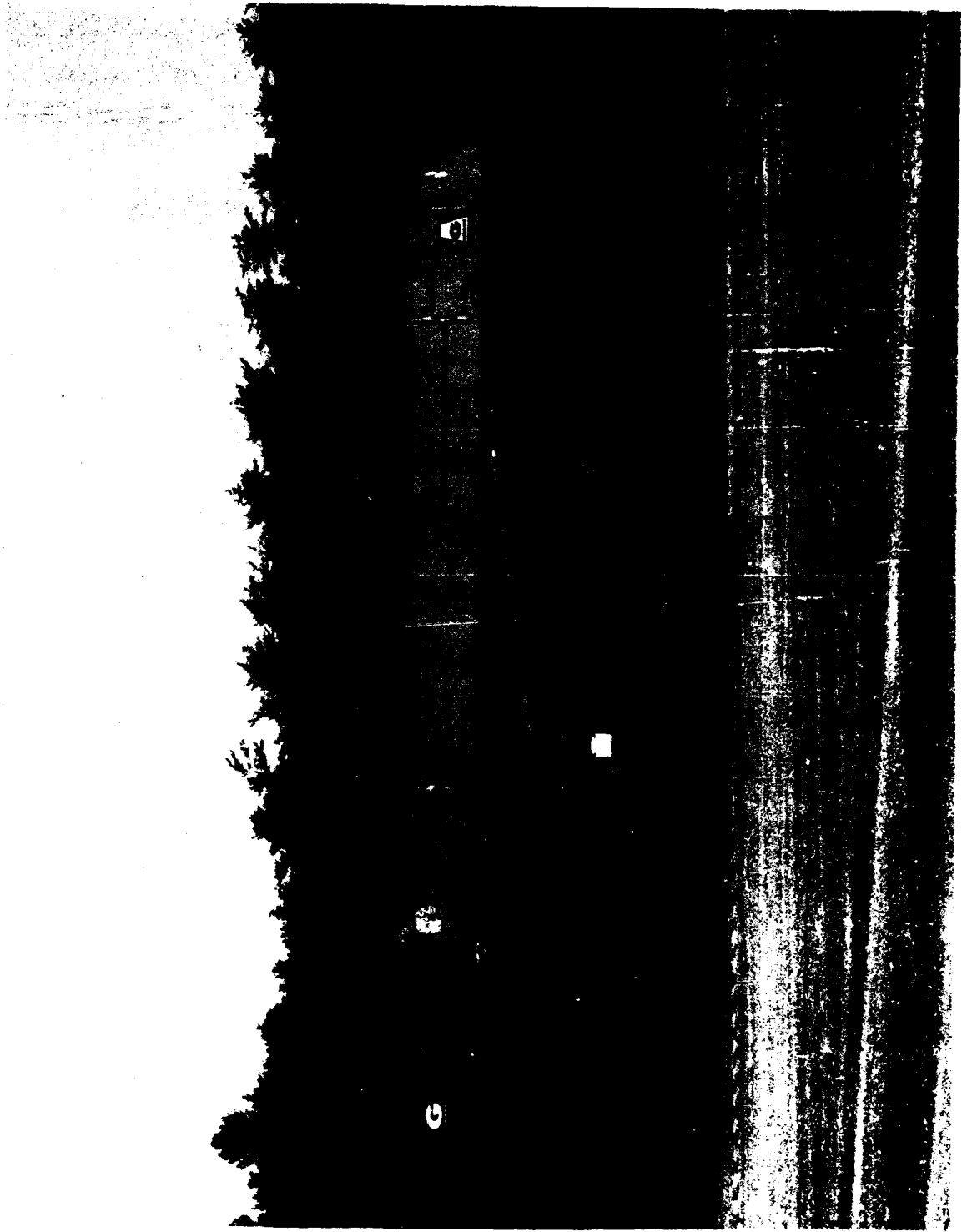

Rough Terrain Container Crane (RTCC)

POINT OF CONTACT

V. Batson
US Army Belvoir RD&E Center, STRBE-FMR
Fort Belvoir, VA 22060-5606
Autovon 354-4490/Commercial (703) 664-4490

ITEM DESCRIPTION

The crane will be commercial design, truck-mounted, capable of lifting a 20-foot container weighing 44,800 pounds at a radius of 27 feet and a 35/40-foot container weighing 67,200 pounds at a radius of 22 feet. General Support (GS) ammunition units will use the RTCC "from a fixed position" for transfer of 20-foot ANSI/ISO containers from one mode of transportation to another or to ground/ load containers from/to waiting transportation in the Theater and Corps ammunition storage areas. Transportation units will use the crane to augment the 50,000-pound Rough Terrain Container Handler in the transfer and handling of 20-, 35-, or 40-foot containers and other cargo between transportation modes and in storage areas.

STATUS

A Market Investigation has been completed and a specification prepared. Two candidate cranes were leased and evaluated. The crane was type classified standard and was transitioned to the US Army Tank-Automotive Command (TACOM). A contract was awarded to Grove Manufacturing Company. Preproduction testing was conducted 1QFY88 to 4QFY88. Initial production testing is currently being conducted.

PROGRAM PLAN

TACOM procurement schedule is:

FY89 - 170 trucks
FY90 - 84 trucks

Production will begin 2QFY89 and delivery will begin 2QFY89.

140-Ton, Truck-Mounted, Container Handling Crane

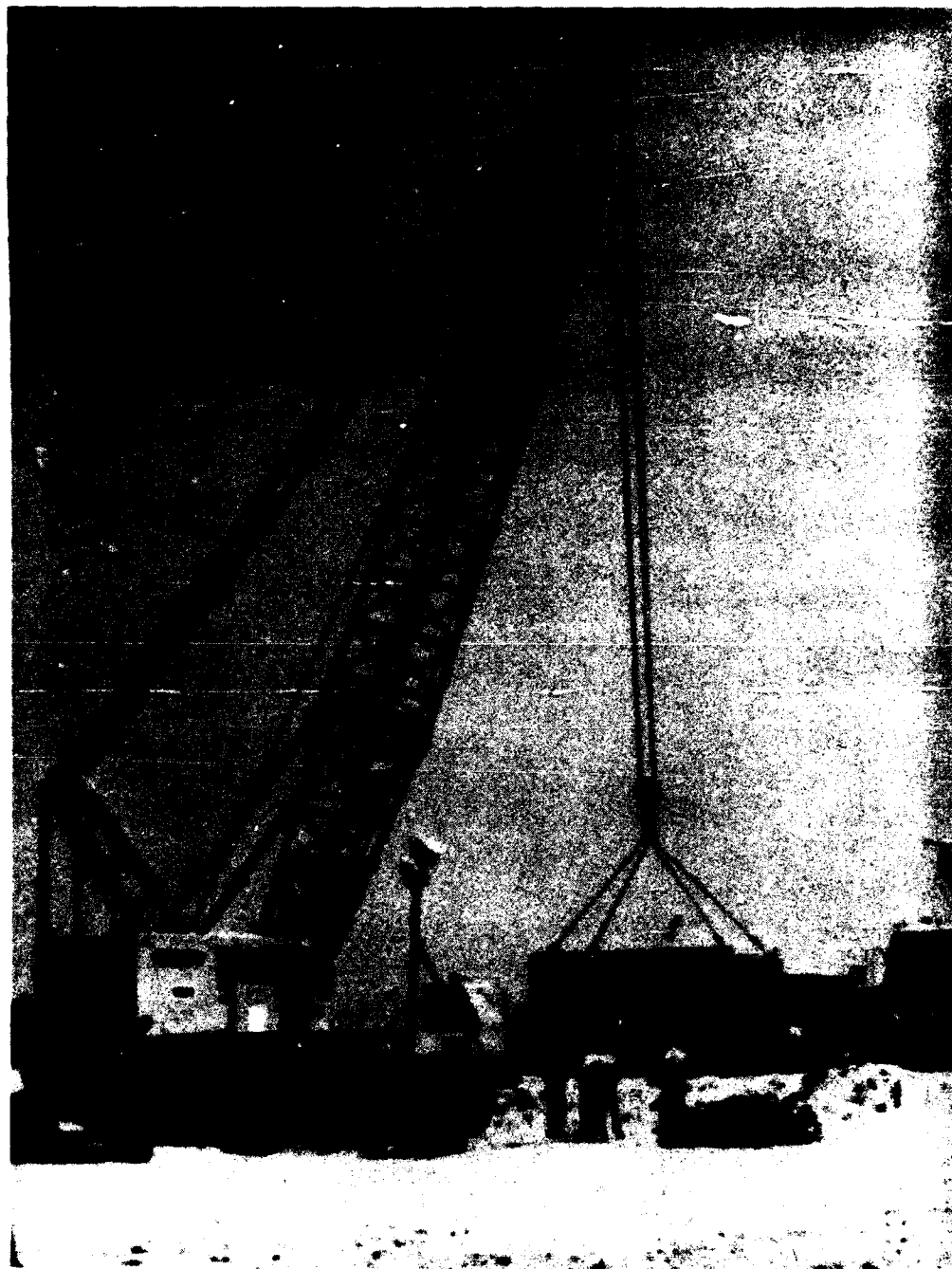

**CAPACITY: 140 TONS APPROXIMATELY 12 FEET
LENGTH WITH 50 FOOT BOOM: 873 INCHES
WIDTH: 132.5 INCHES
HEIGHT: 157.8 INCHES
WEIGHT WITH 120 FOOT BOOM: 195,000 POUNDS**

140-Ton, Truck-Mounted, Container Handling Crane

POINT OF CONTACT

P. Shively
US Army Belvoir RD&E Center, STRBE-FM
Fort Belvoir, VA 22060-5606
Autovon 354-5731/Commercial (703) 664-5731

ITEM DESCRIPTION

The crane is a commercial design, truck-mounted, and has 140-ton maximum capacity. It has an 8 x 4 truck chassis and a 50-foot basic boom which can be extended in length up to 130 feet with the use of various lengths of lattice boom. The crane is used in the loading and unloading of containers from ships in a fixed port operation or landing craft in a Logistics-Over-the-Shore (LOTS) operation and for handling containers in a marshalling area and terminal sites.

STATUS

A multi-year contract was awarded to FMC Corporation in September 1980 for 28 cranes. Deliveries began in January 1982 and were completed during FY85.

PROGRAM PLAN

Update technical data package for future procurements.

250/300-Ton, Truck-Mounted, Container Handling Crane

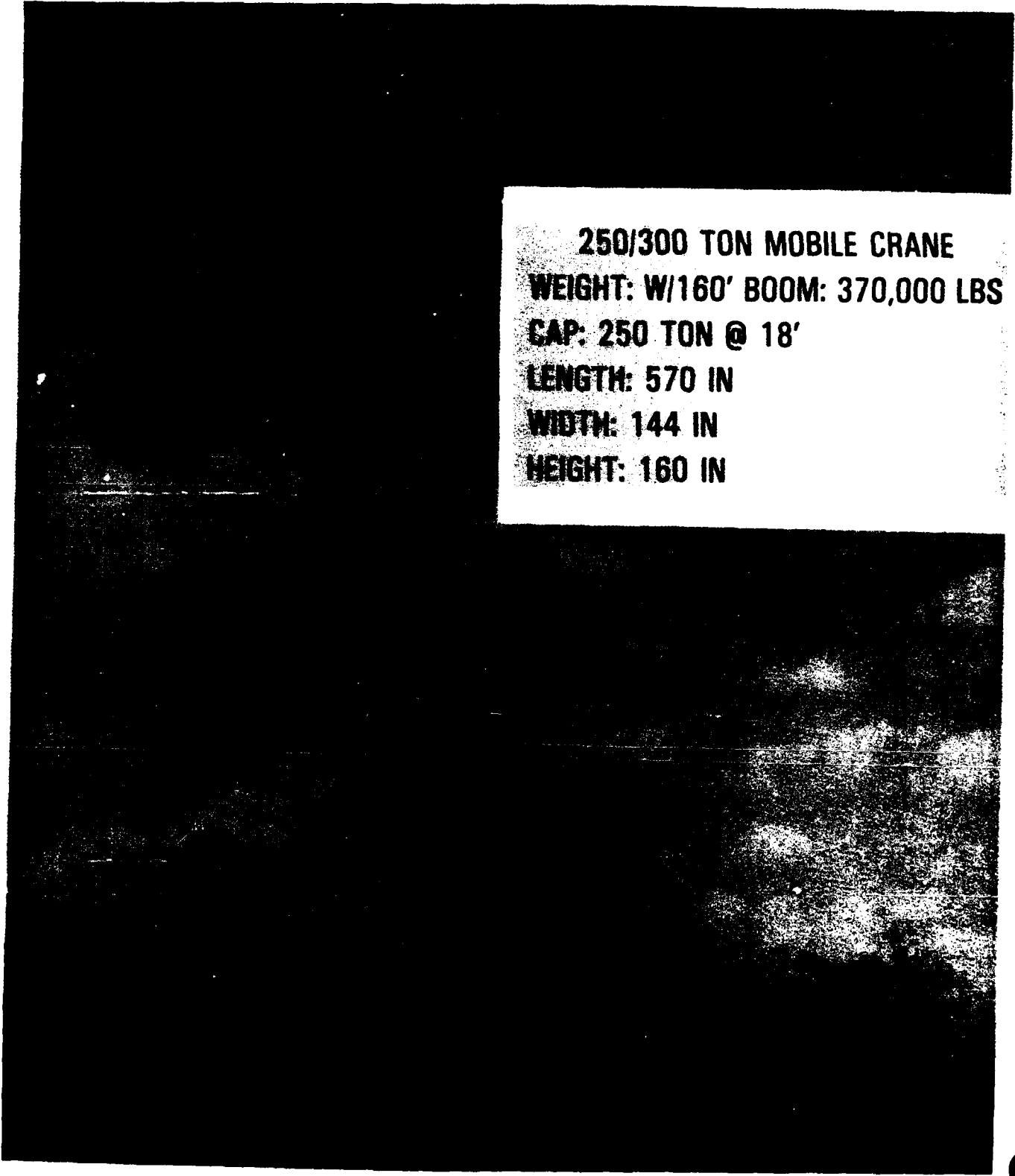

250/300 TON MOBILE CRANE
WEIGHT: W/160' BOOM: 370,000 LBS
CAP: 250 TON @ 18'
LENGTH: 570 IN
WIDTH: 144 IN
HEIGHT: 160 IN

250/300-Ton, Truck-Mounted, Container Handling Crane

POINT OF CONTACT

P. Shively
US Army Belvoir RD&E Center, STRBE-FM
Fort Belvoir, VA 22060-5606
Autovon 354-5731/Commercial (703) 664-5731

ITEM DESCRIPTION

The crane is a commercial design, truck-mounted, and has a 250-ton maximum capacity. It has a 12 x 6 truck chassis and a 70-foot boom which can be extended in length up to 130-feet with the use of various lengths of lattice boom. The crane is used in the loading and unloading of containers from ships in a fixed port and alongside these ships on barges, piers, and floating platforms in a Logistics-Over-the-Shore (LOTS) environment. The crane is also used for the loading and unloading of containers from lighters over the beach in a LOTS environment.

STATUS

A total of eight cranes have been delivered by Harnischfeger Corporation, satisfying the Army's total requirement. A Product Improvement Program (PIP) was approved to incorporate the Rider Block Tagline System (RBTS) developed by the Navy to minimize the pendulation problem in the sea environment. A contract to design, fabricate, install, and test an RBTS prototype was awarded in FY84. An RBTS prototype unit was installed on a 250-ton crane mounted on a "B" DeLong Barge. The RBTS was successfully tested during the FY84 J-LOTS exercise. Due to the development of the Navy TACS Ship, further development of the RBTS has been terminated.

PROGRAM PLAN

None.

Crane Rotator

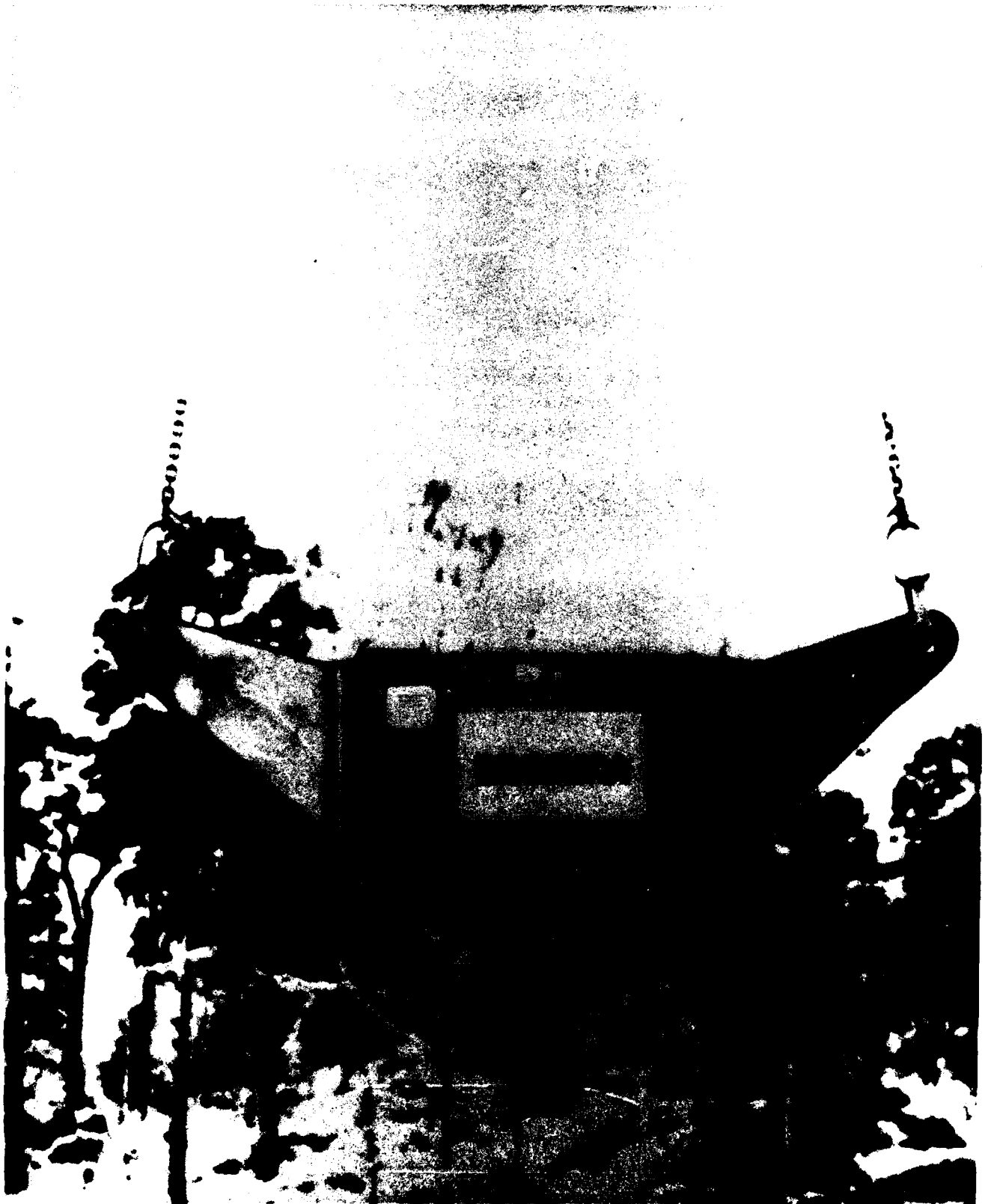

Crane Rotator

POINT OF CONTACT

R. Riley
US Army Belvoir RD&E Center, STRBE-FMR
Fort Belvoir, VA 22060-5606
Autovon 354-4490/Commercial (703) 664-4490

ITEM DESCRIPTION

A gasoline engine driven, hydraulically-operated, crane operator-actuated rotating device used for rotating ISO and intermodal containers up to 360 degrees by a crane for easy placement and retrieval.

STATUS

A contract was awarded to BROMMA, Inc., in FY85 for one gasoline engine-driven, hydraulically - operated crane rotator. Concept Evaluation Program (CEP) tests were conducted at Fort Eustis, VA, during FY86. Results of the CEP tests were evaluated during FY87. The Transportation School recommended that additional CEP testing be conducted. The additional CEP testing was conducted at Fort Eustis, VA, during 4QFY88.

PROGRAM PLAN

Results from the additional CEP testing will be used to support a Product Improvement Program (PIP) for the Army's container handling cranes.

Part III

Transportation Equipment

Logistics Vehicle System



MK 48/MK 14

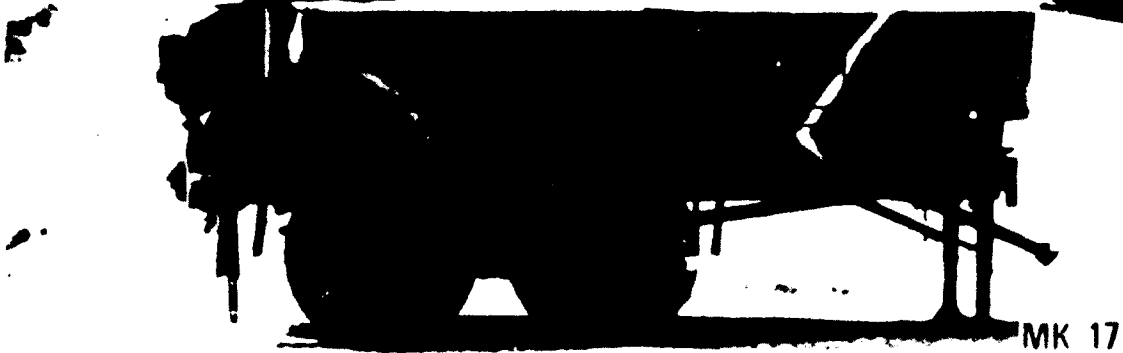

MK 17

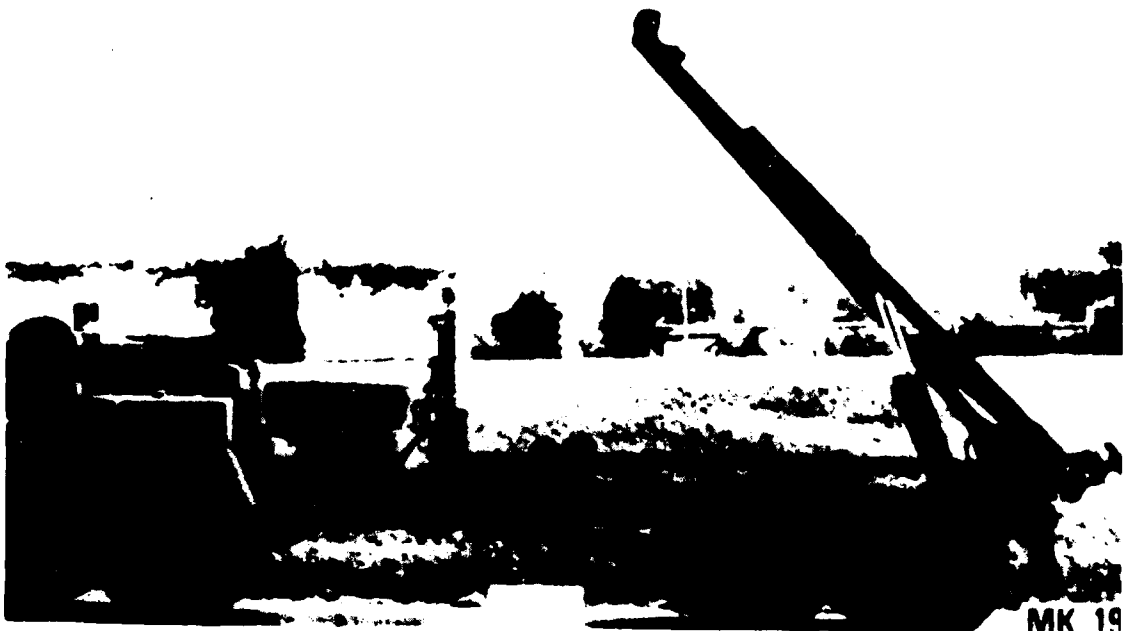

MK 19

Logistics Vehicle System

POINT OF CONTACT

MAJ R. Zant
Marine Corps RD&A Command, Code SSCMT
Washington, DC 20380-0001
Autovon 225-3088/Commercial (202) 695-3088

ITEM DESCRIPTION

The Logistics Vehicle System consists of one front power unit (MK48) and any one of five rear body unit configurations. The MK14, Container Hauler, is an ISO twist-lock equipped, 22.5-ton capacity; rear body unit designed to transport standard ISO 8 x 8 x 20-foot containers, shelters, and modules. The MK17, Dropside Cargo with crane, is a rear body unit with an 8 x 16-foot loading area designed as a troop carrier as well as a carrier for fuel/water modules, and 8 x 8 x 10-foot shelters/containers. The MK19 is a hydraulically powered tilt bed rear body unit designed to load/offload ISO containers, ribbon bridge components or fill material without the assistance of material handling equipment.

STATUS

Approval for service use for the MK48 Front Power Unit and MK14 Container Hauler Rear Body Unit was obtained in July 1982. Approval for the MK17 Dropside Cargo variant was obtained in August 1983. The MK19, Self-loading Bridge Transporter/Container Handler, is a conceptual item and is scheduled for production in FY89. A 5-year letter contract was signed in September 1983 for 1,686 total Logistics Vehicle Systems. The Logistics Vehicle System consisting of the MK48/14/17 began delivery to selected units in August 1985 with a subsequent initial operational capability (IOC) of March 1986.

PROGRAM PLAN

R&D (prototype) testing for the MK19 commenced 3QFY88 and production contracting is scheduled for 2QFY89. There are currently 1,447 Logistics Vehicle Systems which have been delivered.

Chassis, Semitrailer: Coupleable, MILVAN Container Transporter

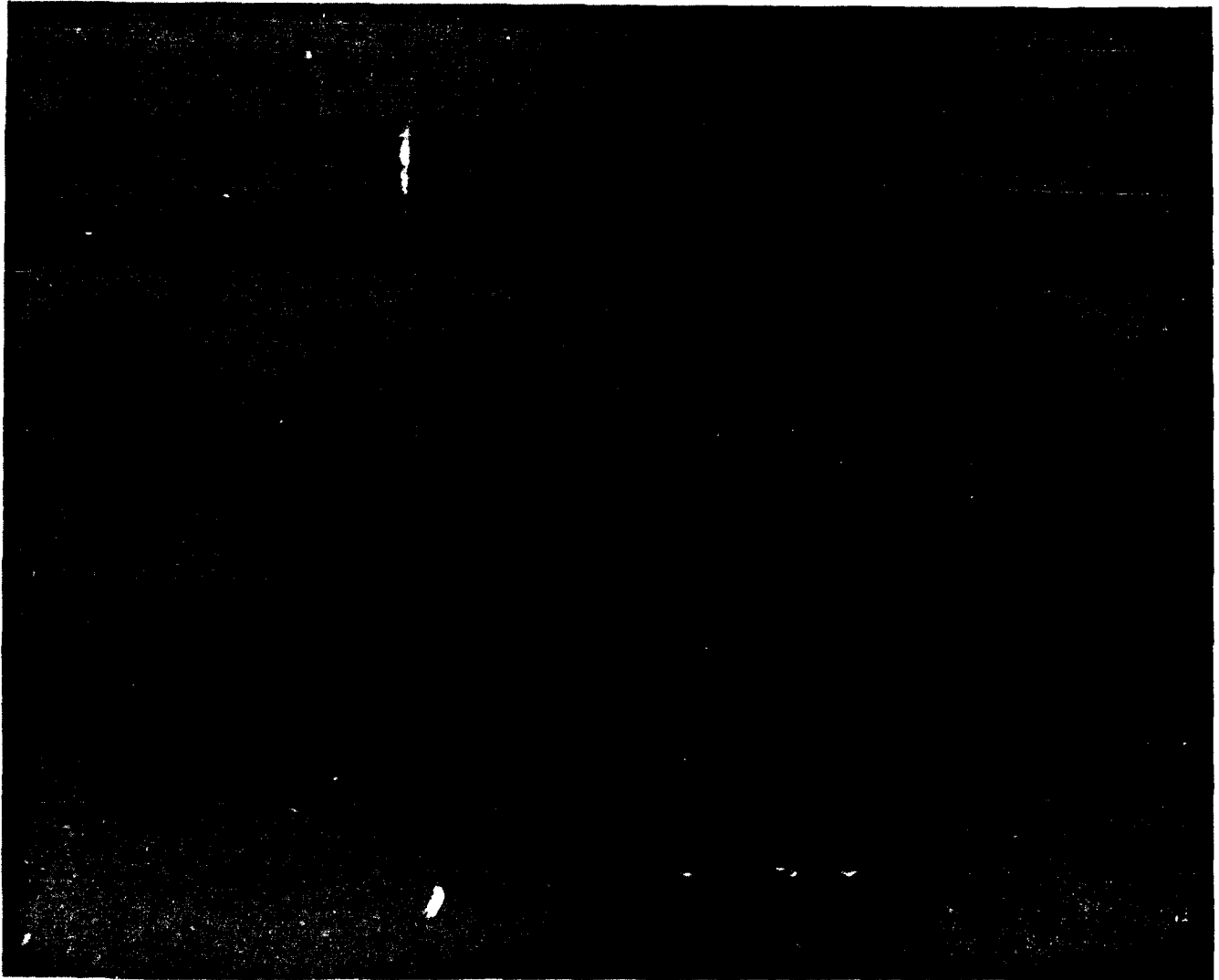

20-FOOT UNIT

SINGLE BOGIE
LENGTH: 242 INCHES
WIDTH: 96 INCHES
HEIGHT: 53.5 INCHES*
WEIGHT: 4,000 POUNDS

20-FOOT UNIT

DOUBLE BOGIE
LENGTH: 242 INCHES
WIDTH: 96 INCHES
HEIGHT: 53.5 INCHES*
WEIGHT: 5,850 POUNDS

40-FOOT UNIT

DOUBLE BOGIE
LENGTH: 484 INCHES
WIDTH: 96 INCHES
HEIGHT: 53.5 INCHES*
WEIGHT: 8,000 POUNDS

*HEIGHT WHEN UNLOADED AND SUPPORTED ON LANDING LEGS WITH DECK LEVEL

Chassis, Semitrailer: Coupleable, MILVAN Container Transporter

POINT OF CONTACT

E. Glaza
US Army Tank-Automotive Command, AMSTA-UEC
Warren, MI 48397-5000
Autovon 786-5969/Commercial (313) 574-5969

ITEM DESCRIPTION

The MILVAN chassis was procured to attain a military owned, centrally controlled fleet for movement of military cargo over primary hard surface roads principally in CONUS. The chassis consists of a 20-foot frame, landing gear, and single-axle bogie. The bogie is movable along the length of the frame. The frame has provisions for coupling two 20-foot units to form a 40-foot chassis, with the bogies under the rear frame to form a tandem-axle configuration. Each frame has twist locks to accept ISO containers. There is provision for lowering the twist locks flush with the top of the frame so that 40-foot containers can be transported on a coupled chassis. The single bogie chassis configuration is 96 inches wide, 53.5 inches high, 242 inches long, and weighs 4,000 pounds. The MILVAN chassis was competitively procured from industry utilizing a performance military specification.

STATUS

The MILVAN chassis is currently deployed. From 1969-1971, 5,620 were procured; 5,106 are currently in inventory and are used as an interim vehicle to haul the refrigerator container in USAREUR. A 4-year overhaul program for 700 units was begun in FY84.

PROGRAM PLAN

There is no current plan to procure additional units.

Truck Tractor, Linehaul, 6 x 4, M915

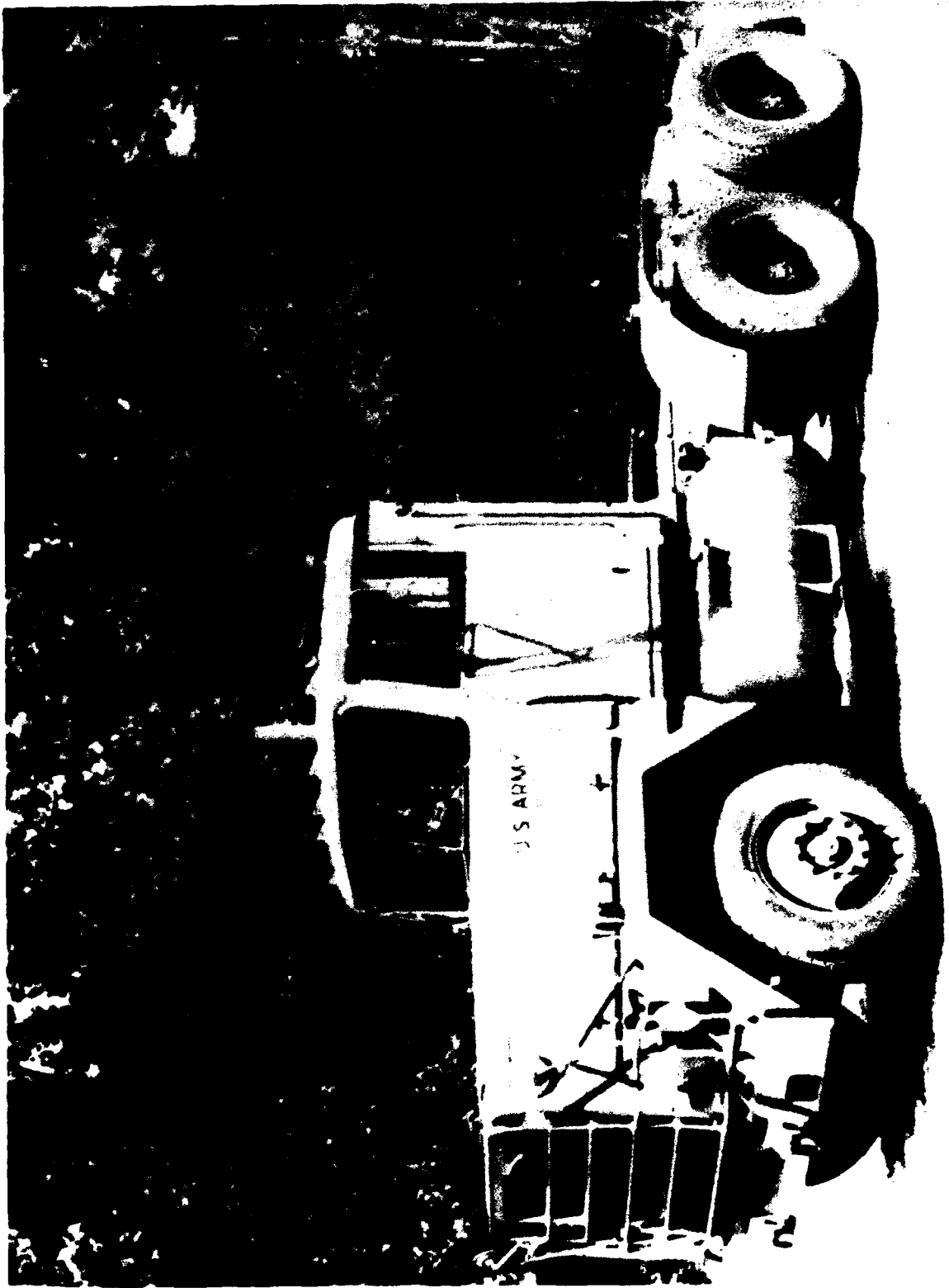

Truck Tractor, Linehaul 6 x 4, M915

POINT OF CONTACT

M. Musotto
US Army Tank-Automotive Command, AMCPM-TVH
Warren, MI 48397-5000
Autovon 786-8065/Commercial (313) 574-8065

ITEM DESCRIPTION

The M915 is the on-road prime mover for the M872 Breakbulk/Container Transporter Semitrailer (105,000-pound Gross Combination Weight Rating) and is used in linehaul operations from the port of debarkation to the division rear boundary. It partially replaces or augments the M818/M931 5-ton Tactical Tractor fleet. The M915 is part of a single procurement action which fielded a six-vehicle family. The other vehicles within the combined procurement are the M916 Light Equipment Transporter, M920 Medium Equipment Transporter, M917 20-Ton Dump Truck, M918 Bituminous Distributor, and M919 Concrete Mobile.

STATUS

Initial production vehicles were satisfactorily tested at Aberdeen Proving Ground, MD; Yuma Proving Ground, AZ; Belvoir RD&E Center, VA; and the Cold Region Test Center, AK, during March 1978 through March 1979. Four vehicles with companion M872 semitrailers satisfactorily completed Force Development Test and Evaluation (FDTE) at Fort Campbell, KY, between January and April 1979. Production was completed in June 1980 and the entire fleet of 2,498 vehicles has been fielded.

PROGRAM PLAN

Provide support for fielded items.

Truck Tractor, Linehaul, 6 x 4, M915A1

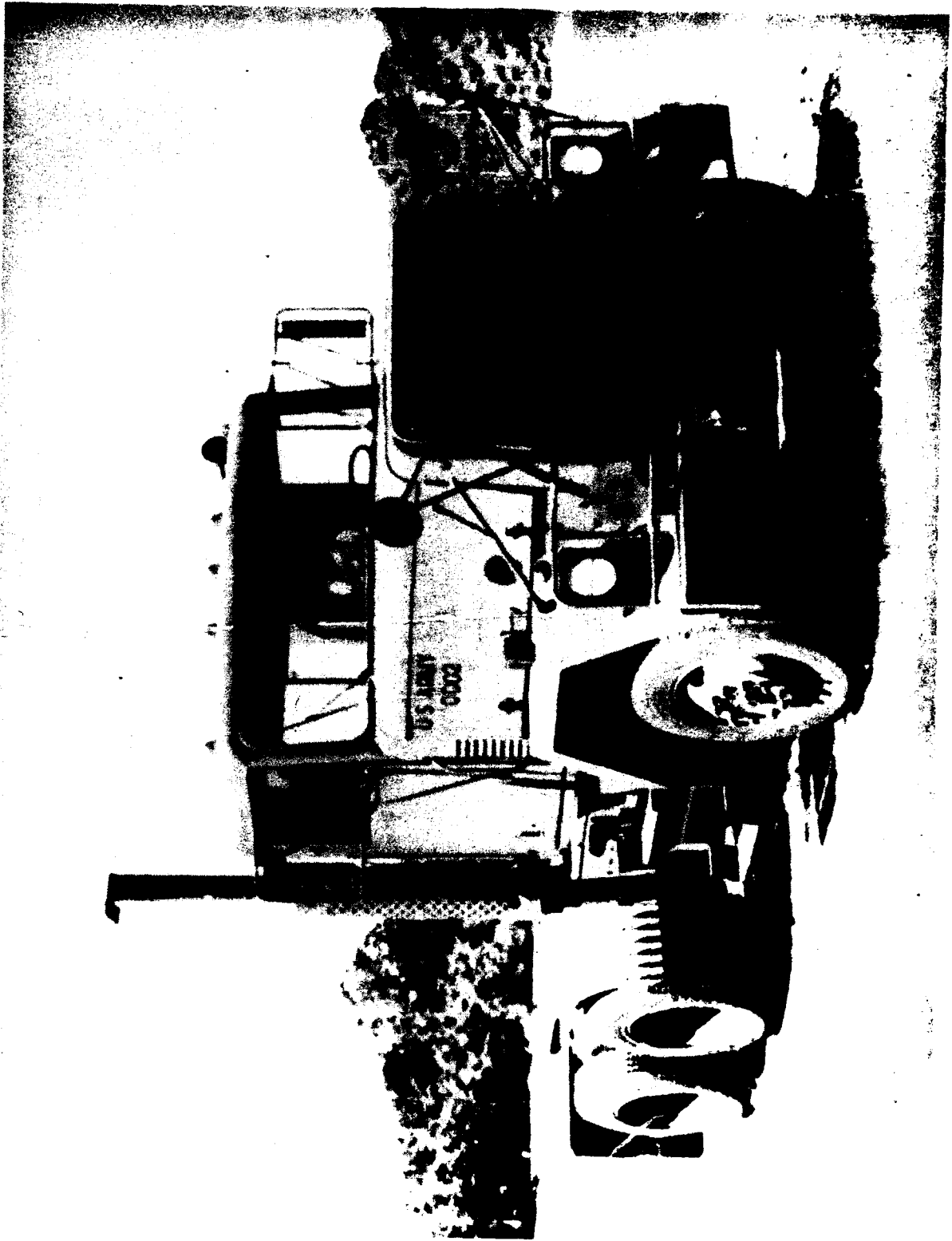

Truck Tractor, Linehaul 6 x 4, M915A1

POINT OF CONTACT

M. Musotto
US Army Tank-Automotive Command, AMCPM-TVH
Warren, MI 48397-5000
Autovon 786-8065/Commercial (313) 574-8065

ITEM DESCRIPTION

The M915A1 is a military adaption of a commercial 6 x 4 tractor and is a rebuy of the M915. It has been improved to include state-of-the-art advances in heavy truck technology. It is intended for linehaul operation from the port of debarkation to the division rear boundary. While the M915A1 is used primarily with the M872 semitrailers, it is capable of operating with a variety of military and commercial trailers.

The M915A2 is a later version of the M915A1. It has a dual purpose of being the prime mover for the M1062, a 7,500 gallon petroleum tanker, as well as the M872 semitrailers.

STATUS

AM General produced 2,342 M915A1s. Deployment to USAREUR, US Army Reserves, and Army National Guard was made between August 1983 and July 1984 to 37 Medium Transportation Companies.

In September 1988, a contract was awarded to Freight Liner Corp. to produce the M915A2 tractor. This contract was for approximately 633 with options for more.

PROGRAM PLAN

Provide support for fielded items and field additional tractors.

Truck Tractor, Yard Type, 4 x 2, M878A1



**CURB WEIGHT: 16,280 POUNDS
OVERALL LENGTH: 182.5 INCHES
OVERALL WIDTH: 98.125 INCHES
OVERALL HEIGHT: 120 INCHES
WHEEL BASE: 116 INCHES
FIFTH WHEEL HEIGHT: 48 INCHES TO 64 INCHES**

Truck Tractor, Yard Type, 4 x 2, M878A1

POINT OF CONTACT

S. Ostman
US Army Tank-Automotive Command, AMSTA-FTM
Warren, MI 48397-5000
Autovon 786-5225/Commercial (313) 574-5225

ITEM DESCRIPTION

The yard type truck tractor is primarily used to provide a capability to shuttle semitrailers loaded with containers or breakbulk cargo within fixed ports, prepared beaches, Logistics-Over-the-Shore (LOTS), or trailer transfer areas. The vehicle is a highly maneuverable commercial tractor with an automatic locking, hydraulic-lift fifth wheel which facilitates semitrailer coupling and disengagement, and allows movement of the semitrailer/chassis without retracting landing legs. It is capable of moving vehicles weighing between 21,000 and 60,000 pounds.

STATUS

A total of 28 trucks was competitively procured from Ottawa Truck Company for use during Joint-Logistics-Over-the-Shore (J-LOTS) testing in 1977. Based on the favorable results of this test, 16 additional trucks were ordered. The truck passed First Article Test, and a third buy contract was awarded to Ottawa Truck Company for a quantity of 175 trucks. Of these 175 vehicles, 56 were issued in 1983 to fill initial CONUS requirements. A full AR 700-34 release of the M878A1 was granted in October 1985. A total of 43 trucks have been deployed to USAREUR and nine deployed to Korea. The remaining vehicles are in long term storage and are planned to be used to support Logistics Unit Productivity System (LUPS) requirements.

PROGRAM PLAN

Continue to fully support fielded vehicles. There are no current plans for additional procurements.

Semitrailer, Linehaul, Breakbulk/Container, M872 Series

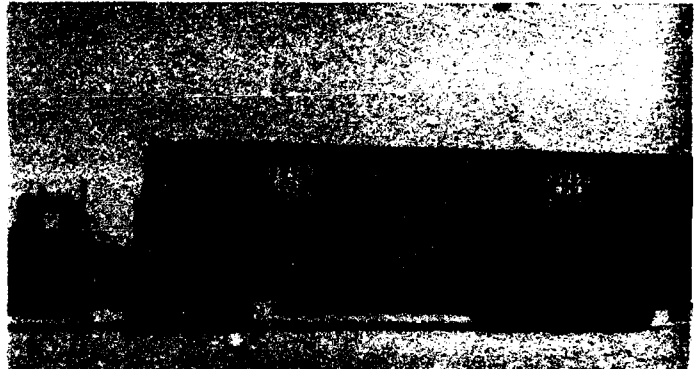
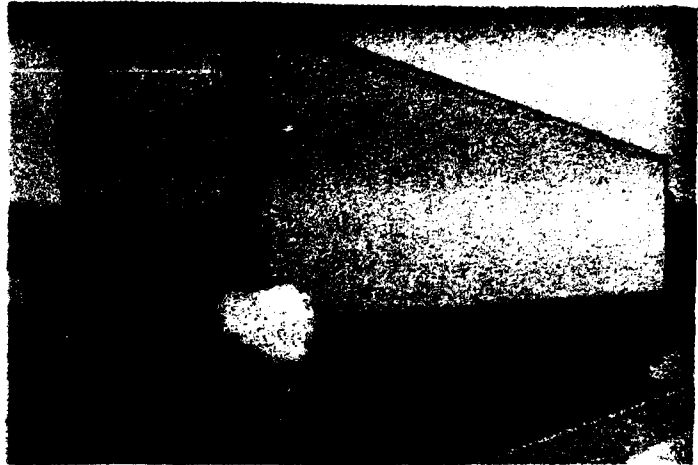
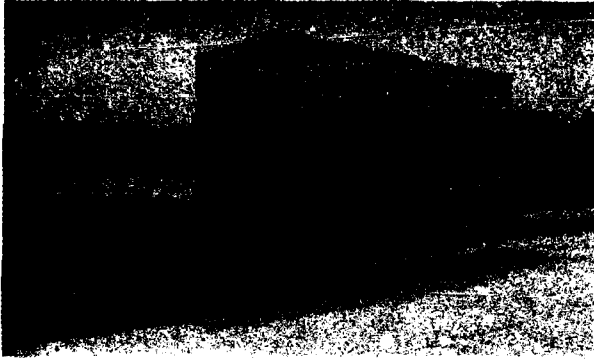

CURB WEIGHT: 17,400 POUNDS
RATED PAYLOAD: 67,200 POUNDS
GROSS WEIGHT: 84,600 POUNDS
OVERALL LENGTH: 489 INCHES
OVERALL WIDTH: 96 INCHES
PLATFORM HEIGHT: 59 INCHES*
FIFTH WHEEL HEIGHT: 50 INCHES (LOADED)

TIRES: 10:00 x 20 TUBE TYPE
BRAKES: CAM/AIR
ELECTRICAL: 12/24 VOLT
LANDING GEAR: HAND/MECHANICAL
SIDE PANEL HEIGHT: 48 INCHES
CONTAINER LOCKS: 20 FEET, 35 FEET,
40 FEET, 24 FEET, 5 FEET, 6½ FEET,
AND 10 FEET

***HEIGHT WHEN UNLOADED AND SUPPORTED ON LANDING LEGS WITH DECK LEVEL**

Semitrailer, Linehaul, Breakbulk/Container, M872 Series

POINT OF CONTACT

M. Musotto
US Army Tank-Automotive Command, AMCPM-TVH
Warren, MI 48397-5000
Autovon 786-8065/Commercial (313) 574-8065

ITEM DESCRIPTION

The M872 Semitrailer Series are commercial design flatbed semitrailers of 34-ton capacity used in the linehaul of containers, breakbulk cargo, and M113 Armored Personnel Carriers (APCs). The M915/M915A1 truck tractor is the prime mover.

STATUS

Procurement of the total requirement of 8,656 semitrailers was accomplished by five separate contracts as follows:

Model	Contractor	Quantity
M872	Theurer	1,364
M872	Southwest	1,304
M872A1	Theurer	2,713
M872A1	Heller	212
M872A2*	Theurer	125
M872A2*	Heller	125
M872A3	Southwest	2,813
		<u>8,656 Total</u>

* Model M872A2 has a tapered gooseneck configuration which has been modified by installing a saddle to the gooseneck.

All contracts are complete. All medium transportation companies have 100% fill of the M872.

PROGRAM PLAN

Provide support for fielded items.

Semitrailer, Tactical, Dual Purpose Breakbulk/Container Transporter, 22¹/₂-Ton, M871 Series



RATED PAYLOAD: 44,800 POUNDS
OVERALL LENGTH: 358 INCHES
OVERALL WIDTH: 96 INCHES
PLATFORM HEIGHT: 55 INCHES*

TIRES: 11:00 x 20
ELECTRICAL: 12/24 VOLT
LANDING GEAR: HAND/MECHANICAL
SIDE PANEL HEIGHT: 48 INCHES
CONTAINER LOCKS: 20 FEET, 10 FEET,
6¹/₂ FEET, AND 5 FEET

***HEIGHT WHEN UNLOADED AND SUPPORTED ON LANDING LEGS WITH DECK LEVEL**

Semitrailer, Tactical, Dual Purpose Breakbulk/Container Transporter, 22¹/₂-Ton, M871 Series

POINTS OF CONTACT

M. Musotto

US Army Tank-Automotive Command, AMCPM-TVH
Warren, MI 48397-5000

Autovon 786-8065/Commercial (313) 574-8065

J. Hollern

US Army Tank-Automotive Command, AMCPM-TVH
Warren, MI 48397-5000

Autovon 786-7657/Commercial (313) 574-7657

ITEM DESCRIPTION

The M871 is a commercial design tactical semitrailer whose primary application will be the delivery and retrograde of containers and shelters up to 20 feet long, and breakbulk cargo in an overseas theater of operation between the Corps General Support Supply Activities (GSSA) and the Division Support Command (DISCOM). On occasion it may also be used to deliver containers to forward distribution points or to using units. The prime movers in these roles will be the M818, M915, and M932 truck tractors. The tactical semitrailer will also be used on the linehaul mission as a means of clearing 20 foot or smaller containers from the port area. The prime mover in this role will normally be the M915 linehaul tractor.

STATUS

A flatbed configuration was selected by the Logistics Center in December 1977, after consideration was given to the conflicting requirements dictated by breakbulk and container transport mission. A 5-year multi-year contract was awarded to Southwest Truck Body in March 1979 for a quantity of 2,349 trailers. Initial Production Testing was completed in August 1980 and initial delivery to Anniston Army Depot for storage started in June 1980. The option was exercised to procure an additional unit with the missile tie-down fixtures. A contract for 246 M871s was awarded to Schoals American Industries, Inc., in 3QFY85. The vehicle completed Initial Production Testing in 3QFY88.

PROGRAM PLAN

Deployment is planned to USAREUR and Army Interchange Customers with FUE expected in FY90. A contract for the M871A2 was awarded during 4QFY88 to Dynaweld Inc. The contract is a 3-year contract for 1,809 units with 100% options per year. Initial Production Testing is scheduled for 4QFY89-2QFY90 with delivery beginning 2QFY90 and FUE is scheduled for 3QFY90.

Railway Car, Flat (Heavy Duty), 140-Ton Capacity, DS

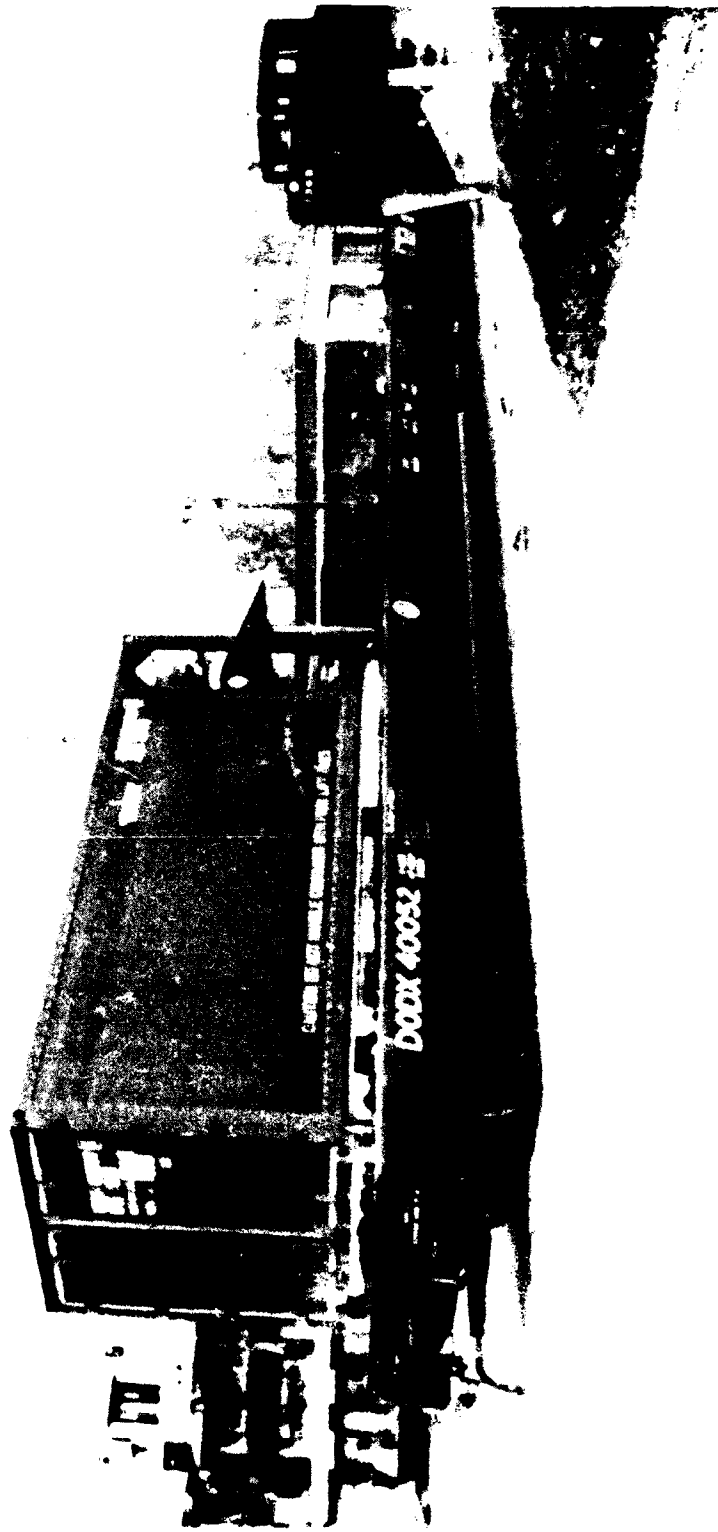

Railway Car, Flat (Heavy Duty), 140-Ton Capacity, DS

POINT OF CONTACT

M. Boynton
US Army Belvoir RD&E Center, STRBE-FMT
Fort Belvoir, VA 22060-5606
Autovon 354-5581/Commercial (703) 664-5581

ITEM DESCRIPTION

The 140-ton flat car is designed for unrestricted interchange use while transporting both oversized tracked vehicles and multiple ANSI/ISO containers loaded with Class A explosives and other commodities. Of welded construction, the all-steel car is equipped with integral securement systems to restrain both kinds of lading. For intermodal containers, the securement system will accommodate a single 40-foot container, three 20-foot containers or a combination of both sizes. The tiedown units are of the pedestal type that lock automatically when the container is set in place and released automatically when the containers are lifted. The flat car is approximately 68 feet long and 10 feet, 5 inches wide, and is supported by two three-axle trucks. The car is designed to carry up to a 140-ton load.

STATUS

Three production contracts yielding 569 cars have been completed.

PROGRAM PLAN

Procurement of 40 additional cars is planned for FY90 and will constitute a buy out of mission requirements.

5-Ton Truck Bed with ISO-Configured Locking Devices

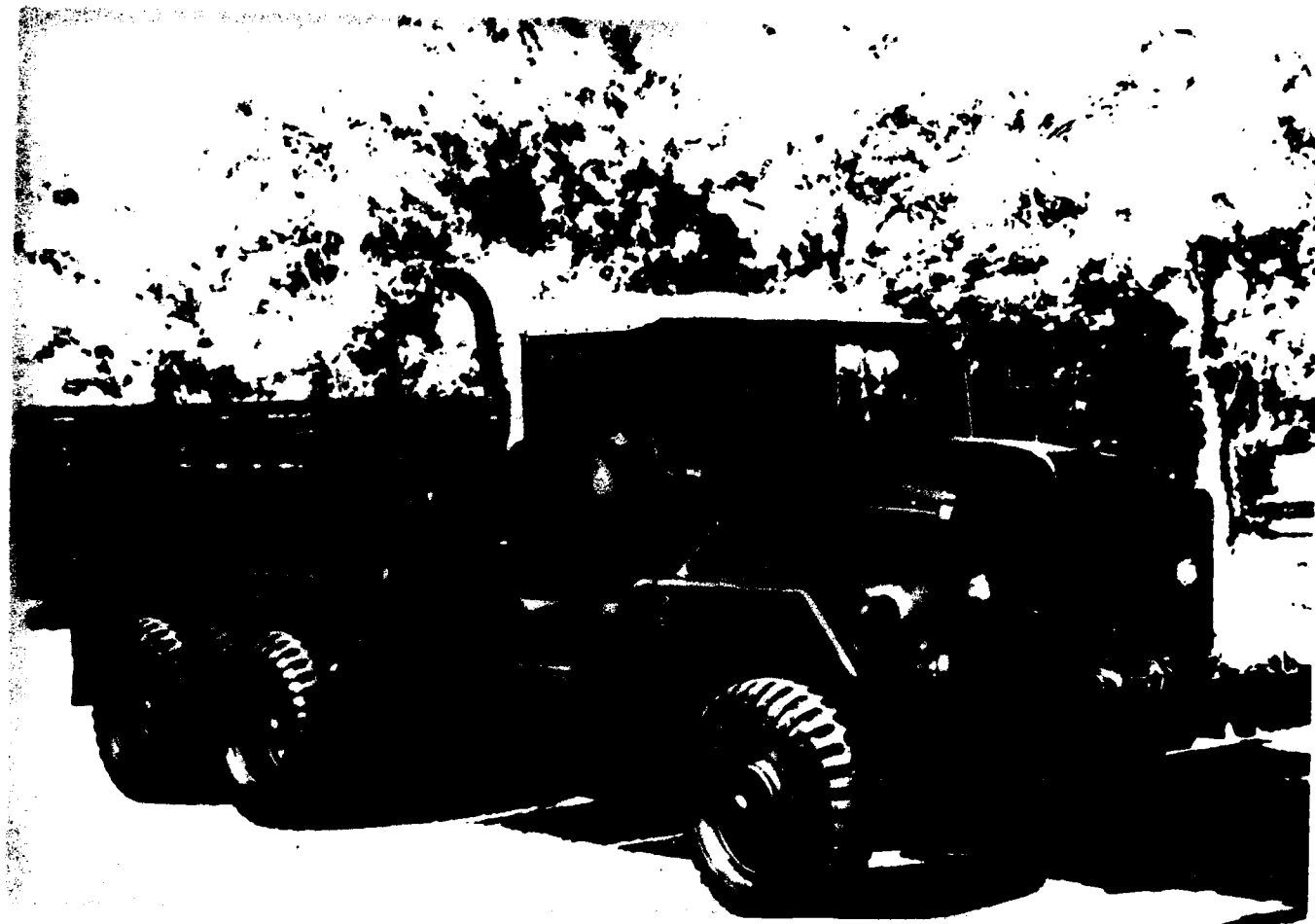

5-Ton Truck Bed with ISO-Configured Locking Devices

POINT OF CONTACT

CAPT K. Burns
Marine Corps RD&A Command, Code SSCMT-TS
Quantico, VA 22134-5080
Autovon 278-2633/Commercial (703) 640-2633

ITEM DESCRIPTION

The ISO-configured truck bed is a modification that will be installed on 5-ton trucks to facilitate the transport of ISO-configured containers such as the SIX CON modules.

STATUS

A contract was awarded in 3QFY88.

PROGRAM PLAN

Shipment of the beds will commence by 4QFY89. Many 5-ton cargo trucks will be modified with the ISO bed. The majority of this work will occur during the inspect and repair program only as necessary, commencing 1QFY90.

Part IV

LOTS, Harbor, and Container Offloading and Transfer Equipment

Lighter Air Cushion Vehicle, 30-Ton (LACV-30)

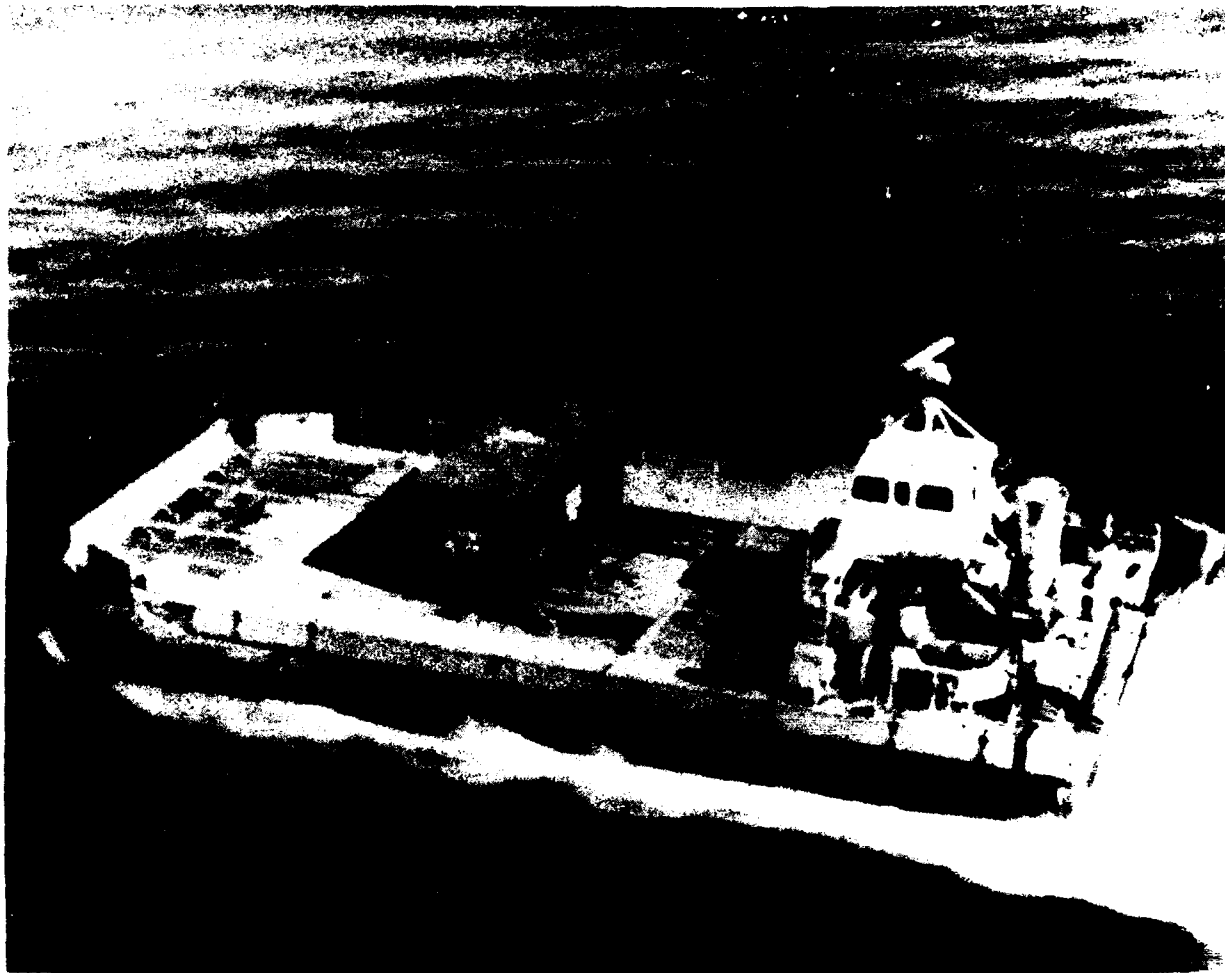

LENGTH: 76 FT 3 IN
WIDE: 36 FT 8 IN
DECK LENGTH: 51 FT 6 IN
DECK WIDTH: 32 FT 6 IN
HEIGHT (HOVERING): 28 FT 11 IN
CARGO DECK HEIGHT: 3 FT 11.5 IN

DESIGN GROSS WEIGHT: 57,344 LB
SPEED AT MAX CONTINUOUS POWER:
40 MPH AT ALL-UP WEIGHT
ENDURANCE: APPROX 5 HRS OF
LOGISTICS-OVER-THE-SHORE W/25 TON
PAYLOAD

Lighter Air Cushion Vehicle, 30-Ton (LACV-30)

POINT OF CONTACT

J. Walter
US Army Belvoir RD&E Center, STRBE-FMD
Fort Belvoir, VA 22060-5606
Autovon 354-5498/Commercial (703) 664-5498

ITEM DESCRIPTION

This vehicle is a military adaption of the Bell Aerospace Company air cushion vehicle *Voyageur* for use primarily in Logistics-Over-the-Shore (LOTS) operations. It is used to provide the logistical system with a rapid lift capability of moving cargo and equipment over water, marsh areas, beaches, ice, snow, and land. The LACV-30 provides a method of augmenting congested port facilities or replacing lost or reduced port capabilities. The LACV-30 is also intended to support secondary missions such as coastal, harbor, inland waterway operations, support of amphibious operations, ship-to-shore operations, transport operations, and search and rescue operations. The LACV-30 can negotiate Sea State 2 and 8-foot plunging surf.

STATUS

Two prototype craft were built and successfully passed operational and developmental tests. The LACV-30 was subsequently type classified. Twenty-four production craft have been built under two separate contracts with Bell Aerospace. The first 12 craft have been assigned to the 331st Transportation Company and the second 12 craft to the 8th Transportation Company. All 24 are stationed at Fort Story, VA. The two prototype craft are being used for Product Improvement Program (PIP) testing in support of the many PIPs underway to improve the LACV-30s.

PROGRAM PLAN

Complete PIPs and retrofit all craft in the 331st and 8th Transportation Companies with the improvements.

Lighter, Amphibian, Heavy-Lift (LAMP-H)

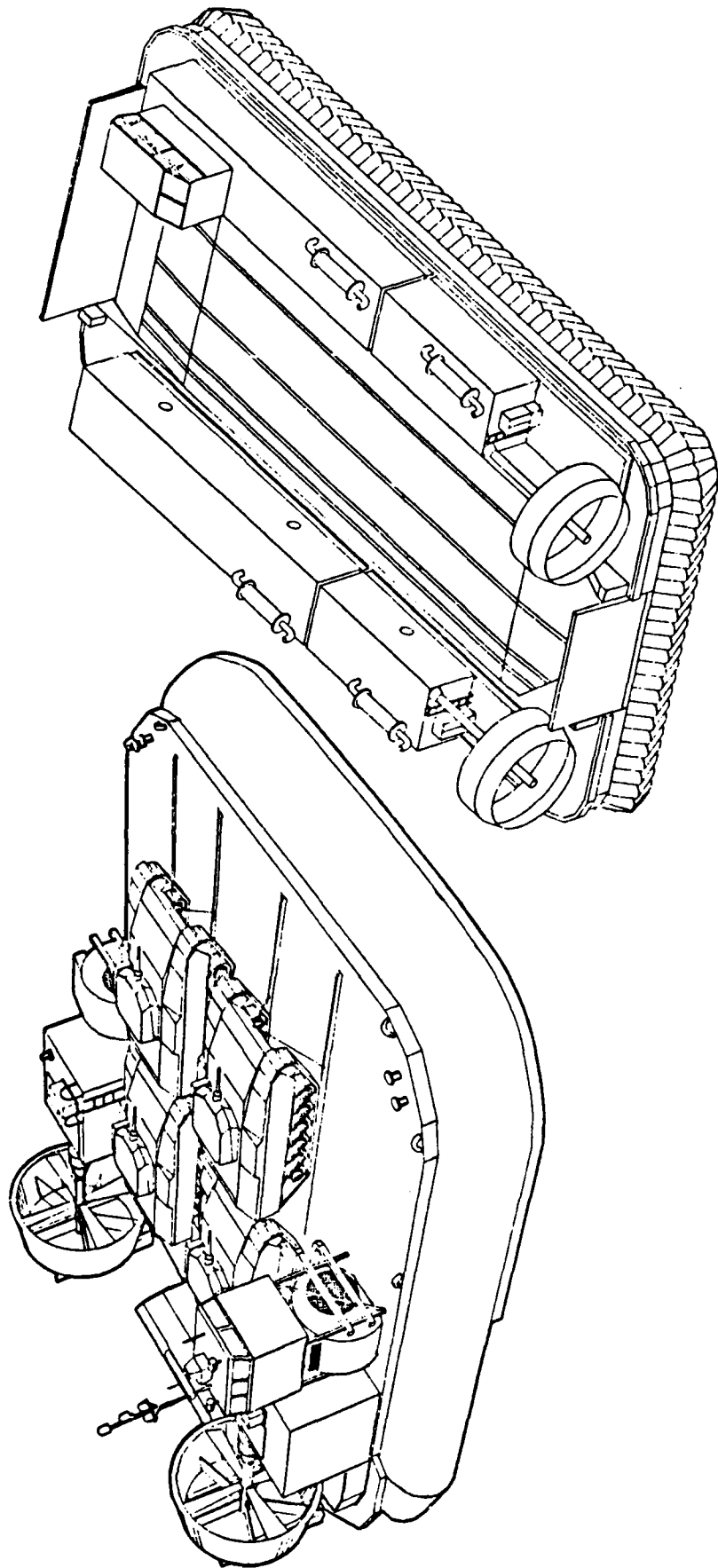

Lighter, Amphibian, Heavy-Lift (LAMP-H)

POINT OF CONTACT

R. Schmidt
US Army Belvoir RD&E Center, STRBE-FMD
Fort Belvoir, VA 22060-5606
Autovon 354-4266/Commercial (703) 664-4266

ITEM DESCRIPTION

The LAMP-H is a heavy-lift air cushioned vehicle with amphibious capability, developed to perform in Army Logistics-Over-The-Shore (LOTS) missions. The primary cargo will be vehicles and outsized cargo, with a secondary role of containerized cargo transfer. The craft will be capable of carrying over 100 short tons of cargo, at a speed of 8 to 15 knots. The LAMP-H will have bow and stern ramps and an open cargo deck area, making it capable of roll-on/roll-off and easy crane loading and unloading.

STATUS

After restructuring of the program, a new Operational and Organizational (O&O) was approved in August 1988. System concepts and designs are being evaluated in preparation of the Concept Formulation Package for Milestone I/II.

PROGRAM PLAN

Based upon the Army Streamlined Acquisition Process, a Milestone I/II decision is scheduled for 3QFY89. Contract award of a Development/Production Prove Out phase prototype is scheduled for 2QFY90. Testing and evaluation will be conducted during FY91 with LAMP-H craft production following in FY92. FUE is scheduled for early FY94.

Logistics Support Vessel (LSV)



Logistics Support Vessel (LSV)

POINT OF CONTACT

O. Martinovitch
US Army Belvoir RD&E Center, STRBE-FMS
Fort Belvoir, VA 22060-5606
Autovon 354-5319/Commercial (703) 664-5319

ITEM DESCRIPTION

The LSV has the capability of intra-theater linehaul of cargo to support the unit deployment/relocation, tactical and sustained resupply to remote, undeveloped areas along coastlines and on inland waterways. Additionally, the LSV is capable of self-delivery to a theater of operations. Mission requirements include the capability to assist in discharging and backloading ships in a roll-on/roll-off or LOTS operations with its drive-through capability and of transporting heavy, outsized cargo. The vessel has a self-delivery range of 6,500 nautical miles at service speed of 11.5 knots and is capable of sustaining a crew of 29 for a minimum of 30 days. Utilizing 10,500 square feet of deck cargo space, the LSV can transport 2,000 short tons of cargo consisting of rolling stock, general cargo or containers. Principal characteristics of the LSV are: length (overall), 273 feet; beam (molded), 60 feet; beaching draft, 4-feet at the bow, with 900 tons of cargo distributed uniformly over the deck; twin screw diesel propulsion; 3,900 shaft horsepower; bow thruster; bow and stern ramps; and deck sockets to secure all types of cargo transported.

STATUS

The LSV was type classified Standard, Logistics Control Code (LCC) A in September 1983. After a competitive solicitation, contract for four LSVs was awarded to Moss Point Marine of Escatawpa, MS, on 19 September 1986. Subsequent to contract award, the need for a fifth vessel has been identified and validated. Construction of the fifth LSV is pending approval and issuance of funds.

PROGRAM PLAN

The LSV was initially fielded in November 1987 and was commissioned as a US Army vessel. The delivery dates for the LSV are as follows:

Hull No.	Name	Delivery Date	Gaining Command
LSV-1	GEN Frank S. Besson, Jr.	November 1987	FORSCOM
LSV-2	CW3 Harold C. Clinger	February 1988	WESTCOM
LSV-3	GEN Brehon B. Sommervell	April 1988	NGB
LSV-4	LTC William B. Bunker	May 1988	FORSCOM
LSV-5	*TBD	TBD	TBD

* To be determined

Landing Craft, Utility (LCU)

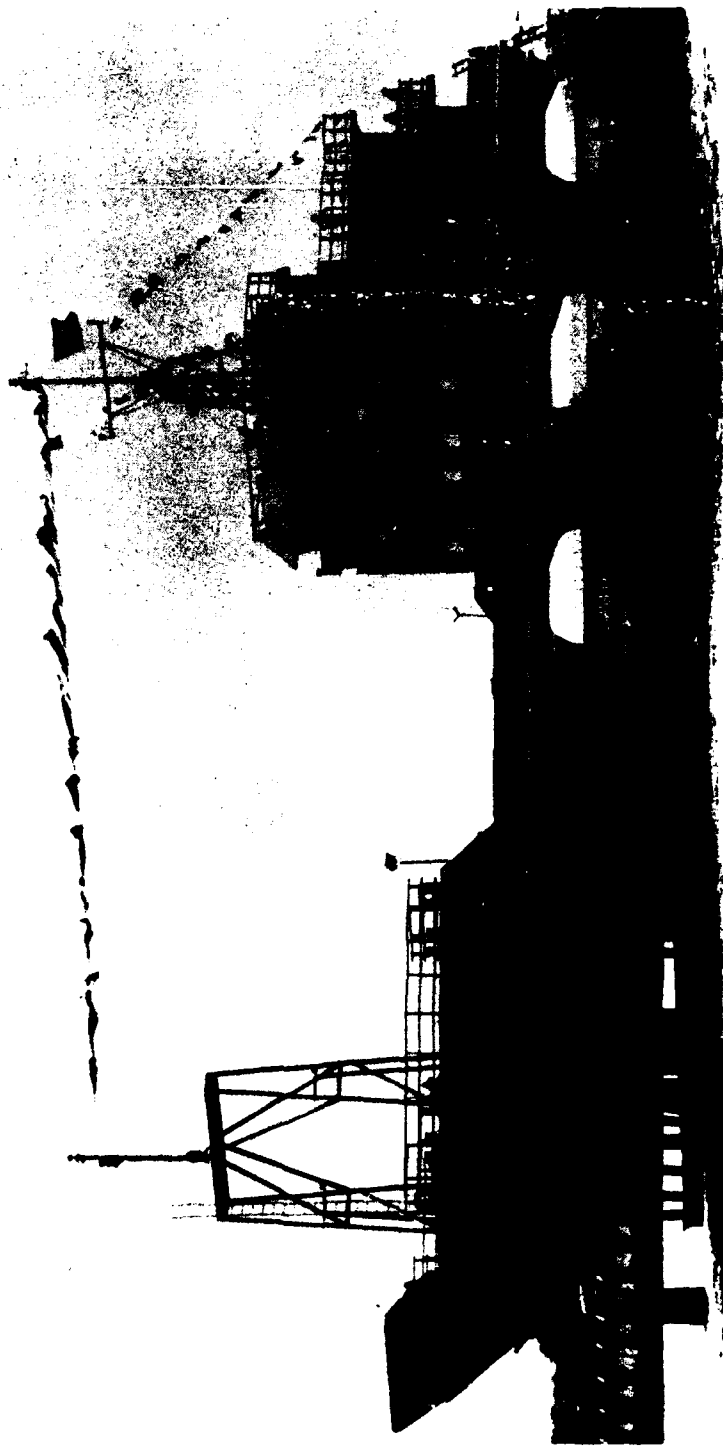

Landing Craft, Utility (LCU)

POINT OF CONTACT

J. Wersching
US Army Belvoir RD&E Center, STRBE-FMS
Fort Belvoir, VA 22060-5606
Autovon 354-5971/Commercial (703) 664-5971

ITEM DESCRIPTION

The LCU 2000 is the latest in the evolution of the landing craft designs, succeeding the 1646 Class LCU and replacing the 1466 Class in the active Army and reserve inventories. The mission of the LCU 2000 is to provide transportation of rolling and tracked vehicles, containers, and outsized and general cargo in support of LOTS operations as well as Coastal, Harbor, and Inland (CHI) waterway missions. The LCU 2000 is assigned to TOE 55-129, Transportation Heavy Boat Company. The LCU 2000 has an overall length of 174 feet, a beam of 42 feet, and a full load design draft of 8 feet. It is capable of carrying up to 28 20-foot or 12 40-foot ISO freight containers secured on its 2,500 square foot cargo deck, and can carry a full load of 350 short tons. It is configured to deliver 175 short tons through its 16 foot wide bow ramp to shallow 1/30 gradient beaches without exceeding a 4-foot bow draft. The LCU's 2 Cummins V16 turbo-charged diesels with 2,500 installed horsepower will provide a full load speed of 10 knots, and a light delivery speed of 12 knots. The 300 HP Cummins powered Bow Thruster provides added maneuverability during docking or undocking operations. It is classed by the American Bureau of Shipping (ABS) for full ocean service and one-man engine room operations, and is built to US Coast Guard standards. LCUs are equipped with the latest navigation, communication, and electronic equipment including an automatic pilot and steering system. The LCU 2000 will be capable of sustaining its crew of two warrant officers and 11 enlisted personnel for periods of up to 18 days and over 6,000 nautical miles without refueling. The LCU 2000 will be fielded with full organic support.

STATUS

The LCU 2000 utilizes a modified commercial design based on an existing vessel performing a similar mission in private commercial trade. The procurement of the LCU 2000 utilizes the Non-Developmental Item (NDI) acquisition strategy, and is managed by the Product Manager for Amphibians and Watercraft (PM-AWC) with specifications prepared by the Belvoir RD&E Center. The LCU 2000 is now in full production and is being constructed by Lockheed Shipbuilding Company, Savannah, GA, Division, as part of a 5-year multi-year firm fixed price contract awarded in June 1986 by the US Army Troop Support Command (TROSCOM) of St. Louis, MO. The lead vessel, LCU 2001, christened the *US Army Runnymede*, was launched on 14 August 1987 and sea trials were conducted 12-14 July 88.

PROGRAM PLAN

Delivery of LCU 2001 is scheduled for the end of 2QFY89. LCU 2002, *US Army Kenesaw Mountain*, is scheduled for delivery in 3QFY89. The LCU 2000 program plan calls for a total of 25 vessels, with options for 15 additional, funded over a 5-year period from FY85-89. The last LCU is scheduled for delivery in early 1992. Active Army units scheduled to receive the LCU 2000 include the 97th and 329th Transportation Companies, Fort Eustis, VA, and the 5th Transportation Company, Fort Shafter, HI.

Temporary Container Discharge Facility (TCDF)

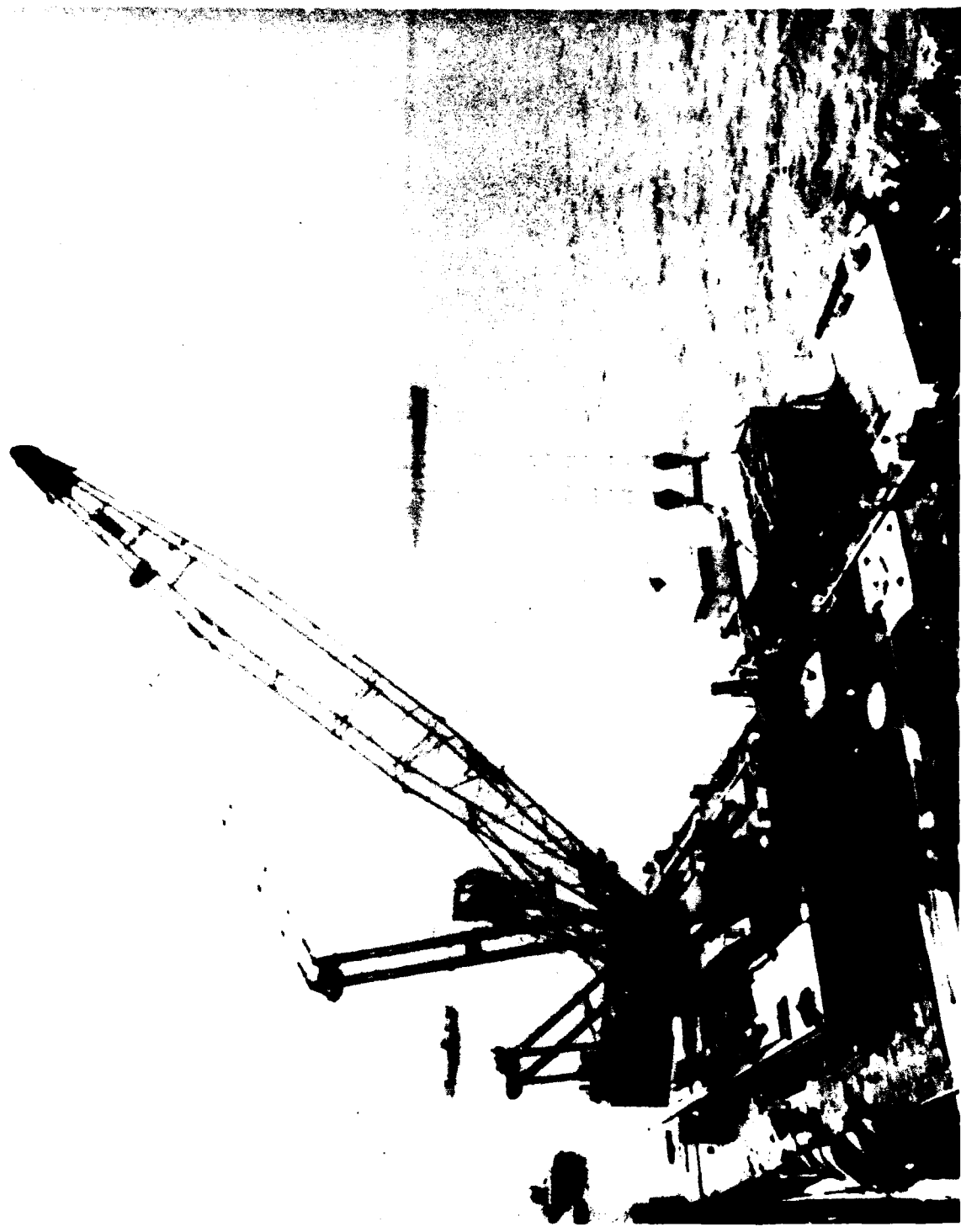

Temporary Container Discharge Facility (TCDF)

POINT OF CONTACT

P. Shively
US Army Belvoir RD&E Center, STRBE-FM
Fort Belvoir, VA 22060-5606
Autovon 354-5731/Commercial (703) 664-5731

ITEM DESCRIPTION

The TCDF is comprised of the Army's 250-ton, truck-mounted, container crane mounted on a 'B'-DeLong barge. The crane is supported on two bridging beams and uses the reduced load bearing Malkiel Float assembly. The crane on barge configuration has the mission requirement to handle 67,200 pounds at 65 feet in sea conditions up to and including Sea State 3.

A SEABEE class surface vessel will be used to transport the TCDF to its operating theater as the 'B'-DeLong barge is structurally inadequate for safe ocean tow with a mounted crane. The SEABEE ship will transport and discharge the TCDF by utilizing the 2,000-light ton capacity elevator at the stern. The elevator submerges so barge cargo can be floated over it for hoisting.

The TCDF is to be used for the discharge of containers from non-self-sustaining containerships within a non-port environment. Containerships are moored off-shore with the TCDF alongside, separated by fenders. Containers are transported from the containership to lighterage, using the TCDF's crane, for shipment to shore.

STATUS

A securing system was implemented to the TCDF for overseas transport on a SEABEE class surface vessel. The securing system was implemented by VSE Corporation based on a study conducted by J. J. Henry Company, Inc. This effort was completed on 1 April 1984. The securing system was successfully tested during the deployment phase of the FY84 J-LOTS II exercise, 15 April 1984 - 4 May 1984. The Technical Data Package (TDP) for the securing system was finalized in June 1985.

PROGRAM PLAN

The program has been terminated due to the requirements being met by the Auxiliary Crane Ship (T-ACS).

Fast Logistic Ship (T-AKR) Program



Fast Logistic Ship (T-AKR) Program

POINT OF CONTACT

M. Fink
Naval Sea Systems Command, PMS-377K
Washington, DC 20362-5101
Autovon 222-4834/Commercial (202) 692-4834

ITEM DESCRIPTION

The Fast Logistic Ship (T-AKR) Program includes the procurement of eight SL-7 class high-speed containerships and their subsequent conversion to a cargo configuration specifically designed for rapid load/unload of military vehicles and equipment, including tanks and helicopters. T-AKR ships will enhance the ability to quickly deploy military equipment and supplies from the continental United States to potential objective areas throughout the world. The conversion design includes installation of decks midship to permit roll-on/roll-off of vehicles, addition of a flight deck for helicopter operations, and retention of the existing container cells aft. The T-AKR provides the capability to transport 78 special-purpose heavy-duty flatracks in the aft part of the ship: 53 (35 feet long x 8 feet wide x 13.5 feet high), 22 (35 feet long x 8 feet wide x 10.5 feet high), 3 (35 feet long x 8 feet wide x 8.5 feet high), 46 containers (20 feet long x 8 feet wide x 8 feet high)*, and 8 SEASHEDs (35 feet long x 25 feet wide x 12.5 feet high). The 35-foot special-purpose flatracks were designed specifically for use on-board the T-AKR and are capable of carrying an M-1 tank (134,000 pounds) across two adjoining flatracks. These flatracks have been designed with hinged edge flaps installed along one side to provide the ability to span the gaps between flatracks in container cells resulting basically in a series of *tween decks*.

STATUS

Contracts for conversion of four SL-7 ships were awarded in September 1982 to three shipyards with options for four additional ship conversions: Avondale Shipyards, Inc. (ASI) (one firm, two options); National Steel and Shipbuilding Company (two firm, one option); and Pennsylvania Shipbuilding Company (one firm, one option). The options for conversion of the remaining four ships were exercised on 31 October 1983. The eight ships have been redelivered as follows: USNS ALGOL (T-AKR 287) 6/84; USNS CAPELLA (T-AKR 293) 6/84; USNS ALTAIR (T-AKR 294) 7/84; USNS BELLATRIX (T-AKR 288) 9/84; USNS REGULUS (T-AKR 292) 8/85; USNS DENEbola (T-AKR 289) 10/85; USNS ALTAIR (T-AKR 291) 11/85; and USNS POLLUX (T-AKR 290) 3/86. Deliveries of SEASHEDs and flatracks to the eight T-AKR ships were completed in September 1984. Each T-AKR is also equipped with two 35-foot spreaders, two 20-foot spreaders, and one 40-foot spreader to enhance load/offload operations.

PROGRAM PLAN

Program completed. The Fast Logistic Ships are under operational control of the Military Sealift Command.

* 44 containers (20 feet long x 8 feet wide x 8 feet high) on USNS ALGOL (T-AKR 287), USNS BELLATRIX (T-AKR 288) and USNS REGULUS (T-AKR 292).

Auxiliary Crane Ship (T-ACS)

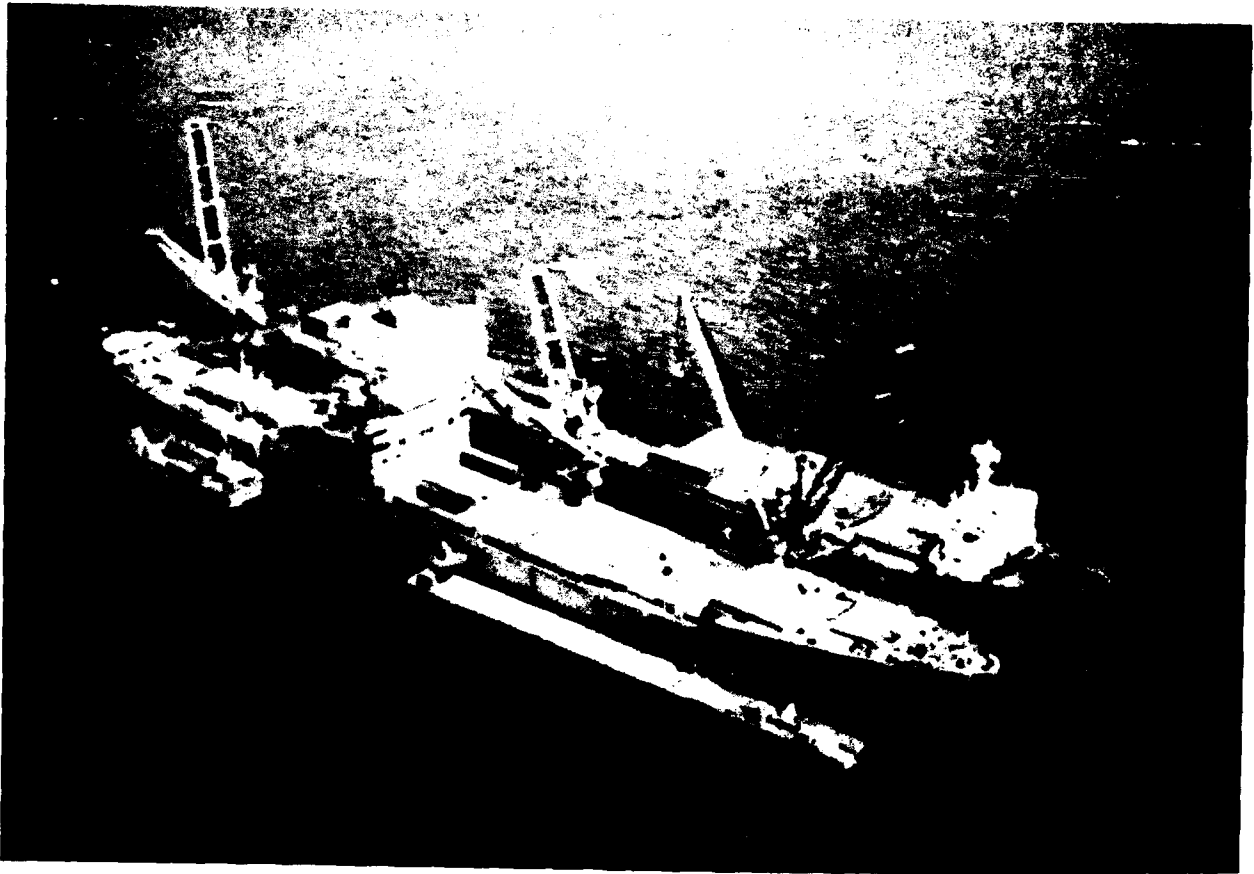

Auxiliary Crane Ship (T-ACS)

POINT OF CONTACT

M. Baig
Naval Sea Systems Command, PMS-377K2
Washington, DC 20362-5101
Autovon 222-7881/Commercial (202) 692-7881

ITEM DESCRIPTION

The T-ACS is a converted containership from the MARAD Reserve Force modified by the installation of twin-boom marine cranes. Auxiliary features supporting crane operation include upgraded or supplementary living quarters, upgraded messing facilities, upgraded communications suites, additional generator capacity, semi-permanent or permanent ballast, modification of some container cells to permit installation of SEASHEDs, lighterage stowage capability, and upgraded mooring and fendering capabilities.

The primary mission of the ship is to offload non-self-sustaining cargo (container) ships moored alongside with offload operations conducted at anchor, in the stream, or in an underdeveloped or damaged port. The ship also has the capability to discharge its own cargo.

The cranes on the T-ACS are evolutionary variations of the level luffing type crane already in widespread merchant service. All T-ACS classes have twin boom rotating pedestal cranes. The T-ACS 1 has three twin cranes capable of offloading 30 long tons with a single boom, 60 long tons with twin booms, and 105 long tons in tandem (four booms). The T-ACS 4 has two twin cranes capable of offloading 30 long tons with a single boom, 60 long tons with twin booms, and 120 long tons in tandem. T-ACS 7 through 12 will have the same crane design and capability as those of the T-ACS 4. The T-ACS 7 and T-ACS 11 will have three twin cranes. The T-ACS 9 will have two twin cranes.

STATUS

T-ACS 1, SS KEYSTONE STATE, began conversion in March 1983 by Bay Shipbuilding Corporation, Sturgeon Bay, WI, and was delivered in May 1984. The ship successfully completed J-LOTS II exercises in October 1984. The second ship, T-ACS 2, SS GEM STATE, began conversion in September 1984 at Continental Maritime of San Francisco, Inc., San Francisco, CA, and was delivered in October 1985. Dillingham Ship Repair, Portland, OR, began conversion of T-ACS 3, SS GRAND CANYON STATE, in September 1985 and delivered the ship in October 1986. The conversion contract for T-ACS 4, SS GOPHER STATE, T-ACS 5, SS FLICKERTAIL STATE, and T-ACS 6, SS CORNHUSKER STATE, was awarded to Norfolk Shipbuilding and Drydock Corporation, Norfolk, VA, in August 1986. Redeliveries for T-ACS 4, 5, and 6 were October 1987, February 1988, and April 1988, respectively. The conversion contract for T-ACS 7 and 8 was awarded to Tampa Shipyards, Inc., Tampa, FL, in September 1987. T-ACS 7 was redelivered February 1989 and T-ACS 8 is planned for 3QFY89. The conversion contract for T-ACS 9 and 10 was awarded to Norfolk Shipbuilding and Drydock Corporation in January 1989. Scheduled redeliveries for T-ACS 9 and 10 are March 1990 and April 1990, respectively.

PROGRAM PLAN

The T-ACS program calls for conversion of a total of 12 ships from the MARAD Reserve Force. T-ACS 11 and 12 are scheduled to undergo conversion in FY90 and FY91, respectively.

Containership Strikeup System (CSUS)

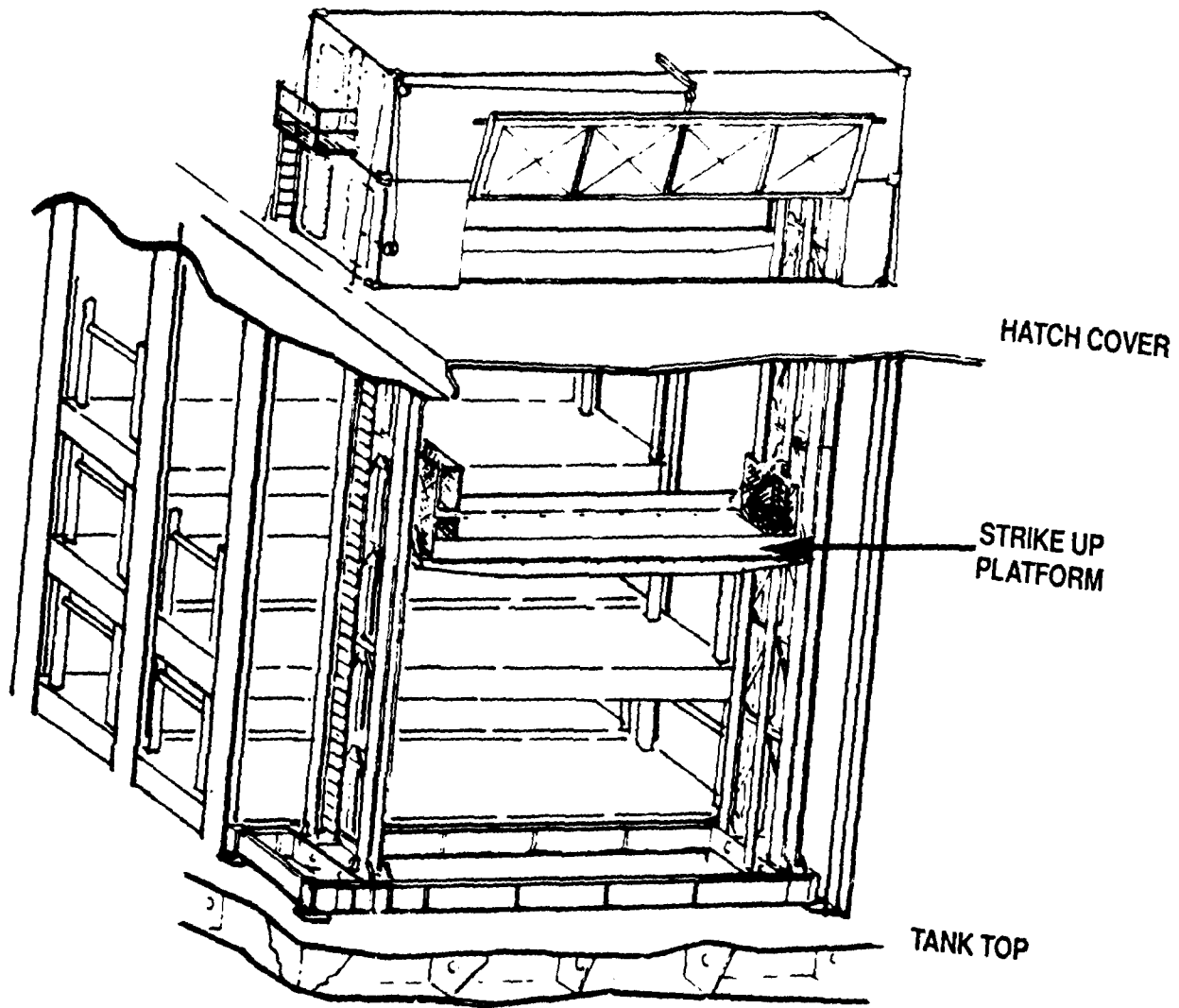

Containership Strikeup System (CSUS)

POINT OF CONTACT

M. Fink
Naval Sea Systems Command, PMS-377K
Washington, DC 20362-5101
Autovon 222-4834/Commercial (202) 692-4834

ITEM DESCRIPTION

The Containership Strikeup System (CSUS) is a modular elevator system designed to fit in one cell of a containership. The system will be composed of modular sections that will allow the system to fit in holds from three to six containers deep. The system will penetrate the hatch cover on which the access module and machinery module will rest. The weight of that portion of the system below the hatch cover rests on the container hard points. Lift capacity of the system is 20,000 pounds. The CSUS will be used in conjunction with flatracks and SEASHEDs that provide temporary *'tween decks* for stowage and athwartships movement of cargo. In this concept, the cargo will be broken out at sea (anchored or underway), struck up by the CSUS, and transferred at sea by a STREAM rig.

STATUS

First-article design production and test contract were awarded. Land based tests of the first article were completed by the end of FY86.

PROGRAM PLAN

No current plans for follow-on production.

Causeway Section, Powered (CSP)

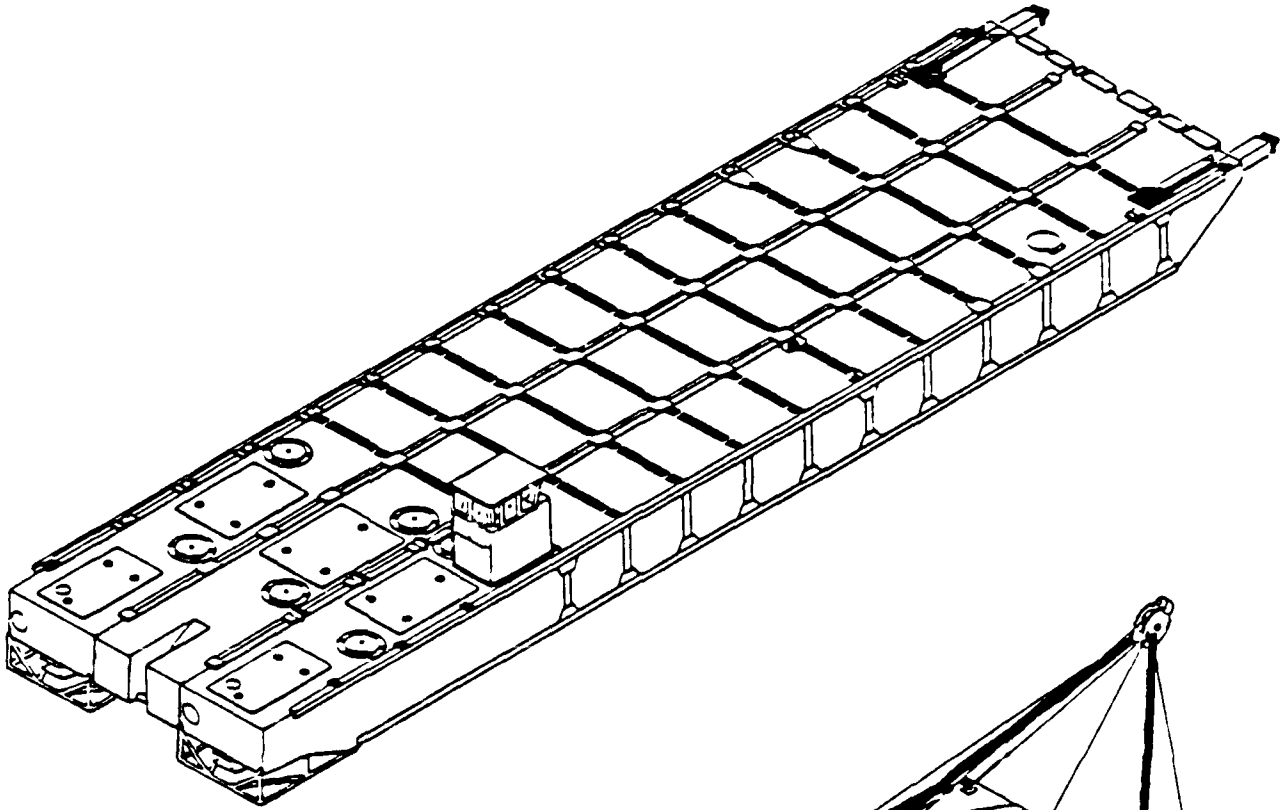

CAUSEWAY SECTION, POWERED

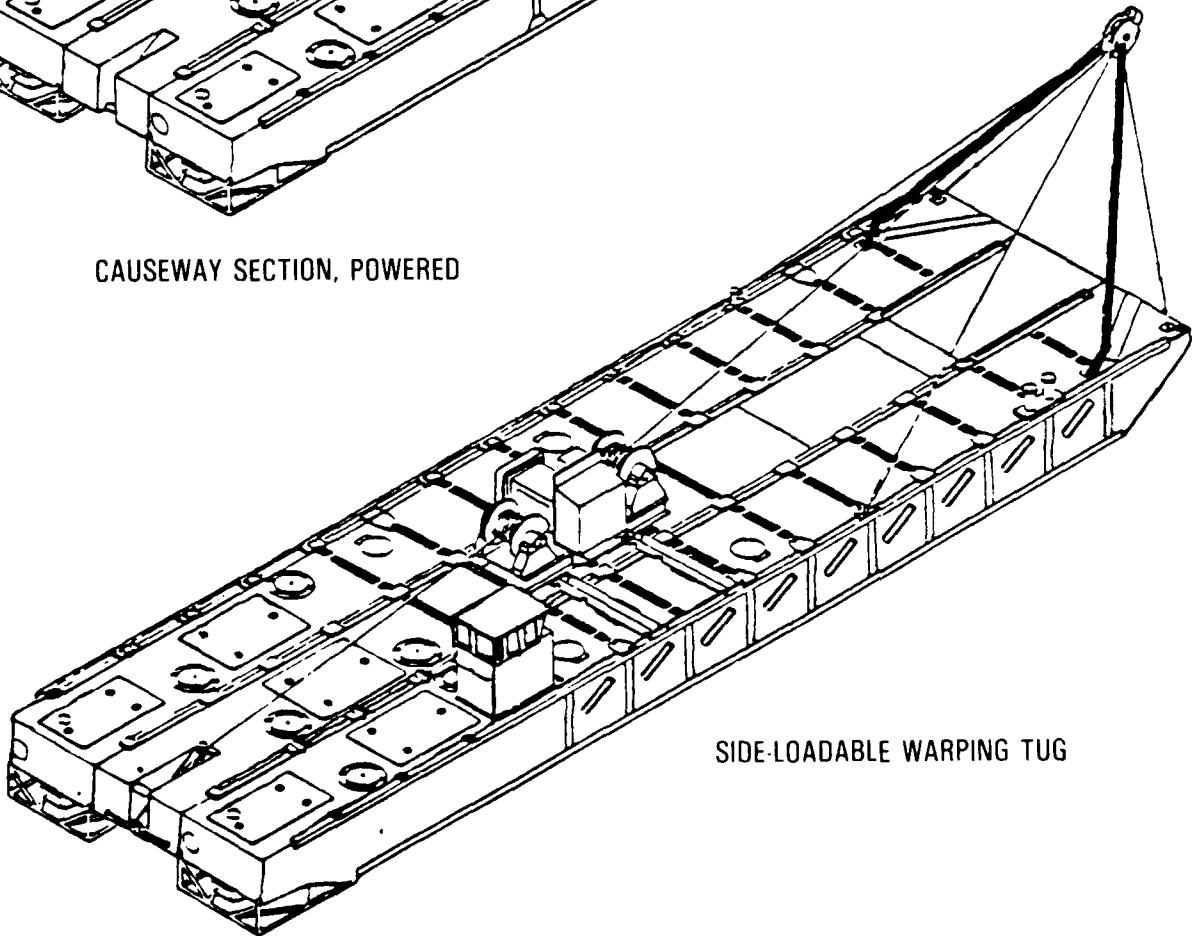

SIDE-LOADABLE WARPING TUG

Causeway Section, Powered (CSP)

POINTS OF CONTACT

G. Walker

Naval Facilities Engineer Command, Code 061A
Alexandria, VA 22332
Autovon 222-8535/Commercial (703) 325-8535

B. Karrh

Naval Civil Engineering Laboratory, NCEL-L65
Port Hueneme, CA 93043-5003
Autovon 360-3711/Commercial (805) 982-3711

ITEM DESCRIPTION

The Causeway Section, Powered (CSP) Navy Lighterage (NL) version will be procured by the Army through the Navy. The NL version of the CSP and the Side Loadable Warming Tug (SLWT) are shown. The NL versions are constructed with 5 x 5 x 7-foot NL pontoons and three Waterjet Propulsion Assemblies. Propulsion modules consist of a drive engine and a waterjet pump system. The SLWT can be side carried on a Landing Ship Tank (LST). The CSP can carry 40 tons of cargo and is used to push causeway ferries. A causeway ferry consists of a CSP and Causeway Sections, Non Powered (CSNPs). Each CSNP carries 100 tons of cargo.

STATUS

The Navy awarded a contract in 4QFY87 to Costal Engineering and Manufacturing Co. for 37 SLWT/CSP NL version units. Delivery is planned for 3Q or 4QFY90.

PROGRAM PLAN

The Navy plans to procure 11 additional units in 4QFY89.

Cantilevered Elevated Causeway (CANTELICAS)

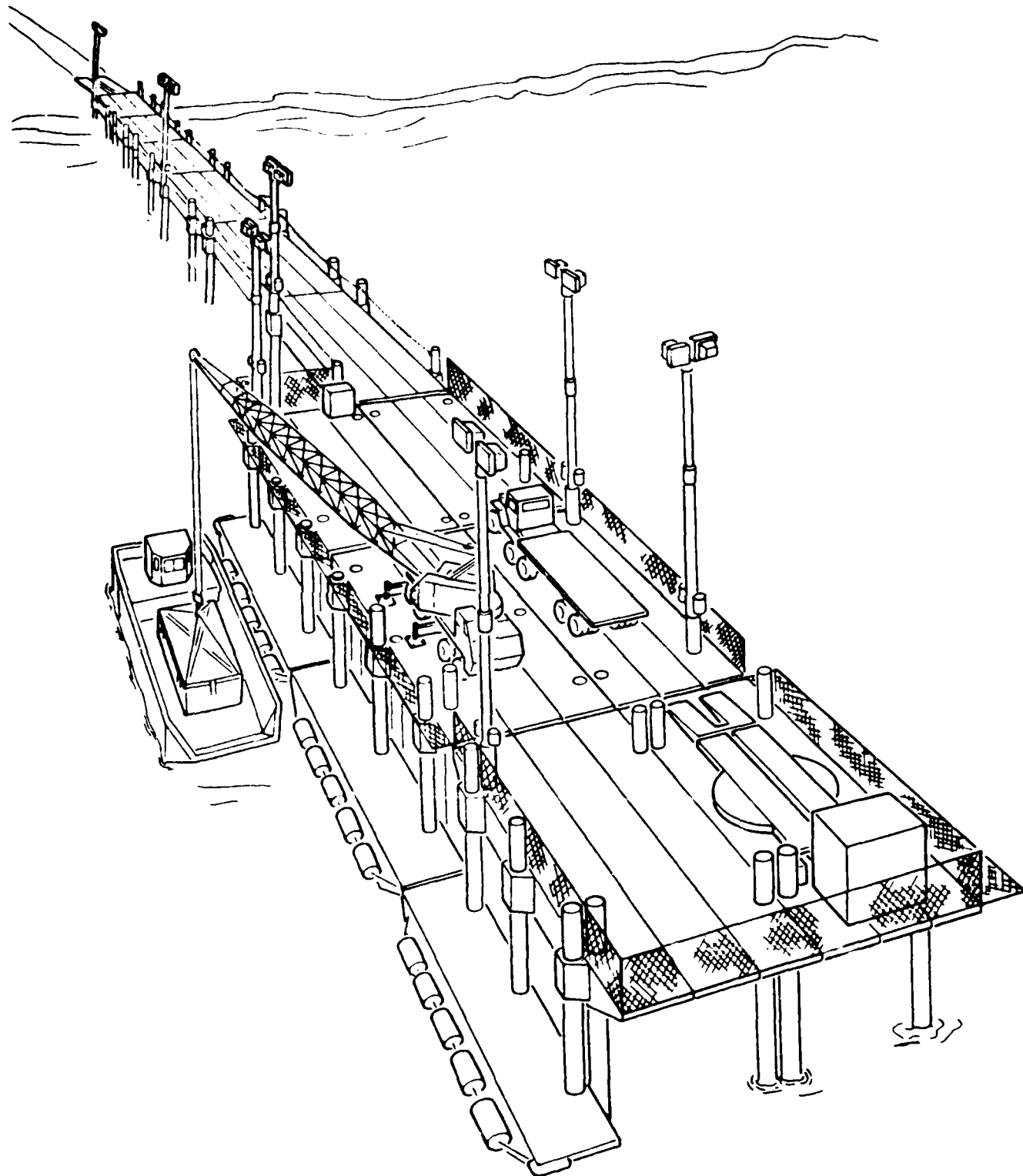

Cantilevered Elevated Causeway (CANTELCAS)

POINTS OF CONTACT

J. Anderson

US Army Belvoir RD&E Center, STRBE-FMS
Fort Belvoir, VA 22060-5606

Autovon 354-5319/Commercial (703) 664-5319

G. Walker

Naval Facilities Engineer Command, Code 061A
Alexandria, VA 22332

Autovon 221-8535/Commercial (703) 325-8535

ITEM DESCRIPTION

The Cantilevered Elevated Causeway (CANTELCAS) is a modular pier facility, composed of container-compatible modules, providing an interface between displacement craft carrying containers and the beach. The CANTELCAS will have a nominal length of up to 3,000 feet, as required, to reach a 20-foot water depth at the pierhead and is 15 feet above the mean low water level. The pierhead will be 72 feet wide by 240 feet long. The two long sides of the pierhead will have a fendering system to accommodate unscathed, lighter interface. The CANTELCAS is constructed by erecting initial section(s) and mounting a construction crane on top of them. Subsequent sections will be cantilevered from the previously erected sections and secured in place with piles. The CANTELCAS section measures 24 x 40 feet, consisting of three ISO pontoons, each measuring 40 x 8 x 4.5 feet. Emplaced on the CANTELCAS pierhead are two vehicle turntables for truck turnarounds which are supported by 48-inch air bearings. Two container-handling cranes will be stationed on the CANTELCAS pierhead to transfer cargo from lighters to container handling vehicles for subsequent transport to shore. The constructed CANTELCAS will be equipped with a lighting system. Side-loadable Warping Tugs will be used to install, maintain, and retrieve the CANTELCAS system.

STATUS

An Army Operational and Organizational (O&O) Plan for the Elevated Causeway (ELCAS) was approved by the CG, TRADOC, on 9 August 1985. A draft Operational Requirement (OR) for the CANTELCAS has been prepared by the Naval Facilities Engineering Command, and will be reviewed by the Army to determine compliance with Army Regulations.

PROGRAM PLAN

The Army may procure two CANTELCAS systems, one in FY92 and one in FY93.

Container Offloading and Transfer System (COTS) Cantilever Lift Beam



SELF-SUSTAINING

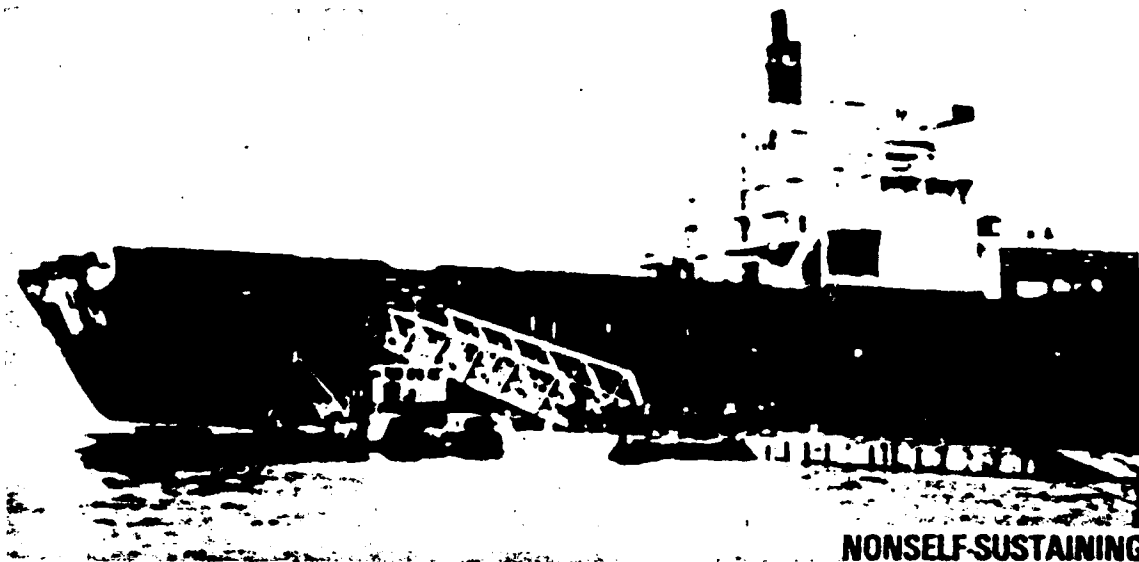

NONSELF-SUSTAINING

1004
104

Roll-On/Roll-Off Discharge Platform (RO/RO DP)

POINTS OF CONTACT

J. Anderson

US Army Belvoir RD&E Center, STRBE-FMS
Fort Belvoir, VA 22060-5606

Autovon 354-5319/Commercial (703) 664-5319

G. Walker

Naval Facilities Engineer Command, Code 061A
Alexandria, VA 22332

Autovon 221-8535/Commercial (703) 325-8535

T. Vaughters

David Taylor Research Center, DTRC-125
Annapolis, MD 21402-5067

Autovon 281-2261/Commercial (301) 267-2261

ITEM DESCRIPTION

The Roll-On/Roll-Off Discharge Platform (RO/RO DP) consists of six 90-foot x 21-foot causeway sections. Each section is composed of 45 standard P-Series (MIL-P-19380) watertight pontoons (5 x 7 x 5 feet) bolted together in 3 rows of 15 pontoons. The RO/RO DP will be approximately 189 feet long by 65 feet wide. A seventh causeway section, frequently called "B" or "Sea" section, is added to the end of the RO/RO DP for marriage with the Landing Craft Utility. The RO/RO DP will maintain a Calm Water Ramp (CWR), which provides an interface between discharging cargo ships and Army lighters. The CWR is normally 120 x 14 x 10 feet. The RO/RO DP will have a lighting and fendering system. Side-Loadable Warping Tugs (SLWTs) will be used to install, maintain, and retrieve the RO/RO DP in cargo transfer operations. The SLWT will consist of a complete Waterjet Propulsion Assembly (WPA) connected to a pontoon structure, ten pontoons long by three pontoons wide, and equipped with a deck-mounted winch, an A-frame, and a stern anchor.

STATUS

A RO/RO DP facility was granted type classification Limited Procurement Urgent (LPU) in the 21 March 1985 Milestone I and II In-Process Review (IPR) for this system. Standard A type classification for the RO/RO DP by the Army is contingent upon resolution of TRADOC issues surfaced at the IPR. Exploratory development is underway to determine concepts for Sea State 3 discharge capability.

PROGRAM PLAN

Three RO/RO DP systems will be procured by the Army in FY89-93. Initial procurement of a RO/RO DP system will occur during FY89. Army Initial Operational Capability (IOC) is expected by 3QFY90.

Container Offloading and Transfer System (COTS) Cantilever Lift Beam

POINTS OF CONTACT

G. Walker

Naval Facilities Engineer Command, Code 061A
Alexandria, VA 22332

Autovon 221-8535/Commercial (703) 325-8535

T. Vaughters

David Taylor Research Center, DTRC-125

Annapolis, MD 21402-5067

Autovon 281-2261/Commercial (301) 267-2261

ITEM DESCRIPTION

The COTS has the capability to deploy aboard commercial LASH vessels with heavy, oversized equipment and off-load offshore. A special lifting device attaches to the LASH ship's gantry crane (designed to lift 30 x 60-foot barges up to 500 short tons), and enables the lift of non-barges, eccentric loads up to 200 tons approximately 60 feet wide x 90 feet long. The beam was designed to be mated to the four lifting sockets of either the Morgan or Alliance lighter crane lifting frames. The design concept, called *Cantilever Lift Beam*, has been accepted as a National Defense feature by MARAD. Certification by the American Bureau of Shipping will be based on the capability of the eccentric loaded crane.

STATUS

Development is underway to provide quick-release devices for the rigging gear to allow Sea State 3 offload of causeways from a LASH ship. Existing design is under procurement for a total of 14 units, delivery starting in FY81. The quick release device was tested during LOG-X 88 on a TACS ship.

PROGRAM PLAN

Complete procurement of 14 units. Change rigging design if development is successful and continue procurement of device with lift beam, when available.

Floating Causeway (FC)



Floating Causeway (FC)

POINTS OF CONTACT

J. Anderson

US Army Belvoir RD&E Center, STRBE-FMS
Fort Belvoir, VA 22060-5606

Autovon 354-5319/Commercial (703) 664-5319

G. Walker

Naval Facilities Engineering Command, Code 061A
Alexandria, VA 22332

Autovon 221-8535/Commercial (703) 325-8535

ITEM DESCRIPTION

The Floating Causeway (FC) consists of 17 90 x 21-foot sections. Each section is composed of 45 standard P-series (MIL-P-19380) watertight pontoons (5 x 7 x 5 feet) bolted together in three rows of 15 pontoons. These 17 causeway sections will extend 1,530 feet from shore when connected end to end. The offshore section (frequently called "B" or "Sea" section), will have an end adapter for marriage to the LCU, bitts for mooring lines, and a rhino horn to mate with the LCU bow ramp. The inshore section will be fitted with folddown ramps on one end to allow offloading of vehicular traffic. The remaining 15 sections (intermediate sections) are of similar configuration within themselves and compose the largest portion of the FC. An anchor mooring system composed of 12 offshore mooring legs and 4 onshore mooring legs will be utilized when a 17-section FC is emplaced in the worst weather and sea conditions. Two Side Loadable Warping Tugs (SLWTs) are used to move, position, and tender the causeway sections, and to set and remove the anchors. Additionally, two bulldozers are required to assist in the beach preparation and to beach the causeway sections.

STATUS

The FC Facility was granted type classification Limited Procurement Urgent (LPU) in the 21 March 1985 Milestone I and II (IPR) for this system. Standard Code A Type Classification for the FC by the Army is contingent upon resolution of TRADOC issues surfaced at the IPR.

PROGRAM PLAN

Initial procurement of two FC systems will occur during FY89. Army Initial Operational Capability (IOC) is expected by 2QFY90.

SEASHED System

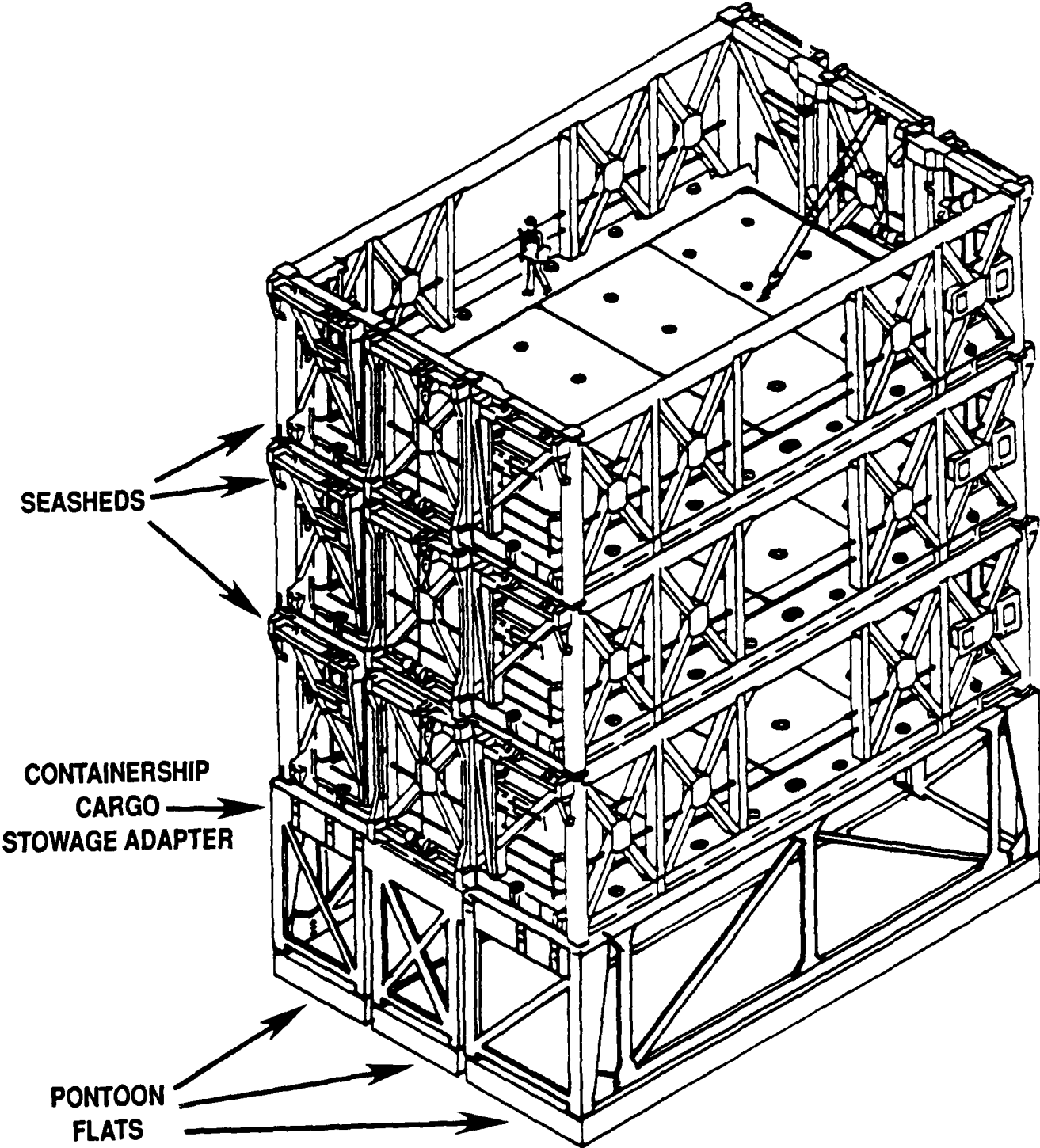

SEASHED System

POINT OF CONTACT

M. Baig
Naval Sea Systems Command, PMS 377 K2
Washington, DC 20362-5101
Autovon 222-7881/Commercial (202) 692-7881

ITEM DESCRIPTION

The SEASHED System consists of a stack of up to three SEASHEDs on a Container Cargo Stowage Adapter (CCSA).

SEASHEDs are open-topped large cargo containers that fit into the container cells of a containership to provide the capability to carry large, heavy or oversized cargo such as Army and Marine Corps tanks and helicopters. Each SEASHED occupies the space of three 40-foot containers in width and has the overall height of 1-1/2 containers, having dimensions of 25 feet wide, 40 feet long, and 12-1/2 feet high. The maximum cargo capacity of each SEASHED is 220,000 pounds. Each SEASHED weighs 76,000 pounds. The floor of the SEASHED opens to allow cargo to be lowered through to the SEASHED or CCSA below. The clear opening of the floor is 30 feet x 18 feet. The CCSA has two elements, the adapter frame and three pontoon flats which provide the same storage capability of a SEASHED. The quantity to be procured is to satisfy contingency logistics requirements for heavy lift shipment via Ready Reserve Force (RRF), US Flag, and allied containerships.

STATUS

Approximately 678 SEASHED and 32 CCSA units have been delivered as of March 1989. The inventory objective is for 1,000 SEASHED units and 359 CCSA units.

PROGRAM PLAN

Continue receiving units ordered under 1988 and 1989 contracts.

Basic Merchant Ship Naval Augmentation Program (MSNAP) Module

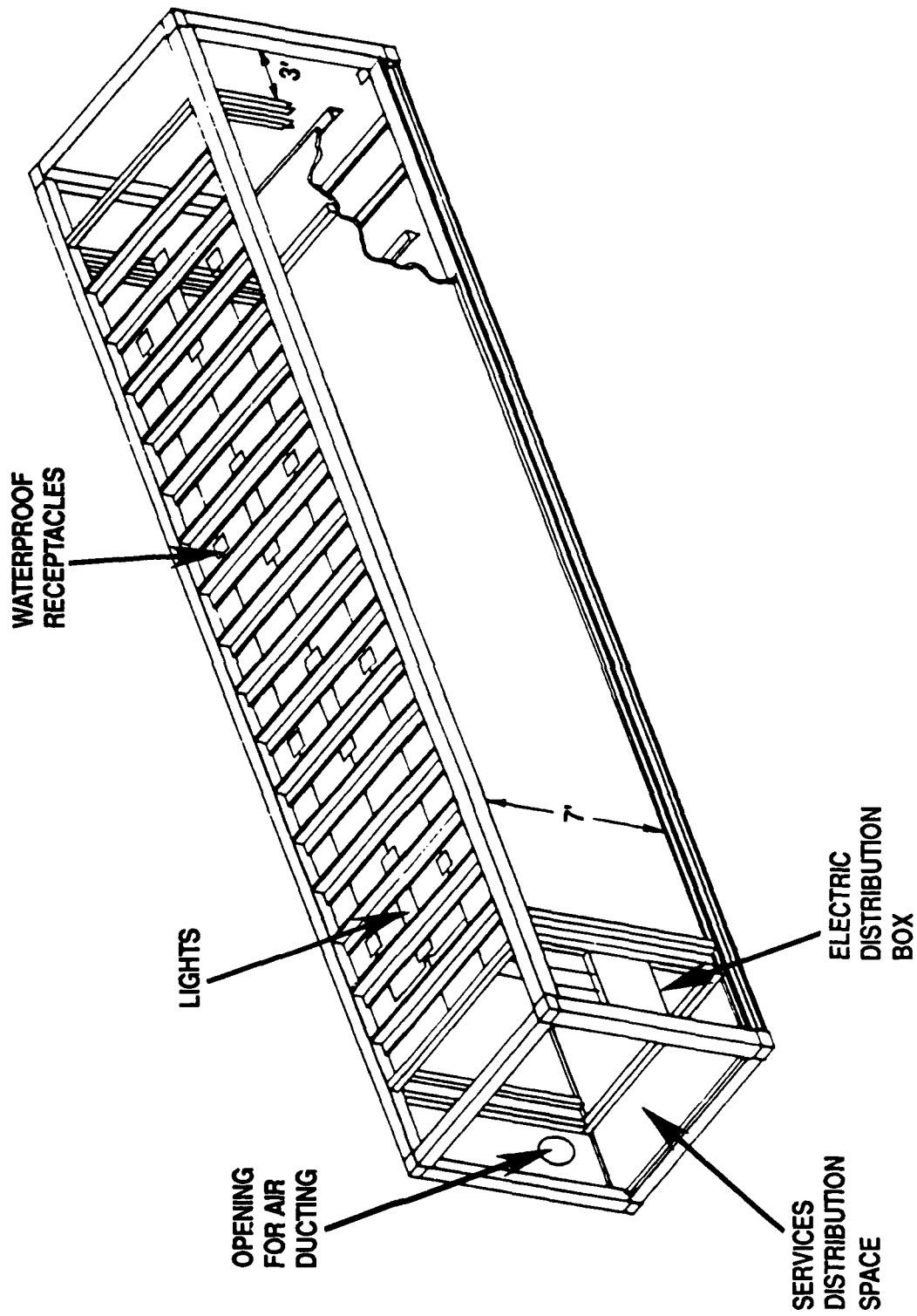

BASIC 40 FT MODULE STRUCTURE

Basic Merchant Ship Naval Augmentation Program (MSNAP) Module

POINTS OF CONTACT

M. Fink

Naval Sea Systems Command, PMS 377 K

Washington, DC 20362-5101

Autovon 222-4834/Commercial (202) 692-4834

B. Nolte

Naval Coastal Systems Center, Code 3320

Panama City, FL 32407-5000

Autovon 436-4489/Commercial (904) 234-4489

ITEM DESCRIPTION

The 8 x 8.5 x 40 foot Basic MSNAP Module is an RDT&E development effort. The goal is an ISO-compatible structure which can readily be configured to provide a live-in or work-in shelter within the hold spaces of a containership, breakbulk ship or RO/RO ship. The module features a 3-foot utility compartment at either end. It can be readily outfitted with overhead lighting; a heating/cooling unit; ventilation ducting; reinforced decking; and connections for electrical, plumbing, and other utilities. The structure is the basis for workshop modules of the MSNAP Modular Repair System (MMRS), and for a variety of below-deck modules of the MSNAP Habitability and Utility Support System (HUSS).

STATUS

Design of the Basic MSNAP Module was completed in FY86.

PROGRAM PLAN

The MSNAP is currently unfunded and no activity is planned.

Habitability and Utility Support System (HUSS)

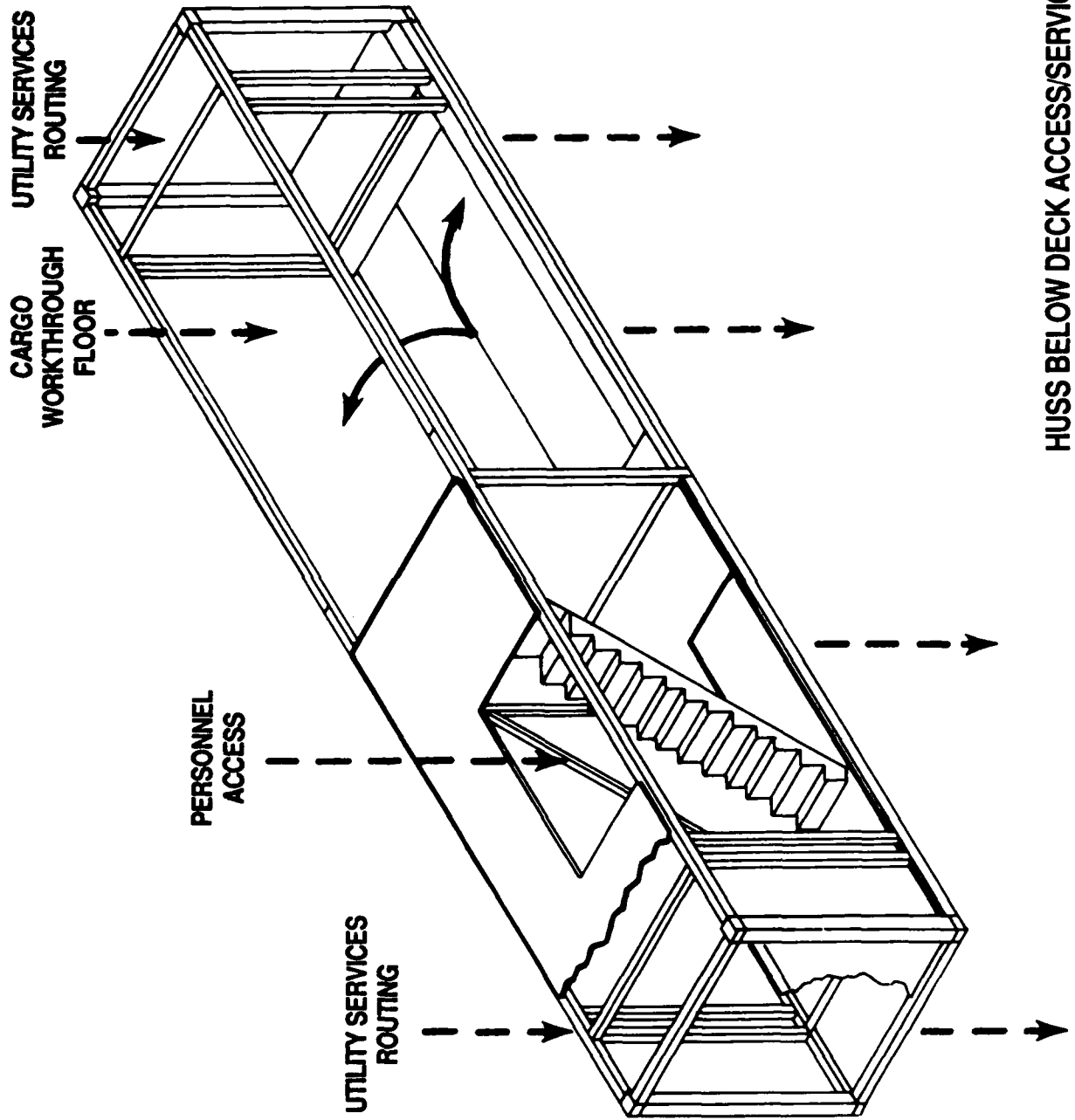

Habitability and Utility Support System (HUSS)

POINTS OF CONTACT

M. Fink

Naval Sea Systems Command, PMS 377 K

Washington, DC 20362-5101

Autovon 222-4834/Commercial (202) 692-4834

B. Nolte

Naval Coastal Systems Center, Code 3320

Panama City, FL 32407-5000

Autovon 436-4489/Commercial (904) 234-4489

ITEM DESCRIPTION

HUSS is a system of personnel- and utility-oriented containerized modules which can be selectively installed and employed above deck and in hold spaces of Strategic Sealift containerships. The HUSS system provides integrated support to other Merchant Ship Naval Augmentation Program (MSNAP) systems installed and operating in a fleet augmentation role. The majority of the HUSS modules will utilize the 40-foot Basic MSNAP Module design. Above-deck module functions will include heating, ventilation, and air conditioning; electrical power generation; system fuel storage; and personnel and equipment access for below-deck spaces. Initial below-deck module functions being designed include personnel and equipment access to all hold levels and utility distribution. Other functions being considered include berthing, head and shower, waste management, galley, messing, sickbay, laundry, administrative, recreation, and storage support.

STATUS

Preliminary design of HUSS access modules was completed in FY86.

PROGRAM PLAN

The MSNAP is currently unfunded and no activity is planned.

Modular Mobile Repair System (MMRS)

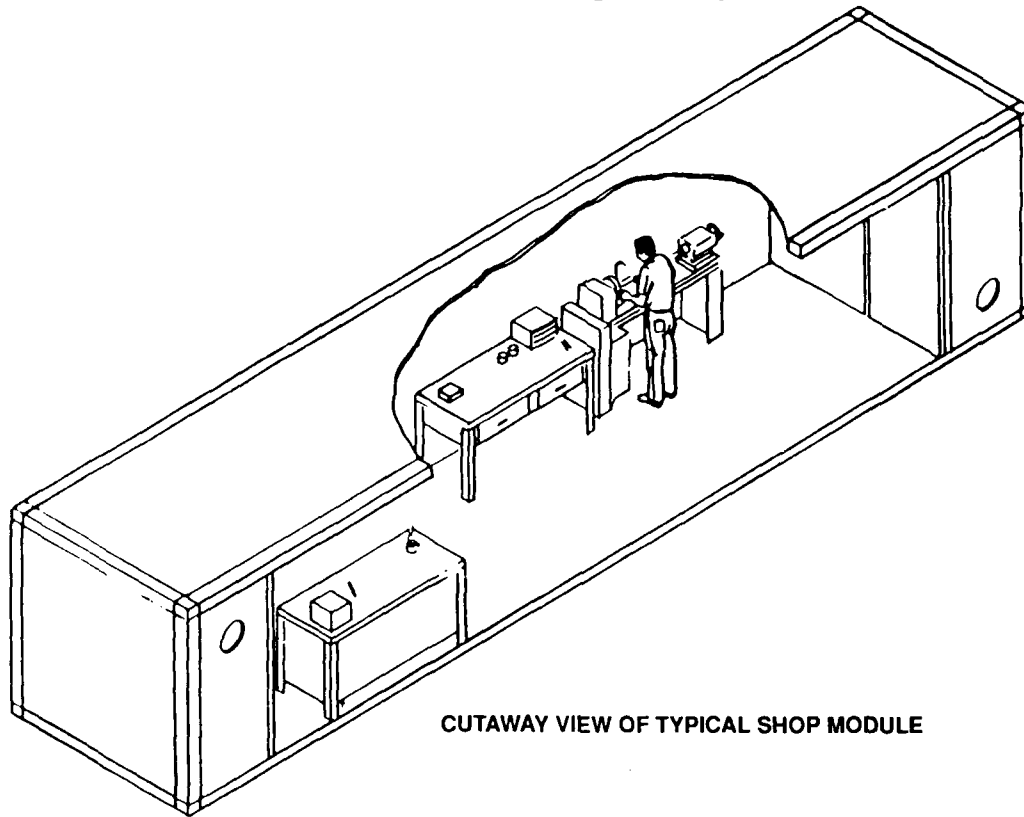

CUTAWAY VIEW OF TYPICAL SHOP MODULE

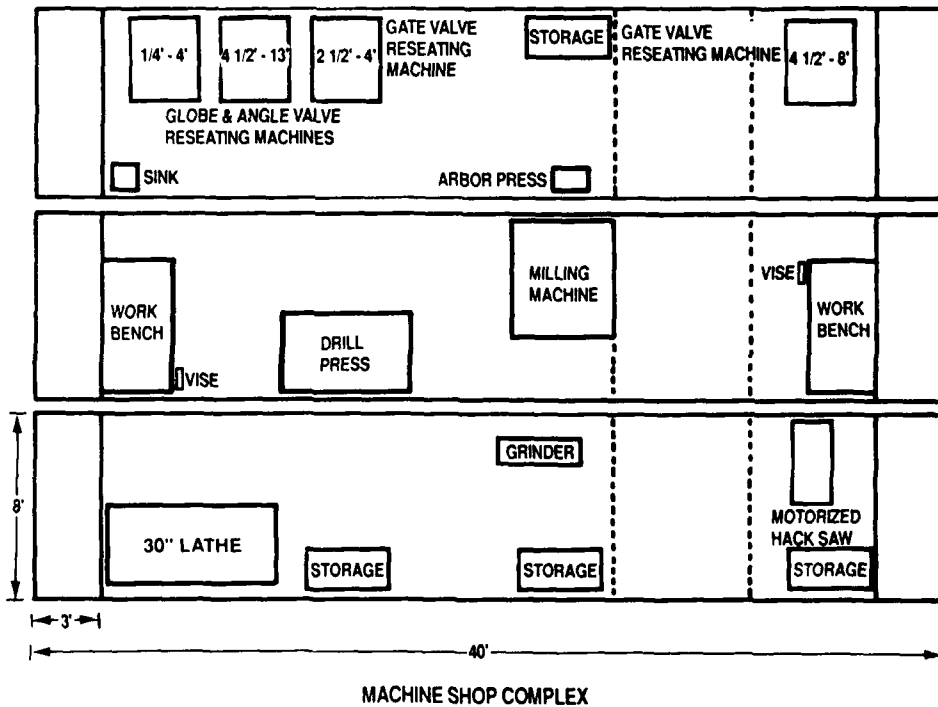

MACHINE SHOP COMPLEX

Modular Mobile Repair System (MMRS)

POINTS OF CONTACT

M. Fink

Naval Sea Systems Command, PMS 377 K
Washington, DC 20362-5101

Autovon 222-4834/Commercial (202) 692-4834

B. Nolte

Naval Coastal Systems Center, Code 3320
Panama City, FL 32407-5000

Autovon 436-4489/Commercial (904) 234-4489

ITEM DESCRIPTION

The MMRS is a system of modular workshops which can be installed and operated in Strategic Sealift merchant ships to provide fleet augmentation support. Shop equipment will be installed in the Basic MSNAP Module. Deployment will provide workshop suites comprised of one or more 40-foot modules. These modules in conjunction with selected Habitability and Utility Support System (HUSS) modules, make up the overall, multi-level MMRS complex.

STATUS

MMRS design work commenced at NAVCOASTSYSCEN under the Merchant Ship Naval Augmentation Program (MSNAP) in FY85. Detailed design and specification of the first advanced development model was completed in early FY87.

PROGRAM PLAN

The MSNAP is currently unfunded and no activity is planned.

Causeway Ferry (CF)

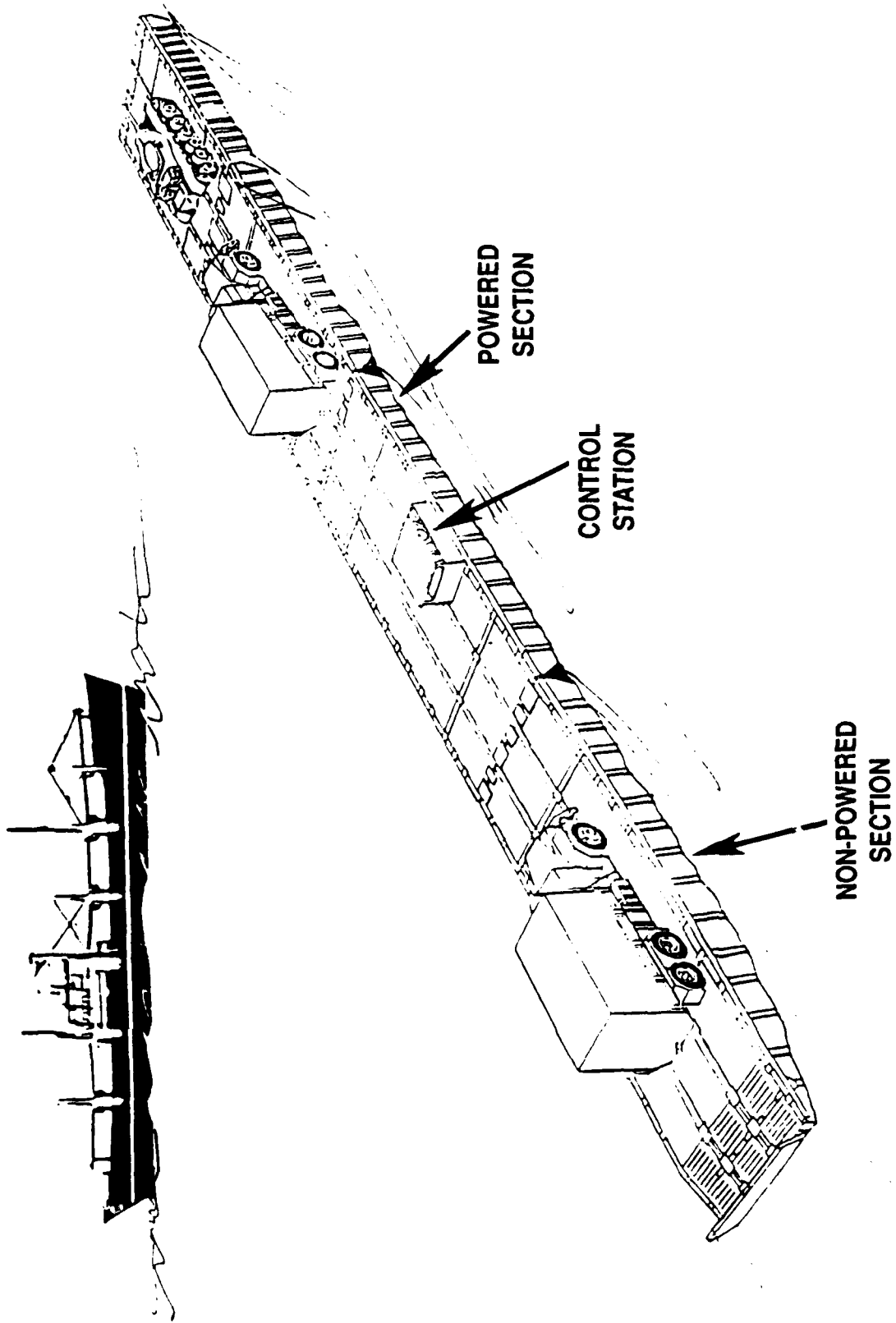

Causeway Ferry (CF)

POINTS OF CONTACT

J. Anderson

US Army Belvoir RD&E Center, STRBE-FMS
Fort Belvoir VA 22060-5606
Autovon 354-5319/Commercial (703) 664-5319

G. Walker

Naval Facilities Engineering Command, Code 061A
Alexandria, VA 22332
Autovon 221-8535/Commercial (703) 325-8535

ITEM DESCRIPTION

The Causeway Ferry (CF) consists of a powered section and three non-powered stations, joined end-to-end in a 320 foot x 24 foot self-powered causeway configuration. Each section will be formed by joining six ISO modular pontoons in a 2 x 3-arrangement, utilizing 40-foot pontoons (4.5 x 8 x 40 feet). Powered sections are composed of several propulsion modules with inherent propulsions subsystems and a control station. The pontoons can be stored, transported, and assembled on commercial containerships (on the ship's deck or in calm water). They can be lifted from the container cells with standard container spreader bars. The system will operate in the movement of RO/RO cargo and containers. Upon arrival in the objective area, pontoons will be unloaded and assembled into the appropriately sized system. Each system will be provided with necessary communication equipment, permitting communications between the operator and his forward lookout, and between the operator, commercial ships, and the lighter control center.

STATUS

An Army Operational and Organizational (O&O) Plan has been approved for the Causeway Ferry. System design and development will be conducted by the Navy under NAVFAC cognizance. The Army provided requirements in FY86 to the NAVFAC program manager. The Army will furnish NAVFAC any specific test requirements for inclusion in the First Article Test.

PROGRAM PLAN

The Army will pursue a Non-Developmental Item (NDI) acquisition strategy for the Causeway Ferry. Type classification will be achieved in 2QFY90 as LCC A. Seven Causeway Ferry systems will be procured by the Army using FY87-90 funds.

High Sea State Container Transfer System (HISEACOTS)

HIGH SEA STATE CONTAINER TRANSFER SYSTEM (HISEACOTS)



LENGTH: 120 FT
GANTRY HEIGHT: 32 FT
WIDTH: 56 FT
WEIGHT: 250 STON
(MODULES W/GANTRY)

High Sea State Container Transfer System (HISEACOTS)

POINT OF CONTACT

B. David
US Army Belvoir RD&E Center, STRBE-FMD
Fort Belvoir, VA 22060-5606
Autovon 354-4266/Commercial (703) 664-4266

ITEM DESCRIPTION

The HISEACOTS is a system that has been developed to stabilize the offloading/lighter interface in high sea states (SS 3/4). The system consists of a floating platform made up of modular ISO pontoons (120 x 56 foot), with fore and aft floodable ramps, and batterboards to guide air cushion vehicles (i.e., US Army LACV-30) onto the platform. This platform is fitted with a specially designed gantry crane that is used to offload containers/vehicles. The gantry crane has a pendulation attenuator bar that mitigates all pendulation motions through friction forces generated at the bar by the container slings. A positive lock/spar device further reduces any heave motions present and allows the offload of eccentrically loaded containers. The HISEACOTS is designed to offload containers/cargo weighing up to 50,000 pounds in sea state 4.

STATUS

The HISEACOTS is currently in the concept exploration phase. A Small Business Innovation Research (SBIR) Program contract was awarded (Phase I) in 1986 for concept design. A Phase II SBIR contract was awarded in 1988 for a detailed HISEACOTS system design and additional fabrication and testing of the special gantry crane. Land based testing of the Gantry Crane is scheduled for 4QFY89. A joint Army/Navy technology demonstration of an air cushion "fly-on/fly-off" platform is scheduled for 4QFY89.

PROGRAM PLAN

Transition into a development - production prove-out phase in FY91.

Pontoon Air Cushion Kit (PACK)



**LENGTH: 80 FT (HARD STRUCTURE)
97 FT (INFLATED)**

**HEIGHT: 4.5 FT (HARD STRUCTURE)
CUSHION HEIGHT: 3 FT**

**LIGHTSHIP DISPLACEMENT: 154,600 LB
FULL LOAD DISPLACEMENT: 354,600 LB
WEIGHT: 10 STONS (W/O PONTOONS)**

**BEAM: 24 FT (HARD STRUCTURE)
41 FT (INFLATED)**

**HEIGHT: 11 FT (INFLATED)
CUSHION AREA: 2,400 SQF**

CUSHION PERIPHERAL LENGTH: 225FT

Pontoon Air Cushion Kit (PACK)

POINT OF CONTACT

B. David

US Army Belvoir RD&E Center, STRBE-FMD

Fort Belvoir, VA 22060-5606

Autovon 354-4266/Commercial (703) 664-4266

ITEM DESCRIPTION

The PACK consists of a lightweight peripheral skirt system with an autonomous air supply unit that can be attached in the field to a modular causeway section (80 x 24 foot) converting it into an air cushion supported platform capable of carrying 100 stons of cargo.

There are two diesel engine (GM 8V-71) fan units (centrifugal) which supply pressurized air to the skirt system. The diesel engine/fan units are skid mounted for easy deployment. The skids utilize existing attachment points on the deck of the module pontoons for fastening purposes. The engine/fan units are provided with an integral fuel tank and additional flexible fuel tanks for extended operations.

There are approximately 32 straight rail skirt/rail segments (60 inch wide), 4 straight skirt/rail segments (32 inch wide), 4 corner skirt/rail segments, 8 straight bag segments (20 ft long), and 2 end bag segments that make up the peripheral skirt system.

The PACK is supplied with "pusher knees" that can be attached to one end of the causeway section to facilitate warping operations with US Army lighters. A tow bridle is incorporated into the end skirt/rail segment for towing operations. The PACK is transportable in a 40-foot ISO container.

STATUS

A contract was awarded for the detailed design and fabrication of a full-scale technology demonstrator in February 1989. A Concept Evaluation Program (CEP) user test is scheduled for April 1990. An eighth-scale model of the PACK has been fabricated and is currently undergoing model testing to determine cushion flows, acceptable LCG/TCG, drag under load in various sea state conditions, etc. The model testing is scheduled for completion July 1989.

PROGRAM PLAN

The PACK technology demonstrator will undergo CEP tests in FY90. Immediately following, a user in-process review will be held to determine if a materiel change program for the Modular Causeway System is desired.

Part V

Aerial Port/ Terminal Equipment

40,000-Pound 463L Aircraft Loader

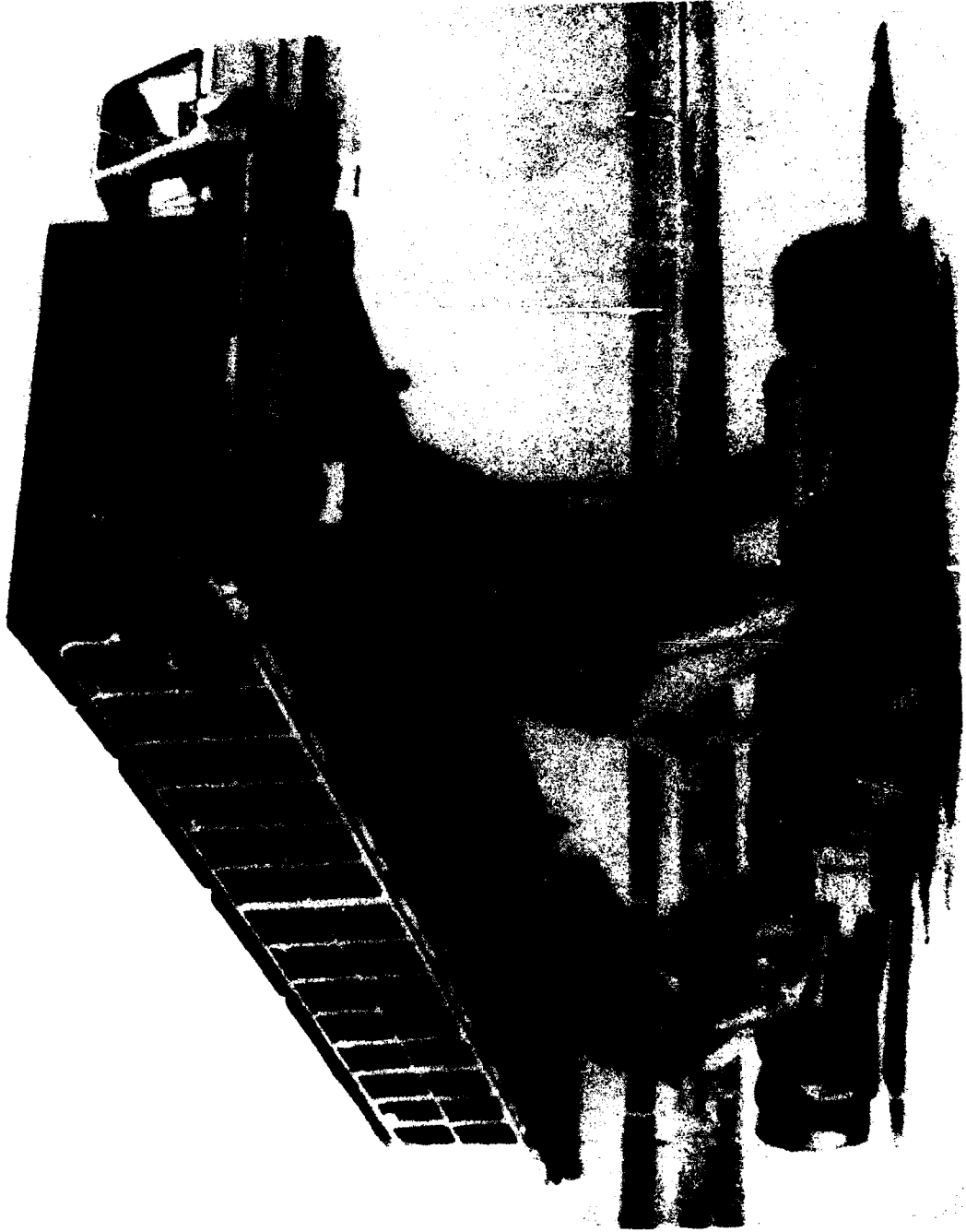

40,000-Pound 463L Aircraft Loader

POINT OF CONTACT

COL Drum

Warner Robins Air Logistics Center, WRALC/MMVV

Robins AFB, GA 31098-5609

Autovon 468-2062/Commercial (912) 926-2062

ITEM DESCRIPTION

This aircraft loader has the capacity to transport 40,000-pound palletized loads to and from cargo aircraft. It has a platform length of 41 1/2 feet, a width of 10 feet, and a lifting range of 3 1/3 to 13 feet at 10 FPM. The unit will accommodate five 463L pallets. The loaders are air transportable and are available at all major aerial ports. The 40,000-pound loader can also accommodate an ISO container loaded on married 463L pallets or other adapter systems.

STATUS

The Air Force has 286 40,000-pound loaders on hand.

PROGRAM PLAN

The 40,000-pound loader will be replaced by the 60,000-pound Capacity Loader which is scheduled for procurement in 2QFY94. The 60,000-pound Capacity Loader will be air transportable, a member of the 463L Materiel Handling System, and capable of loading all aircraft including the C-17.

25,000-Pound 463L Aircraft Loader



25,000-Pound 463L Aircraft Loader

POINT OF CONTACT

COL Drum
Warner Robins Air Logistics Center, WRALC/MMVV
Robins AFB, GA 31098-5609
Autovon 468-2062/Commercial (912) 926-2062

ITEM DESCRIPTION

This diesel-powered loader has the capacity to transport 25,000-pound palletized aircraft loads to and from cargo aircraft. It has a platform length of 24 feet, a width of 10 feet, and can accommodate three 463L pallets. The 25,000-pound loader is air transportable by C-130 aircraft and available at major aerial ports. The 25,000-pound loader can accommodate ISO containers with gross weight, including 463L adapter systems, of 25,000 pounds.

STATUS

The Air Force currently has 485 units on hand. A contract was awarded 1 July 1987 for 189 additional 25,000-pound aircraft loaders, with a start delivery date of 1QFY90.

PROGRAM PLAN

The inventory objective is 783 units.

35-Ton Bridge Crane



35-Ton Bridge Crane

POINT OF CONTACT

MSG Bowen
HQ Military Airlift Command, TRXF
Scott AFB, IL 62225
Autovon 576-4697/Commercial (618) 256-4697

ITEM DESCRIPTION

This item provides major aerial ports the capability to build up pallets for air drop missions and transfer fully loaded ISO shelters, air/land or surface containers from trucks/trailers to adapter systems and aircraft loaders. The bridge crane is not mobile and provides the capability to support limited container movements.

STATUS

Bridge cranes are installed at the following aerial ports: Dover, Travis, Mildenhall, Ramstein, Rhein-Main, Clark, and Kadena.

PROGRAM PLAN

None.

Elevator Loader

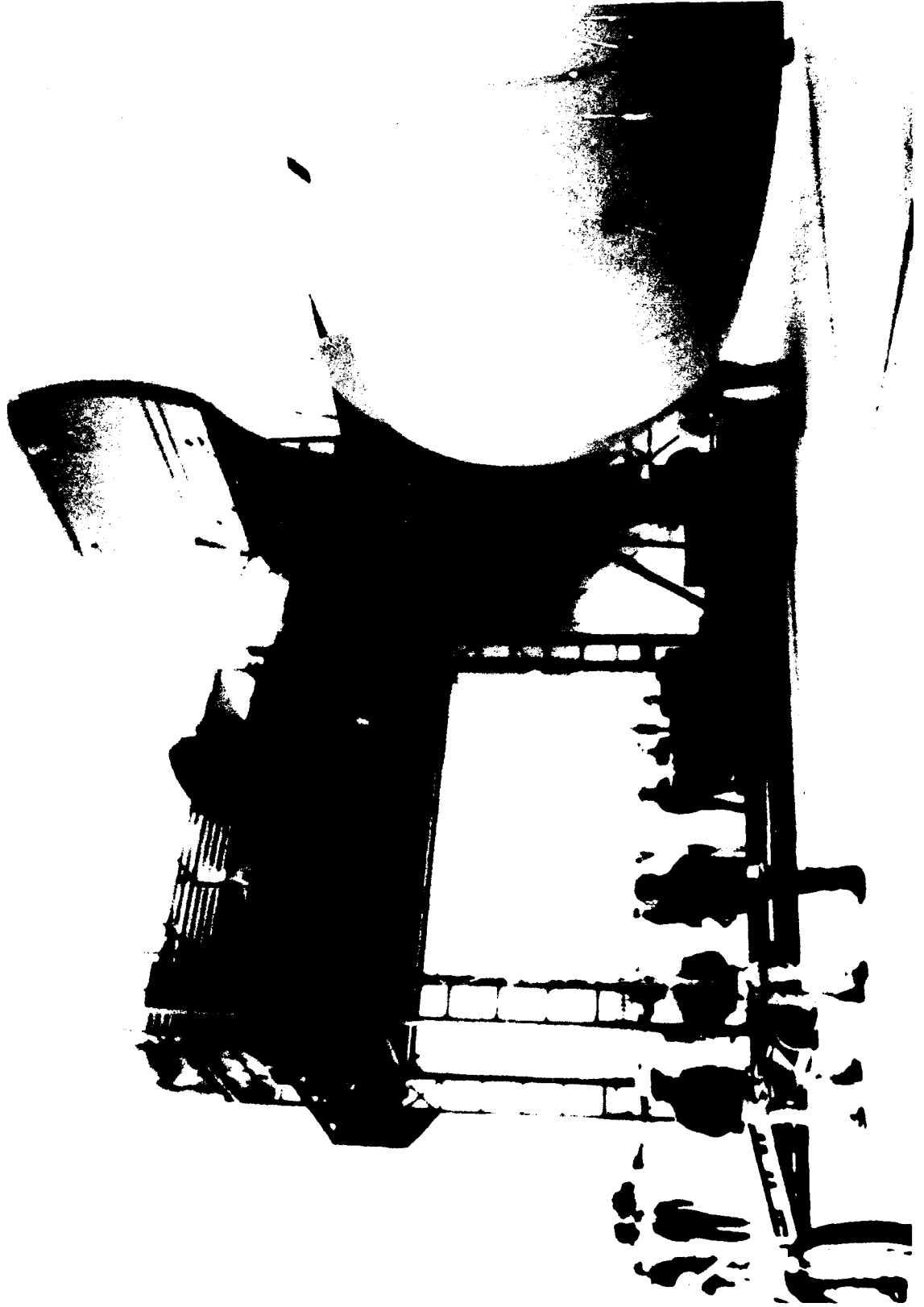

Elevator Loader

POINT OF CONTACT

COL Drum
Warner Robins Air Logistics Center, WRALC/MMVV
Robins AFB, GA 31098-5609
Autovon 468-2062/Commercial (912) 926-2062

ITEM DESCRIPTION

This item is air transportable on a C-130 aircraft. There are three models of elevator loaders currently in the Air Force inventory. The Cochran Model 316A has a two-pallet, 25,000-pound capability. The Cochran Model 316E and the Wilson have a three-pallet, or one air/land container, 40,000-pound capability. The Elevator Loader can also be used to load/unload rolling stock up to its capacity. It is compatible with wide-body aircraft upper deck nose doors and side doors, with maximum transfer height of 18-feet, 6 inches. It is used at major aerial ports for efficient mechanized loading/offloading of cargo between wide-body aircraft and other materials handling equipment.

STATUS

The Air Force has 101 elevator loaders on hand. 59 CL3 elevator loaders were recently refurbished.

PROGRAM PLAN

The remaining 42 elevator loaders will undergo a refurbishment program beginning in 1Q or 2QFY90. The elevator loaders will eventually be replaced by the 60,000-pound Capacity Loader which is scheduled for procurement in 2QFY94.

463L/ISO Adapter System

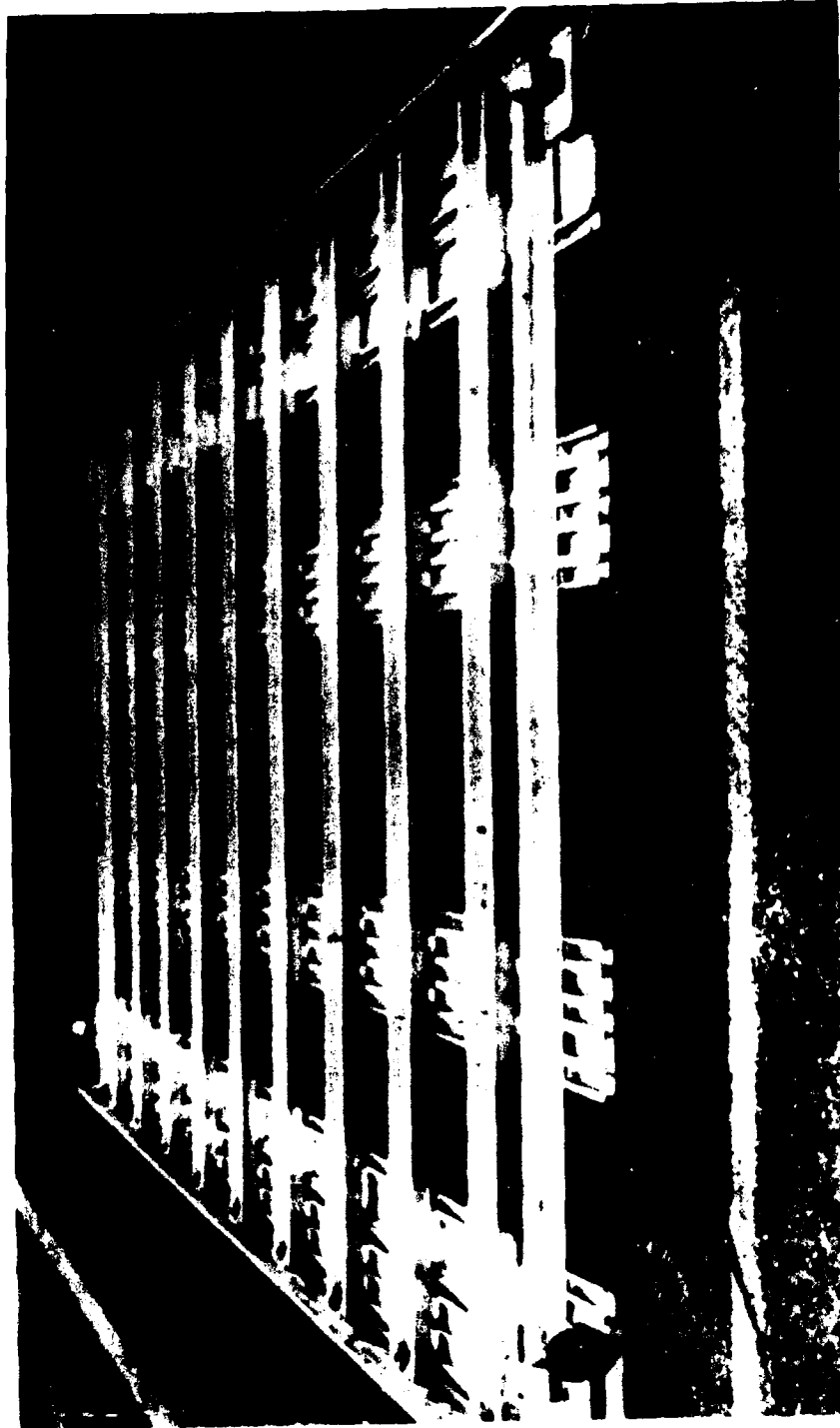

463L/ISO Adapter System

POINT OF CONTACT

COL Drum
Warner Robins Air Logistics Center, WRALC/MMVV
Robins AFB, GA 31098-5609
Autovon 468-2062/Commercial (912) 926-2062

ITEM DESCRIPTION

The adapter tactical shelter system provides a means for handling ISO air/surface containers and, to a limited extent, surface containers in the 463L aircraft material handling system. The system adapts the ISO 96-inch width to the 463L 108-inch width and provides an interface with the aircraft roller system.

STATUS

The Air Force has tested and evaluated several different adapter systems to date:

- Two prototype open-grid adapter pallets were procured and successfully tested under the MODCOM Program in 1974. A buy program for this pallet was deferred in favor of a flat platform.
- Brooks and Perkins, Inc., designed a system using A/E 29H1 airdrop platforms (single-managed by US Army) using Brooks and Perkins side rails and end plates with installed ISO corner fittings. AFSC/ESD evaluated this alternative, though stress tests conducted by US Army Natick Labs, Natick, MA, determined that airdrop platforms do not provide adequate features to accommodate movement of containers. Therefore, this initiative was terminated.
- The Military Airlift Command submitted a Statement of Operational Need (SON) for an adapter system which was approved by the Air Force in February 1983. Later the SON was withdrawn.
- Two companies developed a solid platform adapter pallet capable of handling air/land, SEAVAN, and tactical shelters.
- The Air Force Electronic Systems Division, Hanscom Field, MA, designed a system using two detachable rails to satisfy the requirement. During FY88, three prototype systems were built and tested.

PROGRAM PLAN

The requirements for this program are not firm at this point and no procurements are currently scheduled.

Mobile Straddle Crane



Mobile Straddle Crane

POINT OF CONTACT

MSG Bowen
HQ Military Airlift Command, TRXF
Scott AFB, IL 62225
Autovon 576-4697/Commercial (618) 256-4697

ITEM DESCRIPTION

This item is for use by major aerial ports to handle the movement of ISO carrier/shelters by air. The Mobile Straddle Crane has the capability of lifting ISO tactical shelters, surface containers, and air/surface containers weighing up to 47,000 pounds. The unit is able to operate within the confines of an aerial port and provide the capability to transfer shelters and containers from/to trailers, aerial port high-line docks, and 25K/40K aircraft loaders. There are two types of Mobile Straddle Cranes: one being air transportable in a C-130 and another for use at strategic aerial ports.

STATUS

The Air Force does not have Mobile Straddle Cranes currently assigned. The Mobile Straddle Crane has successfully completed tests to assess its military utility as a container handling system, to determine its deployability by air, and to assess its suitability for use in military airlift operations. The tests were conducted at Pope AFB, NC, by the USAF Airlift Center. It was also tested in Korea during a test shipment of Air Force containerized munitions. The Mobile Straddle Crane was tested at the discharge pier and during the train offloading at the ammunition storage site. The test successfully demonstrated the deployability of the crane and identified constraints while working in an area not specifically designed for container operations.

The Military Airlift Command (MAC) Statement of Operational Need (SON) for a Mobile Straddle Crane was approved by the Air Force. The present MAC requirement is for 34 strategic loaders and 16 air transportable loaders. Funding was programmed for FY85-86 to satisfy this requirement.

PROGRAM PLAN

A production contract was awarded to Mi Jack during 4QFY88 to produce both types of Mobile Straddle Cranes to meet the requirement.

22,000-Pound Capacity Forklift

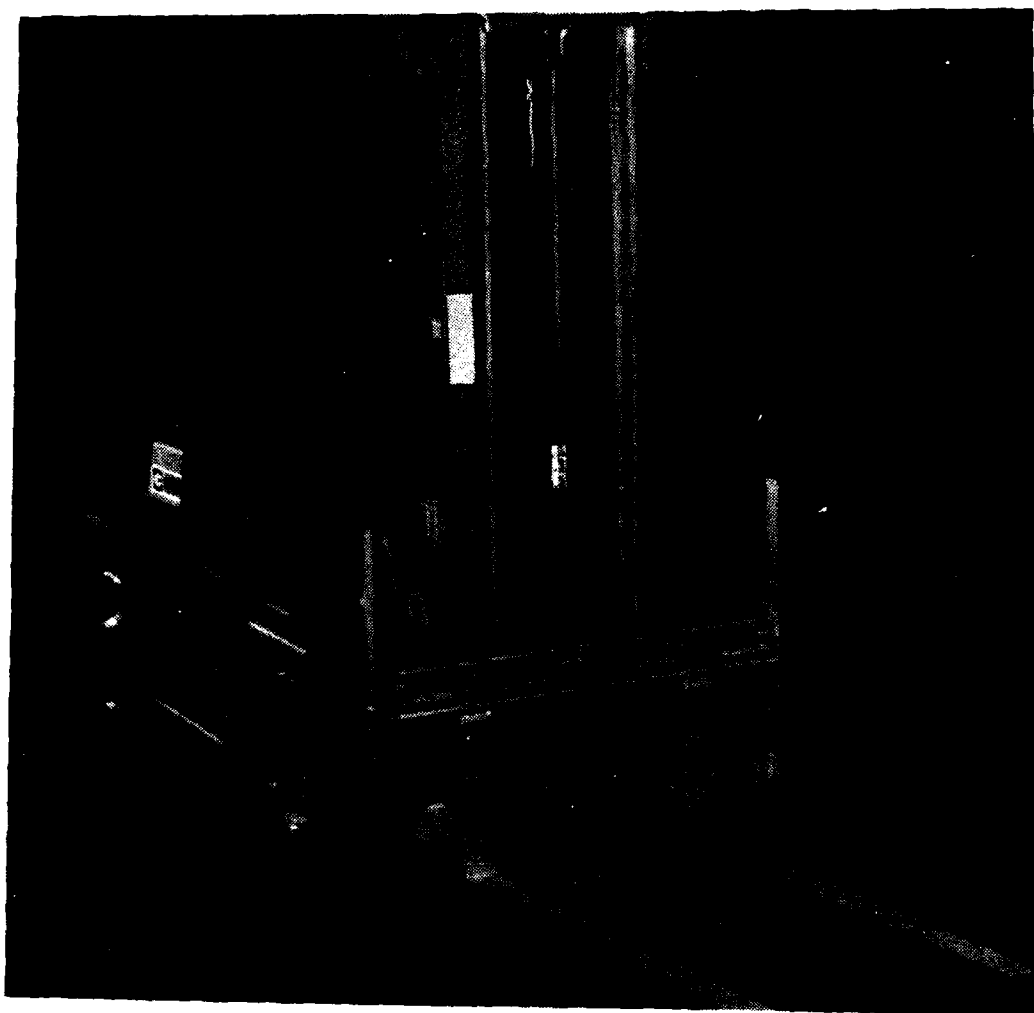

22,000-Pound Capacity Forklift

POINT OF CONTACT

CMS C. Luby
HQ TAC/LGTV
Langley AFB, VA 23665-5001
Autovon 574-3406/Commercial (804) 764-3406

ITEM DESCRIPTION

This 22,000-pound capacity forklift at a 48-inch load center will be used to handle tactical shelters at TAC and PACAF bases. Some Air Force shelters have a maximum gross weight of 20,000 pounds. The forklift is a commercially available vehicle. Rough terrain capability is not required, side shift carriage is mandatory, and air transportability on C-141 aircraft is desired.

STATUS

A contract for 40 units was awarded in FY88 to Clark Equipment Co.

PROGRAM PLAN

Both TAC and PACAF will replace, through attrition, existing 15,000-pound capacity forklifts with the 22,000-pound forklifts.