

AD-A276 059



2

ARMY RESEARCH LABORATORY



Electrothermal-Chemical (ETC)
Extensions to IBHVG2 With
a New User's Tutorial

Jon Eamhart
Niels Winsor
GT-DEVICES, INC.



Gloria P. Wren
U.S. ARMY RESEARCH LABORATORY

ARL-TR-348

January 1994

105 pg

94-06103



APPROVED FOR PUBLIC RELEASE; DISTRIBUTION IS UNLIMITED.

94-06103

NOTICES

Destroy this report when it is no longer needed. DO NOT return it to the originator.

Additional copies of this report may be obtained from the National Technical Information Service, U.S. Department of Commerce, 5285 Port Royal Road, Springfield, VA 22161.

The findings of this report are not to be construed as an official Department of the Army position, unless so designated by other authorized documents.

The use of trade names or manufacturers' names in this report does not constitute indorsement of any commercial product.

REPORT DOCUMENTATION PAGE

Form Approved
OMB No 0704-0188

Public reporting burden for this collection of information is estimated to average 1 hour per response, including the time for reviewing the instructions, searching existing data sources, gathering and maintaining the data needed, and completing and reviewing the collection of information. Send comments regarding this burden estimate or any other aspect of this collection of information, including suggestions for reducing this burden, to Washington Headquarters Services, Directorate for Information Operations and Reports, 1215 Jefferson Davis Highway, Suite 1204, Arlington, VA 22202-4302, and to the Office of Management and Budget, Paperwork Reduction Project (0704-0188), Washington, DC 20503.

1. AGENCY USE ONLY (Leave blank)	2. REPORT DATE January 1994	3. REPORT TYPE AND DATES COVERED Final, Aug 91 - Aug 92
----------------------------------	---------------------------------------	---

4. TITLE AND SUBTITLE Electrothermal-Chemical (ETC) Extensions to IBHVG2 With a New User's Tutorial	5. FUNDING NUMBERS PR: 11162618A1FL
---	---

6. AUTHOR(S) Jon Earnhart,* Niels Winsor,* and Gloria P. Wren	
---	--

7. PERFORMING ORGANIZATION NAME(S) AND ADDRESS(ES) U.S. Army Research Laboratory ATTN: AMSRL-WT-PA Aberdeen Proving Ground, MD 21005-5066	8. PERFORMING ORGANIZATION REPORT NUMBER
---	--

9. SPONSORING / MONITORING AGENCY NAME(S) AND ADDRESS(ES) U.S. Army Research Laboratory ATTN: AMSRL-OP-CI-B (Tech Lib) Aberdeen Proving Ground, MD 21005-5066	10. SPONSORING / MONITORING AGENCY REPORT NUMBER ARL-TR-348
---	---

11. SUPPLEMENTARY NOTES
***GT-Devices, Inc., 5705A General Washington Drive, Alexandria, VA 22312-2408.
Supported by General Dynamics, Land System Division, Internal Research and Development**

12a. DISTRIBUTION / AVAILABILITY STATEMENT Approved for public release; distribution is unlimited.	12b. DISTRIBUTION CODE
--	------------------------

13. ABSTRACT (Maximum 200 words)

IBHVG2, the computer code named for Interior Ballistics of High Velocity Guns, is a lumped parameter (zero dimensional) interior ballistics code which has been widely utilized to model solid propellant charges both nationally and internationally. Over the past 10 years a number of user options such as automated search routines and metric units have been added to the code. In this report we describe the extension of the code to allow the addition of electrical energy to the propellant gases to simulate electrothermal-chemical (ETC) guns. In addition, this report serves to update the original user manual and includes a description of the current input variables and sample output.

14. SUBJECT TERMS electrothermal, interior ballistics, high velocity, guns	15. NUMBER OF PAGES 100
	16. PRICE CODE

17. SECURITY CLASSIFICATION OF REPORT UNCLASSIFIED	18. SECURITY CLASSIFICATION OF THIS PAGE UNCLASSIFIED	19. SECURITY CLASSIFICATION OF ABSTRACT UNCLASSIFIED	20. LIMITATION OF ABSTRACT UL
--	---	--	---

INTENTIONALLY LEFT BLANK.

PREFACE

On 30 September 1992, the U.S. Army Ballistic Research Laboratory (BRL) was deactivated and subsequently became part of the U.S. Army Research Laboratory (ARL) on 1 October 1992.

Acquisition For	
Final Report	<input checked="" type="checkbox"/>
Final Report	<input type="checkbox"/>
Final Report	<input type="checkbox"/>
Final Report	<input type="checkbox"/>
By	
Y	
Date	
A-1	

INTENTIONALLY LEFT BLANK.

ACKNOWLEDGMENTS

Bruce VanDeusen and Mel Widner direct the General Dynamics Land Systems Internal Research and Development program, under which this modeling work was done. The task of preparing this documentation has been made easier with the advice and assistance of Ron Anderson, Bill Oberle (Army Research Laboratory), Hugh McElroy (Olin Corporation), and Bob Greig (GT-Devices). This document follows MIL-STD-847B.

INTENTIONALLY LEFT BLANK.

TABLE OF CONTENTS

	<u>Page</u>
PREFACE	iii
ACKNOWLEDGMENTS	v
LIST OF FIGURES	ix
1. INTRODUCTION	1
2. THE INPUT FILE	2
3. DESCRIPTION AND DISCUSSION OF THE INPUT DECKS	4
3.1 \$GUN Deck	4
3.2 \$INFO Deck	7
3.3 \$PROJ Deck	10
3.4 \$PRIM Deck	10
3.5 \$PROP Deck	10
3.6 \$END Card	14
3.7 \$RESI Deck	14
3.8 \$HEAT Deck	14
3.9 \$ETC Deck	15
3.10 \$RECO Deck	16
3.11 \$COMM Deck	17
3.12 \$SAVE Deck	17
3.13 \$TDIS Deck	17
3.14 \$PDIS Deck	17
3.15 \$FIND Deck	18
3.16 \$PARA Deck	18
3.17 \$PMAX Deck	19
4. TEST CASES	19
5. CONCLUSIONS	21
6. REFERENCES	23
APPENDIX A: SUMMARY OF INPUT DECKS	25
APPENDIX B: SAMPLE CASES	49
B1: SAMPLE CASE 1	51
B2: SAMPLE CASE 2	62
B3: SAMPLE CASE 3	72
B4: SAMPLE CASE 4	83
DISTRIBUTION LIST	95

INTENTIONALLY LEFT BLANK.

LIST OF FIGURES

<u>Figure</u>		<u>Page</u>
1.	Generic electrothermal-chemical (ETC) gun	1
2.	Additional parameters required for a gun with a rifled bore	5
3.	Pressure probe location schematic for 30-mm experiments	6
4.	Chambrage parameters	6
5.	Summary of POPT options	9
6.	Details of the transition depths for a layered propellant grain	11
7.	Example of the interpolation scheme for a layered grain	12
8.	\$TDIS deck example	17
9.	\$PDIS deck example for parametric output of the web of the second propellant deck	18
10.	Breech pressure (MPa) vs. time (ms)	20

INTENTIONALLY LEFT BLANK.

1. INTRODUCTION

The Interior Ballistics of High Velocity Guns (IBHVG2) program has a wide and loyal following. It has developed in capabilities and sophistication over three decades, which is a very long time in computing. IBHVG2 is the standard against which many other interior ballistics modeling projects must first demonstrate their accuracy. In view of this, an update of the code documentation has been needed, since the "User's Guide" (Fickie and Anderson 1987) is based on Version 4.00, which is in English units, while Version 5.01, which is presently the most commonly used one, is in metric units.

In addition, recent propulsion systems, referred to as electrothermal-chemical (ETC) guns and generically shown in Figure 1, have combined electrical energy in the form of a plasma with propellants. Endothermic, exothermic, solid, liquid, gel, and slurries have been considered for the propellant. Although various designs have been tested, it is useful to develop a generic, zero-dimensional simulation capability to explore both the physics of the plasma-propellant interaction and baseline performance predictions.

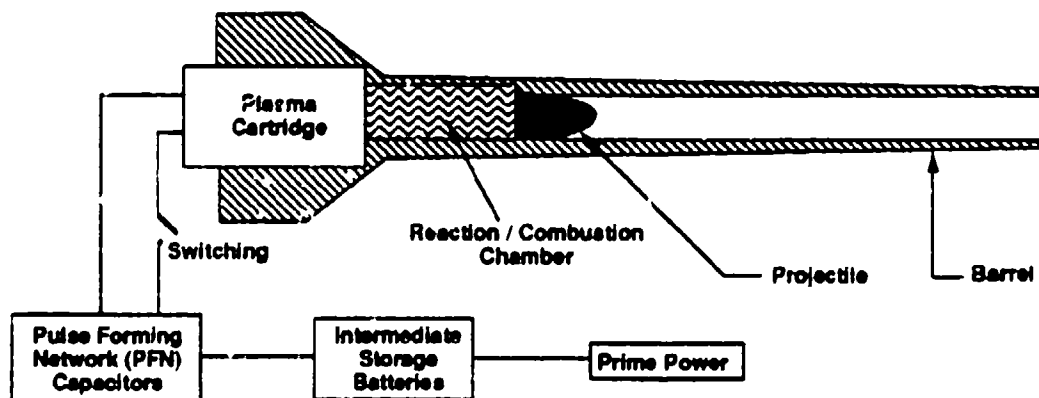

Figure 1. Generic electrothermal-chemical (ETC) gun.

IBHVG2 is a lumped parameter (zero-dimensional) interior ballistic code which has been distributed by the Weapons Technology Directorate, Army Research Laboratory (WTD/ARL), formerly the Ballistic Research Laboratory (BRL), to researchers involved with gun propulsion technology. The code is capable of modeling the ballistic cycle of multiple solid propellants from propellant ignition to the blowdown of

combustion gases after the projectile exits from the muzzle. Various automated search techniques are available for finding optimized gun parameters, desired propellant characteristics, or matching experimental data. The code also has an expansive output capability which allows the user to analyze variables of interest over the time of the simulation. All the available options are activated from an input file, making IBHVG2 an ideal tool for the scientist who does not wish to program.

This tutorial provides current information on how to use the metric version of IBHVG2. The first part of the tutorial describes the key differences between Version 5.04 and Version 4.00. It also includes a description of extensions to the code for electrothermal (ET) and electrothermal-chemical (ETC) calculations. The second part of the tutorial provides an updated summary of the input decks and presents sample code calculations using the ETC enhancements. The major enhancements are (1) revision of the energy equation to account for electrical energy; (2) provision for description of input power; and (3) provision for a generalized gas generation rate. All search techniques in the original code have been maintained.

2. THE INPUT FILE

The input format for IBHVG2 consists of an input file composed of various descriptive input decks. All the input deck titles and variables are written in uppercase letters. Each input deck is qualified by a dollar sign in column 1, followed immediately by the title of the deck. A dollar sign in any other column indicates to the code that what follows on that line is a comment. No tabs are allowed anywhere in the input file.

Within an input deck, variables are defined by an equals sign followed by the value, with spaces about the equals sign squeezed out. Some variable names have synonyms which can be found in the "User's Guide." Arrayed variables can be allocated values either by individually defining them,

```
GLOC(1)=10  
GLOC(2)=20  
GLOC(3)=30
```

or by separating the values by commas,

```
GLOC = 10, 20, 30
```

noting that a space after a value (instead of a comma) indicates the end of the variable's definition. When multiple entries are contained within an input deck, the code uses the last definition for the simulation.

Character strings must be included in quotes or apostrophes when defined, for example,

SHOW = 'GAGE(2)'

The most recent version of IBHVG2 distributed by the ARL is version 5.04, which uses metric units. The standard measure of length is in meters, weight is in kilograms, and pressure is in MegaPascals. All input and output parameters are described in these units. The only exception to this is when a user references a pressure value from a \$TDIS or \$PDIS deck. In these cases, the referenced pressure is in Pascals.

A summary of the input decks available in an input file follows.

REQUIRED INPUT DECKS

- \$GUN -- Defines gun physical dimensions and pressure probe locations.
- \$INFO -- Defines error tolerance of run, pressure gradient selection, timestep of simulation, and output print options.
- \$PROJ -- Defines projectile parameters (mass).
- \$PRIM -- Defines primer, which is assumed all burnt at time 0.
- \$PROP -- Defines main propellant charge(s) (grain dimensions, physical properties, burn rate and ignition behavior).
- \$END -- Defines end of input file.

OPTIONAL INPUT DECKS

- \$RESI -- Defines gun tube resistance to projectile motion (shot start resistance), and air resistance to projectile in gun tube.
- \$HEAT -- Defines heat loss from combustion gases to a thin shell of the gun tube (included by default).
- \$ETC -- Defines electrical power input, and, if desired, time-dependent gas generation rate.
- \$RECO -- Defines weight of gun which is used to calculate an energy loss due to recoil.
- \$COMM-- Comment deck.
- \$SAVE -- Used after the \$END card, saves previous input, and allows the user to change only desired parameters for another run.

PRINTOUT OPTIONS

\$TDIS -- Specifies user-selected trajectory variables for printing.

\$PDIS -- Specifies user-selected variables to be printed after each parametric run.

SEARCH OPTIONS

\$FIND -- Searches on any parameter to give a desired output variable.

\$PARA -- Performs a systematic variation of any parameter.

\$PMAX-- Searches on a desired propellant characteristic to give a selected maximum breech pressure.

The following are not input decks, but are lists of variables to choose from for output printing and for the \$FIND search option.

\$TRAJ -- List of trajectory variables (see Appendix A). Additional variables are available to include ETC parameters, see \$ETC deck description.

\$OUT -- List of output variables (see Appendix A).

3. DESCRIPTION AND DISCUSSION OF THE INPUT DECKS

3.1 \$GUN Deck. The \$GUN deck describes the gun tube and chamber physical dimensions to be used by the code. The chamber volume (CHAM), tube diameter, and length must be specified. If the gun tube is smooth-bore, the diameter is defined by the LAND parameter. (See Figure 1.) The TRAV parameter defines the length of the gun barrel from the rear sealing point of the projectile to the muzzle.

If a gun tube with rifling is to be modeled, the diameter of the groove (GRVE) must be input with a value of twist (TWST) in calibers per turn. A value for the groove over land surface area (G/L) must also be included. (See Figure 2.) The code uses these parameters to calculate a rotational kinetic energy of the projectile.

Pressure probe locations in the gun tube and chamber are specified in the \$GUN deck. NGAG defines the number of pressure probes (up to 30), and GLOC is an array of size NGAG which defines the locations of each respective probe. Distances are measured from the projectile base, "-" into the chamber

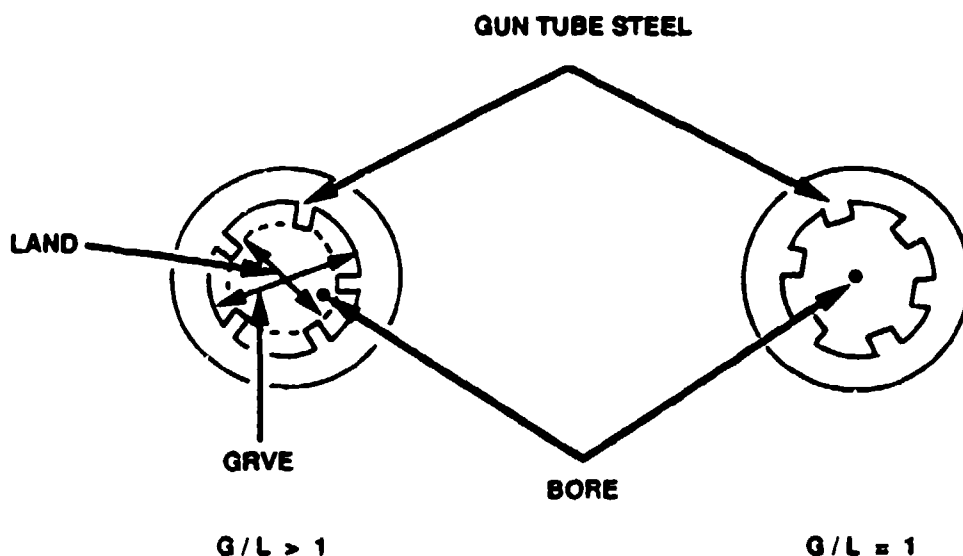

Figure 2. Additional parameters required for a gun with a rifled bore.

or "+" down the barrel. The effective length of the chamber (CLEN), should be input to the code when using in-chamber pressure probes. For example, Figure 3 contains the simulated pressure probe locations used for 30-mm experiments at GT-Devices (McElroy, Grieg, and Juhasz 1991).

The maximum pressure calculated by the code in the gun at any given time is always located at the breech face. The pressure at the in-chamber pressure probe locations are scaled down using the selected pressure gradient model (chosen in the \$INFO deck). The code calculates the pressure scaling for the in-chamber pressure probes using CLEN, which by default is the chamber volume divided by the bore area.

If chambrage is present in the gun chamber, IBHVG2 has been modified to calculate the effect of the change of diameter in the shoulder region on the developed pressure (Robbins, Gough, and Anderson 1989). The chambrage pressure gradient model is selected in the \$INFO deck, but the physical dimensions are entered in the \$GUN deck. The location of the diameter change, DIST, is referenced from the breech face. The diameter at the location corresponding to DIST is input as DIAM. The number of location-diameter pairs is input as CPTS, with a maximum of five allowed. (See Figure 4.)

Number of Pressure Probes - NGAG = 6

Positions - GLOC = -0.116, -0.055, 0.06, 0.148, 0.338, 1.301
PC1 PC2 PB1 PB2 PB3 PB4

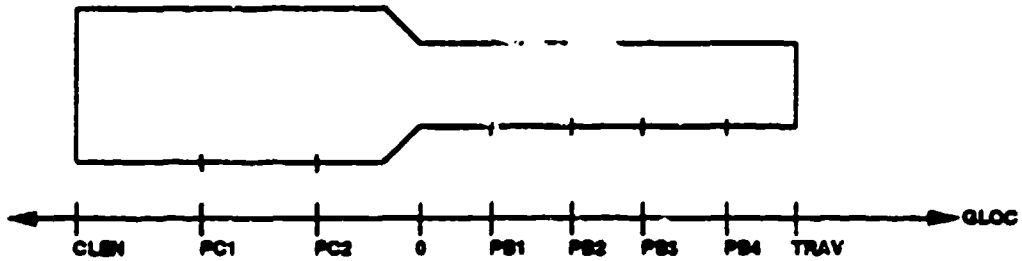
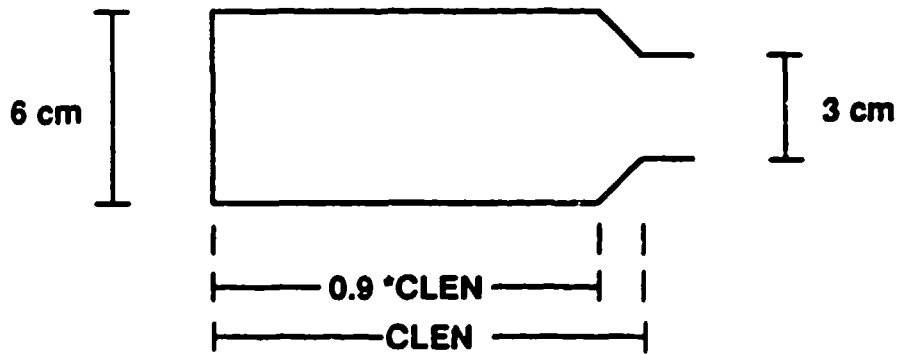

Figure 3. Pressure probe location schematic for 30-mm experiments.



CLEN = 10 cm

CPTS = 3

DIST = 0, 0.09, 0.10

DIAM = 0.06, 0.06, 0.03

Figure 4. Chambrage parameters.

3.2 SINFO Deck. The SINFO deck defines the run options for a simulation. The title of the run (up to 48 characters) is defined in this input deck by the variable, RUN, and is printed at the top of each page of the output.

The maximum integration timestep is set by DELT, and the printout timestep is set by DELP. Generally, if comparison to experimental data is desired, it is useful to set the printout timestep to match the digitizer sampling rate.

If printout is desired in steps of projectile travel, set the parameter DLPU equal to 2 and note that DELP is now the printout step in units of projectile travel.

EPS is the maximum allowed error for the integrator timestep adjustment in Runga-Kutta integration subroutine. This parameter ultimately controls the run time for convergence of the program. If the code terminates during a simulation or continues to run for an excessively long time, the EPS parameter is the most suspect. Generally, if the EPS parameter is increased, the code converges to a solution quicker. Conversely, if greater accuracy is desired, this parameter should be decreased.

The models used for determining the pressure drop down the gun tube from the breech face can be chosen from the Lagrange (GRAD=1), Pidduck-Kent (GRAD=2), or chambrage (GRAD=3) pressure gradients. The Lagrange pressure gradient is appropriate for propellant charge over projectile mass (C/M) ratios of less than 2. The Pidduck-Kent pressure gradient is often utilized for C/M ratios of greater than one and is the best choice for large C/M ratios. If chambrage is present, a pressure gradient model incorporating the changes in chamber diameter is available. The physical dimensions of the diameter changes in the chamber is input in the \$GUN deck.

Output file print options are specified by the POPT variable array, which contains five elements. The default values for each element is 1, except POPT(4) which has a default of 0.

POPT(1) set equal to 1 echoes the input file specifications at the beginning of the output file (setting to 0 turns off this option). This can be of help in locating errors in the input format, since the code will locate by card number and column an input it does not understand.

The second element of the array, POPT(2), represents the type of "trajectory" variables vs. time a user might want to specify for a simulation. POPT(2) set equal to 0 instructs the code to skip the trajectory printout. When POPT(2) is set equal to 1, trajectory print includes time, projectile travel, projectile velocity, projectile acceleration, breech pressure, mean pressure, base pressure, mean temperature, and the fraction of each propellant deck burned. The user can select to print out desired trajectory variables from the \$TRAJ list by setting POPT(2) equal to 2. Each user-defined output trajectory variable must then be specified in a \$TDIS deck, which allows a multiplication or division of the variable to accommodate a change in units. Up to 11 variables are allowed to be specified via \$TDIS specifications.

The third variable, POPT(3), when set equal to 1, activates a summary of the simulation which provides the default trajectory values at both the maximum breech pressure and at muzzle exit. This summary is very convenient since it provides ballistic performance in compact form. Setting equal to 0 turns off this option.

POPT(4) provides the user a choice of including a pressure blowdown phase after the projectile leaves the muzzle. Set equal to 0, the code ignores this option. When POPT(4) equals 1, the code calculates blowdown until the rarefaction wave reaches the breech face. When POPT(4) equals 2 or 3, an additional parameter, BLPR, must be included. This parameter limits the blowdown calculation to a desired breech pressure. The results of the blowdown calculations are printed at the end of the output file.

POPT(5) is a print option similar to POPT(2), except that it provides output selections for parametric variation runs. When POPT(5) equals 0, the previously defined trajectory printout options, via POPT(2) specifications, are used for each result of the parametric calculations. When POPT(5) is set equal to 1, the code prints a full trajectory output for the first run and a single line summary for each additional run. POPT(5) set equal to 2 activates a user-defined parametric summary printout for each run via \$PDIS specifications. Each \$PDIS deck defines one variable to be printed. \$PDIS decks are similar to \$TDIS decks, although the variable selection is made from input variables, \$TRAJ list, or in the case of the single line summary, the \$OUT list. The output selections, for example, can be made to contain the changing input parameters as well as desired output values. A summary of the print options is contained in Figure 5.

POPT(1)	= 0	No input echo
	= 1	Echoes input
POPT(2)	= 0	No trajectory printout
	= 1	Default trajectory printout
	= 2	User-defined trajectory printout via \$TDIS specifications
POPT(3)	= 0	No interior ballistics summary
	= 1	Interior ballistics summary
POPT(4)	= 0	No blowdown calculations
	= 1	Blowdown calculations until rarefaction wave reaches breech face
	= 2	Blowdown calculations until reaching a desired breech pressure, BLPR (reduced printing)
	= 3	Blowdown calculations until reaching a desired breech pressure, BLPR (expanded printing)
POPT(5)	= 0	Printout for each parametric calculations in format consistent with POPT(2) specification
	= 1	Printout for parametric calculations with a complete trajectory printout for the first run and single line summary for each additional parametric run
	= 2	User-defined parametric summary printout via \$PDIS specifications

Figure 5. Summary of POPT options.

The information following the input echo and before the trajectory printout is the codes interpretation of the variables defined in the input file. These specifications represent the values the code will use for the simulation. The code is very capable (through default values, user input errors, etc.) of misinterpreting a user's intentions without generating a parsing error.

A table of the energy distribution of the simulation is contained at the end of the output file after the internal ballistics summary. Various parameters are calculated after the run and are printed at the end of the input file: loading density, C/M, piezometric efficiency (mean pressure/max. breech pressure), electrical enhancement factor (ρ_{ro}), KE/electrical energy, and the expansion ratio (chamber volume + bore volume/chamber volume).

To obtain the maximum efficiency of a specific gun fixture, a constant pressure option is also available in this input deck. The code holds a constant pressure during the ballistic cycle by varying the burning rate (CONP=1) or the surface area (CONP=2) of a single propellant. The desired constant pressure is defined by PRES, with an error tolerance on the pressure defined as TOL. Only one propellant deck

containing a homogeneous (non-layered) grain can be included in this simulation. The propellant deck must begin burning at the start of the simulation with no ignition delay.

3.3 \$PROJ Deck. This deck defines projectile parameters for the simulation. The only required parameter is the projectile weight, PRWT. Parameters for complex projectiles are also available, but will not be discussed.

By specifying the C/M parameter, an option of calculating either the projectile weight given a total charge weight (COPT=1), or calculating a total charge weight given a projectile weight (COPT=2) is available. If COPT=2 is used, the calculated total charge weight is distributed according to the relative percentages of the initial individual charge weights.

3.4 \$PRIM Deck. The primer deck is required by the code for each simulation. Required parameters are the specific heat ratio (GAMA), impetus (FORC), covolume (COV), flame temperature (TEMP), and charge weight (CHWT). Enough energetic material should be included to raise the chamber pressure to at least 0.34 MPa (50 psi). The primer is assumed to be completely burned at time 0.

3.5 \$PROP Deck. The propellant deck defines the main propellant charge characteristics. Up to five different decks are allowed by the code. The grain density (RHO), GAMA, FORC, COV, TEMP, CHWT, grain geometric shape, and burning rate must be specified for each charge.

Various form functions for defining propellant grain geometries (GRAN) can be chosen, including a completely general form function which is defined by surface areas at a depth burned. The simplest form function is the spherical grain (GRAN="SPHR"), which only requires a value of DIAM for physical description. The form function for ball powder grains, such as WC891, is GRAN="CAKE", which requires a DIAM and a thickness (THCK) for physical description. The perforated grains used in large-caliber guns for increased surface area require the most detail (inner and outer web, perforation diameter, outer dimensions, etc.) for complete physical description. Fortunately, examples and illustrations for the more complex grain geometries are contained in the "User's Guide." The general form function is specified by the number of depth burned-surface area pairs (NSUR), with the array of depths defined as DEPB and the array of surface areas at the corresponding depth burned defined as SURF. Ratios of a grain dimension to one or the other given dimensions are available which allow optimization via the search options to find desired propellant grain size characteristics.

The code in its present form can describe a variation of propellant properties (thermochemistry and burn rate) within a single grain with up to four points at desired depths into the grain. Descriptive information is input for each layer boundary into arrayed variables of length four, which have different names than those previously discussed for homogeneous grains. Density at a layer boundary is now input as RHOL, specific heat ratio as GAML, impetus as FRCL, covolume as COVL, and flame temperature as TMPL. An example for a four-layer density input is as follows:

```
RHOL = 1000, 1200, 1300, 1350
density: layer 1, layer 2, layer 3, core.
```

The last letter in all of these layered variables corresponds to the surface in question: L for lateral, E for end, and P for perforation. In the case of the CAKE form function, i.e., ball powder, only lateral surface definitions are required. This is also the case for spherical grains.

Transition depths from layer to layer are required and are input into the DEPL array of length 3. These transition depths from one layer boundary to the next are flagged during the simulation in the trajectory printout as the burn progresses into the next layer. An example for a spherical grain is presented in Figure 6.

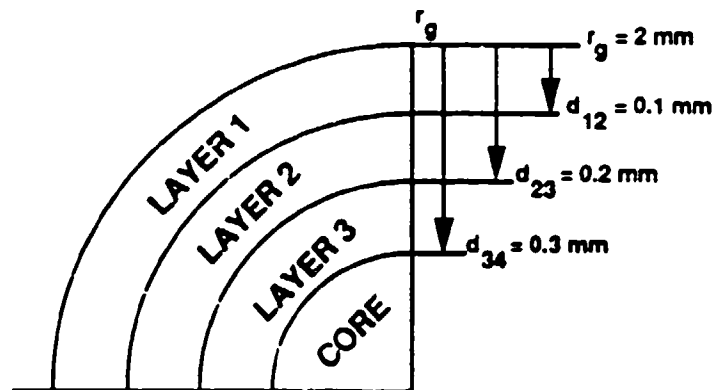

Spherical grain

```
DEPL = 0.0001, 0.0002, 0.0003
DIAM = 0.002
```

Figure 6. Details of the transition depths for a layered propellant grain.

For propellants which can be defined with less than four layers, the user is still required to fill the four element arrays (for the propellant properties), although it is sufficient to just duplicate the values for the remaining unused layers. If only one layer is present, it is taken to be the core layer and only one set of values is needed. The transition depth array must contain values of all three elements which are distinct and increasing.

Note that the code linearly interpolates the given values from one layer boundary to the next, including burn rate, with the center of the grain (layer 4) having constant properties throughout. An example of the code interpretation for the variation in density for a layered grain is shown in Figure 7.

Propellant burn rates can be specified either by direct input of burn rate versus pressure or by defining coefficients and exponents for the classical exponential burn rate function $r = \beta P^\alpha$.

RHOL = 1000, 1200, 1300, 1400

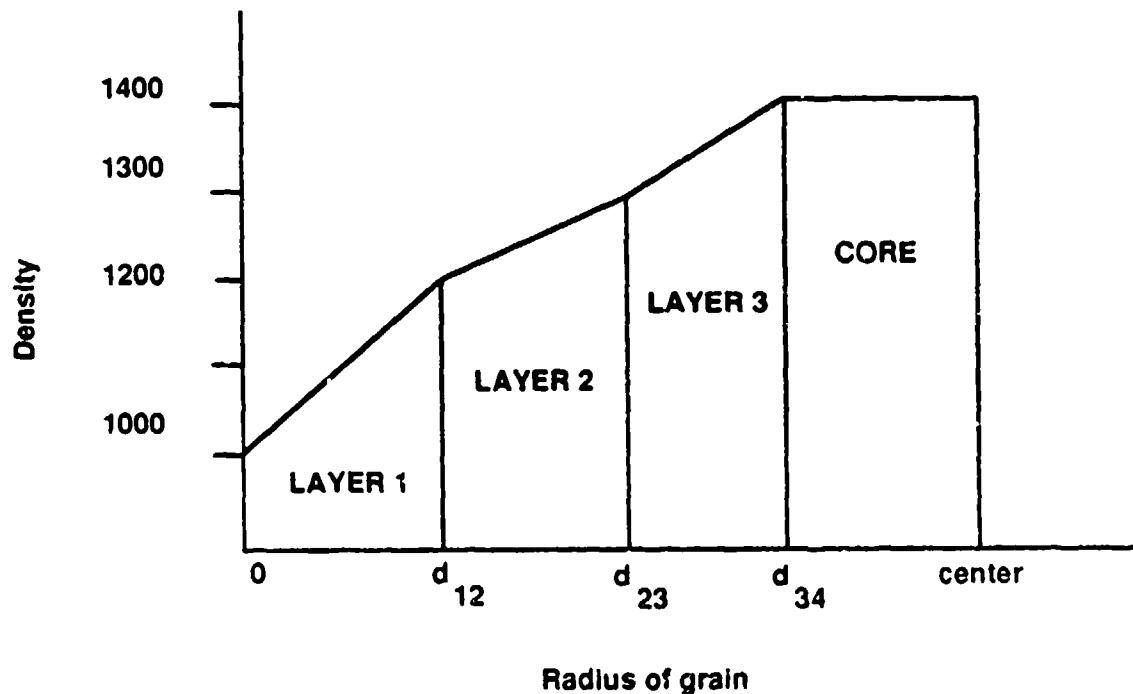

Figure 7. Example of the interpolation scheme for a layered grain.

To input the burn rate as a function of pressure, set NTBL to the number of burn rate-pressure pairs. PR1L is the pressure array, and BR1L is the burn rate at that respective pressure.

If the grain is homogeneous and the burn rate is desired to be specified in the exponential form by a single coefficient-exponent pair, the coefficient variable is BETA, and exponent variable is ALPH (NTBL can be ignored or set equal to 0).

Otherwise, to input the burn rate in the exponential form, set NTBL to the number of coefficient/exponent-pressure pairs but make it negative. The minus sign signifies to the code that the desired entry format is the exponential burn rate function. PR1L is the pressure array, CF1L is the coefficient array, and EX1L is the exponent array at the corresponding pressure. If the pressure array is deleted, the values of the coefficient and exponent are constant for all pressures (NTBL=-1).

The numbers in these variable names correspond to the referenced layer. If a homogeneous grain is modeled, the code requires all the necessary input in the array at the location corresponding to the fourth layer boundary (core). Therefore, the number in these variables should be set equal to 4, for example, PR4L, BR4L, or PR4L; CF4L, and EX4L. The last letter corresponds to the surface, as previously discussed.

The propellant decks by default will begin burning at time 0, although an ignition delay can be incorporated into a simulation through a variety of means. The variable IGNC in the propellant deck controls the ignition specification. A \$PROP deck may be ignited at a specified time (IGNC=1), projectile position (IGNC=2), mean pressure (IGNC=3), or at a mass fraction burned of the previous propellant deck (IGNC=4). The threshold values for these specifications is input via the THRC variable.

An additional ignition variation may be activated, IGNS, which ignites specific surfaces of the individual propellant grains at thresholds specified by THRS. IGNS and THRS are arrays of length 3, with each element corresponding to the P, E, and L grain surfaces, respectively. The same ignition codes are used as with IGNC variable.

The propellant deck contains many options and is therefore the most complicated input deck. Errors are easily made, and the user should carefully inspect the code interpretation of the input values in the output file, especially for a newly created propellant deck. The user will find propellant decks take the

most time to create and debug. Therefore, using previously created ones, if available, is desirable. Sample test cases containing various propellant decks can be found at the end of the "User's Guide."

3.6 \$END Card. The end of an input file is signified to IBHVG2 by an \$END card. No additional lines are allowed after an \$END card, except a \$SAVE deck.

3.7 \$RESI Deck. Gun tube resistance to the motion of the projectile is input via the resistance deck. The resistance profile can be very important in an interior ballistics simulation because it controls how fast the combustion volume is increasing. This affects the mean pressure, upon which the propellant burn rate is highly dependent.

NPTS is the number of distance-resistance pressure pairs, with a maximum of 20 points allowed. TRAV (array of length NPTS) is the distance from shot start at which a given resistance to motion occurs, and PRES (array of length NPTS) is the magnitude of the resistance pressure at the respective distance. Note that the code linearly interpolates between the resistance pressure points.

A multiplication factor, FACT, is available to quickly scale the resistance pressure profile up or down to match experimental data. RFPT is a parameter which defines the first point in the resistance array to begin multiplying by FACT.

Air resistance to the motion of the projectile in the gun tube is calculated by the code when the parameter AIR is set equal to 1.

3.8 \$HEAT Deck. Heat loss from the combustion gases to the gun barrel is defined in the \$HEAT input deck. The parameter HL is the toggle switch for including heat loss (HL=1). To turn off this option, set HL=0. Heat is transferred from the combustion gases to the barrel through a convective heat transfer coefficient, HO (default is 11.35 W/m²-K). Over the time scale of the simulations (milliseconds), the gun barrel heat sink is modeled as a thin shell (default, TSHL=0.1) with a given specific heat. The shell is initially at room temperature (TWAL=293 K) by default. For guns in different thermal environments, the initial temperature can be defined with the TWAL parameter. Default values, which cover a wide range of steels, are given for the gun tube density (RSHL=7861.1 kg/m³) and specific heat (CSHL=460.3 J/K).

Unless changes are desired for the input parameters given above, the inclusion of the \$HEAT input deck in an input file is not required; by default all the calculations are performed.

The code is capable of modeling only one heat sink, therefore Lexan chamber liners and capillary liners present in ET guns cannot be modeled in addition to the steel gun tube.

3.9 \$ETC Deck. In the solid propellant electrothermal-chemical (SPETC) gun, electrical energy in the form of a plasma is utilized in the combustion chamber to perform various roles. A discussion of ETC guns can be found in the literature (Juhasz et al).

The parameters incorporated into this deck are electrical power addition and time-dependent gas generation rate of the propellant. Each of these parameters is input as a piecewise linear function of time. This feature allows easy input, for example, from an experimental gun electrical power-time curve by just entering points from the experimental power curve.

The addition of electrical power input directly into IBHVG2 updates the previous method which required the user first to input the electrical energy in the form of electrons into the BLAKE (Freedman, 1982; Bunte and Oberle 1989) thermochemistry code. The output parameters from BLAKE on the electrically augmented propellant were then input into IBHVG2. This laborious process is no longer needed, assuming the electrical energy does not alter propellant thermochemistry or propellant burn rate, and that propellant gas properties determined at a fixed loading density are applicable. However, it is noted that the BLAKE calculations show that this assumption may not be strictly valid (Wren and Oberle 1992). With the present code, ETC gun electrical energy augmentation is modeled directly in IBHVG2 with unmodified propellant thermochemistry.

The electrical power input, ϕ , is provided in the \$ETC deck as a piecewise linear function of time. This function is integrated in closed form, and the resulting energy is added to the left side of the energy balance equation, Eq. (A.01), which becomes

$$\sum_{i,j} m_{ij} c_{v,ij} T_{f,ij} + m_s c_{v,s} T_{f,s} + \int_0^t \phi dt = \left[\sum_{i,j} m_{ij} c_{v,ij} + m_s c_{v,s} \right] T_{mean} + L \quad (1)$$

The complexity of specifying burn rates as a function of pressure, or providing coefficients and exponents for the burn rate can be overridden to allow input of a gas generation rate as a function of time.

An exotic propellant can be modeled without attempting to determine both the burn rate and the surface areas by providing an estimate of the gas generation rate versus time. The system designer can then perform simulations to determine a gas generation rate which meets system requirements, and then subsequently design the propellant surface areas and burn rates which can produce the optimal gas generation rate. The gas generation rate is also specified as a piecewise linear function of time. This function replaces m_{ij} in Eq. (A.15).

The input parameters related to ETC gun modeling are:

ELECTRICAL POWER

- NPWR - integer number of power-time pairs (min = 2, max = 20)
- TPWR - time (s)
- PWR - power in Watts at time TPWR

GAS GENERATION RATE

- NBRN - integer number of gas generation rate-time pairs (min = 2, max = 20)
- TBRN - time (s)
- BRN - gas generation rate at time TBRN (kg/s)

The following related parameters have been added to the STRAJ deck:

- EPWR - Electrical power (Watts)
- EENE - Electrical energy integrated from t=0 (Joules)
- XBRN - Gas generation rate (kg/s)

Any or all of these can be specified in a \$TDIS deck, and the corresponding variable will be printed out as a function of time during the run.

3.10 \$RECO Deck. Recoil losses for a gun system can be calculated in the code through the use of the recoil input deck. The only required parameter is the weight of the recoiling system (RCWT). Generally, the energy expended in recoil of a gun is of the order of a tenth of a percent of the total energy, therefore the inclusion of recoil in a simulation has a negligible effect.

3.11 \$COMM Deck. This input deck is used for making comments which identify a simulation. Everything that follows until the next input deck is considered a comment. Multiple comment decks are allowed.

3.12 \$SAVE Deck. The \$SAVE input deck, after a \$END card, allows the user to save all the previous information given in the input decks and change only desired variables to make a variation on the previous simulation all in the same run. The input deck(s) which contains the variable(s) to be changed must be referenced, followed by the variable redefinition. Another \$END card must follow the changes to indicate to the code that the end of the input has been reached.

3.13 \$TDIS Deck. Each \$TDIS deck defines a single trajectory variable, from the \$TRAJ list, to be printed in the output as a function of time. A maximum of 11 \$TDIS decks are allowed in a simulation. The parameter SHOW identifies the variable to be printed. A multiplication (MULT) or division (DIV) of the selected output parameter is available to allow a change in units. At the top of each printed page of the trajectory output, a remark (REM1) is printed which helps identify each column. An example is shown in Figure 8.

\$TDIS

```
SHOW = 'GAGE(1)' REM1 = 'LOC:-.116 m (PSI)' DIV = 6895
```

Figure 8. \$TDIS deck example.

Note that POPT(2) must be set equal to 2 in the \$INFO deck to activate the \$TDIS option.

3.14 \$PDIS Deck. This deck is similar to the \$TDIS deck except the \$PDIS deck is for specifying a desired output for a parametric variation search. Again, only 11 \$PDIS decks are allowed. In general, this can help identify which variables have changed during a parametric variation and relevant related output. The variables can be selected from any deck except \$FIND, \$PARA, \$PMAX, \$PDIS or \$TDIS. SHOW identifies which variable is to be printed, DECK identifies the name of the deck containing the variable, and NTH corresponds to the number of the deck (if there is more than one). A MULT or DIV of the selected parameter is available to allow a change in units. An REM1 to identify the column of output is also available. An example of a \$PDIS deck is contained in Figure 9.

\$PDIS

SHOW = "WEB" DECK = "PROP" NTH = 2

Figure 9. \$PDIS deck example for parametric output of the web of the second propellant deck.

POPT(5) must be set equal to 2, in the \$INFO deck, for this option to be activated.

3.15 \$FIND Deck. The \$FIND deck instructs the code to optimize a desired output variable (from the \$OUT list) through a search over a selected input parameter. The desired output variable is specified by OUTV and the parameter to be searched over is defined by VARY. The location of the VARY parameter is defined by DECK and NTH (if there is more than one). The initial value for the parameter to be varied is defined by FROM. Bounds can be placed on the VARY parameter with the MIN and MAX variables. EPS (incorrectly defined in the "User's Guide") is the smallest allowable change in the parameter to be varied.

CODE must be set to 0 to achieve a desired value (defined by VAL) of OUTV. If CODE is set equal to 1, the code will attempt to maximize the value of OUTV.

Up to six \$FIND decks are permissible. If multiple \$FIND decks are used, the parameter MULT is a user-defined weighting of each find deck.

The \$FIND deck has a problem in selecting the correct increment to change the VARY parameter. This results in the code overshooting the exact point of VAL the user desires, although by adjustment of EPS, usable results can be found. This problem may be much more critical if one is using the \$FIND deck to maximize an output variable (OUTV) with CODE equal to one.

3.16 \$PARA Deck. A \$PARA search routine performs a systematic variation of any chosen input variable, defined by VARY. The input deck containing the variable to be changed must be specified with the DECK parameter. If there are multiple decks, NTH is set to identify which deck contains the variable to be varied. The initial value of the variable to be tried is set by FROM, the increment of change by BY, and the final value by TO.

Up to four \$PARA decks are simultaneously permissible, which means a four-dimensional variation matrix can be filled. A multidimensional parametric variation can result in many hundreds or thousands of runs, therefore the user must clearly identify the region of interest as narrowly as possible to minimize excessive run time.

The print options for the parametric variations are selected by POPT(5) in the \$INFO deck.

3.17 \$PMAX Deck. The \$PMAX option performs an internal search over a selected propellant characteristic to achieve a maximum breech pressure. To use this option, the user must specify the propellant variable to be varied with the VARY parameter and give two initial guesses, TRY1 and TRY2. The following guesses are based on interpolation from these values. If multiple propellant decks are present the NTH parameter must be set to identify which propellant deck is to undergo the changes. The user-defined maximum breech pressure is PMAX and the allowed error is EPS. Bounds can be set on the range of variations with the MIN and MAX variables. The LOOP parameter sets a limit on the maximum number of iterations allowed in the search (default is 20).

The user can minimize convergence time of the search by adjusting LOOP and EPS. If there are multiple local pressure maximums, the specific peak can be specified with the NPMX parameter. If intermediate information during the search is desired, the parameter PRNT can be set to 1.

4. TEST CASES

Following the conclusions, four sample calculations are performed using metric units. The first is a simplification of the standard test case number 6 from the IBHVG2 "User's Guide." It is simplified by merging the two propellant decks into one, and removing the multiple \$PMAX and \$PARA decks, which iterate for a specific pressure and parametrically vary the propellant geometry.

The resulting test deck is a representative example of an optimized 120-mm gun loaded with JA2. The first three sample calculations show:

1. performance of the unmodified gun;
2. adding 1 kilojoule electric per gram of JA2; and
3. additionally designing the propellant for a flat pressure pulse.

These three cases are illustrated in Figure 10. A fourth case shows how the trajectory output can be printed in English units.

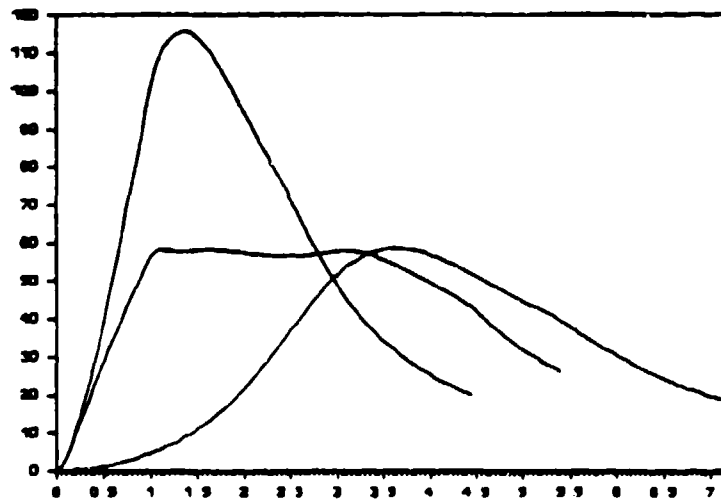

Figure 10. Breech pressure (MPa) vs. time (ms).

Case 1 shows a typical propellant burn, with the rising pressure curve, peaking at about 3.5 ms. Due to the relatively long time involved in this pressure rise, the projectile has time to accelerate down the barrel before the propellant has an opportunity to do its most efficient work. This reduces the gun efficiency.

In Case 2, the electrical energy, which is only 16.5% of the total, is delivered in a trapezoidal pulse during the first millisecond of the shot, to speed up the propellant combustion. The result is an early, steep pressure rise, which increases the muzzle kinetic energy by 46%, but also overpressures the gun.

In Case 3, the propellant gas generation rate is adjusted to restrain the maximum pressure so the gun is not overpressured. The muzzle kinetic energy improvement of 27% is less than for Case 2, but still well above Case 1. In this age of "designer" propellants, the gas generation rate versus time plot, combined with the pressure history from the simulation, can provide the guidance to the propellant designer to construct a layered propellant that meets the required performance specifications.

5. CONCLUSIONS

IBHVG2 is capable of modeling a wide variety of solid propellants of interest to the propulsion community with relative ease of use. The input file is capable of specifying and activating all available options for a simulation. Once the propellant deck is satisfactorily complete, variations in loading density, gun dimensions, and other optimizations are automated and relatively simple to make. With the modifications to allow the addition of parameters important in ET processes, modeling with IBHVG2 has been extended to include ETC guns. It is hoped that experimental thrusts can be accentuated and directed from results obtained using IBHVG2. In addition, safety in the laboratory may be increased by finding overpressure situations for a specific gun fixture.

The authors hope that this tutorial will be an aid to the new user of IBHVG2. Comments or suggestions for a future version are welcome.

INTENTIONALLY LEFT BLANK.

6. REFERENCES

- Bunte, S. W., and W. F. Oberle. "A Thermochemical Analysis of Proposed Working Fluids for Electrothermal Guns." U.S. Army Ballistic Research Laboratory, BRL-TR-3000, Aberdeen Proving Ground, MD, June 1989.
- Fickie, K., and R. Anderson. "IBHVG2—A User's Guide." U.S. Army Ballistic Research Laboratory, BRL-TR-2829, Aberdeen Proving Ground, MD, July 1987.
- Freedman, E. "BLAKE—A Thermodynamics Code Based on TIGER: "User's Guide" and Manual." BRL-TR-02411, U.S. Army Ballistic Research Laboratory, Aberdeen Proving Ground, MD, July 1982.
- Juhasz, A., K. Jamison, K. White, and G. Wren. "Introduction to Electrothermal Gun Propulsion." Proceedings of the 25th JANNAF Combustion Meeting, CPIA 498, Marshall Space Flight Center, Huntsville, AL, October 1988.
- McElroy, H. A., J. R. Greig, and A. A. Juhasz. "Plasma Augmented Gun Propellant." Proceedings of 5th International Gun Propellant and Propulsion Symposium, Picatinny Arsenal, NJ, 19-21 November 1991.
- Robbins, F. W., R. D. Anderson, and P. S. Gough. "New Pressure Gradient Equations for Lumped Parameter Interior Ballistic Codes." BRL-TR-3097, U.S. Army Ballistic Research Laboratory, Aberdeen Proving Ground, MD, May 1990.
- Wren, G. P., and W. F. Oberle. "A Coupled Thermochemistry - Interior Ballistic Model and Application to Electrothermal-Chemical (ETC) Guns." ARL-TR-63, U.S. Army Research Laboratory, Aberdeen Proving Ground, MD, February 1993.

INTENTIONALLY LEFT BLANK.

APPENDIX A:
SUMMARY OF INPUT DECKS
(Updated Version of Appendix in BRL-TR-2829)

INTENTIONALLY LEFT BLANK.

A. SYNTAX RULES

Input data stream for IBHVG2 consists of a series of "decks." The start of each deck is identified by a line starting with a "\$" in the first column and followed by a four letter mnemonic. All lines of input data between decks should in principle be closely related ballistic parameters.

Inputs are free format in that more than one can be included per line. Comments may be incorporated by preceding them with a "\$" in any column other than the first. The formats are

variable =value

for ordinary unsubscripted variables and

variable (sub) =value₁, ... , value_n

for subscripted variables, with commas and/or blanks between consecutive variable/value constructs. Integer and real formats are legal for all numerical values. Character strings must be delimited with either apostrophes or quotes. All keywords, to include deck cards and variable names, must be in uppercase.

The first blank between consecutive variable/value fields is the legal delimiter; any additional ones are ignored. Blanks embedded in variable names, subscripts, or numeric values are illegal. Leading blanks in character strings are squeezed out.

An omitted "(sub)" in a subscripted variable is taken to be 1. Consecutive values fill locations sub, sub+1, sub+2, etc., while pairs of commas with nothing or blanks between them advance to the next subscript (i.e., a subscript is skipped over). All character variables default to blank strings while numerical variables default to either zero or a convenient value listed below. If a variable is multiply-defined, the last input overrides all previous ones. All syntax errors are flagged. A list of all valid deck names follows as well as descriptions of all variables within each deck.

IBHVG2 Version 500 series is a conversion to metric units from the previous level of IBHVG2 (Version 408) which uses Imperial units of pounds, inches, feet, and psi. In Version 500 series, all measurements of length are based on the meter (m), all mass measurements on the kilogram (kg), and pressure input units are the mega-pascal (MPa). A list of the constants used is in subroutine DATINP.

There are a few discrepancies. Units of pressure in the FORTRAN-coded equations use Pascals (Pa), while the unit of choice for input is the Mega-Pascal. Therefore, most instances of pressure during the input phase are converted internally from MPa to Pa without the user's knowledge. Three instances remain distinct and must be recognized by any program user attempting a FIND process or outputs via PDIS and TDIS. In these three cases, any reference to a pressure value from the \$TRAJ list assumes that pressures will be used in units of Pascals. PDIS and TDIS, as special cases for dealing with output displays, have provision for multiplication (MULT) or division (DIV) of the output values. The FIND deck as an input for an internal search process, has no such factor; any reference to a pressure value from the \$TRAJ deck must be in Pascals.

B. Decks in Alphabetical Order

\$COMM

All cards between a \$COMM and the next deck card are ignored to allow the tagging of a data input file with user comments.

\$END

This control card signifies end-of-input for the current case. IBHVG2 will then execute. Afterwards, it will start reading the next card, if any. This is to allow the processing of other runs or for the code itself to generate runs internally. An end-of-input condition for a user's input deck is processed as if the \$END card was read in. *A frequent mistake by novice users is to include the \$END and follow it by a blank line.* The code assumes this is another run and proceeds to produce errors due to insufficient information.

\$ETC

Allows introduction of electrical energy into the combustion chamber for electrothermal-chemical (ETC) gun simulation. This deck also allows the gas generation rate to be specified as a piecewise linear function of time. This option overrides the calculation of the surface areas and other features of the chemistry.

NPWR	number of power-time pairs (min = 2, max = 20)
TPWR	time of power input (s)
PWR	power at time TPWR (watts)
NBRN	number of gas generation rate-time pairs (min = 2, max = 20)
TBRN	time of gas generation (s)
BRN	gas generation rate at time TBRN (kg/s)

\$FIND

For inputs to a general variation-and-search algorithm, utilizing function minimization techniques. Up to six \$FIND decks may be submitted in one run allowing a variation in six dimensions. A list of additional option variables for outputting is found at the end of this section.

VARY	name of parameter including any subscript
DECK	name of deck containing parameter; four characters max; may not be PARA, PDIS, FIND, PMAX, or TDIS
NTH	number of deck if there are several with same name [default = 1]
FROM	initial value of parameter in proper units
EPS	convergence criteria for the varying parameter
OUTV	name of desired output variable from run completion variables (see end of this section)
CODE	0 to achieve desired value of OUTV variable 1 to maximize OUTV variable
VAL	desired value if CODE is 0, else ignored
MULT	multiplier for function-minimizer residual [default = 1.0]
MIN	minimum allowable value of VARY parameter [default = 0.0]
MAX	maximum allowable value of VARY parameter [default = 1.0E+10]

SGUN

For variables related to gun-tube geometry, namely:

NAME TYPE	name of gun; 28 characters max
CHAM CV CVOL	chamber volume [m ³]
GRVE	groove diameter [m]
LAND	land diameter [m]
TRAV LENG	travel to shot-exit [m]
G/L	ratio of groove to land surface area; smooth-bore if G/L=0 [default]
TWST	rifling twist [calibers/turn] [default = 999]
LOPT	0 [default] to ignore LDEN 1 to calculate CHAM from total charge weight and LDEN 2 to calculate total charge weight from CHAM and LDEN; primer and charge weights must be specified; they are scaled proportionally to sum to required total charge weight
LDEN	ratio total charge weight/chamber volume kg/m ³ ; used when LOPT = 1 or 2 [default = 0.2] <i>CAUTION: LDEN calculations are done after C. ch may have altered charge weights) is used.</i>
CLEN	effective chamber length [in] for scaling in-chamber pressure gauge locations [default = CV/bore area]
NGAG	number of gauge locations [default = 0, max = 30]
GLOC	gauge location array of size NGAG [m] [defaults = 0.0]. Distance is measured (+) downtube from the breech or (-) into chamber from the initial position of the projectile base. <i>CAUTION: IBHVG2 will discard duplicate or out-of-range values and will rearrange distances in ascending order, if necessary. This should be kept in mind when using, for example, a \$SAVE deck—the position you reference may not be the one the computer code decided upon.</i>

\$HEAT

For heat-loss-related variables, namely:

TSHL	tube shell thickness for heat sink [m] (default = 0.0001016)
CSHL	shell specific heat [J/kg-K] covering a broad range of steels (default = 460.316318)
RSHL	shell material density [kg/m ³] (default = 7861.0916)
TWAL	initial wall temperature [K] (default = 293.0)
HO	free convective heat transfer coefficient for air in the tube [W/m ² -K] (default = 11.34821852)
HL	0 to ignore heat losses in energy balance 1 [default] to include heat losses

\$INFO

For run-related inputs, the variables are:

DELT	max integration time step [s] (default = 0.0001)
DLPU	1 [default] for DELP in units of time [s] 2 for DELP in units of projectile travel [m]
DELP	integrator logout and print step [s] or [m]; reset to DELT if DLPU = 1 and DELP < DELT
SOPT	0 to suppress file storage of run output (default) 1 to write trajectory data for each run into output file STORE for post-processing 2 to write only single-line summaries for each parametric run into file STORE; ignored if nonparametric runs are being conducted
GRAD	1 for Lagrange gradient (default) 2 for Pidduck-Kent gradient 3 Chambrage gradient. Requires description of chamber geometry in \$GUN in form of pairs of chamber diameter DIAM versus distance from breech face DIST with CPTS points in all
UNIT	unit system for output; not implemented yet, but will be a choice between 0 for SI and 1 for English

POPT	print option array of size 6 [all defaults = 1]. Detailed descriptions given below between the double bars:
POPT(1)	0 to suppress 1 to print
POPT(2)	0 to suppress trajectory print 1 to print default trajectory variables 2 to print user-specified \$TDIS variables
POPT(3)	0 to suppress 1 to print IB summary
POPT(4)	0 to suppress blowdown calculation 1 tube blowdown (to include tube recoil when the recoil options is in effect, see \$RECO) until first rarefaction wave reaches breach face 2 tube blowdown until specified breach pressure BLRP in \$INFO has been reached (reduced printing) 3 tube blowdown as in (2) but with more detailed intermediate printing NOTE: Analysis for POPT(4) = 2 or 3 is an extension of Con.LR's equations in POPT(4) = 1, although this analysis is strictly valid only until rarefaction wave reaches breach face.
POPT(5)	0 to honor above print options for every run of parametric variation 1 to honor above print options for first run of parametric variation and print a single-line summary thereafter 2 like 1, but summary print variables supplied via \$PDIS specifications
POPT(6)	is currently unused
RUN TITL	run title on output pages; 48 characters max
EPS	maximum error for integrator time-step adjustment and transition tolerances [default = 0.0002]
CONP	0 for usual non-constant pressure run (default) 1 for run with constant pressure maintained by varying the burning rate of the single charge 2 for run with constant pressure maintained by varying the surface area of the single charge
PRES	desired constant breach pressure (psi) when CONP option is 1 or 2
BLPR	desired breach pressure for blowdown calculation with POPT(4) = 2 or 3 in \$INFO
TOL	error tolerance (MPa) for PRES [default = 1.0]

SPARA

For parametric variations: up to four SPARA decks per run permit a four-dimensional matrix to be systematically tried. The DECK must contain a nominal value of the variable to be VARY'd.

VARY	name of parametric variable including any subscript
DECK	name of deck containing variable; four chars max; may not be PARA, PDIS, FIND, PMAX, or TDIS
NTH	deck number if there is more than one [default = 1]
FROM	initial value of variable
TO	final value of variable
BY	increment/decrement value

SPDIS

Each deck defines one variable to be printed in lieu of the default set for each line of the parametric summary print. There can be up to 11 SPDIS decks in effect: 1 for each variable printed for the interior ballistic cycle. Be sure to include the line POPT(5)=2 (print option) in the \$INFO deck. To write the summary information to a file attached to UNIT=7, include the line SOPT=2 in the \$INFO deck. (SPDIS is similar to the \$TDIS deck.) A list of additional option variables for outputting is found at the end of this section.

SHOW	name of variable to print; four chars max
DECK	name of deck containing the desired variable; any deck may be named except PARA, PDIS, FIND, and PMAX
NTH	number of deck if more than one [default = 1]
MULT	number to multiply data value by [default = 1.0]
DIV	number to divide data value by [default = 1.0]
REMI REMK	20 character remark string to identify the variable being displayed

\$PMAX

For variation of charge weight or web to achieve a desired maximum breech pressure. If web is varied, grain ratios rather than grain dimensions may be the better choices in the \$PROP deck concerned. The \$PROP deck must contain a nominal value of charge weight and web, even though one or the other will be varied in the \$PMAX operation. Note that a DECK='PROP' card is not needed in a \$PMAX; the program knows that it must be varying some propellant characteristic. If you include DECK='PROP', the program will complain but will still do the proper things.

VARY	variable name in a \$PROP deck including any subscript
NTH	number of \$PROP deck [default = 1]
TRY1	first value of VARY to try
TRY2	second value of VARY to try; third and subsequent guesses are based on interpolation. NOTE: the last two guesses from the previous run are employed as the first two guesses in second and subsequent \$PARA runs
PMAX	maximum breech pressure [MPa] sought
EPS	error tolerance [MPa] for PMAX; [default = 1.0]
LOOP	max number of tries before quitting [default = 20]
MIN	minimum allowable value of VARY parameter [default = 0.0]
MAX	maximum allowable value of VARY parameter [default = 1.0E+10]
NPMX	0 [default] if PMAX refers to the max breech pressure ever achieved during the run n where $n \in \{1,2,\dots,5\}$ if PMAX refers to the NPMX-th local breech pressure maximum achieved

\$PRIM

For primer data. The "primer" is considered completely burned at the start of integration. For this reason, it is considered wise to include only enough primer to reach sufficient pressurization to ignite the propelling charge. Real primers are usually modelled with IBHVG2 by simulating the function with both a \$PRIM and a \$PROP deck. A typical correspondence is 10% by weight for the \$PRIM and 90% as a \$PROP. Constant-pressure runs may include or exclude a primer. A primer is mandatory for conventional simulations.

NAME	name of primer; 28 characters max
TYPE	
GAMA	specific heat ratio
FORC	force [J/kg]
COV	covolume (m ³ /kg)
TEMP	flame temperature [K]
CHWT	weight [kg]
WT	
CHGW	
C	
CW	

SPROJ

For projectile-related variables.

NAME	projectile designation; 28 characters max
TYPE	
PRWT	projectile weight [kg]
WT	
COPT	0 [default] to ignore C/M 1 to calculate PRWT from total charge weight and C/M 2 to calculate total charge weight from PRWT and C/M; primer and all charge weights must be specified, but they will be scaled proportionally to sum to the required total charge weight
C/M	used when COPT=1 or 2; ratio of total charge weight and projectile weight [default = 1.0]
SOPT	0 [default] bypass PRWT calculation based on subprojectile parameters and sabot formula 1 find PRWT based on projectile weight estimation formula of Burns 2 find PRWT based on same weight estimation formula using coefficients yielding 15% lighter sabot
WTSP	subprojectile weight [kg]
LSP	subprojectile length [m]
DSP	subprojectile diameter [m]
PD&S	max design pressure [MPa] for sabot projectile
SABO	sabot weight [kg]; <i>not input—set by IBHVG2</i>

SPROP

Defines a main propelling charge element IBHVG2 will recognize up to five such decks and considers them independently (i.e., order is unimportant). The following are basic input variables most useful for describing homogeneous, undeterred grains:

NAME TYPE	name of propellant; 28 chars max
RHO DENS	density (kg/m ³)
GAMA	specific heat ratio
FORC	force (J/kg)
COV	covolume (m ³ /kg)
TEMP	flame temperature (K)
CHWT WT CHGW C CW	weight (kg)
ALPHA	burning rate exponent, α
BETA	burning rate coefficient, β (m/s - MPa ^{α}) [where burning rate = βP^α (m/s) where P is mean pressure in (MPa)]
EROS	erosive burning coefficient, empirical factor multiplied by projectile velocity (m/s) to add to burning rate (default = 0.0)
GRAN FORM	granulation code chosen from 7PF (or 7P), 1PF (1P), CORD, RECT (SLAB), SPHR (BALL), SLOT, 37HX (37H), 19HX (19H), 19PF (19P), GEN, PIE (STAR), GHEX (HEX), MONO

The following form functions have been added to IBHVG2 since the User's Guide (Anderson and Fickie 1987) was published.

- a) Flattened ball powder grains produced from ball powder by rolling to a pancake shape with constant thickness. The form function name is PAN or CAKE, and the geometry is defined by DIAM and THCK. DIAM corresponds to the outer diameter or maximum width. THCK corresponds to the thickness of the rolled portion or distance between parallel plane surfaces. If

only the original ball diameter and target thickness are known, the form function will calculate the final disk diameter when DIAM is the negative of the value of the original ball diameter ($DIAM < 0$). In this case, the computed disk diameter is printed during the propellant description phase of program output.

- b) Rosette form function ROSE. The geometry is similar to that described in ARBRL-MR-03380. The required dimensions are: perf diameter, web thickness (as WEB or as WI and WO where WO corresponds only to outermost web), and length. Additionally, the number of perf rings NRNG as described in the general hexagon form function must be specified. Layering is allowed on any or all surfaces.
- c) General hexagon (GHEX) form function. GHEX may have a different thickness of the outer web. Previously, all webs were equal.

FORM	PAN(CAKE) ROSE
------	-------------------

WI WIN	inner web for cylindrical/hexagonal grains (m)
WO WOUT	outer web for cylindrical/hexagonal grains (m)
WM WMID	middle web for cylindrical/hexagonal grains (m)
WEB WB	common value of all inner, middle, and outer webs (m); also resets WI/O
D DIAM GDIA	grain diameter, if applicable (m)
PD DP PDIA	perf diameter, if applicable (m) [default = 0]
SLOT	slot width in SLOT and PIE grains (m)
NSLT	number of diametral slots in PIE grain ≥ 2
NRNG	number of concentric rings of perfs around central perf in HEX and rosette grains; ≥ 0 [default = 2]
L GL LEN GLEN	grain length, if applicable (m)
WIDTH	grain width in RECT grains (m)
THCK	grain thickness in RECT grains (m)
NSUR	number of depth/surface pairs for GEN grain (default = 1, max = 20)
DEPB	depths-burned array (m) for GEN grains; ignored if NSUR = 1
SURF	surface area array (m ²) for GEN grains
IGNC	code specifying charge ignition: 0 to ignite at start of integration (default) 1 to ignite at some time (s) 2 to ignite at some projectile travel (m) 3 to ignite at some mean pressure (MPa) 4 to ignite at some Z (mass fraction burned) of the charge described by the previous \$PROP deck

THRC	threshold value for ignition if IGNC > 0
IGNS	array of size 3 specifying ignition codes for the perf, end, and lateral grain surfaces, respectively; same codes as IGNC; ignored if IGNC > 0.0
THRS	array of threshold values for surface ignition
PA-B	0 (default) for standard treatment of charge; set automatically if grain has no perfs or if runs has either constant-pressure option set 1 for perf-augmented burning of charge until grain fracture
DSCF	Robbins-Horst discharge coefficient in weight flux computation for perf-augmented burning model (default = 1.0)
FRAC	0 (default) for no user-defined grain fracture criterion of charge with PA-B = 1. NOTE: web burn-through turns off perf-augmented burning. 1 to specify pressure-difference grain fracture threshold for charge with PA-B = 1. NOTE: web burn-through triggers fracture.
NFRG	number of fragments when 1PF grain fracture \geq 1
THRF	absolute value of difference between chamber and perf pressures for grain fracture [MPa]; ignored if FRAC = 0 (default = 0.0)

IBHVG2 will calculate grain dimensions if given either actual measurements, or alternatively, a single measurement combined with ratio specifications. This latter technique is quite useful when the code is used to optimize a charge design. For example, a CORD grain can be defined by D and L, or by L and the ratio L/D. For a 7-perforated grain, WI and DP together with WI/O, D/DP, and L/D will completely specify the grain geometry. The slot width of a SLOT or PIE grain will be calculated given SW/D and D. Care must be taken to avoid over-specified or inconsistent information since the computer program may make arbitrary or poor decisions. IBHVG2 prints the grain dimensions prior to ballistic calculations; experienced users of the code always scrutinize this portion of the output for any surprises.

L/D	grain length/grain diameter
L/DP	grain length/perf diameter
L/PD	
D/DP	grain diameter/perf diameter
D/PD	

L/WD	grain length/grain width
WD/T	grain width/grain thickness
SW/D	slot width/grain diameter
W/O	inner web/outer web for multiperforated grains; web eccentricity for single perf grains [default = 1.0]

For deterred grains, further (or replacement) inputs to handle variable thermochemistry and burning rates are necessary. Visualize each grain having, in general, three disjoint surfaces:

Surface	Description
P	perf (includes the slot, if any)
E	end
L	lateral

Extending inward from each surface are layers 1, 2, 3, and 4 (the innermost or "core"), and any or all of the first three may be of zero thickness (nonexistent) on one or more of the P, E, or L surfaces. The core layer is always present and its properties, unlike those of the outer layers, are independent of depth. As there is only one common 4th layer, L-specifications for the core override all others to prevent conflicts. All depth-varying properties are consecutively defined at the outer surface of each layer from the outside in so each of the following is an array of size 4. Linear interpolation is performed by IBHVG2 when intermediate values are required.

RHOP	density [kg/m ³]	on P surfaces
RHOE		on E surfaces
RHOL		on L surfaces
GAMP	specific heat ratio	on P surfaces
GAME		on E surfaces
GAML		on L surfaces
FRCP	force [J/kg]	on P surfaces
FRCE		on E surfaces
FRCL		on L surfaces
COVP	covolume [m ³ /kg]	on P surfaces
COVE		on E surfaces
COVL		on L surfaces
TMPP	flame temperature [K]	on P surfaces
TMPE		on E surfaces
TMPL		on L surfaces

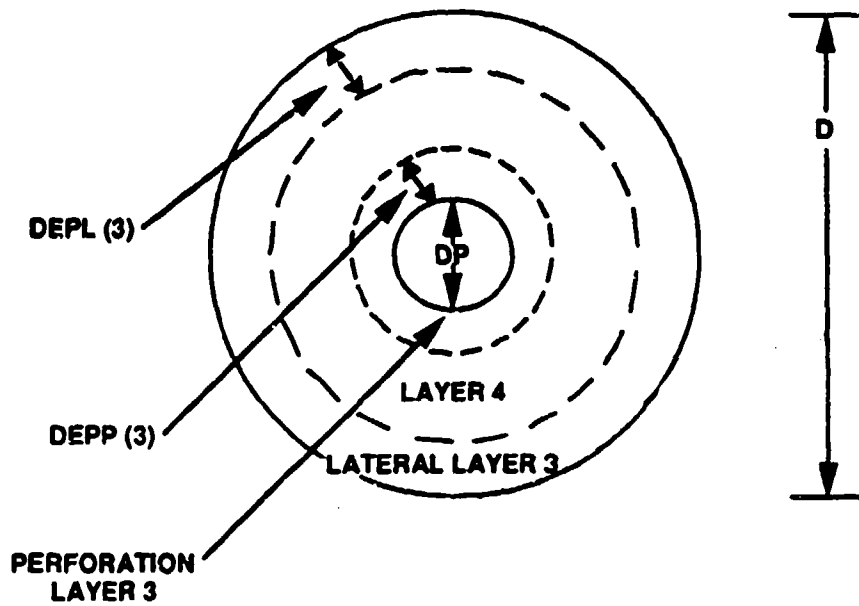

Figure A-2. Two-layer, single-perf grain (end view).

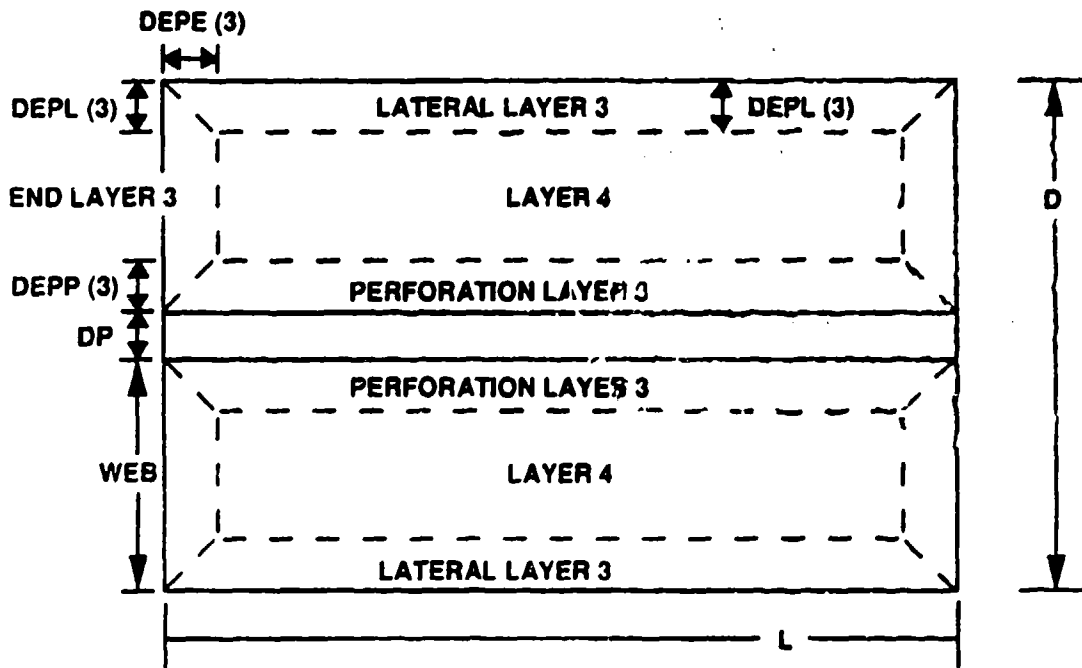

Figure A-3. Two-layer, single-perf grain (lateral-view).

Array of size 3 specify the transition depths [m] between the first and second, the second and third, and the third and fourth layers, respectively, for each surface (measuring from the surface).

DEPP	transition depths	on P surfaces
DEPE		on E surfaces
DEPL		on L surfaces
	[defaults = 0.0]	

Transition depths will be calculated by IBHVG2 if positive ratios specifying transition depths as fractions of surface-to-surface distance are input. Arrays of size 3 store the ratios (the default for all values is 0.0).

DP/S	ratios of transition depths on P surfaces to WI; used for perforated grains only
DE/S	ratios of transition depths on E surfaces to: <ul style="list-style-type: none"> • min(GL, WIDTH) for RECT • GL for perforated and CORD grains
DL/S	ratios of transition depths on L surfaces to: <ul style="list-style-type: none"> • D for CORD and SPHR grains • THCK for RECT grains • WI for perforated grains
FP/L	ratios of DP/S to DL/S; DP/S values will be found given FP/L and DL/S; useful for defining a relation between transition depths on P and L surfaces

Finally, burning rate for the outer surface of each layer may be incorporated via several alternative methods. It should be noted that interpolation is linear for depths and betas, but logarithmic for alphas and tables of pressure versus burning rates.

NTBL	method of specifying burning rate inputs ... absolute value is number of table entries on every surface layer; range of values: -10 to +10 < 0 to specify betas and alphas as tabular functions of mean pressure [MPa], NTBL triples in all = 0 to define one beta/alpha pair [default] > 0 to specify burning rates [m/s] as tabular functions of mean pressure [MPa], NTBL pairs in all. NOTE: if NTBL = 1, burning rate is constant so corresponding pressure value, if any, is ignored.
PRIL	pressures [MPa] on outside of layer 1, L surface. PR2L, PR3L, PR4L, PR1E, PR2E, PR3E, PR4E, PR1P, PR2P, PR3P, PR4P are defined similarly.

BR1L	burning rates (m/s) on outside of layer 1, L surface. BR2L, BR3L, BR4L, BR1E, BR2E, BR3E, BR4E, BR1P, BR2P, BR3P, BR4P are defined similarly.
CF1L	burning rate coefficients (betas) on outside of layer 1, L surface. CF2L, CF3L, CF4L, CF1P, CF2P, CF3P, CF4P are defined similarly
EX1L	burning rate exponents (alphas) on outside of layer 1, L surface. EX2L, EX3L, EX4L, EX1E, EX2E, EX3E, EX4E, EX1P, EX2P, EX3P, EX4P are defined similarly

\$RECO

For recoil data. In the model currently available, the gun tube freely recoils under the influence of breech pressure less resistance pressure. This option has not been fully tested and should not be considered reliable.

RECO	0 for fixed tube, no recoil (default) 1 to employ recoil option
RCWT WT	weight (kg) of tube and recoiling parts
NAME TYPE	name of recoil system; 28 characters max

\$RESI

This precedes resistance pressure inputs. The variables are:

NPTS	number of travel/pressure pairs (min = 0, max = 20)
TRAV	projectile travel array of size 20 (m)
PRES	resistance pressure array of size 20 (MPa)
AIR	0 to suppress adding in air resistance 1 to include air resistance (default)
HTFR	fraction of work done to overcome barrel resistance which is used to pre-heat tube wall; $0.0 \leq \text{HTFR} \leq 1.0$ (default = 0.0)

A factor to allow the bore resistance profile to be raised or lowered during an iterative searching process can be specified. The factor works in conjunction with \$FIND or \$PARA.

FACT	factor by which the resistances (in MPa) will be multiplied [default = 1.0]
RFPT	point in the PRES ana, where factoring will begin; factor will be applied to all subsequent points [default = 3]

\$SAVE

Actually, not a deck card, but a control card. If it is the first card in a run after an \$END card, the values of all input variables are retained, so that succeeding decks need only update selected variables. If an \$END card is not followed by a \$SAVE card, all input variables must be reinitialized.

\$TDIS

Each deck defines one variable to be printed in lieu of the default set for each line of the trajectory print. There can be up to 11 \$TDIS decks in effect—one for each variable printed for the interior ballistic cycle. Be sure to include the line POPT(2)=2 (print option) in the \$INFO deck. To write the trajectory information to a file attached to UNIT=7, include the line SOPT=2 in the \$INFO deck. (\$TDIS is similar to the \$PDIS deck). The list of option variables available for use is found at the end of this section.

SHOW	name of variable to print from deck TRAJ; four characters max
MULT	number to multiply data value by [default = 1.0]
DIV	number to divide data value by [default = 1.0]
REMI	20 character remark string to identify the variable being displayed
REMK	

Trajectory Variables

Below is a list of keyword variables which can be used in conjunction with the \$TDIS, \$FIND, and \$PDIS decks to reference quantities other than the default set. To use them with \$PDIS and \$FIND, one

must include the line DECK='TRAJ'; a reference within \$TDIS assumes the keyword will come from the following list. Test cases 3 demonstrates the use of \$TDIS to change the trajectory display printed during the ballistic cycle.

MEAN	mean gas pressure in chamber [Pa]
PRFP	array of size 5 of mean gas pressure in perfs [Pa] of each charge; equal to mean if no perf-augmented burning in that charge at current time step
GAGE	array of size 30 of gauge pressure [Pa]
BRCH	breech pressure [Pa]
BASE	pressure at projectile base [Pa]
PDOT	d(mean chamber pressure)/dt [Pa/s]
PDTP	array of size 5 of d(mean perf pressure)/dt [Pa/s], one for each charge
TBAR	mean gas temperature in chamber [K]
PRFT	array of size 5 of mean gas temperature in perfs [K] of each charge; equal to TBAR if no perf-augmented burning in that charge at current time step
FRCR	bore-friction resistance pressure [Pa]
AIRR	air resistance pressure [Pa]
TOTR	sum of FRCR and AIRR
TWAL	temperature of tube wall shell [K]
WTB	array of size 5 of weight burned of each charge [kg]; reference by subscript
WTBR	array of size 5 of weight-burning rate of each charge [kg/s]; reference by subscript
WTBT	total weight of gas in chamber [kg]
PREJ	projectile translational kinetic energy [J]
PRJ%	PRJE * 100 / TOTE
PRPE	propellant and gas kinetic energy [J]
PRP%	PRPE * 100 / TOTE
ROTE	projectile rotational kinetic energy [J]
ROT%	ROTE * 100 / TOTE

FRTE	barrel-frictional work to tube [J]
FRT%	$FRCE * 100 / TOTE$
FREE	barrel-frictional work not absorbed as heat to the tube wall [J]
FRE%	$FREE * 100 / TOTE$
DRGE	work done against air in barrel [J]
DRG%	$DRGE * 100 / TOTE$
RECE	kinetic energy of recoiling tube [J]
REC%	$RECE * 100 / TOTE$
HETE	energy lost as heat convected to tube wall [J]
HET%	$HETE * 100 / TOTE$
LOSE	sum of all energy losses [J]
LOS%	$LOSE * 100 / TOTE$
TOTE	total chemical energy released by combustion [J]
EDOT	$d(TOTE)/dt$ [J/s]
GASE	internal energy of gas [J], i.e., $TOTE - LOSE$
GAS%	$GASE * 100 / TOTE$
SRF	array of size 5 of burning-surface area of each charge (m^2); reference by subscript
SRFT	total surface area of all ignited charges (m^2)
TIME	time [s]
TRAV	projectile displacement from initial position [m]
VEL	ground-based projectile velocity [m/s]
ACCL	projectile acceleration [G's]
Z	array of size 5 of charge weight fractions burned; reference by subscript
DB-P	array of size 5 of depth burned into P surface of each charge [m]; reference by subscript
DB-E	same as above for E surfaces
DB-L	same as above for L surfaces
DB-F	same as above for F (fracture) surfaces
BR-P	array of size 5 of burning rate on P surface of each charge [m/s]; reference by subscript

BR-E	same as above for E surfaces
BR-L	same as above for L surfaces
BR-F	same as above for F (fracture) surfaces
EPWR	electrical power (watts)
EENE	electrical energy integrated from t=0 [J]
XBRN	gas generation rate [kg/s]

RUN COMPLETION VARIABLES

These are output variables defined after a complete IBHVG2 run. Typically they represent some global extrema which can only be ascertained at the conclusion of ballistic computation. For example, a maximum pressure is determined after shot ejection, while there could be several local maxima during the pressure history. The variables may be referenced by name using \$PDIS (with DECK='OUT') or by \$FIND as the value inserted for OUTV.

PMAX	max breech pressure [MPa]
HUMP	array of size 5 of local breech pressure maxima [MPa]
GMAX	array of size 30 of gauge pressure maxima [MPa]
VMUZ	muzzle velocity [m/s]
AMAX	max acceleration [g's]
BMAX	max base pressure [MPa]
X@BO	array of size 5 of projectile position [m] at charge burnouts; reference by subscript
PMUZ	base pressure at shot exit [MPa]
ZMUZ	array of size 5 of charge weight fractions burned at shot exit; reference by subscript
IMPL	final impulse (momentum [N-s])
LDEN	calculated loading density [kg/m ³]

INTENTIONALLY LEFT BLANK.

**APPENDIX B:
SAMPLE CASES**

INTENTIONALLY LEFT BLANK.

B.1. SAMPLE CASE 1

This is a simplified version of IBHVG2 Benchmark test case 6. The simplifications are the removal of the \$PMA and \$PARA decks, and combination of the two propellant decks into a single, 8-kg load.

While the input is basically the same, the output is not. The \$TDIS decks direct the display of three new variables: the electric power, the integrated electric energy, and the propellant gas generation rate. The first two of these are 0 in this case. The third shows the gas generation rate as a function of time.

This case is a baseline against which the other two cases should be compared. The breech pressure traces for all three cases are shown in Figure 10 on page 20.

The input deck:

```
SCOMM
SIMPLIFIED IBHVG2 BENCHMARK TEST CASE 6

SINFO
RUN = '120MM T6 WITHOUT PRESSURE CONSTRAINT' DELT = 5E-6 DELP = 5E-5
GRAD = 2          POPT = 1,2,1,0,3      SOPT = 0
EPS = 0.001

SHEAT
TSHL = 0.0001143   CSHL = 460.3163186   RSHL = 7861.0916
TWAL = 293         HO = 11.348218      HL = 1

SGUN
NAME = '120MM GUN TEST CASE'   CHAM = 0.009946948   GRVE = 0.1199896
LAND = 0.1199896      G/L = 1.          TRAV = 4.752594
TWST = 99

$PROJ
NAME = 'APFSUS'   PRMT = 7.09872

SCOMM
'POIS' VALUES USED WITH PARAMETRIC PRINT OPTION POPT(5)=2
$PDIS
SHOW='PMA' DECK='OUT' DIV=6894.757
$PDIS
SHOW='CHWT' DECK='PROP' NTH=2 DIV=0.45359237
$PDIS
SHOW='DIAM' DECK='PROP' NTH=2 DIV=0.0254
$PDIS
SHOW='PD' DECK='PROP' NTH=2 DIV=0.0254
$PDIS
SHOW='WEB' DECK='PROP' NTH=2 DIV=0.0254
$PDIS
SHOW='VMU2' DECK='OUT' DIV=0.3048
$PDIS
SHOW='ZMU2(2)' DECK='OUT'
$PDIS
SHOW='LDEN' DECK='OUT'
```

SRESI
NPTS = 4 AIR = 1
TRAV = 0, 0.02032, 0.0762, 4.7498
PRES = 0.6894757, 17.2368925, 0.6894757, 0.6894757

STDIS SHOW-'TIME'
STDIS SHOW-'TRAV' DIV=.0254 REMK-'INCHES'
STDIS SHOW-'VEL' MULT=3.2808333 REMK-'FT/S'
STDIS SHOW-'ACCL' REMK-'GRAVITIES'
STDIS SHOW-'BACH' DIV=6894.757 REMK-'PSI'
STDIS SHOW-'MEAN' DIV=6894.757 REMK-'PSI'
STDIS SHOW-'BASE' DIV=6894.757 REMK-'PSI'
STDIS SHOW-'EPWR' REMK-'WATTS ELECTRIC'
STDIS SHOW-'EDNE' REMK-'JOULES ELECTRIC'
STDIS SHOW-'Z(1)'
STDIS SHOW-'XBRN' REMK-'BURN RATE'

SRECO NAME = 'NONE' RECO = 0 RCWT = 0

SPRIM NAME = 'BENITE' CHWT = 0.001573966
 GAMA = 1.25 FORC = 635176.7375
 COV = 0.001083819 TEMP = 2000

SPROP NAME = 'JA2 79' CHWT = 8.0 GRAM = '79F'
 RHO = 1586.611868 GAMA = 1.2257 FORC = 1142277.932
 COV = 0.000992778 TEMP = 3400 EROS = 0.0000000
 NTBL=4
 PR4L= 13.788514, 27.579028, 68.94757, 172.368925
 BR4L= 0.02667, 0.038608, 0.074422, 0.166624
 LEN = 0.0163322 DIAM = 0.010668 PD = 0.000508
 WI = 0.0019304 WO = 0.0018796

SEND

Produced the following output:

1 --> SCOMM SIMPLIFIED IBHVG2 BENCHMARK TEST CASE 6
 2 --> CARD 3 --> INFO
 4 --> RUN = '120MM T6 WITHOUT PRESSURE CONSTRAINT' DELT = 5E-6 DELP = 5E-5
 5 --> GRAD = 2 POPT = 1,2,1,0,2 SOPT = 0
 6 --> EPS = 0.001
 7 --> SHEAT
 8 --> TSHL = 0.0001143 CSHL = 460.3143186 RSHL = 7861.0916
 9 --> TWAL = 293 HO = 11.348218 HL = 1
 10 --> NAME = '120MM GUN TEST CASE' CHAM = 0.009946948 CRVE = 0.1199896
 11 --> LAND = 0.1199896 G/L = 1. TRAV = 4.752594
 12 --> TWST = 99
 13 --> NAME = 'APFSDS' PRMT = 7.09872
 14 --> \$PROJ
 15 --> \$SCUMH
 16 --> 'POIS' VALUES USED WITH PARAMETRIC PRINT OPTION POPT(5)=2
 17 --> \$PDIS
 18 --> SHOM-'PHAX' DECK-'OUT' DIV-6894.757
 19 --> \$PDIS
 20 --> SHOM-'CHMT' DECK-'PROP' NTH=2 DIV=0.45359237
 21 --> \$PDIS
 22 --> SHOM-'DIAM' DECK-'PROP' NTH=2 DIV=C.0254
 23 --> \$PDIS
 24 --> SHOM-'PD' DECK-'PROP' NTH=2 DIV=0.0254
 25 --> \$PDIS
 26 --> SHOM-'WEB' DECK-'PROP' NTH=2 DIV=0.0254
 27 --> \$PDIS
 28 --> SHOM-'WUZ' DECK-'OUT' DIV=0.3048
 29 --> \$PDIS
 30 --> SHC-'ZMUZ(2)' DECK-'OUT'
 31 --> \$PDI
 32 --> SHC '-LDEN' DECK-'OUT'
 33 --> \$RESI
 34 --> NPIS = 4 AIR = 1
 35 --> TRAV = 0, 0.02032, 0.0762, 4.7498
 36 --> PRES = 0.6894757, 17.2368925, 0.6894757, 0.6894757
 37 --> \$TDIS
 38 --> SHOM-'TIME'
 39 --> \$TDIS
 40 --> SHOM-'TRAV' DIV-.0254 REMK-'INCHES'
 41 --> \$TDIS
 42 --> SHOM-'VEL' MULT=3.2808333 REMK-'FT/S'
 43 --> \$TDIS
 44 --> SHOM-'ACCL' REMK-'GRAVITIES'
 45 --> \$TDIS
 46 --> SHOM-'BRCH' DIV=6894.757 REMK-'PSI'
 47 --> \$TDIS
 48 --> \$TDIS
 49 --> \$TDIS
 50 --> \$TDIS

CARD 51 ---> \$TDIS SHOWN-'MEAN' DIV-6894.757 REMK-'PSI'
 CARD 52 ---> \$TDIS SHOWN-'BASE' DIV-6894.757 REMK-'PSI'
 CARD 53 ---> \$TDIS SHOWN-'EPWR' REMK-'WATTS ELECTRIC'
 CARD 54 ---> \$TDIS SHOWN-'EENE' REMK-'JOULES ELECTRIC'
 CARD 55 ---> \$TDIS SHOWN-'2(1)'
 CARD 56 ---> \$TDIS SHOWN-'XBNN' REMK-'BURN RATE'
 CARD 57 ---> \$RECO NAME = 'NONE' RECO = 0 RCWT = 0
 CARD 58 ---> \$SPRIM NAME = 'BENITE' CHMT = 0.001573966
 CARD 59 ---> \$SPRIM GAMA = 1.25 FORC = 635176.7375
 CARD 60 ---> \$SPRIM COV = 0.001563819 TEMP = 2000
 CARD 61 ---> \$SPROP NAME = 'JAZ 7P' CHMT = 0.0 GRAN = '7PP'
 CARD 62 ---> \$SPROP RHC = 1586.511968 GAMA = 1.257 FORC = 1142277.932
 CARD 63 ---> \$SPROP COV = 0.000392178 TEMP = 3400 EROS = 0.0000000
 CARD 64 ---> \$SPROP NZBL=4 PREL= 13.789514. 27.579028. 68.94757. 177.368925
 CARD 65 ---> \$SPROP BRIL= 0.02667. 6.036806. 0.074427. 0.156624
 CARD 66 ---> \$SPROP LEN = 0.014322 DIAM = 0.010668 PD = 0.000508
 CARD 67 ---> \$SPROP MI = 0.0019304 MO = 0.0018736
 CARD 71 ---> \$SUMD
 CARD 81 ---> \$SUMD

--- GUN TUBE ---
 TYPE: PUMP GUN TEST CASE
 GROOVE DIAMETER (M): 0.11999
 TWIST (CALS/TURN): 98.0
 SHELL THICKNESS (M): 0.003114
 INITIAL SHELL TEMP (K): 293.
 CHAMBER VOLUME (M3):
 LAND DIAMETER (M):
 BORE AREA (M2):
 SHELL CP (J/KG-K):
 AIR HO (W/M**2-K):

TRAVEL (M): 4.75259
 GROOVE/LAND RATIO (-): 1.000
 HEAT-LOSS OPTION:
 SHELL DENSITY (KG/M3): 7861.0920

0.00995
 0.11999
 0.01131
 460.3163
 11.3482

--- PROJECTILE ---
 TYPE: APFSDS
 TOTAL WEIGHT (KG): 7.099
 WEIGHT PREDICTOR OPTION: 0

--- RESISTANCE ---
 AIR RESISTANCE OPTION: 1
 RESISTIVE PRESSURE MELT INDEX: 3
 WALL HEATING FRACTION:
 RESISTIVE FACTOR: 0.000
 1.000
 I TRAVEL (M) PRESSURE (MPA) I TRAVEL (M) PRESSURE (MPA)
 1 0.000 0.689 3 0.076 0.689
 2 0.020 17.237 4 4.750 0.689

--- GENERAL ---
 MAX TIME STEP (S): J.000005
 PRINT OPTIONS: 1 2 1 0 2 1
 GRADIENT MODEL: PIDDUCK-RENT
 PRINT STEP (S):
 STORE OPTION:
 MAX RELATIVE ERROR (-): 0.00100
 CONSTANT-PRESSURE OPTION: 0

--- RECOIL ---
 RECOIL OPTION: 0
 TYPE: NONE
 RECOILING WEIGHT (KG): 0.

--- PRIMER ---
 TYPE: BENITE
 COVOLUME (M3/KG): 1.0838E-03
 GAMMA (-):
 FLAME TEMP (K):
 FORCE (J/KG): 635177.
 WEIGHT (KG): 0.001574

120MM T6 WITHOUT PRESSURE CONSTRAINT

10HVG2.504

DATE

TIME

--- CHARGE 1 ---

TYPE: JA2 7P
 EROSIIVE COEFF (-):
 GRAIN LENGTH (M):
 INNER WEB (M):

0.000000
 0.016332
 0.001930

GRAINS:
 CHARGE IGN CODE:
 GRAIN DIAMETER (M):
 OUTER WEB (M):

4805.1
 0
 0.009144
 0.001880

WEIGHT (KG):
 CHARGE IGN AT (S):
 PERF DIAMETER (M):

8.0000
 0.00000E+00
 0.000508

PROPERTIES AT LAYER BOUNDARIES OF PERF SURFACES
 1ST 2ND 3RD 4TH

AT DEPTH (M):
 ADJACENT LAYER WT %:
 DENSITY (KG/M3):
 GAMMA (-):
 FORCE (J/KG):
 COVOLUME (M3/KG):
 FLAME TEMP (K):
 MEAN PRESSURES (MPA):
 MEAN PRESSURES (MPA):
 MEAN PRESSURES (MPA):
 MEAN PRESSURES (MPA):
 BURNING RATES (M/S):
 BURNING RATES (M/S):
 BURNING RATES (M/S):

0.00000
 100.000
 1586.612
 1.2257
 1142278.
 9.9278E-04
 3400.0
 13.790
 27.579
 68.948
 172.369
 0.02667
 0.03861
 0.07442
 0.16662

PROPERTIES AT LAYER BOUNDARIES OF END SURFACES
 1ST 2ND 3RD 4TH

0.00000
 100.000
 1586.612
 1.2257
 1142278.
 9.9278E-04
 3400.0
 13.790
 27.579
 68.948
 172.369
 0.02667
 0.03861
 0.07442
 0.16662

PROPERTIES AT LAYER BOUNDARIES OF LAT SURFACES
 1ST 2ND 3RD 4TH

AT DEPTH (M):
 ADJACENT LAYER WT %:
 DENSITY (KG/M3):
 GAMMA (-):
 FORCE (J/KG):
 COVOLUME (M3/KG):
 FLAME TEMP (K):
 MEAN PRESSURES (MPA):
 MEAN PRESSURES (MPA):
 MEAN PRESSURES (MPA):
 MEAN PRESSURES (MPA):
 BURNING RATES (M/S):
 BURNING RATES (M/S):
 BURNING RATES (M/S):

0.00000
 100.000
 1586.612
 1.2257
 1142278.
 9.9278E-04
 3400.0
 13.790
 27.579
 68.948
 172.369
 0.02667
 0.03861
 0.07442
 0.16662

PROPERTIES AT LAYER BOUNDARIES OF END SURFACES
 1ST 2ND 3RD 4TH

0.00000
 100.000
 1586.612
 1.2257
 1142278.
 9.9278E-04
 3400.0
 13.790
 27.579
 68.948
 172.369
 0.02667
 0.03861
 0.07442
 0.16662

PROGRAM TO WITHOUT PRESSURE CONSTRAINT
 TRAJECTORY VARIABLES: / 1/ TRAJ 1 TIME
 / 2/ TRAJ 1 TRAV
 / 3/ TRAJ 1 VEL
 / 4/ TRAJ 1 ACCL
 / 5/ TRAJ 1 BRCH
 / 6/ TRAJ 1 MEAN
 / 7/ TRAJ 1 BASE
 / 8/ TRAJ 1 EPR
 / 9/ TRAJ 1 EENE
 /10/ TRAJ 1 Z(1)
 /11/ TRAJ 1 XBRN

INCHES
 FT/S
 GRAVITIES
 PSI
 PSI
 WATTS ELECTRIC
 JOULES ELECTRIC
 BURN RATE

	/ 1/	/ 2/	/ 3/	/ 4/	/ 5/	/ 6/	/ 7/	/ 8/	/ 9/	/10/	/11/
0.00000	0.00000	0.00000	0.00000	0.00000	29.574	29.574	29.574	0.00000	0.00000	0.00000	10.065
0.50000E-01	0.00000	0.00000	0.00000	0.00000	66.328	66.328	66.328	0.00000	0.00000	0.13267E-03	15.488
0.84125E-01	0.00000	0.00000	0.00000	0.00000	99.989	99.989	99.989	0.00000	0.00000	0.25594E-03	19.280
SHOT-START PRESSURE ACHIEVED											
0.10000	0.00000	0.00000	0.00000	0.00000	134.73	134.73	134.73	0.00000	0.00000	0.32255E-03	21.071
0.15000	0.35929E-05	0.24670E-01	42.820	211.78	211.78	185.64	138.25	0.00000	0.00000	0.57140E-03	26.820
BARREL RESISTANCE OVERCOME - PROJECTILE MOVING											
0.20000	0.49734E-04	0.14788	112.63	307.47	307.47	269.52	200.72	0.00000	0.00000	0.88093E-03	32.720
0.25000	0.20569E-03	0.39437	196.10	422.36	422.36	370.23	275.72	0.00000	0.00000	0.12527E-02	38.754
0.30000	0.55204E-03	0.78618	293.31	556.92	556.92	488.19	363.57	0.00000	0.00000	0.16591E-02	44.904
0.35000	0.11826E-02	1.3454	404.27	711.40	711.40	623.77	452.55	0.00000	0.00000	0.21805E-02	51.173
0.40000	0.22045E-02	2.0944	528.90	886.18	886.18	777.33	578.91	0.00000	0.00000	0.27550E-02	57.536
0.45000	0.37379E-02	3.0544	667.07	1082.8	1082.8	949.18	706.90	0.00000	0.00000	0.33808E-02	63.989
0.50000	0.59164E-02	4.2476	818.58	1300.1	1300.1	1139.6	848.74	0.00000	0.00000	0.40910E-02	70.546
0.55000	0.88860E-02	5.6951	983.16	1799.4	1799.4	1348.9	1004.6	0.00000	0.00000	0.48625E-02	77.139
0.60000	0.12806E-01	7.4177	1160.5	1799.5	1799.5	1577.4	1174.8	0.00000	0.00000	0.57043E-02	83.824
0.65000	0.17846E-01	9.4355	1350.2	2082.2	2082.2	1825.2	1359.3	0.00000	0.00000	0.66174E-02	90.574
0.70000	0.24191E-01	11.768	1551.8	2387.1	2387.1	2092.5	1558.4	0.00000	0.00000	0.76027E-02	97.385
0.75000	0.32035E-01	14.434	1764.9	2714.6	2714.6	2379.6	1772.2	0.00000	0.00000	0.86609E-02	104.25
0.80000	0.41583E-01	17.452	1988.7	3064.8	3064.8	2686.5	2000.8	0.00000	0.00000	0.97931E-02	111.17
0.85000	0.53051E-01	20.839	2222.8	3437.8	3437.8	3013.4	2244.3	0.00000	0.00000	0.11000E-01	118.13
0.90000	0.66666E-01	24.609	2466.4	3833.6	3833.6	3360.4	2502.7	0.00000	0.00000	0.12282E-01	125.13
0.95000	0.82662E-01	28.779	2718.7	4252.3	4252.3	3727.4	2776.1	0.00000	0.00000	0.13641E-01	132.16
1.0000	0.10128	33.361	2979.2	4694.2	4694.2	4114.8	3064.6	0.00000	0.00000	0.15077E-01	139.95
1.0500	0.12278	38.370	3251.3	5165.4	5165.4	4527.8	3372.2	0.00000	0.00000	0.16612E-01	149.77
1.1000	0.14442	43.828	3536.6	5668.9	5668.9	4969.2	3700.9	0.00000	0.00000	0.18258E-01	159.97
1.1500	0.17547	49.756	3814.7	6203.7	6203.7	5439.8	4051.4	0.00000	0.00000	0.20014E-01	173.55
1.2000	0.20722	55.173	4145.5	6776.9	6776.9	5940.4	4424.2	0.00000	0.00000	0.21890E-01	187.49
1.25	0.24298	61.100	4468.6	7383.4	7383.4	6472.0	4820.2	0.00000	0.00000	0.23890E-01	192.81
1.3000	0.28305	67.557	4803.6	8025.9	8025.9	7035.3	5239.6	0.00000	0.00000	0.26018E-01	204.49
1.3500	0.32776	74.561	5149.9	8705.2	8705.2	7630.7	5683.1	0.00000	0.00000	0.28279E-01	216.52
1.4000	0.37743	82.132	5506.9	9422.0	9422.0	8259.0	6151.1	0.00000	0.00000	0.30678E-01	228.89
1.4500	0.43243	90.484	5873.7	10177.7	10177.7	8920.6	6643.8	0.00000	0.00000	0.33219E-01	241.61
1.5000	0.49310	106.03	6249.4	10970.7	10970.7	9615.7	7161.5	0.00000	0.00000	0.35907E-01	254.64
1.5500	0.55979	116.40	6633.9	11802.7	11802.7	10346.7	770.1	0.00000	0.00000	0.38752E-01	269.48
1.6000	0.63290	127.39	7032.3	12681.7	12681.7	11118.6	8280.3	0.00000	0.00000	0.41785E-01	286.71
1.6500	0.71279	139.03	7445.7	13616.7	13616.7	11936.7	8889.3	0.00000	0.00000	0.45023E-01	304.74
1.7000	0.79987	151.35	7873.8	14602.7	14602.7	12800.7	9533.1	0.00000	0.00000	0.48475E-01	323.57
1.7500	0.89462	164.71	8749.5	15643.7	15643.7	13712.7	10212.7	0.00000	0.00000	0.52154E-01	343.20

12UMP To WITHHIT PRESSURE CONSTRAINT

TRAJECTORY VARIABLES: / 1/ TRAJ 1 TIME
 / 2/ TRAJ 1 TRAV
 / 3/ TRAJ 1 VE.
 / 4/ TRAJ 1 ACCL
 / 5/ TRAJ 1 BRCH
 / 6/ TRAJ 1 MEAN
 / 7/ TRAJ 1 BASE
 / 8/ TRAJ 1 EMR
 / 9/ TRAJ 1 EENE
 /10/ TRAJ 1 Z(1)
 /11/ TRAJ 1 XORN

1BHV2.504 DATE TIME

INCHES
 FT/S
 GRAVITIES
 PSI
 PSI
 PSI
 WATTS ELECTRIC
 JOULE ELECTRIC
 BURN RATE

	/ 1/	/ 2/	/ 3/	/ 4/	/ 5/	/ 6/	/ 7/	/ 8/	/ 9/	/10/	/11/
1.8000	0.99781	179.53	9676.4	16739.	14673.	10928.	0.00000	0.00000	0.00000	0.56072E-01	363.63
1.8500	1.1104	195.87	10656.	17691.	15682.	11680.	0.00000	0.00000	0.00000	0.60239E-01	384.83
1.9000	1.2332	213.84	11688.	19098.	16741.	12468.	0.00000	0.00000	0.00000	0.64668E-01	406.77
1.9500	1.3673	233.51	12774.	20360.	17847.	13292.	0.00000	0.00000	0.00000	0.69371E-01	429.43
2.0000	1.5138	256.97	13915.	21676.	19001.	14151.	0.00000	0.00000	0.00000	0.74360E-01	452.76
2.0500	1.6736	278.31	15110.	23045.	20200.	15044.	0.00000	0.00000	0.00000	0.79866E-01	476.69
2.1000	1.8481	303.61	16359.	24463.	21443.	15970.	0.00000	0.00000	0.00000	0.85242E-01	501.16
2.1500	2.0384	330.97	17662.	25927.	22727.	16926.	0.00000	0.00000	0.00000	0.91157E-01	526.09
2.2000	2.2457	360.46	19016.	27434.	24048.	17910.	0.00000	0.00000	0.00000	0.97403E-01	551.38
2.2500	2.4714	392.18	20420.	28979.	25402.	18918.	0.00000	0.00000	0.00000	0.10399	576.82
2.3000	2.7168	426.19	21871.	30555.	26783.	19947.	0.00000	0.00000	0.00000	0.11092	602.61
2.3500	2.9833	462.57	23366.	32156.	28187.	20993.	0.00000	0.00000	0.00000	0.11822	628.30
2.4000	3.2723	501.14	24869.	33775.	29606.	22049.	0.00000	0.00000	0.00000	0.12587	653.86
2.4500	3.5850	541.62	26579.	35404.	31034.	23113.	0.00000	0.00000	0.00000	0.13390	679.16
2.5000	3.9226	584.02	28450.	37035.	32464.	24178.	0.00000	0.00000	0.00000	0.14230	704.06
2.5500	4.2862	628.33	29137.	38661.	33889.	25239.	0.00000	0.00000	0.00000	0.15107	728.41
2.6000	4.6770	674.54	29313.	40371.	35300.	26291.	0.00000	0.00000	0.00000	0.16022	752.08
2.6500	5.0961	722.63	30471.	41858.	36691.	27327.	0.00000	0.00000	0.00000	0.16975	774.92
2.7000	5.5445	772.56	31605.	43412.	38054.	28341.	0.00000	0.00000	0.00000	0.17965	796.80
2.7500	6.0235	824.30	32709.	44924.	39379.	29328.	0.00000	0.00000	0.00000	0.18992	817.59
2.8000	6.5340	877.78	33773.	46386.	40661.	30283.	0.00000	0.00000	0.00000	0.20055	837.16
2.8500	7.0772	932.94	34798.	47789.	41891.	31199.	0.00000	0.00000	0.00000	0.21154	855.42
2.9000	7.6539	989.71	35773.	49126.	43062.	32072.	0.00000	0.00000	0.00000	0.22288	872.26
2.9500	8.2651	1048.0	36694.	50389.	44170.	32896.	0.00000	0.00000	0.00000	0.23455	887.61
3.0000	8.9118	1107.7	37556.	51573.	45208.	33669.	0.00000	0.00000	0.00000	0.24654	901.39
3.0500	9.5947	1168.8	38356.	52672.	46171.	34386.	0.00000	0.00000	0.00000	0.25885	913.57
3.1000	10.315	1231.1	39091.	53681.	47055.	35045.	0.00000	0.00000	0.00000	0.27145	924.10
3.1500	11.072	1294.5	39757.	54598.	47859.	35644.	0.00000	0.00000	0.00000	0.28432	932.98
3.2000	11.868	1359.0	40354.	55419.	48579.	36180.	0.00000	0.00000	0.00000	0.29746	940.20
3.2500	12.703	1424.3	40880.	56144.	49214.	36653.	0.00000	0.00000	0.00000	0.31084	945.78
3.3000	13.578	1490.5	41334.	56772.	49765.	37063.	0.00000	0.00000	0.00000	0.32444	949.76
3.3500	14.492	1557.3	41718.	57303.	50230.	37410.	0.00000	0.00000	0.00000	0.33824	952.18
3.4000	15.447	1624.7	42032.	57740.	50613.	37695.	0.00000	0.00000	0.00000	0.35224	953.10
3.4500	16.442	1692.5	42279.	58083.	50914.	37919.	0.00000	0.00000	0.00000	0.36639	952.58
3.5000	17.476	1760.7	42459.	58317.	51136.	38085.	0.00000	0.00000	0.00000	0.38070	950.70
3.5500	18.554	1829.1	42575.	58504.	51381.	38194.	0.00000	0.00000	0.00000	0.39513	947.54
3.6000	19.672	1897.6	42631.	58588.	51557.	38249.	0.00000	0.00000	0.00000	0.40967	943.19
3.6288	20.336	1937.1	42637.	58601.	51368.	38257.	0.00000	0.00000	0.00000	0.41810	940.17

LOCAL PRESSURE MAX DETECTED

120MM T6 WITHOUT PRESSURE CONSTRAINT

IBHVC2.504

TIME

TRAJECTORY VARIABLES: / 1/ TRAJ 1 TIME
 / 2/ TRAJ 1 TRAV
 / 3/ TRAJ 1 VEL
 / 4/ TRAJ 1 ACCL
 / 5/ TRAJ 1 BRCH
 / 6/ TRAJ 1 MEAN
 / 7/ TRAJ 1 BASE
 / 8/ TRAJ 1 EPWR
 / 9/ TRAJ 1 EENE
 /10/ TRAJ 1 2(1)
 /11/ TRAJ 1 XBRN

INCHES
 FT/S
 GRAVITIES
 PSI
 PSI
 PSI
 WATTS ELECTRIC
 JOULES ELECTRIC
 BURN RATE

	/ 1/	/ 2/	/ 3/	/ 4/	/ 5/	/ 6/	/ 7/	/ 8/	/ 9/	/ 10/	/ 11/
3.6500	20.831	1966.2	42630.	58594.	51362.	38253.	0.00000	0.00000	0.00000	0.42430	937.73
3.7000	22.031	2034.7	42574.	58526.	51302.	38208.	0.00000	0.00000	0.00000	0.43900	931.25
3.7500	23.273	2103.1	42468.	58390.	51183.	38119.	0.00000	0.00000	0.00000	0.45376	923.85
3.8000	24.555	2171.3	42315.	58189.	51007.	37988.	0.00000	0.00000	0.00000	0.46857	915.62
3.8500	25.878	2239.2	42119.	57929.	50779.	37819.	0.00000	0.00000	0.00000	0.48339	906.64
3.9000	27.242	2306.8	41883.	57616.	50504.	37614.	0.00000	0.00000	0.00000	0.49823	896.99
3.9500	28.646	2374.0	41610.	57253.	50186.	37377.	0.00000	0.00000	0.00000	0.51307	886.76
4.0000	30.091	2440.7	41305.	56845.	49829.	37111.	0.00000	0.00000	0.00000	0.52789	876.03
4.0500	31.575	2506.9	40971.	56398.	49436.	36819.	0.00000	0.00000	0.00000	0.54268	864.87
4.1000	33.099	2572.5	40611.	55915.	49013.	36503.	0.00000	0.00000	0.00000	0.55744	853.35
4.1500	34.662	2637.5	40227.	55400.	48562.	36167.	0.00000	0.00000	0.00000	0.57214	841.52
4.2000	36.264	2701.9	39823.	54858.	48087.	35814.	0.00000	0.00000	0.00000	0.58679	829.46
4.2500	37.904	2765.6	39402.	54292.	47591.	35444.	0.00000	0.00000	0.00000	0.60137	817.21
4.3000	39.583	2828.7	38966.	53706.	47077.	35061.	0.00000	0.00000	0.00000	0.61588	804.82
4.3500	41.298	2891.0	38517.	53102.	46548.	34667.	0.00000	0.00000	0.00000	0.63031	792.35
4.4000	43.052	2952.6	38058.	52485.	46007.	34264.	0.00000	0.00000	0.00000	0.64465	779.82
4.4500	44.841	3013.4	37590.	51856.	45455.	33853.	0.00000	0.00000	0.00000	0.65889	767.28
4.5000	46.668	3073.5	37115.	51217.	44895.	33437.	0.00000	0.00000	0.00000	0.67304	754.76
4.5500	48.529	3132.8	36636.	50572.	44330.	33016.	0.00000	0.00000	0.00000	0.68709	742.29
4.6000	50.427	3191.4	36153.	49922.	43760.	32591.	0.00000	0.00000	0.00000	0.70103	729.89
4.6500	52.359	3249.2	35667.	49270.	43188.	32165.	0.00000	0.00000	0.00000	0.71485	717.50
4.7000	54.326	3306.1	35181.	48616.	42615.	31738.	0.00000	0.00000	0.00000	0.72857	705.40
4.7500	56.326	3362.3	34695.	47962.	42042.	31312.	0.00000	0.00000	0.00000	0.74217	693.34
4.8000	58.360	3417.8	34211.	47310.	41471.	30886.	0.00000	0.00000	0.00000	0.75565	681.44
4.8500	60.427	3472.4	33728.	46661.	40902.	30462.	0.00000	0.00000	0.00000	0.76902	669.69
4.9000	62.527	3526.3	33248.	46016.	40336.	30041.	0.00000	0.00000	0.00000	0.78226	658.12
4.9500	64.659	3579.4	32772.	45376.	39775.	29623.	0.00000	0.00000	0.00000	0.79538	646.72
5.0000	66.822	3631.7	32299.	44741.	39219.	29209.	0.00000	0.00000	0.00000	0.80838	635.52
5.0500	69.017	3683.3	31832.	44113.	38668.	28798.	0.00000	0.00000	0.00000	0.82125	624.50
5.1000	71.242	3734.1	31369.	43491.	38123.	28393.	0.00000	0.00000	0.00000	0.83400	613.69
5.1500	73.498	3784.2	30912.	42877.	37585.	27992.	0.00000	0.00000	0.00000	0.84663	603.07
5.2000	75.783	3833.6	30461.	42271.	37053.	27596.	0.00000	0.00000	0.00000	0.85913	592.66
5.2499	78.098	3882.2	29987.	41633.	36495.	27180.	0.00000	0.00000	0.00000	0.87091	499.79
5.2999	80.441	3930.1	29488.	40963.	35907.	26742.	0.00000	0.00000	0.00000	0.88187	452.76
5.3499	82.814	3977.1	28961.	40252.	35284.	26278.	0.00000	0.00000	0.00000	0.89184	416.24
5.3999	85.214	4023.2	28393.	39486.	34612.	25778.	0.00000	0.00000	0.00000	0.90050	385.03
5.4499	87.641	4068.4	27809.	38698.	33921.	25264.	0.00000	0.00000	0.00000	0.90832	357.53
5.4999	90.096	4112.7	27217.	37899.	33241.	24742.	0.00000	0.00000	0.00000	0.91543	332.84
5.5499	92.576	4156.0	26623.	37097.	32518.	24218.	0.00000	0.00000	0.00000	0.92194	310.44

120MM T6 WITHOUT PRESSURE CONSTRAINT

TRAJECTORY VARIABLES: / 1/ / 2/ / 3/ / 4/ / 5/ / 6/ / 7/ / 8/ / 9/ / 10/ / 11/

INCHES
F7/S
GRAVITIES
PSI
PSI
PSI
MATT'S ELECTRIC
JOULES ELECTRIC
BURN RATE

IBHVG2.504

DATE

TIME

TRAJ 1 TIME
TRAJ 1 TRAV
TRAJ 1 VEL
TRAJ 1 ACCL
TRAJ 1 BRCM
TRAJ 1 MEAN
TRAJ 1 BASE
TRAJ 1 EPWR
TRAJ 1 EENE
TRAJ 1 Z(1)
TRAJ 1 XBRN

5.5999	95.083	4198.4	26030.	36297.	31817.	23696.	0.00000	0.00000	0.92792	289.95
5.6499	97.614	4238.0	25442.	35502.	31120.	23177.	0.00000	0.00000	0.93342	271.11
5.6999	100.17	4280.2	24860.	34717.	30431.	22664.	0.00000	0.00000	0.93899	253.72
5.7499	102.75	4319.7	24286.	33942.	29752.	22158.	0.00000	0.00000	0.94317	237.60
5.7999	105.35	4358.4	23721.	33179.	29084.	21651.	0.00000	0.00000	0.94748	222.64
5.8499	107.98	4396.1	23167.	32430.	28427.	21172.	0.00000	0.00000	0.95146	208.73
5.8999	110.63	4432.9	22623.	31696.	27784.	20693.	0.00000	0.00000	0.95514	195.76
5.9499	113.30	4468.9	22091.	30978.	27154.	20224.	0.00000	0.00000	0.95852	183.65
5.9999	115.99	4504.0	21570.	30275.	26539.	19765.	0.00000	0.00000	0.96165	172.34
6.0499	118.70	4538.3	21062.	29589.	25937.	19317.	0.00000	0.00000	0.96453	161.76
6.0999	121.44	4571.8	20566.	28919.	25350.	18880.	0.00000	0.00000	0.96718	151.85
6.1499	124.19	4604.4	20082.	28266.	24777.	18453.	0.00000	0.00000	0.96961	142.56
6.1999	126.96	4636.4	19610.	27630.	24219.	18038.	0.00000	0.00000	0.97185	133.85
6.2499	129.75	4667.5	19150.	27009.	23676.	17633.	0.00000	0.00000	0.97390	125.67
6.2999	132.56	4698.0	18703.	26406.	23146.	17239.	0.00000	0.00000	0.97578	117.98
6.3499	135.39	4727.7	18267.	25818.	22632.	16855.	0.00000	0.00000	0.97751	110.76
6.3999	138.24	4756.8	17845.	25249.	22132.	16484.	0.00000	0.00000	0.97914	103.98
6.4499	141.10	4785.2	17435.	24696.	21648.	16123.	0.00000	0.00000	0.98067	97.594
6.4999	143.98	4812.9	17038.	24161.	21178.	15773.	0.00000	0.00000	0.98211	91.587
6.5499	146.87	4840.0	16652.	23641.	20723.	15431.	0.00000	0.00000	0.98346	85.930
6.5999	149.79	4866.5	16278.	23136.	20281.	15104.	0.00000	0.00000	0.98473	80.599
6.6499	152.71	4892.4	15915.	22647.	19852.	14785.	0.00000	0.00000	0.98592	75.572
6.6999	155.66	4917.7	15562.	22172.	19435.	14475.	0.00000	0.00000	0.98704	70.828
6.7499	158.62	4942.4	15220.	21711.	19031.	14174.	0.00000	0.00000	0.98809	66.350
6.7999	161.58	4966.6	14888.	21264.	18639.	13882.	0.00000	0.00000	0.98907	62.120
6.8499	164.58	4990.3	14565.	20830.	18259.	13599.	0.00000	0.00000	0.98999	58.121
6.8999	167.58	5013.5	14252.	20408.	17889.	13323.	0.00000	0.00000	0.99085	54.341
6.9499	170.59	5036.2	13948.	19999.	17530.	13056.	0.00000	0.00000	0.99166	50.765
6.9999	173.62	5058.4	13652.	19601.	17182.	12797.	0.00000	0.00000	0.99241	47.380
7.0499	176.66	5080.1	13365.	19215.	16844.	12545.	0.00000	0.00000	0.99311	44.175
7.0999	179.72	5101.4	13087.	18840.	16515.	12303.	0.00000	0.00000	0.99377	41.139
7.1499	182.78	5122.2	12815.	18476.	16195.	12062.	0.00000	0.00000	0.99438	38.262
7.1999	185.86	5142.6	12552.	18122.	15885.	11831.	0.00000	0.00000	0.99495	35.534
7.2201	187.11	5150.8	12448.	17981.	15762.	11739.	0.00000	0.00000	0.99517	34.472

PROJECTILE EXIT

CONDITIONS AT: PMAX MUZZLE
 TIME (MS): 3.629 7.220
 TRAVEL (M): 0.5165 4.7526
 VELOCITY (M/S): 590.44 1569.95
 ACCELERATION (G): 42637. 12400
 BRECH PRESS (MPA): 404.0304 123.9772
 MEAN PRESS (MPA): 354.1676 108.6746
 BASE PRESS (MPA): 263.7730 80.9375
 MEAN TEMP (K): 3003. 2285.
 Z CHARGE I (-): 0.418 0.995

ENERGY BALANCE SUMMARY

	JOULES	%
ELECTRICAL ENERGY:	0.	0.00
CHEMICAL ENERGY:	40296660.	100.00
TOTAL ENERGY:	40296660.	100.00
(1) INTERNAL GAS:	26847150.	66.62
(2) WORK AND LOSSES:	13449520.	33.38
(A) PROJECTILE KINETIC:	8740316.	21.71
(B) GAS KINETIC:	2998033.	7.44
(C) PROJECTILE ROTATIONAL:	4405.	0.01
(D) FRICTIONAL WORK TO TUBE:	0.	0.00
(E) OTHER FRICTIONAL WORK:	44182.	0.11
(F) WORK DONE AGAINST AIR:	117853.	0.29
(G) HEAT CONVECTED TO BORE:	1536728.	3.81
(H) RECOIL ENERGY:	0.	0.00

LOADING DENSITY (KG/M3): 804.425
 CHARGE WT/PROJECTILE WT: 1.127
 PIEZOMETRIC EFFICIENCY: 0.403
 ELECTRICAL ENHANCEMENT FACTOR: 0.000
 EXPANSION RATIO: 6.403

B.2. SAMPLE CASE 2

This case differs from sample case 1 by the addition of 1 kJ of electric energy per gram of JA2 propellant. For 8 kg of JA2, that means 8 MJ of electrical energy.

This energy is (arbitrarily) delivered by means of a trapezoidal pulse in approximately 1 ms. The precise details are shown in the \$ETC deck below. The trapezoid rises linearly in the first 100 μ s, remains flat for 900 μ s, and then drops linearly in a final 100 μ s. The two triangular rising and falling segments may be combined geometrically to show that the net result is a 1-ms pulse.

This early delivery of energy causes the JA2 to reach higher pressures than it was originally designed for, increasing the burn rate and therefore substantially increasing the peak pressure and decreasing the time required to reach it.

The input deck:

```
$COMM
SIMPLIFIED IBHVG2 BENCHMARK TEST CASE 6
WITH A 1 MS FLAT ELECTRIC PULSE
CONTAINING A TOTAL OF 1KJ ELECTRIC PER GRAM OF PROPELLANT

$INFO
RUN = '120MM T6 WITH 1 KJ/G ELECTRIC' DELT = 5E-5 DELP = 5E-5
GRAD = 2 POPT = 1,2,1,0,2 SOPT = 0
EPS = 0.05

$HEAT
TSHL = 0.0001143 CSHL = 460.3163186 RSHL = 7861.0916
TWAL = 293 HO = 11.340218 HL = 1

$GUN
NAME = '120MM GUN TEST CASE' CHAM = 0.009946948 CRVE = 0.1199896
LAND = 0.1199896 G/L = 1. TRAV = 4.752594
TWST = 99

$PROJ
NAME = 'APFSOS' PRMT = 7.09872

$COMM
'PDIS' VALUES USED WITH PARAMETRIC PRINT OPTION POPT(5)=2
$PDIS
SHOW='PMAX' DECK='OUT' DIV=6894.757
$PDIS
SHOW='CHWT' DECK='PROP' NTH=2 DIV=0.45359237
$PDIS
SHOW='DIAM' DECK='PROP' NTH=2 DIV=0.0254
$PDIS
SHOW='PD' DECK='PROP' NTH=2 DIV=0.0254
$PDIS
SHOW='WEB' DECK='PROP' NTH=2 DIV=0.0254
$PDIS
SHOW='VMU2' DECK='OUT' DIV=0.3048
$PDIS
SHOW='ZMU2(2)' DECK='OUT'
$PDIS
SHOW='LDEN' DECK='OUT'

$RESI
NPTS = 4 AIR = 1
TRAV = 0, 0.02032, 0.0762, 4.7498
PRES = 0.6894757, 17.2368925, 0.6894757, 0.6894757

$STDIS
SHOW='TIME'
$STDIS
SHOW='TRAV' DIV=.0254 REMK='INCHES'
```

```

$DIS  SHOW-'VEL'   MULT=3.2808333 REMK-'FT/S'
$DIS  SHOW-'ACCL' REMK-'GRAVITIES'
$DIS  SHOW-'BRCH' DIV=6894.757 REMK-'PSI'
$DIS  SHOW-'MEAN' DIV=6894.757 REMK-'PSI'
$DIS  SHOW-'BASE' DIV=6894.757 REMK-'PSI'
$DIS  SHOW-'EPWR' REMK-'WATTS ELECTRIC'
$DIS  SHOW-'EENE' REMK-'JOULES ELECTRIC'
$DIS  SHOW-'Z(1)'
$DIS  SHOW-'XBRN' REMK-'BURN RATE'

$RECO  NAME - 'NONE'          RECO - 0          RCWT - 0

$PRIM  NAME - 'BENITE'        CHWT - 0.001573966
       GAMA - 1.25           FORC - 635176.7375
       COV - 0.001083819    TEMP - 2000

$PROP  NAME - 'JA2 7P'       CHWT - 0.0          GRAN - '7PF'
       RHO - 1586.611868    GAMA - 1.225       FORC - 1142277.932
       COV - 0.000992778    TEMP - 3400        EROS - 0.0000000
       NTBL=4
       PR4L= 13.789514, 27.579028, 68.94757, 172.368925
       BR4L= 0.02667, 0.038608, 0.074422, 0.166624
       LEN - 0.0163322     DIAM - 0.010668    ZD - 0.000508
       WI - 0.0019304     WC - 0.0018796

$COMM  DEFINE A TRAPEZOIDAL ELECTRIC POWER PULSE
       8 GIGAWATTS FOR 1 MILLISECOND,
       WITH 100 MICROSECOND LINEAR RAMPS UP AND DOWN.

$SETC  NPWR - 4
       PWR -0.0, 8E9, 8E9, 0.0
       TPWR=0.000,0.0001,0.001,0.0011

$END

```

Produced the following output:

CARD 1 ---> SCOMM SIMPLIFIED IBHVC2 BENCHMARK TEST CASE 6
 CARD 2 ---> WITH A 1 MS FLAT ELECTRIC PULSE
 CARD 3 ---> CONTAINING A TOTAL OF 10J ELECTRIC PER GRAM OF PROPELLANT
 CARD 4 --->
 CARD 5 ---> SINFO
 CARD 6 ---> RUN - '120MM T6 WITH 1 KJ/G ELECTRIC' DELT - 5E-5 DELP - 5E-5
 CARD 7 ---> GRAD - 2 POPT - 1,2,1,0,2 SOFT - 0
 CARD 8 ---> EPS - 0.05
 CARD 9 ---> SHEAT
 CARD 10 ---> TSHL - 0.0001143 CSHL - 460.3163186 RSHL - 7861.0916
 CARD 11 ---> TML - 293 NO - 11.348218 HL - 1
 CARD 12 ---> SCUN
 CARD 13 ---> NAME - '120MM GUN TEST CASE' CHAM - 0.009946948 CRVE - 0.2199896
 CARD 14 ---> LAND - 0.1199896 S/L - 1. TRAV - 4.752594
 CARD 15 ---> TNST - 99
 CARD 16 ---> SPROJ
 CARD 17 ---> NAME - 'APFSDS' PRWT - 7.09872
 CARD 18 --->
 CARD 19 ---> SCOMM
 CARD 20 ---> 'PDIS' VALUES USED WITH PARAMETRIC PRINT OPTION POPT(5)-2
 CARD 21 ---> SPDIS SHOM-'PHAX' DECK-'OUT' DIV-6894.757
 CARD 22 ---> SHOM-'CHWT' DECK-'PROP' NTH-2 DIV-0.45359237
 CARD 23 ---> SPDIS
 CARD 24 ---> SHOM-'DIAX' DECK-'PROP' NTH-2 DIV-0.0254
 CARD 25 ---> SPDIS
 CARD 26 ---> SHOM-'PD' DECK-'PROP' NTH-2 DIV-0.0254
 CARD 27 ---> SPDIS
 CARD 28 ---> SHOM-'WEB' DECK-'PROP' NTH-2 DIV-0.0254
 CARD 29 ---> SPDIS
 CARD 30 ---> SHOM-'VNUZ' DECK-'OUT' DIV-0.3048
 CARD 31 ---> SPDIS
 CARD 32 ---> SHOM-'ZNUZ(2)' DECK-'OUT'
 CARD 33 ---> SPDIS
 CARD 34 ---> SHOM-'IDEN' DECK-'OUT'
 CARD 35 ---> SPDIS
 CARD 36 ---> SRESI
 CARD 37 ---> NPTS - 4 AIR - 1
 CARD 38 ---> TRAV - 0.02032 0.0762 4.7498
 CARD 39 ---> PRES - 0.6894757, 17.2368925, 0.6894757, 0.6894757
 CARD 40 --->
 CARD 41 --->
 CARD 42 ---> STDIS SHOM-'TIME'
 CARD 43 ---> STDIS
 CARD 44 ---> STDIS SHOM-'TRAV' DIV-.0254 REMK-'INCHES'
 CARD 45 ---> STDIS SHOM-'VEL' MULT-3.2808333 REMK-'FT/S'
 CARD 46 ---> STDIS
 CARD 47 ---> STDIS
 CARD 48 ---> STDIS
 CARD 49 ---> STDIS SHOM-'ACCL' REMK-'GRAVITIES'
 CARD 50 --->

TIME

DATE

IBHVC2.504

120MM T6 WITH 1 KJ/G ELECTRIC

CARD 51 ---> \$TD1S
 CARD 52 ---> \$TD1S
 CARD 53 ---> \$TD1S
 CARD 54 ---> \$TD1S
 CARD 55 ---> \$TD1S
 CARD 56 ---> \$TD1S
 CARD 57 ---> \$TD1S
 CARD 58 ---> \$TD1S
 CARD 59 ---> \$TD1S
 CARD 60 ---> \$TD1S
 CARD 61 ---> \$TD1S
 CARD 62 ---> \$TD1S
 CARD 63 ---> \$TD1S
 CARD 64 ---> \$SRECO
 CARD 65 ---> \$SPRIM
 CARD 66 ---> \$SPROP
 CARD 67 ---> \$SPROP
 CARD 68 ---> \$SPROP
 CARD 69 ---> \$SPROP
 CARD 70 ---> \$SPROP
 CARD 71 ---> \$SPROP
 CARD 72 ---> \$SPROP
 CARD 73 ---> \$SPROP
 CARD 74 ---> \$SPROP
 CARD 75 ---> \$SPROP
 CARD 76 ---> \$SPROP
 CARD 77 ---> \$SPROP
 CARD 78 ---> \$SPROP
 CARD 79 ---> \$SPROP
 CARD 80 ---> \$SPROP
 CARD 81 ---> \$SPROP
 CARD 82 ---> \$SPROP
 CARD 83 ---> \$SCOMM
 CARD 84 ---> \$SCOMM
 CARD 85 ---> \$SCOMM
 CARD 86 ---> \$SETC
 CARD 87 ---> \$SETC
 CARD 88 ---> \$SETC
 CARD 89 ---> \$SETC
 CARD 90 ---> \$SETC
 CARD 91 ---> \$SETC
 CARD 92 ---> \$SEND

SHOW-'BRCH' DIV-6894.757 REMK-'PSI'
 SHOW-'MEAN' DIV-6894.757 REMK-'PSI'
 SHOW-'BASE' DIV-6894.757 REMK-'PSI'
 SHOW-'CPWR' REMK-'MATTIS ELECTRIC'
 SHOW-'GENE' REMK-'JOULES ELECTRIC'
 SHOW-'2(1)'
 SHOW-'XBNN' REMK-'BURN RATE'
 NAME - 'MOWE' RECO - 0 RCMT - 0
 NAME - 'BENITE' CHMT - 0.001373966
 GAMMA - 1.25 FORC - 635176.7375
 COV - 0.001063819 TEMP - 2000
 NAME - 'JAZ 7P' CHMT - 8.0 GRAN - '7PF'
 RHO - 1586.621868 GAMA - 1.2257 FORC - 1142277.932
 COV - 0.000992778 TEMP - 3400 ENOS - 0.0000000
 NTBL=4
 PRAL= 13.789514, 27.579028, 68.94757, 172.368925
 BRAL= 0.02667, 0.038608, 0.074422, 0.166624
 LEN = 0.0163322 DIAM = 0.010668 PD = 0.000508
 WI = 0.0019304 MO = 0.0018796

DEFINE A TRAPEZOIDAL ELECTRIC POWER PULSE
 8 GIGAWATTS FOR 1 MILLISECOND,
 WITH 100 MICROSECOND LINEAR RAMP'S UP AND DOWN.
 NPMR = 4
 PWR = 0.0, 8E9, 0.0
 TPMR = 0.000, 0.0001, 0.001, 0.0011

120MM T6 WITH 1 KJ/G ELECTRIC

IBHVC2.504

DATE

TIME

- GUN TUBE -

TYPE: 120MM GUN TEST CASE
GROOVE DIAMETER (M): 0.11999
TWIST (CALS/TURN): 99.0
SHELL THICKNESS (M): 0.000114
INITIAL SHELL TEMP (K): 293.

CHAMBER VOLUME (M3):
LAND DIAMETER (M):
BORE AREA (M2):
SHELL CP (J/KG-R):
AIR HD (M/M**2-R):

0.00995
0.11999
0.01131
460.3163
11.3682

TRAVEL (M): 4.75259
GROOVE/LAND RATIO (-): 1.000
HEAT-LOSS OPTION: 1
SHELL DENSITY (KG/M3): 7861.0920

- PROJECTILE -

TYPE: APFSDS

TOTAL WEIGHT (KG):

7.099

WEIGHT PREDICTOR OPTION: 0

- RESISTANCE -

AIR RESISTANCE OPTION: 1
RESISTIVE PRESSURE MULT INDEX: 3
1 TRAVEL (M) PRESSURE (MPA)
2 0.000 0.689
0.020 17.237

WALL HEATING FRACTION:
RESISTIVE FACTOR

0.000
1.000

FRICTION TABLE LENGTH: 4

- GENERAL -

MAX TIME STEP (S): 0.000050
PRINT OPTIONS: 1 2 1 0 2 1
GRADIENT MODEL: PIDDUCK-WENT

PRINT STEP (S):
STORE OPTION:

0.000050
0

MAX RELATIVE ERROR (-): 0.05000
CONSTANT-PRESSURE OPTION: 0

- RECOIL -

RECOIL OPTION: 0

TYPE: NONE

RECOILING WEIGHT (KG): 0.

- PRIMER -

TYPE: BENITE
COVOLUME (M3/KG): 1.0830E-03

GAMMA (-):
FLAME TEMP (K):

1.2500
2000.0

FORCE (J/KG): 635177.
WEIGHT (KG): 0.001574

 - CHARGE 1 -

TYPE: JA2 7P	GRAINS: 4805.1	7PF 0	HEIGHT (KG):	9.0000
EROSIVE COEFF (-):	CHARGE IGN CODE:	0.009144	CHARGE IGN AT (S):	0.00000E+00
GRAIN LENGTH (M):	GRAIN DIAMETER (M):	0.001880	PERF DIAMETER (M):	0.0000508
INNER WEB (M):	OUTER WEB (M):			

AT DEPTH (M):	PROPERTIES AT LAYER BOUNDARIES OF PERF SURFACES	PROPERTIES AT LAYER BOUNDARIES OF	END SURFACES
ADJACENT LAYER WT %:	1ST	2ND	3RD
DENSITY (KG/M3):	4TH		4TH
GAMMA (-):			
FORCE (J/KG):			
COVOLUME (M3/KG):			
FLAME TEMP (K):			
MEAN PRESSURES (MPA):			
MEAN PRESSURES (MPA):			
MEAN PRESSURES (MPA):			
BURNING RATES (M/S):			
BURNING RATES (M/S):			
BURNING RATES (M/S):			

AT DEPTH (M):	PROPERTIES AT LAYER BOUNDARIES OF LAT SURFACES
ADJACENT LAYER WT %:	1ST
DENSITY (KG/M3):	2ND
GAMMA (-):	3RD
FORCE (J/KG):	4TH
COVOLUME (M3/KG):	
FLAME TEMP (K):	
MEAN PRESSURES (MPA):	
MEAN PRESSURES (MPA):	
MEAN PRESSURES (MPA):	
BURNING RATES (M/S):	
BURNING RATES (M/S):	
BURNING RATES (M/S):	

TRAJECTORY VARIABLES: / 1/ TRAJ 1 TIME
 / 2/ TRAJ 1 TRAV
 / 3/ TRAJ 1 VEL
 / 4/ TRAJ 1 ACCL
 / 5/ TRAJ 1 BRCH
 / 6/ TRAJ 1 MEAN
 / 7/ TRAJ 1 BASE
 / 8/ TRAJ 1 EPMR
 / 9/ TRAJ 1 EENE
 /10/ TRAJ 1 Z(1)
 /11/ TRAJ 1 XBRN

INCHES
 FT/S
 GRAVITIES
 PSI
 PSI
 MATTS ELECTRIC
 JOULES ELECTRIC
 BURN RATE

	/ 1/	/ 2/	/ 3/	/ 4/	/ 5/	/ 6/	/ 7/	/ 8/	/ 9/	/10/	/11/
0.00000	0.00000	0.00000	0.00000	0.00000	29.574	29.574	29.574	0.00000	0.00000	0.00000	10.065
0.14212E-01	0.00000	0.00000	0.00000	0.00000	99.507	99.507	99.507	0.11370E+10	8079.5	0.40390E-04	19.232
SHOT-START PRESSURE ACHIEVED											
0.50000E-01	0.29462E-04	0.24966	564.64		925.71	811.47	604.26	0.40000E+10	0.10000E+06	0.32698E-03	58.936
BARREL RESISTANCE OVERCOME - PROJECTILE MOVING											
0.10000	0.70340E-03	2.5094	2452.0		3510.3	3077.0	2291.6	0.80000E+10	0.40000E+06	0.12544E-02	119.98
0.15000	0.38016E-02	8.5096	5032.7		7034.3	6183.6	4605.3	0.80000E+10	0.80000E+06	0.28496E-02	188.41
0.20000	0.11772E-01	18.783	7163.4		10826	9489.8	7067.6	0.80000E+10	0.12000E+07	0.51731E-02	255.79
0.25000	0.27245E-01	33.566	10644		14837	13006	9686.3	0.80000E+10	0.16000E+07	0.82524E-02	334.16
0.30000	0.53005E-01	53.117	13689		19121	16761	12483	0.80000E+10	0.20000E+07	0.12203E-01	416.93
0.35000	0.91990E-01	77.694	16892		23682	20759	15460	0.80000E+10	0.24000E+07	0.17063E-01	502.15
0.40000	0.14129	107.55	20245		28523	25002	18621	0.80000E+10	0.28000E+07	0.23876E-01	589.85
0.45000	0.22215	142.90	23736		33642	29490	21963	0.80000E+10	0.32000E+07	0.29687E-01	679.93
0.50000	0.31992	183.98	27348		39034	34216	25483	0.80000E+10	0.36000E+07	0.37544E-01	772.16
0.55000	0.44410	230.95	31063		44686	39170	29173	0.80000E+10	0.40000E+07	0.46498E-01	866.21
0.60000	0.59827	283.96	34853		50580	43337	33021	0.80000E+10	0.44000E+07	0.56599E-01	961.59
0.65000	0.78608	343.11	38688		56591	49694	37010	0.80000E+10	0.48000E+07	0.67896E-01	1057.7
0.70000	1.0114	409.15	43499		62984	55210	41119	0.30000E+10	0.52000E+07	0.80437E-01	1153.9
0.75000	1.2787	483.15	48523		69413	60846	45316	0.80000E+10	0.56000E+07	0.94265E-01	1249.3
0.80000	1.5928	565.33	53663		75921	66550	49564	0.80000E+10	0.60000E+07	0.10942	1342.8
0.85000	1.9587	655.84	58873		82440	72264	53820	0.80000E+10	0.64000E+07	0.12592	1433.4
0.90000	2.3815	754.75	64104		88994	77921	58033	0.80000E+10	0.68000E+07	0.14380	1519.9
0.95000	2.8661	862.07	69301		95198	83448	62149	0.80000E+10	0.72000E+07	0.16305	1601.0
1.0000	3.4176	977.37	73895		0.10127E+06	88767	66111	0.80000E+10	0.76000E+07	0.18366	1675.6
1.0500	4.0403	1099.4	77583		0.10633E+06	93194	69408	0.40000E+10	0.78000E+07	0.20558	1732.8
1.1000	4.7378	1226.3	79975		0.10960E+06	96072	71551	9533.2	0.80000E+07	0.22854	1762.6
1.1500	5.5124	1356.3	81547		0.11176E+06	97965	72961	0.00000	0.80000E+07	0.25226	1775.4
1.2000	6.3658	1488.5	82773		0.11345E+06	99446	74064	0.00000	0.80000E+07	0.27663	1780.9
1.2500	7.2990	1622.4	83650		0.11465E+06	0.10051E+06	74855	0.00000	0.80000E+07	0.30156	1779.2
1.3000	8.3129	1757.4	84181		0.11540E+06	0.10116E+06	75339	0.00000	0.80000E+07	0.32696	1770.7
1.3500	9.4080	1893.0	84378		0.11569E+06	0.10141E+06	75525	0.00000	0.80000E+07	0.35275	1756.0
1.3576	9.5817	1913.7	84380		0.11569E+06	0.10141E+06	75528	0.00000	0.80000E+07	0.35670	1753.2
LOCAL PRESSURE MAX DETECTED											
1.4000	10.585	2028.7	84261		0.11554E+06	0.10128E+06	75430	0.00000	0.80000E+07	0.37883	1735.6
1.4500	11.842	2164.0	83853		0.11500E+06	0.10081E+06	75077	0.00000	0.80000E+07	0.40511	1710.1
1.5000	13.181	2298.4	83182		0.11410E+06	0.10002E+06	74490	0.00000	0.80000E+07	0.43152	1680.4
1.5500	14.600	2431.5	82279		0.11288E+06	98951	73696	0.00000	0.80000E+07	0.45796	1647.0
1.6000	16.099	2563.0	81176		0.11139E+06	97645	72723	0.00000	0.80000E+07	0.48438	1610.8
1.6500	17.675	2692.6	79902		0.10967E+06	96136	71599	0.00000	0.80000E+07	0.51070	1572.3

120MM I6 WITH 1 KJ/G ELECTRIC

ISHVG2.504

DATE TIME

TRAJECTORY VARIABLES: / 1/ / 2/ / 3/ / 4/ / 5/ / 6/ / 7/ / 8/ / 9/ / 10/ / 11/

TRAJ 1 TIME
 TRAJ 1 TRAV
 TRAJ 1 VEL
 TRAJ 1 ACCL
 TRAJ 1 BRCH
 TRAJ 1 MEAN
 TRAJ 1 BASE
 TRAJ 1 EPWR
 TRAJ 1 EENE
 TRAJ 1 Z(1)
 TRAJ 1 XBRN

INCHES
 FT/S
 GRAVITIES
 PSI
 PSI
 PSI
 MATIS ELECTRIC
 JOULES ELECTRIC
 BURN RATE

/ 1/	/ 2/	/ 3/	/ 4/	/ 5/	/ 6/	/ 7/	/ 8/	/ 9/	/ 10/	/ 11/
1.7000	19.329	2820.0	78488.	0.10776E+06	94459.	70350.	0.00000	0.80000E+07	0.53686	1532.1
1.7500	21.059	2945.1	76963.	0.10569E+06	92649.	69002.	0.70000	0.80000E+07	0.56282	1490.9
1.8000	22.863	3067.6	75350.	0.10351E+06	90735.	67576.	0.00000	0.80000E+07	0.58852	1448.9
1.8500	24.740	3187.4	73674.	0.10124E+06	88745.	66094.	0.00000	0.80000E+07	0.61393	1406.8
1.9000	26.687	3304.6	71955.	98912.	86703.	64574.	0.00000	0.80000E+07	0.63902	1364.7
1.9500	28.704	3418.9	70210.	96548.	84631.	63030.	0.00000	0.80000E+07	0.66376	1323.0
2.0000	30.789	3530.5	68455.	94170.	82546.	61478.	0.00000	0.80000E+07	0.68814	1282.0
2.0500	32.940	3639.2	66701.	91795.	80464.	59927.	0.00000	0.80000E+07	0.71213	1241.8
2.1000	35.156	3745.1	64961.	89437.	78398.	58388.	0.00000	0.80000E+07	0.73572	1202.5
2.1500	37.434	3848.2	63242.	87109.	76357.	56868.	0.00000	0.80000E+07	0.75890	1164.3
2.2000	39.773	3948.6	61551.	84819.	74350.	55374.	0.00000	0.80000E+07	0.78168	1127.2
2.2500	42.172	4046.3	59894.	82576.	72384.	53909.	0.00000	0.80000E+07	0.80404	1091.4
2.3000	44.628	4141.3	58275.	80385.	70463.	52479.	0.00000	0.80000E+07	0.82599	1056.7
2.3500	47.141	4233.8	56697.	78250.	68591.	51085.	0.00000	0.80000E+07	0.84753	1023.3
2.4000	49.708	4323.7	55146.	76151.	66751.	49714.	0.00000	0.80000E+07	0.86841	871.12
2.4500	52.329	4411.1	53484.	73900.	64778.	48245.	0.00000	0.80000E+07	0.88875	716.08
2.5000	55.001	4495.7	51888.	71462.	62642.	46654.	0.00000	0.80000E+07	0.90861	543.06
2.5500	57.723	4577.4	49831.	68947.	60437.	45011.	0.00000	0.80000E+07	0.92822	588.09
2.6000	60.493	4656.1	47978.	66434.	58234.	43371.	0.00000	0.80000E+07	0.94752	504.90
2.6500	63.310	4731.8	46154.	63961.	56066.	41756.	0.00000	0.80000E+07	0.96661	450.44
2.7000	66.171	4804.6	44376.	61549.	53952.	40182.	0.00000	0.80000E+07	0.98591	402.90
2.7500	69.075	4874.6	42653.	59212.	51903.	38657.	0.00000	0.80000E+07	0.99491	361.05
2.8000	72.020	4941.9	40990.	56958.	49928.	37184.	0.00000	0.80000E+07	0.99613	323.98
2.8500	75.005	5006.5	39392.	54791.	48028.	35770.	0.00000	0.80000E+07	0.96156	291.00
2.9000	78.027	5068.6	37860.	52714.	46207.	34414.	0.00000	0.80000E+07	0.96629	261.56
2.9500	81.086	5128.3	36394.	50726.	44465.	33116.	0.00000	0.80000E+07	0.97040	235.43
3.0000	84.181	5185.8	34992.	48827.	42800.	31876.	0.00000	0.80000E+07	0.97396	211.53
3.0500	87.309	5241.0	33634.	47014.	41211.	30693.	0.00000	0.80000E+07	0.97704	190.23
3.1000	90.470	5294.1	32383.	45291.	39701.	29568.	0.00000	0.80000E+07	0.97978	171.05
3.1500	93.661	5345.2	31175.	43655.	38266.	28500.	0.00000	0.80000E+07	0.98224	153.74
3.2000	96.883	5394.4	30027.	42101.	36904.	27485.	0.00000	0.80000E+07	0.98446	138.10
3.2500	100.13	5441.8	28937.	40525.	35611.	26522.	0.00000	0.80000E+07	0.98646	123.97
3.3000	103.41	5487.5	27901.	38222.	34381.	25606.	0.00000	0.80000E+07	0.98825	111.06
3.3500	106.72	5531.6	26916.	37889.	33217.	24736.	0.00000	0.80000E+07	0.98986	99.365
3.4000	110.05	5574.2	25978.	36621.	32101.	23908.	0.00000	0.80000E+07	0.99130	88.723
3.4500	113.41	5615.2	25084.	35414.	31045.	23120.	0.00000	0.80000E+07	0.99259	79.023
3.5000	116.79	5654.9	24236.	34265.	30036.	22370.	0.00000	0.80000E+07	0.99373	70.169
3.5500	120.19	5693.2	23427.	33171.	29076.	21655.	0.00000	0.80000E+07	0.99475	62.078
3.6000	123.62	5730.3	22655.	32127.	28162.	20974.	0.00000	0.80000E+07	0.99565	54.676

20MM T6 WITH 1 KJ/G ELECTRIC

IBHVG2.504

DATE

TIME

TRAJECTORY VARIABLES: / 1/ TRAJ 1 TIME
 / 2/ TRAJ 1 TRAV
 / 3/ TRAJ 1 VEL
 / 4/ TRAJ 1 ACCL
 / 5/ TRAJ 1 BRCH
 / 6/ TRAJ 1 MEAN
 / 7/ TRAJ 1 BASE
 / 8/ TRAJ 1 EPWR
 / 9/ TRAJ 1 EEME
 /10/ TRAJ 1 Z(1)
 /11/ TRAJ 1 XBRN

INCHES
 FT/S
 GRAVITIES
 PSI
 PSI
 WATTS ELECTRIC
 JOULES ELECTRIC
 BURN RATE

	/ 1/	/ 2/	/ 3/	/ 4/	/ 5/	/ 6/	/ 7/	/ 8/	/ 9/	/10/	/11/
3.6500	127.07	5766.1	21919.	31133.	27290.	20325.	0.00000	0.80000E+07	0.80000E+07	0.99644	47.897
3.7000	130.54	5800.8	21216.	30184.	26458.	19705.	0.00000	0.80000E+07	0.80000E+07	0.99713	41.682
3.7500	134.03	5834.4	20546.	28278.	25644.	19114.	0.00000	0.80000E+07	0.80000E+07	0.99773	35.979
3.8000	137.54	5867.0	19905.	26412.	24805.	18549.	0.00000	0.80000E+07	0.80000E+07	0.99823	30.740
3.8500	141.07	5898.5	19292.	24585.	24180.	18009.	0.00000	0.80000E+07	0.80000E+07	0.99869	25.924
3.9000	144.62	5929.0	18706.	22794.	23487.	17492.	0.00000	0.80000E+07	0.80000E+07	0.99906	21.494
3.9500	148.19	5958.7	18145.	21037.	22823.	16988.	0.00000	0.80000E+07	0.80000E+07	0.99936	17.416
4.0000	151.77	5987.4	17607.	19312.	22188.	16525.	0.00000	0.80000E+07	0.80000E+07	0.99960	13.659
4.0500	155.37	6015.3	17093.	17618.	21579.	16072.	0.00000	0.80000E+07	0.80000E+07	0.99979	10.195
4.1000	158.99	6042.4	16589.	16018.	20996.	15637.	0.00000	0.80000E+07	0.80000E+07	0.99992	7.0007
4.1500	162.62	6068.8	16126.	14415.	20437.	15221.	0.00000	0.80000E+07	0.80000E+07	1.00000	4.0530
4.2000	166.27	6094.3	15672.	12812.	19900.	14821.	0.00000	0.80000E+07	0.80000E+07	1.00000	1.3316
4.2260	168.17	6107.3	15443.	11612.	19430.	14620.	0.00000	0.80000E+07	0.80000E+07	1.00000	0.31865E-04
PROPELLANT 1 BURNED OUT											
4.2500	169.93	6119.2	15236.	10415.	19085.	14438.	0.00000	0.80000E+07	0.80000E+07	1.00000	0.31865E-04
4.3000	173.61	6143.4	14817.	9215.	18692.	14070.	0.00000	0.80000E+07	0.80000E+07	1.00000	0.31865E-04
4.3500	177.31	6166.9	14416.	8011.	18318.	13717.	0.00000	0.80000E+07	0.80000E+07	1.00000	0.31865E-04
4.4000	181.01	6189.7	14031.	6803.	17963.	13379.	0.00000	0.80000E+07	0.80000E+07	1.00000	0.31865E-04
4.4500	184.73	6212.0	13661.	5595.	17627.	13054.	0.00000	0.80000E+07	0.80000E+07	1.00000	0.31865E-04
4.4816	187.11	6225.9	13433.	4388.	17298.	12853.	0.00000	0.80000E+07	0.80000E+07	1.00000	0.31865E-04

PROJECTILE EXIT

120MM 26 WITH 1 KJ/G ELECTRIC

1BHV62.504

DATE

TIME

CONDITIONS AT: PMAZ MUZZLE

TIME (MS): 1.358 4.982
 TRAVEL (M): 0.2434 4.7526
 VELOCITY (M/S): 583.30 1897.66
 ACCELERATION (G): 84386. 13433.
 BRECH PRESS (MPA): 797.6605 135.7855
 MEAN PRESS (MPA): 699.2045 118.9903
 BASE PRESS (MPA): 520.7457 88.6203
 MEAN TEMP (K): 4826 2467.
 Z CHARGE 1 (-): 0.357 1.000

ENERGY BALANCE SUMMARY

	JOULES	0
ELECTRICAL ENERGY:	8000001.	16.50
CHEMICAL ENERGY:	40494540.	83.50
TOTAL ENERGY:	48494540.	100.00
(1) INTERNAL GAS:	29387890.	60.60
(2) WORK AND LOSSES:	19106650.	39.40
(A) PROJECTILE KINETIC:	12781610.	26.36
(B) GAS KINETIC:	4380237.	9.03
(C) PROJECTILE ROTATIONAL:	6436.	0.01
(D) FRICTIONAL WORK TO TUBE:	0.	0.00
(E) OTHER FRICTIONAL WORK:	44183.	0.09
(F) WORK DONE AGAINST AIR:	186391.	0.38
(G) HEAT CONVECTED TO BORE:	1707790.	3.52
(H) RECOIL ENERGY:	0.	0.00

LOADING DENSITY (KG/M³): 804.425
 CHARGE WT/PROJECTILE WT: 1.127
 PIEZOMETRIC EFFICIENCY: 0.298
 ELECTRICAL ENHANCEMENT FACTOR: 1.598
 EXPANSION RATIO: 6.403

B.3. SAMPLE CASE 3

Here, sample case 2 has been modified with the addition of propellant burn rate control. The burn rate has been adjusted to produce a constant-breech-pressure case. The gas generation rate table appears in the SETC deck below, after the electrical power input deck.

The table was constructed incrementally, by performing a series of runs, and adjusting each data point, working from left to right, to smooth out the pressure-versus-time trace. Note that this could not have been done with a model which assumes burn rate is a function of pressure alone. Over the long, flat region, the gas generation rate varies from 800 to 4,000 kg/s, even though the mean pressure, on which it "depends," remains nearly constant.

The input deck:

```
SCOMP1
SIMPLIFIED IBHVO2 BENCHMARK TEST CASE 6
WITH 5.1 MS FLAT ELECTRIC PULSE
CONTAINING A TOTAL OF 1KJ ELECTRIC PER GRAM OF PROPELLANT
PROPELLANT BURN RATE TAILORED FOR FLAT PRESSURE PULSE

SINFO
PUN = 'T6, . KJ/G ELECTRIC, DESIGNER BURN RATE' DELT = 5E-6 DELP = 5E-5
CRAD = 2          POPT = 1,2,1,0,2      SOPT = 0
EPS = 0.001

SHEAT
TSHL = 0.0001143      CSHL = 460.3143186      RSHL = 7861.0916
TWAL = 293           HO = 11.348218      HL = 1

SGUN
NAME = '120MM GUN TEST CASP'      CHAM = 0.009946948      ORVE = 0.1199896
LAND = 0.1199896      G/L = 1.          TRAV = 4.752594
TWST = 99

SPROJ
NAME = 'APFSBS'      PRMT = 7.09872

SCOMP
'PDIS' VALUES USED WITH PARAMETRIC PRINT OPTION POPT(5)-2
SPDIS
SHOW='MAX' DECK='OUT' DIV=6894.757
SPDIS
SHOW='CHMT' DECK='PROP' NTH=2 DIV=0.45359237
SPDIS
SHOW='U'AM' DECK='PROP' NTH=2 DIV=0.0254
SPDIS
SHOW='PD' DECK='PROP' NTH=2 DIV=0.0254
SPDIS
SHOW='WEB' DECK='PROP' NTH=2 DIV=.0254
SPDIS
SHOW='VMU2' DECK='OUT' DIV=0.3048
SPDIS
SHOW='M' (7)' DECK='OUT'
SPDIS
SHOW='LDEN' DECK='OUT'

SRES1
NPTS = 4          AIR = 1
TRAV = 0, 0.02022, 0.0762, 4.7490
PRES = 0.6894757, 17.2368925, 0.6894757, 0.6894757
```

```

STDIS SHOW='TIME'
STDIS SHOW='TRAV' DIV=.0254 REMK='INCHES'
STDIS SHOW='VEL' MULT=3.2808333 REMK='FT/S'
STDIS SHOW='ACCL' REMK='GRAVITIES'
STDIS SHOW='BRCH' DIV=6894.757 REMK='PSI'
STDIS SHOW='MEAN' DIV=6894.757 REMK='PSI'
STDIS SHOW='BASE' DIV=6894.757 REMK='PSI'
STDIS SHOW='EPWR' REMK='WATTS ELECTRIC'
STDIS SHOW='ECNE' REMK='JOULES ELECTRIC'
STDIS SHOW='Z(1)'
STDIS SHOW='XBRN' REMK='BURN RATE'

$RECO NAME = 'NONE' RECO = 0 RCWT = 0

$PRIM NAME = 'BENITE' CHMT = 0.001573966
      CAMA = 1.25 FORC = 635176.7375
      COV = 0.001083819 TTMP = 2000

$PROP NAME = 'JA2 7p' CHMT = 0.0 GRAN = '7PF'
      RHO = 1586.611868 CAMA = 1.2257 FORC = 1142277.932
      COV = 0.00092778 TEMP = 3400 EROS = 0.0000000
      NTBL=4
      PR4L= 13.789514, 27.579028, 68.94757, 172.368925
      BR4L= 0.02667, 0.038608, 0.074422, 0.166624
      LEN = 0.0163322 DIAM = 0.010668 PD = 0.000508
      WI = 0.0019304 WO = 0.0018796

$COMH DEFINE A TRAPEZOIDAL ELECTRIC POWER PULSE
      100 MEGAWATTS FOR 1 MILLISECOND,
      WITH 100 MICROSECOND LINEAR RAMP UP AND DOWN.

$ETC NPWR = 4
      PWR = 0.0, 8E9, 8E9, 0.0
      TPWR = 0.000, 0.0001, 0.001, 0.0011
      NBRN = 9
      TBRN = 0.000, 0.0001, 0.0005, 0.001, 0.0015, 0.002, 0.0025, 0.003, 0.004
      BRN = 10.0, 60.0, 200.0, 500.0, 1750.0, 2500.0, 3000.0, 4500.0, 5000.0

$END

```

.....
Produced the following output:

1 --> SCORR SIMPLIFIED IBAVG2 BENCHMARK TEST CASE 6
 2 --> WITH A 1 MS FLAT ELECTRIC PULSE
 3 --> CONTAINING A TOTAL OF 1KJ ELECTRIC PER GRAM OF PROPELLANT
 4 --> PROPELLANT BURN RATE TAILORED FOR FLAT PRESSURE PULSE
 5 -->
 6 --> \$INFO
 7 --> MUM = .76, 1 M/G ELECTRIC, DESIGNER BURN RATE, DELT = 5E-6 DELP = 5E-5
 8 --> GRAV = 2 POPT = 1.2,1.0,2 SOPT = 0
 9 --> EPS = 0.001
 10 --> SWEAT
 11 --> TSHL = 0.0001143 CSHL = 460.3163186 RSHL = 7861.0916
 12 --> TWAL = 293 HO = 11.348218 HL = 1
 13 --> SGLM
 14 --> NAME = '120MM GUM TEST CASE' CLAM = 0.009946948 GRVE = 0.1199896
 15 --> LAMD = 0.1199896 G/L = 1. TRAV = 4.752594
 16 --> TRST = 99
 17 --> \$PROJ NAME = 'APTSOS' PRMT = 7.09872
 18 -->
 19 --> SCORR
 20 --> 'POIS' VALUES USED WITH PARAMETRIC PRINT OPTION PORT(5)-2
 21 --> \$POIS
 22 --> \$POIS 'PMALY' DECE-'OUT' DIV-6894.757
 23 --> \$POIS
 24 --> \$POIS 'CBMT' DECE-'PROP' MTR-2 DIV-0.45359237
 25 --> \$POIS
 26 --> \$POIS 'DIMY' DECE-'PROP' MTR-2 DIV-0.0254
 27 --> \$POIS
 28 --> \$POIS 'PD' DECE-'PROP' MTR-2 DIV-0.0254
 29 --> \$POIS
 30 --> \$POIS 'WED' DECE-'PROP' MTR-2 DIV-0.0254
 31 --> \$POIS
 32 --> \$POIS 'WEEZ' DECE-'OUT' DIV-0.1048
 33 --> \$POIS
 34 --> \$POIS 'ZHU(2)' DECE-'OUT'
 35 --> \$POIS
 36 --> \$POIS
 37 --> \$POIS
 38 --> \$POIS
 39 --> \$RESI
 40 --> MPTS = 4 AIR = 1
 41 --> TRAV = C. 0.02032, 0.0762, 4.7498
 42 --> PRES = 0.6894757, 17.2368925, 0.6894757, 0.6894757
 43 -->
 44 --> \$TDIS
 45 --> \$TDIS
 46 --> \$TDIS
 47 --> \$TDIS
 48 --> \$TDIS
 49 --> \$TDIS
 50 --> \$TDIS

CARD 51 --> STD15 SHON--ACCL' REMK--GRAVITIES'
 CARD 52 --> STD15 SHON--BRCH' DIV-6894.757 REMK--PSI'
 CARD 53 --> STD15 SHON--MEAN' DIV-6894.757 REMK--PSI'
 CARD 54 --> STD15 SHON--BASE' DIV-6894.757 REMK--PSI'
 CARD 55 --> STD15 SHON--CPWR' REMK--WATTS ELECTRIC'
 CARD 56 --> STD15 SHON--EDNE' REMK--JOULES ELECTRIC'
 CARD 57 --> STD15 SHON--Z(1)'
 CARD 58 --> STD15 SHON--XDRM' REMK--BURN RATE'
 CARD 59 --> STD15
 CARD 60 --> STD15
 CARD 61 --> STD15
 CARD 62 --> STD15
 CARD 63 --> STD15
 CARD 64 --> STD15
 CARD 65 --> STD15
 CARD 66 --> STD15
 CARD 67 --> STD15
 CARD 68 --> STD15
 CARD 69 --> STD15
 CARD 70 --> STD15
 CARD 71 --> STD15
 CARD 72 --> STD15
 CARD 73 --> STD15
 CARD 74 --> STD15
 CARD 75 --> STD15
 CARD 76 --> STD15
 CARD 77 --> STD15
 CARD 78 --> STD15
 CARD 79 --> STD15
 CARD 80 --> STD15
 CARD 81 --> STD15
 CARD 82 --> STD15
 CARD 83 --> STD15
 CARD 84 --> STD15
 CARD 85 --> STD15
 CARD 86 --> STD15
 CARD 87 --> STD15
 CARD 88 --> STD15
 CARD 89 --> STD15
 CARD 90 --> STD15
 CARD 91 --> STD15
 CARD 92 --> STD15
 CARD 93 --> STD15
 CARD 94 --> STD15
 CARD 95 --> STD15

NAME - 'BURN' RECO - 0 NCWT - 0
 NAME - 'BENITE' CHWT - 0.001573966
 CWR - 1581.611868 GAWR - 1.2257
 COW - 0.000987778 TDRP - 3400
 NAME - 'JAZ 7P' CHWT - 0.0
 RW - 1581.611868 GAWR - 1.2257
 COW - 0.000987778 TDRP - 3400
 PRAL- 13.789514, 27.579028, 68.94757, 172.368925
 BRAL- 0.02667, 0.038608, 0.078422, 0.166828
 LER - 0.0163322 DIMM - 0.010468 PD - 0.000508
 WI - 0.0019304 WO - 0.0018736
 NAME - 'GRAM' CHWT - 0.0
 RW - 1581.611868 GAWR - 1.2257
 COW - 0.000987778 TDRP - 3400
 PRAL- 13.789514, 27.579028, 68.94757, 172.368925
 BRAL- 0.02667, 0.038608, 0.078422, 0.166828
 LER - 0.0163322 DIMM - 0.010468 PD - 0.000508
 WI - 0.0019304 WO - 0.0018736

DEFINE A TRIANGULAR ELECTRIC POWER PULSE
 100 MICROSECONDS FOR 1 MILLISECOND,
 WITH 100 MICROSECOND LINEAR RAMP'S UP AND DOWN.
 NAME - 4
 PWR - 0.0, 8E9, 0.0
 TDRP - 0.000, 0.0001, 0.001, 0.0011
 NAME - 5
 TDRP - 0.000, 0.0001, 0.0005, 0.001, 0.0015, 0.002, 0.0025, 0.003, 0.004
 NAME - 10
 TDRP - 0.0, 60.0, 200.0, 500.0, 1750.0, 2500.0, 3000.0, 4500.0, 5000.0

6. . KJ/G ELECTRIC, DESIGNER BURN RATE

IBHVC2.504

DATE

TIME

--- GUN TYPE ---

TYPE: 20MM GUN TEST CASE
GROOVE DIAMETER (M): 0.11999
TWIST (CAL/TURN): 99.0
SHELL THICKNESS (M): 0.000114
INITIAL SHELL TEMP (K): 293.

CHAMBER VOLUME (M3):
LAND DIAMETER (M):
BORE AREA (M2):
SHELL CR (1/RC-M):
AIR NO (M/M**2-M):

0.00995
0.11999
0.01131
460.3163
11.3482

TRAVEL (M): 4.75259
GROOVE/LAND RATIO (-): 1.000
HEAT-LOSS OPTION: 1
SHELL DENSITY (KG/M3): 7861.0918

--- PROJECTILE ---

TYPE: A7FSOS

TOTAL WEIGHT (KG):

7.099

WEIGHT PREDICTOR OPTION: 0

--- RESISTANCE ---

AIR RESISTANCE OPTION: 1
RESISTIVE PRESSURE MULTI INDEX: 3

WALL HEATING FRACTION:
RESISTIVE FACTOR

0.000
1.000

FRICTION TABLE LENGTH: 4

I TRAVEL (M) PRESSURE (MPA)
1 0.000 0.689
2 0.020 17.237

I TRAVEL (M) PRESSURE (MPA)
3 0.076 0.689

I TRAVEL (M) PRESSURE (MPA)
4 4.750 0.689

--- GENERAL ---

MAX TIME STEP (S): 0.000005
PRINT OPTIONS: 1 2 1 0 2 1
GRADIENT MODEL: P1D0UCC-KENT

PRINT STEP (S):
STORE OPTION:

0.000050
0

MAX RELATIVE ERROR (-): 0.00100
CONSTANT-PRESSURE OPTION: 0

--- RECOIL ---

RECOIL OPTION: 0

TYPE: NONE

RECOILING WEIGHT (KG): 0.

--- PRIMER ---

TYPE: BENITE
COVOLUME (M3/KG): 1.0838E-03

CANNA (-):
FLAME TEMP (K):

1.2500
2000.0

FORCE (17/KG): 635177.
WEIGHT (KG): 0.001576

 - CHARGE 1 -

TYPE: JAZ 7P
 EXPOSIVE COEFF (-): 0.000050
 GRAIN LENGTH (M): 0.016332
 INNER WEB (M): 0.001930

GRAINS:
 CHANGE ICM CODE: 4805.1 TPF 0
 GRAIN DIAMETER (M): 0.009144
 OUTER WEB (M): 0.001800

WEIGHT (KG): 8.0000
 CHANGE ICM AT (S): 0.00000E+00
 PERF DIAMETER (M): 0.000508

PROPERTIES AT LAYER BOUNDARIES OF PERF SURFACES

	1ST	2ND	3RD	4TH
AT DEPTH (M):	---	---	---	0.00000
ADJACENT LAYER WT %:	---	---	---	100.000
DENSITY (KG/ML):	---	---	---	1586.612
GAMMA (-):	---	---	---	1.2257
FORCE (J/KG):	---	---	---	1142278.
COVOLUME (M ³ /KG):	---	---	---	9.9278E-04
FLAME TEMP (K):	---	---	---	3400.0
MEAN PRESSURES (MPA):	---	---	---	13.790
MEAN PRESSURES (MPA):	---	---	---	27.579
MEAN PRESSURES (MPA):	---	---	---	68.948
MEAN PRESSURES (MPA):	---	---	---	172.369
BURNING RATES (M/S):	---	---	---	0.02667
BURNING RATES (M/S):	---	---	---	0.03861
BURNING RATES (M/S):	---	---	---	0.07442
BURNING RATES (M/S):	---	---	---	0.16662

PROPERTIES AT LAYER BOUNDARIES OF END SURFACES

	1ST	2ND	3RD	4TH
AT DEPTH (M):	---	---	---	0.00000
ADJACENT LAYER WT %:	---	---	---	100.000
DENSITY (KG/ML):	---	---	---	1586.612
GAMMA (-):	---	---	---	1.2257
FORCE (J/KG):	---	---	---	1142278.
COVOLUME (M ³ /KG):	---	---	---	9.9278E-04
FLAME TEMP (K):	---	---	---	3400.0
MEAN PRESSURES (MPA):	---	---	---	13.790
MEAN PRESSURES (MPA):	---	---	---	27.579
MEAN PRESSURES (MPA):	---	---	---	68.948
MEAN PRESSURES (MPA):	---	---	---	172.369
BURNING RATES (M/S):	---	---	---	0.02667
BURNING RATES (M/S):	---	---	---	0.03861
BURNING RATES (M/S):	---	---	---	0.07442
BURNING RATES (M/S):	---	---	---	0.16662

PROPERTIES AT LAYER BOUNDARIES OF LAT SURFACES

	1ST	2ND	3RD	4TH
AT DEPTH (M):	---	---	---	0.00000
ADJACENT LAYER WT %:	---	---	---	100.000
DENSITY (KG/ML):	---	---	---	1586.612
GAMMA (-):	---	---	---	1.2257
FORCE (J/KG):	---	---	---	1142278.
COVOLUME (M ³ /KG):	---	---	---	9.9278E-04
FLAME TEMP (K):	---	---	---	3400.0
MEAN PRESSURES (MPA):	---	---	---	13.790
MEAN PRESSURES (MPA):	---	---	---	27.579
MEAN PRESSURES (MPA):	---	---	---	68.948
MEAN PRESSURES (MPA):	---	---	---	172.369
BURNING RATES (M/S):	---	---	---	0.02667
BURNING RATES (M/S):	---	---	---	0.03861
BURNING RATES (M/S):	---	---	---	0.07442
BURNING RATES (M/S):	---	---	---	0.16662

16. J. K&C ELECTRIC. DESIGNER BURN RATE

TRAJECTORY VARIABLES: / 1/ TRAJ 1 TIME
 / 2/ TRAJ 1 TRAV
 / 3/ TRAJ 1 YCL
 / 4/ TRAJ 1 ACCL
 / 5/ TRAJ 1 BRCH
 / 6/ TRAJ 1 NCAN
 / 7/ TRAJ 1 BASE
 / 8/ TRAJ 1 EPWR
 / 9/ TRAJ 1 EPMC
 /10/ TRAJ 1 2(1)
 /11/ TRAJ 1 XORN

INCHES
 FT/SEC
 GRAVITIES
 PSI
 PSI
 WATTS ELECTRIC
 JOULES ELECTRIC
 BURN RATE

18HV62.504

TIME

DATE

/ 1/	/ 2/	/ 3/	/ 4/	/ 5/	/ 6/	/ 7/	/ 8/	/ 9/	/10/	/11/
0.00500	0.00000	0.00000	0.00000	0.00000	29.574	29.574	0.00000	0.00000	0.00000	10.000
0.1470E-01	0.00000	0.00000	0.00000	0.00000	100.02	100.02	0.11784E+10	8679.3	0.25194E-04	17.365
SWITCH START PRESSURE ACHIEVED										
0.5000E-01	0.27739E-04	0.33379	534.44		984.45	577.79	0.40000E+10	0.10000E+06	0.14062E-03	35.000
BARREL RESISTANCE OVERCOME - PROJECTILE MOVING										
0.10000	0.54482E-03	2.1661	3204.5		2900.2	2159.7	0.80000E+10	0.40000E+06	0.43750E-03	60.000
0.15000	0.25713E-02	7.9459	6504.2		5701.4	4285.9	0.80000E+10	0.80000E+06	0.8719E-03	77.500
0.20000	0.10947E-01	17.264	9823.3		9721.5	6341.7	0.60000E+10	0.12000E+07	0.14062E-02	95.000
0.25000	0.25035E-01	59.724	3255.4		12987.	11349.	0.80000E+10	0.18000E+07	0.20347E-02	112.50
0.30000	0.48068E-01	87.079	11370.		14200.	10576.	0.80000E+10	0.20000E+07	0.28125E-02	130.00
0.35000	0.82265E-01	67.573	1784.1		19454.	14576.	0.80000E+10	0.24000E+07	0.36797E-02	147.50
0.40000	0.12982	91.368	16049.		22730.	14838.	0.35000E+10	0.28000E+07	0.46542E-02	165.00
0.45000	0.19289	119.18	18236.		25285.	15864.	0.80000E+10	0.32000E+07	0.57422E-02	182.50
0.50000	0.27353	150.72	20326.		28218.	18664.	0.80000E+10	0.36000E+07	0.69375E-02	200.00
0.55000	0.37340	184.54	22330.		32418.	21183.	0.80000E+10	0.40000E+07	0.82812E-02	230.00
0.60000	0.49561	222.02	24237.		36916.	23233.	0.80000E+10	0.44000E+07	0.98125E-02	260.00
0.65000	0.64081	262.66	26030.		41761.	25270.	0.80000E+10	0.48000E+07	0.11531E-01	290.00
0.70000	0.81112	305.69	27740.		46607.	27263.	0.80000E+10	0.52000E+07	0.13431E-01	320.00
0.75000	1.0282	352.14	29150.		51470.	29201.	0.80000E+10	0.56000E+07	0.15521E-01	350.00
0.80000	1.0488	361.83	30570.		56276.	29530.	0.80000E+10	0.58751E+07	0.15945E-01	355.63
LOCAL PRESSURE MAX DETECTED										
0.80000	1.2348	402.67	32510.		61593.	31071.	0.80000E+10	0.60000E+07	0.17013E-01	380.00
LOCAL PRESSURE MIN CALCULATED										
0.85000	1.3923	456.64	34834.		67228.	32859.	0.80000E+10	0.64000E+07	0.20281E-01	410.00
0.90000	1.5736	514.71	37086.		73228.	34554.	0.80000E+10	0.68000E+07	0.22938E-01	440.00
0.95000	1.7807	574.14	39284.		79363.	36143.	0.80000E+10	0.72000E+07	0.25781E-01	470.00
1.00000	2.0154	643.06	41360.		85823.	37618.	0.80000E+10	0.76000E+07	0.28812E-01	500.00
1.05000	2.2825	708.53	42946.		91822.	38595.	0.40000E+10	0.79000E+07	0.32378E-01	525.00
1.10000	2.5767	778.44	43240.		97325.	39730.	0.00000	0.80000E+07	0.36625E-01	550.00
1.15000	1.8148	847.80	42967.		10237.	38489.	0.00000	0.80000E+07	0.41703E-01	575.00
LOCAL PRESSURE MAX DETECTED										
1.20000	4.3440	916.74	42758.		10675.	38706.	0.00000	0.80000E+07	0.47563E-01	1000.0
1.25000	4.8146	985.40	42620.		10877.	38776.	0.00000	0.80000E+07	0.54205E-01	1125.0
1.30000	5.3264	1033.9	42520.		10958.	38098.	0.00000	0.80000E+07	0.61625E-01	1250.0
1.35000	6.1792	1122.2	42481.		10933.	38069.	0.00000	0.80000E+07	0.43828E-01	1375.0
1.40000	6.7910	1132.5	42482.		10933.	38069.	0.00000	0.80000E+07	0.71130E-01	1393.8
LOCAL PRESSURE MIN DETECTED										
1.40000	6.0730	1190.6	42456.		10936.	38084.	0.00000	0.90000E+07	0.78812E-01	1500.0
1.45000	7.0079	1258.0	42555.		10936.	38140.	0.00000	0.30000E+07	0.86578E-01	1625.0

16. 1 KJ/C ELECTRIC. DESIGNER BURN RATE

TRAJECTORY VARIABLES:											INCHES		GRAVITIES		PSI		WATTS ELECTRIC		JOULES ELECTRIC		BURN RATE				
1/	2/	3/	4/	5/	6/	7/	8/	9/	10/	11/	12/	13/	14/	15/	16/	17/	18/	19/	20/	21/	22/	23/	24/		
1.5000	1.5000	1.6000	1.6500	1.7000	1.7500	1.8000	1.8500	1.9000	1.9500	2.0000	2.0114	2.0114	2.0114	2.0114	2.0114	2.0114	2.0114	2.0114	2.0114	2.0114	2.0114	2.0114	2.0114	2.0114	
8.3038	9.2010	10.059	10.959	11.900	12.883	13.907	14.973	16.081	17.230	18.421	19.657	20.939	22.267	23.643	25.067	26.539	28.061	29.633	31.255	32.927	34.649	36.421	38.243	40.115	
1327.5	1396.2	1465.1	1534.1	1603.3	1672.5	1741.8	1811.2	1880.6	1950.0	2019.4	2088.8	2158.2	2227.6	2297.0	2366.4	2435.8	2505.2	2574.6	2644.0	2713.4	2782.8	2852.2	2921.6	2991.0	3060.4
42656.	42767.	42862.	42942.	43008.	43061.	43102.	43132.	43152.	43164.	43167.	43166.	43154.	43116.	43057.	42979.	42884.	42774.	42652.	42519.	42376.	42226.	42068.	41901.	41726.	41544.
50565.	50723.	50860.	50975.	51072.	51151.	51215.	51263.	51298.	51322.	51335.	51336.	51326.	51283.	51211.	51114.	50993.	50853.	50696.	50524.	50340.	50145.	49938.	49721.	49494.	49258.
51336.	51475.	51594.	51696.	51781.	51850.	51906.	51948.	51979.	52000.	52011.	52012.	52003.	51966.	51903.	51817.	51712.	51589.	51451.	51300.	51139.	50968.	50784.	50587.	50378.	50157.
30233.	30337.	30426.	30502.	30562.	30616.	30659.	30689.	30712.	30728.	30736.	30737.	30730.	30702.	30656.	30592.	30513.	30422.	30319.	30207.	30087.	29959.	29823.	29679.	29528.	29370.
0.00000E+07	0.00000E+07	0.00000E+07	0.00000E+07	0.00000E+07	0.00000E+07	0.00000E+07	0.00000E+07	0.00000E+07	0.00000E+07	0.00000E+07	0.00000E+07	0.00000E+07	0.00000E+07	0.00000E+07	0.00000E+07	0.00000E+07	0.00000E+07	0.00000E+07	0.00000E+07	0.00000E+07	0.00000E+07	0.00000E+07	0.00000E+07	0.00000E+07	0.00000E+07
0.99125E-01	0.11030	0.12194	0.13403	0.14662	0.15967	0.17319	0.18717	0.20162	0.21655	0.23194	0.23550	0.24772	0.26381	0.28294	0.31397	0.34897	0.38897	0.43494	0.48822	0.54994	0.62022	0.70022	0.79022	0.89022	1.00022
1750.0	1825.0	1900.0	1975.0	2050.0	2125.0	2200.0	2275.0	2350.0	2425.0	2500.0	2511.4	2550.0	2600.0	2650.0	2700.0	2750.0	2800.0	2850.0	2900.0	2950.0	3000.0	3050.0	3100.0	3150.0	3200.0

T5, 1 KJ/G ELECTRIC, DESIGNER BUJN RATE

TRAJECTORY VARIABLES:											INCHES											FT/S											GRAVITIES											PSI											WATTS ELECTRIC											JOULES ELECTRIC											BURN RATE											DATE											TIME																																																																																																																																																																																																																																																																																																																			
/ 1/	' 2/	/ 3/	/ 4/	/ 5/	/ 6/	/ 7/	/ 8/	/ 9/	/ 10/	/ 11/	/ 1/	/ 2/	/ 3/	/ 4/	/ 5/	/ 6/	/ 7/	/ 8/	/ 9/	/ 10/	/ 11/	/ 1/	/ 2/	/ 3/	/ 4/	/ 5/	/ 6/	/ 7/	/ 8/	/ 9/	/ 10/	/ 11/	/ 1/	/ 2/	/ 3/	/ 4/	/ 5/	/ 6/	/ 7/	/ 8/	/ 9/	/ 10/	/ 11/	/ 1/	/ 2/	/ 3/	/ 4/	/ 5/	/ 6/	/ 7/	/ 8/	/ 9/	/ 10/	/ 11/	/ 1/	/ 2/	/ 3/	/ 4/	/ 5/	/ 6/	/ 7/	/ 8/	/ 9/	/ 10/	/ 11/	/ 1/	/ 2/	/ 3/	/ 4/	/ 5/	/ 6/	/ 7/	/ 8/	/ 9/	/ 10/	/ 11/																																																																																																																																																																																																																																																																																																																																										
3.2500	61.568	3731.6	43090.	59222.	52175.	38858.	0.00000	0.80000E+07	0.78076	4625.0	3.3000	63.828	3800.9	43103.	59554.	52208.	38880.	0.00000	0.80000E+07	0.80375	4650.0	3.3292	65.167	3843.4	43100.	59559.	52208.	38883.	0.00000	0.80000E+07	0.80375	4664.6	3.3500	66.129	3870.2	43094.	59557.	52206.	38881.	0.00000	0.80700E+07	0.80388	4675.0	3.4000	68.472	3939.5	43063.	59532.	52184.	38865.	0.00000	0.80000E+07	0.80618	4700.0	3.4500	70.856	4008.8	43013.	59481.	52139.	38832.	0.00000	0.80000E+07	0.80763	4725.0	3.5000	73.282	4077.9	42948.	59407.	52074.	38783.	0.00000	0.80000E+07	0.82724	4750.0	3.5500	75.750	4146.9	42867.	59312.	51991.	38721.	0.00000	0.80000E+07	0.95701	4775.0	3.6000	78.259	4215.6	42771.	59198.	51891.	38647.	0.00000	0.80000E+07	0.98693	4800.0	3.6247	79.511	4249.7	42625.	59007.	51724.	38522.	0.00000	0.80000E+07	1.00000	0.00000	3.6500	80.809	4284.2	41827.	59223.	50774.	37815.	0.00000	0.80000E+07	1.00000	0.00000	3.7000	83.199	4350.2	40309.	59664.	48969.	36471.	0.00000	0.80000E+07	1.00000	0.00000	3.7500	86.028	4413.9	38865.	53906.	47252.	35192.	0.00000	0.80000E+07	1.00000	0.00000	3.8000	88.695	4475.3	37490.	52042.	45618.	33975.	0.00000	0.80000E+07	1.00000	0.00000	3.8500	91.398	4534.5	36182.	50268.	44063.	32617.	0.00000	0.80000E+07	1.00000	0.00000	3.9000	94.136	4591.7	34936.	48579.	42583.	31714.	0.00000	0.80000E+07	1.00000	0.00000	3.9500	96.908	4647.0	33749.	46971.	41173.	30664.	0.00000	0.80000E+07	1.00000	0.00000	4.0000	99.712	4700.4	32618.	45438.	39830.	29664.	0.00000	0.80000E+07	1.00000	0.00000	4.0500	102.55	4751.9	31539.	43978.	38549.	28710.	0.00000	0.80000E+07	1.00000	0.00000	4.1000	105.41	4801.9	30511.	42505.	37329.	27801.	0.00000	0.80000E+07	1.00000	0.00000	4.1500	108.31	4850.1	29530.	41256.	36164.	26934.	0.00000	0.80000E+07	1.00000	0.00000	4.2000	111.23	4896.9	28593.	39988.	35052.	26108.	0.00000	0.80000E+07	1.00000	0.00000	4.2500	114.19	4942.2	27698.	38777.	33977.	25316.	0.00000	0.80000E+07	1.00000	0.00000	4.3000	117.16	4986.0	26843.	37621.	32977.	24560.	0.00000	0.80000E+07	1.00000	0.00000	4.3500	120.17	5028.5	26025.	36515.	32008.	23839.	0.00000	0.80000E+07	1.00000	0.00000	4.4000	123.20	5069.8	25242.	35458.	31081.	23148.	0.00000	0.80000E+07	1.00000	0.00000	4.4500	126.25	5109.8	24495.	34458.	30195.	22488.	0.00000	0.80000E+07	1.00000	0.00000	4.5000	129.33	5148.6	23778.	33478.	29346.	21856.	0.00000	0.80000E+07	1.00000	0.00000	4.5500	132.43	5186.3	23092.	32551.	28533.	21250.	0.00000	0.80000E+07	1.00000	0.00000	4.6000	135.55	5222.9	22434.	31662.	27754.	20670.	0.00000	0.80000E+07	1.00000	0.00000	4.6500	138.70	5258.5	21803.	30810.	27007.	20114.	0.00000	0.80000E+07	1.00000	0.00000	4.7000	141.86	5293.1	21198.	29993.	26291.	19581.	0.00000	0.80000E+07	1.00000	0.00000	4.7500	145.05	5326.7	20617.	29209.	25604.	19069.	0.00000	0.80000E+07	1.00000	0.00000	4.8000	148.26	5359.4	20059.	28457.	24944.	18578.	0.00000	0.80000E+07	1.00000	0.00000	4.8500	151.48	5391.3	19523.	27857.	24310.	18106.	0.00000	0.80000E+07	1.00000	0.00000	4.9000	154.72	5422.2	19008.	27309.	23701.	17652.	0.00000	0.80000E+07	1.00000	0.00000	4.9500	157.99	5452.4	18513.	26771.	23116.	17216.	0.00000	0.80000E+07	1.00000	0.00000

T6. 1 MJ/G ELECTRIC, DESIGNER BURN RATE		1BHV02.504										
TRAJECTORY VARIABLES:		TIME										
		DATE										
		TIME										
		DATE										
		TIME										
		/ 1/	/ 2/	/ 3/	/ 4/	/ 5/	/ 6/	/ 7/	/ 8/	/ 9/	/ 10/	/ 11/
5.0000	161.27	5481.8	18036.	25728.	25110.	22552.	16796.	0.00000	0.80000E+07	1.0000	0.00000	0.00000
5.0500	164.57	5510.5	17577.	25110.	22070.	22070.	16393.	0.00000	0.80000E+07	1.0000	0.00000	0.00000
5.1000	167.88	5538.4	17135.	24514.	21489.	21489.	16004.	0.00000	0.80000E+07	1.0000	0.00000	0.00000
5.1500	171.21	5565.6	16710.	23941.	20986.	20986.	15630.	0.00000	0.80000E+07	1.0000	0.00000	0.00000
5.2000	174.56	5592.2	16299.	23388.	20501.	20501.	15249.	0.00000	0.80000E+07	1.0000	0.00000	0.00000
5.2499	177.92	5618.1	15903.	22856.	20034.	20034.	14921.	0.00000	0.80000E+07	1.0000	0.00000	0.00000
5.2999	181.30	5643.3	15522.	22342.	19584.	19584.	14586.	0.00000	0.80000E+07	1.0000	0.00000	0.00000
5.3499	184.69	5668.0	15153.	21846.	19150.	19150.	14262.	0.00000	0.80000E+07	1.0000	0.00000	0.00000
5.3854	187.11	5685.2	14899.	21505.	18850.	18850.	14039.	0.00000	0.80000E+07	1.0000	0.00000	0.00000
PROJECTILE EXIT												

CONDITIONS AT: PMAX MUZZLE
 TIME (MS): 3.329 5.385
 TRAVEL (M): 1.6552 4.7526
 VELOCITY (M/S): 1170.86 1732.84
 ACCELERATION (G): 43100. 14899.
 BREACH PRESS (MPa): 410.6479 148.2700
 MEAN PRESS (MPa): 359.9613 129.9689
 BASE PRESS (MPa): 260.0890 96.7968
 MEAN TEMP (K): 3437. 2695.
 Z CHANGE 1 (-): 0.827 1.000

ENERGY BALANCE SUMMARY

	JOULES	0
ELECTRICAL ENERGY:	8000001.	16.50
CHEMICAL ENERGY:	40481124.	87.50
TOTAL ENERGY:	48487424.	100.00
(1) INTERNAL GAS:	32100188.	66.20
(2) WORK AND LOSSES:	16387236.	33.80
(A) PROJECTILE KINETIC:	10657754.	21.98
(B) GAS KINETIC:	3652394.	7.53
(C) PROJECTILE ROTATIONAL:	5366.	0.01
(D) FRICTIONAL WORK TO TUBE:	0.	0.00
(E) OTHER FRICTIONAL WORK:	44182.	0.09
(F) WORK DONE AGAINST AIR:	140603.	0.29
(G) HEAT CONVECTED TO BORE:	1886935.	3.89
(H) RECOIL ENERGY:	0.	0.00

LOADING DENSITY (KG/ND): 904.425
 CHARGE WT/PROJECTILE WT: .127
 PIEZOMETRIC EFFICIENCY: 0.483
 ELECTRICAL ENHANCEMENT FACTOR: 1.332
 EXPANSION RATIO: 6.403

B.4. SAMPLE CASE 4

The physics of this case is identical with that of sample case 3. Changes have been made in the STDIS decks to display the trajectory data in English units. The purpose is to illustrate the flexibility of the output. The user is free to choose the units of his choice.

This facility is provided through three parameters: MULT, DIV, and REMK. The MULT and DIV parameters are constants by which the metric variable is multiplied or divided before being printed in the trajectory. The REMK is a 20-character field which is printed at the top of each page next to the column number of the variable being displayed in the trajectory. This, plus the 12-character name of the variable, provides enough space to document on each page the actual units in which the variable is being printed. It is of course, the responsibility of the user to insure that the factor is consistent with the claimed conversion!

The input deck:

```
SCOMM
  SIMPLIFIED ISHVG2 BENCHMARK TEST CASE 6
  WITH A 1 MS FLAT ELECTRIC PULSE
  CONTAINING A TOTAL OF 1KJ ELECTRIC PER GRAM OF PROPELLANT
  PROPELLANT BURN RATE TAILORED FOR FLAT PRESSURE PULSE
  TRAJECTORY DATA CONVERTED TO ENGLISH UNITS

SINFO
  RUN = 'T6, 1 KJ/G ELECTRIC, DESIGNER BURN RATE' DELT = 5E-6 DELP = 5E-5
  GRAD = 2          POPT = 1,2,1,0,2      SOPT = 0
  EPS = 0.001

SHEAT
  TSHL = 0.0001143      CSHL = 460.3163186  RSHL = 7861.0916
  TWAL = 293           HO = 11.348218      HL = 1

SGUN
  NAME = '120MM GUN TEST CASE'  CHAM = 0.009946948  GRVE = 0.1199896
  LAND = 0.1199896      G/L = 1.          TRAV = 4.752594
  TWST = 99

$PROJ
  NAME = 'APFSDS'  PRMT = 7.09872

$RESI
  NPTS = 4          AIR = 1
  TRAV = 0, 0.02032, 0.0762, 4.7498
  PRES = 0.6894757, 17.2368925, 0.6894757, 0.6894757

STDIS
  SHOW='TIME' REMK='MILLISECONDS'
STDIS
  SHOW='TRAV' DIV=0.0254 REMK='INCHES'
STDIS
  SHOW='VEL' MULT=3.2808333 REMK='FT/S'
STDIS
  SHOW='ACCL' DIV=9.8067 REMK='GRAVITIES'
STDIS
  SHOW='BRCH' DIV=6894.757 REMK='PRESSURE, PSI'
STDIS
  SHOW='MEAN' DIV=6894.757 REMK='PRESSURE, PSI'
STDIS
  SHOW='BASE' DIV=6894.757 REMK='PRESSURE, PSI'
STDIS
  SHOW='EPWR' DIV=746.0 REMK='HORSEPOWER, ELECTRIC'
```

```

STDIS  SHOW='EENE'  MULT=1.356  REMK='FOOT-POUNDS ELECTRIC'
STDIS  SHOW='Z(1)'
STDIS  SHOW='XBRN'  DIV=0.0254  REMK='BURN RATE (IN/SEC)'
SRECO  NAME='NONE'      RECO = 0      RCWT = 0
SPRIM  NAME = 'BENITE'    CHWT = 0.001573966
      GAMA = 1.25        FORC = 635176.7375
      COV = 0.001083819  TEMP = 2000
STDIS  SHOW='BASE'  DIV=6894.757  REMK='PSI'
STDIS  SHOW='EPWR'  REMK='WATTS ELECTRIC'
STDIS  SHOW='EENE'  REMK='JOULES ELECTRIC'
STDIS  SHOW='Z(1)'
STDIS  SHOW='XBRN'  REMK='BURN RATE'
SRECO  NAME = 'NONE'      RECO = 0      RCWT = 0
SSPRIM NAME = 'BENITE'    CHWT = 0.001573966
      GAMA = 1.25        FORC = 635176.7375
      COV = 0.001083819  TEMP = 2000
SPROP  NAME = 'JA2 7P'    CHWT = 8.0      GRAN = '7PF'
      RHO = 1586.611868  GAMA = 1.2257  FORC = 1142277.932
      COV = 0.000992778  TEMP = 3400   EROS = 0.0000000
      NTBL=4
      PR4L= 13.789514, 27.579028, 68.94757, 172.368925
      BR4L= 0.02667, 0.038608, 0.074422, 0.166624
      LEN = 0.0163322    DIAM = 0.010668    PD = 0.000508
      WI = 0.0019304    WO = 0.0018796
SCOMM  DEFINE A TRAPEZOIDAL ELECTRIC POWER PULSE
      100 MEGAWATTS FOR 1 MILLISECOND,
      WITH 100 MICROSECOND LINEAR RAMPs UP AND DOWN.
SETC  NPWR = 4
      PWR =0.0, 8E9, 8E9, 0.0
      TPWR=0.000,0.0001,0.001,0.0011
      NBRN=9
      TBRN=0.000,0.0001,0.0005,0.001,0.0015, 0.002,0.0025, 0.003, 0.004
      BRN= 10.0, 60.0, 200.0,500.0,1750.0,2500.0,3000.0,4500.0, 5000.0
SEND

```

Produced the following output:

1 --- SCOMM
 2 --- SIMPLIFIED IBHVG2 BENCHMARK TEST CASE 6
 3 --- WITH A 1 MS FLAT ELECTRIC PULSE
 4 --- CONTAINING A TOTAL OF 1KJ ELECTRIC PER GRAM OF PROPELLANT
 5 --- PROPELLANT BURN RATE TAILORED FOR FLAT PRESSURE PULSE
 6 --- TRAJECTORY DATA CONVERTED TO ENGLISH UNITS
 7 ---
 8 --- SINFO
 9 --- RUN = 'T6, 1 KJ/G ELECTRIC, DESIGNER BURN RATE' DELT = 5E-6 DELP = 5E-5
 10 --- GRAD = 2 POPT = 1.2,1.0,2 SOPT = 0
 11 --- EPS = 0.001
 12 --- SHEAT
 13 --- ISHL = 0.0001143 CSHL = 460.3163186 RSHL = 7861.0916
 14 --- TVAL = 293 MO = 11.340210 HL = 1
 15 --- \$GUN
 16 --- NAME = '120MM GUN TEST CASE' CHAM = 0.009946948 GRVE = 0.1199896
 17 --- LAND = 0.1199896 C/L = 1. TRAV = 4.752594
 18 --- TWST = 99
 19 --- SFROJ
 20 --- NAME = 'APFSDS' PRMT = 7.09872
 21 ---
 22 --- SRESI
 23 --- NPTS = 4 AIR = 1
 24 --- TRAV = 0.02032 0.0762 4.7498
 25 --- PRES = 0.6894757, 17.2368 0.6894757 0.6894757
 26 ---
 27 --- \$TDIS
 28 --- SHOM='TIME' REMK='MILLISECONDS'
 29 --- SHOM='TRAV' DIV=0.0254 REMK='INCHES'
 30 --- SHOM='VEL' MULTI=3.2808333 REMK='FT/5'
 31 --- SHOM='ACCL' DIV=9.8067 REMK='GRAVITIES'
 32 --- SHOM='BRCH' DIV=6894.757 REMK='PRESSURE, PSI'
 33 --- SHOM='MEAN' DIV=6894.757 REMK='PRESSURE, PSI'
 34 --- SHOM='BASE' DIV=6894.757 REMK='PRESSURE, PSI'
 35 --- SHOM='EPWR' DIV=746.0 REMK='HORSEPOWER, ELECTRIC'
 36 --- SHOM='LENE' MULTI=1.356 REMK='FOOT-POUNDS ELECTRIC'
 37 --- SHOM='Z(1)'
 38 --- SHOM='XBRN' DIV=.0254 REMK='BURN RATE' (IN/SEC)'
 39 ---
 40 --- \$TDIS
 41 ---
 42 --- \$TDIS
 43 ---
 44 --- \$TDIS
 45 ---
 46 --- \$TDIS
 47 ---
 48 --- \$TDIS
 49 ---
 50 --- SRECO

16, 1 KJ/G ELECTRIC, DESIGNER BURN RATE 18HVG2.504 DATE TIME

CARD 51 ---> NAME = 'NONE' RECO = 0 RCMT = 0
 CARD 52 ---> SPRIM
 CARD 53 ---> NAME = 'BENITE' CHMT = 0.001573966
 CARD 54 ---> CANA = 1.25 FORC = 635176.7375
 CARD 55 ---> COV = 0.001083819 TEMP = 2000
 CARD 56 ---> SPROP
 CARD 57 ---> NAME = 'JAZ 7p' CHMT = 0.0 GRAN = '78F'
 CARD 58 ---> RHO = 1586.61 CANA = 1.2257 FORC = 1142277.932
 CARD 59 ---> COV = 0.000992778 TEMP = 3400 EROS = 0.0000000
 CARD 60 ---> NTBL=4
 CARD 61 ---> PABL= 13.789514, 27.579028, 68.94797, 172.368923
 CARD 62 ---> SABL= 0.02667, 0.038608, 0.074422 0.166824
 CARD 63 ---> LEM = 0.0183322 DIAM = 0.010668 PD = 0.000508
 CARD 64 ---> WT = 0.0019304 WO = 0.0018796
 CARD 65 --->
 CARD 66 --->
 CARD 67 ---> SCOMM
 CARD 68 ---> DEFINE A TRAPEZOIDAL ELECTRIC POWER PULSE
 CARD 69 ---> 100 MEGAWATTS FOR 1 MILLISECOND
 CARD 70 ---> WITH 100 MICROSECOND LINEAR RAMP'S UP AND DOWN.
 CARD 71 ---> SETC
 CARD 72 ---> NPMR = 4
 CARD 73 ---> PMR = 0.0, BE9 0.0
 CARD 74 ---> TPR=0.000,0.0001,0.001,0.0011
 CARD 75 ---> NBR=9
 CARD 76 ---> TBR=0.000,0.0001,0.0005,0.001,0.0015,0.002,0.0025,0.003,0.004
 CARD 77 ---> BRN= 10.0, 80.0, 200.0,500.0,1750.0,2500.0,3000.0,4500.0, 5000.0
 CARD 78 ---> SEND

TO: J. K./G. ELECTRIC. DESIGNER BURN RATE

IBHYG2.504

DATE

TIME

- GUN TUBE -

TYPE: 120MM GUN TEST CASE
GROOVE DIAMETER (M): 0.11999
TWIST (CALS/TURN): 99.0
SHELL THICKNESS (M): 0.000114
INITIAL SHELL TEMP (K): 293.

CHAMBER VOLUME (M3):
LAND DIAMETER (M):
BORE AREA (M2):
SHELL CP (J/KG-K):
AIR NO (M/M^2-2-K):

0.00995
0.11999
0.01131
460.3183
11.3482

TRAVEL (M): 4.75259
GROOVE/LAND RATIO (-): 1.000
HEAT-LOSS OPTION: 1
SHELL DENSITY (KG/M3): 7861.0918

- PROJECTILE -

TYPE: APFSDS

TOTAL WEIGHT (KG):

7.099

WEIGHT PREDICTOR OPTION:

0

- RESISTANCE -

AIR RESISTANCE OPTION: 1
RESISTIVE PRESSURE MULT INDEX: 3

WALL HEATING FRACTION:
RESISTIVE FACTOR

0.000
1.000

FRICTION TABLE LENGTH: 4

1 TRAVEL (M) PRESSURE (MPA)
1 0.000 0.689
2 0.020 17.237

1 TRAVEL (M) PRESSURE (MPA)
3 0.076 0.689

1 TRAVEL (M) PRESSURE (MPA)
4 4.750 0.689

- GENERAL -

MAX TIME STEP (S): 0.000005
PRINT OPTIONS: 1 2 1 0 2 1
GRADIENT MODEL: PIDDUCK-RENT

PRINT STEP (S):
STORE OPTION:

0.000050
0

MAX RELATIVE ERROR (-): 0.00100
CONSTANT-PRESSURE OPTION: 0

- RECOIL -

RECOIL OPTION: 0

TYPE: NONE

RECOILING WEIGHT (KG):

0.

- PRIMER -

TYPE: BENITE
COVOLUME (M3/KG): 1.0838E-03

GAMMA (-):
FLAME TEMP (K):

1.2500
2000.0

FORCE (J/KG):
WEIGHT (KG):

635177.
0.001574

 - CHARGE 1 -

TYPE: JA2 7P
 EROSION COEFF (-): 0.000000
 GRAIN LENGTH (M): 0.016332
 INNER WEB (M): 0.001930

GRAINS: 4805.1
 CHARGE ICM CODE: 7PF 0
 GRAIN DIAMETER (M): 0.009144
 OUTER WEB (M): 0.001880

WEIGHT (KG): 8.0000
 CHANGE ICM AT (S): 0.00000E+00
 PERF DIAMETER (M): 0.000508

	PROPERTIES AT LAYER BOUNDARIES OF PERF SURFACES				PROPERTIES AT LAYER BOUNDARIES OF EMO SURFACES			
	1ST	2ND	3RD	4TH	1ST	2ND	3RD	4TH
AT DEPTH (M):	-----	-----	-----	0.00000	-----	-----	-----	0.00000
ADJACENT LAYER WT %:	-----	-----	-----	100.000	-----	-----	-----	100.000
DENSITY (KG/M3):	-----	-----	-----	1586.612	-----	-----	-----	1586.612
GAMMA (-):	-----	-----	-----	1.2257	-----	-----	-----	1.2257
FORCE (J/KG):	-----	-----	-----	1142278.	-----	-----	-----	1142278.
COVOLUME (M3/KG):	-----	-----	-----	9.9278E-04	-----	-----	-----	9.9278E-04
FLAME TEMP (K):	-----	-----	-----	3400.0	-----	-----	-----	3400.0
MEAN PRESSURES (MPA):	-----	-----	-----	13.790	-----	-----	-----	13.790
MEAN PRESSURES (MPA):	-----	-----	-----	27.579	-----	-----	-----	27.579
MEAN PRESSURES (MPA):	-----	-----	-----	68.948	-----	-----	-----	68.948
MEAN PRESSURES (MPA):	-----	-----	-----	172.369	-----	-----	-----	172.369
BURNING RATES (M/S):	-----	-----	-----	0.02667	-----	-----	-----	0.02667
BURNING RATES (M/S):	-----	-----	-----	0.03861	-----	-----	-----	0.03861
BURNING RATES (M/S):	-----	-----	-----	0.07442	-----	-----	-----	0.07442
BURNING RATES (M/S):	-----	-----	-----	0.16662	-----	-----	-----	0.16662

	PROPERTIES AT LAYER BOUNDARIES OF LAT SURFACES			
	1ST	2ND	3RD	4TH
AT DEPTH (M):	-----	-----	-----	0.00000
ADJACENT LAYER WT %:	-----	-----	-----	100.000
DENSITY (KG/M3):	-----	-----	-----	1586.612
GAMMA (-):	-----	-----	-----	1.2257
FORCE (J/KG):	-----	-----	-----	1142278.
COVOLUME (M3/KG):	-----	-----	-----	9.9278E-04
FLAME TEMP (K):	-----	-----	-----	3400.0
MEAN PRESSURES (MPA):	-----	-----	-----	13.790
MEAN PRESSURES (MPA):	-----	-----	-----	27.579
MEAN PRESSURES (MPA):	-----	-----	-----	68.948
MEAN PRESSURES (MPA):	-----	-----	-----	172.369
BURNING RATES (M/S):	-----	-----	-----	0.02667
BURNING RATES (M/S):	-----	-----	-----	0.03861
BURNING RATES (M/S):	-----	-----	-----	0.07442
BURNING RATES (M/S):	-----	-----	-----	0.16662

FIG. 1 K/J/G ELECTRIC, DESIGNER BURN RATE

TRAJECTORY VARIABLES:		/ 1/		/ 2/		/ 3/		/ 4/		/ 5/		/ 6/		/ 7/		/ 8/		/ 9/		/ 10/		/ 11/	
INCHES	FT/S	GRAVITIES	PSI	PSI	MATTS ELECTRIC	JOULES ELECTRIC	BURN RATE																
0.0000	0.0000	0.0000	0.0000	0.0000	0.0000	0.0000	0.0000	0.0000	0.0000	0.0000	0.0000	0.0000	0.0000	0.0000	0.0000	0.0000	0.0000	0.0000	0.0000	0.0000	0.0000	0.0000	0.0000
0.14730E-01	0.00000	0.00000	0.00000	0.00000	0.00000	0.00000	0.00000	0.00000	0.00000	0.00000	0.00000	0.00000	0.00000	0.00000	0.00000	0.00000	0.00000	0.00000	0.00000	0.00000	0.00000	0.00000	0.00000
SHOT-START PRESSURE ACHIEVED																							
0.50000E-01	0.27239E-04	0.23379	534.44																				
BARREL RESISTANCE OVERCOME - PROJECTILE MOVING																							
0.10000	0.66482E-03	2.3661	2304.4																				
0.15000	0.35713E-02	7.9459	4631.0																				
0.20000	0.10947E-01	17.264	6953.3																				
0.25000	0.2.035E-01	30.314	9269.4																				
0.30000	0.4E768E-01	47.079	11570.																				
0.35000	0.82265E-01	67.523	13841.																				
0.40000	0.12982	91.588	16069.																				
0.45000	0.19288	119.19	18236.																				
0.50000	0.27351	150.22	20326.																				
0.55000	0.37380	184.54	22330.																				
0.60000	0.49561	222.01	24337.																				
0.65000	0.64081	262.46	26030.																				
0.70000	0.81112	305.69	27740.																				
0.75000	1.0083	352.26	30150.																				
0.75939	1.0485	361.43	30598.																				
LOCAL PRESSURE MAX DETECTED																							
0.80000	1.2346	402.67	32518.																				
LOCAL PRESSURE MIN DETECTED																							
0.85000	1.4923	456.86	34834.																				
0.90000	1.7836	514.71	37086.																				
0.95000	2.1107	576.14	39264.																				
1.0000	2.4756	641.00	41360.																				
1.0500	2.8805	708.93	42946.																				
1.1000	3.3267	778.46	43740.																				
1.1500	3.9146	847.60	42767.																				
LOCAL PRESSURE MAX DETECTED																							
1.2000	4.3440	916.74	47758.																				
1.2500	4.9146	985.40	42610.																				
1.3000	5.5264	1053.9	42520.																				
1.3500	6.1792	1122.2	42483.																				
1.3575	6.2810	1132.5	42482.																				
LOCAL PRESSURE MIN DETECTED																							
1.4000	6.8730	1190.7	42496.																				
1.4500	7.6079	1259.0	42555.																				

TO, I KVA ELECTRIC, DESIGNER BURN RATE

TRAJECTORY VARIABLES: / 1/ TRAJ 1 TIME / 4/ / 5/ / 6/ / 7/ / 8/ / 9/ / 10/ / 11/

/ 2/ TRAJ 1 TRAV / 4/ / 5/ / 6/ / 7/ / 8/ / 9/ / 10/ / 11/

/ 3/ TRAJ 1 VEL / 4/ / 5/ / 6/ / 7/ / 8/ / 9/ / 10/ / 11/

/ 4/ TRAJ 1 ACCL / 4/ / 5/ / 6/ / 7/ / 8/ / 9/ / 10/ / 11/

/ 5/ TRAJ 1 BRCH / 4/ / 5/ / 6/ / 7/ / 8/ / 9/ / 10/ / 11/

/ 6/ TRAJ 1 MEAN / 4/ / 5/ / 6/ / 7/ / 8/ / 9/ / 10/ / 11/

/ 7/ TRAJ 1 BASE / 4/ / 5/ / 6/ / 7/ / 8/ / 9/ / 10/ / 11/

/ 8/ TRAJ 1 EPWR / 4/ / 5/ / 6/ / 7/ / 8/ / 9/ / 10/ / 11/

/ 9/ TRAJ 1 EENE / 4/ / 5/ / 6/ / 7/ / 8/ / 9/ / 10/ / 11/

/ 10/ TRAJ 1 Z(1) / 4/ / 5/ / 6/ / 7/ / 8/ / 9/ / 10/ / 11/

/ 11/ TRAJ 1 XBRN / 4/ / 5/ / 6/ / 7/ / 8/ / 9/ / 10/ / 11/

18HV2.504 DATE TIME

INCHES / 5/ / 6/ / 7/ / 8/ / 9/ / 10/ / 11/

FT/S / 5/ / 6/ / 7/ / 8/ / 9/ / 10/ / 11/

GRAVITIES / 5/ / 6/ / 7/ / 8/ / 9/ / 10/ / 11/

PSI / 5/ / 6/ / 7/ / 8/ / 9/ / 10/ / 11/

PSI / 5/ / 6/ / 7/ / 8/ / 9/ / 10/ / 11/

MATTS ELECTRIC / 5/ / 6/ / 7/ / 8/ / 9/ / 10/ / 11/

JOULES ELECTRIC / 5/ / 6/ / 7/ / 8/ / 9/ / 10/ / 11/

BURN RATE / 5/ / 6/ / 7/ / 8/ / 9/ / 10/ / 11/

1.5000	0.3030	1327.5	42656.	58585.	51336.	38233.	0.00000	0.80000E+07	0.99125E-01	1750.0
1.5500	9.2010	1396.2	42767.	58723.	51475.	38337.	0.00000	0.80000E+07	0.11030	1625.0
1.6000	10.059	1465.1	42862.	58860.	51594.	38426.	0.00000	0.80000E+07	0.12194	1900.0
1.6500	10.959	1534.1	42942.	58975.	51701.	38502.	0.00000	0.80000E+07	0.13405	1975.0
1.7000	11.900	1603.3	43008.	59072.	51781.	38565.	0.00000	0.80000E+07	0.14662	2050.0
1.7500	12.883	1672.5	43061.	59151.	51850.	38616.	0.00000	0.80000E+07	0.15967	2125.0
1.8000	13.907	1741.8	43102.	59215.	51906.	38658.	0.00000	0.80000E+07	0.17319	2200.0
1.8500	14.973	1811.2	43132.	59263.	51948.	38689.	0.00000	0.80000E+07	0.18717	2275.0
1.9000	16.081	1880.6	43152.	59298.	51979.	38712.	0.00000	0.80000E+07	0.20162	2350.0
1.9500	17.230	1950.0	43164.	59322.	52000.	38728.	0.00000	0.80000E+07	0.21655	2425.0
2.0000	18.421	2019.4	43167.	59335.	52011.	38736.	0.00000	0.80000E+07	0.23198	2500.0
2.0114	18.697	2035.2	43166.	59336.	52012.	38737.	0.00000	0.80000E+07	0.23550	2511.4
LOCAL PRESSURE MAX DETECTED										
2.0500	19.653	2088.9	43154.	59326.	52003.	38730.	0.00000	0.80000E+07	0.24772	2550.0
2.1000	20.927	2158.3	43116.	59283.	51966.	38702.	0.00000	0.80000E+07	0.26381	2600.0
2.1500	22.243	2227.6	43057.	59211.	51903.	38656.	0.00000	0.80000E+07	0.28022	2650.0
2.2000	23.600	2296.8	42979.	59116.	51817.	38592.	0.00000	0.80000E+07	0.29694	2700.0
2.2500	24.999	2365.8	42884.	58993.	51712.	38513.	0.00000	0.80000E+07	0.31397	2750.0
2.3000	26.439	2434.7	42774.	58853.	51589.	38422.	0.00000	0.80000E+07	0.33131	2800.0
2.3500	27.921	2503.5	42652.	58696.	51451.	38319.	0.00000	0.80000E+07	0.34897	2850.0
2.4000	29.443	2572.0	42519.	58524.	51300.	38207.	0.00000	0.80000E+07	0.36694	2900.0
2.4500	31.007	2640.3	42376.	58340.	51139.	38087.	0.00000	0.80000E+07	0.38522	2950.0
2.5000	32.612	2708.3	42226.	58145.	50968.	37959.	0.00000	0.80000E+07	0.40381	3000.0
2.5500	34.257	2776.1	42098.	57980.	50824.	37852.	0.00000	0.80000E+07	0.42303	3150.0
2.6000	35.943	2843.8	42017.	57881.	50737.	37787.	0.00000	0.80000E+07	0.44319	3300.0
2.6500	37.670	2911.3	41979.	57841.	50701.	37761.	0.00000	0.80000E+07	0.46428	3450.0
2.6618	38.081	2927.2	41976.	57839.	50700.	37760.	0.00000	0.80000E+07	0.46938	3485.3
LOCAL PRESSURE MIN DETECTED										
2.7000	39.436	2978.9	41980.	57854.	50713.	37770.	0.00000	0.80000E+07	0.48631	3600.0
2.7500	41.244	3046.4	42017.	57916.	50768.	37810.	0.00000	0.80000E+07	0.50928	3750.0
2.8000	43.092	3114.1	42085.	58022.	50860.	37879.	0.00000	0.80000E+07	0.53318	3900.0
2.8500	44.981	3181.8	42182.	58167.	50988.	37974.	0.00000	0.80000E+07	0.55803	4050.0
2.9000	46.910	3249.8	42305.	58348.	51146.	38092.	0.00000	0.80000E+07	0.58381	4200.0
2.9500	48.881	3318.0	42450.	58560.	51332.	38230.	0.00000	0.80000E+07	0.61053	4350.0
3.0000	50.892	3386.4	42616.	58800.	51542.	38387.	0.00000	0.80000E+07	0.63818	4500.0
3.0500	52.944	3455.1	42773.	59029.	51743.	38537.	0.00000	0.80000E+07	0.66639	4525.0
3.1000	55.038	3524.0	42897.	59213.	51904.	38656.	0.00000	0.80000E+07	0.69475	4550.0
3.1500	57.173	3593.1	42989.	59334.	52028.	38749.	0.00000	0.80000E+07	0.72324	4575.0
3.2000	59.350	3662.3	43053.	59456.	52117.	38815.	0.00000	0.80000E+07	0.75193	4600.0

Fig. 1 KJ-3 ELECTRIC, DESIGNER BURN RATE

TRAJECTORY VARIABLES:		DESIGNER BURN RATE										
1/	2/	3/	4/	5/	6/	7/	8/	9/	10/	11/	TIME	
3.2500	61.568	3731.6	4309.0	59522.	52175.	38858.	0.00000	0.80000E+07	0.78076	4625.0		
3.3000	63.828	3800.9	43103.	59554.	52204.	38880.	0.00000	0.80000E+07	0.80975	4650.0		
3.3292	65.167	3841.4	43100.	59559.	52208.	38883.	0.00000	0.80000E+07	0.82675	4664.6		
LOCAL PRESSURE MAX DETECTED												
3.3500	66.129	3870.2	43094.	59557.	52206.	38881.	0.00000	0.80000E+07	0.83888	4675.0		
3.4000	68.472	3939.5	43063.	59532.	52184.	38865.	0.00000	0.80000E+07	0.86918	4700.0		
3.4500	70.856	4008.8	43015.	59481.	52139.	38832.	0.00000	0.80000E+07	0.89763	4725.0		
3.5000	73.282	4077.9	42948.	59407.	52074.	38783.	0.00000	0.80000E+07	0.92724	4750.0		
3.5500	75.750	4146.9	42867.	59312.	51991.	38721.	0.00000	0.80000E+07	0.95701	4775.0		
3.6000	78.259	4215.8	42771.	59198.	51891.	38647.	0.00000	0.80000E+07	0.98693	4800.0		
3.6247	79.511	4249.7	42625.	59007.	51724.	38522.	0.00000	0.80000E+07	1.0000	0.00000		
PROPELLANT 1 BURNED OUT												
3.6500	80.809	4284.2	41827.	57923.	50774.	37815.	0.00000	0.80000E+07	1.0000	0.00000		
3.7000	83.399	4350.2	40309.	55864.	48969.	36471.	0.00000	0.80000E+07	1.0000	0.00000		
3.7500	86.028	4413.9	38865.	53906.	47252.	35192.	0.00000	0.80000E+07	1.0000	0.00000		
3.8000	88.695	4475.3	37490.	52042.	45618.	33975.	0.00000	0.80000E+07	1.0000	0.00000		
3.8500	91.398	4534.5	36182.	50268.	44063.	32817.	0.00000	0.80000E+07	1.0000	0.00000		
3.9000	94.136	4591.7	34936.	48579.	42583.	31714.	0.00000	0.80000E+07	1.0000	0.00000		
3.9500	96.908	4647.0	33749.	46971.	41173.	30664.	0.00000	0.80000E+07	1.0000	0.00000		
4.0000	99.712	4700.4	32618.	45438.	39830.	29664.	0.00000	0.80000E+07	1.0000	0.00000		
4.0500	102.55	4751.9	31539.	43978.	38549.	28710.	0.00000	0.80000E+07	1.0000	0.00000		
4.1000	105.41	4801.9	30511.	42585.	37329.	27801.	0.00000	0.80000E+07	1.0000	0.00000		
4.1500	108.31	4850.1	29530.	41256.	36164.	26934.	0.00000	0.80000E+07	1.0000	0.00000		
4.2000	111.23	4896.9	28593.	39988.	35052.	26106.	0.00000	0.80000E+07	1.0000	0.00000		
4.2500	114.19	4942.2	27698.	38777.	33991.	25316.	0.00000	0.80000E+07	1.0000	0.00000		
4.3000	117.16	4986.0	26843.	37621.	32977.	24560.	0.00000	0.80000E+07	1.0000	0.00000		
4.3500	120.17	5028.5	26025.	36515.	32008.	23839.	0.00000	0.80000E+07	1.0000	0.00000		
4.4000	123.20	5069.8	25243.	35458.	31081.	23148.	0.00000	0.80000E+07	1.0000	0.00000		
4.4500	126.25	5109.8	24495.	34446.	30195.	22488.	0.00000	0.80000E+07	1.0000	0.00000		
4.5000	129.33	5148.6	23778.	33478.	29346.	21856.	0.00000	0.80000E+07	1.0000	0.00000		
4.5500	132.43	5186.3	23092.	32551.	28533.	21250.	0.00000	0.80000E+07	1.0000	0.00000		
4.6000	135.55	5222.9	22434.	31662.	27754.	20670.	0.00000	0.80000E+07	1.0000	0.00000		
4.6500	138.70	5258.5	21803.	30810.	27037.	20114.	0.00000	0.80000E+07	1.0000	0.00000		
4.7000	141.86	5293.1	21198.	29993.	26291.	19581.	0.00000	0.80000E+07	1.0000	0.00000		
4.7500	145.05	5326.7	20617.	29209.	25604.	19069.	0.00000	0.80000E+07	1.0000	0.00000		
4.8000	148.26	5359.4	20059.	28457.	24944.	18578.	0.00000	0.80000E+07	1.0000	0.00000		
4.8500	151.48	5391.3	19523.	27734.	24310.	18106.	0.00000	0.80000E+07	1.0000	0.00000		
4.9000	154.72	5422.2	19008.	27039.	23701.	17652.	0.00000	0.80000E+07	1.0000	0.00000		
4.9500	157.99	5452.4	18513.	26371.	23116.	17216.	0.00000	0.80000E+07	1.0000	0.00000		

TIME

DATE

IBHV2.504

16, 1 KJ/G ELECTRIC, DESIGNER BURN RATE

TRAJECTORY VARIABLES:		TRAJECTORY VARIABLES:										
		/ 1/	/ 2/	/ 3/	/ 4/	/ 5/	/ 6/	/ 7/	/ 8/	/ 9/	/ 10/	/ 11/
5.0000	161.27	5481.8	18036.	23728.	22552.	16796.	0.00000	0.00000	0.00000	0.80000E+07	1.0000	0.00000
5.0500	164.37	5510.5	17577.	25110.	22010.	16393.	0.00000	0.00000	0.00000	0.80000E+07	1.0000	0.00000
5.1000	167.88	5538.4	17135.	24514.	21489.	16004.	0.00000	0.00000	0.00000	0.80000E+07	1.0000	0.00000
5.1500	171.21	5565.6	16710.	23941.	20986.	15630.	0.00000	0.00000	0.00000	0.80000E+07	1.0000	0.00000
5.2000	174.56	5592.2	16299.	23388.	20501.	15269.	0.00000	0.00000	0.00000	0.80000E+07	1.0000	0.00000
5.2499	177.92	5618.1	15903.	22856.	20034.	14921.	0.00000	0.00000	0.00000	0.80000E+07	1.0000	0.00000
5.2999	181.30	5643.3	15522.	22342.	19584.	14586.	0.00000	0.00000	0.00000	0.80000E+07	1.0000	0.00000
5.3499	184.69	5668.0	15153.	21846.	19150.	14262.	0.00000	0.00000	0.00000	0.80000E+07	1.0000	0.00000
5.3854	187.11	5685.2	14899.	21505.	18850.	14039.	0.00000	0.00000	0.00000	0.80000E+07	1.0000	0.00000

INCHES
FT/S
GRAVITIES
PSI
PSI
WATTS ELECTRIC
JOULES ELECTRIC
BURN RATE

TRAJ 1 TIME
TRAJ 1 TRAV
TRAJ 1 VEL
TRAJ 1 ACCL
TRAJ 1 BRCK
TRAJ 1 MEAN
TRAJ 1 BASE
TRAJ 1 EPWR
TRAJ 1 EENE
TRAJ 1 Z(1)
TRAJ 1 XBRN

PROJECTILE EXIT

CONDITIONS AT: PMAX MUZZLE

TIME (MS): 3.329 5.385
 TRAVEL (M): 1.6552 4.7526
 VELOCITY (M/S): 1170.86 1732.84
 ACCELERATION (G): 43100. 14899.
 BREACH PRESS (MPA): 410.6479 148.2700
 MEAN PRESS (MPA): 359.9613 129.9689
 BASE PRESS (MPA): 268.0880 96.7968
 MEAN TEMP (K): 3437. 2695.
 Z CHARGE 1 (-): 0.827 1.000

ENERGY BALANCE SUMMARY

	JOULES	g
ELECTRICAL ENERGY:	8000001.	16.50
CHEMICAL ENERGY:	40487424.	83.50
TOTAL ENERGY:	48487424.	100.00
(1) INTERNAL GAS:	32100188.	66.20
(2) WORK AND LOSSES:	16387236.	33.80
(A) PROJECTILE KINETIC:	10657754.	21.98
(B) GAS KINETIC:	3652394.	7.53
(C) PROJECTILE ROTATIONAL:	5366.	0.01
(D) FRICTIONAL WORK TO TUBE:	0.	0.00
(E) OTHER FRICTIONAL WORK:	44182.	0.09
(F) WORK DONE AGAINST AIR:	1406C5.	0.29
(G) HEAT CONVECTED TO BORE:	1886935.	3.89
(H) RECOIL ENERGY:	0.	0.00

LOADING DENSITY (KG/M3): 804.425
 CHARGE WT/PROJECTILE WT: 1.127
 PIEZOMETRIC EFFICIENCY: 0.483
 ELECTRICAL ENHANCEMENT FACTOR: 1.332
 EXPANSION RATIO: 6.403

INTENTIONALLY LEFT BLANK.

<u>No. of Copies</u>	<u>Organization</u>	<u>No. of Copies</u>	<u>Organization</u>
2	Administrator Defense Technical Info Center ATTN: DTIC-DDA Cameron Station Alexandria, VA 22304-6145	1	Commander U.S. Army Missile Command ATTN: AMSMI-RD-CS-R (DOC) Redstone Arsenal, AL 35898-5010
1	Commander U.S. Army Materiel Command ATTN: AMCAM 5001 Eisenhower Ave. Alexandria, VA 22333-0001	1	Commander U.S. Army Tank-Automotive Command ATTN: AMSTA-JSK (Armor Eng. Br.) Warren, MI 48397-5000
1	Director U.S. Army Research Laboratory ATTN: AMSRL-OP-CI-AD, Tech Publishing 2800 Powder Mill Rd. Adelphi, MD 20783-1145	1	Director U.S. Army TRADOC Analysis Command ATTN: ATRC-WSR White Sands Missile Range, NM 88002-5502
1	Director U.S. Army Research Laboratory ATTN: AMSRL-OP-CI-AD, Records Management 2800 Powder Mill Rd. Adelphi, MD 20783-1145	(Class. only) 1	Commandant U.S. Army Infantry School ATTN: ATSH-CD (Security Mgr.) Fort Benning, GA 31905-5660
2	Commander U.S. Army Armament Research, Development, and Engineering Center ATTN: SMCAR-IMI-1 Picatinny Arsenal, NJ 07806-5000	(Unclass. only) 1	Commandant U.S. Army Infantry School ATTN: ATSH-WCB-O Fort Benning, GA 31905-5000
2	Commander U.S. Army Armament Research, Development, and Engineering Center ATTN: SMCAR-TDC Picatinny Arsenal, NJ 07806-5000	1	WL/MNOI Eglin AFB, FL 32542-5000 <u>Aberdeen Proving Ground</u>
1	Director Benet Weapons Laboratory U.S. Army Armament Research, Development, and Engineering Center ATTN: SMCAR-CCB-TL Watervliet, NY 12189-4050	2	Dir, USAMSAA ATTN: AMXSY-D AMXSY-MP, H. Cohen
1	Director U.S. Army Advanced Systems Research and Analysis Office (ATCOM) ATTN: AMSAT-R-NR, M/S 219-1 Ames Research Center Moffett Field, CA 94035-1000	1	Cdr, USATECOM ATTN: AMSTE-TC
		1	Dir, USAERDEC ATTN: SCBRD-RT
		1	Cdr, USACBDCOM ATTN: AMSCB-CII
		1	Dir, USARL ATTN: AMSRL-SL-I
		5	Dir, USARL ATTN: AMSRL-OP-CI-B (Tech Lib)

<u>No. of Copies</u>	<u>Organization</u>	<u>No. of Copies</u>	<u>Organization</u>
1	OSD/SDIO/IST ATTN: Dr. Len Caveny Pentagon Washington, DC 20301-7100	6	Director Benet Laboratories U.S. Army Watervliet Arsenal ATTN: SARWV-RD L. Johnson G. Carafano R. Thierry R. Hasenbein P. Vouis P. Alto Watervliet, NY 12189
1	Director U.S. Army BMD Advanced Technology Center P.O. Box 1500 Huntsville, AL 35807	3	Commander U.S. Army AMCCOM ATTN: AMSMC-IRC, G. Cowan SMCAR-ESM(R), W. Fortune R. Zastrow Rock Island, IL 61299-7300
1	Chairman DOD Explosives Safety Board Room 856-C Hoffman Bldg. 1 2461 Eisenhower Ave. Alexandria, VA 22331-0600	1	Commander, USACECOM R&D Technical Library ATTN: ASQNC-ELC-IS-L-R, Myer Center Fort Monmouth, NJ 07703-5301
1	Department of the Army Office of the Product Manager 155mm Howitzer, M109A6, Paladin ATTN: SFAE-AR-HIP-IP, Mr. R. De Kleine Picatinny Arsenal, NJ 07806-5000	1	Commandant U.S. Army Aviation School ATTN: Aviation Agency Fort Rucker, AL 36360
1	Commander Production Base Modernization Agency U.S. Army Armament Research, Development, and Engineering Center ATTN: AMSMC-PBM-E, L. Laibson Picatinny Arsenal, NJ 07806-5000	1	Director HQ, TRAC RPD ATTN: ATCD-MA, MAJ Williams Fort Monroe, VA 23651-5143
1	PEO-Armaments Project Manager Tank Main Armament Systems ATTN: AMCPM-TMA, K. Russell Picatinny Arsenal, NJ 07806-5000	1	Headquarters U.S. Army Materiel Command ATTN: AMCICP-AD, Michael F. Fisette 5001 Eisenhower Ave. Alexandria, VA 22333-0001
1	PEO-Armaments Project Manager Tank Main Armament Systems ATTN: AMCPM-TMA-105 Picatinny Arsenal, NJ 07806-5000	1	Commander U.S. Army Armament Research Development, and Engineering Center ATTN: SMCAR-CCS Picatinny Arsenal, NJ 07806-5000
1	PEO-Armaments Project Manager Tank Main Armament Systems ATTN: AMCPM-TMA-120 Picatinny Arsenal, NJ 07806-5000		

<u>No. of Copies</u>	<u>Organization</u>	<u>No. of Copies</u>	<u>Organization</u>
1	Commander U.S. Army Armament Research Development, and Engineering Center ATTN: SMCAR-CCH-T, L. Rosendorf Picatinny Arsenal, NJ 07806-5000	1	Commander U.S. Army Armament Research, Development, and Engineering Center ATTN: SMCAR-AES, S. Kaplowitz Picatinny Arsenal, NJ 07806-5000
1	Commander U.S. Army Armament Research Development, and Engineering Center ATTN: SMCAR-CCH-V, E. Fennell Picatinny Arsenal, NJ 07806-5000	1	Commander U.S. Army Armament Research, Development, and Engineering Center ATTN: SMCAR-FSA-T, M. Salisbury Picatinny Arsenal, NJ 07806-5000
2	Commander U.S. Army Research Office ATTN: Technical Library D. Mann P.O. Box 1221 Research Triangle Park, NC 27709-2211	6	Commander U.S. Army Armament Research, Development, and Engineering Center ATTN: SMCAR-FSE, T. Gora B. Knutelsky K. C. Pan W. Davis C. Durham A. Graf Picatinny Arsenal, NJ 07806-5000
1	Commander U.S. Army TRAC - Fort Lee Defense Logistics Studies Fort Lee, VA 23801-6140		
1	Commander U.S. Army Armament Research, Development, and Engineering Center ATTN: SMCAR-AE, J. Picard Picatinny Arsenal, NJ 07806-5000	6	Commander U.S. Army Armament Research, Development, and Engineering Center ATTN: SMCAR-EG, G. Ferdinand H. Naber-Libby R. Lundberg J. Niles R. Moreira W. Morelli Picatinny Arsenal, NJ 07806-5000
5	Commander U.S. Army Armament Research, Development, and Engineering Center ATTN: SMCAR-AEE-B, A. Beardell D. Downs S. Einstein A. Bracuti D. Chiu Picatinny Arsenal, NJ 07806-5000	1	Commander U.S. Army Belvoir R&D Center ATTN: STRBE-WC Technical Library (V2ult) Bldg. 315 Fort Belvoir, VA 22060-5606
1	Commander U.S. Army Armament Research, Development, and Engineering Center ATTN: SMCAR-AEE, J. Lannon Picatinny Arsenal, NJ 07806-5000	1	President U.S. Army Artillery Board Fort Sill, OK 73563

<u>No. of Copies</u>	<u>Organization</u>
1	Commandant U.S. Army Command and General Staff College Fort Leavenworth, KS 66027-5200
1	Commandant U.S. Army Special Warfare School ATTN: Rev and Tng Lit Div Fort Bragg, NC 28307
1	Commander Radford Army Ammunition Plant ATTN: SMCRA-QA/HI Library Radford, VA 24141
1	Commandant U.S. Army Field Artillery School ATTN: STSF-TSM-CN Fort Sill, OK 73503-5600
4	Deputy Commander Strategic Defense Command ATTN: SFAE-SD-HVL, S. Smith LTC Kee D. Lianos T. Aden P.O. Box 1500 Huntsville, AL 35887-8801
2	Commander U.S. Army Foreign Science and Technology Center ATTN: AMXST-MC-3, S. LeBeau C. Beiter 220 Seventh St, NE Charlottesville, VA 22901
1	Commandant U.S. Army Field Artillery Center and School ATTN: ATSF-CO-MW, B. Willis Fort Sill, OK 73503
1	Naval Sea System Command Department of the Navy ATTN: CSEA, CDR Dampier 06KR12 Washington, DC 20361-5101

<u>No. of Copies</u>	<u>Organization</u>
1	Office of Naval Research ATTN: Code 473, R. S. Miller 800 N. Quincy St. Arlington, VA 22217
2	Commander Naval Sea Systems Command ATTN: SEA 62R SEA 64 Washington, DC 20361-5101
1	Commander Naval Air Systems Command ATTN: AJR-954-Technical Library Washington, DC 20360
1	Naval Research Laboratory Technical Library Washington, DC 20375
2	Commander Naval Surface Warfare Center ATTN: J. P. Consaga C. Gotzmer Silver Spring, MD 20902-5000
2	Commander Naval Surface Warfare Center ATTN: K. Kim/Code R-13 R. Bernecker/Code R-13 Silver Spring, MD 20902-5000
3	Commander Naval Surface Warfare Center Indian Head Division ATTN: 610, C. Smith 6110J, K. Rice 6110C, S. Peters Indian Head, MD 20640-5035
1	Commander Naval Underwater Systems Center Energy Conversion Dept. ATTN: Technical Library Newport, RI 02840

<u>No. of Copies</u>	<u>Organization</u>	<u>No. of Copies</u>	<u>Organization</u>
6	Commander Naval Surface Warfare Center ATTN: Code G33, T. Doran J. Copley Code G30, Guns and Munitions Division Code G301, D. Wilson Code G32, Gun Systems Division Code E23, Technical Library Dahlgren, VA 22448-5000	1	Director Lawrence Livermore National Laboratory ATTN: M. S. L-355, A. Buckingham P.O. Box 808 Livermore, CA 94550
1	Commander Naval Weapons Center ATTN: Code 388, C. F. Price Info Science Div China Lake, CA 93555-6001	2	Director Sandia National Laboratories Combustion Research Facility ATTN: R. Armstrong S. Vosen Division 8357 Livermore, CA 94551-0469
1	OLAC PL/TSTL ATTN: D. Shiplett Edwards AFB, CA 93523-5000	1	University of Illinois Dept. of Mech./Indust. Engr. ATTN: Prof. Herman Krier, 144 MEB 1206 N. Green St. Urbana, IL 61801
10	Central Intelligence Agency Office of Central Reference Dissemination Branch Room GE-47 HQS Washington, DC 20502	1	Johns Hopkins University/CPIA ATTN: T. Christian 10630 Little Patuxent Parkway, Suite 202 Columbia, MD 21044-3200
1	Central Intelligence Agency ATTN: Joseph E. Backofen NHB, Room 5N01 Washington, DC 20505	1	Pennsylvania State University Dept. of Mechanical Engr. ATTN: Dr. K. Kuo 312 Mechanical Engineering Bldg. University Park, PA 16802
5	Director Sandia National Laboratories ATTN: T. Hitchcock R. Woodfin D. Benson S. Kempka R. Beasley Advanced Projects Div 14 Organization 9123 Albuquerque, NM 87185	1	North Carolina State University ATTN: John G. Gilligan Box 7909 1110 Burlington Engineering Labs Raleigh, NC 27695-7909
2	Director Los Alamos National Laboratory ATTN: B. Kaswhia H. Davis Los Alamos, NM 87545	1	State University of New York at Buffalo Department of Electrical Engineering ATTN: Dr. W. J. Sargeant Bonner Hall - Room 312 Buffalo, NY 14260
		2	Institute for Advanced Technology ATTN: Dr. H. Fair Dr. T. Kichne 4030-2 West Baker Lane Austin, TX 78759-5329

<u>No. of Copies</u>	<u>Organization</u>
1	SRI International Propulsion Sciences Division ATTN: Technical Library 333 Ravenswood Ave. Menlo Park, CA 94025
1	SPARTA ATTN: Dr. Michael Holland 9455 Towne Center Dr. San Diego, CA 92121-1964
5	FMC Corporation ATTN: Mr. G. Johnson Mr. M. Scale Dr. A. Giovanetti Mr. J. Dyvik Dr. D. Cook 4800 East River Rd. Minneapolis, MN 55421-1498
10	GT Devices ATTN: Dr. S. Goldstein Dr. R. J. Greig Dr. N. Winsor (8 cp) 5705A General Washington Dr. Alexandria, VA 22312
3	General Dynamics Land Systems ATTN: Dr. B. VanDeusen Mr. F. Lunsford Dr. M. Weidner P.O. Box 2074 Warren, MI 48090-2074
2	Alliant Techsystems, Inc. ATTN: R. E. Tompkins J. Kennedy MN38-330 10400 Yellow Circle Dr. Minnetonka, MN 55343
2	Olin Ordnance ATTN: V. McDonald, Library Hugh McElroy P.O. Box 222 St. Marks, FL 32355

<u>No. of Copies</u>	<u>Organization</u>
1	Paul Gough Associates, Inc. ATTN: P. S. Gough 1048 South St. Portsmouth, NH 03801-5423
1	Physics International Library ATTN: H. Wayne Wampler P.O. Box 5010 San Leandro, CA 94577-0599
2	Rockwell International Rocketdyne Division ATTN: BA08, J. E. Flanagan J. Gray 6633 Canoga Ave. Canoga Park, CA 91304
2	Princeton Combustion Resch Lab ATTN: M. Summerfield N. Messina Princeton Corporate Plaza 11 Deerpark Drive Bldg. IV, Suite 119 Monmouth Junction, NJ 08852
2	Science Applications, Inc. ATTN: J. Batteh L. Thornhill 1519 Johnson Ferry Rd. Suite 300 Marietta, GA 30062-6438
1	Eli Freedman & Associates ATTN: E. Freedman 2411 Diana Rd. Baltimore MD 21209
1	Veritay Technology, Inc. 4845 Millersport Hwy. P.O. Box 305 East Amherst, NY 14051-0305
1	Battelle TWSTIAC 505 King Ave. Columbus, OH 43201-2693

No. of

Copies Organization

- 2 California Institute of Technology
Jet Propulsion Laboratory
ATTN: L. D. Strand, MS 125-224
D. Elliot
4800 Oak Grove Dr.
Pasadena, CA 91109
- 1 General Electric Co.
Defense Systems Division
ATTN: Dr. J. Mandzy
Mail Drop 43-220
100 Plastics Ave.
Pittsfield, MA 01201
- 2 SAIC
ATTN: Mr. N. Sinha
Dr. S. Dash
501 Office Center Dr.
Fort Washington, PA 19034-3211
- 1 Science Application International Corporation
ATTN: Dr. G. Chryssamellis
8400 Normandele Blvd.
Suite 939
Minneapolis, MN 55437

Aberdeen Proving Ground

- 4 Commander, USACSTA
ATTN: S. Walton
G. Rice
D. Lacey
C. Herud

**No. of
Copies Organization**

- 2 RARDE
GS2 Division
Bldg. R31
ATTN: Dr. C. Woodley
Dr. G. Cook
Fort Halstead
Sevenoaks, Kent TN14 7BP
England
- 2 Director
Fraunhofer - Institut für Kurzzeiddynamik
Ernst - Mach Institut
ATTN: Dr. G. Schroeder
Prof. G. Klingerberg
Hauptstraße 18
D-7858 Weil am Rhein
Germany
- 3 Soreq Nuclear Research Center
Israel Atomic Energy Commission
ATTN: Dr. D. Saphier
Dr. R. Alimi
Ms. D. Plotnik
Yavne 70660, Israel

USER EVALUATION SHEET/CHANGE OF ADDRESS

This Laboratory undertakes a continuing effort to improve the quality of the reports it publishes. Your comments/answers to the items/questions below will aid us in our efforts.

1. ARL Report Number ARL-TR-348 Date of Report January 1994

2. Date Report Received _____

3. Does this report satisfy a need? (Comment on purpose, related project, or other area of interest for which the report will be used.) _____

4. Specifically, how is the report being used? (Information source, design data, procedure, source of ideas, etc.) _____

5. Has the information in this report led to any quantitative savings as far as man-hours or dollars saved, operating costs avoided, or efficiencies achieved, etc? If so, please elaborate. _____

6. General Comments. What do you think should be changed to improve future reports? (Indicate changes to organization, technical content, format, etc.) _____

CURRENT
ADDRESS

Organization

Name

Street or P.O. Box No.

City, State, Zip Code

7. If indicating a Change of Address or Address Correction, please provide the Current or Correct address above and the Old or Incorrect address below.

OLD
ADDRESS

Organization

Name

Street or P.O. Box No.

City, State, Zip Code

(Remove this sheet, fold as indicated, tape closed, and mail.)
(DO NOT STAPLE)

DEPARTMENT OF THE ARMY

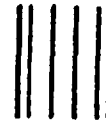

OFFICIAL BUSINESS

BUSINESS REPLY MAIL
FIRST CLASS PERMIT No 0001, APG, MD

Postage will be paid by addressee.

NO POSTAGE
NECESSARY
IF MAILED
IN THE
UNITED STATES

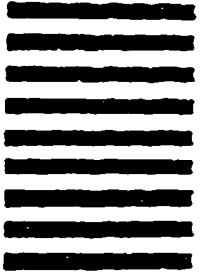

Director
U.S. Army Research Laboratory
ATTN: AMSRL-OP-CI-B (Tech Lib)
Aberdeen Proving Ground, MD 21005-5066