

AD-A112 255

AIR FORCE WRIGHT AERONAUTICAL LABS WRIGHT-PATTERSON AFB OH F/8 1/3
AFWAL FY80 TECHNICAL ACCOMPLISHMENTS REPORT.(U)

UNCLASSIFIED

DEC 81 R S HOFF
AFWAL-TR-81-0001

NL

1981
August

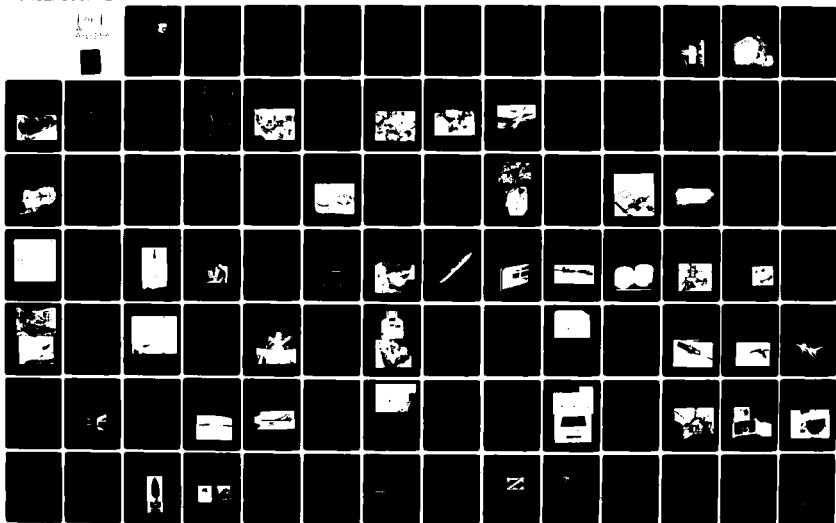

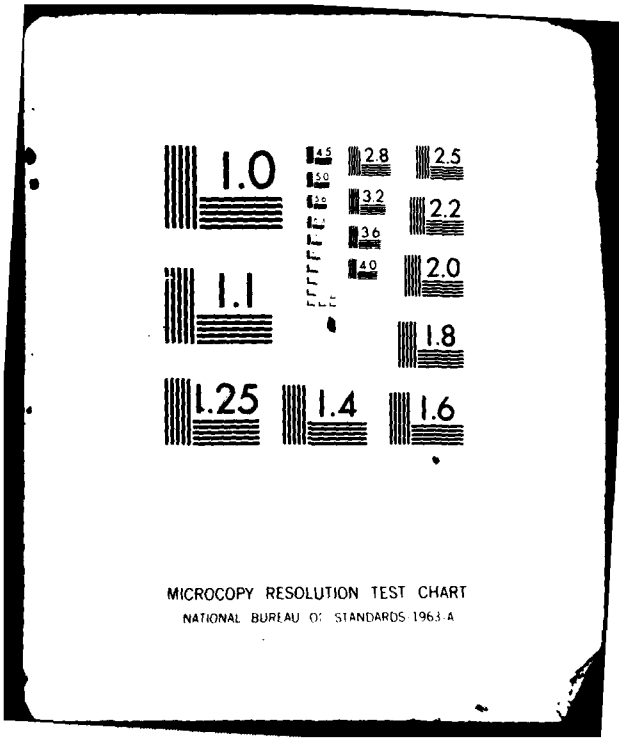

MICROCOPY RESOLUTION TEST CHART
NATIONAL BUREAU OF STANDARDS 1963-A

100

ADA112255

AFWAL-TR-81-0001

AFWAL FY 80 TECHNICAL ACCOMPLISHMENTS REPORT

R. S. HOFF

Programs Branch
Plans & Programs Office



December 1981

Final Report for Period 1 October 1979 to 30 September 1980

Approved for public release: distribution unlimited

DTIC FILE COPY

DTIC
COPYRIGHT
MAR 22 1982

AIR FORCE WRIGHT AERONAUTICAL LABORATORIES
AIR FORCE SYSTEMS COMMAND
WRIGHT-PATTERSON AIR FORCE BASE, OHIO 45433

82 03 22 237

NOTICE

When Government drawings, specifications, or other data are used for any purpose other than in connection with a definitely related Government procurement operation, the United States Government thereby incurs no responsibility nor any obligation whatsoever; and the fact that the government may have formulated, furnished, or in any way supplied the said drawings, specifications, or other data, is not to be regarded by implication or otherwise as in any manner licensing the holder or any other person or corporation, or conveying any rights or permission to manufacture use, or sell any patented invention that may in any way be related thereto.

This report has been reviewed by the Office of Public Affairs (ASD/PA) and is releasable to the National Technical Information Service (NTIS). At NTIS, it will be available to the general public, including foreign nations.

This technical report has been reviewed and is approved for publication.



RUSSELL S. HOFF, Jr.
Integrated Programs Group

FOR THE COMMANDER

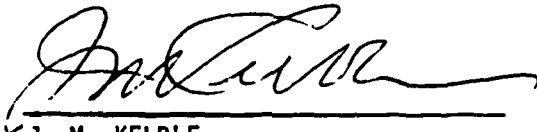

J. M. KELBLE
Deputy Director of Management Services
AF Wright Aeronautical Laboratories

"If your address has changed, if you wish to be removed from our mailing list, or if the addressee is no longer employed by your organization please notify AFWAL/XRPI, W-PAFB, OH 45433 to help us maintain a current mailing list."

Copies of this report should not be returned unless return is required by security considerations, contractual obligations, or notice on a specific document.

Unclassified

SECURITY CLASSIFICATION OF THIS PAGE (When Data Entered)

REPORT DOCUMENTATION PAGE		READ INSTRUCTIONS BEFORE COMPLETING FORM
1. REPORT NUMBER AFWAL-TR-81-0001	2. GOVT ACCESSION NO.	3. RECIPIENT'S CATALOG NUMBER
4. TITLE (and Subtitle) AFWAL FY80 Technical Accomplishments	5. TYPE OF REPORT & PERIOD COVERED Final Technical Report FY80	
	6. PERFORMING ORG. REPORT NUMBER	
7. AUTHOR(s) Russell S. Hoff, Jr.	8. CONTRACT OR GRANT NUMBER(s)	
9. PERFORMING ORGANIZATION NAME AND ADDRESS Integrated Programs Group (XRPI) Air Force Wright Aeronautical Laboratories Wright-Patterson Air Force Base OH 45433	10. PROGRAM ELEMENT, PROJECT, TASK AREA & WORK UNIT NUMBERS	
11. CONTROLLING OFFICE NAME AND ADDRESS Directorate of Management Services (GL) Air Force Wright Aeronautical Laboratories Wright-Patterson Air Force Base Oh 45433	12. REPORT DATE December 1981	
	13. NUMBER OF PAGES 98	
14. MONITORING AGENCY NAME & ADDRESS (if different from Controlling Office)	15. SECURITY CLASS. (of this report) Unclassified	
	15a. DECLASSIFICATION/DOWNGRADING SCHEDULE	
16. DISTRIBUTION STATEMENT (of this Report) Approved for public release; distribution unlimited.		
17. DISTRIBUTION STATEMENT (of the abstract entered in Block 20, if different from Report)		
18. SUPPLEMENTARY NOTES		
19. KEY WORDS (Continue on reverse side if necessary and identify by block number) Avionics, Flight Dynamics, Materials, Aero Propulsion		
20. ABSTRACT (Continue on reverse side if necessary and identify by block number) This Air Force Wright Aeronautical Laboratories report on technical accomplishments contains highlights of significant achievements made during FY 80. The document indicates the broad range of R&D activities being undertaken within the four AFWAL Laboratories and the significance of the technological contributions being made to enhance Air Force operational capabilities. The accomplishment descriptions and associated illustrations have been grouped by Laboratory to assist the reader in understanding the technologies covered.		

DTIC
ELECTE
MAR 22 1982
H

Unclassified

SECURITY CLASSIFICATION OF THIS PAGE(When Data Entered)

Block 20 continued.

The report was prepared in accordance with AFM 172-1, Paragraph 8-5. Points of contact have been identified for each topic, if additional information on the subject is desired.

SECURITY CLASSIFICATION OF THIS PAGE(When Data Entered)

PREFACE

Although originally established in July 1975, the current Air Force Wright Aeronautical Laboratories (AFWAL) organization has only been functioning as a single Air Force unit under the direction of the AFWAL Commander since January 1980. Comprised of five organizational elements, i.e., Aero Propulsion Laboratory, Avionics Laboratory, Flight Dynamics Laboratory, Materials Laboratory, and the Directorate of Management Services, AFWAL plans and executes basic research, exploratory development, advanced development, manufacturing technology, and selected engineering development programs in a wide variety of technology areas.

This report has the distinction of being the first annual AFWAL Tech Accomplishments Report and contains accomplishments from all AFWAL Laboratories. The technology developed as a result of these efforts has the potential to enhance Air Force capability through application to future weapon systems and equipment or to improve producibility and/or reduced life cycle cost. Although the report was prepared by the Programs Branch, acknowledgement is made to all engineers who submitted the initial technical narratives and associated illustrations. Inquiries regarding individual subjects may be directed to the point of contact listed at the end of each accomplishment. Commercial telephone users should dial the number indicated. Telephone users with access to the Defense Communication System automatic voice switching network (AUTOVON) may dial 78 plus the last five digits. Comments for improving the format of this report are encouraged and should be addressed to:

AFWAL/XRPI
Wright-Patterson AFB, OH 45433



Accession For	
NTIS GRA&I	<input checked="" type="checkbox"/>
DTIC TAB	<input type="checkbox"/>
Unannounced	<input type="checkbox"/>
Justification	
By	
Distribution	
Availability Codes	
Number	
Date	
A	

TABLE OF CONTENTS

SECTION	PAGE
I AERO PROPULSION LABORATORY	
Condition Monitoring of Aircraft Turbine Engine Lubricants	2
Rapid Detection of Aircraft Fires	3
USAF/Navy Variable Cycle Technology Demonstrator Engine	4
High Quality Jet Fuel Economically Produced from Shale Oil	5
Aircraft Fuel Tank Protection	6
Expendable Gasifier for Small Turbine Engines	7
Air-Lubricated Foil Bearing Development for Aircraft Auxiliary Power Units	18
New Closed-Cycle Rare Gas Laser	10
Fuel Effects on Jet Engines	11
Turbo-Structures Research Laboratory	12
High Performance Auxiliary Power Unit	13
Freejet Demonstration of Tactical Liquid Fuel Ramjet	14
Solid Fuel Ramjet	15
High Efficiency Solar to Electrical Energy Conversion for Space Applications	16
Variable Geometry Combustor	17
Turbine Engine Fault Detection and Isolation Program	18
Advanced Turbine Engine Gas Generator Durability Demonstration	20
II AVIONICS LABORATORY	
Fiber Optic/Integrated Optic Phase Reversal Switch	22
HBr/Overtone Hydrogen Halide Laser	23
Electric Pulse Initiated Chemical Laser	24
35 GHz Active Aperture	25
High Speed Digital Phase Locked Loop Circuit	26
Digital Avionics Information System	27
FLIR Technology Demonstration	29
40GHz Solid State Amplifier	30
Magnetostatic Wave Device	31
Tactical Decision Aid	32
High Speed Micro Signal Processor	33
Computer Support Software Package	36
Millimeter Wave Mixer	36
GaAs Microwave Diodes Achieve New High Power and Frequencies	37
III FLIGHT DYNAMICS LABORATORY	
CRACKS-PD: A Crack Growth Analysis for Preliminary Design	39
Wing/Store Flutter Suppression Wind Tunnel Test Demonstration	40
Advanced Metallic Structures Missile Shroud Development	41
Sonic Fatigue Design Techniques for Advanced Composite Aircraft Structures	42

TABLE OF CONTENTS (Cont'd)

SECTION	PAGE
Primary Adhesively Bonded Structures Technology Transitioned	43
Superplastically Formed and Diffusion Bonded Titanium Landing Gear Component Study.....	44
Fire Extinguishing System for Ballistic Protection	45
Computer Simulation of Aircraft Transparency Response to Bird Impact.....	46
F-16 Laminated Canopy.....	47
Mobility Development Laboratory Unveiled	49
Tanker Avionics and Aircrew Complement Evaluation	51
Boom Operator's Heads-Up Display	52
Advanced Fighter Cockpit Development Program	53
First Exact Computation of Spike-Tipped Body Buzz.....	55
Mission Adaptive Wing - The Wing for the 1990's.....	56
Aerodynamic Configured Missile Development.....	58
Advanced Exhaust Nozzle System Concepts Demonstration Program	60
AFTI F-16 Design Configuration.....	61
First Accurate Computation of Airfoil Stall Characteristics	62
Navier-Stokes Nozzle Computation.....	63
Development of Laser Velocimeter for Turbulence Measurements.....	64
Aeromechanic Applications of Favorable Aerodynamic Interference	65
KC-135 Winglet	66
Cryogenic Radiator Test Unit.....	67
 IV MATERIALS LABORATORY	
Significant New Advance in Electroluminescent Lighting Materials	70
"Soft" (Improperly Quenched) Aluminum Evaluation Results	72
Robots and Automation	73
Autoscan Metal Flaw Detection	74
Cast Aluminum Structures Technology	75
First RSR Radial Wafer Blade Engine Test Successful	76
Nonflammable Hydraulic Fluid/Seal Materials Development	77
Missile Radome Development	78
Detector Grade Intrinsic Silicon	79
Photochemical Deposition Process	80
Titanium Alloy in Gas Turbine Engine Compressor Environment.....	81
Fracture of Brittle Materials Under Laser Irradiation	82
Cure Monitoring of Adhesive Bonded Joints by Dielectrometry	83
New PBT Polymer Yield Outstanding Fiber Properties.....	84
Camouflage Radome Coatings	85
Dynamic Simulation Used to Assess Bearing Design.....	86
Promising New Resin (ATS) Development.....	87
High Strength Protective Carbon Fabrics.....	88
New Approach to Investigation of Polymer Cures	89

SECTION I
AERO PROPULSION LABORATORY

CONDITIONING MONITORING OF AIRCRAFT TURBINE ENGINE LUBRICANTS

Lubricant monitoring studies at Wright-Patterson AFB have produced a technique for identifying abnormal rates of lubricant degradation in aircraft turbines. Using the COBRA instrument (Complete Oil Breakdown Rate Analyzer), a change in lubricant condition can be detected in approximately one minute.

The rate and degree of lubricant degradation in a turbine engine is dependent upon such factors as the degree of lubricant aeration, lubricant temperature, oil consumption, oil system capacity and, to a lesser degree, lubricant formulation. For engines operating normally, the rate and degree of lubricant degradation is low. Changes in engine operating conditions that result in higher aeration (increased oxygen availability) or higher oil temperatures cause a significant increase in the rate of lubricant degradation. This increased degradation produces a change in the electrochemical properties of the lubricant as

measured by the COBRA instrument.

During a current field monitoring test program, the COBRA monitoring technique was successful in identifying 14 to 15 engines exhibiting malfunctions that would cause excessive lubricant degradation. Since the technique requires only two drops of the lubricant, COBRA measurements can be conducted in normal spectrometric oil analysis laboratories, using the same sample and recording the COBRA test data on the same oil analysis record form as in more time-consuming spectrometric techniques.

COBRA measurements correlate with other techniques for measuring lubricant degradation such as changes in total acid numbers and viscosities but these take considerably more time to determine and are less sensitive to early changes in lubricant degradation.

H.A. Smith/513-255-4667

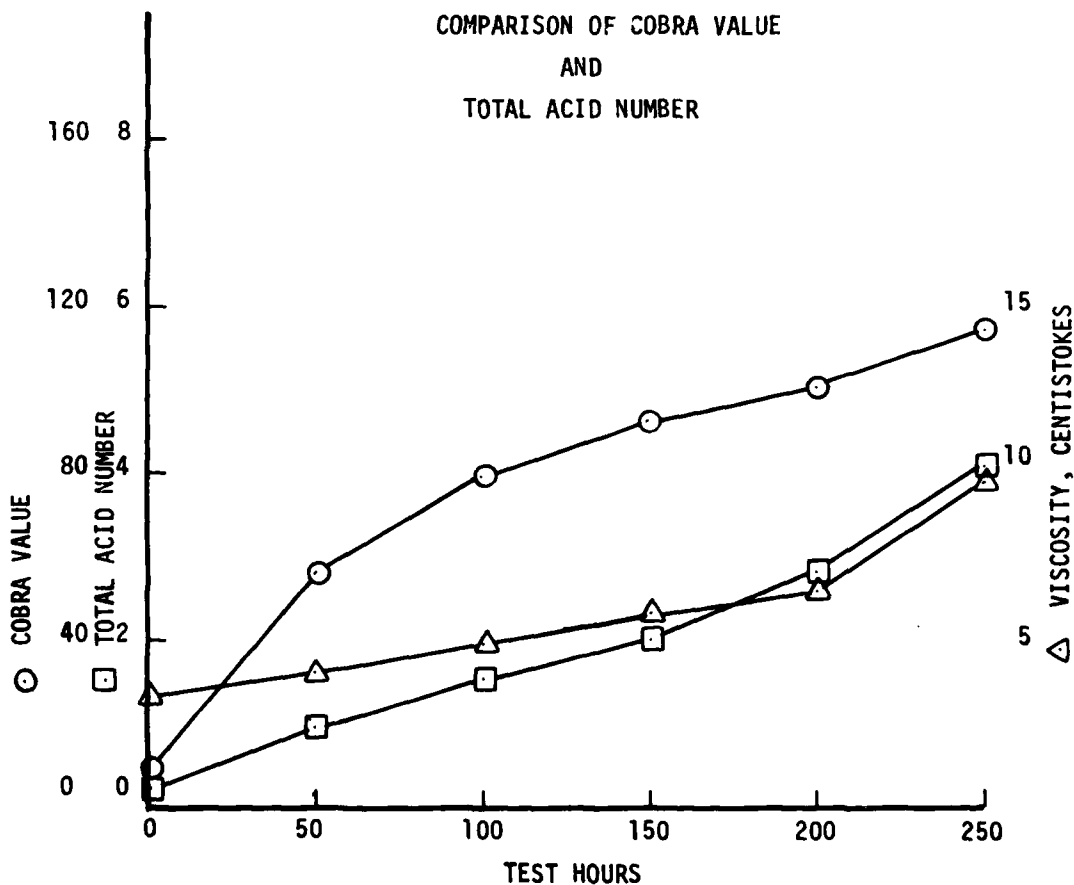

RAPID DETECTION OF AIRCRAFT FIRES

Detection is the first and probably most important single factor in control of aircraft engine fires. If a fire can be detected immediately after it starts, the probability is good that it can be brought under control. On the other hand, if a fire is allowed to become well established before detection, the aircraft will probably be lost. This is particularly true for aircraft with engines mounted in the fuselage or wing (as opposed to pod mounting).

A new radiation sensitive fire detector system has been developed. This system, also referred to as an "optical" or "visual" type, is sensitive to the ultraviolet radiation emitted by flames, yet insensitive to solar radiation (solar blind). This is achieved by making the sensor insensitive to radiation wavelengths above approximately 280 nanometers - the approximate cutoff for solar radiation. In theory, response time of the UV sensor can be on the order of microseconds; however, up to 1 second system response time is allowed to minimize the possibility of false signals due to cosmic radiation, lightning or other transient conditions. While the use of UV sensors (as well as other radiation sensitive devices) is not new, this system uses the newer microprocessor technology

to achieve a higher degree of flexibility and reliability than was previously possible. The system uses dual sensor detectors programmed such that, if one sensor "detects" a fire, another sensor in an adjacent detector must "verify" the fire before an alarm is given. Also, if both sensors of one detector fail, the system automatically reconfigures itself to permit a fire warning to be given by any two sensors. Should two adjacent detectors fail (total of four sensors), then a system fail warning is given indicating the system is incapable of detecting a fire.

In addition, the complete system (all sensors, wiring, computer control) automatically checks itself every 15 seconds. A typical system is shown in the illustration. This system, now being flight tested on an F-111 aircraft, is a simpler version using one sensor per detector and without the "detect" and "verify" feature. The simpler system would be lighter, would cost less, and would be primarily for use in dry bay areas and in multi-engine (pod mounted) aircraft.

G. Beery/513-255-4208

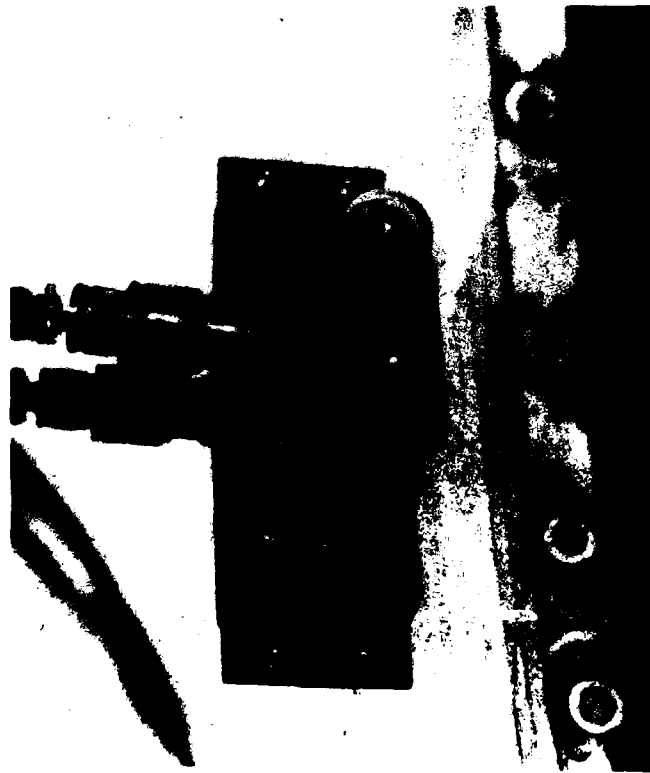

USAF/NAVY VARIABLE CYCLE TECHNOLOGY DEMONSTRATOR ENGINE

In December 1980, initial performance testing of a most successful variable cycle Joint Air Force/Navy Technology Demonstrator Engine (JTDE) was conducted. The GE23 Joint Air Force/Navy Technology Demonstrator Engine, developed under contract with the General Electric Company, is a result of five years of cooperation between the Aero Propulsion Laboratory and the Naval Air Propulsion Center, Trenton, New Jersey. A primary objective of the program was to evaluate advanced variable cycle engine technology and configurations capable of changing their internal component geometry (and performance) to respond to changing air speeds and altitudes.

The current GE23/F1A1 variable cycle configuration was achieved by integrating advanced low pressure spool components, such as a split fan concept and a variable single-stage

turbine, advanced materials, and an electronic control system with a reliable advanced gas generator. The core, which incorporates an 8-stage compressor, a single liner combustor, and a single-stage, high temperature turbine, has undergone extensive durability and cyclic testing.

The GE23 engine's single/double bypass allows for improved operation and fuel efficiency over a large part of the flight envelope. Variable geometry features in the fan stream, such as forward and rear variable area bypass injectors (VABI), are used to convert the JTDE from supersonic to a subsonic mode of operation. The GE23 has several advanced technology features to meet the need of future aircraft to operate efficiently over a range of diverse flight conditions at reduced life cycle cost.

Raymond N. Leo/513-255-2278

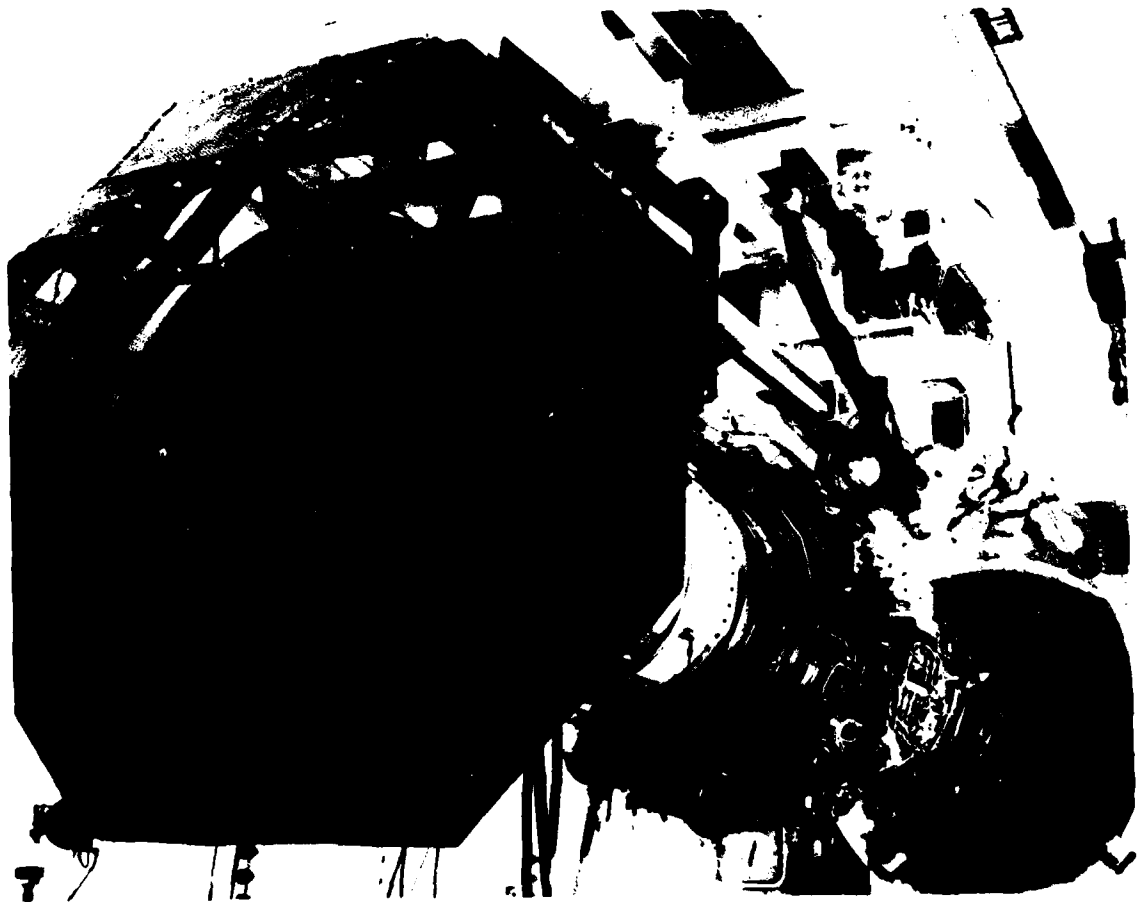

**HIGH QUALITY JET FUEL
ECONOMICALLY PRODUCED FROM SHALE OIL**

For the first time, military specification JP-4 jet fuel was refined in large scale demonstration quantities from whole crude shale oil. A total of 11,300 gallons of fuel meeting or exceeding all JP-4 requirements was produced in a process demonstration unit (PDU) facility belonging to Hydrocarbon Research Incorporated. Using hydrorefining, "Straight Run" technology developed for the Aero Propulsion Laboratory by a Sun Oil subsidiary (Suntech), yields of nearly 35% JP-4 were obtained. A commercially available nickle-molybdenum catalyst was utilized under the relatively severe temperature conditions of 825°F at 2800 psi and a liquid hourly space velocity of 1. This was the largest quantity of JP-4 fuel ever produced from shale oil that met applicable physical and chemical specifications. Also, the remaining heavy product or

bottoms can be further refined into more jet fuel or other transportation fuels. The shale oil was produced by Geokinetics Shale Oil Incorporated under an agreement with the Department of Energy.

Production data can be scaled up to a 100,000 barrel per day refinery where nearly 100% of the shale oil would be refined into specification quality transportation fuels at costs comparable to current fuel costs (\$.94/gal at Jun 1980 cost). Results have enabled the USAF to embark on an operational validation program, whereby shale oil derived JP-4 will be used exclusively at selected bases. The USAF will establish "user" bases for the first commercial shale oil production which could occur as early as 1983.

Eva M. Conley/513-255-2460

SHALE FUEL/MIL SPEC COMPLIANCE

Shale Derived JP-4

Freezing point (degrees F) minus 74
 Aromatics (% by volume) 9.3
 Sulfur (ppm) 6.0
 Olefins (% by volume) 1-2
 Specific gravity (degrees API) 50
 Heat of combustion (Btu/lb.) 18,700
 Reid vapor pressure (psi) 2

Mil Spec
 minus 72 max.
 25 max.
 4,000 max.
 5 max.
 45-57
 18,300 min.
 2-3

AIRCRAFT FUEL TANK PROTECTION

The fuel system is one of the largest vulnerable areas of an aircraft due to the risk of fire and explosion from combat gunfire penetration, lightning strikes, static electricity or other fuel ignition sources. The space in a fuel tank above the liquid level (ullage) contains fuel vapors and air. Ignition of a flammable fuel/air mixture in the unprotected ullage can result in a fuel tank explosion, causing structural damage to the aircraft. In the mid 1960's, the Air Force began installing reticulated (open cell) polyurethane foam into aircraft fuel tanks as a protection against explosions. Other benefits of this type of baffle material were soon realized because the material also reduced blast and fragment damage from a projectile and reduced fuel sloshing during flight.

In looking for improved and advanced materials, the Air Force evaluated an aluminum honeycomb mesh for protecting aircraft fuel tanks. This material, called Explosafe, is manufactured by the Explosafe Division of Vulcan Industrial Packaging Ltd. Toronto, Canada, and the program was therefore conducted as part of the United States-Canadian Defense Production and Development Sharing Project. The Explosafe system has been used for

several years in industrial/commercial gasoline containers and has been successfully applied to automobiles, boats, light aircraft, and railway propane tank cars.

The objective of the Aero Propulsion Laboratory program was to evaluate the system's compatibility with aircraft fuels and fuel tanks and to evaluate explosion suppression performance at reduced weights. Test results indicate that the material is suitable for aircraft use and that its explosion suppression performance is comparable to the foams. *Being made of aluminum and, if properly treated for corrosion, the Explosafe will last the lifetime of an aircraft.* The use of Explosafe is not intended to replace the foam but to supplement it by applying Explosafe in areas where foam cannot be feasibly used, such as in high temperature environments. The foam is most suitable in fuel tanks that require removal for maintenance due to its flexibility, whereas the Explosafe is most suitable in fuel tanks that are welded due to its high heat capacity.

T. Hogan/513-255-4208

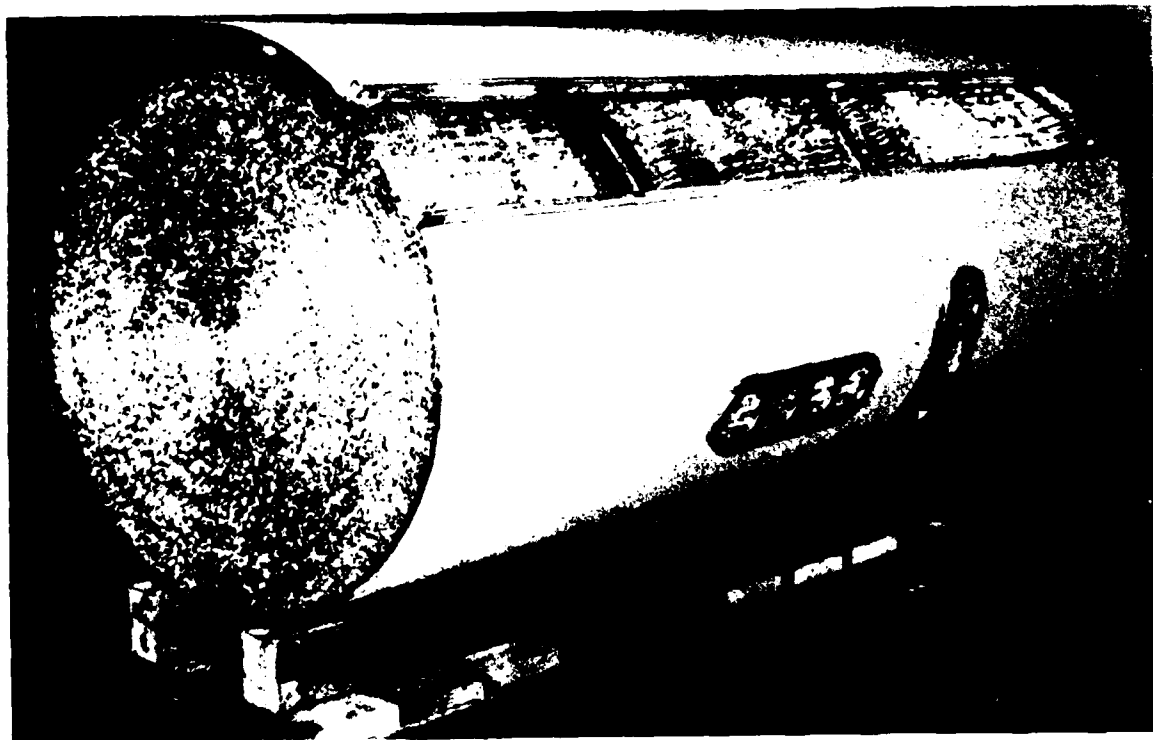

EXPENDABLE GASIFIER FOR SMALL TURBINE ENGINES

The Expendable Gasifier was developed by Teledyne CAE, Toledo, Ohio, under sponsorship of the Aero Propulsion Laboratory. The objective of the program was to use technology that would lower life cycle costs of small turbines. The gasifier was designed to be the core of either a 230 lbf thrust turbojet, a 230 hp jet fuel starter or a 500 lbf thrust turbofan, thus, achieving a greater production base and lowering procurement cost. Other cost saving features include a one-piece cast aluminum main frame, radial pin joint construction, waste fuel lube rear bearing, pot lube reduction gear and thrust

bearing, a 4-stage axial compressor with identical rotor castings machined to different blade heights, and maximum use of cast components. The gasifier core is not designed for overhaul and is discarded after its useful life. The cost of a new gasifier is considerably less than the cost of overhauling equivalent turbines used today. During these tests, the unit achieved 212 lbf thrust and a specific fuel consumption of 1.56 lbm/lbf-hr

Joseph Gottschlich/513-255-6241

EXPENDABLE GASIFIER APPLICATIONS

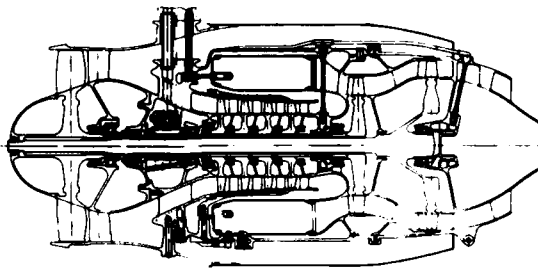

TURBOFAN (500 LB THRUST)

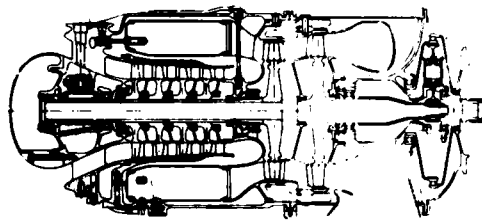

JET FUEL STARTER (230 HP)

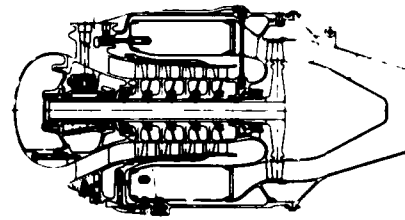

TURBOJET (230 LB THRUST)

21675

AIR-LUBRICATED FOIL BEARING DEVELOPMENT FOR AIRCRAFT AUXILIARY POWER UNITS

The self-acting, air-lubricated foil bearing concept including both radial and thrust load carrying configurations, offers significant advantages over conventional liquid lubricated rolling element bearings. When considered for mainshaft support in small turbomachines, these advantages can include reduced weight, cost savings, reduced maintenance and vulnerability, added reliability and higher operating temperature capability. Realization of these advantages is made possible primarily through elimination of the liquid lubrication system and its attendant oil transfer lines, oil pumps, oil coolers, etc. In the past, foil bearings have had their most extensive application in air cycle machines used in aircraft environmental control systems. This very successful experience has included both military and commercial aircraft. In this application and considering only the journal (radial) configuration, bearing sizing was less than two inches in diameter, bearing unit loading was on the order of 20 psi and bearing operating temperature requirements were less than 550°F. Because of this success and the potential advantages mentioned previously, it was only natural to consider the foil journal bearing for larger turbomachine applications. One very promising area, based on a logical extension of the air cycle machine journal bearing technology, was military aircraft auxiliary power units (APUs). To be successful in this application, development was necessary to increase bearing load carrying capacity requiring larger bearing sizes and higher unit loadings and to

provide bearing coatings with higher operating temperature capability. To that end, the Aero Propulsion Laboratory sponsored a program with the Garrett Turbine Engine Company to develop a foil journal bearing for the hot, turbine end of the GTCP 165 APU. This APU is used in the C5A aircraft and is representative of recent APU technology. Its hot end is a natural location for the foil bearing with its superior thermal capability as compared to the existing conventional liquid lubricated cylindrical roller bearing. Analysis of this APU, retrofitted with a hot end foil bearing, identified the following bearing performance requirements: optimum bearing size of 3.5 inches in diameter; bearing unit loading capability of 22 psi (335 pounds); maximum operating temperature of 790°F; and an overall temperature operating range including starts of -65°F to 790°F. Results from this program, as demonstrated in a test rig simulating the APU foil bearing compartment, were significant. In each case, bearing performance requirements were exceeded. Bearing unit loading achieved with a 3.5 inch diameter bearing (12 foils) was 24 psi (350 pounds). Maximum operating temperature demonstrated was 1020°F and successful starts to full APU operating speed were made at temperatures ranging from -65°F to 990°F. With this successful rig development in hand, future efforts will concentrate on demonstrating this technology in actual APU hardware.

R. D. Dayton/513-255-4347

JOURNAL

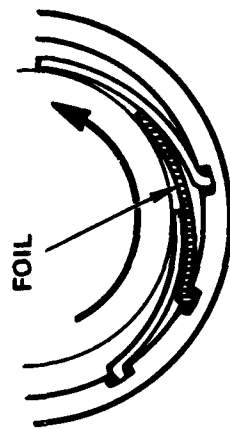
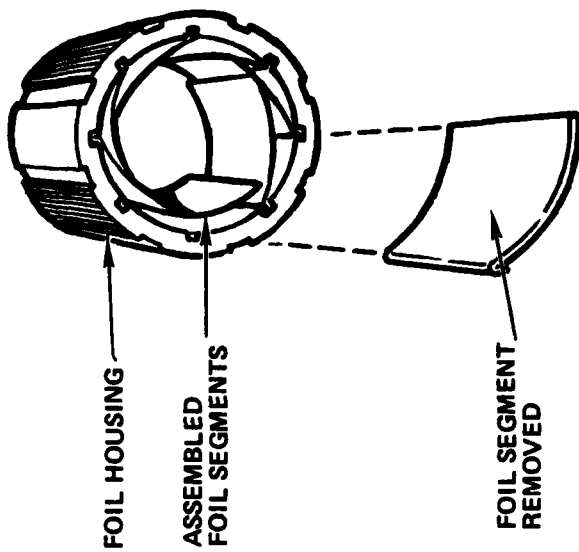

THRUST

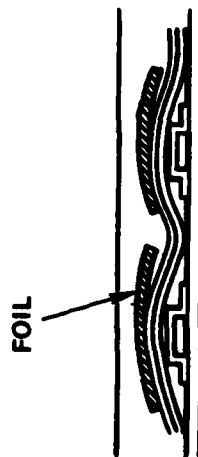
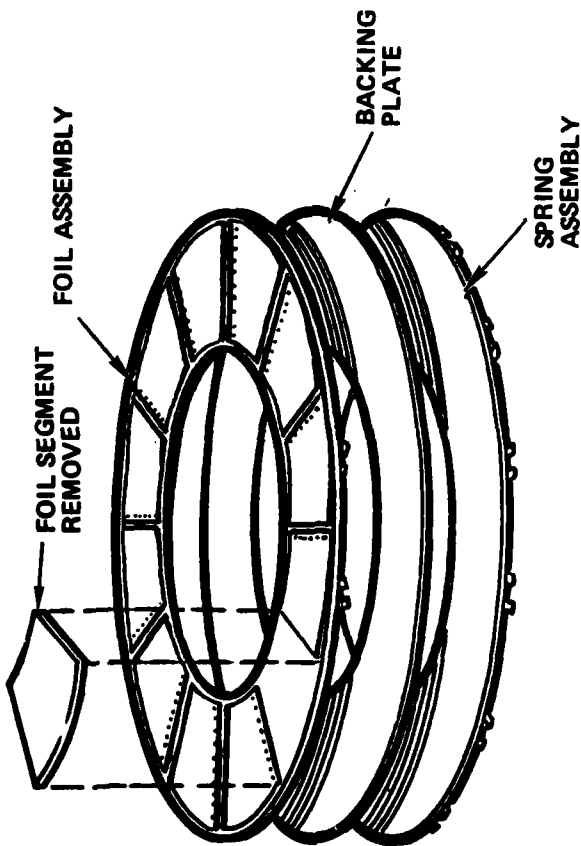

NEW CLOSED-CYCLE RARE GAS LASER

The use of lasers in many practical Air Force applications is limited by optical output power, laser lifetime, and its use of consumables (gases). To achieve higher average powers in gas lasers, a gas flow system has to be incorporated and, to avoid consumption of very expensive gases, a closed cycle system is necessary. Previous research at the Aero Propulsion Laboratory resulted in reliable, long-term operation of a Helium-Xenon atomic gas laser, but the physical configuration of an ordinary rectangular closed-cycle flow system was too large for many airborne applications. A new configuration employing an annular return flow and carefully designed turning and flow conditioning sections has resulted in a very compact system suitable for use on small aircraft. The high quality of the vacuum system allows the laser to be operated with the same gas fill over a period of more than a month. During an actual test, this laser ran continuously for a period of 100 hours with a pulse

repetition rate of 5kHz and 1.1W average output power with no observable deterioration of output power. The total accumulated pulses were over 1.8 billion and may be a record for a flowing gas, sealed-off device. It is also indicative of the lifetime capabilities of other components of the system (switches, energy-storage capacitors, fans, seals, etc.). The output spectrum of this laser is unique, having simultaneous radiation on 5 or more wavelengths distributed over the three important spectral windows in the near-to-medium infrared wavelength range (2 to 2.4 microns, 3 to 4.2 microns, and 4.4 to 5 microns). Characteristics of this multi-wavelength source also include a variable pulse repetition rate to beyond 12kHz. These features, along with its ruggedness, small size, and long operational lifetime, make it an attractive radiation source for many applications.

Dr. Peter Bletzinger/513-255-2923

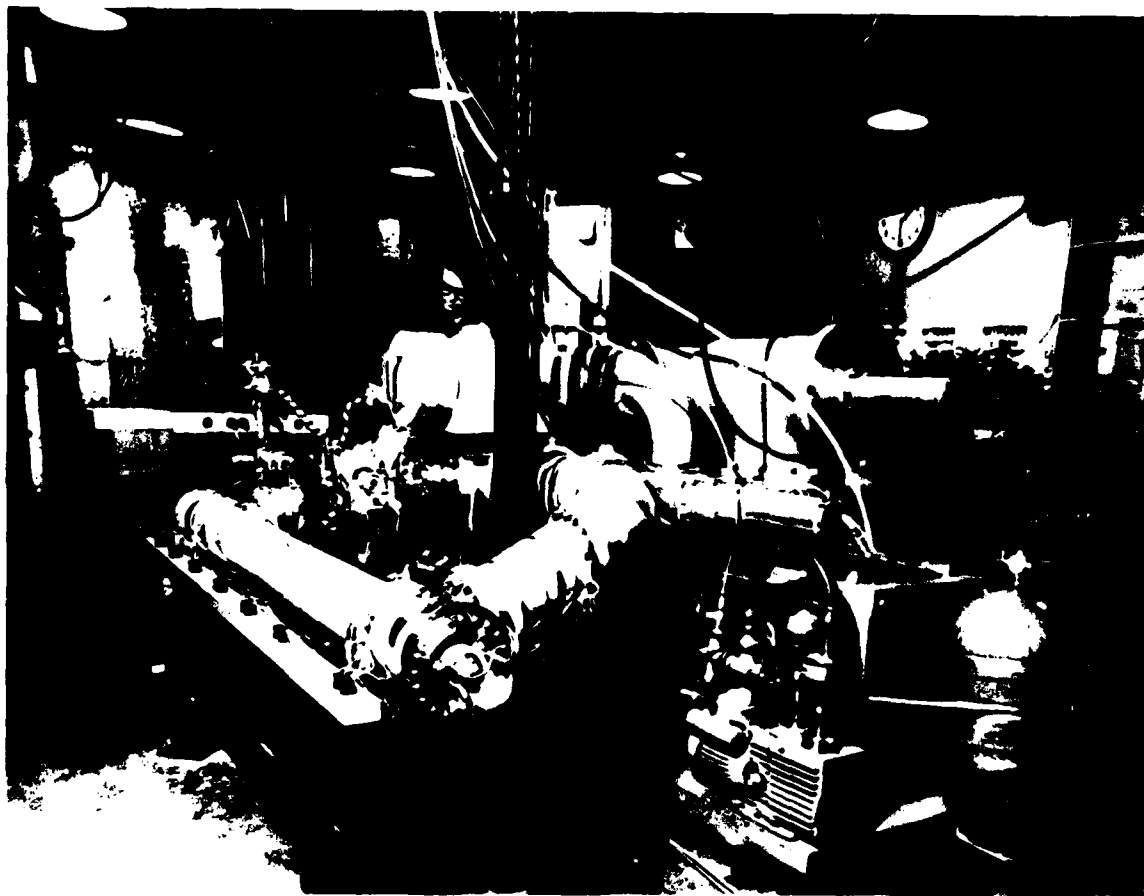

FUEL EFFECTS ON JET ENGINES

The rapid depletion of light, low-sulfur petroleum crude oils will require the use of heavy petroleum crudes, oil shale, tar sands, coal, and possibly biomass as sources of aviation turbine (jet) fuels. To insure adequate jet fuel availability and minimum costs, significant changes to jet fuel properties may be necessary. The Aero Propulsion Laboratory has been investigating the effects of anticipated fuel property changes on performance and durability of jet engine combustors, turbines, and augmentors.

The test results conducted on a conventional J79, a J79 with a low smoke combustor, a TF41, and a F101, revealed significant increases in combustor liner temperatures as the hydrogen content of fuel decreased. This increase in combustor liner temperature degrades combustor liner durability. The production of jet fuels from coal and shale will result in jet fuels with hydrogen contents of about 12% and 13%, respectively, if expensive

hydrogenation processing is not used. Thus, a cheaper fuel, i.e., one having a lower hydrogen content, could be used but at a cost of increased engine maintenance. This tradeoff must be optimized to provide minimum life cycle costs along with acceptable engine life.

Currently, work is in progress to determine how fuel properties affect the generation of soot particles and the effect of soot particle size distribution, concentration, and hardness on turbine nozzle and blade life. The effects of fuel properties on turbine engine augmentor performance and durability are also being assessed.

Data will be used to define fuel specification properties for USAF jet engine fuels of the late 1980s and 1990s.

Charles R. Martel/513-255-2460

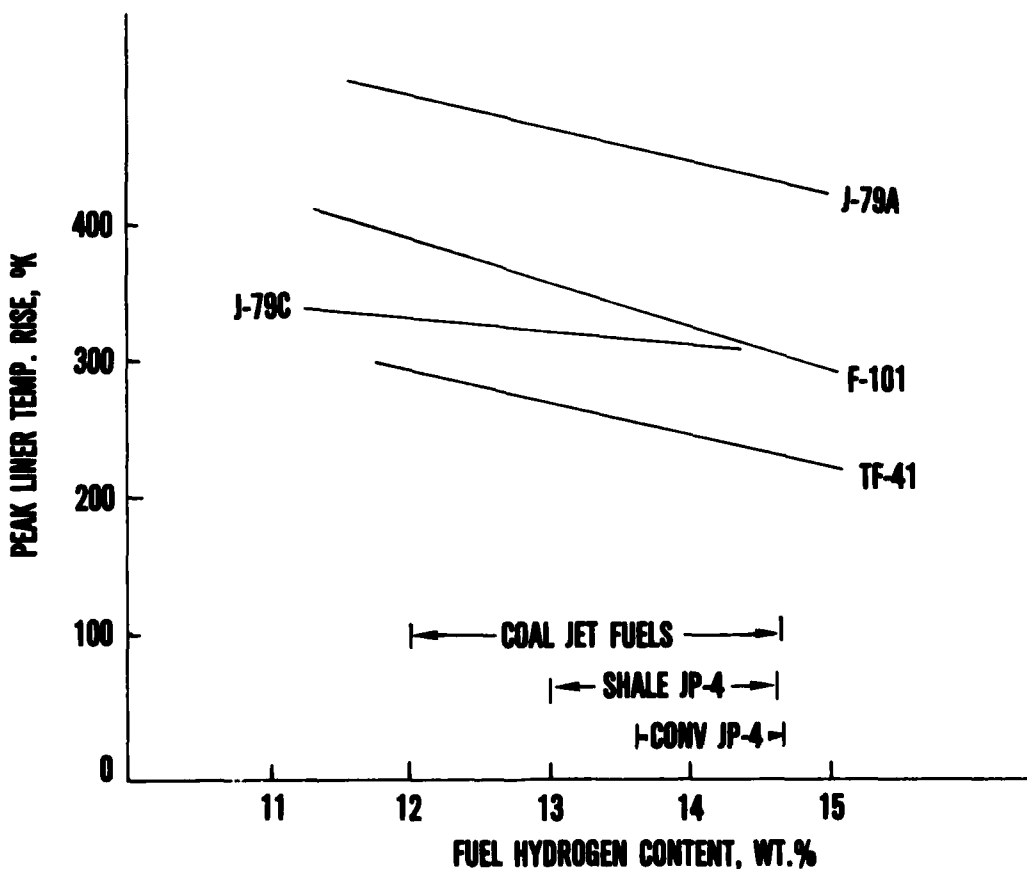

TURBO-STRUCTURES RESEARCH LABORATORY

In Fiscal Year 1980, the Turbo-Structures Research Laboratory used Image Derotated Holographic Interferometry to study the structural dynamics of bladed disk configurations under rotating conditions. The first phase of this research effort which dealt with the use of double pulsed holographic interferometry to record the modal patterns of a rotating disk, was completed and the results published in the journal of Experimental Mechanics. The recently completed second phase of this research effort proved the feasibility of observing a rotating disk's modes of vibration in real time. This accomplishment represents a significant breakthrough in the area of Image Derotated Holographic Interferometry. The results were presented at a meeting of the Society for Experimental Mechanics. The real time derotation technique is described below:

Real-time image derotated holographic interferometry is carried out by replacing the pulsed ruby laser, used in previous tests, with an Argon-ion laser. The Argon-ion laser can be designed to emit a series of pulses using an intra-cavity acousto-optic Q-switched modulator, and, in effect, the laser can be designed to emit a train of pulses having some

preset pulse width, frequency, and phase. Using the strobed laser in conjunction with the image derotator, a rotating disk's resonant structural response at any point in its cycle of revolution can be studied. Following a very fine alignment of the optical system, a hologram is made of the nonrotating disk. The disk is then rotated at some specified speed and the image derotator is used to synchronize the derotated disk image with the holographic image of the disk. Once the two images (derotated disk image and holographic image) are matched to within interferometric tolerances of each other, real-time fringes will appear, and a real-time vibration analysis can be carried out on the rotating disk.

The described technique was used to carry out a real-time holographic vibration analysis on an annular aluminum disk under rotating conditions (2000-4500 RPM). The results of the real-time tests were compared to the same mode shapes obtained under nonrotating conditions. The experimental set-up used to perform real-time derotated holographic interferometry is shown in the figure

Dr. James C. MacBain/513-255-2081

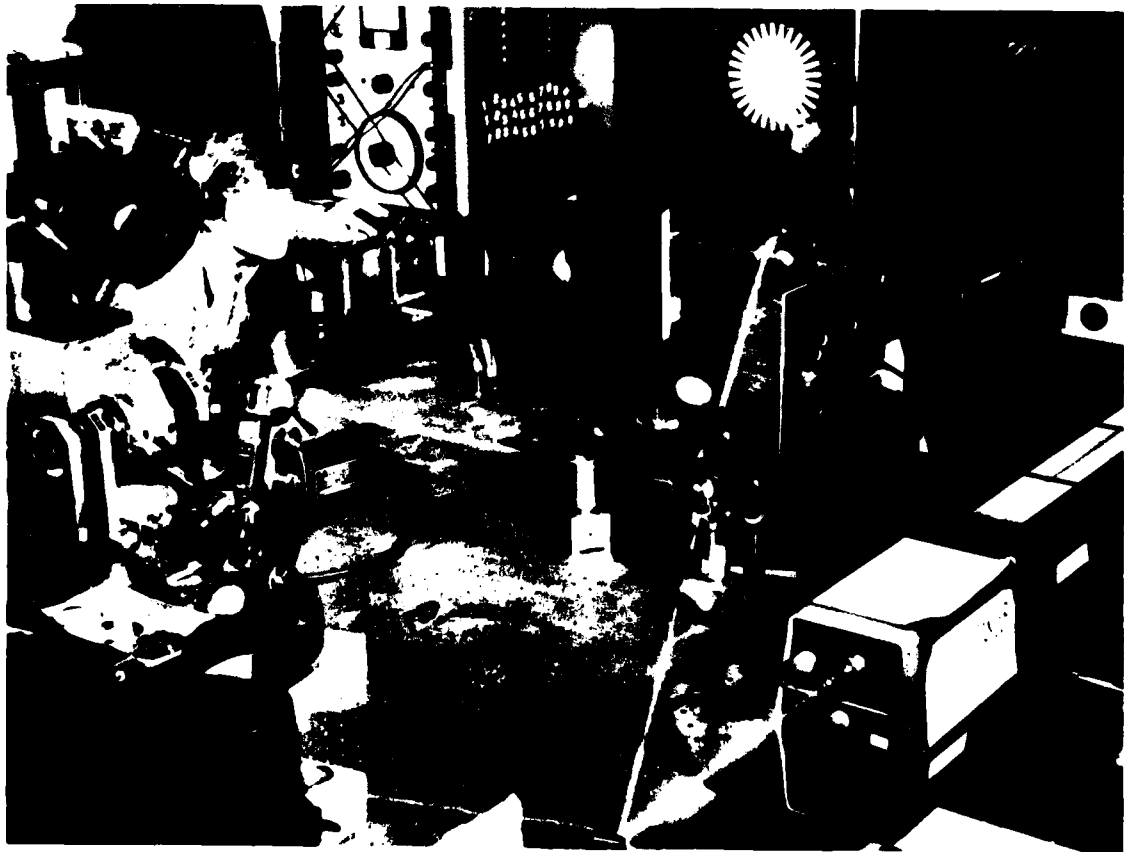

HIGH PERFORMANCE AUXILIARY POWER UNIT

Successful endurance and performance of the High Performance Auxiliary Power Unit (HPAPU), derived from the Lycoming LTS 101 propulsion engine, was completed under Aero Propulsion Laboratory contract. Invited representatives of the Navy, Army, NASA, and the aircraft industry viewed the demonstration of typical operational modes of engine starting and checkout/standby. A teardown and reassembly of major modules, using a training engine, was performed to exhibit the extreme simplicity of the modular design relative to field maintenance provisions.

In the demonstrated configuration, the HPAPU had

a power density of 185 hp/ft³ of hardware volume. An additional very attractive characteristic of this power unit is its proven low fuel consumption. Specific fuel consumption in the range of 0.62 to 0.65 lb/hp-hr was repeatedly demonstrated throughout the HPAPU advanced development testing. The endurance testing demonstration was 50 hours at full power. Except for one unscheduled shutdown, this was a continuous demonstration run. Thus, the aircraft industry has a very attractive APU option available in the 500 hp class.

Beryl L. McFadden/513-255-6241

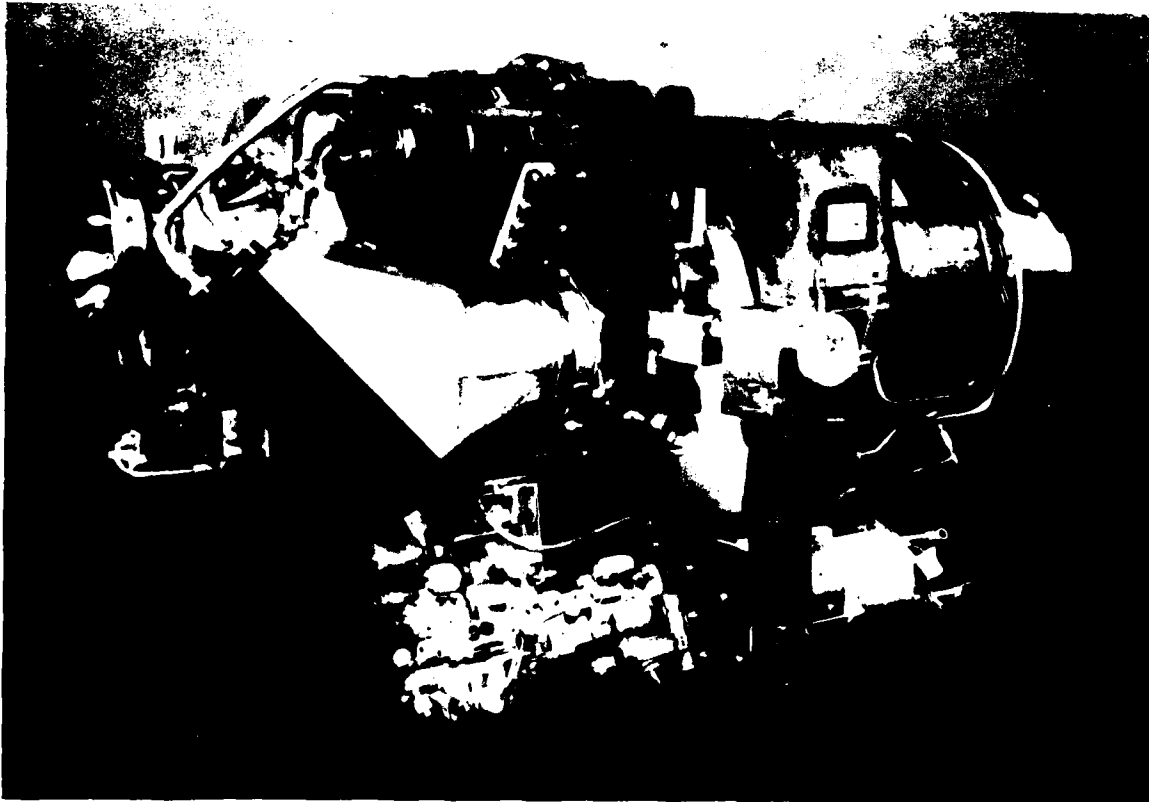

FREEJET DEMONSTRATION OF TACTICAL LIQUID FUEL RAMJET

Performance of a JP-4 fueled ramjet for powering Sparrow-sized missiles to extended ranges was demonstrated in a freejet facility. These tests demonstrated integration of the ramjet components which were previously demonstrated separately in the four-year program by the Marquardt Company. The program included McDonnell Douglas (the subcontractor) preliminary design and wind tunnel testing of a missile into which the ramjet could be advantageously integrated. Missile performance

estimates based on the freejet test results were as predicted and are suitable for providing intercept missile capability. The integral rocket-ramjet propulsion system achieves extended predicted flight range through ramjet engine throttling over a wide range of fuel flows and through use of an improved inlet.

David B. Wilkinson/513-255-2013

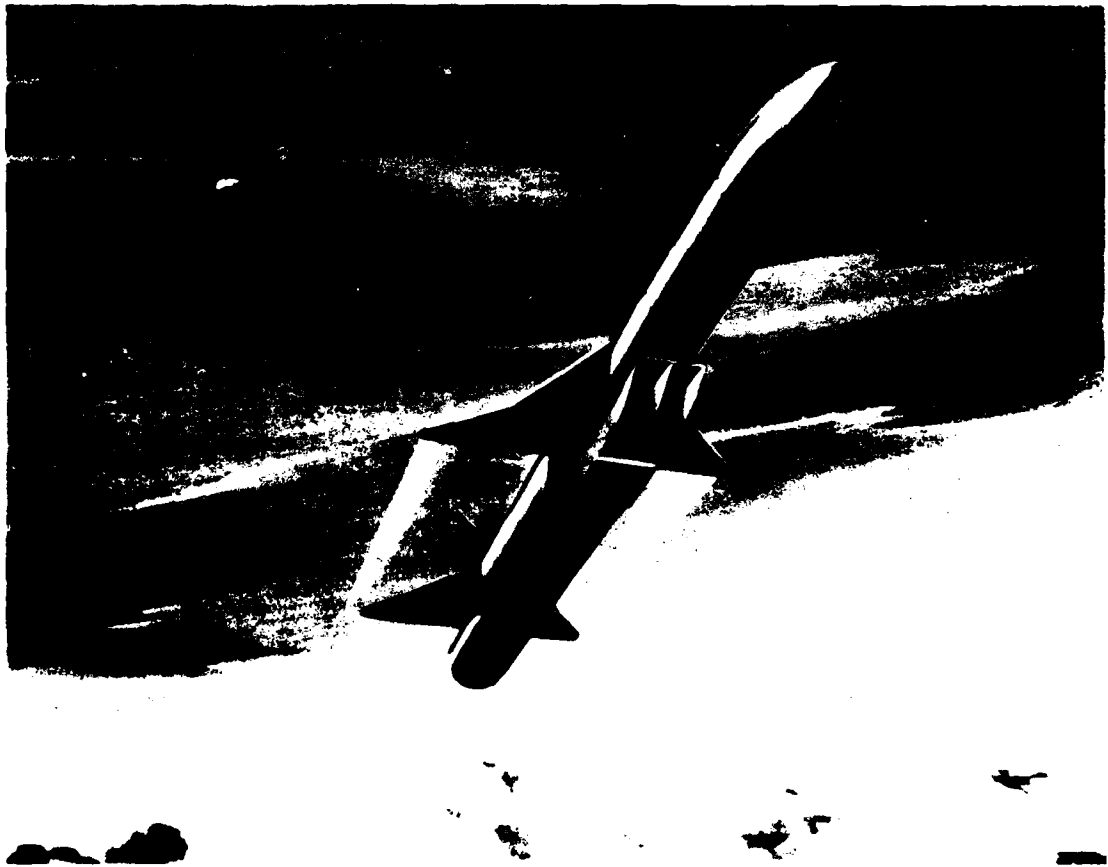

SOLID FUEL RAMJET

This experimental effort had the objective of demonstrating a solid fueled ramjet propulsion system that satisfied the performance requirements of an air-to-air missile. To achieve the performance goals, a bypass design was selected. In this configuration, approximately half the air enters a single forward inlet and consumes a portion of the available fuel in the main combustion chamber. The remainder of the air enters two 180° opposed aft inlets, passes into a mixing chamber, and consumes the rest of the available fuel.

Semi-freejet and wind tunnel tests were conducted to evaluate inlet performance, combustion efficiency, sustainer fuel regression behavior and combustor stability in a 9-inch diameter bypass solid fuel ramjet. Engine performance measured during the course of the semi-freejet and wind tunnel program generally met or exceeded the performance levels used in the initial design stages. Stable combustion was demonstrated over the design operating range, and ignition and sustained

combustion were achieved at the off-design depleted air conditions of the 10x10 tunnel engine tests. Mechanical and thermal protection system components functioned as designed and the inlet performance was close to expected levels. Combustor performance was evaluated at angle of attack and yaw at a single off-design flight condition. Combustion was sustained at this off-design point and with depleted tunnel air. These tests, performed with hydrocarbon fuel grains, demonstrated good fuel utilization and high combustion efficiencies that are consistent with previous direct-connect test results. Dynamic pressure measurements indicated no evidence of combustor or multi-inlet instability at supercritical flow conditions. Inlet performance was documented over a wide Mach number range, angle of attack (-5° to 15°) and yaw (0° to 3°) in the NASA Lewis 10x10 wind tunnel.

Norman A. Hirsch/513-255-2013

HIGH EFFICIENCY SOLAR TO ELECTRICAL ENERGY CONVERSION FOR SPACE APPLICATIONS

The conversion of sunlight directly into electrical power by photovoltaic action (solar cells) has been used for over 20 years aboard military and civilian spacecraft. With increasing emphasis on space missions, the demand for more power (without large increases in weight and area) is generating a corresponding increase in the need for higher conversion efficiency. Recent results in research on higher efficiency photovoltaic devices, under Air Force sponsorship, have shown considerable promise for achieving space sunlight conversion efficiencies in the 25% to 30% range as compared to a range of 14% to 18% for present solar cell technology.

The specific devices of interest are called cascaded multiple bandgap solar cells. These cells consist of two or more photovoltaic junctions connected both optically and electrically in series, in a monolithic structure. The individual subcells, each of a particularly selected semiconductor material, utilize the incoming solar energy more effectively in their respective response bands than does a single junction solar cell acting as a broad band energy converter. The materials used are formed from various combinations of chemical elements from Groups III and V of the table of the elements. The combinations, such as GaAs, AlGaAs, AlGaAsSb, etc., are classed as binary, ternary, and quaternary

III - V semiconductors with bandgaps and lattice constants dictated by the various possible elemental compositions. Since cascaded cells are grown either from vapor or liquid phase in single crystal form, lattice constant matching is necessary to achieve high quality semiconductor properties throughout. Also, since it is required to have "optically matching bandgaps", the choices of the various III - V semiconductor combinations becomes restricted.

The Air Force program is developing the AlGaAs semiconductor system to achieve 25% efficient conversion. The illustration reveals the structure and semiconductor materials used. The research has demonstrated laboratory conversion efficiencies in the neighborhood of 20% without detailed optimization and only two years of effort on the specific material system. Once control of semiconductor material growth parameters is obtained, efficiencies approaching 23% to 25% will be routine.

Research is planned for three cell stack configurations which will provide greater than 30% efficiency. The present two cell stack system now under investigation will establish a sound technology base for the three cell stack device.

Dr. W. Patrick Rahilly/513-255-6235

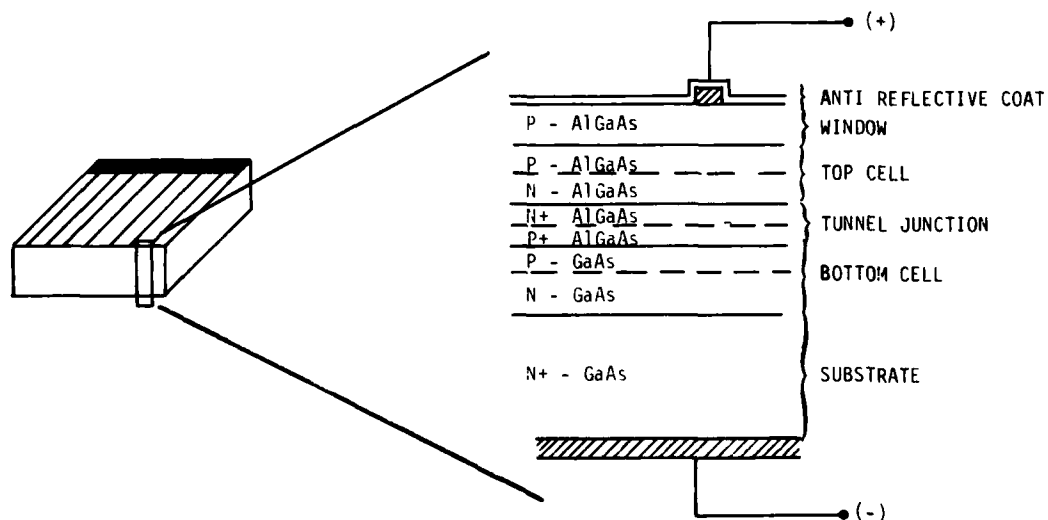

VARIABLE GEOMETRY COMBUSTOR

Several conflicting requirements related to the fuel/air ratio in the combustor front end influence the design of conventional aircraft turbine engine combustors. As engine power is advanced from idle, the mass flow in the combustor front end changes from fuel lean to fuel rich. The amount of air directed to the front end is a compromise between too rich at high power and too lean at low power. Unfortunately, with fixed combustors, there is no getting around this fuel/air ratio change. Overly rich operation at high power creates excessive smoke while attempts to direct additional air to the front end are accompanied by some loss in relight altitude capability, flame-out tendencies during throttle chop, and greater exhaust emissions at low power. With the continuing trend toward higher combustor temperature rise, the front end fuel/air ratio has been allowed to increase at high power and to decrease at low power. This combination is a trade-off. The combustor would benefit if more air could be directed to the front end at high power and less air at low power. The variable geometry combustor (VGC) program solves this problem by admitting additional air to the front end at high

power and closing down the air ports at low power, thus tailoring the front end fuel/air ratio. With VGC, advanced high temperature rise engines will be smoke free and possess excellent relight altitude capability and reduced low power emissions.

In Phase I of the VGC program, two contractors, Garrett Turbine Engine Company (GTEC) and Pratt & Whitney, studied 50 conceptual VGC designs before selecting 8 for bench-scale tests. Phase II calls for full-scale testing of VGC operation in an advanced engine.

In January 1981, GTEC VGC testing exhibited simulated altitude ignition during windmill engine conditions at 45,000 to 65,000 feet. These results should prove the low power superiority of the VGC compared with conventional fixed geometry combustors.

High power tests scheduled for early Fiscal Year 1982 should prove equally superior performance of the VGC during high power operation.

Kenneth N. Hopkins/513-255-5974

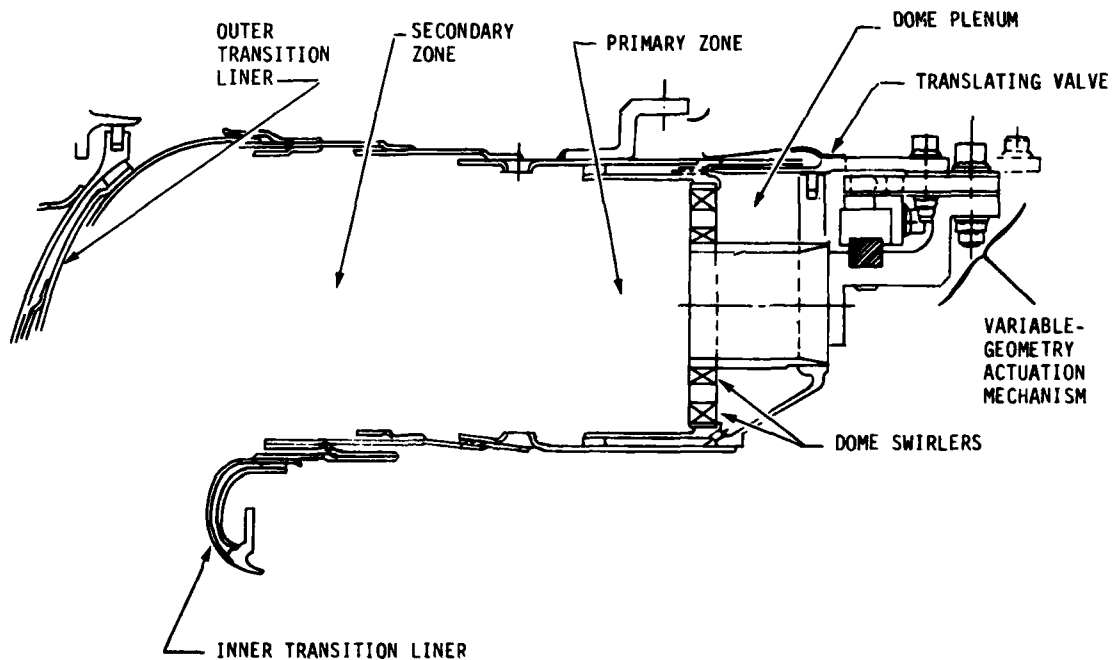

TURBINE ENGINE FAULT DETECTION AND ISOLATION PROGRAM

This Aero Propulsion Laboratory Turbine Engine Fault Detection and Isolation (TEFDI) program is a three-phase research and development program to develop and demonstrate information engineering technology for effective utilization of automated turbine engine health monitoring systems. Phase I encompassed a detailed system analysis study, user survey effort, and task force review by TAC/ALC/AFLC participants leading to the definition of requirements for an engine Maintenance Information Management System (MIMS). Phase II is producing the software architecture and data base design to support these requirements. In Phase III, a functional MIMS system will be implemented using Wright-Patterson Air Force Base computing facilities as a central data bank accessible through remote terminals.

Data gathered from AFLC's A10 Turbine Engine Monitoring System (TEMS) program, ASD's F100 Engine Diagnostic System (EDS) program, and from the Navy's Inflight Engine Condition Monitoring System (IECMS) program make up part of the MIMS data base. These data along with data products from current maintenance procedures, such as SOAP, AFTO 93, AFTO 349, etc., are accessed by the MIMS system.

Demonstrations of the MIMS capabilities to the

various levels of maintenance (base, depot, and command) have led to the further development of the MIMS system in FY 80. MIMS terminals have been installed at SA-ALC, ITFW at Langley Air Force Base, and at McDonnell Douglas Company. The purpose of this phase is to assess the effectiveness of the MIMS to provide concise, accurate information to different levels of the Air Force maintenance system in a timely manner and in a format familiar to each user.

The MIMS system is being further developed under an AFLC contract to continue developing the A10 TEMS system. Under this program, the A10 TEMS system will be installed on a squadron of A10 aircraft at Barksdale Air Force Base, Louisiana. The MIMS system will be the heart of the squadron evaluation. Maintenance data will be input to the central data base through MIMS and all output will be through MIMS. In the squadron evaluation program, the A10 TEMS/MIMS system will replace standard maintenance procedures and will be the only means of detecting engine problems, analyzing engine anomalies, and directing both routine and non routine maintenance actions. A functional schematic of A10 TEMS/MIMS system is shown.

Charles A. Skira/513-255-6690

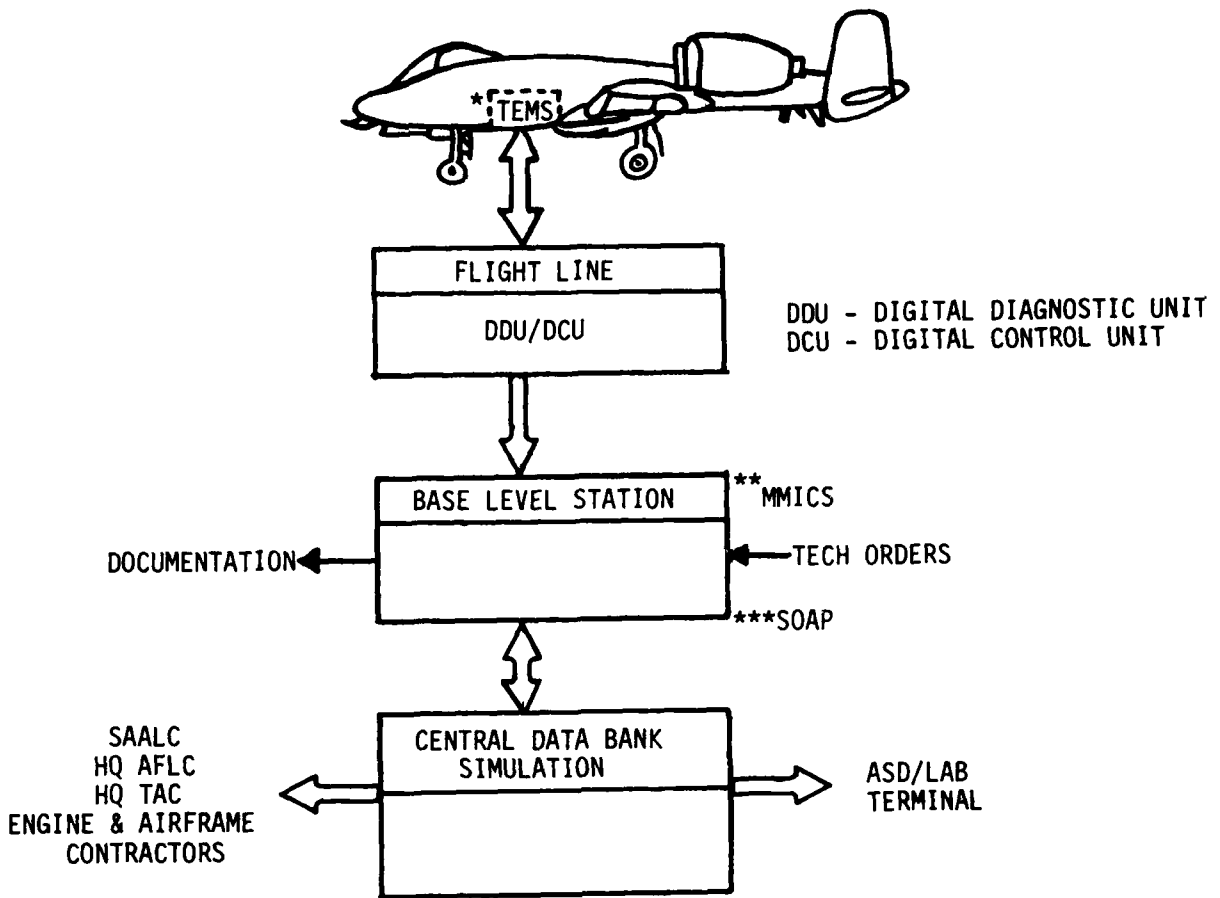

- * TURBINE ENGINE MONITORING SYSTEM
- ** MAINTENANCE MANAGEMENT AND INFORMATION CONTROL SYSTEM
- *** SPECTROMETRIC OIL ANALYSIS PROGRAM

ADVANCED TURBINE ENGINE GAS GENERATOR DURABILITY DEMONSTRATION

In January 1981, the first Advanced Turbine Engine Gas Generator (ATEGG) accelerated life test was successfully completed, and all contract goals and commitments were exceeded. The main objectives of the General Electric Company program were to establish the durability baseline of the advanced GE23 turbine engine core and assess/validate the contractor's current turbine life prediction tools and test techniques. This was accomplished by assessing an array of advanced components/concepts which offer significant durability improvements including the shingle liner combustor, bore entry cooling, boltless retainer, variable high pressure turbine nozzles, and turbine blade coatings and materials, such as Rene' 80 (GE baseline turbine blade material used in TF34, F101 and CF6) and Rene' 150 (4 times the life of Rene' 80). Prior to the test, the turbine blade materials were characterized and the life of each Rene' 80 and Rene' 150 turbine blade predicted for the expected test environment.

The actual test program consisted of two test

phases; a 100 hr creep/rupture phase (extended time at maximum temperature and speed) and a low cycle fatigue test phase. The primary objective was to induce damage and failure mode interactions on the turbine blades and expose other gas generator components to the accelerated test conditions. The GE23 core, used for this test, proved to be the most durable core ever tested under the ATEGG program and accomplished 336 hours of testing and over 2100 thermal cycles. Most importantly, this valuable test time was accrued on advanced components which demonstrated the potential to improve engine durability by up to four-fold.

In addition, the induced failure of 35 Rene' 80 turbine blade airfoils revealed strengths and weaknesses in predicting turbine blade life. Particularly, areas such as heat transfer, materials characterization and instrumentation were noted where improvements could be made which would favorably impact current life prediction techniques.

Z. D. Massie/513-255-3428

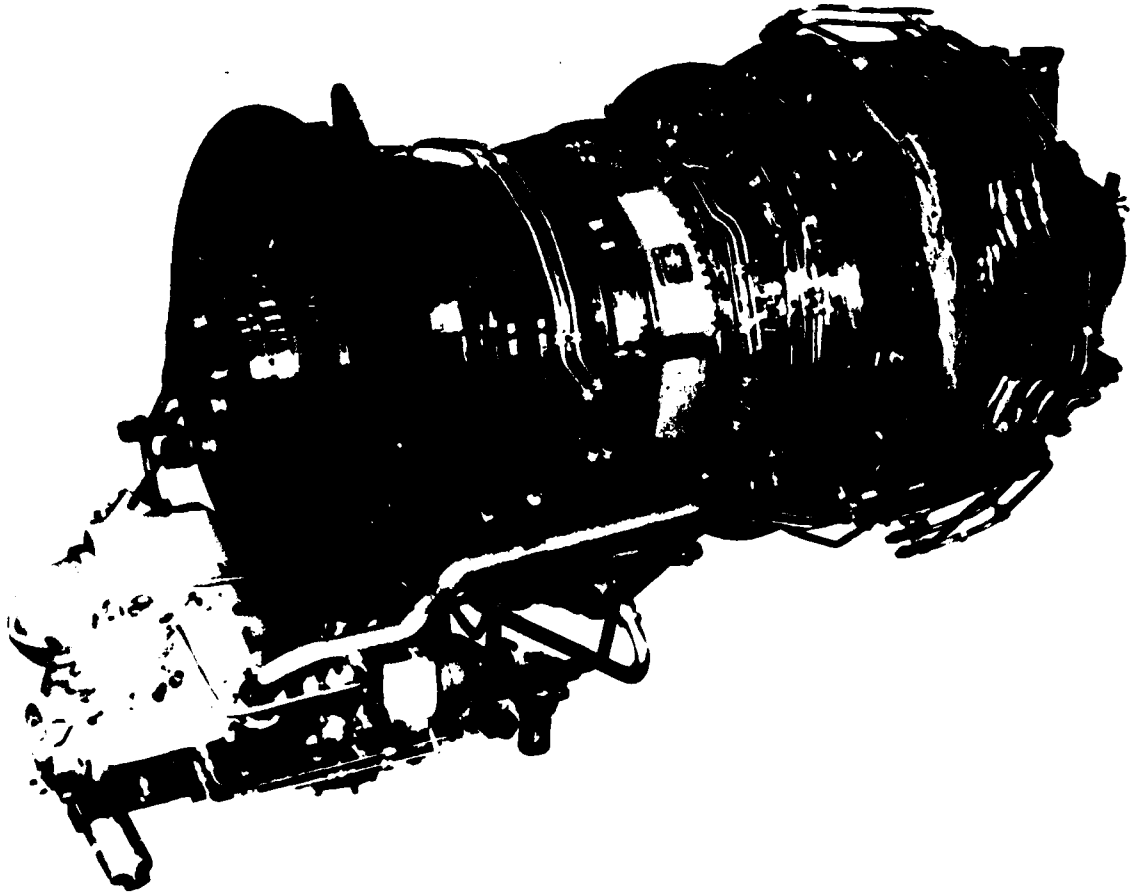

SECTION II
AVIONICS LABORATORY

FIBER OPTIC/INTEGRATED OPTIC PHASE REVERSAL SWITCH

A fiber optic/integrated optic phase reversal switch was developed at Hughes Research Laboratories under sponsorship of the Avionics Laboratory. The following accomplishments were achieved:

a. Both two- and four-section phase reversal versions of the switch were demonstrated operating at a wavelength of 0.85 micron.

b. Less than 1 db coupling loss was demonstrated between LiNbO_3 , Ti-diffused strip waveguides, and single mode fibers.

c. The electro-optic directional coupler switch was assembled with permanently attached single mode fibers, fiber to chip coupling losses of 1.8 db, and total fiber to chip to fiber loss of 7.8 db. The chip contained a four-section reversal switch and was 2.5 cm in length. There were four attached fiber pigtails.

d. The deposition of the buffer layers between waveguides and electrodes was demonstrated successfully.

e. Consistent, flat and chip-free edge polishing

was demonstrated.

f. An anti-reflective coating for interfaces between LiNbO_3 chip and fibers was demonstrated.

g. Losses associated with bends and offsets in waveguides were analyzed and confirmed by experimental data.

In the model switch which was delivered under this program, reflections in the fibers from the integrated optical switch were down by 14 db. Rise time and fall time for the switchable coupler were less than 200 nanoseconds. The switch was demonstrated with on-time of 2 to 4 microseconds per pulse an on-time capability of 500 nanoseconds. The operational bandwidths ranged from 100 Hz to 500 MHz. Switching voltage was 25 volts for the cross state and 50 volts for the parallel state. The switch has potential application in fiber optics gyros and in single fiber communications systems.

E. R. Nichols/513-255-5582

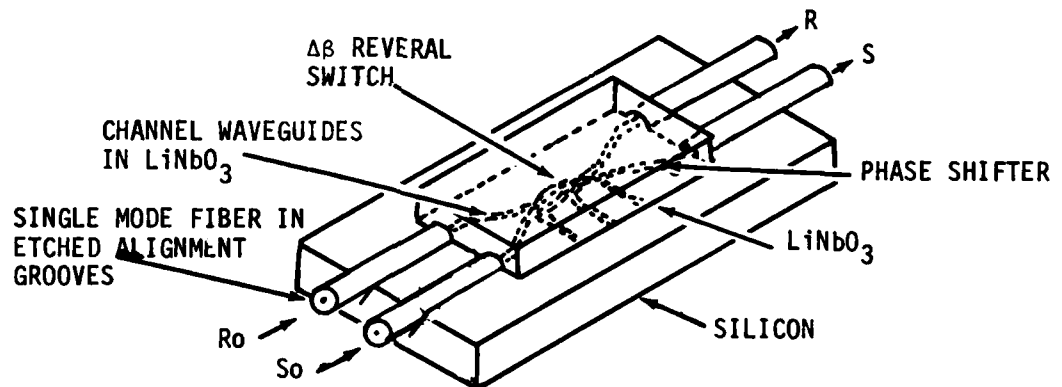

HBr/OVERTONE HYDROGEN HALIDE LASER

Combustion driven interhalogen HBr chemical laser performance with over 100 watts output and 20 lines in the 4 to 4.8 μm region was obtained. This technical effort, developed by United Technologies Research Center for the Avionics Laboratory, surpassed contract requirements with a two order of magnitude increase in HBr laser output. Additionally, a 4 watt output was obtained in DF overtone operation in the 1.8 to 1.9 μm region. The laser has already demonstrated capability for operation in the 2.6 to 3.5 μm region (HF), the 3.7 to

4.1 μm region (DF, HCl), and the 4.8 to 5.4 μm region (Cl). The demonstrated improvement in performance will help, in development of gas laser technology, to enable fabrication of a compact, CW, 2 to 5 μm chemical laser which would have increased power, improved coverage in the spectral range, increased reliability, and capability for efficient airborne application in the range of 10-100 watts.

O. P. Breaux/513-255-2804

ELECTRIC PULSE INITIATED CHEMICAL LASER

A new method to generate laser action in the 4 to 5 μm spectral region was developed by Raytheon Company under an Avionics Laboratory contract. The method extends the spectral coverage of the electric pulse initiated chemical laser to optically pump various isotopes of CO_2 contained in sealed interaction cells. Quantum efficiencies for this process can exceed 50%, while overall conversion efficiency is as high as 10%. Since no

decomposition of CO_2 occurs in the sealed absorption cell, the method demonstrated the first CO_2 laser with the potential for a very long lifetime. Also, the method provides an alternative to the HBr chemical laser, which produces lower laser power in the 4 to 5 μm spectral region and employs a highly corrosive chemical as the laser species.

Lt C. Krabec/513-255-2804

35 GHz ACTIVE APERTURE

A low cost, light weight, millimeter wave integrated antenna/transmitter package was developed by Motorola Company under an Avionics Laboratory contract for use in low cost, high resolution missile guidance systems, particularly in short range or terminal guidance applications.

The unit can be mechanically scanned and delivers 40 kW effective radiated power. The transmitters consist of four double drift silicon IMPATT diodes, each capable of producing in excess of 10 W peak pulse power. Pulse widths of 100-200 ns and repetition rates to 100 kHz were obtained in an injection locked mode with relative intrapulse phase errors of less than ± 10 degrees. Each IMPATT diode feeds one quadrant of the 6 inch diameter antenna aperture and utilizes spatial power combining to reach the 40 kW ERP level. The antenna consists of a strip-line feed, image element, and slot array. The image element concept allows the use of a highly

thinned array (only 16 active elements per quadrant) that minimizes associated feedline losses typically incurred in a conventional corporate fed filled array. Subdividing the array into quadrants facilitates the incorporation of dual axis monopulse circuits on receive, which, like the transmitter chain, is strip-line printed on low cost printed circuit boards. The transmitter/antenna is entirely self contained and requires only DC power to function. While no receiver beyond the RF monopulse circuits was incorporated, it could easily be accommodated on the back of the aperture in place of the waveguide outputs. The 40 kW ERP transmitter/antenna system coupled with a minimal receiver could yield a 6 km active guidance system for short-range applications.

Bob Neidhard/513-255-2965

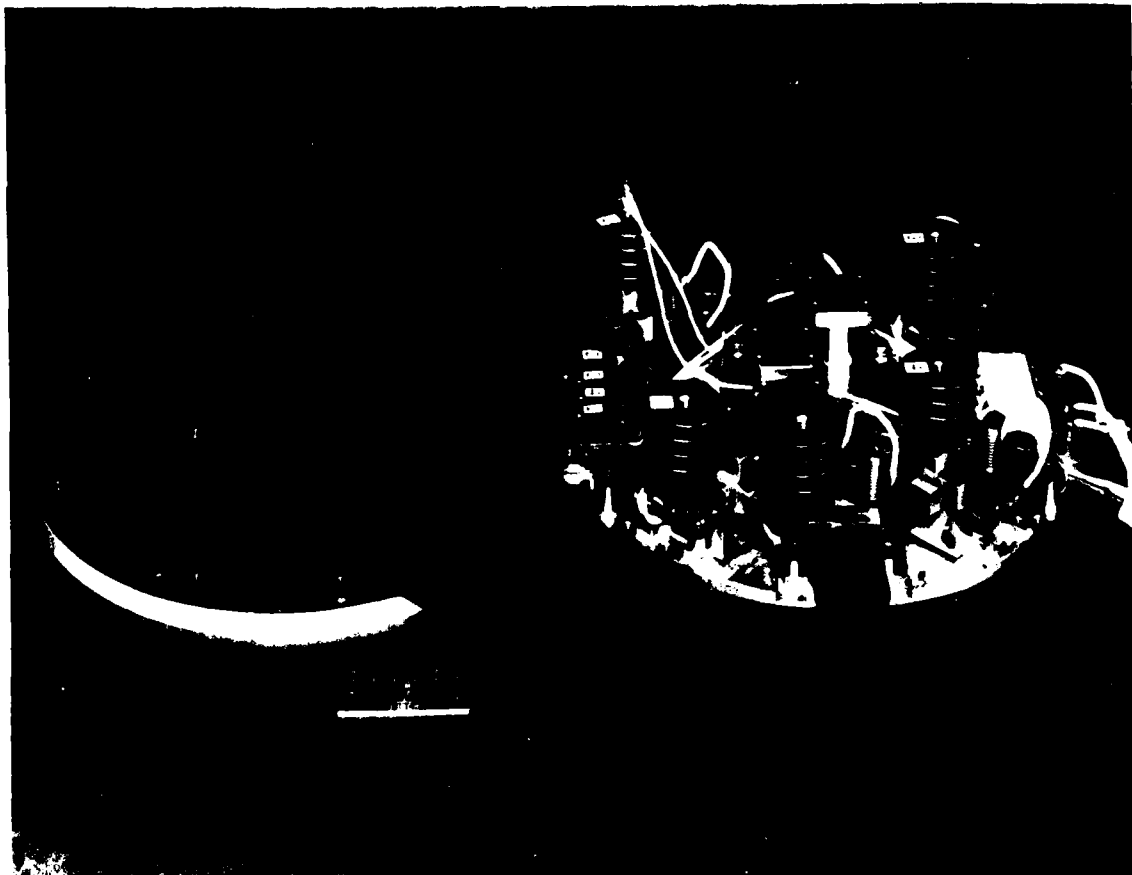

HIGH SPEED DIGITAL PHASE LOCKED LOOP CIRCUIT

The digital locked loop circuit (DPLL), an integrated circuit developed recently by Texas Instruments under an Avionics Laboratory contract, overcomes the problems of analog phase or frequency filtering and phase to digital conversion. The DPLL, with integrated circuit digital techniques to perform the necessary filtering and conversion functions, operates over a wide frequency range. It has an easily programmable bandwidth from very wide to very narrow. Because of its monolithic construction and digital operation, the DPLL is virtually

insensitive to environmental conditions and small power supply variations. The accuracy of the DPLL depends only upon the accuracy of the system clock. The DPLL can be utilized in all systems in which information is present as phase or frequency variations. This includes telemetry, navigation systems, frequency synthesis, TV and radio tuners, and control systems utilizing feedback.

W. Williams/513-255-5362

DIGITAL AVIONICS INFORMATION SYSTEM

The Digital Avionics Information System (DAIS) was an advanced development effort of the Avionics Laboratory aimed at reducing proliferation of digital avionics hardware and software, the cost of its development, acquisition and maintenance, thereby reducing the cost and complexity of future avionics updates. DAIS increases mission effectiveness through the use of modern techniques incorporating redundant data paths and the ability to reconfigure a system automatically to compensate for battle damage. DAIS was the only advanced development program that addressed avionics standardization from a total weapon system perspective. The main goals of this program were to develop standard hardware and software that would have broad applicability to many avionics systems and to fully demonstrate the system in a ground-based laboratory test facility.

Avionics systems such as the inertial navigation set, radio navigation set, radar altimeter, communications radios, stores management system, and their associated controls and displays were integrated via the DAIS architecture and used to perform a simulated combat mission.

Only a decade ago, all avionics were analog. Today, the majority of such systems are digital and DAIS provides for orderly management and design of digital avionics systems. The commercial computer industry has consistently achieved payoffs from their investments in standard interfaces, flexible designs, commonality, and interchangeability of devices. DAIS will afford the Air Force similar

payoffs.

The DAIS program was completed in September 1980. A real-time, pilot operated demonstration of the DAIS information management system concept was successfully accomplished. This was done using three architecture standards: MIL-STD-1553B Multiplex, MIL-STD-1750 Computer Instruction Set, and MIL-STD-1589B J73 Higher Order Language. Detailed specifications, manuals, test plans, and procedures are available describing DAIS system level concepts, the integrated test facility, the hardware configuration for the ground based laboratory, the real-time executive system, and the mission level hardware and software developed during the DAIS program for use in validation and verification of the concept.

The DAIS concept uses a standard 1MHz Multiplex data bus in a time sharing manner to carry system or subsystem information around the aircraft. Standard processors, multiplex equipment, shared controls, and displays are used to reduce avionics black box count and to reduce avionics systems Life Cycle Cost. A key characteristic of the DAIS concept is the real-time executive software. This software (written in MIL-STD-1589B) provides mission independent executive software services and contains a standard executive to apply software interfaces for independent development of mission dependent software.

Mr. T. A. Brim/513-255-4854

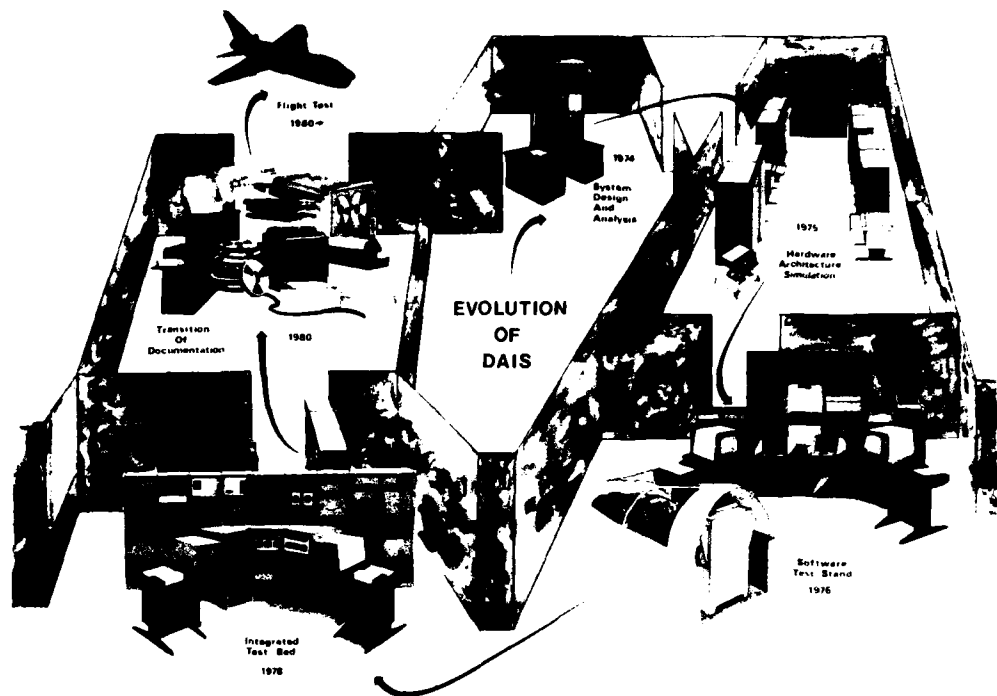

FLIR TECHNOLOGY DEMONSTRATION

In the Forward Looking Infrared (FLIR) Technology Demonstration Program, the Avionics Laboratory funded development of second generation scanned focal plane array FLIR sensors. Of pivotal importance was development of extrinsically doped silicon focal plane array technology providing chips with several thousand detectors and associated on-chip signal processing for the 8-12 micron spectral region. In FY 80, using indium interconnect technology, Hughes Aircraft Company successfully fabricated high density chips containing thousands of detectors and successfully produced images with single chips representing one-sixth of a required focal plane. Later, two chips butted together produced images that demonstrated the feasibility of fabricating a complete focal plane using this approach. Continued development of this FLIR technology will increase the Air Force's tactical capability by increasing night or adverse weather target acquisition and weapon delivery ranges and by reducing the FLIR sensor's size and weight. In fact, it will allow target recognition at twice the range of current FLIRs if the same size FLIR window is used. Alternately, the additional resolution and

sensitivity can be used to decrease required FLIR size or to increase probability of correct target recognition by a factor of two. In a Low Altitude Navigation Targeting Infrared for Night (LANTIRN) application, a second generation FLIR would allow dramatically fewer false alarms (therefore, fewer wasted missiles), enough resolution to distinguish anti-air threat systems from tanks (therefore, prioritized weapon delivery), and an easier weapon delivery timeline (thus, assuring release of all weapons even in degraded weather or countermeasure conditions).

Second generation FLIRs will allow subsystems with smaller size for our smaller aircraft and substantially increased target acquisition and prioritization capability. Further maturing of silicon focal plane array technology and subsequent exploitation in subsystem development provide an opportunity for later application of Very High Speed Integrated Circuits (VHSIC) signal processing technology.

A. Grandjean/513-255-5922

40 GHz SOLID STATE AMPLIFIER

Medium power, millimeter wavelength solid state amplifiers were developed by TRW under an Avionics Laboratory contract. These amplifiers demonstrate recent improvements in frequency of operation and output power of solid state devices. At 40 GHz, a two-stage silicon impact ionization avalanche transit time (IMPATT) diode amplifier, generating a 10-watt continuous wave 3 db gain, has been developed. The final amplifier stage employs 12 diodes, in a resonant combiner circuit, to achieve the desired output level. Each diode has an individual bias regulation circuit, and each amplifier

stage has a telemetry circuit for monitoring its performance. Extensive RF and environmental measurements have been conducted on the amplifier, including IMPATT diode accelerated life tests. The 40 GHz amplifier has potential use in satellite communications down link transmitters. Advantages of high reliability and small size enables the solid state amplifier to be an attractive candidate for space communications applications.

Tim Kemerley/513-255-2062

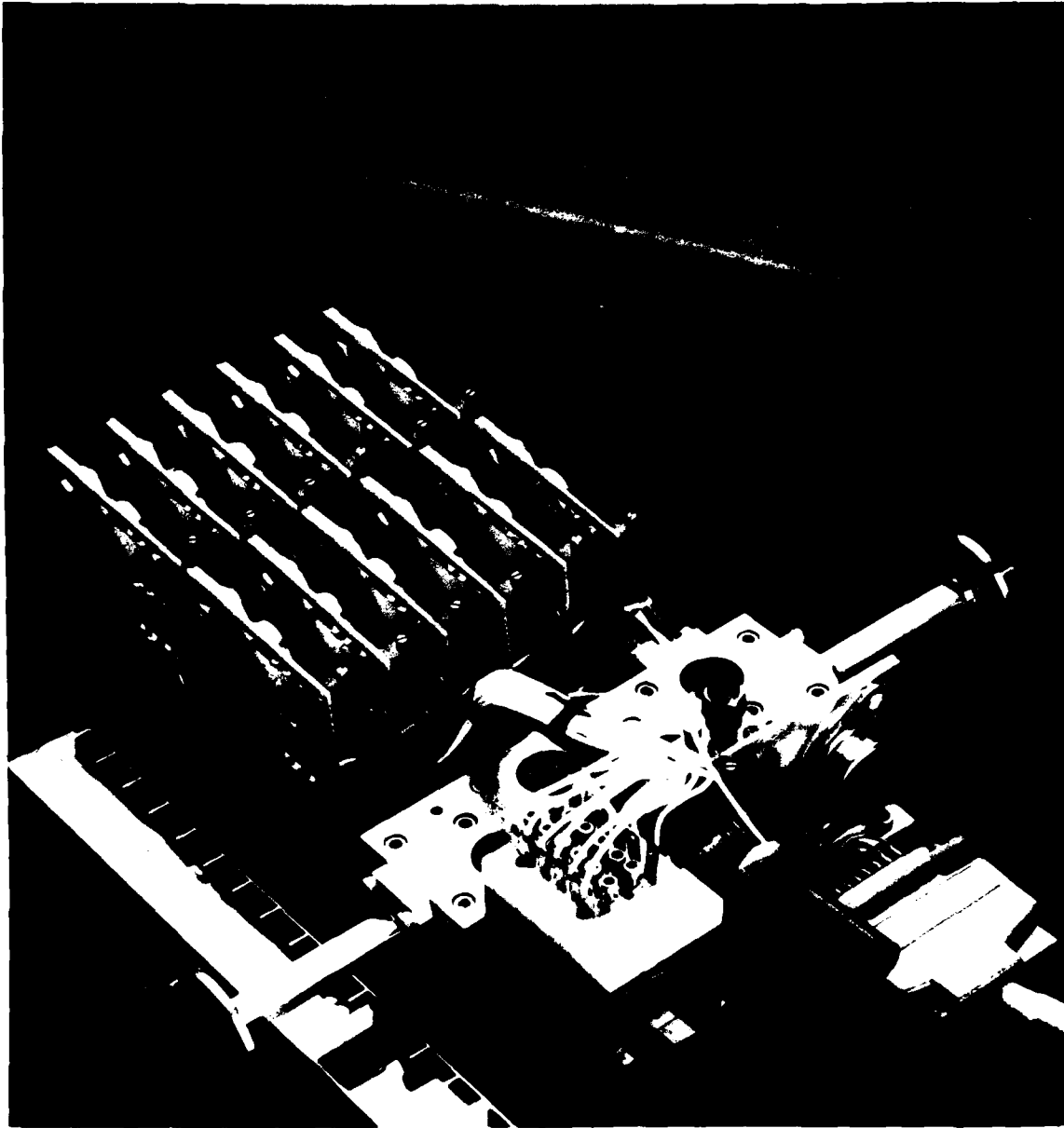

MAGNETOSTATIC WAVE DEVICE

Signal processing devices, developed by Westinghouse under an Avionics Laboratory contract, was demonstrated at 9 GHz, based on the propagation of magnetostatic waves in epitaxial yttrium iron garnet. A typical delay line with single input/output transducers is shown. Volume wave propagation losses of 3 db for 100 nanoseconds was achieved. The delay line concept was used to develop a ten channel filter bank with 3 db bandwidth of 50 MHz and insertion loss of 16 db, a dispersive chirp delay line with a bandwidth of 1

GHz and a time bandwidth product of 216, a programmable four-tap delay demonstrating the generation and detection of Barker codes, and a delay stabilized oscillator with stability of ± 1 MHz over 0°C to $+65^{\circ}\text{C}$. All devices had center frequencies of approximately 9 GHz. Signal processing at microwave frequencies using magnetostatic wave technology is emerging.

Alan Mertz/513-255-2062

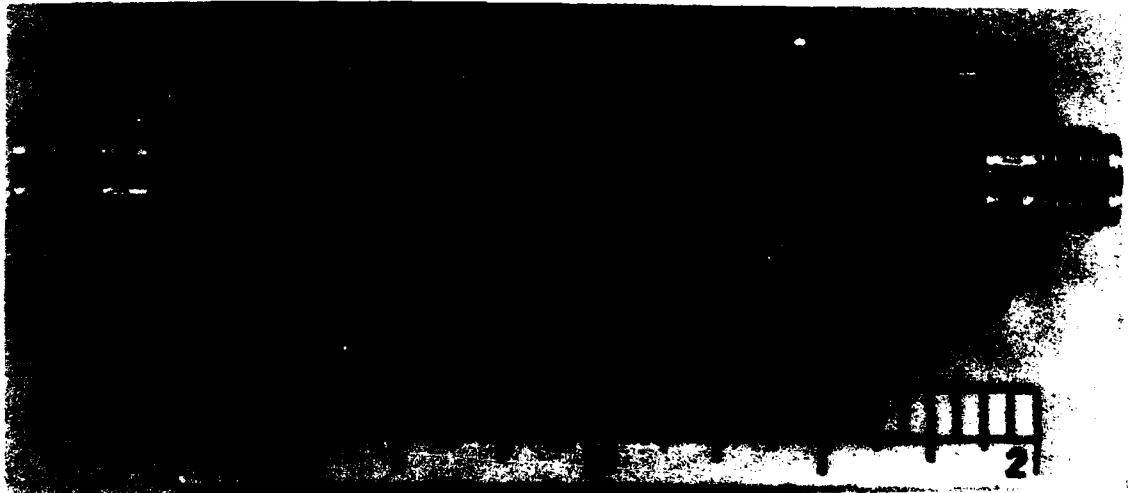

TACTICAL DECISION AID

The Tactical Decision Aid (TDA) is a computer model developed by the Avionics Laboratory for use by tactical commanders in combat operations. It will forecast inherent thermal contrast between a ground target and its surrounding background and the effects of the atmosphere on IR Systems (i.e., maximum acquisition and maximum lock-on ranges). The TDA is composed of four individual computer models which have been integrated in a fully mechanized fashion. These four models are:

a. An interactive processor which interfaces directly with the analyst to define the scenario, environmental parameters, and the desired thermal contrast prediction times.

b. A thermal contrast prediction model which predicts the inherent radiance of a ground target and its surrounding background by simulating the effects of the environment on the temperatures of

the object.

c. An infrared system performance model which simulates the entire operation of an infrared sensor and a human observer in the defined scenario and environment.

d. An interactive graphics output processor which provides on-line presentations of thermal contrast and IR system lock-on and acquisition range as a function of time of day.

The TDA is written in an interactive mode which allows the user to answer questions resulting in the desired output of inherent thermal contrast and applicable range. A Preliminary Tactical Decision Aid (PTDA) is currently available for use by Air Weather Service (AWS) during the Maverick IOT&E.

Capt. Steven James/513-255-3765

HIGH SPEED MICRO SIGNAL PROCESSOR

Today's sophisticated Air Force systems dictate the need for small, low power, high speed processors. Commercially available microprocessors or microcomputers can either meet our high speed requirements at the sacrifice of size and weight or our size and weight requirements at the expense of speed. In an attempt to satisfy all of these requirements in one processor, the Avionics Laboratory sponsored a program at Raytheon Corporation to develop a CMOS/SOS High Speed Micro Signal Processor (HSMSP).

The HSMSP is a 12-bit general purpose, programmable, pipe-line signal processor designed to perform digital filtering and vector processing algorithms. It is well suited for medium performance signal processing applications (0.5 MOPS to 3 MOPS), where small size and low power requirements predominate. The HSMSP provides a versatile building block for many diverse signal processing applications and is a major time/cost savings over former hard wired processors. The architecture of the HSMSP represents a unique design capable of a wide range of applications without excessive interconnecting, complex micro coding, or algorithm inflexibility. The architecture elements consist of a high speed pipe-line arithmetic unit, a dedicated program sequencer,

and data address memories. This functional dedication provides a high degree of parallelism providing computation rates consistent with medium to high performance signal processors. Typical applications for the HSMSP that have been analyzed include:

- Cruise Missile Guidance
- Precision Ballistic Missile Reentry Guidance
- Air-to-Air Missile Seeker Processing
- Synthetic Aperture Radar Processing
- Undersea Surveillance, Sonar Beam Processing
- Infrared Image Correlation, FLIR/Missile
- Air Defense Radar Signal Processing

Application analysis has indicated a set of desirable features that result in direct extensions of the existing design. It is emphasized that these features, developed as a peripheral chip set to the basic processor, will yield a more cost effective and universally usable system than leaving new chip designs to the specific user. These features fall into four categories: support software, speed enhancement, memory options, and built-in test.

R. Bobb/513-255-4448

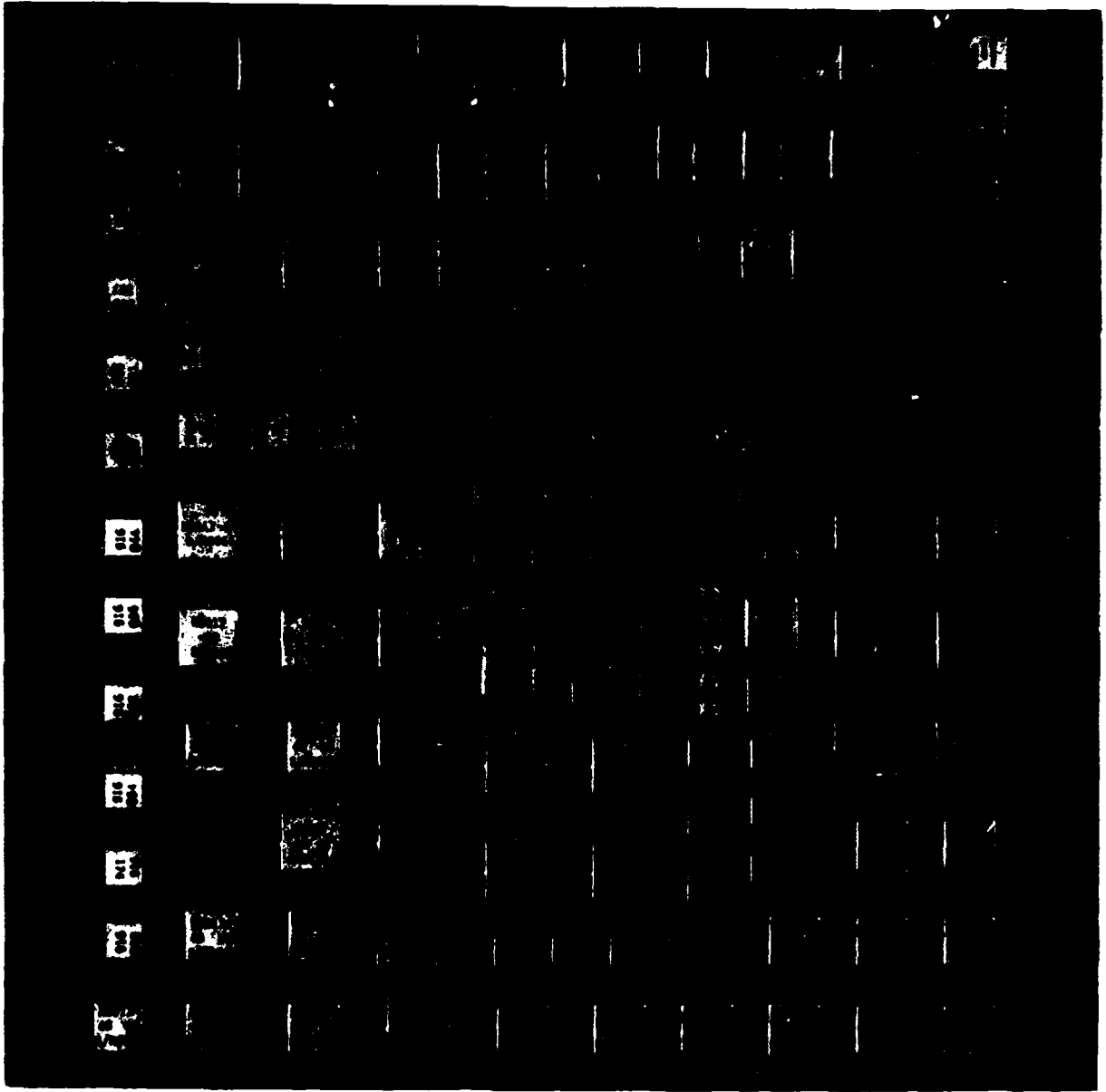

COMPUTER SUPPORT SOFTWARE PACKAGE

MIL-STD-1750/1750A describes a 16-bit computer architecture that has been adopted as a standard for use in avionics systems. A support software package developed by the Avionics Laboratory facilitates development and test of software for any MIL-STD-1750/1750A computer. The support software package consists of an assembler, a linker, and a simulator, each of which is based on an ITEL AS/5 (IBM 360/370 compatible) computer and DEC System-10 computer and is described as follows:

a. The Assembler produces relocatable object modules which are suitable for linking and loading for execution in hardware using the standard. The Assembler produces program listings describing the results of the assembly and is available on both the DEC System-10 and ITEL (IBM 360/370 compatible) computers.

b. The Linker uses the relocatable object module of the assembler (or AFWAL JOVIAL J73 Compiler), resolving all unresolved program addresses, and produces an absolute Load Module which is

suitable for loading and execution on any MIL-STD-1750/1750A hardware. A Load Map which describes the Load Module is also produced so that the load may be understood by the programmer. The Linker availability is as follows:

1750 version, available on DEC System-10 and ITEL (IBM 360/370 compatible) machine

1750A (non-expanded memory) version, available on same machine

1750A (expanded memory) version, available on DEC System-10 and ITEL machine.

c. The simulator uses absolute load modules which was assembled and linked by the assembler and linker to simulate the execution of the computer program at a machine instruction level for 1750/1750A hardware. This provides a means of checking, verifying, and debugging the computer program for any 1750/1750A application.

Capt. Zelasco/513-255-2446

MILLIMETER WAVE MIXER

A broadband, balanced millimeter wave mixer with an RF center frequency of 90 GHz was developed by TRW under an Avionics Laboratory contract. The mixer employs a crossbar design in which two honeycomb mixer diodes are mounted in a double ridged waveguide circuit. The mixer RF instantaneous frequency range is 80 to 100 GHz with a conversion loss of less than 6 db and an IF bandwidth of 2 GHz. The GaAs mixer diodes do not

require DC bias. The mixer uses a fundamental Gunn diode local oscillator, producing 40 Mw of output power. It was operated over the full WR-10 waveguide band of 75 to 110 GHz with an associated conversion loss of less than 7.5 db. This millimeter wave mixer has potential use in ECM and communications.

Tim Kemerley/513-255-2062

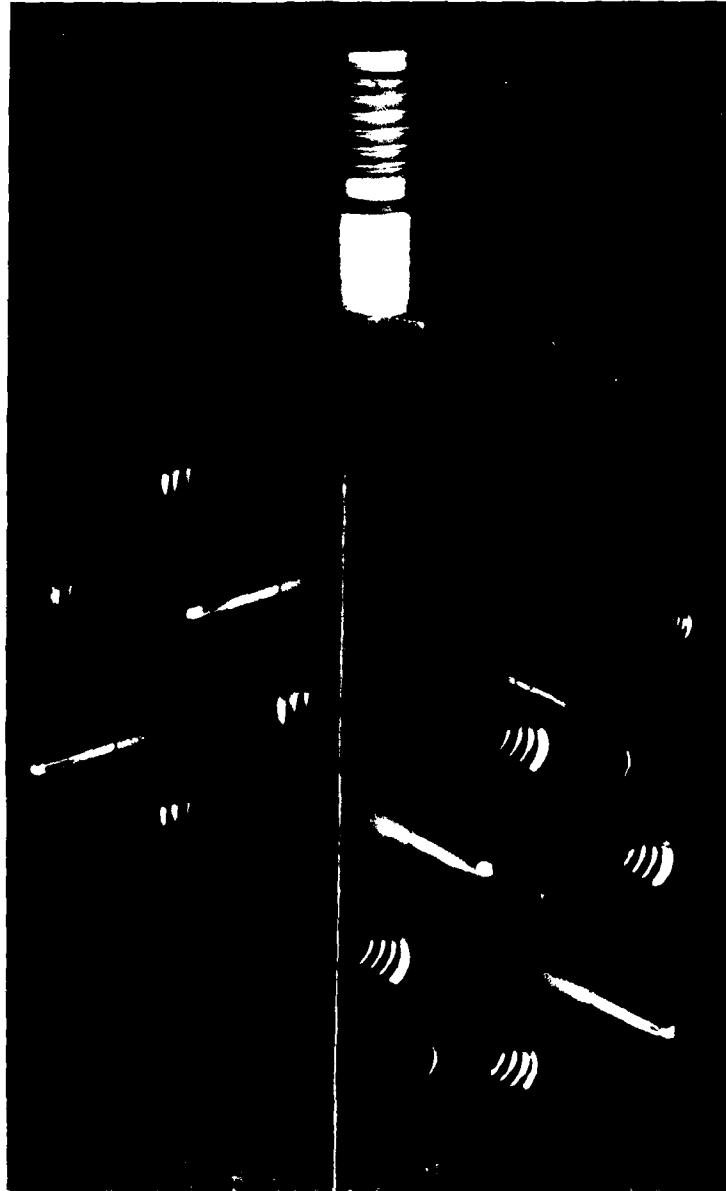

GaAs MICROWAVE DIODES ACHIEVE NEW HIGH POWER AND FREQUENCIES

Gallium arsenide (GaAs) semiconductor materials research performed by Raytheon Company for the Avionics Laboratory has provided a significant state-of-the-art increase in available solid state RF power at 10 GHz. Demonstrated peak output powers of 47 watts were achieved for a 300 nsec pulse width at 30% duty cycle. This represents a 50% increase over the previous power obtained at this X band frequency. This achievement was the result of an in-depth theoretical and experimental research effort which encompassed advances in GaAs crystal growth techniques, packaging technology, diode matching oscillator circuitry, and improved measurement and analysis methods of the physical properties of the Impact Avalanche Transit Time (IMPATT) diode. Several specific areas of technology advancement were achieved during this program. Microprocessor control of the vapor phase crystal growth reactor increased GaAs wafer

yields to greater than 70%. GaAs wafer characterization measurements were automated so that device performance expectations can be quickly formulated. The multimesa diode concept for pulsed diodes was adapted, thereby achieving minimal diode thermal resistance. Improved oscillator circuitry was developed which enhances the diode's performance at the frequency of operation while minimizing subharmonic signal degradation. New diode models were evolved which further the understanding of the physics of operation. The overall impact of this technology advancement is that GaAs IMPATT diodes are now viable candidates for AF system applications which include missile guidance and seekers, radar, ECM, and communications.

Chuck Stevens/513-255-4902



SECTION III
FLIGHT DYNAMICS LABORATORY

CRACKS PD: A CRACK GROWTH ANALYSIS FOR PRELIMINARY DESIGN

All new USAF flight vehicle structures must demonstrate either design life or inspection interval requirements as a function of a safe crack growth period. The introduction of these requirements at the earliest possible stages of preliminary design and material selection has significant cost and development time advantages. The CRACKS-PD computer program was developed by the Flight Dynamics Laboratory to provide the capability for calculating the realistic life estimates needed to perform materials evaluation based on the minimum of input information typically available during preliminary design. The program is written in BASIC to operate on a desk top programmable computer in a class having 32K⁸ bytes of available memory. The program is divided into two segments: the first containing the crack growth analysis and the second containing an extensive plotting package.

The analysis segment of the program, depicted schematically, is divided into four parts: (1) input, (2) stress history generation, (3) critical crack

length determination, and (4) crack growth analysis. The input is entirely computer prompted and is broken up into three basic sections: geometry, material properties, and load spectrum definition. The critical crack length is determined by an iterative procedure using the input crack geometry, the maximum stress in the spectrum, and the input fracture toughness, K_{IC} . Load interaction effects (retardation) are accounted for by using a smeared Wheeler model. The plot segment is automatically loaded when a positive response is given to the plot query. A table of options is then displayed. The plots essentially follow the same pattern as the analysis segment. One may plot input parameters (da/dN vs K), stress exceedance curves, critical crack length (K_{max} vs a), and crack growth analysis output (a vs fts , da/dF vs K). Solution times on the order of five to ten minutes per design stress level provide a significant improvement over turnaround times for large scale batch computer runs.

Robert M. Engle/513-255-6104

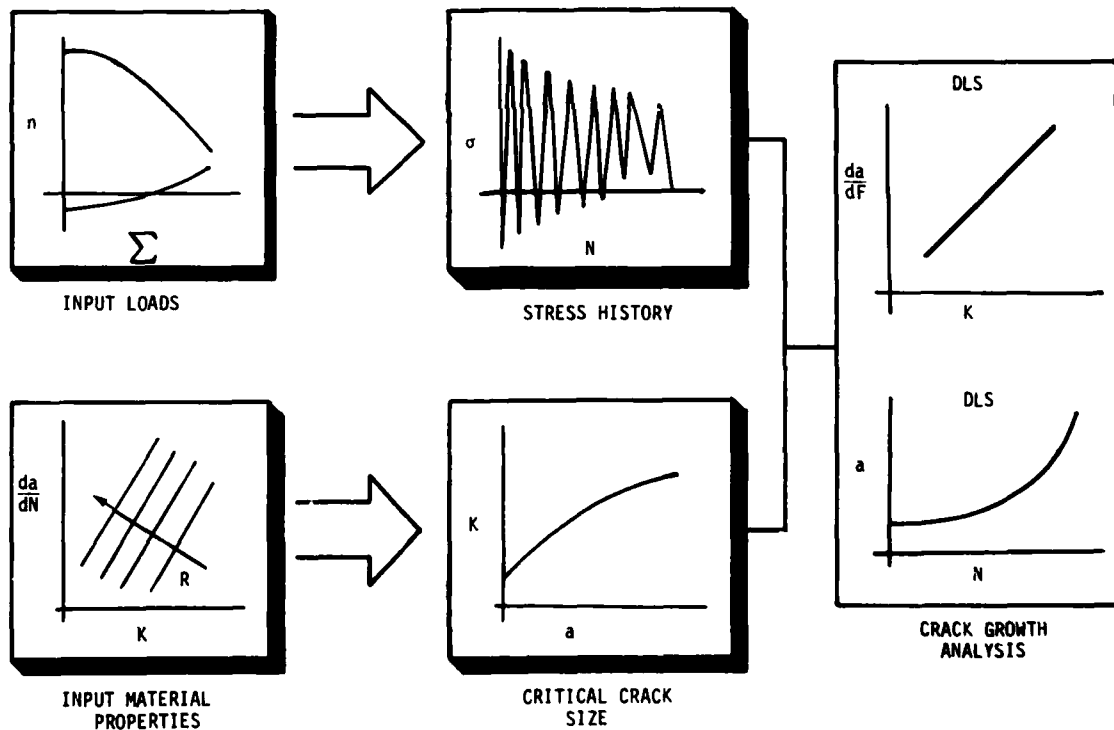

G-

WING/STORE FLUTTER SUPPRESSION WIND TUNNEL TEST DEMONSTRATION

The application of several active control concepts for the alleviation of wing/store flutter problems on fighter-attack aircraft was thoroughly demonstrated and evaluated using the Flight Dynamics Laboratory active flutter suppression model in tests conducted in the NASA LRC 16-foot transonic dynamics tunnel (Reference AFWAL-TR-80-3093). The figure shows the model mounted in the wind tunnel. In addition to Northrup Corporation, researchers in England, France, Germany, and Israel (NASA grant) designed and submitted control laws for the performance evaluation. In all, ten different control laws, which used either the leading edge, the trailing edge, or both surfaces acting together, and various sensor combinations, were tested at transonic speeds. The NASA decoupler pylon concept, which is a passive flutter prevention device that isolates the wing from the effects of store pitch inertia, was also tested. Most of the control laws tested provided very respectable flutter velocity increases. Several were tested and evaluated at speeds that exceeded the passive (unaugmented) flutter speed by 30%. The decoupler pylon test results also showed significant promise as a viable flutter prevention tool to be

considered in the future.

As a result of these tests the USAF was able to obtain valuable information on the applicability of various control law design philosophies. The international participants, in turn, received transonic test evaluation of their control law using a sophisticated flutter model typical of today's fighter aircraft, and were provided the opportunity to exchange viewpoints on the technology with a group of individuals that represented the leading experts in this field.

This wind tunnel test demonstration establishes the technology base for extending the principles of active flutter suppression into a flight test evaluation. The major payoffs of the technology are to increase the store carrying capabilities and mission effectiveness of multirole military aircraft. The removal of flutter speed restrictions offers an expanded flight envelope and improvements in aircraft survivability to ground fire during a low level-high speed penetration mission.

Larry Huttzell/513-255-6832



ADVANCED METALLIC STRUCTURES MISSILE SHROUD DEVELOPMENT

The feasibility of transitioning the super-plastic forming and diffusion bonding of titanium technology that was developed on fighter/bomber structure to missile system application was demonstrated. The Flight Dynamics Laboratory, working with and acquiring the full cooperation of the Ballistic Missile Office and the MX missile contractors designed an advanced technology shroud to the form, fit, and function of the MX prototype/production missile. It was the goal of the

program to achieve a shroud design which was both cost effective (less acquisition and maintenance costs) and lightweight. The resulting design shown in the figure has a projected 31% weight reduction in production as well as a significant acquisition cost savings. The advanced technology shroud design offers the MX an alternate design should system cost or weight relief be necessary.

Charles Waitz/513-255-5006

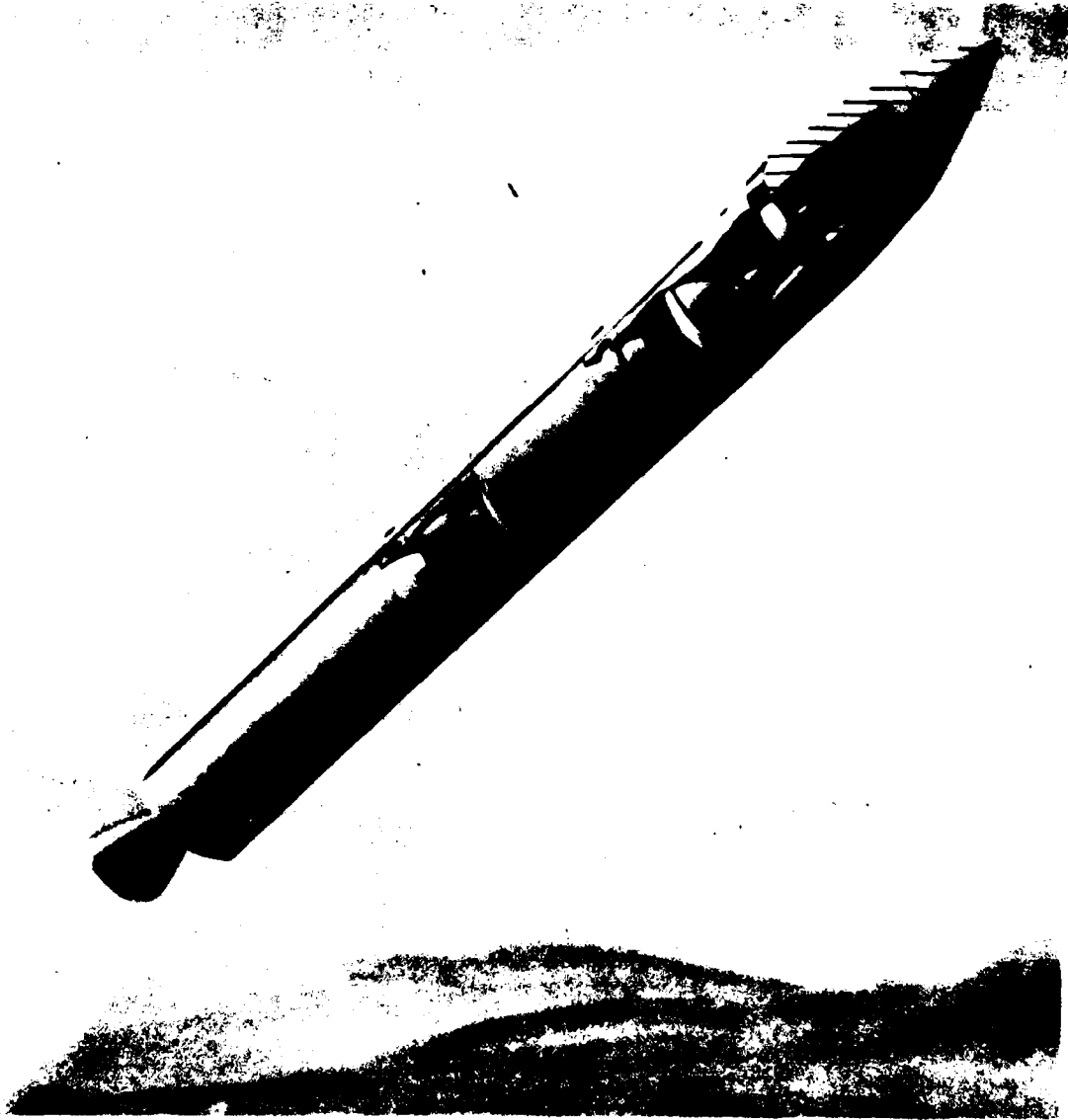

SONIC FATIGUE DESIGN TECHNIQUES FOR ADVANCED COMPOSITE AIRCRAFT STRUCTURES

Prediction methods were developed by the Flight Dynamics Laboratory to determine the sonic fatigue life of graphite-epoxy skin-stringer panels when exposed to high intensity acoustic excitation. Sonic fatigue has become a recognizable and persistent structural design problem over the past 25 years. Although not usually a catastrophic problem in terms of human lives, sonic fatigue has resulted in structural failures adversely affecting maintenance costs, mission effectiveness, and often requiring major structural redesigns. Sonic fatigue problems were characterized by a significant degree of inherent unpredictability that has so far denied the structural designer the precise analytical tools that are available in other areas of structural analysis. These limitations were accompanied by the need for minimum weight designs in increasingly severe and varied acoustic environments. Recent advanced composite materials development led to a widespread aerospace application of non-metallic structures in the interest of cost and weight savings.

A combined analytical and experimental program was conducted to determine the factors that affect the random fatigue life of typical aircraft structural joint configurations. A range of multi-bay panels were subjected to high intensity noise environments in a progressive wave tube. The figure depicts the fatigue damage experienced by one of these test panels. Shaker tests were also performed to provide additional random fatigue data. Finite element analyses were performed on the test panel designs, generating static strains and frequencies. Multiple stepwise regression analysis was used to develop the semi-empirical sonic fatigue design method. Design charts for skin stiffened graphite epoxy structures were developed to predict rms strain and sonic fatigue life. Comparisons of sonic fatigue resistance between graphite and aluminum panels indicate that graphite offers a 2:1 weight savings for comparable sonic fatigue resistance.

Ken Wentz/513-255-5229

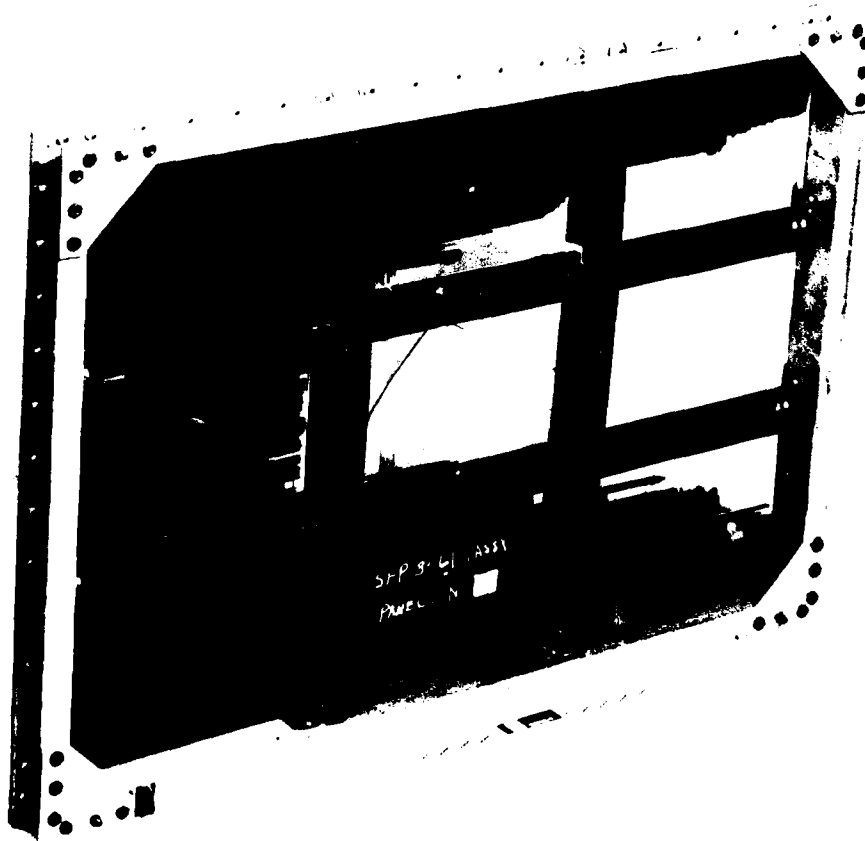

PRIMARY ADHESIVELY BONDED STRUCTURES TECHNOLOGY TRANSITIONED

Primary Adhesively Bonded Structure Technology (PABST) exceeds expectations! This was the bottom line to the recently completed 5-year, \$18.6 million dollar Flight Dynamics Laboratory program. All critical fabrication, assembly and cyclic fatigue testing of the full scale, 42 foot long, 18 foot diameter adhesively bonded fuselage section shown in the figure was successfully completed.

PABST's program objectives were to demonstrate application of the new technology of adhesive bonding in safety of flight critical joints in lieu of conventional mechanical fasteners. A 20% acquisition and maintenance cost savings and a 15% weight reduction were program goals. In addition, PABST reaps life cycle cost savings by eliminating burdensome maintenance costs of fatigue cracks emanating out of fastener holes and by producing environmentally tight joints which

preclude faying surface corrosion. Supported by extensive environmental testing, PABST is also confirming the superior durability characteristics of the latest generation adhesive bonding technology. The potential application of the PABST technology to the YC-15 is depicted in the figure.

Technology of the PABST program results was achieved with the publication of AFWAL-TR-80-3112, "Primary Adhesive Bonded Structure Technology Full Scale Test Report," and Technical Bulletin No. 20, "Analysis of Assembly Suboptimum Anodize." In addition, a technical paper entitled "Durability and Damage Tolerance Behavior of Adhesively Bonded Primary Structure," was presented at the ASTM Symposium on the Design of Fatigue Resistant Structure.

William Shelton/513-255-5664



SUPERPLASTICALLY FORMED AND DIFFUSION BONDED TITANIUM LANDING GEAR COMPONENT STUDY

The first successful fabrication of a heavy wall Superplastically Formed and Diffusion Bonded Titanium (SPF/DB TI) sandwich cylindrical tube section was achieved under this study. This program demonstrated that a titanium truss core cylinder suitable for landing gear components can be fabricated using SPF/DB TI technology. An in-depth evaluation of various candidate advanced composites, metal matrix composites, and advanced metallic materials against a baseline steel design completed in 1978 identified SPF/DB TI technology as the most promising candidate for landing gear component fabrication. This effort was initiated to demonstrate that SPF/DB TI technology could be used for landing gear cylinder fabrication, the application providing a maximum payoff. Previously, only very thin wall, small diameter tube structures had been fabricated using SPF/DB TI technology. Due to the cylindrical shape of the sandwich, many problems required resolution

which were not present in the fabrication of SPF/DB TI flat or slightly curved sandwich structures. The 4.75 inch ID, 6.802 inch OD, and 6 inch long cylinder fabricated was designed to satisfy the requirements imposed on a similar cylinder section for a baseline F-100 fighter aircraft main landing gear. The SPF/DB TI cylinder, shown in the figure, was successfully tested to 158% of design load under the worst-case or critical load condition on the outer cylinder. A breakthrough in SPF/DB TI design and fabrication technology and a major step toward improved landing gear components was achieved by this effort.

An SPF/DB TI landing gear promises not only weight savings, but because of its inherent corrosion resistance, it will reduce maintenance problems and thus considerably improve the landing gear maintenance cost picture.

George Sperry/513-255-7258

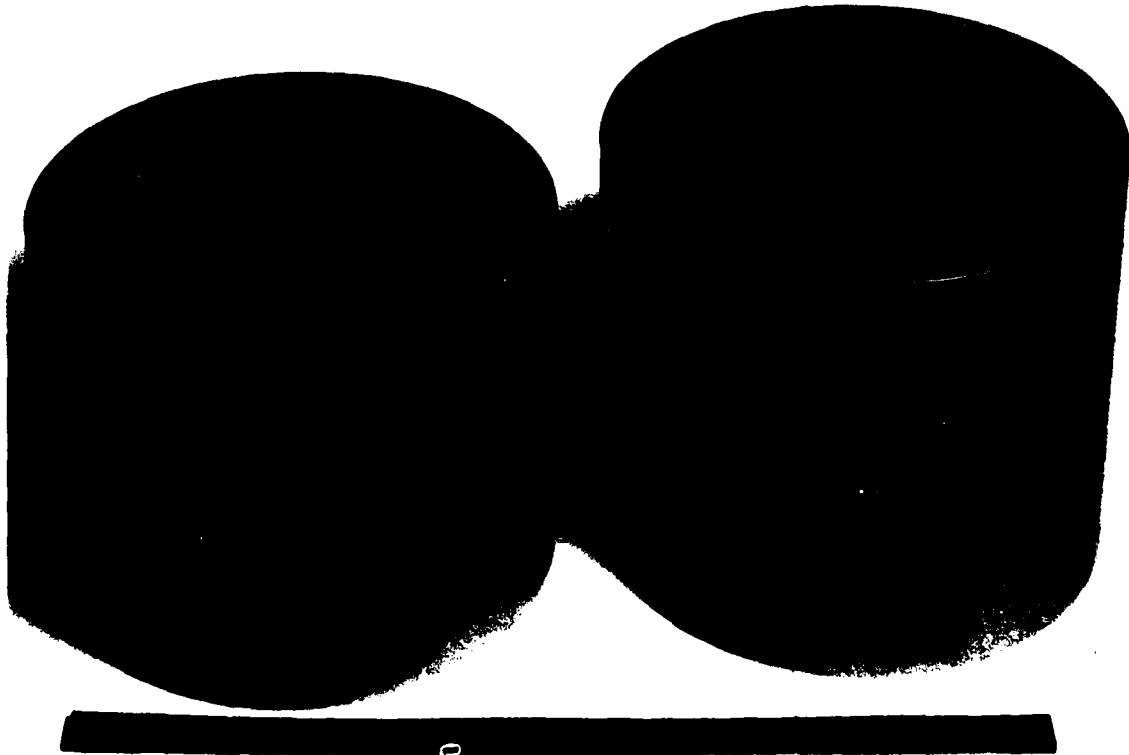

FIRE EXTINGUISHING SYSTEM FOR BALLISTIC PROTECTION

A unique experimental program was conducted at the Flight Dynamics Laboratory's Aircraft Survivability Research Facility (ASRF) to evaluate various fire extinguishing system concepts to prevent fires in aircraft compartments due to ballistic impact of any type. Ballistic threats (especially HEI projectiles) can produce severe damage to aircraft skin which will then allow significant airflow in a particular compartment. The airflow through battle damage has a significant effect on extinguisher performance. To properly design a fire extinguisher system for ballistic protection, the aircraft designer must be able to estimate the airflow present after ballistic impact. An aircraft compartment with a battle damage wound is basically a cavity with airflow passing across the opening. One of the primary goals of the test program was to measure the mass exchange of air across the cavity boundary. This measurement was performed indirectly by devising a system (the test facility is shown in the figure) to measure the mass flow rate of fire extinguishing agent ejected into the compartment and the concentration of agent within the compartment. If these two

parameters are known, then the mass exchange rate can be calculated. In addition to obtaining mass exchange data, two different types of fire extinguishing systems were tested. These were the MIL-C-22284 bottles and a high rate discharge system (Cobra system, designed and built by Thermal Control Ltd, UK). The MIL-C-22284 bottles are relatively slow response bottles which are designed to provide, in excess of 0.5, second coverage. Therefore, they are affected by the ventilation rates. The high rate discharge system is fast enough to fully disperse agent and extinguish a fire before ventilation can significantly affect the agent. Both of these systems were tested several times under full scale high realism ballistic tests. In every case, both systems were completely successful in preventing or extinguishing the fuel fires that might otherwise have been started with 23mm HEI impacts. This program provided full scale proof of performance test results for open dry bays as well as data to the designer on how to design the systems.

Curtis Fett/513-255-6302

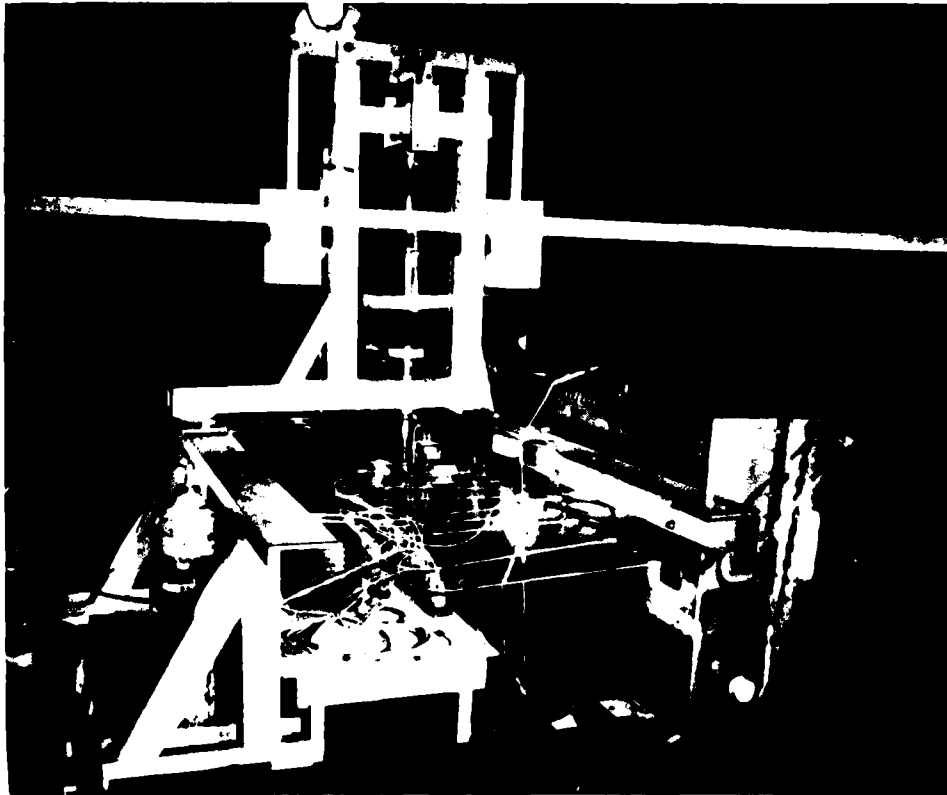

COMPUTER SIMULATION OF AIRCRAFT TRANSPARENCY RESPONSE TO BIRD IMPACT

The application of nonlinear finite element analysis for solution of the dynamic response of aircraft transparency structures to bird impact loading was demonstrated by the Flight Dynamics Laboratory. The USAF is now in position to reduce the development costs of new or redesigned bird-resistant aircraft transparency systems by phasing the use of this new analysis tool into the development cycle. The relatively inexpensive (~\$500) computer analyses can be substituted for a portion of the full-scale bird impact tests included in the development of any new transparency system. Since the fabrication and bird impact test of one shipset of transparencies can cost as much as \$100,000, the cost savings can be substantial.

The development of this new computer program (Materially and Geometrically Nonlinear Analysis,

MAGNA) required an advancement of the state of the art in finite element analysis methods. Validation of the computer program was achieved through simulation of full scale bird impact tests conducted at AEDC with F-16A canopies. The figure shows the comparison between computed and actual canopy deformations.

The major payoff of this new technology will not only be reduced cost and time associated with transparency system development, but the realization of increased structural efficiency for a given level of bird impact protection. Design improvement programs are already underway for the T-38 and F-16 aircraft canopies utilizing the MAGNA code as an analytical tool.

Robert McCarty/513-255-2516

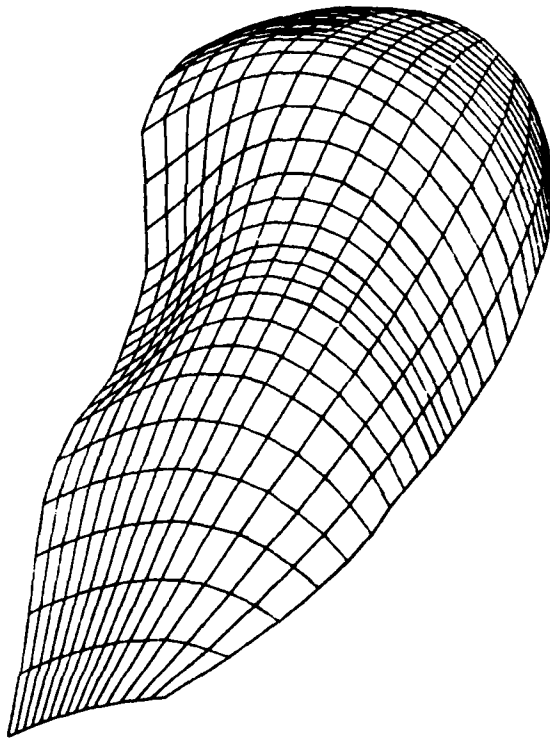

F-16A LAMINATED CANOPY

The F-16 aircraft utilizes a unique one-piece coated monolithic polycarbonate transparency as the windshield/canopy system. Examination of a number of the F-16A canopies on full scale development and prototype aircraft revealed serious loss-of-coating problems resulting in erosion and pitting of the polycarbonate substrates. This exposes the polycarbonate material to damage from ice crystals, moisture, cleaning materials, etc., which ultimately results in unacceptable optics and birdstrike protection. At the request of the F-16 SPO, the Flight Dynamics Laboratory developed and flight qualified an "alternate" laminated canopy design which consists of one or two structural layers of polycarbonate, an outer surface of acrylic and interlays of either silicone or urethane material.

This new laminated plastic transparency provides 350 knot, 4-pound birdstrike protection and multi-year service life. Two versions of this design were selected by the F-16 SPO for use on production F-16 aircraft. These laminated canopies will be provided as government furnished equipment (GFE) to General Dynamic Corporation effective 1 October 1981.

The Flight Dynamics Laboratory program resulted in two qualified sources for fabrication of the F16A laminated canopies. By using two sources, the USAF enhanced competition and provided for alternate production options while saving \$8.6 million for the balance of the 998 USAF and European aircraft production program. Since the laminated canopies are expected to be in service twice as long as the coated polycarbonate configuration now in use, a significant decrease in life cycle costs is also anticipated. This life cycle cost savings for the USAF aircraft alone are estimated to be \$175 million for the total 1,388 USAF F-16 aircraft buy. The improved life cycle characteristics enabled the USAF to negotiate, for the first time, a service warranty period. The laminated canopies will be installed beginning with the 426th USAF and 267th European F-16 aircraft. The first figure shows the F-16A Canopy in the AEDC target area prior to a birdstrike test under controlled temperature conditions. The second figure shows the F-16A canopy successfully undergoing a 350 knot, 4 pound birdstrike test at AEDC.

Richard Peterson/513-255-6524

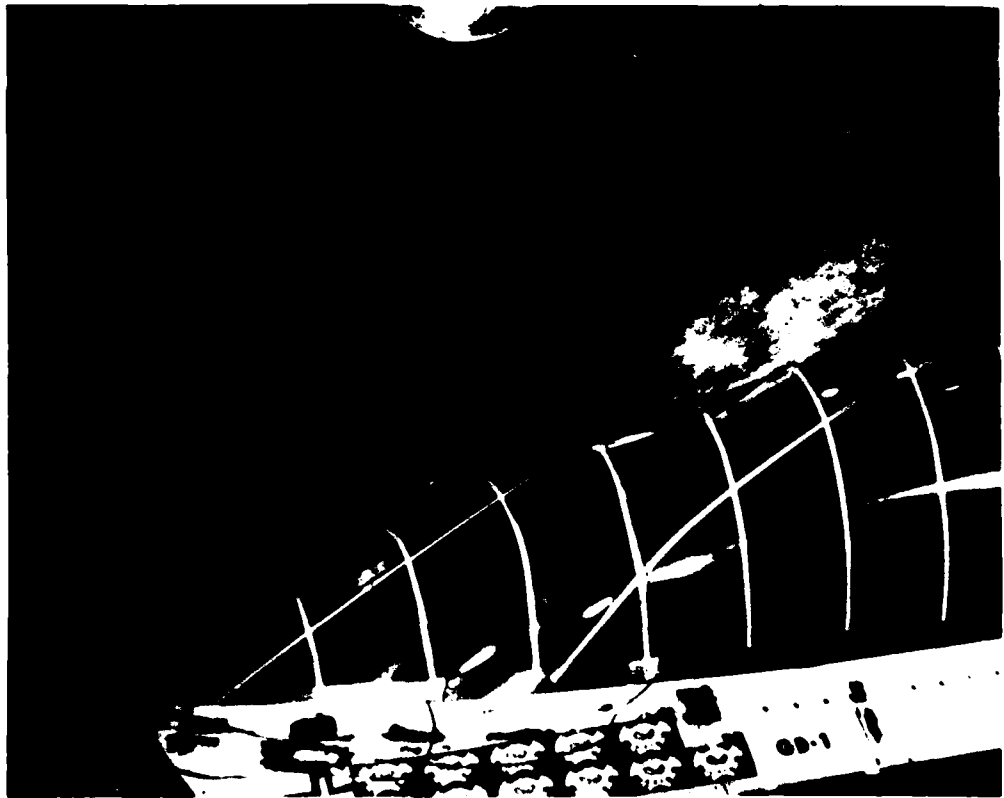
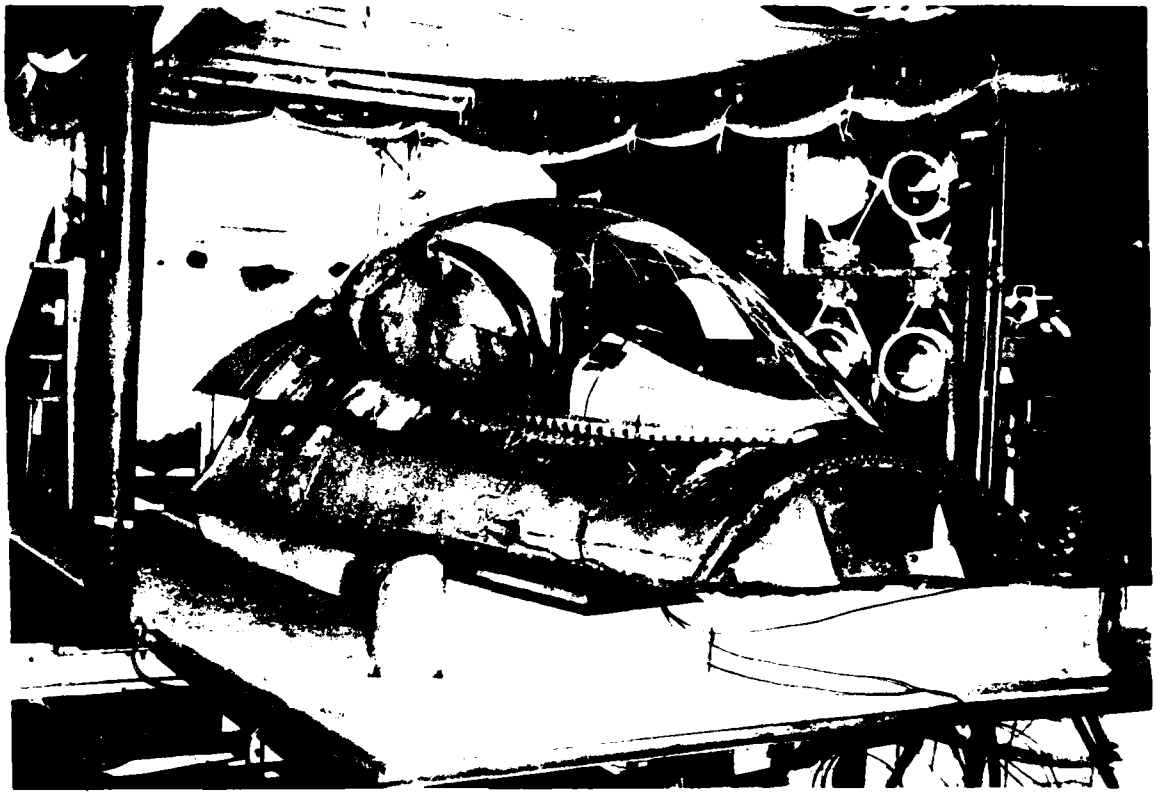

MOBILITY DEVELOPMENT LABORATORY UNVEILED

The Flight Dynamics Laboratory has opened a new facility for testing models of aircraft and ground support equipment with unconventional undercarriage designs for greater mobility in deploying and sustaining operations in any battle environment. The Mobility Development Laboratory, valued at more than \$1.5 million and covering an area of 20,000 square feet, is managed by the laboratory's Vehicle Equipment Division. Air Force engineers will use the new laboratory for research on air cushion systems for aircraft, ground support equipment, and ground effects take-off and landing systems. An air cushion is simply a low pressure chamber located beneath the vehicle. The air pressure within the chamber is not much higher than atmospheric and is sealed off by rubber-like, flexible skirts. The flexible skirts also act as shock absorbers allowing the vehicle to traverse rough terrain without transmitting harsh impact loads to the hard structure. Air cushion systems are an attractive alternative in a ground mobility scenario since they can move a vehicle (whether it is an aircraft or supply truck) across a ditch or obstacle that would not support or might break conventional landing gears and wheels. Engineers in the Mobility Development Laboratory also expect to look at some new schemes for landing future aircraft that are very large, those with gross weights of more than one million pounds. Whereas, conventional landing gear on such aircraft would exert extremely high tire footprint pressures on runways, air

cushion systems could operate at less than two pounds per square inch ground pressure. The second figure shows a scale model of an air cushion ground transport vehicle mounted at the tip of the arm. The arm moves around a circular track at speeds up to 50 mph and its powerplant is a DC drive, 60 horsepower motor. The tip of the arm was specially designed so that test models could be interchanged easily. The other major test device in the new mobility laboratory is a plexiglass platform 24 feet in diameter. The static test platform was designed for close examination of the air cushion or "skirt" on scale models of vehicles. The clear plexiglass platform is raised four feet off the floor and studded with over 600 tiny holes instrumented so that, in effect, pressure readings can be taken whenever a vehicle "taxi" across the platform or is dropped onto it from an overhead crane. From these pressure readings, engineers can determine two important variables that previously were unmeasurable on air cushion vehicles: precise air pressure distribution under the vehicle and energy absorption during "landings" (drops) and taxiing. Since the platform is transparent, engineers can also observe deformation of the air cushion during testing as well as allow motion pictures to be taken for later study. Both the whirling arm and static test platform are controlled and monitored from a trailer within the mobility development laboratory.

David Perez/513-255-2129

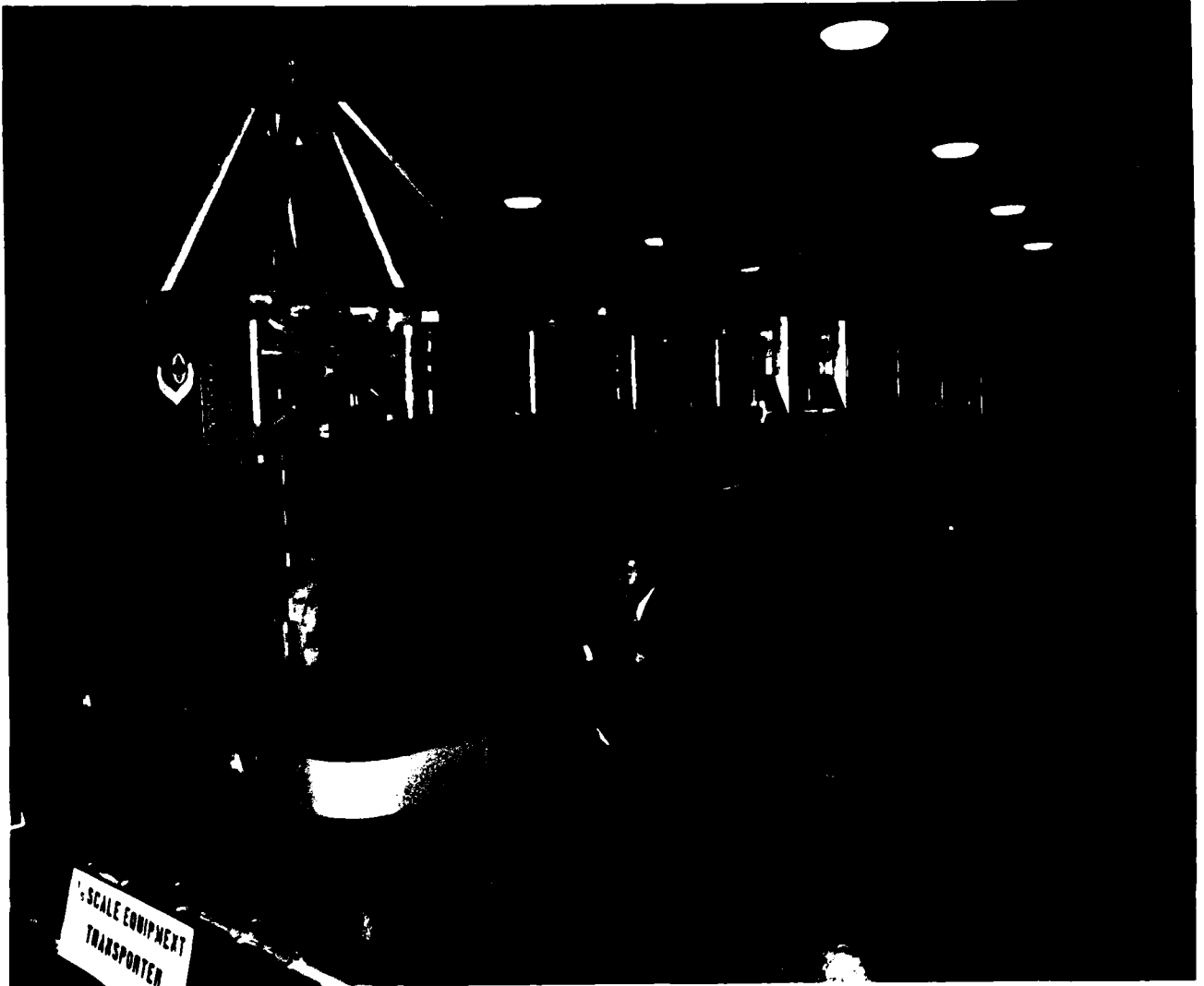

TANKER AVIONICS AND AIRCREW COMPLEMENT EVALUATION

In response to a request from the Aeronautical Systems Division, the Flight Dynamics Laboratory accomplished a full mission simulation in which operationally qualified SAC tanker crews validated a KC-135 cockpit configuration designed to permit tanker operation without a navigator. Key to this configuration evaluation was the heavy emphasis placed on participation of Strategic Air Command personnel throughout the analysis, design, and testing phases to provide optimum assurance of system compliance with user requirements. Early stages of the effort included first hand observation of SAC tanker operations, interviews with tanker crew members, and discussions with SAC Headquarters' personnel relative to overall SAC mission objectives and requirements. Prior to full mission simulation, three candidate crew system

concepts were developed and evaluated by nine SAC aircrews during preliminary mockup studies. This preliminary design assessment led to the development of a fourth "composite" configuration which incorporated the most desirable characteristics of the three previous designs. This composite configuration was evaluated by five SAC crews during full mission simulation. Using the flight simulator the crews were required to fly the airplane, rendezvous with various types of receivers, offload fuel during representative mission profiles, perform mission communications, and accomplish cockpit procedures and checklists. The participating crew members agreed that the cockpit configuration permitted completion of all KC-135 mission tasks with a reduced crew complement.
Richard Moss/513-255-6931

BOOM OPERATOR'S HEAD-UP DISPLAY

The completion of flight tests of the Boom Operator's Head-Up Display (HUD) during KC-135 operational missions represents the successful application of an innovative Flight Dynamics Laboratory technology, the Solid Path Head-Up Display, to resolve a current Air Force crew system problem. During refueling operations, the boom operator must visually estimate distances and angles while operating controls which can only be seen when looking down (away from the actual engagement being attempted). It was recommended that Strategic Air Command (SAC) flight test the Solid Path HUD developed by Flight Dynamics Laboratory for the A-10 aircraft as a

possible solution. SAC flight tested the display and their boom operators reported that the HUD does eliminate the need to look down and permits the operator to more precisely control the boom.

The boom operator's Head-Up Display has demonstrated increased aerial safety, reduced refueling time and usefulness as a training aid for inexperienced crew members. Due to its excellent flight test performance, SAC has written the requirement for HUD capability into the required operational capability (ROC) to update the KC-135.

William Augustine/513-255-6670

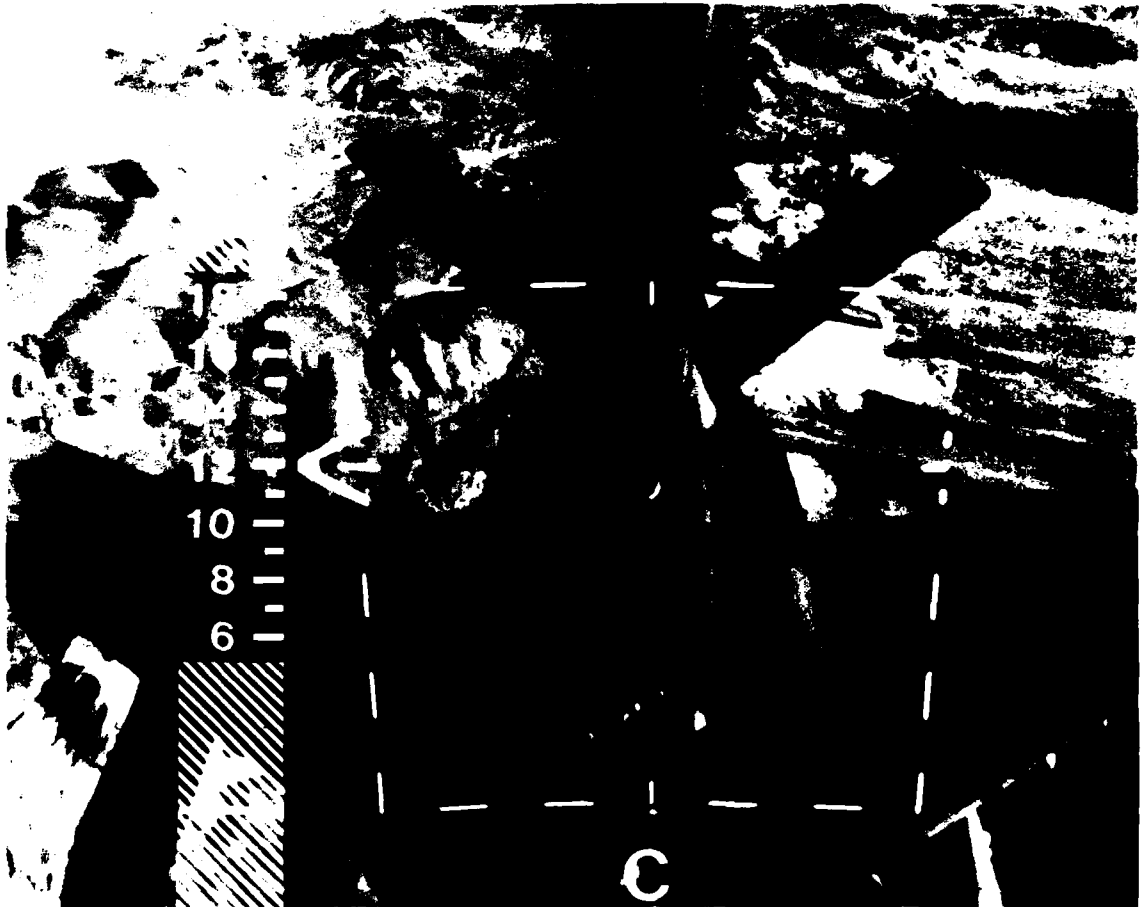

ADVANCED FIGHTER COCKPIT DEVELOPMENT PROGRAM

The earliest military aircraft cockpits required only a few controls and displays because of their relatively unsophisticated systems and slower speeds. Over the years the aircraft systems have increased in sophistication necessitating an increase in number and complexity of corresponding cockpit controls and displays. The trend in cockpit design has been to place more dedicated electro-mechanical instruments in front of the pilot. As newer and more sophisticated systems (JTIDS, GPS, Electronic Terrain Map, 4-D Nav, etc.) are added to the aircraft the point of running out of cockpit real estate is being reached.

The objective of the Flight Dynamics Laboratory's Advanced Fighter Cockpit Development Program is to determine how advanced display technologies can best be used to integrate the information needed by the pilot and effectively present this information in a directly usable form. Research investigations are concentrating on demonstrating the feasibility of using electro-optical (EO) displays (controlled by an onboard computer) in place of the traditional electro-mechanical instruments. Two in-house research facilities play a key role in the studies and evaluations of the integrated display and multifunction control technologies being examined under this program. They are the Digital Synthesis Simulator (DIGISYN) and the F-16 Cockpit Dynamic Mock-up.

During DIGISYN facility experiments, experienced pilots perform a series of tasks with the new control or display while flying a simulated mission. During the simulations, the cockpit dynamics, displays, and overall experimental control are computer-driven. The experiments are conducted by a research team composed of human factors psychologists, engineers, software/hardware experts, and fighter pilots. The pilot member of the team plays the role of an airborne command post, assigning mission-related tasks to the subject pilot throughout the simulations. Other team members monitor the cockpit displays and record performance data and pilot comments.

Recent results from the Study of Logic and Engine

Displays (SLED) experiment accomplished using the DIGISYN facility, shown in the first figure, were analyzed, documented, and the technology transitioned to the technical community. The primary purpose of the SLED experiment was to evaluate the integration of information pertaining to all engine instruments onto a single cockpit CRT. The pilot must currently gather this information from eight separate instruments scattered throughout the cockpit. A secondary purpose of the SLED experiment was to compare pilot performance using both a black-and-white (B&W) and a color CRT engine display. For this particular display, pilots were able to use the B&W as effectively as the color. This is a cost effective finding because B&W CRTs are easier to integrate into the cockpit and less expensive than color CRTs. The results of this experiment also help in the determination of the number of color CRTs required for an advanced fighter cockpit so that a proper mix of B&W and color CRTs can be chosen.

The running of simulation experiments has become increasingly expensive in terms of software programming costs, time delays, and actual running costs. To minimize these expenses, in FY80, Flight Dynamics Laboratory personnel completed development of a dynamic mock-up as a preliminary design tool. The mock-up, shown in the second figure, is a modular F-16 type of cockpit which uses five 35mm slide projectors to simulate cockpit displays. Each new format (or series of formats, if a dynamic symbology is desired) is created on 35mm slides so that it can be initially evaluated by pilots both inexpensively and rapidly.

The overall significance of the Advanced Fighter Cockpit Development Program is its responsiveness in finding ways to reduce the high pilot workload inherent in the 1990's fighter aircraft and combat environment. The ultimate goal is to minimize pilot head-down time by presenting only the information needed by the pilot at any one time and by presenting that information to the pilot in the most usable form in the optimal locations.

John Reising/513-255-6895

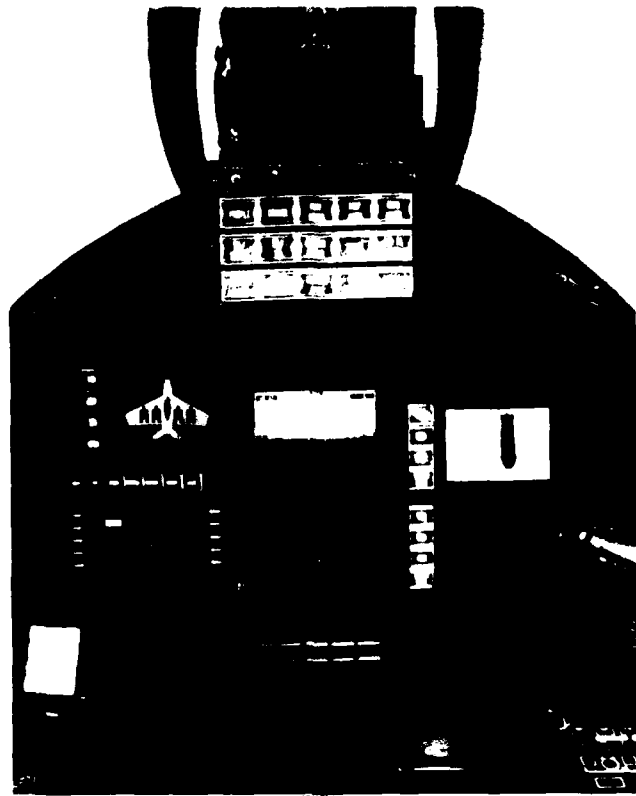

FIRST EXACT COMPUTATION OF SPIKE-TIPPED BODY BUZZ

The occurrence of self-sustained oscillations ("buzz") on spike tipped configurations and reentry nose tips is a phenomenon that has plagued the aerospace design engineer for many years. Although it has been investigated for several years, no analytical calculation existed to simulate this phenomenon until the development of the numerical solution of the time-dependent Navier-Stokes equations by Flight Dynamics Laboratory scientists. This numerical solution predicts accurately the frequency and amplitude of the fundamental frequency and commensurable higher modes of oscillation observed in experiments with spike tipped configurations. Computations performed using a vectorized 3-D Navier-Stokes program on the Star 100 computer confirmed the experimental result that "buzz" occurs within a limited range of the protruded spike length-to-shoulder height ratio.

The bow shock wave induced by the hemispherical tip is clearly evident. The disturbance propagates downstream toward the afterbody and amplifies in magnitude. After the oscillatory shear layer impingement, the reflected pressure wave is propagated upstream through the subsonic separated region to reinforce the oscillatory phenomenon by reintroducing a disturbance into the free shear layer. The entire process then repeats itself.

This Flight Dynamics Laboratory technical achievement provides the aerospace industry with the first prediction method for buzz which accurately simulates true flight conditions. In a broader sense, it also demonstrated that numerical solutions are useful for investigating the stability of viscous flows.

Dr. Joseph Shang/513-255-7127

Dr. Wilbur Hankey, Jr./513-255-7127

MISSION ADAPTIVE WING - THE WING FOR THE 1990'S

Approval of the AFTI/F-111 Mission Adaptive Wing (MAW) mechanization system design was recommended by an Aeronautical Systems Division Independent Modification Review Team, NASA - Hugh L. Dryden and Langley Research Center, Air Force Flight Test Center, and Flight Dynamics Laboratory engineers. The preliminary design effort was based on experimental data from over 800 wind tunnel test hours and a loads/actuation test program. The figure shows the test model mounted in the wind tunnel.

The Mission Adaptive Wing (MAW) program is a joint USAF/NASA project to develop and evaluate a variable camber wing system on the NF-111 research aircraft. The MAW is expected to lead to dramatic performance increases for a wide variety of aircraft. The MAW, with its smooth, flexible leading and trailing edges, can change its airfoil shape in response to various flight conditions of both tactical and strategic missions.

Current approaches for varying camber are primarily designed to aid take off and landing by wing devices such as: (a) plain flaps, (b) split flaps, (c) external airfoil flaps, (d) slotted flaps, and (e) leading edge flaps. All of the above approaches produce sharp breaks or gaps in the upper surface.

These discontinuities cause high drag by introducing flow separations at off design conditions. By using a smooth flexible upper skin, these breaks are eliminated so controlled lift can be achieved at all flight conditions.

The reason for changing the shape (camber) of the airfoil is to obtain the most effective aerodynamic flow for all flight conditions. A conventional wing is most efficient at only one altitude, speed, and aircraft weight. For peak efficiency a different wing shape is required for each of the following conditions: (1) subsonic flight, (2) transonic maneuver, and (3) supersonic flight. By varying the camber in flight, the most efficient shape for the given wing planform and sweep is obtained.

The MAW will out perform conventional fixed shape wings. MAW will improve payload/range, improve maneuverability, be more versatile, and be more cost effective. For a newly designed aircraft using the MAW there will be a weight reduction compared to a conventional wing. Maintainability will improve due to the sealed upper surface which prevents moisture and dirt from entering the mechanism.

Ron DeCamp/513-255-6789



TACTICAL/STRATEGIC MISSION REQUIREMENTS

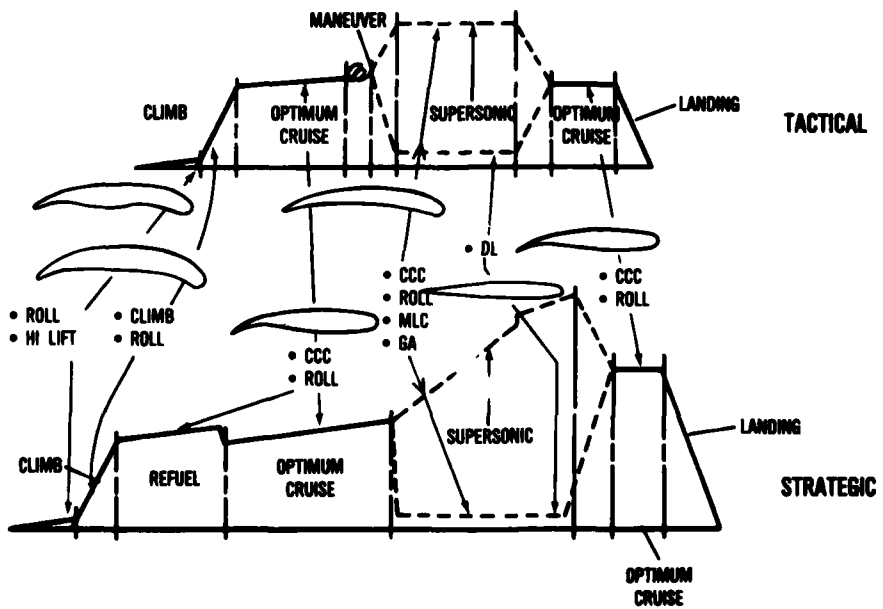

↳

AERODYNAMIC CONFIGURED MISSILE DEVELOPMENT

A Flight Dynamics Laboratory sponsored program to develop advanced supersonic cruise and maneuvering missile concepts with high aerodynamic performance potential has been completed after three years of intensive experimental and analytical investigations.

The Aerodynamic Configured Missile (ACM) Development Program was accomplished in three phases. During Phase I, air launched missile performance was examined by selecting representative mission segments. Along each segment, the sensitivity of performance to aerodynamic characteristics was determined. Unconstrained configurations were conceived which produced the most favorable levels of aerodynamics. Ninety-eight configuration options of arbitrary shape in five body classes, shown in the first figure, were analyzed. Of these, 27 were tested for force, moment, pressure, and oil flow data. Two of the wind tunnel test models are shown in the second figure. The capability to predict aerodynamic characteristics of arbitrarily shaped configurations was developed. The experimental data verified that aerodynamic shaping can improve missile performance significantly over current technology missile designs when unconstrained by subsystem requirements. Thirteen concepts of high performance potential were selected for further development in Phase II, in which constraints due to propulsion and control would be considered.

To realize maximum aerodynamic potential during constraint integration, a procedure described as "aerodynamic tailoring" was applied to each concept during Phase II. Instead of designing the missile around the subsystems and constraints, resulting in traditional missile configurations,

aerodynamic features producing high aerodynamic performance were given priority and were maintained whenever possible. Innovative integration approaches which did not compromise moldline were sought. If constraints could not be accommodated without large reduction in aerodynamic potential, advanced technology requirements were defined for the particular constraint. An experimental program was conducted to verify the high aerodynamic potential of selected configurations. The Phase III effort involved more detailed missile design and evaluation of two of the most promising configurations.

The key technological advancements achieved by the ACM program are the identification of the following:

- I. Important Design Integration Considerations
 - Drop Away Booster
 - Small Diameter Combustors
 - Variable Geometry Inlets/Nozzles
 - Fuel Packaging Straight Forward
 - Easy Packaging of Avionics/Warhead
 - Single Curvature Shapes Reduce Cost
- II. Key ACM technology requirements:
 - Variable Geometry Inlets and Nozzles
 - Low Weight Structures
 - Seeker Integration with Non Circular Radomes
- III. Performance Payoffs
 - Long Range Supersonic Cruise
 - Boost - Lift - Glide
 - Low Radar Signature
 - Long Range Air to Air

Val Dahlem/513-255-5806

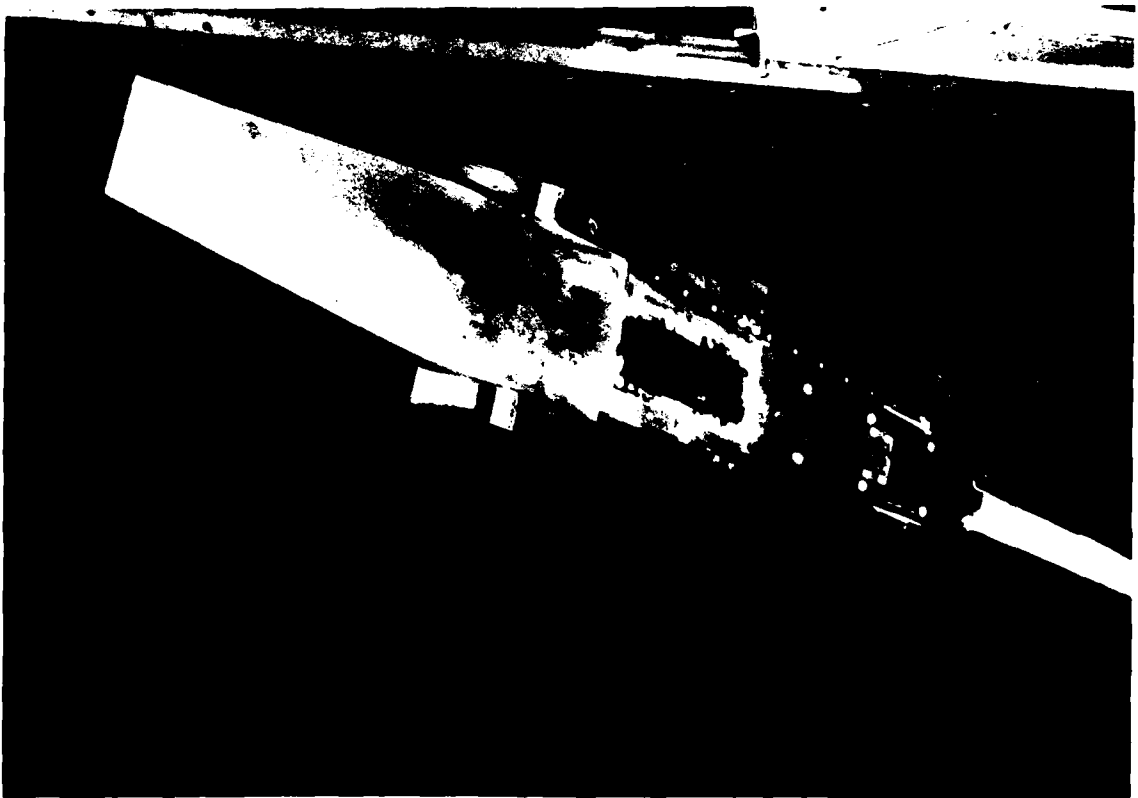
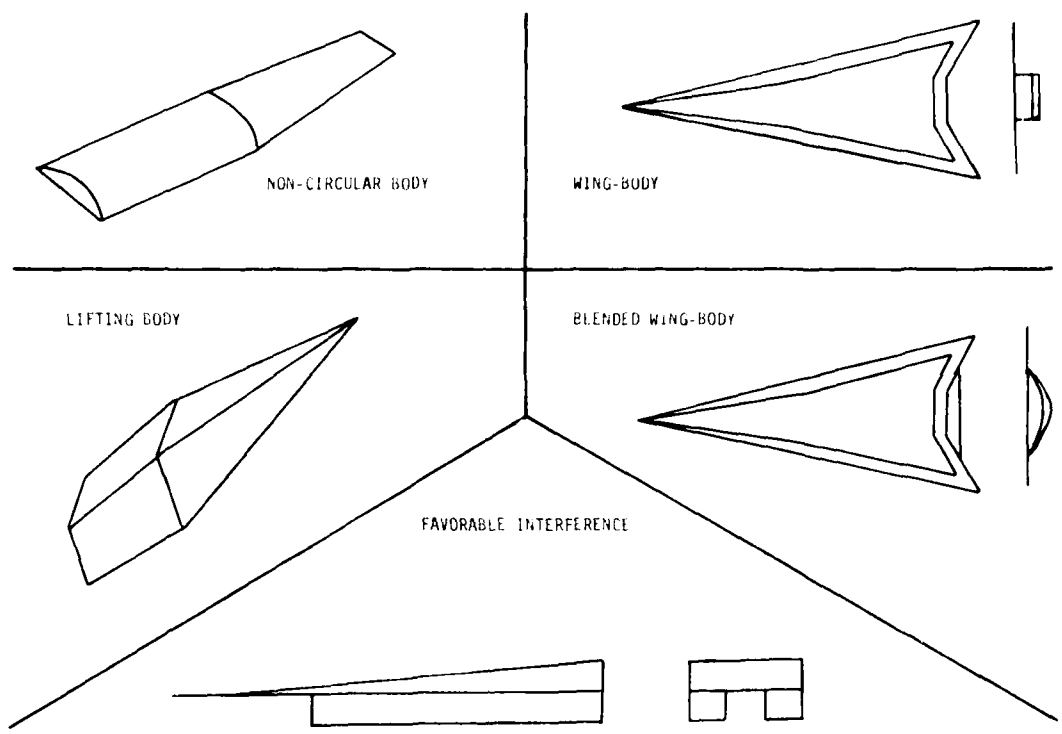

ADVANCED EXHAUST NOZZLE SYSTEM CONCEPTS DEMONSTRATION PROGRAM

The state of the art for aerodynamic integration of advanced exhaust nozzles for air-to-surface and air-to-air aircraft was significantly advanced by this program. The FY 80 emphasis was on the air-to-surface aircraft utilizing various advanced multi-function exhaust nozzles integrated into this Mach 2.0 cruise aircraft configuration.

Building on earlier tests in the AEDC Propulsion Wind Tunnel, tests in the supersonic wind tunnel up to a 2.2 Mach number have completed the data set for supersonic cruise aircraft, shown in the figure, with fuselage installed advanced exhaust nozzles. Nozzle concepts investigated included a baseline axisymmetric, and advanced axisymmetric, 2-dimensional convergent-divergent versions with different aspect ratios and a single expansion ramp (SERN). Both jet effects and flow through models of the air-to-surface vehicle were tested over a Mach number range of 0.6 to 2.2 at representative nozzle pressure ratios and angles of attack. Several of the nozzle concepts were tested in the thrust vectoring and thrust reversing modes. These advanced nozzle concepts, when incorporated into an advanced tactical fighter, offer the potential for significant improvement in maneuverability, agility, and survivability.

The data from this test program and the resulting aircraft performance analysis indicate several

potential benefits of these advanced exhaust nozzles as well as several technical areas which are deficient, and will be used to further AFWAL nozzle programs. One significant payoff is the reduction of aircraft cruise drag by utilizing nozzle thrust vectoring for trim. When used in conjunction with a canard for trim, the thrust vectoring exhaust nozzle allows the aircraft to fly at a reduced cruise drag with subsequent increase in aircraft performance.

For STOL operation, the multi-function exhaust nozzles with thrust vectoring and thrust reversing show large reductions in landing ground roll. The advanced axisymmetric and nonaxisymmetric exhaust nozzles with thrust reversing reduced the ground roll from 2500 feet to approximately 900 feet for this 42,000 pound class aircraft. Also, identified by this program was the extent of the exhaust plume/aircraft interaction which impacts aircraft stability and control during reverse thrust operation.

For those multi-function nozzles which offer significant performance payoffs for advanced aircraft, a relative ranking in terms of weight and internal performance was determined. Deficiencies in the aerodynamic integration were identified and the technical focus for future programs was defined.

Doug Bowers/513-255-6207

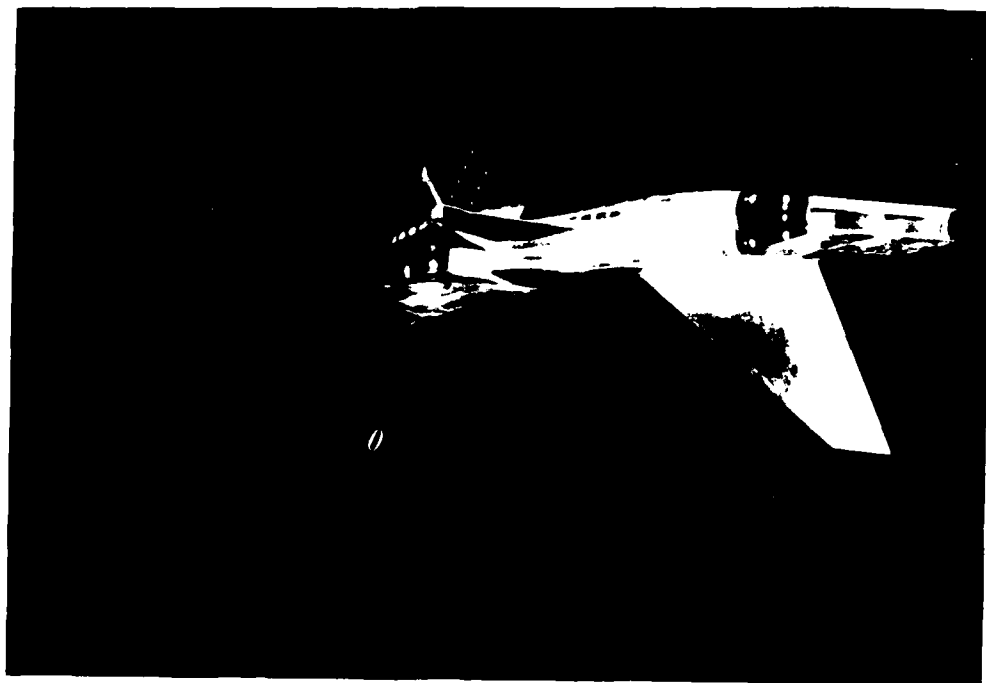

AFTI/F-16 DESIGN CONFIGURATION

The Advanced Fighter Technology Integration (AFTI/F-16) Program is a joint program involving the USAF, Navy, and NASA, with the AFTI/F-16 Advanced Development Program Office of the Flight Dynamics Laboratory serving as the responsible developmental agency.

The AFTI/F-16 shown in the figure will develop and flight validate advanced technologies which improve fighter lethality and survivability. Capabilities for the air-to-surface precision attack from highly survivable (low altitude) maneuvering deliveries, and all aspect air-to-air gunnery, will be validated. The capabilities are achieved by the integration of mission task-tailored, digital flight controls with a director-type fire control system, and advanced aircraft flight control modes to achieve improved agility and weapon line pointing. Integration of these technologies into a single vehicle permits accomplishment of a realistic evaluation of technology benefits, penalties, and overall mission effectiveness that will facilitate transition to current and future aircraft.

Currently designed into this aircraft are the new digital flight control system, advanced cockpit displays and controls, a highly integrated avionics system, and new aerodynamic surfaces for advanced control feature. The inlet-mounted canards, in conjunction with the rudder, produce a sideforce that enables flat turns (turning without changing direction of the flight path). Flap deflections, in conjunction with the horizontal tail, enable corresponding pitch pointing and vertical translation like an elevator. This technology demonstrator aircraft is now being assembled at General Dynamics Corporation, Fort Worth, Texas, and flight testing is scheduled to begin in the summer of 1981. A subsequent modification will couple the fire control system with the flight control system and add new attack sensors. Flight test of this Automated Maneuvering Attack System will be accomplished in 1983.

Lt. Col. A. J. Bianco/513-255-4778



FIRST ACCURATE COMPUTATION OF AIRFOIL STALL CHARACTERISTICS

Much effort has been expended by the aeronautical community in determining the aerodynamic characteristics of airfoils and aerospace vehicles. Linear methods are extensively used in design work for small angles of attack with negligible flow separation. Experimental investigations are used to determine the characteristics near stall where separation phenomena become important. Recent developments in numerical techniques and increased experimental costs stimulated research on another approach, namely the numerical solution of the general aerodynamic equations. These equations include the viscous effects which contribute to stall.

In this investigation, numerical solutions using finite difference methods are obtained for two-dimensional incompressible turbulent viscous flow over stalled airfoils of arbitrary geometry. An algebraic turbulence model is developed for separated adverse pressure gradient flows.

The figures show the flow streamline contours for a NACA 0012 airfoil as it approaches the stalled condition at a chord Reynolds number of 170,000. Computed separation bubble characteristics including the criteria for separation, bubble type, and turbulent transition agree with empirical results. The predicted lift and drag coefficients agree with the experimental values. The computed lift coefficients near stall are within 5% of the experimental measurements. The numerical drag coefficients are within the aircraft industry goal of ten drag counts in the region of maximum lift to drag ratio.

This Flight Dynamics Laboratory technical achievement provides the aerospace industry with the first prediction method which accurately determines the aerodynamic characteristics of stalled airfoils.

Capt. Harwood A. Hegna/513-255-2455

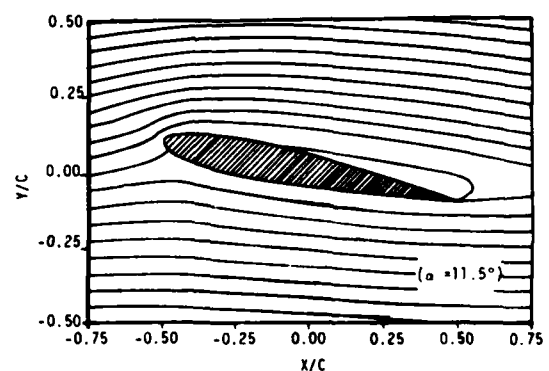
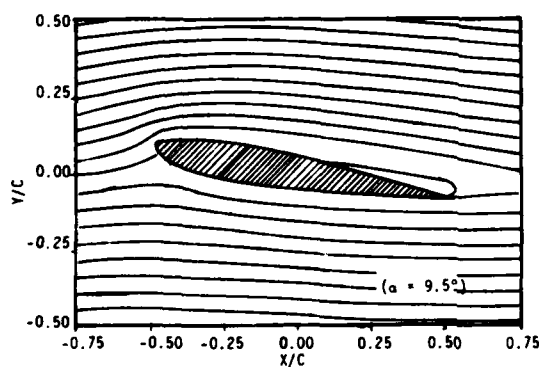
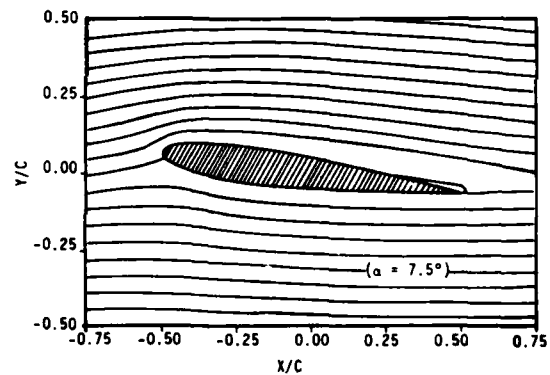
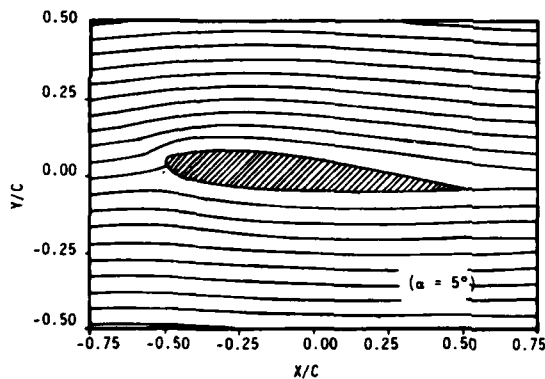

NAVIER-STOKES NOZZLE COMPUTATION

The increased importance of the aft-end drag problem associated with nozzle installations in current and future high performance aircraft has led to extensive and very costly experimental nozzle test programs. Computational aerodynamics shows great promise as a field which can have a favorable impact on this requirement for nozzle testing. It was shown that boundary layer and shear layer growth, separation, shock formation and reflection, and plume blockage and entrainment characteristic of nozzle flows can be analyzed using computational techniques. Since the cost of computational analysis is decreasing as more advanced computers are developed (while experimental costs are steadily increasing) computational analysis in this area is being investigated in much more detail.

This Flight Dynamics Laboratory project consisted of numerically solving the complete Navier-Stokes equations for a domain containing an axisymmetric coflowing nozzle ($M_\infty=1.94$, $M_{jet}=3.0$). Five jet

pressure ratio conditions ranging from a highly overexpanded case which exhibits a Mach disc shock formation to a slightly underexpanded case were examined and solved numerically. As shown in the figure, both the complex shock wave structure and the viscous effects were accurately reproduced by the numerical technique. Computational values of the nozzle base pressure, in direct relation to aft end drag, were also in good agreement with the experimental data.

This is the first full Navier-Stokes computation that has accurately simulated the viscous-inviscid interactions present in the supersonic coflowing nozzle at off-design conditions where the strong Mach disc shock structure is present. This Flight Dynamics Laboratory technical achievement demonstrates that numerical solutions can be extremely useful in investigating nozzle performance and the aft-end drag problem.

Captain Gerald Hasen/513-255-2455

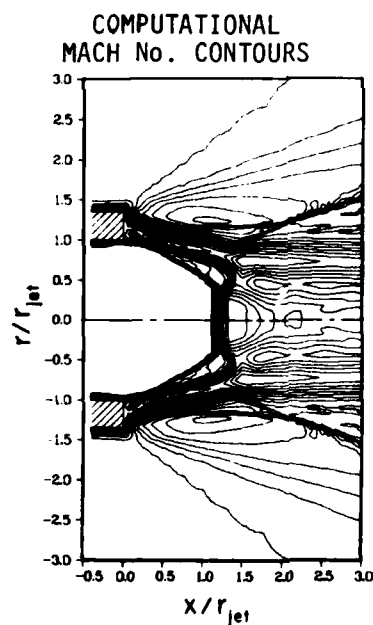

DEVELOPMENT OF LASER VELOCIMETER FOR TURBULENCE MEASUREMENTS

A program to develop a non-intrusive flow diagnostic technique for use in the Flight Dynamics Laboratory experimental wind tunnel facilities was completed. Thus, the capability now exists for measuring the statistical properties including mean and fluctuating velocities in complicated flow configurations where accurate experimental information was previously unattainable.

One of the key elements to the present design is to use a photon correlation processing scheme. The advantage of this processing technique is that the laser velocimeter can be operated in investigations where artificial seeding of the flow is either impractical or would introduce large errors in the data obtained. A second important feature is the inclusion of a frequency shifting oscillator which eliminates the directional ambiguity normally present in a laser velocimeter arrangement.

The photon correlation laser velocimeter was used

to investigate the turbulence properties of several different configurations. A schematic of the test set-up and the actual hardware are shown in the figure. Basic configurations such as a freely expanding turbulent jet and the flows behind a blunt body and behind a two-dimensional cylinder were documented and the results compared to hot wire anemometer data. Confidence was established in the credibility of the laser technique.

The non-intrusive nature of the laser velocimeter is being fully exploited in a present research project involving an ejector wing design. No other technique can be employed to measure the flow field in the critical region of interest, namely, downstream of the ejector nozzle and in the region between the lower and upper airfoils. Yet, without this information, the effectiveness of the ejector wing design cannot be established.

Capt. George Catalano/513-255-56207

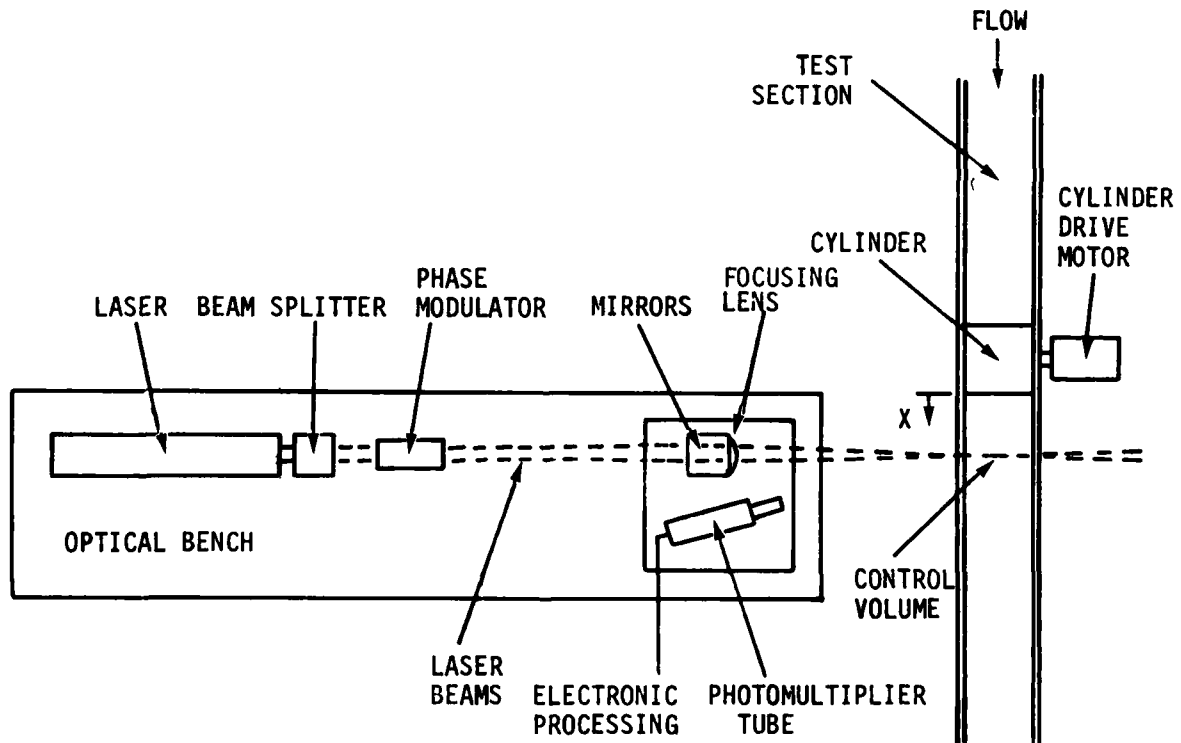

AEROMECHANIC APPLICATIONS OF FAVORABLE AERODYNAMIC INTERFERENCE

Numerous analytical and experimental studies on advanced high-speed interceptor concepts designed for operation above Mach 4 were carried out during the 1970-1975 time period. At the conclusion of these efforts, a high degree of confidence has been achieved in the aerodynamic analysis procedures, as well as a large data base generated and available for extrapolation. Now, the time was right for a 'first-look' at innovative aerodynamic concepts that might yield a substantial improvement in overall aerodynamic efficiency. One such concept was favorable aerodynamic interference.

Favorable aerodynamic interference involves the unique positioning of the aircraft component parts such that their interfering flow fields produce a beneficial impact on the overall configuration performance. Although primarily associated with very high speed flight (due to more simplified analysis procedures at hypersonic speeds), studies have indicated potential usefulness down to Mach numbers on the order of 3. The concept may be applied in a dedicated manner where configuration performance is to be optimized, or in an incremental manner for such conditions as trim enhancement, etc.

The Flight Dynamics Laboratory investigations were initiated in the 1976-1977 time period, on

configurations designed for sustained cruise at Mach numbers from 3.0-4.5. These studies involved both analytical and experimental phases with follow on efforts continuing through FY 81.

During FY 80, two experimental studies were conducted. One involved a force and moment investigation on a double parasol type wing arrangement utilizing nacelle-to-wing interference. The second provided a first evaluation of the aerothermal problem and utilized a pylon-mounted parasol wing arrangement which employed fuselage-to-wing favorable interference. A photograph of the configuration of the sting mounted for wind tunnel tests is shown. In-house analytical studies concentrated on the verification of the analytic model and its application in the interfering flow fields, as well as design sensitivity studies on advanced wing concepts for improved performance.

Future studies will involve detailed investigation on advanced wing designs with subsequent experimental programs to verify the analyses. The net pay off will be an alternate design option that will offer improved performance for aircraft concepts optimized for sustained cruise at high supersonic Mach numbers.

Peter R. Gord/513-255-5464

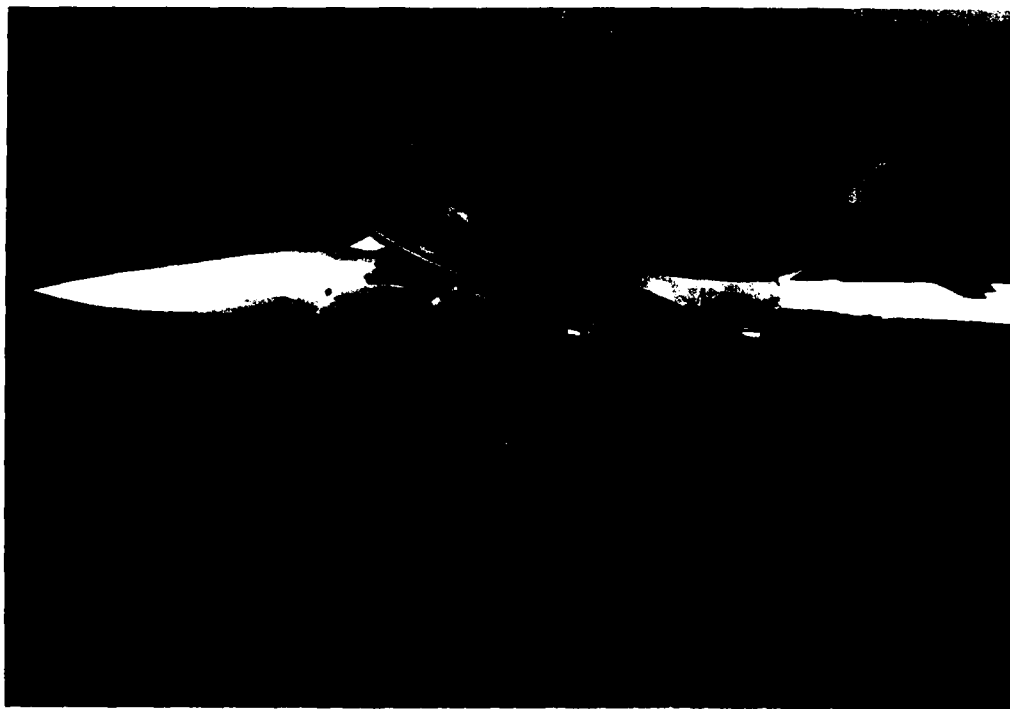

KC-135 WINGLET

The KC-135 Winglet Program is a joint Air Force/NASA research program to demonstrate fuel conservation due to winglet technology. Unlike end plates, which have been suggested for a number of years as a means for reducing drag, the winglet is designed with the same careful attention to airfoil shape and local flow conditions as designs of the wing itself.

During FY 80, flight test of the winglet was accomplished. A total of 20 flights of approximately 6.5 hours each were flown. Performance, loads, and

flutter data were obtained for both the baseline and winglet configuration.

Shown in the figure is the test aircraft with the winglet installed. Flight test data demonstrated a 5 to 7% drag reduction and a 5-6% fuel mileage increase at best cruise speed and altitude. This translates into a fuel mileage increase of 4.5 to 5.5% for the composite SAC mission. This fuel mileage increase translates into a fuel savings of 24 million gallons of fuel per year for the KC-135 force.

David Selegan/513-255-4613



CRYOGENIC RADIATOR TEST UNIT

Very low temperature (cryogenic) radiators can be used to provide direct, passive cooling for infrared sensors carried on space satellites. Future space-based infrared detection systems may be used for surveillance, warning, and tracking functions. Direct, passive, thermal radiation to cold space is the most reliable and lowest cost method of cooling critical components in these systems when temperature requirements and orbital conditions are suitable. Small cryogenic radiators presently used by the Air Force and NASA provide up to 0.1 watt of cooling at temperatures between 80 and 100°K. A multi-watt cooling capability at lower temperatures is needed for future systems. In response to this requirement, the Flight Dynamics Laboratory awarded a contract to Rockwell International to design and fabricate a 100 square foot radiator using advanced technology components. This full scale, test model radiator has thermal shielding appropriate for use in geosynchronous orbits. It has two stages for operation at 70°K and three stages to reach 40°K. Cryogenic heat pipes transport the cooling load from a simulated focal plane to the radiator and distribute this energy over the radiating surfaces. Structural supports with very low thermal conductance are used to mount the radiator from a support pan and allow for significant contraction during cooldown. Under Flight Dynamics

Laboratory direction, the radiator was thermally tested at the Arnold Engineering Development Center (AEDC) before and after an acoustic test which simulated the most critical launch environment. The two-stage radiator installed in the AEDC chamber is shown in the first figure. Completion of the test series in July 1980 demonstrated five watts of useful cooling at 70°K and 0.2 watt at 40°K. The tests showed the feasibility of large cryogenic radiators with open view factors. The second figure depicts use of the radiator on a spacecraft. Other large radiators for use in suitable orbits can be scaled directly from this unit which establishes a new capability for future systems.

In contrast to the small, conically shielded radiators now in operational use, demonstration of a radiator with 50 times greater cooling capability at significantly lower temperatures extends the availability of this cooling method to be more compatible with mosaic focal planes now being developed. Successful completion of full scale radiator testing in less than two years after start of design illustrates the straightforward nature of this cooling method and the effectiveness of the program. A new level of technology has been established for systems which will be of critical importance in this decade.

W. L. Haskin/513-255-4853



PASSIVELY COOLED ON-ORBIT CONFIGURATION

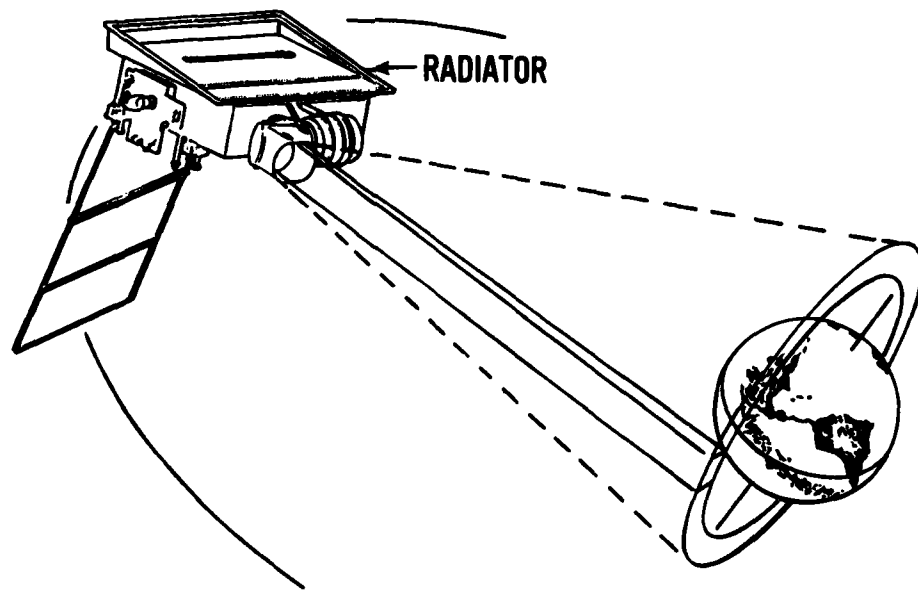

SECTION IV
MATERIALS LABORATORY

SIGNIFICANT NEW ADVANCE IN ELECTROLUMINESCENT LIGHTING MATERIALS

The illumination of aircraft instrument panels and airfields under austere lighting conditions has been a serious challenge for many years. Major strides in lighting materials have recently been made as a direct result of in-house research within the Materials Laboratory. A patent has been awarded to Mr. Sidney Allinikov, AFWAL/MLSE, for his research and development of a procedure for micro-encapsulating electroluminescent (EL) phosphors. This development permits the first practical application of the EL characteristic of certain phosphors - their ability to emit light when excited by an alternating electrical current. Although this phenomenon was first noted by scientists in 1936, lighting manufacturers have, until now, been unable to develop sufficiently durable lighting systems for Air Force uses due partially to low light output, color shifts, damage by moisture, and ultraviolet radiation. Microencapsulation of the phosphor crystals has provided the durability for Air Force applications. The EL phosphors are sealed against moisture and have shown as much as five-to-seven-fold increase in resistance to humidity and no adverse effect due to ultraviolet radiation. Their superiority over currently used conventional (incandescent) lighting systems has been demonstrated in a number of service tests.

The PRAM Program Office, ASD/RAOE, with the technical support of the Materials Laboratory, has conducted a number of successful application demonstrations of EL materials. These demonstrations have included a very successful service test by the Tactical Air Command (TAC) of several A-10 aircraft with EL lighted instrument panels; installation of EL instrument and interior lighting in the Pave Low helicopters as required by a Program Management Directive; and a number of

successful tests of EL portable runway lighting. In reference to the latter demonstration, the Vice Commander of the Military Airlift Command (MAC) stated that "EL lighting provided the first major advance in austere airfield lighting in the last 15 years".

The payoffs of EL lighting versus incandescent lighting are significant. For aircraft instrument panel lighting, the uniformity and quality of EL lighting is far superior, particularly under night time conditions. The acquisition costs are expected to be reduced 50% with a 50 to 60% reduction in power consumption. Weight reductions and reduced heat load are other benefits. In austere airfield lighting, EL lights are three times more visible than incandescent lighting and eliminate glare and the halo effect of standard runway lights that often disorient pilot when landing. The incandescent light halos make the more distant lights appear larger than those nearer the landing aircraft (see figure). With the EL lights, the near lights look larger than the far lights regardless of fog and dust, thus, allowing the aircrews to rely on their normal depth perception. Also, the EL lights are more portable than conventional portable runway lights due to their lighter weight construction, use of lightweight wire, and compact shape (see figure).

In addition to its military usefulness, numerous commercial spinoff possibilities are foreseen for EL lighting. It lends itself for use in lighting automobile instruments, home security signs, appliance lights and, since EL lighting can be seen through smoke and haze and without halo effect, it has further application for fire and exit lights.

A. Olevitch/513-255-3691

**PHOTO COMPARISON OF EL (RECTANGULAR)
AND STANDARD INCANDESCENT PORTABLE
RUNWAY LIGHTS (ROUND)**

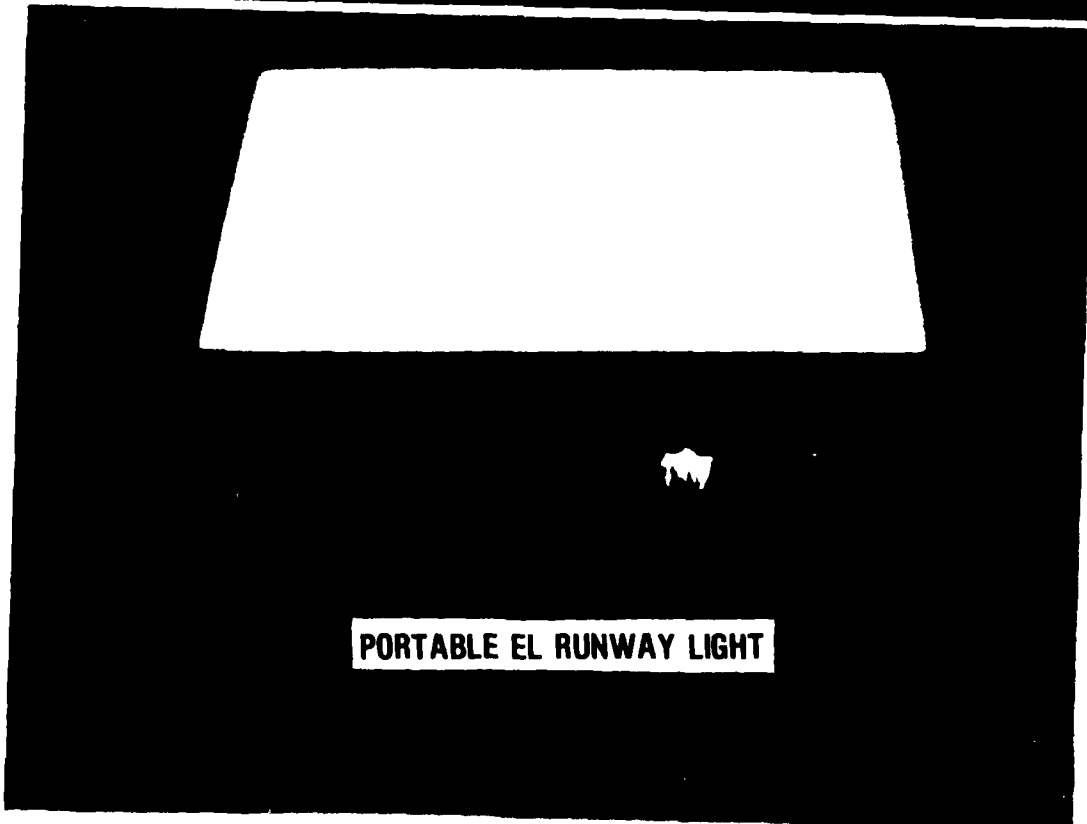
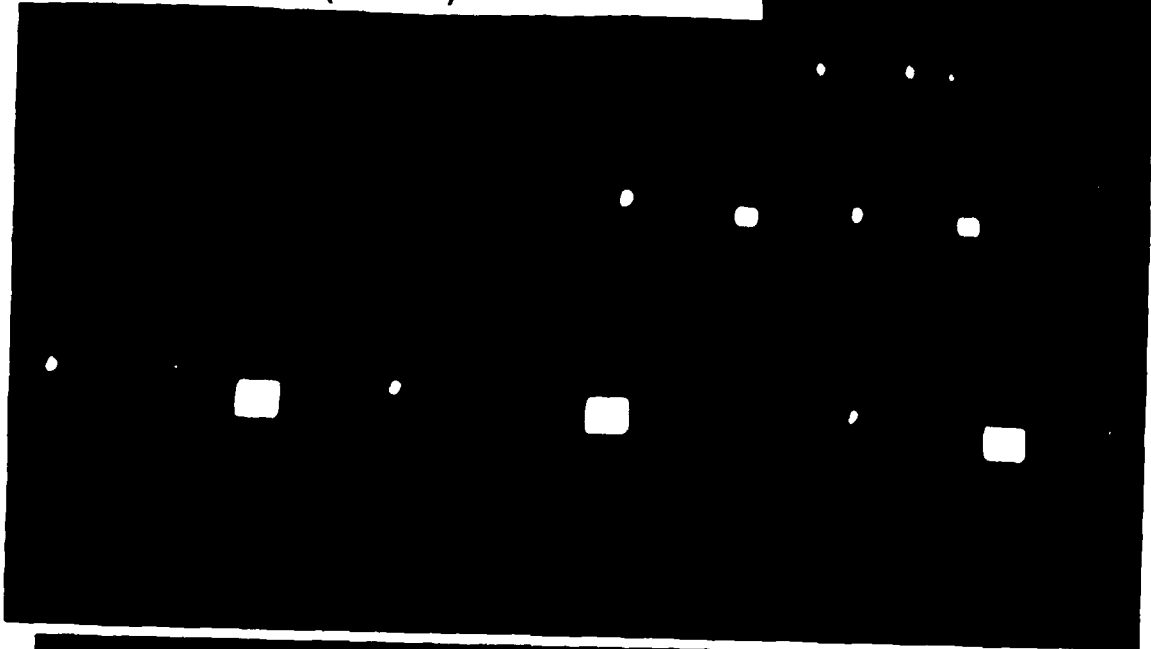

PORTABLE EL RUNWAY LIGHT

"SOFT" (IMPROPERLY QUENCHED) ALUMINUM EVALUATION RESULTS

Undetected mill processing and quality assurance problems at one of the major aluminum producers resulted in a serious situation for major airframe manufacturers. Thirty-five million pounds of aluminum plate material were suspected of having been produced and delivered containing "soft" (improperly quenched) areas randomly distributed on some plates having substantial mechanical property reductions. The extent of the problem was widespread enough that all of DoD was affected, as well as all the aerospace industry. The Materials Laboratory performed a major portion of the aluminum testing and evaluation necessary to bring about the eventual resolution of the "soft aluminum" issue.

The Materials Laboratory activities focused on three main concerns: correlation of nondestructive testing results with tensile properties, design mechanical property evaluations to assess the safety aspects of parts possibly containing soft aluminum which could have been built into an aircraft, and spectrum loading fatigue tests to assess potential degradation of the structural life. With these data inputs, the Aeronautical Systems Division evaluated and approved for continued usage all possibly affected aircraft structures, thus eliminating the need to tear down, inspect and/or rebuild substantial numbers of aircraft.

C. Harmsworth/513-255-5128

ROBOTS AND AUTOMATION

Productivity (or lack of it) has become increasingly critical to all aspects of aerospace and other manufacturing. The Materials Laboratory (Manufacturing Technology Division) is taking the lead in learning how to use robots and other automation techniques to manufacture aircraft. In fact, as a result of these efforts, the first industrial robots used in aircraft manufacturing were recently introduced into everyday production, drilling holes in components for the F-16 aircraft at General Dynamics/Ft. Worth Division. Automated composite manufacturing methods using robots and other types of automated processing have been demonstrated at Northrup Corporation, Hawthorne, California, Grumman, Beth Page, New York, and General Dynamics, Ft. Worth, Texas. At Northrup, a robot is used for composite ply handling and layup working with a computer-controlled high speed

mechanical cutter, overhead rail material transfer, automated materials dispensing, and quality control provision - all under computer control. Composite T-38 flight evaluation articles are being made using this process. Grumman has built a fully integrated machine concept using multiple gantries on rails that automatically perform the fabrication functions for advanced composite complex structure. Where applicable, contoured shapes are automatically "stitched" together with a sewing machine to eliminate fasteners. The General Dynamics Corporation's F-16 facility utilizes numerical-control tape laying machines integrated into the total production facility. Automated-in-process control of composite laminate material has been incorporated into the F-16 production line. Lt. Gordon Mayer/513-255-7371
Robert L. Rapson/513-255-7277

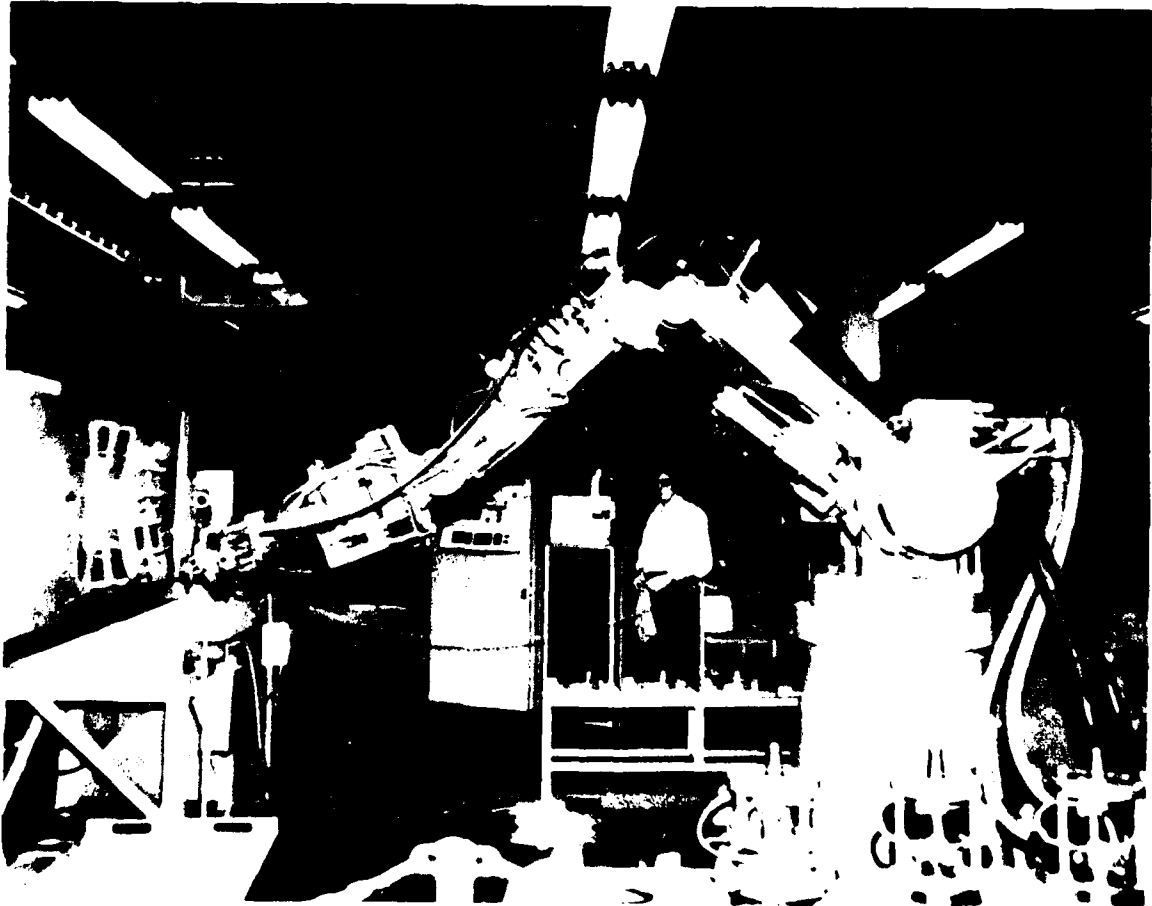

AUTOSCAN METAL FLAW DETECTION

In aircraft, fatigue cracks start at weak spots which are caused by fastener holes. The Materials Laboratory has perfected an ultrasonic process (Autoscan) for detecting fatigue cracks in metal that pinpoints flaws, cracks, and defects. During periodic inspections of aircraft, depending on the size and type (fighter, cargo, etc.), experience had dictated the necessity for inspection of from 10 to thousands of critical fastener holes. With techniques employed prior to the development of Autoscan, fasteners had to be removed so that the

holes could be inspected resulting in a two hour process costing about \$200 per hole. Autoscan, aided by microprocessor control and signal processing, provides a quality analysis of fastener holes. In addition to the capability to inspect 60 holes per hour, the Autoscan technique does not require potentially damaging fastener removal. As a result, aircraft spend less time in the depot, and the flight safety margin is greatly enhanced.

R. Rowland/513-255-3612

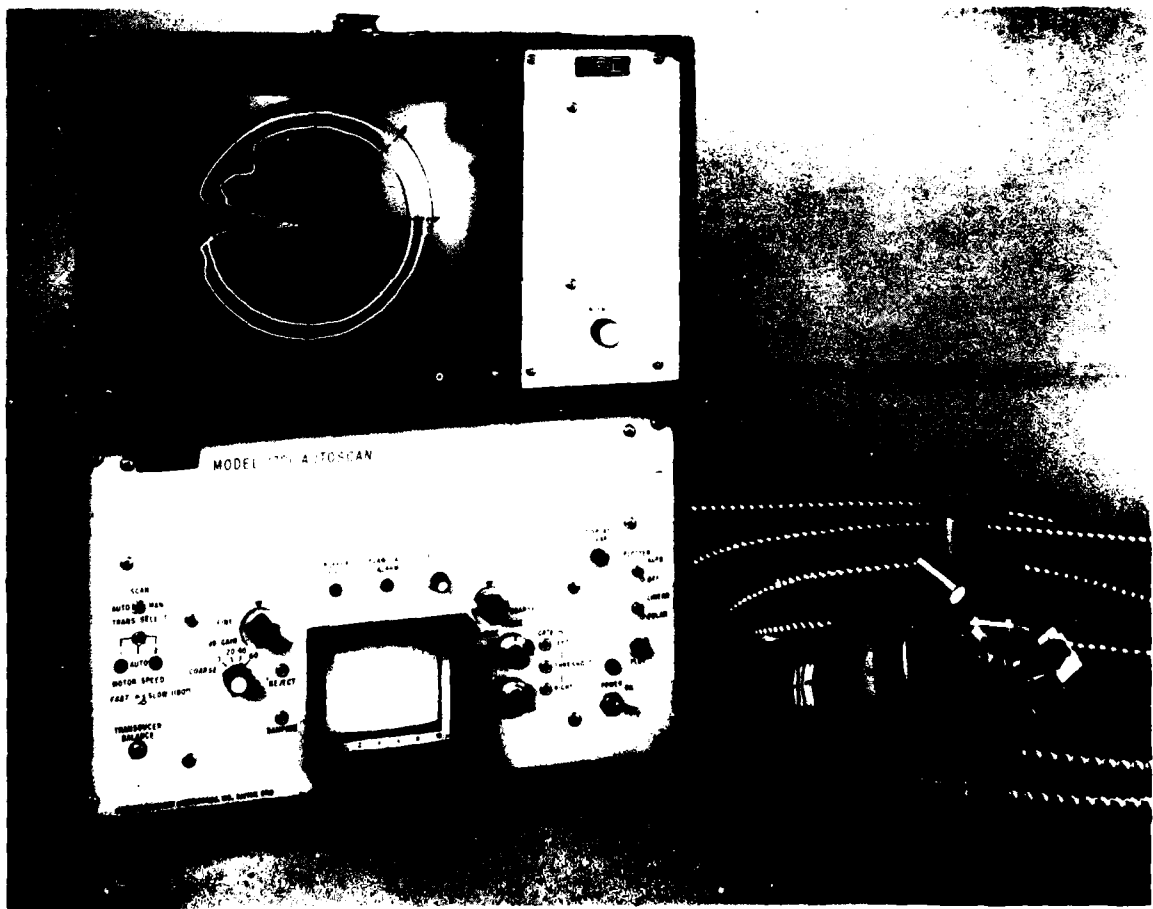

CAST ALUMINUM STRUCTURES TECHNOLOGY

The Cast Aluminum Structures Technology (CAST) program of the Materials and Flight Dynamics Laboratories has successfully established the necessary structural and manufacturing technologies and demonstrated the integrity, producibility, and reliability of cast aluminum primary aircraft structures. This joint program was undertaken as a direct result of the escalating costs of conventional aircraft fabrication methods. The Air Force YC-14 body/nose landing gear support bulkhead was selected as the baseline demonstration component because of its high cost, complex shape, numerous parts (over 400 parts and 4000 fasteners), large size, and primary structure application. Twenty single-piece bulkhead castings with no fasteners were successfully fabricated. The cost of the cast bulkhead is 38% less than the

conventional sheet metal buildup fabrication. Testing has shown that the cast unit satisfies or exceeds all durability, damage tolerance, and design strength requirements. Encouraged by the early data being generated in this program, The Boeing Company initiated a redesign of their Air Launched Cruise Missile (ALCM). This redesign resulted in replacement of over 28 intricately machined and welded forgings with four thin-wall aluminum castings, machined only at the mating surfaces. These and other castings, such as the engine inlet duct, represent approximately 90% of the ALCM structure. It is estimated that this fabrication procedure resulted in a cost avoidance of \$150 million for the projected production run of over 3000 missiles.

Mr. J. Williamson/513-255-5037

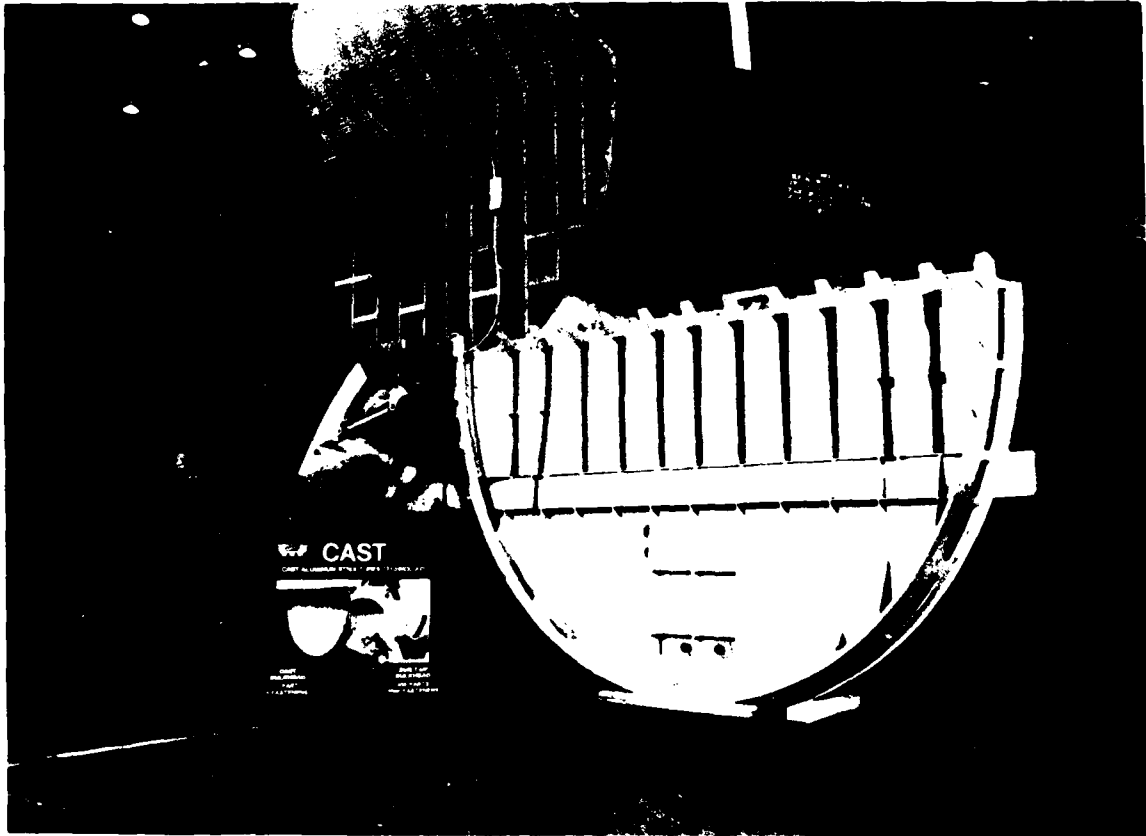

FIRST RSR RADIAL WAFER BLADE ENGINE TEST SUCCESSFUL

Durability has proven to be a continuing problem with first stage turbine blades and vanes of the F100 engine. A turbine blade design using new fabrication techniques has been developed in an attempt to correct this problem. The Pratt and Whitney Group has successfully completed initial engine testing of two advanced design turbine blades fabricated from rapid solidification rate (RSR) powder. The blades were of diffusion bonded wafer construction, having a high degree of cooling efficiency, and fabricated under a DARPA/Materials Laboratory contract using a newly developed high strength Ni-Mo-Al-W alloy. When processed by the RSR powder route, this alloy has a high degree of homogeneity and a fine, uniform, stable gamma

prime strengthening phase. When processed to a directional grain structure having a high modulus orientation, typical stress rupture strengths would allow application at a metal temperature in excess of 150°F greater than currently used directionally solidified airfoils. State of the art coatings were applied to the blades prior to testing in the first stage of the F100 engine core. The blades were in excellent condition following 7.6 hours of operation, including 25 equivalent Tactical Air Command cycles and one hour at intermediate power. This test is considered to be a significant demonstration of this new technology.

A. M. Adair/513-255-5430

R. J. Ondercin/513-255-2413

NONFLAMMABLE HYDRAULIC FLUID/SEAL MATERIALS DEVELOPMENT

Over the past several years, aircraft have sustained losses related to hydraulic system fires. To stem this trend, a comprehensive fluid/elastomer materials development program has been carried out within the Materials Laboratory to attain a nonflammable hydraulic system package. Many fluid and elastomeric material options were evaluated under this program. Oligomer of chlorotrifluoroethylene (CTFE), one of the fluids evaluated, emerged as the primary candidate for meeting the criteria of being truly nonflammable when exposed to ignition threats. This candidate nonflammable fluid has

exhibited performance equivalent to the current highly flammable MIL-H-5606 hydraulic fluid over the -65°F to 275°F temperature range. Advanced seal materials based on phosphonitrilic fluoroelastomer (PNF) were also developed by Materials Laboratory for use with the CTFE fluid. Dynamic testing has shown this elastomeric material to be effective over the -65°F to 275°F temperature range at a system pressure of 3000 psig.

B. D. McConnell/513-255-5731

MISSILE RADOME DEVELOPMENT

The Materials Laboratory recognized a possible critical deficiency in the performance of the base-line Advanced Medium Range Air-to-Air Missile (AMRAAM) radome and, as a result, initiated a program to develop alternative radome materials. Included in the program were development, manufacturing, and testing tasks for advanced ceramic radomes and a new innovative plastic radome concept, as well as tasks for detailed evaluation of the current base-line radome material. Under the materials development program, materials that meet the severe AMRAAM environmental requirements have been identified and tested. The decision has been made to transition the new materials to full scale testing by

the prime contractors and to initiate Manufacturing Technology programs to provide radome production readiness. As a result of this program, a new generation of radome materials has been developed that not only provides solution to a critical system problem, but also provides the DoD with a technology that will have very broad applications in the field of high performance missiles and reentry vehicles. The ceramic and ablative materials developed will have significant impact on the technology for many years in terms of performance capabilities and substantially reduced costs.

Dr. G. Denman/513-255-3808

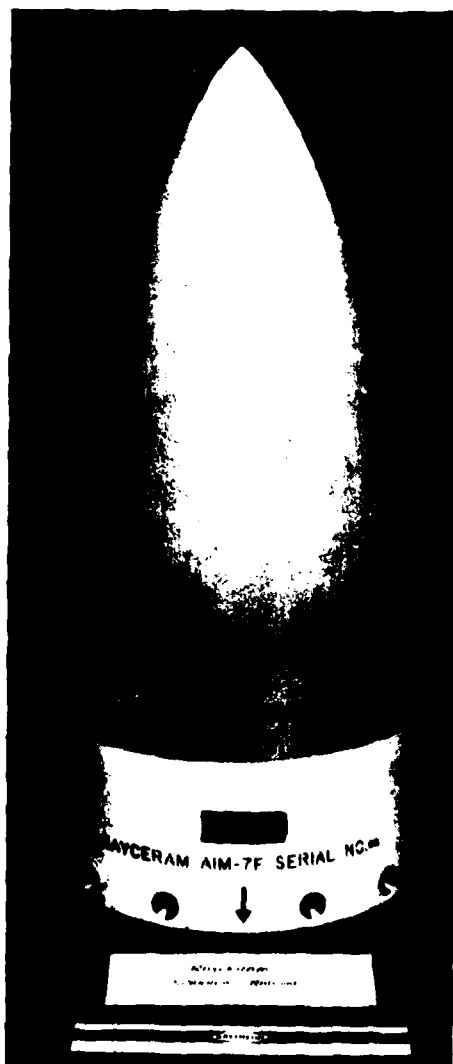

DETECTOR GRADE INTRINSIC SILICON

In prior years intrinsic silicon for the fabrication of detectors for Air Force and Army laser guided weapon systems was purchased as a by-product from foreign silicon producers. Cost of the material was \$30 per gram and the supply was erratic. Joint Air Force/Army planning defined a current need for 100 kilograms per year and an estimated future need growing to 200 kilograms per year. Strategic concerns dictated that a domestic source of the material be established.

To correct this, a joint Air Force/Army program through the Materials Laboratory was awarded to Hughes Aircraft Company, Industrial Products Division. The objective was to establish production of detector grade intrinsic silicon with resistivities in the ranges of 15,000 to 30,000 ohm-cm and 9,000 to 20,000 ohm-cm, p type, with low dislocation density ($1,000 \text{ cm}^{-2}$), for use in the fabrication of 1.06 micron laser detectors and to establish a domestic

source of supply. The single crystal silicon is produced from high purity polysilicon using a multiple-pass vacuum float zoning process. Processes were also established for the fabrication of slices polished on both sides to precise dimensions. Evaluation data, including results of use for detector manufacture, confirmed the suitability and high quality of the silicon ingots and slices.

Establishment of the domestic capability, even in prototype form, had the immediate effect of lowering the costs to user agencies. A 66% reduction in the cost of the intrinsic silicon ingot from \$30 per gm to \$10 per gm was established based on full scale domestic production to supply the joint Air Force/Army need.

Major John K. Erbacher/513-255-3812



MANUFACTURING PROBLEM
Supply Of 1.06 μ M Detector Grade Silicon Erratic, Expensive and Off-Shore

APPROACH

- Develop A Reliable, Domestic Source Of High-Resistivity For Detectors

ACCOMPLISHMENTS

- Process Developed For Silicon Which Makes Superior Detectors
- Domestic Source Established For All DoD Systems
- Price Cut In Half

PHOTOCHEMICAL DEPOSITION PROCESS

The Solid State Area has a requirement for low temperature processes to prevent property degradation that occur at higher temperatures. As a consequence of this recognized problem, the Hughes Aircraft Company, under contract to the Material Laboratory, has developed a process for the photochemical deposition of dense films of silicon dioxide for the passivation of semiconductors. Excellent films can be deposited at about 200 angstroms per minute on silicon substrates held at 200°C. Good films can be deposited on infrared detector materials at temperatures below 100°C. This is important because detectors have to be processed at low temperatures to maintain their properties.

The photochemical deposition of silicon dioxides involves the reaction of silane with an oxidizer in a chamber illuminated by a mercury lamp. The lamp energy is absorbed by a small amount of mercury vapor in the chamber. The excited mercury atoms transfer their energy to the silane and to the oxidizer converting them to free radicals which interact with the unactivated silane and oxidizer to produce dense, stoichiometric silicon dioxide films on the heated substrate. The results of the process developed under this contract looks so favorable that further development is underway for integrated circuit application under VHSIC.

R. L. Hickmott/513-255-4474

TITANIUM ALLOY IN GAS TURBINE ENGINE COMPRESSOR ENVIRONMENT

Energy in several forms, i.e., radiation, frictional heating, or aerodynamic heating of sufficient intensity, are known to cause titanium and its alloys to undergo self-sustained combustion in aerodynamic environments.

An understanding of the factors controlling or influencing the sustained combustion of titanium alloys by experimentally examining the combustion in a wind tunnel under varying air pressure, temperature, and flow conditions has evolved through cooperative effort of the Materials and Propulsion Laboratories. In addition to an extensive experimental characterization of the combustion of Ti-6Al-4V as a function of pressure, temperature, and velocity, a program has been completed to evaluate the influence of selected alloy chemistry on self-sustained combustion.

Some 18 commercially available or developmental alloys with other compositions, such as binary alloys, low melting point alloys, and aluminides have been studied to identify effects of alloy properties or chemistries on the degree of

combustion.

While many commercially available titanium alloys (including most engine materials) exhibit combustion equivalent to the common Ti-6Al-4V alloy, several beta alloys have been found less combustible, quite often requiring substantially higher gas pressures before significant metal burning begins. Many low-melting point compositions either did not combust or damage severely until very high gas pressures were reached. Certain compositions in the titanium aluminide system are not combustible.

These experiments, the first to evaluate massive metal self-sustained combustion in elevated temperature-pressure air flows, provide information to engine designers on alloy selection for static and rotating components, as well as engine cases and other applications of titanium alloys to aerospace systems.

Stephen R. Lyon/513-255-2110
Charles W. Elrod/513-255-6720

FRACTURE OF BRITTLE MATERIALS UNDER LASER IRRADIATION

A primary high energy laser threat to infrared and radar guided missiles is brittle fracture of the vulnerable dome. Current techniques for evaluating dome materials are based on simplified closed form solutions which have, more often than not, been inappropriately used in developing a correlation to data from loosely controlled tests. Consequently, the relations developed are weak, provide questionable insight for materials development, provide inadequate guidelines for appropriate testing of materials, and cannot be applied to structures of interest.

Materials Laboratory scientists have developed and confirmed techniques for the analytical and experimental determination of the temperature, stress and strain within, or on the surface of brittle materials under laser irradiation. The chosen pilot material was Corning 9606 Pyroceram, a current

radome material. The analytical effort included the generation and selection of material property data appropriate to the test and the threat conditions, characterization of the irradiation pattern of the 15 kilowatt CW carbon dioxide laser, and selection of an optimized finite element model for use with advanced computer codes. The experimental approach utilized miniature thermocouples and strain gages, optical pyrometers which were calibrated for 9606 Pyroceram and other accessories to collect data on temperature and strain. The illustration symbolizes the comparison of data at the end of the analytical and experimental routes. This comparison is for both the temperature and strain and, therefore, provides reinforcement of the correctness of the separate routes.

Dr. P. Land/513-255-6652

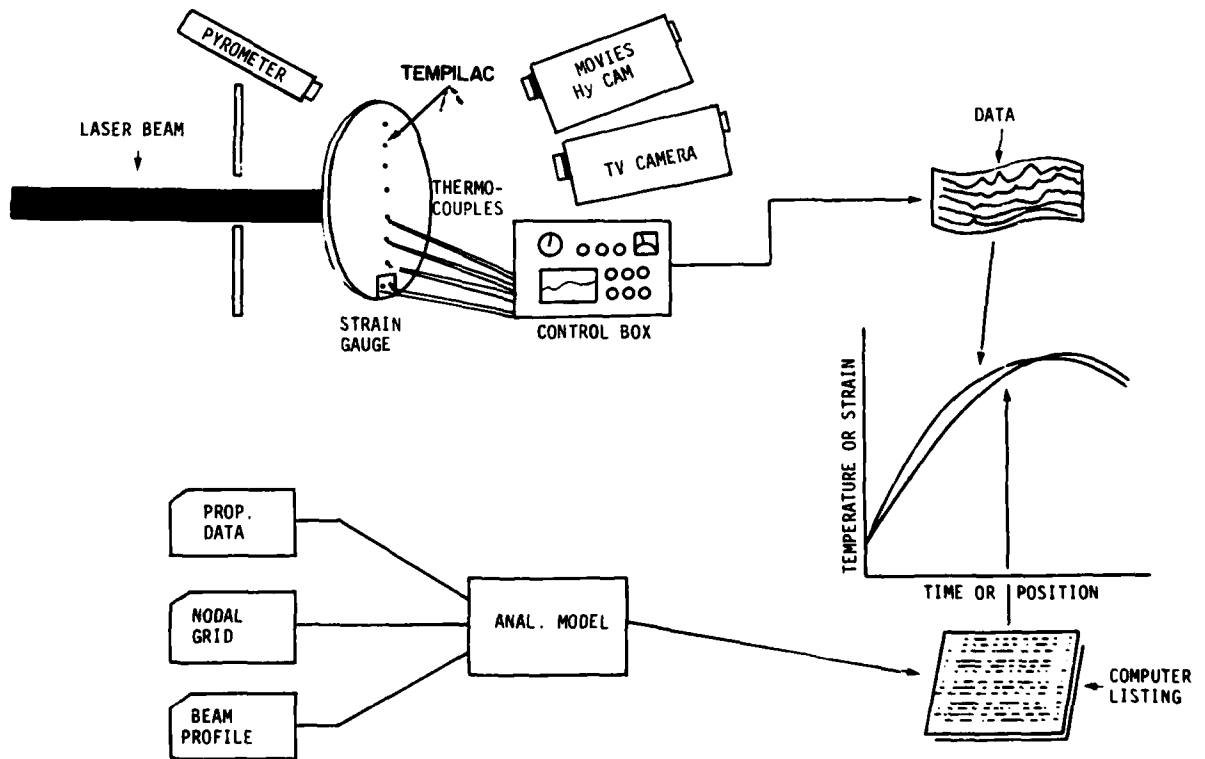

CURE MONITORING OF ADHESIVE BONDED JOINTS BY DIELECTROMETRY

The usage of adhesive bonded structures in Air Force systems is expected to increase significantly due to recent improvements in durability of the materials and processes. As the size and complexity of production parts increase, manufacturers have, from time to time, been experiencing quality and reproducibility problems that have been traced to the temperature-time cycle for curing of the adhesives. In the past, the recommended adhesive curing cycles were established empirically, based on mechanical tests of laboratory prepared bonded test panels, cured by several different candidate cure cycles. It was then assumed that if production bonded parts were cured according to this same temperature-time cycle, they would be cured properly. In some cases, however, due to uneven heat flow and other effects in large or complex configuration production parts, such "standard" cycles do not give proper cure.

To circumvent this problem, a new technique known as dielectric cure monitoring has been developed under Materials Laboratory sponsorship. In this technique, electrical signals from a small

probe or sensor placed in the bond line indicate physical and chemical reactions which the adhesive undergoes as the temperature is increased. When the signals indicate a cessation of these reactions, the adhesive is considered to be cured. Each chemical type of adhesive has its own characteristic graph or "fingerprint" of signal output versus temperature for a given rate of temperature rise. These graphs can be used as a "standard" to check similar graphs from production parts to ensure that they have been cured properly. This Materials Laboratory study has laid the groundwork for the development of new automated cure monitoring equipment. The signal from a bondline sensor could be used in a feedback control loop to automatically adjust the rate of temperature rise or control the point during the cure cycle at which bonding pressure is applied. This will provide manufacturers with automatic control of cure and will greatly increase the reproducibility and reliability of the bonded structures.

H. S. Schwartz/513-255-3308

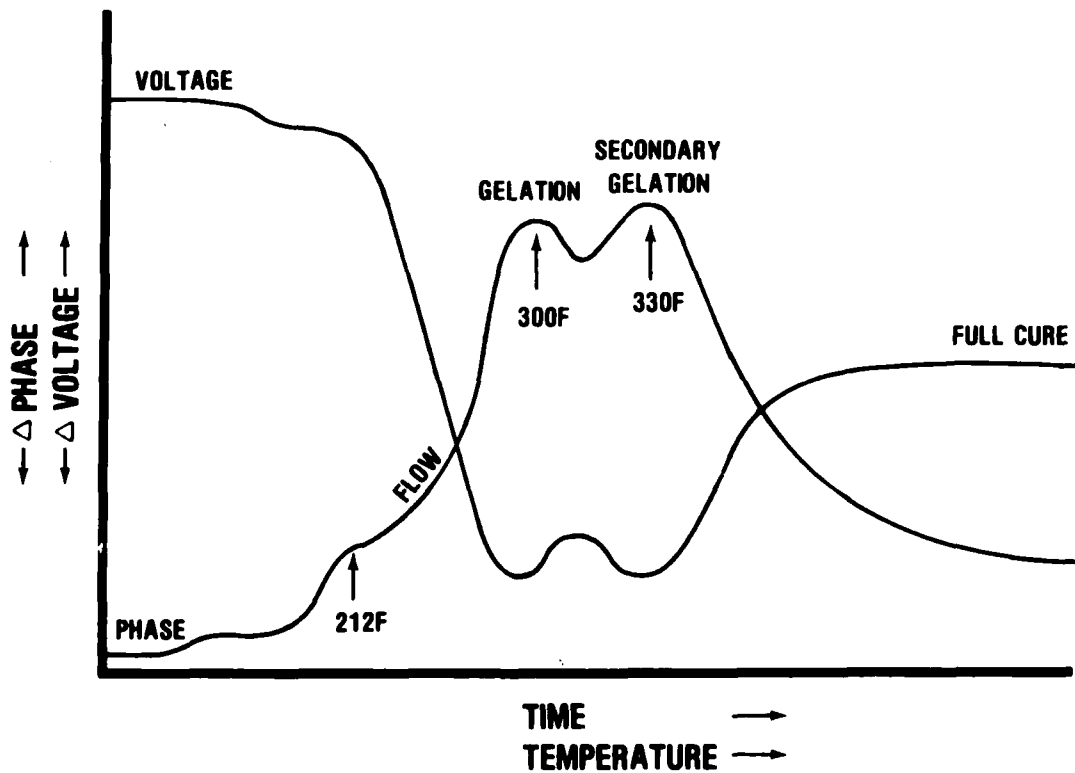

NEW PBT POLYMER YIELDS OUTSTANDING FIBER PROPERTIES

A new "ordered" or rigid-rod molecule polymer, poly-paraphenylene benzobisthiazole (PBT), synthesized and processed under the auspices of the Materials Laboratory has exhibited outstanding properties when spun into a fiber. The PBT research material withstands the effects of thermo-oxidative environments better than aluminum or commercially available plastics, such as aromatic polyamides. For its weight, the tensile strength and modulus properties obtained from PBT fibers exceed those of metallic structural materials such as aluminum, titanium, steel, and such nonmetals as

glass, nylon, and T300 graphite. The outstanding properties obtained in this research show great promise for the development of a superior fibrous material. Based on excellent PBT thin film mechanical properties, prospects for being able to utilize ordered polymer film in the fabrication of composite structures appear good. The ordered polymer research was initiated and pursued in-house by Materials Laboratory scientists and is now being exploited under Materials Laboratory managed contracts.

R. VanDeusen/513-255-2340



ORDERED POLYMERS

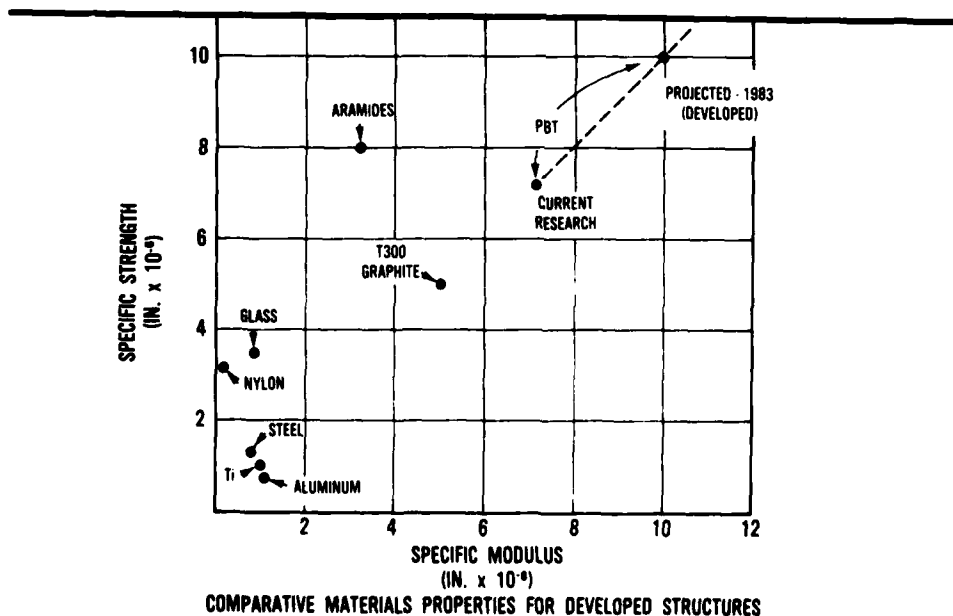

CAMOUFLAGE RADOME COATINGS

The development of camouflage radome coatings has enabled the application, for the first time ever, of a multiple color rain erosion resistant coating to a single aircraft radome. These fluoroelastomer coatings, which have been developed under Materials Laboratory sponsorship, are antistatic and thermal flash resistant while being tailored in color, rain erosion resistant, and dielectrically

transparent. The scheme applied to the radome was white on the bottom, tan on the sides and green on the top when viewed with the radome in the horizontal position as mounted on the aircraft. The ability to camouflage the aircraft radome will significantly improve the survivability of current and advanced tactical and strategic aircraft.
G. F. Schmitt/513-255-7377

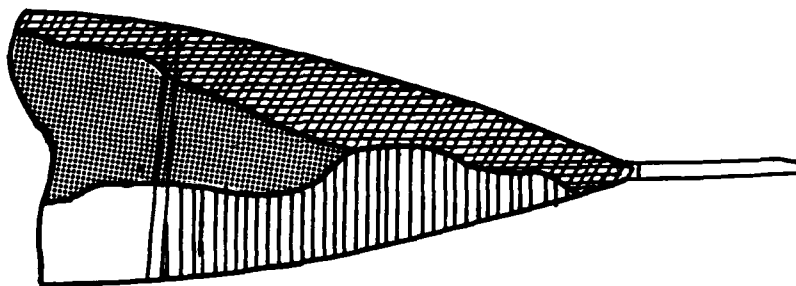

Right Side



White, Type III



Green, Type v



Tan, Type V

CAMOUFLAGE COATINGS SCHEME ON RADOME

DYNAMIC SIMULATION USED TO ASSESS BEARING DESIGN

The Air Force has had a longstanding need for methods to assess the performance of bearings which are expected to achieve lifetimes of 10 to 15 years unattended in a space environment. Life testing of such bearings is impractical because of the cost and time involved. Researchers within the Materials Laboratory have developed a new dynamic simulation computer program that provides a means to assess the performance of bearing designs before fabrication and to study behavior to an extent which is not practical experimentally.

The performance of a bearing in a Reaction Wheel Assembly (RWA) has been studied using this computer program for Dynamics of Rolling Element

Bearings (DREB). The studies showed that the design of the retainer (shown schematically) led to instabilities in bearing motion under certain conditions which were detrimental to bearing performance. Studies also showed that performance could be improved by altering the cage design. The altered design has been fabricated and tested and has shown improved performance. This technique is expected to see broad application in bearing design and will lead to bearings with improved and more reliable performance. It is also expected to give reductions in both time and money required to develop bearing designs.

Dr. H. Bandow/513-255-5731

BEARING RETAINER SCHEMATIC

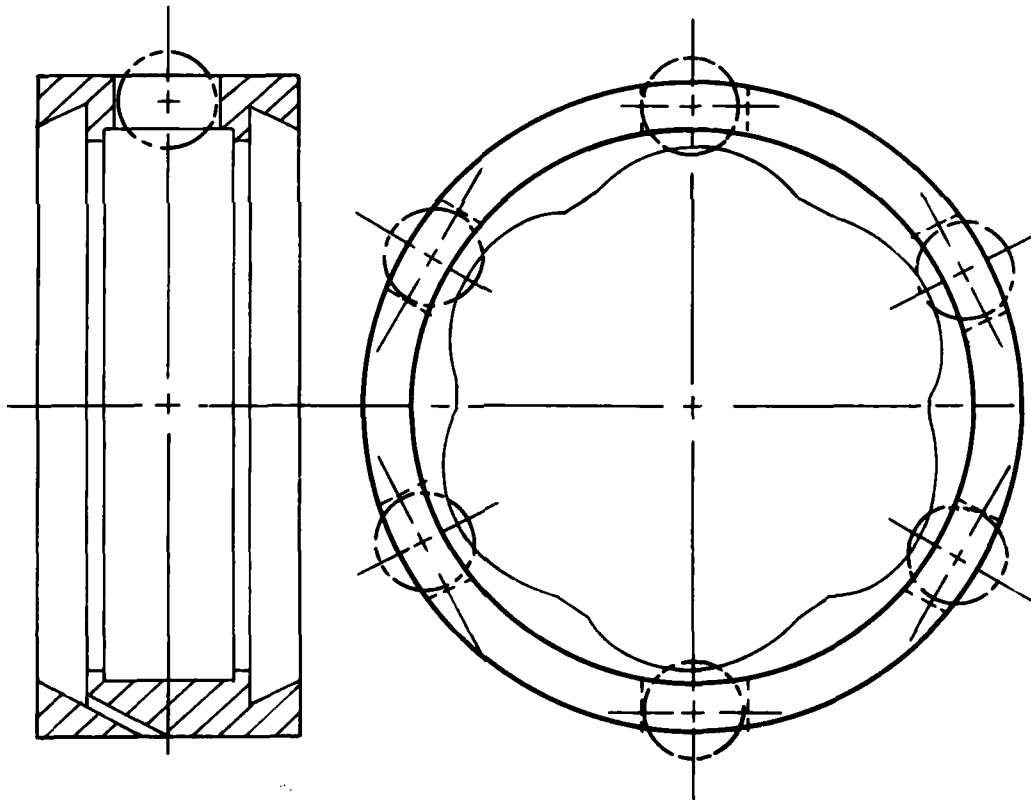

PROMISING NEW RESIN (ATS) DEVELOPMENT

A new and promising thermoset matrix resin, acetylene terminated sulfone (ATS) developed at the Materials Laboratory has an excellent combination of mechanical properties, processability, and moisture resistance. Advanced composite applications are increasingly important in aerospace systems to lower costs, save weight, and reduce corrosion. The new ATS resins promise to be of value because they process like an epoxy. Composite structures made with these resins have mechanical properties superior to those from conventional resins. The ATS resin contains an

ether sulfone "backbone" and is based on the polymer technology of thermally induced addition reactions of aromatic and/or heterocyclic diacetylenes. Utilizing the acetylene end-groups for additional cure reactions, the internal molecular structure of the backbone was tailored to provide the improved resin properties. Under a contractual effort, procedures for a low cost synthesis and a scale-up to pound quantities have been developed for ATS.

R. VanDeusen/513-255-2340

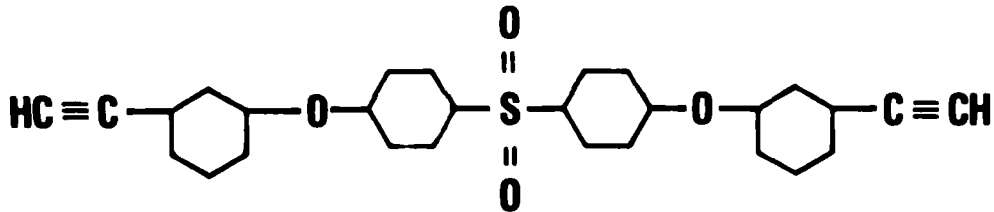

HIGH STRENGTH PROTECTIVE CARBON FABRICS

POLYACRYLONITRILE (PAN)-based carbon fabrics with ten times the strength of state of the art rayon-based carbon fabrics have been developed under Materials Laboratory sponsorship for thermal protection, insulation, and structural composites. Special grades of carbon fabrics were manufactured by pyrolysis of PAN-based yarns followed by weaving into 8-harness satin constructions. The specialty fabrics were tapewrapped into phenolic composites and their engineering properties generated. Significant

improvements in thermal insulation have been demonstrated as evidenced by the greater than 35% reduction in thermal conductivity shown for the PAN-based DG-112 fabric as compared to the rayon-based material (see figure). The new carbon fabrics are expected to provide lighter weight thermal protection systems, e.g., reentry vehicle heatshields and very high strength structures.

D. L. Schmidt/513-255-5767

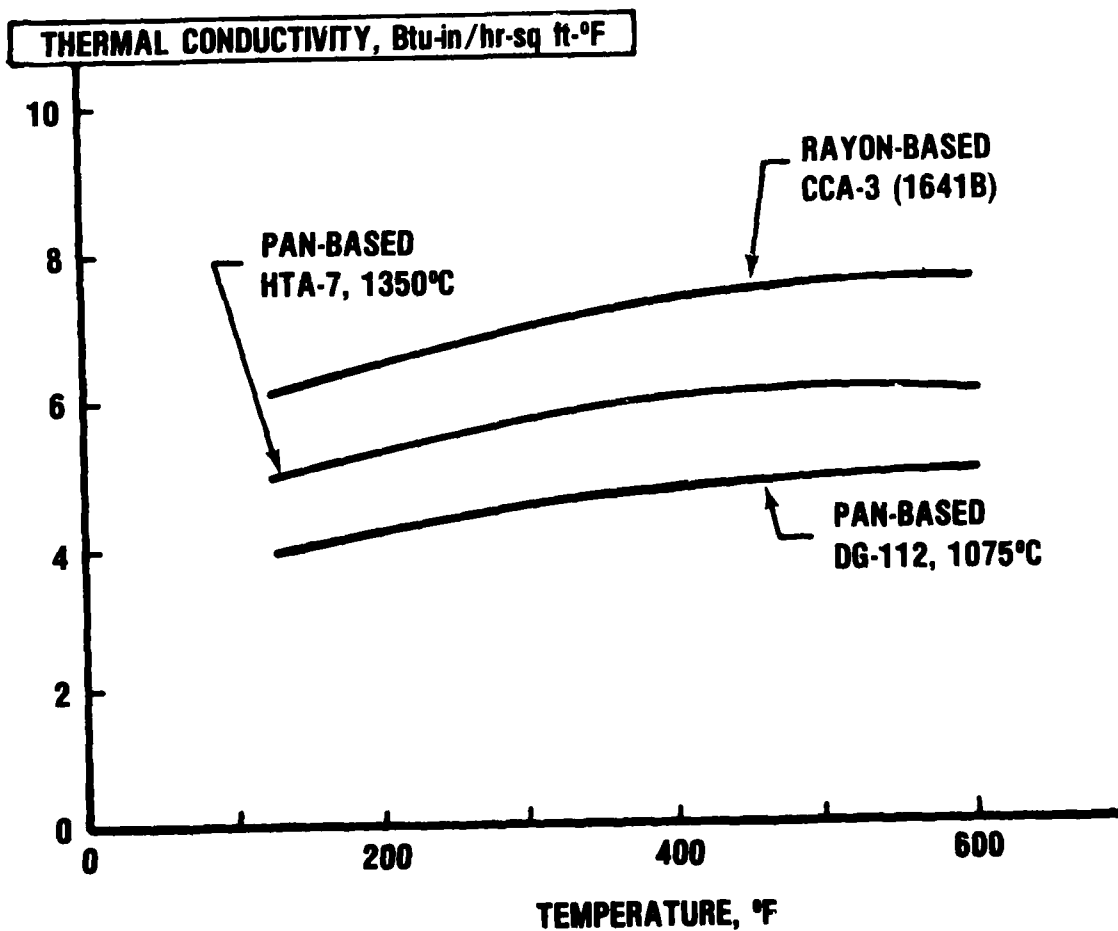

NEW APPROACH TO INVESTIGATION OF POLYMER CURES

Accurate glass transition temperatures (T_g) in partially cured complex polymer systems, were previously impossible to measure. They have now been measured using a new analytical approach developed at the Materials Laboratory. The ability to determine T_g in partially cured polymers is an important and critical factor in polymer research, particularly that aimed at the discovery of higher use temperature resins. The successful measurement technique, Torsion Impregnated Cloth Analysis (TICA), invented by Materials Laboratory scientists, utilizes sophisticated mechanical spectrometry. Formerly unobtainable experimental data on T_g as a function of cure have

been generated utilizing the new technique. The TICA technique is of great significance in characterizing thermosetting resin systems. Its unique feature of constant/multi-frequency scans distinguishes kinetic and thermal effects. The ability of the technique to measure both solid and liquid phase responses from the same specimen makes possible data acquisition in the region of additional cure. The capability now exists of interpreting material behavior during cure leading to a better understanding of resin curing properties and processing characteristics which is invaluable in the development of new advanced resin materials.
Dr. R. VanDeusen/513-255-2340

END