

AD-A142 065

IONIZING EMISSIONS AND ELECTRONICS(U) FOREIGN  
TECHNOLOGY DIV WRIGHT-PATTERSON AFB OH L G SHIRSHEV  
22 MAY 84 FTD-ID(RS)T-1655-83

1/4

UNCLASSIFIED

F/G 17/2.1 NL

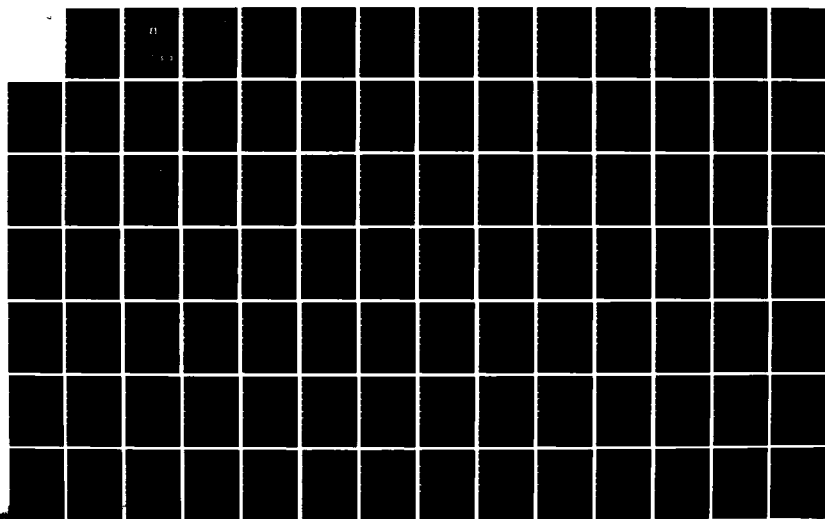

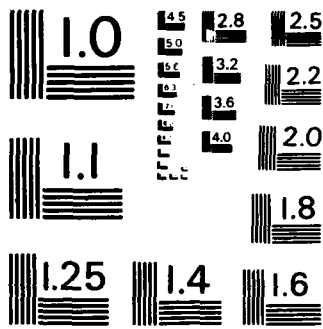

MICROCOPY RESOLUTION TEST CHART  
NATIONAL BUREAU OF STANDARDS-1963-A

2

FTD-ID(RS)T-1675-83

# FOREIGN TECHNOLOGY DIVISION

AD-A142 065



IONIZING EMISSIONS AND ELECTRONICS

by

L. G. Shirshv

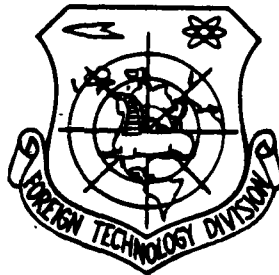

**DTIC**  
**ELECTE**  
JUN 15 1984  
**S** **D**  
**D**

DTIC FILE COPY

Approved for public release;  
distribution unlimited.



84 06 14 027

# UNEDITED MACHINE TRANSLATION

FTD-ID(RS)T-1675-83

22 May 1984

MICROFICHE NR: FTD-84-C-000515

IONIZING EMISSIONS AND ELECTRONICS

By: L. G. Shirshv

English pages: 328

Source: Ioniziruyushchiye Izlucheniya i Elektronika,  
Publishing House "Sovetskoye Radio", Moscow,  
1969, pp. 1-191

Country of origin: USSR

This document is a machine translation

Requester: FTD/TQTD

Approved for public release; distribution unlimited.

Accession For	
NTIS GRA&I	<input checked="" type="checkbox"/>
DTIC TAB	<input type="checkbox"/>
Unannounced	<input type="checkbox"/>
Justification	
By _____	
Distribution/	
Availability Codes	
Dist	Avail and/or Special
A/1	

THIS TRANSLATION IS A RENDITION OF THE ORIGINAL FOREIGN TEXT WITHOUT ANY ANALYTICAL OR EDITORIAL COMMENT. STATEMENTS OR THEORIES ADVOCATED OR IMPLIED ARE THOSE OF THE SOURCE AND DO NOT NECESSARILY REFLECT THE POSITION OR OPINION OF THE FOREIGN TECHNOLOGY DIVISION.

PREPARED BY:

TRANSLATION DIVISION  
FOREIGN TECHNOLOGY DIVISION  
WP-AFB, OHIO.



TABLE OF CONTENTS

U. S. Board on Geographic Names Transliteration System..... ii

Introduction..... 3

1. Short Characteristics of Ionizing Radiation, That Affect the  
Radio-Electronic Equipment..... 7

2. Physical Quantities of Ionizing Emissions..... 39

3. Possible Conditions of Operation of Electronic Equipment and Its  
Completing Articles in Fields of the Effect of Ionizing Radiation..... 112

4. Change in the Properties of Materials and Elements of Radio-Electronic  
Equipment Under the Effect of the Ionizing Radiations..... 189

Appendices..... 313

Literature..... 323

U. S. BOARD ON GEOGRAPHIC NAMES TRANSLITERATION SYSTEM

Block	Italic	Transliteration	Block	Italic	Transliteration
А а	<i>А а</i>	A, a	Р р	<i>Р р</i>	R, r
Б б	<i>Б б</i>	B, b	С с	<i>С с</i>	S, s
В в	<i>В в</i>	V, v	Т т	<i>Т т</i>	T, t
Г г	<i>Г г</i>	G, g	У у	<i>У у</i>	U, u
Д д	<i>Д д</i>	D, d	Ф ф	<i>Ф ф</i>	F, f
Е е	<i>Е е</i>	Ye, ye; E, e*	Х х	<i>Х х</i>	Kh, kh
Ж ж	<i>Ж ж</i>	Zh, zh	Ц ц	<i>Ц ц</i>	Ts, ts
З з	<i>З з</i>	Z, z	Ч ч	<i>Ч ч</i>	Ch, ch
И и	<i>И и</i>	I, i	Ш ш	<i>Ш ш</i>	Sh, sh
Й й	<i>Й й</i>	Y, y	Щ щ	<i>Щ щ</i>	Shch, shch
К к	<i>К к</i>	K, k	Ъ ъ	<i>Ъ ъ</i>	"
Л л	<i>Л л</i>	L, l	Ы ы	<i>Ы ы</i>	Y, y
М м	<i>М м</i>	M, m	Ь ь	<i>Ь ь</i>	'
Н н	<i>Н н</i>	N, n	Э э	<i>Э э</i>	E, e
О о	<i>О о</i>	O, o	Ю ю	<i>Ю ю</i>	Yu, yu
П п	<i>П п</i>	P, p	Я я	<i>Я я</i>	Ya, ya

\*ye initially, after vowels, and after ь, ь; e elsewhere.  
When written as ë in Russian, transliterate as yë or ë.

RUSSIAN AND ENGLISH TRIGONOMETRIC FUNCTIONS

Russian	English	Russian	English	Russian	English
sin	sin	sh	sinh	arc sh	sinh <sup>-1</sup>
cos	cos	ch	cosh	arc ch	cosh <sup>-1</sup>
tg	tan	th	tanh	arc th	tanh <sup>-1</sup>
ctg	cot	cth	coth	arc cth	coth <sup>-1</sup>
sec	sec	sch	sech	arc sch	sech <sup>-1</sup>
cosec	csc	csch	csch	arc csch	csch <sup>-1</sup>

Russian English

rot curl  
lg log

GRAPHICS DISCLAIMER

All figures, graphics, tables, equations, etc.  
merged into this translation were extracted  
from the best quality copy available.

DOC = 83167501

PAGE 1

Page 001.

IONIZING EMISSIONS AND ELECTRONICS.

L. G. Shirshov.

Page 002.

Brief information according to forms and properties of the ionizing radiations/emissions, which affect the radio-electronic equipment and its elements/cells is given in the monograph.

The information on ones of the measurement of the physical quantities of the ionizing radiations/emissions is given; these data are represented taking into account the conventional units measurements in the USSR in connection with the introduction/input of international system of units the measurement of SI. The possible conditions for the work of electronic equipment and its completing elements/cells in the fields of the effect of the ionizing radiations/emissions are examined. Physical representations about the character of interaction of the charged/loaded particles and quantum radiation/emission with the substance are presented. The forms of radiation damages in materials and elements/cells of electronic devices are examined. Some data on the radiation durability of radio engineering materials, radioelements and separate electronic devices are given.

The book is intended for the specialists, who carry out development and operation of radio-electronic equipment, and also for the students of the corresponding specialties.



Page 003.

Introduction.

In recent years, considerable attention is paid to the study of the character of the effect of the ionizing radiations/emissions on the electronic equipment, the instruments and the elements/cells of electronics and radio engineering materials.

Interest in a question of the effect of the ionizing radiations/emissions on electronic engineering is caused by the fact that in our time, radio-electronic equipment is the integral part of different kind of technical devices/equipment and units, including such, which can be operated in the fields of intense nuclear radiation. Such fields of the ionizing radiations/emissions in the locations of electronic equipment can arise close to nuclear power and power plants, used on the atomic power plants, in the atomic electric generators also on other technical objects. Upon the entry of object into the zone of nuclear explosion the equipment can undergo the action of the impulse/momentum/pulse of penetrating radiation. And finally on onboard equipment of space objects will act the ionizing radiations/emissions outer spaces.

The ionizing radiations/emissions of nuclear installations, nuclear explosions and cosmic radiation are distinguished by its composition (neutrons,  $\gamma$ -quantum, electrons, protons, beta-, alpha- and other particles), its energy spectrum, the density of flows, duration of effect, etc.

The effect of similar radiations/emissions leads to structural changes in the materials, emergence of ionization, heating, appearance of induced radioactivity and many other phenomena, which disrupt physical and chemical processes in the technical devices/equipment.

Page 004.

The studies of efficiency of radio-electronic equipment in the conditions of the effect of different forms of radiation showed that the ionizing radiations/emissions exert harmful effect on many elements/cells of equipment. The reversible and irreversible changes in the parameters of radioelements, which lead to the complete or partial loss of efficiency of equipment, can be the results of these effects.

The author set as his goal to examine the series/row of the bases *nyx* questions, which must be known, during construction and

operation of the electronic and electrotechnical equipment, intended for the work under the conditions of the effect of those ionizing, radiation/emission. This served as the reason for association in one book of different forms of scientific-technical questions.

The set-forth materials are illustrated by the data, published in the Soviet and foreign press.

In Chapter 1 are given the classification and the basic properties of the corpuscular and quantum radiations/emissions, capable of damaging elements/cells and diagrams electronic equipment.

Chapter 2 contains the material on ones of the measurement of the physical characteristics of the fields of the ionizing radiations/emissions and quantitative content of radioactive materials in the materials.

The possible sources of the ionizing radiations/emissions and the radiation fields, created by these sources in the zone of the work of electronic equipment, are examined in Chapter 3.

The processes of interaction of the charged/loaded particles, neutrons and gamma-quanta with materials and elements/cells of radio-electronic devices/equipment are examined in Chapter 4.

The book can be useful for the technical personnel, which works in the field of creation and operating of radio-electronic means, elements/cells and materials, and also to students and to the instructors of schools of higher education.

The author expresses large appreciation to all comrades, who contributed to the appearance of this book.

Page 005.

1. Short characteristics of ionizing radiation/~~emission~~, that affect the radio-electronic equipment.

In order to understand the processes of interaction of the ionizing radiations/emissions with the radio engineering materials, the elements/cells, the diagrams and the equipment as a whole, it is necessary to know, first of all, the forms of radiations/emissions and their property. Basic forms and characteristics of the ionizing radiations/emissions are given in Chapter 1; the necessary supplementary data about them can be obtained in monographs [1-3].

1.1. Forms of the ionizing radiations/emissions.

The ionizing radiations/emissions appear as a result of natural or artificial radioactive decay of substances, nuclear fission reactions in the reactors, nuclear explosions and some physical processes in space.

According to the Soviet terminology accepted by ionizing radiation/emission is understood any radiation/emission, whose interaction with the substance leads to the formation of the electric

charges of different signs. Below in the text is given terminology in accordance with the recommendations of the committee of scientific-technical terminology with the Academy of Sciences of the USSR taking into account the recommendations of international board for radiation units and to measurements [4, 5].

The ionizing radiations/emissions consist of the directly or indirectly ionizing particles or the mixture of those, etc. To directly (directly) the ionizing particles are carried the particles (electrons, alpha particle, protons, etc.), which possess a sufficient kinetic energy in order to carry out ionization of atoms by direct collision.

Page 006.

The indirectly ionizing particles include the uncharged particles [neutrons, the quanta (photons), etc.], which cause ionization through the secondary effects.

The ionizing radiations/emissions are subdivided into the corpuscular ones and the quantum ones. Corpuscular radiation are the flows of the rapidly moving elementary particles (neutrons, protons, beta- and of other particles), and also the atomic nuclei of chemical elements. The quantum radiation/emission includes the electromagnetic

ionizing radiations/emissions (gamma- and X-radiation).

Neutron and gamma-radiation, which are formed as a result of fission reactions during the nuclear explosions and in nuclear reactors, is accepted to call penetrating radiation or penetrating radiation/emission.

The ionizing radiations/emissions by their energy spectrum are divided into the monoenergetic ones (monochromatic) and the nonmonoenergetic ones (heterochromatic). Monoenergetic (uniform) radiation/emission - this is the radiation/emission, which consists of the particles of one form with the identical kinetic energy or of the quanta of identical energy. Nonmonoenergetic (heterogeneous) radiation/emission - this is the radiation/emission, which consists of the particles of one form with the different kinetic energy or of the quanta of different energy.

The ionizing radiation/emission, which consists of the particles of different form or particles and quanta, is called complex radiation.

#### 1.2. Properties of the ionizing radiations/emissions.

The physical parameters, which characterize the basic properties

of the ionizing radiations/emissions, from the point of view of their effect to the materials are: charge, rest mass, rate of motion and kinetic energy of particles or quanta (photons).

Particle charge in nuclear physics usually is expressed in the units of the elementary electric charge (electron charge), equal to  $1.60 \cdot 10^{-19}$  k, either  $4.80 \times 10^{-10}$  cgs esu or  $1.60 \cdot 10^{-19}$  cgs emu.

The mass of particle is measured in the atomic units of mass (amu).

Page 007.

One atomic unit of mass is equal to 1/16 neutral isotopes of oxygen  $O^{16}$ .

$$1 \text{ a. e. m.} \approx \frac{1}{16} \cdot \frac{16}{N_A} = 1,66 \cdot 10^{-27} \text{ kg} = 1,66 \cdot 10^{-24} \text{ g}$$

Key: (1). amu. (2). kg. (3). g.

where  $N_A$  — Avogadro number, equal to  $6.02 \cdot 10^{23}$  kmole $^{-1}$ .

Kinetic energy of relativistic, i.e., moving at a velocity, close to the speed of light, particle can be found from the formula



$$E = mc^2 - m_0c^2 = m_0c^2 \left( \frac{1}{\sqrt{1-\beta^2}} - 1 \right), \quad (1.1)$$

where  $m_0$  - rest mass of particle;

$\beta = \frac{v}{c}$  - ratio of particle speed to the speed of light.

Kinetic energy of particle with  $\beta \ll 1$  ( $v \ll c$ ) is equal to  $E = \frac{m_0v^2}{2}$ .

In practice, as a rule, they deal with the particle flux of different kinetic energy. Therefore, with the stream conditions of those ionizing, radiation/emission must be indicated energy flow diagram.

When for the practical purposes to sufficiently know average/mean kinetic energy of the particles of entire spectrum or its specific range, medium energy  $\bar{E}$  is determined from the relationship/ratio

$$\bar{E} = \frac{\int_0^{E_{\text{max}}} EN(E) dE}{\int_0^{E_{\text{max}}} N(E) dE}, \quad (1.2)$$

where  $N$  - the relative number of particles with the energy in the range from  $E$  to  $E+dE$ , that fall to the single energy range of the spectrum;

maximum energy of particles in the spectrum.

The calculated values of rates for the different values of energy are given as examples for the protons and neutrons in Tables 1.1, for the electrons - 1.3.

Fig. 1.1-1.3 gives dependences  $\beta = \frac{v}{c}$  and  $\gamma = (1 - \beta^2)^{-1/2}$  on the kinetic energy of electrons, protons and alpha particles [7].

Page 008.

The charged/loaded particles during the motion in the magnetic field are deflected/diverted. In the case of particle motion in the direction, perpendicular to magnetostatic field, it will move in a circle; in the general case, the particle motion in the magnetic field will occur along the helix, whose axis is parallel to the direction of field.

Table 1.1. Rates  $v$  the wavelength  $\lambda$  of protons and neutrons, corresponding to different kinetic energies  $E$ .

(1) $E, \text{MeV}$	(2) $v, \text{m/sec}$	$\lambda, \text{m}$	$E, \text{MeV}$ (1)	$v, \text{m/sec}$ (2)	$\lambda, \text{m}$
$0,025 \cdot 10^{-6}$	$2,19 \cdot 10^3$	$1,81 \cdot 10^{-10}$	1,0	$1,38 \cdot 10^7$	$2,86 \cdot 10^{-14}$
$1 \cdot 10^{-6}$	$1,38 \cdot 10^6$	$2,86 \cdot 10^{-11}$	2,0	$1,94 \cdot 10^7$	$2,02 \cdot 10^{-14}$
$1 \cdot 10^{-6}$	$1,38 \cdot 10^6$	$2,86 \cdot 10^{-12}$	5,0	$3,08 \cdot 10^7$	$1,28 \cdot 10^{-14}$
$1 \cdot 10^{-2}$	$1,38 \cdot 10^6$	$2,86 \cdot 10^{-12}$	10	$4,36 \cdot 10^7$	$9,05 \cdot 10^{-15}$
$2 \cdot 10^{-2}$	$1,94 \cdot 10^6$	$2,02 \cdot 10^{-12}$	20	$6,13 \cdot 10^7$	$6,41 \cdot 10^{-15}$
$5 \cdot 10^{-2}$	$3,08 \cdot 10^6$	$1,28 \cdot 10^{-12}$	50	$9,74 \cdot 10^7$	$4,05 \cdot 10^{-15}$
0,1	$4,36 \cdot 10^6$	$9,05 \cdot 10^{-14}$	100	$1,28 \cdot 10^8$	$2,19 \cdot 10^{-15}$
0,2	$6,13 \cdot 10^6$	$6,41 \cdot 10^{-14}$	200	$1,80 \cdot 10^8$	$1,98 \cdot 10^{-15}$
0,5	$9,74 \cdot 10^6$	$4,05 \cdot 10^{-14}$	500	$2,86 \cdot 10^8$	$1,25 \cdot 10^{-15}$

Key: (1). MeV. (2). m/s.

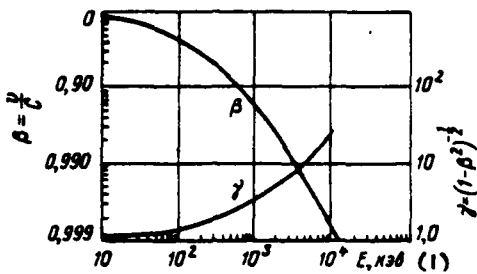

Fig. 1.1. Dependence  $\beta$  and  $\gamma$  on kinetic energy of electrons.

Key: (1). keV.

The divergence of the charged/loaded particles in the magnetic field is calculated from the following relationship/ratio:

$$Br = K \frac{\mu}{\sqrt{1-\beta^2}}, \quad (1.3)$$

where B - magnetic induction G;

r - radius of curvature;

K - coefficient, equal: for the electrons  $k=1.705 \cdot 10^3$  G·cm; for the protons  $k=3.13 \times 10^6$  G·cm; for the  $\alpha$ -particles  $k=6.218 \cdot 10^6$  G·cm [6].

Quantum radiations/emissions in many processes exhibit corpuscular nature. The particles of quantum radiation/emission are called quanta or photons. The rest mass of quanta is equal to zero, velocity of propagation is equal to the speed of light.

Quantum energy of electromagnetic radiation is equal to Planck's constant h, multiplied by the frequency  $\nu$ , namely:

$$E_1 = h\nu = \frac{h \cdot c}{\lambda}. \quad (1.4)$$

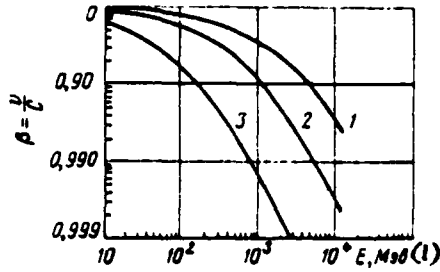

Fig. 1.2.

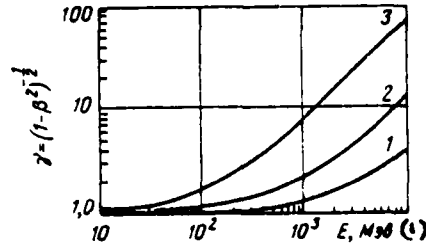

Fig. 1.3.

Fig. 1.2. Dependence  $\beta$  on kinetic energy: 1 -  $\alpha$ -particles; 2 - protons; 3 - mesons.

Key: (1). MeV.

Fig. 1.3. Dependence  $\gamma$  on kinetic energy: 1 -  $\alpha$ -particles; 2 - protons; 3 - mesons.

Key: (1). MeV.

Page 010.

The relationships/ratios between the wavelengths with the quantum energy will be given in Table 1.5.

The impulse/momentum/pulse of quantum is equal to the ratio of Planck's constant to the wavelength ( $h/\lambda$ ).

### 1.3. Atomic nuclei.

Atomic nuclei conditionally are subdivided into the lungs (with the mass number  $A < 25$ )<sup>1</sup>, average/mean ( $25 \leq A < 80$ ) and heavy ( $A \geq 80$ ).

With the classification of the cosmic rays of nucleus with the close reference numbers  $Z$  are united into the following groups of nuclei: light with  $Z=3-5$  and by average atomic number  $\bar{A}=10$ , average/mean with  $Z=6-9$  and  $\bar{A}=14$ , heavy with  $Z \geq 10$  and  $\bar{A}=31$  and very heavy with  $Z \geq 20$  and  $\bar{A}=51$ .

The nuclei of hydrogen (protons) and helium ( $\alpha$ -particle) are carried, as a rule, to the group of elementary particles. All nuclei (except the nucleus of hydrogen) consist of protons and neutrons (called nucleons), connected with nuclear forces. Nuclear radius in different elements/cells is within the limits  $(2-8) \cdot 10^{-15}$  of m and is calculated from the following approximation semi-empirical formula:

$$\underline{R} = 1,4 \cdot 10^{-16} A^{1/3} \text{ m.}$$

The atomic radius is equal to approximately/exemplarily  $10^{-10}$  m.

A number of neutrons and in the nucleus is equal to A-Z. In the stable atoms, the relationship/ratio between a quantity of protons containing in them and neutrons is described by empirical formula [3]

$$Z = \frac{A}{1,98 + 0,015A^{2/3}}$$

If this relationship/ratio is disrupted, nuclei are radioactive.

FOOTNOTE <sup>1</sup>. The total number of protons and neutrons in the nucleus is called mass number and is designated by A or sometimes M.

<sup>2</sup>. Z (atomic number of substance) corresponds to nuclear charge and is equal to number of protons in nucleus or electrons in atom shell it coincides with reference number of element/cell in periodic system of D. I. Mendeleev. ENDFOOTNOTE.

Page 011.

In this case, the nuclei with the high content (surplus) of protons emit positrons, nuclei with the high content of neutrons - electrons.

Depending on a change in the composition (in the content of protons and neutrons) atomic nuclei of one and the same element/cell

can be isotopes, isobars and isotones.

Isotopes - nucleus of one element/cell with the identical values of a number of protons  $Z$ , but the different values of a number of neutrons  $N$ . The majorities of chemical elements have two and more than isotopes.

Isobars - atomic nuclei with the identical mass numbers  $A$ , but the different content of protons  $Z$ .

Isotones - atomic nuclei with an identical number of neutrons  $N$ , but different mass numbers  $A$ .

The atomic nuclei of one and the same radioactive elements with the identical ordinal and mass numbers can be found in different metastable energy states, by virtue of which have different radioactive properties (type of radioactive radiation, the half-life period, radiant energy, etc.). Such atomic nuclei are called isomers.

#### 1.4. Elementary particles.

To a number of ionizing radiations/emissions, which call considerable changes in the properties of radio engineering materials, it is accepted to at present carry the following forms of



radiations/emissions: neutron, proton, electronic, alpha particles and gamma-quanta.

Neutrons.

Neutron - elementary particle, which does not have electric charge<sup>1</sup>; is the component part of atomic nuclei; it is designated by symbol  $n$  or  $n^1$ .

The mass of neutron is close in the value to the nuclear mass of hydrogen atom and composes 1838.63 electronic masses and is equal to  $m_n = 1.008981$  to a.e.m. = 939.55 MeV, i.e., it is approximately/exemplarily 1.3 MeV more than the mass of proton.

FOOTNOTE <sup>1</sup>. It follows from the experiences of Fermi and Marshal [8] that if the neutron possesses electric charge, then its value is not more than  $10^{-16}$  electron charges. ENDFOOTNOTE.

Page 012.

The neutron exists not long in the free form, since it is rapidly seized by atomic nuclei or is converted by electron emission into the proton according to the diagram

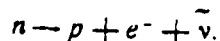

Therefore neutron is occasionally referred to as the simplest beta-active "nucleus". The period of the half-life of free neutrons from the results of the latter determination is equal to  $11.7 \pm 0.3$  min [9]. The wavelength of neutron depends on its energy  $E_n$  and it can be determined (without taking into account relativistic corrections) from the expression

$$\lambda \approx \frac{h}{\sqrt{2m_n E_n}}$$

The wave properties of neutrons become apparent when the length of neutron is compared with the interatomic distance, i.e., with low energy and at long wave lengths. With an increase in the energy and, consequently, also with the decrease of wavelength the neutron exhibits its corpuscular properties.

The wavelengths and the velocities of neutrons, which correspond to different kinetic energy, are given in Table 1.1 [10]. The velocity of neutron was computed according to the formula

$$v = 1,38 \cdot 10^7 \sqrt{E_n} \text{ m/s} \quad (1.5)$$

where  $E_n$  kinetic neutron energy, MeV.

Neutrons are formed as a result of natural and artificial radioactive decay of the atomic nuclei of substance, nuclear fission reactions, which take place in nuclear reactors and during the nuclear explosions, the thermonuclear addition reactions of the atomic nuclei of light elements, and also as a result of the nuclear bombardment of the atoms of substances with the fast charged/loaded particles and with gamma-quanta.

The character of interaction of neutrons with the atomic nuclei of substance depends on neutron energy. In accordance with this it is accepted to class neutrons according to the ranges of their kinetic energies. These ranges are selected so that the neutrons of one group would possess the specific prevailing form of interaction with the substance, had the similar methods of obtaining of flow and its recording. The selection of ranges has the certain degree of freedom.

Page 013.

Usually neutrons over the ranges of kinetic energies are subdivided into the following groups:

- cold neutrons with the energy from 0 to 0.005 eV ( $E_n < 0.005$  eV);

- the thermal neutrons (neutrons, which are found in the thermal equilibrium with the atoms of the substances, energy of thermal condition of which is equal to  $E_{\text{thermal}} = kT^\circ$ , where  $k$  - Boltzmann constant,  $T^\circ$  - absolute temperature) with the energy from 0.005 to 0.5 eV ( $0.005 \text{ eV} < E_n < 0.5 \text{ eV}$ ), the medium energy (at a room temperature  $T^\circ = 300^\circ \text{ K}$ ) it is equal to 0.025 eV;

- neutrons of intermediate energy with the energy from 0.5 to  $10^3/10^4$  eV ( $0.5 \text{ eV} < E_n < 1-10 \text{ keV}$ ). They call also them epithermal, epithermal, resonance. As upper boundary of the range of energy of this group it can be accepted as 100 keV;

- fast neutrons with the energy from  $(0.1-0.5) \cdot 10^6$  to  $(10-20) \cdot 10^6$  eV ( $0.1-0.5 \text{ MeV} < E_n < 10-20 \text{ MeV}$ ). In the thermal-neutron reactors this group includes neutrons with the energy more than 10 keV;

- ultrahigh-speed or relativistic neutrons with the energy of more  $20 \cdot 10^6$  eV ( $E_n > 20 \text{ MeV}$ ). Energy of these neutrons exceeds energy of binding of nucleons in the nucleus, which can lead to the complicated nuclear reactions.

During the larger/coarser division of neutrons into the groups over the ranges of neutron energy with the energies from 0 to  $1 \cdot 10^3$  eV are carried to the slow ones, from  $1 \cdot 10^3$  to  $(0.1-0.5) \times 10^6$  eV to intermediate, from  $(0.1-0.5) \cdot 10^6$  to  $(10-20) \cdot 10^6$  eV - to the rapid ones and with the energy of more  $20 \cdot 10^6$  eV - to the ultrahigh-speed ones.

The neutrons, emitted during the fission of heavy nuclei, possess the energy spectrum characteristic for them, which is called fission spectrum. The neutrons of this spectrum (using the method of their obtaining) are carried to the group of fission neutrons.

During the evaluation of the radiation durability of radio engineering materials, elements/cells of electronic engineering and equipment, on the basis, in essence, of the physical processes of interaction of neutrons with the semiconductor materials, the neutrons with the energy to 14-15 MeV over the ranges of energy can be divided into two groups:

- slow neutrons with the energy to  $0.1 \cdot 10^6$  eV ( $E_n < 0.1$  MeV) and
- fast neutrons with the energy of more  $0.1 \cdot 10^6$  eV ( $E_n \geq 0.1$  MeV) <sup>1</sup>.

Page 014.

Protons.

Proton - stable elementary particle with the positive elementary electric charge, equal in the absolute magnitude of the charge of electron ( $1.6 \cdot 10^{-19}$  K); is designated by symbol p or  ${}^1_1\text{N}$ . Proton is the nucleus of the lightest hydrogen isotope (protium), therefore, the mass of proton is equal to the mass of hydrogen atom without the mass of electron and is 1.00759 amu, or  $1.672 \cdot 10^{-27}$  kg.

Protons together with the neutrons are included in all atomic nuclei. Proton is carried to the stable elementary particles. Computed values of the wavelengths and rates of motion for different energies of protons are given in Table 1.1.

The mean free path of protons with the energy to 1000 MeV in the substance depends, in essence, from the ionizing losses; therefore the mean path of proton can be determined as follows [11]:

$$R(E_p) = \int_0^{E_p} \frac{dR}{dE} dE = - \int_0^{E_p} \frac{dE}{\left(\frac{dE}{dx}\right)_{\text{ion}}}$$

Since, for low energies of protons, the theory of ionizing losses proves to be unsuitable, usually integration is produced not from zero, but from some wave energy of proton then

$$R(E_p) = R(E_{p,1}) + \int_{E_{p,1}}^{E_p} \frac{dE}{-\left(\frac{dE}{dx}\right)_{\text{ion}}}. \quad (1.6)$$

where  $\left(\frac{dE}{dx}\right)_{\text{ion}}$  -value of the ionizing losses of protons, MeV/g·cm<sup>-2</sup> (or MeV/kg·m<sup>-2</sup>).

FOOTNOTE 1. In the foreign, to literature sometimes to the fast neutrons are carried the neutrons with the energy of more than 0.3-0.5 MeV. ENDFOOTNOTE.

Page 015.

Table 1.2 gives the landing runs of protons with the energy from 2 to 100.000 MeV in the beryllium, carbon, aluminum, copper, lead and air, calculated by Sternheimer [12].

Protons are emitted by atomic nuclei as a result of the bombardment with their charged/loaded particles, by neutrons, gamma-quanta, etc. For example, proton was for the first time discovered by Rutherford during the nuclear disintegration of nitrogen with the aid of the alpha particles. The protons with the

energy to  $10^{18}$ - $10^{21}$  eV are included in cosmic rays.

#### Alpha particles.

Alpha particle is the nucleus of helium, which consists of two protons and two neutrons, therefore, with the positive electric charge, two times large (in the absolute value) of electron charge; it is designated by symbol  $\alpha$  or  ${}^4\text{He}^+$ ; atomic weight 4.003; mass  $6.644 \cdot 10^{-27}$  kg, which corresponds to energy 3727.07 MeV.

In contrast to other elementary particles of the  $\alpha$ -particle they have the smallest mean free path in the materials; therefore they virtually do not affect the elements/cells of equipment, which are shielded by jacket/case/housing or other screens or coatings. The mean free path of  $\alpha$ -particles in air is approximately/exemplarily proportional to the cube of their range. The dependence of the landing run of  $\alpha$ -particles in air (for the landing runs of more than 1 cm) from their kinetic energy can be calculated according to following approximation formula [13]:

$$x_0 = 0,32E_\alpha^{3/2}. \quad (1.7)$$

where  $x_0$  - length of the mean path of  $\alpha$ -particle in air, cm;

$E_\alpha$  - kinetic energy of  $\alpha$ -particle, MeV.



In terms of the known value of the landing run of  $\alpha$ -particles in air it is possible to calculate their landing run in other substance from the following relationship/ratio:

$$x = 3,2 \cdot 10^{-4} x_0 \frac{\sqrt{\lambda}}{\rho} \text{ cm.} \quad (1.8)$$

where  $\rho$  - density of substance, g/cm<sup>3</sup>.

Alpha particles are emitted upon decay of heavy radioactive nuclei (uranium, thorium, radium, etc.). To the discovery/opening of protons and neutrons, they were utilized as the only bombarding particles for obtaining the nuclear reactions.

Pages 16-17.

Table 1.2. Landing runs of protons in the substances.

(1) E <sub>p</sub> , Мэв	(2) Пробег (кв/м <sup>2</sup> ) в:					
	(3) бериллия	(4) углероде	(5) алюминия	(6) медя	(7) свинце	(8) воздухе
2	0,091	0,084	0,115	0,190	0,410	0,087
3	0,180	0,168	0,221	0,350	0,676	0,175
4	0,296	0,275	0,355	0,513	0,988	0,287
5	0,436	0,406	0,517	0,724	1,345	0,423
6	0,601	0,558	0,704	0,967	1,746	0,581
7	0,789	0,732	0,917	1,240	2,190	0,761
8	0,999	0,926	1,155	1,542	2,674	0,963
9	1,232	1,141	1,416	1,874	3,198	1,185
10	1,487	1,376	1,700	2,234	3,761	1,428
20	5,175	4,759	5,742	7,276	11,38	4,920
25	7,750	7,116	8,526	10,71	16,44	7,346
30	10,79	9,891	11,79	14,72	22,29	10,20
35	14,26	13,07	15,51	19,27	28,85	13,46
40	18,17	16,63	19,67	24,34	36,14	17,12
45	22,49	20,57	24,27	29,92	44,11	21,16
50	27,22	24,88	29,28	35,99	52,75	25,57
55	32,34	29,54	34,69	42,53	62,02	30,35
60	37,84	34,56	40,51	49,54	71,92	35,49
65	43,71	39,91	46,70	56,99	82,43	40,97
70	49,95	45,59	53,27	64,88	93,52	46,78
75	56,55	51,60	60,21	73,21	105,2	52,93
80	63,49	57,92	67,50	81,95	117,4	59,40
90	78,40	71,48	83,13	100,6	143,5	73,27
100	94,61	86,23	100,1	120,9	171,7	88,35
110	112,1	102,1	118,4	142,7	201,9	104,6
120	130,8	119,1	137,9	165,8	234,0	122,0
130	150,6	137,2	158,6	190,4	268,0	140,4
140	171,6	156,2	180,4	216,3	303,7	159,9
150	193,7	176,3	203,4	243,5	341,1	180,3
200	319,1	290,2	333,4	397,1	551,4	296,4
250	466,7	424,2	486,1	576,6	796,1	432,9
300	633,3	575,3	657,9	778,2	1 070	586,8
350	816,4	741,2	846,2	998,5	1 367	755,6
400	1 014	919,9	1 049	1 235	1 686	937,3
450	1 223	1 110	1 264	1 486	2 023	1 130
500	1 444	1 310	1 489	1 749	2 376	1 333
600	1 913	1 734	1 967	2 305	3 120	1 763
700	2 413	2 186	2 476	2 895	3 905	2 220
800	2 937	2 659	3 007	3 509	4 722	2 698
900	3 481	3 149	3 556	4 144	5 563	3 192
1 000	4 040	3 653	4 120	4 794	6 422	3 700
1 500	6 988	6 307	7 077	8 187	10 880	6 357
2 000	10 070	9 073	10 140	11 680	15 430	9 103
2 500	13 190	11 880	13 240	15 200	19 960	11 870
3 000	16 330	14 690	16 340	18 710	24 450	14 630
4 000	22 590	20 290	22 500	25 660	33 260	20 080
5 000	28 790	25 840	28 570	32 480	41 850	25 430
6 000	34 930	31 330	34 560	39 190	50 240	30 670
7 000	41 000	36 750	40 460	45 800	58 470	35 830
8 000	47 020	42 120	46 290	52 320	66 550	40 890
9 000	52 980	47 430	52 060	58 760	74 500	45 890
10 000	58 890	52 700	57 770	65 120	82 340	50 810
25 000	143 700	128 200	139 010	155 250	191 840	119 500
50 000	277 110	246 770	265 500	294 910	358 830	223 360
100 000	531 580	472 780	505 090	558 630	670 070	415 190

note. The thickness of the layer of substance in the grams to the square centimeter is equal to the product of mean free path to density ( $x \cdot \rho$ );  $1 \text{ g/cm}^2 = 10 \text{ kg/m}^2$ .

Key: (1). MeV. (2). Landing run ( $\text{kg/m}^2$ ) in. (3). beryllium. (4). carbon. (5). aluminum. (6). copper. (7). lead. (8). air.

Page 018.

Alpha particles are emitted in the presence of the nuclear reactions in nuclear reactors and during the nuclear explosions and enter into the composition of cosmic rays, and also they can be obtained on the accelerator facilities by accelerating the ionized atoms of helium.

Electrons and positrons.

An electron-stable elementary particle with a mass of  $9.108 \cdot 10^{-31} \text{ kg}$ , the rest energy 0.511 MeV and the negative elementary electric charge, equal to  $4.8029 \cdot 10^{-10} \text{ cgs esu}$ , or  $1.6 \cdot 10^{-19} \text{ k}$ . It is designated by symbols  $e$ ,  $e^-$  or  $\beta^-$ .

Positron is the antiparticle of electron. In contrast to the electron, the positron has positive elementary electric charge and it

is considered as the short-lived particle. Positron is designated by symbols  $e^+$  or  $\beta^+$ .

The wavelengths and rate of electrons and positrons for different energies are given in Table 1.3.

The penetrating power of  $\beta$ -radiation (electrons and positrons) many times more than  $\alpha$ -particles and the protons of the same energy.

Fig. 1.4 shows the relative decrease of a quantity of electrons of different energy in proportion to their passage through the layer of substance [13]. In this case, the landing runs of electrons in different substances, represented in the kilograms to the square meter, are accepted (with a sufficient accuracy for practical purposes) identical. Table 1.4 gives the maximum landing runs of  $\beta$ -particles with different energy in aluminum, water and air.

Table 1.3. Rates  $v$  the wavelengths  $\lambda$ , which correspond to different kinetic energies  $E$  of electrons and positrons.

(1) $E, \text{eV}$	(2) $v, \text{m/sec}$	$\lambda, \mu$	(1) $E, \text{eV}$	(2) $v, \text{m/sec}$	$\lambda, \mu$
0	0		$10^3$	$1,88 \cdot 10^7$	$3,88 \cdot 10^{-11}$
1	$5,93 \cdot 10^8$	$1,23 \cdot 10^{-9}$	$10^4$	$5,85 \cdot 10^7$	$1,22 \cdot 10^{-11}$
10	$1,88 \cdot 10^9$	$3,83 \cdot 10^{-10}$	$10^5$	$1,64 \cdot 10^8$	$3,70 \cdot 10^{-12}$
$10^3$	$5,93 \cdot 10^8$	$1,23 \cdot 10^{-10}$	$10^6$	$2,84 \cdot 10^8$	$8,72 \cdot 10^{-13}$

Key: (1). eV. (2). m/s.

Page 019.

During the estimation of the penetrating power of  $\beta$ -radiation, the practical length of their landing run in the substance, equal to the value of the thickness of screen, obtained during the intersection of the continuation of the straight/direct section of the curve of beam attenuation of electrons (dotted line in Fig. 1.4) with the axis of abscissas is determined.

The practical mean free path of  $\beta$ -particles with the energy from 15 keV to 100 MeV in the substance can be calculated according to the approximation formula of Gloker [15]:

$$R = x\rho = 4,9 \cdot 10^{-6} \cdot E^{1,72}, \quad (1.9)$$

where  $X$  is expressed in cm,  $\rho$  - in g/cm<sup>3</sup> and  $E$  - in keV.

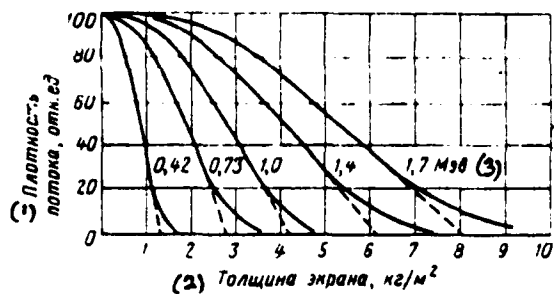

Fig. 1.4. Relative decrease of electron density depending on thickness of screen.

Key: (1). Density of flow, rel. un. (2). Thickness of screen, kg/m<sup>2</sup>. (3). MeV.

Table 1.4. Maximum landing runs of  $\beta$ -particles depending on their energy.

(1) Максимальная энергия р-частиц, MeV	(2) Максимальный пробег (мм) в:		
	(3) алюминии	(4) воде	(5) воздухе
0,01	0,0006	0,002	0,13
0,05	0,0144	0,046	2,91
0,1	0,050	1,58	10,1
0,5	0,593	1,87	199
1	1,52	4,80	306
2	3,51	11,1	710
3	5,5	17,4	1100
5	9,4	29,8	1900
10	19,2	60,8	3900

Key: (1). Maximum energy of  $\beta$ -particles, MeV. (2). Maximum landing

run (mm) in. (3). aluminum. (4). to water. (5). air.

Page 020.

Radioactive isotopes are the sources of  $\beta$ -particles. Beta particles are emitted during the nuclear explosions and in the presence of the reactions in nuclear reactors. The electrons of high energy can be obtained with the aid of the charged particle accelerators. Beta particles also are formed as a result of the course of Compton effects, effects of the formation of vapors, Auger effect. Electrons are the component part of the cosmic radiation. Free electrons can be isolated from the substance with the aid of the heating (the thermionic emission), the irradiation by light/world (photoelectric effect) and with the aid of the electric field (the autoelectric emission). Energy of the  $\beta$ -particles, emitted by radioactive nuclei and in the space artificial and natural radiation belts, reaches several ones million electronvolt. Recently electrons with the energy of more than 300 MeV are discovered in outer space (beyond the limits of the atmosphere).

#### 1.5. Quantum radiation/emission.

Quantum radiation/emission is one of the forms of the manifestation of electromagnetic radiation and is the flows of the

quanta (photons) of different energy. Depending on quantum energy distinguish: the gamma-, X-ray, ultraviolet, visible, infrared rays and radio emissions <sup>1</sup>. The relationship/ratio between the quantum energy and the wavelength is determined by the equation of Planck (1.4).

The broad band of electromagnetic waves from very short waves on the order of  $10^{-14}$  m to waves on the order of 104 m is well studied. The scale of electromagnetic waves is represented in Fig. 1.5.

Electromagnetic waves in the specific ranges possess different properties.

FOOTNOTE <sup>1</sup>. Subsequently in the text for the purpose of reduction we will apply the terms:  $\gamma$ -rays,  $\gamma$ -quanta and  $\gamma$ -radiation, understanding under them any quantum radiation/emission. ENDFOOTNOTE.

Page 021.

Therefore for the characteristic of the processes, which take place during the generation, propagation and the absorption of electromagnetic waves, besides the general/common/total parameters, which relate to any wave of the electromagnetic scale, are special parameters, which relate to any range and characteristic specific



special features/peculiarities of this range. To the electromagnetic ionizing radiations/emissions it is accepted to carry gamma- and X-radiation.

Gamma-radiation is the quantum radiation/emission of atomic nuclei. Energy of these quanta corresponds to the wavelength of shorter than 0.06 Å.

Quantum radiation/emission with wavelengths of from 0.06 to 20 Å is carried to the X-radiation.

The relationships/ratios between the energy of electromagnetic waves and their length for the photons of space, gamma-, X-ray and ultraviolet rays, calculated by formula (1.4), are given in table 1.5. The spectrum of  $\gamma$ -quanta beyond the limits of the atmosphere is at present measured in the region of energies to  $10^4$ - $10^7$  eV.

The energy absorption of  $\gamma$ -radiation in the layer of substance by thickness  $dx$  is determined from the equality

$$dE = -\varphi E_1 \mu dx, \quad (1.10)$$

where  $\varphi$  - density of the flow of quanta;

$E_1$  - energy of the falling/incident quanta;

$\mu$  - linear coefficient of absorption of  $\gamma$ -radiation/emission.

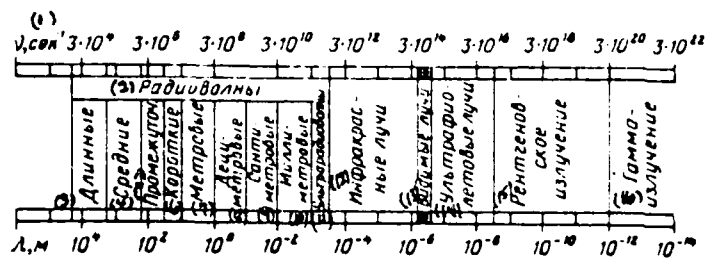

Fig. 1.5. Scale of electromagnetic waves ( $\nu$  - frequency,  $\lambda$  - wavelength).

Key: (1).  $s^{-1}$ . (2). Radio waves. (3). Long. (4). Average/mean. (5). Intermediate. (6). Short. (7). Meter. (8). Decimeter. (9). Centimeter. (10). Millimeter. (11). Ultraradio waves. (12). Infrared rays. (13). Visible rays/beams. (14). Ultraviolet rays. (15). X-radiation. (16). Gamma-radiation.

Page 022.

Table 1.5. Wavelength and the corresponding to it quantum energy (rounded values).

(1) Излучение	(2) Длина волны, Å (10 <sup>-10</sup> м)	(3) Энергия кванта			
		(4) Дж	(5) эрг	(6) кал	(7) эв
(8) Фотоны космических лучей	0,00001	2·10 <sup>-18</sup>	2·10 <sup>-2</sup>	4,8·10 <sup>-11</sup>	1240·10 <sup>6</sup>
(9) Гамма-лучи	0,0001	2·10 <sup>-11</sup>	2·10 <sup>-4</sup>	4,8·10 <sup>-12</sup>	124·10 <sup>6</sup>
	0,001	2·10 <sup>-12</sup>	2·10 <sup>-5</sup>	4,8·10 <sup>-12</sup>	12,4·10 <sup>6</sup>
	0,005	4·10 <sup>-12</sup>	4·10 <sup>-5</sup>	9,6·10 <sup>-12</sup>	2,48·10 <sup>6</sup>
	0,01	2·10 <sup>-12</sup>	2·10 <sup>-5</sup>	4,8·10 <sup>-12</sup>	1,24·10 <sup>6</sup>
	0,05	4·10 <sup>-12</sup>	4·10 <sup>-5</sup>	9,6·10 <sup>-12</sup>	248·10 <sup>6</sup>
(10) Рентгеновские лучи	0,1	2·10 <sup>-14</sup>	2·10 <sup>-7</sup>	4,8·10 <sup>-15</sup>	124·10 <sup>4</sup>
	1,0	2·10 <sup>-15</sup>	2·10 <sup>-8</sup>	4,8·10 <sup>-15</sup>	12,4·10 <sup>4</sup>
	5	4·10 <sup>-16</sup>	4·10 <sup>-9</sup>	9,6·10 <sup>-17</sup>	2,48·10 <sup>4</sup>
	10	2·10 <sup>-16</sup>	2·10 <sup>-9</sup>	4,8·10 <sup>-17</sup>	1,24·10 <sup>4</sup>
(11) Ультрафиолетовые лучи	50	4·10 <sup>-17</sup>	4·10 <sup>-10</sup>	9,6·10 <sup>-18</sup>	248
	100	2·10 <sup>-17</sup>	2·10 <sup>-10</sup>	4,8·10 <sup>-18</sup>	124
	1000	2·10 <sup>-18</sup>	2·10 <sup>-11</sup>	4,8·10 <sup>-19</sup>	12,4
	10000	2·10 <sup>-19</sup>	2·10 <sup>-12</sup>	4,8·10 <sup>-20</sup>	1,24

Key: (1). Radiation/emission. (2). Wavelength. (3). Quantum energy.  
 (4). J. (5). erg. (6). cal. (7). eV. (8). Photons of cosmic rays.  
 (9). Gamma-rays. (10). X-rays. (11). Ultraviolet rays.

Page 023.

The sources of gamma-radiation are "energetically excited" of atomic nucleus, i.e., the atomic nuclei, which have energy excess in

comparison with their normal state. Contemporary nuclear physics established/installed, that the nucleus cannot prolongedly exist in the excited state and after only the time interval, equal to approximately  $10^{-13}$  s, it is freed/released from the excess energy most frequently by emitting the quanta of electromagnetic radiation. With the work of nuclear reactors, gamma- and X-radiation appear as a result of division, and also due to the "luminescence" (radioactive radiation) of the activated elements of structures and heat-transfer agent.

During the nuclear explosions, their formation/education occurs also in the process of nuclear fission reaction, but by the basic sources of electromagnetic radiation during the nuclear explosion are radioactive fission fragments, which are located in the zone of explosion and which occupy during the first several seconds a comparatively small volume of approximately/exemplarily spherical form, and capture reaction of neutrons the atomic nuclei of air.

Furthermore, X-ray and gamma-rays appear as a result of braking the charged/loaded particles with their passage through the substance (bremsstrahlung) and as a result of the annihilation of positrons and electrons (annihilation radiation/emission).

Gamma-rays are encountered also in the composition of cosmic rays.

Page 24.

## 2. Physical quantities of ionizing emissions.

The fields of the ionizing radiations/emissions<sup>1</sup>, in which can prove to be radio-electronic equipment, are characterized by physical quantities. The possible conditions for work and the radiation durability of equipment and its completing elements/cells and materials are estimated with the aid of these physical quantities.

The physical characteristics of the ionizing radiations/emissions quantitatively are expressed in ones the measurement of radioactivity and ionizing radiations/emissions.

For the first time the need for the quantitative estimation of the effect of the ionizing radiations/emissions arose after discovery/opening in 1895 of X-rays and detection of their harmful effect on the man. In 1925 was carried out the first international congress for radiology, at which for the purpose of the establishment of the necessary physical units in the region of radiology and mining the recommendations regarding the standards was created international

board for radiological units and to measurements. At the second international congress of radiologists (1928) as the unit of the dose of X-radiation was accepted one by the name "roentgen". This unit was applied also in the USSR. But in 1934 in the USSR they were developed and they were put into operation OST VKS 7623 [1], which legalized units of X-radiation, and OST VKS 7159 [2] on the units of radioactivity.

In 1942 of first nuclear reactor together with the works on radiation safety of man the works in the area of nuclear technology were begun after launching/starting and arose the need for the creation of ones measurement, that characterize neutron radiations/emissions.

FOOTNOTE <sup>1</sup>. By radiation field is understood the space-time distribution of the ionizing radiation/emission in the volume in question. With the characteristic of the distribution of radiation dosage in some space it is accepted to speak about the field of radiation dosages. ENDFOOTNOTE.

Page 25.

Mastery/adoption by man of outer space in turn posed the problem about level measurement of cosmic radiation and determination of ones

for these measurements.

On the basis of works in the region of dosimetry and radiometry of the Soviet and foreign scientists of K. K. <sup>n</sup>Aglintsev, N. T. Gusev, V. I. Ivanov, I. O. Leypun'skiy, R. T. Yeger and many other scientists and practitioners continuously were improved the methods of dosimetry, and together with them n of one the measurement of the ionizing radiations/emissions.

In GOST [ГОСТ - All-Union State Standard] 8848-58 [3] together with the units of the dose of the ionizing radiation/emission and the units of the activity of radioisotopes were introduced ones the measurement of absorbed energy in the materials and of the unit of the intensity of the ionizing radiations/emissions.

In 1962 by international board for radiological units and to measurements were comprised the recommendations regarding the values and the units of ionizing radiations/emissions [4, 5]. The new designations of some values are proposed in them; for measuring the radiation/emission is introduced the system MKSA, which is the part of the international system of the units of SI, used for measuring the electrical values; it is more precisely formulated the series/row of determinations.

In accordance with the introduction of the international system of the units of SI [6-15] and the recommendations of international board for the radiological units and to measurements (MKRE) in the USSR was refined the system of units the measurement of radioactivity and ionizing radiations/emissions. This system of units is legalized by GOST 8848-63, put into operation from 1 July, 1964, [16]. The terminology of physical quantities, used below, is given taking into account the recommendations, given in [4, 5, 11, 17-23].

In present chapter, together with units of measurement of the radioactivity and ionizing radiation/emission, established/installed GOST 8848-63 and recommended MKRE, are examined also units, which are encountered in the literature and in practice. The relationships/ratios between ones of the ionizing radiations/emissions of separate measuring systems are given at the end of the chapter (Tables 2.11 and 2.12).

In the examination of the units of the measurements of the ionizing radiations/emissions they subdivide them into two groups [20].

Page 26.

The values of the first group are intended for the



characteristic of the field of the ionizing radiations/emissions and its effect on the substance. This group includes the following units the measurement: flow and particle flux density (quanta), energy spectrum and the energy flow of radiation/emission, the intensity of the ionizing radiations/emissions, the absorbed dose and the power of the absorbed dose, exposure dose and the power of exposure dose.

The second group of values serves for evaluating the quantitative content of radioactive materials in the materials. These values include the activity and the concentration of radioactive isotope in the materials or in the medium.

#### 2.1. Flow and kinetic energy of the ionizing radiations/emissions.

Particle flux or quanta.

The flow of the ionizing particles or quanta is a number of particles or quanta, which penetrate through this surface. Flow  $\Phi$  is defined as quotient during division of  $N$  on  $\Delta S$ , where  $N$  - number of particles, which is located in the region of section of surface  $\Delta S$ ,

$$\Phi = \frac{N}{\Delta S}. \quad (2.1)$$

The flow value of particles (quanta) according to the system of SI is expressed numerically of particles, which fall to the square meter (part./m<sup>2</sup>), i.e.,  $\alpha$ -part./m<sup>2</sup>, beta-part./m<sup>2</sup>, neutron/m<sup>2</sup>,

proton/m<sup>2</sup>, meson/m<sup>2</sup> and the like. In the abbreviation of the units of the flow of those ionizing radiation/emission is allowed/assumed the use of letters of Greek and Latin alphabets, and in accordance with this and the abbreviations:  $\alpha$ -part./m<sup>2</sup> ( $\alpha$ /m<sup>2</sup>),  $\beta$ -part./m<sup>2</sup> ( $\beta$ /m<sup>2</sup>), n/m<sup>2</sup>, p/m<sup>2</sup>,  $\gamma$ -quant./m<sup>2</sup> ( $\gamma$ /m<sup>2</sup>) [16].

In the practice the most frequently met unit measurement is one particle to square centimeter (part./cm<sup>2</sup>).

Page 27.

Thus, for instance, in neutron physics the very propagated quantitative estimation of neutron radiation/emission is the total (integral) flow of irradiation, expressed by a number of neutrons, per square centimeter (n/cm<sup>2</sup>)<sup>2</sup> or in nvt, where n - neutron density (number of neutrons in 1 cm<sup>3</sup>), v - the average speed of neutrons (cm/s) and t - exposure time (s). For the isotopic radiations/emissions the neutron flux, expressed in nvt, covers the neutrons, which move in any direction and they intersect area/site into one square centimeter.

Sometimes one Mwd (megawatt-day of the energy, produced to the ton of uranium) is used for measuring the neutron fluxes in the reactors. One Mwd in the graphite-moderated reactor at a temperature,

close to the room, corresponds approximately/exemplarily  $10^{17}$  nvt epithermal neutrons or  $6.5 \cdot 10^{17}$  nvt predominantly thermal neutrons.

With the stream conditions of the ionizing radiations/emissions kinetic energy of particles (quanta) usually is indicated. For example, neutron flux with the energy of more than one tenth of mega-electron-volt is written/recorded in following abbreviated/reduced form  $\Phi_n$  with  $E > 0.1$  MeV or  $\Phi_n(E > 0.1 \text{ MeV})$ , and is sometimes simple  $\Phi_n(>0.1 \text{ MeV})$ .

Particle flux density or quanta.

Particle flux density or quanta  $\varphi$  - this designed per unit of the cross-sectional area of elementary sphere number of particles (quanta), which penetrate per unit time into the volume of this sphere:

$$\varphi = \frac{\Delta\Phi}{\Delta t}. \quad (2.2)$$

The particle flux density (quanta), which proceeds from point source (without taking into account the effects of scattering and absorption), can be determined on the output of particles (quanta) from this source, namely:

$$\varphi = \frac{n}{4\pi R^2}. \quad (2.3)$$

where  $n$  - output of particles or quanta from the source of the ionizing radiation/emission (see §2.4);

R - distance from the source.

FOOTNOTE <sup>1</sup>. Symbol "H" is not recommended to apply with the designation of neutron flux, since according to GOST 9867-61 by this symbol it is accepted to designate one - newton. Instead of the symbol "H" GOST 8848-63 established/installed the abbreviation of neutron "n". ENDFOOTNOTE.

Page 28.

One density measurement of flow is particle per second to the square meter, namely:

$\alpha / \overset{(1)}{\text{сек}}^2 \cdot \text{м}^2$	и/лИ	$\alpha / \text{s} \cdot \text{м}^2$ ,
$\beta / \overset{(1)}{\text{сек}} \cdot \text{м}^2$	и/лИ	$\beta / \text{s} \cdot \text{м}^2$ ,
$n / \overset{(1)}{\text{сек}} \cdot \text{м}^2$	и/лИ	$n / \text{s} \cdot \text{м}^2$ ,
$\gamma / \overset{(1)}{\text{сек}} \cdot \text{м}^2$	и/лИ	$\gamma / \text{s} \cdot \text{м}^2$ ,
$\rho / \overset{(1)}{\text{сек}} \cdot \text{м}^2$	и/лИ	$\rho / \text{s} \cdot \text{м}^2$ .

Key: (1).  $\text{s}^2 \cdot \text{м}^2$ . (2). or.

In nuclear physics the particle flux density (quanta) most frequently is measured in the particles per second to the square centimeter or  $n \cdot v$  [15].

Spectral density of flow.

The spectral particle flux density (quanta) is their density, designed per unit of spectral interval.

The most widely used unit the measurement of the spectral density of flow is a number of particles (alpha, beta, neutrons, protons, etc.) or quanta per second to the square meter and to the specific given energy of data of particles in the mega-electron-volts. For example:  $\alpha/s \cdot m^2 \cdot MeV$ ,  $\beta/s \cdot m^2 \cdot MeV$ ,  $n/s \cdot m^2 \cdot MeV$ .

Kinetic energy of the ionizing radiations/emissions.

Ones the measurement of kinetic energy of the ionizing radiations/emissions as any energy, are in the international system of the units measurement (GOST 9867-61) joule (J), in other systems - erg (erg), watt-hour (Watt-hour), calorie (cal.), kilogrammeter (kgfm).

$$1 \text{ J} = 10^7 \text{ erg} = 2.78 \cdot 10^{-4} \text{ W. Dimensionality of joule} - m^2 \cdot kg \cdot s^{-2}.$$

Most frequently the measurements of kinetic energy of the ionizing radiation/emission in radiation electronics and nuclear physics are made in the electron volts (eV).

Page 29.

The calculation of kinetic energy b electron volts is conducted according to the formula

$$E = ZU, \quad (2.4)$$

where E - kinetic energy, eV;

Z - particle charge;

U - potential difference, V.

One electron volt is equal to kinetic energy, which acquires (or it loses) the once charged/loaded particle, whose charge is equal to electron charge ( $e=1.60 \cdot 10^{-19}$ ,  $\kappa=4 \cdot 10^{-10}$  cgs esu with the passage of a potential difference into one volt.

Derived units from the electron volt they are:

kiloelectronvolt ( $1 \text{ keV} = 1 \cdot 10^3 \text{ eV}$ ),

mega-electron-volt ( $1 \text{ MeV} = 10^6 \text{ eV}$ ),

gigaelectron-volt ( $1 \text{ GeV} = 10^9 \text{ eV}$ ).

BeV (billion electron volt) use frequently instead of GeV, since 10<sup>9</sup> call frequently billion (биллион), but not billion (миллиард).

$1 \text{ eV} = 1.602 \cdot 10^{-19} \text{ J} = 1.602 \cdot 10^{-12} \text{ erg}$ .

Table 2.1 gives the values of coefficients for the translation/conversion of energy of particles (quanta) from the mega-electron-volts (MeV) into the joules.

Energy flow of radiation/emission.

The energy flow of particles or quanta (more precise the surface energy flow of particles or quanta) is characterized by the energy, transferred by particles (quanta) through the unit of area. Are encountered also term-synonyms "quantity of radiation/emission" and "temporary/time integral of intensity".

The energy flow of particles (quanta)  $F$  can be calculated according to the formula

$$F = \frac{\Delta E_p}{\Delta S}, \quad (2.5)$$

or as the sum of the products of particle fluxes (quanta) to the kinetic energy of particles in these flows

$$F = \frac{\sum_i N_i E_i}{\Delta S} = \sum_i \Phi_i E_i, \quad (2.6)$$

where  $\Delta E_F$  - sum of energy (with exception of rest energy) of all particles, which enter into the sphere with a cross-sectional area of  $\Delta S$ ;

$E_i$  - energy of the particles (quanta) of the  $i$  radiant flux.



Page 30.

Table 2.1. Conversion of the values of energies of particles from the mega-electron-volts into the joules. (For obtaining the energy in the joules of the numbers, placed in the table, one should multiply by  $10^{-13}$ ).

(1) MeV	(2) Мегаэлектронвольты										D MeV
	0	1	2	3	4	5	6	7	8	9	
0	0	1,602	3,204	4,806	6,408	8,010	9,612	11,21	12,82	14,42	0
10	16,02	17,62	19,22	20,83	22,43	24,03	25,63	27,23	28,84	30,44	10
20	32,04	33,64	35,24	36,85	38,45	40,05	41,65	43,25	44,86	46,46	20
30	48,06	49,66	51,26	52,87	54,47	56,07	57,67	59,27	60,88	62,48	30
40	64,08	65,68	67,28	68,89	70,49	72,09	73,69	75,29	76,90	78,50	40
50	80,10	81,70	83,30	84,91	86,51	88,11	89,71	91,31	92,92	94,52	50
60	96,12	97,72	99,32	100,9	102,5	104,1	105,7	107,3	108,9	110,5	60
70	112,1	113,7	115,3	116,9	118,5	120,2	121,8	123,4	125,0	126,6	70
80	128,2	129,8	131,4	133,0	134,6	136,2	137,8	139,4	141,0	142,6	80
90	144,2	145,8	147,4	149,0	150,6	152,2	153,8	155,4	157,0	158,6	90

Key: (1). MeV. (2). Mega-electron-volts.

Page 31.

For the gamma- and X-radiation

$$F_i = \frac{\sum_i N_i h\nu_i}{\Delta S} = \sum_i \Psi_i h\nu_i, \quad (2.7)$$

where  $h\nu_i$  - quantum energy of the  $i$  radiant flux, i.e., the radiant flux of the  $i$  frequency.

Concept "energy flow" is useful only for describing the parallel radiant flux in the void or distributing the radiation/emission around point source. For example, already in the case of two point radiation sources the area/site, perpendicular to the flow from one source, can prove to be not perpendicular to the flow from another source, passing through this area/site.

With the passage of the ionizing radiation/emission in the absorbing medium scattered radiation with another direction of propagation appears; therefore term "energy flow" can be used only for the primary photons and the particles.

The energy flow of particles (quanta) is measured in the system of SI in the joules to the square meter ( $J/m^2$ ). Its dimensionality  $kg \cdot s^{-2}$ . Energy flow also can be measured in other energy units per units of area, among which is found the greatest use electron volt to square centimeter ( $eV/cm^2$ ), mega-electron-volt to square centimeter ( $MeV/cm^2$ ) and erg to the square centimeter ( $erg/cm^2$ ).

Intensity of radiation/emission.

The intensity of radiation/emission (energy current density) - this is energy of the ionizing radiations/emissions, falling per unit time to the surface of elementary sphere and in reference to the unit of the cross-sectional area of this sphere, it is calculated from the formula

$$J = \frac{\Delta F}{\Delta t}, \quad (2.8)$$

where  $\Delta F$  - energy flow for the time  $\Delta t$ .

Page 32.

Time  $\Delta t$  must be considerably more than the period of oscillation of electromagnetic radiation, since the calculated average/mean power for the interval of time, compared with the oscillatory period, can prove to be erroneous in view of the fact that in the limits of the oscillatory period the power is changed from the zero to the maximum value.

As one intensity measurement of the ionizing radiation/emission is accepted the watt to square meter ( $W/m^2$ ).

The most widely used units are in nuclear physics: the electron volt per second to square centimeter ( $eV/s \cdot cm^2$ ) and

mega-electron-volt per second to square centimeter (MeV/s·cm<sup>2</sup>).

2.2. Units of measurement, which characterize interaction of radiations/emissions with the substance.

Absorbed energy.

The energy of the ionizing radiation/emission, converted in the medium into other forms of energy, is implied by absorbed energy of any ionizing radiation/emission.

The energy, transmitted by the ionizing radiation/emission to substance in the assigned volume, is a difference between the sum of energies of all directly or indirectly ionizing particles, which form part of the given volume, and the sum of energy of the same particles, which left the given volume, minus the energy, equivalent to any increase of the rest mass in the volume in question as a result of nuclear reactions, namely:

$$\Delta E_D = E_D - E_{\text{out}} - m_0 c^2, \quad (2.9)$$

where  $\Delta E_D$  - energy, transmitted by the ionizing radiation/emission to substance in the assigned volume;

$E_D$  - sum of energy of all ionizing particles, which entered the volume in question;

$E_{\text{BMX}}$  - sum of energies of all ionizing particles, which they left the volume in question;

$m_0 c^2$  - energy, equivalent to an increase in the mass

rest.

Page 33.

The energy content, transferred to substance in the given volume, is frequently called the integral absorbed dose in this volume.

One the measurement of the energy, transferred to substance as any energy, is joule (J), erg, electron volt (eV) and others. Gram rad is considered as the special unit.

$$1 \text{ g rad} = 100 \text{ erg} = 10^{-5} \text{ J.}$$

The degree of ionization of substance, and also a quantity of radiant energy absorbed by substance are the measure for interaction of the ionizing radiations/emissions with the substance.

As control gauge for evaluating the effect of the ionizing radiations/emissions on the substance it is accepted to take the radiant energy, transmitted to substance per unit of mass. This value is called the absorbed radiation dosage or radiation dosage. For the brevity frequently they speak the "absorbed dose" or simply "dose", omitting the word of "radiation/emission". The concept of the absorbed dose just as the concept of temperature, is applicable with the averaging of the transmitted to medium energy by certain not too small a volume. Otherwise it can be obtained that the absorbed dose is exclusively great in the locations of the ionized atoms, and on the remaining medium it is equal to zero.

Absorbed dose and power of the absorbed dose of the ionizing radiations/emissions.

The absorbed dose  $D$  of X-ray, gamma- and any corpuscular radiation is defined as the quotient, obtained as a result of division  $\Delta E_D$  on  $\Delta m$ ,

$$D = \frac{\Delta E_D}{\Delta m}, \quad (2.10)$$

where  $\Delta E_D$  - energy, reported to the substance with a mass of  $\Delta m$  by the ionizing radiation/emission.

The unit of the absorbed dose can be any value, which has the dimensionality of energy to the mass for any substance, in which is absorbed the radiant energy.

Pages 34-35.

Table 2.2. Relationships/ratios between different units of radiation dosages (rounded values).

(1) Наименование	(2) Сокращенные обозначения		(5) рад	р	(6) эрг/г	(7) дж/г	(8) дж/кг	(9) кал/г
	(3) русскими буквами	(4) латинскими буквами						
(10) Рад	(10) рад	rad	1	1,14	100	$10^{-3}$	$10^{-2}$	$2,39 \cdot 10^{-6}$
(11) Рентген	р	r	0,877	1	87,7	$8,77 \cdot 10^{-6}$	$8,77 \cdot 10^{-3}$	$2,1 \cdot 10^{-6}$
(12) Эрг на грамм	(12) эрг/г	erg/g	$10^{-2}$	$1,14 \cdot 10^{-2}$	1	$10^{-7}$	$10^{-4}$	$2,39 \cdot 10^{-8}$
(13) Джоуль на грамм	(13) Дж/г	J/g	$10^5$	$1,14 \cdot 10^5$	$10^7$	1	$10^3$	0,239
(14) Джоуль на килограмм	(14) Дж/кг	J/kg	$10^2$	114	$10^4$	$10^{-3}$	1	$2,39 \cdot 10^{-6}$
(15) Калория малая на грамм	(15) кал/г	cal/g	$4,19 \cdot 10^5$	$3,67 \cdot 10^5$	$4,19 \cdot 10^7$	4,19	$4,19 \cdot 10^3$	1
(16) Ватт-час на грамм	(16) вт-час/г	Wh/g	$3,6 \cdot 10^8$	$3,16 \cdot 10^8$	$3,6 \cdot 10^{10}$	$3,6 \cdot 10^3$	$3,6 \cdot 10^6$	$8,6 \cdot 10^2$
(17) Электронвольт на грамм	(17) эв/г	ev/g	$1,6 \cdot 10^{-14}$	$1,4 \cdot 10^{-14}$	$1,6 \cdot 10^{-12}$	$1,6 \cdot 10^{-19}$	$1,6 \cdot 10^{-15}$	$3,83 \cdot 10^{-20}$
(18) Мегаэлектронвольт на грамм	(18) Мэв/г	Mev/g	$1,6 \cdot 10^{-8}$	$1,4 \cdot 10^{-8}$	$1,6 \cdot 10^{-6}$	$1,6 \cdot 10^{-13}$	$1,6 \cdot 10^{-10}$	$3,83 \cdot 10^{14}$
(19) Килограммометр на грамм	(19) кгм/г	kGm/g	$9,81 \cdot 10^5$	$8,6 \cdot 10^5$	$9,81 \cdot 10^7$	9,81	$9,81 \cdot 10^3$	2,34
(20) Кулон на грамм	(20) к/г	C/g	$3,4 \cdot 10^6$	$2,98 \cdot 10^6$	$3,4 \cdot 10^8$	34	$3,4 \cdot 10^4$	8,1
(21) Кулон на килограмм	(21) к/кг	C/kg	$3,4 \cdot 10^3$	$2,98 \cdot 10^3$	$3,4 \cdot 10^5$	$3,4 \cdot 10^{-2}$	34	$8,1 \cdot 10^{-2}$

(1)	(2)		(17) вт-час/г	(18) эв/г	(19) Мэв/г	(22) кгм/г	(23) к/г	(24) к/кг
	(3) русскими буквами	(4) латинскими буквами						
(10) Рад	(10) рад	rad	$2,78 \cdot 10^{-8}$	$6,25 \cdot 10^{12}$	$6,25 \cdot 10^7$	$1,02 \cdot 10^{-6}$	$2,94 \cdot 10^{-7}$	$2,94 \cdot 10^{-4}$
(11) Рентген	р	r	$2,44 \cdot 10^{-8}$	$5,5 \cdot 10^{12}$	$5,5 \cdot 10^7$	$9 \cdot 10^{-5}$	$2,58 \cdot 10^{-7}$	$2,58 \cdot 10^{-4}$
(12) Эрг на грамм	(12) эрг/г	erg/g	$2,78 \cdot 10^{-11}$	$6,25 \cdot 10^{11}$	$6,25 \cdot 10^5$	$1,02 \cdot 10^{-8}$	$2,94 \cdot 10^{-9}$	$2,94 \cdot 10^{-6}$
(13) Джоуль на грамм	(13) Дж/г	J/g	$2,78 \cdot 10^{-4}$	$6,25 \cdot 10^{18}$	$6,25 \cdot 10^{12}$	0,102	$2,94 \cdot 10^{-3}$	29,4
(14) Джоуль на килограмм	(14) Дж/кг	J/kg	$2,78 \cdot 10^{-7}$	$6,25 \cdot 10^{15}$	$6,25 \cdot 10^9$	$1,02 \cdot 10^{-4}$	$2,94 \cdot 10^{-5}$	$2,94 \cdot 10^{-2}$
(15) Калория малая на грамм	(15) кал/г	cal/g	$1,16 \cdot 10^{-3}$	$2,61 \cdot 10^{10}$	$2,61 \cdot 10^{13}$	0,427	0,123	$1,23 \cdot 10^3$
(16) Ватт-час на грамм	(16) вт-час/г	Wh/g	1	$2,25 \cdot 10^{22}$	$2,25 \cdot 10^{16}$	$3,67 \cdot 10^5$	$1,06 \cdot 10^2$	$1,06 \cdot 10^5$
(17) Электронвольт на грамм	(17) эв/г	ev/g	$4,45 \cdot 10^{-23}$	1	$10^{-6}$	$1,63 \cdot 10^{-20}$	$4,7 \cdot 10^{-21}$	$4,7 \cdot 10^{-18}$
(18) Мегаэлектронвольт на грамм	(18) Мэв/г	Mev/g	$4,45 \cdot 10^{-17}$	$10^6$	1	$1,63 \cdot 10^{-14}$	$4,7 \cdot 10^{-15}$	$4,7 \cdot 10^{-12}$
(19) Килограммометр на грамм	(19) кгм/г	kGm/g	$2,7 \cdot 10^{-3}$	$6,1 \cdot 10^{19}$	$6,1 \cdot 10^{13}$	1	0,258	$2,86 \cdot 10^2$
(20) Кулон на грамм	(20) к/г	C/g	$9,4 \cdot 10^{-3}$	$2,1 \cdot 10^{20}$	$2,1 \cdot 10^{14}$	3,47	1	$10^3$
(21) Кулон на килограмм	(21) к/кг	C/kg	$9,4 \cdot 10^{-6}$	$2,1 \cdot 10^{17}$	$2,1 \cdot 10^{11}$	$3,47 \cdot 10^{-2}$	$10^{-2}$	1



Note. The relationships/ratios between the roentgen and other units are given for the radiation/emission ionizing actions on 1 g of air.

Key: (1). Designation. (2). Abbreviations. (3). by Russian letters. (4). Latin. (5). rad. (6). erg/g. (7). J/g. (8). J/kg. (9). cal/g. (10). rad. (11). Roentgen. (12). Ergs to gram. (13). Joule to gram. (14). Joule to kilogram. (15). Calorie, small to gram. (16). Watt-hour to gram. (17). W·h/g. (18). Electron volt to gram. (19). eV/g. (20). Mega-electron-volts to gram. (21). MeV/g. (22). Kilogrammeter to gram. (23). kg-m/g. (24). Coulomb to gram. (25). C/g. (26). Coulomb to kilogram. (27). C/kg.

Page 36.

As one the measurement of the absorbed dose of the ionizing radiation/emission is accepted the joule to the kilogram (J/kg). Is allowed/assumed also (GOST 8448-63) in accordance with the recommendations of international board for radiological units and to measurements the use/application of an extrasystemic unit measurement only for the absorbed dose - rad <sup>1</sup>.

$$1 \text{ rad} = 1 \cdot 10^{-2} \text{ J/kg} = 100 \text{ erg/g.}$$

The units of radiation dosages and scaling factors between them are given in Table 2.2.

FER (the roentgen physical equivalent) they refused from the unit of radiation dosage, but it is encountered in the literary publications of past years. Under FER the dose (absorbed energy) of any ionizing radiation/emission, which is absorbed by one gram of fabric during irradiation by its one roentgen of gamma- or X-radiation, i.e., the quantity of absorbed in the fabric energy of the ionizing radiations/emissions, equivalent to one roentgen, was understood. For fabric 1  $fer=93$  erg/g. For air 1  $fer=87.7$  erg/g.

The power of the absorbed radiation dosage or the radiation dose rate  $P$  represents the absorbed radiation dosage per unit time

$$P = \frac{\Delta D}{\Delta t}, \quad (2.11)$$

where  $\Delta D$  - increase in the absorbed dose for the time  $\Delta t$ .

For the unit of power of the absorbed dose of the ionizing radiation/emission in the system of SI (GOST 8848-63) the watt is accepted to the kilogram (W/kg).

Rad per second and derivative of it (rad/min, rad/hour,  $\mu$ rad/s,

Mrad/min, Mrad/h, etc.) is the special unit of power of radiation dosage.

If time is measured by days, weeks, months and for years, then instead of the power of the absorbed dose sometimes apply terms "daytime dose", "monthly dose", "annual dose". Data, given in Table 2.3, facilitate the recalculation of the power of the absorbed doses.

FOOTNOTE 1. Term "rad" is formed from the initial letters Radiation absorbed dose. ENDFOOTNOTE.

Page 37.

Different forms and spectra of the ionizing radiations/emissions possess different effectiveness on the effect on the same materials and on a change in their electrical and other parameters, i.e., with the identical absorbed doses of different forms and energies of the ionizing radiations/emissions in one and the same substance are observed the ionizing radiations/emissions in one and the same substance they are observed different physical, chemical and biological (for the living tissues) effects. Is feasible such case, when one form of radiation/emission will produce change in the defined parameters in the materials, the instruments and the parts of electronic engineering, while another form of radiation/emission will

not affect a change in these parameters.

Table 2.4 as an example gives the radiation equivalents of destruction for different forms and different energies of the ionizing radiations/emissions, which call identical changes of the lifetime of minority carriers in the p-n or n-p junctions of silicon elements/cells [24].

With the passage of the ionizing radiations/emissions through the substance is changed their composition, energy spectrum, intensity of radiation/emission and density of flow. These changes occur in view of weakening falling/incident to the body of radiation/emission, formation/education of secondary radiation, scattering of radiation/emission, self-protection, etc. Therefore the numerical values of the absorbed dose in the different sections of substance usually prove to be dissimilar. During the evaluation of radiation effect on the materials and the objects/subjects (for example, to instruments and parts of electronic engineering) it is necessary to consider the factor of the nonuniform distribution of the absorbed dose on the irradiated object. In the practical targets, in view of the impossibility of the complete account of the nonuniform distribution of the absorbed dose, the radiation effect is usually described by the average absorbed dose

$$D = \frac{1}{M} \int_M D dm, \quad (2.12)$$

where M - mass of body, or that of complete integral absorbed dosage transmitted to body

$$E_D = DM = \int_M D dm, \quad (2.13)$$

Pages 38-39.

A change in electrical, physical and other parameters in the radio engineering materials, the elements/cells diagrams depends not only on the absorbed radiation dosage, but also on its power. Thus, for instance conducted electrical insulating materials it increases with the power increase of radiation dosage and does not depend (within certain limits) on radiation dosage.

Thus, the numerical value of the absorbed dose in any place of the field of the ionizing radiation/emission (neutron field, gamma-field, etc.) will depend on the form of radiation/emission, density of flow, spectral composition of radiation/emission at the point of field, composition of substance and mass of the irradiated object in question.

Consequently, the effectiveness of the action of this form of the ionizing radiation/emission is determined the absorbed radiation dosage, multiplied by the appropriate coefficients, which consider the characteristics of radiation field, composition and the mass of the irradiated object. Coefficients the considering energy

conversion, is conventionally designated as the conversion factors of energy or east factors.

For example, the coefficient, which considers the linear transformation of energy, is called qualitative factor (QF). In order to obtain one and the same scale for measuring the dose (for all forms of the ionizing radiations/emissions), it is necessary to multiply the absorbed dose by the coefficient.

Table 2.3. Relationships/ratios between ones of power measurement of the absorbed dose.

(1) Наименование	(2) С. в. (русские) обозначение	(3) мк рад/сек	(4) м рад/сек	(5) м рад/мин	(6) м рад/час	(7) рад/сек	(8) рад/мин	(9) рад/час	(10) рад/сутки	(11) рад/год
(12) Микро рад в секунду	мк рад/сек	1	$10^{-6}$	$6 \cdot 10^{-5}$	3,6	$10^{-6}$	$6 \cdot 10^{-5}$	$3,6 \cdot 10^{-4}$	$8,64 \cdot 10^{-3}$	31,5
(13) Милли рад в секунду	м рад/сек	$10^3$	1	60	$3,6 \cdot 10^3$	$10^{-3}$	$6 \cdot 10^{-2}$	3,6	86,4	$3,15 \cdot 10^6$
(14) Милли рад в минуту	м рад/мин	17	$1,7 \cdot 10^{-3}$	1	60	$1,7 \cdot 10^{-4}$	$10^{-2}$	$6 \cdot 10^{-2}$	1,44	526
(15) Милли рад в час	м рад/час	0,28	$0,28 \cdot 10^{-3}$	$1,7 \cdot 10^{-3}$	1	$2,8 \cdot 10^{-4}$	$1,7 \cdot 10^{-2}$	$1 \cdot 10^{-2}$	$2,4 \cdot 10^{-2}$	8,76
(16) Рад в секунду	рад/сек	$10^6$	$10^3$	$6 \cdot 10^4$	$3,6 \cdot 10^6$	1	60	$3,6 \cdot 10^3$	$8,64 \cdot 10^4$	$3,15 \cdot 10^7$
(17) Рад в минуту	рад/мин	$1,7 \cdot 10^4$	17	$10^3$	$6 \cdot 10^4$	$1,7 \cdot 10^{-2}$	1	60	$1,44 \cdot 10^3$	$5,26 \cdot 10^5$
(18) Рад в час	рад/час	280	0,28	17	$10^3$	$2,8 \cdot 10^{-2}$	$1,7 \cdot 10^{-2}$	1	24	$8,76 \cdot 10^4$
(19) Рад в сутки	рад/сутки	11,6	$1,18 \cdot 10^{-2}$	0,696	42	$1,18 \cdot 10^{-2}$	$6,96 \cdot 10^{-2}$	$4,2 \cdot 10^{-2}$	1	$3,65 \cdot 10^{-4}$
(20) Рад в год	рад/год	$3,17 \cdot 10^{-3}$	$3,17 \cdot 10^{-4}$	$1,9 \cdot 10^{-3}$	0,114	$3,17 \cdot 10^{-5}$	$1,9 \cdot 10^{-3}$	$1,14 \cdot 10^{-2}$	$2,74 \cdot 10^{-2}$	1

Note. For obtaining the amounts of the power of exposure doses necessary to replace rad with roentgens.

Key: (1). Designation. (2). Abbreviation. (3).  $\mu$ rad/s. (4). mrad/s. (5). mrad/min. (6). mrad/h. (7). rad/s. (8). rad/min. (9). rad/hour. (10). rads/day. (11). rads/yr. (12). microrad per second. (13). millirad per second. (14). millirad per minute. (15). millirad per hour. (16). rad per second. (17). rad per minute. (18). rad per hour. (19). rad in a 24 hour period. (20). rad per annum.

Table 2.4. Radiation is equivalent destruction for the silicon elements/cells (on the lifetime of minority carriers).

(1) Параметры ионизирующих излучений	$n/m^2$	$p/m^2$	$\beta/m^2$	(2) $\text{rad (Co-60)}$	$\gamma/m^2 \text{ (Co-60)}$
1 $n/m^2$ (спектр деления)	1	0,3	$1,2 \cdot 10^8$	$8 \cdot 10^{-8}$	$1,4 \cdot 10^8$
1 $p/m^2$ (4) ( $E = 30 \text{ МэВ}$ )	3	1	$4 \cdot 10^8$	$2,5 \cdot 10^{-8}$	$4,3 \cdot 10^8$
1 $\beta/m^2$ (3) ( $E = 1 \text{ МэВ}$ )	$8 \cdot 10^{-4}$	$2,5 \cdot 10^{-4}$	1	$1,6 \cdot 10^{-12}$	100
1 $\text{rad (Co-60)}$	$1,2 \cdot 10^8$	$4 \cdot 10^7$	$1,7 \cdot 10^{11}$	1	$1,7 \cdot 10^8$
1 $\gamma/m^2 \text{ (Co-60)}$	$7 \cdot 10^{-8}$	$2,3 \cdot 10^{-8}$	$1 \cdot 10^{-2}$	$6 \cdot 10^{-16}$	1

Key: (1). Parameters of the ionizing radiations/emissions. (2). rad. (3). (fission spectrum). (4). MeV.

Page 40.

Coefficient, which considers intensity (energy density of the ionizing radiation/emission, it is possible to name/call beam factor (QJ). The factor of distribution (DF) can be used for the expression of the conversion of effect in the fabric (biological effect) or in other substance as a result of the nonuniform energy absorption of radiation/emission.

The product of the absorbed dose to the appropriate factors is called dose equivalent (DE):

$$(DE) = D(QF)(DF)(QJ). \quad (2.14)$$



By international board for radiological units and by international board but to radiation shielding dose equivalent was recommended as the value for the calculations of radiation protection [4, 5]. It goes without saying, the concept of dose equivalent can be used also for the numerical expression of radiation dosage with the determination of the radiation durability of radio engineering materials, radioelements and electronic circuits. In this case only will have to consider, together with above noted factors, the effect of design features, modes of operation (factor of construction/design, the factor of mode/conditions), etc.

In the radiobiology for the evaluation of the biological effect of different forms and spectra of the ionizing radiations/emissions the radiobiological effectiveness (OBE) is recommended the applying of term.

OBE depends on the form, the density of flow, radiation spectrum, degree of biological damage/defeat, and also on the special features/peculiarities of the irradiated organism or tissue. OBE of one form of radiation/emission with respect to another is defined as the inverse relation of the absorbed doses, which call identical biological effect. At present as the "specimen radiation/emission", as a rule, they accept the ionizing radiation/emission with the average/mean linear loss of energy 3 keV in the layer of the water

with a thickness of 1  $\mu\text{m}$  [17].

As an example Table 2.5 gives coefficients OBE for some types of irradiation, which call identical (on the average) changes in the status of the health of man.

Page 41.

As the criterion is undertaken the maximum permissible biological radiation dose<sup>1</sup>, obtained during 40 hour in the working week.

REM (rem) is the unit of dose equivalent. Dose in rems is numerically equal to the dose in rad, multiplied by the appropriate factors. The term rem (реп) more frequently is applied in the USSR instead of the term of rem (рем).

Biological dose in rems (rems) is equal to the dose in rad, multiplied by the value of coefficient OBE ( $\eta$ ).

Dose in rems (rems) and absorbed dose in rad are characterized by only dimensionless coefficient; therefore they have identical dimensionality. The conversion factors of some units measurement into others are given in Table 2.6.

On the strength of the fact that the numerical value of the absorbed dose depends on the composition of the irradiated substance, it cannot without further concrete definition serve as the measure of a quantity of ionizing radiation/emission. Therefore as the single-valued characteristics of a quantity of ionizing radiation/emission are accepted the units of absorbed energy by the specially selected standard either specimen substances or by model media. These units are called exposure doses.

This substance for the X-ray and gamma-radiation in the USSR selected dry standard air, in the USA - carbon.

FOOTNOTE <sup>1</sup>. Maximum value of biological radiation dose, established/installed by the appropriate rules of radiation safety.

ENDFOOTNOTE.

Table 2.5. Coefficient OBE for chronic irradiation [25].

(1) Вид излучения	(2) Ионизационные потери энергии, кэВ/мм, ткани	(3) Коэффициент ОБЭ
(4) Рентгеновское и гамма-излучения	0,2—5	1
(5) Бета-частицы и электроны	0,5—5	1
(6) Тепловые нейтроны	5—20	3
(7) Быстрые нейтроны	20—60	10
(8) Протоны и альфа-частицы	20—200	10
(9) Многозарядные ионы и ядра отдачи	150—5000	20

Key: (1). Form of radiation/emission. (2). Ionizing losses of energy, keV/μm, tissue. (3). Coefficient. (4). X-ray and gamma-radiation. (5). Beta particles and electrons. (6). Thermal neutrons. (7). Fast neutrons. (8). Protons and alpha particle. (9). Polyvalent ions and recoil nucleus.

Page 42.

For the neutron radiation/emission one should determine dose on the ionization of tissue-equivalent gas. The absorbed dose of cosmic radiation is determined with the aid of the crystal of the sodium iodide, activated by thallium.

Table 2.6. Conversion factors for the calculations of doses in different media.

(1) От единицы	(2) К единице	(3) Множитель
(4) Рад	(5) Дж/кг (6) эрг/г (7) эв/г	10 <sup>-2</sup> 100 6,25 · 10 <sup>10</sup>
(8) Рентген	(9) Дж/кг (для воздуха) (4) (6) эрг/г (для воздуха) (6) (7) эв/г (для воздуха) (7) (14) рад (для воздуха) (14)	87,7 · 10 <sup>-4</sup> 87,7 5,5 · 10 <sup>10</sup> 1,14
(10) Физический эквивалент рентгена (ФЭР)	(5) Дж/кг (для ткани) (11) (6) эрг/г (для ткани) (6) (14) рад (для ткани) (14) (12) нейтрон/см <sup>2</sup> (E > 10 кэв) (13) нейтрон/см <sup>2</sup> (тепловые)	93 · 10 <sup>-4</sup> 93 1,075 2,8 · 10 <sup>8</sup> 9 · 10 <sup>8</sup>
(14) Рад (для ткани)	(5) Дж/кг (для воздуха) (5) (6) эрг/г (для воздуха) (6) (12) нейтрон/см <sup>2</sup> (E > 10 кэв) (13) нейтрон/см <sup>2</sup> (тепловые)	87,7 · 10 <sup>-4</sup> 87,7 3 · 10 <sup>8</sup> 10 <sup>8</sup>
(15) Рем (бэр)	(12) нейтрон/см <sup>2</sup> (E > 10 кэв) (13) нейтрон/см <sup>2</sup> (тепловые)	3 · 10 <sup>7</sup> 3 · 10 <sup>8</sup>
(16) Квант на квадратный сантиметр для E <sub>T</sub> = 1 Мэв (18)	(17) фэр	5,1 · 10 <sup>-10</sup>
(18) Квант на квадратный метр для E <sub>T</sub> = 1 Мэв (18)	(17) фэр	5,1 · 10 <sup>-6</sup>

Key: (1). From one. (2). To one. (3). Factor. (4). rad. (5). J/kg. (6). erg/g. (7). eV/g. (8). Roentgen. (9). (for air). (10). Roentgen physical equivalent (FER). (11). (for tissue). (12). neutrons/cm<sup>2</sup> (E > 10 keV). (13). neutrons/cm<sup>2</sup>. (14). rad (for tissue). (15). Rem (rem). (16). Quantum to square centimeter for. (17). FER. (18). MeV

FOOTNOTE <sup>1</sup>. For the X-ray ones and the gamma-rays there is a following approximate linear relationship/ratio  $1 p=1.9 \cdot 10^9/E$   $\gamma$ -quant./cm<sup>2</sup>, which is correct with the accuracy approximately/exemplarily  $\pm 15\%$  in the range of energy of  $\gamma$ -quanta from 0.02 to 2 MeV. ENDFOOTNOTE.

(19). Quantum to square meter for.

Page 43.

2.3. Physical quantities of the exposure doses, used for the evaluation of the radiation durability of radio-electronic equipment and its elements/cells.

Exposure dose is absorbed energy in the specimen substance or the model medium, determined from the concrete/specific/actual reaction, which occurs in this substance under the influence of the ionizing radiation/emission.

As the measured reaction, in essence, is applied the ionization (energy, transferred to electrons and positrons). Therefore exposure doses are called sometimes ionic doses.

At present exposure doses are determined for the X-ray and

gamma-, neutron and space (proton and electronic) radiations/emissions.

Exposure dose of X-ray and gamma-radiation.

The exposure dose of X-ray and gamma-radiation is established/installed for the quantitative estimation of X-ray and gamma-radiation. This term differs from that recommended by international board for radiological units and to the measurements (MKRE) of the term "exposure", which eliminates the word "dose", which is used for the designation only of one value - the "absorbed dose".

Air is selected as the specimen substance during the establishment of the unit of exposure dose, while as the measured reaction - ionization. This selection gives the possibility to determine the amount of exposure dose and its power in one and the same units, regardless of the energy spectrum of radiation/emission.

The energy, transferred by gamma-quanta serves as this measure to electrons and positrons. They consider that the average/mean ionization potential of gamma-quanta in air is constant in the range of energies from 20 keV to 3 MeV and is equal to 34 eV.

Page 44.

The exposure dose of X-ray and gamma-radiation in the general case is not equal to the absorbed dose of these radiations/emissions, since exposure dose determines the energy, transmitted to the charged/loaded particles, but the absorbed dose - absorbed energy of radiation/emission. Exposure dose the equal absorbed dose on the effect of ionization under the conditions of electronic equilibrium becomes. Therefore the measurement of the absorbed dose in air is carried out under the conditions of electromagnetic equilibrium, i.e., in free airspace at a distance from other bodies, greater than the landing run of secondary electrons. Absorbed dose measured under these conditions in air is called exposure dose [22].

The exposure dose of X-ray and gamma-radiation  $X$  is calculated from the formula

$$X = \frac{\Delta Q}{\Delta m}, \quad (2.15)$$

where  $\Delta m$  - mass of the element of volume of air;

$\Delta Q$  - sum of electrical ion charges, which have identical sign and which appear in air, when all electrons (negative electrons and positrons), freed with the aid of the quanta of X-ray and gamma-radiation in the element of volume of air, completely are braked.



In  $\Delta Q$  are not connected electrical ion charges, which appear as a result of ionization caused by the bremsstrahlung of secondary electrons.

The exposure dose of X-ray and gamma-radiation is measured in quantities of electrical ion charge of one sign per unit of the mass of air. One measurement established/installed coulomb to the kilogram (C/kg), the dimensionality  $\text{kg}^{-1}\text{s}\cdot\text{A}$ .

It is allowed/assumed to also measure the exposure dose in widespread in the practice and the theories the units of roentgens (r) and respectively in the multiple or lobate units. The unit of the exposure dose of X-ray and gamma-radiation coulomb per kilogram, and also extrasystem unit of roentgens it is possible to apply for the measurements of radiations/emissions with the quantum energy, not exceeding 0.5 p-joules ( $\approx 3$  MeV).

The conversion of the values of the exposure dose of X-ray and gamma-radiation from the Roentgens into the coulombs for the kilogram is given in Table 2.7.

Page 45.

Table 2.7. Conversion of the values of exposure radiation dosage from the Roentgens into the coulombs for the kilogram ( $1 \text{ p} = 2.57976 \cdot 10^{-4} \text{ C/kg}$ ). (For obtaining the exposure radiation dosage into C/kg of the numbers, placed in the table, one should multiply by  $10^{-4}$ ).

(1) Pentren	Pentren										Pentren
	0	1	2	3	4	5	6	7	8	9	
0	0	2,57976	5,15952	7,73928	10,3190	12,8988	15,4786	18,0583	20,6381	23,2178	0
10	25,7976	28,3774	30,9571	33,5369	36,1166	38,6964	41,2762	43,8559	46,4357	49,0154	10
20	51,5952	54,1750	56,7547	59,3345	61,9142	64,4940	67,0738	69,6535	72,2333	74,8130	20
30	77,3928	79,9726	82,5523	85,1321	87,7118	90,2916	92,8714	95,4511	98,0309	100,611	30
40	103,190	105,770	108,350	110,930	113,509	116,089	118,669	121,249	123,828	126,408	40
50	129,988	131,568	134,148	136,727	139,307	141,887	144,467	147,046	149,626	152,206	50
60	154,786	157,365	159,945	162,525	165,105	167,684	170,264	172,844	175,424	178,003	60
70	180,583	183,163	185,743	188,322	190,902	193,482	196,062	198,642	201,221	203,801	70
80	206,381	208,961	211,540	214,120	216,700	219,280	221,859	224,439	227,019	229,599	80
90	232,178	234,758	237,338	239,918	242,497	245,077	247,657	250,237	252,816	255,396	90

Note. Table can also serve for the conversion of the power coefficients of exposure dose of the R/s in A/kg, there as  $1 \text{ R/s} = 2.57976 \cdot 10^{-4} \text{ A/kg}$ .

Key: (1). Roentgen.

Page 046.

From the comparison of the units of roentgen and rad it follows that for air with electronic equilibrium and exposure dose 1 the absorbed dose is equal to 0.877 rad.

The relationships/ratios between the energy units, absorbed in the unit of the mass of air, and roentgen are given in Table 2.2. Sometimes is encountered one measurement, called gram roentgen. Gram roentgen - these are the value of absorbed energy of radiation/emission in one gram of the irradiated substance under the conditions of electronic equilibrium in the exposure dose is one roentgen. Large use/application finds gram roentgen in the measurement of tissue doses of organism; its numerical value proves to be different for the different coupling effects.

On the average for the soft tissues with an accuracy to 10% gram roentgen it is possible to take as equal to 93 ergs [22].

This value is occasionally referred to as cloth roentgen.

Power of the exposure dose of X-ray and gamma-radiation.

The power of the exposure dose of X-ray and gamma-radiation (according to recommendation MKRE - "power of exposure") is determined from the expression

$$P_T = \frac{\Delta X}{\Delta t}, \quad (2.16)$$

where  $P_T$  - power of exposure dose;

$\Delta X$  - increase in the exposure dose for the time  $\Delta t$ .

The power of exposure dose can be also determined through the intensity of radiation/emission according to the formula

$$P_T = \int_0^{E_m} \frac{M_k}{\rho} J dE_T, \quad (2.17)$$

where  $M_k/\rho$  - mass conversion factor of energy for the gamma-quanta with energy  $E_T$  in air;

$J dE_T$  - intensity of the region of the spectrum of that falling from the torching with the energies of gamma-quanta from  $E_T$  to  $E_T + dE_T$ ,

or

$$P_T = \overline{M_k/\rho} J,$$

where  $\overline{M_k/\rho}$  - average mass conversion factor of energy for air;

$J$  - the total intensity of radiation/emission.

Page 047.

One power measurement of exposure dose is ampere per kilogram (A/kg) or coulomb per second to the kilogram ( $C/s \cdot kg = A \cdot s/s \cdot kg$ ). Roentgen per unit time (R/s, R/min, R/h, etc.) is the special unit of power of exposure dose. The conversion factors between different amounts of the power of exposure doses, expressed in the lobate values of roentgen and referred to different units of time, are given in Table 2.3.

The conversion of the power coefficients of the exposure dose of ones of measurements R/s in units A/kg can be produced with the aid of the coefficients, given in Table 2.7.

Exposure dose of neutron radiation/emission [20, 23, 26].

The neutron sources and field of neutron radiation/emission are characterized by the neutron flux density and by their energy spectrum, which undoubtedly is very complicated with the use in the practice. Therefore it is expedient to introduce the concept of the exposure dose of neutron radiation/emission (analogous to concept exposure(dose of X-ray and gamma-radiation), intended for the

characteristic of neutron fields, and also the concept of the characteristic of neutron yield from different radiation sources.

As the model medium for the neutrons is recommended the accepting of "tissue-equivalent gas", i.e., such mixture of gases, which in percentage (weight) content of hydrogen and nitrogen is analogous to their content in the soft tissue of man. The composition of tissue-equivalent gas in the percentages of partial pressures is the following: methane - 64.4%, carbon dioxide - 32.5%, nitrogen - 3.1%.

In accordance with the international measuring system one should as the unit of the exposure dose of neutron radiation/emission apply unit ned (neutron unit of dose) [23].

Page 048.

Ned - exposure dose of neutron radiation/emission, in which to the kilogram of tissue-equivalent gas are formed in this gas the ions, which carry charge into one coulomb of the electricity of each sign:

$$1 \text{ ned} = 1 \text{ C/kg.}$$

Unit ned can be used in the measurement of the doses of neutron

radiation/emission, created by neutrons with the energies from 0.2 to 20 MeV, where by the basic process of interaction of neutrons with the atoms of tissue-equivalent substance are elastic collisions, and also to a certain extent in the measurement of the doses of thermal neutrons.

Power of the exposure dose of neutron radiation/emission.

The power of the exposure dose of neutron radiation/emission is defined as the exposure dose of neutron radiation/emission per unit time. One power measurement is weeks per second or ampere per the kilogram:

$$1 \text{ ned/s} = 1 \text{ A/kg.}$$

Exposure dose of cosmic radiation.

The characteristic of outer space on the radiation field (or dose field) it is accepted to produce according to the exposure dose and the power of the exposure dose of proton and electronic radiation/emission.

The crystal of sodium iodide, activated by thallium (NaJ, Tl), is selected as the specimen substance for determining the exposure

dose of protons and electrons. In the process of action of protons and electrons in crystal NaJ, with the diameter of 20 mm and by the height/altitude of 20 mm, arranged/located under the protection 1 g/cm<sup>2</sup> (10 kg/m<sup>2</sup>) of aluminum, is measured the luminescence efficiency.

The determination of absorbed energy is conducted via comparison reading/indication on the luminescence efficiency under the influence on the standard crystal NaJ of the space ionizing radiation/emission with the data, obtained under laboratory conditions (graphic dependences), on the luminescence efficiency depending on absorbed energy of the calibrated flows of protons and electrons.

Page 049.

This method gives the possibility to measure the exposure dose of proton and electronic radiations/emissions with an accuracy to several percentages over a wide range of energy for the protons from 20 to 800 MeV, for the electrons from several kiloelectronvolts to several mega-electron-volts.

In the measurement of the exposure radiation dosage of electrons with energy less than 0.1 MeV, the disagreements can be to the side of overestimate 2-5 times. The latter is explained by the fact that



the isotropy of the angular separation of electrons increases in proportion to the decrease of energy.

Unit of the measurement of the exposure dose of cosmic radiation is rad, equal to absorbed energy  $1 \cdot 10^{-5}$  J (or 100 ergs) in 1 g ( $1 \cdot 10^{-3}$  kg) of the crystal of the sodium iodide, activated by thallium.

Power of the exposure dose of cosmic radiation.

Power of the exposure dose of cosmic radiation - exposure dose per unit time. As the units of power of exposure doses for practical purposes rad are accepted in hour (rad/hour), rad in a 24 hour period (rads/day) and rad per annum (rads/yr.). The units of power rad in a 24 hour period and rad per annum are called also respectively daily dose and annual dose.

Kerma and power of kerma.

These units the measurement of the ionizing radiations/emissions are recommended by international board for the radiological units and to measurements (MKRE) into 1962 and are intended for the characteristic of indirect ionizing radiation/emission [4, 5]. The proposed designation "kerma" (kerma) is composed of the initial

letters of the words Kinetic energy released in material (kinetic energy, freed in the material).

Terms "kerma" and "power of kerma" in the USSR are not accepted. Kerma  $K$  indicates kinetic energy of the directly ionizing particles, created in the material with the indirectly ionizing particles, and can be calculated according to the formula

$$K = \frac{\Delta E_k}{\Delta m}, \quad (2.18)$$

where  $\Delta E_k$  -- sum of initial kinetic energies with all of the charged/loaded particles, created with the indirectly ionizing particles in certain element of volume of special (specimen) material (medium);

$\Delta m$  - mass of the volume of material (medium) in question.

Page 050.

On the basis of the definition, the kerma is proportional to the energy flow of particles ( $F$ ) and to the mass conversion factor of energy ( $M_u/\rho$ ), and consequently:

$$K = F \frac{M_u}{\rho}.$$

In formula (2.18) value  $\Delta m$  must be, on one hand, so small that its introduction would not introduce noticeable disturbance/breakdown to

the region of radiation/emission; on the other hand, volume must be sufficient so that the necessary number of interactions would occur in it.

In contrast to the exposure dose of X-ray and gamma-radiation the kerma encompasses the ionization, caused by the braking electron emission and positrons.

The bremsstrahlung in air can be disregarded/neglected for the energies of gamma-quanta to 10 MeV. Then kerma in the steady equilibrium of the charged/loaded particles is equal to the absorbed dose of gamma-radiation in air.

The determination of the value of kerma for the neutron fluxes on the basis of ionizing measurements (at equilibrium of the charged/loaded particles) in tissue-equivalent gas will coincide with the absorbed neutron dose. In the absence of the equilibrium of the charged/loaded particles the kerma will always be less than the absorbed dose.

To the flows of gamma-quanta and neutrons, whose energy is more than examined, can occur the transient equilibrium of the charged/loaded particles. In this case the kerma is considerably less than the absorbed dose.

Page 051.

For example, during interaction of gamma-quanta with the energy 25-100 MeV with air the electrons formed in air have this high initial kinetic energy, that the created by them bremsstrahlung partially exceeds the limits of the volume,  $V$  which is made its measurement. Consequently, the measured values of ionizing current and the measured value of kerma will be understated. As one the measurement of kerma is proposed the joule to the kilogram (J/kg) or in the system CGS of ergs to the gram (erg/g).

The power of kerma - ratio  $\Delta K/\Delta t$ , where  $\Delta K$  - increase in the kerma for the time  $\Delta t$ .

By one power measurement of kerma is proposed joule per second to kilogram (J/s·kg) or watt to the kilogram (W/kg); in the system CGS - erg per second to gram (erg/s·g).

2.4. Induced radioactivity in the materials and the elements/cells and the units of radioactivity.

Radioactivity of substance.

Radioactivity is the ability of some atomic nuclei spontaneously to decompose with the emission of  $\alpha$ -particles, positrons, electrons and atomic nuclei.

There are following types of radioactivity: beta-radioactivity, electronic capture, alpha-radioactivity, spontaneous fission and nuclear isomerism.

Beta- radioactivity is determined by escape from the atomic nucleus of electrons or positrons. Electron capture by nucleus can occur in beta-unstable atoms, i.e., occurs the so-called process of electronic capture, also, therefore the conversion of atom into isobars with the charge less by one. Beta-radioactivity and electronic capture are frequently accompanied by the emission of  $\gamma$ -quanta or internal conversion electrons. The energy, which is freed/released during the radioactive conversions of  $\beta$ -isotopes, reaches several mega-electron-volts.

Alpha-radioactivity is accompanied by the emission of the nuclei of helium ( $\alpha$ -particles) with the energy from 4 to 7 MeV.

During the spontaneous fission the nuclear decomposition of atom to two fragments with the average mass number occurs; this decomposition/decay is accompanied by the emission of two-three neutrons, electrons, and also it can be accompanied by the emission of  $\alpha$ -particles. The fragments, which appear during the division, contain neutron excess and are subjected to train of electronic ( $\beta^-$ ) decomposition/decays. The elements/cells, which are formed as a result of these ( $\beta^-$ ) decomposing, can emit neutrons approximately/exemplarily during 1 min after division. The energy, isolated during the spontaneous fission, can reach order 160 MeV.

With the nuclear isomerism occur the nuclear conversions, as a result of which the atomic nucleus, which is found in the excited metastable state, converts/transfers to another, intermediate or basis, level. The emission of quantum or internal conversion electron occurs as a result of this process, and nucleus converts/transfers into another energy state, but in this case the numerical values of the magnitude of the charge and mass number of atomic nucleus do not change.

The radioactivity of substance can be natural and artificial (induced).

In the practice of the operation of radio-electronic equipment they usually deal concerning induced radioactivity, besides the cases, when in the construction/design of radioelements and diagrams are used the radioisotopes of natural or obtained artificially elements/cells.

Induced radioactivity arises from; radioactive contamination or as a result of the emergence of radioactive isotopes during irradiation of the materials of radio-electronic equipment and its completing elements/cells by the ionizing radiations/emissions.

Radioactive contamination occurs during the nuclear explosions and during the operation of equipment near the radioactive radiation sources (near nuclear reactors and with the works with the radioactive isotopes) <sup>R</sup> During the nuclear explosions the radioactive contamination occurs as a result of precipitation of the fission products and unreacting part of nuclear fuel, and also as a result of precipitation of the radioactive isotopes, which appear during irradiation by the neutron fluxes of the materials of the construction/design of A-bomb, soil and other substances of different objects, which are located in the zone of action of nuclear explosion. The contamination of equipment can be, also, in the area

of the motion of radioactive cloud.

Page 053.

With the work near the radioactive sources the contamination of equipment occurs due to the isolation/liberation by these sources of gaseous ones, etc. of radioactive products. For the preservation from the radioactive contamination, which is formed as a result of precipitation on the equipment of radioactive products, the decontamination (deactivation/decontamination) is produced by the mechanical removal of radioactive materials from the infected objects.

Induced radioactivity in the materials of equipment and its structural elements/cells appears as a result of changing the atomic nuclei of these materials under the influence on them, in essence, the neutron fluxes, and also other forms of the ionizing radiations/emissions. Especially large induced radioactivity is characteristic for the electro-radio parts, which consist of the elements/cells of the second part of the Mendeleev Periodic Table. Thus, for instance, cermet lamps two weeks after removal/distance from the reactor, where they were irradiated by neutron flux  $10^{21}$  n/m<sup>2</sup>, possessed residual/remanent radioactivity with a power of the exposure dose of gamma-radiation of more than 100 r/h (27].



By the basic forms of the artificial ionizing radiations/emissions, emitted by materials and elements/cells, used in the radio-electronic equipment, after their irradiation are beta-, gamma- and alpha radiation.

As ones, which characterize radioactive decay of the nuclei of substance, are accepted: the activity of isotope in the radioactive source, radioactive decay constant, half-life period, specific activity of radioactive material and concentration of radioactive materials in certain medium (air, water, etc.). The output of particles (quanta) and the source power of radiation/emission are the basic physical values, which characterize the sources of the ionizing radiations/emissions.

The activity of isotope in the radioactive source (activity of nuclide) is the GOST-standardized unit (according to GOST 8848-63), which characterizes radioactive decay.

Activity of isotope in a radioactive source.

The activity of isotope in the radioactive source (or is simple activity - the expression most frequently used in the practice) characterizes the general/common/total property of radioactive materials (natural and artificial) - the ability spontaneously to decompose.

The activity (A) of a quantity of radioactive isotopes exists quotient, obtained during the division  $\Delta N$  on  $\Delta t$ :

$$A = \frac{\Delta N}{\Delta t}, \quad (2.19)$$

where  $\Delta N$  - number of nuclear conversions, which occurs in this quantity of substance for the delay time  $\Delta t$ .

As the unit of activity GOST 8848-63 is established/installed the unit of the system of SI - one decomposition/decay in one second (decay/s). Dimensionality of the unit of activity  $s^{-1}$ , (1/s). The use/application of an extrasystemic unit (curie) is allowed/assumed also. Curie - this is the activity of the preparation of this isotope, in which in one second it occurs  $3.700 \cdot 10^{10}$  the reports/events of decomposition/decay.

Furthermore, is encountered the unit of activity - rutherford, which was not acknowledged international;

1 rutherford = of  $10^6 s^{-1}$ .



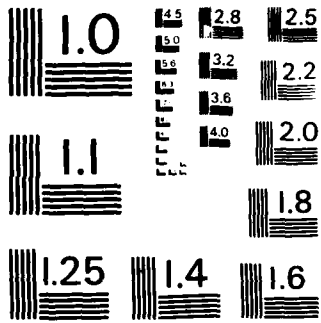

MICROCOPY RESOLUTION TEST CHART  
NATIONAL BUREAU OF STANDARDS-1963-A

The relationship/ratio between the units of the activity of isotope in the radioactive source is given in Table 2.8. The conversions of the values of activity from the curie into the decomposition/decay per second are given in Table 2.9.

Radium gamma-equivalent.

For the comparison of the radioactive preparations, which give gamma-radiation, the value, called the radium gamma-equivalent of preparation, is applied.

The comparison of radioactive preparations is conducted according to the dose rate, which they can create under one and the same conditions. For the standard, on which are estimated all remaining preparations, is accepted one milligram of the element/cell of radium. With its aid is established/installed the unit of radium gamma-equivalent. This unit is called the milliequivalent of radium and is designated by mg-equiv. of radium or mg-eg Ra.

The milliequivalent of radium exists "... gamma-equivalent of the radioactive preparation, whose gamma-radiation during this filtration, under the identical conditions for measurement creates

the same dose rate, as gamma-radiation of one milligram of radium of the state standard of radium of the USSR with the platinum filter with a thickness of 0.5 mm" [3].

Page 55.

Table 2.8. Relationship/ratio between the units of activity.

(1) Наименование	(2) Сокращенное обозначение	(3) Распад в секунду	(4) Резерфорд	(5) Килокюри	(6) Кюри	(7) Милликюри	(8) Микрокюри	(9) Нанокюри
(3) Распад в се- кунду	(10) $\text{сек}^{-1}$	1	$10^{-6}$	$0,27 \cdot 10^{-12}$	$0,27 \cdot 10^{-10}$	$0,27 \cdot 10^{-7}$	$0,27 \cdot 10^{-4}$	$0,27 \cdot 10^{-1}$
(4) Резерфорд	(11) <i>резерфорд</i>	$10^6$	1	$0,27 \cdot 10^{-7}$	$0,27 \cdot 10^{-4}$	$0,27 \cdot 10^{-1}$	27	$2,7 \cdot 10^4$
(5) Килокюри	(12) <i>кюри</i>	$3,7 \cdot 10^{12}$	$3,7 \cdot 10^9$	1	$10^3$	$10^6$	$10^9$	$10^{12}$
(6) Кюри	(6) <i>кюри</i>	$3,7 \cdot 10^{10}$	$3,7 \cdot 10^7$	$10^{-3}$	1	$10^3$	$10^6$	$10^9$
(7) Милликюри	(13) <i>мюри</i>	$3,7 \cdot 10^7$	37	$10^{-6}$	$10^{-3}$	1	$10^3$	$10^6$
(8) Микрокюри	(14) <i>микюри</i>	$3,7 \cdot 10^4$	$3,7 \cdot 10^{-2}$	$10^{-9}$	$10^{-6}$	$10^{-3}$	1	$10^3$
(9) Нанокюри	(15) <i>нюри</i>	37	$3,7 \cdot 10^{-8}$	$10^{-12}$	$10^{-9}$	$10^{-6}$	$10^{-3}$	1

Key: (1). Designation. (2). Abbreviation. (3). Decomposition/decay per second. (4). Rutherfords. (5). Kilocuries. (6). Curie. (7). Millicurie. (8). Microcurie. (9). Nano-Curie. (10).  $\text{s}^{-1}$ . (11). rutherford. (12). kcurie. (13). mCi. (14). microcurie. (15). ncurie.

Page 56.

Table 2.9. Conversion of the values of the activity of radioactive preparations from ones curie in the units of SI (decomposition/decay per second) of 1 curie =  $3.700 \cdot 10^{10} \text{ s}^{-1}$ . (For obtaining the activity in the decomposition/decays per second of the numbers, placed in the table, one should multiply by  $10^{10}$ ).

(1) Кюри	0	1	2	3	4	5	6	7	8	9	① Кюри
0	0	3,7	7,4	11,1	14,8	18,5	22,2	25,9	29,6	33,3	0
10	37,0	40,7	44,4	48,1	51,8	55,5	59,2	62,9	66,6	70,3	10
20	74,0	77,7	81,4	85,1	88,8	92,5	96,2	99,9	103,6	107,3	20
30	111,0	114,7	118,4	122,1	125,8	129,5	133,2	136,9	140,6	144,3	30
40	148,0	151,7	155,4	159,1	162,8	166,5	170,2	173,9	177,6	181,3	40
50	185,0	188,7	192,4	196,1	199,8	203,5	207,2	210,9	214,6	218,3	50
60	222,0	225,7	229,4	233,1	236,8	240,5	244,2	247,9	251,6	255,3	60
70	259,0	262,7	266,4	270,1	273,8	277,5	281,2	284,9	288,6	292,3	70
80	296,0	299,7	303,4	307,1	310,8	314,5	318,2	321,9	325,6	329,3	80
90	333,0	336,7	340,4	344,1	347,8	351,5	355,9	358,9	362,6	366,3	90

Key: (1). Curie.

Page 057.

Usually they accept, that 1 mg of radium with the platinum filter with a thickness of 0.5 mm creates the power of the exposure dose of 8.4 R/h at a distance of 1 cm from the source, which is



assumed to be point.

Consequently, transition from the activity of preparation A (mCi) to activity  $A_{Ra}$  (mg-equiv. of radium) can be realized according to the formula

$$A_{Ra} = A \frac{\kappa_{\gamma}}{8,4}, \quad (2.20)$$

where  $\kappa_{\gamma}$  — power of the exposure dose of X-ray and gamma-radiations/emissions of this isotope ( $R/h$ ) at distance 1 cm from point source by activity 1 mCi (under the condition of the absence of radiation absorption).

Value  $\kappa_{\gamma}$  is called the complete gamma-constant (ionine constant) of radioactive isotope and is the sum of differential gamma-constants (relating to the specific monoenergetic lines of the gamma-spectrum of isotope).

For measuring the radioactivity of the element/cell, which radiates simultaneously gamma-rays, alpha- and beta particle, is accepted the unit of the activity of radon (or radon), which is the radioactivity of radon, which is found in the radioactive equilibrium with one gram of radium.

Radioactive decay constant.

The value, equal to the portion of the radioactive atoms, which decompose 1 s (more precise - the disintegration probability of atom for the unit of time) is called radioactive decay constant (disintegration constant). If  $N_0$  - a number of atoms of certain radioactive material into zero time, and  $N$  - a number of atoms, which remained up to the moment/torque of time  $t$ , then

$$N = N_0 e^{-\lambda t}. \quad (2.21)$$

Pages 058 and 059.

Differentiating equation (2.21) on the time, we obtain

$$\frac{dN}{dt} = -\lambda N,$$

or  $A = -\lambda N$  and  $-\lambda = A/N$  i.e. disintegration constant  $\lambda$  is equal to the activity  $A$ , divided into a number of radioactive atoms.

Half-life period.

The period of half-life  $T$  is called the time, during which on the average decomposes half of all atoms of this radioactive material.

Substituting the value  $2N=N_0$ , in the equation of decomposition/decay (2.21), we obtain

$$T = \frac{\ln 2}{\lambda} = \frac{0.693}{\lambda}. \quad (2.22)$$

The periods of the half-lives of different known isotopes are within the limits from  $10^{-7}$  s to  $10^{11}$  years.

Concentration of radioactive materials.

The activity of the medium, which contains radioactive materials, is measured by the units of the concentration of radioactive materials in this medium. The units of activity, in reference to the unit volumes of medium, are the units of concentration. Such units they can be: curie to the cubic meter ( $\text{curie/m}^3$ ), the curie to a liter ( $\text{Curie/l}$ ), a number of decomposition/decays to a cubic meter ( $\text{m}^{-3}$ ), a number of decomposition/decays to the cubic centimeter ( $\text{cm}^{-3}$ ), etc.

As the concentration of radon (radon) are applied special units eman and by Mache (Mache's unit).

$1 \text{ eman} = 1 \cdot 10^{-10} \text{ Curie/l} = 1 \cdot 10^{-7} \text{ Curie/m}^3 = 3.67 \times 10^3 \text{ decay/s} \cdot \text{m}^3 = 3.67 \text{ decay/s} \cdot \text{l}$ .

One unit of Mache is the thousandth part of the ionizing current, measured in the units of cgs esu, which is created in 1

liter by the alpha-radiation of emanium with poly-ohm the use of a landing run of the alpha particles:

$$1 \text{ Mache} = 3.64 \text{ eman} = 3.64 \cdot 10^{-7} \text{ curie/m}^3.$$

Strictly speaking, the unit of Mache is not quantitative unit, although as the same it frequently is utilized.

Concentration also is measured in units stat per unit volume. 1 stat - quantity of emanium, which with the complete expenditure of energy of radiation/emission for the ionization of air creates saturation current in 1 unit cgs esu per second.

1 cgs esu =  $1/3 \cdot 10^9$  A, means 1 stat will create the current, equal to approximately/exemplarily  $3.3 \cdot 10^{-10}$  A.

Table 2.10. Relationships/ratios between the units of concentrations (rounded values).

(1) Наименование	(2) Сокращенное обозначение	(3) кюри/м³	(4) кюри/л	(5) расп./м³·сек	(6) расп./л·сек	(7) стат/м³	(8) стат/л	(9) эман (в 1 л)	(10) махе (в 1 л)
Кюри на кубический метр	③ кюри/м³	1	10 <sup>-3</sup>	3,7 · 10 <sup>10</sup>	3,7 · 10 <sup>7</sup>	2,75 · 10 <sup>8</sup>	2,75 · 10 <sup>5</sup>	10 <sup>7</sup>	2,75 · 10 <sup>8</sup>
Кюри на литр	④ кюри/л	10 <sup>3</sup>	1	3,7 · 10 <sup>13</sup>	3,7 · 10 <sup>10</sup>	2,75 · 10 <sup>11</sup>	2,75 · 10 <sup>8</sup>	10 <sup>10</sup>	2,75 · 10 <sup>9</sup>
Распад на кубический метр	⑤ расп./м³·сек	2,7 · 10 <sup>-11</sup>	2,7 · 10 <sup>-14</sup>	1	10 <sup>-3</sup>	7,4 · 10 <sup>-3</sup>	7,4 · 10 <sup>-6</sup>	2,7 · 10 <sup>-4</sup>	7,4 · 10 <sup>-4</sup>
Распад на литр	⑥ расп./л·сек	2,7 · 10 <sup>-8</sup>	2,7 · 10 <sup>-11</sup>	10 <sup>3</sup>	1	7,4 · 10 <sup>-3</sup>	7,4 · 10 <sup>-6</sup>	0,27	7,4 · 10 <sup>-3</sup>
Стат на кубический метр	⑦ стат/м³	3,64 · 10 <sup>-7</sup>	3,64 · 10 <sup>-10</sup>	1,35 · 10 <sup>8</sup>	13,5	1	10 <sup>-3</sup>	3,64	1
Стат на литр	⑧ стат/л	3,64 · 10 <sup>-4</sup>	3,64 · 10 <sup>-7</sup>	1,35 · 10 <sup>11</sup>	1,35 · 10 <sup>8</sup>	10 <sup>3</sup>	1	3,64 · 10 <sup>3</sup>	10 <sup>3</sup>
Эман (в 1 литре)	⑨ эман	10 <sup>-7</sup>	10 <sup>-10</sup>	3,7 · 10 <sup>3</sup>	3,7	0,275	2,75 · 10 <sup>-4</sup>	1	0,275
Единица Махе (в 1 литре)	⑩ махе	3,64 · 10 <sup>-7</sup>	3,64 · 10 <sup>-10</sup>	1,35 · 10 <sup>8</sup>	13,5	1	10 <sup>-3</sup>	3,64	1

Key: (1). Designation. (2). Abbreviation. (3). curie/m<sup>3</sup>. (4). Curie/l. (5). decay/m<sup>3</sup>·s. (6). decay/l·s. (7). stat/m<sup>3</sup>. (8). stat/l. (9). eman (in 1 l). (10). Mache (in 1 l). (11). Curie to cubic meter. (12). Curie to liter. (13). Decomposition/decay to cubic meter. (14). Decomposition/decay to liter. (15). stat to cubic meter. (16). stat to liter. (17). Eman (in 1 liter). (18). eman. (19). Unit of Mache (in 1 liter). (20). Mache.

Pages 60-63.

Table 2.11. Units of the ionizing radiations/emissions and radioactivity in the international system of the units of SI.

(1) Наименование величины	(2) Обозначение	(3) Единица измерения	(4) Соответствующие общепринятые обозначения		(7) Размерные единицы	(8) Размерность единицы
			(5) русскими буквами	(6) латинскими буквами		
(9) Поток ионизирующих частиц или квантов	$\Phi$ (17)	(10) Частица (квант) / м <sup>2</sup>	(11) част./м <sup>2</sup>	1/м <sup>2</sup>	(12) (1 частица) / (1 м <sup>2</sup> )	м <sup>-2</sup>
(13) Плотность потока ионизирующих частиц или квантов	$\varphi$	(14) Частица (квант) / секунду на квадратный метр	(15) част./сек.м <sup>2</sup>	1/с.м <sup>2</sup>	(16) (1 частица) / (1 сек.) · (1 м <sup>2</sup> )	(17) м <sup>-2</sup> · сек <sup>-1</sup>
(18) Качественная энергия ионизирующих частиц или квантов	$E$	(19) Джоуль	(20) Дж	J	(21) (1 м) · (1 м)	(22) м <sup>2</sup> · кг · сек <sup>-2</sup>
(23) Поток энергии частиц (квантов)	$F$	(24) Джоуль на квадратный метр	(25) Дж/м <sup>2</sup>	J/м <sup>2</sup>	(26) (1 Дж) : (1 м <sup>2</sup> )	(27) кг · сек <sup>-2</sup>
(28) Интенсивность излучения (плотность потока энергии)	$I$	(29) Ватт на квадратный метр	(30) Вт/м <sup>2</sup>	W/м <sup>2</sup>	(31) (1 Вт) : (1 м <sup>2</sup> )	(32) кг · сек <sup>-3</sup>
(33) Переданная энергия (интегральная поглощенная доза)	$E_D$	(34) Джоуль	(35) Дж	J	(36) (1 м) · (1 м)	(37) м <sup>2</sup> · кг · сек <sup>-2</sup>
(38) Поглощенная доза излучения (доза излучения)	$D$	(39) Джоуль на килограмм; рад	(40) Дж/кг; рад	J/kg; rad	(41) (1 Дж) : (1 кг); (36) рад	(42) м <sup>2</sup> · сек <sup>-2</sup> ; рад
(43) Мощность поглощенной дозы излучения (мощность дозы излучения)	$P$	(44) Ватт на килограмм; рад в секунду	(45) Вт/кг; рад/сек	W/kg; rad/s	(46) (1 Вт) : (1 кг); (1 рад) : (1 сек)	(47) м <sup>2</sup> · сек <sup>-3</sup> ; рад · сек <sup>-1</sup>
(48) Экспозиционная доза рентгеновского в гамма-излучения <sup>a</sup>	$X(D_T)$	(49) Кулон на килограмм воздуха, рентген	(50) Кл/кг; р	C/kg; r	(51) (1 Кл) : (1 кг); (1 р) : (1 сек)	(52) Кл · м <sup>-1</sup> · с; р · сек <sup>-1</sup>
(49) Мощность экспозиционной дозы рентгеновского и гамма-излучения <sup>a</sup>	$P_T$	(53) Ампер на килограмм воздуха, рентген в секунду	(54) А/кг; р/сек	A/kg; r/s	(55) (1 А) : (1 кг); (1 р) : (1 сек)	(56) Кл · м <sup>-1</sup> · с <sup>2</sup> ; р · сек <sup>-1</sup>
(50) Экспозиционная доза нейтронного излучения <sup>a</sup>	$X_n(D_n)$	(57) Неп (кулон на килограмм эквивалентного материала)	(58) Кл/кг; (59) мкп	— (C/kg)	(60) (1 Кл) : (1 кг); (59) мкп	мкп; Кл · м <sup>-1</sup> · с · г
(51) Мощность экспозиционной дозы нейтронного излучения <sup>a</sup>	$P_n$	(61) Неп в секунду (ампер на килограмм эквивалентного материала)	(62) мкп/сек; (63) а/кг	— (C/kg)	(64) (1 мкп) : (1 сек); (1 А) : (1 кг); (61)	мкп · сек <sup>-1</sup> ; Кл · м <sup>-1</sup> · с <sup>2</sup> ; (62)
(65) Экспозиционная доза космического излучения <sup>a</sup>	$X_c(D_c)$	(66) Рад	(67) рад	rad	(68) (рад)	(69) рад
(70) Мощность экспозиционной дозы космического излучения	$P_c$	(71) Рад в секунду	(72) рад/сек	rad/s	(73) (1 рад) : (1 сек)	(74) рад · сек <sup>-1</sup>
(75) Активность источника в радиоактивном источнике	$A$	(76) Распад в секунду; кюри	(77) 1/сек; кюри	1/с	(78) (1 распад) : (1 сек); (3,7 · 10 <sup>10</sup> распадов) : (1 сек)	(79) сек <sup>-1</sup> ; кюри

Note. The extrasystemic units the measurement of rad, rad per second, roentgen per second and curie are allowed/assumed to the use/application in the USSR (GOST 8848-63); unit ned, ned per second, rad and rad per second of cosmic radiation in the recommendations MKRE and GOST 8848-63 are absent.

Key: (1). Designation of value. (2). Designations. (3). One measurement. (4). Abbreviations. (5). by Russian letters. (6). by Latin letters. (7). Dimensions of units. (8). Dimensionality of units. (9). Flow of ionizing particles or quanta. (10). Particle (quantum) <sup>1</sup> to square meter.

FOOTNOTE <sup>1</sup>. They include: the  $\alpha$ -particle,  $\beta$ -particle, neutron, proton, the  $\gamma$ -quanta of X-ray and gamma-radiation. ENDFOOTNOTE.

(11). part./m<sup>2</sup>. (12). (1 particle)/(1 m<sup>2</sup>). (13). Density of flow of ionizing particles or quanta. (14). Particle (quantum) per second to square meter. (15). part./s·m<sup>2</sup>. (16). (1 particle)/(1 s)·(1 m<sup>2</sup>). (17). m<sup>-2</sup>·s<sup>-1</sup>. (18). Kinetic energy of ionizing particles or quanta. (19). Joule. (20). J. (21). (1 n)·(1 m). (22). m<sup>2</sup>·kg·s<sup>-2</sup>. (23). Energy flow of particles (quanta). (24). Joule to square meter. (25). J/m<sup>2</sup>. (26). (1 J):(1 m<sup>2</sup>). (27). kg·s<sup>-2</sup>. (28). Intensity of radiation/emission (energy current density). (29). Watts to square

meter. (30).  $W/m^2$ . (31). (1 W):(1  $m^2$ ). (32). Transmitted energy (integral absorbed dose). (33). Absorbed radiation dosage (radiation dosage). (34). Joule to kilogram; rad. (35). J/kg; rad. (36). (1 J):(1 kg); rad. (37).  $m^2 \cdot s^{-2}$ ; rad. (38). Power of absorbed radiation dosage (radiation dose rate). (39). Watts to kilogram; rad per second. (40). W/kg; rad/s. (41). (1 W):(1 kg); (1 rad):(1 s). (42).  $m^2 \cdot s^{-2}$ ;  $rad \cdot s^{-1}$ . (43). Exposure dose of X-ray and gamma-radiation <sup>2</sup>.

FOOTNOTE <sup>2</sup>. The unit of the exposure dose of X-ray and gamma-radiation coulomb per kilogram, and also extrasystemic unit of roentgens can be applied for the measurements of radiations/emissions with the quantum energy, which does not exceed 0.5 nJ ( $0.5 \cdot 10^{-12}$  J or approximately 3 MeV). ENDFOOTNOTE.

(44). Coulomb to kilogram of air, roentgens. (45). C/kg; r. (46). (1 k):(1 kg); (1 r). (47).  $kg^{-1} \cdot s \cdot A$ ; r. (48). Power of exposure dose of X-ray and gamma-radiation <sup>2</sup>. (49). Amperes per kilogram of air, roentgens per second. (50). A/kg; R/s. (51). (1 A):(1 kg); (1 R):(1 s). (52).  $kg^{-1} \cdot A$ ;  $R \cdot s^{-1}$ . (53). Exposure dose of neutron radiation/emission <sup>2</sup>.

FOOTNOTE <sup>3</sup>. Ned (neutron unit of dose) it is recommended to apply for the measurements of radiations/emissions with the neutron energy from 0.2 to 20 MeV and the thermal neutrons (GOST 8848-63 unit is not



determined). ENDFOOTNOTE.

(54). Weeks (coulomb to kilogram of tissue-equivalent material. (55).  
 ned; (C/kg). (56). (ned); (1 k):(1 kg). (57). ned;  $\text{kg}^{-1} \text{ s} \cdot \text{A}$ . (58).  
 Power of exposure dose of neutron radiation/emission <sup>3</sup>. (59). Weeks  
 per second (ampere per kilogram of tissue-equivalent material). (60).  
 ned/s; (A/kg). (61). (1 <sup>ned</sup> weeks):(1 s); (1 A):(1 kg). (62).  $\text{ned} \cdot \text{s}^{-1}$ ;  
 $\text{kg}^{-1} \cdot \text{A}$ . (63). Exposure dose of cosmic radiation <sup>4</sup>.

FOOTNOTE <sup>4</sup>. Rad of cosmic radiation (rad) - the exposure dose of  
 cosmic radiation (electrons and protons), which is equal to absorbed  
 energy  $1 \cdot 10^{-8}$  J (or 100 ergs) in 1 gram ( $1 \cdot 10^{-3}$  kg) of the crystal of  
 the sodium iodide, activated by thallium. ENDFOOTNOTE.

(64). rad. (65). Power of exposure dose of cosmic radiation. (66).  
 rad per second. (67). rad/s. (68). (1 rad):(1 s). (69).  $\text{rad} \cdot \text{s}^{-1}$ .  
 (70). Activity of isotope in radioactive source. (71).  
 Decomposition/decay per second; curie. (72). 1/s; curie. (73). (1  
 decomposition/decay):(1 s); ( $3.7 \cdot 10^{10}$  decomposition/decay):(1 s).  
 (74).  $\text{s}^{-1}$ ; curie.

1 stat= $3.64 \cdot 10^{-7}$  curie, while to 1 Mache = $3.64 \cdot 10^{-7}$  curie/ $\text{m}^3$ ,  
 therefore, 1 unit of Mache is solution/opening concentration, with  
 which in each cubic meter of liquid or gas is located unit stat of

the emanium:

1 Mache = stat/m<sup>3</sup>.

Table 2.10 gives the relationships/ratios between the units of concentrations.

Output of particles (quanta) and the source power of radiation/emission.

For the quantitative characteristic of the sources of the ionizing radiations/emissions frequently is applied value - output of elementary particles or quanta. Sometimes they call also it the velocity of the emission of the elementary particles (quanta) or source intensity.

Page 063.

This value designates a number of elementary particles or quanta of this form, emitted by source beyond its limits per unit time, and can be determined from the expression

$$n = \frac{N_t}{\Delta t}, \quad (2.23)$$

where n - output of elementary particles or quanta;

$N_t$ — number of particles of this form, emitted by source for the time  $\Delta t$ .

As one output measurement of particles or quanta is accepted a number of particles per unit time, namely: neutron per second (n/s), proton per second (p/s), electron per second (e/s), gamma-quantum per second ( $\gamma$ /s), or neutron per minute (n/min), neutron per hour (n/h), etc. If these values fall per unit of solid angle, then unit of measurement will be a number of particles per unit time to the steradian, for example, gamma-quantum per second to steradian ( $\gamma/s \cdot sr$ ).

The sources of the ionizing radiations/emissions are also characterized sometimes by the specific output of particles (quanta), by which is understood the ratio of a number of this type of the particles (quanta), emitted by source, to the activity of isotope in the radioactive source (for the radioactive sources) or to the current of the charged/loaded particles, emitted to the target (for the accelerators).

Pages 64-65.

Table 2.12. Units of the ionizing radiations/emissions (in the system CGS, extrasystemic or special).

(1) Наименование величины	(2) В системе CGS				(7) Сотношения в единицах СИ	(9) Специальные или исключительные		
	(3) Единица измерения	(4) Сокращенные обозначения		(5) Единица измерения		(6) Специальные обозначения		(8) Сотношения с единицами СИ
		(5) русскими буквами	(6) латинскими буквами			(5) русскими буквами	(6) латинскими буквами	
(10) Поток ионизирующей частиц или квантов	(11) Частица (квант) на квадратный сантиметр	(12) $\frac{шт}{см^2}$	$\frac{1}{см^2}$	(13) $1 шт \cdot см^{-2} \cdot 10^4 шт^{-1}$	(14) шт (только для потока нейтронов)	-	шт	(15) $1 шт \cdot см^{-2} \cdot 10^4 шт^{-1}$
(16) Плотность потока ионизирующей частиц или квантов	(17) Частица (квант) в секунду на квадратный сантиметр	(18) $\frac{шт}{см^2 \cdot с}$	$\frac{1}{см^2 \cdot с}$	(19) $1 шт \cdot см^{-2} \cdot с^{-1} \cdot 10^4 шт^{-1} \cdot см^2 \cdot с$	(20) шт (только для плотности потока нейтронов)	-	шт	(21) $1 шт \cdot см^{-2} \cdot с^{-1} \cdot 10^4 шт^{-1} \cdot см^2 \cdot с$ <b>180</b>
(22) Кинетическая энергия ионизирующей частиц или квантов	(23) Эрг	(24) эрг	эрг	(25) $1 эрг \cdot 10^{-7} Дж$	(26) Ваттметр	(27) вт	вт	(28) $1 вт \cdot 10^{-7} Дж$
(30) Поток энергии частиц или квантов	(31) Эрг на квадратный сантиметр	(32) $\frac{эрг}{см^2}$	$\frac{эрг}{см^2}$	(33) $1 эрг \cdot см^{-2} \cdot 10^4 эрг^{-1} \cdot см^2$	(34) Ваттметр на квадратный сантиметр	(35) $\frac{вт}{см^2}$	$\frac{вт}{см^2}$	(36) $1 вт \cdot см^{-2} \cdot 10^4 эрг^{-1} \cdot см^2$
(38) Интенсивность излучения (плотность потока энергии)	(39) Эрг в секунду на квадратный сантиметр	(40) $\frac{эрг}{см^2 \cdot с}$	$\frac{эрг}{см^2 \cdot с}$	(41) $1 эрг \cdot см^{-2} \cdot с^{-1} \cdot 10^4 эрг^{-1} \cdot см^2 \cdot с$	(42) Ваттметр в секунду на квадратный сантиметр	(43) $\frac{вт}{см^2 \cdot с}$	$\frac{вт}{см^2 \cdot с}$	(44) $1 вт \cdot см^{-2} \cdot с^{-1} \cdot 10^4 эрг^{-1} \cdot см^2 \cdot с$
(46) Передача энергии (поглощенная доза)	(47) Эрг	(48) эрг	эрг	(49) $1 эрг \cdot 10^{-7} Дж$	(50) Грамм-рад	(51) г.рад	г.рад	(52) $1 г.рад = 10^{-2} Дж$
(54) Поглощенная доза излучения (для излучения)	(55) Эрг на грамм	(56) $\frac{эрг}{г}$	$\frac{эрг}{г}$	(57) $1 эрг \cdot г^{-1} \cdot 10^4 эрг^{-1} \cdot г$	(58) Ра	(59) рад	рад	(60) $1 рад = 10^{-2} Дж \cdot г^{-1}$
(62) Интенсивность поглощенной дозы излучения (плотность дозы излучения)	(63) Эрг в секунду на грамм	(64) $\frac{эрг}{г \cdot с}$	$\frac{эрг}{г \cdot с}$	(65) $1 эрг \cdot г^{-1} \cdot с^{-1} \cdot 10^4 эрг^{-1} \cdot г \cdot с$	(66) Ра в секунду	(67) $\frac{рад}{с}$	$\frac{рад}{с}$	(68) $1 рад \cdot с^{-1} \cdot 10^4 эрг^{-1} \cdot г \cdot с$
(70) Эквивалентная доза рентгеновского и гамма-излучения	(71) Единица эквивалента СИ в грамме	(72) $\frac{СИ}{г}$	-	(73) $1 СИ \cdot г^{-1} \cdot 10^4 СИ^{-1} \cdot г$	(74) Рентген	(75) р	r	(76) $1 р = 10^{-2} СИ \cdot г^{-1}$
(78) Интенсивность эквивалентной дозы рентгеновского и гамма-излучения	(79) Единица эквивалента СИ в грамме (единица сама того СИ в грамме)	(80) $\frac{СИ}{г \cdot с}$	-	(81) $1 СИ \cdot г^{-1} \cdot с^{-1} \cdot 10^4 СИ^{-1} \cdot г \cdot с$	(82) Рентген в секунду	(83) $\frac{р}{с}$	$\frac{р}{с}$	(84) $1 р \cdot с^{-1} \cdot 10^4 СИ^{-1} \cdot г \cdot с$
(86) Дозиметрический эквивалент	-	-	-	-	(85) Ра (дозиметрический эквивалент рента)	(86) рр(доз)	рр	(87) Доза в рррр, умноженная на соответствующий фактор

Key: (1). Denomination of value. (2). In system CGS. (3). One measurement unit. (4). Abbreviations. (5). by Russian letters. (6). by Latin letters. (7). Relationships/ratios with SI units. (8). No key. (9). Extrasystemic or special. (10). Flow of ionizing particles or

quanta. (11). Particle (quantum) to square centimeter. (12).  
part./cm<sup>2</sup>. (13). (only for neutron flux). (14). Density of flow of  
ionizing particles or quanta. (15). Particle (quantum) per second to  
square centimeter. (16). part./s·cm<sup>2</sup>. (17).  $1 \text{ cm}^{-2} \cdot \text{s}^{-1} = 1 \cdot 10^4 \text{ m}^{-2} \cdot \text{s}^{-1}$ .  
(18). (only for neutron flux density). (18a).  $1 \text{ nv} = 1 \cdot 10^1 \text{ m}^{-2} \cdot \text{s}^{-1}$ .  
(19). Kinetic energy of ionizing particles or quanta. (20). Ergs.  
(21).  $1 \text{ 3rg} = 1 \cdot 10^{-7} \text{ J}$ . (22). Electron volt. (23). eV. (24).  $1 \text{ eV}$   
 $= 1.6 \cdot 10^{-19} \text{ J}$ . (25). Energy flow of particles or quanta. (26). Ergs to  
square centimeter. (27). erg/cm<sup>2</sup>. (28).  $1 \text{ erg} \cdot \text{cm}^{-2} = 1 \cdot 10^{-3} \text{ J} \cdot \text{m}^{-2}$ .  
(29). Electron volt to square centimeter. (30). eV/cm<sup>2</sup>. (31).  $1$   
 $\text{eV} \cdot \text{cm}^{-2} = 1.6 \cdot 10^{-19} \text{ J} \cdot \text{m}^{-2}$ . (32). Intensity of radiation/emission  
(energy current density). (33). Ergs per second to square centimeter.  
(34). erg/s·cm<sup>2</sup>. (35).  $1 \text{ erg} \cdot \text{cm}^{-2} \cdot \text{s}^{-1} = 1 \cdot 10^{-3} \text{ W} \cdot \text{m}^{-2}$ . (36). Electron  
volt per second to square centimeter. (37). eV/s·cm<sup>2</sup>. (38).  $1$   
 $\text{eV} \cdot \text{cm}^{-2} = 1.6 \cdot 10^{-19} \text{ J} \cdot \text{m}^{-2}$ . (39). No key. (40). Transmitted energy  
(integral absorbed dose). (41). Gram rad. (42). g·rad. (43).  $1$   
 $\text{g} \cdot \text{rad} = 10^{-5} \text{ J}$ . (44). Absorbed radiation dosage (radiation dosage).  
(45). Ergs to gram. (46). erg/g. (47).  $1 \text{ erg} \cdot \text{g}^{-1} = 1 \cdot 10^{-4} \text{ J} \cdot \text{kg}^{-1}$ . (48).  
rad. (49).  $1 \text{ rad} = 1 \cdot 10^{-2} \text{ J} \cdot \text{kg}^{-1}$ . (50). Power of absorbed radiation  
dosage (radiation dose rate). (51). Ergs per second to gram. (52).  
erg/s·g. (53).  $1 \text{ erg} \cdot \text{g}^{-1} \cdot \text{s}^{-1} = 1 \cdot 10^{-4} \text{ W} \cdot \text{kg}^{-1}$ . (54). rad per second.  
(55). rad/s. (56).  $1 \text{ rad} \cdot \text{s}^{-1} = 1 \cdot 10^{-2} \text{ W} \cdot \text{kg}^{-1}$ . (57). Exposure dose of  
X-ray and gamma-radiation. (58). Unit charge cgs esu to gram. (59).  
g. (60).  $\cdot \text{g}^{-1} = 1/3 \cdot 10^{-5} \text{ C} \cdot \text{kg}^{-1}$ . (61). Roentgen. (62). r. (63). 1

$R=2.58 \cdot 10^{-4} \text{ C} \cdot \text{kg}^{-1}$ . (64). Power of exposure dose of X-ray and gamma-radiation. (65). Unit charge cgs esu per second to gram (abstatampere to gram). (66).  $\frac{\text{cgs esu}}{\text{g}} = \frac{\text{cgs esu}}{\text{g}}$ . (67).  $\frac{\text{cgs esu}}{\text{g}} \cdot \text{g}^{-1} \cdot \text{s}^{-1} = 1/3 \cdot 10^{-3} \text{ A} \cdot \text{kg}^{-1}$ . (68). Roentgen per second. (69).  $\rho/\text{s}$ . (70).  $1 \text{ R} \cdot \text{s}^{-1} = 2.58 \cdot 10^{-4} \text{ A} \cdot \text{kg}^{-1}$ . (71). Dose equivalent. (72). Rem (biological equivalent of rad). (73). rem(rem). (74). Dose in rad, multiplied by appropriate factors.

Page 66.

The intensity of the emitted by source energy via elementary particles (quanta), i.e., the energy content, emitted by source per unit time, is called the source power of radiation/emission.

The source power of radiation/emission is equal to the product of the output of the elementary particles (quanta) of sources to their energy and is measured in the energy units per unit of the time: joule per second (J/s, W), mega-electron-volt per second (MeV/s), calorie per second (cal/s), etc. For example, the power of nuclear reactor is measured in the watts, the kilowatts and the megawatts.

2.5. Relationship/ratio between the physical quantities of those ionizing radiations/emissions.

During the determination of physical quantities are applied, in fact, all basic and supplementary units the measurement of the international system of SI, and also derivatives of these units.

In the practice at present it should be used only ones the measurement of the international system of SI, established/installed by appropriate state standards [6, 16, 28].

In this paragraph (Table 2.11-2.12) gives some relationships/ratios between the units of the international system of SI and other measuring systems, most frequently used during the determination of ones the measurement of the ionizing radiations/emissions.

Page 67.

**3. POSSIBLE CONDITIONS OF OPERATION OF ELECTRONIC EQUIPMENT AND ITS COMPLETING ARTICLES IN FIELDS OF THE EFFECT OF IONIZING RADIATION.**

Radiation operating conditions are determined by the forms of radiations/emissions and by the physical parameters of the fields of these forms of the ionizing radiations/emissions (by intensities of radioactivity).

The knowledge of the possible intensities of radioactivity (flows and the densities of flows, doses and the radiation dose rates), which can act on equipment, is made it possible for engineer correct to select the completing articles, materials, circuit solutions and design concept, to establish/install the location of equipment on the object and if necessary to take measures for the protection of equipment or its separate elements/cells.

The possible sources of the ionizing radiations/emissions and the radiation fields, created by these sources in the zone of the work of radio-electronic equipment, are examined in this chapter.



### 3.1. Sources of the ionizing radiations/emissions.

The sources of the ionizing radiations/emissions can be natural and artificial.

They are the natural sources of the ionizing radiations/emissions:

- natural radioactive materials, which are located in the minerals, to water and to the Earth's atmosphere;
- natural (internal and external) Earth radiation belts;
- rays/beams of galactic origin;
- solar rays/beams and radiation/emission during the solar flares.

Page 68.

Furthermore, to the natural sources of the ionizing radiations/emissions should be related the flows of corpuscular and

quantum radiations/emissions, which appear as a result of interaction of the rays/beams of galactic and solar origin with the atoms of the atmosphere.

As the sources of artificial radiation it is accepted to consider:

- nuclear (atomic) and thermonuclear explosions;
- sections of radioactive contamination of locality/terrain, which appear during the ground-based (above-water) and air (surface) nuclear explosions;
- artificial space Earth radiation belts, which are formed during the high-altitude (beyond the limits of the atmosphere) nuclear explosions;
- nuclear reactors, used in different energy and power plants;
- different sources of artificial and natural radioisotopes.

The sources of the artificial radiation, in the radiation field of which can prove to be radio-electronic equipment and its completing articles, are also different kind the accelerators of the

charged/loaded elementary particles and nuclei of chemical elements and pulse nuclear reactors.

Radio-electronic equipment can undergo the action of one or several forms of natural or artificial radiations/emissions. Thus, to the equipment of space objects can act the space ionizing radiations/emissions of all forms. Radio-electronic equipment of rockets and space satellites can undergo the effect of the pulse radiation of nuclear or thermonuclear explosion in space or at the high altitudes in the atmosphere. Equipment of flying units, space vehicles, atomic ships and other types of technology with the nuclear power and power plants is exposed to irradiation by the continuous prolonged radiation of installations. The radiation/emission of the artificial radiation fields, created by high-altitude nuclear explosions, also can act on the equipment of rockets and different kind of space objects.

Page 69.

The ionizing radiations/emissions of natural and artificial Earth radiation belts, solar flares, nuclear and thermonuclear explosions and nuclear energy and power plants [2] present the greatest danger to the radio-electronic equipment.

To the radio-electronic equipment, arranged/located on the surface of the Earth, virtually exert influence the ionizing radiations/emissions with the low density of flow (with dose rate), which consist of the cosmic ray particles and radiation/emission naturally of those distributed of soil and atmosphere of natural radioactive materials (rhodon, the decay products of uranium, actinium, thorium, radium, substances, which contain potassium, etc.). The intensity of radioactivity (natural radiation background) created by them does not exceed 100 mrad per annum (Table 3.1), i.e., it is considerably lower than the radiation dosages (on the order of  $10^4$  rad), during irradiation by which are observed noticeable changes in the electrical parameters of radioelements.

During the determination of the conditions for the work of radio-electronic equipment in outer space, as a rule, do not consider those forms of the radiations/emissions, which do not create essential intensities of radioactivity within the space object or after the available protective coating. To these forms of radiations/emissions is carried solar low-energy corpuscular radiation (the corpuscular fluxes and the solar wind, the containing protons with the energy less than 10 keV and electrons with the energy to 10 eV) and constant solar radiation (protons with the energy to 1 keV and electrons - to 1 eV).

Table 3.1. Power of the exposure doses of natural radiation on the surface of the Earth [1].

(1) Источники излучения	(2) Мощность экспозиционной дозы, мрад/год
(3) Космические лучи (на уровне моря у экватора)	23
(4) Почвы:	
(5) вулканического происхождения	66
(6) глинистый сланец	53
(7) песчаник	28
(8) известняк	11

Key: (1). Radiation sources. (2). Power of exposure dose, mrad/year. (3). Cosmic rays (at the level of sea in equator). (4). Soils. (5). volcanic origin. (6). clay shale. (7). sandstone. (8). limestone.

Page 70.

Also are not considered the emitted by the Sun X-rays, the neutrons, given birth to by cosmic rays, and the diffuse reflected protons, the densities of flows of which are small in comparison with the flows of protons and electrons [2-4].

The sources of the ionizing radiations/emissions examined can be characterized by a number of radioactive decay per unit time (by units of activity) or by an output of the ionizing particles. As the units of measurements, which characterize intensities of radioactivity, during the estimation of the conditions for the work

of radio-electronic equipment and its completing elements/cells it should be applied:

- for the neutron radiation/emission - flow and neutron flux density with the energy are more than 0.1 MeV; in certain cases are considered the slow neutrons;

- for the quantum radiation/emission - exposure dose and the power of the exposure dose of X-ray and gamma-radiation;

- for the cosmic radiation - exposure dose and the power of the exposure dose of the space ionizing radiation/emission.

The determinations of the enumerated forms of physical quantities, one their measurements, established/installed in accordance with the international system of the units of SI, and scaling factors between ones in different measuring systems are given in Chapter 2.

### 3.2. Penetrating radiation of nuclear explosion.

Characteristic of the damaging factors.

Nuclear weapons of explosive action is based on the use of

intranuclear energy, which is freed/released in the presence of the nuclear reaction of explosive character. The basic damaging factors of the airburst of nuclear and thermonuclear weapons, which affect the radio-electronic equipment, are shock wave, luminous radiation and penetrating radiation.

The parameters of the damaging factors of nuclear explosion and their effectiveness depend on the following properties of the environment: temperature, pressure, density and composition. For the airburst the effectiveness of action, first of all, is determined by the density of air medium, i.e., it depends on the height/altitude of point of impact.

Page 71.

Shock wave (50% of entire energy of nuclear explosion) is the main damaging factor during the air (surface) and surface bursts. Its destructive effect is determined by overpressure in the shock wave front, whose effectiveness from the decrease of atmospheric pressure (with an increase in the height/altitude of point of impact) falls also in effect it will be absent under the space conditions.

Radio-electronic equipment can go out of order at the overpressures in the shock wave front from 0.15 to 1 kg/cm<sup>2</sup>

( $1 \cdot 10^3 - 1 \cdot 10^4$  kg/m<sup>2</sup>) [5]. On the average it is accepted to count overpressure 0.35 kg/cm<sup>2</sup> by dangerous for unprotected radio-electronic equipment [6, 7].

The luminous radiation of explosion, which is the flow of the ultraviolet, visible and infrared rays, during interaction with the materials of the elements/cells of equipment can substantially change their physical properties. Such materials, as organic glass, polyethylene, teflon, cellulose, bakelite, insulating coatings of cables, and other materials and articles made of the organic matter under the effect of luminous flux on the order of 60-70 cal/cm<sup>2</sup> will be fused and grow dark, and with the large flows some of them can be ignited [5, 6]. It should be noted that the majority of materials and radioelements of equipment, as a rule, are sheltered from the direct effect of the luminous radiation of explosion by different screens (jackets/cases/housings of the units of equipment, the housing of object, etc.), and damaging effect of luminous radiation significantly is weakened/attenuated. They consider that under the influence of light impulse/momentum/pulse 100 cal/cm<sup>2</sup> the failures of radio-electronic equipment can occur. This impulse/momentum/pulse is observed at the distances of the order of several kilometers during the high-altitude nuclear explosions of large power.

The ionizing radiation/emission of nuclear explosion is the flow



of  $\gamma$ -quanta, neutrons,  $\beta$ -particles and small quantity of  $\alpha$ -particles. Almost all neutrons and part of  $\gamma$ -quanta are emitted in the process of division. The neutrons, which are formed in the process of division, interact partially with the atomic nuclei of different materials, which are the component parts of the construction/design of ammunition. These processes are accompanied by the radiation/emission of  $\gamma$ -quanta.

Page 72.

Furthermore, the part of the neutrons, which flew out from the zone of fission reaction or synthesis, interacts with the nuclei of the substances of the environment, forming  $\gamma$ -radiation.

Gamma-quanta and  $\beta$ -particles are emitted during certain period of time as a result of radioactive decay of fission products. In the process of radioactive decay of the nuclear fuel (uranium, plutonium), which was not subjected to division during the explosion, occurs the radiation/emission of  $\gamma$ -quanta. Usually in view of a small mean free path  $\alpha$ - and  $\beta$ -particles they disregard their action on the equipment, and so-called, penetrating radiation consider that the basic damaging ionizing radiations/emissions of nuclear explosion are the gamma- and neutron radiation/emission.

During the air (surface) and ground-based nuclear explosions the densities of the flows of penetrating radiation at those distances, where the shock wave renders inoperable the unprotected radio-electronic equipment, in essence, are safe. But with an increase in altitude of explosion penetrating radiation acquires increasing importance in the damage/defeat of equipment. During the explosions at the high altitudes and in space the basic damaging factor becomes the impulse/momentum/pulse of penetrating radiation.

(See Chapter 4) it follows from the data on the durability of the elements/cells <sup>and</sup> of radio-electronic devices/equipment under the conditions of the effect of the gamma- and neutron radiation/emission that equipment can give failures with the neutron fluxes  $10^{16}$ - $10^{17}$  n/m<sup>2</sup>, the power of the exposure dose of  $\gamma$ -radiation  $10^7$  rad/s and to the exposure dose of  $10^8$  rad and more. A change in the parameters of elements/cells and equipment can occur, also, at the smaller values of the flows of penetrating radiation. For determining the radii of the lethal areas of radio-electronic equipment as the criterial values of radiation fluxes are accepted the following [6-8]:

$10^{17}$  n/m<sup>2</sup> - from the neutron flux;

$10^8$  rad - on the exposure dose of  $\gamma$ -radiation;

10<sup>7</sup> rad/s - according to the power of the exposure dose of  $\gamma$ -radiation.

Fig. 3.1 shows radii of the zones of action of the damaging factors of nuclear air burst (at the level of sea) in the dependence on the TNT equivalent.

Page 73.

The expected power coefficients of exposure dose, neutron flux, heat flux and exposure dose at different distances from the burst center of megaton nuclear charge are given in Fig. 3.2. Horizontal dotted line indicates, at what values of the parameters of the damaging factors the equipment will malfunction.

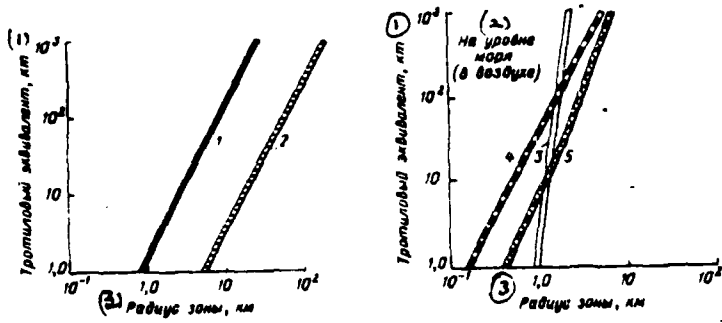

Fig. 3.1. Radii of the lethal areas of radio-electronic equipment depending on the TNT equivalent of nuclear charge for the criterial values:  $\gamma$ -radiation with the power of  $10^7$  r/s (2, 3); the luminous flux in  $100 \text{ cal/cm}^2$  (1, 4) and shock wave with the overpressure in the front  $0.35 \text{ kg/cm}^2$  (5).

Key: (1). The TNT equivalent, kt. (2). At the level of sea (in air). (3). Radius of zone, km.

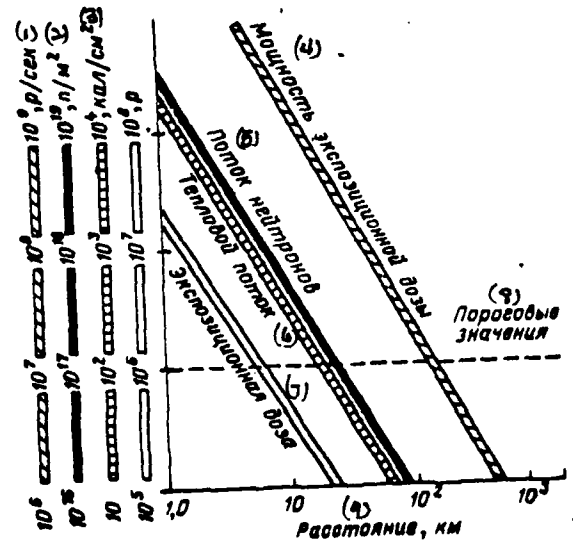

Fig. 3.2.

Fig. 3.2. Change in parameters of damaging factors of nuclear explosion with power of 1 Mt. in dependence from distance to burst center.

Key: (1). r/s. (2). n/m<sup>2</sup>. (3). cal/cm<sup>2</sup>. (4). Power of exposure dose. (5). Neutron flux. (6). Heat flux. (7). Exposure dose. (8). Threshold values. (9). Distance, km.

Page 74.

It is evident from given in the figures data that the greatest danger to the radio-electronic equipment they present the radiated power of  $\gamma$ -quanta and neutron flux. The quanta of  $\gamma$ -radiation are spread with the speed of light, reaching the differently distant points of the surrounding space almost simultaneously. The neutrons, which are isolated simultaneously with  $\gamma$ -quanta, have lower speed; therefore first of all the point of space in question will achieve  $\gamma$ -quantum, and then neutrons. Among the neutrons more rapidly pass the assigned distance the neutrons with the topmost energy and lastly slow neutrons. The qualitative picture of a change in the neutron flux density and  $\gamma$ -quanta in the fixed point of space is represented in Fig. 3.3.

Consequently, in proportion to the propagation of the

penetrating radiation/emission of nuclear explosion in the space the separation of gamma- and neutron radiations/emissions in the time occurs. Therefore, taking into account also different character of interaction of gamma-quanta and neutrons with the materials, during the determination of the radiation durability of radio-electronic equipment one should examine separately effect on the equipment of gamma- and neutron impulses/momenta/pulses.

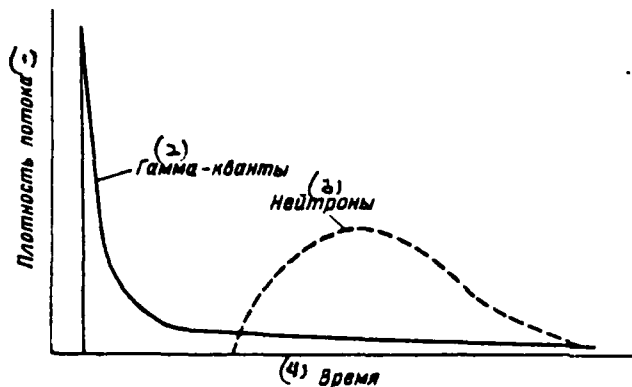

Fig. 3.3. Change in the neutron flux density and  $\gamma$ -quanta (or the rate of the dose of  $\gamma$ -radiation) at certain removal/distance from the center of nuclear explosion.

Key: (1). Density of flow. (2). Gamma-quanta. (3). Neutrons. (4). Time.

Page 75.

Characteristic of the impulse/momentum/pulse of  $\gamma$ -radiation.

During the nuclear explosion are formed three forms of the  $\gamma$ -radiation: instantaneous, trapping and fragmentation.

Directly during the nuclear explosion during the tenths of microsecond the emission of instantaneous  $\gamma$ -quanta occurs. To one

fission is emitted about 7 $\gamma$ -quanta with the general/common/total energy of approximately/exemplarily 7.8 MeV. Medium energy  $\gamma$ -quantum is equal to approximately 1.1 MeV [9, 10]. The spectrum of  $\gamma$ -radiation at the moment of division is represented in Table 3.2.

Instantaneous  $\gamma$ -radiation is the main source of the high rate of the dose of  $\gamma$ -radiation, but its role in the formation/education of dose is small.

Trapping  $\gamma$ -radiation appears due to capture reactions of fission neutrons. It includes the  $\gamma$ -radiation, which is formed during the inelastic scattering and neutron capture by the nuclei of the environment, and the  $\gamma$ -radiation of the radioactive nuclei, which appear in the presence of the reaction with the neutrons. Capture reaction of neutrons by nitrogen of air is one of the basic sources of the  $\gamma$ -radiation of airburst.



Table 3.2. Spectrum of instantaneous  $\gamma$ -radiation.

(1) Диапазон энергии, Мев	(2) Число $\gamma$ -квантов на один акт деле- ния в данном интервале энергии	(1) Диапазон энергии, Мев	(2) Число $\gamma$ -квантов на один акт де- ления в данном интервале энергии
0,25—0,75	3,1	3,75—4,25	0,065
0,75—1,25	1,9	4,25—4,75	0,024
1,25—1,75	0,84	4,75—5,25	0,019
1,75—2,25	0,55	5,25—5,75	0,017
2,25—2,75	0,29	5,75—6,25	0,007
2,75—3,25	0,15	6,25—6,75	0,004
3,25—3,75	0,062	—	—

Key: (1). Range of energy, MeV. (2). Number of  $\gamma$ -quanta to one fission in this energy range.

Page 76.

To one absorbed in to air neutron it is 0.64 MeV of energy of  $\gamma$ -radiation. The medium energy of trapping  $\gamma$ -radiation is equal to 6 MeV. The hard/rigid part of the energy spectrum of the  $\gamma$ -radiation of capture reaction of neutrons by nitrogen of air is given in Table 3-3 [9].

The time of action of trapping  $\gamma$ -radiation is determined by the lifetime of neutrons, which in air comprises fractions of a second. Intensity and density of the flow of trapping  $\gamma$ -radiation, in essence, depends on it is density air (quantity of nitrogen),

quantity of neutrons, which are freed/released during the explosion, and the composition of structural materials.

During several seconds (10-15 s), beginning from the moment/torque of explosion, in the volume about the burst center the fission products, which give fragmentation  $\gamma$ -radiation, are formed. Radioactive fission fragments have half-life periods of up to several years. The medium energy of the quanta of fragmentation  $\gamma$ -radiation in the first seconds after explosion is equal to approximately/exemplarily 2 MeV. The radiant density of fission fragments decreases sufficiently rapidly in the first seconds after explosion due to the decomposition/decay of the short-lived (low-lived) isotopes, subsequently density change occurs more slowly. The dose rate, created by fragmentation  $\gamma$ -radiation, are considerably lower than the dose rate, created by trapping and, all the more, by the instantaneous  $\gamma$ -radiation of nuclear explosion [9-11].

The general/common/total flow of  $\gamma$ -quanta in outer space depends on energy (power) and design features of nuclear charge and can be calculated according to the formula

$$\Phi_{\gamma} = \frac{N}{4\pi R^2}, \quad (3.1)$$

where N - total number of  $\gamma$ -quanta, which left beyond the limits of the shell of nuclear charge in the process of explosion.

Table 3.3. Radiation spectrum  $N^{14} (n, \gamma) N^{15}$  (hard/rigid part of the spectrum).

(1) Энергия кванта, Мев	4,48	5,29	5,55	6,32	7,16	7,36	8,08	9,16	10,82
(2) Относительная плотность пото- ка $\gamma$ -квантов, %	18,3	30,5	2,44	12,2	0,6	4,9	2,4	0,6	6,1

Notes.

1. 45% of energy of hard/rigid part of spectrum are connected with quanta, which have energy 5.3-6.3 MeV.

2. 15% of energy are connected with quanta, which have energy of more than 7 MeV.

Key: (1). Quantum energy, MeV. (2). Relative density of flow of  $\gamma$ -quanta, %.

Page 77.

Using formula (3.1), let us calculate the possible power of the exposure dose of instantaneous  $\gamma$ -radiation at a distance of 10 km during the explosion of charge 9 kt. During the nuclear explosion by energy 1 kt occurs the division  $1.45 \times 10^{23}$  of nuclei [5]. To one nuclear fission approximately 1.1 MeV (general/common/total energy of

$\gamma$ -quanta is equal to 7.8 MeV) are emitted on the average of 7 quanta of instantaneous  $\gamma$ -radiation with the energy. Consequently, in all during the explosion 1 kt of ammunition it will be isolated approximately/exemplarily  $1 \cdot 10^{24}$  quanta and general/common/total energy of instantaneous  $\gamma$ -radiation will be equal to approximately  $1.1 \cdot 10^{24}$  MeV.

Assuming that only 1% of instantaneous  $\gamma$ -quanta exceeds the limits of the shell of nuclear weapon, then for explosion of 1 kt the energy flow of radiation/emission at a distance from the burst center R will compose

$$F = \frac{1.1 \cdot 10^{24}}{4\pi R^2}, \text{ MeV/cm}^2.$$

The dependence of exposure dose on the energy flow of  $\gamma$ -quanta is determined by the expression

$$D_1 = 1.46 \cdot 10^{-6} \mu_a F, \text{ p}, \quad (3.2)$$

where  $\mu_a = 8 \cdot 10^{-5} \text{ cm}^{-1}$  - linear coefficient of absorption of  $\gamma$ -quanta in air.

After substituting into formula (3.2) value of F, we will obtain

$$D_1 = \frac{1 \cdot 10^8}{R^2}, \quad (3.3)$$

where  $D_1$  - in the roentgens, and R - in the meters.

The power of exposure dose for the duration of pulse  $10^{-7}$  s and 1 kt of charge will be respectively equal to

$$P_1 = \frac{1 \cdot 10^{18}}{R^3},$$

but for charge q kt

$$P_1 = \frac{1 \cdot 10^{18}}{R^3} \cdot q, \text{ r/s.} \quad (3.4)$$

Page 78.

It is easy to be convinced, after producing the appropriate calculations that the power of the exposure doses of trapping and fragmentation  $\gamma$ -radiations will be considerably less.

During the explosion of atomic ammunition in air the power of exposure dose and exposure dose will be less because of the presence of the effects of absorption and scattering. General formula for calculating the exposure dose of  $\gamma$ -radiation takes the form

$$D_1 = \frac{K}{R^3} e^{-\frac{R}{\lambda_{\text{eff}}}}, \quad (3.5)$$

where K - factor, which considers energy (power) of explosion and shock-wave effect;

$\lambda_{\text{eff}}$  - effective absorption path of energy of  $\gamma$ -radiation, i.e., the distance, at which the dose of  $\gamma$ -radiation is weakened/attenuated  $e=2.718$  times.

The effective absorption path of energy of  $\gamma$ -radiation with the decrease of air density increases, namely:

$$\lambda_H = \lambda_0 \frac{\rho_0}{\rho_H},$$

where  $\lambda_0$  and  $\lambda_H$  - effective absorption paths of radiant energy in air with a density of  $\rho_0$  and  $\rho_H$  (at height/altitude  $H$ ) respectively.

For fragmentation  $\gamma$ -radiation  $\lambda_{\text{эфп}} = 300$  m, and value  $K = 1.4 \cdot 10^7 q(1 + 0.2^{0.45K})$ , where  $1 + 0.2^{0.45K}$  - coefficient, which considers the factor of cavity <sup>1</sup>. Consequently, the exposure dose of fragmentation  $\gamma$ -radiation can be calculated according to formula [9]

$$D_{\text{оцк}} = 1.4 \cdot 10^7 q (1 + 0.2^{0.45K}) \frac{e^{-\frac{R\rho}{300}}}{R^2}, \quad (3.6)$$

where  $q$  - in the kilotons,  $R$  - in the meters,  $\rho$  - air density in the kilograms to the cubic meter.

FOOTNOTE <sup>1</sup>. The factor, which shows, in how often the dose rate in the presence of shock wave of more than dose rate at the same moment of time, but in the absence of shock wave, it is called the factor of the cavity of dose rate. ENDFOOTNOTE.

For trapping  $\gamma$ -radiation  $\lambda_{\text{eff}}=410$  m, and value  $K=5 \cdot 10^4$ , since this radiation/emission has the harder/more rigid spectrum and acts during 0.2-0.3 s, when shock wave cannot virtually affect the propagation of  $\gamma$ -quanta. Consequently, for the trapping  $\gamma$ -radiation the calculation of exposure dose can be obtained from the formula

$$D_s = \frac{5 \cdot 10^4 q}{R^2} e^{-\frac{R\rho}{410}} \quad (3.7)$$

Instantaneous  $\gamma$ -radiation has softer energy spectrum in comparison with the trapping and fragmentation radiations/emissions, and therefore the value of value  $\lambda_{\text{eff}}$  will be less than 300. A number of  $\gamma$ -quanta of instantaneous radiation/emission during the explosion of nuclear weapon is considerably lower than the total number of trapping and fragmentation radiation/emission. Thus, for instance, during the first minute after air or surface burst a quantity of delaying and trapping  $\gamma$ -quanta proves to be 100 times more than a quantity of instantaneous  $\gamma$ -quanta, which form part of the nuclear radiation, observed at the same distance from the burst center [5]. However, the density of the flow of instantaneous  $\gamma$ -quanta, in connection with the short time of their radiation/emission ( $10^{-7}$  s), will be, apparently, several orders higher.

Thus, during the explosion of charge the rate of the dose of  $\gamma$ -radiation will be determined by instantaneous ones, and total dose - by trapping and fragmentation  $\gamma$ -quanta.

Neutrons are the second component of penetrating radiation of nuclear explosion. The characteristic of the impulse/momentum/pulse of the neutron flux of nuclear explosion is given below.

Characteristic of the impulse/momentum/pulse of neutron flux.

The neutrons, which are formed during the nuclear explosion, are subdivided into the instantaneous ones and delaying.

Furthermore, certain part of the neutrons is freed/released as a result of the effect of  $\gamma$ -quanta, which possess high energy, on the nuclei of the substances, which form part of nuclear weapon. These neutrons compose the negligible part of their total number and therefore their contribution and general/common/total neutron flux can be disregarded/neglected.

Page 80.

Prompt neutrons are formed directly during the nuclear explosion as a result of the course of the nuclear chain reactions of division and synthesis. In their portion fall more than 99% entire number of forming during the explosion neutrons. The time, necessary for the course of fission reaction, comprises the tenths of microsecond [10].



Prompt fission neutrons have energy in the range from the thermal (0.025 eV) to 14 MeV, average/mean value of energy equally approximately/exemplarily to 2 MeV. The differential energy spectrum of prompt neutrons during the division of uranium-235 by slow neutrons in general form is determined by following expression [10]:

$$N(E)dE = \sqrt{\frac{2}{\pi e}} [\text{sh}(2E)]^{1/2} e^{-E} dE, \quad (3.8)$$

where  $N(E)dE$  - number of neutrons with the energy  $E$  in the energy range from  $E$  to  $E+dE$ ;

$E$  - neutron energy, MeV.

In energy range from 4 to 12 MeV differential neutron spectrum can be calculated of the following simpler correlation:

$$N(E)dE \approx 1,4e^{-0,72E} dE.$$

Graphically the fission spectrum of uranium-235 and plutonium-239 is represented in Fig. 3.4 [12]. Basic part of the spectrum compose fission neutrons with the energy several mega-electron-volts. The portion of neutrons with the energy 10 MeV and is more insignificant (in the figure not shown).

Besides the prompt neutrons are formed the delayed neutrons, which are emitted as a result of the process of decomposing/decaying fission fragments with the half-life period from 0.4 to 55.6 s. The medium energy of delayed neutrons is equal to

approximately/exemplarily 0.4-0.6 MeV. The portion of delayed neutrons in the general/common/total neutron flux of nuclear explosion during the division of uranium-235 composes 0.73%, and plutonium-239 composes 0.36% [10, 11].

As already mentioned above, the velocity of propagation of neutrons depends on their kinetic energy; therefore an increase in the duration of neutron pulse occurs with the removal/distance from the burst center.

Page 81.

In the simplest case, when the absorbing medium is absent, the shape of neutron pulse depends from the distance to the burst center and initial impulse/momentum/pulse of neutron radiation/emission and can be described by following expression [13]:

$$\varphi = \frac{2,22 \cdot 10^8 E^{2/3}}{R^2} N(E), \quad (3.9)$$

where  $\varphi$  - neutron flux density at the moment of time  $t$ ,  $n/s \cdot m^2$ ;

$N(E)$  - the spectral density of emitted neutrons during the explosion;

$E$  - neutron energy, eV.

The time, in which the neutrons will achieve the point of space

indicated, and their kinetic energy at this point can be determined from the relationship/ratio

$$t = R [1,38 \cdot 10^6 E^{1/2}]^{-1} \text{ s}, \quad (3.10)$$

where R - in the meters, E - in the electron volts.

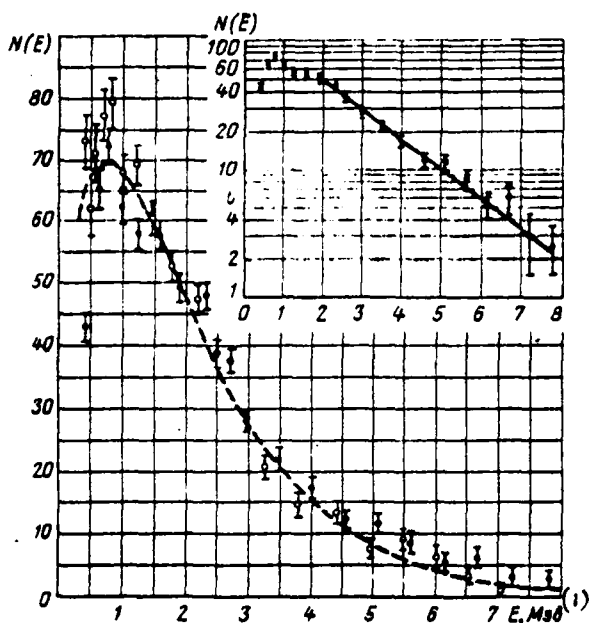

Fig. 3.4. Energy fission spectrum uranium-235 (O) and plutonium-239 (●). To the right on the inset the spectrum of plutonium on the semilogarithmic scale.

Key: (1). MeV.

Page 82.

Simultaneously with a change in the shape of neutron pulse occurs its delay relative to the impulse/momentum/pulse of the  $\gamma$ -radiation (see Fig. 3.3), which for the case of the absence of the absorbing medium can be determined according to the formula

$$\Delta t = R \left( \frac{1}{1,38 \cdot 10^8 \sqrt{E_{\text{max}}}} - \frac{1}{c} \right), \quad (3.11)$$

where  $E_{\text{max}}$  - maximum energy of the emitted neutrons;

$c$  - speed of light.

In the presence of the environment the duration of neutron pulse and time lag will grow/rise.

In spite of the elongation of neutron impulse/momentum/pulse, during the practical calculations of the effectiveness of the action of neutron flux on the radio-electronic equipment one should examine neutrons as common group with the specific energy distribution, independent of distance of the burst center.

The flow construction of neutrons depending on the explosive energy, distance and atmospheric density can be produced from the following relationship/ratio:

$$\Phi_n = \frac{K}{R^2} e^{-\frac{R}{\lambda_n}}, \quad (3.12)$$

where  $K$  - coefficient depending on the explosive force and effect of wave;

$\lambda_n$  - effective attenuation length of neutron flux, i.e., the distance, at which  $\Phi_n$  is weakened/attenuated in  $e=2.718$  times; for air with the density, which composes 0.9 its density at the level of sea,  $\lambda_n=190$  m [5].

Assuming that the neutron flux is directly proportional to explosive energy and does not depend on shock-wave effect (distance from the burst center), then it is possible to calculate it (for the atmosphere  $\rho/\rho_0=0.9$ ) from the formula

$$\Phi_n \approx \frac{7.5 \cdot 10^{22} q}{R^2} e^{-\frac{R}{190}}, \text{ neutron/m}^2,$$

where  $q$  -trotyl equivalent of charge, kt.

Page 83.

At other heights/altitudes

$$\Phi \approx \frac{7.5 \cdot 10^{22} q}{R^2} e^{-\frac{R\rho}{170}} \text{ neutron/m}^2.$$

Neutron fluxes at different distances from the burst center of ammunition 1 Mt. in space are shown in Fig. 3.2.

Thus, the levels of penetrating radiation of nuclear explosion, which can act on radio-electronic technology, will depend from the explosive energy, height/altitude of explosion (ambient density), distance to the point of impact and vulnerability of equipment.

According to the recommendations, expressed in work [6], on the basis of a comparative evaluation of the effect of the damaging factors of nuclear explosions at the level of sea and in space, radio-electronic equipment can undergo the effect of the following levels of the impulse/momentum/pulse of penetrating radiation: the exposure dose of  $\gamma$ -radiation  $10^{-1}$ - $10^6$  r for the duration of pulse  $10^{-3}$ - $10^{-8}$  s, the power of the exposure dose of  $\gamma$ -radiation  $10^2$ - $10^{13}$  r/s; neutron flux  $10^{15}$ - $10^{20}$  n/m<sup>2</sup> for the duration of pulse  $10^{-1}$ - $10^{-6}$  s, the neutron flux density  $10^{12}$ - $10^{22}$  n/s·m<sup>2</sup>.

3.3. Radiation conditions, created by nuclear installations, in the places of the arrangement/position of radio-electronic equipment on the technical objects.

Development of contemporary technology is closely related to the use/application of a nuclear fuel. Nuclear installations in essence are utilized as the power and energy engines. Thus, use of rocket nuclear engines on the space objects gives the possibility to obtain operating characteristics by an order of better than the characteristics of widely used at present chemical engines [14]. Atomic power plants on the vessels of different designation/purpose have indisputable advantage with respect to the savings of the space,

occupied by fuel/propellant.

Page 84.

Use/application of nuclear reactors as the power systems on the space objects instead of the chemical and solar cells and the systems gives gain in the weight at the power of these installations 20 and more kilowatts. But at the power of power systems from 100 to several thousand kilowatts, when questions of overall sizes and weight have vital importance, electric power is most economically can be obtained only with the aid of the nuclear sources (Fig. 3.5) [15]. Thus, radio-electronic equipment can undergo the effect of the ionizing radiations/emissions from the nuclear power and power plants. From a number of these installations greatest use find nuclear reactors. The use of radioisotope energy sources is limited, since with the aid of them can be obtained power to 1 kW.



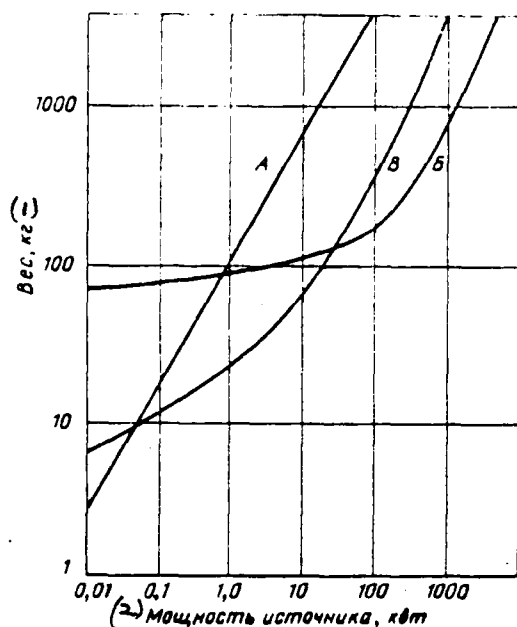

Fig. 3.5. Curves of the dependence of the weight of power systems of space objects on their power: A - solar cells, Б - the nuclear unprotected system with the closed cycle, В - solar system with the closed cycle.

Key: (1). Weight, kg. (2). Source power, kW.

Page 85.

Nuclear reactors, used as the power and power plants, are subdivided into three forms: reactors on the fast, thermal and intermediate neutrons. These groups of reactors differ from each other in terms of the relationship/ratio of the containing in them

heavy nuclei of fuel/propellant and light nuclei of retarder.

In the fast-neutron reactors there is no retarder; therefore radiation spectrum is characterized by the presence of a large number of fast neutrons. In the thermal-neutron reactors there is a retarder, in which fast neutrons decelerate to the thermal ones. The relationship/ratio between a quantity of fast and slow neutrons depends on the type of retarder. Intermediate-neutron reactors occupy the mid-position between the reactors on the fast and thermal neutrons.

The composition of the radiation/emission of nuclear reactors is very complex: the instantaneous and delayed fission neutrons, the  $\gamma$ -radiation, emitted during the division, the  $\gamma$ -radiation of the radioactive fission products and materials of the elements of construction/design,  $\beta$ -radiation and X-rays. In the examination of the flows of the ionizing radiations/emissions, which can act on radio-electronic equipment, they usually disregard the action of  $\beta$ -radiation and X-rays, in connection with the smallest depth of their penetration into the material.

Prompt fission neutrons have kinetic energy from the thermal (0.025 eV) to several mega-electron-volts. The energy fission spectra for the majority of the fissionable isotopes are close to each other

(Fig. 3.4).

Delayed neutrons are emitted by some radioactive fission products and have medium energy on the order of 0.5 MeV.

Instantaneous  $\gamma$ -rays have an energy from 0.5 to 6.5 MeV (see Table 3.2),  $\gamma$ -rays of fission products - from 0.1 to several mega-electron-volts.

In the trapping  $\gamma$ -radiation, which consists, in essence, from  $\gamma$ -quanta, which are formed as a result of absorbing the thermal neutrons, the radiation spectrum depends on the material, on which the neutrons act, and it has maximum energy to 10 MeV. As a whole entire flow of  $\gamma$ -quanta has medium energy of approximately 1 MeV [16].

Page 86.

The neutron flux densities and  $\gamma$ -quanta (in the reactor core) directly depend on heat output of reactor and its overall dimensions. It is known according to the data of work [17] that on 1 W of the heat output of reactor it falls on the average  $3.1 \cdot 10^{10}$  of divisions per second. A number of the prompt neutrons, emitted to one fission of heavy nuclei, on the average is equal to 2.5. Then 1 s it is

emitted  $7.8 \cdot 10^{10}$  neutrons. From this number of neutrons because of the large self-absorption of radiation/emission within the reactor about 1-2% of neutrons only reach its surface. Consequently, with the release 1 W of energy it emerges about  $7.8 \cdot 10^8$  neutrons/s. Thus, the neutron flux density will be equal to the heat output of reactor in the watts, multiplied by  $7.8 \cdot 10^8$  and that divided into the area, through which they pass. Reactors according to their heat output usually are subdivided into the powerful/thick ones and the low-power ones.

Some data on penetrating radiation from powerful/thick and low-power nuclear reactors are given in Table 3.4 [14, 18].

Depending on the location of radio-electronic equipment on the object with the nuclear installation it is possible to subdivide it into three categories.

1. Equipment, which is located in reactor core (sensors, thermocouple, etc.).

2. Equipment, located in reactor compartment (separate units of television and other equipment).

Table 3.4. Characteristics of reactors.

(1) Вид реактора	(2) Тепловая мощность, Мвт	(3) Излучение в активной зоне	
		(4) плотность потока нейтронов, п/сек·м <sup>2</sup>	(5) мощность экспозиционной дозы $\gamma$ -излучения, р/сек
(6) Мощные реакторы	10—5000	$10^{18}$ — $10^{19}$	$10^4$ — $10^6$
(7) Маломощные реакторы	$10^{-4}$ —10	$10^{18}$ — $10^{19}$	$10^1$ — $10^4$

Key: (1). Type of reactor. (2). Heat output, MW. (3). Radiation/emission in active region/core. (4). neutron flux density, n/s·m<sup>2</sup>. (5). power of exposure dose of  $\gamma$ -radiation, r/s. (6). Powerful/thick reactors. (7). Low-power reactors.

Page 87.

3. Equipment, placed in uninhabited and crew compartments of ships, atomic aircraft, artificial Earth satellites, etc.

The neutron flux densities and power of the exposure doses, which can act on the equipment, located in the reactor, inhabited and uninhabited sections of the objects of different designation/purpose, depend on the vulnerability and distance from the active region/core to the place of the arrangement/position of radio-electronic equipment. The exemplary/approximate boundaries of the identical levels of gamma- and neutron radiations/emissions in different locations of radio-electronic equipment are given in Fig. 3.6-3.8 [14, 18].

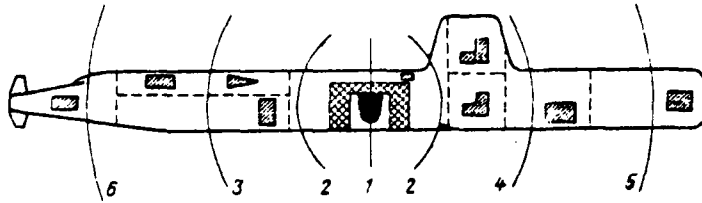

Fig. 3.6. the exemplary/approximate boundaries of the identical levels of gamma- and neutron radiations/emissions on the nuclear powered submarine of the type "Nautilus": 1 - density of flow  $\phi=10^{16}-10^{18}$  n/s·m<sup>2</sup>,  $\rho_T=10^4+10^6$  r/s; 2, 3, 4, 5, 6 - line of identical intensities of radioactivity at different distances from the reactor.

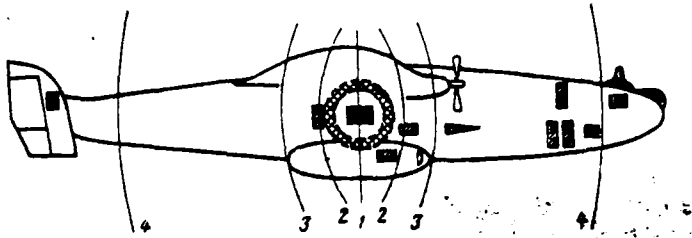

Fig. 3.7. Exemplary/approximate boundaries of identical levels of gamma- and neutron radiations/emissions on atomic aircraft: 1 - density of flow  $\phi=10^{16}-10^{18}$  n/s·m<sup>2</sup>,  $\rho_T=10^4+10^6$  r/s, 2, 3, 4 - line of identical intensities of radioactivity at different distances from reactor.

Page 88.

In these figures continuous filling designated reactor core, by dual shading - locations of the protection of screens, by single shading - places of the possible arrangement/position of

radio-electronic equipment on the nuclear powered submarine, the atomic aircraft and the artificial satellite with the nuclear power plant aboard, the curved lines and the numerals are indicated equal radiation levels at different distances from nuclear reactor.

On the basis of data of work [19] Fig. 3.9 gives the neutron flux densities and power of exposure doses at different distances from the unshielded nuclear oscillator with a power of 30 kW, established/installed on the space object.

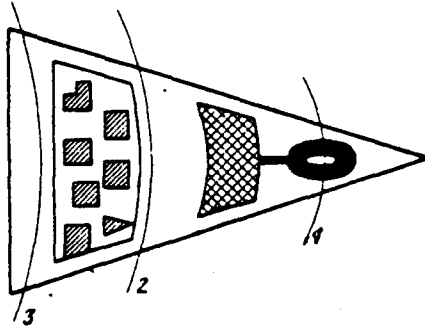

Fig. 3.8. The exemplary/approximate boundaries of the identical levels of gamma- and neutron radiations/emissions on the artificial satellite with the nuclear power plant aboard: 1 - density of flow  $\phi = 10^{10} - 10^{14}$  n/s·m<sup>2</sup>,  $P_T = 10 + 10^6$  r/s; 2, 3 - line of identical intensities of radioactivity at different distances from the reactor.

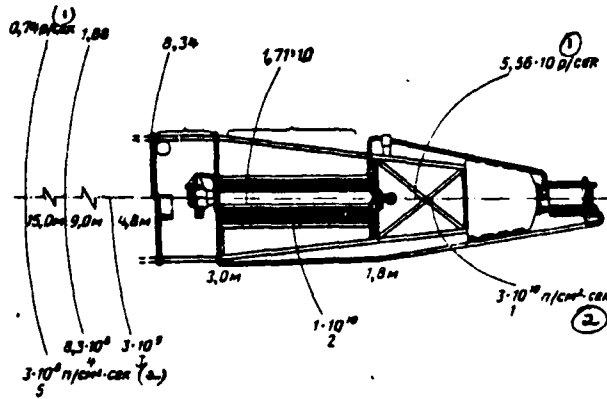

Fig. 3.9. Neutron flux densities and power of exposure doses of  $\gamma$ -radiations, created by nuclear reactor with power of 30 kW.

Key: (1). r/s. (2). n/cm<sup>2</sup>·s.



Page 89.

Total neutron flux and exposure dose of the  $\gamma$ -radiations, obtained by equipment for the operating time of reactor, are determined by the duration of the work of nuclear reactor and by its power (i.e. with the neutron flux density and  $\gamma$ -quanta). In the period of the disconnection of reactor to the equipment can act the secondary  $\gamma$ -radiation of the activated constructions/designs of reactor, reflector and especially - the delaying  $\gamma$ -radiation of fission products, and also secondary radiation of screens and other elements of the construction/design of the object, on which is arranged/located nuclear installation. The background noise level of nuclear reactor and elements of the construction/design of object depends on the duration of operation and composition of the materials, from which the reactor and unit are prepared, and it can reach the significant magnitude. The definition of the power of the exposure doses of  $\gamma$ -radiation, obtained by equipment from secondary radiation, is conducted just as from the radioisotope sources.

Among the radioisotope sources of the ionizing radiations/emissions the greatest danger to the radio-electronic equipment present the sources of  $\gamma$ -quanta (for example, the sources, which contain plutonium-239, uranium-235, uranium-233, cobalt-60, etc.).

The power of exposure dose from these sources is found depending on activity and spectrum of the  $\gamma$ -radiation of source, distance from the source and from the ambient density.

During the determination of the exposure dose of  $\gamma$ -radiation or its power, created at the specific distance from the radiation source of this form and weight, accept the usually following assumptions, which simplify the calculations:

- self-absorption of  $\gamma$ -radiation in the very isotope (substance) of source is absent;
- source of  $\gamma$ -radiation is point.

The first assumption leads to somewhat high values of exposure doses of  $\gamma$ -radiation. The second assumption can be substantiated, if the sizes/dimensions of source are small in comparison with the distance from the source to the irradiated object.

Page 90.

The power of the exposure dose of  $\gamma$ -radiation from point source

is calculated from the formula

$$P_{\gamma} = \frac{\Gamma A}{R^2} \quad (3.14)$$

In formula (3.14) A - activity of the radioactive isotope of point source, determined from expression (2.19), R - distance from point source,  $\Gamma$  - specific gamma-constant the gamma-emitting radioactive isotopes or in abbreviated form - the specific gamma-constant of radiation/emission.

The specific gamma-constant of radiation/emission - this is the power of exposure dose, created by the  $\gamma$ -radiation of point source with the unit of activity at a distance from it in the unit of the length (it is assumed that by weakening in the source and along the propagation of  $\gamma$ -quanta it is possible to disregard).

From expression (3.14)

$$\Gamma = \frac{R^2 \cdot P_{\gamma}}{A}$$

Value  $\Gamma$  can be used for the characteristic of the output of  $\gamma$ -radiation from the real sources under the conditions for their practical use/application. If value  $\Gamma$  is utilized for the characteristic of the  $\gamma$ -radiation of separate isotopes, then it will coincide with the value by complete gamma-constant, represented by itself the sum of the differential gamma-constants of this radioactive isotope. The values of values differential gamma-constant ( $K_{\gamma}$ ), designed for the specific monochromatic lines of the energy

spectrum of isotope, can be obtained from the dependence, shown in Fig. 3.10 [18].

During the calculation of the intensities of radioactivity, created by radioactive sources in different media and after different barriers/obstacles, it is necessary to consider the effects of absorption and scattering of  $\gamma$ -quanta in the substance.

Page 91.

General formula for the calculation of power of exposure dose from point source takes the form

$$P_{\gamma} = \Gamma A \frac{e^{-\mu R}}{R^2} B, \quad (3.15)$$

where  $\mu$  - linear coefficient of absorption of  $\gamma$ -radiation in the substance;

B - buildup factor of the scattered  $\gamma$ -rays.

Numerical values  $\mu$  and B for different values of energy of  $\gamma$ -quanta are given in the application/appendix.

#### 3.4. Cosmic radiation.

The evaluation of the radiological situation in the near-earth

outer space is very complex problem. This is explained by the fact that the portion of radiation, introduced by the components of space radiation sources, is different in different regions of outer space. At the same time, during the estimation of the conditions for the work of radio-electronic equipment of space objects it is necessary to consider the dynamics of motion and the concrete/specific/actual mode of orbit or trajectory, along which moves the spacecraft.

Therefore initial data for evaluating the levels of the space ionizing radiations/emissions, which affect the equipment of the space object, which moves along the specific trajectory, are the spatial distribution of these characteristics and the equation of motion of space object.

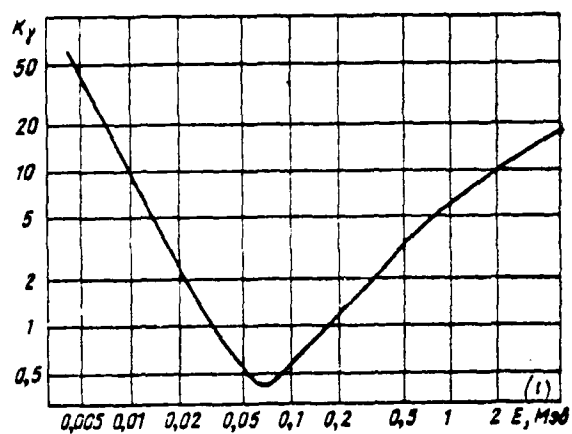

Fig. 3.10. Values of the quantity of gamma-constant depending on kinetic energy of  $\gamma$ -quanta.  $K_\gamma$  is given in units  $\text{R}/\text{cm}^2 \cdot \text{h}/\text{mcurie}$ .

Key: (1). MeV.

Page 92.

The following present the greatest danger to the onboard radioelectronic equipment:

- primary (galactic) space radiation;
- solar cosmic radiation, appearing during the intense chromospheric solar bursts;
- proton and electronic radiations/emissions of internally Earth radiation belt;
- electronic radiation/emission of the external radiation belt/zone of the Earth;
- electronic radiation/emission of artificial Earth radiation belts.

The possible forms of the ionizing radiations/emissions and their physical parameters in different regions of outer space are

examined below.

Primary space and solar radiations.

The ionizing galactic rays/beams, which enter and galactic spaces, are in the main flows of protons and  $\alpha$ -particles. The content of the nuclei of other chemical elements does not exceed 2%.

Composition of primary cosmic radiation yes in Table 3.5 [14].



Table 3.5. Content of the nuclei of chemical elements in the primary cosmic radiation and their relative abundance on the universe.

(1) Группы элементарных частиц и ядер химических элементов	(2) Заряд ядра (в единицах элементарного электрического заряда)	(3) Средний атомный номер	(4) Количество ядер, %	(5) Распростра- ненность по Все- ленной, %
Протоны <sup>(6)</sup>	1	1	100*	100*
$\alpha$ -частицы <sup>(7)</sup>	2	4	15,5	7,7
Легкие ядра <sup>(8)</sup>	3—5	10	0,24	10-*
Средние ядра <sup>(9)</sup>	6—9	14	1,20	0,20
Тяжелые ядра <sup>(10)</sup>	$\geq 10$	31	0,4	0,03
Очень <sup>(11)</sup> тяжелые ядра	$\geq 20$	51	0,1	0,003

Key: (1). Groups of elementary particles and nuclei of chemical elements. (2). Nuclear charge (in units of elementary electric charge). (3). Average atomic number. (4). Quantity of nuclei, %. (5). Abundance on universe, %. (6). Protons. (7).  $\alpha$ -particle. (8). Light nuclei. (9). Medium nuclei. (10). Heavy nuclei. (11). Very heavy nuclei.

FOOTNOTE <sup>1</sup>. 100%, since protons are contained in all nuclei of the elements of cosmic radiation and nuclei of natural elements.

ENDFOOTNOTE.

It follows from given data that the relative content of the nuclei of different chemical elements approximately/exemplarily corresponds to their abundance in the universe.

The particles of galactic rays/beams possess medium energy in ones and tens of gigaelectron-volts, but they can have an energy, also, to  $10^{18}$  eV, and for heavy nuclei and  $10^{17}$  eV. The particles with the energy of less than 100 MeV virtually are absent. The differential energy spectrum of galactic rays/beams with the energy of more than 1 GeV/nucleon takes form [14]:

$$\varphi(E)dE = CE^{-2.4}dE. \quad (3.16)$$

In equation (3.16)  $E$  - useful energy of particle, which falls to one nucleon and equal to  $E = E_k + m_p c^2$ ;  $E_k$  - kinetic energy of particle;  $m_p c^2$  - rest energy;  $C$  - dimensionless coefficient.

As an example Fig. 3.11 gives some computed values of differential energy spectra, to the corresponding period of high solar activity, for the nuclei of galactic rays/beams. The spectrum of nuclei with the energy  $10^{11}$  eV and no longer is given, since the density of the flows of these nuclei is insignificant. According to the measurement data, carried out at the scientific space stations "Proton-1" and "Proton-2", the integral energy spectrum of primary

cosmic-rays in the range  $4 \cdot 10^{10} - 2 \cdot 10^{14}$  eV can be described by the law

$$\Phi(>E) \approx E^{-\gamma},$$

with the value  $\gamma=1.73$  [20].

The density of the flow of galactic cosmic rays vary with time. For the periods, which correspond to the maximum activity of the Sun, the density of flow is equal to approximately/exemplarily  $1 \cdot 10^4$  part./m<sup>2</sup>·s. In the years of minimum solar activity the density of flow increases to  $(2.3-2.5) \cdot 10^4$  part./m<sup>2</sup>·s, moreover the created ionization increases 1.5-2 times.

Page 94.

It is necessary to note that the available at present data on the effect of primary cosmic radiation on the substances and on the measurement of radiation dosages are given without taking into account the degree of the effect of multicharged nuclei with the high energy (high energy nuclei) which they can have its special features/peculiarities during interaction with the substances. For example, the probability of inelastic collisions of protons with carbon atoms increases with the increase of kinetic energy of protons from  $10^{10}$  to  $10^{12}$  eV approximately/exemplarily one and a half times [20].

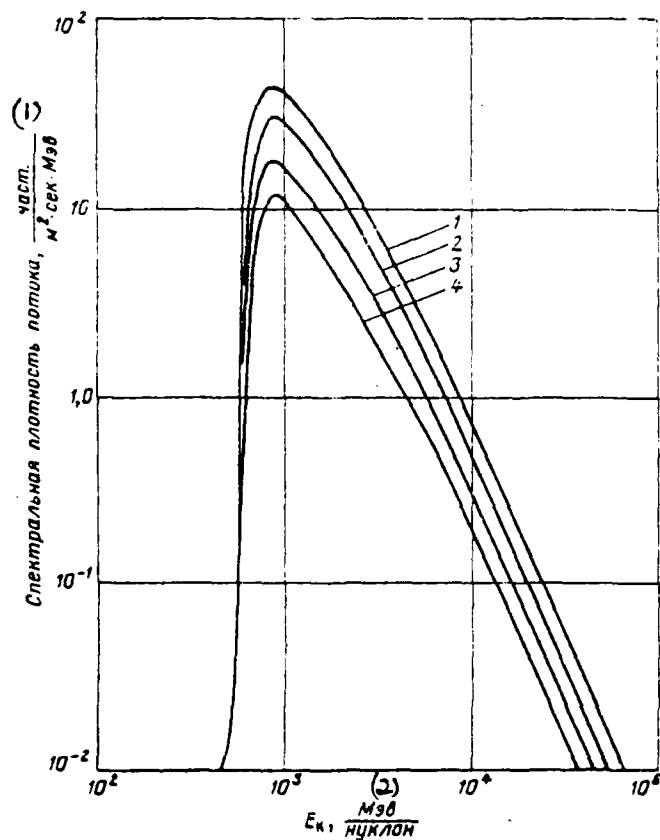

Fig. 3.11. The differential energy spectra of the components of the galactic cosmic rays: 1 - heavy nuclei; 2 - light nuclei; 3 -  $\alpha$ -particles  $\times 10$ ; 4 - protons; medium nuclei  $\times 10^2$ .

Key: (1). The spectral density of flow, part./m<sup>2</sup>·s·MeV. (2). MeV/nucleon.

The shielding from them of radio-electronic equipment is in practice little effective as a result of the high hardness of cosmic rays.

To the solar cosmic radiation it is accepted to carry the ionizing radiation/emission, which appears as a result of solar burst and observed during the short time interval. It consists, in essence, from the protons, and also of  $\alpha$ -particles and nuclei of elements/cells with the charges from 6 to 18 elementary charges. The nuclei of elements/cells are approximately 0.15-0.25%,  $\alpha$ - particles - from 3 to 15%.

Furthermore, in the composition of solar cosmic rays were observed electrons, and also X-ray and gamma-radiation of insignificant intensity. Their formation/education can be explained by generation during the flashes/bursts of braking and radio emissions. Solar flares significantly affect the composition of natural Earth radiation belts [21, 22, 31].

In comparison with the primary cosmic radiation solar cosmic rays have considerably smaller energies of the emitted particles, but the densities of their flow many times (to  $10^6$ ) exceed the densities of the flow of galactic particles.

Maximum energy of the protons of solar cosmic rays of approximately  $10^{10}$  eV.

They at present consider that the average annual effectiveness of production of high-energy particles in the solar bursts approximately composes  $10^{17}$  per annum (with the energy of more than 20 MeV), and average flux density  $2 \cdot 10^{13}$  part./m<sup>2</sup>·year [24]. The densities of the flows of protons during the solar flares in outer space can change (to oscillate) in the limits to seven orders.

The density of the flow of protons for the large flashes/bursts is equal to approximately/exemplarily  $10^{10}$  protons/m<sup>2</sup>·s; for the time solar p of the flash/burst, whose average duration is 24 hrs, the flow of protons with the energy of more than 30 MeV reaches the values of  $10^{14}$  proto-N/m<sup>2</sup>, with the energy of more than 5 MeV - values of  $10^{13}$  protons/m<sup>2</sup>.

The radiation/emission of protons during the solar flare continues usually days, but can continue for the separate flashes/bursts to 100 hour.

Page 96.

Was especially in detail investigated the characteristic of

solar rays/beams during the flash/burst on 12 November, 1960. The differential energy spectrum of the components of this solar flare is shown in Fig. 3.12; flows and integral doses of the protons of different energy are given in Table 3.6 [14, 25].

Electrons and bremsstrahlung of solar flares have insignificant densities and therefore their dose of the ionization, which affects the equipment, can be disregarded/neglected. Thus, the power of exposure dose on the boundary of the atmosphere for the bremsstrahlung comprises not more than  $10^{-6}$  R/s [14, 21, 26].

The degree of the irradiation of equipment of space object by the solar ionizing radiations depends on the probability of its entry into the zone of the radiation of solar flare.

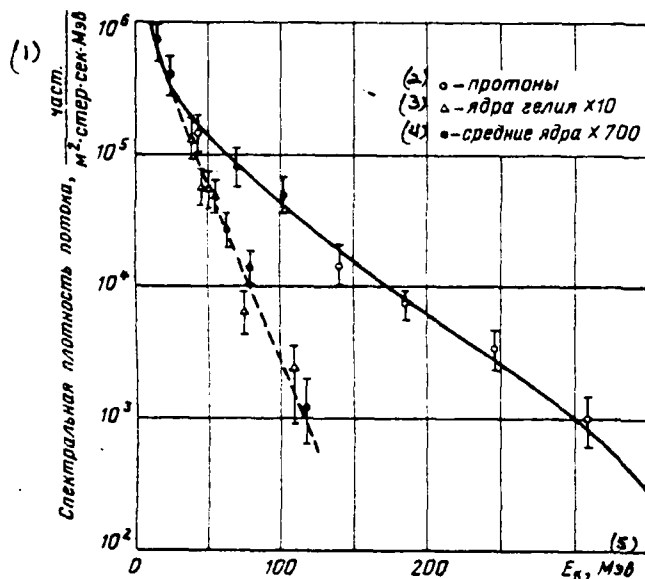

Fig. 3.12. Differential energy spectrum of protons,  $\alpha$ -particles and medium nuclei ( $6 \leq Z \leq 9$ ) during the solar flare on 12 November, 1960.

Key: (1). The spectral density of flow, part./m<sup>2</sup>·sr·s·MeV. (2). protons. (3). nucleus of helium. (4). medium nuclei. (5) MeV.

Page 97.

The example to the probabilities of the appearance of flashes/bursts with the assigned flow value of radiation/emission for the period of the maximum of solar activity is represented in Fig. 3.13 [27]. The probability of the appearance of flashes/bursts with the given number of particles is considerably lower in the period of the minimum of solar activity.



Table 3.6. Flows and the integral doses of proton radiation/emission during the solar flare on 12 November, 1960.

(1) Энергия E, Мэв	(2) Поток протонов p/m <sup>2</sup>	(3) Интегральная доза, рад
30 < E < 80	8,45 · 10 <sup>18</sup>	1790
80 < E < 440	6 · 10 <sup>18</sup>	62
440 < E < 6 · 10 <sup>8</sup>	3,5 · 10 <sup>18</sup>	0,11
(4) Итого	9,1 · 10 <sup>18</sup>	1852

Key: (1). Energy E, MeV. (2). Flow of protons R/m<sup>2</sup>. (3). Integral dose, rad. (4). Altogether.

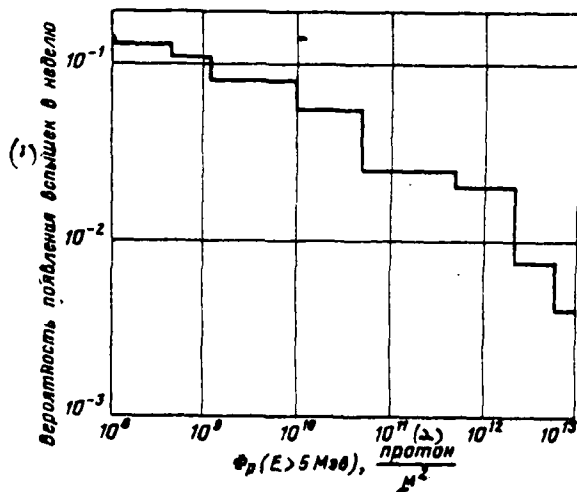

Fig. 3.13. Probability of appearance of flashes/bursts of different power in years of maximum of solar activity.

Key: (1). Probability of the appearance of flashes/bursts in the week. (2). proto-N/m<sup>2</sup>.

Page 98.

Table 3.7. Doses of primary space and high-energy solar radiations.

(1) Тип излучения	(2) Энергия частиц, эв	(3) Длина пробега, кг/м <sup>2</sup>	(4) Годовая доза ионизации, рад/год		
			(5) поверхностный слой	(6) слой в $1 \cdot 10^{10}$ кг/м <sup>2</sup>	(7) слой в $10$ кг/м <sup>2</sup>
(7) Частицы большой энергии, порожденные солнечной вспышкой					
Протоны (8)	$2 \cdot 10^7 - 10^8$	$10 - 10^4$	$10^2 - 10^4$	$10^2 - 10^4$	$10^2 - 10^4$
Электроны (9)	$\approx 5 \cdot 10^4$	$10^{-1}$	$10^2 - 10^7$ (?)	$10^2 - 10^7$ (?)	0
Тормозное излучение (10)	$\approx 5 \cdot 10^4$	$10 - 10^2$	$1 - 10^2$ (?)	$1 - 10^2$ (?)	$1 - 10^2$ (?)
(11) Полная доза солнечного излучения			$10^2 - 10^7$ (?)	$10^2 - 10^7$ (?)	$10^2 - 10^2$ (?)
(12) Первичное космическое излучение					
(13) Протоны	$10^2 - 10^{10}$	$> 1$	1-10	1-10	1-10

Note. The sign of a question designates the not entirely precision determination of the values indicated.

Key: (1). Type of radiation/emission. (2). Energy of particles, eV. (3). Mean free path, kg/m<sup>2</sup>. (4). Annual dose of ionization, rads/yr. (5). surface layer. (6). layer in  $10$  kg/m<sup>2</sup>. (7). High energy particles, generated by solar flare. (8). Protons. (9). Electrons. (10). Bremsstrahlung. (11). Complete dose of solar radiation. (12). Primary cosmic radiation. (13). Protons.

Page 99.

Thus, the data, met in the press/printing, about the possible intensities of radioactivity of primary space and solar radiations can essentially be distinguished. According to the data of survey/coverage [3] Table 3.7 approximately/exemplarily with an accuracy to one order (in the opinion of the authors of survey/coverage) gives maximally possible annual doses of primary space and solar radiations.

The indicated Table 3.7 values gives for the surface layer, the layer in  $1 \cdot 10^{-2}$  kg/m<sup>2</sup> (1 mg/cm<sup>2</sup>) and 10 kg/m<sup>2</sup> (1 g/cm<sup>2</sup>) on the ionizing effect.

Natural earth radiation belts.

Natural Earth radiation belts are the vast regions of the near-earth outer space, in which exist intense flows of elementary particles - electrons and protons.

At present it is customary to assume that there are to Java zones of radiation around the Earth:

- equatorial belt high(ly)-and particle densities (internal

radiation belts),

- external radiation belts.

In Fig. 3.14, according to the data of Van Allen - Vernov, the picture of the location of radiation belts with respect to the Earth is shown. The same figure gives the lines of the equal particle flux densities, recorded with the aid of a Geiger counter, arranged/located after the protective shield with a thickness of 12 kg/m<sup>2</sup> [3, 23, 26].

The spatial distribution of the charged/loaded particles, which form radiation belts, seems in the form of tori/Torr that the linin of the magnetic field of the Earth depends on the configuration of power ones. At large distances from the surface of the Earth (from 0.5 to 7-10 radii) the magnetic field is well the field of dipole. At the low altitudes, approximately/exemplarily to 2000 km, the magnetic field strongly differs from dipole. In view of this field of the cosmic radiation of natural radiation belts have very complex configuration, and the flows, the densities of flows and the differential spectra of elementary particles, which depend, in essence, from the processes, which occur in the Sun, are the complex functions of the space coordinates, whose value is known only at the isolated points of outer space.

Page 100.

Internal Earth radiation belt consists, mainly, of protons with the energy to hundreds of mega-electron-volts. It is arranged/located symmetrically relative to magnetic equator and is limited by magnetic lines of force, "proceeding" from the Earth on the geomagnetic latitude of approximately  $45^\circ$ . Lower boundary of inner belt depending on geographic latitude is located from the surface of the Earth at a distance from 600 to 1500 km. This scatter is connected with the bias/displacement of dipole relative to the center of the Earth up to the distance of approximately 500 km. Upper boundary of belt/zone stretches to the heights/altitudes of 5000-10000 km.

External radiation belts consists of electrons with the kinetic energy to 4-5 MeV. A large part of the electrons has kinetic energy on the order of hundreds of kiloelectronvolts.

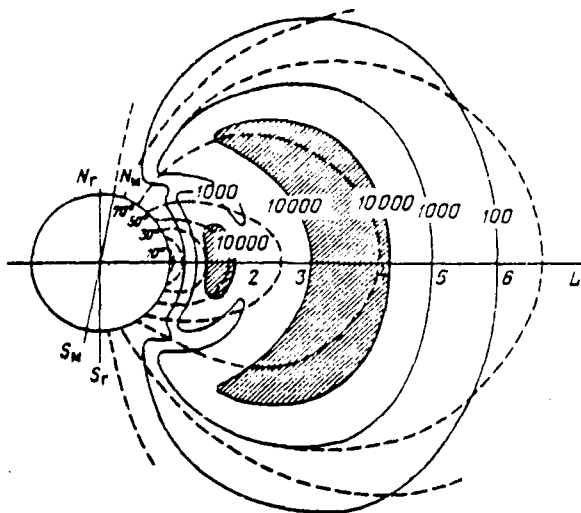

Fig. 3.14. The geometric structure of natural Earth radiation belts ( $N_r, S_r$  - geographical of the pole of the Earth;  $N_m, S_m$  - magnetic of the pole of the Earth).

Page 101.

External radiation belts is included between two surfaces, formed by the lines of force of the magnetic field of the Earth, "proceeding" from its surface on geomagnetic latitudes of  $69 \pm 2^\circ$  and  $65 \pm 2^\circ$  respectively for the northern and southern hemispheres. Belt/zone at the heights/altitudes of approximately 10000 km (near the geomagnetic equator) begins and it stretches depending on solar activity to the heights/altitudes of 60000-85000 km.

Composition, densities of flows and energy spectra of particles in the radiation belts depend on the time variations, connected in essence with the processes, which occur in the Sun. Therefore changes in the intensities of radioactivity, which occur in the internal and external earth radiation belts, with difficulty yield to account. For the orientation Fig. 3.15 gives the sufficiently approximate average/mean probable particle flux densities to the dependence on the geomagnetic latitude and the distances from the center of the earth [4, 23]. The energy spectra of these radiations/emissions can be calculated according to the approximation empirical formulas.

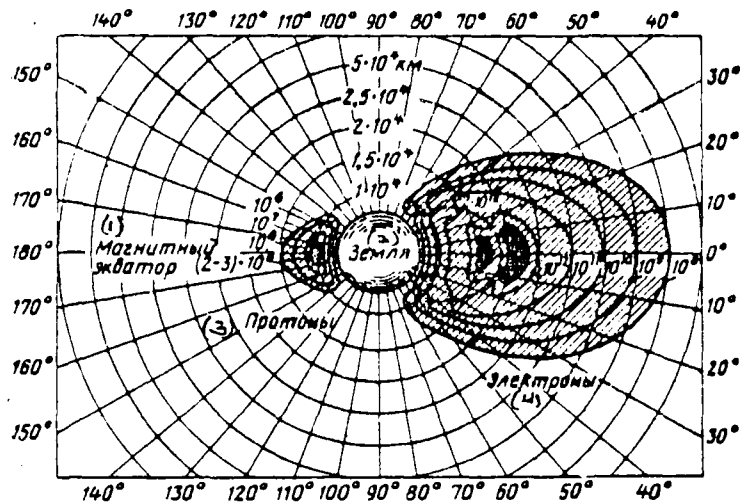

Fig. 3.15. Densities of the electron streams and protons depending on height/altitude and geomagnetic latitude. To the left in the figure reduced densities [part./m<sup>2</sup>·s] of the flows of protons with the energy of more than 40 MeV, to the right - the densities of electron streams with the energy are more than 20 keV.

Key: (1). Magnetic equator. (2). Earth. (3). Protons. (4). Electrons.

Page 102.

For the internal (proton) radiation belts the spectrum of protons in the range of energies from 1 to 700 MeV is calculated from formula [14]



$$\varphi(E)dE = 1,14E^{-1.66}dE \text{ protons/s} \cdot \text{cm}^2 \cdot \text{MeV}^{-0.66}. \quad (3.17)$$

For the external radiation belts the differential energy spectrum of electrons for the energy range from 0.05 to 5 MeV is equal to [14, 28]

$$\varphi(E)dE = 2 \cdot 10^{10} E^{-2} dE. \quad (3.18)$$

During the determination of the degree of the effect of proton and electronic radiations/emissions on the equipment and its completing articles, arranged/located after the protective shields, it is necessary to consider secondary radiation, formed in the material of protection. According to available experimental data [29], the absorbed dose from secondary particles (in essence, neutrons), which appear in aluminum with a thickness of up to 200 kg/m<sup>2</sup>, is approximately 5-10% of the complete dose of proton radiation/emission. In the case of applying the protective materials with the large atomic number, the dose of secondary radiation can reach 30-40%. The relative contribution to the total absorbed dose of secondary particles grows/rises with an increase in the thickness of protective shield.

Electrons with the energy spectrum to 5 MeV make an insignificant contribution to the total dose after the shell of space object. However, during interaction of electrons with the atoms of substance appears the bremsstrahlung, whose penetrating power

considerably higher than penetrating power of electrons.

The spectral distribution of the quanta of bremsstrahlung during calculations easily is determined on the relative contribution  $X$  to the density of the bremsstrahlung of different spectral components [14] (see Table 3.8).

The percentage of density for the specific energy range Table 3.8 gives in the calculation with respect to the complete density of the flow of  $\gamma$ -quanta of bremsstrahlung.

Page 103.

Table 3.8. Relative contributions of different spectral components to the density of the flow of the bremsstrahlung of monoenergetic electrons.

$h\nu/E_0$	$\alpha, \%$	$h\nu/E_0$	$\alpha, \%$
0—0.1	26,9	0,5—0,6	6,5
0,1—0,2	20,5	0,6—0,7	4,5
0,2—0,3	15,8	0,7—0,8	2,8
0,3—0,4	12,1	0,8—0,9	1,5
0,4—0,5	9,0	0,9—1,0	0,4

Table 3.9. Dependence of allowance for the buildup factor of the scattered  $\gamma$ -quanta from the energy of electrons ( $E_0$ )

(1) $E_0, \text{MeV}$	(2) Величина поправки, %	(1) $E_0, \text{MeV}$	(2) Величина поправки, %
0,05	2400	1,00	100
0,10	650	5,00	15
0,30	200		

Key: (1). MeV. (2). Allowance, %.

Table 3.10. Rates of the doses of braking and electronic radiations/emissions depending on the thickness of shielding spherical screen from graphite, mrad/h.

(1) Толщина экрана кг/м <sup>2</sup>	1	2	5	10	30	50	100
(2) Электронное излу- чение (3)	29 200	13 600	2 340	394	0,08	0	0
тормозное излуче- ние (4)	230	200	140	107	82,3	48,6	17,9
Полное излучение	29 430	13 800	2 480	501	82,4	48,6	17,9

Key: (1). Thickness of screen, kg/m<sup>2</sup>. (2). Electronic radiation/emission. (3). Bremsstrahlung. (4). Complete radiation/emission.

Page 104.

Table 3.11.

Doses of the ionizing radiations/emissions of internal and external Earth radiation belts.

Note. The question mark means a not quite precise determination of the indicated values.

(1) Тип излучения	(2) Энергия частиц, эв	(3) Длина пробега частиц, кг/м <sup>2</sup>	(4) Годовая доза ионизации, рад/год		
			(5) поверхностный слой	(6) слой в 1·10 <sup>-2</sup> , кг/м <sup>2</sup>	(7) слой в 10 кг/м <sup>2</sup>
(7) Внутренний радиационный пояс					
(8) Протоны	10 <sup>3</sup> (?) — 7·10 <sup>3</sup>	10 <sup>-6</sup> (?) — 10 <sup>4</sup>	10 <sup>10</sup> (?)	10 <sup>9</sup>	10 <sup>5</sup>
(9) Электроны	< 2·10 <sup>4</sup> — 1·10 <sup>5</sup>	10 <sup>-2</sup> — 10	10 <sup>12</sup> (?)	10 <sup>12</sup>	0
(10) Тормозное излучение	< 2·10 <sup>4</sup> — 1·10 <sup>5</sup>	1 — 10 <sup>2</sup>	10 <sup>5</sup> (?)	10 <sup>5</sup>	10 <sup>5</sup> — 10 <sup>6</sup>
(11) Полное излучение			10 <sup>12</sup> (?)	10 <sup>12</sup>	10 <sup>5</sup> — 10 <sup>6</sup>
(12) Внешний радиационный пояс					
(8) Электроны	2·10 <sup>4</sup> — 5·10 <sup>5</sup>	10 <sup>-2</sup> — 3·10	10 <sup>11</sup> — 10 <sup>12</sup>	10 <sup>11</sup> — 10 <sup>12</sup>	10 <sup>5</sup>
(10) Тормозное излучение	2·10 <sup>4</sup> — 5·10 <sup>5</sup>	10 — 10 <sup>2</sup>	10 <sup>5</sup> — 10 <sup>7</sup>	10 <sup>5</sup> — 10 <sup>7</sup>	10 <sup>4</sup> — 10 <sup>6</sup>
(11) Полное излучение			10 <sup>11</sup> — 10 <sup>12</sup>	10 <sup>11</sup> — 10 <sup>12</sup>	10 <sup>4</sup> — 10 <sup>6</sup>

Key: (1). Type of radiation/emission. (2). Energy of particles, eV. (3). Mean free path of particles, kg/m<sup>2</sup>. (4). Annual dose of ionization, rads/yr. (5). surface layer. (6). layer in kg/m<sup>2</sup>. (7). Internal radiation belts. (8). Protons. (9). Electrons. (10). Bremsstrahlung. (11). Complete radiation/emission.

Page 105.

For evaluating the contribution to the total power table 3.10 shows the doses of electronic and bremsstrahlung (taking into account correction for the buildup factor of scattered  $\gamma$ -quanta, Table 3.9) for the comparison of the power coefficient of exposure doses after the protective shields of the spherical form of different thickness, prepared from graphite.

It follows from these data that with the screens with the thickness of less than  $10 \text{ kg/m}^2$  the basic contribution to the total power of dose give the electrons, and with the thicknesses more than  $10 \text{ kg/m}^2$  the  $\gamma$ -quanta of bremsstrahlung give.

In conclusion Table 3.11 gives for information tentative data (with the accuracy approximately one order) of maximally possible annual doses of the ionizing radiations/emissions internal and external radiation m of the belts/zones of the Earth [3].

Radiation of the artificial belts/zones of the Earth.

Artificial radiation belts are formed as a result of nuclear and thermonuclear explosions at high heights/altitudes. The volume of space, occupied by artificial belt/zone, is determined by the power of ammunition and depends on the coordinates of the center of explosion.

Artificial belt/zone, in essence, consists of electrons. Fission fragments, which are the unstable isotopes of different chemical elements, subjected to  $\beta$ -decay, are the sources of these electrons predominantly.

Table 3.12. The integrated spectrum of the electrons, which are formed with the  $\beta$ -decay of fission fragments.

(1) Энергия электро- нов $E$ , Мэв	0	1	2	3	4
(2) Доля электронов с энергией более $E$ , %	100	47	20	7,7	2,7

(1) Энергия электро- нов $E$ , Мэв	5	6	7	8	9
(2) Доля электронов с энергией более $E$ , %	0,84	0,24	$6,0 \cdot 10^{-2}$	$1,3 \cdot 10^{-2}$	$2,4 \cdot 10^{-3}$

Key: (1). Energy of electrons  $E$ , MeV. (2). Portion of electrons with energy is more than  $E$ , %.

Page 106.

The energy spectrum of electrons (characteristic for the  $\beta$ -decay of fission fragments stretches to the energies of 10 MeV. The integrated spectrum of the electrons of fission fragments is given in Table 3.12.

The density of electron stream depends on the explosive force, sizes/dimensions of belt/zone and capture efficiency of electrons by magnetic field. During the determination of possible electron streams it is necessary to consider that the intensity of the



radiation/emission of the seized particles cannot exceed the density of magnetic energy.

A radius of the dispersion/divergence of fission fragments determines the sizes/dimensions of artificial radiation belts. A maximum radius of the dispersion/divergence of fission fragments in the direction, perpendicular to the magnetic intensity of the Earth, can be calculated from formula [22]

$$R = 51,2 \sqrt[3]{\frac{q}{B^2}} \quad (3.19)$$

where R - radius of the fragmentation pattern, km;

q - power of ammunition, km;

B - magnetic induction, G.

However, not all fission fragments participate in the formation/education of artificial Earth radiation belt, since only the particles, which have sufficiently large slope angles between the particle speed and the line of force of magnetic field, are seized by the magnetic field of the Earth. Thus, for instance, during the nuclear explosion, carried out as a result of operation/process "Starfish", by magnetic field the Earth were seized only several percentages of a total number of chosen electrons.

The rate of the  $\beta$ -decay of fission fragments, which determines the rate of formation of artificial radiation belts, it is estimated with the aid of following approximation [41]:

$$N_e \approx (1,96 + 1,17t) \cdot e^{-0,018t},$$

where  $N_e$  - quantity of electrons;

t - time after explosion, s.

The lifetime of artificial belt/zone is determined by the lifetime of electrons. According to the estimation conducted the lifetime of the electrons of artificial belt/zone can comprise to one even more than years [30, 31].

Page 107.

The first artificial radiation belts was formed as a result of three nuclear explosions with the TNT equivalent 1-2 kt at the height/altitude of approximately 500 km. According to the calculations the density of electron stream in this belt/zone comprised approximately/exemplarily  $3 \cdot 10^7$  electrons/s·m<sup>2</sup>. Belt/zone existed several months [32-34].

The most powerful/thickest artificial radiation belts was formed on 9 July, 1962, at the height/altitude of 400 km as a result of

conducting the operation/process "Starfish" (explosive force 1.4 Mt.) [31, 35-39]. The maximum density of electron stream with the energy of above 40 keV reached the values approximately/exemplarily  $10^{13}$  electrons/s·m<sup>2</sup>.

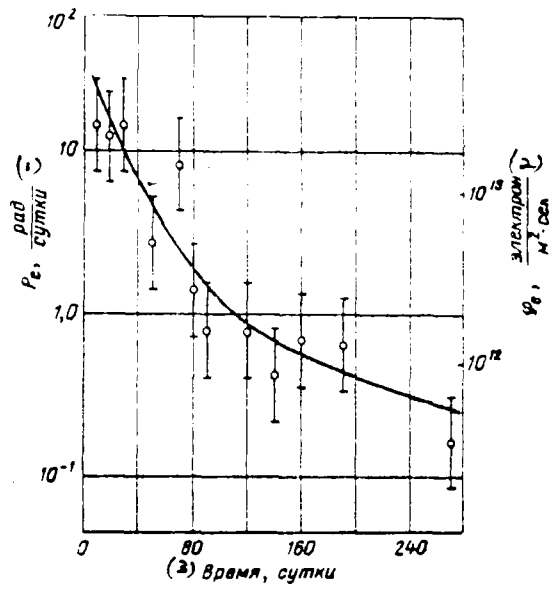

Fig. 3.16. Change in the density of the electron stream and power of exposure dose in the time after nuclear explosion with power 1.4 at the height/altitude of 400 km (for the circular polar orbit). Curve corresponds to the expected average/mean value.

Key: (1). rads/day. (2). electron/m<sup>2</sup>.s. (3). Time, days.

Page 108.

The middle part of the belt/zone was found in the plane of geomagnetic equator at the height/altitude of approximately/exemplarily 800 km; its edge were located approximately 300 km. The thickness of belt/zone was



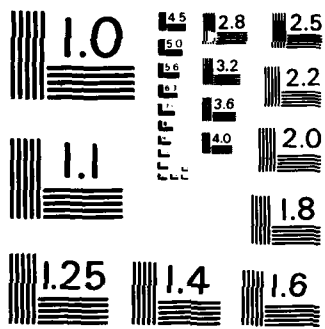

MICROCOPY RESOLUTION TEST CHART  
NATIONAL BUREAU OF STANDARDS-1963-A

650 km, width - about 6500 km.

Artificial belt/zone poured with the inner belt of natural radiation at the height/altitude of approximately 1100 km. As a result of forming this belt/zone the region of maximum electron density was displaced from the height/altitude, which corresponds to maximum electron density in the external radiation belt, to the height/altitude of 1100 km. From 9 July to the end/lead of August of 1962 the density of electron stream in the belt/zone was lowered by 50%. The character of a change in the density of the electron stream and power of exposure dose in the time after explosion is shown in Fig. 3.16 [39, 40].

From the analysis of existing knowledges about it is ionized X cosmic radiation evident that at present on the basis of these data it is possible to produce only the rough estimate of the intensities of radioactivity, which can act on radio-electronic equipment of space objects.

Page 109.

4. Change in the properties of materials and elements/~~cells~~ of radio-electronic equipment under the effect of the ionizing radiations/~~emissions~~.

Radio-electronic equipment, which is located in the zone of the effect of the ionizing radiations/emissions, can substantially change its parameters and go out of order. These damages occur as a result of changing the physical and chemical properties of the radio engineering (semiconductor, insulating, metallic, etc.) materials, parameters of instruments and elements/cells of electronic engineering, articles of electrical engineering and radio-electronic circuit devices/equipment.

The ability of articles to fulfill their functions and to retain the characteristics and the parameters within the limits of the established/installed norms during and after the effect of those ionizing radiation/emission is called radiation durability.

The degree of radiation damages in the irradiated system depends both on the content of energy, transmitted during irradiation, and on the speed of transmission of this energy. A quantity of absorbed energy and the speed of transmission of its in turn depend on form and parameters of radiation/emission and nuclear physics characteristics of the substances, from which is prepared the irradiated object.



Let us examine the processes, which occur in the materials<sup>1</sup> and the radioelements under the action of different forms of the ionizing radiations/emissions. In this case by materials are implied the substances, from which are prepared the elements of the constructions/designs of radio-electronic equipment, and the substances, which form part of the environment (for example, air, etc.).

FOOTNOTE<sup>1</sup>. For the purpose of reduction subsequently we will use term radioelements or simply elements/cells, implying by it instruments and elements/cells of electronic engineering and article of electrical engineering. ENDFOOTNOTE.

Page 110.

#### 4.1. Radiation damages in materials and elements/cells of equipment.

Defects in the materials under the influence on them of the ionizing radiations/emissions.

All forms of electromagnetic and corpuscular radiation, passing through the substance, interact either with the atomic nuclei or with the orbit electrons, leading to a change in the properties of the irradiated substance.

The primary and secondary stages of this process usually are distinguished. Primary stage, or direct effect, consists of the electron excitation, of the atomic displacement from the lattice points, in atomic excitation and molecules and in the nuclear conversions. Secondary processes consist of further excitation and damage of structure, dislodged/chased (displaced) "of their places" by atoms, by ions and with elementary particles as a result of primary processes. Laws, by which they are subordinated, the same as the laws, which control the primary stages of process. Thus, particles or high-energy quanta can cause cascade process with the formation/education of a large number of displaced atoms, vacancies, ionized atoms, electrons, etc.

The contemporary interpretation of changes in the properties of substances, which appear as a result of interaction of the ionizing radiations/emissions, is based on the examination of the process of forming different defects in the material.

Radiation changes in the materials are the following: vacancy (vacant sites); impurity atoms (admixed atoms); collision during the substitutions; thermal (thermal) peaks; the peaks of bias/displacement and ionizing effects. Physics of these processes is

described in labor/works [1-6]; therefore let us pause briefly at their characteristic.

Vacancy is the lattice point, in which atom or ion is absent. Vacant sites can be formed during the collision of high energy particles with the atoms of solid body as a result of the what in the lattice latter they can be formed empty places.

Page 111.

If energy of displaced atom is sufficiently great, then atom during the subsequent collisions creates the supplementary empty places in the lattice. Consequently, primary collisions can produce the cascade/stage of the collisions, which lead to the formation of vacancies (to initiate).

Interstitial atoms - these are the atoms, which, after being displaced from their equilibrium, stable positions in the lattice, are braked in the intermediate or nonequilibrium positions. If they do not recombine immediately with the adjacent empty place, then they can remain in the intermediate, unstable position.

A question about the form of the existence of surplus, dislodged/chased from their normal positions in the lattice, atoms is

sufficiently difficult. Thus, for instance, in tight packings, characteristic for the metals, there is no sufficient space for positioning/arranging these excess atoms. Therefore their location inside the cell leads either to a sharp increase in its volume with the retention/preservation/maintaining of form or to the distortion of the form of cell; the latter can cause the disturbance/breakdown of the stability of the surrounding this cell configuration. There were the assumptions that in this case the surplus atom displaces one of the atoms of adjacent cell so that both of them together occupy the place of one structural lattice point. It is assumed in the representation about so-called crowdions that the intermediate atom is included in the composition of the atomic series/row of tight packing, i.e., in certain section/segment of this series/row instead of the  $n$  atoms it is placed  $n+1$  atoms, the atoms of series/row testing/experiencing appropriate relaxation [6].

Vacancies and interstitial atoms can move in the crystal. Vacancy is moved via transfer of adjacent atom into the vacancy. The motion of interstitial atom can be more complicated. For example, in the solid solutions the interstitial atom of solute jumps of one interstice into the adjacent. The formed defects can aggregate, i.e., to form vapors or complexes, which contain several vacancies. Vacancies and interstitial atoms can be associated with the edge dislocations or the boundaries of complicated dislocations. In this

case they form steps/stages on the dislocation line. Such steps/stages have opposite directions and can be moved along the dislocation line until they are encountered and eliminate each other.

Page 112.

Vacancies and interstitial atoms can also form the "atmospheres" around the dislocations. Furthermore, vacancies can be connected with the interstitial atoms. Such connected vacancies retard the diffusion of some admixtures/impurities.

The atoms of different admixtures/impurities are formed as a result of the nuclear reactions, which take place in essence during irradiation by neutrons, and also by introduction to solid body of the fragments, which are formed in the process of division. Nuclear reactions lead to the formation of the atomic decay products, radioactive and stable isotopes. Being introduced in the lattice of the irradiated substance, they can considerably change its properties. For example, gaseous decay products (helium, xenon, etc.) are accumulated/stored in the form of pores and bubbles in the substances, as a result of which the form of one or the other article even changes, and hermetic sealing/pressurization can be destroyed in the hermetically sealed elements/cells.

Collisions during the substitutions. If the collision between those moving by the taking root atom and atom of the lattice point leads to the fact that the latter escapes from its stationary position, and interstitial atom loses kinetic energy to this value, which is insufficient for the removal/distance of this atom from the vacancy formed by it, then interstitial atom recombines with the formed vacancy.

In this case it scatters its kinetic energy - in the form of thermal lattice vibrations. In this case does not appear new defect, but occurs the atomic substitution, which leads to the disordering of crystal lattice.

Thermal peaks. The appearance of this damage of structure is caused by the oscillations of the lattice points. These oscillations appear along the path of motion of fast particle (fragment from the nuclear fission, or charged/loaded, dislodged/chased from its atom site of lattice) in crystal lattice. The atom, which during the collision obtains the impulse/momentum/pulse, sufficient only for an increase in the amplitude of its oscillation around the point of lattice (but insufficient for its bias/displacement from the node/unit), it transfers energy to the adjacent atoms, which in this case become highly excited. The release of considerable energy occurs as a result in the limited volumes of substance (on the order of

$10^{-17}$  cm<sup>3</sup>).

Page 113.

The conversion of this energy into the heat can in the region, which contains several thousand atoms, lead to the large overheatings (approximately/exemplarily to 1000°K), which exist during from  $10^{-11}$  to  $10^{-10}$  s. The region of excitation is expanded subsequently, which leads to a sharp temperature drop.

This process is called also thermal wedge, since in this case rapid heating occurs and hardening/quenching the insignificant volume of substance. The fact that they stimulate the diverse physicochemical processes, which require under the normal conditions of high-temperature heating, is the distinctive special feature/peculiarity of thermal peaks.

The peaks of bias/displacement can be formed at the end of the landing run of the moving/driving atoms, when kinetic energy of atom becomes less than the transition energy (which depends on atomic number) atom into the new state; the mean pathlength of the mean free path between the collisions, which lead to the biases/displacements, by order of value it approaches an interatomic distance. Thus, each collision leads to the formation of displaced atom and the final part

of the path of the landing run of the moving/driving atom is the region, which contains from thousand to tens of thousands of atoms, in which during the very short time interval occurred the local melting of the lattice of substance and turbulent mixing.

They assume [1] that the vacancies and the taking root atoms will be "reconstructed" in this region, being mutually recombined, and lattice imperfections in the form of the loops of dislocations or small disoriented regions will remain. Such phenomena, called also wedges of bias/displacement, have a value, probably, only in the processes, which occur in the heavy metals.

**Ionizing effects.** All ionizing radiations/emissions, passing through the substances, cause ionization and electron excitation.

The ionization, caused by the effect of the ionizing radiations/emissions, is the process of the formation of electron-hole pairs, free ions and electrons in the substance as a result of the interruption/discontinuity of interatomic bonds, disruption/separation of electrons from the electron shells.

Page 114.

Simultaneously with the ionization continues the process of



recombination of ions, i.e., the formation of neutral atom from the positive ion and the electron. The more are formed the charged/loaded particles, the greater the possibility of their collision, and consequently, the process of recombination more rapidly continues.

Therefore during irradiation by constant dose rate in some substances (for example, in the gases) can be observed the equilibrium of positively and negatively charged/loaded particles, in which a number of newly forming ion pairs will be on the average equal to a number of recombined ions (particles). In particular, in the atmosphere of the Earth because of the effect of natural of those ionizing radiation/emission with the gaseous products are always ions, whose content composes order  $10^8$ - $10^{10}$  ions in the cubic meter ( $10^2$ - $10^4$  ions/cm<sup>3</sup>).

The processes of ionization in turn in some substances can lead to the bond breaking and the formation of free radicals, the chemical reactions, the luminescence, the emergence of the diverse color centers, photoconductivity, an increase in the temperature, the change in the crystalline anisotropy and other changes in the properties of substances.

All disturbances/breakdowns examined in the materials will depend on the character of the interaction of different forms of

radiation/emission with the atoms of one or the other substance.

Forms of radiation damages.

The radiation damages, which lead to the reversible (temporary/time) and irreversible (residual/remanent) changes in their electrical ones, etc. of the parameters (Fig. 4.1), appear as a result of the effect of the ionizing radiations/emissions in the materials, the elements/cells and the schematics of radio-electronic equipment.

The reversible changes include the changes, which attack in the materials, elements/cells and diagrams simultaneously since the beginning of the irradiations, which are preservable in the period of irradiation and virtually which disappear after the break-down of the ionizing radiation/emission or its sharp weakening (Fig. 4.1a). The reversible changes, as a rule, are the consequence of the ionization of the materials and the environment.

Page 115.

The common picture of the effects of ionization under the influence of different forms of the ionizing radiations/emissions is shown in Fig. 4.2. The quantitative estimation of the reversible changes can

be determined on the effect of ionization. Under the influence of different forms of the ionizing radiations/emissions the effect of ionization depends on state of aggregation of substance. The average/mean values of energy for one ionizing event for the substances in the gaseous state are given in Table 4.10, for the solid dielectrics

or the semiconductors the medium energy of ionization is approximately/exemplarily equal to the triple value of width of forbidden band, for the metals - about 10-20 eV.

The reversible changes become apparent in an increase in the concentration of the current carriers, leading to the increase leak/leakage and a reduction in resistance in the insulating, semiconductor, conducting materials and the gas-filled gaps. The ignition voltages in gas-discharge instruments decrease as a result of these changes, anode current in vacuum-tube instruments grows/rises, decrease resistances of resistors, inverse currents in semiconductor devices grow/rise, increase (due to the supplementary radiation heating) winding impedances of transformers, engines, etc.

The quantitative values of changes in the electrical parameters of each type of element/cell are determined by rate of dose or by radiation flux density and depend on the pulse duration.

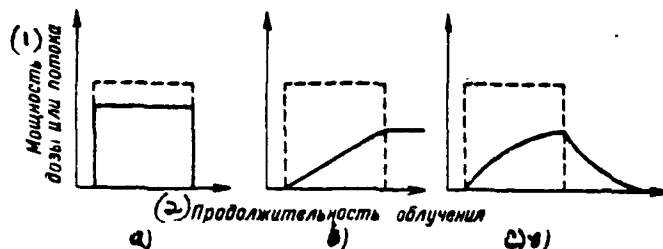

Fig. 4.1. Forms of changes in the properties of materials and radioelectronic elements under the influence of the ionizing radiations/emissions: a) reversed, b) not reversed, c) the partially restorable changes.

Key: (1). Rate of dose or flow. (2). Duration of irradiation.

Page 116.

Under the radiation effect the recombination of charge carriers simultaneously with the ionization occurs, which leads to the decrease of their density. After the break-down of radiation/emission occurs a reduction in the density of charge carriers, the velocity of decrease in which is determined by the properties of the materials, used in the elements/cells.

Recovery time of the parameters also depends on the rate of dose or radiation flux density. As a result of the ionizing processes (at

the specific densities of flows) the reversible changes in the radioelements and the materials can lead to the temporary/time or total loss of efficiency of equipment. For example, with the intense radiation can occur the erroneous starting/launching of thyatron, etc.

The degree of a change in the parameters also depends on the relationship/ratio between the duration of irradiation and the relaxation time, i.e., the spontaneous recovery rates of the properties of material. If the duration of pulse irradiation is less than the relaxation time, then these changes are determined mainly by rate of dose or by radiation flux density [7]. .

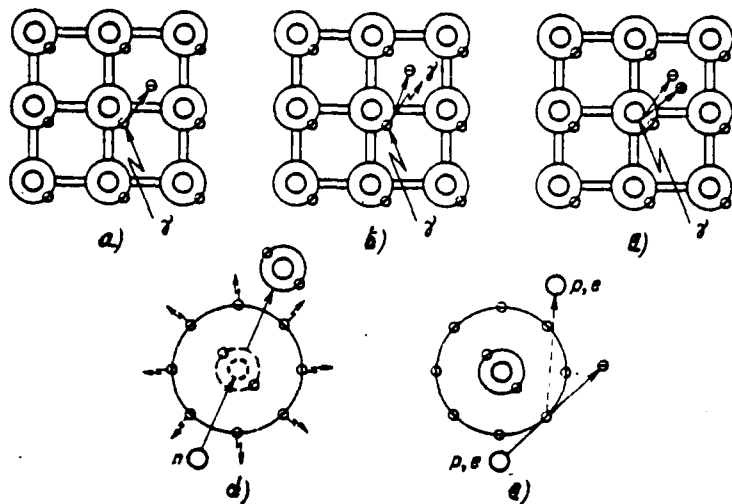

Fig. 4.2. Effects of ionization under the influence of the ionizing radiations/emissions on the materials. Gamma-quanta: a) photo effect, b) the Compton effect, c) the effect of pair formation electron - positron. Neutrons, protons, electrons; d) ionization with the atomic displacement (during the collisions of neutron with the nucleus), e) ionization during interaction of the charged/loaded particles with the electrons of atom.

Page 117.

Irreversible changes - this of a change in the electrical parameters of radioelements, materials and circuits, that appear simultaneously since the beginning of the irradiations, which increase with an increase in the absorbed energy of

radiation/emission and which are preservable partially or completely after the cessation/discontinuation of irradiation (Fig. 4.1b). Irreversible injuries are connected with changes in the structure of the materials, from which are prepared the radioelements. The effect of the ionizing radiations/emissions on the organic materials leads mainly to the transformation of molecules in these materials, which is accompanied by the chemical reactions, which call the irreversible changes in nature of substance.

In the semiconductor and inorganic materials the changes under the effect of irradiation are explained mainly by the damage of the structure of crystal lattice of substance. Data of disturbance/breakdown are, apparently, consequence in essence of the formation/education of defects in crystal lattice. The graphic representation of the mechanism of atomic displacement in crystal lattice is given in Fig. 4.3.

Defects in crystal lattice usually are evaluated according to a number of displaced atoms in the material. A quantity of displaced atoms per unit of volume of material under the influence of different forms of the ionizing radiations/emissions, in accordance with the conventional theory of the formation/education of simple point biases/displacements, can be calculated by the formula, given in work [15], namely:

$$N_d = \int \varphi(E) t q_d(E) \bar{v}(E) dE, \quad (4.1)$$

where  $N_d$  - number of the displaced atoms, which appear per unit of volume of substance under the influence of the flow of the ionizing radiations/emissions;

$\varphi(E)dE$  - density of the flow of the ionizing radiations/emissions with the energy from  $E$  to  $E+\Delta E$ ;

$q$  - number of atoms per unit of volume of substance;

$\bar{v}(E)$  - an average number of displaced atoms to one report/event of interaction of the ionizing radiation/emission with the substance;

$t$  - duration of the irradiation of substance.



Page 118.

Integral in formula (4.1) is taken along entire energy spectrum of the affecting radiation/emission. In the radioelements frequently the effect of irreversible injuries is determined with respect to a change in the parameters of materials, most sensitive to this form of radiation/emission. In works [8-10] shown that the irreversible changes in the materials depend only on absorbed energy (absorbed dose or radiant flux and its energy), i.e., they carry cumulative character. However, these conclusions/outputs are insufficiently precise.

In a number of cases the irreversible injuries of radioelements can depend on the rate of dose or density of the flow of the ionizing radiations/emissions. Thus, for instance, at the large exposure rate can occur the breakdown of air gap, which is located under high voltage, the burning of the contacts of relay, etc.

During irradiation of lubricating oils at high temperatures it was established/installed [11], that the resistance of oils to oxidation depends on the power of the exposure dose of

gamma-irradiation in the identical total exposure dose, equal to  $1.2 \cdot 10^8$  R.

The rate of the course of chemical processes in the high-molecular organic matter depends on the concentration of free radicals, which in turn depends on the rate of required work, i.e., the power of the absorbed dose.

The irreversible changes lead to the partial or total loss of efficiency of radioelements and diagrams.

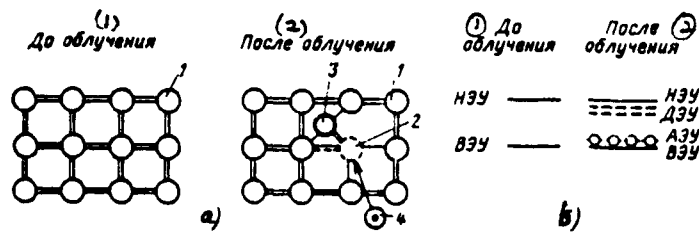

Fig. 4.3. The defects of bias/displacement under the influence of the ionizing radiations/emissions: a) the atomic displacement of lattice; b) the formation/education of energy levels; 1 - atom of lattice, 2 - vacancy, 3 - introduction, 4 - interacting particle, NEU - the lower electrical level of the zone of conductivity, VEU - the upper energy level of valence band, DEU - donor energy level, AEU - acceptor energy level.

Page 119.

They also can lead to a deterioration in such important characteristics as service life, period of storage, thermo- and hydrostability, reduction in the mechanical strength, reliability, etc. Thus, for instance, disturbances/breakdowns of shielding insulating ones coating radio parts and glass cylinders of vacuum-tube instruments (appearance of microcracks, difficultly detected in the process of irradiation) can lead to a noticeable change of the properties of elements/cells in the process of operation.

Is feasible the third form of a change in the properties of materials and radioelements (Fig. 4.1c). A change in the properties begins simultaneously since the beginning of the irradiation, is developed with an increase in the absorbed energy and in the specific time after the termination of irradiation partially or completely disappears. For example, after the irradiation of organic materials by the impulse/momentum/pulse of penetrating radiation with the power of the exposure dose of  $10^7$  r/s [12] the restoration/reduction of conductivity occurred: to 10% of equilibrium value for polyethylene after 3 min, for the polytetrafluoroethylene after 6 hours, for the polystyrene after 3 hours and for the polymethyl methacrylate after 10 hours; to 1% of equilibrium value for the same materials after 30 min, 35, 20 and 50 hours respectively.

Thus, the degree of the effect of the ionizing radiations/emissions on the materials, the radioelements and the diagrams under given conditions for operation and electrical modes/conditions depends on the form of the affecting radiation/emission, dose or flow, rate of dose or particle flux density (quanta), energy distribution of radiation along the spectrum, and also on nature of the irradiated object (structure of substance, construction of element/cell, its technology of

production) and the environmental conditions (temperature, pressure, humidity, etc.).

Depending on the form of radiation/emission and its energy the processes in the radioelements and the materials can occur throughout entire volume or in the surface layer. In particular, neutrons and  $\gamma$ -quanta possess high penetrability and therefore the changes caused by them in the specific volumes prove to be distributed on entire object, i.e., they carry volumetric character and, naturally, they can produce surface effects. The effects of  $\alpha$ -particles and fragments of nuclei, as a result of a small mean free path in the substance, have surface character.

Page 120.

The depth of the effect of protons and electrons in the substance to a great degree is determined by their energy and processes of emergence in this material of the secondary ionizing radiations/emissions (neutrons,  $\gamma$ -quanta, etc.), and consequently, defects in the materials can appear in the surface layer and throughout entire volume.

Together with the direct damage of the structure of materials during irradiation by their ionizing radiations/emissions, a change

in the properties occurs also as a result of different kind of the physicochemical processes, which most strongly become apparent during irradiation. A number of such processes includes: radiation heating, emergence of color centers, change in the anisotropy of the properties of crystalline substances, oxidations, structuring and destruction (in the polymers), decomposition of materials, luminescence, etc.

Heating radioelements occurs as a result of the conversion of absorbed energy of the ionizing radiation/emission into the thermal. A quantity thermal energy, that remains (isolating) in the article, proportional to the density of the flow (dose rate) of radiation/emission and for the case of short-term irradiation can be determined from the expression

$$Q = \varphi \sum_{i=1}^n K_i V_i = \varphi \sum_{i=1}^n K_i \frac{m_i}{\rho_i}, \quad (4.2)$$

where  $Q$  - quantity of isolated thermal energy, W;

$\varphi$  - particle flux density (quanta) of the ionizing radiation/emission, part./m<sup>2</sup>·s;

$V_i$  - volume of the  $i$  material, m<sup>3</sup>;

$m_i$  and  $\rho_i$  - mass and the density of the  $i$  material;

$K_i$  - coefficient of the heat release of the  $i$  material, W·s/m·part.;

$n$  - quantity of materials, entering the article.

For the case of the prolonged irradiation of article in the vacuum conditions a quantity of thermal energy, which remains in the article, can be determined from the expression:

$$q = Q - \epsilon_1 \sigma T_1^4 - \epsilon_2 \sigma T_2^4 = \varphi \sum_{i=1}^n K_i \frac{m_i}{\rho_i} - \epsilon_1 \sigma T_1^4 - \epsilon_2 \sigma T_2^4. \quad (4.3)$$

Page 121.

Here  $\epsilon_1$  and  $\epsilon_2$  - emissivity from external  $m$  and internal surface of article;

$T_1$  and  $T_2$  - temperature of the external and internal surface of article;

$$\sigma = 5,78 \cdot 10^{-8} \text{ W/m}^2 \cdot \text{h} \cdot \text{K}^{\circ}.$$

The coefficient of heat release for this form of the ionizing radiation/emission depends in essence on nature of the irradiated material. Thus, for instance, during irradiation by penetrating

gamma-neutron radiation (with the fission spectrum) of articles made of the heavy materials (in particular, metals) determining is gamma-component of radiation/emission. For the polymeric (especially connections with the high content of hydrogen), borate, cadmium materials the effect of neutron component (in essence of slow and thermal neutrons) of radiation/emission on their heating becomes commensurable or even exceeds the effect of gamma-component, since a smaller quantity of neutrons is compensated by the larger value of their absorption cross-section.

As a result of the energy absorption of radiation/emission and its conversion into the thermal the radioelements and equipment as a whole can be heated to the sufficiently high temperatures (order of 200°) and go out of order due to the thermal breakdown. Especially large overheatings are observed during irradiation of massive articles. Therefore use/application in the equipment of different kind of heat-transferring elements will contribute to its heating, and consequently, to a reduction in the service life and reliability.

The oxidation of contacts and surfaces of electrodes can occur as a result of chemical reactions. Gases of the environment in the connection with the moisture during irradiation form acids, which also can exert harmful effect on the materials.



In the articles made of the organic materials are possible two forms of the transformation of the molecules of the substance: destruction and join. During the destruction the interruption/discontinuity of the main chains of the molecules of polymer occurs. Due to the destruction in these materials can occur the following changes in the properties: softening, decrease of tensile strength, increase in elongation at rupture, decrease of resistance by the shear/section, reduction in the melting point, increase of solubility.

Page 122.

Because of the processes of cross-linking in polymers occurs cross linking, and consequently, the creation of the branched molecules. As a result of the intermolecular crosslinking can be observed the increase of hardness and brittleness, an increase in the value of Young's modulus, an increase in the melting point, a decrease of solubility, an increase in the density.

In the presence of the chemical reactions, which occur during irradiation in the inorganic and organic materials is possible the generation of gas in the organic materials the formation of dust-figurative products. Liberation of gas in the closed volume can lead to the mechanical damages of the articles of radio-electronic

equipment, and in the vacuum-tube instruments - to poisoning of cathodes.

The entry/incidence of dust-figurative products to the contacts causes the disturbance/breakdown of contacts in such elements/cells as relays, potentiometers, switches, etc.

During irradiation of inorganic insulation their volume expansion can be observed. Thus, for instance, in work [13] it is shown that during irradiation by neutron flux  $10^{24}$  n/m<sup>2</sup> insulation are expanded by 1%.

In the process of irradiation also change spectral characteristics and mechanical strength of glass. so, the optical transmission of glass can already noticeably deteriorate with the exposure dose of  $\gamma$ -radiation  $10^6$ - $10^7$  r and the neutron flux of  $10^{18}$ - $10^{19}$  n/m<sup>2</sup>. A change in the optical transmission of glass can affect, for example, the sensitivity of photocells. Lead and phosphate glass are most stable, less stable - silicate and especially borate glass, which have large neutron-capture cross section [14].

And finally it is necessary to note the possibility of formation/education in the materials of the radioelements of the

admixtures/impurities of the radioactive materials, which will be the sources of the ionizing radiations/emissions and they can exert influence on a partial change in the electrical parameters of radioelements and circuits, and also impede repair and operation of equipment. The duration of the luminescence of radioactive elements can continue for months and even for years.

Page 123.

Greatest induced radioactivity acquire the articles, prepared from the materials, in which are included boron, manganese, cadmium and other substances with the high value of the transverse capture of the ionizing radiations/emissions. Table 4.1 as an example gives the periods of half-life and energy of the  $\gamma$ -radiation of some radioactive chemical elements, which are formed as a result of capture reactions of neutrons.

After the examination of the possible forms of damages in the materials and the elements/cells, prepared from these materials, let us pause briefly at the character of interaction of those ionizing radiation/emission with materials and elements/cells of electronic devices.

4.2. Character of interaction of neutrons with the substance.

Neutron bombardment causes sufficiently complicated and deep changes in the structure of substance.

In the absence of electric charge electromagnetic interaction of neutrons with the electrons and coulomb field of nucleus is insignificant. It is possible to consider that interaction of neutrons and electrons is not reflected in the behavior of neutrons and it is unessential for describing interaction of neutrons with the substance.

Table 4. Activity of the materials, which are formed as a result of capture reaction of neutrons.

(1) Наименование элемента	(2) Содержание активируемого изотопа, %	(3) Период полу- распада	(4) Энергия излучения, Мэв
Алюминий (5)	100	2,3 мин (6)	1,8
Железо (7)	0,34	47,1 дня (8)	0,2; 1,1; 1,28
Кальций (9)	0,0032	4,3 дня (8)	1,4
Натрий (10)	100	15 час (11)	1,4; 2,8
Калий (12)	6,9	12,5 час (11)	1,5
Магний (13)	11,3	9,4 мин (6)	0,84; 1,06
Марганец (14)	100	2,6 час (11)	0,85; 1,8; 2,13
Кислород (15)	0,2	27 сек (16)	1,2

Key: (1). Designation of element/cell. (2). Content of activated/promoted isotope, %. (3). Half-life period. (4). Radiant energy, MeV. (5). Aluminum. (6). min. (7). iron. (8). day. (9). Calcium. (10). Sodium. (11). hour. (12). Potassium. (13). Magnesium. (14). Manganese. (15). Oxygen. (16). s.

Page 124.

Neutrons can exist comparatively for a long time in the equilibrium with the nuclei of substance, as a result of which they sufficiently easily penetrate to the nuclei (up to the heavy ones). The very strong interaction, caused by nuclear attracting forces, appears at short distances from the nucleus (about  $10^{-13}$  m) between the neutron and nucleus.

With the passage of the neutrons through the substance can m occur their following reactions with the nuclei of different elements/cells [5, 16-18]:

- elastic scattering according to the reaction (n, n) with the time of scattering  $10^{-14}$ - $10^{-21}$  s;

- absorption (capture) of neutrons with the formation of compound nucleus. The formed compound nucleus will be found in the excited state. Excitation energy is approximately/exemplarily equal to the sum of kinetic energy of absorbed neutron and its binding energy in the formed compound nucleus.

During the elastic neutron scattering loses the part of its kinetic energy (its rate it decreases), transferring to its atomic nucleus of the bombarded substance, and it differs from initial direction of motion. In this case total kinetic energy and impulse/momentum/pulse of the colliding particles is not changed. This process is analogous to the process of the shock of two elastic bodies, for an example of billiard spheres. In this case the nucleus, with which the neutron had interaction, is usually called "recoil nucleus".

The excited compound nuclei, which were being formed as a result of neutron capture, exist during  $10^{-12}$ - $10^{-13}$  s. The transition of the excited nuclei into the normal state occurs by the neutron emission, gamma-rays, protons, alpha- and other particles or with the formation/education of fission fragments.

Capture reaction of neutron with its subsequent emission of form (n, n) outwardly does not differ from elastic scattering. In actuality it in contrast to elastic scattering occurs with the formation of the composite/compound excited nucleus and, therefore, the duration of this process is into millions of times more than the duration of the process of elastic scattering. If as a result of this reaction the energy state of nucleus coincides with its initial energy state (to neutron capture), then this process of interaction of neutrons with the atomic nuclei of substance also is conventionally designated as elastic scattering.

Page 125.

There can be such case, when nucleus after neutron emission remains in the excited state; in this case the part of the kinetic energy of the bombarding neutron will be expended/consumed on the

excitation of nucleus and as a result of reaction total kinetic neutron energy and nucleus after collision will be less than their total energy to the collision. Such phenomenon, when the part of absorbed energy of the falling/incident (bombarding) neutron is converted into the internal energy of nucleus, and the emitted neutron has smaller energy in comparison with that falling, they call the inelastic scattering of neutrons and conditionally write/record in the form  $(n, n')$ . In this case the energy excess of the excited nucleus, as a rule, is emitted in the form of  $\gamma$ -quantum.

The course of the reaction of inelastic scattering is possible only with the neutron energy, which exceed the energy, necessary for the excitation of nucleus. Therefore the process of inelastic scattering is virtually feasible for the fast neutrons.

Other processes of capture by the nuclei of neutrons in contrast to the processes of scattering are accompanied by the nuclear reactions, which lead to the formation of new nuclei in the substance. They include:

- reactions of radiation capture of the type  $(n, \gamma)$ , accompanied by emission by the excited nucleus of one or several  $\gamma$ -quanta;
- cleavage reaction throated of the charged/loaded particles of



the types (n, d) (n, p) (n,  $\alpha$ ) and others;

- reaction throated of several neutrons (n, 2n) (n, 3n) and so forth;

- fission reaction of heavy nuclei (n, f).

In the conventional designations of the reactions examined, and also subsequently in the text are accepted the following designations: n - neutrons,  $\gamma$  - gamma-rays, p - protons,  $\alpha$  - alpha particles, d - deuterons, f - fission fragments; the first letter in the brackets - particle, which interacts with the nucleus, the second - particle, which is formed as a result of the occurring nuclear reaction.

The new nuclei of substance, which appear as a result of capture reactions, can be stable and radioactive.

Page 126.

The probability of the processes of interaction of neutrons with the nuclei depends mainly on neutron energy and nature of target nuclei (mass number, etc.). This probability they quantitatively characterize with effective interaction cross section.

By cross section  $\sigma$  it is accepted to understand the area of the circle, circumscribed around target nucleus, upon falling of neutron in which is realized the reaction of this type. If the neutron flux, equal to  $\Phi_n$ , falls GA plate with thickness  $X$ , which contains in  $1 \text{ m}^3$  a number of nuclei  $q_0$ , then a number of nuclear processes ( $N$ ) can be determined from the following expression:

$$N = \Phi_n q_0 X \sigma,$$

whence

$$\sigma = \frac{N}{\Phi_n} \cdot \frac{1}{q}, \quad (4.4)$$

where  $q = q_0 X$  - number of nuclei, which are contained in the irradiated volume of plate from this material.

Thus, the value of cross section is the probability of interaction of neutron with the substance when to each square meter of the irradiated surface with walks one nucleus. It is measured in the units of area. One measurement is the barn:

$$1 \text{ barn} = 10^{-28} \text{ m}^2 = 10^{-24} \text{ cm}^2.$$

Complete effective interaction cross section designate  $\sigma$  or  $\bar{\sigma}$ . It is the sum of all effective ones interaction cross section with the nuclei of this substance, i.e., the section of elastic and inelastic

scattering  $\sigma_s$  and  $\sigma'_s$ , the radiation-capture cross section  $\sigma_r$ , of sections  $\sigma_p$  and  $\sigma_\alpha$ , reactions (n, p) and (n,  $\alpha$ ), section  $\sigma_f$  of division (n, f) and so forth:

$$\sigma_t = \sigma = \sigma_s + \sigma'_s + \sigma_a, \quad (4.5)$$

where

$$\sigma_a = \sigma_r + \sigma_p + \sigma_\alpha + \sigma_f + \dots,$$

i.e.  $\sigma_a$  designates effective reaction cross-section, as a result of which are absorbed the neutrons.

Page 127.

The complete effective interaction cross sections of neutrons with the nuclei of the substances at present are known almost for all chemical elements/cells and wide interval of neutron energy and are most fully given in handbooks [17]. The sections of the separate reactions of interaction of neutrons with the atomic nuclei, especially scattering cross section, are known with the smaller accuracy.

For the neutrons with the kinetic energy from 10 keV to 20 MeV the value of effective interaction cross section approximately equal to the cross-sectional area of nucleus it is target [17]  $\sigma = \pi r^2$ , where  $r$  - nuclear radius.

The cross sections of the separate forms of chemical elements for the wide energy spectrum of neutrons range from  $10^{-28}$  to  $10^{-22}$  m<sup>2</sup> ( $10^{-2}$ - $10^3$  barn). For the separate most widely used types of chemical elements Table 4.2 gives the effective capture cross-sections and scattering for the thermal neutrons and the neutrons with the energy 1 MeV. Some data over the interaction cross sections of neutrons with the energy from 0.01 eV that of 10 MeV with the atomic nuclei of hydrogen, carbon, nitrogen, oxygen, lithium, boron and cadmium are shown in Table 4.3.

Table 4.2. The cross sections of chemical elements (in the barns).

(1) Наименование элемента	(2) Теплые нейтроны		(3) Нейтроны с энергией 1 Mev	
	(4) сечение захвата	(5) сечение рассеяния	(4) сечение захвата	(5) сечение рассеяния
Водород (6)	0,33	36,0	—	4,3
Углерод (7)	0,0045	5,0	—	2,6
Азот (8)	1,78	13,0	0,01	1,5
Кислород (9)	<0,0002	4,2	—	8,0
Алюминий (10)	0,21	1,4	0,00037	2,5
Кремний (11)	0,13	1,7	—	4,5
Марганец (12)	12,7	2,3	0,0038	3,0
Кобальт (13)	35,4	5,0	0,0011	3,1
Медь (14)	3,6	7,2	—	3,5
Магний (15)	—	3,6	—	—

Key: (1). Designation of element/cell. (2). Thermal neutrons. (3). Neutrons with energy 1 MeV. (4). capture cross section. (5). scattering cross section. (6). Hydrogen. (7). Carbon. (8). Nitrogen. (9). Oxygen. (10). Aluminum. (11). Silicon. (12). Manganese. (13). Cobalt. (14). Copper. (15). Magnesium.

Page 128.

Table 4.3. Interaction cross sections of neutrons with light nuclei and cadmium in the range of energies 0.01-10<sup>7</sup> eV.

(1) Энергия ней- тронов, эв	(2) Сечение взаимодействия, барн (10 <sup>-28</sup> м <sup>2</sup> )										
	(3) водород		(4) углерод		(5) азот		(6) кислород		(7) литий	(8) бериллий	(9) кадмий
	$\sigma$	$\sigma$ (Л, Г)	$\sigma$	$\sigma_a$	$\sigma$	$\sigma_a$	$\sigma$	$\sigma_a$	$\tau$ (Л, Г)	$\tau$ (Л, Г)	$\tau$
0,01	49	—	4	—	15	—	4,8	0,0002	—	—	3 500
0,025	36	0,33	5	0,003	13	1,88	4,2	—	71	755	2 550
0,1	27	—	4,8	—	11,5	—	3,8	—	36	380	3 500
1,0	21	—	4,8	—	10,5	—	3,8	—	12	120	23
10	20	—	4,6	—	10	—	3,8	—	4	36	5
10 <sup>2</sup>	20	—	4,6	—	9,7	—	3,8	—	—	12	7
10 <sup>3</sup>	20	—	4,6	—	8,1	—	3,8	—	—	3,7	6
10 <sup>4</sup>	19	—	4,6	—	—	—	—	—	—	1,7	7
10 <sup>5</sup>	12,5	—	4,5	—	4	—	3,4	—	0,1	0,65	7
10 <sup>6</sup>	4,3	—	2,6	—	1,5	0,01—0,2	8,0	—	—	0,4	6
10 <sup>7</sup>	0,95	—	1,1	—	—	—	1	—	—	—	4

Key: (1). Neutron energy, eV. (2). Interaction cross section, barn (10<sup>-28</sup> m<sup>2</sup>). (3). hydrogen. (4). carbon. (5). nitrogen. (6). oxygen. (7). lithium. (8). beryllium. (9). cadmium.

Page 129.

Together with the effective interaction cross section of neutrons with the substance, for calculating weakening the density of

the directed neutron fluxes during their propagation (passage) through different materials is used the concept about the macroscopic cross section  $\Sigma$  (more frequently they say macroscopic cross section or simply macroscopic section). Dimensionality of macroscopic cross section  $1/m$  ( $m^{-1}$ ). This value is analogous to the linear coefficient of weakening  $\gamma$ -radiation.

The value, reciprocal to macroscopic section, is the mean free path  $\lambda$  of neutron in the material, namely:

$$\lambda = \frac{1}{\Sigma}.$$

The numerical value of the quantity of mean free path is equal to the layer of the material, with passage of which the neutron flux is weakened/attenuated in  $e$  (approximately/exemplarily into 2.7) of times. Thus, for instance, mean free paths in the water for the neutrons with different energy are equal to: 0.28 cm for the thermal neutrons with the energy 0.025 eV; 2.45 cm for the neutrons with the energy 1 MeV and 11 cm for the neutrons with the energy 10 MeV.

In actuality in electronics we deal concerning the materials, which consist of the mixture of natural chemical elements; therefore during the determination of cross section  $\sigma$  or macroscopic cross section  $\Sigma$  it is necessary to consider the atomic (more precise nuclear) composition of material.

It follows from the known data over the effective cross sections that the processes of elastic scattering and radiation capture energetically can occur with any neutron energy almost for all nuclei.

For the fast and intermediate neutrons (with the kinetic energy from 0.5 eV to 20 MeV) the elastic scattering is the most important process of interaction with the substance. The probability of capturing the fast neutrons is into hundreds of times less than the probability of scattering. True, with the neutron energy 10-20 MeV the penetration probability of the reactions of inelastic scattering and nuclear reactions is compared with the probability of elastic scattering [17].

Page 130.

For some light nuclei (lithium, boron, helium and nitrogen) during interaction with the intermediate neutrons most probable are exothermic capture reactions of neutrons with further formation/education of the charged/loaded particles of the types  $(n, \alpha)$  and  $(n, p)$ , in particular:



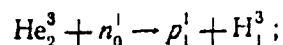
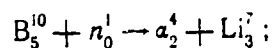
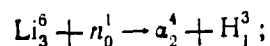

Similar type reactions for other nuclei of substance are considerably less probable.

In connection with the fact that the charged/loaded particle with the escape from the nucleus must overcome the potential Coulomb barrier of the excited nucleus, reaction with the emission of the charged/loaded elementary particles, as a rule, are endothermic (reactions, which take place with the energy absorption) and they are possible with the neutron energy, which exceed certain specific threshold value. Energy of the potential threshold is proportional to the reference number of atomic nucleus to degree of  $2/3$  ( $Z^{2/3}$ ) [17]. Reactions with the emission of the charged/loaded particles are most probable during interaction of neutrons with the high energy (as a rule, more than 1 MeV) with the nuclei of light elements ( $A < 25$ ).

The probability of the reactions of inelastic scattering ( $n, n'$ )

← is also insignificant. The course of it is possible for the neutrons with the energy of more than energy of the first excitation

level of nucleus. For the light nuclei the first excitation levels have energy on the order of 0.5-5 MeV, for heavy nuclei ( $A > 80$ ) - not more than 100 keV.

Finally, reactions throated of several neutrons and charged/loaded particles, i.e., types  $(n, 2n)$   $(n, 3n)$   $(n, np)$ , are possible during the bombardment of the atomic nuclei of substances with neutrons with the energy 20 MeV and more [17], with exception of reaction  $(n, 2n)$ , which can flow/occur/last with the neutron energy of approximately 9 MeV [19]. The nuclear reactions throated of  $\pi$ -mesons are possible for the neutrons with the energy 140 MeV.

Page 131.

During the elastic collisions the energy, transferred to atomic nucleus, is within the limits from zero (during grazing collisions) to maximum value  $E_{\text{max}}$ . On the basis of the laws of the conservation of energy and moment of momentum

$$E_{\pi} = \frac{4m_n M}{(m_n + M)^2} E_n \cos^2 \theta, \quad (4.6)$$

where  $E_{\pi}$  - energy, transferred to the nucleus of substance;

$m_n$  - mass of neutron;

$M$  - nuclear mass of atom;

$E_n$  - neutron energy;

$\theta$  - angle between the initial direction of neutron and the direction of the motion of "nucleus from the giving".

The differential cross section of the energy transfer from  $E$  to  $E+dE$  can be calculated according to the formula

$$d\sigma = \frac{\sigma_t}{E_{\text{mass}}} dE, \quad (4.7)$$

where  $\sigma_t$  - complete neutron cross section, when the cross section is wholly determined by elastic collisions. Medium energy  $\bar{E}$ , transferred during the elastic collisions (under these conditions), will be equal to  $R = E_{\text{mass}}/2$ .

As a result of processes of elastic scattering on the nuclei of substance the neutrons transfer the part of their energy and, naturally, stall. A decrease in the velocity and, consequently, also kinetic neutron energy depends on the nuclear mass of substance, and also on the value of scattering angle. It is evident from formula (4.6) that the less the nuclear mass and the greater the scattering angle, the more energy the neutron loses. Energy losses to the elastic scattering are insignificant for the heavy elements. Thus, for instance, for reducing the kinetic energy of fast neutrons to the

energy of thermal neutrons it is necessary to 18 collision with the nuclei of hydrogen (mass number equal to one) and 2000 collisions with the nuclei of lead (mass number equal to 207).

As a result of gradual moderation of neutrons acquires an energy of the thermal agitation of atoms of substance, i.e., energy 0.025 eV at a room temperature.

Page 132.

By the most probable reactions during capture of thermal and slow neutrons the nuclei of substance are the reactions of radiation capture, for example, reaction throated  $\gamma$ -quantum with the energy 2.23 MeV of the type  $H^1 (n, \gamma) H^2$ . The reactions of radiation capture lead, as a rule, to the formation of beta-radioactive isotopes. Capture reaction of thermal neutrons with the subsequent emission of the charged/loaded particles the sufficiently rare.

Fission reactions are characteristic for the heavy nuclei (for example, uranium-233, uranium-235, plutonium 239, etc.) and occur under the influence both of thermal and fast neutrons, but it is most characteristic for the neutrons with the kinetic energy into several mega-electron-volts. These reactions are accompanied by release of high energy (approximately/exemplarily 200 MeV to each fission) and

by neutron emission [17, 19].

As was already noted above, neutron, being electrically neutral particle, virtually does not interact directly with the electrons of atoms, in connection with which it relates to the indirectly ionizing particles. The ionization of substance in transit through it of neutrons is conducted due to the effect of "recoil nuclei", which appears during the elastic scattering, and also due to the effect of the charged/loaded particles and gamma-quanta, which appear in the presence of capture reactions. Furthermore, it is necessary to note that as a result of displacing the nuclei, the latter carry along with themselves their electron cloud, but in this case the peripheral electrons, which have the orbital speeds of less than the rate of "recoil nucleus", they can "fall behind" the nucleus. It is obvious that such processes also lead to the ionization of substance.

If "recoil nuclei" and charged/loaded particles even in the thin layers, as a rule, are absorbed by the completely irradiated material, then the scattered neutrons and  $\gamma$ -quanta (appearing in the presence of the reactions of radiation capture) can leave the attenuating material, having incompletely consumed its energy.

During the nuclear explosions and from nuclear reactors on the elements/cells and schematic of electronic engineering will act

simultaneously the neutrons of different energy. The spectra of these neutrons will depend in essence on the form of emitter, character of the media or retarder, through which are passed the neutrons.

Page 133.

Therefore in each specific case for determining the probable disturbances/breakdowns in the radio engineering materials it is necessary to calculate neutron distribution on the basis of energies. But in certain cases during the rough estimates they use the medium energy of this neutron spectrum, which can be determined according to formula (1.2). In this case it is only necessary to demarcate the effects of the action of slow (with the kinetic energy of less than 0.1 MeV, including of thermal ones) and fast neutrons (with the energy of more than 0.1 MeV).

The majorities of the articles of radio-electronic equipment are made from the nonfissionable materials, on which fast neutrons act in essence, since the effective capture cross-sections of slow neutrons in them are insignificant in comparison with the interaction cross sections of fast neutrons. Therefore the action of slow neutrons during the practical estimation of the majority of radio engineering articles can be disregarded/neglected.

Thus, during the evaluation of the effect of the action of neutrons on the materials, used in the radio-electronic equipment, it is necessary first of all to consider the effects of bias/displacement. During the calculation of a number of biases/displacements for each concrete/specific/actual material is accepted specific energy threshold  $E_d$ , equal to energy, which it must transfer neutron to recoil atom so that the latter could leave the node/unit of crystal lattice. Thus, for the atoms of silicon and germanium this energy is equal to approximately/exemplarily 15 eV.

A number of displaced atoms per unit of volume of material can be approximately determined according to the formula

$$N_d = \sigma_s q \bar{\nu} \phi t,$$

where  $q$  - number of atoms per unit of volume of material;

$\phi$  - neutron flux density;

$\bar{\nu}$  - average number of biases/displacements to one report/event of interaction of neutrons with the medium (when  $E_d < E_n < 2E_d$  a number bias/displacement  $\bar{\nu}=1$ );

$t$  - duration of irradiation.

During irradiation of materials by the gamma-neutron flow, which

appears as a result of fission reactions, they usually disregard the contribution to the ionization from the neutrons.

Page 134.

As already mentioned, during irradiation by the neutrons of materials in the latter the admixtures/impurities can be formed. The formation/education of such admixtures/impurities is connected with the processes of the radiation capture of neutrons of the type  $(n, \gamma)$ . The section of this reaction is inversely proportional to square root of neutron energy, i.e.,  $1/\sqrt{E_n}$ . The maximum of the section of this reaction is located in the region of thermal neutrons. In the series of elements (gold, indium, boron, silver, cadmium, etc.) with the specific energies are observed the resonance peaks, with which the values of effective radiation-capture cross section reach hundred and thousand barn.

The formation of radioactive nuclei occurs as a result of radiation capture. In the process of decomposing/decaying these nuclei occurs the radiation, which can lead to a change in the characteristics of materials. Therefore during the investigation of the action of neutrons on the materials, the elements/cells and the schematics of radio-electronic equipment it is necessary to consider the effect of thermal and slow neutrons and the action of induced



radioactivity, and with the work with the irradiated radio-electronic equipment it is expedient to apply protective measures.

#### 4.3. Interaction of the charged/loaded particles with the substance.

With the passage of the charged/loaded particles through the substance they produce ionization, directly interacting with the electrons of atoms.

The nuclear reactions or nuclear scattering occur as a result of colliding of elementary particles and atomic nuclei. The degree of interaction of the charged/loaded particles with the atomic nuclei depends on kinetic energy of incident particles, potential of nuclear forces, and it is also determined by the potential threshold of nucleus (by forces of Coulomb repulsion). During the collisions of the charged/loaded particles with the kinetic energy of less than the potential threshold with the nuclei the scattering occurs mainly. During the elastic scattering the sum of energies of the colliding particles and nuclei before and after collision does not change. When the part of the energy is expended/consumed on the excitation of nucleus, then such an interaction is carried to the inelastic scattering. In this case the excited nucleus usually emits  $\gamma$ -quanta.

The charged/loaded particles with the energy, which exceeds the potential threshold, penetrate directly the zone of action of the nuclear forces, as a result of acting which occur the nuclear reactions.

Electron collisions, ions, atoms, molecules with the energy not more than  $10^4$ - $10^5$  eV carry usually to the collisions atomic. The charged/loaded particles with this energy interact, in essence, with electronic atom shell of the substance (effect of nuclear forces on them usually is not considered). Atomic collisions also are elastic and inelastic. During the elastic collisions the direction of motion changes, But the internal state of the charged/loaded particles is not changed. A change in the internal energy of particles occurs as a result of inelastic collisions, which leads to secondary radiation. During the atomic collisions can occur the change in the particle structure, caused by ionizing effects, by the processes of overcharging, etc.

Let us pause briefly at the processes of interaction of protons and electrons with the substances.

Character of interaction of protons with the substance.

The effect of protons on the substance is caused, on one hand, by electromagnetic interaction, and on the other hand, by the absorption of protons by the atomic nuclei of substance. From the point of view of protection from proton radiation/emission these processes are in detail examined in [21]. Let us pause only at some general laws, characteristic for describing interaction of protons with the materials of radio engineering articles and diagrams.

Electromagnetic interaction of protons can be with the electrons and with the atomic nuclei of substance. With electromagnetic interaction with the atom occurs excitation both the ionization of atoms and the formation/education of the delta-electrons, which in turn cause the ionization of atoms. During electromagnetic interaction of proton with coulomb field of nucleus the elastic scattering occurs.

Page 136.

Energy, transferred to the electron of atom by the bombarding proton, which passes at the distances from the nucleus, large by the proton, which passes at the distances from the nucleus, ionization.

The degree of ionization, during electromagnetic interaction of protons with the substance, depends on the energy, absorbed in the material.

For the protons with the energy from 2 to  $10^5$  MeV (with the range of energy, most characteristic to cosmic radiation), which can produce essential disturbances/breakdowns in the radio-electronic diagrams and the radioelements, Table 4.4 gives computed values of the ionizing energy losses of protons in the beryllium, carbon, air, aluminum, copper and lead. The calculation of these losses for different energies of protons was conducted according to the method of Sternheimer [22].

When proton passes at the distances from a nucleus less than the size/dimension of atom, it tests/experiences Coulomb scattering in the nuclear field. Energy of proton in this case noticeably is not changed, i.e., it is possible to consider that the elastic electromagnetic scattering occurs. The probability of scattering in the field of the electrons of atom substantially less and it usually is not considered.

The divergence of protons in the nuclear field occurs, as a rule, it is repeated to comparatively small angles. Scattering the initial beam of protons with its passage through the substance occurs

as a result of repeated divergence.

Elastic and inelastic scattering can occur as a result of the proton bombardment of the nuclei of substance. Elastic scattering is the consequence of interaction, as soon as which was noted, Coulomb forces, nuclear forces, and also by the consequence of optical properties of nuclei [21]. Inelastic collisions lead to the course of the following intranuclear processes:

- the inelastic scattering of protons of the type  $(p, p')$ ;
- the nuclear reactions of types  $(p, n)$   $(p, d)$   $(p, \alpha)$ , etc.;
- reaction of the overcharging of a proton of the type  $(p, n)$ ;
- cleavage reactions, which occur with the emission of a large number of particles of the types  $(p, pn)$   $(p, 2n)$   $(p, p2n)$  and so forth, and also the nucleon groupings of types  $H^2$   $H^3$ ,  $He^3$ ,  $He^4$ ;
- nuclear reactions, leading to the formation/education of nuclear fragments with atomic number 3 or more ( $Z \geq 3$ ) or the so-called fragmentations.

Pages 137-138.

Table 4.4. Ionizing energy losses of protons in the substances.

(1) E <sub>p</sub> , Мэв	(2) Ионизационные потери, Мэв/ке·м <sup>2</sup> в:					
	(3) бериллии	(4) углероде	(5) алюминии	(6) меди	(7) свинце	(8) воздухе
2	13,19	14,06	11,08	7,893	4,114	13,4
3	9,745	10,44	8,316	6,183	3,462	9,986
4	7,806	8,397	6,744	5,127	2,985	8,053
5	6,559	7,074	5,719	4,408	2,636	6,800
6	5,669	6,126	4,984	3,873	2,365	5,899
7	5,015	5,428	4,438	3,471	2,154	5,232
8	4,503	4,881	4,009	3,150	1,981	4,711
9	4,099	4,447	3,667	2,894	1,840	4,296
10	3,763	4,087	3,380	2,677	1,718	3,951
20	2,138	2,334	1,970	1,591	1,073	2,266
25	1,780	1,946	1,652	1,342	0,9163	1,893
30	1,534	1,679	1,431	1,168	0,8050	1,635
35	1,353	1,482	1,267	1,038	0,7203	1,444
40	1,215	1,332	1,141	0,9383	0,6548	1,298
45	1,105	1,212	1,041	0,8584	0,6020	1,182
50	1,016	1,114	0,9584	0,7925	0,5681	1,087
55	0,9412	1,033	0,8902	0,7378	0,5213	1,009
60	0,8788	0,9645	0,8325	0,6914	0,4900	0,942
65	0,8254	0,9062	0,7831	0,6514	0,4629	0,8852
70	0,7791	0,8556	0,7402	0,6167	0,4391	0,8360
75	0,7380	0,8112	0,7026	0,5861	0,4181	0,7928
80	0,7026	0,7719	0,6693	0,5590	0,3996	0,7546
90	0,6424	0,7061	0,6132	0,5133	0,3682	0,6904
100	0,5933	0,6526	0,5674	0,4760	0,3424	0,6382
110	0,5527	0,6079	0,5292	0,4449	0,3209	0,5950
120	0,5187	0,5706	0,4973	0,4187	0,3027	0,5587

130	0,4896	0,5388	0,4700	0,3961	0,2870	0,5276
140	0,4644	0,5112	0,4464	0,3767	0,2734	0,5007
150	0,4424	0,4872	0,4258	0,3594	0,2616	0,4773
200	0,3647	0,4016	0,3522	0,2989	0,2189	0,3942
250	0,3173	0,3497	0,3072	0,2616	0,1924	0,3434
300	0,2853	0,3148	0,2771	0,2366	0,1747	0,3093
350	0,2625	0,2896	0,2555	0,2185	0,1619	0,2848
400	0,2453	0,2709	0,2392	0,2049	0,1523	0,2666
450	0,2321	0,2563	0,2268	0,1945	0,1448	0,2524
500	0,2215	0,2448	0,2169	0,1863	0,1390	0,2413
600	0,2059	0,2278	0,2022	0,1741	0,1305	0,2249
700	0,1950	0,2159	0,1921	0,1658	0,1246	0,2136
800	0,1871	0,2074	0,1849	0,1598	0,1205	0,2055
900	0,1812	0,2009	0,1795	0,1555	0,1175	0,1995
1 000	0,1767	0,1960	0,1754	0,1522	0,1153	0,1950
1 500	0,1649	0,1833	0,1649	0,1443	0,1104	0,1838
2 000	0,1608	0,1791	0,1618	0,1422	0,1099	0,1809
2 500	0,1595	0,1778	0,1611	0,1422	0,1108	0,1808
3 000	0,1593	0,1778	0,1615	0,1429	0,1121	0,1818
4 000	0,1604	0,1793	0,1635	0,1452	0,1150	0,1851
5 000	0,1621	0,1813	0,1659	0,1478	0,1178	0,1889
6 000	0,1638	0,1834	0,1682	0,1502	0,1204	0,1924
7 000	0,1655	0,1854	0,1704	0,1524	0,1227	0,1958
8 000	0,1670	0,1873	0,1724	0,1544	0,1248	0,1989
9 000	0,1685	0,1890	0,1743	0,1562	0,1267	0,2017
10 000	0,1699	0,1905	0,1759	0,1579	0,1284	0,2044
25 000	0,1822	0,2050	0,1913	0,1729	0,1436	0,2296
50 000	0,1915	0,2156	0,2027	0,1839	0,1546	0,2499
100 000	0,2005	0,2257	0,2134	0,1941	0,1648	0,2687

Key: (1). MeV. (2). Ionizing losses, MeV/kg·m<sup>2</sup> in. (3). Beryllium.  
 (4). carbon. (5). aluminum. (6). copper. (7). lead. (8). air.

The process of division occurs also under the action of high-energy protons in the heavy nuclei.

The probability of different processes of interaction of protons with the nuclei depends in essence on energy of protons and nature of the nuclei of substance. This probability, as for the neutron radiation/emission, it is characterized by the effective interaction cross section of proton with the nucleus of the bombarded substance. Complete effective interaction cross section is equal to the sum of the effective sections of all interaction of protons with the nuclei of the substance

$$\sigma_t = \sigma = \sigma_s + \sigma_a. \quad (4.8)$$

In formula (4.8), it is analogous with designations for the cross sections of neutrons in expression (4.5), by  $\sigma_t$  and  $\sigma$  understands complete cross section, by  $\sigma_s$  - elastic-scattering cross section, the characteristic "blurring" of the directed flow of protons, and  $\sigma_a$  - the cross section of all reactions, in the presence of which occurs the absorption of protons, i.e., section, which characterizes knocking out of protons from the incident flux.

Effective elastic-scattering cross section can reach the value, equal to the geometric cross section of nucleus, i.e.,  $\sigma_s = \pi r^2$ , and generally it, as a rule, always is less than this value. Sometimes  $\sigma_s = 3,2 \pi r^2$  [12].



The value of the cross section of inelastic nuclear interaction determines, in the first place, the process of absorbing the protons, and in the second place, characterizes the output of secondary particles from the substance. If the energy of protons is several times of more than the value of Coulomb barrier, approximately/exemplarily is equal to [21]

$$\sigma_0 = \pi (1,3 \cdot 10^{-15} A^{1/3})^2, \mu^2. \quad (4.9)$$

Consequently, a change in the properties of substance will depend on the direct effect of protons, and also on the effect of secondary particles, which were being formed as a result of interaction of protons with this substance.

Page 140.

During interaction of protons with the energy, which does not exceed 100 MeV, the radiation/emission of secondary particles is small and their energy small. With an increase in the energy of protons grows/rises a number of secondary particles and their energy. The formation/education of secondary low-energy and high-energy particles [21] is characteristic for the protons with the energy of more than 500 MeV. Secondary particles with the energy of less than 100 MeV, which consist in essence of the neutrons, the protons, the deuterons and the more heavy nuclei, carry to the low-energy ones. Particles the energy 100 MeV and more consider high-energy. They consist mainly of neutrons, protons and  $\pi$ -mesons. The latter have sufficiently great possibility of decomposition/decay to two quanta.

Formed secondary particles in turn can interact with the substance, causing nuclear reactions and ionization. The development of cascade nuclear process determine high-energy secondary particles, which are spread in the direction, close to the direction of the bombarding proton, being gradually scattered with the passage into the depths of the substance.

The role of nuclear interactions in comparison with the ionizing processes with an increase in the energy of the primary incident protons and thickness of substance (for example, the material of protective shield) grows/rises. Therefore during the calculation of the absorptions of a number of protons in the material it is necessary to consider nuclear interactions.

As an example Table 4.5 gives the relationships/ratios between nuclear and electromagnetic interactions of protons in carbon and lead depending on the thickness of material with the energies from 100 to 1000 MeV [21]. It is evident from these data that for the radioelements, whose thickness is equal to the landing run of protons or more its (thickness of landing runs they are given to table 1.2), nuclear interactions they can play the significant role. Furthermore, it is necessary to note that the probability of nuclear interactions considerably grows/rises with an increase in the depth of penetration of protons into the materials and barely depends on their energy in the range of energy from 100 to 1000 MeV.

Page 141.

But during the evaluation of the effect of protons on the substances

and the radioelements it is necessary to consider the effect of secondary particles of the radiation/emission; especially it exerts a substantial influence under the influence of the protons of high energies, which can cause also intranuclear cascade processes.

As a result of the energy absorption of incident proton it is consistently transferred to the separate nucleons of nucleus. The latter can also adjacent nucleons of nucleus, transferring by them energy. In turn, secondary recoil nucleons act on the following nucleons of nucleus, etc.

Table 4.5. Probability of nuclear and electromagnetic interactions depending on the depth of penetration of protons into the substance.

(1) Энергия протона, Мев	(2) Глубина проникновения, кг/м <sup>2</sup>	(3) Количество протонов (%), испытывающих взаимодействие			
		(4) в углеводе		(7) в свинце	
		(5) ядерные	(6) электромагнитные	(5) ядерные	(6) электромагнитные
100	50	5	95	2	98
150	50	5	95	2	98
150	100	10	90	5	95
300	50	5	95	2	98
300	100	9	91	4	96
300	500	39	61	20	80
600	50	5	95	3	97
600	100	10	90	5	95
600	500	42	58	23	77
600	1000	67	33	41	59
600	1500	81	19	54	46
1000	50	5	95	2	98
1000	100	10	90	5	95
1000	500	40	60	21	79
1000	1000	66	34	38	62
1000	1500	80	20	51	49
1000	2000	88	12	62	38

Key: (1). Energy of proton, MeV. (2). Depth of penetration, kg/m<sup>2</sup>.  
 (3). Quantity of protons (%), which experienced interaction. (4). in carbon. (5). nuclear. (6). electromagnetic. (7). in lead.

Page 142.

Thus, occurs avalanche-type process, or the so-called intranuclear cascade. The nucleons, which have a sufficient energy for the escape

from the nucleus, are called cascade particles [21].

The formation/education of cascade particles as a result of inelastic collisions of protons with the nuclei of substance and their relationship/ratio depend on energy of the bombarding proton and characteristics of atomic nucleus.

Some information about the average/mean values of the outputs of cascade protons, neutrons and  $\pi$ -mesons ( $\pi^0$ ,  $\pi^+$  and  $\pi^-$ ) depending on energy of that falling heating, from which it follows that the output of cascade particles increases with an increase in the energy of the bombarded proton, they are given in Table 4.6. Output of cascade particles decreases for the bombarded protons with the energy of less than 800 MeV with the increase of mass number, and with the energies of more than 800-1000 MeV an increase in the output of cascade particles is noted. Kinetic energies of cascade particles can reach the values of energies of the bombarded proton. The lower limit of energy spectrum is determined for the protons by the Coulomb barrier of nucleus, for the neutrons the spectrum somewhat soft, since to their output from the nucleus Coulomb barrier does not exert effect.

After the output of cascade particles the nucleus remains in the excited state, since the part of absorbed energy was transmitted to recoil nucleons, which did not escape from the nucleus. This

excitation energy is redistributed between the nucleons of nucleus and as a result of the fluctuation can be transmitted to one or several nucleons, which can in view of this leave nucleus. This process by analogy with the process of evaporating the heated drop of liquid was named the evaporative stage of the inelastic nuclear interaction of proton, and the emitted particles - by evaporative particles. Evaporative particles consist in essence of neutrons (about 50%) and protons (about 25%), and also there are among them deuterons, triton, helium-3 and  $\alpha$ -particles. Heavier particles are formed in a larger quantity at high energies of the bombarding protons.

The energy spectra of evaporative particles, as a rule, especially for the charged/loaded particles, little depend on energy of the bombarding proton.

Page 143.

Thus, for instance, during the nuclear bombardment of nickel, silver and gold by protons with the energy 190 MeV the energy spectrum of evaporative neutrons is spread to 10-15 MeV (maximum with the energy of approximately 1 MeV), in evaporative protons and deuterons the maximum is shifted into the range of energies 5-10 MeV, in  $\alpha$ -particles - into the range 10-15 MeV (21].

The information about the outputs of evaporative and cascade particles from the nuclei of substance during the bombardment with their protons of different energies at present are very insignificant. Consequently, it is possible to only very tentatively rate/estimate the effects of disturbance/breakdown in the materials and those in the elements of construction/design and the electronic circuits under the influence on their proton radiations/emissions.

Character of interaction of electrons with substance

Electrons, passing through the substance, interact with the electrons of atoms or with coulomb field of nucleus.



Table 4.6. Output values of cascade protons, neutrons and  $\pi$ -mesons, that fall for one inelastic interaction of proton with the target nucleus.

(1) Энергия про- тона, Мэв	(2) Величина выхода из								
	(3) алюминий-27			(7) медь-64			(8) уран-238		
	(4) про- то- нов	(5) нейт- ронов	(6) $\pi$ -ме- зонов	(4) про- то- нов	(5) нейт- ронов	(6) $\pi$ -ме- зонов	(4) про- то- нов	(5) нейт- ронов	(6) $\pi$ -ме- зонов
82	0,80	0,67	—	0,6	0,63	—	0,18	0,39	—
158	—	—	—	0,87	0,83	—	0,41	0,82	—
239	1,37	1,03	—	1,15	1,07	—	0,65	1,05	—
290	—	—	—	1,27	1,27	—	—	—	—
460	1,9	1,5	0,144	1,63	1,67	0,110	1,00	1,94	0,108
690	—	—	—	2,13	2,17	0,308	—	—	—
940	—	—	—	2,46	2,83	0,540	1,76	3,54	0,430
1840	3,5	3,22	1,170	3,77	4,23	1,056	2,83	5,90	1,017

Key: (1). Energy of proton, MeV. (2). Value of output from. (3). aluminum-27. (4). protons. (5). neutrons. (6).  $\pi$ -mesons. (7). copper 64. (8). uranium-238.

Page 144.

During the elastic interactions with the electrons of atoms the energy of the passing electrons is not lost, but direction of their motion sharply changes, which leads to the dissipation of energy and weakening of flow. During inelastic collisions the passing electron transfers the part of its energy to the bound electrons of atom. Depending on a quantity of transmitted energy occurs excitation or

the ionization of atoms. The secondary electrons, pulled out from the atom, have in the majority of the cases energy several hundred electron volts, sufficient for the ionization of the adjacent atoms. Such electrons are called  $\delta$ -electrons.

With low energies of electrons the losses are almost completely ionizing.

In transit through the substance of electrons with the high energy, simultaneously with the ionizing losses, occurs the energy conversion of electrons into the braking electromagnetic radiation. These, so-called, radiation losses compose the significant part of the total losses of energy, when the velocity of electrons is close to the speed of light. According to Bethe and Heitler the ratio of the radiation energy losses to the ionizing losses is described by the expression

$$A = \frac{\left(\frac{dE}{dx}\right)_{\text{рад}}^{(1)}}{\left(\frac{dE}{dx}\right)_{\text{иониз}}^{(2)}} \approx \frac{EZ}{1500 \text{ mc}^2} \quad (4.10)$$

Key: (1). rad. (2). ioniz. (3).  $\text{ms}^2$ .

where E - the wave energy of electron;

Z- the atomic number of the substance of absorber.

Table 4.7 gives for some materials the critical values of energy of electrons, which correspond to  $A=1$ .

For the light-density materials, when energy of the falling/incident electrons does not exceed several million electron volts (for example, the electrons of external and artificial Earth radiation belts), radiation losses are only certain correction to the total loss of energy. For the heavy materials this correction can be essential.

Page 145.

With the passage of the fast electrons through the substance the direct excitation of lattice vibrations occurs, but the energy losses of electrons in this case are insignificant in comparison with ionizing losses [15]. Is possible also the direct drive of energy to the atoms of substance, which under certain conditions leads to the emergence of structural defects.

Table 4.7. Critical values of energy of electrons.

(1) Химический элемент	(2) Атомный номер	(3) Значение энергии при $A=1$ , Мэв
(4) Алюминий	13	273
(5) Кремний	14	58,6
(6) Германий	32	25,6
(7) Олово	50	16,4
(8) Свинец	80	10,0

Key: (1). Chemical element. (2). Atomic number. (3). Value of energy with  $A=1$ , MeV.

#### 4.4. Character of interaction of X-ray and gamma-radiation with the substance.

Energy of X-ray ones and gamma-quanta with their passage through the substance is expended/consumed on interaction with the electrons, the nucleons, the field of electric charges and the meson field of atomic nucleus. The possible forms of the effects of absorption, elastic and inelastic scattering are given in Table 4.8 [28].

The absorption and scattering of  $\gamma$ -quanta occurs as a result of these interactions. During the energy absorption of  $\gamma$ -quanta completely is converted into other forms of energy, while during the elastic scattering a change in the direction of propagation of radiation/emission occurs. Inelastic scattering leads to a change in

the direction of propagation of quantum and to the partial absorption of energy.

In  $\gamma$ -quanta with the energy to 10 MeV are observed three processes of interaction of  $\gamma$ -radiation with the substance: photoelectric absorption (photo effect), Compton effect (Compton effect or the Compton effect) and effect of the formation of electron-positron pairs or is simple the effect of the formation of the pairs (see Fig. 4.2).

Page 146.

They usually disregard the processes of nuclear photo effect, nuclear scattering, etc. with the energies of  $\gamma$ -quanta to 10 MeV. With the high energies of the primary  $\gamma$ -quanta, characteristic for the cosmic radiation, these processes can give the significant contribution to the general/common/total effect of the action of  $\gamma$ -radiation on the substance. Thus, for instance, if quantum energy exceeds energy of binding of nucleon in the atomic nucleus, then during interaction of quantum with the nucleus the extraction of the nucleon (this process by analogy with the photo effect of atom is called nuclear photo effect) can occur.

As a result of interaction of  $\gamma$ -quanta with the substance occurs

the absorption of their energy and emergence in the substances of secondary radiation namely: fluorescence, bremsstrahlung, annihilation radiation/emission. The appearing charged/loaded ions can lead to the formation of atomic defects (intermediate atom-vacancy).

Photoelectric absorption is characterized by the process of interaction  $\gamma$ -quantum with the electron of the atom, with which  $\gamma$ -quanta it is absorbed by atom.

Table 4.8. Classification of the possible forms of interaction of  $\gamma$ -radiation with substance.

(1) Объект взаимодействия	(2) Виды процессов		
	(3) Поглощение	(4) Упругое рассеяние	(5) Неупругое рассеяние
(6) Атомные электроны	(7) Фотоэффект	(8) Классическое рассеяние на электронах	(9) Комптоновское рассеяние
Нуклоны (10)	Ядерный фотоэффект (11)	(12) Классическое рассеяние на ядрах	—
(13) Кулоновское поле	(14) Образование пар	(15) Рассеяние Дельбрюка	—
(16) Мезонное поле	(17) Мезонное взаимодействие		—

Key: (1). Object of interaction. (2). Forms of processes. (3). Absorption. (4). Elastic scattering. (5). Inelastic scattering. (6). Atomic electrons. (7). Photo effect. (8). Classical scattering on electrons. (9). Compton effect. (10). Nucleons. (11). Nuclear photo effect. (12). Classical scattering on nuclei. (13). Coulomb field. (14). Pair formation. (15). Scattering Delbruck. (16). Meson field. (17). Meson interaction.

Page 147.

Energy  $\gamma$ -quantum is expended/consumed on the communication/report to electron of the speed (it converts/transfers into the kinetic energy of electron) and on overcoming of electron-binding energy in the atom. Consequently, energy  $\gamma$ -quantum must be compulsorily more than

electron-binding energy in the atom.

The formation/education of vacant place (empty level) at the appropriate energy level of electron shell is the consequence of photo effect. In this place it can in turn pass electron from another energy level, which leads to the emission of the quantum of characteristic radiation/emission. The transition of electrons to the empty levels causes the isolation/liberation of the energy excess, which can be the consequence of the Auger effect - escape from the atom of electron from the external electron level.

Thus, with the photo effect energy of  $\gamma$ -quanta is expended/consumed on the extraction from the atom of photoelectrons and Auger electrons and communication/report to them of kinetic energy, and also in insignificant quantities for the formation/education of the quanta of characteristic radiation/emission.

The degree of the energy absorption of  $\gamma$ -radiation is considered with the aid of the photoelectric absorption coefficient. Linear photoelectric absorption coefficient  $\tau$  is equal to the sum of the linear coefficients, which consider energy conversion of  $\gamma$ -quanta into the kinetic energy of electrons  $\tau_K$  and energy of characteristic radiation/emission  $\tau_0$ , namely:

$$\tau = \tau_K + \tau_0.$$

(4.11)



It is possible to accept in the majority of the practical cases for the radio engineering materials that during the photoelectric absorption entire/all energy of  $\gamma$ -radiation converts/transfers into the energy of photoelectrons.

Compton effect occurs on the electrons of atom. In this case  $\gamma$ -quanta loses the part of its energy and is changed direction of motion, i.e., occurs the process of scattering; the energy, transmitted to electron, is expended/consumed on the electron detachment from the atom and the communications/reports to it of speed (kinetic energy). Quanta can be scattered in any directions.

Page 148.

The greater the energy  $\gamma$ -quantum, the less the mean angle of its divergence from the initial direction. Electrons from the atom can escape in the limits of angle [25]

$$\frac{\pi}{2} > \theta > -\frac{\pi}{2}$$

The scattered  $\gamma$ -radiation is formed as a result of processes of Compton interaction of  $\gamma$ -quanta with the substance. If the

sizes/dimensions of dissipative material are sufficiently great, then the value of quantum energy descends as a result of repeated processes of scattering also the effect of photoelectric absorption occurs finally.

With the decrease of energy the  $\gamma$ -quantum decreases and the portion of its energy, lost by the scattering, since photo effect becomes more probable.

The linear coefficient of Compton interaction  $\sigma$  can be represented in the form

$$\sigma = \sigma_K + \sigma_s, \quad (4.12)$$

where  $\sigma_K$  and  $\sigma_s$  - linear interaction coefficients, which determine energy conversion  $\gamma$ -quantum into the energy of recoil electrons and energy of the scattered quanta respectively.

The effect of the formation of electron-positron pairs is observed during interaction of  $\gamma$ -quanta with coulomb field of nucleus. As a result of this interaction of  $\gamma$ -quanta completely loses its energy and is formed the pair of particles positron-electron. Consequently, this effect can occur with the energy the  $\gamma$ -quantum, which is more than total rest energy of positron and electron, i.e., it is more than the doubled rest energy of electron  $2m_0s^2=1.02$  MeV. The remaining part of the energy  $\gamma$ -quantum (minus energy  $2m_0s^2$ ) is

converted into the kinetic energy of electron and positron. Positron in turn interacts with the electron of medium; this interaction leads to the formation of two quanta of annihilation radiation/emission. This secondary radiation occurs with the larger probability in the positrons, which were retarded to the kinetic energy, close to zero, i.e., energy of  $\gamma$ -quanta will be equal to approximately 0.51 MeV.

Page 149.

During the calculation of the effect of pair formation they use the appropriate coefficients. The linear pair-production coefficient it is accepted to designate  $K$  or  $\kappa$ , and the part of the coefficient, which characterizes energy consumption  $\gamma$ -quantum, that proceeds with communication/report to electron and to the positron of kinetic energy, designate  $K_{\kappa}$  and calculate from relationship/ratio [26]

$$K_{\kappa} = \frac{E_{\gamma} - 1.02}{E_{\gamma}} K, \quad (4.13)$$

where  $E_{\gamma}$  - energy of primary  $\gamma$ -quantum.

In the practice under the influence of  $\gamma$ -radiation on the articles of electronic engineering they usually deal concerning the flow of  $\gamma$ - quanta of different energy, which, as a rule, interact with different substances. Therefore the absorption of  $\gamma$ -quanta in the articles of electronic engineering will occur simultaneously as a

result of the course of the processes of photoabsorption, Compton effect and effect of pair formation. The relationship/ratio between these effects depends in essence on the energy radiation spectrum and atomic number of substance.

Fig. 4.4 shows the regions of energies of elements/cells with different atomic numbers, in which predominates one or another the effect. The dividing lines are carried out so that the probability for the adjacent processes is identical along these lines.

For  $\gamma$ -quanta with low energy characteristically photoelectric absorption. With an increase in the atomic number of substance increases the range of energy of  $\gamma$ -quanta, with which predominates the probability of photo effect (region A Fig. 4.4). For example, in lead with  $Z=82$  this process predominates to the energy 0.5 MeV.

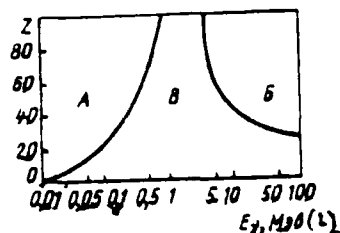

Fig. 4.4. The regions of energies, in which predominate different basic processes during interaction of  $\gamma$ -quanta with the substance (according to Evans): A - photoelectric effect; B - pair formation B - Compton effect.

Key: (1). MeV.

Page 150.

The effect of pair formation is predominant for  $\gamma$ -quanta with the high energy and its probability increases with an increase in the atomic number of the irradiated substance (region B Fig. 4.4).

Compton effect is most characteristic for the light substances, i.e., substances with the small atomic number, in the sufficiently broad band of energies of  $\gamma$ -quanta (region B Fig. 4.4). The probability of interaction of  $\gamma$ -radiation with the substance, and also the probability of weakening the flow of  $\gamma$ -quanta are characterized by the linear coefficient of absorption (weakening), by

cross section, mass coefficient of weakening, by electronic and atomic absorption coefficients [5, 16, 26, 27].

The linear coefficient of weakening  $\mu$  for  $\gamma$ -quanta, and for the particles of the straight/direct ionization is also the probability of interaction of quantum (particle) with the substance per unit of the length of its path in this substance. For the monoenergetic beam of  $\gamma$ -radiation the linear coefficient of weakening is calculated from the formula

$$\mu = \tau + \sigma + K. \quad (4.14)$$

Dimensionality  $\mu$  is expressed in reciprocal values of length ( $m^{-1}$ ,  $cm^{-1}$ , etc.).

The value, reciprocal to the linear coefficient of weakening,  $1/\mu$ , is called mean free path  $\gamma$ -quantum (or any other particles) in this substance or medium.

The complete cross section of interaction of  $\gamma$ -quanta designed for one atom, is equal

$$\sigma_t = \frac{\mu}{q} = \frac{\tau}{q} + \frac{\sigma}{q} + \frac{K}{q}, \quad (4.15)$$

where  $q$  - number of atoms in  $1 m^3$  of substance.

The mass coefficient of weakening  $\mu/\rho$  is the probability of

interaction of quantum (particle) with the substance and has a dimensionality  $m^2 \cdot kg^{-1}$  or  $cm^2 \cdot g^{-1}$ .

Consequently, the mass coefficient of weakening - these are a number of interactions of quantum (particle) with the substance with the passage by them the unit of the cross-sectional area of substance from the mass assigned by one.

Page 151.

The mass coefficient of weakening consists of the sum of the coefficients

$$\frac{\mu}{\rho} = \frac{\tau}{\rho} + \frac{\sigma}{\rho} + \frac{K}{\rho}, \quad (4.16)$$

where  $\frac{\tau}{\rho}$ ,  $\frac{\sigma}{\rho}$  and  $\frac{K}{\rho}$  - mass coefficients of weakening due to photoelectric absorption, Compton effect and the effect of pair formation respectively;

$\rho$  - substance density.

The mass coefficient of weakening in the substance can be determined also according to the formula

$$\frac{\mu}{\rho} = \frac{1}{\rho N} \cdot \frac{dN}{dx}, \quad (4.17)$$

where  $N$  - number of  $\gamma$ -quanta, which fall normally to the layer of the

substance with a thickness of  $dx$  and density  $\rho$ ;

$dN$  - number of  $\gamma$ -quanta, which are found in interaction with the atoms in this layer of substance.

Dependence (4.17) is valid during the determination of the mass coefficients of weakening for the photo effect, the Compton effect and the effect of pair formation. In this case  $dN$  corresponds to a number of  $\gamma$ -quanta, which interact in the layer of substance according to the reactions, characteristic for this effect.

The values examined, as already mentioned earlier, characterize the total probability of interaction of  $\gamma$ -radiation with the substance, but they do not give the possibility to determine the value of transferred in this case energy of  $\gamma$ -quanta. The transferred energy includes the energy, transmitted to electrons in the processes of photo effect, scatterings and pair formation. The energy, expended for the formation/educations of the quanta of characteristic and annihilation radiations/emissions, and energies of the scattered quanta are not considered.

Page 152.

Thus, the mass coefficient of weakening  $\gamma$ -radiation is equal to



the sum of two coefficients, namely:

$$\frac{\mu}{\rho} = \frac{\mu_K}{\rho} + \frac{\mu_e}{\rho}, \quad (4.18)$$

where  $\frac{\mu_e}{\rho}$  - part of the mass coefficient of weakening, which considers the energy conversion of  $\gamma$ -quanta into the energy of secondary quantum radiation/emission (scattered quanta, characteristic rays/beams, annihilation radiation/emission);

$\frac{\mu_K}{\rho}$  - part of the mass coefficient of weakening, which considers the conversion of energy of  $\gamma$ -quanta into the kinetic energy of electrons.

$\frac{\mu_K}{\rho}$  in accordance with the recommendations of international board for radiological units and to measurements they call the mass conversion factor of energy, while  $\mu_K$  - by linear gear ratio/transmission factor of energy [27]. Sometimes in the scientific-technical literature coefficient  $\mu_K$  is called the coefficient of proper absorption and they designate  $\mu$ , or by the coefficient of electronic conversion ( $\gamma$ ).

The mass conversion factor of energy considers the transmitted energy of primary  $\gamma$ -quanta to the electrons of substance and therefore it can be also determined from the relationship/ratio

$$\frac{\mu_K}{\rho} = \frac{dE_K}{\rho E dx}, \quad (4.19)$$

where E - sum of energies of  $\gamma$ -quanta of the primary

radiation/emission, passing through the layer of the substance with a thickness of  $dx$ , arranged/located normal to the direction of propagation of radiant flux;

$dE_k$  - sum of initial kinetic energies of all charged/loaded particles, which appear as a result of interaction of  $\gamma$ -quanta with the substance in the layer with a thickness of  $dx$ .

It is necessary to consider that the energy, transferred by  $\gamma$ -radiation to substance, can be expended/consumed in turn not only on the communication/report to the electrons of kinetic energy, but also on the bremsstrahlung.

Page 153.

Therefore the mass conversion factor of energy can be more than the coefficient of energy absorption, and consequently, it will not always characterize absorbed energy.

$$\frac{\mu_{en}}{\rho} = \frac{\mu_w}{\rho_l} (1 - \varphi), \quad (4.20)$$

where  $\frac{\mu_{en}}{\rho}$  - mass coefficient of the energy absorption of quanta;

$\varphi$  - coefficient, which considers the lost energy of secondary charged/loaded particles to the bremsstrahlung in this substance.

Coefficients  $\frac{\mu_{\text{tr}}}{\rho}$  and  $\frac{\mu_{\text{en}}}{\rho}$  virtually have identical values, until kinetic energy of secondary charged/loaded particles more or is compared with their rest energy. Usually energy of bremsstrahlung in the substances with the atomic number less than 15 with the energy of primary  $\gamma$ -radiation of below 10 MeV are disregarded. If with the energy of initial  $\gamma$ -quanta to 10 MeV virtually it was possible to consider that kinetic energy of the formed charged/loaded particles is completely transferred to the medium (they disregarded radiation losses), then at the values of energy of  $\gamma$ -quanta, large 10 MeV, energy consumption per bremsstrahlung plays the significant role. This is explained by the fact that during interaction with the substance of  $\gamma$ -quanta with the energy in several ten-hundred million electron volt are formed electrons and positrons from the somewhat smaller values of energy. The latter, passing through the substance, convert the significant part of the energy into the bremsstrahlung, which in turn leads to formation of pair electron-positron and so forth (Fig. 4.5) [26].

With the bremsstrahlung annihilation radiation/emission simultaneously occurs. The increase of particle flux to quanta depends on the irradiated substance, its thickness and initial energy of  $\gamma$ -quanta. Consequently, energy of initial  $\gamma$ -quanta is expended/consumed on the avalanche-type flow of an enormous number of positrons, electrons and  $\gamma$ -quanta. In this case the energy of the

subsequent particles and quanta decreases. The photoelectric absorption of  $\gamma$ -quanta occurs finally.

Page 154.

Since the large part of the energy of positrons and electrons is converted into the quantum energy of bremsstrahlung, the transmitted energy of primary  $\gamma$ -radiation cannot be the equal absorbed energy.

Thus, as a result of the effects examined in the substances occurs the formation of electrons. Energy of the generatrices of electrons is expended/consumed on ionization and atomic excitation and molecules, also to an increase in the temperature of substance and to the energy of bremsstrahlung. During interaction of primary electrons with the atoms and by molecules are formed the secondary electrons and positive ions. With the energies of secondary ones, tertiary and so forth of the electrons lower than ionization energy they decelerate to thermal energy of the motion of the atoms of substance and can be connected to neutral atom or molecule of substance, forming negative ions. If energy of the electrons higher than ionization energy of the atoms (usually them they call  $\delta$ -electrons), then they produce ionization.

For the  $\gamma$ -radiation, which appears in the processes of the

artificial divisions of uranium and plutonium isotopes, during the practical calculations of absorbed energy in the substance only the coefficient of Compton effect is considered. Table 4.9 gives the values of the medium energy of the Compton electrons, which appear during the bombardment of substance with  $\gamma$ -quanta.

The ionizing action of electrons and  $\gamma$ -radiation in this substance usually is evaluated according to the medium energy of the ionization (sometimes is applied term "average/mean ionization potential"), expended for the formation/education of one ion pair.

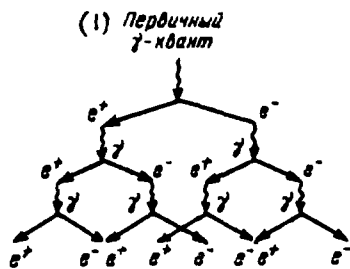

Fig. 4.5. Diagram of the formation/education of avalanche-type radiation/emission.

Key: (1). Primary of  $\gamma$ -quanta.

Page 155.

Medium energy for the formation/education of ion pair in the gas is equal to

$$W = \frac{E}{N_w}, \quad (4.21)$$

where E - energy, spent on the ionization and excitation. The value of absorbed energy of  $\gamma$ -quanta represents for the  $\gamma$ -radiation E;

$N_w$  - average number of forming ion pairs under the condition of the complete retardation of the charged/loaded particles in the substance.

During the calculation of the medium energy of ionization it is

assumed that during the braking in the substance of particle the number of ion pairs, proportional to its wave energy and which does not depend on the type of particle, is formed; this energy loss to the formation/education of ion pair depends only on nature of gas.

Table 4.9. The medium energy of the Compton electrons, which appear in the substance during irradiation by  $\gamma$ -quanta.

(1) Энергия $\gamma$ -квантов, Мэв	(2) Средняя энергия комптоновского электрона, Мэв	(1) Энергия $\gamma$ -квантов, Мэв	(2) Средняя энергия комптоновского электрона, Мэв
0,010	0,0002	1,50	0,742
0,015	0,0004	2,00	1,061
0,020	0,0007	3,00	1,731
0,030	0,0016	4,00	2,428
0,040	0,0027	5,00	3,140
0,050	0,0040	6,00	3,864
0,060	0,0056	8,00	5,338
0,080	0,0094	10	6,835
0,100	0,0138	15	10,65
0,15	0,0272	20	14,53
0,20	0,0432	30	22,42
0,30	0,0809	40	30,4
0,40	0,124	50	38,5
0,50	0,171	60	46,6
0,60	0,221	80	62,9
0,80	0,327	100	79,4
1,00	0,440		

Key: (1). Energy of  $\gamma$ -quanta, MeV. (2). Medium energy of Compton electron, MeV.

Page 156.

The numerical values of the medium energy of ionization for the gases little change in the range of energies from several kiloelectronvolts and it is above and in effect for different gases they are within the limits from 27 to 42 eV (Table 4.10) [24].



According to the experimental data it is established/installed [26], that the medium energy for the formation/education of ion pair in air is constant in energy range from 20 keV to 3 MeV and is equal to in average/mean 34 eV. Table 4.11 gives the average/mean values of ionization energy in air for some forms of the ionizing radiations/emissions.

Besides the processes of ionization under the influence of  $\gamma$ -radiation on the substance, as a result of elastic collisions of primary electrons with the nuclei occurs the atomic displacement.

Table 4.10. The medium energy of ionization for different gases under the influence of the charged/loaded particles.

(1) Газ	(2) Средняя энергия, эв	(3) Газ	(4) Средняя энергия, эв
Водород (3)	36,3	Воздух (4)	35,5
Гелий (5)	42,7	Кислород (6)	32,5
Неон (7)	36,8	Азот (8)	36,6
Аргон (9)	26,4	Метан (10)	29,2
Криптон (11)	24,1	Этилен (12)	28,0
Углекислый газ (13)	34,5	Этан (14)	26,6

Key: (1). Gas. (2). Medium energy, eV. (3). Hydrogen. (4). Air. (5). Helium. (6). Oxygen. (7). Neon. (8). Nitrogen. (9). Argon. (10). Methane. (11). Krypton. (12). Ethylene. (13). Carbon dioxide. (14). Ethane.

Table 4.11. The medium energy of the ionization of some types of radiation/emission for air.

(1) Тип излучения	(2) Средняя энергия ионизации, эв
(3) Электроны с энергией: 0—17,5 Мэв (4) 1—34 Мэв (5)	34,3 33,8
(6) Гамма-кванты с энергией 2 Мэв	33,9
(6) Протоны с энергией 340 Мэв	33,6

Key: (1). Type of radiation/emission. (2). Medium energy of ionization, eV. (3). Electrons with energy. (4). MeV. (5). Gamma-quanta with energy 2 MeV. (6). Protons with energy 340 MeV.

Page 157.

The probability of the occurrence of displaced atoms as a result of direct interaction of  $\gamma$ -quanta with the nuclei of substance is very small (for the energies of  $\gamma$ -quanta to 10 MeV).

Thus, for instance, energy of bias/displacement for the substance with an atomic weight of 30, transferred by  $\gamma$ -quantum with the energy 1 MeV by means the photoelectron, there will be only 36 eV. It is necessary to note that the dominant role in the atomic displacement, just as with the ionization, plays Compton interaction of  $\gamma$ -radiation with the substance. For  $\gamma$ -quanta from the energy 1 MeV

and less a number of atomic displacements rapidly falls from an increase in the atomic number of substance. Table 4.12 gives some values of the value of the effective cross section of atomic displacement under the action of  $\gamma$ -rays as a result of the Compton effect; threshold energy of bias/displacement was accepted equal to 25 eV [3].

Atomic biases/displacements in the substance due to the conversion of energy of electronic excitation into the energy of bias/displacement are possible also under the action of  $\gamma$ -quanta. These mechanisms must be especially characteristic for insulation.

According to Seitz's assumption [29] during irradiation of  $\gamma$ -quanta are formed exciton-localized regions of electronic excitation.

Table 4.12. Calculated values of the effective cross section of atomic displacement under the action of  $\gamma$ -radiation by the Compton mechanism.

(1) Элемент	(2) Энергия $\gamma$ -квантов, Мэв	(3) Эффективное попе- речное смещение атомов, барн
(4) Углерод	0,5	0,02
	1,0	0,14
	2,0	0,43
(5) Медь	0,5	0
	1,0	0,046
	2,0	1,40
(6) Золото	0,5	0
	1,0	0

Key: (1). Element/cell. (2). Energy of  $\gamma$ -quanta, MeV. (3). Effective transverse displacement of atoms, barn. (4). Carbon. (5). Copper. (6). Gold.

Page 158.

Excitons move in the crystal until they meet any lattice imperfection; here exciton energy is transferred to lattice and local hot region is formed. This transmission of energy can be in the places of inequalities in the dislocation lines, which will produce the short-term heating of lattice in these places and the attachment of dislocation, i.e., on such inequalities can occur the "boil-off" of vacancies. Possible also that the free electrons and holes will recombine and free/release energy in these places.

Varli [30], examining substances with the strong ionic bonds, it assumed that during irradiation by  $\gamma$ -quanta, by X-rays and by the charged/loaded particles some negative ions will be deprived of two and more than electrons and as a result of this to acquire positive charge. The formed positive ion under the effect its of other its positive ions can be ejected into the interstice, where it acquires a sufficient quantity of electrons for the neutralization. The emergent vacancy lattice can take electron and become into the f-center. Interstitial atom will remain in the interstice or it will diffuse and finally it will prove to be any seized defect.

In the case, most the frequently encountered in the practice, simultaneous effect gamma- and neutron radiation/emission with the approximately/exemplarily equal energies and the densities of flows the contribution of  $\gamma$ -quanta to the total effect of bias/displacement it is possible to disregard.

#### 4.5. Radiation durability of materials.

In the radio-electronic equipment are applied the elements/cells, in which are included the following four classes of materials: metals, inorganic materials (mainly dielectrics),



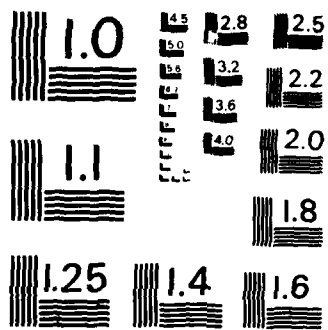

MICROCOPY RESOLUTION TEST CHART  
NATIONAL BUREAU OF STANDARDS-1963-A



semiconductors and different organic compound-dielectrics, resin, fillers, etc.

Among these materials the metals are least sensitive to the radiation, since the high concentration of free carriers is characteristic to metals, and, at the same time, the properties of metals little depend on the presence of lattice defects. Semiconductor and organic materials are most sensitive to the effect of radiation.

Page 159.

Table 4.13. Maximum permissible neutron fluxes and exposure doses of  $\gamma$ -radiations for the radio engineering materials.

(1) Вид материала	(2) Допустимый поток нейтронов, $n/m^2$	(3) Допустимая экспози- ционная доза $\gamma$ -облу- чения, $r$
(4) Материалы с очень низкой радиационной стойкостью		
(5) Полупроводники	$10^{16}-10^{17}$	$10^6-10^8$
(6) Политетрафторэтилен	$10^{17}$	$10^6-10^8$
(7) Кремний-органическое ма- сло	$7 \cdot 10^{17}-3 \cdot 10^{18}$	$10^6$
(8) Метилметакрилат (органи- ческое стекло)	$10^{18}$	$10^6$
(9) Материалы с низкой радиационной стойкостью		
(9) Ацетат-целлюлоза (бумага)	$10^{18}-10^{19}$	$5 \cdot 10^6-4 \cdot 10^7$
(10) Фенольные смолы (без на- полнителя)	$7 \cdot 10^{18}$	$10^7$
(11) Полиамиды	$4 \cdot 10^{18}$	$7 \cdot 10^6$
(12) Поливинилхлорид	$10^{18}$	$10^6$
(13) Материалы со средней радиационной стойкостью		
(13) Фенольные смолы с орга- ническим наполнителем	$10^{19}$	$10^6$
(14) Полиэтилен	$10^{21}$	$10^6$
(15) Стеклоткань	$10^{20}$	$10^6$
(16) Эпоксидные лаки	—	$5 \cdot 10^6-10^8$
(17) Нитролак	—	$5 \cdot 10^6$
(18) Материалы с высокой радиационной стойкостью		
(18) Стекло	$10^{21}-10^{22}$	$3 \cdot 10^6$
(19) Слюда	$10^{22}$	$10^{10}$
(20) Полистирол	$10^{22}-10^{23}$	$5 \cdot 10^6$
(21) Материалы с очень высокой радиационной стойкостью		
(21) Кварц	$10^{23}$	$10^{10}$
(22) Стеклослюда	$10^{23}$	$10^{11}$
(23) Керамика (стеатит)	$10^{23}$	$10^{12}$
(24) Металлы	$10^{24}-10^{25}$	

Note. By maximum permissible by flow and by dose are understood such flows (doses), with which the characteristics of materials

deteriorate to 25%; these flows (doses) were determined at the density of flows  $10^{15}$ - $10^{16}$  n/s·m<sup>2</sup> and the rate of dose  $10^3$ - $10^4$  p/s.

Key: (1). Form of material. (2). Permissible neutron flux, n/m<sup>2</sup>. (3). Permissible exposure dose of gamma-irradiation, p. (4). Materials with very low radiation durability. (5). Semiconductors. (6). Polytetrafluoroethylene. (7). Silicon oil. (8). Methyl methacrylate (organic glass). (9). Materials with low radiation durability. (10). Cellulose acetate (paper). (11). Phenolic resin (without filler). (12). Polyamides. (13). Polyvinyl chloride. (14). Materials with average/mean radiation durability. (15). Phenolic resin with organic filler. (16). Polyethylene. (17). Fiberglass fabric. (18). Epoxy varnishes. (19). Nitrate dope. (20). Materials with high radiation durability. (21). Glass. (22). Mica. (23). Polystyrene. (24). Materials with very high radiation durability. (25). Quartz. (26). Glass-mica. (27). Ceramics (steatite). (28). Metals.

Page 160.

As a result of the effect of the ionizing radiations/emissions on the semiconductor materials change their following fundamental characteristics: conductivity, lifetime of minority carriers, mobility of carriers and Hall coefficient. Under the influence of the ionizing radiations/emissions on the organic insulating and dielectric materials such parameters, as electrical conductivity, dielectric constant and loss tangent change.

Inorganic materials (ceramics, glass, quartz, etc.) are less sensitive to the effect of radiation than organic materials. For the inorganic dielectrics under the effect of those ionizing radiation/emission it is also characteristic a change in electrical conductivity, dielectric constant and loss tangent.

Table 4.14. The exposure doses of the space ionizing radiations/emissions, during which occurs a noticeable change in the properties of materials.

(1) Материал	(2) Свойства	(3) Экспозиционные дозы ионизиции, рад
(4) Политетрафторэтилен	(5) Механические и электрические: (6) на воздухе (7) без воздуха	$10^6 - 10^8$ $10^7 - 10^8$
Другие пластмассы (8)	(9) Оптическая прозрачность (10) Механические и электрические	$10^6 - 10^{11}$ $10^7 - 10^{10}$
Масла и смазки (11)	(12) Смазочные, консистентность	$10^6 - 10^{12}$
Керамика, стекло (13)	(14) Оптическая прозрачность (15) Механические (16) Электрические	$10^6 - 10^{10}$ $\geq 10^{11}$ $> 10^{11}$
Плавленный кварц (17)	(18) Оптическая прозрачность	$10^7 - 10^{11}$
Полупроводники (19)	(20) Неосновная электропроводность	$10^4 - 10^6$
Металлы (21)	(22) Ферромагнетизм (23) Механические и электрические	$10^{18}$ $> 10^{18}$

Key: (1). Material. (2). Properties. (3). Exposure dose of ionization, rad. (4). Polytetrafluoroethylene. (5). Mechanical and electrical. (6). in air. (7). without air. (8). Other plastics. (9). Optical transmission. (10). Oils and lubrication. (11). Lubricating, consistency. (12). Ceramics, glass. (13). Mechanical. (14). Electrical. (15). Vitreosil. (16). Semiconductors. (17). Nonbasic/minority electrical conductivity. (18). Metals. (19). Ferromagnetism.

Page 161.

Table 4.15. Change in the properties of materials under the effect of the space ionizing radiation/emission (time of radiation effect from several months to several years) [31].

(1) Материал	(2) Свойства	(3) Внутренний радиа- ционный пойс		(4) Внешний радиа- ционный пойс		(5) Солнечная радиация		(6) Первичное космиче- ское излу- чение, слой до 100 кг/м <sup>2</sup>
		(7) поверхно- стный слой	(8) слой 10 кг/м <sup>2</sup>	(9) поверхно- стный слой	(10) слой 10 кг/м <sup>2</sup>	(11) поверхно- стный слой	(12) слой 10 кг/м <sup>2</sup>	
(9) Политетрафторэтилен	(15) Механические и электри- ческие: (11) на воздухе (12) без воздуха	X	X	X	X	X	-	-
(13) Другие пластмассы	(14) Оптические, механиче- ские, электрические	X	+	X	+	X	-	-
(15) Масла и смолы	(16) Смазочные, консистент- ность	X	-	X	-	-	-	-
(17) Керамика и стекло	(17) Оптическая прозрачность (18) Механические, электри- ческие	X	+	X	+	X	+	-
(14) Пыляемый кварц	(19) Оптическая прозрачность	X	+	X	+	X	+	-
(20) Полупроводники	(20) Неосновная электро- проводность	X	X	+	+	X	+	-
(22) Металлы	(21) Основная электропро- водность (22) Ферромагнетизм, элект- рические, механические	X	+	-	-	X	-	-
		X?	-	-	-	X	-	-

The conventional designations:

- - practical changes are not observed;

+ - radiation/emission does produce change in the properties in especially sensitive materials;

+ + - radiation/emission does produce change in the properties in the

majority of materials of this type;

X - properties of materials do have substantial changes;

? - not entirely precision determination of the values indicated.

Key: (1). Material. (2). Properties. (3). Internal radiation belts. (4). External radiation belts. (5). Solar radiation. (6). Primary cosmic radiation, layer to 100 kg/m<sup>2</sup>. (7). surface layer. (8). layer 10 kg/m<sup>2</sup>. (9). Polytetrafluoroethylene. (10). Mechanical and electrical. (11). in air. (12). without air. (13). Other plastics. (14). Optical, mechanical, electrical. (15). Oils and lubrication. (16). Lubricating, consistency. (17). Ceramics and glass. (18). Optical transmission. (19). Vitreosil. (20). Semiconductors. (21). Nonbasic/minority electrical conductivity. (22). Basic electrical conductivity. (23). Metals. (24). Ferromagnetism, electrical, mechanical.

Page 162.

Together with a change in the electrical parameters of materials a change in their mechanical, optical and other properties occurs in a number of cases, as already mentioned. Therefore the sensitivity of radio engineering materials to the effect of the ionizing

radiations/emissions it is desirable to define both with respect to the change in the electrical parameters and with respect to a change in other properties, which can lead to a change in the parameters of radioelements, prepared from these materials.

Table 4-13 gives the tentative information about the maximum permissible neutron fluxes and the exposure doses of gamma-irradiation for the radio engineering materials; information is grouped on the durability of materials, determined with respect to a change in the electrical and mechanical parameters<sup>1</sup>.

The exemplary/approximate estimated values of the exposure doses of the space ionizing radiations/emissions, during which are observed changes in the mechanical, electrical and optical properties of materials, according to the data of work [31] are shown in Table 4.14.

According to the degree of a change in the parameters of materials and expected intensities of radioactivity it is possible to determine the degree of the damage of materials in the process of their operation under the actual conditions. As an example Table 4.15 gives possible changes in the properties of materials under the effect of the ionizing radiations/emissions of the Earth radiation belts, solar and cosmic rays. Table is comprised according to the



results of the comparison of the conditions of the work (see Table 3.7, 3.11) and the radiation durability of materials (Table 4.14).

#### 4.6. Radiation durability of radioelements and electronic devices.

The reaction of electric vacuum and semiconductor devices, radio parts, radio components and articles of electrical engineering to the effect of the ionizing radiations/emissions is more complicated than the reaction of materials.

FOOTNOTE <sup>1</sup>. For insulation the data in essence are cited according to the results of the foreign materials, generalized by Z. A. Zharkovskaya. Data using other materials are cited in [2, 4, 33].  
ENDFOOTNOTE.

Page 163.

This is explained by the fact that in each element/cell are included several forms of different materials, in which different processes can occur under the effect of the ionizing radiations/emissions, in this case the effect of one process on another is possible. Consequently, in the radioelements under the radiation effect a change in almost all electrical and operating characteristics, which depend on the course of the processes of ionization and damage of the structure of materials, is possible.

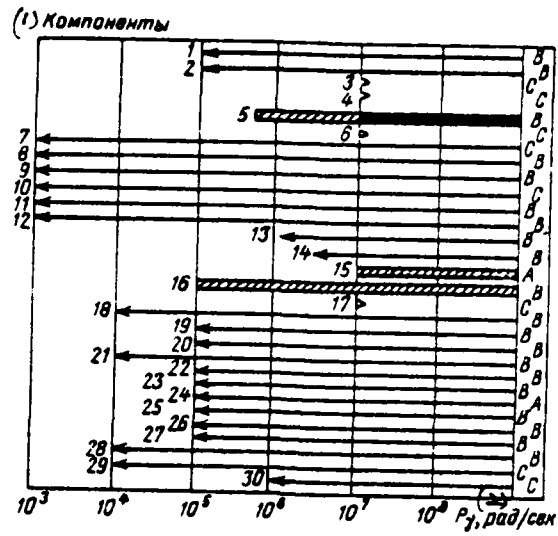

Fig. 4.6. Change of the parameters of materials and radioelements in the dependence on the power of the exposure dose of  $\gamma$ -radiation (on carbon). Arrow/pointer to the left indicates the beginning of the emergence of the reversible changes; solid (black strips) - elements/cells malfunctioned; the shaded strips - elements/cells still can work. Sign > means that a change in the parameters occurs at the rate of the dose, greater than  $10^7$  rad/s. Letters characterize the degree of the authenticity: A - good, B - incomplete, C - insufficient. 1 - transistors; 2 - diodes of the general purpose; 3 - Zener's diodes; 4 - Esaki's diodes; 5 - rectifiers; 6 - magnetic materials; 7 - solar batteries; 8 - phosphoruses; 9 - optical instruments; 10 - the optical glasses; 11 - elements/cells of IR technology; 12 - photocells; 13 - resistors; 14 - electron tube; 15 - thyratrons; 16 - spark dischargers/gaps; 17 - battery; 18 -

dielectric materials; 19 - organic materials; 20 - ceramic materials; 21 - air; 22 - capacitors/condensers; 23 - aluminum chemical capacitors; 24 - tantalum capacitors; 25 - polyethylene terephthalate capacitors/condensers; 26 - mica capacitors; 27 - paper capacitors; 28 - microcircuit; 29 - semiconductors; 30 - integrated circuits of the type TMM.

Key: (1). Components. (2). rad/s.

Page 164.

Table 4.16. Electrical parameters of radioelements, most susceptible/most critical to the effect of the ionizing radiations/emissions.

(1) Виды и классы элементов	(2) Наиболее критичные параметры при прохождении в элементах	
	(3) обратимых изменений	(4) необратимых изменений
(5) Транзисторы	(6) Токи через обратносмещенные переходы	(7) Коэффициент усиления, обратный коллекторный ток
(8) Полупроводниковые диоды	(9) Ток насыщения, прямое падение напряжения	(10) Обратная (у германиевых) и прямая (у кремниевых) ветвь вольтамперной характеристики
(11) Резисторы	(12) Сопротивление (особенно у высокоомных)	(13) Сопротивление
(14) Конденсаторы	(15) Сопротивление изоляции, тангенс угла диэлектрических потерь	(16) Емкость, сопротивление изоляции
(17) Генераторные, модуляторные и приемно-усилительные лампы	(18) Токи утечек между электродами, электрическая прочность	(19) Ток эмиссии катода, ток анода, крутизна характеристики
(20) Газоразрядные приборы	(21) Электрическая прочность (напряжение-зажигания)	(22) Напряжение зажигания „анод—катод“, сеточный ток зажигания, сеточное отпирающее напряжение, падение напряжения „сетка—катод“, „анод—катод“
(23) Фотосопротивления	(24) Темновое сопротивление	(25) Вольтовая чувствительность, темновое сопротивление
(26) Фотодиоды	(27) Темновой ток	(28) Интегральная чувствительность
(29) Электротехнические изделия	(30) Сопротивление изоляции, электрическая прочность	(31) Сопротивление изоляции, износоустойчивость, контактное сопротивление

Key: (1). Forms and the classes of elements/cells. (2). Most susceptible/most critical parameters at passage in elements/cells. (3). reversible changes. (4). irreversible changes. (5). Transistors. (6). Currents through reverse-biased transitions. (7). Amplification factor, opposite collector current. (8). Semiconductor diodes. (9). Saturation current, straight/direct voltage drop. (10). Reverse/inverse (in germanium ones) and straight/direct (in silicon ones) branch of volt-ampere characteristic. (11). Resistors. (12). Resistance (especially in high-impedance ones). (13). Resistance. (14). Capacitors/condensers. (15). Insulation resistance, dielectric power factor. (16). Capacity/capacitance, insulation resistance. (17). Generator, modulator and receiver-amplifier lamps. (18). Leakage currents between electrodes, dielectric strength. (19). Emission current of cathode, current of anode, mutual conductance. (20). Gas-discharge instruments. (21). Dielectric strength (voltage-ignitions). (22). Ignition voltage "anode-cathode", grid current of ignition, grid triggering stress/voltage, drop in voltage "space charge grid" "anode-cathode". (23). Photoresistors. (24). Dark resistance. (25). Volt sensitivity, dark resistance. (26). Photodiodes. (27). Leakage current. (28). Integral sensitivity. (29). Electrotechnical articles. (30). Insulation resistance, dielectric strength. (31). Insulation resistance, wear resistance, contact resistance.

Page 165.

The basic electrical parameters, which determine the radiation durability of the radioelements of different forms and classes, are given in Table 4.16.

Presents some generalized work [32] data according to the results of the investigation of a change in the electrical parameters of radioelements under the effect of neutron and  $\gamma$ -radiations in Fig. 4.6-4.8.

On the diagram, given in Fig. 4.9, the radiation stability of silicon and germanium transistors with the different thickness of basis is shown. Data relate to 28 types of transistors. The left boundaries of rectangles correspond to the values of the neutron fluxes and exposure doses, in which become noticeable the irreversible changes, caused mainly by the decrease of the lifetime of minority carriers, and right boundaries - values of flows and doses, in which the characteristics of transistor are located on the face of suitability [33].

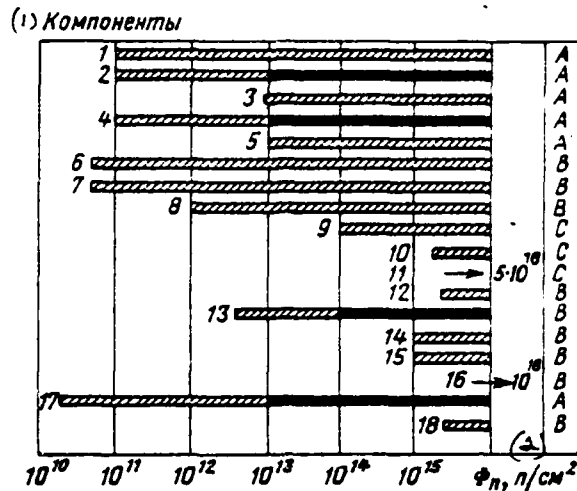

Fig. 4.7. Change of the parameters of materials and radioelements in the dependence on the neutron flux (designation the same as in Fig. 4.6. Arrow/pointer to the right - change is observed with the flows indicated). 1 - transistors; 2 - germanium lf transistors; 3 - germanium hf transistors; 4 - silicon lf transistors; 5 - silicon hf transistors; 6 - diodes; 7 - the silicon diodes of the general purpose; 8 - germanium diodes of the general purpose; 9 - Zener's diodes; 10 - Esaki's diodes silicon; 11 - Esaki's diodes germanium; 12 - resistors; 13 - rectifiers; 14 - magnetic materials; 15 - supermalloy; 16 - iron silicide; 17 - solar batteries; 18 - electron tube (glass).

Key: (1). Components. (2). n/cm².

From Fig. 4.6-4.9, it follows that the radiation stability of radioelements oscillates in the large range of the flows (doses) of the ionizing particles. Therefore by the correct selection of the nomenclature of elements/cells it is possible to increase substantially the radiation stability of radio-electronic equipment. Thus, for instance, by the specialists of firm Bendix [34] was studied the advisability of using the vacuum-tube instruments as more radiation-resistant, instead of the semiconductor devices in the equipment of spacecraft with the nuclear power plants aboard. In this case the estimation of the advisability of replacement according to the total weight of equipment and protective shields was produced. Table 4.17 gives conditions, with which this replacement can be acknowledged advisable.



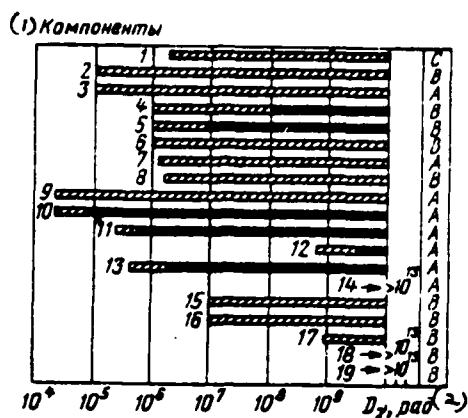

Fig. 4.8. A change of the parameters of materials and radioelements in the dependence on the exposure dose of  $\gamma$ -radiation (on carbon) (designations are the same as in Fig. 4.6 and 4.7). 1 - phosphoruses; 2 - optical instruments; 3 - the optical glasses; 4 - elements/cells of IR technology; 5 - photocells; 6 - resistors; 7 - electron tube; 8 - battery; 9 - dielectric materials; 10 - teflon; 11 - polyester/polyether; 12 - polystyrene; 13 - polysulfide rubber; 14 - ceramics; 15 - capacitors/condensers; 16 - capacitors/condensers tantalum; 17 - capacitors/condensers polystyrene; 18 - capacitors/condensers mica; 19 - ceramics.

Key: (1). Components. (2). rad.

Page 167.

The recommendations (for the exceptional cases) given in Table

4.17 are designed for the following conditions: radio-electronic equipment is placed at the most end/lead distant from the reactor of the instrument container of space object and the distance between the equipment and reactor is not less than 5, 10 and 15 m for SNAP-2, SNAP-8 and SNAP-50 respectively; protective shield consists of hydride of lithium and tungsten.

Thus, the radiation stability of radio-electronic equipment, first of all, depends on the stability of the elements/cells used in it, and also the circuit and design concept. The radiation stability of semiconductor devices (transistors, diodes, photoresistors, photodiodes), some types of capacitors and resistors and gas-filled instruments is determining in this case.

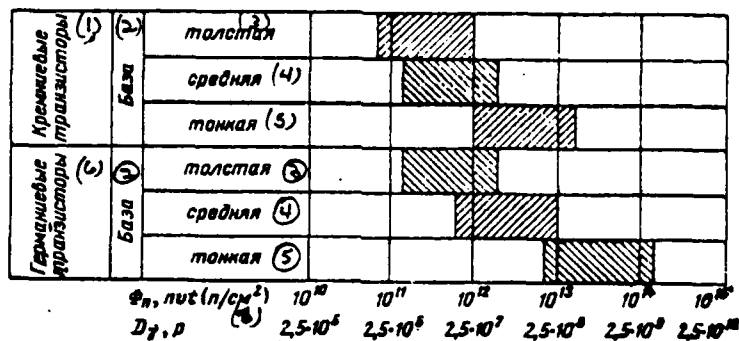

Fig. 4.9. Stability of silicon and germanium transistors with the different thickness of basis under the conditions of the effect of gamma-neutron radiation/emission.

Key: (1). Silicon transistors. (2). Basis. (3). thick. (4). average/mean. (5). thin. (6). Germanium transistors. (7). (n/cm<sup>2</sup>).

Table 4.17. Conditions of replacing the semiconductor devices.

(1) Тип ядерного реактора	(2) Тепловая мощность ядерного реактора, кВт не менее	(3) Число активных элементов, при котором целесообразно иметь полупроводниковые электронные приборы, шт. не более
SNAP-2	3	4 000
SNAP-8	30	10 000
SNAP-50	300	20 000

Key: (1). Type of nuclear reactor. (2). Heat output of nuclear reactor, kW is not less. (3). Number of active elements/cells, with which is advisable replacement of semiconductors by vacuum-tube instruments, pieces is not more.

Page 168.

If changes in the parameters of radioelements are known to dependence on the intensities of radioactivity, then the output parameters of circuits, assemblies, blocks/modules/units and radio-electronic devices/equipment (under the condition of the normal law of distribution of a change in the parameters of elements/cells in the dependence on the radiation) can be determined from the expression:

$$y_i = f_i(x_1, x_2, \dots, x_j), \quad (4.22)$$

where  $i$  - output circuit parameters;

$j$  - electrical parameters of elements/cells.

Here the electrical parameters of elements/cells are the random flow values (dose) of the ionizing radiation/emission.

The random functions of random arguments are determined from the relationship/ratio

$$Y_i(\Phi) = f_i[X_1(\Phi), X_2(\Phi), \dots, X_n(\Phi)]. \quad (4.23)$$

In formula (4.23) mathematical expectation and root-mean-square divergence are calculated from the following expressions:

$$\begin{aligned}
m_{y_i}(\Psi) &= f_i \{ [m_{x_1}(\Psi), m_{x_2}(\Psi), \dots, m_{x_n}(\Psi)] + \\
&\quad + \frac{1}{2} \sum_{j=1}^n \left( \frac{\partial^2 y_i}{\partial x_j^2} \right)_{m_{x_j}(\Psi)} \sigma_{x_j}^2(\Psi) \}; \\
\sigma_{y_i}(\Psi) &= \sum_{j=1}^n \left( \frac{\partial y_i}{\partial x_j} \right)_{m_{x_j}(\Psi)}^2 \sigma_{x_j}^2(\Psi) + \\
&\quad + \frac{1}{2} \sum_{j=1}^n \left( \frac{\partial^2 y_i}{\partial x_j^2} \right)_{m_{x_j}(\Psi)} \sigma_{x_j}^2(\Psi) + \\
&\quad + \sum_{\substack{l < v \\ m_{x_l}(\Psi) \\ m_{x_v}(\Psi)}} \left( \frac{\partial^2 y_i}{\partial x_l \partial x_v} \right)_{m_{x_l}(\Psi), m_{x_v}(\Psi)}^2 \sigma_{x_l}^2(\Psi) \sigma_{x_v}^2(\Psi),
\end{aligned}$$

where  $m_{y_i}(\Psi)$  - dependence of the mathematical expectation of the output  $i$  circuit parameter on the flow (dose) or the density of the flow of the ionizing radiation/emission;

$\sigma_{y_i}(\Psi)$  - dependence of the root-mean-square divergence of the output  $i$  circuit parameter from the flow (dose) or the density of the flow of the ionizing radiation/emission;

$m_{x_j}$  - mathematical expectation of the electrical parameter of the  $j$  element/cell at the assigned flow (dose) or the density of the flow of the ionizing radiation/emission;

$\sigma_{x_j}$  - root-mean-square divergence of the electrical parameter of the  $j$  element/cell at the assigned flow (dose) or the density of the flow of the ionizing radiation/emission;

$v=1, 2, \dots, n$  - number of basic electrical parameters and elements/cells in the equipment;

$\Phi(\varphi)$  - the flow (density of flow) of the ionizing radiation/emission.

Page 169.

The results of the experimental studies of some electronic devices are given in tables 4.18 and 4.19 [35-37]. Table 4.18 shows a change in the output parameters of transistor circuits depending on the neutron flux of pulse radiation/emission. Table 4.19 gives the results, obtained during the continuous gamma-neutron irradiation on nuclear reactors of aircraft radio-electronic equipment.

These data attest to the fact that the equipment, designed with the use/application relative to radiation-resistant semiconductor devices, does not go out of order with the neutron fluxes to  $10^{16}-10^{17}$  n/m<sup>2</sup>, but equipment on the vacuum-tube instruments reliably works with the flows  $10^{18}$  n/m<sup>2</sup>.

It is evident from the data examined on the radiation stability of equipment and radioelements that a change in the parameters of

radio-electronic devices/equipment can occur over a wide range of the flows (doses) of the ionizing radiations/emissions. Therefore the need for taking measures for increase in the radiation stability or weakening of the effect of the ionizing radiations/emissions on the equipment appears in a number of cases.

Page 170.

Toward a number of basic actions, directed toward weakening of the effect of the ionizing radiations/emissions on the radio-electronic equipment and its elements/cells, can be attributed the following:

1) use/application in the equipment of radiation-resistant elements/cells and materials. Fulfilling this requirement is especially important for the elements/cells, arranged/located out of the protection from the ionizing radiation;

2) use/application on the objects of the special passive screens, which shield equipment from the straight/direct effect of the ionizing radiations/emissions, or active protection from the effect of the flows of the charged/loaded particles. Sometimes, for the protection of equipment from the ionizing radiations/emissions can be used the elements of the construction/design of the object, on

which is established/installed this equipment;

3) the use/application of diagrams, it is small the electrical parameters of elements/cells susceptible/critical to the changes, also, with the low constant values of the time of separate circuits. Use in the diagrams of feedback, nonlinear elements/cells and dual elements/cells, whose parameters under the effect of radiation change in opposite directions;

4) the decrease of the sensitivity of switching circuits to a change in the amplitude of input signals and supply voltages and bias/displacement.



Table 4.18. Results of changing the electrical characteristics of radio-electronic devices/equipment under the influence on them of the pulse neutron irradiation (for the pulse duration of less than 1 ms).

(1) Вид схемы	(2) Относительная величина выходного напряжения в % при потоках нейтронов $n/m^2$			
	$10^{14}$	$10^{15}$	$10^{16}$	$10^{17}$
(3) Генератор синусоидальных колебаний на транзисторе типа 301	100	100	100	100
(4) Усилитель класса А на транзисторах 2N138 и 2N30	100	100	80—90	50—60
(5) Высокочастотный выпрямитель (сочетание генератора высокой частоты с выпрямителем) на транзисторе 2N105	100	85—95	30	15—20
(6) Триггеры на транзисторах типов 302 и 2N35	(7) Срабатывают			

Key: (1). Form of diagram. (2). Relative value of exit stress/voltage in % with neutron fluxes  $n/m^2$ . (3). Sine wave oscillator on transistor of type 301. (4). Amplifier of class A on transistors 2N138 and 2N30. (5). High-frequency rectifier (combination of high-frequency oscillator with rectifier) on transistor 2N105. (6). Triggers on transistors of types 302 and 2N35. (7). They operate/wear.

Page 171.

Table 4.19. Some data on the radiation resistance of radio-electronic equipment to the effect of continuous gamma-neutron radiation.

(1) Тип аппаратуры	(2) Виды и типы применяемых элементов	(3) Полный поток нейтронов $n/m^2$	(4) Экспозиционная доза, р	(5) Результаты испытаний
(6) Запросчик-ответчик системы опознавания	(7) Полупроводниковые приборы	$1,2 \cdot 10^{18}$	$9 \cdot 10^6$	(8) Наблюдалось уменьшение эффективности
(9) Ответчик системы опознавания	(10) Электроракуумные приборы	$2 \cdot 10^{18}$	$8 \cdot 10^6$	(11) Без заметных нарушений работоспособности
(12) Бортовая радиостанция	(13) Электроракуумные приборы, кварцы и диоды 1N69	$5,4 \cdot 10^{17}$	$5 \cdot 10^6$	(14) Отказ в работе
(15) Самолетное переговорное устройство	(10) Электроракуумные приборы	$2 \cdot 10^{18}$	$10^7$	(16) Без заметных нарушений работоспособности

Key: (1). Type of equipment. (2). Forms and types of elements/cells used. (3). Total flux of neutrons  $n/m^2$ . (4). Exposure dose, r. (5). Results of tests. (6). Interrogator-responder of identification system. (7). Semiconductor devices. (8). Decrease of effectiveness was observed. (9). Responder of identification system. (10). Vacuum-tube instruments. (11). Without noticeable disturbances/breakdowns of efficiency. (12). Onboard radio station. (13). Vacuum-tube instruments, quartzes and diodes 1N69. (14).

Failure. (15). Crew intercommunication equipment. (16). Without noticeable disturbances/breakdowns of efficiency.

Page 172.

For decreasing the probability of the ignition of the gas-discharge instruments of discrete/digital action, which are found up to the moment/torque of the effect of pulse radiation in the waiting mode/conditions, it is necessary to decrease the feeding voltage on the anode and to increase the negative bias/displacement of grids or to utilize protection circuits;

5) the guarantee of actions for the protection from the false responses at the moment of the effect of pulse radiation by use/application blocking or compensating for spill currents and the stress/voltage of diagrams;

6) the use/application of different devices/equipment of those turning off/disconnecting electronic circuits, but in certain cases and the network elements, on the period of the effect of pulse radiation;

7) the use/application of different kind of the fillings, which do not conduct current during irradiation, that prevent the

possibility of inleakage with ionization environment;

8) an increase in the distances between the elements/cells, alive load, a reduction in the operating stresses/voltages on them; the selection of form and material of the current-conducting surfaces; the control of thermal and electrical loads on the elements/cells and an improvement in the distribution stress/voltage.

Taking the enumerated actions is conducted in such a case, when the radiation stability of equipment is lower than the conditions, in which it must work. Possible radiation conditions during the operation of equipment can be determined on the basis of data, given in the preceding/previous chapter.

DOC = 83167509

PAGE 313

Page 173.

Appendices.

Page 174.

Appendix I.

Wilson's nomogram for the approximate determination of energy according to range.

On the left and right scales are deposited/postponed the ranges in  $\text{g/cm}^2$  and  $\text{kg/m}^2$  respectively: on the average/mean scale - kinetic energy in MeV; on the scales  $\alpha$ ,  $p$ ,  $\pi$ ,  $\mu$  - atomic number  $Z$  of the inhibiting substance. Appropriate energy, landing run (left scale) and atomic number are arranged/located on one straight line.

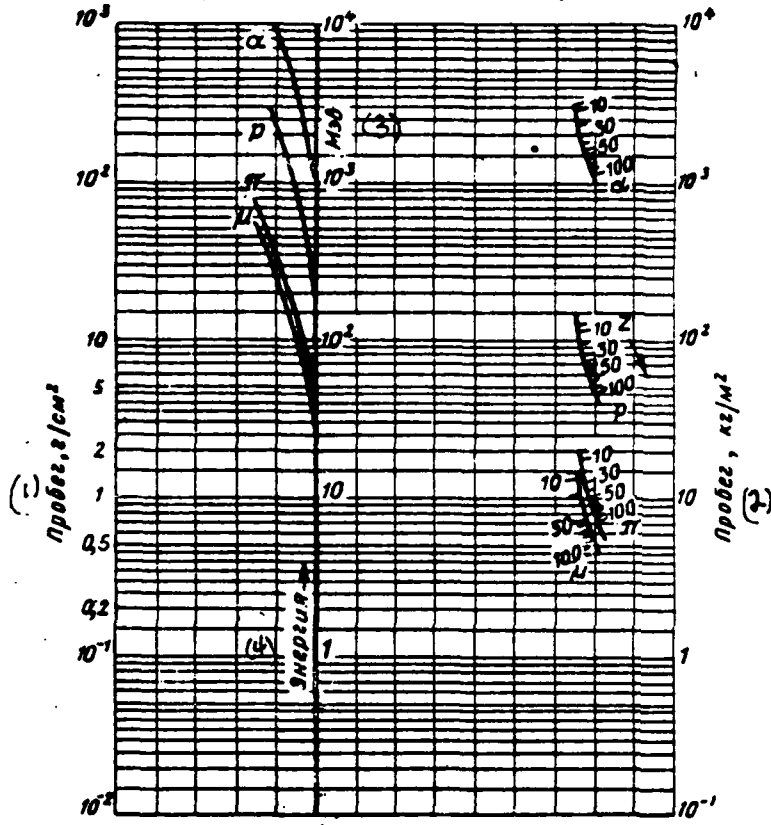

Key: (1). Range, g/cm<sup>2</sup>. (2). Range, kg/m<sup>2</sup>. (3). MeV. (4). Energy.

DOC = 83167509

PAGE 316

Page 175.

Appendix II.

Dependence of the buildup factor of dose  $B$ , ( $\mu R$ ) on energy  $E$  of point source of quanta with the passage of  $\gamma$ -radiation in the infinite medium for the water, aluminum, iron and lead.



(1) Вещество	(2) Энергия кванта E, Mev	(3) Факторы накопления дозы B <sub>p</sub> (μR) на расстояниях μR						
		1	2	4	7	10	15	20
(4) Вода	0,255	3,09	7,14	23,0	72,9	166	456	982
	0,5	2,52	5,14	14,3	38,8	77,6	178	334
	1,0	2,13	3,71	7,68	16,2	27,1	50,4	82,2
	2,0	1,83	2,77	4,88	8,46	12,4	19,5	27,7
	3,0	1,69	2,42	3,91	6,23	8,63	12,8	17,0
	4,0	1,58	2,17	3,34	5,13	6,84	9,97	12,9
	6,0	1,46	1,91	2,76	3,99	5,18	7,09	8,85
	8,0	1,38	1,74	2,40	3,34	4,25	5,66	6,95
	10,0	1,38	1,63	2,19	2,97	3,72	4,90	5,98
(5) Алюминий	0,5	2,37	4,24	9,47	21,5	38,9	80,8	141
	1,0	2,02	3,31	6,57	13,1	21,2	37,9	58,5
	2,0	1,75	2,61	4,62	8,05	11,9	18,7	26,3
	3,0	1,64	2,32	3,78	6,14	8,65	13,0	17,7
	4,0	1,53	2,08	3,22	5,01	6,88	10,1	13,4
	6,0	1,42	1,85	2,70	4,05	5,49	7,97	10,4
	8,0	1,34	1,68	2,37	3,45	4,58	6,56	8,52
	10,0	1,28	1,55	2,12	3,01	3,96	5,63	7,32
	(6) Железо	0,5	1,98	3,09	5,98	11,7	19,2	35,4
1,0		1,87	2,89	5,39	10,2	16,2	28,3	42,7
2,0		1,76	2,43	4,13	7,25	10,9	17,6	25,1
3,0		1,55	2,15	3,51	5,85	8,51	13,5	19,1
4,0		1,45	1,94	3,03	4,91	7,11	11,2	16,0
6,0		1,34	1,72	2,58	4,14	6,02	9,89	14,7
8,0		1,27	1,56	2,23	3,49	5,07	8,50	13,0
10,0		1,20	1,42	1,95	2,99	4,35	7,54	12,4
(7) Свинец		0,5	1,24	1,42	1,69	2,00	2,27	2,65
	1,0	1,37	1,69	2,26	3,02	3,74	4,81	5,88
	2,0	1,39	1,76	2,51	3,66	4,84	6,87	9,00
	3,0	1,34	1,68	2,43	3,75	5,30	8,44	12,3
	6,0	1,18	1,40	1,97	3,34	5,69	13,8	32,7
	8,0	1,14	1,30	1,74	2,89	5,07	14,1	44,6
	10,0	1,11	1,23	1,58	2,52	4,34	12,5	39,2

Key: (1). Substance. (2). Quantum energy E, MeV. (3). Buildup factors of dose at the distances μR. (4). Water. (5). Aluminum. (6). Iron. (7). Lead.

Pages 176-177.

Appendix III.

Coefficients of absorption and mean free path of  $\gamma$ -quanta in different media.

(1) Энергия кванта, Мэв	(2) Воздух (0,00129 г/см <sup>3</sup> )			(3) Вода (1 г/см <sup>3</sup> )			(4) Алюминий (2,7 г/см <sup>3</sup> )			(5) Железо (7,8 г/см <sup>3</sup> )			(6) Свинец (11,3 г/см <sup>3</sup> )		
	$\mu/\rho$ , см <sup>2</sup> /г	$\mu$ , см <sup>-1</sup>	$\lambda$ , см	$\mu/\rho$ , см <sup>2</sup> /г	$\mu$ , см <sup>-1</sup>	$\lambda$ , см	$\mu/\rho$ , см <sup>2</sup> /г	$\mu$ , см <sup>-1</sup>	$\lambda$ , см	$\mu/\rho$ , см <sup>2</sup> /г	$\mu$ , см <sup>-1</sup>	$\lambda$ , см	$\mu/\rho$ , см <sup>2</sup> /г	$\mu$ , см <sup>-1</sup>	$\lambda$ , см
0,1	0,153	0,197 · 10 <sup>-3</sup>	50,8	0,171	0,171	5,86	0,169	0,457	2,19	0,370	2,88	0,347	5,46	81,7	0,0182
0,15	0,133	0,172 · 10 <sup>-3</sup>	58,2	0,151	0,151	6,63	0,138	0,372	2,69	0,196	1,53	0,654	1,92	21,7	0,0461
0,2	0,123	0,159 · 10 <sup>-3</sup>	62,9	0,137	0,137	7,30	0,122	0,329	3,04	0,146	1,14	0,877	0,942	10,6	0,0943
0,3	0,107	0,138 · 10 <sup>-3</sup>	72,5	0,119	0,119	8,40	0,104	0,281	3,56	0,110	0,857	1,17	0,378	4,27	0,234
0,4	0,096	0,124 · 10 <sup>-3</sup>	80,6	0,106	0,106	9,44	0,0927	0,250	4,00	0,0939	0,733	1,38	0,220	2,46	0,403
0,5	0,087	0,112 · 10 <sup>-3</sup>	89,3	0,0967	0,0967	10,3	0,0844	0,228	4,38	0,0840	0,665	1,53	0,152	1,72	0,581
0,6	0,081	0,104 · 10 <sup>-3</sup>	96,2	0,0894	0,0894	11,2	0,0779	0,210	4,77	0,0769	0,600	1,67	0,119	1,34	0,746
0,8	0,071	0,0915 · 10 <sup>-3</sup>	109	0,0786	0,0786	12,7	0,0693	0,184	5,44	0,0668	0,521	1,92	0,0866	0,978	1,03
1,0	0,0636	0,0818 · 10 <sup>-3</sup>	122	0,0706	0,0706	14,2	0,0614	0,166	6,02	0,0608	0,467	2,14	0,0703	0,706	1,26
1,5	0,0515	0,0664 · 10 <sup>-3</sup>	151	0,0676	0,0676	17,4	0,0500	0,135	7,42	0,0484	0,378	2,94	0,0523	0,591	1,60
2,0	0,0435	0,0561 · 10 <sup>-3</sup>	178	0,0493	0,0493	20,3	0,0431	0,116	8,63	0,0422	0,329	3,04	0,0456	0,515	1,94
3,0	0,0350	0,0452 · 10 <sup>-3</sup>	221	0,0396	0,0396	25,2	0,0353	0,0953	10,5	0,0359	0,280	3,57	0,0413	0,467	2,14
4,0	0,0305	0,0393 · 10 <sup>-3</sup>	254	0,0339	0,0339	29,5	0,0310	0,0837	11,9	0,0330	0,258	3,87	0,0416	0,470	2,13
5,0	0,0270	0,0348 · 10 <sup>-3</sup>	287	0,0302	0,0302	33,1	0,0284	0,0767	13,0	0,0314	0,245	4,08	0,0430	0,488	2,06
6,0	0,0245	0,0316 · 10 <sup>-3</sup>	316	0,0277	0,0277	36,1	0,0266	0,0718	13,9	0,0305	0,238	4,20	0,0445	0,508	1,99
8,0	0,0220	0,0284 · 10 <sup>-3</sup>	352	0,0242	0,0242	41,3	0,0243	0,0656	15,2	0,0298	0,232	4,31	0,0471	0,529	1,88
10,0	0,0200	0,0258 · 10 <sup>-3</sup>	388	0,0221	0,0221	45,2	0,0232	0,0627	15,9	0,0300	0,234	4,27	0,0503	0,568	1,76

Note.  $\mu/\rho$  - mass coefficient in the glazings,  $\mu$  - linear absorption coefficient,  $\lambda$  - mean free path.

Key: (1). Quantum energy, MeV. (2). Air ( $0.00129 \text{ g/cm}^3$ ). (3).  $\text{cm}^2/\text{g}$ .  
(4). Water ( $1 \text{ g/cm}^3$ ). (5). Aluminum ( $2.7 \text{ g/cm}^3$ ). (6). Iron ( $7.8 \text{ g/cm}^3$ ). (7). Lead ( $11.3 \text{ g/cm}^3$ ).

Pages 178-183.

Appendix IV.

Values  $e^{-x}$

$x$	$e^{-x}$	$x$	$e^{-x}$	$x$	$e^{-x}$	$x$	$e^{-x}$
0	1	0,062	0,93988	0,215	0,8065	0,425	0,6538
0,00001	0,99999	0,064	0,93800	0,220	0,8025	0,430	0,6505
0,0001	0,99990	0,066	0,93613	0,225	0,7985	0,435	0,6473
0,0002	0,99980	0,068	0,93426	0,230	0,7945	0,440	0,6440
0,0003	0,99970	0,070	0,93239	0,235	0,7906	0,445	0,6408
0,0004	0,99960	0,072	0,93053	0,240	0,7866	0,450	0,6376
0,0005	0,99950	0,074	0,92867	0,245	0,7827	0,455	0,6344
0,001	0,99900	0,076	0,92682	0,250	0,7788	0,460	0,6313
0,002	0,99800	0,078	0,92496	0,255	0,7749	0,465	0,6281
0,003	0,99700	0,080	0,92312	0,260	0,7710	0,470	0,6250
0,004	0,99601	0,082	0,92127	0,265	0,7672	0,475	0,6219
0,005	0,99501	0,084	0,91943	0,270	0,7634	0,480	0,6188
0,006	0,99402	0,086	0,91759	0,275	0,7596	0,485	0,6157
0,007	0,99302	0,088	0,91576	0,280	0,7558	0,490	0,6126
0,008	0,99203	0,090	0,91393	0,285	0,7520	0,495	0,6096
0,009	0,99104	0,092	0,91211	0,290	0,7483	0,500	0,6065
0,010	0,99005	0,094	0,91028	0,295	0,7445	0,51	0,6005
0,012	0,98807	0,096	0,90846	0,300	0,7408	0,52	0,5945
0,014	0,98610	0,098	0,90665	0,305	0,7371	0,53	0,5886
0,016	0,98413	0,100	0,90484	0,310	0,7334	0,54	0,5827
0,018	0,98216	0,105	0,90032	0,315	0,7298	0,55	0,5769
0,020	0,98020	0,110	0,89583	0,320	0,7261	0,56	0,5712
0,022	0,97824	0,115	0,89136	0,325	0,7225	0,57	0,5655
0,024	0,97629	0,120	0,88692	0,330	0,7189	0,58	0,5599
0,026	0,97434	0,125	0,88249	0,335	0,7153	0,59	0,5543
0,028	0,97239	0,130	0,87809	0,340	0,7118	0,60	0,5488
0,030	0,97045	0,135	0,87372	0,345	0,7082	0,61	0,5434

0,032	0,96851	0,140	0,86936	0,350	0,7047	0,62	0,5396
0,034	0,96657	0,145	0,86502	0,355	0,7012	0,63	0,5326
0,036	0,96464	0,150	0,86071	0,360	0,6977	0,64	0,5273
0,038	0,96271	0,155	0,83642	0,365	0,6942	0,65	0,5220
0,040	0,96079	0,160	0,85214	0,370	0,6907	0,66	0,5169
0,042	0,95887	0,165	0,84789	0,375	0,6873	0,67	0,5117
0,044	0,95695	0,170	0,84366	0,380	0,6839	0,68	0,5066
0,046	0,95504	0,175	0,83946	0,385	0,6804	0,69	0,5016
0,048	0,95313	0,180	0,83527	0,390	0,6770	0,70	0,4966
0,050	0,95123	0,185	0,83110	0,395	0,6737	0,71	0,4916
0,052	0,94933	0,190	0,82695	0,400	0,6703	0,72	0,4868
0,054	0,94743	0,195	0,82283	0,405	0,6670	0,73	0,4819
0,056	0,94554	0,200	0,8187	0,410	0,6636	0,74	0,4771
0,058	0,94365	0,205	0,8146	0,415	0,6603	0,75	0,4724
0,060	0,94196	0,210	0,8106	0,420	0,6570	0,76	0,4677
0,77	0,4630	1,40	0,2466	2,65	0,0707	6,6	1,360-10 <sup>-3</sup>
0,78	0,4584	1,42	0,2417	2,70	0,0672	6,7	1,231
0,79	0,4538	1,44	0,2369	2,75	0,0639	6,8	1,114
0,80	0,4493	1,46	0,2322	2,80	0,0608	6,9	1,008
0,81	0,4449	1,48	0,2276	2,85	0,0578	7,0	9,119-10 <sup>-4</sup>
0,82	0,4404	1,50	0,2231	2,90	0,0550	7,1	8,251
0,83	0,4360	1,52	0,2187	2,95	0,0523	7,2	7,466
0,84	0,4317	1,54	0,2144	3,00	0,0498	7,3	6,755
0,85	0,4274	1,56	0,2101	3,1	0,04505	7,4	6,113
0,86	0,4232	1,58	0,2060	3,2	0,04075	7,5	5,531
0,87	0,4190	1,60	0,2019	3,3	0,03688	7,6	5,005
0,88	0,4148	1,62	0,1979	3,4	0,03337	7,7	4,528
0,89	0,4107	1,64	0,1940	3,5	0,03019	7,8	4,0974

0.90	0.4066	1.66	0.1901	3.6	0.02732	7.9	3.7074
0.91	0.4023	1.68	0.1864	3.7	0.02472	8.0	3.355
0.92	0.3985	1.70	0.1827	3.8	0.02237	8.1	3.035
0.93	0.3946	1.72	0.1791	3.9	0.02024	8.2	2.747
0.94	0.3906	1.74	0.1755	4.0	0.01831	8.3	2.485
0.95	0.3867	1.76	0.1720	4.1	0.01657	8.4	2.247
0.96	0.3829	1.78	0.1686	4.2	0.01500	8.5	2.035
0.97	0.3791	1.80	0.1653	4.3	0.01357	8.6	1.841
0.98	0.3753	1.82	0.1620	4.4	0.01228	8.7	1.666
0.99	0.3716	1.84	0.1588	4.5	0.01111	8.8	1.507
1.00	0.3679	1.86	0.1557	4.6	0.01005	8.9	1.364
1.02	0.3606	1.88	0.1526	4.7	0.00910	9.0	1.234
1.04	0.3534	1.90	0.1496	4.8	0.008230	9.2	1.010
1.06	0.3464	1.92	0.1466	4.9	0.00745	9.4	0.827
1.08	0.3396	1.94	0.1437	5.0	0.006738	9.6	0.677 · 10 <sup>-4</sup>
1.10	0.3328	1.96	0.1408	5.1	0.006097	9.8	0.555
1.12	0.3263	1.98	0.1381	5.2	0.005517	10.0	0.454
1.14	0.3198	2.00	0.1353	5.3	0.004992	11.0	1.670 · 10 <sup>-5</sup>
1.16	0.3135	2.05	0.1287	5.4	0.004517	12	0.614
1.18	0.3073	2.10	0.1225	5.5	0.004087	13	0.226
1.20	0.3012	2.15	0.1169	5.6	0.003698	14	0.08316
1.22	0.2952	2.20	0.1108	5.7	0.003346	15	0.03059
1.24	0.2894	2.25	0.1054	5.8	0.003028	16	1.125 · 10 <sup>-7</sup>
1.26	0.2837	2.30	0.1003	5.9	0.002739	17	0.4140
1.28	0.2780	2.35	0.0954	6.0	2.479 · 10 <sup>-8</sup>	18	0.1523
1.30	0.2725	2.40	0.0907	6.1	2.243	19	0.0560
1.32	0.2671	2.45	0.0863	6.2	2.029	20	2.06 · 10 <sup>-9</sup>
1.34	0.2618	2.50	0.0821	6.3	1.836	25	13.89 · 10 <sup>-12</sup>
1.36	0.2567	2.55	0.0781	6.4	1.662	30	0.094 · 10 <sup>-11</sup>
1.38	0.2516	2.60	0.0743	6.5	1.503	35	1 · 10 <sup>-15</sup>

Page 184.

## LITERATURE

## Literature for Chapter 1.

1. Шпольский Э. В. Атомная физика, т. 1, изд. 5-е. Физматгиз, 1963 и т. 2, изд. 4-е. Гостехиздат, 1951.
2. «Экспериментальная ядерная физика», т. 1—3. Пер. с англ., под ред. Э. Серге. Изд-во иностранной литературы, 1965.
3. Мухин К. Н. Введение в ядерную физику, изд. 2-е. Атомиздат, 1965.
4. «Дозиметрия ионизирующих излучений. Основные понятия». Сборник рекомендуемых терминов, вып. 70. АН СССР. Изд-во «Наука», 1965.
5. Radiation quantities and units. International commission on radiological units and measurements (ICRU). Report 10a, 1962, Handbook 84, United States Department of Commerce National Bureau of Standards.
6. Егер Р. Дозиметрия и защита от излучений. Пер. с нем., под ред. Б. М. Исаева. Атомиздат, 1961.
7. Справочник по ядерной физике. Пер. с англ., под ред. Л. А. Арцимовича. Физматгиз, 1963.
8. Fermi E., Marschall J. Phys. Rev., 1947, v. 72, p. 1139.
9. Прокофьев Ю. А., Спивак П. Е. Исследование распада нейтрона. «Атомная энергия», 1962, т. 12, вып. 4, стр. 278.
10. Юдин М. Ф., Фоминных В. И. Нейтронная дозиметрия. Стандартгиз, 1964.
11. Бобков В. Г., Демин В. П. и др. Радиационная безопасность при космических полетах. Атомиздат, 1964.
12. Sternheimer R. M. Range-energy relations for protons in Be, C, Al, Si, Pb and Air, Phys. Rev., 1959, v. 115, July, № 1, p. 137—142.
13. Ардашников С. Н., Гольдин С. М. и др. Защита от радиоактивных излучений, под ред. А. В. Николаева. Физматгиз, 1961.
14. Лэпп Р. Е., Эндрюс Г. Л. Физика ядерного излучения. Пер. с англ., под ред. К. В. Астахова, Б. Б. Кудрявцева и А. В. Кустовой. Воениздат, 1956.
15. Glocker R. Z. «Nature», 1948, v. 3, p. 147 (цитируется по Р. Егеру [6]).
16. Григоров Н. Л., Савенко И. А., Скуридин Г. А. Космические станции «Протон», газета «Правда» от 16 ноября 1965 г.

## Literature for Chapter 2.

1. ГОСТ ВКС 7623. Единицы рентгеновского излучения.
2. ГОСТ ВКС 7159. Единицы радиоактивности.
3. ГОСТ 8848-58. Единицы рентгеновского и гамма-излучений и радиоактивности.
4. Radiation quantities and units. International commission on radiological units and measurements (ICRU). Report 10a, 1962. Handbook 84. United States Department of Commerce National Bureau of Standards.
5. «Новая рекомендация МКРЕ по величинам и единицам ионизирующих излучений», «Измерительная техника», 1963, № 10, стр. 54—59.
6. ГОСТ 9867-61. Международная система единиц.
7. Бурдун Г. Д., Калашников Н. В., Стоцкий Л. П. Международная система единиц, под ред. Г. Д. Бурдуна. Изд-во «Высшая школа», 1964.
8. Беклемешев Л. Н. Меры и единицы физических величин. Физматгиз, 1964.
9. Внедрение международной системы единиц — важное условие дальнейшего прогресса науки и техники. Стандартгиз, 1964.
10. Долинский Е. Ф., Пилипчук Б. И. Естественные системы единиц. «ЭИКА», 1965, вып. 4, лист 1В3-2.
11. Бурдун Г. Д. Единицы физических величин, изд. 3-е. Стандартгиз, 1963.
12. Чергов А. Г. Международная система единиц измерения. Росвузиздат, 1963.
13. Воробьев А. А. Международная система единиц. Изд-во МХТИ им. Д. И. Менделеева, 1963.
14. «Таблицы перевода единиц измерения». Под ред. К. П. Широкова. Стандартгиз, 1963.
15. Широков К. П. Единицы измерений. Государственные стандарты СССР. «ЭИКА», 1962, вып. 1, лист 1В3-1.
16. ГОСТ 8848-63. Единицы радиоактивности и ионизирующих излучений.
17. «Дозиметрия ионизирующих излучений. Основные понятия». Сборник рекомендуемых терминов, вып. 70. АН СССР, Комитет научно-технической терминологии. Изд-во «Наука», 1965.
18. «Атомная энергия» (краткая энциклопедия). Изд-во «Большая советская энциклопедия», 1958.
19. Единица активности и дозы ионизирующих излучений. Пер. с англ., под ред. Н. Г. Гусева. Изд-во иностранной литературы, 1959.
20. Юдин М. Ф. Единицы измерений ионизирующих излучений и радиоактивности. «ЭИКА», 1965, вып. 4, лист 11М 604.
21. Егер Р. Дозиметрия и защита от излучений (физические и технические константы). Пер. с немец., под ред. Б. М. Исаева. Атомиздат, 1961.
22. Иванов В. И. Дозиметрия ионизирующих излучений, Атомиздат, 1964.
23. Юдин М. Ф., Фоминных В. И. Нейтронная дозиметрия. Стандартгиз, 1964.
24. Rogers S. C. Radiation damage to satellite electronic Systems. IEEE Trans., 1963, v. NS-10, Jan., № 1, p. 97—106.
25. Санитарные правила работы с радиоактивными веществами и источниками ионизирующих излучений. Атомиздат, 1960.
26. Юдин М. Ф. Единица измерения нейтронной дозы. «Измерительная техника», 1960, № 1, стр. 51—53.
27. Johnson E. R. Effects of nuclear radiation on electron tube materials. IRE Wescon Conv. Record, 1959, v. 3, pt. 8, p. 70—72.
28. ГОСТ 7663-55. Образование кратных и дольных единиц измерения.



## Literature for Chapter 3.

1. «Микроэлектроника». Пер. с англ., под ред. Н. П. Богородицкого. Изд-во «Советское радио», 1966.
2. Ширшев Л. Г. Возможные условия работы РТА в полях излучений. НТК по космической радиосвязи. НТО им. Попова, 1968.
3. Джафф, Риттенхауз. Поведение материалов в космических условиях. «Ракетная техника», 1962, № 3, стр. 3—37.
4. Олесен. Проектирование электронной аппаратуры с учетом воздействия космической радиации. «Электроника», 1964, т. 37, № 32, стр. 32—43.
5. «Действие ядерного оружия. Пер. с англ. Воениздат, 1963.
6. Ширшев Л. Г. В зоне ядерного взрыва. «Техника и вооружение», 1967, № 2.
7. Кларк, Хенксам, Вайзер. Последствия кратковременного воздействия радиоактивного облучения электронной аппаратуры. «Электроника», 1961, т. 34, № 6, февр. 10, стр. 23—28.
8. Grittenden I. R. IRE Wescon Conv. Rec., 1960, v. 4, pt. 6, Aug. p. 141—147.
9. Лейлунский О. И. Гамма-излучение атомного взрыва. Атомиздат, 1959.
10. Ямпольский П. А. Нейтроны атомного взрыва. Атомиздат, 1961.
11. Иванов А. И., Рыбкин Г. И. Поражающее действие ядерного взрыва. Воениздат, 1960.
12. Власов Н. А. Нейтроны, под ред. П. И. Лукирского. Гостехиздат, 1955.
13. Voucher R. T. J. Appl. Phys., 1965, v. 36, № 9, p. 2722.
14. Керим-Маркус И. Б., Ковалев Е. Е., Ларичев А. Б. и др. Радиационная безопасность при космических полетах. Атомиздат, 1964.
15. Цвик Ю., Циммерман Р. Энергетические системы для космических кораблей. В сб. «Использование солнечной энергии при космических исследованиях». Пер. с англ., под ред. В. А. Баумана. Изд-во «Мир», 1964, стр. 92—119.
16. «Теория ядерных реакторов». Пер. с англ., под ред. Г. Берихофа и Э. Вигнера. Атомиздат, 1963.
17. Люш Д. В., Николаев Б. Н. Дозиметрический контроль на атомных судах. Судпромгиз, 1962.
18. Федоров Н. Д. Краткий справочник инженера-физика. Атомиздат, 1961.
19. «Aviation Week», 1963, v. 78, June 3, № 22, p. 67.
20. Володичев Н. Н., Григоров Н. Л., Нестеров В. Е. и др. Изучение частиц космических лучей высокой и сверхвысокой энергии и химического состава в области очень тяжелых ядер на научных космических станциях «Протон-1» и «Протон-2». Доклад на Всесоюзном совещании по космическим лучам. Алма-Ата, октябрь 1966.
21. Черяхчян А. Н., Черяхчян Т. Н. Энергетический спектр и полное число фотонов малых энергий в космических лучах стратосферы. ЖЭТФ, 1961, т. 40, вып. 6, стр. 1602—1606.

22. Райзер Ю. П. ПМТФ, 1956, № 6, стр. 19.
23. Вернов С. Н., Чудаков А. Е. и др. Результаты исследования геометрического расположения и состава частиц радиационных поясов Земли по данным спутников «Электрон-1» и «Электрон-2». В сб. «Исследования космического пространства». Изд-во «Наука», 1965, стр. 394.
24. Андерсон К. Высокоэнергетичная солнечная радиация. В сб. «Космическая физика», Пер. с англ., под ред. И. А. Жулина. Изд-во «Мир», 1966, стр. 599—649.
25. Мазли А. Д., Годен А. Д. Полный анализ дозы для вспышки 12 ноября 1960 г. В сб. «Радиационная опасность при космических полетах». Пер. с англ., под ред. В. Е. Нестерова. Изд-во «Мир», 1964, стр. 376—397.
26. Фольш Т. Оценка доз радиации в космическом пространстве по последним данным. В сб. «Радиационная опасность при космических полетах». Пер. с англ., под ред. В. Е. Нестерова. Изд-во «Мир», 1964, стр. 475—516.
26. Peterson L. E., Winckler I. R. Geophys. Res., 1959, v. 64, p. 697.
27. Чапп Е. Л., Вильямс Р. В. Интенсивность испускания протонов Солнцем. В сб. «Радиационная опасность при космических полетах». Пер. с англ., под ред. В. Е. Нестерова. Изд-во «Мир», 1964, стр. 366—375.
28. Вернов С. Н., Григоров Н. Л., Иваненко И. П. и др. Возможный механизм создания «земного корпускулярного излучения» под действием космических лучей. «Доклады АН СССР», 1959, т. 124, № 5, стр. 1022.
29. Бек, Дивита. Оценка доз, получаемых от естественных источников излучения при полете в космическом корабле. «Ракетная техника», 1962, т. 32, № 11, стр. 33—48.
30. Weiss W. N. IEEE Trans., 1963, v. NS-10, Jan., № 1, p. 8—11.
31. Radiation belt will be gone by next July. Electronics, 1962, v. 35, Nov. 23, № 47, p. 7, 8. Wetmore W. C. Aviation Week, 1963, v. 78, Marz. 25, № 12, p. 26.
32. Clark E. Aviation Week, 1959, v. 70, May III, № 13, p. 26, 27. Fuska J. A. Aviation Week, 1959, v. 70, May 11, № 19, p. 63—67.
33. Tord C. D. Missiles and Rockets, 1959, v. 6, May 18, № 20, p. 37, 40, 43, 44, 47, 49.
34. «Операция «Аргус». Пер. с англ. Атомиздат, 1960.
35. New high-altitude tests. Aviation Week, 1962, v. 77, Sept. 17, № 12, p. 32, 33.
36. Radiation belt intensified. Aviation Week, 1962, v. 77, Sept. 10, № 11, p. 35.
37. Kornberg W., Maguire T., Wolf M. Electronics, 1962, v. 35, Dec. 14, № 50, p. 22—24.
38. Heiss W. H. Journal of geophysical research, 1963, v. 68, Feb. 1, № 3, p. 667—684.
39. «Операция «Морская звезда». Пер. с англ. Атомиздат, 1964.
40. Ganes E. E., Geass R. A. Journal of geophysical research, 1964, v. 69, p. 1271.
  
41. Kawnecki J. Journal of geophysical research, 1963, № 68, p. 5461.

## Literature for Chapter 4.

1. Конобеевский С. Т. Современные представления о действии ядерных излучений на твердые тела. Сб. докладов «Действие ядерных излучений на материалы». Отв. ред. С. Т. Конобеевский. Изд-во АН СССР, 1962, стр. 5—20.
2. Влияние ядерных излучений на материалы. Пер. с англ., под ред. Дж. Хэрвуда. Судпромгиз, 1961.
3. Динс Дж., Винчард Дж. Радиационные эффекты в твердых телах. Пер. с англ., под ред. Г. С. Жданова. Изд-во иностранной литературы, 1960.
4. Чарлсби А. Ядерные излучения и полимеры. Пер. с англ., под ред. Ю. С. Лазуркина и В. Л. Карпова. Изд-во иностранной литературы, 1962.
5. Экспериментальная ядерная физика, т. 1—3. Пер. с англ., под ред. Э. Серге. Изд-во иностранной литературы, 1955.
6. Глен Д. В. Радиационные эффекты в твердых телах, УФН, 1956, т. 60, вып. 3, стр. 445—563.  
Кинчин Г. Н., Пиз Р. С. Смещение атомов в твердых телах под действием излучения. УФН, 1956, т. 60, вып. 4, стр. 590—615.
7. Clark J. W., Handcome T. D., Wisse H. L. Electronics, 1961, Feb. 10, v. 34, № 6, p. 62—65.
8. Clark J. W., Handcome T. D. Nucleonics, 1960, v. 18, Sept., № 9.
9. Innes R. The Journal of the British Institution of Radio Engineers, 1961, v. 22, Sept., № 3, p. 241—250.
10. Kaplan A. L. Aerospace Engineering, 1962, v. 21, July, № 7, p. 40—50.
11. Заславский Ю. С. Радиационная стойкость смазочных материалов. Атомиздат, 1961.
12. Electronics, 1960, v. 33, № 30, p. 40—41.
13. Bagrat P. Electronics, 1962, v. 35, March 16, № 11, p. 51—57.
14. Действие излучений на материалы и детали. Сборник статей. Пер. с англ. Атомиздат, 1959, стр. 17—29.
15. Вавилов В. С. Действие излучений на полупроводники. Физматгиз, 1963.
16. Шпольский Э. В. Атомная физика, т. 2, изд. 2-е. Гостехиздат, 1963.
17. Юдин М. Ф., Фоминых В. И. Нейтронная дозиметрия. Стандартгиз, 1964.
18. Власов Н. А. Нейтроны. Гостехиздат, 1955.
19. Иванов А. И., Рыбкин Г. И. Поражающее действие ядерного взрыва. Воениздат, 1960.
20. Гордеев И. В., Кардашев Д. А., Малышев А. В. Ядерно-физические константы. Справочник. Атомиздат, 1963.  
Юз Д. Д. Нейтронные эффективные сечения. Изд-во иностранной литературы, 1959.  
«Атлас нейтронных эффективных сечений». Изд-во «Академикита», 1955.

21. Ковалев Е. Е., Смиренный Л. Н., Ларичев А. В. и др. Радиационная безопасность при космических полетах. Атомиздат, 1964.
22. Sternheimer R. M. Phys. Rev., 1959, v. 118, July, № 4, p. 137—142.
23. Нойфельд Дж., Снайдер В. Определение рассеяния энергии тяжелыми заряженными частицами в ткани. «Сборник материалов симпозиума по отдельным вопросам дозиметрии». Атомиздат, 1962.
24. Справочник по ядерной физике. Пер. с англ., под ред. Л. А. Арцимовича. Физматгиз, 1963.
25. Лейпунский О. И. Гамма-излучение атомного взрыва. Атомиздат, 1959.
26. Иванов В. И. Дозиметрия ионизирующих излучений. Атомиздат, 1964.
27. «Новая рекомендация МКРЭ по величинам и единицам ионизирующих излучений». «Измерительная техника», 1963, стр. 54—59.
28. Аглинцев К. К. Дозиметрия ионизирующих излучений, Гостехиздат, 1957.
29. Seitz F. Rev. Mod. Phys., 1954, v. 26, № 1. —
30. Конобеевский С. Т. Действие облучения на материалы. Атомиздат, 1967.
31. Джафф, Риттенхауз. Поведение материалов в космических условиях. «Ракетная техника», 1962, т. 32, № 3, стр. 3—37.
32. Keister, Glenn L. Electron. Inds., 1962, v. 21, № 4, p. 108—111.
33. Bertolotti M. Alta Frequenza, 1961, v. 30, Dec. 30, p. 862—872 или англ. перев. статьи в журнале «Alta Frequenza» (English Issue, № 4), 1962, v. 31, Nov., № 11, p. 753—763.
34. Aviation Week, 1963, June 3, v. 78, № 22, p. 67.
35. Grittenden J. K. Electrical Engineering, 1959, v. 78, Sept., № 9, p. 898—901.
36. Levin J. H., Ekern W. F. Electronics, 1960, v. 33, Apr. 22, № 17, p. 69—70, 72.
37. Ширшев Л. Г. В зоне ядерного взрыва. «Техника и вооружение», 1967, № 2.

Pages 190-191.

No typing.

END

FILMED

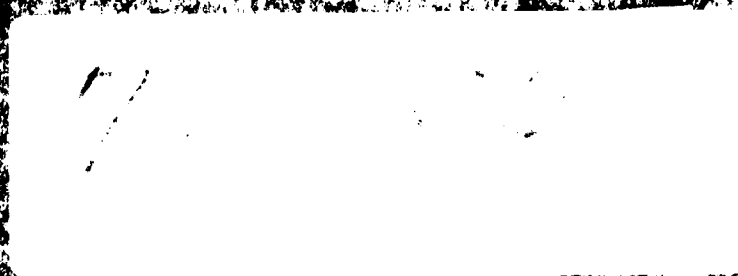

DTIC